

# ETSI TS 138 521-3 V18.5.0 (2025-02)



**5G;  
NR;  
User Equipment (UE) conformance specification;  
Radio transmission and reception;  
Part 3: Range 1 and Range 2 Interworking operation  
with other radios  
(3GPP TS 38.521-3 version 18.5.0 Release 18)**



---

Reference

RTS/TSGR-0538521-3v150

---

Keywords

5G

**ETSI**

650 Route des Lucioles  
F-06921 Sophia Antipolis Cedex - FRANCE

Tel.: +33 4 92 94 42 00 Fax: +33 4 93 65 47 16

Siret N° 348 623 562 00017 - APE 7112B  
Association à but non lucratif enregistrée à la  
Sous-Préfecture de Grasse (06) N° w061004871

---

**Important notice**

The present document can be downloaded from the  
[ETSI Search & Browse Standards application](#).

The present document may be made available in electronic versions and/or in print. The content of any electronic and/or print versions of the present document shall not be modified without the prior written authorization of ETSI. In case of any existing or perceived difference in contents between such versions and/or in print, the prevailing version of an ETSI deliverable is the one made publicly available in PDF format on [ETSI deliver repository](#).

Users should be aware that the present document may be revised or have its status changed, this information is available in the [Milestones listing](#).

If you find errors in the present document, please send your comments to the relevant service listed under [Committee Support Staff](#).

If you find a security vulnerability in the present document, please report it through our [Coordinated Vulnerability Disclosure \(CVD\)](#) program.

---

**Notice of disclaimer & limitation of liability**

The information provided in the present deliverable is directed solely to professionals who have the appropriate degree of experience to understand and interpret its content in accordance with generally accepted engineering or other professional standard and applicable regulations.

No recommendation as to products and services or vendors is made or should be implied.

No representation or warranty is made that this deliverable is technically accurate or sufficient or conforms to any law and/or governmental rule and/or regulation and further, no representation or warranty is made of merchantability or fitness for any particular purpose or against infringement of intellectual property rights.

In no event shall ETSI be held liable for loss of profits or any other incidental or consequential damages.

Any software contained in this deliverable is provided "AS IS" with no warranties, express or implied, including but not limited to, the warranties of merchantability, fitness for a particular purpose and non-infringement of intellectual property rights and ETSI shall not be held liable in any event for any damages whatsoever (including, without limitation, damages for loss of profits, business interruption, loss of information, or any other pecuniary loss) arising out of or related to the use of or inability to use the software.

---

**Copyright Notification**

No part may be reproduced or utilized in any form or by any means, electronic or mechanical, including photocopying and microfilm except as authorized by written permission of ETSI.

The content of the PDF version shall not be modified without the written authorization of ETSI.

The copyright and the foregoing restriction extend to reproduction in all media.

© ETSI 2025.  
All rights reserved.

---

# Intellectual Property Rights

## Essential patents

IPRs essential or potentially essential to normative deliverables may have been declared to ETSI. The declarations pertaining to these essential IPRs, if any, are publicly available for **ETSI members and non-members**, and can be found in ETSI SR 000 314: "*Intellectual Property Rights (IPRs); Essential, or potentially Essential, IPRs notified to ETSI in respect of ETSI standards*", which is available from the ETSI Secretariat. Latest updates are available on the [ETSI IPR online database](#).

Pursuant to the ETSI Directives including the ETSI IPR Policy, no investigation regarding the essentiality of IPRs, including IPR searches, has been carried out by ETSI. No guarantee can be given as to the existence of other IPRs not referenced in ETSI SR 000 314 (or the updates on the ETSI Web server) which are, or may be, or may become, essential to the present document.

## Trademarks

The present document may include trademarks and/or tradenames which are asserted and/or registered by their owners. ETSI claims no ownership of these except for any which are indicated as being the property of ETSI, and conveys no right to use or reproduce any trademark and/or tradename. Mention of those trademarks in the present document does not constitute an endorsement by ETSI of products, services or organizations associated with those trademarks.

**DECT™**, **PLUGTESTS™**, **UMTS™** and the ETSI logo are trademarks of ETSI registered for the benefit of its Members. **3GPP™**, **LTE™** and **5G™** logo are trademarks of ETSI registered for the benefit of its Members and of the 3GPP Organizational Partners. **oneM2M™** logo is a trademark of ETSI registered for the benefit of its Members and of the oneM2M Partners. **GSM®** and the GSM logo are trademarks registered and owned by the GSM Association.

---

# Legal Notice

This Technical Specification (TS) has been produced by ETSI 3rd Generation Partnership Project (3GPP).

The present document may refer to technical specifications or reports using their 3GPP identities. These shall be interpreted as being references to the corresponding ETSI deliverables.

The cross reference between 3GPP and ETSI identities can be found at [3GPP to ETSI numbering cross-referencing](#).

---

# Modal verbs terminology

In the present document "**shall**", "**shall not**", "**should**", "**should not**", "**may**", "**need not**", "**will**", "**will not**", "**can**" and "**cannot**" are to be interpreted as described in clause 3.2 of the [ETSI Drafting Rules](#) (Verbal forms for the expression of provisions).

"**must**" and "**must not**" are **NOT** allowed in ETSI deliverables except when used in direct citation.

# Contents

Intellectual Property Rights .....	2
Legal Notice .....	2
Modal verbs terminology.....	2
Foreword.....	19
1 Scope .....	20
2 References .....	20
3 Definitions, symbols and abbreviations .....	21
3.1 Definitions .....	21
3.2 Symbols.....	21
3.3 Abbreviations .....	22
4 General .....	24
4.1 Relationship between minimum requirements and test requirements .....	24
4.2 Applicability of minimum requirements .....	24
4.3 Specification suffix information.....	25
4.4 Test points analysis .....	26
4.5 Applicability and test coverage rules.....	26
4.5.0 General .....	26
4.5.1 Test coverage across 5G NR connectivity options .....	27
4.6 E-UTRA configuration for EN-DC FR1 tests applying the E-UTRA anchor-agnostic approach .....	27
4.7 E-UTRA configuration for EN-DC FR2 tests applying the E-UTRA anchor-agnostic approach .....	29
4.8 E-UTRA configuration for EN-DC FR1 tests not applying the E-UTRA anchor-agnostic approach .....	31
5 Operating bands and channel arrangement.....	31
5.1 General .....	31
5.2 Operating bands.....	32
5.2A Operating bands for CA .....	32
5.2A.1 Inter-band CA between FR1 and FR2.....	32
5.2B Operating bands for DC .....	32
5.2B.1 General.....	32
5.2B.2 to 5.2B.7 Void .....	32
5.2E Operating bands for V2X .....	32
5.2E.1 Intra-band V2X bands.....	32
5.2E.2 Inter-band V2X bands.....	32
5.3 UE Channel bandwidth .....	33
5.3A UE Channel bandwidth for CA .....	33
5.3A.1 Inter-band CA between FR1 and FR2.....	33
5.3B UE Channel bandwidth for DC .....	33
5.3B.0 General.....	33
5.3B.1 Intra-band EN-DC in FR1.....	34
5.3B.1.1 General .....	34
5.3B.1.2 BCS for Intra-band contiguous EN-DC .....	34
5.3B.1.3 BCS for Intra-band non-contiguous EN-DC .....	34
5.3E UE Channel bandwidth for V2X .....	36
5.3E.0 General.....	36
5.3E.1 Intra-band contiguous V2X in FR1.....	36
5.3E.2 Intra-band non-contiguous V2X in FR1 .....	36
5.3E.3 Inter-band V2X in FR1 .....	36
5.4 Void.....	36
5.4A Channel arrangement for CA.....	36
5.4B Channel arrangement for DC.....	37
5.4B.0 General.....	37
5.4B.1 Channel spacing for intra-band EN-DC carriers.....	37
5.5 Configuration .....	37
5.5A Configuration for CA .....	37

5.5A.1	Inter-band CA configurations between FR1 and FR2.....	37
5.5B	Configuration for DC .....	39
5.5B.1	General.....	39
5.5B.2	Intra-band contiguous EN-DC .....	39
5.5B.3	Intra-band non-contiguous EN-DC.....	40
5.5B.4	Inter-band EN-DC within FR1.....	40
5.5B.4.0	General .....	40
5.5B.4.1	Inter-band EN-DC configurations within FR1 (two bands) .....	41
5.5B.4.2	Inter-band EN-DC configurations within FR1 (three bands) .....	46
5.5B.4.3	Inter-band EN-DC configurations within FR1 (four bands) .....	54
5.5B.4.4	Inter-band EN-DC configurations within FR1 (five bands).....	59
5.5B.4.5	Inter-band EN-DC configurations within FR1 (six bands) .....	61
5.5B.4a	Inter-band NE-DC within FR1.....	62
5.5B.4a.1	Inter-band NE-DC configurations within FR1 (two bands) .....	62
5.5B.5	Inter-band EN-DC including FR2.....	62
5.5B.5.1	Inter-band EN-DC configurations including FR2 (two bands) .....	63
5.5B.5.2	Inter-band EN-DC configurations including FR2 (three bands) .....	66
5.5B.5.3	Inter-band EN-DC configurations including FR2 (four bands).....	72
5.5B.5.4	Inter-band EN-DC configurations including FR2 (five bands).....	76
5.5B.5.5	Void.....	76
5.5B.6	Inter-band EN-DC including FR1 and FR2 .....	76
5.5B.6.1	Void.....	77
5.5B.6.2	Inter-band EN-DC configurations including FR1 and FR2 (three bands).....	77
5.5B.6.3	Inter-band EN-DC configurations including FR1 and FR2 (four bands) .....	77
5.5B.6.4	Inter-band EN-DC configurations including FR1 and FR2 (five bands) .....	77
5.5B.6.5	Inter-band EN-DC configurations including FR1 and FR2 (six bands) .....	77
5.5B.7	Inter-band NR-DC between FR1 and FR2.....	77
5.5B.7.0	General .....	77
5.5B.7.1	Inter-band NR-DC configurations between FR1 and FR2 (two bands) .....	77
5.5E	Configuration for V2X operation .....	77
5.5E.1	General.....	77
5.5E.2	Intra-band contiguous V2X operation in FR1 .....	78
5.5E.3	Intra-band non-contiguous V2X operation in FR1 .....	78
5.5E.4	Inter-band V2X operation in FR1 .....	78
5.5E.4.1	Inter-band V2X configurations within FR1 (two bands).....	78
6	Transmitter characteristics .....	78
6.1	General .....	78
6.2	Transmitter power .....	80
6.2A	Transmitter power for CA without EN-DC.....	80
6.2A.1	UE maximum output power for CA.....	80
6.2A.1.1	UE maximum output power for inter-band NR CA between FR 1 and FR 2 without EN-DC .....	80
6.2A.2	UE maximum output power reduction for CA.....	80
6.2A.2.1	UE maximum output power reduction for inter-band NR CA between FR 1 and FR 2 without EN-DC .....	80
6.2A.3	UE additional maximum output power reduction for CA.....	80
6.2A.3.1	UE additional maximum output power reduction for inter-band NR CA between FR 1 and FR 2 without EN-DC .....	80
6.2A.4	Configured output power level for CA .....	81
6.2A.4.1	Configured output power level for inter-band NR CA between FR 1 and FR 2 without EN-DC.....	81
6.2A.4.2	$\Delta T_{IB,c}$ for CA.....	81
6.2A.4.2.1	$\Delta T_{IB,c}$ for inter-band CA between FR 1 and FR 2.....	81
6.2B	Transmitter power for DC .....	81
6.2B.1	UE Maximum Output Power for DC .....	81
6.2B.1.1	UE Maximum Output Power for Intra-Band Contiguous EN-DC .....	81
6.2B.1.2	UE Maximum Output Power for Intra-Band Non-Contiguous EN-DC .....	86
6.2B.1.3	UE Maximum Output Power for Inter-Band EN-DC within FR1 (1 E-UTRA CC, 1 NR CC) .....	90
6.2B.1.3_1	UE Maximum Output Power for Inter-Band EN-DC within FR1 (2 E-UTRA CCs, 1 NR CC).....	116
6.2B.1.3a	UE Maximum Output Power for Inter-Band NE-DC within FR1.....	121
6.2B.1.4	UE Maximum Output Power for Inter-Band EN-DC including FR2.....	122
6.2B.1.4.1	UE Maximum Output Power for Inter-Band EN-DC including FR2 (1 NR CC) - EIRP and TRP.....	122

6.2B.1.4.2	UE Maximum Output Power for Inter-Band EN-DC including FR2 (1 NR CC) - Spherical Coverage.....	123
6.2B.1.4_1	UE Maximum Output Power for Inter-Band EN-DC including FR2 (>1 NR CC).....	124
6.2B.1.4_1.1	UE Maximum Output Power for Inter-Band EN-DC including FR2 (2 NR CCs).....	124
6.2B.1.4_1.1.1	UE Maximum Output Power for Inter-Band EN-DC including FR2 (2 NR CCs) - EIRP and TRP .....	124
6.2B.1.4_1.1.2	UE Maximum Output Power for Inter-Band EN-DC including FR2 (2 NR CCs) - Spherical Coverage.....	125
6.2B.1.4_1.2	UE Maximum Output Power for Inter-Band EN-DC including FR2 (3 NR CCs).....	126
6.2B.1.4_1.2.1	UE Maximum Output Power for Inter-Band EN-DC including FR2 (3 NR CCs) - EIRP and TRP .....	126
6.2B.1.4_1.2.2	UE Maximum Output Power for Inter-Band EN-DC including FR2 (3 NR CCs) - Spherical Coverage.....	127
6.2B.1.4_1.3	UE Maximum Output Power for Inter-Band EN-DC including FR2 (4 NR CCs).....	128
6.2B.1.4_1.3.1	UE Maximum Output Power for Inter-Band EN-DC including FR2 (4 NR CCs) - EIRP and TRP .....	128
6.2B.1.4_1.3.2	UE Maximum Output Power for Inter-Band EN-DC including FR2 (4 NR CCs) – Spherical Coverage.....	129
6.2B.1.4_1.4	UE Maximum Output Power for Inter-Band EN-DC including FR2 (5 NR CCs).....	130
6.2B.1.4_1.4.1	UE Maximum Output Power for Inter-Band EN-DC including FR2 (5 NR CCs) - EIRP and TRP .....	130
6.2B.1.4_1.4.2	UE Maximum Output Power for Inter-Band EN-DC including FR2 (5 NR CCs) – Spherical Coverage.....	130
6.2B.1.4_1.5	UE Maximum Output Power for Inter-Band EN-DC including FR2 (6 NR CCs).....	130
6.2B.1.4_1.5.1	UE Maximum Output Power for Inter-Band EN-DC including FR2 (6 NR CCs) - EIRP and TRP .....	130
6.2B.1.4_1.5.2	UE Maximum Output Power for Inter-Band EN-DC including FR2 (6 NR CCs) – Spherical Coverage.....	131
6.2B.1.4_1.6	UE Maximum Output Power for Inter-Band EN-DC including FR2 (7 NR CCs).....	131
6.2B.1.4_1.6.1	UE Maximum Output Power for Inter-Band EN-DC including FR2 (7 NR CCs) - EIRP and TRP .....	131
6.2B.1.4_1.6.2	UE Maximum Output Power for Inter-Band EN-DC including FR2 (7 NR CCs) – Spherical Coverage.....	131
6.2B.1.4_1.7	UE Maximum Output Power for Inter-Band EN-DC including FR2 (8 NR CCs).....	131
6.2B.1.4_1.7.1	UE Maximum Output Power for Inter-Band EN-DC including FR2 (8 NR CCs) - EIRP and TRP .....	131
6.2B.1.4_1.7.2	UE Maximum Output Power for Inter-Band EN-DC including FR2 (8 NR CCs) – Spherical Coverage.....	132
6.2B.1.4D	UE Maximum Output Power for Inter-Band EN-DC including FR2 for UL MIMO.....	132
6.2B.1.4D.1	UE Maximum Output Power for Inter-Band EN-DC including FR2 for UL MIMO - EIRP and TRP.....	132
6.2B.1.4D.2	UE Maximum Output Power for Inter-Band EN-DC including FR2 for UL MIMO- Spherical coverage.....	133
6.2B.1.5	UE Maximum Output Power for Inter-Band EN-DC including both FR1 and FR2.....	134
6.2B.1.5D	UE Maximum Output Power for Inter-Band EN-DC including both FR1 and FR2 for UL MIMO ...	134
6.2B.1.6	UE Maximum Output Power for Inter-Band EN-DC including FR2 (1 NR CC) - EIRP with UL Gaps.....	134
6.2B.2	UE Maximum Output Power reduction for DC.....	135
6.2B.2.0	General.....	135
6.2B.2.1	UE Maximum Output Power reduction for Intra-Band Contiguous EN-DC.....	135
6.2B.2.2	UE Maximum Output Power reduction for Intra-Band Non-Contiguous EN-DC.....	148
6.2B.2.3	UE Maximum Output Power reduction for Inter-Band EN-DC within FR1 (1 NR CC).....	158
6.2B.2.3a	UE Maximum Output Power reduction for Inter-Band NE-DC within FR1 (1 NR CC).....	159
6.2B.2.4	UE Maximum Output Power reduction for Inter-Band EN-DC including FR2 (1 NR CC).....	159
6.2B.2.4a	UE Maximum Output Power reduction enhancements for Inter-Band EN-DC including FR2 (1 NR CC).....	160
6.2B.2.4D	UE Maximum Output Power reduction for Inter-Band EN-DC including FR2 for UL MIMO (1 NR CC).....	161
6.2B.2.4_1	UE Maximum Output Power reduction for Inter-Band EN-DC including FR2 (>1 NR CC).....	162
6.2B.2.4_1.1	UE Maximum Output Power reduction for Inter-Band EN-DC including FR2 (2 NR CCs).....	162
6.2B.2.4_1.2	UE Maximum Output Power reduction for Inter-Band EN-DC including FR2 (3 NR CCs).....	163
6.2B.2.4_1.3	UE Maximum Output Power reduction for Inter-Band EN-DC including FR2 (4 NR CCs).....	164

6.2B.2.5	UE Maximum Output power reduction for inter-band EN-DC including both FR1 and FR2 .....	165
6.2B.2.5D	UE Maximum Output power reduction for inter-band EN-DC including both FR1 and FR2 for UL MIMO .....	165
6.2B.3	UE additional maximum output power reduction for EN-DC .....	165
6.2B.3.1	UE Additional Maximum Output Power reduction for Intra-band contiguous EN-DC .....	165
6.2B.3.2	UE Additional Maximum Output Power reduction for Intra-Band Non-Contiguous EN-DC .....	191
6.2B.3.3	UE Additional Maximum Output Power reduction for Inter-Band EN-DC within FR1 (1 NR CC) ..	209
6.2B.3.4	UE Additional Maximum Output Power reduction for Inter-Band EN-DC including FR2 (1 NR CC) .....	210
6.2B.3.4_1	UE Additional Maximum Output power reduction for inter-band EN-DC including FR2 (> 1 NR CC) .....	212
6.2B.3.4_1.1	UE Additional Maximum Output power reduction for inter-band EN-DC including FR2 (2 NR CCs) .....	212
6.2B.3.4_1.2	UE Additional Maximum Output power reduction for inter-band EN-DC including FR2 (3 NR CCs) .....	213
6.2B.3.4_1.3	UE Additional Maximum Output power reduction for inter-band EN-DC including FR2 (4 NR CCs) .....	213
6.2B.3.4D	UE Additional Maximum Output Power reduction for Inter-Band EN-DC including FR2 (1 NR CC) for UL MIMO .....	214
6.2B.3.5	UE Additional Maximum Output power reduction for inter-band EN-DC including both FR1 and FR2 .....	215
6.2B.3.5D	UE Additional Maximum Output power reduction for inter-band EN-DC including both FR1 and FR2 for UL MIMO .....	216
6.2B.4	Configured Output Power for DC .....	216
6.2B.4.1	Configured Output Power Level for EN-DC .....	216
6.2B.4.1.0	Minimum Conformance Requirements .....	216
6.2B.4.1.1	Configured Output Power Level for Intra-Band Contiguous EN-DC .....	226
6.2B.4.1.2	Configured Output Power for Intra-Band Non-Contiguous EN-DC .....	231
6.2B.4.1.3	Configured Output Power for Inter-Band EN-DC within FR1 (1 E-UTRA CC, 1 NR CC) .....	236
6.2B.4.1.3_1	Configured Output Power for Inter-Band EN-DC within FR1 (2 E-UTRA CCs, 1 NR CC) .....	243
6.2B.4.1.4	Configured Output Power for Inter-Band EN-DC including FR2 (1 NR CC) .....	248
6.2B.4.1.4_1	Configured Output Power with Power Boost for Inter-Band EN-DC including FR2 (1 NR CC) .....	249
6.2B.4.1.5	Configured Output Power for Inter-Band EN-DC including both FR1 and FR2 .....	250
6.2B.4.2	$\Delta T_{IB,c}$ for DC .....	250
6.2B.4.2.1	Intra-Band Contiguous EN-DC .....	250
6.2B.4.2.2	Intra-Band non-Contiguous EN-DC .....	250
6.2B.4.2.3	Inter-Band EN-DC within FR1 .....	251
6.2B.4.2.3.5	$\Delta T_{IB,c}$ for EN-DC six bands .....	270
6.2B.4.2.3a	Inter-band NE-DC within FR1 .....	270
6.2B.4.2.4	Inter-band EN-DC including FR2 .....	270
6.2B.4.2.5	Inter-band EN-DC including both FR1 and FR2 .....	271
6.2B.5	Configured Output Power for NR-DC .....	271
6.2B.5.1	Configured Output power Level .....	271
6.2B.5.1.1	Configured Output Power Level for Inter-band NR-DC between FR1 and FR2 .....	271
6.2E	Transmitter power for V2X in FR1 .....	272
6.2E.1	UE Maximum Output Power for V2X .....	272
6.2E.1.0	Minimum conformance requirements .....	272
6.2E.1.1	UE maximum output power for Intra-band contiguous V2X .....	273
6.2E.1.2	UE maximum output power for Intra-band non-contiguous V2X .....	273
6.2E.1.3	UE maximum output power for Inter-band V2X .....	273
6.2E.1.3.1	UE maximum output power for Inter-band V2X with E-UTRA Uu and NR Sidelink .....	273
6.2E.1.3.2	UE maximum output power reduction for Inter-band V2X with NR Uu and E-UTRA V2X .....	275
6.2E.2	UE maximum output power reduction for V2X .....	277
6.2E.2.0	Minimum conformance requirements .....	277
6.2E.2.1	UE maximum output power reduction for Intra-band V2X .....	277
6.2E.2.2	UE maximum output power reduction for Inter-band V2X .....	277
6.2E.2.2.1	UE maximum output power reduction for Inter-band V2X with E-UTRA Uu and NR Sidelink .....	277
6.2E.2.2.2	UE maximum output power reduction for Inter-band V2X with NR Uu and E-UTRA V2X .....	279
6.2H	Transmitter power for DC with UL MIMO .....	281
6.2H.1	UE maximum output power for DC with UL MIMO .....	281

6.2H.1.3	UE maximum output power for inter-band EN-DC with UL MIMO within FR1.....	281
6.2H.2	UE maximum output power reduction for DC with UL MIMO .....	286
6.2H.2.1	.....	286
6.2H.2.2	.....	286
6.2H.2.3	UE maximum output power reduction for inter-band EN-DC with UL MIMO within FR1.....	286
6.2H.3	UE additional maximum output power reduction for EN-DC with UL MIMO.....	288
6.2H.3.1	.....	288
6.2H.3.2	.....	288
6.2H.3.3	UE additional maximum output power reduction for inter-band EN-DC with UL MIMO within FR1 .....	288
6.2H.4	Configured output power for DC with UL MIMO .....	289
6.2H.4.1	.....	289
6.2H.4.2	.....	289
6.2H.4.3	Configured output power level for inter-band EN-DC with UL MIMO within FR1 .....	289
6.2L	Transmitter power for DC with Tx Diversity .....	290
6.2L.1	UE maximum output power for DC with Tx Diversity .....	290
6.2L.1.3	UE maximum output power for inter-band EN-DC with Tx Diversity within FR1 .....	290
6.2L.2	UE maximum output power reduction for DC with Tx Diversity .....	295
6.2L.2.1	.....	295
6.2L.2.2	.....	295
6.2L.2.3	UE maximum output power reduction for inter-band EN-DC with Tx Diversity within FR1 .....	295
6.2L.3	UE additional maximum output power reduction for EN-DC with Tx Diversity .....	297
6.2L.3.1	.....	297
6.2L.3.2	.....	297
6.2L.3.3	UE additional maximum output power reduction for inter-band EN-DC with Tx Diversity within FR1 .....	297
6.2L.4	Configured output power for DC with Tx Diversity.....	298
6.2L.4.1	.....	298
6.2L.4.2	.....	298
6.2L.4.3	Configured output power level for inter-band EN-DC with Tx Diversity within FR1 .....	298
6.3	Output power dynamics.....	299
6.3A	Output Power Dynamics for CA without EN-DC .....	299
6.3A.1	UE Output Power Dynamics for CA .....	299
6.3A.1.1	UE Output Power Dynamics for NR CA between FR 1 and FR 2 without EN-DC.....	299
6.3B	Output power dynamics for DC .....	299
6.3B.1	Minimum Output Power for EN-DC .....	299
6.3B.1.1	Minimum Output Power for intra-band contiguous EN-DC .....	299
6.3B.1.2	Minimum output power for intra-band non-contiguous EN-DC.....	300
6.3B.1.3	Minimum output power for inter-band EN-DC within FR1 (1 NR CC) .....	301
6.3B.1.4	Minimum Output Power for EN-DC Interband including FR2 (1 NR CC) .....	302
6.3B.1.4_1	Minimum output power for inter-band EN-DC including FR2 (>1 NR CC) .....	303
6.3B.1.4_1.1	Minimum output power for inter-band EN-DC including FR2 (2 NR CCs) .....	303
6.3B.1.4_1.2	Minimum output power for inter-band EN-DC including FR2 (3 NR CCs) .....	304
6.3B.1.4_1.3	Minimum output power for inter-band EN-DC including FR2 (4 NR CCs) .....	305
6.3B.1.4_1.4	Minimum output power for inter-band EN-DC including FR2 (5 NR CCs) .....	306
6.3B.1.4_1.5	Minimum output power for inter-band EN-DC including FR2 (6 NR CCs) .....	307
6.3B.1.4_1.6	Minimum output power for inter-band EN-DC including FR2 (7 NR CCs) .....	308
6.3B.1.4_1.7	Minimum output power for inter-band EN-DC including FR2 (8 NR CCs) .....	309
6.3B.1.4D	Minimum output power for inter-band EN-DC including FR2 for UL MIMO.....	310
6.3B.2	Transmit OFF Power for EN-DC.....	310
6.3B.2.1	Transmit OFF Power for intra-band contiguous EN-DC .....	310
6.3B.2.2	Transmit OFF Power for intra-band non-contiguous EN-DC.....	311
6.3B.2.3	Transmit OFF Power for inter-band EN-DC within FR1 (1 NR CC) .....	311
6.3B.2.4	Transmit OFF Power for inter-band EN-DC including FR2 (1 NR CC) .....	312
6.3B.2.4_1	Void.....	313
6.3B.2.4D	Transmit OFF Power for inter-band EN-DC including FR2 for UL-MIMO .....	313
6.3B.3	Transmit ON/OFF time mask/PUCCH time mask for EN-DC.....	313
6.3B.3.1	Transmit ON/OFF time mask for intra-band contiguous EN-DC .....	313
6.3B.3.2	Transmit ON/OFF time mask for intra-band non-contiguous EN-DC.....	314
6.3B.3.3	Transmit ON/OFF time mask for inter-band EN-DC within FR1 (1 NR CC).....	315
6.3B.3.4	Transmit ON/OFF time mask for inter-band EN-DC including FR2 (1 NR CC) .....	316
6.3B.3.4_1	Transmit ON/OFF time mask for Inter-Band EN-DC including FR2 (>1 NR CC) .....	317



6.3B.3.4_1.1	Transmit ON/OFF time mask for Inter-Band EN-DC including FR2 (2 NR CCs) .....	317
6.3B.3.4_1.2	Transmit ON/OFF time mask for Inter-Band EN-DC including FR2 (3 NR CCs) .....	318
6.3B.3.4_1.3	Transmit ON/OFF time mask for Inter-Band EN-DC including FR2 (4 NR CCs) .....	319
6.3B.3.4D	Transmit ON/OFF time mask for inter-band EN-DC including FR2 for UL-MIMO .....	319
6.3B.3_1	E-UTRA and NR switching time mask for switching between two uplink carriers .....	320
6.3B.3_1.1	E-UTRA and NR switching time mask for switching between two uplink carriers for inter-band EN-DC .....	320
6.3B.4	PRACH time mask for EN-DC .....	323
6.3B.4.1	PRACH time mask for intra-band contiguous EN-DC .....	323
6.3B.4.2	PRACH Time Mask for intra-band non-contiguous EN-DC .....	325
6.3B.4.3	PRACH Time Mask for inter-band EN-DC within FR1 (1 NR CC) .....	326
6.3B.4.4	PRACH Time Mask for inter-band EN-DC including FR2 (1 NR CC) .....	327
6.3B.5	Output power dynamics for EN-DC with UL sharing from UE perspective .....	327
6.3B.5.1	E-UTRA and NR switching time mask for TDM based UL sharing from UE perspective .....	327
6.3B.6	Output power dynamics for intra-band EN-DC without dual PA capability .....	328
6.3B.7	Output power dynamics for intra-band EN-DC with dual PA capability .....	328
6.3B.8	Power control for EN-DC .....	328
6.3B.8.1	Absolute power tolerance for EN-DC .....	328
6.3B.8.1.1	Absolute power tolerance for intra-band contiguous EN-DC .....	328
6.3B.8.1.2	Absolute power tolerance for intra-band non-contiguous EN-DC .....	329
6.3B.8.1.3	Absolute power tolerance for inter-band EN-DC within FR1 (1 NR CC) .....	329
6.3B.8.1.4	Absolute power tolerance for inter-band EN-DC including FR2 (1 NR CC) .....	330
6.3B.8.1.4_1	Absolute power tolerance for inter-band EN-DC including FR2 (>1 NR CC) .....	331
6.3B.8.1.4_1.1	Absolute power tolerance for inter-band EN-DC including FR2 (2 NR CC) .....	331
6.3B.8.1.4_1.2	Absolute power tolerance for inter-band EN-DC including FR2 (3 NR CC) .....	332
6.3B.8.1.4_1.3	Absolute power tolerance for inter-band EN-DC including FR2 (4 NR CC) .....	333
6.3B.8.2	Relative power tolerance for EN-DC .....	333
6.3B.8.2.1	Relative power tolerance for intra-band contiguous EN-DC .....	333
6.3B.8.2.2	Relative power tolerance for intra-band non-contiguous EN-DC .....	334
6.3B.8.2.3	Relative power tolerance for inter-band EN-DC within FR1 (1 NR CC) .....	335
6.3B.8.2.4	Relative power tolerance for inter-band EN-DC including FR2 (1 NR CC) .....	336
6.3B.8.3	Aggregate power tolerance for EN-DC .....	336
6.3B.8.3.1	Aggregate power tolerance for intra-band contiguous EN-DC .....	336
6.3B.8.3.2	Aggregate power tolerance for intra-band non-contiguous EN-DC .....	337
6.3B.8.3.3	Aggregate power tolerance for inter-band EN-DC within FR1 (1 NR CC) .....	338
6.3B.8.3.4	Aggregate power tolerance for inter-band EN-DC including FR2 (1 NR CC) .....	339
6.3B.8.3.4_1	Aggregate power tolerance for inter-band EN-DC including FR2 (>1 NR CC) .....	339
6.3B.8.3.4_1.1	Aggregate power tolerance for inter-band EN-DC including FR2 (2 NR CC) .....	339
6.3B.8.3.4_1.2	Aggregate power tolerance for inter-band EN-DC including FR2 (3 NR CC) .....	340
6.3B.8.3.4_1.3	Aggregate power tolerance for inter-band EN-DC including FR2 (4 NR CC) .....	341
6.3E	Output power dynamics for V2X .....	342
6.3E.0	Minimum conformance requirements .....	342
6.3E.1	Output power dynamics for intra-band V2X operation .....	343
6.3E.2	Output power dynamics for inter-band V2X operation .....	343
6.3H	Output power dynamics for DC with UL MIMO .....	343
6.3H.0	General .....	343
6.3H.1	.....	343
6.3H.2	.....	343
6.3H.3	Output power dynamics for inter-band EN-DC with UL MIMO .....	343
6.3H.3.1	Minimum output power for inter-band EN-DC with UL MIMO within FR1 .....	343
6.3H.3.2	Transmit OFF Power for inter-band EN-DC with UL MIMO within FR1 .....	344
6.3H.3.3	Transmit ON/OFF time mask for inter-band EN-DC with UL MIMO within FR1 .....	344
6.3H.3.4	Power control for inter-band EN-DC with UL MIMO .....	345
6.3H.3.4.1	Absolute power tolerance for inter-band EN-DC with UL MIMO within FR1 .....	345
6.3H.3.4.2	Relative power tolerance for inter-band EN-DC with UL MIMO within FR1 .....	346
6.3H.3.4.3	Aggregate power tolerance for inter-band EN-DC with UL MIMO within FR1 .....	347
6.3L	Output power dynamics for DC with Tx Diversity .....	348
6.3L.1	.....	348
6.3L.2	.....	348
6.3L.3	Output power dynamics for inter-band EN-DC with Tx Diversity .....	348
6.3L.3.1	Minimum output power for inter-band EN-DC with Tx Diversity within FR1 .....	348
6.3L.3.2	Transmit OFF Power for inter-band EN-DC with Tx Diversity within FR1 .....	349

6.3L.3.3	Transmit ON/OFF time mask for Tx Diversity.....	349
6.3L.3.3.1	General ON/OFF time mask for inter-band EN-DC with Tx Diversity within FR1.....	349
6.3L.3.3.2	PRACH time mask for inter-band EN-DC with Tx Diversity within FR1 .....	350
6.3L.3.3.3	SRS time mask for inter-band EN-DC with Tx Diversity within FR1 .....	351
6.3L.3.4	Power control for inter-band EN-DC with Tx Diversity.....	352
6.3L.3.4.1	Absolute power tolerance for inter-band EN-DC with Tx Diversity within FR1 .....	352
6.3L.3.4.2	Relative power tolerance for inter-band EN-DC with Tx Diversity within FR1 .....	352
6.3L.3.4.3	Aggregate power tolerance for inter-band EN-DC with Tx Diversity within FR1.....	353
6.4	Transmit signal quality .....	354
6.4A	Transmit Signal Quality for inter-band NR CA between FR and FR2 without EN-DC.....	354
6.4A.1	Frequency error for inter-band NR CA between FR 1 and FR 2 without EN-DC.....	354
6.4A.2	Transmit Modulation Quality for inter-band NR CA without EN-DC .....	354
6.4A.2.1	Error Vector Magnitude for inter-band NR CA between FR 1 and FR 2 without EN-DC .....	354
6.4A.2.2	Carrier Leakage for inter-band NR CA between FR 1 and FR 2 without EN-DC .....	355
6.4A.2.3	In-band Emissions for inter-band NR CA between FR 1 and FR 2 without EN-DC .....	355
6.4A.2.4	EVM Equalizer Spectral Flatness for inter-band NR CA between FR 1 and FR 2 without EN-DC...355	
6.4B	Transmit Signal Quality for DC .....	356
6.4B.1	Frequency error.....	356
6.4B.1.1	Frequency error for Intra-band contiguous EN-DC .....	356
6.4B.1.2	Frequency error for Intra-band non-contiguous EN-DC .....	356
6.4B.1.3	Frequency error for Inter-band EN-DC within FR1 (1 NR CC) .....	358
6.4B.1.3a	Frequency Error for inter-band NE-DC within FR1 .....	359
6.4B.1.4	Frequency Error for inter-band EN-DC including FR2 (1 NR CC).....	359
6.4B.1.4_1	Frequency Error for Inter-band EN-DC including FR2 (>1 NR CC).....	360
6.4B.1.4_1.1	Frequency Error for Inter-band EN-DC including FR2 (2 NR CCs).....	360
6.4B.1.4_1.2	Frequency Error for Inter-band EN-DC including FR2 (3 NR CCs).....	360
6.4B.1.4_1.3	Frequency Error for Inter-band EN-DC including FR2 (4 NR CCs).....	361
6.4B.1.4_1.4	Frequency Error for Inter-band EN-DC including FR2 (5 NR CCs).....	362
6.4B.1.4_1.5	Frequency Error for Inter-band EN-DC including FR2 (6 NR CCs).....	363
6.4B.1.4_1.6	Frequency Error for Inter-band EN-DC including FR2 (7 NR CCs).....	364
6.4B.1.4_1.7	Frequency Error for Inter-band EN-DC including FR2 (8 NR CCs).....	365
6.4B.1.4D	Frequency error for inter-band EN-DC including FR2 for UL-MIMO .....	366
6.4B.2	Transmit Modulation Quality for DC .....	367
6.4B.2.1	Transmit Modulation Quality for intra-band contiguous EN-DC .....	367
6.4B.2.1.1	Error Vector Magnitude for intra-band contiguous EN-DC .....	367
6.4B.2.1.2	Carrier Leakage for intra-band contiguous EN-DC.....	368
6.4B.2.1.3	In-band Emissions for intra-band contiguous EN-DC.....	369
6.4B.2.1.4	EVM Equalizer Flatness for intra-band contiguous EN-DC .....	374
6.4B.2.2	Transmit Modulation Quality for intra-band non-contiguous EN-DC .....	375
6.4B.2.2.1	Error Vector Magnitude for intra-band non-contiguous EN-DC.....	375
6.4B.2.2.2	Carrier Leakage for intra-band non-contiguous EN-DC .....	377
6.4B.2.2.3	In-band Emissions for intra-band non-contiguous EN-DC .....	378
6.4B.2.2.4	EVM Equalizer Flatness for intra-band non-contiguous EN-DC .....	379
6.4B.2.3	Transmit Modulation Quality for inter-band EN-DC within FR1 .....	380
6.4B.2.3.1	Error Vector Magnitude for inter-band EN-DC within FR1 (1 NR CC) .....	380
6.4B.2.3.2	Carrier Leakage for inter-band EN-DC within FR1 (1 NR CC).....	381
6.4B.2.3.3	In-band Emissions for inter-band EN-DC within FR1 (1 NR CC).....	382
6.4B.2.3.4	EVM Equalizer Flatness for inter-band EN-DC within FR1 (1 NR CC) .....	382
6.4B.2.3a	Transmit Modulation Quality for inter-band NE-DC within FR1 .....	383
6.4B.2.3a.1	Error Vector Magnitude for inter-band NE-DC within FR1.....	383
6.4B.2.3a.2	Carrier Leakage for inter-band NE-DC within FR1 .....	383
6.4B.2.3a.3	In-band Emissions for inter-band NE-DC within FR1 .....	383
6.4B.2.3a.4	EVM Equalizer Flatness for inter-band NE-DC within FR1 (1 NR CC) .....	383
6.4B.2.4	Transmit Modulation Quality for inter-band EN-DC including FR2 .....	384
6.4B.2.4.1	Error Vector Magnitude for inter-band EN-DC including FR2 (1 NR CC) .....	384
6.4B.2.4.1a	Error Vector Magnitude with Power Boost for inter-band EN-DC including FR2 (1 NR CC).....	385
6.4B.2.4.1_1	Error Vector Magnitude for inter-band EN-DC including FR2 (>1 NR CC) .....	386
6.4B.2.4.1_1.1	Error Vector Magnitude for inter-band EN-DC including FR2 (2 NR CCs) .....	386
6.4B.2.4.1_1.2	Error Vector Magnitude for inter-band EN-DC including FR2 (3 NR CCs) .....	387
6.4B.2.4.1_1.3	Error Vector Magnitude for inter-band EN-DC including FR2 (4 NR CCs) .....	387
6.4B.2.4.1_1.4	Error Vector Magnitude for inter-band EN-DC including FR2 (5 NR CCs).....	388
6.4B.2.4.1_1.5	Error Vector Magnitude for inter-band EN-DC including FR2 (6 NR CCs).....	389

6.4B.2.4.1_1.6	Error Vector Magnitude for inter-band EN-DC including FR2 (7 NR CCs) .....	390
6.4B.2.4.1_1.7	Error Vector Magnitude for inter-band EN-DC including FR2 (8 NR CCs) .....	391
6.4B.2.4.1D	Error Vector Magnitude for inter-band EN-DC including FR2 for UL MIMO .....	392
6.4B.2.4.2	Carrier Leakage for inter-band EN-DC including FR2 (1 NR CC) .....	393
6.4B.2.4.2D	Carrier Leakage for inter-band EN-DC including FR2 for UL MIMO .....	394
6.4B.2.4.2_1	Carrier Leakage for inter-band EN-DC including FR2 (>1 NR CC) .....	395
6.4B.2.4.2_1.1	Carrier Leakage for inter-band EN-DC including FR2 (2 NR CCs) .....	395
6.4B.2.4.2_1.2	Carrier Leakage for inter-band EN-DC including FR2 (3 NR CCs) .....	396
6.4B.2.4.2_1.3	Carrier Leakage for inter-band EN-DC including FR2 (4 NR CCs) .....	397
6.4B.2.4.2_1.4	Carrier Leakage for inter-band EN-DC including FR2 (5 NR CCs) .....	397
6.4B.2.4.2_1.5	Carrier Leakage for inter-band EN-DC including FR2 (6 NR CCs) .....	398
6.4B.2.4.2_1.6	Carrier Leakage for inter-band EN-DC including FR2 (7 NR CCs) .....	399
6.4B.2.4.2_1.7	Carrier Leakage for inter-band EN-DC including FR2 (8 NR CCs) .....	400
6.4B.2.4.3	In-band Emissions for inter-band EN-DC including FR2 (1 NR CC) .....	401
6.4B.2.4.3D	In-band Emissions for inter-band EN-DC including FR2 for UL MIMO .....	402
6.4B.2.4.3_1	In-band Emissions for inter-band EN-DC including FR2 (>1 NR CC) .....	403
6.4B.2.4.3_1.1	In-band Emissions for inter-band EN-DC including FR2 (2 NR CCs) .....	403
6.4B.2.4.3_1.2	In-band Emissions for inter-band EN-DC including FR2 (3 NR CCs) .....	404
6.4B.2.4.3_1.3	In-band Emissions for inter-band EN-DC including FR2 (4 NR CCs) .....	404
6.4B.2.4.3_1.4	In-band Emissions for inter-band EN-DC including FR2 (5 NR CCs) .....	405
6.4B.2.4.3_1.5	In-band Emissions for inter-band EN-DC including FR2 (6 NR CCs) .....	406
6.4B.2.4.3_1.6	In-band Emissions for inter-band EN-DC including FR2 (7 NR CCs) .....	407
6.4B.2.4.3_1.7	In-band Emissions for inter-band EN-DC including FR2 (8 NR CCs) .....	408
6.4B.2.4.4	EVM Equalizer Flatness for inter-band EN-DC including FR2 (1 NR CC) .....	409
6.4B.2.4.4D	EVM Equalizer Flatness for inter-band EN-DC including FR2 for UL MIMO .....	410
6.4B.2.4.5	EVM spectral flatness for pi/2 BPSK modulation for inter-band EN-DC including FR2 (1 NR CC) .....	411
6.4E	Transmit signal quality for V2X operation in FR1 .....	412
6.4E.1	Frequency error for V2X .....	412
6.4E.1.0	Minimum conformance requirements .....	412
6.4E.1.1	Frequency error for Intra-band V2X .....	412
6.4E.1.2	Frequency error for Inter-band V2X .....	412
6.4E.2	Transmit modulation quality for V2X .....	412
6.4E.2.1	Error Vector Magnitude for V2X .....	412
6.4E.2.1.1	Error Vector Magnitude for intra-band V2X .....	413
6.4E.2.1.2	Error Vector Magnitude for Inter-band V2X .....	413
6.4E.2.2	Carrier leakage for V2X .....	413
6.4E.2.2.1	Carrier leakage for intra-band V2X .....	413
6.4E.2.3	In-band emissions for V2X .....	413
6.4E.2.3.1	In-band emissions for intra-band V2X .....	414
6.4H	Transmit signal quality for DC with UL MIMO .....	414
6.4H.1	Frequency error for DC with UL MIMO .....	414
6.4H.1.1	.....	414
6.4H.1.2	.....	414
6.4H.1.3	Frequency error for inter-band EN-DC with UL MIMO within FR1 .....	414
6.4H.2	Transmit signal quality for DC with UL MIMO .....	415
6.4H.2.1	.....	415
6.4H.2.2	.....	415
6.4H.2.3	Transmit modulation quality for inter-band EN-DC with UL MIMO .....	415
6.4H.2.3.1	Error Vector Magnitude for inter-band EN-DC with UL MIMO within FR1 .....	415
6.4H.2.3.2	Carrier leakage for inter-band EN-DC with UL MIMO within FR1 .....	416
6.4H.2.3.3	In-band emissions for inter-band EN-DC with UL MIMO within FR1 .....	417
6.4L	Transmit signal quality for DC with Tx Diversity .....	418
6.4L.1	Frequency error for DC with Tx Diversity .....	418
6.4L.1.1	.....	418
6.4L.1.2	.....	418
6.4L.1.3	Frequency error for inter-band EN-DC with Tx Diversity within FR1 .....	418
6.4L.2	Transmit signal quality for DC with Tx Diversity .....	419
6.4L.2.1	.....	419
6.4L.2.2	.....	419
6.4L.2.3	Transmit modulation quality for inter-band EN-DC with Tx Diversity .....	419
6.4L.2.3.1	Error Vector Magnitude for inter-band EN-DC with Tx Diversity within FR1 .....	419

6.4L.2.3.2	Carrier leakage for inter-band EN-DC with Tx Diversity within FR1 .....	420
6.4L.2.3.3	In-band emissions for inter-band EN-DC with Tx Diversity within FR1 .....	420
6.5	Output RF spectrum emissions.....	421
6.5A	Output RF spectrum emissions for CA.....	421
6.5A.1	Occupied bandwidth for CA without EN-DC.....	421
6.5A.2	Out-of-band emissions for CA without EN-DC.....	422
6.5A.2.1	Spectrum emissions mask for CA without EN-DC.....	422
6.5A.2.2	Additional Spectrum emissions mask for CA without EN-DC.....	422
6.5A.2.3	Adjacent channel leakage ratio for CA without EN-DC .....	422
6.5A.3	Spurious emissions for CA without EN-DC.....	422
6.5A.3.1	Inter-band CA between FR1 and FR2.....	422
6.5B	Output RF spectrum emissions for DC.....	423
6.5B.1	Occupied bandwidth for EN-DC .....	423
6.5B.1.1	Occupied bandwidth for Intra-Band Contiguous EN-DC .....	423
6.5B.1.2	Occupied bandwidth for Intra-Band Non-Contiguous EN-DC .....	425
6.5B.1.3	Occupied bandwidth for Inter-Band EN-DC within FR1 (1 NR CC) .....	426
6.5B.1.4	Occupied bandwidth for Inter-Band EN-DC including FR2 (1 NR CC) .....	427
6.5B.1.4_1	Occupied bandwidth for Inter-band EN-DC including FR2 (>1 NR CC).....	428
6.5B.1.4_1.1	Occupied bandwidth for Inter-band EN-DC including FR2 (2 NR CCs).....	428
6.5B.1.4_1.2	Occupied bandwidth for Inter-band EN-DC including FR2 (3 NR CCs).....	429
6.5B.1.4_1.3	Occupied bandwidth for Inter-band EN-DC including FR2 (4 NR CCs).....	430
6.5B.1.4_1.4	Occupied bandwidth for Inter-band EN-DC including FR2 (5 NR CCs).....	431
6.5B.1.4_1.5	Occupied bandwidth for Inter-band EN-DC including FR2 (6 NR CCs).....	432
6.5B.1.4_1.6	Occupied bandwidth for Inter-band EN-DC including FR2 (7 NR CCs).....	432
6.5B.1.4_1.7	Occupied bandwidth for Inter-band EN-DC including FR2 (8 NR CCs).....	433
6.5B.1.4D	Occupied bandwidth for inter-band EN-DC including FR2 for UL MIMO.....	434
6.5B.2	Out-of-band emissions for DC.....	435
6.5B.2.1	Out-of-band emissions for Intra-band contiguous EN-DC.....	435
6.5B.2.1.1	Spectrum emissions mask for intra-band contiguous EN-DC .....	435
6.5B.2.1.2	Additional spectrum emissions mask for intra-band contiguous EN-DC.....	443
6.5B.2.1.3	Adjacent channel leakage ratio for intra-band contiguous EN-DC .....	448
6.5B.2.2	Out-of-band emissions for Intra-band non-contiguous EN-DC .....	451
6.5B.2.2.1	Spectrum emissions mask for intra-band non-contiguous EN-DC.....	451
6.5B.2.2.2	Additional Spectrum emissions mask for intra-band non-contiguous EN-DC.....	452
6.5B.2.2.3	Adjacent channel leakage ratio for intra-band non-contiguous EN-DC .....	454
6.5B.2.3	Out-of-band emissions for Inter-band EN-DC within FR1 .....	456
6.5B.2.3.1	Spectrum emissions mask for Inter-band EN-DC within FR1 (1 NR CC).....	456
6.5B.2.3.2	Additional Spectrum emissions mask for Inter-band EN-DC within FR1 (1 NR CC) .....	457
6.5B.2.3.3	Adjacent channel leakage ratio for inter-band EN-DC within FR1 (1 NR CC) .....	458
6.5B.2.3.3.1	NR - Adjacent channel leakage ratio for inter-band EN-DC within FR1 (1 NR CC).....	458
6.5B.2.3.3.2	UTRA - Adjacent channel leakage ratio for inter-band EN-DC within FR1 (1 NR CC).....	459
6.5B.2.3a	Out-of-band emissions for Inter-band NE-DC within FR1 .....	459
6.5B.2.3a.1	Spectrum emissions mask for Inter-band NE-DC within FR1 .....	459
6.5B.2.3a.2	Additional Spectrum emissions mask for Inter-band NE-DC within FR1 .....	459
6.5B.2.3a.3	Adjacent channel leakage ratio for inter-band NE-DC within FR1 .....	460
6.5B.2.4	Out-of-band emissions for Inter-band EN-DC including FR2 .....	460
6.5B.2.4.1	Spectrum emissions mask for Inter-band EN-DC including FR2 (1 NR CC) .....	460
6.5B.2.4.1a	Spectrum emissions mask with Power Boost for Inter-band EN-DC including FR2 (1 NR CC) .....	461
6.5B.2.4.1_1	Spectrum emissions mask for Inter-band EN-DC including FR2 (>1 NR CC).....	461
6.5B.2.4.1_1.1	Spectrum emissions mask for Inter-band EN-DC including FR2 (2 NR CCs).....	461
6.5B.2.4.1_1.2	Spectrum emissions mask for Inter-band EN-DC including FR2 (3 NR CCs).....	462
6.5B.2.4.1_1.3	Spectrum emissions mask for Inter-band EN-DC including FR2 (4 NR CCs).....	463
6.5B.2.4.1_1.4	Spectrum emissions mask for Inter-band EN-DC including FR2 (5 NR CCs).....	464
6.5B.2.4.1_1.5	Spectrum emissions mask for Inter-band EN-DC including FR2 (6 NR CCs).....	465
6.5B.2.4.1_1.6	Spectrum emissions mask for Inter-band EN-DC including FR2 (7 NR CCs).....	466
6.5B.2.4.1_1.7	Spectrum emissions mask for Inter-band EN-DC including FR2 (8 NR CCs).....	467
6.5B.2.4.1D	Spectrum emissions mask for inter-band EN-DC including FR2 for UL MIMO.....	468
6.5B.2.4.3	Adjacent channel leakage ratio for Inter-band EN-DC including FR2 (1 NR CC) .....	469
6.5B.2.4.3_1	Adjacent channel leakage ratio for Inter-band EN-DC including FR2 (>1 NR CC).....	470
6.5B.2.4.3_1.1	Adjacent channel leakage ratio for Inter-band EN-DC including FR2 (2 NR CCs).....	470
6.5B.2.4.3_1.2	Adjacent channel leakage ratio for Inter-band EN-DC including FR2 (3 NR CCs).....	471

6.5B.2.4.3_1.3	Adjacent channel leakage ratio for Inter-band EN-DC including FR2 (4 NR CCs) .....	471
6.5B.2.4.3_1.4	Adjacent channel leakage ratio for Inter-band EN-DC including FR2 (5 NR CCs) .....	472
6.5B.2.4.3_1.5	Adjacent channel leakage ratio for Inter-band EN-DC including FR2 (6 NR CCs) .....	473
6.5B.2.4.3_1.6	Adjacent channel leakage ratio for Inter-band EN-DC including FR2 (7 NR CCs) .....	474
6.5B.2.4.3_1.7	Adjacent channel leakage ratio for Inter-band EN-DC including FR2 (8 NR CCs) .....	475
6.5B.2.4D.3	Adjacent channel leakage ratio for inter-band EN-DC including FR2 for UL MIMO .....	476
6.5B.3	Spurious emissions for DC .....	477
6.5B.3.1	Spurious Emissions for intra-band contiguous EN-DC .....	477
6.5B.3.1.1	General spurious emissions for intra-band contiguous EN-DC .....	477
6.5B.3.1.2	Spurious emission band UE co-existence for intra-band contiguous EN-DC .....	479
6.5B.3.2	Spurious Emissions for intra-band non-contiguous EN-DC .....	483
6.5B.3.2.1	General spurious emissions for Intra-band non-contiguous EN-DC .....	483
6.5B.3.2.2	Spurious emission band UE co-existence for intra-band non-contiguous EN-DC .....	485
6.5B.3.3	Spurious Emissions for Inter-band EN-DC within FR1 .....	488
6.5B.3.3.1	General spurious emissions for Inter-band EN-DC within FR1 .....	488
6.5B.3.3.2	Spurious emission band UE co-existence for Inter-band within FR1 .....	504
6.5B.3.3a	Inter-band NE-DC within FR1 .....	567
6.5B.3.3a.1	General Spurious Emissions for Inter-band NE-DC within FR1 .....	567
6.5B.3.3a.2	Spurious emission band UE co-existence for Inter-band NE-DC within FR1 .....	567
6.5B.3.4	Spurious Emissions for Inter-band including FR2 .....	567
6.5B.3.4.1	General Spurious Emissions for Inter-band including FR2 (1 NR CC) .....	567
6.5B.3.4.1a	General Spurious Emissions with Power Boost for Inter-band including FR2 (1 NR CC) .....	568
6.5B.3.4.1_1	General Spurious emissions for Inter-band EN-DC including FR2 (>1 NR CC) .....	569
6.5B.3.4.1_1.1	General Spurious emissions for Inter-band EN-DC including FR2 (2 NR CCs) .....	569
6.5B.3.4.1_1.2	General Spurious emissions for Inter-band EN-DC including FR2 (3 NR CCs) .....	570
6.5B.3.4.1_1.3	General Spurious emissions for Inter-band EN-DC including FR2 (4 NR CCs) .....	571
6.5B.3.4.1_1.4	General Spurious emissions for Inter-band EN-DC including FR2 (5 NR CCs) .....	571
6.5B.3.4.1_1.5	General Spurious emissions for Inter-band EN-DC including FR2 (6 NR CCs) .....	572
6.5B.3.4.1_1.6	General Spurious emissions for Inter-band EN-DC including FR2 (7 NR CCs) .....	573
6.5B.3.4.1_1.7	General Spurious emissions for Inter-band EN-DC including FR2 (8 NR CCs) .....	574
6.5B.3.4.1D	General Spurious Emissions for inter-band EN-DC including FR2 for UL MIMO .....	575
6.5B.3.4.2	Spurious emission band UE co-existence for Inter-band including FR2 (1 NR CC) .....	576
6.5B.3.4.2a	Spurious emission band UE co-existence with Power Boost for Inter-band including FR2 (1 NR CC) .....	577
6.5B.3.4.2_1	Spurious emission band UE co-existence for Inter-band EN-DC including FR2 (>1 NR CC) .....	578
6.5B.3.4.2_1.1	Spurious emission band UE co-existence for Inter-band EN-DC including FR2 (2 NR CCs) .....	578
6.5B.3.4.2_1.2	Spurious emission band UE co-existence for Inter-band EN-DC including FR2 (3 NR CCs) .....	579
6.5B.3.4.2_1.3	Spurious emission band UE co-existence for Inter-band EN-DC including FR2 (4 NR CCs) .....	580
6.5B.3.4.2_1.4	Spurious emission band UE co-existence for Inter-band EN-DC including FR2 (5 NR CCs) .....	581
6.5B.3.4.2_1.5	Spurious emission band UE co-existence for Inter-band EN-DC including FR2 (6 NR CCs) .....	582
6.5B.3.4.2_1.6	Spurious emission band UE co-existence for Inter-band EN-DC including FR2 (6 NR CCs) .....	583
6.5B.3.4.2_1.7	Spurious emission band UE co-existence for Inter-band EN-DC including FR2 (8 NR CCs) .....	584
6.5B.3.4.2D	Spurious emission band UE co-existence for inter-band EN-DC including FR2 for UL MIMO .....	585
6.5B.3.5	Spurious emissions for Inter-band including FR1 and FR2 .....	586
6.5B.3.5.1	General Spurious Emissions for Inter-band including FR1 and FR2 .....	586
6.5B.3.5.2	Spurious emission band UE co-existence for Inter-band including FR1 and FR2 .....	586
6.5B.4	Additional Spurious Emissions for EN-DC .....	586
6.5B.4.1	Additional Spurious Emissions for Intra-band contiguous EN-DC .....	586
6.5B.4.2	Additional Spurious Emissions for Intra-band non-contiguous EN-DC .....	590
6.5B.4.3	Additional Spurious Emissions for Inter-band EN-DC within FR1 (1 NR CC) .....	591
6.5B.4.4	Additional Spurious Emissions for Inter-band including FR2 (1 NR CC) .....	592
6.5B.4.4a	Additional Spurious Emissions with Power Boost for Inter-band including FR2 (1 NR CC) .....	592
6.5B.4.4_1	Additional Spurious Emissions for Inter-band including FR2 (>1 NR CC) .....	593
6.5B.4.4_1.1	Additional Spurious Emissions for Inter-band including FR2 (2 NR CC) .....	593
6.5B.4.4_1.2	Additional Spurious Emissions for Inter-band including FR2 (3 NR CC) .....	594

6.5B.4.4_1.3	Additional Spurious Emissions for Inter-band including FR2 (4 NR CC) .....	595
6.5B.4.4D	Additional Spurious Emissions for Inter-band including FR2 for UL MIMO .....	596
6.5B.5	Transmit intermodulation for DC .....	597
6.5B.5.1	Transmit intermodulation for Intra-band contiguous EN-DC .....	597
6.5B.5.2	Transmit intermodulation for Intra-band non-contiguous EN-DC .....	597
6.5B.5.3	Transmit intermodulation for Inter-band EN-DC within FR1 (1 NR CC) .....	598
6.5B.5.3a	Transmit Intermodulation for Inter-band NE-DC within FR1 .....	598
6.5B.5.4	Transmit intermodulation for Inter-band EN-DC including FR2 .....	599
6.5B.5.5	Transmit intermodulation for Inter-band EN-DC including both FR1 and FR2 .....	599
6.5E	Output RF spectrum emissions for V2X operation in FR1 .....	599
6.5E.1	Occupied bandwidth for V2X .....	599
6.5E.1.0	Minimum conformance requirements .....	599
6.5E.1.1	Occupied bandwidth for intra-band V2X .....	599
6.5E.1.2	Occupied bandwidth for inter-band V2X .....	599
6.5E.2	Out of band emission for V2X .....	599
6.5E.2.0	Minimum conformance requirements .....	599
6.5E.2.1	Out of band emission for intra-band V2X .....	600
6.5E.2.2	Out of band emission for inter-band V2X .....	600
6.5E.3	Spurious emissions for V2X .....	600
6.5E.3.1	General spurious emissions for V2X .....	600
6.5E.3.1.1	General spurious emissions for intra-band V2X .....	600
6.5E.3.1.2	General spurious emissions for inter-band V2X .....	601
6.5E.4	Transmit intermodulation for V2X .....	601
6.5E.4.0	Minimum conformance requirements .....	601
6.5E.4.1	Transmit intermodulation for intra-band V2X .....	601
6.5E.4.2	Transmit intermodulation for inter-band V2X .....	601
6.5H	Output RF spectrum emissions for DC with UL MIMO .....	602
6.5H.1	.....	602
6.5H.2	.....	602
6.5H.3	Spurious emission for DC with UL MIMO .....	602
6.5H.3.1	.....	602
6.5H.3.2	.....	602
6.5H.3.3	Spurious emission for inter-band EN-DC with UL MIMO within FR1 .....	602
6.5H.3.3.0	Minimum conformance requirements .....	602
6.5H.3.3.1	General spurious emissions for inter-band EN-DC with UL MIMO within FR1 .....	602
6.5H.3.3.2	Spurious emissions for UE co-existence for inter-band EN-DC with UL MIMO within FR1 .....	604
6.5L	Output RF spectrum emissions for DC with Tx Diversity .....	606
6.5L.1	606	
6.5L.2	606	
6.5L.3	Spurious emission for DC with Tx Diversity .....	606
6.5L.3.1	.....	606
6.5L.3.2	.....	606
6.5L.3.3	Spurious emission for inter-band EN-DC with Tx Diversity within FR1 .....	606
6.5L.3.3.0	Minimum conformance requirements .....	606
6.5L.3.3.1	General spurious emissions for inter-band EN-DC with Tx Diversity within FR1 .....	606
6.5L.3.3.2	Spurious emissions for UE co-existence for inter-band EN-DC with Tx Diversity within FR1 .....	608
6.6	.....	609
6.6B	Beam Correspondence for EN-DC .....	609
6.6B.4	Beam Correspondence for inter-band EN-DC including FR2 (1 NR CC) - EIRP .....	609
6.6B.5	Enhanced Beam Correspondence for inter-band EN-DC including FR2 (1 NR CC) - EIRP .....	610
7	Receiver characteristics .....	611
7.1	General .....	611
7.2	Void .....	613
7.3	Void .....	613
7.3A	Reference sensitivity for CA without EN-DC .....	613
7.3A.1	General .....	613
7.3A.2	Reference sensitivity power level for CA without EN-DC .....	613
7.3A.3	$\Delta R_{IB,c}$ for CA without EN-DC .....	613
7.3A.3.1	$\Delta R_{IB,c}$ for Inter-band CA between FR1 and FR2 without EN-DC .....	613
7.3A.4	Void .....	614
7.3B	Reference sensitivity level for DC .....	614

7.3B.1	General.....	614
7.3B.2	Reference sensitivity for DC.....	614
7.3B.2.0	Minimum Conformance Requirements of Reference sensitivity for DC .....	614
7.3B.2.0.1	Intra-band contiguous EN-DC .....	614
7.3B.2.0.2	Intra-band non-contiguous EN-DC.....	615
7.3B.2.0.3	Inter-band EN-DC within FR1 .....	615
7.3B.2.0.3a	Inter-band NE-DC within FR1 .....	649
7.3B.2.0.4	Inter-band EN-DC including FR2 .....	650
7.3B.2.0.5	Inter-band EN-DC including both FR1 and FR2.....	650
7.3B.2.1	Reference sensitivity for Intra-band Contiguous EN-DC (2 CCs).....	650
7.3B.2.2	Reference sensitivity for Intra-band non-contiguous EN-DC (2 CCs).....	655
7.3B.2.3	Reference sensitivity for Inter-band EN-DC within FR1 (2 CCs) .....	655
7.3B.2.3_1	Reference sensitivity for EN-DC within FR1 (>2 CCs).....	696
7.3B.2.3_1.1	Reference sensitivity for EN-DC within FR1 (3 CCs) .....	696
7.3B.2.3_1.2	Reference sensitivity for EN-DC within FR1 (4 CCs) .....	741
7.3B.2.3_1.3	Reference sensitivity for EN-DC within FR1 (5 CCs) .....	746
7.3B.2.3_1.4	Reference sensitivity for EN-DC within FR1 (6 CCs) .....	749
7.3B.2.4	Reference sensitivity for Inter-band EN-DC including FR2 (1 NR CC).....	749
7.3B.2.4_1	Reference sensitivity for Inter-band EN-DC including FR2 (>1 NR CC) .....	750
7.3B.2.4_1.1	Reference sensitivity for Inter-band EN-DC including FR2 (2 NR CCs) .....	750
7.3B.2.4_1.2	Reference sensitivity for Inter-band EN-DC including FR2 (3 NR CCs) .....	751
7.3B.2.4_1.3	Reference sensitivity for Inter-band EN-DC including FR2 (4 NR CCs) .....	752
7.3B.2.4_1.4	Reference sensitivity for Inter-band EN-DC including FR2 (5 NR CCs) .....	752
7.3B.2.4_1.5	Reference sensitivity for Inter-band EN-DC including FR2 (6 NR CCs) .....	753
7.3B.2.4_1.6	Reference sensitivity for Inter-band EN-DC including FR2 (7 NR CCs) .....	754
7.3B.2.4_1.7	Reference sensitivity for Inter-band EN-DC including FR2 (8 NR CCs) .....	754
7.3B.2.4D	Reference sensitivity for inter-band EN-DC including FR2 for UL MIMO.....	755
7.3B.2.5	Reference sensitivity for Inter-band EN-DC including FR1 and FR2 (3 CCs).....	755
7.3B.2.5D	Reference sensitivity for inter-band EN-DC including FR1 and FR2 for UL MIMO.....	755
7.3B.2.6	Void.....	756
7.3B.3	$\Delta R_{IB,c}$ $\Delta R_{IBNC}$ for DC .....	756
7.3B.3.0	General .....	756
7.3B.3.1	Reference sensitivity $\Delta R_{IB,c}$ for Intra-band Contiguous EN-DC .....	756
7.3B.3.2	Reference sensitivity $\Delta R_{IB,c}$ for Intra-band non-contiguous EN-DC.....	756
7.3B.3.3	$\Delta R_{IB,c}$ for Inter-band EN-DC within FR1 .....	757
7.3B.3.3.1	$\Delta R_{IB,c}$ for EN-DC in two bands .....	757
7.3B.3.3.2	$\Delta R_{IB,c}$ for EN-DC in three bands .....	760
7.3B.3.3.3	$\Delta R_{IB,c}$ for EN-DC in four bands.....	765
7.3B.3.3.4	$\Delta R_{IB,c}$ for EN-DC in five bands .....	769
7.3B.3.3.5	$\Delta R_{IB,c}$ for EN-DC six bands.....	771
7.3B.3.3a	$\Delta R_{IB,c}$ for Inter-band NE-DC within FR1 .....	771
7.3B.3.4	Reference sensitivity for $\Delta R_{IB,c}$ Inter-band EN-DC including FR2 .....	771
7.3B.3.5	Reference sensitivity for $\Delta R_{IB,c}$ Inter-band EN-DC including both FR1 and FR2 .....	771
7.3B.4	EIS Spherical Coverage for Inter-band EN-DC including FR2 (1 NR CC).....	771
7.4	Void.....	772
7.4A	Maximum Input Level for CA.....	772
7.4B	Maximum Input Level for DC.....	772
7.4B.0	Minimum conformance requirement .....	772
7.4B.0.1	Intra-band contiguous EN-DC .....	772
7.4B.0.2	Intra-band non-contiguous EN-DC .....	773
7.4B.0.3	Inter-band EN-DC within FR1 .....	773
7.4B.0.4	Inter-band EN-DC including FR2 .....	773
7.4B.0.5	Inter-band EN-DC including both FR1 and FR2 .....	773
7.4B.1	Maximum Input Level for Intra-Band Contiguous EN-DC (2 CCs).....	773
7.4B.2	Maximum Input Level for Intra-Band Non-Contiguous EN-DC (2 CCs) .....	778
7.4B.3	Maximum Input Level for Inter-band EN-DC within FR1 (1 NR CC).....	780
7.4B.3_1	Maximum Input Level for EN-DC within FR1 (>2 CCs).....	780
7.4B.3_1.1	Maximum Input Level for EN-DC within FR1 (3 CCs) .....	780
7.4B.3_1.2	Maximum Input Level for EN-DC within FR1 (4 CCs) .....	781
7.4B.3_1.3	Maximum Input Level for EN-DC within FR1 (5 CCs) .....	782
7.4B.3_1.4	Maximum Input Level for EN-DC within FR1 (6 CCs) .....	783
7.4B.3a	Maximum Input Level for inter-band NE-DC within FR1 (2 CCs).....	784

7.4B.4	Maximum Input Level for inter-band EN-DC including FR2 (1 NR CC).....	784
7.4B.4_1	Maximum Input Level for inter-band EN-DC including FR2 (>1 NR CC).....	785
7.4B.4_1.1	Maximum Input Level for Inter-Band EN-DC including FR2 (2 NR CCs).....	785
7.4B.4_1.2	Maximum Input Level for Inter-Band EN-DC including FR2 (3 NR CCs).....	786
7.4B.4_1.3	Maximum Input Level for Inter-Band EN-DC including FR2 (4 NR CCs).....	787
7.4B.4_1.4	Maximum Input Level for Inter-Band EN-DC including FR2 (5 NR CCs).....	788
7.4B.4D	Maximum Input Level for inter-band EN-DC including FR2 for UL MIMO.....	788
7.4B.5	Maximum Input Level for inter-band EN-DC including both FR1 and FR2.....	789
7.4B.5D	Maximum Input Level for inter-band EN-DC including FR1 and FR2 for UL MIMO.....	789
7.5	Void.....	789
7.5A	Adjacent Channel Selectivity for CA.....	789
7.5B	Adjacent channel selectivity for DC.....	790
7.5B.0	Minimum Conformance Requirements.....	790
7.5B.0.1	Intra-band contiguous EN-DC.....	790
7.5B.0.2	Intra-band non-contiguous EN-DC.....	790
7.5B.0.3	Inter-band EN-DC within FR1.....	791
7.5B.0.3a	Inter-band NE-DC within FR1.....	791
7.5B.0.4	Inter-band EN-DC including FR2.....	791
7.5B.0.4a	Inter-band NE-DC including FR2.....	791
7.5B.0.5	Inter-band EN-DC including both FR1 and FR2.....	791
7.5B.1	Adjacent Channel Selectivity for intra-band contiguous EN-DC (2 CCs).....	791
7.5B.2	Adjacent Channel Selectivity for intra-band non-contiguous EN-DC (2 CCs).....	794
7.5B.3	Adjacent Channel Selectivity for inter-band EN-DC within FR1 (1 NR CC).....	795
7.5B.3_1	Adjacent Channel Selectivity for EN-DC within FR1 (>2 CCs).....	796
7.5B.3_1.1	Adjacent Channel Selectivity for EN-DC within FR1 (2 NR CCs).....	796
7.5B.3_1.2	Adjacent Channel Selectivity for EN-DC within FR1 (3 NR CCs).....	797
7.5B.3_1.3	Adjacent Channel Selectivity for EN-DC within FR1 (4 NR CCs).....	798
7.5B.3_1.4	Adjacent Channel Selectivity for EN-DC within FR1 (5 NR CCs).....	799
7.5B.3a	Adjacent Channel Selectivity for inter-band NE-DC within FR1 (2 CCs).....	799
7.5B.4	Adjacent Channel Selectivity for inter-band EN-DC including FR2 (1 NR CC).....	800
7.5B.4_1	Adjacent Channel Selectivity for inter-band EN-DC including FR2 (>1 NR CC).....	801
7.5B.4_1.1	Adjacent Channel Selectivity for inter-band EN-DC including FR2 (2 NR CCs).....	801
7.5B.4_1.2	Void.....	802
7.5B.4_1.3	Void.....	802
7.5B.4_1.4	Void.....	802
7.5B.4D	Adjacent Channel Selectivity for inter-band EN-DC including FR2 for UL MIMO.....	802
7.5B.5	Adjacent Channel Selectivity for inter-band EN-DC including both FR1 and FR2.....	803
7.5B.5D	Adjacent Channel Selectivity for inter-band EN-DC including FR1 and FR2 for UL MIMO.....	803
7.6	Void.....	803
7.6A	Blocking characteristics for CA.....	803
7.6B	Blocking characteristics for DC.....	803
7.6B.1	General.....	803
7.6B.2	Inband blocking for DC.....	804
7.6B.2.0	Minimum Conformance Requirements.....	804
7.6B.2.0.1	Intra-band contiguous EN-DC.....	804
7.6B.2.0.2	Intra-band non-contiguous EN-DC.....	804
7.6B.2.0.3	Inter-band EN-DC within FR1.....	804
7.6B.2.0.3a	Inter-band NE-DC within FR1.....	804
7.6B.2.0.4	Inter-band EN-DC including FR2.....	805
7.6B.2.0.5	Inter-band EN-DC including both FR1 and FR2.....	805
7.6B.2.1	Inband blocking for intra-band contiguous EN-DC (2 CCs).....	805
7.6B.2.2	Inband blocking for intra-band non-contiguous EN-DC (2 CCs).....	808
7.6B.2.3	Inband blocking for inter-band EN-DC within FR1 (1 NR CC).....	810
7.6B.2.3_1	Inband blocking for EN-DC within FR1 (>2 CCs).....	810
7.6B.2.3_1.1	Inband blocking for EN-DC within FR1 (3 CCs).....	810
7.6B.2.3_1.2	Inband blocking for EN-DC within FR1 (4 CCs).....	814
7.6B.2.3_1.3	Inband blocking for EN-DC within FR1 (5 CCs).....	817
7.6B.2.3_1.4	Void.....	817
7.6B.2.3a	In-band blocking for inter-band NE-DC within FR1 (2 CCs).....	817
7.6B.2.4	Inband blocking for inter-band EN-DC including FR2 (1 NR CC).....	818
7.6B.2.4_1	Inband blocking for inter-band EN-DC including FR2 (>1 NR CC).....	818
7.6B.2.4_1.1	Inband blocking for inter-band EN-DC including FR2 (2 NR CCs).....	818



7.6B.2.4_1.2	Void .....	819
7.6B.2.4_1.3	Void .....	819
7.6B.2.4_1.4	Void .....	819
7.6B.2.4D	Inband blocking for inter-band EN-DC including FR2 for UL MIMO.....	819
7.6B.2.5	Inband blocking for inter-band EN-DC including both FR1 and FR2 .....	819
7.6B.2.5D	Inband blocking for inter-band EN-DC including FR1 and FR2 for UL MIMO .....	820
7.6B.3	Out-of-band blocking for DC.....	820
7.6B.3.0	Minimum Conformance Requirements .....	820
7.6B.3.0.1	Intra-band contiguous EN-DC .....	820
7.6B.3.0.2	Intra-band non-contiguous EN-DC.....	820
7.6B.3.0.3	Inter-band EN-DC within FR1 .....	821
7.6B.3.0.3a	Inter-band NE-DC within FR1 .....	822
7.6B.3.0.4	Inter-band EN-DC including FR2 .....	822
7.6B.3.0.5	Inter-band EN-DC including both FR1 and FR2.....	822
7.6B.3.1	Out-of-band blocking for intra-band contiguous EN-DC (2 CCs).....	822
7.6B.3.2	Out-of-band blocking for intra-band non-contiguous EN-DC (2 CCs).....	826
7.6B.3.3	Out-of-band blocking for inter-band EN-DC within FR1 (2 CCs).....	827
7.6B.3.3_1	Out-of-band blocking for EN-DC within FR1 (>2 CCs).....	835
7.6B.3.3_1.1	Out-of-band blocking for EN-DC within FR1 (3 CCs) .....	835
7.6B.3.3_1.2	Out-of-band blocking for EN-DC within FR1 (4 CCs) .....	838
7.6B.4	Narrow band blocking for DC .....	841
7.6B.4.0	Minimum Conformance Requirements .....	841
7.6B.4.0.1	Intra-band contiguous EN-DC.....	841
7.6B.4.0.2	Intra-band non-contiguous EN-DC.....	841
7.6B.4.0.3	Inter-band EN-DC within FR1 .....	842
7.6B.4.0.3a	Inter-band NE-DC within FR1 .....	842
7.6B.4.0.4	Inter-band EN-DC including FR2 .....	842
7.6B.4.0.5	Inter-band EN-DC including both FR1 and FR2.....	842
7.6B.4.1	Narrow band blocking for intra-band contiguous EN-DC (2 CCs).....	842
7.6B.4.2	Narrow band blocking for intra-band non-contiguous EN-DC (2 CCs).....	845
7.6B.4.3	Narrow band blocking for inter-band EN-DC within FR1 (1 NR CC) .....	847
7.6B.4.3_1	Narrow band blocking for EN-DC within FR1 (>2 CCs) .....	847
7.6B.4.3_1.1	Narrow band blocking for EN-DC within FR1 (3 CCs).....	847
7.6B.4.3_1.2	Narrow band blocking for EN-DC within FR1 (4 CCs).....	851
7.6B.4.3_1.3	Narrow band blocking for EN-DC within FR1 (5 CCs).....	854
7.6B.4.3_1.4	Void.....	854
7.6B.4.3a	Narrow band blocking for inter-band NE-DC within FR1 (2 CCs) .....	854
7.6E	Blocking characteristics for V2X in FR1 .....	855
7.6E.0	Minimum conformance requirements .....	855
7.6E.1	In-band blocking for V2X operation.....	855
7.6E.2	Out-of-band blocking for V2X operation .....	855
7.7	Void.....	856
7.7A	Spurious response for CA.....	856
7.7B	Spurious response for DC.....	856
7.7B.0	Minimum Conformance Requirements.....	856
7.7B.0.1	Intra-band contiguous EN-DC .....	856
7.7B.0.2	Intra-band non-contiguous EN-DC .....	856
7.7B.0.3	Inter-band EN-DC within FR1 .....	856
7.7B.0.3a	Inter-band NE-DC within FR1 .....	857
7.7B.0.4	Inter-band EN-DC including FR2 .....	857
7.7B.0.5	Inter-band EN-DC including both FR1 and FR2 .....	857
7.7B.1	Spurious Response for intra-band contiguous EN-DC (2 CCs).....	857
7.7B.2	Spurious Response for intra-band non-contiguous EN-DC (2 CCs).....	859
7.7B.3	Spurious Response for inter-band EN-DC within FR1 (2 CCs) .....	860
7.7B.3_1	Spurious Response for EN-DC within FR1 (>2 CCs) .....	863
7.7B.3_1.1	Spurious Response for EN-DC within FR1 (3 CCs).....	863
7.7B.3_1.2	Spurious Response for EN-DC within FR1 (4 CCs).....	865
7.7E	Spurious response for V2X in FR1 .....	867
7.7E.0	Minimum conformance requirements .....	867
7.7E.1	Spurious response for V2X operation.....	868
7.8	Void.....	868
7.8B	Intermodulation characteristics for DC .....	868

7.8B.1	General.....	868
7.8B.2	Wide band Intermodulation .....	868
7.8B.2.0	Minimum Conformance Requirements .....	868
7.8B.2.0.1	Intra-band contiguous EN-DC .....	868
7.8B.2.0.2	Intra-band non-contiguous EN-DC.....	868
7.8B.2.0.3	Inter-band EN-DC within FR1 .....	869
7.8B.2.0.4	Inter-band EN-DC including FR2 .....	869
7.8B.2.0.5	Inter-band EN-DC including both FR1 and FR2.....	869
7.8B.2.1	Wideband Intermodulation for intra-band contiguous EN-DC (2 CCs).....	869
7.8B.2.2	Wideband Intermodulation for intra-band non-contiguous EN-DC (2 CCs) .....	872
7.8B.2.3	Wideband Intermodulation for inter-band EN-DC within FR1 (2 CCs) .....	873
7.8B.2.3_1	Wideband Intermodulation for EN-DC within FR1 (>2 CCs) .....	874
7.8B.2.3_1.1	Wideband Intermodulation for EN-DC within FR1 (3 CCs).....	874
7.8B.2.3_1.2	Wideband Intermodulation for EN-DC within FR1 (4 CCs).....	877
7.8B.2.3_1.3	Wideband Intermodulation for EN-DC within FR1 (5 CCs).....	880
7.8B.2.3_1.4	Wideband Intermodulation for EN-DC within FR1 (6 CCs).....	882
7.8B.2.3a	Wideband Intermodulation for inter-band NE-DC within FR1 (2 CCs) .....	882
7.8B.2.4 to 7.8B.2.9	Void .....	883
7.8E	Intermodulation characteristics for V2X operation in FR1 .....	883
7.8E.1	Wide band Intermodulation for V2X.....	883
7.8E.1.0	Minimum conformance requirements .....	883
7.8E.1.1	Wide band Intermodulation for V2X operation .....	883
7.9	Void.....	883
7.9B	Spurious emissions for DC.....	883
7.9B.0	Minimum Conformance Requirements.....	883
7.9B.0.1	Intra-band contiguous EN-DC .....	883
7.9B.0.2	Intra-band non-contiguous EN-DC .....	883
7.9B.0.3	Inter-band EN-DC within FR1 .....	884
7.9B.0.4	Inter-band EN-DC including FR2 .....	884
7.9B.0.5	Inter-band EN-DC including both FR1 and FR2 .....	884
7.9B.1	Spurious Emissions for intra-band contiguous EN-DC (2 CCs).....	884
7.9B.2	Spurious Emissions for intra-band non-contiguous EN-DC (2 CCs).....	885
7.9B.3	Spurious Emissions for inter-band EN-DC within FR1 (1 NR CC) .....	886
7.9B.3_1	Spurious Emissions for EN-DC within FR1 (>2 CCs) .....	887
7.9B.3_1.1	Spurious Emissions for EN-DC within FR1 (3 CCs).....	887
7.9B.3a	Spurious Emissions for inter-band NE-DC within FR1 (2 CCs) .....	887
7.9B.4	Spurious Emissions for inter-band EN-DC including FR2 (1 NR CC) .....	888
7.9B.5	Spurious Emissions for inter-band EN-DC including both FR1 and FR2 (3 CCs).....	889
<b>Annex A (normative):</b>	<b>Measurement Channels.....</b>	<b>890</b>
A.1	General .....	890
A.2	UL reference measurement channels for E-UTRA TDD Config 2.....	890
A.2.1	General .....	890
A.2.2	Reference measurement channels for E-UTRA .....	891
A.2.2.1	Full RB allocation.....	891
A.2.2.1.1	QPSK .....	891
A.2.2.1.2	16-QAM.....	891
A.2.2.1.3	64-QAM.....	892
A.2.2.1.4	256 QAM .....	893
A.2.2.2	Partial RB allocation.....	894
A.2.2.2.1	QPSK .....	894
A.2.2.2.2	16-QAM.....	896
A.2.2.2.3	64-QAM.....	899
A.2.2.2.4	256 QAM .....	902
A.3	DL reference measurement channels for E-UTRA .....	903
A.3.1	General .....	903
<b>Annex B (normative):</b>	<b>Propagation Conditions.....</b>	<b>908</b>
<b>Annex C (normative):</b>	<b>Downlink Physical Channels.....</b>	<b>909</b>

<b>Annex D (normative):</b>	<b>Characteristics of the Interfering Signal .....</b>	<b>910</b>
<b>Annex E (normative):</b>	<b>Global In-Channel Tx Test .....</b>	<b>910</b>
<b>Annex F (informative):</b>	<b>Measurement uncertainties and Test Tolerances .....</b>	<b>911</b>
F.1	Acceptable uncertainty of Test System (normative) .....	911
F.1.0	General .....	911
F.1.0.1	Conducted Measurements .....	911
F.1.0.2	Radiated Measurements .....	911
F.1.1	Measurement of test environments .....	911
F.1.1.1	Conducted Measurements .....	911
F.1.1.2	Radiated Measurements .....	911
F.1.2	Measurement of transmitter .....	912
F.1.3	Measurement of receiver .....	928
F.2	Interpretation of measurement results (normative) .....	932
F.3	Test Tolerance and Derivation of Test Requirements (informative) .....	932
F.3.1	Measurement of test environments .....	932
F.3.2	Measurement of transmitter .....	933
F.3.3	Measurement of receiver .....	947
F.4	Uplink power window .....	950
F.4.1	Introduction .....	950
F.4.2	Setting the power window above a requirement .....	951
F.4.2.1	NR FR1 .....	951
F.4.2.2	NR FR2 .....	952
F.4.2.3	E-UTRA .....	953
F.4.3	Setting the power window below a requirement .....	954
F.4.3.1	NR FR1 .....	954
F.4.3.2	NR FR2 .....	955
F.4.3.3	E-UTRA .....	956
F.4.4	Setting the power window centred on a target value .....	957
F.4.4.1	NR FR1 .....	957
F.4.4.2	NR FR2 .....	958
F.4.4.3	E-UTRA .....	959
<b>Annex G (normative):</b>	<b>Uplink Physical Channels .....</b>	<b>961</b>
<b>Annex H (normative):</b>	<b>Statistical Testing .....</b>	<b>962</b>
H.1	General .....	962
H.2	Statistical testing of receiver characteristics .....	962
H.2.1	General .....	962
H.2.2	Mapping throughput to error ratio .....	962
H.2.3	Design of the test .....	963
H.2.4	Numerical definition of the pass fail limits .....	964
H.2.5	Pass fail decision rules .....	965
<b>Annex I (normative):</b>	<b>Void .....</b>	<b>966</b>
<b>Annex J (normative):</b>	<b>Test applicability per permitted test method .....</b>	<b>967</b>
<b>Annex K (normative):</b>	<b>EIRP, TRP, and EIS measurement procedures .....</b>	<b>968</b>
<b>Annex L (normative):</b>	<b>Void .....</b>	<b>969</b>
<b>Annex M (normative):</b>	<b>Dual uplink interferer .....</b>	<b>970</b>
<b>Annex N (normative):</b>	<b>Modified MPR behaviour .....</b>	<b>971</b>
<b>Annex O (informative):</b>	<b>Change history .....</b>	<b>972</b>
History .....		1019

---

# Foreword

This Technical Specification has been produced by the 3rd Generation Partnership Project (3GPP).

The contents of the present document are subject to continuing work within the TSG and may change following formal TSG approval. Should the TSG modify the contents of the present document, it will be re-released by the TSG with an identifying change of release date and an increase in version number as follows:

Version x.y.z

where:

- x the first digit:
  - 1 presented to TSG for information;
  - 2 presented to TSG for approval;
  - 3 or greater indicates TSG approved document under change control.
- y the second digit is incremented for all changes of substance, i.e. technical enhancements, corrections, updates, etc.
- z the third digit is incremented when editorial only changes have been incorporated in the document.

The present document is part 3 of a multi-part Technical Specification (TS) covering the New Radio (NR) User Equipment (UE) conformance specification, which is divided in the following parts:

- TS 38.521-1 [8]: "NR; User Equipment (UE) conformance specification; Radio transmission and reception; Part 1: Range 1 Standalone" (the present document).
- TS 38.521-2 [9]: "NR; User Equipment (UE) conformance specification; Radio transmission and reception; Part 2: Range 2 Standalone".
- TS 38.521-3: "NR; User Equipment (UE) conformance specification; Radio transmission and reception; Part 3: Range 1 and Range 2 Interworking operation with other radios".
- TS 38.521-4 [22]: "NR; User Equipment (UE) conformance specification; Radio transmission and reception; Part 4: Performance".
- TS 38.522 [14]: "NR; User Equipment (UE) conformance specification; Applicability of RF and RRM test cases".
- TS 38.533 [23]: "NR; User Equipment (UE) conformance specification; Radio resource management (RRM)".

---

# 1 Scope

The present document specifies the measurement procedures for the conformance test of the user equipment (UE) that contain RF characteristics for carrier aggregation between Range 1 and Range 2 and additional requirements for EN-DC, NE-DC and NGEN-DC.

The requirements are listed in different clauses only if the corresponding parameters deviate. More generally, tests are only applicable to those mobiles that are intended to support the appropriate functionality. To indicate the circumstances in which tests apply, this is noted in the "*definition and applicability*" part of the test.

For example only Release 15 and later UE declared to support 5G-NR shall be tested for this functionality. In the event that for some tests different conditions apply for different releases, this is indicated within the text of the test itself.

---

# 2 References

The following documents contain provisions which, through reference in this text, constitute provisions of the present document.

- References are either specific (identified by date of publication, edition number, version number, etc.) or non-specific.
- For a specific reference, subsequent revisions do not apply.
- For a non-specific reference, the latest version applies. In the case of a reference to a 3GPP document (including a GSM document), a non-specific reference implicitly refers to the latest version of that document *in the same Release as the present document*.

- [1] 3GPP TR 21.905: "Vocabulary for 3GPP Specifications"
- [2] 3GPP TS 38.101-1: "NR; User Equipment (UE) radio transmission and reception; Part 1: Range 1 Standalone".
- [3] 3GPP TS 38.101-2: "NR; User Equipment (UE) radio transmission and reception; Part 2: Range 2 Standalone".
- [4] 3GPP TS 38.101-3: "NR; User Equipment (UE) radio transmission and reception; Part 3: Range 1 and Range 2 Interworking operation with other radios".
- [5] 3GPP TS 36.101: "Evolved Universal Terrestrial Radio Access (E-UTRA); User Equipment (UE) radio transmission and reception".
- [6] 3GPP TS 38.508-1: "5GS; User Equipment (UE) conformance specification; Part 1: Common test environment".
- [7] 3GPP TR 38.905: "NR; Derivation of test points for radio transmission and reception conformance test cases".
- [8] 3GPP TS 38.521-1: "User Equipment (UE) conformance specification; Radio transmission and reception; Part 1: Range 1 Standalone".
- [9] 3GPP TS 38.521-2: "NR; User Equipment (UE) conformance specification; Radio transmission and reception; Part 2: Range 2 Standalone".
- [10] 3GPP TS 36.521-1: "Evolved Universal Terrestrial Radio Access (E-UTRA); User Equipment (UE) conformance specification; Radio transmission and reception; Part 1: Conformance testing"
- [11] 3GPP TS 36.508: "Evolved Universal Terrestrial Radio Access (E-UTRA) and Evolved Packet Core (EPC); Common test environments for User Equipment (UE) conformance testing".
- [12] 3GPP TS 36.133: "Evolved Universal Terrestrial Radio Access (E-UTRA); Requirements for support of radio resource management".
- [13] 3GPP TS 36.211: "E-UTRA; Physical channels and modulation".

- [14] 3GPP TS 38.522: "NR; User Equipment (UE) conformance specification; Applicability of radio transmission, radio reception and radio resource management test cases".
- [15] Void.
- [16] 3GPP TS 38.306: "NR: User Equipment (UE) radio access capabilities".
- [17] 3GPP TS 36.331: "Evolved Universal Terrestrial Radio Access (E-UTRA); Radio Resource Control (RRC); Protocol specification".
- [18] 3GPP TS 38.331: "NR; Radio Resource Control (RRC) protocol specification".
- [19] 3GPP TS 38.213: "NR; Physical layer procedures for control".
- [20] 3GPP TS 36.213: "E-UTRA Physical layer procedures".
- [21] Recommendation ITU-R M.1545: "Measurement uncertainty as it applies to test limits for the terrestrial component of International Mobile Telecommunications-2000".
- [22] 3GPP TS 38.521-4: "NR; User Equipment (UE) conformance specification; Radio transmission and reception; Part 4: Performance".
- [23] 3GPP TS 38.533: "NR; User Equipment (UE) conformance specification; Radio resource management (RRM)".
- [24] 3GPP TS 36.214: "E-UTRA; Physical layer; Measurements".
- [25] 3GPP TS 38.133: "NR; Requirements for support of radio resource management".

---

## 3 Definitions, symbols and abbreviations

### 3.1 Definitions

For the purposes of the present document, the terms and definitions given in TR 21.905 [1] and the following apply. A term defined in the present document takes precedence over the definition of the same term, if any, in TR 21.905 [1].

**Con-current operation:** The simultaneous transmission and reception of sidelink and Uu interfaces while operation is agnostic of the service used on each interface.

### 3.2 Symbols

For the purposes of the present document, the following symbols apply:

$\Delta R_{IB,c}$	Allowed reference sensitivity relaxation due to support for CA or DC operation, for serving cell $c$
$\Delta T_{IB,c}$	Allowed maximum configured output power relaxation due to support for CA or DC operation, for serving cell $c$
$BW_{E-UTRA\_Channel}$	Channel bandwidth of E-UTRA carrier
$BW_{E-UTRA\_Channel\_CA}$	Channel bandwidth of E-UTRA sub-block which is composed of intra-band contiguous CA E-UTRA carriers
$BW_{NR\_Channel}$	Channel bandwidth of NR carrier
$BW_{NR\_Channel\_CA}$	Channel bandwidth of NR sub-block which is composed of intra-band contiguous CA NR carriers
$Ceil(x)$	Rounding upwards; $ceil(x)$ is the smallest integer such that $ceil(x) \geq x$
$EN-DC_{ACLR}$	The ratio of the filtered mean power centred on the aggregated sub-block bandwidth ENBW to the filtered mean power centred on an adjacent bandwidth of the same size ENBW
$E-UTRA_{ACLR}$	E-UTRA ACLR
$F_C$	<i>RF reference frequency</i> for the carrier centre on the channel raster
$F_{DL\_low}$	The lowest frequency of the downlink <i>operating band</i>
$F_{DL\_high}$	The highest frequency of the downlink <i>operating band</i>
$F_{Interferer}$	Frequency of the interferer

$F_{\text{Interferer}}$ (offset)	Frequency offset of the interferer (between the center frequency of the interferer and the carrier frequency of the carrier measured)
$F_{\text{UL\_low}}$	The lowest frequency of the uplink <i>operating band</i>
$F_{\text{UL\_high}}$	The highest frequency of the uplink <i>operating band</i>
$F_{\text{OOB}}$	The boundary between the NR out of band emission and spurious emission domains
$L_{\text{CRB}}$	Transmission bandwidth which represents the length of a contiguous resource block allocation expressed in units of resources blocks
$\text{Max}()$	The largest of given numbers
$\text{Min}()$	The smallest of given numbers
$N_{\text{RACL}}R$	NR ACLR
$N_{\text{RB}}$	Transmission bandwidth configuration, expressed in units of resource blocks
$N_{\text{RB\_agg}}$	The number of the aggregated RBs within the fully allocated aggregated channel bandwidth $N_{\text{RB\_agg}} = \sum_1^j N_{\text{RB}_j} * 2^{\mu_j}$ for carrier 1 to j, where $\mu$ is defined in TS 38.211 [13]
$N_{\text{RB,c}}$	The transmission bandwidth configuration of component carrier c, expressed in units of resource blocks $N_{\text{RB,c}_j} = N_{\text{RB}_j} * 2^{\mu_j}$ for carrier j, where $\mu$ is defined in TS 38.211 [13]
$P_{\text{CMAX}}$	The configured maximum UE output power
$P_{\text{EMAX}}$	Maximum allowed UE output power signalled by higher layers
$P_{\text{Interferer}}$	Modulated mean power of the interferer
$P_{\text{PowerClass}}$	The nominal UE power (i.e. no tolerance)
$P_{\text{UMAX}}$	The measured configured maximum UE output power
$P_{\text{uw}}$	Power of an unwanted DL signal
$P_{\text{w}}$	Power of a wanted DL signal
$\text{RB}_{\text{start}}$	Indicates the lowest RB index of transmitted resource blocks
$W_{\text{gap}}$	The sub-block gap between the two sub-blocks

### 3.3 Abbreviations

For the purposes of the present document, the abbreviations given in TR 21.905 [1] and the following apply. An abbreviation defined in the present document takes precedence over the definition of the same abbreviation, if any, in TR 21.905 [1].

ACLR	Adjacent Channel Leakage Ratio
ACS	Adjacent Channel Selectivity
A-MPR	Additional Maximum Power Reduction
BCS	Bandwidth Combination Set
BPSK	Binary Phase Shift Keying
BW	Bandwidth
CA	Carrier Aggregation
CC	Component Carrier
CG	Carrier Group
CP-OFDM	Cyclic Prefix-OFDM
CQI	Channel quality indicator
CW	Continuous Wave
DC	Dual Connectivity
DCI	Downlink Control Information
DFT-s-OFDM	Discrete Fourier Transform-spread-OFDM
DL	Downlink
DTX	Discontinuous Transmission
EIRP	Equivalent Isotropically Radiated Power
EIS	Effective Isotropic Sensitivity
EN-DC	E-UTRA/NR DC
E-UTRA	Evolved UTRA
EVM	Error Vector Magnitude
FDM	Frequency Division Multiplexing
FFT	Fast Fourier Transformation
FR	Frequency Range
ENBW	The aggregated bandwidth of an E-UTRA sub-block and an adjacent NR sub-block
HARQ	Hybrid automatic repeat request
IDFT	Inverse Discrete Fourier Transformation

ITS	Intelligent Transportation System
ITU-R	Radio communication Sector of the International Telecommunication Union
MBW	Measurement bandwidth defined for the protected band
MCG	Master Cell Group
MPR	Allowed maximum power reduction
MSD	Maximum Sensitivity Degradation
MU	Measurement Uncertainty
MR-DC	Multi-Radio Dual Connectivity
NE-DC	NR-E-UTRA Dual Connectivity
NGEN-DC	NG-RAN E-UTRA-NR Dual Connectivity
NR	New Radio
NR-ARFCN	NR Absolute Radio Frequency Channel Number
NR/5GC	NR connected to 5GC
NS	Network Signalling
NSA	Non-Standalone, a mode of operation where operation of a radio is assisted with another radio
OCNG	OFDMA Channel Noise Generator
OFDM	Orthogonal frequency division multiplex
OOB	Out-of-band
OOBE	Out-of-band emission
OTA	Over The Air
PBCH	Physical broadcast channel
PDCCH	Physical downlink control channel
PDSCH	Physical downlink shared channel
P-MPR	Power Management Maximum Power Reduction
PRACH	Physical random-access channel
PRB	Physical Resource Block
PSCCH	Physical Sidelink Control CHannel
PSSCH	Physical Sidelink Shared CHannel
PUCCH	Physical uplink control channel
PUSCH	Physical uplink shared channel
QAM	Quadrature Amplitude Modulation
QPSK	Quadrature Phase Shift Keying
RE	Resource Element
REFSENS	Reference Sensitivity
RF	Radio Frequency
RMC	Reference Measurement Channel
RNTI	Radio Network Temporary Identifier
Rx	Receiver
SCG	Secondary Cell Group
SCS	Subcarrier spacing
SEM	Spectrum Emission Mask
SL	Sidelink
SRS	Sounding Reference Symbol
SS	Synchronization Symbol / System Simulator
SUL	Supplementary uplink
TDM	Time Division Multiplex
TPC	Transmit Power Control
TRP	Total Radiated Power
TT	Test Tolerance
Tx	Transmitter
UE	User Equipment
UL	Uplink
UL MIMO	Up Link Multiple Antenna transmission
ULSUP	Uplink sharing from UE perspective
V2X	Vehicle to Everything



---

## 4 General

### 4.1 Relationship between minimum requirements and test requirements

TS 38.101-3 [4] is interwork specification for NR UE, covering RF characteristics and minimum performance requirements. Conformance to TS 38.101-3 [4] is demonstrated by fulfilling the test requirements specified in the present document.

The Minimum Requirements given in TS 38.101-3 [4] make no allowance for measurement uncertainty (MU). The present document defines test tolerances (TT). These test tolerances are individually calculated for each test. The test tolerances are used to relax the minimum requirements in TS 38.101-3 [4] to create test requirements. For some requirements, including regulatory requirements, the test tolerance is set to zero.

The measurement results returned by the test system are compared - without any modification - against the test requirements as defined by various levels of "Shared Risk" principle as described below.

- a) Core specification value is not relaxed by any relaxation value ( $TT=0$ ). For each single measurement, the probability of a borderline good UE being judged as FAIL equals the probability of a borderline bad UE being judged as PASS.
  - Test tolerances equal to 0 ( $TT=0$ ) are considered in this specification.
- b) Core specification value is relaxed by a relaxation value ( $TT>0$ ). For each single measurement, the probability of a borderline bad UE being judged as PASS is greater than the probability of a borderline good UE being judged as FAIL.
  - Test tolerances lower than measurement uncertainty and greater than 0 ( $0 < TT < MU$ ) are considered in this specification.
  - Test tolerances high up to measurement uncertainty ( $TT = MU$ ) are considered in this specification which is also known as "Never fail a good DUT" principle.
- c) Core specification value is tightened by a stringent value ( $TT<0$ ). For each single measurement, the probability of a borderline good UE being judged as FAIL is greater than the probability of a borderline bad UE being judged as PASS.
  - Test tolerances lower than 0 ( $TT<0$ ) are not considered in this specification.

The "Never fail a good DUT" and the "Shared Risk" principles are defined in Recommendation ITU-R M.1545 [21].

### 4.2 Applicability of minimum requirements

- a) In TS 38.101-3 [4] the Minimum Requirements are specified as general requirements and additional requirements. Where the Requirement is specified as a general requirement, the requirement is mandated to be met in all scenarios
- b) For specific scenarios for which an additional requirement is specified, in addition to meeting the general requirement, the UE is mandated to meet the additional requirements.
- c) The spurious emissions power requirements are for the long-term average of the power. For the purpose of reducing measurement uncertainty, it is acceptable to average the measured power over a period of time sufficient to reduce the uncertainty due to the statistical nature of the signal.
- d) Terminal that supports EN-DC or NE-DC configuration shall meet E-UTRA requirements as specified in TS 36.101 [5] and NR requirements as in TS 38.101-1 [2] and TS 38.101-2 [3] unless otherwise specified in TS 38.101-3 [4].
- e) All the requirements for intra-band contiguous and non-contiguous EN-DC or NE-DC apply under the assumption of the same uplink-downlink and special subframe configurations in the E-UTRA and slot format

indicated by `UL-DL-configurationCommon` and `UL-DL-configurationDedicated` in the NR for the EN-DC or NE-DC, a time offset between the two RATs configurations may be required.

- f) For EN-DC or NE-DC combinations with CA configurations for E-UTRA and/or NR, all the requirements for E-UTRA and/or NR all the requirements for E-UTRA and/or NR intra-band contiguous and non-contiguous CA apply under the assumption of the same slot format indicated by `UL-DL-configurationCommon` and `UL-DL-configurationDedicated` in the PSCell and SCells for NR and the same uplink-downlink and special subframe configurations in PCell and SCells for E-UTRA.

A terminal which supports an EN-DC or NE-DC configuration shall support:

- If any subsets of the EN-DC or NE-DC configuration do not specify its own bandwidth combination sets in 5.3B, then the terminal shall support the same E-UTRA bandwidth combination sets it signals the support for in E-UTRA CA configuration part of E-UTRA – NR DC and shall support the same NR bandwidth combination sets it signals the support for in NR CA configuration part of E-UTRA – NR DC.
- Else if one of the subsets of the EN-DC or NE-DC configuration specify its own bandwidth combination sets in 5.3B, then the terminal shall support a product set of channel bandwidth for each band specified by E-UTRA bandwidth combination sets, NR bandwidth combination sets, and EN-DC or NE-DC bandwidth combination sets it signals the support.

A terminal which supports an inter-band EN-DC or NE-DC configuration with a certain UL configuration shall support the all lower order DL configurations of the lower order EN-DC or NE-DC combinations, which have this certain UL configuration and the fallbacks of this UL configuration.

A terminal which supports NE-DC configurations shall meet the minimum requirements for corresponding EN-DC configuration, unless otherwise specified.

For CA or DC configurations, which include FR2 intra-band CA combinations with multiple FR2 subblocks, where at least one of the subblocks is contiguous CA combination.

- if the field *partialFR2-FallbackRX-Req* is not present, the UE shall meet all applicable UE RF requirements for the highest order CA configuration and all associated fallback CA configurations;
- if the field *partialFR2-FallbackRX-Req* is present, for each FR2 intra-band CA configuration with multiple sub-blocks that the UE indicates support for explicitly in UE capability signalling: the in-gap UE RF requirements in clauses 7.5A, 7.5B, 7.6A, 7.6B apply as the equivalent requirements for the associated fallback FR2 intra-band CA configurations with the same number of sub-blocks, where at least one of the sub-blocks consists of a contiguous CA configuration. The UE shall meet all applicable UE RF requirements for fallback CA configurations with a lesser number of sub-blocks;
- regardless of the field *partialFR2-FallbackRX-Req*, the UE shall meet all DL out-of-gap requirements for all lower order fallback CA configurations.

Terminal that supports inter-band NR-DC between FR1 and FR2 configuration shall meet the requirements for corresponding CA configuration (suffix A), unless otherwise specified.

For a terminal that supports inter-band Dual-Connectivity (DC) with UL MIMO or Tx diversity operation, the requirements are targeted for FWA form factor in current specification.

## 4.3 Specification suffix information

Unless stated otherwise the following suffixes are used for indicating at 2<sup>nd</sup> level clause, shown in Table 4.3-1.

**Table 4.3-1: Definition of suffixes**

Clause suffix	Variant
None	Single Carrier
A	Carrier Aggregation (CA) between FR1 and FR2
B	Dual-Connectivity (DC) with and without SUL including UL sharing from UE perspective, inter-band NR DC between FR1 and FR2
D	UL MIMO
E	V2X
F	Shared spectrum channel access
H	Dual-Connectivity (DC) with UL MIMO
L	Dual-Connectivity (DC) with Tx Diversity

## 4.4 Test points analysis

The information on test point analysis and test point selection including number of test points for each test case is shown in TR 38.905 [7] clause 4.3.

## 4.5 Applicability and test coverage rules

### 4.5.0 General

- (1) The applicability and test coverage rules for Non-Standalone (NSA) only capable devices shall include the following:
  - a) For each NR band in a device; test all the EN-DC or NE-DC exception test requirements as per test procedures in this specification.
  - b) Test all the EN-DC or NE-DC FR2 non-exception test requirements in this specification with test procedures which refer appropriately back to TS 38.521-2 [9] for each NR band. Test only one EN-DC or NE-DC combination per FR2 band for each EN-DC or NE-DC configuration as defined in clause 5.5B of TS 38.101-3 [4] using LTE anchor agnostic approach.
  - c) Test all the EN-DC or NE-DC FR1 non-exception test requirements in this specification with test procedures which refer appropriately back to TS 38.521-1 [8] for each NR band. Test only one EN-DC or NE-DC combination per FR1 band for each EN-DC or NE-DC configuration as defined in clause 5.5B of 38.101-3 [4] using LTE anchor agnostic approach.
- (2) The applicability and test coverage rules for Standalone (SA) and NSA capable devices shall include the following:
  - a) For each NR band in a device, test all the EN-DC or NE-DC exception test requirements as per test procedures in this specification.
  - b) Test all the Standalone FR2 test requirements as per test procedures in TS 38.521-2 [9] for each NR band. This also fulfils coverage for all non-exception EN-DC or NE-DC FR2 test requirements for that NR band and need not be retested. Alternatively test in EN-DC or NE-DC mode following (1) b) above.
  - c) Test all the Standalone FR1 test requirements as per test procedures in TS 38.521-1 [8] for each NR band. This also fulfils coverage for all non-exception EN-DC or NE-DC FR1 test requirements for that NR band and need not be retested. Alternatively test in EN-DC or NE-DC mode following (1)c) above.
  - d) Test all the Release 16 and forward Standalone FR1 spurious emissions for UE co-existence test requirements for an uplink multi-band combination in NR CA mode or in NR SUL mode as per test

procedures in TS 38.521-1 [8]. This also fulfils coverage for corresponding EN-DC exceptional test requirements in TS 38.521-3 for that uplink combination in EN-DC mode and need not to be retested.

I.E., an uplink multi-band combination in EN-DC mode is DC\_A\_nB or DC\_B\_nA, the corresponding CA mode is CA\_nA-nB, and the corresponding SUL mode is SUL\_nA-nD and SUL\_nB-nC, in which the Band nC and nD are the corresponding SUL bands with same UL frequency range of band (n)A and (n)B, e.g. SUL band n80 has same UL frequency range of band n3.

#### 4.5.1 Test coverage across 5G NR connectivity options

The test cases in this specification cover both NR/5GC (including FR1+FR2 CA or FR1+FR2 NR-DC) as well as EN-DC, NE-DC and NGEN-DC testing. Below shall be the understanding with respect to coverage across 5G NR connectivity options:

- 1) Unless otherwise stated within the test case, it shall be understood that test requirements are agnostic of the EN-DC, NE-DC and NGEN-DC connectivity options configured within the test. The test coverage across the EN-DC, NE-DC and NGEN-DC connectivity options shall be considered fulfilled by executing the test case in one of these connectivity options. In the case of non-exception requirements, test coverage of NE-DC is fulfilled by execution of NR/5GC connectivity option test cases.
- 2) EN-DC is the default connectivity option used for EN-DC, NE-DC and NGEN-DC test cases.
- 3) If a UE does not support EN-DC, any other supported connectivity option of NE-DC or NGEN-DC can be configured to execute the test. The leverage rule detailed in (1) would apply.

**Table 4.5.1-1: Void**

**Table 4.5.1-2: Void**

#### 4.6 E-UTRA configuration for EN-DC FR1 tests applying the E-UTRA anchor-agnostic approach

This clause applies to EN-DC test cases where E-UTRA anchor needs to be configured as per the anchor-agnostic approach outlined in clauses 6.1 and 7.1 of TS 38.101-3 [4]. The LTE anchor-agnostic approach is defined as measurements on the NR carrier under conditions where the LTE anchor resources do not interfere with NR operation. The configuration defined in this clause ensures establishment of such conditions.

For baseline configuration, the E-UTRA carrier will be configured for each test case in clauses 6 and 7 as defined in the equivalent standalone E-UTRA test in TS 36.521-1 [10]. However, the below exceptions defined in Table 4.6-1, 4.6-2, 4.6-3, 4.6-4 and 4.6-5 are applied to ensure that the E-UTRA anchor resources do not interfere with NR operation.

For EN-DC within FR1 band combinations with multiple E-UTRA component carriers, it is sufficient to configure any one E-UTRA carrier from the carrier group whenever it is determined that anchor agnostic approach can be applied. Unless otherwise stated, the number of component carriers (CCs) listed in the test case titles of Clause 6 and clause 7 shall refer to the number of component carriers configured within the test case.

**Table 4.6-1: E-UTRA configuration for EN-DC FR1 tests applying anchor agnostic approach**

Parameter	Value	Comments
Test Frequency during and after connection setup	Mid (See Table 4.6-2)	As defined in TS 36.508 for the LTE band under test
Bandwidth during and after connection setup	5 MHz (See Table 4.6-2)	Supported by all LTE bands.
DL signal levels during connection setup	RS EPRE -85.0 dBm/15kHz	DL physical channels as defined in Annex C0, C.1, C.2 and Annex C.3 of TS 36.521-1 [10]. TS 36.521-1 [10] annex C.0 defines the default DL power level of RS EPRE to be -85dBm/15kHz.
UL Signal levels during connection setup	PUSCH Power	Attained by enabling open loop power control and setting up UL signal levels according to Annex H.0, H.2 and H.3 of TS 36.521-1 [10].
DL/UL RMC after connection setup	0 RB allocation on both DL and UL (see Table 4.6-2)	Once the LTE link is established, then LTE Tx can be restricted by configuring 0 RB allocation on DL and UL. <i>TimeAlignmentTimerDedicated</i> IE to be set to infinity to ensure UE doesn't look for TA adjustments (See Table 4.6-5)
CQI Reports and SRS after connection setup	Disabled (See Table 4.6-3 and 4.6-4)	Disable periodic and aperiodic CQI reports to ensure none of these transmissions occur on the LTE uplink. Since LTE transmissions could easily exceed spurious emissions limits, tests that are intended to measure RF parameters on the NR should simply avoid LTE transmit altogether.
Number of OFDM symbols for PDCCH	3	The PCFICH carries information about the number of OFDM symbols used for transmission of PDCCHs in a subframe, as specified in TS 36.211 [8] clause 6.7

**Table 4.6-2: E-UTRA Test Configuration Table**

E-UTRA Test Parameters					
E-UTRA Channel Bandwidth	E-UTRA Test Frequency	Downlink		Uplink	
		Modulation	RB allocation	Modulation	RB allocation
5 MHz <sup>2</sup>	MidRange <sup>1</sup>	N/A	0	N/A	0
NOTE 1: E-UTRA Test Frequency as specified in TS 36.508 [11] clause 4.3.1.					
NOTE 2: For EN-DC Intra-band tests that need to apply E-UTRA anchor agnostic approach, refer to and pick applicable E-UTRA channel bandwidth from clause 5.3B.1 and indicate within test case if it is different than 5 MHz.					

**Table 4.6-3: CQI-ReportConfig-DEFAULT: Additional E-UTRA Anchor Configuration**

Derivation Path: TS 36.508 [7] clause 4.6.3, Table 4.6.3-2 CQI-ReportConfig-DEFAULT			
Information Element	Value/remark	Comment	Condition
CQI-ReportConfig-DEFAULT ::= SEQUENCE {			
cqi-ReportModeAperiodic	NOT PRESENT		
cqi-ReportPeriodic	NOT PRESENT		
}			

**Table 4.6-4: PhysicalConfigDedicated-DEFAULT: Additional E-UTRA Anchor Configuration**

Derivation Path: TS 36.508 [7] clause 4.8.2, Table 4.8.2.1.6-1 PhysicalConfigDedicated-DEFAULT			
Information Element	Value/remark	Comment	Condition
PhysicalConfigDedicated-DEFAULT ::= SEQUENCE {			
soundingRS-UL-ConfigDedicated	Not present		RBC
}			

**Table 4.6-5: MAC-MainConfig-RBC: Additional E-UTRA Anchor Configuration**

Derivation Path: TS 36.508 [7] clause 4.8.2.1.5, Table 4.8.2.1.5-1 MAC-MainConfig-RBC			
Information Element	Value/remark	Comment	Condition
<i>timeAlignmentTimerDedicated</i>	Infinity		

## 4.7 E-UTRA configuration for EN-DC FR2 tests applying the E-UTRA anchor-agnostic approach

This clause applies to EN-DC test cases where E-UTRA anchor needs to be configured as per the anchor-agnostic approach outlined in clauses 6.1 and 7.1 of TS 38.101-3 [4]. The LTE anchor-agnostic approach is defined as measurements on the NR carrier under conditions where the LTE anchor resources do not interfere with NR operation. The configuration defined in this clause ensures establishment of such conditions.

For baseline configuration, the E-UTRA carrier will be configured for each test case in clauses 6 and 7 as defined in the equivalent standalone E-UTRA test in TS 36.521-1 [10]. However, the below exceptions defined in Table 4.7-1 to 4.7-7 are applied to ensure that the E-UTRA anchor resources do not interfere with NR operation.

Since the E-UTRA link is always a functional link when testing EN-DC including FR2 band combinations, it is sufficient to configure any one E-UTRA carrier from the carrier group, irrespective of the number of E-UTRA carriers in the EN-DC combination under test. Unless otherwise stated, the number of component carriers (CCs) listed in the test case titles of Clause 6 and clause 7 shall refer to the number of component carriers configured within the test case.

**Table 4.7-1: E-UTRA configuration for EN-DC FR2 tests applying anchor agnostic approach**

Parameter	Value	Comments
Test Frequency during and after connection setup	Mid (See Table 4.7-2)	As defined in TS 36.508 for the LTE band under test
Bandwidth during and after connection setup	5 MHz (See Table 4.7-2)	Supported by all LTE bands.
DL signal levels	See table 4.7-3	DL physical channels as defined in Annex C0, C.1, C.2 and Annex C.3 of TS 36.521-1 [10].
UL Signal levels for connection setup and UBF transmission	PUSCH Power	Attained by enabling open loop power control and setting up UL signal levels according to Annex H.0, H.2 and H.3 of TS 36.521-1 [10] with the exception for power control message exception defined in Table 4.7-5
DL/UL RMC after connection setup except for UBF transmission	0 RB allocation on both DL and UL (see Table 4.7-2)	Once the LTE link is established, then LTE Tx can be restricted by configuring 0 RB allocation on DL and UL. <i>TimeAlignmentTimerDedicated</i> IE to be set to infinity to ensure UE doesn't look for TA adjustments (See Table 4.7-7)
CQI Reports and SRS after connection setup	Disabled (See Table 4.7-4 and 4.7-6)	Disable periodic and aperiodic CQI reports to ensure none of these transmissions occur on the LTE uplink. Since LTE transmissions could easily exceed spurious emissions limits, tests that are intended to measure RF parametrics on the NR should simply avoid LTE transmit altogether.
Number of OFDM symbols for PDCCH	3	The PCFICH carries information about the number of OFDM symbols used for transmission of PDCCHs in a subframe, as specified in TS 36.211 [8] clause 6.7

**Table 4.7-2: E-UTRA Test Configuration Table**

E-UTRA Test Parameters					
E-UTRA Channel Bandwidth	E-UTRA Test Frequency	Downlink		Uplink	
		Modulation	RB allocation	Modulation	RB allocation
5 MHz <sup>2</sup>	MidRange <sup>1</sup>	N/A	0	N/A	0
NOTE 1: E-UTRA Test Frequency as specified in TS 36.508 [11] clause 4.3.1					
NOTE 2: For EN-DC Intra-band tests that need to apply E-UTRA anchor agnostic approach, refer to and pick applicable E-UTRA channel bandwidth from clause 5.3B.1 and indicate within test case if it is different than 5 MHz.					

**Table 4.7-3: Default Downlink power levels for E-UTRA anchor**

	Unit	Band Group	Channel Bandwidth					
			1.4 MHz	3 MHz	5MHz	10MHz	15 MHz	20 MHz
RS EPRE	dBm/15kHz	FDD_A, TDD_A	N/A	N/A	≥ -120.0	N/A	N/A	N/A
		FDD_B1, TDD_B1	N/A	N/A	≥ -119.5	N/A	N/A	N/A
		FDD_C, TDD_C	N/A	N/A	≥ -119.0	N/A	N/A	N/A
		FDD_D, TDD_D	N/A	N/A	≥ -118.5	N/A	N/A	N/A
		FDD_E, TDD_E	N/A	N/A	≥ -118.0	N/A	N/A	N/A
		FDD_G, TDD_G	N/A	N/A	≥ -117.0	N/A	N/A	N/A
		FDD_H, TDD_H	N/A	N/A	≥ -116.5	N/A	N/A	N/A
		FDD_N, TDD_N	N/A	N/A	≥ -113.5	N/A	N/A	N/A
NOTE 1: The power level is specified at RSRP reference point as defined in TS 36.214 [24]								
NOTE 2: E-UTRA Band groups are defined in TS 36.133 [12] clause 3.5.1.								

**Table 4.7-4: CQI-ReportConfig-DEFAULT: Additional E-UTRA Anchor Configuration**

Derivation Path: TS 36.508 [7] clause 4.6.3, Table 4.6.3-2 CQI-ReportConfig-DEFAULT			
Information Element	Value/remark	Comment	Condition
CQI-ReportConfig-DEFAULT ::= SEQUENCE {			
cqi-ReportModeAperiodic	NOT PRESENT		
cqi-ReportPeriodic	NOT PRESENT		
}			

**Table 4.7-5: UplinkPowerControlCommon-DEFAULT : Additional E-UTRA Anchor Configuration**

Derivation Path: TS 36.508 [7] clause 4.6.3, UplinkPowerControlCommon-DEFAULT			
Information Element	Value/remark	Comment	Condition
UplinkPowerControlCommon-DEFAULT ::= SEQUENCE {			
p0-NominalPUSCH	-60 (-60 dBm)	To attain maximum power from the DUT	
}			

**Table 4.7-6: PhysicalConfigDedicated-DEFAULT: Additional E-UTRA Anchor Configuration**

Derivation Path: TS 36.508 [7] clause 4.8.2, Table 4.8.2.1.6-1 PhysicalConfigDedicated-DEFAULT			
Information Element	Value/remark	Comment	Condition
PhysicalConfigDedicated-DEFAULT ::= SEQUENCE {			
soundingRS-UL-ConfigDedicated	Not present		RBC
}			

**Table 4.7-7: MAC-MainConfig-RBC: Additional E-UTRA Anchor Configuration**

Derivation Path: TS 36.508 [7] clause 4.8.2.1.5, Table 4.8.2.1.5-1 MAC-MainConfig-RBC			
Information Element	Value/remark	Comment	Condition
<i>timeAlignmentTimerDedicated</i>	Infinity		

## 4.8 E-UTRA configuration for EN-DC FR1 tests not applying the E-UTRA anchor-agnostic approach

Unless otherwise stated, the following message exception defined in tables 4.8-1, 4.8-2 and 4.8-3 apply for EN-DC FR1 tests not applying the E-UTRA anchor-agnostic approach.

**Table 4.8-1: CQI-ReportConfig-DEFAULT: Additional E-UTRA Anchor Configuration**

Derivation Path: TS 36.508 [7] clause 4.6.3, Table 4.6.3-2 CQI-ReportConfig-DEFAULT			
Information Element	Value/remark	Comment	Condition
CQI-ReportConfig-DEFAULT ::= SEQUENCE {			
<i>cqi-ReportModeAperiodic</i>	NOT PRESENT		
<i>cqi-ReportPeriodic</i>	NOT PRESENT		
}			

**Table 4.8-2: PhysicalConfigDedicated-DEFAULT: Additional E-UTRA Anchor Configuration**

Derivation Path: TS 36.508 [7] clause 4.8.2, Table 4.8.2.1.6-1 PhysicalConfigDedicated-DEFAULT			
Information Element	Value/remark	Comment	Condition
PhysicalConfigDedicated-DEFAULT ::= SEQUENCE {			
<i>soundingRS-UL-ConfigDedicated</i>	Not present		RBC
}			

**Table 4.8-3: MAC-MainConfig-RBC: Additional E-UTRA Anchor Configuration**

Derivation Path: TS 36.508 [7] clause 4.8.2.1.5, Table 4.8.2.1.5-1 MAC-MainConfig-RBC			
Information Element	Value/remark	Comment	Condition
<i>timeAlignmentTimerDedicated</i>	Infinity		

# 5 Operating bands and channel arrangement

## 5.1 General

The channel arrangements presented in this clause are based on the operating bands and channel bandwidths defined in the present release of specifications.

NOTE: Other operating bands and channel bandwidths may be considered in future releases.

Requirements throughout the RF specifications are in many cases defined separately for different frequency ranges (FR). The frequency ranges in which NR can operate according to this version of the specifications are identified as described in Table 5.1-1.

**Table 5.1-1: Definition of frequency ranges**

Frequency range designation	Corresponding frequency range
FR1	410 MHz – 7125 MHz
FR2	24250 MHz – 52600 MHz



The present specification covers band combinations including

- at least one FR1 operating band and one FR2 operating band for carrier aggregation and dual connectivity operations;
- at least one E-UTRA operating band for dual connectivity operations.

## 5.2 Operating bands

NR is designed to operate in FR1 operating bands defined in TS 38.101-1 [2] and FR2 operating bands defined in TS 38.101-2 [3]. E-UTRA is designed to operate in operating bands defined in TS 36.101 [4].

### 5.2A Operating bands for CA

#### 5.2A.1 Inter-band CA between FR1 and FR2

NR carrier aggregation is designed to operate in the operating bands defined in Table 5.2A.1-1. The band combinations include at least one FR1 operating band and one FR2 operating band.

If the mandatory simultaneous Rx/Tx capability applies for a lower order band combination, when the applicable lower order band combination is a band pair in a higher order band combination, the mandatory simultaneous Rx/Tx capability also applies for the band pair in the higher order band combination.

**Table 5.2A.1-1: Band combinations for inter-band NR CA between FR1 and FR2**

Editor's note: No band combinations for inter-band NR CA between FR1 and FR2 specified due to the testability issues that combined testing of NR FR1 in conducted mode and NR FR2 in radiated mode.

### 5.2B Operating bands for DC

#### 5.2B.1 General

The operating bands are specified in clause 5.5B for operation with EN-DC, NGEN-DC, NE-DC or NR-DC configured.

#### 5.2B.2 to 5.2B.7 Void

### 5.2E Operating bands for V2X

#### 5.2E.1 Intra-band V2X bands

NR V2X operation is designed to operate with E-UTRA sidelink in TDM mode on the operating bands combinations listed in Table 5.2E.1-1.

**Table 5.2E.1-1: Intra-band V2X operating bands**

E-UTRA V2X-NR V2X Band combination	E-UTRA or NR Band	Interface
V2X_47_n47 <sup>1</sup>	47	PC5
	n47	PC5
NOTE 1: Only single switched SL is supported.		

#### 5.2E.2 Inter-band V2X bands

NR V2X operation is designed to operate concurrent with E-UTRA uplink/downlink on the operating bands combinations listed in Table 5.2E.2-1.

**Table 5.2E.2-1: Inter-band con-current V2X operating bands**

E-UTRA-NR V2X Band Combination	E-UTRA or NR Band	Interface
V2X_n71_47	47	PC5
	n71	Uu
V2X_n71_(n) 47 <sup>1</sup>	47	PC5
	n47	PC5
	n71	Uu
NOTE 1: Only single switched SL in ITS band is supported.		

## 5.3 UE Channel bandwidth

### 5.3A UE Channel bandwidth for CA

#### 5.3A.1 Inter-band CA between FR1 and FR2

For inter-band NR CA between FR1 and FR2, a carrier aggregation configuration is a combination of operating bands, each supporting a carrier aggregation bandwidth class as specified in clause 5.3A.5 of TS 38.101-1 [2] and clause 5.3A.4 of TS 38.101-2 [3] independently.

### 5.3B UE Channel bandwidth for DC

#### 5.3B.0 General

For intra-band contiguous EN-DC, the aggregated channel bandwidth is sum of the individual NR and E-UTRA channel bandwidths assuming nominal EN-DC channel with 0 kHz offset spacing as specified in clause 5.4.

$$ENBW = BW_{NR\_Channel} + BW_{E-UTRA\_Channel}$$

In the case where the NR sub-block and/or the E-UTRA sub-block itself is composed of intra-band contiguous CA carriers, the EN-DC aggregated channel bandwidth is the sum of the aggregated channel bandwidths of the NR and E-UTRA sub-blocks assuming nominal EN-DC channel spacing between the NR sub-block and E-UTRA sub-block.

$$ENBW = BW_{NR\_Channel\_CA} + BW_{E-UTRA\_Channel\_CA}$$

Intra-band contiguous EN-DC configurations are defined using intra-band contiguous EN-DC bandwidth class notation DC\_(n)Xyz where the first EN-DC bandwidth class letter indicates the number of contiguous E-UTRA carriers and the second EN-DC bandwidth class letter indicates the number of contiguous NR carriers for the EN-DC combination of E-UTRA Band X and NR Band nX. Applicable contiguous intraband EN-DC bandwidth classes are listed in Table 5.3B.0-1

**Table 5.3B.0-1: Intra-band contiguous EN-DC bandwidth classes**

Intra-band contiguous EN-DC bandwidth class	Number of contiguous CC	
	E-UTRA	NR
AA	1	1
AB	1	2
CA	2	1
DA	3	1

## 5.3B.1 Intra-band EN-DC in FR1

### 5.3B.1.1 General

The requirements for intra-band EN-DC in this specification are defined for EN-DC configurations with associated bandwidth combination sets.

For each EN-DC configuration, requirements are specified for all bandwidth combinations contained in a *bandwidth combination set*, which is indicated per supported band combination in the UE radio access capability. A UE can indicate support of several bandwidth combination sets per band combination.

### 5.3B.1.2 BCS for Intra-band contiguous EN-DC

For intra-band contiguous EN-DC, an EN-DC configuration is consisting of an E-UTRA band and a corresponding NR band having the same frequency range which supports an intra-band contiguous EN-DC bandwidth class.

Bandwidth combination sets for intra-band contiguous EN-DC are specified in Table 5.3B.1.2-1. The EN-DC configurations and bandwidth combination sets in Table 5.3B.1.2-1 also apply to higher order EN-DC combinations that include inter-band and intra-band EN-DC on the downlink and inter-band EN-DC on the uplink. If no BCS is reported in the UE capabilities for an intra-band combination the default is that the UE supports BCS0.

**Table 5.3B.1.2-1: EN-DC configurations and bandwidth combination sets defined for intra-band contiguous EN-DC**

E-UTRA – NR configuration / Bandwidth combination set						
Downlink EN-DC configuration	Uplink EN-DC configurations	Component carriers in order of increasing carrier frequency			Maximum aggregated bandwidth (MHz)	Bandwidth combination set
		Channel bandwidths for E-UTRA carrier (MHz)	Channel bandwidths for NR carrier (MHz)	Channel bandwidths for E-UTRA carrier (MHz)		
DC_(n)41AA	DC_(n)41AA	20	40, 60, 80,100		120	0
			40, 60, 80,100	20		
		20	40, 50, 60, 80,100		120	1
			40, 50, 60, 80,100	20		
DC_(n)41CA	DC_(n)41AA	20+20	40, 60, 80,100		140	0
			40, 60, 80,100	20+20		
		20+20	40, 50, 60, 80,100		140	1
			40, 50, 60, 80,100	20+20		
DC_(n)71AA	DC_(n)71AA	15	5		20	0
		10	5, 10			
		5	5, 10, 15			
			5	15		
			5, 10	10		
			5, 10, 15	5		

NOTE 1: Void  
NOTE 2: Void  
NOTE 3: Void  
NOTE 4: The channel bandwidths for E-UTRA or NR carrier should be at least supported in one of the BCS indicated in E-UTRA bandwidth combination sets or NR bandwidth combination sets if reported.

### 5.3B.1.3 BCS for Intra-band non-contiguous EN-DC

For intra-band non-contiguous EN-DC, an EN-DC configuration is consisting of an E-UTRA band and a corresponding NR band having the same frequency range which supports E-UTRA and NR carriers, where E-UTRA configuration is

indicated by using E-UTRA CA bandwidth class as defined in TS 36.101 [5] and NR configuration is indicated by using NR CA bandwidth class as defined in TS 38.101-1 [2].

Requirements for intra-band non-contiguous EN-DC are defined for the EN-DC configurations and bandwidth combination sets specified in Table 5.3B.1.3-1. The EN-DC configurations and bandwidth combination sets in Table 5.3B.1.3-1 also apply to higher order EN-DC combinations that include inter-band and intra-band EN-DC on the downlink and inter-band EN-DC on the uplink. If no BCS is reported in the UE capabilities for an intra-band combination the default is that the UE supports BCS0.

**Table 5.3B.1.3-1: EN-DC configurations and bandwidth combination sets defined for intra-band non-contiguous EN-DC**

E-UTRA – NR configuration / Bandwidth combination set						
Downlink EN-DC configuration	Uplink EN-DC configurations	Component carriers in order of increasing carrier frequency			Maximum aggregated bandwidth (MHz)	Bandwidth combination set
		Channel bandwidths for E-UTRA carrier (MHz)	Channel bandwidths for NR carrier (MHz)	Channel bandwidths for E-UTRA carrier (MHz)		
DC_2A_n2A	DC_2A_n2A <sup>2</sup>	5, 10, 15, 20	5, 10, 15, 20		40	0
DC_41A_n41A	DC_41A_n41A	20	40, 60, 80,100		120	0
			40, 60, 80,100	20		
		20	40, 50, 60, 80,100		120	1
DC_41C_n41A	DC_41A_n41A		40, 50, 60, 80,100	20		
		20+20	40, 60, 80,100		140	0
			40, 60, 80,100	20+20		
DC_41D_n41A	DC_41A_n41A	20+20	40, 50, 60, 80,100		140	1
			40, 50, 60, 80,100	20+20		
		20+20+20	40, 60, 80,100		160	0
DC_66A_n66A	DC_66A_n66A <sup>2</sup>	20+20+20	40, 50, 60, 80,100	20+20+20		1
			40, 50, 60, 80,100	20+20+20		
		5, 10, 15, 20	5, 10, 15, 20, 40		50	0
DC_66A_66A-n66A	DC_66A_n66A <sup>2</sup>	5, 10, 15, 20	5, 10, 15, 20, 25, 30, 40		60	1
			5, 10, 15, 20, 25, 30, 40	5, 10, 15, 20		
		CA_66A-66A_BCS0	5, 10, 15, 20, 40		70	0
DC_66A_66A-n66A	DC_66A_n66A <sup>2</sup>	CA_66A-66A_BCS0	5, 10, 15, 20, 25, 30, 40		80	1
			5, 10, 15, 20, 25, 30, 40	CA_66A-66A_BCS0		

NOTE 1: Only single switched UL is supported in Rel-15.  
 NOTE 2: Only single switched UL is supported.  
 NOTE 3: TBD  
 NOTE 4: TBD  
 NOTE 5: The UE supporting the configurations indicates intraBandENDC-Support = 'non-contiguous' with intraBandENDC-Support-UL absent.

## 5.3E UE Channel bandwidth for V2X

### 5.3E.0 General

The requirements specified in clause 5.3B are applicable to NR V2X UE.

### 5.3E.1 Intra-band contiguous V2X in FR1

For intra-band contiguous E-UTRA NR V2X UE, an EN-DC bandwidth class in Table 5.3B.0-1 are considered to specify the V2X transmission/reception configurations.

Bandwidth combination sets and V2X transmission/reception configurations for intra-band contiguous V2X UE are specified in Table 5.3E.1-1.

**Table 5.3E.1-1: E-UTRA-NR V2X configurations and bandwidth combination sets for intra-band contiguous V2X UE**

V2X configuration	SL transmission band	Channel bandwidths for E-UTRA carrier (MHz)	Channel bandwidths for NR carrier (MHz)	Maximum aggregated bandwidth (MHz)	Bandwidth combination set
V2X_(n)47AA	E-UTRA Band 47 or NR band n47	10	10,20,30,40	60	0
		20	10,20,30,40		

### 5.3E.2 Intra-band non-contiguous V2X in FR1

For intra-band non-contiguous E-UTRA NR V2X UE, an EN-DC bandwidth class in Table 5.3B.0-1 are considered to specify the V2X transmission/reception configurations.

Bandwidth combination sets and SL transmission/reception configurations for intra-band non-contiguous V2X are specified in Table 5.3E.2-1.

**Table 5.3E.2-1: E-UTRA-NR V2X configurations and bandwidth combination sets for intra-band non-contiguous V2X UE**

V2X configuration	SL transmission band	Channel bandwidths for E-UTRA carrier (MHz)	Channel bandwidths for NR carrier (MHz)	Maximum aggregated bandwidth (MHz)	Bandwidth combination set
V2X_47A_n47A	E-UTRA Band 47 or NR band n47	10	10,20,30,40	60	0
		20	10,20,30,40		

### 5.3E.3 Inter-band V2X in FR1

For inter-band E-UTRA NR V2X UE, each channel bandwidth for inter-band V2X operations in FR1 is specified in TS 36.101 [4] and TS 38.101-1 [2], respectively.

## 5.4 Void

### 5.4A Channel arrangement for CA

The channel arrangement for CA operations in FR1 and FR2 as specified in TS 38.101-1 [2] and TS 38.101-2 [3], respectively.

## 5.4B Channel arrangement for DC

### 5.4B.0 General

The channel arrangement for intra-band EN-DC operations in FR1 is specified in TS 36.101 [5] and TS 38.101-1 [2], respectively.

#### 5.4B.1 Channel spacing for intra-band EN-DC carriers

The spacing between carriers will depend on the deployment scenario, the size of the frequency block available and the channel bandwidths. The nominal channel spacing between E-UTRA carrier and an adjacent NR carrier for intra-band contiguous EN-DC is defined as following:

- For NR operating bands with 100 kHz channel raster,

$$\text{Nominal Channel spacing} = (BW_{\text{E-UTRA\_Channel}} + BW_{\text{NR\_Channel}})/2$$

- For NR operating bands with 15 kHz channel raster,

$$\text{Nominal Channel spacing} = (BW_{\text{E-UTRA\_Channel}} + BW_{\text{NR\_Channel}})/2 + \{-5\text{kHz}, 0\text{kHz}, 5\text{kHz}\} \text{ for } \Delta F_{\text{Raster}} \text{ equals to } 15 \text{ kHz}$$

$$\text{Nominal Channel spacing} = (BW_{\text{E-UTRA\_Channel}} + BW_{\text{NR\_Channel}})/2 + \{-10\text{kHz}, 0\text{kHz}, 10\text{kHz}\} \text{ for } \Delta F_{\text{Raster}} \text{ equals to } 30 \text{ kHz}$$

where  $BW_{\text{E-UTRA\_Channel}}$  and  $BW_{\text{NR\_Channel}}$  are the channel bandwidths of the E-UTRA and NR carriers,  $\Delta F_{\text{Raster}}$  is the band dependent channel raster granularity defined in TS38.101-1[2]. The channel spacing can be adjusted depending on the channel raster to optimize performance in a particular deployment scenario.

For intra-band non-contiguous EN-DC the channel spacing between E-UTRA and NR carriers shall be larger than the nominal channel spacing defined in this clause.

## 5.5 Configuration

### 5.5A Configuration for CA

#### 5.5A.1 Inter-band CA configurations between FR1 and FR2

**Table 5.5A.1-1: Inter-band CA configurations and bandwidth combinations sets between FR1 and FR2 (two bands)**

Editor's note: No Inter-band CA configurations between FR1 and FR2 (two bands) specified due to the testability issues that combined testing of NR FR1 in conducted mode and NR FR2 in radiated mode.

## 5.5B Configuration for DC

### 5.5B.1 General

The operating bands and bandwidth classes are specified for operation with EN-DC, NGEN-DC, NE-DC or NR-DC configured. The EN-DC, NE-DC or NGEN-DC band combinations include at least one E-UTRA operating band.

For EN-DC or NE-DC configurations indicated by column "Single Uplink allowed" (e.g., problematic band combinations as defined in TS 38.306 [16]) in tables in this clause the UE may indicate capability of not supporting simultaneous dual and triple uplink operation due to possible intermodulation interference to its own primary downlink channel bandwidth of PCell or PSCell if the intermodulation order is 2 or if the intermodulation order is 3 for the combinations when both operating bands are between 450 MHz – 960 MHz or between 1427 MHz – 2690 MHz.

In the case for EN-DC or NE-DC configurations listed in tables in this clause for which the intermodulation products caused by the dual and triple uplink operation fall into the receive band but do not interfere with its own primary downlink channel bandwidth of PCell or PSCell as defined in Annex I the UE is mandated to operate in dual and triple uplink mode. Single Uplink is also allowed for certain band combinations where intermodulation or reverse intermodulation products could create difficulty for meeting emission requirements.

For EN-DC combinations of order 3 or higher, "Single Uplink allowed" UL configurations captured in Table 5.5B.2-1, Table 5.5B.3-1, and Table 5.5B.4-1 apply.

If multiple UL DC configurations are listed for multiple DL DC configurations, valid uplink configurations are such that uplink does not have more carriers than downlink.

Non-contiguous resource allocation and almost contiguous allocation are not applicable for E-UTRA or NR carrier part of intra-band EN-DC configuration.

If the mandatory simultaneous Rx/Tx capability applies for a lower order DC configuration, when the applicable lower order DC configuration is a band pair in a higher order DC configuration, the mandatory simultaneous Rx/Tx capability also applies for the band pair in the higher order DC configuration.

For a higher order EN-DC band combination of which DC\_20\_n28/ DC\_28\_n20/ CA\_20-28/ CA\_n20-n28 is a subset, the frequency range in band n28/28 is restricted for the higher order band combination to 703-733 MHz for the UL and 758-788 MHz for the DL.

For NR inter-band dual connectivity specified in 5.5B.7, the corresponding NR CA configurations in 5.5A.1, i.e., dual uplink inter-band carrier aggregation between FR1 and FR2 with uplink assigned to two NR bands, are applicable to Dual Connectivity.

NOTE 1: Requirements for the dual connectivity configurations are defined in the clause corresponding NR uplink CA between FR1 and FR2 configurations, unless otherwise specified.

### 5.5B.2 Intra-band contiguous EN-DC

Supported channel bandwidths for E-UTRA operating bands are defined in TS 36.521-1 [10] and for NR operating bands in TS 38.521-1 [8].



**Table 5.5B.2-1: Intra-band contiguous EN-DC configurations**

EN-DC Configuration	Uplink EN-DC configuration (NOTE 1)	Single UL allowed
DC_(n)41AA <sup>5</sup> DC_(n)41CA <sup>5</sup>	DC_(n)41AA	Yes <sup>3</sup>
DC_(n)71AA <sup>2</sup>	DC_(n)71AA	No <sup>4</sup>
NOTE 1: Uplink EN-DC configurations are the configurations supported by the present release of specifications.		
NOTE 2: Requirements in this specification apply for NR SCS of 15 kHz only.		
NOTE 3: Single UL allowed due to potential emission issues, not self-interference.		
NOTE 4: For UE(s) supporting dynamic power sharing it is mandatory to do dual simultaneous UL. For UE(s) not supporting dynamic power sharing single UL is allowed.		
NOTE 5: The minimum requirements only apply for non-simultaneous Tx/Rx between all carriers.		

### 5.5B.3 Intra-band non-contiguous EN-DC

Supported channel bandwidths for E-UTRA operating bands are defined in TS 36.521-1 [10] and for NR operating bands in TS 38.521-1 [8].

**Table 5.5B.3-1: Intra-band non-contiguous EN-DC configurations**

EN-DC Configuration	Uplink EN-DC configuration (NOTE 1)	Single UL allowed
DC_2A_n2A	DC_2A_n2A <sup>5</sup>	Yes <sup>5</sup>
DC_41A_n41A <sup>3</sup> DC_41C_n41A <sup>3</sup> DC_41D_n41A <sup>3</sup>	DC_41A_n41A	Yes <sup>4</sup>
DC_66A_n66A	DC_66A_n66A <sup>5</sup>	Yes <sup>5</sup>
DC_66A-66A_n66A	DC_66A_n66A <sup>5</sup>	Yes <sup>5</sup>
NOTE 1: Uplink EN-DC configurations are the configurations supported by the present release of specifications.		
NOTE 2: Only single switched UL is supported in Rel-15		
NOTE 3: The minimum requirements only apply for non-simultaneous Tx/Rx between all carriers.		
NOTE 4: Single UL allowed due to potential emission issues, not self-interference.		
NOTE 5: Only single switched UL is supported.		
NOTE 6: Reserve.		
NOTE 7: Single UL allowed due to potential emission issues and self-interference.		

### 5.5B.4 Inter-band EN-DC within FR1

#### 5.5B.4.0 General

Supported channel bandwidths for E-UTRA operating bands and CA configurations are defined in TS 36.521-1 [10] and for NR operating bands and CA configurations in TS 38.521-1 [8] and present document.

By default, power class 3 is applicable for the EN-DC configurations listed in the following sub-clauses. The applicability of higher power class(es) is described in the EN-DC configuration tables. For higher order EN-DC band combinations, the applicability of higher power class(es) is extended based on the following conditions:

- For an inter-band EN-DC combination with intra-band CA, UE may support the same higher power class(es) that are defined for the inter-band EN-DC combination composed of the same band without intra-band CA.
- For an inter-band EN-DC combination with 4 or more DL bands without intra-band CA, the higher power class(es) may be supported when the same higher power class(es) are specified for all its fallback combinations.

5.5B.4.1 Inter-band EN-DC configurations within FR1 (two bands)

**Table 5.5B.4.1-1: Inter-band EN-DC configurations within FR1 (two bands)**

EN-DC configuration	Uplink EN-DC configuration (NOTE 1)	Single UL allowed	DL interruption allowed (Note 14)
DC_1A_n3A	DC_1A_n3A	DC_1_n3	
DC_1A_n5A	DC_1A_n5A	No	
DC_1A_n7A	DC_1A_n7A	No	
DC_1A_n28A	DC_1A_n28A	No	
DC_1A_n41A <sup>7</sup>	DC_1A_n41A	No	
DC_1A_n77A <sup>7</sup>	DC_1A_n77A	DC_1_n77	No
DC_1A_n77(2A) <sup>7,21</sup>	DC_1A_n77A <sup>21</sup>	DC_1_n77	No
DC_1A_n78A <sup>7</sup>	DC_1A_n78A	No	No
DC_1A_n78C <sup>7</sup>			
DC_1A-1A_n78A	DC_1A_n78A	No	
DC_1A_n79A <sup>7</sup>	DC_1A_n79A	No	No
DC_1A_n79C <sup>7</sup>			
DC_2A_n5A	DC_2A_n5A	No	
DC_2A-2A_n5A	DC_2A_n5A	No	
DC_2A_n41A	DC_2A_n41A	No	
DC_2C_n41A	DC_2C_n41A		
DC_2A_n66A	DC_2A_n66A	DC_2_n66	
DC_2A-2A_n66A	DC_2A_n66A	DC_2_n66	
DC_2A_n71A	DC_2A_n71A	No	
DC_2A_n77A <sup>21</sup>	DC_2A_n77A <sup>21</sup>	DC_2_n77	
DC_2A_n77(2A) <sup>21</sup>	DC_2A_n77A <sup>21</sup>	DC_2_n77	
DC_2A-2A_n77A <sup>21</sup>	DC_2A_n77A <sup>21</sup>	DC_2_n77	
DC_2A-2A_n77(2A) <sup>21</sup>	DC_2A_n77A <sup>21</sup>	DC_2_n77	
DC_2A_n78A	DC_2A_n78A	DC_2_n78	
DC_3A_n1A	DC_3A_n1A	DC_3_n1	
DC_3A_n5A	DC_3A_n5A	DC_3_n5	
DC_3A_n7A	DC_3A_n7A	No	
DC_3A_n28A	DC_3A_n28A	No	
DC_3A_n41A <sup>7</sup>	DC_3A_n41A	DC_3_n41	No
DC_3A_n77A <sup>7</sup>	DC_3A_n77A	DC_3_n77	No
DC_3A_n77(2A) <sup>7,21</sup>	DC_3A_n77A <sup>21</sup>	DC_3_n77	No
DC_3A_n78A <sup>7,23</sup>	DC_3A_n78A <sup>21,23</sup>	DC_3_n78	No
DC_3A_n78C <sup>7</sup>			
DC_3C_n78A <sup>7</sup>			
DC_3A_n79A <sup>7</sup>	DC_3A_n79A	No	No
DC_3A_n79C <sup>7</sup>			
DC_5A_n2A	DC_5A_n2A	No	
DC_5A_n66A	DC_5A_n66A	DC_5_n66	
DC_5A_n77A <sup>21</sup>	DC_5A_n77A <sup>21</sup>	No	
DC_5A_n77(2A) <sup>21</sup>	DC_5A_n77A <sup>21</sup>	No	
DC_5A_n78A <sup>7</sup>	DC_5A_n78A	No	No
DC_5A_n78C <sup>7</sup>			
DC_7A_n1A	DC_7A_n1A	No	
DC_7A_n3A	DC_7A_n3A	No	
DC_7A_n5A	DC_7A_n5A	DC_7_n5	
DC_7A_n28A	DC_7A_n28A	No	
DC_7A_n66A	DC_7A_n66A	No	
DC_7C_n66A			
DC_7A_n71A	DC_7A_n71A	No	
DC_7A_n77A <sup>7</sup>	DC_7A_n77A	No	
DC_7A_n78A <sup>7,23</sup>	DC_7A_n78A <sup>21,23</sup>	No	
DC_7C_n78A <sup>7</sup>			
DC_7A-7A_n78A <sup>7,21</sup>	DC_7A_n78A <sup>21</sup>	No	
DC_8A_n1A	DC_8A_n1A	No	
DC_8A_n3A	DC_8A_n3A	No	
DC_8A_n20A	DC_8A_n20A	Yes	
DC_8A_n41A <sup>7</sup>	DC_8A_n41A	No	No
DC_8A_n77A <sup>7</sup>	DC_8A_n77A	No	No
DC_8A_n78A <sup>7,23</sup>	DC_8A_n78A <sup>21,23</sup>	No	No
DC_8A_n94A	DC_8A_n94A_ULSUP-TDM	N/A	
DC_11A_n77A <sup>7</sup>	DC_11A_n77A	No	No
DC_11A_n78A <sup>7</sup>	DC_11A_n78A	No	No

EN-DC configuration	Uplink EN-DC configuration (NOTE 1)	Single UL allowed	DL interruption allowed (Note 14)
DC_11A_n79A <sup>7</sup>	DC_11A_n79A	No	
DC_12A_n2A	DC_12A_n2A	No	
DC_12A_n5A	DC_12A_n5A	No	
DC_12A_n66A	DC_12A_n66A	No	
DC_12A_n77A <sup>21</sup>	DC_12A_n77A <sup>21</sup>	DC_12_n77	
DC_12A_n77(2A) <sup>21</sup>	DC_12A_n77A <sup>21</sup>	DC_12_n77	
DC_12A_n78A	DC_12A_n78A	DC_12_n78	
DC_13A_n2A	DC_13A_n2A	No	
DC_13A_n66A	DC_13A_n66A	No	
DC_13A_n77A	DC_13A_n77A	No	
DC_14A_n2A	DC_14A_n2A	No	
DC_14A_n66A	DC_14A_n66A	No	
DC_14A_n77A <sup>21</sup>	DC_14A_n77A <sup>21</sup>	No	
DC_14A_n77(2A) <sup>21</sup>	DC_14A_n77A <sup>21</sup>	No	
DC_18A_n77A <sup>7</sup>	DC_18A_n77A	No	No
DC_18A_n78A <sup>7</sup>	DC_18A_n78A	No	No
DC_18A_n79A <sup>7</sup>	DC_18A_n79A	No	
DC_19A_n1A	DC_19A_n1A	No	
DC_19A_n77A <sup>7</sup>	DC_19A_n77A	No	
DC_19A_n77C <sup>7</sup>			
DC_19A_n78A <sup>7</sup>	DC_19A_n78A	No	No
DC_19A_n78C <sup>7</sup>			
DC_19A_n79A <sup>7</sup>	DC_19A_n79A	No	No
DC_20A_n1A	DC_20A_n1A	No	
DC_20A_n3A	DC_20A_n3A	No	
DC_20A_n7A	DC_20A_n7A	DC_20_n7	
DC_20A_n8A	DC_20A_n8A	DC_20_n8	
DC_20A_n28A <sup>8,11,13</sup>	DC_20A_n28A	No	
DC_20A_n78A <sup>7,23</sup>	DC_20A_n78A <sup>23</sup>	No	
DC_20A_n92A	DC_20A_n92A_ULSUP-TDM	N/A	
DC_21A_n1A	DC_21A_n1A	No	
DC_21A_n28A <sup>17</sup>	DC_21A_n28A	DC_21_n28	
DC_21A_n77A <sup>7</sup>	DC_21A_n77A	No	
DC_21A_n78A <sup>7</sup>	DC_21A_n78A	No	No
DC_21A_n78C <sup>7</sup>			
DC_21A_n79A <sup>7</sup>	DC_21A_n79A	No	No
DC_21A_n79C <sup>7</sup>			
DC_25A_n41A	DC_25A_n41A	No	
DC_26A_n41A	DC_26A_n41A	No	
DC_26A_n77A <sup>7</sup>	DC_26A_n77A	No	
DC_26A_n78A <sup>7</sup>	DC_26A_n78A	No	
DC_26A_n79A <sup>7</sup>	DC_26A_n79A	No	
DC_28A_n3A	DC_28A_n3A	No	
DC_28A_n5A	DC_28A_n5A	No	
DC_28A_n7A	DC_28A_n7A	No	
DC_28A_n77A <sup>7</sup>	DC_28A_n77A	No	No
DC_28A_n78A <sup>7,23</sup>	DC_28A_n78A <sup>23</sup>	No	No
DC_28A_n78C <sup>7</sup>			
DC_28A_n79A <sup>7</sup>	DC_28A_n79A	No	
DC_30A_n2A	DC_30A_n2A	No	
DC_30A_n5A	DC_30A_n5A	No	
DC_30A_n66A	DC_30A_n66A	No	
DC_30A_n77A <sup>21</sup>	DC_30A_n77A <sup>21</sup>	No	
DC_30A_n77(2A) <sup>21</sup>	DC_30A_n77A <sup>21</sup>	No	
DC_38A_n78A <sup>7</sup>	DC_38A_n78A	No	
DC_39A_n41A	DC_39A_n41A	No	No
DC_39C_n41A	DC_39C_n41A		
DC_39A_n79A <sup>7</sup>	DC_39A_n79A	No	No
DC_40A_n1A	DC_40A_n1A	No	
DC_40A_n41A	DC_40A_n41A	No	
DC_40A_n78A	DC_40A_n78A <sup>23</sup>	No	
DC_40C_n78A	DC_40C_n78A		

EN-DC configuration	Uplink EN-DC configuration (NOTE 1)	Single UL allowed	DL interruption allowed (Note 14)
DC_40A_n79A <sup>7,12</sup> DC_40C_n79A <sup>7,12</sup>	DC_40A_n79A	No	No
DC_41A_n28A <sup>7</sup>	DC_41A_n28A	No	
DC_41A_n77A DC_41C_n77A	DC_41A_n77A	No	
DC_41A_n78A <sup>24</sup> DC_41C_n78A	DC_41A_n78A <sup>24</sup>	No	
DC_41A_n79A <sup>6,7</sup>	DC_41A_n79A	No	No
DC_42A_n77A <sup>3,4,9,11</sup> DC_42C_n77A <sup>3,4,9,11</sup> DC_42D_n77A <sup>3,4,9,11</sup>	N/A	N/A	
DC_42A_n78A <sup>3,4,9,11</sup> DC_42A_n78C <sup>3,4,9,11</sup> DC_42C_n78A <sup>3,4,9,11</sup> DC_42C_n78C <sup>3,4,9,11</sup> DC_42D_n78A <sup>3,4,9,11</sup> DC_42E_n78A <sup>3,4,9,11</sup>	N/A	N/A	
DC_42A_n79A <sup>9,15</sup> DC_42A_n79C <sup>9,15</sup> DC_42C_n79A <sup>9,15</sup> DC_42C_n79C <sup>9,15</sup> DC_42D_n79A <sup>9,15</sup> DC_42E_n79A <sup>9,15</sup>	N/A	N/A	
DC_48A_n46A	DC_48A_n46A	No	
DC_48A_n5A	DC_48A_n5A	No	
DC_48A_n66A	DC_48A_n66A	No	
DC_66A_n2A	DC_66A_n2A	DC_66_n2	
DC_66A-66A_n2A	DC_66A_n2A	DC_66_n2	
DC_66A_n5A	DC_66A_n5A	DC_66_n5	
DC_66A-66A_n5A	DC_66A_n5A	DC_66_n5	
DC_66A_n25A	DC_66A_n25A	DC_66_n25	
DC_66A_n41A	DC_66A_n41A	No	
DC_66A_n71A	DC_66A_n71A	No	
DC_66A_n77A <sup>21</sup>	DC_66A_n77A <sup>21</sup>	DC_66_n77	
DC_66A_n77(2A) <sup>21</sup>	DC_66A_n77A <sup>21</sup>	DC_66_n77	
DC_66A-66A_n77A <sup>21</sup>	DC_66A_n77A <sup>21</sup>	DC_66_n77	
DC_66A-66A_n77(2A) <sup>21</sup>	DC_66A_n77A <sup>21</sup>	DC_66_n77	
DC_66A-66A-66A_n77A <sup>21</sup>	DC_66A_n77A <sup>21</sup>	DC_66_n77	
DC_66A-66A-66A_n77(2A) <sup>21</sup>	DC_66A_n77A <sup>21</sup>	DC_66_n77	
DC_66A_n78A	DC_66A_n78A	No	
DC_71A_n2A	DC_71A_n2A	No	
DC_71A_n66A	DC_71A_n66A	No	

EN-DC configuration	Uplink EN-DC configuration (NOTE 1)	Single UL allowed	DL interruption allowed (Note 14)
<p>NOTE 1: Uplink EN-DC configurations are the configurations supported by the present release of specifications.</p> <p>NOTE 2: Restricted to E-UTRA operation when inter-band carrier aggregation is configured. The downlink operating band for Band 46 is paired with the uplink operating band (external E-UTRA band) of the carrier aggregation configuration that is supporting the configured PCell.</p> <p>NOTE 3: The minimum requirements apply only when there is non-simultaneous Tx/Rx operation between E-UTRA and NR carriers. This restriction applies also for these carriers when applicable EN-DC configuration is part of a higher order EN-DC configuration.</p> <p>NOTE 4: For UEs not indicating <i>interBandMRDC-WithOverlapDL-Bands-r16</i>, the minimum requirements for intra-band non-contiguous EN-DC apply for the Band 42/48 and Band n77/n78 combination. For UEs not indicating <i>interBandMRDC-WithOverlapDL-Bands-r16</i>, when UE capability <i>interBandContiguousMRDC</i> is indicated, the minimum requirements for intra-band-contiguous EN-DC also should be met in addition to intra-band non-contiguous EN-DC. The intra-band requirements also apply for these carriers when applicable EN-DC configuration is a subset of a higher order EN-DC configuration.</p> <p>NOTE 5: The frequency range above 3600 MHz for Band n78 is not used in this combination.</p> <p>NOTE 6: The frequency range below 2506 MHz for Band 41 is not used in this combination.</p> <p>NOTE 7: Applicable for UE supporting inter-band EN-DC with mandatory simultaneous Rx/Tx capability.</p> <p>NOTE 8: The frequency range in band n28 / 28 is restricted for this band combination to 703 - 733 MHz for the UL and 758-788 MHz for the DL.</p> <p>NOTE 9: The combination is not used alone as fallback mode of other band combinations in which UL in Band 42 is not used.</p> <p>NOTE 10: Void.</p> <p>NOTE 11: For UEs not indicating <i>interBandMRDC-WithOverlapDL-Bands-r16</i>, the minimum requirements for inter-band EN-DC apply when the maximum power spectral density imbalance between downlink carriers is within 6 dB. For UEs indicating <i>interBandMRDC-WithOverlapDL-Bands-r16</i>, the power imbalance requirement defined in clause 7.6B.2.6 of 38.101-3 [4] apply. For these UEs, the power spectral density imbalance condition also applies for these carriers when applicable EN-DC configuration is a subset of a higher order EN-DC configuration.</p> <p>NOTE 12: Applicable for frequency range above 4800 MHz for Band n79 in this combination.</p> <p>NOTE 13: For UEs not indicating <i>interBandMRDC-WithOverlapDL-Bands-r16</i>, the minimum requirements apply for synchronized DL carriers with a maximum receive time difference <math>\leq 3</math> usec. The requirements also apply for these carriers when applicable EN-DC configuration is a subset of a higher order EN-DC configuration.</p> <p>NOTE 14: Applicable when dynamic switching between two uplink carriers is conducted. The DL interruption requirements for NR DL carrier(s) and E-UTRA DL carrier(s) are specified in clause 8.2.1.2.14 of 38.133 [25] and clause 7.32.2.12 of 36.133 [12] respectively.</p> <p>NOTE 15: Simultaneous Rx/Tx capability does not apply for UEs supporting band 42 with a n77 implementation only. Same restrictions are applied to related higher order configurations.</p> <p>NOTE 16: Reserved.</p> <p>NOTE 17: The frequency range in band n28 is restricted for this band combination to 728 - 738 MHz for the UL and 783 - 793 MHz for the DL. This restriction applies also for these band combinations when applicable EN-DC configuration is part of a higher order EN-DC configuration. Test Frequencies as specified in TS 38.508-1 [6] clause 4.3.1.</p> <p>NOTE 18: Reserved.</p> <p>NOTE 19: Reserved.</p> <p>NOTE 20: Reserved.</p> <p>NOTE 21: Minimum requirements for PC2 are applicable for this uplink EN-DC configuration in this downlink/uplink EN-DC configuration with 1Tx antenna connector in each band.</p> <p>NOTE 22: The PC2 Uplink EN-DC configuration supported in Table 6.2B.1.3-1 is applicable to the same EN-DC configuration without additional indication of NOTE 21.</p> <p>NOTE 23: Minimum requirements for Power Class 2 are applicable for this EN-DC configuration with 1Tx antenna connector in one band and 2Tx antenna connectors in the other band.</p> <p>NOTE 24: Minimum requirements for Power Class 2 are applicable for this EN-DC configuration with 1Tx antenna connector in one band and 2Tx antenna connectors in the other band.</p>			

5.5B.4.2 Inter-band EN-DC configurations within FR1 (three bands)

**Table 5.5B.4.2-1: Inter-band EN-DC configurations within FR1 (three bands)**

EN-DC configuration	Uplink EN-DC configuration (NOTE 1)
DC_1A-3A_n28A	DC_1A_n28A DC_3A_n28A
DC_1A-3A_n41A <sup>5</sup>	DC_1A_n41A DC_3A_n41A
DC_1A-3A_n77A <sup>5</sup>	DC_1A_n77A DC_3A_n77A
DC_1A-3A_n77(2A) <sup>5,14</sup>	DC_1A_n77A <sup>14</sup> DC_3A_n77A <sup>14</sup>
DC_1A-3A_n78A <sup>5,14</sup> DC_1A-3C_n78A <sup>5</sup>	DC_1A_n78A <sup>14</sup> DC_3A_n78A <sup>14</sup> DC_3C_n78A
DC_1A-1A-3A_n78A DC_1A-1A-3C_n78A	DC_1A_n78A DC_3A_n78A DC_3C_n78A
DC_1A-3C_n78(2A) <sup>5</sup>	DC_1A_n78A DC_3A_n78A DC_3C_n78A
DC_1A-3A_n79A <sup>5,14</sup>	DC_1A_n79A <sup>14</sup> DC_3A_n79A <sup>14</sup>
DC_1A-5A_n78A <sup>5</sup> DC_1A-5A_n78C <sup>5</sup>	DC_1A_n78A DC_5A_n78A
DC_1A-1A-5A_n78A	DC_1A_n78A DC_5A_n78A
DC_1A-7A_n3A	DC_1A_n3A DC_7A_n3A
DC_1A-7A_n28A <sup>5</sup>	DC_1A_n28A DC_7A_n28A
DC_1A-7A_n78A <sup>5</sup>	DC_1A_n78A DC_7A_n78A
DC_1A-8A_n3A	DC_1A_n3A DC_8A_n3A
DC_1A-8A_n77A <sup>5</sup>	DC_1A_n77A DC_8A_n77A
DC_1A-8A_n77(2A) <sup>5,14</sup>	DC_1A_n77A <sup>14</sup> DC_8A_n77A <sup>14</sup>
DC_1A-8A_n78A <sup>5</sup>	DC_1A_n78A DC_8A_n78A
DC_1A-8A_n78(2A) <sup>5</sup>	DC_1A_n78A DC_8A_n78A
DC_1A-18A_n77A <sup>5</sup>	DC_1A_n77A DC_18A_n77A
DC_1A-19A_n77A <sup>5</sup>	DC_1A_n77A DC_19A_n77A
DC_1A-19A_n78A <sup>5,14</sup> DC_1A-19A_n78C <sup>5</sup>	DC_1A_n78A <sup>14</sup> DC_19A_n78A <sup>14</sup>
DC_1A-19A_n79A <sup>5,14</sup> DC_1A-19A_n79C <sup>5</sup>	DC_1A_n79A <sup>14</sup> DC_19A_n79A <sup>14</sup>
DC_1A-20A_n3A	DC_1A_n3A DC_20A_n3A
DC_1A-20A_n8A	DC_1A_n8A DC_20A_n8A
DC_1A-20A_n28A <sup>6,11,12</sup>	DC_1A_n28A DC_20A_n28A
DC_1A-20A_n78A <sup>5</sup>	DC_1A_n78A DC_20A_n78A
DC_1A-21A_n77A <sup>5</sup>	DC_1A_n77A DC_21A_n77A



EN-DC configuration	Uplink EN-DC configuration (NOTE 1)
DC_1A-21A_n78A <sup>5,14</sup> DC_1A-21A_n78C <sup>5</sup>	DC_1A_n78A <sup>14</sup> DC_21A_n78A <sup>14</sup>
DC_1A-21A_n79A <sup>5,14</sup> DC_1A-21A_n79C <sup>5</sup>	DC_1A_n79A <sup>14</sup> DC_21A_n79A <sup>14</sup>
DC_1A-28A_n3A	DC_1A_n3A DC_28A_n3A
DC_1A-28A_n5A <sup>6</sup>	DC_1A_n5A DC_28A_n5A
DC_1A_n28A-n78A <sup>5</sup>	DC_1A_n28A DC_1A_n78A
DC_1A-28A_n79A DC_1A-28A_n79C	DC_1A_n79A DC_28A_n79A
DC_1A-41A_n28A <sup>5</sup> DC_1A-41C_n28A <sup>5</sup>	DC_1A_n28A DC_41A_n28A DC_41C_n28A
DC_1A-41A_n41A	DC_1A_n41A
DC_1A-41A_n77A	DC_1A_n77A DC_41A_n77A
DC_1A-41A_n78A	DC_1A_n78A DC_41A_n78A
DC_1A-42A_n77A <sup>10,11</sup> DC_1A-42C_n77A <sup>10,11</sup> DC_1A-42D_n77A <sup>10,11</sup>	DC_1A_n77A
DC_1A-42A_n78A <sup>10,11,14</sup> DC_1A-42A_n78C <sup>10,11</sup> DC_1A-42C_n78A <sup>10,11</sup> DC_1A-42C_n78C <sup>10,11</sup> DC_1A-42D_n78A <sup>10,11</sup> DC_1A-42E_n78A <sup>10,11</sup>	DC_1A_n78A <sup>14</sup>
DC_1A-42A_n79A <sup>14</sup> DC_1A-42A_n79C DC_1A-42C_n79A DC_1A-42C_n79C DC_1A-42D_n79A DC_1A-42E_n79A	DC_1A_n79A <sup>14</sup>
DC_1A_n77A-n79A	DC_1A_n77A DC_1A_n79A
DC_1A_n78A-n79A <sup>14</sup>	DC_1A_n78A <sup>14</sup> DC_1A_n79A <sup>14</sup>
DC_2A-5A_n2A	DC_5A_n2A DC_2A_n2A <sup>2</sup>
DC_2A-5A_n66A	DC_2A_n66A DC_5A_n66A
DC_2A-2A-5A_n66A	DC_2A_n66A DC_5A_n66A
DC_2A-5A_n77A <sup>14</sup>	DC_2A_n77A <sup>14</sup> DC_5A_n77A <sup>14</sup>
DC_2A-5A_n77(2A) <sup>14</sup>	DC_2A_n77A <sup>14</sup> DC_5A_n77A <sup>14</sup>
DC_2A-2A-5A_n77A <sup>14</sup>	DC_2A_n77A <sup>14</sup> DC_5A_n77A <sup>14</sup>
DC_2A-2A-5A_n77(2A) <sup>14</sup>	DC_2A_n77A <sup>14</sup> DC_5A_n77A <sup>14</sup>
DC_2A-12A_n66A	DC_2A_n66A DC_12A_n66A
DC_2A-13A_n77A	DC_2A_n77A DC_13A_n77A
DC_2A-14A_n2A	DC_2A_n2A <sup>2</sup> DC_14A_n2A

EN-DC configuration	Uplink EN-DC configuration (NOTE 1)
DC_2A-14A_n66A	DC_2A_n66A DC_14A_n66A
DC_2A-2A-14A_n66A	DC_2A_n66A DC_14A_n66A
DC_2A-14A_n77A <sup>14</sup> DC_2A-2A-14A_n77A <sup>14</sup>	DC_2A_n77A <sup>14</sup> DC_14A_n77A <sup>14</sup>
DC_2A-14A_n77(2A) <sup>14</sup> DC_2A-2A-14A_n77(2A) <sup>14</sup>	DC_2A_n77A <sup>14</sup> DC_14A_n77A <sup>14</sup>
DC_2A-30A_n66A	DC_2A_n66A DC_30A_n66A
DC_2A-66A_n2A	DC_2A_n2A <sup>2</sup> DC_66A_n2A
DC_2A-66A-66A_n2A	DC_66A_n2A
DC_2A-66A_n5A	DC_2A_n5A DC_66A_n5A
DC_2A-2A-66A_n5A	DC_2A_n5A DC_66A_n5A
DC_2A-66A-66A_n5A	DC_2A_n5A DC_66A_n5A
DC_2A-2A-66A-66A_n5A	DC_2A_n5A DC_66A_n5A
DC_2A-66A_n41A	DC_2A_n41A DC_66A_n41A
DC_2A-66A_n66A	DC_2A_n66A DC_66A_n66A <sup>2</sup>
DC_2A-2A-66A_n66A	DC_2A_n66A DC_66A_n66A <sup>2</sup>
DC_2A-66A-66A_n66A	DC_2A_n66A DC_66A_n66A <sup>2</sup>
DC_2A-2A-66A-66A_n66A	DC_2A_n66A
DC_2A-66A_n71A	DC_2A_n71A DC_66A_n71A
DC_2A-66A_n77A <sup>14</sup>	DC_2A_n77A <sup>14</sup> DC_66A_n77A <sup>14</sup>
DC_2A-66A_n77(2A) <sup>14</sup>	DC_2A_n77A <sup>14</sup> DC_66A_n77A <sup>14</sup>
DC_2A-2A-66A_n77A <sup>14</sup>	DC_2A_n77A <sup>14</sup> DC_66A_n77A <sup>14</sup>
DC_2A-2A-66A_n77(2A) <sup>14</sup>	DC_2A_n77A <sup>14</sup> DC_66A_n77A <sup>14</sup>
DC_2A-66A-66A_n77A <sup>14</sup>	DC_2A_n77A <sup>14</sup> DC_66A_n77A <sup>14</sup>
DC_2A-66A-66A_n77(2A) <sup>14</sup>	DC_2A_n77A <sup>14</sup> DC_66A_n77A <sup>14</sup>
DC_2A-2A-66A-66A_n77A <sup>14</sup>	DC_2A_n77A <sup>14</sup> DC_66A_n77A <sup>14</sup>
DC_2A-(n)71AA	DC_2A_n71A DC_(n)71AA
DC_2A_n5A-n77A <sup>14</sup>	DC_2A_n5A DC_2A_n77A <sup>14</sup>
DC_3A_n1A-n78A <sup>5</sup>	DC_3A_n1A DC_3A_n78A
DC_3A_n1A-n79A <sup>5</sup>	DC_3A_n1A DC_3A_n79A

EN-DC configuration	Uplink EN-DC configuration (NOTE 1)
DC_3A-5A_n78A <sup>5</sup> DC_3A-5A_n78C <sup>5</sup>	DC_3A_n78A DC_5A_n78A
DC_3A-7A_n5A	DC_3A_n5A DC_7A_n5A
DC_3A-7A_n28A	DC_3A_n28A DC_7A_n28A
DC_3A-7A_n78A <sup>5</sup> DC_3C-7A_n78A <sup>5</sup>	DC_3A_n78A DC_7A_n78A
DC_3A-8A_n1A	DC_3A_n1A DC_8A_n1A
DC_3A-8A_n28A	DC_3A_n28A DC_8A_n28A
DC_3A-8A_n77A <sup>5</sup>	DC_3A_n77A DC_8A_n77A
DC_3A-8A_n77(2A) <sup>5,14</sup>	DC_3A_n77A <sup>14</sup> DC_8A_n77A <sup>14</sup>
DC_3A-8A_n78A <sup>5</sup>	DC_3A_n78A DC_8A_n78A
DC_3A-18A_n77A	DC_3A_n77A DC_18A_n77A
DC_3A-8A_n78(2A)	DC_3A_n78A DC_8A_n78A
DC_3A-18A_n78A	DC_3A_n78A DC_18A_n78A
DC_3A-19A_n77A <sup>5</sup>	DC_3A_n77A DC_19A_n77A
DC_3A-19A_n78A <sup>5,14</sup> DC_3A-19A_n78C <sup>5</sup>	DC_3A_n78A <sup>14</sup> DC_19A_n78A <sup>14</sup>
DC_3A-19A_n79A <sup>5,14</sup> DC_3A-19A_n79C <sup>5</sup>	DC_3A_n79A <sup>14</sup> DC_19A_n79A
DC_3A-20A_n1A	DC_3A_n1A DC_20A_n1A
DC_3A-20A_n28A <sup>5,6,11,12</sup>	DC_3A_n28A DC_20A_n28A
DC_3A-20A_n78A <sup>5</sup>	DC_3A_n78A DC_20A_n78A
DC_3A-21A_n77A <sup>5</sup>	DC_3A_n77A DC_21A_n77A
DC_3A-21A_n78A <sup>5,14</sup> DC_3A-21A_n78C <sup>5</sup>	DC_3A_n78A <sup>14</sup> DC_21A_n78A <sup>14</sup>
DC_3A-21A_n79A <sup>5,14</sup> DC_3A-21A_n79C <sup>5</sup>	DC_3A_n79A <sup>14</sup> DC_21A_n79A <sup>14</sup>
DC_3A-28A_n78A <sup>5</sup>	DC_3A_n78A DC_28A_n78A
DC_3A_n28A-n78A <sup>5</sup>	DC_3A_n28A DC_3A_n78A
DC_3A-40A_n1A	DC_3A_n1A DC_40A_n1A
DC_3A-41A_n28A <sup>5</sup> DC_3A-41C_n28A <sup>5</sup>	DC_3A_n28A DC_41A_n28A DC_41C_n28A
DC_3A-41A_n41A	DC_3A_n41A
DC_3A-41A_n77A DC_3A-41C_n77A	DC_3A_n77A DC_41A_n77A
DC_3A-41A_n77(2A)	DC_3A_n77A DC_41A_n77A

EN-DC configuration	Uplink EN-DC configuration (NOTE 1)
DC_3A-42A_n77A <sup>10,11</sup> DC_3A-42C_n77A <sup>10,11</sup> DC_3A-42D_n77A <sup>10,11</sup>	DC_3A_n77A
DC_3A-42A_n78A <sup>10,11,14</sup> DC_3A-42A_n78C <sup>10,11</sup> DC_3A-42C_n78A <sup>10,11</sup> DC_3A-42C_n78C <sup>10,11</sup> DC_3A-42D_n78A <sup>10,11</sup> DC_3A-42E_n78A <sup>10,11</sup>	DC_3A_n78A <sup>14</sup>
DC_3A-42A_n79A <sup>14</sup> DC_3A-42A_n79C DC_3A-42C_n79A DC_3A-42C_n79C DC_3A-42D_n79A DC_3A-42E_n79A	DC_3A_n79A <sup>14</sup>
DC_3A_n77A-n79A	DC_3A_n77A DC_3A_n79A
DC_3A_n78A-n79A <sup>14</sup>	DC_3A_n78A <sup>14</sup> DC_3A_n79A <sup>14</sup>
DC_5A-7A_n78A	DC_5A_n78A DC_7A_n78A
DC_5A-30A_n66A	DC_5A_n66A DC_30A_n66A
DC_5A-66A_n2A	DC_5A_n2A DC_66A_n2A
DC_5A-66A-66A_n2A	DC_5A_n2A DC_66A_n2A
DC_5A-66A_n66A	DC_5A_n66A
DC_5A-66A_n77A <sup>14</sup>	DC_5A_n77A <sup>14</sup> DC_66A_n77A <sup>14</sup>
DC_5A-66A_n77(2A) <sup>14</sup>	DC_5A_n77A <sup>14</sup> DC_66A_n77A <sup>14</sup>
DC_5A-66A-66A_n77A <sup>14</sup>	DC_5A_n77A <sup>14</sup> DC_66A_n77A <sup>14</sup>
DC_5A-66A-66A_n77(2A) <sup>14</sup>	DC_5A_n77A <sup>14</sup> DC_66A_n77A <sup>14</sup>
DC_7A_n5A-n78A DC_7C_n5A-n78A	DC_7A_n5A DC_7C_n5A DC_7A_n78A DC_7C_n78A
DC_7A-8A_n1A	DC_7A_n1A DC_8A_n1A
DC_7A-8A_n3A	DC_7A_n3A DC_8A_n3A
DC_7A-20A_n1A	DC_7A_n1A DC_20A_n1A
DC_7A-20A_n3A	DC_7A_n3A DC_20A_n3A
DC_7A-20A_n8A	DC_7A_n8A DC_20A_n8A
DC_7A-20A_n28A <sup>6,11,12</sup>	DC_7A_n28A DC_20A_n28A
DC_7A-20A_n78A <sup>5</sup>	DC_7A_n78A DC_20A_n78A
DC_7A-28A_n3A	DC_7A_n3A DC_28A_n3A
DC_7A-28A_n5A <sup>6</sup>	DC_7A_n5A DC_28A_n5A

EN-DC configuration	Uplink EN-DC configuration (NOTE 1)
DC_7A-28A_n78A <sup>5</sup>	DC_7A_n78A DC_28A_n78A
DC_7A_n28A-n78A <sup>5</sup> DC_7C_n28A-n78A	DC_7A_n28A DC_7A_n78A DC_7C_n28A DC_7C_n78A
DC_12A-30A_n66A	DC_12A_n66A DC_30A_n66A
DC_13A-66A_n2A	DC_13A_n2A DC_66A_n2A
DC_13A-66A_n77A	DC_13A_n77A DC_66A_n77A
DC_13A_n2A-n77A <sup>14</sup>	DC_13A_n2A DC_13A_n77A <sup>14</sup>
DC_14A-66A_n66A	DC_14A_n66A DC_66A_n66A <sup>2</sup>
DC_14A-66A_n77A <sup>14</sup> DC_14A-66A-66A_n77A <sup>14</sup>	DC_14A_n77A <sup>14</sup> DC_66A_n77A <sup>14</sup>
DC_14A-66A_n77(2A) <sup>14</sup> DC_14A-66A-66A_n77(2A) <sup>14</sup>	DC_14A_n77A <sup>14</sup> DC_66A_n77A <sup>14</sup>
DC_18A-41A_n3A	DC_18A_n3A DC_41A_n3A
DC_18A-41A_n77A DC_18A-41C_n77A	DC_18A_n77A DC_41A_n77A DC_41C_n77A
DC_18A-41A_n78A DC_18A-41C_n78A	DC_18A_n78A DC_41A_n78A DC_41C_n78A
DC_19A_n1A-n78A <sup>5</sup>	DC_19A_n1A DC_19A_n78A
DC_19A_n1A-n79A <sup>5</sup>	DC_19A_n1A DC_19A_n79A
DC_19A-21A_n77A <sup>5</sup>	DC_19A_n77A DC_21A_n77A
DC_19A-21A_n78A <sup>5,14</sup> DC_19A-21A_n78C <sup>5</sup>	DC_19A_n78A <sup>14</sup> DC_21A_n78A <sup>14</sup>
DC_19A-21A_n79A <sup>5,14</sup> DC_19A-21A_n79C <sup>5</sup>	DC_19A_n79A <sup>14</sup> DC_21A_n79A <sup>14</sup>
DC_19A-42A_n77ADC_19A-42C_n77A	DC_19A_n77A
DC_19A-42A_n78A <sup>14</sup> DC_19A-42C_n78A DC_19A-42A_n78C DC_19A-42C_n78C	DC_19A_n78A <sup>14</sup>
DC_19A-42A_n79A <sup>14</sup> DC_19A-42C_n79A DC_19A-42A_n79C DC_19A-42C_n79C	DC_19A_n79A <sup>14</sup>
DC_19A_n77A-n79A	DC_19A_n77A DC_19A_n79A
DC_19A_n78A-n79A <sup>14</sup>	DC_19A_n78A <sup>14</sup> DC_19A_n79A <sup>14</sup>
DC_20A_n28A-n78A <sup>5,6,11,12</sup>	DC_20A_n28A DC_20A_n78A
DC_20A_n76A-n78A <sup>5</sup>	DC_20A_n78A
DC_21A_n1A-n78A <sup>5</sup>	DC_21A_n1A DC_21A_n78A
DC_21A_n1A-n79A <sup>5</sup>	DC_21A_n1A DC_21A_n79A

EN-DC configuration	Uplink EN-DC configuration (NOTE 1)
DC_21A-42A_n77A <sup>10,11</sup> DC_21A-42C_n77A <sup>10,11</sup>	DC_21A_n77A
DC_21A-42A_n78A <sup>10,11,14</sup> DC_21A-42A_n78C <sup>10,11</sup> DC_21A-42C_n78A <sup>10,11</sup> DC_21A-42C_n78C <sup>10,11</sup>	DC_21A_n78A <sup>14</sup>
DC_21A-42A_n79A <sup>14</sup> DC_21A-42A_n79C DC_21A-42C_n79A DC_21A-42C_n79C	DC_21A_n79A <sup>14</sup>
DC_21A_n77A-n79A	DC_21A_n77A DC_21A_n79A
DC_21A_n78A-n79A <sup>14</sup>	DC_21A_n78A <sup>14</sup> DC_21A_n79A <sup>14</sup>
DC_28A_n7A-n78A	DC_28A_n7A DC_28A_n78A
DC_28A-42A_n78A <sup>10,11</sup>	DC_28A_n78A
DC_41A-42A_n78A <sup>10,11</sup>	DC_41A_n78A
DC_66A_n2A-n77A <sup>14</sup>	DC_66A_n2A DC_66A_n77A <sup>14</sup>
DC_66A_n5A-n77A <sup>14</sup>	DC_66A_n5A DC_66A_n77A <sup>14</sup>
DC_66A-(n)71AA	DC_66A_n71A DC_(n)71AA
<p>NOTE 1: Uplink EN-DC configurations are the configurations supported by the present release of specifications.</p> <p>NOTE 2: Only single switched UL is supported.</p> <p>NOTE 3: Restricted to E-UTRA operation when inter-band carrier aggregation is configured. The downlink operating band for Band 46 is paired with the uplink operating band (external E-UTRA band) of the carrier aggregation configuration that is supporting the configured PCell.</p> <p>NOTE 4: If a UE is configured with both NR UL and NR SUL carriers in a cell, the switching time between NR UL carrier and NR SUL carrier can be up to 140us and placed in SUL resources.</p> <p>NOTE 5: Applicable for UE supporting inter-band EN-DC with mandatory simultaneous Rx/Tx capability</p> <p>NOTE 6: The frequency range in band n28 is restricted for this band combination to 703-733 MHz for the UL and 758-788 MHz for the DL.</p> <p>NOTE 7: Void.</p> <p>NOTE 8: Reserved.</p> <p>NOTE 9: Reserved.</p> <p>NOTE 10: For UEs not indicating <i>interBandMRDC-WithOverlapDL-Bands-r16</i>, the minimum requirements for intra-band non-contiguous EN-DC apply for the Band 42 and Band n77/n78 combination. For UEs not indicating <i>interBandMRDC-WithOverlapDL-Bands-r16</i>, when UE capability <i>interBandContiguousMRDC</i> is indicated, the minimum requirements for intra-band-contiguous EN-DC also should be met in addition to intra-band non-contiguous EN-DC.</p> <p>NOTE 11: For UEs not indicating <i>interBandMRDC-WithOverlapDL-Bands-r16</i>, the minimum requirements for inter-band EN-DC apply when the maximum power spectral density imbalance between downlink carriers contained in overlapping or partially overlapping DL bands is within 6 dB.</p> <p>NOTE 12: For UEs not indicating <i>interBandMRDC-WithOverlapDL-Bands-r16</i>, the minimum requirements apply for synchronized DL carriers with a maximum receive time difference <math>\leq 3</math> usec between overlapping or partially overlapping DL bands contained in different cell groups.</p> <p>NOTE 13: Reserved.</p> <p>NOTE 14: Minimum requirements for PC2 are applicable for this uUplink EN-DC configuration in this downlink/uplink to EN-DC configuration.</p>	

5.5B.4.3 Inter-band EN-DC configurations within FR1 (four bands)

**Table 5.5B.4.3-1: Inter-band EN-DC configurations within FR1 (four bands)**

EN-DC configuration	Uplink EN-DC configuration (NOTE 1)
DC_1A-3A-7A_n28A	DC_1A_n28A DC_3A_n28A DC_7A_n28A
DC_1A-3A-7A_n78A <sup>2</sup>	DC_1A_n78A DC_3A_n78A DC_7A_n78A
DC_1A-3A-8A_n77A <sup>2</sup>	DC_1A_n77A DC_3A_n77A DC_8A_n77A
DC_1A-3A-8A_n78A <sup>2</sup>	DC_1A_n78A DC_3A_n78A DC_8A_n78A
DC_1A-3A-19A_n77A <sup>2</sup>	DC_1A_n77A DC_3A_n77A DC_19A_n77A
DC_1A-3A-19A_n78A <sup>2</sup>	DC_1A_n78A DC_3A_n78A DC_19A_n78A
DC_1A-3A-19A_n79A <sup>2</sup>	DC_1A_n79A DC_3A_n79A DC_19A_n79A
DC_1A-3A-20A_n28A <sup>3,7,8</sup>	DC_1A_n28A DC_3A_n28A DC_20A_n28A
DC_1A-3A-20A_n78A <sup>2</sup>	DC_1A_n78A DC_3A_n78A DC_20A_n78A
DC_1A-3A-21A_n77A <sup>2</sup>	DC_1A_n77A DC_3A_n77A DC_21A_n77A
DC_1A-3A-21A_n78A <sup>2</sup>	DC_1A_n78A DC_3A_n78A DC_21A_n78A
DC_1A-3A-21A_n79A <sup>2</sup>	DC_1A_n79A DC_3A_n79A DC_21A_n79A
DC_1A-3A-28A_n78A <sup>2</sup>	DC_1A_n78A DC_3A_n78A DC_28A_n78A
DC_1A-3A_n28A-n78A <sup>2</sup>	DC_1A_n28A DC_1A_n78A DC_3A_n28A DC_3A_n78A
DC_1A-3A-42A_n78A <sup>6,7</sup> DC_1A-3A-42C_n78A <sup>6,7</sup> DC_1A-3A-42D_n78A <sup>6,7</sup>	DC_1A_n78A DC_3A_n78A
DC_1A-3A-42A_n79A DC_1A-3A-42C_n79ADC_1A-3A-42D_n79A	DC_1A_n79A DC_3A_n79A
DC_1A-7A-20A_n28A <sup>3,7,8</sup>	DC_1A_n28A DC_7A_n28A DC_20A_n28A
DC_1A-7A-20A_n78A <sup>2</sup>	DC_1A_n78A DC_7A_n78A DC_20A_n78A
DC_1A-7A-28A_n78A	DC_1A_n78A DC_7A_n78A DC_28A_n78A
DC_1A-7A_n28A-n78A <sup>2</sup>	DC_1A_n28A DC_1A_n78A DC_7A_n28A DC_7A_n78A



EN-DC configuration	Uplink EN-DC configuration (NOTE 1)
DC_1A-19A-21A_n77A	DC_1A_n77A DC_19A_n77A DC_21A_n77A
DC_1A-19A-21A_n78A <sup>2</sup> DC_1A-19A-21A_n78C <sup>2</sup>	DC_1A_n78A DC_19A_n78A DC_21A_n78A
DC_1A-19A-21A_n79A DC_1A-19A-21A_n79C	DC_1A_n79A DC_19A_n79A DC_21A_n79A
DC_1A-19A-42A_n77A <sup>6,7</sup> DC_1A-19A-42C_n77A <sup>6,7</sup>	DC_19A_n77A
DC_1A-19A-42A_n78A DC_1A-19A-42A_n78C DC_1A-19A-42C_n78A DC_1A-19A-42C_n78C	DC_1A_n78A DC_19A_n78A
DC_1A-19A-42A_n79A DC_1A-19A-42A_n79C DC_1A-19A-42C_n79A DC_1A-19A-42C_n79C	DC_1A_n79A DC_19A_n79A
DC_1A-20A_n28A-n78A <sup>2,3,7,8</sup>	DC_1A_n28A DC_1A_n78A DC_20A_n28A DC_20A_n78A
DC_1A-21A-42A_n77A <sup>6,7</sup> DC_1A-21A-42C_n77A <sup>6,7</sup>	DC_1A_n77A DC_21A_n77A
DC_1A-21A-42A_n78A <sup>6,7</sup> DC_1A-21A-42A_n78C <sup>6,7</sup> DC_1A-21A-42C_n78A <sup>6,7</sup> DC_1A-21A-42C_n78C <sup>6,7</sup>	DC_1A_n78A DC_21A_n78A
DC_1A-21A-42A_n79A DC_1A-21A-42A_n79C DC_1A-21A-42C_n79A DC_1A-21A-42C_n79C	DC_1A_n79A DC_21A_n79A
DC_2A-7A-13A_n66A DC_2A-7C-13A_n66A	DC_2A_n66A DC_7A_n66A DC_13A_n66A
DC_2A-7A-7A-13A_n66A	DC_2A_n66A DC_7A_n66A DC_13A_n66A
DC_2A-7A-66A_n66A DC_2A-7C-66A_n66A	DC_2A_n66A DC_7A_n66A DC_66A_n66A <sup>4</sup>
DC_2A-7A-7A-66A_n66A	DC_2A_n66A DC_7A_n66A DC_66A_n66A <sup>4</sup>
DC_2A-7C-66A_n78A	DC_2A_n78A DC_7A_n78A DC_66A_n78A
DC_2A-7A-7A-66A_n78A	DC_2A_n78A DC_7A_n78A DC_66A_n78A
DC_2A-13A-66A_n77A <sup>9</sup>	DC_2A_n77A <sup>9</sup> DC_13A_n77A <sup>9</sup> DC_66A_n77A <sup>9</sup>
DC_2A-14A-66A_n2A	DC_2A_n2A <sup>4</sup> DC_14A_n2A DC_66A_n2A
DC_2A-14A-66A-66A_n2A	DC_2A_n2A <sup>4</sup> DC_14A_n2A DC_66A_n2A

EN-DC configuration	Uplink EN-DC configuration (NOTE 1)
DC_2A-14A-66A_n66A	DC_2A_n66A DC_14A_n66A DC_66A_n66A <sup>4</sup>
DC_2A-2A-14A-66A_n66A	DC_2A_n66A DC_14A_n66A DC_66A_n66A <sup>4</sup>
DC_2A-66A_n5A-n77A <sup>9</sup>	DC_2A_n5A DC_2A_n77A <sup>9</sup> DC_66A_n5A DC_66A_n77A <sup>9</sup>
DC_2A-66A-(n)71AA	DC_2A_n71A DC_66A_n71A DC_(n)71AA
DC_3A-7A-20A_n8A	DC_3A_n8A DC_7A_n8A DC_20A_n8A
DC_3A-7A-20A_n28A <sup>3,7,8</sup>	DC_3A_n28A DC_7A_n28A DC_20A_n28A
DC_3A-7A-20A_n78A <sup>2</sup>	DC_3A_n78A DC_7A_n78A DC_20A_n78A
DC_3A-7A-28A_n78A <sup>2</sup>	DC_3A_n78A DC_7A_n78A DC_28A_n78A
DC_3A-7A_n28A-n78A <sup>2</sup>	DC_3A_n28A DC_3A_n78A DC_7A_n28A DC_7A_n78A
DC_3A-19A-21A_n78A <sup>2</sup> DC_3A-19A-21A_n78C <sup>2</sup>	DC_3A_n78A DC_19A_n78A DC_21A_n78A
DC_3A-19A-21A_n79A <sup>2</sup> DC_3A-19A-21A_n79C <sup>2</sup>	DC_3A_n79A DC_19A_n79A DC_21A_n79A
DC_3A-19A-42A_n77A <sup>6,7</sup> DC_3A-19A-42C_n77A <sup>6,7</sup>	DC_3A_n77A DC_19A_n77A
DC_3A-19A-42A_n78A <sup>6,7</sup> DC_3A-19A-42A_n78C <sup>6,7</sup> DC_3A-19A-42C_n78A <sup>6,7</sup> DC_3A-19A-42C_n78C <sup>6,7</sup>	DC_3A_n78A DC_19A_n78A
DC_3A-19A-42A_n79A <sup>2</sup> DC_3A-19A-42A_n79C <sup>2</sup> DC_3A-19A-42C_n79A <sup>2</sup> DC_3A-19A-42C_n79C <sup>2</sup>	DC_3A_n79A DC_19A_n79A
DC_3A-20A_n28A-n78A <sup>2,3,7,8</sup>	DC_3A_n28A DC_3A_n78A DC_20A_n28A DC_20A_n78A
DC_3A-21A-42A_n77A <sup>6,7</sup> DC_3A-21A-42C_n77A <sup>6,7</sup>	DC_3A_n77A DC_21A_n77A
DC_3A-21A-42A_n78A <sup>6,7</sup> DC_3A-21A-42A_n78C <sup>6,7</sup> DC_3A-21A-42C_n78A <sup>6,7</sup> DC_3A-21A-42C_n78C <sup>6,7</sup>	DC_3A_n78A DC_21A_n78A
DC_3A-21A-42A_n79A DC_3A-21A-42A_n79C DC_3A-21A-42C_n79A DC_3A-21A-42C_n79C	DC_3A_n79A DC_21A_n79A

EN-DC configuration	Uplink EN-DC configuration (NOTE 1)
DC_7A-20A_n28A-n78A <sup>2,3,7,8</sup>	DC_7A_n28A DC_7A_n78A DC_20A_n28A DC_20A_n78A
DC_13A-66A_n2A-n77A <sup>9</sup>	DC_13A_n2A DC_13A_n77A <sup>9</sup> DC_66A_n2A DC_66A_n77A <sup>9</sup>
DC_19A-21A-42A_n77A <sup>6,7</sup> DC_19A-21A-42C_n77A <sup>6,7</sup>	DC_19A_n77A DC_21A_n77A
DC_19A-21A-42A_n78A <sup>6,7</sup> DC_19A-21A-42A_n78C <sup>6,7</sup> DC_19A-21A-42C_n78A <sup>6,7</sup> DC_19A-21A-42C_n78C <sup>6,7</sup>	DC_19A_n78A DC_21A_n78A
DC_19A-21A-42A_n79A DC_19A-21A-42A_n79C DC_19A-21A-42C_n79A DC_19A-21A-42C_n79C	DC_19A_n79A DC_21A_n79A
<p>NOTE 1: Uplink EN-DC configurations are the configurations supported by the present release of specifications.</p> <p>NOTE 2: Applicable for UE supporting inter-band EN-DC with mandatory simultaneous Rx/Tx capability</p> <p>NOTE 3: The frequency range in band n28 is restricted for this band combination to 703-733 MHz for the UL and 758-788 MHz for the DL.</p> <p>NOTE 4: Only single switched UL is supported.</p> <p>NOTE 5: UL carrier shall be supported in Band 2 or band 66 only. Power imbalance between downlink carriers on Band 7 and Band 38 is assumed to be within 6dB.</p> <p>NOTE 6: For UEs not indicating <i>interBandMRDC-WithOverlapDL-Bands-r16</i>, the minimum requirements for intra-band non-contiguous EN-DC apply for the Band 42 and Band n77/n78 combination. For UEs not indicating <i>interBandMRDC-WithOverlapDL-Bands-r16</i>, when UE capability <i>interBandContiguousMRDC</i> is indicated, the minimum requirements for intra-band-contiguous EN-DC also should be met in addition to intra-band non-contiguous EN-DC.</p> <p>NOTE 7: For UEs not indicating <i>interBandMRDC-WithOverlapDL-Bands-r16</i>, the minimum requirements for inter-band EN-DC apply when the maximum power spectral density imbalance between downlink carriers contained in overlapping or partially overlapping DL bands is within 6 dB.</p> <p>NOTE 8: For UEs not indicating <i>interBandMRDC-WithOverlapDL-Bands-r16</i>, the minimum requirements apply for synchronized DL carriers with a maximum receive time difference <math>\leq 3</math> usec between overlapping or partially overlapping DL bands contained in different cell groups.</p> <p>NOTE 9: Minimum requirements for PC2 are applicable for this uplink EN-DC configuration in this downlink/uplink EN-DC configuration.</p>	

5.5B.4.4 Inter-band EN-DC configurations within FR1 (five bands)

**Table 5.5B.4.4-1: Inter-band EN-DC configurations within FR1 (five bands)**

EN-DC configuration	Uplink EN-DC configuration (NOTE 1)
DC_1A-3A-7A-20A_n28A <sup>3,6,7</sup>	DC_1A_n28A DC_3A_n28A DC_7A_n28A DC_20A_n28A
DC_1A-3A-7A-20A_n78A <sup>2</sup>	DC_1A_n78A DC_3A_n78A DC_7A_n78A DC_20A_n78A
DC_1A-3A-7A_n28A-n78A <sup>2</sup>	DC_1A_n28A DC_1A_n78A DC_3A_n28A DC_3A_n78A DC_7A_n28A DC_7A_n78A
DC_1A-3A-7A-28A_n78A	DC_1A_n78A DC_3A_n78A DC_7A_n78A DC_28A_n78A
DC_1A-3A-19A-42A_n78A <sup>5,6</sup> DC_1A-3A-19A-42C_n78A <sup>5,6</sup>	DC_1A_n78A DC_3A_n78A DC_19A_n78A
DC_1A-3A-19A-42A_n79A DC_1A-3A-19A-42C_n79A	DC_1A_n79A DC_3A_n79A DC_19A_n79A
DC_1A-3A-20A_n28A-n78A <sup>2,3,6,7</sup>	DC_1A_n28A DC_1A_n78A DC_3A_n28A DC_3A_n78A DC_20A_n28A DC_20A_n78A
DC_1A-3A-21A-42A_n78A <sup>5,6</sup> DC_1A-3A-21A-42C_n78A <sup>5,6</sup>	DC_1A_n78A DC_3A_n78A DC_21A_n78A
DC_1A-3A-21A-42A_n79A DC_1A-3A-21A-42C_n79A	DC_1A_n79A DC_3A_n79A DC_21A_n79A
DC_1A-7A-20A_n28A-n78A <sup>2,3,6,7</sup>	DC_1A_n28A DC_1A_n78A DC_7A_n28A DC_7A_n78A DC_20A_n28A DC_20A_n78A
DC_1A-19A-21A-42A_n78A <sup>5,6</sup> DC_1A-19A-21A-42A_n78C <sup>5,6</sup> DC_1A-19A-21A-42C_n78A <sup>5,6</sup> DC_1A-19A-21A-42C_n78C <sup>5,6</sup>	DC_1A_n78A DC_19A_n78A DC_21A_n78A
DC_1A-19A-21A-42A_n79A DC_1A-19A-21A-42A_n79C DC_1A-19A-21A-42C_n79A DC_1A-19A-21A-42C_n79C	DC_1A_n79A DC_19A_n79A DC_21A_n79A
DC_3A-7A-20A_n28A-n78A <sup>2,3,6,7</sup>	DC_3A_n28A DC_3A_n78A DC_7A_n28A DC_7A_n78A DC_20A_n28A DC_20A_n78A
DC_3A-19A-21A-42A_n78A <sup>5,6</sup> DC_3A-19A-21A-42C_n78A <sup>5,6</sup>	DC_3A_n78A DC_19A_n78A DC_21A_n78A
DC_3A-19A-21A-42A_n79A <sup>5,6</sup> DC_3A-19A-21A-42C_n79A <sup>5,6</sup>	DC_3A_n79A DC_19A_n79A DC_21A_n79A

EN-DC configuration	Uplink EN-DC configuration (NOTE 1)
NOTE 1: Uplink EN-DC configurations are the configurations supported by the present release of specifications.	
NOTE 2: Applicable for UE supporting inter-band EN-DC with mandatory simultaneous Rx/Tx capability	
NOTE 3: The frequency range in band n28 is restricted for this band combination to 703-733 MHz for the UL and 758-788 MHz for the DL	
NOTE 4: Reserved.	
NOTE 5: For UEs not indicating <i>interBandMRDC-WithOverlapDL-Bands-r16</i> , the minimum requirements for intra-band non-contiguous EN-DC apply for the Band 42 and Band n77/n78 combination. For UEs not indicating <i>interBandMRDC-WithOverlapDL-Bands-r16</i> , when UE capability <i>interBandContiguousMRDC</i> is indicated, the minimum requirements for intra-band-contiguous EN-DC also should be met in addition to intra-band non-contiguous EN-DC.	
NOTE 6: For UEs not indicating <i>interBandMRDC-WithOverlapDL-Bands-r16</i> , the minimum requirements for inter-band EN-DC apply when the maximum power spectral density imbalance between downlink carriers contained in overlapping or partially overlapping DL bands is within 6 dB.	
NOTE 7: For UEs not indicating <i>interBandMRDC-WithOverlapDL-Bands-r16</i> , the minimum requirements apply for synchronized DL carriers with a maximum receive time difference $\leq 3$ usec between overlapping or partially overlapping DL bands contained in different cell groups.	

5.5B.4.5 Inter-band EN-DC configurations within FR1 (six bands)

Table 5.5B.4.5-1: Inter-band EN-DC configurations within FR1 (six bands)

EN-DC configuration	Uplink EN-DC configuration (NOTE 1)
DC_1A-3A-7A-20A_n28A-n78A <sup>2,3,5,6</sup>	DC_1A_n28A DC_1A_n78A DC_3A_n28A DC_3A_n78A DC_7A_n28A DC_7A_n78A DC_20A_n28A DC_20A_n78A
NOTE 1: Uplink EN-DC configurations are the configurations supported by the present release of specifications.	
NOTE 2: Applicable for UE supporting inter-band EN-DC with mandatory simultaneous Rx/Tx capability.	
NOTE 3: The frequency range in band n28 is restricted for this band combination to 703-733 MHz for the UL and 758-788 MHz for the DL.	
NOTE 4: Reserved	
NOTE 5: For UEs not indicating <i>interBandMRDC-WithOverlapDL-Bands-r16</i> , the minimum requirements for inter-band EN-DC apply when the maximum power spectral density imbalance between downlink carriers contained in overlapping or partially overlapping DL bands is within 6 dB.	
NOTE 6: For UEs not indicating <i>interBandMRDC-WithOverlapDL-Bands-r16</i> , the minimum requirements apply for synchronized DL carriers with a maximum receive time difference $\leq 3$ usec between overlapping or partially overlapping DL bands contained in different cell groups.	

## 5.5B.4a Inter-band NE-DC within FR1

### 5.5B.4a.1 Inter-band NE-DC configurations within FR1 (two bands)

**Table 5.5B.4a.1-1: Inter-band NE-DC configurations within FR1 (two bands)**

NE-DC configuration	Uplink NE-DC configuration (NOTE 1)	Single UL allowed
DC_n28A_3A DC_n28A_3C	DC_n28A_3A	No
DC_n28A_39A DC_n28A_39C	DC_n28A_39A	No
NOTE 1: Uplink EN-DC configurations are the configurations supported by the present release of specifications.		

## 5.5B.5 Inter-band EN-DC including FR2

Supported channel bandwidths for E-UTRA operating bands and CA configurations are defined in TS 36.521-1 [10] and for NR operating bands and CA configurations in TS 38.521-1 [8], TS 38.521-2 [9] and present document.

## 5.5B.5.1 Inter-band EN-DC configurations including FR2 (two bands)

Table 5.5B.5.1-1: Inter-band EN-DC configurations including FR2 (two bands)

EN-DC configuration	Uplink EN-DC configuration (NOTE 1)
DC_1A_n257A	DC_1A_n257A
DC_2A_n257A	DC_2A_n257A
DC_2A_n257(2A)	DC_2A_n257A
DC_2A_n260A DC_2A_n260G DC_2A_n260H DC_2A_n260I DC_2A_n260J DC_2A_n260K DC_2A_n260L DC_2A_n260M DC_2C_n260A	DC_2A_n260A DC_2A_n260G DC_2A_n260H
DC_2A_n261A DC_2A_n261G DC_2A_n261H DC_2A_n261I DC_2A_n261J DC_2A_n261M	DC_2A_n261A DC_2A_n261G DC_2A_n261H DC_2A_n261I
DC_2A_n261(2A) DC_2A_n261(3A)	DC_2A_n261A
DC_2A_n261(2G) DC_2A_n261(2H)	DC_2A_n261A DC_2A_n261G DC_2A_n261H
DC_2A_n261(A-G) DC_2A_n261(A-2G) DC_2A_n261(A-H) DC_2A_n261(A-I) DC_2A_n261(G-H) DC_2A_n261(G-I) DC_2A_n261(H-I) DC_2A_n261(2A-G) DC_2A_n261(2A-I)	DC_2A_n261A DC_2A_n261G DC_2A_n261H DC_2A_n261I
DC_2A_n261(A-G-H) DC_2A_n261(A-G-I)	DC_2A_n261A DC_2A_n261G DC_2A_n261H DC_2A_n261I
DC_3A_n257G DC_3A_n257H DC_3A_n257I	DC_3A_n257G DC_3A_n257H DC_3A_n257I



EN-DC configuration	Uplink EN-DC configuration (NOTE 1)
DC_5A_n260A DC_5A_n260G DC_5A_n260H DC_5A_n260I DC_5A_n260J DC_5A_n260K DC_5A_n260L DC_5A_n260M DC_5A_n260ODC_5B_n260A	DC_5A_n260A DC_5A_n260G DC_5A_n260H DC_5A_n260O DC_5A_n260P DC_5A_n260Q
DC_5A_n261A DC_5A_n261G DC_5A_n261H DC_5A_n261I DC_5A_n261J DC_5A_n261M	DC_5A_n261A DC_5A_n261G DC_5A_n261H DC_5A_n261I
DC_5A_n261(2A) DC_5A_n261(3A) DC_5A_n261(4A)	DC_5A_n261A DC_5A_n261G DC_5A_n261H DC_5A_n261I
DC_8A_n257A DC_8A_n257D DC_8A_n257E DC_8A_n257F DC_8A_n257G DC_8A_n257H DC_8A_n257I DC_8A_n257J DC_8A_n257K DC_8A_n257L DC_8A_n257M	DC_8A_n257A
DC_13A_n257A	DC_13A_n257A
DC_13A_n260A DC_13A_n260G DC_13A_n260H DC_13A_n260I DC_13A_n260J DC_13A_n260M	DC_13A_n260A DC_13A_n260G DC_13A_n260H DC_13A_n260O
DC_13A_n261A	DC_13A_n261A
DC_14A_n260A DC_14A_n260G DC_14A_n260H DC_14A_n260I	DC_14A_n260A DC_14A_n260G DC_14A_n260H DC_14A_n260I
DC_18A_n257A DC_18A_n257G DC_18A_n257I	DC_18A_n257A DC_18A_n257G DC_18A_n257I
DC_19A_n257A DC_19A_n257D DC_19A_n257G DC_19A_n257H DC_19A_n257I	DC_19A_n257A DC_19A_n257G DC_19A_n257H DC_19A_n257I
DC_20A_n257A	DC_20A_n257A
DC_21A_n257A DC_21A_n257G	DC_21A_n257A DC_21A_n257G

EN-DC configuration	Uplink EN-DC configuration (NOTE 1)
DC_66A_n260A DC_66A_n260D DC_66A_n260E DC_66A_n260F DC_66A_n260G DC_66A_n260H DC_66A_n260I DC_66A_n260J DC_66A_n260K DC_66A_n260L DC_66A_n260M DC_66A_n260O	DC_66A_n260A DC_66A_n260G DC_66A_n260H DC_66A_n260O DC_66A_n260P DC_66A_n260Q
DC_66A-66A_n260A DC_66A-66A_n260G DC_66A-66A_n260H DC_66A-66A_n260I DC_66A-66A_n260J DC_66A-66A_n260K DC_66A-66A_n260L DC_66A-66A_n260M	DC_66A_n260A DC_66A_n260G DC_66A_n260H DC_66A_n260I
DC_66A_n261G DC_66A_n261H DC_66A_n261I DC_66A_n261J DC_66A_n261K DC_66A_n261L DC_66A_n261M	DC_66A_n261A DC_66A_n261G DC_66A_n261H DC_66A_n261I
DC_66A_n261(2G) DC_66A_n261(2H)	DC_66A_n261A DC_66A_n261G DC_66A_n261H
DC_66A_n261(A-2G) DC_66A_n261(2A-G) DC_66A_n261(2A-H) DC_66A_n261(2A-I)	DC_66A_n261A DC_66A_n261G DC_66A_n261H DC_66A_n261I
DC_66A_n261(A-G-H) DC_66A_n261(A-G-I)	DC_66A_n261A DC_66A_n261G DC_66A_n261H DC_66A_n261I
DC_66A-66A_n260G DC_66A-66A_n260H DC_66A-66A_n260I DC_66A-66A_n260J DC_66A-66A_n260K DC_66A-66A_n260L DC_66A-66A_n260M	DC_66A_n261A DC_66A_n261G DC_66A_n261H DC_66A_n261I
NOTE 1: Uplink EN-DC configurations are the configurations supported by the present release of specifications.	
NOTE 2: Applicable for UE supporting inter-band EN-DC with mandatory simultaneous Rx/Tx capability for all of the above combinations	

5.5B.5.2 Inter-band EN-DC configurations including FR2 (three bands)

**Table 5.5B.5.2-1: Inter-band EN-DC configurations including FR2 (three bands)**

EN-DC configuration	Uplink EN-DC configuration (NOTE 1)
DC_1A-3A_n257A <sup>2</sup> DC_1A-3A_n257G DC_1A-3A_n257H DC_1A-3A_n257I	DC_1A_n257A DC_3A_n257A DC_3A_n257G DC_3A_n257H DC_3A_n257I
DC_1A-18A_n257A <sup>2</sup> DC_1A-18A_n257I	DC_1A_n257A DC_1A_n257I DC_18A_n257A DC_18A_n257I
DC_1A-19A_n257A <sup>2</sup> DC_1A-19A_n257G DC_1A-19A_n257H DC_1A-19A_n257I	DC_1A_n257A DC_1A_n257G DC_1A_n257H DC_1A_n257I DC_19A_n257A
DC_1A-21A_n257A <sup>2</sup> DC_1A-21A_n257G DC_1A-21A_n257H DC_1A-21A_n257I	DC_1A_n257A DC_1A_n257G DC_1A_n257H DC_1A_n257I DC_21A_n257A DC_21A_n257G DC_21A_n257H DC_21A_n257I
DC_1A-41A_n257A DC_1A-41A_n257I	DC_1A_n257A DC_1A_n257I DC_41A_n257A DC_41A_n257I
DC_1A-42A_n257A DC_1A-42A_n257G DC_1A-42A_n257H DC_1A-42A_n257I DC_1A-42C_n257A DC_1A-42D_n257A DC_1A-42D_n257G DC_1A-42D_n257H DC_1A-42D_n257I DC_1A-42E_n257A DC_1A-42E_n257G DC_1A-42E_n257H DC_1A-42E_n257I	DC_1A_n257A DC_1A_n257G DC_1A_n257H DC_1A_n257I DC_42A_n257A
DC_2A-5A_n257A <sup>2</sup>	DC_2A_n257A DC_5A_n257A
DC_2A-5A_n260A DC_2A-5A_n260G DC_2A-5A_n260H DC_2A-5A_n260I DC_2A-5A_n260J DC_2A-5A_n260K DC_2A-5A_n260L DC_2A-5A_n260M	DC_2A_n260A DC_5A_n260A
DC_2A-5A_n261A DC_2A-5A_n261G DC_2A-5A_n261H DC_2A-5A_n261I DC_2A-5A_n261J DC_2A-5A_n261K DC_2A-5A_n261L DC_2A-5A_n261M	DC_2A_n261A DC_5A_n261A DC_2A_n261G DC_5A_n261G DC_2A_n261H DC_5A_n261H DC_2A_n261I DC_5A_n261I
DC_2A-13A_n260A <sup>2</sup>	DC_2A_n260A DC_13A_n260A

EN-DC configuration	Uplink EN-DC configuration (NOTE 1)
DC_2A-13A_n261A DC_2A-13A_n261G DC_2A-13A_n261H DC_2A-13A_n261I DC_2A-13A_n261J DC_2A-13A_n261K DC_2A-13A_n261L DC_2A-13A_n261M	DC_2A_n261A DC_13A_n261A DC_2A_n261G DC_13A_n261G DC_2A_n261H DC_13A_n261H
DC_2A-13A_n261(2A) DC_2A-13A_n261(2G) DC_2A-13A_n261(2H) DC_2A-13A_n261(3A)	DC_2A_n261A DC_13A_n261A DC_2A_n261G DC_13A_n261G DC_2A_n261H DC_13A_n261H
DC_2A-13A_n261(A-G) DC_2A-13A_n261(A-2G) DC_2A-13A_n261(A-H) DC_2A-13A_n261(A-I) DC_2A-13A_n261(G-H) DC_2A-13A_n261(G-I) DC_2A-13A_n261(H-I) DC_2A-13A_n261(2A-G) DC_2A-13A_n261(2A-H) DC_2A-13A_n261(2A-I)	DC_2A_n261A DC_13A_n261A DC_2A_n261G DC_13A_n261G DC_2A_n261H DC_13A_n261H
DC_2A-13A_n261(A-G-H) DC_2A-13A_n261(A-G-I)	DC_2A_n261A DC_13A_n261A DC_2A_n261G DC_13A_n261G DC_2A_n261H DC_13A_n261H
DC_2A-14A_n260A DC_2A-14A_n260G DC_2A-14A_n260H DC_2A-14A_n260I	DC_2A_n260A DC_2A_n260G DC_2A_n260H DC_2A_n260I DC_14A_n260A DC_14A_n260G DC_14A_n260H DC_14A_n260I
DC_2A-2A-14A_n260A DC_2A-2A-14A_n260G DC_2A-2A-14A_n260H DC_2A-2A-14A_n260I	DC_2A_n260A DC_2A_n260G DC_2A_n260H DC_2A_n260I DC_14A_n260A DC_14A_n260G DC_14A_n260H DC_14A_n260I
DC_2A-30A_n260A DC_2A-30A_n260G DC_2A-30A_n260H DC_2A-30A_n260I DC_2A-30A_n260J DC_2A-30A_n260K DC_2A-30A_n260L DC_2A-30A_n260M	DC_2A_n260A DC_30A_n260A
DC_2A-66A_n257A <sup>2</sup>	DC_2A_n257A DC_66A_n257A
DC_2A-66A_n260A DC_2A-66A_n260G DC_2A-66A_n260H DC_2A-66A_n260I DC_2A-66A_n260J DC_2A-66A_n260K DC_2A-66A_n260L DC_2A-66A_n260M	DC_2A_n260A DC_66A_n260A DC_2A_n260G DC_66A_n260G DC_2A_n260H DC_66A_n260H DC_2A_n260I DC_66A_n260I

EN-DC configuration	Uplink EN-DC configuration (NOTE 1)
DC_3A-18A_n257A DC_3A-18A_n257I	DC_3A_n257A DC_3A_n257I DC_18A_n257A DC_18A_n257I
DC_3A-19A_n257A <sup>2</sup> DC_3A-19A_n257D <sup>2</sup> DC_3A-19A_n257G DC_3A-19A_n257H DC_3A-19A_n257I	DC_3A_n257A DC_3A_n257D DC_3A_n257G DC_3A_n257H DC_3A_n257I DC_19A_n257A DC_19A_n257D
DC_3A-21A_n257A <sup>2</sup> DC_3A-21A_n257D <sup>2</sup> DC_3A-21A_n257G DC_3A-21A_n257H DC_3A-21A_n257I	DC_3A_n257A DC_3A_n257D DC_3A_n257G DC_3A_n257H DC_3A_n257I DC_21A_n257A DC_21A_n257D
DC_3A-41A_n257A DC_3A-41A_n257I	DC_3A_n257A DC_3A_n257I DC_41A_n257A DC_41A_n257I
DC_3A-42A_n257A <sup>2</sup> DC_3A-42A_n257D <sup>2</sup> DC_3A-42A_n257G DC_3A-42A_n257H DC_3A-42A_n257I DC_3A-42C_n257A <sup>2</sup> DC_3A-42C_n257D <sup>2</sup> DC_3A-42C_n257G DC_3A-42C_n257H DC_3A-42C_n257I DC_3A-42D_n257A <sup>2</sup> DC_3A-42D_n257G DC_3A-42D_n257H DC_3A-42D_n257I DC_3A-42E_n257A <sup>2</sup> DC_3A-42E_n257G DC_3A-42E_n257H DC_3A-42E_n257I	DC_3A_n257A DC_3A_n257D DC_3A_n257G DC_3A_n257H DC_3A_n257I DC_42A_n257A DC_42A_n257D
DC_5A-7A_n257A <sup>2</sup>	DC_5A_n257A DC_7A_n257A
DC_5A-30A_n260A DC_5A-30A_n260G DC_5A-30A_n260H DC_5A-30A_n260I DC_5A-30A_n260J DC_5A-30A_n260K DC_5A-30A_n260L DC_5A-30A_n260M	DC_5A_n260A DC_30A_n260A
DC_5A-66A_n257A	DC_5A_n257A DC_66A_n257A
DC_5A-66A_n260A DC_5A-66A_n260G DC_5A-66A_n260H DC_5A-66A_n260I DC_5A-66A_n260J DC_5A-66A_n260K DC_5A-66A_n260L DC_5A-66A_n260M	DC_5A_n260A DC_66A_n260A

EN-DC configuration	Uplink EN-DC configuration (NOTE 1)
DC_12A-30A_n260A DC_12A-30A_n260G DC_12A-30A_n260H DC_12A-30A_n260I DC_12A-30A_n260J DC_12A-30A_n260K DC_12A-30A_n260L DC_12A-30A_n260M	DC_12A_n260A DC_30A_n260A
DC_12A-66A_n260A DC_12A-66A_n260G DC_12A-66A_n260H DC_12A-66A_n260I DC_12A-66A_n260J DC_12A-66A_n260K DC_12A-66A_n260L DC_12A-66A_n260M	DC_12A_n260A DC_66A_n260A
DC_13A-66A_n260A <sup>2</sup>	DC_13A_n260A DC_66A_n260A
DC_14A-30A_n260A DC_14A-30A_n260G DC_14A-30A_n260H DC_14A-30A_n260I	DC_14A_n260A DC_14A_n260G DC_14A_n260H DC_30A_n260A DC_30A_n260G DC_30A_n260H DC_30A_n260I
DC_14A-66A_n260A DC_14A-66A_n260G DC_14A-66A_n260H DC_14A-66A_n260I	DC_14A_n260A DC_14A_n260G DC_14A_n260H DC_14A_n260I DC_66A_n260A DC_66A_n260G DC_66A_n260H DC_66A_n260I
DC_14A-66A-66A_n260A DC_14A-66A-66A_n260G DC_14A-66A-66A_n260H DC_14A-66A-66A_n260I	DC_14A_n260A DC_14A_n260G DC_14A_n260H DC_14A_n260I DC_66A_n260A DC_66A_n260G DC_66A_n260H DC_66A_n260I
DC_19A-21A_n257A <sup>2</sup> DC_19A-21A_n257D <sup>2</sup> DC_19A-21A_n257G DC_19A-21A_n257H DC_19A-21A_n257I	DC_19A_n257A DC_19A_n257D DC_21A_n257A DC_21A_n257D DC_21A_n257G
DC_19A-42A_n257A <sup>2</sup> DC_19A-42A_n257D <sup>2</sup> DC_19A-42A_n257G <sup>2</sup> DC_19A-42A_n257H <sup>2</sup> DC_19A-42A_n257I <sup>2</sup> DC_19A-42C_n257A <sup>2</sup> DC_19A-42C_n257G <sup>2</sup> DC_19A-42C_n257H <sup>2</sup> DC_19A-42C_n257I <sup>2</sup>	DC_19A_n257A DC_19A_n257D DC_19A_n257G DC_19A_n257H DC_19A_n257I DC_42A_n257A DC_42A_n257D DC_42A_n257G DC_42A_n257H DC_42A_n257I

EN-DC configuration	Uplink EN-DC configuration (NOTE 1)
DC_21A-42A_n257A <sup>2</sup> DC_21A-42A_n257D <sup>2</sup> DC_21A-42A_n257G DC_21A-42A_n257H DC_21A-42A_n257I DC_21A-42C_n257A <sup>2</sup> DC_21A-42C_n257G DC_21A-42C_n257H DC_21A-42C_n257I	DC_21A_n257A DC_21A_n257D DC_21A_n257G DC_21A_n257H DC_21A_n257I DC_42A_n257A DC_42A_n257D
DC_28A-42A_n257A <sup>2</sup>	DC_28A_n257A DC_42A_n257A
DC_30A-66A_n260A DC_30A-66A_n260G DC_30A-66A_n260H DC_30A-66A_n260I DC_30A-66A_n260J DC_30A-66A_n260K DC_30A-66A_n260L DC_30A-66A_n260M	DC_30A_n260A DC_66A_n260A
DC_41A-42A_n257A	DC_41A_n257A DC_42A_n257A
NOTE 1: Uplink EN-DC configurations are the configurations supported by the present release of specifications.	
NOTE 2: Applicable for UE supporting inter-band EN-DC with mandatory simultaneous Rx/Tx capability for all of the above combinations.	



5.5B.5.3 Inter-band EN-DC configurations including FR2 (four bands)

**Table 5.5B.5.3-1: Inter-band EN-DC configurations including FR2 (four bands)**

EN-DC configuration	Uplink EN-DC configuration (NOTE 1)
DC_1A-3A-18A_n257A DC_1A-3A-18A_n257I	DC_1A_n257A DC_1A_n257I DC_3A_n257A DC_3A_n257I DC_18A_n257A DC_18A_n257I
DC_1A-3A-19A_n257A <sup>2</sup> DC_1A-3A-19A_n257G DC_1A-3A-19A_n257H DC_1A-3A-19A_n257I	DC_1A_n257A DC_3A_n257A DC_3A_n257G DC_3A_n257H DC_3A_n257I DC_19A_n257A
DC_1A-3A-21A_n257A <sup>2</sup> DC_1A-3A-21A_n257G DC_1A-3A-21A_n257H DC_1A-3A-21A_n257I	DC_1A_n257A DC_3A_n257A DC_3A_n257G DC_3A_n257H DC_3A_n257I DC_21A_n257A
DC_1A-3A-41A_n257A DC_1A-3A-41A_n257I	DC_1A_n257A DC_1A_n257I DC_3A_n257A DC_3A_n257I DC_41A_n257A DC_41A_n257I
DC_1A-3A-42A_n257A DC_1A-3A-42A_n257G DC_1A-3A-42A_n257H DC_1A-3A-42A_n257I DC_1A-3A-42C_n257A DC_1A-3A-42C_n257G DC_1A-3A-42C_n257H DC_1A-3A-42C_n257I DC_1A-3A-42D_n257G DC_1A-3A-42D_n257H DC_1A-3A-42D_n257I	DC_1A_n257A DC_1A_n257G DC_1A_n257H DC_1A_n257I DC_3A_n257A DC_3A_n257G DC_3A_n257H DC_3A_n257I
DC_1A-19A-21A_n257G DC_1A-19A-21A_n257H DC_1A-19A-21A_n257I	DC_1A_n257G DC_1A_n257H DC_1A_n257I DC_21A_n257G DC_21A_n257H DC_21A_n257I

EN-DC configuration	Uplink EN-DC configuration (NOTE 1)
DC_1A-19A-42A_n257A DC_1A-19A-42A_n257G DC_1A-19A-42A_n257H DC_1A-19A-42A_n257I DC_1A-19A-42C_n257A DC_1A-19A-42C_n257G DC_1A-19A-42C_n257H DC_1A-19A-42C_n257I	DC_1A_n257A DC_1A_n257G DC_1A_n257H DC_1A_n257I DC_19A_n257A DC_42A_n257A
DC_1A-21A-42A_n257A DC_1A-21A-42A_n257G DC_1A-21A-42A_n257H DC_1A-21A-42A_n257I DC_1A-21A-42C_n257A DC_1A-21A-42C_n257G DC_1A-21A-42C_n257H DC_1A-21A-42C_n257I	DC_1A_n257A DC_1A_n257G DC_1A_n257H DC_1A_n257I DC_21A_n257A DC_21A_n257G DC_21A_n257H DC_21A_n257I DC_42A_n257A DC_42A_n257D
DC_2A-14A-30A_n260A DC_2A-14A-30A_n260G DC_2A-14A-30A_n260H DC_2A-14A-30A_n260I	DC_2A_n260A DC_2A_n260G DC_2A_n260H DC_2A_n260I DC_14A_n260A DC_14A_n260G DC_14A_n260H DC_14A_n260I DC_30A_n260A DC_30A_n260G DC_30A_n260H DC_30A_n260I
DC_2A-14A-66A_n260A DC_2A-14A-66A_n260G DC_2A-14A-66A_n260H DC_2A-14A-66A_n260I	DC_2A_n260A DC_2A_n260G DC_2A_n260H DC_2A_n260I DC_14A_n260A DC_14A_n260G DC_14A_n260H DC_14A_n260I DC_66A_n260A DC_66A_n260G DC_66A_n260H DC_66A_n260I
DC_2A-14A-66A-66A_n260A DC_2A-14A-66A-66A_n260G DC_2A-14A-66A-66A_n260H DC_2A-14A-66A-66A_n260I	DC_2A_n260A DC_2A_n260G DC_2A_n260H DC_2A_n260I DC_14A_n260A DC_14A_n260G DC_14A_n260H DC_14A_n260I DC_66A_n260A DC_66A_n260G DC_66A_n260H DC_66A_n260I
DC_3A-19A-21A_n257A <sup>2</sup>	DC_3A_n257A DC_19A_n257A DC_21A_n257A

EN-DC configuration	Uplink EN-DC configuration (NOTE 1)
<p>DC_3A-19A-42A_n257A                      DC_3A-19A-42A_n257G                      DC_3A-19A-42A_n257H                      DC_3A-19A-42A_n257I                      DC_3A-19A-42C_n257A                      DC_3A-19A-42C_n257D                      DC_3A-19A-42C_n257G                      DC_3A-19A-42C_n257H                      DC_3A-19A-42C_n257I</p>	<p>DC_3A_n257A                      DC_3A_n257D                      DC_3A_n257G                      DC_3A_n257H                      DC_3A_n257I                      DC_19A_n257A                      DC_19A_n257D                      DC_19A_n257G                      DC_19A_n257H                      DC_19A_n257I                      DC_42A_n257A                      DC_42A_n257D                      DC_42A_n257G                      DC_42A_n257H                      DC_42A_n257I</p>
<p>DC_3A-21A-42A_n257A                      DC_3A-21A-42A_n257G                      DC_3A-21A-42A_n257H                      DC_3A-21A-42A_n257I                      DC_3A-21A-42C_n257A                      DC_3A-21A-42C_n257D                      DC_3A-21A-42C_n257G                      DC_3A-21A-42C_n257H                      DC_3A-21A-42C_n257I</p>	<p>DC_3A_n257A                      DC_3A_n257D                      DC_3A_n257G                      DC_3A_n257H                      DC_3A_n257I                      DC_21A_n257A                      DC_21A_n257D                      DC_21A_n257G                      DC_21A_n257H                      DC_21A_n257I                      DC_42A_n257A                      DC_42A_n257D                      DC_42A_n257G                      DC_42A_n257H                      DC_42A_n257I</p>
<p>DC_14A-30A-66A_n260A                      DC_14A-30A-66A_n260G                      DC_14A-30A-66A_n260H                      DC_14A-30A-66A_n260I</p>	<p>DC_14A_n260A                      DC_14A_n260G                      DC_14A_n260H                      DC_14A_n260I                      DC_30A_n260A                      DC_30A_n260G                      DC_30A_n260H                      DC_30A_n260I                      DC_66A_n260A                      DC_66A_n260G                      DC_66A_n260H                      DC_66A_n260I</p>
<p>DC_14A-30A-66A-66A_n260A                      DC_14A-30A-66A-66A_n260G                      DC_14A-30A-66A-66A_n260H                      DC_14A-30A-66A-66A_n260I</p>	<p>DC_14A_n260A                      DC_14A_n260G                      DC_14A_n260H                      DC_14A_n260I                      DC_30A_n260A                      DC_30A_n260G                      DC_30A_n260H                      DC_30A_n260I                      DC_66A_n260A                      DC_66A_n260G                      DC_66A_n260H                      DC_66A_n260I</p>

EN-DC configuration	Uplink EN-DC configuration (NOTE 1)
DC_19A-21A-42A_n257A <sup>2</sup> DC_19A-21A-42A_n257G <sup>2</sup> DC_19A-21A-42A_n257H <sup>2</sup> DC_19A-21A-42A_n257I <sup>2</sup> DC_19A-21A-42C_n257A <sup>2</sup> DC_19A-21A-42C_n257D <sup>2</sup> DC_19A-21A-42C_n257G <sup>2</sup> DC_19A-21A-42C_n257H <sup>2</sup> DC_19A-21A-42C_n257I <sup>2</sup>	DC_19A_n257A DC_19A_n257D DC_19A_n257G DC_19A_n257H DC_19A_n257I DC_21A_n257A DC_21A_n257D DC_21A_n257G DC_21A_n257H DC_21A_n257I DC_42A_n257A DC_42A_n257D DC_42A_n257G DC_42A_n257H DC_42A_n257I
NOTE 1: Uplink EN-DC configurations are the configurations supported by the present release of specifications.	
NOTE 2: Applicable for UE supporting inter-band EN-DC with mandatory simultaneous Rx/Tx capability for all of the above combinations.	

## 5.5B.5.4 Inter-band EN-DC configurations including FR2 (five bands)

Table 5.5B.5.4-1: Inter-band EN-DC configurations including FR2 (five bands)

EN-DC configuration	Uplink EN-DC configuration (NOTE 1)
DC_1A-3A-19A-42A_n257A DC_1A-3A-19A-42A_n257G DC_1A-3A-19A-42A_n257H DC_1A-3A-19A-42A_n257I DC_1A-3A-19A-42C_n257A DC_1A-3A-19A-42C_n257G DC_1A-3A-19A-42C_n257H DC_1A-3A-19A-42C_n257I	DC_1A_n257A DC_3A_n257A DC_3A_n257G DC_3A_n257H DC_3A_n257I DC_19A_n257A DC_42A_n257A
DC_1A-3A-21A-42A_n257A DC_1A-3A-21A-42C_n257A DC_1A-3A-21A-42C_n257G DC_1A-3A-21A-42C_n257H DC_1A-3A-21A-42C_n257I	DC_1A_n257A DC_3A_n257A DC_3A_n257G DC_3A_n257H DC_3A_n257I DC_3A_n257J DC_21A_n257A DC_42A_n257A
DC_1A-19A-21A-42A_n257A DC_1A-19A-21A-42A_n257G DC_1A-19A-21A-42A_n257H DC_1A-19A-21A-42A_n257I DC_1A-19A-21A-42C_n257A DC_1A-19A-21A-42C_n257G DC_1A-19A-21A-42C_n257H DC_1A-19A-21A-42C_n257I	DC_1A_n257A DC_1A_n257G DC_1A_n257H DC_1A_n257I DC_19A_n257A DC_21A_n257A DC_21A_n257G DC_21A_n257H DC_21A_n257I DC_42A_n257A
DC_2A-14A-30A-66A_n260A DC_2A-14A-30A-66A_n260G DC_2A-14A-30A-66A_n260H DC_2A-14A-30A-66A_n260I	DC_2A_n260A DC_2A_n260G DC_2A_n260H DC_2A_n260I DC_14A_n260A DC_14A_n260G DC_14A_n260H DC_14A_n260I DC_30A_n260A DC_30A_n260G DC_30A_n260H DC_30A_n260I DC_66A_n260A DC_66A_n260G DC_66A_n260H DC_66A_n260I
NOTE 1: Uplink EN-DC configurations are the configurations supported by the present release of specifications.	

## 5.5B.5.5 Void

## 5.5B.6 Inter-band EN-DC including FR1 and FR2

Supported channel bandwidths for E-UTRA operating bands and CA configurations are defined in TS 36.521-1 [10] and for NR operating bands and CA configurations in TS 38.521-1 [8], TS 38.521-2 [9] and present document.

### 5.5B.6.1 Void

### 5.5B.6.2 Inter-band EN-DC configurations including FR1 and FR2 (three bands)

#### **Table 5.5B.6.2-1: Inter-band EN-DC configurations including FR1 and FR2 (three bands)**

*Editor's note: No Inter-band EN-DC configurations including FR1 and FR2 (three bands) specified due to the testability issues that combined testing of NR FR1 in conducted mode and NR FR2 in radiated mode.*

### 5.5B.6.3 Inter-band EN-DC configurations including FR1 and FR2 (four bands)

#### **Table 5.5B.6.3-1: Inter-band EN-DC configurations including FR1 and FR2 (four bands)**

*Editor's note: No Inter-band EN-DC configurations including FR1 and FR2 (four bands) specified due to the testability issues that combined testing of NR FR1 in conducted mode and NR FR2 in radiated mode.*

### 5.5B.6.4 Inter-band EN-DC configurations including FR1 and FR2 (five bands)

#### **Table 5.5B.6.4-1: Inter-band EN-DC configurations including FR1 and FR2 (five bands)**

*Editor's note: No Inter-band EN-DC configurations including FR1 and FR2 (five bands) specified due to the testability issues that combined testing of NR FR1 in conducted mode and NR FR2 in radiated mode.*

### 5.5B.6.5 Inter-band EN-DC configurations including FR1 and FR2 (six bands)

#### **Table 5.5B.6.5-1: Inter-band EN-DC configurations including FR1 and FR2 (six bands)**

*Editor's note: No Inter-band EN-DC configurations including FR1 and FR2 (six bands) specified due to the testability issues that combined testing of NR FR1 in conducted mode and NR FR2 in radiated mode.*

## 5.5B.7 Inter-band NR-DC between FR1 and FR2

Supported channel bandwidths for E-UTRA operating bands and CA configurations are defined in TS 36.521-1 [10] and for NR operating bands and CA configurations in TS 38.521-1 [8], TS 38.521-2 [9] and present document.

### 5.5B.7.0 General

The configurations and bandwidth combination sets for the FR1-FR2 NR-DC combinations in the following sub-section are defined in the tables for FR1-FR2 carrier aggregation in section 5.5A.1.

### 5.5B.7.1 Inter-band NR-DC configurations between FR1 and FR2 (two bands)

#### **Table 5.5B.7-1: Inter-band NR-DC configurations between FR1 and FR2 (two bands)**

*Editor's note: No Inter-band NR-DC configurations between FR1 and FR2 (two bands) specified due to the testability issues that combined testing of NR FR1 in conducted mode and NR FR2 in radiated mode.*

## 5.5E Configuration for V2X operation

### 5.5E.1 General

The operating bands and bandwidth classes are specified for V2X operation.

## 5.5E.2 Intra-band contiguous V2X operation in FR1

**Table 5.5E.2-1: Intra-band contiguous V2X configurations**

V2X configuration	SL transmission
V2X_(n)47AA	E-UTRA Band 47 or NR band n47
NOTE 1: Only single switched SL is supported.	

## 5.5E.3 Intra-band non-contiguous V2X operation in FR1

**Table 5.5E.3-1: Intra-band non-contiguous V2X configurations**

V2X configuration	SL transmission
V2X_47A_n47A	E-UTRA Band 47 or NR band n47
NOTE 1: Only single switched SL is supported.	

## 5.5E.4 Inter-band V2X operation in FR1

### 5.5E.4.1 Inter-band V2X configurations within FR1 (two bands)

**Table 5.5E.4.1-1: Inter-band V2X configurations**

V2X configuration	V2X transmission configuration
V2X_n71A_47A	V2X_n71A_47A
NOTE 1: V2X transmission configurations are the configurations supported by the present release of specifications.	

# 6 Transmitter characteristics

## 6.1 General

**Editor's note: Test configurations/environments that require new spherical scan shall be included in test procedure clause and identifying such scenarios is currently FFS and owned by RAN5.**

Unless otherwise stated the transmitter, characteristics are specified at the antenna connector(s) of the UE for the bands operating on frequency range 1 and over the air of the UE for the bands operating on frequency range 2. The requirements for frequency range 1 and frequency range 2 can be verified separately. For the carrier in frequency range 1, requirements can be verified with NR FR2 link disabled. For the carrier in frequency range 2, requirements can be verified in OTA mode with E-UTRA connecting to the network by OTA without calibration.

For NR FR2 Tx test cases the identified beam peak direction can be stored and reused for a device under test in various configurations/environments for the full duration of device testing as long as beam peak direction is the same.

Unless otherwise stated, requirements for NR transmitter written in TS 38.521-1 [8] and TS 38.521-2 [9] apply and are assumed anchor agnostic. Requirements are verified under conditions where anchor resources do not interfere NR operation. For Rel-15, unless otherwise stated, if UE indicates IE `maxNumberSRS-Ports-PerResource = n2` in NR standalone operation mode, the said UE shall meet the NR requirements for either power class 2 or power class 3 in EN-DC within FR1 if UE indicates IE `maxNumberSRS-Ports-PerResource = n1` for EN-DC on this NR band. For Rel-16 and forward, if UE indicates IE `powerClassNRPart-r16` as defined in TS 38.331 [18] in EN-DC, UE shall meet NR requirements according to this power class.

Unless otherwise stated, Channel Bandwidth shall be prioritized in the selecting of test points. Subcarrier spacing shall be selected after Test Channel Bandwidth is selected.

For conformance testing involving FR2 test cases in this specification, the UE under test shall be pre-configured with UL Tx diversity schemes disabled to account for single polarization System Simulator (SS) in the test environment. The UE under test may transmit with dual polarization.

Uplink RB allocations for NR FR1 carrier given in TS 38.521-1 [8] Table 6.1-1 are used throughout this clause, unless otherwise stated by the test case.

Uplink RB allocations for NR FR2 carrier given in TS 38.521-2 [9] Table 6.1-1 are used throughout this clause, unless otherwise stated by the test case.

Uplink RB allocations for E-UTRA carrier and E-UTRA intra-band contiguous CA (2CC) given in Table 6.1-1 and Table 6.1-2 respectively are used throughout this clause, unless otherwise stated by the test case.

**Table 6.1-1: Common uplink configuration for E-UTRA carrier**

Channel Bandwidth	RB allocation			
	Full_Allocation	Partial_Allocation	1RB_Left	1RB_Right
1.4MHz	6@0	5@0	1@0	1@5
3MHz	15@0	4@0	1@0	1@14
5MHz	25@0	8@0	1@0	1@24
10MHz	50@0	12@0	1@0	1@49
15MHz	75@0	16@0	1@0	1@74
20MHz	100@0	18@0	1@0	1@99
NOTE: Partial_Allocation corresponds to the test points with 0dB MPR <sub>single,E-UTRA</sub> for QPSK modulation type included in TS 36.521-1 Table 6.2.2.4.1-1.				

**Table 6.1-2 Common uplink RB allocation for E-UTRA intra-band contiguous CA (2CC)**

Smallest Component Carrier Transmission Bandwidth	PCC & SCC RB allocation					
	Partial_Allocation		1RB_Left		1RB_Right	
	PCC	SCC	PCC	SCC	PCC	SCC
5MHz	P_8@0	S_0@0	P_1@0	S_0@0	P_1@RBmax	S_0@0
10MHz	P_12@0	S_0@0	P_1@0	S_0@0	P_1@RBmax	S_0@0
15MHz	P_16@0	S_0@0	P_1@0	S_0@0	P_1@RBmax	S_0@0
20MHz	P_18@0	S_0@0	P_1@0	S_0@0	P_1@RBmax	S_0@0
NOTE: Partial_Allocation corresponds to the test points with 0dB MPR <sub>E-UTRA, CA</sub> for QPSK modulation type included in TS 36.521-1 Table 6.2.2.4.1-1.						



## 6.2 Transmitter power

### 6.2A Transmitter power for CA without EN-DC

#### 6.2A.1 UE maximum output power for CA

##### 6.2A.1.1 UE maximum output power for inter-band NR CA between FR 1 and FR 2 without EN-DC

###### 6.2A.1.1.1 Test purpose

Same test purpose as in clause 6.2.1 in TS 38.521-1 [8] for NR/5GC FR1 carrier(s) and clause 6.2.1 in TS 38.521-2 [9] for NR/5GC FR2 carrier(s).

###### 6.2A.1.1.2 Test applicability

The requirements in this test are not testable due to issues with combined testing of NR/5GC FR1 conducted mode with NR/5GC FR2 in radiated mode. Therefore, the conducted and radiated requirements are tested separately.

No test case details are specified. The NR/5GC requirements for maximum output power apply and are tested in TS 38.521-1 [8] clauses 6.2 and 6.2A and TS 38.521-2 [9] clauses 6.2 and 6.2A.

#### 6.2A.2 UE maximum output power reduction for CA

##### 6.2A.2.1 UE maximum output power reduction for inter-band NR CA between FR 1 and FR 2 without EN-DC

###### 6.2A.2.1.1 Test purpose

Same test purpose as in clause 6.2.2 in TS 38.521-1 [8] for NR FR1 carrier(s) and clause 6.2.2 in TS 38.521-2 [9] for NR FR2 carrier(s).

###### 6.2A.2.1.2 Test applicability

The requirements in this test are not testable due to issues with combined testing of NR FR1 conducted mode with NR FR2 in radiated mode. Therefore, the conducted and radiated requirements are tested separately.

No test case details are specified. The SA requirements for additional spectrum emissions mask apply and are tested in TS 38.521-1 [8] clauses 6.2 and 6.2A and TS 38.521-2 [9] clauses 6.2 and 6.2A.

#### 6.2A.3 UE additional maximum output power reduction for CA

##### 6.2A.3.1 UE additional maximum output power reduction for inter-band NR CA between FR 1 and FR 2 without EN-DC

###### 6.2A.3.1.1 Test purpose

Same test purpose as in clause 6.2.3.1 in TS 38.521-1 [8] for NR FR1 carrier and clause 6.2.3.1 in TS 38.521-2 [9] for NR FR2 carrier.

###### 6.2A.3.1.2 Test applicability

The requirements in this test are not testable due to issues with combined testing of NR FR1 and E-UTRA in conducted mode with NR FR2 in radiated mode. Therefore, the conducted and radiated requirements are tested separately.

No test case details are specified. The single carrier requirements for Additional Maximum Output Power apply and are tested as part of clause 6.2.3 in TS 38.521-1 [8] for NR FR1 carrier and clause 6.2.3 in TS 38.521-2 [9] for NR FR2 carrier.

## 6.2A.4 Configured output power level for CA

### 6.2A.4.1 Configured output power level for inter-band NR CA between FR 1 and FR 2 without EN-DC

#### 6.2A.4.1.1 Test purpose

Same test purpose as in clause 6.2.4 in TS 38.521-1 [8] for NR FR1 carrier(s) and clause 6.2.4 in TS 38.521-2 [9] for NR FR2 carrier(s).

#### 6.2A.4.1.2 Test applicability

The requirements in this test are not testable due to issues with combined testing of NR FR1 conducted mode with NR FR2 in radiated mode. Therefore, the conducted and radiated requirements are tested separately.

No test case details are specified. The NR/5GC requirements for configured output power level apply and are tested in TS 38.521-1 [8] clauses 6.2 and 6.2A and TS 38.521-2 [9] clauses 6.2 and 6.2A.

### 6.2A.4.2 $\Delta T_{IB,c}$ for CA

#### 6.2A.4.2.1 $\Delta T_{IB,c}$ for inter-band CA between FR 1 and FR 2

For the UE which supports inter-band NR CA configuration,  $\Delta T_{IB,c}$  in Table 6.2A.4.2.1-1 applies. Unless otherwise stated,  $\Delta T_{IB,c}$  is set to zero.

**Table 6.2A.4.2.1-1: Void**

## 6.2B Transmitter power for DC

### 6.2B.1 UE Maximum Output Power for DC

#### 6.2B.1.1 UE Maximum Output Power for Intra-Band Contiguous EN-DC

**Editor's note:**

- For overlapping transmission there is no test point satisfying 0dB MPR according to RAN4 specification.

#### 6.2B.1.1.1 Test purpose

To verify that the error of the UE maximum output power does not exceed the range prescribed by the specified nominal maximum output power and tolerance.

An excess maximum output power has the possibility to interfere to other channels or other systems. A small maximum output power decreases the coverage area.

#### 6.2B.1.1.2 Test applicability

This test applies to all types of E-UTRA UE release 15 and forward, supporting intra-band contiguous EN-DC operation on FR1.

## 6.2B.1.1.3 Minimum conformance requirements

The following UE Power Classes define the total maximum output power for any transmission bandwidth(s) of the CG(s) configured.

The maximum output power is measured as the total maximum output power across the UE antenna connector(s). The period of measurement shall be at least one sub frame.

**Table 6.2B.1.1.3-1: Maximum output power for EN-DC (continuous sub-blocks)**

DC configuration	Power class 2 (dBm)	Tolerance (dB)	Power class 3 (dBm)	Tolerance (dB)
DC_(n)71AA			23	+2/-3
DC_(n)41AA	26	+2/-3 <sup>1</sup>	23	+2/-3 <sup>1</sup>
NOTE 1: An uplink EN-DC configuration in which the band has NOTE 3 in Table 6.2.1-1 in TS 38.101-1 or NOTE 2 in Table 6.2.2-1 in TS 36.101 is allowed to reduce the lower tolerance limit by 1.5 dB when the transmission bandwidths of at least one of the bands are confined within $F_{UL\_low}$ and $F_{UL\_low} + 4$ MHz or $F_{UL\_high} - 4$ MHz and $F_{UL\_high}$ .				
NOTE 2: Power Class 3 is the default power class unless otherwise stated.				

If UE supports a different power class than the default UE power class for EN-DC band combination, and the supported power class enables higher maximum output power than that of the default power class:

- if the E-UTRA UL/DL configuration is 0 or 6; or
- if the E-UTRA UL/DL configuration is 1 and special subframe configuration is 0 or 5; or
- if the IE *p-maxUE-FR1-r15* as defined in TS 36.331 [17] is provided and set to the maximum output power of the default power class or lower;
  - apply all requirements for the default power class, and set the configured transmitted power as specified in clause 6.2B.4;
- else
  - apply all requirements for the supported power class, and set the configured transmitted power class as specified in subclause 6.2B.4;

The normative reference for this requirement is TS 38.101-3 [4] clause 6.2B.1.

LTE anchor agnostic approach is not applied. E-UTRA test point analysis is included and E-UTRA measurements are performed.

## 6.2B.1.1.4 Test description

## 6.2B.1.1.4.1 Initial condition

Initial conditions are a set of test configurations the UE needs to be tested in and the steps for the SS to take with the UE to reach the correct measurement state.

The initial test configurations consist of environmental conditions, test frequencies and channel bandwidths based on EN-DC operating bands specified in clause 5.3B.1.2, channel bandwidths and sub-carrier spacings for the NR cell specified in TS 38.521-1 [8] clause 5.3 and channel bandwidth for the E-UTRA cell are specified in TS 36.521-1 [10] clause 5.4.2. All of these configurations shall be tested with applicable test parameters for each EN-DC configuration specified in clause 5.3B.1.2, and are shown in table 6.2B.1.1.4.1-1. The details of the uplink reference measurement channels (RMCs) are specified in Annex A, clause A.2.2 for E-UTRA RMC for TDD, TS 36.521-1 [10] Annex A, clause A.2.2 for E-UTRA RMC for FDD, and TS 38.521-1 [8] Annex A, clause A.2 for NR RMC. Configurations of PDSCH and PDCCH before measurement are specified in TS 36.521-1 [10] Annex C, clause C.2 and in TS 38.521-1 [8] Annex C, clause C.2 for E-UTRA CG and NR CG respectively.

**Table 6.2B.1.1.4.1-1: Test configuration table for Intra-Band Contiguous EN-DC**

Initial Conditions					
Test Environment as specified in TS 38.508-1 [5] clause 4.1		Normal, TL/VL, TL/VH, TH/VL, TH/VH			
NR Test Frequencies as specified in TS 38.508-1 [5] clause 4.3.1 E-UTRA Test Frequencies as specified in TS 36.508-1 [11] clause 4.3.1		Mid range			
Test EN-DC bandwidth combination as specified in TS 38.508-1 [5] clause 4.3.1		Highest $N_{RB\_agg}$			
NR Test SCS as specified in Table 5.3.5-1 in TS 38.521-1 [8]		Highest (NOTE 3)			
NR/E-UTRA Test Parameters					
Test ID	Downlink Configuration	EN-DC Uplink Configuration			
		E-UTRA Cell		NR Cell	
		Modulation	RB allocation (NOTE 2)	Modulation	RB allocation (NOTE 1)
1	N/A	QPSK	Partial_Allocation	N/A	N/A
2	N/A	QPSK	1RB_Left	N/A	N/A
3	N/A	N/A	N/A	DFT-s-OFDM QPSK	Inner Full
4	N/A	N/A	N/A	DFT-s-OFDM QPSK	Inner_1RB_LEFT
NOTE 1: The specific configuration of each RB allocation is defined in Table 6.1-1 in TS 38.521-1 [8].					
NOTE 2: The specific configuration of each RB allocation is defined in Table 6.1-1 in current specification.					
NOTE 3: For DC_(n)71AA, only NR SCS of 15 kHz is tested.					

**Table 6.2B.1.1.4.1-2: Void**

1. Connect the SS to the UE antenna connectors as shown in TS 38.508-1 [6] clause A.3.1.1 for SS diagram and clause A.3.2.1 for UE diagram.
2. The parameter settings for the E-UTRA cell are set up according to TS 36.508 [11] clause 4.4.3, and the parameter settings for the NR cell are set up according to TS 38.508-1 [6] clause 4.4.3.
3. Downlink signals are initially set up according to TS 36.521-1 [10] Annex C, clause C.0 and TS 38.521-1 [8] Annex C, clause C.0 for E-UTRA CG and NR CG respectively, and uplink signals according to TS 36.521-1 [10] Annex H and TS 38.521-1 [8] Annex G for E-UTRA CG and NR CG respectively.
4. The UL Reference Measurement channels are set for E-UTRA CG and NR CG respectively.
5. Propagation conditions are set according to TS 36.521-1 [10] Annex B.0 and TS 38.521-1 [8] Annex B, clause B.0 for E-UTRA CG and NR CG respectively.
6. Ensure the UE is in state RRC\_CONNECTED with generic procedure parameters Connectivity EN-DC, DC bearer MCG and SCG, Connected without release *On* according to TS 38.508-1 [6] clause 4.5. Message contents are defined in clause 6.2B.1.1.4.3.
7. When E-UTRA and NR bands are TDD, ensure the same uplink-downlink configuration by giving SCG a delay of 3 E-UTRA subframes, or by giving MCG a delay of 2 subframes.

#### 6.2B.1.1.4.2 Test procedure

1. SS sends uplink scheduling information for each UL HARQ process via PDCCH DCI format 0 and DCI format 0\_1 for C\_RNTI to schedule the UL RMC according to table 6.2B.1.1.4.1-1 on E-UTRA CC and NR CC respectively. Since the UL has no payload and no loopback data to send, the UE sends uplink MAC padding bits on the UL RMC.

2. Send continuously uplink power control "up" commands to the UE for NR and E-UTRA carrier until the UE transmits at its  $P_{UMAX}$  level; allow at least 200 ms from the first TPC command for the UE to reach  $P_{UMAX}$  level.
3. For a UE supporting dynamic power sharing, measure the mean power over all component carriers. For a UE not supporting dynamic power sharing, measure the power of each component carrier individually. For the tested EN-DC configuration, the requirements described in clause 6.2B.2.1.5 shall be met. The period of the measurement shall be at least the continuous duration of one active sub-frame (1 ms). For TDD slots with transient periods are not under test.
4. For UEs supporting Power Class 2, repeat steps 1~3 on the applicable bands with message exception defined in Table 6.2B.1.1.4.3-5.

6.2B.1.1.4.3 Message contents

Message contents are according to TS 36.508 [11] clause 4.6.1 and TS 38.508-1 [6] clause 4.6.1 with the following exceptions.

**Table 6.2B.1.1.4.3-0: PUSCH-Config**

Derivation Path: TS 38.508-1 [6], Table 4.6.3-118 with condition TRANSFORM_PRECODER_ENABLED
---

**Table 6.2B.1.1.4.3-1: PhysicalCellGroupConfig**

Derivation Path: TS 38.508-1 [6], Table 4.6.3-106			
Information Element	Value/remark	Comment	Condition
p-NR-FR1	23		Power Class 3 UE
	26		Power Class 2 UE

**Table 6.2B.1.1.4.3-2: RRCConnectionReconfiguration: nr-Config-r15**

Derivation Path: TS 36.508 [11], Table 4.6.1-8			
Information Element	Value/remark	Comment	Condition
p-MaxEUTRA-r15	23		Power Class 3 UE
	26		Power Class 2 UE

**Table 6.2B.1.1.4.3-3: RRCConnectionReconfiguration: tdm-PatternConfig if operating on FDD band**

Derivation Path: TS 36.508 [11], Table 4.6.1-8			
Information Element	Value/remark	Comment	Condition
tdm-PatternConfig-r15 ::= CHOICE{ setup ::= SEQUENCE {			Test IDs 7-15
subframeAssignment-r15	sa2	Apply if operating on FDD band for a UE NOT indicating support of dynamicPowerSharing in the <i>UE-MRDC-Capability</i> IE according to TS 38.213 [x] clause 7.6.1	
harq-Offset-r15	0		
}			
}			

**Table 6.2B.1.1.4.3-4: SystemInformationBlockType1: tdd-Config if operating on TDD band**

Derivation Path: TS 36.508 [11], Table 4.6.3-23			
Information Element	Value/remark	Comment	Condition
TDD-Config-DEFAULT ::= SEQUENCE {		Operating on TDD band	
subframeAssignment	sa2		
specialSubframePatterns	ssp7		
}			

**Table 6.2B.1.1.4.3-5: RRCConnectionReconfiguration: p-MaxUE-FR1-r15 (step 4 in 6.2B.1.1.4.2)**

Derivation Path: TS 36.508 [11], Table 4.6.1-8			
Information Element	Value/remark	Comment	Condition
nonCriticalExtension SEQUENCE {		RRCConnectionReconfiguration-v1530-IEs	
p-MaxUE-FR1-r15	23		Power Class 2 UE
}			

### 6.2B.1.1.5 Test requirements

The maximum output power for the DC configuration, derived in step 3 shall be within the range prescribed by the DC UE Power Class and tolerance in Table 6.2B.1.1.5-1 for power class 3 UE and Table 6.2B.1.1.5-2 for power class 2 UE. The corresponding requirements is specified in Table 6.2.2.5-1, 6.2.2\_1.5-1 in TS 36.521-1 [10] or Table 6.2.1.5-1, 6.2.1.5-2 in TS 38.521-1 [8].

The maximum output power for the DC configuration, derived in step 4 shall be within the range prescribed in Table 6.2B.1.1.5-1.

**Table 6.2B.1.1.5-1: Maximum output power for EN-DC (continuous sub-blocks) for power class 3**

DC configuration	Power class2	Tolerance (dB)	Power class 3 (dBm)	Tolerance (dB)
DC_(n)71AA			23	+2+TT/-3-TT
DC_(n)41AA			23	+2+TT/-3 <sup>1</sup> +TT

NOTE 1: It is allowed to reduce the lower tolerance limit by 1.5 dB when the transmission bandwidths of at least one of the bands are confined within  $F_{UL\_low}$  and  $F_{UL\_low} + 4$  MHz or  $F_{UL\_high} - 4$  MHz and  $F_{UL\_high}$ .

NOTE 2: TT for each frequency and channel bandwidth is specified in Table 6.2B.1.1.5-3.

**Table 6.2B.1.1.5-2: Maximum output power for EN-DC (continuous sub-blocks) for Power Class 2 for Rel-15**

DC configuration	Carrier	Power class2	Tolerance (dB)	Condition	Comment
DC_(n)41AA	NR carrier	26	+2+TT/-3 <sup>1</sup> -TT	UE indicates PC2 on NR band	UE meets power class 2 requirements
		23	+2+TT/-3 <sup>1</sup> -TT	UE indicates PC3 on NR band	UE meets power class 3 requirements
	E-UTRA carrier	26	+2+TT/-3 <sup>1</sup> -TT	UE indicates PC2 ON E-UTRA band	UE meets power class 2 requirements
		23	+2+TT/-3 <sup>1</sup> -TT	UE indicates PC3 on E-UTRA band	UE meets power class 3 requirements

NOTE 1: It is allowed to reduce the lower tolerance limit by 1.5 dB when the transmission bandwidths of at least one of the bands are confined within  $F_{UL\_low}$  and  $F_{UL\_low} + 4$  MHz or  $F_{UL\_high} - 4$  MHz and  $F_{UL\_high}$ .

NOTE 2: TT for each frequency and channel bandwidth is specified in Table 6.2B.1.1.5-3

**Table 6.2B.1.1.5-2a: Maximum output power for EN-DC (continuous sub-blocks) for Power Class 2 for Rel-16 and forward**

DC configuration	Carrier	Power class2	Tolerance (dB)	Condition	Comment
DC_(n)41AA	NR carrier	26	+2+TT/-3 <sup>1</sup> -TT	UE reporting (PC2 by $P_{\text{PowerClass,NR}}$ , and PC2 or Not present by <i>powerClassNRPart-r16</i> )	UE meets power class 2 requirements
		23	+2+TT/-3 <sup>1</sup> -TT	UE reporting (PC2 by $P_{\text{PowerClass,NR}}$ , and PC3 by <i>powerClassNRPart-r16</i> ) or UE reporting (PC3 by $P_{\text{PowerClass,NR}}$ )	UE meets power class 3 requirements
	E-UTRA carrier	26	+2+TT/-3 <sup>1</sup> -TT	UE indicates PC2 ON E-UTRA band	UE meets power class 2 requirements
		23	+2+TT/-3 <sup>1</sup> -TT	UE indicates PC3 on E-UTRA band	UE meets power class 3 requirements

NOTE 1: It is allowed to reduce the lower tolerance limit by 1.5 dB when the transmission bandwidths of at least one of the bands are confined within  $F_{\text{UL\_low}}$  and  $F_{\text{UL\_low}} + 4$  MHz or  $F_{\text{UL\_high}} - 4$  MHz and  $F_{\text{UL\_high}}$ .

NOTE 2: TT for each frequency and channel bandwidth is specified in Table 6.2B.1.1.5-3.

**Table 6.2B.1.1.5-3: Test Tolerance (Maximum Output Power for Intra-Band Contiguous EN-DC)**

	$f \leq 3.0\text{GHz}$	$3.0\text{GHz} < f \leq 6\text{GHz}$
$\text{ENBW} \leq 40\text{MHz}$	0.7 dB	1.0 dB
$40\text{MHz} < \text{ENBW} \leq 100\text{MHz}$	1.0 dB	1.0 dB

## 6.2B.1.2 UE Maximum Output Power for Intra-Band Non-Contiguous EN-DC

**Editor's note:**

- For overlapping transmission there is no test point satisfying 0dB MPR according to RAN4 specification.

### 6.2B.1.2.1 Test purpose

To verify that the error of the UE maximum output power does not exceed the range prescribed by the specified nominal maximum output power and tolerance.

An excess maximum output power has the possibility to interfere to other channels or other systems. A small maximum output power decreases the coverage area.

### 6.2B.1.2.2 Test applicability

This test applies to all types of E-UTRA UE release 15 and forward, supporting intra-band non-contiguous EN-DC operation on FR1.

### 6.2B.1.2.3 Minimum conformance requirements

The following UE Power Classes define the total maximum output power for any transmission bandwidth(s) of the CG(s) configured.

The maximum output power is measured as the total maximum output power across the UE antenna connector(s). The period of measurement shall be at least one sub frame.

**Table 6.2B.1.2.3-1: Maximum output power for EN-DC (non-continuous sub-blocks)**

DC configuration	Power class 2 (dBm)	Tolerance (dB)	Power class 3 (dBm)	Tolerance (dB)
DC_2A_n2A <sup>4</sup>			23	+2/-3
DC_41A_n41A	26	+2/-3 <sup>1</sup>	23	+2/-3 <sup>1</sup>
DC_66A_n66A <sup>4</sup>			23	+2/-3

NOTE 1: An uplink EN-DC configuration in which the band has NOTE 3 in Table 6.2.1-1 in TS 38.101-1 or NOTE 2 in Table 6.2.2-1 in TS 36.101 is allowed to reduce the lower tolerance limit by 1.5 dB when the transmission bandwidths of at least one of the bands are confined within  $F_{UL\_low}$  and  $F_{UL\_low} + 4$  MHz or  $F_{UL\_high} - 4$  MHz and  $F_{UL\_high}$ .

NOTE 2: Only single switched UL is supported in Rel-15.

NOTE 3: Power Class 3 is the default power class unless otherwise stated.

NOTE 4: Only single switched UL is supported.

If UE supports a different power class than the default UE power class for EN-DC band combination, and the supported power class enables higher maximum output power than that of the default power class:

- if the E-UTRA UL/DL configuration is 0 or 6; or
- if the E-UTRA UL/DL configuration is 1 and special subframe configuration is 0 or 5; or
- if the IE *p-maxUE-FR1-r15* as defined in TS 36.331 [17] is provided and set to the maximum output power of the default power class or lower:
  - apply all requirements for the default power class, and set the configured transmitted power as specified in subclause 6.2B.4;
- else
  - apply all requirements for the supported power class, and set the configured transmitted power class as specified in subclause 6.2B.4.

The normative reference for this requirement is TS 38.101-3 [4] clause 6.2B.1.

LTE anchor agnostic approach is not applied. E-UTRA test point analysis is included and E-UTRA measurements are performed.

#### 6.2B.1.2.4 Test description

##### 6.2B.1.2.4.1 Initial condition

Initial conditions are a set of test configurations the UE needs to be tested in and the steps for the SS to take with the UE to reach the correct measurement state.

The initial test configurations consist of environmental conditions, test frequencies and channel bandwidths based on EN-DC operating bands specified in Table 5.3B.1.3-1, channel bandwidths and sub-carrier spacings for the NR cell are specified in TS 38.521-1 [8] clause 5.3 and channel bandwidth for the E-UTRA cell are specified in TS 36.521-1 [10] clause 5.4.2. All of these configurations shall be tested with applicable test parameters for each EN-DC configuration specified in Table 5.3B.1.3-1, and are shown in table 6.2B.1.2.4.1-1. The details of the uplink reference measurement channels (RMCs) are specified in Annex A, clause A.2.2 for E-UTRA RMC for TDD, TS 36.521-1 [10] Annex A, clause A.2.2 for E-UTRA RMC for FDD, and TS 38.521-1 [8] Annex A, clause A.2 for NR RMC Configurations of PDSCH and PDCCH before measurement are specified in TS 36.521-1 [10] Annex C, clause C.2 and in TS 38.521-1 [8] Annex C, clause C.2 for E-UTRA CG and NR CG respectively.



**Table 6.2B.1.2.4.1-1: Test configuration table for intra-band non-contiguous EN-DC**

Initial Conditions					
Test Environment as specified in TS 38.508-1 [5] clause 4.1		Normal, TL/VL, TL/VH, TH/VL, TH/VH			
NR Test Frequencies as specified in TS 38.508-1 [5] clause 4.3.1 E-UTRA Test Frequencies as specified in TS 36.508-1 [11] clause 4.3.1		Minimum Wgap, Maximum Wgap			
Test EN-DC bandwidth combination as specified in TS 38.508-1 [5] clause 4.3.1		Highest $N_{RB\_agg}$			
NR Test SCS as specified in Table 5.3.5-1 in TS 38.521-1 [8]		Highest			
NR/E-UTRA Test Parameters					
Test ID	Downlink Configuration	EN-DC Uplink Configuration			
		E-UTRA Cell		NR Cell	
		Modulation	RB allocation (NOTE 2)	Modulation	RB allocation (NOTE 1)
1	N/A	QPSK	Partial_Allocation	N/A	N/A
2	N/A	QPSK	1RB_Left	N/A	N/A
3	N/A	N/A	N/A	DFT-s-OFDM QPSK	Inner Full
4	N/A	N/A	N/A	DFT-s-OFDM QPSK	Inner_1RB_LEFT
NOTE 1: The specific configuration of each RB allocation is defined in Table 6.1-1 in TS 38.521-1 [8].					
NOTE 2: The specific configuration of each RB allocation is defined in Table 6.1-1 in current specification.					

1. Connect the SS to the UE antenna connectors as shown in TS 38.508-1 [6] A.3.1.1 for SS diagram and A.3.2.1 for UE diagram.
2. The parameter settings for the cell are set up according to TS 38.508-1 [6] clause 4.4.3.
3. Downlink signals are initially set up according to TS 36.521-1 [10] Annex C.0 and TS 38.521-1 [8] Annex C.0 for E-UTRA CG and NR CG respectively, and uplink signals according to TS 36.521-1 [10] Annex H and TS 38.521-1 [8] Annex G for E-UTRA CG and NR CG respectively.
4. The UL Reference Measurement channels are set for E-UTRA CG and NR CG respectively.
5. Propagation conditions are set according to TS 36.521-1 [10] Annex B.0 and TS 38.521-1 [8] Annex B.0 for E-UTRA CG and NR CG respectively.
6. Ensure the UE is in state RRC\_CONNECTED with generic procedure parameters Connectivity EN-DC, DC bearer MCG and SCG, Connected without release  $On$  according to TS 38.508-1 [6] clause 4.5. Message contents are defined in clause 6.2B.1.2.4.3.
7. When E-UTRA and NR bands are TDD, ensure the same uplink-downlink configuration by giving SCG a delay of 3 E-UTRA subframes, or by giving MCG a delay of 2 subframes.

#### 6.2B.1.2.4.2 Test procedure

1. SS sends uplink scheduling information for each UL HARQ process via PDCCH DCI format 0 and DCI format 0\_1 for C\_RNTI to schedule the UL RMC according to table 6.2B.1.2.4.1-1 on E-UTRA CC and NR CC respectively. Since the UL has no payload and no loopback data to send the UE sends uplink MAC padding bits on the UL RMC.
2. Send continuously uplink power control "up" commands to the UE for NR and E-UTRA carrier until the UE transmits at its  $P_{UMAX}$  level; allow at least 200 ms from the first TPC command for the UE to reach  $P_{UMAX}$  level for Power class 3.

3. Measure the mean transmitted power over all EN-DC component carriers in the EN-DC, which shall meet the requirements described in table 6.2B.1.2.5-1 and the period of the measurement shall be at least the continuous duration of one active sub-frame.
4. For UEs supporting Power Class 2, repeat steps 1~3 on the applicable bands with message exception defined in Table 6.2B.1.1.4.3-5.

6.2B.1.2.4.3 Message contents

Same message contents as specified in 6.2B.1.1.4.3.

6.2B.1.2.5 Test requirements

The maximum output power for the DC configuration, derived in step 3 shall be within the range prescribed by the DC UE Power Class and tolerance in Table 6.2B.1.2.5-1 for power class 3 UE and Table 6.2B.1.2.5-2 for power class 2 UE. The corresponding requirements is specified in table 6.2.2.5-1, 6.2.2\_1.5-1 in TS 36.521-1 [10] or table 6.2.1.5-1, 6.2.1.5-2 in TS 38.521-1 [8].

The maximum output power for the DC configuration, derived in step 4 shall be within the range prescribed in Table 6.2B.1.2.5-1.

**Table 6.2B.1.2.5-1: Maximum output power for EN-DC (non-continuous sub-blocks) for power class 3**

DC configuration	Power class 2 (dBm)	Tolerance (dB)	Power class 3 (dBm)	Tolerance (dB)
DC_2A_n2A <sup>4</sup>			23	+2+TT/-3-TT
DC_41A_n41A			23	+2+TT/-3 <sup>1</sup> -TT
DC_66A_n66A <sup>4</sup>			23	+2+TT/-3-TT

NOTE 1: It is allowed to reduce the lower tolerance limit by 1.5 dB when the transmission bandwidths of at least one of the bands are confined within  $F_{UL\_low}$  and  $F_{UL\_low} + 4$  MHz or  $F_{UL\_high} - 4$  MHz and  $F_{UL\_high}$ .

NOTE 2: Only single switched UL is supported in Rel-15.

NOTE 3: TT for each frequency and channel bandwidth is specified in Table 6.2B.1.2.5-3

NOTE 4: Only single switched UL is supported.

**Table 6.2B.1.2.5-2: Maximum output power for EN-DC (non-continuous sub-blocks) for power class 2 for Rel-15**

DC configuration	Carrier	Power class2	Tolerance (dB)	Condition	Comment
DC_41A_n41A	NR carrier	26	+2+TT/-3 <sup>1</sup> -TT	UE indicates PC2 on NR band	UE meets power class 2 requirements
		23	+2+TT/-2 <sup>1</sup> -TT	UE indicates PC3 on NR band	UE meets power class 3 requirements
	E-UTRA carrier	26	+2+TT/-3 <sup>1</sup> -TT	UE indicates PC3 on E-UTRA carrier of this DC_Configuration	UE meets power class 2 requirements
		23	+2+TT/-2 <sup>1</sup> -TT	UE indicates PC3 on E-UTRA carrier of this DC_Configuration	UE meets power class 3 requirements

NOTE 1: It is allowed to reduce the lower tolerance limit by 1.5 dB when the transmission bandwidths of at least one of the bands are confined within  $F_{UL\_low}$  and  $F_{UL\_low} + 4$  MHz or  $F_{UL\_high} - 4$  MHz and  $F_{UL\_high}$ .

NOTE 2: TT for each frequency and channel bandwidth is specified in Table 6.2B.1.1.5-3

**Table 6.2B.1.2.5-2a: Maximum output power for EN-DC (non-continuous sub-blocks) for power class 2 for Rel-16 and forward**

DC configuration	Carrier	Power class2	Tolerance (dB)	Condition	Comment
DC_41A_n41A	NR carrier	26	+2+TT/-3 <sup>1</sup> -TT	UE reporting (PC2 by $P_{PowerClass,NR}$ , and PC2 or Not present by <i>powerClassNRPart-r16</i> )	UE meets power class 2 requirements
		23	+2+TT/-2 <sup>1</sup> -TT	UE reporting (PC2 by $P_{PowerClass,NR}$ , and PC3 by <i>powerClassNRPart-r16</i> ) or UE reporting (PC3 by $P_{PowerClass,NR}$ )	UE meets power class 3 requirements
	E-UTRA carrier	26	+2+TT/-2 <sup>1</sup> -TT	UE indicates PC2 ON E-UTRA carrier of this DC_Configuration	UE meets power class 2 requirements
		23	+2+TT/-2 <sup>1</sup> -TT	UE indicates PC3 on E-UTRA carrier of this DC_Configuration	UE meets power class 3 requirements
NOTE 1: It is allowed to reduce the lower tolerance limit by 1.5 dB when the transmission bandwidths of at least one of the bands are confined within $F_{UL\_low}$ and $F_{UL\_low} + 4$ MHz or $F_{UL\_high} - 4$ MHz and $F_{UL\_high}$ .					
NOTE 2: TT for each frequency and channel bandwidth is specified in Table 6.2B.1.2.5-3					

**Table 6.2B.1.2.5-3: Test Tolerance**

Uplink TX		$f \leq 3.0\text{GHz}$	$3.0\text{GHz} < f \leq 4.2\text{GHz}$	$4.2\text{GHz} < f \leq 6\text{GHz}$
E-UTRA	$BW \leq 20\text{MHz}$	0.7 dB	1.0 dB	N/A
NR	$BW \leq 40\text{MHz}$	0.7 dB	1.0 dB	1.0 dB
	$40\text{MHz} < BW \leq 100\text{MHz}$	1.0 dB	1.0 dB	1.0 dB

### 6.2B.1.3 UE Maximum Output Power for Inter-Band EN-DC within FR1 (1 E-UTRA CC, 1 NR CC)

#### 6.2B.1.3.1 Test purpose

To verify that the error of the UE maximum output power does not exceed the range prescribed by the specified nominal maximum output power and tolerance.

An excess maximum output power has the possibility to interfere to other channels or other systems. A small maximum output power decreases the coverage area.

#### 6.2B.1.3.2 Test applicability

This test applies to all types of E-UTRA UE release 15 and forward, supporting inter-band EN-DC with 1 E-UTRA CC and 1 NR CC operating on FR1.

#### 6.2B.1.3.3 Minimum conformance requirements

For inter-band EN-DC of E-UTRA and NR in FR1, the following UE Power Classes define the maximum output power for any transmission bandwidth within the aggregated channel bandwidth. The maximum output power is measured as the sum of the maximum output power at each UE antenna connector. The period of measurement shall be at least one sub frame (1ms). UE maximum output power shall be measured over all component carriers from different bands. If

each band has separate antenna connectors, maximum output power is measured as the sum of maximum output power at each UE antenna connector.

**Table 6.2B.1.3.3-1: Maximum output power for inter-band EN-DC (two bands)**

EN-DC configuration	Power class 2 (dBm)	Tolerance (dB)	Power class 3 (dBm)	Tolerance (dB)
DC_1A_n3A			23	+2/-3
DC_1A_n5A			23	+2/-3
DC_1A_n7A			23	+2/-3
DC_1A_n8A			23	+2/-3
DC_1A_n28A			23	+2/-3
DC_1A_n41A	26 <sup>6</sup>	+2/-3	23	+2/-3
DC_1A_n77A	26 <sup>6</sup>	+2/-3	23	+2/-3
DC_1A_n78A	26 <sup>6</sup>	+2/-3	23	+2/-3
DC_1A_n79A	26 <sup>6</sup>	+2/-3	23	+2/-3
DC_2A_n5A			23	+2/-3
DC_2A_n41A	26 <sup>6</sup>	+2/-3	23	+2/-3
DC_2A_n66A			23	+2/-3
DC_2A_n71A			23	+2/-3
DC_2A_n77A	26 <sup>6</sup>	+2/-3	23	+2/-3
DC_2A_n78A			23	+2/-3
DC_3A_n1A			23	+2/-3
DC_3A_n5A			23	+2/-3
DC_3A_n7A			23	+2/-3
DC_3A_n8A			23	+2/-3
DC_3A_n28A			23	+2/-3
DC_3A_n41A	26 <sup>6</sup>	+2/-3	23	+2/-3
DC_3A_n77A	26 <sup>6</sup>	+2/-3	23	+2/-3
DC_3A_n78A	26 <sup>6</sup>	+2/-3	23	+2/-3
DC_3A_n79A	26 <sup>6</sup>	+2/-3	23	+2/-3
DC_5A_n2A			23	+2/-3
DC_5A_n40A			23	+2/-3
DC_5A_n66A			23	+2/-3
DC_5A_n77A	26 <sup>6</sup>	+2/-3	23	+2/-3
DC_5A_n78A			23	+2/-3
DC_7A_n1A			23	+2/-3
DC_7A_n3A			23	+2/-3
DC_7A_n5A			23	+2/-3
DC_7A_n8A			23	+2/-3
DC_7A_n28A			23	+2/-3
DC_7A_n66A			23	+2/-3
DC_7A_n78A			23	+2/-3
DC_8A_n1A			23	+2/-3
DC_8A_n3A			23	+2/-3
DC_8A_n20A			23	+2/-3
DC_8A_n28A			23	+2/-3
DC_8A_n41A			23	+2/-3
DC_8A_n77A			23	+2/-3
DC_8A_n78A	26 <sup>6</sup>	+2/-3	23	+2/-3
DC_8A_n81A_ULSUP-TDM_n78A			23	+2/-3
DC_11A_n77A			23	+2/-3

EN-DC configuration	Power class 2 (dBm)	Tolerance (dB)	Power class 3 (dBm)	Tolerance (dB)
DC_11A_n78A			23	+2/-3
DC_11A_n79A			23	+2/-3
DC_12A_n2A			23	+2/-3
DC_12A_n5A			23	+2/-3
DC_12A_n66A			23	+2/-3
DC_12A_n77A	26 <sup>6</sup>	+2/-3	23	+2/-3
DC_12A_n78A			23	+2/-3
DC_13A_n2A			23	+2/-3
DC_13A_n66A			23	+2/-3
DC_13A_n77A	26 <sup>6</sup>	+2/-3	23	+2/-3
DC_14A_n2A			23	+2/-3
DC_14A_n66A			23	+2/-3
DC_14A_n77A	26 <sup>6</sup>	+2/-3	23	+2/-3
DC_18A_n77A	26 <sup>6</sup>	+2/-3	23	+2/-3
DC_18A_n78A			23	+2/-3
DC_19A_n1A			23	+2/-3
DC_18A_n79A			23	+2/-3
DC_19A_n77A			23	+2/-3
DC_19A_n78A	26 <sup>6</sup>	+2/-3	23	+2/-3
DC_19A_n79A	26 <sup>6</sup>	+2/-3	23	+2/-3
DC_20A_n1A			23	+2/-3
DC_20A_n3A			23	+2/-3
DC_20A_n7A			23	+2/-3
DC_20A_n8A			23	+2/-3
DC_20A_n28A			23	+2/-3
DC_20A_n78A			23	+2/-3
DC_21A_n1A			23	+2/-3
DC_21A_n28A			23	+2/-3
DC_21A_n77A			23	+2/-3
DC_21A_n78A	26 <sup>6</sup>	+2/-3	23	+2/-3
DC_21A_n79A	26 <sup>6</sup>	+2/-3	23	+2/-3
DC_25A_n41A			23	+2/-3
DC_26A_n41A			23	+2/-3
DC_26A_n77A			23	+2/-3
DC_26A_n78A			23	+2/-3
DC_26A_n79A			23	+2/-3
DC_28A_n3A			23	+2/-3
DC_28A_n5A			23	+2/-3
DC_28A_n7A			23	+2/-3
DC_28A_n77A	26 <sup>6</sup>	+2/-3	23	+2/-3
DC_28A_n78A	26 <sup>6</sup>	+2/-3	23	+2/-3
DC_28A_n79A			23	+2/-3
DC_30A_n2A			23	+2/-3
DC_30A_n5A			23	+2/-3
DC_30A_n66A			23	+2/-3
DC_30A_n77A	26 <sup>6</sup>	+2/-3	23	+2/-3

EN-DC configuration	Power class 2 (dBm)	Tolerance (dB)	Power class 3 (dBm)	Tolerance (dB)
DC_38A_n78A			23	+2/-3
DC_39A_n41A	26 <sup>5</sup>	+2/-3	23	+2/-2
DC_39A_n79A	26 <sup>5</sup>	+2/-3	23	+2/-3
DC_40A_n1A			23	+2/-3
DC_40A_n41A			23	+2/-3
DC_40A_n78A			23	+2/-3
DC_40A_n79A			23	+2/-3
DC_41A_n28A			23	+2/-3
DC_41A_n77A	26 <sup>6</sup>	+2/-3	23	+2/-3
DC_41A_n78A			23	+2/-3
DC_41A_n79A	26 <sup>5</sup>	+2/-3	23	+2/-3
DC_42A_n77A			N/A	N/A
DC_42A_n78A			N/A	N/A
DC_42A_n79A			N/A	N/A
DC_48A_n5A			23	+2/-3
DC_48A_n66A			23	+2/-3
DC_48A_n66A			23	+2/-3
DC_66A_n2A			23	+2/-3
DC_66A_n5A			23	+2/-3
DC_66A_n41A			23	+2/-3
DC_66A_n71A			23	+2/-3
DC_66A_n77A	26 <sup>6</sup>	+2/-3	23	+2/-3
DC_66A_n78A			23	+2/-3
DC_71A_n2A			23	+2/-3
DC_71A_n66A			23	+2/-3

NOTE 1: An uplink DC configuration in which at least one of the bands has NOTE 3 in Table 6.2.1-1 in TS 38.101-1 or NOTE 2 in Table 6.2.2-1 in TS 36.101 is allowed to reduce the lower tolerance limit by 1.5 dB when the transmission bandwidths of at least one of the bands is confined within  $F_{UL\_low}$  and  $F_{UL\_low} + 4$  MHz or  $F_{UL\_high} - 4$  MHz and  $F_{UL\_high}$ .

NOTE 2:  $P_{PowerClass, EN-DC}$  is the maximum UE power specified without taking into account the tolerance.

NOTE 3: For inter-band EN-DC the maximum power requirement should apply to the total transmitted power over all component carriers (per UE).

NOTE 4: Power Class 3 is the default power class unless otherwise stated.

NOTE 5: The UE is not required to support PC2 within each individual cell group. Power class support within each individual cell group is signaled separately by the UE.

NOTE 6: The UE supports PC3 within E-UTRA cell group, and supports either PC3 or PC2 within NR cell group. Power class support within each individual cell group is signaled separately by the UE.

NOTE 7: Only single switched UL is supported.

NOTE 8: The UE that supports a PC2 uplink EN-DC configuration with single carrier for each individual band and a composite of supporting PC3 within a TDD or FDD band and PC2 within a second TDD band may signal a *higherPowerLimitMRDC-r17* capability whereby the maximum output power indicated in the table may be exceeded in accordance with sub-clause 6.2B.4.1.3.

If a UE supports a different power class than the default UE power class for an EN-DC band combination and NR TDD inter-band EN-DC combination and the supported power class enables higher maximum output power than that of the default power class:

- if the field of UE capability *maxUplinkDutyCycle-interBandENDC-TDD-PC2-r16* is absent and the percentage of NR uplink symbols transmitted in a certain evaluation period is larger than 30% (The exact evaluation period is no less than one radio frame); or
- if the field of UE capability *maxUplinkDutyCycle-interBandENDC-TDD-PC2-r16* is not absent and the percentage of NR uplink symbols transmitted in a certain evaluation period is larger than *maxUplinkDutyCycle-*



*interBandENDC-TDD-PC2-r16* as defined in TS38.331 (The exact evaluation period is no less than one radio frame); or

- if the IE *p-maxUE-FRI* as defined in TS 38.331 is provided and set to the maximum output power of the default power class or lower;
  - shall apply all requirements for the default power class to the supported power class and set the configured transmitted power as specified clause 6.2B.4;
- Else if the IE *p-maxUE-FRI* as defined in TS 38.331 is not provided or set to the higher value than the maximum output power of the default power class and the percentage of uplink symbols transmitted in a certain evaluation period is less than or equal to *maxUplinkDutyCycle-interBandENDC-TDD-PC2-r16* as defined in TS 38.331; or
- if the IE *p-maxUE-FRI* as defined in TS 38.331 is not provided or set to the higher value than the maximum output power of the default power class and the percentage of NR uplink symbols transmitted in a certain evaluation period is less than or equal to 30% when *maxUplinkDutyCycle-interBandENDC-TDD-PC2-r16* is absent. (The exact evaluation period is no less than one radio frame):
  - shall apply all requirements for the supported power class and set the configured transmitted power class as specified in clause 6.2B.4.

If a UE supports a different power class than the default UE power class for an E-UTRA FDD and NR TDD EN-DC band combination and the supported power class enables higher maximum output power than that of the default power class:

If UE indicating the two capabilities *maxUplinkDutyCycle-FDD-TDD-EN-DC1* and *maxUplinkDutyCycle-FDD-TDD-EN-DC2*:

- if the IE *p-maxUE-FRI* as defined in TS 38.331 is not provided or set to the higher value than the maximum output power of the default power class, and the percentage of E-UTRA uplink symbols transmitted in a certain evaluation period is between 40% and 70%, and the percentage of NR uplink symbols transmitted in a certain evaluation period is less than or equal to *maxUplinkDutyCycle-FDD-TDD-EN-DC1* as defined in TS 38.331 (The exact evaluation period is no less than one radio frame); or
  - if the IE *p-maxUE-FRI* as defined in TS 38.331 is not provided or set to the higher value than the maximum output power of the default power class, and the percentage of E-UTRA uplink symbols transmitted in a certain evaluation period is no larger than 40%, and the percentage of NR uplink symbols transmitted in a certain evaluation period is less than or equal to *maxUplinkDutyCycle-FDD-TDD-EN-DC2* as defined in TS 38.331 (The exact evaluation period is no less than one radio frame)
    - shall apply all requirements for the supported power class and set the configured transmitted power class as specified in sub-clause 6.2B.4.
  - else
    - shall apply all requirements for the default power class and set the configured transmitted power as specified sub-clause 6.2B.4;
- else
- shall apply all requirements for the supported power class and set the configured transmitted power as specified sub-clause 6.2B.4;

The normative reference for this requirement is TS 38.101-3 [4] clause 6.2B.1.

LTE anchor agnostic approach is not applied. E-UTRA test point analysis is included and E-UTRA measurements are performed.

6.2B.1.3.4 Test description

6.2B.1.3.4.1 Initial condition

Initial conditions are a set of test configurations the UE needs to be tested in and the steps for the SS to take with the UE to reach the correct measurement state.

The initial test configurations consist of environmental conditions, test frequencies, DC configuration specified in clause 5.5B.4 and test channel bandwidths specified in TS 36.508 [11] clause 4.3.1 and TS 38.508-1 [6] clause 4.3.1, and sub-carrier spacing based on NR operating bands specified in TS 38.521-1 [8] clause 5.3. All of these configurations shall be tested with applicable test parameters for each EN-DC configuration, and are shown in table 6.2B.1.3.4.1-1. The details of the uplink reference measurement channels (RMCs) are specified in Annex A, clause A.2.2 for E-UTRA RMC for TDD, TS 36.521-1 [10] Annex A, clause A.2.2 for E-UTRA RMC for FDD, and TS 38.521-1 [8] Annex A, clause A.2 for NR RMC. Configurations of PDSCH and PDCCH before measurement are specified in TS 36.521-1 [10] Annex C, clause C.2 and in TS 38.521-1 [8] Annex C, clause C.2 for E-UTRA CG and NR CG respectively.

**Table 6.2B.1.3.4.1-1: Test configuration table**

Default Conditions								
Test Environment as specified in TS 38.508-1 [6] clause 4.1					Normal, TL/VL, TL/VH, TH/VL, TH/VH			
Test Frequencies as specified in TS 38.508-1 [6] clause 4.3.1 and TS 36.508 [6]					Low range for E-UTRA CC1 and NR CC1, Mid range for E-UTRA CC1 and NR CC1, High range for E-UTRA CC1 and NR CC1 (NOTE 6)			
Test EN-DC channel bandwidth as specified in TS 36.508 [6] clause 4.3.1 and TS 38.508-1 clause 4.3.1					5MHz for E-UTRA CC1 and Lowest for NR CC1, Highest for E-UTRA CC1 and Highest for NR CC1 (NOTE 4)			
Test SCS for the NR cell as specified in TS 38.521-1 [8] Table 5.3.5-1					Lowest, Highest			
Test Parameters								
Test ID	Test Freq	E-UTRA BW	NR BW	Downlink Configuration	EN-DC Uplink Configuration			
					E-UTRA Cell		NR Cell	
					Modulation	RB allocation (NOTE 1)	Modulation (NOTE 3)	RB allocation (NOTE 2)
1 <sup>5</sup>	High	Default	Default	N/A	QPSK	1RB_Right	DFT-s-OFDM PI/2 BPSK	Inner_1RB_Right
2 <sup>5</sup>	Low	Default	Default		QPSK	1RB_Left	DFT-s-OFDM PI/2 BPSK	Inner_1RB_Left
3 <sup>5</sup>	Default	Default	Default		QPSK	Partial_Allocation	DFT-s-OFDM PI/2 BPSK	Inner_Full
4 <sup>5</sup>	High	Default	Default		QPSK	1RB_Right	DFT-s-OFDM QPSK	Inner_1RB_Right
5 <sup>5</sup>	Low	Default	Default		QPSK	1RB_Left	DFT-s-OFDM QPSK	Inner_1RB_Left
6 <sup>5</sup>	Default	Default	Default		QPSK	Partial_Allocation	DFT-s-OFDM QPSK	Inner_Full
7	High	5MHz, Highest	Lowest		QPSK	1RB_Right	N/A	N/A
8	Low	5MHz, Highest	Lowest		QPSK	1RB_Left	N/A	N/A
9	Default	5MHz, Highest	Lowest		QPSK	Partial_Allocation	N/A	N/A
10	High	5MHz	Lowest, Highest		N/A	N/A	DFT-s-OFDM PI/2 BPSK	Inner_1RB_Right
11	Low	5MHz	Lowest, Highest		N/A	N/A	DFT-s-OFDM PI/2 BPSK	Inner_1RB_Left
12	Default	5MHz	Lowest, Highest		N/A	N/A	DFT-s-OFDM PI/2 BPSK	Inner_Full
13	High	5MHz	Lowest, Highest		N/A	N/A	DFT-s-OFDM QPSK	Inner_1RB_Right
14	Low	5MHz	Lowest, Highest		N/A	N/A	DFT-s-OFDM QPSK	Inner_1RB_Left
15	Default	5MHz	Lowest, Highest		N/A	N/A	DFT-s-OFDM QPSK	Inner_Full
NOTE 1: The specific configuration of each RB allocation is defined in Table 6.1-1 in current specification.								
NOTE 2: The specific configuration of each RB allocation is defined in Table 6.1-1 in TS 38.521-1 [8].								
NOTE 3: DFT-s-OFDM PI/2 BPSK test applies only for UEs which supports Pi/2 BPSK in NR FR1.								
NOTE 4: For NR band n28, the Highest test channel bandwidth is replaced by 20MHz due to MPR is always larger than 0dB for 30MHz bandwidth.								
NOTE 5: Only applicable to UEs not supporting UE capability <i>singleUL-Transmission</i> .								
NOTE 6: For EN-DC configurations with NOTE 8 in Table 5.5B.4.1-1, test channel bandwidth of 20MHz or more is tested with only Low range test frequency in band n28 / 28.								

1. Connect the SS to the UE antenna connectors as shown in TS 38.508-1 [6] clause A.3.1.1 for SS and clause A.3.2.1 for UE.
2. The parameter settings for the E-UTRA cell are set up according to TS 36.508 [11] clause 4.4.3, and the parameter settings for the cell are set up according to TS 38.508-1 [6] clause 4.4.3.

3. Downlink signals are initially set up according to TS 36.521-1 [10] Annex C.0 and TS 38.521-1 [8] Annex C.0 for E-UTRA CG and NR CG respectively, and uplink signals according to TS 36.521-1 [10] Annex H and TS 38.521-1 [8] Annex G for E-UTRA CG and NR CG respectively.
4. The UL Reference Measurement channels are set according to Table 6.2B.1.3.3-1.
5. Propagation conditions are set according to TS 36.521-1 [10] and TS 38.521-1 [8] Annex B.0 for E-UTRA CG and NR CG respectively.
6. Ensure the UE is in state RRC\_CONNECTED with generic procedure parameters Connectivity EN-DC, DC bearer *MCG* and *SCG*, Connected without release *On* according to TS 38.508-1 [6] clause 4.5. Message contents are defined in clause 6.2B.1.3.4.3.
7. For the case of testing overlapping E-UTRA and NR UL transmission scenario when both bands are TDD, ensure E-UTRA UL transmission overlaps with NR UL transmission in time by giving SCG a delay of 3 E-UTRA subframes, or by giving MCG a delay of 2 subframes.

#### 6.2B.1.3.4.2 Test procedure

1. SS sends uplink scheduling information for each UL HARQ process via PDCCH DCI format 0 and DCI format 0\_1 for C\_RNTI to schedule the UL RMC according to table 6.2B.1.3.4.1-1 on E-UTRA CC and NR CC respectively. Since the UL has no payload and no loopback data to send the UE sends uplink MAC padding bits on the UL RMC. For an E-UTRA FDD and NR TDD EN-DC band combination, if UE supports PC2, the percentage of EUTRA uplink symbols transmitted in each radio frame shall be less than 40%.
2. Send continuously uplink power control "up" commands to the UE for NR and E-UTRA carrier until the UE transmits at its  $P_{UMAX}$  level; allow at least 200 ms from the first TPC command for the UE to reach  $P_{UMAX}$  level.
3. For test ID 1~6 measure the sum of mean transmitted power over all EN-DC component carriers in the EN-DC, which shall meet the requirements described in table 6.2B.1.3.5-1 and the period of the measurement shall be at least the continuous duration of one active sub-frame. For FDD band in inter-band CA with both TDD band and FDD band, only slots overlapping with only UL symbols in TDD are under test.

For test ID 7~15 measure the mean transmitted power over E-UTRA carrier or NR carrier, which shall meet the requirements described in table 6.2.2.5-1 in TS 36.521-1 [10] or table 6.2.1.5-1 in TS 38.521-1 [8] respectively. The period of the measurement shall be at least the continuous duration of one active sub-frame.

4. For UEs supporting Power Class 2, repeat steps 1~3 on the applicable bands with message exception defined in Table 6.2B.1.3.4.3-5.

#### 6.2B.1.3.4.3 Message contents

Message contents are according to TS 36.508 [11] clause 4.6.1 and TS 38.508-1 [6] clause 4.6.1 with the following exceptions:

**Table 6.2B.1.3.4.3-0: PUSCH-Config**

Derivation Path: TS 38.508-1 [6], Table 4.6.3-118 with condition TRANSFORM_PRECODER_ENABLED
---

**Table 6.2B.1.3.4.3-1: PhysicalCellGroupConfig**

Derivation Path: TS 38.508-1 [6], Table 4.6.3-106			
Information Element	Value/remark	Comment	Condition
PhysicalCellGroupConfig ::= SEQUENCE {			
p-NR-FR1	20	For simultaneous E-UTRA and NR transmission	Power Class 3 UE Test IDs 1-6
	23	For Test IDs 7~9 NR carrier is configured but not measured.	Power Class 3 UE Test IDs 7-15
	23	For simultaneous E-UTRA and NR transmission	Power Class 2 UE Test IDs 1-6
	26	For Test IDs 7~9 NR carrier is configured but not measured.	Power Class 2 UE Test IDs 7-15
	26	For simultaneous E-UTRA and NR transmission	Power Class 2 UE Test IDs 1-6 if UE indicates support of <i>higherPowerLimitMRDC-r17</i>
}			

**Table 6.2B.1.3.4.3-2: RRCConnectionReconfiguration: nr-Config-r15**

Derivation Path: TS 36.508 [11], Table 4.6.1-8			
Information Element	Value/remark	Comment	Condition
p-MaxEUTRA-r15	20	For simultaneous E-UTRA and NR transmission	Power Class 3 UE Test IDs 1-6
	23	For Test IDs 10~15 E-UTRA carrier is configured but not measured.	Power Class 3 UE Test IDs 7-15
	23	For simultaneous E-UTRA and NR transmission	Power Class 2 UE Test IDs 1-6
	26	For Test IDs 10~15 E-UTRA carrier is configured but not measured.	Power Class 2 UE Test IDs 7-15

**Table 6.2B.1.3.4.3-3: RRCConnectionReconfiguration: tdm-PatternConfig if E-UTRA on FDD band and UE does not support dynamic power sharing**

Derivation Path: TS 36.508 [11], Table 4.6.1-8			
Information Element	Value/remark	Comment	Condition
tdm-PatternConfig-r15 CHOICE{			Test IDs 7-15
setup SEQUENCE {			
subframeAssignment-r15	sa2		
harq-Offset-r15	0		
}			
}			

**Table 6.2B.1.3.4.3-4: SystemInformationBlockType1: tdd-Config if E-UTRA on TDD band**

Derivation Path: TS 36.508 [11], Table 4.6.3-23			
Information Element	Value/remark	Comment	Condition
TDD-Config-DEFAULT ::= SEQUENCE {		Operating on TDD band	
subframeAssignment	sa2		
specialSubframePatterns	ssp7		
}			

**Table 6.2B.1.3.4.3-5: RRCConnectionReconfiguration: p-MaxUE-FR1-r15 (step 4 in 6.2B.1.3.4.2)**

Derivation Path: TS 36.508 [11], Table 4.6.1-8			
Information Element	Value/remark	Comment	Condition
nonCriticalExtension SEQUENCE {		RRCConnectionReconfiguration-v1530-IEs	
p-MaxUE-FR1-r15	23		Power Class 2 UE
}			

### 6.2B.1.3.5 Test requirements

For test ID 1~6 the maximum output power for the DC configuration, derived in step 3 shall be within the range prescribed by the UE Power Class and tolerance in Table 6.2B.1.3.5-1.

For test ID 7~15 the maximum output power for the DC configuration, derived in step 3 shall be within the range prescribed by the UE Power Class and tolerance in table 6.2.2.5-1 in TS 36.521-1 [10] or table 6.2.1.5-1 in TS 38.521-1 [8] for E-UTRA carrier and NR carrier respectively for Power class 3, and in Table 6.2B.1.3.5-2a for Power class 2.

For test ID 1~6 the maximum output power for the DC configuration, derived in step 4 shall be within the range prescribed by Power Class 3 and tolerance in Table 6.2B.1.3.5-1.

For test ID 7~15 the maximum output power for the DC configuration, derived in step 4 shall be within the range prescribed by Power Class 3 and tolerance in table 6.2.2.5-1 in TS 36.521-1 [10] or table 6.2.1.5-1 in TS 38.521-1 [8] for E-UTRA carrier and NR carrier respectively.

**Table 6.2B.1.3.5-1: Maximum output power for inter-band EN-DC (two bands), for overlapping UL transmission**

EN-DC configuration	Power class 2 (dBm)	Tolerance (dB)	Power class 3 (dBm)	Tolerance (dB)
DC_1A_n3A			23	+2 +TT/-3-TT
DC_1A_n5A			23	+2 +TT/-3-TT
DC_1A_n7A			23	+2 +TT/-3-TT
DC_1A_n28A			23	+2 +TT/-3-TT
DC_1A_n41A	26 <sup>8</sup>	+2+TT/-3-TT	23	+2 +TT/-3-TT
DC_1A_n77A	26 <sup>8</sup>	+2+TT/-3-TT	23	+2 +TT/-3-TT
DC_1A_n78A	26 <sup>8</sup> , 27.8 <sup>9</sup>	+2+TT/-3-TT	23	+2 +TT/-3-TT
DC_1A_n79A	26 <sup>8</sup>	+2+TT/-3-TT	23	+2 +TT/-3-TT
DC_2A_n5A			23	+2 +TT/-3-TT
DC_2A_n41A	26 <sup>8</sup>	+2+TT/-3-TT	23	+2 +TT/-3-TT
DC_2A_n66A			23	+2 +TT/-3-TT
DC_2A_n71A			23	+2 +TT/-3-TT
DC_2A_n77A	26 <sup>8</sup> , 27.8 <sup>9</sup>	+2+TT/-3-TT	23	+2+TT/-3-TT
DC_2A_n78A			23	+2 +TT/-3-TT
DC_3A_n1A			23	+2 +TT/-3-TT
DC_3A_n5A			23	+2 +TT/-3-TT
DC_3A_n7A			23	+2 +TT/-3-TT
DC_3A_n8A			23	+2 +TT/-3-TT
DC_3A_n28A			23	+2 +TT/-3-TT
DC_3A_n41A	26 <sup>8</sup> , 27.8 <sup>9</sup>	+2+TT/-3-TT <sup>3</sup>	23	+2+TT/-3-TT
DC_3A_n77A	26 <sup>8</sup>	+2+TT/-3-TT	23	+2 +TT/-3-TT
DC_3A_n78A	26 <sup>8</sup> , 27.8 <sup>9</sup>	+2+TT/-3-TT <sup>3</sup>	23	+2 +TT/-3-TT
DC_3A_n79A	26 <sup>8</sup>	+2+TT/-3-TT	23	+2 +TT/-3-TT
DC_5A_n2A			23	+2 +TT/-3-TT
DC_5A_n66A			23	+2 +TT/-3-TT
DC_5A_n77A	26 <sup>8</sup> , 27.8 <sup>9</sup>	+2+TT/-3-TT	23	+2+TT/-3-TT
DC_5A_n78A			23	+2 +TT/-3-TT
DC_7A_n1A			23	+2 +TT/-3-TT
DC_7A_n3A			23	+2 +TT/-3-TT
DC_7A_n5A			23	+2 +TT/-3-TT
DC_7A_n28A			23	+2 +TT/-3-TT
DC_7A_n66A			23	+2 +TT/-3-TT
DC_7A_n78A			23	+2 +TT/-3-TT
DC_8A_n1A				+2 +TT/-3-TT
DC_8A_n3A				+2 +TT/-3-TT
DC_8A_n20A			23	+2 +TT/-3-TT
DC_8A_n41A			23	+2 +TT/-3-TT
DC_8A_n77A			23	+2 +TT/-3-TT
DC_8A_n78A	26 <sup>8</sup> , 27.8 <sup>9</sup>	+2+TT/-3-TT	23	+2 +TT/-3-TT
DC_11A_n77A			23	+2 +TT/-3-TT
DC_11A_n78A			23	+2 +TT/-3-TT
DC_11A_n79A			23	+2 +TT/-3-TT
DC_12A_n2A			23	+2 +TT/-3-TT
DC_12A_n5A			23	+2 +TT/-3-TT
DC_12A_n66A			23	+2 +TT/-3-TT
DC_12A_n77A	26 <sup>8</sup> , 27.8 <sup>9</sup>	+2+TT/-3-TT	23	+2 +TT/-3-TT



EN-DC configuration	Power class 2 (dBm)	Tolerance (dB)	Power class 3 (dBm)	Tolerance (dB)
DC_12A_n78A			23	+2 +TT/-3-TT
DC_13A_n2A			23	+2 +TT/-3-TT
DC_13A_n66A			23	+2 +TT/-3-TT
DC_13A_n77A	26 <sup>8</sup> , 27.8 <sup>9</sup>	+2+TT/-3-TT	23	+2+TT/-3-TT
DC_14A_n2A			23	+2 +TT/-3-TT
DC_14A_n66A			23	+2 +TT/-3-TT
DC_14A_n77A	26 <sup>8</sup> , 27.8 <sup>9</sup>	+2+TT/-3-TT	23	+2 +TT/-3-TT
DC_18A_n77A	26 <sup>8</sup>	+2+TT/-3-TT	23	+2 +TT/-3-TT
DC_18A_n78A			23	+2 +TT/-3-TT
DC_18A_n79A			23	+2 +TT/-3-TT
DC_19A_n1A			23	+2 +TT/-3-TT
DC_19A_n77A			23	+2 +TT/-3-TT
DC_19A_n78A	26 <sup>8</sup>	+2+TT/-3-TT	23	+2 +TT/-3-TT
DC_19A_n79A	26 <sup>8</sup>	+2+TT/-3-TT	23	+2 +TT/-3-TT
DC_20A_n1A			23	+2 +TT/-3-TT
DC_20A_n3A			23	+2 +TT/-3-TT
DC_20A_n7A			23	+2 +TT/-3-TT
DC_20A_n8A			23	+2 +TT/-3-TT
DC_20A_n28A			23	+2 +TT/-3-TT
DC_20A_n78A			23	+2 +TT/-3-TT
DC_21A_n1A			23	+2 +TT/-3-TT
DC_21A_n28A			23	+2 +TT/-3-TT
DC_21A_n77A			23	+2 +TT/-3-TT
DC_21A_n78A	26 <sup>8</sup>	+2+TT/-3-TT	23	+2 +TT/-3-TT
DC_21A_n79A	26 <sup>8</sup>	+2+TT/-3-TT	23	+2 +TT/-3-TT
DC_25A_n41A			23	+2 +TT/-3-TT
DC_26A_n41A			23	+2 +TT/-3-TT
DC_26A_n77A			23	+2 +TT/-3-TT
DC_26A_n78A			23	+2 +TT/-3-TT
DC_26A_n79A			23	+2 +TT/-3-TT
DC_28A_n3A			23	+2 +TT/-3-TT
DC_28A_n5A			23	+2 +TT/-3-TT
DC_28A_n7A			23	+2 +TT/-3-TT
DC_28A_n77A	26 <sup>8</sup>	+2+TT/-3-TT	23	+2 +TT/-3-TT
DC_28A_n78A	26 <sup>8</sup>	+2+TT/-3-TT	23	+2 +TT/-3-TT
DC_28A_n79A			23	+2 +TT/-3-TT
DC_30A_n2A			23	+2 +TT/-3-TT
DC_30A_n5A			23	+2 +TT/-3-TT
DC_30A_n66A			23	+2 +TT/-3-TT
DC_30A_n77A	26 <sup>8</sup> , 27.8 <sup>9</sup>	+2+TT/-3-TT	23	+2 +TT/-3-TT
DC_38A_n78A			23	+2 +TT/-3-TT
DC_39A_n41A	26, 27.8 <sup>9</sup>	+2/-3 <sup>1</sup>	23	+2 +TT/-3-TT
DC_39A_n79A	26, 27.8 <sup>9</sup>	+2/-3	23	+2 +TT/-3-TT
DC_40A_n1A			23	+2 +TT/-3-TT
DC_40A_n41A			23	+2 +TT/-3-TT
DC_40A_n78A			23	+2 +TT/-3-TT

EN-DC configuration	Power class 2 (dBm)	Tolerance (dB)	Power class 3 (dBm)	Tolerance (dB)
DC_40A_n79A			23	+2 +TT/-3-TT
DC_41A_n77A	26 <sup>8</sup>	+2+TT/-3-TT	23	+2 +TT/-3-TT
DC_41A_n78A			23	+2 +TT/-3-TT
DC_41A_n79A	26, 27.8 <sup>9</sup>	+2/-3 <sup>1</sup>	23	+2 +TT/-3-TT
DC_42A_n77A			N/A	N/A
DC_42A_n78A			N/A	N/A
DC_42A_n79A			N/A	N/A
DC_48A_n5A			23	+2 +TT/-3-TT
DC_48A_n46A			23	+2 +TT/-3-TT
DC_48A_n66A			23	+2 +TT/-3-TT
DC_66A_n2A			23	+2 +TT/-3-TT
DC_66A_n5A			23	+2 +TT/-3-TT
DC_66A_n41A			23	+2 +TT/-3-TT
DC_66A_n71A			23	+2 +TT/-3-TT
DC_66A_n77A	26 <sup>8</sup> , 27.8 <sup>9</sup>	+2+TT/-3-TT	23	+2+TT/-3-TT
DC_66A_n78A			23	+2 +TT/-3-TT
DC_71A_n2A			23	+2 +TT/-3-TT
DC_71A_n66A			23	+2 +TT/-3-TT

NOTE 1: TT applies to output power in each UL carrier with E-UTRA UL transmission not overlapping with NR UL transmission in time, and its value is the same as TT of standalone E-UTRA or NR transmission. For detailed values refer to Table 6.2B.1.3.5-4.

NOTE 2: TT applies to overall output power with E-UTRA UL transmission overlapping with NR UL transmission in time, and its value is the maximum TT among all E-UTRA and NR UL carriers. For detailed values refer to Table 6.2B.1.3.5-3.

NOTE 3: An uplink DC configuration in which at least one of the bands has NOTE 3 in Table 6.2.1.3-1 in TS 38.521-1 [8] or NOTE 2 in Table 6.2.2.3-1 in TS 36.521-1 [21] is allowed to reduce the lower tolerance limit by 1.5 dB when the transmission bandwidths of at least one of the bands is confined within  $F_{UL\_low}$  and  $F_{UL\_low} + 4$  MHz or  $F_{UL\_high} - 4$  MHz and  $F_{UL\_high}$ .

NOTE 4:  $P_{PowerClass, EN-DC}$  is the maximum UE power specified without taking into account the tolerance.

NOTE 5: For inter-band EN-DC the maximum power requirement should apply to the total transmitted power over all component carriers (per UE).

NOTE 6: Power Class 3 is the default power class unless otherwise stated.

NOTE 7: The UE is not required to support PC2 within each individual cell group. Power class support within each individual cell group is signaled separately by the UE.

NOTE 8: The UE supports PC3 within E-UTRA cell group and supports either PC3 or PC2 within NR cell group. Power class support within each individual cell group is signalled separately by the UE.

NOTE 9: The UE that supports PC3 within a TDD or FDD band and supports PC2 within a second TDD band and indicates support of *higherPowerLimitMRDC-r17* capability.

Table 6.2B.1.3.5-2: Void

**Table 6.2B.1.3.5-2a: Maximum output power for inter-band EN-DC (two bands), for non-overlapping UL transmission for power class 2**

EN-DC configuration	Carrier	Power class 2 (dBm)	Tolerance (dB)	Condition	Comment
DC_1A_n41A	NR carrier	26	+2+TT/-3-TT	Rel-15 UE indicates PC2 on NR band, Rel-16 and forward UE reporting (PC2 by $P_{PowerClass,NR}$ , and PC2 or Not present by <i>powerClassNRPart-r16</i> )	UE meets power class 2 requirements
		23	+2+TT/-3-TT	Rel-15 and forward UE indicates PC3 on NR band, Rel-16 and forward UE reporting (PC2 by $P_{PowerClass,NR}$ , and PC3 by <i>powerClassNRPart-r16</i> )	UE meets power class 3 requirements
	E-UTRA carrier	23	+2+TT/-2-TT	UE indicates PC3 on E-UTRA band	UE meets power class 3 requirements
DC_1A_n77A	NR carrier	26	+2+TT/-3-TT	Rel-15 UE indicates PC2 on NR band, Rel-16 and forward UE reporting (PC2 by $P_{PowerClass,NR}$ , and PC2 or Not present by <i>powerClassNRPart-r16</i> )	UE meets power class 2 requirements
		23	+2+TT/-3-TT	Rel-15 and forward UE indicates PC3 on NR band, Rel-16 and forward UE reporting (PC2 by $P_{PowerClass,NR}$ , and PC3 by <i>powerClassNRPart-r16</i> )	UE meets power class 3 requirements
	E-UTRA carrier	23	+2+TT/-2-TT	UE indicates PC3 on E-UTRA band	UE meets power class 3 requirements
DC_1A_n78A	NR carrier	26	+2+TT/-3-TT	Rel-15 UE indicates PC2 on NR band, Rel-16 and forward UE reporting (PC2 by $P_{PowerClass,NR}$ , and PC2 or Not present by <i>powerClassNRPart-r16</i> )	UE meets power class 2 requirements
		23	+2+TT/-3-TT	Rel-15 and forward UE indicates PC3 on NR band, Rel-16 and forward UE reporting (PC2 by $P_{PowerClass,NR}$ , and PC3 by <i>powerClassNRPart-r16</i> )	UE meets power class 3 requirements
	E-UTRA carrier	23	+2+TT/-2-TT	UE indicates PC3 on E-UTRA band	UE meets power class 3 requirements

DC_1A_n79A	NR carrier	26	+2+TT/-3-TT	Rel-15 UE indicates PC2 on NR band, Rel-16 and forward UE reporting (PC2 by $P_{\text{PowerClass,NR}}$ , and PC2 or Not present by <i>powerClassNRPart-r16</i> )	UE meets power class 2 requirements
		23	+2+TT/-3-TT	Rel-15 and forward UE indicates PC3 on NR band, Rel-16 and forward UE reporting (PC2 by $P_{\text{PowerClass,NR}}$ , and PC3 by <i>powerClassNRPart-r16</i> )	UE meets power class 3 requirements
	E-UTRA carrier	23	+2+TT/-2-TT	UE indicates PC3 on E-UTRA band	UE meets power class 3 requirements
DC_2A_n41A	NR carrier	26	+2+TT/-3-TT	Rel-15 UE indicates PC2 on NR band, Rel-16 and forward UE reporting (PC2 by $P_{\text{PowerClass,NR}}$ , and PC2 or Not present by <i>powerClassNRPart-r16</i> )	UE meets power class 2 requirements
		23	+2+TT/-3-TT	Rel-15 and forward UE indicates PC3 on NR band, Rel-16 and forward UE reporting (PC2 by $P_{\text{PowerClass,NR}}$ , and PC3 by <i>powerClassNRPart-r16</i> )	UE meets power class 3 requirements
	E-UTRA carrier	23	+2+TT/-2-TT	UE indicates PC3 on E-UTRA band	UE meets power class 3 requirements
DC_2A_n77A	NR carrier	26	+2+TT/-3-TT	Rel-15 UE indicates PC2 on NR band, Rel-16 and forward UE reporting (PC2 by $P_{\text{PowerClass,NR}}$ , and PC2 or Not present by <i>powerClassNRPart-r16</i> )	UE meets power class 2 requirements
		23	+2+TT/-3-TT	Rel-15 and forward UE indicates PC3 on NR band, Rel-16 and forward UE reporting (PC2 by $P_{\text{PowerClass,NR}}$ , and PC3 by <i>powerClassNRPart-r16</i> )	UE meets power class 3 requirements
	E-UTRA carrier	23	+2+TT/-2-TT	UE indicates PC3 on E-UTRA band	UE meets power class 3 requirements

DC_3A_n41A	NR carrier	26	+2+TT/-3-TT	Rel-15 UE indicates PC2 on NR band, Rel-16 and forward UE reporting (PC2 by $P_{\text{PowerClass,NR}}$ , and PC2 or Not present by <i>powerClassNRPart-r16</i> )	UE meets power class 2 requirements
		23	+2+TT/-2-TT	Rel-15 and forward UE indicates PC3 on NR band, Rel-16 and forward UE reporting (PC2 by $P_{\text{PowerClass,NR}}$ , and PC3 by <i>powerClassNRPart-r16</i> )	UE meets power class 3 requirements
	E-UTRA carrier	23	+2+TT/-2-TT	UE indicates PC3 on E-UTRA band	UE meets power class 3 requirements
DC_3A_n77A	NR carrier	26	+2+TT/-3-TT	Rel-15 UE indicates PC2 on NR band, Rel-16 and forward UE reporting (PC2 by $P_{\text{PowerClass,NR}}$ , and PC2 or Not present by <i>powerClassNRPart-r16</i> )	UE meets power class 2 requirements
		23	+2+TT/-3-TT	Rel-15 and forward UE indicates PC3 on NR band, Rel-16 and forward UE reporting (PC2 by $P_{\text{PowerClass,NR}}$ , and PC3 by <i>powerClassNRPart-r16</i> )	UE meets power class 3 requirements
	E-UTRA carrier	23	+2+TT/-2-TT	UE indicates PC3 on E-UTRA band	UE meets power class 3 requirements
DC_3A_n78A	NR carrier	26	+2+TT/-3-TT	Rel-15 UE indicates PC2 on NR band, Rel-16 and forward UE reporting (PC2 by $P_{\text{PowerClass,NR}}$ , and PC2 or Not present by <i>powerClassNRPart-r16</i> )	UE meets power class 2 requirements
		23	+2+TT/-3-TT	Rel-15 and forward UE indicates PC3 on NR band, Rel-16 and forward UE reporting (PC2 by $P_{\text{PowerClass,NR}}$ , and PC3 by <i>powerClassNRPart-r16</i> )	UE meets power class 3 requirements
	E-UTRA carrier	23	+2+TT/-2-TT	UE indicates PC3 on E-UTRA band	UE meets power class 3 requirements

DC_3A_n79A	NR carrier	26	+2+TT/-3-TT	Rel-15 UE indicates PC2 on NR band, Rel-16 and forward UE reporting (PC2 by $P_{\text{PowerClass,NR}}$ , and PC2 or Not present by <i>powerClassNRPart-r16</i> )	UE meets power class 2 requirements
		23	+2+TT/-3-TT	Rel-15 and forward UE indicates PC3 on NR band, Rel-16 and forward UE reporting (PC2 by $P_{\text{PowerClass,NR}}$ , and PC3 by <i>powerClassNRPart-r16</i> )	UE meets power class 3 requirements
	E-UTRA carrier	23	+2+TT/-2-TT	UE indicates PC3 on E-UTRA band	UE meets power class 3 requirements
DC_5A_n77A	NR carrier	26	+2+TT/-3-TT	Rel-15 UE indicates PC2 on NR band, Rel-16 and forward UE reporting (PC2 by $P_{\text{PowerClass,NR}}$ , and PC2 or Not present by <i>powerClassNRPart-r16</i> )	UE meets power class 2 requirements
		23	+2+TT/-3-TT	Rel-15 and forward UE indicates PC3 on NR band, Rel-16 and forward UE reporting (PC2 by $P_{\text{PowerClass,NR}}$ , and PC3 by <i>powerClassNRPart-r16</i> ) or UE reporting (PC3 by $P_{\text{PowerClass,NR}}$ )	UE meets power class 3 requirements
	E-UTRA carrier	23	+2+TT/-2-TT	UE indicates PC3 on E-UTRA band	UE meets power class 3 requirements
DC_8A_n78A	NR carrier	26	+2+TT/-3-TT	Rel-15 UE indicates PC2 on NR band, Rel-16 and forward UE reporting (PC2 by $P_{\text{PowerClass,NR}}$ , and PC2 or Not present by <i>powerClassNRPart-r16</i> )	UE meets power class 2 requirements
		23	+2+TT/-3-TT	Rel-15 and forward UE indicates PC3 on NR band, Rel-16 and forward UE reporting (PC2 by $P_{\text{PowerClass,NR}}$ , and PC3 by <i>powerClassNRPart-r16</i> )	UE meets power class 3 requirements
	E-UTRA carrier	23	+2+TT/-2-TT	UE indicates PC3 on E-UTRA band	UE meets power class 3 requirements

DC_12A_n77A	NR carrier	26	+2+TT/-3-TT	Rel-15 UE indicates PC2 on NR band, Rel-16 and forward UE reporting (PC2 by $P_{PowerClass,NR}$ , and PC2 or Not present by <i>powerClassNRPart-r16</i> )	UE meets power class 2 requirements
		23	+2+TT/-3-TT	Rel-15 and forward UE indicates PC3 on NR band, Rel-16 and forward UE reporting (PC2 by $P_{PowerClass,NR}$ , and PC3 by <i>powerClassNRPart-r16</i> )	UE meets power class 3 requirements
	E-UTRA carrier	23	+2+TT/-2-TT	UE indicates PC3 on E-UTRA band	UE meets power class 3 requirements
DC_13A_n77A	NR carrier	26	+2+TT/-3-TT	Rel-15 UE indicates PC2 on NR band, Rel-16 and forward UE reporting (PC2 by $P_{PowerClass,NR}$ , and PC2 or Not present by <i>powerClassNRPart-r16</i> )	UE meets power class 2 requirements
		23	+2+TT/-3-TT	Rel-15 and forward UE indicates PC3 on NR band, Rel-16 and forward UE reporting (PC2 by $P_{PowerClass,NR}$ , and PC3 by <i>powerClassNRPart-r16</i> )	UE meets power class 3 requirements
	E-UTRA carrier	23	+2+TT/-2-TT	UE indicates PC3 on E-UTRA band	UE meets power class 3 requirements
DC_14A_n77A	NR carrier	26	+2+TT/-3-TT	Rel-15 UE indicates PC2 on NR band, Rel-16 and forward UE reporting (PC2 by $P_{PowerClass,NR}$ , and PC2 or Not present by <i>powerClassNRPart-r16</i> )	UE meets power class 2 requirements
		23	+2+TT/-3-TT	Rel-15 and forward UE indicates PC3 on NR band, Rel-16 and forward UE reporting (PC2 by $P_{PowerClass,NR}$ , and PC3 by <i>powerClassNRPart-r16</i> )	UE meets power class 3 requirements
	E-UTRA carrier	23	+2+TT/-2-TT	UE indicates PC3 on E-UTRA band	UE meets power class 3 requirements



DC_18A_n77A	NR carrier	26	+2+TT/-3-TT	Rel-15 UE indicates PC2 on NR band, Rel-16 and forward UE reporting (PC2 by $P_{PowerClass,NR}$ , and PC2 or Not present by <i>powerClassNRPart-r16</i> )	UE meets power class 2 requirements
		23	+2+TT/-3-TT	Rel-15 and forward UE indicates PC3 on NR band, Rel-16 and forward UE reporting (PC2 by $P_{PowerClass,NR}$ , and PC3 by <i>powerClassNRPart-r16</i> )	UE meets power class 3 requirements
	E-UTRA carrier	23	+2+TT/-2-TT	UE indicates PC3 on E-UTRA band	UE meets power class 3 requirements
DC_19A_n78A	NR carrier	26	+2+TT/-3-TT	Rel-15 UE indicates PC2 on NR band, Rel-16 and forward UE reporting (PC2 by $P_{PowerClass,NR}$ , and PC2 or Not present by <i>powerClassNRPart-r16</i> )	UE meets power class 2 requirements
		23	+2+TT/-3-TT	Rel-15 and forward UE indicates PC3 on NR band, Rel-16 and forward UE reporting (PC2 by $P_{PowerClass,NR}$ , and PC3 by <i>powerClassNRPart-r16</i> )	UE meets power class 3 requirements
	E-UTRA carrier	23	+2+TT/-2-TT	UE indicates PC3 on E-UTRA band	UE meets power class 3 requirements
DC_19A_n79A	NR carrier	26	+2+TT/-3-TT	Rel-15 UE indicates PC2 on NR band, Rel-16 and forward UE reporting (PC2 by $P_{PowerClass,NR}$ , and PC2 or Not present by <i>powerClassNRPart-r16</i> )	UE meets power class 2 requirements
		23	+2+TT/-3-TT	Rel-15 and forward UE indicates PC3 on NR band, Rel-16 and forward UE reporting (PC2 by $P_{PowerClass,NR}$ , and PC3 by <i>powerClassNRPart-r16</i> )	UE meets power class 3 requirements
	E-UTRA carrier	23	+2+TT/-2-TT	UE indicates PC3 on E-UTRA band	UE meets power class 3 requirements

DC_21A_n78A	NR carrier	26	+2+TT/-3-TT	Rel-15 UE indicates PC2 on NR band, Rel-16 and forward UE reporting (PC2 by $P_{\text{PowerClass,NR}}$ , and PC2 or Not present by <i>powerClassNRPart-r16</i> )	UE meets power class 2 requirements
		23	+2+TT/-3-TT	Rel-15 and forward UE indicates PC3 on NR band, Rel-16 and forward UE reporting (PC2 by $P_{\text{PowerClass,NR}}$ , and PC3 by <i>powerClassNRPart-r16</i> )	UE meets power class 3 requirements
	E-UTRA carrier	23	+2+TT/-2-TT	UE indicates PC3 on E-UTRA band	UE meets power class 3 requirements
DC_21A_n79A	NR carrier	26	+2+TT/-3-TT	Rel-15 UE indicates PC2 on NR band, Rel-16 and forward UE reporting (PC2 by $P_{\text{PowerClass,NR}}$ , and PC2 or Not present by <i>powerClassNRPart-r16</i> )	UE meets power class 2 requirements
		23	+2+TT/-3-TT	Rel-15 and forward UE indicates PC3 on NR band, Rel-16 and forward UE reporting (PC2 by $P_{\text{PowerClass,NR}}$ , and PC3 by <i>powerClassNRPart-r16</i> )	UE meets power class 3 requirements
	E-UTRA carrier	23	+2+TT/-2-TT	UE indicates PC3 on E-UTRA band	UE meets power class 3 requirements
DC_28A_n77A	NR carrier	26	+2+TT/-3-TT	Rel-15 UE indicates PC2 on NR band, Rel-16 and forward UE reporting (PC2 by $P_{\text{PowerClass,NR}}$ , and PC2 or Not present by <i>powerClassNRPart-r16</i> )	UE meets power class 2 requirements
		23	+2+TT/-3-TT	Rel-15 and forward UE indicates PC3 on NR band, Rel-16 and forward UE reporting (PC2 by $P_{\text{PowerClass,NR}}$ , and PC3 by <i>powerClassNRPart-r16</i> )	UE meets power class 3 requirements
	E-UTRA carrier	23	+2+TT/-2-TT	UE indicates PC3 on E-UTRA band	UE meets power class 3 requirements

DC_28A_n78A	NR carrier	26	+2+TT/-3-TT	Rel-15 UE indicates PC2 on NR band, Rel-16 and forward UE reporting (PC2 by $P_{PowerClass,NR}$ , and PC2 or Not present by <i>powerClassNRPart-r16</i> )	UE meets power class 2 requirements
		23	+2+TT/-3-TT	Rel-15 and forward UE indicates PC3 on NR band, Rel-16 and forward UE reporting (PC2 by $P_{PowerClass,NR}$ , and PC3 by <i>powerClassNRPart-r16</i> )	UE meets power class 3 requirements
	E-UTRA carrier	23	+2+TT/-2-TT	UE indicates PC3 on E-UTRA band	UE meets power class 3 requirements
DC_30A_n77A	NR carrier	26	+2+TT/-3-TT	Rel-15 UE indicates PC2 on NR band, Rel-16 and forward UE reporting (PC2 by $P_{PowerClass,NR}$ , and PC2 or Not present by <i>powerClassNRPart-r16</i> )	UE meets power class 2 requirements
		23	+2+TT/-3-TT	Rel-15 and forward UE indicates PC3 on NR band, Rel-16 and forward UE reporting (PC2 by $P_{PowerClass,NR}$ , and PC3 by <i>powerClassNRPart-r16</i> )	UE meets power class 3 requirements
	E-UTRA carrier	23	+2+TT/-2-TT	UE indicates PC3 on E-UTRA band	UE meets power class 3 requirements
DC_39A_n41A	NR carrier	26	+2+TT/-3-TT	Rel-15 UE indicates PC2 on NR band, Rel-16 and forward UE reporting (PC2 by $P_{PowerClass,NR}$ , and PC2 or Not present by <i>powerClassNRPart-r16</i> )	UE meets power class 2 requirements
		23	+2+TT/-2-TT	Rel-15 and forward UE indicates PC3 on NR band, Rel-16 and forward UE reporting (PC2 by $P_{PowerClass,NR}$ , and PC3 by <i>powerClassNRPart-r16</i> )	UE meets power class 3 requirements
	E-UTRA carrier	23	+2+TT/-2-TT	UE indicates PC3 on E-UTRA band	UE meets power class 3 requirements

DC_39A_n79A	NR carrier	26	+2+TT/-3-TT	Rel-15 UE indicates PC2 on NR band, Rel-16 and forward UE reporting (PC2 by $P_{PowerClass,NR}$ , and PC2 or Not present by <i>powerClassNRPart-r16</i> )	UE meets power class 2 requirements
		23	+2+TT/-3-TT	Rel-15 and forward UE indicates PC3 on NR band, Rel-16 and forward UE reporting (PC2 by $P_{PowerClass,NR}$ , and PC3 by <i>powerClassNRPart-r16</i> )	UE meets power class 3 requirements
	E-UTRA carrier	23	+2+TT/-2-TT	UE indicates PC3 on E-UTRA band	UE meets power class 3 requirements
DC_41A_n77A	NR carrier	26	+2+TT/-3-TT	Rel-15 UE indicates PC2 on NR band, Rel-16 and forward UE reporting (PC2 by $P_{PowerClass,NR}$ , and PC2 or Not present by <i>powerClassNRPart-r16</i> )	UE meets power class 2 requirements
		23	+2+TT/-3-TT	Rel-15 and forward UE indicates PC3 on NR band, Rel-16 and forward UE reporting (PC2 by $P_{PowerClass,NR}$ , and PC3 by <i>powerClassNRPart-r16</i> )	UE meets power class 3 requirements
	E-UTRA carrier	23	+2+TT/-2-TT	UE indicates PC3 on E-UTRA band	UE meets power class 3 requirements
DC_41A_n79A	NR carrier	26	+2+TT/-3-TT	Rel-15 UE indicates PC2 on NR band, Rel-16 and forward UE reporting (PC2 by $P_{PowerClass,NR}$ , and PC2 or Not present by <i>powerClassNRPart-r16</i> )	UE meets power class 2 requirements
		23	+2+TT/-3-TT	Rel-15 and forward UE indicates PC3 on NR band, Rel-16 and forward UE reporting (PC2 by $P_{PowerClass,NR}$ , and PC3 by <i>powerClassNRPart-r16</i> )	UE meets power class 3 requirements
	E-UTRA carrier	26	+2+TT/-2-TT	UE indicates PC2 on E-UTRA band	UE meets power class 2 requirements
		23	+2+TT/-2-TT	UE indicates PC3 on E-UTRA band	UE meets power class 3 requirements

DC_66A_n77A	NR carrier	26	+2+TT/-3-TT	Rel-15 UE indicates PC2 on NR band, Rel-16 and forward UE reporting (PC2 by $P_{PowerClass,NR}$ , and PC2 or Not present by <i>powerClassNRPart-r16</i> )	UE meets power class 2 requirements
		23	+2+TT/-3-TT	Rel-15 and forward UE indicates PC3 on NR band, Rel-16 and forward UE reporting (PC2 by $P_{PowerClass,NR}$ , and PC3 by <i>powerClassNRPart-r16</i> )	UE meets power class 3 requirements
	E-UTRA carrier	23	+2+TT/-2-TT	UE indicates PC3 on E-UTRA band	UE meets power class 3 requirements
<p>NOTE 1: TT applies to output power in each UL carrier with E-UTRA UL transmission not overlapping with NR UL transmission in time, and its value is the same as TT of standalone E-UTRA or NR transmission. For detailed values refer to Table 6.2B.1.3.5-4.</p> <p>NOTE 2: An uplink DC configuration in which at least one of the bands has NOTE 3 in Table 6.2.1.3-1 in TS 38.521-1 [8] or NOTE 2 in Table 6.2.2.3-1 in TS 36.521-1 [21] is allowed to reduce the lower tolerance limit by 1.5 dB when the transmission bandwidths of at least one of the bands is confined within <math>F_{UL\_low}</math> and <math>F_{UL\_low} + 4</math> MHz or <math>F_{UL\_high} - 4</math> MHz and <math>F_{UL\_high}</math>.</p> <p>NOTE 3: <math>P_{PowerClass, EN-DC}</math> is the maximum UE power specified without taking into account the tolerance.</p>					

**Table 6.2B.1.3.5-3: Test Tolerance for UE maximum output power (Overlapping UL transmission)**

TT for overall output power											
			NR								
			BW ≤ 20MHz			20 MHz < BW ≤ 40MHz			40MHz < BW ≤ 100MHz		
			f ≤ 3.0GHz	3.0GHz < f ≤ 4.2GHz	4.2GHz < f ≤ 6.0GHz	f ≤ 3.0GHz	3.0GHz < f ≤ 4.2GHz	4.2GHz < f ≤ 6.0GHz	f ≤ 3.0GHz	3.0GHz < f ≤ 4.2GHz	4.2GHz < f ≤ 6.0GHz
E-UTRA	BW ≤ 20MHz	f ≤ 3.0GHz	0.7 dB	1.0 dB	1.0 dB	0.7 dB	1.0 dB	1.0 dB	1.0 dB	1.0 dB	1.0 dB
		3.0GHz < f ≤ 4.2GHz	1.0 dB	1.0 dB	1.0 dB	1.0 dB	1.0 dB	1.0 dB	1.0 dB	1.0 dB	1.0 dB

**Table 6.2B.1.3.5-4: Test Tolerance for UE maximum output power (Separate measurements over E-UTRA and NR CCs)**

Uplink TX		f ≤ 3.0GHz	3.0GHz < f ≤ 4.2GHz	4.2GHz < f ≤ 6GHz
E-UTRA	BW ≤ 20MHz	0.7 dB	1.0 dB	N/A
NR	BW ≤ 40MHz	0.7 dB	1.0 dB	1.0 dB
	40MHz < BW ≤ 100MHz	1.0 dB	1.0 dB	1.0 dB

6.2B.1.3\_1 UE Maximum Output Power for Inter-Band EN-DC within FR1 (2 E-UTRA CCs, 1 NR CC)

6.2B.1.3\_1.1 Test purpose

Same test purpose as in clause 6.2B.1.3.1

## 6.2B.1.3\_1.2 Test applicability

This test applies to all types of E-UTRA UE release 16 and forward, supporting inter-band EN-DC with 2 E-UTRA CCs and 1 NR CC operating on FR1.

## 6.2B.1.3\_1.3 Minimum conformance requirements

For inter-band EN-DC of E-UTRA and NR in FR1, the following UE Power Classes define the maximum output power for any transmission bandwidth within the aggregated channel bandwidth. The maximum output power is measured as the sum of the maximum output power at each UE antenna connector. The period of measurement shall be at least one sub frame (1ms). UE maximum output power shall be measured over all component carriers from different bands. If each band has separate antenna connectors, maximum output power is measured as the sum of maximum output power at each UE antenna connector.

**Table 6.2B.1.3\_1.3-1: Maximum output power for inter-band EN-DC (two bands)**

EN-DC configuration	Power class 2 (dBm)	Tolerance (dB)	Power class 3 (dBm)	Tolerance (dB)
DC_7C_n78A			23	+2/-3
<p>NOTE 1: For the transmission bandwidths confined within <math>F_{UL\_low}</math> and <math>F_{UL\_low} + 4</math> MHz or <math>F_{UL\_high} - 4</math> MHz and <math>F_{UL\_high}</math>, the maximum output power requirement is relaxed by reducing the lower tolerance limit by 1.5 dB.</p> <p>NOTE 2: <math>P_{PowerClass, EN-DC}</math> is the maximum UE power specified without taking into account the tolerance.</p> <p>NOTE 3: For inter-band EN-DC the maximum power requirement should apply to the total transmitted power over all component carriers (per UE).</p> <p>NOTE 4: Power Class 3 is the default power class unless otherwise stated.</p> <p>NOTE 5: The UE is not required to support PC2 within each individual cell group. Power class support within each individual cell group is signalled separately by the UE.</p> <p>NOTE 6: The UE supports PC3 within E-UTRA cell group, and supports either PC3 or PC2 within NR cell group. Power class support within each individual cell group is signalled separately by the UE.</p>				

The normative reference for this requirement is TS 38.101-3 [4] clause 6.2B.1.

LTE anchor agnostic approach is not applied. E-UTRA test point analysis is included and E-UTRA measurements are performed.

## 6.2B.1.3\_1.4 Test description

## 6.2B.1.3\_1.4.1 Initial condition

Initial conditions are a set of test configurations the UE needs to be tested in and the steps for the SS to take with the UE to reach the correct measurement state.

The initial test configurations consist of environmental conditions, test frequencies, DC configuration specified in clause 5.5B.4 and test channel bandwidths specified in TS 36.508 [11] clause 4.3.1 and TS 38.508-1 [6] clause 4.3.1, and sub-carrier spacing based on NR operating bands specified in TS 38.521-1 [8] clause 5.3. All of these configurations shall be tested with applicable test parameters for each EN-DC configuration, and are shown in table 6.2B.1.3\_1.4.1-1. The details of the uplink reference measurement channels (RMCs) are specified in Annex A, clause A.2.2 for E-UTRA RMC for TDD, TS 36.521-1 [10] Annex A, clause A.2.2 for E-UTRA RMC for FDD, and TS 38.521-1 [8] Annex A, clause A.2 for NR RMC. Configurations of PDSCH and PDCCH before measurement are specified in TS 36.521-1 [10] Annex C, clause C.2 and in TS 38.521-1 [8] Annex C, clause C.2 for E-UTRA CG and NR CG respectively.

**Table 6.2B.1.3\_1.4.1-1: Test configuration table**

Default Conditions								
Test Environment as specified in TS 38.508-1 [6] clause 4.1				Normal, TL/VL, TL/VH, TH/VL, TH/VH				
Test Frequencies as specified in TS 38.508-1 [6] clause 4.3.1 and TS 36.508 [6]				Low range for MCG and SCG, High range for MCG and SCG				
Test EN-DC channel bandwidth as specified in TS 36.508 [6] clause 4.3.1 and TS 38.508-1 clause 4.3.1				Lowest N <sub>RB_agg</sub> for E-UTRA CCs and Lowest for NR CC1, Highest N <sub>RB_agg</sub> for E-UTRA CCs and Highest for NR CC1				
Test SCS for the NR cell as specified in TS 38.521-1 [8] Table 5.3.5-1				Lowest, Highest				
Test Parameters								
Test ID	Test Freq	E-UTRA BW	NR BW	Downlink Configuration	EN-DC Uplink Configuration			
					MCG – EUTRA PCC&SCC		SCG - NR	
					Modulation	RB allocation (NOTE 1)	Modulation (NOTE 3)	RB allocation (NOTE 2)
1	High	Default	Default	N/A	QPSK	1RB_Right	DFT-s-OFDM Pi/2 BPSK	Inner_1RB_Right
2	Low	Default	Default		QPSK	1RB_Left	DFT-s-OFDM Pi/2 BPSK	Inner_1RB_Left
3	Default	Default	Default		QPSK	Partial_Allocation	DFT-s-OFDM Pi/2 BPSK	Inner_Full
4	High	Default	Default		QPSK	1RB_Right	DFT-s-OFDM QPSK	Inner_1RB_Right
5	Low	Default	Default		QPSK	1RB_Left	DFT-s-OFDM QPSK	Inner_1RB_Left
6	Default	Default	Default		QPSK	Partial_Allocation	DFT-s-OFDM QPSK	Inner_Full
7	High	Lowest N <sub>RB_agg</sub> , Highest N <sub>RB_agg</sub>	Lowest		QPSK	1RB_Right	N/A	N/A
8	Low	Lowest N <sub>RB_agg</sub> , Highest N <sub>RB_agg</sub>	Lowest		QPSK	1RB_Left	N/A	N/A
9	Default	Lowest N <sub>RB_agg</sub> , Highest N <sub>RB_agg</sub>	Lowest		QPSK	Partial_Allocation	N/A	N/A
10	High	Lowest N <sub>RB_agg</sub>	Lowest, Highest		N/A	N/A	DFT-s-OFDM Pi/2 BPSK	Inner_1RB_Right
11	Low	Lowest N <sub>RB_agg</sub>	Lowest, Highest		N/A	N/A	DFT-s-OFDM Pi/2 BPSK	Inner_1RB_Left
12	Default	Lowest N <sub>RB_agg</sub>	Lowest, Highest		N/A	N/A	DFT-s-OFDM Pi/2 BPSK	Inner_Full
13	High	Lowest N <sub>RB_agg</sub>	Lowest, Highest		N/A	N/A	DFT-s-OFDM QPSK	Inner_1RB_Right
14	Low	Lowest N <sub>RB_agg</sub>	Lowest, Highest		N/A	N/A	DFT-s-OFDM QPSK	Inner_1RB_Left
15	Default	Lowest N <sub>RB_agg</sub>	Lowest, Highest		N/A	N/A	DFT-s-OFDM QPSK	Inner_Full
<p>NOTE 1: The specific configuration of each RB allocation is defined in Table 6.1-2 in current specification. For 1RB_Left allocation, the PCC is located on the lower frequency while SCC is located on the higher frequency. For 1RB_Right allocation, the PCC is located on the higher frequency while SCC is located on the lower frequency.</p> <p>NOTE 2: The specific configuration of each RB allocation is defined in Table 6.1-1 in TS 38.521-1 [8].</p> <p>NOTE 3: DFT-s-OFDM Pi/2 BPSK test applies only for UEs which supports Pi/2 BPSK in NR FR1.</p>								

1. Connect the SS to the UE antenna connectors as shown in TS 38.508-1 [6] clause A.3.1.1 for SS and clause A.3.2.1 for UE.

2. The parameter settings for the E-UTRA cell are set up according to TS 36.508 [11] clause 4.4.3, and the parameter settings for the NR cell are set up according to TS 38.508-1 [6] clause 4.4.3.
3. Downlink signals are initially set up according to TS 36.521-1 [10] Annex C.0 and TS 38.521-1 [8] Annex C.0 for E-UTRA CG PCC and NR CG respectively, and uplink signals according to TS 36.521-1 [10] Annex H and TS 38.521-1 [8] Annex G for E-UTRA CG and NR CG respectively.
4. The UL Reference Measurement channels are set according to Table 6.2B.1.3\_1.3-1.
5. Propagation conditions are set for E-UTRA CG and NR CG respectively.
6. Ensure the UE is in state RRC\_CONNECTED with generic procedure parameters Connectivity EN-DC, DC bearer *MCG* and *SCG*, Connected without release *On* according to TS 38.508-1 [6] clause 4.5. Message contents are defined in clause 6.2B.1.3\_1.4.3.
7. For the case of testing overlapping E-UTRA and NR UL transmission scenario when both bands are TDD, ensure E-UTRA UL transmission overlaps with NR UL transmission in time by giving SCG a delay of 3 E-UTRA subframes, or by giving MCG a delay of 2 subframes.

#### 6.2B.1.3\_1.4.2 Test procedure

1. Configure E-UTRA SCC according to TS 36.521-1 [10] Annex C.0, C.1 and Annex C.3.0 for all E-UTRA downlink physical channels.
2. The SS shall configure SCC as per TS 36.508 [11] clause 5.2A.4. Message contents are defined in clause 6.2B.1.3\_1.4.3.
3. SS activates SCC by sending the activation MAC-CE (Refer TS 36.321, clauses 5.13, 6.1.3.8). Wait for at least 2 seconds (Refer TS 36.133 [12], clauses 8.3.3.2).
4. SS sends uplink scheduling information for each UL HARQ process via PDCCH DCI format 0 and DCI format 0\_1 for C\_RNTI to schedule the UL RMC according to Table 6.2B.1.3\_1.4.1-1 on E-UTRA PCC and SCC and NR CC respectively. Since the UL has no payload and no loopback data to send the UE sends uplink MAC padding bits on the UL RMC.
5. Send continuously uplink power control "up" commands in every uplink scheduling information to the UE until the UE transmits at its  $P_{UMAX}$  level; allow at least 200 ms from the first TPC command for the UE to reach  $P_{UMAX}$  level.
6. For test ID 1~6 measure the sum of mean transmitted power over all EN-DC component carriers in the EN-DC, which shall meet the requirements described in table 6.2B.1.3\_1.5-1 and the period of the measurement shall be at least the continuous duration of one active sub-frame.

For test ID 7~9 measure the sum of mean transmitted power over all E-UTRA component carriers, which shall meet the requirements described in Table 6.2.2A.1.5-1 in TS 36.521-1 [10]. The period of the measurement shall be at least the continuous duration of one active sub-frame.

For test ID 10~15 measure the mean transmitted power over NR carrier, which shall meet the requirements described in Table 6.2.1.5-1 in TS 38.521-1 [8] respectively. The period of the measurement shall be at least the continuous duration of one active sub-frame.

#### 6.2B.1.3\_1.4.3 Message contents

Message contents are according to TS 36.508 [11] clause 4.6.1 and TS 38.508-1 [6] clause 4.6.1 with the following exceptions:

**Table 6.2B.1.3\_1.4.3-1: PUSCH-Config**

Derivation Path: TS 38.508-1 [6], Table 4.6.3-118 with condition TRANSFORM_PRECODER_ENABLED
---



**Table 6.2B.1.3\_1.4.3-2: PhysicalCellGroupConfig**

Derivation Path: TS 38.508-1 [6], Table 4.6.3-106			
Information Element	Value/remark	Comment	Condition
PhysicalCellGroupConfig ::= SEQUENCE {			
p-NR-FR1	20	For simultaneous E-UTRA and NR transmission	Power Class 3 UE Test IDs 1-6
	23	For Test IDs 7~9 NR carrier is configured but not measured.	Power Class 3 UE Test IDs 7-15
}			

**Table 6.2B.1.3\_1.4.3-3: RRCConnectionReconfiguration: nr-Config-r15**

Derivation Path: TS 36.508 [11], Table 4.6.1-8			
Information Element	Value/remark	Comment	Condition
p-MaxEUTRA-r15	20	For simultaneous E-UTRA and NR transmission	Power Class 3 UE Test IDs 1-6
	23	For Test IDs 10~15 E-UTRA carrier is configured but not measured.	Power Class 3 UE Test IDs 7-15

**Table 6.2B.1.3\_1.4.3-4: RRCConnectionReconfiguration: tdm-PatternConfig if E-UTRA on FDD band and UE does not support dynamic power sharing**

Derivation Path: TS 36.508 [11], Table 4.6.1-8			
Information Element	Value/remark	Comment	Condition
tdm-PatternConfig-r15 CHOICE{			Test IDs 7-15
setup SEQUENCE {			
subframeAssignment-r15	sa2		
harq-Offset-r15	0		
}			
}			

**Table 6.2B.1.3\_1.4.3-5: SystemInformationBlockType1: tdd-Config if E-UTRA on TDD band**

Derivation Path: TS 36.508 [11], Table 4.6.3-23			
Information Element	Value/remark	Comment	Condition
TDD-Config-DEFAULT ::= SEQUENCE {		Operating on TDD band	
subframeAssignment	sa2		
specialSubframePatterns	ssp7		
}			

### 6.2B.1.3\_1.5 Test requirements

For test ID 1~6 the maximum output power for the DC configuration, derived in step 6 shall be within the range prescribed by the UE Power Class and tolerance in Table 6.2B.1.3\_1.5-1.

For test ID 7~15 the maximum output power for the DC configuration, derived in step 6 shall be within the range prescribed by the UE Power Class and tolerance in Table 6.2.2A.1.5-1 in TS 36.521-1 [10] or Table 6.2.1.5-1 in TS 38.521-1 [8] for E-UTRA CG and NR CG respectively for Power class 3.

**Table 6.2B.1.3\_1.5-1: Maximum output power for inter-band EN-DC (two bands), for overlapping UL transmission**

EN-DC configuration	Power class 2 (dBm)	Tolerance (dB)	Power class 3 (dBm)	Tolerance (dB)
DC_7C_n78A			23	+2+TT/-3-TT
<p>NOTE 1: TT applies to output power in each UL carrier with E-UTRA UL transmission not overlapping with NR UL transmission in time, and its value is the same as TT of standalone E-UTRA or NR transmission. For detailed values refer to Table 6.2B.1.3_1.5-2.</p> <p>NOTE 2: TT applies to overall output power with E-UTRA UL transmission overlapping with NR UL transmission in time, and its value is the maximum TT among all E-UTRA and NR UL carriers. For detailed values refer to Table 6.2B.1.3_1.5-2.</p> <p>NOTE 3: For the transmission bandwidths confined within <math>F_{UL\_low}</math> and <math>F_{UL\_low} + 4</math> MHz or <math>F_{UL\_high} - 4</math> MHz and <math>F_{UL\_high}</math>, the maximum output power requirement is relaxed by reducing the lower tolerance limit by 1.5 dB.</p> <p>NOTE 4: <math>P_{PowerClass, EN-DC}</math> is the maximum UE power specified without taking into account the tolerance.</p> <p>NOTE 5: For inter-band EN-DC the maximum power requirement should apply to the total transmitted power over all component carriers (per UE).</p> <p>NOTE 6: Power Class 3 is the default power class unless otherwise stated.</p> <p>NOTE 7: The UE is not required to support PC2 within each individual cell group. Power class support within each individual cell group is signalled separately by the UE.</p> <p>NOTE 8: The UE supports PC3 within E-UTRA cell group, and supports either PC3 or PC2 within NR cell group. Power class support within each individual cell group is signalled separately by the UE.</p>				

**Table 6.2B.1.3\_1.5-2: Test Tolerance for UE maximum output power (Overlapping UL transmission)**

		TT for overall output power									
		NR									
		BW ≤ 20MHz			20 MHz < BW ≤ 40MHz			40MHz < BW ≤ 100MHz			
		f ≤ 3.0GHz	3.0GHz < f ≤ 4.2GHz	4.2GHz < f ≤ 6.0GHz	f ≤ 3.0GHz	3.0GHz < f ≤ 4.2GHz	4.2GHz < f ≤ 6.0GHz	f ≤ 3.0GHz	3.0GHz < f ≤ 4.2GHz	4.2GHz < f ≤ 6.0GHz	
E-UTRA	BW ≤ 20MHz	f ≤ 3.0GHz	0.7 dB	1.0 dB	1.0 dB	0.7 dB	1.0 dB	1.0 dB	1.0 dB	1.0 dB	1.0 dB
		3.0GHz < f ≤ 4.2GHz	1.0 dB	1.0 dB	1.0 dB	1.0 dB	1.0 dB	1.0 dB	1.0 dB	1.0 dB	1.0 dB

**6.2B.1.3a UE Maximum Output Power for Inter-Band NE-DC within FR1**

**6.2B.1.3a.1 Test purpose**

Same test purpose as in clause 6.2B.1.3.1.

**6.2B.1.3a.2 Test applicability**

This test applies to all types of E-UTRA UE release 15 and forward, supporting inter-band NE-DC operating on FR1.

**6.2B.1.3a.3 Minimum conformance requirements**

For inter-band NE-DC of E-UTRA and NR in FR1, the following UE power classes define the maximum output power for any transmission bandwidth within the aggregated channel bandwidth. The maximum output power is measured as the sum of the maximum output power at each UE antenna connector. The period of measurement shall be at least one sub frame (1 ms). UE maximum output power shall be measured over all component carriers from different bands. If each band has separate antenna connectors, maximum output power is measured as the sum of maximum output power at each UE antenna connector.

**Table 6.2B.1.3a.3-1: Maximum output power for inter-band NE-DC (two bands)**

NE-DC configuration	Power class 3 (dBm)	Tolerance (dB)
DC_n28A_3A DC_n28A_3C	23	+2/-3
DC_n28A_39A	23	+2/-3

The normative reference for this requirement is TS 38.101-3 [4] clause 6.2B.1.3a.

#### 6.2B.1.3a.4 Test description

##### 6.2B.1.3a.4.1 Initial condition

Same initial condition as in clause 6.2B.1.3.4.1 with the following exception:

Step 6 of Initial conditions will be updated as below:

- Ensure the UE is in state RRC\_CONNECTED with generic procedure parameters Connectivity NE-DC, DC bearer *MCG* and *SCG*, Connected without release *On* according to TS 38.508-1 [6] clause 4.5. Message contents are defined in clause 6.2B.1.3a.4.3.

##### 6.2B.1.3a.4.2 Test procedure

Same test procedure as in clause 6.2B.1.3.4.2

##### 6.2B.1.3a.4.3 Message contents

Same message contents as in clause 6.2B.1.3.4.3.

##### 6.2B.1.3a.5 Test requirements

For test ID 1~6 the maximum output power for the DC configuration, derived in step 3 shall be within the range prescribed by the UE Power Class and tolerance in Table 6.2B.1.3a.5-1 for NE-DC.

**Table 6.2B.1.3a.5-1: Maximum output power for inter-band NE-DC (two bands), for overlapping UL transmission**

NE-DC configuration	Power class 3 (dBm)	Tolerance (dB)
DC_n28A_3A DC_n28A_3C	23	+2+TT/-3-TT
DC_n28A_39A	23	+2+TT/-3-TT

Same Test Tolerance as in Table 6.2B.1.3.5-3.

#### 6.2B.1.4 UE Maximum Output Power for Inter-Band EN-DC including FR2

##### 6.2B.1.4.1 UE Maximum Output Power for Inter-Band EN-DC including FR2 (1 NR CC) - EIRP and TRP

**Editor's note: The following aspects are either missing or not yet determined:**

- The referred test case 6.2.1.1 in TS 38.521-2 is incomplete for power class other than 1, 3, 5,6 and 7.

##### 6.2B.1.4.1.1 Test purpose

Same test purpose as in clause 6.2.1.1.1 in TS 38.521-2 [9] for the NR carrier.

#### 6.2B.1.4.1.2 Test applicability

This test case applies to all types of E-UTRA UE release 15 and forward, supporting inter-band EN-DC including FR2 with 1 NR UL CC.

#### 6.2B.1.4.1.3 Minimum conformance requirements

UE maximum output power requirement for E-UTRA single carrier and CA operation specified in subclauses 6.2.2 and 6.2.2A of TS 36.101 [10] and for NR single carrier and CA operation specified in subclause 6.2.1, 6.2A.1, and 6.2D.1 of TS 38.101-2 [9] apply.

No exception requirements applicable to NR or E-UTRA. LTE anchor agnostic approach is applied.

The normative reference for this requirement is TS 38.101-3 [4] clause 6.2B.1.4.

#### 6.2B.1.4.1.4 Test description

Same test description as in clause 6.2.1.1.4 in TS 38.521-2 [9] for the *NR* carrier with the following exception:

The initial test configurations for E-UTRA band consist of environmental conditions, test frequencies, and channel bandwidths based on E-UTRA bands specified in Table 4.7-1.

For initial conditions as in clause 6.2.1.1.4.1 in TS 38.521-2 [9], the following steps will be added to configure E-UTRA component:

2.1 The parameter settings for E-UTRA cell are set up according to TS 36.508 [11] clause 4.4.3.

3.1 The E-UTRA downlink signal level, uplink signal level are set according to Table 4.7-1 and propagation conditions are set according to Annex B.0 of TS 36.521-1 [10].

Step 6 of Initial conditions as in clause 6.2.1.1.4.1 in TS 38.521-2 [9] is replaced by:

6. Ensure the UE is in state RRC\_CONNECTED with generic procedure parameters Connectivity EN-DC, DC bearer MCG and SCG, Connected without release On according to TS 38.508-1 [6] clause 4.5.

Same test procedure as in clause 6.2.1.1.4.2 in TS 38.521-2 [9] with the following steps added for E-UTRA component:

1.1 On the E-UTRA carrier, disable periodic and aperiodic CQI reports, disable SRS, set *TimeAlignmentTimerDedicated* IE to infinity and disable downlink and uplink scheduling, all as per Table 4.7-1 under clause 4.7.

#### 6.2B.1.4.1.5 Test requirement

Same test requirement as in clause 6.2.1.1.5 in TS 38.521-2 [9] for the *NR* carrier.

#### 6.2B.1.4.2 UE Maximum Output Power for Inter-Band EN-DC including FR2 (1 NR CC) - Spherical Coverage

**Editor's note: The following aspects are either missing or not yet determined:**

- **Measurement Uncertainties and Test Tolerances are FFS for power class other than 1, 3, 5 and 7.**

#### 6.2B.1.4.2.1 Test purpose

Same test purpose as in clause 6.2.1.2.1 in TS 38.521-2 [9] for the *NR* carrier.

#### 6.2B.1.4.2.2 Test applicability

This test case applies to all types of E-UTRA UE release 15 and forward, supporting inter-band EN-DC including FR2 with 1 NR UL CC.

### 6.2B.1.4.2.3 Minimum conformance requirements

UE maximum output power requirement for E-UTRA single carrier and CA operation specified in subclauses 6.2.2 and 6.2.2A of TS 36.101 [10] and for NR single carrier and CA operation specified in subclause 6.2.1, 6.2A.1, and 6.2D.1 of TS 38.101-2 [9] apply.

No exception requirements applicable to NR or E-UTRA. LTE anchor agnostic approach is applied.

The normative reference for this requirement is TS 38.101-3 [4] clause 6.2B.1.4.

### 6.2B.1.4.2.4 Test description

Same test description as in clause 6.2.1.2.4 in TS 38.521-2 [9] for the *NR* carrier with the following exception:

The initial test configurations for E-UTRA band consist of environmental conditions, test frequencies, and channel bandwidths based on E-UTRA bands specified in Table 4.7-1.

For initial conditions as in clause 6.2.1.2.4.1 in TS 38.521-2 [9], the following steps will be added to configure E-UTRA component:

- 2.1 The parameter settings for E-UTRA cell are set up according to TS 36.508 [11] clause 4.4.3.
- 3.1 The E-UTRA downlink signal level, uplink signal level are set according to Table 4.7-1 and propagation conditions are set according to Annex B.0 of TS 36.521-1 [10].

Step 6 of initial conditions as in clause 6.2.1.2.4.1 in TS 38.521-2 [9] is replaced by:

- 6. Ensure the UE is in state RRC\_CONNECTED with generic procedure parameters Connectivity EN-DC, DC bearer MCG and SCG, Connected without release On according to TS 38.508-1 [6] clause 4.5.

Same test procedure as in clause 6.2.1.2.4.2 in TS 38.521-2 [9] with the following steps added for E-UTRA component:

1.1 On the E-UTRA carrier, disable periodic and aperiodic CQI reports, disable SRS, set *TimeAlignmentTimerDedicated* IE to infinity and disable downlink and uplink scheduling, all as per Table 4.7-1 under clause 4.7.

### 6.2B.1.4.2.5 Test requirement

Same test requirement as in clause 6.2.1.2.5 in TS 38.521-2 [9] for the *NR* carrier.

## 6.2B.1.4\_1 UE Maximum Output Power for Inter-Band EN-DC including FR2 (>1 NR CC)

### 6.2B.1.4\_1.1 UE Maximum Output Power for Inter-Band EN-DC including FR2 (2 NR CCs)

#### 6.2B.1.4\_1.1.1 UE Maximum Output Power for Inter-Band EN-DC including FR2 (2 NR CCs) - EIRP and TRP

**Editor's note: The following aspects are either missing or not yet determined:**

- The referred test case 6.2A.1.1.1 in TS 38.521-2 [9] is incomplete for aggregated BW > 400MHz.
- The referred test case 6.2A.1.1.1 in TS 38.521-2 [9] is incomplete for power class 1, 2 and 4.
- Test Procedures for EIRP beam peak Extreme Conditions are FFS.

#### 6.2B.1.4\_1.1.1.1 Test purpose

Same test purpose as in clause 6.2A.1.1.1.1 in TS 38.521-2 [9] for the *NR* carrier.

#### 6.2B.1.4\_1.1.1.2 Test applicability

This test case applies to all types of E-UTRA UE release 15 and forward, supporting inter-band EN-DC including FR2 with 2 NR UL CCs.

### 6.2B.1.4\_1.1.1.3 Minimum conformance requirements

Same minimum conformance requirements as in clause 6.2A.1.1.1.3 in TS 38.521-2 [9].

### 6.2B.1.4\_1.1.1.4 Test description

#### 6.2B.1.4\_1.1.1.4.1 Initial condition

Same test description as in clause 6.2A.1.1.1.4 in TS 38.521-2 [9] for the *NR* carriers with the following exception:

The initial test configurations for E-UTRA band consist of environmental conditions, test frequencies, and channel bandwidths based on E-UTRA bands specified in Table 4.7-1.

For Initial conditions as in clause 6.2A.1.1.1.4.1 in TS 38.521-2 [9], the following steps will be added to configure E-UTRA component:

- 2.1. The parameter settings for E-UTRA cell are set up according to TS 36.508 [11] clause 4.4.3.
- 3.1. The E-UTRA downlink signal level, uplink signal level are set according to Table 4.7-1 and propagation conditions are set according to Annex B.0 of TS 36.521-1 [10].

Step 6 of Initial conditions as in clause 6.2A.1.1.1.4.1 in TS 38.521-2 [9] is replaced by:

6. Ensure the UE is in state RRC\_CONNECTED with generic procedure parameters Connectivity EN-DC, DC bearer MCG and SCG, Connected without release On according to TS 38.508-1 [6] clause 4.5.

Same test procedure as in clause 6.2A.1.1.1.4.2 in TS 38.521-2 [9] with the following steps added for E-UTRA component:

- 1.1 On the E-UTRA carrier, disable periodic and aperiodic CQI reports, disable SRS, set *TimeAlignmentTimerDedicated* IE to infinity and disable downlink and uplink scheduling, all as per Table 4.7-1 under clause 4.7.

### 6.2B.1.4\_1.1.1.5 Test Requirements

Same test requirement as in clause 6.2A.1.1.1.5 in TS 38.521-2 [9] for the *NR* carriers.

### 6.2B.1.4\_1.1.2 UE Maximum Output Power for Inter-Band EN-DC including FR2 (2 NR CCs) - Spherical Coverage

**Editor's note: The following aspects are either missing or not yet determined:**

- The referred test case 6.2A.1.2.1 in TS 38.521-2 is incomplete for aggregated BW > 400MHz.
- The referred test case 6.2A.1.2.1 in TS 38.521-2 is incomplete for power class 1, 2 and 4.

#### 6.2B.1.4\_1.1.2.1 Test purpose

Same test purpose as in clause 6.2A.1.2.1.1 in TS 38.521-2 [9] for the *NR* carrier.

#### 6.2B.1.4\_1.1.2.2 Test applicability

This test case applies to all types of E-UTRA UE release 15 and forward, supporting inter-band EN-DC including FR2 with 2NR UL CCs.

### 6.2B.1.4\_1.1.2.3 Minimum conformance requirements

Same minimum conformance requirements as in clause 6.2A.1.2.1.3 in TS 38.521-2 [9].

#### 6.2B.1.4\_1.1.2.4 Test description

##### 6.2B.1.4\_1.1.2.4.1 Initial condition

Same test description as in clause 6.2A.1.2.1.4 in TS 38.521-2 [9] for the *NR* carriers with the following exception:

The initial test configurations for E-UTRA band consist of environmental conditions, test frequencies, and channel bandwidths based on E-UTRA bands specified in Table 4.7-1.

For Initial conditions as in clause 6.2A.1.2.1.4.1 in TS 38.521-2 [9], the following steps will be added to configure E-UTRA component:

- 2.1. The parameter settings for E-UTRA cell are set up according to TS 36.508 [11] subclause 4.4.3.
- 3.1. The E-UTRA downlink signal level, uplink signal level are set according to Table 4.7-1 and propagation conditions are set according to Annex B.0 of TS 36.521-1 [10].

Step 6 of Initial conditions as in clause 6.2A.1.2.1.4.1 in TS 38.521-2 [9] is replaced by:

6. Ensure the UE is in state RRC\_CONNECTED with generic procedure parameters Connectivity EN-DC, DC bearer MCG and SCG, Connected without release On according to TS 38.508-1 [6] clause 4.5.

Same test procedure as in clause 6.2A.1.2.1.4.2 in TS 38.521-2 [9] with the following steps added for E-UTRA component:

- 1.1 On the E-UTRA carrier, disable periodic and aperiodic CQI reports, disable SRS, set TimeAlignmentTimerDedicated IE to infinity and disable downlink and uplink scheduling, all as per Table 4.7-1 under clause 4.7.

#### 6.2B.1.4\_1.1.2.5 Test Requirements

Same test requirement as in clause 6.2A.1.2.1.5 in TS 38.521-2 [9] for the *NR* carriers.

#### 6.2B.1.4\_1.2 UE Maximum Output Power for Inter-Band EN-DC including FR2 (3 NR CCs)

##### 6.2B.1.4\_1.2.1 UE Maximum Output Power for Inter-Band EN-DC including FR2 (3 NR CCs) - EIRP and TRP

**Editor's note: The following aspects are either missing or not yet determined:**

- The referred test case 6.2A.1.1.2 in TS 38.521-2 is incomplete for aggregated BW > 400MHz.
- The referred test case 6.2A.1.1.2 in TS 38.521-2 is incomplete for power class 1, 2 and 4.
- Test Procedures for EIRP beam peak Extreme Conditions are FFS.

##### 6.2B.1.4\_1.2.1.1 Test purpose

Same test purpose as in clause 6.2A.1.1.2.1 in TS 38.521-2 [9] for the *NR* carriers.

##### 6.2B.1.4\_1.2.1.2 Test applicability

This test case applies to all types of E-UTRA UE release 15 and forward, supporting inter-band EN-DC including FR2 with 3NR UL CCs.

##### 6.2B.1.4\_1.2.1.3 Minimum conformance requirements

Same minimum conformance requirements as in clause 6.2A.1.1.2.3 in TS 38.521-2 [9].

#### 6.2B.1.4\_1.2.1.4 Test description

##### 6.2B.1.4\_1.2.1.4.1 Initial condition

Same test description as in clause 6.2A.1.1.2.4 in TS 38.521-2 [9] for the *NR* carriers with the following exception:

The initial test configurations for E-UTRA band consist of environmental conditions, test frequencies, and channel bandwidths based on E-UTRA bands specified in Table 4.7-1.

For Initial conditions as in clause 6.2A.1.1.1.4.1 in TS 38.521-2 [9], the following steps will be added to configure E-UTRA component:

- 2.1. The parameter settings for E-UTRA cell are set up according to TS 36.508 [11] clause 4.4.3.
- 3.1. The E-UTRA downlink signal level, uplink signal level are set according to Table 4.7-1 and propagation conditions are set according to Annex B.0 of TS 36.521-1 [10].

Step 6 of Initial conditions as in clause 6.2A.1.1.1.4.1 in TS 38.521-2 [9] is replaced by:

6. Ensure the UE is in state RRC\_CONNECTED with generic procedure parameters Connectivity EN-DC, DC bearer MCG and SCG, Connected without release On according to TS 38.508-1 [6] clause 4.5.

Same test procedure as in clause 6.2A.1.1.1.4.2 in TS 38.521-2 [9] with the following steps added for E-UTRA component:

- 1.1 On the E-UTRA carrier, disable periodic and aperiodic CQI reports, disable SRS, set *TimeAlignmentTimerDedicated* IE to infinity and disable downlink and uplink scheduling, all as per Table 4.7-1 under clause 4.7.

#### 6.2B.1.4\_1.2.1.5 Test Requirements

Same test requirement as in clause 6.2A.1.1.2.5 in TS 38.521-2 [9] for the *NR* carrier.

#### 6.2B.1.4\_1.2.2 UE Maximum Output Power for Inter-Band EN-DC including FR2 (3 NR CCs) - Spherical Coverage

**Editor's note: The following aspects are either missing or not yet determined:**

- The referred test case 6.2A.1.2.2 in TS 38.521-2 is incomplete for aggregated BW > 400MHz.
- The referred test case 6.2A.1.2.2 in TS 38.521-2 is incomplete for power class 1, 2 and 4.

#### 6.2B.1.4\_1.2.2.1 Test purpose

Same test purpose as in clause 6.2A.1.2.2.1 in TS 38.521-2 [9] for the *NR* carriers.

#### 6.2B.1.4\_1.2.2.2 Test applicability

This test case applies to all types of E-UTRA UE release 15 and forward, supporting inter-band EN-DC including FR2 with 3 NR UL CCs.

#### 6.2B.1.4\_1.2.2.3 Minimum conformance requirements

Same minimum conformance requirements as in clause 6.2A.1.2.2.3 in TS 38.521-2 [9].

#### 6.2B.1.4\_1.2.2.4 Test description

##### 6.2B.1.4\_1.2.2.4.1 Initial condition

Same test description as in clause 6.2A.1.2.2.4 in TS 38.521-2 [9] for the *NR* carriers with the following exception:

The initial test configurations for E-UTRA band consist of environmental conditions, test frequencies, and channel bandwidths based on E-UTRA bands specified in Table 4.7-1.



For Initial conditions as in clause 6.2A.1.2.1.4.1 in TS 38.521-2 [9], the following steps will be added to configure E-UTRA component:

- 2.1. The parameter settings for E-UTRA cell are set up according to TS 36.508 [11] subclause 4.4.3.
- 3.1. The E-UTRA downlink signal level, uplink signal level are set according to Table 4.7-1 and propagation conditions are set according to Annex B.0 of TS 36.521-1 [10].

Step 6 of Initial conditions as in clause 6.2A.1.2.1.4.1 in TS 38.521-2 [9] is replaced by:

6. Ensure the UE is in state RRC\_CONNECTED with generic procedure parameters Connectivity EN-DC, DC bearer MCG and SCG, Connected without release On according to TS 38.508-1 [6] clause 4.5.

Same test procedure as in clause 6.2A.1.2.1.4.2 in TS 38.521-2 [9] with the following steps added for E-UTRA component:

- 1.1 On the E-UTRA carrier, disable periodic and aperiodic CQI reports, disable SRS, set TimeAlignmentTimerDedicated IE to infinity and disable downlink and uplink scheduling, all as per Table 4.7-1 under clause 4.7.

#### 6.2B.1.4\_1.2.2.5 Test Requirements

Same test requirement as in clause 6.2A.1.2.2.5 in TS 38.521-2 [9] for the NR carriers.

#### 6.2B.1.4\_1.3 UE Maximum Output Power for Inter-Band EN-DC including FR2 (4 NR CCs)

##### 6.2B.1.4\_1.3.1 UE Maximum Output Power for Inter-Band EN-DC including FR2 (4 NR CCs) - EIRP and TRP

**Editor's note: The following aspects are either missing or not yet determined:**

- The referred test case 6.2A.1.1.3 in TS 38.521-2 is incomplete for aggregated BW > 400MHz.
- The referred test case 6.2A.1.1.3 in TS 38.521-2 is incomplete for power class 1, 2 and 4.
- Test Procedures for EIRP beam peak Extreme Conditions are FFS.

##### 6.2B.1.4\_1.3.1.1 Test purpose

Same test purpose as in clause 6.2A.1.1.3.1 in TS 38.521-2 [9] for the NR carriers.

##### 6.2B.1.4\_1.3.1.2 Test applicability

This test case applies to all types of E-UTRA UE release 15 and forward, supporting inter-band EN-DC including FR2 with 4NR UL CCs.

##### 6.2B.1.4\_1.3.1.3 Minimum conformance requirements

Same minimum conformance requirements as in clause 6.2A.1.1.3.3 in TS 38.521-2 [9].

##### 6.2B.1.4\_1.3.1.4 Test description

###### 6.2B.1.4\_1.3.1.4.1 Initial condition

Same test description as in clause 6.2A.1.1.3.4 in TS 38.521-2 [9] for the NR carriers with the following exception:

The initial test configurations for E-UTRA band consist of environmental conditions, test frequencies, and channel bandwidths based on E-UTRA bands specified in Table 4.7-1.

For Initial conditions as in clause 6.2A.1.1.1.4.1 in TS 38.521-2 [9], the following steps will be added to configure E-UTRA component:

- 2.1. The parameter settings for E-UTRA cell are set up according to TS 36.508 [11] clause 4.4.3.

- 3.1. The E-UTRA downlink signal level, uplink signal level are set according to Table 4.7-1 and propagation conditions are set according to Annex B.0 of TS 36.521-1 [10].

Step 6 of Initial conditions as in clause 6.2A.1.1.1.4.1 in TS 38.521-2 [9] is replaced by:

6. Ensure the UE is in state RRC\_CONNECTED with generic procedure parameters Connectivity EN-DC, DC bearer MCG and SCG, Connected without release On according to TS 38.508-1 [6] clause 4.5.

Same test procedure as in clause 6.2A.1.1.1.4.2 in TS 38.521-2 [9] with the following steps added for E-UTRA component:

- 1.1 On the E-UTRA carrier, disable periodic and aperiodic CQI reports, disable SRS, set *TimeAlignmentTimerDedicated* IE to infinity and disable downlink and uplink scheduling, all as per Table 4.7-1 under clause 4.7.

#### 6.2B.1.4\_1.3.1.5 Test Requirements

Same test requirement as in clause 6.2A.1.1.3.5 in TS 38.521-2 [9] for the NR carriers.

#### 6.2B.1.4\_1.3.2 UE Maximum Output Power for Inter-Band EN-DC including FR2 (4 NR CCs) – Spherical Coverage

**Editor's note: The following aspects are either missing or not yet determined:**

- The referred test case 6.2A.1.2.3 in TS 38.521-2 is incomplete for aggregated BW > 400MHz.
- The referred test case 6.2A.1.2.3 in TS 38.521-2 is incomplete for power class 1, 2 and 4.

#### 6.2B.1.4\_1.3.2.1 Test purpose

Same test purpose as in clause 6.2A.1.2.3.1 in TS 38.521-2 [9] for the NR carriers.

#### 6.2B.1.4\_1.3.2.2 Test applicability

This test case applies to all types of E-UTRA UE release 15 and forward, supporting inter-band EN-DC including FR2 with 4NR UL CCs.

#### 6.2B.1.4\_1.3.2.3 Minimum conformance requirements

Same minimum conformance requirements as in clause 6.2A.1.2.3.3 in TS 38.521-2[9].

#### 6.2B.1.4\_1.3.2.4 Test description

##### 6.2B.1.4\_1.3.2.4.1 Initial condition

Same test description as in clause 6.2A.1.2.3.4 in TS 38.521-2 [9] for the NR carriers with the following exception:

The initial test configurations for E-UTRA band consist of environmental conditions, test frequencies, and channel bandwidths based on E-UTRA bands specified in Table 4.7-1.

For Initial conditions as in clause 6.2A.1.2.1.4.1 in TS 38.521-2 [9], the following steps will be added to configure E-UTRA component:

- 2.1. The parameter settings for E-UTRA cell are set up according to TS 36.508 [11] subclause 4.4.3.
- 3.1. The E-UTRA downlink signal level, uplink signal level are set according to Table 4.7-1 and propagation conditions are set according to Annex B.0 of TS 36.521-1 [10].

Step 6 of Initial conditions as in clause 6.2A.1.2.1.4.1 in TS 38.521-2 [9] is replaced by:

6. Ensure the UE is in state RRC\_CONNECTED with generic procedure parameters Connectivity EN-DC, DC bearer MCG and SCG, Connected without release On according to TS 38.508-1 [6] clause 4.5.

Same test procedure as in clause 6.2A.1.2.1.4.2 in TS 38.521-2 [9] with the following steps added for E-UTRA component:

- 1.1 On the E-UTRA carrier, disable periodic and aperiodic CQI reports, disable SRS, set TimeAlignmentTimerDedicated IE to infinity and disable downlink and uplink scheduling, all as per Table 4.7-1 under clause 4.7.

#### 6.2B.1.4\_1.3.2.5 Test Requirements

Same test requirement as in clause 6.2A.1.2.3.5 in TS 38.521-2 [9] for the *NR* carriers.

#### 6.2B.1.4\_1.4 UE Maximum Output Power for Inter-Band EN-DC including FR2 (5 NR CCs)

##### 6.2B.1.4\_1.4.1 UE Maximum Output Power for Inter-Band EN-DC including FR2 (5 NR CCs) - EIRP and TRP

##### 6.2B.1.4\_1.4.1.1 Test purpose

Same test purpose as in clause 6.2A.1.1.4.1 in TS 38.521-2 [9] for the *NR* carriers.

##### 6.2B.1.4\_1.4.1.2 Test applicability

The requirements in this test are not testable due to lack of appropriate test points since there's no configuration satisfying MPR=0dB requirements in RAN4 for FR2 *NR* carrier.

No test case details are specified

##### 6.2B.1.4\_1.4.1.5 Test Requirements

Same test requirement as in clause 6.2A.1.1.4.5 in TS 38.521-2 [9] for the *NR* carriers.

##### 6.2B.1.4\_1.4.2 UE Maximum Output Power for Inter-Band EN-DC including FR2 (5 NR CCs) – Spherical Coverage

##### 6.2B.1.4\_1.4.2.1 Test purpose

Same test purpose as in clause 6.2A.1.2.4.1 in TS 38.521-2 [9] for the *NR* carriers.

##### 6.2B.1.4\_1.4.2.2 Test applicability

The requirements in this test are not testable due to lack of appropriate test points since there's no configuration satisfying MPR=0dB requirements in RAN4 for FR2 *NR* carrier.

No test case details are specified.

##### 6.2B.1.4\_1.4.2.5 Test Requirements

Same test requirement as in clause 6.2A.1.2.4.5 in TS 38.521-2 [9] for the *NR* carriers.

#### 6.2B.1.4\_1.5 UE Maximum Output Power for Inter-Band EN-DC including FR2 (6 NR CCs)

##### 6.2B.1.4\_1.5.1 UE Maximum Output Power for Inter-Band EN-DC including FR2 (6 NR CCs) - EIRP and TRP

##### 6.2B.1.4\_1.5.1.1 Test purpose

Same test purpose as in clause 6.2A.1.1.5.1 in TS 38.521-2 [9] for the *NR* carriers.

**6.2B.1.4\_1.5.1.2** Test applicability

The requirements in this test are not testable due to lack of appropriate test points since there's no configuration satisfying MPR=0dB requirements in RAN4 for FR2 NR carrier.

No test case details are specified.

**6.2B.1.4\_1.5.2** UE Maximum Output Power for Inter-Band EN-DC including FR2 (6 NR CCs) – Spherical Coverage**6.2B.1.4\_1.5.2.1** Test purpose

Same test purpose as in clause 6.2A.1.2.5.1 in TS 38.521-2 [9] for the NR carriers.

**6.2B.1.4\_1.5.2.2** Test applicability

The requirements in this test are not testable due to lack of appropriate test points since there's no configuration satisfying MPR=0dB requirements in RAN4 for FR2 NR carrier.

No test case details are specified.

**6.2B.1.4\_1.6** UE Maximum Output Power for Inter-Band EN-DC including FR2 (7 NR CCs)**6.2B.1.4\_1.6.1** UE Maximum Output Power for Inter-Band EN-DC including FR2 (7 NR CCs) - EIRP and TRP**6.2B.1.4\_1.6.1.1** Test purpose

Same test purpose as in clause 6.2A.1.1.6.1 in TS 38.521-2 [9] for the NR carriers.

**6.2B.1.4\_1.6.1.2** Test applicability

The requirements in this test are not testable due to lack of appropriate test points since there's no configuration satisfying MPR=0dB requirements in RAN4 for FR2 NR carrier.

No test case details are specified.

**6.2B.1.4\_1.6.2** UE Maximum Output Power for Inter-Band EN-DC including FR2 (7 NR CCs) – Spherical Coverage**6.2B.1.4\_1.6.2.1** Test purpose

Same test purpose as in clause 6.2A.1.2.6.1 in TS 38.521-2 [9] for the NR carriers.

**6.2B.1.4\_1.6.2.2** Test applicability

The requirements in this test are not testable due to lack of appropriate test points since there's no configuration satisfying MPR=0dB requirements in RAN4 for FR2 NR carrier.

No test case details are specified.

**6.2B.1.4\_1.7** UE Maximum Output Power for Inter-Band EN-DC including FR2 (8 NR CCs)**6.2B.1.4\_1.7.1** UE Maximum Output Power for Inter-Band EN-DC including FR2 (8 NR CCs) - EIRP and TRP**6.2B.1.4\_1.7.1.1** Test purpose

Same test purpose as in clause 6.2A.1.1.7.1 in TS 38.521-2 [9] for the NR carriers.

#### 6.2B.1.4\_1.7.1.2 Test applicability

The requirements in this test are not testable due to lack of appropriate test points since there's no configuration satisfying MPR=0dB requirements in RAN4 for FR2 NR carrier.

No test case details are specified.

#### 6.2B.1.4\_1.7.2 UE Maximum Output Power for Inter-Band EN-DC including FR2 (8 NR CCs) – Spherical Coverage

##### 6.2B.1.4\_1.7.2.1 Test purpose

Same test purpose as in clause 6.2A.1.2.7.1 in TS 38.521-2 [9] for the NR carriers.

##### 6.2B.1.4\_1.7.2.2 Test applicability

The requirements in this test are not testable due to lack of appropriate test points since there's no configuration satisfying MPR=0dB requirements in RAN4 for FR2 NR carrier.

No test case details are specified.

#### 6.2B.1.4D UE Maximum Output Power for Inter-Band EN-DC including FR2 for UL MIMO

##### 6.2B.1.4D.1 UE Maximum Output Power for Inter-Band EN-DC including FR2 for UL MIMO - EIRP and TRP

**Editor's note: The following aspects are either missing or not yet determined:**

- **The referred test case 6.2D.1.1 in TS 38.521-2 [9] is incomplete for ETC.**

##### 6.2B.1.4D.1.1 Test purpose

Same test purpose as in clause 6.2D.1.1.1 in TS 38.521-2 [9] for the NR carrier.

##### 6.2B.1.4D.1.2 Test applicability

This test case applies to all types of E-UTRA UE release 15 and forward, supporting inter-band EN-DC including FR2 with UL MIMO.

##### 6.2B.1.4D.1.3 Minimum conformance requirements

Same minimum conformance requirements as in clause 6.2D.1.1.3 in TS 38.521-2 [9] for the NR carrier.

No exception requirements applicable to NR or LTE. LTE anchor agnostic approach is applied.

The normative reference for this measurement is TS 38.101-3 [4] clause 6.2B.1.4.

##### 6.2B.1.4D.1.4 Test description

Same test description as in clause 6.2D.1.1.4 in TS 38.521-2 [9] for the NR carrier with the following exception:

The initial test configurations for E-UTRA band consist of environmental conditions, test frequencies, and channel bandwidths based on E-UTRA bands specified in Table 4.7-1. For Initial conditions as in clause 6.2D.1.1.4.1 in TS 38.521-2 [9], the following steps will be added to configure E-UTRA component:

- 2.1. The parameter settings for E-UTRA cell are set up according to TS 36.508 [11] clause 4.4.3.
- 3.1. The E-UTRA downlink signal level, uplink signal level are set according to Table 4.7-1 and propagation conditions are set according to Annex B.0 of TS 36.521-1 [10].

Step 6 of Initial conditions as in clause 6.2D.1.1.4.1 in TS 38.521-2 [9] is replaced by the following two steps:

6. Ensure the UE is in state RRC\_CONNECTED with generic procedure parameters Connectivity EN-DC, DC bearer MCG and SCG, Connected without release *On* according to TS 38.508-1 [6] clause 4.5.
7. On the E-UTRA carrier, disable periodic and aperiodic CQI reports, disable SRS, set TimeAlignmentTimerDedicated IE to infinity and disable downlink and uplink scheduling, all as per Table 4.7-1 under clause 4.6.

#### 6.2B.1.4D.1.5 Test requirement

Same test requirement as in clause 6.2D.1.1.5 of TS 38.521-2 [9] for the NR carrier.

#### 6.2B.1.4D.2 UE Maximum Output Power for Inter-Band EN-DC including FR2 for UL MIMO-Spherical coverage

##### 6.2B.1.4D.2.1 Test purpose

Same test purpose as in clause 6.2D.1.2.1 in TS 38.521-2 [9] for the NR carrier.

##### 6.2B.1.4D.2.2 Test applicability

This test case applies to all types of E-UTRA UE release 15 and forward, supporting inter-band EN-DC including FR2 with UL MIMO.

##### 6.2B.1.4D.2.3 Minimum conformance requirements

Same minimum conformance requirements as in clause 6.2D.1.2.3 in TS 38.521-2 [9] for the NR carrier.

No exception requirements applicable to NR or LTE. LTE anchor agnostic approach is applied.

The normative reference for this measurement is TS 38.101-3 [4] clause 6.2B.1.4.

##### 6.2B.1.4D.2.4 Test description

Same test description as in clause 6.2D.1.2.4 in TS 38.521-2 [9] for the NR carrier with the following exception:

The initial test configurations for E-UTRA band consist of environmental conditions, test frequencies, and channel bandwidths based on E-UTRA bands specified in Table 4.7-1. For Initial conditions as in clause 6.2D.1.2.4.1 in TS 38.521-2 [9], the following steps will be added to configure E-UTRA component:

- 2.1. The parameter settings for E-UTRA cell are set up according to TS 36.508 [11] clause 4.4.3.
- 3.1. The E-UTRA downlink signal level, uplink signal level are set according to Table 4.7-1 and propagation conditions are set according to Annex B.0 of TS 36.521-1 [10].

Step 6 of Initial conditions as in clause 6.2D.1.2.4.1 in TS 38.521-2 [9] is replaced by the following two steps:

6. Ensure the UE is in state RRC\_CONNECTED with generic procedure parameters Connectivity EN-DC, DC bearer MCG and SCG, Connected without release *On* according to TS 38.508-1 [6] clause 4.5.
7. On the E-UTRA carrier, disable periodic and aperiodic CQI reports, disable SRS, set TimeAlignmentTimerDedicated IE to infinity and disable downlink and uplink scheduling, all as per Table 4.7-1 under clause 4.7.

#### 6.2B.1.4D.2.5 Test requirement

Same test requirement as in clause 6.2D.1.2.5 of TS 38.521-2 [9] for the NR carrier.

## 6.2B.1.5 UE Maximum Output Power for Inter-Band EN-DC including both FR1 and FR2

### 6.2B.1.5.1 Test purpose

Same test purpose as in clause 6.2.1.1 in TS 38.521-1 [8] for NR FR1 carrier and 6.2.1.1 in TS 38.521-2 [9] for NR FR2 carrier.

### 6.2B.1.5.2 Test applicability

The requirements in this test are not testable due to issues with combined testing of NR FR1 and E-UTRA in conducted mode with NR FR2 in radiated mode. Therefore, the conducted and radiated requirements are tested separately.

No test case details are specified. The EN-DC requirements for maximum output power apply and are tested as part of the EN-DC within FR1 and EN-DC including FR2 test cases in clause 6.2B.

## 6.2B.1.5D UE Maximum Output Power for Inter-Band EN-DC including both FR1 and FR2 for UL MIMO

### 6.2B.1.5D.1 Test purpose

Same test purpose as in clause 6.2.1.1 in TS 38.521-1 [8] for NR FR1 carrier and 6.2.1.1 in TS 38.521-2 [9] for NR FR2 carrier.

### 6.2B.1.5D.2 Test applicability

The requirements in this test are not testable due to issues with combined testing of NR FR1 and E-UTRA in conducted mode with NR FR2 in radiated mode. Therefore, the conducted and radiated requirements are tested separately.

No test case details are specified. The EN-DC requirements for maximum output power apply and are tested as part of the EN-DC within FR1 as in clause 6.2.1 in TS 38.521-1 [8] and EN-DC within FR2 as in clause 6.2.1 in TS 38.521-2 [9].

## 6.2B.1.6 UE Maximum Output Power for Inter-Band EN-DC including FR2 (1 NR CC) - EIRP with UL Gaps

**Editor's note: This clause is incomplete. The associated standalone test 6.2.5 in TS 38.521-2 [9] is incomplete as the following aspects are either missing or not yet determined:**

- The test case is incomplete for band n259.
- Initial conditions are pending analysis for PC1, PC5, PC6 and PC7.
- MU and TT are pending for PC1, PC5, PC6 and PC7.
- MU and TT is not finalized for PC3 extreme testing conditions

### 6.2B.1.6.1 Test purpose

Same test purpose as in clause 6.2.5 in TS 38.521-2 [9] for the NR carrier.

### 6.2B.1.6.2 Test applicability

This test case applies to all types of E-UTRA UE release 17 and forward, supporting inter-band EN-DC including FR2 with 1 NR UL CC along with support for UL-gaps

### 6.2B.1.6.3 Minimum conformance requirements

Same minimum conformance requirements as in clause 6.2.5 in TS 38.521-2 [9] for the *NR* carrier.

No exception requirements applicable to NR or LTE. LTE anchor agnostic approach is applied.

The normative reference for this requirement is TS 38.101-3 [4] clause 6.2B.1.6.

### 6.2B.1.6.4 Test description

Same test description as in clause 6.2.5 in TS 38.521-2 [9] for the *NR* carrier with the following exception:

The initial test configurations for E-UTRA band consist of environmental conditions, test frequencies, and channel bandwidths based on E-UTRA bands specified in Table 4.7-1.

For initial conditions as in clause 6.2.5 in TS 38.521-2 [9], the following steps will be added to configure E-UTRA component:

- 2.1. The parameter settings for E-UTRA cell are set up according to TS 36.508 [11] clause 4.4.3.
- 3.1. The E-UTRA downlink signal level, uplink signal level are set according to Table 4.7-1 and propagation conditions are set according to Annex B.0 of TS 36.521-1 [10].

Step 6 of initial conditions as in clause 6.2.5 in TS 38.521-2 [9] is replaced by:

6. Ensure the UE is in state RRC\_CONNECTED with generic procedure parameters Connectivity EN-DC, DC bearer MCG and SCG, Connected without release On according to TS 38.508-1 [6] clause 4.5.

Same test procedure as in clause 6.2.5 in TS 38.521-2 [9] with the following steps added for E-UTRA component:

- 1.1 On the E-UTRA carrier, disable periodic and aperiodic CQI reports, disable SRS, set *TimeAlignmentTimerDedicated* IE to infinity and disable downlink and uplink scheduling, all as per Table 4.7-1 under clause 4.7.

### 6.2B.1.6.5 Test requirements

Same test requirement as in clause 6.2.5 in TS 38.521-2 [9] for the NR carrier.

## 6.2B.2 UE Maximum Output Power reduction for DC

### 6.2B.2.0 General

The UE maximum output power reduction (MPR) specified in this clause is applicable for UEs configured with EN-DC when NS\_01 is indicated in the MCG and the SCG. The MPR applies subject to indication in the field *modifiedMPRbehavior* for the SCG [2].

### 6.2B.2.1 UE Maximum Output Power reduction for Intra-Band Contiguous EN-DC

#### 6.2B.2.1.1 Test purpose

Same test purpose as in clause 6.2.2.1 in TS 38.521-1 [8] for the NR carrier.

#### 6.2B.2.1.2 Test applicability

This test case applies to all types of E-UTRA power class 3 and power class 2 UE release 15 and forward, supporting intra-band contiguous EN-DC.

NOTE: Test execution is not necessary if clause 6.5B.2.1.3 ACLR is executed since MPR requirement is verified in this test case.



## 6.2B.2.1.3 Minimum conformance requirements

## 6.2B.2.1.3.1 General

When the UE is configured for intra-band contiguous EN-DC, the UE determines the total allowed maximum output power reduction as specified in this clause.

For UE supporting dynamic power sharing the following:

- for the MCG,  $MPR_c$  in accordance with TS 36.101 [5]
- for the SCG,

$$MPR'_c = MPR_{NR} = \text{MAX}(MPR_{\text{single,NR}}, MPR_{\text{ENDC}})$$

- for the total configured transmission power,

$$MPR_{\text{tot}} = P_{\text{PowerClass,EN-DC}} - \min(P_{\text{PowerClass,EN-DC}}, 10 \cdot \log_{10}(10^{(P_{\text{PowerClass,E-UTRA}} - MPR_{\text{E-UTRA}})/10}) + 10^{(P_{\text{PowerClass,NR}} - MPR_{\text{NR}})/10}))$$

where

$$MPR_{\text{E-UTRA}} = \text{MAX}(MPR_{\text{single,E-UTRA}}, MPR_{\text{ENDC}})$$

with

- $MPR_{\text{single,E-UTRA}}$  is the MPR defined for the E-UTRA transmission in TS 36.101 [5]
- $MPR_{\text{single,NR}}$  is the MPR defined for the NR transmission in TS 38.101-1 [2]

For UEs not supporting dynamic power sharing the following

- for the MCG,

$$MPR_c = \text{MAX}(MPR_{\text{single,E-UTRA}}, MPR_{\text{ENDC}})$$

- for the SCG,

$$MPR'_c = \text{MAX}(MPR_{\text{single,NR}}, MPR_{\text{ENDC}})$$

where

- $MPR_{\text{single,NR}}$  is the MPR defined for the NR transmission in TS 38.101-1 [2]
- $MPR_{\text{single,E-UTRA}}$  is the MPR defined for the E-UTRA transmission in TS 36.101 [5]

$MPR_{\text{ENDC}}$  is defined in Clause 6.2B.2.1.3.2.

## 6.2B.2.1.3.2 MPR for power class 3 and power class 2

MPR in this subclause is applicable for power class 3 and power class 2 UEs indicating IE *dualPA-Architecture* supported with ENDC power class being the same as the E-UTRA and NR power class, otherwise the UE can use as much MPR as needed to fulfil emissions requirements when scheduled with dual uplink transmission. For UEs scheduled with single uplink transmission, MPR in subclause 6.2.4 of TS 36.101 [5] and 6.2.2 of TS 38.101-1 [2] apply. For a UE supporting dynamic power sharing for DC\_(n)71AA for which dual simultaneous uplink transmissions are mandatory and A-MPR defined in subclause 6.2B.3.1.1 is applied as MPR. The allowed maximum output power reduction for IM3 related emissions applied to transmission on the MCG and the SCG is defined as follows:

$$MPR_{\text{ENDC}} = M_A$$

Where  $M_A$  is defined as follows

$$M_A = \begin{cases} 15; & 0 \leq B < 0.5 \\ 10; & 0.5 \leq B < 1.0 \\ 8; & 1.0 \leq B < 2.0 \end{cases}$$

6;  $2.0 < B$

Where:

For UEs supporting dynamic power sharing,

$$B = (L_{\text{CRB\_alloc, E-UTRA}} * 12 * \text{SCS}_{\text{E-UTRA}} + L_{\text{CRB\_alloc, NR}} * 12 * \text{SCS}_{\text{NR}}) / 1,000,000$$

For UEs not supporting dynamic power sharing,

For E-UTRA

$$B = (L_{\text{CRB\_alloc, E-UTRA}} * 12 * \text{SCS}_{\text{E-UTRA}} + 12 * \text{SCS}_{\text{NR}}) / 1,000,000$$

Where  $\text{SCS}_{\text{NR}} = 15$  kHz is assumed in calculation of B.

For NR

$$B = (12 * \text{SCS}_{\text{E-UTRA}} + L_{\text{CRB\_alloc, NR}} * 12 * \text{SCS}_{\text{NR}}) / 1,000,000$$

Where  $\text{SCS}_{\text{E-UTRA}} = 15$  kHz is assumed in calculation of B.

and  $M_A$  is reduced by 1 dB for  $B < 2$ .

The normative reference for this requirement is TS 38.101-3 [4] clause 6.2B.2.1.

Exception requirements for both NR and E-UTRA are defined for this test when transmission on E-UTRA doesn't overlap in time with NR. LTE anchor agnostic approach is not applied for this case. E-UTRA test point analysis is included and E-UTRA measurements are performed.

No exception requirements for NR or E-UTRA are defined for this test when transmission on E-UTRA doesn't overlap in time with NR, for a UE that supports dynamic power sharing. LTE anchor agnostic approach is not applied for this case based on the test point analysis in TS 38.905 [7].

#### 6.2B.2.1.4 Test description

##### 6.2B.2.1.4.1 Initial conditions

Initial conditions are a set of test configurations the UE needs to be tested in and the steps for the SS to take with the UE to reach the correct measurement state.

The initial test configurations consist of environmental conditions, test frequencies and test channel bandwidths based on NR operating bands specified in clause 5.3B.1.2, channel bandwidths and sub-carrier spacings for the NR cell specified in TS 38.521-1 [8] clause 5.3 and channel bandwidth for the E-UTRA cell are specified in TS 36.521-1 [10] clause 5.4.2. All of these configurations shall be tested with applicable test parameters for each EN-DC combination of test channel bandwidth and sub-carrier spacing, and are shown in table 6.4B.2.1.4.1-1. The details of the uplink reference measurement channels (RMCs) are specified in Annex A, clause A.2.2 for E-UTRA RMC for TDD, TS 36.521-1 [10] Annex A, clause A.2.2 for E-UTRA RMC for FDD, and TS 38.521-1 [8] Annex A, clause A.2 for NR RMC. Configurations of PDSCH and PDCCH before measurement are specified in TS 36.521.1 [10] Annex C.2 and in TS 38.521-1 [8] Annex C.2 for E-UTRA CG and NR CG respectively.

**Table 6.2B.2.1.4.1-1: Test configuration table**

Initial Conditions									
Test Environment as specified in TS 38.508-1 [6] clause 4.1.				Normal, TL/VL, TL/VH, TH/VL, TH/VH					
Test Frequencies as specified in TS 38.508-1 [6] clause 4.3.1.				Low range, High range					
Test EN-DC bandwidth combination as specified in Table 5.3B.1.2-1.				Lowest $N_{RB\_agg}$ , Highest $N_{RB\_agg}$ (Note 2)					
Test SCS for the NR cell as specified in TS 38.521-1 [8] Table 5.3.5-1.				Lowest, Highest (NOTE 10)					
Test Parameters									
Test ID	Freq	ChBw	SCS	Downlink Configuration	EN-DC Uplink Configuration				
					E-UTRA Cell		NR Cell		Common
					Modulation	RB allocation (Note 5)	Modulation	RB allocation (NOTE 1)	Power config (NOTE 8)
1	Default	Default	Default	N/A	16QAM	Outer_Full	DFT-s-OFDM Pi/2 BPSK	Outer_Full	B
2 (Note 3)	Default				16QAM	Outer_1RB_Left	DFT-s-OFDM Pi/2 BPSK	Edge_1RB_Right	B
3 (Note 3)	Low				16QAM	Outer_1RB_Left	DFT-s-OFDM Pi/2 BPSK	N/A	A
4 (Note 3)	High				16QAM	N/A	DFT-s-OFDM Pi/2 BPSK	Edge_1RB_Right	A
5 (Note 4)	Default				16QAM	Outer_1RB_Right	DFT-s-OFDM Pi/2 BPSK	Edge_1RB_Left	B
6 (Note 4)	Low				16QAM	N/A	DFT-s-OFDM Pi/2 BPSK	Edge_1RB_Left	A
7 (Note 4)	High				16QAM	Outer_1RB_Right	DFT-s-OFDM Pi/2 BPSK	N/A	A
8	Default				16QAM	Outer_Full	DFT-s-OFDM QPSK	Outer_Full	B
9 (Note 3)	Default				16QAM	Outer_1RB_Left	DFT-s-OFDM QPSK	Edge_1RB_Right	B
10 (Note 3)	Low				16QAM	Outer_1RB_Left	DFT-s-OFDM QPSK	N/A	A
11 (Note 3)	High				16QAM	N/A	DFT-s-OFDM QPSK	Edge_1RB_Right	A
12 (Note 4)	Default				16QAM	Outer_1RB_Right	DFT-s-OFDM QPSK	Edge_1RB_Left	B
13 (Note 4)	Low				16QAM	N/A	DFT-s-OFDM QPSK	Edge_1RB_Left	A
14 (Note 4)	High				16QAM	Outer_1RB_Right	DFT-s-OFDM QPSK	N/A	A

15	Default				16QAM	Outer_Full	DFT-s-OFDM 16QAM	Outer_Full	B
16 (Not e 3)	Default				16QAM	Outer_1RB_Left	DFT-s-OFDM 16QAM	Edge_1RB_Right	B
17 (Not e 3)	Low				16QAM	Outer_1RB_Left	DFT-s-OFDM 16QAM	N/A	A
18 (Not e 3)	High				16QAM	N/A	DFT-s-OFDM 16QAM	Edge_1RB_Right	A
19 (Not e 4)	Default				16QAM	Outer_1RB_Right	DFT-s-OFDM 16QAM	Edge_1RB_Left	B
20 (Not e 4)	Low				16QAM	N/A	DFT-s-OFDM 16QAM	Edge_1RB_Left	A
21 (Not e 4)	High				16QAM	Outer_1RB_Right	DFT-s-OFDM 16QAM	N/A	A
22	Default				16QAM	Outer_Full	DFT-s-OFDM 64QAM	Outer_Full	B
23 (Not e 3)	Low				16QAM	Outer_1RB_Left	DFT-s-OFDM 64QAM	Edge_1RB_Right	B
24 (Not e 4)	High				16QAM	Outer_1RB_Right	DFT-s-OFDM 64QAM	Edge_1RB_Left	B
25	Default				16QAM	Outer_Full	DFT-s-OFDM 256QAM	Outer_Full	B
26 (Not e 3)	Low				16QAM	Outer_1RB_Left	DFT-s-OFDM 256QAM	Edge_1RB_Right	B
27 (Not e 4)	High				16QAM	Outer_1RB_Right	DFT-s-OFDM 256QAM	Edge_1RB_Left	B
28	Default				16QAM	Outer_Full	CP-OFDM QPSK	Outer_Full	B
29 (Not e 3)	Default				16QAM	Outer_1RB_Left	CP-OFDM QPSK	Edge_1RB_Right	B
30 (Not e 3)	Low				16QAM	Outer_1RB_Left	CP-OFDM QPSK	N/A	A
31 (Not e 3)	High				16QAM	N/A	CP-OFDM QPSK	Edge_1RB_Right	A
32 (Not e 4)	Default				16QAM	Outer_1RB_Right	CP-OFDM QPSK	Edge_1RB_Left	B
33 (Not e 4)	Low				16QAM	N/A	CP-OFDM QPSK	Edge_1RB_Left	A
34 (Not e 4)	High				16QAM	Outer_1RB_Right	CP-OFDM QPSK	N/A	A
35	Default				16QAM	Outer_Full	CP-OFDM 16QAM	Outer_Full	B
36 (Not e 3)	Default				16QAM	Outer_1RB_Left	CP-OFDM 16QAM	Edge_1RB_Right	B

37 (Not e 3)	Low				16QAM	Outer_1RB_L eft	CP- OFDM 16QAM	N/A	A
38 (Not e 3)	High				16QAM	N/A	CP- OFDM 16QAM	Edge_1RB_Ri ght	A
39 (Not e 4)	Defau lt				16QAM	Outer_1RB_Ri ght	CP- OFDM 16QAM	Edge_1RB_Le ft	B
40 (Not e 4)	Low				16QAM	N/A	CP- OFDM 16QAM	Edge_1RB_Le ft	A
41 (Not e 4)	High				16QAM	Outer_1RB_Ri ght	CP- OFDM 16QAM	N/A	A
42	Defau lt				16QAM	Outer_Full	CP- OFDM 64QAM	Outer_Full	B
43 (Not e 3)	Low				16QAM	Outer_1RB_L eft	CP- OFDM 64QAM	Edge_1RB_Ri ght	B
44 (Not e 4)	High				16QAM	Outer_1RB_Ri ght	CP- OFDM 64QAM	Edge_1RB_Le ft	B
45	Defau lt				16QAM	Outer_Full	CP- OFDM 256QAM	Outer_Full	B
46 (Not e 3)	Low				16QAM	Outer_1RB_L eft	CP- OFDM 256QAM	Edge_1RB_Ri ght	B
47 (Not e 4)	High				16QAM	Outer_1RB_Ri ght	CP- OFDM 256QAM	Edge_1RB_Le ft	B
48 (Not e 4)	Defau lt				16QAM	Edge_Full_Rig ht	CP- OFDM 256QAM	Edge_Full_Lef t	B

NOTE 1: The specific configuration of each RB allocation is defined in Table 6.1-1 in TS 38.521-1 [8].

NOTE 2: If the UE supports multiple CC combinations in the EN-DC configuration with the same  $N_{RB\_agg}$ , select the combination to test as follows:

- Lowest ENBW: NR component with lowest  $N_{RB}$  is tested.
- Highest ENBW: NR component with highest  $N_{RB}$  is tested.

NOTE 3: Applicable when E-UTRA cell carrier frequency is lower than NR cell carrier.

NOTE 4: Applicable when NR cell carrier frequency is lower than E-UTRA cell carrier.

NOTE 5: Outer\_Full defined as the transmission bandwidth configuration  $N_{RB}$  per channel bandwidth for the E-UTRA component as indicated in TS 36.521 [10] Table 5.4.2-1. Outer\_1RB\_Left defined as 1 RB allocated at the left edge of the E-UTRA component. Edge\_Full\_Right is defined as 2 RBs allocated at the right edge of the E-UTRA component. Outer\_1RB\_Right defined as 1 RB allocated at the right edge of the E-UTRA component.

NOTE 6: DFT-s-OFDM Pi/2 BPSK test applies only for UEs which supports Pi/2 BPSK in FR1

NOTE 7: Test IDs with simultaneous E-UTRA and NR UL transmission only apply for UEs indicating dualIPA-Architecture.

NOTE 8: Power config as specified in Table 6.2B.2.1.4.3-3 and Table 6.2B.2.1.4.3-4 for PC3 UE or Table 6.2B.2.1.4.3-5 and Table 6.2B.2.1.4.3-6 for PC2 UE.

NOTE 9: Test IDs with simultaneous E-UTRA and NR UL transmission don't apply to DC\_(n)71AA for a UE supporting dynamic power sharing (A-MPR is applied as MPR and covered by 6.2B.3.1.1).

NOTE 10: For DC\_(n)71AA, only NR SCS of 15 kHz is tested.

1. Connect the SS to the UE antenna connectors as shown in TS 38.508-1 [6] Annex A, Figure A.3.1.1 for TE diagram and clause A.3.2.1 for UE diagram.
2. The parameter settings for the E-UTRA cell are set up according to TS 36.508 [11] clause 4.4.3, and the parameter settings for the NR cell are set up according to TS 38.508-1 [6] clause 4.4.3.
3. Downlink signals are initially set up according to TS 36.521-1 [10] Annex C.0 and TS 38.521-1 [8] Annex C.0 for E-UTRA CG and NR CG respectively, and uplink signals according to TS 36.521-1 [10] Annex H and TS 38.521-1 [8] Annex G for E-UTRA CG and NR CG respectively.

4. NR downlink signals are initially set up according to Annex C.0, C.1, and C.2 and uplink signals according to Annex G.0, G.1, G.2, and G.3.0 of TS 38.521-1 [8].
5. The UL Reference Measurement channels are set for E-UTRA CG and NR CG respectively.
6. Propagation conditions are set according to TS 36.521-1 [10] Annex B.0 and TS 38.521-1 [8] Annex B.0 for E-UTRA CG and NR CG respectively.
7. Ensure the UE is in state RRC\_CONNECTED with generic procedure parameters Connectivity EN-DC, DC bearer *MCG* and *SCG*, Connected without release *On* according to TS 38.508-1 [6] clause 4.5. Message contents are defined in clause 6.2B.2.1.4.3.
8. When E-UTRA and NR bands are TDD, ensure the same uplink-downlink configuration by giving SCG a delay of 3 E-UTRA subframes, or by giving MCG a delay of 2 subframes.

#### 6.2B.2.1.4.2 Test procedure

1. SS sends uplink scheduling information for each UL HARQ process via PDCCH DCI format 0 and DCI format 0\_1 for C\_RNTI to schedule the UL RMC according to Table 6.2B.2.1.4.1-1 on E-UTRA CC and NR CC respectively. For test points configured with message in Table 6.2B.2.1.4.3-7, NR SS only schedules UL RMC on NR slots that does not overlap with E-UTRA uplink subframe. Since the UL has no payload and no loopback data to send, the UE transmits uplink MAC padding bits on the UL RMC.
2. Send continuously uplink power control "up" commands to the UE for NR and E-UTRA carrier until the UE transmits at its  $P_{UMAX}$  level; allow at least 200 ms from the first TPC command starting in this step for the UE to reach  $P_{UMAX}$  level.
3. For a UE supporting dynamic power sharing, measure the mean power over all component carriers. For a UE not supporting dynamic power sharing, measure the power of each component carrier individually. For the tested EN-DC configuration, the requirements described in clause 6.2B.2.1.5 shall be met. The period of the measurement shall be at least the continuous duration of one active sub-frame (1 ms). For TDD slots with transient periods are not under test.
4. For UEs supporting Power Class 2, repeat steps 1~3 for Test ID 2 and 4 in Table 6.2B.2.1.4.1-1 on the applicable bands with message exception defined in Table 6.2B.2.1.4.3-7.

NOTE 1: When switching to DFT-s-OFDM waveform, as specified in the test configuration table 6.2B.2.1.4.1-1, send an NR RRCReconfiguration message according to TS 38.508-1 [6] clause 4.6.3 Table 4.6.3-118 PUSCH-Config with TRANSFORM\_PRECODER\_ENABLED condition.

#### 6.2B.2.1.4.3 Message contents

Message contents are according to TS 38.508-1 [6] clause 4.6.1 with the following exceptions:

**Table 6.2B.2.1.4.3-1: AdditionalSpectrumEmission for MCG**

Derivation Path: 36.508 [11] clause 4.6.3, Table 4.4.3.3-1			
Information Element	Value/remark	Comment	Condition
AdditionalSpectrumEmission	0 (NS_01)		

**Table 6.2B.2.1.4.3-2: AdditionalSpectrumEmission for SCG**

Derivation Path: 38.508-1 [5] clause 4.6.3, Table 4.6.3-1			
Information Element	Value/remark	Comment	Condition
AdditionalSpectrumEmission	0 (NS_01)		

**Table 6.2B.2.1.4.3-3: PhysicalCellGroupConfig for PC3**

Derivation Path: TS 38.508-1 [6], Table 4.6.3-106			
Information Element	Value/remark	Comment	Condition
p-NR-FR1	23		Power config A (NOTE 1)
	20		Power config B (NOTE 2)
NOTE 1: Applies when E-UTRA UL transmission not overlapping with NR UL transmission in time.			
NOTE 2: Applies when E-UTRA UL transmission overlapping with NR UL transmission in time.			

**Table 6.2B.2.1.4.3-4: RRCConnectionReconfiguration: nr-Config-r15 for PC3**

Derivation Path: TS 36.508 [11], Table 4.6.1-8			
Information Element	Value/remark	Comment	Condition
p-MaxEUTRA-r15	23		Power config A (NOTE 1)
	20		Power config B (NOTE 2)
NOTE 1: Applies when E-UTRA UL transmission not overlapping with NR UL transmission in time.			
NOTE 2: Applies when E-UTRA UL transmission overlapping with NR UL transmission in time.			

**Table 6.2B.2.1.4.3-5: PhysicalCellGroupConfig for PC2**

Derivation Path: TS 38.508-1 [6], Table 4.6.3-106			
Information Element	Value/remark	Comment	Condition
p-NR-FR1	26		Power config A (NOTE 1)
	23		Power config B (NOTE 2)
NOTE 1: Applies when E-UTRA UL transmission not overlapping with NR UL transmission in time.			
NOTE 2: Applies when E-UTRA UL transmission overlapping with NR UL transmission in time.			

**Table 6.2B.2.1.4.3-6: RRCConnectionReconfiguration: nr-Config-r15 for PC2**

Derivation Path: TS 36.508 [11], Table 4.6.1-8			
Information Element	Value/remark	Comment	Condition
p-MaxEUTRA-r15	26		Power config A (NOTE 1)
	23		Power config B (NOTE 2)
NOTE 1: Applies when E-UTRA UL transmission not overlapping with NR UL transmission in time.			
NOTE 2: Applies when E-UTRA UL transmission overlapping with NR UL transmission in time.			

**6.2B.2.1.4.3-7: RRCConnectionReconfiguration: p-MaxUE-FR1-r15 (step 4 in 6.2B.2.1.4.2)**

Derivation Path: TS 36.508 [11], Table 4.6.1-8			
Information Element	Value/remark	Comment	Condition
nonCriticalExtension SEQUENCE {		RRCConnectionReconfiguration-v1530-IEs	
p-MaxUE-FR1-r15	23		Power Class 2 UE
}			



**Table 6.2B.2.1.4.3-8: RRCConnectionReconfiguration: tdm-PatternConfig if operating on FDD band**

Derivation Path: TS 36.508 [11], Table 4.6.1-8			
Information Element	Value/remark	Comment	Condition
tdm-PatternConfig-r15 ::= CHOICE{			Power config A (NOTE 1)
setup ::= SEQUENCE {		Apply if operating on FDD band for a UE NOT indicating support of dynamicPowerSharing in the <i>UE-MRDC-Capability</i> IE according to TS 38.213 [x] clause 7.6.1	
subframeAssignment-r15	sa2		
harq-Offset-r15	0		
}			
}			
NOTE 1: Applies when E-UTRA UL transmission not overlapping with NR UL transmission in time.			

**6.2B.2.1.4.3-9: SystemInformationBlockType1: tdd-Config if E-UTRA on TDD band**

Derivation Path: TS 36.508 [11], Table 4.6.3-23			
Information Element	Value/remark	Comment	Condition
TDD-Config-DEFAULT ::= SEQUENCE {		Operating on TDD band	
subframeAssignment	sa2		
specialSubframePatterns	ssp7		
}			

6.2B.2.1.5 Test requirement

The maximum output power, derived in step 3 shall be within the range prescribed by the UE Power Class, the nominal maximum output power and tolerance in Table 6.2B.2.1.5-1 ~ Table 6.2B.2.1.5-6a.

The maximum output power, derived in step 4 shall be within the range prescribed by Power Class 3, the nominal maximum output power and tolerance in Table 6.2B.2.1.5-1 ~ Table 6.2B.2.1.5-3a.

**Table 6.2B.2.1.5-1: UE Power Class 3 test requirements, UE supporting dynamic power sharing, E-UTRA UL transmission overlapping with NR UL transmission**

Configuration ID	Test SCS (kHz)	MPR <sub>tot</sub> (dB)	P <sub>EN-DC, tot_L</sub> (dBm)	P <sub>EN-DC, tot_H</sub> (dBm)	T <sub>LOW</sub> (P <sub>CMAX_L</sub> ) (dB)	T <sub>HIGH</sub> (P <sub>CMAX_H</sub> ) (dB)	Upper limit (dBm)	Lower limit (dBm)
1, 8, 15, 22, 25, 28, 35, 42, 45 (NOTE 1)	15, 30, 60	3.0	20.0	23.0	6.0	2.0	25.0 + TT	14.0 - TT
2, 5, 9, 12, 16, 19, 23, 24, 26, 27, 29, 32, 36, 39, 43, 44, 46, 47 (NOTE 2)	15	11.0	12.0	23.0	6.0	2.0	25.0 + TT	6.0 - TT
	30, 60	6.0	17.0	23.0	5.0	2.0	25.0 + TT	12.0 - TT
48 (NOTE 3)	15	7.0	16.0	23.0	5.0	2.0	25.0 + TT	11.0 - TT
	30, 60	5.0	18.0	23.0	5.0	2.0	25.0 + TT	13.0 - TT
NOTE 1: Test configuration IDs with transmission overlap with full RB allocation, requirements in TS 38.101-3 [4] apply.								
NOTE 2: Test configuration IDs with transmission overlap with 1RB allocation, requirements in TS 38.101-3 [4] apply.								
NOTE 3: Test configuration IDs with transmission overlap with edge full RB allocation, requirements in TS 38.101-3 [4] apply.								

**Table 6.2B.2.1.5-2: UE Power Class 3 test requirements, UE with/without supporting dynamic power sharing, E-UTRA UL transmission not overlapping with NR UL transmission**

Configuration ID	Test SCS (kHz)	MPR (dB)	$P_{\text{CMAX, L}}$ (dBm)	$P_{\text{CMAX, H}}$ (dBm)	$T_{\text{LOW}} (P_{\text{CMAX, L}})$ (dB)	$T_{\text{HIGH}} (P_{\text{CMAX, H}})$ (dB)	Upper limit (dBm)	Lower limit (dBm)
3, 7, 10, 14, 17, 21, 30, 34, 37, 41 (NOTE 1)	N/A	1.0	22.0	23.0	2.0	2.0	25.0 + TT	20.0 - TT
4, 6 (NOTE 2)	15, 30, 60	3.5	19.5	23.0	2.0	2.0	25.0 + TT	17.5 - TT
11, 13 (NOTE 2)	15, 30, 60	1	22.0	23.0	2.0	2.0	25.0 + TT	20.0 - TT
18, 20 (NOTE 2)	15, 30, 60	2	21.0	23.0	2.0	2.0	25.0 + TT	19.0 - TT
31, 33, 38, 40 (NOTE 2)	15, 30, 60	3	20.0	23.0	2.0	2.0	25.0 + TT	18.0 - TT

NOTE 1: Test configuration IDs without transmission overlap with E-UTRA allocation, MPR requirements in TS 36.101 [4] apply.  
NOTE 2: Test configuration IDs without transmission overlap with NR allocation, MPR requirements in TS 38.101-1 [2] apply.

**Table 6.2B.2.1.5-3: UE Power Class 3 E-UTRA carrier test requirements, UE not supporting dynamic power sharing, E-UTRA UL transmission overlapping with NR UL transmission**

Configuration ID	Test SCS (kHz)	MCG MPR <sub>c</sub> (dB)	$P_{\text{CMAX, L}}$ (dBm)	$P_{\text{CMAX, H}}$ (dBm)	$T_{\text{LOW}} (P_{\text{CMAX, L}})$ (dB)	$T_{\text{HIGH}} (P_{\text{CMAX, H}})$ (dB)	Upper limit (dBm)	Lower limit (dBm)
1, 8, 15, 22, 25, 28, 35, 42, 45 (NOTE 1)	15, 30, 60	6.0	17.0	20.0	5.0	2.5	22.5 + TT	12.0 - TT
2, 5, 9, 12, 16, 19, 23, 24, 26, 27, 29, 32, 36, 39, 43, 44, 46, 47 (NOTE 2)	15, 30, 60	14.0	9.0	20.0	6.0	2.5	22.5 + TT	3.0 - TT
48 (NOTE 3)	15, 30, 60	9.0	14.0	20.0	5.0	2.5	22.5 + TT	9.0 - TT

NOTE 1: Test configuration IDs with transmission overlap with full RB allocation, requirements in TS 38.101-3 [4] apply.  
NOTE 2: Test configuration IDs with transmission overlap with 1RB allocation, requirements in TS 38.101-3 [4] apply.  
NOTE 3: Test configuration IDs with transmission overlap with edge full RB allocation, requirements in TS 38.101-3 [4] apply.

**Table 6.2B.2.1.5-3a: UE Power Class 3 NR carrier test requirements, UE not supporting dynamic power sharing, E-UTRA UL transmission overlapping with NR UL transmission**

Configuration ID	Test SCS (kHz)	SCG MPR' <sub>c</sub> (dB)	P <sub>CMAX, L</sub> (dBm)	P <sub>CMAX, H</sub> (dBm)	T <sub>LOW</sub> (P <sub>CMAX, L</sub> ) (dB)	T <sub>HIGH</sub> (P <sub>CMAX, H</sub> ) (dB)	Upper limit (dBm)	Lower limit (dBm)
1, 8, 15, 22, 25, 28, 35, 42, 45 (NOTE 1)	15, 30, 60	6.0	17.0	20.0	5.0	2.5	22.5 + TT	12.0 - TT
2, 5, 9, 12, 16, 19, 23, 24, 26, 27, 29, 32, 36, 39, 43, 44, 46, 47 (NOTE 2)	15	14.0	9.0	20.0	6.0	2.5	22.5 + TT	3.0 - TT
	30, 60	9.0	14.0	20.0	5.0	2.5	22.5 + TT	9.0 - TT
48 (NOTE 3)	15, 30	9.0	14.0	20.0	5.0	2.5	22.5 + TT	9.0 - TT
	60	7.0	16.0	20.0	5.0	2.5	22.5 + TT	11.0 - TT

NOTE 1: Test configuration IDs with transmission overlap with full RB allocation, requirements in TS 38.101-3 [4] apply.  
NOTE 2: Test configuration IDs with transmission overlap with 1RB allocation, requirements in TS 38.101-3 [4] apply.  
NOTE 3: Test configuration IDs with transmission overlap with edge full RB allocation, requirements in TS 38.101-3 [4] apply.

**Table 6.2B.2.1.5-4: UE Power Class 2 test requirements, UE supporting dynamic power sharing, E-UTRA UL transmission overlapping with NR UL transmission**

Configuration ID	Test SCS (kHz)	MPR <sub>tot</sub> (dB)	P <sub>EN-DC, tot_L</sub> (dBm)	P <sub>EN-DC, tot_H</sub> (dBm)	T <sub>LOW</sub> (P <sub>CMAX, L</sub> ) (dB)	T <sub>HIGH</sub> (P <sub>CMAX, H</sub> ) (dB)	Upper limit (dBm)	Lower limit (dBm)
1, 8, 15, 22, 25, 28, 35, 42, 45 (NOTE 1)	15, 30, 60	3.0	23.0	26.0	3.0	2.0	28.0 + TT	20.0 - TT
2, 5, 9, 12, 16, 19, 23, 24, 26, 27, 29, 32, 36, 39, 43, 44, 46, 47 (NOTE 2)	15	11.0	15.0	26.0	6.0	2.0	28.0 + TT	9.0 - TT
	30, 60	6.0	20.0	26.0	6.0	2.0	28.0 + TT	14.0 - TT
48 (NOTE 3)	15	7.0	19.0	26.0	5.0	2.0	28.0 + TT	14.0 - TT
	30, 60	5.0	21.0	26.0	5.0	2.0	28.0 + TT	16.0 - TT

NOTE 1: Test configuration IDs with transmission overlap with full RB allocation, requirements in TS 38.101-3 [4] apply.  
NOTE 2: Test configuration IDs with transmission overlap with 1RB allocation, requirements in TS 38.101-3 [4] apply.  
NOTE 3: Test configuration IDs with transmission overlap with edge full RB allocation, requirements in TS 38.101-3 [4] apply.

**Table 6.2B.2.1.5-5: UE Power Class 2 test requirements, UE with/without supporting dynamic power sharing, E-UTRA UL transmission not overlapping with NR UL transmission (Rel-15 UE indicates PC2 on NR band Rel-16 and forward UE reporting (PC2 by  $P_{PowerClass,NR}$ , and PC2 or Not present by *powerClassNRPart-r16*))**

Configuration ID	Test SCS (kHz)	MPR (dB)	$P_{CMAX,L}$ (dBm)	$P_{CMAX,H}$ (dBm)	$T_{LOW}$ ( $P_{CMAX,L}$ ) (dB)	$T_{HIGH}$ ( $P_{CMAX,H}$ ) (dB)	Upper limit (dBm)	Lower limit (dBm)
3, 7, 10, 14, 17, 21, 30, 34, 37, 41 (NOTE 1)	N/A	1.0	25.0	26.0	2.0	2.0	28.0 + TT	23.0 - TT
4, 6 (NOTE 2)	15, 30, 60	3.5	22.5	26.0	2.0	2.0	28.0 + TT	20.5 - TT
11, 13 (NOTE 2)	15, 30, 60	3.5	22.5	26.0	2.0	2.0	28.0 + TT	20.5 - TT
18, 20 (NOTE 2)	15, 30, 60	3.5	22.5	26.0	2.0	2.0	28.0 + TT	20.5 - TT
31,33, 38, 40 (NOTE 2)	15, 30, 60	3.5	22.5	26.0	2.0	2.0	28.0 + TT	20.5 - TT

NOTE 1: Test configuration IDs without transmission overlap with E-UTRA allocation, MPR requirements in TS 36.101 [4] apply.

NOTE 2: Test configuration IDs without transmission overlap with NR allocation, MPR requirements in TS 38.101-1 [2] apply.

**Table 6.2B.2.1.5-5a: UE Power Class 2 test requirements, UE with/without supporting dynamic power sharing, E-UTRA UL transmission not overlapping with NR UL transmission (Rel-15 and forward UE indicates PC3 on NR band, Rel-16 and forward UE reporting (PC2 by  $P_{PowerClass,NR}$ , and PC3 by *powerClassNRPart-r16*))**

Configuration ID	Test SCS (kHz)	MPR (dB)	$P_{CMAX,L}$ (dBm)	$P_{CMAX,H}$ (dBm)	$T_{LOW}$ ( $P_{CMAX,L}$ ) (dB)	$T_{HIGH}$ ( $P_{CMAX,H}$ ) (dB)	Upper limit (dBm)	Lower limit (dBm)
3, 7, 10, 14, 17, 21, 30, 34, 37, 41 (NOTE 1)	N/A	1.0	25.0	26.0	2.0	2.0	28.0 + TT	23.0 - TT
4, 6 (NOTE 2)	15, 30, 60	0.5	22.5	23.0	2.0	2.0	25.0 + TT	20.5 - TT
11, 13 (NOTE 2)	15, 30, 60	1.0	22.0	23.0	2.0	2.0	25.0 + TT	20.0 - TT
18, 20 (NOTE 2)	15, 30, 60	2.0	21.0	23.0	2.0	2.0	25.0 + TT	19.0 - TT
31,33, 38, 40 (NOTE 2)	15, 30, 60	3.0	20.0	23.0	2.5	2.0	25.0 + TT	17.5 - TT

NOTE 1: Test configuration IDs without transmission overlap with NR allocation, MPR requirements in TS 36.101 [4] apply.

NOTE 2: Test configuration IDs without transmission overlap with E-UTRA allocation, MPR requirements in TS 38.101-1 [2] apply.

**Table 6.2B.2.1.5-6: UE Power Class 2 E-UTRA carrier test requirements, UE not supporting dynamic power sharing, E-UTRA UL transmission overlapping with NR UL transmission**

Configuration ID	Test SCS (kHz)	MCG MPR <sub>c</sub> (dB)	P <sub>CMAX, L</sub> (dBm)	P <sub>CMAX, H</sub> (dBm)	T <sub>LOW</sub> (P <sub>CMAX, L</sub> ) (dB)	T <sub>HIGH</sub> (P <sub>CMAX, H</sub> ) (dB)	Upper limit (dBm)	Lower limit (dBm)
1, 8, 15, 22, 25, 28, 35, 42, 45 (NOTE 1)	15, 30, 60	6.0	20.0	23.0	2.5	2.0	25.0 + TT	17.5 - TT
2, 5, 9, 12, 16, 19, 23, 24, 26, 27, 29, 32, 36, 39, 43, 44, 46, 47 (NOTE 2)	15, 30, 60	14.0	12.0	23.0	6.0	2.0	25.0 + TT	6.0 - TT
48 (NOTE 3)	15, 30, 60	9.0	17.0	23.0	5.0	2.0	25.0 + TT	12.0 - TT

NOTE 1: Test configuration IDs with transmission overlap with full RB allocation, requirements in TS 38.101-3 [4] apply.  
NOTE 2: Test configuration IDs with transmission overlap with 1RB allocation, requirements in TS 38.101-3 [4] apply.  
NOTE 3: Test configuration IDs with transmission overlap with edge full RB allocation, requirements in TS 38.101-3 [4] apply.

**Table 6.2B.2.1.5-6a: UE Power Class 2 NR carrier test requirements, UE not supporting dynamic power sharing, E-UTRA UL transmission overlapping with NR UL transmission**

Configuration ID	Test SCS (kHz)	SCG MPR' <sub>c</sub> (dB)	P <sub>CMAX, L</sub> (dBm)	P <sub>CMAX, H</sub> (dBm)	T <sub>LOW</sub> (P <sub>CMAX, L</sub> ) (dB)	T <sub>HIGH</sub> (P <sub>CMAX, H</sub> ) (dB)	Upper limit (dBm)	Lower limit (dBm)
1, 8, 15, 22, 25, 28, 35, 42, 45 (NOTE 1)	15, 30, 60	6.0	20.0	23.0	2.5	2.0	25.0 + TT	17.5 - TT
2, 5, 9, 12, 16, 19, 23, 24, 26, 27, 29, 32, 36, 39, 43, 44, 46, 47 (NOTE 2)	15	14.0	12.0	23.0	6.0	2.0	25.0 + TT	6.0 - TT
	30, 60	9.0	17.0	23.0	5.0	2.0	25.0 + TT	12.0 - TT
48 (NOTE 3)	15, 30	9.0	17.0	23.0	5.0	2.0	25.0 + TT	12.0 - TT
	60	7.0	19.0	23.0	3.5	2.0	25.0 + TT	15.5 - TT

NOTE 1: Test configuration IDs with transmission overlap with full RB allocation, requirements in TS 38.101-3 [4] apply.  
NOTE 2: Test configuration IDs with transmission overlap with 1RB allocation, requirements in TS 38.101-3 [4] apply.  
NOTE 3: Test configuration IDs with transmission overlap with edge full RB allocation, requirements in TS 38.101-3 [4] apply.

**Table 6.2B.2.1.5-7: Test Tolerance**

	f ≤ 3.0GHz	3.0GHz < f ≤ 6GHz
ENBW ≤ 40MHz	0.7 dB	1.0 dB
40MHz < ENBW ≤ 100MHz	1.0 dB	1.0 dB

**6.2B.2.2 UE Maximum Output Power reduction for Intra-Band Non-Contiguous EN-DC****6.2B.2.2.1 Test purpose**

Same test purpose as in clause 6.2B.2.1.1.

**6.2B.2.2.2 Test applicability**

This test case applies to all types of E-UTRA UE release 15 and forward, supporting intra-band non-contiguous EN-DC.

NOTE: Test execution is not necessary if clause 6.5B.2.2.3 ACLR is executed since MPR requirement is verified in this test case.

## 6.2B.2.2.3 Minimum conformance requirements

## 6.2B.2.2.3.1 General

When the UE is configured for intra-band non-contiguous EN-DC, the UE determines the total allowed maximum output power reduction as specified in this subclause.

For UE supporting dynamic power sharing the following:

- for the MCG,  $MPR_c$  in accordance with TS 36.101 [4]
- for the SCG,

$$MPR'_c = MPR_{NR} = \text{MAX}(MPR_{\text{single,NR}}, MPR_{\text{ENDC}})$$

- for the total configured transmission power,

$$MPR_{\text{tot}} = P_{\text{PowerClass,EN-DC}} - \min(P_{\text{PowerClass,EN-DC}}, 10 * \log_{10}(10^{((P_{\text{PowerClass,E-UTRA}} - MPR_{\text{E-UTRA}})/10)} + 10^{((P_{\text{PowerClass,NR}} - MPR_{\text{NR}})/10)}))$$

where

$$MPR_{\text{E-UTRA}} = \text{MAX}(MPR_{\text{single,E-UTRA}}, MPR_{\text{ENDC}})$$

with

- $MPR_{\text{single,E-UTRA}}$  is the MPR defined for the E-UTRA transmission in TS 36.101 [4]
- $MPR_{\text{single,NR}}$  is the MPR defined for the NR transmission in TS 38.101-1 [2]

For UEs not supporting dynamic power sharing the following

- for the MCG,

$$MPR_c = \text{MAX}(MPR_{\text{single,E-UTRA}}, MPR_{\text{ENDC}})$$

- for the SCG,

$$MPR'_c = \text{MAX}(MPR_{\text{single,NR}}, MPR_{\text{ENDC}})$$

where

- $MPR_{\text{single,NR}}$  is the MPR defined for the NR transmission in TS 38.101-1 [2]
- $MPR_{\text{single,E-UTRA}}$  is the MPR defined for the E-UTRA transmission in TS 36.101 [4]

$MPR_{\text{ENDC}}$  is defined in Clause 6.2B.2.2.3.2.

## 6.2B.2.2.3.2 MPR for power class 3 and power class 2

MPR in this subclause is applicable for power class 3 and power class 2 UEs indicating IE *dualPA-Architecture* supported with ENDC power class being the same as the E-UTRA and NR power class, otherwise the UE can use as much MPR as needed to fulfil emissions requirements when scheduled with dual uplink transmission. For UEs scheduled with single uplink transmission, MPR in subclause 6.2.4 of TS 36.101 [5] and 6.2.3 of TS 38.101-1 [2] apply. The allowed maximum output power reduction for IM3 related emissions applied to transmission on the MCG and the SCG is defined as follows:

$$MPR_{\text{ENDC}} = M_A$$

Where  $M_A$  is defined as follows

$$M_A = \begin{array}{ll} 18 ; & 0 \leq B < 1.0 \\ 17 ; & 1.0 \leq B < 2.0 \\ 16 ; & 2.0 \leq B < 5.0 \\ 15 ; & 5.0 \leq B \end{array}$$

Where:

For UEs supporting dynamic power sharing,

$$B = (L_{CRB\_alloc, E-UTRA} * 12 * SCS_{E-UTRA} + L_{CRB\_alloc, NR} * 12 * SCS_{NR}) / 1,000.000$$

For UEs not supporting dynamic power sharing,

For E-UTRA

$$B = (L_{CRB\_alloc, E-UTRA} * 12 * SCS_{E-UTRA} + 12 * SCS_{NR}) / 1,000.000$$

Where  $SCS_{NR} = 15$  kHz is assumed in calculation of B.

For NR

$$B = (12 * SCS_{E-UTRA} + L_{CRB\_alloc, NR} * 12 * SCS_{NR}) / 1,000.000$$

Where  $SCS_{E-UTRA} = 15$  kHz is assumed in calculation of B.

and  $M_A$  is reduced by 1 dB for  $B < 2$ .

The normative reference for this requirement is TS 38.101-3 [4] clause 6.2B.2.2.

Exception requirements for both NR and E-UTRA are defined for this test when transmission on E-UTRA overlap in time with NR. LTE anchor agnostic approach is not applied for this case. E-UTRA test point analysis is included and E-UTRA measurements are performed.

No exception requirements for NR or E-UTRA are defined for this test when transmission on E-UTRA doesn't overlap in time with NR. LTE anchor agnostic approach is not applied for this case based on the test point analysis in TS 38.905 [7].

6.2B.2.2.4 Test description

6.2B.2.2.4.1 Initial conditions

Same initial conditions as described in clause 6.2B.2.1.4.1 for both E-UTRA and NR carriers with the following exception:

- Instead of Table 6.2B.2.1.4.1-1 --> use Table 6.2B.2.2.4.1-1.

**Table 6.2B.2.2.4.1-1: Test Configuration Table**

Initial Conditions									
Test Environment as specified in TS 38.508-1 [6] clause 4.1.				Normal, TL/VL, TL/VH, TH/VL, TH/VH					
Test Frequencies as specified in TS 38.508 [7] clause 4.3.1 for different DC bandwidth classes				Low with maxWgap (NR low – E-UTRA high); High with maxWgap (E-UTRA low – NR high)					
Test EN-DC bandwidth combination as specified in Table 5.3B.1.3-1.				Lowest $N_{RB\_agg}$ , Highest $N_{RB\_agg}$ (Note 2)					
Test SCS for the NR cell as specified in TS 38.521-1 [8] Table 5.3.5-1.				Lowest, Highest					
Test Parameters									
Test ID	Freq	ChBw	SCS	Downlink Configuration	EN-DC Uplink Configuration				
					E-UTRA Cell		NR Cell		Common Power config (NOTE 6)
					Modulation	RB allocation (Note 3)	Modulation	RB allocation (NOTE 1)	

1	Default	Default	Default	N/A	QPSK	Outer_Full	DFT-s-OFDM Pi/2 BPSK	Outer_Full	B
2	High				QPSK	Outer_1RB_Left	DFT-s-OFDM Pi/2 BPSK	Edge_1RB_Right	B
3	High				QPSK	Outer_1RB_Left	DFT-s-OFDM Pi/2 BPSK	N/A	A
4	High				QPSK	N/A	DFT-s-OFDM Pi/2 BPSK	Edge_1RB_Right	A
5	Low				QPSK	Outer_1RB_Right	DFT-s-OFDM Pi/2 BPSK	Edge_1RB_Left	B
6	Low				QPSK	N/A	DFT-s-OFDM Pi/2 BPSK	Edge_1RB_Left	A
7	Low				QPSK	Outer_1RB_Right	DFT-s-OFDM Pi/2 BPSK	N/A	A
8	Default				QPSK	Outer_Full	DFT-s-OFDM QPSK	Outer_Full	B
9	High				QPSK	Outer_1RB_Left	DFT-s-OFDM QPSK	Edge_1RB_Right	B
10	High				QPSK	Outer_1RB_Left	DFT-s-OFDM QPSK	N/A	A
11	High				QPSK	N/A	DFT-s-OFDM QPSK	Edge_1RB_Right	A
12	Low				QPSK	Outer_1RB_Right	DFT-s-OFDM QPSK	Edge_1RB_Left	B
13	Low				QPSK	N/A	DFT-s-OFDM QPSK	Edge_1RB_Left	A
14	Low				QPSK	Outer_1RB_Right	DFT-s-OFDM QPSK	N/A	A
15	Default				16QAM	Outer_Full	DFT-s-OFDM 16QAM	Outer_Full	B
16	High				16QAM	Outer_1RB_Left	DFT-s-OFDM 16QAM	Edge_1RB_Right	B
17	High				16QAM	Outer_1RB_Left	DFT-s-OFDM 16QAM	N/A	A
18	High				16QAM	N/A	DFT-s-OFDM 16QAM	Edge_1RB_Right	A
19	Low				16QAM	Outer_1RB_Right	DFT-s-OFDM 16QAM	Edge_1RB_Left	B
20	Low				16QAM	N/A	DFT-s-OFDM 16QAM	Edge_1RB_Left	A
21	Low				16QAM	Outer_1RB_Right	DFT-s-OFDM 16QAM	N/A	A
22	Default				16QAM	Outer_Full	DFT-s-OFDM 64QAM	Outer_Full	B



23	High				16QAM	Outer_1RB_Left	DFT-s-OFDM 64QAM	Edge_1RB_Right	B
24	Low				16QAM	Outer_1RB_Right	DFT-s-OFDM 64QAM	Edge_1RB_Left	B
2	Default				16QAM	Outer_Full	DFT-s-OFDM 256QAM	Outer_Full	B
26	High				16QAM	Outer_1RB_Left	DFT-s-OFDM 256QAM	Edge_1RB_Right	B
27	Low				16QAM	Outer_1RB_Right	DFT-s-OFDM 256QAM	Edge_1RB_Left	B
28	Default				QPSK	Outer_Full	CP-OFDM QPSK	Outer_Full	B
29	High				QPSK	Outer_1RB_Left	CP-OFDM QPSK	Edge_1RB_Right	B
30	High				QPSK	Outer_1RB_Left	CP-OFDM QPSK	N/A	A
31	High				QPSK	N/A	CP-OFDM QPSK	Edge_1RB_Right	A
32	Low				QPSK	Outer_1RB_Right	CP-OFDM QPSK	Edge_1RB_Left	B
33	Low				QPSK	N/A	CP-OFDM QPSK	Edge_1RB_Left	A
34	Low				QPSK	Outer_1RB_Right	CP-OFDM QPSK	N/A	A
3	Default				16QAM	Outer_Full	CP-OFDM 16QAM	Outer_Full	B
36	High				16QAM	Outer_1RB_Left	CP-OFDM 16QAM	Edge_1RB_Right	B
37	High				16QAM	Outer_1RB_Left	CP-OFDM 16QAM	N/A	A
38	High				16QAM	N/A	CP-OFDM 16QAM	Edge_1RB_Right	A
39	Low				16QAM	Outer_1RB_Right	CP-OFDM 16QAM	Edge_1RB_Left	B
40	Low				16QAM	N/A	CP-OFDM 16QAM	Edge_1RB_Left	A
41	Low				16QAM	Outer_1RB_Right	CP-OFDM 16QAM	N/A	A
42	Default				16QAM	Outer_Full	CP-OFDM 64QAM	Outer_Full	B
43	High				16QAM	Outer_1RB_Left	CP-OFDM 64QAM	Edge_1RB_Right	B
44	Low				16QAM	Outer_1RB_Right	CP-OFDM 64QAM	Edge_1RB_Left	B
45	Default				16QAM	Outer_Full	CP-OFDM 256QAM	Outer_Full	B
46	High				16QAM	Outer_1RB_Left	CP-OFDM 256QAM	Edge_1RB_Right	B
47	Low				16QAM	Outer_1RB_Right	CP-OFDM 256QAM	Edge_1RB_Left	B
48	Low				16QAM	Edge_Full_Right	CP-OFDM 256QAM	Edge_Full_Left	B

NOTE 1:	The specific configuration of each RB allocation is defined in Table 6.1-1 in TS 38.521-1 [8].
NOTE 2:	If the UE supports multiple CC combinations in the EN-DC configuration with the same $N_{RB\_agg}$ , select the combination to test as follows: <ul style="list-style-type: none"> <li>- Lowest ENBW: NR component with lowest <math>N_{RB}</math> is tested.</li> <li>- Highest ENBW: NR component with highest <math>N_{RB}</math> is tested.</li> </ul>
NOTE 3:	Outer_Full defined as the transmission bandwidth configuration $N_{RB}$ per channel bandwidth for the E-UTRA component as indicated in TS 36.521 [10] Table 5.4.2-1. Outer_1RB_Left defined as 1 RB allocated at the left edge of the E-UTRA component. Edge_Full_Right is defined as 2 RBs allocated at the right edge of the E-UTRA component. Outer_1RB_Right defined as 1 RB allocated at the right edge of the E-UTRA component.
NOTE 4:	DFT-s-OFDM Pi/2 BPSK test applies only for UEs which supports Pi/2 BPSK in FR1
NOTE 5:	Test IDs with simultaneous E-UTRA and NR UL transmission only apply for UEs indicating dualPA-Architecture.
NOTE 6:	Power config as specified in Table 6.2B.2.1.4.3-3 and Table 6.2B.2.1.4.3-4 for PC3 UE or Table 6.2B.2.1.4.3-5 and Table 6.2B.2.1.4.3-6 for PC2 UE.

#### 6.2B.2.2.4.2 Test procedure

Same test procedure as described in clause 6.2B.2.1.4.2.

#### 6.2B.2.2.4.3 Message contents

Same message contents as in clause 6.2B.2.1.4.3.

#### 6.2B.2.2.5 Test requirement

The maximum output power, derived in step 3 shall be within the range prescribed by the nominal maximum output power and tolerance in Table 6.2B.2.2.5-1 ~ Table 6.2B.2.2.5-8a.

**Table 6.2B.2.2.5-1: UE Power Class 3 test requirements, UE supporting dynamic power sharing, E-UTRA UL transmission overlapping with NR UL transmission**

Configuration ID	Test SCS (kHz)	$MPR_{tot}$ (dB)	$P_{EN-DC, tot\_L}$ (dBm)	$P_{EN-DC, tot\_H}$ (dBm)	$T_{LOW}$ ( $P_{CMAX\_L}$ ) (dB)	$T_{HIGH}$ ( $P_{CMAX\_H}$ ) (dB)	Upper limit (dBm)	Lower limit (dBm)
1, 8, 15, 22, 25, 28, 35, 42, 45 (NOTE 1)	15, 30, 60	12.0	11.0	23.0	6.0	4.0	27.0 + TT	5.0 - TT
2, 5, 9, 12, 16, 19, 23, 24, 26, 27, 29, 32, 36, 39, 43, 44, 46, 47 (NOTE 2)	15,30, 60	15.0	8.0	23.0	7.0	4.0	27.0 + TT	1.0 - TT
48 (NOTE 3)	15	14.0	9.0	23.0	7.0	4.0	27.0 + TT	2.0 - TT
	30, 60	13.0	10.0	23.0	7.0	4.0	27.0 + TT	3.0 - TT
NOTE 1: Test configuration IDs with transmission overlap with full RB allocation, requirements in TS 38.101-3 [4] apply.								
NOTE 2: Test configuration IDs with transmission overlap with 1RB allocation, requirements in TS 38.101-3 [4] apply.								
NOTE 3: Test configuration IDs with transmission overlap with edge full RB allocation, requirements in TS 38.101-3 [4] apply.								

**Table 6.2B.2.2.5-2: UE Power Class 3 test requirements, UE with/without supporting dynamic power sharing, E-UTRA UL transmission not overlapping with NR UL transmission**

Configuration ID	Test SCS (kHz)	MPR (dB)	$P_{\text{CMAX, L}}$ (dBm)	$P_{\text{CMAX, H}}$ (dBm)	$T_{\text{LOW}} (P_{\text{CMAX, L}})$ (dB)	$T_{\text{HIGH}} (P_{\text{CMAX, H}})$ (dB)	Upper limit (dBm)	Lower limit (dBm)
3, 7, 10, 14, 17, 21, 30, 34, 37, 41 (NOTE 1)	15, 30, 60	1.0	22.0	23.0	2.0	2.0	25.0 + TT	20.0 - TT
4, 6 (NOTE 2)	15, 30, 60	3.5	19.5	23.0	2.0	2.0	25.0 + TT	17.5 - TT
11, 13 (NOTE 2)	15, 30, 60	1	22.0	23.0	2.0	2.0	25.0 + TT	20.0 - TT
18, 20 (NOTE 2)	15, 30, 60	2	21.0	23.0	2.0	2.0	25.0 + TT	19.0 - TT
31, 33, 38, 40 (NOTE 2)	15, 30, 60	3	20.0	23.0	2.0	2.0	25.0 + TT	18.0 - TT

NOTE 1: Test configuration IDs without transmission overlap with E-UTRA allocation, MPR requirements in TS 36.101 [4] apply.  
NOTE 2: Test configuration IDs without transmission overlap with NR allocation, MPR requirements in TS 38.101-1 [2] apply.

**Table 6.2B.2.2.5-3: UE Power Class 3 E-UTRA carrier test requirements, UE not supporting dynamic power sharing, E-UTRA UL transmission overlapping with NR UL transmission**

Configuration ID	Test SCS (kHz)	MCG MPR <sub>c</sub> (dB)	$P_{\text{CMAX, L}}$ (dBm)	$P_{\text{CMAX, H}}$ (dBm)	$T_{\text{LOW}} (P_{\text{CMAX, L}})$ (dB)	$T_{\text{HIGH}} (P_{\text{CMAX, H}})$ (dB)	Upper limit (dBm)	Lower limit (dBm)
1, 8, 15, 22, 25, 28, 35, 42, 45 (NOTE 1)	15, 30, 60	15.0	8.0	20.0	6.0	2.5	22.5 + TT	2.0 - TT
2, 5, 9, 12, 16, 19, 23, 24, 26, 27, 29, 32, 36, 39, 43, 44, 46, 47 (NOTE 2)	15, 30, 60	17.0	6.0	20.0	7.0	2.5	22.5 + TT	-1.0 - TT
48 (NOTE 3)	15, 30, 60	17.0	6.0	20.0	7.0	2.5	22.5 + TT	-1.0 - TT

NOTE 1: Test configuration IDs with transmission overlap with full RB allocation, requirements in TS 38.101-3 [4] apply.  
NOTE 2: Test configuration IDs with transmission overlap with 1RB allocation, requirements in TS 38.101-3 [4] apply.  
NOTE 3: Test configuration IDs with transmission overlap with edge full RB allocation, requirements in TS 38.101-3 [4] apply.

**Table 6.2B.2.2.5-3a: UE Power Class 3 NR carrier test requirements, UE not supporting dynamic power sharing, E-UTRA UL transmission overlapping with NR UL transmission**

Configuration ID	Test SCS (kHz)	SCG MPR' <sub>c</sub> (dB)	P <sub>CMAX, L</sub> (dBm)	P <sub>CMAX, H</sub> (dBm)	T <sub>LOW</sub> (P <sub>CMAX, L</sub> ) (dB)	T <sub>HIGH</sub> (P <sub>CMAX, H</sub> ) (dB)	Upper limit (dBm)	Lower limit (dBm)
1, 8, 15, 22, 25, 28, 35, 42, 45 (NOTE 1)	15, 30, 60	15.0	8.0	20.0	6.0	2.5	22.5 + TT	2.0 - TT
2, 5, 9, 12, 16, 19, 23, 24, 26, 27, 29, 32, 36, 39, 43, 44, 46, 47 (NOTE 2)	15, 30, 60	17.0	6.0	20.0	7.0	2.5	22.5 + TT	-1.0 - TT
48 (NOTE 3)	15, 30	17.0	6.0	20.0	7.0	2.5	22.5 + TT	-1.0 - TT
	60	16.0	7.0	20.0	7.0	2.5	22.5 + TT	- TT

NOTE 1: Test configuration IDs with transmission overlap with full RB allocation, requirements in TS 38.101-3 [4] apply.  
NOTE 2: Test configuration IDs with transmission overlap with 1RB allocation, requirements in TS 38.101-3 [4] apply.  
NOTE 3: Test configuration IDs with transmission overlap with edge full RB allocation, requirements in TS 38.101-3 [4] apply.

**Table 6.2B.2.2.5-4: Void****Table 6.2B.2.2.5-5: UE Power Class 2 test requirements, UE supporting dynamic power sharing, E-UTRA UL transmission overlapping with NR UL transmission**

Configuration ID	Test SCS (kHz)	MPR <sub>tot</sub> (dB)	P <sub>EN-DC, tot, L</sub> (dBm)	P <sub>EN-DC, tot, H</sub> (dBm)	T <sub>LOW</sub> (P <sub>CMAX, L</sub> ) (dB)	T <sub>HIGH</sub> (P <sub>CMAX, H</sub> ) (dB)	Upper limit (dBm)	Lower limit (dBm)
1, 8, 15, 22, 25, 28, 35, 42, 45 (NOTE 1)	15, 30, 60	12.0	14.0	26.0	6.0	4.0	30.0 + TT	8.0 - TT
2, 5, 9, 12, 16, 19, 23, 24, 26, 27, 29, 32, 36, 39, 43, 44, 46, 47 (NOTE 2)	15, 30, 60	15.0	11.0	26.0	6.0	4.0	30.0 + TT	5.0 - TT
48 (NOTE 3)	15	14.0	12.0	26.0	6.0	4.0	30.0 + TT	6.0 - TT
	30, 60	13.0	13.0	26.0	6.0	4.0	30.0 + TT	7.0 - TT

NOTE 1: Test configuration IDs with transmission overlap with full RB allocation, requirements in TS 38.101-3 [4] apply.  
NOTE 2: Test configuration IDs with transmission overlap with 1RB allocation, requirements in TS 38.101-3 [4] apply.  
NOTE 3: Test configuration IDs with transmission overlap with edge full RB allocation, requirements in TS 38.101-3 [4] apply.

**Table 6.2B.2.2.5-6: UE Power Class 2 test requirements, UE with/without supporting dynamic power sharing, E-UTRA UL transmission not overlapping with NR UL transmission (Rel-15 UE indicates PC2 on NR band, Rel-16 and forward UE reporting (PC2 by  $P_{PowerClass,NR}$ , and PC2 or Not present by *powerClassNRPart-r16*))**

Configuration ID	Test SCS (kHz)	MPR (dB)	$P_{CMAX,L}$ (dBm)	$P_{CMAX,H}$ (dBm)	$T_{LOW}$ ( $P_{CMAX,L}$ ) (dB)	$T_{HIGH}$ ( $P_{CMAX,H}$ ) (dB)	Upper limit (dBm)	Lower limit (dBm)
3, 7, 10, 14, 17, 21, 30, 34, 37, 41 (NOTE 1)	15, 30, 60	1.0	25.0	26.0	2.0	2.0	28.0 + TT	23.0 - TT
4, 6 (NOTE 2)	15, 30, 60	3.5	22.5	26.0	2.0	2.0	28.0 + TT	20.5 - TT
11, 13 (NOTE 2)	15, 30, 60	3.5	22.5	26.0	2.0	2.0	28.0 + TT	20.5 - TT
18, 20 (NOTE 2)	15, 30, 60	3.5	22.5	26.0	2.0	2.0	28.0 + TT	20.5 - TT
31,33, 38, 40 (NOTE 2)	15, 30, 60	3.5	22.5	26.0	2.0	2.0	28.0 + TT	20.5 - TT

NOTE 1: Test configuration IDs without transmission overlap with E-UTRA allocation, MPR requirements in TS 36.101 [4] apply.  
NOTE 2: Test configuration IDs without transmission overlap with NR allocation, MPR requirements in TS 38.101-1 [2] apply.

**Table 6.2B.2.2.5-6a: UE Power Class 2 test requirements, UE with/without supporting dynamic power sharing, E-UTRA UL transmission not overlapping with NR UL transmission (Rel-15 and forward UE indicates PC3 on NR band, Rel-16 and forward UE reporting (PC2 by  $P_{PowerClass,NR}$ , and PC3 by *powerClassNRPart-r16*))**

Configuration ID	Test SCS (kHz)	MPR (dB)	$P_{CMAX,L}$ (dBm)	$P_{CMAX,H}$ (dBm)	$T_{LOW}$ ( $P_{CMAX,L}$ ) (dB)	$T_{HIGH}$ ( $P_{CMAX,H}$ ) (dB)	Upper limit (dBm)	Lower limit (dBm)
3, 7, 10, 14, 17, 21, 30, 34, 37, 41 (NOTE 1)	15, 30, 60	1.0	25.0	26.0	2.0	2.0	28.0 + TT	23.0 - TT
4, 6 (NOTE 2)	15, 30, 60	0.5	22.5	23.0	2.0	2.0	25.0 + TT	20.5 - TT
11, 13 (NOTE 2)	15, 30, 60	1.0	22.0	23.0	2.0	2.0	25.0 + TT	20.0 - TT
18, 20 (NOTE 2)	15, 30, 60	2.0	21.0	23.0	2.0	2.0	25.0 + TT	19.0 - TT
31,33, 38, 40 (NOTE 2)	15, 30, 60	3.0	20.0	23.0	2.0	2.0	25.0 + TT	17.5 - TT

NOTE 1: Test configuration IDs without transmission overlap with E-UTRA allocation, MPR requirements in TS 36.101 [4] apply.  
NOTE 2: Test configuration IDs without transmission overlap with NR allocation, MPR requirements in TS 38.101-1 [2] apply.

**Table 6.2B.2.2.5-7: UE Power Class 2 E-UTRA carrier test requirements, UE not supporting dynamic power sharing, E-UTRA UL transmission overlapping with NR UL transmission**

Configuration ID	Test SCS (kHz)	MCG MPR <sub>c</sub> (dB)	P <sub>CMAX, L</sub> (dBm)	P <sub>CMAX, H</sub> (dBm)	T <sub>LOW</sub> (P <sub>CMAX, L</sub> ) (dB)	T <sub>HIGH</sub> (P <sub>CMAX, H</sub> ) (dB)	Upper limit (dBm)	Lower limit (dBm)
1, 8, 15, 22, 25, 28, 35, 42, 45 (NOTE 1)	15, 30, 60	15.0	11.0	23.0	6.0	2.0	25.0 + TT	5.0 - TT
2, 5, 9, 12, 16, 19, 23, 24, 26, 27, 29, 32, 36, 39, 43, 44, 46, 47 (NOTE 2)	15, 30, 60	17.0	9.0	23.0	6.0	2.0	25.0 + TT	3.0 - TT
48 (NOTE 3)	15, 30, 60	17.0	9.0	23.0	6.0	2.0	25.0 + TT	3.0 - TT

NOTE 1: Test configuration IDs with transmission overlap with full RB allocation, requirements in TS 38.101-3 [4] apply.  
NOTE 2: Test configuration IDs with transmission overlap with 1RB allocation, requirements in TS 38.101-3 [4] apply.  
NOTE 3: Test configuration IDs with transmission overlap with edge full RB allocation, requirements in TS 38.101-3 [4] apply.

**Table 6.2B.2.2.5-7a: UE Power Class 2 NR carrier test requirements, UE not supporting dynamic power sharing, E-UTRA UL transmission overlapping with NR UL transmission**

Configuration ID	Test SCS (kHz)	SCG MPR' <sub>c</sub> (dB)	P <sub>CMAX, L</sub> (dBm)	P <sub>CMAX, H</sub> (dBm)	T <sub>LOW</sub> (P <sub>CMAX, L</sub> ) (dB)	T <sub>HIGH</sub> (P <sub>CMAX, H</sub> ) (dB)	Upper limit (dBm)	Lower limit (dBm)
1, 8, 15, 22, 25, 28, 35, 42, 45 (NOTE 1)	15, 30, 60	15.0	11.0	23.0	6.0	2.0	25.0 + TT	5.0 - TT
2, 5, 9, 12, 16, 19, 23, 24, 26, 27, 29, 32, 36, 39, 43, 44, 46, 47 (NOTE 2)	15, 30, 60	17.0	9.0	23.0	6.0	2.0	25.0 + TT	3.0 - TT
48 (NOTE 3)	15, 30	17.0	9.0	23.0	6.0	2.0	25.0 + TT	3.0 - TT
	60	16.0	10.0	23.0	6.0	2.0	25.0 + TT	4.0 - TT

NOTE 1: Test configuration IDs with transmission overlap with full RB allocation, requirements in TS 38.101-3 [4] apply.  
NOTE 2: Test configuration IDs with transmission overlap with 1RB allocation, requirements in TS 38.101-3 [4] apply.  
NOTE 3: Test configuration IDs with transmission overlap with edge full RB allocation, requirements in TS 38.101-3 [4] apply.

**Table 6.2B.2.2.5-8: Void****Table 6.2B.2.2.5-8a: Void****Table 6.2B.2.2.5-9: Test Tolerance for UE maximum output power (Combined measurements of E-UTRA and NR CCs)**

TT for overall output power											
			NR								
			BW ≤ 20MHz			20 MHz < BW ≤ 40MHz			40MHz < BW ≤ 100MHz		
			f ≤ 3.0GHz	3.0GHz < f ≤ 4.2GHz	4.2GHz < f ≤ 6.0GHz	f ≤ 3.0GHz	3.0GHz < f ≤ 4.2GHz	4.2GHz < f ≤ 6.0GHz	f ≤ 3.0GHz	3.0GHz < f ≤ 4.2GHz	4.2GHz < f ≤ 6.0GHz
E-UTRA	BW ≤ 20MHz	f ≤ 3.0GHz	0.7 dB	1.0 dB	1.0 dB	0.7 dB	1.0 dB	1.0 dB	1.0 dB	1.0 dB	1.0 dB
		3.0GHz < f ≤ 4.2GHz	1.0 dB	1.0 dB	1.0 dB	1.0 dB	1.0 dB	1.0 dB	1.0 dB	1.0 dB	1.0 dB

**Table 6.2B.2.2.5-9a: Test Tolerance for UE maximum output power (Separate measurements over E-UTRA and NR CCs)**

Uplink TX		f ≤ 3.0GHz	3.0GHz < f ≤ 4.2GHz	4.2GHz < f ≤ 6GHz
E-UTRA	BW ≤ 20MHz	0.7 dB	1.0 dB	N/A
NR	BW ≤ 40MHz	0.7 dB	1.0 dB	1.0 dB
	40MHz < BW ≤ 100MHz	1.0 dB	1.0 dB	1.0 dB

### 6.2B.2.3 UE Maximum Output Power reduction for Inter-Band EN-DC within FR1 (1 NR CC)

#### 6.2B.2.3.1 Test purpose

Same test purpose as in clause 6.2.2.1 in TS 38.521-1 [8] for the NR carrier.

#### 6.2B.2.3.2 Test applicability

The requirements of this test apply to all types of E-UTRA UE release 15 and forward, supporting inter-band EN-DC within FR1 with 1 NR UL CC.

NOTE: Test execution is not necessary if clause 6.5B.2.3.3 ACLR is executed since MPR requirement is verified in this test cases.

#### 6.2B.2.3.3 Minimum conformance requirements

For inter-band EN-DC between E-UTRA and NR FR1, UE maximum output power reduction specified in TS 36.101 [5] and TS 38.101-1 [2] apply for E-UTRA and NR respectively.

The normative reference for this requirement is TS 38.101-3 [4] clause 6.2B.2.3.

No exception requirements applicable to NR or LTE. LTE anchor agnostic approach is applied.

#### 6.2B.2.3.4 Test description

Same test description as in clause 6.2.2.4 in TS 38.521-1 [8] for the NR carrier with the following exceptions:

The initial test configurations for E-UTRA band consist of environmental conditions, test frequencies, and channel bandwidths based on E-UTRA bands specified in Table 4.6-1.

For Initial conditions as in clause 6.2.2.4.1 in TS 38.521-1 [8], the following steps will be added to configure E-UTRA component:

- 2.1. The parameter settings for the E-UTRA cell are set up according to TS 36.508 [11] clause 4.4.3 with E-UTRA channel bandwidth and test frequencies defined in Table 4.6-1.
- 3.1. Downlink E-UTRA signals are initially set up according to TS 36.521-1 [10] Annex C0, C.1 and C.3.0, and uplink signals according to Annex H.1 and H.3.0.

4.1. The E-UTRA UL Reference Measurement channels are set according to Table 4.6-1.

Step 6 of Initial conditions as in clause 6.2.2.4.1 in TS 38.521-1 [8] is replaced by the following two steps:

6. Ensure the UE is in state RRC\_CONNECTED with generic procedure parameters Connectivity EN-DC, DC bearer MCG and SCG, Connected without release *On* according to TS 38.508-1 [6] clause 4.5.
7. On the E-UTRA carrier, disable periodic and aperiodic CQI reports, disable SRS, set *TimeAlignmentTimerDedicated* IE to infinity and disable downlink and uplink scheduling, all as per Table 4.6-1 under clause 4.6.

Same test procedure as in clause 6.2.2.4.2 in TS 38.521-1 [8].

#### 6.2B.2.3.5 Test requirement

For PC3 UE, same test requirement as in clause 6.2.2.5 in TS 38.521-1 [8].

For PC2 UE (Rel-15 UE indicates PC2 on NR band, Rel-16 and forward UE reporting (PC2 by  $P_{\text{PowerClass,NR}}$ , and PC2 or Not present by *powerClassNRPart-r16*), same test requirement for PC2 UE as in clause 6.2.2.5 in TS 38.521-1 [8]. For PC2 UE (Rel-15 and forward UE indicates PC3 on NR band, Rel-16 and forward UE reporting (PC2 by  $P_{\text{PowerClass,NR}}$ , and PC3 by *powerClassNRPart-r16*)), same test requirement for PC3 UE as in clause 6.2.2.5 in TS 38.521-1 [8].

#### 6.2B.2.3a UE Maximum Output Power reduction for Inter-Band NE-DC within FR1 (1 NR CC)

No exception requirements applicable to NR or E-UTRA.

No test case details are specified. The requirements for NR carrier in this test case are tested in 6.2.2 of TS 38.521-1 [8], and the requirements for LTE carrier(s) in this test case are tested in 6.2.3 and 6.2.3A of TS 36.521-1 [10]. Neither NR carrier nor LTE carrier(s) needs to be tested again.

#### 6.2B.2.4 UE Maximum Output Power reduction for Inter-Band EN-DC including FR2 (1 NR CC)

**Editor's note: Following aspects are missing or under discussion**

- **The referred test case 6.2.2 in TS 38.521-2 [9] is incomplete for other than 1, 3, 5,6 and 7.**

##### 6.2B.2.4.1 Test purpose

To verify that the error of the UE maximum output power does not exceed the range prescribed by the specified maximum output power with MPR and tolerance.

An excess maximum output power has the possibility to interfere to other channels or other systems. A small maximum output power decreases the coverage area.

##### 6.2B.2.4.2 Test applicability

This test case applies to all types of E-UTRA UE release 15 and forward, supporting inter-band EN-DC including FR2 with 1 NR UL CC.

##### 6.2B.2.4.3 Minimum conformance requirements

UE maximum output power reduction requirement for E-UTRA single carrier and CA operation specified in clauses 6.2.3 and 6.2.3A of TS 36.101[5] and for NR single carrier and CA operation specified in clauses 6.2.2, 6.2A.2, and 6.2D.2 of TS 38.101-2 [3] apply.

The normative reference for this requirement is TS 38.101-3 [4] clause 6.2B.2.4.

No exception requirements applicable to NR or E-UTRA. LTE anchor agnostic approach is applied.



#### 6.2B.2.4.4 Test description

##### 6.2B.2.4.4.1 Initial conditions

Same test description as in clause 6.2.2.4 in TS 38.521-2 [9] for the NR carrier with the following exceptions:

The initial test configurations for E-UTRA band consist of environmental conditions, test frequencies, and channel bandwidths based on E-UTRA bands specified in Table 4.7-1.

For Initial conditions as in clause 6.2.2.4.1 in TS 38.521-2 [9], the following steps will be added to configure E-UTRA component:

- 2.1. The parameter settings for the E-UTRA cell are set up according to TS 36.508 [11] clause 4.4.3 with E-UTRA channel bandwidth and test frequencies defined in Table 4.7-1.
- 3.1. Downlink E-UTRA signals are initially set up according to TS 36.521-1 [10] Annex C, clauses C.0, C.1 and C.3.0, and uplink signals according to Annex H, clauses H.1 and H.3.0.
- 4.1. The E-UTRA UL Reference Measurement channels are set according to Table 4.7-1.

Step 6 of Initial conditions as in clause 6.2.2.4.1 in TS 38.521-2 [9] is replaced by:

6. Ensure the UE is in state RRC\_CONNECTED with generic procedure parameters Connectivity EN-DC, DC bearer MCG and SCG according to TS 38.508 [6] clause 4.5.

Same test procedure as in clause 6.2.2.4.2 in TS 38.521-2 [9] with the following steps added for E-UTRA component:

- 1.1 On the E-UTRA carrier, disable periodic and aperiodic CQI reports, disable SRS, set *TimeAlignmentTimerDedicated* IE to infinity and disable downlink and uplink scheduling, all as per Table 4.7-1 under clause 4.7.

#### 6.2B.2.4.5 Test requirement

Same test requirement as in clause 6.2.2.5 in TS 38.521-2 [9] for the NR carrier.

### 6.2B.2.4a UE Maximum Output Power reduction enhancements for Inter-Band EN-DC including FR2 (1 NR CC)

#### 6.2B.2.4a.1 Test purpose

Same test purpose as in clause 6.2.2\_1 in TS 38.521-2 [9] for the NR carrier.

#### 6.2B.2.4a.2 Test applicability

This test case applies to:

- All types of E-UTRA PC3 UE release 15 supporting inter-band EN-DC including FR2 with 1 NR UL CC and *modifiedMPRbehaviour* bit 0 capability (according to Annex P.1 in TS38.521-2 [9]).
- All types of E-UTRA PC3 UE release 16 and forward supporting inter-band EN-DC including FR2 with 1 NR UL CC.

#### 6.2B.2.4a.3 Minimum conformance requirements

UE maximum output power reduction requirement for E-UTRA single carrier and CA operation specified in clauses 6.2.3 and 6.2.3A of TS 36.101[5] and for NR single carrier and CA operation specified in clauses 6.2.2, 6.2A.2, and 6.2D.2 of TS 38.101-2 [3] apply.

Same minimum conformance requirements as in clause 6.2.2\_1.3 in TS 38.521-2 [9] for the NR carrier.

The normative reference for this requirement is TS 38.101-3 [4] clause 6.2B.2.4.

No exception requirements applicable to NR or E-UTRA. LTE anchor agnostic approach is applied.

#### 6.2B.2.4a.4 Test description

Same test description as in clause 6.2.2\_1.4 in TS 38.521-2 [9] for the NR carrier with the following exceptions:

The initial test configurations for E-UTRA band consist of environmental conditions, test frequencies, and channel bandwidths based on E-UTRA bands specified in Table 4.6-1.

For Initial conditions as in clause 6.2.2\_1.4.1 in TS 38.521-2 [9], the following steps will be added to configure E-UTRA component:

- 2.1. The parameter settings for the E-UTRA cell are set up according to TS 36.508 [11] clause 4.4.3 with E-UTRA channel bandwidth and test frequencies defined in Table 4.6-1.
- 3.1. Downlink E-UTRA signals are initially set up according to TS 36.521-1 [10] Annex C, clauses C.0, C.1 and C.3.0, and uplink signals according to Annex H, clauses H.1 and H.3.0.
- 4.1. The E-UTRA UL Reference Measurement channels are set according to Table 4.6-1.

Step 6 of Initial conditions as in clause 6.2.2\_1.4.1 in TS 38.521-2 [9] is replaced by:

6. Ensure the UE is in state RRC\_CONNECTED with generic procedure parameters Connectivity EN-DC, DC bearer MCG and SCG according to TS 38.508 [6] clause 4.5.

Same test procedure as in clause 6.2.2\_1.4.2 in TS 38.521-2 [9] with the following steps added for E-UTRA component:

- 1.1 On the E-UTRA carrier, disable periodic and aperiodic CQI reports, disable SRS, set *TimeAlignmentTimerDedicated* IE to infinity and disable downlink and uplink scheduling, all as per Table 4.7-1 under clause 4.7.

#### 6.2B.2.4a.5 Test requirement

Same test requirement as in clause 6.2.2\_1.5 in TS 38.521-2 [9] for the NR carrier.

### 6.2B.2.4D UE Maximum Output Power reduction for Inter-Band EN-DC including FR2 for UL MIMO (1 NR CC)

#### 6.2B.2.4D.1 Test purpose

To verify that the error of the UE maximum output power does not exceed the range prescribed by the specified maximum output power with MPR and tolerance.

An excess maximum output power has the possibility to interfere to other channels or other systems. A small maximum output power decreases the coverage area.

#### 6.2B.2.4D.2 Test applicability

This test case applies to all types of E-UTRA UE release 15 and forward, supporting inter-band EN-DC including FR2 with 1 NR UL CC with UL MIMO.

#### 6.2B.2.4D.3 Minimum conformance requirements

UE maximum output power reduction requirement for E-UTRA single carrier and CA operation specified in clauses 6.2.3 and 6.2.3A of TS 36.101[5] and for NR single carrier and CA operation specified in clauses 6.2.2, 6.2A.2, and 6.2D.2 of TS 38.101-2 [3] apply.

The normative reference for this requirement is TS 38.101-3 [4] clause 6.2B.2.4.

No exception requirements applicable to NR or LTE. LTE anchor agnostic approach is applied.

#### 6.2B.2.4D.4 Test description

##### 6.2B.2.4D.4.1 Initial conditions

Same test description as in clause 6.2D.2.4 in TS 38.521-2 [9] for the NR carrier with the following exceptions:

The initial test configurations for E-UTRA band consist of environmental conditions, test frequencies, and channel bandwidths based on E-UTRA bands specified in Table 4.6-1.

For Initial conditions as in clause 6.2D.2.4.1 in TS 38.521-2 [9], the following steps will be added to configure E-UTRA component:

- 2.1. The parameter settings for the E-UTRA cell are set up according to TS 36.508 [11] clause 4.4.3 with E-UTRA channel bandwidth and test frequencies defined in Table 4.6-1.
- 3.1. Downlink E-UTRA signals are initially set up according to TS 36.521-1 [10] Annex C, clauses C.0, C.1 and C.3.0, and uplink signals according to Annex H, clauses H.1 and H.3.0.
- 4.1. The E-UTRA UL Reference Measurement channels are set according to Table 4.6-1.

Step 6 of Initial conditions as in clause 6.2D.2.4.1 in TS 38.521-2 [9] is replaced by:

6. Ensure the UE is in state RRC\_CONNECTED with generic procedure parameters Connectivity EN-DC, DC bearer MCG and SCG according to TS 38.508 [6] clause 4.5.

Same test procedure as in clause 6.2D.2.4.2 in TS 38.521-2 [9] with the following steps added for E-UTRA component:

- 1.1 On the E-UTRA carrier, disable periodic and aperiodic CQI reports, disable SRS, set *TimeAlignmentTimerDedicated* IE to infinity and disable downlink and uplink scheduling, all as per Table 4.7-1 under clause 4.7.

#### 6.2B.2.4.5 Test requirement

Same test requirement as in clause 6.2D.2.5 in TS 38.521-2 [9] for the NR carrier.

#### 6.2B.2.4\_1 UE Maximum Output Power reduction for Inter-Band EN-DC including FR2 (>1 NR CC)

##### 6.2B.2.4\_1.1 UE Maximum Output Power reduction for Inter-Band EN-DC including FR2 (2 NR CCs)

**Editor's note: The following aspects are either missing or not yet determined:**

- The referred test case 6.2A.2.1 in TS 38.521-2 [9] is incomplete for aggregated BW > 400MHz and intra-band non-contiguous CA.
- The referred test case 6.2A.2.1 in TS 38.521-2 [9] is incomplete for power class other than 3 and 5.

##### 6.2B.2.4\_1.1.1 Test purpose

Same test purpose as in clause 6.2.2.1 in TS 38.521-2 [9] for the NR carrier.

##### 6.2B.2.4\_1.1.2 Test applicability

This test case applies to all types of E-UTRA UE release 15 and forward, supporting inter-band EN-DC including FR2 with 2 NR UL CCs.

##### 6.2B.2.4\_1.1.3 Minimum conformance requirements

Same minimum conformance requirements as in clause 6.2B.2.4.3.

#### 6.2B.2.4\_1.1.4 Test description

##### 6.2B.2.4\_1.1.4.1 Initial condition

Same test description as in clause 6.2A.2.1.4 in TS 38.521-2 [9] for the *NR* carriers with the following exception:

The initial test configurations for E-UTRA band consist of environmental conditions, test frequencies, and channel bandwidths based on E-UTRA bands specified in Table 4.7-1.

For Initial conditions as in clause 6.2A.2.1.4.1 in TS 38.521-2 [9], the following steps will be added to configure E-UTRA component:

- 2.1. The parameter settings for E-UTRA cell are set up according to TS 36.508 [11] clause 4.4.3.
- 3.1. The E-UTRA downlink signal level, uplink signal level are set according to Table 4.7-1 and propagation conditions are set according to Annex B.0 of TS 36.521-1 [10].

Step 6 of Initial conditions as in clause 6.2A.2.1.4.1 in TS 38.521-2 [9] is replaced by:

6. Ensure the UE is in state RRC\_CONNECTED with generic procedure parameters Connectivity EN-DC, DC bearer MCG and SCG, Connected without release On according to TS 38.508-1 [6] clause 4.5.

Same test procedure as in clause 6.2A.2.1.4.2 in TS 38.521-2 [9] with the following steps added for E-UTRA component:

- 1.1 On the E-UTRA carrier, disable periodic and aperiodic CQI reports, disable SRS, set *TimeAlignmentTimerDedicated* IE to infinity and disable downlink and uplink scheduling, all as per Table 4.7-1 under clause 4.7.

#### 6.2B.2.4\_1.1.5 Test Requirements

Same test requirement as in clause 6.2A.2.1.5 in TS 38.521-2 [9] for the *NR* carriers.

#### 6.2B.2.4\_1.2 UE Maximum Output Power reduction for Inter-Band EN-DC including FR2 (3 NR CCs)

**Editor's note: The following aspects are either missing or not yet determined:**

- The referred test case 6.2A.2.2 in TS 38.521-2 [9] is incomplete for aggregated BW > 400MHz and intra-band non-contiguous CA.
- The referred test case 6.2A.2.2 in TS 38.521-2 [9] is incomplete for power class 1, 2 and 4.

#### 6.2B.2.4\_1.2.1 Test purpose

Same test purpose as in clause 6.2.2.1 in TS 38.521-2 [9] for the *NR* carrier.

#### 6.2B.2.4\_1.2.2 Test applicability

This test case applies to all types of E-UTRA UE release 15 and forward, supporting inter-band EN-DC including FR2 with 3 NR UL CCs.

#### 6.2B.2.4\_1.2.3 Minimum conformance requirements

Same minimum conformance requirements as in clause 6.2B.2.4.3.

#### 6.2B.2.4\_1.2.4 Test description

##### 6.2B.2.4\_1.2.4.1 Initial condition

Same test description as in clause 6.2A.2.2.4 in TS 38.521-2 [9] for the *NR* carriers with the following exception:

The initial test configurations for E-UTRA band consist of environmental conditions, test frequencies, and channel bandwidths based on E-UTRA bands specified in Table 4.7-1.

For Initial conditions as in clause 6.2A.2.2.4.1 in TS 38.521-2 [9], the following steps will be added to configure E-UTRA component:

- 2.1. The parameter settings for E-UTRA cell are set up according to TS 36.508 [11] clause 4.4.3.
- 3.1. The E-UTRA downlink signal level, uplink signal level are set according to Table 4.7-1 and propagation conditions are set according to Annex B.0 of TS 36.521-1 [10].

Step 6 of Initial conditions as in clause 6.2A.2.2.4.1 in TS 38.521-2 [9] is replaced by:

6. Ensure the UE is in state RRC\_CONNECTED with generic procedure parameters Connectivity EN-DC, DC bearer MCG and SCG, Connected without release On according to TS 38.508-1 [6] clause 4.5.

Same test procedure as in clause 6.2A.2.2.4.2 in TS 38.521-2 [9] with the following steps added for E-UTRA component:

- 1.1 On the E-UTRA carrier, disable periodic and aperiodic CQI reports, disable SRS, set *TimeAlignmentTimerDedicated* IE to infinity and disable downlink and uplink scheduling, all as per Table 4.7-1 under clause 4.7.

#### 6.2B.2.4\_1.2.5 Test Requirements

Same test requirement as in clause 6.2A.2.2.5 in TS 38.521-2 [9] for the NR carriers.

#### 6.2B.2.4\_1.3 UE Maximum Output Power reduction for Inter-Band EN-DC including FR2 (4 NR CCs)

**Editor's note: The following aspects are either missing or not yet determined:**

- The referred test case 6.2A.2.3 in TS 38.521-2 [9] is incomplete for aggregated BW > 400MHz and intra-band non-contiguous CA.
- The referred test case 6.2A.2.3 in TS 38.521-2 [9] is incomplete for power class 1, 2 and 4.

#### 6.2B.2.4\_1.3.1 Test purpose

Same test purpose as in clause 6.2.2.1 in TS 38.521-2 [9] for the NR carrier.

#### 6.2B.2.4\_1.3.2 Test applicability

This test case applies to all types of E-UTRA UE release 15 and forward, supporting inter-band EN-DC including FR2 with 4 NR UL CCs.

#### 6.2B.2.4\_1.3.3 Minimum conformance requirements

Same minimum conformance requirements as in clause 6.2B.2.4.3.

#### 6.2B.2.4\_1.3.4 Test description

##### 6.2B.2.4\_1.3.4.1 Initial condition

Same test description as in clause 6.2A.2.3.4 in TS 38.521-2 [9] for the NR carriers with the following exception:

The initial test configurations for E-UTRA band consist of environmental conditions, test frequencies, and channel bandwidths based on E-UTRA bands specified in Table 4.7-1.

For Initial conditions as in clause 6.2A.2.3.4.1 in TS 38.521-2 [9], the following steps will be added to configure E-UTRA component:

- 2.1. The parameter settings for E-UTRA cell are set up according to TS 36.508 [11] clause 4.4.3.

- 3.1. The E-UTRA downlink signal level, uplink signal level are set according to Table 4.7-1 and propagation conditions are set according to Annex B.0 of TS 36.521-1 [10].

Step 6 of Initial conditions as in clause 6.2A.2.3.4.1 in TS 38.521-2 [9] is replaced by:

6. Ensure the UE is in state RRC\_CONNECTED with generic procedure parameters Connectivity EN-DC, DC bearer MCG and SCG, Connected without release On according to TS 38.508-1 [6] clause 4.5.

Same test procedure as in clause 6.2A.2.3.4.2 in TS 38.521-2 [9] with the following steps added for E-UTRA component:

- 1.1 On the E-UTRA carrier, disable periodic and aperiodic CQI reports, disable SRS, set *TimeAlignmentTimerDedicated* IE to infinity and disable downlink and uplink scheduling, all as per Table 4.7-1 under clause 4.7.

#### 6.2B.2.4\_1.3.5 Test Requirements

Same test requirement as in clause 6.2A.2.3.5 in TS 38.521-2 [9] for the NR carriers.

### 6.2B.2.5 UE Maximum Output power reduction for inter-band EN-DC including both FR1 and FR2

#### 6.2B.2.5.1 Test purpose

Same test purpose as in clause 6.2B.2.3.1 in TS 38.521-1 [8] for NR FR1 carrier(s) and clause 6.2B.2.4.1 in TS 38.521-2 [9] for NR FR2 carrier(s).

#### 6.2B.2.5.2 Test applicability

The requirements in this test are not testable due to issues with combined testing of NR FR1 and E-UTRA in conducted mode with NR FR2 in radiated mode. Therefore, the conducted and radiated requirements are tested separately.

No test case details are specified. The EN-DC requirements for maximum output power apply and are tested as part of the EN-DC within FR1 and EN-DC including FR2 test cases in clause 6.2B.

### 6.2B.2.5D UE Maximum Output power reduction for inter-band EN-DC including both FR1 and FR2 for UL MIMO

#### 6.2B.2.5D.1 Test purpose

Same test purpose as in clause 6.2D.2.1 in TS 38.521-1 [8] for NR FR1 carrier(s) and clause 6.2D.2.1 in TS 38.521-2 [9] for NR FR2 carrier(s).

#### 6.2B.2.5D.2 Test applicability

The requirements in this test are not testable due to issues with combined testing of NR FR1 and E-UTRA in conducted mode with NR FR2 in radiated mode. Therefore, the conducted and radiated requirements are tested separately.

No test case details are specified. The EN-DC requirements for maximum output power apply and are tested as part of the EN-DC within FR1 and EN-DC including FR2 test cases in clause 6.2B.

## 6.2B.3 UE additional maximum output power reduction for EN-DC

### 6.2B.3.1 UE Additional Maximum Output Power reduction for Intra-band contiguous EN-DC

**Editor's note:**

- Test requirements for non-overlapping transmission of non-DPS UE need further investigation

### 6.2B.3.1.1 Test purpose

Additional emission requirements can be signalled by the network with network signalling value indicated by the field *additionalSpectrumEmission*. To meet these additional requirements, additional maximum power reduction (A-MPR) is allowed for the maximum output power as specified in Table 6.2B.1.1.3-1. Unless stated otherwise, an A-MPR of 0 dB shall be used.

### 6.2B.3.1.2 Test applicability

The requirements of this test apply in test case 6.5B.2.1.2 Additional spectrum emission mask for network signalled values NS\_04 and NS\_35 to all types of E-UTRA power class 3 and power class 2 UE release 15 and forward, supporting intra-band contiguous EN-DC.

### 6.2B.3.1.3 Minimum conformance requirements

For intra-band contiguous EN-DC band combinations with additional requirements the allowed A-MPR is specified in table 6.2B.3.1.3-1 for UEs configured with EN-DC and combinations of network signalling values indicated in the E-UTRA and NR cell groups.

Unless otherwise stated the A-MPR specified in clause 6.2B.3.1 for intra-band contiguous EN-DC configurations is the total power reduction allowed including MPR.

**Table 6.2B.3.1.3-1: Additional maximum power reduction for Intra-band contiguous EN-DC**

DC configuration	Requirement (subclause)	E-UTRA network signalling value	NR network signalling value	A-MPR (clause)
DC_(n)71AA	6.5B.2.1.2.3.1	NS_35	NS_35	6.2B.3.1.3.1 <sup>3</sup>
DC_(n)41AA <sup>1</sup>	6.5B.2.1.2.3.2	NS_01 or NS_04	NS_04	6.2B.3.1.3.2 <sup>4</sup>
NOTE 1: Only applies to UEs that support dual UL transmission for this EN-DC combination.				
NOTE 2: The additional emission requirement is indicated when the combination of network signalling values in the two CGs is set (only for UEs configured with EN-DC).				
NOTE 3: The A-MPR is applied as MPR if NS_35 is not signalled.				
NOTE 4: Void.				

The normative reference for this requirement is TS 38.101-3 [4] clause 6.2B.3.1.

Exception requirements for both NR and E-UTRA are defined for this test when transmission on E-UTRA overlap in time with NR.LTE anchor agnostic approach is not applied for this case. E-UTRA test point analysis is included and E-UTRA measurements are performed.

Exception requirements for both NR and E-UTRA are defined for this test when transmission on E-UTRA doesn't overlap in time with NR, for a UE that doesn't support dynamic power sharing. LTE anchor agnostic approach is not applied for this case. E-UTRA test point analysis is included and E-UTRA measurements are performed.

No exception requirements for NR or E-UTRA are defined for this test when transmission on E-UTRA doesn't overlap in time with NR, for a UE that supports dynamic power sharing. LTE anchor agnostic approach is not applied for this case.

#### 6.2B.3.1.3.1 A-MPR for DC\_(n)71AA

For UE supporting dynamic power sharing the following:

- for the MCG,  $A-MPR_c$  in accordance with TS 36.101 [5]
- for the SCG,  $A-MPR'_c = [A-MPR_{DC}]$
- for the total configured transmission power,  $A-MPR_{tot} = A-MPR_{DC}$

with  $A-MPR_{DC}$  as defined in this subclause.

For UEs not supporting dynamic power sharing the following

- for the MCG,

$$A\text{-MPR}_c = A\text{-MPR}_{E\text{-UTRA}}$$

- for the SCG,

$$A\text{-MPR}'_c = A\text{-MPR}_{NR}$$

with  $A\text{-MPR}_{E\text{-UTRA}}$  and  $A\text{-MPR}_{NR}$  as defined in this subclause.

For DC\_(n)71AA with configured with network signaling values as per Table 6.2B.3.1.0-1 the allowed A-MPR is defined by

- for UE indicating support of dynamicPowerSharing in the *UE-MRDC-Capability* IE

$$A\text{-MPR}_{DC} = \text{CEIL}\{ M_{A,DC}(A), 0.5 \}$$

where  $A\text{-MPR}_{DC}$  is the total power reduction allowed (dB),

- for OFDM:

$$M_{A,DC} = 11.00 - 11.67 * A; \quad 0.00 < A \leq 0.30$$

$$8.10 - 2.00 * A; \quad 0.30 < A \leq 0.80$$

$$6.50; \quad 0.80 < A \leq 1.00$$

- for DFT-S-OFDM:

$$M_{A,DC} = 11.00 - 13.33 * A; \quad 0.00 < A \leq 0.30$$

$$8.00 - 3.33 * A; \quad 0.30 < A \leq 0.60$$

$$6.00; \quad 0.60 < A \leq 1.00$$

where:

$$A = \frac{L_{CRB,E\text{-UTRA}} + L_{CRB,NR}}{N_{RB,E\text{-UTRA}} + N_{RB,NR}}$$

with  $L_{CRB,E\text{-UTRA}}$  and  $N_{RB,E\text{-UTRA}}$  the number of allocated PRB and transmission bandwidth for MCG,  $L_{CRB,NR}$  and  $N_{RB,NR}$  the number of allocated PRB and transmission bandwidth for SCG with SCS = 15 kHz.

- for UE not indicating support of dynamicPowerSharing

$$A\text{-MPR}_{E\text{-UTRA}} = \text{CEIL}\{ M_{A,E\text{-UTRA}}, 0.5 \}$$

$$A\text{-MPR}_{NR} = \text{CEIL}\{ M_{A,NR}, 0.5 \}$$

where A-MPR is the total power reduction allowed per CG with

$$M_{A,E\text{-UTRA}} = M_{A,DC}(A_{E\text{-UTRA},wc}) - 1 - \Delta_{E\text{-UTRA}} M_{A,NR} = M_{A,DC}(A_{NR,wc}) - 1 - \Delta_{NR} A_{E\text{-UTRA},wc} =$$

$$\frac{L_{CRB,E\text{-UTRA}} + 1}{N_{RB,E\text{-UTRA}} + N_{RB,NR}} A_{NR,wc} = \frac{1 + L_{CRB,NR}}{N_{RB,E\text{-UTRA}} + N_{RB,NR}} \Delta_{E\text{-UTRA}} = 10 \log_{10} \frac{N_{RB,E\text{-UTRA}}}{N_{RB,E\text{-UTRA}} + N_{RB,NR}} \Delta_{NR} =$$

$$10 \log_{10} \frac{N_{RB,NR}}{N_{RB,E\text{-UTRA}} + N_{RB,NR}} \quad M_{A,E\text{-UTRA}} = M_{A,DC}(A_{E\text{-UTRA},wc}) - 1 - \Delta_{E\text{-UTRA}}$$

$$M_{A,NR} = M_{A,DC}(A_{NR,wc}) - 1 - \Delta_{NR}$$

$$A_{E\text{-UTRA},wc} = \frac{L_{CRB,E\text{-UTRA}} + 1}{N_{RB,E\text{-UTRA}} + N_{RB,NR}}$$

$$A_{NR,wc} = \frac{1 + L_{CRB,NR}}{N_{RB,E\text{-UTRA}} + N_{RB,NR}}$$

$$a? \Delta_{E\text{-UTRA}} = 10 \log_{10} \frac{N_{RB,E\text{-UTRA}}}{N_{RB,E\text{-UTRA}} + N_{RB,NR}}$$

$$a? \Delta_{NR} = 10 \log_{10} \frac{N_{RB,NR}}{N_{RB,E\text{-UTRA}} + N_{RB,NR}}$$



Where  $L_{CRB,NR}$  and  $N_{RB,NR}$  the number of allocated PRB and transmission bandwidth for SCG with SCS = 15 kHz.

### 6.2B.3.1.3.2 A-MPR for NS\_04

#### 6.2B.3.1.3.2.0 General

When the UE is configured for B41/n41 intra-band contiguous EN-DC and it receives IE NS\_04, the UE determines the total allowed maximum output power reduction as specified in this clause. The A-MPR for EN-DC defined in this clause is used instead of MPR defined in 6.2B.2.2, not additively, so EN-DC MPR = 0 when NS\_04 is signaled. For UEs scheduled with single uplink transmission, AMPR in subclause 6.2.4 of [5] and 6.2.3 of [2] apply.

For UE supporting dynamic power sharing the following:

- for the MCG,  $A-MPR_c$  in accordance with 36.101 [5]
- for the SCG,

$$A-MPR'_c = A-MPR_{NR} = \text{MAX}( A-MPR_{\text{single,NR}}, A-MPR_{IM3} )$$

- for the total configured transmission power,

$$A-MPR_{\text{tot}} = P_{\text{PowerClass,EN-DC}} - \min( P_{\text{PowerClass,EN-DC}}, 10 \cdot \log_{10}( 10^{(P_{\text{PowerClass,E-UTRA}} - A-MPR_{E-UTRA})/10} + 10^{(P_{\text{PowerClass,NR}} - A-MPR_{NR})/10} ) )$$

where

$$A-MPR_{E-UTRA} = \text{MAX}( A-MPR_{\text{single,E-UTRA}} + MPR_{\text{single,E-UTRA}}, A-MPR_{IM3} )$$

with

- $A-MPR_{\text{single,E-UTRA}}$  is the A-MPR defined for the E-UTRA transmission in TS 36.101 [5]
- $A-MPR_{\text{single,NR}}$  is the A-MPR defined for the NR transmission in TS 38.101-1 [2]
- $MPR_{\text{single,E-UTRA}}$  is the MPR defined for the E-UTRA transmission in TS 36.101 [5]

For UEs not supporting dynamic power sharing the following

- for the MCG,

$$A-MPR_c = \text{MAX}( A-MPR_{\text{single,E-UTRA}} + MPR_{\text{single,E-UTRA}}, A-MPR_{IM3} )$$

- for the SCG,

$$A-MPR'_c = \text{MAX}( A-MPR_{\text{single,NR}}, A-MPR_{IM3} )$$

where

- $A-MPR_{\text{single,E-UTRA}}$  is the A-MPR defined for the E-UTRA transmission in TS 36.101 [5]
- $A-MPR_{\text{single,NR}}$  is the A-MPR defined for the NR transmission in TS 38.101-1 [2]
- $MPR_{\text{single,E-UTRA}}$  is the MPR defined for the E-UTRA transmission in TS 36.101 [5]

The UE determines the Channel Configuration Case and the value of  $A-MPR_{IM3}$  as follows:

If  $F_{IM3,low\_block,low} < 2490.5$  MHz

Channel Configuration Case B.  $A-MPR_{IM3}$  defined in clause 6.2B.3.1.3.2.2.

Else

Channel Configuration Case A.  $A-MPR_{IM3}$  defined in clause 6.2B.3.1.3.2.1.

where

- $F_{IM3,low\_block,low} = (2 * F_{low\_channel,low\_edge}) - F_{high\_channel,high\_edge}$

- $F_{\text{low\_channel,low\_edge}}$  is the lowermost frequency of lower transmission bandwidth configuration.
- $F_{\text{high\_channel,high\_edge}}$  is the uppermost frequency of upper transmission bandwidth configuration.

Where the transmission bandwidth configuration for NR is the maximum frequency span covering all the configured SCSSpecificCarrier for scenarios that carrier bandwidths with different SCS can be fully overlapped.

#### 6.2B.3.1.3.2.1 A-MPR<sub>IM3</sub> for NS\_04 to meet -13 dBm / 1MHz for 26dBm UE power

A-MPR in this subclause is relative to 26 dBm for a power class 2 Cell Group. The same A-MPR is used relative to 23 dBm for a power class 3 Cell Group. For the UE is configured with channel configurations Case A or Case C (defined in Clause 6.2B.3.2.3.1), the allowed maximum output power reduction for IM3s applied to transmission on the MCG and the SCG with non-contiguous resource allocation is defined as follows:

$$A\text{-MPR}_{\text{IM3}} = M_A$$

Where  $M_A$  is defined as follows

$$M_A = 15 ; 0 \leq B < 0.5$$

$$10 ; 0.5 \leq B < 1.0$$

$$8 ; 1.0 \leq B < 2.0$$

$$6 ; 2.0 \leq B$$

Where:

For UEs supporting dynamic power sharing,

$$B = (L_{\text{CRB\_alloc, E-UTRA}} * 12 * \text{SCS}_{\text{E-UTRA}} + L_{\text{CRB\_alloc, NR}} * 12 * \text{SCS}_{\text{NR}}) / 1,000,000$$

For UEs not supporting dynamic power sharing,

For E-UTRA

$$B = (L_{\text{CRB\_alloc, E-UTRA}} * 12 * \text{SCS}_{\text{E-UTRA}} + 12 * \text{SCS}_{\text{NR}}) / 1,000,000$$

Where  $\text{SCS}_{\text{NR}} = 15$  kHz is assumed in calculation of B.

For NR

$$B = (12 * \text{SCS}_{\text{E-UTRA}} + L_{\text{CRB\_alloc, NR}} * 12 * \text{SCS}_{\text{NR}}) / 1,000,000$$

Where  $\text{SCS}_{\text{E-UTRA}} = 15$  kHz is assumed in calculation of B

and  $M_A$  is reduced by 1 dB for  $B < 2.0$ .

#### 6.2B.3.1.3.2.2 A-MPR for NS\_04 to meet -25 dBm / 1MHz for 26 dBm UE power

A-MPR in this subclause is relative to 26 dBm for a power class 2 Cell Group. The same A-MPR is used relative to 23 dBm for a power class 3 Cell Group. For the UE is configured with channel configurations Case B or Case D (defined in clause 6.2B.3.2.1), the allowed maximum output power reduction for IM3s applied to transmission on the MCG and the SCG with non-contiguous resource allocation is defined as follows:

$$A\text{-MPR}_{\text{IM3}} = M_A$$

Where  $M_A$  is defined as follows

$$M_A = 15 ; 0 \leq B < 1.0$$

$$14 ; 1.0 \leq B < 2.0$$

$$13 ; 2.0 \leq B < 5.0$$

$$12 ; 5.0 \leq B$$

Where:

For UEs supporting dynamic power sharing,

$$B = (L_{CRB\_alloc,E-UTRA} * 12 * SCS_{E-UTRA} + L_{CRB\_alloc,NR} * 12 * SCS_{NR}) / 1,000,000$$

For UEs not supporting dynamic power sharing,

For E-UTRA

$$B = (L_{CRB\_alloc,E-UTRA} * 12 * SCS_{E-UTRA} + 12 * SCS_{NR}) / 1,000,000$$

Where  $SCS_{NR} = 15$  kHz is assumed in calculation of B.

For NR

$$B = (12 * SCS_{E-UTRA} + L_{CRB\_alloc,NR} * 12 * SCS_{NR}) / 1,000,000$$

Where  $SCS_{E-UTRA} = 15$  kHz is assumed in calculation of B

and MA is reduced by 1 dB.

#### 6.2B.3.1.4 Test description

##### 6.2B.3.1.4.1 Initial conditions

Initial conditions are a set of test configurations the UE needs to be tested in and the steps for the SS to take with the UE to reach the correct measurement state.

The initial test configurations consist of environmental conditions, test frequencies and channel bandwidths based on NR operating bands specified in clause 5.3B.1.2, channel bandwidths and sub-carrier spacings for the NR cell specified in TS 38.521-1 [8] clause 5.3 and channel bandwidth for the E-UTRA cell are specified in TS 36.521-1 [10] clause 5.4.2. All these configurations shall be tested with applicable test parameters for each EN-DC configuration specified in clause 5.3B.1.2 and are shown in table 6.2B.3.1.4.1-1 through 6.2B.3.1.4.1-2. The details of the uplink reference measurement channels (RMCs) are specified in Annex A, clause A.2.2 for E-UTRA RMC for TDD, TS 36.521-1 [10] Annex A, clause A.2.2 for E-UTRA RMC for FDD, and TS 38.521-1 [8] Annex A, clause A.2 for NR RMC. Configurations of PDSCH and PDCCH before measurement are specified in TS 36.521-1 [10] Annex C.2 and in TS 38.521-1 [8] Annex C.2 for E-UTRA CG and NR CG respectively.

Table 6.2B.3.1.4.1-0: Void

**Table 6.2B.3.1.4.1-1: Test configuration table (network signalled value "NS\_35")**

Initial Conditions							
Test Environment as specified in TS 38.508-1 [6] clause 4.1			Normal				
Test Frequencies as specified in TS 38.508-1 [6] clause 4.3.1			Low range, High range				
Test EN-DC bandwidth combination as specified in Table 5.3B.1.2-1			Lowest N <sub>RB_agg</sub> , Highest N <sub>RB_agg</sub> (Note 2)				
Test SCS for the NR cell as specified in TS 38.521-1 [8] Table 5.3.5-1			Lowest, Highest				
Test Parameters							
Test ID	Freq	Downlink Configuration	EN-DC Uplink Configuration				
			E-UTRA Cell		NR Cell		Common Power config (Note 8)
			Modulation	RB allocation (Note 5)	Modulation	RB allocation (Note 1)	
1	Default	N/A	16QAM	Outer_Full	DFT-s-OFDM Pi/2 BPSK	Outer_Full	B
2 (Note 3)	Default		16QAM	Outer_1RB_Left	DFT-s-OFDM Pi/2 BPSK	Edge_1RB_Right	B
3 (Note 3)	Low		16QAM	Outer_1RB_Left	DFT-s-OFDM Pi/2 BPSK	N/A	A
4 (Note 3)	High		16QAM	N/A	DFT-s-OFDM Pi/2 BPSK	Edge_1RB_Right	A
5 (Note 4)	Default		16QAM	Outer_1RB_Right	DFT-s-OFDM Pi/2 BPSK	Edge_1RB_Left	B
6 (Note 4)	Low		16QAM	N/A	DFT-s-OFDM Pi/2 BPSK	Edge_1RB_Left	A
7 (Note 4)	High		16QAM	Outer_1RB_Right	DFT-s-OFDM Pi/2 BPSK	N/A	A
8	Default		16QAM	Outer_Full	DFT-s-OFDM QPSK	Outer_Full	B
9 (Note 3)	Default		16QAM	Outer_1RB_Left	DFT-s-OFDM QPSK	Edge_1RB_Right	B
10 (Note 3)	Low		16QAM	Outer_1RB_Left	DFT-s-OFDM QPSK	N/A	A
11 (Note 3)	High		16QAM	N/A	DFT-s-OFDM QPSK	Edge_1RB_Right	A
12 (Note 4)	Default		16QAM	Outer_1RB_Right	DFT-s-OFDM QPSK	Edge_1RB_Left	B
13 (Note 4)	Low		16QAM	N/A	DFT-s-OFDM QPSK	Edge_1RB_Left	A
14 (Note 4)	High		16QAM	Outer_1RB_Right	DFT-s-OFDM QPSK	N/A	A
15	Default		16QAM	Outer_Full	DFT-s-OFDM 16QAM	Outer_Full	B
16 (Note 3)	Default		16QAM	Outer_1RB_Left	DFT-s-OFDM 16QAM	Edge_1RB_Right	B
17 (Note 3)	Low		16QAM	Outer_1RB_Left	DFT-s-OFDM 16QAM	N/A	A
18 (Note 3)	High		16QAM	N/A	DFT-s-OFDM 16QAM	Edge_1RB_Right	A
19 (Note 4)	Default		16QAM	Outer_1RB_Right	DFT-s-OFDM 16QAM	Edge_1RB_Left	B
20 (Note 4)	Low		16QAM	N/A	DFT-s-OFDM 16QAM	Edge_1RB_Left	A
21 (Note 4)	High		16QAM	Outer_1RB_Right	DFT-s-OFDM 16QAM	N/A	A
22	Default		16QAM	Outer_Full	DFT-s-OFDM 64QAM	Outer_Full	B
23 (Note 3)	Low		16QAM	Outer_1RB_Left	DFT-s-OFDM 64QAM	Edge_1RB_Right	B
24 (Note 4)	High		16QAM	Outer_1RB_Right	DFT-s-OFDM 64QAM	Edge_1RB_Left	B
25	Default		16QAM	Outer_Full	DFT-s-OFDM 256QAM	Outer_Full	B
26 (Note 3)	Low		16QAM	Outer_1RB_Left	DFT-s-OFDM 256QAM	Edge_1RB_Right	B

27 (Note 4)	High		16QAM	Outer_1RB_Right	DFT-s-OFDM 256QAM	Edge_1RB_Left	B
28	Default		16QAM	Outer_Full	CP-OFDM QPSK	Outer_Full	B
29 (Note 3)	Default		16QAM	Outer_1RB_Left	CP-OFDM QPSK	Edge_1RB_Right	B
30 (Note 3)	Low		16QAM	Outer_1RB_Left	CP-OFDM QPSK	N/A	A
31 (Note 3)	High		16QAM	N/A	CP-OFDM QPSK	Edge_1RB_Right	A
32 (Note 4)	Default		16QAM	Outer_1RB_Right	CP-OFDM QPSK	Edge_1RB_Left	B
33 (Note 4)	Low		16QAM	N/A	CP-OFDM QPSK	Edge_1RB_Left	A
34 (Note 4)	High		16QAM	Outer_1RB_Right	CP-OFDM QPSK	N/A	A
35	Default		16QAM	Outer_Full	CP-OFDM 16QAM	Outer_Full	B
36 (Note 3)	Default		16QAM	Outer_1RB_Left	CP-OFDM 16QAM	Edge_1RB_Right	B
37 (Note 3)	Low		16QAM	Outer_1RB_Left	CP-OFDM 16QAM	N/A	A
38 (Note 3)	High		16QAM	N/A	CP-OFDM 16QAM	Edge_1RB_Right	A
39 (Note 4)	Default		16QAM	Outer_1RB_Right	CP-OFDM 16QAM	Edge_1RB_Left	B
40 (Note 4)	Low		16QAM	N/A	CP-OFDM 16QAM	Edge_1RB_Left	A
41 (Note 4)	High		16QAM	Outer_1RB_Right	CP-OFDM 16QAM	N/A	A
42	Default		16QAM	Outer_Full	CP-OFDM 64QAM	Outer_Full	B
43 (Note 3)	Low		16QAM	Outer_1RB_Left	CP-OFDM 64QAM	Edge_1RB_Right	B
44 (Note 4)	High		16QAM	Outer_1RB_Right	CP-OFDM 64QAM	Edge_1RB_Left	B
45	Default		16QAM	Outer_Full	CP-OFDM 256QAM	Outer_Full	B
46 (Note 3)	Low		16QAM	Outer_1RB_Left	CP-OFDM 256QAM	Edge_1RB_Right	B
47 (Note 4)	High		16QAM	Outer_1RB_Right	CP-OFDM 256QAM	Edge_1RB_Left	B
48 (Note 4)	Default		16QAM	Edge_Full_Right	CP-OFDM 256QAM	Edge_Full_Left	B

NOTE 1: The specific configuration of each RB allocation is defined in Table 6.1-1 in TS 38.521-1 [8].

NOTE 2: If the UE supports multiple CC combinations in the EN-DC configuration with the same  $N_{RB\_agg}$ , select the combination to test as follows:

- Lowest ENBW: NR component with lowest  $N_{RB}$  is tested.
- Highest ENBW: NR component with highest  $N_{RB}$  is tested.

NOTE 3: Applicable when E-UTRA cell carrier frequency is lower than NR cell carrier.

NOTE 4: Applicable when NR cell carrier frequency is lower than E-UTRA cell carrier.

NOTE 5: Outer\_Full defined as the transmission bandwidth configuration  $N_{RB}$  per channel bandwidth for the E-UTRA component as indicated in TS 36.521 [10] Table 5.4.2-1. Outer\_1RB\_Left defined as 1 RB allocated at the left edge of the E-UTRA component. Edge\_Full\_Right is defined as 2 RBs allocated at the right edge of the E-UTRA component. Outer\_1RB\_Right defined as 1 RB allocated at the right edge of the E-UTRA component.

NOTE 6: DFT-s-OFDM Pi/2 BPSK test applies only for UEs which supports Pi/2 BPSK in FR1.

NOTE 7: Test IDs with simultaneous E-UTRA and NR UL transmission only apply for UEs indicating dualPA-Architecture.

NOTE 8: Power config as specified in Table 6.2B.3.1.4.3-1-1 to 6.2B.3.1.4.3-2 (PC3) or Table 6.2B.3.1.4.3-3 to 6.2B.3.1.4.3-4 (PC2).

**Table 6.2B.3.1.4.1-2: NR test configuration table for NS\_04**

Initial Conditions							
Test Environment as specified in TS 38.508-1 [6] clause 4.1			Normal				
Test Frequencies as specified in TS 38.508-1 [6] clause 4.3.1			Low range, High range (Note 7)				
Test EN-DC bandwidth combination as specified in Table 5.3B.1.2-1			Lowest $N_{RB\_agg}$ , Highest $N_{RB\_agg}$ (Note 2)				
Test SCS for the NR cell as specified in TS 38.521-1 [8] Table 5.3.5-1			Lowest, Highest				
Test Parameters							
Test ID	Freq	Downlink Configuration	EN-DC Uplink Configuration				
			E-UTRA Cell		NR Cell		Common Power config (Note 8)
			Modulation	RB allocation (Note 5)	Modulation	RB allocation (Note 1)	
1	Default	N/A	16QAM	Outer_Full	DFT-s-OFDM Pi/2 BPSK	Outer_Full	B
2 (Note 3)	Default		16QAM	Outer_1RB_Left	DFT-s-OFDM Pi/2 BPSK	Edge_1RB_Right	B
3 (Note 3)	Low		16QAM	Outer_1RB_Left	DFT-s-OFDM Pi/2 BPSK	N/A	A
4 (Note 3)	High		16QAM	N/A	DFT-s-OFDM Pi/2 BPSK	Edge_1RB_Right	A
5 (Note 4)	Default		16QAM	Outer_1RB_Right	DFT-s-OFDM Pi/2 BPSK	Edge_1RB_Left	B
6 (Note 4)	Low		16QAM	N/A	DFT-s-OFDM Pi/2 BPSK	Edge_1RB_Left	A
7 (Note 4)	High		16QAM	Outer_1RB_Right	DFT-s-OFDM Pi/2 BPSK	N/A	A
8	Default		16QAM	Outer_Full	DFT-s-OFDM QPSK	Outer_Full	B
9 (Note 3)	Default		16QAM	Outer_1RB_Left	DFT-s-OFDM QPSK	Edge_1RB_Right	B
10 (Note 3)	Low		16QAM	Outer_1RB_Left	DFT-s-OFDM QPSK	N/A	A
11 (Note 3)	High		16QAM	N/A	DFT-s-OFDM QPSK	Edge_1RB_Right	A
12 (Note 4)	Default		16QAM	Outer_1RB_Right	DFT-s-OFDM QPSK	Edge_1RB_Left	B
13 (Note 4)	Low		16QAM	N/A	DFT-s-OFDM QPSK	Edge_1RB_Left	A
14 (Note 4)	High		16QAM	Outer_1RB_Right	DFT-s-OFDM QPSK	N/A	A
15	Default		16QAM	Outer_Full	DFT-s-OFDM 16QAM	Outer_Full	B
16 (Note 3)	Default		16QAM	Outer_1RB_Left	DFT-s-OFDM 16QAM	Edge_1RB_Right	B
17 (Note 3)	Low		16QAM	Outer_1RB_Left	DFT-s-OFDM 16QAM	N/A	A
18 (Note 3)	High		16QAM	N/A	DFT-s-OFDM 16QAM	Edge_1RB_Right	A
19 (Note 4)	Default		16QAM	Outer_1RB_Right	DFT-s-OFDM 16QAM	Edge_1RB_Left	B
20 (Note 4)	Low		16QAM	N/A	DFT-s-OFDM 16QAM	Edge_1RB_Left	A
21 (Note 4)	High		16QAM	Outer_1RB_Right	DFT-s-OFDM 16QAM	N/A	A
22	Default		16QAM	Outer_Full	DFT-s-OFDM 64QAM	Outer_Full	B
23 (Note 3)	Low		16QAM	Outer_1RB_Left	DFT-s-OFDM 64QAM	Edge_1RB_Right	B
24 (Note 4)	High		16QAM	Outer_1RB_Right	DFT-s-OFDM 64QAM	Edge_1RB_Left	B
25	Default		16QAM	Outer_Full	DFT-s-OFDM 256QAM	Outer_Full	B
26 (Note 3)	Low		16QAM	Outer_1RB_Left	DFT-s-OFDM 256QAM	Edge_1RB_Right	B



27 (Note 4)	High		16QAM	Outer_1RB_Right	DFT-s-OFDM 256QAM	Edge_1RB_Left	B
28	Default		16QAM	Outer_Full	CP-OFDM QPSK	Outer_Full	B
29 (Note 3)	Default		16QAM	Outer_1RB_Left	CP-OFDM QPSK	Edge_1RB_Right	B
30 (Note 3)	Low		16QAM	Outer_1RB_Left	CP-OFDM QPSK	N/A	A
31 (Note 3)	High		16QAM	N/A	CP-OFDM QPSK	Edge_1RB_Right	A
32 (Note 4)	Default		16QAM	Outer_1RB_Right	CP-OFDM QPSK	Edge_1RB_Left	B
33 (Note 4)	Low		16QAM	N/A	CP-OFDM QPSK	Edge_1RB_Left	A
34 (Note 4)	High		16QAM	Outer_1RB_Right	CP-OFDM QPSK	N/A	A
35	Default		16QAM	Outer_Full	CP-OFDM 16QAM	Outer_Full	B
36 (Note 3)	Default		16QAM	Outer_1RB_Left	CP-OFDM 16QAM	Edge_1RB_Right	B
37 (Note 3)	Low		16QAM	Outer_1RB_Left	CP-OFDM 16QAM	N/A	A
38 (Note 3)	High		16QAM	N/A	CP-OFDM 16QAM	Edge_1RB_Right	A
39 (Note 4)	Default		16QAM	Outer_1RB_Right	CP-OFDM 16QAM	Edge_1RB_Left	B
40 (Note 4)	Low		16QAM	N/A	CP-OFDM 16QAM	Edge_1RB_Left	A
41 (Note 4)	High		16QAM	Outer_1RB_Right	CP-OFDM 16QAM	N/A	A
42	Default		16QAM	Outer_Full	CP-OFDM 64QAM	Outer_Full	B
43 (Note 3)	Low		16QAM	Outer_1RB_Left	CP-OFDM 64QAM	Edge_1RB_Right	B
44 (Note 4)	High		16QAM	Outer_1RB_Right	CP-OFDM 64QAM	Edge_1RB_Left	B
45	Default		16QAM	Outer_Full	CP-OFDM 256QAM	Outer_Full	B
46 (Note 3)	Low		16QAM	Outer_1RB_Left	CP-OFDM 256QAM	Edge_1RB_Right	B
47 (Note 4)	High		16QAM	Outer_1RB_Right	CP-OFDM 256QAM	Edge_1RB_Left	B
48 (Note 4)	Default		16QAM	Edge_Full_Right	CP-OFDM 256QAM	Edge_Full_Left	B

NOTE 1: The specific configuration of each RB allocation is defined in Table 6.1-1 in TS 38.521-1 [8].  
 NOTE 2: If the UE supports multiple CC combinations in the EN-DC configuration with the same  $N_{RB,agg}$ , select the combination to test as follows:  
 - Lowest ENBW: NR component with lowest  $N_{RB}$  is tested.  
 - Highest ENBW: NR component with highest  $N_{RB}$  is tested.  
 NOTE 3: Applicable when E-UTRA cell carrier frequency is lower than NR cell carrier.  
 NOTE 4: Applicable when NR cell carrier frequency is lower than E-UTRA cell carrier.  
 NOTE 5: Outer\_Full defined as the transmission bandwidth configuration  $N_{RB}$  per channel bandwidth for the E-UTRA component as indicated in TS 36.521 [10] Table 5.4.2-1. Outer\_1RB\_Left defined as 1 RB allocated at the left edge of the E-UTRA component. Edge\_Full\_Right is defined as 2 RBs allocated at the right edge of the E-UTRA component. Outer\_1RB\_Right defined as 1 RB allocated at the right edge of the E-UTRA component.  
 NOTE 6: DFT-s-OFDM Pi/2 BPSK test applies only for UEs which supports Pi/2 BPSK in FR1.  
 NOTE 7: Additional IM3 test frequencies may apply.  
 NOTE 8: Power config as specified in Table 6.2B.3.1.4.3-1 to 6.2B.3.1.4.3-2 (PC3) or Table 6.2B.3.1.4.3-3 to 6.2B.3.1.4.3-4 (PC2).  
 NOTE 9: Test IDs with simultaneous E-UTRA and NR UL transmission only apply for UEs indicating dualPA-Architecture.

**Table 6.2B.3.1.4.1-3: Additional IM3 Test Frequencies for NS\_04 intra-band contiguous EN-DC**

Additional Initial Condition	
Additional IM3 Test Frequencies	if SCS 15 kHz, 15 kHz NR raster, and NR ChBw 40 MHz or 50 MHz then IM3 test frequencies as specified in Table 6.2B.3.1.4.1-4.  if SCS 30 kHz, 30 kHz NR raster, and NR ChBw 40 MHz, 50 MHz or 60 MHz then IM3 test frequencies as specified in Table 6.2B.3.1.4.1-5.  if SCS 60 kHz, 15 kHz NR raster, and NR ChBw 40 MHz, 50 MHz or 60 MHz then IM3 test frequencies as specified in Table 6.2B.3.1.4.1-6.

Table 6.2B.3.1.4.1-4: EN-DC combination DC\_(n)41AA, intra-band contiguous, SCS 15 kHz, 15 kHz NR raster, IM3 test frequencies

EN-DC channel bandwidth combination	CC	Bandwidth [MHz]	carrier Bandwidth [PRBs]	Range		Carrier centre [MHz] Note 2	Carrier centre [ARFCN]	point A [MHz]	absolute Frequency Point A [ARFCN]	offset ToCarrier [Carrier PRBs]	SS block SCS [kHz]	GSCN	absoluteFrequencySSB [ARFCN]
				Downlink & Uplink	IM3								
E-UTRA: 20MHz + NR: 40MHz	E-UTRA CC1	20	100	Downlink & Uplink	IM3	2600.400	40694	-	-	-	-	-	-
	NR CC1	40	216	Downlink & Uplink	IM3	2570.400	514080	2550.96	510192	0	15	6384	514080
E-UTRA: 20MHz + NR: 50MHz	E-UTRA CC1	20	100	Downlink & Uplink	IM3	2620.400	40894	-	-	-	-	-	-
	NR CC1	50	270	Downlink & Uplink	IM3	2585.400	517080	2561.1	512220	0	15	6408	517080

Table 6.2B.3.1.4.1-5: EN-DC combination DC\_(n)41AA, intra-band contiguous, SCS 30 kHz, 30 kHz NR raster, IM3 test frequencies

EN-DC channel bandwidth combination	CC	Bandwidth [MHz]	carrier Bandwidth [PRBs]	Range		Carrier centre [MHz] Note 2	Carrier centre [ARFCN]	point A [MHz]	absolute Frequency Point A [ARFCN]	offset ToCarrier [Carrier PRBs]	SS block SCS [kHz]	GSCN	absoluteFrequencySSB [ARFCN]
				Downlink & Uplink	IM3								
E-UTRA: 20MHz + NR: 40MHz	E-UTRA CC1	20	100	Downlink & Uplink	IM3	2600.400	40694	-	-	-	-	-	-
	NR CC1	40	216	Downlink & Uplink	IM3	2570.400	514080	2550.96	510192	0	15	6384	514080
E-UTRA: 20MHz + NR: 50MHz	E-UTRA CC1	20	100	Downlink & Uplink	IM3	2620.400	40894	-	-	-	-	-	-
	NR CC1	50	270	Downlink & Uplink	IM3	2585.400	517080	2561.1	512220	0	15	6408	517080
E-UTRA: 20MHz + NR: 60MHz	E-UTRA CC1	20	100	Downlink & Uplink	IM3	2640.500	41095	-	-	-	-	-	-
	NR CC1	60	162	Downlink & Uplink	IM3	2600.500	520100	2571.34	514268	0	30	6438	520100

Table 6.2B.3.1.4.1-6: EN-DC combination DC\_(n)41AA, intra-band contiguous, SCS 60 kHz, 15 kHz NR raster, IM3 test frequencies

EN-DC channel bandwidth combination	CC	Bandwidth [MHz]	carrier Bandwidth [PRBs]	Range		Carrier centre [MHz] Note 2	Carrier centre [ARFCN]	point A [MHz]	absolute FrequencyPointA [ARFCN]	offset ToCarrier [Carrier PRBs]	SS block SCS [kHz]	GSCN	absoluteFrequencySSB [ARFCN]
E-UTRA: 20MHz + NR: 40MHz	E-UTRA CC1	20	100	Downlink & Uplink	IM3	2600.400	40694	-	-	-	-	-	-
	NR CC1	40	51	Downlink & Uplink	IM3	2570.400	514080	2552.04	510408	0	15	6387	514080
E-UTRA: 20MHz + NR: 50MHz	E-UTRA CC1	20	100	Downlink & Uplink	IM3	2620.400	40894	-	-	-	-	-	-
	NR CC1	50	65	Downlink & Uplink	IM3	2585.400	517080	2562	512400	0	15	6411	517080
E-UTRA: 20MHz + NR: 60MHz	E-UTRA CC1	20	100	Downlink & Uplink	IM3	2640.500	41095	-	-	-	-	-	-
	NR CC1	60	79	Downlink & Uplink	IM3	2600.500	520100	2572.06	514412	0	15	6435	520100

Editor's note: The following lines belong at the end of clause 6.2B.3.1.4.1. As new tables are added to this clause, these lines should always follow the tables.

The initial test configurations for E-UTRA consist of test frequency based on E-UTRA operating band and test channel bandwidth as specified in Table 4.6-1.

1. Connect the SS to the UE antenna connectors as shown in TS 38.508-1 [6] Annex A, Figure A.3.1.1 for TE diagram and clause A.3.2.1 for UE diagram.
2. The parameter settings for E-UTRA the cell are set up according to TS 36.508 [11] clause 4.4.3, and the parameter settings for the NR cell are set up according to TS 38.508-1 [6] clause 4.4.3.
3. Downlink signals are initially set up according to TS 36.521-1 [10] Annex C.0 and TS 38.521-1 [8] Annex C.0 for E-UTRA CG and NR CG respectively, and uplink signals according to TS 36.521-1 [10] Annex H and TS 38.521-1 [8] Annex G for E-UTRA CG and NR CG respectively.
4. NR downlink signals are initially set up according to Annex C.0, C.1, and C.2 and uplink signals according to Annex G.0, G.1, G.2, and G.3.0 of TS 38.521-1 [8].
5. The UL Reference Measurement channels are set for E-UTRA CG and NR CG link respectively.
6. Propagation conditions are set according to TS 36.521-1 [10] Annex B.0 and TS 38.521-1 [8] Annex B.0 for E-UTRA CG and NR CG respectively.
7. Ensure the UE is in state RRC\_CONNECTED with generic procedure parameters Connectivity EN-DC, DC bearer MCG and SCG, Connected without release  $On$  according to TS 38.508-1 [6] clause 4.5. Message contents are defined in clause 6.2B.3.1.4.3.
8. When E-UTRA and NR bands are TDD, ensure the same uplink-downlink configuration by giving SCG a delay of 3 E-UTRA subframes, or by giving MCG a delay of 2 subframes.

#### 6.2B.3.1.4.2 Test procedure

1. SS sends uplink scheduling information for each UL HARQ process via PDCCH DCI format 0 and DCI format 0\_1 for C\_RNTI to schedule the UL RMC according to table 6.2B.3.1.4.1-1 or 6.2B.3.1.4.1-2 on both EN-DC component carriers. Since the UL has no payload and no loopback data to send the UE sends uplink MAC padding bits on the UL RMC.
2. Send continuously uplink power control "up" commands to the UE for NR and E-UTRA carrier until the UE transmits at its  $P_{UMAX}$  level; allow at least 200 ms starting from the first TPC command in this step for the UE to reach  $P_{UMAX}$  level.
3. Measure the mean power over all component carriers for the EN-DC configuration, which shall meet the requirements described in table 6.2B.3.1.5.1-1 through to 6.2B.3.1.5.2-6. The period of the measurement shall be at least the continuous duration of one active sub-frame (1ms). For TDD, only slots consisting of only UL symbols are under test.

NOTE 1: When switching to DFT-s-OFDM waveform, as specified in the test configuration table 6.2B.3.1.4.1-1 or 6.2B.3.1.4.1-2, send an NR RRCReconfiguration message according to TS 38.508-1 [6] clause 4.6.3 Table 4.6.3-118 PUSCH-Config with TRANSFORM\_PRECODER\_ENABLED condition.

#### 6.2B.3.1.4.3 Message contents

Message contents are according to TS 38.508-1 [6] clause 4.6.1, with the following exceptions.

**Table 6.2B.3.1.4.3-1: RRCConnectionReconfiguration: nr-Config-r15 for PC3**

Derivation Path: TS 36.508 [11], Table 4.6.1-8			
Information Element	Value/remark	Comment	Condition
p-MaxEUTRA-r15	23		Power config A (NOTE 1)
	20		Power config B (NOTE 2)
NOTE 1: Applies when E-UTRA UL transmission not overlapping with NR UL transmission in time.			
NOTE 2: Applies when E-UTRA UL transmission overlapping with NR UL transmission in time.			

**Table 6.2B.3.1.4.3-2: PhysicalCellGroupConfig for PC3**

Derivation Path: TS 38.508-1 [6], Table 4.6.3-106			
Information Element	Value/remark	Comment	Condition
p-NR-FR1	23		Power config A (NOTE 1)
	20		Power config B (NOTE 2)
NOTE 1: Applies when E-UTRA UL transmission not overlapping with NR UL transmission in time.			
NOTE 2: Applies when E-UTRA UL transmission overlapping with NR UL transmission in time.			

**Table 6.2B.3.1.4.3-3: RRCConnectionReconfiguration: nr-Config-r15 for PC2**

Derivation Path: TS 36.508 [11], Table 4.6.1-8			
Information Element	Value/remark	Comment	Condition
p-MaxEUTRA-r15	26		Power config A (NOTE 1)
	23		Power config B (NOTE 2)
NOTE 1: Applies when E-UTRA UL transmission not overlapping with NR UL transmission in time.			
NOTE 2: Applies when E-UTRA UL transmission overlapping with NR UL transmission in time.			

**Table 6.2B.3.1.4.3-4: PhysicalCellGroupConfig for PC2**

Derivation Path: TS 38.508-1 [6], Table 4.6.3-106			
Information Element	Value/remark	Comment	Condition
p-NR-FR1	26		Power config A (NOTE 1)
	23		Power config B (NOTE 2)
NOTE 1: Applies when E-UTRA UL transmission not overlapping with NR UL transmission in time.			
NOTE 2: Applies when E-UTRA UL transmission overlapping with NR UL transmission in time.			

**6.2B.3.1.4.3-5: SystemInformationBlockType1: tdd-Config if E-UTRA on TDD band**

Derivation Path: TS 36.508 [11], Table 4.6.3-23			
Information Element	Value/remark	Comment	Condition
TDD-Config-DEFAULT ::= SEQUENCE {		Operating on TDD band	
subframeAssignment	sa2		
specialSubframePatterns	ssp7		
}			

**Table 6.2B.3.1.4.3-6: RRCConnectionReconfiguration: tdm-PatternConfig if E-UTRA on FDD band and UE does not support dynamic power sharing**

Derivation Path: TS 36.508 [11], Table 4.6.1-8			
Information Element	Value/remark	Comment	Condition
tdm-PatternConfig-r15 CHOICE{			Power config A (NOTE 1)
setup SEQUENCE {			
subframeAssignment-r15	sa2		
harq-Offset-r15	0		
}			
}			

NOTE 1: Applies when E-UTRA UL transmission not overlapping with NR UL transmission in time.

6.2B.3.1.4.3.1 Message contents exceptions (network signalled value "NS\_04")

Message contents are according to TS 38.508-1 [6] clause 4.6.1 with the following exceptions for NS\_04:

**Table 6.2B.3.1.4.3.1-1: AdditionalSpectrumEmission for MCG and "NS\_04"**

Derivation Path: 36.508 [11] clause 4.6.3, Table 4.4.3.3-1			
Information Element	Value/remark	Comment	Condition
AdditionalSpectrumEmission	1 (NS_04)		

**Table 6.2B.3.1.4.3.1-2: AdditionalSpectrumEmission for SCG and "NS\_04"**

Derivation Path: TS 38.508-1 [6] clause 4.6.3, Table 4.6.3-1			
Information Element	Value/remark	Comment	Condition
AdditionalSpectrumEmission	1 (NS_04)		

6.2B.3.1.4.3.2 Message contents exceptions (network signalled value "NS\_35")

Message contents are according to TS 38.508-1 [6] clause 4.6.1 with the following exceptions for NS\_35:

**Table 6.2B.3.1.4.3.2-1: AdditionalSpectrumEmission for MCG and "NS\_35"**

Derivation Path: 36.508 [11] clause 4.6.3, Table 4.4.3.3-1			
Information Element	Value/remark	Comment	Condition
AdditionalSpectrumEmission	1 (NS_35)		

**Table 6.2B.3.1.4.3.2-2: AdditionalSpectrumEmission for for SCG "NS\_35"**

Derivation Path: TS 38.508-1 [5] clause 4.6.3, Table 4.6.3-1			
Information Element	Value/remark	Comment	Condition
AdditionalSpectrumEmission	1 (NS_35)		

6.2B.3.1.5 Test requirement

**Table: 6.2B.3.1.5-1: Test Tolerance for UE maximum output power**

	$f \leq 3.0\text{GHz}$	$3.0\text{GHz} < f \leq 6\text{GHz}$
<b>ENBW <math>\leq 40\text{MHz}</math></b>	0.7 dB	1.0 dB
<b><math>40\text{MHz} &lt; \text{ENBW} \leq 100\text{MHz}</math></b>	1.0 dB	1.0 dB

#### 6.2B.3.1.5.1 Test requirement for network signalled value "NS\_35"

The maximum output power, derived in step 3 shall be within the range prescribed by the nominal maximum output power and tolerance in table 6.2B.3.1.5.1-1. The allowed A-MPR values specified in table 6.2B.3.1.3-1 are in addition to the allowed MPR requirements specified in clause 6.2B.1.1.3. For the UE maximum output power modified by MPR and/or A-MPR, the power limits specified in table 6.2B.1.1.3-1 apply.

**Table 6.2B.3.1.5.1-1: UE Power Class test requirements for network signalled value "NS\_35" for UEs not supporting dynamic power sharing**

Test ID	Test frequency	E-UTRA BW	NR BW	Modulation	$P_{PowerClass}$ (dBm)	$\Delta P_{PowerClass}$ (dB)	A-MPR <sub>c</sub> (dB)	$\Delta TC_{c}$ (dB) Note 7	$P_{CMAX,c}$ (dBm)	$T(P_{CMAX_{L,f,c}})$ (dB)	$T_{L,c}$ (dB)	Upper limit	Lower limit
1, 8, 15, 22, 25	Low	5	5	E-UTRA/NR	23	0	6.0	0	17.0	5	+2/-3	25+TT	12-TT
1, 8, 15, 22, 25	Low	5	15	E-UTRA/NR	23	0	6.0	0	17.0	5	+2/-3	25+TT	12-TT
1, 8, 15, 22, 25	High	5	5	E-UTRA/NR	23	0	6.0	0	17.0	5	+2/-3	25+TT	12-TT
1, 8, 15, 22, 25	High	15	5	E-UTRA/NR	23	0	6.0	0	17.0	5	+2/-3	25+TT	12-TT
2, 5, 9, 12, 16, 19, 23, 24, 2, 26, 27	Low	5	5	E-UTRA/NR	23	0	10.5	0	12.5	6	+2/-3	25+TT	6.5-TT
2, 5, 9, 12, 16, 19, 23, 24, 2, 26, 27	Low	5	15	E-UTRA/NR	23	0	11.0	0	12.0	6	+2/-3	25+TT	6-TT
2, 5, 9, 12, 16, 19, 23, 24, 2, 26, 27	High	5	5	E-UTRA/NR	23	0	10.5	0	12.5	6	+2/-3	25+TT	6.5-TT
2, 5, 9, 12, 16, 19, 23, 24, 2, 26, 27	High	15	5	E-UTRA/NR	23	0	11.0	0	12.0	6	+2/-3	25+TT	6-TT
3, 10, 17	Low	5	5	E-UTRA/NR	23	0	12.5	0	10.5	6	+2/-3	25+TT	4.5-TT
3, 14, 17	Low	5	15	E-UTRA/NR	23	0	16.0	0	7.0	7	+2/-3	25+TT	0-TT
4, 11, 18	High	5	5	E-UTRA/NR	23	0	12.5	0	10.5	12.5	+2/-3	25+TT	4.5-TT
4, 11, 18	High	15	5	E-UTRA/NR	23	0	16.0	0	7.0	16.0	+2/-3	25+TT	0-TT
6, 13, 20	Low	5	5	E-UTRA/NR	23	0	11.0	0	12.0	6	+2/-3	25+TT	6-TT
6, 13, 20	Low	5	15	E-UTRA/NR	23	0	11.0	0	12.0	6	+2/-3	25+TT	6-TT
7, 14, 21	High	5	5	E-UTRA/NR	23	0	11.0	0	12.0	6	+2/-3	25+TT	6-TT
7, 14, 21	High	15	5	E-UTRA/NR	23	0	11.0	0	12.0	6	+2/-3	25+TT	6-TT
28, 35, 42, 45	Low	5	5	E-UTRA/NR	23	0	6.5	0	16.5	5	+2/-3	25+TT	11.5-TT
28, 35, 42, 45	Low	5	15	E-UTRA/NR	23	0	6.5	0	16.5	5	+2/-3	25+TT	11.5-TT
28, 35, 42, 45	High	5	5	E-UTRA/NR	23	0	6.5	0	16.5	5	+2/-3	25+TT	11.5-TT
28, 35, 42, 45	High	15	5	E-UTRA/NR	23	0	6.5	0	16.5	5	+2/-3	25+TT	11.5-TT
29, 35, 42, 45	Low	5	5	E-UTRA/NR	23	0	11.0	0	12.0	6	+2/-3	25+TT	6.5-TT
29, 35, 42, 45	Low	5	15	E-UTRA/NR	23	0	11.0	0	12.0	6	+2/-3	25+TT	6-TT
29, 35, 42, 45	High	5	5	E-UTRA/NR	23	0	11.0	0	12.0	6	+2/-3	25+TT	6.5-TT
29, 35, 42, 45	High	15	5	E-UTRA/NR	23	0	11.0	0	12.0	6	+2/-3	25+TT	6-TT
30, 34, 37, 41	Low	5	5	E-UTRA/NR	23	0	11.0	0	12.0	6	+2/-3	25+TT	6-TT
30, 34, 37, 41	Low	5	15	E-UTRA/NR	23	0	11.0	0	12.0	6	+2/-3	25+TT	6-TT
31, 33, 38, 40	High	5	5	E-UTRA/NR	23	0	11.0	0	12.0	6	+2/-3	25+TT	6-TT
31, 33, 38, 40	High	15	5	E-UTRA/NR	23	0	11.0	0	12.0	6	+2/-3	25+TT	6-TT



**Table 6.2B.3.1.5.1-1A: UE Power Class test requirements for network signalled value "NS\_35" for UEs supporting dynamic power sharing**

Test ID	Test frequency	E-UTRA BW	NR BW	Modulation	$P_{PowerClass}$ (dBm)	$\Delta P_{PowerClass}$ (dB)	A-MPR <sub>c</sub> (dB)	$\Delta T_{c,c}$ (dB) Note 7	$P_{CMAX,c}$ (dBm)	$T(P_{CMAX\_L,f,c})$ (dB)	$T_{L,c}$ (dB)	Upper limit	Lower limit
1, 8, 15, 22, 25	Low	5	5	E-UTRA	23	0	8.5	0	14.5	5	+2/-3	25+T <sub>T</sub>	9.5-TT
1, 8, 15, 22, 25	Low	5	5	NR	23	0	8.5	0	14.5	5	+2/-3	25+T <sub>T</sub>	9.5-TT
1, 8, 15, 22, 25	Low	5	15	E-UTRA	23	0	13.0	0	10.0	6	+2/-3	25+T <sub>T</sub>	4-TT
1, 8, 15, 22, 25	Low	5	15	NR	23	0	6.5	0	16.5	5	+2/-3	25+T <sub>T</sub>	11.5-TT
1, 8, 15, 22, 25	High	5	5	E-UTRA	23	0	8.5	0	14.5	5	+2/-3	25+T <sub>T</sub>	9.5-TT
1, 8, 15, 22, 25	High	5	5	NR	23	0	8.5	0	14.5	5	+2/-3	25+T <sub>T</sub>	9.5-TT
1, 8, 15, 22, 25	High	15	5	E-UTRA	23	0	6.5	0	16.5	5	+2/-3	25+T <sub>T</sub>	11.5-TT
1, 8, 15, 22, 25	High	15	5	NR	23	0	13.0	0	10.0	6	+2/-3	25+T <sub>T</sub>	4-TT
2, 5, 9, 12, 16, 19, 23, 24, 2, 26, 27	Low	5	5	E-UTRA	23	0	13.0	0	10.0	6	+2/-3	25+T <sub>T</sub>	4-TT
2, 5, 9, 12, 16, 19, 23, 24, 2, 26, 27	Low	5	5	NR	23	0	13.0	0	10.0	6	+2/-3	25+T <sub>T</sub>	4-TT
2, 5, 9, 12, 16, 19, 23, 24, 2, 26, 27	Low	5	15	E-UTRA	23	0	16.0	0	7.0	7	+2/-3	25+T <sub>T</sub>	0-TT

2, 5, 9, 12, 16, 19, 23, 24, 2, 26, 27	Low	5	15	NR	23	0	11.0	0	12.0	6	+2/-3	25+T T	6-TT
2, 5, 9, 12, 16, 19, 23, 24, 2, 26, 27	High	5	5	E-UTRA	23	0	13.0	0	10.0	6	+2/-3	25+T T	4-TT
2, 5, 9, 12, 16, 19, 23, 24, 2, 26, 27	High	5	5	NR	23	0	13.0	0	10.0	6	+2/-3	25+T T	4-TT
2, 5, 9, 12, 16, 19, 23, 24, 2, 26, 27	High	15	5	E-UTRA	23	0	11.5	0	11.5	6	+2/-3	25+T T	5.5-TT
2, 5, 9, 12, 16, 19, 23, 24, 2, 26, 27	High	15	5	NR	23	0	16.0	0	7.0	7	+2/-3	25+T T	0-TT
3, 10, 17	Low	5	5	E-UTRA/	23	0	12.5	0	10.5	6	+2/-3	25+T T	4.5-TT
3, 10, 17	Low	5	15	E-UTRA	23	0	16.0	0	7.0	7	+2/-3	25+T T	0-TT
4, 11, 18	High	5	5	NR	23	0	13.0	0	10.0	6	+2/-3	25+T T	4-TT
4, 11, 18	High	15	5	NR	23	0	16.0	0	7.0	7	+2/-3	25+T T	0-TT
6, 17, 20	Low	5	5	E-UTRA/	23	0	13.0	0	10.0	6	+2/-3	25+T T	4-TT
6, 17, 20	Low	5	15	E-UTRA	23	0	16.5	0	6.5	7	+2/-3	25+T T	-0.5-TT

7, 14, 21	High	5	5	NR	23	0	13.0	0	10.0	6	+2/-3	25+T T	4-TT
7, 14, 21	High	15	5	NR	23	0	16.0	0	7.0	7	+2/-3	25+T T	0-TT
28, 35, 42, 45	Low	5	5	E-UTRA	23	0	9.5	0	13.5	5	+2/-3	25+T T	8.5-TT
28, 35, 42, 45	Low	5	5	NR	23	0	9.5	0	13.5	5	+2/-3	25+T T	8.5-TT
28, 35, 42, 45	Low	5	15	E-UTRA	23	0	13.5	0	9.5	6	+2/-3	25+T T	3.5-TT
28, 35, 42, 45	Low	5	15	NR	23	0	7.0	0	16.0	5	+2/-3	25+T T	11-TT
28, 35, 42, 45	High	5	5	E-UTRA	23	0	9.5	0	13.5	5	+2/-3	25+T T	8.5-TT
28, 35, 42, 45	High	5	5	NR	23	0	9.5	0	13.5	5	+2/-3	25+T T	8.5-TT
28, 35, 42, 45	High	15	5	E-UTRA	23	0	7.0	0	16.0	5	+2/-3	25+T T	11-TT
28, 35, 42, 45	High	15	5	NR	23	0	13.0	0	10.0	6	+2/-3	25+T T	4-TT
29, 36, 43, 46	Low	5	5	E-UTRA	23	0	13.0	0	10.0	6	+2/-3	25+T T	4-TT
29, 36, 43, 46	Low	5	5	NR	23	0	13.0	0	10.0	6	+2/-3	25+T T	4-TT
29, 36, 43, 46	Low	5	15	E-UTRA	23	0	16.0	0	7.0	7	+2/-3	25+T T	0-TT
29, 36, 43, 46	Low	5	15	NR	23	0	11.0	0	12.0	6	+2/-3	25+T T	6-TT
29, 36, 43, 46	High	5	5	E-UTRA	23	0	13.0	0	10.0	6	+2/-3	25+T T	4-TT
29, 36, 43, 46	High	5	5	NR	23	0	13.0	0	10.0	6	+2/-3	25+T T	4-TT
29, 36, 43, 46	High	15	5	E-UTRA	23	0	11.5	0	11.5	6	+2/-3	25+T T	0-TT

29, 36, 43, 46	High	15	5	NR	23	0	16.0	0	7.0	7	+2/-3	25+T T	5.5- TT
30, 37	Low	5	5	E-UTRA/	23	0	13.0	0	10.0	6		25+T T	4-TT
30, 37	Low	5	15	E-UTRA	23	0	16.0	0	7.0	7		25+T T	0-TT
31, 38	High	5	5	NR	23	0	13.0	0	10.0	6		25+T T	4-TT
31, 38	High	15	5	NR	23	0	16.0	0	7.0	7		25+T T	0-TT
34, 41	High	5	5	NR	23	0	13.0	0	10.0	6		25+T T	4-TT
34, 41	High	15	5	NR	23	0	16.0	0	7.0	7		25+T T	0-TT
33, 40	Low	5	5	E-UTRA/	23	0	13.0	0	10.0	6		25+T T	4-TT
33, 40	Low	5	15	E-UTRA	23	0	16.5	0	6.5	7		25+T T	-0.5- TT

NOTE 8: TT for each frequency and channel bandwidth is specified in Table 6.2B.3.1.5-1

6.2B.3.1.5.2 Test requirement for network signalled value "NS\_04"

**Table 6.2B.3.1.5.2-1: UE Power Class 3 test requirements for NS\_04, supporting dynamic power sharing and E-UTRA UL transmission overlapping with NR UL transmission**

Test ID	Test SCS (kHz)	A-MPR <sub>tot</sub> (dB)	P <sub>EN-DC, tot_L</sub> (dBm)	P <sub>EN-DC, tot_H</sub> (dBm)	T <sub>LOW</sub> (P <sub>CMAX_L</sub> ) (dB)	T <sub>HIGH</sub> (P <sub>CMAX_H</sub> ) (dB)	Upper limit (dBm)	Lower limit (dBm)
1, 8, 15, 22, 25, 28, 35, 42, 45 (Note 1, 4)	15, 30, 60	3	20	23	6	2	25+TT	14-TT
1, 8, 15, 22, 25, 28, 35, 42, 45 (Note 1, 5)	15, 30, 60	9	14	23	6	2	25+TT	8-TT
2, 5, 9, 12, 16, 19, 23, 24, 26, 27, 29, 32, 36, 39, 43, 44, 46, 47 (Note 2, 4, 5)	15	11	12	23	6	2	25+TT	6-TT
2, 5, 9, 12, 16, 19, 23, 24, 26, 27, 29, 32, 36, 39, 43, 44, 46, 47 (Note 2, 4)	30, 60	6	17	23	5	2	25+TT	12-TT
2, 5, 9, 12, 16, 19, 23, 24, 26, 27, 29, 32, 36, 39, 43, 44, 46, 47 (Note 2, 5)	30, 60	11	12	23	6	2	25+TT	6-TT
48 (Note 3, 4)	15	7	16	23	5	2	25+TT	11-TT
48 (Note 3, 4)	30, 60	12	11	23	6	2	25+TT	5-TT
48 (Note 3, 5)	15, 30, 60	7	16	23	5	2	25+TT	11-TT

NOTE 1: Test configuration IDs with transmission overlap with full RB allocation, requirements in TS 38.101-3 [4] apply.  
 NOTE 2: Test configuration IDs with transmission overlap with 1RB allocation, requirements in TS 38.101-3 [4] apply.  
 NOTE 3: Test configuration IDs with transmission overlap with edge full RB allocation, requirements in TS 38.101-3 [4] apply.  
 NOTE 4: When  $F_{IM3,low\_block,low} \geq 2490.5$  MHz (Case A)  
 NOTE 5: When  $F_{IM3,low\_block,low} < 2490.5$  MHz (Case B)  
 NOTE 6: TT for each frequency and channel bandwidth is specified in Table 6.2B.3.1.5-1.

**Table 6.2B.3.1.5.2-2: UE Power Class 3 test requirements for NS\_04, supporting dynamic power sharing and E-UTRA UL transmission not overlapping with NR UL transmission**

Test ID	Test SCS (kHz)	MPR (dB)	A-MPR (dB)	$P_{EN-DC, tot\_L}$ (dBm)	$P_{EN-DC, tot\_H}$ (dBm)	$T_{LOW} (P_{C_{MAX\_L}})$ (dB)	$T_{HIGH} (P_{C_{MAX\_H}})$ (dB)	Upper limit (dBm)	Lower limit (dBm)
3, 7, 10, 14, 17, 21, 30, 34, 37, 41 (Note 1)	15, 30, 60	0	3	20	23	4	2	25+TT	16-TT
4 (Note 2)	15, 30, 60	0.5	0	22.5	23	2	2	25+TT	20.5-TT
6 (Note 2)	15, 30, 60	0	3.5	19.5	23	3.5	2	25+TT	16-TT
11 (Note 2)	15, 30, 60	1	0	22	23	2	2	25+TT	20-TT
13 (Note 2)	15, 30, 60	0	4	19	23	3.5	2	25+TT	15.5-TT
18 (Note 2)	15, 30, 60	2	0	21	23	2	2	25+TT	19-TT
20 (Note 2)	15, 30, 60	0	4	19	23	3.5	2	25+TT	15.5-TT
31 (Note 2)	15, 30, 60	3	0	20	23	2.5	2	25+TT	17.5-TT
33 (Note 2)	15, 30, 60	0	5.5	17.5	23	5	2	25+TT	12-TT
38 (Note 2)	15, 30, 60	3	0	20	23	2.5	2	25+TT	17.5-TT
40 (Note 2)	15, 30, 60	0	5.5	17.5	23	5	2	25+TT	12-TT

NOTE 1: Test configuration IDs without transmission overlap, 1RB E-UTRA allocation, A-MPR requirements in TS 36.101 [5] apply

NOTE 2: Test configuration IDs without transmission overlap, 1RB NR allocation, A-MPR requirements in TS 38.101-1 [2] apply.

NOTE 3: Void.

NOTE 4: Void.

NOTE 5: Void.

NOTE 6: TT for each frequency and channel bandwidth is specified in Table 6.2B.3.1.5-1.

**Table 6.2B.3.1.5.2-3: UE Power Class 3 test requirements for NS\_04, not supporting dynamic power sharing and E-UTRA UL transmission overlapping with NR UL transmission**

Test ID	Test SCS (kHz)	A-MPR <sub>tot</sub> (dB)	$P_{EN-DC, tot\_L}$ (dBm)	$P_{EN-DC, tot\_H}$ (dBm)	$T_{LOW} (P_{C_{MAX\_L}})$ (dB)	$T_{HIGH} (P_{C_{MAX\_H}})$ (dB)	Upper limit (dBm)	Lower limit (dBm)
1, 8, 15, 22, 25, 28, 35, 42, 45 (Note 1, 4)	15, 30, 60	6	17	23	5	2	25+TT	12-TT
1, 8, 15, 22, 25, 28, 35, 42, 45 (Note 1, 5)	15, 30, 60	12	11	23	6	2	25+TT	5-TT
2, 5, 9, 12, 16, 19, 23, 24, 26, 27, 29, 32, 36, 39, 43, 44, 46, 47 (Note 2, 4, 5)	15	14	9	23	7	2	25+TT	2-TT
2, 5, 9, 12, 16, 19, 23, 24, 26, 27, 29, 32, 36, 39, 43, 44, 46, 47 (Note 2, 4)	30, 60	9	14	23	6	2	25+TT	8-TT
2, 5, 9, 12, 16, 19, 23, 24, 26, 27, 29, 32, 36, 39, 43, 44, 46, 47 (Note 2, 5)	30, 60	14	9	23	7	2	25+TT	2-TT
48 (Note 3, 4)	15	10	13	23	6	2	25+TT	7-TT
48 (Note 3, 4)	30, 60	15	8	23	7	2	25+TT	1-TT
48 (Note 3, 5)	15, 30, 60	10	13	23	6	2	25+TT	7-TT

NOTE 1: Test configuration IDs with transmission overlap with full RB allocation, requirements in TS 38.101-3 [4] apply.

NOTE 2: Test configuration IDs with transmission overlap with 1RB allocation, requirements in TS 38.101-3 [4] apply.

NOTE 3: Test configuration IDs with transmission overlap with edge full RB allocation, requirements in TS 38.101-3 [4] apply.

NOTE 4: When  $F_{IM3,low\_block,low} \geq 2490.5$  MHz (Case A)

NOTE 5: When  $F_{IM3,low\_block,low} < 2490.5$  MHz (Case B)

NOTE 6: TT for each frequency and channel bandwidth is specified in Table 6.2B.3.1.5-1.

**Table 6.2B.3.1.5.2-4: UE Power Class 2 test requirements for NS\_04, supporting dynamic power sharing and E-UTRA UL transmission overlapping with NR UL transmission**

Test ID	Test SCS (kHz)	A-MPR <sub>tot</sub> (dB)	P <sub>EN-DC, tot_L</sub> (dBm)	P <sub>EN-DC, tot_H</sub> (dBm)	T <sub>LOW</sub> (P <sub>CMAX_L</sub> ) (dB)	T <sub>HIGH</sub> (P <sub>CMAX_H</sub> ) (dB)	Upper limit (dBm)	Lower limit (dBm)
1, 8, 15, 22, 25, 28, 35, 42, 45 (Note 1, 4)	15, 30, 60	3	23	26	3	2	28+TT	20-TT
1, 8, 15, 22, 25, 28, 35, 42, 45 (Note 1, 5)	15, 30, 60	9	17	26	5	2	28+TT	12-TT
2, 5, 9, 12, 16, 19, 23, 24, 26, 27, 29, 32, 36, 39, 43, 44, 46, 47 (Note 2, 4, 5)	15	11	15	26	6	2	28+TT	9-TT
2, 5, 9, 12, 16, 19, 23, 24, 26, 27, 29, 32, 36, 39, 43, 44, 46, 47 (Note 2, 4)	30, 60	6	20	26	6	2	28+TT	14-TT
2, 5, 9, 12, 16, 19, 23, 24, 26, 27, 29, 32, 36, 39, 43, 44, 46, 47 (Note 2, 5)	30, 60	11	15	26	6	2	28+TT	9-TT
48 (Note 3, 4)	15	7	19	26	5	2	28+TT	14-TT
48 (Note 3, 4)	30, 60	12	14	26	6	2	28+TT	8-TT
48 (Note 3, 5)	15, 30, 60	7	19	26	5	2	28+TT	14-TT

NOTE 1: Test configuration IDs with transmission overlap with full RB allocation, requirements in TS 38.101-3 [4] apply.  
 NOTE 2: Test configuration IDs with transmission overlap with 1RB allocation, requirements in TS 38.101-3 [4] apply.  
 NOTE 3: Test configuration IDs with transmission overlap with edge full RB allocation, requirements in TS 38.101-3 [4] apply.  
 NOTE 4: When F<sub>IM3,low\_block,low</sub> ≥ 2490.5 MHz (Case A)  
 NOTE 5: When F<sub>IM3,low\_block,low</sub> < 2490.5 MHz (Case B)  
 NOTE 6: TT for each frequency and channel bandwidth is specified in Table 6.2B.3.1.5-1.

**Table 6.2B.3.1.5.2-5: UE Power Class 2 test requirements for NS\_04, supporting dynamic power sharing and E-UTRA UL transmission not overlapping with NR UL transmission (Rel-15 UE indicates PC2 on NR band, Rel-16 and forward UE reporting (PC2 by P<sub>PowerClass,NR</sub>, and PC2 or Not present by powerClassNRPart-r16))**

Test ID	Test SCS (kHz)	MPR (dB)	A-MPR (dB)	P <sub>EN-DC, tot_L</sub> (dBm)	P <sub>EN-DC, tot_H</sub> (dBm)	T <sub>LOW</sub> (P <sub>CMAX_L</sub> ) (dB)	T <sub>HIGH</sub> (P <sub>CMAX_H</sub> ) (dB)	Upper limit (dBm)	Lower limit (dBm)
3, 7, 10, 14, 17, 21, 30, 34, 37, 41 (Note 1)	15, 30, 60	0	3	23	26	2	2	28+TT	21-TT
4 (Note 2)	15, 30, 60	3.5	0	22.5	26	2	2	28+TT	20.5-TT
6 (Note 2)	15, 30, 60	0	5.5	20.5	26	2.5	2	28+TT	18-TT
11 (Note 2)	15, 30, 60	3.5	0	22.5	26	2	2	28+TT	20.5-TT
13 (Note 2)	15, 30, 60	0	6	20	26	2.5	2	28+TT	17.5-TT
18 (Note 2)	15, 30, 60	3.5	0	22.5	26	2	2	28+TT	20.5-TT
20 (Note 2)	15, 30, 60	0	6	20	26	2.5	2	28+TT	17.5-TT
31 (Note 2)	15, 30, 60	3.5	0	22.5	26	2	2	28+TT	20.5-TT
33 (Note 2)	15, 30, 60	0	7.5	18.5	26	4	2	28+TT	14.5-TT
38 (Note 2)	15, 30, 60	3.5	0	22.5	26	2	2	28+TT	20.5-TT
40 (Note 2)	15, 30, 60	0	7.5	18.5	26	4	2	28+TT	14.5-TT

NOTE 1: Test configuration IDs without transmission overlap, 1RB E-UTRA allocation, A-MPR requirements in TS 36.101 [5] apply.  
 NOTE 2: Test configuration IDs without transmission overlap, 1RB NR allocation, A-MPR requirements in TS 38.101-1 [2] apply.  
 NOTE 3: Void.  
 NOTE 4: Void.  
 NOTE 5: Void.  
 NOTE 6: TT for each frequency and channel bandwidth is specified in Table 6.2B.3.1.5-1.

**Table 6.2B.3.1.5.2-5a: UE Power Class 2 test requirements for NS\_04, E-UTRA UL transmission not overlapping with NR UL transmission (Rel-15 and forward UE indicates PC3 on NR band, Rel-16 and forward UE reporting (PC2 by  $P_{PowerClass,NR}$ , and PC3 by  $powerClassNRPart-r16$ ))**

Test ID	Test SCS (kHz)	MPR (dB)	A-MPR (dB)	$P_{EN-DC, tot\_L}$ (dBm)	$P_{EN-DC, tot\_H}$ (dBm)	$T_{LOW} (P_{CMAX\_L})$ (dB)	$T_{HIGH} (P_{CMAX\_H})$ (dB)	Upper limit (dBm)	Lower limit (dBm)
3, 7, 10, 14, 17, 21, 30, 34, 37, 41 (Note 1)	15, 30, 60	0	3	23	26	2	2	28+TT	21+TT
4 (Note 2)	15, 30, 60	0.5	0	22.5	23	2	2	25+TT	20.5+TT
6 (Note 2)	15, 30, 60	0	3.5	19.5	23	3.5	2	25+TT	16+TT
11 (Note 2)	15, 30, 60	1	0	22	23	2	2	25+TT	20+TT
13 (Note 2)	15, 30, 60	0	4	19	23	3.5	2	25+TT	15.5+TT
18 (Note 2)	15, 30, 60	2	0	21	23	2	2	25+TT	19+TT
20 (Note 2)	15, 30, 60	0	4	19	23	3.5	2	25+TT	15.5+TT
31 (Note 2)	15, 30, 60	3	0	20	23	2.5	2	25+TT	17.5+TT
33 (Note 2)	15, 30, 60	0	5.5	17.5	23	5	2	25+TT	12.5+TT
38 (Note 2)	15, 30, 60	3	0	20	23	2.5	2	25+TT	17.5+TT
40 (Note 2)	15, 30, 60	0	5.5	17.5	23	5	2	25+TT	12.5+TT

NOTE 1: Test configuration IDs without transmission overlap, 1RB E-UTRA allocation, A-MPR requirements in TS 36.101 [5] apply.  
NOTE 2: Test configuration IDs without transmission overlap, 1RB NR allocation, A-MPR requirements in TS 38.101- [2] apply.  
NOTE 3: TT for each frequency and channel bandwidth is specified in Table 6.2B.3.1.5-1.

**Table 6.2B.3.1.5.2-6: UE Power Class 2 test requirements for NS\_04, not supporting dynamic power sharing and E-UTRA UL transmission overlapping with NR UL transmission**

Test ID	Test SCS (kHz)	A-MPR <sub>tot</sub> (dB)	$P_{EN-DC, tot\_L}$ (dBm)	$P_{EN-DC, tot\_H}$ (dBm)	$T_{LOW} (P_{CMAX\_L})$ (dB)	$T_{HIGH} (P_{CMAX\_H})$ (dB)	Upper limit (dBm)	Lower limit (dBm)
1, 8, 15, 22, 25, 28, 35, 42, 45 (Note 1, 4)	15, 30, 60	6	20	26	6	2	28+TT	14-TT
1, 8, 15, 22, 25, 28, 35, 42, 45 (Note 1, 5)	15, 30, 60	12	14	26	6	2	28+TT	8-TT
2, 5, 9, 12, 16, 19, 23, 24, 26, 27, 29, 32, 36, 39, 43, 44, 46, 47 (Note 2, 4, 5)	15	14	12	26	6	2	28+TT	6-TT
2, 5, 9, 12, 16, 19, 23, 24, 26, 27, 29, 32, 36, 39, 43, 44, 46, 47 (Note 2, 4)	30, 60	9	17	26	5	2	28+TT	12-TT
2, 5, 9, 12, 16, 19, 23, 24, 26, 27, 29, 32, 36, 39, 43, 44, 46, 47 (Note 2, 5)	30, 60	14	12	26	6	2	28+TT	6-TT
48 (Note 3, 4)	15	10	16	26	5	2	28+TT	11-TT
48 (Note 3, 4)	30, 60	15	11	26	6	2	28+TT	5-TT
48 (Note 3, 5)	15, 30, 60	10	16	26	5	2	28+TT	11-TT

NOTE 1: Test configuration IDs with transmission overlap with full RB allocation, requirements in TS 38.101-3 [4] apply.  
NOTE 2: Test configuration IDs with transmission overlap with 1RB allocation, requirements in TS 38.101-3 [4] apply.  
NOTE 3: Test configuration IDs with transmission overlap with edge full RB allocation, requirements in TS 38.101-3 [4] apply.  
NOTE 4: When  $F_{IM3,low\_block,low} \geq 2490.5$  MHz (Case A)  
NOTE 5: When  $F_{IM3,low\_block,low} < 2490.5$  MHz (Case B)  
NOTE 6: TT for each frequency and channel bandwidth is specified in Table 6.2B.3.1.5-1.

### 6.2B.3.2 UE Additional Maximum Output Power reduction for Intra-Band Non-Contiguous EN-DC

Editor's note: This test case is incomplete. The following aspects are either missing or not yet determined:

- Test frequencies for the Minimum  $W_{GAP}$
- Test requirements for non-overlapping transmission of non-DPS UE need further investigation



### 6.2B.3.2.1 Test purpose

Additional emission requirements can be signalled by the network with network signalling value indicated by the field *additionalSpectrumEmission*. To meet these additional requirements, additional maximum power reduction (A-MPR) is allowed for the maximum output power as specified in Table 6.2B.1.1.3-1. Unless stated otherwise, an A-MPR of 0 dB shall be used.

### 6.2B.3.2.2 Test applicability

The requirements of this test apply in test case 6.5B.2.2.2 Additional spectrum emission mask for network signalled values NS\_04 to all types of E-UTRA UE release 15 and forward, supporting intra-band non-contiguous EN-DC.

### 6.2B.3.2.3 Minimum conformance requirements

For intra-band non-contiguous EN-DC band combinations with additional requirements the A-MPR allowed are specified in table 6.2B.3.2.3-1 for UEs configured with EN-DC and combinations of network signalling values indicated in the E-UTRA and NR cell group(s). Unless otherwise stated the A-MPR specified in subclause 6.2B.3.2 for intra-band non-contiguous EN-DC configurations is the total power reduction allowed including MPR. For UEs scheduled with single uplink transmission, AMPR in subclause 6.2.4 of [4] and 6.2.3 of [2] apply.

**Table 6.2B.3.2.3-1: Allowed power reduction for intra-band non-contiguous EN-DC**

DC configuration	Requirement (clause)	E-UTRA network signalling value	NR network signalling value	A-MPR (clause)
DC_41A_n41A <sup>1</sup>	6.6.3.3.19 and 6.6.2.2.2 of TS 36.101 [5] and 6.5.2.3.2 and 6.5.3.3.1 of TS 38.101-1 [2]	NS_01 or NS_04	NS_04	6.2B.3.2.3.1
NOTE 1: Only applies to UEs that support dual UL transmission for this EN-DC combination. NOTE 2: The requirement applies when the combination of network signalling values in the two CGs is set (only for UEs configured with EN-DC).				

The normative reference for this requirement is TS 38.101-3 [4] clause 6.2B.3.2.

Exception requirements for both NR and E-UTRA are defined for this test when transmission on E-UTRA overlap in time with NR.LTE anchor agnostic approach is not applied for this case and referred to as sub-test 1. E-UTRA test point analysis is included and E-UTRA measurements are performed.

Exception requirements for both NR and E-UTRA are defined for this test when transmission on E-UTRA doesn't overlap in time with NR, for a UE that doesn't support dynamic power sharing. LTE anchor agnostic approach is not applied for this case. E-UTRA test point analysis is included and E-UTRA measurements are performed.

No exception requirements for NR or E-UTRA are defined for this test when transmission on E-UTRA doesn't overlap in time with NR, for a UE that supports dynamic power sharing. LTE anchor agnostic approach is not applied for this case.

#### 6.2B.3.2.3.1 A-MPR for NS\_04

When the UE is configured for B41/n41 intra-band non-contiguous EN-DC and it receives IE NS\_04, the UE determines the total allowed maximum output power reduction as specified in this clause. The A-MPR for EN-DC defined in this clause is used instead of MPR defined in 6.2B.2.2, not additively, so EN-DC MPR=0 when NS\_04 is signalled.

For UE supporting dynamic power sharing the following:

- for the MCG, A-MPR<sub>c</sub> in accordance with TS 36.101 [5]
- for the SCG,

$$A\text{-MPR}'_c = A\text{-MPR}_{\text{NR}} = \text{MAX}(A\text{-MPR}_{\text{single,NR}}, A\text{-MPR}_{\text{EN-DC}})$$

- for the total configured transmission power,

$$A\text{-MPR}_{\text{tot}} = P_{\text{PowerClass,EN-DC}} - \min(P_{\text{PowerClass,EN-DC}}, 10 \cdot \log_{10}(10^{(P_{\text{PowerClass,E-UTRA}} - A\text{-MPR}_{\text{E-UTRA}})/10}) + 10^{(P_{\text{PowerClass,NR}} - A\text{-MPR}_{\text{NR}})/10}))$$

where

$$A\text{-MPR}_{\text{E-UTRA}} = \text{MAX}(A\text{-MPR}_{\text{single,E-UTRA}} + \text{MPR}_{\text{single,E-UTRA}}, A\text{-MPR}_{\text{EN-DC}})$$

$$A\text{-MPR}_{\text{EN-DC}} = \text{MAX}(A\text{-MPR}_{\text{IM3}}, A\text{-MPR}_{\text{ACLROverlap}})$$

with

- $A\text{-MPR}_{\text{single,E-UTRA}}$  is the A-MPR defined for the E-UTRA transmission in TS 38.101-3 [4]
- $A\text{-MPR}_{\text{single,NR}}$  is the A-MPR defined for the NR transmission in TS 38.101-1 [2]
- $\text{MPR}_{\text{single,E-UTRA}}$  is the MPR defined for the E-UTRA transmission in TS 38.101-3 [4]

For UEs not supporting dynamic power sharing the following

- for the MCG,

$$A\text{-MPR}_c = \text{MAX}(A\text{-MPR}_{\text{single,E-UTRA}} + \text{MPR}_{\text{single,E-UTRA}}, A\text{-MPR}_{\text{IM3}}, A\text{-MPR}_{\text{ACLROverlap}})$$

- for the SCG,

$$A\text{-MPR}'_c = \text{MAX}(A\text{-MPR}_{\text{single,NR}}, A\text{-MPR}_{\text{IM3}}, A\text{-MPR}_{\text{ACLROverlap}})$$

where

- $A\text{-MPR}_{\text{single,E-UTRA}}$  is the A-MPR defined for the E-UTRA transmission in TS 36.101 [5]
- $A\text{-MPR}_{\text{single,NR}}$  is the A-MPR defined for the NR transmission in TS 38.101-1 [2]
- $\text{MPR}_{\text{single,E-UTRA}}$  is the MPR defined for the E-UTRA transmission in TS 36.101 [5]

The UE determines the Channel Configuration Case and the value of  $A\text{-MPR}_{\text{IM3}}$  as follows:

$$\text{If } \text{AND}(F_{\text{IM3,low\_block,high}} < F_{\text{filter,low}}, \text{MAX}(\text{SEM}_{-13,\text{high}}, F_{\text{IM3,high\_block,low}}) > F_{\text{filter,high}})$$

Channel Configuration Case C.  $A\text{-MPR}_{\text{IM3}}$  defined in Clause 6.2B.3.1.3.2.1

Else

Channel Configuration Case D.  $A\text{-MPR}_{\text{IM3}}$  defined in Clause 6.2B.3.1.3.2.2

where

- $F_{\text{IM3,low\_block,high}} = (2 * F_{\text{low\_channel,high\_edge}}) - F_{\text{high\_channel,low\_edge}}$
- $F_{\text{IM3,high\_block,low}} = (2 * F_{\text{high\_channel,low\_edge}}) - F_{\text{low\_channel,high\_edge}}$
- $F_{\text{low\_channel,low\_edge}}$  is the lowermost frequency of lower transmission bandwidth configuration.
- $F_{\text{low\_channel,high\_edge}}$  is the uppermost frequency of lower transmission bandwidth configuration.
- $F_{\text{high\_channel,low\_edge}}$  is the lowermost frequency of upper transmission bandwidth configuration.
- $F_{\text{high\_channel,high\_edge}}$  is the uppermost frequency of upper transmission bandwidth configuration.
- $F_{\text{filter,low}} = 2480$  MHz
- $F_{\text{filter,high}} = 2745$  MHz
- $\text{SEM}_{-13,\text{high}} =$  Threshold frequency where upper spectral emission mask for upper channel drops from -13 dBm / 1MHz to -25 dBm / 1MHz, as specified in Clause 6.6.2.2.2 in [5] and Subclause 6.5.2.3.2 in [2] respectively.

Where the transmission bandwidth configuration for NR is the maximum frequency span covering all the configured SCSSpecificCarrier for scenarios that carrier bandwidths with different SCS can be fully overlapped.

The UE determines the value of  $A\text{-MPR}_{\text{ACLROverlap}}$  as specified in Table 6.2B.3.2.3.1-1:

**Table 6.2B.3.2.3.1-1:  $A\text{-MPR}_{\text{ACLROverlap}}$**

$W_{\text{gap}}$	$A\text{-MPR}_{\text{ACLROverlap}}$
$< BW_{\text{channel,E-UTRA}} + BW_{\text{channel,NR}}$	4 dB
$\geq BW_{\text{channel,E-UTRA}} + BW_{\text{channel,NR}}$	0 dB
NOTE 1: $W_{\text{gap}} = F_{\text{high\_channel,low\_edge}} - F_{\text{low\_channel,high\_edge}}$	

6.2B.3.2.4 Test description

6.2B.3.2.4.1 Initial conditions

Initial conditions are a set of test configurations the UE needs to be tested in and the steps for the SS to take with the UE to reach the correct measurement state.

The initial test configurations consist of environmental conditions, test frequencies, test channel bandwidths and sub-carrier spacing based on NR operating bands specified in table 5.5B.3-1. All of these configurations shall be tested with applicable test parameters for each combination of test channel bandwidth and sub-carrier spacing, and are shown in test configuration table 6.2B.3.1.4.1-1 through 6.2B.3.1.4.1-2 with additional IM3 test frequencies for NS\_04 in 6.2B.3.2.4.1-1. The details of the uplink reference measurement channels (RMCs) are specified in Annex A, clause A.2.2 for E-UTRA RMC for TDD, TS 36.521-1 [10] Annex A, clause A.2.2 for E-UTRA RMC for FDD, and TS 38.521-1 [8] Annex A, clause A.2 for NR RMC. Configurations of PDSCH and PDCCH before measurement are specified in Annex TS 36.521-1 [10] Annex C and in Annex C2 for LTE link and NR link respectively.

**Table 6.2B.3.2.4.1-0: E-UTRA test configuration table**

E-UTRA Test Parameters				
E-UTRA Channel Bandwidth	E-UTRA Test Frequency (Note 1)	Downlink	Uplink	
		N/A for A-MPR testing	Modulation	RB allocation
20 MHz	Low range and High range (Note 2)		QPSK	100
NOTE 1: E-UTRA Test Frequency as specified in TS 36.508 [6] clause 4.3.1				
NOTE 2: NR carrier shall be the outermost carrier during test.				

**Table 6.2B.3.2.4.1-1: Additional IM3 Test Frequencies for NS\_04 intra-band non-contiguous EN-DC**

Additional Initial Condition	
Additional IM3 Test Frequencies	if maximum $W_{\text{GAP}} > 88.4$ MHz, and SCS 15 kHz, 15 kHz NR raster then IM3 test frequencies as specified in Table 6.2B.3.2.4.1-2.  if maximum $W_{\text{GAP}} > 88.4$ MHz, and SCS 15 kHz, 30 kHz NR raster then IM3 test frequencies as specified in Table 6.2B.3.2.4.1-3.  if maximum $W_{\text{GAP}} > 88.4$ MHz, and SCS 15 kHz, 60 kHz NR raster then IM3 test frequencies as specified in Table 6.2B.3.2.4.1-4.

Table 6.2B.3.2.4.1-2: EN-DC combination DC\_41A\_n41A, intra-band non-contiguous, SCS 15 kHz, 15 kHz NR raster, IM3 test frequencies

EN-DC channel bandwidth combination	CC	Bandwidth [MHz]	carrierBandwidth [PRBs]	Range		Carrier centre [MHz] Note 2	Carrier centre [ARFCN]	point A [MHz]	absolute FrequencyPoint A [ARFCN]	offsetTo Carrier [Carrier PRBs]	SS block SCS [kHz]	GSC N	absoluteF requency SSB [ARFCN]
				Downlink & Uplink	IM3								
E-UTRA: 20MHz + NR: 40MHz	E-UTRA CC1	20	100	Downlink & Uplink	IM3	2666.700	41357	-	-	-	-	-	-
	NR CC1	40	216	Downlink & Uplink	IM3	2548.300	509660	2528.86	505772	0	15	6327	509660
NR: 40MHz + E-UTRA: 20MHz	E-UTRA CC1	20	100	Downlink & Uplink	IM3	2558.300	40273	-	-	-	-	-	-
	NR CC1	40	216	Downlink & Uplink	IM3	2676.700	535340	2657.26	531452	0	15	6648	535340
E-UTRA: 20MHz + NR: 50MHz	E-UTRA CC1	20	100	Downlink & Uplink	IM3	2524.900	39939	-	-	-	-	-	-
	NR CC1	50	270	Downlink & Uplink	IM3	2665.000	533000	2640.7	528140	0	15	6606	533000
NR: 50MHz + E-UTRA: 20MHz	E-UTRA CC1	20	100	Downlink & Uplink	IM3	2666.700	41357	-	-	-	-	-	-
	NR CC1	50	270	Downlink & Uplink	IM3	2543.300	508660	2519	503800	0	15	6303	508660

Table 6.2B.3.2.4.1-3: EN-DC combination DC\_41A\_n41A, intra-band non-contiguous, SCS 30 kHz, 30 kHz NR raster, IM3 test frequencies

EN-DC channel bandwidth combination	CC	Bandwidth [MHz]	carrierBandwidth [PRBs]	Range		Carrier centre [MHz] Note 2	Carrier centre [ARFCN]	point A [MHz]	absolute FrequencyPoint A [ARFCN]	offsetTo Carrier [Carrier PRBs]	SS block SCS [kHz]	GSC N	absoluteFrequency SSB [ARFCN]
				Downlink & Uplink	IM3								
E-UTRA: 20MHz + NR: 40MHz	E-UTRA CC1	20	100	Downlink & Uplink	IM3	2666.700	41357	-	-	-	-	-	-
	NR CC1	40	106	Downlink & Uplink	IM3	2548.300	509660	2529.22	505844	0	30	6333	509660
NR: 40MHz + E-UTRA: 20MHz	E-UTRA CC1	20	100	Downlink & Uplink	IM3	2558.300	40273	-	-	-	-	-	-
	NR CC1	40	106	Downlink & Uplink	IM3	2676.700	535340	2657.62	531524	0	30	6654	535340
E-UTRA: 20MHz + NR: 50MHz	E-UTRA CC1	20	100	Downlink & Uplink	IM3	2524.900	39939	-	-	-	-	-	-
	NR CC1	50	133	Downlink & Uplink	IM3	2665.000	533000	2641.06	528212	0	30	6612	533000
NR: 50MHz + E-UTRA: 20MHz	E-UTRA CC1	20	100	Downlink & Uplink	IM3	2666.700	41357	-	-	-	-	-	-
	NR CC1	50	133	Downlink & Uplink	IM3	2543.300	508660	2519.36	503872	0	30	6309	508660

Table 6.2B.3.2.4.1-4: EN-DC combination DC\_41A\_n41A, intra-band non-contiguous, SCS 60 kHz, 15 kHz NR raster, IM3 test frequencies

EN-DC channel bandwidth combination	CC	Bandwidth [MHz]	carrierBandwidth [PRBs]	Range		Carrier centre [MHz] Note 2	Carrier centre [ARFCN]	point A [MHz]	absolute FrequencyPoint A [ARFCN]	offsetTo Carrier [Carrier PRBs]	SS block SCS [kHz]	GSC N	absoluteFrequency SSB [ARFCN]
				Downlink & Uplink	IM3								
E-UTRA: 20MHz + NR: 40MHz	E-UTRA CC1	20	100	Downlink & Uplink	IM3	2666.700	41357	-	-	-	-	-	-
	NR CC1	40	51	Downlink & Uplink	IM3	2548.300	509660	2529.94	505988	0	15	6330	509660
NR: 40MHz + E-UTRA: 20MHz	E-UTRA CC1	20	100	Downlink & Uplink	IM3	2558.300	40273	-	-	-	-	-	-
	NR CC1	40	51	Downlink & Uplink	IM3	2676.700	535340	2658.34	531668	0	15	6651	535340
E-UTRA: 20MHz + NR: 50MHz	E-UTRA CC1	20	100	Downlink & Uplink	IM3	2524.900	39939	-	-	-	-	-	-
	NR CC1	50	65	Downlink & Uplink	IM3	2665.000	535340	2653.3	530660	0	15	6639	535340
NR: 50MHz + E-UTRA: 20MHz	E-UTRA CC1	20	100	Downlink & Uplink	IM3	2666.700	41357	-	-	-	-	-	-
	NR CC1	50	65	Downlink & Uplink	IM3	2543.300	508660	2519.9	503980	0	15	6306	508660

Editor's note: The following lines belong at the end of clause 6.2B.3.2.4.1. As new tables are added to this clause, these lines should always follow the tables.

1. Connect the SS to the UE antenna connectors as shown in TS 38.508-1 [6] Annex A, Figure A.3.1.1.1 for TE diagram and clause A.3.2.1 for UE diagram.
2. The parameter settings for the cell are set up according to TS 38.508-1 [6] clause 4.4.3.
3. Downlink signals are initially set up according to TS 36.521-1 [10] Annex C.0 and TS 38.521-1 [8] Annex C.0 for E-UTRA CG and NR CG respectively, and uplink signals according to TS 36.521-1 [10] Annex H and TS 38.521-1 [8] Annex G for E-UTRA CG and NR CG respectively.
4. NR downlink signals are initially set up according to Annex C.0, C.1, and C.2 and uplink signals according to Annex G.0, G.1, G.2, and G.3.0 of TS 38.521-1 [8].
5. The UL Reference Measurement channels are set for LTE link and NR link respectively.
6. Propagation conditions are set according to TS 36.521-1 [10] Annex B.0 and TS 38.521-1 [8] Annex B.0 for E-UTRA CG and NR CG respectively.
7. Ensure the UE is in state RRC\_CONNECTED with generic procedure parameters Connectivity EN-DC, DC bearer *MCG* and *SCG*, Connected without release *On* according to TS 38.508-1 [6] clause 4.5. Message contents are defined in clause 6.2B.3.2.4.3.
8. When E-UTRA and NR bands are TDD, ensure the same uplink-downlink configuration by giving SCG a delay of 3 E-UTRA subframes, or by giving MCG a delay of 2 subframes.

#### 6.2B.3.2.4.2 Test procedure

1. SS sends uplink scheduling information for each UL HARQ process via PDCCH DCI format 0 and DCI format 0\_1 for C\_RNTI to schedule the UL RMC according to table 6.2B.3.2.4.1-1 on both EN-DC component carriers. Since the UL has no payload and no loopback data to send the UE sends uplink MAC padding bits on the UL RMC.
2. Send continuously uplink power control "up" commands to the UE for NR and E-UTRA carrier until the UE transmits at its  $P_{UMAX}$  level; allow at least 200 ms starting from the first TPC command in this step for the UE to reach  $P_{UMAX}$  level.
3. Measure the mean power over all component carriers for the EN-DC configuration, which shall meet the requirements described in table 6.2B.3.2.5-1. The period of the measurement shall be at least the continuous duration of one sub-frame (1ms).

NOTE 1: When switching to DFT-s-OFDM waveform, as specified in the test configuration table 6.2B.3.1.4.1-2, send an NR RRCReconfiguration message according to TS 38.508-1 [6] clause 4.6.3 Table 4.6.3-118 PUSCH-Config with TRANSFORM\_PRECODER\_ENABLED condition.

#### 6.2B.3.2.4.3 Message contents

Message contents are according to TS 38.508-1 [6] clause 4.6.1, with the following exceptions.

**Table 6.2B.3.2.4.3-1: RRCConnectionReconfiguration: nr-Config-r15**

Derivation Path: TS 36.508 [11], Table 4.6.1-8			
Information Element	Value/remark	Comment	Condition
p-MaxEUTRA-r15	23		Apply if run test points with E-UTRA UL transmission not overlapping with NR UL transmission in time for PC3 UE
	20		Apply if run test points with E-UTRA UL transmission overlapping with NR UL transmission in time for PC3 UE, and UE doesn't support dynamic power sharing.
P-Max	23		Apply if run test points with E-UTRA UL transmission not overlapping with NR UL transmission in time for PC3 UE
	20		Apply if run test points with E-UTRA UL transmission overlapping with NR UL transmission in time for PC3 UE, and UE doesn't support dynamic power sharing.

**6.2B.3.2.4.3-2: SystemInformationBlockType1: tdd-Config if E-UTRA on TDD band**

Derivation Path: TS 36.508 [11], Table 4.6.3-23			
Information Element	Value/remark	Comment	Condition
TDD-Config-DEFAULT ::= SEQUENCE {		Operating on TDD band	
subframeAssignment	sa2		
specialSubframePatterns	ssp7		
}			

**Table 6.2B.3.2.4.3-3: RRCConnectionReconfiguration: tdm-PatternConfig if E-UTRA on FDD band and UE does not support dynamic power sharing**

Derivation Path: TS 36.508 [11], Table 4.6.1-8			
Information Element	Value/remark	Comment	Condition
tdm-PatternConfig-r15 CHOICE{			Apply if run test points with E-UTRA UL transmission not overlapping with NR UL transmission in time for PC3 UE
setup SEQUENCE {			
subframeAssignment-r15	sa2		
harq-Offset-r15	0		
}			
}			

NOTE 1: Applies when E-UTRA UL transmission not overlapping with NR UL transmission in time.



## 6.2B.3.2.4.3.1 Message contents exceptions (network signalled value "NS\_04")

For "NS\_04" see A-MPR test case in table 6.2B.3.1.4.3.1-1 and table 6.2B.3.1.4.3.1-2.

## 6.2B.3.2.5 Test requirement

The maximum output power, derived in step 3 shall be within the range prescribed by the nominal maximum output power and tolerance in Table 6.2B.3.2.5-0 to Table 6.2B.3.2.5-2a. The allowed A-MPR values specified in Table 6.2B.3.2.3-1 are in addition to the allowed MPR requirements specified in clause 6.2B.1.1.3. For the UE maximum output power modified by MPR and/or A-MPR, the power limits specified in Table 6.2B.1.1.3-1 apply.

**Table 6.2B.3.2.5-0: Test Tolerance for UE maximum output power (LTE, NR TX separately)**

Uplink TX		$f \leq 3.0\text{GHz}$	$3.0\text{GHz} < f \leq 4.2\text{GHz}$	$4.2\text{GHz} < f \leq 6\text{GHz}$
LTE	$\text{BW} \leq 20\text{MHz}$	0.7 dB	1.0 dB	N/A
NR	$\text{BW} \leq 40\text{MHz}$	0.7 dB	1.0 dB	1.0 dB
	$40\text{MHz} < \text{BW} \leq 100\text{MHz}$	1.0 dB	1.0 dB	1.0 dB

**Table 6.2B.3.2.5-1: UE Power Class 3 test requirements for network signalled value "NS\_04"**

Test ID	Modulation	$\Delta P_{PowerClass}$ (dB)	MPR (dB)	A-MPR (dB)	A-MPR <sub>EN-DC</sub> (dB)	A-MPR <sub>c</sub> (dB)	$\Delta TC_{,c}$ (dB) Note 7	$P_{CMAX,c}$ (dBm)	$T(P_{CMAX,L,f,c})$ (dB)	$T_{L,c}$ (dB)	Upper limit	Lower limit
1, 8, 15, 22, 25, 28, 35, 42 and 45	E-UTRA Note 1	0	2	0	6	6	0 (1.5)	17 (15.5)	5 (5)	2 (3.5)	25+TT	12-TT (10.5-TT)
1, 8, 15, 22, 25, 28, 35, 42 and 45	E-UTRA Note 2	0	2	0	11	11	0 (1.5)	12 (10.5)	6 (6)	2 (3.5)	25+TT	6-TT (4.5-TT)
1, 8, 15, 22, 25, 28, 35, 42 and 45	NR, Note 1	0	-	Note 5	6	6	0 (1.5)	17 (15.5)	5 (5)	2 (3.5)	25+TT	12-TT (10.5-TT)
1, 8, 15, 22, 25, 28, 35, 42 and 45	NR, Note 2	0	-	Note 5	11	11	0 (1.5)	12 (10.5)	6 (6)	2 (3.5)	25+TT	6-TT (4.5-TT)
2, 5, 9, 16, 19, 23, 24, 26, 27, 29, 32, 36, 39, 43, 44, 46, and 47	E-UTRA Note 1, 3	0	1	Note 6	14	14	0 (1.5)	9 (7.5)	6 (7)	2 (3.5)	25+TT	3-TT (0.5-TT)
2, 5, 9, 16, 19, 23, 24, 26, 27, 29, 32, 36, 39, 43, 44, 46, and 47	E-UTRA Note 1, 4	0	1	Note 6	9	9	0 (1.5)	14 (12.5)	5 (6)	2 (3.5)	25+TT	9-TT (6.5-TT)
2, 5, 9, 16, 19, 23, 24, 26, 27, 29, 32, 36, 39, 43, 44, 46, and 47	E-UTRA Note 2	0	1	Note 6	14	14	0 (1.5)	9 (7.5)	6	2 (3.5)	25+TT	3-TT (0.5-TT)
2, 5, 9, 16, 19, 23, 24, 26, 27, 29, 32, 36, 39, 43, 44, 46, and 47	NR Note 1, 3	0	-	Note 5	14	14	0 (1.5)	9 (7.5)	6 (7)	2 (3.5)	25+TT	3-TT (0.5-TT)
2, 5, 9, 16, 19, 23, 24, 26, 27, 29, 32, 36, 39, 43, 44, 46, and 47	NR Note 1, 4	0	-	Note 5	9	9	0 (1.5)	14 (12.5)	5 (6)	2 (3.5)	25+TT	9-TT (6.5-TT)

2, 5, 9, 16, 19, 23, 24, 26, 27, 29, 32, 36, 39, 43, 44, 46, and 47	NR Note 2	0	-	Note 5	11	11	0 (1.5)	9 (7.5)	6 (6)	2 (3.5)	25+TT	3-TT (0.5-TT)
3, 7, 10, 14, 17, 21, 30, 34, 37, 41	E-UTRA Note 1	0	1	Note 6	14	14	0 (1.5)	9 (7.5)	6 (7)	2 (3.5)	25+TT	3-TT (0.5-TT)
3, 7, 10, 14, 17, 21, 30, 34, 37 and 41	E-UTRA Note 2	0	1	Note 6	14	14	0 (1.5)	9 (7.5)	6 (7)	2 (3.5)	25+TT	3-TT (0.5-TT)
4	NR	0	0.5	Note 9	0	0	0 (1.5)	22.5 (21)	2 (2)	2 (3.5)	25+TT	20.5-TT (19-TT)
6	NR	0	0	Note 9	3.5	3.5	0 (1.5)	19.5 (18)	3.5 (4)	2 (3.5)	25+TT	16-TT (14-TT)
11	NR	0	1	Note 9	0	0	0 (1.5)	22 (20.5)	2 (2.5)	2 (3.5)	25+TT	20-TT (18-TT)
13	NR	0	0	Note 9	4	4	0 (1.5)	19 (17.5)	3.5 (5)	2 (3.5)	25+TT	15.5-TT (12.5-TT)
18	NR	0	2	Note 9	0	0	0 (1.5)	21 (19.5)	2 (3.5)	2 (3.5)	25+TT	19-TT (16-TT)
20	NR	0	0	Note 9	4	4	0 (1.5)	19 (17.5)	3.5 (5)	2 (3.5)	25+TT	15.5-TT (12.5-TT)
31	NR	0	3	Note 9	0	0	0 (1.5)	20 (18.5)	2.5 (4)	2 (3.5)	25+TT	17.5-TT (14.5-TT)
33	NR	0	0	Note 9	5.5	5.5	0 (1.5)	17.5 (16)	5 (5)	2 (3.5)	25+TT	12-TT (11-TT)
38	NR	0	3	Note 9	0	0	0 (1.5)	20 (18.5)	2.5 (4)	2 (3.5)	25+TT	17.5-TT (14.5-TT)
40	NR	0	0	Note 9	5.5	5.5	0 (1.5)	17.5 (16)	5 (5)	2 (3.5)	25+TT	12-TT (11-TT)

NOTE 1: When  $F_{IM3,low\_block,low} \geq 2490.5$  MHz (Case A)

NOTE 2: When  $F_{IM3,low\_block,low} < 2490.5$  MHz (Case B)

NOTE 3: When NR SCS = 15kHz.

NOTE 4: When NR SCS = 30 kHz or 60 kHz.

NOTE 5: NR A-MPR values for NS\_04 are defined in Table 6.2.3.3.2-1.

NOTE 6: E-UTRA A-MPR= 3 dB for 1 RB and  $f_c < 2517.5$  MHz, otherwise 0 dB.

NOTE 7:  $\Delta T_{C,c} = 1.5$  dB for transmission bandwidths confined within  $F_{UL,low}$  and  $F_{UL,low} + 4$  MHz or  $F_{UL,high} - 4$  MHz and  $F_{UL,high}$ , otherwise 0 dB.

NOTE 8: TT for each frequency and channel bandwidth is specified in Table 6.2B.3.2.5-0.

NOTE 9: Apply for UE supporting dynamic power sharing. NR A-MPR values for NS\_04 are defined in TS 38.101-1 [2].

**Table 6.2B.3.2.5-2: UE Power Class 2 test requirements for network signalled value "NS\_04" (Rel-15 UE indicates PC2 on NR band, Rel-16 and forward UE reporting (PC2 by  $P_{\text{PowerClass,NR}}$ , and PC2 or Not present by *powerClassNRPart-r16*))**

Test ID	Modulation	$\Delta P_{\text{PowerClass}}$ (dB)	MPR (dB)	A-MPR (dB)	A-MPR <sub>EN-DC</sub> (dB)	A-MPR <sub>c</sub> (dB)	$\Delta T_{C,c}$ (dB) Note 7	$P_{\text{CMAX},c}$ (dBm)	$T(P_{\text{CMAX},L,f,c})$ (dB)	$T_{L,c}$ (dB)	Upper limit	Lower limit
1, 8, 15, 22, 25, 28, 35, 42 and 45	E-UTRA Note 1	3	2	0	6	6	0 (1.5)	17 (15.5)	5 (5)	2 (3.5)	28+TT	12-TT (10.5-TT)
1, 8, 15, 22, 25, 28, 35, 42 and 45	E-UTRA Note 2	3	2	0	11	11	0 (1.5)	12 (10.5)	6 (6)	2 (3.5)	28+TT	6-TT (4.5-TT)
1, 8, 15, 22, 25, 28, 35, 42 and 45	NR, Note 1	3	-	Note 5	6	6	0 (1.5)	17 (15.5)	5 (5)	2 (3.5)	28+TT	12-TT (10.5-TT)
1, 8, 15, 22, 25, 28, 35, 42 and 45	NR, Note 2	3	-	Note 5	11	11	0 (1.5)	12 (10.5)	6 (6)	2 (3.5)	28+TT	6-TT (4.5-TT)
2, 5, 9, 16, 19, 23, 24, 26, 27, 29, 32, 36, 39, 43, 44, 46, and 47	E-UTRA Note 1, 3	3	1	Note 6	14	14	0 (1.5)	9 (7.5)	6 (7)	2 (3.5)	28+TT	3-TT (0.5-TT)
2, 5, 9, 16, 19, 23, 24, 26, 27, 29, 32, 36, 39, 43, 44, 46, and 47	E-UTRA Note 1, 4	3	1	Note 6	9	9	0 (1.5)	14 (12.5)	5 (6)	2 (3.5)	28+TT	9-TT (6.5-TT)
2, 5, 9, 16, 19, 23, 24, 26, 27, 29, 32, 36, 39, 43, 44, 46, and 47	E-UTRA Note 2	3	1	Note 6	14	14	0 (1.5)	9 (7.5)	6	2 (3.5)	28+TT	3-TT (0.5-TT)
2, 5, 9, 16, 19, 23, 24, 26, 27, 29, 32, 36, 39, 43, 44, 46, and 47	NR Note 1, 3	3	-	Note 5	14	14	0 (1.5)	9 (7.5)	6 (7)	2 (3.5)	28+TT	3-TT (0.5-TT)
2, 5, 9, 16, 19, 23, 24, 26, 27, 29, 32, 36, 39, 43, 44, 46, and 47	NR Note 1, 4	3	-	Note 5	9	9	0 (1.5)	14 (12.5)	5 (6)	2 (3.5)	28+TT	9-TT (6.5-TT)

2, 5, 9, 16, 19, 23, 24, 26, 27, 29, 32, 36, 39, 43, 44, 46, and 47	NR Note 2	3	-	Note 5	11	11	0 (1.5)	9 (7.5)	6 (6)	2 (3.5)	28+TT	3-TT (0.5-TT)
3, 7, 10, 14, 17, 21, 30, 34, 37, 41	E-UTRA Note 1	0	1	Note 6	14	14	0 (1.5)	9 (7.5)	6 (7)	2 (3.5)	28+TT	3-TT (0.5-TT)
3, 7, 10, 14, 17, 21, 30, 34, 37 and 41	E-UTRA Note 2	0	1	Note 6	14	14	0 (1.5)	9 (7.5)	6 (7)	2 (3.5)	28+TT	3-TT (0.5-TT)
4	NR	0	3.5	Note 9	0	0	0 (1.5)	22.5 (21)	2 (2)	2 (3.5)	28+TT	20.5-TT (19-TT)
6	NR	0	0	Note 9	5.5	5.5	0 (1.5)	20.5 (19)	2.5 (3.5)	2 (3.5)	28+TT	18-TT (15.5-TT)
11	NR	0	3.5	Note 9	0	0	0 (1.5)	22.5 (21)	2 (2)	2 (3.5)	28+TT	20.5-TT (19-TT)
13	NR	0	0	Note 9	6	6	0 (1.5)	20 (18.5)	2.5 (4)	2 (3.5)	28+TT	17.5-TT (14.5-TT)
18	NR	0	3.5	Note 9	0	0	0 (1.5)	22.5 (21)	2 (2)	2 (3.5)	28+TT	20.5-TT (19-TT)
20	NR	0	0	Note 9	6	6	0 (1.5)	20 (18.5)	2.5 (4)	2 (3.5)	28+TT	17.5-TT (14.5-TT)
31	NR	0	3.5	Note 9	0	0	0 (1.5)	22.5 (21)	2 (2)	2 (3.5)	28+TT	20.5-TT (19-TT)
33	NR	0	0	Note 9	7.5	7.5	0 (1.5)	18.5 (17)	4 (5)	2 (3.5)	28+TT	14.5-TT (12-TT)
38	NR	0	3.5	Note 9	0	0	0 (1.5)	22.5 (21)	2 (2)	2 (3.5)	28+TT	20.5-TT (19-TT)
40	NR	0	0	Note 9	7.5	7.5	0 (1.5)	18.5 (17)	4 (5)	2 (3.5)	28+TT	14.5-TT (12-TT)

NOTE 1: When  $F_{IM3,low\_block,low} \geq 2490.5$  MHz (Case A).

NOTE 2: When  $F_{IM3,low\_block,low} < 2490.5$  MHz (Case B).

NOTE 3: When NR SCS = 15kHz.

NOTE 4: When NR SCS = 30 kHz or 60 kHz.

NOTE 5: NR A-MPR values for NS\_04 are defined in Table 6.2.3.3.2-1.

NOTE 6: E-UTRA A-MPR= 3 dB for 1 RB and  $f_c < 2517.5$  MHz, otherwise 0 dB.

NOTE 7:  $\Delta T_{C,c} = 1.5$  dB for transmission bandwidths confined within  $F_{UL,low}$  and  $F_{UL,low} + 4$  MHz or  $F_{UL,high} - 4$  MHz and  $F_{UL,high}$ , otherwise 0 dB.

NOTE 8: TT for each frequency and channel bandwidth is specified in Table 6.2B.3.2.5-0.

NOTE 9: Apply for UE supporting dynamic power sharing. NR A-MPR values for NS\_04 are defined in TS 38.101-1 [24].

**Table 6.2B.3.2.5-2a: UE Power Class 2 test requirements for network signalled value "NS\_04" (Rel-15 and forward UE indicates PC3 on NR band, Rel-16 and forward UE reporting (PC2 by  $P_{\text{PowerClass, NR}}$ , and PC3 by *powerClassNRPart-r16*))**



Test ID	Modulation	$\Delta P_{PowerClass}$ (dB)	MPR (dB)	A-MPR (dB)	A-MPR <sub>EN-DC</sub> (dB)	A-MPR <sub>c</sub> (dB)	$\Delta T_{C,c}$ (dB) Note 7	$P_{C_{MAX,c}}$ (dBm)	$T(P_{C_{MAX,L,f,c}})$ (dB)	$T_{L,c}$ (dB)	Upper limit	Lower limit
1, 8, 15, 22, 25, 28, 35, 42 and 45	E-UTRA Note 1	3	2	0	6	6	0 (1.5)	17 (15.5)	5 (5)	2 (3.5)	28+TT	12-TT (10.5-TT)
1, 8, 15, 22, 25, 28, 35, 42 and 45	E-UTRA Note 2	3	2	0	11	11	0 (1.5)	12 (10.5)	6 (6)	2 (3.5)	28+TT	6-TT (4.5-TT)
1, 8, 15, 22, 25, 28, 35, 42 and 45	NR, Note 1	3	-	Note 5	6	6	0 (1.5)	17 (15.5)	5 (5)	2 (3.5)	28+TT	12-TT (10.5-TT)
1, 8, 15, 22, 25, 28, 35, 42 and 45	NR, Note 2	3	-	Note 5	11	11	0 (1.5)	12 (10.5)	6 (6)	2 (3.5)	28+TT	6-TT (4.5-TT)
2, 5, 9, 16, 19, 23, 24, 26, 27, 29, 32, 36, 39, 43, 44, 46, and 47	E-UTRA Note 1, 3	3	1	Note 6	14	14	0 (1.5)	9 (7.5)	6 (7)	2 (3.5)	28+TT	3-TT (0.5-TT)
2, 5, 9, 16, 19, 23, 24, 26, 27, 29, 32, 36, 39, 43, 44, 46, and 47	E-UTRA Note 1, 4	3	1	Note 6	9	9	0 (1.5)	14 (12.5)	5 (6)	2 (3.5)	28+TT	9-TT (6.5-TT)
2, 5, 9, 16, 19, 23, 24, 26, 27, 29, 32, 36, 39, 43, 44, 46, and 47	E-UTRA Note 2	3	1	Note 6	14	14	0 (1.5)	9 (7.5)	6	2 (3.5)	28+TT	3-TT (0.5-TT)
2, 5, 9, 16, 19, 23, 24, 26, 27, 29, 32, 36, 39, 43, 44, 46, and 47	NR Note 1, 3	3	-	Note 5	14	14	0 (1.5)	9 (7.5)	6 (7)	2 (3.5)	28+TT	3-TT (0.5-TT)
2, 5, 9, 16, 19, 23, 24, 26, 27, 29, 32, 36, 39, 43, 44, 46, and 47	NR Note 1, 4	3	-	Note 5	9	9	0 (1.5)	14 (12.5)	5 (6)	2 (3.5)	28+TT	9-TT (6.5-TT)

2, 5, 9, 16, 19, 23, 24, 26, 27, 29, 32, 36, 39, 43, 44, 46, and 47	NR Note 2	3	-	Note 5	11	11	0 (1.5)	9 (7.5)	6 (6)	2 (3.5)	28+TT	3-TT (0.5-TT)
3, 7, 10, 14, 17, 21, 30, 34, 37, 41	E-UTRA Note 1	3	1	Note 6	14	14	0 (1.5)	9 (7.5)	6 (7)	2 (3.5)	28+TT	3-TT (0.5-TT)
3, 7, 10, 14, 17, 21, 30, 34, 37 and 41	E-UTRA Note 2	3	1	Note 6	14	14	0 (1.5)	9 (7.5)	6 (7)	2 (3.5)	28+TT	3-TT (0.5-TT)
4	NR	0	0.5	Note 9	0	0	0 (1.5)	22.5 (21)	2 (2)	2 (3.5)	25+TT	20.5-TT (19-TT)
6	NR	0	0	Note 9	3.5	3.5	0 (1.5)	19.5 (18)	3.5 (4)	2 (3.5)	25+TT	16-TT (14-TT)
11	NR	0	1	Note 9	0	0	0 (1.5)	22 (20.5)	2 (2.5)	2 (3.5)	25+TT	20-TT (18-TT)
13	NR	0	0	Note 9	4	4	0 (1.5)	19 (17.5)	3.5 (5)	2 (3.5)	25+TT	15.5-TT (12.5-TT)
18	NR	0	2	Note 9	0	0	0 (1.5)	21 (19.5)	2 (3.5)	2 (3.5)	25+TT	19-TT (16-TT)
20	NR	0	0	Note 9	4	4	0 (1.5)	19 (17.5)	3.5 (5)	2 (3.5)	25+TT	15.5-TT (12.5-TT)
31	NR	0	3	Note 9	0	0	0 (1.5)	20 (18.5)	2.5 (4)	2 (3.5)	25+TT	17.5-TT (14.5-TT)
33	NR	0	0	Note 9	5.5	5.5	0 (1.5)	17.5 (16)	5 (5)	2 (3.5)	25+TT	12-TT (11-TT)
38	NR	0	3	Note 9	0	0	0 (1.5)	20 (18.5)	2.5 (4)	2 (3.5)	25+TT	17.5-TT (14.5-TT)
40	NR	0	0	Note 9	5.5	5.5	0 (1.5)	17.5 (16)	5 (5)	2 (3.5)	25+TT	12-TT (11-TT)

NOTE 1: When  $F_{IM3,low\_block,low} \geq 2490.5$  MHz (Case A).

NOTE 2: When  $F_{IM3,low\_block,low} < 2490.5$  MHz (Case B).

NOTE 3: When NR SCS = 15kHz.

NOTE 4: When NR SCS = 30 kHz or 60 kHz.

NOTE 5: NR A-MPR values for NS\_04 are defined in Table 6.2.3.3.2-1.

NOTE 6: E-UTRA A-MPR= 3 dB for 1 RB and  $f_c < 2517.5$  MHz, otherwise 0 dB.

NOTE 7:  $\Delta T_{C,c} = 1.5$  dB for transmission bandwidths confined within  $F_{UL,low}$  and  $F_{UL,low} + 4$  MHz or  $F_{UL,high} - 4$  MHz and  $F_{UL,high}$ , otherwise 0 dB.

NOTE 8: TT for each frequency and channel bandwidth is specified in Table 6.2B.3.2.5-0.

NOTE 9: Apply for UE supporting dynamic power sharing. NR A-MPR values for NS\_04 are defined in TS 38.101-1 [2].

### 6.2B.3.3 UE Additional Maximum Output Power reduction for Inter-Band EN-DC within FR1 (1 NR CC)

#### 6.2B.3.3.1 Test purpose

Same test purpose as in clause 6.2.3.1 in TS 38.521-1 [8] for the NR carrier.

### 6.2B.3.3.2 Test applicability

The requirements of this test apply to all types of E-UTRA UE release 15 and forward, supporting inter-band EN-DC within FR1 with 1 NR UL CC.

NOTE: Test execution is not necessary if clause 6.5B.2.3.2, 6.5B.2.3.3.2 and 6.5B.4.3 are executed since A-MPR requirements are verified in these test cases.

### 6.2B.3.3.3 Minimum conformance requirements

For inter-band EN-DC between E-UTRA and NR FR1, UE additional maximum output power reduction specified in TS 36.101 [5] and TS 38.101-1 [2] apply for E-UTRA and NR respectively.

The normative reference for this requirement is TS 38.101-3 [4] clause 6.2B.3.3.

No exception requirements applicable to NR or E-UTRA. LTE anchor agnostic approach is applied

### 6.2B.3.3.4 Test description

Same test description as in clause 6.2.3.4 in TS 38.521-1 [8] for the NR carrier with the following exceptions:

The initial test configurations for E-UTRA band consist of environmental conditions, test frequencies, and channel bandwidths based on E-UTRA bands specified in Table 4.6-1.

For Initial conditions as in clause 6.2.3.4.1 in TS 38.521-1 [8], the following steps will be added to configure E-UTRA component:

- 2.1. The parameter settings for the E-UTRA cell are set up according to TS 36.508 [11] clause 4.4.3 with E-UTRA channel bandwidth and test frequencies defined in Table 6.2B.3.3.4-1.
- 3.1. Downlink E-UTRA signals are initially set up according to TS 36.521-1 [10] Annex C0, C.1 and C.3.0, and uplink signals according to Annex H.1 and H.3.0.
- 4.1. The E-UTRA UL Reference Measurement channels are set according to Table 6.2B.3.3.4-1.

Step 6 of Initial conditions as in clause 6.2.3.4.1 in TS 38.521-1 [8] is replaced by the following two steps:

6. Ensure the UE is in state RRC\_CONNECTED with generic procedure parameters Connectivity EN-DC, DC bearer MCG and SCG, Connected without release *On* according to TS 38.508-1 [6] clause 4.5.
7. On the E-UTRA carrier, disable periodic and aperiodic CQI reports, disable SRS, set *TimeAlignmentTimerDedicated* IE to infinity and disable downlink and uplink scheduling, all as per Table 4.6-1 under clause 4.6. Same test procedure as in clause 6.2.3.4.2 in TS 38.521-1 [8].

### 6.2B.3.3.5 Test requirement

For PC3 UE, same test requirement as in clause 6.2.2.5 in TS 38.521-1 [8].

For PC2 UE (Rel-15 UE indicates PC2 on NR band, Rel-16 and forward UE reporting (PC2 by  $P_{PowerClass,NR}$ , and PC2 or Not present by *powerClassNRPart-r16*)), same test requirement for PC2 UE as in clause 6.2.3.5 in TS 38.521-1 [8]. For PC2 UE (Rel-15 and forward UE indicates PC3 on NR band, Rel-16 and forward UE reporting (PC2 by  $P_{PowerClass,NR}$ , and PC3 by *powerClassNRPart-r16*)), same test requirement for PC3 UE as in clause 6.2.3.5 in TS 38.521-1 [8].

## 6.2B.3.4 UE Additional Maximum Output Power reduction for Inter-Band EN-DC including FR2 (1 NR CC)

### 6.2B.3.4.1 Test purpose

Same test purpose as in clause 6.2.3.1 in TS 38.521-2 [9] for the NR carrier.

## 6.2B.3.4.2 Test applicability

This test case applies to all types of E-UTRA UE release 15 and forward, supporting inter-band EN-DC including FR2 with 1 NR UL CC.

## 6.2B.3.4.3 Minimum conformance requirements

Same minimum conformance requirements as in clause 6.2.2.3 in TS 38.521-2 [9] for the NR carrier.

No exception requirements applicable to NR or E-UTRA. LTE anchor agnostic approach is applied.

## 6.2B.3.4.4 Test description

## 6.2B.3.4.4.1 Initial conditions

Same test description as in clause 6.2.3.4 in TS 38.521-2 [9] for the NR carrier with the following exception:

The initial test configurations for E-UTRA band consist of environmental conditions, test frequencies, and channel bandwidths based on E-UTRA bands specified in Table 4.7-1. For Initial conditions as in clause 6.2.3.4.1 in TS 38.521-2 [9], the following steps will be added to configure E-UTRA component:

- 2.1. The parameter settings for E-UTRA cell are set up according to TS 36.508 [11] clause 4.4.3.
- 3.1. The E-UTRA downlink signal level, uplink signal level are set according to Table 4.7-1 and propagation conditions are set according to Annex B.0 of TS 36.521-1 [10].

Step 6 of Initial conditions as in clause 6.2.3.4.1 in TS 38.521-2 [9] is replaced by:

6. Ensure the UE is in state RRC\_CONNECTED with generic procedure parameters Connectivity EN-DC, DC bearer MCG and SCG, Connected without release On according to TS 38.508-1 [6] clause 4.5.

## 6.2B.3.4.4.2 Test procedure

Same test procedure as in clause 6.2.3.4.2 in TS 38.521-2 [9] with the following steps added for E-UTRA component:

- 1.1 On the E-UTRA carrier, disable periodic and aperiodic CQI reports, disable SRS, set *TimeAlignmentTimerDedicated* IE to infinity and disable downlink and uplink scheduling, all as per Table 4.7-1 under clause 4.7.

## 6.2B.3.4.4.3 Message contents

Message contents are according to TS 38.508-1 [5] clause 4.6 with the following exceptions for each network signalled value.

1. Information element *AdditionalSpectrumEmission* for NR can be set in *nr-SecondaryCellGroupConfig* according to TS 38.331 [15]. This exception indicates that the UE shall meet the additional spurious emission requirement for a specific deployment scenario.

**Table 6.2B.3.4.4.3-1: AdditionalSpectrumEmission: Additional spurious emissions test requirement**

Derivation Path: TS 38.508-1 [5] clause 4.6.3, Table 4.6.3-1			
Information Element	Value/remark	Comment	Condition
AdditionalSpectrumEmission	1 (NS_202)	for band n257	
AdditionalSpectrumEmission	2 (NS_202)	for band n258	
AdditionalSpectrumEmission	3 (NS_203)	for band n258	

## 6.2B.3.4.5 Test requirement

Same test requirement as in clause 6.2.3.5 in TS 38.521-2 [9] for the NR carrier.

### 6.2B.3.4\_1 UE Additional Maximum Output power reduction for inter-band EN-DC including FR2 (> 1 NR CC)

#### 6.2B.3.4\_1.1 UE Additional Maximum Output power reduction for inter-band EN-DC including FR2 (2 NR CCs)

##### 6.2B.3.4\_1.1.1 Test purpose

Same test purpose as in clause 6.2A.3.1.1 in TS 38.521-2 [9] for the NR carrier.

##### 6.2B.3.4\_1.1.2 Test applicability

This test case applies to all types of E-UTRA UE release 15 and forward, supporting inter-band EN-DC including FR2 with 2 NR UL CCs.

##### 6.2B.3.4\_1.1.3 Minimum conformance requirements

UE additional maximum output power reduction requirement for E-UTRA single carrier and CA operation specified in clauses 6.2.4 and 6.2.4A of TS 36.101 [5] and for NR single carrier, CA operation and UL-MIMO specified in clause 6.2.3, 6.2A.3 and 6.2D.3 of TS 38.101-2 [3] apply.

The normative reference for this requirement is TS 38.101-3 [4] clause 6.2B.3.4.

Same minimum conformance requirements as in clause 6.2A.3.1.3 in TS 38.521-2 [9] for the NR carrier.

No exception requirements applicable to NR or E-UTRA. LTE anchor agnostic approach is applied.

##### 6.2B.3.4\_1.1.4 Test description

Same test description as in clause 6.2A.3.1.4 in TS 38.521-2 [9] for the NR carrier with the following exception:

The initial test configurations for E-UTRA band consist of environmental conditions, test frequencies, and channel bandwidths based on E-UTRA bands specified in Table 4.7-1.

For Initial conditions as in clause 6.2A.3.1.4.1 in TS 38.521-2 [9], the following steps will be added to configure E-UTRA component:

- 2.1. The parameter settings for E-UTRA cell are set up according to TS 36.508 [11] clause 4.4.3.
- 3.1. The E-UTRA downlink signal level, uplink signal level are set according to Table 4.7-1 and propagation conditions are set according to Annex B.0 of TS 36.521-1 [10].

Step 6 of Initial conditions as in clause 6.2A.3.1.4.1 in TS 38.521-2 [9] is replaced by:

6. Ensure the UE is in state RRC\_CONNECTED with generic procedure parameters Connectivity EN-DC, DC bearer MCG and SCG, Connected without release On according to TS 38.508-1 [6] clause 4.5.

Same test procedure as in clause 6.2A.3.1.4.2 in TS 38.521-2 [9] with the following steps added for E-UTRA component:

- 1.1 On the E-UTRA carrier, disable periodic and aperiodic CQI reports, disable SRS, set *TimeAlignmentTimerDedicated* IE to infinity and disable downlink and uplink scheduling, all as per Table 4.7-1 under clause 4.7.

##### 6.2B.3.4\_1.1.5 Test requirement

Same test requirement as in clause 6.2A.3.1.5 in TS 38.521-2 [9] for the NR carrier.

## 6.2B.3.4\_1.2 UE Additional Maximum Output power reduction for inter-band EN-DC including FR2 (3 NR CCs)

### 6.2B.3.4\_1.2.1 Test purpose

Same test purpose as in clause 6.2A.3.2.1 in TS 38.521-2 [9] for the NR carrier.

### 6.2B.3.4\_1.2.2 Test applicability

This test case applies to all types of E-UTRA UE release 15 and forward, supporting inter-band EN-DC including FR2 with 3 NR UL CCs.

### 6.2B.3.4\_1.2.3 Minimum conformance requirements

UE additional maximum output power reduction requirement for E-UTRA single carrier and CA operation specified in clauses 6.2.4 and 6.2.4A of TS 36.101 [5] and for NR single carrier, CA operation and UL-MIMO specified in clause 6.2.3, 6.2A.3 and 6.2D.3 of TS 38.101-2 [3] apply.

The normative reference for this requirement is TS 38.101-3 [4] clause 6.2B.3.4.

Same minimum conformance requirements as in clause 6.2A.3.2.3 in TS 38.521-2 [9] for the NR carrier.

No exception requirements applicable to NR or E-UTRA. LTE anchor agnostic approach is applied.

### 6.2B.3.4\_1.2.4 Test description

Same test description as in clause 6.2A.3.2.4 in TS 38.521-2 [9] for the NR carrier with the following exception:

The initial test configurations for E-UTRA band consist of environmental conditions, test frequencies, and channel bandwidths based on E-UTRA bands specified in Table 4.7-1.

For Initial conditions as in clause 6.2A.3.2.4.1 in TS 38.521-2 [9], the following steps will be added to configure E-UTRA component:

- 2.1. The parameter settings for E-UTRA cell are set up according to TS 36.508 [11] clause 4.4.3.
- 3.1. The E-UTRA downlink signal level, uplink signal level are set according to Table 4.7-1 and propagation conditions are set according to Annex B.0 of TS 36.521-1 [10].

Step 6 of Initial conditions as in clause 6.2A.3.2.4.1 in TS 38.521-2 [9] is replaced by:

6. Ensure the UE is in state RRC\_CONNECTED with generic procedure parameters Connectivity EN-DC, DC bearer MCG and SCG, Connected without release On according to TS 38.508-1 [6] clause 4.5.

Same test procedure as in clause 6.2A.3.2.4.2 in TS 38.521-2 [9] with the following steps added for E-UTRA component:

- 1.1 On the E-UTRA carrier, disable periodic and aperiodic CQI reports, disable SRS, set *TimeAlignmentTimerDedicated* IE to infinity and disable downlink and uplink scheduling, all as per Table 4.7-1 under clause 4.7.

### 6.2B.3.4\_1.2.5 Test requirement

Same test requirement as in clause 6.2A.3.2.5 in TS 38.521-2 [9] for the NR carrier.

## 6.2B.3.4\_1.3 UE Additional Maximum Output power reduction for inter-band EN-DC including FR2 (4 NR CCs)

### 6.2B.3.4\_1.3.1 Test purpose

Same test purpose as in clause 6.2A.3.3.1 in TS 38.521-2 [9] for the NR carrier.

#### 6.2B.3.4\_1.3.2 Test applicability

This test case applies to all types of E-UTRA UE release 15 and forward, supporting inter-band EN-DC including FR2 with 3 NR UL CCs.

#### 6.2B.3.4\_1.3.3 Minimum conformance requirements

UE additional maximum output power reduction requirement for E-UTRA single carrier and CA operation specified in clauses 6.2.4 and 6.2.4A of TS 36.101 [5] and for NR single carrier, CA operation and UL-MIMO specified in clause 6.2.3, 6.2A.3 and 6.2D.3 of TS 38.101-2 [3] apply.

The normative reference for this requirement is TS 38.101-3 [4] clause 6.2B.3.4.

Same minimum conformance requirements as in clause 6.2A.3.3.3 in TS 38.521-2 [9] for the NR carrier.

No exception requirements applicable to NR or E-UTRA. LTE anchor agnostic approach is applied.

#### 6.2B.3.4\_1.3.4 Test description

Same test description as in clause 6.2A.3.3.4 in TS 38.521-2 [9] for the NR carrier with the following exception:

The initial test configurations for E-UTRA band consist of environmental conditions, test frequencies, and channel bandwidths based on E-UTRA bands specified in Table 4.7-1.

For Initial conditions as in clause 6.2A.3.3.4.1 in TS 38.521-2 [9], the following steps will be added to configure E-UTRA component:

- 2.1. The parameter settings for E-UTRA cell are set up according to TS 36.508 [11] clause 4.4.3.
- 3.1. The E-UTRA downlink signal level, uplink signal level are set according to Table 4.7-1 and propagation conditions are set according to Annex B.0 of TS 36.521-1 [10].

Step 6 of Initial conditions as in clause 6.2A.3.3.4.1 in TS 38.521-2 [9] is replaced by:

6. Ensure the UE is in state RRC\_CONNECTED with generic procedure parameters Connectivity EN-DC, DC bearer MCG and SCG, Connected without release On according to TS 38.508-1 [6] clause 4.5.

Same test procedure as in clause 6.2A.3.3.4.2 in TS 38.521-2 [9] with the following steps added for E-UTRA component:

- 1.1 On the E-UTRA carrier, disable periodic and aperiodic CQI reports, disable SRS, set *TimeAlignmentTimerDedicated* IE to infinity and disable downlink and uplink scheduling, all as per Table 4.7-1 under clause 4.7.

#### 6.2B.3.4\_1.3.5 Test requirement

Same test requirement as in clause 6.2A.3.3.5 in TS 38.521-2 [9] for the NR carrier.

### 6.2B.3.4D UE Additional Maximum Output Power reduction for Inter-Band EN-DC including FR2 (1 NR CC) for UL MIMO

#### 6.2B.3.4D.1 Test purpose

Same test purpose as in clause 6.2D.3.1 in TS 38.521-2 [9] for the NR carrier.

#### 6.2B.3.4D.2 Test applicability

This test case applies to all types of E-UTRA UE release 15 and forward, supporting inter-band EN-DC including FR2 with 1 NR UL CC with UL MIMO.

#### 6.2B.3.4D.3 Minimum conformance requirements

Same minimum conformance requirements as in clause 6.2D.2.3 in TS 38.521-2 [9] for the NR carrier.

No exception requirements applicable to NR or LTE. LTE anchor agnostic approach is applied.

#### 6.2B.3.4D.4 Test description

##### 6.2B.3.4D.4.1 Initial conditions

Same test description as in clause 6.2D.3.4 in TS 38.521-2 [9] for the NR carrier with the following exception:

The initial test configurations for E-UTRA band consist of environmental conditions, test frequencies, and channel bandwidths based on E-UTRA bands specified in Table 4.7-1. For Initial conditions as in clause 6.2D.3.4.1 in TS 38.521-2 [9], the following steps will be added to configure E-UTRA component:

- 2.1. The parameter settings for E-UTRA cell are set up according to TS 36.508 [11] clause 4.4.3.
- 3.1. The E-UTRA downlink signal level, uplink signal level are set according to Table 4.7-1 and propagation conditions are set according to Annex B.0 of TS 36.521-1 [10].

Step 6 of Initial conditions as in clause 6.2D.3.4.1 in TS 38.521-2 [9] is replaced by:

6. Ensure the UE is in state RRC\_CONNECTED with generic procedure parameters Connectivity EN-DC, DC bearer MCG and SCG, Connected without release On according to TS 38.508-1 [6] clause 4.5.

##### 6.2B.3.4D.4.2 Test procedure

Same test procedure as in clause 6.2D.3.4.2 in TS 38.521-2 [9] with the following steps added for E-UTRA component:

- 1.1 On the E-UTRA carrier, disable periodic and aperiodic CQI reports, disable SRS, set *TimeAlignmentTimerDedicated* IE to infinity and disable downlink and uplink scheduling, all as per Table 4.7-1 under clause 4.7.

##### 6.2B.3.4D.4.3 Message contents

Message contents are according to TS 38.508-1 [5] clause 4.6 ensuring Table 4.6.3-182 with condition 2TX\_UL\_MIMO, with the following exceptions for each network signalled value.

1. Information element *AdditionalSpectrumEmission* for NR can be set in *nr-SecondaryCellGroupConfig* according to TS 38.331 [15]. This exception indicates that the UE shall meet the additional spurious emission requirement for a specific deployment scenario.

**Table 6.2B.3.4D.4.3-1: *AdditionalSpectrumEmission*: Additional spurious emissions test requirement**

Derivation Path: TS 38.508-1 [5] clause 4.6.3, Table 4.6.3-1			
Information Element	Value/remark	Comment	Condition
AdditionalSpectrumEmission	1 (NS_202)	for band n257	
AdditionalSpectrumEmission	2 (NS_202)	for band n258	
AdditionalSpectrumEmission	3 (NS_203)	for band n258	

##### 6.2B.3.4D.5 Test requirement

Same test requirement as in clause 6.2D.3.5 in TS 38.521-2 [9] for the NR carrier.

#### 6.2B.3.5 UE Additional Maximum Output power reduction for inter-band EN-DC including both FR1 and FR2

##### 6.2B.3.5.1 Test purpose

Same test purpose as in clause 6.2.3.1 in TS 38.521-1 [8] for NR FR1 carrier and clause 6.2.3.1 in TS 38.521-2 [9] for NR FR2 carrier.



### 6.2B.3.5.2 Test applicability

The requirements in this test are not testable due to issues with combined testing of NR FR1 and E-UTRA in conducted mode with NR FR2 in radiated mode. Therefore, the conducted and radiated requirements are tested separately.

No test case details are specified. The EN-DC requirements for Additional Maximum Output Power apply and are tested as part of the EN-DC within FR1 and EN-DC including FR2 test cases in clause 6.2B.3.

### 6.2B.3.5D UE Additional Maximum Output power reduction for inter-band EN-DC including both FR1 and FR2 for UL MIMO

#### 6.2B.3.5D.1 Test purpose

Same test purpose as in clause 6.2D.3.1 in TS 38.521-1 [8] for NR FR1 carrier(s) and clause 6.2D.3.1 in TS 38.521-2 [9] for NR FR2 carrier(s).

#### 6.2B.3.5D.2 Test applicability

The requirements in this test are not testable due to issues with combined testing of NR FR1 and E-UTRA in conducted mode with NR FR2 in radiated mode. Therefore, the conducted and radiated requirements are tested separately.

No test case details are specified. The EN-DC requirements for maximum output power apply and are tested as part of the EN-DC within FR1 and EN-DC including FR2 test cases in clause 6.2B.

## 6.2B.4 Configured Output Power for DC

### 6.2B.4.1 Configured Output Power Level for EN-DC

#### 6.2B.4.1.0 Minimum Conformance Requirements

##### 6.2B.4.1.0.1 Configured output power level

##### 6.2B.4.1.0.1.1 Intra-band contiguous EN-DC

The following requirements apply for one component carrier per CG configured for synchronous DC.

For intra-band dual connectivity with one uplink serving cell per CG on E-UTRA and NR respectively, the UE is allowed to set its configured maximum output power  $P_{\text{CMAX},c(i),i}$  for serving cell  $c(i)$  of CG  $i$ ,  $i = 1, 2$ , and its total configured maximum transmission power for EN-DC operation  $\hat{P}_{\text{total}}^{\text{EN-DC}} = 10\log_{10}(\hat{P}_{\text{total}}^{\text{EN-DC}})$  with  $\hat{P}_{\text{total}}^{\text{EN-DC}}$  as specified in clause 7.6 of TS 38.213 [19].

The configured maximum output power  $P_{\text{CMAX}_E\text{-UTRA},c}(p)$  in sub-frame  $p$  for the configured E-UTRA uplink carrier shall be set within the bounds:

$$P_{\text{CMAX}_L\text{-E-UTRA},c}(p) \leq P_{\text{CMAX}_E\text{-UTRA},c}(p) \leq P_{\text{CMAX}_H\text{-E-UTRA},c}(p)$$

where  $P_{\text{CMAX}_L\text{-E-UTRA},c}$  and  $P_{\text{CMAX}_H\text{-E-UTRA},c}$  are the limits for a serving cell  $c$  as specified in TS 36.101 [5] clause 6.2.5 modified by  $P_{\text{LTE}}$  as follows:

$$P_{\text{CMAX}_L\text{-E-UTRA},c} = \text{MIN} \{ \text{MIN}(P_{\text{EMAX},c}, P_{\text{EMAX,EN-DC}}, P_{\text{LTE}}) - \Delta t_{\text{C-E-UTRA},c}, (P_{\text{PowerClass,EN-DC}} - \Delta P_{\text{PowerClass,EN-DC}}), (P_{\text{PowerClass}} - \Delta P_{\text{PowerClass}}) - \text{MAX}(M\text{PR}_c + A\text{-MPR}_c + \Delta T_{\text{IB},c} + \Delta T_{\text{C-E-UTRA},c} + \Delta T_{\text{ProSe}}, P\text{-MPR}_c) \}$$

$$P_{\text{CMAX}_H\text{-E-UTRA},c} = \text{MIN} \{ P_{\text{EMAX},c}, P_{\text{EMAX,EN-DC}}, P_{\text{LTE}}, P_{\text{PowerClass,EN-DC}}, P_{\text{PowerClass}} - \Delta P_{\text{PowerClass}} \}$$

where

- $P_{\text{EMAX,EN-DC}}$  is the value given by the field *p-maxUE-FR1* of the *RRCConnectionReconfiguration-v1530* IE as defined in TS 36.331 [17];
- $P_{\text{LTE}}$  is the value given by the field *p-maxEUTRA-r15* of the *RRCConnectionReconfiguration-v1510* IE as defined in TS 36.331 [17] which is the same as  $P_{\text{LTE}}$  in TS 38.213 [19];

- $\Delta t_{C\_EUTRA,c} = 1.5$  dB when NOTE 2 in Table 6.2.2-1 of TS 36.101 [5] applies;  $\Delta t_{C\_EUTRA,c} = 0$  dB otherwise;

and whenever NS\_01 is not indicated within CG 1:

- for a UE indicating support of dynamicPowerSharing, the  $MPR_c$  and the A- $MPR_c$  are determined in accordance with the DCI of serving cell  $c$  of the CG 1 and the specification in clause 6.2.4 of TS 36.101 [5];
- for a UE not indicating support of dynamicPowerSharing, the A- $MPR_c$  is determined in accordance with clause 6.2B.3.1 with parameters applicable for UEs not indicating support of dynamicPowerSharing and  $MPR_c = 0$  dB;

and whenever NS\_01 is indicated in CG 1:

- for a UE indicating support of dynamicPowerSharing, the  $MPR_c$  is determined in accordance with the DCI of serving cell  $c$  of the CG 1 and the specification in clause 6.2.4 of TS 36.101 [5];
- for a UE not indicating support of dynamicPowerSharing, the  $MPR_c$  is determined in accordance with clause 6.2B.2.1 with parameters applicable for UEs not indicating support of dynamicPowerSharing and A- $MPR_c = 0$  dB;

The configured maximum output power  $P_{CMAX\_NR,c}(q)$  in physical channel  $q$  for the configured NR carrier shall be set within the bounds:

$$P_{CMAX\_L,f,c,NR}(q) \leq P_{CMAX,f,c,NR}(q) \leq P_{CMAX\_H,f,c,NR}(q)$$

where  $P_{CMAX\_L\_NR,c}$  and  $P_{CMAX\_H\_NR,c}$  are the limits for a serving cell  $c$  as specified in clause 6.2.4 of TS 38.101-1 [2] modified as follows:

$$P_{CMAX\_L,f,c,NR} = \text{MIN} \{ \text{MIN}(P_{EMAX,c}, P_{EMAX,EN-DC}, P_{NR}) - \Delta T_{C\_NR,c}, (P_{PowerClass,EN-DC} - \Delta P_{PowerClass,EN-DC}), (P_{PowerClass} - \Delta P_{PowerClass}) - \text{MAX}(\text{MAX}(MPR_c, A-MPR_c) + \Delta T_{IB,c} + \Delta T_{C\_NR,c} + \Delta T_{RxSRS}, P-MPR_c) \}$$

$$P_{CMAX\_H,f,c,NR} = \text{MIN} \{ P_{EMAX,c}, P_{EMAX,EN-DC}, P_{NR}, P_{PowerClass,EN-DC}, P_{PowerClass} - \Delta P_{PowerClass} \}$$

where

- $P_{EMAX,EN-DC}$  is the value given by the field *p-maxUE-FRI* of the *RRCConnectionReconfiguration-v1530* IE as defined in TS 36.331 [17];
- $P_{LTE}$  signalled by RRC as *p-MaxEUTRA-r15* in TS 36.331 [17]
- $P_{NR}$  is the value given by the field *p-NR-FRI* of the *PhysicalCellGroupConfig* IE as defined in [18] and signalled by RRC;
- $\Delta T_{C\_E-UTRA,c} = 1.5$ dB when NOTE 2 in Table 6.2.2-1 in TS 36.101 [4] applies for a serving cell  $c$ , otherwise  $\Delta T_{C\_E-UTRA,c} = 0$ dB;
- $\Delta T_{C\_NR,c} = 1.5$ dB when NOTE 3 in Table 6.2.1-1 in TS 38.101-1 [2] applies for a serving cell  $c$ , otherwise  $\Delta T_{C\_NR,c} = 0$ dB;
- $\Delta T_{IB,c}$  specified in clause 6.2B.4.2.1 for EN-DC, the individual Power Class defined in table 6.2B.1.1 and any other additional power reductions parameters specified in clauses 6.2B.2 and 6.2B.3 for EN-DC are applicable to  $P_{CMAX\_E-UTRA,c}$  and  $P_{CMAX,f,c,NR}$  evaluations.

$P_{PowerClass,EN-DC}$  is defined in clause 6.2B.1.1 for intra-band contiguous EN-DC;

- $P_{PowerClass,NR}$  is the nominal UE power of the power class that the UE supports for the NR band of the EN-DC combination as defined in clause 6.2.1 of 38.101-1 [2]; in case IE [*powerClassNRPart*] as defined in TS 38.331 [18] is indicated,  $P_{PowerClass,NR}$  should use that value instead.
- $P_{PowerClass,E-UTRA}$  is the nominal UE power of the power class that the UE supports for the E-UTRA band of the EN-DC combination as defined in clause 6.2.2 of 36.101 [5];-

$\Delta P_{PowerClass,EN-DC}$  is 3 dB for a power class 2 capable EN-DC UE when LTE UL/DL configuration is 0 or 6; or LTE UL/DL configuration is 1 and special subframe configuration is 0 or 5;  $\Delta P_{PowerClass,EN-DC} = 3$  dB when the IE *p-maxUE-FRI* as defined in TS 36.331 [17] is provided and set to the maximum output power of the default power class or lower;  $\Delta P_{PowerClass,EN-DC}$  is 6 dB for a power class 1.5 capable EN-DC UE when the LTE UL duty cycle is greater than  $\text{max}(50\%, \text{maxUplinkDutyCycle})$ ;  $\Delta P_{PowerClass,EN-DC}$  is 3 dB for a power class 1.5 capable

EN-DC UE when the LTE UL duty cycle is between  $\max(50\%, \maxUplinkDutyCycle)$  and  $\max(25\%, \maxUplinkDutyCycle/2)$ ; otherwise  $\Delta P_{PowerClass,EN-DC} = 0$  dB;

and whenever NS\_01 is not indicated within CG 2:

- for a UE indicating support of dynamicPowerSharing,  $A-MPR_c = A-MPR'_c$  with  $A-MPR'_c$  determined in accordance with clause 6.2B.3.1 and  $MPR_c = 0$  dB if transmission(s) in subframe  $p$  on CG 1 overlap in time with physical channel  $q$  on CG 2;
- for a UE indicating support of dynamicPowerSharing,  $A-MPR_c$  is determined in accordance with TS 38.101-1 [2] if transmission(s) in subframe  $p$  on CG 1 does not overlap in time with physical channel  $q$  on CG 2;
- for a UE not indicating support of dynamicPowerSharing, the  $A-MPR_c$  is determined in accordance with clause 6.2B.3.1 with parameters applicable for UEs not indicating support of dynamicPowerSharing and  $MPR_c = 0$  dB;

and whenever NS\_01 is indicated in CG 2.

- for a UE indicating support of dynamicPowerSharing,  $MPR_c = MPR'_c$  with  $MPR'_c$  determined in accordance with clause 6.2B.2.1 and  $A-MPR_c = 0$  dB if transmission(s) in subframe  $p$  on CG 1 overlap in time with physical channel  $q$  on CG 2;
- for a UE indicating support of dynamicPowerSharing,  $MPR_c$  is determined in accordance with TS 38.101-1 [2] if transmission(s) in subframe  $p$  on CG 1 does not overlap in time with physical channel  $q$  on CG 2;
- for a UE not indicating support of dynamicPowerSharing, the  $MPR_c$  is determined in accordance with clause 6.2B.2.1 with parameters applicable for UEs not indicating support of dynamicPowerSharing and  $A-MPR_c = 0$  dB;

If the transmissions from NR and E-UTRA do not overlap, then the complete clauses for configured transmitted power for E-UTRA and NR respectively from their own specifications apply with the modifications specified above. The lower value between  $P_{PowerClass, EN-DC}$  or  $P_{EMAX, EN-DC}$  shall not be exceeded at any time by UE.

If the EN-DC UE is not supporting dynamic power sharing, then the complete clauses for configured transmitted power for E-UTRA and NR respectively from their own specifications TS 36.101 [5] and TS 38.101-1 [2] respectively apply with the modifications specified above.

If the UE does not support dynamic power sharing,

$$P_{Total}^{EN-DC} = \text{MIN} \{ P_{EMAX, EN-DC}, P_{PowerClass, EN-DC} - \Delta P_{PowerClass, EN-DC} \} + 0.3 \text{ dB}$$

For UEs indicating support of dynamicPowerSharing in the *UE-MRDC-Capability* IE the UE can configure the total maximum transmission power  $P_{Total}^{EN-DC}$  within the range

$$P_{EN-DC, tot\_L} \leq P_{Total}^{EN-DC} \leq P_{EN-DC, tot\_H}$$

where

$$P_{EN-DC, tot\_L}(p, q) = \text{MIN} \{ P_{PowerClass, EN-DC} - \Delta P_{PowerClass, EN-DC} - \text{MAX} \{ MPR_{tot}, A-MPR_{tot} \}, P_{EMAX, EN-DC} \}$$

$$P_{EN-DC, tot\_H}(p, q) = \text{MIN} \{ P_{PowerClass, EN-DC}, P_{EMAX, EN-DC} \}$$

for sub-frame  $p$  on CG 1 overlapping with physical channel  $q$  on CG 2 and with  $MPR_{tot}$  and  $A-MPR_{tot}$  in accordance with 6.2B.2.1 and clause 6.2B.3.1, respectively.

The measured total maximum output power  $P_{UMAX}$  over both CGs/RATs, measured over the transmission reference time duration is

$$P_{UMAX} = 10 \log_{10} [p_{UMAX, c, E-UTRA} + p_{UMAX, f, c, NR}],$$

where  $p_{UMAX, c, E-UTRA}$  and  $p_{UMAX, c, NR}$  denotes the measured output power of serving cell  $c$  for E-UTRA and NR respectively, expressed in linear scale.

For UEs indicating support of dynamicPowerSharing, the measured total configured maximum output power  $P_{UMAX}$  shall be within the following bounds:

$$P_{CMAX\_L} - T_{LOW}(P_{CMAX\_L}) \leq P_{UMAX} \leq P_{CMAX\_H} + T_{HIGH}(P_{CMAX\_H})$$

with the tolerances  $T_{\text{LOW}}(P_{\text{CMAX\_L}})$  and  $T_{\text{HIGH}}(P_{\text{CMAX\_H}})$  for applicable values of  $P_{\text{CMAX\_L}}$  and  $P_{\text{CMAX\_H}}$  specified in Table 6.2B.4.1.0.1.1-2.

When an UL subframe transmission  $p$  from E-UTRA overlap with a physical channel  $q$  from the NR, then for  $P_{\text{UMAX}}$  evaluation, the E-UTRA subframe  $p$  is taken as reference period  $T_{\text{REF}}$  and always considered as the reference measurement duration and the following rules are applicable.

$T_{\text{REF}}$  and  $T_{\text{eval}}$  are specified in Table 6.2B.4.1.0.1.1-1 when same or different subframes and physical channel durations are used in aggregated carriers.  $P_{\text{PowerClass\_EN-DC}}$  shall not be exceeded by the UE during any evaluation period of time.

**Table 6.2B.4.1.0.1.1-1:  $P_{\text{CMAX}}$  evaluation window**

transmission duration	$T_{\text{REF}}$	$T_{\text{eval}}$
Different transmission duration in different RAT carriers	E-UTRA Subframe	$\text{Min}(T_{\text{no\_hopping}}, \text{Physical Channel Length})$

For each  $T_{\text{REF}}$ , the  $P_{\text{CMAX\_H}}$  is evaluated per  $T_{\text{eval}}$  and given by the maximum value over the transmission(s) within the  $T_{\text{eval}}$  as follows:

$$P_{\text{CMAX\_H}} = \text{MAX} \{ P_{\text{CMAX\_EN-DC\_H}}(p, q), P_{\text{CMAX\_EN-DC\_H}}(p, q+I), \dots, P_{\text{CMAX\_EN-DC\_H}}(p, q+n) \}$$

where  $P_{\text{CMAX\_EN-DC\_H}}$  are the applicable upper limits for each overlapping scheduling unit pairs  $(p, q)$ ,  $(p, q+I)$ , up to  $(p, q+n)$  for each applicable  $T_{\text{eval}}$  duration, where  $q+n$  is the last NR UL physical channel overlapping with LTE subframe  $p$ .

While  $P_{\text{CMAX\_L}}$  is computed as follows:

$$P_{\text{CMAX\_L}} = \text{MIN} \{ P_{\text{CMAX\_EN-DC\_L}}(p, q), P_{\text{CMAX\_EN-DC\_L}}(p, q+I), \dots, P_{\text{CMAX\_EN-DC\_L}}(p, q+n) \}$$

where  $P_{\text{CMAX\_EN-DC\_L}}$  are the applicable lower limits for each overlapping scheduling unit pairs  $(p, q)$ ,  $(p, q+I)$ , up to  $(p, q+n)$  for each applicable  $T_{\text{eval}}$  duration, where  $q+n$  is the last NR UL physical channel overlapping with E-UTRA subframe  $p$ ,

With

$$P_{\text{CMAX\_EN-DC\_H}}(p, q) = \text{MIN} \{ 10 \log_{10} [p_{\text{CMAX\_H\_E-UTRA},c}(p) + p_{\text{CMAX\_H},f,c,NR,c}(q)], P_{\text{EMAX, EN-DC}}, P_{\text{PowerClass, EN-DC}} \}$$

And:

$$a = 10 \log_{10} [p_{\text{CMAX\_E-UTRA},c}(p) + p_{\text{CMAX},f,c,NR,c}(q)] > P_{\text{EN-DC,tot\_L}}$$

$$b = 10 \log_{10} [p_{\text{CMAX\_E-UTRA},c}(p) + p_{\text{CMAX},f,c,NR,c}(q) / X_{\text{scale}}] > P_{\text{EN-DC,tot\_L}}$$

If  $a = \text{FALSE}$  and the configured transmission power spectral density between the MCG and SCG differs by less than 6 dB

$$P_{\text{CMAX\_EN-DC\_L}}(p, q) = \text{MIN} \{ 10 \log_{10} [p_{\text{CMAX\_L\_E-UTRA},c}(p) + p_{\text{CMAX\_L},f,c,NR,c}(q)], P_{\text{EMAX, EN-DC}}, P_{\text{PowerClass, EN-DC}} - \Delta P_{\text{PowerClass, EN-DC}} \}$$

ELSE If  $(a = \text{TRUE})$  AND  $(b = \text{FALSE})$  and the configured transmission power spectral density between the MCG and SCG differs by less than 6 dB

$$P_{\text{CMAX\_EN-DC\_L}}(p, q) = \text{MIN} \{ 10 \log_{10} [p_{\text{CMAX\_L\_E-UTRA},c}(p) + p_{\text{CMAX\_L},f,c,NR,c}(q) / X_{\text{scale}}], P_{\text{EMAX, EN-DC}}, P_{\text{PowerClass, EN-DC}} - \Delta P_{\text{PowerClass, EN-DC}} \}$$

ELSE If  $b = \text{TRUE}$  or the transmission power after power scaling spectral density between the MCG and SCG differs by more than 6 dB

$$P_{\text{CMAX\_EN-DC\_L}}(p, q) = \text{MIN} \{ 10 \log_{10} [p_{\text{CMAX\_L\_E-UTRA},c}(p)], P_{\text{EMAX, EN-DC}}, P_{\text{PowerClass, EN-DC}} - \Delta P_{\text{PowerClass, EN-DC}} \}$$

where

- $p_{\text{CMAX\_H\_E-UTRA},c}(p)$  is the E-UTRA higher limit of the maximum configured power expressed in linear scale;
- $p_{\text{CMAX\_H},NR,c}(q)$  is the NR higher limit of the maximum configured power expressed in linear scale;

- $P_{\text{CMAX\_L\_E-UTRA},c}(p)$  is the E-UTRA lower limit of the maximum configured power expressed in linear scale;
- $P_{\text{CMAX\_L\_NR},c}(q)$  is the NR lower limit of the maximum configured power expressed in linear scale;
- $P_{\text{PowerClass, EN-DC}}$  is defined in clause 6.2B.1.1.3-1 for intra-band EN-DC;
- $X_{\text{scale}}$  is the linear value of X dB which is configured by RRC and can only take values [0, 6] dB
- $P_{\text{CMAX\_E-UTRA},c}(p)$  is the linear value of  $P_{\text{CMAX\_E-UTRA},c}(p)$ , the real configured max power for E-UTRA
- $P_{\text{CMAX},f,c\_NR}(q)$  is the linear value of  $P_{\text{CMAX},f,c\_NR}(q)$ , the real configured max power of NR

**Table 6.2B.4.1.0.1.1-2:  $P_{\text{CMAX}}$  tolerance for Dual Connectivity E-UTRANR**

$P_{\text{CMAX}}(\text{dBm})$	Tolerance $T_{\text{LOW}}(P_{\text{CMAX\_L}})$ (dB)	Tolerance $T_{\text{HIGH}}(P_{\text{CMAX\_H}})$ (dB)
$23 \leq P_{\text{CMAX}} \leq 33$	3.0	2.0
$22 \leq P_{\text{CMAX}} < 23$	5.0	2.0
$21 \leq P_{\text{CMAX}} < 22$	5.0	3.0
$20 \leq P_{\text{CMAX}} < 21$	6.0	4.0
$16 \leq P_{\text{CMAX}} < 20$	5.0	
$11 \leq P_{\text{CMAX}} < 16$	6.0	
$-40 \leq P_{\text{CMAX}} < 11$	7.0	

If the UE supports dynamic power sharing, and when LTE and NR transmissions overlap and the condition (If (a=TRUE) AND (b=FALSE)) is met, SCG shall be transmitted and the following supplementary minimum requirement apply for the measured SCG power,  $P_{\text{UMAX},f,c,NR}(q)$ , under nominal conditions and unless otherwise stated.

$$10\log(p_{\text{CMAX\_L},f,c,NR}(q)/X_{\text{scale}}) - T_{\text{LOW}}(10\log(p_{\text{CMAX\_L},f,c,NR}(q)/X_{\text{scale}})) \leq P_{\text{UMAX},f,c,NR}(q) \leq 10\log(p_{\text{CMAX\_H},f,c,NR}(q)) + T_{\text{HIGH}}(10\log(p_{\text{CMAX\_H},f,c,NR}(q))).$$

with the tolerances  $T_{\text{LOW}}$  and  $T_{\text{HIGH}}$  for applicable values of  $P_{\text{CMAX}}$  specified in Table 6.2B.4.1.0.1.1-2.

If the UE supports dynamic power sharing, the measured maximum output power in subframe  $p$  on CG 1,  $p_{\text{UMAX},c,E-UTRA}$ , shall meet the requirements in clause 6.2.5 in TS 36.101 [5] with the limits  $P_{\text{CMAX\_L},c}$  and  $P_{\text{CMAX\_H},c}$  replaced by  $P_{\text{CMAX\_L\_E-UTRA},c}$  and  $P_{\text{CMAX\_H\_E-UTRA},c}$  as specified above, respectively.

If the configured transmission power spectral density between the MCG and SCG differs by more than 6 dB, then

$$P_{\text{UMAX},f,c,NR}(q) \leq 10\log(p_{\text{CMAX\_H},f,c,NR}(q)) + T_{\text{HIGH}}(10\log(p_{\text{CMAX\_H},f,c,NR}(q))).$$

#### 6.2B.4.1.0.1.2 Intra-band non-contiguous EN-DC

The following requirements apply for one component carrier per CG configured for synchronous DC. The CG(s) are indexed by  $j = 1$  for MCG and  $j = 2$  for SCG.

The configured maximum output power  $P_{\text{CMAX\_E-UTRA},c}(p)$  in sub-frame  $p$  for the configured E-UTRA uplink carrier shall be set in accordance with clause 6.2B.4.1.0.1.1 but where

- for a UE not indicating support of dynamicPowerSharing, the  $A\text{-MPR}_c$  determined in accordance with clause 6.2B.3.2 with parameters applicable for UEs not indicating support of dynamicPowerSharing and  $\text{MPR}_c = 0$  dB;

whenever NS\_01 is not indicated within CG 1 while

- for a UE not indicating support of dynamicPowerSharing, the  $\text{MPR}_c$  determined in accordance with clause 6.2B.2.2 with parameters applicable for UEs not indicating support of dynamicPowerSharing and  $A\text{-MPR}_c = 0$  dB;

whenever NS\_01 is indicated in CG 1.

The configured maximum output power  $P_{\text{CMAX\_NR},c}(q)$  in physical channel  $q$  for the configured NR carrier shall be set in accordance with clause 6.2B.4.1.0.1.1 but where

- for a UE indicating support of dynamicPowerSharing,  $A\text{-MPR}_c = A\text{-MPR}'_c$  with  $A\text{-MPR}'_c$  determined in accordance with clause 6.2B.3.2 and  $\text{MPR}_c = 0$  dB if transmission(s) in subframe  $p$  on CG 1 overlap in time with physical channel  $q$  on CG 2;
- for a UE indicating support of dynamicPowerSharing,  $A\text{-MPR}_c$  is determined in accordance with [2] if transmission(s) in subframe  $p$  on CG 1 does not overlap in time with physical channel  $q$  on CG 2;
- for a UE not indicating support of dynamicPowerSharing, the  $A\text{-MPR}_c$  is determined in accordance with clause 6.2B.3.2 with parameters applicable for UEs not indicating support of dynamicPowerSharing and  $\text{MPR}_c = 0$  dB;

For UEs indicating support of dynamicPowerSharing in the *UE-MRDC-Capability IE*, the UE can configure the total transmission power in accordance with clause 6.2B.4.1.0.1.1 but with  $P_{\text{powerclass,EN-DC}}$  the EN-DC power class of the intra-band non-contiguous band combination configured and  $A\text{-MPR}$  determined in accordance with clause 6.2B.3.2.

whenever NS\_01 is not indicated in CG 2 while

- for a UE indicating support of dynamicPowerSharing,  $\text{MPR}_c = \text{MPR}'_c$  with  $\text{MPR}'_c$  determined in accordance with clause 6.2B.2.2 and  $A\text{-MPR}_c = 0$  dB if transmission(s) in subframe  $p$  on CG 1 overlap in time with physical channel  $q$  on CG 2;
- for a UE indicating support of dynamicPowerSharing,  $\text{MPR}_c$  is determined in accordance with TS 38.101-1 [2] if transmission(s) in subframe  $p$  on CG 1 does not overlap in time with physical channel  $q$  on CG 2;
- for a UE not indicating support of dynamicPowerSharing, the  $\text{MPR}_c$  is determined in accordance with clause 6.2B.2.2 with parameters applicable for UEs not indicating support of dynamicPowerSharing and  $A\text{-MPR}_c = 0$  dB;

whenever NS\_01 is indicated in CG 2.

For UEs indicating support of dynamicPowerSharing in the *UE-MRDC-Capability IE*, the UE can configure the total transmission power in accordance with clause 6.2B.4.1.1 but with  $P_{\text{powerclass,EN-DC}}$  the EN-DC power class of the intra-band non-contiguous band combination configured and  $A\text{-MPR}$  determined in accordance with clause 6.2B.3.2.

The total maximum output power  $P_{\text{UMAX}}$  over both CGs is measured in accordance with clause 6.2B.4.1.0.1.1 and shall be within the limits specified in clause 6.2B.4.1.0.1.1 but with parameters applicable for the non-contiguous band combination configured.

The maximum output power levels  $p_{\text{UMAX,c,E-UTRA}}$  and  $p_{\text{UMAX,f,c,NR}}$  for the CGs are measured in accordance with clause 6.2B.4.1.0.1.1 and shall be within the limits specified in clause 6.2B.4.1.0.1.1 but with parameters applicable for the non-contiguous band combination configured.

### 6.2B.4.1.0.1.3 Inter-band EN-DC within FR1

For inter-band dual connectivity with one uplink serving cell or more than one uplink serving cells configured for intra-band UL CA on the E-UTRA CG and one uplink serving cell on the NR CG or more than one uplink serving cells configured for intra-band UL CA, the UE is allowed to set its configured maximum output power  $P_{\text{CMAX,c}(i),i}$  for serving cell  $c(i)$  of CG  $i$ ,  $i = 1, 2$ , and its total configured maximum transmission power for EN-DC operation,  $P_{\text{Total}}^{\text{EN-DC}} = 10\log_{10}(\hat{P}_{\text{total}}^{\text{EN-DC}})$  with  $\hat{P}_{\text{total}}^{\text{EN-DC}}$  as specified in clause 7.6 of TS 38.213 [19]. For EN-DC with more than one uplink serving cells configured for intra-band UL CA on the E-UTRA CG, the  $P_{\text{CMAX}}$  applies to the entire E-UTRA CG. For EN-DC with more than one uplink serving cells configured for intra-band UL CA on the NR CG, the  $P_{\text{CMAX}}$  applies to the entire NR CG.

For a UE configured with EN-DC and serving cell frame structure type 1, if the UE is configured with *subframeAssignment-r15* for the serving cell and E-UTRA Pcell is FDD, the UE is not expected to be configured with more than one serving cells in the uplink.

The configured maximum output power  $P_{\text{CMAX,E-UTRA,c}}(p)$  in sub-frame  $p$  for the configured E-UTRA uplink carrier shall be set within the bounds:

$$P_{\text{CMAX,L,E-UTRA,c}}(p) \leq P_{\text{CMAX,E-UTRA,c}}(p) \leq P_{\text{CMAX,H,E-UTRA,c}}(p)$$

where  $P_{\text{CMAX,L,E-UTRA,c}}$  and  $P_{\text{CMAX,H,E-UTRA,c}}$  are the limits for a serving cell  $c$  as specified in TS 36.101 [5] clause 6.2.5 modified by  $P_{\text{LTE}}$  as follows:

$$P_{\text{CMAX\_L\_E-UTRA},c} = \text{MIN} \{ P_{\text{EMAX, EN-DC}}, (P_{\text{PowerClass, EN-DC}} - \Delta P_{\text{PowerClass, EN-DC}}), \text{MIN}(P_{\text{EMAX},c}, P_{\text{LTE}}) - \Delta t_{\text{C\_E-UTRA},c}, (P_{\text{PowerClass,E-UTRA}} - \Delta P_{\text{PowerClass,E-UTRA}}) - \text{MAX}(\text{MPR}_c + \text{A-MPR}_c + \Delta T_{\text{IB},c} + \Delta t_{\text{C\_E-UTRA},c} + \Delta T_{\text{ProSe}}, P\text{-MPR}_c) \}$$

$$P_{\text{CMAX\_H\_E-UTRA},c} = \text{MIN} \{ P_{\text{EMAX},c}, P_{\text{EMAX, EN-DC}}, (P_{\text{PowerClass, EN-DC}} - \Delta P_{\text{PowerClass, EN-DC}}), P_{\text{LTE}}, P_{\text{PowerClass, E-UTRA}} - \Delta P_{\text{PowerClass, E-UTRA}} \}$$

For EN-DC with more than one uplink serving cells configured for intra-band UL CA on the E-UTRA CG,  $P_{\text{CMAX\_L\_E-UTRA},c}$  and  $P_{\text{CMAX\_H\_E-UTRA},c}$  are the limits for the E-UTRA CG as specified in TS 36.101 [5] clause 6.2.5A modified by  $P_{\text{LTE}}$  as follows:

$$P_{\text{CMAX\_L\_E-UTRA},c} = \text{MIN} \{ 10 \log_{10} \sum p_{\text{EMAX},c} - \Delta T_{\text{C}}, (P_{\text{PowerClass,E-UTRA}} - \Delta P_{\text{PowerClass,E-UTRA}}) - \text{MAX}(\text{MPR} + \text{A-MPR} + \Delta T_{\text{IB},c} + \Delta T_{\text{C}} + \Delta T_{\text{ProSe}}, P\text{-MPR}), P_{\text{LTE}}, P_{\text{PowerClass,EN-DC}} \}$$

$$P_{\text{CMAX\_H\_E-UTRA},c} = \text{MIN} \{ 10 \log_{10} \sum p_{\text{EMAX},c}, P_{\text{PowerClass,E-UTRA}}, P_{\text{LTE}}, P_{\text{PowerClass,EN-DC}} \}$$

The configured maximum output power  $P_{\text{CMAX\_NR},c}(q)$  in physical-channel  $q$  for the configured NR carrier shall be set within the bounds:

$$P_{\text{CMAX\_L},f,c,\text{NR}}(q) \leq P_{\text{CMAX},f,c,\text{NR}}(q) \leq P_{\text{CMAX\_H},f,c,\text{NR}}(q)$$

where  $P_{\text{CMAX\_L},f,c,\text{NR}}$  and  $P_{\text{CMAX\_H},f,c,\text{NR}}$  are the limits for a serving cell  $c$  as specified in clause 6.2.4 of TS 38.101-1 [2] modified as follows:

$$P_{\text{CMAX\_L},f,c,\text{NR}} = \text{MIN} \{ P_{\text{EMAX, EN-DC}}, (P_{\text{PowerClass, EN-DC}} - \Delta P_{\text{PowerClass, EN-DC}}), \text{MIN}(P_{\text{EMAX},c}, P_{\text{NR}}) - \Delta T_{\text{C\_NR},c}, (P_{\text{PowerClass, NR}} - \Delta P_{\text{PowerClass, NR}}) - \text{MAX}(\text{MAX}(\text{MPR}_c, \text{A-MPR}_c) + \Delta T_{\text{IB},c} + \Delta T_{\text{C\_NR},c} + \Delta T_{\text{RxSRS}}, P\text{-MPR}_c) \}$$

$$P_{\text{CMAX\_H},f,c,\text{NR}} = \text{MIN} \{ P_{\text{EMAX},c}, P_{\text{EMAX, EN-DC}}, (P_{\text{PowerClass, EN-DC}} - \Delta P_{\text{PowerClass}}), P_{\text{NR}}, P_{\text{PowerClass, NR}} - \Delta P_{\text{PowerClass, NR}} \}$$

For EN-DC with more than one uplink serving cells configured for intra-band UL CA on the NR CG,  $P_{\text{CMAX\_L},f,c,\text{NR}}$  and  $P_{\text{CMAX\_H},f,c,\text{NR}}$  are the limits for the NR CG as specified in [2] subclause 6.2A.4 modified by  $P_{\text{NR}}$  as follows:

$$P_{\text{CMAX\_L},f,c,\text{NR}} = \text{MIN} \{ 10 \log_{10} \sum p_{\text{EMAX},c} - \Delta T_{\text{C}}, P_{\text{EMAX,CA}}, P_{\text{PowerClass, NR}} - \text{MAX}(\text{MPR} + \text{A-MPR} + \Delta T_{\text{IB},c} + \Delta T_{\text{NR},c} + \Delta T_{\text{RxSRS}}, P\text{-MPR}), P_{\text{NR}}, P_{\text{PowerClass,EN-DC}} \}$$

$$P_{\text{CMAX\_H},f,c,\text{NR}} = \text{MIN} \{ 10 \log_{10} \sum p_{\text{EMAX},c}, P_{\text{EMAX,CA}}, P_{\text{PowerClass, NR}}, P_{\text{NR}}, P_{\text{PowerClass,EN-DC}} \}$$

where

- $P_{\text{EMAX,EN-DC}}$  is the value given by the field *p-maxUE-FR1* of the *RRCConnectionReconfiguration-v1530* IE as defined in TS 36.331 [17];
- If more than one E-UTRA uplink serving cell is configured as intra-band UL CA in the E-UTRA CG,  $P_{\text{PowerClass}}$  refers to the maximum output power of the E-UTRA intra-band CA power class given in Table 6.2.2A-1 of TS 36.101 [5];
- $P_{\text{LTE}}$  is the value given by the field *p-maxEUTRA-r15* of the *RRCConnectionReconfiguration-v1510* IE as defined in TS 36.331 [17];
- If more than one E-UTRA uplink serving cell is configured as intra-band UL CA in the E-UTRA CG,  $\text{MPR}_c = \text{MPR}$  and  $\text{A-MPR}_c = \text{A-MPR}$  with  $\text{MPR}$  and  $\text{A-MPR}$  specified in clause 6.2.3A and clause 6.2.4A of TS 36.101 [5] respectively. There is one power management term for the UE, denoted  $P\text{-MPR}$ , and  $P\text{-MPR}_c = P\text{-MPR}$ .  $P_{\text{CMAX\_E-UTRA},c}$  is calculated under the assumption that the transmit power is increased by the same amount in dB on all component carriers within the E-UTRA CG.
- If more than one NR uplink serving cell is configured as intra-band UL CA in the NR CG,  $\text{MPR}_c$  and  $\text{A-MPR}_c$  are determined by subclause 6.2.2 of [2]. There is one power management term for the UE, denoted  $P\text{-MPR}$ , and  $P\text{-MPR}_c = P\text{-MPR}$ .
- $P_{\text{NR}}$  is the value given by the field *p-NR-FR1* of the *PhysicalCellGroupConfig* IE as defined TS 38.331 [18];
- $\Delta t_{\text{C\_E-UTRA},c} = 1.5$  dB when NOTE 2 in Table 6.2.2-1 in TS 36.101 [5] applies for a serving cell  $c$ , otherwise  $\Delta t_{\text{C\_E-UTRA},c} = 0$  dB;
- $\Delta T_{\text{C\_NR},c} = 1.5$ dB when NOTE 3 in Table 6.2.1-1 in TS 38.101-1 [2] applies for a serving cell  $c$ , otherwise  $\Delta T_{\text{C\_NR},c} = 0$  dB;  $\Delta T_{\text{C\_NR},c}$  is the highest value  $\Delta T_{\text{C\_NR},c}$  among all serving cells  $c$  if more than one NR uplink serving cell is configured as intra-band UL CA in the NR CG;

- $P_{\text{PowerClass, EN-DC}}$  is defined in clause 6.2B.1.3 for inter-band EN-DC; if the UE indicates *higherPowerLimitMRDC-r17* and  $\Delta P_{\text{PowerClass, EN-DC}} = 0$ ,  $P_{\text{PowerClass, EN-DC}}$  is replaced by the sum of the linear powers of  $P_{\text{PowerClass, NR}}$  and  $P_{\text{PowerClass, E-UTRA}}$  converted to dB;
- $\Delta P_{\text{PowerClass, EN-DC}} = 3$  dB for a power class 2 capable EN-DC UE when requirements of default power class had been applied as specified in sub-clause 6.2B.1; otherwise  $\Delta P_{\text{PowerClass, EN-DC}} = 0$  dB;
- $P_{\text{PowerClass, NR}}$  is the nominal UE power of the power class that the UE supports for the NR band of the EN-DC combination as defined in clause 6.2.1 of 38.101-1 [2]; in case IE [*powerClassNRPart*] as defined in TS 38.331 [18] is indicated,  $P_{\text{PowerClass, NR}}$  should use that value instead.
- $\Delta P_{\text{PowerClass, NR}}$  is 3 dB or 0 dB according to clause 6.2.4 of TS 38.101-1 [2] for a UE that supports power class 2 in the NR band of the EN-DC combination as defined in clause 6.2.1 of TS 38.101-1 [2];
- $P_{\text{PowerClass, E-UTRA}}$  is the nominal UE power of the power class that the UE supports for the E-UTRA band of the EN-DC combination as defined in clause 6.2.2 of 36.101 [5];
- $\Delta P_{\text{PowerClass, E-UTRA}}$  is 3 dB or 0 dB according to clause 6.2.5 of TS 36.101 [5] for a UE that supports power class 2 in the E-UTRA band of the EN-DC combination as defined in clause 6.2.2 of TS 36.101 [5];
- $\Delta T_{\text{IB},c}$  specified in clause 6.2B.4.2.3 for EN-DC, the individual Power Class defined in table 6.2B.1.3 and any other additional power reductions parameters specified in clauses 6.2B.2 and 6.2B.3 for EN-DC are applicable to  $P_{\text{CMAX}_E\text{-UTRA},c}$  and  $P_{\text{CMAX},f,c, NR}$  evaluations.
- $\Delta T_{\text{RxsRS}}$  is the highest value among all serving cells  $c$ .

If the transmissions from NR and E-UTRA do not overlap, then the complete clauses for configured transmitted power for E-UTRA and NR respectively from their own specifications apply with the modifications specified above. The lower value between  $P_{\text{PowerClass, EN-DC}}$  or  $P_{\text{EMAX, EN-DC}}$  shall not be exceeded at any time by UE.

$P_{\text{Total}}^{\text{EN-DC}} = 10 \log_{10}(\hat{P}_{\text{total}}^{\text{EN-DC}})$  with  $P_{\text{Total}}^{\text{EN-DC}}$  the configured maximum transmission power for EN-DC operation as specified in clause 7.6 of TS 38.213 [19].

The total configured maximum transmission power for both synchronous and non-synchronous operation is

$$P_{\text{Total}}^{\text{EN-DC}} = \text{MIN} \{ P_{\text{EMAX, EN-DC}}, P_{\text{PowerClass, EN-DC}} - \Delta P_{\text{PowerClass, EN-DC}} \}$$

If the UE does not support dynamic power sharing,

$$P_{\text{Total}}^{\text{EN-DC}} = \text{MIN} \{ P_{\text{EMAX, EN-DC}}, P_{\text{PowerClass, EN-DC}} - \Delta P_{\text{PowerClass, EN-DC}} \} + 0.3 \text{ dB}$$

If the EN-DC UE does not support dynamic power sharing, then the complete clauses for configured transmitted power for E-UTRA and NR respectively from their own specifications TS 36.101 [5] and TS 38.101-1 [2] respectively apply with the modifications specified above and  $P_{\text{Total}}^{\text{EN-DC}}$  applies.

When a UE supporting dynamic sharing is configured for overlapping E-UTRA uplink and NR uplink transmissions, the UE can set its configured maximum output power  $P_{\text{CMAX}_E\text{-UTRA},c}$  and  $P_{\text{CMAX}_NR,c}$  for the configured E-UTRA and NR uplink carriers, respectively, and its configured maximum transmission power for EN-DC operation,  $\hat{P}_{\text{Total}}^{\text{EN-DC}}$ , as specified above.

The measured total maximum output power  $P_{\text{UMAX}}$  over both CGs/RATs, measured over the transmission reference time duration is

$$P_{\text{UMAX}} = 10 \log_{10} [p_{\text{UMAX},c,E\text{-UTRA}} + p_{\text{UMAX},c, NR}],$$

where  $p_{\text{UMAX},c,E\text{-UTRA}}$  and  $p_{\text{UMAX},c, NR}$  denotes the measured output power of serving cell  $c$  for E-UTRA and NR respectively, expressed in linear scale.

The measured total configured maximum output power  $P_{\text{UMAX}}$  shall be within the following bounds:

$$P_{\text{CMAX}_L} - T_{\text{LOW}}(P_{\text{CMAX}_L}) \leq P_{\text{UMAX}} \leq P_{\text{CMAX}_H} + T_{\text{HIGH}}(P_{\text{CMAX}_H})$$

with the tolerances  $T_{\text{LOW}}(P_{\text{CMAX}_H})$  and  $T_{\text{HIGH}}(P_{\text{CMAX}_H})$  for applicable values of  $P_{\text{CMAX}}$  specified in Table 6.2B.4.1.0.1.3-2. When an UL subframe transmission  $p$  from E-UTRA overlap with a physical-channel  $q$  from the NR, then for  $P_{\text{UMAX}}$  evaluation, the E-UTRA subframe  $p$  is taken as reference period  $T_{\text{REF}}$  and always considered as the reference measurement duration and the following rules are applicable.



$T_{REF}$  and  $T_{eval}$  are specified in Table 6.2B.4.1.0.1.3-1 when same or different subframe and physical-channel durations are used in aggregated carriers. The lesser of  $P_{PowerClass,EN-DC}$  and  $P_{EMAX,EN-DC}$  shall not be exceeded by the UE during any evaluation period of time where  $P_{PowerClass,EN-DC}$  is replaced by the sum of the linear powers of  $P_{PowerClass,NR}$  and  $P_{PowerClass,E-UTRA}$  converted to dB if the UE indicates *higherPowerLimitMRDC-r17*.

**Table 6.2B.4.1.0.1.3-1:  $P_{CMAX}$  evaluation window**

transmission duration	$T_{REF}$	$T_{eval}$
Different transmission duration in different RAT carriers	E-UTRA Subframe on all aggregated cells of E-UTRA	$\text{Min}(T_{no\_hopping}, \text{Physical Channel Length})$ on all aggregated cells of NR

For each  $T_{REF}$ , the  $P_{CMAX,H}$  is evaluated per  $T_{eval}$  and given by the maximum value over the transmission(s) within the  $T_{eval}$  as follows:

$$P_{CMAX,H} = \text{MAX} \{ P_{CMAX,EN-DC,H}(p,q), P_{CMAX,EN-DC,H}(p,q+1), \dots, P_{CMAX,EN-DC,H}(p,q+n) \}$$

where  $P_{CMAX,EN-DC,H}$  are the applicable upper limits for each overlapping scheduling unit pairs  $(p,q)$ ,  $(p,q+1)$ , up to  $(p,q+n)$  for each applicable  $T_{eval}$  duration, where  $q+n$  is the last NR UL physical-channel overlapping with E-UTRA subframe  $p$ .

While  $P_{CMAX,L}$  is computed as follows:

$$P_{CMAX,L} = \text{MIN} \{ P_{CMAX,EN-DC,L}(p,q), P_{CMAX,EN-DC,L}(p,q+1), \dots, P_{CMAX,EN-DC,L}(p,q+n) \}$$

where  $P_{CMAX,EN-DC,L}$  are the applicable lower limits for each overlapping scheduling unit pairs  $(p,q)$ ,  $(p,q+1)$ , up to  $(p,q+n)$  for each applicable  $T_{eval}$  duration, where  $q+n$  is the last NR UL physical-channel overlapping with E-UTRA subframe  $p$ ,

With

$$P_{CMAX,EN-DC,H}(p,q) = \text{MIN} \{ 10 \log_{10} [p_{CMAX,H,E-UTRA,c}(p) + p_{CMAX,H,f,c,NR,c}(q)], P_{EMAX,EN-DC}, P_{PowerClass,EN-DC} \}$$

And:

$$a = 10 \log_{10} [p_{CMAX,E-UTRA,c}(p) + p_{CMAX,f,c,NR}(q)] > P_{Total}^{EN-DC}$$

$$b = 10 \log_{10} [p_{CMAX,E-UTRA,c}(p) + p_{CMAX,f,c,NR}(q) / X_{scale}] > P_{Total}^{EN-DC}$$

If a= FALSE

$$P_{CMAX,EN-DC,L}(p,q) = \text{MIN} \{ 10 \log_{10} [p_{CMAX,L,E-UTRA,c}(p) + p_{CMAX,L,f,c,NR,c}(q)], P_{EMAX,EN-DC}, P_{PowerClass,EN-DC} \}$$

ELSE If (a=TRUE) AND (b=FALSE)

$$P_{CMAX,EN-DC,L}(p,q) = \text{MIN} \{ 10 \log_{10} [p_{CMAX,L,E-UTRA,c}(p) + p_{CMAX,L,f,c,NR,c}(q) / X_{scale}], P_{EMAX,EN-DC}, P_{PowerClass,EN-DC} \}$$

ELSE If b= TRUE

$$P_{CMAX,EN-DC,L}(p,q) = \text{MIN} \{ 10 \log_{10} [p_{CMAX,L,E-UTRA,c}(p)], P_{EMAX,EN-DC}, P_{PowerClass,EN-DC} \}$$

where

- $p_{CMAX,H,E-UTRA,c}(p)$  is the E-UTRA higher limit of the maximum configured power expressed in linear scale;
- $p_{CMAX,L,f,c,NR}(q)$  is the NR higher limit of the maximum configured power expressed in linear scale;
- $p_{CMAX,H,NR,c}(q)$  is the NR higher limit of the maximum configured power expressed in linear scale;
- $p_{CMAX,L,E-UTRA,c}(p)$  is the E-UTRA lower limit of the maximum configured power expressed in linear scale;
- $p_{CMAX,L,NR,c}(q)$  is the NR lower limit of the maximum configured power expressed in linear scale;

- $P_{\text{PowerClass, EN-DC}}$  is defined in clause 6.2B.1.3-1 for inter-band EN-DC; if the UE indicates *higherPowerLimitMRDC-r17*,  $P_{\text{PowerClass, EN-DC}}$  is replaced by the sum of the linear powers of  $P_{\text{PowerClass, NR}}$  and  $P_{\text{PowerClass, E-UTRA}}$  converted to dB;
- $X_{\text{scale}}$  is the linear value of X dB which is configured by RRC and can only take values [0, 6]
- $P_{\text{CMAX, E-UTRA, c}}(p)$  is the linear value of  $P_{\text{CMAX, E-UTRA, c}}(p)$ , the configured max power for E-UTRA. If more than one E-UTRA uplink serving cell is configured as intra-band UL CA in the E-UTRA CG,  $P_{\text{CMAX, E-UTRA, c}}(p)$  will be replaced by  $P_{\text{CMAX}}(p)$  which is the configured maximum power for the entire E-UTRA CG.
- $P_{\text{CMAX, f.c, NR}}(q)$  is the linear value of  $P_{\text{CMAX, f.c, NR}}(q)$ , the configured max power of NR, If more than one NR uplink serving cell is configured as intra-band UL CA in the NR CG,  $P_{\text{CMAX, NR, c}}(q)$  will be replaced by  $P_{\text{CMAX}}(q)$  which is the configured maximum power for the entire NR CG.

**Table 6.2B.4.1.0.1.3-2:  $P_{\text{CMAX}}$  tolerance for Dual Connectivity E-UTRA-NR**

$P_{\text{CMAX}}(\text{dBm})$	Tolerance $T_{\text{LOW}}(P_{\text{CMAX, L}})$ (dB)	Tolerance $T_{\text{HIGH}}(P_{\text{CMAX, H}})$ (dB)
$23 \leq P_{\text{CMAX}} \leq 33$	3.0	2.0
$22 \leq P_{\text{CMAX}} < 23$	5.0	2.0
$21 \leq P_{\text{CMAX}} < 22$	5.0	3.0
$20 \leq P_{\text{CMAX}} < 21$	6.0	4.0
$16 \leq P_{\text{CMAX}} < 20$	5.0	
$11 \leq P_{\text{CMAX}} < 16$	6.0	
$-40 \leq P_{\text{CMAX}} < 11$	7.0	
NOTE 1: For UEs not indicating support of dynamic power sharing, the upper tolerance $T_{\text{high}}$ shall be reduced by 0.3 dB for $P \geq 20$ dBm.		

When E-UTRA and NR transmissions overlap and the condition (If (a=TRUE) AND (b=FALSE)) is met, SCG shall be transmitted and the following supplementary minimum requirement apply for the measured SCG power,  $P_{\text{UMAX, f.c, NR}}(q)$ , under nominal conditions.

$$10\log(p_{\text{CMAX, L, f.c, NR, c}}(q)/X_{\text{scale}}) - T_{\text{LOW}}(10\log(p_{\text{CMAX, L, f.c, NR, c}}(q)/X_{\text{scale}})) \leq P_{\text{UMAX, f.c, NR}}(q) \leq 10\log(p_{\text{CMAX, H, f.c, NR, c}}(q)) + T_{\text{HIGH}}(10\log(p_{\text{CMAX, H, f.c, NR, c}}(q)))$$

with the tolerances  $T_{\text{LOW}}$  and  $T_{\text{HIGH}}$  for applicable values of  $P_{\text{CMAX}}$  specified in Table 6.2B.4.1.0.1.3-2.

#### 6.2B.4.1.0.1.4 Inter-band EN-DC including FR2

For inter-band dual connectivity with one uplink serving cell per CG on E-UTRA and NR respectively, with NR configured in FR2, the UE is allowed to set its configured maximum output power  $P_{\text{CMAX, c(i), i}}$  for serving cell c(i) of CG i,  $i = 1, 2$ .

The UE maximum configured power  $P_{\text{CMAX, c(i)}}$ , on E-UTRA for the subframe i shall be set according to clause 6.2.5 from TS 36.101 [5]. Applicable inter-band  $\Delta T_{\text{IB, c}}$  parameters shall be used according to the clauses 6.2B.4.2.4 or 6.2B.4.2.5.

The UE maximum configured power  $P_{\text{CMAX, c(j)}}$ , on NR for the slot j shall be set according to clause 6.2.4 from TS 38.101-2 [3].

For the configured power measurements TS 36.101 [5] clause 6.2.5 and TS 38.101-2 [3] clause 6.2.4 are applicable.

#### 6.2B.4.1.0.1.5 Inter-band EN-DC including both FR1 and FR2

For inter-band dual connectivity with one uplink serving cell per CG on E-UTRA and NR respectively, with both CGs configured in FR1, the requirements specified in clause 6.2B.4.1.0.1.3 apply.

For inter-band dual connectivity with one uplink serving cell per CG on E-UTRA and NR respectively, with NR configured in FR2, the requirements specified in clause 6.2B.4.1.0.1.4 apply.

For inter-band dual connectivity with one uplink serving cell in first CG on E-UTRA and two uplink serving cells in second CG on NR FR1 and NR FR2 respectively, the UE is allowed to set its configured maximum output power  $P_{\text{CMAX, c(i), i}}$  for serving cell c(i),  $i = 1, 2, 3$  with  $i=1$  for E-UTRA,  $i=2$  for NR FR1 and  $i=3$  for NR FR2.

- For serving cell on FR2, the requirements specified in clause 6.2.4 in TS 38.101-2 [3] apply to the UE maximum configured power  $P_{\text{CMAX},c(3),3}$  and the measured maximum configured power.
- For remaining inter-band dual connectivity involving CG1 and CG2, the requirements specified in clause 6.2B.4.1.0.1.3 apply.

### 6.2B.4.1.1 Configured Output Power Level for Intra-Band Contiguous EN-DC

#### 6.2B.4.1.1.1 Test purpose

To verify the UE does not exceed the power bounds defined by  $P_{\text{CMAX}_L}$  and  $P_{\text{CMAX}_H}$

#### 6.2B.4.1.1.2 Test applicability

This test case applies to all types of E-UTRA UE release 15 and forward, supporting intra-band contiguous EN-DC.

#### 6.2B.4.1.1.3 Minimum conformance requirements

The minimum conformance requirements are defined in clause 6.2B.4.1.0.1.1.

Exception requirements for both NR and E-UTRA are defined for this test and therefore LTE anchor agnostic approach is not applied. E-UTRA test point analysis is included and E-UTRA measurements are performed.

#### 6.2B.4.1.1.4 Test description

##### 6.2B.4.1.1.4.1 Initial conditions

Initial conditions are a set of test configurations the UE needs to be tested in and the steps for the SS to take with the UE to reach the correct measurement state.

The initial test configurations consist of environmental conditions, test frequencies and channel bandwidths based on EN-DC operating bands specified in clause 5.3B.1.2, channel bandwidths and sub-carrier spacings for the NR cell specified in TS 38.521-1 [8] clause 5.3 and channel bandwidth for the E-UTRA cell are specified in TS 36.521-1 [10] clause 5.4.2. All of these configurations shall be tested with applicable test parameters for each EN-DC configuration specified in clause 5.3B.1.2 and are shown in table 6.2B.4.1.1.4.1-1. The details of the uplink reference measurement channels (RMCs) are specified in Annex A, clause A.2.2 for E-UTRA RMC for TDD, TS 36.521-1 [10] Annex A, clause A.2.2 for E-UTRA RMC for FDD, and TS 38.521-1 [8] Annex A, clause A.2 for NR RMC. Configurations of PDSCH and PDCCH before measurement are specified in TS 36.521-1 [10] Annex C.2 and in TS 38.521-1 [8] Annex C.2 for E-UTRA CG and NR CG respectively.

**Table 6.2B.4.1.1.4.1-1: Test configurations table for intra-band contiguous EN-DC**

		Initial Conditions					
Test Environment as specified in TS 38.508-1 [5] clause 4.1		Normal, TL/VL, TL/VH, TH/VL, TH/VH					
NR and E-UTRA Test Frequencies as specified in TS 38.508-1 [5] clause 4.3.1		Mid range					
Test EN-DC bandwidth combination as specified in TS 38.508-1 [5] clause 4.3.1		Lowest $N_{RB\_agg}$ , Highest $N_{RB\_agg}$					
NR Test SCS as specified in Table 5.3.5-1 in TS 38.521-1 [8]		Highest					
NR/E-UTRA Test Parameters for UE supporting DPS							
Test ID (NOTE 3)	Downlink Configuration	EN-DC Uplink Configuration					
		E-UTRA Cell			NR Cell		
		Modulation	RB allocation (NOTE 2)	$P_{LTE}$	Modulation	RB allocation (NOTE 1)	$P_{NR}$
1a-1f	N/A	QPSK	Full_Allocation	{-13, 7, 12, 15, 19, 23} for PC3 UE {-13, 7, 12, 15, 21, 26} for PC2 UE	CP-OFDM QPSK	Outer_Full	{-13, 7, 12, 15, 18, 23} for PC3 UE {-13, 7, 12, 15, 21, 26} for PC2 UE
2a-2c		QPSK	Partial_Allocation	{-10, 10, 15}	N/A	N/A	{-10, 10, 15}
3a-3c		N/A	N/A	{-10, 10, 15}	DFT-s-OFDM QPSK	Inner Full	{-10, 10, 15}
NR/E-UTRA Test Parameters for UE not supporting DPS							
Test ID (NOTE 3)	Downlink Configuration	EN-DC Uplink Configuration					
		E-UTRA Cell			NR Cell		
		Modulation	RB allocation (NOTE 2)	$P_{LTE}$	Modulation	RB allocation (NOTE 1)	$P_{NR}$
1a-1d	N/A	QPSK	Full_Allocation	{-10, 10, 15, 23} for PC3 UE {-10, 10, 15, 26} for PC2 UE	CP-OFDM QPSK	Outer_Full	{-10, 10, 15, 23} for PC3 UE {-10, 10, 15, 26} for PC2 UE
2a-2c		QPSK	Partial_Allocation	{-10, 10, 15}	N/A	N/A	{-10, 10, 15}
3a-3c		N/A	N/A	{-10, 10, 15}	DFT-s-OFDM QPSK	Inner Full	{-10, 10, 15}
NOTE 1: The specific configuration of each RB allocation is defined in Table 6.1-1 in TS 38.521-1 [8].							
NOTE 2: The specific configuration of each RB allocation is defined in Table 6.1-1 in current specification.							
NOTE 3: The suffix in Test ID identifies the configured power level being tested from the $P_{LTE}$ and $P_{NR}$ lists							

**Table 6.2B.4.1.1.4.1-2: Void**

1. Connect the SS to the UE antenna connectors as shown in [6] TS 38.508-1 A.3.1.2.1 for SS diagram and A.3.2.1 for UE diagram.
2. The parameter settings for the E-UTRA cell are set up according to TS 36.508 [11] clause 4.4.3, and the parameter settings for the NR cell are set up according to TS 38.508-1 [6] clause 4.4.3.
3. Downlink signals are initially set up according to TS 36.521-1 [10] Annex C.0 and TS 38.521-1 [8] Annex C.0 for E-UTRA CG and NR CG respectively, and uplink signals according to TS 36.521-1 [10] Annex H and TS 38.521-1 [8] Annex G for E-UTRA CG and NR CG respectively.
4. The UL Reference Measurement channels are set for E-UTRA CG and NR CG respectively.

5. Propagation conditions are set according to TS 36.521-1 [10] Annex B.0 and TS 38.521-1 [8] Annex B.0 for E-UTRA CG and NR CG respectively.
6. Ensure the UE is in state RRC\_CONNECTED with generic procedure parameters Connectivity EN-DC, DC bearer MCG and SCG, Connected without release *On* according to TS 38.508-1 [6] clause 4.5. Message contents are defined in clause 6.2B.4.1.1.4.3.
7. When E-UTRA and NR bands are TDD, ensure the same uplink-downlink configuration by giving SCG a delay of 3 E-UTRA subframes, or by giving MCG a delay of 2 subframes.

6.2B.4.1.1.4.2 Test procedure

1. SS sends uplink scheduling information for each UL HARQ process via PDCCH DCI format 0 and DCI format 0\_1 for C\_RNTI to schedule the UL RMC according table 6.2B.4.1.1.4.1-1 on E-UTRA CC and NR CC respectively. For test points configured with message in Table 6.2B.4.1.1.4.3-1, NR SS only schedules UL RMC on NR slots that does not overlap with E-UTRA uplink subframe. Since the UE has no payload and no loopback data to send the UE sends uplink MAC padding bits on the UL RMC.
2. Send continuously uplink power control "up" commands to the UE for NR and E-UTRA carrier until the UE transmits at its P<sub>UMAX</sub> level; allow at least 200 ms from the first TPC command for the UE to reach P<sub>UMAX</sub> level.
3. Measure the mean transmitted power over E-UTRA component carrier and NR component carrier respectively, or/and measure the sum of mean transmitted power over E-UTRA and NR component carriers according to Table 6.2B.4.1.1.5-1 and Table 6.2B.4.1.1.5-2. The period of the measurement shall be at least the continuous duration of one active sub-frame. For TDD, only slots consisting of only UL symbols are under test.

NOTE 1: When switching to DFT-s-OFDM waveform, as specified in the test configuration Table 6.2B.4.1.1.4.1-1, send an NR RRCReconfiguration message according to TS 38.508-1 [6] clause 4.6.3 Table 4.6.3-118 PUSCH-Config with TRANSFORM\_PRECODER\_ENABLED condition.

6.2B.4.1.1.4.3 Message contents

Message contents are according to TS 36.508 [11] clause 4.6.1 and TS 38.508-1 [6] clause 4.6.1 with the following exceptions.

**Table 6.2B.4.1.1.4.3-1: RRCConnectionReconfiguration: tdm-PatternConfig if E-UTRA on FDD band and UE doesn't support dynamic power sharing**

Derivation Path: TS 36.508 [11], Table 4.6.1-8			
Information Element	Value/remark	Comment	Condition
tdm-PatternConfig-r15 CHOICE{			Test ID 1d
setup SEQUENCE {			
subframeAssignment-r15	sa2		
harq-Offset-r15	0		
}			
}			

**Table 6.2B.4.1.1.4.3-2: SystemInformationBlockType1: tdd-Config if E-UTRA on TDD band**

Derivation Path: TS 36.508 [11], Table 4.6.3-23			
Information Element	Value/remark	Comment	Condition
TDD-Config-DEFAULT ::= SEQUENCE {		Operating on TDD band	
subframeAssignment	sa2		
specialSubframePatterns	ssp7		
}			

**Table 6.2B.4.1.1.4.3-3: RRCConnectionReconfiguration: nr-Config-r15**

Derivation Path: TS 36.508 [11], Table 4.6.1-8			
Information Element	Value/remark	Comment	Condition
p-MaxEUTRA-r15	Defined as P <sub>LTE</sub> in Table 6.2B.4.1.1.4.1-1		

**Table 6.2B.4.1.1.4.3-4: PhysicalCellGroupConfig**

Derivation Path: TS 38.508-1 [6], Table 4.6.3-106			
Information Element	Value/remark	Comment	Condition
PhysicalCellGroupConfig ::= SEQUENCE {			
p-NR-FR1	Defined as P <sub>NR</sub> in Table 6.2B.4.1.1.4.1-1		
}			

**Table 6.2B.4.1.1.4.3-5: RRCConnectionReconfiguration: p-MaxUE-FR1-r15**

Derivation Path: TS 36.508 [11], Table 4.6.1-8			
Information Element	Value/remark	Comment	Condition
nonCriticalExtension		RRCCConnectionReconfiguration-v1530-IEs	
SEQUENCE {			
p-MaxUE-FR1-r15	23		Power Class 3 UE
	26		Power Class 2 UE
}			

6.2B.4.1.1.5 Test requirement

For UE supporting DPS, the output power measured shall not exceed the values specified in Table 6.2B.4.1.1.5-1.

**Table 6.2B.4.1.1.5-1: P<sub>C<sub>MAX</sub></sub> configured UE output power for UE supporting DPS**

	E-UTRA component carrier	NR component carrier	Total power measured over E-UTRA and NR component carriers

Test ID 1a	Not measured	Not measured	-10dBm $\pm$ (7+TT)
Test ID 1b	Not measured	Not measured	10dBm $\pm$ (7+TT)
Test ID 1c	Not measured	Not measured	15 $\pm$ (6+TT)
Test ID 1d	Not measured	Not measured	18 $\pm$ (5+TT)
Test ID 1e	Not measured	18 + (5+TT) / 11 - (6+TT) for PC3 UE	21.54dBm + (3+TT) / 19.64 - (5+TT) for PC3 UE
		21 + (3+TT) / 14 - (6+TT) for PC2 UE (Rel-15 UE indicates PC2 on NR band, Rel-16 and forward UE reporting (PC2 by $P_{PowerClass,NR}$ , and PC2 or Not present by <i>powerClassNRPart-r16</i> ))	24 + (2+TT) / 21.8 - (5+TT) for PC2 UE (Rel-15 UE indicates PC2 on NR band, Rel-16 and forward UE reporting (PC2 by $P_{PowerClass,NR}$ , and PC2 or Not present by <i>powerClassNRPart-r16</i> ))
		21 + (3+TT) / 11 - (6+TT) for PC2 UE (Rel-15 and forward UE indicates PC3 on NR band, Rel-16 and forward UE reporting (PC2 by $P_{PowerClass,NR}$ , and PC3 by <i>powerClassNRPart-r16</i> ))	24 + (2+TT) / 21.4 - (5+TT) for PC2 UE (Rel-15 and forward UE indicates PC3 on NR band, Rel-16 and forward UE reporting (PC2 by $P_{PowerClass,NR}$ , and PC3 by <i>powerClassNRPart-r16</i> ))
Test ID 1f	Maximum output power with reduction as defined in Table 6.2.3.5-1 of TS 36.521-1 [10] for PC3 UE	N/A	Maximum output power with reduction as defined in Table 6.2.3.5-1 of TS 36.521-1 [10] for PC3 UE
	Maximum output power with reduction as defined in Table 6.2.3_1.5-1 of TS 36.521-1 [10] for PC2 UE		Maximum output power with reduction as defined in Table 6.2.3_1.5-1 of TS 36.521-1 [10] for PC2 UE
Test ID 2a	-10dBm $\pm$ (7+TT)	N/A-	Not measured
Test ID 2b	10dBm $\pm$ (6+TT)	N/A-	Not measured
Test ID 2c	15dBm $\pm$ (5+TT)	N/A-	Not measured
Test ID 3a	N/A	-10dBm $\pm$ (7+TT)	Not measured
Test ID 3b	N/A	10dBm $\pm$ (6+TT)	Not measured
Test ID 3c	N/A	15dBm $\pm$ (5+TT)	Not measured
NOTE 1: In addition NOTE 2 in Table 6.2.2-1 in TS 36.101 [5] and/or NOTE 3 in Table 6.2.1-1 in TS 38.101-1 [2] shall apply to the tolerances.			
NOTE 2: TT for each frequency and channel bandwidth is specified in Table 6.2B.4.1.1.5-3			

For UE not supporting DPS, the output power measured shall not exceed the values specified in Table 6.2B.4.1.1.5-2.

**Table 6.2B.4.1.1.5-2:  $P_{C_{MAX}}$  configured UE output power for UE not supporting DPS**

	E-UTRA component carrier	NR component carrier	Total power measured over E-UTRA and NR component carriers
--	--------------------------	----------------------	--

Test ID 1a	-10 dBm $\pm$ (7+TT)	-10 dBm $\pm$ (7+TT)	Not measured
Test ID 1b	10 dBm $\pm$ (6+TT)	10 dBm $\pm$ (6+TT)	Not measured
Test ID 1c	15 dBm $\pm$ (5+TT)	15 dBm $\pm$ (5+TT)	Not measured
Test ID 1d	Maximum output power with reduction as defined in Table 6.2.3.5-1 of TS 36.521-1 [10] for PC3 UE	N/A	Not measured
	Maximum output power with reduction as defined in Table 6.2.3_1.5-1 of TS 36.521-1 [10] for PC2 UE		
Test ID 2a	-10dBm $\pm$ (7+TT)	N/A	Not measured
Test ID 2b	10dBm $\pm$ (6+TT)	N/A	Not measured
Test ID 2c	15dBm $\pm$ (5+TT)	N/A	Not measured
Test ID 3a	N/A	-10dBm $\pm$ (7+TT)	Not measured
Test ID 3b	N/A	10dBm $\pm$ (6+TT)	Not measured
Test ID 3c	N/A	15dBm $\pm$ (5+TT)	Not measured
NOTE 1: In addition NOTE 2 in Table 6.2.2-1 in TS 36.101 [5] and/or NOTE 3 in Table 6.2.1-1 in TS 38.101-1 [2] shall apply to the tolerances.			
NOTE 2: TT for each frequency and channel bandwidth is specified in Table 6.2B.4.1.1.5-3			

**Table 6.2B.4.1.1.5-3: Test Tolerance (UE configured UE output power)**

	$f \leq 3.0\text{GHz}$	$3.0\text{GHz} < f \leq 4.2\text{GHz}$	$4.2\text{GHz} < f \leq 6.0\text{GHz}$
<b>ENBW <math>\leq 40\text{MHz}</math></b>	0.7 dB <sup>1</sup> 1.0 dB <sup>2</sup>	1.0 dB	1.0 dB
<b>40MHz &lt; ENBW <math>\leq 100\text{MHz}</math></b>	1.0 dB	1.0 dB	1.0 dB
Note 1: Applicable for test point with UL power $\geq 0$ dBm.			
Note 2: Applicable for test point with UL power < 0 dBm.			

## 6.2B.4.1.2 Configured Output Power for Intra-Band Non-Contiguous EN-DC

### 6.2B.4.1.2.1 Test purpose

To verify the UE does not exceed the power bounds defined by  $P_{\text{CMAX\_L}}$  and  $P_{\text{CMAX\_H}}$ .

### 6.2B.4.1.2.2 Test applicability

This test case applies to all types of E-UTRA UE release 15 and forward, supporting intra-band non-contiguous EN-DC.

### 6.2B.4.1.2.3 Minimum conformance requirements

The minimum conformance requirements are defined in clause 6.2B.4.1.0.1.2.

Exception requirements for both NR and E-UTRA are defined for this test and therefore LTE anchor agnostic approach is not applied. E-UTRA test point analysis is included and E-UTRA measurements are performed.

### 6.2B.4.1.2.4 Test description

#### 6.2B.4.1.2.4.1 Initial conditions

Initial conditions are a set of test configurations the UE needs to be tested in and the steps for the SS to take with the UE to reach the correct measurement state.

The initial test configurations consist of environmental conditions, test frequencies and channel bandwidths based on EN-DC operating bands specified in clause 5.3B.1.3, channel bandwidths and sub-carrier spacings for the NR cell specified in TS 38.521-1 [8] clause 5.3 and channel bandwidth for the E-UTRA cell are specified in TS 36.521-1 [10] clause 5.4.2. All of these configurations shall be tested with applicable test parameters for each EN-DC configuration specified in clause 5.3B.1.3 and are shown in table 6.2B.4.1.2.4.1-1. The details of the uplink reference measurement channels (RMCs) are specified in Annex A, clause A.2.2 for E-UTRA RMC for TDD, TS 36.521-1 [10] Annex A,



clause A.2.2 for E-UTRA RMC for FDD, and TS 38.521-1 [8] Annex A, clause A.2 for NR RMC. Configurations of PDSCH and PDCCH before measurement are specified in TS 36.521-1 [10] Annex C.2 and in TS 38.521-1 [8] Annex C.2 for E-UTRA CG and NR CG respectively.

**Table 6.2B.4.1.2.4.1-1: Test configurations table for intra-band non-contiguous EN-DC**

		Initial Conditions					
Test Environment as specified in TS 38.508-1 [5] clause 4.1		Normal, TL/VL, TL/VH, TH/VL, TH/VH					
NR and E-UTRA Test Frequencies as specified in TS 38.508-1 [5] clause 4.3.1		Maximum Wgap					
Test EN-DC bandwidth combination as specified in TS 38.508-1 [5] clause 4.3.1		Lowest N <sub>RB_agg</sub> , Highest N <sub>RB_agg</sub>					
NR Test SCS as specified in Table 5.3.5-1 in TS 38.521-1 [8]		Highest (NOTE 4)					
NR/E-UTRA Test Parameters for UE supporting DPS							
Test ID (NOTE 3)	Downlink Configuration	EN-DC Uplink Configuration					
		E-UTRA Cell			NR Cell		
		Modulation	RB allocation (NOTE 2)	P <sub>LTE</sub>	Modulation	RB allocation (NOTE 1)	P <sub>NR</sub>
1a-1d	N/A	QPSK	Full_Allocation	{-13, 7, 10, 23} for PC3 UE {-13, 7, 12, 26} for PC2 UE	CP-OFDM QPSK	Outer_Full	{-13, 7, 10, 23} for PC3 UE {-13, 7, 13, 26} for PC2 UE
2a-2c		QPSK	Partial_Allocation	{-10, 10, 15}	N/A	N/A	{-10, 10, 15}
3a-3c		N/A	N/A	{-10, 10, 15}	DFT-s-OFDM QPSK	Inner Full	{-10, 10, 15}
NR/E-UTRA Test Parameters for UE not supporting DPS							
Test ID (NOTE 3)	Downlink Configuration	EN-DC Uplink Configuration					
		E-UTRA Cell			NR Cell		
		Modulation	RB allocation (NOTE 2)	P <sub>LTE</sub>	Modulation	RB allocation (NOTE 1)	P <sub>NR</sub>
1a-1b	N/A	QPSK	Full_Allocation	{-10, 23} for PC3 UE {-10, 26} for PC2 UE	CP-OFDM QPSK	Outer_Full	{-10, 23} for PC3 UE {-10, 26} for PC2 UE
2a-2c		QPSK	Partial_Allocation	{-10, 10, 15}	N/A	N/A	{-10, 10, 15}
3a-3c		N/A	N/A	{-10, 10, 15}	DFT-s-OFDM QPSK	Inner Full	{-10, 10, 15}
NOTE 1: The specific configuration of each RB allocation is defined in Table 6.1-1 in TS 38.521-1 [8].							
NOTE 2: The specific configuration of each RB allocation is defined in Table 6.1-1 in current specification.							
NOTE 3: The suffix in Test ID identifies the configured power level being tested from the P <sub>LTE</sub> and P <sub>NR</sub> lists.							
NOTE 4: For DC_(n)71AA, only NR SCS of 15 kHz is tested.							

**Table 6.2B.4.1.2.4.1-2: Void**

1. Connect the SS to the UE antenna connectors as shown in [6] TS 38.508-1 A.3.1.2.1 for SS diagram and A.3.2.1 for UE diagram.
2. The parameter settings for the E-UTRA cell are set up according to TS 36.508 [11] clause 4.4.3, and the parameter settings for the NR cell are set up according to TS 38.508-1 [6] clause 4.4.3.

3. Downlink signals are initially set up according to TS 36.521-1 [10] Annex C.0 and TS 38.521-1 [8] Annex C.0 for E-UTRA CG and NR CG respectively, and uplink signals according to TS 36.521-1 [10] Annex H and TS 38.521-1 [8] Annex G for E-UTRA CG and NR CG respectively.
4. The UL Reference Measurement channels are set for E-UTRA CG and NR CG respectively.
5. Propagation conditions are set according to TS 36.521-1 [10] Annex B.0 and TS 38.521-1 [8] Annex B.0 for E-UTRA CG and NR CG respectively.
6. Ensure the UE is in state RRC\_CONNECTED with generic procedure parameters Connectivity EN-DC, DC bearer MCG and SCG, Connected without release On according to TS 38.508-1 [6] clause 4.5. Message contents are defined in clause 6.2B.4.1.2.4.3.
7. When E-UTRA and NR bands are TDD, ensure the same uplink-downlink configuration by giving SCG a delay of 3 E-UTRA subframes, or by giving MCG a delay of 2 subframes.

6.2B.4.1.2.4.2 Test procedure

1. SS sends uplink scheduling information for each UL HARQ process via PDCCH DCI format 0 and DCI format 0\_1 for C\_RNTI to schedule the UL RMC according table 6.2B.4.1.2.4.1-1 on E-UTRA CC and NR CC respectively. Since the UE has no payload and no loopback data to send the UE sends uplink MAC padding bits on the UL RMC.
2. Send continuously uplink power control "up" commands to the UE for NR and E-UTRA carrier until the UE transmits at its P<sub>UMAX</sub> level; allow at least 200 ms from the first TPC command for the UE to reach P<sub>UMAX</sub> level.
3. Measure the mean transmitted power over E-UTRA component carrier and NR component carrier respectively, or/and measure the sum of mean transmitted power over E-UTRA and NR component carriers according to Table 6.2B.4.1.2.5-1 and Table 6.2B.4.1.2.5-2. The period of the measurement shall be at least the continuous duration of one active sub-frame. For TDD, only slots consisting of only UL symbols are under test.

NOTE 1: When switching to DFT-s-OFDM waveform, as specified in the test configuration Table 6.2B.4.1.2.4.1-1, send an NR RRCReconfiguration message according to TS 38.508-1 [6] clause 4.6.3 Table 4.6.3-118 PUSCH-Config with TRANSFORM\_PRECODER\_ENABLED condition.

6.2B.4.1.2.4.3 Message contents

Message contents are according to TS 36.508 [11] clause 4.6.1 and TS 38.508-1 [6] clause 4.6.1 with the following exceptions.

**Table 6.2B.4.1.2.4.3-1: RRCConnectionReconfiguration: tdm-PatternConfig if E-UTRA on FDD band and UE doesn't support dynamic power sharing**

Derivation Path: TS 36.508 [11], Table 4.6.1-8			
Information Element	Value/remark	Comment	Condition
tdm-PatternConfig-r15 CHOICE{			
setup SEQUENCE {			
subframeAssignment-r15	sa2		
harq-Offset-r15	0		
}			
}			

**Table 6.2B.4.1.2.4.3-2: SystemInformationBlockType1: tdd-Config if E-UTRA on TDD band**

Derivation Path: TS 36.508 [11], Table 4.6.3-23			
Information Element	Value/remark	Comment	Condition
TDD-Config-DEFAULT ::= SEQUENCE {		Operating on TDD band	
subframeAssignment	sa2		
specialSubframePatterns	ssp7		
}			

**Table 6.2B.4.1.2.4.3-3: RRCConnectionReconfiguration: nr-Config-r15**

Derivation Path: TS 36.508 [11], Table 4.6.1-8			
Information Element	Value/remark	Comment	Condition
p-MaxEUTRA-r15	Defined as P <sub>LTE</sub> in Table 6.2B.4.1.2.4.1-1		

**Table 6.2B.4.1.2.4.3-4: PhysicalCellGroupConfig**

Derivation Path: TS 38.508-1 [6], Table 4.6.3-106			
Information Element	Value/remark	Comment	Condition
PhysicalCellGroupConfig ::= SEQUENCE {			
p-NR-FR1	Defined as P <sub>NR</sub> in Table 6.2B.4.1.2.4.1-1		
}			

**Table 6.2B.4.1.2.4.3-5: RRCConnectionReconfiguration: p-MaxUE-FR1-r15**

Derivation Path: TS 36.508 [11], Table 4.6.1-8			
Information Element	Value/remark	Comment	Condition
nonCriticalExtension ::= SEQUENCE {		RRCCConnectionReconfiguration-v1530-IEs	
p-MaxUE-FR1-r15	23		Power Class 3 UE
	26		Power Class 2 UE
}			

#### 6.2B.4.1.2.5 Test requirement

For UE supporting DPS, the output power measured shall not exceed the values specified in Table 6.2B.4.1.2.5-1.

**Table 6.2B.4.1.2.5-1: P<sub>C<sub>MAX</sub></sub> configured UE output power for UE supporting DPS**

	E-UTRA component carrier	NR component carrier	Total power measured over E-UTRA and NR component carriers
Test ID 1a	Not measured	Not measured	-10dBm ± (7+TT)
Test ID 1b	Not measured	Not measured	10dBm ± (7+TT)
Test ID 1c	Not measured	$10 + (7+TT) / 2 - (7+TT)$ for PC3 UE	$13.0 + (6+TT) / 10.64 - (7+TT)$ for PC3 UE
		$13 + (6+TT) / 5 - (7+TT)$ for PC2 UE (Rel-15 UE indicates PC2 on NR band, Rel-16 and forward UE reporting (PC2 by P <sub>PowerClass,NR</sub> , and PC2 or Not present by <i>powerClassNRPart-r16</i> ))	$15.5 + (6+TT) / 12.8 - (6+TT)$ for PC2 UE (Rel-15 UE indicates PC2 on NR band, Rel-16 and forward UE reporting (PC2 by P <sub>PowerClass,NR</sub> , and PC2 or Not present by <i>powerClassNRPart-r16</i> ))
		$13 + (6+TT) / 2 - (7+TT)$ for PC2 UE (Rel-15 and forward UE indicates PC3 on NR band, Rel-16 and forward UE reporting (PC2 by P <sub>PowerClass,NR</sub> , and PC3 by <i>powerClassNRPart-r16</i> ))	$15.5 + (6+TT) / 12.4 - (6+TT)$ for PC2 UE (Rel-15 and forward UE indicates PC3 on NR band, Rel-16 and forward UE reporting (PC2 by P <sub>PowerClass,NR</sub> , and PC3 by <i>powerClassNRPart-r16</i> ))
Test ID 1d	Maximum output power with reduction as defined in Table 6.2.3.5-1 of TS 36.521-1 [10] for PC3 UE	N/A	Maximum output power with reduction as defined in Table 6.2.3.5-1 of TS 36.521-1 [10] for PC3 UE
	Maximum output power with reduction as defined in Table 6.2.3_1.5-1 of TS 36.521-1 [10] for PC2 UE		Maximum output power with reduction as defined in Table 6.2.3_1.5-1 of TS 36.521-1 [10] for PC2 UE
Test ID 2a	-10dBm ± (7+TT)	N/A	Not measured
Test ID 2b	10dBm ± (6+TT)	N/A	Not measured
Test ID 2c	15dBm ± (5+TT)	N/A	Not measured
Test ID 3a	N/A	-10dBm ± (7+TT)	Not measured
Test ID 3b	N/A	10dBm ± (6+TT)	Not measured
Test ID 3c	N/A	15dBm ± (5+TT)	Not measured
NOTE 1: In addition NOTE 2 in Table 6.2.2-1 in TS 36.101 [5] and/or NOTE 3 in Table 6.2.1-1 in TS 38.101-1 [2] shall apply to the tolerances.			
NOTE 2: TT for each frequency and channel bandwidth is specified in Table 6.2B.4.1.1.5-3			

For UE not supporting DPS, the output power measured shall not exceed the values specified in Table 6.2B.4.1.1.5-2.

**Table 6.2B.4.1.2.5-2: P<sub>C<sub>MAX</sub></sub> configured UE output power for UE not supporting DPS**

	E-UTRA component carrier	NR component carrier	Total power measured over E-UTRA and NR component carriers
--	--------------------------	----------------------	--

Test ID 1a	-10 dBm ± (7+TT)	-10 dBm ± (7+TT)	Not measured
Test ID 1b	Maximum output power with reduction as defined in Table 6.2.3.5-1 of TS 36.521-1 [10] for PC3 UE	N/A	Not measured
	Maximum output power with reduction as defined in Table 6.2.3_1.5-1 of TS 36.521-1 [10] for PC2 UE		
Test ID 2a	-10dBm ± (7+TT)	N/A	Not measured
Test ID 2b	10dBm ± (6+TT)	N/A	Not measured
Test ID 2c	15dBm ± (5+TT)	N/A	Not measured
Test ID 3a	N/A	-10dBm ± (7+TT)	Not measured
Test ID 3b	N/A	10dBm ± (6+TT)	Not measured
Test ID 3c	N/A	15dBm ± (5+TT)	Not measured
NOTE 1: In addition NOTE 2 in Table 6.2.2-1 in TS 36.101 [5] and/or NOTE 3 in Table 6.2.1-1 in TS 38.101-1 [2] shall apply to the tolerances.			
NOTE 2: TT for each frequency and channel bandwidth is specified in Table 6.2B.4.1.1.5-3			

**Table 6.2B.4.1.2.5-3: Test Tolerance for UE configured UE output power (Separate measurements over E-UTRA and NR CCs)**

Uplink TX		f ≤ 3.0GHz	3.0GHz < f ≤ 4.2GHz	4.2GHz < f ≤ 6GHz
E-UTRA	BW ≤ 20MHz	0.7 dB	1.0 dB	N/A
NR	BW ≤ 40MHz	0.7 dB <sup>1</sup> 1.0 dB <sup>2</sup>	1.0 dB	1.0 dB
	40MHz < BW ≤ 100MHz	1.0 dB	1.0 dB	1.0 dB
Note 1: Applicable for test point with UL power ≥ 0 dBm.				
Note 2: Applicable for test point with UL power < 0 dBm.				

**Table 6.2B.4.1.2.5-4: Test Tolerance for UE configured UE output power (Combined measurements of E-UTRA and NR CCs)**

TT for overall output power											
			NR								
			BW ≤ 20MHz			20 MHz < BW ≤ 40MHz			40MHz < BW ≤ 100MHz		
			f ≤ 3.0GHz	3.0GHz < f ≤ 4.2GHz	4.2GHz < f ≤ 6.0GHz	f ≤ 3.0GHz	3.0GHz < f ≤ 4.2GHz	4.2GHz < f ≤ 6.0GHz	f ≤ 3.0GHz	3.0GHz < f ≤ 4.2GHz	4.2GHz < f ≤ 6.0GHz
E-UTRA	BW ≤ 20MHz	f ≤ 3.0GHz	0.7 dB <sup>1</sup> 1.0 dB <sup>2</sup>	1.0 dB	1.0 dB	0.7 dB <sup>1</sup> 1.0 dB <sup>2</sup>	1.0 dB	1.0 dB	1.0 dB	1.0 dB	1.0 dB
		3.0GHz < f ≤ 4.2GHz	1.0 dB	1.0 dB	1.0 dB	1.0 dB	1.0 dB	1.0 dB	1.0 dB	1.0 dB	1.0 dB
Note 1: Applicable for test point with UL power ≥ 0 dBm.											
Note 2: Applicable for test point with UL power < 0 dBm.											

6.2B.4.1.3 Configured Output Power for Inter-Band EN-DC within FR1 (1 E-UTRA CC, 1 NR CC)

6.2B.4.1.3.1 Test purpose

To verify the UE does not exceed the power bounds defined by P<sub>CMAX</sub> and P<sub>CMAX,H</sub>.

6.2B.4.1.3.2 Test applicability

This test case applies to all types of E-UTRA UE release 15 and forward, supporting inter-band EN-DC with 1 E-UTRA CC and 1 NR CC within FR1.

#### 6.2B.4.1.3.3 Minimum conformance requirements

The minimum conformance requirements are defined in clause 6.2B.4.1.0.1.3.

Exception requirements for both NR and E-UTRA are defined for this test and therefore LTE anchor agnostic approach is not applied. E-UTRA test point analysis is included and E-UTRA measurements are performed.

#### 6.2B.4.1.3.4 Test description

##### 6.2B.4.1.3.4.1 Initial conditions

Initial conditions are a set of test configurations the UE needs to be tested in and the steps for the SS to take with the UE to reach the correct measurement state.

The initial test configurations consist of environmental conditions, test frequencies and channel bandwidths based on EN-DC operating bands specified in clause 5.3B.1.2, channel bandwidths and sub-carrier spacings for the NR cell specified in TS 38.521-1 [8] clause 5.3 and channel bandwidth for the E-UTRA cell are specified in TS 36.521-1 [10] clause 5.4.2. All of these configurations shall be tested with applicable test parameters for each EN-DC configuration specified in clause 5.3B.1.2 and are shown in table 6.2B.4.1.3.4.1-1. The details of the uplink reference measurement channels (RMCs) are specified in Annex A, clause A.2.2 for E-UTRA RMC for TDD, TS 36.521-1 [10] Annex A, clause A.2.2 for E-UTRA RMC for FDD, and TS 38.521-1 [8] Annex A, clause A.2 for NR RMC. Configurations of PDSCH and PDCCH before measurement are specified in TS 36.521-1 [10] Annex C.2 and in TS 38.521-1 [8] Annex C.2 for E-UTRA CG and NR CG respectively.

**Table 6.2B.4.1.3.4.1-1: Test configurations table for inter-band EN-DC**

Initial Conditions							
Test Environment as specified in TS 38.508-1 [5] clause 4.1			Normal, TL/VL, TL/VH, TH/VL, TH/VH				
NR Test Frequencies as specified in TS 38.508-1 [5] clause 4.3.1 E-UTRA Test Frequencies as specified in TS 36.508-1 [11] clause 4.3.1			Mid range (NOTE 4)				
Test EN-DC bandwidth combination as specified in TS 38.508-1 [5] clause 4.3.1			5MHz for E-UTRA CC1 and Lowest for NR CC1, Highest for E-UTRA CC1 and Highest for NR CC1				
NR Test SCS as specified in Table 5.3.5-1 in TS 38.521-1 [8]			Highest				
NR/E-UTRA Test Parameters for UE supporting DPS (NOTE 6)							
Test ID (NOTE 3)	Downlink Configuration	EN-DC Uplink Configuration					
		E-UTRA Cell			NR Cell		
		Modulation	RB allocation (NOTE 2)	P <sub>LTE</sub>	Modulation	RB allocation (NOTE 1)	P <sub>NR</sub>
1a-1h	N/A	QPSK	Partial_Allocation	{-13, 12, 14, 17, 18, 19, 20, 23} for PC3 UE {-13, 12, 14, 17, 18, 19, 23 <sup>7</sup> , 26 <sup>5</sup> } for PC2 UE	DFT-s-OFDM QPSK	Inner_Full	{-13, 12, 14, 17, 18, 19, 23, 23} for PC3 UE {-13, 12, 14, 17, 18, 19, 26 <sup>7</sup> , 26 <sup>5</sup> } for PC2 UE
2a-2c		QPSK	Partial_Allocation	{-10, 10, 15}	N/A	N/A	{-10, 10, 15}
3a-3c		N/A	N/A	{-10, 10, 15}	DFT-s-OFDM QPSK	Inner_Full	{-10, 10, 15}
NR/E-UTRA Test Parameters for UE not supporting DPS							
Test ID (NOTE 3)	Downlink Configuration	EN-DC Uplink Configuration					
		E-UTRA Cell			NR Cell		
		Modulation	RB allocation (NOTE 2)	P <sub>LTE</sub>	Modulation	RB allocation (NOTE 1)	P <sub>NR</sub>
1a-1d	N/A	QPSK	Partial_Allocation	{-10, 10, 15, 23} for PC3 UE {-10, 10, 15, 26} for PC2 UE	CP-OFDM QPSK	Inner_Full	{-10, 10, 15, 23} for PC3 UE {-10, 10, 15, 26} for PC2 UE
2a-2c		QPSK	Partial_Allocation	{-10, 10, 15}	N/A	N/A	{-10, 10, 15}
3a-3c		N/A	N/A	{-10, 10, 15}	DFT-s-OFDM QPSK	Inner_Full	{-10, 10, 15}
<p>NOTE 1: The specific configuration of each RB allocation is defined in Table 6.1-1 in TS 38.521-1 [8].</p> <p>NOTE 2: The specific configuration of each RB allocation is defined in Table 6.1-1 in current specification.</p> <p>NOTE 3: The suffix in Test ID identifies the configured power level being tested from the P<sub>LTE</sub> and P<sub>NR</sub> lists</p> <p>NOTE 4: For NR band n28, 30MHz test channel bandwidth is tested with Low range test frequency.</p> <p>NOTE 5: Only applicable to UEs indicating PC2 on E-UTRA band.</p> <p>NOTE 6: For PC2 UE, Test ID 1g and 1h are not required if UE indicates support of <i>higherPowerLimitMRDC-r17</i>.</p> <p>NOTE 7: The test point is only applicable to Rel-15 UEs supporting PC2 on NR band. Test point is applicable for UEs Rel-16 and forward, supporting PC2 on both NR band and NR part power class, or supporting PC2 on NR band and not supporting NR part power class. The capability of NR part power class is indicated in TS 38.508-2 Table A.4.3.2B.2.3.1-3a.</p> <p>NOTE 7: For band n28 / 28 used in EN-DC configurations with NOTE 8 of Table 5.5B.4.1-1, test channel bandwidth of 20MHz or more is tested with Low range test frequency.</p>							

**Table 6.2B.4.1.3.4.1-2: Void**

1. Connect the SS to the UE antenna connectors as shown in [6] TS 38.508-1 A.3.1.2.1 for SS diagram and A.3.2.1 for UE diagram.
2. The parameter settings for the E-UTRA cell are set up according to TS 36.508 [11] clause 4.4.3, and the parameter settings for the NR cell are set up according to TS 38.508-1 [6] clause 4.4.3.
3. Downlink signals are initially set up according to TS 36.521-1 [10] Annex C.0 and TS 38.521-1 [8] Annex C.0 for E-UTRA CG and NR CG respectively, and uplink signals according to TS 36.521-1 [10] Annex H and TS 38.521-1 [8] Annex G for E-UTRA CG and NR CG respectively.
4. The UL Reference Measurement channels are set for E-UTRA CG and NR CG respectively.
5. Propagation conditions are set according to Table 6.2B.4.1.3.4.1-1.
6. Ensure the UE is in state RRC\_CONNECTED with generic procedure parameters Connectivity EN-DC, DC bearer *MCG* and *SCG*, Connected without release *On* according to TS 38.508-1 [6] clause 4.5. Message contents are defined in clause 6.2B.4.1.3.4.3.
7. For the case of testing overlapping E-UTRA and NR UL transmission scenario when both bands are TDD, ensure E-UTRA UL transmission overlaps with NR UL transmission in time by giving SCG a delay of 3 E-UTRA subframes, or by giving MCG a delay of 2 subframes.

#### 6.2B.4.1.3.4.2 Test procedure

1. SS sends uplink scheduling information for each UL HARQ process via PDCCH DCI format 0 and DCI format 0\_1 for C\_RNTI to schedule the UL RMC according table 6.2B.4.1.3.4.1-1 on E-UTRA CC and NR CC respectively. Since the UE has no payload and no loopback data to send the UE sends uplink MAC padding bits on the UL RMC.
2. Send continuously uplink power control "up" commands to the UE for NR and E-UTRA carrier until the UE transmits at its  $P_{UMAX}$  level; allow at least 200 ms from the first TPC command for the UE to reach  $P_{UMAX}$  level.
3. Measure the mean transmitted power over E-UTRA component carrier and NR component carrier respectively, or/and measure the sum of mean transmitted power over E-UTRA and NR component carriers according to Table 6.2B.4.1.3.5-1 and Table 6.2B.4.1.3.5-2. The period of the measurement shall be at least the continuous duration of one active sub-frame. For TDD, only slots consisting of only UL symbols are under test. For FDD band in inter-band CA with both TDD band and FDD band, only slots overlapping with only UL symbols in TDD are under test.

NOTE 1: When switching to DFT-s-OFDM waveform, as specified in the test configuration Table 6.2B.4.1.3.4.1-1, send an NR RRCReconfiguration message according to TS 38.508-1 [6] clause 4.6.3 Table 4.6.3-118 PUSCH-Config with TRANSFORM\_PRECODER\_ENABLED condition.

#### 6.2B.4.1.3.4.3 Message contents

Message contents are according to TS 36.508 [11] clause 4.6.1 and TS 38.508-1 [6] clause 4.6.1 with the following exceptions.



**Table 6.2B.4.1.3.4.3-1: RRCConnectionReconfiguration: tdm-PatternConfig if E-UTRA on FDD band and UE doesn't support dynamic power sharing**

Derivation Path: TS 36.508 [11], Table 4.6.1-8			
Information Element	Value/remark	Comment	Condition
tdm-PatternConfig-r15 CHOICE{			
setup SEQUENCE {			
subframeAssignment-r15	sa2		
harq-Offset-r15	0		
}			
}			

**Table 6.2B.4.1.3.4.3-2: SystemInformationBlockType1: tdd-Config if E-UTRA on TDD band**

Derivation Path: TS 36.508 [11], Table 4.6.3-23			
Information Element	Value/remark	Comment	Condition
TDD-Config-DEFAULT ::= SEQUENCE {		Operating on TDD band	
subframeAssignment	sa2		
specialSubframePatterns	ssp7		
}			

**Table 6.2B.4.1.3.4.3-3: RRCConnectionReconfiguration: nr-Config-r15**

Derivation Path: TS 36.508 [11], Table 4.6.1-8			
Information Element	Value/remark	Comment	Condition
p-MaxEUTRA-r15	Defined as P <sub>LTE</sub> in Table 6.2B.4.1.3.4.1-1		

**Table 6.2B.4.1.3.4.3-4: PhysicalCellGroupConfig**

Derivation Path: TS 38.508-1 [6], Table 4.6.3-106			
Information Element	Value/remark	Comment	Condition
PhysicalCellGroupConfig ::= SEQUENCE {			
p-NR-FR1	Defined as P <sub>NR</sub> in Table 6.2B.4.1.3.4.1-1		
}			

**Table 6.2B.4.1.3.4.3-5: RRCConnectionReconfiguration: p-MaxUE-FR1-r15**

Derivation Path: TS 36.508 [11], Table 4.6.1-8			
Information Element	Value/remark	Comment	Condition
nonCriticalExtension SEQUENCE {		RRCConnectionReconfiguration-v1530-IEs	
p-MaxUE-FR1-r15	23		Power Class 3 UE
	26		Power Class 2 UE
}			

#### 6.2B.4.1.3.5 Test requirement

For UE supporting DPS, the output power measured shall not exceed the values specified in Table 6.2B.4.1.3.5-1.

**Table 6.2B.4.1.3.5-1: P<sub>C<sub>MAX</sub></sub> configured UE output power for UE supporting DPS**

	E-UTRA component carrier	NR component carrier	Total power measured over E-UTRA and NR component carriers
Test ID 1a	Not measured	Not measured	-10dBm ± (7+TT)
Test ID 1b	Not measured	Not measured	15dBm ± (6+TT)
Test ID 1c	Not measured	Not measured	17 ± (5+TT)
Test ID 1d	Not measured	Not measured	20 + (4+TT) / - (6+TT)
Test ID 1e	Not measured	Not measured	21 + (3+TT) / - (5+TT)
Test ID 1f	Not measured	Not measured	22+ (2+TT) / - (5+TT)
Test ID 1g	Not measured	23 + (2+TT) / 17 - (5+TT) for PC3 UE	23 + (2+TT) / 21.8 - (5+TT) for PC3 UE
		26 + (2+TT) / 20 - (6+TT) for PC2 UE	26 + (2+TT) / 24.8 - (3+TT) for PC2 UE
Test ID 1h	Maximum output power with reduction as defined in Table 6.2.3.5-1 of TS 36.521-1 [10] for PC3 UE.	N/A	Maximum output power with reduction as defined in Table 6.2.3.5-1 of TS 36.521-1 [10] for PC3 UE
	Maximum output power with reduction as defined in Table 6.2.3_1.5-1 of TS 36.521-1 [10] for PC2 UE (For a power class 2 capable UE operating on LTE band)		Maximum output power with reduction as defined in Table 6.2.3_1.5-1 of TS 36.521-1 [10] for PC2 UE (For a power class 2 capable UE operating on LTE band)
Test ID 2a	-10dBm ± (7+TT)	N/A	Not measured
Test ID 2b	10dBm ± (6+TT)	N/A	Not measured
Test ID 2c	15dBm ± (5+TT)	N/A	Not measured
Test ID 3a	N/A	-10dBm ± (7+TT)	Not measured
Test ID 3b	N/A	10dBm ± (6+TT)	Not measured
Test ID 3c	N/A	15dBm ± (5+TT)	Not measured
NOTE 1: In addition NOTE 2 in Table 6.2.2-1 in TS 36.101 [5] and/or NOTE 3 in Table 6.2.1-1 in TS 38.101-1 [2] shall apply to the tolerances.			
NOTE 2: TT for each frequency and channel bandwidth is specified in Table 6.2B.4.1.3.5-3 and Table 6.2B.4.1.3.5-4.			

For UE not supporting DPS, the output power measured shall not exceed the values specified in Table 6.2B.4.1.3.5-2.

**Table 6.2B.4.1.3.5-2: P<sub>C<sub>MAX</sub></sub> configured UE output power for UE not supporting DPS**

	E-UTRA component carrier	NR component carrier	Total power measured over E-UTRA and NR component carriers
--	--------------------------	----------------------	--

Test ID 1a	-10 dBm ± (7+TT)	-10 dBm ± (7+TT)	Not measured
Test ID 1b	10 dBm ± (6+TT)	10 dBm ± (6+TT)	Not measured
Test ID 1c	15 dBm ± (5+TT)	15 dBm ± (5+TT)	Not measured
Test ID 1d	Maximum output power with reduction as defined in Table 6.2.3.5-1 of TS 36.521-1 [10] for PC3 UE	N/A	Not measured
	Maximum output power with reduction as defined in Table 6.2.3_1.5-1 of TS 36.521-1 [10] for PC2 UE (For a power class 2 capable UE operating on LTE band)		
	Maximum output power with reduction as defined in Table 6.2.3.5-1 of TS 36.521-1 [10] for PC2 UE (For a power class 3 UE operating on LTE band)		
Test ID 2a	-10dBm ± (7+TT)	N/A	Not measured
Test ID 2b	10dBm ± (6+TT)	N/A	Not measured
Test ID 2c	15dBm ± (5+TT)	N/A	Not measured
Test ID 3a	N/A	-10dBm ± (7+TT)	Not measured
Test ID 3b	N/A	10dBm ± (6+TT)	Not measured
Test ID 3c	N/A	15dBm ± (5+TT)	Not measured
NOTE 1: In addition NOTE 2 in Table 6.2.2-1 in TS 36.101 [5] and/or NOTE 3 in Table 6.2.1-1 in TS 38.101-1 [2] shall apply to the tolerances.			
NOTE 2: TT for each frequency and channel bandwidth is specified in Table 6.2B.4.1.3.5-3 and Table 6.2B.4.1.3.5-4.			

**Table 6.2B.4.1.3.5-3: Test Tolerance for UE maximum output power (Separate measurements over E-UTRA and NR CCs)**

Uplink TX		f ≤ 3.0GHz	3.0GHz < f ≤ 4.2GHz	4.2GHz < f ≤ 6GHz
E-UTRA	BW ≤ 20MHz	0.7 dB	1.0 dB	N/A
NR	BW ≤ 40MHz	0.7 dB <sup>1</sup> 1.0 dB <sup>2</sup>	1.0 dB	1.0 dB
	40MHz < BW ≤ 100MHz	1.0 dB	1.0 dB	1.0 dB
Note 1: Applicable for test point with UL power ≥ 0 dBm.				
Note 2: Applicable for test point with UL power < 0 dBm.				

**Table 6.2B.4.1.3.5-4: Test Tolerance for UE maximum output power (Combined measurements of E-UTRA and NR CCs)**

TT for overall output power											
			NR								
			BW ≤ 20MHz			20 MHz < BW ≤ 40MHz			40MHz < BW ≤ 100MHz		
			f ≤ 3.0GHz	3.0GHz < f ≤ 4.2GHz	4.2GHz < f ≤ 6.0GHz	f ≤ 3.0GHz	3.0GHz < f ≤ 4.2GHz	4.2GHz < f ≤ 6.0GHz	f ≤ 3.0GHz	3.0GHz < f ≤ 4.2GHz	4.2GHz < f ≤ 6.0GHz
E-UTRA	BW ≤ 20MHz	f ≤ 3.0GHz	0.7 dB <sup>1</sup> 1.0 dB <sup>2</sup>	1.0 dB	1.0 dB	0.7 dB <sup>1</sup> 1.0 dB <sup>2</sup>	1.0 dB	1.0 dB	1.0 dB	1.0 dB	1.0 dB
		3.0GHz < f ≤ 4.2GHz	1.0 dB	1.0 dB	1.0 dB	1.0 dB	1.0 dB	1.0 dB	1.0 dB	1.0 dB	1.0 dB
Note 1: Applicable for test point with UL power ≥ 0 dBm.											
Note 2: Applicable for test point with UL power < 0 dBm.											

For the UE which supports inter-band EN-DC configuration, ΔT<sub>IB,c</sub> in 6.2B.4.2 applies where unless otherwise stated, the same ΔT<sub>IB,c</sub> is applicable to NR band(s) part for DC configurations which have the same NR operating band combination. Unless otherwise stated, ΔT<sub>IB,c</sub> is set to zero.

### 6.2B.4.1.3\_1 Configured Output Power for Inter-Band EN-DC within FR1 (2 E-UTRA CCs, 1 NR CC)

#### 6.2B.4.1.3\_1.1 Test purpose

Same test purpose as in clause 6.2B.4.1.3.1

#### 6.2B.4.1.3\_1.2 Test applicability

This test case applies to all types of E-UTRA UE release 16 and forward, supporting inter-band EN-DC with 2 E-UTRA CCs and 1 NR CC FR1.

#### 6.2B.4.1.3\_1.3 Minimum conformance requirements

The minimum conformance requirements are defined in clause 6.2B.4.1.0.1.3.

Exception requirements for both NR and E-UTRA are defined for this test and therefore LTE anchor agnostic approach is not applied. E-UTRA test point analysis is included and E-UTRA measurements are performed.

#### 6.2B.4.1.3\_1.4 Test description

##### 6.2B.4.1.3\_1.4.1 Initial conditions

Initial conditions are a set of test configurations the UE needs to be tested in and the steps for the SS to take with the UE to reach the correct measurement state.

The initial test configurations consist of environmental conditions, test frequencies and channel bandwidths based on EN-DC operating bands specified in clause 5.3B.1.2, channel bandwidths and sub-carrier spacings for the NR cell specified in TS 38.521-1 [8] clause 5.3 and channel bandwidth for the E-UTRA cell are specified in TS 36.521-1 [10] clause 5.4.2. All of these configurations shall be tested with applicable test parameters for each EN-DC configuration specified in clause 5.3B.1.2 and are shown in table 6.2B.4.1.3\_1.4.1-1. The details of the uplink reference measurement channels (RMCs) are specified in Annex A, clause A.2.2 for E-UTRA RMC for TDD, TS 36.521-1 [10] Annex A, clause A.2.2 for E-UTRA RMC for FDD, and TS 38.521-1 [8] Annex A, clause A.2 for NR RMC. Configurations of PDSCH and PDCCH before measurement are specified in TS 36.521-1 [10] Annex C.2 and in TS 38.521-1 [8] Annex C.2 for E-UTRA CG and NR CG respectively.

Table 6.2B.4.1.3\_1.4.1-1: Test configurations table for inter-band EN-DC

Initial Conditions							
Test Environment as specified in TS 38.508-1 [5] clause 4.1			Normal, TL/VL, TL/VH, TH/VL, TH/VH				
NR Test Frequencies as specified in TS 38.508-1 [5] clause 4.3.1 E-UTRA Test Frequencies as specified in TS 36.508-1 [11] clause 4.3.1			Mid range for MCG and SCG				
Test EN-DC bandwidth combination as specified in TS 38.508-1 [5] clause 4.3.1			Lowest $N_{RB\_agg}$ for E-UTRA CCs and Lowest for NR CC1, Highest $N_{RB\_agg}$ for E-UTRA CCs and Highest for NR CC1				
NR Test SCS as specified in Table 5.3.5-1 in TS 38.521-1 [8]			Highest				
NR/E-UTRA Test Parameters for UE supporting DPS							
Test ID (NOTE 3)	Downlink Configuration	EN-DC Uplink Configuration					
		MCG – EUTRA PCC&SCC			SCG - NR		
		Modulation	RB allocation (NOTE 2)	$P_{LTE}$	Modulation	RB allocation (NOTE 1)	$P_{NR}$
1a-1h	N/A	QPSK	Partial_Allocation	{-13, 12, 14, 17, 18, 19, 20, 23}	DFT-s- OFDM QPSK	Inner_Full	{-13, 12, 14, 17, 18, 19, 23, 23}
2a-2c		QPSK	Partial_Allocation	{-10, 10, 15}	N/A	N/A	{-10, 10, 15}
3a-3c		N/A	N/A	{-10, 10, 15}	DFT-s- OFDM QPSK	Inner Full	{-10, 10, 15}
NR/E-UTRA Test Parameters for UE not supporting DPS							
Test ID (NOTE 3)	Downlink Configuration	EN-DC Uplink Configuration					
		MCG – EUTRA PCC&SCC			SCG - NR		
		Modulation	RB allocation (NOTE 2)	$P_{LTE}$	Modulation	RB allocation (NOTE 1)	$P_{NR}$
1a-1d	N/A	QPSK	Partial_Allocation	{-10, 10, 15, 23}	DFT-s- OFDM QPSK	Inner_Full	{-10, 10, 15, 23}
2a-2c		QPSK	Partial_Allocation	{-10, 10, 15}	N/A	N/A	{-10, 10, 15}
3a-3c		N/A	N/A	{-10, 10, 15}	DFT-s- OFDM QPSK	Inner_Full	{-10, 10, 15}
NOTE 1: The specific configuration of each RB allocation is defined in Table 6.1-1 in TS 38.521-1 [8].							
NOTE 2: The specific configuration of each RB allocation is defined in Table 6.1-2 in current specification.							
NOTE 3: The suffix in Test ID identifies the configured power level being tested from the $P_{LTE}$ and $P_{NR}$ lists.							

1. Connect the SS to the UE antenna connectors as shown in [6] TS 38.508-1 A.3.1.2.1 for SS diagram and A.3.2.1 for UE diagram.
2. The parameter settings for the E-UTRA cell are set up according to TS 36.508 [11] clause 4.4.3, and the parameter settings for the NR cell are set up according to TS 38.508-1 [6] clause 4.4.3.
3. Downlink signals are initially set up according to TS 36.521-1 [10] Annex C.0 and TS 38.521-1 [8] Annex C.0 for E-UTRA CG PCC and NR CG respectively, and uplink signals according to TS 36.521-1 [10] Annex H and TS 38.521-1 [8] Annex G for E-UTRA CG and NR CG respectively.
4. The UL Reference Measurement channels are set according to Table 6.2B.4.1.3\_1.4.1-1.
5. Propagation conditions are set according to TS 36.521-1 [10] Annex B.0 and TS 38.521-1 [8] Annex B.0 for E-UTRA CG and NR CG respectively.
6. Ensure the UE is in state RRC\_CONNECTED with generic procedure parameters Connectivity EN-DC, DC bearer MCG and SCG, Connected without release *On* according to TS 38.508-1 [6] clause 4.5. Message contents are defined in clause 6.2B.4.1.3\_1.4.3.

7. For the case of testing overlapping E-UTRA and NR UL transmission scenario when both bands are TDD, ensure E-UTRA UL transmission overlaps with NR UL transmission in time by giving SCG a delay of 3 E-UTRA subframes, or by giving MCG a delay of 2 subframes.

6.2B.4.1.3\_1.4.2 Test procedure

1. Configure E-UTRA SCC according to TS 36.521-1 [10] Annex C.0, C.1, and Annex C.3.0 for all E-UTRA downlink physical channels.
2. The SS shall configure SCC as per TS 36.508 [11] clause 5.2A.4. Message contents are defined in clause 6.2B.4.1.3\_1.4.3.
3. SS activates SCC by sending the MAC-CE according to TS 36.321 clauses 5.13 and 6.1.3.8. Wait for at least 2 seconds as per TS 36.133 [12] clause 8.3.3.2.
4. SS sends uplink scheduling information for each UL HARQ process via PDCCH DCI format 0 and DCI format 0\_1 for C\_RNTI to schedule the UL RMC according Table 6.2B.4.1.3\_1.4.1-1 on E-UTRA PCC and SCC and NR CC respectively. Since the UE has no payload and no loopback data to send the UE sends uplink MAC padding bits on the UL RMC.
5. Send continuously uplink power control "up" commands in every uplink scheduling information to the UE until the UE transmits at its P<sub>UMAX</sub> level; allow at least 200 ms from the first TPC command for the UE to reach P<sub>UMAX</sub> level.
6. Measure the mean transmitted power over E-UTRA CG and NR CG respectively, or/and measure the sum of mean transmitted power over E-UTRA CG and NR CG according to Table 6.2B.4.1.3\_1.5-1 and Table 6.2B.4.1.3\_1.5-2. The period of the measurement shall be at least the continuous duration of one active sub-frame. For TDD, only slots consisting of only UL symbols are under test.

NOTE 1: When switching to DFT-s-OFDM waveform, as specified in the test configuration Table 6.2B.4.1.3\_1.4.1-1, send an NR RRCReconfiguration message according to TS 38.508-1 [6] clause 4.6.3 Table 4.6.3-118 PUSCH-Config with TRANSFORM\_PRECODER\_ENABLED condition.

6.2B.4.1.3\_1.4.3 Message contents

Message contents are according to TS 36.508 [11] clause 4.6.1 and TS 38.508-1 [6] clause 4.6.1 with the following exceptions.

**Table 6.2B.4.1.3\_1.4.3-1: RRCConnectionReconfiguration: tdm-PatternConfig if E-UTRA on FDD band and UE doesn't support dynamic power sharing**

Derivation Path: TS 36.508 [11], Table 4.6.1-8			
Information Element	Value/remark	Comment	Condition
tdm-PatternConfig-r15 CHOICE{			
setup SEQUENCE {			
subframeAssignment-r15	sa2		
harq-Offset-r15	0		
}			
}			

**Table 6.2B.4.1.3\_1.4.3-2: SystemInformationBlockType1: tdd-Config if E-UTRA on TDD band**

Derivation Path: TS 36.508 [11], Table 4.6.3-23			
Information Element	Value/remark	Comment	Condition
TDD-Config-DEFAULT ::= SEQUENCE {		Operating on TDD band	
subframeAssignment	sa2		
specialSubframePatterns	ssp7		
}			

**Table 6.2B.4.1.3\_1.4.3-3: RRCConnectionReconfiguration: nr-Config-r15**

Derivation Path: TS 36.508 [11], Table 4.6.1-8			
Information Element	Value/remark	Comment	Condition
p-MaxEUTRA-r15	Defined as P <sub>LTE</sub> in Table 6.2B.4.1.3_1.4.1-1		

**Table 6.2B.4.1.3\_1.4.3-4: PhysicalCellGroupConfig**

Derivation Path: TS 38.508-1 [6], Table 4.6.3-106			
Information Element	Value/remark	Comment	Condition
PhysicalCellGroupConfig ::= SEQUENCE {			
p-NR-FR1	Defined as P <sub>NR</sub> in Table 6.2B.4.1.3_1.4.1-1		
}			

**Table 6.2B.4.1.3\_1.4.3-5: RRCConnectionReconfiguration: p-MaxUE-FR1-r15**

Derivation Path: TS 36.508 [11], Table 4.6.1-8			
Information Element	Value/remark	Comment	Condition
nonCriticalExtension SEQUENCE {		RRCConnectionReconfiguration-v1530-IEs	
p-MaxUE-FR1-r15	23		Power Class 3 UE
	26		Power Class 2 UE
}			

#### 6.2B.4.1.3\_1.5 Test requirement

For UE supporting DPS, the output power measured shall not exceed the values specified in Table 6.2B.4.1.3\_1.5-1.

**Table 6.2B.4.1.3\_1.5-1: P<sub>C</sub>MAX configured UE output power for UE supporting DPS for PC3 UE**

	E-UTRA CG	NR CG	Total power measured over all E-UTRA and NR component carriers

Test ID 1a	Not measured	Not measured	-10 dBm ± (7+TT)
Test ID 1b	Not measured	Not measured	15 dBm ± (6+TT)
Test ID 1c	Not measured	Not measured	17 dBm ± (5+TT)
Test ID 1d	Not measured	Not measured	20 dBm + (4+TT)/ - (6+TT)
Test ID 1e	Not measured	Not measured	21 dBm + (3+TT)/ - (5+TT)
Test ID 1f	Not measured	Not measured	22 dBm + (2+TT)/ - (5+TT)
Test ID 1g	Not measured	23 dBm + (2+TT) / 17 dBm – (5+TT)	23 dBm + (2+TT) / 21.8 dBm – (5+TT)
Test ID 1h	Maximum output power with reduction as defined in Table 6.2.3A.1.5-1 of TS 36.521-1 [10] for PC3 UE	N/A	Maximum output power with reduction as defined in Table 6.2.3A.1.5-1 of TS 36.521-1 [10] for PC3 UE
	Maximum output power with reduction as defined in Table 6.2.3A.1_3.5-1 of TS 36.521-1 [10] for PC2 UE		Maximum output power with reduction as defined in Table 6.2.3A.1_3.5-1 of TS 36.521-1 [10] for PC2 UE
Test ID 2a	-10 dBm ± (7+TT)	N/A	Not measured
Test ID 2b	10 dBm ± (6+TT)	N/A	Not measured
Test ID 2c	15 dBm ± (5+TT)	N/A	Not measured
Test ID 3a	N/A	-10 dBm ± (7+TT)	Not measured
Test ID 3b	N/A	10 dBm ± (6+TT)	Not measured
Test ID 3c	N/A	15 dBm ± (5+TT)	Not measured
NOTE 1: In addition NOTE 2 in Table 6.2.2-1 in TS 36.101 [5] and/or NOTE 3 in Table 6.2.1-1 in TS 38.101-1 [2] shall apply to the tolerances.			
NOTE 2: TT for each frequency and channel bandwidth is specified in Table 6.2B.4.1.3_1.5-3 and Table 6.2B.4.1.3_1.5-4.			

For UE not supporting DPS, the output power measured shall not exceed the values specified in Table 6.2B.4.1.3\_1.5-2.

**Table 6.2B.4.1.3\_1.5-2: P<sub>C<sub>MAX</sub></sub> configured UE output power for UE not supporting DPS**

	E-UTRA CG	NR CG	Total power measured over all E-UTRA and NR component carriers
Test ID 1a	-10 dBm ± (7+TT)	-10 dBm ± (7+TT)	Not measured
Test ID 1b	10 dBm ± (6+TT)	10 dBm ± (6+TT)	Not measured
Test ID 1c	15 dBm ± (5+TT)	15 dBm ± (5+TT)	Not measured
Test ID 1d	Maximum output power with reduction as defined in Table 6.2.3A.1.5-1 of TS 36.521-1 [10] for PC3 UE	N/A	Not measured
	Maximum output power with reduction as defined in Table 6.2.3A.1_3.5-1 of TS 36.521-1 [10] for PC2 UE		
Test ID 2a	-10 dBm ± (7+TT)	N/A	Not measured
Test ID 2b	10 dBm ± (6+TT)	N/A	Not measured
Test ID 2c	15 dBm ± (5+TT)	N/A	Not measured
Test ID 3a	N/A	-10 dBm ± (7+TT)	Not measured
Test ID 3b	N/A	10 dBm ± (6+TT)	Not measured
Test ID 3c	N/A	15 dBm ± (5+TT)	Not measured
NOTE 1: In addition NOTE 2 in Table 6.2.2A-1 in TS 36.101 [5] and/or NOTE 3 in Table 6.2.1-1 in TS 38.101-1 [2] shall apply to the tolerances.			
NOTE 2: TT for each frequency and channel bandwidth is specified in Table 6.2B.4.1.3_1.5-3 and Table 6.2B.4.1.3_1.5-4.			



**Table 6.2B.4.1.3\_1.5-3: Test Tolerance for UE maximum output power (Separate measurements over E-UTRA and NR CCs)**

Uplink TX		$f \leq 3.0\text{GHz}$	$3.0\text{GHz} < f \leq 4.2\text{GHz}$	$4.2\text{GHz} < f \leq 6\text{GHz}$
E-UTRA	$\text{BW} \leq 20\text{MHz}$	0.7 dB	1.0 dB	N/A
NR	$\text{BW} \leq 40\text{MHz}$	0.7 dB <sup>1</sup> 1.0 dB <sup>2</sup>	1.0 dB	1.0 dB
	$40\text{MHz} < \text{BW} \leq 100\text{MHz}$	1.0 dB	1.0 dB	1.0 dB

Note 1: Applicable for test point with UL power  $\geq 0$  dBm.  
 Note 2: Applicable for test point with UL power  $< 0$  dBm.

**Table 6.2B.4.1.3\_1.5-4: Test Tolerance for UE maximum output power (Combined measurements of E-UTRA and NR CCs)**

TT for overall output power												
			NR									
			$\text{BW} \leq 20\text{MHz}$			$20\text{MHz} < \text{BW} \leq 40\text{MHz}$			$40\text{MHz} < \text{BW} \leq 100\text{MHz}$			
			$f \leq 3.0\text{GHz}$	$3.0\text{GHz} < f \leq 4.2\text{GHz}$	$4.2\text{GHz} < f \leq 6.0\text{GHz}$	$f \leq 3.0\text{GHz}$	$3.0\text{GHz} < f \leq 4.2\text{GHz}$	$4.2\text{GHz} < f \leq 6.0\text{GHz}$	$f \leq 3.0\text{GHz}$	$3.0\text{GHz} < f \leq 4.2\text{GHz}$	$4.2\text{GHz} < f \leq 6.0\text{GHz}$	
E-UTRA	$\text{BW} \leq 20\text{MHz}$	$f \leq 3.0\text{GHz}$	0.7 dB <sup>1</sup> 1.0 dB <sup>2</sup>	1.0 dB	1.0 dB	0.7 dB <sup>1</sup> 1.0 dB <sup>2</sup>	1.0 dB	1.0 dB	1.0 dB	1.0 dB	1.0 dB	
		$3.0\text{GHz} < f \leq 4.2\text{GHz}$	1.0 dB	1.0 dB	1.0 dB	1.0 dB	1.0 dB	1.0 dB	1.0 dB	1.0 dB	1.0 dB	

Note 1: Applicable for test point with UL power  $\geq 0$  dBm.  
 Note 2: Applicable for test point with UL power  $< 0$  dBm.

For the UE which supports inter-band EN-DC configuration,  $\Delta T_{IB,c}$  in 6.2B.4.2 applies where unless otherwise stated, the same  $\Delta T_{IB,c}$  is applicable to NR band(s) part for DC configurations which have the same NR operating band combination. Unless otherwise stated,  $\Delta T_{IB,c}$  is set to zero.

**6.2B.4.1.4 Configured Output Power for Inter-Band EN-DC including FR2 (1 NR CC)**

**6.2B.4.1.4.1 Test purpose**

Same test purpose as in clause 6.2.4.1 in TS 38.521-2 [9] for the NR carrier.

**6.2B.4.1.4.2 Test applicability**

This test case applies to all types of E-UTRA UE release 15 and forward, supporting inter-band EN-DC including FR2 with 1 NR UL CC.

The requirements of this test for NR carrier are covered in test cases 6.2B.1.4 Maximum output power for Inter-Band EN-DC including FR2, 6.2B.2.4 Maximum output power reduction for Inter-Band EN-DC including FR2 and 6.2B.3.4 UE maximum output power with additional requirements for Inter-Band EN-DC including FR2 to all types of NR UE release 15 and forward.

**6.2B.4.1.4.3 Minimum conformance requirements**

UE configured output power requirement for E-UTRA single carrier and CA operation specified in subclauses 6.2.5 and 6.2.5A of [10] and for NR single carrier and CA operation specified in subclause 6.2.4, 6.2A.4 and 6.2D.4 of [9] apply.

No exception requirements applicable to NR or E-UTRA. LTE anchor agnostic approach is applied.

The normative reference for this requirement is TS 38.101-3 [4] clause 6.2B.4.1.4.

#### 6.2B.4.1.4.4 Test description

This test is covered by clause 6.2B.1.4 Maximum output power for Inter-Band EN-DC including FR2, 6.2B.2.4 Maximum output power reduction for Inter-Band EN-DC including FR2 and 6.2B.3.4 UE maximum output power with additional requirements for Inter-Band EN-DC including FR2.

#### 6.2B.4.1.4.5 Test requirement

This test is covered by clause 6.2B.1.4 Maximum output power for Inter-Band EN-DC including FR2, 6.2B.2.4 Maximum output power reduction for Inter-Band EN-DC including FR2 and 6.2B.3.4 UE maximum output power with additional requirements for Inter-Band EN-DC including FR2.

#### 6.2B.4.1.4\_1 Configured Output Power with Power Boost for Inter-Band EN-DC including FR2 (1 NR CC)

**Editor's note:** The following aspects are either missing or not yet determined:

- The referred test case 6.2.4\_1 in TS 38.521-2 is incomplete for power class 1, 2 and 4.
- The referred test case 6.2.4\_1 in TS 38.521-2 is incomplete for band n259.

#### 6.2B.4.1.4\_1.1 Test purpose

Same test purpose as in clause 6.2.4\_1.1 in TS 38.521-2 [9] for the NR carrier.

#### 6.2B.4.1.4\_1.2 Test applicability

This test case applies to all types of E-UTRA UE release 16 and forward, supporting inter-band EN-DC including FR2 with 1 NR UL CC and supporting *mpr-PowerBoost-FR2-r16* UE capability.

#### 6.2B.4.1.4\_1.3 Minimum conformance requirements

UE configured output power requirement for E-UTRA single carrier and CA operation specified in subclauses 6.2.5 and 6.2.5A of [10] and for NR single carrier specified in subclause 6.2.4\_1 of [9] apply.

No exception requirements applicable to NR or LTE. LTE anchor agnostic approach is applied.

The normative reference for this requirement is TS 38.101-3 [4] clause 6.2B.4.1.4.

#### 6.2B.4.1.4\_1.4 Test description

Same test description as in clause 6.2.4\_1.4 in TS 38.521-2 [9] for the NR carrier with the following exceptions:

The initial test configurations for E-UTRA band consist of environmental conditions, test frequencies, and channel bandwidths based on E-UTRA bands specified in Table 4.6-1.

For Initial conditions as in clause 6.2.4\_1.4.1 in TS 38.521-2 [9], the following steps will be added to configure E-UTRA component:

- 2.1. The parameter settings for the E-UTRA cell are set up according to TS 36.508 [11] clause 4.4.3 with E-UTRA channel bandwidth and test frequencies defined in Table 4.6-1.
- 3.1. Downlink E-UTRA signals are initially set up according to TS 36.521-1 [10] Annex C, clauses C.0, C.1 and C.3.0, and uplink signals according to Annex H, clauses H.1 and H.3.0.
- 4.1. The E-UTRA UL Reference Measurement channels are set according to Table 4.6-1.

Step 6 of Initial conditions as in clause 6.2.4\_1 in TS 38.521-2 [9] is replaced by:

6. Ensure the UE is in state RRC\_CONNECTED with generic procedure parameters Connectivity EN-DC, DC bearer MCG and SCG according to TS 38.508 [6] clause 4.5.

Same test procedure as in clause 6.2.4\_1.4.2 in TS 38.521-2 [9] with the following steps added for E-UTRA component:

1.1 On the E-UTRA carrier, disable periodic and aperiodic CQI reports, disable SRS, set *TimeAlignmentTimerDedicated* IE to infinity and disable downlink and uplink scheduling, all as per Table 4.7-1 under clause 4.7.

#### 6.2B.4.1.4\_1.5 Test requirement

Same test requirement as in clause 6.2.4\_1.5 in TS 38.521-2 [9] for the NR carrier.

#### 6.2B.4.1.5 Configured Output Power for Inter-Band EN-DC including both FR1 and FR2

##### 6.2B.4.1.5.1 Test purpose

Same test purpose as in clause 6.2.4.1 in TS 38.521-1 [8] for NR FR1 carrier and 6.2.4.1 in TS 38.521-2 [9] for NR FR2 carrier.

##### 6.2B.4.1.5.2 Test applicability

The requirements in this test are not testable due to issues with combined testing of NR FR1 and E-UTRA in conducted mode with NR FR2 in radiated mode. Therefore, the conducted and radiated requirements are tested separately.

No test case details are specified. The EN-DC requirements for maximum output power apply and are tested as part of the EN-DC within FR1 and EN-DC including FR2 test cases in clause 6.2B.

#### 6.2B.4.2 $\Delta T_{IB,c}$ for DC

For the UE which supports inter-band EN-DC configuration,  $\Delta T_{IB,c}$  in Tables below applies where unless otherwise stated, the same  $\Delta T_{IB,c}$  is applicable to NR band(s) part for DC configurations which have the same NR operating band combination. Unless otherwise stated,  $\Delta T_{IB,c}$  is set to zero.

Unless  $\Delta T_{IB,c}$  is specified for the NE-DC configuration, the specified  $\Delta T_{IB,c}$  for the EN-DC configuration including same bands as the corresponding NE-DC configuration is applicable for the NE-DC configuration.

##### 6.2B.4.2.1 Intra-Band Contiguous EN-DC

$\Delta T_{IB,c}$  is not applicable for intra-band contiguous EN-DC.

##### 6.2B.4.2.2 Intra-Band non-Contiguous EN-DC

$\Delta T_{IB,c}$  is not applicable for intra-band non-contiguous EN-DC.

6.2B.4.2.3 Inter-Band EN-DC within FR1

6.2B.4.2.3.1  $\Delta T_{IB,c}$  for EN-DC two bands

**Table 6.2B.4.2.3.1-1:  $\Delta T_{IB,c}$  due to EN-DC(two bands)**

Inter-band EN-DC configuration	E-UTRA or NR Band	$\Delta T_{B,c}$ (dB)
DC_1_n3	1	0.3
	n3	0.3
DC_1_n5	1	0.3
	n5	0.3
DC_1_n8	1	0.3
	n8	0.3
DC_1_n28	1	0.3
	n28	0.6
DC_1_n41	1	0.5
	n41	0.5
DC_1_n77	1	0.6
	n77	0.8
DC_1_n78	1	0.3
	n78	0.8
DC_2_n5	2	0.3
	n5	0.3
DC_2_n41	2	0.5
	n41	0.4 <sup>1</sup>
		0.9 <sup>2</sup>
DC_2_n66	2	0.5
	n66	0.5
DC_2_n71	2	0.3
	n71	0.3
DC_2_n77	2	0.6
DC_2-2_n77	n77	0.8
DC_2_n78	2	0.6
	n78	0.8
DC_3_n1	3	0.3
	n1	0.3
DC_3_n5	3	0.3
	n5	0.3
DC_3_n7	3	0.5
	n7	0.5
DC_3_n8	3	0.3
	n8	0.3
DC_3_n28	3	0.3
	n28	0.3
DC_3_n41	3	0.5
	n41	0.3 <sup>3</sup>
		0.8 <sup>4</sup>
DC_3_n77	3	0.6
	n77	0.8
DC_3_n78	3	0.6
	n78	0.8
DC_5_n2, DC_5-5_n2	5	0.3
	n2	0.3
DC_5_n66	5	0.3
	n66	0.3
DC_5_n77	5	0.6
	n77	0.8
DC_5_n78	5	0.6
	n78	0.8
DC_7_n1	7	0.6
	n1	0.5
DC_7_n3	7	0.5
	n3	0.5
DC_7_n5	7	0.3
	n5	0.3
DC_7_n8	7	0.3
	n8	0.6
DC_7_n28	7	0.3
	n28	0.3
	7	0.5

DC_7_n66, DC_7-7_n66	n66	0.5
DC_7_n78, DC_7-7_n78	7	0.5
	n78	0.8
DC_8_n1	8	0.3
	n1	0.3
DC_8_n3	8	0.3
	n3	0.3
DC_8_n20	8	0.4
	n20	0.4
DC_8_n28	8	0.6
	n28	0.5
DC_8_n41	8	0.3
	n41	0.3
DC_8_n77	8	0.6
	n77	0.8
DC_8_n78	8	0.6
	n78	0.8
DC_11_n77	11	0.4
	n77	0.8
DC_11_n78	11	0.4
	n78	0.8
DC_12_n2	12	0.3
	n2	0.3
DC_12_n5	12	0.4
	n5	0.8
DC_12_n66	12	0.8
	n66	0.3
DC_12_n78	12	0.5
	n78	0.8
DC_13_n2	13	0.3
	n2	0.3
DC_13_n66	13	0.3
	n66	0.3
DC_13_n77	13	0.5
	n77	0.8
DC_14_n2	14	0.3
	n2	0.3
DC_14_n66	14	0.3
	n66	0.3
DC_18_n77	18	0.3
	n77	0.8
DC_18_n78	18	0.3
	n78	0.8
DC_19_n77	19	0.3
	n77	0.8
DC_19_n78	19	0.3
	n78	0.8
DC_20_n1	20	0.3
	n1	0.3
DC_20_n3	20	0.3
	n3	0.3
DC_20_n7	20	0.3
	n7	0.3
DC_20_n8	20	0.4
	n8	0.4
DC_20_n28	20	0.5
	n28	0.5
DC_20_n78	20	0.6
	n78	0.8
DC_21_n77	21	0.4
	n77	0.8
DC_21_n78	21	0.4
	n78	0.8
DC_25_n41	25	0.5

	n41	0.4 <sup>1</sup>
		0.9 <sup>2</sup>
DC_26_n41	26	0.3
	n41	0.3
DC_26_n77	26	0.3
	n77	0.8
DC_26_n78	26	0.3
	n78	0.8
DC_28_n5	28	0.5
	n5	0.5
DC_28_n77	28	0.5
	n77	0.8
DC_28_n78	28	0.5
	n78	0.8
DC_30_n5	30	0.3
	n5	0.3
DC_30_n66	30	0.5
	n66	0.8
DC_38_n78	n78	0.5
DC_39_n41	39	0.5
	n41	0.5
DC_39_n79	39	0.3
	n79	0.8
DC_40_n1	n1	0.5
	40	0.5
DC_40_n41	40	0.5
	n41	0.5
DC_40_n78	n78	0.5 <sup>6</sup>
DC_40_n79	40	0.3
	n79	0.8
DC_41_n28	41	0.3
	n28	0.3
DC_41_n77	41	0.3
	n77	0.8
DC_41_n78	41	0.3
	n78	0.8
DC_41_n79	41	0.3
	n79	0.8
DC_48_n5	48	0.3
	n5	0.3
DC_48_n46	48	0.8
DC_48_n66	48	0.8
	n66	0.6
DC_66_n2	66	0.5
	n2	0.5
DC_66_n5	66	0.3
	n5	0.3
DC_66_n41	66	0.5
	n41	0.8 <sup>1</sup>
		1.3 <sup>2</sup>
DC_66_n71	66	0.3
	n71	0.3
DC_66_n77	66	0.6
DC_66-66_n77	n77	0.8
DC_66_n78	66	0.6
	n78	0.8
DC_71_n2	71	0.3
	n2	0.3
DC_71_n66	71	0.3
	N66	0.3

NOTE 1: The requirement is applied for UE transmitting on the frequency range of 2545-2690 MHz.  
NOTE 2: The requirement is applied for UE transmitting on the frequency range of 2496-2545 MHz.  
NOTE 3: Applicable for the frequency range of 2515 - 2690 MHz.  
NOTE 4: Applicable for the frequency range of 2496 - 2515 MHz.  
NOTE 5: Applicable for UE supporting inter-band EN-DC without simultaneous Rx/Tx.  
NOTE 6: Only applicable for UE supporting inter-band carrier aggregation with uplink in one E-UTRA band and without simultaneous Rx/Tx.



6.2B.4.2.3.2  $\Delta T_{IB,c}$  for EN-DC three bands

**Table 6.2B.4.2.3.2-1:  $\Delta T_{IB,c}$  due to EN-DC (three bands)**

Inter-band EN-DC configuration	E-UTRA or NR Band	$\Delta T_{IB,c}$ (dB)
DC_1-3_n28	1	0.3
	3	0.3
	n28	0.6
DC_1-3_n41	1	0.5
	3	0.5
	n41	0.3 <sup>3</sup>
DC_1-3_n77	1	0.6
	3	0.6
	n77	0.8
DC_1-3_n78	1	0.6
	3	0.6
	n78	0.8
DC_1-3_n79	1	0.3
	3	0.3
DC_1-5_n78	1	0.3
	5	0.6
	n78	0.8
DC_1-7_n3	1	0.6
	7	0.6
	n3	0.6
DC_1-7_n28	1	0.5
	7	0.6
	n28	0.6
DC_1-7_n78	1	0.6
	7	0.6
	n78	0.8
DC_1-8_n3	1	0.3
	8	0.3
	n3	0.3
DC_1-8_n77	1	0.3
	8	0.6
	n77	0.8
DC_1-8_n78	1	0.3
	8	0.6
	n78	0.8
DC_1-18_n77	1	0.3
	18	0.3
	n77	0.8
DC_1-19_n77	1	0.3
	19	0.3
	n77	0.8
DC_1-19_n78	1	0.3
	19	0.3
	n78	0.8
DC_1-19_n79	1	0.3
	19	0.3
DC_1-20_n3	1	0.3
	20	0.3
	n3	0.3
DC_1-20_n28	1	0.3
	20	0.6
	n28	0.6
DC_1-20_n78	1	0.3
	20	0.3
	n78	0.8
DC_1-21_n77	1	0.3
	21	0.3
	n77	0.8
DC_1-21_n78	1	0.6
	21	0.4
	n78	0.8
DC_1-21_n79	1	0.3
	21	0.3

DC_1-28_n3	1	0.3
	28	0.6
	n3	0.3
DC_1-28_n78 DC_1_n28-n78	1	0.3
	28 or n28	0.6
	n78	0.8
DC_1_n28-n79	1	0.3
	n28	0.3
DC_1-41_n28	1	0.5
	41	0.5
	n28	0.5
DC_1-41_n41	1	0.5
	41	0.5
	n41	0.5
DC_1-41_n77	1	0.5
	41	0.5
	n77	0.8
DC_1-41_n78	1	0.5
	41	0.5
	n78	0.8
DC_1-42_n77	1	0.6
	42	0.8
	n77	0.8
DC_1-42_n78	1	0.3
	42	0.8
	n78	0.8
DC_1-42_n79	1	0.3
	42	0.8
DC_1_n77-n79	1	0.6
	n77	0.8
DC_1_n78-n79	1	0.3
	n78	0.8
	n79	0.5
DC_2-5_n2	2	0.3
	5	0.3
	n2	0.3
DC_2-5_n66 DC_2-2-5_n66	2	0.5
	5	0.3
	n66	0.5
DC_2-5_n77 DC_2-2-5_n77	2	0.6
	5	0.6
	n77	0.8
DC_2_n5-n77	2	0.6
	n5	0.3
	n77	0.8
DC_2-13_n77	2	0.6
	13	0.5
	n77	0.8
DC_2-14_n2	2	0.3
	14	0.3
	n2	0.3
DC_2-14_n66 DC_2-2-14_n66	2	0.5
	14	0.3
	n66	0.5
DC_2-14_n77 DC_2-2-14_n77	2	0.5
	14	0.3
	n77	0.8
DC_2-30_n66	2	0.5
	30	0.3
	n66	0.5
DC_2-66_n2 DC_2-66-66_n2	2	0.5
	66	0.5
	n2	0.5
	2	0.5
	66	0.5

DC_2-66_n5 DC_2-2-66_n5 DC_2-66-66_n5 DC_2-2-66-66_n5	n5	0.3
DC_2-66_n41	2	0.5
	66	0.5
	n41	0.8 <sup>1</sup>
		1.3 <sup>2</sup>
DC_2-66_n66 DC_2-66-66_n66 DC_2-2-66-66_n66	2	0.5
	66	0.5
	n66	0.5
DC_2-66_n71	2	0.5
	66	0.5
	n71	0.3
DC_2-66_n77 DC_2-2-66_n77 DC_2-66-66_n77 DC_2-2-66-66_n77	2	0.6
	66	0.6
	n77	0.8
DC_2-(n)71	2	0.3
	71	0.3
	n71	
DC_3-5_n78	3	0.6
	5	0.6
	n78	0.8
DC_3-7_n28	3	0.5
	7	0.5
	n28	0.3
DC_3-7_n78	3	0.6
	7	0.6
	n78	0.8
DC_3-8_n77	3	0.6
	8	0.6
	n77	0.8
DC_3-8_n78	3	0.6
	8	0.6
	n78	0.8
DC_3-18_n77	3	0.6
	18	0.3
	n77	0.8
DC_3-18_n78	3	0.6
	18	0.3
	n78	0.8
DC_3-19_n77	3	0.6
	19	0.3
	n77	0.8
DC_3-19_n78	3	0.6
	19	0.3
	n78	0.8
DC_3-19_n79	3	0.3
	19	0.3
DC_3-20_n1	3	0.3
	20	0.3
	n1	0.3
DC_3-20_n28	3	0.3
	20	0.5
	n28	0.5
DC_3-20_n78	3	0.5
	20	0.3
	n78	0.8
DC_3-21_n77	3	0.8
	21	0.9
	n77	0.8
DC_3-21_n78	3	0.8
	21	0.9
	n78	0.8

DC_3-21_n79	3	0.8
	21	0.9
DC_3-28_n78	3	0.5
	28	0.3
	n78	0.8
DC_3_n28-n78	3	0.5
	n28	0.3
	n78	0.8
DC_3-40_n1	3	0.5
	40	0.5
	n1	0.5
DC_3-41_n28	3	0.5
	41	0.3 <sup>3</sup>
		0.8 <sup>4</sup>
n28	0.3	
DC_3-41_n41	3	0.5
	41	0.3 <sup>3</sup>
		0.8 <sup>4</sup>
	n41	0.3 <sup>3</sup>
0.8 <sup>4</sup>		
DC_3-41_n77	3	0.6
	41	0.3 <sup>3</sup>
		0.8 <sup>4</sup>
	n77	0.8
DC_3-42_n77	3	0.6
	42	0.8
	n77	0.8
		0.8
DC_3-42_n78	3	0.6
	42	0.8
	n78	0.8
		0.8
DC_3-42_n79	3	0.6
	42	0.8
DC_3_n77-n79	3	0.6
	n77	0.8
DC_3_n78-n79	3	0.6
	n78	0.8
	n79	0.5
DC_5-7_n78	5	0.6
	7	0.6
	n78	0.8
DC_5-30_n66	5	0.3
	30	0.3
	n66	0.5
DC_5-66_n2 DC_5-66-66_n2	5	0.3
	66	0.5
	n2	0.5
DC_5-66_n66	5	0.3
	66	0.3
	n66	0.3
DC_5-66_n77 DC_5-66-66_n77	5	0.6
	66	0.6
	n77	0.8
DC_7-20_n28	7	0.3
	20	0.6
	n28	0.6
DC_7-20_n1	7	0.6
	20	0.3
	n1	0.5
DC_7-20_n3	7	0.5
	20	0.3
	n3	0.5
DC_7-20_n78	7	0.3
	20	0.3
	n78	0.8
DC_7-28_n3	7	0.5

	28	0.3
	n3	0.5
DC_7-28_n78	7	0.3
	28	0.3
	n78	0.8
DC_7_n28-n78	7	0.3
	n28	0.3
	n78	0.8
DC_13_n2-n77	13	0.3
	n2	0.6
	n77	0.8
DC_13-66-n2	13	0.3
	66	0.5
	n2	0.5
DC_13-66_n77	13	0.5
	66	0.6
	n77	0.8
DC_14-66_n2 DC_14-66-66_n2	14	0.3
	66	0.5
	n2	0.5
DC_14-66_n66	14	0.3
	66	0.3
	n66	0.3
DC_14-66_n77 DC_14-66-66_n77	14	0.6
	66	0.6
	n77	0.8
DC_18-41_n3	18	0.3
	41	0.3 <sup>3</sup>
		0.8 <sup>4</sup>
	n3	0.5
DC_18-41_n77	18	0.3
	41	0.3 <sup>3</sup>
		0.8 <sup>4</sup>
	n77	0.8
DC_18-41_n78	18	0.3
	41	0.3 <sup>3</sup>
	n78	0.8
DC_19-21_n77	19	0.3
	21	0.4
	n77	0.8
DC_19-21_n78	19	0.3
	21	0.4
	n78	0.8
DC_19-21_n79	19	0.3
	21	0.4
DC_19-42_n77	19	0.3
	42	0.8
	n77	0.8
DC_19-42_n78	19	0.3
	42	0.8
	n78	0.8
DC_19-42_n79	19	0.3
	42	0.8
DC_19_n77-n79	19	0.3
	n77	0.8
DC_19_n78-n79	19	0.3
	n78	0.8
	n79	0.5
DC_20_n28-n78	20	0.6
	n28	0.6
	n78	0.8
DC_20_n76-n78	20	0.5
	n78	0.8
DC_21-42_n77	21	0.4

	42	0.8
	n77	0.8
DC_21-42_n78	21	0.4
	42	0.8
	n78	0.8
DC_21-42_n79	21	0.4
	42	0.8
DC_21_n77-n79	21	0.4
	n77	0.8
DC_21_n78-n79	21	0.4
	n78	0.8
	n79	0.5
DC_28_n7-n78	28	0.3
	n7	0.3
	n78	0.8
DC_28-42_n78	28	0.5
	42	0.8
	n78	0.8
DC_41-42_n78	41	0.5
	42	0.8
	n78	0.8
DC_66_n2-n77	66	0.6
	n2	0.6
	n77	0.8
DC_66_n5-n77	66	0.6
	n5	0.3
	n77	0.8
DC_66-(n)71	66	0.3
	71	0.3
	n71	
NOTE 1: The requirement is applied for UE transmitting on the frequency range of 2545-2690 MHz.		
NOTE 2: The requirement is applied for UE transmitting on the frequency range of 2496-2545 MHz.		
NOTE 3: The requirement is applied for UE transmitting on the frequency range of 2515 – 2690 MHz.		
NOTE 4: The requirement is applied for UE transmitting on the frequency range of 2496 – 2515 MHz.		

6.2B.4.2.3.3  $\Delta T_{IB,c}$  for EN-DC four bands

**Table 6.2B.4.2.3.3-1:  $\Delta T_{IB,c}$  due to EN-DC(four bands)**



Inter-band EN-DC configuration	E-UTRA or NR Band	$\Delta T_{IB,c}$ (dB)
DC_1-3-7_n28	1	0.6
	3	0.6
	7	0.6
	n28	0.6
DC_1-3-7_n78	1	0.7
	3	0.7
	7	0.7
	n78	0.8
DC_1-3-8_n77	1	0.6
	3	0.6
	8	0.6
	n77	0.8
DC_1-3-8_n78	1	0.6
	3	0.6
	8	0.6
	n78	0.8
DC_1-3-19_n78	1	0.6
	3	0.6
	19	0.3
	n78	0.8
DC_1-3-19_n79	1	0.3
	3	0.3
	19	0.3
DC_1-3-20_n28	1	0.3
	3	0.3
	20	0.6
	n28	0.6
DC_1-3-20_n78	1	0.6
	3	0.6
	20	0.3
	n78	0.8
DC_1-3-21_n77	1	0.6
	3	0.8
	21	0.9
	n77	0.8
DC_1-3-21_n78	1	0.6
	3	0.8
	21	0.9
	n78	0.8
DC_1-3-21_n79	1	0.3
	3	0.8
	21	0.9
DC_1-3-28_n78 DC_1-3_n28-n78	1	0.6
	3	0.6
	28 or n28	0.6
	n78	0.8
DC_1-3-42_n78	1	0.6
	3	0.6
	42	0.8
	n78	0.8
DC_1-3-42_n79	1	0.6
	3	0.6
	42	0.8
DC_1-7-20_n28	1	0.5
	7	0.6
	20	0.6
	n28	0.6
DC_1-7-20_n78	1	0.6
	7	0.7
	20	0.4
	n78	0.8
DC_1-7-28-n78	1	0.6
	7	0.6

Inter-band EN-DC configuration	E-UTRA or NR Band	$\Delta T_{IB,c}$ (dB)
	28	0.6
	n78	0.8
DC_1-7_n28-n78	1	0.6
	7	0.6
	n28	0.6
	n78	0.8
DC_1-19-42_n77	1	0.6
	19	0.3
	42	0.8
	n77	0.8
DC_1-19-42_n78	1	0.3
	19	0.3
	42	0.8
	n78	0.8
DC_1-19-42_n79	1	0.3
	19	0.3
	42	0.8
DC_1-20_n28-n78	1	0.3
	20	0.6
	n28	0.6
	n78	0.8
DC_1-21-42_n77	1	0.6
	21	0.4
	42	0.8
	n77	0.8
DC_1-21-42_n78	1	0.3
	21	0.4
	42	0.8
	n78	0.8
DC_1-21-42_n79	1	0.3
	21	0.4
	42	0.8
DC_2-7-13_n66 DC_2-7-7-13_n66	2	0.5
	7	0.5
	13	0.3
	n66	0.5
DC_2-7-66_n66 DC_2-7-7-66_n66	2	0.5
	7	0.5
	66	0.5
	n66	
DC_2-7-66_n78 DC_2-7-7-66_n78	2	0.6
	7	0.5
	66	0.6
	n78	0.8
DC_2-13-66_n77	2	0.5
	13	0.3
	66	0.5
	n77	0.8
DC_2-14-66_n2 DC_2-14-66-66_n2	2	0.5
	14	0.3
	66	0.5
	n2	0.5
DC_2-14-66_n66 DC_2-2-14-66_n66	2	0.5
	14	0.3
	66	0.5
	n66	0.5
DC_2-66_n5-n77	2	0.6
	66	0.6
	n5	0.3
	n77	0.8
DC_2-66-(n)71	2	0.5
	66	0.5
	71	0.3

Inter-band EN-DC configuration	E-UTRA or NR Band	$\Delta T_{IB,c}$ (dB)
	n71	
DC_3-7-20_n28	3	0.5
	7	0.5
	20	0.6
	n28	0.5
DC_3-7-20_n78	3	0.6
	7	0.6
	20	0.3
	n78	0.8
DC_3-7-28_n78	3	0.6
	7	0.6
	28	0.6
	n78	0.8
DC_3-7_n28-n78	3	0.6
	7	0.6
	n28	0.6
	n78	0.8
DC_3-19-21_n78	3	0.8
	19	0.3
	21	0.9
	n78	0.8
DC_3-19-21_n79	3	0.8
	19	0.3
	21	0.9
DC_3-19-42_n77	3	0.6
	19	0.3
	42	0.8
	n77	0.8
DC_3-19-42_n78	3	0.6
	19	0.3
	42	0.8
	n78	0.8
DC_3-19-42_n79	3	0.6
	19	0.3
	42	0.8
DC_3-20_n28-n78	3	0.6
	20	0.6
	n28	0.6
	n78	0.8
DC_3-21-42_n77	3	0.8
	21	0.9
	42	0.8
	n77	0.8
DC_3-21-42_n78	3	0.8
	21	0.9
	42	0.8
	n78	0.8
DC_3-21-42_n79	3	0.8
	21	0.9
	42	0.8
DC_7-20_n28-n78	7	0.3
	20	0.6
	n28	0.6
	n78	0.8
DC_13-66_n2-n77	13	0.3
	66	0.6
	n2	0.6
	n77	0.8
DC_19-21-42_n77	19	0.3
	21	0.4
	42	0.8
	n77	0.8
DC_19-21-42_n78	19	0.3

Inter-band EN-DC configuration	E-UTRA or NR Band	$\Delta T_{IB,c}$ (dB)
	21	0.4
	42	0.8
	n78	0.8
DC_19-21-42_n79	19	0.3
	21	0.4
	42	0.8

6.2B.4.2.3.4  $\Delta T_{IB,c}$  for EN-DC five bands

**Table 6.2B.4.2.3.4-1:  $\Delta T_{IB,c}$  due to EN-DC (five bands)**

Inter-band EN-DC configuration	E-UTRA or NR Band	$\Delta T_{IB,c}$ (dB)
DC_1-3-7-20_n28	1	0.6
	3	0.6
	7	0.6
	20	0.6
	n28	0.6
DC_1-3-7-20_n78	1	0.6
	3	0.6
	7	0.6
	20	0.6
	n78	0.6
DC_1-3-7-28-n78	1	0.7
	3	0.7
	7	0.7
	28	0.6
	n78	0.8
DC_1-3-7_n28-n78	1	0.7
	3	0.7
	7	0.7
	n28	0.6
	n78	0.8
DC_1-3-19-42_n78	1	0.6
	3	0.6
	19	0.3
	42	0.8
	n78	0.8
DC_1-3-19-42_n79	1	0.6
	3	0.6
	19	0.3
	42	0.8
DC_1-3-20_n28-n78	1	0.6
	3	0.6
	20	0.6
	n28	0.6
	n78	0.8
DC_1-3-21-42_n78	1	0.6
	3	0.8
	21	0.9
	42	0.8
	n78	0.6
DC_1-3-21-42_n79	1	0.6
	3	0.8
	21	0.9
	42	0.8
DC_1-7-20_n28-n78	1	0.6
	7	0.7
	20	0.6
	n28	0.6
	n78	0.8
DC_1-19-21-42_n78	1	0.3
	19	0.3
	21	0.4
	42	0.8
	n78	0.8
DC_1-19-21-42_n79	1	0.3
	19	0.3
	21	0.4
	42	0.8
DC_3-7-20_n28-n78	3	0.6

Inter-band EN-DC configuration	E-UTRA or NR Band	$\Delta T_{IB,c}$ (dB)
	7	0.6
	20	0.6
	n28	0.6
	n78	0.8

6.2B.4.2.3.5  $\Delta T_{IB,c}$  for EN-DC six bands**Table 6.2B.4.2.3.5-1:  $\Delta T_{IB,c}$  due to EN-DC (six bands)**

Inter-band EN-DC configuration	E-UTRA or NR Band	$\Delta T_{IB,c}$ (dB)
DC_1-3-7-20_n28-n78	1	0.7
	3	0.7
	7	0.7
	20	0.6
	n28	0.6
	n78	0.8

## 6.2B.4.2.3a Inter-band NE-DC within FR1

Unless  $\Delta T_{IB,c}$  is specified in this clause, the value of  $\Delta T_{IB,c}$  for the correspondingly specified EN-DC configuration in clause 6.2B.4.2.3 is applicable.

**Table 6.2B.4.2.3a-1:  $\Delta T_{IB,c}$  due to NE-DC(two bands)**

Inter-band NE-DC configuration	E-UTRA or NR Band	$\Delta T_{IB,c}$ (dB)
DC_n28_39	n28	0.3
	39	0.3

## 6.2B.4.2.4 Inter-band EN-DC including FR2

6.2B.4.2.4.1  $\Delta T_{IB,c}$  for EN-DC two bands

Unless otherwise stated,  $\Delta T_{IB,c}$  for E-UTRA and NR FR2 bands of inter-band EN-DC combinations defined in table 5.5B.5.1-1 is set to zero.

**Table 6.2B.4.2.4.1-1: Void**6.2B.4.2.4.2  $\Delta T_{IB,c}$  for EN-DC three bands

Unless otherwise stated,  $\Delta T_{IB,c}$  for NR FR2 bands is set to zero, and  $\Delta T_{IB,c}$  for constituent E-UTRA bands for inter-band EN-DC defined in table 5.5B.5.2-1 is the same as those for the corresponding E-UTRA CA configuration specified in TS 36.101 [4], without the NR FR2 bands.

**Table 6.2B.4.2.4.2-1: Void**6.2B.4.2.4.3  $\Delta T_{IB,c}$  for EN-DC four bands

Unless otherwise stated,  $\Delta T_{IB,c}$  for NR FR2 bands is set to zero, and  $\Delta T_{IB,c}$  for constituent E-UTRA bands for inter-band EN-DC defined in table 5.5B.5.3-1 is the same as those for the corresponding E-UTRA CA configuration specified in TS 36.101 [4], without the NR FR2 bands.

**Table 6.2B.4.2.4.3-1: Void**6.2B.4.2.4.4  $\Delta T_{IB,c}$  for EN-DC five bands

Unless otherwise stated,  $\Delta T_{IB,c}$  for NR FR2 bands is set to zero, and  $\Delta T_{IB,c}$  for constituent E-UTRA bands for inter-band EN-DC defined in table 5.5B.5.4-1 is the same as those for the corresponding E-UTRA CA configuration specified in TS 36.101 [4], without the NR FR2 bands.

**Table 6.2B.4.2.4.4-1: Void**

## 6.2B.4.2.4.5 Void

## 6.2B.4.2.5 Inter-band EN-DC including both FR1 and FR2

6.2B.4.2.5.1  $\Delta T_{IB,c}$  for EN-DC three bands

Unless otherwise stated, for inter-band EN-DC configurations defined in table 5.5B.6.2-1,  $\Delta T_{IB,c}$  for constituent NR FR2 bands is set to zero, and  $\Delta T_{IB,c}$  for constituent E-UTRA and NR FR1 bands is the same as those for the corresponding inter band EN-DC configuration without the NR FR2 bands specified in 6.2B.4.2.3.

**Table 6.2B.4.2.5.1-1: Void**6.2B.4.2.5.2  $\Delta T_{IB,c}$  for EN-DC four bands

Unless otherwise stated, for inter-band EN-DC configurations defined in table 5.5B.6.3-1,  $\Delta T_{IB,c}$  for constituent NR FR2 bands is set to zero, and  $\Delta T_{IB,c}$  for constituent E-UTRA and NR FR1 bands is the same as those for the corresponding inter band EN-DC configuration without the NR FR2 bands specified in 6.2B.4.2.3.

6.2B.4.2.5.3  $\Delta T_{IB,c}$  for EN-DC five bands

Unless otherwise stated, for inter-band EN-DC configurations defined in table 5.5B.6.4-1,  $\Delta T_{IB,c}$  for constituent NR FR2 bands is set to zero, and  $\Delta T_{IB,c}$  for constituent E-UTRA and NR FR1 bands is the same as those for the corresponding inter band EN-DC configuration without the NR FR2 bands specified in 6.2B.4.2.3.

6.2B.4.2.5.4  $\Delta T_{IB,c}$  for EN-DC six bands

Unless otherwise stated, for inter-band EN-DC configurations defined in table 5.5B.6.5-1,  $\Delta T_{IB,c}$  for constituent NR FR2 bands is set to zero, and  $\Delta T_{IB,c}$  for constituent E-UTRA and NR FR1 bands is the same as those for the corresponding inter band EN-DC configuration without the NR FR2 bands specified in 6.2B.4.2.3.

**6.2B.5 Configured Output Power for NR-DC**

## 6.2B.5.1 Configured Output power Level

## 6.2B.5.1.1 Configured Output Power Level for Inter-band NR-DC between FR1 and FR2

## 6.2B.5.1.1.1 Test purpose

Same test purpose as in clause 6.2.4.1 in TS 38.521-1 [8] for NR FR1 carrier and 6.2.4.1 in TS 38.521-2 [9] for NR FR2 carrier.

## 6.2B.5.1.1.2 Test applicability

The requirements in this test are not testable due to issues with combined testing of NR FR1 in conducted mode with NR FR2 in radiated mode. Therefore, the conducted and radiated requirements are tested separately.

No test case details are specified. The NR/5GC requirements for configured output power apply and are tested as part of the standalone NR within FR1 in clause 6.2.4 in TS 38.521-1 [8] and standalone NR within FR2 in clause 6.2.4 in TS 38.521-2 [9].



## 6.2E Transmitter power for V2X in FR1

### 6.2E.1 UE Maximum Output Power for V2X

#### 6.2E.1.0 Minimum conformance requirements

##### 6.2E.1.0.1 UE maximum output power for Intra-band contiguous V2X

For intra-band contiguous V2X operating UE, the allowed UE maximum output power shall be applied in Table 6.2.2-1 [5] for E-UTRA SL transmission or applied in Table 6.2.1-1 [2] for NR SL transmission, respectively.

**Table 6.2E.1.0.1-1: Maximum output power for V2X combination (continuous sub-blocks)**

V2X configuration	Power class 2 (dBm)	Tolerance (dB)	Power class 3 (dBm)	Tolerance (dB)
V2X_(n)47AA			23	+2/-3 <sup>1</sup>
NOTE 1: If all transmitted resource blocks over all component carriers are confined within $F_{UL\_low}$ and $F_{UL\_low} + 4$ MHz or/and $F_{UL\_high} - 4$ MHz and $F_{UL\_high}$ , the maximum output power requirement is relaxed by reducing the lower tolerance limit by 1.5 dB				
NOTE 2: Power Class 3 is the default power class unless otherwise stated.				
NOTE 3: Only single switched UL is supported				

##### 6.2E.1.0.2 UE maximum output power for Intra-band non-contiguous V2X

For intra-band non-contiguous V2X operating UE, the allowed UE maximum output power shall be applied in Table 6.2.2-1 [5] for E-UTRA SL transmission or applied in Table 6.2.1-1 [2] for NR SL transmission, respectively.

**Table 6.2E.1.0.2-1: Maximum output power for V2X combination (non-contiguous sub-blocks)**

V2X configuration	Power class 2 (dBm)	Tolerance (dB)	Power class 3 (dBm)	Tolerance (dB)
V2X_47A_n47A			23	+2/-3 <sup>1</sup>
NOTE 1: If all transmitted resource blocks over all component carriers are confined within $F_{UL\_low}$ and $F_{UL\_low} + 4$ MHz or/and $F_{UL\_high} - 4$ MHz and $F_{UL\_high}$ , the maximum output power requirement is relaxed by reducing the lower tolerance limit by 1.5 dB				
NOTE 2: Power Class 3 is the default power class unless otherwise stated.				
NOTE 3: Only single switched UL is supported				

##### 6.2E.1.0.3 UE maximum output power for Inter-band V2X

For the inter-band con-current NR V2X operation, the maximum output power is specified in Table 6.2E.1.0.3-1. The period of measurement shall be at least one sub frame (1ms).

**Table 6.2E.1.0.3-1: Con-current V2X UE Power Class**

V2X con-current operating band Configuration	Class 1 (dBm)	Tolerance (dB)	Class 2 (dBm)	Tolerance (dB)	Class 3 (dBm)	Tolerance (dB)	Class 4 (dBm)	Tolerance (dB)
V2X_n71A_47A					23	+2/-3 <sup>4</sup>		
NOTE 1: The con-current band combinations is used for NR V2X Service.								
NOTE 2: $P_{PowerClass}$ is the maximum UE power specified without taking into account the tolerance								
NOTE 3: For inter-band con-current aggregation the maximum power requirement apply to the total transmitted power over all component carriers (per UE).								
NOTE 4: <sup>4</sup> refers to the transmission bandwidths (Figure 5.6-1) confined within $F_{UL\_low}$ and $F_{UL\_low} + 4$ MHz or $F_{UL\_high} - 4$ MHz and $F_{UL\_high}$ , the maximum output power requirement is relaxed by reducing the lower tolerance limit by 1.5 dB								

The normative reference for this requirement is TS 38.101-3 [4] clause 6.2E.1.

## 6.2E.1.1 UE maximum output power for Intra-band contiguous V2X

### 6.2E.1.1.1 Test purpose

To verify that UE's transmit power doesn't exceed the range prescribed by the specified power value.

### 6.2E.1.1.2 Test applicability

No exception requirements applicable to NR V2X operation or E-UTRA V2X operation. Given only single switched SL is supported as per clause 6.2E.1.0.1. The requirements in this test case can be well covered in clause 6.2.2G of TS 36.521-1 [10] and clause 6.2E.1 of TS 38.521-1 [8] and don't need to be tested again.

## 6.2E.1.2 UE maximum output power for Intra-band non-contiguous V2X

### 6.2E.1.1.1 Test purpose

To verify that UE's transmit power doesn't exceed the range prescribed by the specified power value.

### 6.2E.1.1.2 Test applicability

No exception requirements applicable to NR V2X operation or E-UTRA V2X operation. Given only single switched SL is supported as per clause 6.2E.1.0.2. The requirements in this test case can be well covered in clause 6.2.2G of TS 36.521-1 [10] and clause 6.2E.1 of TS 38.521-1 [8] and don't need to be tested again.

## 6.2E.1.3 UE maximum output power for Inter-band V2X

### 6.2E.1.3.1 UE maximum output power for Inter-band V2X with E-UTRA Uu and NR Sidelink

**Editor's note:**

- Connection diagram is FFS
- Generic test procedure is FFS
- Message exception is FFS
- Test requirements are FFS

#### 6.2E.1.3.1.1 Test purpose

Same test purpose as in clause 6.2E.1.1.1 in TS 38.521-1 [8].

#### 6.2E.1.3.1.2 Test applicability

This test applies to all types of E-UTRA UE release 16 and forward supporting concurrent operation between E-UTRA Uu and NR sidelink.

#### 6.2E.1.3.1.3 Minimum conformance requirements

The minimum conformance requirements are defined in clause 6.2E.1.0.3.

#### 6.2E.1.3.1.4 Test description

##### 6.2E.1.3.1.4.1 Initial conditions

Initial conditions are a set of test configurations the UE needs to be tested in and the steps for the SS to take with the UE to reach the correct measurement state.

The initial test configurations consist of environmental conditions, test frequencies and test channel bandwidths based on NR operating bands specified in clause 5.3E.3, channel bandwidths and sub-carrier spacings for the NR sidelink

carrier specified in TS 38.521-1 [8] clause 5.3 and channel bandwidth for the E-UTRA cell are specified in TS 36.521-1 [10] clause 5.4.2. All of these configurations shall be tested with applicable test parameters for each E-UTRA-NR V2X band combination of test channel bandwidth and sub-carrier spacing, and are shown in table 6.2E.1.3.1.4.1-1. The details of the uplink reference measurement channels (RMCs) are specified in Annexes A.2 of TS 36.521-1 [10] for E-UTRA Uu carrier. The details of sidelink reference measurement channels (RMCs) are specified in A.7 of TS 38.521-1 [8] for NR V2X carrier. Configurations of PDSCH and PDCCH before measurement are specified in TS 36.521.1 [10] Annex C.2 for E-UTRA Uu carrier.

**Table 6.2E.1.3.1.4.1-1: Test configuration table**

Initial Conditions					
Test Environment as specified in TS 38.508-1 [6] clause 4.1.		Normal, TL/VL, TL/VH, TH/VL, TH/VH			
Test Frequencies as specified in TS 36.508 [11] subclause 4.3.1 for E-UTRA carrier and TS 38.508-1 [6] clause 4.3.1 for NR carrier.		Low range for E-UTRA Uu carrier and NR sidelink carrier High range for E-UTRA Uu carrier and NR sidelink carrier			
Test inter-band V2X bandwidth combination as specified in clause 5.3E.3.		Lowest for E-UTRA Uu carrier and NR sidelink carrier Highest for E-UTRA Uu carrier and NR sidelink carrier			
Test SCS for the NR carrier as specified in TS 38.521-1 [8] Table 5.3.5-1.		15kHz			
Test Parameters					
Test ID	E-UTRA Uu carrier			NR sidelink Carrier	
	Downlink Configuration	Uplink Configuration		Modulation	PSCCH and PSSCH RB allocation (Note 2)
Modulation		RB allocation (Note 1)			
1	N/A	QPSK	Partial Allocation	CP-OFDM QPSK	Inner_Full
NOTE 1: The specific configuration of each RB allocation is defined in Table 6.1-1 in current specification.					
NOTE 2: The specific configuration of each RB allocation is defined in Table 6.1E-1 in TS 38.521-1 [8].					

1. Connect the SS to the UE antenna connectors as shown in TS 38.508-1 [6] Annex A, FFS for TE diagram and clause FFS for UE diagram.
2. The parameter settings for the E-UTRA cell are set up according to TS 36.508 [11] clause 4.4.3. The parameter settings for the V2X sidelink transmission over PC5 are pre-configured according to TS 38.508-1 [5] clause 4.10. Message content exceptions are defined in clause 6.2E.1.3.1.4.3.
3. Downlink signals are initially set up according to TS 36.521-1 [10] Annex C.0, and uplink signals according to TS 36.521-1 [10] Annex H for the E-UTRA cell.
4. The E-UTRA UL Reference Measurement channels and the V2X Reference Measurement Channel are set according to Table 6.2E.1.3.1.4.1-1.
5. Propagation conditions are set according to TS 36.521-1 [10] Annex B.0 and TS 38.521-1 [8] Annex B.0 for E-UTRA CG and NR CG respectively.
6. Ensure the UE is in State FFS according to TS 36.508 [7] clause FFS.

#### 6.2E.1.3.1.4.2 Test procedure

1. The SS sends uplink scheduling information for each UL HARQ process via PDCCH DCI format 0 for C\_RNTI to schedule the E-UTRA UL RMC according to Table 6.2E.1.3.1.4.1-1. The UE starts to perform the NR sidelink communication according to *SL-PreconfigurationNR*. Since the UE has no payload and no loopback data to send the UE sends uplink MAC padding bits on the E-UTRA UL and NR sidelink RMCs.
2. Send continuously uplink power control "up" commands in the uplink scheduling information to the UE to ensure that the UE transmits at PUMAX level. Configure the UE to transmit PSCCH and PSSCH with the PUMAX level of each test points.
3. Measure the mean power over all component carriers in the inter-band con-current V2X configuration. The period of measurement shall be at least continuous duration of one sub-frame (1ms).

#### 6.2E.1.3.1.4.3 Message contents

Message contents are according to TS 36.508 [11] clause 4.6 for E-UTRA Uu carrier and TS 38.508-1 [6] clause 4.6.3 for NR sidelink carrier with the following exceptions:

FFS

#### 6.2E.1.3.1.5 Test requirement

FFS

#### 6.2E.1.3.2 UE maximum output power reduction for Inter-band V2X with NR Uu and E-UTRA V2X

**Editor's note:**

- Connection diagram is FFS
- Generic test procedure is FFS
- Message exception is FFS
- Test requirements are FFS

#### 6.2E.1.3.2.1 Test purpose

Same test purpose as in clause 6.2E.1.1.1 in TS 38.521-1 [8].

#### 6.2E.1.3.2.2 Test applicability

This test applies to all types of NR UE release 16 and forward supporting concurrent operation between NR Uu and E-UTRA V2X.

#### 6.2E.1.3.2.3 Minimum conformance requirements

The minimum conformance requirements are defined in clause 6.2E.1.0.3.

#### 6.2E.1.3.2.4 Test description

##### 6.2E.1.3.2.4.1 Initial conditions

Initial conditions are a set of test configurations the UE needs to be tested in and the steps for the SS to take with the UE to reach the correct measurement state.

The initial test configurations consist of environmental conditions, test frequencies and test channel bandwidths based on NR operating bands specified in clause 5.3E.3, channel bandwidths and sub-carrier spacings for the NR cell specified in TS 38.521-1 [8] clause 5.3 and channel bandwidth for the E-UTRA V2X carrier are specified in TS 36.521-1 [10] clause 5.4.2. All of these configurations shall be tested with applicable test parameters for each E-UTRA-NR V2X band combination of test channel bandwidth and sub-carrier spacing, and are shown in table 6.2E.1.3.2.4.1-1. The details of the uplink reference measurement channels (RMCs) are specified in Annex A.2 of TS 38.521-1 [8] for NR Uu carrier. The details of sidelink reference measurement channels (RMCs) are specified in Annex A.6 of TS 36.521-1 [10] for E-UTRA V2X carrier. Configurations of PDSCH and PDCCH before measurement are specified in TS 38.521-1 [8] Annex C.2 for NR Uu carrier.

**Table 6.2E.1.3.2.4.1-1: Test configuration table**

Initial Conditions					
Test Environment as specified in TS 38.508-1 [6] clause 4.1.		Normal, TL/VL, TL/VH, TH/VL, TH/VH			
Test Frequencies as specified in TS 36.508 [11] subclause 4.3.1 for E-UTRA carrier and TS 38.508-1 [6] clause 4.3.1 for NR carrier.		Low range for NR Uu carrier and E-UTRA sidelink carrier High range for NR Uu carrier and E-UTR sidelink carrier			
Test inter-band V2X bandwidth combination as specified in clause 5.3E.3.		Lowest for NR Uu carrier and E-UTRA sidelink carrier Highest for NR Uu carrier and E-UTRA sidelink carrier			
Test SCS for the NR carrier as specified in TS 38.521-1 [8] Table 5.3.5-1.		15kHz			
Test Parameters					
Test ID	NR Uu Carrier			E-UTRA V2X Carrier	
	Downlink Configuration	Uplink Configuration		Modulation	PSSCH RB allocation
Modulation		RB allocation (Note 1)			
1	N/A	DFT-s-OFDM QPSK	Inner Full	QPSK	48@2 for 10MHz BW 96@2 for 20MHz BW
NOTE 1: The specific configuration of each RB allocation is defined in Table 6.1E-1 in TS 38.521-1 [8].					

1. Connect the SS to the UE antenna connectors as shown in TS 38.508-1 [6] Annex A, FFS for TE diagram and clause FFS for UE diagram.
2. The parameter settings for the NR cell are set up according to TS 38.508-1 [6] clause 4.4.3. The parameter settings for the E-UTRA V2X sidelink transmission are pre-configured according to TS 38.508-1 [5] subclause 4.10. Message content exceptions are defined in clause 6.2E.1.3.2.4.3.
3. Downlink signals are initially set up according to TS 38.521-1 [8] Annex C.0, and uplink signals according to TS 38.521-1 [8] Annex G for the NR cell.
4. The NR UL Reference Measurement channels and the E-UTRA V2X Reference Measurement Channel are set according to Table 6.2E.1.3.2.4.1-1.
5. Propagation conditions are set according to TS 36.521-1 [10] Annex B.0 and TS 38.521-1 [8] Annex B.0 for E-UTRA CG and NR CG respectively.
8. Ensure the UE is in state FFS according to TS 38.508-1 [6] clause FFS.

#### 6.2E.1.3.2.4.2 Test procedure

1. The SS sends uplink scheduling information for each UL HARQ process via PDCCH DCI format 0\_1 for C\_RNTI to schedule the NR UL RMC according to Table 6.2E.1.3.2.4.1-1 on NR CC. The UE starts to perform the E-UTRA V2X sidelink communication according to SL-V2X-Preconfiguration. Since the UL has no payload and no loopback data to send, the UE transmits uplink MAC padding bits on the NR UL and E-UTRA V2X sidelink RMC.
2. Send continuously uplink power control "up" commands to the UE until the UE transmits at its  $P_{UMAX}$  level; allow at least 200 ms from the first TPC command starting in this step for the UE to reach  $P_{UMAX}$  level.
3. Measure the mean power over all component carriers in the inter-band con-current V2X configuration. The period of the measurement shall be at least the continuous duration of one active sub-frame (1ms). For TDD slots with transient periods are not under test.

#### 6.2E.1.3.2.4.3 Message contents

Message contents are according to TS 38.508-1 [6] clause 4.6.1 for NR Uu carrier and TS 36.508 [11] clause 4.6 for E-UTRA V2X sidelink carrier with the following exceptions:

FFS

#### 6.2E.1.3.2.5 Test requirement

FFS

## 6.2E.2 UE maximum output power reduction for V2X

### 6.2E.2.0 Minimum conformance requirements

#### 6.2E.2.0.1 UE maximum output power reduction for Intra-band V2X

For intra-band V2X operating UE, maximum output power reduction specified in clause 6.2.3G [5] and in clause 6.2E.2 [2] apply, respectively.

#### 6.2E.2.0.2 UE maximum output power reduction for Inter-band V2X

For the inter-band con-current NR V2X operation, the allowed maximum power reduction (MPR) for the maximum output power shall be applied per each component carrier. The MPR requirements in subclause 6.2.3 of TS 36.101 [5] apply for E-UTRA Uu operation in licensed band, and the MPR requirements in subclause 6.2E.2 of TS 38.101-1 [2] apply for NR sidelink operation. The MPR requirements in subclause 6.2.3G of TS 36.101 [5] apply for E-UTRA V2X operation, and the MPR requirements in subclause 6.2.2 of TS 38.101-1 [2] apply for NR Uu operation.

The normative reference for this requirement is TS 38.101-3 [4] clause 6.2E.2.

### 6.2E.2.1 UE maximum output power reduction for Intra-band V2X

#### 6.2E.2.1.1 Test purpose

To verify that the backoff of UE's transmit power doesn't exceed the range prescribed by the specified MPR value and tolerance specified in clause of configured output power.

#### 6.2E.2.1.2 Test applicability

This test applies to all types of UE release 16 and forward, supporting E-UTRA-NR intra-band contiguous V2X configuration or E-UTRA-NR intra-band non-contiguous V2X configuration.

No exception requirements applicable to NR V2X operation or E-UTRA V2X operation. Given only single switched SL is supported as per clause 6.2E.1.1 and 6.2E.1.2. The requirements in this test case can be well covered in clause 6.2.3G of TS 36.521-1 [10] and clause 6.2E.2 of TS 38.521-1 [8] and don't need to be tested again.

### 6.2E.2.2 UE maximum output power reduction for Inter-band V2X

#### 6.2E.2.2.1 UE maximum output power reduction for Inter-band V2X with E-UTRA Uu and NR Sidelink

**Editor's note:**

- Connection diagram is FFS
- Generic test procedure is FFS
- Message exception is FFS
- Test requirements are FFS

#### 6.2E.2.2.1.1 Test purpose

Same test purpose as in clause 6.2E.2.1.1 in TS 38.521-1 [8].

#### 6.2E.2.2.1.2 Test applicability

This test applies to all types of E-UTRA UE release 16 and forward supporting concurrent operation between E-UTRA Uu and NR sidelink.

## 6.2E.2.2.1.3 Minimum conformance requirements

The minimum conformance requirements are defined in clause 6.2E.2.0.2.

## 6.2E.2.2.1.4 Test description

## 6.2E.2.2.1.4.1 Initial conditions

Initial conditions are a set of test configurations the UE needs to be tested in and the steps for the SS to take with the UE to reach the correct measurement state.

The initial test configurations consist of environmental conditions, test frequencies and test channel bandwidths based on NR operating bands specified in clause 5.3E.3, channel bandwidths and sub-carrier spacings for the NR sidelink carrier specified in TS 38.521-1 [8] clause 5.3 and channel bandwidth for the E-UTRA cell are specified in TS 36.521-1 [10] clause 5.4.2. All of these configurations shall be tested with applicable test parameters for each E-UTRA-NR V2X band combination of test channel bandwidth and sub-carrier spacing, and are shown in table 6.2E.2.2.1.4.1-1. The details of the uplink reference measurement channels (RMCs) are specified in Annexes A.2 of TS 36.521-1 [10] for E-UTRA Uu carrier. The details of sidelink reference measurement channels (RMCs) are specified in A.7 of TS 38.521-1 [8] for NR V2X carrier. Configurations of PDSCH and PDCCH before measurement are specified in TS 36.521.1 [10] Annex C.2 for E-UTRA Uu carrier.

**Table 6.2E.2.2.1.4.1-1: Test configuration table**

Initial Conditions					
Test Environment as specified in TS 38.508-1 [6] clause 4.1.		Normal, TL/VL, TL/VH, TH/VL, TH/VH			
Test Frequencies as specified in TS 36.508 [11] subclause 4.3.1 for E-UTRA carrier and TS 38.508-1 [6] clause 4.3.1 for NR carrier.		Low range for E-UTRA Uu carrier and NR sidelink carrier High range for E-UTRA Uu carrier and NR sidelink carrier			
Test inter-band V2X bandwidth combination as specified in clause 5.3E.3.		Lowest for E-UTRA Uu carrier and NR sidelink carrier Highest for E-UTRA Uu carrier and NR sidelink carrier			
Test SCS for the NR carrier as specified in TS 38.521-1 [8] Table 5.3.5-1.		15kHz			
Test Parameters					
Test ID	E-UTRA Uu carrier			NR sidelink Carrier	
	Downlink Configuration	Uplink Configuration		Modulation	PSCCH and PSSCH RB allocation (Note 2)
Modulation		RB allocation (Note 1)			
1	N/A	QPSK	Partial_Allocation	CP-OFDM 16QAM	Inner_Full
2		QPSK	Full_Allocation	CP-OFDM 16QAM	Outer_Full
3		16QAM	Partial_Allocation	CP-OFDM 64QAM	Outer_Full
4		16QAM	Full_Allocation	CP-OFDM 256QAM	Outer_Full
NOTE 1: The specific configuration of each RB allocation is defined in Table 6.1-1 in current specification.					
NOTE 2: The specific configuration of each RB allocation is defined in Table 6.1E-1 in TS 38.521-1 [8].					

1. Connect the SS to the UE antenna connectors as shown in TS 38.508-1 [6] Annex A, FFS for TE diagram and clause FFS for UE diagram.
2. The parameter settings for the E-UTRA cell are set up according to TS 36.508 [11] clause 4.4.3. The parameter settings for the V2X sidelink transmission over PC5 are pre-configured according to TS 38.508-1 [5] clause 4.10. Message content exceptions are defined in clause 6.2E.1.1.4.3.
3. Downlink signals are initially set up according to TS 36.521-1 [10] Annex C.0, and uplink signals according to TS 36.521-1 [10] Annex H for the E-UTRA cell.
4. The E-UTRA UL Reference Measurement channels and the V2X Reference Measurement Channel are set according to Table 6.2E.2.2.1.4.1-1.
5. Propagation conditions are set according to TS 36.521-1 [10] Annex B.0 and TS 38.521-1 [8] Annex B.0 for E-UTRA CG and NR CG respectively.
6. Ensure the UE is in State FFS according to TS 36.508 [7] clause FFS. Message content exceptions are defined in clause 6.2E.2.2.1.4.3.

#### 6.2E.2.2.1.4.2 Test procedure

1. The SS sends uplink scheduling information for each UL HARQ process via PDCCH DCI format 0 for C\_RNTI to schedule the E-UTRA UL RMC according to Table 6.2E.2.2.1.4.1-1. The UE starts to perform the NR sidelink communication according to *SL-PreconfigurationNR*. Since the UE has no payload and no loopback data to send the UE sends uplink MAC padding bits on the E-UTRA UL and NR sidelink RMCs.
2. Send continuously uplink power control "up" commands in the uplink scheduling information to the UE to ensure that the UE transmits at PUMAX level. Configure the UE to transmit PSCCH and PSSCH with the PUMAX level of each test points.
3. Measure the mean power over all component carriers in the inter-band con-current V2X configuration. The period of measurement shall be at least continuous duration of one sub-frame (1ms).

#### 6.2E.2.2.1.4.3 Message contents

Message contents are according to TS 36.508 [11] clause 4.6 for E-UTRA Uu carrier and TS 38.508-1 [6] clause 4.6.3 for NR sidelink carrier with the following exceptions:

FFS

#### 6.2E.2.2.1.5 Test requirement

FFS

#### 6.2E.2.2.2 UE maximum output power reduction for Inter-band V2X with NR Uu and E-UTRA V2X

**Editor's note:**

- Connection diagram is FFS
- Generic test procedure is FFS
- Message exception is FFS
- Test requirements are FFS

#### 6.2E.2.2.2.1 Test purpose

Same test purpose as in clause 6.2E.2.1.1 in TS 38.521-1 [8].

#### 6.2E.2.2.2.2 Test applicability

This test applies to all types of NR UE release 16 and forward supporting concurrent operation between NR Uu and E-UTRA V2X.

#### 6.2E.2.2.2.3 Minimum conformance requirements

The minimum conformance requirements are defined in clause 6.2E.2.0.2.

#### 6.2E.2.2.2.4 Test description

##### 6.2E.2.2.2.4.1 Initial conditions

Initial conditions are a set of test configurations the UE needs to be tested in and the steps for the SS to take with the UE to reach the correct measurement state.

The initial test configurations consist of environmental conditions, test frequencies and test channel bandwidths based on NR operating bands specified in clause 5.3E.3, channel bandwidths and sub-carrier spacings for the NR cell specified in TS 38.521-1 [8] clause 5.3 and channel bandwidth for the E-UTRA V2X carrier are specified in TS 36.521-1 [10] clause 5.4.2. All of these configurations shall be tested with applicable test parameters for each E-UTRA-NR



V2X band combination of test channel bandwidth and sub-carrier spacing, and are shown in table 6.2E.2.2.4.1-1. The details of the uplink reference measurement channels (RMCs) are specified in Annex A.2 of TS 38.521-1 [8] for NR Uu carrier. The details of sidelink reference measurement channels (RMCs) are specified in Annex A.6 of TS 36.521-1 [10] for E-UTRA V2X carrier. Configurations of PDSCH and PDCCH before measurement are specified in TS 38.521-1 [8] Annex C.2 for NR Uu carrier.

**Table 6.2E.2.2.4.1-1: Test configuration table**

Initial Conditions					
Test Environment as specified in TS 38.508-1 [6] clause 4.1.		Normal, TL/VL, TL/VH, TH/VL, TH/VH			
Test Frequencies as specified in TS 36.508 [11] subclause 4.3.1 for E-UTRA carrier and TS 38.508-1 [6] clause 4.3.1 for NR carrier.		Low range for NR Uu carrier and E-UTRA sidelink carrier High range for NR Uu carrier and E-UTRA sidelink carrier			
Test inter-band V2X bandwidth combination as specified in clause 5.3E.3.		Lowest for NR Uu carrier and E-UTRA sidelink carrier Highest for NR Uu carrier and E-UTRA sidelink carrier			
Test SCS for the NR carrier as specified in TS 38.521-1 [8] Table 5.3.5-1.		15kHz			
Test Parameters					
Test ID	Downlink Configuration	NR Uu Carrier		E-UTRA V2X Carrier	
		Uplink Configuration		Modulation	PSSCH RB allocation
		Modulation	RB allocation (Note 1)		
1	N/A	DFT-s-OFDM QPSK	Inner_Full	QPSK	48@2 for 10MHz BW 96@2 for 20MHz BW
2		DFT-s-OFDM QPSK	Outer_Full	QPSK	48@2 for 10MHz BW 96@2 for 20MHz BW
3		DFT-s-OFDM 16QAM	Inner_Full	QPSK	48@2 for 10MHz BW 96@2 for 20MHz BW
4		DFT-s-OFDM 16QAM	Outer_Full	QPSK	48@2 for 10MHz BW 96@2 for 20MHz BW
5		DFT-s-OFDM 64QAM	Outer_Full	QPSK	48@2 for 10MHz BW 96@2 for 20MHz BW
6		DFT-s-OFDM 256QAM	Outer_Full	QPSK	48@2 for 10MHz BW 96@2 for 20MHz BW
7		CP-OFDM QPSK	Inner_Full	16QAM	48@2 for 10MHz BW 96@2 for 20MHz BW
8		CP-OFDM 16PSK	Inner_Full	16QAM	48@2 for 10MHz BW 96@2 for 20MHz BW
9		CP-OFDM 16PSK	Outer_Full	16QAM	48@2 for 10MHz BW 96@2 for 20MHz BW
10		CP-OFDM 64PSK	Outer_Full	16QAM	48@2 for 10MHz BW 96@2 for 20MHz BW
11		CP-OFDM 256PSK	Outer_Full	16QAM	48@2 for 10MHz BW 96@2 for 20MHz BW
NOTE 1: The specific configuration of each RB allocation is defined in Table 6.1E-1 in TS 38.521-1 [8].					

1. Connect the SS to the UE antenna connectors as shown in TS 38.508-1 [6] Annex A, FFS for TE diagram and clause FFS for UE diagram.
2. The parameter settings for the NR cell are set up according to TS 38.508-1 [6] clause 4.4.3. The parameter settings for the E-UTRA V2X sidelink transmission are pre-configured according to TS 38.508-1 [5] subclause 4.10. Message content exceptions are defined in clause 6.2E.1.1.4.3.
3. Downlink signals are initially set up according to TS 38.521-1 [8] Annex C.0, and uplink signals according to TS 38.521-1 [8] Annex G for the NR cell.
4. The NR UL Reference Measurement channels and the E-UTRA V2X Reference Measurement Channel are set according to Table 6.2E.2.2.4.1-1.
5. Propagation conditions are set according to TS 36.521-1 [10] Annex B.0 and TS 38.521-1 [8] Annex B.0 for E-UTRA CG and NR CG respectively.
8. Ensure the UE is in state FFS according to TS 38.508-1 [6] clause FFS. Message contents are defined in clause 6.2E.2.2.4.3.

#### 6.2E.2.2.2.4.2 Test procedure

1. The SS sends uplink scheduling information for each UL HARQ process via PDCCH DCI format 0\_1 for C\_RNTI to schedule the NR UL RMC according to Table 6.2E.2.2.2.4.1-1 on NR CC. The UE starts to perform the E-UTRA V2X sidelink communication according to SL-V2X-Preconfiguration. Since the UL has no payload and no loopback data to send, the UE transmits uplink MAC padding bits on the NR UL and E-UTRA V2X sidelink RMC.
2. Send continuously uplink power control "up" commands to the UE until the UE transmits at its  $P_{UMAX}$  level; allow at least 200 ms from the first TPC command starting in this step for the UE to reach  $P_{UMAX}$  level.
3. Measure the mean power over all component carriers in the inter-band con-current V2X configuration. The period of the measurement shall be at least the continuous duration of one active sub-frame (1ms). For TDD slots with transient periods are not under test.

NOTE 1: When switching to DFT-s-OFDM waveform, as specified in the test configuration table 6.2E.2.2.2.4.1-1, send an NR RRCReconfiguration message according to TS 38.508-1 [6] clause 4.6.3 Table 4.6.3-118 PUSCH-Config with TRANSFORM\_PRECODER\_ENABLED condition.

#### 6.2E.2.2.2.4.3 Message contents

Message contents are according to TS 38.508-1 [6] clause 4.6.1 for NR Uu carrier and TS 36.508 [11] clause 4.6 for E-UTRA V2X sidelink carrier with the following exceptions:

FFS

#### 6.2E.2.2.2.5 Test requirement

FFS

## 6.2H Transmitter power for DC with UL MIMO

### 6.2H.1 UE maximum output power for DC with UL MIMO

#### 6.2H.1.3 UE maximum output power for inter-band EN-DC with UL MIMO within FR1

##### 6.2H.1.3.1 Test purpose

To verify that the error of the UE maximum output power does not exceed the range prescribed by the specified nominal maximum output power and tolerance.

An excess maximum output power has the possibility to interfere to other channels or other systems. A small maximum output power decreases the coverage area.

##### 6.2H.1.3.2 Test applicability

This test applies to all types of E-UTRA UE release 17 and forward, supporting inter-band EN-DC with UL MIMO.

##### 6.2H.1.3.3 Minimum conformance requirements

For inter-band EN-DC of E-UTRA and NR in FR1, the following UE Power Classes define the maximum output power for any transmission bandwidth within the aggregated channel bandwidth. The maximum output power is measured as the sum of the maximum output power at each UE antenna connector. The period of measurement shall be at least one sub frame (1ms). UE maximum output power shall be measured over all component carriers from different bands. If each band has separate antenna connectors, maximum output power is measured as the sum of maximum output power at each UE antenna connector.

**Table 6.2H.1.3.3-1: Maximum output power for inter-band EN-DC with UL MIMO (two bands)**

EN-DC configuration	Power class 2 (dBm)	Tolerance (dB)	Power class 3 (dBm)	Tolerance (dB)
DC_3A_n78A	26 <sup>5</sup>	+2/-3	23	+2/-3
DC_7A_n78A	26 <sup>5</sup>	+2/-3	23	+2/-3
DC_8A_n78A	26 <sup>5</sup>	+2/-3	23	+2/-3
DC_20A_n78A	26 <sup>5</sup>	+2/-3	23	+2/-3
DC_28A_n78A	26 <sup>5</sup>	+2/-3	23	+2/-3
DC_40A_n78A	26	+2/-3	23	+2/-3
DC_41A_n78A	26 <sup>5</sup>	+2/-3	23	+2/-3

NOTE 1: An uplink DC configuration in which at least one of the bands has NOTE 3 in Table 6.2.1-1 in TS 38.101-1 or NOTE 2 in Table 6.2.2-1 in TS 36.101 is allowed to reduce the lower tolerance limit by 1.5 dB when the transmission bandwidths of at least one of the bands is confined within  $F_{UL\_low}$  and  $F_{UL\_low} + 4$  MHz or  $F_{UL\_high} - 4$  MHz and  $F_{UL\_high}$ .

NOTE 2:  $P_{PowerClass, EN-DC}$  is the maximum UE power specified without taking into account the tolerance

NOTE 3: For inter-band EN-DC the maximum power requirement should apply to the total transmitted power over all component carriers (per UE).

NOTE 4: Power Class 3 is the default power class unless otherwise stated.

NOTE 5: The UE supports PC3 in E-UTRA band, and supports PC3 or PC2 with UL MIMO in NR band

NOTE 6: Void

NOTE 7: FWA form factor is targeted unless otherwise stated.

If a UE supports a different power class than the default UE power class for an E-UTRA TDD and NR TDD Inter-band EN-DC band combination and the supported power class enables higher maximum output power than that of the default power class:

- if the field of UE capability *maxUplinkDutyCycle-interBandENDC-TDD-PC2-r16* is absent and the percentage of NR uplink symbols transmitted in a certain evaluation period is larger than 30% (The exact evaluation period is no less than one radio frame); or
- if the field of UE capability *maxUplinkDutyCycle-interBandENDC-TDD-PC2-r16* is present and the percentage of NR uplink symbols transmitted in a certain evaluation period is larger than *maxUplinkDutyCycle-interBandENDC-TDD-PC2-r16* as defined in TS38.331 (The exact evaluation period is no less than one radio frame); or
- if the IE *p-maxUE-FRI* as defined in TS 38.331 is provided and set to the maximum output power of the default power class or lower;
  - shall apply all requirements for the default power class to the supported power class and set the configured transmitted power as specified sub-clause 6.2H.4;
- Else if the IE *p-maxUE-FRI* as defined in TS 38.331 is not provided or set to the higher value than the maximum output power of the default power class and the percentage of NR uplink symbols transmitted in a certain evaluation period is less than or equal to *maxUplinkDutyCycle-interBandENDC-TDD-PC2-r16* as defined in TS 38.331; or
- if the IE *p-maxUE-FRI* as defined in TS 38.331 is not provided or set to the higher value than the maximum output power of the default power class and the percentage of NR uplink symbols transmitted in a certain evaluation period is less than or equal to 30% when *maxUplinkDutyCycle-interBandENDC-TDD-PC2-r16* is absent. (The exact evaluation period is no less than one radio frame):
  - shall apply all requirements for the supported power class and set the configured transmitted power class as specified in sub-clause 6.2H.4.

If a UE supports a different power class than the default UE power class for an E-UTRA FDD and NR TDD EN-DC band combination and the supported power class enables higher maximum output power than that of the default power class:

If UE indicating the two capabilities *maxUplinkDutyCycle-FDD-TDD-EN-DC1* and *maxUplinkDutyCycle-FDD-TDD-EN-DC2*:

- if the IE *p-maxUE-FRI* as defined in TS 38.331 is not provided or set to the higher value than the maximum output power of the default power class, and the percentage of EUTRA uplink symbols transmitted in a certain evaluation period is between 40% and 70%, and the percentage of NR uplink symbols transmitted in a

certain evaluation period is less than or equal to  $maxUplinkDutyCycle-FDD-TDD-EN-DC1$  as defined in TS 38.331 (The exact evaluation period is no less than one radio frame); or

- if the IE  $p-maxUE-FRI$  as defined in TS 38.331 is not provided or set to the higher value than the maximum output power of the default power class, and the percentage of EUTRA uplink symbols transmitted in a certain evaluation period is no larger than 40%, and the percentage of NR uplink symbols transmitted in a certain evaluation period is less than or equal to  $maxUplinkDutyCycle-FDD-TDD-EN-DC2$  as defined in TS 38.331 (The exact evaluation period is no less than one radio frame)
    - shall apply all requirements for the supported power class and set the configured transmitted power class as specified in sub-clause 6.2H.4.
  - else
    - shall apply all requirements for the default power class and set the configured transmitted power as specified sub-clause 6.2H.4;
- else
- shall apply all requirements for the supported power class and set the configured transmitted power as specified sub-clause 6.2H.4;

The normative reference for this requirement is TS 38.101-3 [4] clause 6.2H.1.3.

LTE anchor agnostic approach is not applied. E-UTRA test point analysis is included and E-UTRA measurements are performed.

#### 6.2H.1.3.4 Test description

##### 6.2H.1.3.4.1 Initial condition

Initial conditions are a set of test configurations the UE needs to be tested in and the steps for the SS to take with the UE to reach the correct measurement state.

The initial test configurations consist of environmental conditions, test frequencies, DC configuration specified in clause 5.5B.4 and test channel bandwidths specified in TS 36.508 [11] clause 4.3.1 and TS 38.508-1 [6] clause 4.3.1, and sub-carrier spacing based on NR operating bands specified in TS 38.521-1 [8] clause 5.3. All of these configurations shall be tested with applicable test parameters for each EN-DC configuration, and are shown in Table 6.2H.1.3.4.1-1 to Table 6.2H.1.3.4.1-2. The details of the uplink reference measurement channels (RMCs) are specified in Annex A, clause A.2.2 for E-UTRA RMC for TDD, TS 36.521-1 [10] Annex A, clause A.2.2 for E-UTRA RMC for FDD, and TS 38.521-1 [8] Annex A, clause A.2 for NR RMC. Configurations of PDSCH and PDCCH before measurement are specified in TS 36.521-1 [10] Annex C, clause C.2 and in TS 38.521-1 [8] Annex C, clause C.2 for E-UTRA CG and NR CG respectively.

**Table 6.2H.1.3.4.1-1: Test Configuration Table for 2-layer MIMO (Power Class 2 UEs supporting PC3 in FDD band and PC3 with UL MIMO in TDD band)**

NOTE: No test points are defined since there is no CP-OFDM configuration satisfying  $MPR=0$ dB requirements in TS 38.101-1.

**Table 6.2H.1.3.4.1-2: Test configuration table for 2-layer MIMO (Power Class 3, Power Class 2 UEs supporting PC2 with UL MIMO in TDD band)**

Default Conditions								
Test Environment as specified in TS 38.508-1 [6] clause 4.1				Normal, TL/VL, TL/VH, TH/VL, TH/VH				
Test Frequencies as specified in TS 38.508-1 [6] clause 4.3.1 and TS 36.508 [6]				Low range for E-UTRA CC1 and NR CC1, Mid range for E-UTRA CC1 and NR CC1, High range for E-UTRA CC1 and NR CC1 (NOTE 6)				
Test EN-DC channel bandwidth as specified in TS 36.508 [6] clause 4.3.1 and TS 38.508-1 clause 4.3.1				5MHz for E-UTRA CC1 and Lowest for NR CC1, Highest for E-UTRA CC1 and Highest for NR CC1				
Test SCS for the NR cell as specified in TS 38.521-1 [8] Table 5.3.5-1				Lowest, Highest				
Test Parameters								
Test ID	Test Freq	E-UTRA BW	NR BW	Downlink Configuration	EN-DC Uplink Configuration			
					E-UTRA Cell		NR Cell	
					Modulation	RB allocation (NOTE 1)	Modulation	RB allocation (NOTE 2)
1	High	Default	Default	N/A	QPSK	1RB_Right	CP-OFDM QPSK	Inner_1RB_Right
2	Low	Default	Default		QPSK	1RB_Left	CP-OFDM QPSK	Inner_1RB_Left
3	Default	Default	Default		QPSK	Partial_Allocation	CP-OFDM QPSK	Inner_Full
4	High	Default	Default		QPSK	1RB_Right	CP-OFDM QPSK	Inner_1RB_Right
5	Low	Default	Default		QPSK	1RB_Left	CP-OFDM QPSK	Inner_1RB_Left
6	Default	Default	Default		QPSK	Partial_Allocation	CP-OFDM QPSK	Inner_Full
NOTE 1: The specific configuration of each RB allocation is defined in Table 6.1-1 in current specification.								
NOTE 2: The specific configuration of each RB allocation is defined in Table 6.1-1 in TS 38.521-1 [8].								
NOTE 3: Only applicable to UEs not supporting UE capability <i>singleUL-Transmission</i> .								

1. Connect the SS to the UE antenna connectors as shown in TS 38.508-1 [6] clause A.3.1.1 for SS and clause A.3.2 for UE.
2. The parameter settings for the E-UTRA cell are set up according to TS 36.508 [11] clause 4.4.3, and the parameter settings for the cell are set up according to TS 38.508-1 [6] clause 4.4.3.
3. Downlink signals are initially set up according to TS 36.521-1 [10] Annex C.0 and TS 38.521-1 [8] Annex C.0 for E-UTRA CG and NR CG respectively, and uplink signals according to TS 36.521-1 [10] Annex H and TS 38.521-1 [8] Annex G for E-UTRA CG and NR CG respectively.
4. The UL Reference Measurement channels are set according to Table 6.2H.1.3.4.1-1 to Table 6.2H.1.3.4.1-2.
5. Propagation conditions are set according to TS 36.521-1 [10] and TS 38.521-1 [8] Annex B.0 for E-UTRA CG and NR CG respectively.
6. Ensure the UE is in state RRC\_CONNECTED with generic procedure parameters Connectivity EN-DC, DC bearer MCG and SCG, Connected without release On according to TS 38.508-1 [6] clause 4.5. Message contents are defined in clause 6.2H.1.3.4.3.
7. For the case of testing overlapping E-UTRA and NR UL transmission scenario when both bands are TDD, ensure E-UTRA UL transmission overlaps with NR UL transmission in time by giving SCG a delay of 3 E-UTRA subframes, or by giving MCG a delay of 2 subframes.

6.2H.1.3.4.2 Test procedure

1. SS sends uplink scheduling information for each UL HARQ process via PDCCH DCI format 0 and DCI format 0\_1 for C\_RNTI to schedule the UL RMC according to Table 6.2H.1.3.4.1-1 to Table 6.2H.1.3.4.1-2 on E-UTRA CC and NR CC respectively. Since the UL has no payload and no loopback data to send the UE sends

uplink MAC padding bits on the UL RMC. The PDCCH DCI format 0\_1 for NR CC is specified with the condition 2TX\_UL\_MIMO in 38.508-1 [5] subclause 4.3.6.1.1.2.

2. Send continuously uplink power control "up" commands to the UE for NR and E-UTRA carrier until the UE transmits at its  $P_{UMAX}$  level; allow at least 200 ms from the first TPC command for the UE to reach  $P_{UMAX}$  level.
3. Measure the sum of mean transmitted power from all antenna connectors and all EN-DC component carriers in the EN-DC, which shall meet the requirements described in Table 6.2H.1.3.5-1 and the period of the measurement shall be at least the continuous duration of one active sub-frame. For FDD band in inter-band CA with both TDD band and FDD band, only slots overlapping with only UL symbols in TDD are under test.

#### 6.2H.1.3.4.3 Message contents

Message contents are according to TS 36.508 [11] clause 4.6 and TS 38.508-1 [6] clause 4.6 ensuring Table 4.6.3-182 with the condition 2TX\_UL\_MIMO with the following exceptions:

**Table 6.2H.1.3.4.3-1: PhysicalCellGroupConfig**

Derivation Path: TS 38.508-1 [6], Table 4.6.3-106			
Information Element	Value/remark	Comment	Condition
PhysicalCellGroupConfig ::= SEQUENCE {			
p-NR-FR1	20		Power Class 3 UE
	23		Power Class 2 UE
}			

**Table 6.2H.1.3.4.3-2: RRCConnectionReconfiguration: nr-Config-r15**

Derivation Path: TS 36.508 [11], Table 4.6.1-8			
Information Element	Value/remark	Comment	Condition
p-MaxEUTRA-r15	20		Power Class 3
	23		Power Class 2

**Table 6.2H.1.3.4.3-3: SystemInformationBlockType1: tdd-Config if E-UTRA on TDD band**

Derivation Path: TS 36.508 [11], Table 4.6.3-23			
Information Element	Value/remark	Comment	Condition
TDD-Config-DEFAULT ::= SEQUENCE {		Operating on TDD band	
subframeAssignment	sa2		
specialSubframePatterns	ssp7		
}			

#### 6.2H.1.3.5 Test requirements

The maximum output power for the DC configuration, derived in step 3 shall be within the range prescribed by the UE Power Class and tolerance in Table 6.2H.1.3.5-1.

**Table 6.2H.1.3.5-1: Maximum output power for inter-band EN-DC (two bands) with UL MIMO**

EN-DC configuration	Power class 2 (dBm)	Tolerance (dB)	Power class 3 (dBm)	Tolerance (dB)
DC_3A_n78A	26 <sup>5</sup>	+2+TT/-3-TT	23	+2+TT/-3-TT
DC_7A_n78A	26 <sup>5</sup>	+2+TT/-3-TT	23	+2+TT/-3-TT
DC_8A_n78A	26 <sup>5</sup>	+2+TT/-3-TT	23	+2+TT/-3-TT
DC_20A_n78A	26 <sup>5</sup>	+2+TT/-3-TT	23	+2+TT/-3-TT
DC_28A_n78A	26 <sup>5</sup>	+2+TT/-3-TT	23	+2+TT/-3-TT
DC_40A_n78A	26	+2+TT/-3-TT	23	+2+TT/-3-TT
DC_41A_n78A	26 <sup>5</sup>	+2+TT/-3-TT	23	+2+TT/-3-TT

NOTE 1: An uplink DC configuration in which at least one of the bands has NOTE 3 in Table 6.2.1-1 in TS 38.101-1 or NOTE 2 in Table 6.2.2-1 in TS 36.101 is allowed to reduce the lower tolerance limit by 1.5 dB when the transmission bandwidths of at least one of the bands is confined within F<sub>UL\_low</sub> and F<sub>UL\_low</sub> + 4 MHz or F<sub>UL\_high</sub> - 4 MHz and F<sub>UL\_high</sub>.

NOTE 2: P<sub>PowerClass, EN-DC</sub> is the maximum UE power specified without taking into account the tolerance

NOTE 3: For inter-band EN-DC the maximum power requirement should apply to the total transmitted power over all component carriers (per UE).

NOTE 4: Power Class 3 is the default power class unless otherwise stated.

NOTE 5: The UE supports PC3 in E-UTRA band, and supports PC3 or PC2 with UL MIMO in NR band

NOTE 6: Void

NOTE 7: FWA form factor is targeted unless otherwise stated.

NOTE 8: TT is the maximum TT among all E-UTRA and NR UL carriers. For TT of each UL CC refers to Table 6.2H.1.3.5-2.

**Table 6.2H.1.3.5-2: Test Tolerance for UE maximum output power (Overlapping UL transmission)**

TT for overall output power											
			NR								
			BW ≤ 20MHz			20 MHz < BW ≤ 40MHz			40MHz < BW ≤ 100MHz		
			f ≤ 3.0GHz	3.0GHz < f ≤ 4.2GHz	4.2GHz < f ≤ 6.0GHz	f ≤ 3.0GHz	3.0GHz < f ≤ 4.2GHz	4.2GHz < f ≤ 6.0GHz	f ≤ 3.0GHz	3.0GHz < f ≤ 4.2GHz	4.2GHz < f ≤ 6.0GHz
E-UTRA	BW ≤ 20MHz	f ≤ 3.0GHz	0.7 dB	1.0 dB	1.0 dB	0.7 dB	1.0 dB	1.0 dB	1.0 dB	1.0 dB	1.0 dB
		3.0GHz < f ≤ 4.2GHz	1.0 dB	1.0 dB	1.0 dB	1.0 dB	1.0 dB	1.0 dB	1.0 dB	1.0 dB	1.0 dB

## 6.2H.2 UE maximum output power reduction for DC with UL MIMO

### 6.2H.2.1

### 6.2H.2.2

### 6.2H.2.3 UE maximum output power reduction for inter-band EN-DC with UL MIMO within FR1

#### 6.2H.2.3.1 Test purpose

To verify that the error of the UE maximum output power does not exceed the range prescribed by the specified maximum output power with MPR and tolerance.

An excess maximum output power has the possibility to interfere to other channels or other systems. A small maximum output power decreases the coverage area.

#### 6.2H.2.3.2 Test applicability

This test case applies to all types of NR UE release 17 and forward that support inter-band UL EN-DC with UL MIMO within FR1.

#### 6.2H.2.3.3 Minimum conformance requirements

For inter-band EN-DC between E-UTRA and FR1 NR, UE maximum output power reduction specified in TS 36.101 [4] and TS 38.101-1 [2] apply for E-UTRA and NR respectively.

The normative reference for this requirement is TS 38.101-3 [4] clause 6.2H.2.3.

#### 6.2H.2.3.4 Test procedure

If Standalone FR1 can be tested, this test is covered by 6.2D.2 UE maximum output power reduction for UL MIMO in TS 38.521-1 [8].

If Standalone FR1 cannot be tested (due to test case not being complete or if the UE does not support the band in SA mode), LTE anchor agnostic below is applied.

Same test description as in clause 6.2D.2.4 in TS 38.521-1 [8] for the NR carrier with the following exceptions:

The initial test configurations for E-UTRA band consist of environmental conditions, test frequencies, and channel bandwidths based on E-UTRA bands specified in Table 4.6-1.

For Initial conditions as in clause 6.2D.2.4.1 in TS 38.521-1 [8], the following steps will be added to configure E-UTRA component:

- 2.1. The parameter settings for the E-UTRA cell are set up according to TS 36.508 [11] clause 4.4.3 with E-UTRA channel bandwidth and test frequencies defined in Table 4.6-1.
- 3.1. Downlink E-UTRA signals are initially set up according to TS 36.521-1 [10] Annex C0, C.1 and C.3.0, and uplink signals according to Annex H.1 and H.3.0.
- 4.1. The E-UTRA UL Reference Measurement channels are set according to Table 4.6-1.

Step 6 of Initial conditions as in clause 6.2D.2.4.1 in TS 38.521-1 [8] is replaced by the following two steps:

6. Ensure the UE is in state RRC\_CONNECTED with generic procedure parameters Connectivity EN-DC, DC bearer MCG and SCG, Connected without release *On* according to TS 38.508-1 [6] clause 4.5.
7. On the E-UTRA carrier, disable periodic and aperiodic CQI reports, disable SRS, set *TimeAlignmentTimerDedicated* IE to infinity and disable downlink and uplink scheduling, all as per Table 4.6-1 under clause 4.6.

Same test procedure as in clause 6.2D.2.4.2 in TS 38.521-1 [8].

#### 6.2H.2.3.5 Test requirement

Same test requirement as in clause 6.2D.2.5 in TS 38.521-1 [8].



## 6.2H.3 UE additional maximum output power reduction for EN-DC with UL MIMO

### 6.2H.3.1

### 6.2H.3.2

### 6.2H.3.3 UE additional maximum output power reduction for inter-band EN-DC with UL MIMO within FR1

#### 6.2H.3.3.1 Test purpose

Additional emission requirements can be signalled by the network with network signalling value indicated by the field *additionalSpectrumEmission*. To meet these additional requirements, additional maximum power reduction (A-MPR) is allowed for the maximum output power as specified in Table 6.2H.1.3.3-1. Unless stated otherwise, an A-MPR of 0 dB shall be used.

#### 6.2H.3.3.2 Test applicability

This test case applies to all types of NR UE release 17 and forward that support inter-band UL EN-DC with UL MIMO within FR1.

#### 6.2H.3.3.3 Minimum conformance requirements

For inter-band EN-DC with UL MIMO in NR band, unless specified in Table 6.2B.3.3-1 in 38.101-1 [2], the requirements in 38.101-1 [2] clause 6.2.3 apply for NR uplink component carrier and the requirements in 36.101 [4] clause 6.2.4 apply for LTE uplink component carrier.

The normative reference for this requirement is TS 38.101-3 [4] clause 6.2H.3.3.

#### 6.2H.3.3.4 Test procedure

If Standalone FR1 can be tested, this test is covered by 6.2D.3 UE additional maximum output power reduction for UL MIMO in TS 38.521-1 [8].

If Standalone FR1 cannot be tested (due to test case not being complete or if the UE does not support the band in SA mode), LTE anchor agnostic below is applied.

Same test description as in clause 6.2D.3.4 in TS 38.521-1 [8] for the NR carrier with the following exceptions:

The initial test configurations for E-UTRA band consist of environmental conditions, test frequencies, and channel bandwidths based on E-UTRA bands specified in Table 4.6-1.

For Initial conditions as in clause 6.2D.3.4.1 in TS 38.521-1 [8], the following steps will be added to configure E-UTRA component:

- 2.1. The parameter settings for the E-UTRA cell are set up according to TS 36.508 [11] clause 4.4.3 with E-UTRA channel bandwidth and test frequencies defined in Table 4.6-1.
- 3.1. Downlink E-UTRA signals are initially set up according to TS 36.521-1 [10] Annex C0, C.1 and C.3.0, and uplink signals according to Annex H.1 and H.3.0.
- 4.1. The E-UTRA UL Reference Measurement channels are set according to Table 4.6-1.

Step 6 of Initial conditions as in clause 6.2D.3.4.1 in TS 38.521-1 [8] is replaced by the following two steps:

6. Ensure the UE is in state RRC\_CONNECTED with generic procedure parameters Connectivity EN-DC, DC bearer MCG and SCG, Connected without release *On* according to TS 38.508-1 [6] clause 4.5.

7. On the E-UTRA carrier, disable periodic and aperiodic CQI reports, disable SRS, set *TimeAlignmentTimerDedicated* IE to infinity and disable downlink and uplink scheduling, all as per Table 4.6-1 under clause 4.6.

Same test procedure as in clause 6.2D.3.4.2 in TS 38.521-1 [8].

#### 6.2H.3.3.5 Test requirement

Same test requirement as in clause 6.2D.3.5 in TS 38.521-1 [8].

### 6.2H.4 Configured output power for DC with UL MIMO

#### 6.2H.4.1

#### 6.2H.4.2

#### 6.2H.4.3 Configured output power level for inter-band EN-DC with UL MIMO within FR1

##### 6.2H.4.3.1 Test purpose

To verify the UE does not exceed the power bounds defined by  $P_{\text{CMAX}}$  and  $P_{\text{CMAX}_H}$ .

##### 6.2H.4.3.2 Test applicability

This test case applies to all types of NR UE release 17 and forward that support inter-band UL EN-DC with UL MIMO within FR1.

##### 6.2H.4.3.3 Minimum conformance requirements

For inter-band EN-DC with UL MIMO in one NR band, the requirements in clause 6.2B.4.1.3 apply except that:

- If the NR component carrier is configured with UL MIMO, the MPR<sub>c</sub> and A-MPR<sub>c</sub> are specified in clause 6.2D.2 and clause 6.2D.3 of 38.101-1 [2] respectively.

The normative reference for this requirement is TS 38.101-3 [4] clause 6.2H.4.1.3.

##### 6.2H.4.3.4 Test procedure

If Standalone FR1 can be tested, this test is covered by 6.2D.4 Configured output power level for UL MIMO in TS 38.521-1 [8].

If Standalone FR1 cannot be tested (due to test case not being complete or if the UE does not support the band in SA mode), LTE anchor agnostic below is applied.

Same test description as in clause 6.2D.4.4 in TS 38.521-1 [8] for the NR carrier with the following exceptions:

The initial test configurations for E-UTRA band consist of environmental conditions, test frequencies, and channel bandwidths based on E-UTRA bands specified in Table 4.6-1.

For Initial conditions as in clause 6.2D.4.4.1 in TS 38.521-1 [8], the following steps will be added to configure E-UTRA component:

- 2.1. The parameter settings for the E-UTRA cell are set up according to TS 36.508 [11] clause 4.4.3 with E-UTRA channel bandwidth and test frequencies defined in Table 4.6-1.
- 3.1. Downlink E-UTRA signals are initially set up according to TS 36.521-1 [10] Annex C0, C.1 and C.3.0, and uplink signals according to Annex H.1 and H.3.0.
- 4.1. The E-UTRA UL Reference Measurement channels are set according to Table 4.6-1.

Step 6 of Initial conditions as in clause 6.2D.4.4.1 in TS 38.521-1 [8] is replaced by the following two steps:

6. Ensure the UE is in state RRC\_CONNECTED with generic procedure parameters Connectivity EN-DC, DC bearer MCG and SCG, Connected without release *On* according to TS 38.508-1 [6] clause 4.5.
7. On the E-UTRA carrier, disable periodic and aperiodic CQI reports, disable SRS, set *TimeAlignmentTimerDedicated* IE to infinity and disable downlink and uplink scheduling, all as per Table 4.6-1 under clause 4.6.

Same test procedure as in clause 6.2D.4.4.2 in TS 38.521-1 [8].

#### 6.2H.4.3.5 Test requirement

Same test requirement as in clause 6.2D.4.5 in TS 38.521-1 [8].

## 6.2L Transmitter power for DC with Tx Diversity

### 6.2L.1 UE maximum output power for DC with Tx Diversity

#### 6.2L.1.3 UE maximum output power for inter-band EN-DC with Tx Diversity within FR1

##### 6.2L.1.3.1 Test purpose

To verify that the error of the UE maximum output power does not exceed the range prescribed by the specified nominal maximum output power and tolerance.

An excess maximum output power has the possibility to interfere to other channels or other systems. A small maximum output power decreases the coverage area.

##### 6.2L.1.3.2 Test applicability

This test applies to all types of E-UTRA UE release 17 and forward, supporting inter-band EN-DC with Tx Diversity.

##### 6.2L.1.3.3 Minimum conformance requirements

For inter-band EN-DC of E-UTRA and NR in FR1, the following UE Power Classes define the maximum output power for any transmission bandwidth within the aggregated channel bandwidth. The maximum output power is measured as the sum of the maximum output power at each UE antenna connector. The period of measurement shall be at least one sub frame (1ms). UE maximum output power shall be measured over all component carriers from different bands. If each band has separate antenna connectors, maximum output power is measured as the sum of maximum output power at each UE antenna connector.

**Table 6.2L.1.3-1: Maximum output power for inter-band EN-DC with Tx Diversity (two bands)**

EN-DC configuration	Power class 2 (dBm)	Tolerance (dB)	Power class 3 (dBm)	Tolerance (dB)
DC_3A_n78A	26 <sup>5</sup>	+2/-3	23	+2/-3
DC_7A_n78A	26 <sup>5</sup>	+2/-3	23	+2/-3
DC_8A_n78A	26 <sup>5</sup>	+2/-3	23	+2/-3
DC_20A_n78A	26 <sup>5</sup>	+2/-3	23	+2/-3
DC_28A_n78A	26 <sup>5</sup>	+2/-3	23	+2/-3
DC_40A_n78A	26 <sup>5</sup>	+2/-3	23	+2/-3
DC_41A_n78A	26 <sup>5</sup>	+2/-3	23	+2/-3

NOTE 1: An uplink DC configuration in which at least one of the bands has NOTE 3 in Table 6.2.1-1 in TS 38.101-1 or NOTE 2 in Table 6.2.2-1 in TS 36.101 is allowed to reduce the lower tolerance limit by 1.5 dB when the transmission bandwidths of at least one of the bands is confined within  $F_{UL\_low}$  and  $F_{UL\_low} + 4$  MHz or  $F_{UL\_high} - 4$  MHz and  $F_{UL\_high}$ .

NOTE 2:  $P_{PowerClass, EN-DC}$  is the maximum UE power specified without taking into account the tolerance

NOTE 3: For inter-band EN-DC the maximum power requirement should apply to the total transmitted power over all component carriers (per UE).

NOTE 4: Power Class 3 is the default power class unless otherwise stated.

NOTE 5: The UE supports PC3 in E-UTRA band, and supports PC3 or PC2 with Tx Diversity in NR band

NOTE 6: Void

NOTE 7: FWA form factor is targeted unless otherwise stated.

If a UE supports a different power class than the default UE power class for an E-UTRA TDD and NR TDD Inter-band EN-DC band combination and the supported power class enables higher maximum output power than that of the default power class:

- if the field of UE capability *maxUplinkDutyCycle-interBandENDC-TDD-PC2-r16* is absent and the percentage of NR uplink symbols transmitted in a certain evaluation period is larger than 30% (The exact evaluation period is no less than one radio frame); or
- if the field of UE capability *maxUplinkDutyCycle-interBandENDC-TDD-PC2-r16* is present and the percentage of NR uplink symbols transmitted in a certain evaluation period is larger than *maxUplinkDutyCycle-interBandENDC-TDD-PC2-r16* as defined in TS38.331 (The exact evaluation period is no less than one radio frame); or
- if the IE *p-maxUE-FRI* as defined in TS 38.331 is provided and set to the maximum output power of the default power class or lower;
  - shall apply all requirements for the default power class to the supported power class and set the configured transmitted power as specified sub-clause 6.2L.4;
- Else if the IE *p-maxUE-FRI* as defined in TS 38.331 is not provided or set to the higher value than the maximum output power of the default power class and the percentage of NR uplink symbols transmitted in a certain evaluation period is less than or equal to *maxUplinkDutyCycle-interBandENDC-TDD-PC2-r16* as defined in TS 38.331; or
- if the IE *p-maxUE-FRI* as defined in TS 38.331 is not provided or set to the higher value than the maximum output power of the default power class and the percentage of NR uplink symbols transmitted in a certain evaluation period is less than or equal to 30% when *maxUplinkDutyCycle-interBandENDC-TDD-PC2-r16* is absent. (The exact evaluation period is no less than one radio frame):
  - shall apply all requirements for the supported power class and set the configured transmitted power class as specified in sub-clause 6.2L.4.

If a UE supports a different power class than the default UE power class for an E-UTRA FDD and NR TDD EN-DC band combination and the supported power class enables higher maximum output power than that of the default power class:

If UE indicating the two capabilities *maxUplinkDutyCycle-FDD-TDD-EN-DC1* and *maxUplinkDutyCycle-FDD-TDD-EN-DC2*:

- if the IE *p-maxUE-FRI* as defined in TS 38.331 is not provided or set to the higher value than the maximum output power of the default power class, and the percentage of EUTRA uplink symbols transmitted in a certain evaluation period is between 40% and 70%, and the percentage of NR uplink symbols transmitted in a

certain evaluation period is less than or equal to  $maxUplinkDutyCycle-FDD-TDD-EN-DC1$  as defined in TS 38.331 (The exact evaluation period is no less than one radio frame); or

- if the IE  $p-maxUE-FRI$  as defined in TS 38.331 is not provided or set to the higher value than the maximum output power of the default power class, and the percentage of EUTRA uplink symbols transmitted in a certain evaluation period is no larger than 40%, and the percentage of NR uplink symbols transmitted in a certain evaluation period is less than or equal to  $maxUplinkDutyCycle-FDD-TDD-EN-DC2$  as defined in TS 38.331 (The exact evaluation period is no less than one radio frame)
    - shall apply all requirements for the supported power class and set the configured transmitted power class as specified in sub-clause 6.2L.4.
  - else
    - shall apply all requirements for the default power class and set the configured transmitted power as specified sub-clause 6.2L.4;
- else
- shall apply all requirements for the supported power class and set the configured transmitted power as specified sub-clause 6.2L.4;

The normative reference for this requirement is TS 38.101-3 [4] clause 6.2L.1.3.

LTE anchor agnostic approach is not applied. E-UTRA test point analysis is included and E-UTRA measurements are performed.

#### 6.2L.1.3.4 Test description

##### 6.2L.1.3.4.1 Initial condition

Initial conditions are a set of test configurations the UE needs to be tested in and the steps for the SS to take with the UE to reach the correct measurement state.

The initial test configurations consist of environmental conditions, test frequencies, DC configuration specified in clause 5.5B.4 and test channel bandwidths specified in TS 36.508 [11] clause 4.3.1 and TS 38.508-1 [6] clause 4.3.1, and sub-carrier spacing based on NR operating bands specified in TS 38.521-1 [8] clause 5.3. All of these configurations shall be tested with applicable test parameters for each EN-DC configuration, and are shown in Table 6.2L.1.3.4.1-1. The details of the uplink reference measurement channels (RMCs) are specified in Annex A, clause A.2.2 for E-UTRA RMC for TDD, TS 36.521-1 [10] Annex A, clause A.2.2 for E-UTRA RMC for FDD, and TS 38.521-1 [8] Annex A, clause A.2 for NR RMC. Configurations of PDSCH and PDCCH before measurement are specified in TS 36.521-1 [10] Annex C, clause C.2 and in TS 38.521-1 [8] Annex C, clause C.2 for E-UTRA CG and NR CG respectively.

Table 6.2L.1.3.4.1-1: Test configuration table

Default Conditions								
Test Environment as specified in TS 38.508-1 [6] clause 4.1				Normal, TL/VL, TL/VH, TH/VL, TH/VH				
Test Frequencies as specified in TS 38.508-1 [6] clause 4.3.1 and TS 36.508 [6]				Low range for E-UTRA CC1 and NR CC1, Mid range for E-UTRA CC1 and NR CC1, High range for E-UTRA CC1 and NR CC1 (NOTE 6)				
Test EN-DC channel bandwidth as specified in TS 36.508 [6] clause 4.3.1 and TS 38.508-1 clause 4.3.1				5MHz for E-UTRA CC1 and Lowest for NR CC1, Highest for E-UTRA CC1 and Highest for NR CC1				
Test SCS for the NR cell as specified in TS 38.521-1 [8] Table 5.3.5-1				Lowest, Highest				
Test Parameters								
Test ID	Test Freq	E-UTRA BW	NR BW	Downlink Configuration	EN-DC Uplink Configuration			
					E-UTRA Cell		NR Cell	
					Modulation	RB allocation (NOTE 1)	Modulation	RB allocation (NOTE 2)
1	High	Default	Default	N/A	QPSK	1RB_Right	DFT-s-OFDM QPSK	Inner_1RB_Right
2	Low	Default	Default		QPSK	1RB_Left	DFT-s-OFDM QPSK	Inner_1RB_Left
3	Default	Default	Default		QPSK	Partial_Allocation	DFT-s-OFDM QPSK	Inner_Full
4	High	Default	Default		QPSK	1RB_Right	DFT-s-OFDM QPSK	Inner_1RB_Right
5	Low	Default	Default		QPSK	1RB_Left	DFT-s-OFDM QPSK	Inner_1RB_Left
6	Default	Default	Default		QPSK	Partial_Allocation	DFT-s-OFDM QPSK	Inner_Full
NOTE 1: The specific configuration of each RB allocation is defined in Table 6.1-1 in current specification.								
NOTE 2: The specific configuration of each RB allocation is defined in Table 6.1-1 in TS 38.521-1 [8].								
NOTE 3: DFT-s-OFDM Pi/2 BPSK test applies only for UEs which supports Pi/2 BPSK in NR FR1.								
NOTE 4: Only applicable to UEs not supporting UE capability <i>singleUL-Transmission</i> .								

1. Connect the SS to the UE antenna connectors as shown in TS 38.508-1 [6] clause A.3.1.1 for SS and clause A.3.2 for UE.
2. The parameter settings for the E-UTRA cell are set up according to TS 36.508 [11] clause 4.4.3, and the parameter settings for the cell are set up according to TS 38.508-1 [6] clause 4.4.3.
3. Downlink signals are initially set up according to TS 36.521-1 [10] Annex C.0 and TS 38.521-1 [8] Annex C.0 for E-UTRA CG and NR CG respectively, and uplink signals according to TS 36.521-1 [10] Annex H and TS 38.521-1 [8] Annex G for E-UTRA CG and NR CG respectively.
4. The UL Reference Measurement channels are set according to Table 6.2L.1.3.4.1-1.
5. Propagation conditions are set according to TS 36.521-1 [10] and TS 38.521-1 [8] Annex B.0 for E-UTRA CG and NR CG respectively.
6. Ensure the UE is in state RRC\_CONNECTED with generic procedure parameters Connectivity EN-DC, DC bearer MCG and SCG, Connected without release *On* according to TS 38.508-1 [6] clause 4.5. Message contents are defined in clause 6.2L.1.3.4.3.
7. For the case of testing overlapping E-UTRA and NR UL transmission scenario when both bands are TDD, ensure E-UTRA UL transmission overlaps with NR UL transmission in time by giving SCG a delay of 3 E-UTRA subframes, or by giving MCG a delay of 2 subframes.

#### 6.2L.1.3.4.2 Test procedure

1. SS sends uplink scheduling information for each UL HARQ process via PDCCH DCI format 0 and DCI format 0\_1 for C\_RNTI to schedule the UL RMC according to Table 6.2L.1.3.4.1-1 on E-UTRA CC and NR CC respectively. Since the UL has no payload and no loopback data to send the UE sends uplink MAC padding bits on the UL RMC.

2. Send continuously uplink power control "up" commands to the UE for NR and E-UTRA carrier until the UE transmits at its  $P_{UMAX}$  level; allow at least 200 ms from the first TPC command for the UE to reach  $P_{UMAX}$  level.
3. Measure the sum of mean transmitted power from all antenna connectors and all EN-DC component carriers in the EN-DC, which shall meet the requirements described in Table 6.2L.1.3.5-1 and the period of the measurement shall be at least the continuous duration of one active sub-frame. For FDD band in inter-band CA with both TDD band and FDD band, only slots overlapping with only UL symbols in TDD are under test.

#### 6.2L.1.3.4.3 Message contents

Message contents are according to TS 36.508 [11] clause 4.6.1 and TS 38.508-1 [6] clause 4.6 with the following exceptions:

**Table 6.2B.1.3.4.3-0: PUSCH-Config**

Derivation Path: TS 38.508-1 [6], Table 4.6.3-118 with condition TRANSFORM\_PRECODER\_ENABLED

**Table 6.2L.1.3.4.3-1: PhysicalCellGroupConfig**

Derivation Path: TS 38.508-1 [6], Table 4.6.3-106			
Information Element	Value/remark	Comment	Condition
PhysicalCellGroupConfig ::= SEQUENCE {			
p-NR-FR1	20		Power Class 3 UE
	23		Power Class 2 UE
}			

**Table 6.2L.1.3.4.3-2: RRCConnectionReconfiguration: nr-Config-r15**

Derivation Path: TS 36.508 [11], Table 4.6.1-8			
Information Element	Value/remark	Comment	Condition
p-MaxEUTRA-r15	20		Power Class 3 UE
	23		Power Class 2 UE

**Table 6.2L.1.3.4.3-3: SystemInformationBlockType1: tdd-Config if E-UTRA on TDD band**

Derivation Path: TS 36.508 [11], Table 4.6.3-23			
Information Element	Value/remark	Comment	Condition
TDD-Config-DEFAULT ::= SEQUENCE {		Operating on TDD band	
subframeAssignment	sa2		
specialSubframePatterns	ssp7		
}			

#### 6.2L.1.3.5 Test requirements

The maximum output power for the DC configuration, derived in step 3 shall be within the range prescribed by the UE Power Class and tolerance in Table 6.2L.1.3.5-1.

**Table 6.2L.1.3.5-1: Maximum output power for inter-band EN-DC (two bands) with Tx Diversity**

EN-DC configuration	Power class 2 (dBm)	Tolerance (dB)	Power class 3 (dBm)	Tolerance (dB)
DC_3A_n78A	26 <sup>5</sup>	+2+TT/-3-TT	23	+2+TT/-3-TT
DC_7A_n78A	26 <sup>5</sup>	+2+TT/-3-TT	23	+2+TT/-3-TT
DC_8A_n78A	26 <sup>5</sup>	+2+TT/-3-TT	23	+2+TT/-3-TT
DC_20A_n78A	26 <sup>5</sup>	+2+TT/-3-TT	23	+2+TT/-3-TT
DC_28A_n78A	26 <sup>5</sup>	+2+TT/-3-TT	23	+2+TT/-3-TT
DC_40A_n78A	26	+2+TT/-3-TT	23	+2+TT/-3-TT
DC_41A_n78A	26 <sup>5</sup>	+2+TT/-3-TT	23	+2+TT/-3-TT

NOTE 1: An uplink DC configuration in which at least one of the bands has NOTE 3 in Table 6.2.1-1 in TS 38.101-1 or NOTE 2 in Table 6.2.2-1 in TS 36.101 is allowed to reduce the lower tolerance limit by 1.5 dB when the transmission bandwidths of at least one of the bands is confined within F<sub>UL\_low</sub> and F<sub>UL\_low</sub> + 4 MHz or F<sub>UL\_high</sub> - 4 MHz and F<sub>UL\_high</sub>.

NOTE 2: P<sub>PowerClass, EN-DC</sub> is the maximum UE power specified without taking into account the tolerance

NOTE 3: For inter-band EN-DC the maximum power requirement should apply to the total transmitted power over all component carriers (per UE).

NOTE 4: Power Class 3 is the default power class unless otherwise stated.

NOTE 5: The UE supports PC3 in E-UTRA band, and supports PC3 or PC2 with Tx Diversity in NR band

NOTE 6: Void

NOTE 7: FWA form factor is targeted unless otherwise stated.

NOTE 8: TT is the maximum TT among all E-UTRA and NR UL carriers. For TT of each UL CC refers to Table 6.2L.1.3.5-2.

**Table 6.2L.1.3.5-2: Test Tolerance for UE maximum output power (Overlapping UL transmission)**

TT for overall output power											
			NR								
			BW ≤ 20MHz			20 MHz < BW ≤ 40MHz			40MHz < BW ≤ 100MHz		
			f ≤ 3.0GHz	3.0GHz < f ≤ 4.2GHz	4.2GHz < f ≤ 6.0GHz	f ≤ 3.0GHz	3.0GHz < f ≤ 4.2GHz	4.2GHz < f ≤ 6.0GHz	f ≤ 3.0GHz	3.0GHz < f ≤ 4.2GHz	4.2GHz < f ≤ 6.0GHz
E-UTRA	BW ≤ 20MHz	f ≤ 3.0GHz	0.7 dB	1.0 dB	1.0 dB	0.7 dB	1.0 dB	1.0 dB	1.0 dB	1.0 dB	1.0 dB
		3.0GHz < f ≤ 4.2GHz	1.0 dB	1.0 dB	1.0 dB	1.0 dB	1.0 dB	1.0 dB	1.0 dB	1.0 dB	1.0 dB

## 6.2L.2 UE maximum output power reduction for DC with Tx Diversity

### 6.2L.2.1

### 6.2L.2.2

### 6.2L.2.3 UE maximum output power reduction for inter-band EN-DC with Tx Diversity within FR1

#### 6.2L.2.3.1 Test purpose

To verify that the error of the UE maximum output power does not exceed the range prescribed by the specified maximum output power with MPR and tolerance.

An excess maximum output power has the possibility to interfere to other channels or other systems. A small maximum output power decreases the coverage area.



#### 6.2L.2.3.2 Test applicability

This test case applies to all types of NR UE release 17 and forward that support inter-band UL EN-DC with Tx Diversity within FR1.

#### 6.2L.2.3.3 Minimum conformance requirements

For inter-band EN-DC between E-UTRA and FR1 NR, UE maximum output power reduction specified in TS 36.101 [4] and TS 38.101-1 [2] apply for E-UTRA and NR respectively.

The normative reference for this requirement is TS 38.101-3 [4] clause 6.2L.2.3.

#### 6.2L.2.3.4 Test procedure

If Standalone FR1 can be tested, this test is covered by 6.2G.2 UE maximum output power reduction for Tx Diversity in TS 38.521-1 [8].

If Standalone FR1 cannot be tested (due to test case not being complete or if the UE does not support the band in SA mode), LTE anchor agnostic below is applied.

Same test description as in clause 6.2G.2.4 in TS 38.521-1 [8] for the NR carrier with the following exceptions:

The initial test configurations for E-UTRA band consist of environmental conditions, test frequencies, and channel bandwidths based on E-UTRA bands specified in Table 4.6-1.

For Initial conditions as in clause 6.2G.2.4.1 in TS 38.521-1 [8], the following steps will be added to configure E-UTRA component:

- 2.1. The parameter settings for the E-UTRA cell are set up according to TS 36.508 [11] clause 4.4.3 with E-UTRA channel bandwidth and test frequencies defined in Table 4.6-1.
- 3.1. Downlink E-UTRA signals are initially set up according to TS 36.521-1 [10] Annex C0, C.1 and C.3.0, and uplink signals according to Annex H.1 and H.3.0.
- 4.1. The E-UTRA UL Reference Measurement channels are set according to Table 4.6-1.

Step 6 of Initial conditions as in clause 6.2G.2.4.1 in TS 38.521-1 [8] is replaced by the following two steps:

6. Ensure the UE is in state RRC\_CONNECTED with generic procedure parameters Connectivity EN-DC, DC bearer MCG and SCG, Connected without release *On* according to TS 38.508-1 [6] clause 4.5.
7. On the E-UTRA carrier, disable periodic and aperiodic CQI reports, disable SRS, set *TimeAlignmentTimerDedicated* IE to infinity and disable downlink and uplink scheduling, all as per Table 4.6-1 under clause 4.6.

Same test procedure as in clause 6.2G.2.4.2 in TS 38.521-1 [8].

#### 6.2L.2.3.5 Test requirement

Same test requirement as in clause 6.2G.2.5 in TS 38.521-1 [8].

## 6.2L.3 UE additional maximum output power reduction for EN-DC with Tx Diversity

### 6.2L.3.1

### 6.2L.3.2

### 6.2L.3.3 UE additional maximum output power reduction for inter-band EN-DC with Tx Diversity within FR1

#### 6.2L.3.3.1 Test purpose

Additional emission requirements can be signalled by the network with network signalling value indicated by the field *additionalSpectrumEmission*. To meet these additional requirements, additional maximum power reduction (A-MPR) is allowed for the maximum output power as specified in Table 6.2L.1.3.3-1. Unless stated otherwise, an A-MPR of 0 dB shall be used.

#### 6.2L.3.3.2 Test applicability

This test case applies to all types of NR UE release 17 and forward that support inter-band UL EN-DC with Tx Diversity within FR1.

#### 6.2L.3.3.3 Minimum conformance requirements

For inter-band EN-DC with Tx Diversity in NR band, unless specified in Table 6.2B.3.3-1 in 38.101-1 [2], the requirements in 38.101-1 [2] clause 6.2.3 apply for NR uplink component carrier and the requirements in 36.101 [4] clause 6.2.4 apply for LTE uplink component carrier.

The normative reference for this requirement is TS 38.101-3 [4] clause 6.2L.3.3.

#### 6.2L.3.3.4 Test procedure

If Standalone FR1 can be tested, this test is covered by 6.2G.3 UE additional maximum output power reduction for Tx Diversity in TS 38.521-1 [8].

If Standalone FR1 cannot be tested (due to test case not being complete or if the UE does not support the band in SA mode), LTE anchor agnostic below is applied.

Same test description as in clause 6.2G.3.4 in TS 38.521-1 [8] for the NR carrier with the following exceptions:

The initial test configurations for E-UTRA band consist of environmental conditions, test frequencies, and channel bandwidths based on E-UTRA bands specified in Table 4.6-1.

For Initial conditions as in clause 6.2G.3.4.1 in TS 38.521-1 [8], the following steps will be added to configure E-UTRA component:

- 2.1. The parameter settings for the E-UTRA cell are set up according to TS 36.508 [11] clause 4.4.3 with E-UTRA channel bandwidth and test frequencies defined in Table 4.6-1.
- 3.1. Downlink E-UTRA signals are initially set up according to TS 36.521-1 [10] Annex C0, C.1 and C.3.0, and uplink signals according to Annex H.1 and H.3.0.
- 4.1. The E-UTRA UL Reference Measurement channels are set according to Table 4.6-1.

Step 6 of Initial conditions as in clause 6.2G.3.4.1 in TS 38.521-1 [8] is replaced by the following two steps:

6. Ensure the UE is in state RRC\_CONNECTED with generic procedure parameters Connectivity EN-DC, DC bearer MCG and SCG, Connected without release *On* according to TS 38.508-1 [6] clause 4.5.

7. On the E-UTRA carrier, disable periodic and aperiodic CQI reports, disable SRS, set *TimeAlignmentTimerDedicated* IE to infinity and disable downlink and uplink scheduling, all as per Table 4.6-1 under clause 4.6.

Same test procedure as in clause 6.2G.3.4.2 in TS 38.521-1 [8].

#### 6.2L.3.3.5 Test requirement

Same test requirement as in clause 6.2G.3.5 in TS 38.521-1 [8].

### 6.2L.4 Configured output power for DC with Tx Diversity

#### 6.2L.4.1

#### 6.2L.4.2

#### 6.2L.4.3 Configured output power level for inter-band EN-DC with Tx Diversity within FR1

##### 6.2L.4.3.1 Test purpose

To verify the UE does not exceed the power bounds defined by  $P_{\text{CMAX}}$  and  $P_{\text{CMAX}_H}$ .

##### 6.2L.4.3.2 Test applicability

This test case applies to all types of NR UE release 17 and forward that support inter-band UL EN-DC with Tx Diversity within FR1.

##### 6.2L.4.3.3 Minimum conformance requirements

For inter-band EN-DC with Tx Diversity in one NR band, the requirements in clause 6.2B.4.1.3 apply except that:

- If the NR component carrier is configured with Tx Diversity, the MPR<sub>c</sub> and A-MPR<sub>c</sub> are specified in clause 6.2G.2 and clause 6.2G.3 of 38.101-1 [2] respectively.

The normative reference for this requirement is TS 38.101-3 [4] clause 6.2L.4.1.3.

##### 6.2L.4.3.4 Test procedure

If Standalone FR1 can be tested, this test is covered by 6.2G.4 Configured output power level for Tx Diversity in TS 38.521-1 [8].

If Standalone FR1 cannot be tested (due to test case not being complete or if the UE does not support the band in SA mode), LTE anchor agnostic below is applied.

Same test description as in clause 6.2G.4.4 in TS 38.521-1 [8] for the NR carrier with the following exceptions:

The initial test configurations for E-UTRA band consist of environmental conditions, test frequencies, and channel bandwidths based on E-UTRA bands specified in Table 4.6-1.

For Initial conditions as in clause 6.2G.4.4.1 in TS 38.521-1 [8], the following steps will be added to configure E-UTRA component:

- 2.1. The parameter settings for the E-UTRA cell are set up according to TS 36.508 [11] clause 4.4.3 with E-UTRA channel bandwidth and test frequencies defined in Table 4.6-1.
- 3.1. Downlink E-UTRA signals are initially set up according to TS 36.521-1 [10] Annex C0, C.1 and C.3.0, and uplink signals according to Annex H.1 and H.3.0.
- 4.1. The E-UTRA UL Reference Measurement channels are set according to Table 4.6-1.

Step 6 of Initial conditions as in clause 6.2G.4.4.1 in TS 38.521-1 [8] is replaced by the following two steps:

6. Ensure the UE is in state RRC\_CONNECTED with generic procedure parameters Connectivity EN-DC, DC bearer MCG and SCG, Connected without release *On* according to TS 38.508-1 [6] clause 4.5.
7. On the E-UTRA carrier, disable periodic and aperiodic CQI reports, disable SRS, set *TimeAlignmentTimerDedicated* IE to infinity and disable downlink and uplink scheduling, all as per Table 4.6-1 under clause 4.6.

Same test procedure as in clause 6.2G.4.4.2 in TS 38.521-1 [8].

#### 6.2L.4.3.5 Test requirement

Same test requirement as in clause 6.2G.4.5 in TS 38.521-1 [8].

## 6.3 Output power dynamics

### 6.3A Output Power Dynamics for CA without EN-DC

#### 6.3A.1 UE Output Power Dynamics for CA

##### 6.3A.1.1 UE Output Power Dynamics for NR CA between FR 1 and FR 2 without EN-DC

###### 6.3A.1.1.1 Test purpose

Same test purpose as in clause 6.3 in TS 38.521-1 [8] for NR FR1 carrier(s) and clause 6.3 in TS 38.521-2 [9] for NR FR2 carrier(s).

###### 6.3A.1.1.2 Test applicability

The requirements in this test are not testable due to issues with combined testing of NR FR1 conducted mode with NR FR2 in radiated mode. Therefore, the conducted and radiated requirements are tested separately.

No test case details are specified. The NR/5GC requirements for maximum output power apply and are tested in TS 38.521-1 [8] clauses 6.3 and 6.2A and TS 38.521-2 [9] clauses 6.3 and 6.3A.

### 6.3B Output power dynamics for DC

#### 6.3B.1 Minimum Output Power for EN-DC

##### 6.3B.1.1 Minimum Output Power for intra-band contiguous EN-DC

###### 6.3B.1.1.1 Test purpose

Same test purpose as in clause 6.3.1.1 in TS 38.521-1 [8] for the NR carrier.

###### 6.3B.1.1.2 Test applicability

This test applies to all types of E-UTRA UE release 15 and forward, supporting intra-band contiguous EN-DC.

###### 6.3B.1.1.3 Minimum conformance requirements

Same minimum conformance requirements as in clause 6.3.1.3 in TS 38.521-1 [8] for the NR carrier.

Same minimum conformance requirements as in clause 6.3.2.3 in TS 36.521-1 [10] for E-UTRA carrier.

For intra-band contiguous EN-DC operation in FR1, minimum output power requirements specified in clause 6.3.1 of TS 38.101-1 [2] and clause 6.3.2 of TS 36.101 [5] shall only apply when the power of all NR and E-UTRA carriers are set to minimum value.

Exception requirements for both NR and E-UTRA are defined for this test and therefore LTE anchor agnostic approach is not applied.

The normative reference for this requirement is TS 38.101-3 [4] clause 6.3.

#### 6.3B.1.1.4 Test description

Same test descriptions as in clause 6.3.1.4 in TS 38.521-1 [8] for the NR carrier with the following exceptions:

**Table 6.3B.1.1.4-1: Test configuration table**

E-UTRA Test Parameters				
E-UTRA Channel Bandwidth	E-UTRA Test Frequency	Downlink	Uplink	
		N/A for min output power test	Modulation	RB allocation
5 MHz	MidRange		QPSK	25
NOTE 1: E-UTRA Test Frequency as specified in TS 36.508 [11] clause 4.3.1.				

For Initial conditions as in clause 6.3.1.4.1 in TS 38.521-1 [8], the following steps will be added to configure E-UTRA component:

- 2.1. The parameter settings for the E-UTRA cell are set up according to TS 36.508 [11] clause 4.4.3 with E-UTRA channel bandwidth and test frequencies defined in Table 6.3B.1.1.4-1.
- 3.1. Downlink signals are initially set up according to TS 36.521-1 [10] Annex C.0, C.1 and C.3.0, and uplink signals according to Annex H.1 and H.3.0.
- 4.1. The UL Reference Measurement channels are set according to Table 6.3B.1.1.4-1.

Step 6 of Initial conditions as in clause 6.3.1.4.1 in TS 38.521-1 [8] is replaced by the following two steps:

6. Ensure the UE is in state RRC\_CONNECTED with generic procedure parameters Connectivity EN-DC, DC bearer *MCG* and *SCG*, Connected without release *On* according to TS 38.508-1 [6] clause 4.5.
7. When E-UTRA and NR bands are TDD, ensure the same uplink-downlink configuration by giving SCG a delay of 3 E-UTRA subframes, or by giving MCG a delay of 2 subframes.

Same test procedure as in clause 6.3.1.4.2 in TS 38.521-1 [8] with the following steps added for E-UTRA component:

- 1.1. For E-UTRA component, SS sends uplink scheduling information for each UL HARQ process via PDCCH DCI format 0 for C\_RNTI to schedule the UL RMC according to table 6.3B.1.1.4-1. Since the UE has no payload and no loopback data to send the UE sends uplink MAC padding bits on the UL RMC.
- 2.1. For E-UTRA component, send continuously uplink power control "down" commands in every uplink scheduling information to the UE.

#### 6.3B.1.1.5 Test requirements

Same test requirement as in clause 6.3.1.5 in TS 38.521-1 [8] for the NR carrier.

### 6.3B.1.2 Minimum output power for intra-band non-contiguous EN-DC

#### 6.3B.1.2.1 Test purpose

Same test purpose as in clause 6.3.1.1 in TS 38.521-1 [8] for the NR carrier.

### 6.3B.1.2.2 Test applicability

This test applies to all types of E-UTRA UE release 15 and forward, supporting intra-band non-contiguous EN-DC.

### 6.3B.1.2.3 Minimum conformance requirements

Same minimum conformance requirements as in clause 6.3.1.3 in TS 38.521-1 [8] for the NR carrier.

No exception requirements applicable to NR or E-UTRA. LTE anchor agnostic approach is applied.

The normative reference for this requirement is TS 38.101-1 [2] clause 6.3.

### 6.3B.1.2.4 Test description

Same test descriptions as in clause 6.3.1.4 in TS 38.521-1 [8] for the NR carrier with the following exceptions:

**Table 6.3B.1.2.4-1: Test Configuration Table**

Initial Conditions	
Test Frequencies as specified in TS 38.508-1 [6] clause 4.3.1 for different EN-DC bandwidth classes	Low with maxWGap, High with maxWGap
Test EN-DC bandwidth combination as specified in Table 5.3B.1.3-1 across bandwidth combination sets supported by the UE	Lowest $N_{RB\_agg}$ , Highest $N_{RB\_agg}$ (NOTE 1)
NOTE 1: If the UE supports multiple CC Combinations in the EN-DC Configuration with the same $N_{RB\_agg}$ , only the combination with the lowest $N_{RB\_SCG}$ and highest $N_{RB\_SCG}$ are tested for Lowest $N_{RB\_agg}$ , and Highest $N_{RB\_agg}$ , respectively.	

The initial test configurations for E-UTRA as specified in Table 4.6-1 except for the parameters specified in Table 6.3B.1.2.4-1.

For Initial conditions as in clause 6.3.1.4.1 in TS 38.521-1 [8], the following steps will be added to configure E-UTRA component:

- 2.1. The parameter settings for the E-UTRA cell are set up according to TS 36.508 [11] clause 4.4.3 with E-UTRA channel bandwidth and test frequencies defined in Table 6.3B.1.2.4-1.
- 3.1. Downlink signals are initially set up according to TS 36.521-1 [10] Annex C, clauses C.0, C.1 and C.3.0, and uplink signals according to Annex H, clauses H.1 and H.3.0.
- 4.1. The UL Reference Measurement channels are set according to Table 6.3B.1.2.4-1.

Step 6 of Initial conditions as in clause 6.3.1.4.1 in TS 38.521-1 [8] is replaced by the following three steps:

6. Ensure the UE is in state RRC\_CONNECTED with generic procedure parameters Connectivity EN-DC, DC bearer MCG and SCG, Connected without release On according to TS 38.508-1 [6] clause 4.5.
7. On the E-UTRA carrier, disable periodic and aperiodic CQI reports, disable SRS, set *TimeAlignmentTimerDedicated* IE to infinity and disable downlink and uplink scheduling, all as per Table 4.6-1 under clause 4.6.
8. When E-UTRA and NR bands are TDD, ensure the same uplink-downlink configuration by giving SCG a delay of 3 E-UTRA subframes, or by giving MCG a delay of 2 subframes.

### 6.3B.1.2.5 Test requirements

Same test requirement as in clause 6.3.1.5 in TS 38.521-1 [8] for the NR carrier.

## 6.3B.1.3 Minimum output power for inter-band EN-DC within FR1 (1 NR CC)

### 6.3B.1.3.1 Test purpose

Same test purpose as in clause 6.3.1.1 in TS 38.521-1 [8] for the NR carrier.

#### 6.3B.1.3.2 Test applicability

This test case applies to all types of E-UTRA UE release 15 and forward, supporting inter-band EN-DC within FR1 with 1 NR UL CC.

#### 6.3B.1.3.3 Minimum conformance requirements

Same minimum conformance requirements as in clause 6.3.1.3 in TS 38.521-1 [8] for the NR carrier.

No exception requirements applicable to NR or E-UTRA. LTE anchor agnostic approach is applied.

The normative reference for this requirement is TS 38.101-3 [4] clause 6.3.

#### 6.3B.1.3.4 Test description

Same test descriptions as in clause 6.3.1.4 in TS 38.521-1 [8] for the NR carrier with the following exceptions:

The initial test configurations for E-UTRA band consist of environmental conditions, test frequencies, and channel bandwidths based on E-UTRA bands specified in Table 4.6-1. For Initial conditions as in clause 6.3.1.4.1 in TS 38.521-1 [8], the following steps will be added to configure E-UTRA component:

- 2.1. The parameter settings for E-UTRA cell are set up according to TS 36.508 [11] clause 4.4.3.
- 3.1. The E-UTRA downlink signal level, uplink signal level are set according to Table 4.6-1 and propagation conditions are set according to Annex B.0 of TS 36.521-1 [10].

Step 6 of Initial conditions as in clause 6.3.1.4.1 in TS 38.521-1 [8] is replaced by the following two steps:

6. Ensure the UE is in state RRC\_CONNECTED with generic procedure parameters Connectivity EN-DC, DC bearer *MCG* and *SCG*, Connected without release *On* according to TS 38.508-1 [6] clause 4.5.
7. On the E-UTRA carrier, disable periodic and aperiodic CQI reports, disable SRS, set TimeAlignmentTimerDedicated IE to infinity and disable downlink and uplink scheduling, all as per Table 4.6-1 under clause 4.6.

#### 6.3B.1.3.5 Test requirements

Same test requirement as in clause 6.3.1.5 in TS 38.521-1 [8] for the NR carrier.

#### 6.3B.1.4 Minimum Output Power for EN-DC Interband including FR2 (1 NR CC)

**Editor's note: The following aspects of the clause are for future consideration:**

- Measurement Uncertainties and Test Tolerances are FFS for power class other than 1, 3, 5, 6 and 7.

#### 6.3B.1.4.1 Test purpose

Same test purpose as in clause 6.3.1.1 in TS 38.521-2 [9] for the NR carrier.

#### 6.3B.1.4.2 Test applicability

This test case applies to all types of E-UTRA UE release 15 and forward, supporting inter-band EN-DC including FR2 with 1 NR UL CC.

#### 6.3B.1.4.3 Minimum conformance requirements

Same minimum conformance requirements as in clause 6.3.1.3 in TS 38.521-2 [9] for the NR carrier.

No exception requirements applicable to NR or E-UTRA. LTE anchor agnostic approach is applied.

The normative reference for this requirement is TS 38.101-3 [4] clause 6.3B.1.

#### 6.3B.1.4.4 Test description

Same test description as in clause 6.3.1.4 in TS 38.521-2 [9] for the *NR* carrier with the following exception:

The initial test configurations for E-UTRA band consist of environmental conditions, test frequencies, and channel bandwidths based on E-UTRA bands specified in Table 4.7-1.

For initial conditions as in clause 6.3.1.4.1 in TS 38.521-2 [9], the following steps will be added to configure E-UTRA component:

- 2.1. The parameter settings for E-UTRA cell are set up according to TS 36.508 [11] clause 4.4.3.
- 3.1. The E-UTRA downlink signal level, uplink signal level are set according to Table 4.7-1 and propagation conditions are set according to Annex B.0 of TS 36.521-1 [10].

Step 6 of initial conditions as in clause 6.3.1.4.1 in TS 38.521-2 [9] is replaced by:

6. Ensure the UE is in state `RRC_CONNECTED` with generic procedure parameters Connectivity EN-DC, DC bearer MCG and SCG, Connected without release On according to TS 38.508-1 [6] clause 4.5.

Same test procedure as in clause 6.3.1.4.2 in TS 38.521-2 [9] with the following steps added for E-UTRA component:

- 1.1 On the E-UTRA carrier, disable periodic and aperiodic CQI reports, disable SRS, set *TimeAlignmentTimerDedicated* IE to infinity and disable downlink and uplink scheduling, all as per Table 4.7-1 under clause 4.7.

#### 6.3B.1.4.5 Test requirements

Same test requirement as in clause 6.3.1.5 in TS 38.521-2 [9] for the *NR* carrier.

#### 6.3B.1.4\_1 Minimum output power for inter-band EN-DC including FR2 (>1 NR CC)

##### 6.3B.1.4\_1.1 Minimum output power for inter-band EN-DC including FR2 (2 NR CCs)

**Editor's note: The following aspects are either missing or not yet determined:**

- The referred test case 6.3A.1.1 in TS 38.521-2 [9] is incomplete for NR aggregated channel bandwidth wider than 400MHz and power class other than 3 and 5.

##### 6.3B.1.4\_1.1.1 Test purpose

Same test purpose as in clause 6.3.1.1 in TS 38.521-2 [9] for the *NR* carrier.

##### 6.3B.1.4\_1.1.2 Test applicability

This test case applies to all types of E-UTRA UE release 15 and forward, supporting inter-band EN-DC including FR2 with 2 NR UL CCs.

##### 6.3B.1.4\_1.1.3 Minimum conformance requirements

Same minimum conformance requirements as in clause 6.3.1.3 in TS 38.521-2 [9] for the *NR* carrier.

No exception requirements applicable to *NR* or E-UTRA. LTE anchor agnostic approach is applied.

The normative reference for this requirement is TS 38.101-3 [4] clause 6.3B.

##### 6.3B.1.4\_1.1.4 Test description

###### 6.3B.1.4\_1.1.4.1 Initial condition

Same test description as in clause 6.3A.1.1.4 in TS 38.521-2 [9] for the *NR* carrier with the following exception:



The initial test configurations for E-UTRA band consist of environmental conditions, test frequencies, and channel bandwidths based on E-UTRA bands specified in Table 4.7-1.

For Initial conditions as in clause 6.3A.1.1.4.1 in TS 38.521-2 [9], the following steps will be added to configure E-UTRA component:

- 2.1. The parameter settings for E-UTRA cell are set up according to TS 36.508 [11] clause 4.4.3.
- 3.1. The E-UTRA downlink signal level, uplink signal level are set according to Table 4.7-1 and propagation conditions are set according to Annex B.0 of TS 36.521-1 [10].

Step 6 of Initial conditions as in clause 6.3A.1.1.4.1 in TS 38.521-2 [9] is replaced by:

6. Ensure the UE is in state RRC\_CONNECTED with generic procedure parameters Connectivity EN-DC, DC bearer MCG and SCG, Connected without release On according to TS 38.508-1 [6] clause 4.5.

Same test procedure as in clause 6.3A.1.1.4.2 in TS 38.521-2 [9] with the following steps added for E-UTRA component:

- 1.1 On the E-UTRA carrier, disable periodic and aperiodic CQI reports, disable SRS, set *TimeAlignmentTimerDedicated* IE to infinity and disable downlink and uplink scheduling, all as per Table 4.7-1 under clause 4.7.

#### 6.3B.1.4\_1.1.5 Test Requirements

Same test requirement as in clause 6.3A.1.1.5 in TS 38.521-2 [9] for the NR carrier.

#### 6.3B.1.4\_1.2 Minimum output power for inter-band EN-DC including FR2 (3 NR CCs)

**Editor's note: The following aspects are either missing or not yet determined:**

- The referred test case 6.3A.1.2 in TS 38.521-2 [9] is incomplete for NR aggregated channel bandwidth wider than 400MHz and power classes 1, 2, 4.

#### 6.3B.1.4\_1.2.1 Test purpose

Same test purpose as in clause 6.3.1.1 in TS 38.521-2 [9] for the NR carrier.

#### 6.3B.1.4\_1.2.2 Test applicability

This test case applies to all types of E-UTRA UE release 15 and forward, supporting inter-band EN-DC including FR2 with 3 NR UL CCs.

#### 6.3B.1.4\_1.2.3 Minimum conformance requirements

Same minimum conformance requirements as in clause 6.3.1.3 in TS 38.521-2 [9] for the NR carrier.

No exception requirements applicable to NR or E-UTRA. LTE anchor agnostic approach is applied.

The normative reference for this requirement is TS 38.101-3 [4] clause 6.3B.

#### 6.3B.1.4\_1.2.4 Test description

##### 6.3B.1.4\_1.2.4.1 Initial condition

Same test description as in clause 6.3A.1.2.4 in TS 38.521-2 [9] for the NR carrier with the following exception:

The initial test configurations for E-UTRA band consist of environmental conditions, test frequencies, and channel bandwidths based on E-UTRA bands specified in Table 4.7-1.

For Initial conditions as in clause 6.3A.1.2.4.1 in TS 38.521-2 [9], the following steps will be added to configure E-UTRA component:

- 2.1. The parameter settings for E-UTRA cell are set up according to TS 36.508 [11] clause 4.4.3.

- 3.1. The E-UTRA downlink signal level, uplink signal level are set according to Table 4.7-1 and propagation conditions are set according to Annex B.0 of TS 36.521-1 [10].

Step 6 of Initial conditions as in clause 6.3A.1.2.4.1 in TS 38.521-2 [9] is replaced by:

6. Ensure the UE is in state RRC\_CONNECTED with generic procedure parameters Connectivity EN-DC, DC bearer MCG and SCG, Connected without release On according to TS 38.508-1 [6] clause 4.5.

Same test procedure as in clause 6.3A.1.2.4.2 in TS 38.521-2 [9] with the following steps added for E-UTRA component:

- 1.1 On the E-UTRA carrier, disable periodic and aperiodic CQI reports, disable SRS, set *TimeAlignmentTimerDedicated* IE to infinity and disable downlink and uplink scheduling, all as per Table 4.7-1 under clause 4.7.

#### 6.3B.1.4\_1.2.5 Test Requirements

Same test requirement as in clause 6.3A.1.2.5 in TS 38.521-2 [9] for the NR carrier.

#### 6.3B.1.4\_1.3 Minimum output power for inter-band EN-DC including FR2 (4 NR CCs)

**Editor's note: The following aspects are either missing or not yet determined:**

- The referred test case 6.3A.1.3 in TS 38.521-2 [9] is incomplete for NR aggregated channel bandwidth wider than 400MHz and power classes 1, 2, 4.

#### 6.3B.1.4\_1.3.1 Test purpose

Same test purpose as in clause 6.3.1.1 in TS 38.521-2 [9] for the NR carrier.

#### 6.3B.1.4\_1.3.2 Test applicability

This test case applies to all types of E-UTRA UE release 15 and forward, supporting inter-band EN-DC including FR2 with 4 NR UL CCs.

#### 6.3B.1.4\_1.3.3 Minimum conformance requirements

Same minimum conformance requirements as in clause 6.3.1.3 in TS 38.521-2 [9] for the NR carrier.

No exception requirements applicable to NR or E-UTRA. LTE anchor agnostic approach is applied.

The normative reference for this requirement is TS 38.101-3 [4] clause 6.3B.

#### 6.3B.1.4\_1.3.4 Test description

##### 6.3B.1.4\_1.3.4.1 Initial condition

Same test description as in clause 6.3A.1.3.4 in TS 38.521-2 [9] for the NR carrier with the following exception:

The initial test configurations for E-UTRA band consist of environmental conditions, test frequencies, and channel bandwidths based on E-UTRA bands specified in Table 4.7-1.

For Initial conditions as in clause 6.3A.1.3.4.1 in TS 38.521-2 [9], the following steps will be added to configure E-UTRA component:

- 2.1. The parameter settings for E-UTRA cell are set up according to TS 36.508 [11] clause 4.4.3.
- 3.1. The E-UTRA downlink signal level, uplink signal level are set according to Table 4.7-1 and propagation conditions are set according to Annex B.0 of TS 36.521-1 [10].

Step 6 of Initial conditions as in clause 6.3A.1.3.4.1 in TS 38.521-2 [9] is replaced by:

6. Ensure the UE is in state RRC\_CONNECTED with generic procedure parameters Connectivity EN-DC, DC bearer MCG and SCG, Connected without release On according to TS 38.508-1 [6] clause 4.5.

Same test procedure as in clause 6.3A.1.3.4.2 in TS 38.521-2 [9] with the following steps added for E-UTRA component:

- 1.1 On the E-UTRA carrier, disable periodic and aperiodic CQI reports, disable SRS, set *TimeAlignmentTimerDedicated* IE to infinity and disable downlink and uplink scheduling, all as per Table 4.7-1 under clause 4.7.

#### 6.3B.1.4\_1.3.5 Test Requirements

Same test requirement as in clause 6.3A.1.3.5 in TS 38.521-2 [9] for the NR carrier.

#### 6.3B.1.4\_1.4 Minimum output power for inter-band EN-DC including FR2 (5 NR CCs)

**Editor's note: This clause is incomplete. The following aspects are either missing or not yet determined:**

- **The referred test case 6.3A.1.3 in TS 38.521-2 [9] is incomplete for NR aggregated channel bandwidth wider than 400MHz and power classes 1, 2, 4.**
- **Measurement Uncertainty and Test Tolerance are FFS.**

#### 6.3B.1.4\_1.4.1 Test purpose

Same test purpose as in clause 6.3.1.1 in TS 38.521-2 [9] for the NR carrier.

#### 6.3B.1.4\_1.4.2 Test applicability

This test case applies to all types of E-UTRA UE release 15 and forward, supporting inter-band EN-DC including FR2 with 5 NR UL CCs.

#### 6.3B.1.4\_1.4.3 Minimum conformance requirements

Same minimum conformance requirements as in clause 6.3.1.3 in TS 38.521-2 [9] for the NR carrier.

No exception requirements applicable to NR or E-UTRA. LTE anchor agnostic approach is applied.

The normative reference for this requirement is TS 38.101-3 [4] clause 6.3B.

#### 6.3B.1.4\_1.4.4 Test description

##### 6.3B.1.4\_1.4.4.1 Initial condition

Same test description as in clause 6.3A.1.4.4 in TS 38.521-2 [9] for the NR carrier with the following exception:

The initial test configurations for E-UTRA band consist of environmental conditions, test frequencies, and channel bandwidths based on E-UTRA bands specified in Table 4.7-1.

For Initial conditions as in clause 6.3A.1.4.4.1 in TS 38.521-2 [9], the following steps will be added to configure E-UTRA component:

- 2.1. The parameter settings for E-UTRA cell are set up according to TS 36.508 [11] clause 4.4.3.
- 3.1. The E-UTRA downlink signal level, uplink signal level are set according to Table 4.7-1 and propagation conditions are set according to Annex B.0 of TS 36.521-1 [10].

Step 6 of Initial conditions as in clause 6.3A.1.4.4.1 in TS 38.521-2 [9] is replaced by:

6. Ensure the UE is in state RRC\_CONNECTED with generic procedure parameters Connectivity EN-DC, DC bearer MCG and SCG, Connected without release On according to TS 38.508-1 [6] clause 4.5.

Same test procedure as in clause 6.3A.1.4.4.2 in TS 38.521-2 [9] with the following steps added for E-UTRA component:

1.1 On the E-UTRA carrier, disable periodic and aperiodic CQI reports, disable SRS, set *TimeAlignmentTimerDedicated* IE to infinity and disable downlink and uplink scheduling, all as per Table 4.7-1 under clause 4.7.

#### 6.3B.1.4\_1.4.5 Test Requirements

Same test requirement as in clause 6.3A.1.4.5 in TS 38.521-2 [9] for the NR carrier.

#### 6.3B.1.4\_1.5 Minimum output power for inter-band EN-DC including FR2 (6 NR CCs)

**Editor's note: This clause is incomplete. The following aspects are either missing or not yet determined:**

- The referred test case 6.3A.1.3 in TS 38.521-2 [9] is incomplete for NR aggregated channel bandwidth wider than 400MHz and power classes 1, 2, 4.
- Measurement Uncertainty and Test Tolerance are FFS.

#### 6.3B.1.4\_1.5.1 Test purpose

Same test purpose as in clause 6.3.1.1 in TS 38.521-2 [9] for the NR carrier.

#### 6.3B.1.4\_1.5.2 Test applicability

This test case applies to all types of E-UTRA UE release 15 and forward, supporting inter-band EN-DC including FR2 with 6 NR UL CCs.

#### 6.3B.1.4\_1.5.3 Minimum conformance requirements

Same minimum conformance requirements as in clause 6.3.1.3 in TS 38.521-2 [9] for the NR carrier.

No exception requirements applicable to NR or E-UTRA. LTE anchor agnostic approach is applied.

The normative reference for this requirement is TS 38.101-3 [4] clause 6.3B.

#### 6.3B.1.4\_1.5.4 Test description

##### 6.3B.1.4\_1.5.4.1 Initial condition

Same test description as in clause 6.3A.1.5.4 in TS 38.521-2 [9] for the NR carrier with the following exception:

The initial test configurations for E-UTRA band consist of environmental conditions, test frequencies, and channel bandwidths based on E-UTRA bands specified in Table 4.7-1.

For Initial conditions as in clause 6.3A.1.5.4.1 in TS 38.521-2 [9], the following steps will be added to configure E-UTRA component:

- 2.1. The parameter settings for E-UTRA cell are set up according to TS 36.508 [11] clause 4.4.3.
- 3.1. The E-UTRA downlink signal level, uplink signal level are set according to Table 4.7-1 and propagation conditions are set according to Annex B.0 of TS 36.521-1 [10].

Step 6 of Initial conditions as in clause 6.3A.1.5.4.1 in TS 38.521-2 [9] is replaced by:

6. Ensure the UE is in state RRC\_CONNECTED with generic procedure parameters Connectivity EN-DC, DC bearer MCG and SCG, Connected without release On according to TS 38.508-1 [6] clause 4.5.

Same test procedure as in clause 6.3A.1.5.4.2 in TS 38.521-2 [9] with the following steps added for E-UTRA component:

- 1.1 On the E-UTRA carrier, disable periodic and aperiodic CQI reports, disable SRS, set *TimeAlignmentTimerDedicated* IE to infinity and disable downlink and uplink scheduling, all as per Table 4.7-1 under clause 4.7.

### 6.3B.1.4\_1.5.5 Test Requirements

Same test requirement as in clause 6.3A.1.5.5 in TS 38.521-2 [9] for the NR carrier.

### 6.3B.1.4\_1.6 Minimum output power for inter-band EN-DC including FR2 (7 NR CCs)

**Editor's note: This clause is incomplete. The following aspects are either missing or not yet determined:**

- **The referred test case 6.3A.1.3 in TS 38.521-2 [9] is incomplete for NR aggregated channel bandwidth wider than 400MHz and power classes 1, 2, 4.**
- **Measurement Uncertainty and Test Tolerance are FFS.**

#### 6.3B.1.4\_1.6.1 Test purpose

Same test purpose as in clause 6.3.1.1 in TS 38.521-2 [9] for the NR carrier.

#### 6.3B.1.4\_1.6.2 Test applicability

This test case applies to all types of E-UTRA UE release 15 and forward, supporting inter-band EN-DC including FR2 with 7 NR UL CCs.

#### 6.3B.1.4\_1.6.3 Minimum conformance requirements

Same minimum conformance requirements as in clause 6.3.1.3 in TS 38.521-2 [9] for the NR carrier.

No exception requirements applicable to NR or E-UTRA. LTE anchor agnostic approach is applied.

The normative reference for this requirement is TS 38.101-3 [4] clause 6.3B.

#### 6.3B.1.4\_1.6.4 Test description

##### 6.3B.1.4\_1.6.4.1 Initial condition

Same test description as in clause 6.3A.1.6.4 in TS 38.521-2 [9] for the NR carrier with the following exception:

The initial test configurations for E-UTRA band consist of environmental conditions, test frequencies, and channel bandwidths based on E-UTRA bands specified in Table 4.7-1.

For Initial conditions as in clause 6.3A.1.6.4.1 in TS 38.521-2 [9], the following steps will be added to configure E-UTRA component:

- 2.1. The parameter settings for E-UTRA cell are set up according to TS 36.508 [11] clause 4.4.3.
- 3.1. The E-UTRA downlink signal level, uplink signal level are set according to Table 4.7-1 and propagation conditions are set according to Annex B.0 of TS 36.521-1 [10].

Step 6 of Initial conditions as in clause 6.3A.1.6.4.1 in TS 38.521-2 [9] is replaced by:

6. Ensure the UE is in state RRC\_CONNECTED with generic procedure parameters Connectivity EN-DC, DC bearer MCG and SCG, Connected without release On according to TS 38.508-1 [6] clause 4.5.

Same test procedure as in clause 6.3A.1.6.4.2 in TS 38.521-2 [9] with the following steps added for E-UTRA component:

- 1.1 On the E-UTRA carrier, disable periodic and aperiodic CQI reports, disable SRS, set *TimeAlignmentTimerDedicated* IE to infinity and disable downlink and uplink scheduling, all as per Table 4.7-1 under clause 4.7.

### 6.3B.1.4\_1.6.5 Test Requirements

Same test requirement as in clause 6.3A.1.6.5 in TS 38.521-2 [9] for the NR carrier.

### 6.3B.1.4\_1.7 Minimum output power for inter-band EN-DC including FR2 (8 NR CCs)

Editor's note: This clause is incomplete. The following aspects are either missing or not yet determined:

- The referred test case 6.3A.1.3 in TS 38.521-2 [9] is incomplete for NR aggregated channel bandwidth wider than 400MHz and power classes 1, 2, 4.
- Measurement Uncertainty and Test Tolerance are FFS.

#### 6.3B.1.4\_1.7.1 Test purpose

Same test purpose as in clause 6.3.1.1 in TS 38.521-2 [9] for the NR carrier.

#### 6.3B.1.4\_1.7.2 Test applicability

This test case applies to all types of E-UTRA UE release 15 and forward, supporting inter-band EN-DC including FR2 with 8 NR UL CCs.

#### 6.3B.1.4\_1.7.3 Minimum conformance requirements

Same minimum conformance requirements as in clause 6.3.1.3 in TS 38.521-2 [9] for the NR carrier.

No exception requirements applicable to NR or E-UTRA. LTE anchor agnostic approach is applied.

The normative reference for this requirement is TS 38.101-3 [4] clause 6.3B.

#### 6.3B.1.4\_1.7.4 Test description

##### 6.3B.1.4\_1.7.4.1 Initial condition

Same test description as in clause 6.3A.1.7.4 in TS 38.521-2 [9] for the NR carrier with the following exception:

The initial test configurations for E-UTRA band consist of environmental conditions, test frequencies, and channel bandwidths based on E-UTRA bands specified in Table 4.7-1.

For Initial conditions as in clause 6.3A.1.7.4.1 in TS 38.521-2 [9], the following steps will be added to configure E-UTRA component:

- 2.1. The parameter settings for E-UTRA cell are set up according to TS 36.508 [11] clause 4.4.3.
- 3.1. The E-UTRA downlink signal level, uplink signal level are set according to Table 4.7-1 and propagation conditions are set according to Annex B.0 of TS 36.521-1 [10].

Step 6 of Initial conditions as in clause 6.3A.1.7.4.1 in TS 38.521-2 [9] is replaced by:

6. Ensure the UE is in state RRC\_CONNECTED with generic procedure parameters Connectivity EN-DC, DC bearer MCG and SCG, Connected without release On according to TS 38.508-1 [6] clause 4.5.

Same test procedure as in clause 6.3A.1.7.4.2 in TS 38.521-2 [9] with the following steps added for E-UTRA component:

- 1.1 On the E-UTRA carrier, disable periodic and aperiodic CQI reports, disable SRS, set *TimeAlignmentTimerDedicated* IE to infinity and disable downlink and uplink scheduling, all as per Table 4.7-1 under clause 4.7.

#### 6.3B.1.4\_1.7.5 Test Requirements

Same test requirement as in clause 6.3A.1.7.5 in TS 38.521-2 [9] for the NR carrier.

## 6.3B.1.4D Minimum output power for inter-band EN-DC including FR2 for UL MIMO

### 6.3B.1.4D.1 Test purpose

Same test purpose as in clause 6.3D.1.1 in TS 38.521-2 [9] for the NR carrier.

### 6.3B.1.4D.2 Test applicability

This test case applies to all types of E-UTRA UE release 15 and forward, supporting inter-band EN-DC FR2.

### 6.3B.1.4D.3 Minimum conformance requirements

Same minimum conformance requirements as in clause 6.3D.1.3 in TS 38.521-2 [9] for the NR carrier.

No exception requirements applicable to NR or E-UTRA. LTE anchor agnostic approach is applied.

The normative reference for this measurement is TS 38.101-3 [4] clause 6.3B.

### 6.3B.1.4D.4 Test Description

Same test description as in clause 6.3D.1.4 in TS 38.521-2 [9] for the NR carrier with the following exceptions:

The initial test configurations for E-UTRA consist of test frequency based on E-UTRA operating band and test channel bandwidth as specified in Table 4.7-1.

For Initial conditions as in clause 6.3D.1.4.1 in TS 38.521-2 [9], the following steps will be added to configure E-UTRA component:

- 2.1. The parameter settings for the cell are set up according to TS 36.508 [11] subclause 4.4.3.
- 3.1. The E-UTRA downlink signal level, uplink signal level are set according to Table 4.7-1 and propagation conditions are set according to Annex B.0 of TS 36.521-1 [10].

Step 6 of Initial conditions as in clause 6.3D.1.4.1 in TS 38.521-2 [9] is replaced by:

6. Ensure the UE is in state RRC\_CONNECTED with generic procedure parameters Connectivity EN-DC, DC bearer MCG and SCG, Connected without release *On* according to TS 38.508-1 [6] clause 4.5.

Same Test procedure as in clause 6.3D.1.4.2 in TS 38.521-2 [9] with the following steps added for E-UTRA component:

- 1.1. On the E-UTRA carrier, disable periodic and aperiodic CQI reports, disable SRS, set TimeAlignmentTimerDedicated IE to infinity and disable downlink and uplink scheduling, all as per Table 4.7-1 under clause 4.7.

### 6.3B.1.4D.5 Test Requirement

Same test requirement as specified in clause 6.3D.1.5 of TS 38.521-2 [9] for the NR carrier(s).

## 6.3B.2 Transmit OFF Power for EN-DC

### 6.3B.2.1 Transmit OFF Power for intra-band contiguous EN-DC

#### 6.3B.2.1.1 Test purpose

Same test purpose as in clause 6.3.2.1 in TS 38.521-1 [8] for the NR carrier.

#### 6.3B.2.1.2 Test applicability

The requirements of this test apply in Clause 6.3B.3 Tx ON/OFF time mask/PUCCH time mask to all types of E-UTRA UE release 15 and forward, supporting intra-band contiguous EN-DC.

### 6.3B.2.1.3 Minimum conformance requirements

Same minimum conformance requirements as in clause 6.3.2.3 in TS 38.521-1 [8] for the NR carrier.

The normative reference for this requirement is TS 38.101-3 [4] clause 6.3.

### 6.3B.2.1.4 Test description

This test is covered by Clause 6.3B.3 Tx ON/OFF time mask/PUCCH time mask for EN-DC.

### 6.3B.2.1.5 Test requirements

Same test requirement as in clause 6.3.2.5 in TS 38.521-1 [8] for the NR carrier.

## 6.3B.2.2 Transmit OFF Power for intra-band non-contiguous EN-DC

### 6.3B.2.2.1 Test purpose

Same test purpose as in clause 6.3.2.1 in TS 38.521-1 [8] for the NR carrier.

### 6.3B.2.2.2 Test applicability

The requirements of this test apply in clause 6.3B.3 Tx ON/OFF time mask/PUCCH time mask to all types of E-UTRA UE Release 15 and forward, supporting intra-band non-contiguous EN-DC.

### 6.3B.2.2.3 Minimum conformance requirements

Same minimum conformance requirements as in clause 6.3.2.3 in TS 38.521-1 [8] for the NR carrier.

The normative reference for this requirement is TS 38.101-3 [4] clause 6.3.

### 6.3B.2.2.4 Test description

This test is covered by Clause 6.3B.3 Tx ON/OFF time mask/PUCCH time mask for EN-DC.

### 6.3B.2.2.5 Test requirements

Same test requirement as in clause 6.3.2.5 in TS 38.521-1 [8] for the NR carrier.

## 6.3B.2.3 Transmit OFF Power for inter-band EN-DC within FR1 (1 NR CC)

### 6.3B.2.3.1 Test purpose

Same test purpose as in clause 6.3.2.1 in TS 38.521-1 [8] for the NR carrier.

### 6.3B.2.3.2 Test applicability

The requirements of this test apply in Clause 6.3B.3.3 Tx ON/OFF time mask/PUCCH time mask to all types of E-UTRA UE release 15 and forward, supporting inter-band EN-DC within FR1 with 1 NR UL CC.

### 6.3B.2.3.3 Minimum conformance requirements

Same minimum conformance requirements as in clause 6.3.2.3 in TS 38.521-1 [8] for the NR carrier.

No exception requirements applicable to NR or E-UTRA. LTE anchor agnostic approach is applied.

The normative reference for this requirement is TS 38.101-3 [4] clause 6.3.

### 6.3B.2.3.4 Test description

This test is covered by Clause 6.3B.3 Tx ON/OFF time mask/PUCCH time mask for EN-DC.



#### 6.3B.2.3.5 Test requirements

Same test requirement as in clause 6.3.2.5 in TS 38.521-1 [8] for the NR carrier.

#### 6.3B.2.4 Transmit OFF Power for inter-band EN-DC including FR2 (1 NR CC)

**Editor's note: Following aspects are either missing or not yet determined:**

**- Measurement Uncertainties and Test Tolerances are FFS for power class other than 1, 3, 5 and 6.**

##### 6.3B.2.4.1 Test purpose

Same test purpose as in clause 6.3.2.1 in TS 38.521-2 [9] for the NR carrier.

##### 6.3B.2.4.2 Test applicability

This test case applies to all types of E-UTRA UE release 15 and forward, supporting inter-band EN-DC including FR2 with 1 NR UL CC.

##### 6.3B.2.4.3 Minimum conformance requirements

Same minimum conformance requirements as in clause 6.3.2.3 in TS 38.521-2 [9] for the NR carrier.

No exception requirements applicable to NR or E-UTRA. LTE anchor agnostic approach is applied.

The normative reference for this requirement is TS 38.101-3 [4] clause 6.3.

##### 6.3B.2.4.4 Test description

Same test description as in clause 6.3.2.4 in TS 38.521-2 [9] for the NR carrier with the following exception:

The initial test configurations for E-UTRA band consist of environmental conditions, test frequencies, and channel bandwidths based on E-UTRA bands specified in Table 4.7-1.

For Initial conditions as in clause 6.3.2.4.1 in TS 38.521-2 [9], the following steps will be added to configure E-UTRA component:

- 2.1. The parameter settings for E-UTRA cell are set up according to TS 36.508 [11] clause 4.4.3.
- 3.1. The E-UTRA downlink signal level, uplink signal level are set according to Table 4.7-1 and propagation conditions are set according to Annex B.0 of TS 36.521-1 [10].

Step 6 of Initial conditions as in clause 6.3.2.4.1 in TS 38.521-2 [9] is replaced by:

6. Ensure the UE is in state RRC\_CONNECTED with generic procedure parameters Connectivity EN-DC, DC bearer MCG and SCG, Connected without release On according to TS 38.508-1 [6] clause 4.5.

Same test procedure as in clause 6.3.2.4.2 in TS 38.521-2 [9] with the following steps added for E-UTRA component:

- 1.1 On the E-UTRA carrier, disable periodic and aperiodic CQI reports, disable SRS, set *TimeAlignmentTimerDedicated* IE to infinity and disable downlink and uplink scheduling, all as per Table 4.7-1 under clause 4.7.

##### 6.3B.2.4.5 Test requirements

Same test requirement as in clause 6.3.2.5 in TS 38.521-2 [8] for the NR carrier.

### 6.3B.2.4\_1 Void

### 6.3B.2.4D Transmit OFF Power for inter-band EN-DC including FR2 for UL-MIMO

#### 6.3B.2.4D.1 Test purpose

Same test purpose as in clause 6.3D.2.1 in TS 38.521-2 [9] for the NR carrier.

#### 6.3B.2.4D.2 Test applicability

This test case applies to all types of E-UTRA UE release 15 and forward, supporting inter-band EN-DC including FR2 for UL-MIMO.

#### 6.3B.2.4D.3 Minimum conformance requirements

Same minimum conformance requirements as in clause 6.3D.2.3 in TS 38.521-2 [9] for the NR carrier.

No exception requirements applicable to NR or E-UTRA. LTE anchor agnostic approach is applied.

The normative reference for this measurement is TS 38.101-3 [4] clause 6.3B.

#### 6.3B.2.4D.4 Test Description

Same test description as in clause 6.3D.2.4 in TS 38.521-2 [9] for the NR carrier with the following exceptions:

The initial test configurations for E-UTRA consist of test frequency based on E-UTRA operating band and test channel bandwidth as specified in Table 4.7-1.

For Initial conditions as in clause 6.3D.2.4.1 in TS 38.521-2 [9], the following steps will be added to configure E-UTRA component:

- 2.1. The parameter settings for the cell are set up according to TS 36.508 [11] subclause 4.4.3.
- 3.1. The E-UTRA downlink signal level, uplink signal level are set according to Table 4.7-1 and propagation conditions are set according to Annex B.0 of TS 36.521-1 [10].

Step 6 of Initial conditions as in clause 6.3D.2.4.1 in TS 38.521-2 [9] is replaced by:

6. Ensure the UE is in state RRC\_CONNECTED with generic procedure parameters Connectivity EN-DC, DC bearer MCG and SCG, Connected without release *On* according to TS 38.508-1 [6] clause 4.5.

Same Test procedure as in clause 6.3D.2.4.2 in TS 38.521-2 [9] with the following steps added for E-UTRA component:

- 1.1. On the E-UTRA carrier, disable periodic and aperiodic CQI reports, disable SRS, set TimeAlignmentTimerDedicated IE to infinity and disable downlink and uplink scheduling, all as per Table 4.7-1 under clause 4.7.

#### 6.3B.2.4D.5 Test Requirement

Same test requirement as specified in clause 6.3D.2.5 of TS 38.521-2 [9] for the NR carrier(s).

### 6.3B.3 Transmit ON/OFF time mask/PUCCH time mask for EN-DC

#### 6.3B.3.1 Transmit ON/OFF time mask for intra-band contiguous EN-DC

##### 6.3B.3.1.1 Test purpose

Same test purpose as in clause 6.3.3.2.1 in TS 38.521-1 [8] for the NR carrier.

#### 6.3B.3.1.2 Test applicability

This test applies to all types of E-UTRA UE release 15 and forward, supporting intra-band contiguous EN-DC.

#### 6.3B.3.1.3 Minimum conformance requirements

Same minimum conformance requirements as in clause 6.3.3.2.3 in TS 38.521-1 [8] for the NR carrier.

No exception requirements applicable to NR or E-UTRA. LTE anchor agnostic approach is applied.

The normative reference for this requirement is TS 38.101-3 [4] clause 6.3.

#### 6.3B.3.1.4 Test description

Same test descriptions as in clause 6.3.3.2.4 in TS 38.521-1 [8] for the NR carrier with the following exceptions:

The initial test configurations for E-UTRA band consist of environmental conditions, test frequencies, and channel bandwidths based on E-UTRA bands specified in Table 4.6-1.

For Initial conditions as in clause 6.3.3.2.4.1 in TS 38.521-1 [8], the following steps will be added to configure E-UTRA component:

2.1. The parameter settings for the E-UTRA cell are set up according to TS 36.508 [11] clause 4.4.3.

3.1. The E-UTRA Downlink signal level, uplink signal level are set according to Table 4.6-1 and propagation conditions are set according to Annex B.0 of TS 36.521-1 [10].

Step 6 of Initial conditions as in clause 6.3.3.2.4.1 in TS 38.521-1 [8] is replaced by the following two steps:

6. Ensure the UE is in state RRC\_CONNECTED with generic procedure parameters Connectivity EN-DC, DC bearer *MCG* and *SCG*, *Connected without release On* according to TS 38.508-1 [6] clause 4.5.

7. When E-UTRA and NR bands are TDD, ensure the same uplink-downlink configuration by giving SCG a delay of 3 E-UTRA subframes, or by giving MCG a delay of 2 subframes.

Same test procedure as in clause 6.3.3.2.4.2 in TS 38.521-1 [8] with the following steps added for E-UTRA component:

1.1. On the E-UTRA carrier, disable periodic and aperiodic CQI reports, disable SRS, set *TimeAlignmentTimerDedicated* IE to infinity and disable downlink and uplink scheduling, all as per Table 4.6-1 under clause 4.6.

#### 6.3B.3.1.5 Test requirements

Same test requirement as in clause 6.3.3.2.5 in TS 38.521-1 [8] for the NR carrier.

### 6.3B.3.2 Transmit ON/OFF time mask for intra-band non-contiguous EN-DC

#### 6.3B.3.2.1 Test purpose

Same test purpose as in clause 6.3.3.2.1 in TS 38.521-1 [8] for the NR carrier.

#### 6.3B.3.2.2 Test applicability

This test applies to all types of E-UTRA UE release 15 and forward, supporting intra-band non-contiguous EN-DC.

#### 6.3B.3.2.3 Minimum conformance requirements

Same minimum conformance requirements as in clause 6.3.3.2.3 in TS 38.521-1 [8] for the NR carrier.

No exception requirements applicable to NR or E-UTRA. LTE anchor agnostic approach is applied.

The normative reference for this requirement is TS 38.101-3 [4] clause 6.3.

#### 6.3B.3.2.4 Test description

Same test descriptions as in clause 6.3.3.2.4 in TS 38.521-1 [8] for the NR carrier with the following exceptions:

The initial test configurations for E-UTRA band consist of environmental conditions, test frequencies, and channel bandwidths based on E-UTRA bands specified in Table 4.6-1.

For Initial conditions as in clause 6.3.3.2.4.1 in TS 38.521-1 [8], the following steps will be added to configure E-UTRA component:

- 2.1. The parameter settings for the E-UTRA cell are set up according to TS 36.508 [11] clause 4.4.3.
- 3.1. The E-UTRA Downlink signal level, uplink signal level are set according to Table 4.6-1 and propagation conditions are set according to Annex B.0 of TS 36.521-1 [10].

Step 6 of Initial conditions as in clause 6.3.3.2.4.1 in TS 38.521-1 [8] is replaced by the following two steps:

6. Ensure the UE is in state RRC\_CONNECTED with generic procedure parameters Connectivity EN-DC, DC bearer MCG and SCG, *Connected without release On* according to TS 38.508-1 [6] clause 4.5.
7. When E-UTRA and NR bands are TDD, ensure the same uplink-downlink configuration by giving SCG a delay of 3 E-UTRA subframes, or by giving MCG a delay of 2 subframes.

Same test procedure as in clause 6.3.3.2.4.2 in TS 38.521-1 [8] with the following steps added for E-UTRA component:

- 1.1. On the E-UTRA carrier, disable periodic and aperiodic CQI reports, disable SRS, set *TimeAlignmentTimerDedicated* IE to infinity and disable downlink and uplink scheduling, all as per Table 4.6-1 under clause 4.6.

#### 6.3B.3.2.5 Test requirements

Same test requirement as in clause 6.3.3.2.5 in TS 38.521-1 [8] for the NR carrier.

### 6.3B.3.3 Transmit ON/OFF time mask for inter-band EN-DC within FR1 (1 NR CC)

#### 6.3B.3.3.1 Test purpose

Same test purpose as in clause 6.3.3.2.1 in TS 38.521-1 [8] for the NR carrier.

#### 6.3B.3.3.2 Test applicability

This test applies to all types of E-UTRA UE release 15 and forward, supporting inter-band EN-DC within FR1 with 1 NR UL CC.

#### 6.3B.3.3.3 Minimum conformance requirements

Same minimum conformance requirements as in clause 6.3.3.2.3 in TS 38.521-1 [8] for the NR carrier.

No exception requirements applicable to NR or E-UTRA. LTE anchor agnostic approach is applied.

The normative reference for this requirement is TS 38.101-3 [4] clause 6.3.

#### 6.3B.3.3.4 Test description

Same test descriptions as in clause 6.3.3.2.4 in TS 38.521-1 [8] for the NR carrier with the following exceptions:

The initial test configurations for E-UTRA band consist of environmental conditions, test frequencies, and channel bandwidths based on E-UTRA bands specified in Table 4.6-1.

For Initial conditions as in clause 6.3.3.2.4.1 in TS 38.521-1 [8], the following steps will be added to configure E-UTRA component:

- 2.1. The parameter settings for the E-UTRA cell are set up according to TS 36.508 [11] clause 4.4.3.

3.1. The E-UTRA Downlink signal level, uplink signal level are set according to Table 4.6-1 and propagation conditions are set according to Annex B.0 of TS 36.521-1 [10].

Step 6 of Initial conditions as in clause 6.3.3.2.4.1 in TS 38.521-1 [8] is replaced by:

6. Ensure the UE is in state RRC\_CONNECTED with generic procedure parameters Connectivity EN-DC, DC bearer MCG and SCG, Connected without release *On* according to TS 38.508-1 [6] clause 4.5.

Same test procedure as in clause 6.3.3.2.4.2 in TS 38.521-1 [8] with the following steps added for E-UTRA component:

1.1. On the E-UTRA carrier, disable periodic and aperiodic CQI reports, disable SRS, set *TimeAlignmentTimerDedicated* IE to infinity and disable downlink and uplink scheduling, all as per Table 4.6-1 under clause 4.6.

#### 6.3B.3.3.5 Test requirements

Same test requirement as in clause 6.3.3.2.5 in TS 38.521-1 [8] for the NR carrier.

#### 6.3B.3.4 Transmit ON/OFF time mask for inter-band EN-DC including FR2 (1 NR CC)

**Editor's note: The following aspects are either missing or not yet determined:**

- The referred test case 6.3.3.2 in TS 38.521-2 [9] is incomplete for power class 1, 2 and 4.
- The referred test case 6.3.3.2 in TS 38.521-2 [9] is incomplete for band n259.

#### 6.3B.3.4.1 Test purpose

Same test purpose as in clause 6.3.3.2.1 in TS 38.521-2 [9] for the NR carrier.

#### 6.3B.3.4.2 Test applicability

This test case applies to all types of E-UTRA UE release 15 and forward, supporting inter-band EN-DC FR2 with 1 NR UL CC.

#### 6.3B.3.4.3 Minimum conformance requirements

Same minimum conformance requirements as in clause 6.3.3.2.3 in TS 38.521-2 [9] for the NR carrier.

No exception requirements applicable to NR or E-UTRA. LTE anchor agnostic approach is applied.

The normative reference for this measurement is TS 38.101-3 [4] clause 6.3B.

#### 6.3B.3.4.4 Test Description

Same test description as in clause 6.3.3.2.4 in TS 38.521-2 [9] for the NR carrier with the following exceptions:

The initial test configurations for E-UTRA consist of test frequency based on E-UTRA operating band and test channel bandwidth as specified in Table 4.7-1.

For Initial conditions as in clause 6.3.3.2.4.1 in TS 38.521-2 [9], the following steps will be added to configure E-UTRA component:

2.1. The parameter settings for the cell are set up according to TS 36.508 [11] subclause 4.4.3.

3.1. The E-UTRA downlink signal level, uplink signal level are set according to Table 4.7-1 and propagation conditions are set according to Annex B.0 of TS 36.521-1 [10].

Step 6 of Initial conditions as in clause 6.3.3.2.4.1 in TS 38.521-2 [9] is replaced by:

6. Ensure the UE is in state RRC\_CONNECTED with generic procedure parameters Connectivity EN-DC, DC bearer MCG and SCG, Connected without release *On* according to TS 38.508-1 [6] clause 4.5.

Same Test procedure as in clause 6.3.3.2.4.2 in TS 38.521-2 [9] with the following steps added for E-UTRA component:

- 1.1 On the E-UTRA carrier, disable periodic and aperiodic CQI reports, disable SRS, set *TimeAlignmentTimerDedicated* IE to infinity and disable downlink and uplink scheduling, all as per Table 4.7-1 under clause 4.7.

#### 6.3B.3.4.5 Test Requirement

Same test requirement as specified in clause 6.3.3.2.5 of TS 38.521-2 [9] for the NR carrier(s).

#### 6.3B.3.4\_1 Transmit ON/OFF time mask for Inter-Band EN-DC including FR2 (>1 NR CC)

##### 6.3B.3.4\_1.1 Transmit ON/OFF time mask for Inter-Band EN-DC including FR2 (2 NR CCs)

**Editor's note: The following aspects are either missing or not yet determined:**

- **Measurement Uncertainties and Test Tolerances for intra-band contiguous CA supporting aggregated BW > 400MHz is TBD.**
- **Measurement Uncertainties and Test Tolerances are FFS for power class 1, 2, 4, 5, 6 and 7.**

##### 6.3B.3.4\_1.1.1 Test purpose

Same test purpose as in clause 6.3A.3.1.1.1 in TS 38.521-2 [9] for the NR carriers.

##### 6.3B.3.4\_1.1.2 Test applicability

This test case applies to all types of E-UTRA UE release 15 and forward, supporting inter-band EN-DC including FR2 with 2 NR UL CCs.

##### 6.3B.3.4\_1.1.3 Minimum conformance requirements

Same minimum conformance requirements as in clause 6.3A.3.1.1.3 in TS 38.521-2 [9] for the NR carrier.

No exception requirements applicable to NR or E-UTRA. LTE anchor agnostic approach is applied.

The normative reference for this measurement is TS 38.101-3 [4] clause 6.3B.

##### 6.3B.3.4\_1.1.4 Test description

Same test description as in clause 6.3A.3.1.1.4 in TS 38.521-2 [9] for the NR carriers with the following exception:

The initial test configurations for E-UTRA band consist of environmental conditions, test frequencies, and channel bandwidths based on E-UTRA bands specified in Table 4.7-1.

For Initial conditions as in clause 6.3A.3.1.1.4.1 in TS 38.521-2 [9], the following steps will be added to configure E-UTRA component:

- 2.1. The parameter settings for E-UTRA cell are set up according to TS 36.508 [11] clause 4.4.3.
- 3.1. The E-UTRA downlink signal level, uplink signal level are set according to Table 4.7-1 and propagation conditions are set according to Annex B.0 of TS 36.521-1 [10].

Step 6 of Initial conditions as in clause 6.3A.3.1.1.4.1 in TS 38.521-2 [9] is replaced by:

6. Ensure the UE is in state RRC\_CONNECTED with generic procedure parameters Connectivity EN-DC, DC bearer MCG and SCG, Connected without release On according to TS 38.508-1 [6] clause 4.5.

Same test procedure as in clause 6.3A.3.1.1.4.2 in TS 38.521-2 [9] with the following steps added for E-UTRA component:

1.1 On the E-UTRA carrier, disable periodic and aperiodic CQI reports, disable SRS, set *TimeAlignmentTimerDedicated* IE to infinity and disable downlink and uplink scheduling, all as per Table 4.7-1 under clause 4.7 of TS 36.508 [11].

#### 6.3B.3.4\_1.1.5 Test Requirements

Same test requirement as in clause 6.3A.3.1.1.5 in TS 38.521-2 [9] for the *NR* carriers.

#### 6.3B.3.4\_1.2 Transmit ON/OFF time mask for Inter-Band EN-DC including FR2 (3 NR CCs)

**Editor's note: The following aspects are either missing or not yet determined:**

- Measurement Uncertainties and Test Tolerances for intra-band contiguous CA supporting aggregated BW > 400MHz is TBD.
- Measurement Uncertainties and Test Tolerances are FFS for power class 1, 2, 4, 5, 6 and 7.

#### 6.3B.3.4\_1.2.1 Test purpose

Same test purpose as in clause 6.3A.3.1.2.1 in TS 38.521-2 [9] for the NR carriers.

#### 6.3B.3.4\_1.2.2 Test applicability

This test case applies to all types of E-UTRA UE release 15 and forward, supporting inter-band EN-DC including FR2 with 3 NR UL CCs.

#### 6.3B.3.4\_1.2.3 Minimum conformance requirements

Same minimum conformance requirements as in clause 6.3A.3.1.2.3 in TS 38.521-2 [9] for the NR carrier.

No exception requirements applicable to NR or E-UTRA. LTE anchor agnostic approach is applied.

The normative reference for this measurement is TS 38.101-3 [4] clause 6.3B.

#### 6.3B.3.4\_1.2.4 Test description

Same test description as in clause 6.3A.3.1.2.4 in TS 38.521-2 [9] for the *NR* carriers with the following exception:

The initial test configurations for E-UTRA band consist of environmental conditions, test frequencies, and channel bandwidths based on E-UTRA bands specified in Table 4.7-1.

For Initial conditions as in clause 6.3A.3.1.1.4.1 in TS 38.521-2 [9], the following steps will be added to configure E-UTRA component:

- 2.1. The parameter settings for E-UTRA cell are set up according to TS 36.508 [11] clause 4.4.3.
- 3.1. The E-UTRA downlink signal level, uplink signal level are set according to Table 4.7-1 and propagation conditions are set according to Annex B.0 of TS 36.521-1 [10].

Step 6 of Initial conditions as in clause 6.3A.3.1.1.4.1 in TS 38.521-2 [9] is replaced by:

6. Ensure the UE is in state RRC\_CONNECTED with generic procedure parameters Connectivity EN-DC, DC bearer MCG and SCG, Connected without release On according to TS 38.508-1 [6] clause 4.5.

Same test procedure as in clause 6.3A.3.1.1.4.2 in TS 38.521-2 [9] with the following steps added for E-UTRA component:

- 1.1 On the E-UTRA carrier, disable periodic and aperiodic CQI reports, disable SRS, set *TimeAlignmentTimerDedicated* IE to infinity and disable downlink and uplink scheduling, all as per Table 4.7-1 under clause 4.7 of TS 36.508 [11].

#### 6.3B.3.4\_1.2.5 Test Requirements

Same test requirement as in clause 6.3A.3.1.2.5 in TS 38.521-2 [9] for the *NR* carriers.

### 6.3B.3.4\_1.3 Transmit ON/OFF time mask for Inter-Band EN-DC including FR2 (4 NR CCs)

Editor's note: The following aspects are either missing or not yet determined:

- Measurement Uncertainties and Test Tolerances for intra-band contiguous CA supporting aggregated BW > 400MHz is TBD.
- Measurement Uncertainties and Test Tolerances are FFS for power class 1, 2, 4, 5, 6 and 7.

#### 6.3B.3.4\_1.3.1 Test purpose

Same test purpose as in clause 6.3A.3.1.3.1 in TS 38.521-2 [9] for the NR carriers.

#### 6.3B.3.4\_1.3.2 Test applicability

This test case applies to all types of E-UTRA UE release 15 and forward, supporting inter-band EN-DC including FR2 with 4 NR UL CCs.

#### 6.3B.3.4\_1.3.3 Minimum conformance requirements

Same minimum conformance requirements as in clause 6.3A.3.1.3.3 in TS 38.521-2 [9] for the NR carrier.

No exception requirements applicable to NR or E-UTRA. LTE anchor agnostic approach is applied.

The normative reference for this measurement is TS 38.101-3 [4] clause 6.3B.

#### 6.3B.3.4\_1.3.4 Test description

Same test description as in clause 6.3A.3.1.3.4 in TS 38.521-2 [9] for the NR carriers with the following exception:

The initial test configurations for E-UTRA band consist of environmental conditions, test frequencies, and channel bandwidths based on E-UTRA bands specified in Table 4.7-1.

For Initial conditions as in clause 6.3A.3.1.1.4.1 in TS 38.521-2 [9], the following steps will be added to configure E-UTRA component:

- 2.1. The parameter settings for E-UTRA cell are set up according to TS 36.508 [11] clause 4.4.3.
- 3.1. The E-UTRA downlink signal level, uplink signal level are set according to Table 4.7-1 and propagation conditions are set according to Annex B.0 of TS 36.521-1 [10].

Step 6 of Initial conditions as in clause 6.3A.3.1.1.4.1 in TS 38.521-2 [9] is replaced by:

6. Ensure the UE is in state RRC\_CONNECTED with generic procedure parameters Connectivity EN-DC, DC bearer MCG and SCG, Connected without release On according to TS 38.508-1 [6] clause 4.5.

Same test procedure as in clause 6.3A.3.1.1.4.2 in TS 38.521-2 [9] with the following steps added for E-UTRA component:

- 1.1 On the E-UTRA carrier, disable periodic and aperiodic CQI reports, disable SRS, set *TimeAlignmentTimerDedicated* IE to infinity and disable downlink and uplink scheduling, all as per Table 4.7-1 under clause 4.7 of TS 36.508 [11].

#### 6.3B.3.4\_1.3.5 Test Requirements

Same test requirement as in clause 6.3A.3.1.3.5 in TS 38.521-2 [9] for the NR carriers.

### 6.3B.3.4D Transmit ON/OFF time mask for inter-band EN-DC including FR2 for UL-MIMO

Editor's note: This clause is incomplete. The following aspects are either missing or not yet determined:

- The referred test case 6.3D.3 in TS 38.521-2 [9] is incomplete



#### 6.3B.3.4D.1 Test purpose

Same test purpose as in clause 6.3D.3.1.1 in TS 38.521-2 [9] for the NR carrier.

#### 6.3B.3.4D.2 Test applicability

This test case applies to all types of E-UTRA UE release 15 and forward, supporting inter-band EN-DC FR2.

#### 6.3B.3.4D.3 Minimum conformance requirements

Same minimum conformance requirements as in clause 6.3D.3.1.3 in TS 38.521-2 [9] for the NR carrier.

No exception requirements applicable to NR or E-UTRA. LTE anchor agnostic approach is applied.

The normative reference for this measurement is TS 38.101-3 [4] clause 6.3B.

#### 6.3B.3.4D.4 Test Description

Same test description as in clause 6.3D.3.1.4 in TS 38.521-2 [9] for the NR carrier with the following exceptions:

The initial test configurations for E-UTRA consist of test frequency based on E-UTRA operating band and test channel bandwidth as specified in Table 4.7-1.

For Initial conditions as in clause 6.3D.3.1.4.1 in TS 38.521-2 [9], the following steps will be added to configure E-UTRA component:

- 2.1. The parameter settings for the cell are set up according to TS 36.508 [11] subclause 4.4.3.
- 3.1. The E-UTRA downlink signal level, uplink signal level are set according to Table 4.7-1 and propagation conditions are set according to Annex B.0 of TS 36.521-1 [10].

Step 6 of Initial conditions as in clause 6.3D.3.1.4.1 in TS 38.521-2 [9] is replaced by:

6. Ensure the UE is in state RRC\_CONNECTED with generic procedure parameters Connectivity EN-DC, DC bearer MCG and SCG, Connected without release *On* according to TS 38.508-1 [6] clause 4.5.

Same Test procedure as in clause 6.3D.3.1.4.2 in TS 38.521-2 [9] with the following steps added for E-UTRA component:

- 1.1. On the E-UTRA carrier, disable periodic and aperiodic CQI reports, disable SRS, set TimeAlignmentTimerDedicated IE to infinity and disable downlink and uplink scheduling, all as per Table 4.7-1 under clause 4.7.

#### 6.3B.3.4D.5 Test Requirement

Same test requirement as specified in TS 38.521-2 [9] clause 6.3D.3.1.5 for the NR carrier(s).

### 6.3B.3\_1 E-UTRA and NR switching time mask for switching between two uplink carriers

#### 6.3B.3\_1.1 E-UTRA and NR switching time mask for switching between two uplink carriers for inter-band EN-DC

**Editor's note: This clause is incomplete. The following aspects are either missing or not yet determined:**

- **The test clause number needs further discussion.**

##### 6.3B.3\_1.1.1 Test purpose

To verify that the E-UTRA and NR switching time mask for switching between two uplink carriers for inter-band EN-DC meets the requirements given in 6.3B.4.1 in TS 38.101-3 [4].

The E-UTRA and NR switching time mask for switching between two uplink carriers for inter-band EN-DC defines the transient period(s) and the switching period allowed between two uplink carriers for an uplink band pair of an inter-band EN-DC configuration when the capability *uplinkTxSwitchingPeriod* is present.

### 6.3B.3\_1.1.2 Test applicability

This test case applies to all types of E-UTRA UE release 16 and forward, supporting 2UL inter-band EN-DC and dynamic UL Tx switching.

### 6.3B.3\_1.1.3 Minimum conformance requirements

In addition to the requirements in 6.3B.0 and the maximum output power requirement specified in Table 6.2B.1.3-1 with inter-band EN-DC (two bands), the switching time mask specified in this sub-clause is applicable for an uplink band pair of an inter-band EN-DC configuration without SUL band when the capability *uplinkTxSwitchingPeriod* is present, and is only applicable for uplink switching mechanisms specified in sub-clause 6.1.6 of TS 38.214 [14], where E-UTRA UL carrier 1 is capable of one transmit antenna connector and NR UL carrier 2 is capable of two transmit antenna connectors, and the two uplink carriers are in different bands with different carrier frequencies. The UE shall support the switch between single layer transmission with one antenna port and two-layer transmission with two antenna ports on the two uplink carriers following the scheduling commands and rank adaptation, i.e., both single layer and two-layer transmission with 2 antenna ports, and single layer transmission with 1 antenna port shall be supported on NR UL carrier 2.

The switching periods described in Figure 6.3B.4.1-1 are only located in NR carrier, and the length of uplink switching period  $X$  is less than the value indicated by UE capability *uplinkTxSwitchingPeriod*.

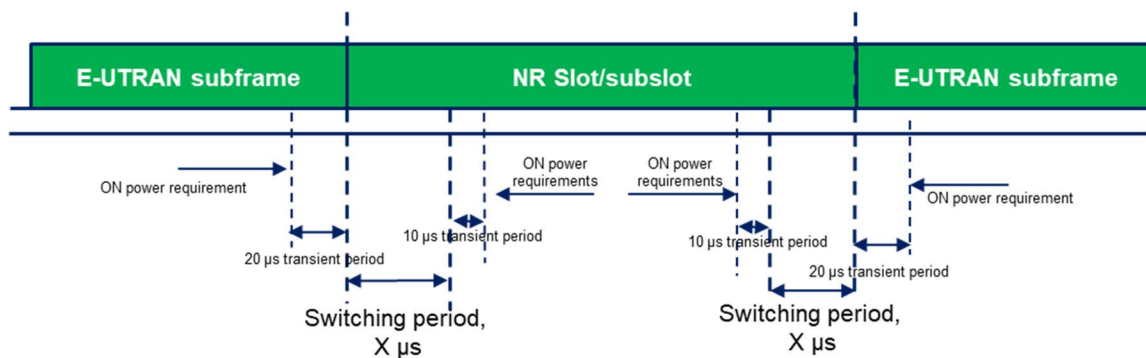

**Figure 6.3B.4.1-1: Time mask for switching between E-UTRA UL carrier and NR UL carrier, where the switching period is located in NR carrier**

The requirements apply for the case of co-located and synchronized network deployment with the max receiving timing difference of 3 $\mu$ s between the two carriers.

The normative reference for this requirement is TS 38.101-3 [4] clause 6.3B.4.1 for the NR and the E-UTRA carrier.

Exception requirements for both NR and E-UTRA are defined for this test and therefore LTE anchor agnostic approach is not applied.

### 6.3B.3\_1.1.4 Test description

#### 6.3B.3\_1.1.4.1 Initial condition

Initial conditions are a set of test configurations the UE needs to be tested in and the steps for the SS to take with the UE to reach the correct measurement state.

The initial test configurations consist of environmental conditions, test frequencies and channel bandwidths based on EN-DC operating bands specified in clause 5.3B.1.2, channel bandwidths and sub-carrier spacings for the NR cell specified in TS 38.521-1 [8] clause 5.3 and channel bandwidth for the E-UTRA cell are specified in TS 36.521-1 [10] clause 5.4.2. All of these configurations shall be tested with applicable test parameters for each EN-DC configuration specified in clause 5.3B.1.2, and are shown in table 6.3B.3\_1.1.4.1-1. The details of the uplink reference measurement channels (RMCs) are specified in Annex A, clause A.2.2 for E-UTRA RMC for TDD, TS 36.521-1 [10] Annex A, clause A.2.2 for E-UTRA RMC for FDD, and TS 38.521-1 [8] Annex A, clause A.2 for NR RMC. Configurations of

PDSCH and PDCCH before measurement are specified in TS 36.521-1 [10] Annex C, clause C.2 and in TS 38.521-1 [8] Annex C, clause C.2 for E-UTRA CG and NR CG respectively.

**Table 6.3B.3\_1.1.4.1-1: Test configuration table for Inter-band EN-DC Uplink switching**

Initial Conditions					
Test Environment as specified in TS 38.508-1 [5] clause 4.1		Normal			
NR Test Frequencies as specified in TS 38.508-1 [5] clause 4.3.1 E-UTRA Test Frequencies as specified in TS 36.508-1 [11] clause 4.3.1		Mid range for E-UTRA CC1 and NR CC1 (NOTE 3)			
Test EN-DC bandwidth combination as specified in TS 38.508-1 [5] clause 4.3.1		Highest for E-UTRA CC1 and NR CC1			
NR Test SCS as specified in Table 5.3.5-1 in TS 38.521-1 [8]		Highest			
NR/E-UTRA Test Parameters					
Test ID	Downlink Configuration	EN-DC Uplink Configuration			
		E-UTRA Cell		NR Cell	
		Modulation	RB allocation (NOTE 2)	Modulation	RB allocation (NOTE 1)
1	N/A	QPSK	Outer Full	DFT-s-OFDM QPSK	Inner Full
NOTE 1: The specific configuration of each RB allocation is defined in Table 6.1-1 in TS 38.521-1 [8].					
NOTE 2: The specific configuration of each RB allocation is defined in Table 6.1-1 in current specification.					
NOTE 3: For NR band n28, 30MHz test channel bandwidth is tested with Low range test frequency.					

1. Connect the SS to the UE antenna connectors as shown in TS 38.508-1 [6] Annex A, Figure A.3.1.1.2 for TE diagram and clause A.3.2 for UE diagram.
2. The parameter settings for the E-UTRA cell are set up according to TS 36.508 [11] clause 4.4.3, and the parameter settings for the NR cell are set up according to TS 38.508-1 [6] clause 4.4.3.
3. Downlink signals are initially set up according to TS 36.521-1 [10] Annex C.0 and TS 38.521-1 [8] Annex C.0 for E-UTRA CG and NR CG respectively, and uplink signals according to TS 36.521-1 [10] Annex H and TS 38.521-1 [8] Annex G for E-UTRA CG and NR CG respectively.
4. NR downlink signals are initially set up according to Annex C.0, C.1, and C.2 and uplink signals according to Annex G.0, G.1, G.2, and G.3.0 of TS 38.521-1 [8].
5. The UL Reference Measurement Channel is set according to Table 6.3A.3.1\_1.4.1-1 for E-UTRA CG and NR CG respectively.
6. Propagation conditions are set according to TS 36.521-1 [10] Annex B.0 and TS 38.521-1 [8] Annex B.0 for E-UTRA CG and NR CG respectively.
7. Ensure the UE is in state RRC\_CONNECTED with generic procedure parameters Connectivity EN-DC, DC bearer *MCG* and *SCG*, Connected without release *On* according to TS 38.508-1 [6] clause 4.5. Message contents are defined in clause 6.3A.3.1\_1.4.3 in TS 38.521-1 [8] for the NR CG.

#### 6.3B.3\_1.1.4.2 Test procedure

Carrier 1 and Carrier 2 refers to the E-UTRA component and the NR carrier respectively

1. Configure Carrier 2 according to Annex C.0, C.1, C.2 for all downlink physical channels.
2. The SS shall configure Carrier 2 as per TS 38.508-1 [5] clause 5.5.1. Message contents are defined in clause 6.3A.3.1\_1.4.3 in TS 38.521-1 [8] for the NR Carrier 2.
3. For Carrier 1, SS sends uplink scheduling information for each UL HARQ process via PDCCH DCI format 0 for C\_RNTI to schedule the UL RMC according to Table 6.3B.3\_1.1.4.1-1 on E-UTRA subframe *n-1*, where E-UTRA subframe *n* is an uplink slot for Carrier 2 and  $n-1 \geq 20$  when SCS=15 kHz ( $n-1 \geq 40$  when SCS=30 kHz,

$n-1 \geq 80$  when SCS=60 kHz). Since the UE has no payload and no loopback data to send the UE sends uplink MAC padding bits on the UL RMC.

4. Send continuously uplink power control "up" commands to the UE for NR and E-UTRA carrier until the UE transmits at its  $P_{UMAX}$  level; allow at least 200ms starting from the first TPC command in this step for the UE to reach  $P_{UMAX}$  level.
5. The SS sends uplink scheduling information via DCI format 0\_1 for C\_RNTI to schedule the UL RMC according to Table 6.3B.3\_1.1.4.1-1 on Carrier 2 on slot  $n$  ( $n \geq 1$ ) and slot  $m$ , with both slot  $n$  and slot  $m$  being uplink slots for Carrier 2 and  $m \geq n+20$  when SCS=15kHz ( $m \geq n+40$  when SCS=30 kHz,  $m \geq n+80$  when SCS=60 kHz). Since the UE has no payload and no loopback data to send the UE sends uplink MAC padding bits on the UL RMC. The PDCCH DCI format 0\_1 is specified with the condition 2TX\_UL\_MIMO in TS 38.508-1 [5] subclause 4.3.6.1.1.2.
6. Measure the output power of UE PUSCH transmission for Carrier 1 during the E-UTRA subframe  $n-1$ , for Carrier 1 excluding a transient period of 20  $\mu$ s in the end of the E-UTRA subframe  $n-1$ .
7. Measure the sum of output power of UE PUSCH transmission on Carrier 2 over all antenna connectors during slot  $n$  and slot  $m$  excluding a switching period  $X$  and a transient period of 10  $\mu$ s in the beginning of slot  $n$  and in the end of slot  $m$ . The length of uplink switching period  $X$  is indicated by UE capability *uplinkTxSwitchingPeriod*.
8. For Carrier 1, SS sends uplink scheduling information for each UL HARQ process via PDCCH DCI format 0 for C\_RNTI to schedule the UL RMC according to Table 6.3B.3\_1.1.4.1-1 on E-UTRA subframe  $m+1$ . Since the UE has no payload and no loopback data to send the UE sends uplink MAC padding bits on the UL RMC.
9. Measure the output power of UE PUSCH transmission for Carrier 1 during slot  $m+1$  excluding a transient period of 20  $\mu$ s in the beginning of slot  $m+1$ .

6.3B.3\_1.1.5 Test requirements

The requirements for the power of Carrier 1 measured in step 6, step 9 of the test procedure, and the power of Carrier 2 measured in step 7 shall not exceed the values specified in Table 6.3B.3\_1.1.5-1 and Table 6.3B.3\_1.1.5-2, respectively.

**Table 6.3B.3\_1.1.5-1: E-UTRA and NR switching time mask for switching between two uplink carriers for inter-band EN-DC (On power on the E-UTRA Carrier)**

Measured output power	
Transmit ON power	For each E-UTRA band tested, same as the requirements in Table 6.2.3.5-1 of TS 36.521-1 [10] as appropriate.

**Table 6.3B.3\_1.1.5-2: E-UTRA and NR switching time mask for switching between two uplink carriers for inter-band EN-DC (On power on the NR Carrier)**

Measured output power	
Transmit ON power	For each NR band tested, same as Test ID 9 in Table 6.2.2.5-1 to Table 6.2.2.5-3 of TS 38.521-1 [8] as appropriate
NOTE1: TT or each frequency and channel bandwidth of Transmit ON power is specified in Table 6.2.2.5-5 of TS 38.521-1 [8]	

6.3B.4 PRACH time mask for EN-DC

6.3B.4.1 PRACH time mask for intra-band contiguous EN-DC

6.3B.4.1.1 Test purpose

Same test purpose as in clause 6.3.3.4.1 in TS 38.521-1 [8] for the NR carrier.

## 6.3B.4.1.2 Test applicability

This test applies to all types of E-UTRA UE release 15 and forward, supporting intra-band contiguous EN-DC.

## 6.3B.4.1.3 Minimum conformance requirements

Same minimum conformance requirements as in clause 6.3.3.4.3 in TS 38.521-1 [8] for the NR carrier.

The normative reference for this requirement is TS 38.101-3 [4] clause 6.3.

No exception requirements applicable to NR or E-UTRA. LTE anchor agnostic approach is applied.

## 6.3B.4.1.4 Test description

Same test description as in clause 6.3.3.4.4 in TS 38.521-1 [8] with the following exception:

**Table 6.3B.4.1.4-1: Test Configuration Table**

Initial Conditions	
Test Frequencies as specified in TS 38.508-1 [6] clause 4.3.1 for different DC bandwidth classes.	Mid range
Test EN-DC bandwidth combination as specified in Table 5.3B.1.2-1 across bandwidth combination sets supported by the UE	Highest NRB_agg (NOTE 1)
NOTE 1: If the UE supports multiple CC Combinations in the EN-DC Configuration with the same NRB_agg , only the combination with the highest NRB_SCG is tested	

The initial test configurations for E-UTRA as specified in Table 4.6-1 except for the parameters specified in Table 6.3B.4.1.4-1.

For Initial conditions as in clause 6.3.3.4.4.1 in TS 38.521-1 [8], the following steps will be added to configure E-UTRA component:

- 2.1. The parameter settings for E-UTRA cell are set up according to TS 36.508 [11] clause 4.4.3.
- 3.1. The E-UTRA downlink signal level, uplink signal level are set according to Table 4.6-1 and propagation conditions are set according to Annex B.0 of TS 36.521-1 [10].

Step 5 of Initial conditions as in clause 6.3.3.4.4.1 in TS 38.521-1 [8] is replaced by the following three steps:

5. Ensure the UE is in state RRC\_CONNECTED with generic procedure parameters Connectivity EN-DC, DC bearer MCG and SCG, Connected without release *On* according to TS 38.508-1 [6] clause 4.5.
6. On the E-UTRA carrier, disable periodic and aperiodic CQI reports, disable SRS, set *TimeAlignmentTimerDedicated* IE to infinity and disable downlink and uplink scheduling, all as per Table 4.6-1 under clause 4.6.
7. When E-UTRA and NR bands are TDD, ensure the same uplink-downlink configuration by giving SCG a delay of 3 E-UTRA subframes, or by giving MCG a delay of 2 subframes.

For Message contents as in clause 6.3.3.4.4.3 in TS 38.521-1 [8], the following exception:

**Table 6.3B.4.1.4-2: RACH-ConfigGeneric: PRACH measurement**

Derivation Path: TS 38.508-1[5], Table 4.6.3-130			
Information Element	Value/remark	Comment	Condition
RACH-ConfigGeneric ::= SEQUENCE {			
prach-ConfigurationIndex	14	Unpaired Spectrum	PRACH Format 0
	128	Unpaired Spectrum	PRACH Format A3

## 6.3B.4.1.5 Test requirements

Same test requirement as in clause 6.3.3.4.5 in TS 38.521-1 [8].

## 6.3B.4.2 PRACH Time Mask for intra-band non-contiguous EN-DC

## 6.3B.4.2.1 Test purpose

Same test purpose as in clause 6.3.3.4.1 in TS 38.521-1 [8] for the NR carrier.

## 6.3B.4.2.2 Test applicability

This test applies to all types of E-UTRA UE release 15 and forward, supporting intra-band non-contiguous EN-DC.

## 6.3B.4.2.3 Minimum conformance requirements

Same minimum conformance requirements as in clause 6.3.3.4.3 in TS 38.521-1 [8] for the NR carrier.

The normative reference for this requirement is TS 38.101-3 [4] clause 6.3.

No exception requirements applicable to NR or E-UTRA. LTE anchor agnostic approach is applied.

## 6.3B.4.2.4 Test description

Same test description as in clause 6.3.3.4.4 in TS 38.521-1 [8] with the following exception:

**Table 6.3B.4.2.4-1: Test Configuration Table**

Initial Conditions	
Test Frequencies as specified in TS 36TS 38.508-1 [76] clause 4.3.1 for different EN-DC bandwidth classes	MaxWGap
Test EN-DC bandwidth combination as specified in Table 5.3B.1.3-1 across bandwidth combination sets supported by the UE	Highest NRB_agg (NOTE 1)
NOTE 1: If the UE supports multiple CC Combinations in the EN-DC Configuration with the same NRB_agg , only the combination with the highest NRB_SCG is tested	

The initial test configurations for E-UTRA as specified in Table 4.6-1 except for the parameters specified in Table 6.3B.4.2.4-1.

For Initial conditions as in clause 6.3.3.4.4.1 in TS 38.521-1 [8], the following steps will be added to configure E-UTRA component:

- 2.1. The parameter settings for E-UTRA cell are set up according to TS 36.508 [11] clause 4.4.3.
- 3.1. The E-UTRA downlink signal level, uplink signal level are set according to Table 4.6-1 and propagation conditions are set according to Annex B.0 of TS 36.521-1 [10].

Step 5 of Initial conditions as in clause 6.3.3.4.4.1 in TS 38.521-1 [8] is replaced by the following three steps:

5. Ensure the UE is in state RRC\_CONNECTED with generic procedure parameters Connectivity EN-DC, DC bearer MCG and SCG, Connected without release *On* according to TS 38.508-1 [6] clause 4.5.
6. On the E-UTRA carrier, disable periodic and aperiodic CQI reports, disable SRS, set TimeAlignmentTimerDedicated IE to infinity and disable downlink and uplink scheduling, all as per Table 4.6-1 under clause 4.6.
7. When E-UTRA and NR bands are TDD, ensure the same uplink-downlink configuration by giving SCG a delay of 3 E-UTRA subframes, or by giving MCG a delay of 2 subframes.

For Message contents as in clause 6.3.3.4.4.3 in TS 38.521-1 [8], the following exception:

**Table 6.3B.4.2.4-2: RACH-ConfigGeneric: PRACH measurement**

Derivation Path: TS 38.508-1[5], Table 4.6.3-130			
Information Element	Value/remark	Comment	Condition
RACH-ConfigGeneric ::= SEQUENCE {			
prach-ConfigurationIndex	14	Unpaired Spectrum	PRACH Format 0
	128	Unpaired Spectrum	PRACH Format A3

#### 6.3B.4.2.5 Test requirements

Same test requirement as in clause 6.3.3.4.5 in TS 38.521-1 [8].

#### 6.3B.4.3 PRACH Time Mask for inter-band EN-DC within FR1 (1 NR CC)

##### 6.3B.4.3.1 Test purpose

Same test purpose as in clause 6.3.3.4.1 in TS 38.521-1 [8] for the NR carrier.

##### 6.3B.4.3.2 Test applicability

This test applies to all types of E-UTRA UE release 15 and forward, supporting inter-band EN-DC within FR1 with 1 NR UL CC.

##### 6.3B.4.3.3 Minimum conformance requirements

Same minimum conformance requirements as in clause 6.3.3.4.3 in TS 38.521-1 [8] for the NR carrier.

The normative reference for this requirement is TS 38.101-3 [4] clause 6.3.

No exception requirements applicable to NR or E-UTRA. LTE anchor agnostic approach is applied.

##### 6.3B.4.3.4 Test description

Same test description as in clause 6.3.3.4.4 in TS 38.521-1 [8] for the NR carrier with the following exception:

For band n28 / 28 used in EN-DC configurations with NOTE 8 of Table 5.5B.4.1-1, test channel bandwidth of 20MHz or more is tested with Low range test frequency.

The initial test configurations for E-UTRA band consist of environmental conditions, test frequencies, and channel bandwidths based on E-UTRA bands specified in Table 4.6-1. For Initial conditions as in clause 6.3.3.4.4.1 in TS 38.521-1 [8], the following steps will be added to configure E-UTRA component:

- 2.1. The parameter settings for E-UTRA cell are set up according to TS 36.508 [11] clause 4.4.3.
- 3.1. The E-UTRA downlink signal level, uplink signal level are set according to Table 4.6-1 and propagation conditions are set according to Annex B.0 of TS 36.521-1 [10].

Step 5 of Initial conditions as in clause 6.3.3.4.4.1 in TS 38.521-1 [8] is replaced by the following two steps:

5. Ensure the UE is in state RRC\_CONNECTED with generic procedure parameters Connectivity EN-DC, DC bearer MCG and SCG, Connected without release *On* according to TS 38.508-1 [6] clause 4.5.
6. On the E-UTRA carrier, disable periodic and aperiodic CQI reports, disable SRS, set *TimeAlignmentTimerDedicated* IE to infinity and disable downlink and uplink scheduling, all as per Table 4.6-1 under clause 4.6.

Same test requirement as in clause 6.3.3.4.5 in TS 38.521-1 [8].

## 6.3B.4.4 PRACH Time Mask for inter-band EN-DC including FR2 (1 NR CC)

Editor's note: This clause is incomplete. The following aspects are either missing or not yet determined:

- The referred test case 6.3.3.4 in TS 38.521-2 [9] is incomplete

### 6.3B.4.4.1 Test purpose

Same test purpose as in clause 6.3.3.4.1 in TS 38.521-2 [9] for the NR carrier.

### 6.3B.4.4.2 Test applicability

This test case applies to all types of E-UTRA UE release 15 and forward, supporting inter-band EN-DC including FR2 .

### 6.3B.4.4.3 Minimum conformance requirements

Same minimum conformance requirements as in clause 6.3.3.4.3 in TS 38.521-2 [9] for the NR carrier.

The normative reference for this requirement is TS 38.101-3 [4] clause 6.3.

No exception requirements applicable to NR or LTE. LTE anchor agnostic approach is applied.

### 6.3B.4.4.4 Test description

Same test description as in clause 6.3.3.4.4 in TS 38.521-2 [9] for the NR carrier with the following exceptions:

The initial test configurations for E-UTRA consist of test frequency based on E-UTRA operating band and test channel bandwidth as specified in Table 4.7-1.

For Initial conditions as in clause 6.3.3.4.4.1 in TS 38.521-2 [9], the following steps will be added to configure E-UTRA component:

- 2.1. The parameter settings for the cell are set up according to TS 36.508 [11] subclause 4.4.3.
- 3.1. The E-UTRA downlink signal level, uplink signal level are set according to Table 4.7-1 and propagation conditions are set according to Annex B.0 of TS 36.521-1 [10].

Step 5 of Initial conditions as in clause 6.3.3.4.4.1 in TS 38.521-2 [9] is replaced by the following two steps:

5. Ensure the UE is in state RRC\_CONNECTED with generic procedure parameters Connectivity EN-DC, DC bearer MCG and SCG, Connected without release *On* according to TS 38.508-1 [6] clause 4.5.
6. On the E-UTRA carrier, disable periodic and aperiodic CQI reports, disable SRS, set *TimeAlignmentTimerDedicated* IE to infinity and disable downlink and uplink scheduling, all as per Table 4.7-1 under clause 4.7.

### 6.3B.4.4.5 Test requirement

Same test requirement as specified in clause 6.3.3.4.5 of TS 38.521-2 [9] for the NR carrier(s).

## 6.3B.5 Output power dynamics for EN-DC with UL sharing from UE perspective

### 6.3B.5.1 E-UTRA and NR switching time mask for TDM based UL sharing from UE perspective

No test case details are specified. Current test procedures for time masks are based on power measurement in relatively long period compared with transient period. For time masks between 2 active time slots with different power level, the test procedure can't provide enough resolution to identify non-conformant UEs. Therefore the minimum requirement is not testable.



## 6.3B.6 Output power dynamics for intra-band EN-DC without dual PA capability

No test case details are specified. Current test procedures for time masks are based on power measurement in relatively long period compared with transient period. For time masks between 2 active time slots with different power level, the test procedure can't provide enough resolution to identify non-conformant UEs. Therefore the minimum requirement is not testable.

## 6.3B.7 Output power dynamics for intra-band EN-DC with dual PA capability

No test case details are specified. Current test procedures for time masks are based on power measurement in relatively long period compared with transient period. For time masks between 2 active time slots with different power level, the test procedure can't provide enough resolution to identify non-conformant UEs. Therefore the minimum requirement is not testable.

## 6.3B.8 Power control for EN-DC

### 6.3B.8.1 Absolute power tolerance for EN-DC

#### 6.3B.8.1.1 Absolute power tolerance for intra-band contiguous EN-DC

##### 6.3B.8.1.1.1 Test purpose

Same test purpose as in clause 6.3.4.2.1 in TS 38.521-1 [8] for the NR FR1 carrier(s),

##### 6.3B.8.1.1.2 Test applicability

This test case applies to all types of E-UTRA UE release 15 and forward, supporting intra-band contiguous EN-DC.

##### 6.3B.8.1.1.3 Minimum conformance requirements

Same minimum conformance requirements as in clause 6.3.4.2.3 in TS 38.521-1 [8] for the NR carrier.

No exception requirements applicable to NR or E-UTRA. LTE anchor agnostic approach is applied.

##### 6.3B.8.1.1.4 Test description

Same test description as in clause 6.3.4.2.4 in TS 38.521-1 [8] for the NR carrier with the following exception:

Notes defined in Table 6.3.4.2.4.1-1 will be updated as below.

The initial test configurations for E-UTRA band consist of environmental conditions, test frequencies, and channel bandwidths based on E-UTRA bands specified in Table 4.6-1. For Initial conditions as in clause 6.3.4.2.4.1 in TS 38.521-1 [8], the following steps will be added to configure E-UTRA component:

- 2.1. The parameter settings for E-UTRA cell are set up according to TS 36.508 [11] clause 4.4.3.
- 3.1. The E-UTRA downlink signal level, uplink signal level are set according to Table 4.6-1 and propagation conditions are set according to Annex B, clause B.0 of TS 36.521-1 [10].

Step 6 of Initial conditions as in clause 6.3.4.2.4.1 in TS 38.521-1 [8] is replaced by the following three steps:

6. Ensure the UE is in state RRC\_CONNECTED with generic procedure parameters Connectivity EN-DC, DC bearer MCG and SCG, Connected without release *On* according to TS 38.508-1 [6] clause 4.5.
7. On the E-UTRA carrier, disable periodic and aperiodic CQI reports, disable SRS, set TimeAlignmentTimerDedicated IE to infinity and disable downlink and uplink scheduling, all as per Table 4.6-1 under clause 4.6.

8. When E-UTRA and NR bands are TDD, ensure the same uplink-downlink configuration by giving SCG a delay of 3 E-UTRA subframes, or by giving MCG a delay of 2 subframes.

#### 6.3B.8.1.1.5 Test Requirement

Same test requirement as in clause 6.3.4.2.5 in TS 38.521-1 [8] for the NR carrier.

#### 6.3B.8.1.2 Absolute power tolerance for intra-band non-contiguous EN-DC

##### 6.3B.8.1.2.1 Test purpose

Same test purpose as in clause 6.3.4.2.1 in TS 38.521-1 [8] for the NR FR1 carrier(s).

##### 6.3B.8.1.2.2 Test applicability

This test case applies to all types of E-UTRA UE release 15 and forward, supporting intra-band non-contiguous EN-DC.

##### 6.3B.8.1.2.3 Minimum conformance requirements

Same minimum conformance requirements as in clause 6.3.4.2.3 in TS 38.521-1 [8] for the NR carrier.

No exception requirements applicable to NR or E-UTRA. LTE anchor agnostic approach is applied.

##### 6.3B.8.1.2.4 Test description

Same test description as in clause 6.3.4.2.4 in TS 38.521-1 [8] for the NR carrier with the following exception:

Notes defined in Table 6.3.4.2.4.1-1 will be updated as below.

The initial test configurations for E-UTRA band consist of environmental conditions, test frequencies, and channel bandwidths based on E-UTRA bands specified in Table 4.6-1. For Initial conditions as in clause 6.3.4.2.4.1 in TS 38.521-1 [8], the following steps will be added to configure E-UTRA component:

- 2.1. The parameter settings for E-UTRA cell are set up according to TS 36.508 [11] clause 4.4.3.
- 3.1. The E-UTRA downlink signal level, uplink signal level are set according to Table 4.6-1 and propagation conditions are set according to Annex B, clause B.0 of TS 36.521-1 [10].

Step 6 of Initial conditions as in clause 6.3.4.2.4.1 in TS 38.521-1 [8] is replaced by the following three steps:

6. Ensure the UE is in state RRC\_CONNECTED with generic procedure parameters Connectivity EN-DC, DC bearer MCG and SCG, Connected without release *On* according to TS 38.508-1 [6] clause 4.5.
7. On the E-UTRA carrier, disable periodic and aperiodic CQI reports, disable SRS, set TimeAlignmentTimerDedicated IE to infinity and disable downlink and uplink scheduling, all as per Table 4.6-1 under clause 4.6.
8. When E-UTRA and NR bands are TDD, ensure the same uplink-downlink configuration by giving SCG a delay of 3 E-UTRA subframes, or by giving MCG a delay of 2 subframes.

#### 6.3B.8.1.2.5 Test Requirement

Same test requirement as in clause 6.3.4.2.5 in TS 38.521-1 [8] for the NR carrier.

#### 6.3B.8.1.3 Absolute power tolerance for inter-band EN-DC within FR1 (1 NR CC)

##### 6.3B.8.1.3.1 Test purpose

Same test purpose as in clause 6.3.4.2.1 in TS 38.521-1 [8] for the NR FR1 carrier(s).

#### 6.3B.8.1.3.2 Test applicability

This test case applies to all types of E-UTRA UE release 15 and forward, supporting inter-band EN-DC within FR1 with 1 NR UL CC.

#### 6.3B.8.1.3.3 Minimum conformance requirements

Same minimum conformance requirements as in clause 6.3.4.2.3 in TS 38.521-1 [8] for the NR carrier.

No exception requirements applicable to NR or E-UTRA. LTE anchor agnostic approach is applied.

#### 6.3B.8.1.3.4 Test description

Same test description as in clause 6.3.4.2.4 in TS 38.521-1 [8] for the NR carrier with the following exception:

Notes defined in Table 6.3.4.2.4.1-1 will be updated as below.

For band n28 / 28 used in EN-DC configurations with NOTE 8 of Table 5.5B.4.1-1, test channel bandwidth of 20MHz or more is tested with Low range test frequency.

The initial test configurations for E-UTRA band consist of environmental conditions, test frequencies, and channel bandwidths based on E-UTRA bands specified in Table 4.6-1. For Initial conditions as in clause 6.3.4.2.4.1 in TS 38.521-1 [8], the following steps will be added to configure E-UTRA component:

- 2.1. The parameter settings for E-UTRA cell are set up according to TS 36.508 [11] clause 4.4.3.
- 3.1. The E-UTRA downlink signal level, uplink signal level are set according to Table 4.6-1 and propagation conditions are set according to Annex B, clause B.0 of TS 36.521-1 [10].

Step 6 of Initial conditions as in clause 6.3.4.2.4.1 in TS 38.521-1 [8] is replaced by the following two steps:

6. Ensure the UE is in state RRC\_CONNECTED with generic procedure parameters Connectivity EN-DC, DC bearer MCG and SCG, Connected without release *On* according to TS 38.508 [6] clause 4.5.
7. On the E-UTRA carrier, disable periodic and aperiodic CQI reports, disable SRS, set TimeAlignmentTimerDedicated IE to infinity and disable downlink and uplink scheduling, all as per Table 4.6-1 under clause 4.6.

#### 6.3B.8.1.3.5 Test Requirement

Same test requirement as in clause 6.3.4.2.5 in TS 38.521-1 [8] for the NR carrier.

#### 6.3B.8.1.4 Absolute power tolerance for inter-band EN-DC including FR2 (1 NR CC)

**Editor's note: The following aspects are either missing or not yet determined:**

- The referred test case 6.3.4.2 in TS 38.521-2 [9] is incomplete for extreme conditions.
- The referred test case 6.3.4.2 in TS 38.521-2 [9] is incomplete for PC 1, 2, and 4.

#### 6.3B.8.1.4.1 Test purpose

Same test purpose as in clause 6.3.4.2.1 in TS 38.521-2 [9] for NR FR2 carrier(s).

#### 6.3B.8.1.4.2 Test applicability

This test case applies to all types of E-UTRA UE release 15 and forward, supporting inter-band EN-DC including FR2 with 1 NR UL CC.

#### 6.3B.8.1.4.3 Minimum conformance requirements

Same minimum conformance requirements as in clause 6.3.4.2.3 in TS 38.521-2 [9] for the NR carrier.

No exception requirements applicable to NR or E-UTRA. LTE anchor agnostic approach is applied.

#### 6.3B.8.1.4.4 Test description

Same test description as in clause 6.3.4.2.4 in TS 38.521-2 [9] for the NR carrier with the following exception:

Notes defined in Table 6.3.4.2.4.1-1 will be updated as below.

The initial test configurations for E-UTRA band consist of environmental conditions, test frequencies, and channel bandwidths based on E-UTRA bands specified in Table 4.7-1. For Initial conditions as in clause 6.3.4.2.4.1 in TS 38.521-2 [9], the following steps will be added to configure E-UTRA component:

- 2.1. The parameter settings for E-UTRA cell are set up according to TS 36.508 [11] clause 4.4.3.
- 3.1. The E-UTRA downlink signal level, uplink signal level are set according to Table 4.7-1 and propagation conditions are set according to Annex B, clause B.0 of TS 36.521-1 [10].

Step 6 of Initial conditions as in clause 6.3.4.2.4.1 in TS 38.521-2 [9] is replaced by the following two steps:

6. Ensure the UE is in state RRC\_CONNECTED with generic procedure parameters Connectivity EN-DC, DC bearer MCG and SCG, Connected without release *On* according to TS 38.508-1 [6] clause 4.5.
7. On the E-UTRA carrier, disable periodic and aperiodic CQI reports, disable SRS, set TimeAlignmentTimerDedicated IE to infinity and disable downlink and uplink scheduling, all as per Table 4.6-1 under clause 4.7.

#### 6.3B.8.1.4.5 Test Requirement

Same test requirement as in clause 6.3.4.2.5 in TS 38.521-2 [9] for the NR carrier.

#### 6.3B.8.1.4\_1 Absolute power tolerance for inter-band EN-DC including FR2 (>1 NR CC)

##### 6.3B.8.1.4\_1.1 Absolute power tolerance for inter-band EN-DC including FR2 (2 NR CC)

**Editor's note: The following aspects are either missing or not yet determined:**

- The referred test case 6.3A.4.2.1 in TS 38.521-2 [9] is incomplete for power classes other than PC3

##### 6.3B.8.1.4\_1.1.1 Test purpose

Same test purpose as in clause 6.3A.4.2.1.1 in TS 38.521-2 [9] for NR FR2 carrier(s).

##### 6.3B.8.1.4\_1.1.2 Test applicability

This test case applies to all types of E-UTRA UE release 16 and forward, supporting inter-band EN-DC including FR2 with 2 NR UL CC.

##### 6.3B.8.1.4\_1.1.3 Minimum conformance requirements

Same minimum conformance requirements as in clause 6.3A.4.2.1.3 in TS 38.521-2 [9] for the NR carrier.

No exception requirements applicable to NR or E-UTRA. LTE anchor agnostic approach is applied.

##### 6.3B.8.1.4\_1.1.4 Test description

Same test description as in clause 6.3A.4.2.1.4 in TS 38.521-2 [9] for the NR carrier with the following exception:

Notes defined in Table 6.3A.4.2.1.4.1-1 will be updated as below.

The initial test configurations for E-UTRA band consist of environmental conditions, test frequencies, and channel bandwidths based on E-UTRA bands specified in Table 4.7-1. For Initial conditions as in clause 6.3A.4.2.1.4.1 in TS 38.521-2 [9], the following steps will be added to configure E-UTRA component:

- 2.1. The parameter settings for E-UTRA cell are set up according to TS 36.508 [11] clause 4.4.3.

- 3.1. The E-UTRA downlink signal level, uplink signal level are set according to Table 4.7-1 and propagation conditions are set according to Annex B, clause B.0 of TS 36.521-1 [10].

Step 6 of Initial conditions as in clause 6.3A.4.2.1.4.1 in TS 38.521-2 [9] is replaced by the following two steps:

6. Ensure the UE is in state RRC\_CONNECTED with generic procedure parameters Connectivity EN-DC, DC bearer MCG and SCG, Connected without release *On* according to TS 38.508-1 [6] clause 4.5.
7. On the E-UTRA carrier, disable periodic and aperiodic CQI reports, disable SRS, set TimeAlignmentTimerDedicated IE to infinity and disable downlink and uplink scheduling, all as per Table 4.6-1 under clause 4.7.

#### 6.3B.8.1.4\_1.1.5 Test Requirement

Same test requirement as in clause 6.3A.4.2.1.5 in TS 38.521-2 [9] for the NR carrier.

#### 6.3B.8.1.4\_1.2 Absolute power tolerance for inter-band EN-DC including FR2 (3 NR CC)

**Editor's note: The following aspects are either missing or not yet determined:**

- The referred test case 6.3A.4.2.2 in TS 38.521-2 [9] is incomplete for power classes other than PC3

#### 6.3B.8.1.4\_1.2.1 Test purpose

Same test purpose as in clause 6.3A.4.2.2.1 in TS 38.521-2 [9] for NR FR2 carrier(s).

#### 6.3B.8.1.4\_1.2.2 Test applicability

This test case applies to all types of E-UTRA UE release 16 and forward, supporting inter-band EN-DC including FR2 with 3 NR UL CC.

#### 6.3B.8.1.4\_1.2.3 Minimum conformance requirements

Same minimum conformance requirements as in clause 6.3A.4.2.2.3 in TS 38.521-2 [9] for the NR carrier.

No exception requirements applicable to NR or E-UTRA. LTE anchor agnostic approach is applied.

#### 6.3B.8.1.4\_1.2.4 Test description

Same test description as in clause 6.3A.4.2.2.4 in TS 38.521-2 [9] for the NR carrier with the following exception:

Notes defined in Table 6.3A.4.2.2.4.1-1 will be updated as below.

The initial test configurations for E-UTRA band consist of environmental conditions, test frequencies, and channel bandwidths based on E-UTRA bands specified in Table 4.7-1. For Initial conditions as in clause 6.3A.4.2.2.4.1 in TS 38.521-2 [9], the following steps will be added to configure E-UTRA component:

- 2.1. The parameter settings for E-UTRA cell are set up according to TS 36.508 [11] clause 4.4.3.
- 3.1. The E-UTRA downlink signal level, uplink signal level are set according to Table 4.7-1 and propagation conditions are set according to Annex B, clause B.0 of TS 36.521-1 [10].

Step 6 of Initial conditions as in clause 6.3A.4.2.2.4.1 in TS 38.521-2 [9] is replaced by the following two steps:

6. Ensure the UE is in state RRC\_CONNECTED with generic procedure parameters Connectivity EN-DC, DC bearer MCG and SCG, Connected without release *On* according to TS 38.508-1 [6] clause 4.5.
7. On the E-UTRA carrier, disable periodic and aperiodic CQI reports, disable SRS, set TimeAlignmentTimerDedicated IE to infinity and disable downlink and uplink scheduling, all as per Table 4.6-1 under clause 4.7.

#### 6.3B.8.1.4\_1.2.5 Test Requirement

Same test requirement as in clause 6.3A.4.2.2.5 in TS 38.521-2 [9] for the NR carrier.

### 6.3B.8.1.4\_1.3 Absolute power tolerance for inter-band EN-DC including FR2 (4 NR CC)

Editor's note: The following aspects are either missing or not yet determined:

- The referred test case 6.3A.4.2.3 in TS 38.521-2 [9] is incomplete for power classes other than PC3

#### 6.3B.8.1.4\_1.3.1 Test purpose

Same test purpose as in clause 6.3A.4.2.3.1 in TS 38.521-2 [9] for NR FR2 carrier(s).

#### 6.3B.8.1.4\_1.3.2 Test applicability

This test case applies to all types of E-UTRA UE release 16 and forward, supporting inter-band EN-DC including FR2 with 3 NR UL CC.

#### 6.3B.8.1.4\_1.3.3 Minimum conformance requirements

Same minimum conformance requirements as in clause 6.3A.4.2.3.3 in TS 38.521-2 [9] for the NR carrier.

No exception requirements applicable to NR or E-UTRA. LTE anchor agnostic approach is applied.

#### 6.3B.8.1.4\_1.3.4 Test description

Same test description as in clause 6.3A.4.2.3.4 in TS 38.521-2 [9] for the NR carrier with the following exception:

Notes defined in Table 6.3A.4.2.3.4.1-1 will be updated as below.

The initial test configurations for E-UTRA band consist of environmental conditions, test frequencies, and channel bandwidths based on E-UTRA bands specified in Table 4.7-1. For Initial conditions as in clause 6.3A.4.2.3.4.1 in TS 38.521-2 [9], the following steps will be added to configure E-UTRA component:

- 2.1. The parameter settings for E-UTRA cell are set up according to TS 36.508 [11] clause 4.4.3.
- 3.1. The E-UTRA downlink signal level, uplink signal level are set according to Table 4.7-1 and propagation conditions are set according to Annex B, clause B.0 of TS 36.521-1 [10].

Step 6 of Initial conditions as in clause 6.3A.4.2.3.4.1 in TS 38.521-2 [9] is replaced by the following two steps:

6. Ensure the UE is in state RRC\_CONNECTED with generic procedure parameters Connectivity EN-DC, DC bearer MCG and SCG, Connected without release *On* according to TS 38.508-1 [6] clause 4.5.
7. On the E-UTRA carrier, disable periodic and aperiodic CQI reports, disable SRS, set TimeAlignmentTimerDedicated IE to infinity and disable downlink and uplink scheduling, all as per Table 4.6-1 under clause 4.7.

#### 6.3B.8.1.4\_1.3.5 Test Requirement

Same test requirement as in clause 6.3A.4.2.3.5 in TS 38.521-2 [9] for the NR carrier.

### 6.3B.8.2 Relative power tolerance for EN-DC

#### 6.3B.8.2.1 Relative power tolerance for intra-band contiguous EN-DC

##### 6.3B.8.2.1.1 Test purpose

Same test purpose as in clause 6.3.4.3.1 in TS 38.521-1 [8] for the NR FR1 carrier(s).

##### 6.3B.8.2.1.2 Test applicability

This test case applies to all types of E-UTRA UE release 15 and forward, supporting intra-band contiguous EN-DC.

### 6.3B.8.2.1.3 Minimum conformance requirements

Same minimum conformance requirements as in clause 6.3.4.3.3 in TS 38.521-1 [8] for the *NR* carrier.

No exception requirements applicable to NR or E-UTRA. LTE anchor agnostic approach is applied.

### 6.3B.8.2.1.4 Test description

Same test description as in clause 6.3.4.3.4 in TS 38.521-1 [8] for the NR carrier with the following exception:

Notes defined in Table 6.3.4.3.4.1-1 will be updated as below.

The initial test configurations for E-UTRA band consist of environmental conditions, test frequencies, and channel bandwidths based on E-UTRA bands specified in Table 4.6-1. For Initial conditions as in clause 6.3.4.3.4.1 in TS 38.521-1 [8], the following steps will be added to configure E-UTRA component:

- 2.1. The parameter settings for E-UTRA cell are set up according to TS 36.508 [11] clause 4.4.3.
- 3.1. The E-UTRA downlink signal level, uplink signal level are set according to Table 4.6-1 and propagation conditions are set according to Annex B, clause B.0 of TS 36.521-1 [10].

Step 6 of Initial conditions as in clause 6.3.4.3.4.1 in TS 38.521-1 [8] is replaced by the following three steps:

6. Ensure the UE is in state RRC\_CONNECTED with generic procedure parameters Connectivity EN-DC, DC bearer MCG and SCG, Connected without release *On* according to TS 38.508-1 [6] clause 4.5.
7. On the E-UTRA carrier, disable periodic and aperiodic CQI reports, disable SRS, set TimeAlignmentTimerDedicated IE to infinity and disable downlink and uplink scheduling, all as per Table 4.6-1 under clause 4.6.
8. When E-UTRA and NR bands are TDD, ensure the same uplink-downlink configuration by giving SCG a delay of 3 E-UTRA subframes, or by giving MCG a delay of 2 subframes.

### 6.3B.8.2.1.5 Test Requirement

Same test requirement as in clause 6.3.4.3.5 in TS 38.521-1 [8] for the NR carrier.

## 6.3B.8.2.2 Relative power tolerance for intra-band non-contiguous EN-DC

### 6.3B.8.2.2.1 Test purpose

Same test purpose as in clause 6.3.4.3.1 in TS 38.521-1 [8] for the NR FR1 carrier(s).

### 6.3B.8.2.2.2 Test applicability

This test case applies to all types of E-UTRA UE release 15 and forward, supporting intra-band non-contiguous EN-DC.

### 6.3B.8.2.2.3 Minimum conformance requirements

Same minimum conformance requirements as in clause 6.3.4.3.3 in TS 38.521-1 [8] for the *NR* carrier.

No exception requirements applicable to NR or E-UTRA. LTE anchor agnostic approach is applied.

### 6.3B.8.2.2.4 Test description

Same test description as in clause 6.3.4.3.4 in TS 38.521-1 [8] for the NR carrier with the following exception:

Notes defined in Table 6.3.4.3.4.1-1 will be updated as below.

The initial test configurations for E-UTRA band consist of environmental conditions, test frequencies, and channel bandwidths based on E-UTRA bands specified in Table 4.6-1. For Initial conditions as in clause 6.3.4.3.4.1 in TS 38.521-1 [8], the following steps will be added to configure E-UTRA component:

- 2.1. The parameter settings for E-UTRA cell are set up according to TS 36.508 [11] clause 4.4.3.
- 3.1. The E-UTRA downlink signal level, uplink signal level are set according to Table 4.6-1 and propagation conditions are set according to Annex B, clause B.0 of TS 36.521-1 [10].

Step 6 of Initial conditions as in clause 6.3.4.3.4.1 in TS 38.521-1 [8] is replaced by the following three steps:

- 6. Ensure the UE is in state RRC\_CONNECTED with generic procedure parameters Connectivity EN-DC, DC bearer MCG and SCG, Connected without release *On* according to TS 38.508-1 [6] clause 4.5.
- 7. On the E-UTRA carrier, disable periodic and aperiodic CQI reports, disable SRS, set *TimeAlignmentTimerDedicated* IE to infinity and disable downlink and uplink scheduling, all as per Table 4.6-1 under clause 4.6.
- 8. When E-UTRA and NR bands are TDD, ensure the same uplink-downlink configuration by giving SCG a delay of 3 E-UTRA subframes, or by giving MCG a delay of 2 subframes.

#### 6.3B.8.2.2.5 Test Requirement

Same test requirement as in clause 6.3.4.3.5 in TS 38.521-1 [8] for the NR carrier.

#### 6.3B.8.2.3 Relative power tolerance for inter-band EN-DC within FR1 (1 NR CC)

##### 6.3B.8.2.3.1 Test purpose

Same test purpose as in clause 6.3.4.3.1 in TS 38.521-1 [8] for the NR FR1 carrier(s).

##### 6.3B.8.2.3.2 Test applicability

This test case applies to all types of E-UTRA UE release 15 and forward, supporting inter-band EN-DC within FR1 with 1 NR UL CC.

##### 6.3B.8.2.3.3 Minimum conformance requirements

Same minimum conformance requirements as in clause 6.3.4.3.3 in TS 38.521-1 [8] for the NR carrier.

No exception requirements applicable to NR or E-UTRA. LTE anchor agnostic approach is applied.

##### 6.3B.8.2.3.4 Test description

Same test description as in clause 6.3.4.3.4 in TS 38.521-1 [8] for the NR carrier with the following exception:

Notes defined in Table 6.3.4.3.4.1-1 will be updated as below.

The initial test configurations for E-UTRA band consist of environmental conditions, test frequencies, and channel bandwidths based on E-UTRA bands specified in Table 4.6-1. For Initial conditions as in clause 6.3.4.3.4.1 in TS 38.521-1 [8], the following steps will be added to configure E-UTRA component:

- 2.1. The parameter settings for E-UTRA cell are set up according to TS 36.508 [11] clause 4.4.3.
- 3.1. The E-UTRA downlink signal level, uplink signal level are set according to Table 4.6-1 and propagation conditions are set according to Annex B, clause B.0 of TS 36.521-1 [10].

Step 6 of Initial conditions as in clause 6.3.4.3.4.1 in TS 38.521-1 [8] is replaced by the following two steps:

- 6. Ensure the UE is in state RRC\_CONNECTED with generic procedure parameters Connectivity EN-DC, DC bearer MCG and SCG, Connected without release *On* according to TS 38.508-1 [6] clause 4.5.
- 7. On the E-UTRA carrier, disable periodic and aperiodic CQI reports, disable SRS, set *TimeAlignmentTimerDedicated* IE to infinity and disable downlink and uplink scheduling, all as per Table 4.6-1 under clause 4.6.



#### 6.3B.8.2.3.5 Test Requirement

Same test requirement as in clause 6.3.4.3.5 in TS 38.521-1 [8] for the NR carrier.

#### 6.3B.8.2.4 Relative power tolerance for inter-band EN-DC including FR2 (1 NR CC)

**Editor's note: This clause is incomplete. The following aspects are either missing or not yet determined:**

- **The referred test case 6.3.4.3 in TS 38.521-2 [9] is incomplete**

##### 6.3B.8.2.4.1 Test purpose

Same test purpose as in clause 6.3.4.3.1 in TS 38.521-2 [9] for NR FR2 carrier(s).

##### 6.3B.8.2.4.2 Test applicability

This test case applies to all types of E-UTRA UE release 15 and forward, supporting inter-band EN-DC including FR2 with 1 NR UL CC.

##### 6.3B.8.2.4.3 Minimum conformance requirements

Same minimum conformance requirements as in clause 6.3.4.3.3 in TS 38.521-2 [9] for the NR carrier.

No exception requirements applicable to NR or E-UTRA. LTE anchor agnostic approach is applied.

##### 6.3B.8.2.4.4 Test description

Same test description as in clause 6.3.4.3.4 in TS 38.521-2 [9] for the NR carrier with the following exception:

Notes defined in Table 6.3.4.3.4.1-1 will be updated as below.

The initial test configurations for E-UTRA band consist of environmental conditions, test frequencies, and channel bandwidths based on E-UTRA bands specified in Table 4.7-1. For Initial conditions as in clause 6.3.4.3.4.1 in TS 38.521-2 [9], the following steps will be added to configure E-UTRA component:

- 2.1. The parameter settings for E-UTRA cell are set up according to TS 36.508 [11] clause 4.4.3.
- 3.1. The E-UTRA downlink signal level, uplink signal level are set according to Table 4.7-1 and propagation conditions are set according to Annex B, clause B.0 of TS 36.521-1 [10].

Step 6 of Initial conditions as in clause 6.3.4.3.4.1 in TS 38.521-2 [9] is replaced by the following two steps:

6. Ensure the UE is in state RRC\_CONNECTED with generic procedure parameters Connectivity EN-DC, DC bearer MCG and SCG, Connected without release *On* according to TS 38.508-1 [6] clause 4.5.
7. On the E-UTRA carrier, disable periodic and aperiodic CQI reports, disable SRS, set TimeAlignmentTimerDedicated IE to infinity and disable downlink and uplink scheduling, all as per Table 4.6-1 under clause 4.7.

##### 6.3B.8.2.4.5 Test Requirement

Same test requirement as in clause 6.3.4.3.5 in TS 38.521-2 [9] for the NR carrier.

#### 6.3B.8.3 Aggregate power tolerance for EN-DC

##### 6.3B.8.3.1 Aggregate power tolerance for intra-band contiguous EN-DC

###### 6.3B.8.3.1.1 Test purpose

Same test purpose as in clause 6.3.4.4.1 in TS 38.521-1 [8] for the NR FR1 carrier(s).

#### 6.3B.8.3.1.2 Test applicability

This test case applies to all types of E-UTRA UE release 15 and forward, supporting intra-band contiguous EN-DC.

#### 6.3B.8.3.1.3 Minimum conformance requirements

Same minimum conformance requirements as in clause 6.3.4.4.3 in TS 38.521-1 [8] for the *NR* carrier.

No exception requirements applicable to NR or E-UTRA. LTE anchor agnostic approach is applied.

#### 6.3B.8.3.1.4 Test description

Same test description as in clause 6.3.4.4.4 in TS 38.521-1 [8] for the NR carrier with the following exception:

Notes defined in Table 6.3.4.4.4.1-1 will be updated as below.

The initial test configurations for E-UTRA band consist of environmental conditions, test frequencies, and channel bandwidths based on E-UTRA bands specified in Table 4.6-1. For Initial conditions as in clause 6.3.4.4.4.1 in TS 38.521-1 [8], the following steps will be added to configure E-UTRA component:

- 2.1. The parameter settings for E-UTRA cell are set up according to TS 36.508 [11] clause 4.4.3.
- 3.1. The E-UTRA downlink signal level, uplink signal level are set according to Table 4.6-1 and propagation conditions are set according to Annex B, clause B.0 of TS 36.521-1 [10].

Step 6 of Initial conditions as in clause 6.3.4.3.4.1 in TS 38.521-1 [8] is replaced by the following three steps:

6. Ensure the UE is in state `RRC_CONNECTED` with generic procedure parameters Connectivity EN-DC, DC bearer MCG and SCG, Connected without release *On* according to TS 38.508-1 [6] clause 4.5.
7. On the E-UTRA carrier, disable periodic and aperiodic CQI reports, disable SRS, set `TimeAlignmentTimerDedicated` IE to infinity and disable downlink and uplink scheduling, all as per Table 4.6-1 under clause 4.6.
8. When E-UTRA and NR bands are TDD, ensure the same uplink-downlink configuration by giving SCG a delay of 3 E-UTRA subframes, or by giving MCG a delay of 2 subframes.

#### 6.3B.8.3.1.5 Test Requirement

Same test requirement as in clause 6.3.4.4.5 in TS 38.521-1 [8] for the NR carrier.

### 6.3B.8.3.2 Aggregate power tolerance for intra-band non-contiguous EN-DC

#### 6.3B.8.3.2.1 Test purpose

Same test purpose as in clause 6.3.4.4.1 in TS 38.521-1 [8] for the NR FR1 carrier(s).

#### 6.3B.8.3.2.2 Test applicability

This test case applies to all types of E-UTRA UE release 15 and forward, supporting intra-band non-contiguous EN-DC.

#### 6.3B.8.3.2.3 Minimum conformance requirements

Same minimum conformance requirements as in clause 6.3.4.4.3 in TS 38.521-1 [8] for the *NR* carrier.

No exception requirements applicable to NR or E-UTRA. LTE anchor agnostic approach is applied.

#### 6.3B.8.3.2.4 Test description

Same test description as in clause 6.3.4.4.4 in TS 38.521-1 [8] for the NR carrier with the following exception:

Notes defined in Table 6.3.4.4.4.1-1 will be updated as below.

The initial test configurations for E-UTRA band consist of environmental conditions, test frequencies, and channel bandwidths based on E-UTRA bands specified in Table 4.6-1. For Initial conditions as in clause 6.3.4.4.4.1 in TS 38.521-1 [8], the following steps will be added to configure E-UTRA component:

- 2.1. The parameter settings for E-UTRA cell are set up according to TS 36.508 [11] clause 4.4.3.
- 3.1. The E-UTRA downlink signal level, uplink signal level are set according to Table 4.6-1 and propagation conditions are set according to Annex B, clause B.0 of TS 36.521-1 [10].

Step 6 of Initial conditions as in clause 6.3.4.4.4.1 in TS 38.521-1 [8] is replaced by the following three steps:

6. Ensure the UE is in state RRC\_CONNECTED with generic procedure parameters Connectivity EN-DC, DC bearer MCG and SCG, Connected without release *On* according to TS 38.508-1 [6] clause 4.5.
7. On the E-UTRA carrier, disable periodic and aperiodic CQI reports, disable SRS, set *TimeAlignmentTimerDedicated* IE to infinity and disable downlink and uplink scheduling, all as per Table 4.6-1 under clause 4.6.
8. When E-UTRA and NR bands are TDD, ensure the same uplink-downlink configuration by giving SCG a delay of 3 E-UTRA subframes, or by giving MCG a delay of 2 subframes.

#### 6.3B.8.3.2.5 Test Requirement

Same test requirement as in clause 6.3.4.4.5 in TS 38.521-1 [8] for the NR carrier.

#### 6.3B.8.3.3 Aggregate power tolerance for inter-band EN-DC within FR1 (1 NR CC)

##### 6.3B.8.3.3.1 Test purpose

Same test purpose as in clause 6.3.4.4.1 in TS 38.521-1 [8] for the NR FR1 carrier(s).

##### 6.3B.8.3.3.2 Test applicability

This test case applies to all types of E-UTRA UE release 15 and forward, supporting inter-band EN-DC within FR1 with 1 NR UL CC.

##### 6.3B.8.3.3.3 Minimum conformance requirements

Same minimum conformance requirements as in clause 6.3.4.4.3 in TS 38.521-1 [8] for the NR carrier.

No exception requirements applicable to NR or E-UTRA. LTE anchor agnostic approach is applied.

##### 6.3B.8.3.3.4 Test description

Same test description as in clause 6.3.4.4.4 in TS 38.521-1 [8] for the NR carrier with the following exception:

Notes defined in Table 6.3.4.4.4.1-1 will be updated as below.

For band n28 / 28 used in EN-DC configurations with NOTE 8 of Table 5.5B.4.1-1, test channel bandwidth of 20MHz or more is tested with Low range test frequency.

The initial test configurations for E-UTRA band consist of environmental conditions, test frequencies, and channel bandwidths based on E-UTRA bands specified in Table 4.6-1. For Initial conditions as in clause 6.3.4.4.4.1 in TS 38.521-1 [8], the following steps will be added to configure E-UTRA component:

- 2.1. The parameter settings for E-UTRA cell are set up according to TS 36.508 [11] clause 4.4.3.
- 3.1. The E-UTRA downlink signal level, uplink signal level are set according to Table 4.6-1 and propagation conditions are set according to Annex B, clause B.0 of TS 36.521-1 [10].

Step 6 of Initial conditions as in clause 6.3.4.4.4.1 in TS 38.521-1 [8] is replaced by the following two steps:

6. Ensure the UE is in state RRC\_CONNECTED with generic procedure parameters Connectivity EN-DC, DC bearer MCG and SCG, Connected without release *On* according to TS 38.508-1 [6] clause 4.5.

7. On the E-UTRA carrier, disable periodic and aperiodic CQI reports, disable SRS, set *TimeAlignmentTimerDedicated* IE to infinity and disable downlink and uplink scheduling, all as per Table 4.6-1 under clause 4.6.

#### 6.3B.8.3.3.5 Test Requirement

Same test requirement as in clause 6.3.4.4.5 in TS 38.521-1 [8] for the NR carrier.

#### 6.3B.8.3.4 Aggregate power tolerance for inter-band EN-DC including FR2 (1 NR CC)

**Editor's note: The following aspects are either missing or not yet determined:**

- The referred test case 6.3.4.4 in TS 38.521-2 [9] is incomplete for PC 1, 2, and 4.

#### 6.3B.8.3.4.1 Test purpose

Same test purpose as in clause 6.3.4.4.1 in TS 38.521-2 [9] for NR FR2 carrier(s).

#### 6.3B.8.3.4.2 Test applicability

This test case applies to all types of E-UTRA UE release 15 and forward, supporting inter-band EN-DC including FR2 with 1 NR UL CC.

#### 6.3B.8.3.4.3 Minimum conformance requirements

Same minimum conformance requirements as in clause 6.3.4.4.3 in TS 38.521-2 [9] for the NR carrier.

No exception requirements applicable to NR or E-UTRA. LTE anchor agnostic approach is applied.

#### 6.3B.8.3.4.4 Test description

Same test description as in clause 6.3.4.4.4 in TS 38.521-2 [9] for the NR carrier with the following exception:

Notes defined in Table 6.3.4.4.4.1-1 will be updated as below.

The initial test configurations for E-UTRA band consist of environmental conditions, test frequencies, and channel bandwidths based on E-UTRA bands specified in Table 4.7-1. For Initial conditions as in clause 6.3.4.4.4.1 in TS 38.521-2 [9], the following steps will be added to configure E-UTRA component:

- 2.1. The parameter settings for E-UTRA cell are set up according to TS 36.508 [11] clause 4.4.3.
- 3.1. The E-UTRA downlink signal level, uplink signal level are set according to Table 4.7-1 and propagation conditions are set according to Annex B, clause B.0 of TS 36.521-1 [10].

Step 6 of Initial conditions as in clause 6.3.4.4.4.1 in TS 38.521-2 [9] is replaced by the following steps:

6. Ensure the UE is in state RRC\_CONNECTED with generic procedure parameters Connectivity EN-DC, DC bearer MCG and SCG, Connected without release *On* according to TS 38.508-1 [6] clause 4.5.
7. On the E-UTRA carrier, disable periodic and aperiodic CQI reports, disable SRS, set *TimeAlignmentTimerDedicated* IE to infinity and disable downlink and uplink scheduling, all as per Table 4.7-1 under clause 4.7.

#### 6.3B.8.3.4.5 Test Requirement

Same test requirement as in clause 6.3.4.4.5 in TS 38.521-2 [9] for the NR carrier.

#### 6.3B.8.3.4\_1 Aggregate power tolerance for inter-band EN-DC including FR2 (>1 NR CC)

#### 6.3B.8.3.4\_1.1 Aggregate power tolerance for inter-band EN-DC including FR2 (2 NR CC)

**Editor's note: The following aspects are either missing or not yet determined:**

- The referred test case 6.3A.4.4.1 in TS 38.521-2 [9] is incomplete for power classes other than PC3

#### 6.3B.8.3.4\_1.1.1 Test purpose

Same test purpose as in clause 6.3A.4.4.1.1 in TS 38.521-2 [9] for NR FR2 carrier(s).

#### 6.3B.8.3.4\_1.1.2 Test applicability

This test case applies to all types of E-UTRA UE release 15 and forward, supporting inter-band EN-DC including FR2 with 2 NR UL CC.

#### 6.3B.8.3.4\_1.1.3 Minimum conformance requirements

Same minimum conformance requirements as in clause 6.3A.4.4.1.3 in TS 38.521-2 [9] for the NR carrier.

No exception requirements applicable to NR or E-UTRA. LTE anchor agnostic approach is applied.

#### 6.3B.8.3.4\_1.1.4 Test description

Same test description as in clause 6.3A.4.4.1.4 in TS 38.521-2 [9] for the NR carrier with the following exception:

Notes defined in Table 6.3A.4.4.1.4.1-1 will be updated as below.

The initial test configurations for E-UTRA band consist of environmental conditions, test frequencies, and channel bandwidths based on E-UTRA bands specified in Table 4.7-1. For Initial conditions as in clause 6.3A.4.4.1.4.1 in TS 38.521-2 [9], the following steps will be added to configure E-UTRA component:

- 2.1. The parameter settings for E-UTRA cell are set up according to TS 36.508 [11] clause 4.4.3.
- 3.1. The E-UTRA downlink signal level, uplink signal level are set according to Table 4.7-1 and propagation conditions are set according to Annex B, clause B.0 of TS 36.521-1 [10].

Step 6 of Initial conditions as in clause 6.3A.4.4.1.4.1 in TS 38.521-2 [9] is replaced by the following steps:

6. Ensure the UE is in state RRC\_CONNECTED with generic procedure parameters Connectivity EN-DC, DC bearer MCG and SCG, Connected without release *On* according to TS 38.508-1 [6] clause 4.5.
7. On the E-UTRA carrier, disable periodic and aperiodic CQI reports, disable SRS, set *TimeAlignmentTimerDedicated* IE to infinity and disable downlink and uplink scheduling, all as per Table 4.7-1 under clause 4.7.

#### 6.3B.8.3.4\_1.1.5 Test Requirement

Same test requirement as in clause 6.3A.4.4.1.5 in TS 38.521-2 [9] for the NR carrier.

#### 6.3B.8.3.4\_1.2 Aggregate power tolerance for inter-band EN-DC including FR2 (3 NR CC)

**Editor's note: The following aspects are either missing or not yet determined:**

- The referred test case 6.3A.4.4.2 in TS 38.521-2 [9] is incomplete for power classes other than PC3

#### 6.3B.8.3.4\_1.2.1 Test purpose

Same test purpose as in clause 6.3A.4.4.2.1 in TS 38.521-2 [9] for NR FR2 carrier(s).

#### 6.3B.8.3.4\_1.2.2 Test applicability

This test case applies to all types of E-UTRA UE release 15 and forward, supporting inter-band EN-DC including FR2 with 3 NR UL CC.

#### 6.3B.8.3.4\_1.2.3 Minimum conformance requirements

Same minimum conformance requirements as in clause 6.3A.4.4.2.3 in TS 38.521-2 [9] for the NR carrier.

No exception requirements applicable to NR or E-UTRA. LTE anchor agnostic approach is applied.

#### 6.3B.8.3.4\_1.2.4 Test description

Same test description as in clause 6.3A.4.4.2.4 in TS 38.521-2 [9] for the NR carrier with the following exception:

Notes defined in Table 6.3A.4.4.2.4.1-1 will be updated as below.

The initial test configurations for E-UTRA band consist of environmental conditions, test frequencies, and channel bandwidths based on E-UTRA bands specified in Table 4.7-1. For Initial conditions as in clause 6.3A.4.4.2.4.1 in TS 38.521-2 [9], the following steps will be added to configure E-UTRA component:

- 2.1. The parameter settings for E-UTRA cell are set up according to TS 36.508 [11] clause 4.4.3.
- 3.1. The E-UTRA downlink signal level, uplink signal level are set according to Table 4.7-1 and propagation conditions are set according to Annex B, clause B.0 of TS 36.521-1 [10].

Step 6 of Initial conditions as in clause 6.3A.4.4.2.4.1 in TS 38.521-2 [9] is replaced by the following steps:

6. Ensure the UE is in state RRC\_CONNECTED with generic procedure parameters Connectivity EN-DC, DC bearer MCG and SCG, Connected without release *On* according to TS 38.508-1 [6] clause 4.5.
7. On the E-UTRA carrier, disable periodic and aperiodic CQI reports, disable SRS, set *TimeAlignmentTimerDedicated* IE to infinity and disable downlink and uplink scheduling, all as per Table 4.7-1 under clause 4.7.

#### 6.3B.8.3.4\_1.2.5 Test Requirement

Same test requirement as in clause 6.3A.4.4.2.5 in TS 38.521-2 [9] for the NR carrier.

#### 6.3B.8.3.4\_1.3 Aggregate power tolerance for inter-band EN-DC including FR2 (4 NR CC)

**Editor's note: The following aspects are either missing or not yet determined:**

- **The referred test case 6.3A.4.4.3 in TS 38.521-2 [9] is incomplete for power classes other than PC3**

#### 6.3B.8.3.4\_1.3.1 Test purpose

Same test purpose as in clause 6.3A.4.4.3.1 in TS 38.521-2 [9] for NR FR2 carrier(s).

#### 6.3B.8.3.4\_1.3.2 Test applicability

This test case applies to all types of E-UTRA UE release 15 and forward, supporting inter-band EN-DC including FR2 with 4 NR UL CC.

#### 6.3B.8.3.4\_1.3.3 Minimum conformance requirements

Same minimum conformance requirements as in clause 6.3A.4.4.3.3 in TS 38.521-2 [9] for the NR carrier.

No exception requirements applicable to NR or E-UTRA. LTE anchor agnostic approach is applied.

#### 6.3B.8.3.4\_1.3.4 Test description

Same test description as in clause 6.3A.4.4.3.4 in TS 38.521-2 [9] for the NR carrier with the following exception:

Notes defined in Table 6.3A.4.4.3.4.1-1 will be updated as below.

The initial test configurations for E-UTRA band consist of environmental conditions, test frequencies, and channel bandwidths based on E-UTRA bands specified in Table 4.7-1. For Initial conditions as in clause 6.3A.4.4.3.4.1 in TS 38.521-2 [9], the following steps will be added to configure E-UTRA component:

- 2.1. The parameter settings for E-UTRA cell are set up according to TS 36.508 [11] clause 4.4.3.

- 3.1. The E-UTRA downlink signal level, uplink signal level are set according to Table 4.7-1 and propagation conditions are set according to Annex B, clause B.0 of TS 36.521-1 [10].

Step 6 of Initial conditions as in clause 6.3A.4.4.3.4.1 in TS 38.521-2 [9] is replaced by the following steps:

6. Ensure the UE is in state RRC\_CONNECTED with generic procedure parameters Connectivity EN-DC, DC bearer MCG and SCG, Connected without release *On* according to TS 38.508-1 [6] clause 4.5.
7. On the E-UTRA carrier, disable periodic and aperiodic CQI reports, disable SRS, set *TimeAlignmentTimerDedicated* IE to infinity and disable downlink and uplink scheduling, all as per Table 4.7-1 under clause 4.7.

#### 6.3B.8.3.4\_1.3.5 Test Requirement

Same test requirement as in clause 6.3A.4.4.3.5 in TS 38.521-2 [9] for the NR carrier.

## 6.3E Output power dynamics for V2X

### 6.3E.0 Minimum conformance requirements

#### 6.3E.0.1 General

The E-UTRA SL and NR SL switching time mask defines the observation period between E-UTRA subframe and NR slot/mini-slot boundary. Both E-UTRA subframe and NR slot/mini-slot have ON power transmissions. The ON power is defined as the mean power over the symbol duration excluding any transient period. For E-UTRA subframe or NR slot/mini-slot having OFF power transmission, the general time mask for E-UTRA or NR shall apply.

#### 6.3E.0.2 Output power dynamics for intra-band V2X operation

For intra-band V2X operation bands specified in subclause 5.3E.1 and 5.3E.2, the SL switching time masks in Figure 6.3E.2-1 shall apply.

The switching time shall be located on the RAT of lower priority when NR SL and LTE SL have different priorities based on priority information specified in TS 38.213. It is up to UE implementation when NR SL and LTE SL have the same priority based on priority information specified in TS 38.213.

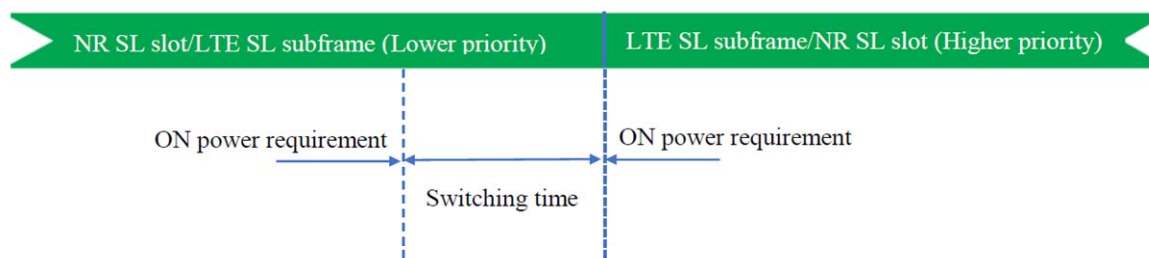

**Figure 6.3E.0.2-1: Time mask for switching between NR SL and E-UTRA SL**

#### 6.3E.0.3 Output power dynamics for inter-band V2X con-current operation

For inter-band con-current NR V2X operation, the output power dynamics requirement shall be applied per each component carrier. The output dynamic requirements specified in clause 6.3 of TS 36.101 [5] apply for E-UTRA UL transmission and the requirements specified in clause 6.3E of TS 38.101-1 [2] apply for NR SL transmission. The output dynamic requirements specified in clause 6.3.2G, 6.3.3G, 6.3.4G of TS 36.101 [5] apply for E-UTRA SL transmission and the requirements specified in clause 6.3 of TS 38.101-1 [2] apply for NR UL transmission.

The normative reference for this requirement is TS 38.101-3 [4] clause 6.3E.

## 6.3E.1 Output power dynamics for intra-band V2X operation

SL switching time mask requirements are specified for intra-band V2X operation, giving criteria on how the switching period position is decided based on priority information. No test is needed for this time mask requirement.

## 6.3E.2 Output power dynamics for inter-band V2X operation

For inter-band V2X operation, no exception requirements are specified for the E-UTRA/NR Uu carrier and E-UTRA/NR SL carrier.

For inter-band V2X configuration with E-UTRA Uu and NR sidelink, the requirements in this test case can be well covered in clause 6.3.2, 6.3.3, 6.3.4 and 6.3.5 of TS 36.521-1 [10] for E-UTRA Uu carrier and clause 6.3E.1.1, [6.3E.2.2, 6.3E.3.2.1, 6.3E.3.3.1 and 6.3E.3.4.1] of TS 38.521-1 [8] and don't need to be tested again.

For inter-band V2X configuration with NU Uu and E-UTRA V2X sidelink, the requirements in this test case can be well covered in clause 6.3.1, 6.3.2, 6.3.3 and 6.3.4 of TS 38.521-1 [8] for NR Uu carrier and clause 6.3.2G.1, 6.3.3G.1, 6.3.4G.1 and 6.3.4G.4 of TS 36.521-1 [10] and don't need to be tested again.

## 6.3H Output power dynamics for DC with UL MIMO

### 6.3H.0 General

### 6.3H.1

### 6.3H.2

### 6.3H.3 Output power dynamics for inter-band EN-DC with UL MIMO

#### 6.3H.3.1 Minimum output power for inter-band EN-DC with UL MIMO within FR1

##### 6.3H.3.1.1 Test purpose

Same test purpose as in clause 6.3D.1.1 in TS 38.521-1 [8] for the NR carrier.

##### 6.3H.3.1.2 Test applicability

This test applies to all types of E-UTRA UE release 17 and forward, supporting inter-band EN-DC with UL MIMO.

##### 6.3H.3.1.3 Minimum conformance requirements

Same minimum conformance requirements as in clause 6.3D.1.3 in TS 38.521-1 [8] for the NR carrier.

The normative reference for this requirement is TS 38.101-3 [4] clause 6.3H.3.

##### 6.3H.3.1.4 Test description

If Standalone FR1 can be tested, this test is covered by 6.3D.1 Minimum output power for UL MIMO in TS 38.521-1 [8].

If Standalone FR1 cannot be tested (due to test case not being complete or if the UE does not support the band in SA mode), LTE anchor agnostic below is applied.

Same test descriptions as in clause 6.3D.1.4 in TS 38.521-1 [8] for the NR carrier with the following exceptions:

The initial test configurations for E-UTRA band consist of environmental conditions, test frequencies, and channel bandwidths based on E-UTRA bands specified in Table 4.6-1. For Initial conditions as in clause 6.3D.1.4.1 in TS 38.521-1 [8], the following steps will be added to configure E-UTRA component:



- 2.1. The parameter settings for E-UTRA cell are set up according to TS 36.508 [11] clause 4.4.3.
- 3.1. The E-UTRA downlink signal level, uplink signal level are set according to Table 4.6-1 and propagation conditions are set according to Annex B.0 of TS 36.521-1 [10].

Step 6 of Initial conditions as in clause 6.3D.1.4.1 in TS 38.521-1 [8] is replaced by the following two steps:

6. Ensure the UE is in state RRC\_CONNECTED with generic procedure parameters Connectivity EN-DC, DC bearer *MCG* and *SCG*, Connected without release *On* according to TS 38.508-1 [6] clause 4.5.
7. On the E-UTRA carrier, disable periodic and aperiodic CQI reports, disable SRS, set TimeAlignmentTimerDedicated IE to infinity and disable downlink and uplink scheduling, all as per Table 4.6-1 under clause 4.6.

#### 6.3H.3.1.5 Test requirements

Same test requirement as in clause 6.3D.1.5 in TS 38.521-1 [8] for the NR carrier.

### 6.3H.3.2 Transmit OFF Power for inter-band EN-DC with UL MIMO within FR1

#### 6.3H.3.2.1 Test purpose

Same test purpose as in clause 6.3D.2.1 in TS 38.521-1 [8] for the NR carrier.

#### 6.3H.3.2.2 Test applicability

This test applies to all types of E-UTRA UE release 17 and forward, supporting inter-band EN-DC with UL MIMO.

#### 6.3H.3.2.3 Minimum conformance requirements

Same minimum conformance requirements as in clause 6.3D.2.3 in TS 38.521-1 [8] for the NR carrier.

The normative reference for this requirement is TS 38.101-3 [4] clause 6.3H.3.

#### 6.3H.3.2.4 Test description

This test is covered by clause 6.3H.3.3 Transmit ON/OFF time mask for inter-band EN-DC with UL MIMO.

#### 6.3H.3.2.5 Test requirements

Same test requirement as in clause 6.3D.2.5 in TS 38.521-1 [8] for the NR carrier.

### 6.3H.3.3 Transmit ON/OFF time mask for inter-band EN-DC with UL MIMO within FR1

#### 6.3H.3.3.1 Test purpose

Same test purpose as in clause 6.3D.3.1 in TS 38.521-1 [8] for the NR carrier.

#### 6.3H.3.3.2 Test applicability

This test applies to all types of E-UTRA UE release 17 and forward, supporting inter-band EN-DC with UL MIMO.

#### 6.3H.3.3.3 Minimum conformance requirements

Same minimum conformance requirements as in clause 6.3D.3.3 in TS 38.521-1 [8] for the NR carrier.

The normative reference for this requirement is TS 38.101-3 [4] clause 6.3H.3.

#### 6.3H.3.3.4 Test description

If Standalone FR1 can be tested, this test is covered by 6.3D.3 Transmit ON/OFF time mask for UL MIMO in TS 38.521-1 [8].

If Standalone FR1 cannot be tested (due to test case not being complete or if the UE does not support the band in SA mode), LTE anchor agnostic below is applied.

Same test descriptions as in clause 6.3D.3.4 in TS 38.521-1 [8] for the NR carrier with the following exceptions:

The initial test configurations for E-UTRA band consist of environmental conditions, test frequencies, and channel bandwidths based on E-UTRA bands specified in Table 4.6-1.

For Initial conditions as in clause 6.3D.3.4.1 in TS 38.521-1 [8], the following steps will be added to configure E-UTRA component:

- 2.1. The parameter settings for the E-UTRA cell are set up according to TS 36.508 [11] clause 4.4.3.
- 3.1. The E-UTRA Downlink signal level, uplink signal level are set according to Table 4.6-1 and propagation conditions are set according to Annex B.0 of TS 36.521-1 [10].

Step 6 of Initial conditions as in clause 6.3D.3.4.1 in TS 38.521-1 [8] is replaced by:

6. Ensure the UE is in state RRC\_CONNECTED with generic procedure parameters Connectivity EN-DC, DC bearer *MCG* and *SCG*, *Connected without release On* according to TS 38.508-1 [6] clause 4.5.

Same test procedure as in clause 6.3D.3.4.2 in TS 38.521-1 [8] with the following steps added for E-UTRA component:

- 1.1. On the E-UTRA carrier, disable periodic and aperiodic CQI reports, disable SRS, set *TimeAlignmentTimerDedicated* IE to infinity and disable downlink and uplink scheduling, all as per Table 4.6-1 under clause 4.6.

#### 6.3H.3.3.5 Test requirements

Same test requirement as in clause 6.3D.3.5 in TS 38.521-1 [8] for the NR carrier.

### 6.3H.3.4 Power control for inter-band EN-DC with UL MIMO

#### 6.3H.3.4.1 Absolute power tolerance for inter-band EN-DC with UL MIMO within FR1

##### 6.3H.3.4.1.1 Test purpose

Same test purpose as in clause 6.3D.4.1.1 in TS 38.521-1 [8] for the NR carrier.

##### 6.3H.3.4.1.2 Test applicability

This test applies to all types of E-UTRA UE release 17 and forward, supporting inter-band EN-DC with UL MIMO.

##### 6.3H.3.4.1.3 Minimum conformance requirements

Same minimum conformance requirements as in clause 6.3D.4.1.3 in TS 38.521-1 [8] for the NR carrier.

The normative reference for this requirement is TS 38.101-3 [4] clause 6.3H.3.

##### 6.3H.3.4.1.4 Test description

If Standalone FR1 can be tested, this test is covered by 6.3D.4.1 Absolute power tolerance for UL MIMO in TS 38.521-1 [8].

If Standalone FR1 cannot be tested (due to test case not being complete or if the UE does not support the band in SA mode), LTE anchor agnostic below is applied.

Same test description as in clause 6.3D.4.1.4 in TS 38.521-1 [8] for the NR carrier with the following exception:

The initial test configurations for E-UTRA band consist of environmental conditions, test frequencies, and channel bandwidths based on E-UTRA bands specified in Table 4.6-1. For Initial conditions as in clause 6.3D.4.1.4.1 in TS 38.521-1 [8], the following steps will be added to configure E-UTRA component:

- 2.1. The parameter settings for E-UTRA cell are set up according to TS 36.508 [11] clause 4.4.3.
- 3.1. The E-UTRA downlink signal level, uplink signal level are set according to Table 4.6-1 and propagation conditions are set according to Annex B, clause B.0 of TS 36.521-1 [10].

Step 6 of Initial conditions as in clause 6.3D.4.1.4.1 in TS 38.521-1 [8] is replaced by the following two steps:

6. Ensure the UE is in state RRC\_CONNECTED with generic procedure parameters Connectivity EN-DC, DC bearer MCG and SCG, Connected without release *On* according to TS 38.508 [6] clause 4.5.
7. On the E-UTRA carrier, disable periodic and aperiodic CQI reports, disable SRS, set TimeAlignmentTimerDedicated IE to infinity and disable downlink and uplink scheduling, all as per Table 4.6-1 under clause 4.6.

#### 6.3H.3.4.1.5 Test Requirement

Same test requirement as in clause 6.3D.4.1.5 in TS 38.521-1 [8] for the NR carrier.

#### 6.3H.3.4.2 Relative power tolerance for inter-band EN-DC with UL MIMO within FR1

##### 6.3H.3.4.2.1 Test purpose

Same test purpose as in clause 6.3D.4.2.1 in TS 38.521-1 [8] for the NR carrier.

##### 6.3H.3.4.2.2 Test applicability

This test applies to all types of E-UTRA UE release 17 and forward, supporting inter-band EN-DC with UL MIMO.

##### 6.3H.3.4.2.3 Minimum conformance requirements

Same minimum conformance requirements as in clause 6.3D.4.2.3 in TS 38.521-1 [8] for the NR carrier.

The normative reference for this requirement is TS 38.101-3 [4] clause 6.3H.3.

##### 6.3H.3.4.2.4 Test description

If Standalone FR1 can be tested, this test is covered by 6.3D.4.2 Relative power tolerance for UL MIMO in TS 38.521-1 [8].

If Standalone FR1 cannot be tested (due to test case not being complete or if the UE does not support the band in SA mode), LTE anchor agnostic below is applied.

Same test description as in clause 6.3D.4.2.4 in TS 38.521-1 [8] for the NR carrier with the following exception:

The initial test configurations for E-UTRA band consist of environmental conditions, test frequencies, and channel bandwidths based on E-UTRA bands specified in Table 4.6-1. For Initial conditions as in clause 6.3D.4.2.4.1 in TS 38.521-1 [8], the following steps will be added to configure E-UTRA component:

- 2.1. The parameter settings for E-UTRA cell are set up according to TS 36.508 [11] clause 4.4.3.
- 3.1. The E-UTRA downlink signal level, uplink signal level are set according to Table 4.6-1 and propagation conditions are set according to Annex B, clause B.0 of TS 36.521-1 [10].

Step 6 of Initial conditions as in clause 6.3D.4.2.4.1 in TS 38.521-1 [8] is replaced by the following two steps:

6. Ensure the UE is in state RRC\_CONNECTED with generic procedure parameters Connectivity EN-DC, DC bearer MCG and SCG, Connected without release *On* according to TS 38.508-1 [6] clause 4.5.

7. On the E-UTRA carrier, disable periodic and aperiodic CQI reports, disable SRS, set *TimeAlignmentTimerDedicated* IE to infinity and disable downlink and uplink scheduling, all as per Table 4.6-1 under clause 4.6.

#### 6.3H.3.4.2.5 Test Requirement

Same test requirement as in clause 6.3D.4.2.5 in TS 38.521-1 [8] for the NR carrier.

#### 6.3H.3.4.3 Aggregate power tolerance for inter-band EN-DC with UL MIMO within FR1

##### 6.3H.3.4.3.1 Test purpose

Same test purpose as in clause 6.3D.4.3.1 in TS 38.521-1 [8] for the NR carrier.

##### 6.3H.3.4.3.2 Test applicability

This test applies to all types of E-UTRA UE release 17 and forward, supporting inter-band EN-DC with UL MIMO.

##### 6.3H.3.4.3.3 Minimum conformance requirements

Same minimum conformance requirements as in clause 6.3D.4.3.3 in TS 38.521-1 [8] for the NR carrier.

The normative reference for this requirement is TS 38.101-3 [4] clause 6.3H.3.

##### 6.3H.3.4.3.4 Test description

If Standalone FR1 can be tested, this test is covered by 6.3D.4.3 Aggregate power tolerance for UL MIMO in TS 38.521-1 [8].

If Standalone FR1 cannot be tested (due to test case not being complete or if the UE does not support the band in SA mode), LTE anchor agnostic below is applied.

Same test description as in clause 6.3D.4.3.4 in TS 38.521-1 [8] for the NR carrier with the following exception:

The initial test configurations for E-UTRA band consist of environmental conditions, test frequencies, and channel bandwidths based on E-UTRA bands specified in Table 4.6-1. For Initial conditions as in clause 6.3D.4.3.4.1 in TS 38.521-1 [8], the following steps will be added to configure E-UTRA component:

- 2.1. The parameter settings for E-UTRA cell are set up according to TS 36.508 [11] clause 4.4.3.
- 3.1. The E-UTRA downlink signal level, uplink signal level are set according to Table 4.6-1 and propagation conditions are set according to Annex B, clause B.0 of TS 36.521-1 [10].

Step 6 of Initial conditions as in clause 6.3D.4.3.4.1 in TS 38.521-1 [8] is replaced by the following two steps:

6. Ensure the UE is in state RRC\_CONNECTED with generic procedure parameters Connectivity EN-DC, DC bearer MCG and SCG, Connected without release *On* according to TS 38.508-1 [6] clause 4.5.
7. On the E-UTRA carrier, disable periodic and aperiodic CQI reports, disable SRS, set *TimeAlignmentTimerDedicated* IE to infinity and disable downlink and uplink scheduling, all as per Table 4.6-1 under clause 4.6.

#### 6.3H.3.4.3.5 Test Requirement

Same test requirement as in clause 6.3D.4.3.5 in TS 38.521-1 [8] for the NR carrier.

## 6.3L Output power dynamics for DC with Tx Diversity

### 6.3L.1

### 6.3L.2

## 6.3L.3 Output power dynamics for inter-band EN-DC with Tx Diversity

### 6.3L.3.1 Minimum output power for inter-band EN-DC with Tx Diversity within FR1

#### 6.3L.3.1.1 Test purpose

Same test purpose as in clause 6.3G.1.1 in TS 38.521-1 [8] for the NR carrier.

#### 6.3L.3.1.2 Test applicability

This test applies to all types of E-UTRA UE release 17 and forward, supporting inter-band EN-DC with Tx Diversity.

#### 6.3L.3.1.3 Minimum conformance requirements

Same minimum conformance requirements as in clause 6.3G.1.3 in TS 38.521-1 [8] for the NR carrier.

The normative reference for this requirement is TS 38.101-3 [4] clause 6.3L.3.

#### 6.3L.3.1.4 Test description

If Standalone FR1 can be tested, this test is covered by 6.3G.1 Minimum output power for Tx Diversity in TS 38.521-1 [8].

If Standalone FR1 cannot be tested (due to test case not being complete or if the UE does not support the band in SA mode), LTE anchor agnostic below is applied.

Same test descriptions as in clause 6.3G.1.4 in TS 38.521-1 [8] for the NR carrier with the following exceptions:

The initial test configurations for E-UTRA band consist of environmental conditions, test frequencies, and channel bandwidths based on E-UTRA bands specified in Table 4.6-1. For Initial conditions as in clause 6.3G.1.4 in TS 38.521-1 [8], the following steps will be added to configure E-UTRA component:

- 2.1. The parameter settings for E-UTRA cell are set up according to TS 36.508 [11] clause 4.4.3.
- 3.1. The E-UTRA downlink signal level, uplink signal level are set according to Table 4.6-1 and propagation conditions are set according to Annex B.0 of TS 36.521-1 [10].

Step 6 of Initial conditions as in clause 6.3G.1.4 in TS 38.521-1 [8] is replaced by the following two steps:

6. Ensure the UE is in state RRC\_CONNECTED with generic procedure parameters Connectivity EN-DC, DC bearer *MCG* and *SCG*, Connected without release *On* according to TS 38.508-1 [6] clause 4.5.
7. On the E-UTRA carrier, disable periodic and aperiodic CQI reports, disable SRS, set TimeAlignmentTimerDedicated IE to infinity and disable downlink and uplink scheduling, all as per Table 4.6-1 under clause 4.6.

#### 6.3L.3.1.5 Test requirements

Same test requirement as in clause 6.3G.1.5 in TS 38.521-1 [8] for the NR carrier.

## 6.3L.3.2 Transmit OFF Power for inter-band EN-DC with Tx Diversity within FR1

### 6.3L.3.2.1 Test purpose

Same test purpose as in clause 6.3G.2.1 in TS 38.521-1 [8] for the NR carrier.

### 6.3L.3.2.2 Test applicability

This test applies to all types of E-UTRA UE release 17 and forward, supporting inter-band EN-DC with Tx Diversity.

### 6.3L.3.2.3 Minimum conformance requirements

Same minimum conformance requirements as in clause 6.3G.2.3 in TS 38.521-1 [8] for the NR carrier.

The normative reference for this requirement is TS 38.101-3 [4] clause 6.3L.3.

### 6.3L.3.2.4 Test description

This test is covered by clause 6.3L.3.3 Transmit ON/OFF time mask for inter-band EN-DC with Tx Diversity.

### 6.3L.3.2.5 Test requirements

Same test requirement as in clause 6.3G.2.5 in TS 38.521-1 [8] for the NR carrier.

## 6.3L.3.3 Transmit ON/OFF time mask for Tx Diversity

### 6.3L.3.3.1 General ON/OFF time mask for inter-band EN-DC with Tx Diversity within FR1

#### 6.3L.3.3.1.1 Test purpose

Same test purpose as in clause 6.3G.3.1 in TS 38.521-1 [8] for the NR carrier.

#### 6.3L.3.3.1.2 Test applicability

This test applies to all types of E-UTRA UE release 17 and forward, supporting inter-band EN-DC with Tx Diversity.

#### 6.3L.3.3.1.3 Minimum conformance requirements

Same minimum conformance requirements as in clause 6.3G.3.1.3 in TS 38.521-1 [8] for the NR carrier.

The normative reference for this requirement is TS 38.101-3 [4] clause 6.3L.3.

#### 6.3L.3.3.1.4 Test description

If Standalone FR1 can be tested, this test is covered by 6.3G.3.1 General ON/OFF time mask for Tx Diversity in TS 38.521-1 [8].

If Standalone FR1 cannot be tested (due to test case not being complete or if the UE does not support the band in SA mode), LTE anchor agnostic below is applied.

Same test descriptions as in clause 6.3G.3.1.4 in TS 38.521-1 [8] for the NR carrier with the following exceptions:

The initial test configurations for E-UTRA band consist of environmental conditions, test frequencies, and channel bandwidths based on E-UTRA bands specified in Table 4.6-1.

For Initial conditions as in clause 6.3G.3.1.4 in TS 38.521-1 [8], the following steps will be added to configure E-UTRA component:

- 2.1. The parameter settings for the E-UTRA cell are set up according to TS 36.508 [11] clause 4.4.3.

3.1. The E-UTRA Downlink signal level, uplink signal level are set according to Table 4.6-1 and propagation conditions are set according to Annex B.0 of TS 36.521-1 [10].

Step 6 of Initial conditions as in clause 6.3G.3.1.4 in TS 38.521-1 [8] is replaced by:

6. Ensure the UE is in state `RRC_CONNECTED` with generic procedure parameters Connectivity EN-DC, DC bearer *MCG* and *SCG*, *Connected without release On* according to TS 38.508-1 [6] clause 4.5.

Same test procedure as in clause 6.3G.3.1.4 in TS 38.521-1 [8] with the following steps added for E-UTRA component:

1.1. On the E-UTRA carrier, disable periodic and aperiodic CQI reports, disable SRS, set *TimeAlignmentTimerDedicated* IE to infinity and disable downlink and uplink scheduling, all as per Table 4.6-1 under clause 4.6.

#### 6.3L.3.3.1.5 Test requirements

Same test requirement as in clause 6.3G.3.1.5 in TS 38.521-1 [8] for the NR carrier.

#### 6.3L.3.3.2 PRACH time mask for inter-band EN-DC with Tx Diversity within FR1

##### 6.3L.3.3.2.1 Test purpose

Same test purpose as in clause 6.3G.3.2.1 in TS 38.521-1 [8] for the NR carrier.

##### 6.3L.3.3.2.2 Test applicability

This test applies to all types of E-UTRA UE release 17 and forward, supporting inter-band EN-DC with Tx Diversity.

##### 6.3L.3.3.2.3 Minimum conformance requirements

Same minimum conformance requirements as in clause 6.3G.3.2.3 in TS 38.521-1 [8] for the NR carrier.

The normative reference for this requirement is TS 38.101-3 [4] clause 6.3L.3.

##### 6.3L.3.3.2.4 Test description

If Standalone FR1 can be tested, this test is covered by 6.3G.3.2 PRACH time mask for Tx Diversity in TS 38.521-1 [8].

If Standalone FR1 cannot be tested (due to test case not being complete or if the UE does not support the band in SA mode), LTE anchor agnostic below is applied.

Same test descriptions as in clause 6.3G.3.2.4 in TS 38.521-1 [8] for the NR carrier with the following exceptions:

The initial test configurations for E-UTRA band consist of environmental conditions, test frequencies, and channel bandwidths based on E-UTRA bands specified in Table 4.6-1.

For Initial conditions as in clause 6.3G.3.2.4 in TS 38.521-1 [8], the following steps will be added to configure E-UTRA component:

2.1. The parameter settings for the E-UTRA cell are set up according to TS 36.508 [11] clause 4.4.3.

3.1. The E-UTRA Downlink signal level, uplink signal level are set according to Table 4.6-1 and propagation conditions are set according to Annex B.0 of TS 36.521-1 [10].

Step 6 of Initial conditions as in clause 6.3G.3.2.4 in TS 38.521-1 [8] is replaced by:

6. Ensure the UE is in state `RRC_CONNECTED` with generic procedure parameters Connectivity EN-DC, DC bearer *MCG* and *SCG*, *Connected without release On* according to TS 38.508-1 [6] clause 4.5.

Same test procedure as in clause 6.3G.3.2.4 in TS 38.521-1 [8] with the following steps added for E-UTRA component:

- 1.1. On the E-UTRA carrier, disable periodic and aperiodic CQI reports, disable SRS, set *TimeAlignmentTimerDedicated* IE to infinity and disable downlink and uplink scheduling, all as per Table 4.6-1 under clause 4.6.

#### 6.3L.3.3.2.5 Test requirements

Same test requirement as in clause 6.3G.3.2.5 in TS 38.521-1 [8] for the NR carrier.

#### 6.3L.3.3.3 SRS time mask for inter-band EN-DC with Tx Diversity within FR1

##### 6.3L.3.3.3.1 Test purpose

Same test purpose as in clause 6.3G.3.3.1 in TS 38.521-1 [8] for the NR carrier.

##### 6.3L.3.3.3.2 Test applicability

This test applies to all types of E-UTRA UE release 17 and forward, supporting inter-band EN-DC with Tx Diversity.

##### 6.3L.3.3.3.3 Minimum conformance requirements

Same minimum conformance requirements as in clause 6.3G.3.3.3 in TS 38.521-1 [8] for the NR carrier.

The normative reference for this requirement is TS 38.101-3 [4] clause 6.3L.3.

##### 6.3L.3.3.3.4 Test description

If Standalone FR1 can be tested, this test is covered by 6.3G.3.3 SRS time mask for Tx Diversity in TS 38.521-1 [8].

If Standalone FR1 cannot be tested (due to test case not being complete or if the UE does not support the band in SA mode), LTE anchor agnostic below is applied.

Same test descriptions as in clause 6.3G.3.3.4 in TS 38.521-1 [8] for the NR carrier with the following exceptions:

The initial test configurations for E-UTRA band consist of environmental conditions, test frequencies, and channel bandwidths based on E-UTRA bands specified in Table 4.6-1.

For Initial conditions as in clause 6.3G.3.3.4 in TS 38.521-1 [8], the following steps will be added to configure E-UTRA component:

- 2.1. The parameter settings for the E-UTRA cell are set up according to TS 36.508 [11] clause 4.4.3.
- 3.1. The E-UTRA Downlink signal level, uplink signal level are set according to Table 4.6-1 and propagation conditions are set according to Annex B.0 of TS 36.521-1 [10].

Step 6 of Initial conditions as in clause 6.3G.3.3.4 in TS 38.521-1 [8] is replaced by:

6. Ensure the UE is in state RRC\_CONNECTED with generic procedure parameters Connectivity EN-DC, DC bearer *MCG* and *SCG*, *Connected without release On* according to TS 38.508-1 [6] clause 4.5.

Same test procedure as in clause 6.3G.3.3.4 in TS 38.521-1 [8] with the following steps added for E-UTRA component:

- 1.1. On the E-UTRA carrier, disable periodic and aperiodic CQI reports, disable SRS, set *TimeAlignmentTimerDedicated* IE to infinity and disable downlink and uplink scheduling, all as per Table 4.6-1 under clause 4.6.

#### 6.3L.3.3.3.5 Test requirements

Same test requirement as in clause 6.3G.3.3.5 in TS 38.521-1 [8] for the NR carrier.



## 6.3L.3.4 Power control for inter-band EN-DC with Tx Diversity

### 6.3L.3.4.1 Absolute power tolerance for inter-band EN-DC with Tx Diversity within FR1

#### 6.3L.3.4.1.1 Test purpose

Same test purpose as in clause 6.3G.4.1.1 in TS 38.521-1 [8] for the NR carrier.

#### 6.3L.3.4.1.2 Test applicability

This test applies to all types of E-UTRA UE release 17 and forward, supporting inter-band EN-DC with Tx Diversity.

#### 6.3L.3.4.1.3 Minimum conformance requirements

Same minimum conformance requirements as in clause 6.3G.4.1.3 in TS 38.521-1 [8] for the NR carrier.

The normative reference for this requirement is TS 38.101-3 [4] clause 6.3L.3.

#### 6.3L.3.4.1.4 Test description

If Standalone FR1 can be tested, this test is covered by 6.3G.4.1 Absolute power tolerance for Tx Diversity in TS 38.521-1 [8].

If Standalone FR1 cannot be tested (due to test case not being complete or if the UE does not support the band in SA mode), LTE anchor agnostic below is applied.

Same test description as in clause 6.3G.4.1.4 in TS 38.521-1 [8] for the NR carrier with the following exception:

The initial test configurations for E-UTRA band consist of environmental conditions, test frequencies, and channel bandwidths based on E-UTRA bands specified in Table 4.6-1. For Initial conditions as in clause 6.3G.4.1.4 in TS 38.521-1 [8], the following steps will be added to configure E-UTRA component:

- 2.1. The parameter settings for E-UTRA cell are set up according to TS 36.508 [11] clause 4.4.3.
- 3.1. The E-UTRA downlink signal level, uplink signal level are set according to Table 4.6-1 and propagation conditions are set according to Annex B, clause B.0 of TS 36.521-1 [10].

Step 6 of Initial conditions as in clause 6.3G.4.1.4 in TS 38.521-1 [8] is replaced by the following two steps:

6. Ensure the UE is in state RRC\_CONNECTED with generic procedure parameters Connectivity EN-DC, DC bearer MCG and SCG, Connected without release  $O_n$  according to TS 38.508 [6] clause 4.5.
7. On the E-UTRA carrier, disable periodic and aperiodic CQI reports, disable SRS, set TimeAlignmentTimerDedicated IE to infinity and disable downlink and uplink scheduling, all as per Table 4.6-1 under clause 4.6.

#### 6.3L.3.4.1.5 Test Requirement

Same test requirement as in clause 6.3G.4.1.5 in TS 38.521-1 [8] for the NR carrier.

### 6.3L.3.4.2 Relative power tolerance for inter-band EN-DC with Tx Diversity within FR1

#### 6.3L.3.4.2.1 Test purpose

Same test purpose as in clause 6.3G.4.2.1 in TS 38.521-1 [8] for the NR carrier.

#### 6.3L.3.4.2.2 Test applicability

This test applies to all types of E-UTRA UE release 17 and forward, supporting inter-band EN-DC with Tx Diversity.

### 6.3L.3.4.2.3 Minimum conformance requirements

Same minimum conformance requirements as in clause 6.3G.4.2.3 in TS 38.521-1 [8] for the NR carrier.

The normative reference for this requirement is TS 38.101-3 [4] clause 6.3L.3.

### 6.3L.3.4.2.4 Test description

If Standalone FR1 can be tested, this test is covered by 6.3G.4.2 Relative power tolerance for Tx Diversity in TS 38.521-1 [8].

If Standalone FR1 cannot be tested (due to test case not being complete or if the UE does not support the band in SA mode), LTE anchor agnostic below is applied.

Same test description as in clause 6.3G.4.2.4 in TS 38.521-1 [8] for the NR carrier with the following exception:

The initial test configurations for E-UTRA band consist of environmental conditions, test frequencies, and channel bandwidths based on E-UTRA bands specified in Table 4.6-1. For Initial conditions as in clause 6.3G.4.2.4 in TS 38.521-1 [8], the following steps will be added to configure E-UTRA component:

- 2.1. The parameter settings for E-UTRA cell are set up according to TS 36.508 [11] clause 4.4.3.
- 3.1. The E-UTRA downlink signal level, uplink signal level are set according to Table 4.6-1 and propagation conditions are set according to Annex B, clause B.0 of TS 36.521-1 [10].

Step 6 of Initial conditions as in clause 6.3G.4.2.4 in TS 38.521-1 [8] is replaced by the following two steps:

6. Ensure the UE is in state RRC\_CONNECTED with generic procedure parameters Connectivity EN-DC, DC bearer MCG and SCG, Connected without release *On* according to TS 38.508-1 [6] clause 4.5.
7. On the E-UTRA carrier, disable periodic and aperiodic CQI reports, disable SRS, set TimeAlignmentTimerDedicated IE to infinity and disable downlink and uplink scheduling, all as per Table 4.6-1 under clause 4.6.

### 6.3L.3.4.2.5 Test Requirement

Same test requirement as in clause 6.3G.4.2.5 in TS 38.521-1 [8] for the NR carrier.

## 6.3L.3.4.3 Aggregate power tolerance for inter-band EN-DC with Tx Diversity within FR1

### 6.3L.3.4.3.1 Test purpose

Same test purpose as in clause 6.3G.4.3.1 in TS 38.521-1 [8] for the NR carrier.

### 6.3L.3.4.3.2 Test applicability

This test applies to all types of E-UTRA UE release 17 and forward, supporting inter-band EN-DC with Tx Diversity.

### 6.3L.3.4.3.3 Minimum conformance requirements

Same minimum conformance requirements as in clause 6.3G.4.3.3 in TS 38.521-1 [8] for the NR carrier.

The normative reference for this requirement is TS 38.101-3 [4] clause 6.3L.3.

### 6.3L.3.4.3.4 Test description

If Standalone FR1 can be tested, this test is covered by 6.3G.4.3 Aggregate power tolerance for Tx Diversity in TS 38.521-1 [8].

If Standalone FR1 cannot be tested (due to test case not being complete or if the UE does not support the band in SA mode), LTE anchor agnostic below is applied.

Same test description as in clause 6.3G.4.3.4 in TS 38.521-1 [8] for the NR carrier with the following exception:

The initial test configurations for E-UTRA band consist of environmental conditions, test frequencies, and channel bandwidths based on E-UTRA bands specified in Table 4.6-1. For Initial conditions as in clause 6.3G.4.3.4 in TS 38.521-1 [8], the following steps will be added to configure E-UTRA component:

- 2.1. The parameter settings for E-UTRA cell are set up according to TS 36.508 [11] clause 4.4.3.
- 3.1. The E-UTRA downlink signal level, uplink signal level are set according to Table 4.6-1 and propagation conditions are set according to Annex B, clause B.0 of TS 36.521-1 [10].

Step 6 of Initial conditions as in clause 6.3G.4.3.4 in TS 38.521-1 [8] is replaced by the following two steps:

6. Ensure the UE is in state RRC\_CONNECTED with generic procedure parameters Connectivity EN-DC, DC bearer MCG and SCG, Connected without release *On* according to TS 38.508-1 [6] clause 4.5.
7. On the E-UTRA carrier, disable periodic and aperiodic CQI reports, disable SRS, set *TimeAlignmentTimerDedicated* IE to infinity and disable downlink and uplink scheduling, all as per Table 4.6-1 under clause 4.6.

#### 6.3L.3.4.3.5 Test Requirement

Same test requirement as in clause 6.3G.4.3.5 in TS 38.521-1 [8] for the NR carrier.

## 6.4 Transmit signal quality

### 6.4A Transmit Signal Quality for inter-band NR CA between FR and FR2 without EN-DC

#### 6.4A.1 Frequency error for inter-band NR CA between FR 1 and FR 2 without EN-DC

##### 6.4A.1.1 Test purpose

Same test purpose as in clause 6.4.1 in TS 38.521-1 [8] for NR FR1 carrier(s) and clause 6.4.1 in TS 38.521-2 [9] for NR FR2 carrier(s).

##### 6.4A.1.2 Test applicability

The requirements in this test are not testable due to issues with combined testing of NR FR1 conducted mode with NR FR2 in radiated mode. Therefore, the conducted and radiated requirements are tested separately.

No test case details are specified. The NR/5GC requirements for frequency error apply and are tested in TS 38.521-1 [8] clauses 6.4 and 6.4A and TS 38.521-2 [9] clauses 6.4 and 6.4A.

#### 6.4A.2 Transmit Modulation Quality for inter-band NR CA without EN-DC

##### 6.4A.2.1 Error Vector Magnitude for inter-band NR CA between FR 1 and FR 2 without EN-DC

###### 6.4A.2.1.1 Test purpose

Same test purpose as in clause 6.4.2.1 in TS 38.521-1 [8] for NR FR1 carrier(s) and clause 6.4.2.1 in TS 38.521-2 [9] for NR FR2 carrier(s).

###### 6.4A.2.1.2 Test applicability

The requirements in this test are not testable due to issues with combined testing of NR FR1 conducted mode with NR FR2 in radiated mode. Therefore, the conducted and radiated requirements are tested separately.

No test case details are specified. The NR/5GC requirements for error vector magnitude apply and are tested in TS 38.521-1 [8] clauses 6.4 and 6.4A and TS 38.521-2 [9] clauses 6.4 and 6.4A.

#### 6.4A.2.2 Carrier Leakage for inter-band NR CA between FR 1 and FR 2 without EN-DC

##### 6.4A.2.2.1 Test purpose

Same test purpose as in clause 6.4.2.2 in TS 38.521-1 [8] for NR FR1 carrier(s) and clause 6.4.2.2 in TS 38.521-2 [9] for NR FR2 carrier(s).

##### 6.4A.2.2.2 Test applicability

The requirements in this test are not testable due to issues with combined testing of NR FR1 conducted mode with NR FR2 in radiated mode. Therefore, the conducted and radiated requirements are tested separately.

No test case details are specified. The NR/5GC requirements for carrier leakage apply and are tested in TS 38.521-1 [8] clauses 6.4 and 6.4A and TS 38.521-2 [9] clauses 6.4 and 6.4A.

#### 6.4A.2.3 In-band Emissions for inter-band NR CA between FR 1 and FR 2 without EN-DC

##### 6.4A.2.3.1 Test purpose

Same test purpose as in clause 6.4.2.3 in TS 38.521-1 [8] for NR FR1 carrier(s) and clause 6.4.2.3 in TS 38.521-2 [9] for NR FR2 carrier(s).

##### 6.4A.2.3.2 Test applicability

The requirements in this test are not testable due to issues with combined testing of NR FR1 conducted mode with NR FR2 in radiated mode. Therefore, the conducted and radiated requirements are tested separately.

No test case details are specified. The NR/5GC requirements for in-band emissions apply and are tested in TS 38.521-1 [8] clauses 6.4 and 6.4A and TS 38.521-2 [9] clauses 6.4 and 6.4A.

#### 6.4A.2.4 EVM Equalizer Spectral Flatness for inter-band NR CA between FR 1 and FR 2 without EN-DC

##### 6.4A.2.4.1 Test purpose

Same test purpose as in clause 6.4.2.4 in TS 38.521-1 [8] for NR FR1 carrier(s) and clause 6.4.2.4 in TS 38.521-2 [9] for NR FR2 carrier(s).

##### 6.4A.2.4.2 Test applicability

The requirements in this test are not testable due to issues with combined testing of NR FR1 conducted mode with NR FR2 in radiated mode. Therefore, the conducted and radiated requirements are tested separately.

No test case details are specified. The NR/5GC requirements for EVM equalizer spectral flatness apply and are tested in TS 38.521-1 [8] clauses 6.4 and 6.4A and TS 38.521-2 [9] clauses 6.4 and 6.4A.

## 6.4B Transmit Signal Quality for DC

### 6.4B.1 Frequency error

#### 6.4B.1.1 Frequency error for Intra-band contiguous EN-DC

##### 6.4B.1.1.1 Test purpose

Same test purpose as in clause 6.4.1 in TS 38.521-1 [8] for the NR carrier.

##### 6.4B.1.1.2 Test applicability

This test case applies to all types of E-UTRA UE release 15 and forward, supporting intra-band contiguous EN-DC.

##### 6.4B.1.1.3 Minimum conformance requirements

For intra-band contiguous EN-DC, the requirement shall apply on each component carrier as defined in clause 6.5.1 in TS 38.101-3 [4] and in clause 6.4.1 in TS 38.101-1 [2], respectively.

No exception requirements applicable to NR or E-UTRA. LTE anchor agnostic approach is applied.

The normative reference for this measurement is TS 38.101-3 [4] clause 6.4B.1.1.

##### 6.4B.1.1.4 Test description

Same test description as in clause 6.4.1.4 in TS 38.521-1 [8] for the NR carrier with the following exception:

Notes defined in Table 6.4.1.4.1-1 will be updated as below.

The initial test configurations for E-UTRA band consist of environmental conditions, test frequencies, and channel bandwidths based on E-UTRA bands specified in Table 4.6-1. For Initial conditions as in clause 6.4.1.4.1 in TS 38.521-1 [8], the following steps will be added to configure E-UTRA component:

- 2.1. The parameter settings for E-UTRA cell are set up according to TS 36.508 [11] clause 4.4.3.
- 3.1. The E-UTRA downlink signal level, uplink signal level are set according to Table 4.6-1 and propagation conditions are set according to Annex B, clause B.0 of TS 36.521-1 [10].

Step 6 of Initial conditions as in clause 6.4.1.4.1 in TS 38.521-1 [8] is replaced by the following three steps:

6. Ensure the UE is in state RRC\_CONNECTED with generic procedure parameters Connectivity EN-DC, DC bearer MCG and SCG, Connected without release *On* according to TS 38.508-1 [6] clause 4.5.
7. On the E-UTRA carrier, disable periodic and aperiodic CQI reports, disable SRS, set TimeAlignmentTimerDedicated IE to infinity and disable downlink and uplink scheduling, all as per Table 4.6-1 under clause 4.6.
8. When E-UTRA and NR bands are TDD, ensure the same uplink-downlink configuration by giving SCG a delay of 3 E-UTRA subframes, or by giving MCG a delay of 2 subframes.

##### 6.4B.1.1.5 Test Requirement

The 10 frequency error  $\Delta f$  results must fulfil the test requirement defined in clause 6.4.1.5 TS 38.521-1 [8].

#### 6.4B.1.2 Frequency error for Intra-band non-contiguous EN-DC

##### 6.4B.1.2.1 Test purpose

Same test purpose as in clause 6.4.1 in TS 38.521-1 [8] for the NR carrier.

## 6.4B.1.2.2 Test applicability

This test case applies to all types of E-UTRA UE release 15 and forward, supporting intra-band non-contiguous EN-DC.

## 6.4B.1.2.3 Minimum conformance requirements

For intra-band non-contiguous EN-DC, the requirement shall apply on each component carrier as defined in clause 6.5.1 in TS 38.101-3 [4] and in clause 6.4.1 in TS 38.101-1 [2], respectively.

No exception requirements applicable to NR or E-UTRA. LTE anchor agnostic approach is applied.

The normative reference for this measurement is TS 38.101-3 [4] clause 6.4B.1.2.

## 6.4B.1.2.4 Test description

Same test description as in clause 6.4.1.4 in TS 38.521-1 [8] for the NR carrier with the following exception:

The initial test configurations consist of environmental conditions, test frequencies and channel bandwidths based on EN-DC operating bands specified in clause 5.5B.3, all of these configurations shall be tested with applicable test parameters for each intra-band non-contiguous EN-DC configuration specified in clause 5.3B.1.3, and are shown in table 6.4B.1.2.4-1.

**Table 6.4B.1.2.4-1: Test Configuration Table**

Initial Conditions				
Test Environment as specified in TS 38.508-1 [6] clause 4.1		Normal, TL/VL, TL/VH, TH/VL, TH/VH		
Test Frequencies as specified in TS 38.508-1 [6] clause 4.3.1 for different EN-DC bandwidth classes		MinWgap , MaxWgap		
Test Channel Bandwidths as specified in TS 38.508-1 [6] clause 4.3.1		Highest $N_{RB\_agg}$ (NOTE3)		
Test SCS as specified in Table 5.3.5-1		Lowest		
Test Parameters				
Test ID	Downlink Configuration		Uplink Configuration	
	Modulation	RB allocation	Modulation	RB allocation
1	CP-OFDM QPSK	Full RB (NOTE 1)	DFT-s-OFDM QPSK	REFSENS (NOTE 2)
NOTE 1: Full RB allocation shall be used per each SCS and channel BW as specified in Table 7.3.2.4.1-2.				
NOTE 2: REFSENS refers to Table 7.3.2.4.1-3 which defines uplink RB configuration and start RB location for each SCS, channel BW and NR band.				
NOTE 3: If the UE supports multiple CC Combinations in the EN-DC Configuration with the same $N_{RB\_agg}$ , only the combination with the highest $N_{RB\_SCG}$ is tested.				

The initial test configurations for E-UTRA band consist of environmental conditions, test frequencies, and channel bandwidths based on E-UTRA bands specified in Table 4.6-1 with the exception that E-UTRA test frequency are specified in Table 7.4B.2.4.1-1 based on intra-band non-contiguous EN-DC configuration specified in clause 5.3B.1.3.

For Initial conditions as in clause 6.4.1.4.1 in TS 38.521-1 [8], the following steps will be added to configure E-UTRA component:

- 2.1. The parameter settings for E-UTRA cell are set up according to TS 36.508 [11] clause 4.4.3.
- 3.1. The E-UTRA downlink signal level, uplink signal level are set according to Table 4.6-1 and propagation conditions are set according to Annex B, clause B.0 of TS 36.521-1 [10].

Steps 4 and 6 of Initial conditions as in clause 6.4.1.4.1 in TS 38.521-1 [8] is replaced by:

4. The DL and UL Reference Measurement frequencies are set according to Table 6.4B.1.2.4-1.

6. Ensure the UE is in state RRC\_CONNECTED with generic procedure parameters Connectivity EN-DC, DC bearer MCG and SCG, Connected without release *On* according to TS 38.508-1 [6] clause 4.5.
7. On the E-UTRA carrier, disable periodic and aperiodic CQI reports, disable SRS, set TimeAlignmentTimerDedicated IE to infinity and disable downlink and uplink scheduling, all as per Table 4.6-1 under clause 4.6.
8. When E-UTRA and NR bands are TDD, ensure the same uplink-downlink configuration by giving SCG a delay of 3 E-UTRA subframes, or by giving MCG a delay of 2 subframes.

#### 6.4B.1.2.5 Test Requirement

The 10 frequency error  $\Delta f$  results must fulfil the test requirement defined in TS 38.521-1 [8], clause 6.4.1.5.

### 6.4B.1.3 Frequency error for Inter-band EN-DC within FR1 (1 NR CC)

#### 6.4B.1.3.1 Test purpose

Same test purpose as in clause 6.4.1 in TS 38.521-1 [8] for the NR carrier.

#### 6.4B.1.3.2 Test applicability

This test case applies to all types of E-UTRA UE release 15 and forward, supporting inter-band EN-DC within FR1 with 1 NR UL.

#### 6.4B.1.3.3 Minimum conformance requirements

For inter-band EN-DC with uplink assigned to one E-UTRA band and one NR band, the requirements shall apply on each component carrier as defined in clause 6.5.1 in TS 36.101 [5] and in clause 6.4.1 in TS 38.101-1 [2], respectively, with all component carriers active. If multiple component carriers are assigned to one E-UTRA band, the requirements in clauses 6.5.1A in TS 36.101 [5] apply for those component carriers, and if multiple component carriers are assigned to one NR band, the requirements in clauses 6.4A.1 in TS 38.101-1 [2] apply for those component carriers.

No exception requirements applicable to NR or E-UTRA. LTE anchor agnostic approach is applied.

The normative reference for this measurement is TS 38.101-3 [4] clause 6.4B.1.3.

#### 6.4B.1.3.4 Test description

Same test description as in clause 6.4.1.4 in TS 38.521-1 [8] for the NR carrier with the following exception:

For band n28 / 28 used in EN-DC configurations with NOTE 8 of Table 5.5B.4.1-1, test channel bandwidth of 20MHz or more is tested with Low range test frequency.

The initial test configurations for E-UTRA band consist of environmental conditions, test frequencies, and channel bandwidths based on E-UTRA bands specified in Table 4.6-1. For Initial conditions as in clause 6.4.1.4.1 in TS 38.521-1 [8], the following steps will be added to configure E-UTRA component:

- 2.1. The parameter settings for E-UTRA cell are set up according to TS 36.508 [11] clause 4.4.3.
- 3.1. The E-UTRA downlink signal level, uplink signal level are set according to Table 4.6-1 and propagation conditions are set according to Annex B.0 of TS 36.521-1 [10].

Step 6 of Initial conditions as in clause 6.4.1.4.1 in TS 38.521-1 [8] is replaced by the following two steps:

6. Ensure the UE is in state RRC\_CONNECTED with generic procedure parameters Connectivity EN-DC, DC bearer MCG and SCG, Connected without release *On* according to TS 38.508-1 [6] clause 4.5.
7. On the E-UTRA carrier, disable periodic and aperiodic CQI reports, disable SRS, set TimeAlignmentTimerDedicated IE to infinity and disable downlink and uplink scheduling, all as per Table 4.6-1 under clause 4.6.

#### 6.4B.1.3.5 Test Requirement

The 10 frequency error  $\Delta f$  results must fulfil the test requirement defined in 6.4.1.5 TS 38.521-1 [8].

#### 6.4B.1.3a Frequency Error for inter-band NE-DC within FR1

No exception requirements applicable to E-UTRA or LTE.

No test case details are specified. The requirements for NR carrier(s) in this test case are tested in 6.4.1 and 6.4A.1 of TS 38.521-1 [8], and the requirements for LTE carrier(s) in this test case are tested in 6.5.1 and 6.5.1A of TS 36.521-1 [10]. Neither NR carrier(s) nor LTE carrier(s) needs to be tested again.

#### 6.4B.1.4 Frequency Error for inter-band EN-DC including FR2 (1 NR CC)

##### 6.4B.1.4.1 Test purpose

Same test purpose as in clause 6.4.1.1 in TS 38.521-2 [9] for the *NR* carrier.

##### 6.4B.1.4.2 Test applicability

This test applies to all types of E-UTRA UE release 15 and forward, supporting intra-band EN-DC including FR2 with 1 NR UL CC.

##### 6.4B.1.4.3 Minimum conformance requirements

Same minimum conformance requirements as in clause 6.4.1.3 in TS 38.521-2 [9] for the *NR* carrier.

No exception requirements applicable to NR or E-UTRA. LTE anchor agnostic approach is applied.

The normative reference for this requirement is TS 38.101-3 [4] clause 6.4B.

##### 6.4B.1.4.4 Test description

Same test description as in clause 6.4.1.4 in TS 38.521-2 [9] for the *NR* carrier with the following exception:

The initial test configurations for E-UTRA band consist of environmental conditions, test frequencies, and channel bandwidths based on E-UTRA bands specified in Table 4.7-1.

For initial conditions as in clause 6.4.1.4.1 in TS 38.521-2 [9], the following steps will be added to configure E-UTRA component:

- 2.1. The parameter settings for E-UTRA cell are set up according to TS 36.508 [11] clause 4.4.3.
- 3.1. The E-UTRA downlink signal level, uplink signal level are set according to Table 4.7-1 and propagation conditions are set according to Annex B.0 of TS 36.521-1 [10].

Step 6 of Initial conditions as in clause 6.4.1.4.1 in TS 38.521-2 [9] is replaced by:

6. Ensure the UE is in state RRC\_CONNECTED with generic procedure parameters Connectivity EN-DC, DC bearer MCG and SCG, Connected without release On according to TS 38.508-1 [6] clause 4.5.

Same test procedure as in clause 6.4.1.4.2 in TS 38.521-2 [9] with the following steps added for E-UTRA component:

- 1.1 On the E-UTRA carrier, disable periodic and aperiodic CQI reports, disable SRS, set *TimeAlignmentTimerDedicated* IE to infinity and disable downlink and uplink scheduling, all as per Table 4.7-1 under clause 4.7.

##### 6.4B.1.4.5 Test requirements

Same test requirement as in clause 6.4.1.5 in TS 38.521-2 [9] for the *NR* carrier.



## 6.4B.1.4\_1 Frequency Error for Inter-band EN-DC including FR2 (>1 NR CC)

### 6.4B.1.4\_1.1 Frequency Error for Inter-band EN-DC including FR2 (2 NR CCs)

#### 6.4B.1.4\_1.1.1 Test purpose

Same test purpose as in clause 6.4.1.1 in TS 38.521-2 [9] for the NR carrier.

#### 6.4B.1.4\_1.1.2 Test applicability

This test case applies to all types of E-UTRA UE release 15 and forward, supporting inter-band EN-DC including FR2 with 2 NR UL CCs.

#### 6.4B.1.4\_1.1.3 Minimum conformance requirements

Same minimum conformance requirements as in clause 6.4.1.3 in TS 38.521-2 [9] for the NR carrier.

No exception requirements applicable to NR or E-UTRA. LTE anchor agnostic approach is applied.

The normative reference for this requirement is TS 38.101-3 [4] clause 6.4B.1.4.

#### 6.4B.1.4\_1.1.4 Test description

##### 6.4B.1.4\_1.1.4.1 Initial condition

Same test description as in clause 6.4A.1.1.4 in TS 38.521-2 [9] for the NR carrier with the following exception:

The initial test configurations for E-UTRA band consist of environmental conditions, test frequencies, and channel bandwidths based on E-UTRA bands specified in Table 4.7-1.

For Initial conditions as in clause 6.4A.1.1.4.1 in TS 38.521-2 [9], the following steps will be added to configure E-UTRA component:

- 2.1. The parameter settings for E-UTRA cell are set up according to TS 36.508 [11] clause 4.4.3.
- 3.1. The E-UTRA downlink signal level, uplink signal level are set according to Table 4.7-1 and propagation conditions are set according to Annex B.0 of TS 36.521-1 [10].

Step 6 of Initial conditions as in clause 6.4A.1.1.4.1 in TS 38.521-2 [9] is replaced by:

6. Ensure the UE is in state RRC\_CONNECTED with generic procedure parameters Connectivity EN-DC, DC bearer MCG and SCG, Connected without release On according to TS 38.508-1 [6] clause 4.5.

Same test procedure as in clause 6.4A.1.1.4.2 in TS 38.521-2 [9] with the following steps added for E-UTRA component:

- 1.1 On the E-UTRA carrier, disable periodic and aperiodic CQI reports, disable SRS, set *TimeAlignmentTimerDedicated* IE to infinity and disable downlink and uplink scheduling, all as per Table 4.7-1 under clause 4.7.

#### 6.4B.1.4\_1.1.5 Test Requirements

Same test requirement as in clause 6.4A.1.1.5 in TS 38.521-2 [9] for the NR carrier.

### 6.4B.1.4\_1.2 Frequency Error for Inter-band EN-DC including FR2 (3 NR CCs)

#### 6.4B.1.4\_1.2.1 Test purpose

Same test purpose as in clause 6.4.1.1 in TS 38.521-2 [9] for the NR carrier.

#### 6.4B.1.4\_1.2.2 Test applicability

This test case applies to all types of E-UTRA UE release 15 and forward, supporting inter-band EN-DC including FR2 with 3 NR UL CCs.

#### 6.4B.1.4\_1.2.3 Minimum conformance requirements

Same minimum conformance requirements as in clause 6.4.1.3 in TS 38.521-2 [9] for the NR carrier.

No exception requirements applicable to NR or E-UTRA. LTE anchor agnostic approach is applied.

The normative reference for this requirement is TS 38.101-3 [4] clause 6.4B.1.4.

#### 6.4B.1.4\_1.2.4 Test description

##### 6.4B.1.4\_1.2.4.1 Initial condition

Same test description as in clause 6.4A.1.2.4 in TS 38.521-2 [9] for the NR carrier with the following exception:

The initial test configurations for E-UTRA band consist of environmental conditions, test frequencies, and channel bandwidths based on E-UTRA bands specified in Table 4.7-1.

For Initial conditions as in clause 6.4A.1.2.4.1 in TS 38.521-2 [9], the following steps will be added to configure E-UTRA component:

- 2.1. The parameter settings for E-UTRA cell are set up according to TS 36.508 [11] clause 4.4.3.
- 3.1. The E-UTRA downlink signal level, uplink signal level are set according to Table 4.7-1 and propagation conditions are set according to Annex B.0 of TS 36.521-1 [10].

Step 6 of Initial conditions as in clause 6.4A.1.2.4.1 in TS 38.521-2 [9] is replaced by:

6. Ensure the UE is in state RRC\_CONNECTED with generic procedure parameters Connectivity EN-DC, DC bearer MCG and SCG, Connected without release On according to TS 38.508-1 [6] clause 4.5.

Same test procedure as in clause 6.4A.1.2.4.2 in TS 38.521-2 [9] with the following steps added for E-UTRA component:

- 1.1 On the E-UTRA carrier, disable periodic and aperiodic CQI reports, disable SRS, set *TimeAlignmentTimerDedicated* IE to infinity and disable downlink and uplink scheduling, all as per Table 4.7-1 under clause 4.7.

#### 6.4B.1.4\_1.2.5 Test Requirements

Same test requirement as in clause 6.4A.1.2.5 in TS 38.521-2 [9] for the NR carrier.

#### 6.4B.1.4\_1.3 Frequency Error for Inter-band EN-DC including FR2 (4 NR CCs)

##### 6.4B.1.4\_1.3.1 Test purpose

Same test purpose as in clause 6.4.1.1 in TS 38.521-2 [9] for the NR carrier.

##### 6.4B.1.4\_1.3.2 Test applicability

This test case applies to all types of E-UTRA UE release 15 and forward, supporting inter-band EN-DC including FR2 with 4 NR UL CCs.

##### 6.4B.1.4\_1.3.3 Minimum conformance requirements

Same minimum conformance requirements as in clause 6.4.1.3 in TS 38.521-2 [9] for the NR carrier.

No exception requirements applicable to NR or E-UTRA. LTE anchor agnostic approach is applied.

The normative reference for this requirement is TS 38.101-3 [4] clause 6.4B.1.4.

#### 6.4B.1.4\_1.3.4 Test description

##### 6.4B.1.4\_1.3.4.1 Initial condition

Same test description as in clause 6.4A.1.3.4 in TS 38.521-2 [9] for the NR carrier with the following exception:

The initial test configurations for E-UTRA band consist of environmental conditions, test frequencies, and channel bandwidths based on E-UTRA bands specified in Table 4.7-1.

For Initial conditions as in clause 6.4A.1.3.4.1 in TS 38.521-2 [9], the following steps will be added to configure E-UTRA component:

- 2.1. The parameter settings for E-UTRA cell are set up according to TS 36.508 [11] clause 4.4.3.
- 3.1. The E-UTRA downlink signal level, uplink signal level are set according to Table 4.7-1 and propagation conditions are set according to Annex B.0 of TS 36.521-1 [10].

Step 6 of Initial conditions as in clause 6.4A.1.3.4.1 in TS 38.521-2 [9] is replaced by:

6. Ensure the UE is in state RRC\_CONNECTED with generic procedure parameters Connectivity EN-DC, DC bearer MCG and SCG, Connected without release On according to TS 38.508-1 [6] clause 4.5.

Same test procedure as in clause 6.4A.1.3.4.2 in TS 38.521-2 [9] with the following steps added for E-UTRA component:

- 1.1 On the E-UTRA carrier, disable periodic and aperiodic CQI reports, disable SRS, set *TimeAlignmentTimerDedicated* IE to infinity and disable downlink and uplink scheduling, all as per Table 4.7-1 under clause 4.7.

#### 6.4B.1.4\_1.3.5 Test Requirements

Same test requirement as in clause 6.4A.1.3.5 in TS 38.521-2 [9] for the NR carrier.

#### 6.4B.1.4\_1.4 Frequency Error for Inter-band EN-DC including FR2 (5 NR CCs)

**Editor's note: This clause is incomplete. The following aspects are either missing or not yet determined:**

- The referred test case 6.4A.1.4 in TS 38.521-2 [9] is incomplete.
- Measurement Uncertainty and Test Tolerance are FFS.

##### 6.4B.1.4\_1.4.1 Test purpose

Same test purpose as in clause 6.4.1.1 in TS 38.521-2 [9] for the NR carrier.

##### 6.4B.1.4\_1.4.2 Test applicability

This test case applies to all types of E-UTRA UE release 15 and forward, supporting inter-band EN-DC including FR2 with 5 NR UL CCs.

##### 6.4B.1.4\_1.4.3 Minimum conformance requirements

Same minimum conformance requirements as in clause 6.4.1.3 in TS 38.521-2 [9] for the NR carrier.

No exception requirements applicable to NR or E-UTRA. LTE anchor agnostic approach is applied.

The normative reference for this requirement is TS 38.101-3 [4] clause 6.4B.1.4.

## 6.4B.1.4\_1.4.4 Test description

## 6.4B.1.4\_1.4.4.1 Initial condition

Same test description as in clause 6.4A.1.4.4 in TS 38.521-2 [9] for the *NR* carrier with the following exception:

The initial test configurations for E-UTRA band consist of environmental conditions, test frequencies, and channel bandwidths based on E-UTRA bands specified in Table 4.7-1.

For Initial conditions as in clause 6.4A.1.4.4.1 in TS 38.521-2 [9], the following steps will be added to configure E-UTRA component:

- 2.1. The parameter settings for E-UTRA cell are set up according to TS 36.508 [11] clause 4.4.3.
- 3.1. The E-UTRA downlink signal level, uplink signal level are set according to Table 4.7-1 and propagation conditions are set according to Annex B.0 of TS 36.521-1 [10].

Step 6 of Initial conditions as in clause 6.4A.1.4.4.1 in TS 38.521-2 [9] is replaced by:

6. Ensure the UE is in state RRC\_CONNECTED with generic procedure parameters Connectivity EN-DC, DC bearer MCG and SCG, Connected without release On according to TS 38.508-1 [6] clause 4.5.

Same test procedure as in clause 6.4A.1.4.4.2 in TS 38.521-2 [9] with the following steps added for E-UTRA component:

- 1.1 On the E-UTRA carrier, disable periodic and aperiodic CQI reports, disable SRS, set *TimeAlignmentTimerDedicated* IE to infinity and disable downlink and uplink scheduling, all as per Table 4.7-1 under clause 4.7.

## 6.4B.1.4\_1.4.5 Test Requirements

Same test requirement as in clause 6.4A.1.4.5 in TS 38.521-2 [9] for the *NR* carrier.

## 6.4B.1.4\_1.5 Frequency Error for Inter-band EN-DC including FR2 (6 NR CCs)

**Editor's note: This clause is incomplete. The following aspects are either missing or not yet determined:**

- The referred test case 6.4A.1.5 in TS 38.521-2 [9] is incomplete.
- Measurement Uncertainty and Test Tolerance are FFS.

## 6.4B.1.4\_1.5.1 Test purpose

Same test purpose as in clause 6.4.1.1 in TS 38.521-2 [9] for the *NR* carrier.

## 6.4B.1.4\_1.5.2 Test applicability

This test case applies to all types of E-UTRA UE release 15 and forward, supporting inter-band EN-DC including FR2 with 6 NR UL CCs.

## 6.4B.1.4\_1.5.3 Minimum conformance requirements

Same minimum conformance requirements as in clause 6.4.1.3 in TS 38.521-2 [9] for the *NR* carrier.

No exception requirements applicable to *NR* or E-UTRA. LTE anchor agnostic approach is applied.

The normative reference for this requirement is TS 38.101-3 [4] clause 6.4B.1.4.

## 6.4B.1.4\_1.5.4 Test description

## 6.4B.1.4\_1.5.4.1 Initial condition

Same test description as in clause 6.4A.1.5.4 in TS 38.521-2 [9] for the *NR* carrier with the following exception:

The initial test configurations for E-UTRA band consist of environmental conditions, test frequencies, and channel bandwidths based on E-UTRA bands specified in Table 4.7-1.

For Initial conditions as in clause 6.4A.1.5.4.1 in TS 38.521-2 [9], the following steps will be added to configure E-UTRA component:

- 2.1. The parameter settings for E-UTRA cell are set up according to TS 36.508 [11] clause 4.4.3.
- 3.1. The E-UTRA downlink signal level, uplink signal level are set according to Table 4.7-1 and propagation conditions are set according to Annex B.0 of TS 36.521-1 [10].

Step 6 of Initial conditions as in clause 6.4A.1.5.4.1 in TS 38.521-2 [9] is replaced by:

6. Ensure the UE is in state RRC\_CONNECTED with generic procedure parameters Connectivity EN-DC, DC bearer MCG and SCG, Connected without release On according to TS 38.508-1 [6] clause 4.5.

Same test procedure as in clause 6.4A.1.5.4.2 in TS 38.521-2 [9] with the following steps added for E-UTRA component:

- 1.1 On the E-UTRA carrier, disable periodic and aperiodic CQI reports, disable SRS, set *TimeAlignmentTimerDedicated* IE to infinity and disable downlink and uplink scheduling, all as per Table 4.7-1 under clause 4.7.

#### 6.4B.1.4\_1.5.5 Test Requirements

Same test requirement as in clause 6.4A.1.5.5 in TS 38.521-2 [9] for the NR carrier.

#### 6.4B.1.4\_1.6 Frequency Error for Inter-band EN-DC including FR2 (7 NR CCs)

**Editor's note: This clause is incomplete. The following aspects are either missing or not yet determined:**

- The referred test case 6.4A.1.6 in TS 38.521-2 [9] is incomplete.
- Measurement Uncertainty and Test Tolerance are FFS.

#### 6.4B.1.4\_1.6.1 Test purpose

Same test purpose as in clause 6.4.1.1 in TS 38.521-2 [9] for the NR carrier.

#### 6.4B.1.4\_1.6.2 Test applicability

This test case applies to all types of E-UTRA UE release 15 and forward, supporting inter-band EN-DC including FR2 with 7 NR UL CCs.

#### 6.4B.1.4\_1.6.3 Minimum conformance requirements

Same minimum conformance requirements as in clause 6.4.1.3 in TS 38.521-2 [9] for the NR carrier.

No exception requirements applicable to NR or E-UTRA. LTE anchor agnostic approach is applied.

The normative reference for this requirement is TS 38.101-3 [4] clause 6.4B.1.4.

#### 6.4B.1.4\_1.6.4 Test description

##### 6.4B.1.4\_1.6.4.1 Initial condition

Same test description as in clause 6.4A.1.6.4 in TS 38.521-2 [9] for the NR carrier with the following exception:

The initial test configurations for E-UTRA band consist of environmental conditions, test frequencies, and channel bandwidths based on E-UTRA bands specified in Table 4.7-1.

For Initial conditions as in clause 6.4A.1.6.4.1 in TS 38.521-2 [9], the following steps will be added to configure E-UTRA component:

2.1. The parameter settings for E-UTRA cell are set up according to TS 36.508 [11] clause 4.4.3.

3.1. The E-UTRA downlink signal level, uplink signal level are set according to Table 4.7-1 and propagation conditions are set according to Annex B.0 of TS 36.521-1 [10].

Step 6 of Initial conditions as in clause 6.4A.1.6.4.1 in TS 38.521-2 [9] is replaced by:

6. Ensure the UE is in state RRC\_CONNECTED with generic procedure parameters Connectivity EN-DC, DC bearer MCG and SCG, Connected without release On according to TS 38.508-1 [6] clause 4.5.

Same test procedure as in clause 6.4A.1.6.4.2 in TS 38.521-2 [9] with the following steps added for E-UTRA component:

1.1 On the E-UTRA carrier, disable periodic and aperiodic CQI reports, disable SRS, set *TimeAlignmentTimerDedicated* IE to infinity and disable downlink and uplink scheduling, all as per Table 4.7-1 under clause 4.7.

#### 6.4B.1.4\_1.6.5 Test Requirements

Same test requirement as in clause 6.4A.1.6.5 in TS 38.521-2 [9] for the NR carrier.

#### 6.4B.1.4\_1.7 Frequency Error for Inter-band EN-DC including FR2 (8 NR CCs)

**Editor's note: This clause is incomplete. The following aspects are either missing or not yet determined:**

- The referred test case 6.4A.1.7 in TS 38.521-2 [9] is incomplete.
- Measurement Uncertainty and Test Tolerance are FFS.

#### 6.4B.1.4\_1.7.1 Test purpose

Same test purpose as in clause 6.4.1.1 in TS 38.521-2 [9] for the NR carrier.

#### 6.4B.1.4\_1.7.2 Test applicability

This test case applies to all types of E-UTRA UE release 15 and forward, supporting inter-band EN-DC including FR2 with 8 NR UL CCs.

#### 6.4B.1.4\_1.7.3 Minimum conformance requirements

Same minimum conformance requirements as in clause 6.4.1.3 in TS 38.521-2 [9] for the NR carrier.

No exception requirements applicable to NR or E-UTRA. LTE anchor agnostic approach is applied.

The normative reference for this requirement is TS 38.101-3 [4] clause 6.4B.1.4.

#### 6.4B.1.4\_1.7.4 Test description

##### 6.4B.1.4\_1.7.4.1 Initial condition

Same test description as in clause 6.4A.1.7.4 in TS 38.521-2 [9] for the NR carrier with the following exception:

The initial test configurations for E-UTRA band consist of environmental conditions, test frequencies, and channel bandwidths based on E-UTRA bands specified in Table 4.7-1.

For Initial conditions as in clause 6.4A.1.7.4.1 in TS 38.521-2 [9], the following steps will be added to configure E-UTRA component:

2.1. The parameter settings for E-UTRA cell are set up according to TS 36.508 [11] clause 4.4.3.

3.1. The E-UTRA downlink signal level, uplink signal level are set according to Table 4.7-1 and propagation conditions are set according to Annex B.0 of TS 36.521-1 [10].

Step 6 of Initial conditions as in clause 6.4A.1.7.4.1 in TS 38.521-2 [9] is replaced by:

6. Ensure the UE is in state RRC\_CONNECTED with generic procedure parameters Connectivity EN-DC, DC bearer MCG and SCG, Connected without release On according to TS 38.508-1 [6] clause 4.5.

Same test procedure as in clause 6.4A.1.7.4.2 in TS 38.521-2 [9] with the following steps added for E-UTRA component:

- 1.1 On the E-UTRA carrier, disable periodic and aperiodic CQI reports, disable SRS, set *TimeAlignmentTimerDedicated* IE to infinity and disable downlink and uplink scheduling, all as per Table 4.7-1 under clause 4.7.

#### 6.4B.1.4\_1.7.5 Test Requirements

Same test requirement as in clause 6.4A.1.7.5 in TS 38.521-2 [9] for the NR carrier.

#### 6.4B.1.4D Frequency error for inter-band EN-DC including FR2 for UL-MIMO

##### 6.4B.1.4D.1 Test purpose

Same test purpose as in clause 6.4D.1.1 in TS 38.521-2 [9] for the NR carrier.

##### 6.4B.1.4D.2 Test applicability

This test case applies to all types of E-UTRA UE release 15 and forward, supporting inter-band EN-DC including FR2 and UL MIMO.

##### 6.4B.1.4D.3 Minimum conformance requirements

For inter-band EN-DC including FR2 or both FR1 and FR2, transmit modulation quality for EN-DC operations in FR1 and FR2 as specified in TS 36.101 [5], 38.101-1 [2] and 38.101-2 [3] apply for E-UTRA, NR FR1 and NR FR2 respectively.

The normative reference for this requirement is TS 38.101-3 [4] clause 6.4B.1.4.

Same minimum conformance requirements as in clause 6.4D.1.3 in TS 38.521-2 [9] for the NR carrier.

No exception requirements applicable to NR or E-UTRA. LTE anchor agnostic approach is applied.

##### 6.4B.1.4D.4 Test description

##### 6.4B.1.4D.4.1 Initial conditions

Same test description as in clause 6.4D.1.4 in TS 38.521-2 [9] for the NR carrier with the following exception:

The initial test configurations for E-UTRA band consist of environmental conditions, test frequencies, and channel bandwidths based on E-UTRA bands specified in Table 4.7-1. For Initial conditions as in clause 6.4D.1.4.1 in TS 38.521-2 [9], the following steps will be added to configure E-UTRA component:

- 2.1. The parameter settings for E-UTRA cell are set up according to TS 36.508 [11] clause 4.4.3.
- 3.1. The E-UTRA downlink signal level, uplink signal level are set according to Table 4.7-1 and propagation conditions are set according to Annex B.0 of TS 36.521-1 [10].

Step 6 of Initial conditions as in clause 6.4D.1.4.1 in TS 38.521-2 [9] is replaced by:

6. Ensure the UE is in state RRC\_CONNECTED with generic procedure parameters Connectivity EN-DC, DC bearer MCG and SCG, Connected without release On according to TS 38.508-1 [6] clause 4.5.

Same test procedure as in clause 6.4D.1.4.2 in TS 38.521-2 [9] with the following steps added for E-UTRA component:

- 1.1 On the E-UTRA carrier, disable periodic and aperiodic CQI reports, disable SRS, set *TimeAlignmentTimerDedicated* IE to infinity and disable downlink and uplink scheduling, all as per Table 4.7-1 under clause 4.7.

## 6.4B.1.4D.5 Test requirement

Same test requirement as in clause 6.4D.1.5 in TS 38.521-2 [9] for the NR carrier.

## 6.4B.2 Transmit Modulation Quality for DC

### 6.4B.2.1 Transmit Modulation Quality for intra-band contiguous EN-DC

#### 6.4B.2.1.1 Error Vector Magnitude for intra-band contiguous EN-DC

##### 6.4B.2.1.1.1 Test purpose

The Error Vector Magnitude is a measure of the difference between the reference waveform and the measured waveform. This difference is called the error vector. Before calculating the EVM the measured waveform is corrected by the sample timing offset and RF frequency offset. Then the carrier leakage shall be removed from the measured waveform before calculating the EVM.

The measured waveform is further equalised using the channel estimates subjected to the EVM equaliser spectrum flatness requirement specified in clause 6.4B.2.1.4.3. For DFT-s-OFDM waveforms, the EVM result is defined after the front-end FFT and IDFT as the square root of the ratio of the mean error vector power to the mean reference power expressed as a %. For CP-OFDM waveforms, the EVM result is defined after the front-end FFT as the square root of the ratio of the mean error vector power to the mean reference power expressed as a %.

The basic EVM measurement interval in the time domain is one preamble sequence for the PRACH and the duration of PUCCH/PUSCH channel, or one hop, if frequency hopping is enabled for PUCCH and PUSCH in the time domain. The EVM measurement interval is reduced by any symbols that contains an allowable power transient as defined in clause 6.3.3.3 of TS 38.521-1 [8].

##### 6.4B.2.1.1.2 Test applicability

This test case applies to all types of E-UTRA UE release 15 and forward, supporting intra-band EN-DC.

##### 6.4B.2.1.1.3 Minimum conformance requirements

For the intra-band contiguous EN-DC with one component carrier per CG the EVM requirement applies with PRB allocation in one of the CG and the other CG unallocated.

The EVM requirements for each CG are according to clause 6.5.2 of TS 36.101 [5] for the MCG and clause 6.4.2 of TS 38.101-1 [2] for the SCG with EN-DC configured.

The normative reference for this requirement is TS 38.101-3 [4] clause 6.4B.2.1.1.

No exception requirements applicable to NR or E-UTRA. LTE anchor agnostic approach is applied.

##### 6.4B.2.1.1.4 Test description

Same test description as in clause 6.4.2.1.4 in TS 38.521-1 [8] for the NR carrier with the following exception:

**Table 6.4B.2.1.1.4-1: Test Configuration Table**

Initial Conditions	
Test Frequencies as specified in TS 38.508-1 [6] clause 4.3.1	Mid range
Test EN-DC bandwidth combination as specified in Table 5.3B.1.2-1	Highest NRB_agg (NOTE 1)
NOTE 1: If the UE supports multiple CC Combinations in the EN-DC Configuration with the same NRB_agg, only the combination with the highest NRB_SCG is tested.	

The initial test configurations for E-UTRA as specified in Table 4.6-1 except for the parameters specified in Table 6.4B.2.1.1.4-1.



For Initial conditions as in clause 6.4.2.1.4.1 in TS 38.521-1 [8], the following steps are added to configure E-UTRA component:

- 2.1. The parameter settings for E-UTRA cell are set up according to TS 36.508 [11] clause 4.4.3.
- 3.1. The E-UTRA downlink signal level, uplink signal level are set according to Table 4.6-1 and propagation conditions are set according to Annex B.0 of TS 36.521-1 [10].

Step 6 of Initial conditions as in clause 6.4.2.1.4.1 in TS 38.521-1 [8] is replaced by the following three steps:

- 6. Ensure the UE is in state RRC\_CONNECTED with generic procedure parameters Connectivity EN-DC, DC bearer MCG and SCG, Connected without release *On* according to TS 38.508-1 [6] clause 4.5.
- 7. On the E-UTRA carrier, disable periodic and aperiodic CQI reports, disable SRS, set TimeAlignmentTimerDedicated IE to infinity and disable downlink and uplink scheduling, all as per Table 4.6-1 under clause 4.6.
- 8. When E-UTRA and NR bands are TDD, ensure the same uplink-downlink configuration by giving SCG a delay of 3 E-UTRA subframes, or by giving MCG a delay of 2 subframes.

Same test procedure as in clause 6.4.2.1.4.2 in TS 38.521-1 [8].

For Message contents as in clause 6.4.2.1.4.3 in TS 38.521-1 [8], the following exception:

**Table 6.4B.2.1.1.4-2: RACH-ConfigGeneric: PRACH measurement**

Derivation Path: TS 38.508-1[5], Table 4.6.3-130			
Information Element	Value/remark	Comment	Condition
RACH-ConfigGeneric ::= SEQUENCE { prach-ConfigurationIndex	14	Unpaired Spectrum	PRACH Format 0 AND delay is given to SCG in Step 8 of Initial conditions
	12	Unpaired Spectrum	PRACH Format 0 AND delay is given to MCG in Step 8 of Initial conditions

6.4B.2.1.1.5 Test requirements

Same test requirement as in clause 6.4.2.1.5 in TS 38.521-1 [8] for the NR carrier.

6.4B.2.1.2 Carrier Leakage for intra-band contiguous EN-DC

6.4B.2.1.2.1 Test purpose

Carrier leakage expresses itself as unmodulated sine wave with the carrier frequency or centre frequency of aggregated transmission bandwidth configuration. It is an interference of approximately constant amplitude and independent of the amplitude of the wanted signal. Carrier leakage interferes with the centre sub carriers of the UE under test (if allocated), especially, when their amplitude is small. The measurement interval is defined over one slot in the time domain.

The purpose of this test is to exercise the UE transmitter to verify its modulation quality in terms of carrier leakage.

6.4B.2.1.2.2 Test applicability

This test case applies to all types of E-UTRA UE release 15 and forward, supporting intra-band EN-DC.

### 6.4B.2.1.2.3 Minimum conformance requirements

The carrier leakage requirements for each CG are according to clause 6.5.2 of TS 36.101 [5] for the MCG and clause 6.4.2 of TS 38.101-1 [2] for the SCG with EN-DC configured.

The normative reference for this requirement is TS 38.101-3 [4] clause 6.4B.2.1.2.

No exception requirements applicable to NR or E-UTRA. LTE anchor agnostic approach is applied.

### 6.4B.2.1.2.4 Test description

Same test description as in clause 6.4.2.2.4 in TS 38.521-1 [8] for the NR carrier with the following exception:

**Table 6.4B.2.1.2.4-1: Test Configuration**

Initial Conditions	
Test Frequencies as specified in TS 38.508-1 [6] clause 4.3.1	Mid range
Test EN-DC bandwidth combination as specified in Table 5.3B.1.2-1	Highest NRB_agg (NOTE 1)
NOTE 1: If the UE supports multiple CC Combinations in the EN-DC Configuration with the same NRB_agg , only the combination with the highest NRB_SCG is tested.	

The initial test configurations for E-UTRA as specified in Table 4.6-1 except for the parameters specified in Table 6.4B.2.1.2.4-1. For Initial conditions as in clause 6.4.2.2.4.1 in TS 38.521-1 [8], the following steps will be added to configure E-UTRA component:

- 2.1. The parameter settings for E-UTRA cell are set up according to TS 36.508 [11] clause 4.4.3.
- 3.1. The E-UTRA downlink signal level, uplink signal level are set according to Table 4.6-1 and propagation conditions are set according to Annex B.0 of TS 36.521-1 [10].

Step 6 of Initial conditions as in clause 6.4.2.2.4.1 in TS 38.521-1 [8] is replaced by the following three steps:

6. Ensure the UE is in state RRC\_CONNECTED with generic procedure parameters Connectivity EN-DC, DC bearer MCG and SCG, Connected without release *On* according to TS 38.508-1 [6] clause 4.5.
7. On the E-UTRA carrier, disable periodic and aperiodic CQI reports, disable SRS, set TimeAlignmentTimerDedicated IE to infinity and disable downlink and uplink scheduling, all as per Table 4.6-1 under clause 4.6.
8. When E-UTRA and NR bands are TDD, ensure the same uplink-downlink configuration by giving SCG a delay of 3 E-UTRA subframes, or by giving MCG a delay of 2 subframes.

### 6.4B.2.1.2.5 Test requirements

Same test requirement as in clause 6.4.2.2.5 in TS 38.521-1 [8] for the NR carrier.

## 6.4B.2.1.3 In-band Emissions for intra-band contiguous EN-DC

### 6.4B.2.1.3.1 Test purpose

The in-band emissions are a measure of the interference falling into the non-allocated resources blocks.

The in-band emission is defined as the average emission across 12 sub-carriers and as a function of the RB offset from the edge of the allocated UL transmission bandwidth. The in-band emission is measured as the ratio of the UE output power in a non-allocated RB to the UE output power in an allocated RB.

The basic in-band emissions measurement interval is defined over one slot in the time domain, however, the minimum requirement applies when the in-band emission measurement is averaged over 10 sub-frames. When the PUSCH or PUCCH transmission slot is shortened due to multiplexing with SRS, the in-band emissions measurement interval is reduced by one or more symbols, accordingly.

The purpose of this test is to exercise the UE transmitter to verify its modulation quality in terms of in-band emissions.

#### 6.4B.2.1.3.2 Test applicability

This test applies to all types of E-UTRA UE release 15 and forward, supporting intra-band contiguous EN-DC.

#### 6.4B.2.1.3.3 Minimum conformance requirements

For the MCG the in-band emission requirements in Table 6.5.2A.3.1-1 and Table 6.5.2A.3.1-2 in TS 36.101 [5] apply within the aggregated transmission bandwidth configuration of the EN-DC bandwidth with the carriers of both CGs active and one single contiguous PRB allocation of bandwidth  $L_{CRB}$  within the MCG at the edge of the said aggregated transmission bandwidth configuration.

For the SCG the in-band emission requirements in Table 6.5.2A.3.1-1 and Table 6.5.2A.3.1-2 in TS 36.101 [5] apply within the aggregated transmission bandwidth configuration of the EN-DC bandwidth with the carriers of both CGs active and one single contiguous PRB allocation of bandwidth  $L_{CRB}$  within the SCG at the edge of the aggregated transmission bandwidth configuration.

The normative reference for this requirement is TS 38.101-3 [4] clause 6.4B.2.1.3

Exception requirements for both NR and E-UTRA are defined for this test and therefore LTE anchor agnostic approach is not applied. E-UTRA test point analysis is included and E-UTRA measurements are performed.

#### 6.4B.2.1.3.4 Test description

##### 6.4B.2.1.3.4.1 Initial condition

Initial conditions are a set of test configurations the UE needs to be tested in and the steps for the SS to take with the UE to reach the correct measurement state.

The initial test configurations consist of environmental conditions, test frequencies and test channel bandwidths based on NR operating bands specified in clause 5.3B.1.2, channel bandwidths and sub-carrier spacings for the NR cell specified in TS 38.521-1 [8] clause 5.3 and channel bandwidth for the E-UTRA cell are specified in TS 36.521-1 [10] clause 5.4.2. All of these configurations shall be tested with applicable test parameters for each EN-DC combination of test channel bandwidth and sub-carrier spacing, and are shown in table 6.4B.2.1.3.4.1-1. The details of the uplink reference measurement channels (RMCs) are specified in Annex A, clause A.2.2 for E-UTRA RMC for TDD, TS 36.521-1 [10] Annex A, clause A.2.2 for E-UTRA RMC for FDD, and TS 38.521-1 [8] Annex A, clause A.2 for NR RMC. Configurations of PDSCH and PDCCH before measurement are specified in TS 36.521.1 [10] Annex C.2 and in TS 38.521-1 [8] Annex C.2 for E-UTRA CG and NR CG respectively.

Table 6.4B.2.1.3.4.1-1: Test configuration table

Initial Conditions					
Test Environment as specified in TS 38.508-1 [6] clause 4.1		Normal			
Test Frequencies as specified in TS 38.508-1 [6] clause 4.3.1		Low range, Mid range, High range			
Test EN-DC bandwidth combination as specified in Table 5.3B.1.2-1		Lowest $N_{RB\_agg}$ , Highest $N_{RB\_agg}$ (NOTE 2)			
Test SCS for the NR cell as specified in TS 38.521-1 [8] Table 5.3.5-1		Lowest			
Test Parameters					
Test ID	Downlink Configuration	EN-DC Uplink Configuration			
		E-UTRA Cell		NR Cell	
		Modulation	RB allocation (NOTE 5)	Modulation	RB allocation (NOTE 1)
1 (NOTE3)	N/A for In-band emission test	QPSK	0	DFT-s-OFDM QPSK	Inner_1RB_Right
2 (NOTE 4)		QPSK	0	DFT-s-OFDM QPSK	Inner_1RB_Left
3 (NOTE3)		QPSK	0	CP-OFDM QPSK	Inner_1RB_Right
4 (NOTE 4)		QPSK	0	CP-OFDM QPSK	Inner_1RB_Left
5 (NOTE3)		QPSK	Outer_1RB_Left	DFT-s-OFDM QPSK	0
6 (NOTE 4)		QPSK	Outer_1RB_Right	DFT-s-OFDM QPSK	0
NOTE 1: The specific configuration of each RB allocation is defined in Table 6.1-1 in TS 38.521-1 [8].					
NOTE 2: If the UE supports multiple CC combinations in the EN-DC configuration with the same $N_{RB\_agg}$ , select the combination to test as follows: - Lowest ENBW: NR component with lowest $N_{RB}$ is tested. - Highest ENBW: NR component with highest $N_{RB}$ is tested.					
NOTE 3: Applicable when E-UTRA cell carrier frequency is lower than NR cell carrier.					
NOTE 4: Applicable when NR cell carrier frequency is lower than E-UTRA cell carrier.					
NOTE 5: Outer_1RB_Left defined as 1 RB allocated at the left edge of the E-UTRA component. Outer_1RB_Right defined as 1 RB allocated at the right edge of the E-UTRA component.					

1. Connect the SS to the UE antenna connectors as shown in TS 38.508-1 [6] Annex A, Figure A.3.1.1 for TE diagram and clause A.3.2.1 for UE diagram.
2. The parameter settings for the E-UTRA cell are set up according to TS 36.508 [11] clause 4.4.3, and the parameter settings for the NR cell are set up according to TS 38.508-1 [6] clause 4.4.3.
3. Downlink signals are initially set up according to TS 36.521-1 [10] Annex C.0 and TS 38.521-1 [8] Annex C.0 for E-UTRA CG and NR CG respectively, and uplink signals according to TS 36.521-1 [10] Annex H and TS 38.521-1 [8] Annex G for E-UTRA CG and NR CG respectively.
4. NR downlink signals are initially set up according to Annex C.0, C.1, and C.2 and uplink signals according to Annex G.0, G.1, G.2, and G.3.0 of TS 38.521-1 [8].
5. The UL Reference Measurement channels are set for E-UTRA CG and NR CG respectively.
6. Propagation conditions are set according to TS 36.521-1 [10] Annex B.0 and TS 38.521-1 [8] Annex B.0 for E-UTRA CG and NR CG respectively.
7. Ensure the UE is in state RRC\_CONNECTED with generic procedure parameters Connectivity EN-DC, DC bearer MCG and SCG, Connected without release *On* according to TS 38.508-1 [6] clause 4.5. Message contents are defined in clause 6.4B.2.1.3.4.3.
8. When E-UTRA and NR bands are TDD, ensure the same uplink-downlink configuration by giving SCG a delay of 3 E-UTRA subframes, or by giving MCG a delay of 2 subframes.

## 6.4B.2.1.3.4.2 Test procedure

1. SS sends uplink scheduling information for each UL HARQ process via PDCCH DCI format 0 and DCI format 0\_1 for C\_RNTI to schedule the UL RMC according to Table 6.4B.2.1.3.4.1-1 on E-UTRA CC and NR CC respectively. Since the UL has no payload and no loopback data to send, the UE transmits uplink MAC padding bits on the UL RMC.
2. For NR CC, send uplink power control commands to the UE using 1dB power step size to ensure that the UE output power measured by the test system is within the Uplink power control window, defined as  $+MU$  to  $+(MU + \text{Uplink power control window size})$  dB of the target power level 0dBm, where:
  - $MU$  is the test system uplink power measurement uncertainty and is specified in Table F.1.2-1 for the carrier frequency  $f$  and the channel bandwidth  $BW$ .
  - Uplink power control window size = 1dB (UE power step size) + 0.7dB (UE power step tolerance) + (Test system relative power measurement uncertainty), where, the UE power step tolerance is specified in TS 38.101-1 [2], Table 6.3.4.3-1 and is 0.7dB for 1dB power step size, and the Test system relative power measurement uncertainty is specified in Table F.1.2-1.
3. Measure In-band emission on NR CC using Global In-Channel Tx-Test (Annex E). Measure power spectral density on E-UTRA CC. For TDD slots with transient periods are not under test.
4. For NR CC, send uplink power control commands to the UE using 1dB power step size to ensure that the UE output power measured by the test system is within the Uplink power control window, defined as  $+MU$  to  $+(MU + \text{Uplink power control window size})$  dB of the target power level -30dBm, where  $MU$  and Uplink power control window size are defined above.
5. Measure In-band emission on NR CC using Global In-Channel Tx-Test (Annex E). Measure power spectral density on E-UTRA CC. For TDD slots with transient periods are not under test
6. For NR CC, send uplink power control commands to the UE using 1dB power step size to ensure that the UE output power measured by the test system is within the Uplink power control window, defined as  $+MU$  to  $+(MU + \text{Uplink power control window size})$  dB of the target power level -40dBm, where  $MU$  and Uplink power control window size are defined above.
7. Measure In-band emission on NR CC using Global In-Channel Tx-Test (Annex E). Measure power spectral density on E-UTRA CC. For TDD slots with transient periods are not under test.
8. For E-UTRA CC, send uplink power control commands to the UE using 1dB power step size to ensure that the UE output power measured by the test system is within the Uplink power control window, defined as  $+MU$  to  $+(MU + \text{Uplink power control window size})$  dB of the target power level 0dBm, where:
  - $MU$  is the test system uplink power measurement uncertainty and is specified in Table F.1.2-1 for the carrier frequency  $f$  and the channel bandwidth  $BW$ .
  - Uplink power control window size = 1dB (UE power step size) + 1.0dB (UE power step tolerance) + (Test system relative power measurement uncertainty), where, the UE power step tolerance is specified in TS 36.101 [5], Table 6.3.5.2.1-1 and is 1.0dB for 1dB power step size, and the Test system relative power measurement uncertainty is specified in Table F.1.2-1.
9. Measure In-band emission on E-UTRA CC using Global In-Channel Tx-Test (Annex E). Measure power spectral density on NR CC. For TDD slots with transient periods are not under test.
10. For E-UTRA CC, send uplink power control commands to the UE using 1dB power step size to ensure that the UE output power measured by the test system is within the Uplink power control window, defined as  $+MU$  to  $+(MU + \text{Uplink power control window size})$  dB of the target power level -30dBm, where  $MU$  and Uplink power control window size are defined above.
11. Measure In-band emission on E-UTRA CC using Global In-Channel Tx-Test (Annex E). Measure power spectral density on NR CC. For TDD slots with transient periods are not under test
12. For E-UTRA CC, send uplink power control commands to the UE using 1dB power step size to ensure that the UE output power measured by the test system is within the Uplink power control window, defined as  $+MU$  to  $+(MU + \text{Uplink power control window size})$  dB of the target power level -40dBm, where  $MU$  and Uplink power control window size are defined above.

13. Measure In-band emission on E-UTRA CC using Global In-Channel Tx-Test (Annex E). Measure power spectral density on NR CC. For TDD slots with transient periods are not under test.

NOTE 1: When switching to DFT-s-OFDM waveform, as specified in the test configuration table 6.4B.2.1.3.4.1-1, send an NR RRCReconfiguration message according to TS 38.508-1 [6] clause 4.6.3 Table 4.6.3-118 PUSCH-Config with TRANSFORM\_PRECODER\_ENABLED condition.

NOTE 2: The purpose of the Uplink power control window is to ensure that the actual UE output power is no less than the target power level, and as close as possible to the target power level. The relationship between the Uplink power control window, the target power level and the corresponding possible actual UE Uplink power window is illustrated in Annex F, clause F.4.

**Table 6.4B.2.1.3.4.2-1: Void**

**Table 6.4B.2.1.3.4.2-2: Void**

#### 6.4B.2.1.3.4.3 Message contents

Message contents are according to TS 36.508-1 [11] clause 4.6 and TS 38.508-1 [6] clause 4.6.1.

#### 6.4B.2.1.3.5 Test requirements

Each of the [20] In-band emissions results, derived in Annex E.4.3 shall not exceed the corresponding values in Table 6.4B.2.1.3.5-1.

**Table 6.4B.2.1.3.5-1: Test requirements for in-band emissions (allocated component carrier)**

Parameter	Unit	Limit		Applicable Frequencies
General	dB	$\max \left\{ -25 - 10 \cdot \log_{10} (N_{RB} / L_{CRB}), \right.$ $20 \cdot \log_{10} EVM - 3 - 5 \cdot ( \Delta_{RB}  - 1) / L_{CRB},$ $\left. -57 \text{ dBm} / 180 \text{ kHz} - P_{RB} \right\} + TT$		Any non-allocated (NOTE 2)
IQ Image	dB	-25		Exception for IQ image (NOTE 3)
Carrier leakage	dBc	25 + TT	Output power > 0 dBm	Exception for Carrier frequency (NOTE 4)
		20 + TT	-30 dBm ≤ Output power ≤ 0 dBm	
		10 + TT	-40 dBm ≤ Output power < -30 dBm	
<p>NOTE 1: An in-band emissions combined limit is evaluated in each non-allocated RB. For each such RB, the minimum requirement is calculated as the higher of <math>P_{RB} - 30</math> dB and the power sum of all limit values (General, IQ Image or Carrier leakage) that apply. <math>P_{RB}</math> is defined in NOTE 9. The limit is evaluated in each non-allocated RB.</p> <p>NOTE 2: The measurement bandwidth is 1 RB and the limit is expressed as a ratio of measured power in one non-allocated RB to the measured average power per allocated RB, where the averaging is done across all allocated RBs</p> <p>NOTE 3: Exceptions to the general limit are allowed for up to <math>L_{CRBs} + 1</math> RBs within a contiguous width of <math>L_{CRBs} + 1</math> non-allocated RBs. The measurement bandwidth is 1 RB.</p> <p>NOTE 4: Exceptions to the general limit are allowed for up to two contiguous non-allocated RBs. The measurement bandwidth is 1 RB and the limit is expressed as a ratio of measured power in the non-allocated RB to the measured total power in all allocated RBs.</p> <p>NOTE 5: <math>L_{CRB}</math> is the Transmission Bandwidth (see Figure 5.6-1) not exceeding <math>\lfloor N_{RB} / 2 - 1 \rfloor</math></p> <p>NOTE 6: <math>N_{RB}</math> is the Transmission Bandwidth Configuration (see Figure 5.6-1) of the component carrier with RBs allocated.</p> <p>NOTE 7: <math>EVM</math> is the limit specified in Table 6.5.2.1.1-1 for the modulation format used in the allocated RBs.</p> <p>NOTE 8: <math>\Delta_{RB}</math> is the starting frequency offset between the allocated RB and the measured non-allocated RB (e.g. <math>\Delta_{RB} = 1</math> or <math>\Delta_{RB} = -1</math> for the first adjacent RB outside of the allocated bandwidth).</p> <p>NOTE 9: <math>P_{RB}</math> is the transmitted power per 180 kHz in allocated RBs, measured in dBm.</p> <p>NOTE 10: Test tolerance TT = 0.8 dB.</p>				

The in-band emissions results, measured with the spectral test shall not exceed the corresponding values in Table 6.4B.2.1.3.5-2.

**Table 6.4B.2.1.3.5-2: Test requirements for in-band emissions (not allocated component carrier)**

Parameter	Unit	Meas BW NOTE 1	Limit	remark	Applicable Frequencies	
General	dB	BW of 1 RB (180KHz rectangular)	$\max \left\{ -25 - 10 \cdot \log_{10} (N_{RB} / L_{CRB}), 20 \cdot \log_{10} EVM - 3 - 5 \cdot (\Delta_{RB} - 1) / L_{CRB}, -57 \text{ dBm} / 180\text{kHz} - P_{RB} \right\}$	The reference value is the average power per allocated RB in the allocated component carrier	Any RB in the non-allocated component carrier. The frequency raster of the RBs is derived when this component carrier is allocated with RBs	
IQ Image	dB	BW of 1 RB (180KHz rectangular)	-25 + TT	The reference value is the average power per allocated RB in the allocated component carrier	The frequencies of the $L_{CRB}$ contiguous non-allocated RBs are unknown. The frequency raster of the RBs is derived when this component carrier is allocated with RBs	
			NOTE 2			
Carrier leakage	dBc	BW of 1 RB (180KHz rectangular)	NOTE 3		The reference value is the total power of the allocated RBs in the allocated component carrier	The frequencies of the up to 2 non-allocated RBs are unknown. The frequency raster of the RBs is derived when this component carrier is allocated with RBs
			-25 + TT	Output power > 0 dBm		
			-20 + TT	-30 dBm ≤ Output power ≤ 0 dBm		
			-10 + TT	-40 dBm ≤ Output power < -30 dBm		
<p>NOTE 1: Resolution BWs smaller than the measurement BW may be integrated to achieve the measurement bandwidth.</p> <p>NOTE 2: Exceptions to the general limit is are allowed for up to <math>L_{CRB} + 1</math> RBs within a contiguous width of <math>L_{CRB} + 1</math> non-allocated RBs.</p> <p>NOTE 3: Two Exceptions to the general limit are allowed for up to two contiguous non-allocated RBs</p> <p>NOTE 4: NOTES 1, 5, 6, 7, 8, 9 from Table 6.5.2A.3.1-1 apply for Table 6.5.2A.3.1-2 as well.</p> <p>NOTE 5: <math>\Delta_{RB}</math> for measured non-allocated RB in the non-allocated component carrier may take non-integer values when the carrier spacing between the CCs is not a multiple of RB.</p> <p>NOTE 6: Test tolerance TT = 0.8 dB.</p>						

6.4B.2.1.4 EVM Equalizer Flatness for intra-band contiguous EN-DC

6.4B.2.1.4.1 Test purpose

Same test purpose as in clause 6.4.2.4 in TS 38.521-1 [8] for the NR carrier.

#### 6.4B.2.1.4.2 Test applicability

This test case applies to all types of E-UTRA UE release 15 and forward, supporting intra-band contiguous EN-DC.

#### 6.4B.2.1.4.3 Minimum conformance requirements

Same minimum conformance requirements as in clause 6.4.2.4.3 in TS 38.521-1 [8] for the NR carrier.

No exception requirements applicable to NR or E-UTRA. LTE anchor agnostic approach is applied.

#### 6.4B.2.1.4.4 Test description

Same test description as in clause 6.4.2.4.4 in TS 38.521-1 [8] for the NR carrier with the following exception:

**Table 6.4B.2.1.4.4-1: Test Configuration Table**

Initial Conditions	
Test Frequencies as specified in TS 38.508-1 [6] clause 4.3.1	Mid range
Test EN-DC bandwidth combination as specified in Table 5.3B.1.2-1	Highest NRB_agg (NOTE 1)
NOTE 1: If the UE supports multiple CC Combinations in the EN-DC Configuration with the same NRB_agg, only the combination with the highest NRB_SCG is tested.	

The initial test configurations for E-UTRA band consist of environmental conditions, test frequencies, and channel bandwidths based on E-UTRA bands specified in Table 4.6-1.

For Initial conditions as in clause 6.4.2.4.4.1 in TS 38.521-1 [8], the following steps will be added to configure E-UTRA component:

- 2.1. The parameter settings for E-UTRA cell are set up according to TS 36.508 [11] clause 4.4.3.
- 3.1. The E-UTRA downlink signal level, uplink signal level are set according to Table 4.6-1 and propagation conditions are set according to Annex B.0 of TS 36.521-1 [10].

Step 6 of Initial conditions as in clause 6.4.2.4.4.1 in TS 38.521-1 [8] is replaced by the following two steps:

6. Ensure the UE is in state RRC\_CONNECTED with generic procedure parameters Connectivity EN-DC, DC bearer MCG and SCG, Connected without release On according to TS 38.508-1 [6] clause 4.5.
7. When E-UTRA and NR bands are TDD, ensure the same uplink-downlink configuration by giving SCG a delay of 3 E-UTRA subframes, or by giving MCG a delay of 2 subframes.

Same test procedure as in clause 6.4.2.4.4.2 in TS 38.521-1 [8] with the following steps added for E-UTRA component:

- 1.1. On the E-UTRA carrier, disable periodic and aperiodic CQI reports, disable SRS, set *TimeAlignmentTimerDedicated* IE to infinity and disable downlink and uplink scheduling, all as per Table 4.6-1 under clause 4.6.

#### 6.4B.2.1.4.5 Test requirement

Same test requirement as in clause 6.4.2.4.5 in TS 38.521-1 [8] for the NR carrier.

### 6.4B.2.2 Transmit Modulation Quality for intra-band non-contiguous EN-DC

#### 6.4B.2.2.1 Error Vector Magnitude for intra-band non-contiguous EN-DC

##### 6.4B.2.2.1.1 Test purpose

Same test purpose as in clause 6.4.2.1.1 in TS 38.521-1 [8] for the NR carrier.



#### 6.4B.2.2.1.2 Test applicability

This test case applies to all types of E-UTRA UE release 15 and forward, supporting intra-band non-contiguous EN-DC.

#### 6.4B.2.2.1.3 Minimum conformance requirements

For the intra-band non-contiguous EN-DC with one component carrier per CG the EVM requirement applies with PRB allocation in one of the CG and the other CG unallocated.

The EVM requirements for each CG are according to clause 6.5.2.1 of TS 36.101 [5] for the MCG and clause 6.4.2.1.3 of TS 38.521-1 [8] for the SCG with EN-DC configured.

The normative reference for this requirement is TS 38.101-3 [4] clause 6.4B.2.2.1.

No exception requirements applicable to NR or E-UTRA. LTE anchor agnostic approach is applied.

#### 6.4B.2.2.1.4 Test description

Same test description as in clause 6.4.2.1.4 in TS 38.521-1 [8] for the NR carrier with the following exception:

The initial test configurations for E-UTRA band consist of environmental conditions, test frequencies, and channel bandwidths based on E-UTRA bands specified in Table 4.6-1. For Initial conditions as in clause 6.4.2.1.4.1 in TS 38.521-1 [8], the following steps will be added to configure E-UTRA component:

- 2.1. The parameter settings for E-UTRA cell are set up according to TS 36.508 [11] clause 4.4.3.
- 3.1. The E-UTRA downlink signal level, uplink signal level are set according to Table 4.6-1 and propagation conditions are set according to Annex B.0 of TS 36.521-1 [10].

Step 6 of Initial conditions as in clause 6.4.2.1.4.1 in TS 38.521-1 [8] is replaced by the following three steps:

6. Ensure the UE is in state RRC\_CONNECTED with generic procedure parameters Connectivity EN-DC, DC bearer MCG and SCG, Connected without release *On* according to TS 38.508-1 [6] clause 4.5.
7. On the E-UTRA carrier, disable periodic and aperiodic CQI reports, disable SRS, set TimeAlignmentTimerDedicated IE to infinity and disable downlink and uplink scheduling, all as per Table 4.6-1 under clause 4.6.
8. When E-UTRA and NR bands are TDD, ensure the same uplink-downlink configuration by giving SCG a delay of 3 E-UTRA subframes, or by giving MCG a delay of 2 subframes.

Same test procedure as in clause 6.4.2.1.4.2 in TS 38.521-1 [8].

For Message contents as in clause 6.4.2.1.4.3 in TS 38.521-1 [8], the following exception:

**Table 6.4B.2.2.1.4-1: RACH-ConfigGeneric: PRACH measurement**

Derivation Path: TS 38.508-1[5], Table 4.6.3-130			
Information Element	Value/remark	Comment	Condition
RACH-ConfigGeneric ::= SEQUENCE { prach-ConfigurationIndex	14	Unpaired Spectrum	PRACH Format 0 AND delay is given to SCG in Step 8 of Initial conditions
	12	Unpaired Spectrum	PRACH Format 0 AND delay is given to MCG in Step 8 of Initial conditions

**6.4B.2.2.1.5 Test requirement**

Same test requirement as in clause 6.4.2.1.5 in TS 38.521-1 [8] for the NR carrier.

**6.4B.2.2.2 Carrier Leakage for intra-band non-contiguous EN-DC****6.4B.2.2.2.1 Test purpose**

Same test purpose as in clause 6.4.2.2.1 in TS 38.521-1 [8] for the NR carrier.

**6.4B.2.2.2.2 Test applicability**

This test case applies to all types of E-UTRA UE release 15 and forward, supporting intra-band non-contiguous EN-DC.

**6.4B.2.2.2.3 Minimum conformance requirements**

The carrier leakage requirements for each CG are according to clause 6.5.2.2 of TS 36.101 [5] for the MCG and clause 6.4.2.2.3 of TS 38.521-1 [8] for the SCG with EN-DC configured and PRB allocation only in the CG being measured.

The normative reference for this requirement is TS 38.101-3 [4] clause 6.4B.2.2.2.

No exception requirements applicable to NR or E-UTRA. LTE anchor agnostic approach is applied.

**6.4B.2.2.2.4 Test description**

Same test description as in clause 6.4.2.2.4 in TS 38.521-1 [8] for the NR carrier with the following exception:

The initial test configurations for E-UTRA band consist of environmental conditions, test frequencies, and channel bandwidths based on E-UTRA bands specified in Table 4.6-1.

For Initial conditions as in clause 6.4.2.2.4.1 in TS 38.521-1 [8], the following steps will be added to configure E-UTRA component:

- 2.1. The parameter settings for E-UTRA cell are set up according to TS 36.508 [11] clause 4.4.3.
- 3.1. The E-UTRA downlink signal level, uplink signal level are set according to Table 4.6-1 and propagation conditions are set according to Annex B.0 of TS 36.521-1 [10].

Step 6 of Initial conditions as in clause 6.4.2.2.4.1 in TS 38.521-1 [8] is replaced by the following three steps:

6. Ensure the UE is in state RRC\_CONNECTED with generic procedure parameters Connectivity EN-DC, DC bearer MCG and SCG, Connected without release *On* according to TS 38.508 [6] clause 4.5.
7. On the E-UTRA carrier, disable periodic and aperiodic CQI reports, disable SRS, set *TimeAlignmentTimerDedicated* IE to infinity and disable downlink and uplink scheduling, all as per Table 4.6-1 under clause 4.6.
8. When E-UTRA and NR bands are TDD, ensure the same uplink-downlink configuration by giving SCG a delay of 3 E-UTRA subframes, or by giving MCG a delay of 2 subframes.

#### 6.4B.2.2.2.5 Test requirement

Same test requirement as in clause 6.4.2.2.5 in TS 38.521-1 [8] for the NR carrier.

#### 6.4B.2.2.3 In-band Emissions for intra-band non-contiguous EN-DC

##### 6.4B.2.2.3.1 Test purpose

Same test purpose as in clause 6.4.2.3.1 in TS 38.521-1 [8] for the NR carrier.

##### 6.4B.2.2.3.2 Test applicability

This test case applies to all types of E-UTRA UE release 15 and forward, supporting intra-band non-contiguous EN-DC.

##### 6.4B.2.2.3.3 Minimum conformance requirements

For the MCG the in-band emission requirements in Table 6.5.2A.3.1-1 and Table 6.5.2A.3.1-2 in TS 36.101 [5] apply within the transmission bandwidth configuration of the MCG with the carriers of both CGs active and one single contiguous PRB allocation of bandwidth  $L_{CRB}$  within the MCG at the edge of the transmission bandwidth configuration.

For the SCG the in-band emission requirements in Table 6.4.2.3-1 TS 38.101-1 [2] apply within the transmission bandwidth configuration of the SCG with the carriers of both CGs active and one single contiguous PRB allocation of bandwidth  $L_{CRB}$  within the SCG at the edge of the transmission bandwidth configuration.

The normative reference for this requirement is TS 38.101-3 [4] clause 6.4B.2.2.3.

No exception requirements applicable to NR or E-UTRA. LTE anchor agnostic approach is applied.

##### 6.4B.2.2.3.4 Test description

Same test description as in clause 6.4.2.3.4 in TS 38.521-1 [8] for the NR carrier with the following exception:

**Table 6.4B.2.2.3.4-1: Test Configuration Table**

Initial Conditions	
Test Frequencies as specified in TS 38.508-1 [6] clause 4.3.1	Low range, Mid range, High range
Test EN-DC bandwidth combination as specified in Table 5.3B.1.3-1	Lowest $N_{RB\_agg}$ , Highest $N_{RB\_agg}$ (NOTE 1)
NOTE 1: If the UE supports multiple CC Combinations in the EN-DC Configuration with the same $N_{RB\_agg}$ , only the combination with the highest $N_{RB\_SCG}$ is tested for Lowest $N_{RB\_agg}$ and Highest $N_{RB\_agg}$ .	

The initial test configurations for E-UTRA as specified in Table 4.6-1 except for the parameters specified in Table 6.4B.2.2.3.4-1.

For Initial conditions as in clause 6.4.2.3.4.1 in TS 38.521-1 [8], the following steps are added to configure E-UTRA component:

- 2.1. The parameter settings for E-UTRA cell are set up according to TS 36.508 [11] clause 4.4.3.

- 3.1. The E-UTRA downlink signal level, uplink signal level are set according to Table 4.6-1 and propagation conditions are set according to Annex B.0 of TS 36.521-1 [10].

Step 6 of Initial conditions as in clause 6.4.2.3.4.1 in TS 38.521-1 [8] is replaced by the following three steps:

6. Ensure the UE is in state RRC\_CONNECTED with generic procedure parameters Connectivity EN-DC, DC bearer MCG and SCG, Connected without release *On* according to TS 38.508-1 [6] clause 4.5.
7. On the E-UTRA carrier, disable periodic and aperiodic CQI reports, disable SRS, set TimeAlignmentTimerDedicated IE to infinity and disable downlink and uplink scheduling, all as per Table 4.6-1 under clause 4.6.
8. When E-UTRA and NR bands are TDD, ensure the same uplink-downlink configuration by giving SCG a delay of 3 E-UTRA subframes, or by giving MCG a delay of 2 subframes.

#### 6.4B.2.2.3.5 Test requirements

Same test requirement as in clause 6.4.2.3.5 in TS 38.521-1 [8] for the NR carrier.

#### 6.4B.2.2.4 EVM Equalizer Flatness for intra-band non-contiguous EN-DC

##### 6.4B.2.2.4.1 Test purpose

Same test purpose as in clause 6.4.2.4 in TS 38.521-1 [8] for the NR carrier.

##### 6.4B.2.2.4.2 Test applicability

This test case applies to all types of E-UTRA UE release 15 and forward, supporting intra-band non-contiguous EN-DC.

##### 6.4B.2.2.4.3 Minimum conformance requirements

Same minimum conformance requirements as in clause 6.4.2.4.3 in TS 38.521-1 [8] for the NR carrier.

No exception requirements applicable to NR or E-UTRA. LTE anchor agnostic approach is applied.

##### 6.4B.2.2.4.4 Test description

Same test description as in clause 6.4.2.4.4 in TS 38.521-1 [8] for the NR carrier with the following exception:

**Table 6.4B.2.2.4.4-1: Test Configuration Table**

Initial Conditions			
Test Environment as specified in TS 38.508-1 [6] clause 4.1		Normal, TL/VL, TL/VH, TH/VL, TH/VH	
Test Frequencies as specified in TS 38.508-1 [6] clause 4.3.1		MaxWGap	
Test Channel Bandwidths as specified in TS 38.508-1 [6] clause 4.3.1		Highest $N_{RB\_agg}$ (NOTE 1, 2)	
Test SCS as specified in Table 5.3.5-1		Lowest	
Test parameters			
Test ID	Downlink Configuration N/A for EVM equalizer flatness testing	Uplink Configuration	
		Modulation	NR RB allocation (NOTE 3)
		1	DFT-s-OFDM QPSK
2	CP-OFDM QPSK	Outer Full	
NOTE 1: Test Channel Bandwidths are checked separately for each NR band, which applicable channel bandwidths are specified in Table 5.3.5-1 of 38.521-1 [8].			
NOTE 2: Lowest and highest allowed NR channel BW as specified in Table 5.3B.1.3-1. If the UE supports multiple CC Combinations in the EN-DC Configuration with the same $N_{RB\_agg}$ , only the combination with the highest $N_{RB\_SCG}$ is tested.			
NOTE 3: The specific configuration of each RB allocation is defined in Table 6.1-1 of 38.521-1 [8].			

The initial test configurations for E-UTRA band consist of environmental conditions, test frequencies, and channel bandwidths based on E-UTRA bands specified in Table 4.6-1.

For Initial conditions as in clause 6.4.2.4.4.1 in TS 38.521-1 [8], the following steps will be added to configure E-UTRA component:

- 2.1. The parameter settings for E-UTRA cell are set up according to TS 36.508 [11] clause 4.4.3.
- 3.1. The E-UTRA downlink signal level, uplink signal level are set according to Table 4.6-1 and propagation conditions are set according to Annex B.0 of TS 36.521-1 [10].

Step 6 of Initial conditions as in clause 6.4.2.4.4.1 in TS 38.521-1 [8] is replaced by the following two steps:

6. Ensure the UE is in state RRC\_CONNECTED with generic procedure parameters Connectivity EN-DC, DC bearer MCG and SCG, Connected without release On according to TS 38.508-1 [6] clause 4.5.
7. When E-UTRA and NR bands are TDD, ensure the same uplink-downlink configuration by giving SCG a delay of 3 E-UTRA subframes, or by giving MCG a delay of 2 subframes.

Same test procedure as in clause 6.4.2.4.4.2 in TS 38.521-1 [8] with the following steps added for E-UTRA component:

- 1.1 On the E-UTRA carrier, disable periodic and aperiodic CQI reports, disable SRS, set *TimeAlignmentTimerDedicated* IE to infinity and disable downlink and uplink scheduling, all as per Table 4.6-1 under clause 4.6.

#### 6.4B.2.2.4.5 Test requirement

Same test requirement as in clause 6.4.2.4.5 in TS 38.521-1 [8] for the NR carrier.

### 6.4B.2.3 Transmit Modulation Quality for inter-band EN-DC within FR1

#### 6.4B.2.3.1 Error Vector Magnitude for inter-band EN-DC within FR1 (1 NR CC)

##### 6.4B.2.3.1.1 Test purpose

Same test purpose as in clause 6.4.2.1.1 in TS 38.521-1 [8] for the NR carrier.

##### 6.4B.2.3.1.2 Test applicability

This test case applies to all types of E-UTRA UE release 15 and forward, supporting inter-band EN-DC within FR1 with 1 NR UL.

##### 6.4B.2.3.1.3 Minimum conformance requirements

Same minimum conformance requirements as in clause 6.4.2.1.3 in TS 38.521-1 [8] for the NR carrier.

The normative reference for this requirement is TS 38.101-3 [4] clause 6.4B.2.

No exception requirements applicable to NR or E-UTRA. LTE anchor agnostic approach is applied.

##### 6.4B.2.3.1.4 Test description

Same test description as in clause 6.4.2.1.4 in TS 38.521-1 [8] for the NR carrier with the following exception:

The initial test configurations for E-UTRA band consist of environmental conditions, test frequencies, and channel bandwidths based on E-UTRA bands specified in Table 4.6-1. For Initial conditions as in clause 6.4.2.1.4.1 in TS 38.521-1 [8], the following steps will be added to configure E-UTRA component:

- 2.1. The parameter settings for E-UTRA cell are set up according to TS 36.508 [11] clause 4.4.3.
- 3.1. The E-UTRA downlink signal level, uplink signal level are set according to Table 4.6-1 and propagation conditions are set according to Annex B.0 of TS 36.521-1 [10].

Step 6 of Initial conditions as in clause 6.4.2.1.4.1 in TS 38.521-1 [8] is replaced by the following two steps:

6. Ensure the UE is in state RRC\_CONNECTED with generic procedure parameters Connectivity EN-DC, DC bearer MCG and SCG, Connected without release *On* according to TS 38.508 [6] clause 4.5.
7. On the E-UTRA carrier, disable periodic and aperiodic CQI reports, disable SRS, set *TimeAlignmentTimerDedicated* IE to infinity and disable downlink and uplink scheduling, all as per Table 4.6-1 under clause 4.6.

Same test procedure as in clause 6.4.2.1.4.2 in TS 38.521-1 [8].

#### 6.4B.2.3.1.5 Test requirement

Same test requirement as in clause 6.4.2.1.5 in TS 38.521-1 [8] for the NR carrier.

#### 6.4B.2.3.2 Carrier Leakage for inter-band EN-DC within FR1 (1 NR CC)

##### 6.4B.2.3.2.1 Test purpose

Same test purpose as in clause 6.4.2.2.1 in TS 38.521-1 [8] for the NR carrier.

##### 6.4B.2.3.2.2 Test applicability

This test case applies to all types of E-UTRA UE release 15 and forward, supporting inter-band EN-DC within FR1 with 1 NR UL.

##### 6.4B.2.3.2.3 Minimum conformance requirements

Same minimum conformance requirements as in clause 6.4.2.2.3 in TS 38.521-1 [8] for the NR carrier.

The normative reference for this requirement is TS 38.101-3 [4] clause 6.4B.2.

No exception requirements applicable to NR or E-UTRA. LTE anchor agnostic approach is applied.

##### 6.4B.2.3.2.4 Test description

Same test description as in clause 6.4.2.2.4 in TS 38.521-1 [8] for the NR carrier with the following exception:

The initial test configurations for E-UTRA band consist of environmental conditions, test frequencies, and channel bandwidths based on E-UTRA bands specified in Table 4.6-1.

For Initial conditions as in clause 6.4.2.2.4.1 in TS 38.521-1 [8], the following steps will be added to configure E-UTRA component:

- 2.1. The parameter settings for E-UTRA cell are set up according to TS 36.508 [11] clause 4.4.3.
- 3.1. The E-UTRA downlink signal level, uplink signal level are set according to Table 4.6-1 and propagation conditions are set according to Annex B.0 of TS 36.521-1 [10].

Step 6 of Initial conditions as in clause 6.5.2.2.4.1 in TS 38.521-1 [8] is replaced by the following two steps:

6. Ensure the UE is in state RRC\_CONNECTED with generic procedure parameters Connectivity EN-DC, DC bearer MCG and SCG, Connected without release *On* according to TS 38.508 [6] clause 4.5.
7. On the E-UTRA carrier, disable periodic and aperiodic CQI reports, disable SRS, set *TimeAlignmentTimerDedicated* IE to infinity and disable downlink and uplink scheduling, all as per Table 4.6-1 under clause 4.6.

#### 6.4B.2.3.2.5 Test requirement

Same test requirement as in clause 6.4.2.2.5 in TS 38.521-1 [8] for the NR carrier.

### 6.4B.2.3.3 In-band Emissions for inter-band EN-DC within FR1 (1 NR CC)

#### 6.4B.2.3.3.1 Test purpose

Same test purpose as in clause 6.4.2.3.1 in TS 38.521-1 [8] for the NR carrier.

#### 6.4B.2.3.3.2 Test applicability

This test case applies to all types of E-UTRA UE release 15 and forward, supporting inter-band EN-DC within FR1 with 1 NR UL.

#### 6.4B.2.3.3.3 Minimum conformance requirements

Same minimum conformance requirements as in clause 6.4.2.3.3 in TS 38.521-1 [8] for the NR carrier.

The normative reference for this requirement is TS 38.101-3 [4] clause 6.4B.2.

No exception requirements applicable to NR or E-UTRA. LTE anchor agnostic approach is applied.

#### 6.4B.2.3.3.4 Test description

Same test description as in clause 6.4.2.3.4 in TS 38.521-1 [8] for the NR carrier with the following exception:

The initial test configurations for E-UTRA band consist of environmental conditions, test frequencies, and channel bandwidths based on E-UTRA bands specified in Table 4.6-1. For Initial conditions as in clause 6.4.2.3.4.1 in TS 38.521-1 [8], the following steps will be added to configure E-UTRA component:

- 2.1. The parameter settings for E-UTRA cell are set up according to TS 36.508 [11] clause 4.4.3.
- 3.1. The E-UTRA downlink signal level, uplink signal level are set according to Table 4.6-1 and propagation conditions are set according to Annex B.0 of TS 36.521-1 [10].

Step 6 of Initial conditions as in clause 6.4.2.3.4.1 in TS 38.521-1 [8] is replaced by:

6. Ensure the UE is in state RRC\_CONNECTED with generic procedure parameters Connectivity EN-DC, DC bearer MCG and SCG, Connected without release *On* according to TS 38.508 [6] clause 4.5.
7. On the E-UTRA carrier, disable periodic and aperiodic CQI reports, disable SRS, set *TimeAlignmentTimerDedicated* IE to infinity and disable downlink and uplink scheduling, all as per Table 4.6-1 under clause 4.6.

Same test procedure as in clause 6.4.2.3.4.2 in TS 38.521-1 [8].

#### 6.4B.2.3.3.5 Test requirement

Same test requirement as in clause 6.4.2.3.5 in TS 38.521-1 [8] for the NR carrier.

### 6.4B.2.3.4 EVM Equalizer Flatness for inter-band EN-DC within FR1 (1 NR CC)

#### 6.4B.2.3.4.1 Test purpose

Same test purpose as in clause 6.4.2.4 in TS 38.521-1 [8] for the NR carrier.

#### 6.4B.2.3.4.2 Test applicability

This test case applies to all types of E-UTRA UE release 15 and forward, supporting inter-band EN-DC within FR1 with 1 NR UL.

#### 6.4B.2.3.4.3 Minimum conformance requirements

Same minimum conformance requirements as in clause 6.4.2.4.3 in TS 38.521-1 [8] for the NR carrier.

No exception requirements applicable to NR or E-UTRA. LTE anchor agnostic approach is applied.

#### 6.4B.2.3.4.4 Test description

##### 6.4B.2.3.4.4.1 Initial conditions

Same test description as in clause 6.4.2.4.4 in TS 38.521-1 [8] for the NR carrier with the following exception:

The initial test configurations for E-UTRA band consist of environmental conditions, test frequencies, and channel bandwidths based on E-UTRA bands specified in Table 4.6-1.

For Initial conditions as in clause 6.4.2.4.4.1 in TS 38.521-1 [8], the following steps will be added to configure E-UTRA component:

- 2.1. The parameter settings for E-UTRA cell are set up according to TS 36.508 [11] clause 4.4.3.
- 3.1. The E-UTRA downlink signal level, uplink signal level are set according to Table 4.6-1 and propagation conditions are set according to Annex B.0 of TS 36.521-1 [10].

Step 6 of Initial conditions as in clause 6.4.2.4.4.1 in TS 38.521-1 [8] is replaced by:

6. Ensure the UE is in state RRC\_CONNECTED with generic procedure parameters Connectivity EN-DC, DC bearer MCG and SCG, Connected without release On according to TS 38.508-1 [6] clause 4.5.

Same test procedure as in clause 6.4.2.4.4.2 in TS 38.521-1 [8] with the following steps added for E-UTRA component:

- 1.1 On the E-UTRA carrier, disable periodic and aperiodic CQI reports, disable SRS, set *TimeAlignmentTimerDedicated* IE to infinity and disable downlink and uplink scheduling, all as per Table 4.6-1 under clause 4.6.

#### 6.4B.2.3.4.5 Test requirement

Same test requirement as in clause 6.4.2.4.5 in TS 38.521-1 [8] for the NR carrier.

### 6.4B.2.3a Transmit Modulation Quality for inter-band NE-DC within FR1

#### 6.4B.2.3a.1 Error Vector Magnitude for inter-band NE-DC within FR1

No exception requirements applicable to NR or E-UTRA.

No test case details are specified. The requirements for NR carrier(s) in this test case are tested covered in 6.4.2.1 and 6.4A.2.1 of TS 38.521-1 [8], and the requirements for LTE carrier(s) in this test case are tested in 6.5.2.1 and 6.5.2A.1 of TS 36.521-1 [10]. Neither NR carrier(s) nor LTE carrier(s) needs to be tested again.

#### 6.4B.2.3a.2 Carrier Leakage for inter-band NE-DC within FR1

No exception requirements applicable to NR or E-UTRA.

No test case details are specified. The requirements for NR carrier(s) in this test case are tested in 6.4.2.2 and 6.4A.2.2 of TS 38.521-1 [8], and the requirements for LTE carrier(s) in this test case are tested in 6.5.2.2 and 6.5.2A.2 of TS 36.521-1 [10]. Neither NR carrier(s) nor LTE carrier(s) needs to be tested again.

#### 6.4B.2.3a.3 In-band Emissions for inter-band NE-DC within FR1

No exception requirements applicable to NR or E-UTRA.

No test case details are specified. The requirements for NR carrier(s) in this test case are tested in 6.4.2.3 and 6.4A.2.3 of TS 38.521-1 [8], and the requirements for LTE carrier(s) in this test case are tested in 6.5.2 and 6.5.2A.3 of TS 36.521-1 [10]. Neither NR carrier(s) nor LTE carrier(s) needs to be tested again.

#### 6.4B.2.3a.4 EVM Equalizer Flatness for inter-band NE-DC within FR1 (1 NR CC)

No exception requirements applicable to NR or E-UTRA.



No test case details are specified. The requirements for NR carrier in this test case are tested in 6.4.2.4 and 6.4.2.5 of TS 38.521-1 [8], and the requirements for LTE carrier in this test case are tested in 6.5.2.4 of TS 36.521-1 [10]. Neither NR carrier(s) nor LTE carrier(s) needs to be tested again.

## 6.4B.2.4 Transmit Modulation Quality for inter-band EN-DC including FR2

### 6.4B.2.4.1 Error Vector Magnitude for inter-band EN-DC including FR2 (1 NR CC)

**Editor's note:** This clause is complete for PUSCH with PC1 in FR2a, PC3 in FR2a and FR2b, PC5 in FR2a. The following aspects of the clause are for future consideration in the referred test case 6.4.2.1 in TS 38.521-2 [9]:

- Measurement Uncertainty and Test Tolerance are FFS except for PUSCH, PC3 in FR2a and FR2b, PC1 in FR2a and PC5 in FR2a.

#### 6.4B.2.4.1.1 Test purpose

Same test purpose as in clause 6.4.2.1 in TS 38.521-2 [9] for the NR carrier.

#### 6.4B.2.4.1.2 Test applicability

This test case applies to all types of E-UTRA UE release 15 and forward, supporting inter-band EN-DC including FR2 with 1 NR UL CC.

#### 6.4B.2.4.1.3 Minimum conformance requirements

For inter-band EN-DC including FR2 or both FR1 and FR2, transmit modulation quality for EN-DC operations in FR1 and FR2 as specified in TS 36.101 [5], 38.101-1 [2] and 38.101-2 [3] apply for E-UTRA, NR FR1 and NR FR2 respectively.

The normative reference for this requirement is TS 38.101-3 [4] clause 6.4B.2.4.

Same minimum conformance requirements as in clause 6.4.2.1.3 in TS 38.521-2 [9] for the NR carrier.

No exception requirements applicable to NR or LTE. LTE anchor agnostic approach is applied.

#### 6.4B.2.4.1.4 Test description

##### 6.4B.2.4.1.4.1 Initial conditions

Same test description as in clause 6.4.2.1.4 in TS 38.521-2 [9] for the NR carrier with the following exception:

The initial test configurations for E-UTRA band consist of environmental conditions, test frequencies, and channel bandwidths based on E-UTRA bands specified in Table 4.7-1. For Initial conditions as in clause 6.4.2.1.4.1 in TS 38.521-2 [9], the following steps will be added to configure E-UTRA component:

- 2.1. The parameter settings for E-UTRA cell are set up according to TS 36.508 [11] clause 4.4.3.
- 3.1. The E-UTRA downlink signal level, uplink signal level are set according to Table 4.7-1 and propagation conditions are set according to Annex B.0 of TS 36.521-1 [10].

Step 6 of Initial conditions as in clause 6.4.2.4.1 in TS 38.521-2 [9] is replaced by:

6. Ensure the UE is in state RRC\_CONNECTED with generic procedure parameters Connectivity EN-DC, DC bearer MCG and SCG, Connected without release On according to TS 38.508-1 [6] clause 4.5.

Same test procedure as in clause 6.4.2.1.4.1 in TS 38.521-2 [9] with the following steps added for E-UTRA component:

- 1.1 On the E-UTRA carrier, disable periodic and aperiodic CQI reports, disable SRS, set *TimeAlignmentTimerDedicated* IE to infinity and disable downlink and uplink scheduling, all as per Table 4.7-1 under clause 4.7.

#### 6.4B.2.4.1.5 Test requirement

Same test requirement as in clause 6.4.2.1.5 in TS 38.521-2 [9] for the NR carrier.

#### 6.4B.2.4.1a Error Vector Magnitude with Power Boost for inter-band EN-DC including FR2 (1 NR CC)

**Editor's note: This clause is incomplete. The following aspects are either missing or not yet determined in the referred test case 6.4.2.1\_1 in TS 38.521-2 [9]:**

- **Measurement Uncertainty and Test Tolerance are FFS except for PUSCH, PC3 in FR2a and FR2b.**

#### 6.4B.2.4.1a.1 Test purpose

Same test purpose as in clause 6.4.2.1\_1 in TS 38.521-2 [9] for the NR carrier.

#### 6.4B.2.4.1a.2 Test applicability

This test case applies to all types of NR UE release 16 and forward supporting *mpr-PowerBoost-FR2-r16* UE capability, supporting inter-band EN-DC including FR2 with 1 NR UL CC.

#### 6.4B.2.4.1a.3 Minimum conformance requirements

For inter-band EN-DC including FR2 or both FR1 and FR2, transmit modulation quality for EN-DC operations in FR1 and FR2 as specified in TS 36.101 [5], 38.101-1 [2] and 38.101-2 [3] apply for E-UTRA, NR FR1 and NR FR2 respectively.

The normative reference for this requirement is TS 38.101-3 [4] clause 6.4B.2.4.

Same minimum conformance requirements as in clause 6.4.2.1\_1.3 in TS 38.521-2 [9] for the NR carrier.

No exception requirements applicable to NR or LTE. LTE anchor agnostic approach is applied.

#### 6.4B.2.4.1a.4 Test description

Same test description as in clause 6.4.2.1\_1.4 in TS 38.521-2 [9] for the NR carrier with the following exceptions:

The initial test configurations for E-UTRA band consist of environmental conditions, test frequencies, and channel bandwidths based on E-UTRA bands specified in Table 4.7-1. For Initial conditions as in clause 6.4.2.1\_1.4.1 in TS 38.521-2 [9], the following steps will be added to configure E-UTRA component:

- 2.1. The parameter settings for E-UTRA cell are set up according to TS 36.508 [11] clause 4.4.3.
- 3.1. The E-UTRA downlink signal level, uplink signal level are set according to Table 4.7-1 and propagation conditions are set according to Annex B.0 of TS 36.521-1 [10].

Step 6 of Initial conditions as in clause 6.4.2.1\_1.4.1 in TS 38.521-2 [9] is replaced by:

6. Ensure the UE is in state RRC\_CONNECTED with generic procedure parameters Connectivity EN-DC, DC bearer MCG and SCG, Connected without release On according to TS 38.508-1 [6] clause 4.5.

Same test procedure as in clause 6.4.2.1\_1.4.1 in TS 38.521-2 [9] with the following steps added for E-UTRA component:

- 1.1 On the E-UTRA carrier, disable periodic and aperiodic CQI reports, disable SRS, set *TimeAlignmentTimerDedicated* IE to infinity and disable downlink and uplink scheduling, all as per Table 4.7-1 under clause 4.7.

#### 6.4B.2.4.1\_2.5 Test requirement

Same test requirement as in clause 6.4.2.1\_1.5 in TS 38.521-2 [9] for the NR carrier.

#### 6.4B.2.4.1\_1 Error Vector Magnitude for inter-band EN-DC including FR2 (>1 NR CC)

##### 6.4B.2.4.1\_1.1 Error Vector Magnitude for inter-band EN-DC including FR2 (2 NR CCs)

Editor's note: This clause is incomplete. The following aspects are either missing or not yet determined:

- The referred test case 6.4A.2.1.1 in TS 38.521-2 [9] is incomplete.
- Test configuration table is FFS.
- This test is incomplete due to lack of RRC framework for LO position retrieval

##### 6.4B.2.4.1\_1.1.1 Test purpose

Same test purpose as in clause 6.4.2.1.1 in TS 38.521-2 [9] for the NR carrier.

##### 6.4B.2.4.1\_1.1.2 Test applicability

This test case applies to all types of E-UTRA UE release 15 and forward, supporting inter-band EN-DC including FR2 with 2 NR UL CCs.

##### 6.4B.2.4.1\_1.1.3 Minimum conformance requirements

Same minimum conformance requirements as in clause 6.4.2.1.3 in TS 38.521-2 [9] for the NR carrier.

No exception requirements applicable to NR or E-UTRA. LTE anchor agnostic approach is applied.

The normative reference for this requirement is TS 38.101-3 [4] clause 6.4B.2.4.

##### 6.4B.2.4.1\_1.1.4 Test description

###### 6.4B.2.4.1\_1.1.4.1 Initial condition

Same test description as in clause 6.4A.2.1.1.4 in TS 38.521-2 [9] for the NR carrier with the following exception:

The initial test configurations for E-UTRA band consist of environmental conditions, test frequencies, and channel bandwidths based on E-UTRA bands specified in Table 4.7-1.

For Initial conditions as in clause 6.4A.2.1.1.4.1 in TS 38.521-2 [9], the following steps will be added to configure E-UTRA component:

- 2.1. The parameter settings for E-UTRA cell are set up according to TS 36.508 [11] clause 4.4.3.
- 3.1. The E-UTRA downlink signal level, uplink signal level are set according to Table 4.7-1 and propagation conditions are set according to Annex B.0 of TS 36.521-1 [10].

Step 6 of Initial conditions as in clause 6.4A.2.1.1.4.1 in TS 38.521-2 [9] is replaced by:

6. Ensure the UE is in state RRC\_CONNECTED with generic procedure parameters Connectivity EN-DC, DC bearer MCG and SCG, Connected without release On according to TS 38.508-1 [6] clause 4.5.

Same test procedure as in clause 6.4A.2.1.1.4.2 in TS 38.521-2 [9] with the following steps added for E-UTRA component:

- 1.1 On the E-UTRA carrier, disable periodic and aperiodic CQI reports, disable SRS, set *TimeAlignmentTimerDedicated* IE to infinity and disable downlink and uplink scheduling, all as per Table 4.7-1 under clause 4.7.

##### 6.4B.2.4.1\_1.1.5 Test Requirements

Same test requirement as in clause 6.4A.2.1.1.5 in TS 38.521-2 [9] for the NR carrier.

#### 6.4B.2.4.1\_1.2 Error Vector Magnitude for inter-band EN-DC including FR2 (3 NR CCs)

**Editor's note: This clause is incomplete. The following aspects are either missing or not yet determined:**

- The referred test case 6.4A.2.1.2 in TS 38.521-2 [9] is incomplete.
- Test configuration table is FFS.

#### 6.4B.2.4.1\_1.2.1 Test purpose

Same test purpose as in clause 6.4.2.1.1 in TS 38.521-2 [9] for the NR carrier.

#### 6.4B.2.4.1\_1.2.2 Test applicability

This test case applies to all types of E-UTRA UE release 15 and forward, supporting inter-band EN-DC including FR2 with 3 NR UL CCs.

#### 6.4B.2.4.1\_1.2.3 Minimum conformance requirements

Same minimum conformance requirements as in clause 6.4.2.1.3 in TS 38.521-2 [9] for the NR carrier.

No exception requirements applicable to NR or E-UTRA. LTE anchor agnostic approach is applied.

The normative reference for this requirement is TS 38.101-3 [4] clause 6.4B.2.4.

#### 6.4B.2.4.1\_1.2.4 Test description

##### 6.4B.2.4.1\_1.2.4.1 Initial condition

Same test description as in clause 6.4A.2.1.2.4 in TS 38.521-2 [9] for the NR carrier with the following exception:

The initial test configurations for E-UTRA band consist of environmental conditions, test frequencies, and channel bandwidths based on E-UTRA bands specified in Table 4.7-1.

For Initial conditions as in clause 6.4A.2.1.2.4.1 in TS 38.521-2 [9], the following steps will be added to configure E-UTRA component:

- 2.1. The parameter settings for E-UTRA cell are set up according to TS 36.508 [11] clause 4.4.3.
- 3.1. The E-UTRA downlink signal level, uplink signal level are set according to Table 4.7-1 and propagation conditions are set according to Annex B.0 of TS 36.521-1 [10].

Step 6 of Initial conditions as in clause 6.4A.2.1.2.4.1 in TS 38.521-2 [9] is replaced by:

6. Ensure the UE is in state RRC\_CONNECTED with generic procedure parameters Connectivity EN-DC, DC bearer MCG and SCG, Connected without release On according to TS 38.508-1 [6] clause 4.5.

Same test procedure as in clause 6.4A.2.1.2.4.2 in TS 38.521-2 [9] with the following steps added for E-UTRA component:

- 1.1 On the E-UTRA carrier, disable periodic and aperiodic CQI reports, disable SRS, set *TimeAlignmentTimerDedicated* IE to infinity and disable downlink and uplink scheduling, all as per Table 4.7-1 under clause 4.7.

#### 6.4B.2.4.1\_1.2.5 Test Requirements

Same test requirement as in clause 6.4A.2.1.2.5 in TS 38.521-2 [9] for the NR carrier.

#### 6.4B.2.4.1\_1.3 Error Vector Magnitude for inter-band EN-DC including FR2 (4 NR CCs)

**Editor's note: This clause is incomplete. The following aspects are either missing or not yet determined:**

- The referred test case 6.4A.2.1.3 in TS 38.521-2 [9] is incomplete.

- Test configuration table is FFS.

#### 6.4B.2.4.1\_1.3.1 Test purpose

Same test purpose as in clause 6.4.2.1.1 in TS 38.521-2 [9] for the NR carrier.

#### 6.4B.2.4.1\_1.3.2 Test applicability

This test case applies to all types of E-UTRA UE release 15 and forward, supporting inter-band EN-DC including FR2 with 4 NR UL CCs.

#### 6.4B.2.4.1\_1.3.3 Minimum conformance requirements

Same minimum conformance requirements as in clause 6.4.2.1.3 in TS 38.521-2 [9] for the NR carrier.

No exception requirements applicable to NR or E-UTRA. LTE anchor agnostic approach is applied.

The normative reference for this requirement is TS 38.101-3 [4] clause 6.4B.2.4.

#### 6.4B.2.4.1\_1.3.4 Test description

##### 6.4B.2.4.1\_1.3.4.1 Initial condition

Same test description as in clause 6.4A.2.1.3.4 in TS 38.521-2 [9] for the NR carrier with the following exception:

The initial test configurations for E-UTRA band consist of environmental conditions, test frequencies, and channel bandwidths based on E-UTRA bands specified in Table 4.7-1.

For Initial conditions as in clause 6.4A.2.1.3.4.1 in TS 38.521-2 [9], the following steps will be added to configure E-UTRA component:

- 2.1. The parameter settings for E-UTRA cell are set up according to TS 36.508 [11] clause 4.4.3.
- 3.1. The E-UTRA downlink signal level, uplink signal level are set according to Table 4.7-1 and propagation conditions are set according to Annex B.0 of TS 36.521-1 [10].

Step 6 of Initial conditions as in clause 6.4A.2.1.3.4.1 in TS 38.521-2 [9] is replaced by:

6. Ensure the UE is in state RRC\_CONNECTED with generic procedure parameters Connectivity EN-DC, DC bearer MCG and SCG, Connected without release On according to TS 38.508-1 [6] clause 4.5.

Same test procedure as in clause 6.4A.2.1.3.4.2 in TS 38.521-2 [9] with the following steps added for E-UTRA component:

- 1.1 On the E-UTRA carrier, disable periodic and aperiodic CQI reports, disable SRS, set *TimeAlignmentTimerDedicated* IE to infinity and disable downlink and uplink scheduling, all as per Table 4.7-1 under clause 4.7.

#### 6.4B.2.4.1\_1.3.5 Test Requirements

Same test requirement as in clause 6.4A.2.1.3.5 in TS 38.521-2 [9] for the NR carrier.

#### 6.4B.2.4.1\_1.4 Error Vector Magnitude for inter-band EN-DC including FR2 (5 NR CCs)

**Editor's note: This clause is incomplete. The following aspects are either missing or not yet determined:**

- Measurement Uncertainty and Test Tolerance are FFS.

#### 6.4B.2.4.1\_1.4.1 Test purpose

Same test purpose as in clause 6.4.2.1.1 in TS 38.521-2 [9] for the NR carrier.

#### 6.4B.2.4.1\_1.4.2 Test applicability

This test case applies to all types of E-UTRA UE release 15 and forward, supporting inter-band EN-DC including FR2 with 5 NR UL CCs.

#### 6.4B.2.4.1\_1.4.3 Minimum conformance requirements

Same minimum conformance requirements as in clause 6.4.2.1.3 in TS 38.521-2 [9] for the NR carrier.

No exception requirements applicable to NR or E-UTRA. LTE anchor agnostic approach is applied.

The normative reference for this requirement is TS 38.101-3 [4] clause 6.4B.2.4.

#### 6.4B.2.4.1\_1.4.4 Test description

##### 6.4B.2.4.1\_1.4.4.1 Initial condition

Same test description as in clause 6.4A.2.1.4.4 in TS 38.521-2 [9] for the NR carrier with the following exception:

The initial test configurations for E-UTRA band consist of environmental conditions, test frequencies, and channel bandwidths based on E-UTRA bands specified in Table 4.7-1.

For Initial conditions as in clause 6.4A.2.1.4.4.1 in TS 38.521-2 [9], the following steps will be added to configure E-UTRA component:

- 2.1. The parameter settings for E-UTRA cell are set up according to TS 36.508 [11] clause 4.4.3.
- 3.1. The E-UTRA downlink signal level, uplink signal level are set according to Table 4.7-1 and propagation conditions are set according to Annex B.0 of TS 36.521-1 [10].

Step 6 of Initial conditions as in clause 6.4A.2.1.4.4.1 in TS 38.521-2 [9] is replaced by:

6. Ensure the UE is in state RRC\_CONNECTED with generic procedure parameters Connectivity EN-DC, DC bearer MCG and SCG, Connected without release On according to TS 38.508-1 [6] clause 4.5.

Same test procedure as in clause 6.4A.2.1.4.4.2 in TS 38.521-2 [9] with the following steps added for E-UTRA component:

- 1.1 On the E-UTRA carrier, disable periodic and aperiodic CQI reports, disable SRS, set *TimeAlignmentTimerDedicated* IE to infinity and disable downlink and uplink scheduling, all as per Table 4.7-1 under clause 4.7.

#### 6.4B.2.4.1\_1.4.5 Test Requirements

Same test requirement as in clause 6.4A.2.1.4.5 in TS 38.521-2 [9] for the NR carrier.

#### 6.4B.2.4.1\_1.5 Error Vector Magnitude for inter-band EN-DC including FR2 (6 NR CCs)

**Editor's note: This clause is incomplete. The following aspects are either missing or not yet determined:**

- **Measurement Uncertainty and Test Tolerance are FFS.**

##### 6.4B.2.4.1\_1.5.1 Test purpose

Same test purpose as in clause 6.4.2.1.1 in TS 38.521-2 [9] for the NR carrier.

##### 6.4B.2.4.1\_1.5.2 Test applicability

This test case applies to all types of E-UTRA UE release 15 and forward, supporting inter-band EN-DC including FR2 with 6 NR UL CCs.

#### 6.4B.2.4.1\_1.5.3 Minimum conformance requirements

Same minimum conformance requirements as in clause 6.4.2.1.3 in TS 38.521-2 [9] for the NR carrier.

No exception requirements applicable to NR or E-UTRA. LTE anchor agnostic approach is applied.

The normative reference for this requirement is TS 38.101-3 [4] clause 6.4B.2.4.

#### 6.4B.2.4.1\_1.5.4 Test description

##### 6.4B.2.4.1\_1.5.4.1 Initial condition

Same test description as in clause 6.4A.2.1.5.4 in TS 38.521-2 [9] for the NR carrier with the following exception:

The initial test configurations for E-UTRA band consist of environmental conditions, test frequencies, and channel bandwidths based on E-UTRA bands specified in Table 4.7-1.

For Initial conditions as in clause 6.4A.2.1.5.4.1 in TS 38.521-2 [9], the following steps will be added to configure E-UTRA component:

- 2.1. The parameter settings for E-UTRA cell are set up according to TS 36.508 [11] clause 4.4.3.
- 3.1. The E-UTRA downlink signal level, uplink signal level are set according to Table 4.7-1 and propagation conditions are set according to Annex B.0 of TS 36.521-1 [10].

Step 6 of Initial conditions as in clause 6.4A.2.1.5.4.1 in TS 38.521-2 [9] is replaced by:

6. Ensure the UE is in state RRC\_CONNECTED with generic procedure parameters Connectivity EN-DC, DC bearer MCG and SCG, Connected without release On according to TS 38.508-1 [6] clause 4.5.

Same test procedure as in clause 6.4A.2.1.5.4.2 in TS 38.521-2 [9] with the following steps added for E-UTRA component:

- 1.1 On the E-UTRA carrier, disable periodic and aperiodic CQI reports, disable SRS, set *TimeAlignmentTimerDedicated* IE to infinity and disable downlink and uplink scheduling, all as per Table 4.7-1 under clause 4.7.

#### 6.4B.2.4.1\_1.5.5 Test Requirements

Same test requirement as in clause 6.4A.2.1.5.5 in TS 38.521-2 [9] for the NR carrier.

#### 6.4B.2.4.1\_1.6 Error Vector Magnitude for inter-band EN-DC including FR2 (7 NR CCs)

**Editor's note: This clause is incomplete. The following aspects are either missing or not yet determined:**

- **Measurement Uncertainty and Test Tolerance are FFS.**

##### 6.4B.2.4.1\_1.6.1 Test purpose

Same test purpose as in clause 6.4.2.1.1 in TS 38.521-2 [9] for the NR carrier.

##### 6.4B.2.4.1\_1.6.2 Test applicability

This test case applies to all types of E-UTRA UE release 15 and forward, supporting inter-band EN-DC including FR2 with 7 NR UL CCs.

##### 6.4B.2.4.1\_1.6.3 Minimum conformance requirements

Same minimum conformance requirements as in clause 6.4.2.1.3 in TS 38.521-2 [9] for the NR carrier.

No exception requirements applicable to NR or E-UTRA. LTE anchor agnostic approach is applied.

The normative reference for this requirement is TS 38.101-3 [4] clause 6.4B.2.4.

#### 6.4B.2.4.1\_1.6.4 Test description

##### 6.4B.2.4.1\_1.6.4.1 Initial condition

Same test description as in clause 6.4A.2.1.6.4 in TS 38.521-2 [9] for the NR carrier with the following exception:

The initial test configurations for E-UTRA band consist of environmental conditions, test frequencies, and channel bandwidths based on E-UTRA bands specified in Table 4.7-1.

For Initial conditions as in clause 6.4A.2.1.6.4.1 in TS 38.521-2 [9], the following steps will be added to configure E-UTRA component:

- 2.1. The parameter settings for E-UTRA cell are set up according to TS 36.508 [11] clause 4.4.3.
- 3.1. The E-UTRA downlink signal level, uplink signal level are set according to Table 4.7-1 and propagation conditions are set according to Annex B.0 of TS 36.521-1 [10].

Step 6 of Initial conditions as in clause 6.4A.2.1.6.4.1 in TS 38.521-2 [9] is replaced by:

6. Ensure the UE is in state RRC\_CONNECTED with generic procedure parameters Connectivity EN-DC, DC bearer MCG and SCG, Connected without release On according to TS 38.508-1 [6] clause 4.5.

Same test procedure as in clause 6.4A.2.1.6.4.2 in TS 38.521-2 [9] with the following steps added for E-UTRA component:

- 1.1 On the E-UTRA carrier, disable periodic and aperiodic CQI reports, disable SRS, set *TimeAlignmentTimerDedicated* IE to infinity and disable downlink and uplink scheduling, all as per Table 4.7-1 under clause 4.7.

#### 6.4B.2.4.1\_1.6.5 Test Requirements

Same test requirement as in clause 6.4A.2.1.6.5 in TS 38.521-2 [9] for the NR carrier.

#### 6.4B.2.4.1\_1.7 Error Vector Magnitude for inter-band EN-DC including FR2 (8 NR CCs)

**Editor's note: This clause is incomplete. The following aspects are either missing or not yet determined:**

- **Measurement Uncertainty and Test Tolerance are FFS.**

##### 6.4B.2.4.1\_1.7.1 Test purpose

Same test purpose as in clause 6.4.2.1.1 in TS 38.521-2 [9] for the NR carrier.

##### 6.4B.2.4.1\_1.7.2 Test applicability

This test case applies to all types of E-UTRA UE release 15 and forward, supporting inter-band EN-DC including FR2 with 8 NR UL CCs.

##### 6.4B.2.4.1\_1.7.3 Minimum conformance requirements

Same minimum conformance requirements as in clause 6.4.2.1.3 in TS 38.521-2 [9] for the NR carrier.

No exception requirements applicable to NR or E-UTRA. LTE anchor agnostic approach is applied.

The normative reference for this requirement is TS 38.101-3 [4] clause 6.4B.2.4.

##### 6.4B.2.4.1\_1.7.4 Test description

##### 6.4B.2.4.1\_1.7.4.1 Initial condition

Same test description as in clause 6.4A.2.1.7.4 in TS 38.521-2 [9] for the NR carrier with the following exception:



The initial test configurations for E-UTRA band consist of environmental conditions, test frequencies, and channel bandwidths based on E-UTRA bands specified in Table 4.7-1.

For Initial conditions as in clause 6.4A.2.1.7.4.1 in TS 38.521-2 [9], the following steps will be added to configure E-UTRA component:

- 2.1. The parameter settings for E-UTRA cell are set up according to TS 36.508 [11] clause 4.4.3.
- 3.1. The E-UTRA downlink signal level, uplink signal level are set according to Table 4.7-1 and propagation conditions are set according to Annex B.0 of TS 36.521-1 [10].

Step 6 of Initial conditions as in clause 6.4A.2.1.7.4.1 in TS 38.521-2 [9] is replaced by:

6. Ensure the UE is in state RRC\_CONNECTED with generic procedure parameters Connectivity EN-DC, DC bearer MCG and SCG, Connected without release On according to TS 38.508-1 [6] clause 4.5.

Same test procedure as in clause 6.4A.2.1.7.4.2 in TS 38.521-2 [9] with the following steps added for E-UTRA component:

- 1.1 On the E-UTRA carrier, disable periodic and aperiodic CQI reports, disable SRS, set *TimeAlignmentTimerDedicated* IE to infinity and disable downlink and uplink scheduling, all as per Table 4.7-1 under clause 4.7.

#### 6.4B.2.4.1\_1.7.5 Test Requirements

Same test requirement as in clause 6.4A.2.1.7.5 in TS 38.521-2 [9] for the NR carrier.

#### 6.4B.2.4.1D Error Vector Magnitude for inter-band EN-DC including FR2 for UL MIMO

**Editor's note: This clause is incomplete. The following aspects are either missing or not yet determined:**

- The referred test case 6.4D.2.1 in TS 38.521-2 [9] is incomplete.
- Measurement Uncertainty and Test Tolerance are FFS and Annex F needs to be updated.

##### 6.4B.2.4.1D.1 Test purpose

Same test purpose as in clause 6.4D.2.1.1 in TS 38.521-2 [9] for the NR carrier.

##### 6.4B.2.4.1D.2 Test applicability

This test case applies to all types of E-UTRA UE release 15 and forward, supporting inter-band EN-DC including FR2 and UL MIMO.

##### 6.4B.2.4.1D.3 Minimum conformance requirements

For inter-band EN-DC including FR2 or both FR1 and FR2, transmit modulation quality for EN-DC operations in FR1 and FR2 as specified in TS 36.101 [5], 38.101-1 [2] and 38.101-2 [3] apply for E-UTRA, NR FR1 and NR FR2 respectively.

The normative reference for this requirement is TS 38.101-3 [4] clause 6.4B.2.4.

Same minimum conformance requirements as in clause 6.4D.2.1.3 in TS 38.521-2 [9] for the NR carrier.

No exception requirements applicable to NR or E-UTRA. LTE anchor agnostic approach is applied.

##### 6.4B.2.4.1D.4 Test description

###### 6.4B.2.4.1D.4.1 Initial conditions

Same test description as in clause 6.4D.2.1.4 in TS 38.521-2 [9] for the NR carrier with the following exception:

The initial test configurations for E-UTRA band consist of environmental conditions, test frequencies, and channel bandwidths based on E-UTRA bands specified in Table 4.7-1. For Initial conditions as in clause 6.4D.2.1.4.1 in TS 38.521-2 [9], the following steps will be added to configure E-UTRA component:

- 2.1. The parameter settings for E-UTRA cell are set up according to TS 36.508 [11] clause 4.4.3.
- 3.1. The E-UTRA downlink signal level, uplink signal level are set according to Table 4.7-1 and propagation conditions are set according to Annex B.0 of TS 36.521-1 [10].

Step 6 of Initial conditions as in clause 6.4D.2.4.1 in TS 38.521-2 [9] is replaced by:

6. Ensure the UE is in state RRC\_CONNECTED with generic procedure parameters Connectivity EN-DC, DC bearer MCG and SCG, Connected without release On according to TS 38.508-1 [6] clause 4.5.

Same test procedure as in clause 6.4D.2.1.4.1 in TS 38.521-2 [9] with the following steps added for E-UTRA component:

- 1.1 On the E-UTRA carrier, disable periodic and aperiodic CQI reports, disable SRS, set *TimeAlignmentTimerDedicated* IE to infinity and disable downlink and uplink scheduling, all as per Table 4.7-1 under clause 4.7.

#### 6.4B.2.4.1D.5 Test requirement

Same test requirement as in clause 6.4D.2.1.5 in TS 38.521-2 [9] for the NR carrier.

#### 6.4B.2.4.2 Carrier Leakage for inter-band EN-DC including FR2 (1 NR CC)

**Editor's note: The following aspects are either missing or not yet determined:**

- Measurement Uncertainty and Test Tolerance are FFS for power class other than 1, 3, 5 and 7.
- The test case is incomplete for band n259.

##### 6.4B.2.4.2.1 Test purpose

Same test purpose as in clause 6.4.2.2 in TS 38.521-2 [9] for the NR carrier.

##### 6.4B.2.4.2.2 Test applicability

This test case applies to all types of E-UTRA UE release 15 and forward, supporting inter-band EN-DC including FR2 with 1 NR UL CC.

##### 6.4B.2.4.2.3 Minimum conformance requirements

For inter-band EN-DC including FR2 or both FR1 and FR2, transmit modulation quality for EN-DC operations in FR1 and FR2 as specified in TS 36.101 [5], 38.101-1 [2] and 38.101-2 [3] apply for E-UTRA, NR FR1 and NR FR2 respectively.

The normative reference for this requirement is TS 38.101-3 [4] clause 6.4B.2.4.

Same minimum conformance requirements as in clause 6.4.2.2.3 in TS 38.521-2 [9] for the NR carrier.

No exception requirements applicable to NR or E-UTRA. LTE anchor agnostic approach is applied

##### 6.4B.2.4.2.4 Test description

###### 6.4B.2.4.2.4.1 Initial conditions

Same test description as in clause 6.4.2.2.4 in TS 38.521-2 [9] for the NR carrier with the following exception:

The initial test configurations for E-UTRA band consist of environmental conditions, test frequencies, and channel bandwidths based on E-UTRA bands specified in Table 4.7-1. For Initial conditions as in clause 6.4.2.2.4.1 in TS 38.521-2 [9], the following steps will be added to configure E-UTRA component:

2.1. The parameter settings for E-UTRA cell are set up according to TS 36.508 [11] clause 4.4.3.

3.1. The E-UTRA downlink signal level, uplink signal level are set according to Table 4.7-1 and propagation conditions are set according to Annex B.0 of TS 36.521-1 [10].

Step 6 of Initial conditions as in clause 6.4.2.4.1 in TS 38.521-2 [9] is replaced by:

6. Ensure the UE is in state RRC\_CONNECTED with generic procedure parameters Connectivity EN-DC, DC bearer MCG and SCG, Connected without release On according to TS 38.508-1 [6] clause 4.5.

Same test procedure as in clause 6.4.2.2.4.1 in TS 38.521-2 [9] with the following steps added for E-UTRA component:

1.1 On the E-UTRA carrier, disable periodic and aperiodic CQI reports, disable SRS, set *TimeAlignmentTimerDedicated* IE to infinity and disable downlink and uplink scheduling, all as per Table 4.7-1 under clause 4.7.

#### 6.4B.2.4.2.5 Test requirement

Same test requirement as in clause 6.4.2.2.5 in TS 38.521-2 [9] for the NR carrier.

#### 6.4B.2.4.2D Carrier Leakage for inter-band EN-DC including FR2 for UL MIMO

**Editor's note: This clause is incomplete. The following aspects are either missing or not yet determined:**

- The referred test case 6.4D.2.2 in TS 38.521-2 [9] is incomplete.
- Measurement Uncertainty and Test Tolerance are FFS and Annex F needs to be updated.

#### 6.4B.2.4.2D.1 Test purpose

Same test purpose as in clause 6.4D.2.2.1 in TS 38.521-2 [9] for the NR carrier.

#### 6.4B.2.4.2D.2 Test applicability

This test case applies to all types of E-UTRA UE release 15 and forward, supporting inter-band EN-DC including FR2 and UL MIMO.

#### 6.4B.2.4.2D.3 Minimum conformance requirements

For inter-band EN-DC including FR2 or both FR1 and FR2, transmit modulation quality for EN-DC operations in FR1 and FR2 as specified in TS 36.101 [5], 38.101-1 [2] and 38.101-2 [3] apply for E-UTRA, NR FR1 and NR FR2 respectively.

The normative reference for this requirement is TS 38.101-3 [4] clause 6.4B.2.4.

Same minimum conformance requirements as in clause 6.4D.2.2.3 in TS 38.521-2 [9] for the NR carrier.

No exception requirements applicable to NR or E-UTRA. LTE anchor agnostic approach is applied

#### 6.4B.2.4.2D.4 Test description

##### 6.4B.2.4.2D.4.1 Initial conditions

Same test description as in clause 6.4D.2.2.4 in TS 38.521-2 [9] for the NR carrier with the following exception:

The initial test configurations for E-UTRA band consist of environmental conditions, test frequencies, and channel bandwidths based on E-UTRA bands specified in Table 4.7-1. For Initial conditions as in clause 6.4D.2.2.4.1 in TS 38.521-2 [9], the following steps will be added to configure E-UTRA component:

2.1. The parameter settings for E-UTRA cell are set up according to TS 36.508 [11] clause 4.4.3.

3.1. The E-UTRA downlink signal level, uplink signal level are set according to Table 4.7-1 and propagation conditions are set according to Annex B.0 of TS 36.521-1 [10].

Step 6 of Initial conditions as in clause 6.4D.2.4.1 in TS 38.521-2 [9] is replaced by:

6. Ensure the UE is in state RRC\_CONNECTED with generic procedure parameters Connectivity EN-DC, DC bearer MCG and SCG, Connected without release On according to TS 38.508-1 [6] clause 4.5.

Same test procedure as in clause 6.4D.2.2.4.1 in TS 38.521-2 [9] with the following steps added for E-UTRA component:

- 1.1 On the E-UTRA carrier, disable periodic and aperiodic CQI reports, disable SRS, set *TimeAlignmentTimerDedicated* IE to infinity and disable downlink and uplink scheduling, all as per Table 4.7-1 under clause 4.7.

#### 6.4B.2.4.2D.5 Test requirement

Same test requirement as in clause 6.4D.2.2.5 in TS 38.521-2 [9] for the NR carrier.

#### 6.4B.2.4.2\_1 Carrier Leakage for inter-band EN-DC including FR2 (>1 NR CC)

##### 6.4B.2.4.2\_1.1 Carrier Leakage for inter-band EN-DC including FR2 (2 NR CCs)

**Editor's note: This clause is incomplete. The following aspects are either missing or not yet determined:**

- The referred test case 6.4A.2.2.1 in TS 38.521-2 [9] is incomplete.
- Measurement Uncertainty and Test Tolerance are FFS.
- This test is incomplete due to lack of RRC framework for LO position retrieval.

##### 6.4B.2.4.2\_1.1.1 Test purpose

Same test purpose as in clause 6.4.2.2 in TS 38.521-2 [9] for the NR carrier.

##### 6.4B.2.4.2\_1.1.2 Test applicability

This test case applies to all types of E-UTRA UE release 15 and forward, supporting inter-band EN-DC including FR2 with 2 NR CCs.

##### 6.4B.2.4.2\_1.1.3 Minimum conformance requirements

Same minimum conformance requirements as in clause 6.4B.2.4.2.3.

##### 6.4B.2.4.2\_1.1.4 Test Description

###### 6.4B.2.4.2\_1.1.4.1 Initial conditions

Same test description as in clause 6.4A.2.2.1.4 in TS 38.521-2 [9] for the NR carrier with the following exception:

The initial test configurations for E-UTRA band consist of environmental conditions, test frequencies, and channel bandwidths based on E-UTRA bands specified in Table 4.7-1.

For Initial conditions as in clause 6.4A.2.2.1.4.1 in TS 38.521-2 [9], the following steps will be added to configure E-UTRA component:

- 2.1. The parameter settings for E-UTRA cell are set up according to TS 36.508 [11] clause 4.4.3.
- 3.1. The E-UTRA downlink signal level, uplink signal level are set according to Table 4.7-1 and propagation conditions are set according to Annex B.0 of TS 36.521-1 [10].

Step 6 of Initial conditions as in clause 6.4A.2.2.1.4.1 in TS 38.521-2 [9] is replaced by:

6. Ensure the UE is in state RRC\_CONNECTED with generic procedure parameters Connectivity EN-DC, DC bearer MCG and SCG, Connected without release On according to TS 38.508-1 [6] clause 4.5.

Same test procedure as in clause 6.4A.2.2.1.4.2 in TS 38.521-2 [9] with the following steps added for E-UTRA component:

- 1.1 On the E-UTRA carrier, disable periodic and aperiodic CQI reports, disable SRS, set *TimeAlignmentTimerDedicated* IE to infinity and disable downlink and uplink scheduling, all as per Table 4.7-1 under clause 4.7.

#### 6.4B.2.4.2\_1.1.5 Test Requirement

Same test requirement as in clause 6.4A.2.2.1.5 in TS 38.521-2 [9] for the NR carrier.

#### 6.4B.2.4.2\_1.2 Carrier Leakage for inter-band EN-DC including FR2 (3 NR CCs)

**Editor's note: This clause is incomplete. The following aspects are either missing or not yet determined:**

- The referred test case 6.4A.2.2.2 in TS 38.521-2 [9] is incomplete.
- Measurement Uncertainty and Test Tolerance are FFS.

#### 6.4B.2.4.2\_1.2.1 Test purpose

Same test purpose as in clause 6.4.2.2 in TS 38.521-2 [9] for the NR carrier.

#### 6.4B.2.4.2\_1.2.2 Test applicability

This test case applies to all types of E-UTRA UE release 15 and forward, supporting inter-band EN-DC including FR2 with 3 NR CCs.

#### 6.4B.2.4.2\_1.2.3 Minimum conformance requirements

Same minimum conformance requirements as in clause 6.4B.2.4.2.3.

#### 6.4B.2.4.2\_1.2.4 Test Description

##### 6.4B.2.4.2\_1.2.4.1 Initial conditions

Same test description as in clause 6.4A.2.2.2.4 in TS 38.521-2 [9] for the NR carrier with the following exception:

The initial test configurations for E-UTRA band consist of environmental conditions, test frequencies, and channel bandwidths based on E-UTRA bands specified in Table 4.7-1.

For Initial conditions as in clause 6.4A.2.2.2.4.1 in TS 38.521-2 [9], the following steps will be added to configure E-UTRA component:

- 2.1. The parameter settings for E-UTRA cell are set up according to TS 36.508 [11] clause 4.4.3.
- 3.1. The E-UTRA downlink signal level, uplink signal level are set according to Table 4.7-1 and propagation conditions are set according to Annex B.0 of TS 36.521-1 [10].

Step 6 of Initial conditions as in clause 6.4A.2.2.2.4.1 in TS 38.521-2 [9] is replaced by:

6. Ensure the UE is in state RRC\_CONNECTED with generic procedure parameters Connectivity EN-DC, DC bearer MCG and SCG, Connected without release On according to TS 38.508-1 [6] clause 4.5.

Same test procedure as in clause 6.4A.2.2.2.4.2 in TS 38.521-2 [9] with the following steps added for E-UTRA component:

- 1.1 On the E-UTRA carrier, disable periodic and aperiodic CQI reports, disable SRS, set *TimeAlignmentTimerDedicated* IE to infinity and disable downlink and uplink scheduling, all as per Table 4.7-1 under clause 4.7.

#### 6.4B.2.4.2\_1.2.5 Test Requirement

Same test requirement as in clause 6.4A.2.2.2.5 in TS 38.521-2 [9] for the NR carrier.

#### 6.4B.2.4.2\_1.3 Carrier Leakage for inter-band EN-DC including FR2 (4 NR CCs)

**Editor's note: This clause is incomplete. The following aspects are either missing or not yet determined:**

- The referred test case 6.4A.2.2.3 in TS 38.521-2 [9] is incomplete.
- Measurement Uncertainty and Test Tolerance are FFS.

#### 6.4B.2.4.2\_1.3.1 Test purpose

Same test purpose as in clause 6.4.2.2 in TS 38.521-2 [9] for the NR carrier.

#### 6.4B.2.4.2\_1.3.2 Test applicability

This test case applies to all types of E-UTRA UE release 15 and forward, supporting inter-band EN-DC including FR2 with 4 NR UL CCs.

#### 6.4B.2.4.2\_1.3.3 Minimum conformance requirements

Same minimum conformance requirements as in clause 6.4B.2.4.2.3.

#### 6.4B.2.4.2\_1.3.4 Test Description

##### 6.4B.2.4.2\_1.3.4.1 Initial conditions

Same test description as in clause 6.4A.2.2.3.4 in TS 38.521-2 [9] for the NR carrier with the following exception:

The initial test configurations for E-UTRA band consist of environmental conditions, test frequencies, and channel bandwidths based on E-UTRA bands specified in Table 4.7-1.

For Initial conditions as in clause 6.4A.2.2.3.4.1 in TS 38.521-2 [9], the following steps will be added to configure E-UTRA component:

- 2.1. The parameter settings for E-UTRA cell are set up according to TS 36.508 [11] clause 4.4.3.
- 3.1. The E-UTRA downlink signal level, uplink signal level are set according to Table 4.7-1 and propagation conditions are set according to Annex B.0 of TS 36.521-1 [10].

Step 6 of Initial conditions as in clause 6.4A.2.2.3.4.1 in TS 38.521-2 [9] is replaced by:

6. Ensure the UE is in state RRC\_CONNECTED with generic procedure parameters Connectivity EN-DC, DC bearer MCG and SCG, Connected without release On according to TS 38.508-1 [6] clause 4.5.

Same test procedure as in clause 6.4A.2.2.3.4.2 in TS 38.521-2 [9] with the following steps added for E-UTRA component:

- 1.1 On the E-UTRA carrier, disable periodic and aperiodic CQI reports, disable SRS, set *TimeAlignmentTimerDedicated* IE to infinity and disable downlink and uplink scheduling, all as per Table 4.7-1 under clause 4.7.

#### 6.4B.2.4.2\_1.3.5 Test Requirement

Same test requirement as in clause 6.4A.2.2.3.5 in TS 38.521-2 [9] for the NR carrier.

#### 6.4B.2.4.2\_1.4 Carrier Leakage for inter-band EN-DC including FR2 (5 NR CCs)

**Editor's note: This clause is incomplete. The following aspects are either missing or not yet determined:**

- The referred test case 6.4A.2.2.4 in TS 38.521-2 [9] is incomplete.

- Measurement Uncertainty and Test Tolerance are FFS.

#### 6.4B.2.4.2\_1.4.1 Test purpose

Same test purpose as in clause 6.4.2.2 in TS 38.521-2 [9] for the NR carrier.

#### 6.4B.2.4.2\_1.4.2 Test applicability

This test case applies to all types of E-UTRA UE release 15 and forward, supporting inter-band EN-DC including FR2 with 5 NR UL CCs.

#### 6.4B.2.4.2\_1.4.3 Minimum conformance requirements

Same minimum conformance requirements as in clause 6.4B.2.4.2.3.

#### 6.4B.2.4.2\_1.4.4 Test Description

##### 6.4B.2.4.2\_1.4.4.1 Initial conditions

Same test description as in clause 6.4A.2.2.4.4 in TS 38.521-2 [9] for the NR carrier with the following exception:

The initial test configurations for E-UTRA band consist of environmental conditions, test frequencies, and channel bandwidths based on E-UTRA bands specified in Table 4.7-1.

For Initial conditions as in clause 6.4A.2.2.4.4.1 in TS 38.521-2 [9], the following steps will be added to configure E-UTRA component:

- 2.1. The parameter settings for E-UTRA cell are set up according to TS 36.508 [11] clause 4.4.3.
- 3.1. The E-UTRA downlink signal level, uplink signal level are set according to Table 4.7-1 and propagation conditions are set according to Annex B.0 of TS 36.521-1 [10].

Step 6 of Initial conditions as in clause 6.4A.2.2.4.4.1 in TS 38.521-2 [9] is replaced by:

6. Ensure the UE is in state RRC\_CONNECTED with generic procedure parameters Connectivity EN-DC, DC bearer MCG and SCG, Connected without release On according to TS 38.508-1 [6] clause 4.5.

Same test procedure as in clause 6.4A.2.2.4.4.2 in TS 38.521-2 [9] with the following steps added for E-UTRA component:

- 1.1 On the E-UTRA carrier, disable periodic and aperiodic CQI reports, disable SRS, set *TimeAlignmentTimerDedicated* IE to infinity and disable downlink and uplink scheduling, all as per Table 4.7-1 under clause 4.7.

#### 6.4B.2.4.2\_1.4.5 Test Requirement

Same test requirement as in clause 6.4A.2.2.4.5 in TS 38.521-2 [9] for the NR carrier.

#### 6.4B.2.4.2\_1.5 Carrier Leakage for inter-band EN-DC including FR2 (6 NR CCs)

**Editor's note: This clause is incomplete. The following aspects are either missing or not yet determined:**

- The referred test case 6.4A.2.2.5 in TS 38.521-2 [9] is incomplete.
- Measurement Uncertainty and Test Tolerance are FFS.

#### 6.4B.2.4.2\_1.5.1 Test purpose

Same test purpose as in clause 6.4.2.2 in TS 38.521-2 [9] for the NR carrier.

#### 6.4B.2.4.2\_1.5.2 Test applicability

This test case applies to all types of E-UTRA UE release 15 and forward, supporting inter-band EN-DC including FR2 with 6 NR UL CCs.

#### 6.4B.2.4.2\_1.5.3 Minimum conformance requirements

Same minimum conformance requirements as in clause 6.4B.2.4.2.3.

#### 6.4B.2.4.2\_1.5.4 Test Description

##### 6.4B.2.4.2\_1.5.4.1 Initial conditions

Same test description as in clause 6.4A.2.2.5.4 in TS 38.521-2 [9] for the NR carrier with the following exception:

The initial test configurations for E-UTRA band consist of environmental conditions, test frequencies, and channel bandwidths based on E-UTRA bands specified in Table 4.7-1.

For Initial conditions as in clause 6.4A.2.2.5.4.1 in TS 38.521-2 [9], the following steps will be added to configure E-UTRA component:

- 2.1. The parameter settings for E-UTRA cell are set up according to TS 36.508 [11] clause 4.4.3.
- 3.1. The E-UTRA downlink signal level, uplink signal level are set according to Table 4.7-1 and propagation conditions are set according to Annex B.0 of TS 36.521-1 [10].

Step 6 of Initial conditions as in clause 6.4A.2.2.5.4.1 in TS 38.521-2 [9] is replaced by:

6. Ensure the UE is in state RRC\_CONNECTED with generic procedure parameters Connectivity EN-DC, DC bearer MCG and SCG, Connected without release On according to TS 38.508-1 [6] clause 4.5.

Same test procedure as in clause 6.4A.2.2.5.4.2 in TS 38.521-2 [9] with the following steps added for E-UTRA component:

- 1.1 On the E-UTRA carrier, disable periodic and aperiodic CQI reports, disable SRS, set *TimeAlignmentTimerDedicated* IE to infinity and disable downlink and uplink scheduling, all as per Table 4.7-1 under clause 4.7.

#### 6.4B.2.4.2\_1.5.5 Test Requirement

Same test requirement as in clause 6.4A.2.2.5.5 in TS 38.521-2 [9] for the NR carrier.

#### 6.4B.2.4.2\_1.6 Carrier Leakage for inter-band EN-DC including FR2 (7 NR CCs)

**Editor's note: This clause is incomplete. The following aspects are either missing or not yet determined:**

- **The referred test case 6.4A.2.2.6 in TS 38.521-2 [9] is incomplete.**
- **Measurement Uncertainty and Test Tolerance are FFS.**

##### 6.4B.2.4.2\_1.6.1 Test purpose

Same test purpose as in clause 6.4.2.2 in TS 38.521-2 [9] for the NR carrier.

##### 6.4B.2.4.2\_1.6.2 Test applicability

This test case applies to all types of E-UTRA UE release 15 and forward, supporting inter-band EN-DC including FR2 with 7 NR UL CCs.

##### 6.4B.2.4.2\_1.6.3 Minimum conformance requirements

Same minimum conformance requirements as in clause 6.4B.2.4.2.3.



#### 6.4B.2.4.2\_1.6.4 Test Description

##### 6.4B.2.4.2\_1.6.4.1 Initial conditions

Same test description as in clause 6.4A.2.2.6.4 in TS 38.521-2 [9] for the NR carrier with the following exception:

The initial test configurations for E-UTRA band consist of environmental conditions, test frequencies, and channel bandwidths based on E-UTRA bands specified in Table 4.7-1.

For Initial conditions as in clause 6.4A.2.2.6.4.1 in TS 38.521-2 [9], the following steps will be added to configure E-UTRA component:

- 2.1. The parameter settings for E-UTRA cell are set up according to TS 36.508 [11] clause 4.4.3.
- 3.1. The E-UTRA downlink signal level, uplink signal level are set according to Table 4.7-1 and propagation conditions are set according to Annex B.0 of TS 36.521-1 [10].

Step 6 of Initial conditions as in clause 6.4A.2.2.6.4.1 in TS 38.521-2 [9] is replaced by:

6. Ensure the UE is in state RRC\_CONNECTED with generic procedure parameters Connectivity EN-DC, DC bearer MCG and SCG, Connected without release On according to TS 38.508-1 [6] clause 4.5.

Same test procedure as in clause 6.4A.2.2.6.4.2 in TS 38.521-2 [9] with the following steps added for E-UTRA component:

- 1.1 On the E-UTRA carrier, disable periodic and aperiodic CQI reports, disable SRS, set *TimeAlignmentTimerDedicated* IE to infinity and disable downlink and uplink scheduling, all as per Table 4.7-1 under clause 4.7.

#### 6.4B.2.4.2\_1.6.5 Test Requirement

Same test requirement as in clause 6.4A.2.2.6.5 in TS 38.521-2 [9] for the NR carrier.

#### 6.4B.2.4.2\_1.7 Carrier Leakage for inter-band EN-DC including FR2 (8 NR CCs)

**Editor's note: This clause is incomplete. The following aspects are either missing or not yet determined:**

- The referred test case 6.4A.2.2.7 in TS 38.521-2 [9] is incomplete.
- Measurement Uncertainty and Test Tolerance are FFS.

#### 6.4B.2.4.2\_1.7.1 Test purpose

Same test purpose as in clause 6.4.2.2 in TS 38.521-2 [9] for the NR carrier.

#### 6.4B.2.4.2\_1.7.2 Test applicability

This test case applies to all types of E-UTRA UE release 15 and forward, supporting inter-band EN-DC including FR2 with 8 NR UL CCs.

#### 6.4B.2.4.2\_1.7.3 Minimum conformance requirements

Same minimum conformance requirements as in clause 6.4B.2.4.2.3.

#### 6.4B.2.4.2\_1.7.4 Test Description

##### 6.4B.2.4.2\_1.7.4.1 Initial conditions

Same test description as in clause 6.4A.2.2.7.4 in TS 38.521-2 [9] for the NR carrier with the following exception:

The initial test configurations for E-UTRA band consist of environmental conditions, test frequencies, and channel bandwidths based on E-UTRA bands specified in Table 4.7-1.

For Initial conditions as in clause 6.4A.2.2.7.4.1 in TS 38.521-2 [9], the following steps will be added to configure E-UTRA component:

- 2.1. The parameter settings for E-UTRA cell are set up according to TS 36.508 [11] clause 4.4.3.
- 3.1. The E-UTRA downlink signal level, uplink signal level are set according to Table 4.7-1 and propagation conditions are set according to Annex B.0 of TS 36.521-1 [10].

Step 6 of Initial conditions as in clause 6.4A.2.2.7.4.1 in TS 38.521-2 [9] is replaced by:

6. Ensure the UE is in state RRC\_CONNECTED with generic procedure parameters Connectivity EN-DC, DC bearer MCG and SCG, Connected without release On according to TS 38.508-1 [6] clause 4.5.

Same test procedure as in clause 6.4A.2.2.7.4.2 in TS 38.521-2 [9] with the following steps added for E-UTRA component:

- 1.1 On the E-UTRA carrier, disable periodic and aperiodic CQI reports, disable SRS, set *TimeAlignmentTimerDedicated* IE to infinity and disable downlink and uplink scheduling, all as per Table 4.7-1 under clause 4.7.

#### 6.4B.2.4.2\_1.7.5 Test Requirement

Same test requirement as in clause 6.4A.2.2.7.5 in TS 38.521-2 [9] for the NR carrier.

#### 6.4B.2.4.3 In-band Emissions for inter-band EN-DC including FR2 (1 NR CC)

**Editor's note: This clause is incomplete. The following aspects are either missing or not yet determined:**

- The referred test case 6.4.2.3 in TS 38.521-2 [9] is incomplete.
- Measurement Uncertainty and Test Tolerance are FFS.
- 38.101-2 [3] clause 6.3.4.3: Relative power tolerances are in square brackets.

##### 6.4B.2.4.3.1 Test purpose

Same test purpose as in clause 6.4.2.3 in TS 38.521-2 [9] for the NR carrier.

##### 6.4B.2.4.3.2 Test applicability

This test case applies to all types of E-UTRA UE release 15 and forward, supporting inter-band EN-DC including FR2 with 1 NR UL CC.

##### 6.4B.2.4.3.3 Minimum conformance requirements

For inter-band EN-DC including FR2 or both FR1 and FR2, transmit modulation quality for EN-DC operations in FR1 and FR2 as specified in TS 36.101 [5], TS 38.101-1 [2] and TS 38.101-2 [3] apply for E-UTRA, NR FR1 and NR FR2 respectively.

The normative reference for this requirement is TS 38.101-3 [4] clause 6.4B.2.4.

Same minimum conformance requirements as in clause 6.4.2.3.3 in TS 38.521-2 [9] for the NR carrier.

No exception requirements applicable to NR or E-UTRA. LTE anchor agnostic approach is applied.

##### 6.4B.2.4.3.4 Test description

###### 6.4B.2.4.3.4.1 Initial conditions

Same test description as in clause 6.4.2.3.4 in TS 38.521-2 [9] for the NR carrier with the following exception:

The initial test configurations for E-UTRA band consist of environmental conditions, test frequencies, and channel bandwidths based on E-UTRA bands specified in Table 4.7-1. For Initial conditions as in clause 6.4.2.3.4.1 in TS 38.521-2 [9], the following steps will be added to configure E-UTRA component:

2.1. The parameter settings for E-UTRA cell are set up according to TS 36.508 [11] clause 4.4.3.

3.1. The E-UTRA downlink signal level, uplink signal level are set according to Table 4.7-1 and propagation conditions are set according to Annex B.0 of TS 36.521-1 [10].

Step 6 of Initial conditions as in clause 6.4.2.4.1 in TS 38.521-2 [9] is replaced by:

6. Ensure the UE is in state RRC\_CONNECTED with generic procedure parameters Connectivity EN-DC, DC bearer MCG and SCG, Connected without release On according to TS 38.508-1 [6] clause 4.5.

Same test procedure as in clause 6.4.2.3.4.1 in TS 38.521-2 [9] with the following steps added for E-UTRA component:

1.1 On the E-UTRA carrier, disable periodic and aperiodic CQI reports, disable SRS, set *TimeAlignmentTimerDedicated* IE to infinity and disable downlink and uplink scheduling, all as per Table 4.7-1 under clause 4.7.

#### 6.4B.2.4.3.5 Test requirement

Same test requirement as in clause 6.4.2.3.5 in TS 38.521-2 [9] for the NR carrier.

#### 6.4B.2.4.3D In-band Emissions for inter-band EN-DC including FR2 for UL MIMO

**Editor's note: This clause is incomplete. The following aspects are either missing or not yet determined:**

- The referred test case 6.4D.2.3 in TS 38.521-2 [9] is incomplete.
- Measurement Uncertainty and Test Tolerance are FFS and Annex F needs to be updated.

#### 6.4B.2.4.3D.1 Test purpose

Same test purpose as in clause 6.4D.2.3.1 in TS 38.521-2 [9] for the NR carrier.

#### 6.4B.2.4.3D.2 Test applicability

This test case applies to all types of E-UTRA UE release 15 and forward, supporting inter-band EN-DC including FR2 and UL MIMO.

#### 6.4B.2.4.3D.3 Minimum conformance requirements

For inter-band EN-DC including FR2 or both FR1 and FR2, transmit modulation quality for EN-DC operations in FR1 and FR2 as specified in TS 36.101 [5], TS 38.101-1 [2] and TS 38.101-2 [3] apply for E-UTRA, NR FR1 and NR FR2 respectively.

The normative reference for this requirement is TS 38.101-3 [4] clause 6.4B.2.4.

Same minimum conformance requirements as in clause 6.4D.2.3.3 in TS 38.521-2 [9] for the NR carrier.

No exception requirements applicable to NR or E-UTRA. LTE anchor agnostic approach is applied.

#### 6.4B.2.4.3D.4 Test description

##### 6.4B.2.4.3D.4.1 Initial conditions

Same test description as in clause 6.4D.2.3.4 in TS 38.521-2 [9] for the NR carrier with the following exception:

The initial test configurations for E-UTRA band consist of environmental conditions, test frequencies, and channel bandwidths based on E-UTRA bands specified in Table 4.7-1. For Initial conditions as in clause 6.4D.2.3.4.1 in TS 38.521-2 [9], the following steps will be added to configure E-UTRA component:

2.1. The parameter settings for E-UTRA cell are set up according to TS 36.508 [11] clause 4.4.3.

3.1. The E-UTRA downlink signal level, uplink signal level are set according to Table 4.7-1 and propagation conditions are set according to Annex B.0 of TS 36.521-1 [10].

Step 6 of Initial conditions as in clause 6.4D.2.3.4.1 in TS 38.521-2 [9] is replaced by:

6. Ensure the UE is in state RRC\_CONNECTED with generic procedure parameters Connectivity EN-DC, DC bearer MCG and SCG, Connected without release On according to TS 38.508-1 [6] clause 4.5.

Same test procedure as in clause 6.4D.2.3.4.1 in TS 38.521-2 [9] with the following steps added for E-UTRA component:

- 1.1 On the E-UTRA carrier, disable periodic and aperiodic CQI reports, disable SRS, set *TimeAlignmentTimerDedicated* IE to infinity and disable downlink and uplink scheduling, all as per Table 4.7-1 under clause 4.7.

#### 6.4B.2.4.3D.5 Test requirement

Same test requirement as in clause 6.4D.2.3.5 in TS 38.521-2 [9] for the NR carrier.

#### 6.4B.2.4.3\_1 In-band Emissions for inter-band EN-DC including FR2 (>1 NR CC)

##### 6.4B.2.4.3\_1.1 In-band Emissions for inter-band EN-DC including FR2 (2 NR CCs)

**Editor's note: This clause is incomplete. The following aspects are either missing or not yet determined:**

- The referred test case 6.4A.2.3.1 in TS 38.521-2 [9] is incomplete.
- Measurement Uncertainty and Test Tolerance are FFS.
- This test is incomplete due to lack of RRC framework for LO position retrieval.

##### 6.4B.2.4.3\_1.1.1 Test purpose

Same test purpose as in clause 6.4.2.3 in TS 38.521-2 [9] for the NR carrier.

##### 6.4B.2.4.3\_1.1.2 Test applicability

This test case applies to all types of E-UTRA UE release 15 and forward, supporting inter-band EN-DC including FR2 with 2NR UL CCs.

##### 6.4B.2.4.3\_1.1.3 Minimum conformance requirements

Same minimum conformance requirements as in clause 6.4B.2.4.3.3.

##### 6.4B.2.4.3\_1.1.4 Test description

###### 6.4B.2.4.3\_1.1.4.1 Initial conditions

Same test description as in clause 6.4A.2.3.1.4 in TS 38.521-2 [9] for the NR carrier with the following exception:

The initial test configurations for E-UTRA band consist of environmental conditions, test frequencies, and channel bandwidths based on E-UTRA bands specified in Table 4.7-1. For Initial conditions as in clause 6.4A.2.3.1.4.1 in TS 38.521-2 [9], the following steps will be added to configure E-UTRA component:

- 2.1. The parameter settings for E-UTRA cell are set up according to TS 36.508 [11] clause 4.4.3.
- 3.1. The E-UTRA downlink signal level, uplink signal level are set according to Table 4.7-1 and propagation conditions are set according to Annex B.0 of TS 36.521-1 [10].

Step 6 of Initial conditions as in clause 6.4A.2.3.1.4.1 in TS 38.521-2 [9] is replaced by:

6. Ensure the UE is in state RRC\_CONNECTED with generic procedure parameters Connectivity EN-DC, DC bearer MCG and SCG, Connected without release On according to TS 38.508-1 [6] clause 4.5.

Same test procedure as in clause 6.4A.2.3.1.4.2 in TS 38.521-2 [9] with the following steps added for E-UTRA component:

1.1 On the E-UTRA carrier, disable periodic and aperiodic CQI reports, disable SRS, set *TimeAlignmentTimerDedicated* IE to infinity and disable downlink and uplink scheduling, all as per Table 4.7-1 under clause 4.7.

#### 6.4B.2.4.3\_1.1.5 Test requirement

Same test requirement as in clause 6.4A.2.3.1.5 in TS 38.521-2 [9] for the NR carrier.

#### 6.4B.2.4.3\_1.2 In-band Emissions for inter-band EN-DC including FR2 (3 NR CCs)

**Editor's note: This clause is incomplete. The following aspects are either missing or not yet determined:**

- **The referred test case 6.4A.2.3.2 in TS 38.521-2 [9] is incomplete.**
- **Measurement Uncertainty and Test Tolerance are FFS.**

#### 6.4B.2.4.3\_1.2.1 Test purpose

Same test purpose as in clause 6.4.2.3 in TS 38.521-2 [9] for the NR carrier.

#### 6.4B.2.4.3\_1.2.2 Test applicability

This test case applies to all types of E-UTRA UE release 15 and forward, supporting inter-band EN-DC including FR2 with 3NR UL CCs.

#### 6.4B.2.4.3\_1.2.3 Minimum conformance requirements

Same minimum conformance requirements as in clause 6.4B.2.4.3.3.

#### 6.4B.2.4.3\_1.2.4 Test description

##### 6.4B.2.4.3\_1.2.4.1 Initial conditions

Same test description as in clause 6.4A.2.3.2.4 in TS 38.521-2 [9] for the NR carrier with the following exception:

The initial test configurations for E-UTRA band consist of environmental conditions, test frequencies, and channel bandwidths based on E-UTRA bands specified in Table 4.7-1. For Initial conditions as in clause 6.4A.2.3.2.4.1 in TS 38.521-2 [9], the following steps will be added to configure E-UTRA component:

- 2.1. The parameter settings for E-UTRA cell are set up according to TS 36.508 [11] clause 4.4.3.
- 3.1. The E-UTRA downlink signal level, uplink signal level are set according to Table 4.7-1 and propagation conditions are set according to Annex B.0 of TS 36.521-1 [10].

Step 6 of Initial conditions as in clause 6.4A.2.3.2.4.1 in TS 38.521-2 [9] is replaced by:

6. Ensure the UE is in state RRC\_CONNECTED with generic procedure parameters Connectivity EN-DC, DC bearer MCG and SCG, Connected without release On according to TS 38.508-1 [6] clause 4.5.

Same test procedure as in clause 6.4A.2.3.2.4.2 in TS 38.521-2 [9] with the following steps added for E-UTRA component:

- 1.1 On the E-UTRA carrier, disable periodic and aperiodic CQI reports, disable SRS, set *TimeAlignmentTimerDedicated* IE to infinity and disable downlink and uplink scheduling, all as per Table 4.7-1 under clause 4.7.

#### 6.4B.2.4.3\_1.2.5 Test requirement

Same test requirement as in clause 6.4A.2.3.2.5 in TS 38.521-2 [9] for the NR carrier.

#### 6.4B.2.4.3\_1.3 In-band Emissions for inter-band EN-DC including FR2 (4 NR CCs)

**Editor's note: This clause is incomplete. The following aspects are either missing or not yet determined:**

- The referred test case 6.4A.2.3.3 in TS 38.521-2 [9] is incomplete.
- Measurement Uncertainty and Test Tolerance are FFS.

#### 6.4B.2.4.3\_1.3.1 Test purpose

Same test purpose as in clause 6.4.2.3 in TS 38.521-2 [9] for the NR carrier.

#### 6.4B.2.4.3\_1.3.2 Test applicability

This test case applies to all types of E-UTRA UE release 15 and forward, supporting inter-band EN-DC including FR2 with 4 NR UL CCs.

#### 6.4B.2.4.3\_1.3.3 Minimum conformance requirements

Same minimum conformance requirements as in clause 6.4B.2.4.3.3.

#### 6.4B.2.4.3\_1.3.4 Test description

##### 6.4B.2.4.3\_1.3.4.1 Initial conditions

Same test description as in clause 6.4A.2.3.3.4 in TS 38.521-2 [9] for the NR carrier with the following exception:

The initial test configurations for E-UTRA band consist of environmental conditions, test frequencies, and channel bandwidths based on E-UTRA bands specified in Table 4.7-1. For Initial conditions as in clause 6.4A.2.3.3.4.1 in TS 38.521-2 [9], the following steps will be added to configure E-UTRA component:

- 2.1. The parameter settings for E-UTRA cell are set up according to TS 36.508 [11] clause 4.4.3.
- 3.1. The E-UTRA downlink signal level, uplink signal level are set according to Table 4.7-1 and propagation conditions are set according to Annex B.0 of TS 36.521-1 [10].

Step 6 of Initial conditions as in clause 6.4A.2.3.3.4.1 in TS 38.521-2 [9] is replaced by:

6. Ensure the UE is in state RRC\_CONNECTED with generic procedure parameters Connectivity EN-DC, DC bearer MCG and SCG, Connected without release On according to TS 38.508-1 [6] clause 4.5.

Same test procedure as in clause 6.4A.2.3.3.4.2 in TS 38.521-2 [9] with the following steps added for E-UTRA component:

- 1.1 On the E-UTRA carrier, disable periodic and aperiodic CQI reports, disable SRS, set *TimeAlignmentTimerDedicated* IE to infinity and disable downlink and uplink scheduling, all as per Table 4.7-1 under clause 4.7.

#### 6.4B.2.4.3\_1.3.5 Test requirement

Same test requirement as in clause 6.4A.2.3.3.5 in TS 38.521-2 [9] for the NR carrier.

#### 6.4B.2.4.3\_1.4 In-band Emissions for inter-band EN-DC including FR2 (5 NR CCs)

**Editor's note: This clause is incomplete. The following aspects are either missing or not yet determined:**

- The referred test case 6.4A.2.3.4 in TS 38.521-2 [9] is incomplete.
- Measurement Uncertainty and Test Tolerance are FFS.

#### 6.4B.2.4.3\_1.4.1 Test purpose

Same test purpose as in clause 6.4.2.3 in TS 38.521-2 [9] for the NR carrier.

#### 6.4B.2.4.3\_1.4.2 Test applicability

This test case applies to all types of E-UTRA UE release 15 and forward, supporting inter-band EN-DC including FR2 with 5 NR UL CCs.

#### 6.4B.2.4.3\_1.4.3 Minimum conformance requirements

Same minimum conformance requirements as in clause 6.4B.2.4.3.3.

#### 6.4B.2.4.3\_1.4.4 Test description

##### 6.4B.2.4.3\_1.4.4.1 Initial conditions

Same test description as in clause 6.4A.2.3.4.4 in TS 38.521-2 [9] for the NR carrier with the following exception:

The initial test configurations for E-UTRA band consist of environmental conditions, test frequencies, and channel bandwidths based on E-UTRA bands specified in Table 4.7-1. For Initial conditions as in clause 6.4A.2.3.4.4.1 in TS 38.521-2 [9], the following steps will be added to configure E-UTRA component:

- 2.1. The parameter settings for E-UTRA cell are set up according to TS 36.508 [11] clause 4.4.3.
- 3.1. The E-UTRA downlink signal level, uplink signal level are set according to Table 4.7-1 and propagation conditions are set according to Annex B.0 of TS 36.521-1 [10].

Step 6 of Initial conditions as in clause 6.4A.2.3.4.4.1 in TS 38.521-2 [9] is replaced by:

6. Ensure the UE is in state RRC\_CONNECTED with generic procedure parameters Connectivity EN-DC, DC bearer MCG and SCG, Connected without release On according to TS 38.508-1 [6] clause 4.5.

Same test procedure as in clause 6.4A.2.3.4.4.2 in TS 38.521-2 [9] with the following steps added for E-UTRA component:

- 1.1 On the E-UTRA carrier, disable periodic and aperiodic CQI reports, disable SRS, set *TimeAlignmentTimerDedicated* IE to infinity and disable downlink and uplink scheduling, all as per Table 4.7-1 under clause 4.7.

#### 6.4B.2.4.3\_1.4.5 Test requirement

Same test requirement as in clause 6.4A.2.3.4.5 in TS 38.521-2 [9] for the NR carrier.

#### 6.4B.2.4.3\_1.5 In-band Emissions for inter-band EN-DC including FR2 (6 NR CCs)

**Editor's note: This clause is incomplete. The following aspects are either missing or not yet determined:**

- The referred test case 6.4A.2.3.5 in TS 38.521-2 [9] is incomplete.
- Measurement Uncertainty and Test Tolerance are FFS.

##### 6.4B.2.4.3\_1.5.1 Test purpose

Same test purpose as in clause 6.4.2.3 in TS 38.521-2 [9] for the NR carrier.

##### 6.4B.2.4.3\_1.5.2 Test applicability

This test case applies to all types of E-UTRA UE release 15 and forward, supporting inter-band EN-DC including FR2 with 6 NR UL CCs.

##### 6.4B.2.4.3\_1.5.3 Minimum conformance requirements

Same minimum conformance requirements as in clause 6.4B.2.4.3.5.



#### 6.4B.2.4.3\_1.5.4 Test description

##### 6.4B.2.4.3\_1.5.4.1 Initial conditions

Same test description as in clause 6.4A.2.3.5.4 in TS 38.521-2 [9] for the NR carrier with the following exception:

The initial test configurations for E-UTRA band consist of environmental conditions, test frequencies, and channel bandwidths based on E-UTRA bands specified in Table 4.7-1. For Initial conditions as in clause 6.4A.2.3.5.4.1 in TS 38.521-2 [9], the following steps will be added to configure E-UTRA component:

- 2.1. The parameter settings for E-UTRA cell are set up according to TS 36.508 [11] clause 4.4.3.
- 3.1. The E-UTRA downlink signal level, uplink signal level are set according to Table 4.7-1 and propagation conditions are set according to Annex B.0 of TS 36.521-1 [10].

Step 6 of Initial conditions as in clause 6.4A.2.3.5.4.1 in TS 38.521-2 [9] is replaced by:

6. Ensure the UE is in state RRC\_CONNECTED with generic procedure parameters Connectivity EN-DC, DC bearer MCG and SCG, Connected without release On according to TS 38.508-1 [6] clause 4.5.

Same test procedure as in clause 6.4A.2.3.5.4.2 in TS 38.521-2 [9] with the following steps added for E-UTRA component:

- 1.1 On the E-UTRA carrier, disable periodic and aperiodic CQI reports, disable SRS, set *TimeAlignmentTimerDedicated* IE to infinity and disable downlink and uplink scheduling, all as per Table 4.7-1 under clause 4.7.

#### 6.4B.2.4.3\_1.5.5 Test requirement

Same test requirement as in clause 6.4A.2.3.5.5 in TS 38.521-2 [9] for the NR carrier.

#### 6.4B.2.4.3\_1.6 In-band Emissions for inter-band EN-DC including FR2 (7 NR CCs)

**Editor's note: This clause is incomplete. The following aspects are either missing or not yet determined:**

- **The referred test case 6.4A.2.3.6 in TS 38.521-2 [9] is incomplete.**
- **Measurement Uncertainty and Test Tolerance are FFS.**

##### 6.4B.2.4.3\_1.6.1 Test purpose

Same test purpose as in clause 6.4.2.3 in TS 38.521-2 [9] for the NR carrier.

##### 6.4B.2.4.3\_1.6.2 Test applicability

This test case applies to all types of E-UTRA UE release 15 and forward, supporting inter-band EN-DC including FR2 with 7 NR UL CCs.

##### 6.4B.2.4.3\_1.6.3 Minimum conformance requirements

Same minimum conformance requirements as in clause 6.4B.2.4.3.3.

#### 6.4B.2.4.3\_1.6.4 Test description

##### 6.4B.2.4.3\_1.6.4.1 Initial conditions

Same test description as in clause 6.4A.2.3.6.4 in TS 38.521-2 [9] for the NR carrier with the following exception:

The initial test configurations for E-UTRA band consist of environmental conditions, test frequencies, and channel bandwidths based on E-UTRA bands specified in Table 4.7-1. For Initial conditions as in clause 6.4A.2.3.6.4.1 in TS 38.521-2 [9], the following steps will be added to configure E-UTRA component:

- 2.1. The parameter settings for E-UTRA cell are set up according to TS 36.508 [11] clause 4.4.3.



- 3.1. The E-UTRA downlink signal level, uplink signal level are set according to Table 4.7-1 and propagation conditions are set according to Annex B.0 of TS 36.521-1 [10].

Step 6 of Initial conditions as in clause 6.4A.2.3.6.4.1 in TS 38.521-2 [9] is replaced by:

6. Ensure the UE is in state RRC\_CONNECTED with generic procedure parameters Connectivity EN-DC, DC bearer MCG and SCG, Connected without release On according to TS 38.508-1 [6] clause 4.5.

Same test procedure as in clause 6.4A.2.3.6.4.2 in TS 38.521-2 [9] with the following steps added for E-UTRA component:

- 1.1 On the E-UTRA carrier, disable periodic and aperiodic CQI reports, disable SRS, set *TimeAlignmentTimerDedicated* IE to infinity and disable downlink and uplink scheduling, all as per Table 4.7-1 under clause 4.7.

#### 6.4B.2.4.3\_1.6.5 Test requirement

Same test requirement as in clause 6.4A.2.3.6.5 in TS 38.521-2 [9] for the NR carrier.

#### 6.4B.2.4.3\_1.7 In-band Emissions for inter-band EN-DC including FR2 (8 NR CCs)

**Editor's note: This clause is incomplete. The following aspects are either missing or not yet determined:**

- The referred test case 6.4A.2.3.7 in TS 38.521-2 [9] is incomplete.
- Measurement Uncertainty and Test Tolerance are FFS.

#### 6.4B.2.4.3\_1.7.1 Test purpose

Same test purpose as in clause 6.4.2.3 in TS 38.521-2 [9] for the NR carrier.

#### 6.4B.2.4.3\_1.7.2 Test applicability

This test case applies to all types of E-UTRA UE release 15 and forward, supporting inter-band EN-DC including FR2 with 8 NR UL CCs.

#### 6.4B.2.4.3\_1.7.3 Minimum conformance requirements

Same minimum conformance requirements as in clause 6.4B.2.4.3.3.

#### 6.4B.2.4.3\_1.7.4 Test description

##### 6.4B.2.4.3\_1.7.4.1 Initial conditions

Same test description as in clause 6.4A.2.3.7.4 in TS 38.521-2 [9] for the NR carrier with the following exception:

The initial test configurations for E-UTRA band consist of environmental conditions, test frequencies, and channel bandwidths based on E-UTRA bands specified in Table 4.7-1. For Initial conditions as in clause 6.4A.2.3.7.4.1 in TS 38.521-2 [9], the following steps will be added to configure E-UTRA component:

- 2.1. The parameter settings for E-UTRA cell are set up according to TS 36.508 [11] clause 4.4.3.
- 3.1. The E-UTRA downlink signal level, uplink signal level are set according to Table 4.7-1 and propagation conditions are set according to Annex B.0 of TS 36.521-1 [10].

Step 6 of Initial conditions as in clause 6.4A.2.3.7.4.1 in TS 38.521-2 [9] is replaced by:

6. Ensure the UE is in state RRC\_CONNECTED with generic procedure parameters Connectivity EN-DC, DC bearer MCG and SCG, Connected without release On according to TS 38.508-1 [6] clause 4.5.

Same test procedure as in clause 6.4A.2.3.7.4.2 in TS 38.521-2 [9] with the following steps added for E-UTRA component:

1.1 On the E-UTRA carrier, disable periodic and aperiodic CQI reports, disable SRS, set *TimeAlignmentTimerDedicated* IE to infinity and disable downlink and uplink scheduling, all as per Table 4.7-1 under clause 4.7.

#### 6.4B.2.4.3\_1.7.5 Test requirement

Same test requirement as in clause 6.4A.2.3.7.5 in TS 38.521-2 [9] for the NR carrier.

#### 6.4B.2.4.4 EVM Equalizer Flatness for inter-band EN-DC including FR2 (1 NR CC)

**Editor's note: This clause is incomplete. The following aspects are either missing or not yet determined:**

- The referred test case 6.4.2.4 in TS 38.521-2 [9] is incomplete.
- Measurement Uncertainty and Test Tolerance are FFS.

##### 6.4B.2.4.4.1 Test purpose

Same test purpose as in clause 6.4.2.4 in TS 38.521-2 [9] for the NR carrier.

##### 6.4B.2.4.4.2 Test applicability

This test case applies to all types of E-UTRA UE release 15 and forward, supporting inter-band EN-DC including FR2 with 1 NR UL CC.

##### 6.4B.2.4.4.3 Minimum conformance requirements

For inter-band EN-DC including FR2 or both FR1 and FR2, transmit modulation quality for EN-DC operations in FR1 and FR2 as specified in TS 36.101 [5], TS 38.101-1 [2] and TS 38.101-2 [3] apply for E-UTRA, NR FR1 and NR FR2 respectively.

The normative reference for this requirement is TS 38.101-3 [4] clause 6.4B.2.4.

Same minimum conformance requirements as in clause 6.4.2.4.3 in TS 38.521-2 [9] for the NR carrier.

No exception requirements applicable to NR or E-UTRA. LTE anchor agnostic approach is applied.

##### 6.4B.2.4.4.4 Test description

###### 6.4B.2.4.4.4.1 Initial conditions

Same test description as in clause 6.4.2.4.4 in TS 38.521-2 [9] for the NR carrier with the following exception:

The initial test configurations for E-UTRA band consist of environmental conditions, test frequencies, and channel bandwidths based on E-UTRA bands specified in Table 4.7-1. For Initial conditions as in clause 6.4.2.4.4.1 in TS 38.521-2 [9], the following steps will be added to configure E-UTRA component:

- 2.1. The parameter settings for E-UTRA cell are set up according to TS 36.508 [11] clause 4.4.3.
- 3.1. The E-UTRA downlink signal level, uplink signal level are set according to Table 4.7-1 and propagation conditions are set according to Annex B.0 of TS 36.521-1 [10].

Step 6 of Initial conditions as in clause 6.4.2.4.1 in TS 38.521-2 [9] is replaced by:

6. Ensure the UE is in state RRC\_CONNECTED with generic procedure parameters Connectivity EN-DC, DC bearer MCG and SCG, Connected without release On according to TS 38.508-1 [6] clause 4.5.

Same test procedure as in clause 6.4.2.4.4.1 in TS 38.521-2 [9] with the following steps added for E-UTRA component:

- 1.1 On the E-UTRA carrier, disable periodic and aperiodic CQI reports, disable SRS, set *TimeAlignmentTimerDedicated* IE to infinity and disable downlink and uplink scheduling, all as per Table 4.7-1 under clause 4.7.

## 6.4B.2.4.4.5 Test requirement

Same test requirement as in clause 6.4.2.4.5 in TS 38.521-2 [9] for the NR carrier.

## 6.4B.2.4.4D EVM Equalizer Flatness for inter-band EN-DC including FR2 for UL MIMO

**Editor's note: This clause is incomplete. The following aspects are either missing or not yet determined:**

- The referred test case 6.4D.2.4 in TS 38.521-2 [9] is incomplete.
- Measurement Uncertainty and Test Tolerance are FFS and Annex F needs to be updated.

## 6.4B.2.4.4D.1 Test purpose

Same test purpose as in clause 6.4D.2.4.1 in TS 38.521-2 [9] for the NR carrier.

## 6.4B.2.4.4D.2 Test applicability

This test case applies to all types of E-UTRA UE release 15 and forward, supporting inter-band EN-DC including FR2 and UL MIMO.

## 6.4B.2.4.4D.3 Minimum conformance requirements

For inter-band EN-DC including FR2 or both FR1 and FR2, transmit modulation quality for EN-DC operations in FR1 and FR2 as specified in TS 36.101 [5], TS 38.101-1 [2] and TS 38.101-2 [3] apply for E-UTRA, NR FR1 and NR FR2 respectively.

The normative reference for this requirement is TS 38.101-3 [4] clause 6.4B.2.4.

Same minimum conformance requirements as in clause 6.4D.2.4.3 in TS 38.521-2 [9] for the NR carrier.

No exception requirements applicable to NR or E-UTRA. LTE anchor agnostic approach is applied.

## 6.4B.2.4.4D.4 Test description

## 6.4B.2.4.4D.4.1 Initial conditions

Same test description as in clause 6.4D.2.4.4 in TS 38.521-2 [9] for the NR carrier with the following exception:

The initial test configurations for E-UTRA band consist of environmental conditions, test frequencies, and channel bandwidths based on E-UTRA bands specified in Table 4.7-1. For Initial conditions as in clause 6.4D.2.4.4.1 in TS 38.521-2 [9], the following steps will be added to configure E-UTRA component:

- 2.1. The parameter settings for E-UTRA cell are set up according to TS 36.508 [11] clause 4.4.3.
- 3.1. The E-UTRA downlink signal level, uplink signal level are set according to Table 4.7-1 and propagation conditions are set according to Annex B.0 of TS 36.521-1 [10].

Step 6 of Initial conditions as in clause 6.4D.2.4.1 in TS 38.521-2 [9] is replaced by:

6. Ensure the UE is in state RRC\_CONNECTED with generic procedure parameters Connectivity EN-DC, DC bearer MCG and SCG, Connected without release On according to TS 38.508-1 [6] clause 4.5.

Same test procedure as in clause 6.4D.2.4.4.1 in TS 38.521-2 [9] with the following steps added for E-UTRA component:

- 1.1 On the E-UTRA carrier, disable periodic and aperiodic CQI reports, disable SRS, set *TimeAlignmentTimerDedicated* IE to infinity and disable downlink and uplink scheduling, all as per Table 4.7-1 under clause 4.7.

## 6.4B.2.4.4D.5 Test requirement

Same test requirement as in clause 6.4D.2.4.5 in TS 38.521-2 [9] for the NR carrier.

#### 6.4B.2.4.5 EVM spectral flatness for pi/2 BPSK modulation for inter-band EN-DC including FR2 (1 NR CC)

**Editor's note: This clause is incomplete. The following aspects are either missing or not yet determined:**

- The referred test case 6.4.2.5 in TS 38.521-2 [9] is incomplete.

##### 6.4B.2.4.5.1 Test purpose

Same test purpose as in clause 6.4.2.5 in TS 38.521-2 [9] for the NR carrier.

##### 6.4B.2.4.5.2 Test applicability

This test case applies to all types of E-UTRA UE release 15 and forward, supporting inter-band EN-DC including FR2 with 1 NR UL CC.

##### 6.4B.2.4.5.3 Minimum conformance requirements

Transmit modulation quality requirement for E-UTRA single carrier and CA operation specified in clauses 6.5.2 and 6.5.2A of TS 36.101 [4] and for NR single carrier, CA operation and UL-MIMO specified in clause 6.4.2, 6.4A.2 and 6.4D.2 of TS 38.101-2 [3] apply.

The normative reference for this requirement is TS 38.101-3 [4] clause 6.4B.2.4.

Same minimum conformance requirements as in clause 6.4.2.5.3 in TS 38.521-2 [9] for the NR carrier.

No exception requirements applicable to NR or E-UTRA. LTE anchor agnostic approach is applied.

##### 6.4B.2.4.5.4 Test description

###### 6.4B.2.4.5.4.1 Initial conditions

Same test description as in clause 6.4.2.5.4 in TS 38.521-2 [9] for the NR carrier with the following exception:

The initial test configurations for E-UTRA band consist of environmental conditions, test frequencies, and channel bandwidths based on E-UTRA bands specified in Table 4.7-1. For Initial conditions as in clause 6.4.2.5.4.1 in TS 38.521-2 [9], the following steps will be added to configure E-UTRA component:

- 2.1. The parameter settings for E-UTRA cell are set up according to TS 36.508 [11] clause 4.4.3.
- 3.1. The E-UTRA downlink signal level, uplink signal level are set according to Table 4.7-1 and propagation conditions are set according to Annex B.0 of TS 36.521-1 [10].

Step 6 of Initial conditions as in clause 6.4.2.5.4.1 in TS 38.521-2 [9] is replaced by:

6. Ensure the UE is in state RRC\_CONNECTED with generic procedure parameters Connectivity EN-DC, DC bearer MCG and SCG, Connected without release On according to TS 38.508-1 [6] clause 4.5.

Same test procedure as in clause 6.4.2.5.4.2 in TS 38.521-2 [9] with the following steps added for E-UTRA component:

- 1.1 On the E-UTRA carrier, disable periodic and aperiodic CQI reports, disable SRS, set *TimeAlignmentTimerDedicated* IE to infinity and disable downlink and uplink scheduling, all as per Table 4.7-1 under clause 4.7.

##### 6.4B.2.4.5.5 Test requirement

Same test requirement as in clause 6.4.2.5.5 in TS 38.521-2 [9] for the NR carrier.

## 6.4E Transmit signal quality for V2X operation in FR1

### 6.4E.1 Frequency error for V2X

#### 6.4E.1.0 Minimum conformance requirements

For intra-band V2X operating UE, the requirement shall apply on each component carrier as defined in clause 6.5.1G in TS 36.101 [5] and in clause 6.4E.1 in TS 38.101-1 [2], respectively.

For the inter-band con-current NR V2X operation, the requirements specified in subclause 6.4.1 of TS 36.101 [5] shall apply for the E-UTRA uplink in licensed band and the requirements specified in subclause 6.4E.1 of TS 38.101-1 [2] shall apply for the sidelink in NR Band n47.

The normative reference for this requirement is TS 38.101-3 [4] clause 6.4E.1.

#### 6.4E.1.1 Frequency error for Intra-band V2X

##### 6.4E.1.1.1 Test purpose

This test verifies the ability of both, the receiver and the transmitter, to process frequency correctly.

Receiver: to extract the correct frequency from the stimulus signal, offered by the System simulator, under ideal propagation conditions and low level.

Transmitter: to derive the correct modulated carrier frequency from the results, gained by the receiver.

##### 6.4E.1.1.2 Test applicability

No exception requirements applicable to NR V2X operation or E-UTRA V2X operation. Given only single switched SL is supported as per clause 6.4E.1.0. The requirements in this test case can be well covered in clause 6.5.1G of TS 36.521-1 [10] and clause 6.4E.1 of TS 38.521-1 [8] and don't need to be tested again.

#### 6.4E.1.2 Frequency error for Inter-band V2X

##### 6.4E.1.2.1 Test purpose

Same test purpose as in clause 6.4E.1 in TS 38.521-1 [8].

##### 6.4E.1.2.2 Test applicability

For inter-band V2X operation, no exception requirements are specified for the E-UTRA/NR Uu carrier and E-UTRA/NR SL carrier.

For inter-band V2X configuration with E-UTRA Uu and NR sidelink, the requirements in this test case can be well covered in clause 6.5.1 of TS 36.521-1 [10] for E-UTRA Uu carrier and clause 6.4E.1.1 of TS 38.521-1 [8] and don't need to be tested again.

### 6.4E.2 Transmit modulation quality for V2X

#### 6.4E.2.1 Error Vector Magnitude for V2X

##### 6.4E.2.1.0 Minimum conformance requirements

For intra-band V2X operating UE, the requirement shall apply on each SL transmission as defined in clause 6.5.2G.1 in TS 36.101 [5] and in clause 6.4E.2.1 in TS 38.101-1 [2], respectively.

For the inter-band con-current NR V2X operation, the requirements specified in subclause 6.5.2 of TS 36.101 [5] shall apply for the E-UTRA uplink in licensed band and the requirements specified in subclause 6.4E.2.1 of TS 38.101-1 [2] shall apply for the sidelink in NR Band n47.

The normative reference for this requirement is TS 38.101-3 [4] clause 6.4E.2.1.1.

#### 6.4E.2.1.1 Error Vector Magnitude for intra-band V2X

##### 6.4E.2.1.1.1 Test purpose

Same test purpose as in clause 6.4E.2 in TS 38.521-1 [8].

##### 6.4E.2.1.1.2 Test applicability

No exception requirements applicable to NR V2X operation or E-UTRA V2X operation. Given only single switched SL is supported as per clause 6.4E.2.1.0. The requirements in this test case can be well covered in clause 6.5.2.1G of TS 36.521-1 [10] and clause 6.4E.2.1 of TS 38.521-1 [8] and don't need to be tested again.

#### 6.4E.2.1.2 Error Vector Magnitude for Inter-band V2X

##### 6.4E.2.1.2.1 Test purpose

Same test purpose as in clause 6.4E.2 in TS 38.521-1 [8].

##### 6.4E.2.1.2.2 Test applicability

For inter-band V2X operation, no exception requirements are specified for the E-UTRA/NR Uu carrier and E-UTRA/NR SL carrier.

For inter-band V2X configuration with E-UTRA Uu and NR sidelink, the requirements in this test case can be well covered in clause 6.5.2.1 of TS 36.521-1 [10] for E-UTRA Uu carrier and clause 6.4E.2.2.1 of TS 38.521-1 [8] and don't need to be tested again.

#### 6.4E.2.2 Carrier leakage for V2X

##### 6.4E.2.2.0 Minimum conformance requirements

For intra-band V2X operating UE, the requirement shall apply on each SL transmission as defined in clause 6.5.2G.2 in TS 36.101 [5] and in clause 6.4E.2.2 in TS 38.101-1 [2], respectively.

The normative reference for this requirement is TS 38.101-3 [4] clause 6.4E.2.2.2.

##### 6.4E.2.2.1 Carrier leakage for intra-band V2X

###### 6.4E.2.2.1.1 Test purpose

Same test purpose as in clause 6.4E.2.3.1 in TS 38.521-1 [8].

###### 6.4E.2.2.1.2 Test applicability

No exception requirements applicable to NR V2X operation or E-UTRA V2X operation. Given only single switched SL is supported as per clause 6.2E.1.0. The requirements in this test case can be well covered in clause 6.5.2.2G of TS 36.521-1 [10] and clause 6.4E.2.3 of TS 38.521-1 [8] and don't need to be tested again.

#### 6.4E.2.3 In-band emissions for V2X

##### 6.4E.2.3.0 Minimum conformance requirements

For intra-band V2X operating UE, the requirement shall apply on each SL transmission as defined in clause 6.5.2G.3 in TS 36.101 [5] and in clause 6.4E.2.3 in TS 38.101-1 [2], respectively.

The normative reference for this requirement is TS 38.101-3 [4] clause 6.4E.2.2.3.

## 6.4E.2.3.1 In-band emissions for intra-band V2X

### 6.4E.2.3.1.1 Test purpose

Same test purpose as in clause 6.4E.2.4.1 in TS 38.521-1 [8].

### 6.4E.2.3.1.2 Test applicability

No exception requirements applicable to NR V2X operation or E-UTRA V2X operation. Given only single switched SL is supported as per clause 6.2E.1.0. The requirements in this test case can be well covered in clause 6.5.2.3G of TS 36.521-1 [10] and clause 6.4E.2.4 of TS 38.521-1 [8] and don't need to be tested again.

## 6.4H Transmit signal quality for DC with UL MIMO

### 6.4H.1 Frequency error for DC with UL MIMO

#### 6.4H.1.1

#### 6.4H.1.2

#### 6.4H.1.3 Frequency error for inter-band EN-DC with UL MIMO within FR1

##### 6.4H.1.3.1 Test purpose

Same test purpose as in clause 6.4D.1 in TS 38.521-1 [8] for the NR carrier.

##### 6.4H.1.3.2 Test applicability

This test case applies to all types of NR UE release 17 and forward that support inter-band EN-DC with UL MIMO.

##### 6.4H.1.3.3 Minimum conformance requirements

For inter-band EN-DC with UL MIMO and uplink assigned to one E-UTRA band and one NR band, the requirements shall apply on each component carrier as defined in clause 6.5.1 in TS 36.101 [5] and in clause 6.4D.1 in TS 38.101-1 [2], respectively, with all component carriers active.

The normative reference for this requirement is TS 38.101-1 [2] clause 6.4H.1.3.

##### 6.4H.1.3.4 Test description

If Standalone FR1 can be tested, this test is covered by 6.4D.1 Frequency Error for UL MIMO in TS 38.521-1 [8].

If Standalone FR1 cannot be tested (due to test case not being complete or if the UE does not support the band in SA mode), LTE anchor agnostic below is applied.

Same test description as in clause 6.4D.1.4 in TS 38.521-1 [8] for the NR carrier with the following exceptions:

The initial test configurations for E-UTRA band consist of environmental conditions, test frequencies, and channel bandwidths based on E-UTRA bands specified in Table 4.6-1.

For Initial conditions as in clause 6.4D.1.4 in TS 38.521-1 [8], the following steps will be added to configure E-UTRA component:

- 2.1. The parameter settings for the E-UTRA cell are set up according to TS 36.508 [11] clause 4.4.3 with E-UTRA channel bandwidth and test frequencies defined in Table 4.6-1.
- 3.1. Downlink E-UTRA signals are initially set up according to TS 36.521-1 [10] Annex C0, C.1 and C.3.0, and uplink signals according to Annex H.1 and H.3.0.
- 4.1. The E-UTRA UL Reference Measurement channels are set according to Table 4.6-1.

Step 6 of Initial conditions as in clause 6.4D.1.4 in TS 38.521-1 [8] is replaced by the following two steps:

6. Ensure the UE is in state RRC\_CONNECTED with generic procedure parameters Connectivity EN-DC, DC bearer MCG and SCG, Connected without release *On* according to TS 38.508-1 [6] clause 4.5.
7. On the E-UTRA carrier, disable periodic and aperiodic CQI reports, disable SRS, set *TimeAlignmentTimerDedicated* IE to infinity and disable downlink and uplink scheduling, all as per Table 4.6-1 under clause 4.6.

#### 6.4H.1.3.5 Test requirement

Same test requirement as 6.4D.1.5 in TS 38.521-1 [8].

## 6.4H.2 Transmit signal quality for DC with UL MIMO

### 6.4H.2.1

### 6.4H.2.2

### 6.4H.2.3 Transmit modulation quality for inter-band EN-DC with UL MIMO

#### 6.4H.2.3.1 Error Vector Magnitude for inter-band EN-DC with UL MIMO within FR1

##### 6.4H.2.3.1.1 Test purpose

Same test purpose as in clause 6.4D.2.1 in TS 38.521-1 [8] for the NR carrier.

##### 6.4H.2.3.1.2 Test applicability

This test case applies to all types of NR UE release 17 and forward that support inter-band EN-DC with UL MIMO.

##### 6.4H.2.3.1.3 Minimum conformance requirements

For inter-band EN-DC with UL MIMO and uplink assigned to one E-UTRA band and one NR band, the requirements shall apply on each component carrier as defined in clause 6.5.2 in TS 36.101 [5] and in clause 6.4D.2 in TS 38.101-1 [2], respectively, with all component carriers active.

The normative reference for this requirement is TS 38.101-1 [2] clause 6.4H.2.3.

##### 6.4H.2.3.1.4 Test description

If Standalone FR1 can be tested, this test is covered by 6.4D.2.1 Error Vector Magnitude for UL MIMO in TS 38.521-1 [8].

If Standalone FR1 cannot be tested (due to test case not being complete or if the UE does not support the band in SA mode), LTE anchor agnostic below is applied.

Same test description as in clause 6.4D.2.1.4 in TS 38.521-1 [8] for the NR carrier with the following exceptions:

The initial test configurations for E-UTRA band consist of environmental conditions, test frequencies, and channel bandwidths based on E-UTRA bands specified in Table 4.6-1.

For Initial conditions as in clause 6.4D.2.1.4 in TS 38.521-1 [8], the following steps will be added to configure E-UTRA component:

- 2.1. The parameter settings for the E-UTRA cell are set up according to TS 36.508 [11] clause 4.4.3 with E-UTRA channel bandwidth and test frequencies defined in Table 4.6-1.
- 3.1. Downlink E-UTRA signals are initially set up according to TS 36.521-1 [10] Annex C0, C.1 and C.3.0, and uplink signals according to Annex H.1 and H.3.0.



4.1. The E-UTRA UL Reference Measurement channels are set according to Table 4.6-1.

Step 6 of Initial conditions as in clause 6.4D.2.1.4 in TS 38.521-1 [8] is replaced by the following two steps:

6. Ensure the UE is in state RRC\_CONNECTED with generic procedure parameters Connectivity EN-DC, DC bearer MCG and SCG, Connected without release *On* according to TS 38.508-1 [6] clause 4.5.
7. On the E-UTRA carrier, disable periodic and aperiodic CQI reports, disable SRS, set *TimeAlignmentTimerDedicated* IE to infinity and disable downlink and uplink scheduling, all as per Table 4.6-1 under clause 4.6.

#### 6.4H.2.3.1.5 Test requirement

Same test requirement as 6.4D.2.1 for the band supporting UL MIMO and 6.4.2.1 for the other band.

#### 6.4H.2.3.2 Carrier leakage for inter-band EN-DC with UL MIMO within FR1

##### 6.4H.2.3.2.1 Test purpose

Same test purpose as in clause 6.4D.2.2 in TS 38.521-1 [8] for the NR carrier.

##### 6.4H.2.3.2.2 Test applicability

This test case applies to all types of NR UE release 17 and forward that support inter-band EN-DC with UL MIMO.

##### 6.4H.2.3.2.3 Minimum conformance requirements

For inter-band EN-DC with UL MIMO and uplink assigned to one E-UTRA band and one NR band, the requirements shall apply on each component carrier as defined in clause 6.5.2 in TS 36.101 [5] and in clause 6.4D.2 in TS 38.101-1 [2], respectively, with all component carriers active.

The normative reference for this requirement is TS 38.101-1 [2] clause 6.4H.2.3.

##### 6.4H.2.3.2.4 Test description

If Standalone FR1 can be tested, this test is covered by 6.4D.2.2 Carrier leakage for UL MIMO in TS 38.521-1 [8].

If Standalone FR1 cannot be tested (due to test case not being complete or if the UE does not support the band in SA mode), LTE anchor agnostic below is applied.

Same test description as in clause 6.4D.2.2.4 in TS 38.521-1 [8] for the NR carrier with the following exceptions:

The initial test configurations for E-UTRA band consist of environmental conditions, test frequencies, and channel bandwidths based on E-UTRA bands specified in Table 4.6-1.

For Initial conditions as in clause 6.4D.2.2.4 in TS 38.521-1 [8], the following steps will be added to configure E-UTRA component:

- 2.1. The parameter settings for the E-UTRA cell are set up according to TS 36.508 [11] clause 4.4.3 with E-UTRA channel bandwidth and test frequencies defined in Table 4.6-1.
- 3.1. Downlink E-UTRA signals are initially set up according to TS 36.521-1 [10] Annex C0, C.1 and C.3.0, and uplink signals according to Annex H.1 and H.3.0.
- 4.1. The E-UTRA UL Reference Measurement channels are set according to Table 4.6-1.

Step 6 of Initial conditions as in clause 6.4D.2.2.4 in TS 38.521-1 [8] is replaced by the following two steps:

6. Ensure the UE is in state RRC\_CONNECTED with generic procedure parameters Connectivity EN-DC, DC bearer MCG and SCG, Connected without release *On* according to TS 38.508-1 [6] clause 4.5.
7. On the E-UTRA carrier, disable periodic and aperiodic CQI reports, disable SRS, set *TimeAlignmentTimerDedicated* IE to infinity and disable downlink and uplink scheduling, all as per Table 4.6-1 under clause 4.6.

#### 6.4H.2.3.2.5 Test requirement

Same test requirement as 6.4D.2.2 for the band supporting UL MIMO and 6.4.2.2 for the other band.

#### 6.4H.2.3.3 In-band emissions for inter-band EN-DC with UL MIMO within FR1

##### 6.4H.2.3.3.1 Test purpose

Same test purpose as in clause 6.4D.2.3 in TS 38.521-1 [8] for the NR carrier.

##### 6.4H.2.3.3.2 Test applicability

This test case applies to all types of NR UE release 17 and forward that support inter-band EN-DC with UL MIMO.

##### 6.4H.2.3.3.3 Minimum conformance requirements

For inter-band EN-DC with UL MIMO and uplink assigned to one E-UTRA band and one NR band, the requirements shall apply on each component carrier as defined in clause 6.5.2 in TS 36.101 [5] and in clause 6.4D.2 in TS 38.101-1 [2], respectively, with all component carriers active.

The normative reference for this requirement is TS 38.101-1 [2] clause 6.4H.2.3.

##### 6.4H.2.3.3.4 Test description

If Standalone FR1 can be tested, this test is covered by 6.4D.2.3 In-band emissions for UL MIMO in TS 38.521-1 [8].

If Standalone FR1 cannot be tested (due to test case not being complete or if the UE does not support the band in SA mode), LTE anchor agnostic below is applied.

Same test description as in clause 6.4D.2.3.4 in TS 38.521-1 [8] for the NR carrier with the following exceptions:

The initial test configurations for E-UTRA band consist of environmental conditions, test frequencies, and channel bandwidths based on E-UTRA bands specified in Table 4.6-1.

For Initial conditions as in clause 6.4D.2.3.4 in TS 38.521-1 [8], the following steps will be added to configure E-UTRA component:

- 2.1. The parameter settings for the E-UTRA cell are set up according to TS 36.508 [11] clause 4.4.3 with E-UTRA channel bandwidth and test frequencies defined in Table 4.6-1.
- 3.1. Downlink E-UTRA signals are initially set up according to TS 36.521-1 [10] Annex C0, C.1 and C.3.0, and uplink signals according to Annex H.1 and H.3.0.
- 4.1. The E-UTRA UL Reference Measurement channels are set according to Table 4.6-1.

Step 6 of Initial conditions as in clause 6.4D.2.3.4 in TS 38.521-1 [8] is replaced by the following two steps:

6. Ensure the UE is in state RRC\_CONNECTED with generic procedure parameters Connectivity EN-DC, DC bearer MCG and SCG, Connected without release *On* according to TS 38.508-1 [6] clause 4.5.
7. On the E-UTRA carrier, disable periodic and aperiodic CQI reports, disable SRS, set *TimeAlignmentTimerDedicated* IE to infinity and disable downlink and uplink scheduling, all as per Table 4.6-1 under clause 4.6.

#### 6.4H.2.3.3.5 Test requirement

Same test requirement as 6.4D.2.3 for the band supporting UL MIMO and 6.4.2.3 for the other band.

## 6.4L Transmit signal quality for DC with Tx Diversity

### 6.4L.1 Frequency error for DC with Tx Diversity

#### 6.4L.1.1

#### 6.4L.1.2

#### 6.4L.1.3 Frequency error for inter-band EN-DC with Tx Diversity within FR1

##### 6.4L.1.3.1 Test purpose

Same test purpose as in clause 6.4G.1 in TS 38.521-1 [8] for the NR carrier.

##### 6.4L.1.3.2 Test applicability

This test case applies to all types of NR UE release 17 and forward that support inter-band EN-DC with Tx Diversity.

##### 6.4L.1.3.3 Minimum conformance requirements

For inter-band EN-DC with Tx Diversity and uplink assigned to one E-UTRA band and one NR band, the requirements shall apply on each component carrier as defined in clause 6.5.1 in TS 36.101 [5] and in clause 6.4G.1 in TS 38.101-1 [2], respectively, with all component carriers active.

The normative reference for this requirement is TS 38.101-1 [2] clause 6.4L.1.3.

##### 6.4L.1.3.4 Test description

If Standalone FR1 can be tested, this test is covered by 6.4G.1 Frequency Error for Tx Diversity in TS 38.521-1 [8].

If Standalone FR1 cannot be tested (due to test case not being complete or if the UE does not support the band in SA mode), LTE anchor agnostic below is applied.

Same test description as in clause 6.4G.1.4 in TS 38.521-1 [8] for the NR carrier with the following exceptions:

The initial test configurations for E-UTRA band consist of environmental conditions, test frequencies, and channel bandwidths based on E-UTRA bands specified in Table 4.6-1.

For Initial conditions as in clause 6.4G.1.4 in TS 38.521-1 [8], the following steps will be added to configure E-UTRA component:

- 2.1. The parameter settings for the E-UTRA cell are set up according to TS 36.508 [11] clause 4.4.3 with E-UTRA channel bandwidth and test frequencies defined in Table 4.6-1.
- 3.1. Downlink E-UTRA signals are initially set up according to TS 36.521-1 [10] Annex C0, C.1 and C.3.0, and uplink signals according to Annex H.1 and H.3.0.
- 4.1. The E-UTRA UL Reference Measurement channels are set according to Table 4.6-1.

Step 6 of Initial conditions as in clause 6.4G.1.4 in TS 38.521-1 [8] is replaced by the following two steps:

6. Ensure the UE is in state RRC\_CONNECTED with generic procedure parameters Connectivity EN-DC, DC bearer MCG and SCG, Connected without release *On* according to TS 38.508-1 [6] clause 4.5.
7. On the E-UTRA carrier, disable periodic and aperiodic CQI reports, disable SRS, set *TimeAlignmentTimerDedicated* IE to infinity and disable downlink and uplink scheduling, all as per Table 4.6-1 under clause 4.6.

##### 6.4L.1.3.5 Test requirement

Same test requirement as 6.4G.1.5 in TS 38.521-1 [8].

## 6.4L.2 Transmit signal quality for DC with Tx Diversity

### 6.4L.2.1

### 6.4L.2.2

### 6.4L.2.3 Transmit modulation quality for inter-band EN-DC with Tx Diversity

#### 6.4L.2.3.1 Error Vector Magnitude for inter-band EN-DC with Tx Diversity within FR1

##### 6.4L.2.3.1.1 Test purpose

Same test purpose as in clause 6.4G.2.1 in TS 38.521-1 [8] for the NR carrier.

##### 6.4L.2.3.1.2 Test applicability

This test case applies to all types of NR UE release 17 and forward that support inter-band EN-DC with Tx Diversity.

##### 6.4L.2.3.1.3 Minimum conformance requirements

For inter-band EN-DC with Tx Diversity and uplink assigned to one E-UTRA band and one NR band, the requirements shall apply on each component carrier as defined in clause 6.5.2 in TS 36.101 [5] and in clause 6.4G.2 in TS 38.101-1 [2], respectively, with all component carriers active.

The normative reference for this requirement is TS 38.101-1 [2] clause 6.4L.2.3.

##### 6.4L.2.3.1.4 Test description

If Standalone FR1 can be tested, this test is covered by 6.4G.2.1 Error Vector Magnitude for Tx Diversity in TS 38.521-1 [8].

If Standalone FR1 cannot be tested (due to test case not being complete or if the UE does not support the band in SA mode), LTE anchor agnostic below is applied.

Same test description as in clause 6.4G.2.1.4 in TS 38.521-1 [8] for the NR carrier with the following exceptions:

The initial test configurations for E-UTRA band consist of environmental conditions, test frequencies, and channel bandwidths based on E-UTRA bands specified in Table 4.6-1.

For Initial conditions as in clause 6.4G.2.1.4 in TS 38.521-1 [8], the following steps will be added to configure E-UTRA component:

- 2.1. The parameter settings for the E-UTRA cell are set up according to TS 36.508 [11] clause 4.4.3 with E-UTRA channel bandwidth and test frequencies defined in Table 4.6-1.
- 3.1. Downlink E-UTRA signals are initially set up according to TS 36.521-1 [10] Annex C0, C.1 and C.3.0, and uplink signals according to Annex H.1 and H.3.0.
- 4.1. The E-UTRA UL Reference Measurement channels are set according to Table 4.6-1.

Step 6 of Initial conditions as in clause 6.4G.2.1.4 in TS 38.521-1 [8] is replaced by the following two steps:

6. Ensure the UE is in state RRC\_CONNECTED with generic procedure parameters Connectivity EN-DC, DC bearer MCG and SCG, Connected without release *On* according to TS 38.508-1 [6] clause 4.5.
7. On the E-UTRA carrier, disable periodic and aperiodic CQI reports, disable SRS, set *TimeAlignmentTimerDedicated* IE to infinity and disable downlink and uplink scheduling, all as per Table 4.6-1 under clause 4.6.

#### 6.4L.2.3.1.5 Test requirement

Same test requirement as 6.4G.2.1 for the band supporting Tx Diversity and 6.4.2.1 for the other band.

#### 6.4L.2.3.2 Carrier leakage for inter-band EN-DC with Tx Diversity within FR1

##### 6.4L.2.3.2.1 Test purpose

Same test purpose as in clause 6.4G.2.2 in TS 38.521-1 [8] for the NR carrier.

##### 6.4L.2.3.2.2 Test applicability

This test case applies to all types of NR UE release 17 and forward that support inter-band EN-DC with Tx Diversity.

##### 6.4L.2.3.2.3 Minimum conformance requirements

For inter-band EN-DC with Tx Diversity and uplink assigned to one E-UTRA band and one NR band, the requirements shall apply on each component carrier as defined in clause 6.5.2 in TS 36.101 [5] and in clause 6.4G.2 in TS 38.101-1 [2], respectively, with all component carriers active.

The normative reference for this requirement is TS 38.101-1 [2] clause 6.4L.2.3.

##### 6.4L.2.3.2.4 Test description

If Standalone FR1 can be tested, this test is covered by 6.4G.2.2 Carrier leakage for Tx Diversity in TS 38.521-1 [8].

If Standalone FR1 cannot be tested (due to test case not being complete or if the UE does not support the band in SA mode), LTE anchor agnostic below is applied.

Same test description as in clause 6.4G.2.2.4 in TS 38.521-1 [8] for the NR carrier with the following exceptions:

The initial test configurations for E-UTRA band consist of environmental conditions, test frequencies, and channel bandwidths based on E-UTRA bands specified in Table 4.6-1.

For Initial conditions as in clause 6.4G.2.2.4 in TS 38.521-1 [8], the following steps will be added to configure E-UTRA component:

- 2.1. The parameter settings for the E-UTRA cell are set up according to TS 36.508 [11] clause 4.4.3 with E-UTRA channel bandwidth and test frequencies defined in Table 4.6-1.
- 3.1. Downlink E-UTRA signals are initially set up according to TS 36.521-1 [10] Annex C0, C.1 and C.3.0, and uplink signals according to Annex H.1 and H.3.0.
- 4.1. The E-UTRA UL Reference Measurement channels are set according to Table 4.6-1.

Step 6 of Initial conditions as in clause 6.4G.2.2.4 in TS 38.521-1 [8] is replaced by the following two steps:

6. Ensure the UE is in state RRC\_CONNECTED with generic procedure parameters Connectivity EN-DC, DC bearer MCG and SCG, Connected without release *On* according to TS 38.508-1 [6] clause 4.5.
7. On the E-UTRA carrier, disable periodic and aperiodic CQI reports, disable SRS, set *TimeAlignmentTimerDedicated* IE to infinity and disable downlink and uplink scheduling, all as per Table 4.6-1 under clause 4.6.

#### 6.4L.2.3.2.5 Test requirement

Same test requirement as 6.4G.2.2 for the band supporting Tx Diversity and 6.4.2.2 for the other band.

#### 6.4L.2.3.3 In-band emissions for inter-band EN-DC with Tx Diversity within FR1

##### 6.4L.2.3.3.1 Test purpose

Same test purpose as in clause 6.4G.2.3 in TS 38.521-1 [8] for the NR carrier.

#### 6.4L.2.3.3.2 Test applicability

This test case applies to all types of NR UE release 17 and forward that support inter-band EN-DC with Tx Diversity.

#### 6.4L.2.3.3.3 Minimum conformance requirements

For inter-band EN-DC with Tx Diversity and uplink assigned to one E-UTRA band and one NR band, the requirements shall apply on each component carrier as defined in clause 6.5.2 in TS 36.101 [5] and in clause 6.4G.2 in TS 38.101-1 [2], respectively, with all component carriers active.

The normative reference for this requirement is TS 38.101-1 [2] clause 6.4L.2.3.

#### 6.4L.2.3.3.4 Test description

If Standalone FR1 can be tested, this test is covered by 6.4G.2.3 In-band emissions for Tx Diversity in TS 38.521-1 [8].

If Standalone FR1 cannot be tested (due to test case not being complete or if the UE does not support the band in SA mode), LTE anchor agnostic below is applied.

Same test description as in clause 6.4G.2.3.4 in TS 38.521-1 [8] for the NR carrier with the following exceptions:

The initial test configurations for E-UTRA band consist of environmental conditions, test frequencies, and channel bandwidths based on E-UTRA bands specified in Table 4.6-1.

For Initial conditions as in clause 6.4G.2.3.4 in TS 38.521-1 [8], the following steps will be added to configure E-UTRA component:

- 2.1. The parameter settings for the E-UTRA cell are set up according to TS 36.508 [11] clause 4.4.3 with E-UTRA channel bandwidth and test frequencies defined in Table 4.6-1.
- 3.1. Downlink E-UTRA signals are initially set up according to TS 36.521-1 [10] Annex C0, C.1 and C.3.0, and uplink signals according to Annex H.1 and H.3.0.
- 4.1. The E-UTRA UL Reference Measurement channels are set according to Table 4.6-1.

Step 6 of Initial conditions as in clause 6.4G.2.3.4 in TS 38.521-1 [8] is replaced by the following two steps:

6. Ensure the UE is in state RRC\_CONNECTED with generic procedure parameters Connectivity EN-DC, DC bearer MCG and SCG, Connected without release *On* according to TS 38.508-1 [6] clause 4.5.
7. On the E-UTRA carrier, disable periodic and aperiodic CQI reports, disable SRS, set *TimeAlignmentTimerDedicated* IE to infinity and disable downlink and uplink scheduling, all as per Table 4.6-1 under clause 4.6.

#### 6.4L.2.3.3.5 Test requirement

Same test requirement as 6.4G.2.3 for the band supporting Tx Diversity and 6.4.2.3 for the other band.

## 6.5 Output RF spectrum emissions

### 6.5A Output RF spectrum emissions for CA

#### 6.5A.1 Occupied bandwidth for CA without EN-DC

##### 6.5A.1.1 Test purpose

Same test purpose as in clause 6.5.1 in TS 38.521-1 [8] for NR FR1 carrier(s) and clause 6.5.1 in TS 38.521-2 [9] for NR FR2 carrier(s).

### 6.5A.1.2 Test applicability

The requirements in this test are not testable due to issues with combined testing of NR FR1 conducted mode with NR FR2 in radiated mode. Therefore, the conducted and radiated requirements are tested separately.

No test case details are specified. The NR/5GC requirements for occupied bandwidth apply and are tested in TS 38.521-1 [8] clauses 6.5 and 6.5A and TS 38.521-2 [9] clauses 6.5 and 6.5A.

## 6.5A.2 Out-of-band emissions for CA without EN-DC

### 6.5A.2.1 Spectrum emissions mask for CA without EN-DC

#### 6.5A.2.1.1 Test purpose

Same test purpose as in clause 6.5.2.2 in TS 38.521-1 [8] for NR FR1 carrier(s) and clause 6.5.2.1 in TS 38.521-2 [9] for NR FR2 carrier(s).

#### 6.5A.2.1.2 Test applicability

The requirements in this test are not testable due to issues with combined testing of NR FR1 conducted mode with NR FR2 in radiated mode. Therefore, the conducted and radiated requirements are tested separately.

No test case details are specified. The NR/5GC requirements for additional spectrum emissions mask apply and are tested in TS 38.521-1 [8] clauses 6.5 and 6.5A and TS 38.521-2 [9] clauses 6.5 and 6.5A.

### 6.5A.2.2 Additional Spectrum emissions mask for CA without EN-DC

#### 6.5A.2.2.1 Test purpose

Same test purpose as in clause 6.5.2.3 in TS 38.521-1 [8] for NR FR1 carrier(s) and clause 6.5.2.2 in TS 38.521-2 [9] for NR FR2 carrier(s).

#### 6.5A.2.2.2 Test applicability

The requirements in this test are not testable due to issues with combined testing of NR FR1 conducted mode with NR FR2 in radiated mode. Therefore, the conducted and radiated requirements are tested separately.

No test case details are specified. The NR/5GC requirements for additional spectrum emissions mask apply and are tested in TS 38.521-1 [8] clauses 6.5 and 6.5A and TS 38.521-2 [9] clauses 6.5 and 6.5A.

### 6.5A.2.3 Adjacent channel leakage ratio for CA without EN-DC

No test case details specified as there are no exception requirements applicable to NR FR1 or NR FR2 as per TS 38.101-3 [4], clause 6.5A.2. The NR/5GC requirement for ACLR applies and is tested in TS 38.521-1 [8] and TS 38.521-2 [9] for FR1 and FR2 respectively.

## 6.5A.3 Spurious emissions for CA without EN-DC

### 6.5A.3.1 Inter-band CA between FR1 and FR2

#### 6.5A.3.1.1 Test purpose

Same test purpose as in clause 6.5.3 in TS 38.521-1 [8] for NR FR1 carrier(s) and clause 6.5.3 in TS 38.521-2 [9] for NR FR2 carrier(s).

#### 6.5A.3.1.2 Test applicability

The requirements in this test are not testable due to issues with combined testing of NR FR1 conducted mode with NR FR2 in radiated mode. Therefore, the conducted and radiated requirements are tested separately.

No test case details are specified. The NR/5GC requirements for spurious emission for inter-band CA between FR1 and FR2 and UE co-existence requirements apply for each component carrier and are tested in TS 38.521-1 [8] clauses 6.5 and 6.5A and TS 38.521-2 [9] clauses 6.5 and 6.5A.

## 6.5B Output RF spectrum emissions for DC

### 6.5B.1 Occupied bandwidth for EN-DC

#### 6.5B.1.1 Occupied bandwidth for Intra-Band Contiguous EN-DC

**Editor's note: This clause is incomplete. The following aspects are either missing or not yet determined:**

- measurement uncertainty for ENBW > 100 MHz is FFS.

##### 6.5B.1.1.1 Test purpose

To verify that the UE occupied bandwidth for intra-band contiguous EN-DC for all transmission bandwidth configurations supported by the UE are less than their specific limits.

##### 6.5B.1.1.2 Test applicability

This test case applies to all types of E-UTRA UE release 15 and forward, supporting intra-band contiguous EN-DC.

##### 6.5B.1.1.3 Minimum conformance requirements

For intra-band contiguous EN-DC, the occupied bandwidth is a measure of the bandwidth containing the 99% of the total integrated power of the transmitted spectrum. The OBW shall be less than the aggregated channel bandwidth for EN-DC, denoted as EN-BW in clause 5.3B.

The normative reference for this measurement is TS 38.101-3 [4] clause 6.5B.1.

Exception requirements for both NR and E-UTRA are defined for this test and therefore LTE anchor agnostic approach is not applied. E-UTRA test point analysis is included and E-UTRA measurements are performed.

##### 6.5B.1.1.4 Test description

###### 6.5B.1.1.4.1 Initial condition

Initial conditions are a set of test configurations the UE needs to be tested in and the steps for the SS to take with the UE to reach the correct measurement state.

The initial test configurations consist of environmental conditions, test frequencies and channel bandwidths based on EN-DC operating bands specified in clause 5.3B.1.2, channel bandwidths and sub-carrier spacings for the NR cell specified in TS 38.521-1 [8] clause 5.3 and channel bandwidth for the E-UTRA cell are specified in TS 36.521-1 [10] clause 5.4.2. All of these configurations shall be tested with applicable test parameters for each EN-DC configuration specified in clause 5.3B.1.2 and are shown in table 6.5B.1.1.4.1-1. The details of the uplink reference measurement channels (RMCs) are specified in Annex A, clause A.2.2 for E-UTRA RMC for TDD, TS 36.521-1 [10] Annex A, clause A.2.2 for E-UTRA RMC for FDD, and TS 38.521-1 [8] Annex A, clause A.2 for NR RMC. Configurations of PDSCH and PDCCH before measurement are specified in TS 36.521-1 [10] Annex C.2 and in TS 38.521-1 [8] Annex C.2 for E-UTRA CG and NR CG respectively.



Table 6.5B.1.1.4.1-1: Test configuration table

Initial Conditions					
Test Environment as specified in TS 38.508-1 [6] clause 4.1		Normal			
Test Frequencies as specified in TS 38.508-1 [6] clause 4.3.1		Mid range			
Test EN-DC bandwidth combination as specified in Table 5.3B.1.2-1		All			
Test SCS for the NR cell as specified in TS 38.521-1 [8] Table 5.3.5-1		Lowest SCS per Channel Bandwidth			
Test Parameters					
Test ID	Downlink Configuration	EN-DC Uplink Configuration			
		E-UTRA Cell		NR Cell	
		Modulation	RB allocation (NOTE 2)	Modulation	RB allocation (NOTE 1)
1	N/A for OBW testing.	QPSK	Outer_Full	CP-OFDM QPSK	Outer_Full
NOTE 1: The specific configuration of each RB allocation is defined in Table 6.1-1 in TS 38.521-1 [8].					
NOTE 2: Outer_Full defined as the transmission bandwidth configuration $N_{RB}$ per channel bandwidth for the E-UTRA component as indicated in TS 36.521-1 [10] Table 5.4.2-1.					

1. Connect the SS to the UE antenna connectors as shown in [6] TS 38.508-1 A.3.1.2.1 for SS diagram and A.3.2.1 for UE diagram.
2. The parameter settings for the E-UTRA cell are set up according to TS 36.508 [11] clause 4.4.3, and the parameter settings for the NR cell are set up according to TS 38.508-1 [6] clause 4.4.3.
3. Downlink signals are initially set up according to TS 36.521-1 [10] Annex C.0 and TS 38.521-1 [8] Annex C.0 for E-UTRA CG and NR CG respectively, and uplink signals according to TS 36.521-1 [10] Annex H and TS 38.521-1 [8] Annex G for E-UTRA CG and NR CG respectively.
4. The UL Reference Measurement channels are set for E-UTRA CG and NR CG respectively.
5. Propagation conditions are set according to TS 36.521-1 [10] Annex B.0 and TS 38.521-1 [8] Annex B.0 for E-UTRA CG and NR CG respectively.
6. Ensure the UE is in state RRC\_CONNECTED with generic procedure parameters Connectivity EN-DC, DC bearer MCG and SCG, Connected without release *On* according to TS 38.508-1 [6] clause 4.5. Message contents are defined in clause 6.2B.1.1.4.3.
7. When E-UTRA and NR bands are TDD, ensure the same uplink-downlink configuration by giving SCG a delay of 3 E-UTRA subframes, or by giving MCG a delay of 2 subframes.

#### 6.5B.1.1.4.2 Test procedure

1. SS sends uplink scheduling information for each UL HARQ process via PDCCH DCI format 0 and DCI format 0\_1 for C\_RNTI to schedule the UL RMC according to table 6.5B.1.1.4.1-1 on E-UTRA CC and NR CC respectively. Since the UL has no payload and no loopback data to send the UE sends uplink MAC padding bits on the UL RMC.
2. Send continuously uplink power control "up" commands to the UE for NR and E-UTRA carrier until the UE transmits at its  $P_{UMAX}$  level; allow at least 200 ms from the first TPC command for the UE to reach  $P_{UMAX}$  level.
3. Measure the power spectrum distribution over all EN-DC component carriers in the EN-DC within two times or more range over the requirement for Occupied Bandwidth specification for intra-band contiguous EN-DC centring on the current carrier frequency in the EN-DC configuration. The characteristics of the filter shall be approximately Gaussian (typical spectrum analyser filter). Other methods to measure the power spectrum distribution are allowed. The measuring duration is at least 1ms over consecutive active uplink slots.
4. Calculate the total power within the range of all frequencies measured in step 3 and save this value as "Total power".

5. Sum up the power upward from the lower boundary of the measured frequency range in step 3 and seek the limit frequency point by which this sum becomes 0.5% of "Total power" and save this point as "Lower Frequency".
6. Sum up the power downward from the upper boundary of the measured frequency range in step 3 and seek the limit frequency point by which this sum becomes 0.5% of "Total power" and save this point as "Upper Frequency".
7. Calculate the difference "Upper Frequency" – "Lower Frequency" = "Occupied Bandwidth" between the two limit frequencies obtained in step 5 and step 6.

#### 6.5B.1.1.4.3 Message contents

Message contents are according to TS 36.508 [11] clause 4.6.1 and TS 38.508-1 [6] clause 4.6.1 with the following exceptions.

**Table 6.5B.1.1.4.3-1: RRCConnectionReconfiguration: nr-Config-r15**

Derivation Path: TS 36.508 [11], Table 4.6.1-8			
Information Element	Value/remark	Comment	Condition
p-MaxEUTRA-r15	23		Power Class 2 UE AND simultaneous E-UTRA and NR transmission
	20		Power Class 3 UE AND simultaneous E-UTRA and NR transmission

**Table 6.5B.1.1.4.3-2: PhysicalCellGroupConfig**

Derivation Path: TS 38.508-1 [6] Table 4.6.3-106			
Information Element	Value/remark	Comment	Condition
p-NR-FR1	23		Power Class 2 UE AND simultaneous E-UTRA and NR transmission
	20		Power Class 3 UE AND simultaneous E-UTRA and NR transmission

**Table 6.5B.1.1.4.3-4: SystemInformationBlockType1: tdd-Config if operating on TDD band**

Derivation Path: TS 36.508 [11], Table 4.6.3-23			
Information Element	Value/remark	Comment	Condition
TDD-Config-DEFAULT ::= SEQUENCE {		Operating on TDD band	
subframeAssignment	sa2		
specialSubframePatterns	ssp7		
}			

#### 6.5B.1.1.5 Test requirements

The measured Occupied Bandwidth shall not exceed values of aggregated channel bandwidth as defined in clause 5.3B.1.2 for intra-band contiguous EN-DC.

#### 6.5B.1.2 Occupied bandwidth for Intra-Band Non-Contiguous EN-DC

##### 6.5B.1.2.1 Test purpose

Same test purpose as in clause 6.5.1.1 in TS 38.521-1 [8] for the NR carrier.

##### 6.5B.1.2.2 Test applicability

This test case applies to all types of E-UTRA UE release 15 and forward, supporting intra-band non-contiguous EN-DC.

### 6.5B.1.2.3 Minimum conformance requirements

Same minimum conformance requirements as in clause 6.5.1.3 in TS 38.521-1 [8] for the NR carrier.

The normative reference for this requirement is TS 38.101-3 [4] clause 6.5B.1.

No exception requirements applicable to NR or E-UTRA. LTE anchor agnostic approach is applied.

### 6.5B.1.2.4 Test description

Same test description as in clause 6.5.1.4 in TS 38.521-1 [8] for the NR carrier with the following exceptions:

**Table 6.5B.1.2.4-1: Test Configuration Table**

Initial Conditions	
Test Frequencies as specified in TS 38.508-1 [6] clause 4.3.1.4.3 for cases with single E-UTRA carrier	Low with maxWgap (NR low – E-UTRA high)
Test Channel Bandwidths as specified in TS 38.508-1 [6] subclause 4.3.1.4.3	All for NR; Lowest for E-UTRA

For Initial conditions as in clause 6.5.1.4.1 in TS 38.521-1 [8], the following steps will be added to configure E-UTRA component:

- 2.1. The parameter settings for E-UTRA cell are set up according to TS 36.508 [11] clause 4.4.3.
- 3.1. The E-UTRA downlink signal level, uplink signal level are set according to Table 4.6-1 and propagation conditions are set according to Annex B.0 of TS 36.521-1 [10].

Step 6 of Initial conditions as in clause 6.5.1.4.1 in TS 38.521-1 [8] is replaced by the following three steps:

6. Ensure the UE is in state RRC\_CONNECTED with generic procedure parameters Connectivity EN-DC, DC bearer MCG and SCG, Connected without release *On* according to TS 38.508 [6] clause 4.5.
7. On the E-UTRA carrier, disable periodic and aperiodic CQI reports, disable SRS, set *TimeAlignmentTimerDedicated* IE to infinity and disable downlink and uplink scheduling, all as per Table 4.6-1 under clause 4.6.
8. When E-UTRA and NR bands are TDD, ensure the same uplink-downlink configuration by giving SCG a delay of 3 E-UTRA subframes, or by giving MCG a delay of 2 subframes.

Same test procedure as in clause 6.5.1.4.2 in TS 38.521-1 [8].

### 6.5B.1.2.5 Test requirement

Same test requirement as in clause 6.5.1.5 in TS 38.521-1 [8] for the NR carrier.

## 6.5B.1.3 Occupied bandwidth for Inter-Band EN-DC within FR1 (1 NR CC)

### 6.5B.1.3.1 Test purpose

Same test purpose as in clause 6.5.1.1 in TS 38.521-1 [8] for the NR carrier.

### 6.5B.1.3.2 Test applicability

This test case applies to all types of E-UTRA UE release 15 and forward, supporting inter-band EN-DC within FR1 with 1 NR UL.

### 6.5B.1.3.3 Minimum conformance requirements

Same minimum conformance requirements as in clause 6.5.1.3 in TS 38.521-1 [8] for the NR carrier.

The normative reference for this requirement is TS 38.101-3 [4] clause 6.5B.1.

No exception requirements applicable to NR or E-UTRA. LTE anchor agnostic approach is applied.

#### 6.5B.1.3.4 Test description

Same test description as in clause 6.5.1.4 in TS 38.521-1 [8] for the NR carrier with the following exceptions:

The initial test configurations for E-UTRA consist of test frequency based on E-UTRA operating band and test channel bandwidth as specified in Table 4.6-1.

For Initial conditions as in clause 6.5.1.4.1 in TS 38.521-1 [8], the following steps will be added to configure E-UTRA component:

- 2.1. The parameter settings for the cell are set up according to TS 36.508 [11] clause 4.4.3.
- 3.1. The E-UTRA downlink signal level, uplink signal level are set according to Table 4.6-1 and propagation conditions are set according to Annex B.0 of TS 36.521-1 [10].

Step 6 of Initial conditions as in clause 6.5.1.4.1 in TS 38.521-1 [8] is replaced by:

6. Ensure the UE is in state RRC\_CONNECTED with generic procedure parameters Connectivity EN-DC, DC bearer MCG and SCG, Connected without release *On* according to TS 38.508 [6] clause 4.5.
7. On the E-UTRA carrier, disable periodic and aperiodic CQI reports, disable SRS, set *TimeAlignmentTimerDedicated* IE to infinity and disable downlink and uplink scheduling, all as per Table 4.6-1 under clause 4.6.

#### 6.5B.1.3.5 Test requirement

Same test requirement as in clause 6.5.1.5 in TS 38.521-1 [8] for the NR carrier.

#### 6.5B.1.4 Occupied bandwidth for Inter-Band EN-DC including FR2 (1 NR CC)

**Editor's note: The following aspects are either missing or not yet determined:**

- **The referred test case 6.5.1 in TS 38.521-2 [9] is incomplete for some scenarios (band, bandwidth, power class etc...) as indicated in its editor's note.**

#### 6.5B.1.4.1 Test purpose

Same test purpose as in clause 6.5.1.1 in TS 38.521-2 [9] for the NR carrier.

#### 6.5B.1.4.2 Test applicability

This test case applies to all types of E-UTRA UE release 15 and forward, supporting inter-band EN-DC including FR2 with 1 NR UL CC.

#### 6.5B.1.4.3 Minimum conformance requirements

Same minimum conformance requirements as in clause 6.5.1.3 in TS 38.521-2 [9] for the NR carrier.

No exception requirements applicable to NR or E-UTRA. LTE anchor agnostic approach is applied.

#### 6.5B.1.4.4 Test description

##### 6.5B.1.4.4.1 Initial conditions

Same test description as in clause 6.5.1.4 in TS 38.521-2 [9] for the NR carrier with the following exception:

The initial test configurations for E-UTRA band consist of environmental conditions, test frequencies, and channel bandwidths based on E-UTRA bands specified in Table 4.7-1. For Initial conditions as in clause 6.5.1.4.1 in TS 38.521-2 [9], the following steps will be added to configure E-UTRA component:

- 2.1. The parameter settings for E-UTRA cell are set up according to TS 36.508 [11] clause 4.4.3.

- 3.1. The E-UTRA downlink signal level, uplink signal level are set according to Table 4.7-1 and propagation conditions are set according to Annex B.0 of TS 36.521-1 [10].

Step 6 of Initial conditions as in clause 6.5.1.4.1 in TS 38.521-2 [9] is replaced by:

6. Ensure the UE is in state RRC\_CONNECTED with generic procedure parameters Connectivity EN-DC, DC bearer MCG and SCG, Connected without release On according to TS 38.508-1 [6] clause 4.5.

Same test procedure as in clause 6.5.1.4.2 in TS 38.521-2 [9] with the following steps added for E-UTRA component:

- 1.1 On the E-UTRA carrier, disable periodic and aperiodic CQI reports, disable SRS, set *TimeAlignmentTimerDedicated* IE to infinity and disable downlink and uplink scheduling, all as per Table 4.7-1 under clause 4.7.

#### 6.5B.1.4.5 Test requirement

Same test requirement as in clause 6.5.1.5 in TS 38.521-2 [9] for the NR carrier.

### 6.5B.1.4\_1 Occupied bandwidth for Inter-band EN-DC including FR2 (>1 NR CC)

**Editor's note: Test applicability, Test Description in below sub-clauses requires updates to clarify number of E-UTRA carriers that will be configured during the test that will be limited to only 1 E-UTRA CC**

#### 6.5B.1.4\_1.1 Occupied bandwidth for Inter-band EN-DC including FR2 (2 NR CCs)

**Editor's note: This clause is incomplete. The following aspects are either missing or not yet determined:**

- **The referred test case 6.5A.1.1 in TS 38.521-2 [9] is incomplete for some scenarios (band, aggregated bandwidth, CA configuration, power class etc...) as indicated in its editor's note.**

##### 6.5B.1.4\_1.1.1 Test purpose

Same test purpose as in clause 6.5.1.1 in TS 38.521-2 [9] for the NR carrier.

##### 6.5B.1.4\_1.1.2 Test applicability

This test case applies to all types of E-UTRA UE release 15 and forward, supporting inter-band EN-DC including FR2 with 2 NR UL CCs.

##### 6.5B.1.4\_1.1.3 Minimum conformance requirements

Same minimum conformance requirements as in clause 6.5.1.3 in TS 38.521-2 [9] for the NR carrier.

No exception requirements applicable to NR or E-UTRA. LTE anchor agnostic approach is applied.

The normative reference for this requirement is TS 38.101-3 [4] clause 6.5B.1.

##### 6.5B.1.4\_1.1.4 Test description

###### 6.5B.1.4\_1.1.4.1 Initial condition

Same test description as in clause 6.5A.1.1.4 in TS 38.521-2 [9] for the NR carrier with the following exception:

The initial test configurations for E-UTRA band consist of environmental conditions, test frequencies, and channel bandwidths based on E-UTRA bands specified in Table 4.7-1.

For Initial conditions as in clause 6.5A.1.1.4.1 in TS 38.521-2 [9], the following steps will be added to configure E-UTRA component:

- 2.1. The parameter settings for E-UTRA cell are set up according to TS 36.508 [11] clause 4.4.3.
- 3.1. The E-UTRA downlink signal level, uplink signal level are set according to Table 4.7-1 and propagation conditions are set according to Annex B.0 of TS 36.521-1 [10].

Step 6 of Initial conditions as in clause 6.5A.1.1.4.1 in TS 38.521-2 [9] is replaced by:

6. Ensure the UE is in state RRC\_CONNECTED with generic procedure parameters Connectivity EN-DC, DC bearer MCG and SCG, Connected without release On according to TS 38.508-1 [6] clause 4.5.

Same test procedure as in clause 6.5A.1.1.4.2 in TS 38.521-2 [9] with the following steps added for E-UTRA component:

- 1.1 On the E-UTRA carrier, disable periodic and aperiodic CQI reports, disable SRS, set *TimeAlignmentTimerDedicated* IE to infinity and disable downlink and uplink scheduling, all as per Table 4.7-1 under clause 4.7.

#### 6.5B.1.4\_1.1.5 Test Requirements

Same test requirement as in clause 6.5A.1.1.5 in TS 38.521-2 [9] for the NR carrier.

#### 6.5B.1.4\_1.2 Occupied bandwidth for Inter-band EN-DC including FR2 (3 NR CCs)

**Editor's note: This clause is incomplete. The following aspects are either missing or not yet determined:**

- **The referred test case 6.5A.1.2 in TS 38.521-2 [9] is incomplete for some scenarios (band, aggregated bandwidth, CA configuration, power class etc...) as indicated in its editor's note.**

#### 6.5B.1.4\_1.2.1 Test purpose

Same test purpose as in clause 6.5.1.1 in TS 38.521-2 [9] for the NR carrier.

#### 6.5B.1.4\_1.2.2 Test applicability

This test case applies to all types of E-UTRA UE release 15 and forward, supporting inter-band EN-DC including FR2 with 3 NR UL CCs.

#### 6.5B.1.4\_1.2.3 Minimum conformance requirements

Same minimum conformance requirements as in clause 6.5.1.3 in TS 38.521-2 [9] for the NR carrier.

No exception requirements applicable to NR or E-UTRA. LTE anchor agnostic approach is applied.

The normative reference for this requirement is TS 38.101-3 [4] clause 6.5B.1.

#### 6.5B.1.4\_1.2.4 Test description

##### 6.5B.1.4\_1.2.4.1 Initial condition

Same test description as in clause 6.5A.1.2.4 in TS 38.521-2 [9] for the NR carrier with the following exception:

The initial test configurations for E-UTRA band consist of environmental conditions, test frequencies, and channel bandwidths based on E-UTRA bands specified in Table 4.7-1.

For Initial conditions as in clause 6.5A.1.2.4.1 in TS 38.521-2 [9], the following steps will be added to configure E-UTRA component:

- 2.1. The parameter settings for E-UTRA cell are set up according to TS 36.508 [11] clause 4.4.3.
- 3.1. The E-UTRA downlink signal level, uplink signal level are set according to Table 4.7-1 and propagation conditions are set according to Annex B.0 of TS 36.521-1 [10].

Step 6 of Initial conditions as in clause 6.5A.1.2.4.1 in TS 38.521-2 [9] is replaced by:

6. Ensure the UE is in state RRC\_CONNECTED with generic procedure parameters Connectivity EN-DC, DC bearer MCG and SCG, Connected without release On according to TS 38.508-1 [6] clause 4.5.

Same test procedure as in clause 6.5A.1.2.4.2 in TS 38.521-2 [9] with the following steps added for E-UTRA component:

1.1 On the E-UTRA carrier, disable periodic and aperiodic CQI reports, disable SRS, set *TimeAlignmentTimerDedicated* IE to infinity and disable downlink and uplink scheduling, all as per Table 4.7-1 under clause 4.7.

#### 6.5B.1.4\_1.2.5 Test Requirements

Same test requirement as in clause 6.5A.1.2.5 in TS 38.521-2 [9] for the NR carrier.

#### 6.5B.1.4\_1.3 Occupied bandwidth for Inter-band EN-DC including FR2 (4 NR CCs)

**Editor's note: This clause is incomplete. The following aspects are either missing or not yet determined:**

- **The referred test case 6.5A.1.1 in TS 38.521-2 [9] is incomplete for some scenarios (band, aggregated bandwidth, CA configuration, power class etc...) as indicated in its editor's note.**

#### 6.5B.1.4\_1.3.1 Test purpose

Same test purpose as in clause 6.5.1.1 in TS 38.521-2 [9] for the NR carrier.

#### 6.5B.1.4\_1.3.2 Test applicability

This test case applies to all types of E-UTRA UE release 15 and forward, supporting inter-band EN-DC including FR2 with 4 NR UL CCs.

#### 6.5B.1.4\_1.3.3 Minimum conformance requirements

Same minimum conformance requirements as in clause 6.5.1.3 in TS 38.521-2 [9] for the NR carrier.

No exception requirements applicable to NR or E-UTRA. LTE anchor agnostic approach is applied.

The normative reference for this requirement is TS 38.101-3 [4] clause 6.5B.1.

#### 6.5B.1.4\_1.3.4 Test description

##### 6.5B.1.4\_1.3.4.1 Initial condition

Same test description as in clause 6.5A.1.3.4 in TS 38.521-2 [9] for the NR carrier with the following exception:

The initial test configurations for E-UTRA band consist of environmental conditions, test frequencies, and channel bandwidths based on E-UTRA bands specified in Table 4.7-1.

For Initial conditions as in clause 6.5A.1.3.4.1 in TS 38.521-2 [9], the following steps will be added to configure E-UTRA component:

- 2.1. The parameter settings for E-UTRA cell are set up according to TS 36.508 [11] clause 4.4.3.
- 3.1. The E-UTRA downlink signal level, uplink signal level are set according to Table 4.7-1 and propagation conditions are set according to Annex B.0 of TS 36.521-1 [10].

Step 6 of Initial conditions as in clause 6.5A.1.3.4.1 in TS 38.521-2 [9] is replaced by:

6. Ensure the UE is in state RRC\_CONNECTED with generic procedure parameters Connectivity EN-DC, DC bearer MCG and SCG, Connected without release On according to TS 38.508-1 [6] clause 4.5.

Same test procedure as in clause 6.5A.1.3.4.2 in TS 38.521-2 [9] with the following steps added for E-UTRA component:

- 1.1 On the E-UTRA carrier, disable periodic and aperiodic CQI reports, disable SRS, set *TimeAlignmentTimerDedicated* IE to infinity and disable downlink and uplink scheduling, all as per Table 4.7-1 under clause 4.7.

## 6.5B.1.4\_1.3.5 Test Requirements

Same test requirement as in clause 6.5A.1.3.5 in TS 38.521-2 [9] for the *NR* carrier.

## 6.5B.1.4\_1.4 Occupied bandwidth for Inter-band EN-DC including FR2 (5 NR CCs)

**Editor's note: This clause is incomplete. The following aspects are either missing or not yet determined:**

- The referred test case 6.5A.1.4 in TS 38.521-2 [9] is incomplete for intra-band contiguous CA supporting aggregated BW > 400MHz are TBD.
- Measurement Uncertainties and Test Tolerances are FFS.

## 6.5B.1.4\_1.4.1 Test purpose

Same test purpose as in clause 6.5.1.1 in TS 38.521-2 [9] for the *NR* carrier.

## 6.5B.1.4\_1.4.2 Test applicability

This test case applies to all types of E-UTRA UE release 15 and forward, supporting inter-band EN-DC including FR2 with 5 NR UL CCs.

## 6.5B.1.4\_1.4.3 Minimum conformance requirements

Same minimum conformance requirements as in clause 6.5.1.3 in TS 38.521-2 [9] for the *NR* carrier.

No exception requirements applicable to *NR* or E-UTRA. LTE anchor agnostic approach is applied.

The normative reference for this requirement is TS 38.101-3 [4] clause 6.5B.1.

## 6.5B.1.4\_1.4.4 Test description

## 6.5B.1.4\_1.4.4.1 Initial condition

Same test description as in clause 6.5A.1.4.4 in TS 38.521-2 [9] for the *NR* carrier with the following exception:

The initial test configurations for E-UTRA band consist of environmental conditions, test frequencies, and channel bandwidths based on E-UTRA bands specified in Table 4.7-1.

For Initial conditions as in clause 6.5A.1.4.4.1 in TS 38.521-2 [9], the following steps will be added to configure E-UTRA component:

- 2.1. The parameter settings for E-UTRA cell are set up according to TS 36.508 [11] clause 4.4.3.
- 3.1. The E-UTRA downlink signal level, uplink signal level are set according to Table 4.7-1 and propagation conditions are set according to Annex B.0 of TS 36.521-1 [10].

Step 6 of Initial conditions as in clause 6.5A.1.4.4.1 in TS 38.521-2 [9] is replaced by:

6. Ensure the UE is in state *RRC\_CONNECTED* with generic procedure parameters Connectivity EN-DC, DC bearer MCG and SCG, Connected without release On according to TS 38.508-1 [6] clause 4.5.

Same test procedure as in clause 6.5A.1.4.4.2 in TS 38.521-2 [9] with the following steps added for E-UTRA component:

- 1.1 On the E-UTRA carrier, disable periodic and aperiodic CQI reports, disable SRS, set *TimeAlignmentTimerDedicated* IE to infinity and disable downlink and uplink scheduling, all as per Table 4.7-1 under clause 4.7.

## 6.5B.1.4\_1.4.5 Test Requirements

Same test requirement as in clause 6.5A.1.4.5 in TS 38.521-2 [9] for the *NR* carrier.



### 6.5B.1.4\_1.5 Occupied bandwidth for Inter-band EN-DC including FR2 (6 NR CCs)

**Editor's note:** This clause is incomplete. The following aspects are either missing or not yet determined:

- The referred test case 6.5A.1.5 in TS 38.521-2 [9] is incomplete for intra-band contiguous CA supporting aggregated BW > 400MHz are TBD.
- Measurement Uncertainties and Test Tolerances are FFS.

#### 6.5B.1.4\_1.5.1 Test purpose

Same test purpose as in clause 6.5.1.1 in TS 38.521-2 [9] for the NR carrier.

#### 6.5B.1.4\_1.5.2 Test applicability

This test case applies to all types of E-UTRA UE release 15 and forward, supporting inter-band EN-DC including FR2 with 6 NR UL CCs.

#### 6.5B.1.4\_1.5.3 Minimum conformance requirements

Same minimum conformance requirements as in clause 6.5.1.3 in TS 38.521-2 [9] for the NR carrier.

No exception requirements applicable to NR or E-UTRA. LTE anchor agnostic approach is applied.

The normative reference for this requirement is TS 38.101-3 [4] clause 6.5B.1.

#### 6.5B.1.4\_1.5.4 Test description

##### 6.5B.1.4\_1.5.4.1 Initial condition

Same test description as in clause 6.5A.1.5.4 in TS 38.521-2 [9] for the NR carrier with the following exception:

The initial test configurations for E-UTRA band consist of environmental conditions, test frequencies, and channel bandwidths based on E-UTRA bands specified in Table 4.7-1.

For Initial conditions as in clause 6.5A.1.5.4.1 in TS 38.521-2 [9], the following steps will be added to configure E-UTRA component:

- 2.1. The parameter settings for E-UTRA cell are set up according to TS 36.508 [11] clause 4.4.3.
- 3.1. The E-UTRA downlink signal level, uplink signal level are set according to Table 4.7-1 and propagation conditions are set according to Annex B.0 of TS 36.521-1 [10].

Step 6 of Initial conditions as in clause 6.5A.1.5.4.1 in TS 38.521-2 [9] is replaced by:

6. Ensure the UE is in state RRC\_CONNECTED with generic procedure parameters Connectivity EN-DC, DC bearer MCG and SCG, Connected without release On according to TS 38.508-1 [6] clause 4.5.

Same test procedure as in clause 6.5A.1.5.4.2 in TS 38.521-2 [9] with the following steps added for E-UTRA component:

- 1.1 On the E-UTRA carrier, disable periodic and aperiodic CQI reports, disable SRS, set *TimeAlignmentTimerDedicated* IE to infinity and disable downlink and uplink scheduling, all as per Table 4.7-1 under clause 4.7.

#### 6.5B.1.4\_1.5.5 Test Requirements

Same test requirement as in clause 6.5A.1.5.5 in TS 38.521-2 [9] for the NR carrier.

### 6.5B.1.4\_1.6 Occupied bandwidth for Inter-band EN-DC including FR2 (7 NR CCs)

**Editor's note:** This clause is incomplete. The following aspects are either missing or not yet determined:

- The referred test case 6.5A.1.6 in TS 38.521-2 [9] is incomplete for intra-band contiguous CA supporting aggregated BW > 400MHz are TBD.
- Measurement Uncertainties and Test Tolerances are FFS.

#### 6.5B.1.4\_1.6.1 Test purpose

Same test purpose as in clause 6.5.1.1 in TS 38.521-2 [9] for the NR carrier.

#### 6.5B.1.4\_1.6.2 Test applicability

This test case applies to all types of E-UTRA UE release 15 and forward, supporting inter-band EN-DC including FR2 with 7 NR UL CCs.

#### 6.5B.1.4\_1.6.3 Minimum conformance requirements

Same minimum conformance requirements as in clause 6.5.1.3 in TS 38.521-2 [9] for the NR carrier.

No exception requirements applicable to NR or E-UTRA. LTE anchor agnostic approach is applied.

The normative reference for this requirement is TS 38.101-3 [4] clause 6.5B.1.

#### 6.5B.1.4\_1.6.4 Test description

##### 6.5B.1.4\_1.6.4.1 Initial condition

Same test description as in clause 6.5A.1.6.4 in TS 38.521-2 [9] for the NR carrier with the following exception:

The initial test configurations for E-UTRA band consist of environmental conditions, test frequencies, and channel bandwidths based on E-UTRA bands specified in Table 4.7-1.

For Initial conditions as in clause 6.5A.1.6.4.1 in TS 38.521-2 [9], the following steps will be added to configure E-UTRA component:

- 2.1. The parameter settings for E-UTRA cell are set up according to TS 36.508 [11] clause 4.4.3.
- 3.1. The E-UTRA downlink signal level, uplink signal level are set according to Table 4.7-1 and propagation conditions are set according to Annex B.0 of TS 36.521-1 [10].

Step 6 of Initial conditions as in clause 6.5A.1.6.4.1 in TS 38.521-2 [9] is replaced by:

6. Ensure the UE is in state RRC\_CONNECTED with generic procedure parameters Connectivity EN-DC, DC bearer MCG and SCG, Connected without release On according to TS 38.508-1 [6] clause 4.5.

Same test procedure as in clause 6.5A.1.6.4.2 in TS 38.521-2 [9] with the following steps added for E-UTRA component:

- 1.1 On the E-UTRA carrier, disable periodic and aperiodic CQI reports, disable SRS, set *TimeAlignmentTimerDedicated* IE to infinity and disable downlink and uplink scheduling, all as per Table 4.7-1 under clause 4.7.

#### 6.5B.1.4\_1.6.5 Test Requirements

Same test requirement as in clause 6.5A.1.6.5 in TS 38.521-2 [9] for the NR carrier.

#### 6.5B.1.4\_1.7 Occupied bandwidth for Inter-band EN-DC including FR2 (8 NR CCs)

**Editor's note:** This clause is incomplete. The following aspects are either missing or not yet determined:

- The referred test case 6.5A.1.7 in TS 38.521-2 [9] is incomplete for intra-band contiguous CA supporting aggregated BW > 400MHz are TBD.
- Measurement Uncertainties and Test Tolerances are FFS.

#### 6.5B.1.4\_1.7.1 Test purpose

Same test purpose as in clause 6.5.1.1 in TS 38.521-2 [9] for the NR carrier.

#### 6.5B.1.4\_1.7.2 Test applicability

This test case applies to all types of E-UTRA UE release 15 and forward, supporting inter-band EN-DC including FR2 with 8 NR UL CCs.

#### 6.5B.1.4\_1.7.3 Minimum conformance requirements

Same minimum conformance requirements as in clause 6.5.1.3 in TS 38.521-2 [9] for the NR carrier.

No exception requirements applicable to NR or E-UTRA. LTE anchor agnostic approach is applied.

The normative reference for this requirement is TS 38.101-3 [4] clause 6.5B.1.

#### 6.5B.1.4\_1.7.4 Test description

##### 6.5B.1.4\_1.7.4.1 Initial condition

Same test description as in clause 6.5A.1.7.4 in TS 38.521-2 [9] for the NR carrier with the following exception:

The initial test configurations for E-UTRA band consist of environmental conditions, test frequencies, and channel bandwidths based on E-UTRA bands specified in Table 4.7-1.

For Initial conditions as in clause 6.5A.1.7.4.1 in TS 38.521-2 [9], the following steps will be added to configure E-UTRA component:

- 2.1. The parameter settings for E-UTRA cell are set up according to TS 36.508 [11] clause 4.4.3.
- 3.1. The E-UTRA downlink signal level, uplink signal level are set according to Table 4.7-1 and propagation conditions are set according to Annex B.0 of TS 36.521-1 [10].

Step 6 of Initial conditions as in clause 6.5A.1.7.4.1 in TS 38.521-2 [9] is replaced by:

6. Ensure the UE is in state RRC\_CONNECTED with generic procedure parameters Connectivity EN-DC, DC bearer MCG and SCG, Connected without release On according to TS 38.508-1 [6] clause 4.5.

Same test procedure as in clause 6.5A.1.7.4.2 in TS 38.521-2 [9] with the following steps added for E-UTRA component:

- 1.1 On the E-UTRA carrier, disable periodic and aperiodic CQI reports, disable SRS, set *TimeAlignmentTimerDedicated* IE to infinity and disable downlink and uplink scheduling, all as per Table 4.7-1 under clause 4.7.

#### 6.5B.1.4\_1.7.5 Test Requirements

Same test requirement as in clause 6.5A.1.7.5 in TS 38.521-2 [9] for the NR carrier.

### 6.5B.1.4D Occupied bandwidth for inter-band EN-DC including FR2 for UL MIMO

#### 6.5B.1.4D.1 Test purpose

Same test purpose as in clause 6.5D.1.1 in TS 38.521-2 [9] for the NR carrier.

#### 6.5B.1.4D.2 Test applicability

This test case applies to all types of E-UTRA UE release 15 and forward, supporting inter-band EN-DC including FR2 with 2 UL CCs.

### 6.5B.1.4D.3 Minimum conformance requirements

Same minimum conformance requirements as in clause 6.5D.1.3 in TS 38.521-2 [9] for the NR carrier.

No exception requirements applicable to NR or E-UTRA. LTE anchor agnostic approach is applied.

### 6.5B.1.4D.4 Test description

#### 6.5B.1.4D.4.1 Initial conditions

Same test description as in clause 6.5D.1.4 in TS 38.521-2 [9] for the NR carrier with the following exception:

The initial test configurations for E-UTRA band consist of environmental conditions, test frequencies, and channel bandwidths based on E-UTRA bands specified in Table 4.7-1. For Initial conditions as in clause 6.5D.1.4.1 in TS 38.521-2 [9], the following steps will be added to configure E-UTRA component:

- 2.1. The parameter settings for E-UTRA cell are set up according to TS 36.508 [11] clause 4.4.3.
- 3.1. The E-UTRA downlink signal level, uplink signal level are set according to Table 4.7-1 and propagation conditions are set according to Annex B.0 of TS 36.521-1 [10].

Step 6 of Initial conditions as in clause 6.5D.1.4.1 in TS 38.521-2 [9] is replaced by:

6. Ensure the UE is in state RRC\_CONNECTED with generic procedure parameters Connectivity EN-DC, DC bearer MCG and SCG, Connected without release On according to TS 38.508-1 [6] clause 4.5.

Same test procedure as in clause 6.5D.1.4.2 in TS 38.521-2 [9] with the following steps added for E-UTRA component:

- 1.1 On the E-UTRA carrier, disable periodic and aperiodic CQI reports, disable SRS, set *TimeAlignmentTimerDedicated* IE to infinity and disable downlink and uplink scheduling, all as per Table 4.7-1 under clause 4.7.

### 6.5B.1.4D.5 Test requirement

Same test requirement as in clause 6.5D.1.5 in TS 38.521-2 [9] for the NR carrier.

## 6.5B.2 Out-of-band emissions for DC

### 6.5B.2.1 Out-of-band emissions for Intra-band contiguous EN-DC

#### 6.5B.2.1.1 Spectrum emissions mask for intra-band contiguous EN-DC

##### 6.5B.2.1.1.1 Test purpose

To verify that the power of any UE emissions shall not exceed specified level for the specified aggregated bandwidth for the EN-DC intra-band contiguous.

##### 6.5B.2.1.1.2 Test applicability

This test case applies to all types of E-UTRA UE release 15 and forward, supporting intra-band contiguous EN-DC.

##### 6.5B.2.1.1.3 Minimum conformance requirements

The general spectrum emission for intra-band contiguous EN-DC is specified in Table 6.5B.2.1.1.3-1.

**Table 6.5B.2.1.1.3-1: General spectrum emission mask for intra-band contiguous EN-DC**

$\Delta f_{\text{OoB}}$ (MHz)	Spectrum emission limit (dBm)	Measurement bandwidth
$\pm 0 - 1$	$\text{Max}(\text{Round}(10 \cdot \log(0.15/\text{ENBW})), -24)$	30 kHz
$\pm 1 - 5$	-10	1 MHz
$\pm 5 - \text{ENBW}$	-13	1 MHz
$\pm \text{ENBW} - (\text{ENBW} + 5)$	-25	1 MHz
NOTE: ENBW refers to the aggregated channel bandwidth in MHz as defined in clause 5.3B.		

The normative reference for this measurement is TS 38.101-3 [4] clause 6.5B.2.1.1.

Exception requirements for both NR and E-UTRA are defined for this test and therefore LTE anchor agnostic approach is not applied. E-UTRA test point analysis is included and E-UTRA measurements are performed.

#### 6.5B.2.1.1.4 Test description

##### 6.5B.2.1.1.4.1 Initial conditions

Initial conditions are a set of test configurations the UE needs to be tested in and the steps for the SS to take with the UE to reach the correct measurement state.

The initial test configurations consist of environmental conditions, test frequencies and channel bandwidths based on EN-DC operating bands specified in clause 5.3B.1.2, channel bandwidths and sub-carrier spacings for the NR cell specified in TS 38.521-1 [8] clause 5.3 and channel bandwidth for the E-UTRA cell are specified in TS 36.521-1 [10] clause 5.4.2. All of these configurations shall be tested with applicable test parameters for each EN-DC configuration specified in clause 5.3B.1.2 and are shown in table 6.5B.2.1.1.4.1-1. The details of the uplink reference measurement channels (RMCs) are specified in Annex A, clause A.2.2 for E-UTRA RMC for TDD, TS 36.521-1 [10] Annex A, clause A.2.2 for E-UTRA RMC for FDD, and TS 38.521-1 [8] Annex A, clause A.2 for NR RMC. Configurations of PDSCH and PDCCH before measurement are specified in TS 36.521-1 [10] Annex C.2 and in TS 38.521-1 [8] Annex C.2 for E-UTRA CG and NR CG respectively.

**Table 6.5B.2.1.1.4.1-1: Test configuration table**

Initial Conditions									
Test Environment as specified in TS 38.508-1 [6] clause 4.1				Normal					
Test Frequencies as specified in TS 38.508-1 [6] clause 4.3.1				Low range, High range					
Test EN-DC bandwidth combination as specified in Table 5.3B.1.2-1				Lowest $N_{RB\_agg}$ , Highest $N_{RB\_agg}$ (Note 2)					
Test SCS for the NR cell as specified in TS 38.521-1 [8] Table 5.3.5-1				Lowest, Highest (NOTE 10)					
Test Parameters									
Test ID	Freq	ChBw	SCS	Downlink Configuration	EN-DC Uplink Configuration				
					E-UTRA Cell		NR Cell		Common Power config (NOTE 8)
					Modulation	RB allocation (Note 5)	Modulation	RB allocation (NOTE 1)	
1	Default	Default	Default	N/A	16QAM	Outer_Full	DFT-s-OFDM Pi/2 BPSK	Outer_Full	B
2 (Note 3)	Default				16QAM	Outer_1RB_Left	DFT-s-OFDM Pi/2 BPSK	Edge_1RB_Right	B
3 (Note 3)	Low				16QAM	Outer_1RB_Left	DFT-s-OFDM Pi/2 BPSK	N/A	A
4 (Note 3)	High				16QAM	N/A	DFT-s-OFDM Pi/2 BPSK	Edge_1RB_Right	A
5 (Note 4)	Default				16QAM	Outer_1RB_Right	DFT-s-OFDM Pi/2 BPSK	Edge_1RB_Left	B
6 (Note 4)	Low				16QAM	N/A	DFT-s-OFDM Pi/2 BPSK	Edge_1RB_Left	A
7 (Note 4)	High				16QAM	Outer_1RB_Right	DFT-s-OFDM Pi/2 BPSK	N/A	A
8	Default				16QAM	Outer_Full	DFT-s-OFDM QPSK	Outer_Full	B
9 (Note 3)	Default				16QAM	Outer_1RB_Left	DFT-s-OFDM QPSK	Edge_1RB_Right	B
10 (Note 3)	Low				16QAM	Outer_1RB_Left	DFT-s-OFDM QPSK	N/A	A
11 (Note 3)	High				16QAM	N/A	DFT-s-OFDM QPSK	Edge_1RB_Right	A
12 (Note 4)	Default				16QAM	Outer_1RB_Right	DFT-s-OFDM QPSK	Edge_1RB_Left	B
13 (Note 4)	Low				16QAM	N/A	DFT-s-OFDM QPSK	Edge_1RB_Left	A
14 (Note 4)	High				16QAM	Outer_1RB_Right	DFT-s-OFDM QPSK	N/A	A

15	Default				16QAM	Outer_Full	DFT-s-OFDM 16QAM	Outer_Full	B
16 (Not e 3)	Default				16QAM	Outer_1RB_Left	DFT-s-OFDM 16QAM	Edge_1RB_Right	B
17 (Not e 3)	Low				16QAM	Outer_1RB_Left	DFT-s-OFDM 16QAM	N/A	A
18 (Not e 3)	High				16QAM	N/A	DFT-s-OFDM 16QAM	Edge_1RB_Right	A
19 (Not e 4)	Default				16QAM	Outer_1RB_Right	DFT-s-OFDM 16QAM	Edge_1RB_Left	B
20 (Not e 4)	Low				16QAM	N/A	DFT-s-OFDM 16QAM	Edge_1RB_Left	A
21 (Not e 4)	High				16QAM	Outer_1RB_Right	DFT-s-OFDM 16QAM	N/A	A
22	Default				16QAM	Outer_Full	DFT-s-OFDM 64QAM	Outer_Full	B
23 (Not e 3)	Low				16QAM	Outer_1RB_Left	DFT-s-OFDM 64QAM	Edge_1RB_Right	B
24 (Not e 4)	High				16QAM	Outer_1RB_Right	DFT-s-OFDM 64QAM	Edge_1RB_Left	B
25	Default				16QAM	Outer_Full	DFT-s-OFDM 256QAM	Outer_Full	B
26 (Not e 3)	Low				16QAM	Outer_1RB_Left	DFT-s-OFDM 256QAM	Edge_1RB_Right	B
27 (Not e 4)	High				16QAM	Outer_1RB_Right	DFT-s-OFDM 256QAM	Edge_1RB_Left	B
28	Default				16QAM	Outer_Full	CP-OFDM QPSK	Outer_Full	B
29 (Not e 3)	Default				16QAM	Outer_1RB_Left	CP-OFDM QPSK	Edge_1RB_Right	B
30 (Not e 3)	Low				16QAM	Outer_1RB_Left	CP-OFDM QPSK	N/A	A
31 (Not e 3)	High				16QAM	N/A	CP-OFDM QPSK	Edge_1RB_Right	A
32 (Not e 4)	Default				16QAM	Outer_1RB_Right	CP-OFDM QPSK	Edge_1RB_Left	B
33 (Not e 4)	Low				16QAM	N/A	CP-OFDM QPSK	Edge_1RB_Left	A
34 (Not e 4)	High				16QAM	Outer_1RB_Right	CP-OFDM QPSK	N/A	A
35	Default				16QAM	Outer_Full	CP-OFDM 16QAM	Outer_Full	B
36 (Not e 3)	Default				16QAM	Outer_1RB_Left	CP-OFDM 16QAM	Edge_1RB_Right	B



37 (Not e 3)	Low				16QAM	Outer_1RB_Left	CP-OFDM 16QAM	N/A	A
38 (Not e 3)	High				16QAM	N/A	CP-OFDM 16QAM	Edge_1RB_Right	A
39 (Not e 4)	Default				16QAM	Outer_1RB_Right	CP-OFDM 16QAM	Edge_1RB_Left	B
40 (Not e 4)	Low				16QAM	N/A	CP-OFDM 16QAM	Edge_1RB_Left	A
41 (Not e 4)	High				16QAM	Outer_1RB_Right	CP-OFDM 16QAM	N/A	A
42	Default				16QAM	Outer_Full	CP-OFDM 64QAM	Outer_Full	B
43 (Not e 3)	Low				16QAM	Outer_1RB_Left	CP-OFDM 64QAM	Edge_1RB_Right	B
44 (Not e 4)	High				16QAM	Outer_1RB_Right	CP-OFDM 64QAM	Edge_1RB_Left	B
45	Default				16QAM	Outer_Full	CP-OFDM 256QAM	Outer_Full	B
46 (Not e 3)	Low				16QAM	Outer_1RB_Left	CP-OFDM 256QAM	Edge_1RB_Right	B
47 (Not e 4)	High				16QAM	Outer_1RB_Right	CP-OFDM 256QAM	Edge_1RB_Left	B
48 (Not e 4)	Default				16QAM	Edge_Full_Right	CP-OFDM 256QAM	Edge_Full_Left	B

NOTE 1: The specific configuration of each RB allocation is defined in Table 6.1-1 in TS 38.521-1 [8].

NOTE 2: If the UE supports multiple CC combinations in the EN-DC configuration with the same  $N_{RB\_agg}$ , select the combination to test as follows:

- Lowest ENBW: NR component with lowest  $N_{RB}$  is tested.
- Highest ENBW: NR component with highest  $N_{RB}$  is tested.

NOTE 3: Applicable when E-UTRA cell carrier frequency is lower than NR cell carrier.

NOTE 4: Applicable when NR cell carrier frequency is lower than E-UTRA cell carrier.

NOTE 5: Outer\_Full defined as the transmission bandwidth configuration  $N_{RB}$  per channel bandwidth for the E-UTRA component as indicated in TS 36.521 [10] Table 5.4.2-1. Outer\_1RB\_Left defined as 1 RB allocated at the left edge of the E-UTRA component. Outer\_1RB\_Right defined as 1 RB allocated at the right edge of the E-UTRA component. Edge\_Full\_Right is defined as 2 RBs allocated at the right edge of the E-UTRA component.

NOTE 6: DFT-s-OFDM Pi/2 BPSK test applies only for UEs which supports Pi/2 BPSK in FR1

NOTE 7: Power config as specified in Table 6.5B.2.1.2.4.3-3 (PC3) or 6.5B.2.1.2.4.3-4 (PC2).

NOTE 8: All test points in this table must also exist in table 6.2B.2.1.4.1-1 (MPR).

NOTE 9: Test IDs with simultaneous E-UTRA and NR UL transmission only apply for UEs indicating dualIPA-Architecture.

NOTE 10: For DC\_(n)71AA, only NR SCS of 15 kHz is tested.

1. Connect the SS to the UE antenna connectors as shown in [6] TS 38.508-1 A.3.1.2.1 for SS diagram and A.3.2.1 for UE diagram.
2. The parameter settings for the E-UTRA cell are set up according to TS 36.508 [11] clause 4.4.3, and the parameter settings for the NR cell are set up according to TS 38.508-1 [6] clause 4.4.3.
3. Downlink signals are initially set up according to TS 36.521-1 [10] Annex C.0 and TS 38.521-1 [8] Annex C.0 for E-UTRA CG and NR CG respectively, and uplink signals according to TS 36.521-1 [10] Annex H and TS 38.521-1 [8] Annex G for E-UTRA CG and NR CG respectively.
4. The UL Reference Measurement channels are set for E-UTRA CG and NR CG respectively.

5. Propagation conditions are set according to TS 36.521-1 [10] Annex B.0 and TS 38.521-1 [8] Annex B.0 for E-UTRA CG and NR CG respectively.
6. Ensure the UE is in state RRC\_CONNECTED with generic procedure parameters Connectivity EN-DC, DC bearer MCG and SCG, Connected without release *On* according to TS 38.508-1 [6] clause 4.5. Message contents are defined in clause 6.2B.2.1.1.4.3.
7. When E-UTRA and NR bands are TDD, ensure the same uplink-downlink configuration by giving SCG a delay of 3 E-UTRA subframes, or by giving MCG a delay of 2 subframes.

6.5B.2.1.1.4.2 Test procedure

1. SS sends uplink scheduling information for each UL HARQ process via PDCCH DCI format 0 and DCI format 0\_1 for C\_RNTI to schedule the UL RMC according to Table 6.5B.2.1.1.4.1-1 on E-UTRA CC and NR CC respectively. Since the UL has no payload and no loopback data to send the UE sends uplink MAC padding bits on the UL RMC.
2. Send continuously uplink power control "up" commands to the UE for NR and E-UTRA carrier until the UE transmits at its P<sub>UMAX</sub> level; allow at least 200 ms from the first TPC command for the UE to reach P<sub>UMAX</sub> level.
3. For a UE supporting dynamic power sharing, measure the mean power over all component carriers. For a UE not supporting dynamic power sharing, measure the power of each component carrier individually. The measure transmitted power shall meet the requirements in clause 6.2B.2.1.5. The period of measurement shall be at least the continuous duration of 1ms over consecutive active uplink slots For TDD, only slots consisting of only UL symbols are under test.
4. Measure the power of the transmitted signal with a measurement filter of bandwidths according to Table 6.5B.2.1.1.5-1 and using a rms detector. If the sweep count is higher than one, the trace mode shall be average. The centre frequency of the filter shall be stepped in continuous steps according to the same table. The measured power shall be recorded for each step. The measurement period shall capture the active TSs.

NOTE 1: When switching to DFT-s-OFDM waveform, as specified in the test configuration Table 6.5B.2.1.1.4.1-1, send an NR RRCReconfiguration message according to TS 38.508-1 [6] clause 4.6.3 Table 4.6.3-118 PUSCH-Config with TRANSFORM\_PRECODER\_ENABLED condition.

6.5B.2.1.1.4.3 Message contents

Message contents are according to TS 38.508-1 [6] clause 4.6.1 with the following exceptions:

**Table 6.5B.2.1.1.4.3-1: AdditionalSpectrumEmission for MCG**

Derivation Path: 36.508 [11] clause 4.6.3, Table 4.4.3.3-1			
Information Element	Value/remark	Comment	Condition
AdditionalSpectrumEmission	0 (NS_01)		

**Table 6.5B.2.1.1.4.3-2: AdditionalSpectrumEmission for SCG**

Derivation Path: 38.508-1 [5] clause 4.6.3, Table 4.6.3-1			
Information Element	Value/remark	Comment	Condition
AdditionalSpectrumEmission	0 (NS_01)		

**Table 6.5B.2.1.1.4.3-3: PhysicalCellGroupConfig for PC3**

Derivation Path: TS 38.508-1 [6], Table 4.6.3-106			
Information Element	Value/remark	Comment	Condition
p-NR-FR1	23		Power config A (NOTE 1)
	20		Power config B (NOTE 2)
NOTE 1: Applies when E-UTRA UL transmission not overlapping with NR UL transmission in time.			
NOTE 2: Applies when E-UTRA UL transmission overlapping with NR UL transmission in time.			

**Table 6.5B.2.1.1.4.3-4: RRCConnectionReconfiguration: nr-Config-r15 for PC3**

Derivation Path: TS 36.508 [11], Table 4.6.1-8			
Information Element	Value/remark	Comment	Condition
p-MaxEUTRA-r15	23		Power config A (NOTE 1)
	20		Power config B (NOTE 2)
NOTE 1: Applies when E-UTRA UL transmission not overlapping with NR UL transmission in time.			
NOTE 2: Applies when E-UTRA UL transmission overlapping with NR UL transmission in time.			

**Table 6.5B.2.1.1.4.3-5: PhysicalCellGroupConfig for PC2**

Derivation Path: TS 38.508-1 [6], Table 4.6.3-106			
Information Element	Value/remark	Comment	Condition
p-NR-FR1	26		Power config A (NOTE 1)
	23		Power config B (NOTE 2)
NOTE 1: Applies when E-UTRA UL transmission not overlapping with NR UL transmission in time.			
NOTE 2: Applies when E-UTRA UL transmission overlapping with NR UL transmission in time.			

**Table 6.5B.2.1.1.4.3-6: RRCConnectionReconfiguration: nr-Config-r15 for PC2**

Derivation Path: TS 36.508 [11], Table 4.6.1-8			
Information Element	Value/remark	Comment	Condition
p-MaxEUTRA-r15	26		Power config A (NOTE 1)
	23		Power config B (NOTE 2)
NOTE 1: Applies when E-UTRA UL transmission not overlapping with NR UL transmission in time.			
NOTE 2: Applies when E-UTRA UL transmission overlapping with NR UL transmission in time.			

**Table 6.5B.2.1.1.4.3-7: RRCConnectionReconfiguration: tdm-PatternConfig if operating on FDD band**

Derivation Path: TS 36.508 [11], Table 4.6.1-8			
Information Element	Value/remark	Comment	Condition
tdm-PatternConfig-r15 ::= CHOICE{			Power config A (NOTE 1)
setup ::= SEQUENCE {		Apply if operating on FDD band for a UE NOT indicating support of dynamicPowerSharing in the <i>UE-MRDC-Capability</i> IE according to TS 38.213 [x] clause 7.6.1	
subframeAssignment-r15	sa2		
harq-Offset-r15	0		
}			
}			

NOTE 1: Applies when E-UTRA UL transmission not overlapping with NR UL transmission in time.

**Table 6.5B.2.1.1.4.3-8: SystemInformationBlockType1: tdd-Config if E-UTRA on TDD band**

Derivation Path: TS 36.508 [11], Table 4.6.3-23			
Information Element	Value/remark	Comment	Condition
TDD-Config-DEFAULT ::= SEQUENCE {		Operating on TDD band	
subframeAssignment	sa2		
specialSubframePatterns	ssp7		
}			

## 6.5B.2.1.1.5 Test requirements

The power of any UE emissions shall fulfil requirements in Table 6.5B.2.1.1.5-1.

**Table 6.5B.2.1.1.5-1: General spectrum emission mask for intra-band contiguous EN-DC**

$\Delta f_{\text{OoB}}$ (MHz)	Spectrum emission limit (dBm)	Measurement bandwidth
$\pm 0 - 1$	$\text{Max}(\text{Round}(10 \cdot \log(0.15/\text{ENBW})), -24)$	30 kHz
$\pm 1 - 5$	$-10 + \text{TT}$	1 MHz
$\pm 5 - \text{ENBW}$	$-13 + \text{TT}$	1 MHz
$\pm \text{ENBW} - (\text{ENBW} + 5)$	$-25 + \text{TT}$	1 MHz

NOTE: ENBW refers to the aggregated channel bandwidth in MHz as defined in clause 5.3B.

**Table 6.5B.2.1.1.5-2: Test Tolerance (Spectrum Emission Mask)**

$f \leq 3.0\text{GHz}$	$3.0\text{GHz} < f \leq 4.2\text{GHz}$	$4.2\text{GHz} < f \leq 6.0\text{GHz}$
1.5 dB	1.8 dB	1.8 dB

## 6.5B.2.1.2 Additional spectrum emissions mask for intra-band contiguous EN-DC

## 6.5B.2.1.2.1 Test purpose

To verify that UE transmitter does not cause unacceptable interference to other channels or other systems in terms of transmitter spurious emissions under the deployment scenarios where additional requirements are specified.

## 6.5B.2.1.2.2 Test applicability

This test case applies to all types of E-UTRA power class 3 and power class 2 UE release 15 and forward, supporting intra-band contiguous EN-DC.

## 6.5B.2.1.2.3 Minimum conformance requirements

## 6.5B.2.1.2.3.1 Minimum requirement for network signalled value "NS\_35"

For contiguous intra-band EN-DC configuration of DC\_(n)71AA when NS\_35 is indicated for the UE the requirements in table 6.5B.2.1.2.3-1 apply in the frequency ranges immediately adjacent and outside the aggregation of the said sub-blocks

When NS\_35 is indicated in the MCG and NS\_35 is indicated in the SCG the requirements in table 6.5B.2.1.2.3.1-1 apply in the frequency ranges immediately adjacent and outside the aggregated sub-blocks of the EN-DC configuration for DC\_(n)71AA.

**Table 6.5B.2.1.2.3.1-1: Additional requirements**

	Frequency offset of measurement filter centre frequency, $f_{\text{offset}}$	Minimum requirement (dBm)	Measurement bandwidth
$0 \text{ MHz} \leq \Delta f < 0.1 \text{ MHz}$	$0.015 \text{ MHz} \leq f_{\text{offset}} < 0.085 \text{ MHz}$	-13	30 kHz
$0.1 \text{ MHz} \leq \Delta f < \text{ENBW}$	$0.15 \text{ MHz} \leq f_{\text{offset}} < \text{ENBW} - 0.05 \text{ MHz}$	-13	100 kHz
$\text{ENBW} \leq \Delta f < \text{ENBW} + 5 \text{ MHz}$	$\text{ENBW} + 0.5 \text{ MHz} \leq f_{\text{offset}} < \text{ENBW} + 4.5 \text{ MHz}$	-25	1 MHz
NOTE: ENBW is the aggregated bandwidth of an E-UTRA sub-block and an adjacent NR sub-block; there is no frequency separation between the said sub-blocks. The sub-block bandwidths include any internal guard bands.			

The normative reference for this requirement is TS 38.101-3 [4] clause 6.5B.2.1.2.1.

Exception requirements for both NR and E-UTRA are defined for this test when transmission on E-UTRA overlap in time with NR.LTE and therefore LTE anchor agnostic approach is not applied. E-UTRA test point analysis is included and E-UTRA measurements are performed.

Exception requirements for both NR and E-UTRA are defined for this test when transmission on E-UTRA doesn't overlap in time with NR, for a UE that doesn't support dynamic power sharing. LTE anchor agnostic approach is not applied for this case. E-UTRA test point analysis is included and E-UTRA measurements are performed.

No exception requirements for NR or E-UTRA are defined for this test when transmission on E-UTRA doesn't overlap in time with NR, for a UE that supports dynamic power sharing. LTE anchor agnostic approach is not applied for this case.

## 6.5B.2.1.2.3.2 Minimum requirement for network signalled value "NS\_04"

Additional spectrum emission requirements are signalled by the network to indicate that the UE shall meet an additional requirement for a specific deployment scenario as part of the cell handover/broadcast message.

The Band 41/n41 SEM transition point from -13 dBm/MHz to -25 dBm/MHz is based on the emission bandwidth. The emission bandwidth is defined as the width of the signal between two points, one below the carrier centre frequency and one above the carrier centre frequency, outside of which all emissions are attenuated at least 26 dB below the transmitter power. Since the 26 dB emission bandwidth is implementation dependent, the transmission bandwidths occupied by RBs is used for the SEM. The emission bandwidth for LTE carriers is document in TS 36.101 [5], and the emission bandwidth for NR carriers is documented in TS 38.101-1 [2]. The total emission bandwidth for contiguous intra-band EN-DC is the sum of the emission bandwidth for each CC plus the guard band between contiguous CCs.

When "NS\_04" is indicated in the cell, the power of any UE emission shall not exceed the levels specified in Table 6.5B.2.1.2.3.2-1.

**Table 6.5B.2.1.2.3.2-1: n41 SEM with NS\_04**

<b>Δf<sub>OOB</sub> MHz</b>	<b>Spectrum emission limit (dBm)/ measurement bandwidth for each channel bandwidth</b>						<b>Measurement bandwidth</b>
	<b>10 MHz</b>	<b>15 MHz</b>	<b>20 MHz</b>	<b>40 MHz</b>	<b>50 MHz</b>	<b>&gt; 50 MHz</b>	
± 0 - 1	-18	-20	-21	-24	-25		30 kHz
± 1 - 5	-10						1 MHz
± 5 - X	-13						
± X - (BW <sub>Channel</sub> + 5 MHz)	-25						

NOTE 1: X is defined as the sum of the emission bandwidth of the component carriers plus the guard band between contiguous CCs.

The normative reference for this requirement is TS 38.101-3 [4] clause 6.5B.2.1.2.2.

Exception requirements for both NR and E-UTRA are defined for this test and therefore LTE anchor agnostic approach is not applied. E-UTRA test point analysis is included and E-UTRA measurements are performed.

**6.5B.2.1.2.4 Test description**

**6.5B.2.1.2.4.1 Initial conditions**

Initial conditions are a set of test configurations the UE needs to be tested in and the steps for the SS to take with the UE to reach the correct measurement state.

The initial test configurations consist of environmental conditions, test frequencies and channel bandwidths based on EN-DC operating bands specified in clause 5.3B.1.2, channel bandwidths and sub-carrier spacings for the NR cell specified in TS 38.521-1 [8] clause 5.3 and channel bandwidth for the E-UTRA cell are specified in TS 36.521-1 [10] clause 5.4.2. All these configurations shall be tested with applicable test parameters for each EN-DC configuration specified in clause 5.3B.1.2 and are shown in test configuration table 6.2B.3.1.4.1-1 through 6.2B.3.1.4.1-2. The details of the uplink reference measurement channels (RMCs) are specified in Annex A, clause A.2.2 for E-UTRA RMC for TDD, TS 36.521-1 [10] Annex A, clause A.2.2 for E-UTRA RMC for FDD, and TS 38.521-1 [8] Annex A, clause A.2 for NR RMC. Configurations of PDSCH and PDCCCH before measurement are specified in TS 36.521-1 [10] Annex C.2 and in TS 38.521-1 [8] Annex C.2 for E-UTRA CG and NR CG respectively.

Table 6.5B.2.1.2.4.1-0: E-UTRA test configuration table

<b>E-UTRA Test Parameters</b>				
<b>E-UTRA Channel Bandwidth</b>	<b>E-UTRA Test Frequency (Note 1)</b>	<b>Downlink</b>	<b>Uplink</b>	
		N/A for A-MPR testing.	<b>Modulation</b>	<b>RB allocation</b>
20 MHz	Low range and High range (Note 2)		QPSK	100

NOTE 1: E-UTRA Test Frequency as specified in TS 36.508 [6] clause 4.3.1  
 NOTE 2: NR carrier shall be the outermost carrier during test.

The initial test configurations for E-UTRA consist of test frequency based on E-UTRA operating band and test channel bandwidth as specified in Table 4.6-1.

1. Connect the SS to the UE antenna connectors as shown in TS 38.508-1 [6] Annex A, Figure A.3.1.2.1 for SS diagram and clause A.3.2.1 for UE diagram.
2. The parameter settings for the E-UTRA cell are set up according to TS 36.508 [11] clause 4.4.3, and the parameter settings for the NR cell are set up according to TS 38.508-1 [6] clause 4.4.3.
3. Downlink signals are initially set up according to TS 36.521-1 [10] Annex C.0 and TS 38.521-1 [8] Annex C.0 for E-UTRA CG and NR CG respectively, and uplink signals according to TS 36.521-1 [10] Annex H and TS 38.521-1 [8] Annex G for E-UTRA CG and NR CG respectively.
4. NR downlink signals are initially set up according to Annex C.0, C.1, and C.2 and uplink signals according to Annex G.0, G.1, G.2, and G.3.0 of TS 38.521-1 [8].

5. The UL Reference Measurement channels are set for E-UTRA CG link and NR CG link respectively.
6. Propagation conditions are set according to TS 36.521-1 [10] Annex B.0 and TS 38.521-1 [8] Annex B.0 for E-UTRA CG link and NR CG link respectively.
7. Ensure the UE is in state RRC\_CONNECTED with generic procedure parameters Connectivity EN-DC, DC bearer MCG and SCG, Connected without release On according to TS 38.508-1 [6] clause 4.5. Message contents are defined in clause 6.5B.2.1.2.4.3.
8. When E-UTRA and NR bands are TDD, ensure the same uplink-downlink configuration by giving SCG a delay of 3 E-UTRA subframes, or by giving MCG a delay of 2 subframes.

6.5B.2.1.2.4.2 Test procedure

1. SS sends uplink scheduling information for each UL HARQ process via PDCCH DCI format 0 and DCI format 0\_1 for C\_RNTI to schedule the UL RMC according to table 6.2B.3.1.4.1-1 on both EN-DC component carriers. Since the UL has no payload and no loopback data to send the UE sends uplink MAC padding bits on the UL RMC.
2. Send continuously uplink power control "up" commands to the UE for NR and E-UTRA carrier until the UE transmits at its P<sub>UMAX</sub> level; allow at least 200 ms from the first TPC command starting from the first TPC command in this step for the UE to reach P<sub>UMAX</sub> level.
3. Measure the mean power over all component carriers for the EN-DC configuration, which shall meet the requirements described in table 6.5B.2.1.2.5.1-1 through to 6.5B.2.1.2.5.2-1. The period of the measurement shall be at least the continuous duration of one active sub-frame (1ms).
4. Measure the power of the transmitted signal with a measurement filter of bandwidths according to table 6.5B.2.1.2.5-1 through to 6.5B.2.1.2.5.2-1 and using a rms detector. If the sweep count is higher than one, the trace mode shall be average. The centre frequency of the filter shall be stepped in contiguous steps according to the same table. The measured power shall be recorded for each step. The measurement period shall capture the active time slots.

NOTE 1: When switching to DFT-s-OFDM waveform, as specified in the test configuration table 6.2B.3.1.4.1-2, send an NR RRCReconfiguration message according to TS 38.508-1 [6] clause 4.6.3 Table 4.6.3-118 PUSCH-Config with TRANSFORM\_PRECODER\_ENABLED condition.

6.5B.2.1.2.4.3 Message contents

Message contents are according to TS 38.508-1 [6] clause 4.6.1, with the following exceptions.

**Table 6.5B.2.1.2.4.3-1: PhysicalCellGroupConfig for PC3**

Derivation Path: TS 38.508-1 [6] Table 4.6.3-106			
Information Element	Value/remark	Comment	Condition
p-NR-FR1	23		Power config A (NOTE 1)
	20		Power config B (NOTE 2)
NOTE 1: Applies when E-UTRA UL transmission not overlapping with NR UL transmission in time.			
NOTE 2: Applies when E-UTRA UL transmission overlapping with NR UL transmission in time.			

**Table 6.5B.2.1.2.4.3-1: RRCConnectionReconfiguration: nr-Config-r15 for PC3**

Derivation Path: TS 36.508 [11], Table 4.6.1-8			
Information Element	Value/remark	Comment	Condition
p-MaxEUTRA-r15	23		Power config A (NOTE 1)
	20		Power config B (NOTE 2)
P-Max	23		
	20		
NOTE 1: Applies when E-UTRA UL transmission not overlapping with NR UL transmission in time.			
NOTE 2: Applies when E-UTRA UL transmission overlapping with NR UL transmission in time.			

**Table 6.5B.2.1.2.4.3-3: PhysicalCellGroupConfig for PC2**

Derivation Path: TS 38.508-1 [6], Table 4.6.3-106			
Information Element	Value/remark	Comment	Condition
p-NR-FR1	26		Power config A (NOTE 1)
	23		Power config B (NOTE 2)
NOTE 1: Applies when E-UTRA UL transmission not overlapping with NR UL transmission in time.			
NOTE 2: Applies when E-UTRA UL transmission overlapping with NR UL transmission in time.			

**Table 6.5B.2.1.2.4.3-4: RRCConnectionReconfiguration: nr-Config-r15 for PC2**

Derivation Path: TS 36.508 [11], Table 4.6.1-8			
Information Element	Value/remark	Comment	Condition
p-MaxEUTRA-r15	26		Power config A (NOTE 1)
	23		Power config B (NOTE 2)
NOTE 1: Applies when E-UTRA UL transmission not overlapping with NR UL transmission in time.			
NOTE 2: Applies when E-UTRA UL transmission overlapping with NR UL transmission in time.			

**Table 6.5B.2.1.2.4.3-5: SystemInformationBlockType1: tdd-Config if E-UTRA on TDD band**

Derivation Path: TS 36.508 [11], Table 4.6.3-23			
Information Element	Value/remark	Comment	Condition
TDD-Config-DEFAULT ::= SEQUENCE {		Operating on TDD band	
subframeAssignment	sa2		
specialSubframePatterns	ssp7		
}			

6.5B.2.1.2.4.3.1 Message contents exceptions for network signalled value "NS\_35"

For "NS\_35" see A-MPR test case in table 6.2B.3.1.4.3.2-1 and table 6.2B.3.1.4.3.2-2.

6.5B.2.1.2.4.3.2 Message contents exceptions for network signalled value "NS\_04"

For "NS\_04" see A-MPR test case in table 6.2B.3.1.4.3.1-1 and table 6.2B.3.1.4.3.1-2.



## 6.5B.2.1.2.5 Test requirement

**6.5B.2.1.2.5-1: Test Tolerance (Additional Spectrum Emission Mask)**

$f \leq 3.0\text{GHz}$	$3.0\text{GHz} < f \leq 4.2\text{GHz}$	$4.2\text{GHz} < f \leq 6.0\text{GHz}$
1.5 dB	1.8 dB	1.8 dB

## 6.5B.2.1.2.5.1 Test requirement for network signalled value "NS\_35"

When "NS\_35" is indicated in the cell measured UE mean power in the channel bandwidth, derived in step 3, shall fulfil requirements in table 6.2B.3.1.5.1-1, and the power of any UE shall not exceed the described values in table 6.5B.2.1.2.5.1-1. The requirements in the table apply in the frequency ranges immediately adjacent and outside the aggregation of the sub-blocks.

**Table 6.5B.2.1.2.5.1-1: Additional requirements for "NS\_35"**

$\Delta f_{\text{foob}}$	Frequency offset of measurement filter centre frequency, $f_{\text{offset}}$	Minimum requirement [dBm]	Measurement bandwidth
$0 \text{ MHz} \leq \Delta f < 0.1 \text{ MHz}$	$0.015 \text{ MHz} \leq f_{\text{offset}} < 0.085 \text{ MHz}$	-13+TT	30 kHz
$0.1 \text{ MHz} \leq \Delta f < \text{ENBW}$	$0.15 \text{ MHz} \leq f_{\text{offset}} < \text{ENBW} - 0.05 \text{ MHz}$	-13+TT	100 kHz
$\text{ENBW} \leq \Delta f < \text{ENBW} + 5 \text{ MHz}$	$\text{ENBW} + 0.5 \text{ MHz} \leq f_{\text{offset}} < \text{ENBW} + 4.5 \text{ MHz}$	-25+TT	1 MHz
NOTE: ENBW is the aggregated bandwidth of an E-UTRA sub-block and an adjacent NR sub-block; there is no frequency separation between the said sub-blocks. The sub-block bandwidths include any internal guard bands.			

## 6.5B.2.1.2.5.2 Test requirement for network signalled value "NS\_04"

When "NS\_04" is indicated in the cell measured UE mean power in the channel bandwidth, derived in step 3, shall fulfil requirements in tables 6.2B.3.1.5.2-1, and the power of any UE shall not exceed the described values in table 6.5B.2.1.2.5.2-1. The requirements in the table apply in the frequency ranges immediately adjacent and outside the aggregation of the sub-blocks.

**Table 6.5B.2.1.2.5.2-1: Additional requirements for n41 SEM with NS\_04**

$\Delta f_{\text{foob}}$ MHz	Spectrum emission limit (dBm)/ measurement bandwidth for each channel bandwidth						Measurement bandwidth
	10 MHz	15 MHz	20 MHz	40 MHz	50 MHz	> 50 MHz	
$\pm 0 - 1$	-18+TT	-20+TT	-21+TT	-24+TT	-25+TT		30 kHz
$\pm 1 - 5$	-10+TT						1 MHz
$\pm 5 - X$	-13+TT						
$\pm X - (\text{BW}_{\text{Channel}} + 5 \text{ MHz})$	-25+TT						
NOTE 1: X is defined as the sum of the emission bandwidth of the component carriers plus the guard band between contiguous CCs.							

## 6.5B.2.1.3 Adjacent channel leakage ratio for intra-band contiguous EN-DC

## 6.5B.2.1.3.1 Test purpose

To verify that UE transmitter does not cause unacceptable interference to adjacent channels in terms of Adjacent Channel Leakage Power Ratio (ACLR).

## 6.5B.2.1.3.2 Test applicability

This test case applies to all types of E-UTRA UE release 15 and forward, supporting intra-band contiguous EN-DC.

### 6.5B.2.1.3.3 Minimum conformance requirements

For EN-DC operation with an E-UTRA sub-block immediately adjacent to an NR sub-block, the ACLR is defined as the ratio of the filtered mean power centred on the aggregated sub-block bandwidth ENBW to the filtered mean power centred on an adjacent bandwidth of the same size ENBW at nominal channel spacing. The UE shall meet the ACLR minimum requirement EN-DC<sub>ACLR</sub> specified in Table 6.5B.2.1.3.3-1 with ENBW the sum of the sub-block bandwidths.

The assigned channel power and adjacent channel power are measured with rectangular filters with measurement bandwidths specified in 6.5B.2.1.3.3-1.

**Table 6.5B.2.1.3.3-1: ACLR for intra-band EN-DC (contiguous sub-blocks)**

Parameter	Unit	Value
EN-DC <sub>ACLR</sub> for PC3	dBc	30
EN-DC <sub>ACLR</sub> for PC2	dBc	31
Measurement bandwidth of EN-DC channel		1.00*ENBW
Measurement bandwidth of adjacent channel		0.95*ENBW
Frequency offset of adjacent channel		ENBW / -ENBW
NOTE 1: ENBW is the aggregated bandwidth in MHz as defined in clause 5.3B.		
NOTE 2: The frequency offset is that in between the centre frequencies of the measurement filters		

The normative reference for this requirement is TS 38.101-3 [4] clause 6.5B.2.1.3.

Exception requirements for both NR and E-UTRA are defined for this test and therefore LTE anchor agnostic approach is not applied. E-UTRA test point analysis is included and E-UTRA measurements are performed.

### 6.5B.2.1.3.4 Test description

#### 6.5B.2.1.3.4.1 Initial conditions

Initial conditions are a set of test configurations the UE needs to be tested in and the steps for the SS to take with the UE to reach the correct measurement state.

The initial test configurations consist of environmental conditions, test frequencies and channel bandwidths based on EN-DC operating bands specified in clause 5.3B.1.2, channel bandwidths and sub-carrier spacings for the NR cell specified in TS 38.521-1 [8] clause 5.3 and channel bandwidth for the E-UTRA cell are specified in TS 36.521-1 [10] clause 5.4.2. All of these configurations shall be tested with applicable test parameters for each EN-DC configuration specified in clause 5.3B.1.2 and are shown in test configuration tables defined in section 6.2B.2.1.4.1. The details of the uplink reference measurement channels (RMCs) are specified in Annex A, clause A.2.2 for E-UTRA RMC for TDD, TS 36.521-1 [10] Annex A, clause A.2.2 for E-UTRA RMC for FDD, and TS 38.521-1 [8] Annex A, clause A.2 for NR RMC. Configurations of PDSCH and PDCCH before measurement are specified in TS 36.521-1 [10] Annex C.2 and in TS 38.521-1 [8] Annex C.2 for E-UTRA CG and NR CG respectively.

1. Connect the SS to the UE antenna connectors as shown in [6] TS 38.508-1 A.3.1.2.1 for SS diagram and A.3.2.1 for UE diagram.
2. The parameter settings for the E-UTRA cell are set up according to TS 36.508 [11] clause 4.4.3, and the parameter settings for the NR cell are set up according to TS 38.508-1 [6] clause 4.4.3.
3. Downlink signals are initially set up according to TS 36.521-1 [10] Annex C.0 and TS 38.521-1 [8] Annex C.0 for E-UTRA CG and NR CG respectively, and uplink signals according to TS 36.521-1 [10] Annex H and TS 38.521-1 [8] Annex G for E-UTRA CG and NR CG respectively.
4. The UL Reference Measurement channels are set for E-UTRA CG and NR CG respectively.
5. Propagation conditions are set according to TS 36.521-1 [10] Annex B.0 and TS 38.521-1 [8] Annex B.0 for E-UTRA CG and NR CG respectively.

6. Ensure the UE is in state RRC\_CONNECTED with generic procedure parameters Connectivity EN-DC, DC bearer MCG and SCG, Connected without release On according to TS 38.508-1 [6] clause 4.5. Message contents are defined in clause 6.5B.2.1.3.4.3.
7. When E-UTRA and NR bands are TDD, ensure the same uplink-downlink configuration by giving SCG a delay of 3 E-UTRA subframes, or by giving MCG a delay of 2 subframes.

#### 6.5B.2.1.3.4.2 Test procedure

1. SS sends uplink scheduling information for each UL HARQ process via PDCCH DCI format 0 and DCI format 0\_1 for C\_RNTI to schedule the UL RMC according to test configuration tables defined in section 6.2B.2.1.4.1 on both EN-DC component carriers. Since the UL has no payload and no loopback data to send the UE sends uplink MAC padding bits on the UL RMC.
2. Send continuously uplink power control "up" commands to the UE for NR and E-UTRA carrier until the UE transmits at its P<sub>UMAX</sub> level; allow at least 200ms for the UE to reach P<sub>UMAX</sub> level.
3. Measure the mean power of the UE in the channel bandwidth of the radio access mode according to the test configuration, which shall meet the requirements in clause 6.2B.2.1.5 as appropriate. The period of the measurement shall be at least the continuous duration of 1ms over consecutive active uplink slots. For TDD, only slots consisting of only UL symbols are under test.
4. Measure the filtered mean power of the transmitted signal centred on the aggregated sub-block ENBW with a measurement filter of bandwidth according to test configuration tables defined in section 6.2B.2.1.4.1 and using a rms detector. If the sweep count is higher than one, the trace mode shall be average. The period of the measurement shall be at least the continuous duration of 1ms over consecutive active uplink slots For TDD, only slots consisting of only UL symbols are under test.
5. Measure the filtered mean power of the first adjacent channel on both lower and upper side of the assigned NR + E-UTRA channel, respectively with a frequency offset and measurement filter of bandwidth according to test configuration tables defined in section 6.2B.2.1.4.1 and using a rms detector. If the sweep count is higher than one, the trace mode shall be average.
6. Calculate the ratios of the power between the values measured in step 4 over step 5 for lower and upper side respectively.

NOTE 1: When switching to DFT-s-OFDM waveform, as specified in the test configuration tables defined in section 6.2B.2.1.4.1, send an NR RRCReconfiguration message according to TS 38.508-1 [6] clause 4.6.3 Table 4.6.3-118 PUSCH-Config with TRANSFORM\_PRECODER\_ENABLED condition.

#### 6.5B.2.1.3.4.3 Message contents

Same message contents as in clause 6.2B.2.1.4.3.

#### 6.5B.2.1.3.5 Test requirement

The measured adjacent channel power ratio, derived in step 6, shall be higher than the limits in Table 6.5B.2.1.3.5-1.

**Table 6.5B.2.1.3.5-1: ACLR requirement for intra-band EN-DC (contiguous sub-blocks)**

	Power class 2	Power class 3
NR ACLR	31 - TT dBc	30 - TT dBc
NOTE 1: TT for each frequency and channel bandwidth is specified in Table 6.5B.2.1.3.5-2.		

**Table 6.5B.2.1.3.5-2: Test Tolerance**

	f ≤ 4.0GHz	4.0GHz < f ≤ 6.0GHz
BW ≤ 100MHz	0.8 dB	1.0 dB

## 6.5B.2.2 Out-of-band emissions for Intra-band non-contiguous EN-DC

### 6.5B.2.2.1 Spectrum emissions mask for intra-band non-contiguous EN-DC

#### 6.5B.2.2.1.1 Test purpose

To verify that the power of any UE emissions shall not exceed specified level for the specified channel bandwidth.

#### 6.5B.2.2.1.2 Test applicability

This test case applies to all types of E-UTRA UE release 15 and forward, supporting intra-band non-contiguous EN-DC.

#### 6.5B.2.2.1.3 Minimum conformance requirements

The spectral emission mask for intra-band non-contiguous EN-DC is a composite of the emission mask for each CC with the level set to the maximum value from each mask for each frequency outside of the transmission bandwidth of either carrier. A composite spectrum emission mask is a combination of individual CC spectrum emissions masks. Where two masks overlap the most relaxed limit is used. Composite spectrum emission mask applies to frequencies up to  $\pm \Delta f_{\text{OOB}}$  starting from the edges of the sub-blocks. If for some frequency an individual CC spectrum emission mask overlaps with the bandwidth of another CC then the emission mask does not apply for that frequency.

The normative reference for this requirement is TS 38.101-3 [4] clause 6.5B.2.2.1.

The spectral emission mask for intra-band non-contiguous EN-DC is a composite of the emission mask for each CC with the level set to the maximum value from each mask and therefore LTE anchor agnostic approach is not applied.

#### 6.5B.2.2.1.4 Test description

##### 6.5B.2.2.1.4.1 Initial conditions

Initial conditions are a set of test configurations the UE needs to be tested in and the steps for the SS to take with the UE to reach the correct measurement state.

The initial test configurations consist of environmental conditions, test frequencies and channel bandwidths based on EN-DC operating bands specified in TS 38.508-1 [6] clause 4.3.1.4.3, channel bandwidths and sub-carrier spacings for the NR cell specified in TS 38.521-1 [8] clause 5.3 and channel bandwidth for the E-UTRA cell are specified in TS 36.521-1 [10] clause 5.4.2. All of these configurations shall be tested with applicable test parameters for each EN-DC configuration specified in TS 38.508-1 [6] clause 4.3.1.4.3 and are shown in Table 6.5B.2.2.1.4.1-1. The details of the uplink reference measurement channels (RMCs) are specified in Annex A, clause A.2.2 for E-UTRA RMC for TDD, TS 36.521-1 [10] Annex A, clause A.2.2 for E-UTRA RMC for FDD, and TS 38.521-1 [8] Annex A, clause A.2 for NR RMC. Configurations of PDSCH and PDCCH before measurement are specified in TS 36.521-1 [10] Annex C.2 and in TS 38.521-1 [8] Annex C.2 for E-UTRA CG and NR CG respectively.

**Table 6.5B.2.2.1.4.1-1: Test Configuration Table**

Initial Conditions and Test Parameters	
Same as defined in Table 6.2B.2.2.4.1-1 with the following exceptions.	
Test Environment as specified in TS 38.508-1 [5] subclause 4.1	Normal

1. Connect the SS to the UE antenna connectors as shown in TS 38.508-1 [6] Annex A, Figure A.3.1.1.1 for TE diagram and clause A.3.2.1 for UE diagram.
2. The parameter settings for the E-UTRA cell are set up according to TS 36.508 [11] clause 4.4.3, and the parameter settings for the NR cell are set up according to TS 38.508-1 [6] clause 4.4.3.
3. Downlink signals are initially set up according to TS 36.521-1 [10] Annex C.0 and TS 38.521-1 [8] Annex C.0 for E-UTRA CG and NR CG respectively, and uplink signals according to TS 36.521-1 [10] Annex H and TS 38.521-1 [8] Annex G for E-UTRA CG and NR CG respectively.

4. The UL Reference Measurement channels are set for E-UTRA CG and NR CG respectively.
5. Propagation conditions are set according to TS 36.521-1 [10] Annex B.0 and TS 38.521-1 [8] Annex B.0 for E-UTRA CG and NR CG respectively.
6. Ensure the UE is in state RRC\_CONNECTED with generic procedure parameters Connectivity EN-DC, DC bearer *MCG* and *SCG*, Connected without release *On* according to TS 38.508-1 [6] clause 4.5. Message contents are defined in clause 6.2B.3.2.4.3.
7. When E-UTRA and NR bands are TDD, ensure the same uplink-downlink configuration by giving SCG a delay of 3 E-UTRA subframes, or by giving MCG a delay of 2 subframes.

#### 6.5B.2.2.1.4.2 Test Procedure

1. For NR carrier, SS sends uplink scheduling information for each UL HARQ process via PDCCH DCI format 0\_1 for C\_RNTI to schedule the UL RMC according to Table 6.5B.2.2.1.4.1-1. Since the UL has no payload and no loopback data to send the UE sends uplink MAC padding bits on the UL RMC.
2. For E-UTRA carrier, SS sends uplink scheduling information via PDCCH DCI format 0 for C\_RNTI to schedule the UL RMC according to Table 6.5B.2.2.1.4.1-1. Since the UE has no payload data to send, the UE transmits uplink MAC padding bits on the UL RMC.
3. Send continuously uplink power control "up" commands to the UE for NR and E-UTRA carrier until the UE transmits at its  $P_{UMAX}$  level; allow at least 200 ms from the first TPC command starting in this step for the UE to reach  $P_{UMAX}$  level.
4. For a UE supporting dynamic power sharing, measure the mean power over all component carriers. For a UE not supporting dynamic power sharing, measure the power of each component carrier individually. The measure transmitted power shall meet the requirements in clause 6.2B.2.2.5. The period of the measurement shall be at least the continuous duration of one active sub-frame (1ms). For TDD slots with transient periods are not under test.
5. Measure the power of the transmitted signal with a measurement filter of bandwidths according to clause 6.5B.2.2.1.5 and using a rms detector. If the sweep count is higher than one, the trace mode shall be average. The centre frequency of the filter shall be stepped in continuous steps according to the same table. The measured power shall be recorded for each step. The measurement period shall capture the active TSs. If for some frequency an individual CC spectrum emission mask overlaps with the bandwidth of another CC then the emission mask does not apply for that frequency.

NOTE 1: When switching to DFT-s-OFDM waveform, send an NR RRCReconfiguration message according to TS 38.508-1 [6] clause 4.6.3 Table 4.6.3-118 PUSCH-Config with TRANSFORM\_PRECODER\_ENABLED condition.

#### 6.5B.2.2.1.4.3 Message Content

Same message contents as in clause 6.2B.2.2.4.3.

#### 6.5B.2.2.1.5 Test requirement

-For NR carrier frequency masks not overlapping with E-UTRA carrier frequency masks, the power of any UE emission shall fulfil requirements in Table 6.5.2.2.5-1 defined in TS 38.521-1 [8].

-For E-UTRA carrier frequency masks not overlapping with NR carrier frequency masks, the power of any UE emission shall fulfil requirements in Table 6.6.2.1.5-1 or 6.6.2.1.5-2 in TS 36.521-1 [10], as applicable.

-For NR carrier frequency masks overlapping with E-UTRA carrier frequency masks, the most relaxed limit is used between requirements in Table 6.5.2.2.5-1 defined in TS 38.521-1 [8] and Table 6.6.2.1.5-1 or 6.6.2.1.5-2 in TS 36.521-1 [10], as applicable.

#### 6.5B.2.2.2 Additional Spectrum emissions mask for intra-band non-contiguous EN-DC

**Editor's note: This clause is incomplete. The following aspects are either missing or not yet determined:**

- For  $W_{gap} < NR \Delta f_{OOB} + E-UTRA \Delta f_{OOB}$ , test description and test requirements are FFS.

#### 6.5B.2.2.2.1 Test purpose

Same test purpose as in clause 6.5.2.3 in TS 38.521-1 [8] for the NR carrier.

#### 6.5B.2.2.2.2 Test applicability

This test case applies to all types of E-UTRA UE release 15 and forward, supporting intra-band non-contiguous EN-DC.

#### 6.5B.2.2.2.3 Minimum conformance requirements

The spectral emission mask for intra-band non-contiguous EN-DC is a composite of the emission mask for each CC with the level set to the maximum value from each mask for each frequency outside of the transmission bandwidth of either carrier. A composite spectrum emission mask is a combination of individual CC spectrum emissions masks. Where two masks overlap the most relaxed limit is used. Composite spectrum emission mask applies to frequencies up to  $\pm \Delta f_{\text{OOB}}$  starting from the edges of the sub-blocks. If for some frequency an individual CC spectrum emission mask overlaps with the bandwidth of another CC then the emission mask does not apply for that frequency.

The normative reference for this requirement is TS 38.101-3 [4] clause 6.5B.2.2.2.

No exception requirements applicable to NR or E-UTRA when  $W_{\text{gap}} > \text{NR } \Delta f_{\text{OOB}} + \text{E-UTRA } \Delta f_{\text{OOB}}$ . LTE anchor agnostic approach is applied when  $W_{\text{gap}} > \text{NR } \Delta f_{\text{OOB}} + \text{E-UTRA } \Delta f_{\text{OOB}}$ .

Exception requirements for both NR and E-UTRA are defined for this test when  $W_{\text{gap}} < \text{NR } \Delta f_{\text{OOB}} + \text{E-UTRA } \Delta f_{\text{OOB}}$  and therefore LTE anchor agnostic approach is not applied when  $W_{\text{gap}} < \text{NR } \Delta f_{\text{OOB}} + \text{E-UTRA } \Delta f_{\text{OOB}}$ .

#### 6.5B.2.2.2.4 Test description

For  $W_{\text{gap}} > \text{NR } \Delta f_{\text{OOB}} + \text{E-UTRA } \Delta f_{\text{OOB}}$ :

Same test description as in clause 6.5.2.3.4 in TS 38.521-1 [8] for the NR carrier with the following exception:

The initial test configurations for E-UTRA band consist of environmental conditions, test frequencies, and channel bandwidths based on E-UTRA bands specified in Table 4.6-1. For Initial conditions as in clause 6.5.2.3.4.1 in TS 38.521-1 [8], the following steps will be added to configure E-UTRA component:

- 2.1. The parameter settings for E-UTRA cell are set up according to TS 36.508 [11] clause 4.4.3.
- 3.1. The E-UTRA downlink signal level, uplink signal level are set according to Table 4.6-1 and propagation conditions are set according to Annex B.0 of TS 36.521-1 [10].

Step 6 of Initial conditions as in clause 6.5.2.2.4.1 in TS 38.521-1 [8] is replaced by the following three steps:

6. Ensure the UE is in state RRC\_CONNECTED with generic procedure parameters Connectivity EN-DC, DC bearer MCG and SCG according to TS 38.508 [6] clause 4.5.
7. On the E-UTRA carrier, disable periodic and aperiodic CQI reports, disable SRS, set *TimeAlignmentTimerDedicated* IE to infinity and disable downlink and uplink scheduling, all as per Table 4.6-1 under clause 4.6.
8. When E-UTRA and NR bands are TDD, ensure the same uplink-downlink configuration by giving SCG a delay of 3 E-UTRA subframes, or by giving MCG a delay of 2 subframes.

Same test procedure as in clause 6.5.2.3.4.2 in TS 38.521-1 [8] with the following steps exception:

3. Measure the mean power of the UE in the channel bandwidth of the radio access mode according to the test configuration. The period of the measurement shall be at least the continuous duration of 1ms over consecutive active uplink slots. For TDD, only slots consisting of only UL symbols are under test.

For  $W_{\text{gap}} < \text{NR } \Delta f_{\text{OOB}} + \text{E-UTRA } \Delta f_{\text{OOB}}$ :

FFS.

## 6.5B.2.2.2.4.3 Message Content

Message contents are according to TS 36.508-1 [11] clause 4.6 and TS 38.508-1 [6] clause 4.6.1 with the following exceptions.

**Table 6.5B.2.2.2.4.3-1: RRCConnectionReconfiguration: nr-Config-r15 when  $W_{\text{gap}} < \text{NR } \Delta f_{\text{OOB}} + \text{E-UTRA } \Delta f_{\text{OOB}}$**

Derivation Path: TS 36.508 [11], Table 4.6.1-8			
Information Element	Value/remark	Comment	Condition
p-MaxEUTRA-r15	23		Power Class 2 UE
	20		Power Class 3 UE

**Table 6.5B.2.2.2.4.3-2: PhysicalCellGroupConfig when  $W_{\text{gap}} < \text{NR } \Delta f_{\text{OOB}} + \text{E-UTRA } \Delta f_{\text{OOB}}$**

Derivation Path: TS 38.508-1 [6] Table 4.6.3-106			
Information Element	Value/remark	Comment	Condition
p-NR-FR1	23		Power Class 2 UE
	20		Power Class 3 UE

**Table 6.5B.2.2.2.4.3-3: SystemInformationBlockType1: tdd-Config if E-UTRA on TDD band when  $W_{\text{gap}} < \text{NR } \Delta f_{\text{OOB}} + \text{E-UTRA } \Delta f_{\text{OOB}}$**

Derivation Path: TS 36.508 [11], Table 4.6.3-23			
Information Element	Value/remark	Comment	Condition
TDD-Config-DEFAULT ::= SEQUENCE {		Operating on TDD band	
subframeAssignment	sa2		
specialSubframePatterns	ssp7		
}			

## 6.5B.2.2.2.5 Test requirement

For  $W_{\text{gap}} > \text{NR } \Delta f_{\text{OOB}} + \text{E-UTRA } \Delta f_{\text{OOB}}$ :

Power of any UE emission shall fulfil requirements in Table 6.5.2.3.5-1 defined in TS 38.521-1 [8] for the NR carrier.

For  $W_{\text{gap}} < \text{NR } \Delta f_{\text{OOB}} + \text{E-UTRA } \Delta f_{\text{OOB}}$ :

FFS.

## 6.5B.2.2.3 Adjacent channel leakage ratio for intra-band non-contiguous EN-DC

## 6.5B.2.2.3.1 Test purpose

To verify that UE transmitter does not cause unacceptable interference to adjacent channels in terms of Adjacent Channel Leakage power Ratio (ACLR).

## 6.5B.2.2.3.2 Test applicability

This test case applies to all types of E-UTRA UE release 15 and forward, supporting intra-band non-contiguous EN-DC.

## 6.5B.2.2.3.3 Minimum conformance requirements

For intra-band non-contiguous EN-DC, the EN-DC Adjacent Channel Leakage power Ratio ( $\text{EN-DC}_{\text{ACLR}}$ ) is the ratio of the sum of the filtered mean powers centred on the assigned E-UTRA and NR sub-block frequencies to the filtered mean power centred on an adjacent channel frequency at nominal channel spacing. In case the sub-block gap bandwidth  $W_{\text{gap}}$  is smaller than an E-UTRA or NR sub-block bandwidth, no  $\text{EN-DC}_{\text{ACLR}}$  requirement is set for the corresponding

sub-block for the gap. The assigned EN-DC sub-block power and adjacent channel power are measured with rectangular filters with measurement bandwidths specified in TS 36.101 [5] for the E-UTRA sub-block, and TS 38.101-1 [2] for the NR sub-block. If the measured adjacent channel power is greater than  $-50\text{dBm}$  then the  $\text{EN-DC}_{\text{ACLR}}$  shall be higher than the value specified in for  $\text{E-UTRA}_{\text{ACLR}}$  and  $\text{NR}_{\text{ACLR}}$ .

The normative reference for this requirement is TS 38.101-3 [4] clause 6.5B.2.2.3.

Adjacent Channel Leakage power Ratio must be measured for both NR and E-UTRA and therefore LTE anchor agnostic approach is not applied.

#### 6.5B.2.2.3.4 Test description

##### 6.5B.2.2.3.4.1 Initial conditions

Initial conditions are a set of test configurations the UE needs to be tested in and the steps for the SS to take with the UE to reach the correct measurement state.

The initial test configurations consist of environmental conditions, test frequencies and channel bandwidths based on EN-DC operating bands specified in TS 38.508-1 [6] clause 4.3.1.4.3, channel bandwidths and sub-carrier spacings for the NR cell specified in TS 38.521-1 [8] clause 5.3 and channel bandwidth for the E-UTRA cell are specified in TS 36.521-1 [10] clause 5.4.2. All of these configurations shall be tested with applicable test parameters for each EN-DC configuration specified in TS 38.508-1 [6] clause 4.3.1.4.3 and are shown in Table 6.5B.2.2.3.4.1-1. The details of the uplink reference measurement channels (RMCs) are specified in Annex A, clause A.2.2 for E-UTRA RMC for TDD, TS 36.521-1 [10] Annex A, clause A.2.2 for E-UTRA RMC for FDD, and TS 38.521-1 [8] Annex A, clause A.2 for NR RMC. Configurations of PDSCH and PDCCH before measurement are specified in TS 36.521-1 [10] Annex C.2 and in TS 38.521-1 [8] Annex C.2 for E-UTRA CG and NR CG respectively.

**Table 6.5B.2.2.3.4.1-1: Test Configuration Table**

Initial Conditions and Test Parameters
Same as defined in Table 6.2B.2.2.4.1-1

1. Connect the SS to the UE antenna connectors as shown in TS 38.508-1 [6] Annex A, Figure A.3.1.1.1 for TE diagram and clause A.3.2.1 for UE diagram.
2. The parameter settings for the E-UTRA cell are set up according to TS 36.508 [11] clause 4.4.3, and the parameter settings for the NR cell are set up according to TS 38.508-1 [6] clause 4.4.3.
3. Downlink signals are initially set up according to TS 36.521-1 [10] Annex C.0 and TS 38.521-1 [8] Annex C.0 for E-UTRA CG and NR CG respectively, and uplink signals according to TS 36.521-1 [10] Annex H and TS 38.521-1 [8] Annex G for E-UTRA CG and NR CG respectively.
4. The UL Reference Measurement channels are set for E-UTRA CG and NR CG respectively.
5. Propagation conditions are set according to TS 36.521-1 [10] Annex B.0 and TS 38.521-1 [8] Annex B.0 for E-UTRA CG and NR CG respectively.
6. Ensure the UE is in state `RRC_CONNECTED` with generic procedure parameters Connectivity EN-DC, DC bearer *MCG* and *SCG*, Connected without release *On* according to TS 38.508-1 [6] clause 4.5. Message contents are defined in clause 6.2B.3.2.4.3.
7. When E-UTRA and NR bands are TDD, ensure the same uplink-downlink configuration by giving SCG a delay of 3 E-UTRA subframes, or by giving MCG a delay of 2 subframes.

##### 6.5B.2.2.3.4.2 Test Procedure

1. For NR carrier, SS sends uplink scheduling information for each UL HARQ process via PDCCH DCI format 0\_1 for `C_RNTI` to schedule the UL RMC according to Table 6.5B.2.2.3.4.1-1. Since the UL has no payload and no loopback data to send the UE sends uplink MAC padding bits on the UL RMC.
2. For E-UTRA carrier, SS sends uplink scheduling information for each UL HARQ process via PDCCH DCI format 0 for `C_RNTI` to schedule the UL RMC according to Table 6.5B.2.2.3.4.1-1. Since the UE has no payload data to send, the UE transmits uplink MAC padding bits on the UL RMC.



3. Send continuously power control “up” commands to the UE for NR and E-UTRA until the UE transmits at  $P_{UMAX}$  level. Allow at least 200ms for the UE to reach  $P_{UMAX}$  level.
4. Measure the mean power of the UE in the channel bandwidth of the radio access mode according to the test configuration, which shall meet the requirements in clause 6.2B.2.2.5 as appropriate. The period of the measurement shall be at least the continuous duration of 1ms over consecutive active uplink slots. For TDD, only slots consisting of only UL symbols are under test.
5. Measure the rectangular filtered mean power for the assigned NR channel using a rms detector. If the sweep count is higher than one, the trace mode shall be average.
6. Measure the rectangular filtered mean power of the first NR adjacent channel on both lower and upper side of the assigned NR channel using a rms detector, respectively. If the sweep count is higher than one, the trace mode shall be average. Skip the measurement within the  $W_{gap}$  in case  $W_{gap} < NR$  sub-block bandwidth.
7. Calculate the ratios of the power between the values measured in step 4 over step 5 for lower and upper NR  $_{ACLR}$ , respectively.
8. Measure the rectangular filtered mean power for E-UTRA channel using a rms detector. If the sweep count is higher than one, the trace mode shall be average.
9. Measure the rectangular filtered mean power of the first E-UTRA adjacent channel on both lower and upper side of the E-UTRA channel using a rms detector, respectively. If the sweep count is higher than one, the trace mode shall be average. Skip the measurement within the  $W_{gap}$  in case  $W_{gap} < E-UTRA$  sub-block bandwidth.
10. Calculate the ratios of the power between the values measured in step 7 over step 8 for lower and upper E-UTRA  $_{ACLR}$ , respectively.

NOTE 1: When switching to DFT-s-OFDM waveform, send an NR RRCReconfiguration message according to TS 38.508-1 [6] clause 4.6.3 Table 4.6.3-118 PUSCH-Config with TRANSFORM\_PRECODER\_ENABLED condition.

#### 6.5B.2.2.3.4.3 Message Content

Same message contents as in clause 6.2B.2.2.4.3.

#### 6.5B.2.2.3.5 Test requirement

For NR ACLR, if the measured adjacent channel power is greater than  $-50$  dBm then the measured NR ACLR shall be higher than the limits in Table 6.5.2.4.1.5-2 defined in clause 6.5.2.4.1.5 in TS 38.521-1 [8] for the NR carrier.

For E-UTRA ACLR, if the measured adjacent channel power is greater than  $-50$  dBm then the measured E-UTRA ACLR shall be higher than the limits in Table 6.6.2.3.5.1-1 defined in clause 6.6.2.3.5 in TS 36.521-1 [10] for the E-UTRA carrier.

### 6.5B.2.3 Out-of-band emissions for Inter-band EN-DC within FR1

#### 6.5B.2.3.1 Spectrum emissions mask for Inter-band EN-DC within FR1 (1 NR CC)

##### 6.5B.2.3.1.1 Test purpose

Same test purpose as in clause 6.5.2.2 in TS 38.521-1 [8] for the NR carrier.

##### 6.5B.2.3.1.2 Test applicability

This test case applies to all types of E-UTRA UE release 15 and forward, supporting inter-band EN-DC within FR1 with 1 NR UL.

##### 6.5B.2.3.1.3 Minimum conformance requirements

Same minimum conformance requirements as in clause 6.5.2.2.3 in TS 38.521-1 [8] for the NR carrier.

The normative reference for this requirement is TS 38.101-3 [4] clause 6.5B.2.3.

No exception requirements applicable to NR or E-UTRA. LTE anchor agnostic approach is applied.

#### 6.5B.2.3.1.4 Test description

Same test description as in clause 6.5.2.2.4 in TS 38.521-1 [8] for the NR carrier with the following exception:

The initial test configurations for E-UTRA band consist of environmental conditions, test frequencies, and channel bandwidths based on E-UTRA bands specified in Table 4.6-1. For Initial conditions as in clause 6.5.2.2.4.1 in TS 38.521-1 [8], the following steps will be added to configure E-UTRA component:

- 2.1. The parameter settings for E-UTRA cell are set up according to TS 36.508 [11] clause 4.4.3.
- 3.1. The E-UTRA downlink signal level, uplink signal level are set according to Table 4.6-1 and propagation conditions are set according to Annex B.0 of TS 36.521-1 [10].

Step 6 of Initial conditions as in clause 6.5.2.2.4.1 in TS 38.521-1 [8] is replaced by the following two steps:

6. Ensure the UE is in state RRC\_CONNECTED with generic procedure parameters Connectivity EN-DC, DC bearer MCG and SCG according to TS 38.508 [6] clause 4.5.
7. On the E-UTRA carrier, disable periodic and aperiodic CQI reports, disable SRS, set *TimeAlignmentTimerDedicated* IE to infinity and disable downlink and uplink scheduling, all as per Table 4.6-1 under clause 4.6.

#### 6.5B.2.3.1.5 Test requirement

Power of any UE emission shall fulfil requirements in Table 6.5.2.2.5-1 defined in TS 38.521-1 [8] for the NR carrier. 6.5B.2.3.2.

### 6.5B.2.3.2 Additional Spectrum emissions mask for Inter-band EN-DC within FR1 (1 NR CC)

#### 6.5B.2.3.2.1 Test purpose

Same test purpose as in clause 6.5.2.3.1 in TS 38.521-1 [8] for the NR carrier.

#### 6.5B.2.3.2.2 Test applicability

This test case applies to all types of E-UTRA UE release 15 and forward, supporting inter-band EN-DC within FR1 with 1 NR UL.

#### 6.5B.2.3.2.3 Minimum conformance requirements

Same minimum conformance requirements as in clause 6.5.2.3.3 in TS 38.521-1 [8] for the NR carrier.

The normative reference for this requirement is TS 38.101-3 [4] clause 6.5B.2.3.

No exception requirements applicable to NR or E-UTRA. LTE anchor agnostic approach is applied.

#### 6.5B.2.3.2.4 Test description

Same test description as in clause 6.5.2.3.4 in TS 38.521-1 [8] for the NR carrier with the following exception:

The initial test configurations for E-UTRA band consist of environmental conditions, test frequencies, and channel bandwidths based on E-UTRA bands specified in Table 4.6-1. For Initial conditions as in clause 6.5.2.3.4.1 in TS 38.521-1 [8], the following steps will be added to configure E-UTRA component:

- 2.1. The parameter settings for E-UTRA cell are set up according to TS 36.508 [11] clause 4.4.3.
- 3.1. The E-UTRA downlink signal level, uplink signal level are set according to Table 4.6-1 and propagation conditions are set according to Annex B.0 of TS 36.521-1 [10].

Step 6 of Initial conditions as in clause 6.5.2.3.4.1 in TS 38.521-1 [8] is replaced by the following two steps:

6. Ensure the UE is in state RRC\_CONNECTED with generic procedure parameters Connectivity EN-DC, DC bearer MCG and SCG according to TS 38.508 [6] clause 4.5.
7. On the E-UTRA carrier, disable periodic and aperiodic CQI reports, disable SRS, set *TimeAlignmentTimerDedicated* IE to infinity and disable downlink and uplink scheduling, all as per Table 4.6-1 under clause 4.6.

#### 6.5B.2.3.2.5 Test requirement

Power of any UE emission shall fulfil requirements in applicable table from Table 6.5.2.3.5-1 to Table 6.5.2.3.5.2-1 defined in TS 38.521-1 [8] for the NR carrier.

#### 6.5B.2.3.3 Adjacent channel leakage ratio for inter-band EN-DC within FR1 (1 NR CC)

##### 6.5B.2.3.3.1 NR - Adjacent channel leakage ratio for inter-band EN-DC within FR1 (1 NR CC)

##### 6.5B.2.3.3.1.1 Test purpose

Same test purpose as in clause 6.5.2.4.1.1 in TS 38.521-1 [8].

##### 6.5B.2.3.3.1.2 Test applicability

This test case applies to all types of E-UTRA UE release 15 and forward, supporting inter-band EN-DC within FR1 with 1 NR UL.

##### 6.5B.2.3.3.1.3 Minimum conformance requirements

Same minimum conformance requirements as in clause 6.5.2.4.1.3 in TS 38.521-1 [8] for the NR carrier.

The normative reference for this requirement is TS 38.101-3 [4] clause 6.5B.2.3.

No exception requirements applicable to NR or E-UTRA. LTE anchor agnostic approach is applied

##### 6.5B.2.3.3.1.4 Test description

Same test description as in clause 6.5.2.4.1.4 in TS 38.521-1 [8] for the NR carrier with the following exception:

The initial test configurations for E-UTRA band consist of environmental conditions, test frequencies, and channel bandwidths based on E-UTRA bands specified in Table 4.6-1.

For Initial conditions as in clause 6.5.2.4.1.4.1 in TS 38.521-1 [8], the following steps will be added to configure E-UTRA component:

- 2.1. The parameter settings for E-UTRA cell are set up according to TS 36.508 [11] clause 4.4.3.
- 3.1. The E-UTRA downlink signal level, uplink signal level are set according to Table 4.6-1 and propagation conditions are set according to Annex B.0 of TS 36.521-1 [10].

Step 6 of Initial conditions as in clause 6.5.2.4.1.4.1 in TS 38.521-1 [8] is replaced by the following two steps:

6. Ensure the UE is in state RRC\_CONNECTED with generic procedure parameters Connectivity EN-DC, DC bearer MCG and SCG, Connected without release *On* according to TS 38.508 [6] clause 4.5.
7. On the E-UTRA carrier, disable periodic and aperiodic CQI reports, disable SRS, set *TimeAlignmentTimerDedicated* IE to infinity and disable downlink and uplink scheduling, all as per Table 4.6-1 under clause 4.6.

##### 6.5B.2.3.3.1.5 Test requirement

Same test requirement as in clause 6.5.2.4.1.5 in TS 38.521-1 [8].

6.5B.2.3.3.2 UTRA - Adjacent channel leakage ratio for inter-band EN-DC within FR1 (1 NR CC)

6.5B.2.3.3.2.1 Test purpose

Same test purpose as in clause 6.5.2.4.2.1 in TS 38.521-1 [8].

6.5B.2.3.3.2.2 Test applicability

This test case applies to all types of E-UTRA UE release 15 and forward, supporting inter-band EN-DC within FR1 with 1 NR UL.

6.5B.2.3.3.2.3 Minimum conformance requirements

Same minimum conformance requirements as in clause 6.5.2.4.2.3 in TS 38.521-1 [8] for the NR carrier.

The normative reference for this requirement is TS 38.101-3 [4] clause 6.5B.2.3.

No exception requirements applicable to NR or E-UTRA. LTE anchor agnostic approach is applied

6.5B.2.3.3.2.4 Test description

Same test description as in clause 6.5.2.4.2.4 in TS 38.521-1 [8] for the NR carrier with the following exception:

The initial test configurations for E-UTRA band consist of environmental conditions, test frequencies, and channel bandwidths based on E-UTRA bands specified in Table 4.6-1.

For Initial conditions as in clause 6.5.2.4.2.4.1 in TS 38.521-1 [8], the following steps will be added to configure E-UTRA component:

- 2.1. The parameter settings for E-UTRA cell are set up according to TS 36.508 [11] clause 4.4.3.
- 3.1. The E-UTRA downlink signal level, uplink signal level are set according to Table 4.6-1 and propagation conditions are set according to Annex B.0 of TS 36.521-1 [10].

Step 6 of Initial conditions as in clause 6.5.2.4.2.4.1 in TS 38.521-1 [8] is replaced by the following two steps:

6. Ensure the UE is in state RRC\_CONNECTED with generic procedure parameters Connectivity EN-DC, DC bearer MCG and SCG, Connected without release *On* according to TS 38.508 [6] clause 4.5.
7. On the E-UTRA carrier, disable periodic and aperiodic CQI reports, disable SRS, set *TimeAlignmentTimerDedicated* IE to infinity and disable downlink and uplink scheduling, all as per Table 4.6-1 under clause 4.6.

6.5B.2.3.3.2.5 Test requirement

Same test requirement as in clause 6.5.2.4.2.5 in TS 38.521-1 [8].

6.5B.2.3a Out-of-band emissions for Inter-band NE-DC within FR1

6.5B.2.3a.1 Spectrum emissions mask for Inter-band NE-DC within FR1

No exception requirements applicable to NR or LTE.

No test case details are specified. The requirements for NR carrier(s) in this test case are tested in 6.5.2.2 and 6.5A.2.2 of TS 38.521-1 [8], and the requirements for LTE carrier(s) in this test case are tested in 6.6.2.1 and 6.6.2.1A of TS 36.521-1 [10]. Neither NR carrier(s) nor LTE carrier(s) needs to be tested again.

6.5B.2.3a.2 Additional Spectrum emissions mask for Inter-band NE-DC within FR1

No exception requirements applicable to NR or E-UTRA.

No test case details are specified. The requirements for NR carrier(s) in this test case are tested in 6.5.2.3 of TS 38.521-1 [8], and the requirements for LTE carrier(s) in this test case are tested in 6.6.2.2 and 6.6.2.2A of TS 36.521-1 [10]. Neither NR carrier(s) nor LTE carrier(s) needs to be tested again.

### 6.5B.2.3a.3 Adjacent channel leakage ratio for inter-band NE-DC within FR1

No exception requirements applicable to NR or E-UTRA.

No test case details are specified. The requirements for NR carrier(s) in this test case are tested in 6.5.2.4 and 6.5A.2.4 of TS 38.521-1 [8], and the requirements for LTE carrier(s) in this test case are tested in 6.6.2.3 and 6.6.2.3A of TS 36.521-1 [10]. Neither NR carrier(s) nor LTE carrier(s) needs to be tested again.

### 6.5B.2.4 Out-of-band emissions for Inter-band EN-DC including FR2

#### 6.5B.2.4.1 Spectrum emissions mask for Inter-band EN-DC including FR2 (1 NR CC)

**Editor's note: The following aspects are either missing or not yet determined:**

- **Measurement Uncertainties and Test Tolerances are FFS for power class other than 1 FR2a, 3, 5 and 6.**

##### 6.5B.2.4.1.1 Test purpose

Same test purpose as in clause 6.5.2.1.1 in TS 38.521-2 [9] for the NR carrier.

##### 6.5B.2.4.1.2 Test applicability

This test case applies to all types of E-UTRA UE release 15 and forward, supporting inter-band EN-DC including FR2 with 1 NR UL CC.

##### 6.5B.2.4.1.3 Minimum conformance requirements

Same minimum conformance requirements as in clause 6.5.2.1.3 in TS 38.521-2 [9] for the NR carrier.

No exception requirements applicable to NR or E-UTRA. LTE anchor agnostic approach is applied.

##### 6.5B.2.4.1.4 Test description

###### 6.5B.2.4.1.4.1 Initial conditions

Same test description as in clause 6.5.2.1.4 in TS 38.521-2 [9] for the NR carrier with the following exception:

The initial test configurations for E-UTRA band consist of environmental conditions, test frequencies, and channel bandwidths based on E-UTRA bands specified in Table 4.7-1. For Initial conditions as in clause 6.5.2.1.4.1 in TS 38.521-2 [9], the following steps will be added to configure E-UTRA component:

- 2.1. The parameter settings for E-UTRA cell are set up according to TS 36.508 [11] clause 4.4.3.
- 3.1. The E-UTRA downlink signal level, uplink signal level are set according to Table 4.7-1 and propagation conditions are set according to Annex B.0 of TS 36.521-1 [10].

Step 6 of Initial conditions as in clause 6.5.2.1.4.1 in TS 38.521-2 [9] is replaced by:

6. Ensure the UE is in state RRC\_CONNECTED with generic procedure parameters Connectivity EN-DC, DC bearer MCG and SCG, Connected without release On according to TS 38.508-1 [6] clause 4.5.

Same test procedure as in clause 6.5.2.1.4.2 in TS 38.521-2 [9] with the following steps added for E-UTRA component:

- 1.1 On the E-UTRA carrier, disable periodic and aperiodic CQI reports, disable SRS, set *TimeAlignmentTimerDedicated* IE to infinity and disable downlink and uplink scheduling, all as per Table 4.7-1 under clause 4.7.

## 6.5B.2.4.1.5 Test requirement

Same test requirement as in clause 6.5.2.1.5 in TS 38.521-2 [9] for the NR carrier.

## 6.5B.2.4.1a Spectrum emissions mask with Power Boost for Inter-band EN-DC including FR2 (1 NR CC)

**Editor's note: The following aspects are either missing or not yet determined:**

- The referred test case 6.5.2.1\_1 in TS 38.521-2 is incomplete for power class 1, 2 and 4.

## 6.5B.2.4.1a.1 Test purpose

Same test purpose as in clause 6.5.2.1\_1.1 in TS 38.521-2 [9] for the NR carrier.

## 6.5B.2.4.1a.2 Test applicability

This test case applies to all types of NR UE release 16 and forward supporting *mpr-PowerBoost-FR2-r16* UE capability, supporting inter-band EN-DC including FR2 with 1 NR UL CC.

## 6.5B.2.4.1a.3 Minimum conformance requirements

Same minimum conformance requirements as in clause 6.5.2.1\_1.3 in TS 38.521-2 [9] for the NR carrier.

No exception requirements applicable to NR or E-UTRA. LTE anchor agnostic approach is applied.

## 6.5B.2.4.1a.4 Test description

Same test description as in clause 6.5.2.1\_1.4 in TS 38.521-2 [9] for the NR carrier with the following exception:

The initial test configurations for E-UTRA band consist of environmental conditions, test frequencies, and channel bandwidths based on E-UTRA bands specified in Table 4.7-1. For Initial conditions as in clause 6.5.2.1.4.1 in TS 38.521-2 [9], the following steps will be added to configure E-UTRA component:

- 2.1. The parameter settings for E-UTRA cell are set up according to TS 36.508 [11] clause 4.4.3.
- 3.1. The E-UTRA downlink signal level, uplink signal level are set according to Table 4.7-1 and propagation conditions are set according to Annex B.0 of TS 36.521-1 [10].

Step 6 of Initial conditions as in clause 6.2.4\_1.4.1 in TS 38.521-2 [9] is replaced by:

6. Ensure the UE is in state RRC\_CONNECTED with generic procedure parameters Connectivity EN-DC, DC bearer MCG and SCG, Connected without release On according to TS 38.508-1 [6] clause 4.5.

Same test procedure as in clause 6.5.2.1\_1.4.2 in TS 38.521-2 [9] with the following steps added for E-UTRA component:

- 1.1 On the E-UTRA carrier, disable periodic and aperiodic CQI reports, disable SRS, set *TimeAlignmentTimerDedicated* IE to infinity and disable downlink and uplink scheduling, all as per Table 4.7-1 under clause 4.7.

## 6.5B.2.4.1a.5 Test requirement

Same test requirement as in clause 6.5.2.1\_1.5 in TS 38.521-2 [9] for the NR carrier.

## 6.5B.2.4.1\_1 Spectrum emissions mask for Inter-band EN-DC including FR2 (&gt;1 NR CC)

**Editor's note: Test applicability, Test Description in below sub-clauses requires updates to clarify number of E-UTRA carriers that will be configured during the test**

## 6.5B.2.4.1\_1.1 Spectrum emissions mask for Inter-band EN-DC including FR2 (2 NR CCs)

**Editor's note: The following aspects are either missing or not yet determined:**

- The referred test case 6.5A.2.1.1 in TS 38.521-2 [9] is incomplete for intra-band contiguous CA supporting aggregated BW > 400MHz are TBD.

#### 6.5B.2.4.1\_1.1.1 Test purpose

Same test purpose as in clause 6.5.2.1.1 in TS 38.521-2 [9] for the NR carrier.

#### 6.5B.2.4.1\_1.1.2 Test applicability

This test case applies to all types of E-UTRA UE release 15 and forward, supporting inter-band EN-DC including FR2 with 2 NR UL CCs.

#### 6.5B.2.4.1\_1.1.3 Minimum conformance requirements

Same minimum conformance requirements as in clause 6.5.2.1.3 in TS 38.521-2 [9] for the NR carrier.

No exception requirements applicable to NR or E-UTRA. LTE anchor agnostic approach is applied.

The normative reference for this requirement is TS 38.101-3 [4] clause 6.4B.1.4.

#### 6.5B.2.4.1\_1.1.4 Test description

##### 6.5B.2.4.1\_1.1.4.1 Initial condition

Same test description as in clause 6.5A.2.1.1.4 in TS 38.521-2 [9] for the NR carrier with the following exception:

The initial test configurations for E-UTRA band consist of environmental conditions, test frequencies, and channel bandwidths based on E-UTRA bands specified in Table 4.7-1.

For Initial conditions as in clause 6.5A.2.1.1.4.1 in TS 38.521-2 [9], the following steps will be added to configure E-UTRA component:

- 2.1. The parameter settings for E-UTRA cell are set up according to TS 36.508 [11] clause 4.4.3.
- 3.1. The E-UTRA downlink signal level, uplink signal level are set according to Table 4.7-1 and propagation conditions are set according to Annex B.0 of TS 36.521-1 [10].

Step 6 of Initial conditions as in clause 6.5A.2.1.1.4.1 in TS 38.521-2 [9] is replaced by:

6. Ensure the UE is in state RRC\_CONNECTED with generic procedure parameters Connectivity EN-DC, DC bearer MCG and SCG, Connected without release On according to TS 38.508-1 [6] clause 4.5.

Same test procedure as in clause 6.5A.2.1.1.4.2 in TS 38.521-2 [9] with the following steps added for E-UTRA component:

- 1.1 On the E-UTRA carrier, disable periodic and aperiodic CQI reports, disable SRS, set *TimeAlignmentTimerDedicated* IE to infinity and disable downlink and uplink scheduling, all as per Table 4.7-1 under clause 4.7.

#### 6.5B.2.4.1\_1.1.5 Test Requirements

Same test requirement as in clause 6.5A.2.1.1.5 in TS 38.521-2 [9] for the NR carrier.

#### 6.5B.2.4.1\_1.2 Spectrum emissions mask for Inter-band EN-DC including FR2 (3 NR CCs)

**Editor's note: This clause is incomplete. The following aspects are either missing or not yet determined:**

- The referred test case 6.5A.2.1.2 in TS 38.521-2 [9] is incomplete for intra-band contiguous CA supporting aggregated BW > 400MHz are TBD.

#### 6.5B.2.4.1\_1.2.1 Test purpose

Same test purpose as in clause 6.5.2.1.1 in TS 38.521-2 [9] for the NR carrier.

#### 6.5B.2.4.1\_1.2.2 Test applicability

This test case applies to all types of E-UTRA UE release 15 and forward, supporting inter-band EN-DC including FR2 with 3 NR UL CCs.

#### 6.5B.2.4.1\_1.2.3 Minimum conformance requirements

Same minimum conformance requirements as in clause 6.5.2.1.3 in TS 38.521-2 [9] for the NR carrier.

No exception requirements applicable to NR or E-UTRA. LTE anchor agnostic approach is applied.

The normative reference for this requirement is TS 38.101-3 [4] clause 6.4B.1.4.

#### 6.5B.2.4.1\_1.2.4 Test description

##### 6.5B.2.4.1\_1.2.4.1 Initial condition

Same test description as in clause 6.5A.2.1.2.4 in TS 38.521-2 [9] for the NR carrier with the following exception:

The initial test configurations for E-UTRA band consist of environmental conditions, test frequencies, and channel bandwidths based on E-UTRA bands specified in Table 4.7-1.

For Initial conditions as in clause 6.5A.2.1.2.4.1 in TS 38.521-2 [9], the following steps will be added to configure E-UTRA component:

- 2.1. The parameter settings for E-UTRA cell are set up according to TS 36.508 [11] clause 4.4.3.
- 3.1. The E-UTRA downlink signal level, uplink signal level are set according to Table 4.7-1 and propagation conditions are set according to Annex B.0 of TS 36.521-1 [10].

Step 6 of Initial conditions as in clause 6.5A.2.1.2.4.1 in TS 38.521-2 [9] is replaced by:

6. Ensure the UE is in state RRC\_CONNECTED with generic procedure parameters Connectivity EN-DC, DC bearer MCG and SCG, Connected without release On according to TS 38.508-1 [6] clause 4.5.

Same test procedure as in clause 6.5A.2.1.2.4.2 in TS 38.521-2 [9] with the following steps added for E-UTRA component:

- 1.1 On the E-UTRA carrier, disable periodic and aperiodic CQI reports, disable SRS, set *TimeAlignmentTimerDedicated* IE to infinity and disable downlink and uplink scheduling, all as per Table 4.7-1 under clause 4.7.

#### 6.5B.2.4.1\_1.2.5 Test Requirements

Same test requirement as in clause 6.5A.2.1.2.5 in TS 38.521-2 [9] for the NR carrier.

#### 6.5B.2.4.1\_1.3 Spectrum emissions mask for Inter-band EN-DC including FR2 (4 NR CCs)

**Editor's note: This clause is incomplete. The following aspects are either missing or not yet determined:**

- **The referred test case 6.5A.2.1.3 in TS 38.521-2 [9] is incomplete for intra-band contiguous CA supporting aggregated BW > 400MHz are TBD.**

##### 6.5B.2.4.1\_1.3.1 Test purpose

Same test purpose as in clause 6.5.2.1.1 in TS 38.521-2 [9] for the NR carrier.

##### 6.5B.2.4.1\_1.3.2 Test applicability

This test case applies to all types of E-UTRA UE release 15 and forward, supporting inter-band EN-DC including FR2 with 4 NR UL CCs.



#### 6.5B.2.4.1\_1.3.3 Minimum conformance requirements

Same minimum conformance requirements as in clause 6.5.2.1.3 in TS 38.521-2 [9] for the NR carrier.

No exception requirements applicable to NR or E-UTRA. LTE anchor agnostic approach is applied.

The normative reference for this requirement is TS 38.101-3 [4] clause 6.4B.1.4.

#### 6.5B.2.4.1\_1.3.4 Test description

##### 6.5B.2.4.1\_1.3.4.1 Initial condition

Same test description as in clause 6.5A.2.1.3.4 in TS 38.521-2 [9] for the NR carrier with the following exception:

The initial test configurations for E-UTRA band consist of environmental conditions, test frequencies, and channel bandwidths based on E-UTRA bands specified in Table 4.7-1.

For Initial conditions as in clause 6.5A.2.1.3.4.1 in TS 38.521-2 [9], the following steps will be added to configure E-UTRA component:

- 2.1. The parameter settings for E-UTRA cell are set up according to TS 36.508 [11] clause 4.4.3.
- 3.1. The E-UTRA downlink signal level, uplink signal level are set according to Table 4.7-1 and propagation conditions are set according to Annex B.0 of TS 36.521-1 [10].

Step 6 of Initial conditions as in clause 6.5A.2.1.3.4.1 in TS 38.521-2 [9] is replaced by:

6. Ensure the UE is in state RRC\_CONNECTED with generic procedure parameters Connectivity EN-DC, DC bearer MCG and SCG, Connected without release On according to TS 38.508-1 [6] clause 4.5.

Same test procedure as in clause 6.5A.2.1.3.4.2 in TS 38.521-2 [9] with the following steps added for E-UTRA component:

- 1.1 On the E-UTRA carrier, disable periodic and aperiodic CQI reports, disable SRS, set *TimeAlignmentTimerDedicated* IE to infinity and disable downlink and uplink scheduling, all as per Table 4.7-1 under clause 4.7.

#### 6.5B.2.4.1\_1.3.5 Test Requirements

Same test requirement as in clause 6.5A.2.1.3.5 in TS 38.521-2 [9] for the NR carrier.

#### 6.5B.2.4.1\_1.4 Spectrum emissions mask for Inter-band EN-DC including FR2 (5 NR CCs)

**Editor's note: This clause is incomplete. The following aspects are either missing or not yet determined:**

- The referred test case 6.5A.2.1.4 in TS 38.521-2 [9] is incomplete for intra-band contiguous CA supporting aggregated BW > 400MHz are TBD.
- Measurement Uncertainties and Test Tolerances are FFS.

##### 6.5B.2.4.1\_1.4.1 Test purpose

Same test purpose as in clause 6.5.2.1.1 in TS 38.521-2 [9] for the NR carrier.

##### 6.5B.2.4.1\_1.4.2 Test applicability

This test case applies to all types of E-UTRA UE release 15 and forward, supporting inter-band EN-DC including FR2 with 5 NR UL CCs.

##### 6.5B.2.4.1\_1.4.3 Minimum conformance requirements

Same minimum conformance requirements as in clause 6.5.2.1.3 in TS 38.521-2 [9] for the NR carrier.

No exception requirements applicable to NR or E-UTRA. LTE anchor agnostic approach is applied.

The normative reference for this requirement is TS 38.101-3 [4] clause 6.4B.1.4.

#### 6.5B.2.4.1\_1.4.4 Test description

##### 6.5B.2.4.1\_1.4.4.1 Initial condition

Same test description as in clause 6.5A.2.1.4.4 in TS 38.521-2 [9] for the *NR* carrier with the following exception:

The initial test configurations for E-UTRA band consist of environmental conditions, test frequencies, and channel bandwidths based on E-UTRA bands specified in Table 4.7-1.

For Initial conditions as in clause 6.5A.2.1.4.4.1 in TS 38.521-2 [9], the following steps will be added to configure E-UTRA component:

- 2.1. The parameter settings for E-UTRA cell are set up according to TS 36.508 [11] clause 4.4.3.
- 3.1. The E-UTRA downlink signal level, uplink signal level are set according to Table 4.7-1 and propagation conditions are set according to Annex B.0 of TS 36.521-1 [10].

Step 6 of Initial conditions as in clause 6.5A.2.1.4.4.1 in TS 38.521-2 [9] is replaced by:

6. Ensure the UE is in state `RRC_CONNECTED` with generic procedure parameters Connectivity EN-DC, DC bearer MCG and SCG, Connected without release On according to TS 38.508-1 [6] clause 4.5.

Same test procedure as in clause 6.5A.2.1.4.4.2 in TS 38.521-2 [9] with the following steps added for E-UTRA component:

- 1.1 On the E-UTRA carrier, disable periodic and aperiodic CQI reports, disable SRS, set *TimeAlignmentTimerDedicated* IE to infinity and disable downlink and uplink scheduling, all as per Table 4.7-1 under clause 4.7.

#### 6.5B.2.4.1\_1.4.5 Test Requirements

Same test requirement as in clause 6.5A.2.1.4.5 in TS 38.521-2 [9] for the *NR* carrier

##### 6.5B.2.4.1\_1.5 Spectrum emissions mask for Inter-band EN-DC including FR2 (6 NR CCs)

**Editor's note: This clause is incomplete. The following aspects are either missing or not yet determined:**

- The referred test case 6.5A.2.1.5 in TS 38.521-2 [9] is incomplete for intra-band contiguous CA supporting aggregated BW > 400MHz are TBD.
- Measurement Uncertainties and Test Tolerances are FFS.

##### 6.5B.2.4.1\_1.5.1 Test purpose

Same test purpose as in clause 6.5.2.1.1 in TS 38.521-2 [9] for the *NR* carrier.

##### 6.5B.2.4.1\_1.5.2 Test applicability

This test case applies to all types of E-UTRA UE release 15 and forward, supporting inter-band EN-DC including FR2 with 6 NR UL CCs.

##### 6.5B.2.4.1\_1.5.3 Minimum conformance requirements

Same minimum conformance requirements as in clause 6.5.2.1.3 in TS 38.521-2 [9] for the *NR* carrier.

No exception requirements applicable to *NR* or E-UTRA. LTE anchor agnostic approach is applied.

The normative reference for this requirement is TS 38.101-3 [4] clause 6.4B.1.4.

#### 6.5B.2.4.1\_1.5.4 Test description

##### 6.5B.2.4.1\_1.5.4.1 Initial condition

Same test description as in clause 6.5A.2.1.5.4 in TS 38.521-2 [9] for the *NR* carrier with the following exception:

The initial test configurations for E-UTRA band consist of environmental conditions, test frequencies, and channel bandwidths based on E-UTRA bands specified in Table 4.7-1.

For Initial conditions as in clause 6.5A.2.1.5.4.1 in TS 38.521-2 [9], the following steps will be added to configure E-UTRA component:

- 2.1. The parameter settings for E-UTRA cell are set up according to TS 36.508 [11] clause 4.4.3.
- 3.1. The E-UTRA downlink signal level, uplink signal level are set according to Table 4.7-1 and propagation conditions are set according to Annex B.0 of TS 36.521-1 [10].

Step 6 of Initial conditions as in clause 6.5A.2.1.5.4.1 in TS 38.521-2 [9] is replaced by:

6. Ensure the UE is in state RRC\_CONNECTED with generic procedure parameters Connectivity EN-DC, DC bearer MCG and SCG, Connected without release On according to TS 38.508-1 [6] clause 4.5.

Same test procedure as in clause 6.5A.2.1.5.4.2 in TS 38.521-2 [9] with the following steps added for E-UTRA component:

- 1.1 On the E-UTRA carrier, disable periodic and aperiodic CQI reports, disable SRS, set *TimeAlignmentTimerDedicated* IE to infinity and disable downlink and uplink scheduling, all as per Table 4.7-1 under clause 4.7.

#### 6.5B.2.4.1\_1.5.5 Test Requirements

Same test requirement as in clause 6.5A.2.1.5.5 in TS 38.521-2 [9] for the *NR* carrier

#### 6.5B.2.4.1\_1.6 Spectrum emissions mask for Inter-band EN-DC including FR2 (7 NR CCs)

**Editor's note: This clause is incomplete. The following aspects are either missing or not yet determined:**

- The referred test case 6.5A.2.1.6 in TS 38.521-2 [9] is incomplete for intra-band contiguous CA supporting aggregated BW > 400MHz are TBD.
- Measurement Uncertainties and Test Tolerances are FFS.

#### 6.5B.2.4.1\_1.6.1 Test purpose

Same test purpose as in clause 6.5.2.1.1 in TS 38.521-2 [9] for the *NR* carrier.

#### 6.5B.2.4.1\_1.6.2 Test applicability

This test case applies to all types of E-UTRA UE release 15 and forward, supporting inter-band EN-DC including FR2 with 7 NR UL CCs.

#### 6.5B.2.4.1\_1.6.3 Minimum conformance requirements

Same minimum conformance requirements as in clause 6.5.2.1.3 in TS 38.521-2 [9] for the *NR* carrier.

No exception requirements applicable to *NR* or E-UTRA. LTE anchor agnostic approach is applied.

The normative reference for this requirement is TS 38.101-3 [4] clause 6.4B.1.4.

#### 6.5B.2.4.1\_1.6.4 Test description

##### 6.5B.2.4.1\_1.6.4.1 Initial condition

Same test description as in clause 6.5A.2.1.6.4 in TS 38.521-2 [9] for the *NR* carrier with the following exception:

The initial test configurations for E-UTRA band consist of environmental conditions, test frequencies, and channel bandwidths based on E-UTRA bands specified in Table 4.7-1.

For Initial conditions as in clause 6.5A.2.1.6.4.1 in TS 38.521-2 [9], the following steps will be added to configure E-UTRA component:

- 2.1. The parameter settings for E-UTRA cell are set up according to TS 36.508 [11] clause 4.4.3.
- 3.1. The E-UTRA downlink signal level, uplink signal level are set according to Table 4.7-1 and propagation conditions are set according to Annex B.0 of TS 36.521-1 [10].

Step 6 of Initial conditions as in clause 6.5A.2.1.6.4.1 in TS 38.521-2 [9] is replaced by:

6. Ensure the UE is in state RRC\_CONNECTED with generic procedure parameters Connectivity EN-DC, DC bearer MCG and SCG, Connected without release On according to TS 38.508-1 [6] clause 4.5.

Same test procedure as in clause 6.5A.2.1.6.4.2 in TS 38.521-2 [9] with the following steps added for E-UTRA component:

- 1.1 On the E-UTRA carrier, disable periodic and aperiodic CQI reports, disable SRS, set *TimeAlignmentTimerDedicated* IE to infinity and disable downlink and uplink scheduling, all as per Table 4.7-1 under clause 4.7.

#### 6.5B.2.4.1\_1.6.5 Test Requirements

Same test requirement as in clause 6.5A.2.1.6.5 in TS 38.521-2 [9] for the *NR* carrier

#### 6.5B.2.4.1\_1.7 Spectrum emissions mask for Inter-band EN-DC including FR2 (8 NR CCs)

**Editor's note: This clause is incomplete. The following aspects are either missing or not yet determined:**

- **The referred test case 6.5A.2.1.7 in TS 38.521-2 [9] is incomplete for intra-band contiguous CA supporting aggregated BW > 400MHz are TBD.**
- **Measurement Uncertainties and Test Tolerances are FFS.**

#### 6.5B.2.4.1\_1.7.1 Test purpose

Same test purpose as in clause 6.5.2.1.1 in TS 38.521-2 [9] for the *NR* carrier.

#### 6.5B.2.4.1\_1.7.2 Test applicability

This test case applies to all types of E-UTRA UE release 15 and forward, supporting inter-band EN-DC including FR2 with 8 NR UL CCs.

#### 6.5B.2.4.1\_1.7.3 Minimum conformance requirements

Same minimum conformance requirements as in clause 6.5.2.1.3 in TS 38.521-2 [9] for the *NR* carrier.

No exception requirements applicable to *NR* or E-UTRA. LTE anchor agnostic approach is applied.

The normative reference for this requirement is TS 38.101-3 [4] clause 6.4B.1.4.

#### 6.5B.2.4.1\_1.7.4 Test description

##### 6.5B.2.4.1\_1.7.4.1 Initial condition

Same test description as in clause 6.5A.2.1.7.4 in TS 38.521-2 [9] for the *NR* carrier with the following exception:

The initial test configurations for E-UTRA band consist of environmental conditions, test frequencies, and channel bandwidths based on E-UTRA bands specified in Table 4.7-1.

For Initial conditions as in clause 6.5A.2.1.7.4.1 in TS 38.521-2 [9], the following steps will be added to configure E-UTRA component:

- 2.1. The parameter settings for E-UTRA cell are set up according to TS 36.508 [11] clause 4.4.3.
- 3.1. The E-UTRA downlink signal level, uplink signal level are set according to Table 4.7-1 and propagation conditions are set according to Annex B.0 of TS 36.521-1 [10].

Step 6 of Initial conditions as in clause 6.5A.2.1.7.4.1 in TS 38.521-2 [9] is replaced by:

6. Ensure the UE is in state RRC\_CONNECTED with generic procedure parameters Connectivity EN-DC, DC bearer MCG and SCG, Connected without release On according to TS 38.508-1 [6] clause 4.5.

Same test procedure as in clause 6.5A.2.1.7.4.2 in TS 38.521-2 [9] with the following steps added for E-UTRA component:

- 1.1 On the E-UTRA carrier, disable periodic and aperiodic CQI reports, disable SRS, set *TimeAlignmentTimerDedicated* IE to infinity and disable downlink and uplink scheduling, all as per Table 4.7-1 under clause 4.7.

#### 6.5B.2.4.1\_1.7.5 Test Requirements

Same test requirement as in clause 6.5A.2.1.7.5 in TS 38.521-2 [9] for the *NR* carrier

#### 6.5B.2.4.1D Spectrum emissions mask for inter-band EN-DC including FR2 for UL MIMO

##### 6.5B.2.4.1D.1 Test purpose

Same test purpose as in clause 6.5D.2.1 in TS 38.521-2 [9] for the *NR* carrier.

##### 6.5B.2.4.1D.2 Test applicability

This test case applies to all types of E-UTRA UE release 15 and forward, supporting inter-band EN-DC FR2.

##### 6.5B.2.4.1D.3 Minimum conformance requirements

Same minimum conformance requirements as in clause 6.5D.2.1 in TS 38.521-2 [9] for the *NR* carrier.

No exception requirements applicable to *NR* or E-UTRA. LTE anchor agnostic approach is applied.

The normative reference for this measurement is TS 38.101-3 [4] clause 6.2B.2.4.

##### 6.5B.2.4.1D.4 Test description

Same test description as in clause [6.5D.2.1] in TS 38.521-2 [9] for the *NR* carrier with the following exception:

The initial test configurations for E-UTRA band consist of environmental conditions, test frequencies, and channel bandwidths based on E-UTRA bands specified in Table 4.6-1. For Initial conditions as in clause [6.5D.2.1] in TS 38.521-2 [9], the following steps will be added to configure E-UTRA component:

- 2.1. The parameter settings for E-UTRA cell are set up according to TS 36.508 [11] clause 4.4.3.
- 3.1. The E-UTRA downlink signal level, uplink signal level are set according to Table 4.7-1 and propagation conditions are set according to Annex B.0 of TS 36.521-1 [10].

[Step 6] of Initial conditions as in clause [6.5D.2.1] in TS 38.521-2 [9] is replaced by:

6. Ensure the UE is in state RRC\_CONNECTED with generic procedure parameters Connectivity EN-DC, DC bearer MCG and SCG according to TS 38.508 [6] clause 4.5.

#### 6.5B.2.4.1D.5 Test Requirement

Same test requirement as in clause 6.5D.2.1.5 of TS 38.521-2 [9] for the NR carrier.

#### 6.5B.2.4.3 Adjacent channel leakage ratio for Inter-band EN-DC including FR2 (1 NR CC)

**Editor's note: The following aspects are either missing or not yet determined:**

- The referred test case 6.5.2.3 in TS 38.521-2 [9] is incomplete for power class other than 1, 3, 5 and 6.-

#### 6.5B.2.4.3.1 Test purpose

Same test purpose as in clause 6.5.2.3.1 in TS 38.521-2 [9] for the NR carrier.

#### 6.5B.2.4.3.2 Test applicability

This test case applies to all types of E-UTRA UE release 15 and forward, supporting inter-band EN-DC including FR2 with 1 NR UL CC.

#### 6.5B.2.4.3.3 Minimum conformance requirements

Same minimum conformance requirements as in clause 6.5.2.3.3 in TS 38.521-2 [9] for the NR carrier.

No exception requirements applicable to NR or E-UTRA. LTE anchor agnostic approach is applied.

#### 6.5B.2.4.3.4 Test description

##### 6.5B.2.4.3.4.1 Initial conditions

Same test description as in clause 6.5.2.3.4 in TS 38.521-2 [9] for the NR carrier with the following exception:

The initial test configurations for E-UTRA band consist of environmental conditions, test frequencies, and channel bandwidths based on E-UTRA bands specified in Table 4.7-1. For Initial conditions as in clause 6.5.2.3.4.1 in TS 38.521-2 [9], the following steps will be added to configure E-UTRA component:

- 2.1. The parameter settings for E-UTRA cell are set up according to TS 36.508 [11] clause 4.4.3.
- 3.1. The E-UTRA downlink signal level, uplink signal level are set according to Table 4.7-1 and propagation conditions are set according to Annex B.0 of TS 36.521-1 [10].

Step 6 of Initial conditions as in clause 6.5.2.3.4.1 in TS 38.521-2 [9] is replaced by:

6. Ensure the UE is in state RRC\_CONNECTED with generic procedure parameters Connectivity EN-DC, DC bearer MCG and SCG, Connected without release On according to TS 38.508-1 [6] clause 4.5.

Same test procedure as in clause 6.5.2.3.4.2 in TS 38.521-2 [9] with the following steps added for E-UTRA component:

- 1.1 On the E-UTRA carrier, disable periodic and aperiodic CQI reports, disable SRS, set *TimeAlignmentTimerDedicated* IE to infinity and disable downlink and uplink scheduling, all as per Table 4.7-1 under clause 4.7.

#### 6.5B.2.4.3.5 Test requirement

Same test requirement as in clause 6.5.2.3.5 in TS 38.521-2 [9] for the NR carrier.

### 6.5B.2.4.3\_1 Adjacent channel leakage ratio for Inter-band EN-DC including FR2 (>1 NR CC)

Editor's note: Test applicability, Test Description in below sub-clauses requires updates to clarify number of E-UTRA carriers that will be configured during the test

#### 6.5B.2.4.3\_1.1 Adjacent channel leakage ratio for Inter-band EN-DC including FR2 (2 NR CCs)

Editor's note: The following aspects are either missing or not yet determined:

- The referred test case 6.5A.2.2.1 in TS 38.521-2 [9] is incomplete for intra-band contiguous CA supporting aggregated BW > 400MHz are TBD.

#### 6.5B.2.4.3\_1.1.1 Test purpose

Same test purpose as in clause 6.5.2.3.1 in TS 38.521-2 [9] for the NR carrier.

#### 6.5B.2.4.3\_1.1.2 Test applicability

This test case applies to all types of E-UTRA UE release 15 and forward, supporting inter-band EN-DC including FR2 with 2 NR UL CCs.

#### 6.5B.2.4.3\_1.1.3 Minimum conformance requirements

Same minimum conformance requirements as in clause 6.5.2.3.3 in TS 38.521-2 [9] for the NR carrier.

No exception requirements applicable to NR or E-UTRA. LTE anchor agnostic approach is applied.

The normative reference for this requirement is TS 38.101-3 [4] clause 6.4B.2.4.

#### 6.5B.2.4.3\_1.1.4 Test description

##### 6.5B.2.4.3\_1.1.4.1 Initial condition

Same test description as in clause 6.5A.2.2.1.4 in TS 38.521-2 [9] for the NR carrier with the following exception:

The initial test configurations for E-UTRA band consist of environmental conditions, test frequencies, and channel bandwidths based on E-UTRA bands specified in Table 4.7-1.

For Initial conditions as in clause 6.5A.2.2.1.4.1 in TS 38.521-2 [9], the following steps will be added to configure E-UTRA component:

- 2.1. The parameter settings for E-UTRA cell are set up according to TS 36.508 [11] clause 4.4.3.
- 3.1. The E-UTRA downlink signal level, uplink signal level are set according to Table 4.7-1 and propagation conditions are set according to Annex B.0 of TS 36.521-1 [10].

Step 6 of Initial conditions as in clause 6.5A.2.2.1.4.1 in TS 38.521-2 [9] is replaced by:

6. Ensure the UE is in state RRC\_CONNECTED with generic procedure parameters Connectivity EN-DC, DC bearer MCG and SCG, Connected without release On according to TS 38.508-1 [6] clause 4.5.

Same test procedure as in clause 6.5A.2.2.1.4.2 in TS 38.521-2 [9] with the following steps added for E-UTRA component:

- 1.1 On the E-UTRA carrier, disable periodic and aperiodic CQI reports, disable SRS, set *TimeAlignmentTimerDedicated* IE to infinity and disable downlink and uplink scheduling, all as per Table 4.7-1 under clause 4.7.

#### 6.5B.2.4.3\_1.1.5 Test Requirements

Same test requirement as in clause 6.5A.2.2.1.5 in TS 38.521-2 [9] for the NR carrier.

### 6.5B.2.4.3\_1.2 Adjacent channel leakage ratio for Inter-band EN-DC including FR2 (3 NR CCs)

**Editor's note: The following aspects are either missing or not yet determined:**

- The referred test case 6.5A.2.2.2 in TS 38.521-2 [9] is incomplete for intra-band contiguous CA supporting aggregated BW > 400MHz are TBD.

#### 6.5B.2.4.3\_1.2.1 Test purpose

Same test purpose as in clause 6.5.2.3.1 in TS 38.521-2 [9] for the NR carrier.

#### 6.5B.2.4.3\_1.2.2 Test applicability

This test case applies to all types of E-UTRA UE release 15 and forward, supporting inter-band EN-DC including FR2 with 3 NR UL CCs.

#### 6.5B.2.4.3\_1.2.3 Minimum conformance requirements

Same minimum conformance requirements as in clause 6.5.2.3.3 in TS 38.521-2 [9] for the NR carrier.

No exception requirements applicable to NR or E-UTRA. LTE anchor agnostic approach is applied.

The normative reference for this requirement is TS 38.101-3 [4] clause 6.4B.2.4.

#### 6.5B.2.4.3\_1.2.4 Test description

##### 6.5B.2.4.3\_1.2.4.1 Initial condition

Same test description as in clause 6.5A.2.2.2.4 in TS 38.521-2 [9] for the NR carrier with the following exception:

The initial test configurations for E-UTRA band consist of environmental conditions, test frequencies, and channel bandwidths based on E-UTRA bands specified in Table 4.7-1.

For Initial conditions as in clause 6.5A.2.2.2.4.1 in TS 38.521-2 [9], the following steps will be added to configure E-UTRA component:

- 2.1. The parameter settings for E-UTRA cell are set up according to TS 36.508 [11] clause 4.4.3.
- 3.1. The E-UTRA downlink signal level, uplink signal level are set according to Table 4.7-1 and propagation conditions are set according to Annex B.0 of TS 36.521-1 [10].

Step 6 of Initial conditions as in clause 6.5A.2.2.2.4.1 in TS 38.521-2 [9] is replaced by:

6. Ensure the UE is in state RRC\_CONNECTED with generic procedure parameters Connectivity EN-DC, DC bearer MCG and SCG, Connected without release On according to TS 38.508-1 [6] clause 4.5.

Same test procedure as in clause 6.5A.2.2.2.4.2 in TS 38.521-2 [9] with the following steps added for E-UTRA component:

- 1.1 On the E-UTRA carrier, disable periodic and aperiodic CQI reports, disable SRS, set *TimeAlignmentTimerDedicated* IE to infinity and disable downlink and uplink scheduling, all as per Table 4.7-1 under clause 4.7.

#### 6.5B.2.4.3\_1.2.5 Test Requirements

Same test requirement as in clause 6.5A.2.2.2.5 in TS 38.521-2 [9] for the NR carrier.

### 6.5B.2.4.3\_1.3 Adjacent channel leakage ratio for Inter-band EN-DC including FR2 (4 NR CCs)

**Editor's note: The following aspects are either missing or not yet determined:**

- The referred test case 6.5A.2.2.3 in TS 38.521-2 [9] is incomplete for intra-band contiguous CA supporting aggregated BW > 400MHz are TBD.



#### 6.5B.2.4.3\_1.3.1 Test purpose

Same test purpose as in clause 6.5.2.3.1 in TS 38.521-2 [9] for the NR carrier.

#### 6.5B.2.4.3\_1.3.2 Test applicability

This test case applies to all types of E-UTRA UE release 15 and forward, supporting inter-band EN-DC including FR2 with 4 NR UL CCs.

#### 6.5B.2.4.3\_1.3.3 Minimum conformance requirements

Same minimum conformance requirements as in clause 6.5.2.3.3 in TS 38.521-2 [9] for the NR carrier.

No exception requirements applicable to NR or E-UTRA. LTE anchor agnostic approach is applied.

The normative reference for this requirement is TS 38.101-3 [4] clause 6.4B.2.4.

#### 6.5B.2.4.3\_1.3.4 Test description

##### 6.5B.2.4.3\_1.3.4.1 Initial condition

Same test description as in clause 6.5A.2.2.3.4 in TS 38.521-2 [9] for the NR carrier with the following exception:

The initial test configurations for E-UTRA band consist of environmental conditions, test frequencies, and channel bandwidths based on E-UTRA bands specified in Table 4.7-1.

For Initial conditions as in clause 6.5A.2.2.3.4.1 in TS 38.521-2 [9], the following steps will be added to configure E-UTRA component:

- 2.1. The parameter settings for E-UTRA cell are set up according to TS 36.508 [11] clause 4.4.3.
- 3.1. The E-UTRA downlink signal level, uplink signal level are set according to Table 4.7-1 and propagation conditions are set according to Annex B.0 of TS 36.521-1 [10].

Step 6 of Initial conditions as in clause 6.5A.2.2.3.4.1 in TS 38.521-2 [9] is replaced by:

6. Ensure the UE is in state RRC\_CONNECTED with generic procedure parameters Connectivity EN-DC, DC bearer MCG and SCG, Connected without release On according to TS 38.508-1 [6] clause 4.5.

Same test procedure as in clause 6.5A.2.2.3.4.2 in TS 38.521-2 [9] with the following steps added for E-UTRA component:

- 1.1 On the E-UTRA carrier, disable periodic and aperiodic CQI reports, disable SRS, set *TimeAlignmentTimerDedicated* IE to infinity and disable downlink and uplink scheduling, all as per Table 4.7-1 under clause 4.7.

#### 6.5B.2.4.3\_1.3.5 Test Requirements

Same test requirement as in clause 6.5A.2.2.3.5 in TS 38.521-2 [9] for the NR carrier.

#### 6.5B.2.4.3\_1.4 Adjacent channel leakage ratio for Inter-band EN-DC including FR2 (5 NR CCs)

**Editor's note: The test case is incomplete. The following aspects are either missing or not yet determined:**

- The referred test case 6.5A.2.2.4 in TS 38.521-2 [9] is incomplete for intra-band contiguous CA supporting aggregated BW > 400MHz are TBD.
- Measurement Uncertainties and Test Tolerances is incomplete.

#### 6.5B.2.4.3\_1.4.1 Test purpose

Same test purpose as in clause 6.5.2.3.1 in TS 38.521-2 [9] for the NR carrier.

#### 6.5B.2.4.3\_1.4.2 Test applicability

This test case applies to all types of E-UTRA UE release 15 and forward, supporting inter-band EN-DC including FR2 with 5 NR UL CCs.

#### 6.5B.2.4.3\_1.4.3 Minimum conformance requirements

Same minimum conformance requirements as in clause 6.5.2.3.3 in TS 38.521-2 [9] for the NR carrier.

No exception requirements applicable to NR or LTE. LTE anchor agnostic approach is applied.

The normative reference for this requirement is TS 38.101-3 [4] clause 6.5B.2.4.

#### 6.5B.2.4.3\_1.4.4 Test description

##### 6.5B.2.4.3\_1.4.4.1 Initial condition

Same test description as in clause 6.5A.2.2.4.4 in TS 38.521-2 [9] for the *NR* carrier with the following exception:

The initial test configurations for E-UTRA band consist of environmental conditions, test frequencies, and channel bandwidths based on E-UTRA bands specified in Table 4.7-1.

For Initial conditions as in clause 6.5A.2.2.1.4.1 in TS 38.521-2 [9], the following steps will be added to configure E-UTRA component:

- 2.1. The parameter settings for E-UTRA cell are set up according to TS 36.508 [11] clause 4.4.3.
- 3.1. The E-UTRA downlink signal level, uplink signal level are set according to Table 4.7-1 and propagation conditions are set according to Annex B.0 of TS 36.521-1 [10].

Step 6 of Initial conditions as in clause 6.5A.2.2.1.4.1 in TS 38.521-2 [9] is replaced by:

6. Ensure the UE is in state RRC\_CONNECTED with generic procedure parameters Connectivity EN-DC, DC bearer MCG and SCG, Connected without release On according to TS 38.508-1 [6] clause 4.5.

Same test procedure as in clause 6.5A.2.2.1.4.2 in TS 38.521-2 [9] with the following steps added for E-UTRA component:

- 1.1 On the E-UTRA carrier, disable periodic and aperiodic CQI reports, disable SRS, set *TimeAlignmentTimerDedicated* IE to infinity and disable downlink and uplink scheduling, all as per Table 4.7-1 under clause 4.7.

#### 6.5B.2.4.3\_1.4.5 Test Requirements

Same test requirement as in clause 6.5A.2.2.4.5 in TS 38.521-2 [9] for the *NR* carrier.

#### 6.5B.2.4.3\_1.5 Adjacent channel leakage ratio for Inter-band EN-DC including FR2 (6 NR CCs)

**Editor's note: The test case is incomplete. The following aspects are either missing or not yet determined:**

- The referred test case 6.5A.2.2.4 in TS 38.521-2 [9] is incomplete for intra-band contiguous CA supporting aggregated BW > 400MHz are TBD.
- Measurement Uncertainties and Test Tolerances is incomplete.

#### 6.5B.2.4.3\_1.5.1 Test purpose

Same test purpose as in clause 6.5.2.3.1 in TS 38.521-2 [9] for the NR carrier.

#### 6.5B.2.4.3\_1.5.2 Test applicability

This test case applies to all types of E-UTRA UE release 15 and forward, supporting inter-band EN-DC including FR2 with 6 NR UL CCs.

### 6.5B.2.4.3\_1.5.3 Minimum conformance requirements

Same minimum conformance requirements as in clause 6.5.2.3.3 in TS 38.521-2 [9] for the NR carrier.

No exception requirements applicable to NR or LTE. LTE anchor agnostic approach is applied.

The normative reference for this requirement is TS 38.101-3 [4] clause 6.5B.2.4.

### 6.5B.2.4.3\_1.5.4 Test description

#### 6.5B.2.4.3\_1.5.4.1 Initial condition

Same test description as in clause 6.5A.2.2.5.4 in TS 38.521-2 [9] for the NR carrier with the following exception:

The initial test configurations for E-UTRA band consist of environmental conditions, test frequencies, and channel bandwidths based on E-UTRA bands specified in Table 4.7-1.

For Initial conditions as in clause 6.5A.2.2.1.4.1 in TS 38.521-2 [9], the following steps will be added to configure E-UTRA component:

- 2.1. The parameter settings for E-UTRA cell are set up according to TS 36.508 [11] clause 4.4.3.
- 3.1. The E-UTRA downlink signal level, uplink signal level are set according to Table 4.7-1 and propagation conditions are set according to Annex B.0 of TS 36.521-1 [10].

Step 6 of Initial conditions as in clause 6.5A.2.2.1.4.1 in TS 38.521-2 [9] is replaced by:

6. Ensure the UE is in state RRC\_CONNECTED with generic procedure parameters Connectivity EN-DC, DC bearer MCG and SCG, Connected without release On according to TS 38.508-1 [6] clause 4.5.

Same test procedure as in clause 6.5A.2.2.1.4.2 in TS 38.521-2 [9] with the following steps added for E-UTRA component:

- 1.1 On the E-UTRA carrier, disable periodic and aperiodic CQI reports, disable SRS, set *TimeAlignmentTimerDedicated* IE to infinity and disable downlink and uplink scheduling, all as per Table 4.7-1 under clause 4.7.

### 6.5B.2.4.3\_1.5.5 Test Requirements

Same test requirement as in clause 6.5A.2.2.5.5 in TS 38.521-2 [9] for the NR carrier.

### 6.5B.2.4.3\_1.6 Adjacent channel leakage ratio for Inter-band EN-DC including FR2 (7 NR CCs)

**Editor's note: The test case is incomplete. The following aspects are either missing or not yet determined:**

- The referred test case 6.5A.2.2.4 in TS 38.521-2 [9] is incomplete for intra-band contiguous CA supporting aggregated BW > 400MHz are TBD.
- Measurement Uncertainties and Test Tolerances is incomplete.

#### 6.5B.2.4.3\_1.6.1 Test purpose

Same test purpose as in clause 6.5.2.3.1 in TS 38.521-2 [9] for the NR carrier.

#### 6.5B.2.4.3\_1.6.2 Test applicability

This test case applies to all types of E-UTRA UE release 15 and forward, supporting inter-band EN-DC including FR2 with 7 NR UL CCs.

### 6.5B.2.4.3\_1.6.3 Minimum conformance requirements

Same minimum conformance requirements as in clause 6.5.2.3.3 in TS 38.521-2 [9] for the NR carrier.

No exception requirements applicable to NR or LTE. LTE anchor agnostic approach is applied.

The normative reference for this requirement is TS 38.101-3 [4] clause 6.5B.2.4.

#### 6.5B.2.4.3\_1.6.4 Test description

##### 6.5B.2.4.3\_1.6.4.1 Initial condition

Same test description as in clause 6.5A.2.2.6.4 in TS 38.521-2 [9] for the *NR* carrier with the following exception:

The initial test configurations for E-UTRA band consist of environmental conditions, test frequencies, and channel bandwidths based on E-UTRA bands specified in Table 4.7-1.

For Initial conditions as in clause 6.5A.2.2.1.4.1 in TS 38.521-2 [9], the following steps will be added to configure E-UTRA component:

- 2.1. The parameter settings for E-UTRA cell are set up according to TS 36.508 [11] clause 4.4.3.
- 3.1. The E-UTRA downlink signal level, uplink signal level are set according to Table 4.7-1 and propagation conditions are set according to Annex B.0 of TS 36.521-1 [10].

Step 6 of Initial conditions as in clause 6.5A.2.2.1.4.1 in TS 38.521-2 [9] is replaced by:

6. Ensure the UE is in state RRC\_CONNECTED with generic procedure parameters Connectivity EN-DC, DC bearer MCG and SCG, Connected without release On according to TS 38.508-1 [6] clause 4.5.

Same test procedure as in clause 6.5A.2.2.1.4.2 in TS 38.521-2 [9] with the following steps added for E-UTRA component:

- 1.1 On the E-UTRA carrier, disable periodic and aperiodic CQI reports, disable SRS, set *TimeAlignmentTimerDedicated* IE to infinity and disable downlink and uplink scheduling, all as per Table 4.7-1 under clause 4.7.

#### 6.5B.2.4.3\_1.6.5 Test Requirements

Same test requirement as in clause 6.5A.2.2.6.5 in TS 38.521-2 [9] for the *NR* carrier.

##### 6.5B.2.4.3\_1.7 Adjacent channel leakage ratio for Inter-band EN-DC including FR2 (8 NR CCs)

**Editor's note: The test case is incomplete. The following aspects are either missing or not yet determined:**

- The referred test case 6.5A.2.2.4 in TS 38.521-2 [9] is incomplete for intra-band contiguous CA supporting aggregated BW > 400MHz are TBD.
- Measurement Uncertainties and Test Tolerances is incomplete.

##### 6.5B.2.4.3\_1.7.1 Test purpose

Same test purpose as in clause 6.5.2.3.1 in TS 38.521-2 [9] for the *NR* carrier.

##### 6.5B.2.4.3\_1.7.2 Test applicability

This test case applies to all types of E-UTRA UE release 15 and forward, supporting inter-band EN-DC including FR2 with 8 NR UL CCs.

##### 6.5B.2.4.3\_1.7.3 Minimum conformance requirements

Same minimum conformance requirements as in clause 6.5.2.3.3 in TS 38.521-2 [9] for the *NR* carrier.

No exception requirements applicable to *NR* or *LTE*. *LTE* anchor agnostic approach is applied.

The normative reference for this requirement is TS 38.101-3 [4] clause 6.5B.2.4.

#### 6.5B.2.4.3\_1.7.4 Test description

##### 6.5B.2.4.3\_1.7.4.1 Initial condition

Same test description as in clause 6.5A.2.2.7.4 in TS 38.521-2 [9] for the *NR* carrier with the following exception:

The initial test configurations for E-UTRA band consist of environmental conditions, test frequencies, and channel bandwidths based on E-UTRA bands specified in Table 4.7-1.

For Initial conditions as in clause 6.5A.2.2.1.4.1 in TS 38.521-2 [9], the following steps will be added to configure E-UTRA component:

- 2.1. The parameter settings for E-UTRA cell are set up according to TS 36.508 [11] clause 4.4.3.
- 3.1. The E-UTRA downlink signal level, uplink signal level are set according to Table 4.7-1 and propagation conditions are set according to Annex B.0 of TS 36.521-1 [10].

Step 6 of Initial conditions as in clause 6.5A.2.2.1.4.1 in TS 38.521-2 [9] is replaced by:

6. Ensure the UE is in state RRC\_CONNECTED with generic procedure parameters Connectivity EN-DC, DC bearer MCG and SCG, Connected without release On according to TS 38.508-1 [6] clause 4.5.

Same test procedure as in clause 6.5A.2.2.1.4.2 in TS 38.521-2 [9] with the following steps added for E-UTRA component:

- 1.1 On the E-UTRA carrier, disable periodic and aperiodic CQI reports, disable SRS, set *TimeAlignmentTimerDedicated* IE to infinity and disable downlink and uplink scheduling, all as per Table 4.7-1 under clause 4.7.

#### 6.5B.2.4.3\_1.7.5 Test Requirements

Same test requirement as in clause 6.5A.2.2.7.5 in TS 38.521-2 [9] for the *NR* carrier.

#### 6.5B.2.4D.3 Adjacent channel leakage ratio for inter-band EN-DC including FR2 for UL MIMO

##### 6.5B.2.4D.3.1 Test purpose

Same test purpose as in clause 6.5D.2.2 in TS 38.521-2 [9] for the *NR* carrier.

##### 6.5B.2.4D.3.2 Test applicability

This test case applies to all types of E-UTRA UE release 15 and forward, supporting inter-band EN-DC FR2.

No exception requirements applicable to *NR* or E-UTRA. LTE anchor agnostic approach is applied.

##### 6.5B.2.4D.3.3 Minimum conformance requirements

Same minimum conformance requirements as in clause 6.5D.2.2 in TS 38.521-2 [9] for the *NR* carrier.

No exception requirements applicable to *NR* or LTE. LTE anchor agnostic approach is applied.

The normative reference for this measurement is TS 38.101-3 [4] clause 6.2B.2.4.

##### 6.5B.2.4D.3.4 Test description

Same test description as in clause 6.5D.2.2 in TS 38.521-2 [9] for the *NR* carrier with the following exception:

The initial test configurations for E-UTRA band consist of environmental conditions, test frequencies, and channel bandwidths based on E-UTRA bands specified in Table 4.6-1. For Initial conditions as in clause 6.5D.2.2 in TS 38.521-2 [9], the following steps will be added to configure E-UTRA component:

- 2.1. The parameter settings for E-UTRA cell are set up according to TS 36.508 [11] clause 4.4.3.

- 3.1. The E-UTRA downlink signal level, uplink signal level are set according to Table 4.7-1 and propagation conditions are set according to Annex B.0 of TS 36.521-1 [10].

[Step 6] of Initial conditions as in clause 6.5D.2.2 in TS 38.521-2 [9] is replaced by:

6. Ensure the UE is in state RRC\_CONNECTED with generic procedure parameters Connectivity EN-DC, DC bearer MCG and SCG according to TS 38.508 [6] clause 4.5.

Same test procedure as in clause 6.5D.2.2 in TS 38.521-2 [9] with the following steps added for E-UTRA component:

- 1.1 On the E-UTRA carrier, disable periodic and aperiodic CQI reports, disable SRS, set TimeAlignmentTimerDedicated IE to infinity and disable downlink and uplink scheduling, all as per Table 4.7-1 under clause 4.7.

#### 6.5B.2.4D.3.5 Test Requirement

Same test requirement as in clause 6.5D.2.2 of TS 38.521-2 [9] for the NR carrier.

### 6.5B.3 Spurious emissions for DC

Spurious emissions are emissions which are caused by unwanted transmitter effects such as harmonics emission, parasitic emissions, intermodulation products and frequency conversion products, but exclude out of band emissions. The spurious emission limits are specified in terms of general requirements in line with SM.329 [3] and NR operating band requirement to address UE co-existence.

To improve measurement accuracy, sensitivity and efficiency, the resolution bandwidth may be smaller than the measurement bandwidth. When the resolution bandwidth is smaller than the measurement bandwidth, the result should be integrated over the measurement bandwidth in order to obtain the equivalent noise bandwidth of the measurement bandwidth.

#### 6.5B.3.1 Spurious Emissions for intra-band contiguous EN-DC

##### 6.5B.3.1.1 General spurious emissions for intra-band contiguous EN-DC

###### 6.5B.3.1.1.1 Test purpose

To verify that UE transmitter does not cause unacceptable interference to other channels or other systems in terms of transmitter spurious emissions.

###### 6.5B.3.1.1.2 Test applicability

This test case applies to all types of E-UTRA UE release 15 and forward, supporting intra-band contiguous EN-DC.

###### 6.5B.3.1.1.3 Minimum conformance requirements

The general spurious emissions requirements specified in clause 6.6.3.1 of TS 36.101 [5] and clause 6.5.3.1 of TS 38.101-1 [2] apply beyond any frequencies for which the out-of-band emissions requirements in clause 6.5B.2.1 of TS 38.101-3 [4] apply.

The normative reference for this requirement is TS 38.101-3 [4] clause 6.5B.3.1.1.

No exception requirements applicable to NR or E-UTRA. LTE anchor agnostic approach is applied.

###### 6.5B.3.1.1.4 Test description

Same test description as in clause 6.5.3.1.4 in TS 38.521-1 [8] for the NR carrier with the following exceptions:

**Table 6.5B.3.1.1.4-1: Test Configuration Table**

Initial Conditions	
Test Frequencies as specified in TS 38.508-1 [6] clause 4.3.1 for different EN-DC bandwidth classes	Low range, Mid range, High range
Test EN-DC bandwidth combination as specified in Table 5.3B.1.2-1 across bandwidth combination sets supported by the UE	Lowest $N_{RB\_agg}$ , Highest $N_{RB\_agg}$ (NOTE 1)
NOTE 1: If the UE supports multiple CC Combinations in the EN-DC Configuration with the same $N_{RB\_agg}$ , only the combination with the highest $N_{RB\_SCG}$ is tested for Lowest $N_{RB\_agg}$ and Highest $N_{RB\_agg}$ , respectively.	

The initial test configurations for E-UTRA band consist of environmental conditions, test frequencies, and channel bandwidths are specified in Table 4.6-1 except for the parameters specified in Table 6.5B.3.1.1.4-1.

For Initial conditions as in clause 6.5.3.1.4 in TS 38.521-1 [8], the following steps will be added to configure E-UTRA component:

- 2.1 The parameter settings for the E-UTRA cell are set up according to TS 36.508 [11] clause 4.4.3 with E-UTRA channel bandwidth and test frequencies defined in Table 6.5B.3.1.1.4-1.
- 3.1. The E-UTRA downlink signal level, uplink signal level are set according to Table 4.6-1 and propagation conditions are set according to Annex B.0 of TS 36.521-1 [10].
- 4.1. The UL Reference Measurement channels are set according to Table 6.5B.3.1.1.4-1.

Step 6 of Initial conditions as in clause 6.5.3.1.4 in TS 38.521-1 [8] is replaced by the following three steps:

6. Ensure the UE is in state RRC\_CONNECTED with generic procedure parameters Connectivity EN-DC, DC bearer MCG and SCG, Connected without release *On* according to TS 38.508-1 [6] clause 4.5.
7. On the E-UTRA carrier, disable periodic and aperiodic CQI reports, disable SRS, set *TimeAlignmentTimerDedicated* IE to infinity and disable downlink and uplink scheduling, all as per Table 4.6-1 under clause 4.6.
8. When E-UTRA and NR bands are TDD, ensure the same uplink-downlink configuration by giving SCG a delay of 3 E-UTRA subframes, or by giving MCG a delay of 2 subframes.

Same test procedure as in clause 6.5.3.1.4 in TS 38.521-1 [8].

#### 6.5B.3.1.1.5 Test Requirement

The measured average power of spurious emission, derived in step 5, shall not exceed the described value in Table 6.5B.3.1.1.5-1.

Unless otherwise stated, the spurious emission limits apply for the frequency ranges that are more than  $\Delta f_{OOB}$  (MHz) from the edge of the channel bandwidth shown in Table 6.5.3.1.3-1 of TS 38.521-1 [8] for NR carrier, and Table 6.6.3.1.3-1 of TS 36.521-1[10] for E-UTRA carrier.

NOTE: For measurement conditions at the edge of each frequency range, the lowest frequency of the measurement position in each frequency range should be set at the lowest boundary of the frequency range plus MBW/2. The highest frequency of the measurement position in each frequency range should be set at the highest boundary of the frequency range minus MBW/2. MBW denotes the measurement bandwidth defined for the protected band.

**Table 6.5B.3.1.1.5-1: General spurious emissions test requirements**

Frequency Range	Maximum Level	Measurement bandwidth	NOTE
$9 \text{ kHz} \leq f < 150 \text{ kHz}$	-36 dBm	1 kHz	
$150 \text{ kHz} \leq f < 30 \text{ MHz}$	-36 dBm	10 kHz	
$30 \text{ MHz} \leq f < 1000 \text{ MHz}$	-36 dBm	100 kHz	
$1 \text{ GHz} \leq f < 12.75 \text{ GHz}$	-30 dBm	1 MHz	4
	-25 dBm	1 MHz	3
12.75 GHz $\leq f <$ 5th harmonic of the upper frequency edge of the UL operating band in GHz	-30 dBm	1 MHz	1
$12.75 \text{ GHz} < f < 26 \text{ GHz}$	-30 dBm	1 MHz	2
NOTE 1: Applies for Band that the upper frequency edge of the UL Band more than 2.69 GHz.			
NOTE 2: Applies for Band that the upper frequency edge of the UL Band more than 5.2 GHz.			
NOTE 3: Applies for Band n41, CA configurations including Band n41, and EN-DC configurations that include n41 specified in clause 5.2B of TS 36.101 [5] when NS_04 is signalled.			
NOTE 4: Does not apply for Band n41, CA configurations including Band n41, and EN-DC configurations that include n41 specified in subclause 5.2B of TS 38.101-3 [4] when NS_04 is signalled.			

## 6.5B.3.1.2 Spurious emission band UE co-existence for intra-band contiguous EN-DC

### 6.5B.3.1.2.1 Test purpose

To verify that UE transmitter does not cause unacceptable interference to other channels or other systems in terms of transmitter spurious emissions for band UE co-existence for intra-band contiguous EN-DC.

### 6.5B.3.1.2.2 Test applicability

This test case applies to all types of NR UE release 15 and forward supporting intra-band contiguous EN-DC.

### 6.5B.3.1.2.3 Minimum conformance requirements

This clause specifies the requirements for the specified EN-DC configurations for coexistence with protected bands.

The requirements in Tables 6.5B.3.1.2.3-1 and 6.5B.3.1.2.3-1a apply on each component carrier with all component carriers are active.



Table 6.5B.3.1.2.3-1: Requirements for intra band contiguous EN-DC

EN-DC Configuration	Spurious emission						
	Protected band	Frequency range (MHz)			Maximum Level (dBm)	MBW (MHz)	NOTE
DC_(n)71	E-UTRA Band 4, 5, 12, 13, 14, 17, 24, 26, 30, 48, 66	F <sub>DL_low</sub>	-	F <sub>DL_high</sub>	-50	1	
	E-UTRA Band 2, 25, 41, 70 NR Band n77 <sup>5</sup>	F <sub>DL_low</sub>	-	F <sub>DL_high</sub>	-50	1	2
	E-UTRA Band 29	F <sub>DL_low</sub>	-	F <sub>DL_high</sub>	-38	1	3
	E-UTRA Band 71	F <sub>DL_low</sub>	-	F <sub>DL_high</sub>	-50	1	3
DC_(n)41	E-UTRA Band 1, 2, 3, 4, 5, 8, 10, 11, 12, 13, 14, 17, 18, 19, 21, 24, 25, 26, 27, 28, 29, 30, 34, 39, 42, 44, 45, 48, 50, 51, 66, 70, 71, 73, 74 NR Band n77, n78	F <sub>DL_low</sub>	-	F <sub>DL_high</sub>	-50	1	
	Frequency range	1884.5	-	1915.7	-41	0.3	4
	NR Band n79	F <sub>DL_low</sub>	-	F <sub>DL_high</sub>	-50	1	2
NOTE 1: F <sub>DL_low</sub> and F <sub>DL_high</sub> refer to each frequency band specified in Table 5.5-1 in TS 36.101 [5] or in Table 5.2-1 in TS 38.101-1 [2].							
NOTE 2: As exceptions, measurements with a level up to the applicable requirements defined in Table 6.6.3.1-2 in TS 36.101 [5] and Table 6.5.3.1-2 in TS 38.101-1 [2] are permitted for each assigned carrier used in the measurement due to 2 <sup>nd</sup> , 3 <sup>rd</sup> , 4 <sup>th</sup> or 5 <sup>th</sup> harmonic spurious emissions. Due to spreading of the harmonic emission the exception is also allowed for the first 1 MHz frequency range immediately outside the harmonic emission on both sides of the harmonic emission. This results in an overall exception interval centred at the harmonic emission of (2MHz + N x L <sub>CRB</sub> x 180kHz), where N is 2, 3, 4, 5 for the 2 <sup>nd</sup> , 3 <sup>rd</sup> , 4 <sup>th</sup> or 5 <sup>th</sup> harmonic respectively. The exception is allowed if the measurement bandwidth (MBW) totally or partially overlaps the overall exception interval.							
NOTE 3: These requirements also apply for the frequency ranges that are less than F <sub>OOB</sub> (MHz) in Table 6.6.3.1-1, Table 6.6.3.1A-1 in TS 36.101 [5] or in Table 6.5.3.1-1 in TS 38.101-1 [2] from the edge of the channel bandwidth.							
NOTE 4: Applicable when co-existence with PHS system operating in 1884.5 - 1915.7 MHz.							
NOTE 5: Only applies to NR UE release 16 and forward supporting intra-band contiguous EN-DC.							

Table 6.5B.3.1.2.3-1a: Requirements for intra band contiguous EN-DC in Rel-18

EN-DC Configuration	Spurious emission						
	Protected band	Frequency range (MHz)			Maximum Level (dBm)	MBW (MHz)	NOTE
DC_(n)71	E-UTRA Band 4, 5, 12, 13, 14, 17, 24, 26, 30, 48, 54 66	F <sub>DL_low</sub>	-	F <sub>DL_high</sub>	-50	1	
	E-UTRA Band 2, 25, 41, 70 NR Band n77 <sup>5</sup>	F <sub>DL_low</sub>	-	F <sub>DL_high</sub>	-50	1	2
	E-UTRA Band 29	F <sub>DL_low</sub>	-	F <sub>DL_high</sub>	-38	1	3
	E-UTRA Band 71	F <sub>DL_low</sub>	-	F <sub>DL_high</sub>	-50	1	3
DC_(n)41	E-UTRA Band 1, 2, 3, 4, 5, 8, 10, 11, 12, 13, 14, 17, 18, 19, 21, 24, 25, 26, 27, 28, 29, 30, 34, 39, 42, 44, 45, 48, 50, 51, 54 66, 70, 71, 73, 74 NR Band n77, n78	F <sub>DL_low</sub>	-	F <sub>DL_high</sub>	-50	1	
	Frequency range	1884.5	-	1915.7	-41	0.3	4
	NR Band n79	F <sub>DL_low</sub>	-	F <sub>DL_high</sub>	-50	1	2
NOTE 1: F <sub>DL_low</sub> and F <sub>DL_high</sub> refer to each frequency band specified in Table 5.5-1 in TS 36.101 [5] or in Table 5.2-1 in TS 38.101-1 [2].							
NOTE 2: As exceptions, measurements with a level up to the applicable requirements defined in Table 6.6.3.1-2 in TS 36.101 [5] and Table 6.5.3.1-2 in TS 38.101-1 [2] are permitted for each assigned carrier used in the measurement due to 2 <sup>nd</sup> , 3 <sup>rd</sup> , 4 <sup>th</sup> or 5 <sup>th</sup> harmonic spurious emissions. Due to spreading of the harmonic emission the exception is also allowed for the first 1 MHz frequency range immediately outside the harmonic emission on both sides of the harmonic emission. This results in an overall exception interval centred at the harmonic emission of (2MHz + N x L <sub>CRB</sub> x 180kHz), where N is 2, 3, 4, 5 for the 2 <sup>nd</sup> , 3 <sup>rd</sup> , 4 <sup>th</sup> or 5 <sup>th</sup> harmonic respectively. The exception is allowed if the measurement bandwidth (MBW) totally or partially overlaps the overall exception interval.							
NOTE 3: These requirements also apply for the frequency ranges that are less than F <sub>OOB</sub> (MHz) in Table 6.6.3.1-1, Table 6.6.3.1A-1 in TS 36.101 [5] or in Table 6.5.3.1-1 in TS 38.101-1 [2] from the edge of the channel bandwidth.							
NOTE 4: Applicable when co-existence with PHS system operating in 1884.5 - 1915.7 MHz.							
NOTE 5: Only applies to NR UE release 16 and forward supporting intra-band contiguous EN-DC.							

NOTE: To simplify the above Table, E-UTRA band numbers are listed for bands which are specified only for E-UTRA operation or both E-UTRA and NR operation. NR band numbers are listed for bands which are specified only for NR operation.

The normative reference for this requirement is TS 38.101-3 [4] clause 6.5B.3.1.2.

Exception requirements for both NR and E-UTRA are defined for this test and therefore LTE anchor agnostic approach is not applied. E-UTRA test point analysis is included, and E-UTRA measurements are performed.

#### 6.5B.3.1.2.4 Test description

#### 6.5B.3.1.2.4.1 Initial conditions

Initial conditions are a set of test configurations the UE needs to be tested in and the steps for the SS to take with the UE to reach the correct measurement state.

The initial test configurations consist of environmental conditions, test frequencies and channel bandwidths based on EN-DC operating bands specified in clause 5.5B.2, and the channel bandwidth combination for E-UTRA and NR component carriers shall follow the value specified in Table 5.3B.1.2-1. All these configurations shall be tested with applicable test parameters for each EN-DC configuration specified in clause 5.3B.1.2 and are shown in Table 6.5B.3.1.2.4.1-1. The details of the uplink reference measurement channels (RMCs) are specified in Annex A, clause A.2.2 for E-UTRA RMC for TDD, TS 36.521-1 [10] Annex A, clause A.2.2 for E-UTRA RMC for FDD, and TS 38.521-1 [8] Annex A, clause A.2 for NR RMC. Configurations of PDSCH and PDCCH before measurement are specified in TS 36.521-1 [10] Annex C.2 and in TS 38.521-1 [8] Annex C.2 for E-UTRA CG and NR CG respectively.

**Table 6.5B.3.1.2.4.1-1: Test configuration table**

Initial Conditions					
Test Environment as specified in TS 38.508-1 [6] clause 4.1		Normal			
Test Frequencies as specified in TS 38.508-1 [6] clause 4.3.1		Low range, High range			
Test EN-DC bandwidth combination as specified in Table 5.3B.1.2-1		Lowest and Highest $N_{RB\_agg}$ (NOTE 3)			
Test SCS for the NR cell as specified in TS 38.521-1 [8] Table 5.3.5-1		Lowest SCS per Channel Bandwidth			
<b>Test Parameters</b>					
Test ID	Downlink Configuration	EN-DC Uplink Configuration			
		E-UTRA Cell		NR Cell	
		Modulation	RB allocation (NOTE 2)	Modulation	RB allocation (NOTE 1)
1	N/A for Spurious emission.	QPSK	Outer_1RB_Left	CP-OFDM QPSK	Edge_1RB_Right
2		QPSK	Outer_Full	CP-OFDM QPSK	Outer_Full
NOTE 1: The specific configuration of each RB allocation is defined in Table 6.1-1 in TS 38.521-1 [8].					
NOTE 2: Outer_Full defined as the transmission bandwidth configuration $N_{RB}$ per channel bandwidth for the E-UTRA component as indicated in TS 36.521-1 [10] Table 5.4.2-1. Outer_1RB_Left defined as 1 RB allocated at the left edge of the E-UTRA component. Outer_1RB_Right defined as 1 RB allocated at the right edge of the E-UTRA component.					
NOTE 3: If the UE supports multiple CC Combinations in the EN-DC Configuration with the same aggregated channel BW, only the combination with the highest NR BW is tested.					
NOTE 4: The test configuration applies to intra-band contiguous EN-DC indicating support of dual simultaneous UL as defined in clause 5.5B.2.					

1. Connect the SS to the UE antenna connectors as shown in TS 38.508-1 [6] Annex A, Figure A.3.1.1.1 for TE diagram and clause A.3.2.1 for UE diagram.
2. The parameter settings for the E-UTRA cell are set up according to TS 36.508 [11] clause 4.4.3, and the parameter settings for the NR cell are set up according to TS 38.508-1 [6] clause 4.4.3.
3. E-UTRA downlink signals are initially set up according to Annex C0, C.1 and C.3.0, and uplink signals according to Annex H.1 and H.3.0 of TS 36.521-1 [10].
4. NR downlink signals are initially set up according to Annex C.0, C.1 and C.2, and uplink signals according to Annex G.0, G.1, G.2, G.3.0 of TS 38.521-1 [8].
5. The UL Reference Measurement channels are set for E-UTRA CG and NR CG, respectively.
6. Propagation conditions are set according to TS 36.521-1 [10] Annex B.0 and TS 38.521-1 [8] Annex B.0 for E-UTRA CG and NR CG, respectively.
7. Ensure the UE is in state RRC\_CONNECTED with generic procedure parameters Connectivity EN-DC, DC bearer MCG and SCG, Connected without release *On* according to TS 38.508-1 [6] clause 4.5. Message contents are defined in clause 6.5B.3.1.2.4.3.
8. When E-UTRA and NR bands are TDD, ensure the same uplink-downlink configuration by giving SCG a delay of 3 E-UTRA subframes, or by giving MCG a delay of 2 subframes.

#### 6.5B.3.1.2.4.2 Test Procedure

1. E-UTRA SS sends uplink scheduling information for each UL HARQ process via PDCCH DCI format 0 for C\_RNTI to schedule the UL RMC according to Table 6.5B.3.1.2.4.1-1. Since the UE has no payload data to send, the UE transmits uplink MAC padding bits on the UL RMC.
2. NR SS sends uplink scheduling information for each UL HARQ process via PDCCH DCI format 0\_1 for C\_RNTI to schedule the UL RMC according to Table 6.5B.3.1.2.4.1-1. Since the UE has no payload data to send, the UE transmits uplink MAC padding bits on the UL RMC.

3. Both NR and E-UTRA SS send continuously uplink power control "up" commands in the uplink scheduling information to the UE until the UE transmits at  $P_{UMAX}$  level; allow at least 200 ms starting from the first TPC command in this step for the UE to reach  $P_{UMAX}$  level.
4. Measure the power of the transmitted signal with a measurement filter of bandwidths according to Table 6.5B.3.1.2.3-1. The centre frequency of the filter shall be stepped in contiguous steps according to Table 6.5B.3.1.2.3-1. The measured power shall be verified for each step. The measurement period shall capture the active time slots. During measurement the spectrum analyser shall be set to 'Detector' = RMS. If the sweep count is higher than one, the trace mode shall be average.

#### 6.5B.3.1.2.4.3 Message Contents

Message contents are according to TS 36.508 [11] clause 4.6 and TS 38.508-1 [6] clause 4.6.1 with the following exceptions:

**Table 6.5B.3.1.2.4.3-1: RRCConnectionReconfiguration: nr-Config-r15**

Derivation Path: TS 36.508 [11], Table 4.6.1-8			
Information Element	Value/remark	Comment	Condition
p-MaxEUTRA-r15	23		Power Class 2 UE
	20		Power Class 3 UE

**Table 6.5B.3.1.2.4.3-2: PhysicalCellGroupConfig**

Derivation Path: TS 38.508-1 [6] Table 4.6.3-106			
Information Element	Value/remark	Comment	Condition
p-NR-FR1	23		Power Class 2 UE
	20		Power Class 3 UE

**Table 6.5B.3.1.2.4.3-3: SystemInformationBlockType1: tdd-Config if operating on TDD band**

Derivation Path: TS 36.508 [11], Table 4.6.3-23			
Information Element	Value/remark	Comment	Condition
TDD-Config-DEFAULT ::= SEQUENCE {		Operating on TDD band	
subframeAssignment	sa2		
specialSubframePatterns	ssp7		
}			

#### 6.5B.3.1.2.5 Test Requirement

Test requirements for Spurious Emissions UE Co-existence for intra-band contiguous EN-DC are the same as the minimum requirements described in clause 6.5B.3.1.2.3 minimum requirements and are not repeated in this clause.

The requirements for the UE are release specific and can be found in Tables 6.5B.3.1.2.3-1 to 6.5B.3.1.2.3-1a. If the UE support a band, which is not defined in the table corresponding UE's release, the requirements for this band are taken from the table of earliest release where requirements for this band are defined.

### 6.5B.3.2 Spurious Emissions for intra-band non-contiguous EN-DC

#### 6.5B.3.2.1 General spurious emissions for Intra-band non-contiguous EN-DC

##### 6.5B.3.2.1.1 Test purpose

To verify that UE transmitter does not cause unacceptable interference to other channels or other systems in terms of transmitter spurious emissions.

## 6.5B.3.2.1.2 Test applicability

This test case applies to all types of E-UTRA UE release 15 and forward supporting intra-band non-contiguous EN-DC.

## 6.5B.3.2.1.3 Minimum conformance requirements

The general spurious emissions requirements specified in clause 6.6.3.1 of TS 36.521-1 [10] and clause 6.5.3.1 of TS 38.521-1 [8] apply beyond any frequencies for which the out-of-band emissions requirements in clause 6.5B.2.2 of TS 38.101-3 [4] apply. If for some frequency an individual CC spurious emission requirement overlaps with the general spectrum emission mask or the bandwidth of another CC then it does not apply.

The normative reference for this requirement is TS 38.101-3 [4] clause 6.5B.3.2.1.

No exception requirements applicable to NR or E-UTRA. LTE anchor agnostic approach is applied.

## 6.5B.3.2.1.4 Test description

Same test description as in clause 6.5.3.1.4 in TS 38.521-1 [8] for the NR carrier with the following exceptions:

**Table 6.5B.3.2.1.4-1: Test Configuration Table**

Initial Conditions	
Test Frequencies as specified in TS 38.508-1 [6] clause 4.3.1 for different EN-DC bandwidth classes	Low with maxWgap High with maxWgap
Test EN-DC bandwidth combination as specified in Table 5.3B.1.3-1 across bandwidth combination sets supported by the UE	Lowest $N_{RB\_agg}$ , Highest $N_{RB\_agg}$ (NOTE 1)
NOTE 1: If the UE supports multiple CC Combinations in the EN-DC Configuration with the same $N_{RB\_agg}$ , only the combination with the highest $N_{RB\_SCG}$ is tested for Lowest $N_{RB\_agg}$ and Highest $N_{RB\_agg}$ , respectively.	

The initial test configurations for E-UTRA band consist of environmental conditions, test frequencies, and channel bandwidths are specified in Table 4.6-1 except for the parameters specified in Table 6.5B.3.2.1.4-1.

For Initial conditions as in clause 6.5.3.1.4 in TS 38.521-1 [8], the following steps will be added to configure E-UTRA component:

- 2.1. The parameter settings for the E-UTRA cell are set up according to TS 36.508 [11] clause 4.4.3 with E-UTRA channel bandwidth and test frequencies defined in Table 6.5B.3.2.1.4-1.
- 3.1. The E-UTRA downlink signal level, uplink signal level are set according to Table 4.6-1 and propagation conditions are set according to Annex B.0 of TS 36.521-1 [10].

Step 6 of Initial conditions as in clause 6.5.3.1.4.1 in TS 38.521-1 [8] is replaced by the following three steps:

6. Ensure the UE is in state RRC\_CONNECTED with generic procedure parameters Connectivity EN-DC, DC bearer MCG and SCG, Connected without release *On* according to TS 38.508-1 [6] clause 4.5.
7. On the E-UTRA carrier, disable periodic and aperiodic CQI reports, disable SRS, set *TimeAlignmentTimerDedicated* IE to infinity and disable downlink and uplink scheduling, all as per Table 4.6-1 under clause 4.6.
8. When E-UTRA and NR bands are TDD, ensure the same uplink-downlink configuration by giving SCG a delay of 3 E-UTRA subframes, or by giving MCG a delay of 2 subframes.

Same test procedure as in clause 6.5.3.1.4.2 in TS 38.521-1 [8].

## 6.5B.3.2.1.5 Test Requirement

Same test requirement as in clause 6.5B.3.1.1.5.

6.5B.3.2.2 Spurious emission band UE co-existence for intra-band non-contiguous EN-DC

6.5B.3.2.2.1 Test purpose

To verify that UE transmitter does not cause unacceptable interference to other channels or other systems in terms of transmitter spurious emissions for band UE co-existence for intra-band non-contiguous EN-DC.

6.5B.3.2.2.2 Test applicability

This test case applies to all types of E-UTRA UE release 15 and forward supporting intra-band non-contiguous EN-DC.

6.5B.3.2.2.3 Minimum conformance requirements

This clause specifies the requirements for the specified EN-DC configurations for co-existence with protected bands.

The requirements in Tables 6.5B.3.2.2.3-1 and 6.5B.3.2.2.3-1a apply with all component carriers are active.

**Table 6.5B.3.2.2.3-1: Requirements for intra-band non-contiguous EN-DC**

EN-DC Configuration	Spurious emission						
	Protected band	Frequency range (MHz)			Maximum Level (dBm)	MBW (MHz)	NOTE
...							
DC_41A_n41A	E-UTRA Band 1, 2, 3, 4, 5, 8, 10, 11, 12, 13, 14, 17, 18, 19, 21, 24, 25, 26, 27, 28, 29, 34, 39, 42, 44, 45, 48, 50, 51, 66, 70, 71, 73, 74 NR Band n77, n78 and n79	F <sub>DL_low</sub>	-	F <sub>DL_high</sub>	-50	1	
	Frequency range	1884.5	-	1915.7	-41	0.3	3
	E-UTRA Band 30, 40	F <sub>DL_low</sub>	-	F <sub>DL_high</sub>	-40	1	
...							
<p>NOTE 1: F<sub>DL_low</sub> and F<sub>DL_high</sub> refer to each E-UTRA frequency band specified in Table 5.5-1 in TS 36.101 [5] or in Table 5.2-1 in TS 38.101-1 [2].</p> <p>NOTE 2: As exceptions, measurements with a level up to the applicable requirements defined in Table 6.6.3.1-2 in TS 36.101 [5] and Table 6.5.3.1-2 in TS 38.101-1 [2] are permitted for each assigned carrier used in the measurement due to 2<sup>nd</sup>, 3<sup>rd</sup>, 4<sup>th</sup>, or 5<sup>th</sup> harmonic spurious emissions. Due to spreading of the harmonic emission the exception is also allowed for the first 1 MHz frequency range immediately outside the harmonic emission on both sides of the harmonic emission. This results in an overall exception interval centred at the harmonic emission of (2MHz + N x L<sub>CRB</sub> x 180kHz), where N is 2, 3, 4, 5 for the 2<sup>nd</sup>, 3<sup>rd</sup>, 4<sup>th</sup> or 5<sup>th</sup> harmonic respectively. The exception is allowed if the measurement bandwidth (MBW) totally or partially overlaps the overall exception interval.</p> <p>NOTE 3: Applicable when co-existence with PHS system operating in 1884.5 - 1915.7 MHz.</p>							

Table 6.5B.3.2.2.3-1a: Requirements for intra-band non-contiguous EN-DC in Rel-18

EN-DC Configuration	Spurious emission						
	Protected band	Frequency range (MHz)		Maximum Level (dBm)	MBW (MHz)	NOTE	
...							
DC_41A_n41A	E-UTRA Band 1, 2, 3, 4, 5, 8, 10, 11, 12, 13, 14, 17, 18, 19, 21, 24, 25, 26, 27, 28, 29, 34, 39, 42, 44, 45, 48, 50, 51, 54, 66, 70, 71, 73, 74 NR Band n77, n78 and n79	F <sub>DL_low</sub>	-	F <sub>DL_high</sub>	-50	1	
	Frequency range	1884.5	-	1915.7	-41	0.3	3
	E-UTRA Band 30, 40	F <sub>DL_low</sub>	-	F <sub>DL_high</sub>	-40	1	
...							
NOTE 1: F <sub>DL_low</sub> and F <sub>DL_high</sub> refer to each E-UTRA frequency band specified in Table 5.5-1 in TS 36.101 [5] or in Table 5.2-1 in TS 38.101-1 [2].							
NOTE 2: As exceptions, measurements with a level up to the applicable requirements defined in Table 6.6.3.1-2 in TS 36.101 [5] and Table 6.5.3.1-2 in TS 38.101-1 [2] are permitted for each assigned carrier used in the measurement due to 2 <sup>nd</sup> , 3 <sup>rd</sup> , 4 <sup>th</sup> , or 5 <sup>th</sup> harmonic spurious emissions. Due to spreading of the harmonic emission the exception is also allowed for the first 1 MHz frequency range immediately outside the harmonic emission on both sides of the harmonic emission. This results in an overall exception interval centred at the harmonic emission of (2MHz + N x L <sub>CRB</sub> x 180kHz), where N is 2, 3, 4, 5 for the 2 <sup>nd</sup> , 3 <sup>rd</sup> , 4 <sup>th</sup> or 5 <sup>th</sup> harmonic respectively. The exception is allowed if the measurement bandwidth (MBW) totally or partially overlaps the overall exception interval.							
NOTE 3: Applicable when co-existence with PHS system operating in 1884.5 - 1915.7 MHz.							

NOTE: To simplify the above Table, E-UTRA band numbers are listed for bands which are specified only for EUTRA operation or both E-UTRA and NR operation. NR band numbers are listed for bands which are specified only for NR operation.

The normative reference for this requirement is TS 38.101-3 [4] clause 6.5B.3.2.2.

Exception requirements are applicable for NR but not for E-UTRA within this test. LTE anchor agnostic approach is not applied. E-UTRA configuration is included.

#### 6.5B.3.2.2.4 Test description

##### 6.5B.3.2.2.4.1 Initial conditions

Initial conditions are a set of test configurations the UE needs to be tested in and the steps for the SS to take with the UE to reach the correct measurement state.

The initial test configurations consist of environmental conditions, test frequencies and channel bandwidths based on EN-DC operating bands specified in clause 5.5B.3, and the channel bandwidth combination for E-UTRA and NR component carriers shall follow the value specified in Table 5.3B.1.3-1. All these configurations shall be tested with applicable test parameters for each EN-DC configuration specified in clause 5.3B.1.3 and are shown in Table 6.5B.3.2.2.4.1-1. The details of the uplink reference measurement channels (RMCs) are specified in Annex A, clause A.2.2 for E-UTRA RMC for TDD, TS 36.521-1 [10] Annex A, clause A.2.2 for E-UTRA RMC for FDD, and TS 38.521-1 [8] Annex A, clause A.2 for NR RMC. Configurations of PDSCH and PDCCH before measurement are specified in TS 36.521-1 [10] Annex C.2 and in TS 38.521-1 [8] Annex C.2 for E-UTRA CG and NR CG respectively.

Table 6.5B.3.2.2.4.1-1: Test configuration table

Initial Conditions					
Test Environment as specified in TS 38.508-1 [6] clause 4.1		Normal			
Test Frequencies as specified in TS 38.508-1 [6] clause 4.3.1		Low with maxWgap High with maxWgap			
Test EN-DC bandwidth combination as specified in Table 5.3B.1.3-1		Lowest and Highest $N_{RB\_agg}$ (NOTE 3)			
Test SCS for the NR cell as specified in TS 38.521-1 [8] Table 5.3.5-1		Lowest SCS per Channel Bandwidth			
Test Parameters					
Test ID	Downlink Configuration	EN-DC Uplink Configuration			
		E-UTRA Cell		NR Cell	
		Modulation	RB allocation (NOTE 2)	Modulation	RB allocation (NOTE 1)
1	N/A for Spurious emission.	QPSK	Outer_1RB_Left	CP-OFDM QPSK	Edge_1RB_Right
2		QPSK	Outer_Full	CP-OFDM QPSK	Outer_Full
NOTE 1: The specific configuration of each RB allocation is defined in Table 6.1-1 in TS 38.521-1 [8].					
NOTE 2: Outer_Full defined as the transmission bandwidth configuration $N_{RB}$ per channel bandwidth for the E-UTRA component as indicated in TS 36.521-1 [10] Table 5.4.2-1. Outer_1RB_Left defined as 1 RB allocated at the left edge of the E-UTRA component. Outer_1RB_Right defined as 1 RB allocated at the right edge of the E-UTRA component.					
NOTE 3: If the UE supports multiple CC Combinations in the EN-DC Configuration with the same aggregated channel BW, only the combination with the highest NR BW is tested.					
NOTE 4: The test configuration applies to intra-band non-contiguous EN-DC indicating support of dual simultaneous UL as defined in clause 5.5B.3.					

1. Connect the SS to the UE antenna connectors as shown in TS 38.508-1 [6] Annex A, Figure A.3.1.1.1 for SS diagram and clause A.3.2.1 for UE diagram.
2. The parameter settings for the cell are set up according to TS 38.508-1 [6] clause 4.4.3.
3. E-UTRA downlink signals are initially set up according to Annex C.0, C.1 and C.3.0, and uplink signals according to Annex H.1 and H.3.0 of TS 36.521-1 [10].
4. NR downlink signals are initially set up according to Annex C.0, C.1 and C.2, and uplink signals according to Annex G.0, G.1, G.2, G.3.0 of TS 38.521-1 [8].
5. The UL Reference Measurement channels are set for E-UTRA CG and NR CG respectively.
6. Propagation conditions are set according to TS 36.521-1 [10] Annex B and TS 38.521-1 [8] Annex B for E-UTRA link and NR link respectively.
7. Ensure the UE is in state RRC\_CONNECTED with generic procedure parameters Connectivity EN-DC, DC bearer MCG and SCG, Connected without release *On* according to TS 38.508-1 [6] clause 4.5. Message contents are defined in clause 6.5B.3.2.2.4.3.
8. When E-UTRA and NR bands are TDD, ensure the same uplink-downlink configuration by giving SCG a delay of 3 E-UTRA subframes, or by giving MCG a delay of 2 subframes.

#### 6.5B.3.2.2.4.2 Test Procedure

1. E-UTRA SS sends uplink scheduling information for each UL HARQ process via PDCCH DCI format 0 for C\_RNTI to schedule the UL RMC according to Table 6.5B.3.2.2.4.1-1. Since the UE has no payload data to send, the UE transmits uplink MAC padding bits on the UL RMC.
2. NR SS sends uplink scheduling information for each UL HARQ process via PDCCH DCI format 0\_1 for C\_RNTI to schedule the UL RMC according to Table 6.5B.3.2.2.4.1-1. Since the UE has no payload data to send, the UE transmits uplink MAC padding bits on the UL RMC.



3. Send continuously uplink power control "up" commands to the UE for both NR and E-UTRA carriers until the UE transmits at its  $P_{UMAX}$  level; allow at least 200 ms starting from the first TPC command in this step for the UE to reach  $P_{UMAX}$  level.
4. Measure the power of the transmitted signal with a measurement filter of bandwidths according to Table 6.5B.3.2.2.3-1. The centre frequency of the filter shall be stepped in contiguous steps according to the same table. The measured power shall be verified for each step. The measurement period shall capture the active time slots. During measurement the spectrum analyser shall be set to 'Detector' = RMS. If the sweep count is higher than one, the trace mode shall be average.

#### 6.5B.3.2.2.4.3 Message Contents

Message contents are according to TS 36.508 [11] clause 4.6 and TS 38.508-1 [6] clause 4.6.1 with the following exceptions.

**Table 6.5B.3.2.2.4.3-1: RRCConnectionReconfiguration: nr-Config-r15.**

Derivation Path: TS 36.508 [11], Table 4.6.1-8			
Information Element	Value/remark	Comment	Condition
p-MaxEUTRA-r15	23		Power Class 2 UE
	20		Power Class 3 UE

**Table 6.5B.3.2.2.4.3-2: PhysicalCellGroupConfig**

Derivation Path: TS 38.508-1 [6] Table 4.6.3-106			
Information Element	Value/remark	Comment	Condition
p-NR-FR1	23		Power Class 2 UE
	20		Power Class 3 UE

**Table 6.5B.3.2.2.4.3-3: SystemInformationBlockType1: tdd-Config if operating on TDD band**

Derivation Path: TS 36.508 [11], Table 4.6.3-23			
Information Element	Value/remark	Comment	Condition
TDD-Config-DEFAULT ::= SEQUENCE {		Operating on TDD band	
subframeAssignment	sa2		
specialSubframePatterns	ssp7		
}			

#### 6.5B.3.2.2.5 Test Requirement

Test requirements for Spurious Emissions UE Co-existence for intra-band non-contiguous EN-DC are the same as the minimum requirements described in clause 6.5B.3.2.2.3 and are not repeated in this clause.

The requirements for the UE are release specific and can be found in Tables 6.5B.3.2.2.3-1 to 6.5B.3.2.2.3-1a. If the UE support a band, which is not defined in the table corresponding UE's release, the requirements for this band are taken from the table of earliest release where requirements for this band are defined.

### 6.5B.3.3 Spurious Emissions for Inter-band EN-DC within FR1

#### 6.5B.3.3.1 General spurious emissions for Inter-band EN-DC within FR1

##### 6.5B.3.3.1.1 Test purpose

To verify that UE transmitter does not cause unacceptable interference to other channels or other systems in terms of transmitter spurious emissions.

#### 6.5B.3.3.1.2 Test applicability

This test case applies to all types of NR UE release 15 and forward supporting inter-band EN-DC.

#### 6.5B.3.3.1.3 Minimum conformance requirements

The general spurious emissions requirements specified in subclause 6.6.3.1 of TS 36.101 [5], subclause 6.5.3.1 of TS 38.101-1 [2] and TS 38.101-2 [3] apply for each component carrier. For the case of inter-band EN-DC with a single carrier per cell group, the general spurious emissions requirements also apply with both downlink carrier and both uplink carriers active. Limits on configured maximum output power for the uplink according to subclause 6.2B.4 apply. If for some frequency a spurious emission requirement of an individual component carrier overlaps with the spectrum emission mask or channel bandwidth of another component carrier then it does not apply.

**NOTE:** The general spurious emission requirements with both uplink carriers active are allowed to be verified for only a single inter-band EN-DC configuration per NR band. Furthermore, the requirements are allowed to be verified by measuring spurious emissions at the specific frequencies where second and third order intermodulation products generated by the two transmitted carriers can occur.

The normative reference for this requirement is TS 38.101-3 [4] clause 6.5B.3.3.1. Exception requirements applicable for both NR and LTE, therefore LTE anchor agnostic approach is not applied.

#### 6.5B.3.3.1.4 Test description

##### 6.5B.3.3.1.4.1 Initial condition

Initial conditions are a set of test configurations the UE needs to be tested in and the steps for the SS to take with the UE to reach the correct measurement state.

The initial test configurations consist of environmental conditions, test frequencies, DC configuration specified in Table 5.5B.4.1-1 and test channel bandwidths specified in TS 36.508 [11] clause 4.3.1 and TS 38.508-1 [6] clause 4.3.1, and sub-carrier spacing based on NR operating bands specified in TS 38.521-1 [8] clause 5.3. All of these configurations shall be tested with applicable test parameters for each EN-DC configuration, and are shown in Table 6.5B.3.3.1.4.1-1. The details of the uplink reference measurement channels (RMCs) are specified in Annex A, clause A.2.2 for E-UTRA RMC for TDD, TS 36.521-1 [10] Annex A, clause A.2.2 for E-UTRA RMC for FDD, and TS 38.521-1 [8] Annex A, clause A.2 for NR RMC. Configurations of PDSCH and PDCCH before measurement are specified in TS 36.521-1 [10] Annex C.2 and in TS 38.521-1 [8] Annex C.2 for E-UTRA CG and NR CG respectively.

Table 6.5B.3.3.1.4.1-1: Test configuration table

Initial Conditions					
Test Environment as specified in TS 38.508-1 [6] clause 4.1		Normal			
Test Frequencies as specified in TS 38.508-1 [6] clause 4.3.1		Low range for PCC and SCC High range for PCC and SCC			
Test EN-DC channel bandwidth as specified in TS 36.508 [11] clause 4.3.1 and TS 38.508-1 [6] clause 4.3.1		5 MHz for E-UTRA CC and Lowest for NR CC Highest for E-UTRA CC and Highest for NR CC			
Test SCS for the NR cell as specified in TS 38.521-1 [8] Table 5.3.5-1		Lowest SCS per Channel Bandwidth			
Test Parameters					
Test ID	Downlink Configuration	EN-DC Uplink Configuration			
		E-UTRA Cell		NR Cell	
		Modulation	RB allocation (NOTE 2)	Modulation	RB allocation (NOTE 1)
1	N/A for Spurious emission.	QPSK	Outer_1RB_Left	CP-OFDM QPSK	Edge_1RB_Left
2		QPSK	Outer_1RB_Right	CP-OFDM QPSK	Edge_1RB_Right
3		QPSK	Outer_Full	CP-OFDM QPSK	Outer_Full
NOTE 1: The specific configuration of each RB allocation is defined in Table 6.1-1 in TS 38.521-1 [8].					
NOTE 2: Outer_Full defined as the transmission bandwidth configuration $N_{RB}$ per channel bandwidth for the E-UTRA component as indicated in TS 36.521-1 [10] Table 5.4.2-1. Outer_1RB_Left defined as 1 RB allocated at the left edge of the E-UTRA component. Outer_1RB_Right defined as 1 RB allocated at the right edge of the E-UTRA component.					
NOTE 3: Only applicable to UEs not supporting UE capability <i>singleUL-Transmission</i> .					
NOTE 4: Only one EN-DC combination per FR1 band is tested for each EN-DC configuration as defined in clause 5.5B.4.					

1. Connect the SS to the UE antenna connectors as shown in TS 38.508-1 [6] Annex A, Figure A.3.1.1.1 for SS diagram and clause A.3.2.1 for UE diagram.
2. The parameter settings for the cell are set up according to TS 38.508-1 [6] clause 4.4.3.
3. E-UTRA downlink signals are initially set up according to Annex C.0, C.1 and C.3.0, and uplink signals according to Annex H.1 and H.3.0 of TS 36.521-1 [10].
4. NR downlink signals are initially set up according to Annex C.0, C.1 and C.2, and uplink signals according to Annex G.0, G.1, G.2, G.3.0 of TS 38.521-1 [8].
5. The UL Reference Measurement channels are set for E-UTRA CG and NR CG respectively.
6. Propagation conditions are set according to TS 36.521-1 [10] Annex B and TS 38.521-1 [8] Annex B for E-UTRA link and NR link respectively.
7. Ensure the UE is in state RRC\_CONNECTED with generic procedure parameters Connectivity EN-DC, DC bearer MCG and SCG, Connected without release *On* according to TS 38.508-1 [6] clause 4.5. Message contents are defined in clause 6.5B.3.3.1.4.3.
8. For both E-UTRA and NR UL uplink carriers active when both bands are TDD, ensure E-UTRA UL transmission overlaps with NR UL transmission in time by giving SCG a delay of 3 E-UTRA subframes, or by giving MCG a delay of 2 subframes.

#### 6.5B.3.3.1.4.2 Test procedure

1. E-UTRA SS sends uplink scheduling information for each UL HARQ process via PDCCH DCI format 0 for C\_RNTI to schedule the UL RMC according to Table 6.5B.3.3.1.4.1-1. Since the UE has no payload data to send, the UE transmits uplink MAC padding bits on the UL RMC.

2. NR SS sends uplink scheduling information for each UL HARQ process via PDCCH DCI format 0\_1 for C\_RNTI to schedule the UL RMC according to Table 6.5B.3.3.1.4.1-1. Since the UE has no payload data to send, the UE transmits uplink MAC padding bits on the UL RMC.
3. Send continuously uplink power control "up" commands to the UE for both NR and E-UTRA carriers until the UE transmits at its P<sub>UMAX</sub> level; allow at least 200 ms starting from the first TPC command in this step for the UE to reach P<sub>UMAX</sub> level.
4. Measure the power of the transmitted signal with a measurement filter of bandwidths according to Table 6.5B.3.3.1.5-1 (for EN-DC configurations listed in Table 6.5B.3.3.1.5-1) or Table 6.5.3.1.5-1 in TS 38.521-1 [8] (for EN-DC configurations not listed in Table 6.5B.3.3.1.5-1). The centre frequency of the filter shall be stepped in contiguous steps according to the same table. The measured power shall be verified for each step. The measurement period shall capture the active time slots. During measurement the spectrum analyser shall be set to 'Detector' = RMS. If the sweep count is higher than one, the trace mode shall be average.
5. For UE operating on EN-DC configuration with Band n41, redo the test for frequency range 1 GHz ≤ f < 12.75 GHz with the message content in step 7 of initial conditions with exceptions defined in Table 6.5B.3.3.1.4.3-4.

In addition to test configuration and test procedure above, UEs not tested under NR/5GC mode in the tested band need to be tested according to LTE anchor agnostic below for EN-DC configurations listed in Table 6.5B.3.3.1.5-1.

Same test description as in clause 6.5.3.1.4 in TS 38.521-1 [8] for the NR carrier with the following exceptions:

The initial test configurations for E-UTRA consist of test frequency based on E-UTRA operating band and test channel bandwidth as specified in Table 4.6-1.

For Initial conditions as in clause 6.5.3.1.4.1 in TS 38.521-1 [8], the following steps will be added to configure E-UTRA component:

- 2.1. The parameter settings for the cell are set up according to TS 36.508 [11] clause 4.4.3.
- 3.1. The E-UTRA downlink signal level, uplink signal level are set according to Table 4.6-1 and propagation conditions are set according to Annex B.0 of TS 36.521-1 [10].

Step 6 of Initial conditions as in clause 6.5.3.1.4.1 in TS 38.521-1 [8] is replaced by the following two steps:

6. Ensure the UE is in state RRC\_CONNECTED with generic procedure parameters Connectivity EN-DC, DC bearer MCG and SCG, Connected without release *On* according to TS 38.508 [6] clause 4.5.
7. On the E-UTRA carrier, disable periodic and aperiodic CQI reports, disable SRS, set *TimeAlignmentTimerDedicated* IE to infinity and disable downlink and uplink scheduling, all as per Table 4.6-1 under clause 4.6.

**6.5B.3.3.1.4.3 Message Contents**

Message contents are according to TS 36.508 [11] clause 4.6 and TS 38.508-1 [6] clause 4.6.1 with the following exceptions.

**Table 6.5B.3.3.1.4.3-1: SystemInformationBlockType1: tdd-Config if E-UTRA on TDD band**

Derivation Path: TS 36.508 [11], Table 4.6.3-23			
Information Element	Value/remark	Comment	Condition
TDD-Config-DEFAULT ::= SEQUENCE {		Operating on TDD band	
subframeAssignment	Sa2		
specialSubframePatterns	Ssp7		
}			

**Table 6.5B3.3.1.4.3-1a: Void**

**Table 6.5B.3.3.1.4.3-2: RRCConnectionReconfiguration: nr-Config-r15**

Derivation Path: TS 36.508 [11], Table 4.6.1-8			
Information Element	Value/remark	Comment	Condition
p-MaxEUTRA-r15	23		Power Class 2 UE AND simultaneous E-UTRA and NR transmission
	20		Power Class 3 UE AND simultaneous E-UTRA and NR transmission

**Table 6.5B.3.3.1.4.3-3: PhysicalCellGroupConfig**

Derivation Path: TS 38.508-1 [6] Table 4.6.3-106			
Information Element	Value/remark	Comment	Condition
p-NR-FR1	23		Power Class 2 UE AND simultaneous E-UTRA and NR transmission
	20		Power Class 3 UE AND simultaneous E-UTRA and NR transmission

Exception for step 5 in test procedure:

**Table 6.5B.3.3.1.4.3-4: Message contents**

Derivation Path: TS 38.508-1 [5], Table 4.6.3-1			
Information Element	Value/remark	Comment	Condition
additionalSpectrumEmission	1 (NS_04)		

#### 6.5B.3.3.1.5 Test Requirement

For EN-DC configurations listed in Table 6.5B.3.3.1.5-1, the corresponding test requirements of the same table apply and are required to be tested with both LTE and NR carriers active.

For EN-DC configurations not listed in Table 6.5B.3.3.1.5-1, the test requirements in Table 6.5.3.1.5-1 in TS 38.521-1 [8] shall apply and are required to be tested with both LTE and NR carriers active.

For EN-DC configurations listed in Table 6.5B.3.3.1.5-1 test requirements for NR carrier are the same as Table 6.5.3.1.5-1 in TS 38.521-1 [8] and are tested with anchor agnostic approach.

**Table 6.5B.3.3.1.5-1: General spurious emissions test requirements**

Frequency Range	Maximum Level	Measurement Bandwidth	Note
<b>Test requirements for DC_1A_n3A configuration</b>			
135 MHz ≤ f ≤ 270 MHz	-36 dBm	100 kHz	
1440 MHz ≤ f ≤ 1650 MHz 2055 MHz ≤ f ≤ 2250 MHz 3630 MHz ≤ f ≤ 3765 MHz 5340 MHz ≤ f ≤ 5745 MHz	-30 dBm	1 MHz	
<b>Test requirements for DC_1A_n5A configuration</b>			
222 MHz ≤ f ≤ 332 MHz	-36 dBm	100 kHz	
1071 MHz ≤ f ≤ 1156 MHz 2744 MHz ≤ f ≤ 2829 MHz 2991 MHz ≤ f ≤ 3136 MHz 3568 MHz ≤ f ≤ 3678 MHz 4664 MHz ≤ f ≤ 4809 MHz	-30 dBm	1 MHz	
<b>Test requirements for DC_1A_n7A configuration</b>			
520 MHz ≤ f ≤ 650 MHz	-36 dBm	100 kHz	
1270 MHz ≤ f ≤ 1460 MHz 3020 MHz ≤ f ≤ 3220 MHz 4420 MHz ≤ f ≤ 4550 MHz 6340 MHz ≤ f ≤ 6530 MHz 6920 MHz ≤ f ≤ 7120 MHz	-30 dBm	1 MHz	
<b>Test requirements for DC_1A_n8A configuration</b>			
90 MHz ≤ f ≤ 220 MHz	-36 dBm	100 kHz	
1005 MHz ≤ f ≤ 1100 MHz 2800 MHz ≤ f ≤ 2895 MHz 2925 MHz ≤ f ≤ 3080 MHz 3680 MHz ≤ f ≤ 3810 MHz 4720 MHz ≤ f ≤ 4875 MHz	-30 dBm	1 MHz	
<b>Test requirements for DC_1A_n28A configuration</b>			
424 MHz ≤ f ≤ 574 MHz	-36 dBm	100 kHz	
1172 MHz ≤ f ≤ 1277 MHz 2623 MHz ≤ f ≤ 2728 MHz 3092 MHz ≤ f ≤ 3257 MHz 3326 MHz ≤ f ≤ 3476 MHz 4543 MHz ≤ f ≤ 4708 MHz	-30 dBm	1 MHz	
<b>Test requirements for DC_1A_n41A configuration</b>			
516 MHz ≤ f ≤ 770 MHz	-36 dBm	100 kHz	
1150 MHz ≤ f ≤ 1464 MHz 3012 MHz ≤ f ≤ 3460 MHz 4416 MHz ≤ f ≤ 4670 MHz 6336 MHz ≤ f ≤ 6650 MHz 6912 MHz ≤ f ≤ 7360 MHz	-30 dBm	1 MHz	
<b>Test requirements for DC_1A_n77A Configuration</b>			
360 MHz ≤ f ≤ 660 MHz	-36 dBm	100 kHz	
1320 MHz ≤ f ≤ 2280 MHz 4620 MHz ≤ f ≤ 6480 MHz 7140 MHz ≤ f ≤ 8160 MHz 8520 MHz ≤ f ≤ 10380 MHz	-30 dBm	1 MHz	
<b>Test requirements for DC_1A_n78A Configuration</b>			
40 MHz ≤ f ≤ 660 MHz	-36 dBm	100 kHz	
1320 MHz ≤ f ≤ 1880 MHz 4620 MHz ≤ f ≤ 5780 MHz 7140 MHz ≤ f ≤ 7760 MHz 8520 MHz ≤ f ≤ 9580 MHz	-30 dBm	1 MHz	
<b>Test requirements for DC_1A_n79A Configuration</b>			
440 MHz ≤ f ≤ 1000 MHz	-36 dBm	100 kHz	
1000 MHz ≤ f ≤ 1160 MHz 2420 MHz ≤ f ≤ 3080 MHz 6320 MHz ≤ f ≤ 8080 MHz 8240 MHz ≤ f ≤ 8960 MHz 10720 MHz ≤ f ≤ 11980 MHz	-30 dBm	1 MHz	

<b>Test requirements for DC_2A_n5A Configuration</b>			
152 MHz ≤ f ≤ 262 MHz	-36 dBm	100 kHz	
1001 MHz ≤ f ≤ 1086 MHz 2674 MHz ≤ f ≤ 2759 MHz 2851 MHz ≤ f ≤ 2996 MHz 3498 MHz ≤ f ≤ 3608 MHz 4524 MHz ≤ f ≤ 4669 MHz	-30 dBm	1 MHz	
<b>Test requirements for DC_2A_n41A Configuration</b>			
586 MHz ≤ f ≤ 840 MHz	-36 dBm	100 kHz	
1010 MHz ≤ f ≤ 1324 MHz 3082 MHz ≤ f ≤ 3530 MHz	-30 dBm	1 MHz	2
4346 MHz ≤ f ≤ 4600 MHz 6196 MHz ≤ f ≤ 6510 MHz 6842 MHz ≤ f ≤ 7290 MHz	-25 dBm	1 MHz	1
<b>Test requirements for DC_2A_n66A Configuration</b>			
70 MHz ≤ f < 200 MHz	-36 dBm	100 kHz	
1510 MHz ≤ f ≤ 1710 MHz 1920 MHz ≤ f ≤ 2110 MHz 3560 MHz ≤ f ≤ 3690 MHz 5270 MHz ≤ f ≤ 5600 MHz	-30 dBm	1 MHz	
<b>Test requirements for DC_2A_n71A Configuration</b>			
454 MHz ≤ f ≤ 584 MHz	-36 dBm	100 kHz	
1152 MHz ≤ f ≤ 1247 MHz 2513 MHz ≤ f ≤ 2608 MHz 3002 MHz ≤ f ≤ 3157 MHz 3176 MHz ≤ f ≤ 3306 MHz 4363 MHz ≤ f ≤ 4518 MHz	-30 dBm	1 MHz	
<b>Test requirements for DC_2A_n77A Configuration</b>			
500 MHz ≤ f ≤ 520 MHz	-36 dBm	100 kHz	
1390 MHz ≤ f ≤ 2350 MHz 4690 MHz ≤ f ≤ 6550 MHz 7000 MHz ≤ f ≤ 8020 MHz 8450 MHz ≤ f ≤ 10310 MHz	-30 dBm	1 MHz	
<b>Test requirements for DC_3A_n1A Configuration</b>			
135 MHz ≤ f ≤ 270 MHz	-36 dBm	100 kHz	
1440 MHz ≤ f ≤ 1650 MHz 2055 MHz ≤ f ≤ 2250 MHz 3630 MHz ≤ f ≤ 3765 MHz 5340 MHz ≤ f ≤ 5745 MHz	-30 dBm	1 MHz	
<b>Test requirements for DC_3A_n5A Configuration</b>			
12 MHz ≤ f ≤ 30 MHz	-36 dBm	10 kHz	
30 MHz ≤ f ≤ 137 MHz 861 MHz ≤ f ≤ 961 MHz	-36 dBm	100 kHz	
2534 MHz ≤ f ≤ 2746 MHz 3358 MHz ≤ f ≤ 3483 MHz 4244 MHz ≤ f ≤ 4419 MHz	-30 dBm	1 MHz	
<b>Test requirements for DC_3A_n7A Configuration</b>			
715 MHz ≤ f < 1000 MHz	-36 dBm	100 kHz	
1000 MHz ≤ f ≤ 1070 MHz 3215 MHz ≤ f ≤ 3430 MHz 4210 MHz ≤ f ≤ 4355 MHz 5920 MHz ≤ f ≤ 6140 MHz 6710 MHz ≤ f ≤ 6925 MHz	-30 dBm	1 MHz	
<b>Test requirements for DC_3A_n8A Configuration</b>			
25 MHz ≤ f ≤ 30 MHz	-36 dBm	10 kHz	
30 MHz ≤ f ≤ 120 MHz 795 MHz ≤ f ≤ 905 MHz	-36 dBm	100 kHz	
2505 MHz ≤ f ≤ 2700 MHz 3470 MHz ≤ f ≤ 3615 MHz 4300 MHz ≤ f ≤ 4485 MHz	-30 dBm	1 MHz	
<b>Test requirements for DC_3A_n28A Configuration</b>			
214 MHz ≤ f ≤ 379 MHz 962 MHz ≤ f ≤ 1000 MHz	-36 dBm	100 kHz	



1000 MHz $\leq f \leq$ 1082 MHz 2413 MHz $\leq f \leq$ 2533 MHz 2672 MHz $\leq f \leq$ 2867 MHz 3116 MHz $\leq f \leq$ 3281 MHz 4123 MHz $\leq f \leq$ 4318 MHz	-30 dBm	1 MHz	
<b>Test requirements for DC_3A_n41A Configuration</b>			
711 MHz $\leq f <$ 1000 MHz	-36 dBm	100 kHz	
1000MHz $\leq f \leq$ 1074 MHz	-30 dBm	1 MHz	2
3207MHz $\leq f \leq$ 3670 MHz 4206MHz $\leq f \leq$ 4475 MHz 5916MHz $\leq f \leq$ 6260 MHz 6702MHz $\leq f \leq$ 7165 MHz	-25 dBm	1 MHz	1
<b>Test requirements for DC_3A_n77A Configuration</b>			
270 MHz $\leq f \leq$ 780 MHz	-36 dBm	100 kHz	
1515 MHz $\leq f \leq$ 2490 MHz 4815 MHz $\leq f \leq$ 6690 MHz 6720 MHz $\leq f \leq$ 7770 MHz 8310 MHz $\leq f \leq$ 10185 MHz	-30 dBm	1 MHz	
<b>Test requirements for DC_3A_n78A Configuration</b>			
270 MHz $\leq f \leq$ 380 MHz	-36 dBm	100 kHz	
1515 MHz $\leq f \leq$ 2090 MHz 4815 MHz $\leq f \leq$ 5890 MHz 6720 MHz $\leq f \leq$ 7370 MHz 8310 MHz $\leq f \leq$ 9385 MHz	-30 dBm	1 MHz	
<b>Test requirements for DC_3A_n79A Configuration</b>			
830 MHz $\leq f \leq$ 1000 MHz	-36 dBm	100 kHz	
1000 MHz $\leq f \leq$ 1580 MHz 2615 MHz $\leq f \leq$ 3290 MHz 6110 MHz $\leq f \leq$ 6785 MHz 7015 MHz $\leq f \leq$ 8570 MHz 10510 MHz $\leq f \leq$ 11785 MHz	-30 dBm	1 MHz	
<b>Test requirements for DC_5A_n2A Configuration</b>			
152 MHz $\leq f \leq$ 262 MHz	-36 dBm	100 kHz	
1001 MHz $\leq f \leq$ 1086 MHz 2674 MHz $\leq f \leq$ 2759 MHz 2851 MHz $\leq f \leq$ 2996 MHz 3498 MHz $\leq f \leq$ 3608 MHz 4524 MHz $\leq f \leq$ 4669 MHz	-30 dBm	1 MHz	
<b>Test requirements for DC_5A_n66A Configuration</b>			
12 MHz $\leq f \leq$ 30 MHz	-36 dBm	10 kHz	
30 MHz $\leq f \leq$ 132 MHz 861 MHz $\leq f \leq$ 956 MHz	-36 dBm	100 kHz	
2534 MHz $\leq f \leq$ 2736 MHz 3358 MHz $\leq f \leq$ 3478 MHz 4244 MHz $\leq f \leq$ 4409 MHz	-30 dBm	1 MHz	
<b>Test requirements for DC_5A_n77A Configuration</b>			
1602 MHz $\leq f \leq$ 3376 MHz 4124 MHz $\leq f \leq$ 9249 MHz	-30 dBm	1 MHz	
<b>Test requirements for DC_5A_n78A Configuration</b>			
1602 MHz $\leq f \leq$ 2152 MHz 2451 MHz $\leq f \leq$ 2976 MHz 4124 MHz $\leq f \leq$ 4649 MHz 4948 MHz $\leq f \leq$ 5498 MHz 5751 MHz $\leq f \leq$ 6776 MHz 7424 MHz $\leq f \leq$ 8449 MHz	-30 dBm	1 MHz	
<b>Test requirements for DC_7A_n1A Configuration</b>			
520 MHz $\leq f \leq$ 650 MHz	-36 dBm	100 kHz	
1270 MHz $\leq f \leq$ 1460 MHz 3020 MHz $\leq f \leq$ 3220 MHz 4420 MHz $\leq f \leq$ 4550 MHz 6340 MHz $\leq f \leq$ 6530 MHz 6920 MHz $\leq f \leq$ 7120 MHz	-30 dBm	1 MHz	
<b>Test requirements for DC_7A_n3A Configuration</b>			
715 MHz $\leq f <$ 1000 MHz	-36 dBm	100 kHz	

1000 MHz ≤ f ≤ 1070 MHz 3215 MHz ≤ f ≤ 3430 MHz 4210 MHz ≤ f ≤ 4355 MHz 5920 MHz ≤ f ≤ 6140 MHz 6710 MHz ≤ f ≤ 6925 MHz	-30 dBm	1 MHz	
<b>Test requirements for DC_7A_n5A Configuration</b>			
802 MHz ≤ f ≤ 922 MHz	-36 dBm	100 kHz	
1651 MHz ≤ f ≤ 1746 MHz 3324 MHz ≤ f ≤ 3419 MHz 4148 MHz ≤ f ≤ 4316 MHz 5824 MHz ≤ f ≤ 5989 MHz	-30 dBm	1 MHz	
<b>Test requirements for DC_7A_n8A Configuration</b>			
670 MHz ≤ f ≤ 810 MHz	-36 dBm	100 kHz	
1585 MHz ≤ f ≤ 1690 MHz 3380 MHz ≤ f ≤ 3485 MHz 4085 MHz ≤ f ≤ 4400 MHz 5880 MHz ≤ f ≤ 6055 MHz	-30 dBm	1 MHz	
<b>Test requirements for DC_7A_n28A Configuration</b>			
1004 MHz ≤ f ≤ 1164 MHz 1752 MHz ≤ f ≤ 1867 MHz 3203 MHz ≤ f ≤ 3318 MHz 3906 MHz ≤ f ≤ 4066 MHz 4252 MHz ≤ f ≤ 4437 MHz 5703 MHz ≤ f ≤ 5888 MHz	-30 dBm	1 MHz	
<b>Test requirements for DC_7A_n78A Configuration</b>			
730 MHz ≤ f ≤ 1000 MHz	-36 dBm	100 kHz	
1000 MHz ≤ f ≤ 1840 MHz 4030 MHz ≤ f ≤ 5100 MHz 5800 MHz ≤ f ≤ 6370 MHz 8300 MHz ≤ f ≤ 8940 MHz 9100 MHz ≤ f ≤ 10170 MHz	-30 dBm	1 MHz	
<b>Test requirements for DC_8A_n1A Configuration</b>			
90 MHz ≤ f ≤ 220 MHz	-36 dBm	100 kHz	
1005 MHz ≤ f ≤ 1100 MHz 2800 MHz ≤ f ≤ 2895 MHz 2925 MHz ≤ f ≤ 3080 MHz 3680 MHz ≤ f ≤ 3810 MHz 4720 MHz ≤ f ≤ 4875 MHz	-30 dBm	1 MHz	
<b>Test requirements for DC_8A_n3A Configuration</b>			
25 MHz ≤ f < 30 MHz	-36 dBm	10 kHz	
30 MHz ≤ f ≤ 120 MHz 795 MHz ≤ f ≤ 905 MHz	-36 dBm	100 kHz	
2505 MHz ≤ f ≤ 2700 MHz 3470 MHz ≤ f ≤ 3615 MHz 4300 MHz ≤ f ≤ 4485 MHz	-30 dBm	1 MHz	
<b>Test requirements for DC_8A_n20A Configuration</b>			
18 MHz ≤ f < 30 MHz	-36 dBm	10 kHz	
30 MHz ≤ f ≤ 83 MHz 749 MHz ≤ f ≤ 844 MHz 898 MHz ≤ f ≤ 998 MHz	-36 dBm	100 kHz	
1712 MHz ≤ f ≤ 1777 MHz 2544 MHz ≤ f ≤ 2692 MHz	-30 dBm	1 MHz	
<b>Test requirements for DC_8A_n28A Configuration</b>			
132 MHz ≤ f ≤ 212 MHz 491 MHz ≤ f ≤ 616 MHz	-36 dBm	100 kHz	
1012 MHz ≤ f ≤ 1127 MHz 1583 MHz ≤ f ≤ 1663 MHz 2286 MHz ≤ f ≤ 2411 MHz 2463 MHz ≤ f ≤ 2578 MHz	-30 dBm	1 MHz	
<b>Test requirements for DC_8A_n41A Configuration</b>			
666 MHz ≤ f ≤ 930 MHz	-36 dBm	100 kHz	
1581 MHz ≤ f ≤ 1810 MHz	-30 dBm	1 MHz	2
3376 MHz ≤ f ≤ 3605 MHz 4077 MHz ≤ f ≤ 4520 MHz 5872 MHz ≤ f ≤ 6295 MHz	-25 dBm	1 MHz	1
<b>Test requirements for DC_8A_n77A Configuration</b>			

1470 MHz ≤ f ≤ 3320 MHz 4180 MHz ≤ f ≤ 9315 MHz	-30 dBm	1 MHz	
<b>Test requirements for DC_8A_n78A Configuration</b>			
1470 MHz ≤ f ≤ 2040 MHz 2385 MHz ≤ f ≤ 2920 MHz 4180 MHz ≤ f ≤ 4715 MHz 5060 MHz ≤ f ≤ 5630 MHz 5685 MHz ≤ f ≤ 6720 MHz 7480 MHz ≤ f ≤ 8515 MHz	-30 dBm	1 MHz	
<b>Test requirements for DC_11A_n77A Configuration</b>			
404.2 MHz ≤ f ≤ 1000 MHz	-36 dBm	100 kHz	
1000 MHz ≤ f ≤ 1344.2 MHz 1852.1 MHz ≤ f ≤ 2772.1 MHz 4727.9 MHz ≤ f ≤ 7095.8 MHz 8027.9 MHz ≤ f ≤ 9847.9 MHz	-30 dBm	1 MHz	
<b>Test requirements for DC_11A_n78A Configuration</b>			
404.2 MHz ≤ f ≤ 944.2 MHz	-36 dBm	100 kHz	
1852.1 MHz ≤ f ≤ 2372.1 MHz 4727.9 MHz ≤ f ≤ 6695.8 MHz 8027.9 MHz ≤ f ≤ 9047.9 MHz	-30 dBm	1 MHz	
<b>Test requirements for DC_11A_n79A Configuration</b>			
1504.2 MHz ≤ f ≤ 2144.2 MHz 2952.1 MHz ≤ f ≤ 3572.1 MHz 5827.9 MHz ≤ f ≤ 6447.9 MHz 7255.8 MHz ≤ f ≤ 8572.1 MHz 10227.9 MHz ≤ f ≤ 11447.9 MHz	-30 dBm	1 MHz	
<b>Test requirements for DC_12A_n2A Configuration</b>			
418 MHz ≤ f ≤ 512 MHz	-36 dBm	100 kHz	
1134 MHz ≤ f ≤ 1211 MHz 2549 MHz ≤ f ≤ 2626 MHz 2984 MHz ≤ f ≤ 3121 MHz 3248 MHz ≤ f ≤ 3342 MHz 4399 MHz ≤ f ≤ 4536 MHz	-30 dBm	1 MHz	
<b>Test requirements for DC_12A_n66A Configuration</b>			
278 MHz ≤ f ≤ 382 MHz 994 MHz ≤ f < 1000 MHz	-36 dBm	100 kHz	
1000 MHz ≤ f ≤ 1081 MHz 2409 MHz ≤ f ≤ 2496 MHz 2704 MHz ≤ f ≤ 2861 MHz 3108 MHz ≤ f ≤ 3212 MHz 4119 MHz ≤ f ≤ 4276 MHz	-30 dBm	1 MHz	
<b>Test requirements for DC_12A_n77A Configuration</b>			
1868 MHz ≤ f ≤ 3501 MHz 3999 MHz ≤ f ≤ 5632 MHz 5884 MHz ≤ f ≤ 9116 MHz	-30 dBm	1 MHz	
<b>Test requirements for DC_12A_n78A Configuration</b>			
1868 MHz ≤ f ≤ 2402 MHz 2584 MHz ≤ f ≤ 3101 MHz 3999 MHz ≤ f ≤ 4516 MHz 4698 MHz ≤ f ≤ 5232 MHz 5884 MHz ≤ f ≤ 6901 MHz 7299 MHz ≤ f ≤ 8316 MHz	-30 dBm	1 MHz	
<b>Test requirements for DC_13A_n2A Configuration</b>			
276 MHz ≤ f ≤ 356 MHz	-36 dBm	100 kHz	
1063 MHz ≤ f ≤ 1133 MHz 2627 MHz ≤ f ≤ 2697 MHz 2913 MHz ≤ f ≤ 3043 MHz 3404 MHz ≤ f ≤ 3484 MHz 4477 MHz ≤ f ≤ 4607 MHz	-30 dBm	1 MHz	
<b>Test requirements for DC_13A_n66A Configuration</b>			
136 MHz ≤ f ≤ 226 MHz 923 MHz ≤ f ≤ 1000 MHz	-36 dBm	100 kHz	

1000 MHz $\leq f \leq$ 1003 MHz 2487 MHz $\leq f \leq$ 2567 MHz 2633 MHz $\leq f \leq$ 2783 MHz 3264 MHz $\leq f \leq$ 3354 MHz 4197 MHz $\leq f \leq$ 4347 MHz	-30 dBm	1 MHz	
<b>Test requirements for DC_13A_n77A Configuration</b>			
1726 MHz $\leq f \leq$ 3423 MHz 4077 MHz $\leq f \leq$ 5774 MHz 5813 MHz $\leq f \leq$ 9187 MHz	-30 dBm	1 MHz	
<b>Test requirements for DC_14A_n2A Configuration</b>			
254 MHz $\leq f \leq$ 334 MHz	-36 dBm	100 kHz	
1052 MHz $\leq f \leq$ 1122 MHz 2638 MHz $\leq f \leq$ 2708 MHz 2902 MHz $\leq f \leq$ 3032 MHz 3426 MHz $\leq f \leq$ 3506 MHz 4488 MHz $\leq f \leq$ 4618 MHz	-30 dBm	1 MHz	
<b>Test requirements for DC_14A_n66A Configuration</b>			
114 MHz $\leq f \leq$ 204 MHz 912 MHz $\leq f \leq$ 992 MHz	-36 dBm	100 kHz	
2498 MHz $\leq f \leq$ 2578 MHz 2622 MHz $\leq f \leq$ 2772 MHz 3286 MHz $\leq f \leq$ 3376 MHz 4208 MHz $\leq f \leq$ 4358 MHz	-30 dBm	1 MHz	
<b>Test requirements for DC_14A_n77A Configuration</b>			
1704 MHz $\leq f \leq$ 3412 MHz 4088 MHz $\leq f \leq$ 5796 MHz 5808 MHz $\leq f \leq$ 9198 MHz	-30 dBm	1 MHz	
<b>Test requirements for DC_18A_n77A Configuration</b>			
1640 MHz $\leq f \leq$ 3385 MHz 4115 MHz $\leq f \leq$ 5860 MHz 5770 MHz $\leq f \leq$ 9230 MHz	-30dBm	1MHz	
<b>Test requirements for DC_18A_n78A Configuration</b>			
1640 MHz $\leq f \leq$ 2170 MHz 2470 MHz $\leq f \leq$ 2985 MHz 4115 MHz $\leq f \leq$ 4630 MHz 4930 MHz $\leq f \leq$ 5460 MHz 5770 MHz $\leq f \leq$ 6785 MHz 7415 MHz $\leq f \leq$ 8430 MHz	-30dBm	1MHz	
<b>Test requirements for DC_19A_n1A Configuration</b>			
230 MHz $\leq f \leq$ 320 MHz	-36 dBm	100 kHz	
1075 MHz $\leq f \leq$ 1150 MHz 2750 MHz $\leq f \leq$ 2825 MHz 2995 MHz $\leq f \leq$ 3130 MHz 3580 MHz $\leq f \leq$ 3670 MHz 4670 MHz $\leq f \leq$ 4805 MHz	-30 dBm	1 MHz	
<b>Test requirements for DC_19A_n77A Configuration</b>			
1610 MHz $\leq f \leq$ 3370 MHz 4130 MHz $\leq f \leq$ 5890 MHz 5755 MHz $\leq f \leq$ 9245 MHz	-30 dBm	1 MHz	
<b>Test requirements for DC_19A_n78A Configuration</b>			
1610 MHz $\leq f \leq$ 2140 MHz 2455 MHz $\leq f \leq$ 2970 MHz 4130 MHz $\leq f \leq$ 4645 MHz 4960 MHz $\leq f \leq$ 5490 MHz 5755 MHz $\leq f \leq$ 6770 MHz 7430 MHz $\leq f \leq$ 8445 MHz	-30 dBm	1 MHz	
<b>Test requirements for DC_19A_n79A Configuration</b>			
2710 MHz $\leq f \leq$ 3340 MHz 3555 MHz $\leq f \leq$ 4170 MHz 5230 MHz $\leq f \leq$ 5845 MHz 6060 MHz $\leq f \leq$ 6690 MHz 7955 MHz $\leq f \leq$ 9170 MHz 9630 MHz $\leq f \leq$ 10845 MHz	-30 dBm	1 MHz	
<b>Test requirements for DC_20A_n1A Configuration</b>			
196 MHz $\leq f \leq$ 316 MHz	-36 dBm	100 kHz	

1058 MHz ≤ f ≤ 1148 MHz 2752 MHz ≤ f ≤ 2842 MHz 2978 MHz ≤ f ≤ 3128 MHz 3584 MHz ≤ f ≤ 3704 MHz 4672 MHz ≤ f ≤ 4822 MHz	-30 dBm	1 MHz	
<b>Test requirements for DC_20A_n3A Configuration</b>			
14 MHz ≤ f < 30 MHz	-36 dBm	10 kHz	
30 MHz ≤ f ≤ 121 MHz 848 MHz ≤ f ≤ 953 MHz	-36 dBm	100 kHz	
2542 MHz ≤ f ≤ 2738 MHz 3374 MHz ≤ f ≤ 3509 MHz 4252 MHz ≤ f ≤ 4432 MHz	-30 dBm	1 MHz	
<b>Test requirements for DC_20A_n7A Configuration</b>			
776 MHz ≤ f ≤ 906 MHz	-36 dBm	100 kHz	
1638 MHz ≤ f ≤ 1738 MHz 3332 MHz ≤ f ≤ 3432 MHz 4138 MHz ≤ f ≤ 4308 MHz 5832 MHz ≤ f ≤ 6002 MHz	-30 dBm	1 MHz	
<b>Test requirements for DC_20A_n8A Configuration</b>			
18 MHz ≤ f < 30 MHz	-36 dBm	10 kHz	
30 MHz ≤ f ≤ 83 MHz 749 MHz ≤ f ≤ 844 MHz 898 MHz ≤ f ≤ 998 MHz	-36 dBm	100 kHz	
1712 MHz ≤ f ≤ 1777 MHz 2544 MHz ≤ f ≤ 2692 MHz	-30 dBm	1 MHz	
<b>Test requirements for DC_20A_n28A Configuration</b>			
84 MHz ≤ f ≤ 159 MHz 544 MHz ≤ f ≤ 664 MHz 916 MHz ≤ f ≤ 1000 MHz	-36 dBm	100 kHz	
1000 MHz ≤ f ≤ 1021 MHz 1535 MHz ≤ f ≤ 1610 MHz 2238 MHz ≤ f ≤ 2358 MHz 2367 MHz ≤ f ≤ 2472 MHz	-30 dBm	1 MHz	
<b>Test requirements for DC_20A_n78A Configuration</b>			
1576 MHz ≤ f ≤ 2136 MHz 2438 MHz ≤ f ≤ 2968 MHz 4132 MHz ≤ f ≤ 4662 MHz 4964 MHz ≤ f ≤ 5524 MHz 5738 MHz ≤ f ≤ 6768 MHz 7432 MHz ≤ f ≤ 8462 MHz	-30 dBm	1 MHz	
<b>Test requirements for DC_21A_n1A Configuration</b>			
457.1 MHz ≤ f ≤ 532.1 MHz 915.8 MHz ≤ f ≤ 1000 MHz	-36 dBm	100 kHz	
2377.1 MHz ≤ f ≤ 2512.1 MHz 3367.9 MHz ≤ f ≤ 3442.9 MHz 4815.8 MHz ≤ f ≤ 4905.8 MHz 5287.9 MHz ≤ f ≤ 5422.9 MHz	-30 dBm	1 MHz	
<b>Test requirements for DC_21A_n28A Configuration</b>			
6.9 MHz ≤ f ≤ 28.1 MHz	-36 dBm	10 kHz	
709.9 MHz ≤ f ≤ 734.9 MHz	-36 dBm	100 kHz	
2157.8 MHz ≤ f ≤ 2200.9 MHz 2903.9 MHz ≤ f ≤ 2938.9 MHz 3623.8 MHz ≤ f ≤ 3663.8 MHz	-30 dBm	1 MHz	4
<b>Test requirements for DC_21A_n77A Configuration</b>			
374.2 MHz ≤ f ≤ 1000 MHz	-36 dBm	100 kHz	
1000 MHz ≤ f ≤ 1304.2 MHz 1837.1 MHz ≤ f ≤ 2752.1 MHz 4747.9 MHz ≤ f ≤ 7125.8 MHz 8047.9 MHz ≤ f ≤ 9862.9 MHz	-30 dBm	1 MHz	
<b>Test requirements for DC_21A_n78A Configuration</b>			
374.2 MHz ≤ f ≤ 904.2 MHz	-36 dBm	100 kHz	
1837.1 MHz ≤ f ≤ 2352.1 MHz 4747.9 MHz ≤ f ≤ 6152.1 MHz 6195.8 MHz ≤ f ≤ 6725.8 MHz 8047.9 MHz ≤ f ≤ 9062.9 MHz	-30 dBm	1 MHz	
<b>Test requirements for DC_21A_n79A Configuration</b>			

1474.2 MHz ≤ f ≤ 2104.2 MHz 2937.1 MHz ≤ f ≤ 3552.1 MHz 5847.9 MHz ≤ f ≤ 6462.9 MHz 7295.8 MHz ≤ f ≤ 8552.1 MHz 10247.9 MHz ≤ f ≤ 11462.9 MHz	-30 dBm	1 MHz	
<b>Test requirements for DC_25A_n41A Configuration</b>			
581 MHz ≤ f ≤ 840 MHz	-36 dBm	100 kHz	
1010 MHz ≤ f ≤ 1334 MHz	-30 dBm	1 MHz	2
3077 MHz ≤ f ≤ 3530 MHz 4346 MHz ≤ f ≤ 4605 MHz 6196 MHz ≤ f ≤ 6520 MHz 6842 MHz ≤ f ≤ 7295 MHz	-25 dBm	1 MHz	1
<b>Test requirements for DC_26A_n41A Configuration</b>			
798 MHz ≤ f < 1000 MHz	-36 dBm	100 kHz	
1000 MHz ≤ f ≤ 1062 MHz	-30 dBm	1 MHz	2
1647 MHz ≤ f ≤ 1876 MHz 3310 MHz ≤ f ≤ 3539 MHz 4124 MHz ≤ f ≤ 4566 MHz 5806 MHz ≤ f ≤ 6229 MHz	-25 dBm	1 MHz	1
<b>Test requirements for DC_26A_n77A Configuration</b>			
1602 MHz ≤ f ≤ 3386 MHz 4114 MHz ≤ f ≤ 5898 MHz 5751 MHz ≤ f ≤ 9249 MHz	-30 dBm	1 MHz	
<b>Test requirements for DC_26A_n78A Configuration</b>			
1602 MHz ≤ f ≤ 2172 MHz 2451 MHz ≤ f ≤ 2986 MHz 4114 MHz ≤ f ≤ 4649 MHz 4928 MHz ≤ f ≤ 5498 MHz 5751 MHz ≤ f ≤ 6786 MHz 7414 MHz ≤ f ≤ 8449 MHz	-30 dBm	1 MHz	
<b>Test requirements for DC_26A_n79A Configuration</b>			
2702 MHz ≤ f ≤ 3372 MHz 3551 MHz ≤ f ≤ 4186 MHz 5214 MHz ≤ f ≤ 5849 MHz 6028 MHz ≤ f ≤ 6698 MHz 7951 MHz ≤ f ≤ 9186 MHz 9614 MHz ≤ f ≤ 10849 MHz	-30 dBm	1 MHz	
<b>Test requirements for DC_28A_n3A Configuration</b>			
214 MHz ≤ f ≤ 379 MHz 962 MHz ≤ f < 1000 MHz	-36 dBm	100 kHz	
1000 MHz ≤ f ≤ 1082 MHz 2413 MHz ≤ f ≤ 2533 MHz 2672 MHz ≤ f ≤ 2867 MHz 3116 MHz ≤ f ≤ 3281 MHz 4123 MHz ≤ f ≤ 4318 MHz	-30 dBm	1 MHz	
<b>Test requirements for DC_28A_n5A Configuration</b>			
76 MHz ≤ f ≤ 146 MHz 557 MHz ≤ f ≤ 672 MHz 900 MHz ≤ f ≤ 995 MHz	-36 dBm	100 kHz	
1527 MHz ≤ f ≤ 1597 MHz 2230 MHz ≤ f ≤ 2345 MHz 2351 MHz ≤ f ≤ 2446 MHz	-30 dBm	1 MHz	
<b>Test requirements for DC_28A_n7A Configuration</b>			
1004 MHz ≤ f ≤ 1164 MHz 1752 MHz ≤ f ≤ 1867 MHz 3203 MHz ≤ f ≤ 3318 MHz 3906 MHz ≤ f ≤ 4066 MHz 4252 MHz ≤ f ≤ 4437 MHz 5703 MHz ≤ f ≤ 5888 MHz	-30 dBm	1 MHz	
<b>Test requirements for DC_28A_n77A Configuration</b>			
1804 MHz ≤ f ≤ 3497 MHz 4003 MHz ≤ f ≤ 5696 MHz 5852 MHz ≤ f ≤ 9148 MHz	-30 dBm	1 MHz	
<b>Test requirements for DC_28A_n78A Configuration</b>			

1804 MHz ≤ f ≤ 2394 MHz 2552 MHz ≤ f ≤ 3097 MHz 4003 MHz ≤ f ≤ 4548 MHz 4706 MHz ≤ f ≤ 5296 MHz 5852 MHz ≤ f ≤ 6897 MHz 7303 MHz ≤ f ≤ 8348 MHz	-30 dBm	1 MHz	
<b>Test requirements for DC_28A_n79A Configuration</b>			
2904 MHz ≤ f ≤ 3594 MHz 3652 MHz ≤ f ≤ 4297 MHz 5103 MHz ≤ f ≤ 5748 MHz 5806 MHz ≤ f ≤ 6496 MHz 8052 MHz ≤ f ≤ 9297 MHz 9503 MHz ≤ f ≤ 10748 MHz	-30 dBm	1 MHz	
<b>Test requirements for DC_30A_n2A Configuration</b>			
395 MHz ≤ f < 465 MHz	-36 dBm	100 kHz	
1385 MHz ≤ f ≤ 1515 MHz 2700 MHz ≤ f ≤ 2780 MHz 4155 MHz ≤ f ≤ 4225 MHz 6005 MHz ≤ f ≤ 6135 MHz 6460 MHz ≤ f ≤ 6540 MHz	-30 dBm	1 MHz	
<b>Test requirements for DC_30A_n5A Configuration</b>			
607 MHz ≤ f ≤ 667 MHz	-36 dBm	100 kHz	
1456 MHz ≤ f ≤ 1491 MHz 3129 MHz ≤ f ≤ 3164 MHz 3761 MHz ≤ f ≤ 3806 MHz 3953 MHz ≤ f ≤ 4013 MHz 5434 MHz ≤ f ≤ 5479 MHz	-30 dBm	1 MHz	
<b>Test requirements for DC_30A_n66A Configuration</b>			
525 MHz ≤ f < 605 MHz	-36 dBm	100 kHz	
1105 MHz ≤ f ≤ 1255 MHz 2830 MHz ≤ f ≤ 2920 MHz 4015 MHz ≤ f ≤ 4095 MHz 5725 MHz ≤ f ≤ 5875 MHz 6320 MHz ≤ f ≤ 6410 MHz	-30 dBm	1 MHz	
<b>Test requirements for DC_30A_n77A Configuration</b>			
410 MHz ≤ f < 1000 MHz	-36 dBm	100 kHz	
1000 MHz ≤ f ≤ 1895 MHz 4285 MHz ≤ f ≤ 5615 MHz 7910 MHz ≤ f ≤ 8830 MHz 8905 MHz ≤ f ≤ 10715 MHz	-30 dBm	1 MHz	
<b>Test requirements for DC_39A_n41A Configuration</b>			
576 MHz ≤ f < 810 MHz	-36 dBm	100 kHz	
1070MHz ≤ f ≤ 1344 MHz	-30 dBm	1 MHz	2
3072MHz ≤ f ≤ 3500 MHz 4376MHz ≤ f ≤ 4610 MHz 6256MHz ≤ f ≤ 6530 MHz 6872MHz ≤ f ≤ 7300 MHz	-25 dBm	1 MHz	1
<b>Test requirements for DC_39A_n79A Configuration</b>			
560 MHz ≤ f ≤ 1000 MHz	-36 dBm	100 kHz	
1000 MHz ≤ f ≤ 1240 MHz 2480 MHz ≤ f ≤ 3120 MHz 6280 MHz ≤ f ≤ 8120 MHz 8160 MHz ≤ f ≤ 8840 MHz 10680 MHz ≤ f ≤ 11920 MHz	-30 dBm	1 MHz	
<b>Test requirements for DC_40A_n1A Configuration</b>			
320 MHz ≤ f ≤ 480 MHz	-36 dBm	100 kHz	
1440 MHz ≤ f ≤ 1660 MHz 2620 MHz ≤ f ≤ 2880 MHz 4220 MHz ≤ f ≤ 4380 MHz 6140 MHz ≤ f ≤ 6360 MHz 6520 MHz ≤ f ≤ 6780 MHz	-30 dBm	1 MHz	
<b>Test requirements for DC_40A_n41A Configuration</b>			
96 MHz ≤ f < 390 MHz	-36 dBm	100 kHz	
1910 MHz ≤ f ≤ 2304 MHz	-30 dBm	1 MHz	2
2592 MHz ≤ f ≤ 3080 MHz 4796 MHz ≤ f ≤ 5090 MHz 7096 MHz ≤ f ≤ 7780 MHz	-25 dBm	1 MHz	1

<b>Test requirements for DC_40A_n78A Configuration</b>			
800 MHz ≤ f ≤ 1000 MHz	-36 dBm	100 kHz	
1000 MHz ≤ f ≤ 1500 MHz 4200 MHz ≤ f ≤ 5300 MHz 5600 MHz ≤ f ≤ 6200 MHz 7900 MHz ≤ f ≤ 8600 MHz 8900 MHz ≤ f ≤ 10000 MHz	-30 dBm	1 MHz	
<b>Test requirements for DC_40A_n79A Configuration</b>			
2000 MHz ≤ f ≤ 2700 MHz 6400 MHz ≤ f ≤ 7700 MHz 9000 MHz ≤ f ≤ 9800 MHz 11100 MHz ≤ f ≤ 12400 MHz	-30 dBm	1 MHz	
<b>Test requirements for DC_41A_n28A Configuration</b>			
1000 MHz ≤ f ≤ 1284 MHz 1748 MHz ≤ f ≤ 1987 MHz 3199 MHz ≤ f ≤ 3438 MHz 3902 MHz ≤ f ≤ 4186 MHz 4244 MHz ≤ f ≤ 4677 MHz 5695 MHz ≤ f ≤ 6128 MHz	-30 dBm	1 MHz	
<b>Test requirements for DC_41A_n77A Configuration</b>			
610 MHz ≤ f ≤ 1000 MHz	-36 dBm	100 kHz	
1000 MHz ≤ f ≤ 2080 MHz 3910 MHz ≤ f ≤ 6890 MHz 8292 MHz ≤ f ≤ 11090 MHz	-30 dBm	1 MHz	
<b>Test requirements for DC_41A_n78A Configuration</b>			
610 MHz ≤ f ≤ 1000 MHz	-36 dBm	100 kHz	
1000 MHz ≤ f ≤ 2080 MHz 3910 MHz ≤ f ≤ 5104 MHz 5796 MHz ≤ f ≤ 6490 MHz 8292 MHz ≤ f ≤ 10290 MHz	-30 dBm	1 MHz	
<b>Test requirements for DC_41A_n79A Configuration</b>			
8 MHz ≤ f ≤ 30 MHz	-36 dBm	10 kHz	
30 MHz ≤ f ≤ 980 MHz	-36 dBm	100 kHz	
1710 MHz ≤ f ≤ 2504 MHz 6110 MHz ≤ f ≤ 7690 MHz 9392 MHz ≤ f ≤ 10380 MHz 11296 MHz ≤ f ≤ 12690 MHz	-30 dBm	1 MHz	
<b>Test requirements for DC_42A_n77A Configuration</b>			
300 MHz ≤ f ≤ 800 MHz	-36 dBm	100 kHz	
2600 MHz ≤ f ≤ 5000 MHz 6700 MHz ≤ f ≤ 7800 MHz 10000 MHz ≤ f ≤ 12000 MHz	-30 dBm	1 MHz	
<b>Test requirements for DC_48A_n5A Configuration</b>			
1852 MHz ≤ f ≤ 2052 MHz 2701 MHz ≤ f ≤ 2876 MHz 4374 MHz ≤ f ≤ 4549 MHz 5198 MHz ≤ f ≤ 5398 MHz 6251 MHz ≤ f ≤ 6576 MHz 7924 MHz ≤ f ≤ 8249 MHz	-30 dBm	1 MHz	
<b>Test requirements for DC_48A_n66A Configuration</b>			
10 MHz ≤ f < 30 MHz	-36 dBm	10 KHz	
30 MHz ≤ f ≤ 280 MHz	-36 dBm	100 KHz	
1770 MHz ≤ f ≤ 1990 MHz 5260 MHz ≤ f ≤ 5690 MHz 6970 MHz ≤ f ≤ 7260 MHz 8810 MHz ≤ f ≤ 9180 MHz	-30 dBm	1 MHz	
<b>Test requirements for DC_66A_n5A Configuration</b>			
12 MHz ≤ f ≤ 30 MHz	-36 dBm	10 kHz	
30 MHz ≤ f ≤ 132 MHz 861 MHz ≤ f ≤ 956 MHz	-36 dBm	100 kHz	
2534 MHz ≤ f ≤ 2736 MHz 3358 MHz ≤ f ≤ 3478 MHz 4244 MHz ≤ f ≤ 4409 MHz	-30 dBm	1 MHz	
<b>Test requirements for DC_66A_n41A Configuration</b>			
716 MHz ≤ f < 1000 MHz	-36 dBm	100 kHz	



1000 MHz ≤ f ≤ 1064 MHz 3212 MHz ≤ f ≤ 3670 MHz 4206 MHz ≤ f ≤ 4470 MHz 5916 MHz ≤ f ≤ 6250 MHz 6702 MHz ≤ f ≤ 7160 MHz	-30 dBm	1 MHz	2
	-25 dBm	1 MHz	1
<b>Test requirements for DC_66A_n71A Configuration</b>			
314 MHz ≤ f ≤ 454 MHz	-36 dBm	100 kHz	
1102 MHz ≤ f ≤ 1117 MHz 2373 MHz ≤ f ≤ 2478 MHz 2722 MHz ≤ f ≤ 2897 MHz 3036 MHz ≤ f ≤ 3176 MHz 4083 MHz ≤ f ≤ 4258 MHz	-30 dBm	1 MHz	
<b>Test requirements for DC_66A_n77A Configuration</b>			
260MHz ≤ f ≤ 780 MHz	-36 dBm	100 kHz	
1520 MHz ≤ f ≤ 2490MHz 5010 MHz ≤ f ≤ 6690 MHz 6720 MHz ≤ f ≤ 7760 MHz 8310 MHz ≤ f ≤ 10180 MHz	-30 dBm	1 MHz	
<b>Test requirements for DC_66A_n78A Configuration</b>			
260 MHz ≤ f ≤ 380 MHz	-36 dBm	100 kHz	
1520 MHz ≤ f ≤ 2090 MHz 4820 MHz ≤ f ≤ 5890 MHz 6720 MHz ≤ f ≤ 7360 MHz 8310 MHz ≤ f ≤ 9380 MHz	-30 dBm	1 MHz	
<b>Test requirements for DC_71A_n2A Configuration</b>			
454 MHz ≤ f ≤ 584 MHz	-36 dBm	100 kHz	
1152 MHz ≤ f ≤ 1247 MHz 2513 MHz ≤ f ≤ 2608 MHz 3002 MHz ≤ f ≤ 3157 MHz 3176 MHz ≤ f ≤ 3306 MHz 4363 MHz ≤ f ≤ 4518 MHz	-30 dBm	1 MHz	
<b>Test requirements for DC_71A_n66A Configuration</b>			
314 MHz ≤ f ≤ 454 MHz	-36 dBm	100 kHz	
1012 MHz ≤ f ≤ 1117 MHz 2373 MHz ≤ f ≤ 2478 MHz 2722 MHz ≤ f ≤ 2897 MHz 3036 MHz ≤ f ≤ 3176 MHz 4083 MHz ≤ f ≤ 4258 MHz	-30 dBm	1 MHz	
NOTE 1: Applies for Band n41, CA configurations including Band n41, and EN-DC configurations that include n41 specified in clause 5.2B of TS 36.101 [5] when NS_04 is signalled.			
NOTE 2: Does not apply for Band n41, CA configurations including Band n41, and EN-DC configurations that include n41 specified in subclause 5.2B of TS 38.101-3 [4] when NS_04 is signalled.			

### 6.5B.3.3.2 Spurious emission band UE co-existence for Inter-band within FR1

**Editor's note:** The default and additional test configuration is analysed based on the assumption that only intermodulation products need to be tested. The band combinations without TP analysis in TR 38.905 are incomplete.

#### 6.5B.3.3.2.1 Test purpose

To verify that UE transmitter does not cause unacceptable interference to other channels or other systems in terms of transmitter spurious emissions for band UE co-existence for inter-band EN-DC.

#### 6.5B.3.3.2.2 Test applicability

This test case applies to all types of E-UTRA UE release 15 and forward supporting inter-band EN-DC.

#### 6.5B.3.3.2.3 Minimum conformance requirements

For Release 15:

This clause specifies the requirements for the specified EN-DC, for coexistence with protected bands. The requirements in Table 6.5B.3.3.2.3-1 apply on each component carrier with all component carriers are active.

NOTE: For inter-band EN-DC with uplink assigned to one LTE band and one NR band the requirements in Table 6.5B.3.3.2.3-1 could be verified by measuring spurious emissions at the specific frequencies where second and third order intermodulation products generated by the two transmitted carriers can occur.

For Release 16/17/18:

This clause specifies the additional requirements for uplink EN-DC coexistence with protected bands with the single CC uplink assigned to E-UTRA and NR bands for the specified uplink carrier aggregation configurations in Table 6.5B.3.3.2.3-2 to Table 6.5B.3.3.2.3-4. The intersection of the requirements for the individual bands specified in clause 6.5.3.2 of [2] and clause 6.6.3.2 of [5] shall also apply for the specified uplink EN-DC configurations. Intersection of a requirement means that both UL constituent bands have the same protected band requirement specified and if one or both protected bands have note(s) associated those note(s) also apply.

The requirements in Table 6.5B.3.3.2.3-2 to Table 6.5B.3.3.2.3-4 and the intersection of the requirements for the individual bands specified in clause 6.5.3.2 of [2] and clause 6.6.3.2 of [4] apply on each component carrier with all component carriers are active. For Release 18, unless otherwise stated, the spurious emission for UE co-existence requirements are not applicable to the frequency ranges where out-of-band emissions requirements in clause 6.5B.2 are defined.

NOTE: For inter-band EN-DC with uplink assigned to one LTE band and one NR band the requirements in Table 6.5B.3.3.2.3-2 to Table 6.5B.3.3.2.3-4 could be verified by measuring spurious emissions at the specific frequencies where second and third order intermodulation products generated by the two transmitted carriers can occur; in that case, the requirements for remaining applicable frequencies in Table 6.5B.3.3.2.3-2 to Table 6.5B.3.3.2.3-4 and in 6.5.3.2 of [2] and clause 6.6.3.2 of [5] would be considered to be verified by the measurements verifying the uplink single carrier UE to UE co-existence requirements.

**Table 6.5B.3.3.2.3-1: Spurious emission band UE co-existence limits Rel-15**

EN-DC Configuration	Spurious emission						
	Protected band	Frequency range (MHz)			Maximum Level (dBm)	MBW (MHz)	NOTE
DC_1_n28	E-UTRA Band 5, 7, 8, 18, 19, 20, 26, 27, 31, 38, 40, 41, 72, 73 NR band n79	F <sub>DL_low</sub>	-	F <sub>DL_high</sub>	-50	1	
	E-UTRA Band 1, 22, 32, 42, 43, 50, 51, 52, 65, 74, 75, 76 NR band n77, n78	F <sub>DL_low</sub>	-	F <sub>DL_high</sub>	-50	1	2
	E-UTRA band n3, n34	F <sub>DL_low</sub>	-	F <sub>DL_high</sub>	-50	1	5
	E-UTRA Band 11, 21	F <sub>DL_low</sub>	-	F <sub>DL_high</sub>	-50	1	9, 11
	E-UTRA Band 1, 65	F <sub>DL_low</sub>	-	F <sub>DL_high</sub>	-50	1	9, 10
	Frequency range	470	-	694	-42	8	5, 17
	Frequency range	470	-	710	-26.2	6	14
	Frequency range	758	-	773	-32	1	5
	Frequency range	773	-	803	-50	1	
	Frequency range	662	-	694	-26.2	6	5
	Frequency range	1880	-	1895	-40	1	5, 16
	Frequency range	1895	-	1915	-15.5	5	5, 7, 16
Frequency range	1915	-	1920	+1.6	5	5, 7, 16	
DC_1_n77	E-UTRA Band 1, 3, 5, 7, 8, 11, 18, 19, 20, 21, 26, 28, 34, 40, 41, 65, 74	F <sub>DL_low</sub>	-	F <sub>DL_high</sub>	-50	1	
	Frequency range	1880	-	1895	-40	1	5, 16
	Frequency range	1895	-	1915	-15.5	5	5, 7, 16
	Frequency range	1915	-	1920	+1.6	5	5, 7, 16
DC_1_n78	E-UTRA Band 1, 3, 5, 7, 8, 11, 18, 19, 20, 21, 26, 28, 34, 40, 41, 65, 74	F <sub>DL_low</sub>	-	F <sub>DL_high</sub>	-50	1	
	Frequency range	1880	-	1895	-40	1	5, 16
	Frequency range	1895	-	1915	-15.5	5	5, 7, 16
	Frequency range	1915	-	1920	+1.6	5	5, 7, 16
DC_1_n79	E-UTRA Band 1, 3, 5, 7, 8, 11, 18, 19, 21, 26, 28, 34, 40, 41, 42, 65, 74	F <sub>DL_low</sub>	-	F <sub>DL_high</sub>	-50	1	
	Frequency range	1880	-	1895	-40	1	5, 16
	Frequency range	1895	-	1915	-15.5	5	5, 7, 16
	Frequency range	1915	-	1920	+1.6	5	5, 7, 16
DC_2_n5	E-UTRA Bands 4, 5, 12, 13, 14, 17, 24, 26, 28, 29, 30, 42, 48, 50, 51, 66, 70, 71, 74, 85	F <sub>DL_low</sub>	-	F <sub>DL_high</sub>	-50	1	
	E-UTRA Bands 2, 25	F <sub>DL_low</sub>	-	F <sub>DL_high</sub>	-50	1	2
	E-UTRA Band 41, 43, 53	F <sub>DL_low</sub>	-	F <sub>DL_high</sub>	-50	1	2
DC_2_n66	E-UTRA Bands 4, 5, 12, 13, 14, 17, 24, 26, 27, 28, 29, 30, 41, 50, 51, 66, 70, 71, 74, 85	F <sub>DL_low</sub>	-	F <sub>DL_high</sub>	-50	1	
	E-UTRA Bands 2, 25	F <sub>DL_low</sub>	-	F <sub>DL_high</sub>	-50	1	5
	E-UTRA Bands 42, 48	F <sub>DL_low</sub>	-	F <sub>DL_high</sub>	-50	1	2
DC_2_n71	E-UTRA Band 4, 5, 12, 13, 14, 17, 24, 26, 29, 30, 48, 66	F <sub>DL_low</sub>	-	F <sub>DL_high</sub>	-50	1	
	E-UTRA Band 2, 25, 41, 70	F <sub>DL_low</sub>	-	F <sub>DL_high</sub>	-50	1	2
	E-UTRA Band n71	F <sub>DL_low</sub>	-	F <sub>DL_high</sub>	-50	1	5
DC_2_n78	E-UTRA Band 4, 5, 12, 13, 14, 17, 24, 26, 27, 28, 29, 30, 41, 50, 51, 66, 70, 71, 74, 85	F <sub>DL_low</sub>	-	F <sub>DL_high</sub>	-50	1	
	E-UTRA Band 2, 25	F <sub>DL_low</sub>	-	F <sub>DL_high</sub>	-50	1	2
DC_3_n7	E-UTRA Band 1, 5, 7, 8, 20, 26, 27, 28, 31, 32, 33, 34, 40, 43, 44, 50, 51, 65, 67, 72, 74, 75, 76	F <sub>DL_low</sub>	-	F <sub>DL_high</sub>	-50	1	
	E-UTRA band 3	F <sub>DL_low</sub>	-	F <sub>DL_high</sub>	-50	1	5
	E-UTRA band 22, 42	F <sub>DL_low</sub>	-	F <sub>DL_high</sub>	-50	1	2
	Frequency range	2570	-	2575	+1.6	5	5, 6, 7
	Frequency range	2575	-	2595	-15.5	5	5, 6, 7
Frequency range	2595	-	2620	-40	1	5, 6	

DC_3_n8	E-UTRA Band 1, 11, 20, 21, 28, 31, 32, 33, 34, 38, 39, 40, 45, 50, 51, 65, 67,68, 69, 72, 73, 74, 75, 76	F <sub>DL_low</sub>	-	F <sub>DL_high</sub>	-50	1	
	E-UTRA band 3, 8	F <sub>DL_low</sub>	-	F <sub>DL_high</sub>	-50	1	2, 5
	E-UTRA band 7, 22, 41, 42, 43, 52 NR Band n77, n78, n79	F <sub>DL_low</sub>	-	F <sub>DL_high</sub>	-50	1	2
	Frequency range	1884.5	-	1915.7	-41	0.3	3
DC_3_n28	E-UTRA Band 1, 42, 43, 50, 51, 65, 74, 75, 76 NR band n77, n78, n79	F <sub>DL_low</sub>	-	F <sub>DL_high</sub>	-50	1	2
	E-UTRA band 1	F <sub>DL_low</sub>	-	F <sub>DL_high</sub>	-50	1	9, 11
	E-UTRA band 3	F <sub>DL_low</sub>	-	F <sub>DL_high</sub>	-50	1	5
	E-UTRA Band 5, 7, 8, 18, 19, 20, 26, 27, 31, 34, 38, 40, 41, 72	F <sub>DL_low</sub>	-	F <sub>DL_high</sub>	-50	1	
	E-UTRA Band 11, 21	F <sub>DL_low</sub>	-	F <sub>DL_high</sub>	-50	1	9, 10
	Frequency range	1884.5	-	1915.7	-41	0.3	13
	Frequency range	470	-	710	-26.2	6	14
	Frequency range	758	-	773	-32	1	5
	Frequency range	773	-	803	-50	1	
Frequency range	1884.5	-	1915.7	-41	0.3	3, 9	
DC_3_n77	E-UTRA Band 1, 3, 5, 7, 8, 11, 18, 19, 20, 21, 26, 28, 34, 39, 40, 41, 65, 74	F <sub>DL_low</sub>	-	F <sub>DL_high</sub>	-50	1	
	Frequency range	1884.5	-	1915.7	-41	0.3	3
DC_3_n78 DC_3_n80_ULS UP-TDM_n78	E-UTRA Band 1, 3, 5, 7, 8, 11, 18, 19, 20, 21, 26, 28, 34, 39, 40, 41, 65, 74	F <sub>DL_low</sub>	-	F <sub>DL_high</sub>	-50	1	
	Frequency range	1884.5	-	1915.7	-41	0.3	3
DC_3_n79	E-UTRA Band 1, 3, 5, 8, 11, 18, 19, 21, 28, 34, 39, 40, 41, 65, 74	F <sub>DL_low</sub>	-	F <sub>DL_high</sub>	-50	1	
	E-UTRA Band 42	F <sub>DL_low</sub>	-	F <sub>DL_high</sub>	-50	1	2
	Frequency range	1884.5	-	1915.7	-41	0.3	3
DC_5_n66	E-UTRA Band 1, 2, 3, 4, 5, 6, 7, 8, 12, 13, 14, 17, 24, 25, 28, 29, 30, 34, 38, 40, 43, 45, 50, 51, 65, 66, 70, 71, 85	F <sub>DL_low</sub>	-	F <sub>DL_high</sub>	-50	1	
	E-UTRA Band 26	859	-	869	-27	1	
	E-UTRA Band 41, 42, 48, 52	F <sub>DL_low</sub>	-	F <sub>DL_high</sub>	-50	1	2
DC_5_n78	E-UTRA Band 1, 2, 3, 4, 5, 7, 8, 12, 13, 14, 17, 24, 25, 28, 29, 30, 31, 34, 38, 40, 45, 65, 66, 70	F <sub>DL_low</sub>	-	F <sub>DL_high</sub>	-50	1	
	E-UTRA Band 26	859	-	869	-27	1	
	E-UTRA Band 41	F <sub>DL_low</sub>	-	F <sub>DL_high</sub>	-50	1	2,7
DC_7_n28	E-UTRA Band 2, 3, 5, 7, 8, 20, 26, 27, 31, 34, 40, 72	F <sub>DL_low</sub>	-	F <sub>DL_high</sub>	-50	1	
	E-UTRA Band 1, 4, 42, 43, 50, 65, 66, 74, 75, 76 NR band n78	F <sub>DL_low</sub>	-	F <sub>DL_high</sub>	-50	1	2
	E-UTRA band 1	F <sub>DL_low</sub>	-	F <sub>DL_high</sub>	-50	1	9, 10
	Frequency range	758	-	773	-32	1	5
	Frequency range	773	-	803	-50	1	
	Frequency range	2570	-	2575	+1.6	5	5, 6, 7
	Frequency range	2575	-	2595	-15.5	5	5, 6, 7
Frequency range	2595	-	2620	-40	1	5, 6	
DC_7_n78	E-UTRA Band 1, 2, 3, 4, 5, 7, 8, 11, 18, 19, 20, 21, 26, 27, 28, 31, 32, 33, 34, 40, 50, 51, 65, 66, 67, 68, 72, 74, 75, 76	F <sub>DL_low</sub>	-	F <sub>DL_high</sub>	-50	1	
	Frequency range	2570	-	2575	+1.6	5	5, 6, 7
	Frequency range	2575	-	2595	-15.5	5	5, 6, 7
	Frequency range	2595	-	2620	-40	1	5, 6
DC_8_n77	E-UTRA Band 1, 20, 28, 31, 32, 33, 34, 38, 39, 40, 44, 45, 50, 51, 65, 67, 68, 69, 72, 73, 74, 75, 76	F <sub>DL_low</sub>	-	F <sub>DL_high</sub>	-50	1	

	E-UTRA band 3, 7, 41	F <sub>DL_low</sub>	-	F <sub>DL_high</sub>	-50	1	2
	E-UTRA Band 8	F <sub>DL_low</sub>	-	F <sub>DL_high</sub>	-50	1	5
	E-UTRA Band 11, 21	F <sub>DL_low</sub>	-	F <sub>DL_high</sub>	-50	1	12
	Frequency range	860	-	890	-40	1	5, 12
	Frequency range	1884.5	-	1915.7	-41	0.3	3, 12
DC_8_n78	E-UTRA Band 1, 20, 28, 34, 39, 40, 65, 74	F <sub>DL_low</sub>	-	F <sub>DL_high</sub>	-50	1	
	E-UTRA Band 3, 7, 41	F <sub>DL_low</sub>	-	F <sub>DL_high</sub>	-50	1	2
	E-UTRA Band 8	F <sub>DL_low</sub>	-	F <sub>DL_high</sub>	-50	1	5
	E-UTRA Band 11, 21	F <sub>DL_low</sub>	-	F <sub>DL_high</sub>	-50	1	12
	Frequency range	860	-	890	-40	1	5, 12
	Frequency range	1884.5	-	1915.7	-41	0.3	3, 12
DC_11_n77	E-UTRA Band 1, 3, 18, 19, 28, 34, 40, 65	F <sub>DL_low</sub>	-	F <sub>DL_high</sub>	-50	1	
	Frequency range	945	-	960	-50	1	
	Frequency range	1884.5	-	1915.7	-41	0.3	3
	Frequency range	2545	-	2575	-50	1	
	Frequency range	2595	-	2645	-50	1	
DC_11_n78	E-UTRA Band 1, 3, 18, 19, 28, 34, 40, 65	F <sub>DL_low</sub>	-	F <sub>DL_high</sub>	-50	1	
	Frequency range	945	-	960	-50	1	
	Frequency range	1884.5	-	1915.7	-41	0.3	3
	Frequency range	2545	-	2575	-50	1	
	Frequency range	2595	-	2645	-50	1	
DC_11_n79	E-UTRA Band 1, 3, 18, 19, 28, 34, 40, 42, 65	F <sub>DL_low</sub>	-	F <sub>DL_high</sub>	-50	1	
	Frequency range	945	-	960	-50	1	
	Frequency range	1884.5	-	1915.7	-41	0.3	3
	Frequency range	2545	-	2575	-50	1	
	Frequency range	2595	-	2645	-50	1	
DC_12_n66	E-UTRA Band 2, 5, 13, 14, 17, 25, 26, 27, 30, 41, 71, 74	F <sub>DL_low</sub>	-	F <sub>DL_high</sub>	-50	1	
	E-UTRA Bands 4, 48, 50, 51, 66, 70	F <sub>DL_low</sub>	-	F <sub>DL_high</sub>	-50	1	2
	E-UTRA Band 12, 85	F <sub>DL_low</sub>	-	F <sub>DL_high</sub>	-50	1	5
DC_19_n77	E-UTRA Band 1, 3, 11, 21, 28, 34, 40, 65, 74	F <sub>DL_low</sub>	-	F <sub>DL_high</sub>	-50	1	
	Frequency range	945	-	960	-50	1	
	Frequency range	1884.5	-	1915.7	-41	0.3	3
	Frequency range	2545	-	2575	-50	1	
	Frequency range	2595	-	2645	-50	1	
DC_19_n78	E-UTRA Band 1, 3, 11, 21, 28, 34, 40, 65, 74	F <sub>DL_low</sub>	-	F <sub>DL_high</sub>	-50	1	
	Frequency range	945	-	960	-50	1	
	Frequency range	1884.5	-	1915.7	-41	0.3	3
	Frequency range	2545	-	2575	-50	1	
	Frequency range	2595	-	2645	-50	1	
DC_19_n79	E-UTRA Band 1, 3, 11, 21, 28, 34, 40, 42, 65, 74	F <sub>DL_low</sub>	-	F <sub>DL_high</sub>	-50	1	
	Frequency range	945	-	960	-50	1	
	Frequency range	1884.5	-	1915.7	-41	0.3	3
	Frequency range	2545	-	2575	-50	1	
	Frequency range	2595	-	2645	-50	1	
DC_20_n28	E-UTRA Band 3, 7, 8, 31, 34	F <sub>DL_low</sub>	-	F <sub>DL_high</sub>	-50	1	
	E-UTRA Band 1, 22, 32, 38, 42, 43, 65, 75, 76	F <sub>DL_low</sub>	-	F <sub>DL_high</sub>	-50	1	2
	NR Band n78						
DC_20_n78	E-UTRA Band 1, 3, 7, 8, 31, 32, 33, 34, 40, 50, 51, 65, 67, 68, 72, 74, 75, 76	F <sub>DL_low</sub>	-	F <sub>DL_high</sub>	-50	1	
	E-UTRA Band 20	F <sub>DL_low</sub>	-	F <sub>DL_high</sub>	-50	1	5
	E-UTRA Band 38, 69	F <sub>DL_low</sub>	-	F <sub>DL_high</sub>	-50	1	2
DC_21_n77	E-UTRA Band 1, 3, 18, 19, 21, 28, 34, 40, 42, 65	F <sub>DL_low</sub>	-	F <sub>DL_high</sub>	-50	1	
	Frequency range	945	-	960	-50	1	
	Frequency range	1884.5	-	1915.7	-41	0.3	3

	Frequency range	2545	-	2575	-50	1	
	Frequency range	2595	-	2645	-50	1	
DC_21_n78	E-UTRA Band 1, 3, 18, 19, 21, 28, 34, 40, 65	F <sub>DL_low</sub>	-	F <sub>DL_high</sub>	-50	1	
	Frequency range	945	-	960	-50	1	
	Frequency range	1884.5	-	1915.7	-41	0.3	3
	Frequency range	2545	-	2575	-50	1	
	Frequency range	2595	-	2645	-50	1	
DC_21_n79	E-UTRA Band 1, 3, 18, 19, 21, 28, 34, 42, 65	F <sub>DL_low</sub>	-	F <sub>DL_high</sub>	-50	1	
	Frequency range	945	-	960	-50	1	
	Frequency range	1884.5	-	1915.7	-41	0.3	3
	Frequency range	2545	-	2575	-50	1	
	Frequency range	2595	-	2645	-50	1	
DC_25_n41	E-UTRA band 4, 5, 12, 13, 14, 17, 24, 26, 27, 28, 29, 30, 42, 45, 66, 70,71	F <sub>DL_low</sub>	-	F <sub>DL_high</sub>	-50	1	
	E-UTRA Band 48	F <sub>DL_low</sub>	-	F <sub>DL_high</sub>	-50	1	2
	E-UTRA/NR Band 2, 25	F <sub>DL_low</sub>	-	F <sub>DL_high</sub>	-50	1	5
DC_26_n41	E-UTRA/NR Band 1, 2, 3, 4, 5, 11, 12, 13, 14, 17, 18, 19, 21, 24, 25, 26, 29, 30, 31, 34, 39, 42, 43, 48, 50, 51, 65, 66, 70, 71, 74	F <sub>DL_low</sub>	-	F <sub>DL_high</sub>	-50	1	
	Frequency range	1884.5	-	1915.7	-41	0.3	3
	Frequency range	703	-	799	-50	1	
	Frequency range	799	-	803	-40	1	5
	Frequency range	945	-	960	-50	1	
DC_26_n77	E-UTRA Band 1, 3, 5, 11, 18, 19, 21, 26, 34, 39, 40, 65, 74	F <sub>DL_low</sub>	-	F <sub>DL_high</sub>	-50	1	
	E-UTRA Band 41	F <sub>DL_low</sub>	-	F <sub>DL_high</sub>	-50	1	2
	Frequency range	703	-	799	-50	1	
	Frequency range	799	-	803	-40	1	5
	Frequency range	945	-	960	-50	1	
	Frequency range	1884.5	-	1915.7	-41	0.3	3
	Frequency range	2545	-	2575	-50	1	2
	Frequency range	2595	-	2645	-50	1	
DC_26_n78	E-UTRA Band 1, 3, 5, 11, 18, 19, 21, 26, 34, 39, 40, 65, 74	F <sub>DL_low</sub>	-	F <sub>DL_high</sub>	-50	1	
	E-UTRA Band 41	F <sub>DL_low</sub>	-	F <sub>DL_high</sub>	-50	1	2
	Frequency range	703	-	799	-50	1	
	Frequency range	799	-	803	-40	1	5
	Frequency range	945	-	960	-50	1	
	Frequency range	1884.5	-	1915.7	-41	0.3	3
	Frequency range	2545	-	2575	-50	1	2
	Frequency range	2595	-	2645	-50	1	
DC_26_n79	E-UTRA Band 1, 3, 5, 11, 18, 19, 21, 26, 34, 39, 40, 42, 65, 74	F <sub>DL_low</sub>	-	F <sub>DL_high</sub>	-50	1	
	E-UTRA Band 41	F <sub>DL_low</sub>	-	F <sub>DL_high</sub>	-50	1	2
	Frequency range	703	-	799	-50	1	
	Frequency range	799	-	803	-40	1	5
	Frequency range	945	-	960	-50	1	
	Frequency range	1884.5	-	1915.7	-41	0.3	3
	Frequency range	2545	-	2575	-50	1	2
	Frequency range	2595	-	2645	-50	1	
DC_28_n77	E-UTRA Band 3, 5, 7, 8, 18, 19, 20, 26, 34, 39, 40, 41	F <sub>DL_low</sub>	-	F <sub>DL_high</sub>	-50	1	
	E-UTRA Band 1, 65, 74	F <sub>DL_low</sub>	-	F <sub>DL_high</sub>	-50	1	2
	E-UTRA Band 1	F <sub>DL_low</sub>	-	F <sub>DL_high</sub>	-50	1	9, 11
	E-UTRA Band 11, 21	F <sub>DL_low</sub>	-	F <sub>DL_high</sub>	-50	1	9, 10
	Frequency range	758	-	773	-32	1	
	Frequency range	773	-	803	-50	1	
	Frequency range	1884.5	-	1915.7	-41	0.3	3, 9
DC_28_n78	E-UTRA Band 3, 5, 7, 8, 18, 19, 20, 26, 34, 39, 40, 41	F <sub>DL_low</sub>	-	F <sub>DL_high</sub>	-50	1	
	E-UTRA Band 1, 65, 74	F <sub>DL_low</sub>	-	F <sub>DL_high</sub>	-50	1	2

	E-UTRA Band 1	F <sub>DL_low</sub>	-	F <sub>DL_high</sub>	-50	1	9, 11
	E-UTRA Band 11, 21	F <sub>DL_low</sub>	-	F <sub>DL_high</sub>	-50	1	9, 10
	Frequency range	758	-	773	-32	1	
	Frequency range	773	-	803	-50	1	
	Frequency range	1884.5	-	1915.7	-41	0.3	3, 9
DC_28_n79	E-UTRA Band 3, 5, 8, 18, 19, 34, 39, 40, 41	F <sub>DL_low</sub>	-	F <sub>DL_high</sub>	-50	1	
	E-UTRA Band 1, 42, 65, 74	F <sub>DL_low</sub>	-	F <sub>DL_high</sub>	-50	1	2
	E-UTRA Band 1	F <sub>DL_low</sub>	-	F <sub>DL_high</sub>	-50	1	9, 11
	E-UTRA Band 11, 21	F <sub>DL_low</sub>	-	F <sub>DL_high</sub>	-50	1	9, 10
	Frequency range	758	-	773	-32	1	
	Frequency range	773	-	803	-50	1	
	Frequency range	1884.5	-	1915.7	-41	0.3	3, 9
DC_30_n5	E-UTRA Band 2, 4, 5, 7, 12, 13, 14, 17, 24, 25, 26, 29, 30, 38, 48, 66, 70, 71, 85	F <sub>DL_low</sub>	-	F <sub>DL_high</sub>	-50	1	
	E-UTRA Band 41, 48, 52	F <sub>DL_low</sub>	-	F <sub>DL_high</sub>	-50	1	2
DC_38_n78	N/A						
DC_39_n79	E-UTRA Band 1, 8, 28, 34, 40, 41, 44, 45	F <sub>DL_low</sub>	-	F <sub>DL_high</sub>	-50	1	
	Frequency range	1805	-	1855	-40	1	18
	Frequency range	1855	-	1880	-15.5	5	18
DC_41_n77	E-UTRA Band 1, 3, 5, 8, 11, 18, 19, 21, 26, 28, 33, 34, 39, 40, 44, 45, 73, 74	F <sub>DL_low</sub>	-	F <sub>DL_high</sub>	-50	1	
	Frequency range	1884.5	-	1915.7	-41	0.3	3
DC_41_n78	E-UTRA Band 1, 3, 5, 8, 11, 18, 19, 21, 26, 28, 34, 39, 40, 44, 45, 74	F <sub>DL_low</sub>	-	F <sub>DL_high</sub>	-50	1	
	Frequency range	1884.5	-	1915.7	-41	0.3	3
DC_41_n79	E-UTRA Band 1, 3, 5, 8, 11, 18, 19, 21, 26, 28, 34, 40, 42, 44, 45, 65, 74	F <sub>DL_low</sub>	-	F <sub>DL_high</sub>	-50	1	
	Frequency range	1884.5	-	1915.7	-41	0.3	3
DC_42_n77	N/A						
DC_42_n78	N/A						
DC_42_n79	N/A						
DC_66_n5	E-UTRA Band 1, 2, 3, 4, 5, 6, 7, 8, 12, 13, 14, 17, 24, 25, 26, 28, 29, 30, 34, 38, 40, 43, 45, 50, 51, 65, 66, 70, 71, 85	F <sub>DL_low</sub>	-	F <sub>DL_high</sub>	-50	1	
	E-UTRA Band 41, 42, 48, 52	F <sub>DL_low</sub>	-	F <sub>DL_high</sub>	-50	1	2
DC_66_n71	E-UTRA Band 4, 5, 13, 14, 17, 24, 26, 27, 29, 30, 43, 50, 51, 66, 74	F <sub>DL_low</sub>	-	F <sub>DL_high</sub>	-50	1	
	E-UTRA Band 2, 7, 22, 25, 41, 42, 48, 70	F <sub>DL_low</sub>	-	F <sub>DL_high</sub>	-50	1	2
	E-UTRA Band 71	F <sub>DL_low</sub>	-	F <sub>DL_high</sub>	-50	1	5
DC_66_n78	E-UTRA Band 1, 3, 5, 7, 8, 20, 26, 28, 34, 39, 40, 41, 65	F <sub>DL_low</sub>	-	F <sub>DL_high</sub>	-50	1	



- NOTE 1:  $F_{DL\_low}$  and  $F_{DL\_high}$  refer to each frequency band specified in Table 5.5-1 of TS 36.101 [5] or in Table 5.2-1 in TS 38.101-1 [2].
- NOTE 2: As exceptions, measurements with a level up to the applicable requirements defined in Table 6.6.3.1-2 in TS 36.101 [5] and Table 6.5.3.1-2 in TS 38.101-1 [2] are permitted for each assigned carrier used in the measurement due to 2<sup>nd</sup>, 3<sup>rd</sup>, 4<sup>th</sup> or 5<sup>th</sup> harmonic spurious emissions. Due to spreading of the harmonic emission the exception is also allowed for the first 1 MHz frequency range immediately outside the harmonic emission on both sides of the harmonic emission. This results in an overall exception interval centred at the harmonic emission of  $(2\text{MHz} + N \times L_{CRB} \times 180\text{kHz})$ , where N is 2, 3, 4, 5 for the 2<sup>nd</sup>, 3<sup>rd</sup>, 4<sup>th</sup> or 5<sup>th</sup> harmonic respectively. The exception is allowed if the measurement bandwidth (MBW) totally or partially overlaps the overall exception interval.
- NOTE 3: Applicable when co-existence with PHS system operating in 1884.5 - 1915.7MHz.
- NOTE 4: Void.
- NOTE 5: These requirements also apply for the frequency ranges that are less than  $F_{OOB}$  (MHz) in Table 6.6.3.1-1, Table 6.6.3.1A-1 in TS 36.101 [5] or in Table 6.5.3.1-1 in TS 38.101-1 [2] from the edge of the channel bandwidth.
- NOTE 6: This requirement is applicable for any channel bandwidths within the range 2500 - 2570 MHz with the following restriction: for carriers of 15 MHz bandwidth when carrier centre frequency is within the range 2560.5 - 2562.5 MHz and for carriers of 20 MHz bandwidth when carrier centre frequency is within the range 2552 - 2560 MHz the requirement is applicable only for an uplink transmission bandwidth less than or equal to 54 RB.
- NOTE 7: For these adjacent bands, the emission limit could imply risk of harmful interference to UE(s) operating in the protected operating band.
- NOTE 8: Void
- NOTE 9: Applicable when the assigned E-UTRA or NR carrier is confined within 718 MHz and 748 MHz and when the channel bandwidth used is 5 or 10 MHz.
- NOTE 10: As exceptions, measurements with a level up to the applicable requirement of -38 dBm/MHz is permitted for each assigned E-UTRA carrier used in the measurement due to 2<sup>nd</sup> harmonic spurious emissions. An exception is allowed if there is at least one individual RB within the transmission bandwidth (see Figure 5.6-1) for which the 2<sup>nd</sup> harmonic totally or partially overlaps the measurement bandwidth (MBW).
- NOTE 11: As exceptions, measurements with a level up to the applicable requirement of -36 dBm/MHz is permitted for each assigned E-UTRA carrier used in the measurement due to 3<sup>rd</sup> harmonic spurious emissions. An exception is allowed if there is at least one individual RB within the transmission bandwidth (see Figure 5.6-1) for which the 3<sup>rd</sup> harmonic totally or partially overlaps the measurement bandwidth (MBW).
- NOTE 12: This requirement is applicable only for the following cases:  
 A: for carriers of 5 MHz channel bandwidth when carrier centre frequency ( $F_c$ ) is within the range  $902.5 \text{ MHz} \leq F_c < 907.5 \text{ MHz}$  with an uplink transmission bandwidth less than or equal to 20 RB;  
 B: for carriers of 5 MHz channel bandwidth when carrier centre frequency ( $F_c$ ) is within the range  $907.5 \text{ MHz} \leq F_c \leq 912.5 \text{ MHz}$  without any restriction on uplink transmission bandwidth.  
 C: for carriers of 10 MHz channel bandwidth when carrier centre frequency ( $F_c$ ) is  $F_c = 910 \text{ MHz}$  with an uplink transmission bandwidth less than or equal to 32 RB with  $RB_{start} > 3$ .
- NOTE 13: Void.
- NOTE 14: This requirement is applicable for 5 and 10 MHz E-UTRA or NR channel bandwidth allocated within 718-728MHz. For carriers of 10 MHz bandwidth, this requirement applies for an uplink transmission bandwidth less than or equal to 30 RB with  $RB_{start} > 1$  and  $RB_{start} < 48$ .
- NOTE 15: Void.
- NOTE 16: This requirement is applicable for any channel bandwidths within the range 1920 - 1980 MHz with the following restriction: for carriers of 15 MHz bandwidth when carrier centre frequency is within the range 1927.5 - 1929.5 MHz and for carriers of 20 MHz bandwidth when carrier centre frequency is within the range 1930 - 1938 MHz the requirement is applicable only for an uplink transmission bandwidth less than or equal to 54 RB.
- NOTE 17: This requirement is applicable in the case of a 10 MHz E-UTRA or NR carrier confined within 703 MHz and 733 MHz, otherwise the requirement of -25 dBm with a measurement bandwidth of 8 MHz applies.
- NOTE 18: This requirement is only applicable for E-UTRA carriers with bandwidth confined within 1885 - 1920 MHz (requirement for carriers with at least 1RB confined within 1880 - 1885 MHz is not specified). This requirement applies for an uplink transmission bandwidth less than or equal to 54 RB for E-UTRA carriers of 15 MHz bandwidth when carrier centre frequency is within the range 1892.5 - 1894.5 MHz and for E-UTRA carriers of 20 MHz bandwidth when carrier centre frequency is within the range 1895 - 1903 MHz.
- NOTE 19: Void.

**Table 6.5B.3.3.2.3-2: Spurious emission band UE co-existence limits Rel-16**

EN-DC Configuration	Spurious emission				
	Protected band	Frequency range (MHz)	Maximum Level (dBm)	MBW (MHz)	NOTE

DC_1_n3	Frequency range	1880		1895	-40	1	5,16
	Frequency range	1895		1915	-15.5	5	5, 7, 16
	Frequency range	1915		1920	+1.6	5	5, 7, 16
DC_1_n7	Frequency range	1880		1895	-40	1	5,16
	Frequency range	1895		1915	-15.5	5	5, 7, 16
	Frequency range	1915		1920	+1.6	5	5, 7, 16
	Frequency range	2570	-	2575	+1.6	5	5, 6, 7
	Frequency range	2575	-	2595	-15.5	5	5, 6, 7
	Frequency range	2595	-	2620	-40	1	5, 6
DC_1_n8	Frequency range	1880		1895	-40	1	5, 16
	Frequency range	1895		1915	-15.5	5	5, 7, 16
	Frequency range	1915		1920	+1.6	5	5, 7, 16
DC_1_n28	Frequency range	470	-	694	-42	8	5, 17
	Frequency range	470	-	710	-26.2	6	14
	Frequency range	758	-	773	-32	1	5
	Frequency range	773	-	803	-50	1	
	Frequency range	662	-	694	-26.2	6	5
	Frequency range	1880	-	1895	-40	1	5, 16
	Frequency range	1895	-	1915	-15.5	5	5, 7, 16
	Frequency range	1915	-	1920	+1.6	5	5, 7, 16
DC_1_n77	Frequency range	1880	-	1895	-40	1	5, 16
	Frequency range	1895	-	1915	-15.5	5	5, 7, 16
	Frequency range	1915	-	1920	+1.6	5	5, 7, 16
DC_1_n78	Frequency range	1880	-	1895	-40	1	5, 16
	Frequency range	1895	-	1915	-15.5	5	5, 7, 16
	Frequency range	1915	-	1920	+1.6	5	5, 7, 16
DC_1_n79	Frequency range	1880	-	1895	-40	1	5, 16
	Frequency range	1895	-	1915	-15.5	5	5, 7, 16
	Frequency range	1915	-	1920	+1.6	5	5, 7, 16
DC_3_n1	Frequency range	1880	-	1895	-40	1	5,16
	Frequency range	1895	-	1915	-15.5	5	5, 7, 16
	Frequency range	1915	-	1920	+1.6	5	5, 7, 16
DC_3_n5	Frequency range	1884.5	-	1915.7	-41	0.3	3
DC_3_n7	Frequency range	2570	-	2575	+1.6	5	5, 6, 7
	Frequency range	2575	-	2595	-15.5	5	5, 6, 7
	Frequency range	2595	-	2620	-40	1	5, 6
DC_3_n28	Frequency range	1884.5	-	1915.7	-41	0.3	13
	Frequency range	470	-	710	-26.2	6	14
	Frequency range	758	-	773	-32	1	5
	Frequency range	773	-	803	-50	1	
	Frequency range	1884.5	-	1915.7	-41	0.3	3, 9
DC_3_n41	Frequency range	1884.5	-	1915.7	-41	0.3	3
DC_3_n77	Frequency range	1884.5	-	1915.7	-41	0.3	3
DC_3_n78 DC_3_n80_ULS UP-TDM_n78	Frequency range	1884.5	-	1915.7	-41	0.3	3
DC_3_n79	Frequency range	1884.5	-	1915.7	-41	0.3	3
DC_7_n1	Frequency range	1880	-	1895	-40	1	5,16
	Frequency range	1895	-	1915	-15.5	5	5, 7,16
	Frequency range	1915	-	1920	+1.6	5	5, 7,16
	Frequency range	2570	-	2575	+1.6	5	5, 6, 7
	Frequency range	2575	-	2595	-15.5	5	5, 6, 7
	Frequency range	2595	-	2620	-40	1	5, 6
DC_7_n3	Frequency range	2570	-	2575	+1.6	5	5, 6, 7
	Frequency range	2575	-	2595	-15.5	5	5, 6, 7
	Frequency range	2595	-	2620	-40	1	5, 6
DC_7_n5	Frequency range	2570	-	2575	+1.6	5	5, 7, 6
	Frequency range	2575	-	2595	-15.5	5	5, 7, 6
	Frequency range	2595	-	2620	-40	1	5, 14
DC_7_n8	Frequency range	2570	-	2575	+1.6	5	5, 6, 7
	Frequency range	2575	-	2595	-15.5	5	5, 6, 7
	Frequency range	2595	-	2620	-40	1	5, 6
DC_7_n28	Frequency range	758	-	773	-32	1	5
	Frequency range	773	-	803	-50	1	
	Frequency range	2570	-	2575	+1.6	5	5, 6, 7

	Frequency range	2575	-	2595	-15.5	5	5, 6, 7
	Frequency range	2595	-	2620	-40	1	5, 6
DC_7_n66	Frequency range	2570	-	2575	+1.6	5	5, 6, 7
	Frequency range	2575	-	2595	-15.5	5	5, 6, 7
	Frequency range	2595	-	2620	-40	1	5, 6
DC_7_n78	Frequency range	2570	-	2575	+1.6	5	5, 6, 7
	Frequency range	2575	-	2595	-15.5	5	5, 6, 7
	Frequency range	2595	-	2620	-40	1	5, 6
DC_8_n1	Frequency range	860	-	890	-40	1	5, 12
	Frequency range	1880	-	1895	-40	1	5, 16
	Frequency range	1895	-	1915	-15.5	5	5, 7, 16
	Frequency range	1915	-	1920	+1.6	5	5, 7, 16
DC_8_n3	Frequency range	1884.5	-	1915.7	-41	0.3	3, 12
	Frequency range	860	-	890	-40	1	5, 12
DC_8_n20	Frequency range	758	-	788	-50	1	
DC_8_n28	Frequency range	470	-	694	-42	8	5, 17
	Frequency range	470	-	710	-26.2	6	14
	Frequency range	662	-	694	-26.2	6	5
	Frequency range	758	-	773	-32	1	5
	Frequency range	773	-	803	-50	1	
	Frequency range	860	-	890	-40	1	5, 12
	Frequency range	1884.5	-	1915.7	-41	0.3	3, 9, 12
DC_8_n41	Frequency range	860	-	890	-40	1	5, 12
	Frequency range	1884.5	-	1915.7	-41	0.3	3
DC_8_n77	Frequency range	860	-	890	-40	1	5, 12
	Frequency range	1884.5	-	1915.7	-41	0.3	3, 12
DC_8_n78	Frequency range	860	-	890	-40	1	5, 12
	Frequency range	1884.5	-	1915.7	-41	0.3	3, 12
DC_11_n77	Frequency range	945	-	960	-50	1	
	Frequency range	1884.5	-	1915.7	-41	0.3	3
	Frequency range	2545	-	2575	-50	1	
	Frequency range	2595	-	2645	-50	1	
DC_11_n78	Frequency range	945	-	960	-50	1	
	Frequency range	1884.5	-	1915.7	-41	0.3	3
	Frequency range	2545	-	2575	-50	1	
	Frequency range	2595	-	2645	-50	1	
DC_11_n79	Frequency range	945	-	960	-50	1	
	Frequency range	1884.5	-	1915.7	-41	0.3	3
	Frequency range	2545	-	2575	-50	1	
	Frequency range	2595	-	2645	-50	1	
DC_12_n78	Frequency range	1884.5	-	1915.7	-41	0.3	3
DC_13_n2	Frequency range	769	-	775	-35	0.006 25	5
	Frequency range	799	-	805	-35	0.006 25	5
DC_13_n66	Frequency range	769	-	775	-35	0.006 25	5
	Frequency range	799	-	803	-35	0.006 25	5
DC_14_n2	Frequency range	769	-	775	-35	0.006 25	5
	Frequency range	799	-	805	-35	0.006 25	5
DC_14_n66	Frequency range	769	-	775	-35	0.006 25	5
	Frequency range	799	-	805	-35	0.006 25	5

DC_19_n77	Frequency range	945	-	960	-50	1	
	Frequency range	1884.5	-	1915.7	-41	0.3	3
	Frequency range	2545	-	2575	-50	1	
	Frequency range	2595	-	2645	-50	1	
DC_19_n78	Frequency range	945	-	960	-50	1	
	Frequency range	1884.5	-	1915.7	-41	0.3	3
	Frequency range	2545	-	2575	-50	1	
	Frequency range	2595	-	2645	-50	1	
DC_19_n79	Frequency range	945	-	960	-50	1	
	Frequency range	1884.5	-	1915.7	-41	0.3	3
	Frequency range	2545	-	2575	-50	1	
	Frequency range	2595	-	2645	-50	1	
DC_20_n1	Frequency range	758	-	788	-50	1	
DC_20_n3	Frequency range	758	-	788	-50	1	
DC_21_n77	Frequency range	945	-	960	-50	1	
	Frequency range	1884.5	-	1915.7	-41	0.3	3
	Frequency range	2545	-	2575	-50	1	
	Frequency range	2595	-	2645	-50	1	
DC_21_n78	Frequency range	945	-	960	-50	1	
	Frequency range	1884.5	-	1915.7	-41	0.3	3
	Frequency range	2545	-	2575	-50	1	
	Frequency range	2595	-	2645	-50	1	
DC_21_n79	Frequency range	945	-	960	-50	1	
	Frequency range	1884.5	-	1915.7	-41	0.3	3
	Frequency range	2545	-	2575	-50	1	
	Frequency range	2595	-	2645	-50	1	
DC_26_n41	Frequency range	1884.5	-	1915.7	-41	0.3	3
	Frequency range	703	-	799	-50	1	
	Frequency range	799	-	803	-40	1	5
	Frequency range	945	-	960	-50	1	
DC_26_n77	Frequency range	703	-	799	-50	1	
	Frequency range	799	-	803	-40	1	5
	Frequency range	945	-	960	-50	1	
	Frequency range	1884.5	-	1915.7	-41	0.3	3
	Frequency range	2545	-	2575	-50	1	2
	Frequency range	2595	-	2645	-50	1	
DC_26_n78	Frequency range	703	-	799	-50	1	
	Frequency range	799	-	803	-40	1	5
	Frequency range	945	-	960	-50	1	
	Frequency range	1884.5	-	1915.7	-41	0.3	3
	Frequency range	2545	-	2575	-50	1	2
	Frequency range	2595	-	2645	-50	1	
DC_26_n79	Frequency range	703	-	799	-50	1	
	Frequency range	799	-	803	-40	1	5
	Frequency range	945	-	960	-50	1	
	Frequency range	1884.5	-	1915.7	-41	0.3	3
	Frequency range	2545	-	2575	-50	1	
	Frequency range	2595	-	2645	-50	1	
DC_28_n3	Frequency range	470	-	710	-26.2	6	14
	Frequency range	758	-	773	-32	1	5
	Frequency range	773	-	803	-50	1	
	Frequency range	1884.5	-	1915.7	-41	0.3	3, 9
DC_28_n5	Frequency range	1884.5	-	1915.7	-41	0.3	3, 9
	Frequency range	470	-	694	-42	8	5, 17
	Frequency range	470	-	710	-26.2	6	14
	Frequency range	662	-	694	-26.2	6	5
	Frequency range	758	-	773	-32	1	5
	Frequency range	773	-	803	-50	1	
	Frequency range	773	-	803	-50	1	
DC_28_n7	Frequency range	758	-	773	-32	1	5
	Frequency range	773	-	803	-50	1	
	Frequency range	2570	-	2575	+1.6	5	5, 6, 7
	Frequency range	2575	-	2595	-15.5	5	5, 6, 7
	Frequency range	2595	-	2620	-40	1	5, 6
DC_28_n77	Frequency range	758	-	773	-32	1	
	Frequency range	773	-	803	-50	1	

	Frequency range	1884.5	-	1915.7	-41	0.3	3, 9
DC_28_n78	Frequency range	758	-	773	-32	1	
	Frequency range	773	-	803	-50	1	
	Frequency range	1884.5	-	1915.7	-41	0.3	3
DC_28_n79	Frequency range	758	-	773	-32	1	
	Frequency range	773	-	803	-50	1	
	Frequency range	1884.5	-	1915.7	-41	0.3	3, 9
DC_39_n41	Frequency range	1805	-	1855	-40	1	5
	Frequency range	1855	-	1880	-15.5	5	5, 7, 19
DC_39_n79	Frequency range	1805	-	1855	-40	1	18
	Frequency range	1855	-	1880	-15.5	5	18
DC_40_n78	Frequency range	1884.5	-	1915.7	-41	0.3	3
DC_40_n79	Frequency range	1884.5	-	1915.7	-41	0.3	3
DC_41_n77	Frequency range	1884.5		1915.7	-41	0.3	3
DC_41_n78	Frequency range	1884.5		1915.7	-41	0.3	3
DC_41_n79	Frequency range	1884.5	-	1915.7	-41	0.3	3
DC_48_n5	Frequency range	1884.5	-	1915.7	-41	0.3	3

- NOTE 1:  $F_{DL\_low}$  and  $F_{DL\_high}$  refer to each frequency band specified in Table 5.5-1 in TS 36.101 [5] or in Table 5.2-1 in TS 38.101-1 [2].
- NOTE 2: As exceptions, measurements with a level up to the applicable requirements defined in Table 6.6.3.1-2 in TS 36.101 [5] and Table 6.5.3.1-2 in TS 38.101-1 [2] are permitted for each assigned carrier used in the measurement due to 2<sup>nd</sup>, 3<sup>rd</sup>, 4<sup>th</sup> or 5<sup>th</sup> harmonic spurious emissions. Due to spreading of the harmonic emission the exception is also allowed for the first 1 MHz frequency range immediately outside the harmonic emission on both sides of the harmonic emission. This results in an overall exception interval centred at the harmonic emission of  $(2 \text{ MHz} + N \times L_{CRB} \times 180 \text{ kHz})$ , where N is 2, 3, 4, 5 for the 2<sup>nd</sup>, 3<sup>rd</sup>, 4<sup>th</sup> or 5<sup>th</sup> harmonic respectively. The exception is allowed if the measurement bandwidth (MBW) totally or partially overlaps the overall exception interval.
- NOTE 3: Applicable when co-existence with PHS system operating in 1884.5 - 1915.7 MHz
- NOTE 4: Void.
- NOTE 5: These requirements also apply for the frequency ranges that are less than  $F_{OoB}$  (MHz) in Table 6.6.3.1-1, Table 6.6.3.1A-1 in TS 36.101 [5] or in Table 6.5.3.1-1 in TS 38.101-1 [2] from the edge of the channel bandwidth.
- NOTE 6: This requirement is applicable for any channel bandwidths within the range 2500 - 2570 MHz with the following restriction: for carriers of 15 MHz bandwidth when carrier centre frequency is within the range 2560.5 - 2562.5 MHz and for carriers of 20 MHz bandwidth when carrier centre frequency is within the range 2552 - 2560 MHz the requirement is applicable only for an uplink transmission bandwidth less than or equal to 54 RB.
- NOTE 7: For these adjacent bands, the emission limit could imply risk of harmful interference to UE(s) operating in the protected operating band.
- NOTE 8: Void.
- NOTE 9: Applicable when the assigned E-UTRA or NR carrier is confined within 718 MHz and 748 MHz and when the channel bandwidth used is 5 or 10 MHz.
- NOTE 10: As exceptions, measurements with a level up to the applicable requirement of -38 dBm/MHz is permitted for each assigned E-UTRA carrier used in the measurement due to 2<sup>nd</sup> harmonic spurious emissions. An exception is allowed if there is at least one individual RB within the transmission bandwidth (see Figure 5.6-1) for which the 2<sup>nd</sup> harmonic totally or partially overlaps the measurement bandwidth (MBW).
- NOTE 11: As exceptions, measurements with a level up to the applicable requirement of -36 dBm/MHz is permitted for each assigned E-UTRA carrier used in the measurement due to 3<sup>rd</sup> harmonic spurious emissions. An exception is allowed if there is at least one individual RB within the transmission bandwidth (see Figure 5.6-1) for which the 3<sup>rd</sup> harmonic totally or partially overlaps the measurement bandwidth (MBW).
- NOTE 12: This requirement is applicable only for the following cases: A: for carriers of 5 MHz channel bandwidth when carrier centre frequency ( $F_c$ ) is within the range  $902.5 \text{ MHz} \leq F_c < 907.5 \text{ MHz}$  with an uplink transmission bandwidth less than or equal to 20 RB; B: for carriers of 5 MHz channel bandwidth when carrier centre frequency ( $F_c$ ) is within the range  $907.5 \text{ MHz} \leq F_c \leq 912.5 \text{ MHz}$  without any restriction on uplink transmission bandwidth; C: for carriers of 10 MHz channel bandwidth when carrier centre frequency ( $F_c$ ) is  $F_c = 910 \text{ MHz}$  with an uplink transmission bandwidth less than or equal to 32 RB with  $RB_{start} > 3$ .
- NOTE 13: Void.
- NOTE 14: This requirement is applicable for 5 and 10 MHz E-UTRA or NR channel bandwidth allocated within 718-728MHz. For carriers of 10 MHz bandwidth, this requirement applies for an uplink transmission bandwidth less than or equal to 30 RB with  $RB_{start} > 1$  and  $RB_{start} < 48$ .
- NOTE 15: Void.
- NOTE 16: This requirement is applicable for any channel bandwidths within the range 1920 - 1980 MHz with the following restriction: for carriers of 15 MHz bandwidth when carrier centre frequency is within the range 1927.5 - 1929.5 MHz and for carriers of 20 MHz bandwidth when carrier centre frequency is within the range 1930 - 1938 MHz the requirement is applicable only for an uplink transmission bandwidth less than or equal to 54 RB.
- NOTE 17: This requirement is applicable in the case of a 10 MHz E-UTRA or NR carrier confined within 703 MHz and 733 MHz, otherwise the requirement of -25 dBm with a measurement bandwidth of 8 MHz applies.
- NOTE 18: This requirement is only applicable for E-UTRA carriers with bandwidth confined within 1885 - 1920 MHz (requirement for carriers with at least 1RB confined within 1880 - 1885 MHz is not specified). This requirement applies for an uplink transmission bandwidth less than or equal to 54 RB for E-UTRA carriers of 15 MHz bandwidth when carrier centre frequency is within the range 1892.5 - 1894.5 MHz and for E-UTRA carriers of 20 MHz bandwidth when carrier centre frequency is within the range 1895 - 1903 MHz.
- NOTE 19: Void.
- NOTE 20: Void.
- NOTE 21: Void.
- NOTE 22: This requirement is applicable for power class 3 UE for any channel bandwidths within the range 2570 - 2615 MHz with the following restriction: for carriers of 15 MHz bandwidth when carrier centre frequency is within the range 2605.5 - 2607.5 MHz and for carriers of 20 MHz bandwidth when carrier centre frequency is within the range 2597 - 2605 MHz the requirement is applicable only for an uplink transmission bandwidth less than or equal to 54 RB.

**Table 6.5B.3.3.2.3-3: Spurious emission band UE co-existence limits Rel-17**

EN-DC Configuration	Spurious emission						
	Protected band	Frequency range (MHz)			Maximum Level (dBm)	MBW (MHz)	NOTE
DC_1_n3	Frequency range	1880		1895	-40	1	5, 16
	Frequency range	1895		1915	-15.5	5	5, 7, 16
	Frequency range	1915		1920	+1.6	5	5, 7, 16
DC_1_n7	Frequency range	1880		1895	-40	1	5, 16
	Frequency range	1895		1915	-15.5	5	5, 7, 16
	Frequency range	1915		1920	+1.6	5	5, 7, 16
	Frequency range	2570	-	2575	+1.6	5	5, 6, 7
	Frequency range	2575	-	2595	-15.5	5	5, 6, 7
	Frequency range	2595	-	2620	-40	1	5, 6
DC_1_n8	Frequency range	1880		1895	-40	1	5, 16
	Frequency range	1895		1915	-15.5	5	5, 7, 16
	Frequency range	1915		1920	+1.6	5	5, 7, 16
DC_1_n28	Frequency range	470	-	694	-42	8	5, 17
	Frequency range	470	-	710	-26.2	6	14
	Frequency range	758	-	773	-32	1	5
	Frequency range	773	-	803	-50	1	
	Frequency range	662	-	694	-26.2	6	5
	Frequency range	1880	-	1895	-40	1	5, 16
	Frequency range	1895	-	1915	-15.5	5	5, 7, 16
	Frequency range	1915	-	1920	+1.6	5	5, 7, 16
DC_1_n41	Frequency range	1880		1895	-40	1	5, 16
	Frequency range	1895		1915	-15.5	5	5, 7, 16
	Frequency range	1915		1920	+1.6	5	5, 7, 16, 20
DC_1_n77	Frequency range	1880	-	1895	-40	1	5, 16
	Frequency range	1895	-	1915	-15.5	5	5, 7, 16
	Frequency range	1915	-	1920	+1.6	5	5, 7, 16
DC_1_n78	Frequency range	1880	-	1895	-40	1	5, 16
	Frequency range	1895	-	1915	-15.5	5	5, 7, 16
	Frequency range	1915	-	1920	+1.6	5	5, 7, 16
DC_1_n79	Frequency range	1880	-	1895	-40	1	5, 16
	Frequency range	1895	-	1915	-15.5	5	5, 7, 16
	Frequency range	1915	-	1920	+1.6	5	5, 7, 16
DC_2_n7	Frequency range	2570	-	2575	1.6	5	5, 6, 7
	Frequency range	2575	-	2595	-15.5	5	5, 6, 7
	Frequency range	2595	-	2620	-40	1	5, 6
DC_3_n1	Frequency range	1880		1895	-40	1	5, 16
	Frequency range	1895		1915	-15.5	5	5, 7, 16
	Frequency range	1915		1920	+1.6	5	5, 7, 16
DC_3_n5	Frequency range	1884.5	-	1915.7	-41	0.3	3
DC_3_n8	Frequency range	1884.5	-	1915.7	-41	0.3	3
DC_3_n28	Frequency range	1884.5	-	1915.7	-41	0.3	13
	Frequency range	470	-	710	-26.2	6	14
	Frequency range	758	-	773	-32	1	5
	Frequency range	773	-	803	-50	1	
	Frequency range	1884.5	-	1915.7	-41	0.3	3, 9
DC_3_n41	Frequency range	1884.5	-	1915.7	-41	0.3	3
DC_3_n77	Frequency range	1884.5	-	1915.7	-41	0.3	3
DC_3_n78	Frequency range	1884.5	-	1915.7	-41	0.3	3
DC_3_n80_ULSUP-TDM_n78	Frequency range	1884.5	-	1915.7	-41	0.3	3
DC_3_n79	Frequency range	1884.5	-	1915.7	-41	0.3	3
DC_5_n7	Frequency range	2570	-	2575	+1.6	5	5, 7, 6
	Frequency range	2575	-	2595	-15.5	5	5, 7, 6
	Frequency range	2595	-	2620	-40	1	5, 14
DC_5_n30	Frequency range	1884.5	-	1915.7	-41	0.3	3
DC_5_n77	Frequency range	1884.5	-	1915.7	-41	0.3	3
DC_7_n1	Frequency range	1880		1895	-40	1	5, 16
	Frequency range	1895		1915	-15.5	5	5, 7, 16
	Frequency range	1915		1920	+1.6	5	5, 7, 16
	Frequency range	2570	-	2575	+1.6	5	5, 6, 7
	Frequency range	2575	-	2595	-15.5	5	5, 6, 7



EN-DC Configuration	Spurious emission						
	Protected band	Frequency range (MHz)		Maximum Level (dBm)	MBW (MHz)	NOTE	
	Frequency range	2595	-	2620	-40	1	5, 6
DC_7_n2	Frequency range	2570	-	2575	1.6	5	5, 6, 7
	Frequency range	2575	-	2595	-15.5	5	5, 6, 7
	Frequency range	2595	-	2620	-40	1	5, 6
DC_7_n3	Frequency range	2570	-	2575	+1.6	5	5, 6, 7
	Frequency range	2575	-	2595	-15.5	5	5, 6, 7
	Frequency range	2595	-	2620	-40	1	5, 6
DC_7_n5	Frequency range	2570	-	2575	+1.6	5	5, 7, 6
	Frequency range	2575	-	2595	-15.5	5	5, 7, 6
	Frequency range	2595	-	2620	-40	1	5, 14
DC_7_n8	Frequency range	2570	-	2575	+1.6	5	5, 6, 7
	Frequency range	2575	-	2595	-15.5	5	5, 6, 7
	Frequency range	2595	-	2620	-40	1	5, 6
DC_7_n28	Frequency range	758	-	773	-32	1	5
	Frequency range	773	-	803	-50	1	
	Frequency range	2570	-	2575	+1.6	5	5, 6, 7
	Frequency range	2575	-	2595	-15.5	5	5, 6, 7
	Frequency range	2595	-	2620	-40	1	5, 6
DC_7_n66	Frequency range	2570	-	2575	+1.6	5	5, 6, 7
	Frequency range	2575	-	2595	-15.5	5	5, 6, 7
	Frequency range	2595	-	2620	-40	1	5, 6
DC_7_n71	Frequency range	2570	-	2575	1.6	5	5, 6, 7
	Frequency range	2575	-	2595	-15.5	5	5, 6, 7
	Frequency range	2595	-	2620	-40	1	5, 6
DC_7_n77	Frequency range	2570	-	2575	+1.6	5	5, 6, 7
	Frequency range	2575	-	2595	-15.5	5	5, 6, 7
	Frequency range	2595	-	2620	-40	1	5, 6
DC_7_n78	Frequency range	2570	-	2575	+1.6	5	5, 6, 7
	Frequency range	2575	-	2595	-15.5	5	5, 6, 7
	Frequency range	2595	-	2620	-40	1	5, 6
DC_7_n80	Frequency range	2570	-	2575	+1.6	5	5, 6, 7
	Frequency range	2575	-	2595	-15.5	5	5, 6, 7
	Frequency range	2595	-	2620	-40	1	5, 6
DC_8_n1	Frequency range	860	-	890	-40	1	5, 12
	Frequency range	1880		1895	-40	1	5, 16
	Frequency range	1895		1915	-15.5	5	5, 7, 16
	Frequency range	1915		1920	+1.6	5	5, 7, 16
DC_8_n3	Frequency range	1884.5	-	1915.7	-41	0.3	3, 12
	Frequency range	860	-	890	-40	1	5, 12
DC_8_n20	Frequency range	758	-	788	-50	1	
DC_8_n28	Frequency range	470	-	694	-42	8	5, 17
	Frequency range	470	-	710	-26.2	6	14
	Frequency range	662	-	694	-26.2	6	5
	Frequency range	758	-	773	-32	1	5
	Frequency range	773	-	803	-50	1	
	Frequency range	860	-	890	-40	1	5, 12
	Frequency range	1884.5	-	1915.7	-41	0.3	3, 9, 12
DC_8_n41	Frequency range	860	-	890	-40	1	5, 12
	Frequency range	1884.5		1915.7	-41	0.3	3
DC_8_n77	Frequency range	860	-	890	-40	1	5, 12
	Frequency range	1884.5	-	1915.7	-41	0.3	3, 12
DC_8_n78	Frequency range	860	-	890	-40	1	5, 12
	Frequency range	1884.5	-	1915.7	-41	0.3	3, 12
DC_11_n77	Frequency range	945	-	960	-50	1	
	Frequency range	1884.5	-	1915.7	-41	0.3	3
	Frequency range	2545	-	2575	-50	1	
	Frequency range	2595	-	2645	-50	1	
DC_11_n78	Frequency range	945	-	960	-50	1	
	Frequency range	1884.5	-	1915.7	-41	0.3	3
	Frequency range	2545	-	2575	-50	1	
	Frequency range	2595	-	2645	-50	1	

EN-DC Configuration	Spurious emission						
	Protected band	Frequency range (MHz)			Maximum Level (dBm)	MBW (MHz)	NOTE
DC_11_n79	Frequency range	945	-	960	-50	1	
	Frequency range	1884.5	-	1915.7	-41	0.3	3
	Frequency range	2545	-	2575	-50	1	
	Frequency range	2595	-	2645	-50	1	
DC_12_n7	Frequency range	2570	-	2575	+1.6	5	5, 6, 7
	Frequency range	2575	-	2595	-15.5	5	5, 6, 7
	Frequency range	2595	-	2620	-40	1	5, 6
DC_12_n78	Frequency range	1884.5	-	1915.7	-41	0.3	3
DC_13_n2	Frequency range	769	-	775	-35	0.00625	5
	Frequency range	799	-	805	-35	0.00625	5
DC_13_n5	Frequency range	769	-	775	-35	0.00625	5
	Frequency range	799	-	805	-35	0.00625	5
DC_13_n7	Frequency range	769	-	775	-35	0.00625	5
	Frequency range	799	-	805	-35	0.00625	5
	Frequency range	2570	-	2575	+1.6	5	5, 6, 7
	Frequency range	2575	-	2595	-15.5	5	5, 6, 7
	Frequency range	2595	-	2620	-40	1	5, 6
DC_13_n48	Frequency range	769	-	775	-35	0.00625	5
	Frequency range	799	-	805	-35	0.00625	5
DC_13_n66	Frequency range	769	-	775	-35	0.00625	5
	Frequency range	799	-	803	-35	0.00625	5
DC_13_n71	Frequency range	769	-	775	-35	0.00625	5
	Frequency range	799	-	805	-35	0.00625	5
DC_13_n77	Frequency range	769	-	775	-35	0.00625	5
	Frequency range	799	-	805	-35	0.00625	5
	Frequency range	1884.5	-	1915.7	-41	0.3	3
DC_14_n2	Frequency range	769	-	775	-35	0.00625	5
	Frequency range	799	-	805	-35	0.00625	5
DC_14_n30	Frequency range	769	-	775	-35	0.00625	5
	Frequency range	799	-	805	-35	0.00625	5
DC_14_n77	Frequency range	769	-	775	-35	0.00625	5
	Frequency range	799	-	805	-35	0.00625	5
DC_14_n66	Frequency range	769	-	775	-35	0.00625	5
	Frequency range	799	-	805	-35	0.00625	5
DC_18_n3	Frequency range	945	-	960	-50	1	
	Frequency range	1884.5	-	1915.7	-41	0.3	3
	Frequency range	2545	-	2575	-50	1	
	Frequency range	2595	-	2645	-50	1	
DC_18_n79	Frequency range	945	-	960	-50	1	
	Frequency range	1884.5	-	1915.7	-41	0.3	3
	Frequency range	2545	-	2575	-50	1	
	Frequency range	2595	-	2645	-50	1	
DC_19_n1	Frequency range	945	-	960	-50	1	
	Frequency range	1880	-	1895	-40	1	5, 16
	Frequency range	1895	-	1915	-15.5	5	5, 7, 16
	Frequency range	1915	-	1920	+1.6	5	5, 7, 16
	Frequency range	2545	-	2575	-50	1	
	Frequency range	2595	-	2645	-50	1	
DC_19_n77	Frequency range	945	-	960	-50	1	
	Frequency range	1884.5	-	1915.7	-41	0.3	3
	Frequency range	2545	-	2575	-50	1	
	Frequency range	2595	-	2645	-50	1	
DC_19_n78	Frequency range	945	-	960	-50	1	
	Frequency range	1884.5	-	1915.7	-41	0.3	3
	Frequency range	2545	-	2575	-50	1	
	Frequency range	2595	-	2645	-50	1	
DC_19_n79	Frequency range	945	-	960	-50	1	
	Frequency range	1884.5	-	1915.7	-41	0.3	3
	Frequency range	2545	-	2575	-50	1	
	Frequency range	2595	-	2645	-50	1	
DC_20_n1	Frequency range	758	-	788	-50	1	

EN-DC Configuration	Spurious emission						
	Protected band	Frequency range (MHz)			Maximum Level (dBm)	MBW (MHz)	NOTE
DC_20_n3	Frequency range	758	-	788	-50	1	
DC_20A_91A_ULSUP-TDM, DC_20A_92A_ULSUP-TDM	Frequency range	758	-	788	-50	1	
DC_21_n1	Frequency range	945	-	960	-50	1	
	Frequency range	1880	-	1895	-40	1	5, 16
	Frequency range	1895	-	1915	-15.5	5	5, 7, 16
	Frequency range	1915	-	1920	+1.6	5	5, 7, 16
	Frequency range	2545	-	2575	-50	1	
DC_21_n28	Frequency range	2595	-	2645	-50	1	
	Frequency range	470	-	694	-42	8	5, 17
	Frequency range	470	-	710	-26.2	6	14
	Frequency range	662	-	694	-26.2	6	5
	Frequency range	758	-	773	-32	1	5
	Frequency range	773	-	803	-50	1	
	Frequency range	945	-	960	-50	1	
	Frequency range	1884.5	-	1915.7	-41	0.3	3, 9
DC_21_n77	Frequency range	2545	-	2575	-50	1	
	Frequency range	945	-	960	-50	1	
	Frequency range	1884.5	-	1915.7	-41	0.3	3
	Frequency range	2595	-	2645	-50	1	
DC_21_n78	Frequency range	945	-	960	-50	1	
	Frequency range	1884.5	-	1915.7	-41	0.3	3
	Frequency range	2545	-	2575	-50	1	
DC_21_n79	Frequency range	2595	-	2645	-50	1	
	Frequency range	945	-	960	-50	1	
	Frequency range	1884.5	-	1915.7	-41	0.3	3
	Frequency range	2545	-	2575	-50	1	
DC_26_n41	Frequency range	2595	-	2645	-50	1	
	Frequency range	1884.5	-	1915.7	-41	0.3	3
	Frequency range	703	-	799	-50	1	
	Frequency range	799	-	803	-40	1	5
DC_26_n77	Frequency range	945	-	960	-50	1	
	Frequency range	703	-	799	-50	1	
	Frequency range	799	-	803	-40	1	5
	Frequency range	945	-	960	-50	1	
	Frequency range	1884.5	-	1915.7	-41	0.3	3
	Frequency range	2545	-	2575	-50	1	
DC_26_n78	Frequency range	2595	-	2645	-50	1	
	Frequency range	703	-	799	-50	1	
	Frequency range	799	-	803	-40	1	5
	Frequency range	945	-	960	-50	1	
	Frequency range	1884.5	-	1915.7	-41	0.3	3
	Frequency range	2545	-	2575	-50	1	
DC_26_n79	Frequency range	2595	-	2645	-50	1	
	Frequency range	703	-	799	-50	1	
	Frequency range	799	-	803	-40	1	5
	Frequency range	945	-	960	-50	1	
	Frequency range	1884.5	-	1915.7	-41	0.3	3
DC_28_n3	Frequency range	2545	-	2575	-50	1	
	Frequency range	470	-	710	-26.2	6	14
	Frequency range	758	-	773	-32	1	5
	Frequency range	773	-	803	-50	1	
DC_28_n5	Frequency range	1884.5	-	1915.7	-41	0.3	3, 9
	Frequency range	1884.5	-	1915.7	-41	0.3	3, 9
	Frequency range	470	-	694	-42	8	5, 17
	Frequency range	470	-	710	-26.2	6	14
	Frequency range	662	-	694	-26.2	6	5

EN-DC Configuration	Spurious emission						
	Protected band	Frequency range (MHz)			Maximum Level (dBm)	MBW (MHz)	NOTE
	Frequency range	758	-	773	-32	1	5
	Frequency range	773	-	803	-50	1	
	Frequency range	773	-	803	-50	1	
DC_28_n7	Frequency range	758	-	773	-32	1	5
	Frequency range	773	-	803	-50	1	
	Frequency range	2570	-	2575	+1.6	5	5, 6, 7
	Frequency range	2575	-	2595	-15.5	5	5, 6, 7
	Frequency range	2595	-	2620	-40	1	5, 6
DC_28_n41 DC_28_n83_ULSUP- TDM_n41	Frequency range	470	-	694	-42	8	5, 17
	Frequency range	470	-	710	-26.2	6	14
	Frequency range	662	-	694	-26.2	6	5
	Frequency range	758	-	773	-32	1	5
	Frequency range	773	-	803	-50	1	
	Frequency range	1884.5	-	1915.7	-41	0.3	3, 9
DC_28_n77	Frequency range	758	-	773	-32	1	
	Frequency range	773	-	803	-50	1	
	Frequency range	1884.5	-	1915.7	-41	0.3	3, 9
DC_28_n78	Frequency range	758	-	773	-32	1	
	Frequency range	773	-	803	-50	1	
	Frequency range	1884.5	-	1915.7	-41	0.3	3, 9
DC_28_n79	Frequency range	758	-	773	-32	1	
	Frequency range	773	-	803	-50	1	
	Frequency range	1884.5	-	1915.7	-41	0.3	3, 9
DC_39_n40	Frequency range	1805		1855	-40	1	18
	Frequency range	1855		1880	-15.5	5	5, 7, 18
DC_39_n41	Frequency range	1805	-	1855	-40	1	5
	Frequency range	1855	-	1880	-15.5	5	5, 7, 19
DC_39_n79	Frequency range	1805	-	1855	-40	1	18
	Frequency range	1855	-	1880	-15.5	5	18
DC_40_n1	Frequency range	1884.5	-	1915.7	-41	0.3	3
DC_40_n41	Frequency range	1884.5	-	1915.7	-41	0.3	3
DC_40_n78	Frequency range	1884.5	-	1915.7	-41	0.3	3
DC_40_n79	Frequency range	1884.5	-	1915.7	-41	0.3	3
DC_41_n28	Frequency range	470	-	694	-42	8	5, 17
	Frequency range	470	-	710	-26.2	6	14
	Frequency range	662	-	694	-26.2	6	5
	Frequency range	758	-	773	-32	1	5
	Frequency range	773	-	803	-50	1	
	Frequency range	1884.5	-	1915.7	-41	0.3	3, 9
DC_41_n77	Frequency range	1884.5		1915.7	-41	0.3	3
DC_41_n78	Frequency range	1884.5	-	1915.7	-41	0.3	3
DC_41_n79	Frequency range	1884.5	-	1915.7	-41	0.3	3
DC_42_n1	Frequency range	1880	-	1895	-40	1	5, 16
	Frequency range	1895	-	1915	-15.5	5	5, 7, 16
	Frequency range	1915	-	1920	+1.6	5	5, 7, 16
DC_42_n3	Frequency range	1884.5	-	1915.7	-41	0.3	3
DC_48_n5	Frequency range	1884.5	-	1915.7	-41	0.3	3
DC_66_n7	Frequency range	2570	-	2575	+1.6	5	5, 6, 7
	Frequency range	2575	-	2595	-15.5	5	5, 6, 7
	Frequency range	2595	-	2620	-40	1	5, 6
DC_66_n38	Frequency range	2620	-	2645	-15.5	5	5, 7, 22
	Frequency range	2645	-	2690	-40	1	5, 22

EN-DC Configuration	Spurious emission				
	Protected band	Frequency range (MHz)	Maximum Level (dBm)	MBW (MHz)	NOTE
NOTE 1:	F <sub>DL_low</sub> and F <sub>DL_high</sub> refer to each frequency band specified in Table 5.5-1 in TS 36.101 [4] or in Table 5.2-1 in TS 38.101-1 [2].				
NOTE 2:	As exceptions, measurements with a level up to the applicable requirements defined in Table 6.6.3.1-2 in TS 36.101 [4] and Table 6.5.3.1-2 in TS 38.101-1 [2] are permitted for each assigned carrier used in the measurement due to 2 <sup>nd</sup> , 3 <sup>rd</sup> , 4 <sup>th</sup> or 5 <sup>th</sup> harmonic spurious emissions. Due to spreading of the harmonic emission the exception is also allowed for the first 1 MHz frequency range immediately outside the harmonic emission on both sides of the harmonic emission. This results in an overall exception interval centred at the harmonic emission of (2 MHz + N x L <sub>CRB</sub> x 180 kHz), where N is 2, 3, 4, 5 for the 2 <sup>nd</sup> , 3 <sup>rd</sup> , 4 <sup>th</sup> or 5 <sup>th</sup> harmonic respectively. The exception is allowed if the measurement bandwidth (MBW) totally or partially overlaps the overall exception interval.				
NOTE 3:	Applicable when co-existence with PHS system operating in 1884.5 - 1915.7 MHz				
NOTE 4:	Void				
NOTE 5:	These requirements also apply for the frequency ranges that are less than F <sub>OOB</sub> (MHz) in Table 6.6.3.1-1, Table 6.6.3.1A-1 in TS 36.101 [4] or in Table 6.5.3.1-1 in TS 38.101-1 [2] from the edge of the channel bandwidth.				
NOTE 6:	This requirement is applicable for any channel bandwidths within the range 2500 - 2570 MHz with the following restriction: for carriers of 15 MHz bandwidth when carrier centre frequency is within the range 2560.5 - 2562.5 MHz and for carriers of 20 MHz bandwidth when carrier centre frequency is within the range 2552 - 2560 MHz the requirement is applicable only for an uplink transmission bandwidth less than or equal to 54 RB.				
NOTE 7:	For these adjacent bands, the emission limit could imply risk of harmful interference to UE(s) operating in the protected operating band.				
NOTE 8:	Void.				
NOTE 9:	Applicable when the assigned E-UTRA or NR carrier is confined within 718 MHz and 748 MHz and when the channel bandwidth used is 5 or 10 MHz.				
NOTE 10:	As exceptions, measurements with a level up to the applicable requirement of -38 dBm/MHz is permitted for each assigned E-UTRA carrier used in the measurement due to 2 <sup>nd</sup> harmonic spurious emissions. An exception is allowed if there is at least one individual RB within the transmission bandwidth (see Figure 5.6-1) for which the 2 <sup>nd</sup> harmonic totally or partially overlaps the measurement bandwidth (MBW).				
NOTE 11:	As exceptions, measurements with a level up to the applicable requirement of -36 dBm/MHz is permitted for each assigned E-UTRA carrier used in the measurement due to 3 <sup>rd</sup> harmonic spurious emissions. An exception is allowed if there is at least one individual RB within the transmission bandwidth (see Figure 5.6-1) for which the 3 <sup>rd</sup> harmonic totally or partially overlaps the measurement bandwidth (MBW).				
NOTE 12:	This requirement is applicable only for the following cases: A: for carriers of 5 MHz channel bandwidth when carrier centre frequency (F <sub>c</sub> ) is within the range 902.5 MHz ≤ F <sub>c</sub> < 907.5 MHz with an uplink transmission bandwidth less than or equal to 20 RB; B: for carriers of 5 MHz channel bandwidth when carrier centre frequency (F <sub>c</sub> ) is within the range 907.5 MHz ≤ F <sub>c</sub> ≤ 912.5 MHz without any restriction on uplink transmission bandwidth; C: for carriers of 10 MHz channel bandwidth when carrier centre frequency (F <sub>c</sub> ) is F <sub>c</sub> = 910 MHz with an uplink transmission bandwidth less than or equal to 32 RB with RB <sub>start</sub> > 3.				
NOTE 13:	Void				
NOTE 14:	This requirement is applicable for 5 and 10 MHz E-UTRA or NR channel bandwidth allocated within 718-728MHz. For carriers of 10 MHz bandwidth, this requirement applies for an uplink transmission bandwidth less than or equal to 30 RB with RB <sub>start</sub> > 1 and RB <sub>start</sub> < 48.				
NOTE 15:	Void				
NOTE 16:	This requirement is applicable for any channel bandwidths within the range 1920 - 1980 MHz with the following restriction: for carriers of 15 MHz bandwidth when carrier centre frequency is within the range 1927.5 - 1929.5 MHz and for carriers of 20 MHz bandwidth when carrier centre frequency is within the range 1930 - 1938 MHz the requirement is applicable only for an uplink transmission bandwidth less than or equal to 54 RB.				
NOTE 17:	This requirement is applicable in the case of a 10 MHz E-UTRA or NR carrier confined within 703 MHz and 733 MHz, otherwise the requirement of -25 dBm with a measurement bandwidth of 8 MHz applies.				
NOTE 18:	This requirement is only applicable for E-UTRA carriers with bandwidth confined within 1885 - 1920 MHz (requirement for carriers with at least 1RB confined within 1880 - 1885 MHz is not specified). This requirement applies for an uplink transmission bandwidth less than or equal to 54 RB for E-UTRA carriers of 15 MHz bandwidth when carrier center frequency is within the range 1892.5 - 1894.5 MHz and for E-UTRA carriers of 20 MHz bandwidth when carrier center frequency is within the range 1895 - 1903 MHz.				
NOTE 19:	Void				
NOTE 20:	Void.				
NOTE 21:	Void				
NOTE 22:	This requirement is applicable for power class 3 UE for any channel bandwidths within the range 2570 - 2615 MHz with the following restriction: for carriers of 15 MHz bandwidth when carrier centre frequency is within the range 2605.5 - 2607.5 MHz and for carriers of 20 MHz bandwidth when carrier centre frequency is within the range 2597 - 2605 MHz the requirement is applicable only for an uplink transmission bandwidth less than or equal to 54 RB.				

**Table 6.5B.3.3.2.3-4: Spurious emission band UE co-existence limits Rel-18**

EN-DC Configuration	Spurious emission						
	Protected band	Frequency range (MHz)			Maximum Level (dBm)	MBW (MHz)	NOTE
DC_1_n3	Frequency range	1880		1895	-40	1	5, 16
	Frequency range	1895		1915	-15.5	5	5, 7, 16
	Frequency range	1915		1920	+1.6	5	5, 7, 16
DC_1_n7	Frequency range	1880		1895	-40	1	5, 16
	Frequency range	1895		1915	-15.5	5	5, 7, 16
	Frequency range	1915		1920	+1.6	5	5, 7, 16
	Frequency range	2570	-	2575	+1.6	5	5, 6, 7
	Frequency range	2575	-	2595	-15.5	5	5, 6, 7
	Frequency range	2595	-	2620	-40	1	5, 6
DC_1_n8	Frequency range	1880		1895	-40	1	5, 16
	Frequency range	1895		1915	-15.5	5	5, 7, 16
	Frequency range	1915		1920	+1.6	5	5, 7, 16
DC_1_n28	Frequency range	470	-	694	-42	8	5, 17
	Frequency range	470	-	710	-26.2	6	14
	Frequency range	758	-	773	-32	1	5
	Frequency range	773	-	803	-50	1	
	Frequency range	662	-	694	-26.2	6	5
	Frequency range	1880	-	1895	-40	1	5, 16
	Frequency range	1895	-	1915	-15.5	5	5, 7, 16
	Frequency range	1915	-	1920	+1.6	5	5, 7, 16
DC_1_n41	Frequency range	1880		1895	-40	1	5, 16
	Frequency range	1895		1915	-15.5	5	5, 7, 16
	Frequency range	1915		1920	+1.6	5	5, 7, 16, 20
DC_1_n77	Frequency range	1880	-	1895	-40	1	5, 16
	Frequency range	1895	-	1915	-15.5	5	5, 7, 16
	Frequency range	1915	-	1920	+1.6	5	5, 7, 16
DC_1_n78	Frequency range	1880	-	1895	-40	1	5, 16
	Frequency range	1895	-	1915	-15.5	5	5, 7, 16
	Frequency range	1915	-	1920	+1.6	5	5, 7, 16
DC_1_n79	Frequency range	1880	-	1895	-40	1	5, 16
	Frequency range	1895	-	1915	-15.5	5	5, 7, 16
	Frequency range	1915	-	1920	+1.6	5	5, 7, 16
DC_2_n7	Frequency range	2570	-	2575	1.6	5	5, 6, 7
	Frequency range	2575	-	2595	-15.5	5	5, 6, 7
	Frequency range	2595	-	2620	-40	1	5, 6
DC_3_n1	Frequency range	1880		1895	-40	1	5, 16
	Frequency range	1895		1915	-15.5	5	5, 7, 16
	Frequency range	1915		1920	+1.6	5	5, 7, 16
DC_3_n5	Frequency range	1884.5	-	1915.7	-41	0.3	3
DC_3_n7	Frequency range	2570	-	2575	+1.6	5	5, 6, 7
	Frequency range	2575	-	2595	-15.5	5	5, 6, 7
	Frequency range	2595	-	2620	-40	1	5, 6
DC_3_n8	Frequency range	1884.5	-	1915.7	-41	0.3	3
DC_3_n28	Frequency range	1884.5	-	1915.7	-41	0.3	13
	Frequency range	470	-	710	-26.2	6	14
	Frequency range	758	-	773	-32	1	5
	Frequency range	773	-	803	-50	1	
	Frequency range	1884.5	-	1915.7	-41	0.3	3, 9
DC_3_n41	Frequency range	1884.5	-	1915.7	-41	0.3	3
DC_3_n77	Frequency range	1884.5	-	1915.7	-41	0.3	3
DC_3_n78	Frequency range	1884.5	-	1915.7	-41	0.3	3
DC_3_n80_ULSUP-TDM_n78	Frequency range	1884.5	-	1915.7	-41	0.3	3
DC_3_n79	Frequency range	1884.5	-	1915.7	-41	0.3	3
DC_5_n7	Frequency range	2570	-	2575	+1.6	5	5, 7, 6
	Frequency range	2575	-	2595	-15.5	5	5, 7, 6
	Frequency range	2595	-	2620	-40	1	5, 14
DC_5_n30	Frequency range	1884.5	-	1915.7	-41	0.3	3
DC_5_n77	Frequency range	1884.5	-	1915.7	-41	0.3	3
DC_7_n1	Frequency range	1880		1895	-40	1	5, 16
	Frequency range	1895		1915	-15.5	5	5, 7, 16

EN-DC Configuration	Spurious emission						
	Protected band	Frequency range (MHz)		Maximum Level (dBm)	MBW (MHz)	NOTE	
	Frequency range	1915	-	1920	+1.6	5	5, 7, 16
	Frequency range	2570	-	2575	+1.6	5	5, 6, 7
	Frequency range	2575	-	2595	-15.5	5	5, 6, 7
	Frequency range	2595	-	2620	-40	1	5, 6
DC_7_n2	Frequency range	2570	-	2575	1.6	5	5, 6, 7
	Frequency range	2575	-	2595	-15.5	5	5, 6, 7
	Frequency range	2595	-	2620	-40	1	5, 6
DC_7_n3	Frequency range	2570	-	2575	+1.6	5	5, 6, 7
	Frequency range	2575	-	2595	-15.5	5	5, 6, 7
	Frequency range	2595	-	2620	-40	1	5, 6
DC_7_n5	Frequency range	2570	-	2575	+1.6	5	5, 7, 6
	Frequency range	2575	-	2595	-15.5	5	5, 7, 6
	Frequency range	2595	-	2620	-40	1	5, 14
DC_7_n8	Frequency range	2570	-	2575	+1.6	5	5, 6, 7
	Frequency range	2575	-	2595	-15.5	5	5, 6, 7
	Frequency range	2595	-	2620	-40	1	5, 6
DC_7_n28	Frequency range	758	-	773	-32	1	5
	Frequency range	773	-	803	-50	1	
	Frequency range	2570	-	2575	+1.6	5	5, 6, 7
	Frequency range	2575	-	2595	-15.5	5	5, 6, 7
	Frequency range	2595	-	2620	-40	1	5, 6
DC_7_n66	Frequency range	2570	-	2575	+1.6	5	5, 6, 7
	Frequency range	2575	-	2595	-15.5	5	5, 6, 7
	Frequency range	2595	-	2620	-40	1	5, 6
DC_7_n71	Frequency range	2570	-	2575	1.6	5	5, 6, 7
	Frequency range	2575	-	2595	-15.5	5	5, 6, 7
	Frequency range	2595	-	2620	-40	1	5, 6
DC_7_n77	Frequency range	2570	-	2575	+1.6	5	5, 6, 7
	Frequency range	2575	-	2595	-15.5	5	5, 6, 7
	Frequency range	2595	-	2620	-40	1	5, 6
DC_7_n78	Frequency range	2570	-	2575	+1.6	5	5, 6, 7
	Frequency range	2575	-	2595	-15.5	5	5, 6, 7
	Frequency range	2595	-	2620	-40	1	5, 6
DC_7_n80	Frequency range	2570	-	2575	+1.6	5	5, 6, 7
	Frequency range	2575	-	2595	-15.5	5	5, 6, 7
	Frequency range	2595	-	2620	-40	1	5, 6
DC_8_n1	Frequency range	860	-	890	-40	1	5, 12
	Frequency range	1880		1895	-40	1	5, 16
	Frequency range	1895		1915	-15.5	5	5, 7, 16
	Frequency range	1915		1920	+1.6	5	5, 7, 16
DC_8_n3	Frequency range	1884.5	-	1915.7	-41	0.3	3, 12
	Frequency range	860	-	890	-40	1	5, 12
DC_8_n20	Frequency range	758	-	788	-50	1	
DC_8_n28	Frequency range	470	-	694	-42	8	5, 17
	Frequency range	470	-	710	-26.2	6	14
	Frequency range	662	-	694	-26.2	6	5
	Frequency range	758	-	773	-32	1	5
	Frequency range	773	-	803	-50	1	
	Frequency range	860	-	890	-40	1	5, 12
	Frequency range	1884.5	-	1915.7	-41	0.3	3, 9, 12
DC_8_n41	Frequency range	860	-	890	-40	1	5, 12
	Frequency range	1884.5	-	1915.7	-41	0.3	3
DC_8_n77	Frequency range	860	-	890	-40	1	5, 12
	Frequency range	1884.5	-	1915.7	-41	0.3	3, 12
DC_8_n78	Frequency range	860	-	890	-40	1	5, 12
	Frequency range	1884.5	-	1915.7	-41	0.3	3, 12
DC_11_n77	Frequency range	945	-	960	-50	1	
	Frequency range	1884.5	-	1915.7	-41	0.3	3
	Frequency range	2545	-	2575	-50	1	
	Frequency range	2595	-	2645	-50	1	
DC_11_n78	Frequency range	945	-	960	-50	1	



EN-DC Configuration	Spurious emission						
	Protected band	Frequency range (MHz)			Maximum Level (dBm)	MBW (MHz)	NOTE
	Frequency range	1884.5	-	1915.7	-41	0.3	3
	Frequency range	2545	-	2575	-50	1	
	Frequency range	2595	-	2645	-50	1	
DC_11_n79	Frequency range	945	-	960	-50	1	
	Frequency range	1884.5	-	1915.7	-41	0.3	3
	Frequency range	2545	-	2575	-50	1	
	Frequency range	2595	-	2645	-50	1	
DC_12_n7	Frequency range	2570	-	2575	+1.6	5	5, 6, 7
	Frequency range	2575	-	2595	-15.5	5	5, 6, 7
	Frequency range	2595	-	2620	-40	1	5, 6
DC_12_n78	Frequency range	1884.5	-	1915.7	-41	0.3	3
DC_13_n2	Frequency range	769	-	775	-35	0.00625	5
	Frequency range	799	-	805	-35	0.00625	5
DC_13_n5	Frequency range	769	-	775	-35	0.00625	5
	Frequency range	799	-	805	-35	0.00625	5
DC_13_n7	Frequency range	769	-	775	-35	0.00625	5
	Frequency range	799	-	805	-35	0.00625	5
	Frequency range	2570	-	2575	+1.6	5	5, 6, 7
	Frequency range	2575	-	2595	-15.5	5	5, 6, 7
	Frequency range	2595	-	2620	-40	1	5, 6
DC_13_n48	Frequency range	769	-	775	-35	0.00625	5
	Frequency range	799	-	805	-35	0.00625	5
DC_13_n66	Frequency range	769	-	775	-35	0.00625	5
	Frequency range	799	-	803	-35	0.00625	5
DC_13_n71	Frequency range	769	-	775	-35	0.00625	5
	Frequency range	799	-	805	-35	0.00625	5
DC_13_n77	Frequency range	769	-	775	-35	0.00625	5
	Frequency range	799	-	805	-35	0.00625	5
	Frequency range	1884.5	-	1915.7	-41	0.3	3
DC_14_n2	Frequency range	769	-	775	-35	0.00625	5
	Frequency range	799	-	805	-35	0.00625	5
DC_14_n30	Frequency range	769	-	775	-35	0.00625	5
	Frequency range	799	-	805	-35	0.00625	5
DC_14_n77	Frequency range	769	-	775	-35	0.00625	5
	Frequency range	799	-	805	-35	0.00625	5
DC_14_n66	Frequency range	769	-	775	-35	0.00625	5
	Frequency range	799	-	805	-35	0.00625	5
DC_18_n79	Frequency range	945	-	960	-50	1	
	Frequency range	1884.5	-	1915.7	-41	0.3	3
	Frequency range	2545	-	2575	-50	1	
	Frequency range	2595	-	2645	-50	1	
DC_18_n3	Frequency range	945	-	960	-50	1	
	Frequency range	1884.5	-	1915.7	-41	0.3	3
	Frequency range	2545	-	2575	-50	1	
DC_18_n79	Frequency range	2595	-	2645	-50	1	
	Frequency range	945	-	960	-50	1	
	Frequency range	1884.5	-	1915.7	-41	0.3	3
	Frequency range	2545	-	2575	-50	1	
DC_19_n1	Frequency range	2595	-	2645	-50	1	
	Frequency range	945	-	960	-50	1	
	Frequency range	1880	-	1895	-40	1	5, 16
	Frequency range	1895	-	1915	-15.5	5	5, 7, 16
	Frequency range	1915	-	1920	+1.6	5	5, 7, 16
DC_19_n77	Frequency range	2545	-	2575	-50	1	
	Frequency range	945	-	960	-50	1	
	Frequency range	1884.5	-	1915.7	-41	0.3	3
	Frequency range	2545	-	2575	-50	1	
DC_19_n78	Frequency range	2595	-	2645	-50	1	
	Frequency range	945	-	960	-50	1	
	Frequency range	1884.5	-	1915.7	-41	0.3	3

EN-DC Configuration	Spurious emission						
	Protected band	Frequency range (MHz)			Maximum Level (dBm)	MBW (MHz)	NOTE
	Frequency range	2545	-	2575	-50	1	
	Frequency range	2595	-	2645	-50	1	
DC_19_n79	Frequency range	945	-	960	-50	1	
	Frequency range	1884.5	-	1915.7	-41	0.3	3
	Frequency range	2545	-	2575	-50	1	
	Frequency range	2595	-	2645	-50	1	
	Frequency range	758	-	788	-50	1	
DC_20_n1	Frequency range	758	-	788	-50	1	
DC_20_n3	Frequency range	758	-	788	-50	1	
DC_20A_91A_ULSUP-TDM, DC_20A_92A_ULSUP-TDM	Frequency range	758	-	788	-50	1	
DC_21_n1	Frequency range	945	-	960	-50	1	
	Frequency range	1880	-	1895	-40	1	5, 16
	Frequency range	1895	-	1915	-15.5	5	5, 7, 16
	Frequency range	1915	-	1920	+1.6	5	5, 7, 16
	Frequency range	2545	-	2575	-50	1	
	Frequency range	2595	-	2645	-50	1	
DC_21_n28	Frequency range	470	-	694	-42	8	5, 17
	Frequency range	470	-	710	-26.2	6	14
	Frequency range	662	-	694	-26.2	6	5
	Frequency range	758	-	773	-32	1	5
	Frequency range	773	-	803	-50	1	
	Frequency range	945	-	960	-50	1	
	Frequency range	1884.5	-	1915.7	-41	0.3	3, 9
	Frequency range	2545	-	2575	-50	1	
	Frequency range	945	-	960	-50	1	
	Frequency range	1884.5	-	1915.7	-41	0.3	3
DC_21_n77	Frequency range	2545	-	2575	-50	1	
	Frequency range	945	-	960	-50	1	
	Frequency range	1884.5	-	1915.7	-41	0.3	3
	Frequency range	2595	-	2645	-50	1	
DC_21_n78	Frequency range	945	-	960	-50	1	
	Frequency range	1884.5	-	1915.7	-41	0.3	3
	Frequency range	2545	-	2575	-50	1	
	Frequency range	2595	-	2645	-50	1	
DC_21_n79	Frequency range	945	-	960	-50	1	
	Frequency range	1884.5	-	1915.7	-41	0.3	3
	Frequency range	2545	-	2575	-50	1	
	Frequency range	2595	-	2645	-50	1	
DC_26_n41	Frequency range	1884.5	-	1915.7	-41	0.3	3
	Frequency range	703	-	799	-50	1	
	Frequency range	799	-	803	-40	1	5
	Frequency range	945	-	960	-50	1	
DC_26_n77	Frequency range	703	-	799	-50	1	
	Frequency range	799	-	803	-40	1	5
	Frequency range	945	-	960	-50	1	
	Frequency range	1884.5	-	1915.7	-41	0.3	3
	Frequency range	2545	-	2575	-50	1	
	Frequency range	2595	-	2645	-50	1	
DC_26_n78	Frequency range	703	-	799	-50	1	
	Frequency range	799	-	803	-40	1	5
	Frequency range	945	-	960	-50	1	
	Frequency range	1884.5	-	1915.7	-41	0.3	3
	Frequency range	2545	-	2575	-50	1	
DC_26_n79	Frequency range	2595	-	2645	-50	1	
	Frequency range	703	-	799	-50	1	
	Frequency range	799	-	803	-40	1	5
	Frequency range	945	-	960	-50	1	
	Frequency range	1884.5	-	1915.7	-41	0.3	3
	Frequency range	2545	-	2575	-50	1	
DC_26_n79	Frequency range	2595	-	2645	-50	1	
	Frequency range	470	-	710	-26.2	6	14
	Frequency range	758	-	773	-32	1	5
	Frequency range	703	-	799	-50	1	
	Frequency range	799	-	803	-40	1	5

EN-DC Configuration	Spurious emission						
	Protected band	Frequency range (MHz)			Maximum Level (dBm)	MBW (MHz)	NOTE
	Frequency range	773	-	803	-50	1	
	Frequency range	1884.5	-	1915.7	-41	0.3	3, 9
DC_28_n5	Frequency range	1884.5	-	1915.7	-41	0.3	3, 9
	Frequency range	470	-	694	-42	8	5, 17
	Frequency range	470	-	710	-26.2	6	14
	Frequency range	662	-	694	-26.2	6	5
	Frequency range	758	-	773	-32	1	5
	Frequency range	773	-	803	-50	1	
	Frequency range	773	-	803	-50	1	
DC_28_n7	Frequency range	758	-	773	-32	1	5
	Frequency range	773	-	803	-50	1	
	Frequency range	2570	-	2575	+1.6	5	5, 6, 7
	Frequency range	2575	-	2595	-15.5	5	5, 6, 7
DC_28_n41 DC_28_n83_ULSUP- TDM_n41	Frequency range	2595	-	2620	-40	1	5, 6
	Frequency range	470	-	694	-42	8	5, 17
	Frequency range	470	-	710	-26.2	6	14
	Frequency range	662	-	694	-26.2	6	5
	Frequency range	758	-	773	-32	1	5
DC_28_n77	Frequency range	773	-	803	-50	1	
	Frequency range	1884.5	-	1915.7	-41	0.3	3, 9
	Frequency range	758	-	773	-32	1	
DC_28_n78	Frequency range	773	-	803	-50	1	
	Frequency range	1884.5	-	1915.7	-41	0.3	3, 9
	Frequency range	758	-	773	-32	1	
DC_28_n79	Frequency range	773	-	803	-50	1	
	Frequency range	1884.5	-	1915.7	-41	0.3	3, 9
	Frequency range	758	-	773	-32	1	
DC_39_n40	Frequency range	1805		1855	-40	1	18
	Frequency range	1855		1880	-15.5	5	5, 7, 18
DC_39_n41	Frequency range	1805	-	1855	-40	1	5
	Frequency range	1855	-	1880	-15.5	5	5, 7, 19
DC_39_n79	Frequency range	1805	-	1855	-40	1	18
	Frequency range	1855	-	1880	-15.5	5	18
DC_40_n1	Frequency range	1884.5	-	1915.7	-41	0.3	3
DC_40_n41	Frequency range	1884.5	-	1915.7	-41	0.3	3
DC_40_n78	Frequency range	1884.5	-	1915.7	-41	0.3	3
DC_40_n79	Frequency range	1884.5	-	1915.7	-41	0.3	3
DC_41_n28	Frequency range	470	-	694	-42	8	5, 17
	Frequency range	470	-	710	-26.2	6	14
	Frequency range	662	-	694	-26.2	6	5
	Frequency range	758	-	773	-32	1	5
	Frequency range	773	-	803	-50	1	
	Frequency range	1884.5	-	1915.7	-41	0.3	3, 9
DC_41_n77	Frequency range	1884.5		1915.7	-41	0.3	3
DC_41_n78	Frequency range	1884.5	-	1915.7	-41	0.3	3
DC_41_n79	Frequency range	1884.5	-	1915.7	-41	0.3	3
DC_42_n1	Frequency range	1880	-	1895	-40	1	5, 16
	Frequency range	1895	-	1915	-15.5	5	5, 7, 16
	Frequency range	1915	-	1920	+1.6	5	5, 7, 16
DC_42_n3	Frequency range	1884.5	-	1915.7	-41	0.3	3
DC_48_n5	Frequency range	1884.5	-	1915.7	-41	0.3	3
DC_66_n7	Frequency range	2570	-	2575	+1.6	5	5, 6, 7
	Frequency range	2575	-	2595	-15.5	5	5, 6, 7
	Frequency range	2595	-	2620	-40	1	5, 6
DC_66_n38	Frequency range	2620	-	2645	-15.5	5	5, 7, 22
	Frequency range	2645	-	2690	-40	1	5, 22

EN-DC Configuration	Spurious emission				
	Protected band	Frequency range (MHz)	Maximum Level (dBm)	MBW (MHz)	NOTE
NOTE 1:	F <sub>DL_low</sub> and F <sub>DL_high</sub> refer to each frequency band specified in Table 5.5-1 in TS 36.101 [4] or in Table 5.2-1 in TS 38.101-1 [2].				
NOTE 2:	As exceptions, measurements with a level up to the applicable requirements defined in Table 6.6.3.1-2 in TS 36.101 [4] and Table 6.5.3.1-2 in TS 38.101-1 [2] are permitted for each assigned carrier used in the measurement due to 2 <sup>nd</sup> , 3 <sup>rd</sup> , 4 <sup>th</sup> or 5 <sup>th</sup> harmonic spurious emissions. Due to spreading of the harmonic emission the exception is also allowed for the first 1 MHz frequency range immediately outside the harmonic emission on both sides of the harmonic emission. This results in an overall exception interval centred at the harmonic emission of (2 MHz + N x L <sub>CRB</sub> x 180 kHz), where N is 2, 3, 4, 5 for the 2 <sup>nd</sup> , 3 <sup>rd</sup> , 4 <sup>th</sup> or 5 <sup>th</sup> harmonic respectively. The exception is allowed if the measurement bandwidth (MBW) totally or partially overlaps the overall exception interval.				
NOTE 3:	Applicable when co-existence with PHS system operating in 1884.5 - 1915.7 MHz				
NOTE 4:	Void				
NOTE 5:	These requirements also apply for the frequency ranges that are less than F <sub>OOB</sub> (MHz) in Table 6.6.3.1-1, Table 6.6.3.1A-1 in TS 36.101 [4] or in Table 6.5.3.1-1 in TS 38.101-1 [2] from the edge of the channel bandwidth.				
NOTE 6:	This requirement is applicable for any channel bandwidths within the range 2500 - 2570 MHz with the following restriction: for carriers of 15 MHz bandwidth when carrier centre frequency is within the range 2560.5 - 2562.5 MHz and for carriers of 20 MHz bandwidth when carrier centre frequency is within the range 2552 - 2560 MHz the requirement is applicable only for an uplink transmission bandwidth less than or equal to 54 RB.				
NOTE 7:	For these adjacent bands, the emission limit could imply risk of harmful interference to UE(s) operating in the protected operating band.				
NOTE 8:	Void.				
NOTE 9:	Applicable when the assigned E-UTRA or NR carrier is confined within 718 MHz and 748 MHz and when the channel bandwidth used is 5 or 10 MHz.				
NOTE 10:	As exceptions, measurements with a level up to the applicable requirement of -38 dBm/MHz is permitted for each assigned E-UTRA carrier used in the measurement due to 2 <sup>nd</sup> harmonic spurious emissions. An exception is allowed if there is at least one individual RB within the transmission bandwidth (see Figure 5.6-1) for which the 2 <sup>nd</sup> harmonic totally or partially overlaps the measurement bandwidth (MBW).				
NOTE 11:	As exceptions, measurements with a level up to the applicable requirement of -36 dBm/MHz is permitted for each assigned E-UTRA carrier used in the measurement due to 3 <sup>rd</sup> harmonic spurious emissions. An exception is allowed if there is at least one individual RB within the transmission bandwidth (see Figure 5.6-1) for which the 3 <sup>rd</sup> harmonic totally or partially overlaps the measurement bandwidth (MBW).				
NOTE 12:	This requirement is applicable only for the following cases: A: for carriers of 5 MHz channel bandwidth when carrier centre frequency (F <sub>c</sub> ) is within the range 902.5 MHz ≤ F <sub>c</sub> < 907.5 MHz with an uplink transmission bandwidth less than or equal to 20 RB; B: for carriers of 5 MHz channel bandwidth when carrier centre frequency (F <sub>c</sub> ) is within the range 907.5 MHz ≤ F <sub>c</sub> ≤ 912.5 MHz without any restriction on uplink transmission bandwidth; C: for carriers of 10 MHz channel bandwidth when carrier centre frequency (F <sub>c</sub> ) is F <sub>c</sub> = 910 MHz with an uplink transmission bandwidth less than or equal to 32 RB with RB <sub>start</sub> > 3.				
NOTE 13:	Void				
NOTE 14:	This requirement is applicable for 5 and 10 MHz E-UTRA or NR channel bandwidth allocated within 718-728MHz. For carriers of 10 MHz bandwidth, this requirement applies for an uplink transmission bandwidth less than or equal to 30 RB with RB <sub>start</sub> > 1 and RB <sub>start</sub> < 48.				
NOTE 15:	Void				
NOTE 16:	This requirement is applicable for any channel bandwidths within the range 1920 - 1980 MHz with the following restriction: for carriers of 15 MHz bandwidth when carrier centre frequency is within the range 1927.5 - 1929.5 MHz and for carriers of 20 MHz bandwidth when carrier centre frequency is within the range 1930 - 1938 MHz the requirement is applicable only for an uplink transmission bandwidth less than or equal to 54 RB.				
NOTE 17:	This requirement is applicable in the case of a 10 MHz E-UTRA or NR carrier confined within 703 MHz and 733 MHz, otherwise the requirement of -25 dBm with a measurement bandwidth of 8 MHz applies.				
NOTE 18:	This requirement is only applicable for E-UTRA carriers with bandwidth confined within 1885 - 1920 MHz (requirement for carriers with at least 1RB confined within 1880 - 1885 MHz is not specified). This requirement applies for an uplink transmission bandwidth less than or equal to 54 RB for E-UTRA carriers of 15 MHz bandwidth when carrier center frequency is within the range 1892.5 - 1894.5 MHz and for E-UTRA carriers of 20 MHz bandwidth when carrier center frequency is within the range 1895 - 1903 MHz.				
NOTE 19:	Void				
NOTE 20:	Void.				
NOTE 21:	Void				
NOTE 22:	This requirement is applicable for power class 3 UE for any channel bandwidths within the range 2570 - 2615 MHz with the following restriction: for carriers of 15 MHz bandwidth when carrier centre frequency is within the range 2605.5 - 2607.5 MHz and for carriers of 20 MHz bandwidth when carrier centre frequency is within the range 2597 - 2605 MHz the requirement is applicable only for an uplink transmission bandwidth less than or equal to 54 RB.				

NOTE: To simplify the above Tables, E-UTRA band numbers are listed for bands which are specified only for E-UTRA operation or both E-UTRA and NR operation. NR band numbers are listed for bands which are specified only for NR operation.

The normative reference for this requirement is TS 38.101-3 [4] clause 6.5B.3.3.2.

Exception requirements for both NR and E-UTRA are defined for this test and therefore LTE anchor agnostic approach is not applied. E-UTRA test point analysis is included and E-UTRA measurements are performed.

6.5B.3.3.2.4 Test description

6.5B.3.3.2.4.1 Initial conditions

Same initial conditions as described in clause 6.5B.3.1.2.4.1 with the following exceptions:

- Instead of Table 6.5B.3.1.2.4.1-1 --> use Table 6.5B.3.3.2.4.1-1.

**Table 6.5B.3.3.2.4.1-1: Test Configuration Table**

Initial Conditions											
Test Environment as specified in TS 38.508-1 [6] clause 4.1						Normal					
Test Frequencies as specified in TS 38.508-1 [6] clause 4.3.1						For test frequencies refer to "Range" columns.					
Test EN-DC channel bandwidth as specified in TS 36.508 [11] clause 4.3.1 and TS 38.508-1 [6] clause 4.3.1						Refer to "NR N <sub>RB</sub> " and "E-UTRA N <sub>RB</sub> " columns					
Test SCS for the NR cell as specified in TS 38.521-1 [8] Table 5.3.5-1						Lowest SCS per Channel Bandwidth					
Test Parameters for DC Configurations											
ID	DC Configuration / N <sub>RB,agg</sub>					DL Allocation			UL Allocation (Note 1,2)		
	DC Configuration				E-UTRA Ch BW/N <sub>RB</sub>	NR Ch BW/N <sub>RB</sub>	CC MOD E-UTRA/NR	E-UTRA & NR RB allocation	CC MOD E-UTRA/NR	E-UTRA & NR allocations (L <sub>CRB</sub> @ RB <sub>start</sub> )	
	E-UTRA		NR								
	Band	Range	Band	Range							
Default Test Settings for a DC_XA_nYA Configuration											
1	X	Low	nY	Low	Highest Ch BW /Highest N <sub>RB</sub>	Highest Ch BW /Highest N <sub>RB</sub>	QPSK/CP-OFDM QPSK	NA	QPSK / CP-OFDM QPSK	1@0	1@0
2	X	High	nY	High	Highest Ch BW /Highest N <sub>RB</sub>	Highest Ch BW /Highest N <sub>RB</sub>	QPSK/CP-OFDM QPSK	NA	QPSK / CP-OFDM QPSK	1@RB <sub>max</sub> x	1@RB <sub>max</sub> x
Test Setting for DC_1A_n3A Configuration											
1	1	Low	n3	Low	10/50	30/160	QPSK/CP-OFDM QPSK	NA	QPSK / CP-OFDM QPSK	1@0	1@0
2	1	High	n3	Mid	10/50	30/160	QPSK/CP-OFDM QPSK	NA	QPSK / CP-OFDM QPSK	1@49	1@0
Test Setting for DC_1A_n7A Configuration											
1	1	High	n7	Low	20/100	20/106	QPSK/CP-OFDM QPSK	NA	QPSK / CP-OFDM QPSK	1@99	1@0
2	1	High	n7	Mid	20/100	20/106	QPSK/CP-OFDM QPSK	NA	QPSK / CP-OFDM QPSK	1@99	1@14
Test Setting for DC_1A_n8A Configuration											
1	1	Low	n8	Low	20/100	20/106	QPSK/CP-OFDM QPSK	NA	QPSK / CP-OFDM QPSK	1@0	1@0
Test Setting for DC_1A_n28A Configuration											
1	1	Low	n28	Low	20/100	20/106	QPSK/CP-OFDM QPSK	NA	QPSK / CP-OFDM QPSK	1@0	1@0
2	1	Low	n28	High	20/100	20/106	QPSK/CP-OFDM QPSK	NA	QPSK / CP-OFDM QPSK	1@0	1@0
3	1	High	n28	High	20/100	20/106	QPSK/CP-OFDM QPSK	NA	QPSK / CP-OFDM QPSK	1@99	1@105
Test Setting for DC_1A_n41A Configuration											

1	1	Low	n41	High	20/100	100/273	QPSK/CP-OFDM QPSK	NA	QPSK / CP-OFDM QPSK	1@99	1@250
2	1	Low	n41	High	20/100	100/273	QPSK/CP-OFDM QPSK	NA	QPSK / CP-OFDM QPSK	1@99	1@272
3	1	Low	n41	High	20/100	100/273	QPSK/CP-OFDM QPSK	NA	QPSK / CP-OFDM QPSK	1@0	1@272
4	1	High	n41	High	20/100	100/273	QPSK/CP-OFDM QPSK	NA	QPSK / CP-OFDM QPSK	1@0	1@247
5	1	High	n41	Low	20/100	100/273	QPSK/CP-OFDM QPSK	NA	QPSK / CP-OFDM QPSK	1@99	1@0
6	1	High	n41	Low	20/100	100/273	QPSK/CP-OFDM QPSK	NA	QPSK / CP-OFDM QPSK	1@99	1@85
7	1	High	n41	Low	20/100	100/273	QPSK/CP-OFDM QPSK	NA	QPSK / CP-OFDM QPSK	1@0	1@272
<b>Test Setting for DC_1A_n77A Configuration</b>											
1	1	High	n77	High	10/50	100/273	QPSK/CP-OFDM QPSK	NA	QPSK / CP-OFDM QPSK	1@49	1@0
2	1	Low	n77	Mid	10/50	100/273	QPSK/CP-OFDM QPSK	NA	QPSK / CP-OFDM QPSK	1@0	1@272
3	1	Low	n77	Low	10/50	100/273	QPSK/CP-OFDM QPSK	NA	QPSK / CP-OFDM QPSK	1@0	1@272
4	1	Low	n77	NOTE 18	10/50	100/273	QPSK/CP-OFDM QPSK	NA	QPSK / CP-OFDM QPSK	1@0	1@0
5	1	Low	n77	NOTE 18	10/50	100/273	QPSK/CP-OFDM QPSK	NA	QPSK / CP-OFDM QPSK	1@0	1@0
6	1	Low	n77	NOTE 18	10/50	100/273	QPSK/CP-OFDM QPSK	NA	QPSK / CP-OFDM QPSK	1@0	1@0
7	1	Low	n77	NOTE 18	10/50	100/273	QPSK/CP-OFDM QPSK	NA	QPSK / CP-OFDM QPSK	1@0	1@0
8	1	Low	n77	NOTE 18	10/50	100/273	QPSK/CP-OFDM QPSK	NA	QPSK / CP-OFDM QPSK	1@0	1@0
<b>Test Setting for DC_1A_n78A Configuration</b>											
1	1	High	n78	High	20/100	100/273	QPSK/CP-OFDM QPSK	NA	QPSK / CP-OFDM QPSK	1@99	1@272



2	1	Low	n78	Low	20/100	100/273	QPSK/CP-OFDM QPSK	NA	QPSK / CP-OFDM QPSK	1@0	1@272
3	1	Low	n78	Note 8	20/100	100/273	QPSK/CP-OFDM QPSK	NA	QPSK / CP-OFDM QPSK	1@0	1@0
<b>Test Setting for DC_1A_n79A Configuration</b>											
1	1	Low	n79	Mid	20/100	100/273	QPSK/CP-OFDM QPSK	NA	QPSK / CP-OFDM QPSK	1@0	1@172
2	1	High	n79	Mid	20/100	100/273	QPSK/CP-OFDM QPSK	NA	QPSK / CP-OFDM QPSK	1@99	1@0
3	1	High	n79	High	20/100	100/273	QPSK/CP-OFDM QPSK	NA	QPSK / CP-OFDM QPSK	1@99	1@0
4	1	Low	n79	Mid	20/100	100/273	QPSK/CP-OFDM QPSK	NA	QPSK / CP-OFDM QPSK	1@0	1@201
5	1	High	n79	Mid	20/100	100/273	QPSK/CP-OFDM QPSK	NA	QPSK / CP-OFDM QPSK	1@99	1@272
<b>Test Setting for DC_2A_n66A Configuration</b>											
1	2	Low	n66	Low	20/100	40/216	QPSK/CP-OFDM QPSK	NA	QPSK / CP-OFDM QPSK	1@0	1@0
2	2	High	n66	High	20/100	40/216	QPSK/CP-OFDM QPSK	NA	QPSK / CP-OFDM QPSK	<a href="#">1@99</a>	1@215
3	2	High	n66	Low	20/100	40/216	QPSK/CP-OFDM QPSK	NA	QPSK / CP-OFDM QPSK	<a href="#">1@99</a>	1@0
4	2	High	n66	Low	20/100	40/216	QPSK/CP-OFDM QPSK	NA	QPSK / CP-OFDM QPSK	1@0	1@0
5	2	High	n66	High	20/100	40/216	QPSK/CP-OFDM QPSK	NA	QPSK / CP-OFDM QPSK	1@0	1@215
<b>Test Setting for DC_2A_n71A Configuration</b>											
1	2	Low	n71	Low	20/100	20/106	QPSK/CP-OFDM QPSK	NA	QPSK / CP-OFDM QPSK	1@0	1@0
<b>Test Setting for DC_2A_n78A Configuration</b>											
1	2	Low	n78	Low	20/100	100/273	QPSK/CP-OFDM QPSK	NA	QPSK / CP-OFDM QPSK	1@0	1@272
2	2	Low	n78	Low	20/100	100/273	QPSK/CP-OFDM QPSK	NA	QPSK / CP-OFDM QPSK	1@99	1@0

3	2	High	n78	Low	20/100	100/273	QPSK/CP-OFDM QPSK	NA	QPSK / CP-OFDM QPSK	1@99	1@272
4	2	Low	n78	High	20/100	100/273	QPSK/CP-OFDM QPSK	NA	QPSK / CP-OFDM QPSK	1@0	1@272
<b>Test Settings for DC_3A_n1A Configuration</b>											
1	3	Low	n1	Low	20/100	20/106	QPSK/CP-OFDM QPSK	NA	QPSK / CP-OFDM QPSK	1@0	1@0
2	3	Low	n1	High	20/100	20/106	QPSK/CP-OFDM QPSK	NA	QPSK / CP-OFDM QPSK	1@99	1@105
<b>Test Setting for DC_3A_n5A Configuration</b>											
1	3	Low	n5	Low	20/100	20/106	QPSK/CP-OFDM QPSK	NA	QPSK / CP-OFDM QPSK	1@0	1@77
2	3	High	n5	High	20/100	20/106	QPSK/CP-OFDM QPSK	NA	QPSK / CP-OFDM QPSK	1@99	1@105
3	3	Low	n5	Low	20/100	20/106	QPSK/CP-OFDM QPSK	NA	QPSK / CP-OFDM QPSK	1@99	1@0
4	3	Low	n5	Low	20/100	20/106	QPSK/CP-OFDM QPSK	NA	QPSK / CP-OFDM QPSK	1@0	1@0
5	3	High	n5	Low	20/100	20/106	QPSK/CP-OFDM QPSK	NA	QPSK / CP-OFDM QPSK	1@99	1@0
<b>Test Setting for DC_3A_n7A Configuration</b>											
1	3	Low	n7	High	20/100	10/52	QPSK/CP-OFDM QPSK	NA	QPSK / CP-OFDM QPSK	1@47	1@51
2	3	Mid	n7	High	20/100	10/52	QPSK/CP-OFDM QPSK	NA	QPSK / CP-OFDM QPSK	1@99	1@51
3	3	Low	n7	Low	20/100	10/52	QPSK/CP-OFDM QPSK	NA	QPSK / CP-OFDM QPSK	1@0	1@51
4	3	Mid	n7	Low	20/100	10/52	QPSK/CP-OFDM QPSK	NA	QPSK / CP-OFDM QPSK	1@99	1@0
5	3	Low	n7	High	20/100	10/52	QPSK/CP-OFDM QPSK	NA	QPSK / CP-OFDM QPSK	1@0	1@51
<b>Test Setting for DC_3A_n8A Configuration</b>											
1	3	Low	n8	Low	20/100	20/106	QPSK/CP-OFDM QPSK	NA	QPSK / CP-OFDM QPSK	<a href="#">1@0</a>	<a href="#">1@0</a>

2	3	High	n8	High	20/100	20/106	QPSK/CP-OFDM QPSK	NA	QPSK / CP-OFDM QPSK	<a href="#">1@99</a>	<a href="#">1@105</a>
3	3	Low	n8	High	20/100	20/106	QPSK/CP-OFDM QPSK	NA	QPSK / CP-OFDM QPSK	<a href="#">1@0</a>	<a href="#">1@105</a>
<b>Test Settings for DC_3A_n28A Configuration</b>											
1	3	Low	n28	Low	20/100	20/106	QPSK/CP-OFDM QPSK	NA	QPSK / CP-OFDM QPSK	1@0	1@0
2	3	Low	n28	High	20/100	20/106	QPSK/CP-OFDM QPSK	NA	QPSK / CP-OFDM QPSK	1@0	1@105
3	3	High	n28	High	20/100	20/106	QPSK/CP-OFDM QPSK	NA	QPSK / CP-OFDM QPSK	1@99	1@105
<b>Test Settings for DC_3A_n41A Configuration</b>											
1	3	Low	n41	Low	20/100	100/273	QPSK/CP-OFDM QPSK	NA	QPSK / CP-OFDM QPSK	1@0	1@0
2	3	High	n41	High	20/100	100/273	QPSK/CP-OFDM QPSK	NA	QPSK / CP-OFDM QPSK	1@99	1@272
3	3	Mid	n41	High	20/100	100/273	QPSK/CP-OFDM QPSK	NA	QPSK / CP-OFDM QPSK	1@0	1@272
4	3	Note 4	n41	High	10/50	100/273	QPSK/CP-OFDM QPSK	NA	QPSK / CP-OFDM QPSK	1@49	1@272
<b>Test Setting for DC_3A_n77A Configuration</b>											
1	3	Low	n77	NOTE 19	20/100	100/273	QPSK/CP-OFDM QPSK	NA	QPSK / CP-OFDM QPSK	1@0	1@0
2	3	Low	n77	NOTE 19	20/100	100/273	QPSK/CP-OFDM QPSK	NA	QPSK / CP-OFDM QPSK	1@0	1@0
3	3	Low	n77	High	20/100	100/273	QPSK/CP-OFDM QPSK	NA	QPSK / CP-OFDM QPSK	1@0	1@272
4	3	Low	n77	Mid	20/100	100/273	QPSK/CP-OFDM QPSK	NA	QPSK / CP-OFDM QPSK	1@0	1@75
5	3	Low	n77	NOTE 19	20/100	100/273	QPSK/CP-OFDM QPSK	NA	QPSK / CP-OFDM QPSK	1@0	1@0
6	3	Low	n77	High	20/100	100/273	QPSK/CP-OFDM QPSK	NA	QPSK / CP-OFDM QPSK	1@0	1@0

7	3	High	n77	Low	20/100	100/273	QPSK/CP-OFDM QPSK	NA	QPSK / CP-OFDM QPSK	1@99	1@0
<b>Test Setting for DC_3A_n78A Configuration</b>											
1	3	High	n78	High	20/100	100/273	QPSK/CP-OFDM QPSK	NA	QPSK / CP-OFDM QPSK	1@99	1@272
2	3	High	n78	Mid	20/100	100/273	QPSK/CP-OFDM QPSK	NA	QPSK / CP-OFDM QPSK	1@99	1@272
3	3	Low	n78	Mid	20/100	100/273	QPSK/CP-OFDM QPSK	NA	QPSK / CP-OFDM QPSK	1@0	1@272
<b>Test Settings for DC_3A_n79A Configuration</b>											
1	3	High	n79	Low	20/100	100/273	QPSK/CP-OFDM QPSK	NA	QPSK / CP-OFDM QPSK	1@99	1@105
2	3	High	n79	Low	20/100	100/273	QPSK/CP-OFDM QPSK	NA	QPSK / CP-OFDM QPSK	1@99	1@272
3	3	Low	n79	High	20/100	100/273	QPSK/CP-OFDM QPSK	NA	QPSK / CP-OFDM QPSK	1@0	1@0
4	3	High	n79	Low	20/100	100/273	QPSK/CP-OFDM QPSK	NA	QPSK / CP-OFDM QPSK	1@99	1@134
5	3	Low	n79	High	20/100	100/273	QPSK/CP-OFDM QPSK	NA	QPSK / CP-OFDM QPSK	1@0	1@66
<b>Test Settings for DC_5A_n2A Configuration</b>											
1	5	Low	n2	Low	10/50	20/106	QPSK	NA	QPSK / CP-OFDM QPSK	1@0	1@0
2	5	High	n2	High	10/50	20/106	QPSK	NA	QPSK / CP-OFDM QPSK	1@49	<a href="#">1@105</a>
<b>Test Settings for DC_5A_n66A Configuration</b>											
1	5	High	n66	Mid	10/50	40/216	QPSK/CP-OFDM QPSK	NA	QPSK / CP-OFDM QPSK	1@49	1@0
2	5	High	n66	High	10/50	40/216	QPSK/CP-OFDM QPSK	NA	QPSK / CP-OFDM QPSK	1@49	1@215
3	5	Low	n66	Low	10/50	40/216	QPSK/CP-OFDM QPSK	NA	QPSK / CP-OFDM QPSK	1@0	1@215
4	5	High	n66	Low	10/50	40/216	QPSK/CP-OFDM QPSK	NA	QPSK / CP-OFDM QPSK	1@49	1@0
<b>Test Setting for DC_5A_n77A Configuration</b>											

1	5	High	n77	Mid	10/50	100/273	QPSK/CP-OFDM QPSK	NA	QPSK / CP-OFDM QPSK	1@49	1@0
2	5	Low	n77	Mid	10/50	100/273	QPSK/CP-OFDM QPSK	NA	QPSK / CP-OFDM QPSK	1@0	1@272
3	5	Low	n77	Note 28	10/50	100/273	QPSK/CP-OFDM QPSK	NA	QPSK / CP-OFDM QPSK	1@49	1@272
4	5	Low	n77	Note 28	10/50	100/273	QPSK/CP-OFDM QPSK	NA	QPSK / CP-OFDM QPSK	1@0	1@0
5	5	Low	n77	Note 28	10/50	100/273	QPSK/CP-OFDM QPSK	NA	QPSK / CP-OFDM QPSK	1@0	1@0
6	5	Low	n77	Low	10/50	100/273	QPSK/CP-OFDM QPSK	NA	QPSK / CP-OFDM QPSK	1@0	1@272
7	5	High	n77	High	10/50	100/273	QPSK/CP-OFDM QPSK	NA	QPSK / CP-OFDM QPSK	1@49	1@272
8	5	High	n77	Low	10/50	100/273	QPSK/CP-OFDM QPSK	NA	QPSK / CP-OFDM QPSK	1@0	1@140
<b>Test Setting for DC_5A_n78A Configuration</b>											
1	5	Low	n78	High	10/50	100/273	QPSK/CP-OFDM QPSK	NA	QPSK / CP-OFDM QPSK	1@0	1@272
2	5	Low	n78	Mid	10/50	100/273	QPSK/CP-OFDM QPSK	NA	QPSK / CP-OFDM QPSK	1@0	1@272
3	5	Low	n78	Mid	10/50	100/273	QPSK/CP-OFDM QPSK	NA	QPSK / CP-OFDM QPSK	1@0	1@0
4	5	High	n78	High	10/50	100/273	QPSK/CP-OFDM QPSK	NA	QPSK / CP-OFDM QPSK	1@49	1@29
5	5	Low	n78	Low	10/50	100/273	QPSK/CP-OFDM QPSK	NA	QPSK / CP-OFDM QPSK	1@0	1@272
<b>Test Setting for DC_7A_n1A Configuration</b>											
1	7	Low	n1	Low	20/100	20/106	QPSK/CP-OFDM QPSK	NA	QPSK / CP-OFDM QPSK	1@0	1@0
2	7	Low	n1	High	20/100	20/106	QPSK/CP-OFDM QPSK	NA	QPSK / CP-OFDM QPSK	1@0	1@105
3	7	Mid	n1	High	20/100	20/106	QPSK/CP-OFDM QPSK	NA	QPSK / CP-OFDM QPSK	1@22	1@105

Test Setting for DC_7A_n3A Configuration											
1	7	High	n3	Low	20/100	30/160	QPSK/CP-OFDM QPSK	NA	QPSK / CP-OFDM QPSK	1@99	1@77
2	7	Low	n3	Low	20/100	30/160	QPSK/CP-OFDM QPSK	NA	QPSK / CP-OFDM QPSK	1@0	1@59
3	7	High	n3	High	20/100	30/160	QPSK/CP-OFDM QPSK	NA	QPSK / CP-OFDM QPSK	1@99	1@86
4	7	High	n3	Low	10/50	5/25	QPSK/CP-OFDM QPSK	NA	QPSK / CP-OFDM QPSK	1@49	1@0
5	7	High	n3	Low	20/100	30/160	QPSK/CP-OFDM QPSK	NA	QPSK / CP-OFDM QPSK	1@99	1@0
6	7	Low	n3	Mid	20/100	30/160	QPSK/CP-OFDM QPSK	NA	QPSK / CP-OFDM QPSK	1@0	1@66
Test Setting for DC_7A_n5A Configuration											
1	7	High	n5	High	20/100	20/106	QPSK/CP-OFDM QPSK	NA	QPSK / CP-OFDM QPSK	1@99	1@105
2	7	Low	n5	Low	20/100	20/106	QPSK/CP-OFDM QPSK	NA	QPSK / CP-OFDM QPSK	1@0	1@0
Test Setting for DC_7A_n8A Configuration											
1	7	High	n8	Mid	20/100	20/106	QPSK/CP-OFDM QPSK	NA	QPSK / CP-OFDM QPSK	<a href="#">1@99</a>	<a href="#">1@0</a>
2	7	High	n8	Mid	20/100	20/106	QPSK/CP-OFDM QPSK	NA	QPSK / CP-OFDM QPSK	<a href="#">1@99</a>	<a href="#">1@105</a>
3	7	Low	n8	Low	20/100	20/106	QPSK/CP-OFDM QPSK	NA	QPSK / CP-OFDM QPSK	<a href="#">1@0</a>	<a href="#">1@0</a>
Test Setting for DC_7A_n28A Configuration											
1	7	High	n28	High	20/100	20/106	QPSK/CP-OFDM QPSK	NA	QPSK / CP-OFDM QPSK	1@99	1@105
Test Setting for DC_7A_n66A Configuration											
1	7	Low	n66	High	20/100	40/216	QPSK/CP-OFDM QPSK	NA	QPSK / CP-OFDM QPSK	1@99	1@215
2	7	Low	n66	High	20/100	40/216	QPSK/CP-OFDM QPSK	NA	QPSK / CP-OFDM QPSK	1@0	1@0
3	7	Mid	n66	High	20/100	40/216	QPSK/CP-OFDM QPSK	NA	QPSK / CP-OFDM QPSK	1@50	1@215

4	7	Low	n66	High	20/100	40/216	QPSK/CP-OFDM QPSK	NA	QPSK / CP-OFDM QPSK	1@0	1@215
5	7	Mid	n66	Low	20/100	40/216	QPSK/CP-OFDM QPSK	NA	QPSK / CP-OFDM QPSK	1@99	1@0
6	7	High	n66	Low	20/100	40/216	QPSK/CP-OFDM QPSK	NA	QPSK / CP-OFDM QPSK	1@99	1@0
<b>Test Setting for DC_7A_n78A Configuration</b>											
1	7	Low	n78	Low	20/100	100/273	QPSK/CP-OFDM QPSK	NA	QPSK / CP-OFDM QPSK	1@0	1@0
2	7	Mid	n78	Low	20/100	100/273	QPSK/CP-OFDM QPSK	NA	QPSK / CP-OFDM QPSK	1@99	1@0
3	7	Low	n78	Low	20/100	100/273	QPSK/CP-OFDM QPSK	NA	QPSK / CP-OFDM QPSK	1@0	1@196
4	7	Low	n78	Low	20/100	100/273	QPSK/CP-OFDM QPSK	NA	QPSK / CP-OFDM QPSK	1@99	1@272
5	7	High	n78	High	20/100	100/273	QPSK/CP-OFDM QPSK	NA	QPSK / CP-OFDM QPSK	1@77	1@0
6	7	Mid	n78	Mid	20/100	100/273	QPSK/CP-OFDM QPSK	NA	QPSK / CP-OFDM QPSK	1@99	1@272
7	7	High	n78	Mid	20/100	100/273	QPSK/CP-OFDM QPSK	NA	QPSK / CP-OFDM QPSK	1@0	1@272
8	7	High	n78	Low	20/100	100/273	QPSK/CP-OFDM QPSK	NA	QPSK / CP-OFDM QPSK	1@99	1@0
9	7	High	n78	Mid	20/100	100/273	QPSK/CP-OFDM QPSK	NA	QPSK / CP-OFDM QPSK	1@99	1@0
10	7	Low	n78	Low	20/100	100/273	QPSK/CP-OFDM QPSK	NA	QPSK / CP-OFDM QPSK	1@0	1@165
<b>Test Settings for DC_8A_n1A Configuration</b>											
1	8	Low	n1	Low	10/50	20/106	QPSK/CP-OFDM QPSK	NA	QPSK / CP-OFDM QPSK	1@0	1@0
<b>Test Settings for DC_8A_n3A Configuration</b>											
1	8	High	n3	Low	10/50	30/160	QPSK/CP-OFDM QPSK	NA	QPSK / CP-OFDM QPSK	1@49	1@0

2	8	Low	n3	Low	10/50	30/160	QPSK/CP-OFDM QPSK	NA	QPSK / CP-OFDM QPSK	1@0	1@159
3	8	High	n3	High	10/50	30/160	QPSK/CP-OFDM QPSK	NA	QPSK / CP-OFDM QPSK	1@49	1@159
<b>Test Settings for DC_8A_n20A Configuration</b>											
1	8	High	n20	Low	10/50	20/106	QPSK/CP-OFDM QPSK	NA	QPSK / CP-OFDM QPSK	<a href="#">1@49</a>	1@12
2	8	High	n20	High	10/50	20/106	QPSK/CP-OFDM QPSK	NA	QPSK / CP-OFDM QPSK	<a href="#">1@49</a>	1@105
3	8	Low	n20	Low	10/50	20/106	QPSK/CP-OFDM QPSK	NA	QPSK / CP-OFDM QPSK	1@0	1@0
<b>Test Settings for DC_8A_n28A Configuration</b>											
1	8	High	n28	High	10/50	20/106	QPSK/CP-OFDM QPSK	NA	QPSK / CP-OFDM QPSK	<a href="#">1@49</a>	<a href="#">1@105</a>
2	8	Low	n28	Low	10/50	20/106	QPSK/CP-OFDM QPSK	NA	QPSK / CP-OFDM QPSK	<a href="#">1@0</a>	<a href="#">1@105</a>
<b>Test Settings for DC_8A_n41A Configuration</b>											
1	8	Low	n41	Mid	10/50	100/273	QPSK/CP-OFDM QPSK	NA	QPSK / CP-OFDM QPSK	1@0	1@0
2	8	Low	n41	High	10/50	100/273	QPSK/CP-OFDM QPSK	NA	QPSK / CP-OFDM QPSK	1@0	1@272
3	8	Low	n41	Low	10/50	100/273	QPSK/CP-OFDM QPSK	NA	QPSK / CP-OFDM QPSK	1@0	1@0
4	8	High	n41	High	10/50	100/273	QPSK/CP-OFDM QPSK	NA	QPSK / CP-OFDM QPSK	1@49	1@272
5	8	Low	n41	Low	10/50	100/273	QPSK/CP-OFDM QPSK	NA	QPSK / CP-OFDM QPSK	1@0	1@155
<b>Test Settings for DC_8A_n77A Configuration</b>											
1	8	Low	n77	Note 9	10/50	100/273	QPSK/CP-OFDM QPSK	NA	QPSK / CP-OFDM QPSK	1@0	1@0
2	8	High	n77	Low	10/50	100/273	QPSK/CP-OFDM QPSK	NA	QPSK / CP-OFDM QPSK	1@49	1@37
3	8	High	n77	Mid	10/50	100/273	QPSK/CP-OFDM QPSK	NA	QPSK / CP-OFDM QPSK	1@49	1@97



4	8	Low	n77	Mid	10/50	100/273	QPSK/CP-OFDM QPSK	NA	QPSK / CP-OFDM QPSK	1@0	1@211
5	8	Low	n77	Note 9	10/50	100/273	QPSK/CP-OFDM QPSK	NA	QPSK / CP-OFDM QPSK	1@0	1@0
6	8	High	n77	High	10/50	100/273	QPSK/CP-OFDM QPSK	NA	QPSK / CP-OFDM QPSK	1@49	1@272
7	8	High	n77	Mid	10/50	100/273	QPSK/CP-OFDM QPSK	NA	QPSK / CP-OFDM QPSK	1@49	1@0
8	8	Low	n77	Note 9	10/50	100/273	QPSK/CP-OFDM QPSK	NA	QPSK / CP-OFDM QPSK	1@0	1@0
9	8	High	n77	Low	10/50	100/273	QPSK/CP-OFDM QPSK	NA	QPSK / CP-OFDM QPSK	1@49	1@85
10	8	Low	n77	Note 9	10/50	100/273	QPSK/CP-OFDM QPSK	NA	QPSK / CP-OFDM QPSK	1@49	1@0
<b>Test Settings for DC_8A_n78A Configuration</b>											
1	8	High	n78	Mid	10/50	100/273	QPSK/CP-OFDM QPSK	NA	QPSK / CP-OFDM QPSK	1@49	1@272
2	8	High	n78	Low	10/50	100/273	QPSK/CP-OFDM QPSK	NA	QPSK / CP-OFDM QPSK	1@0	1@0
3	8	Low	n78	High	10/50	100/273	QPSK/CP-OFDM QPSK	NA	QPSK / CP-OFDM QPSK	1@49	1@272
4	8	High	n78	High	10/50	100/273	QPSK/CP-OFDM QPSK	NA	QPSK / CP-OFDM QPSK	1@0	1@0
5	8	High	n78	High	10/50	100/273	QPSK/CP-OFDM QPSK	NA	QPSK / CP-OFDM QPSK	1@49	1@0
6	8	Mid	n78	Low	10/50	100/273	QPSK/CP-OFDM QPSK	NA	QPSK / CP-OFDM QPSK	1@25	1@0
<b>Test Settings for DC_11A_n77A Configuration</b>											
1	11	Low	n77	Note 10	10/50	100/273	QPSK/CP-OFDM QPSK	NA	QPSK / CP-OFDM QPSK	1@0	1@0
2	11	Low	n77	Low	10/50	100/273	QPSK/CP-OFDM QPSK	NA	QPSK / CP-OFDM QPSK	1@0	1@0
3	11	Low	n77	Mid	10/50	100/273	QPSK/CP-OFDM QPSK	NA	QPSK / CP-OFDM QPSK	1@0	1@63

4	11	Low	n77	Mid	10/50	100/273	QPSK/CP-OFDM QPSK	NA	QPSK / CP-OFDM QPSK	1@0	1@104
5	11	Low	n77	Note 10	10/50	100/273	QPSK/CP-OFDM QPSK	NA	QPSK / CP-OFDM QPSK	1@0	1@0
6	11	Low	n77	Note 10	10/50	100/273	QPSK/CP-OFDM QPSK	NA	QPSK / CP-OFDM QPSK	1@0	1@0
7	11	Low	n77	Note 10	10/50	100/273	QPSK/CP-OFDM QPSK	NA	QPSK / CP-OFDM QPSK	1@0	1@0
8	11	Low	n77	Low	10/50	100/273	QPSK/CP-OFDM QPSK	NA	QPSK / CP-OFDM QPSK	1@0	1@75
9	11	Low	n77	Note 10	10/50	100/273	QPSK/CP-OFDM QPSK	NA	QPSK / CP-OFDM QPSK	1@0	1@0
10	11	Low	n77	Note 10	10/50	100/273	QPSK/CP-OFDM QPSK	NA	QPSK / CP-OFDM QPSK	1@0	1@0
<b>Test Settings for DC_11A_n78A Configuration</b>											
1	11	Low	n78	Mid	10/50	100/273	QPSK/CP-OFDM QPSK	NA	QPSK / CP-OFDM QPSK	1@0	1@184
2	11	Low	n78	Low	10/50	100/273	QPSK/CP-OFDM QPSK	NA	QPSK / CP-OFDM QPSK	1@0	1@0
3	11	Low	n78	High	10/50	100/273	QPSK/CP-OFDM QPSK	NA	QPSK / CP-OFDM QPSK	1@0	1@63
4	11	Low	n78	High	10/50	100/273	QPSK/CP-OFDM QPSK	NA	QPSK / CP-OFDM QPSK	1@0	1@104
5	11	Low	n78	Note 11	10/50	100/273	QPSK/CP-OFDM QPSK	NA	QPSK / CP-OFDM QPSK	1@0	1@0
6	11	Low	n78	Note 11	10/50	100/273	QPSK/CP-OFDM QPSK	NA	QPSK / CP-OFDM QPSK	1@0	1@0
7	11	Low	n78	Low	10/50	100/273	QPSK/CP-OFDM QPSK	NA	QPSK / CP-OFDM QPSK	1@0	1@75
<b>Test Settings for DC_11A_n79A Configuration</b>											
1	11	Low	n79	High	10/50	100/273	QPSK/CP-OFDM QPSK	NA	QPSK / CP-OFDM QPSK	1@0	1@272
2	11	Low	n79	Mid	10/50	100/273	QPSK/CP-OFDM QPSK	NA	QPSK / CP-OFDM QPSK	1@0	1@132

3	11	High	n79	High	10/50	100/273	QPSK/CP-OFDM QPSK	NA	QPSK / CP-OFDM QPSK	1@49	1@30
4	11	Low	n79	Mid	10/50	100/273	QPSK/CP-OFDM QPSK	NA	QPSK / CP-OFDM QPSK	1@0	1@272
<b>Test Setting for DC_12A_n66A Configuration</b>											
1	12	Low	n66	Low	10/50	40/216	QPSK/CP-OFDM QPSK	NA	QPSK / CP-OFDM QPSK	1@0	1@0
2	12	High	n66	High	10/50	40/216	QPSK/CP-OFDM QPSK	NA	QPSK / CP-OFDM QPSK	1@49	1@215
3	12	Low	n66	High	10/50	40/216	QPSK/CP-OFDM QPSK	NA	QPSK / CP-OFDM QPSK	1@49	1@215
<b>Test Setting for DC_12A_n78A Configuration</b>											
1	12	Low	n78	Low	10/50	100/273	QPSK/CP-OFDM QPSK	NA	QPSK / CP-OFDM QPSK	1@0	1@0
2	12	High	n78	Low	10/50	100/273	QPSK/CP-OFDM QPSK	NA	QPSK / CP-OFDM QPSK	1@49	1@272
3	12	Low	n78	Mid	10/50	100/273	QPSK/CP-OFDM QPSK	NA	QPSK / CP-OFDM QPSK	1@0	1@136
<b>Test Setting for DC_13A_n2A Configuration</b>											
1	13	Low	n2	Low	10/50	20/106	QPSK/CP-OFDM QPSK	NA	QPSK / CP-OFDM QPSK	1@0	1@0
<b>Test Setting for DC_13A_n77A Configuration</b>											
1	13	Mid	n77	Note 29	10/50	100/273	QPSK/CP-OFDM QPSK	NA	QPSK / CP-OFDM QPSK	1@49	1@272
2	13	Mid	n77	Mid	10/50	100/273	QPSK/CP-OFDM QPSK	NA	QPSK / CP-OFDM QPSK	1@49	1@0
3	13	Mid	n77	Note 29	10/50	100/273	QPSK/CP-OFDM QPSK	NA	QPSK / CP-OFDM QPSK	1@0	1@210
4	13	Low	n77	Note 29	10/50	100/273	QPSK/CP-OFDM QPSK	NA	QPSK / CP-OFDM QPSK	1@0	1@0
5	13	Low	n77	Note 29	10/50	100/273	QPSK/CP-OFDM QPSK	NA	QPSK / CP-OFDM QPSK	1@0	1@0
6	13	High	n77	High	10/50	100/273	QPSK/CP-OFDM QPSK	NA	QPSK / CP-OFDM QPSK	1@49	1@272

7	13	Low	n77	Low	10/50	100/273	QPSK/CP-OFDM QPSK	NA	QPSK / CP-OFDM QPSK	1@0	1@0
<b>Test Setting for DC_14A_n2A Configuration</b>											
1	14	Low	n2	Low	10/50	20/106	QPSK/CP-OFDM QPSK	NA	QPSK / CP-OFDM QPSK	1@0	1@0
<b>Test Setting for DC_14A_n66A Configuration</b>											
1	14	Low	n66	Low	10/50	40/216	QPSK/CP-OFDM QPSK	NA	QPSK / CP-OFDM QPSK	1@0	1@0
2	14	High	n66	High	10/50	40/216	QPSK/CP-OFDM QPSK	NA	QPSK / CP-OFDM QPSK	1@49	1@215
<b>Test Setting for DC_19A_n1A Configuration</b>											
1	19	Low	n1	Low	15/75	20/106	QPSK/CP-OFDM QPSK	NA	QPSK / CP-OFDM QPSK	1@0	1@0
<b>Test Setting for DC_19A_n77A Configuration</b>											
1	19	Low	n77	Mid	15/75	100/273	QPSK/CP-OFDM QPSK	NA	QPSK / CP-OFDM QPSK	1@0	1@272
2	19	Low	n77	Note 26	15/75	100/273	QPSK/CP-OFDM QPSK	NA	QPSK / CP-OFDM QPSK	1@0	1@0
3	19	High	n77	Mid	15/75	100/273	QPSK/CP-OFDM QPSK	NA	QPSK / CP-OFDM QPSK	1@74	1@0
4	19	Low	n77	Note 26	15/75	100/273	QPSK/CP-OFDM QPSK	NA	QPSK / CP-OFDM QPSK	1@0	1@0
5	19	Low	n77	Note 26	15/75	100/273	QPSK/CP-OFDM QPSK	NA	QPSK / CP-OFDM QPSK	1@0	1@0
6	19	Low	n77	Low	15/75	100/273	QPSK/CP-OFDM QPSK	NA	QPSK / CP-OFDM QPSK	1@0	1@272
7	19	Low	n77	Note 26	15/75	100/273	QPSK/CP-OFDM QPSK	NA	QPSK / CP-OFDM QPSK	1@0	1@0
<b>Test Setting for DC_19A_n78A Configuration</b>											
1	19	High	n78	High	15/75	100/273	QPSK/CP-OFDM QPSK	NA	QPSK / CP-OFDM QPSK	1@74	1@272
2	19	Low	n78	Mid	15/75	100/273	QPSK/CP-OFDM QPSK	NA	QPSK / CP-OFDM QPSK	1@0	1@0
3	19	High	n78	High	15/75	100/273	QPSK/CP-OFDM QPSK	NA	QPSK / CP-OFDM QPSK	1@74	1@0

4	19	Low	n78	Mid	15/75	100/273	QPSK/CP-OFDM QPSK	NA	QPSK / CP-OFDM QPSK	1@0	1@165
5	19	Low	n78	Low	15/75	100/273	QPSK/CP-OFDM QPSK	NA	QPSK / CP-OFDM QPSK	1@0	1@272
6	19	Low	n78	Note 17	15/75	100/273	QPSK/CP-OFDM QPSK	NA	QPSK / CP-OFDM QPSK	1@0	1@0
<b>Test Setting for DC_19A_n79A Configuration</b>											
1	19	Low	n79	Low	15/75	100/273	QPSK/CP-OFDM QPSK	NA	QPSK / CP-OFDM QPSK	1@0	1@0
<b>Test Setting for DC_20A_n1A Configuration</b>											
1	20	Low	n1	Low	20/100	20/106	QPSK/CP-OFDM QPSK	NA	QPSK / CP-OFDM QPSK	1@0	1@0
2	20	High	n1	High	20/100	20/106	QPSK/CP-OFDM QPSK	NA	QPSK / CP-OFDM QPSK	1@99	1@105
<b>Test Setting for DC_20A_n3A Configuration</b>											
1	20	Low	n3	Low	20/100	30/160	QPSK/CP-OFDM QPSK	NA	QPSK / CP-OFDM QPSK	1@0	1@0
2	20	High	n3	High	20/100	30/160	QPSK/CP-OFDM QPSK	NA	QPSK / CP-OFDM QPSK	1@99	1@159
3	20	Low	n3	High	20/100	30/160	QPSK/CP-OFDM QPSK	NA	QPSK / CP-OFDM QPSK	1@0	1@159
<b>Test Setting for DC_20A_n8A Configuration</b>											
1	20	Low	n8	Low	20/100	20/106	QPSK/CP-OFDM QPSK	NA	QPSK / CP-OFDM QPSK	<a href="#">1@0</a>	<a href="#">1@0</a>
2	20	High	n8	High	20/100	20/106	QPSK/CP-OFDM QPSK	NA	QPSK / CP-OFDM QPSK	<a href="#">1@99</a>	<a href="#">1@105</a>
3	20	Low	n8	High	20/100	20/106	QPSK/CP-OFDM QPSK	NA	QPSK / CP-OFDM QPSK	<a href="#">1@0</a>	<a href="#">1@105</a>
<b>Test Setting for DC_20A_n28A Configuration</b>											
1	20	Low	n28	Low	20/100	20/106	QPSK/CP-OFDM QPSK	NA	QPSK / CP-OFDM QPSK	1@0	1@105
<b>Test Setting for DC_20A_n78A Configuration</b>											
1	20	Low	n78	High	20/100	100/273	QPSK/CP-OFDM QPSK	NA	QPSK / CP-OFDM QPSK	1@0	1@272

2	20	Low	n78	Mid	20/100	100/273	QPSK/CP-OFDM QPSK	NA	QPSK / CP-OFDM QPSK	1@0	1@0
3	20	Low	n78	Mid	20/100	100/273	QPSK/CP-OFDM QPSK	NA	QPSK / CP-OFDM QPSK	1@0	1@205
4	20	High	n78	High	20/100	100/273	QPSK/CP-OFDM QPSK	NA	QPSK / CP-OFDM QPSK	1@99	1@104
5	20	Low	n78	Note 24	20/100	100/273	QPSK/CP-OFDM QPSK	NA	QPSK / CP-OFDM QPSK	1@0	1@0
<b>Test Setting for DC_21A_n1A Configuration</b>											
1	21	Low	n1	Low	15/75	20/106	QPSK/CP-OFDM QPSK	NA	QPSK / CP-OFDM QPSK	1@0	1@0
2	21	High	n1	High	15/75	20/106	QPSK/CP-OFDM QPSK	NA	QPSK / CP-OFDM QPSK	1@74	1@105
3	21	Low	n1	Low	15/75	20/106	QPSK/CP-OFDM QPSK	NA	QPSK / CP-OFDM QPSK	1@0	1@105
<b>Test Setting for DC_21A_n28A Configuration</b>											
1	21	Low	n28	Low	15/75	5/25	QPSK/CP-OFDM QPSK	NA	QPSK / CP-OFDM QPSK	1@0	1@0
<b>Test Setting for DC_21A_n77A Configuration</b>											
1	21	Low	n77	Note 21	15/75	100/273	QPSK/CP-OFDM QPSK	NA	QPSK / CP-OFDM QPSK	1@0	1@0
2	21	Low	n77	Low	15/75	100/273	QPSK/CP-OFDM QPSK	NA	QPSK / CP-OFDM QPSK	1@0	1@0
3	21	Low	n77	Mid	15/75	100/273	QPSK/CP-OFDM QPSK	NA	QPSK / CP-OFDM QPSK	1@0	1@174
4	21	Low	n77	Mid	15/75	100/273	QPSK/CP-OFDM QPSK	NA	QPSK / CP-OFDM QPSK	1@0	1@215
5	21	High	n77	Mid	15/75	100/273	QPSK/CP-OFDM QPSK	NA	QPSK / CP-OFDM QPSK	1@74	1@0
6	21	Low	n77	Note 21	15/75	100/273	QPSK/CP-OFDM QPSK	NA	QPSK / CP-OFDM QPSK	1@0	1@0
7	21	Low	n77	Note 21	15/75	100/273	QPSK/CP-OFDM QPSK	NA	QPSK / CP-OFDM QPSK	1@0	1@0

8	21	Low	n77	Low	15/75	100/273	QPSK/CP-OFDM QPSK	NA	QPSK / CP-OFDM QPSK	1@0	1@130
9	21	Low	n77	Note 21	15/75	100/273	QPSK/CP-OFDM QPSK	NA	QPSK / CP-OFDM QPSK	1@0	1@0
10	21	High	n77	High	15/75	100/273	QPSK/CP-OFDM QPSK	NA	QPSK / CP-OFDM QPSK	1@74	1@0
<b>Test Setting for DC_21A_n78A Configuration</b>											
1	21	Low	n78	Mid	15/75	100/273	QPSK/CP-OFDM QPSK	NA	QPSK / CP-OFDM QPSK	1@0	1@272
2	21	Low	n78	Low	15/75	100/273	QPSK/CP-OFDM QPSK	NA	QPSK / CP-OFDM QPSK	1@0	1@0
3	21	High	n78	High	15/75	100/273	QPSK/CP-OFDM QPSK	NA	QPSK / CP-OFDM QPSK	1@74	1@272
4	21	Low	n78	High	15/75	100/273	QPSK/CP-OFDM QPSK	NA	QPSK / CP-OFDM QPSK	1@0	1@215
5	21	High	n78	High	15/75	100/273	QPSK/CP-OFDM QPSK	NA	QPSK / CP-OFDM QPSK	1@74	1@0
6	21	Low	n78	Note 20	15/75	100/273	QPSK/CP-OFDM QPSK	NA	QPSK / CP-OFDM QPSK	1@0	1@0
7	21	Low	n78	Low	15/75	100/273	QPSK/CP-OFDM QPSK	NA	QPSK / CP-OFDM QPSK	1@0	1@130
<b>Test Setting for DC_21A_n79A Configuration</b>											
1	21	Low	n79	Mid	15/75	100/273	QPSK/CP-OFDM QPSK	NA	QPSK / CP-OFDM QPSK	1@0	1@272
2	21	Low	n79	Low	15/75	100/273	QPSK/CP-OFDM QPSK	NA	QPSK / CP-OFDM QPSK	1@0	1@0
3	21	Low	n79	High	15/75	100/273	QPSK/CP-OFDM QPSK	NA	QPSK / CP-OFDM QPSK	1@0	1@38
4	21	Low	n79	Note 22	15/75	100/273	QPSK/CP-OFDM QPSK	NA	QPSK / CP-OFDM QPSK	1@0	1@0
<b>Test Setting for DC_25A_n41A Configuration</b>											
1	25	Low	n41	Low	20/100	100/273	QPSK/CP-OFDM QPSK	NA	QPSK / CP-OFDM QPSK	1@0	1@272

2	25	Low	n41	High	20/100	100/273	QPSK/CP-OFDM QPSK	NA	QPSK / CP-OFDM QPSK	1@0	1@30
3	25	Low	n41	High	20/100	100/273	QPSK/CP-OFDM QPSK	NA	QPSK / CP-OFDM QPSK	1@0	1@62
4	25	Low	n41	Low	20/100	100/273	QPSK/CP-OFDM QPSK	NA	QPSK / CP-OFDM QPSK	1@0	1@209
5	25	High	n41	High	20/100	100/273	QPSK/CP-OFDM QPSK	NA	QPSK / CP-OFDM QPSK	1@99	1@272
6	25	Low	n41	Low	20/100	100/273	QPSK/CP-OFDM QPSK	NA	QPSK / CP-OFDM QPSK	1@0	1@0
<b>Test Setting for DC_26A_n41A Configuration</b>											
1	26	High	n41	High	15/75	100/273	QPSK/CP-OFDM QPSK	NA	QPSK / CP-OFDM QPSK	1@74	1@272
2	26	Low	n41	Low	15/75	100/273	QPSK/CP-OFDM QPSK	NA	QPSK / CP-OFDM QPSK	1@0	1@12
3	26	Low	n41	Low	15/75	100/273	QPSK/CP-OFDM QPSK	NA	QPSK / CP-OFDM QPSK	1@0	1@41
4	26	High	n41	Low	15/75	100/273	QPSK/CP-OFDM QPSK	NA	QPSK / CP-OFDM QPSK	1@74	1@0
5	26	Low	n41	Low	15/75	100/273	QPSK/CP-OFDM QPSK	NA	QPSK / CP-OFDM QPSK	1@0	1@232
6	26	High	n41	Low	15/75	100/273	QPSK/CP-OFDM QPSK	NA	QPSK / CP-OFDM QPSK	1@0	1@25
<b>Test Setting for DC_26A_n77A Configuration</b>											
1	26	Low	n77	Mid	15/75	100/273	QPSK/CP-OFDM QPSK	NA	QPSK / CP-OFDM QPSK	1@0	1@272
2	26	Low	n77	NOTE 25	15/75	100/273	QPSK/CP-OFDM QPSK	NA	QPSK / CP-OFDM QPSK	1@0	1@0
3	26	High	n77	Mid	15/75	100/273	QPSK/CP-OFDM QPSK	NA	QPSK / CP-OFDM QPSK	1@74	1@34
4	26	Low	n77	NOTE 25	15/75	100/273	QPSK/CP-OFDM QPSK	NA	QPSK / CP-OFDM QPSK	1@0	1@0
5	26	Low	n77	NOTE 25	15/75	100/273	QPSK/CP-OFDM QPSK	NA	QPSK / CP-OFDM QPSK	1@0	1@0



6	26	Low	n77	Low	15/75	100/273	QPSK/CP-OFDM QPSK	NA	QPSK / CP-OFDM QPSK	1@0	1@201
7	26	Low	n77	High	15/75	100/273	QPSK/CP-OFDM QPSK	NA	QPSK / CP-OFDM QPSK	1@0	1@272
8	26	Low	n77	NOTE 25	15/75	100/273	QPSK/CP-OFDM QPSK	NA	QPSK / CP-OFDM QPSK	1@0	1@0
<b>Test Setting for DC_26A_n78A Configuration</b>											
1	26	Low	n78	High	15/75	100/273	QPSK/CP-OFDM QPSK	NA	QPSK / CP-OFDM QPSK	1@0	1@272
2	26	Low	n78	Mid	15/75	100/273	QPSK/CP-OFDM QPSK	NA	QPSK / CP-OFDM QPSK	1@0	1@0
3	26	High	n78	High	15/75	100/273	QPSK/CP-OFDM QPSK	NA	QPSK / CP-OFDM QPSK	1@74	1@34
4	26	Low	n78	Mid	15/75	100/273	QPSK/CP-OFDM QPSK	NA	QPSK / CP-OFDM QPSK	1@0	1@78
5	26	Low	n78	Low	15/75	100/273	QPSK/CP-OFDM QPSK	NA	QPSK / CP-OFDM QPSK	1@0	1@201
6	26	Low	n78	Note 13	15/75	100/273	QPSK/CP-OFDM QPSK	NA	QPSK / CP-OFDM QPSK	1@0	1@0
<b>Test Setting for DC_26A_n79A Configuration</b>											
N/A (Note 14)											
<b>Test Setting for DC_28A_n3A Configuration</b>											
1	28	Low	n3	Low	20/100	30/160	QPSK/CP-OFDM QPSK	NA	QPSK / CP-OFDM QPSK	1@0	1@0
2	28	High	n3	High	20/100	30/160	QPSK/CP-OFDM QPSK	NA	QPSK / CP-OFDM QPSK	1@99	1@159
3	28	High	n3	Low	20/100	30/160	QPSK/CP-OFDM QPSK	NA	QPSK / CP-OFDM QPSK	1@99	1@0
<b>Test Setting for DC_28A_n5A Configuration</b>											
1	28	High	n5	High	20/100	20/106	QPSK/CP-OFDM QPSK	NA	QPSK / CP-OFDM QPSK	<a href="#">1@99</a>	1@105
2	28	Low	n5	Low	20/100	20/106	QPSK/CP-OFDM QPSK	NA	QPSK / CP-OFDM QPSK	1@0	1@0
3	28	High	n5	Low	20/100	20/106	QPSK/CP-OFDM QPSK	NA	QPSK / CP-OFDM QPSK	1@99	<a href="#">1@0</a>

Test Setting for DC_28A_n7A Configuration											
1	28	High	n7	High	20/100	20/106	QPSK/CP-OFDM QPSK	NA	QPSK / CP-OFDM QPSK	1@99	1@105
Test Setting for DC_28A_n77A Configuration											
1	28	High	n77	Low	20/100	100/273	QPSK/CP-OFDM QPSK	NA	QPSK / CP-OFDM QPSK	1@99	1@0
2	28	Low	n77	Low	20/100	100/273	QPSK/CP-OFDM QPSK	NA	QPSK / CP-OFDM QPSK	1@0	1@158
3	28	High	n77	High	20/100	100/273	QPSK/CP-OFDM QPSK	NA	QPSK / CP-OFDM QPSK	1@99	1@130
4	28	Low	n77	Note 23	20/100	100/273	QPSK/CP-OFDM QPSK	NA	QPSK / CP-OFDM QPSK	1@0	1@0
5	28	Low	n77	Low	20/100	100/273	QPSK/CP-OFDM QPSK	NA	QPSK / CP-OFDM QPSK	1@0	1@0
6	28	Low	n77	Mid	20/100	100/273	QPSK/CP-OFDM QPSK	NA	QPSK / CP-OFDM QPSK	1@0	1@272
7	28	Low	n77	Note 23	20/100	100/273	QPSK/CP-OFDM QPSK	NA	QPSK / CP-OFDM QPSK	1@0	1@0
Test Setting for DC_28A_n78A Configuration											
1	28	Low	n78	Low	10/50	100/273	QPSK/CP-OFDM QPSK	NA	QPSK / CP-OFDM QPSK	1@0	1@0
2	28	High	n78	High	10/50	100/273	QPSK/CP-OFDM QPSK	NA	QPSK / CP-OFDM QPSK	1@49	1@272
3	28	Mid	n78	Mid	10/50	100/273	QPSK/CP-OFDM QPSK	NA	QPSK / CP-OFDM QPSK	1@49	1@272
4	28	High	n78	Low	10/50	100/273	QPSK/CP-OFDM QPSK	NA	QPSK / CP-OFDM QPSK	1@49	1@190
5	28	High	n78	Mid	10/50	100/273	QPSK/CP-OFDM QPSK	NA	QPSK / CP-OFDM QPSK	1@0	1@0
Test Setting for DC_28A_n79A Configuration											
1	28	High	n79	High	20/100	100/273	QPSK/CP-OFDM QPSK	NA	QPSK / CP-OFDM QPSK	1@99	1@272
Test Setting for DC_30A_n5A Configuration											
1	30	High	n5	High	10/50	20/106	QPSK/CP-OFDM QPSK	NA	QPSK / CP-OFDM QPSK	1@49	1@105

Test Settings for DC_39A_n41A Configuration											
1	39	High	n41	High	20/100	100/273	QPSK/CP-OFDM QPSK	NA	QPSK / CP-OFDM QPSK	1@99	1@272
Test Settings for DC_39A_n79A Configuration											
1	39	Low	n79	Mid	20/100	100/273	QPSK/CP-OFDM QPSK	NA	QPSK / CP-OFDM QPSK	1@0	1@146
2	39	Low	n79	Note 5	20/100	100/273	QPSK/CP-OFDM QPSK	NA	QPSK / CP-OFDM QPSK	1@0	1@0
Test Settings for DC_40A_n1A Configuration											
1	40	Low	n1	Low	20/100	20/106	QPSK/CP-OFDM QPSK	NA	QPSK / CP-OFDM QPSK	1@0	1@0
2	40	High	n1	Low	20/100	20/106	QPSK/CP-OFDM QPSK	NA	QPSK / CP-OFDM QPSK	1@99	1@105
3	40	High	n1	Mid	20/100	20/106	QPSK/CP-OFDM QPSK	NA	QPSK / CP-OFDM QPSK	1@99	1@56
4	40	High	n1	Low	20/100	20/106	QPSK/CP-OFDM QPSK	NA	QPSK / CP-OFDM QPSK	1@99	1@77
5	40	High	n1	Low	20/100	20/106	QPSK/CP-OFDM QPSK	NA	QPSK / CP-OFDM QPSK	1@99	1@39
Test Settings for DC_40A_n41A Configuration											
1	40	Low	n41	Low	20/100	100/273	QPSK/CP-OFDM QPSK	NA	QPSK / CP-OFDM QPSK	1@0	1@0
2	40	High	n41	High	20/100	100/273	QPSK/CP-OFDM QPSK	NA	QPSK / CP-OFDM QPSK	1@99	1@272
3	40	Mid	n41	High	20/100	100/273	QPSK/CP-OFDM QPSK	NA	QPSK / CP-OFDM QPSK	1@50	1@272
4	40	Low	n41	High	20/100	100/273	QPSK/CP-OFDM QPSK	NA	QPSK / CP-OFDM QPSK	1@0	1@272
Test Settings for DC_40A_n78A Configuration											
1	40	Low	n78	High	20/100	100/273	QPSK/CP-OFDM QPSK	NA	QPSK / CP-OFDM QPSK	1@0	1@79
2	40	High	n78	Low	20/100	100/273	QPSK/CP-OFDM QPSK	NA	QPSK / CP-OFDM QPSK	1@99	1@110
3	40	Low	n78	High	20/100	100/273	QPSK/CP-OFDM QPSK	NA	QPSK / CP-OFDM QPSK	1@99	1@0

4	40	Low	n78	High	20/100	100/273	QPSK/CP-OFDM QPSK	NA	QPSK / CP-OFDM QPSK	1@0	1@234
5	40	High	n78	Low	20/100	100/273	QPSK/CP-OFDM QPSK	NA	QPSK / CP-OFDM QPSK	1@99	1@29
6	40	Low	n78	High	20/100	100/273	QPSK/CP-OFDM QPSK	NA	QPSK / CP-OFDM QPSK	1@0	1@50
7	40	Low	n78	High	15/75	100/273	QPSK/CP-OFDM QPSK	NA	QPSK / CP-OFDM QPSK	1@0	1@272
8	40	High	n78	Low	20/100	100/273	QPSK/CP-OFDM QPSK	NA	QPSK / CP-OFDM QPSK	1@99	1@0
9	40	Low	n78	High	20/100	100/273	QPSK/CP-OFDM QPSK	NA	QPSK / CP-OFDM QPSK	1@0	1@110
10	40	Low	n78	High	20/100	100/273	QPSK/CP-OFDM QPSK	NA	QPSK / CP-OFDM QPSK	1@0	1@155
11	40	High	n78	Low	20/100	100/273	QPSK/CP-OFDM QPSK	NA	QPSK / CP-OFDM QPSK	1@99	1@183
12	40	Low	n78	Low	20/100	100/273	QPSK/CP-OFDM QPSK	NA	QPSK / CP-OFDM QPSK	1@0	1@272
<b>Test Settings for DC_40A_n79A Configuration</b>											
1	40	Low	n79	Low	20/100	50/270	QPSK/CP-OFDM QPSK	NA	QPSK / CP-OFDM QPSK	1@0	<a href="#">1@269</a>
2	40	High	n79	Low	20/100	50/270	QPSK/CP-OFDM QPSK	NA	QPSK / CP-OFDM QPSK	1@0	1@0
3	40	High	n79	High	20/100	50/270	QPSK/CP-OFDM QPSK	NA	QPSK / CP-OFDM QPSK	1@99	<a href="#">1@269</a>
<b>Test Settings for DC_41A_n28A Configuration</b>											
1	41	High	n28	Low	20/100	15/79	QPSK/CP-OFDM QPSK	NA	QPSK / CP-OFDM QPSK	1@0	1@0
2	41	Note 33	n28	High	5/25	15/79	QPSK/CP-OFDM QPSK	NA	QPSK / CP-OFDM QPSK	1@0	1@78
3	41	Mid	n28	Low	10/50	15/79	QPSK/CP-OFDM QPSK	NA	QPSK / CP-OFDM QPSK	1@49	1@78
<b>Test Settings for DC_41A_n77A Configuration</b>											

1	41	Mid	n77	Low	20/100	100/273	QPSK/CP-OFDM QPSK	NA	QPSK / CP-OFDM QPSK	1@0	1@0
2	41	Low	n77	Low	20/100	100/273	QPSK/CP-OFDM QPSK	NA	QPSK / CP-OFDM QPSK	1@0	1@185
3	41	Low	n77	High	20/100	100/273	QPSK/CP-OFDM QPSK	NA	QPSK / CP-OFDM QPSK	1@0	1@57
4	41	Low	n77	Note 15	20/100	100/273	QPSK/CP-OFDM QPSK	NA	QPSK / CP-OFDM QPSK	1@0	1@0
5	41	Low	n77	High	20/100	100/273	QPSK/CP-OFDM QPSK	NA	QPSK / CP-OFDM QPSK	1@99	1@0
6	41	High	n77	High	20/100	100/273	QPSK/CP-OFDM QPSK	NA	QPSK / CP-OFDM QPSK	1@99	1@201
7	41	Mid	n77	Mid	20/100	100/273	QPSK/CP-OFDM QPSK	NA	QPSK / CP-OFDM QPSK	1@99	1@46
8	41	Low	n77	Low	20/100	100/273	QPSK/CP-OFDM QPSK	NA	QPSK / CP-OFDM QPSK	1@0	1@214
9	41	Low	n77	High	20/100	100/273	QPSK/CP-OFDM QPSK	NA	QPSK / CP-OFDM QPSK	1@0	1@29
10	41	High	n77	High	20/100	100/273	QPSK/CP-OFDM QPSK	NA	QPSK / CP-OFDM QPSK	1@99	1@272
11	41	Mid	n77	Mid	20/100	100/273	QPSK/CP-OFDM QPSK	NA	QPSK / CP-OFDM QPSK	1@99	1@0
12	41	Low	n77	Low	20/100	100/273	QPSK/CP-OFDM QPSK	NA	QPSK / CP-OFDM QPSK	1@99	1@0
13	41	Low	n77	High	20/100	100/273	QPSK/CP-OFDM QPSK	NA	QPSK / CP-OFDM QPSK	1@0	1@272
14	41	Mid	n77	Low	20/100	100/273	QPSK/CP-OFDM QPSK	NA	QPSK / CP-OFDM QPSK	1@99	1@0
15	41	High	n77	Low	20/100	100/273	QPSK/CP-OFDM QPSK	NA	QPSK / CP-OFDM QPSK	1@99	1@161
16	41	High	n77	High	20/100	100/273	QPSK/CP-OFDM QPSK	NA	QPSK / CP-OFDM QPSK	1@99	1@122
17	41	Mid	n77	Mid	20/100	100/273	QPSK/CP-OFDM QPSK	NA	QPSK / CP-OFDM QPSK	1@0	1@27

18	41	Low	n77	High	20/100	100/273	QPSK/CP-OFDM QPSK	NA	QPSK / CP-OFDM QPSK	1@99	1@240
19	41	Mid	n77	Note 15	20/100	100/273	QPSK/CP-OFDM QPSK	NA	QPSK / CP-OFDM QPSK	1@0	1@125
<b>Test Settings for DC_41A_n78A Configuration</b>											
1	41	High	n78	Mid	20/100	100/273	QPSK/CP-OFDM QPSK	NA	QPSK / CP-OFDM QPSK	1@99	1@0
2	41	Low	n78	Low	20/100	100/273	QPSK/CP-OFDM QPSK	NA	QPSK / CP-OFDM QPSK	1@0	1@185
3	41	High	n78	Mid	20/100	100/273	QPSK/CP-OFDM QPSK	NA	QPSK / CP-OFDM QPSK	1@0	1@272
4	41	Low	n78	Mid	20/100	100/273	QPSK/CP-OFDM QPSK	NA	QPSK / CP-OFDM QPSK	1@0	1@0
5	41	Low	n78	Low	20/100	100/273	QPSK/CP-OFDM QPSK	NA	QPSK / CP-OFDM QPSK	1@0	1@214
6	41	Low	n78	Mid	20/100	100/273	QPSK/CP-OFDM QPSK	NA	QPSK / CP-OFDM QPSK	1@99	1@69
7	41	Low	n78	Low	20/100	100/273	QPSK/CP-OFDM QPSK	NA	QPSK / CP-OFDM QPSK	1@99	1@0
8	41	High	n78	Low	20/100	100/273	QPSK/CP-OFDM QPSK	NA	QPSK / CP-OFDM QPSK	1@99	1@161
9	41	Mid	n78	Low	20/100	100/273	QPSK/CP-OFDM QPSK	NA	QPSK / CP-OFDM QPSK	1@99	1@0
10	41	Low	n78	Mid	20/100	100/273	QPSK/CP-OFDM QPSK	NA	QPSK / CP-OFDM QPSK	1@0	1@98
<b>Test Settings for DC_41A_n79A Configuration</b>											
1	41	Low	n79	Mid	20/100	100/273	QPSK/CP-OFDM QPSK	NA	QPSK / CP-OFDM QPSK	1@0	1@0
2	41	High	n79	Low	20/100	100/273	QPSK/CP-OFDM QPSK	NA	QPSK / CP-OFDM QPSK	1@99	1@272
3	41	High	n79	Low	20/100	100/273	QPSK/CP-OFDM QPSK	NA	QPSK / CP-OFDM QPSK	1@0	1@188
4	41	High	n79	Low	20/100	100/273	QPSK/CP-OFDM QPSK	NA	QPSK / CP-OFDM QPSK	1@99	1@93

5	41	Mid	n79	Low	20/100	100/273	QPSK/CP-OFDM QPSK	NA	QPSK / CP-OFDM QPSK	1@0	1@0
6	41	High	n79	Mid	20/100	100/273	QPSK/CP-OFDM QPSK	NA	QPSK / CP-OFDM QPSK	1@99	1@151
7	41	High	n79	High	20/100	100/273	QPSK/CP-OFDM QPSK	NA	QPSK / CP-OFDM QPSK	1@99	1@272
8	41	Low	n79	Low	20/100	100/273	QPSK/CP-OFDM QPSK	NA	QPSK / CP-OFDM QPSK	1@0	1@0
<b>Test Setting for DC_42A_n77A Configuration</b>											
N/A (Note 14)											
<b>Test Settings for DC_48A_n5A Configuration</b>											
1	48	High	n5	High	20/100	20/106	QPSK/CP-OFDM QPSK	NA	QPSK / CP-OFDM QPSK	1@0	1@105
2	48	High	n5	High	20/100	20/106	QPSK/CP-OFDM QPSK	NA	QPSK / CP-OFDM QPSK	1@99	1@105
3	48	Low	n5	Low	20/100	20/106	QPSK/CP-OFDM QPSK	NA	QPSK / CP-OFDM QPSK	1@0	1@0
<b>Test Settings for DC_66A_n5A Configuration</b>											
1	66	Low	n5	High	20/100	20/106	QPSK/CP-OFDM QPSK	NA	QPSK / CP-OFDM QPSK	1@0	1@0
2	66	High	n5	High	20/100	20/106	QPSK/CP-OFDM QPSK	NA	QPSK / CP-OFDM QPSK	1@99	1@105
3	66	Low	n5	Low	20/100	20/106	QPSK/CP-OFDM QPSK	NA	QPSK / CP-OFDM QPSK	1@99	1@0
4	66	High	n5	Low	20/100	20/106	QPSK/CP-OFDM QPSK	NA	QPSK / CP-OFDM QPSK	1@99	1@0
<b>Test Settings for DC_66A_n71A Configuration</b>											
N/A (Note 14)											
<b>Test Settings for DC_66A_n78A Configuration</b>											
1	66	Low	n78	Mid	20/100	100/273	QPSK/CP-OFDM QPSK	NA	QPSK / CP-OFDM QPSK	1@0	1@143
2	66	High	n78	High	20/100	100/273	QPSK/CP-OFDM QPSK	NA	QPSK / CP-OFDM QPSK	1@99	1@272
3	66	Low	n78	Mid	20/100	100/273	QPSK/CP-OFDM QPSK	NA	QPSK / CP-OFDM QPSK	1@0	1@272

- Note 1: Use DC Configuration – specific test points if present in the table, otherwise use test points from matching Group Test Settings, if present in the table. Otherwise use the Default Test Settings test points.
- Note 2: X, nY correspond to the different bands in the DC Configuration. E.g. for DC\_1A\_n3A, X=1, nY=n3.
- Note 3: Void.
- Note 4: Test Point ID 4 for DC\_3A\_n41A have the centre carrier frequency of 1773 MHz in Band 3 (EARFCN=19830).
- Note 5: Test Point ID 4 for DC\_39A\_n79A has the centre carrier frequency of 4649.96 MHz in Band 79 (NR ARFCN=709998).
- Note 6: Void.
- Note 7: Void.
- Note 8: Test Point ID 3 for DC\_1A\_n78A has the centre carrier frequency of 3473.43 MHz in Band 78 (NR ARFCN=631562).
- Note 9: Test Point ID 1 for DC\_8A\_n77A has the centre carrier frequency of 3950.13 MHz in Band n77 (NR ARFCN=663342). Test Point ID 5 has the centre carrier frequency of 3524.55 MHz in Band n77 (NR ARFCN=634970). Test Point ID 8 has the centre carrier frequency of 3584.55 MHz in Band n77 (NR ARFCN=638970). Test Point ID 10 has centre carrier frequency of 3500 MHz in Band n77 (NR ARFCN=633333).
- Note 10: Test Point ID 1 for DC\_11A\_n77A has the centre carrier frequency of 3617.43 MHz in Band n77 (NR ARFCN=641162). Test Point ID 5 has the centre carrier frequency of 3686.43 MHz in Band n77 (NR ARFCN=645762). Test Point ID 6 has the centre carrier frequency of 3494.94 MHz in Band n77 (NR ARFCN=632996). Test Point ID 7 has the centre carrier frequency of 3858.42 MHz in Band n77 (NR ARFCN=657228). Test Point ID 9 has the centre carrier frequency of 4037.43 MHz in Band n77 (NR ARFCN=669162). Test Point ID 10 has the centre carrier frequency of 4097.43 MHz in Band n77 (NR ARFCN=673162).
- Note 11: Test Point ID 5 for DC\_11A\_n78A has the centre carrier frequency of 3686.43 MHz in Band n78 (NR ARFCN=645762). Test Point ID 6 has the centre carrier frequency of 3494.94 MHz in Band n78 (NR ARFCN=632996).
- Note 12: Void.
- Note 13: Test Point ID 6 for DC\_26A\_n78A has the centre carrier frequency of 3483.78 MHz in Band n78 (NR ARFCN=632252).
- Note 14: Test case not applicable for the EN-DC configuration as no IM products occurs in the protected bands.
- Note 15: Test Point ID 4 for DC\_41A\_n77A has the centre carrier frequency of 3488.55 MHz in Band n77 (NR ARFCN=632570). Test Point ID 19 has the centre carrier frequency of 3500 MHz in Band n77 (NR ARFCN=633333).
- Note 16: Void.
- Note 17: Test Point ID 6 for DC\_19A\_n78A has the centre carrier frequency of 3499.8 MHz in Band n78 (NR ARFCN=633320).
- Note 18: Test Point ID 4 for DC\_1A\_n77A has the centre carrier frequency of 3472.95 MHz in Band n77 (NR ARFCN=631530). Test Point ID 5 has the centre carrier frequency of 3987.03 MHz in Band n77 (NR ARFCN=665802). Test Point ID 6 has the centre carrier frequency of 3857.04 MHz in Band n77 (NR ARFCN=657136). Test Point ID 7 has the centre carrier frequency of 3874.53 MHz in Band n77 (NR ARFCN=658302). Test Point ID 8 has the centre carrier frequency of 3887.04 MHz in Band n77 (NR ARFCN=659136).
- Note 19: Test Point ID 1 for DC\_3A\_n77A has the centre carrier frequency of 3900.03 MHz in Band n77 (NR ARFCN=660002). Test Point ID 2 has the centre carrier frequency of 3602.55 MHz in Band n77 (NR ARFCN=640170). Test Point ID 5 has the centre carrier frequency of 3660.15 MHz in Band n77 (NR ARFCN=644010).
- Note 20: Test Point ID 6 for DC\_21A\_n78A has the centre carrier frequency of 3515.19 MHz in Band n78 (NR ARFCN=634346).
- Note 21: Test Point ID 1 for DC\_21A\_n77A has the centre carrier frequency of 3637.68 MHz in Band n77 (NR ARFCN=642512). Test Point ID 6 has the centre carrier frequency of 3515.19 MHz in Band n77 (NR ARFCN=634346). Test Point ID 7 has the centre carrier frequency of 3898.92 MHz in Band n77 (NR ARFCN=659928). Test Point ID 9 has the centre carrier frequency of 4057.68 MHz in Band n77 (NR ARFCN=670512).
- Note 22: Test Point ID 4 for DC\_21A\_n79A has the centre carrier frequency of 4846.53 MHz in Band n79 (NR ARFCN=723102).
- Note 23: Test Point ID 4 for DC\_28A\_n77A has the centre carrier frequency of 3474,63 MHz in Band n77 (NR ARFCN=631642). Test Point ID 7 for have the centre carrier frequency of 3597,12 MHz in Band n77 (NR ARFCN=639808).
- Note 24: Test Point ID 5 for DC\_20A\_n78A has the centre carrier frequency of 3477.03 MHz in Band n78 (NR ARFCN=631802).
- Note 25: Test Point ID 2 for DC\_26A\_n77A has the centre carrier frequency of 3521.13 MHz in Band n77 (NR ARFCN=634742). Test Point ID 4 has the centre carrier frequency of 3578.73 MHz in Band n77 (NR ARFCN=638582). Test Point ID 5 has the centre carrier frequency of 4028.64 MHz in Band n77 (NR ARFCN=668576). Test Point ID 8 has the centre carrier frequency of 3483.78 MHz in Band n77 (NR ARFCN=632252).
- Note 26: Test Point ID 2 for DC\_19A\_n77A has the centre carrier frequency of 3553.14 MHz in Band n77 (NR ARFCN=636876). Test Point ID 4 has the centre carrier frequency of 4060.62 MHz in Band n77 (NR ARFCN=670708). Test Point ID 5 has the centre carrier frequency of 3610.74 MHz in Band n77 (NR



	ARFCN=640716). Test Point ID 7 has the centre carrier frequency of 3499.8 MHz in Band n77 (NR ARFCN=633320).
Note 27:	Void.
Note 28:	Test Point ID 3 for DC_5A_n77A has the centre carrier frequency of 4000 MHz in Band n77 (NR ARFCN=666667). Test Point ID 4 has the centre carrier frequency of 3600 MHz in Band n77 (NR ARFCN=640000). Test Point ID 5 has the centre carrier frequency of 3658.14 MHz in Band n77 (NR ARFCN=643876).
Note 29:	Test Point ID 1 for DC_13A_n77A has the centre carrier frequency of 3500 MHz in Band n77 (NR ARFCN=633333). Test Point ID 3 has the centre carrier frequency of 3880 MHz in Band n77 (NR ARFCN=658668). Test Point ID 4 has the centre carrier frequency of 3611.64 MHz in Band n77 (NR ARFCN=640776). Test Point ID 5 has the centre carrier frequency of 3504.24 MHz in Band n77 (NR ARFCN=633616).
Note 30:	Void.
Note 31:	Test Point ID 2 for DC_18A_n77A have the centre carrier frequency of 3441,39 MHz in Band n77 (NR ARFCN=649400). Test Point ID 3 and 5 for DC_18A_n77A have the centre carrier frequency of 3602,55 MHz in Band n77 (NR ARFCN=640170). Test Point ID 4 for DC_18A_n77A have the centre carrier frequency of 4049,76 MHz in Band n77 (NR ARFCN=669984).
Note 32:	Test Point ID 2 for DC_18A_n78A have the centre carrier frequency of 3441,39 MHz in Band n78 (NR ARFCN=629400). Test Point ID 3 for DC_18A_n78A have the centre carrier frequency of 3602,55 MHz in Band n78 (NR ARFCN=640170).
Note 33:	Test Point ID 2 for DC_41A_n28 A and Band 41 is defined as a carrier with CBW=5MHz and centre frequency at 2660.1MHz (NR ARFCN=532020).
Note 34:	Void.
Note 35:	Void.

Additional step 9 when both bands are TDD:

8. For both E-UTRA and NR UL uplink carriers active when both bands are TDD, ensure E-UTRA UL transmission overlaps with NR UL transmission in time by giving SCG a delay of 3 E-UTRA subframes, or by giving MCG a delay of 2 subframes.

#### 6.5B.3.3.2.4.2 Test Procedure

Same test procedure as described in clause 6.5B.3.1.2.4.2 with the following exceptions:

Instead of Table 6.5B.3.1.2.3-1 --> use Table 6.5B.3.3.2.5-1.

In addition to test configurations above, UEs not tested under NR/5GC mode in the tested band needs to be tested according to LTE anchor agnostic approach below.

Same test description as in clause 6.5.3.2.4 in TS 38.521-1 [8] for the NR carrier with the following exceptions:

The initial test configurations for E-UTRA consist of test frequency based on E-UTRA operating band and test channel bandwidth as specified in Table 4.6-1.

For Initial conditions as in clause 6.5.3.2.4.1 in TS 38.521-1 [8], the following steps will be added to configure E-UTRA component:

- 2.1. The parameter settings for the cell are set up according to TS 36.508 [11] clause 4.4.3.
- 3.1. The E-UTRA downlink signal level, uplink signal level are set according to Table 4.6-1 and propagation conditions are set according to Annex B.0 of TS 36.521-1 [10].

Step 6 of Initial conditions as in clause 6.5.3.2.4.1 in TS 38.521-1 [8] is replaced by:

6. Ensure the UE is in state RRC\_CONNECTED with generic procedure parameters Connectivity EN-DC, DC bearer MCG and SCG, Connected without release *On* according to TS 38.508 [6] clause 4.5.
7. On the E-UTRA carrier, disable periodic and aperiodic CQI reports, disable SRS, set *TimeAlignmentTimerDedicated* IE to infinity and disable downlink and uplink scheduling, all as per Table 4.6-1 under clause 4.6.

6.5B.3.3.2.4.3 Message Contents

Message contents are according to TS 36.508 [11] clause 4.6 and TS 38.508-1 [6] clause 4.6.1 with the following exceptions.

**Table 6.5B.3.3.2.4.3-1: SystemInformationBlockType1: tdd-Config if E-UTRA on TDD band**

Derivation Path: TS 36.508 [11], Table 4.6.3-23			
Information Element	Value/remark	Comment	Condition
TDD-Config-DEFAULT ::= SEQUENCE {		Operating on TDD band	
subframeAssignment	Sa2		
specialSubframePatterns	Ssp7		
}			

**Table 6.5B3.3.2.4.3-1a: Void**

**Table 6.5B.3.3.2.4.3-2: RRCConnectionReconfiguration: nr-Config-r15**

Derivation Path: TS 36.508 [11], Table 4.6.1-8			
Information Element	Value/remark	Comment	Condition
p-MaxEUTRA-r15	23		Power Class 2 UE AND simultaneous E-UTRA and NR transmission
	20		Power Class 3 UE AND simultaneous E-UTRA and NR transmission

**Table 6.5B.3.3.2.4.3-3: PhysicalCellGroupConfig**

Derivation Path: TS 38.508-1 [6] Table 4.6.3-106			
Information Element	Value/remark	Comment	Condition
p-NR-FR1	23		Power Class 2 UE AND simultaneous E-UTRA and NR transmission
	20		Power Class 3 UE AND simultaneous E-UTRA and NR transmission

6.5B.3.3.2.5 Test Requirement

Test requirements for Spurious Emissions UE Co-existence when both LTE and NR carriers are required to be active are release specific and can be found in Table 6.5B.3.3.2.5-1 If the UE support a band combination from a later release, the requirements for this band combination are taken from the table of earliest release where requirements for this band combination are defined.

Test requirements for Spurious Emissions UE Co-existence when using LTE anchor agnostic approach can be found in clause 6.5.3.2.5 in TS 38.521-1 [8].

For inter-band EN\_DC with the uplink assigned to one LTE band and one NR band, the test requirements in Table 6.5B.3.3.2.5-1 can be verified by measuring spurious emissions at the specific frequencies where second and third order intermodulation products generated by the two transmitted carriers can occur.

For Release 18, unless otherwise stated, the spurious emission for UE co-existence requirements are not applicable to the frequency ranges where out-of-band emissions requirements in clause 6.5B.2 are defined.

**Table 6.5B.3.3.2.5-1: Requirements for inter-band within FR1 according to UE NR release**

EN-DC Configuration	Release	Spurious emission				
		Protected band	Frequency range (MHz)	Maximum Level (dBm)	MBW (MHz)	NOTE

DC_1_n28	Rel-15	E-UTRA Band 7, 31, 41, 72, 73 NR Band n79	F <sub>DL_low</sub>	-	F <sub>DL_high</sub>	-50	1	
		E-UTRA Band 42, 52 NR Band n77, n78	F <sub>DL_low</sub>	-	F <sub>DL_high</sub>	-50	1	2
	Rel-15 Rel-16	Frequency range	470	-	694	-42	8	5, 17
	Rel-17 Rel-18	Frequency range	470	-	710	-26.2	6	14
DC_1_n77	Rel-15	E-UTRA Band 1, 3, 11, 21, 34, 65, 74	F <sub>DL_low</sub>	-	F <sub>DL_high</sub>	-50	1	
		Frequency range	1880	-	1895	-40	1	5, 16
	Rel-15 Rel-16 Rel-17 Rel-18	Frequency range	1895	-	1915	-15.5	5	5, 7, 16
		Frequency range	1915	-	1920	1.6	5	5, 7, 16
DC_1_n78	Rel-15	E-UTRA Band 3, 11, 21, 74	F <sub>DL_low</sub>	-	F <sub>DL_high</sub>	-50	1	
	Rel-15 Rel-16 Rel-17 Rel-18	Frequency range	1880	-	1895	-40	1	5, 16
DC_1_n79	Rel-15	E-UTRA Band 5, 7, 8, 18, 19, 26, 28, 41	F <sub>DL_low</sub>	-	F <sub>DL_high</sub>	-50	1	
DC_2_n5	Rel-15	E-UTRA Band 42, 48	F <sub>DL_low</sub>	-	F <sub>DL_high</sub>	-50	1	
		E-UTRA Band 41, 43	F <sub>DL_low</sub>	-	F <sub>DL_high</sub>	-50	1	2
DC_2_n66	Rel-15	E-UTRA Band 4, 10, 24, 50, 66, 70, 74	F <sub>DL_low</sub>	-	F <sub>DL_high</sub>	-50	1	
		E-UTRA Band 2, 25	F <sub>DL_low</sub>	-	F <sub>DL_high</sub>	-50	1	5
		E-UTRA Band 42, 48	F <sub>DL_low</sub>	-	F <sub>DL_high</sub>	-50	1	2
DC_2_n71	Rel-15	E-UTRA Band 41	F <sub>DL_low</sub>	-	F <sub>DL_high</sub>	-50	1	2
DC_2_n78	Rel-15	E-UTRA Band 24, 50, 51, 74	F <sub>DL_low</sub>	-	F <sub>DL_high</sub>	-50	1	
		E-UTRA Band 2, 25	F <sub>DL_low</sub>	-	F <sub>DL_high</sub>	-50	1	2
DC_3_n7	Rel-15	E-UTRA Band 5, 8, 20, 26, 27, 28, 44, 67	F <sub>DL_low</sub>	-	F <sub>DL_high</sub>	-50	1	
		E-UTRA Band 42	F <sub>DL_low</sub>	-	F <sub>DL_high</sub>	-50	1	2
DC_3_n8	Rel-15	E-UTRA Band 20, 28, 38, 69	F <sub>DL_low</sub>	-	F <sub>DL_high</sub>	-50	1	
		E-UTRA Band 7, 22, 41, 42, 43 NR band n77, n78, n79	F <sub>DL_low</sub>	-	F <sub>DL_high</sub>	-50	1	2
DC_3_n28	Rel-15	NR band n77	F <sub>DL_low</sub>	-	F <sub>DL_high</sub>	-50	1	2
		E-UTRA Band 7, 41	F <sub>DL_low</sub>	-	F <sub>DL_high</sub>	-50	1	
DC_3_n77	Rel-15	E-UTRA Band 1, 3, 28, 34, 39, 40, 65, 74	F <sub>DL_low</sub>	-	F <sub>DL_high</sub>	-50	1	
	Rel-15 Rel-16 Rel-17 Rel-18	Frequency range	1884.5	-	1915.7	-41	0.3	3
DC_3_n78	Rel-15	E-UTRA Band 3, 34, 39	F <sub>DL_low</sub>	-	F <sub>DL_high</sub>	-50	1	
	Rel-15 Rel-16 Rel-17 Rel-18	Frequency range	1884.5	-	1915.7	-41	0.3	3
DC_3_n79	Rel-15	E-UTRA Band 5, 8, 11, 18, 19, 21, 41, 74	F <sub>DL_low</sub>	-	F <sub>DL_high</sub>	-50	1	
DC_5_n66	Rel-15	E-UTRA Band 5, 6, 7, 8, 38	F <sub>DL_low</sub>	-	F <sub>DL_high</sub>	-50	1	
		E-UTRA Band 26	859	-	869	-27	1	
		E-UTRA Band 41, 42, 52	F <sub>DL_low</sub>	-	F <sub>DL_high</sub>	-50	1	2
DC_5_n77	Rel-17 Rel-18	Frequency range	1884.5	-	1915.7	-41	0.3	3
DC_5_n78	Rel-15	E-UTRA Band 1, 2, 3, 4, 7, 25, 34, 38, 65, 66, 70	F <sub>DL_low</sub>	-	F <sub>DL_high</sub>	-50	1	
		E-UTRA Band 41	F <sub>DL_low</sub>	-	F <sub>DL_high</sub>	-50	1	2, 7

DC_7_n28	Rel-15	E-UTRA Band 3	F <sub>DL_low</sub>	-	F <sub>DL_high</sub>	-50	1	
		NR band n78	F <sub>DL_low</sub>	-	F <sub>DL_high</sub>	-50	1	2
DC_7_n78	Rel-15	E-UTRA Band 3, 5, 8, 11, 18, 19, 20, 21, 26, 27, 28, 32, 50, 51, 67, 68, 74, 75, 76	F <sub>DL_low</sub>	-	F <sub>DL_high</sub>	-50	1	
DC_8_n3	Rel-16 Rel-17 Rel-18	Frequency range	860	-	890	-40	1	5, 12
DC_8_n20	Rel-16 Rel-17 Rel-18	Frequency range	758	-	788	-50	1	
DC_8_n28	Rel-16 Rel-17 Rel-18	Frequency range	491	-	616	-42	8	5, 17
DC_8_n41	Rel-16 Rel-17 Rel-18	Frequency range	860	-	890	-40	1	5, 12
DC_8_n77	Rel-15	E-UTRA Band 1, 32, 33, 34, 38, 39, 40, 50, 65, 69, 74, 75	F <sub>DL_low</sub>	-	F <sub>DL_high</sub>	-50	1	
		E-UTRA band 3, 7, 41	F <sub>DL_low</sub>	-	F <sub>DL_high</sub>	-50	1	2
		E-UTRA Band 11, 21	F <sub>DL_low</sub>	-	F <sub>DL_high</sub>	-50	1	12
	Rel-15 Rel-16 Rel-17 Rel-18	Frequency range	1884.5	-	1915.7	-41	0.3	3, 12
DC_8_n78	Rel-15	E-UTRA band 34, 39, 40, 74	F <sub>DL_low</sub>	-	F <sub>DL_high</sub>	-50	1	
		E-UTRA Band 3, 7, 41	F <sub>DL_low</sub>	-	F <sub>DL_high</sub>	-50	1	2
		E-UTRA Band 11, 21	F <sub>DL_low</sub>	-	F <sub>DL_high</sub>	-50	1	12
	Rel-15 Rel-16 Rel-17 Rel-18	Frequency range	1884.5	-	1915.7	-41	0.3	3, 12
DC_11_n77	Rel-15	E-UTRA Band 1, 3, 18, 19, 28, 34, 40, 65	F <sub>DL_low</sub>	-	F <sub>DL_high</sub>	-50	1	
		Frequency range	945	-	960	-50	1	
	Rel-15 Rel-16 Rel-17 Rel-18	Frequency range	1884.5	-	1915.7	-41	0.3	3
		Frequency range	2545	-	2575	-50	1	
		Frequency range	2595	-	2645	-50	1	

DC_11_n78	Rel-15	E-UTRA Band 1, 3, 18, 19, 28, 34, 40, 65	F <sub>DL_low</sub>	-	F <sub>DL_high</sub>	-50	1	
	Rel-15 Rel-16 Rel-17 Rel-18	Frequency range	1884.5	-	1915.7	-41	0.3	3
DC_11_n79	Rel-15	E-UTRA Band 1, 3, 34, 42, 65	F <sub>DL_low</sub>	-	F <sub>DL_high</sub>	-50	1	
	Rel-15 Rel-16 Rel-17 Rel-18	Frequency range	1884.5	-	1915.7	-41	0.3	3
DC_12_n66	Rel-15	E-UTRA Band 41,53	F <sub>DL_low</sub>	-	F <sub>DL_high</sub>	-50	1	
		NR Band n77	F <sub>DL_low</sub>	-	F <sub>DL_high</sub>	-50	1	2
DC_12_n78	Rel-16 Rel-17 Rel-18	Frequency range	1884.5	-	1915.7	-41	0.3	3
DC_19_n77	Rel-15	E-UTRA Band 1, 3, 34, 40, 65	F <sub>DL_low</sub>	-	F <sub>DL_high</sub>	-50	1	
	Rel-15 Rel-16 Rel-17 Rel-18	Frequency range	1884.5	-	1915.7	-41	0.3	3
		Frequency range	2545	-	2575	-50	1	
		Frequency range	2595	-	2645	-50	1	
DC_19_n78	Rel-15	E-UTRA Band 1, 3, 34, 65	F <sub>DL_low</sub>	-	F <sub>DL_high</sub>	-50	1	
	Rel-15 Rel-16 Rel-17 Rel-18	Frequency range	1884.5	-	1915.7	-41	0.3	3
		Frequency range	2545	-	2575	-50	1	
		Frequency range	2595	-	2645	-50	1	
DC_19_n79	Rel-15	E-UTRA Band 42	F <sub>DL_low</sub>	-	F <sub>DL_high</sub>	-50	1	
DC_21_n77	Rel-15	E-UTRA Band 1, 3, 18, 19, 28, 34, 40, 65	F <sub>DL_low</sub>	-	F <sub>DL_high</sub>	-50	1	
	Rel-15 Rel-16 Rel-17 Rel-18	Frequency range	945	-	960	-50	1	
		Frequency range	1884.5	-	1915.7	-41	0.3	3
		Frequency range	2545	-	2575	-50	1	
		Frequency range	2595	-	2645	-50	1	
DC_21_n78	Rel-15	E-UTRA Band 1, 3, 18, 19, 28, 34, 40, 65	F <sub>DL_low</sub>	-	F <sub>DL_high</sub>	-50	1	
	Rel-15 Rel-16 Rel-17 Rel-18	Frequency range	1884.5	-	1915.7	-41	0.3	3
DC_21_n79	Rel-15	E-UTRA Band 3, 21, 34, 42	F <sub>DL_low</sub>	-	F <sub>DL_high</sub>	-50	1	
	Rel-15 Rel-16 Rel-17 Rel-18	Frequency range	1884.5	-	1915.7	-41	0.3	3
DC_25_n41	Rel-15	E-UTRA Band 12, 13, 14, 17, 28, 29, 42, 71	F <sub>DL_low</sub>	-	F <sub>DL_high</sub>	-50	1	
DC_26_n41	Rel-15	E-UTRA Band 3, 5, 18, 19, 26, 42	F <sub>DL_low</sub>	-	F <sub>DL_high</sub>	-50	1	
	Rel-15 Rel-16 Rel-17 Rel-18	Frequency range	799	-	803	-40	1	5
		Frequency range	945	-	960	-50	1	
DC_26_n77	Rel-15	E-UTRA Band 1, 3, 34, 39, 40, 65	F <sub>DL_low</sub>	-	F <sub>DL_high</sub>	-50	1	
		E-UTRA Band 41	F <sub>DL_low</sub>	-	F <sub>DL_high</sub>	-50	1	2
	Rel-15 Rel-16 Rel-17 Rel-18	Frequency range	1884.5	-	1915.7	-41	0.3	3

		Frequency range	2545	-	2575	-50	1	
		Frequency range	2595	-	2645	-50	1	
DC_26_n78	Rel-16	Frequency range	1884.5	-	1915.7	-41	0.3	3
	Rel-17	Frequency range	2545	-	2575	-50	1	2
	Rel-18	Frequency range	2595	-	2645	-50	1	
DC_28_n5	Rel-16	Frequency range	557	-	672	-42	8	5, 17
	Rel-17	Frequency range	557	-	672	-26.2	6	14
	Rel-18	Frequency range	662	-	672	-26.2	6	5
DC_28_n77	Rel-15	E-UTRA Band 3, 7, 34, 39, 40, 41	FDL_low	-	FDL_high	-50	1	
		E-UTRA Band 1, 65	FDL_low	-	FDL_high	-50	1	2
		E-UTRA Band 1	FDL_low	-	FDL_high	-50	1	9, 11
	Rel-15 Rel-16 Rel-17 Rel-18	Frequency range	1884.5	-	1915.7	-41	0.3	3, 9
DC_28_n78	Rel-15	E-UTRA Band 3, 7, 34, 39, 40, 41	FDL_low	-	FDL_high	-50	1	
		E-UTRA Band 1, 65	FDL_low	-	FDL_high	-50	1	2
		E-UTRA Band 1	FDL_low	-	FDL_high	-50	1	9, 11
	Rel-15 Rel-16 Rel-17 Rel-18	Frequency range	1884.5	-	1915.7	-41	0.3	3
DC_28_n79	Rel-15	E-UTRA Band 42	FDL_low	-	FDL_high	-50	1	2
DC_30_n5	Rel-15	E-UTRA Band 71	FDL_low	-	FDL_high	-50	1	
DC_39_n41	Rel-15	E-UTRA Band 42, 44	FDL_low	-	FDL_high	-50	1	
		NR Band n77, n78, n79	FDL_low	-	FDL_high	-50	1	2
DC_39_n79	Rel-15	E-UTRA Band 8, 28, 41, 44	FDL_low	-	FDL_high	-50	1	
DC_40_n41	Rel-15	Bands 1, 34, 39, 65	FDL_low	-	FDL_high	-50	1	
		NR Band n79	FDL_low	-	FDL_high	-50	1	2
	Rel-15 Rel-16 Rel-17 Rel-18	Frequency range	1884.5	-	1915.7	-41	0.3	3, 19
DC_41_n28	Rel-16 Rel-17 Rel-18	Frequency range	1884.5	-	1915.7	-41	1	3, 9
DC_41_n77	Rel-15	E-UTRA Band 3, 5, 8, 11, 18, 19, 21, 26, 28, 33, 34, 39, 44, 45, 74	FDL_low	-	FDL_high	-50	1	
	Rel-15 Rel-16 Rel-17 Rel-18	Frequency range	1884.5	-	1915.7	-41	0.3	3
DC_41_n78	Rel-15	E-UTRA Band 3, 5, 8, 11, 18, 19, 21, 26, 28, 34, 39, 44, 45, 74	FDL_low	-	FDL_high	-50	1	
	Rel-15 Rel-16 Rel-17 Rel-18	Frequency range	1884.5	-	1915.7	-41	0.3	3
DC_41_n79	Rel-15	E-UTRA Band 1, 3, 5, 8, 18, 19, 26, 28, 34, 40, 44, 65	FDL_low	-	FDL_high	-50	1	
	Rel-15 Rel-16 Rel-17 Rel-18	Frequency range	1884.5	-	1915.7	-41	0.3	3
DC_48_n5	Rel-16 Rel-17 Rel-18	Frequency range	1884.5	-	1915.7	-41	0.3	3
DC_66_n5	Rel-15	E-UTRA Band 5, 6, 7, 8, 26, 38	FDL_low	-	FDL_high	-50	1	
		E-UTRA Band 41, 42, 52	FDL_low	-	FDL_high	-50	1	2

DC_66_n78	Rel-15	E-UTRA Band 3, 34, 39	F <sub>DL_low</sub>	-	F <sub>DL_high</sub>	-50	1	
NOTE 1:	F <sub>DL_low</sub> and F <sub>DL_high</sub> refer to each frequency band specified in Table 5.5-1 of TS 36.101 [5] or in Table 5.2-1 in TS 38.101-1 [2].							
NOTE 2:	As exceptions, measurements with a level up to the applicable requirements defined in Table 6.6.3.1-2 in TS 36.101 [5] and Table 6.5.3.1-2 in TS 38.101-1 [2] are permitted for each assigned carrier used in the measurement due to 2 <sup>nd</sup> , 3 <sup>rd</sup> , 4 <sup>th</sup> or 5 <sup>th</sup> harmonic spurious emissions. Due to spreading of the harmonic emission the exception is also allowed for the first 1 MHz frequency range immediately outside the harmonic emission on both sides of the harmonic emission. This results in an overall exception interval centred at the harmonic emission of (2MHz + N x L <sub>CRB</sub> x 180kHz), where N is 2, 3, 4, 5 for the 2 <sup>nd</sup> , 3 <sup>rd</sup> , 4 <sup>th</sup> or 5 <sup>th</sup> harmonic respectively. The exception is allowed if the measurement bandwidth (MBW) totally or partially overlaps the overall exception interval.							
NOTE 3:	Applicable when co-existence with PHS system operating in 1884.5 -1915.7MHz							
NOTE 4:	Void.							
NOTE 5:	These requirements also apply for the frequency ranges that are less than F <sub>OOB</sub> (MHz) in Table 6.6.3.1-1, Table 6.6.3.1A-1 in TS 36.101 [5] or in Table 6.5.3.1-1 in TS 38.101-1 [2] from the edge of the channel bandwidth.							
NOTE 6:	This requirement is applicable for any channel bandwidths within the range 2500 - 2570 MHz with the following restriction: for carriers of 15 MHz bandwidth when carrier centre frequency is within the range 2560.5 - 2562.5 MHz and for carriers of 20 MHz bandwidth when carrier centre frequency is within the range 2552 - 2560 MHz the requirement is applicable only for an uplink transmission bandwidth less than or equal to 54 RB.							
NOTE 7:	For these adjacent bands, the emission limit could imply risk of harmful interference to UE(s) operating in the protected operating band.							
NOTE 8:	Void.							
NOTE 9:	Applicable when the assigned E-UTRA or NR carrier is confined within 718 MHz and 748 MHz and when the channel bandwidth used is 5 or 10 MHz.							
NOTE 10:	As exceptions, measurements with a level up to the applicable requirement of -38 dBm/MHz is permitted for each assigned E-UTRA carrier used in the measurement due to 2 <sup>nd</sup> harmonic spurious emissions. An exception is allowed if there is at least one individual RB within the transmission bandwidth (see Figure 5.6-1) for which the 2 <sup>nd</sup> harmonic totally or partially overlaps the measurement bandwidth (MBW).							
NOTE 11:	As exceptions, measurements with a level up to the applicable requirement of -36 dBm/MHz is permitted for each assigned E-UTRA carrier used in the measurement due to 3 <sup>rd</sup> harmonic spurious emissions. An exception is allowed if there is at least one individual RB within the transmission bandwidth (see Figure 5.6-1) for which the 3 <sup>rd</sup> harmonic totally or partially overlaps the measurement bandwidth (MBW).							
NOTE 12:	This requirement is applicable only for the following cases: A: for carriers of 5 MHz channel bandwidth when carrier centre frequency (F <sub>c</sub> ) is within the range 902.5 MHz ≤ F <sub>c</sub> < 907.5 MHz with an uplink transmission bandwidth less than or equal to 20 RB; B: for carriers of 5 MHz channel bandwidth when carrier centre frequency (F <sub>c</sub> ) is within the range 907.5 MHz ≤ F <sub>c</sub> ≤ 912.5 MHz without any restriction on uplink transmission bandwidth; C: for carriers of 10 MHz channel bandwidth when carrier centre frequency (F <sub>c</sub> ) is F <sub>c</sub> = 910 MHz with an uplink transmission bandwidth less than or equal to 32 RB with RBstart > 3.							
NOTE 13:	Void.							
NOTE 14:	This requirement is applicable for 5 and 10 MHz E-UTRA or NR channel bandwidth allocated within 718-728MHz. For carriers of 10 MHz bandwidth, this requirement applies for an uplink transmission bandwidth less than or equal to 30 RB with RBstart > 1 and RBstart < 48.							
NOTE 15:	Void.							
NOTE 16:	This requirement is applicable for any channel bandwidths within the range 1920 - 1980 MHz with the following restriction: for carriers of 15 MHz bandwidth when carrier centre frequency is within the range 1927.5 - 1929.5 MHz and for carriers of 20 MHz bandwidth when carrier centre frequency is within the range 1930 - 1938 MHz the requirement is applicable only for an uplink transmission bandwidth less than or equal to 54 RB.							
NOTE 17:	This requirement is applicable in the case of a 10 MHz E-UTRA or NR carrier confined within 703 MHz and 733 MHz, otherwise the requirement of -25 dBm with a measurement bandwidth of 8 MHz applies.							
NOTE 18:	This requirement is only applicable for E-UTRA carriers with bandwidth confined within 1885 - 1920 MHz (requirement for carriers with at least 1RB confined within 1880 - 1885 MHz is not specified). This requirement applies for an uplink transmission bandwidth less than or equal to 54 RB for E-UTRA carriers of 15 MHz bandwidth when carrier centre frequency is within the range 1892.5 - 1894.5 MHz and for E-UTRA carriers of 20 MHz bandwidth when carrier centre frequency is within the range 1895 - 1903 MHz.							
NOTE 19:	Void.							
NOTE 20:	Void.							
NOTE 21:	Void.							
NOTE 22:	This requirement is applicable for power class 3 UE for any channel bandwidths within the range 2570 - 2615 MHz with the following restriction: for carriers of 15 MHz bandwidth when carrier centre frequency is within the range 2605.5 - 2607.5 MHz and for carriers of 20 MHz bandwidth when carrier centre frequency is within the range 2597 - 2605 MHz the requirement is applicable only for an uplink transmission bandwidth less than or equal to 54 RB.							

**Table 6.5B.3.3.2.5-2: Void**

**Table 6.5B.3.3.2.5-3: Void**

### 6.5B.3.3a Inter-band NE-DC within FR1

#### 6.5B.3.3a.1 General Spurious Emissions for Inter-band NE-DC within FR1

No exception requirements applicable to NR or E-UTRA.

No test case details are specified. The requirements for NR carrier(s) in this test case are tested in 6.5.3.1 and 6.5A.3.1 of TS 38.521-1 [8], and the requirements for LTE carrier(s) in this test case are tested in 6.6.3.1 and 6.6.3.1A of TS 36.521-1 [10]. Neither NR carrier(s) nor LTE carrier(s) needs to be tested again.

#### 6.5B.3.3a.2 Spurious emission band UE co-existence for Inter-band NE-DC within FR1

FFS

### 6.5B.3.4 Spurious Emissions for Inter-band including FR2

**Editor's note:** This clause is complete for Band n257, n258, n259, n260 and n261. The following aspects are either missing or not yet determined:

- The referred test case 6.5.3 in TS 38.521-2 [9] is incomplete for frequency above 87 GHz.

#### 6.5B.3.4.1 General Spurious Emissions for Inter-band including FR2 (1 NR CC)

**Editor's Note:**

- This clause is complete for Band n257, n258, n259, n260 and n261 and for PC1, PC3 and PC5.
- TRP Measurement uncertainty is TBD for above 87 GHz.

##### 6.5B.3.4.1.1 Test purpose

Same test purpose as in clause 6.5.3.1.1 in TS 38.521-2 [9] for the NR carrier.

##### 6.5B.3.4.1.2 Test applicability

This test case applies to all types of E-UTRA UE release 15 and forward, supporting inter-band EN-DC including FR2 with 1 NR UL CC.

##### 6.5B.3.4.1.3 Minimum conformance requirements

Same minimum conformance requirements as in clause 6.5.3.1.3 in TS 38.521-2 [9] for the NR carrier.

No exception requirements applicable to NR or E-UTRA. LTE anchor agnostic approach is applied.

The normative reference for this requirement is TS 38.101-3 [4] clause 6.5B.3.4.

##### 6.5B.3.4.1.4 Test description

###### 6.5B.3.4.1.4.1 Initial conditions

Same test description as in clause 6.5.3.1.4 in TS 38.521-2 [9] for the NR carrier with the following exception:

The initial test configurations for E-UTRA band consist of environmental conditions, test frequencies, and channel bandwidths based on E-UTRA bands specified in Table 4.7-1. For Initial conditions as in clause 6.5.3.1.4.1 in TS 38.521-2 [9], the following steps will be added to configure E-UTRA component:

2.1 The parameter settings for E-UTRA cell are set up according to TS 36.508 [11] clause 4.4.3.

3.1 The E-UTRA downlink signal level, uplink signal level are set according to Table 4.7-1 and propagation conditions are set according to Annex B.0 of TS 36.521-1 [10].

Step 6 of Initial conditions as in clause 6.5.3.1.4.1 in TS 38.521-2 [9] is replaced by:



6. Ensure the UE is in state RRC\_CONNECTED with generic procedure parameters Connectivity EN-DC, DC bearer MCG and SCG, Connected without release On according to TS 38.508-1 [6] clause 4.5.

Same test procedure as in clause 6.5.3.1.4.1 in TS 38.521-2 [9] with the following steps added for E-UTRA component:

- 1.1 On the E-UTRA carrier, disable periodic and aperiodic CQI reports, disable SRS, set *TimeAlignmentTimerDedicated* IE to infinity and disable downlink and uplink scheduling, all as per Table 4.7-1 under clause 4.7.

#### 6.5B.3.4.1.5 Test requirement

Same test requirement as in clause 6.5.3.1.5 in TS 38.521-2 [9] for the NR carrier.

#### 6.5B.3.4.1a General Spurious Emissions with Power Boost for Inter-band including FR2 (1 NR CC)

**Editor's note: This clause is complete for Band n257, n258, n259, n260 and n261 for PC1 and PC3. The following aspects of the clause are for future consideration:**

- **TRP Measurement uncertainty is TBD for above 87 GHz.**

#### 6.5B.3.4.1a.1 Test purpose

Same test purpose as in clause 6.5.3.1\_1.1 in TS 38.521-2 [9] for the NR carrier.

#### 6.5B.3.4.1a.2 Test applicability

This test case applies to all types of NR UE release 16 and forward supporting *mpr-PowerBoost-FR2-r16* UE capability, supporting inter-band EN-DC including FR2 with 1 NR UL CC.

#### 6.5B.3.4.1a.3 Minimum conformance requirements

Same minimum conformance requirements as in clause 6.5.3.1\_1.3 in TS 38.521-2 [9] for the NR carrier.

No exception requirements applicable to NR or E-UTRA. LTE anchor agnostic approach is applied.

The normative reference for this requirement is TS 38.101-3 [4] clause 6.5B.3.4.

#### 6.5B.3.4.1a.4 Test description

Same test description as in clause 6.5.3.1\_1.4 in TS 38.521-2 [9] for the NR carrier with the following exception:

The initial test configurations for E-UTRA band consist of environmental conditions, test frequencies, and channel bandwidths based on E-UTRA bands specified in Table 4.6-1. For Initial conditions as in clause 6.5.3.1.4.1 in TS 38.521-2 [9], the following steps will be added to configure E-UTRA component:

- 2.1 The parameter settings for E-UTRA cell are set up according to TS 36.508 [11] clause 4.4.3.
- 3.1 The E-UTRA downlink signal level, uplink signal level are set according to Table 4.7-1 and propagation conditions are set according to Annex B.0 of TS 36.521-1 [10].

Step 6 of Initial conditions as in clause 6.2.4\_1.4 in TS 38.521-2 [9] is replaced by:

6. Ensure the UE is in state RRC\_CONNECTED with generic procedure parameters Connectivity EN-DC, DC bearer MCG and SCG, Connected without release On according to TS 38.508-1 [6] clause 4.5.

Same test procedure as in clause 6.5.3.1.4.1 in TS 38.521-2 [9] with the following steps added for E-UTRA component:

- 1.1 On the E-UTRA carrier, disable periodic and aperiodic CQI reports, disable SRS, set *TimeAlignmentTimerDedicated* IE to infinity and disable downlink and uplink scheduling, all as per Table 4.7-1 under clause 4.7.

## 6.5B.3.4.1a.5 Test requirement

Same test requirement as in clause 6.5.3.1\_1.5 in TS 38.521-2 [9] for the NR carrier.

## 6.5B.3.4.1\_1 General Spurious emissions for Inter-band EN-DC including FR2 (&gt;1 NR CC)

## 6.5B.3.4.1\_1.1 General Spurious emissions for Inter-band EN-DC including FR2 (2 NR CCs)

**Editor's note: The following aspects are either missing or not yet determined:**

- The referred test case 6.5A.3.1.1 in TS 38.521-2 [9] is incomplete for:
  - Bands other than n257, n258, n260 and n261
  - Power classes 1, 2 and 4

## 6.5B.3.4.1\_1.1.1 Test purpose

Same test purpose as in clause 6.5.3.1 in TS 38.521-2 [9] for the NR carrier.

## 6.5B.3.4.1\_1.1.2 Test applicability

This test case applies to all types of E-UTRA UE release 15 and forward, supporting inter-band EN-DC including FR2 with 2 NR UL CCs.

## 6.5B.3.4.1\_1.1.3 Minimum conformance requirements

Same minimum conformance requirements as in clause 6.5.3.3 in TS 38.521-2 [9] for the NR carrier.

No exception requirements applicable to NR or E-UTRA. LTE anchor agnostic approach is applied.

The normative reference for this requirement is TS 38.101-3 [4] clause 6.4B.3.4.

## 6.5B.3.4.1\_1.1.4 Test description

## 6.5B.3.4.1\_1.1.4.1 Initial condition

Same test description as in clause 6.5A.3.1.1.4 in TS 38.521-2 [9] for the NR carrier with the following exception:

The initial test configurations for E-UTRA band consist of environmental conditions, test frequencies, and channel bandwidths based on E-UTRA bands specified in Table 4.7-1.

For Initial conditions as in clause 6.5A.3.1.1.4.1 in TS 38.521-2 [9], the following steps will be added to configure E-UTRA component:

- 2.1. The parameter settings for E-UTRA cell are set up according to TS 36.508 [11] clause 4.4.3.
- 3.1. The E-UTRA downlink signal level, uplink signal level are set according to Table 4.7-1 and propagation conditions are set according to Annex B.0 of TS 36.521-1 [10].

Step 6 of Initial conditions as in clause 6.5A.3.1.1.4.1 in TS 38.521-2 [9] is replaced by:

6. Ensure the UE is in state RRC\_CONNECTED with generic procedure parameters Connectivity EN-DC, DC bearer MCG and SCG, Connected without release On according to TS 38.508-1 [6] clause 4.5.

Same test procedure as in clause 6.5A.3.1.1.4.2 in TS 38.521-2 [9] with the following steps added for E-UTRA component:

- 1.1 On the E-UTRA carrier, disable periodic and aperiodic CQI reports, disable SRS, set *TimeAlignmentTimerDedicated* IE to infinity and disable downlink and uplink scheduling, all as per Table 4.7-1 under clause 4.7.

#### 6.5B.3.4.1\_1.1.5 Test Requirements

Same test requirement as in clause 6.5A.3.1.1.5 in TS 38.521-2 [9] for the *NR* carrier.

#### 6.5B.3.4.1\_1.2 General Spurious emissions for Inter-band EN-DC including FR2 (3 NR CCs)

**Editor's note: The following aspects are either missing or not yet determined:**

- **The referred test case 6.5A.3.1.2 in TS 38.521-2 [9] is incomplete for:**
  - **Bands other than n257, n258, n260 and n261**
  - **Power classes 1, 2 and 4**

#### 6.5B.3.4.1\_1.2.1 Test purpose

Same test purpose as in clause 6.5.3.1 in TS 38.521-2 [9] for the *NR* carrier.

#### 6.5B.3.4.1\_1.2.2 Test applicability

This test case applies to all types of E-UTRA UE release 15 and forward, supporting inter-band EN-DC including FR2 with 3 NR UL CCs.

#### 6.5B.3.4.1\_1.2.3 Minimum conformance requirements

Same minimum conformance requirements as in clause 6.5.3.3 in TS 38.521-2 [9] for the *NR* carrier.

No exception requirements applicable to *NR* or E-UTRA. LTE anchor agnostic approach is applied.

The normative reference for this requirement is TS 38.101-3 [4] clause 6.4B.3.4.

#### 6.5B.3.4.1\_1.2.4 Test description

##### 6.5B.3.4.1\_1.2.4.1 Initial condition

Same test description as in clause 6.5A.3.1.2.4 in TS 38.521-2 [9] for the *NR* carrier with the following exception:

The initial test configurations for E-UTRA band consist of environmental conditions, test frequencies, and channel bandwidths based on E-UTRA bands specified in Table 4.7-1.

For Initial conditions as in clause 6.5A.3.1.2.4.1 in TS 38.521-2 [9], the following steps will be added to configure E-UTRA component:

- 2.1. The parameter settings for E-UTRA cell are set up according to TS 36.508 [11] clause 4.4.3.
- 3.1. The E-UTRA downlink signal level, uplink signal level are set according to Table 4.7-1 and propagation conditions are set according to Annex B.0 of TS 36.521-1 [10].

Step 6 of Initial conditions as in clause 6.5A.3.1.2.4.1 in TS 38.521-2 [9] is replaced by:

6. Ensure the UE is in state `RRC_CONNECTED` with generic procedure parameters Connectivity EN-DC, DC bearer MCG and SCG, Connected without release On according to TS 38.508-1 [6] clause 4.5.

Same test procedure as in clause 6.5A.3.1.2.4.2 in TS 38.521-2 [9] with the following steps added for E-UTRA component:

- 1.1 On the E-UTRA carrier, disable periodic and aperiodic CQI reports, disable SRS, set *TimeAlignmentTimerDedicated* IE to infinity and disable downlink and uplink scheduling, all as per Table 4.7-1 under clause 4.7.

#### 6.5B.3.4.1\_1.2.5 Test Requirements

Same test requirement as in clause 6.5A.3.1.2.5 in TS 38.521-2 [9] for the *NR* carrier.

### 6.5B.3.4.1\_1.3 General Spurious emissions for Inter-band EN-DC including FR2 (4 NR CCs)

**Editor's note: The following aspects are either missing or not yet determined:**

- The referred test case 6.5A.3.1.3 in TS 38.521-2 [9] is incomplete for:
  - Bands other than n257, n258, n260 and n261
  - Power classes 1, 2 and 4

#### 6.5B.3.4.1\_1.3.1 Test purpose

Same test purpose as in clause 6.5.3.1 in TS 38.521-2 [9] for the NR carrier.

#### 6.5B.3.4.1\_1.3.2 Test applicability

This test case applies to all types of E-UTRA UE release 15 and forward, supporting inter-band EN-DC including FR2 with 4 NR UL CCs.

#### 6.5B.3.4.1\_1.3.3 Minimum conformance requirements

Same minimum conformance requirements as in clause 6.5.3.3 in TS 38.521-2 [9] for the NR carrier.

No exception requirements applicable to NR or E-UTRA. LTE anchor agnostic approach is applied.

The normative reference for this requirement is TS 38.101-3 [4] clause 6.4B.3.4.

#### 6.5B.3.4.1\_1.3.4 Test description

##### 6.5B.3.4.1\_1.3.4.1 Initial condition

Same test description as in clause 6.5A.3.1.3.4 in TS 38.521-2 [9] for the NR carrier with the following exception:

The initial test configurations for E-UTRA band consist of environmental conditions, test frequencies, and channel bandwidths based on E-UTRA bands specified in Table 4.7-1.

For Initial conditions as in clause 6.5A.3.1.3.4.1 in TS 38.521-2 [9], the following steps will be added to configure E-UTRA component:

- 2.1. The parameter settings for E-UTRA cell are set up according to TS 36.508 [11] clause 4.4.3.
- 3.1. The E-UTRA downlink signal level, uplink signal level are set according to Table 4.7-1 and propagation conditions are set according to Annex B.0 of TS 36.521-1 [10].

Step 6 of Initial conditions as in clause 6.5A.3.1.3.4.1 in TS 38.521-2 [9] is replaced by:

6. Ensure the UE is in state RRC\_CONNECTED with generic procedure parameters Connectivity EN-DC, DC bearer MCG and SCG, Connected without release On according to TS 38.508-1 [6] clause 4.5.

Same test procedure as in clause 6.5A.3.1.3.4.2 in TS 38.521-2 [9] with the following steps added for E-UTRA component:

- 1.1 On the E-UTRA carrier, disable periodic and aperiodic CQI reports, disable SRS, set *TimeAlignmentTimerDedicated* IE to infinity and disable downlink and uplink scheduling, all as per Table 4.7-1 under clause 4.7.

#### 6.5B.3.4.1\_1.3.5 Test Requirements

Same test requirement as in clause 6.5A.3.1.3.5 in TS 38.521-2 [9] for the NR carrier.

### 6.5B.3.4.1\_1.4 General Spurious emissions for Inter-band EN-DC including FR2 (5 NR CCs)

**Editor's note: The following aspects are either missing or not yet determined:**

- The referred test case 6.5A.3.1.4 in TS 38.521-2 [9] is incomplete for:
  - Bands other than n257, n258, n260 and n261
  - Power classes 1, 2 and 4
- Measurement Uncertainties and Test Tolerances is incomplete.

#### 6.5B.3.4.1\_1.4.1 Test purpose

Same test purpose as in clause 6.5.3.1 in TS 38.521-2 [9] for the NR carrier.

#### 6.5B.3.4.1\_1.4.2 Test applicability

This test case applies to all types of E-UTRA UE release 15 and forward, supporting inter-band EN-DC including FR2 with 5 NR UL CCs.

#### 6.5B.3.4.1\_1.4.3 Minimum conformance requirements

Same minimum conformance requirements as in clause 6.5.3.3 in TS 38.521-2 [9] for the NR carrier.

No exception requirements applicable to NR or LTE. LTE anchor agnostic approach is applied.

The normative reference for this requirement is TS 38.101-3 [4] clause 6.5B.3.4.

#### 6.5B.3.4.1\_1.4.4 Test description

##### 6.5B.3.4.1\_1.4.4.1 Initial condition

Same test description as in clause 6.5A.3.1.4.4 in TS 38.521-2 [9] for the NR carrier with the following exception:

The initial test configurations for E-UTRA band consist of environmental conditions, test frequencies, and channel bandwidths based on E-UTRA bands specified in Table 4.7-1.

For Initial conditions as in clause 6.5A.3.1.1.4.1 in TS 38.521-2 [9], the following steps will be added to configure E-UTRA component:

- 2.1. The parameter settings for E-UTRA cell are set up according to TS 36.508 [11] clause 4.4.3.
- 3.1. The E-UTRA downlink signal level, uplink signal level are set according to Table 4.7-1 and propagation conditions are set according to Annex B.0 of TS 36.521-1 [10].

Step 6 of Initial conditions as in clause 6.5A.3.1.1.4.1 in TS 38.521-2 [9] is replaced by:

6. Ensure the UE is in state RRC\_CONNECTED with generic procedure parameters Connectivity EN-DC, DC bearer MCG and SCG, Connected without release On according to TS 38.508-1 [6] clause 4.5.

Same test procedure as in clause 6.5A.3.1.1.4.2 in TS 38.521-2 [9] with the following steps added for E-UTRA component:

- 1.1 On the E-UTRA carrier, disable periodic and aperiodic CQI reports, disable SRS, set *TimeAlignmentTimerDedicated* IE to infinity and disable downlink and uplink scheduling, all as per Table 4.7-1 under clause 4.7.

#### 6.5B.3.4.1\_1.4.5 Test Requirements

Same test requirement as in clause 6.5A.3.1.4.5 in TS 38.521-2 [9] for the NR carrier.

#### 6.5B.3.4.1\_1.5 General Spurious emissions for Inter-band EN-DC including FR2 (6 NR CCs)

**Editor's note: The following aspects are either missing or not yet determined:**

- The referred test case 6.5A.3.1.5 in TS 38.521-2 [9] is incomplete for:

- Bands other than n257, n258, n260 and n261
- Power classes 1, 2 and 4
- Measurement Uncertainties and Test Tolerances is incomplete.

#### 6.5B.3.4.1\_1.5.1 Test purpose

Same test purpose as in clause 6.5.3.1 in TS 38.521-2 [9] for the NR carrier.

#### 6.5B.3.4.1\_1.5.2 Test applicability

This test case applies to all types of E-UTRA UE release 15 and forward, supporting inter-band EN-DC including FR2 with 6 NR UL CCs.

#### 6.5B.3.4.1\_1.5.3 Minimum conformance requirements

Same minimum conformance requirements as in clause 6.5.3.3 in TS 38.521-2 [9] for the NR carrier.

No exception requirements applicable to NR or LTE. LTE anchor agnostic approach is applied.

The normative reference for this requirement is TS 38.101-3 [4] clause 6.5B.3.4.

#### 6.5B.3.4.1\_1.5.4 Test description

##### 6.5B.3.4.1\_1.5.4.1 Initial condition

Same test description as in clause 6.5A.3.1.5.4 in TS 38.521-2 [9] for the NR carrier with the following exception:

The initial test configurations for E-UTRA band consist of environmental conditions, test frequencies, and channel bandwidths based on E-UTRA bands specified in Table 4.7-1.

For Initial conditions as in clause 6.5A.3.1.1.4.1 in TS 38.521-2 [9], the following steps will be added to configure E-UTRA component:

- 2.1. The parameter settings for E-UTRA cell are set up according to TS 36.508 [11] clause 4.4.3.
- 3.1. The E-UTRA downlink signal level, uplink signal level are set according to Table 4.7-1 and propagation conditions are set according to Annex B.0 of TS 36.521-1 [10].

Step 6 of Initial conditions as in clause 6.5A.3.1.1.4.1 in TS 38.521-2 [9] is replaced by:

6. Ensure the UE is in state RRC\_CONNECTED with generic procedure parameters Connectivity EN-DC, DC bearer MCG and SCG, Connected without release On according to TS 38.508-1 [6] clause 4.5.

Same test procedure as in clause 6.5A.3.1.1.4.2 in TS 38.521-2 [9] with the following steps added for E-UTRA component:

- 1.1 On the E-UTRA carrier, disable periodic and aperiodic CQI reports, disable SRS, set *TimeAlignmentTimerDedicated* IE to infinity and disable downlink and uplink scheduling, all as per Table 4.7-1 under clause 4.7.

#### 6.5B.3.4.1\_1.5.5 Test Requirements

Same test requirement as in clause 6.5A.3.1.5.5 in TS 38.521-2 [9] for the NR carrier.

#### 6.5B.3.4.1\_1.6 General Spurious emissions for Inter-band EN-DC including FR2 (7 NR CCs)

**Editor's note: The following aspects are either missing or not yet determined:**

- The referred test case 6.5A.3.1.6 in TS 38.521-2 [9] is incomplete for:
  - Bands other than n257, n258, n260 and n261

- Power classes 1, 2 and 4

- Measurement Uncertainties and Test Tolerances is incomplete.

#### 6.5B.3.4.1\_1.6.1 Test purpose

Same test purpose as in clause 6.5.3.1 in TS 38.521-2 [9] for the NR carrier.

#### 6.5B.3.4.1\_1.6.2 Test applicability

This test case applies to all types of E-UTRA UE release 15 and forward, supporting inter-band EN-DC including FR2 with 7 NR UL CCs.

#### 6.5B.3.4.1\_1.6.3 Minimum conformance requirements

Same minimum conformance requirements as in clause 6.5.3.3 in TS 38.521-2 [9] for the NR carrier.

No exception requirements applicable to NR or LTE. LTE anchor agnostic approach is applied.

The normative reference for this requirement is TS 38.101-3 [4] clause 6.5B.3.4.

#### 6.5B.3.4.1\_1.6.4 Test description

##### 6.5B.3.4.1\_1.6.4.1 Initial condition

Same test description as in clause 6.5A.3.1.6.4 in TS 38.521-2 [9] for the NR carrier with the following exception:

The initial test configurations for E-UTRA band consist of environmental conditions, test frequencies, and channel bandwidths based on E-UTRA bands specified in Table 4.7-1.

For Initial conditions as in clause 6.5A.3.1.1.4.1 in TS 38.521-2 [9], the following steps will be added to configure E-UTRA component:

- 2.1. The parameter settings for E-UTRA cell are set up according to TS 36.508 [11] clause 4.4.3.
- 3.1. The E-UTRA downlink signal level, uplink signal level are set according to Table 4.7-1 and propagation conditions are set according to Annex B.0 of TS 36.521-1 [10].

Step 6 of Initial conditions as in clause 6.5A.3.1.1.4.1 in TS 38.521-2 [9] is replaced by:

6. Ensure the UE is in state RRC\_CONNECTED with generic procedure parameters Connectivity EN-DC, DC bearer MCG and SCG, Connected without release On according to TS 38.508-1 [6] clause 4.5.

Same test procedure as in clause 6.5A.3.1.1.4.2 in TS 38.521-2 [9] with the following steps added for E-UTRA component:

- 1.1 On the E-UTRA carrier, disable periodic and aperiodic CQI reports, disable SRS, set *TimeAlignmentTimerDedicated* IE to infinity and disable downlink and uplink scheduling, all as per Table 4.7-1 under clause 4.7.

#### 6.5B.3.4.1\_1.6.5 Test Requirements

Same test requirement as in clause 6.5A.3.1.6.5 in TS 38.521-2 [9] for the NR carrier.

#### 6.5B.3.4.1\_1.7 General Spurious emissions for Inter-band EN-DC including FR2 (8 NR CCs)

Editor's note: The following aspects are either missing or not yet determined:

- The referred test case 6.5A.3.1.7 in TS 38.521-2 [9] is incomplete for:
  - Bands other than n257, n258, n260 and n261
  - Power classes 1, 2 and 4

- **Measurement Uncertainties and Test Tolerances is incomplete.**

#### 6.5B.3.4.1\_1.7.1 Test purpose

Same test purpose as in clause 6.5.3.1 in TS 38.521-2 [9] for the NR carrier.

#### 6.5B.3.4.1\_1.7.2 Test applicability

This test case applies to all types of E-UTRA UE release 15 and forward, supporting inter-band EN-DC including FR2 with 8 NR UL CCs.

#### 6.5B.3.4.1\_1.7.3 Minimum conformance requirements

Same minimum conformance requirements as in clause 6.5.3.3 in TS 38.521-2 [9] for the NR carrier.

No exception requirements applicable to NR or LTE. LTE anchor agnostic approach is applied.

The normative reference for this requirement is TS 38.101-3 [4] clause 6.5B.3.4.

#### 6.5B.3.4.1\_1.7.4 Test description

##### 6.5B.3.4.1\_1.7.4.1 Initial condition

Same test description as in clause 6.5A.3.1.7.4 in TS 38.521-2 [9] for the NR carrier with the following exception:

The initial test configurations for E-UTRA band consist of environmental conditions, test frequencies, and channel bandwidths based on E-UTRA bands specified in Table 4.7-1.

For Initial conditions as in clause 6.5A.3.1.1.4.1 in TS 38.521-2 [9], the following steps will be added to configure E-UTRA component:

- 2.1. The parameter settings for E-UTRA cell are set up according to TS 36.508 [11] clause 4.4.3.
- 3.1. The E-UTRA downlink signal level, uplink signal level are set according to Table 4.7-1 and propagation conditions are set according to Annex B.0 of TS 36.521-1 [10].

Step 6 of Initial conditions as in clause 6.5A.3.1.1.4.1 in TS 38.521-2 [9] is replaced by:

6. Ensure the UE is in state RRC\_CONNECTED with generic procedure parameters Connectivity EN-DC, DC bearer MCG and SCG, Connected without release On according to TS 38.508-1 [6] clause 4.5.

Same test procedure as in clause 6.5A.3.1.1.4.2 in TS 38.521-2 [9] with the following steps added for E-UTRA component:

- 1.1 On the E-UTRA carrier, disable periodic and aperiodic CQI reports, disable SRS, set *TimeAlignmentTimerDedicated* IE to infinity and disable downlink and uplink scheduling, all as per Table 4.7-1 under clause 4.7.

#### 6.5B.3.4.1\_1.7.5 Test Requirements

Same test requirement as in clause 6.5A.3.1.7.5 in TS 38.521-2 [9] for the NR carrier.

#### 6.5B.3.4.1D General Spurious Emissions for inter-band EN-DC including FR2 for UL MIMO

##### 6.5B.3.4.1D.1 Test purpose

Same test purpose as in clause 6.5D.3.1 in TS 38.521-2 [9] for the NR carrier.

##### 6.5B.3.4.1D.2 Test applicability

This test case applies to all types of E-UTRA UE release 15 and forward, supporting inter-band EN-DC FR2.



#### 6.5B.3.4.1D.3 Minimum conformance requirements

Same minimum conformance requirements as in clause 6.5D.3.1 in TS 38.521-2 [9] for the NR carrier.

No exception requirements applicable to NR or E-UTRA. LTE anchor agnostic approach is applied.

The normative reference for this measurement is TS 38.101-3 [4] clause 6.5B.3.4.

#### 6.5B.3.4.1D.4 Test Description

Same test description as in clause 6.5D.3.1 in TS 38.521-2 [9] for the NR carrier with the following exceptions:

The initial test configurations for E-UTRA consist of test frequency based on E-UTRA operating band and test channel bandwidth as specified in Table 4.7-1.

For Initial conditions as in clause 6.5D.3.1 in TS 38.521-2 [9], the following steps will be added to configure E-UTRA component:

- 2.1. The parameter settings for the cell are set up according to TS 36.508 [11] subclause 4.4.3.
- 3.1. The E-UTRA downlink signal level, uplink signal level are set according to Table 4.7-1 and propagation conditions are set according to Annex B.0 of TS 36.521-1 [10].

Step 6 of Initial conditions as in clause 6.5D.3.1 in TS 38.521-2 [9] is replaced by:

6. Ensure the UE is in state RRC\_CONNECTED with generic procedure parameters Connectivity EN-DC, DC bearer MCG and SCG, Connected without release *On* according to TS 38.508 [6] clause 4.5.
7. On the E-UTRA carrier, disable periodic and aperiodic CQI reports, disable SRS, set TimeAlignmentTimerDedicated IE to infinity and disable downlink and uplink scheduling, all as per Table 4.7-1 under clause 4.7.

#### 6.5B.3.4.1D.5 Test Requirement

Same test requirement as specified in clause 6.5D.3.1.5 of TS 38.521-2 [9] for the NR carrier(s).

#### 6.5B.3.4.2 Spurious emission band UE co-existence for Inter-band including FR2 (1 NR CC)

**Editor's note: The following aspects are either missing or not yet determined:**

- The referred test case 6.5.3.2 in TS 38.521-2 [9] is incomplete for power class other than PC1, PC3 and PC5.

##### 6.5B.3.4.2.1 Test purpose

Same test purpose as in clause 6.5.3.2.1 in TS 38.521-2 [9] for the NR carrier.

##### 6.5B.3.4.2.2 Test applicability

This test case applies to all types of E-UTRA UE release 15 and forward, supporting inter-band EN-DC including FR2 with 1 NR UL CC.

##### 6.5B.3.4.2.3 Minimum conformance requirements

Same minimum conformance requirements as in clause 6.5.3.2.3 in TS 38.521-2 [9] for the NR carrier.

No exception requirements applicable to NR or E-UTRA. LTE anchor agnostic approach is applied.

The normative reference for this requirement is TS 38.101-3 [4] clause 6.5B.3.4.1.

##### 6.5B.3.4.2.4 Test description

Same Test description as in clause 6.5.3.2.4 in TS 38.521-2 [9] for the NR carrier with the following exception:

The initial test configurations for E-UTRA band consist of environmental conditions, test frequencies, and channel bandwidths based on E-UTRA bands specified in Table 4.7-1.

For initial conditions as in clause 6.5.3.2.4.1 in TS 38.521-2 [9], the following steps will be added to configure E-UTRA component:

- 2.1 The parameter settings for E-UTRA cell are set up according to TS 36.508 [11] clause 4.4.3.
- 3.1 The E-UTRA downlink signal level, uplink signal level are set according to Table 4.7-1 and propagation conditions are set according to Annex B.0 of TS 36.521-1 [10].

Step 6 of Initial conditions as in clause 6.5.3.2.4.1 in TS 38.521-2 [9] is replaced by:

- 6. Ensure the UE is in state RRC\_CONNECTED with generic procedure parameters Connectivity EN-DC, DC bearer MCG and SCG, Connected without release On according to TS 38.508-1 [6] clause 4.5.

Same test procedure as in clause 6.5.3.2.4.1 in TS 38.521-2 [9] with the following steps added for E-UTRA component:

- 1.1 On the E-UTRA carrier, disable periodic and aperiodic CQI reports, disable SRS, set *TimeAlignmentTimerDedicated* IE to infinity and disable downlink and uplink scheduling, all as per Table 4.7-1 under clause 4.7.

#### 6.5B.3.4.2.5 Test requirement

Same Test requirement as in clause 6.5.3.2.5 in TS 38.521-2 [9] for the *NR* carrier.

#### 6.5B.3.4.2a Spurious emission band UE co-existence with Power Boost for Inter-band including FR2 (1 NR CC)

**Editor's note: The following aspects are either missing or not yet determined:**

- **The referred test case 6.5.3.2\_1 in TS 38.521-2 [9] is incomplete for PC2 and PC4.**

#### 6.5B.3.4.2a.1 Test purpose

Same test purpose as in clause 6.5.3.2\_1.1 in TS 38.521-2 [9] for the *NR* carrier.

#### 6.5B.3.4.2a.2 Test applicability

This test case applies to all types of NR UE release 16 and forward supporting *mpr-PowerBoost-FR2-r16* UE capability, supporting inter-band EN-DC including FR2 with 1 NR UL CC.

#### 6.5B.3.4.2a.3 Minimum conformance requirements

Same minimum conformance requirements as in clause 6.5.3.2\_1.3 in TS 38.521-2 [9] for the *NR* carrier.

No exception requirements applicable to NR or E-UTRA. LTE anchor agnostic approach is applied.

The normative reference for this requirement is TS 38.101-3 [4] clause 6.5B.3.4.1.

#### 6.5B.3.4.2a.4 Test description

Same Test description as in clause 6.5.3.2\_1.4 in TS 38.521-2 [9] for the *NR* carrier with the following exception:

The initial test configurations for E-UTRA band consist of environmental conditions, test frequencies, and channel bandwidths based on E-UTRA bands specified in Table 4.7-1.

For initial conditions as in clause 6.5.3.2.4.1 in TS 38.521-2 [9], the following steps will be added to configure E-UTRA component:

- 2.1 The parameter settings for E-UTRA cell are set up according to TS 36.508 [11] clause 4.4.3.
- 3.1 The E-UTRA downlink signal level, uplink signal level are set according to Table 4.7-1 and propagation conditions are set according to Annex B.0 of TS 36.521-1 [10].

Step 6 of Initial conditions as in clause 6.2.4\_1.4.1 in TS 38.521-2 [9] is replaced by:

6. Ensure the UE is in state RRC\_CONNECTED with generic procedure parameters Connectivity EN-DC, DC bearer MCG and SCG, Connected without release On according to TS 38.508-1 [6] clause 4.5.

Same test procedure as in clause 6.5.3.2\_1.4.2 in TS 38.521-2 [9] with the following steps added for E-UTRA component:

- 1.1 On the E-UTRA carrier, disable periodic and aperiodic CQI reports, disable SRS, set *TimeAlignmentTimerDedicated* IE to infinity and disable downlink and uplink scheduling, all as per Table 4.7-1 under clause 4.7.

#### 6.5B.3.4.2a.5 Test requirement

Same Test requirement as in clause 6.5.3.2\_1.5 in TS 38.521-2 [9] for the NR carrier.

#### 6.5B.3.4.2\_1 Spurious emission band UE co-existence for Inter-band EN-DC including FR2 (>1 NR CC)

#### 6.5B.3.4.2\_1.1 Spurious emission band UE co-existence for Inter-band EN-DC including FR2 (2 NR CCs)

**Editor's note: The following aspects are either missing or not yet determined:**

- **The referred test case 6.5A.3.2.1 in TS 38.521-2 [9] is incomplete for:**
  - **Testability and relaxation of the requirement for Bands other than n257, n258, n260 and n261**
  - **MU and TT for Power classes 1, 2 and 4**

#### 6.5B.3.4.2\_1.1.1 Test purpose

Same test purpose as in clause 6.5.3.2 in TS 38.521-2 [9] for the NR carrier.

#### 6.5B.3.4.2\_1.1.2 Test applicability

This test case applies to all types of E-UTRA UE release 15 and forward, supporting inter-band EN-DC including FR2 with 2 NR UL CCs.

#### 6.5B.3.4.2\_1.1.3 Minimum conformance requirements

Same minimum conformance requirements as in clause 6.5.3.2 in TS 38.521-2 [9] for the NR carrier.

No exception requirements applicable to NR or E-UTRA. LTE anchor agnostic approach is applied.

The normative reference for this requirement is TS 38.101-3 [4] clause 6.4B.3.2.

#### 6.5B.3.4.2\_1.1.4 Test description

#### 6.5B.3.4.2\_1.1.4.1 Initial condition

Same test description as in clause 6.5A.3.2.1.4 in TS 38.521-2 [9] for the NR carrier with the following exception:

The initial test configurations for E-UTRA band consist of environmental conditions, test frequencies, and channel bandwidths based on E-UTRA bands specified in Table 4.7-1.

For Initial conditions as in clause 6.5A.3.2.1.4.1 in TS 38.521-2 [9], the following steps will be added to configure E-UTRA component:

- 2.1. The parameter settings for E-UTRA cell are set up according to TS 36.508 [11] clause 4.4.3.
- 3.1. The E-UTRA downlink signal level, uplink signal level are set according to Table 4.7-1 and propagation conditions are set according to Annex B.0 of TS 36.521-1 [10].

Step 6 of Initial conditions as in clause 6.5A.3.2.1.4.1 in TS 38.521-2 [9] is replaced by:

6. Ensure the UE is in state RRC\_CONNECTED with generic procedure parameters Connectivity EN-DC, DC bearer MCG and SCG, Connected without release On according to TS 38.508-1 [6] clause 4.5.

Same test procedure as in clause 6.5A.3.2.1.4.2 in TS 38.521-2 [9] with the following steps added for E-UTRA component:

- 1.1 On the E-UTRA carrier, disable periodic and aperiodic CQI reports, disable SRS, set *TimeAlignmentTimerDedicated* IE to infinity and disable downlink and uplink scheduling, all as per Table 4.7-1 under clause 4.7.

#### 6.5B.3.4.2\_1.1.5 Test Requirements

Same test requirement as in clause 6.5A.3.2.1.5 in TS 38.521-2 [9] for the NR carrier.

#### 6.5B.3.4.2\_1.2 Spurious emission band UE co-existence for Inter-band EN-DC including FR2 (3 NR CCs)

**Editor's note: The following aspects are either missing or not yet determined:**

- **The referred test case 6.5A.3.2.2 in TS 38.521-2 [9] is incomplete for:**
  - **Testability and relaxation of the requirement for Bands other than n257, n258, n260 and n261**
  - **MU and TT for Power classes 1, 2 and 4**

#### 6.5B.3.4.2\_1.2.1 Test purpose

Same test purpose as in clause 6.5.3.2 in TS 38.521-2 [9] for the NR carrier.

#### 6.5B.3.4.2\_1.2.2 Test applicability

This test case applies to all types of E-UTRA UE release 15 and forward, supporting inter-band EN-DC including FR2 with 3 NR UL CCs.

#### 6.5B.3.4.2\_1.2.3 Minimum conformance requirements

Same minimum conformance requirements as in clause 6.5.3.3 in TS 38.521-2 [9] for the NR carrier.

No exception requirements applicable to NR or E-UTRA. LTE anchor agnostic approach is applied.

The normative reference for this requirement is TS 38.101-3 [4] clause 6.4B.3.4.

#### 6.5B.3.4.2\_1.2.4 Test description

##### 6.5B.3.4.2\_1.2.4.1 Initial condition

Same test description as in clause 6.5A.3.2.2.4 in TS 38.521-2 [9] for the NR carrier with the following exception:

The initial test configurations for E-UTRA band consist of environmental conditions, test frequencies, and channel bandwidths based on E-UTRA bands specified in Table 4.7-1.

For Initial conditions as in clause 6.5A.3.2.2.4.1 in TS 38.521-2 [9], the following steps will be added to configure E-UTRA component:

- 2.1. The parameter settings for E-UTRA cell are set up according to TS 36.508 [11] clause 4.4.3.
- 3.1. The E-UTRA downlink signal level, uplink signal level are set according to Table 4.7-1 and propagation conditions are set according to Annex B.0 of TS 36.521-1 [10].

Step 6 of Initial conditions as in clause 6.5A.3.2.2.4.1 in TS 38.521-2 [9] is replaced by:

6. Ensure the UE is in state RRC\_CONNECTED with generic procedure parameters Connectivity EN-DC, DC bearer MCG and SCG, Connected without release On according to TS 38.508-1 [6] clause 4.5.

Same test procedure as in clause 6.5A.3.2.2.4.2 in TS 38.521-2 [9] with the following steps added for E-UTRA component:

- 1.1 On the E-UTRA carrier, disable periodic and aperiodic CQI reports, disable SRS, set *TimeAlignmentTimerDedicated* IE to infinity and disable downlink and uplink scheduling, all as per Table 4.7-1 under clause 4.7.

#### 6.5B.3.4.2\_1.2.5 Test Requirements

Same test requirement as in clause 6.5A.3.2.2.5 in TS 38.521-2 [9] for the NR carrier.

#### 6.5B.3.4.2\_1.3 Spurious emission band UE co-existence for Inter-band EN-DC including FR2 (4 NR CCs)

**Editor's note: The following aspects are either missing or not yet determined:**

- **The referred test case 6.5A.3.2.3 in TS 38.521-2 [9] is incomplete for:**
  - **Testability and relaxation of the requirement for Bands other than n257, n258, n260 and n261**
  - **MU and TT for Power classes 1, 2 and 4**

#### 6.5B.3.4.2\_1.3.1 Test purpose

Same test purpose as in clause 6.5.3.1 in TS 38.521-2 [9] for the NR carrier.

#### 6.5B.3.4.2\_1.3.2 Test applicability

This test case applies to all types of E-UTRA UE release 15 and forward, supporting inter-band EN-DC including FR2 with 4 NR UL CCs.

#### 6.5B.3.4.2\_1.3.3 Minimum conformance requirements

Same minimum conformance requirements as in clause 6.5.3.3 in TS 38.521-2 [9] for the NR carrier.

No exception requirements applicable to NR or E-UTRA. LTE anchor agnostic approach is applied.

The normative reference for this requirement is TS 38.101-3 [4] clause 6.4B.3.4.

#### 6.5B.3.4.2\_1.3.4 Test description

##### 6.5B.3.4.2\_1.3.4.1 Initial condition

Same test description as in clause 6.5A.3.2.3.4 in TS 38.521-2 [9] for the NR carrier with the following exception:

The initial test configurations for E-UTRA band consist of environmental conditions, test frequencies, and channel bandwidths based on E-UTRA bands specified in Table 4.7-1.

For Initial conditions as in clause 6.5A.3.2.3.4.1 in TS 38.521-2 [9], the following steps will be added to configure E-UTRA component:

- 2.1. The parameter settings for E-UTRA cell are set up according to TS 36.508 [11] clause 4.4.3.
- 3.1. The E-UTRA downlink signal level, uplink signal level are set according to Table 4.7-1 and propagation conditions are set according to Annex B.0 of TS 36.521-1 [10].

Step 6 of Initial conditions as in clause 6.5A.3.2.3.4.1 in TS 38.521-2 [9] is replaced by:

6. Ensure the UE is in state RRC\_CONNECTED with generic procedure parameters Connectivity EN-DC, DC bearer MCG and SCG, Connected without release On according to TS 38.508-1 [6] clause 4.5.

Same test procedure as in clause 6.5A.3.2.3.4.2 in TS 38.521-2 [9] with the following steps added for E-UTRA component:

- 1.1 On the E-UTRA carrier, disable periodic and aperiodic CQI reports, disable SRS, set *TimeAlignmentTimerDedicated* IE to infinity and disable downlink and uplink scheduling, all as per Table 4.7-1 under clause 4.7.

#### 6.5B.3.4.2\_1.3.5 Test Requirements

Same test requirement as in clause 6.5A.3.2.3.5 in TS 38.521-2 [9] for the *NR* carrier.

#### 6.5B.3.4.2\_1.4 Spurious emission band UE co-existence for Inter-band EN-DC including FR2 (5 NR CCs)

**Editor's note: The following aspects are either missing or not yet determined:**

- The referred test case 6.5A.3.2.4 in TS 38.521-2 [9] is incomplete for:
  - Testability and relaxation of the requirement for Bands other than n257, n258, n260 and n261
  - MU and TT for Power classes 1, 2 and 4
  - Annex F MU, TT tables need to add new rows to include these test cases

#### 6.5B.3.4.2\_1.4.1 Test purpose

Same test purpose as in clause 6.5.3.2 in TS 38.521-2 [9] for the NR carrier.

#### 6.5B.3.4.2\_1.4.2 Test applicability

This test case applies to all types of E-UTRA UE release 15 and forward, supporting inter-band EN-DC including FR2 with 5 NR UL CCs.

#### 6.5B.3.4.2\_1.4.3 Minimum conformance requirements

Same minimum conformance requirements as in clause 6.5A.3.2.0 in TS 38.521-2 [9] for the NR carrier.

No exception requirements applicable to NR or E-UTRA. LTE anchor agnostic approach is applied.

The normative reference for this requirement is TS 38.101-3 [4] clause 6.5B.3.1.

#### 6.5B.3.4.2\_1.4.4 Test description

##### 6.5B.3.4.2\_1.4.4.1 Initial condition

Same test description as in clause 6.5A.3.2.1.4 in TS 38.521-2 [9] for the *NR* carrier with the following exception:

The initial test configurations for E-UTRA band consist of environmental conditions, test frequencies, and channel bandwidths based on E-UTRA bands specified in Table 4.7-1.

For Initial conditions as in clause 6.5A.3.2.1.4.1 in TS 38.521-2 [9], the following steps will be added to configure E-UTRA component:

- 2.1. The parameter settings for E-UTRA cell are set up according to TS 36.508 [11] clause 4.4.3.
- 3.1. The E-UTRA downlink signal level, uplink signal level are set according to Table 4.7-1 and propagation conditions are set according to Annex B.0 of TS 36.521-1 [10].

Step 6 of Initial conditions as in clause 6.5A.3.2.1.4.1 in TS 38.521-2 [9] is replaced by:

6. Ensure the UE is in state RRC\_CONNECTED with generic procedure parameters Connectivity EN-DC, DC bearer MCG and SCG, Connected without release On according to TS 38.508-1 [6] clause 4.5.

Same test procedure as in clause 6.5A.3.2.1.4 in TS 38.521-2 [9] with the following steps added for E-UTRA component:

- 1.1 On the E-UTRA carrier, disable periodic and aperiodic CQI reports, disable SRS, set *TimeAlignmentTimerDedicated* IE to infinity and disable downlink and uplink scheduling, all as per Table 4.7-1 under clause 4.7.

#### 6.5B.3.4.2\_1.4.5 Test Requirements

Same test requirement as in clause 6.5A.3.2.4.5 in TS 38.521-2 [9] for the NR carrier.

#### 6.5B.3.4.2\_1.5 Spurious emission band UE co-existence for Inter-band EN-DC including FR2 (6 NR CCs)

**Editor's note: The following aspects are either missing or not yet determined:**

- The referred test case 6.5A.3.2.5 in TS 38.521-2 [9] is incomplete for:
  - Testability and relaxation of the requirement for Bands other than n257, n258, n260 and n261
  - MU and TT for Power classes 1, 2 and 4
  - Annex F MU, TT tables need to add new rows to include these test cases

#### 6.5B.3.4.2\_1.5.1 Test purpose

Same test purpose as in clause 6.5.3.2 in TS 38.521-2 [9] for the NR carrier.

#### 6.5B.3.4.2\_1.5.2 Test applicability

This test case applies to all types of E-UTRA UE release 15 and forward, supporting inter-band EN-DC including FR2 with 6 NR UL CCs.

#### 6.5B.3.4.2\_1.5.3 Minimum conformance requirements

Same minimum conformance requirements as in clause 6.5A.3.2.0 in TS 38.521-2 [9] for the NR carrier.

No exception requirements applicable to NR or E-UTRA. LTE anchor agnostic approach is applied.

The normative reference for this requirement is TS 38.101-3 [4] clause 6.5B.3.1.

#### 6.5B.3.4.2\_1.5.4 Test description

##### 6.5B.3.4.2\_1.5.4.1 Initial condition

Same test description as in clause 6.5A.3.2.1.4 in TS 38.521-2 [9] for the NR carrier with the following exception:

The initial test configurations for E-UTRA band consist of environmental conditions, test frequencies, and channel bandwidths based on E-UTRA bands specified in Table 4.7-1.

For Initial conditions as in clause 6.5A.3.2.1.4.1 in TS 38.521-2 [9], the following steps will be added to configure E-UTRA component:

- 2.1. The parameter settings for E-UTRA cell are set up according to TS 36.508 [11] clause 4.4.3.
- 3.1. The E-UTRA downlink signal level, uplink signal level are set according to Table 4.7-1 and propagation conditions are set according to Annex B.0 of TS 36.521-1 [10].

Step 6 of Initial conditions as in clause 6.5A.3.2.1.4.1 in TS 38.521-2 [9] is replaced by:

6. Ensure the UE is in state RRC\_CONNECTED with generic procedure parameters Connectivity EN-DC, DC bearer MCG and SCG, Connected without release On according to TS 38.508-1 [6] clause 4.5.

Same test procedure as in clause 6.5A.3.2.1.4 in TS 38.521-2 [9] with the following steps added for E-UTRA component:

- 1.1 On the E-UTRA carrier, disable periodic and aperiodic CQI reports, disable SRS, set *TimeAlignmentTimerDedicated* IE to infinity and disable downlink and uplink scheduling, all as per Table 4.7-1 under clause 4.7.

#### 6.5B.3.4.2\_1.5.5 Test Requirements

Same test requirement as in clause 6.5A.3.2.5.5 in TS 38.521-2 [9] for the NR carrier.

#### 6.5B.3.4.2\_1.6 Spurious emission band UE co-existence for Inter-band EN-DC including FR2 (6 NR CCs)

**Editor's note: The following aspects are either missing or not yet determined:**

- The referred test case 6.5A.3.2.6 in TS 38.521-2 [9] is incomplete for:
- Testability and relaxation of the requirement for Bands other than n257, n258, n260 and n261
- MU and TT for Power classes 1, 2 and 4
  - Annex F MU, TT tables need to add new rows to include these test cases

#### 6.5B.3.4.2\_1.6.1 Test purpose

Same test purpose as in clause 6.5.3.2 in TS 38.521-2 [9] for the NR carrier.

#### 6.5B.3.4.2\_1.6.2 Test applicability

This test case applies to all types of E-UTRA UE release 15 and forward, supporting inter-band EN-DC including FR2 with 7 NR UL CCs.

#### 6.5B.3.4.2\_1.6.3 Minimum conformance requirements

Same minimum conformance requirements as in clause 6.5A.3.2.0 in TS 38.521-2 [9] for the NR carrier.

No exception requirements applicable to NR or E-UTRA. LTE anchor agnostic approach is applied.

The normative reference for this requirement is TS 38.101-3 [4] clause 6.5B.3.1.

#### 6.5B.3.4.2\_1.6.4 Test description

##### 6.5B.3.4.2\_1.6.4.1 Initial condition

Same test description as in clause 6.5A.3.2.1.4 in TS 38.521-2 [9] for the NR carrier with the following exception:

The initial test configurations for E-UTRA band consist of environmental conditions, test frequencies, and channel bandwidths based on E-UTRA bands specified in Table 4.7-1.

For Initial conditions as in clause 6.5A.3.2.1.4.1 in TS 38.521-2 [9], the following steps will be added to configure E-UTRA component:

- 2.1. The parameter settings for E-UTRA cell are set up according to TS 36.508 [11] clause 4.4.3.
- 3.1. The E-UTRA downlink signal level, uplink signal level are set according to Table 4.7-1 and propagation conditions are set according to Annex B.0 of TS 36.521-1 [10].

Step 6 of Initial conditions as in clause 6.5A.3.2.1.4.1 in TS 38.521-2 [9] is replaced by:

6. Ensure the UE is in state RRC\_CONNECTED with generic procedure parameters Connectivity EN-DC, DC bearer MCG and SCG, Connected without release On according to TS 38.508-1 [6] clause 4.5.



Same test procedure as in clause 6.5A.3.2.1.4 in TS 38.521-2 [9] with the following steps added for E-UTRA component:

- 1.1 On the E-UTRA carrier, disable periodic and aperiodic CQI reports, disable SRS, set *TimeAlignmentTimerDedicated* IE to infinity and disable downlink and uplink scheduling, all as per Table 4.7-1 under clause 4.7.

#### 6.5B.3.4.2\_1.6.5 Test Requirements

Same test requirement as in clause 6.5A.3.2.6.5 in TS 38.521-2 [9] for the NR carrier.

#### 6.5B.3.4.2\_1.7 Spurious emission band UE co-existence for Inter-band EN-DC including FR2 (8 NR CCs)

**Editor's note: The following aspects are either missing or not yet determined:**

- The referred test case 6.5A.3.2.7 in TS 38.521-2 [9] is incomplete for:
- Testability and relaxation of the requirement for Bands other than n257, n258, n260 and n261
- MU and TT for Power classes 1, 2 and 4
- Annex F MU, TT tables need to add new rows to include these test cases

#### 6.5B.3.4.2\_1.7.1 Test purpose

Same test purpose as in clause 6.5.3.2 in TS 38.521-2 [9] for the NR carrier.

#### 6.5B.3.4.2\_1.7.2 Test applicability

This test case applies to all types of E-UTRA UE release 15 and forward, supporting inter-band EN-DC including FR2 with 8 NR UL CCs.

#### 6.5B.3.4.2\_1.7.3 Minimum conformance requirements

Same minimum conformance requirements as in clause 6.5A.3.2.0 in TS 38.521-2 [9] for the NR carrier.

No exception requirements applicable to NR or E-UTRA. LTE anchor agnostic approach is applied.

The normative reference for this requirement is TS 38.101-3 [4] clause 6.5B.3.1.

#### 6.5B.3.4.2\_1.7.4 Test description

##### 6.5B.3.4.2\_1.7.4.1 Initial condition

Same test description as in clause 6.5A.3.2.1.4 in TS 38.521-2 [9] for the NR carrier with the following exception:

The initial test configurations for E-UTRA band consist of environmental conditions, test frequencies, and channel bandwidths based on E-UTRA bands specified in Table 4.7-1.

For Initial conditions as in clause 6.5A.3.2.1.4.1 in TS 38.521-2 [9], the following steps will be added to configure E-UTRA component:

- 2.1. The parameter settings for E-UTRA cell are set up according to TS 36.508 [11] clause 4.4.3.
- 3.1. The E-UTRA downlink signal level, uplink signal level are set according to Table 4.7-1 and propagation conditions are set according to Annex B.0 of TS 36.521-1 [10].

Step 6 of Initial conditions as in clause 6.5A.3.2.1.4.1 in TS 38.521-2 [9] is replaced by:

6. Ensure the UE is in state RRC\_CONNECTED with generic procedure parameters Connectivity EN-DC, DC bearer MCG and SCG, Connected without release On according to TS 38.508-1 [6] clause 4.5.

Same test procedure as in clause 6.5A.3.2.1.4 in TS 38.521-2 [9] with the following steps added for E-UTRA component:

- 1.1 On the E-UTRA carrier, disable periodic and aperiodic CQI reports, disable SRS, set *TimeAlignmentTimerDedicated* IE to infinity and disable downlink and uplink scheduling, all as per Table 4.7-1 under clause 4.7.

#### 6.5B.3.4.2\_1.7.5 Test Requirements

Same test requirement as in clause 6.5A.3.2.7.5 in TS 38.521-2 [9] for the NR carrier.

#### 6.5B.3.4.2D Spurious emission band UE co-existence for inter-band EN-DC including FR2 for UL MIMO

##### 6.5B.3.4.2D.1 Test purpose

Same test purpose as in clause 6.5D.3.2 in TS 38.521-2 [9] for the NR carrier.

##### 6.5B.3.4.2D.2 Test applicability

This test case applies to all types of E-UTRA UE release 15 and forward, supporting inter-band EN-DC FR2.

##### 6.5B.3.4.2D.3 Minimum conformance requirements

Same minimum conformance requirements as in clause 6.5D.3.2 in TS 38.521-2 [9] for the NR carrier.

No exception requirements applicable to NR or E-UTRA. LTE anchor agnostic approach is applied.

The normative reference for this measurement is TS 38.101-3 [4] clause 6.5B.3.4.

##### 6.5B.3.4.1D.4 Test Description

Same test description as in clause 6.5D.3.2 in TS 38.521-2 [9] for the NR carrier with the following exceptions:

The initial test configurations for E-UTRA consist of test frequency based on E-UTRA operating band and test channel bandwidth as specified in Table 4.7-1.

For Initial conditions as in clause 6.5D.3.2 in TS 38.521-2 [9], the following steps will be added to configure E-UTRA component:

- 2.1. The parameter settings for the cell are set up according to TS 36.508 [11] subclause 4.4.3.
- 3.1. The E-UTRA downlink signal level, uplink signal level are set according to Table 4.7-1 and propagation conditions are set according to Annex B.0 of TS 36.521-1 [10].

Step 6 of Initial conditions as in clause 6.5D.3.2 in TS 38.521-2 [9] is replaced by:

6. Ensure the UE is in state RRC\_CONNECTED with generic procedure parameters Connectivity EN-DC, DC bearer MCG and SCG, Connected without release *On* according to TS 38.508 [6] clause 4.5.
7. On the E-UTRA carrier, disable periodic and aperiodic CQI reports, disable SRS, set *TimeAlignmentTimerDedicated* IE to infinity and disable downlink and uplink scheduling, all as per Table 4.7-1 under clause 4.7.

##### 6.5B.3.4.1D.5 Test Requirement

Same test requirement as specified in clause 6.5D.3.2.5 of TS 38.521-2 [9] for the NR carrier(s).

## 6.5B.3.5 Spurious emissions for Inter-band including FR1 and FR2

### 6.5B.3.5.1 General Spurious Emissions for Inter-band including FR1 and FR2

#### 6.5B.3.5.1.1 Test purpose

Same test purpose as in clause 6.5.3 in TS 38.521-1 [8] for NR FR1 carrier(s) and clause 6.5.3 in TS 38.521-2 [9] for NR FR2 carrier(s).

#### 6.5B.3.5.1.2 Test applicability

The requirements in this test are not testable due to issues with combined testing of NR FR1 and E-UTRA in conducted mode with NR FR2 in radiated mode. Therefore, the conducted and radiated requirements are tested separately.

No test case details are specified. The EN-DC requirements for spurious emissions apply and are tested as part of the EN-DC within FR1 and EN-DC including FR2 test cases in clause 6.5B.3.

### 6.5B.3.5.2 Spurious emission band UE co-existence for Inter-band including FR1 and FR2

#### 6.5B.3.5.2.1 Test purpose

Same test purpose as in clause 6.5.3 in TS 38.521-1 [8] for NR FR1 carrier(s) and clause 6.5.3 in TS 38.521-2 [9] for NR FR2 carrier(s).

#### 6.5B.3.5.2.2 Test applicability

The requirements in this test are not testable due to issues with combined testing of NR FR1 and E-UTRA in conducted mode with NR FR2 in radiated mode. Therefore, the conducted and radiated requirements are tested separately.

No test case details are specified. The EN-DC requirements for spurious emissions apply and are tested as part of the EN-DC within FR1 and EN-DC including FR2 test cases in clause 6.5B.3.

## 6.5B.4 Additional Spurious Emissions for EN-DC

### 6.5B.4.1 Additional Spurious Emissions for Intra-band contiguous EN-DC

#### 6.5B.4.1.1 Test purpose

To verify that UE transmitter does not cause unacceptable interference to other channels or other systems in terms of transmitter spurious emissions under the deployment scenarios where additional requirements are specified.

#### 6.5B.4.1.2 Test applicability

This test case applies to all types of E-UTRA UE release 15 and forward supporting intra-band contiguous EN-DC.

#### 6.5B.4.1.3 Minimum conformance requirements

These requirements are specified in terms of an additional spectrum emission requirement. Additional spurious emission requirements are signalled by the network to indicate that the UE shall meet an additional requirement for a specific deployment scenario as part of the cell handover/broadcast message.

**NOTE:** For measurement conditions at the edge of each frequency range, the lowest frequency of the measurement position in each frequency range should be set at the lowest boundary of the frequency range plus MBW/2. The highest frequency of the measurement position in each frequency range should be set at the highest boundary of the frequency range minus MBW/2. MBW denotes the measurement bandwidth defined for the protected band.

#### 6.5B.4.1.3.1 Minimum requirement (network signalled value "NS\_04")

When "NS 04" is indicated in the cell, the power of any UE emission shall not exceed the levels specified in Table 6.5B.4.1.3.1-1. This requirement also applies for the frequency ranges that are less than  $F_{\text{OoB}}$  (MHz) in Table 6.5.3.1.3-1 of TS 38.521-1 [8] from the edge of the channel bandwidth.

**Table 6.5B.4.1.3.1-1: Additional requirements**

Frequency band (MHz)	Channel bandwidth / Spectrum emission limit (dBm)	Measurement bandwidth
$2495 \leq f < 2496$	-13	1% of Channel BW for contiguous BW up to 100 MHz, 1 MHz for contiguous BW > 100 MHz
$2490.5 \leq f < 2495$	-13	1 MHz
$0 < f < 2490.5$	-25	1 MHz

The normative reference for this requirement is TS 38.101-3 [4] clause 6.5B.4.1.1.

Exception requirements for both NR and E-UTRA are defined for this test. LTE anchor agnostic approach is not applied. E-UTRA test point analysis is included, and E-UTRA measurements are performed.

#### 6.5B.4.1.4 Test description

##### 6.5B.4.1.4.1 Initial conditions

Initial conditions are a set of test configurations the UE needs to be tested in and the steps for the SS to take with the UE to reach the correct measurement state.

The initial test configurations consist of environmental conditions, test frequencies, test channel bandwidths and sub-carrier spacing based on EN-DC operating bands specified in 5.3B.1.2. All of these configurations shall be tested with applicable test parameters for each combination of test channel bandwidth and sub-carrier spacing are shown in Table 6.5B.4.1.4.1-1 for both E-UTRA and NR. The details of the uplink reference measurement channels (RMCs) are specified in Annex A.2 for NR. Configurations of PDSCH and PDCCH before measurement are specified in TS 36.521-1 [10] Annex C and in TS 38.521-1 [8] Annex C2 for LTE link and NR link respectively.

Table 6.5B.4.1.4.1-1: EN-DC test configuration table for NS\_04

Initial Conditions							
Test Environment as specified in TS 38.508-1 [6] clause 4.1		Normal					
Test Frequencies as specified in TS 38.508-1 [6] clause 4.3.1		Low range, High range					
Test EN-DC bandwidth combination as specified in Table 5.3B.1.2-1		Lowest $N_{RB\_agg}$ , Highest $N_{RB\_agg}$ (Note 2)					
Test SCS for the NR cell as specified in TS 38.521- 1 [8] Table 5.3.5-1		Lowest SCS per Channel Bandwidth					
Test Parameters							
Test ID	Freq	Downlink Configuration	EN-DC Uplink Configuration				
			E-UTRA Cell		NR Cell	Common	
			Modulation	RB allocation (Note 5)	Modulation	RB allocation (Note 1)	Power config (Note 6)
1	Default		16QAM	Outer_Full	DFT-s-OFDM QPSK	Outer_Full	B
2 (Note 3)	Default		16QAM	Outer_1RB_Left	DFT-s-OFDM QPSK	Edge_1RB_Right	B
3 (Note 3)	Low		16QAM	Outer_1RB_Left	DFT-s-OFDM QPSK	N/A	A
4 (Note 3)	High		16QAM	N/A	DFT-s-OFDM QPSK	Edge_1RB_Right	A
5 (Note 4)	Default		16QAM	Outer_1RB_Right	DFT-s-OFDM QPSK	Edge_1RB_Left	B
6 (Note 4)	Low		16QAM	N/A	DFT-s-OFDM QPSK	Edge_1RB_Left	A
7 (Note 4)	High		16QAM	Outer_1RB_Right	DFT-s-OFDM QPSK	N/A	A
8	Default		16QAM	Outer_Full	CP-OFDM 256QAM	Outer_Full	B
9 (Note 3)	Low		16QAM	Outer_1RB_Left	CP-OFDM 256QAM	Edge_1RB_Right	B
10 (Note 4)	High		16QAM	Outer_1RB_Right	CP-OFDM 256QAM	Edge_1RB_Left	B
11 (Note 4)	Default		16QAM	Edge_Full_Right	CP-OFDM 256QAM	Edge_Full_Left	B
NOTE 1: The specific configuration of each RB allocation is defined in Table 6.1-1 in TS 38.521-1 [8].							
NOTE 2: If the UE supports multiple CC combinations in the EN-DC configuration with the same $N_{RB\_agg}$ , select the combination to test as follows:							
- Lowest ENBW: NR component with lowest $N_{RB}$ is tested.							
- Highest ENBW: NR component with highest $N_{RB}$ is tested.							
NOTE 3: Applicable when E-UTRA cell carrier frequency is lower than NR cell carrier.							
NOTE 4: Applicable when NR cell carrier frequency is lower than E-UTRA cell carrier.							
NOTE 5: Outer_Full defined as the transmission bandwidth configuration $N_{RB}$ per channel bandwidth for the E-UTRA component as indicated in TS 36.521-1 [10] Table 5.4.2-1. Outer_1RB_Left defined as 1 RB allocated at the left edge of the E-UTRA component. Outer_1RB_Right defined as 1 RB allocated at the right edge of the E-UTRA component.							
NOTE 6: Power config as specified in Table 6.2B.3.1.4.3-1 to 6.2B.3.1.4.3-2 (PC3) or Table 6.2B.3.1.4.3-3 to 6.2B.3.1.4.3-4 (PC2).							
NOTE 7: Test IDs with simultaneous E-UTRA and NR UL transmission only apply for UEs indicating dualPA-Architecture.							

1. Connect the SS to the UE antenna connectors as shown in TS 38.508-1 [6] Annex A, Figure A.3.1.1.1 for SS diagram and clause A.3.2.1 for UE diagram.
2. The parameter settings for NR cell are set up according to TS 38.508-1 [6] clause 4.4.3.
3. The parameter settings for E-UTRA cell are set up according to TS 36.508 [11] clause 4.4.3.
4. E-UTRA downlink signals are initially set up according to Annex C.0, C.1 and C.3.0, and uplink signals according to Annex H.1 and H.3.0 of TS 36.521-1 [10].
5. NR downlink signals are initially set up according to Annex C.0, C.1 and C.2, and uplink signals according to Annex G.0, G.1, G.2, G.3.0 of TS 38.521-1 [8].

6. The UL Reference Measurement channels are set according to Table 6.5B.4.1.4.1-1.
7. NR propagation conditions are set according to B.0 of TS 38.521-1 [8]. E-UTRA propagation conditions are set according to B.0 of TS 36.521-1 [10].
8. Ensure the UE is in state RRC\_CONNECTED with generic procedure parameters Connectivity EN-DC, DC bearer MCG and SCG, Connected without release *On* according to TS 38.508-1 [6] clause 4.5. Message contents are defined in clause 6.5B.4.1.4.3.
9. When E-UTRA and NR bands are TDD, ensure the same uplink-downlink configuration by giving SCG a delay of 3 E-UTRA subframes, or by giving MCG a delay of 2 subframes.

#### 6.5B.4.1.4.2 Test Procedure

1. E-UTRA SS sends uplink scheduling information for each UL HARQ process via PDCCH DCI format 0 for C\_RNTI to schedule the UL RMC according to Table 6.5B.4.1.4.1-1. Since the UE has no payload data to send, the UE transmits uplink MAC padding bits on the UL RMC.
2. NR SS sends uplink scheduling information for each UL HARQ process via PDCCH DCI format 0\_1 for C\_RNTI to schedule the UL RMC according to Table 6.5B.4.1.4.1-1. Since the UE has no payload data to send, the UE transmits uplink MAC padding bits on the UL RMC.
3. Send continuously uplink power control "up" commands to the UE for both NR and E-UTRA carriers until the UE transmits at its  $P_{UMAX}$  level; allow at least 200 ms starting from the first TPC command in this step for the UE to reach  $P_{UMAX}$  level.
4. Measure the mean power of each component carriers for the EN-DC configuration, which shall meet the requirements described in 6.2B.3.1.5.2 depending on NS-values. The period of the measurement shall be at least the continuous duration of one sub-frame.
5. Measure the power of the transmitted signal with a measurement filter of bandwidths according to Table 6.5B.4.1.3.1-1. The centre frequency of the filter shall be stepped in contiguous steps according to the same table. The measured power shall be recorded for each step. The measurement period shall capture the active time slots. During measurement the spectrum analyser shall be set to 'Detector' = RMS. If the sweep count is higher than one, the trace mode shall be average.

#### 6.5B.4.1.4.3 Message Contents

Message contents are according to TS 38.508-1 [6] clause 4.6 with the following exceptions for each network signalled value.

##### 6.5B.4.1.4.3.1 Message contents exceptions for network signalled value "NS\_04"

1. Information element additionalSpectrumEmission is set to NS\_04. This can be set in *SIB1* as part of the cell broadcast message. This exception indicates that the UE shall meet the additional spurious emission requirement for a specific deployment scenario.

**Table 6.5B.4.1.4.3.1-1: AdditionalSpectrumEmission: Additional spurious emissions test requirement for "NS\_04"**

Derivation Path: TS 38.508-1 [6] clause 4.6.3, Table 4.6.3-1			
Information Element	Value/remark	Comment	Condition
additionalSpectrumEmission	1 (NS_04)		

**Table 6.5B.4.1.4.3.1-2: RRCConnectionReconfiguration: nr-Config-r15**

Derivation Path: TS 36.508 [11], Table 4.6.1-8			
Information Element	Value/remark	Comment	Condition
p-MaxEUTRA-r15	23		Power Class 2 UE AND simultaneous E-UTRA and NR transmission
	20		Power Class 3 UE AND simultaneous E-UTRA and NR transmission

**Table 6.5B.4.1.4.3.1-3: PhysicalCellGroupConfig**

Derivation Path: TS 38.508-1 [6] Table 4.6.3-106			
Information Element	Value/remark	Comment	Condition
p-NR-FR1	23		Power Class 2 UE AND simultaneous E-UTRA and NR transmission
	20		Power Class 3 UE AND simultaneous E-UTRA and NR transmission

#### 6.5B.4.1.5 Test Requirement

Test requirements for additional spurious emissions for intra-band contiguous EN-DC are the same as the minimum requirements described in clause 6.5B.4.1.3 and are not repeated in this clause.

### 6.5B.4.2 Additional Spurious Emissions for Intra-band non-contiguous EN-DC

#### 6.5B.4.2.1 Test purpose

Same minimum conformance requirements as in clause 6.5B.4.1.1.

#### 6.5B.4.2.2 Test applicability

This test case applies to all types of E-UTRA UE release 15 and forward, supporting intra-band non-contiguous EN-DC.

#### 6.5B.4.2.3 Minimum conformance requirements

Same minimum conformance requirements as in clause 6.5B.4.1.3.

#### 6.5B.4.2.4 Test description

##### 6.5B.4.2.4.1 Initial conditions

Same initial conditions as described in clause 6.5B.4.1.4.1 for both E-UTRA and NR carriers with the following exception:

1. For each EN-DC combination specified in Table 5.3B.1.3-1, channel spacing between NR and E-UTRA is specified according to clause 5.4B.1.
2. Set up the NR and E-UTRA test frequencies so that NR carrier is located at the lower frequency side as specified in Table 5.3B.1.3-1. Repeat each testing with E-UTRA carrier frequency is located at the lower side as specified in Table 5.3B.1.3-1.
3. When E-UTRA and NR bands are TDD, ensure the same uplink-downlink configuration by giving SCG a delay of 3 E-UTRA subframes, or by giving MCG a delay of 2 subframes.

##### 6.5B.4.2.4.2 Test Procedure

Same test procedure as described in clause 6.5B.4.1.4.2.

##### 6.5B.4.2.4.3 Message Contents

Message contents are according to TS 38.508-1 [6] clause 4.6 with the following exceptions for each network signalled value.

##### 6.5B.4.2.4.3.1 Message contents exceptions for network signalled value "NS\_04"

1. Information element additionalSpectrumEmission is set to NS\_04. This can be set in *SIB1* as part of the cell broadcast message. This exception indicates that the UE shall meet the additional spurious emission requirement for a specific deployment scenario.

**Table 6.5B.4.2.4.3.1-1: Additional Spectrum Emission: Additional spurious emissions test requirement for "NS\_04"**

Derivation Path: TS 38.508-1 [6] clause 4.6.3, Table 4.6.3-1			
Information Element	Value/remark	Comment	Condition
additionalSpectrumEmission	1 (NS_04)		

#### 6.5B.4.2.5 Test Requirement

Test requirements for Spurious Emissions for intra-band non-contiguous EN-DC are the same as the minimum requirements described in 6.5B.4.2.3 and are not repeated in this clause.

#### 6.5B.4.3 Additional Spurious Emissions for Inter-band EN-DC within FR1 (1 NR CC)

##### 6.5B.4.3.1 Test purpose

Same test purpose as in clause 6.5.3.3.1 in TS 38.521-1 [8] for the NR carrier.

##### 6.5B.4.3.2 Test applicability

This test case applies to all types of E-UTRA UE release 15 and forward supporting inter-band EN-DC within FR1 with 1 NR UL.

##### 6.5B.4.3.3 Minimum conformance requirements

Same minimum conformance requirements as in clause 6.5.3.3.3 in TS 38.521-1 [8] for the NR carrier.

The normative reference for this requirement is TS 38.101-3 [4] clause 6.5B.4.

No exception requirements applicable to NR or E-UTRA. LTE anchor agnostic approach is applied.

##### 6.5B.4.3.4 Test description

Same test description as in clause 6.5.3.3.4 in TS 38.521-1 [8] for the NR carrier with the following exception:

The initial test configurations for E-UTRA band consist of environmental conditions, test frequencies, and channel bandwidths based on E-UTRA bands specified in Table 4.6-1. For Initial conditions as in clause 6.5.3.3.4.1 in TS 38.521-1 [8], the following steps will be added to configure E-UTRA component:

- 2.1. The parameter settings for E-UTRA cell are set up according to TS 36.508 [11] clause 4.4.3.
- 3.1. The E-UTRA downlink signal level, uplink signal level are set according to Table 4.6-1 and propagation conditions are set according to Annex B.0 of TS 36.521-1 [10].

Step 6 of Initial conditions as in clause 6.5.3.3.4.1 in TS 38.521-1 [8] is replaced by the following two steps:

6. Ensure the UE is in state RRC\_CONNECTED with generic procedure parameters Connectivity EN-DC, DC bearer MCG and SCG, Connected without release *On* according to TS 38.508-1 [6] clause 4.5.
7. On the E-UTRA carrier, disable periodic and aperiodic CQI reports, disable SRS, set *TimeAlignmentTimerDedicated* IE to infinity and disable downlink and uplink scheduling, all as per Table 4.6-1 under clause 4.6.

Same test procedure as in clause 6.5.3.3.4.2 in TS 38.521-1 [8].

#### 6.5B.4.3.5 Test Requirement

Same test requirement as in clause 6.5.3.3.5 in TS 38.521-1 [8] for the NR carrier.



#### 6.5B.4.4 Additional Spurious Emissions for Inter-band including FR2 (1 NR CC)

**Editor's note:** This clause is complete for Band n257 and n258 and for PC1, PC3 and PC5. The following aspects are either missing or not yet determined:

- The referred test case 6.5.3.3 in TS 38.521-2 [9] is incomplete for frequency above 87 GHz.

##### 6.5B.4.4.1 Test purpose

Same test purpose as in clause 6.5.3.3.1 in TS 38.521-2 [9] for the NR carrier.

##### 6.5B.4.4.2 Test applicability

This test case applies to all types of E-UTRA UE release 15 and forward, supporting inter-band EN-DC including FR2 with 1 NR UL CC.

##### 6.5B.4.4.3 Minimum conformance requirements

Same minimum conformance requirements as in clause 6.5.3.3.3 in TS 38.521-2 [9] for the NR carrier.

No exception requirements applicable to NR or LTE. LTE anchor agnostic approach is applied.

The normative reference for this requirement is TS 38.101-3 [4] clause 6.5B.4.5.

##### 6.5B.4.4.4 Test description

Same test description as in clause 6.5.3.3.4 in TS 38.521-2 [9] for the NR carrier with the following exception:

The initial test configurations for E-UTRA band consist of environmental conditions, test frequencies, and channel bandwidths based on E-UTRA bands specified in Table 4.6-1.

For Initial conditions as in clause 6.5.3.3.4.1 in TS 38.521-2 [9], the following steps will be added to configure E-UTRA component:

- 2.1 The parameter settings for E-UTRA cell are set up according to TS 36.508 [11] clause 4.4.3.
- 3.1 The E-UTRA downlink signal level, uplink signal level are set according to Table 4.7-1 and propagation conditions are set according to Annex B.0 of TS 36.521-1 [10].

Step 6 of Initial conditions as in clause 6.5.3.3.4.1 in TS 38.521-2 [9] is replaced by:

6. Ensure the UE is in state RRC\_CONNECTED with generic procedure parameters Connectivity EN-DC, DC bearer MCG and SCG, Connected without release On according to TS 38.508-1 [6] clause 4.5.

Same test procedure as in clause 6.5.3.3.4.2 in TS 38.521-2 [9] with the following steps added for E-UTRA component:

- 1.1 On the E-UTRA carrier, disable periodic and aperiodic CQI reports, disable SRS, set *TimeAlignmentTimerDedicated* IE to infinity and disable downlink and uplink scheduling, all as per Table 4.7-1 under clause 4.7.

##### 6.5B.4.4.5 Test requirement

Same test requirement as in clause 6.5.3.3.5 in TS 38.521-2 [9] for the NR carrier.

#### 6.5B.4.4a Additional Spurious Emissions with Power Boost for Inter-band including FR2 (1 NR CC)

**Editor's note:** This clause is complete for Band n257 and n258 and PC3. The following aspects are either missing or not yet determined:

- The referred test case 6.5.3.3\_1 in TS 38.521-2 [9] is incomplete for frequency above 87 GHz.

#### 6.5B.4.4a.1 Test purpose

Same test purpose as in clause 6.5.3.3\_1.1 in TS 38.521-2 [9] for the NR carrier.

#### 6.5B.4.4a.2 Test applicability

This test case applies to all types of NR UE release 16 and forward supporting *mpr-PowerBoost-FR2-r16* UE capability, supporting inter-band EN-DC including FR2 with 1 NR UL CC.

#### 6.5B.4.4a.3 Minimum conformance requirements

Same minimum conformance requirements as in clause 6.5.3.3\_1.3 in TS 38.521-2 [9] for the NR carrier.

No exception requirements applicable to NR or LTE. LTE anchor agnostic approach is applied.

The normative reference for this requirement is TS 38.101-3 [4] clause 6.5B.4.5.

#### 6.5B.4.4a.4 Test description

Same test description as in clause 6.5.3.3\_1.4 in TS 38.521-2 [9] for the NR carrier with the following exception:

The initial test configurations for E-UTRA band consist of environmental conditions, test frequencies, and channel bandwidths based on E-UTRA bands specified in Table 4.6-1.

For Initial conditions as in clause 6.5.3.3\_1.4.1 in TS 38.521-2 [9], the following steps will be added to configure E-UTRA component:

- 2.1 The parameter settings for E-UTRA cell are set up according to TS 36.508 [11] clause 4.4.3.
- 3.1 The E-UTRA downlink signal level, uplink signal level are set according to Table 4.7-1 and propagation conditions are set according to Annex B.0 of TS 36.521-1 [10].

Step 6 of Initial conditions as in clause 6.2.4\_1.4.1 in TS 38.521-2 [9] is replaced by:

6. Ensure the UE is in state RRC\_CONNECTED with generic procedure parameters Connectivity EN-DC, DC bearer MCG and SCG, Connected without release On according to TS 38.508-1 [6] clause 4.5.

Same test procedure as in clause 6.5.3.3\_1.4.2 in TS 38.521-2 [9] with the following steps added for E-UTRA component:

- 1.1 On the E-UTRA carrier, disable periodic and aperiodic CQI reports, disable SRS, set *TimeAlignmentTimerDedicated* IE to infinity and disable downlink and uplink scheduling, all as per Table 4.7-1 under clause 4.7.

#### 6.5B.4.4a.5 Test requirement

Same test requirement as in clause 6.5.3.3\_1.5 in TS 38.521-2 [9] for the NR carrier.

### 6.5B.4.4\_1 Additional Spurious Emissions for Inter-band including FR2 (>1 NR CC)

#### 6.5B.4.4\_1.1 Additional Spurious Emissions for Inter-band including FR2 (2 NR CC)

**Editor's note:** The following aspects are either missing or not yet determined:

- The testability of this test case is pending further analysis on relaxation of the requirement for band other than n257, n258, n260 and n261.
- Test procedure only includes the testing of smartphone and is FFS for laptop and FWA.
- For a transition period until RAN#99, the stability and repeatability of test procedure with PHR (variant b) for Rel-15 UEs is under evaluation.

#### 6.5B.4.4\_1.1.1 Test purpose

Same test purpose as in clause 6.5A.3.3.1.1 in TS 38.521-2 [9] for the NR carrier.

#### 6.5B.4.4\_1.1.2 Test applicability

This test case applies to all types of E-UTRA UE release 15 and forward, supporting inter-band EN-DC including FR2 with 2 NR UL CCs.

#### 6.5B.4.4\_1.1.3 Minimum conformance requirements

Same minimum conformance requirements as in clause 6.5A.3.3.0 in TS 38.521-2 [9] for the NR carrier.

No exception requirements applicable to NR or E-UTRA. LTE anchor agnostic approach is applied.

The normative reference for this requirement is TS 38.101-3 [4] clause 6.5B.4.5.

#### 6.5B.4.4\_1.1.4 Test description

##### 6.5B.4.4\_1.1.4.1 Initial condition

Same test description as in clause 6.5A.3.3.1.4 in TS 38.521-2 [9] for the NR carrier with the following exception:

The initial test configurations for E-UTRA band consist of environmental conditions, test frequencies, and channel bandwidths based on E-UTRA bands specified in Table 4.7-1.

For Initial conditions as in clause 6.5A.3.3.1.4.1 in TS 38.521-2 [9], the following steps will be added to configure E-UTRA component:

- 2.1. The parameter settings for E-UTRA cell are set up according to TS 36.508 [11] clause 4.4.3.
- 3.1. The E-UTRA downlink signal level, uplink signal level are set according to Table 4.7-1 and propagation conditions are set according to Annex B.0 of TS 36.521-1 [10].

Step 6 of Initial conditions as in clause 6.5A.3.3.1.4.1 in TS 38.521-2 [9] is replaced by:

6. Ensure the UE is in state RRC\_CONNECTED with generic procedure parameters Connectivity EN-DC, DC bearer MCG and SCG, Connected without release On according to TS 38.508-1 [6] clause 4.5.

Same test procedure as in clause 6.5A.3.3.1.4.2 in TS 38.521-2 [9] with the following steps added for E-UTRA component:

- 1.1 On the E-UTRA carrier, disable periodic and aperiodic CQI reports, disable SRS, set *TimeAlignmentTimerDedicated* IE to infinity and disable downlink and uplink scheduling, all as per Table 4.7-1 under clause 4.7.

#### 6.5B.4.4\_1.1.5 Test Requirements

Same test requirement as in clause 6.5A.3.3.1.5 in TS 38.521-2 [9] for the NR carrier.

#### 6.5B.4.4\_1.2 Additional Spurious Emissions for Inter-band including FR2 (3 NR CC)

**Editor's note: The following aspects are either missing or not yet determined:**

- The testability of this test case is pending further analysis on relaxation of the requirement for band other than n257, n258, n260 and n261.
- Test procedure only includes the testing of smartphone and is FFS for laptop and FWA.
- For a transition period until RAN#99, the stability and repeatability of test procedure with PHR (variant b) for Rel-15 UEs is under evaluation.

#### 6.5B.4.4\_1.2.1 Test purpose

Same test purpose as in clause 6.5A.3.3.2.1 in TS 38.521-2 [9] for the NR carrier.

#### 6.5B.4.4\_1.2.2 Test applicability

This test case applies to all types of E-UTRA UE release 15 and forward, supporting inter-band EN-DC including FR2 with 3 NR UL CCs.

#### 6.5B.4.4\_1.2.3 Minimum conformance requirements

Same minimum conformance requirements as in clause 6.5A.3.3.0 in TS 38.521-2 [9] for the NR carrier.

No exception requirements applicable to NR or E-UTRA. LTE anchor agnostic approach is applied.

The normative reference for this requirement is TS 38.101-3 [4] clause 6.5B.4.5.

#### 6.5B.4.4\_1.2.4 Test description

##### 6.5B.4.4\_1.2.4.1 Initial condition

Same test description as in clause 6.5A.3.3.2.4 in TS 38.521-2 [9] for the NR carrier with the following exception:

The initial test configurations for E-UTRA band consist of environmental conditions, test frequencies, and channel bandwidths based on E-UTRA bands specified in Table 4.7-1.

For Initial conditions as in clause 6.5A.3.3.2.4.1 in TS 38.521-2 [9], the following steps will be added to configure E-UTRA component:

- 2.1. The parameter settings for E-UTRA cell are set up according to TS 36.508 [11] clause 4.4.3.
- 3.1. The E-UTRA downlink signal level, uplink signal level are set according to Table 4.7-1 and propagation conditions are set according to Annex B.0 of TS 36.521-1 [10].

Step 6 of Initial conditions as in clause 6.5A.3.3.2.4.1 in TS 38.521-2 [9] is replaced by:

6. Ensure the UE is in state RRC\_CONNECTED with generic procedure parameters Connectivity EN-DC, DC bearer MCG and SCG, Connected without release On according to TS 38.508-1 [6] clause 4.5.

Same test procedure as in clause 6.5A.3.3.2.4.2 in TS 38.521-2 [9] with the following steps added for E-UTRA component:

- 1.1 On the E-UTRA carrier, disable periodic and aperiodic CQI reports, disable SRS, set *TimeAlignmentTimerDedicated* IE to infinity and disable downlink and uplink scheduling, all as per Table 4.7-1 under clause 4.7.

#### 6.5B.4.4\_1.2.5 Test Requirements

Same test requirement as in clause 6.5A.3.3.2.5 in TS 38.521-2 [9] for the NR carrier.

#### 6.5B.4.4\_1.3 Additional Spurious Emissions for Inter-band including FR2 (4 NR CC)

**Editor's note: The following aspects are either missing or not yet determined:**

- The testability of this test case is pending further analysis on relaxation of the requirement for band other than n257, n258, n260 and n261.
- Test procedure only includes the testing of smartphone and is FFS for laptop and FWA.
- For a transition period until RAN#99, the stability and repeatability of test procedure with PHR (variant b) for Rel-15 UEs is under evaluation.

#### 6.5B.4.4\_1.3.1 Test purpose

Same test purpose as in clause 6.5A.3.3.3.1 in TS 38.521-2 [9] for the NR carrier.

#### 6.5B.4.4\_1.3.2 Test applicability

This test case applies to all types of E-UTRA UE release 15 and forward, supporting inter-band EN-DC including FR2 with 2 NR UL CCs.

#### 6.5B.4.4\_1.3.3 Minimum conformance requirements

Same minimum conformance requirements as in clause 6.5A.3.3.0 in TS 38.521-2 [9] for the NR carrier.

No exception requirements applicable to NR or E-UTRA. LTE anchor agnostic approach is applied.

The normative reference for this requirement is TS 38.101-3 [4] clause 6.5B.4.5.

#### 6.5B.4.4\_1.3.4 Test description

##### 6.5B.4.4\_1.3.4.1 Initial condition

Same test description as in clause 6.5A.3.3.3.4 in TS 38.521-2 [9] for the NR carrier with the following exception:

The initial test configurations for E-UTRA band consist of environmental conditions, test frequencies, and channel bandwidths based on E-UTRA bands specified in Table 4.7-1.

For Initial conditions as in clause 6.5A.3.3.3.4.1 in TS 38.521-2 [9], the following steps will be added to configure E-UTRA component:

- 2.1. The parameter settings for E-UTRA cell are set up according to TS 36.508 [11] clause 4.4.3.
- 3.1. The E-UTRA downlink signal level, uplink signal level are set according to Table 4.7-1 and propagation conditions are set according to Annex B.0 of TS 36.521-1 [10].

Step 6 of Initial conditions as in clause 6.5A.3.3.3.4.1 in TS 38.521-2 [9] is replaced by:

6. Ensure the UE is in state RRC\_CONNECTED with generic procedure parameters Connectivity EN-DC, DC bearer MCG and SCG, Connected without release On according to TS 38.508-1 [6] clause 4.5.

Same test procedure as in clause 6.5A.3.3.3.4.2 in TS 38.521-2 [9] with the following steps added for E-UTRA component:

- 1.1 On the E-UTRA carrier, disable periodic and aperiodic CQI reports, disable SRS, set *TimeAlignmentTimerDedicated* IE to infinity and disable downlink and uplink scheduling, all as per Table 4.7-1 under clause 4.7.

#### 6.5B.4.4\_1.3.5 Test Requirements

Same test requirement as in clause 6.5A.3.3.3.5 in TS 38.521-2 [9] for the NR carrier.

### 6.5B.4.4D Additional Spurious Emissions for Inter-band including FR2 for UL MIMO

**Editor's note: This clause is complete for Band n257 and n258 and PC3. The following aspects of the clause are for future consideration:**

- **Test procedure only includes the testing of smartphone and is FFS for laptop and FWA.**

#### 6.5B.4.4D.1 Test purpose

Same test purpose as in clause 6.5D.3.3.1 in TS 38.521-2 [9] for the NR carrier.

#### 6.5B.4.4D.2 Test applicability

This test case applies to all types of E-UTRA UE release 15 and forward, supporting inter-band EN-DC including FR2 and UL MIMO.

#### 6.5B.4.4D.3 Minimum conformance requirements

The additional spurious emissions requirements specified for E-UTRA in clause 6.6.3.3 and 6.6.3.3A of TS 36.101 [5] and for NR single carrier, CA operation and UL-MIMO specified in clause 6.5.3.3, 6.5A.3.3 and 6.5D.3 of TS 38.101-2 [3] apply for each component carrier.

The normative reference for this requirement is TS 38.101-3 [4] clause 6.5B.4.5.

Same minimum conformance requirements as in clause 6.5D.3.3.3 in TS 38.521-2 [9] for the NR carrier.

No exception requirements applicable to NR or E-UTRA. LTE anchor agnostic approach is applied.

#### 6.5B.4.4D.4 Test description

Same test description as in clause 6.5D.3.3.4 in TS 38.521-2 [9] for the NR carrier with the following exception:

The initial test configurations for E-UTRA band consist of environmental conditions, test frequencies, and channel bandwidths based on E-UTRA bands specified in Table 4.7-1.

For Initial conditions as in clause 6.5D.3.3.4.1 in TS 38.521-2 [9], the following steps will be added to configure E-UTRA component:

- 2.1. The parameter settings for E-UTRA cell are set up according to TS 36.508 [11] clause 4.4.3.
- 3.1. The E-UTRA downlink signal level, uplink signal level are set according to Table 4.7-1 and propagation conditions are set according to Annex B.0 of TS 36.521-1 [10].

Step 6 of Initial conditions as in clause 6.5D.3.3.4.1 in TS 38.521-2 [9] is replaced by:

6. Ensure the UE is in state RRC\_CONNECTED with generic procedure parameters Connectivity EN-DC, DC bearer MCG and SCG, Connected without release On according to TS 38.508-1 [6] clause 4.5.

Same test procedure as in clause 6.5D.3.3.4.2 in TS 38.521-2 [9] with the following steps added for E-UTRA component:

- 1.1 On the E-UTRA carrier, disable periodic and aperiodic CQI reports, disable SRS, set *TimeAlignmentTimerDedicated* IE to infinity and disable downlink and uplink scheduling, all as per Table 4.7-1 under clause 4.7.

#### 6.5B.4.4D.5 Test Requirements

Same test requirement as in clause 6.5D.3.3.5 in TS 38.521-2 [9] for the NR carrier.

### 6.5B.5 Transmit intermodulation for DC

#### 6.5B.5.1 Transmit intermodulation for Intra-band contiguous EN-DC

No test case details are specified. No transmit intermodulation requirements are applied for intra band contiguous EN DC unless otherwise stated as in clause TS 38.101-3 [4] clause 6.5B.5.1.

#### 6.5B.5.2 Transmit intermodulation for Intra-band non-contiguous EN-DC

No test case details are specified. No transmit intermodulation requirements are applied for intra band contiguous EN DC unless otherwise stated as in clause TS 38.101-3 [4] clause 6.5B.5.2.

### 6.5B.5.3 Transmit intermodulation for Inter-band EN-DC within FR1 (1 NR CC)

#### 6.5B.5.3.1 Test purpose

Same test purpose as in clause 6.5.4 in TS 38.521-1 [8] for the NR carrier.

#### 6.5B.5.3.2 Test applicability

This test applies to all types of E-UTRA UE release 15 and forward, supporting inter-band EN-DC within FR1 with 1 NR UL.

#### 6.5B.5.3.3 Minimum conformance requirements

The transmit intermodulation requirement specified in clauses 6.7.1 and 6.7.1A of TS 36.101 [5] and clauses 6.5.4 and 6.5A.4 of TS 38.101-1 [2] apply for each component carrier in E-UTRA bands and NR bands, respectively.

No exception requirements applicable to NR or E-UTRA. LTE anchor agnostic approach is applied.

The normative reference for this measurement is TS 38.101-3 [4] clause 6.5B.5.3.

#### 6.5B.5.3.4 Test description

Same test description as in clause 6.5.4.4 in TS 38.521-1 [8] for the NR carrier with the following exception:

For band n28 / 28 used in EN-DC configurations with NOTE 8 of Table 5.5B.4.1-1, test channel bandwidth of 20MHz or more is tested with Low range test frequency.

The initial test configurations for E-UTRA band consist of environmental conditions, test frequencies, and channel bandwidths based on E-UTRA bands specified in Table 4.6-1. For Initial conditions as in clause 6.5.4.4.1 in TS 38.521-1 [8], the following steps will be added to configure E-UTRA component:

- 2.1. The parameter settings for E-UTRA cell are set up according to TS 36.508 [11] clause 4.4.3.
- 3.1. The E-UTRA downlink signal level, uplink signal level are set according to Table 4.6-1 and propagation conditions are set according to Annex B.0 of TS 36.521-1 [10].

Step 6 of Initial conditions as in clause 6.5.4.4.1 in TS 38.521-1 [8] is replaced by the following two steps:

6. Ensure the UE is in state RRC\_CONNECTED with generic procedure parameters Connectivity EN-DC, DC bearer MCG and SCG, Connected without release *On* according to TS 38.508-1 [6] clause 4.5.
7. On the E-UTRA carrier, disable periodic and aperiodic CQI reports, disable SRS, set TimeAlignmentTimerDedicated IE to infinity and disable downlink and uplink scheduling, all as per Table 4.6-1 under clause 4.6.

Same test procedure as in clause 6.5.4.4.2 in TS 38.521-1 [8].

#### 6.5B.5.3.5 Test Requirement

The ratio derived in step 6 and 8, shall not exceed the described value in Table 6.5.4.5-1 defined in TS 38.521-1 [8].

### 6.5B.5.3a Transmit Intermodulation for Inter-band NE-DC within FR1

No exception requirements applicable to NR or E-UTRA.

No test case details are specified. The requirements for NR carrier(s) in this test case are tested in 6.5.4 and 6.5A.4 of TS 38.521-1 [8], and the requirements for LTE carrier(s) in this test case are tested in 6.7 and 6.7A of TS 36.521-1 [10]. Neither NR carrier(s) nor LTE carrier(s) needs to be tested again.

6.5B.5.4 Transmit intermodulation for Inter-band EN-DC including FR2

6.5B.5.5 Transmit intermodulation for Inter-band EN-DC including both FR1 and FR2

## 6.5E Output RF spectrum emissions for V2X operation in FR1

### 6.5E.1 Occupied bandwidth for V2X

#### 6.5E.1.0 Minimum conformance requirements

For intra-band V2X, the occupied bandwidth specified in clause 6.6.1G in TS 36.101 [5] and specified in clause 6.5E.1 in TS 38.101-1 [2] apply for each frequency range respectively.

For the inter-band con-current NR V2X operation, the requirements specified in subclause 6.6.1 of TS 36.101 [5] shall apply for the E-UTRA uplink in licensed band and the requirements specified in subclause 6.5E.1 of TS 38.101-1 [2] shall apply for the sidelink in NR Band n47.

The normative reference for this requirement is TS 38.101-3 [4] clause 6.5E.1.

#### 6.5E.1.1 Occupied bandwidth for intra-band V2X

##### 6.5E.1.1.1 Test purpose

Same test purpose as in clause 6.5E.1 in TS 38.521-1 [8].

##### 6.5E.1.1.2 Test applicability

No exception requirements applicable to NR V2X operation or E-UTRA V2X operation. Given only single switched SL is supported as per clause 6.5E.1.0. The requirements in this test case can be well covered in clause 6.6.1G of TS 36.521-1 [10] and clause 6.5E.1 of TS 38.521-1 [8] and don't need to be tested again.

#### 6.5E.1.2 Occupied bandwidth for inter-band V2X

##### 6.5E.1.2.1 Test purpose

Same test purpose as in clause 6.5E.1 in TS 38.521-1 [8].

##### 6.5E.1.2.2 Test applicability

For inter-band V2X operation, no exception requirements are specified for the E-UTRA/NR Uu carrier and E-UTRA/NR SL carrier.

For inter-band V2X configuration with E-UTRA Uu and NR sidelink, the requirements in this test case can be well covered in clause 6.6.1 of TS 36.521-1 [10] for E-UTRA Uu carrier and clause 6.5E.1 of TS 38.521-1 [8] and don't need to be tested again.

### 6.5E.2 Out of band emission for V2X

#### 6.5E.2.0 Minimum conformance requirements

For intra-band V2X, out-of-band emissions specified in clause 6.6.2G in TS 36.101 [5] and specified in clause 6.5E.2 in TS 38.101-1 [2] apply for each frequency range respectively.

For the inter-band con-current NR V2X operation, the general SEM/additional SEM requirements and ACLR specified in subclause 6.6.2 of TS 36.101 [5] shall apply for the E-UTRA uplink in licensed band and the general SEM/additional SEM and ACLR requirements specified in subclause 6.5E.2 of TS 38.101-1 [2] shall apply for the sidelink in NR Band n47.



The normative reference for this requirement is TS 38.101-3 [4] clause 6.5E.2.

### 6.5E.2.1 Out of band emission for intra-band V2X

#### 6.5E.2.1.1 Test purpose

Same test purpose as in clause 6.5E.2 in TS 38.521-1 [8].

#### 6.5E.2.1.2 Test applicability

No exception requirements applicable to NR V2X operation or E-UTRA V2X operation. Given only single switched SL is supported as per clause 6.5E.2.0. The requirements in this test case can be well covered in clause 6.6.2G of TS 36.521-1 [10] and clause 6.5E.2 of TS 38.521-1 [8] and don't need to be tested again.

### 6.5E.2.2 Out of band emission for inter-band V2X

#### 6.5E.2.2.1 Test purpose

Same test purpose as in clause 6.5E.2 in TS 38.521-1 [8].

#### 6.5E.2.2.2 Test applicability

For inter-band V2X operation, no exception requirements are specified for the E-UTRA/NR Uu carrier and E-UTRA/NR SL carrier.

For inter-band V2X configuration with E-UTRA Uu and NR sidelink, the requirements in this test case can be well covered in clause 6.6.2 of TS 36.521-1 [10] for E-UTRA Uu carrier and clause 6.5E.2 of TS 38.521-1 [8] and don't need to be tested again.

## 6.5E.3 Spurious emissions for V2X

### 6.5E.3.1 General spurious emissions for V2X

#### 6.5E.3.1.0 Minimum conformance requirements

For intra-band V2X, the general spurious emissions requirements specified in clause 6.6.3.1 of TS 36.101 [5] and clause 6.5E.3.1 of TS 38.101-1 [2] apply for each frequency range respectively.

For inter-band V2X, the general spurious emissions requirements specified in clause 6.6.3.1 of TS 36.101 [5] and clause 6.5E.3.1 of TS 38.101-1 [2] apply for each frequency range respectively.

The normative reference for this requirement is TS 38.101-3 [4] clause 6.5E.3.

#### 6.5E.3.1.1 General spurious emissions for intra-band V2X

##### 6.5E.3.1.1.1 Test purpose

Same test purpose as in clause 6.5E.3.1 in TS 38.521-1 [8].

##### 6.5E.3.1.1.2 Test applicability

No exception requirements applicable to NR V2X operation or E-UTRA V2X operation. Given only single switched SL is supported as per clause 6.5E.3.1.0. The requirements in this test case can be well covered in clause 6.6.3.1 of TS 36.521-1 [10] and clause 6.5E.3.1 of TS 38.521-1 [8] and don't need to be tested again.

## 6.5E.3.1.2 General spurious emissions for inter-band V2X

### 6.5E.3.1.2.1 Test purpose

Same test purpose as in clause 6.5E.3.1 in TS 38.521-1 [8].

### 6.5E.3.1.2.2 Test applicability

For inter-band V2X operation, no exception requirements are specified for the E-UTRA/NR Uu carrier and E-UTRA/NR SL carrier.

For inter-band V2X configuration with E-UTRA Uu and NR sidelink, the requirements in this test case can be well covered in clause 6.6.3.1 of TS 36.521-1 [10] for E-UTRA Uu carrier and clause 6.5E.3.1 of TS 38.521-1 [8] and don't need to be tested again.

## 6.5E.4 Transmit intermodulation for V2X

### 6.5E.4.0 Minimum conformance requirements

For intra-band V2X, transmit intermodulation requirements specified in clause 6.7G.1 of TS 36.101 [5] and clause 6.5E.4 of TS 38.101-1 [2] apply for each frequency range respectively.

For inter-band con-current NR V2X operation, the requirements specified in subclause 6.7.1 of TS 36.101 [5] shall apply for the E-UTRA uplink in licensed band and the requirements specified in subclause 6.5E.4 of TS 38.101-1 [2] shall apply for the sidelink in NR Band n47.

The normative reference for this requirement is TS 38.101-3 [4] clause 6.5E.4.

### 6.5E.4.1 Transmit intermodulation for intra-band V2X

#### 6.5E.4.1.1 Test purpose

Same test purpose as in clause 6.5E.4.1 in TS 38.521-1 [8].

#### 6.5E.4.1.2 Test applicability

No exception requirements applicable to NR V2X operation or E-UTRA V2X operation. Given only single switched SL is supported as per clause 6.5E.4.1. The requirements in this test case can be well covered in clause 6.7G.1 of TS 36.521-1 [10] and clause 6.5E.4.1 of TS 38.521-1 [8] and don't need to be tested again.

### 6.5E.4.2 Transmit intermodulation for inter-band V2X

#### 6.5E.4.2.1 Test purpose

Same test purpose as in clause 6.5E.4.2 in TS 38.521-1 [8].

#### 6.5E.4.2.2 Test applicability

For inter-band V2X operation, no exception requirements are specified for the E-UTRA/NR Uu carrier and E-UTRA/NR SL carrier.

For inter-band V2X configuration with E-UTRA Uu and NR sidelink, the requirements in this test case can be well covered in clause 6.7.1 of TS 36.521-1 [10] for E-UTRA Uu carrier and clause 6.5E.4.2 of TS 38.521-1 [8] and don't need to be tested again.

## 6.5H Output RF spectrum emissions for DC with UL MIMO

### 6.5H.1

### 6.5H.2

### 6.5H.3 Spurious emission for DC with UL MIMO

#### 6.5H.3.1

#### 6.5H.3.2

#### 6.5H.3.3 Spurious emission for inter-band EN-DC with UL MIMO within FR1

##### 6.5H.3.3.0 Minimum conformance requirements

The requirements in 6.5B.3.3 apply and for the NR component carrier configured with UL MIMO, the configurations of UL MIMO are according to clause 6.5D.3 of TS 38.521-1 [8].

The normative reference for this requirement is TS 38.101-3 [4] subclause 6.5H.3.3.

##### 6.5H.3.3.1 General spurious emissions for inter-band EN-DC with UL MIMO within FR1

###### 6.5H.3.3.1.1 Test purpose

To verify that UE transmitter does not cause unacceptable interference to other channels or other systems in terms of transmitter spurious emissions.

###### 6.5H.3.3.1.2 Test applicability

This test case applies to all types of NR UE release 17 and forward that support inter-band EN-DC with UL MIMO within FR1.

###### 6.5H.3.3.1.3 Minimum conformance requirements

The minimum conformance requirements are defined in subclause 6.5H.3.3.0.

###### 6.5H.3.3.1.4 Test description

Same test description as specified in clause 6.5B.3.3.1.4.1 with following exceptions:

Step 1 of Initial conditions is replaced by:

1. Connect the SS to the UE antenna connectors as shown in TS 38.508-1 [5] Annex A, in section A.3.1.1 for TE diagram and section A.3.2 for UE diagram.

Step 4 of Test procedure is replaced by:

4. Measure the power of the transmitted signal with a measurement filter of bandwidths according to Table 6.5H.3.3.2.5-1. For the carrier configured with UL MIMO, the power is measured as the sum from all UE transmit antenna connectors. The centre frequency of the filter shall be stepped in contiguous steps according to Table 6.5H.3.3.2.5-1. The measured power shall be verified for each step. The measurement period shall capture the active time slots. During measurement the spectrum analyser shall be set to 'Detector' = RMS. If the sweep count is higher than one, the trace mode shall be average.

Message contents are according to TS 36.508 [11] clause 4.6 and TS 38.508-1 [6] clause 4.6 ensuring Table 4.6.3-182 with the condition 2TX\_UL\_MIMO.

## 6.5H.3.3.1.5 Test requirement

The measured average power of spurious emission, derived in step 4, shall not exceed the described value in Table 6.5H.3.3.1.5-1.

**Table 6.5H.3.3.1.5-1: General spurious emissions test requirements**

Frequency Range	Maximum Level	Measurement Bandwidth	Note
<b>Test requirements for DC_3A_n78A Configuration</b>			
270 MHz ≤ f ≤ 380 MHz	-36 dBm	100 kHz	
1515 MHz ≤ f ≤ 2090 MHz 4815 MHz ≤ f ≤ 5890 MHz 6720 MHz ≤ f ≤ 7370 MHz 8310 MHz ≤ f ≤ 9385 MHz	-30 dBm	1 MHz	
<b>Test requirements for DC_5A_n78A Configuration</b>			
1602 MHz ≤ f ≤ 2152 MHz 2451 MHz ≤ f ≤ 2976 MHz 4124 MHz ≤ f ≤ 4649 MHz 4948 MHz ≤ f ≤ 5498 MHz 5751 MHz ≤ f ≤ 6776 MHz 7424 MHz ≤ f ≤ 8449 MHz	-30 dBm	1 MHz	
<b>Test requirements for DC_8A_n78A Configuration</b>			
1470 MHz ≤ f ≤ 2040 MHz 2385 MHz ≤ f ≤ 2920 MHz 4180 MHz ≤ f ≤ 4715 MHz 5060 MHz ≤ f ≤ 5630 MHz 5685 MHz ≤ f ≤ 6720 MHz 7480 MHz ≤ f ≤ 8515 MHz	-30 dBm	1 MHz	
<b>Test requirements for DC_20A_n78A Configuration</b>			
1576 MHz ≤ f ≤ 2136 MHz 2438 MHz ≤ f ≤ 2968 MHz 4132 MHz ≤ f ≤ 4662 MHz 4964 MHz ≤ f ≤ 5524 MHz 5738 MHz ≤ f ≤ 6768 MHz 7432 MHz ≤ f ≤ 8462 MHz	-30 dBm	1 MHz	
<b>Test requirements for DC_28A_n78A Configuration</b>			
1804 MHz ≤ f ≤ 2394 MHz 2552 MHz ≤ f ≤ 3097 MHz 4003 MHz ≤ f ≤ 4548 MHz 4706 MHz ≤ f ≤ 5296 MHz 5852 MHz ≤ f ≤ 6897 MHz 7303 MHz ≤ f ≤ 8348 MHz	-30 dBm	1 MHz	
<b>Test requirements for DC_40A_n78A Configuration</b>			
800 MHz ≤ f ≤ 1000 MHz	-36 dBm	100 kHz	
1000 MHz ≤ f ≤ 1500 MHz 4200 MHz ≤ f ≤ 5300 MHz 5600 MHz ≤ f ≤ 6200 MHz 7900 MHz ≤ f ≤ 8600 MHz 8900 MHz ≤ f ≤ 10000 MHz	-30 dBm	1 MHz	
<b>Test requirements for DC_41A_n78A Configuration</b>			
610 MHz ≤ f ≤ 1000 MHz	-36 dBm	100 kHz	
1000 MHz ≤ f ≤ 2080 MHz 3910 MHz ≤ f ≤ 5104 MHz 5796 MHz ≤ f ≤ 6490 MHz 8292 MHz ≤ f ≤ 10290 MHz	-30 dBm	1 MHz	

### 6.5H.3.3.2 Spurious emissions for UE co-existence for inter-band EN-DC with UL MIMO within FR1

#### 6.5H.3.3.2.1 Test purpose

To verify that UE transmitter does not cause unacceptable interference to co-existing systems for the specified bands which has specific requirements in terms of transmitter spurious emissions for inter-band EN-DC with UL MIMO within FR1.

#### 6.5H.3.3.2.2 Test applicability

This test case applies to all types of NR UE release 17 and forward that support inter-band EN-DC with UL MIMO within FR1.

#### 6.5H.3.3.2.3 Minimum conformance requirements

The minimum conformance requirements are defined in subclause 6.5H.3.3.0.

#### 6.5H.3.3.2.4 Test description

Same test description as specified in clause 6.5B.3.3.2.4.1 with following exceptions:

Step 1 of Initial conditions is replaced by:

1. Connect the SS to the UE antenna connectors as shown in TS 38.508-1 [5] Annex A, in section A.3.1.1 for TE diagram and section A.3.2 for UE diagram.

Step 4 of Test procedure is replaced by:

4. Measure the power of the transmitted signal with a measurement filter of bandwidths according to Table 6.5H.3.3.2.5-1. For the carrier configured with UL MIMO, the power is measured as the sum from all UE transmit antenna connectors. The centre frequency of the filter shall be stepped in contiguous steps according to Table 6.5H.3.3.2.5-1. The measured power shall be verified for each step. The measurement period shall capture the active time slots. During measurement the spectrum analyser shall be set to 'Detector' = RMS. If the sweep count is higher than one, the trace mode shall be average.

Message contents are according to TS 36.508 [11] clause 4.6 and TS 38.508-1 [6] clause 4.6 ensuring Table 4.6.3-182 with the condition 2TX\_UL\_MIMO.

#### 6.5H.3.3.2.5 Test requirement

Test requirements for Spurious Emissions UE Co-existence for inter-band EN-DC are release specific and can be found in Table 6.5H.3.3.2.5-1. If the UE support a band combination, which is not defined in the corresponding UE's release, the requirements for this band combination are taken from the table of earliest release where requirements for this band combination are defined.

**Table 6.5H.3.3.2.5-1: Requirements according to UE NR release**

EN-DC Configuration	Release	Spurious emission			
		Protected band	Frequency range (MHz)	Maximum Level (dBm)	MBW (MHz)

DC_3_n78	Rel-17 Rel-18	Frequency range	1884.5	-	1915.7	-41	0.3	3
DC_8_n78	Rel-17 Rel-18	Frequency range	1884.5	-	1915.7	-41	0.3	3, 12
DC_28_n78	Rel-17 Rel-18	Frequency range	1884.5	-	1915.7	-41	0.3	3
DC_41_n78	Rel-17 Rel-18	Frequency range	1884.5	-	1915.7	-41	0.3	3
<p>NOTE 1: <math>F_{DL\_low}</math> and <math>F_{DL\_high}</math> refer to each frequency band specified in Table 5.5-1 of TS 36.101 [5] or in Table 5.2-1 in TS 38.101-1 [2].</p> <p>NOTE 2: As exceptions, measurements with a level up to the applicable requirements defined in Table 6.6.3.1-2 in TS 36.101 [5] and Table 6.5.3.1-2 in TS 38.101-1 [2] are permitted for each assigned carrier used in the measurement due to 2<sup>nd</sup>, 3<sup>rd</sup>, 4<sup>th</sup> or 5<sup>th</sup> harmonic spurious emissions. Due to spreading of the harmonic emission the exception is also allowed for the first 1 MHz frequency range immediately outside the harmonic emission on both sides of the harmonic emission. This results in an overall exception interval centred at the harmonic emission of <math>(2\text{MHz} + N \times L_{CRB} \times 180\text{kHz})</math>, where N is 2, 3, 4, 5 for the 2<sup>nd</sup>, 3<sup>rd</sup>, 4<sup>th</sup> or 5<sup>th</sup> harmonic respectively. The exception is allowed if the measurement bandwidth (MBW) totally or partially overlaps the overall exception interval.</p> <p>NOTE 3: Applicable when co-existence with PHS system operating in 1884.5 -1915.7MHz</p> <p>NOTE 4: Void.</p> <p>NOTE 5: These requirements also apply for the frequency ranges that are less than <math>F_{OoB}</math> (MHz) in Table 6.6.3.1-1, Table 6.6.3.1A-1 in TS 36.101 [5] or in Table 6.5.3.1-1 in TS 38.101-1 [2] from the edge of the channel bandwidth.</p> <p>NOTE 6: This requirement is applicable for any channel bandwidths within the range 2500 - 2570 MHz with the following restriction: for carriers of 15 MHz bandwidth when carrier centre frequency is within the range 2560.5 - 2562.5 MHz and for carriers of 20 MHz bandwidth when carrier centre frequency is within the range 2552 - 2560 MHz the requirement is applicable only for an uplink transmission bandwidth less than or equal to 54 RB.</p> <p>NOTE 7: For these adjacent bands, the emission limit could imply risk of harmful interference to UE(s) operating in the protected operating band.</p> <p>NOTE 8: Void.</p> <p>NOTE 9: Applicable when the assigned E-UTRA or NR carrier is confined within 718 MHz and 748 MHz and when the channel bandwidth used is 5 or 10 MHz.</p> <p>NOTE 10: As exceptions, measurements with a level up to the applicable requirement of -38 dBm/MHz is permitted for each assigned E-UTRA carrier used in the measurement due to 2nd harmonic spurious emissions. An exception is allowed if there is at least one individual RB within the transmission bandwidth (see Figure 5.6-1) for which the 2nd harmonic totally or partially overlaps the measurement bandwidth (MBW).</p> <p>NOTE 11: As exceptions, measurements with a level up to the applicable requirement of -36 dBm/MHz is permitted for each assigned E-UTRA carrier used in the measurement due to 3rd harmonic spurious emissions. An exception is allowed if there is at least one individual RB within the transmission bandwidth (see Figure 5.6-1) for which the 3rd harmonic totally or partially overlaps the measurement bandwidth (MBW).</p> <p>NOTE 12: This requirement is applicable only for the following cases:  A: for carriers of 5 MHz channel bandwidth when carrier centre frequency (<math>F_c</math>) is within the range <math>902.5 \text{ MHz} \leq F_c &lt; 907.5 \text{ MHz}</math> with an uplink transmission bandwidth less than or equal to 20 RB;  B: for carriers of 5 MHz channel bandwidth when carrier centre frequency (<math>F_c</math>) is within the range <math>907.5 \text{ MHz} \leq F_c \leq 912.5 \text{ MHz}</math> without any restriction on uplink transmission bandwidth;  C: for carriers of 10 MHz channel bandwidth when carrier centre frequency (<math>F_c</math>) is <math>F_c = 910 \text{ MHz}</math> with an uplink transmission bandwidth less than or equal to 32 RB with <math>RB_{start} &gt; 3</math>.</p>								

## 6.5L Output RF spectrum emissions for DC with Tx Diversity

### 6.5L.1

### 6.5L.2

## 6.5L.3 Spurious emission for DC with Tx Diversity

### 6.5L.3.1

### 6.5L.3.2

## 6.5L.3.3 Spurious emission for inter-band EN-DC with Tx Diversity within FR1

### 6.5L.3.3.0 Minimum conformance requirements

The requirements in 6.5B.3.3 apply except that:

- - For the NR component carrier configured with Tx Diversity, the general spurious emissions specified in clause 6.5G.3.1 of TS 38.101-1 [2] are applied, and the coexistence band protection requirements specified in clause 6.5G.3.2 of [2] are applied.

The normative reference for this requirement is TS 38.101-3 [4] subclause 6.5L.3.3.

### 6.5L.3.3.1 General spurious emissions for inter-band EN-DC with Tx Diversity within FR1

#### 6.5L.3.3.1.1 Test purpose

To verify that UE transmitter does not cause unacceptable interference to other channels or other systems in terms of transmitter spurious emissions.

#### 6.5L.3.3.1.2 Test applicability

This test case applies to all types of NR UE release 17 and forward that support inter-band EN-DC with Tx Diversity within FR1.

#### 6.5L.3.3.1.3 Minimum conformance requirements

The minimum conformance requirements are defined in subclause 6.5L.3.3.0.

#### 6.5L.3.3.1.4 Test description

Same test description as specified in clause 6.5B.3.3.1.4.1 with following exceptions:

Step 1 of Initial conditions is replaced by:

1. Connect the SS to the UE antenna connectors as shown in TS 38.508-1 [5] Annex A, in section A.3.1.1 for TE diagram and section A.3.2 for UE diagram.

Step 4 of Test procedure is replaced by:

4. Measure the power of the transmitted signal with a measurement filter of bandwidths according to Table 6.5L.3.3.2.5-1. For the carrier configured with TxD, the power is measured as the sum from all UE transmit antenna connectors. The centre frequency of the filter shall be stepped in contiguous steps according to Table 6.5L.3.3.2.5-1. The measured power shall be verified for each step. The measurement period shall capture the active time slots. During measurement the spectrum analyser shall be set to 'Detector' = RMS. If the sweep count is higher than one, the trace mode shall be average.

## 6.5L.3.3.1.5 Test requirement

The measured average power of spurious emission, derived in step 4, shall not exceed the described value in Table 6.5L.3.3.1.5-1.

**Table 6.5L.3.3.1.5-1: General spurious emissions test requirements**

Frequency Range	Maximum Level	Measurement Bandwidth	Note
<b>Test requirements for DC_3A_n78A Configuration</b>			
270 MHz ≤ f ≤ 380 MHz	-36 dBm	100 kHz	
1515 MHz ≤ f ≤ 2090 MHz 4815 MHz ≤ f ≤ 5890 MHz 6720 MHz ≤ f ≤ 7370 MHz 8310 MHz ≤ f ≤ 9385 MHz	-30 dBm	1 MHz	
<b>Test requirements for DC_5A_n78A Configuration</b>			
1602 MHz ≤ f ≤ 2152 MHz 2451 MHz ≤ f ≤ 2976 MHz 4124 MHz ≤ f ≤ 4649 MHz 4948 MHz ≤ f ≤ 5498 MHz 5751 MHz ≤ f ≤ 6776 MHz 7424 MHz ≤ f ≤ 8449 MHz	-30 dBm	1 MHz	
<b>Test requirements for DC_8A_n78A Configuration</b>			
1470 MHz ≤ f ≤ 2040 MHz 2385 MHz ≤ f ≤ 2920 MHz 4180 MHz ≤ f ≤ 4715 MHz 5060 MHz ≤ f ≤ 5630 MHz 5685 MHz ≤ f ≤ 6720 MHz 7480 MHz ≤ f ≤ 8515 MHz	-30 dBm	1 MHz	
<b>Test requirements for DC_20A_n78A Configuration</b>			
1576 MHz ≤ f ≤ 2136 MHz 2438 MHz ≤ f ≤ 2968 MHz 4132 MHz ≤ f ≤ 4662 MHz 4964 MHz ≤ f ≤ 5524 MHz 5738 MHz ≤ f ≤ 6768 MHz 7432 MHz ≤ f ≤ 8462 MHz	-30 dBm	1 MHz	
<b>Test requirements for DC_28A_n78A Configuration</b>			
1804 MHz ≤ f ≤ 2394 MHz 2552 MHz ≤ f ≤ 3097 MHz 4003 MHz ≤ f ≤ 4548 MHz 4706 MHz ≤ f ≤ 5296 MHz 5852 MHz ≤ f ≤ 6897 MHz 7303 MHz ≤ f ≤ 8348 MHz	-30 dBm	1 MHz	
<b>Test requirements for DC_40A_n78A Configuration</b>			
800 MHz ≤ f ≤ 1000 MHz	-36 dBm	100 kHz	
1000 MHz ≤ f ≤ 1500 MHz 4200 MHz ≤ f ≤ 5300 MHz 5600 MHz ≤ f ≤ 6200 MHz 7900 MHz ≤ f ≤ 8600 MHz 8900 MHz ≤ f ≤ 10000 MHz	-30 dBm	1 MHz	
<b>Test requirements for DC_41A_n78A Configuration</b>			
610 MHz ≤ f ≤ 1000 MHz	-36 dBm	100 kHz	
1000 MHz ≤ f ≤ 2080 MHz 3910 MHz ≤ f ≤ 5104 MHz 5796 MHz ≤ f ≤ 6490 MHz 8292 MHz ≤ f ≤ 10290 MHz	-30 dBm	1 MHz	



### 6.5L.3.3.2 Spurious emissions for UE co-existence for inter-band EN-DC with Tx Diversity within FR1

#### 6.5L.3.3.2.1 Test purpose

To verify that UE transmitter does not cause unacceptable interference to co-existing systems for the specified bands which has specific requirements in terms of transmitter spurious emissions for inter-band EN-DC with Tx Diversity within FR1.

#### 6.5L.3.3.2.2 Test applicability

This test case applies to all types of NR UE release 17 and forward that support inter-band EN-DC with Tx Diversity within FR1.

#### 6.5L.3.3.2.3 Minimum conformance requirements

The minimum conformance requirements are defined in subclause 6.5L.3.3.0.

#### 6.5L.3.3.2.4 Test description

Same test description as specified in clause 6.5B.3.3.2.4.1 with following exceptions:

Step 1 of Initial conditions is replaced by:

1. Connect the SS to the UE antenna connectors as shown in TS 38.508-1 [5] Annex A, in section A.3.1.1 for TE diagram and section A.3.2 for UE diagram.

Step 4 of Test procedure is replaced by:

4. Measure the power of the transmitted signal with a measurement filter of bandwidths according to Table 6.5L.3.3.2.5-1. For the carrier configured with TxD, the power is measured as the sum from all UE transmit antenna connectors. The centre frequency of the filter shall be stepped in contiguous steps according to Table 6.5L.3.3.2.5-1. The measured power shall be verified for each step. The measurement period shall capture the active time slots. During measurement the spectrum analyser shall be set to 'Detector' = RMS. If the sweep count is higher than one, the trace mode shall be average.

#### 6.5L.3.3.2.5 Test requirement

Test requirements for Spurious Emissions UE Co-existence for inter-band EN-DC are release specific and can be found in Table 6.5L.3.3.2.5-1. If the UE support a band combination, which is not defined in the corresponding UE's release, the requirements for this band combination are taken from the table of earliest release where requirements for this band combination are defined.

**Table 6.5L.3.3.2.5-1: Requirements according to UE NR release**

EN-DC Configuration	Release	Spurious emission			
		Protected band	Frequency range (MHz)	Maximum Level (dBm)	MBW (MHz)

DC_3_n78	Rel-17 Rel-18	Frequency range	1884.5	-	1915.7	-41	0.3	3
DC_8_n78	Rel-17 Rel-18	Frequency range	1884.5	-	1915.7	-41	0.3	3, 12
DC_28_n78	Rel-17 Rel-18	Frequency range	1884.5	-	1915.7	-41	0.3	3
DC_41_n78	Rel-17 Rel-18	Frequency range	1884.5	-	1915.7	-41	0.3	3

NOTE 1:  $F_{DL\_low}$  and  $F_{DL\_high}$  refer to each frequency band specified in Table 5.5-1 of TS 36.101 [5] or in Table 5.2-1 in TS 38.101-1 [2].

NOTE 2: As exceptions, measurements with a level up to the applicable requirements defined in Table 6.6.3.1-2 in TS 36.101 [5] and Table 6.5.3.1-2 in TS 38.101-1 [2] are permitted for each assigned carrier used in the measurement due to 2<sup>nd</sup>, 3<sup>rd</sup>, 4<sup>th</sup> or 5<sup>th</sup> harmonic spurious emissions. Due to spreading of the harmonic emission the exception is also allowed for the first 1 MHz frequency range immediately outside the harmonic emission on both sides of the harmonic emission. This results in an overall exception interval centred at the harmonic emission of  $(2\text{MHz} + N \times L_{CRB} \times 180\text{kHz})$ , where N is 2, 3, 4, 5 for the 2<sup>nd</sup>, 3<sup>rd</sup>, 4<sup>th</sup> or 5<sup>th</sup> harmonic respectively. The exception is allowed if the measurement bandwidth (MBW) totally or partially overlaps the overall exception interval.

NOTE 3: Applicable when co-existence with PHS system operating in 1884.5 -1915.7MHz

NOTE 4: Void.

NOTE 5: These requirements also apply for the frequency ranges that are less than  $F_{OoB}$  (MHz) in Table 6.6.3.1-1, Table 6.6.3.1A-1 in TS 36.101 [5] or in Table 6.5.3.1-1 in TS 38.101-1 [2] from the edge of the channel bandwidth.

NOTE 6: This requirement is applicable for any channel bandwidths within the range 2500 - 2570 MHz with the following restriction: for carriers of 15 MHz bandwidth when carrier centre frequency is within the range 2560.5 - 2562.5 MHz and for carriers of 20 MHz bandwidth when carrier centre frequency is within the range 2552 - 2560 MHz the requirement is applicable only for an uplink transmission bandwidth less than or equal to 54 RB.

NOTE 7: For these adjacent bands, the emission limit could imply risk of harmful interference to UE(s) operating in the protected operating band.

NOTE 8: Void.

NOTE 9: Applicable when the assigned E-UTRA or NR carrier is confined within 718 MHz and 748 MHz and when the channel bandwidth used is 5 or 10 MHz.

NOTE 10: As exceptions, measurements with a level up to the applicable requirement of -38 dBm/MHz is permitted for each assigned E-UTRA carrier used in the measurement due to 2nd harmonic spurious emissions. An exception is allowed if there is at least one individual RB within the transmission bandwidth (see Figure 5.6-1) for which the 2nd harmonic totally or partially overlaps the measurement bandwidth (MBW).

NOTE 11: As exceptions, measurements with a level up to the applicable requirement of -36 dBm/MHz is permitted for each assigned E-UTRA carrier used in the measurement due to 3rd harmonic spurious emissions. An exception is allowed if there is at least one individual RB within the transmission bandwidth (see Figure 5.6-1) for which the 3rd harmonic totally or partially overlaps the measurement bandwidth (MBW).

NOTE 12: This requirement is applicable only for the following cases:  
A: for carriers of 5 MHz channel bandwidth when carrier centre frequency ( $F_c$ ) is within the range  $902.5 \text{ MHz} \leq F_c < 907.5 \text{ MHz}$  with an uplink transmission bandwidth less than or equal to 20 RB;  
B: for carriers of 5 MHz channel bandwidth when carrier centre frequency ( $F_c$ ) is within the range  $907.5 \text{ MHz} \leq F_c \leq 912.5 \text{ MHz}$  without any restriction on uplink transmission bandwidth;  
C: for carriers of 10 MHz channel bandwidth when carrier centre frequency ( $F_c$ ) is  $F_c = 910 \text{ MHz}$  with an uplink transmission bandwidth less than or equal to 32 RB with  $RB_{start} > 3$ .

## 6.6

### 6.6B Beam Correspondence for EN-DC

#### 6.6B.4 Beam Correspondence for inter-band EN-DC including FR2 (1 NR CC) - EIRP

Editor's note: The following aspects are either missing or not yet determined:

- The associated standalone test 6.6.1 in TS 38.521-2 [9] is incomplete for band n259.

##### 6.6B.4.1 Test purpose

Same test purpose as in clause 6.6.1.1 in TS 38.521-2 [9] for the NR carrier.

#### 6.6B.4.2 Test applicability

This test case applies to all types of E-UTRA-NR Power Class 3 UE release 15, supporting inter-band EN-DC including FR2 with 1 NR UL CC that do not support beam correspondence without UL beam sweeping.

This test case applies to all types of E-UTRA-NR Power Class 3 UE release 16 and forward, supporting inter-band EN-DC including FR2 with 1 NR UL CC that do not support SSB-based or CSI-RS based enhanced beam correspondence and do not support beam correspondence without UL beam sweeping.

#### 6.6B.4.3 Minimum conformance requirements

Same minimum conformance requirements as in clause 6.6.1.3 in TS 38.521-2 [9] for the NR carrier.

No exception requirements applicable to NR or LTE. LTE anchor agnostic approach is applied.

The normative reference for this requirement is TS 38.101-3 [4] clause 6.6B.4.

#### 6.6B.4.4 Test description

Same test description as in clause 6.6.1.4 in TS 38.521-2 [9] for the NR carrier with the following exception:

The initial test configurations for E-UTRA band consist of environmental conditions, test frequencies, and channel bandwidths based on E-UTRA bands specified in Table 4.7-1.

For initial conditions as in clause 6.6.1.4.1 in TS 38.521-2 [9], the following steps will be added to configure E-UTRA component:

- 2.1. The parameter settings for E-UTRA cell are set up according to TS 36.508 [11] clause 4.4.3.
- 3.1. The E-UTRA downlink signal level, uplink signal level are set according to Table 4.7-1 and propagation conditions are set according to Annex B.0 of TS 36.521-1 [10].

Step 6 of initial conditions as in clause 6.3.1.4.1 in TS 38.521-2 [9] is replaced by:

6. Ensure the UE is in state RRC\_CONNECTED with generic procedure parameters Connectivity EN-DC, DC bearer MCG and SCG, Connected without release On according to TS 38.508-1 [6] clause 4.5.

Same test procedure as in clause 6.3.1.4.2 in TS 38.521-2 [9] with the following steps added for E-UTRA component:

- 1.1 On the E-UTRA carrier, disable periodic and aperiodic CQI reports, disable SRS, set *TimeAlignmentTimerDedicated* IE to infinity and disable downlink and uplink scheduling, all as per Table 4.7-1 under clause 4.7.

#### 6.6B.4.5 Test requirements

Same test requirement for RRC CONNECTED state as in clause 6.6.1.5 in TS 38.521-2 [9] for the NR carrier.

### 6.6B.5 Enhanced Beam Correspondence for inter-band EN-DC including FR2 (1 NR CC) - EIRP

**Editor's note: This clause is incomplete. The following aspects are either missing or not yet determined:**

- **The associated standalone test 6.6.2 in TS 38.521-2 [9] is incomplete.**

#### 6.6B.5.1 Test purpose

Same test purpose as in clause 6.6.2.1 in TS 38.521-2 [9] for the NR carrier.

#### 6.6B.5.2 Test applicability

This test case applies to all types of E-UTRA-NR Power Class 3 UE release 16 and forward, supporting inter-band EN-DC including FR2 with 1 NR UL CC and support either CSI-RS or SSB based beam correspondence and do not support beam correspondence without UL beam sweeping.

### 6.6B.5.3 Minimum conformance requirements

Same minimum conformance requirements as in clause 6.6.2.3 in TS 38.521-2 [9] for the NR carrier.

No exception requirements applicable to NR or LTE. LTE anchor agnostic approach is applied.

The normative reference for this requirement is TS 38.101-3 [4] clause 6.6B.5.

### 6.6B.5.4 Test Procedure

Same test description as in clause 6.6.2.5 in TS 38.521-2 [9] for the NR carrier with the following exception:

The initial test configurations for E-UTRA band consist of environmental conditions, test frequencies, and channel bandwidths based on E-UTRA bands specified in Table 4.7-1.

For initial conditions as in clause 6.6.2.4.1 in TS 38.521-2 [9], the following steps will be added to configure E-UTRA component:

- 2.1. The parameter settings for E-UTRA cell are set up according to TS 36.508 [11] clause 4.4.3.
- 3.1. The E-UTRA downlink signal level, uplink signal level are set according to Table 4.7-1 and propagation conditions are set according to Annex B.0 of TS 36.521-1 [10].

Step 6 of initial conditions as in clause 6.3.1.4.1 in TS 38.521-2 [9] is replaced by:

6. Ensure the UE is in state RRC\_CONNECTED with generic procedure parameters Connectivity EN-DC, DC bearer MCG and SCG, Connected without release On according to TS 38.508-1 [6] clause 4.5.

Same test procedure as in clause 6.3.1.4.2 in TS 38.521-2 [9] with the following steps added for E-UTRA component:

- 1.1 On the E-UTRA carrier, disable periodic and aperiodic CQI reports, disable SRS, set *TimeAlignmentTimerDedicated* IE to infinity and disable downlink and uplink scheduling, all as per Table 4.7-1 under clause 4.7.

### 6.6B.5.5 Test Requirements

Same test requirement as in clause 6.6.2.5 in TS 38.521-2 [9] for the NR carrier.

---

## 7 Receiver characteristics

### 7.1 General

**Editor's note: Test configurations/environments that require new spherical scan shall be included in test procedure clause and identifying such scenarios is currently FFS and owned by RAN5.**

Unless otherwise stated the receiver characteristics are specified at the antenna connector(s) of the UE for the bands operating on frequency range 1 and over the air of the UE for the bands operating on frequency range 2. The requirements for frequency range 1 and frequency range 2 can be verified separately. For the carrier in frequency range 1, requirements can be verified with NR FR2 link disabled. For the carrier in frequency range 2, requirements can be verified in OTA mode with E-UTRA connecting to the network by OTA without calibration.

For NR FR2 Rx test cases the identified beam peak direction can be stored and reused for a device under test in various configurations/environments for the full duration of device testing as long as beam peak direction is the same.

The requirements defined in this clause are the extra requirements compared with the single carrier requirements defined in TS 38.521-1 [8] and TS 38.521-2 [9].

Unless otherwise stated, the UL and DL reference measurement channels are the same with the configurations specified in TS 38.521-1 [8] and TS 38.521-2 [9].

Unless otherwise stated, requirements for NR receiver written in TS 38.521-1 [8] and TS 38.521-2 [9] apply and are assumed anchor agnostic. Requirements are verified under conditions where anchor resources do not interfere NR operation.

For intra-band EN-DC, the output power is configured as follows:

- One E-UTRA uplink carrier with the output power set to 29dB below  $P_{\text{CMAX\_L,c}}$  and the NR band whose downlink is being tested has its uplink carrier output power set to 4dB below  $P_{\text{CMAX\_L,f,c}}$ .
- One NR uplink carrier with the output power set to 29dB below  $P_{\text{CMAX\_L,f,c}}$  and the E-UTRA band whose downlink is being tested has its uplink carrier output power set to 4 dB below  $P_{\text{CMAX\_L,c}}$ .

For the additional requirements for intra-band non-contiguous EN-DC of two sub-blocks, an in-gap test refers to the case when the interfering signal is located at a negative offset with respect to the assigned lowest channel frequency of the highest sub-block and located at a positive offset with respect to the assigned highest channel frequency of the lowest sub-block.

For the additional requirements for intra-band non-contiguous EN-DC of two sub-blocks, an out-of-gap test refers to the case when the interfering signal(s) is (are) located at a positive offset with respect to the assigned channel frequency of the highest carrier frequency or located at a negative offset with respect to the assigned channel frequency of the lowest carrier frequency.

For the additional requirements for intra-band non-contiguous EN-DC of two sub-blocks with channel bandwidth larger than or equal to 5 MHz, the existing adjacent channel selectivity requirements, in-band blocking requirements (for each case), and narrow band blocking requirements apply for in-gap tests only if the corresponding interferer frequency offsets with respect to the two measured carriers satisfy the following condition in relation to the sub-block gap size  $W_{\text{gap}}$  for at least one of the E-UTRA or NR sub-blocks, so that the interferer frequency position does not change the nature of the core requirement tested:

$$W_{\text{gap}} \geq 2 \cdot |F_{\text{Interferer (offset)}}| - BW_{\text{Channel}}$$

For the E-UTRA sub-block, the  $F_{\text{Interferer (offset)}}$ , for a sub-block with a single component carrier is the interferer frequency offset with respect to carrier as specified in clause 7.5.1, clause 7.6.1 and clause 7.6.3 for the respective requirement in TS 36.521 [10] and  $BW_{\text{Channel}}$ .  $F_{\text{Interferer (offset)}}$  for the E-UTRA sub-block with two or more contiguous component carriers is the interference frequency offset with respect to the carrier adjacent to the gap is specified in clause 7.5.1A, 7.6.1A and 7.6.3A in TS 36.521 [10].

For the NR sub-block, the  $F_{\text{Interferer (offset)}}$ , for a sub-block with a single component carrier is the interferer frequency offset with respect to carrier as specified in clause 7.5, clause 7.6.2 and clause 7.6.4 for the respective requirement in TS 38.521-1 [8] and  $BW_{\text{Channel}}$ .

The interferer frequency offsets for adjacent channel selectivity, each in-band blocking case and narrow- band blocking shall be tested separately with a single in-gap interferer at a time.

Unless otherwise stated, the receiver requirements of inter-band EN-DC are applicable to UE with one or two Tx antenna connectors in NR band.

Unless otherwise stated, Channel Bandwidth shall be prioritized in the selecting of test points. Subcarrier spacing shall be selected after Test Channel Bandwidth is selected.

For conformance testing involving FR2 test cases in this specification, the UE under test shall be pre-configured with UL Tx diversity schemes disabled to account for single polarization System Simulator (SS) in the test environment. The UE under test may transmit with dual polarization.

## 7.2 Void

## 7.3 Void

## 7.3A Reference sensitivity for CA without EN-DC

### 7.3A.1 General

For NR CA operation NR single carrier and CA operation of REFSENS requirements defined in TS 38.101-1 [2] and TS 38.101-2 [3] apply to all downlink bands part of NR CA configurations listed in Table 5.2A.1-1 unless sensitivity degradation is allowed as defined in clause 7.3A in TS 38.101-3 [4].

A UE which supports inter-band NR CA configuration is allowed to apply each sensitivity degradation for FR1 specified in clause 7.3A.2 TS 38.101-1 [2] and for FR2 specified in clause 7.3A.2 of TS 38.101-2 [3] independently.

### 7.3A.2 Reference sensitivity power level for CA without EN-DC

#### 7.3A.2.1 Test purpose

Same test purpose as in clause 7.3.2 in TS 38.521-1 [8] for NR FR1 carrier(s) and clause 7.3.2 in TS 38.521-2 [9] for NR FR2 carrier(s).

#### 7.3A.2.2 Test applicability

The requirements in this test are not testable due to issues with combined testing of NR FR1 conducted mode with NR FR2 in radiated mode. Therefore, the conducted and radiated requirements are tested separately.

No test case details are specified. The NR/5GC requirements for receiver sensitivity power level apply and are tested in TS 38.521-1 [8] clauses 7.3 and 7.3A and TS 38.521-2 [9] clauses 7.3 and 7.3A.

### 7.3A.3 $\Delta R_{IB,c}$ for CA without EN-DC

For the UE which supports inter-band NR CA configuration, the minimum requirement for reference sensitivity in clause 7.3.2 in TS 38.101-1 [2] and clause 7.3.2, 7.3A.2 in TS 38.101-2 [3] shall be increased by the amount given in  $\Delta R_{IB,c}$  in Tables below. Unless otherwise stated,  $\Delta R_{IB,c}$  is set to zero.

In case the UE supports more than one of band combinations for CA, SUL or DC, and an operating band belongs to more than one band combinations then

- When the operating band frequency range is  $\leq 1$ GHz, the applicable additional  $\Delta R_{IB,c}$  shall be the average value for all band combinations defined in clause 7.3A, 7.3B, 7.3C in TS 38.101-1 [2] and 7.3A, 7.3B in TS 38.101-3 [4], truncated to one decimal place that apply for that operating band among the supported band combinations. In case there is a harmonic relation between low band UL and high band DL, then the maximum  $\Delta R_{IB,c}$  among the different supported band combinations involving such band shall be applied
- When the operating band frequency range is  $> 1$  GHz, the applicable additional  $\Delta R_{IB,c}$  shall be the maximum value for all band combinations defined in clause 7.3A, 7.3B, 7.3C in TS 38.101-1 [2] and 7.3A, 7.3B in TS 38.101-3 [4] for the applicable operating bands.

#### 7.3A.3.1 $\Delta R_{IB,c}$ for Inter-band CA between FR1 and FR2 without EN-DC

Unless otherwise stated,  $\Delta R_{IB,c}$  for NR FR1 band and FR2 band of inter-band CA defined in table 5.5A.1-1 is set to zero.

## 7.3A.4 Void

# 7.3B Reference sensitivity level for DC

## 7.3B.1 General

For EN-DC, E-UTRA and NR single carrier, CA, and MIMO operation of REFSENS requirements defined in TS 38.101-1 [2], TS 38.101-2 [3] and TS 36.101 [5] apply to all downlink bands of EN-DC configurations listed in clause 5.5B, unless sensitivity degradation exception is allowed in this clause of this specification, clause 7.3 in TS 38.101-1 [2], clause 7.3 in TS 38.101-2 [3] or clause 7.3 in TS 36.101 [5]. Allowed exceptions specified in this clause of the specification, clause 7.3 in TS 38.101-1 [2], clause 7.3 in TS 38.101-2 [3] or clause 7.3 in TS 36.101 [4] also apply to any higher order EN-DC configuration combination containing one of the band combinations that exception is allowed for. Reference sensitivity exceptions are specified by applying maximum sensitivity degradation (MSD) into applicable REFSENS requirement. EN-DC REFSENS requirements shall be met for NR uplink transmissions using QPSK DFT-s-OFDM waveforms as defined in clause 7.3.2 in TS 38.101-1 [2]. Unless otherwise specified UL allocation uses the lowest SCS allowable for a given channel BW. Limits on configured maximum output power for the uplink according to subclause 6.2B.4 shall apply.

In case of interband EN-DC the receiver REFSENS requirements in this clause do not apply for 1.4 and 3 MHz E-UTRA carriers. For the case of inter-band EN-DC with a single carrier per cell group and multi-carrier per cell group, in addition to the E-UTRA and NR single carrier, CA, and MIMO operation of REFSENS requirements defined in TS 38.101-1 [2], TS 38.101-2 [3], and TS 36.101 [5], the REFSENS requirements specified therein also apply with both downlink carriers and both uplink carriers active unless sensitivity exceptions are allowed in this clause of this specification, clause 7.3 in TS 38.101-1 [2] or clause 7.3 in TS 36.101 [5].

For reference sensitivity exception test points where the specified carrier frequency does not correspond to a valid NR-ARFCN, the closest NR-ARFCN as specified in TS 38.101-1 [2] clause 5.4.2 applies.

For operations with 4 Rx antenna ports in an E-UTRA band or an NR band, the MSD in the applicable bands shall be increased by the absolute value of  $\Delta R_{IB,4R}$  in Table 7.3.1-1a of TS 36.101[5] for the E-UTRA band or in Table 7.3.2-2 of TS 38.101-1 [2] for the NR band when  $MSD > 0$ .

NOTE: For inter-band EN-DC, the reference sensitivity requirement with both uplink carriers active is allowed to be verified for only a single inter-band EN-DC configuration per NR band.

## 7.3B.2 Reference sensitivity for DC

### 7.3B.2.0 Minimum Conformance Requirements of Reference sensitivity for DC

#### 7.3B.2.0.1 Intra-band contiguous EN-DC

For intra-band contiguous EN-DC configurations, the reference sensitivity power level REFSENS is the minimum mean power applied to each one of the UE antenna ports at which the throughput for the carrier(s) of the E-UTRA and NR CGs shall meet or exceed the requirements for the specified E-UTRA and NR reference measurement channels. The reference sensitivity requirements apply with all uplink carriers and all downlink carriers active for EN-DC configuration and Uplink EN-DC configuration listed in Table 5.5B.2-1 and Table 5.5B.3-1, as supported by the UE. For EN-DC configurations where uplink is not available in either the MCG or the SCG or for EN-DC configurations where the UE only supports single uplink operation, reference sensitivity requirements apply with single uplink transmission. The downlink carrier(s) from the cell group with uplink shall be configured closer to the uplink operating band than any of the downlink carriers from the cell group without uplink.

Sensitivity degradation is allowed for Intra-band contiguous EN-DC configurations listed in Table 7.3B.2.0.1-1, the reference sensitivity is defined only for the specific uplink and downlink test points which are specified in Table 7.3B.2.0.1-1 and E-UTRA and NR single carrier requirements do not apply.

Table 7.3B.2.0.1-1: Reference sensitivity (MSD) for intra-band contiguous EN-DC

EN-DC configuration/channel allocations/MSD								
EN-DC configuration	E-UTRA/NR band	F <sub>c</sub> (UL) (MHz)	Channel bandwidth (MHz)	UL allocation (L <sub>CRB</sub> )	F <sub>c</sub> (DL) (MHz)	MSD (dB)	Duplex mode	
DC_(n)71AA	71	665.5	5	5 (RB <sub>end</sub> = 24)	619.5	0	FDD	
	n71	675.5	15	15 (RB <sub>start</sub> = 0)	629.5	1.8		
DC_(n)71AA	71	670.5	15	15 (RB <sub>end</sub> = 74)	624.5	0		
	n71	680.5	5	5 (RB <sub>start</sub> = 0)	634.5	1.6		
DC_(n)71AA	71	668	10	10 (RB <sub>end</sub> = 49)	622	0		
	n71	678	10	10 (RB <sub>start</sub> = 0)	632	1.7		
DC_(n)71AA	71	668	10	10 (RB <sub>start</sub> = 0)	622	17.2		
	n71	678	10	10 (RB <sub>end</sub> = 51)	632	29.4		
DC_(n)71AA	71	665.5	5	5 (RB <sub>end</sub> = 24)	619.5	0		FDD
	n71	675.5	151	15 (RB <sub>start</sub> = 0)	6321	2.5		
DC_(n)71AA	71	670.5	15	15 (RB <sub>end</sub> = 74)	624.5	0		
	n71	680.5	51	5 (RB <sub>start</sub> = 0)	6371	2.2		
DC_(n)71AA	71	668	10	10 (RB <sub>end</sub> = 49)	622	0		
	n71	678	101	10 (RB <sub>start</sub> = 0)	634.51	2.5		
DC_(n)71AA	71	668	10	10 (RB <sub>start</sub> = 0)	622	17.2		
	n71	678	101	10 (RB <sub>end</sub> = 51)	634.51	29.1		
NOTE 1: In accordance to BCS1, the NR uplink bandwidth is specified as in this table, but the corresponding NR downlink bandwidth is 5 MHz larger.								
NOTE 2: The transmitters powers shall be set to P <sub>UMAX</sub> , as defined in TS 38.101-1 [2], TS 38.101-2 [3], and TS 36.101 [5], with additional limits on configured maximum output power for the uplink according to subclause 6.2B.4.								

### 7.3B.2.0.2 Intra-band non-contiguous EN-DC

For intra-band non-contiguous EN-DC configurations, the reference sensitivity power level REFSENS is the minimum mean power applied to each one of the UE antenna ports at which the throughput for the carrier(s) of the E-UTRA and NR CGs shall meet or exceed the requirements for the specified E-UTRA and NR reference measurement channels.

For DC\_3A\_n3A intra-band non-contiguous EN-DC combination, only single switched UL is supported in rel.15, therefore, no MSD is specified and E-UTRA and NR single carrier requirements apply.

### 7.3B.2.0.3 Inter-band EN-DC within FR1

Reference sensitivity exceptions are specified for the condition when there is uplink transmission only in the aggressor band.

The reference sensitivity exceptions due to harmonic, harmonic mixing, cross band isolation and power class 2 or power class 3 EN-DC intermodulation interferences are applicable to the UL aggressor band configured with either one Tx antenna connector or two Tx antenna connectors with UL MIMO or Tx diversity operation.

#### 7.3B.2.0.3.1 Reference sensitivity exceptions due to UL harmonic interference for EN-DC in NR FR1

Sensitivity degradation is allowed for different combinations of UL configurations and DL channel bandwidths if a band if it is impacted by UL harmonic interference from another band part of the same EN-DC configuration. Reference sensitivity exceptions for the victim band (high) and uplink/downlink configurations due to UL harmonic from a PC3 aggressor UL band (low) for either single band uplink or PC3 or PC2 EN-DC are specified in Table 7.3B.2.0.3.1-1. For these exceptions, only the listed test points in Table 7.3B.2.0.3.1-1 need to be tested.



**Table 7.3B.2.0.3.1-1: Reference sensitivity exceptions (MSD) due to UL harmonic for EN-DC in NR FR1**

UL band	DL band	UL BW	SCS of UL band	UL RB Allocation	DL BW	MSD	UL/DL fc condition	UL/DL harmonic order
		(MHz)	(kHz)	L <sub>CRB</sub>	(MHz)	(dB)		
1	n77	5	15	25 (RBstart=0)	10	23.9	NOTE 2	UL2/DL1 direct-hit
1	n77	20	15	100 (RBstart=0)	100	13.8	NOTE 2	UL2/DL1 direct-hit
1	n77	5	15	25 (RBstart=0)	10	1.1	NOTE 6	UL2/DL1 near-miss
2	n77	5	15	25 (RBstart=0)	10	23.9	NOTE 2	UL2/DL1 direct-hit
2	n77	10	15	50 (RBstart=0)	100	13.8	NOTE 2	UL2/DL1 direct-hit
2	n77	5	15	25 (RBstart=0)	10	1.1	NOTE 6	UL2/DL1 near-miss
2	n78	5	15	25 (RBstart=0)	10	23.9	NOTE 2	UL2/DL1 direct-hit
2	n78	10	15	50 (RBstart=0)	100	13.8	NOTE 2	UL2/DL1 direct-hit
2	n78	5	15	25 (RBstart=0)	10	1.1	NOTE 6	UL2/DL1 near-miss
3	n77	5	15	25 (RBstart=0)	10	23.9	NOTE 2	UL2/DL1 direct-hit
3	n77	10	15	50 (RBstart=0)	100	13.8	NOTE 2	UL2/DL1 direct-hit
3	n77	5	15	25 (RBstart=0)	10	1.1	NOTE 6	UL2/DL1 near-miss
3	n78	5	15	25 (RBstart=0)	10	23.9	NOTE 2	UL2/DL1 direct-hit
3	n78	10	15	50 (RBstart=0)	100	13.8	NOTE 2	UL2/DL1 direct-hit
3	n78	5	15	25 (RBstart=0)	10	1.1	NOTE 6	UL2/DL1 near-miss
5	n77 <sup>8</sup>	5	15	16 (RBstart=0)	10	10.5	NOTE 4	UL4/DL1 direct-hit
5	n77 <sup>8</sup>	5	15	25 (RBstart=0)	100	1.4	NOTE 4	UL4/DL1 direct-hit
5	n77 <sup>8</sup>	5	15	10 (RBstart=0)	10	10.4	NOTE 5	UL5/DL1 direct-hit
5	n77 <sup>8</sup>	5	15	25 (RBstart=0)	100	0.7	NOTE 5	UL5/DL1 direct-hit
5	n78	5	15	16 (RBstart=0)	10	10.5	NOTE 4	UL4/DL1 direct-hit
5	n78	5	15	25 (RBstart=0)	100	1.4	NOTE 4	UL4/DL1 direct-hit
8	n41	5	15	8 (RBstart=0)	10	13	NOTE 3	UL3/DL1 direct-hit
8	n41	5	15	25 (RBstart=0)	100	3.5	NOTE 3	UL3/DL1 direct-hit
8	n77	5	15	16 (RBstart=0)	10	10.8	NOTE 4	UL4/DL1 direct-hit
8	n77	5	15	25 (RBstart=0)	100	1.4	NOTE 4	UL4/DL1 direct-hit
8	n78	5	15	16 (RBstart=0)	10	10.8	NOTE 4	UL4/DL1 direct-hit
8	n78	5	15	25 (RBstart=0)	100	1.4	NOTE 4	UL4/DL1 direct-hit
8	n79	5	15	10 (RBstart=0)	10	12.0	NOTE 5	UL5/DL1 direct-hit
8	n79	5	15	25 (RBstart=0)	100	4.4	NOTE 5	UL5/DL1 direct-hit
12	n66	5	15	8 (RBstart=0)	5	10	NOTE 3	UL3/DL1 direct-hit

12	n66	5	15	20 (RBstart=0)	40	2.4	NOTE 3	UL3/DL1 direct-hit
12	n77	5	15	10 (RBstart=0)	10	10.4	NOTE 5	UL5/DL1 direct-hit
12	n77	5	15	20 (RBstart=0)	100	0.7	NOTE 5	UL5/DL1 direct-hit
12	n78	5	15	10 (RBstart=0)	10	10.4	NOTE 5	UL5/DL1 direct-hit
12	n78	5	15	20 (RBstart=0)	100	0.7	NOTE 5	UL5/DL1 direct-hit
13	n77	5	15	10 (RBstart=0)	10	10.4	NOTE 5	UL5/DL1 direct-hit
13	n77	5	15	20 (RBstart=0)	100	0.7	NOTE 5	UL5/DL1 direct-hit
14	n77	5	15	10 (RBstart=0)	10	10.4	NOTE 5	UL5/DL1 direct-hit
14	n77	5	15	15 (RBstart=0)	100	0.7	NOTE 5	UL5/DL1 direct-hit
18	n77	5	15	10 (RBstart=0)	10	10.4	NOTE 5	UL5/DL1 direct-hit
18	n77	5	15	25 (RBstart=0)	100	0.7	NOTE 5	UL5/DL1 direct-hit
18	n78	5	15	10 (RBstart=0)	10	10.4	NOTE 5	UL5/DL1 direct-hit
18	n78	5	15	25 (RBstart=0)	100	0.7	NOTE 5	UL5/DL1 direct-hit
19	n77	5	15	10 (RBstart=0)	10	10.4	NOTE 5	UL5/DL1 direct-hit
19	n77	5	15	25 (RBstart=0)	100	0.7	NOTE 5	UL5/DL1 direct-hit
19	n77	5	15	10 (RBstart=0)	10	10.5	NOTE 4	UL4/DL1 direct-hit
19	n77	5	15	25 (RBstart=0)	100	1.4	NOTE 4	UL4/DL1 direct-hit
19	n78	5	15	10 (RBstart=0)	10	10.5	NOTE 4	UL4/DL1 direct-hit
19	n78	5	15	25 (RBstart=0)	100	1.4	NOTE 4	UL4/DL1 direct-hit
20	n77	5	15	16 (RBstart=0)	10	10.8	NOTE 4	UL4/DL1 direct-hit
20	n77	5	15	25 (RBstart=0)	100	1.4	NOTE 4	UL4/DL1 direct-hit
20	n78	5	15	16 (RBstart=0)	10	10.8	NOTE 4	UL4/DL1 direct-hit
20	n78	5	15	25 (RBstart=0)	100	1.4	NOTE 4	UL4/DL1 direct-hit
26	n41	5	15	16 (RBstart=0)	10	10.3	NOTE 3	UL3/DL1 direct-hit
26	n41	5	15	25 (RBstart=0)	100	2.7	NOTE 3	UL3/DL1 direct-hit
26	n77	5	15	16 (RBstart=0)	10	10.8	NOTE 4	UL4/DL1 direct-hit
26	n77	5	15	25 (RBstart=0)	100	1.0	NOTE 4	UL4/DL1 direct-hit
26	n78	5	15	16 (RBstart=0)	10	10.8	NOTE 4	UL4/DL1 direct-hit
26	n78	5	15	25 (RBstart=0)	100	1.0	NOTE 4	UL4/DL1 direct-hit
n28	1	5	15	8 (RBstart=0)	5	10.2	NOTE 3	UL3/DL1 direct-hit
n28	1	5	15	25 (RBstart=0)	20	5.3	NOTE 3	UL3/DL1 direct-hit
n28	21 <sup>12</sup>	NA	NA	NA	NA	NA	NOTE 2	UL2/DL1 direct-hit
n28	21 <sup>12</sup>	NA	NA	NA	NA	NA	NOTE 2	UL2/DL1 direct-hit

28	n51	5	15	12 (RBstart=0)	5	27.8	NOTE 2	UL2/DL1 direct-hit
28	n51	5	15	25 (RBstart=0)	5	1.9	NOTE 6	UL2/DL1 near-miss
28	n77	5	15	10 (RBstart=0)	10	10.4	NOTE 5	UL5/DL1 direct-hit
28	n77	5	15	25 (RBstart=0)	100	0.7	NOTE 5	UL5/DL1 direct-hit
28	n78	5	15	10 (RBstart=0)	10	10.4	NOTE 5	UL5/DL1 direct-hit
28	n78	5	15	25 (RBstart=0)	100	0.7	NOTE 5	UL5/DL1 direct-hit
66	n77	5	15	25 (RBstart=0)	10	23.9	NOTE 2	UL2/DL1 direct-hit
66	n77	20	15	100 (RBstart=0)	100	13.8	NOTE 2	UL2/DL1 direct-hit
66	n77	5	15	25 (RBstart=0)	10	1.1	NOTE 6	UL2/DL1 near-miss
66	n78	5	15	25 (RBstart=0)	10	23.9	NOTE 2	UL2/DL1 direct-hit
66	n78	20	15	100 (RBstart=0)	100	13.8	NOTE 2	UL2/DL1 direct-hit
66	n78	5	15	25 (RBstart=0)	10	1.1	NOTE 6	UL2/DL1 near-miss
71	n29	5	15	25 (RBstart=0)	5	4.6	NOTE 3	UL3/DL1 direct-hit
71	n210	5	15	8 (RBstart=0)	5	1.7	NOTE 3	UL3/DL1 direct-hit
71	n29	5	15	25 (RBstart=0)	20	0.6	NOTE 3	UL3/DL1 direct-hit
71	n210	5	15	8 (RBstart=0)	20	0.6	NOTE 3	UL3/DL1 direct-hit
n71	29	5	15	25 (RBstart=0)	5	4.6	NOTE 3	UL3/DL1 direct-hit
n71	210	5	15	8 (RBstart=0)	5	1.7	NOTE 3	UL3/DL1 direct-hit
n71	29	5	15	25 (RBstart=0)	20	0.6	NOTE 3	UL3/DL1 direct-hit
n71	210	5	15	8 (RBstart=0)	20	0.6	NOTE 3	UL3/DL1 direct-hit
n71	7	5	15	8 (RBstart=0)	5	14.6	NOTE 4	UL4/DL1 direct-hit
n71	7	5	15	25 (RBstart=0)	20	9	NOTE 4	UL4/DL1 direct-hit

NOTE 1:	These requirements apply when there is at least one individual RE within the uplink transmission bandwidth of the aggressor (lower) band for which the 2 <sup>nd</sup> / 3 <sup>rd</sup> / 4 <sup>th</sup> / 5 <sup>th</sup> transmitter harmonic is within the downlink transmission bandwidth of a victim (higher) band.
NOTE 2:	The requirements should be verified for UL EARFCN or NR ARFCN of the aggressor (lower) band (superscript LB) such that $f_{UL}^{LB} = \lfloor f_{DL}^{HB} / 0.2 \rfloor \cdot 0.1$ in MHz and $F_{UL\_low}^{LB} + BW_{Channel}^{LB} / 2 \leq f_{UL}^{LB} \leq F_{UL\_high}^{LB} - BW_{Channel}^{LB} / 2$ with carrier frequency in the victim (higher) band in MHz and the channel bandwidth configured in the lower band.
NOTE 3:	The requirements should be verified for UL EARFCN or NR ARFCN of the aggressor (lower) band (superscript LB) such that $f_{UL}^{LB} = \lfloor f_{DL}^{HB} / 0.3 \rfloor \cdot 0.1$ in MHz and $F_{UL\_low}^{LB} + BW_{Channel}^{LB} / 2 \leq f_{UL}^{LB} \leq F_{UL\_high}^{LB} - BW_{Channel}^{LB} / 2$ with the carrier frequency in the victim (higher) band in MHz and the channel bandwidth configured in the low band.
NOTE 4:	The requirements should be verified for UL EARFCN or NR ARFCN of the aggressor (lower) band (superscript LB) such that $f_{UL}^{LB} = \lfloor f_{DL}^{HB} / 0.4 \rfloor \cdot 0.1$ in MHz and $F_{UL\_low}^{LB} + BW_{Channel}^{LB} / 2 \leq f_{UL}^{LB} \leq F_{UL\_high}^{LB} - BW_{Channel}^{LB} / 2$ with $f_{DL}^{HB}$ carrier frequency in the victim (higher) band in MHz and $BW_{Channel}^{LB}$ the channel bandwidth configured in the lower band.
NOTE 5:	The requirements should be verified for UL EARFCN or NR-ARFCN of the aggressor (lower) band (superscript LB) such that $f_{UL}^{LB} = \lfloor f_{DL}^{HB} / 0.5 \rfloor \cdot 0.1$ in MHz and $F_{UL\_low}^{LB} + BW_{Channel}^{LB} / 2 \leq f_{UL}^{LB} \leq F_{UL\_high}^{LB} - BW_{Channel}^{LB} / 2$ with $f_{DL}^{HB}$ carrier frequency in the victim (higher) band in MHz and $BW_{Channel}^{LB}$ the channel bandwidth configured in the lower band.
NOTE 6:	The requirements are only applicable to channel bandwidths no larger than 20 MHz and with a carrier frequency at $\pm (20 + BW_{Channel}^{HB} / 2)$ MHz offset from $2 \cdot f_{UL}^{LB}$ in the victim (higher band) with $F_{UL\_low}^{LB} + BW_{Channel}^{LB} / 2 \leq f_{UL}^{LB} \leq F_{UL\_high}^{LB} - BW_{Channel}^{LB} / 2$ , where $BW_{Channel}^{LB}$ and $BW_{Channel}^{HB}$ are the channel bandwidths configured in the aggressor (lower) and victim (higher) bands in MHz, respectively.
NOTE 7:	For these bandwidths, the minimum requirements are restricted to operation when carrier is configured as a downlink carrier part of CA configuration.
NOTE 8:	For a UE which supports this band combination only when the Band n77 frequency range restriction defined in NOTE 12 of Table 5.2-1 from TS 38.101-1 applies, the MSD test point(s) cannot be verified for the band combination and the test point(s) can be skipped.
NOTE 9:	These requirements apply when the lower edge frequency of the 5 MHz uplink channel in Band 71 is located at or below 668 MHz and the downlink channel in Band 2 is located with its upper edge at 1990 MHz.
NOTE 10:	These requirements apply when the lower edge frequency of the 10 MHz, 15 MHz, or 20 MHz uplink channel in Band 71 is located at or below 668 MHz and the downlink channel in Band 2 is located with its upper edge at 1990 MHz.
NOTE 11:	No requirements apply when there is at least one individual RE within the uplink transmission bandwidth of the low band for which the 2 <sup>nd</sup> transmitter harmonic is within the downlink transmission bandwidth of the high band. The reference sensitivity for all active downlink component carriers is only verified when this is not the case (the requirements specified in clause 7.3.1 from TS 36.101-1 apply unless otherwise specified).
NOTE 12:	The frequency range in band n28 is restricted for this band combination to 728 - 738 MHz for the UL. This band is subject to 2 <sup>nd</sup> harmonic fall in B21 also which MSD is not specified.

Table 7.3B.2.0.3.1-2: Void

**Table 7.3B.2.0.3.1-3: Reference sensitivity QPSK PREFSENS (EN-DC with n46)**

E-UTRA or NR Band / Channel bandwidth of the affected DL band / MSD												
UL band	DL band	5 MHz (dB)	10 MHz (dB)	15 MHz (dB)	20 MHz (dB)	25 MHz (dB)	40 MHz (dB)	50 MHz (dB)	60 MHz (dB)	80 MHz (dB)	90 MHz (dB)	100 MHz (dB)
n46	48 <sup>2,4</sup>	22.6	19.5	17.8	16.6							
NOTE 1: FFS NOTE 2: These requirements apply when there is at least one individual RE within the uplink transmission bandwidth of the aggressor (higher) band and when the frequency range of relative higher band's uplink channel bandwidth or uplink 1 <sup>st</sup> adjacent channel bandwidth is fully or partially overlapped with the downlink transmission bandwidth of a victim (lower) band. NOTE 3: FFS NOTE 4: The requirements should be verified for UL NR-ARFCN of the aggressor (high) band (superscript HB) such that $f_{UL}^{HB} = \lceil 15 * f_{DL}^{LB} \rceil 0.1$ in MHz and $F_{UL,low}^{HB} + BW_{Channel}^{HB}/2 \leq f_{UL}^{HB} \leq F_{UL,high}^{HB} - BW_{Channel}^{HB}/2$ with $f_{DL}^{LB}$ carrier frequency in the victim (lower) band in MHz and $BW_{Channel}^{HB}$ the channel bandwidth configured in the higher band.												

**Table 7.3B.2.0.3.1-4: Void**

**Table 7.3B.2.0.3.1-5: Uplink configuration for reference sensitivity exceptions due to receiver harmonic mixing for EN-DC pairing with n46**

E-UTRA or NR Band / SCS / Channel bandwidth of the affected DL band / UL RB allocation of the aggressor band													
UL band	DL band	SCS of UL band (kHz)	5 MHz (LCRB)	10 MHz (LCRB)	15 MHz (LCRB)	20 MHz (LCRB)	25 MHz (LCRB)	40 MHz (LCRB)	50 MHz (LCRB)	60 MHz (LCRB)	80 MHz (LCRB)	90 MHz (LCRB)	100 MHz (LCRB)
n46	48	15	12	25	36	50							

**7.3B.2.0.3.2 Reference sensitivity exceptions due to receiver harmonic mixing for EN-DC in NR FR1**

Sensitivity degradation is allowed for different combinations of UL configurations and DL channel bandwidths if a band is impacted by receiver harmonic mixing due to another band part of the same EN-DC configuration. Reference sensitivity exceptions for the victim band (low) and uplink/downlink configurations due to UL harmonic from a PC3 aggressor UL band (high) for either single band uplink or PC3 or PC2 EN-DC are specified in Table 7.3B.2.0.3.2-1.

Reference sensitivity exceptions and uplink/downlink configurations due to harmonic mixing from a PC2 aggressor UL for PC2 EN-DC are specified in Table 7.3B.2.3.2-1a.

For these exceptions, only the listed test points in Table 7.3B.2.3.2-1 and Table 7.3B.2.3.2-1a need to be tested.

**Table 7.3B.2.0.3.2-1: Reference sensitivity exceptions (MSD) due to receiver harmonic mixing for EN-DC in NR FR1**

UL band	DL band	UL BW	SCS of UL band	UL RB Allocation	DL BW	MSD	UL/DL fc condition	UL/DL harmonic order
		(MHz)	(kHz)	L <sub>CRB</sub>	(MHz)	(dB)		
2	n71	5	15	25 (RBstart=0)	5	26.8	NOTE 4	UL1/DL3
2	n71	20	15	50 (RBstart=0)	20	15.6	NOTE 4	UL1/DL3
n2	71	5	15	25 (RBstart=0)	5	26.8	NOTE 4	UL1/DL3
n2	71	20	15	50 (RBstart=0)	20	15.6	NOTE 4	UL1/DL3
n41	26	10	15	25 (RBstart=0)	5	24.3	NOTE 4	UL1/DL3
n41	26	15	15	75 (RBstart=0)	15	22.5	NOTE 4	UL1/DL3
n77	2	10	15	25 (RBstart=0)	5	6.1		
n77	2	20	15	100 (RBstart=0)	20	3.7		
n77	3	10	15	25 (RBstart=0)	5	5.7		
n77	3	20	15	100 (RBstart=0)	20	2.7		
n77	12	10	15	25 (RBstart=0)	5	31	NOTE 2	UL1/DL5
n77	12	10	15	50 (RBstart=0)	10	28	NOTE 2	UL1/DL5
n77	13	10	15	25 (RBstart=0)	5	31	NOTE 2	UL1/DL5
n77	13	10	15	50 (RBstart=0)	10	28	NOTE 2	UL1/DL5
n77	14	10	15	25 (RBstart=0)	5	31	NOTE 2	UL1/DL5
n77	14	10	15	50 (RBstart=0)	10	28	NOTE 2	UL1/DL5
n77	28	10	15	25 (RBstart=0)	5	28	NOTE 2	UL1/DL5
n77	28	20	15	100 (RBstart=0)	20	22	NOTE 2	UL1/DL5
n77	41	10	15	12 (RBstart=0)	5	10.4	NOTE 8	UL2/DL3
n77	41	10	15	50 (RBstart=0)	20	10.4	NOTE 8	UL2/DL3
n78	3	10	15	25 (RBstart=0)	5	5.7		
n78	3	20	15	100 (RBstart=0)	20	2.7		
n78	19	10	15	25 (RBstart=0)	5	7.2		
n78	19	15	15	75 (RBstart=0)	15	3.8		
n78	41	10	15	12 (RBstart=0)	5	10.4	NOTE 8	UL2/DL3
n78	41	20	15	50 (RBstart=0)	20	10.4	NOTE 8	UL2/DL3
n79	11	10	15	25 (RBstart=0)	5	39.3	NOTE 4	UL1/DL3
n79	11	15	15	75 (RBstart=0)	15	34.5	NOTE 4	UL1/DL3
n79	19	10	15	25 (RBstart=0)	5	29.5	NOTE 2	UL1/DL5
n79	19	15	15	75 (RBstart=0)	15	24.7	NOTE 2	UL1/DL5
n79	21	10	15	25 (RBstart=0)	5	39.3	NOTE 4	UL1/DL3
n79	21	15	15	75 (RBstart=0)	15	34.5	NOTE 4	UL1/DL3
n79	26	10	15	25 (RBstart=0)	5	27	NOTE 2	UL1/DL5
n79	26	15	15	75 (RBstart=0)	15	22.2	NOTE 2	UL1/DL5



NOTE 1: These requirements apply when there is at least one individual RE within the uplink transmission bandwidth of the aggressor (higher) band for which the mixing product due to harmonic of victim (lower) band LO with leakage of aggressor (higher) band is within the downlink transmission bandwidth of a victim (lower) band.

NOTE 2: The requirements should be verified for DL EARFCN of the victim (lower) band (superscript LB) such that  $f_{DL}^{LB} = \lfloor f_{UL}^{HB} / 0.5 \rfloor 0.1$  and  $F_{UL\_low}^{HB} + BW_{Channel}^{HB} / 2 \leq f_{UL}^{HB} \leq F_{UL\_high}^{HB} - BW_{Channel}^{HB} / 2$  with  $f_{DL}^{LB}$  the DL carrier frequency in the lower band and  $f_{UL}^{HB}$  the UL carrier frequency and  $BW_{Channel}^{HB}$  the channel bandwidth configured in the higher band, both in MHz.

NOTE 3: Void.

NOTE 4: The requirements should be verified for DL EARFCN or NR ARFCN of the victim (lower) band (superscript LB) such that  $f_{DL}^{LB} = \lfloor f_{UL}^{HB} / 0.3 \rfloor 0.1$  and  $F_{UL\_low}^{HB} + BW_{Channel}^{HB} / 2 \leq f_{UL}^{HB} \leq F_{UL\_high}^{HB} - BW_{Channel}^{HB} / 2$  with  $f_{DL}^{LB}$  the DL carrier frequency in the lower band and  $f_{UL}^{HB}$  the UL carrier frequency and  $BW_{Channel}^{HB}$  the channel bandwidth configured in the higher band, both in MHz.

NOTE 5: Void

NOTE 6: Void

NOTE 7: Void

NOTE 8: The requirements should be verified for DL EARFCN of the victim (lower) band (superscript LB) such that  $f_{DL}^{LB} = \lfloor f_{UL}^{HB} / 0.15 \rfloor 0.1$  and  $F_{UL\_low}^{HB} + BW_{Channel}^{HB} / 2 \leq f_{UL}^{HB} \leq F_{UL\_high}^{HB} - BW_{Channel}^{HB} / 2$  with  $f_{DL}^{LB}$  the DL carrier frequency in the lower band and  $f_{UL}^{HB}$  the UL carrier frequency and  $BW_{Channel}^{HB}$  the channel bandwidth configured in the higher band, both in MHz.

NOTE 9: No requirements apply for the case that there is at least one individual RE within the uplink transmission bandwidth of the relative higher band and when the frequency range of relative higher band's uplink channel bandwidth or uplink 1<sup>st</sup> adjacent channel bandwidth is fully or partially overlapped with the 3 times of the frequency range of the relative lower band's downlink channel bandwidth. The reference sensitivity is only verified when this is not the case.

NOTE 10: MSD test point can be chosen according to supported BW and lowest SCS supported by the UE.

NOTE 11: The MSD test points cannot be verified for the band combination in US due to the Band n77 frequency range restriction.

NOTE 12: The requirements should be verified for the lowest NR ARFCN of the affected DL (lower) band and for the highest NR ARFCN of the UL (higher) band

**Table 7.3B.2.0.3.2-1a: Reference sensitivity exceptions (MSD) due to receiver harmonic mixing for PC2 EN-DC in NR FR1**

UL band	DL band	UL BW	SCS of UL band	UL RB Allocation	DL BW	MSD	UL/DL fc condition	UL/DL harmonic order
		(MHz)	(kHz)	L <sub>CRB</sub>	(MHz)	(dB)		
n77	2	10	15	25 (RBstart=0)	5	9.1		
n77	2	20	15	100 (RBstart=0)	20	6.7		
n77	3	10	15	25 (RBstart=0)	5	8.1		
n77	3	20	15	100 (RBstart=0)	20	5.7		
n77	12	10	15	25 (RBstart=0)	5	34	NOTE 1	UL1/DL5
n77	12	10	15	50 (RBstart=0)	10	31	NOTE 1	UL1/DL5
n77	13	10	15	25 (RBstart=0)	5	34	NOTE 1	UL1/DL5
n77	13	10	15	50 (RBstart=0)	10	31	NOTE 1	UL1/DL5
n77	14	10	15	25 (RBstart=0)	5	34	NOTE 1	UL1/DL5
n77	14	10	15	50 (RBstart=0)	10	31	NOTE 1	UL1/DL5
n77	28	10	15	25 (RBstart=0)	5	32	NOTE 1	UL1/DL5
n77	28	20	15	100 (RBstart=0)	20	25	NOTE 1	UL1/DL5
n77	41	10	15	12 (RBstart=0)	5	19.4	NOTE 4	UL2/DL3
n77	41	20	15	50 (RBstart=0)	20	19.4	NOTE 4	UL2/DL3
n78	19	10	15	25 (RBstart=0)	5	9.8		
n78	19	15	15	75 (RBstart=0)	15	5.8		

n79	19	10	15	25 (RBstart=0)	5	32.5	NOTE 1	UL1/DL5
n79	19	15	15	75 (RBstart=0)	15	27.7	NOTE 1	UL1/DL5
n79	21	10	15	25 (RBstart=0)	5	42.3	NOTE 3	UL1/DL3
n79	21	15	15	75 (RBstart=0)	15	37.5	NOTE 3	UL1/DL3

NOTE 1: The requirements should be verified for DL EARFCN of the victim (lower) band (superscript LB) such that  $f_{DL}^{LB} = \lfloor f_{UL}^{HB} / 0.5 \rfloor 0.1$  and  $F_{UL\_low}^{HB} + BW_{Channel}^{HB} / 2 \leq f_{UL}^{HB} \leq F_{UL\_high}^{HB} - BW_{Channel}^{HB} / 2$  with  $f_{DL}^{LB}$  the DL carrier frequency in the lower band and  $f_{UL}^{HB}$  the UL carrier frequency and  $BW_{Channel}^{HB}$  the channel bandwidth configured in the higher band, both in MHz.

NOTE 2: Void.

NOTE 3: The requirements should be verified for DL EARFCN or NR ARFCN of the victim (lower) band (superscript LB) such that  $f_{DL}^{LB} = \lfloor f_{UL}^{HB} / 0.3 \rfloor 0.1$  and  $F_{UL\_low}^{HB} + BW_{Channel}^{HB} / 2 \leq f_{UL}^{HB} \leq F_{UL\_high}^{HB} - BW_{Channel}^{HB} / 2$  with  $f_{DL}^{LB}$  the DL carrier frequency in the lower band and  $f_{UL}^{HB}$  the UL carrier frequency and  $BW_{Channel}^{HB}$  the channel bandwidth in the higher band, both in MHz.

NOTE 4: The requirements should be verified for DL EARFCN of the victim (lower) band (superscript LB) such that  $f_{DL}^{LB} = \lfloor f_{UL}^{HB} / 0.15 \rfloor 0.1$  and  $F_{UL\_low}^{HB} + BW_{Channel}^{HB} / 2 \leq f_{UL}^{HB} \leq F_{UL\_high}^{HB} - BW_{Channel}^{HB} / 2$  with the DL carrier frequency in the lower band and  $f_{UL}^{HB}$  the UL carrier frequency and  $BW_{Channel}^{HB}$  the channel bandwidth in the higher band, both in MHz.

NOTE 5: Void.

**Table 7.3B.2.0.3.2-2: Void**

7.3B.2.0.3.3 Void

7.3B.2.0.3.4 Reference sensitivity exceptions due to cross band isolation for EN-DC in NR FR1

Sensitivity degradation is allowed for a band if it is impacted by UL of another band part of the same EN-DC configuration due to cross band isolation issues. Reference sensitivity exceptions for the victim band are specified only for the specific uplink and downlink test points specified in Table 7.3B.2.0.3.4-1 and Table 7.3B.2.0.3.4-1a.

**Table 7.3B.2.0.3.4-1: Reference sensitivity exceptions (MSD) due to cross band isolation for PC3 EN-DC in NR FR1**

UL band	DL band	UL F <sub>c</sub>	UL BW	SCS of UL band	UL RB Allocation	DL F <sub>c</sub>	DL BW	MSD	Cross-band Interference source
		(MHz)	(MHz)	(kHz)	LCRB	(MHz)	(MHz)	(dB)	

n1	3	1922.5	5	15	25 (RB <sub>START</sub> =0)	1877.5	5	3	>ACLR2
n1	3	1945	50	15	128 (RB <sub>START</sub> =0)	1877.5	5	19.7	ACLR1
1	n3	1930	20	15	100 (RB <sub>START</sub> =0)	1877.5	5	[7.9]	>ACLR2
1	n3	1922.5	5	15	25 (RB <sub>START</sub> =0)	1877.5	5	3	>ACLR2
1	n40	1970	20	15	100 (RB <sub>START</sub> =0)	2302.5	5	6.6	>ACLR2
1	n41	1970	20	15	100 (RB <sub>START</sub> =0)	2501	10	6.1	>ACLR2
3	n41	1775	20	15	50 (RB <sub>START</sub> =50)	2501	10	0.7	>ACLR2
3	n51	1720	20	15	50 (RB <sub>START</sub> =0)	1429.5	5	6.4	>ACLR2
3	n51	1712.5	5	15	25 (RB <sub>START</sub> =0)	1429.5	5	6.4	>ACLR2
n5	28	834	20	15	20 (RB <sub>START</sub> =0)	800.5	5	17.5	ACLR2
30	n66	2310	10	15	25 (RB <sub>START</sub> =0)	2197.5	5	8.3	>ACLR2
39	n41	1910	20	15	100 (RB <sub>START</sub> =0)	2501	10	[3.3]	>ACLR2
n40	1	2350	100	30	270 (RB <sub>START</sub> =0)	2167.5	5	[21.9]	ACLR2
n41	1	2546	100	30	270 (RB <sub>START</sub> =0)	2167.5	5	9.1	>ACLR2
n41	2	2546	100	30	270 (RB <sub>START</sub> =0)	1987.5	5	0.6	>ACLR2
n41	3	2546	100	30	270 (RB <sub>START</sub> =0)	1877.5	5	0.6	>ACLR2
n41	25	2546	100	30	270 (RB <sub>START</sub> =0)	1992.5	5	0.6	>ACLR2
n41	39	2546	100	30	270 (RB <sub>START</sub> =3)	1917.5	5	1.6	>ACLR2
n41	40	2546	100	30	270 (RB <sub>START</sub> =0)	2397.5	5	31.4	ACLR2
n41	66 <sup>1</sup>	2546	100	30	270 (RB <sub>START</sub> =0)	2197.5	5	3.5	>ACLR2
41	n77	2680	20	15	100 (RB <sub>START</sub> =0)	3305	10	8.3	>ACLR2
41	n78	2680	20	15	100 (RB <sub>START</sub> =0)	3305	10	8.3	>ACLR2
n46	48	5190	80	30	216 (RB <sub>START</sub> =0)	3697.5	5	13.3	>ACLR2
48	n46	3690	20	15	100 (RB <sub>START</sub> =0)	5160	20	7	>ACLR2
n77	41 <sup>1</sup>	3350	100	30	270 (RB <sub>START</sub> =0)	2687.5	5	4.5	>ACLR2
n78	7 <sup>1</sup>	3350	100	30	270 (RB <sub>START</sub> =0)	2687.5	5	4.5	>ACLR2
n78	38	3350	100	30	270 (RB <sub>START</sub> =0)	2617.5	5	3.3	>ACLR2
n78	41 <sup>1</sup>	3350	100	30	270 (RB <sub>START</sub> =0)	2687.5	5	4.5	>ACLR2
n78	46	3750	100	30	270 (RB <sub>START</sub> =3)	5160	20	13.5	>ACLR2
n79	42 <sup>6</sup>	4550	100	30	270 (RB <sub>START</sub> =0)	3597.5	5	2.6	>ACLR2

NOTE 1: Applicable only when harmonic mixing MSD for this combination is not applied.

NOTE 2: The B41 requirements are modified by -0.5dB when carrier frequency of the assigned E-UTRA channel bandwidth is within 2515 – 2690 MHz.

NOTE 3: Void.

NOTE 4: The NR DL band should be configured using the lowest SCS that is compatible with the specified DL CBW.

NOTE 5: Void.

NOTE 6: The requirements only apply for UEs supporting inter-band DC\_42\_n79 ENDC with simultaneous Rx/Tx capability. Simultaneous Rx/Tx capability does not apply for UEs supporting band 42 with a n77 implementation only. These restrictions are applicable to related higher order configurations.

NOTE 7: The MSD exceptions are applicable to the case that interference of UL band 3<sup>rd</sup> order IMD product falls into the affected DL channels.

**Table 7.3B.2.0.3.4-1a: Reference sensitivity exceptions (MSD) due to cross band isolation and uplink/downlink configurations for PC2 EN-DC in NR FR1**

UL band	DL band	UL F <sub>c</sub>	UL BW	SCS of UL band	UL RB Allocation	DL F <sub>c</sub>	DL BW	MSD	Cross-band Interference source
		(MHz)	(MHz)	(kHz)	LCRB	(MHz)	(MHz)	(dB)	

3	n41	1775	20	15	50 (RBstart=50)	2501	10	0.7	>ACLR2
n41	1	2546	100	30	270 (RBstart=0)	2167.5	5	12.4	>ACLR2
n41	2	2546	100	30	270 (RBstart=0)	1987.5	5	1.6	>ACLR2
n41	3	2546	100	30	270 (RBstart=0)	1877.5	5	2.3	>ACLR2
n77	2	3350	100	30	270 (RBstart=0)	1987.5	5	1.0	>ACLR2
n77	41 <sup>1</sup>	3350	100	30	270 (RBstart=0)	2687.5	5	6.5	>ACLR2
n77	66	3350	100	30	270 (RBstart=0)	2197.5	5	1.0	>ACLR2

NOTE 1: Applicable only when harmonic mixing MSD for this combination is not applied.

**Table 7.3B.2.0.3.4-2: Void**

7.3B.2.0.3.5 MSD for intermodulation interference due to dual uplink operation for EN-DC in NR FR1

7.3B.2.0.3.5.0 General

For EN-DC configurations in NR FR1 the UE may indicate capability of not supporting simultaneous dual uplink operation due to possible intermodulation interference overlapping in frequency to its own primary downlink channel bandwidth if

- the intermodulation order is 2;
- the intermodulation order is 3 when both operating bands are between 450 MHz – 960 MHz or between 1427 MHz – 2690 MHz

In the case for EN-DC configurations in NR FR1 for which the intermodulation products caused by dual uplink operation do not interfere with its own primary downlink channel bandwidth as defined in Annex M the UE is mandated to operate in dual and triple uplink mode.

For EN-DC configurations in NR FR1 with uplink and downlink assigned to E-UTRA and NR FR1 bands given in Table 7.3B.2.0.3.5.1-1, Table 7.3B.2.0.3.5.1-1a, Table 7.3B.2.0.3.5.2-0 and Table 7.3B.2.0.3.5.2-1 the reference sensitivity is defined only for the specific uplink and downlink test points specified in Table 7.3B.2.0.3.5.1-1, Table 7.3B.2.0.3.5.1-1a, Table 7.3B.2.0.3.5.2-0 and Table 7.3B.2.0.3.5.2-1. For these test points the reference sensitivity levels specified in clause 7.3.1 in TS 36.101 [5] and 7.3.2 of TS 38.101-1 [2] for the corresponding channel bandwidths or in clause 7.3.1 of TS 36.101 [5] are relaxed by the amount of the parameter MSD given in Table 7.3B.2.0.3.5.1-1, Table 7.3B.2.0.3.5.1-1a, Table 7.3B.2.0.3.5.2-0 and Table 7.3B.2.0.3.5.2-1.

The throughput on each of the CGs shall be  $\geq 95\%$  of the maximum throughput of the respective reference measurement channels as specified in Annex A of TS 38.101-1 [2] and Annex A of TS 36.101 [5], with parameters specified in Table 7.3B.2.0.3.5.1-1, Table 7.3B.2.0.3.5.1-1a, Table 7.3B.2.0.3.5.2-0 and Table 7.3B.2.0.3.5.2-1 with dual UL transmissions overlapping in time unless otherwise stated.

7.3B.2.0.3.5.1 MSD test points for intermodulation interference due to dual uplink operation for PC3 EN-DC in NR FR1 involving two bands

**Table 7.3B.2.0.3.5.1-1: MSD test points for PCell due to dual uplink operation for PC3 EN-DC in NR FR1 (two bands)**

NR or E-UTRA Band / Channel bandwidth / N <sub>RB</sub> / MSD							
EN-DC Configuration	EUTRA or NR band	UL F <sub>c</sub> (MHz)	UL/DL BW (MHz)	UL L <sub>CRB</sub>	DL F <sub>c</sub> (MHz)	MSD (dB)	IMD order
DC_1_n3	1	1950	5	25	2140	23	IMD3
	n3	1760	5	25	1855	N/A	N/A
DC_1A_n8A	1	1965	5	25	2155	6.0	IMD4
	n8	887.5	5	25	932.5	N/A	N/A
DC_1A_n77A DC_1A_SUL_n77A-n84A DC_1A_n77(2A)	1	1950	5	25	2140	29.8	IMD2 <sup>3</sup>
	n77, n78	4090	10	50	4090	N/A	N/A
DC_1A_n77A DC_1A-SUL_n77A-n84A DC_1A_n77(2A) DC_1A_n78A, DC_1A_SUL_n78A-n84A	1	1950	5	25	2140	8.0	IMD4 <sup>3</sup>
	n77, n78	3710	10	50	3710	N/A	N/A
DC_2A_n66A	2	1855	5	25	1935	20	IMD3
	n66	1775	5	25	2175	N/A	N/A
	2	1883.3	5	25	1963.3	N/A	N/A
	n66	1750	5	25	2150	4	IMD5
DC_2A_n77A DC_2A_n77(2A) DC_2A-2A_n77A DC_2A-2A_n77(2A)	2	1855	5	25	1935	26	IMD2
	n77	3790	10	50	3790	N/A	N/A
	2	1900	5	25	1980	8.0	IMD4
	n77	3720	10	50	3720	N/A	N/A
	2	1885	5	25	1965	5	IMD5
	n77	3810	10	50	3810	N/A	N/A
DC_2A_n78A	2	1855	5	25	1935	26	IMD2 <sup>3</sup>
	n78	3790	10	50	3790	N/A	N/A
	2	1885	5	25	1965	8.0	IMD4 <sup>3</sup>
	n78	3690	10	50	3690	N/A	N/A
DC_3_n1	3	1760	5	25	1855	N/A	N/A
	n1	1950	5	25	2140	23	IMD3
DC_3_n5	3	1771	10	50	1866	4	IMD4
	n5	838	5	25	883	N/A	N/A
	3	1721	10	50	1816	N/A	N/A
	n5	838	5	25	883	24	IMD2 <sup>3</sup>
DC_3A_n7A DC_3C_n7A	3	1730	5	25	1825	N/A	N/A
	n7	2535	10	50	2655	10.2 <sup>5</sup>	IMD4
DC_3A_n8A	n8	900	5	25	945	8	IMD4 <sup>3</sup>
	3	1755	10	50	1850	N/A	N/A
	n8	897.5	5	25	942.5	N/A	N/A
	3	1747.5	10	50	1842.5	6.4	IMD5
DC_3A_n41A DC_3C_n41A	3	1740	5	25	1835	8.2	IMD4
	n41	2657.5	10	50	2657.5	N/A	IMD4
DC_3A_SUL_n41A-n80A, DC_3C_SUL_n41A-n80A	3	1740	5	25	1835	8.2	IMD4
	n41	2657.5	10	52	2657.5	N/A	N/A
DC_3A_n77A DC_3A_n77(2A) DC_3A_SUL_n77A-n80A DC_3A_n78A DC_3A-SUL_n78A-n80A, DC_3C_n78A	3	1740	5	25	1835	26	IMD2 <sup>3</sup>
	n77, n78	3575	10	50	3575	N/A	N/A

DC_3A_n77A DC_3A_n77(2A) DC_3A_SUL_n77A- n80A, DC_3A_n78A DC_3A-SUL_n78A- n80A, DC_3C_n78A	3	1765	5	25	1860	8.0	IMD4 <sup>3</sup>
	n77, n78	3435	10	50	3435	N/A	
DC_5A_n66A	5	838	5	25	883	30	IMD2 <sup>3</sup>
	n66	1721	5	25	2121	N/A	N/A
DC_5A_n78A	5	844	5	25	889	8.3	IMD4
	n78	3421	10	50	3421	N/A	N/A
DC_5A_n77A <sup>8</sup> DC_5A_n77(2A) <sup>8</sup>	5	844	5	25	889	8.3	IMD4
	n77	3421	10	50	3421	N/A	N/A
	5	826.5	5	25	871.5	5.5	IMD5
	n77	4177.5	10	50	4177.5	N/A	N/A
DC_7_n3	7	2535	10	50	2655	13	IMD4
	n3	1730	5	25	1825	N/A	N/A
DC_7_n5	7	2547	10	50	2667	N/A	N/A
	n5	834	5	25	879	12	IMD3 <sup>3</sup>
DC_7A_n66A 4DC_7A-7A_n66A DC_7C_n66A	7	2535	10	50	2655	15	IMD4
	n66	1730	5	25	2130	N/A	N/A
DC_7A_n77A	7	2540	5	25	2660	7.1	IMD4
	n77	3870	10	50	3870	N/A	N/A
DC_8A_n1A	8	887.5	5	25	932.5	N/A	N/A
	n1	1965	5	25	2155	6	IMD4
DC_8A_n3A	8	900	5	25	945	8	IMD4 <sup>3</sup>
	n3	1755	10	50	1850	N/A	N/A
	8	897.5	5	25	942.5	N/A	N/A
DC_8A_n20A	n3	1747.5	10	50	1842.5	6.4	IMD5
	n20	849.5	5	25	808.5	25	IMD3 <sup>3</sup>
	8	890.5	5	25	935.5	N/A	N/A
	n20	847.5	5	25	806.5	N/A	N/A
DC_8A_n41A	8	892.5	5	25	937.5	25	IMD3 <sup>3</sup>
	8	882.5	5	25	927.5	12.1	IMD3 <sup>3</sup>
	n41	2685	10	50	2685	N/A	N/A
DC_8A_SUL_n41A- n81A	8	882.5	5	25	927.5	12.1	IMD3 <sup>3</sup>
	n41	2685	10	52	2685	N/A	N/A
DC_8A_n77A DC_8A_n78A DC_8A-n79C, DC_8A-SUL_n78A- n81A	8	897.5	5	25	942.5	8.3	IMD4
	n77, n78	3635	10	50	3635	N/A	H4
DC_12A_n77A DC_12A_n77(2A)	12	702	5	20	732	5.5	IMD5
	n77	3540	10	50	3540	N/A	N/A
DC_12_n78	12	710	5	25	740	5.5	IMD5
	n78	3580	10	50	3580	N/A	N/A
DC_13A_n77A	13	784.5	5	20	753.5	5.5	IMD5
	n77	3891.5	10	50	3891.5	N/A	N/A
DC_14A_n77A DC_14A_n77(2A)	14	795.5	5	15	765.5	5.5	IMD5
	n77	3947.5	10	50	3947.5	N/A	N/A
DC_20A_n3A	20	840	5	25	799	N/A	N/A
	n3	1775	5	25	1870	4	IMD4
	20	847	5	25	806	9	IMD4
DC_8A_n79A DC_8A-SUL_n79A- n81A	n3	1735	5	25	1830	N/A	N/A
	8	897.5	5	25	942.5	4.8	IMD5
DC_8A-SUL_n79A- n81A	n79	4532.5	40	216	4532.5	N/A	N/A
	8	827.5	5	25	872.5	8.4	IMD4 <sup>10</sup>
DC_18A_n77A <sup>10</sup>	n77	3355	10	50	3355	N/A	N/A
	18	817.5	5	25	862.5	4.5	IMD5 <sup>10</sup>
	n77	4130	10	50	4130	N/A	N/A
DC_18A_n78A	18	827.5	5	25	872.5	8.4	IMD4 <sup>11</sup>

	n78	3355	10	50	3355	N/A	N/A
DC_12A_n77A	12	702	5	20	732	5.5	IMD5
	n77	3540	10	50	3540	N/A	N/A
DC_19A_n78A	19	836.5	5	25	881.5	13.6	IMD4
	n78	3391	10	50	3391	N/A	N/A
DC_20_n7	20	851	5	25	810	12	IMD3 <sup>3</sup>
	n7	2512	10	50	2632	N/A	N/A
DC_20A_n8A	20	849.5	5	25	808.5	21	IMD3
	n8	892.5	5	25	937.5	21	IMD3
DC_20A_n77A DC_20A_n78A, DC_20A-SUL_n78A- n82A	20	850	5	25	809	11	IMD4
	n77, n78	3359	10	50	3359	N/A	N/A
DC_20A_n77A	20	840	5	25	799	6.5	IMD5 <sup>4</sup>
	n77	4159	10	50	4159	N/A	N/A
DC_21A_n28A <sup>7</sup>	21	1450.4	5	25	1498.4	2.5	IMD5
	n28	735.5	5	25	790.5	N/A	N/A
DC_21A_n79A	21	1457.5	5	25	1505.5	18.4	IMD3
	n79	4420.5	40	216	4420.5	N/A	N/A
DC_26A_n41A	26	839	5	25	884	15.6	IMD3
	n41	2562	10	50	2562	N/A	N/A
DC_28A_n51A	28	742.3	5	25	797.3	5	IMD 4
	n51	1429.5	5	25	1429.5	N/A	N/A
DC_25A_n77A DC_25A-25A_n77A	25	1855	5	25	1935	26	IMD2
	n77	3790	10	50	3790	N/A	N/A
	25	1900	5	25	1980	8	IMD4
	n77	3720	10	50	3720	N/A	N/A
	25	1885	5	25	1965	5	IMD5
DC_26A_n77A, DC_26A_n78A	n77	3810	10	50	3810	N/A	N/A
	26	836.5	5	25	881.5	11.1	IMD4
DC_28A_n77A, DC_28A_n78A, DC_28A-SUL_n78A- n83A	n77, n78	3391	10	50	3391	N/A	N/A
	28	705.5	5	25	760.5	5.5	IMD5
DC_30A_n77A DC_30A_n77(2A)	n77, n78	3582.5	10	50	3582.5	N/A	N/A
	30	2310	5	25	2355	8.0	IMD4
DC_48A_n66A	n77	3487.5	10	50	3487.5	N/A	N/A
	48	3630	20	100	3630	N/A	N/A
DC_66A_n2A	n66	1715	5	25	2115	4	IMD5
	66	1775	5	25	2175	N/A	N/A
	n2	1855	5	25	1935	20	IMD3
	66	1750	5	25	2150	4	IMD5
DC_66A_n5A	n2	1883.3	5	25	1963.3	N/A	N/A
	n5	838	5	25	883	30	IMD2 <sup>3</sup>
DC_66A_n25A	66	1721	5	25	2121	N/A	N/A
	66	1775	5	25	2175	N/A	N/A
	n25	1855	5	25	1935	20	IMD3
	66	1712.5	5	25	2112.5	23	IMD3
	n25	1912.5	5	25	1992.5	N/A	N/A
	66	1750	5	25	2150	4	IMD5
DC_66A_n71A	n25	1883.3	5	25	1963.3	N/A	N/A
	66	1750	5	25	2150	5	IMD4
DC_66A_n77A DC_66A_n77(2A) DC_66A-66A_n77A DC_66A-66A_n77(2A) DC_66A-66A- 66A_n77A	n71	675	5	25	629	N/A	N/A
	66	1775	5	25	2175	31.0	IMD2
	n77	3950	10	50	3950	N/A	N/A
	66	1760	5	25	2160	5.0	IMD5
	n77	3720	10	50	3720	N/A	N/A
DC_66A_n78A	66	1730	5	25	2130	5.0	IMD5
	n78	3660	5	50	3660	N/A	N/A
DC_71A_n66A	71	675	5	25	629	N/A	N/A
	n66	1750	5	25	2150	5	IMD4



NOTE 1: E-UTRA carrier shall be set to min(+20 dBm, P<sub>CMAX\_L\_E-UTRA,c</sub>) and NR carrier shall be set to min(+20 dBm, P<sub>CMAX\_L\_f,c,NR</sub>) as defined in clause 6.2B.4.1.3.

NOTE 2: RB<sub>START</sub> = 0

NOTE 3: This band is subject to IMD5 also which MSD is not specified.

NOTE 4: Void

NOTE 5: Void.

NOTE 6: For NR band, UL/DL BW and UL L<sub>CRB</sub> can be adjusted according to the supported BW and lowest SCS supported by the UE.

NOTE 7: The frequency range in band n28 is restricted for this band combination to 728 - 738 MHz for the UL and 783 - 793 MHz for the DL. This band is subject to IMD2, IMD4 and IMD5 fall in n28 also which MSD is not specified. In addition, this band is subject to IMD4 fall in B21 also which MSD is not specified.

NOTE 8: For a UE which supports this band combination only when the Band n77 frequency range restriction defined in NOTE 12 of Table 5.2-1 from TS 38.101-1 applies, the MSD test point(s) cannot be verified for the band combination and the test point(s) can be skipped.

NOTE 9: Reserved.

NOTE 10: For a UE which supports this band combination only when the Band n77 frequency range restriction of 3400 - 4100 MHz in Japan applies, the MSD test point(s) cannot be verified for the band combination and the test point(s) can be skipped.

NOTE 11: For a UE which supports this band combination only when the Band n78 frequency range restriction of 3400 - 3800 MHz in Japan applies, the MSD test point(s) cannot be verified for the band combination and the test point(s) can be skipped.

**Table 7.3B.2.0.3.5.1-1a: MSD test points for PCell due to dual uplink operation for PC2 EN-DC in NR FR1 (two bands)**

NR or E-UTRA Band / Channel bandwidth / N <sub>RB</sub> / MSD							
EN-DC Configuration	EUTRA or NR band	UL F <sub>c</sub> (MHz)	UL/DL BW (MHz)	UL L <sub>CRB</sub>	DL F <sub>c</sub> (MHz)	MSD (dB)	IMD order
DC_1A_n77A	1	1950	5	25	2140	35.8	IMD2 <sup>1</sup>
	n77	4090	10	50	4090	N/A	N/A
	1	1950	5	25	2140	17.8	IMD4 <sup>1</sup>
	n77	3710	10	50	3710	N/A	N/A
DC_1A_n78A	1	1950	5	25	2140	17.8	IMD4
	n78	3710	10	50	3710	N/A	N/A
DC_3A_n41A	3	1740	5	25	1835	18.4	IMD4
	n41	2657.5	10	50	2657.5	N/A	N/A
DC_3A_n78A	3	1740	5	25	1835	31.9	IMD2
	n78	3575	10	50	3575	N/A	N/A
	3	1765	5	25	1860	18.5	IMD4
	n78	3435	10	50	3435	N/A	N/A
DC_2A_n77A DC_2A-2A_n77A DC_2A_n77C DC_2A-2A_n77C	2	1855	5	25	1935	32.10	IMD2
	n77	3790	10	50	3790	N/A	N/A
	2	1900	5	25	1980	19.10	IMD4 <sup>1</sup>
	n77	3720	10	50	3720	N/A	N/A
DC_5A_n77A <sup>3</sup> DC_5A_n77C <sup>3</sup>	5	844	5	25	889	18.60	IMD4 <sup>1</sup>
	n77	3421	10	50	3421	N/A	N/A
DC_12A_n77A	12	702	5	20	732	11.7	IMD5
	n77	3540	10	50	3540	N/A	N/A
DC_13A_n77A DC_13A_n77C	13	782	5	20	751	15.37	IMD5
	n77	3879	10	50	3879	N/A	N/A
DC_14A_n77A	14	795.5	5	15	765.5	11.7	IMD5
	n77	3947.5	10	50	3947.5	N/A	N/A
DC_18A_n77A <sup>5</sup>	18	N/A	N/A	N/A	N/A	N/A	IMD4 IMD5
	n77	N/A	N/A	N/A	N/A	N/A	N/A
DC_19A_n78A	19	836.5	5	25	881.5	25.3	IMD4
	n78	3391	10	50	3391	N/A	N/A
DC_21A_n79A	21	1457.5	5	25	1505.5	33.4	IMD3
	n79	4420.5	10	50	4420.5	N/A	N/A
DC_28A_n77A	28	705.5	5	25	760.5	19.2	IMD5

NR or E-UTRA Band / Channel bandwidth / N <sub>RB</sub> / MSD							
EN-DC Configuration	EUTRA or NR band	UL F <sub>c</sub> (MHz)	UL/DL BW (MHz)	UL L <sub>CRB</sub>	DL F <sub>c</sub> (MHz)	MSD (dB)	IMD order
	n77	3582.5	10	50	3582.5	N/A	N/A
DC_30A_n77A	30	2310	5	25	2355	17.6	IMD4
	n77	3487.5	10	50	3487.5	N/A	N/A
DC_66A_n77A DC_66A-66A_n77A DC_66A-66A-66A_n77A DC_66A_n77C DC_66A-66A_n77C DC_66A-66A-66A_n77C	66	1775	5	25	2175	34.33	IMD2
	n77	3950	10	50	3950	N/A	N/A
	66	1760	5	25	2160	11.27	IMD5
	n77	3720	10	50	3720	N/A	N/A
NOTE 1: This band is subject to IMD5 also which MSD is not specified.							
NOTE 2: Void.							
NOTE 3: For a UE which supports this band combination only when the Band n77 frequency range restriction defined in NOTE 12 of Table 5.2-1 from TS 38.101-1 applies, the MSD test point(s) cannot be verified for the band combination and the test point(s) can be skipped.							
NOTE 4: E-UTRA carrier shall be set to min(+23 dBm, P <sub>CMAX_L,E-UTRA,c</sub> ) and NR carrier shall be set to min(+23 dBm, P <sub>CMAX_L,f,c,NR</sub> ) as defined in clause 6.2B.4.1.3.							
NOTE 5: There is no IMD4/5 products in band n18 downlink for n77 operating in 3520 – 3560 MHz, 3700 – 3800MHz and 4000 - 4100MHz frequency range.							

7.3B.2.0.3.5.2 MSD test points for intermodulation interference due to dual uplink operation for EN-DC in NR FR1 involving three bands

**Table 7.3B.2.0.3.5.2-0: MSD test points for PCell due to dual uplink operation for EN-DC in NR FR1 (three bands)**

NR or E-UTRA Band / Channel bandwidth / N <sub>RB</sub> / MSD							
EN-DC Configuration	EUTRA/NR band	UL F <sub>c</sub> (MHz)	UL/DL BW (MHz)	UL L <sub>CRB</sub>	DL F <sub>c</sub> (MHz)	MSD (dB)	IMD order
DC_66A_(n)71AA	66	1750	5	25	2150	5	IMD4
	n71	678	10	10 (RB <sub>start</sub> =0)	632	N/A	N/A
NOTE 1: For NR band, UL/DL BW and UL L <sub>CRB</sub> can be adjusted according to the supported BW and lowest SCS supported by the UE.							
NOTE 2: E-UTRA carrier shall be set to min(+20 dBm, P <sub>CMAX_L,E-UTRA,c</sub> ) and NR carrier shall be set to min(+20 dBm, P <sub>CMAX_L,f,c,NR</sub> ) as defined in clause 6.2B.4.1.3.							

**Table 7.3B.2.0.3.5.2-1: MSD test points for Scell due to dual uplink operation for EN-DC in NR FR1 (three bands)**

NR or E-UTRA Band / Channel bandwidth / NRB / MSD							
EN-DC Configuration	EUTRA/NR band	UL Fc (MHz)	UL/DL BW (MHz)	UL L <sub>CRB</sub>	DL Fc (MHz)	MSD (dB)	IMD order
DC_1A-3A_n28A	1	1975	5	25	2165	N/A	N/A
	n28	710.5	5	25	765.5	N/A	N/A
	3	1723.5	5	25	1818.5	4.0	IMD5
	3	1780	5	25	1875	N/A	N/A
	n28	710.5	5	25	765.5	N/A	N/A
	1	1949	5	25	2139	11.0	IMD4
DC_1A-7A_n28A	1	1935	5	25	2125	N/A	N/A
	n28	718	5	25	773	N/A	N/A
	7	2533	10	50	2653	30.0	IMD2
DC_1A-3A_n77A DC_1A-3A_n77(2A)	1	1950	5	25	2140	N/A	N/A
	3	1712.5	5	25	1807.5	31.5	IMD2
	n77	3757.5	10	50	3757.5	N/A	N/A
	1	1950	5	25	2140	N/A	N/A
	3	1775	5	25	1870	8.5	IMD4
	n77	3980	10	50	3980	N/A	N/A
	1	1950	5	25	2140	31.0	IMD2
	3	1775	5	25	1870	N/A	N/A
	n77	3915	10	50	3915	N/A	N/A
DC_1A-3A_n78A DC_1A-3C_n78A	1	1950	5	25	2140	N/A	N/A
	3	1712.5	5	25	1807.5	31.2	IMD2
	n78	3757.5	10	50	3757.5	N/A	N/A
	1	1935	5	25	2125	2.8	IMD5
	3	1775	5	25	1870	N/A	N/A
DC_1A_n3A-n78A	n78	3725	10	50	3725	N/A	N/A
	1	1950	5	25	2140	N/A	N/A
	n3	1750	5	25	1845	N/A	N/A
	n78	N/A	10	N/A	3700	28.4	IMD2
	1	1950	5	25	2140	N/A	N/A
	n3	N/A	5	N/A	1830	27.9	IMD2
DC_1A-5A_n78A	n78	3780	10	50	3780	N/A	N/A
	1	1932	5	25	2122	18.1	IMD3
	5	829	5	25	874	N/A	N/A
	1	1975	5	25	2165	N/A	N/A
	5	840	5	25	885	3.1	IMD5
	n78	3405	10	50	3405	N/A	N/A
DC_1A-7A_n78A	1	1977.5	5	25	2167.5	N/A	N/A
	7	2507.5	5	25	2627.5	9.1	IMD4
	n78	3305	10	50	3305	N/A	N/A
	1	1950	5	25	2140	8.7	IMD4
	7	2510	10	50	2630	N/A	N/A
	n78	3580	10	50	3580	N/A	N/A
DC_1A_n7A-n78A	1	1977.5	5	25	2167.5	N/A	N/A
	n7	2507.5	5	25	2627.5	9.1	IMD4
	n78	3305	10	50	3305	N/A	N/A
	1	1970	5	25	2160	N/A	N/A
	n7	2520	5	25	2640	N/A	N/A
	n78	3390	10	50	3390	10.1	IMD4
DC_1A-3A_n79A	1	1950	5	25	2140	3.6	IMD5
	3	1750	5	25	1845	N/A	N/A
	n79	4860	40	216	4860	N/A	N/A
DC_1A-8A_n77A DC_1A-8A_n77(2A)	1	1955	5	25	2145	N/A	N/A
	n77	3410	10	50	2145	N/A	N/A
	8	N/A	5	N/A	955	3.3	IMD5
	8	910	5	25	955	N/A	N/A
	n77	3960	10	50	3960	N/A	N/A
	1	N/A	5	N/A	2140	14.4	IMD3
DC_1A-8A_n78A	1	N/A	N/A	N/A	N/A	N/A	N/A
	8	N/A	N/A	N/A	N/A	N/A	IMD5
	n78	N/A	N/A	N/A	N/A	N/A	N/A
	1	1945	5	25	2135	N/A	N/A

NR or E-UTRA Band / Channel bandwidth / NRB / MSD							
EN-DC Configuration	EUTRA/NR band	UL Fc (MHz)	UL/DL BW (MHz)	UL L <sub>CRB</sub>	DL Fc (MHz)	MSD (dB)	IMD order
	8	900	5	25	945	N/A	N/A
	n78	3745	10	52	3745	14.9	IMD3
	1	1940	5	25	2130	N/A	N/A
	8	895	5	25	940	3.3	IMD5
	n78	3380	10	52	3330	N/A	N/A
DC_1A-18A_n77A	1	N/A	N/A	N/A	N/A	N/A	N/A
	18	N/A	N/A	N/A	N/A	N/A	IMD5
	n77	N/A	N/A	N/A	N/A	N/A	N/A
	1	1930	5	25	2120	16.4	IMD3
	18	825	5	25	870	N/A	N/A
DC_1A-18A_n78A	n77	3770	10	50	3770	N/A	N/A
	1	N/A	N/A	N/A	N/A	N/A	N/A
	18	N/A	N/A	N/A	N/A	N/A	IMD5
	n78	N/A	N/A	N/A	N/A	N/A	N/A
	1	1930	5	25	2120	16.4	IMD3
DC_1A-18A_n79A	18	819	5	25	864	N/A	N/A
	n78	3758	10	50	3758	N/A	N/A
	1	1935	5	25	2125	N/A	N/A
	18	822.5	5	25	867.5	18.3	IMD3
	n79	4737.5	40	216	4737.5	N/A	N/A
DC_1A-18A_n79A	1	1930	5	25	2120	N/A	N/A
	18	820	5	25	865	8.9	IMD4
	n79	4925	40	216	4925	N/A	N/A
	1	1935	5	25	2125	8.1	IMD4
	18	822.5	5	25	867.5	N/A	N/A
DC_1A-19A_n77A DC_1A-19A_n78A	n79	4592.5	40	216	4592.5	N/A	N/A
	1	1940	5	25	2130	17.8	IMD3
	19	832.5	5	25	877.5	N/A	N/A
	n77, n78	3795	10	50	3795	N/A	N/A
	1	1940	5	25	2130	N/A	N/A
DC_1A-19A_n79A	19	N/A	5	N/A	880	5.1	IMD5
	n78	3350	10	50	3350	N/A	N/A
	1	1950	5	25	2140	N/A	N/A
	19	837.5	5	25	882.5	18.3	IMD3
	n79	4782.5	40	216	4782.5	N/A	N/A
DC_1A-20A_n8A	1	1950	5	25	2140	8.1	IMD4
	19	837.5	5	25	882.5	N/A	N/A
	n79	4652.5	40	216	4652.5	N/A	N/A
DC_1A-20A_n78A	1	1925	5	25	2115	N/A	N/A
	n8	910	5	25	955	N/A	N/A
	20	846	5	25	805	11.5	IMD4
DC_1A-20A_n78A	1	1930	5	25	2120	20.3	IMD3
	20	835	5	25	794	N/A	N/A
	n78	3790	10	50	3790	N/A	N/A
	1	1950	5	25	2140	N/A	N/A
	20	851	5	25	810	3.0	IMD5
DC_1A-21A_n77A DC_1A-21A_n78A	n78	3330	10	50	3330	N/A	N/A
	1	1964.6	5	25	2154.6	30.6	IMD2
	21	1450.4	5	25	1498.4	N/A	N/A
	n77, n78	3605	10	50	3605	N/A	N/A
	1	N/A	5	N/A	2154.6	3.6	IMD5
	21	1450.4	5	25	1498.4	N/A	N/A
	n78	3647	10	50	3647	N/A	N/A
	1	1950	5	25	2140	N/A	N/A
	21	N/A	5	N/A	1500	31.5	IMD2
	n78	3450	10	50	3450	N/A	N/A
DC_1A-21A_n79A	1	1950	5	25	2140	N/A	N/A
	21	1452	5	25	1500	2.9	IMD5
	n77, n78	3675	10	50	3675	N/A	N/A
	1	N/A	N/A	N/A	N/A	N/A	N/A
	21	N/A	N/A	N/A	N/A	N/A	IMD4

NR or E-UTRA Band / Channel bandwidth / NRB / MSD							
EN-DC Configuration	EUTRA/NR band	UL Fc (MHz)	UL/DL BW (MHz)	UL L <sub>CRB</sub>	DL Fc (MHz)	MSD (dB)	IMD order
	n79	N/A	N/A	N/A	N/A	N/A	N/A
DC_1A-28A_n3A	28	710.5	5	25	765.5	N/A	N/A
	n3	1780	5	25	1875	N/A	N/A
	1	1949	5	25	2139	11.0	IMD4
DC_1A-28A_n78A	1	1960	5	25	2150	15.7	IMD3
	28	740	5	25	795	N/A	N/A
	n78	3630	10	50	3630	N/A	N/A
	1	1970	5	25	2160	N/A	N/A
	28	739	5	25	794	4.2	IMD5
	n78	3352	10	50	3352	N/A	N/A
	1	1950	5	25	2140	N/A	N/A
DC_1A_n28A-n78A	n28	733	5	25	788	N/A	N/A
	n78	3416	10	50	3416	15.7	IMD3
	1	1950	5	25	2140	N/A	N/A
	n78	3320	10	50	3320	N/A	N/A
	n28	735	5	25	790	3.3	IMD5
	1	1930	5	25	2120	N/A	N/A
DC_1A-28A_n79A	28	733	5	25	788	15.2	IMD3
	n79	4648	40	216	4648	N/A	N/A
	1	1925	5	25	2115	N/A	N/A
	28	740	5	25	795	10.0	IMD4
	n79	4980	40	216	4980	N/A	N/A
	1	1977.5	5	25	2167.5	1.2	IMD4
	28	745.5	5	25	800.5	N/A	N/A
	n79	4420	40	216	4420	N/A	N/A
	1	1935	5	25	2125	4.5	IMD5
	28	718	5	25	773	N/A	N/A
	n79	4807	40	216	4807	N/A	N/A
	1	1935	5	25	2125	N/A	N/A
	DC_1A-41A_n28A	n28	718	5	25	773	N/A
41		2653	10	50	2653	30	IMD2
1		1970	5	25	2160	N/A	N/A
DC_1A-41A_n77A	n77	3400	10	50	3400	N/A	N/A
	41	2510	5	25	2510	11.0	IMD4
	1	1950	5	25	2140	9.3	IMD4
	n77	3710	10	50	3710	N/A	N/A
	41	2640	5	25	2640	N/A	N/A
	1	1930	5	25	2120	N/A	N/A
	n77	4150	10	50	4150	N/A	N/A
	41	2510	5	25	2510	3.6	IMD5
DC_1A-41A_n78A	1	1950	5	25	2140	9.3	IMD4
	41	2640	5	25	2640	N/A	N/A
	n78	3710	10	50	3710	N/A	N/A
	1	1975	5	25	2165	N/A	N/A
	41	2515	5	25	2515	12	IMD4
	n78	3410	10	50	3410	N/A	N/A
	1	1955	5	25	2145	8.7	IMD4
	41	2507.5	10	50	2507.5	N/A	N/A
	n78	3580	10	50	3580	N/A	N/A
DC_1A-42A_n79A	1	1977.5	5	25	2167.5	N/A	N/A
	n79	4420	40	216	4420	N/A	N/A
	42	3490	5	25	3490	4.8	IMD5
	42	3402.5	5	25	3402.5	N/A	N/A
	n79	4640	40	216	4640	N/A	N/A
	1	1975	5	25	2165	15.5	IMD3
	42	3450	5	25	3450	N/A	N/A
	n79	4520	40	216	4520	N/A	N/A
DC_1A_n78A-n79A	1	1950	5	25	2140	9.3	IMD4
	1	1950	5	25	2140	N/A	N/A
	n78	3410	10	50	3410	N/A	N/A
	n79	4870	40	216	4870	15.9	IMD3

NR or E-UTRA Band / Channel bandwidth / NRB / MSD								
EN-DC Configuration	EUTRA/NR band	UL Fc (MHz)	UL/DL BW (MHz)	UL L <sub>CRB</sub>	DL Fc (MHz)	MSD (dB)	IMD order	
	1	1950	5	25	2140	N/A	N/A	
	n79	4670	40	216	4670	N/A	N/A	
	n78	3490	10	50	3490	4.6	IMD5	
DC_2A-5A_n77A <sup>11</sup> DC_2A-2A-5A_n77A <sup>11</sup> DC_2A-2A-5A_n77(2A) <sup>11</sup>	2	1907.5	5	25	1987.5	N/A	N/A	
	5	N/A	5	N/A	887.5	3.8	IMD5	
	n77	3305	10	50	3305	N/A	N/A	
	2	N/A	5	N/A	1987	16.5	IMD3	
	5	846.5	5	25	891.5	N/A	N/A	
	n77	3680	10	50	3680	N/A	N/A	
DC_2A_n5A-n77A	2	1880	5	25	1960	N/A	N/A	
	n5	830	5	25	875	N/A	N/A	
	n77	N/A	10	N/A	3540	16.0	IMD3	
DC_2A-12A_n66A	2	N/A	N/A	N/A	N/A	N/A	IMD4	
	12	N/A	N/A	N/A	N/A	N/A	N/A	
	n66	N/A	N/A	N/A	N/A	N/A	N/A	
DC_2A-13A_n77A	2	N/A	5	N/A	1944	16.0	IMD3	
	13	783	5	25	752	N/A	N/A	
	n77	3510	10	50	3510	N/A	N/A	
DC_2A-14A_n66A	2	1874	5	25	1954	7.2	IMD4	
	14	793	5	25	763	N/A	N/A	
	66	1770	5	25	2170	N/A	N/A	
DC_2A-14A_n77A DC_2A-14A_n77(2A) DC_2A-2A-14A_n77A DC_2A-2A-14A_n77(2A)	2	N/A	5	N/A	1954	16.5	IMD3	
	14	793	5	25	763	N/A	N/A	
	n77	3540	10	50	3540	N/A	N/A	
DC_2A-66A_n2A	2	N/A	5	N/A	1980	20	IMD3	
	66	1730	5	25	2130	N/A	N/A	
	n2	1855	5	25	1935	N/A	N/A	
DC_2A-66A_n5A, DC_2A-2A-66A_n5A DC_2A-66A-66A_n5A DC_2A-2A-66A-66A_n5A	2	1900	5	25	1980	N/A	N/A	
	66	1740	5	25	2140	7.2	IMD4	
	n5	830	5	25	875	N/A	N/A	
DC_2A-66A_n41A	2	1860	5	25	1940	22.6	IMD4	
	66	1715	5	25	2115	N/A	N/A	
	n41	2685	5	25	2685	N/A	N/A	
DC_2A-66A_n77A DC_2A-66A_n77(2A) DC_2A-2A-66A_n77A DC_2A-2A-66A_n77(2A) DC_2A-66A-66A_n77A DC_2A-66A-66A_n77(2A) DC_2A-2A-66A-66A_n77A	2	1855	5	25	1935	N/A	N/A	
	66	N/A	5	N/A	2115	29.2	IMD2	
	n77	3970	10	50	3970	N/A	N/A	
	2	1880	5	25	1960	M/A	N/A	
	66	N/A	5	N/A	2140	10.4	IMD4	
	n77	3500	10	50	3500	N/A	N/A	
	2	1885	5	25	1965	M/A	N/A	
	66	N/A	5	N/A	2175	4.0	IMD5	
	n77	3915	10	50	3915	N/A	N/A	
	2	N/A	5	N/A	1960	32.1	IMD2	
	66	1760	5	25	2160	N/A	N/A	
	n77	3720	10	50	3720	N/A	N/A	
	DC_3A-5A_n78A	3	N/A	N/A	N/A	N/A	N/A	IMD3
		5	N/A	N/A	N/A	N/A	N/A	N/A
n78		N/A	N/A	N/A	N/A	N/A	N/A	
DC_3A-7A_n5A	3	1780	10	50	1875	N/A	N/A	
	7	2505	10	50	2625	30.0	IMD2 <sup>x</sup>	
	n5	845	5	25	890	N/A	N/A	
DC_3A-7A_n28A DC_3C-7A_n28A	3	1712.5	5	25	1807.5	N/A	N/A	
	n28	743	5	25	798	N/A	N/A	
	7	2562	10	50	2682	16.9	IMD3	
	7	2543	10	50	2663	N/A	N/A	

NR or E-UTRA Band / Channel bandwidth / NRB / MSD							
EN-DC Configuration	EUTRA/NR band	UL Fc (MHz)	UL/DL BW (MHz)	UL L <sub>CRB</sub>	DL Fc (MHz)	MSD (dB)	IMD order
	n28	710.5	5	25	765.5	N/A	N/A
	3	1737.5	5	25	1832.5	26.0	IMD2
DC_3A-7A_n78A DC_3C-7A_n78A	3	1725	5	25	1820	17.6	IMD3
	7	2565	5	25	2685	N/A	N/A
	n78	3310	10	50	3310	N/A	N/A
	3	1725	5	25	1820	8.6	IMD4
	7	2565	5	25	2685	N/A	N/A
	n78	3475	10	50	3475	N/A	N/A
DC_3A-8A_n77A DC_3A-8A_n77(2A)	3	1715	5	25	1810	N/A	N/A
	n77	4190	10	50	4190	N/A	N/A
	8	N/A	5	N/A	955	9.7	IMD4
	8	910	5	25	955	N/A	N/A
	n77	3640	10	50	3640	N/A	N/A
DC_3A-8A_n78A	3	N/A	5	N/A	1820	16.5	IMD3
	8	910	5	25	955	N/A	N/A
	n78	3640	10	50	3640	N/A	N/A
	3	1725	5	25	1820	16.5	IMD3
DC_3A-18A_n77A	3	N/A	N/A	N/A	N/A	N/A	IMD3



NR or E-UTRA Band / Channel bandwidth / NRB / MSD							
EN-DC Configuration	EUTRA/NR band	UL Fc (MHz)	UL/DL BW (MHz)	UL L <sub>CRB</sub>	DL Fc (MHz)	MSD (dB)	IMD order
DC_3A-18A_n78A	18	N/A	N/A	N/A	N/A	N/A	N/A
	n77, n78	N/A	N/A	N/A	N/A	N/A	N/A
DC_3A-19A_n78A	3	N/A	5	N/A	1850	17.3	IMD3
	19	835	5	25	880	N/A	N/A
	n78	3520	10	50	3520	N/A	N/A
DC_3A-19A_n79A	3	1775	5	25	1870	N/A	N/A
	19	840	5	25	885	[18.5]	IMD3
	n79	4435	40	216	4435	N/A	N/A
	3	1782.5	5	25	1877.5	5.5	IMD4
	19	842.5	5	25	887.5	N/A	N/A
	n79	4420	40	216	4420	N/A	N/A
DC_3A-20A_n28A DC_3C-20A_n28A	20	852	5	25	811	N/A	N/A
	n28	728	5	25	783	N/A	N/A
DC_3A_n20A-n78A	3	1733	5	25	1828	9.4	IMD4
	3	1730	5	25	1825	N/A	N/A
	n20	845	5	25	804	N/A	N/A
DC_3A-20A_n78A	n78	3420	10	50	3420	16.1	IMD3
	3	1725	5	25	1820	17.3	IMD3
	20	845	5	25	804	N/A	N/A
DC_3A-21A_n77A DC_3A-21A_n78A	n78	3510	10	50	3510	N/A	N/A
	3	1767.5	5	25	1862.5	N/A	N/A
	21	1459.5	5	25	1507.5	8.8	IMD4
	n77, n78	3795	10	50	3795	N/A	N/A
	3	N/A	5	N/A	1862.5	30.8	IMD2
	21	1459.5	5	25	1507.5	N/A	N/A
DC_3A-21A_n77A	n78	3322	10	50	3322	N/A	N/A
	3	1771.6	5	25	1866.6	3.4	IMD5
	21	1450.4	5	25	1498.4	N/A	N/A
DC_3A-21A_n79A	n77	3935	10	50	3935	N/A	N/A
	3	N/A	N/A	N/A	N/A	N/A	N/A
	21	N/A	N/A	N/A	N/A	N/A	IMD3
DC_3A-21A_n79A	n79	N/A	N/A	N/A	N/A	N/A	N/A
	3	1774.2	5	25	1869.2	17.8	IMD3
	21	1450.4	5	25	1498.4	N/A	N/A
	n79	4770	40	216	4770	N/A	N/A
	3	1712.5	5	25	1807.5	N/A	N/A
	28	715	5	25	770	15.3	IMD3
DC_3A-28A_n77A	n77	4195	10	50	4195	N/A	N/A
	3	1755	5	25	1850	17.0	IMD3
	28	735	5	25	790	N/A	N/A
	n77	3320	10	50	3320	N/A	N/A
	3	1775	5	25	1870	17.3	IMD3
DC_3A-28A_n78A	28	740	5	25	760	N/A	N/A
	n78	3350	10	25	3350	N/A	N/A
	3	1770	5	25	1865	N/A	N/A
DC_3A-28A_n79A	28	725	5	25	780	10.3	IMD4
	n79	4530	40	216	4530	N/A	N/A
	3	1775	5	25	1870	5.7	IMD5
	28	725	5	25	780	N/A	N/A
	n79	4770	40	216	4770	N/A	N/A
	3	1750	5	25	1845	N/A	N/A
DC_3A_n28A-n78A	n28	743	5	25	798	N/A	N/A
	n78	3764	10	50	3764	4.5	IMD5
	DC_3A-40A_n1A	n1	1950	5	25	2140	N/A
DC_3A-40A_n1A	3	1735	5	25	1830	N/A	N/A
	40	2380	5	25	2380	8.0	IMD5
	DC_3A-41A_n28A DC_3A-41C_n28A	41	2543	10	50	2543	N/A
DC_3A-41A_n28A DC_3A-41C_n28A	n28	710.5	5	25	765.5	N/A	N/A
	3	1737.5	5	25	1832.5	26	IMD2
	3	1780	5	25	1875	N/A	N/A
	n28	738	5	25	793	N/A	N/A

NR or E-UTRA Band / Channel bandwidth / NRB / MSD							
EN-DC Configuration	EUTRA/NR band	UL Fc (MHz)	UL/DL BW (MHz)	UL L <sub>CRB</sub>	DL Fc (MHz)	MSD (dB)	IMD order
	41	2518	5	25	2518	27.4	IMD2
	3	1715	5	25	1810	N/A	N/A
	n28	743	5	25	798	N/A	N/A
	41	2687	5	25	2687	15.9	IMD3
DC_3A-41A_n77A DC_3A-41C_n77A DC_3A-41A_n77(2A)	3	1720	5	25	1815	N/A	N/A
	n77	3900	10	50	3900	N/A	N/A
	41	2640	5	25	2640	5.3	IMD5
	41	2620	5	25	2620	N/A	N/A
	n77	3400	10	50	3400	N/A	N/A
	3	1745	5	25	1840	16.4	IMD3
DC_3A-41A_n78A	41	2620	5	25	2620	N/A	N/A
	n78	3400	10	50	3400	N/A	N/A
	3	1745	5	25	1840	16.4	IMD3
DC_3A_n78A-n79A	3	1770	5	25	1865	N/A	N/A
	n78	3340	10	50	3340	N/A	N/A
	n79	4910	40	216	4910	16.3	IMD3
	3	1770	5	25	1865	N/A	N/A
	n79	4510	40	216	4510	N/A	N/A
DC_3A-SUL_n78A-n82A	n78	3710	10	50	3710	4.2	IMD5
	3	1775	5	25	1870	4	IMD4
DC_3A-21A_n79A	n82A	840	5	25		N/A	N/A
	3	1774.2	5	25	1869.2	17.8	IMD3
	21	1450.4	5	25	1498.4	N/A	N/A
DC_5A-7A_n78A	n79	4770	40	216	4770	N/A	N/A
	5	844	5	25	889	N/A	N/A
	7	2525	5	25	2645	30.1	IMD2
	n78	3489	10	50	3489	N/A	N/A
	5	834	5	25	879	30.2	IMD2
	7	2550	5	25	2670	N/A	N/A
	n78	3429	10	50	3429	N/A	N/A
	5	830	5	25	875	3.3	IMD5
DC_5A-41A_n79A	7	2525	5	25	2645	N/A	N/A
	n78	3350	10	50	3350	N/A	N/A
	5	835	5	25	880	23.9	IMD3
	41	2665	5	25	2665	N/A	N/A
	n79	4450	40	216	4450	N/A	N/A
	5	826.5	5	25	871.5	N/A	N/A
DC_5A-66A_n77A DC_5A-66A_n77(2A)	41	2517.5	5	25	2517.5	1.8	IMD4
	n79	4980	40	216	4980	N/A	N/A
	5	826.5	5	25	871.5	N/A	N/A
DC_5A-66A-66A_n77A DC_5A-66A-66A_n77(2A)	66	N/A	5	N/A	2142	13.2	IMD3
	n77	3795	10	50	3795	N/A	N/A
DC_5A-66A_n2A DC_5A-66A-66A_n2A	5	834	5	25	879	N/A	N/A
	66	N/A	5	N/A	2132	7.2	IMD4
	n2	1900	5	25	1980	N/A	N/A
DC_7A-8A_n3A	n3	1735	5	25	1830	N/A	N/A
	7	2530	10	50	2650	N/A	N/A
	8	895	5	25	940	18.0	IMD3
	n3	1780	5	25	1875	N/A	N/A
	8	890	5	25	935	N/A	N/A
	7	2550	10	50	2670	29.0	IMD2+IMD3 <sup>4</sup>
DC_7A-20A_n1A	7	2510	10	50	2630	N/A	N/A
	20	841	10	50	800	4.5	IMD5
	n1	1940	5	25	2130	N/A	N/A
DC_7A-20A_n3A	7	2543	10	50	2663	N/A	N/A
	20	847	10	20	806	10.5	IMD2
	n3	1737	5	25	1832	N/A	N/A
	7	2510	10	50	2630	26.0	IMD2 <sup>1</sup>
	20	855	5	25	814	N/A	N/A

NR or E-UTRA Band / Channel bandwidth / NRB / MSD							
EN-DC Configuration	EUTRA/NR band	UL Fc (MHz)	UL/DL BW (MHz)	UL L <sub>CRB</sub>	DL Fc (MHz)	MSD (dB)	IMD order
	n3	1775	10	50	1870	N/A	N/A
DC_7A-20A_n8A	7	2565	5	25	2685	N/A	N/A
	n8	885	5	25	930	N/A	N/A
	20	836	5	25	795	17.4	IMD3
	7	2520	5	25	2640	21.1	IMD3
	n8	900	5	25	945	N/A	N/A
	20	840	5	25	799	N/A	N/A
	7	2504	5	25	2624	18.8	IMD3
	n8	910	5	25	955	N/A	N/A
DC_7A-20A_n28A	20	842	5	25	801	N/A	N/A
	n28	728	5	25	783	N/A	N/A
	7	2520	10	50	2640	5.9	IMD5
DC_7A-20A_n78A	7	2560	5	25	2680	N/A	N/A
	20	851	5	25	810	30.5	IMD2
	n78	3370	10	50	3370	N/A	N/A
	7	2560	5	25	2680	N/A	N/A
	20	851	5	25	810	3.0	IMD5
	n78	3435	10	50	3435	N/A	N/A
	7	2555	5	25	2675	30.8	IMD2
	20	845	5	25	804	N/A	N/A
DC_7A-28A_n3A	n78	3520	10	50	3520	N/A	N/A
	7	2543	5	25	2663	N/A	N/A
	28	741	5	25	796.0	20.0	IMD2
	n3	1747	5	25	1842	N/A	N/A
	7	2540	5	25	2685	18	IMD3
	28	745	5	25	800	N/A	N/A
DC_7A-28A_n5A DC_7C-28A_n5A	n3	1715	5	25	1810	N/A	N/A
	7	2540	5	25	2725	N/A	N/A
	28	721	5	25	776	4.4	IMD5
	n5	829	5	25	854	N/A	N/A
	7	2510	5	25	2630	5.9	IMD5
	28	730	5	25	785	N/A	N/A
DC_7A-28A_n78A	n5	840	5	25	874	N/A	N/A
	7	2570	5	25	2670	N/A	N/A
	28	720	5	25	780	8.3	IMD2
	n78	3350	10	50	3421	N/A	N/A
	7	2570	5	25	2670	N/A	N/A
	28	720	5	25	790	3.0	IMD5
	n78	3460	10	50	3421	N/A	N/A
	7	2570	5	25	2650	30.5	IMD2
DC_7A_n28A-n78A DC_7C_n28A-n78A	28	740	5	25	768	N/A	N/A
	n78	3390	10	50	3421	N/A	N/A
	7	2565	5	25	2685	N/A	N/A
	n28	745	5	25	800	28.8	IMD2
	n78	3310	10	50	3310	29.7	IMD2
	7	2565	5	25	2685	N/A	N/A
DC_7A-46A_n78A <sup>6</sup>	n78	3365	10	50	3365	N/A	N/A
	7	N/A	N/A	N/A	N/A	N/A	N/A
	46	N/A	N/A	N/A	N/A	N/A	IMD2, IMD5
DC_13A_n2A-n77A	n78	N/A	N/A	N/A	N/A	N/A	N/A
	13	782	5	25	751	N/A	N/A
	n2	1896	5	25	1976	N/A	N/A
	n77	N/A	10	N/A	3460	17.3	IMD3
	13	782	5	25	751	N/A	N/A
	n2	N/A	5	N/A	1960	16.0	IMD3
DC_13A-66A_n2A	n77	3524	10	50	3524	N/A	N/A
	13	782	5	25	751	N/A	N/A
	66	N/A	5	N/A	2156	7.2	IMD4
	n2	1860	5	25	1940	N/A	N/A

NR or E-UTRA Band / Channel bandwidth / NRB / MSD							
EN-DC Configuration	EUTRA/NR band	UL Fc (MHz)	UL/DL BW (MHz)	UL L <sub>CRB</sub>	DL Fc (MHz)	MSD (dB)	IMD order
DC_13A-66A_n77A	13	782	5	25	751	N/A	N/A
	66	N/A	5	N/A	2156	17.1	IMD3
	n77	3720	10	50	3720	N/A	N/A
DC_14A-66A_n2A DC_14A-66A-66A_n2A	14	793	5	25	763	N/A	N/A
	66	1762	5	25	2162	7.6	IMD4
	n2	1874	5	25	1954	N/A	N/A
DC_14A-66A_n77A DC_14A-66A_n77(2A) DC_14A-66A-66A_n77A DC_14A-66A-66A_n77(2A)	14	N/A	5	N/A	763	15.2	IMD3 <sup>11</sup>
	66	1712.5	5	25	2112.5	N/A	N/A
	n77	4188	10	50	4188	N/A	N/A
	14	793	5	25	763	N/A	N/A
	66	N/A	5	N/A	2155	13.2	IMD3
	n77	3741	10	50	3741	N/A	N/A
DC_18A-28A_n78A	18	819	5	25	864	3.8	IMD5
	28	723	5	25	778	N/A	N/A
	n78	3756	10	50	3756	N/A	N/A
DC_18A-41A_n3A DC_18A-41C_n3A	18	820	5	25	865	N/A	N/A
	n3	1725	5	25	1820	N/A	N/A
	41	2630	5	25	2630	16.0	IMD3
	18	820	5	25	865	28.9	IMD2
	n3	1765	5	25	1820	N/A	N/A
DC_18A-41A_n77A DC_18A-41C_n77A	41	2630	5	25	2630	N/A	N/A
	18	820	5	25	865	3.4	IMD5
	n77	3527.5	10	50	3527.5	N/A	N/A
DC_18A-41A_n78A DC_18A-41C_n78A	41	2640	5	25	2640	N/A	N/A
	18	820	5	25	865	3.4	IMD5
	n78	3527.5	10	50	3527.5	N/A	N/A
DC_19A-21A_n77A DC_19A-21A_n78A	41	2640	5	25	2640	N/A	N/A
	19	837.5	5	25	882.5	18.7	IMD3
	21	1450.4	5	25	1498.4	N/A	N/A
	n77, n78	3783.3	10	50	3783.3	N/A	N/A
	19	N/A	5	N/A	882.5	13.2	IMD4
	21	1450.4	5	25	1498.4	N/A	N/A
DC_19A-21A_n77A	n77, n78	3468.7	10	50	3468.7	N/A	N/A
	19	837.5	5	25	882.5	N/A	N/A
	21	1454.5	5	25	1502.5	9.0	IMD4
DC_19A-21A_n77A	n77	4015	10	50	4015	N/A	N/A
	19	N/A	N/A	N/A	N/A	N/A	IMD5
	21	N/A	N/A	N/A	N/A	N/A	N/A
DC_19A-21A_n79A	n79	N/A	N/A	N/A	N/A	N/A	N/A
	19	837.5	5	25	882.2	N/A	N/A
	21	1452	5	25	1500	3.8	IMD5
	n79	4850	40	216	4850	N/A	N/A
	20	845	5	25	804	N/A	N/A
	n3	1730	5	25	1825	N/A	N/A
DC_20A_n3A-n78A	n78	3420	10	50	3420	16.1	IMD3
	20	845	5	25	804	N/A	N/A
	n3	1765	5	25	1860	15.7	IMD3
	n78	3550	10	50	3550	N/A	N/A
	21	1452	5	25	1500	N/A	N/A
DC_21A-28A_n77A	28	730.5	5	25	785.5	16.9	IMD3
	n77	3689.5	10	50	3689.5	N/A	N/A
	21	1450.5	5	25	1498.5	9.9	IMD4
	28	730.5	5	25	785.5	N/A	N/A
	n77	3690	10	50	3690	N/A	N/A
	21	1450	5	25	1498	5.2	IMD5
DC_21A-28A_n79A	28	730.5	5	25	785.5	N/A	N/A
	n79	4420	40	216	4420	N/A	N/A
	28	745	5	25	800	N/A	N/A
DC_28A_n7A-n78A	n7	2565	5	25	2685	N/A	N/A
	n78	3310	10	50	3310	29.7	IMD2
	28	740	5	25	795	N/A	N/A

NR or E-UTRA Band / Channel bandwidth / NRB / MSD							
EN-DC Configuration	EUTRA/NR band	UL Fc (MHz)	UL/DL BW (MHz)	UL L <sub>CRB</sub>	DL Fc (MHz)	MSD (dB)	IMD order
	n7	2530	5	25	2650	30.5	IMD2
	n78	3390	10	50	3390	N/A	N/A
DC_28A-42A_n79A	28	730	5	25	785	N/A	N/A
	42	3420	5	25	3420	15.3	IMD3
	n79	4880	40	216	4880	N/A	N/A
	28	745	5	25	800	16.2	IMD2
	42	3597.5	5	25	3597.5	N/A	N/A
	n79	4420	40	216	4420	N/A	N/A
DC_19A_n78A-n79A	19	835	5	25	880	N/A	N/A
	n78	3680	10	50	3680	N/A	N/A
	n79	4515	40	216	4515	29.3	IMD2
	19	835	5	25	880	N/A	N/A
	n79	4550	40	216	4550	N/A	N/A
	n78	3715	10	50	3715	28.8	IMD2
DC_20A_n28A-n78A DC_20A_SUL_n78A-n83A	20	857	5	25	816	N/A	N/A
	n28, n83	743	5	25	798	N/A	N/A
	n78	3314	10	50	3314	8.7	IMD4
	20	837	5	25	796	N/A	N/A
	n78	3310	10	50	3310	N/A	N/A
	n28	744	5	25	799	9.4	IMD4
DC_21A_n78A-n79A	21	1453	5	25	1501	N/A	N/A
	n78	3420	10	50	3420	N/A	N/A
	n79	4873	40	216	4873	30.1	IMD2
	21	1453	5	25	1501	N/A	N/A
	n79	4940	40	216	4940	N/A	N/A
	n78	3487	10	50	3487	29.8	IMD2
DC_66A_n2A-n77A	n2	N/A	5	N/A	1960	32.1	IMD2
	66	1760	5	25	2160	N/A	N/A
	n77	3720	10	50	3720	N/A	N/A
DC_66A_n5A-n77A	66	1770	5	25	2170	N/A	N/A
	n5	845	5	25	890	N/A	N/A
	n77	N/A	10	N/A	3460	16.6	IMD3 <sup>9</sup>
<p>NOTE 1: For NR band, UL/DL BW and UL L<sub>CRB</sub> can be adjusted according to the supported BW and lowest SCS supported by the UE.</p> <p>NOTE 2: E-UTRA carrier shall be set to min(+20 dBm, P<sub>CMAX_L,E-UTRA,c</sub>) and NR carrier shall be set to min(+20 dBm, P<sub>CMAX_L,f,c,NR</sub>) as defined in clause 6.2B.4.1.3.</p> <p>NOTE 3: This band is subject to IMD3 also which MSD is not specified.</p> <p>NOTE 4: This MSD requirement apply with both IMD2 and IMD3 products should be generated.</p> <p>NOTE 5 to NOTE 8: FFS</p> <p>NOTE 9: This band is subject to IMD4 also which MSD is not specified.</p> <p>NOTE 10: FFS</p> <p>NOTE 11: For a UE which supports this band combination only when the Band n77 frequency range restriction defined in NOTE 12 of Table 5.2-1 from TS 38.101-1 applies, the MSD test point(s) cannot be verified for the band combination and the test point(s) can be skipped.</p>							

**Table 7.3B.2.0.3.5.2-1a: MSD test points for Scell due to dual uplink operation for PC2 EN-DC in NR FR1 (three bands)**

NR or E-UTRA Band / Channel bandwidth / NRB / MSD							
EN-DC Configuration	EUTRA/NR band	UL Fc (MHz)	UL/DL BW (MHz)	UL L <sub>CRB</sub>	DL Fc (MHz)	MSD (dB)	IMD order
DC_1A-3A_n77A	1	1950	5	25	2140	N/A	N/A
	3	N/A	5	N/A	1807.5	37.5	IMD2 <sup>1</sup>
	n77	3757.5	10	50	3757.5	N/A	N/A
	1	1950	5	25	2140	N/A	N/A
	3	N/A	5	N/A	1870	20.5	IMD4 <sup>1</sup>
	n77	3980	10	50	3980	N/A	N/A
	1	N/A	5	N/A	2140	37.0	IMD2 <sup>1</sup>
	3	1775	5	25	1870	N/A	N/A
DC_1A_3A-n78A	n77	3915	10	50	3915	N/A	N/A
	1	1950	5	25	2140	N/A	N/A
	3	N/A	5	N/A	1807.5	37.2	IMD2 <sup>1</sup>
	n78	3757.5	10	50	3757.5	N/A	N/A
	1	N/A	5	N/A	2125	17.8	IMD5
DC_1A-3A_n79A	3	1775	5	25	1870	N/A	N/A
	n78	3725	10	50	3725	N/A	N/A
	1	N/A	5	N/A	2140	24.6	IMD5
DC_1A-18A_n77A	3	1750	5	25	1845	N/A	N/A
	n79	4860	10	50	4860	N/A	N/A
	1	1970	5	25	2160	N/A	N/A
DC_1A-19A_n78A	18	N/A	5	N/A	870	15.8	IMD5
	n77	3390	10	50	3390	N/A	N/A
	1	N/A	5	N/A	2120	25.0	IMD3
	18	825	5	25	870	N/A	N/A
	n77	3770	10	50	3770	N/A	N/A
	1	N/A	5	N/A	2130	26.7	IMD3
DC_1A-19A_n79A	19	832.5	5	25	877.5	N/A	N/A
	n78	3795	10	50	3795	N/A	N/A
	1	1940	5	25	2130	N/A	N/A
	19	N/A	5	N/A	880	18.5	IMD5
	n78	3350	10	50	3350	N/A	N/A
	1	1950	5	25	2140	N/A	N/A
DC_1A-21A_n78A	19	N/A	5	N/A	882.5	33.3	IMD3 <sup>5</sup>
	n79	4782.5	10	50	4782.5	N/A	N/A
	1	N/A	5	N/A	2140	26.1	IMD4
	19	837.5	5	25	882.5	N/A	N/A
	n79	4652.5	10	50	4652.5	N/A	N/A
	1	N/A	5	N/A	2154.6	36.6	IMD2
DC_1A-21A_n79A <sup>7,8</sup>	21	1450.4	5	25	1498.4	N/A	N/A
	n78	3605	10	50	3605	N/A	N/A
	1	N/A	5	N/A	2154.6	16.2	IMD5
	21	1450.4	5	25	1498.4	N/A	N/A
	n78	3647	10	50	3647	N/A	N/A
	1	1950	5	25	2140	N/A	N/A
	21	N/A	5	N/A	1500	37.5	IMD2
	n78	3450	10	50	3450	N/A	N/A
	1	1950	5	25	2140	N/A	N/A
	21	N/A	5	N/A	1500	14.9	IMD5
	n78	3675	10	50	3675	N/A	N/A
	DC_1A-41A_n77A	1	N/A	N/A	N/A	N/A	N/A
21		N/A	N/A	N/A	N/A	N/A	IMD4
n79		N/A	N/A	N/A	N/A	N/A	N/A
DC_1A-42A_n79A	1	1970	5	25	2160	N/A	N/A
	41	N/A	5	N/A	2510	22.5	IMD4
	n77	3400	10	50	3400	N/A	N/A
	1	1930	5	25	2120	N/A	N/A
	41	N/A	5	N/A	2510	15.6	IMD5
	n77	4150	10	50	4150	N/A	N/A
DC_1A-42A_n79A	1	1977.5	5	25	2167.5	N/A	N/A
	42	N/A	5	N/A	3490	25.8	IMD5
	n79	4420	10	50	4420	N/A	N/A
	1	1950	5	25	2140	N/A	N/A

NR or E-UTRA Band / Channel bandwidth / NRB / MSD								
EN-DC Configuration	EUTRA/NR band	UL Fc (MHz)	UL/DL BW (MHz)	UL L <sub>CRB</sub>	DL Fc (MHz)	MSD (dB)	IMD order	
DC_1A_n78A-n79A	n78	3410	10	50	3410	N/A	N/A	
	n79	N/A	10	N/A	4870	24.9	IMD3 <sup>1</sup>	
	1	1950	5	25	2140	N/A	N/A	
	n78	N/A	10	N/A	3490	22.6	IMD5	
	n79	4670	10	50	4670	N/A	N/A	
DC_2A-5A_n77A <sup>2</sup> DC_2A-5A_n77(2A) <sup>2</sup> DC_2A-2A-5A_n77A <sup>2</sup> DC_2A-2A-5A_n77(2A) <sup>2</sup>	2	1907.5	5	25	1987.5	N/A	N/A	
	5	N/A	5	N/A	887.5	13.6	IMD5	
	n77	3305	10	50	3305	N/A	N/A	
	2	N/A	5	N/A	1987	24.8	IMD3	
	5	846.5	5	25	891.5	N/A	N/A	
	n77	3680	10	50	3680	N/A	N/A	
DC_2A-13A_n77A	2	N/A	5	N/A	1944	24.2	IMD3	
	13	783	5	25	752	N/A	N/A	
	n77	3510	10	50	3510	N/A	N/A	
DC_2A-14A_n77A DC_2A-14A_n77(2A) DC_2A-2A-14A_n77A DC_2A-2A-14A_n77(2A)	2	N/A	5	N/A	1954	24.8	IMD3	
	14	793	5	25	763	N/A	N/A	
	n77	3540	10	50	3540	N/A	N/A	
DC_2A-66A_n77A DC_2A-66A_n77(2A) DC_2A-2A-66A_n77A DC_2A-2A-66A_n77(2A) DC_2A-66A-66A_n77A DC_2A-66A-66A_n77(2A) DC_2A-2A-66A-66A_n77A	2	1855	5	25	1935	N/A	N/A	
	66	N/A	5	N/A	2115	34.7	IMD2	
	n77	3970	10	50	3970	N/A	N/A	
	2	1880	5	25	1960	M/A	N/A	
	66	N/A	5	N/A	2140	21.1	IMD4 <sup>1</sup>	
	n77	3500	10	50	3500	N/A	N/A	
	2	N/A	5	N/A	1960	37.6	IMD2	
	66	1760	5	25	2160	N/A	N/A	
	n77	3720	10	50	3720	N/A	N/A	
	2	N/A	5	N/A	1940	19.8	IMD4 <sup>1,2</sup>	
	66	1775	5	25	2195	N/A	N/A	
	n77	3385	10	50	3385	N/A	N/A	
	DC_3A-18A_n77A	3	N/A	5	N/A	1865	24.2	IMD3
		18	820	5	25	865	N/A	N/A
n77		3505	10	50	3505	N/A	N/A	
DC_3A-19A_n78A	3	N/A	5	N/A	1850	26.3	IMD3	
	19	835	5	25	880	N/A	N/A	
	n78	3520	10	50	3520	N/A	N/A	
DC_3A-19A_n79A	3	1775	5	25	1870	N/A	N/A	
	19	N/A	5	N/A	885	27.5	IMD3 <sup>5</sup>	
	n79	4435	40	50	4435	N/A	N/A	
	3	N/A	5	N/A	1877.5	16.2	IMD4	
	19	842.5	5	25	887.5	N/A	N/A	
	n79	4420	40	50	4420	N/A	N/A	
DC_3A-21A_n78A	3	N/A	5	N/A	1862.5	36.6	IMD2	
	21	1459.5	5	25	1507.5	N/A	N/A	
	n78	3322	10	50	3322	N/A	N/A	
	3	1767.5	5	25	1862.5	N/A	N/A	
	21	1459.5	5	25	1507.5	23.2	IMD4	
	n78	3795	10	50	3795	N/A	N/A	
	3	1767.5	5	25	1862.5	N/A	N/A	



NR or E-UTRA Band / Channel bandwidth / NRB / MSD							
EN-DC Configuration	EUTRA/NR band	UL Fc (MHz)	UL/DL BW (MHz)	UL L <sub>CRB</sub>	DL Fc (MHz)	MSD (dB)	IMD order
	21	N/A	5	N/A	1503.5	9.5	IMD5
	n78	3403	10	50	3403	N/A	N/A
DC_3A-21A_n79A <sup>7</sup>	3	N/A	N/A	N/A	N/A	N/A	N/A
	21	N/A	N/A	N/A	N/A	N/A	IMD3
	n79	N/A	N/A	N/A	N/A	N/A	N/A
	3	N/A	5	N/A	1869.2	32.8	IMD3
	21	1450.4	5	25	1498.4	N/A	N/A
	n79	4770	10	50	4770	N/A	N/A
DC_3A-41A_n77A	3	1720	5	25	1815	N/A	N/A
	n77	3900	10	50	3900	N/A	N/A
	41	N/A	5	N/A	2640	13	IMD5
DC_3A-42A_n79A <sup>9</sup>	3	N/A	N/A	N/A	N/A	N/A	N/A
	42	N/A	N/A	N/A	N/A	N/A	IMD5
	n79	N/A	N/A	N/A	N/A	N/A	N/A
DC_3A_n78A-n79A	3	1770	5	25	1865	N/A	N/A
	n78	3340	10	50	3340	N/A	N/A
	n79	N/A	10	N/A	4910	25.3	IMD3
	3	1770	5	25	1865	N/A	N/A
	n78	N/A	10	N/A	3710	25.2	IMD5
	n79	4510	10	50	4510	N/A	N/A
DC_5A-66A_n77A DC_5A-66A_n77(2A) DC_5A-66A-66A_n77A DC_5A-66A-66A_n77(2A)	5	826.5	5	25	871.5	N/A	N/A
	66	N/A	5	N/A	2142	22.2	IMD3
	n77	3795	10	50	3795	N/A	N/A
DC_13A_n2A-n77A	13	782	5	25	751	N/A	N/A
	n2	N/A	5	N/A	1960	25.0	IMD3
	n77	3524	10	50	3524	N/A	N/A
DC_13A-66A_n77A	13	782	5	25	751	N/A	N/A
	66	N/A	5	N/A	2156	25.3	IMD3
	n77	3720	10	50	3720	N/A	N/A
	13	N/A	5	N/A	750	23.4	IMD3 <sup>2</sup>
	66	1720	5	25	2120	N/A	N/A
	n77	4190	10	50	4190	N/A	N/A
DC_14A-66A_n77A DC_14A-66A_n77(2A) DC_14A-66A-66A_n77A DC_14A-66A-66A_n77(2A)	14	N/A	5	N/A	763	23.5	IMD3 <sup>2</sup>
	66	1712.5	5	25	2112.5	N/A	N/A
	n77	4188	10	50	4188	N/A	N/A
	14	793	5	25	763	N/A	N/A
	66	N/A	5	N/A	2155	21.4	IMD3
	n77	3741	10	50	3741	N/A	N/A
DC_19A-21A_n78A	19	N/A	5	N/A	882.5	27.7	IMD3
	21	1450.4	5	25	1498.4	N/A	N/A
	n78	3783.3	10	50	3783.3	N/A	N/A
	19	N/A	5	N/A	882.5	25.2	IMD4
	21	1450.4	5	25	1498.4	N/A	N/A
	n78	3468.7	10	50	3468.7	N/A	N/A
DC_19A-21A_n79A <sup>7</sup>	19	N/A	N/A	N/A	N/A	N/A	IMD5
	21	N/A	N/A	N/A	N/A	N/A	N/A
	n79	N/A	N/A	N/A	N/A	N/A	N/A
	19	837.5	5	25	882.2	N/A	N/A
	21	N/A	5	N/A	1500	24.8	IMD5
	n79	4850	10	50	4850	N/A	N/A
DC_19A-42A_n79A <sup>10</sup>	19	N/A	N/A	N/A	N/A	N/A	N/A
	42	N/A	N/A	N/A	N/A	N/A	IMD2
	n79	N/A	N/A	N/A	N/A	N/A	N/A
DC_19A_n78A-n79A	19	835	5	25	880	N/A	N/A
	n78	3680	10	50	3680	N/A	N/A
	n79	N/A	40	N/A	4515	35.3	IMD2
	19	835	5	25	880	N/A	N/A

NR or E-UTRA Band / Channel bandwidth / NRB / MSD							
EN-DC Configuration	EUTRA/NR band	UL Fc (MHz)	UL/DL BW (MHz)	UL L <sub>CRB</sub>	DL Fc (MHz)	MSD (dB)	IMD order
	n78	N/A	10	N/A	3715	34.8	IMD2
	n79	4550	40	216	4550	N/A	N/A
DC_21A-42A_n79A <sup>10</sup>	21	N/A	N/A	N/A	N/A	N/A	N/A
	42	N/A	N/A	N/A	N/A	N/A	IMD2
	n79	N/A	N/A	N/A	N/A	N/A	N/A
DC_21A_n78A-n79A	21	1453	5	25	1501	N/A	N/A
	n78	3420	10	50	3420	N/A	N/A
	n79	N/A	10	N/A	4873	36.1	IMD2 <sup>5</sup>
	21	1453	5	25	1501	N/A	N/A
	n78	N/A	10	N/A	3487	38.8	IMD2
	n79	4940	10	50	4940	N/A	N/A
DC_66A_n2A-n77A	n2	N/A	5	N/A	1960	37.6	IMD2
	66	1760	5	25	2160	N/A	N/A
	n77	3720	10	50	3720	N/A	N/A
	n2	N/A	5	N/A	1960	21.1	IMD4 <sup>1,2</sup>
	66	1770	5	25	2170	N/A	N/A
	n77	3350	10	50	3350	N/A	N/A
NOTE 1: This band is subject to IMD5 also which MSD is not specified.							
NOTE 2: For a UE which supports this band combination only when the Band n77 frequency range restriction defined in NOTE 12 of Table 5.2-1 from TS 38.101-1 applies, the MSD test point(s) cannot be verified for the band combination and the test point(s) can be skipped.							
NOTE 4: Void							
NOTE 5: This band is subject to IMD4 also which MSD is not specified.							
NOTE 6: E-UTRA carrier shall be set to min(+23 dBm, P <sub>C<sub>MAX</sub>L<sub>E-UTRA,c</sub></sub> ) and NR carrier shall be set to min(+23 dBm, P <sub>C<sub>MAX</sub>L<sub>f,c,NR</sub></sub> ) as defined in clause 6.2B.4.1.3.							
NOTE 7: The frequency range in band n79 is restricted for this band combination to 4400 - 4900 MHz for both the UL and the DL.							
NOTE 8: The frequency range in band 1 is restricted for this band combination to 1940 - 1960 MHz for the UL and 2130 - 2150 MHz for the DL.							
NOTE 9: The frequency range in band n79 is restricted for this band combination to 4500 - 5000 MHz for both the UL and the DL							
NOTE 10: The frequency range in band n79 is restricted for this band combination to 4500 - 4600 MHz for both the UL and the DL							
NOTE 11: Void							

7.3B.2.0.3.5.3 Void

7.3B.2.0.3a Inter-band NE-DC within FR1

Reference sensitivity exceptions are specified for the condition when there is uplink transmission only in the aggressor band. This subclause addresses directly only NE-DC configurations that don't have a corresponding specified EN-DC configuration or specific NE-DC exceptions.

7.3B.2.0.3a.1 Reference sensitivity exceptions due to UL harmonic interference for NE-DC in NR FR1

Sensitivity degradation is allowed for a band if it is impacted by UL harmonic interference from another band part of the same NE-DC configuration. For the NE-DC configurations that have an EN-DC defined configuration, the reference sensitivity exceptions for the victim band (high) are specified in Table 7.3B.2.3.1-1 with uplink configuration of the aggressor band (low) specified in Table 7.3B.2.3.1-2 are applicable.

### 7.3B.2.0.4 Inter-band EN-DC including FR2

#### 7.3B.2.0.4.1 Void

### 7.3B.2.0.5 Inter-band EN-DC including both FR1 and FR2

#### 7.3B.2.0.5.1 Reference sensitivity exceptions due to UL harmonic interference for EN-DC including both FR1 and FR2

For inter-band EN-DC of E-UTRA and NR in both FR1 and FR2, the UE is allowed to apply each sensitivity degradation for EN-DC in FR1 specified in clause 7.3B.2.3 TS 38.101-3 and for EN-DC including FR2 specified in clause 7.3B.2.3 of TS 38.101-3 independently.

The normative reference for this requirement is TS 38.101-3 [4] clause 7.3B.2.

## 7.3B.2.1 Reference sensitivity for Intra-band Contiguous EN-DC (2 CCs)

**Editor's note: MSD test point selection is based on core spec requirement and shall be added to TP analysis to TS 38.905 [7].**

### 7.3B.2.1.1 Test purpose

To verify the ability of UE that support intra-band contiguous EN-DC configurations to receive data with a given average throughput for a specified reference measurement channel, under conditions of low signal level, ideal propagation and no added noise. A UE unable to meet the throughput requirement under these conditions will decrease the effective coverage area.

### 7.3B.2.1.2 Test applicability

This test applies to all types of NR UE release 15 and forward supporting intra-band contiguous EN-DC in FR1 with 2 DL CCs.

### 7.3B.2.1.3 Minimum conformance requirements

The minimum conformance requirements are defined in clause 7.3B.2.0.

Exception requirements for both NR and E-UTRA are defined for this test and therefore LTE anchor agnostic approach is not applied. E-UTRA test point analysis is included and E-UTRA measurements are performed.

### 7.3B.2.1.4 Test description

#### 7.3B.2.1.4.1 Initial conditions

Initial conditions are a set of test configurations the UE needs to be tested in and the steps for the SS to take with the UE to reach the correct measurement state.

The initial test configurations consist of environmental conditions, test frequencies and channel bandwidths based on EN-DC operating bands specified in clause 5.5B, and the channel bandwidth combination for E-UTRA and NR component carriers shall follow the value specified in Table 5.3B.1.2-1. All of these configurations shall be tested with applicable test parameters for each EN-DC configuration specified in clause 5.3B.1.2, and are shown in Table 7.3B.2.1.4.1-1 for DC\_(n)71AA and Table 7.3B.2.1.4.1-2 for intra-band contiguous EN-DC other than DC\_(n)71AA.

The details of the uplink and downlink reference measurement channels (RMCs) are specified in Annex A.2 and A.3 for E-UTRA RMC, and in TS 38.521-1 [8] Annex A.2 and A.3 for NR RMC respectively. The details of the OCNG patterns used are specified in TS 36.521-1 [10] Annex A.5 and in TS 38.521-1 [8] Annex A.5 for E-UTRA CG and NR CG respectively. Configurations of PDSCH and PDCCH before measurement are specified in TS 36.521-1 [10] Annex C.2 and in TS 38.521-1 [8] Annex C.2 for E-UTRA CG and NR CG respectively.

**Table 7.3B.2.1.4.1-1: Test configurations table for EN-DC configurations affected by Reference sensitivity exceptions**

Initial Conditions							
Test Environment as specified in TS 38.508-1 [6] clause 4.1				Normal, TL/VL, TL/VH, TH/VL, TH/VH			
NR Test Frequencies as specified in TS 38.508-1 [6] clause 4.3.1				Specified below			
E-UTRA Test Frequencies as specified in TS 36.508 [11] clause 4.3.1							
E-UTRA Test Channel Bandwidths as specified in TS 36.508 [11] clause 4.3.1				Specified below			
NR Test Channel Bandwidths as specified in TS 38.508-1 [6] clause 4.3.1				Specified below			
NR Test SCS as specified in Table 5.3.5-1 in TS 38.521-1 [8]				Lowest			
Network signalling value				NS_01 by default, exceptions listed in Table 7.3.3-3 in TS 36.521-1 [10], dependent on PCC Band			
NR/E-UTRA Test Parameters							
Downlink Configuration				Uplink Configuration			
NR Modulation	NR RB allocation	E-UTRA Modulation	E-UTRA RB allocation	NR Modulation	NR RB allocation	E-UTRA Modulation	E-UTRA RB allocation
CP-OFDM QPSK	Full RB (NOTE 1)	QPSK	Full RB	DFT-s-OFDM QPSK		QPSK	
Test Point configurations							
Test Settings for DC_(n)71AA for dual UL UE							
Test ID	E-UTRA/NR band	F <sub>c</sub> (UL) (MHz) N <sub>UL</sub>	UL Channel BW (MHz)	UL allocation (L <sub>CRB</sub> )	F <sub>c</sub> (DL) (MHz) N <sub>DL</sub>	Duplex mode	
1	71	665.5MHz, E <sub>UL</sub> = 133147	5	5@19	619.5 MHz E <sub>DL</sub> = 68611	FDD	
	n71	675.5 N <sub>UL</sub> = 135100	15	15@0	629.5 N <sub>DL</sub> = 125900		
2	71	670.5 E <sub>UL</sub> = 133197	15	15@59	624.5 E <sub>DL</sub> = 68661		
	n71	680.5 N <sub>UL</sub> = 136100	5	5@0	634.5 N <sub>DL</sub> = 126900		
3	71	668 E <sub>UL</sub> = 133172	10	10@39	622 E <sub>DL</sub> = 68636		
	n71	678 N <sub>UL</sub> = 135600	10	10@0	632 N <sub>DL</sub> = 126400		
4	71	668 E <sub>UL</sub> = 133172	10	10@0	622 E <sub>DL</sub> = 68636		
	n71	678 N <sub>UL</sub> = 135600	10	10@41	632 N <sub>DL</sub> = 126400		
5	71	665.5 E <sub>UL</sub> = 133147	5	5@19	619.5 E <sub>DL</sub> = 68611		
	n71	675.5 N <sub>UL</sub> = 135100	15 <sup>3</sup>	15@0	632 <sup>3</sup> N <sub>UL</sub> = 126400		
6	71	670.5 E <sub>UL</sub> = 133197	15	15@59	624.5 E <sub>DL</sub> = 68661		
	n71	680.5 N <sub>UL</sub> = 136100	5 <sup>3</sup>	5@0	637 <sup>3</sup> N <sub>UL</sub> = 127400		
7	71	668 E <sub>UL</sub> = 133172	10	10@39	622 E <sub>DL</sub> = 68636		
	n71	678 N <sub>UL</sub> = 135600	10 <sup>3</sup>	10@0	634.5 <sup>3</sup> N <sub>UL</sub> = 126900		
8	71	668 E <sub>UL</sub> = 133172	10	10@0	622 E <sub>DL</sub> = 68636		
	n71	678 N <sub>UL</sub> = 135600	10 <sup>3</sup>	10@41	634.5 <sup>3</sup> N <sub>UL</sub> = 126900		
Test Settings for DC_(n)71AA for single UL UE							

1	71	default	Highest	0	default	FDD
	n71	default	Highest	REFSENS_NR	default	
<p>NOTE 1: Full RB allocation shall be used per each SCS and channel BW as specified in Table 7.3.2.4.1-2 of TS 38.521-1 [8].</p> <p>NOTE 2: Test Channel Bandwidths are checked separately for each E-UTRA band, which applicable channel bandwidths are specified in Table 5.3B.1.2-1.</p> <p>NOTE 3: In accordance to BCS1, the NR uplink bandwidth is specified as in this table, but the corresponding NR downlink bandwidth is 5 MHz larger.</p> <p>NOTE 4: In an E-UTRA band or FR1 band where UE supports 4Rx, the test shall be performed only with 4Rx antennas ports connected.</p> <p>NOTE 5: REFSENS_NR refers to the single carrier Uplink RB allocation for reference sensitivity according to table 7.3.2.4.1-3 of TS 38.521-1 [8].</p>						

**Table 7.3B.2.1.4.1-2: Test configurations table for EN-DC configurations not affected by Reference sensitivity exceptions, EN-DC configuration other than DC\_(n)71AA**

Initial Conditions								
Test Environment as specified in TS 38.508-1 [6] clause 4.1				Normal, TL/VL, TL/VH, TH/VL, TH/VH				
NR Test Frequencies as specified in TS 38.508-1 [6] clause 4.3.1, E-UTRA Test Frequencies as specified in TS 36.508 [11] clause 4.3.1				Low range, High range				
Test EN-DC bandwidth combination as specified in Table 5.3B.1.2-1 across bandwidth combination sets supported by the UE.				Refer to "NR N <sub>RB</sub> " and "E-UTRA N <sub>RB</sub> " columns				
NR Test SCS as specified in Table 5.3.5-1 in TS 38.521-1 [8]				Lowest supported SCS				
Network signalling value				NS_01 by default, exceptions listed in Table 7.3.3-3 in TS 36.521-1 [10], dependent on PCC Band				
Test Parameters for DC Configurations								
ID	PCC – E-UTRA				SCG -NR			
	Band	Range	N <sub>RB</sub>		Band	Range	N <sub>RB</sub>	
	UL MOD	DL MOD	CH BW	DLalloc / UL alloc	UL MOD	DL MOD	UL/DL Ch BW	DLalloc / UL alloc
Test Settings for a DC_(n)XAA Configuration (Intra-band contiguous EN-DC) – Note 2								
1 (Note 4)	X	default			nX	default		
	QPSK	QPSK	Highest N <sub>RB_agg</sub> (Note 6)	All RBs / REFSENS_LTE	DFT-s-OFDM QPSK	CP-OFDM QPSK	Highest N <sub>RB_agg</sub> (Note 6)	All RBs / REFSENS_NR
2 (Note 5)	X	default			nX	default		
	N/A	QPSK	Highest N <sub>RB</sub>	All RBs / 0	DFT-s-OFDM QPSK	CP-OFDM QPSK	Highest N <sub>RB</sub>	All RBs / REFSENS_NR
<p>Note 1: REFSENS_NR and REFSENS_LTE refer to the single carrier Uplink RB allocation for reference sensitivity according to Table 7.3.2.4.1-3 of TS 38.521-1 [8] and Table 7.3.4.1-1 of TS 36.521 [10] for NR and E-UTRA CC respectively.</p> <p>Note 2: Not LTE anchor agnostic configuration due to exception requirement for intra-band contiguous CA in clause 7.4B, 7.5B, 7.6B.2, 7.6B.3, 7.6B.4, 7.7B, 7.8B, 7.9B test cases</p> <p>Note 3: In a FR1 band where UE supports 4Rx, the test shall be performed only with 4Rx antennas ports connected.</p> <p>Note 4: Test point for UE supporting dual UL.</p> <p>Note 5: Test point for UE supporting single UL.</p> <p>Note 6: If the UE supports multiple CC combinations in the EN-DC configuration with the same N<sub>RB_agg</sub>, select the combination to test as follows:                      - Lowest ENBW: NR component with lowest N<sub>RB</sub> is tested.                      - Highest ENBW: NR component with highest N<sub>RB</sub> is tested.</p>								

1. Connect the SS to the UE antenna connectors as shown in TS 38.508-1 [6] Annex A, Figure A.3.1.1.1 for TE diagram and clause A.3.2.1 for UE diagram.
2. The parameter settings for NR cell are set up according to TS 38.508-1 [6] clause 4.4.3.
3. The parameter settings for E-URA cell are set up according to TS 36.508 [11] clause 4.4.3.
4. NR downlink signals are initially set up according to Annex C.0, C.1, C.2, C.3.1, and uplink signals according to Annex G.0, G.1, G.2, and G.3.1 of TS 38.521-1 [8].
5. E-UTRA downlink signals are initially set up according to Annex C0, C.1 and C.3.0, and uplink signals according to Annex H.1 and H.3.0 of TS 36.521-1 [10].
6. The DL and UL Reference Measurement channels for NR are set according to Table 7.3B.2.1.4.1-1 and Table 7.3B.2.1.4.1-2.
7. The DL and UL Reference Measurement channels for E-UTRA are set according to Table 7.3B.2.1.4.1-1 and Table 7.3B.2.1.4.1-2.
8. NR propagation conditions are set according to Annex B.0 of TS 38.521-1 [8].
9. E-UTRA propagation conditions are set according to Annex B.0 of TS 36.521-1 [10].
10. Ensure the UE is in state RRC\_CONNECTED with generic procedure parameters *Connectivity* EN-DC, DC bearer MCG and SCG, Connected without release *On* according to TS 38.508-1 [6] clause 4.5. Message contents are defined in clause 7.3B.2.1.4.3.
11. When E-UTRA and NR bands are TDD, ensure the same uplink-downlink configuration by giving SCG a delay of 3 E-UTRA subframes, or by giving MCG a delay of 2 subframes.

#### 7.3B.2.1.4.2 Test procedure

1. SS transmits PDSCH via PDCCH DCI format 1A and PDCCH DCI format 1\_1 for C\_RNTI to transmit the DL RMC according to Table 7.3B.2.1.4.1-1 and Table 7.3B.2.1.4.1-2 on the E-UTRA CC and NR CC. The SS sends downlink MAC padding bits on the DL RMC.
2. SS sends uplink scheduling information for each UL HARQ process via PDCCH DCI format 0 and DCI format 0\_1 for C\_RNTI to schedule the UL RMC according to Table 7.3B.2.3.4.1-1 on both EN-DC component carriers. Since the UL has no payload and no loopback data to send the UE sends uplink MAC padding bits on the UL RMC.
3. For test points in Table 7.3B.2.1.4.1-1, set the Downlink signal level to the appropriate REFSENS value defined in Table 7.3B.2.1.5-1. For test points in Table 7.3B.2.1.4.1-2, set the Downlink signal level to the appropriate REFSENS value defined in TS 38.521-1 [8], Table 7.3.3-1 for NR band and TS 36.521-1 [10] Table 7.3.3-1 for E-UTRA band. Send continuously uplink power control "up" commands in the uplink scheduling information to both carriers to ensure the UE transmits PUMAX level for at least the duration of the Throughput measurement.
4. Measure the average throughput of both NR and E-UTRA for a duration sufficient to achieve statistical significance according to Annex H.2 of TS 38.521-1 [8] for NR band, and Annex G.2 of TS 36.521-1 [10] for EUTRA band.

#### 7.3B.2.1.4.3 Message contents

Message contents are according to TS 38.508-1 [6] clause 4.6 Table 4.6.3-118 with condition TRANSFORM\_PRECODER\_ENABLED.

Message contents exceptions are according to TS 36.521-1 [10] clause 7.3.4.3 for each network signalling value.

#### 7.3B.2.1.5 Test requirement

For intra-band contiguous EN-DC configurations DC\_(n)71AA with dual UL, the throughput of each CG shall be  $\geq$  95% of the maximum throughput of the reference measurement channels as specified in Annex A.3.2 with reference receive power level specified in Table 7.3B.2.1.5-1.

Reference sensitivity test requirements for EN-DC configurations other than DC\_(n)71AA with dual UL UE, are specified in Table 7.3.5-1 in TS 36.521-1 [10] for the LTE CC, and Table 7.3.2.5-1 in TS 38.521-1 [8] for the NR CC.

**Table 7.3B.2.1.5-1: Reference sensitivity for intra-band DC\_(n)71AA with dual UL**

EN-DC	E-UTRA/ NR band	SCS (kHz)	Channel BW (MHz)	Ref sensitivity (dBm)	Note	Duplex mode
DC_(n)71AA	71	N/A	5	-96.5	Note 1	FDD
	n71	15	15	-89.8 +TT		
	71	N/A	15	-91.3	Note 2	
	n71	15	5	-95.6 +TT		
	71	N/A	10	-93.5	Note 3	
	n71	15	10	-92.3 +TT		
	71	N/A	10	-76.3	Note 4	
	n71	15	10	-64.6 +TT		
	71	N/A	5	-96.5	Note 5	
	n71	15	15 <sup>9</sup>	-89.1 +TT		
	71	N/A	15	-91.3	Note 6	
	n71	15	5 <sup>9</sup>	-95.0 +TT		
	71	N/A	10	-93.5	Note 7	
	n71	15	10 <sup>9</sup>	-91.5 +TT		
	71	N/A	10	-76.3	Note 8	
n71	15	10 <sup>9</sup>	-64.9 +TT			
NOTE 1: For test configuration specified by Table 7.3B.2.1.4.1-1 Test ID 1. NOTE 2: For test configuration specified by Table 7.3B.2.1.4.1-1 Test ID 2. NOTE 3: For test configuration specified by Table 7.3B.2.1.4.1-1 Test ID 3. NOTE 4: For test configuration specified by Table 7.3B.2.1.4.1-1 Test ID 4. NOTE 5: For test configuration specified by Table 7.3B.2.1.4.1-1 Test ID 5. NOTE 6: For test configuration specified by Table 7.3B.2.1.4.1-1 Test ID 6. NOTE 7: For test configuration specified by Table 7.3B.2.1.4.1-1 Test ID 7. NOTE 8: For test configuration specified by Table 7.3B.2.1.4.1-1 Test ID 8. NOTE 9: In accordance to BCS1, the NR uplink bandwidth is specified as in this table, but the corresponding NR downlink bandwidth is 5 MHz larger.						

**Table 7.3B.2.1.5-2: Test Tolerance (TT) for NR RX sensitivity level**

f ≤ 3.0GHz	3.0GHz < f ≤ 6.0 GHz
0.7 dB	1.0 dB

7.3B.2.2 Reference sensitivity for Intra-band non-contiguous EN-DC (2 CCs)

Editor's note: No test case details specified due to no confirmed industry interest for intra-band non-contiguous EN-DC combinations (removed at RAN5 #97).

7.3B.2.3 Reference sensitivity for Inter-band EN-DC within FR1 (2 CCs)

7.3B.2.3.1 Test purpose

Same as in clause 7.3B.2.1.1.



### 7.3B.2.3.2 Test applicability

This test applies to all types of NR UE release 15 and forward supporting inter-band EN-DC within FR1 with 2 DL CCs.

### 7.3B.2.3.3 Minimum conformance requirements

The minimum conformance requirements are defined in clause 7.3B.2.0.

LTE anchor agnostic approach is not applied.

### 7.3B.2.3.4 Test description

#### 7.3B.2.3.4.1 Void

#### 7.3B.2.3.4.2 Test description

##### 7.3B.2.3.4.2.1 Initial conditions

Initial conditions are a set of test configurations the UE needs to be tested in and the steps for the SS to take with the UE to reach the correct measurement state.

The initial test configurations consist of environmental conditions, test frequencies, test channel bandwidths based on EN-DC operating bands specified in clause 5.5B, channel bandwidths and sub-carrier spacings for the NR cell specified in TS 38.521-1 [8] clause 5.3 and channel bandwidth for the E-UTRA cell are specified in TS 36.521-1 [10] clause 5.4.2. All of these configurations shall be tested with applicable test parameters for each EN-DC configuration, and are shown in Table 7.3B.2.3.4.2.1-0 to Table 7.3B.2.3.4.2.1-6.

The details of the uplink and downlink reference measurement channels (RMCs) are specified in TS 36.521-1 [10] Annex A.2 and A.3 for E-UTRA RMC, and in TS 38.521-1 [8] Annex A.2 and A.3 for NR RMC respectively. The details of the OCNG patterns used are specified in TS 36.521-1 [10] Annex A.5 and in TS 38.521-1 [8] Annex A.5 for E-UTRA CG and NR CG, respectively. Configurations of PDSCH and PDCCH before measurement are specified in TS 36.521-1 [10] Annex C.2 and in TS 38.521-1 [8] Annex C.2 for E-UTRA CG and NR CG, respectively.

For configurations without any reference sensitivity exception, in a FR1 band where UE supports 4Rx, the test shall be performed only with 4Rx antennas ports connected. For configurations with reference sensitivity exception, in an E-UTRA band or FR1 band where UE supports 4Rx, the test shall be performed only with 4Rx antennas ports connected.

**Table 7.3B.2.3.4.2.1-0: Test configurations table for all EN-DC configurations for FR1 non-exception requirements**

Initial Conditions								
Test Environment as specified in TS 38.508-1 [6] clause 4.1				Normal, TL/VL, TL/VH, TH/VL, TH/VH				
NR Test Frequencies as specified in TS 38.508-1 [6] clause 4.3.1, E-UTRA Test Frequencies as specified in TS 36.508 [11] clause 4.3.1				Mid range for E-UTRA and Mid range for NR				
Test EN-DC channel bandwidth as specified in TS 36.508 [11] clause 4.3.1 and TS 38.508-1 [6] clause 4.3.1				Refer to "NR N <sub>RB</sub> "and "E-UTRA N <sub>RB</sub> " columns				
NR Test SCS as specified in Table 5.3.5-1 in TS 38.521-1 [8]				Lowest supported SCS				
Network signalling value				NS_01 by default Unless given by Table 7.3.3-3 in TS 36.521-1 [10] for the E-UTRA band and Table 7.3.2.3-4 in TS 38.521-1 [8] for the NR band.				
Test Parameters for DC Configurations								
ID	PCC – E-UTRA				SCG -NR			
	Band	Range	N <sub>RB</sub>		Band	Range	N <sub>RB</sub>	
	UL MOD	DL MOD	CH BW	DLalloc / UL alloc	UL MOD	DL MOD	UL/DL Ch BW	DLalloc / UL alloc
Test Settings for a DC_XA_nYA Configuration (Inter-band EN-DC) – Note 2								
1	X	default			nY	default		
	N/A	N/A	5 MHz	N/A	DFT-s-OFDM QPSK	CP-OFDM QPSK	Highest N <sub>RB</sub>	All RBs / REFSENS_NR
NOTE 1: REFSENS_NR refers to the single carrier Uplink RB allocation for reference sensitivity according to table 7.3.2.4.1-3 of TS 38.521-1 [8].								
NOTE 2: LTE anchor agnostic configuration								
NOTE 3: In a FR1 band where UE supports 4Rx, the test shall be performed only with 4Rx antennas ports connected.								
NOTE 4: The test configuration table only applies to EN-DC only capable devices and devices not supporting NR/5GC mode in the tested band.								
NOTE 5: Only one EN-DC combination per FR1 band is tested for each EN-DC configuration as defined in clause 5.5B.								

**Table 7.3B.2.3.4.2.1-1: Void**

**Table 7.3B.2.3.4.2.1-2\_1: Void**

**Table 7.3B.2.3.4.2.1-2\_2: Void**

**Table 7.3B.2.3.4.2.1-2\_3: Void**

**Table 7.3B.2.3.4.2.1-2\_4: Void**

**Table 7.3B.2.3.4.2.1-2\_5: Void**

**Table 7.3B.2.3.4.2.1-2\_6: Void**

**Table 7.3B.2.3.4.2.1-2\_7: Void**

**Table 7.3B.2.3.4.2.1-2\_8: Void**

**Table 7.3B.2.3.4.2.1-2\_9: Void**

**Table 7.3B.2.3.4.2.1-2\_11: Void**

**Table 7.3B.2.3.4.2.1-2\_12: Void**

**Table 7.3B.2.3.4.2.1-2\_13: Void**

Table 7.3B.2.3.4.2.1-2\_14: Void

Table 7.3B.2.3.4.2.1-2\_15: Void

Table 7.3B.2.3.4.2.1-2\_16: Void

Table 7.3B.2.3.4.2.1-2\_17: Void

Table 7.3B.2.3.4.2.1-2\_18: Void

Table 7.3B.2.3.4.2.1-2\_19: Void

Table 7.3B.2.3.4.2.1-2\_20: Void

Table 7.3B.2.3.4.2.1-2\_21: Void

Table 7.3B.2.3.4.2.1-2\_22: Void

Table 7.3B.2.3.4.2.1-2\_23: Void

Table 7.3B.2.3.4.2.1-4: Void

Table 7.3B.2.3.4.2.1-4a: Void

Table 7.3B.2.3.4.2.1-4b: Void

Table 7.3B.2.3.4.2.1-4c: Void

Table 7.3B.2.3.4.2.1-4d: Void

Table 7.3B.2.3.4.2.1-4e: Void

Table 7.3B.2.3.4.2.1-4f: Void

Table 7.3B.2.3.4.2.1-4g: Void

Table 7.3B.2.3.4.2.1-4h: Void

Table 7.3B.2.3.4.2.1-4i: Void

Table 7.3B.2.3.4.2.1-4j: Void

Table 7.3B.2.3.4.2.1-4k: Void

Table 7.3B.2.3.4.2.1-4l: Void

Table 7.3B.2.3.4.2.1-4m: Void

Table 7.3B.2.3.4.2.1-4n: Void

Table 7.3B.2.3.4.2.1-5: Void

**Table 7.3B.2.3.4.2.1-6: Test Configuration Table for EN-DC configurations affected by Reference sensitivity exceptions (two bands)**

Initial Conditions								
Test Environment as specified in TS 38.508-1 [6] clause 4.1				Normal, TL/VL, TL/VH, TH/VL, TH/VH				
NR Test Frequencies as specified in TS 38.508-1 [6] clause 4.3.1, E-UTRA Test Frequencies as specified in TS 36.508 [11] clause 4.3.1				For test frequencies refer to "Range" columns.				
Test EN-DC channel bandwidth as specified in TS 36.508 [11] clause 4.3.1 and TS 38.508-1 [6] clause 4.3.1.				Refer to "NR N <sub>RB</sub> " and "E-UTRA N <sub>RB</sub> " columns				
NR Test SCS as specified in Table 5.3.5-1 in TS 38.521-1 [8]				Lowest supported SCS				
Network signalling value				NS_01 by default Unless given by Table 7.3.3-3 in TS 36.521-1 [10] for the E-UTRA band and Table 7.3.2.3-4 in TS 38.521-1 [8] for the NR band.				
Test Parameters for DC Configurations								
ID	PCC – E-UTRA				SCG -NR			
	Band	Range	N <sub>RB</sub>		Band	Range	N <sub>RB</sub>	
	UL MOD	DL MOD	CH BW	DLalloc / UL alloc	UL MOD	DL MOD	UL/DL Ch BW	DLalloc / UL alloc
Test Settings for a DC_1A_n3A Configuration								
12,11	1	Mid			n3	Mid		
	QPSK	QPSK	20 MHz	All RBs / REFSSENS_ENDC_3	N/A	CP-OFDM QPSK	40 MHz	All RBs / 0
2 <sup>4</sup>	1	UL 1950 / DL 2140			n3	UL 1760 / DL 1855		
	QPSK	QPSK	5 MHz	All RBs / REFSSENS_ENDC_4	DFT-s-OFDM QPSK	CP-OFDM QPSK	5 MHz	All RBs / REFSSENS_ENDC_4
3 <sup>6</sup>	1	Low			n3	High		
	QPSK	QPSK	20 MHz	All RBs / REFSSENS_ENDC_3	N/A	CP-OFDM QPSK	40 MHz	All RBs / 0
Test Settings for a DC_1A_n8A Configuration								
1 <sup>4</sup>	1	UL 1965 / DL 2155			n8	UL 887.5 / DL 932.5		
	QPSK	QPSK	5 MHz	All RBs / REFSSENS_ENDC_4	DFT-s-OFDM QPSK	CP-OFDM QPSK	5 MHz	All RBs / REFSSENS_ENDC_4
Test Settings for a DC_1A_n28A Configuration								
1 <sup>3</sup>	1	UL 1950 / DL 2140			n28	UL 713.3 / DL 768.3		
	N/A	QPSK	20 MHz	All RBs / 0	DFT-s-OFDM QPSK	CP-OFDM QPSK	10 MHz	All RBs / REFSSENS_ENDC_1
2 <sup>8</sup>	1	UL 1970 / DL 2160			n28	UL 708 / DL 763		
	N/A	QPSK	20 MHz	All RBs / 0	DFT-s-OFDM QPSK	CP-OFDM QPSK	10 MHz	All RBs / REFSSENS_ENDC_1
Test Settings for a DC_1A_n41A Configuration (PC2 and PC3)								
1 <sup>6</sup>	1	High			n41	Low		
	QPSK	QPSK	20 MHz	All RBs / REFSSENS_ENDC_3	DFT-s-OFDM QPSK	CP-OFDM QPSK	100 MHz	All RBs / 0
2 <sup>6</sup>	1	High			n41	Low		
	QPSK	QPSK	20 MHz	All RBs / 0	DFT-s-OFDM QPSK	CP-OFDM QPSK	50 MHz	All RBs / REFSSENS_ENDC_3
Test Settings for a DC_1A_n77A Configuration (PC2 and PC3)								
1 <sup>3</sup>	1	UL 1950 / DL 2140			n77	UL/DL 3900		
	QPSK	QPSK	20 MHz	All RBs / REFSSENS_ENDC_1	N/A	CP-OFDM QPSK	100 MHz	All RBs / 0

2 <sup>3</sup>	1	UL 1950/ DL 2140			n77	UL/DL 3870		
	QPSK	QPSK	20 MHz	All RBs / REFSENS_ENDC_1	N/A	CP-OFDM QPSK	20 MHz	All RBs / 0
3 <sup>4</sup>	1	UL 1950/ DL 2140			n77	UL/DL 4090.005		
	QPSK	QPSK	5 MHz	All RBs / REFSENS_ENDC_4	DFT-s- OFDM QPSK	CP-OFDM QPSK	10 MHz	All RBs / REFSENS_ENDC_4
4 <sup>4</sup>	1	UL 1950/ DL 2140			n77	UL/DL 3709.995		
	QPSK	QPSK	5 MHz	All RBs / REFSENS_ENDC_4	DFT-s- OFDM QPSK	CP-OFDM QPSK	10 MHz	All RBs / REFSENS_ENDC_4
<b>Test Settings for a DC_1A_n78A Configuration</b>								
1 <sup>4</sup>	1	UL 1950 / DL 2140			n78	UL/DL 3709.995		
	QPSK	QPSK	5 MHz	All RBs / REFSENS_ENDC_4	DFT-s- OFDM QPSK	CP-OFDM QPSK	10 MHz	All RBs / REFSENS_ENDC_4
<b>Test Settings for a DC_2A_n41A Configuration (PC2 and PC3)</b>								
1 <sup>6</sup>	2	High			n41	Low		
	N/A	QPSK	20 MHz	All RBs / REFSENS_LTE	DFT-s- OFDM QPSK	CP-OFDM QPSK	100 MHz	All RBs / REFSENS_ENDC_3
2 <sup>6</sup>	2	DL 1987.5			n41	UL/DL 2546		
	N/A	QPSK	5 MHz	All RBs / 0	DFT-s- OFDM QPSK	CP-OFDM QPSK	100 MHz	All RBs / REFSENS_ENDC_3
<b>Test Settings for a DC_2A_n66A Configuration</b>								
1 <sup>4</sup>	2	UL 1855 / DL 1935			n66	DL 2175		
	QPSK	QPSK	5 MHz	All RBs / REFSENS_ENDC_4	DFT-s- OFDM QPSK	CP-OFDM QPSK	5 MHz	All RBs / REFSENS_ENDC_4
2 <sup>4</sup>	2	UL 1883.3 /DL1963.3			n66	DL 2150		
	QPSK	QPSK	5 MHz	All RBs / REFSENS_ENDC_4	DFT-s- OFDM QPSK	CP-OFDM QPSK	5 MHz	All RBs / REFSENS_ENDC_4
<b>Test Settings for a DC_2A_n71A Configuration</b>								
1 <sup>3</sup>	2	DL 1980 MHZ			n71	UL 665.5 MHZ		
	QPSK	QPSK	20 MHz	All RBs / 0	DFT-s- OFDM QPSK	CP-OFDM QPSK	5 MHz	All RBs / REFSENS_ENDC_1
2 <sup>3</sup>	2	DL1980 MHZ			n71	UL 673 MHz		
	QPSK	QPSK	20 MHz	All RBs / 0	DFT-s- OFDM QPSK	CP-OFDM QPSK	10 MHz	All RBs / REFSENS_ENDC_1
3 <sup>5</sup>	2	UL 1881 MHZ			n71	Low		
	QPSK	QPSK	20 MHz	All RBs / REFSENS_ENDC_2	DFT-s- OFDM QPSK	CP-OFDM QPSK	20 MHz	All RBs / 0
<b>Test Settings for a DC_2A_n77A Configuration</b>								
1 <sup>3</sup>	2	UL 1860			n77	UL/DL 3720		
	QPSK	QPSK	20 MHz	All RBs / REFSENS_ENDC_1	N/A	CP-OFDM QPSK	100 MHz	All RBs / 0
2 <sup>3</sup>	2	UL 1860			n77	UL/DL 3690.005		

	QPSK	QPSK	20 MHz	All RBs / REFSSENS_ENDC_1	N/A	CP-OFDM QPSK	20 MHz	All RBs / 0
3 <sup>8</sup>	2	UL 1860			n77	UL/DL 3850.005		
	QPSK	QPSK	20 MHz	All RBs / REFSSENS_ENDC_1	N/A	CP-OFDM QPSK	10 MHz	All RBs / 0
4 <sup>5</sup>	2	DL Mid			n77	UL/DL 3920.01		
	N/A	QPSK	20 MHz	All RBs / 0	DFT-s-OFDM QPSK	CP-OFDM QPSK	100 MHz	All RBs / REFSSENS_ENDC_2
4a <sup>9</sup>	2	DL Mid			n77	UL/DL Mid		
	N/A	QPSK	20 MHz	All RBs / 0	DFT-s-OFDM QPSK	CP-OFDM QPSK	100 MHz	All RBs / REFSSENS_ENDC_2
5 <sup>4</sup>	2	UL 1855/DL 1935			n77	UL/DL 3790.005		
	QPSK	QPSK	5 MHz	All RBs / REFSSENS_ENDC_4	DFT-s-OFDM QPSK	CP-OFDM QPSK	10 MHz	All RBs / REFSSENS_ENDC_4
6 <sup>4</sup>	2	UL 1900/DL 1980			n77	UL/DL 3720		
	QPSK	QPSK	5 MHz	All RBs / REFSSENS_ENDC_4	DFT-s-OFDM QPSK	CP-OFDM QPSK	10 MHz	All RBs / REFSSENS_ENDC_4
7 <sup>4</sup>	2	UL 1885/DL 1965			n77	UL/DL 3810		
	QPSK	QPSK	5 MHz	All RBs / REFSSENS_ENDC_4	DFT-s-OFDM QPSK	CP-OFDM QPSK	10 MHz	All RBs / REFSSENS_ENDC_4
8 <sup>6, 16</sup>	2	DL 1987.5			n77	UL/DL 3350		
	QPSK	QPSK	5 MHz	All RBs / 0	DFT-s-OFDM QPSK	CP-OFDM QPSK	100 MHz	All RBs / REFSSENS_ENDC_3
<b>Test Settings for a DC_2A_n78A Configuration</b>								
1 <sup>3</sup>	2	UL 1870			n78	UL/DL 3740.01		
	QPSK	QPSK	20 MHz	All RBs / REFSSENS_ENDC_1	N/A	CP-OFDM QPSK	100 MHz	All RBs / 0
2 <sup>3</sup>	2	UL 1885			n78	UL/DL 3739.995		
	QPSK	QPSK	20 MHz	All RBs / REFSSENS_ENDC_1	N/A	CP-OFDM QPSK	20 MHz	All RBs / 0
3 <sup>4</sup>	2	UL 1855/DL 1935			n78	UL/DL 3790.005		
	QPSK	QPSK	5 MHz	All RBs / REFSSENS_ENDC_4	DFT-s-OFDM QPSK	CP-OFDM QPSK	10 MHz	All RBs / REFSSENS_ENDC_4
4 <sup>4</sup>	2	UL 1885/DL 1965			n78	UL/DL 3690		
	QPSK	QPSK	5 MHz	All RBs / REFSSENS_ENDC_4	DFT-s-OFDM QPSK	CP-OFDM QPSK	10 MHz	All RBs / REFSSENS_ENDC_4
<b>Test Settings for a DC_3A_n1A Configuration</b>								
1 <sup>11</sup>	3	Mid			n1	Mid		
	N/A	QPSK	20 MHz	All RBs / 0	DFT-s-OFDM QPSK	CP-OFDM QPSK	50 MHz	All RBs / REFSSENS_ENDC_3
2 <sup>6</sup>	3	High			n1	Low		

	N/A	QPSK	20 MHz	All RBs / 0	DFT-s-OFDM QPSK	CP-OFDM QPSK	50 MHz	All RBs / REFSSENS_ENDC_3
3 <sup>4</sup>	3	UL 1760 / DL 1855			n1	UL 1950 / DL 2140		
	QPSK	QPSK	5 MHz	All RBs / REFSSENS_ENDC_4	DFT-s-OFDM QPSK	CP-OFDM QPSK	5 MHz	All RBs / REFSSENS_ENDC_4
<b>Test Settings for a DC_3A_n5A Configuration</b>								
1 <sup>4</sup>	3	UL 1771 / DL 1866			n5	UL 838 / DL 883		
	QPSK	QPSK	10 MHz	All RBs / REFSSENS_ENDC_4	DFT-s-OFDM QPSK	CP-OFDM QPSK	5 MHz	All RBs / REFSSENS_ENDC_4
2 <sup>4</sup>	3	UL 1721 / DL 1816			n5	UL 838 / DL 883		
	QPSK	QPSK	10 MHz	All RBs / REFSSENS_ENDC_4	DFT-s-OFDM QPSK	CP-OFDM QPSK	5 MHz	All RBs / REFSSENS_ENDC_4
<b>Test Settings for a DC_3A_n7A Configuration</b>								
1 <sup>4</sup>	3	UL 1730 / DL 1825			n7	UL 2535 / DL 2655		
	QPSK	QPSK	5 MHz	All RBs / REFSSENS_ENDC_4	DFT-s-OFDM QPSK	CP-OFDM QPSK	10 MHz	All RBs / REFSSENS_ENDC_4
<b>Test Settings for a DC_3A_n8A Configuration</b>								
1 <sup>4</sup>	3	UL 1755 / DL 1850			n8	UL 900 / DL 945		
	QPSK	QPSK	10 MHz	All RBs / REFSSENS_ENDC_4	DFT-s-OFDM QPSK	CP-OFDM QPSK	5 MHz	All RBs / REFSSENS_ENDC_4
2 <sup>4</sup>	3	UL 1747.5 / DL 1842.5			n8	UL 897.5 / DL 942.5		
	QPSK	QPSK	10 MHz	All RBs / REFSSENS_ENDC_4	DFT-s-OFDM QPSK	CP-OFDM QPSK	5 MHz	All RBs / REFSSENS_ENDC_4
<b>Test Settings for a DC_3A_n41A Configuration</b>								
1 <sup>6</sup>	3	High			n41	Low		
	QPSK	QPSK	20 MHz	All RBs / REFSSENS_ENDC_3	N/A	CP-OFDM QPSK	100 MHz	All RBs / 0
2 <sup>6</sup>	3	High			n41	Low		
	N/A	QPSK	20 MHz	All RBs / 0	DFT-s-OFDM QPSK	CP-OFDM QPSK	50 MHz	All RBs / REFSSENS_ENDC_3
3 <sup>4</sup>	3	UL 1740 / DL 1835			n41	UL/DL 2657.5		
	QPSK	QPSK	5 MHz	All RBs / REFSSENS_ENDC_4	DFT-s-OFDM QPSK	CP-OFDM QPSK	10 MHz	All RBs / REFSSENS_ENDC_4
<b>Test Settings for DC_3A_n77A (PC2 and PC3) and DC_3A_n78A Configurations</b>								
1 <sup>3</sup>	3	Mid			n77/n78	UL/DL 3495		
	QPSK	QPSK	20 MHz	All RBs / REFSSENS_ENDC_1	N/A	CP-OFDM QPSK	100 MHz	All RBs / 0
2 <sup>3</sup>	3	Mid			n77/n78	UL/DL 3525		
	QPSK	QPSK	20 MHz	All RBs / REFSSENS_ENDC_1	N/A	CP-OFDM QPSK	20 MHz	All RBs / 0
3 <sup>5</sup>	3	Mid			n77/n78	UL/DL 3685.005		
	N/A	QPSK	20 MHz	All RBs / 0	DFT-s-OFDM QPSK	CP-OFDM QPSK	20 MHz	All RBs / REFSSENS_ENDC_2
4 <sup>9</sup>	3	Low			n77/n78	High		



	QPSK	QPSK	20 MHz	All RBs/0	DFT-s-OFDM QPSK	CP-OFDM QPSK	20 MHz	All RBs / REFSSENS_ENDC_2
5 <sup>4</sup>	3	UL 1740 / DL 1835			n77/n78	UL/DL 3574.995		
	QPSK	QPSK	5 MHz	All RBs / REFSSENS_ENDC_4	DFT-s-OFDM QPSK	CP-OFDM QPSK	10 MHz	All RBs / REFSSENS_ENDC_4
6 <sup>4</sup>	3	UL 1765 / DL 1860			n77/n78	UL/DL 3435		
	QPSK	QPSK	5 MHz	All RBs / REFSSENS_ENDC_4	DFT-s-OFDM QPSK	CP-OFDM QPSK	10 MHz	All RBs / REFSSENS_ENDC_4
<b>Test Settings for a DC_5A_n66A Configuration</b>								
1 <sup>4</sup>	5	UL 838 / DL 883			n66	UL 1721 / DL 2121		
	QPSK	N/A	5 MHz	All RBs / REFSSENS_ENDC_4	N/A	CP-OFDM QPSK	5 MHz	All RBs / REFSSENS_ENDC_4
<b>Test Settings for a DC_5A_n77A Configuration</b>								
1 <sup>3</sup>	5	UL 837.5			n77	UL/DL 3350.01		
	QPSK	QPSK	10 MHz	All RBs / REFSSENS_ENDC_1	N/A	CP-OFDM QPSK	100 MHz	All RBs / 0
2 <sup>3</sup>	5	UL 829			n77	UL/DL 4145.01		
	QPSK	QPSK	10 MHz	All RBs / REFSSENS_ENDC_1	N/A	CP-OFDM QPSK	100 MHz	All RBs / 0
3 <sup>8</sup>	5	UL Mid (836.5 MHz)			n77	UL/DL Mid		
	QPSK	QPSK	10 MHz	All RBs / REFSSENS_ENDC_1	N/A	CP-OFDM QPSK	100 MHz	All RBs / 0
4 <sup>4, 13</sup>	5	UL 844 / DL 889			n77	UL/DL 3421.005		
	QPSK	QPSK	5 MHz	All RBs / REFSSENS_ENDC_4	DFT-s-OFDM QPSK	CP-OFDM QPSK	10 MHz	All RBs / REFSSENS_ENDC_4
5 <sup>4, 13</sup>	5	UL 826.5 / DL 871.5			n77	UL/DL 4177.5		
	QPSK	QPSK	5 MHz	All RBs / REFSSENS_ENDC_4	DFT-s-OFDM QPSK	CP-OFDM QPSK	10 MHz	All RBs / REFSSENS_ENDC_4
<b>Test Settings for DC_5A_n78A Configuration</b>								
1 <sup>3</sup>	5	UL 840			n78	UL/DL 3360		
	QPSK	QPSK	10 MHz	All RBs / REFSSENS_ENDC_1	N/A	CP-OFDM QPSK	100 MHz	All RBs / 0
2 <sup>8</sup>	5	UL 840			n78	UL/DL 3560.01		
	QPSK	QPSK	10 MHz	All RBs / REFSSENS_ENDC_1	N/A	CP-OFDM QPSK	100 MHz	All RBs / 0
3 <sup>4</sup>	5	UL 844 / DL 889			n78	UL/DL 3421.005		
	QPSK	QPSK	5 MHz	All RBs / REFSSENS_ENDC_4	DFT-s-OFDM QPSK	CP-OFDM QPSK	10 MHz	All RBs / REFSSENS_ENDC_4
<b>Test Settings for a DC_7A_n3A Configuration</b>								
1 <sup>4</sup>	7	DL 2655			n3	DL 1825		

	QPSK	N/A	10 MHz	N/A	N/A	CP-OFDM QPSK	5 MHz	All RBs / REFSSENS_ENDC_4
<b>Test Settings for a DC_7A_n5A Configuration</b>								
1 <sup>4</sup>	7	DL 2667			n5	DL 879		
	QPSK	N/A	10 MHz	N/A	N/A	CP-OFDM QPSK	5 MHz	All RBs / REFSSENS_ENDC_4
<b>Test Settings for a DC_7A_n66A Configuration</b>								
1 <sup>4</sup>	7	DL 2655			n66	DL 2130		
	QPSK		10 MHz	N/A	N/A	CP-OFDM QPSK	5 MHz	All RBs / REFSSENS_ENDC_4
<b>Test Settings for a DC_7A_n71A Configuration</b>								
1 <sup>3</sup>	7	DL 2672			n71	UL / 668		
	QPSK	QPSK	20 MHz	All RBs / REFSSENS_ENDC_1	N/A	CP-OFDM QPSK	5 MHz	All RBs / REFSSENS_ENDC_1
2 <sup>8</sup>	7	DL 2630			n71	UL 668		
	QPSK	QPSK	20 MHz	All RBs / REFSSENS_ENDC_1	N/A	CP-OFDM QPSK	5 MHz	All RBs / REFSSENS_ENDC_1
<b>Test Settings for a DC_7A_n77A Configuration</b>								
1 <sup>4</sup>	7	DL 2660			N77	DL 3870		
	QPSK		5 MHz	N/A	N/A	CP-OFDM QPSK	10 MHz	All RBs / REFSSENS_ENDC_4
<b>Test Settings for a DC_7A_n78A Configuration</b>								
1 <sup>6</sup>	7	High			n78	Low		
	QPSK	QPSK	20 MHz	All RBs / REFSSENS_ENDC_3	N/A	CP-OFDM QPSK	100 MHz	All RBs / 0
<b>Test Settings for a DC_8A_n1A Configuration</b>								
1 <sup>4</sup>	8	DL 932.5			n1	DL 2155		
	QPSK	N/A	5 MHz	N/A	N/A	CP-OFDM QPSK	5 MHz	All RBs / REFSSENS_ENDC_4
<b>Test Settings for a DC_8A_n3A Configuration</b>								
1 <sup>4</sup>	8	DL 945			n3	DL 1850		
	QPSK	N/A	5 MHz	N/A	N/A	CP-OFDM QPSK	10 MHz	All RBs / REFSSENS_ENDC_4
2 <sup>4</sup>	8	DL 942.5			n3	DL 1842.5		
	QPSK	N/A	5 MHz	N/A	N/A	CP-OFDM QPSK	10 MHz	All RBs / REFSSENS_ENDC_4
<b>Test Settings for a DC_8A_n20A Configuration</b>								
1 <sup>4</sup>	8	UL 890.5 / DL 935.5			n20	UL 849.5 / DL 808.5		
	QPSK	QPSK	5 MHz	All RBs / REFSSENS_ENDC_4	DFT-s-OFDM QPSK	CP-OFDM QPSK	5 MHz	All RBs / REFSSENS_ENDC_4
2 <sup>4</sup>	8	UL 892.5 / DL 937.5			n20	UL 847.5 / DL 806.5		
	QPSK	QPSK	5 MHz	All RBs / REFSSENS_ENDC_4	DFT-s-OFDM QPSK	CP-OFDM QPSK	5 MHz	All RBs / REFSSENS_ENDC_4
<b>Test Settings for a DC_8A_n41A Configuration</b>								
1 <sup>3</sup>	8	UL 885 / DL 942.5 MHz			n41	UL / DL 2655 MHz		
	QPSK	QPSK	10 MHz	All RBs / REFSSENS_ENDC_1	N/A	CP-OFDM QPSK	60 MHz	All RBs / 0
2 <sup>8</sup>	8	UL 885 / DL 942.5 MHz			n41	UL / DL 2546 MHz		

	QPSK	QPSK	10 MHz	All RBs / REFSENS_ENDC_1	N/A	CP-OFDM QPSK	60 MHz	All RBs / 0
3 <sup>4</sup>	8	UL 882.5 / DL 927.5 MHz			n41	UL / DL 2685MHz		
	QPSK	QPSK	5 MHz	All RBs / REFSENS_ENDC_4	DFT-s- OFDM QPSK	CP-OFDM QPSK	10 MHz	All RBs / REFSENS_ENDC_4
<b>Test Settings for DC_8A_n77A and DC_8A_n78A Configurations</b>								
1 <sup>3</sup>	8	Mid			n77	UL/DL 3590.01		
	QPSK	QPSK	10 MHz	All RBs / REFSENS_ENDC_1	N/A	CP-OFDM QPSK	100 MHz	All RBs / 0
2 <sup>8</sup>	8	Mid			n77	UL/DL 3520.005		
	QPSK	QPSK	10 MHz	All RBs / REFSENS_ENDC_1	N/A	CP-OFDM QPSK	100 MHz	All RBs / 0
3 <sup>4</sup>	8	UL 897.5			n77	UL/DL 3634.995		
	QPSK	QPSK	5 MHz	All RBs / REFSENS_ENDC_4	DFT-s- OFDM QPSK	CP-OFDM QPSK	10 MHz	All RBs / REFSENS_ENDC_4
<b>Test Settings for a DC_11A_n79A Configuration</b>								
1 <sup>5</sup>	11	Mid			n79	UL/DL 4457.7		
	N/A	QPSK	10 MHz	All RBs / 0	DFT-s- OFDM QPSK	CP-OFDM QPSK	100 MHz	All RBs / REFSENS_ENDC_2
2 <sup>9</sup>	11	Mid			n79	UL/DL 4512.69		
	N/A	QPSK	10 MHz	All RBs / 0	DFT-s- OFDM QPSK	CP-OFDM QPSK	100 MHz	All RBs / REFSENS_ENDC_2
<b>Test Settings for a DC_12A_n66A Configuration</b>								
1 <sup>3</sup>	12	UL 710			n66	UL 1730 /DL 2130		
	QPSK	QPSK	5 MHz	All RBs / REFSENS_ENDC_1	N/A	CP-OFDM QPSK	5 MHz	All RBs / 0
2 <sup>3</sup>	12	UL 710			n66	UL 1730 /DL 2130		
	QPSK	QPSK	5 MHz	All RBs / REFSENS_ENDC_1	N/A	CP-OFDM QPSK	40 MHz	All RBs / 0
3 <sup>8</sup>	12	UL 710			n66	UL 1760 /DL 2160		
	QPSK	QPSK	5 MHz	All RBs / REFSENS_ENDC_1	N/A	CP-OFDM QPSK	40 MHz	All RBs / 0
<b>Test Settings for a DC_12A_n77A Configuration (PC2 and PC3)</b>								
1 <sup>3</sup>	12	Mid			n77	UL/DL 3537.495		
	QPSK	QPSK	10MHz	All RBs / REFSENS_ENDC_1	N/A	CP-OFDM QPSK	100 MHz	All RBs / 0
2 <sup>8</sup>	12	Mid			n77	UL/DL 3351		
	QPSK	QPSK	10MHz	All RBs / REFSENS_ENDC_1	N/A	CP-OFDM QPSK	100 MHz	All RBs / 0
3 <sup>5</sup>	12	Mid			n77	UL/DL 3687.495		
	N/A	QPSK	10 MHz	All RBs / 0	DFT-s- OFDM QPSK	CP-OFDM QPSK	100 MHz	All RBs / REFSENS_ENDC_2

4 <sup>9</sup>	12	Mid			n77	UL/DL 3750		
	N/A	QPSK	10 MHz	All RBs / 0	DFT-s-OFDM QPSK	CP-OFDM QPSK	100 MHz	All RBs / REFSSENS_ENDC_2
5 <sup>4</sup>	12	UL 702/DL 732			n77	UL/DL 3540		
	QPSK	QPSK	5 MHz	All RBs / REFSSENS_ENDC_4	DFT-s-OFDM QPSK	CP-OFDM QPSK	10 MHz	All RBs / REFSSENS_ENDC_4
<b>Test Settings for a DC_12A_n78A Configuration</b>								
1 <sup>3</sup>	12	UL 707/DL 737 MHz			n78	UL/DL 3535 MHz		
	QPSK	QPSK	10 MHz	All RBs / REFSSENS_ENDC_1	N/A	CP-OFDM QPSK	100 MHz	All RBs / 0
2 <sup>8</sup>	12	UL 707/DL 737 MHz			n78	UL/DL 3750 MHz		
	QPSK	QPSK	10 MHz	All RBs / REFSSENS_ENDC_1	N/A	CP-OFDM QPSK	100 MHz	All RBs / 0
3 <sup>4</sup>	12	UL 710/DL 740 MHz			n78	UL/DL 3580 MHz		
	QPSK	QPSK	5 MHz	All RBs / REFSSENS_ENDC_4	DFT-s-OFDM QPSK	CP-OFDM QPSK	10 MHz	All RBs / REFSSENS_ENDC_4
<b>Test Settings for a DC_13A_n77A Configuration</b>								
1 <sup>3</sup>	13	UL Mid			n77	UL/DL 3909.99		
	QPSK	QPSK	10 MHz	All RBs / REFSSENS_ENDC_1	N/A	CP-OFDM QPSK	100 MHz	All RBs / 0
2 <sup>8</sup>	13	UL Mid			n77	UL/DL Mid		
	QPSK	QPSK	10 MHz	All RBs / REFSSENS_ENDC_1	N/A	CP-OFDM QPSK	100 MHz	All RBs / 0
3 <sup>5</sup>	13	DL Mid			n77	UL/DL 3755		
	N/A	QPSK	10 MHz	All RBs / 0	DFT-s-OFDM QPSK	CP-OFDM QPSK	100 MHz	All RBs / REFSSENS_ENDC_2
4 <sup>9</sup>	13	DL Mid			n77	UL/DL 3850		
	N/A	QPSK	10 MHz	All RBs / 0	DFT-s-OFDM QPSK	CP-OFDM QPSK	100 MHz	All RBs / REFSSENS_ENDC_2
5 <sup>4</sup>	13	UL 784.5/DL 753.5			n77	UL/DL 3891.495		
	QPSK	QPSK	5 MHz	All RBs / REFSSENS_ENDC_4	DFT-s-OFDM QPSK	CP-OFDM QPSK	10 MHz	All RBs / REFSSENS_ENDC_4
<b>Test Settings for a DC_14A_n77A Configuration (PC2 and PC3)</b>								
1 <sup>3</sup>	14	Mid			n77	UL/DL 3964.995		
	QPSK	QPSK	10 MHz	All RBs / REFSSENS_ENDC_1	N/A	CP-OFDM QPSK	100 MHz	All RBs / 0
1 <sup>8</sup>	14	Mid			n77	UL/DL 3350.1		
	QPSK	QPSK	10 MHz	All RBs / REFSSENS_ENDC_1	N/A	CP-OFDM QPSK	100 MHz	All RBs / 0
2 <sup>5</sup>	14	Mid			n77	UL/DL 3814.995		

	N/A	QPSK	10 MHz	All RBs / 0	DFT-s-OFDM QPSK	CP-OFDM QPSK	100 MHz	All RBs / REFSSENS_ENDC_2
2 <sup>9</sup>	14	Mid			n77	UL/DL 3350.01		
	N/A	QPSK	10 MHz	All RBs / 0	DFT-s-OFDM QPSK	CP-OFDM QPSK	100 MHz	All RBs / REFSSENS_ENDC_2
3 <sup>4</sup>	14	UL 795.5/DL 765.5			n77	UL/DL 3947.5		
	QPSK	QPSK	5 MHz	All RBs / REFSSENS_ENDC_4	DFT-s-OFDM QPSK	CP-OFDM QPSK	10 MHz	All RBs / REFSSENS_ENDC_4
<b>Test Settings for a DC_18A_n77A Configuration (PC2 and PC3)</b>								
1 <sup>3</sup>	18	UL 820			n77	UL/DL 4100		
	QPSK	QPSK	10 MHz	All RBs / REFSSENS_ENDC_1	N/A	CP-OFDM QPSK	40 MHz	All RBs / 0
2 <sup>8</sup>	18	UL 820			n77	UL/DL 4000		
	QPSK	QPSK	10 MHz	All RBs / REFSSENS_ENDC_1	N/A	CP-OFDM QPSK	40 MHz	All RBs / 0
3 <sup>4.X</sup>	18	UL 827.5 / DL 872.5			n77	UL/DL 3355		
	QPSK	QPSK	5 MHz	All RBs / REFSSENS_ENDC_4	DFT-s-OFDM QPSK	CP-OFDM QPSK	10 MHz	All RBs / REFSSENS_ENDC_4
4 <sup>4.X</sup>	18	UL 817.5 / DL 862.5			n77	UL/DL 4130		
	QPSK	QPSK	5 MHz	All RBs / REFSSENS_ENDC_4	DFT-s-OFDM QPSK	CP-OFDM QPSK	10 MHz	All RBs / REFSSENS_ENDC_4
<b>Test Settings for a DC_18A_n78A Configuration</b>								
1 <sup>4.Y</sup>	18	UL 827.5 / DL 872.5			n77	UL/DL 3355		
	QPSK	QPSK	5 MHz	All RBs / REFSSENS_ENDC_4	DFT-s-OFDM QPSK	CP-OFDM QPSK	10 MHz	All RBs / REFSSENS_ENDC_4
<b>Test Settings for a DC_19A_n77A Configuration</b>								
1 <sup>3</sup>	19	UL 835			n77	UL/DL 4175		
	QPSK	QPSK	10 MHz	All RBs / REFSSENS_ENDC_1	N/A	CP-OFDM QPSK	40 MHz	All RBs / 0
2 <sup>8</sup>	19	UL 835			n77	UL/DL 4100		
	QPSK	QPSK	10 MHz	All RBs / REFSSENS_ENDC_1	N/A	CP-OFDM QPSK	40 MHz	All RBs / 0
3 <sup>3</sup>	19	UL 840			n77	UL/DL3360		
	QPSK	QPSK	10 MHz	All RBs / REFSSENS_ENDC_1	N/A	CP-OFDM QPSK	100 MHz	All RBs / 0
<b>Test Settings for a DC_19A_n78A Configuration (PC2 and PC3)</b>								
1 <sup>3</sup>	19	UL 840			n78	UL/DL3360		
	QPSK	QPSK	5 MHz	All RBs / REFSSENS_ENDC_1	N/A	CP-OFDM QPSK	10 MHz	All RBs / 0
2 <sup>4</sup>	19	UL 836.5/ DL 881.5			n78	UL/DL3391		
	QPSK	QPSK	5 MHz	All RBs / REFSSENS_ENDC_4	DFT-s-OFDM QPSK	CP-OFDM QPSK	10 MHz	All RBs / REFSSENS_ENDC_4
3 <sup>5</sup>	19	DL 880			n78	UL/DL3520		
	N/A	QPSK	5 MHz	All RBs / 0	DFT-s-OFDM QPSK	CP-OFDM QPSK	10 MHz	All RBs / REFSSENS_ENDC_2
<b>Test Settings for a DC_19A_n79A Configuration (PC2 and PC3)</b>								

1 <sup>5</sup>	19	DL 884			n79	UL/DL 4420		
	N/A	QPSK	10 MHz	All RBs / 0	DFT-s-OFDM QPSK	CP-OFDM QPSK	40 MHz	All RBs / REFSSENS_ENDC_2
2 <sup>9</sup>	19	DL 884			n79	UL/DL 4445.025		
	N/A	QPSK	10 MHz	All RBs / 0	DFT-s-OFDM QPSK	CP-OFDM QPSK	40 MHz	All RBs / REFSSENS_ENDC_2
<b>Test Settings for a DC_20A_n3A Configuration</b>								
1 <sup>4</sup>	20	UL 840 / DL 799			n3	UL 1775 / DL 1870		
	QPSK	QPSK	5 MHz	All RBs / REFSSENS_ENDC_4	DFT-s-OFDM QPSK	CP-OFDM QPSK	5 MHz	All RBs / REFSSENS_ENDC_4
2 <sup>4</sup>	20	UL 847 / DL 806			n3	UL 1735 / DL 1830		
	QPSK	QPSK	5 MHz	All RBs / REFSSENS_ENDC_4	DFT-s-OFDM QPSK	CP-OFDM QPSK	5 MHz	All RBs / REFSSENS_ENDC_4
<b>Test Settings for a DC_20A_n7A Configuration</b>								
1 <sup>4</sup>	20	UL 851 / DL 810			n7	UL 2512 / DL 2632		
	QPSK	QPSK	5 MHz	All RBs / REFSSENS_ENDC_4	DFT-s-OFDM QPSK	CP-OFDM QPSK	10 MHz	All RBs / REFSSENS_ENDC_4
<b>Test Settings for a DC_20A_n8A Configuration</b>								
1 <sup>4</sup>	20	UL 849.5 / DL 808.5			n8	UL 892.5 / DL 937.5		
	QPSK	QPSK	5 MHz	All RBs / REFSSENS_ENDC_4	DFT-s-OFDM QPSK	CP-OFDM QPSK	5 MHz	All RBs / REFSSENS_ENDC_4
<b>Test Settings for a DC_20A_n78A Configuration</b>								
1 <sup>8</sup>	20	Mid			n78	Mid		
	QPSK	QPSK	20 MHz	All RBs / REFSSENS_ENDC_1	N/A	CP-OFDM QPSK	100 MHz	All RBs / 0
2 <sup>3</sup>	20	Mid			n78	UL/DL 3387.99		
	QPSK	QPSK	20 MHz	All RBs / REFSSENS_ENDC_1	N/A	CP-OFDM QPSK	100 MHz	All RBs / 0
3 <sup>4</sup>	20	UL 850 / DL 809			n78	UL/DL 3358.995		
	QPSK	QPSK	5 MHz	All RBs / REFSSENS_ENDC_4	DFT-s-OFDM QPSK	CP-OFDM QPSK	10 MHz	All RBs / REFSSENS_ENDC_4
<b>Test Settings for a DC_21A_n28A Configuration</b>								
1 <sup>4</sup>	21	UL 1450.4 / DL 1498.4			n28	UL 735.5 / DL 790.5		
	QPSK	QPSK	5 MHz	All RBs / REFSSENS_ENDC_4	DFT-s-OFDM QPSK	CP-OFDM QPSK	5 MHz	All RBs / REFSSENS_ENDC_4
<b>Test Settings for a DC_21A_n79A Configuration (PC3)</b>								
1 <sup>5</sup>	21	DL 1503.4			n79	UL/DL 4510.2		
	N/A	QPSK	15 MHz	All RBs / 0	DFT-s-OFDM QPSK	QPSK	100 MHz	All RBs / REFSSENS_ENDC_2
2 <sup>9</sup>	21	DL 1503.4			n79	UL/DL 4800		
	N/A	QPSK	15 MHz	All RBs / 0	DFT-s-OFDM QPSK	QPSK	100 MHz	All RBs / REFSSENS_ENDC_2
3 <sup>4</sup>	21	UL 1457.5 / DL 1505.5			n79	UL/DL 4420.5		

	QPSK	QPSK	5 MHz	All RBs / REFSSENS_ENDC_4	DFT-s-OFDM QPSK	CP-OFDM QPSK	40 MHz	All RBs / REFSSENS_ENDC_4
<b>Test Settings for a DC_21A_n79A Configuration (PC2)</b>								
1 <sup>5</sup>	21	DL 1503.4			n79	UL/DL 4510.2		
	N/A	QPSK	15 MHz	All RBs / 0	DFT-s-OFDM QPSK	QPSK	100 MHz	All RBs / REFSSENS_ENDC_2
2 <sup>9</sup>	21	DL 1503.4			n79	UL/DL 4800		
	N/A	QPSK	15 MHz	All RBs / 0	DFT-s-OFDM QPSK	QPSK	100 MHz	All RBs / REFSSENS_ENDC_2
3 <sup>4</sup>	21	UL 1457.5/ DL 1505.5			n79	UL/DL 4420.5		
	QPSK	QPSK	5 MHz	All RBs / REFSSENS_ENDC_4	DFT-s-OFDM QPSK	CP-OFDM QPSK	10 MHz	All RBs / REFSSENS_ENDC_4
<b>Test Settings for a DC_25A_n41A Configuration</b>								
1 <sup>6</sup>	25	High			n41	Low		
	QPSK	QPSK	10 MHz	All RBs / 0	N/A	CP-OFDM QPSK	100 MHz	All RBs / REFSSENS_ENDC_3
2 <sup>6</sup>	25	High			n41	Low		
	QPSK	QPSK	15 MHz	All RBs / 0	N/A	QPSK	100 MHz	All RBs / REFSSENS_ENDC_3
3 <sup>6</sup>	25	High			n41	Mid		
	QPSK	QPSK	20 MHz	All RBs / 0	CP-OFDM QPSK	CP-OFDM QPSK	100 MHz	All RBs / REFSSENS_ENDC_3
<b>Test Settings for a DC_26A_n41A Configuration</b>								
1 <sup>3</sup>	26	High			n41	Low		
	QPSK	QPSK	5 MHz	All RBs / REFSSENS_ENDC_1	DFT-s-OFDM QPSK	CP-OFDM QPSK	100 MHz	All RBs / 0
1a <sup>3</sup>	26	High			n41	UL/DL 2537		
	QPSK	QPSK	5 MHz	All RBs / REFSSENS_ENDC_1	DFT-s-OFDM QPSK	CP-OFDM QPSK	10 MHz	All RBs / 0
2 <sup>8</sup>	26	High			n41	High		
	QPSK	QPSK	5 MHz	All RBs / REFSSENS_ENDC_1	N/A	QPSK	10 MHz	All RBs / 0
3 <sup>4</sup>	26	UL 839			n41	UL/DL 2562		
	QPSK	QPSK	5 MHz	All RBs / REFSSENS_ENDC_4	CP-OFDM QPSK	CP-OFDM QPSK	10 MHz	All RBs / REFSSENS_ENDC_4
4 <sup>5</sup>	26	DL 864			n41	Mid		
	QPSK	QPSK	5 MHz	All RBs / 0	DFT-s-OFDM QPSK	CP-OFDM QPSK	10 MHz	All RBs / REFSSENS_ENDC_2
5 <sup>5</sup>	26	Low			n41	Mid		
	QPSK	QPSK	15 MHz	All RBs / 0	DFT-s-OFDM QPSK	CP-OFDM QPSK	15 MHz	All RBs / REFSSENS_ENDC_2
6 <sup>8</sup>	26	High			n41	Mid		
	QPSK	QPSK	15 MHz	All RBs / 0	DFT-s-OFDM QPSK	CP-OFDM QPSK	15 MHz	All RBs / REFSSENS_ENDC_2
<b>Test Settings for a DC_26A_n77A/DC_26A_n78A Configuration</b>								
1 <sup>3</sup>	26	High			n77/n78	UL/DL 3366		
	QPSK	QPSK	15 MHz	All RBs / REFSSENS_ENDC_1	N/A	CP-OFDM QPSK	100 MHz	All RBs / 0

2 <sup>8</sup>	26	High			n77/n78	UL/DL 3446.01		
	QPSK	QPSK	15 MHz	All RBs / REFSENS_END C_1	N/A	CP-OFDM QPSK	100 MHz	All RBs / 0
3 <sup>4</sup>	26	UL 836.5			n77/n78	UL/DL 3391.005		
	QPSK	QPSK	5 MHz	All RBs / REFSENS_END C_4	CP-OFDM QPSK	CP-OFDM QPSK	10 MHz	All RBs / REFSENS_EN DC_4
<b>Test Settings for a DC_26A_n79A Configuration</b>								
1 <sup>5</sup>	26	High			n79	UL/DL 4432.5		
	N/A	QPSK	15 MHz	All RBs / 0	CP-OFDM QPSK	CP-OFDM QPSK	60 MHz	All RBs / REFSENS_EN DC_2
2 <sup>2.9</sup>	26	High			n79	UL/DL 4470.51		
	N/A	QPSK	15 MHz	All RBs / 0	CP-OFDM QPSK	CP-OFDM QPSK	60 MHz	All RBs / REFSENS_EN DC_2
<b>Test Settings for a DC_28A_n5A Configuration</b>								
1 <sup>6</sup>	28	High			n5	Low		
	QPSK	QPSK	20MHz	All RBs / REFSENS_END C_3	N/A	CP-OFDM QPSK	20 MHz	All RBs / 0
<b>Test Settings for a DC_28A_n77A (PC2 and PC3) /DC_28A_n78A Configuration (Test ID 4 only apply to DC_28A_n77A (PC2 and PC3))</b>								
1 <sup>3</sup>	28	Low			n77/n78	UL/DL 3540		
	QPSK	QPSK	10 MHz	All RBs / REFSENS_ENDC_1	N/A	CP-OFDM QPSK	100 MHz	All RBs / 0
2 <sup>8</sup>	28	Low			n77/n78	Low		
	QPSK	QPSK	10 MHz	All RBs / REFSENS_ENDC_1	N/A	CP-OFDM QPSK	100 MHz	All RBs / 0
3 <sup>4</sup>	28	UL 705.5 / DL 760.5			n77/n78	UL/DL 3582.495		
	QPSK	QPSK	5 MHz	All RBs / REFSENS_ENDC_4	CP- OFDM QPSK	CP-OFDM QPSK	10 MHz	All RBs / REFSENS_END C_4
4 <sup>5</sup>	28	Low			n77	UL/DL 3815.01		
	N/A	QPSK	10 MHz	All RBs / 0	CP- OFDM QPSK	CP-OFDM QPSK	100 MHz	All RBs / REFSENS_END C_2



Test Settings for a DC_30A_n66A Configuration								
1 <sup>6</sup>	30	Low			n66	High		
	N/A	QPSK	10 MHz	All RBs / 0	DFT-s-OFDM QPSK	CP-OFDM QPSK	40 MHz	All RBs / REFSSENS_EN DC_3
Test Settings for a DC_30A_n77A Configuration (PC2 and PC3)								
1 <sup>4</sup>	30	UL 2310			n77	UL/DL 3487.5		
	QPSK	QPSK	5 MHz	All RBs / REFSSENS_EN DC_4	CP-OFDM QPSK	CP-OFDM QPSK	10 MHz	All RBs / REFSSENS_EN DC_4
Test Settings for a DC_38A_n78A Configuration								
1 <sup>6</sup>	38	DL High			n78	UL Low		
	N/A	QPSK	10 MHz	All RBs / 0	DFT-s-OFDM QPSK	CP-OFDM QPSK	20 MHz	All RBs / REFSSENS_EN DC_3
Test Settings for a DC_39A_n41A Configuration								
1 <sup>6</sup>	39	UL 1910			n41	DL 2501		
	QPSK	N/A	20 MHz	All RBs / REFSSENS_EN DC_	DFT-s-OFDM QPSK	CP-OFDM QPSK	10 MHz	All RBs / 0
2 <sup>6</sup>	39	DL 1917.5			n41	UL 2546		
	QPSK	N/A	5 MHz	All RBs / 0_	DFT-s-OFDM QPSK	CP-OFDM QPSK	100 MHz	All RBs / REFSSENS_EN DC_
Test Settings for a DC_40A_n41A Configuration								
1 <sup>6</sup>	40	DL 2397.5			n41	UL 2546		
	QPSK	N/A	5 MHz	All RBs / 0_	DFT-s-OFDM QPSK	CP-OFDM QPSK	100 MHz	All RBs / REFSSENS_EN DC_
Test Settings for a DC_40A_n78A Configuration								
1 <sup>5</sup>	40	Mid			n78	UL/DL 3525		
	N/A	QPSK	20 MHz	All RBs / 0	DFT-s-OFDM QPSK	CP-OFDM QPSK	20 MHz	All RBs / REFSSENS_EN DC_2
2 <sup>9</sup>	40	Low			n78	Mid		
	QPSK	QPSK	20 MHz	All RBs / REFSSENS_EN DC_2	DFT-s-OFDM QPSK	CP-OFDM QPSK	100 MHz	All RBs / REFSSENS_EN DC_2
Test Settings for a DC_41A_n77A (PC2 and PC3)/DC_41A_n78A Configuration								
1 <sup>5</sup>	41	Low			n77/n78	UL/DL 3750		
	N/A	QPSK	20 MHz	All RBs / 0	DFT-s-OFDM QPSK	CP-OFDM QPSK	100 MHz	All RBs / REFSSENS_EN DC_2
2 <sup>6</sup>	41	High			n77/n78	Low		
	N/A	QPSK	20 MHz	All RBs / 0	DFT-s-OFDM QPSK	CP-OFDM QPSK	100 MHz	All RBs / REFSSENS_EN DC_3
3 <sup>6</sup>	41	High			n77/n78	Low		
	QPSK	QPSK	20MHz	All RBs / REFSSENS_EN DC_3	N/A	CP-OFDM QPSK	100 MHz	All RBs / 0
Test Settings for a DC_48A_n66A Configuration								
1 <sup>3</sup>	48	UL/DL 3555			n66	UL 1760 MHZ		
	N/A	QPSK	10 MHz	All RBs / 0	DFT-s-OFDM QPSK	CP-OFDM QPSK	40 MHz	All RBs / REFSSENS_EN DC_1
2 <sup>3</sup>	48	UL/DL 3565			n66	UL 1770		
	N/A	QPSK	10 MHz	All RBs / 0	DFT-s-OFDM QPSK	CP-OFDM QPSK	10 MHz	All RBs / REFSSENS_EN DC_1

3 <sup>8</sup>	48	UL/DL 3600			n66	UL1760		
	N/A	QPSK	10 MHz	All RBs / 0	DFT-s-OFDM QPSK	CP-OFDM QPSK	40 MHz	All RBs / REFSENS_EN DC_1
4 <sup>4</sup>	48	UL/DL 3630			n66	UL 1715 / DL 2115		
	QPSK	QPSK	20 MHz	All RBs / REFSENS_END C_4	DFT-s-OFDM QPSK	CP-OFDM QPSK	5 MHz	All RBs / REFSENS_EN DC_4
<b>Test Settings for a DC_66A_n2A Configuration</b>								
1 <sup>4</sup>	66	UL1775 / DL2175			n2	UL 1855 / DL 1935		
	QPSK	QPSK	5 MHz	All RBs / REFSENS_END C_4	DFT-s-OFDM QPSK	CP-OFDM QPSK	5 MHz	All RBs / REFSENS_EN DC_4
2 <sup>4</sup>	66	UL 1750/ DL 2150			n2	UL 1883.3 / DL 1963.3		
	QPSK	QPSK	5 MHz	All RBs / REFSENS_END C_4	DFT-s-OFDM QPSK	CP-OFDM QPSK	5 MHz	All RBs / REFSENS_EN DC_4
<b>Test Settings for a DC_66A_n5A Configuration</b>								
1 <sup>4</sup>	66	UL 1721/ DL 2121			n5	UL 838/ DL 883		
	QPSK	QPSK	5 MHz	All RBs / REFSENS_END C_4	DFT-s-OFDM QPSK	CP-OFDM QPSK	5 MHz	All RBs / REFSENS_EN DC_4
<b>Test Settings for a DC_66A_n25A Configuration</b>								
1 <sup>4</sup>	66	UL 1775/ DL 2175			n25	UL 1855/ DL 1935		
	QPSK	QPSK	5 MHz	All RBs / REFSENS_END C_4	DFT-s-OFDM QPSK	CP-OFDM QPSK	5 MHz	All RBs / REFSENS_EN DC_4
2 <sup>4</sup>	66	UL 1712.5/ DL 2112.5			n25	UL 1912.5/ DL 1992.5		
	QPSK	QPSK	5 MHz	All RBs / REFSENS_END C_4	DFT-s-OFDM QPSK	CP-OFDM QPSK	5 MHz	All RBs / REFSENS_EN DC_4
3 <sup>4</sup>	66	UL 1750/ DL 2150			n25	UL 1883.3/ DL 1963.3		
	QPSK	QPSK	5 MHz	All RBs / REFSENS_END C_4	DFT-s-OFDM QPSK	CP-OFDM QPSK	5 MHz	All RBs / REFSENS_EN DC_4
<b>Test Settings for a DC_66A_n41A Configuration (PC2 and PC3)</b>								
1 <sup>6</sup>	66	High			n41	Low		
	N/A	QPSK	20 MHz	All RBs / 0	DFT-s-OFDM QPSK	CP-OFDM QPSK	100 MHz	All RBs / REFSENS_EN DC_3
<b>Test Settings for a DC_66A_n71A Configuration</b>								
1 <sup>4</sup>	66	UL 1750/ DL 2150			n71	UL 675/ DL 629		
	QPSK	QPSK	5 MHz	All RBs / REFSENS_END C_4	DFT-s-OFDM QPSK	CP-OFDM QPSK	5 MHz	All RBs / REFSENS_EN DC_4

Test Settings for a DC_66A_n77A Configuration								
1 <sup>3</sup>	66	UL 1720			n77	UL/DL 3440.01		
	QPSK	QPSK	20	All RBs / REFSENS_END C_1	N/A	CP-OFDM QPSK	100 MHz	All RBs / 0
2 <sup>3</sup>	66	UL 1720			n77	UL/DL 3410		
	QPSK	QPSK	20	All RBs / REFSENS_END C_1	N/A	CP-OFDM QPSK	20 MHz	All RBs / 0
3 <sup>8</sup>	66	UL Mid			n77	UL/DL Mid		
	QPSK	QPSK	20	All RBs / REFSENS_END C_1	N/A	CP-OFDM QPSK	100 MHz	All RBs / 0
4 <sup>4</sup>	66	UL 1775/ DL 2175			n77	UL/DL 3949.995		
	QPSK	QPSK	5 MHz	All RBs / REFSENS_END C_4	DFT-s-OFDM QPSK	CP-OFDM QPSK	10 MHz	All RBs / REFSENS_EN DC_4
5 <sup>4</sup>	66	UL 1760 / DL 2160			n77	UL/DL 3720		
	QPSK	QPSK	5 MHz	All RBs / REFSENS_END C_4	DFT-s-OFDM QPSK	CP-OFDM QPSK	10 MHz	All RBs / REFSENS_EN DC_4
6 <sup>6, 16</sup>	66	DL 2197.5			n77	UL/DL 3350		
	QPSK	QPSK	5 MHz	All RBs / 0	DFT-s-OFDM QPSK	CP-OFDM QPSK	100 MHz	All RBs / REFSENS_EN DC_3
Test Settings for a DC_66A_n78A Configuration								
1 <sup>3</sup>	66	UL 1755			n78	UL/DL 3510		
	QPSK	QPSK	20 MHz	All RBs / REFSENS_END C_1	N/A	CP-OFDM QPSK	100 MHz	All RBs / 0
2 <sup>3</sup>	66	UL 1755			n78	UL/DL 3480		
	QPSK	QPSK	20 MHz	All RBs / REFSENS_END C_1	N/A	CP-OFDM QPSK	20 MHz	All RBs / 0
3 <sup>4</sup>	66	UL 1730/ DL2130			n78	UL/DL 3660		
	QPSK	QPSK	5 MHz	All RBs / REFSENS_END C_4	DFT-s-OFDM QPSK	CP-OFDM QPSK	10 MHz	All RBs / REFSENS_EN DC_4
Test Settings for DC_71A_n2A Configuration								
1 <sup>3</sup>	71	UL 665.5			n2	DL 1987.5		
	QPSK	QPSK	5MHz	All RBs / REFSENS_END C_1	DFT-s-OFDM QPSK	CP-OFDM QPSK	5 MHz	All RBs / 0
2 <sup>3</sup>	71	UL 673			n2	DL1980		
	QPSK	QPSK	20 MHz	All RBs / REFSENS_END C_1	DFT-s-OFDM QPSK	CP-OFDM QPSK	20 MHz	All RBs / 0
3 <sup>5</sup>	71	Low			n2	UL 1881		
	QPSK	QPSK	20 MHz	All RBs / 0	DFT-s-OFDM QPSK	CP-OFDM QPSK	20 MHz	All RBs / REFSENS_EN DC_2
4 <sup>9</sup>	71	High			n2	UL 1881		
	QPSK	QPSK	20 MHz	All RBs / 0	DFT-s-OFDM QPSK	CP-OFDM QPSK	20 MHz	All RBs / REFSENS_EN DC_2
Test Settings for DC_71A_n66A Configuration								
1 <sup>4</sup>	71	UL 675/ DL 629			n66	UL1750/ DL 2150		
	QPSK	QPSK	5 MHz	All RBs / REFSENS_END C_4	DFT-s-OFDM QPSK	CP-OFDM QPSK	5 MHz	All RBs / REFSENS_EN DC_4

- NOTE 1: REFSSENS\_LTE refers to the single carrier Uplink RB allocation for reference sensitivity according to table 7.3.3-2 of TS 36.521-1 [10].  
 REFSSENS\_NR refers to the single carrier Uplink RB allocation for reference sensitivity according to table 7.3.2.4.1-3 of TS 38.521-1 [8].  
 REFSSENS\_ENDC\_1 refers to the Uplink RB allocation for reference sensitivity exceptions due to UL harmonic interference according to table 7.3B.2.0.3.1-1.  
 REFSSENS\_ENDC\_2 refers to the Uplink RB allocation for reference sensitivity exceptions due to receiver harmonic mixing according to table 7.3B.2.0.3.2-1.  
 REFSSENS\_ENDC\_3 refers to the Uplink RB allocation for reference sensitivity exceptions due to cross band isolation according to table 7.3B.2.0.3.4-1 for PC3 and Table 7.3B.2.0.3.4-1a for PC2  
 REFSSENS\_ENDC\_4 refers to the Uplink RB allocation for reference sensitivity exceptions due to dual uplink operation for ENDC according to table 7.3B.2.0.3.5.1-1 for PC3 and table 7.3B.2.0.3.5.1-1a for PC2.
- NOTE 2: Void
- NOTE 3: Test ID with UL harmonic exception
- NOTE 4: Test ID with 2UL intermodulation exception. The test point is only applicable to UEs not supporting UE capability *singleUL-Transmission*.
- NOTE 5: Test ID with UL receiver harmonic mixing
- NOTE 6: Test ID with UL cross band isolation
- NOTE 7: Void
- NOTE 8: Test ID with UL harmonic exception avoided
- NOTE 9: Test ID with UL receiving harmonic mixing exception avoided
- NOTE 10: Void
- NOTE 11: Test ID with Cross band isolation exception avoided, which is only applicable to DC\_1\_n3, DC\_3\_n1 and DC\_3\_n84.
- NOTE 12: In an E-UTRA band or FR1 band where UE supports 4Rx, the test shall be performed only with 4Rx antennas ports connected.
- NOTE 13: For a UE which supports this band combination only when the Band n77 frequency range restriction defined in NOTE 12 of Table 5.2-1 from TS 38.101-1 applies, the MSD test point(s) cannot be verified for the band combination and the test point(s) can be skipped.
- NOTE 14: If the NR frequency does not match to a valid NR-ARFCN, apply the closest NR frequency with a valid NR-ARFCN.
- NOTE 15: The test points are executed only when UEs support simultaneous Rx/Tx capability as indicated in Table A.4.3.2B.2.3.1-2 of TS 38.508-2.
- NOTE 16: This test ID is for UL PC2 only.
- NOTE 17: For a UE which supports this band combination only when the Band n77 frequency range restriction of 3400 - 4100 MHz in Japan applies, the MSD test point(s) cannot be verified for the band combination and the test point(s) can be skipped.
- NOTE 18: For a UE which supports this band combination only when the Band n78 frequency range restriction of 3400 - 3800 MHz in Japan applies, the MSD test point(s) cannot be verified for the band combination and the test point(s) can be skipped.

1. Connect the SS to the UE antenna connectors as shown in TS 38.508-1 [6] Annex A, Figure A.3.1.1.1 for TE diagram and clause A.3.2 for UE diagram.
2. The parameter settings for NR cell are set up according to TS 38.508-1 [6] clause 4.4.3.
3. The parameter settings for E-UTRA cell are set up according to TS 36.508 [11] clause 4.4.3.
4. NR downlink signals are initially set up according to Annex C.0, C.1, C.2, C.3.1, and uplink signals according to Annex G.0, G.1, G.2, and G.3.1 of TS 38.521-1 [8].
5. E-UTRA downlink signals are initially set up according to Annex C.0, C.1 and C.3.0, and uplink signals according to Annex H.1 and H.3.0 of TS 36.521-1 [10].
6. The DL and UL Reference Measurement channels are set according to Tables 7.3B.2.3.4.2.1-0 to 7.3B.2.3.4.2.1-6 for E-UTRA CG and NR CG.
7. NR propagation conditions are set according to Annex B.0 of TS 38.521-1 [8]. E-UTRA propagation conditions are set according to Annex B.0 of TS 36.521-1 [10].
8. Ensure the UE is in state RRC\_CONNECTED with generic procedure parameters Connectivity EN-DC, DC bearer MCG and SCG, Connected without release *On* according to TS 38.508-1 [6] clause 4.5. Message contents are defined in clause 7.3B.2.3.4.2.3.
9. On the E-UTRA carrier, disable periodic and aperiodic CQI reports, disable SRS, set *TimeAlignmentTimerDedicated* IE to infinity and disable downlink and uplink scheduling, all as per Table 4.6-1 under clause 4.6. Step 9 only applicable to the test configuration in Table 7.3B.2.3.4.2.1-0.

## 7.3B.2.3.4.2.2 Test procedure

For test points in Table 7.3B.2.3.4.2.1-0:

1. NR SS transmits PDSCH via PDCCH DCI format 1\_1 for C\_RNTI to transmit the DL RMC according to Table 7.3B.2.3.4.2.1-0 on the NR CC. The NR SS sends downlink MAC padding bits on the DL RMC.
2. NR SS sends uplink scheduling information for each UL HARQ process via PDCCH DCI format 0\_1 for C\_RNTI to schedule the UL RMC according to Table 7.3B.2.3.4.2.1-0. Since the UL has no payload and no loopback data to send the UE sends uplink MAC padding bits on the UL RMC.
3. Set the Downlink signal level to the appropriate REFSENS value defined in TS 38.521-1 [8] Table 7.3.2.5-1 for NR band. Send continuously uplink power control "up" commands in the uplink scheduling information to both carriers to ensure the UE transmits PUMAX level for at least the duration of the Throughput measurement.
4. Measure the average throughput of the NR carrier for a duration sufficient to achieve statistical significance according to Annex H.2 of TS 38.521-1 [8] for NR band.

For test points in Table 7.3B.2.3.4.2.1-6:

1. SS transmits PDSCH via PDCCH DCI format 1A and PDCCH DCI format 1\_1 for C\_RNTI to transmit the DL RMC according to Table 7.3B.2.3.4.2.1-6 on the E-UTRA CC and NR CC. The SS sends downlink MAC padding bits on the DL RMC.
2. SS sends uplink scheduling information for each UL HARQ process via PDCCH DCI format 0 and DCI format 0\_1 for C\_RNTI to schedule the UL RMC according to Table 7.3B.2.3.4.2.1-6 on the E-UTRA CC and NR CC. Since the UL has no payload and no loopback data to send the UE sends uplink MAC padding bits on the UL RMC.
3. Set the Downlink signal level for the E-UTRA CC and NR CC to the appropriate REFSENS value defined in clause 7.3B.2.3.5. Send continuously uplink power control "up" commands in the uplink scheduling information to both carriers to ensure the UE transmits PUMAX level for at least the duration of the Throughput measurement.
4. Measure the average throughput of both NR and E-UTRA for a duration sufficient to achieve statistical significance according to Annex H.2 of TS 38.521-1 [8] for NR band, and Annex G.2 of TS 36.521-1 [10] for EUTRA band.

## 7.3B.2.3.4.2.3 Message contents

Message contents are according to TS 38.508-1 [6] clause 4.6 Table 4.6.3-118 with condition TRANSFORM\_PRECODER\_ENABLED for NR band.

Message contents exceptions for E-UTRA band are according to TS 36.521-1 [10] clause 7.3.4.3 for each network signalling value. Message contents exceptions for NR band are according to TS 38.521-1 [8] clause 7.3.2.4.3 for each network signalling value.

For test points with NOTE 4 in Table 7.3B.2.3.4.2.1-6, the following message exception applies:

**Table 7.3B.2.3.4.2.3-1: RRCConnectionReconfiguration: nr-Config-r15**

Derivation Path: TS 36.508 [11], Table 4.6.1-8			
Information Element	Value/remark	Comment	Condition
p-MaxEUTRA-r15	23		Power Class 2 UE
	20		Power Class 3 UE

**Table 7.3B.2.3.4.2.3-2: PhysicalCellGroupConfig**

Derivation Path: TS 38.508-1 [6] Table 4.6.3-106			
Information Element	Value/remark	Comment	Condition
p-NR-FR1	23		Power Class 2 UE
	20		Power Class 3 UE

## 7.3B.2.3.5 Test requirement

For inter-band EN-DC configurations affected by reference sensitivity exceptions, when test points without NOTE 8, 9 and 11 in Table 7.3B.2.3.4.2.1-6 are tested, the throughput of each CG shall be  $\geq 95\%$  of the maximum throughput for the reference receive power level specified in Table 7.3B.2.3.5-0, Table 7.3B.2.3.5-1, Table 7.3B.2.3.5-2, Table 7.3B.2.3.5-3, Table 7.3B.2.3.5-3a, Table 7.3B.2.3.5-4 and Table 7.3B.2.3.5-5 for MSDs due to uplink harmonic, harmonic mixing, cross band isolation for PC3 EN-DC, cross band isolation for PC2 EN-DC, dual uplinks for PC3 EN-DC and dual uplink operation for PC2 EN-DC, respectively. For a given EN-DC combo, if more than one category of MSD applies, UE shall pass all requirement.

For test points with NOTE 8, 9 or 11 in Table 7.3B.2.3.4.2.1-6, reference sensitivity test requirements are specified in Table 7.3.2.5-1 in TS 38.521-1 [8] for the NR CC, and Table 7.3.5-1 in TS 36.521-1 [10] for E-UTRA CC.

Reference sensitivity test requirements for test points in Table 7.3B.2.3.4.2.1-0 are specified in Table 7.3.2.5-1 in TS 38.521-1 [8].

For the UE which supports inter-band EN-DC, the minimum requirement for reference sensitivity in Table 7.3.2.5-1 of TS 38.521-1 [8] for NR band and Table 7.3.5-1 of TS 36.521-1 [10] for EUTRA band, shall be increased by the amount given in  $\Delta R_{IB,c}$  defined in clause 7.3B.3.3 for the applicable two, three, four and five bands operation.

**Table 7.3B.2.3.5-0: Reference sensitivity requirement for PC3 EN-DC**

CA configuration	Test ID	DL band	CBW (MHz)	REFSENS test requirement (dBm)	Exception type
DC_39A_n41A	1	39	20	REFSENS	Cross band isolation
		n41	10	-91.5+TT	
	2	39	5	-97.7	Cross band isolation
		n41	100	REFSENS	
DC_40A_n41A	1	40	5	-67.9	Cross band isolation Cross band isolation
		n41	100	REFSENS	
DC_26A_n41A	1	26	5	REFSENS	UL harmonic interference
		n41	100	-81.8+TT	
	1a	26	5	REFSENS	
		n41	10	-81.1+TT	
	2	26	5	REFSENS	UL harmonic exception avoided
		n41	10	REFSENS	
	3	26	5	-81.2	dual uplink operation
		n41	10	REFSENS	
	4	26	5	-72.5	harmonic mixing
		n41	10	REFSENS	
	5	26	15	-69.5	
		n41	15	REFSENS	
	6	26	15	REFSENS	harmonic mixing avoiding
		n41	15	REFSENS	

NOTE 1: The symbol "REFSENS" in this table refers to the reference sensitivity values for single carrier specified in Table 7.3.5-1 of TS 36.521-1 [10] for 2 antenna port E-UTRA band, Table 7.3\_1.5-1 of TS 36.521-1 [10] for 4 antenna port E-UTRA band, Table 7.3.2.5-1a and Table 7.3.2.5-1b for 2 antenna port NR band, Table 7.3.2.5-2a and Table 7.3.2.5-2b for 4 antenna port NR band.

**Table 7.3B.2.3.5-1: Reference sensitivity due to UL harmonic for EN-DC in NR FR1**

UL band	DL band	SCS (kHz)	5 MHz (dBm)	10 MHz (dBm)	15 MHz (dBm)	20 MHz (dBm)	25 MHz (dBm)	30 MHz (dBm)	40 MHz (dBm)	50 MHz (dBm)	60 MHz (dBm)	80 MHz (dBm)	90 MHz (dBm)	100 MHz (dBm)	
1, 3	n77 <sup>2</sup>	15		-71.4 +TT	-71.4 +TT	-71.3 +TT			- 71.2 +TT	- 71.3 +TT					
		30		-71.7 +TT	-71.5 +TT	-71.5 +TT			- 71.3 +TT	- 71.4 +TT	- 71.4 +TT	- 71.3 +TT	- 71.3 +TT	- 71.3 +TT	
		60		-72.1 +TT	-71.8 +TT	-71.7 +TT			- 71.5 +TT	- 71.5 +TT	- 71.5 +TT	- 71.4 +TT	- 71.4 +TT	- 71.4 +TT	
	n77 <sup>3</sup>	15		-94.2 +TT	-92.7 +TT	-91.9 +TT									
		30		-94.5 +TT	-92.8 +TT	-92.1 +TT									
		60		-94.9 +TT	-93.1 +TT	-92.3 +TT									
2	n77 <sup>2</sup> , 13	15		-71.4 +TT	-71.4 +TT	-71.3 +TT			- 71.2 +TT	- 71.3 +TT					
		30		-71.7 +TT	-71.5 +TT	-71.5 +TT			- 71.3 +TT	- 71.4 +TT	- 71.4 +TT	- 71.3 +TT	- 71.3 +TT	- 71.3 +TT	
		60		-72.1 +TT	-71.8 +TT	-71.7 +TT			- 71.5 +TT	- 71.5 +TT	- 71.5 +TT	- 71.4 +TT	- 71.4 +TT	- 71.4 +TT	
	n77 <sup>3</sup>	15		-94.2 +TT	-92.7 +TT	-91.9 +TT									
		30		-94.5 +TT	-92.8 +TT	-92.1 +TT									
		60		-94.9 +TT	-93.1 +TT	-92.3 +TT									
2	n78 <sup>2</sup>	15		- 71.9+T T	-71.9 +TT	-71.8 +TT			- 71.7 +TT	- 71.8 +TT					
		30		-72.2 +TT	-72.0 +TT	-72.0 +TT			- 71.8 +TT	- 71.9 +TT	- 71.9 +TT	- 71.8 +TT	- 71.8 +TT	- 71.8 +TT	
		60		-72.6 +TT	-72.3 +TT	-72.2 +TT			- 72.0 +TT	- 72.0 +TT	- 72.0 +TT	- 71.9 +TT	- 71.9 +TT	- 71.9 +TT	
2	n78 <sup>3</sup>	15		-94.7 +TT	-93.2 +TT	-92.4 +TT									
		30		-94.9 +TT	-93.3 +TT	-92.6 +TT									
		60		--95.4 +TT	-93.6 +TT	-92.8 +TT									
3	n78 <sup>2</sup>	15		-71.9 +TT	-71.9 +TT	-71.8 +TT			- 71.7 +TT	- 71.8 +TT					
		30		-72.2 +TT	-72.0 +TT	-72.0 +TT			- 71.8 +TT	- 71.9 +TT	- 71.9 +TT	- 71.8 +TT	- 71.8 +TT	- 71.8 +TT	



		60		-72.6 +TT	-72.3 +TT	-72.2 +TT			- 72. 0 +TT	- 72. 0 +TT	- 72. 0 +TT	- 71. 9 +TT	- 71. 9 +TT	- 71. 9 +TT
	n78 <sup>3</sup>	15		-94.7 +TT	-93.2 +TT	-92.4 +TT								
		30		-95.0 +TT	-93.3 +TT	-92.6 +TT								
		60		-95.4 +TT	-93.6 +TT	-92.8 +TT								
5	n78	15		-84.2 +TT	-84.4 +TT				- 84. 2 +TT	- 84. 4 +TT				
		30		-84.3 +TT	-84.5 +TT	-84.4 +TT			- 84. 3 +TT	- 84. 5 +TT	- 84. 4 +TT	- 84. 3 +TT	- 84. 0 +TT	- 84. 2 +TT
		60		-84.5 +TT	-84.6 +TT	-84.5 +TT			- 84. 5 +TT	- 84. 6 +TT	- 84. 5 +TT	- 84. 4 +TT	- 84. 1 +TT	- 84. 3 +TT
8	n77 <sup>6,7</sup> n78 <sup>6,7</sup>	15		-84.5 +TT	-84.4 +TT	-84.2 +TT			- 84. 0 +TT	- 83. 9 +TT				
		30		-84.8 +TT	-84.5 +TT	-84.4 +TT			- 84. 1 +TT	- 84. 0 +TT	- 83. 9 +TT	- 83. 8 +TT	- 83. 5 +TT	- 83. 7 +TT
		60		-85.2 +TT	-84.8 +TT	-84.6 +TT			- 84. 3 +TT	- 84. 1 +TT	- 84. 0 +TT	- 83. 9 +TT	- 83. 6 +TT	- 83. 8 +TT
8	n41	15		-81.8 +TT	-81.7 +TT	-81.7 +TT			- 81. 6 +TT	- 81. 5 +TT				
		30		-82.1 +TT	-81.8 +TT	-81.9 +TT			- 81. 7 +TT	- 81. 6 +TT	- 81. 4 +TT	- 81. 3 +TT	- 81. 2 +TT	- 81. 2 +TT
		60		-82.5 +TT	-82.1 +TT	-81.1 +TT			- 81. 9 +TT	- 81. 7 +TT	- 81. 6 +TT	- 81. 3 +TT	- 81. 2 +TT	- 81. 2 +TT
12	n66	15	- 89. 5 +TT	-88.8 +TT	-88.3 +TT	-87.8 +TT			- 87. 7 +TT					
		30		-89.1 +TT	-88.4 +TT	-88.0 +TT			- 87. 8 +TT					
		60		-89.5 +TT	-88.7 +TT	-88.2 +TT			- 87. 9 +TT					
12	n77 <sup>4,5</sup>	15		-84.9 +TT	-84.6 +TT	-84.4 +TT			- 84. 4 +TT	- 84. 4 +TT				

		30		-85.2 +TT	-84.7 +TT	-84.6 +TT			- 84. 5 +TT	- 84. 5 +TT	- 84. 4 +TT	- 84. 4 +TT	- 84. 4 +TT	- 84. 4 +TT
		60		-85.6 +TT	-85 +TT	-84.8 +TT			- 84. 7 +TT	- 84. 6 +TT	- 84. 5 +TT	- 84. 5 +TT	- 84. 5 +TT	- 84. 5 +TT
12	n78	15		-85.4 +TT	-85.1 +TT	-84.9 +TT	- 84.6+T T	- 84.4+T T	- 84. 9 +TT	- 84. 9 +TT				
		30		-85.7 +TT	-85.2 +TT	-85.1 +TT	- 84.7+T T	- 84.5+T T	- 85. 0 +TT	- 85. 0 +TT	- 84. 9 +TT	- 84. 9 +TT	- 84. 9 +TT	- 84. 9 +TT
		60		-86.1 +TT	-85.5 +TT	-85.3 +TT	- 84.9+T T	- 84.6+T T	- 85. 2 +TT	- 85. 1 +TT	- 85. 0 +TT	- 85. 0 +TT	- 85. 0 +TT	- 85. 0 +TT
13	n77 <sup>4</sup> <sub>,5</sub>	15		-84.9 +TT	-84.6 +TT	-84.4 +TT			- 84. 4 +TT	- 84. 4 +TT				
		30		-85.2 +TT	-84.7 +TT	-84.6 +TT			- 84. 5 +TT	- 84. 5 +TT	- 84. 4 +TT	- 84. 4 +TT	- 84. 4 +TT	- 84. 4 +TT
		60		-85.6 +TT	-85 +TT	-84.8 +TT			- 84. 7 +TT	- 84. 6 +TT	- 84. 5 +TT	- 84. 5 +TT	- 84. 5 +TT	- 84. 5 +TT
14	n77 <sup>4</sup> <sub>,5</sub>	15		-84.9 +TT	-84.6 +TT	-84.4 +TT			- 84. 4 +TT	- 84. 4 +TT				
		30		-85.2 +TT	-84.7 +TT	-84.6 +TT			- 84. 5 +TT	- 84. 5 +TT	- 84. 4 +TT	- 84. 4 +TT	- 84. 4 +TT	- 84. 4 +TT
		60		-85.6 +TT	-85 +TT	-84.8 +TT			- 84. 7 +TT	- 84. 6 +TT	- 84. 5 +TT	- 84. 5 +TT	- 84. 5 +TT	- 84. 5 +TT
18	n77 <sup>4</sup> <sub>,5</sub> n78 <sup>4</sup> <sub>,5</sub>	15		-84.9 +TT	-84.6 +TT	-84.4 +TT			- 84. 4 +TT	- 84. 4 +TT				
		30		-85.2 +TT	-84.7 +TT	-84.6 +TT			- 84. 5 +TT	- 84. 5 +TT	- 84. 4 +TT	- 84. 4 +TT	- 84. 4 +TT	- 84. 4 +TT
		60		-85.6 +TT	-85.0 +TT	-84.8 +TT			- 84. 7 +TT	- 84. 6 +TT	- 84. 5 +TT	- 84. 5 +TT	- 84. 5 +TT	- 84. 5 +TT

19	n77 <sup>4,5</sup>	15		-84.9 +TT	- 84.6 +TT	- 84.4 +T T			- 84.4 +TT	- 84.4 +TT					
		30		-85.2 +TT	- 84.7 +TT	- 84.6 +T T			- 84.5 +TT	- 84.5 +TT	- 84.4 +TT	- 84.4 +TT	- 84.4 +TT	- 84.4 +TT	
		60		-85.6 +TT	- 85.0 +TT	- 84.8 +T T			- 84.7 +TT	- 84.6 +TT	- 84.5 +TT	- 84.5 +TT	- 84.5 +TT	- 84.5 +TT	
	n77 <sup>6,7</sup> n78 <sup>6,7</sup>	15		-84.8 +TT	- 84.6 +TT	- 84.4 +T T			- 83.7 +TT	- 83.9 +TT					
		30		-85.1 +TT	- 84.7 +TT	- 84.6 +T T			- 83.8 +TT	- 84.0 +TT	- 83.9 +TT	- 83.8 +TT	- 83.5 +TT	- 83.7 +TT	
		60		-85.5 +TT	- 85.0 +TT	- 84.8 +T T			- 84.0 +TT	- 84.1 +TT	- 84.0 +TT	- 83.9 +TT	- 83.6 +TT	- 83.8 +TT	
	21	n28	15	- 96.0 +TT	-93.0 +TT	-91.0 +TT	-88.3 +TT			-76.0 +TT					
			30		-93.1 +TT	-91.1 +TT	-89.5 +TT			-76.1 +TT					
	28	n77 <sup>4,5</sup> n78 <sup>4,5</sup>	15		-84.9 +TT	-84.6 +TT	-84.4 +TT			- 84.4 +TT	- 84.4 +TT				
30				-85.2 +TT	-84.7 +TT	-84.6 +TT			- 84.5 +TT	- 84.5 +TT	- 84.4 +TT	- 84.4 +TT	- 84.4 +TT	- 84.4 +TT	
60				-85.6 +TT	-85.0 +TT	-84.8 +TT			- 84.7 +TT	- 84.6 +TT	- 84.5 +TT	- 84.5 +TT	- 84.5 +TT	- 84.5 +TT	
20	n77 <sup>6,7</sup> n78 <sup>6,7</sup>	15		-84.5 +TT	-84.4 +TT	-84.2 +TT			- 83.1 +TT						
		30		-84.8 +TT	-84.5 +TT	-84.4 +TT			- 83.2 +TT						
		60		-85.2 +TT	-84.8 +TT	-84.6 +TT			- 83.4 +TT						
26	n77 <sup>6,7</sup> n78 <sup>6,7</sup>	15		-85.0 +TT	-84.9 +TT	-84.7 +TT			- 83.6 +TT	- 84.6 +TT					
		30		-85.3 +TT	- 85.0+T T	-84.9 +TT			- 83.7 +TT	- 84.7 +TT	- 84.7 +TT	- 84.6 +TT	- 84.6 +TT	- 84.6 +TT	

		60		-85.7 +TT	--85.3 +TT	--85.1 +TT			- 83. 9 +TT	- 84. 8 +TT	- 84. 8 +TT	- 84. 7 +TT	- 84. 7 +TT	- 84. 7 +TT
26	n77 <sup>4</sup> <sub>,5</sub>	15		-84.9 +TT	-84.6 +TT	-84.4 +TT			- 84. 4 +TT	- 84. 4 +TT				
		30		-85.2 +TT	-84.7 +TT	-84.6 +TT			- 84. 5 +TT	- 84. 5 +TT	- 84. 4 +TT	- 84. 4 +TT	- 85. 6 +TT	- 84. 4 +TT
		60		-85.6 +TT	-85.0 +TT	-84.8 +TT			- 84. 7 +TT	- 84. 6 +TT	- 84. 5 +TT	- 84. 5 +TT	- 85. 7 +TT	- 84. 5 +TT
		N/A	- 89. 1	-88.7	-88.3	-88.0								
71	n2 <sup>11</sup>	15	- 93. 4 +T T	-93.8 +TT	-92.3 +TT	-91.2 +TT								
		30		-94.1 +TT	-92.4 +TT	-91.4 +TT								
		60		-94.5 +TT	-92.7 +TT	-91.6 +TT								
71	n2 <sup>12</sup>	15	- 96. 3 +T T	-93.8 +TT	-92.3 +TT	-91.2 +TT								
		30		-94.1 +TT	-92.4 +TT	-91.4 +TT								
		60		-94.5 +TT	-92.7 +TT	-91.6 +TT								
n71	2 <sup>11</sup>	N/A	- 92. 7	-93.3	-91.8	-90.7								
n71	2 <sup>12</sup>	N/A	- 95. 6	-93.3	-91.8	-90.7								
n71	7	N/A	- 82. 7	-82.6	-82.4	-82.3								
66	n77 <sup>2</sup> <sub>,13</sub>	15		-71.4 +TT	-71.4 +TT	-71.3 +TT			- 71. 2 +TT	- 71. 3 +TT				
		30		-71.7 +TT	-71.5 +TT	-71.5 +TT			- 71. 3 +TT	- 71. 4 +TT	- 71. 4 +TT	- 71. 3 +TT	- 71. 3 +TT	- 71. 3 +TT
		60		-72.1 +TT	-71.8 +TT	-71.7 +TT			- 71. 5 +TT	- 71. 5 +TT	- 71. 5 +TT	- 71. 4 +TT	- 71. 4 +TT	- 71. 4 +TT
	n77 <sup>3</sup>	15		-94.2 +TT	-92.7 +TT	-91.9 +TT								

		30		-94.5 +TT	-92.8 +TT	-92.1 +TT									
		60		-94.9 +TT	-93.1 +TT	-92.3 +TT									
66	n78 <sup>2</sup>	15		-71.9 +TT	-71.9 +TT	-71.8 +TT			- 71. 7 +TT	- 71. 8 +TT					
		30		- 72.2+T T	-72.0 +TT	-72.0 +TT			- 71. 8 +TT	- 71. 9 +TT	- 71. 9 +TT	- 71. 8 +TT	- 71. 8 +TT	- 71. 8 +TT	
		60		-72.6 +TT	-72.3 +TT	-72.2 +TT			- 72. 0 +TT	- 72. 0 +TT	- 72. 0 +TT	- 71. 9 +TT	- 71. 9 +TT	- 71. 9 +TT	
	n78 <sup>3</sup>	15		-94.7 +TT	-93.2 +TT	-92.4 +TT									
		30		-95.0 +TT	-93.3 +TT	-92.6 +TT									
		60		-95.4 +TT	-93.6 +TT	-92.8 +TT									
	n66	48 <sup>2,13</sup>	N/A	- 70. 7	-70.6	-70.8	-70.8								
	n66	48 <sup>3</sup>	N/A	- 96. 1	-93.6	-92.3	-91.6								

NOTE 1: Void.

NOTE 2: The requirements should be verified for UL EARFCN or NR ARFCN of the aggressor (lower) band (superscript LB) such that  $f_{UL}^{LB} = \lfloor f_{DL}^{HB} / 0.2 \rfloor 0.1$  in MHz and  $F_{UL\_low}^{LB} + BW_{Channel}^{LB} / 2 \leq f_{UL}^{LB} \leq F_{UL\_high}^{LB} - BW_{Channel}^{LB} / 2$  with carrier frequency in the victim (higher) band in MHz and the channel bandwidth configured in the lower band.

NOTE 3: The requirements are only applicable to channel bandwidths no larger than 20 MHz and with a carrier frequency at  $\pm(20 + BW_{Channel}^{HB} / 2)$  MHz offset from  $2f_{UL}^{LB}$  in the victim (higher band) with  $F_{UL\_low}^{LB} + BW_{Channel}^{LB} / 2 \leq f_{UL}^{LB} \leq F_{UL\_high}^{LB} - BW_{Channel}^{LB} / 2$ , where  $BW_{Channel}^{LB}$  and  $BW_{Channel}^{HB}$  are the channel bandwidths configured in the aggressor (lower) and victim (higher) bands in MHz, respectively.

NOTE 4: These requirements apply when there is at least one individual RE within the uplink transmission bandwidth of the aggressor (lower) band for which the 5<sup>th</sup> transmitter harmonic is within the downlink transmission bandwidth of a victim (higher) band.

NOTE 5: The requirements should be verified for UL EARFCN of the aggressor (lower) band (superscript LB) such that  $f_{UL}^{LB} = \lfloor f_{DL}^{HB} / 0.5 \rfloor 0.1$  in MHz and  $F_{UL\_low}^{LB} + BW_{Channel}^{LB} / 2 \leq f_{UL}^{LB} \leq F_{UL\_high}^{LB} - BW_{Channel}^{LB} / 2$  with carrier frequency in the victim (higher) band in MHz and the channel bandwidth configured in the lower band.

NOTE 6: These requirements apply when there is at least one individual RE within the uplink transmission bandwidth of the aggressor (lower) band for which the 4<sup>th</sup> transmitter harmonic is within the downlink transmission bandwidth of a victim (higher) band.

NOTE 7: The requirements should be verified for UL EARFCN of the aggressor (lower) band (superscript LB) such that  $f_{UL}^{LB} = \lfloor f_{DL}^{HB} / 0.4 \rfloor 0.1$  in MHz and  $F_{UL\_low}^{LB} + BW_{Channel}^{LB} / 2 \leq f_{UL}^{LB} \leq F_{UL\_high}^{LB} - BW_{Channel}^{LB} / 2$  with carrier frequency in the victim (higher) band in MHz and the channel bandwidth configured in the lower band.

NOTE 8: These requirements apply when there is at least one individual RE within the uplink transmission bandwidth of a low band for which the 3<sup>rd</sup> transmitter harmonic is within the downlink transmission bandwidth of a high band.

NOTE 9: The requirements should be verified for UL EARFCN of a low band (superscript LB) such that in MHz and  $F_{UL\_low}^{LB} + BW_{Channel}^{LB} / 2 \leq f_{UL}^{LB} \leq F_{UL\_high}^{LB} - BW_{Channel}^{LB} / 2$  with the carrier frequency of a high band in MHz and the channel bandwidth configured in the low band.

NOTE 10: Void

NOTE 11: These requirements apply when the lower edge frequency of the 5 MHz uplink channel in Band 71 is located at or below 668 MHz and the downlink channel in Band 2 is located with its upper edge at 1990 MHz.

NOTE 12: These requirements apply when the lower edge frequency of the 10 MHz, 15 MHz, or 20 MHz uplink channel in Band 71 is located at or below 668 MHz and the downlink channel in Band 2 is located with its upper edge at 1990 MHz.

NOTE 13: These requirements apply when there is at least one individual RE within the uplink transmission bandwidth of the aggressor (lower) band for which the 2<sup>nd</sup> transmitter harmonic is within the downlink transmission bandwidth of a victim (higher) band and a range  $\Delta F_{HD}$  above and below the edge of this downlink transmission bandwidth. The value  $\Delta F_{HD}$  depends on the EN-DC band combination:  $\Delta F_{HD} = 10$  MHz for DC\_1\_n77, DC\_2\_n48, DC\_2\_n77, DC\_2\_n77, DC\_42\_n3, DC\_48\_n25, DC\_48\_n66, DC\_66\_n48, DC\_66\_n77, DC\_3\_n77, DC\_3\_n78, DC\_11\_n28 and DC\_28\_n50, DC\_28\_n51, DC\_66\_n78, DC\_25\_n77, DC\_25\_n78.

NOTE 14: TT is the same as defined in Table 7.3B.2.3.5-1a.

NOTE 15: Void

NOTE 16: Void

NOTE 17: For a UE which supports this band combination only when the Band n77 frequency range restriction defined in NOTE 12 of Table 5.2-1 from TS 38.101-1 applies, the MSD test point(s) cannot be verified for the band combination and the test point(s) can be skipped.

**Table 7.3B.2.3.5-1a: Test Tolerance (TT) for RX sensitivity level**

$f \leq 3.0\text{GHz}$	$3.0\text{GHz} < f \leq 6.0\text{ GHz}$
0.7 dB	1.0 dB

Reference sensitivity exceptions due to receiver harmonic mixing for EN-DC in NR FR1, are specified in Table 7.3B.2.3.5-2 with uplink configuration specified in Table 7.3B.2.3.4.2.1-3a to Table 7.3B.2.3.4.2.1-3k for each specific EN-DC combination scenario.

Table 7.3B.2.3.5-2: Reference sensitivity due to receiver harmonic mixing for PC3 EN-DC in NR FR1

UL band	DL band	SCS (kHz)	5 MHz (dBm)	10 MHz (dBm)	15 MHz (dBm)	20 MHz (dBm)	25 MHz (dBm)	40 MHz (dBm)	50 MHz (dBm)	60 MHz (dBm)	80 MHz (dBm)	90 MHz (dBm)	100 MHz (dBm)
2	n71 <sup>4</sup>	15	-70.4 +TT	-70.4 +TT	-70.4 +TT	-70.4 +TT							
		30		-70.7 +TT	-70.7 +TT	-71.8 +TT							
		60		-72.4 +TT	-72.7 +TT	-77.0 +TT							
n2	71	N/A	-69.7	-69.9	-70.1	-71.2							
n77	2	N/A	-91.2	-89.3	-88.5	-87.6							
n77	13	N/A		-65.3	-65.3								
n77	12	N/A	-65.3	-65.3									
n77	41 <sup>8</sup>	N/A	-86.9	-83.9	-82.1	-80.9	N/A	N/A	N/A	N/A	N/A	N/A	
n77	14	N/A	-65.3	-65.3									
n77	28 <sup>2</sup>	N/A	-69.8	-69.8	-69.8	-68.3							
n78	3	N/A	-90.6	-89.3	-88.5	-87.6							
n78	19	N/A	-92.1	-91.3	-90.7								
n78	40	N/A	-86.9	-83.9	-82.1	-80.9							
n78	41 <sup>8</sup>	N/A	-86.9	-83.9	-82.1	-80.9	N/A	N/A	N/A	N/A	N/A	N/A	
n79	19 <sup>2</sup>	N/A	-69.8	-69.8	-69.8								
n79	21 <sup>4</sup>	N/A	-60.0	-60.0	-60.0								
n79	26 <sup>2</sup>	N/A	-69.8	-69.8	-69.8	N/A	N/A	N/A	N/A	N/A	N/A		N/A

NOTE 1: These requirements apply when there is at least one individual RE within the uplink transmission bandwidth of the aggressor (higher) band for which the mixing product due to harmonic of victim (lower) band LO with leakage of aggressor (higher) band is within the downlink transmission bandwidth of a victim (lower) band.

NOTE 2: The requirements should be verified for DL EARFCN of the victim (lower) band (superscript LB) such that  $f_{DL}^{LB} = \lfloor f_{UL}^{HB} / 0.5 \rfloor \cdot 0.1$  with  $f_{DL}^{LB}$  the DL carrier frequency in the lower band and  $f_{UL}^{HB}$  the UL carrier frequency in the higher band, both in MHz.

NOTE 3: Void.

NOTE 4: The requirements should be verified for DL EARFCN or NR-ARFCN of the victim (lower) band (superscript LB) such that  $f_{DL}^{LB} = \lfloor f_{UL}^{HB} / 0.3 \rfloor \cdot 0.1$  with  $f_{DL}^{LB}$  the DL carrier frequency in the lower band and  $f_{UL}^{HB}$  the UL carrier frequency in the higher band, both in MHz.

NOTE 5: Void.

NOTE 6: Void.

NOTE 7: The requirements should be verified for DL EARFCN of the victim (higher) band (superscript HB) such that  $f_{DL}^{HB} = \lfloor 50 \times f_{UL}^{LB} \rfloor \cdot 0.03$  with  $f_{DL}^{HB}$  the DL carrier frequency in the higher band and  $f_{UL}^{LB}$  the UL carrier frequency in the lower band, both in MHz.

NOTE 8: The requirements should be verified for DL EARFCN of the victim (lower) band (superscript LB) such that  $f_{DL}^{LB} = a f_{UL}^{HB} / 0.15 a \cdot 0.1$  and  $f_{DL}^{LB} = a f_{UL}^{HB} / 0.15 a \cdot 0.1$  with  $f_{DL}^{LB}$  the DL carrier frequency in the lower band and  $f_{UL}^{HB} f_{DL}^{LB} = a f_{UL}^{HB} / 0.15 a \cdot 0.1$  the UL carrier frequency in the higher band, both in MHz.

NOTE 9: TT is the same as defined in Table 7.3B.2.3.5-1a.

NOTE 10: Void

**Table 7.3B.2.3.5-2a: Reference sensitivity due to receiver harmonic mixing for PC2 EN-DC in NR FR11**

UL band	DL band	SCS (kHz)	5 MHz (dBm)	10 MHz (dBm)	15 MHz (dBm)	20 MHz (dBm)	25 MHz (dBm)	40 MHz (dBm)	50 MHz (dBm)	60 MHz (dBm)	80 MHz (dBm)	90 MHz (dBm)	100 MHz (dBm)
n77	2	N/A	-88.2	-86.3	-85.5	-84.6							
n77	3	N/A	-88.2	-86.3	-85.5	-84.6							
n77	13 <sup>2</sup>	N/A		-62.3	-62.3								
n77	12	N/A	-65.3	-65.3									
n77	14	N/A	-65.3	-65.3									
n77	28 <sup>2</sup>	N/A	-66.8	-66.8	-66.8	-65.3							
n78	19	N/A	-89.5	-89.1	-88.7								
n79	19 <sup>2</sup>	N/A	-66.8	-66.8	-66.8								
n79	21 <sup>4</sup>	N/A	-57.0	-57.0	-57.0								

NOTE 1: These requirements apply when there is at least one individual RE within the uplink transmission bandwidth of the aggressor (higher) band for which the mixing product due to harmonic of victim (lower) band LO with leakage of aggressor (higher) band is within the downlink transmission bandwidth of a victim (lower) band.

NOTE 2: The requirements should be verified for DL EARFCN of the victim (lower) band (superscript LB) such that  $f_{DL}^{LB} = \lfloor f_{UL}^{HB} / 0.5 \rfloor 0.1$  with  $f_{DL}^{LB}$  the DL carrier frequency in the lower band and  $f_{UL}^{HB}$  the UL carrier frequency in the higher band, both in MHz.

NOTE 3: Void.

NOTE 4: The requirements should be verified for DL EARFCN or NR-ARFCN of the victim (lower) band (superscript LB) such that  $f_{DL}^{LB} = \lfloor f_{UL}^{HB} / 0.3 \rfloor 0.1$  with  $f_{DL}^{LB}$  the DL carrier frequency in the lower band and  $f_{UL}^{HB}$  the UL carrier frequency in the higher band, both in MHz.

NOTE 5: Void.

NOTE 6: Void.

NOTE 7: The requirements should be verified for DL EARFCN of the victim (higher) band (superscript HB) such that  $f_{DL}^{HB} = \lfloor 50 \times f_{UL}^{LB} \rfloor 0.03$  with  $f_{DL}^{HB}$  the DL carrier frequency in the higher band and  $f_{UL}^{LB}$  the UL carrier frequency in the lower band, both in MHz.

NOTE 8: The requirements should be verified for DL EARFCN of the victim (lower) band (superscript LB) such that  $f_{DL}^{LB} = a f_{UL}^{HB} / 0.15 a 0.1 f_{DL}^{LB} = a f_{UL}^{HB} / 0.15 a 0.1$  with  $f_{DL}^{LB}$  the DL carrier frequency in the lower band and  $f_{UL}^{HB} f_{DL}^{LB} = a f_{UL}^{HB} / 0.15 a 0.1$  the UL carrier frequency in the higher band, both in MHz.

NOTE 9: TT is the same as defined in Table 7.3B.2.3.5-1a.

NOTE 10: Void

Reference sensitivity exceptions due to cross band isolation for EN-DC in NR FR1, are specified in Table 7.3B.2.3.5-3 with uplink configuration specified in Table 7.3B.2.3.4.2.1-4a to Table 7.3B.2.3.4.2.1-4n.



**Table 7.3B.2.3.5-3: Reference sensitivity exceptions due to cross band isolation for PC3 EN-DC in NR FR1**

E-UTRA or NR Band / Channel bandwidth of the affected DL band															
UL band	DL band	SCS (kHz)	5 MHz (dBm)	10 MHz (dBm)	15 MHz (dBm)	20 MHz (dBm)	25 MHz (dBm)	30 MHz (dBm)	40 MHz (dBm)	50 MHz (dBm)	60 MHz (dBm)	70 MHz (dBm)	80 MHz (dBm)	90 MHz (dBm)	100 MHz (dBm)
n1	3	N/A	-93.3	-91	-89.5	-88.5									
1	n3	15	-94+TT	91.6+TT	90.1+TT	89.1+TT	88.1+TT	87.4+TT	86.2+TT						
1	n41	30		89.0+TT	87.0+TT	85.9+TT		83.9+TT	82.6+TT	81.6+TT	80.8+TT		79.5+TT	79.0+TT	78.6+TT
3	n41	30		94.4+TT	92.4+TT	91.3+TT		89.3+TT	88.0+TT	-87+TT	86.2+TT		84.9+TT	84.4+TT	84.0+TT
n5	28	15	-93.3	-91.8	-90.8	-90									
n41	1	15	90.2	87.2	85.4	84.2									
n41	2	N/A	96.7	93.7	91.9	90.7									
n41	3	N/A	3	n41	30	3									
n41	25	N/A	95.2	92.2	90.4	89.2									
n77	41 <sup>1</sup>	N/A	92.8	89.8	88.0	86.8									
n41	66	N/A	95.3	92.3	90.5	89.3									
41	n77 <sub>3</sub>	30		87.3+TT	85.3+TT	84.1+TT		82.9+TT	82.9+TT	82.9+TT			82.1+TT	81.7+TT	81.3+TT
30	n66	15	91.2+TT	88.0+TT	86.2+TT	85.0+TT			81.8+TT						
n78	7 <sup>1</sup>	N/A	93.5	90.5	88.7	87.5									
n78	38	N/A	96.7	93.7	91.9	90.7									
n78	41 <sup>1</sup>	N/A	92.8	89.8	88.0	86.8									
41	n78	30		87.8+TT	85.8+TT	84.6+TT		83.4+TT	83.4+TT	83.4+TT			82.6+TT	82.2+TT	81.8+TT

NOTE 1: Applicable only when harmonic mixing MSD for this combination is not applied.  
 NOTE 2: TT is the same as defined in Table 7.3B.2.3.5-1a.  
 NOTE 3: The requirement is modified by -0.5 dB when the assigned UE channel bandwidth is confined within 3300 - 3800 MHz.  
 NOTE 4: Void

**Table 7.3B.2.3.5-3a: Reference sensitivity exceptions due to cross band isolation for PC2 EN-DC in NR FR1**

E-UTRA or NR Band / Channel bandwidth of the affected DL band															
UL band	DL band	SCS (kHz)	5 MHz (dBm)	10 MHz (dBm)	15 MHz (dBm)	20 MHz (dBm)	25 MHz (dBm)	30 MHz (dBm)	40 MHz (dBm)	50 MHz (dBm)	60 MHz (dBm)	70 MHz (dBm)	80 MHz (dBm)	90 MHz (dBm)	100 MHz (dBm)
3	n41	30	- 94.4 +TT	- 92.4 +TT	- 91.3 +TT	-	- 89.3 +TT	- 88.0 +TT	- 87.0 +TT	- 86.2 +TT	-	-84.9 +TT	- 84.4 +TT	- 84.0 +TT	-
n41	1	30	- 87.5	- 84.5	- 82.7	- 81.5	-	-	-	-	-	-	-	-	-
n41	2	N/A	- 98.0 +1.6 +TT	- 95.0 +1.6 +TT	- 93.2 +1.6 +TT	- 92.0 +1.6 +TT	-	-	-	-	-	-	-	-	-
n41	3	N/A	- 94.0	- 91.0	- 89.2	- 88.0	-	-	-	-	-	-	-	-	-
n77	2	N/A	- 98.0 +1.0 +TT	-	-	-	-	-	-	-	-	-	-	-	-
n77	41 <sup>1</sup>	30	-	- 83.3	- 81.5	- 80.3	-	-	-	-	-	-	-	-	-
n77	66	N/A	- 99.5 +1.0 +TT	-	-	-	-	-	-	-	-	-	-	-	-

NOTE 1: Applicable only when harmonic mixing MSD for this combination is not applied.  
 NOTE 2: TT is the same as defined in Table 7.3B.2.3.5-1a.

Reference sensitivity exceptions due to dual uplink operation for EN-DC in NR FR1, are specified in Table 7.3B.2.3.5-4 with uplink configuration specified in Table 7.3B.2.3.4.2.1-6.

**Table 7.3B.2.3.5-4: Reference sensitivity exceptions due to dual uplink operation for PC3 EN-DC in NR FR1 (two bands)**

NR or E-UTRA Band / Channel bandwidth									
EN-DC Configuration	EUTRA or NR band	SCS (kHz)	5 MHz (dBm)	10 MHz (dBm)	15 MHz (dBm)	20 MHz (dBm)	40 MHz (dBm)	IMD order	Duplex mode
DC_1A_n3A	1	N/A	[-76.3]	-	-	-	-	IMD3	FDD
	n3	15	REFSENS	-	-	-	-	N/A	TDD
DC_1A_n8A	1	N/A	-93.3	-	-	-	-	IMD4	FDD
	n8	15	REFSENS	-	-	-	-	N/A	FDD
DC_1A_n77A	1	N/A	-69.5	-	-	-	-	IMD2 <sup>3</sup>	FDD
	n77	15	-	REFSENS	-	-	-	N/A	TDD
DC_1A_n77A	1	N/A	-91.3	-	-	-	-	IMD4-	FDD
	n77	15	-	REFSENS	-	-	-	N/A	TDD
DC_1A_n78A	1	N/A	-91.3	-	-	-	-	IMD4	FDD
	n78	15	-	REFSENS	-	-	-	N/A	TDD
DC_2A_n66A	2	N/A	-77.3	-	-	-	-	IMD3	
	n66	15	REFSENS	-	-	-	-	N/A	
DC_2A_n66A	2	N/A	REFSENS	-	-	-	-	N/A	
	n66	15	-95.5 +TT	-	-	-	-	IMD5	
DC_2A_n77A. DC_2A_n77(2A) DC_2A-2A_n77A DC_2A_n77(2A) DC_2A-2A_n77(2A)	2	N/A	-71.3	-	-	-	-	IMD2	FDD
	n77	15	-	REFSENS	-	-	-	N/A	TDD
	2	N/A	-89.3	-	-	-	-	IMD4	FDD
	n77	15	-	REFSENS	-	-	-	N/A	TDD
	2	N/A	-92.3	-	-	-	-	IMD5	FDD
	n77	15	-	REFSENS	-	-	-	N/A	TDD
DC_2A_n78A	2	N/A	-71.3	-	-	-	-	IMD2 <sup>3</sup>	FDD
	n78	15	-	REFSENS	-	-	-	-	TDD
DC_2A_n78A	2	N/A	-89.3	-	-	-	-	N/A	FDD
	n78	15	-	REFSENS	-	-	-	IMD4 <sup>3</sup>	TDD
DC_3A_n1A	3	N/A	REFSENS	-	-	-	-	N/A	FDD
	n1	15	-74.0+TT	-	-	-	-	IMD3	FDD
DC_3A_n5A	3	N/A	-89.3	-	-	-	-	IMD4	FDD
	n5	15	REFSENS	-	-	-	-	N/A	FDD
	3	N/A	-	REFSENS	-	-	-	N/A	FDD
	n5	15	-74.0+TT	-	-	-	-	IMD23	FDD
DC_3A_n7A	3	N/A	REFSENS	-	-	-	-	-	
	n7	15	-	-84.6 +TT <sup>5</sup>	-	-	-	-	
DC_3A_n8A	3	N/A	-	REFSENS	-	-	-	N/A	FDD
	n8	15	-88.3	-	-	-	-	IMD4 <sup>3</sup>	FDD
	3	N/A	-	-86.9	-	-	-	IMD5	FDD
	n8	15	REFSENS	-	-	-	-	N/A	FDD

DC_3A_n41A	3	N/A	-88.1	-	-	-	-	IMD4	FDD
	n41		REFSENS	-	-	-	-		
DC_3A_n77A, DC_3A_n77(2A), DC_3A_SUL_n7 7A-n80A, DC_3A_n78A, DC_3A_SUL_n7 8A-n80A, DC_3A_n78(2A), DC_3C_n78A, DC_3C_n78(2A)	3	N/A	-70.3	-	-	-	-	IMD2 <sup>3</sup>	FDD
			-70.6 <sup>7</sup>	-	-	-	-		
	n77, n78	15	-	REFSEN S	-	-	-	N/A	TDD
DC_3A_n77A, DC_3A_n77(2A), DC_3C_n77A, DC_3C_n77(2A), DC_3A_SUL_n7 7A-n80A, DC_3A_n78A, DC_3A_SUL_n7 8A-n80A, DC_3A_n78(2A), DC_3C_n78A, DC_3C_n78(2A)	3	N/A	-88.3	-	-	-	-	IMD4 <sup>3</sup>	FDD
	n77, n78	15	-	REFSEN S	-	-	-	N/A	TDD
DC_5A_n66A	5	N/A	-67.3	-	-	-	-	IMD2 <sup>3</sup>	FDD
	n66		REFSENS	-	-	-	-	N/A	FDD
DC_5A_n77A <sup>8e</sup>	5	N/A	-89	-	-	-	-	IMD4	FDD
	n77	15	-	REFSEN S	-	-	-	N/A	TDD
	5	N/A	-91.8	-	-	-	-	IMD5	FDD
	n77	15	-	REFSEN S	-	-	-	N/A	TDD
DC_5A_n78A	5	N/A	-89.0	-	-	-	-	IMD4	FDD
	n78	15	-	REFSEN S	-	-	-	N/A	TDD
DC_7A_n3A	7	N/A	-	-81.3	-	-	-	IMD4	FDD
	n3	15	REFSENS	-	-	-	-	N/A	FDD
DC_7A_n5A	7	N/A		REFSEN S	-	-	-	N/A	FDD
	n5	15	-86.0+TT	-	-	-	-	IMD3 <sup>3</sup>	FDD
DC_7A_n66A	7	N/A	-	-79.3	-	-	-	IMD4	FDD
	n66	15	REFSENS	-	-	-	-	N/A	TDD
DC_7A_n77A	7	N/A	-90.2	-	-	-	-	IMD4	FDD
	n77	15	-	REFSEN S	-	-	-	N/A	TDD
DC_8A_n1A	8	N/A	REFSENS	-	-	-	-	N/A	FDD
	n1	15	-94.0 + TT	-	-	--	-	IMD4	FDD
DC_8A_n3A	8	N/A	-88.3	-	-	-	-	IMD4 <sup>3</sup>	FDD
	n3	15	-	REFSEN S	-	-	-	N/A	FDD
	8	N/A	REFSENS	-	-	-	-	N/A	FDD
	n3	15	-	-87.4+ TT	-	-	-	IMD5	FDD
DC_8A_n20A	n20	15	-71.3	-	-	-	-	IMD3	FDD
	8	N/A	REFSENS	-	-	-	-	N/A	FDD

	n20	15	REFSENS	-	-	-	-	N/A	FDD
	8	N/A	-71.3	-	-	-	-	IMD3	FDD
DC_8A_n41A	8	N/A	-84.2	-	-	-	-	IMD3 <sup>3</sup>	FDD
	n41	15	-	REFSEN S	-	-	-	N/A	TDD
DC_8A_n77A DC_8A_n78A DC_8A- SUL_n78A-n81A	8	N/A	-88.0	-	-	-	-	IMD4	FDD
	n77, n78	15	-	REFSEN S	-	-	-	H4	TDD
DC_12A_n77A DC_12A_n77(2A )	12	N/A	-90.8	-	-	-	-	IMD5	FDD
	n77	15	-	REFSEN S	-	-	-	N/A	TDD
DC_12_n78	12	N/A	-90.8	-	-	-	-	IMD5	FDD
	n78	15	-	REFSEN S	-	-	-	N/A	TDD
DC_13A_n77A	13	N/A	-90.8	-	-	-	-	IMD5	FDD
	n77	15	-	REFSEN S	-	-	-	N/A	TDD
DC_14A_n77A DC_14A_n77(2A )	14	N/A	-90.8	-	-	-	-	IMD5	FDD
	n77	15	-	REFSEN S	-	-	-	N/A	TDD
DC_18A_n77A	18	N/A	-90.9	-	-	-	-	IMD4 <sup>X</sup>	FDD
	n77	15	-	REFSEN S	-	-	-	N/A	TDD
	18	N/A	-94.8	-	-	-	-	IMD5 <sup>X</sup>	FDD
	n77	15	-	REFSEN S	-	-	-	N/A	TDD
DC_18A_n78A	18	N/A	-90.9	-	-	-	-	IMD4 <sup>Y</sup>	FDD
	n78	15	-	REFSEN S	-	-	-	N/A	TDD
DC_19A_n78A	19	N/A	-85.7	-	-	-	-	IMD4	FDD
	n78	15	-	REFSEN S	-	-	-	N/A	FDD
DC_20A_n3A	20	N/A	REFSENS	-	-	-	-	N/A	FDD
	n3	15	-93.0 +TT	-	-	-	-	IMD4	FDD
	20	N/A	-87.3	-	-	-	-	IMD4	FDD
	n3	15	REFSENS	-	-	-	-	N/A	FDD
DC_20_n7	20	N/A	-84.3	-	-	-	-	IMD3	FDD
	n7	15	-	REFSEN S	-	-	-	N/A	FDD
DC_20_n8	20	N/A	-71.3	-	-	-	-	IMD3	FDD
	n8	15	-71.3	-	-	-	-	IMD3	FDD
DC_20A_n78A, DC_20A- SUL_n78A-n82A	20	N/A	-74.6	-	-	-	-	IMD4 <sup>4</sup>	FDD
	n78	15	-	REFSEN S	-	-	-	N/A	TDD
DC_21A_n28A	21	N/A	-96.8	-	-	-	-	IMD5	FDD
	n28	15	REFSENS	-	-	-	-	N/A	FDD
DC_21A_n79A	21	N/A	-80.9	-	-	-	-	IMD3	FDD
	n79	15	-	-	-	-	REFSEN S	N/A	TDD
CA_28A_n77A, CA_28A_n78A, DC_28A- SUL_n78A-n83A	28	N/A	-92.3	-	-	-	-	IMD5	FDD
	n77, n78	15	-	REFSEN S	-	-	-	N/A	TDD
DC_30A_n77A DC_30A_n77(2A )	30	N/A	-90.3	-	-	-	-	IMD4	FDD
	n77	15	-	REFSEN S	-	-	-	N/A	TDD
DC_48A_n66A	48	N/A	-	REFSEN S	-	-	-	N/A	TDD
	n66	15	-95.5 +TT	-	-	-	-	IMD5	FDD
DC_66A_n2A	66	N/A	REFSENS	-	-	-	-	N/A	FDD
	n2	15	-78.0+TT	-	-	-	-	IMD3	FDD
	66	N/A	-94.8	-	-	-	-	IMD5	FDD
	n2	15	REFSENS	-	-	-	-	N/A	FDD
DC_66A_n5A	66	N/A	-68.8	-	-	-	-	IMD2 <sup>3</sup>	FDD
	n5	15	REFSENS	-	-	-	-	N/A	FDD

DC_66A_n25A	66	N/A	REFSENS	-	-	-	-	N/A	FDD
	n25	15	-76.5+TT	-	-	-	-	IMD3	FDD
	66	N/A	-75.8	-	-	-	-	IMD3	FDD
	n25	15	REFSENS	-	-	-	-	N/A	FDD
	66	N/A	-94.8	-	-	-	-	IMD5	FDD
DC_66A_n71A	n25	15	REFSENS	-	-	-	-	N/A	FDD
	66	N/A	-93.8	-	-	-	-	IMD4	FDD
DC_66A_n77A DC_66A_n77(2A) ) DC_66A- 66A_n77A DC_66A- 66A_n77(2A)	66	N/A	-67.8	-	-	-	-	IMD2	FDD
	n77	15	-	REFSEN S	-	-	-	N/A	TDD
	66	N/A	-93.8	-	-	-	-	IMD5	FDD
	n77	15	-	REFSEN S	-	-	-	N/A	TDD
	66	N/A	-93.8	-	-	-	-	IMD5	FDD
DC_66A_n78A	n78	15	-	REFSEN S	-	-	-	N/A	TDD
	66	N/A	-93.8	-	-	-	-	IMD5	FDD
DC_71A_n66A	71	N/A	REFSENS	-	-	-	-	N/A	FDD
	n66	15	-94.5 +TT	-	-	-	-	IMD4	FDD

NOTE 1: E-UTRA carrier shall be set to min(+20 dBm, P<sub>CMAX\_L,E-UTRA,c</sub>) and NR carrier shall be set to min(+20 dBm, P<sub>CMAX\_L,f,c,NR</sub>) as defined in clause 6.2B.4.1.3.

NOTE 2: RB<sub>START</sub> = 0

NOTE 3: This band is subject to IMD5 also which MSD is not specified.

NOTE 4: The symbol "REFSENS" in this table refers to the reference sensitivity values for single carrier specified in Table 7.3.5-1 of TS 36.521-1 [10] for 2 antenna port E-UTRA band, Table 7.3\_1.5-1 of TS 36.521-1 [10] for 4 antenna port E-UTRA band, Table 7.3.2.5-1 for 2 antenna port NR band and Table 7.3.2.5-2 for 4 antenna port NR band.

NOTE 5: Void

NOTE 6: TT is the same as defined in Table 7.3B.2.3.5-1a.

NOTE 7: Void.

NOTE 8: For a UE which supports this band combination only when the Band n77 frequency range restriction defined in NOTE 12 of Table 5.2-1 from TS 38.101-1 applies, the MSD test point(s) cannot be verified for the band combination and the test point(s) can be skipped.

NOTE 9: For a UE which supports this band combination only when the Band n77 frequency range restriction of 3400 - 4100 MHz in Japan applies, the MSD test point(s) cannot be verified for the band combination and the test point(s) can be skipped.

NOTE 10: For a UE which supports this band combination only when the Band n78 frequency range restriction of 3400 - 3800 MHz in Japan applies, the MSD test point(s) cannot be verified for the band combination and the test point(s) can be skipped.

**Table 7.3B.2.3.5-5: Reference sensitivity exceptions due to dual uplink operation for PC2 EN-DC in NR FR1 (two bands)**

NR or E-UTRA Band / Channel bandwidth									
EN-DC Configuration	EUTRA or NR band	SCS (kHz)	5 MHz (dBm)	10 MHz (dBm)	15 MHz (dBm)	20 MHz (dBm)	40 MHz (dBm)	IMD order)	Duplex mode
DC_1A_n77A	1	N/A	-63.5	-	-	-	-	IMD2 <sup>3</sup>	FDD
	n77	15	-	REFSENS	-	-	-	N/A	TDD
	1	N/A	-81.5	-	-	-	-	IMD4 <sup>3</sup>	FDD
	n77	15	-	REFSENS	-	-	-	N/A	TDD
DC_1A_n78A	1	N/A	REFSENS-17.8	-	-	-	-	IMD4	
	n78	15	-	REFSENS	-	-	-	N/A	TDD
DC_2A_n77A DC_2A-2A_n77A DC_2A_n77C DC_2A-2A_n77C	2	N/A	-65.2	-	-	-	-	IMD2	FDD
			-65.15 <sup>7</sup>						
	n77	15	-	REFSENS	-	-	-	N/A	TDD
	2	N/A	-78.2	-	-	-	-	IMD4 <sup>9</sup>	FDD
			-78.15 <sup>7</sup>						
	n77	15	-	REFSENS	-	-	-	N/A	TDD
DC_3A_n41A	3	N/A	-77.9	-	-	-	-	IMD4	FDD
			-80.6 <sup>7</sup>						
	n41	15	-	REFSENS	-	-	-	N/A	TDD
DC_3A_n78A	3	N/A	-64.4	-	-	-	-	IMD2	FDD
			-67.1 <sup>7</sup>						
	n78	15	-	REFSENS	-	-	-	N/A	TDD
DC_3A_n78A	3	N/A	-77.8	-	-	-	-	IMD4	FDD
			-80.5 <sup>7</sup>						
	n78	15	-	REFSENS	-	-	-	N/A	TDD
DC_5A_n77A <sup>8</sup> DC_5A_n77C <sup>8</sup>	5	N/A	-78.7	-	-	-	-	IMD4 <sup>9</sup>	FDD
	n77	15	-	REFSENS	-	-	-	N/A	TDD
DC_12A_n77A	12	N/A	-84.6	-	-	-	-	IMD5	FDD
	n77	15	-	REFSENS	-	-	-	N/A	TDD
DC_13A_n77A DC_13A_n77C	13	N/A	-80.93	-	-	-	-	IMD5	FDD
	n77	15	-	REFSENS	-	-	-	N/A	TDD
DC_14A_n77A	14	N/A	-84.6	-	-	-	-	IMD5	FDD
	n77	15	-	REFSENS	-	-	-	N/A	TDD
DC_19A_n78A	19	N/A	-74.0	-	-	-	-	IMD4	FDD
	n78	15	-	REFSENS	-	-	-	N/A	FDD
DC_21A_n79A	21	N/A	-65.9	-	-	-	-	IMD3	FDD
	n79	15	-	REFSENS	-	-	-	N/A	TDD
DC_28A_n77A	28	N/A	-78.6	-	-	-	-	IMD5	FDD
	n77	15	-	REFSENS	-	-	-	N/A	TDD
DC_30A_n77A	30	N/A	-81.4	-	-	-	-	IMD4	FDD
	n77	15	-	REFSENS	-	-	-	N/A	TDD
DC_66A_n77A	66	N/A	-64.47	-	-	-	-	IMD2	FDD



DC_66A-66A_n77A	n77	15	-	REFSENS	-	-	-	N/A	TDD
DC_66A-66A-66A_n77A	66	N/A	-87.53	-	-	-	-	IMD5	FDD
DC_66A-66A-66A_n77C	n77	15	-	REFSENS	-	-	-	N/A	TDD

NOTE 1: E-UTRA carrier shall be set to min(+23 dBm,  $P_{\text{CMAX\_L\_E-UTRA,c}}$ ) and NR carrier shall be set to min(+23 dBm,  $P_{\text{CMAX\_L\_f,c,NR}}$ ) as defined in clause 6.2B.4.1.3.

NOTE 2:  $RB_{\text{START}} = 0$

NOTE 3: This band is subject to IMD5 also which MSD is not specified.

NOTE 4: The symbol "REFSENS" in this table refers to the reference sensitivity values for single carrier specified in Table 7.3.5-1 of TS 36.521-1 [10] for 2 antenna port E-UTRA band, Table 7.3\_1.5-1 of TS 36.521-1 [10] for 4 antenna port E-UTRA band, Table 7.3.2.5-1 for 2 antenna port NR band and Table 7.3.2.5-2 for 4 antenna port NR band.

NOTE 5: For UEs only indicating support of Single UL, this requirement is verified with non-simultaneous uplink transmissions on the E-UTRA and NR CGs.

NOTE 6: TT is the same as defined in Table 7.3B.2.3.5-1a.

NOTE 7: Applicable only if operation with 4 antenna ports is supported in the band with EN-DC configured.

NOTE 8: For a UE which supports this band combination only when the Band n77 frequency range restriction defined in NOTE 12 of Table 5.2-1 from TS 38.101-1 applies, the MSD test point(s) cannot be verified for the band combination and the test point(s) can be skipped.

NOTE 9: This band is subject to IMD5 also which MSD is not specified.

### 7.3B.2.3\_1 Reference sensitivity for EN-DC within FR1 (>2 CCs)

#### 7.3B.2.3\_1.1 Reference sensitivity for EN-DC within FR1 (3 CCs)

**Editor's note:** The test requirements section of this test case contains some EN-DC configurations that have no test points defined meaning these cannot be tested.

**Editor's note:** For EN-DC configurations with >1NR CC, test points in Table 7.3B.2.3\_1.1.4.1-0 only need to be tested if the configuration is a max NR CC of the UE, where detailed execution rules are FFS.

##### 7.3B.2.3\_1.1.1 Test purpose

To verify the ability of UE that support EN-DC configurations to receive data with a given average throughput for a specified reference measurement channel, under conditions of low signal level, ideal propagation and no added noise when no CA exceptions are allowed and single carrier requirements apply whenever possible. A UE unable to meet the throughput requirement under these conditions will decrease the effective coverage area.

##### 7.3B.2.3\_1.1.2 Test applicability

This test applies to all types of NR UE release 15 and forward supporting 3CC EN-DC.

##### 7.3B.2.3\_1.1.3 Minimum conformance requirements

The minimum conformance requirements are defined in clause 7.3B.2.0

Exception requirements for both NR and E-UTRA are defined for this test and therefore LTE anchor agnostic approach is not applied. E-UTRA test point analysis is included and E-UTRA measurements are performed.

7.3B.2.3\_1.1.4 Test description

7.3B.2.3\_1.1.4.1 Initial conditions

Same initial conditions as in clause 7.3B.2.3.4.1 with following exceptions:

The initial test configurations for E-UTRA band and NR band consist of environmental conditions, test frequencies, and channel bandwidths and RB allocations for exceptional test scenarios are specified in Table 7.3B.2.3\_1.1.4.1-0 and 7.3B.2.3\_1.1.4.1-1.

**Table 7.3B.2.3\_1.1.4.1-0: Test Configuration Table for all EN-DC configurations for FR1 non-exception requirements**

Initial Conditions												
Test Environment as specified in TS 38.508-1 [6] clause 4.1						Normal, TL/VL, TL/VH, TH/VL, TH/VH						
NR Test Frequencies as specified in TS 38.508-1 [6] clause 4.3.1, E-UTRA Test Frequencies as specified in TS 36.508 [11] clause 4.3.1						DC_XA_nYA-nZA Mid range for MCG and SCG  DC_XA_nYC: Mid range for XA Low range, High Range for nXC  DC_(n)XCA: Low range, High Range  DC_XA_nY(2A): TBD						
NR Test Channel Bandwidths as specified in TS 38.508-1 [6] clause 4.3.1 E-UTRA Test Channel Bandwidths as specified in TS 36.508 [11] clause 4.3.1.						Refer to "NR N <sub>RB</sub> " and "E-UTRA N <sub>RB</sub> " columns						
Network signalling value						NS_01 by default, exceptions listed in Table 7.3.3-3, dependent on PCC Band						
Test SCS for the NR cell as specified in TS 38.521-1 [8] Table 5.3.5-1						Lowest SCS per Channel Bandwidth						
Test Parameters for DC Configurations												
ID	E-UTRA				EUTRA/NR				NR			
	Band	Range	N <sub>RB</sub>		Band	Range	N <sub>RB</sub>		Band	Range	N <sub>RB</sub>	
	UL MOD	DL MOD	CH BW	DLalloc/UL alloc	UL MOD	DL MOD	UL/DL Ch BW	DLalloc/UL alloc	UL MOD	DL MOD	UL/DL Ch BW	DLalloc/UL alloc
Test Settings for a DC_(n)XCA Configuration (Intra-band contiguous EN-DC with LTE CA)– Note 2												
1	X	default	Highest	All RBs / REFSENS_LTE	X	default	Highest	All RBs / 0	nX	default	Highest	All RBs / REFSENS_NR
	QPSK	QPSK			N/A	QPSK			DFT-s-OFDM QPSK	CP-OFDM QPSK		
Test Settings for a DC_XC_nXA Configuration (Intra-band non-contiguous EN-DC with LTE CA)– Note 3												
							No test required, LTE 1CC fallback is tested in 7.3B.2.2					
Test Settings for a DC_XA-XA_nXA/ DC_XA_(n)XAA Configuration (Intra-band non-contiguous EN-DC with LTE CA)– Note 3												

							No test required, LTE 1CC fallback is tested in 7.3B.2.2						
Test Settings for a DC_XA_nYC Configuration (Inter-band EN-DC with NR CA, 2 bands) – Note 1,5													
1	X	default	5 MHz	0/0	nY	default	Highest	All RBs / 0	nY	default	Highest	All RBs / REFSSENS_NR	
	N/A	N/A			N/A	CP-OFDM QPSK			DFT-s-OFDM QPSK	CP-OFDM QPSK			
Test Settings for a DC_XA_nY(2A) Configuration (Inter-band EN-DC with NR CA, 2 bands) – Note 1,5													
1	X	default	5 MHz	0/0	nY	default	Highest	All RBs / 0	nY	default	Highest	All RBs / REFSSENS_NR	
	N/A	N/A			N/A	CP-OFDM QPSK			DFT-s-OFDM QPSK	CP-OFDM QPSK			
Test Settings for a DC_XC_nYA, DC_XA-XA_nYA Configuration (Inter-band EN-DC with LTE CA, 2 bands) – Note 3													
							No test required, LTE 1CC fallback is tested in 7.3B.2.3						
Default Test Settings for a DC_XA-YA_nZA Configuration (Inter-band EN-DC with LTE CA, 3 bands) – Note 3													
							No test required, LTE 1CC fallback is tested in 7.3B.2.3						
Default Test Settings for a DC_XA_nYA-nZA Configuration (Inter-band EN-DC with NR CA, 3 bands) – Note 1,5													
1	X	Mid	5 MHz	0/0	nY	default	Highest	All RBs / 0	nZ	default	Highest	All RBs / REFSSENS_NR	
	N/A	N/A			N/A	CP-OFDM QPSK			DFT-s-OFDM QPSK	CP-OFDM QPSK			
2	X	Mid	5 MHz	0/0	nZ	default	Highest	All RBs / 0	nY	default	Highest	All RBs / REFSSENS_NR	
	N/A	N/A			N/A	CP-OFDM QPSK			DFT-s-OFDM QPSK	CP-OFDM QPSK			

- |         |  |
|---------|--|
| Note 1: | LTE anchor agnostic configuration  |
| Note 2: | Not LTE anchor agnostic configuration due to exception requirement for intra-band contiguous CA in clause 7.4B, 7.5B, 7.6B.2, 7.6B.3, 7.6B.4, 7.7B, 7.8B, 7.9B test cases  |
| Note 3: | LTE anchor agnostic configuration with LTE CA where LTE CA fallback to 1CC is sufficient to test   |
| Note 4: | In a FR1 band where UE supports 4Rx, the test shall be performed only with 4Rx antennas ports connected.   |
| Note 5: | For UE supporting multiple EN-DC configurations with the same NR CA combination, only one EN-DC configuration is tested.   |
| Note 6: | REFSENS_LTE refers to the single carrier Uplink RB allocation for reference sensitivity according to table 7.3.3-2 of TS 36.521-1 [10].<br>REFSENS_NR refers to the single carrier Uplink RB allocation for reference sensitivity according to table 7.3.2.4.1-3 of TS 38.521-1 [8]. |

**Table 7.3B.2.3\_1.1.4.1-1: Test Configuration Table for EN-DC configurations affected by Reference sensitivity exceptions (three bands)**

Initial Conditions												
Test Environment as specified in TS 38.508-1 [6] clause 4.1						Normal, TL/VL, TL/VH, TH/VL, TH/VH						
NR Test Frequencies as specified in TS 38.508-1 [6] clause 4.3.1, E-UTRA Test Frequencies as specified in TS 36.508 [11] clause 4.3.1						EN-DC configurations containing the following band combinations: 20-n78: Mid in band 20 and Mid in band 78.						
NR Test Channel Bandwidths as specified in TS 38.508-1 [6] clause 4.3.1 E-UTRA Test Channel Bandwidths as specified in TS 36.508 [11] clause 4.3.1.						Refer to "NR N <sub>RB</sub> " and "E-UTRA N <sub>RB</sub> " columns						
Network signalling value						NS_01 by default, exceptions listed in Table 7.3.3-3, dependent on PCC Band						
Test SCS for the NR cell as specified in TS 38.521-1 [8] Table 5.3.5-1						Lowest SCS per Channel Bandwidth						
Test Parameters for DC Configurations												
ID	E-UTRA				EUTRA/NR				NR			
	Band	Range	N <sub>RB</sub>		Band	Range	N <sub>RB</sub>		Band	Range	N <sub>RB</sub>	
	UL MOD	DL MOD	CH BW	DLalloc/UL alloc	UL MOD	DL MOD	UL/DL Ch BW	DLalloc/ULalloc	UL MOD	DL MOD	UL/DL Ch BW	DLalloc/UL alloc
<b>Default Test Settings for a DC_XA_nYC, DC_XA_nY(2A) Configuration (Inter-band EN-DC with NR CA, 2 bands) – Note 7</b>												
No test required, NR 1CC fallback is tested in 7.3B.2.3												
<b>Default Test Settings for a DC_XC_nYA, DC_XA-XA_nYA Configuration (Inter-band EN-DC with LTE CA, 2 bands) – Note 4</b>												
No test required, LTE 1CC fallback is tested in 7.3B.2.3												
<b>Default Test Settings for a DC_XA-YA_nZA Configuration (Inter-band EN-DC with LTE CA, 3 bands) – Note 4</b>												
No test required, LTE 1CC fallback is tested in 7.3B.2.3												
<b>Default Test Settings for a DC_XA_nYA-nZA Configuration (Inter-band EN-DC with NR CA, 3 bands) – Note 7</b>												
No test required, NR 1CC fallback is tested in 7.3B.2.3												
<b>Test Settings for DC_1A-3A_n28A Configuration – Note 3</b>												
1	1	UL 1975 / DL 2165 MHz			3	DL 1818.5 MHz			n28	UL 710.5 / DL 765.5 MHz		
	QPSK	QPSK	5 MHz	All RBs / All RBs	N/A	QPSK	5 MHz	All RBs / 0	DFT-s-OFDM QPSK	CP-OFDM QPSK	5 MHz	All RBs / All RBs
2	3	UL 1780 / DL 1875 MHz			1	DL 2139 MHz			n28	UL 710.5 / DL 765.5 MHz		
	QPSK	QPSK	5 MHz	All RBs / All RBs	N/A	QPSK	5 MHz	All RBs / 0	DFT-s-OFDM QPSK	CP-OFDM QPSK	5 MHz	All RBs / All RBs
<b>Test Settings for DC_1A-7A_n28A Configuration – Note 3</b>												



1	1	UL 1935 / DL 2125 MHz			7	DL 2653 MHz			n28	UL 718 / DL 773 MHz		
	QPSK	QPSK	5 MHz	All RBs / All RBs	N/A	QPSK	10 MHz	All RBs / 0	DFT-s-OFDM QPSK	CP-OFDM QPSK	5 MHz	All RBs / All RBs
<b>Test Settings for DC_1A-3A_n77A Configuration (PC2 &amp; PC3) – Note 3</b>												
1	1	UL 1950 / DL 2140 MHz			3	DL 1807.5 MHz			n77	3757.5 MHz		
	QPSK	QPSK	5 MHz	All RBs / All RBs	N/A	QPSK	5 MHz	All RBs / 0	DFT-s-OFDM QPSK	CP-OFDM QPSK	10 MHz	All RBs / All RBs
2	1	UL 1950 / DL 2140 MHz			3	DL 1870 MHz			n77	3980 MHz		
	QPSK	QPSK	5 MHz	All RBs / All RBs	N/A	QPSK	5 MHz	All RBs / 0	DFT-s-OFDM QPSK	CP-OFDM QPSK	10 MHz	All RBs / All RBs
3	1	DL 2140 MHz			3	UL 1775 MHz / DL 1870 MHz			n77	3915 MHz		
	N/A	QPSK	5 MHz	All RBs / 0	QPSK	QPSK	5 MHz	All RBs / All RBs	DFT-s-OFDM QPSK	CP-OFDM QPSK	10 MHz	All RBs / All RBs
<b>Test Settings for DC_1A-3A_n78A Configuration (PC3 &amp; PC2) – Note 3</b>												
1 <sup>11</sup>	1	UL 1950 / DL 2140 MHz			3	DL 1807.5 MHz			n78	3757.5 MHz		
	QPSK	QPSK	5 MHz	All RBs / All RBs	N/A	QPSK	5 MHz	All RBs / 0	DFT-s-OFDM QPSK	CP-OFDM QPSK	10 MHz	All RBs / All RBs
2 <sup>11</sup>	1	DL 2125 MHz			3	UL 1775 / DL 1870 MHz			n78	3725 MHz		
	N/A	QPSK	5 MHz	All RBs / 0	QPSK	QPSK	5 MHz	All RBs / All RBs	DFT-s-OFDM QPSK	CP-OFDM QPSK	10 MHz	All RBs / All RBs
<b>Test Settings for DC_1A_n3A-n78A Configuration – Note 3</b>												
1	1	UL 1950 / DL 2140 MHz			n3	UL 1750 / DL 1845 MHz			n78	DL 3700 MHz		
	QPSK	QPSK	5 MHz	All RBs / All RBs	DFT-s-OFDM QPSK	CP-OFDM QPSK	5 MHz	All RBs / All RBs	N/A	CP-OFDM QPSK	10 MHz	All RBs / 0

2	1	UL 1950 / DL 2140 MHz			n78	3780 MHz			n3	DL 1830 MHz		
	QPSK	QPSK	5 MHz	All RBs / All RBs	DFT-s- OFDM QPSK	CP-OFDM QPSK	10 MHz	All RBs / All RBs	N/A	CP-OFDM QPSK	5 MHz	All RBs / 0
<b>Test Settings for DC_1A-3A_n79A Configuration (PC3) – Note 3</b>												
1	1	DL 2140 MHz			3	UL 1750 / DL 1845 MHz			n79	4860 MHz		
	N/A	QPSK	5 MHz	All RBs / 0	QPSK	QPSK	5 MHz	All RBs / All RBs	DFT-s- OFDM QPSK	CP-OFDM QPSK	40 MHz	All RBs / All RBs
<b>Test Settings for DC_1A-3A_n79A Configuration (PC2) – Note 3</b>												
1	1	DL 2140 MHz			3	UL 1750 / DL 1845 MHz			n79	4860 MHz		
	N/A	QPSK	5 MHz	All RBs / 0	QPSK	QPSK	5 MHz	All RBs / All RBs	DFT-s- OFDM QPSK	CP-OFDM QPSK	10 MHz	All RBs / All RBs
<b>Test Settings for DC_1A-5A_n78A Configuration – Note 3</b>												
1	1	DL 2122 MHz			5	UL 829 / DL 874 MHz			n78	3780 MHz		
	N/A	QPSK	5 MHz	All RBs / 0	QPSK	QPSK	5 MHz	All RBs / All RBs	DFT-s- OFDM QPSK	CP-OFDM QPSK	10 MHz	All RBs / All RBs
2	1	UL 1975 / DL 2165 MHz			5	DL 885 MHz			n78	3405 MHz		
	QPSK	QPSK	5 MHz	All RBs / All RBs	N/A	QPSK	5 MHz	All RBs / 0	DFT-s- OFDM QPSK	CP-OFDM QPSK	10 MHz	All RBs / All RBs
<b>Test Settings for DC_1A-7A_n78A Configuration – Note 3</b>												
1	1	UL 1977.5 / DL 2167.5 MHz			7	DL 2627.5 MHz			n78	3305 MHz		
	QPSK	QPSK	5 MHz	All RBs / All RBs	N/A	QPSK	5 MHz	All RBs / 0	DFT-s- OFDM QPSK	CP-OFDM QPSK	10 MHz	All RBs / All RBs
2	1	DL 2140 MHz			7	UL 2510 / DL 2630 MHz			n78	3580 MHz		

	N/A	QPSK	5 MHz	All RBs / 0	QPSK	QPSK	10MHz	All RBs / All RBs	DFT-s-OFDM QPSK	CP-OFDM QPSK	10 MHz	All RBs / All RBs
<b>Test Settings for DC_1A-18A_n77A Configuration (PC3) – Note 3</b>												
1	1	DL 2120 MHz			18	UL 825 / DL 870 MHz			n77	3770 MHz		
	N/A	QPSK	5 MHz	All RBs / 0	QPSK	QPSK	5 MHz	All RBs / All RBs	DFT-s-OFDM QPSK	CP-OFDM QPSK	10 MHz	All RBs / All RBs
<b>Test Settings for DC_1A-18A_n77A Configuration (PC2) – Note 3</b>												
1	1	UL 1970 / DL 2160 MHz			18	DL 870 MHz			n77	3390 MHz		
	QPSK	QPSK	5 MHz	All RBs / All RBs	N/A	QPSK	5 MHz	All RBs / 0	DFT-s-OFDM QPSK	CP-OFDM QPSK	10 MHz	All RBs / All RBs
2	1	DL 2120 MHz			18	UL 825 / DL 870 MHz			n77	3770 MHz		
	N/A	QPSK	5 MHz	All RBs / 0	QPSK	QPSK	5 MHz	All RBs / All RBs	DFT-s-OFDM QPSK	CP-OFDM QPSK	10 MHz	All RBs / All RBs
<b>Test Settings for DC_1A-19A_n78A Configuration (PC2 &amp; PC3) – Note 3</b>												
1 <sup>11</sup>	1	DL 2130 MHz			19	UL 832.5 / DL 877.5 MHz			n78	3795 MHz		
	N/A	QPSK	5 MHz	All RBs / 0	QPSK	QPSK	5 MHz	All RBs / All RBs	DFT-s-OFDM QPSK	CP-OFDM QPSK	10 MHz	All RBs / All RBs
2 <sup>11</sup>	1	UL 1940 / DL 2130 MHz			19	DL 880 MHz			n78	3350 MHz		
	QPSK	QPSK	5 MHz	All RBs / All RBs	N/A	QPSK	5 MHz	All RBs / 0	DFT-s-OFDM QPSK	CP-OFDM QPSK	10 MHz	All RBs / All RBs
<b>Test Settings for DC_1A-19A_n79A Configuration (PC3) – Note 3</b>												
1	1	UL 1950 / DL 2140 MHz			19	DL 882.5 MHz			n79	4782.5 MHz		
	QPSK	QPSK	5 MHz	All RBs / All RBs	N/A	QPSK	5 MHz	All RBs / 0	DFT-s-OFDM QPSK	CP-OFDM QPSK	40 MHz	All RBs / All RBs
2	1	DL 2140 MHz			19	UL 837.5 / DL 882.5 MHz			n79	4652.5 MHz		

	N/A	QPSK	5 MHz	All RBs / 0	QPSK	QPSK	5 MHz	All RBs / All RBs	DFT-s-OFDM QPSK	CP-OFDM QPSK	40 MHz	All RBs / All RBs
<b>Test Settings for DC_1A-19A_n79A Configuration (PC2) – Note 3</b>												
1	1	UL 1950 / DL 2140 MHz			19	DL 882.5 MHz			n79	4782.5 MHz		
	QPSK	QPSK	5 MHz	All RBs / All RBs	N/A	QPSK	5 MHz	All RBs / 0	DFT-s-OFDM QPSK	CP-OFDM QPSK	10 MHz	All RBs / All RBs
2	1	DL 2140 MHz			19	UL 837.5 / DL 882.5 MHz			n79	4652.5 MHz		
	N/A	QPSK	5 MHz	All RBs / 0	QPSK	QPSK	5 MHz	All RBs / All RBs	DFT-s-OFDM QPSK	CP-OFDM QPSK	10 MHz	All RBs / All RBs
<b>Test Settings for DC_1A-20A_n8A Configuration – Note 3</b>												
1	1	UL 1925 / DL 2115 MHz			20	DL 805 MHz			n8	UL 910 / DL 955 MHz		
	QPSK	QPSK	5 MHz	All RBs / All RBs	N/A	QPSK	5 MHz	All RBs / 0	DFT-s-OFDM QPSK	CP-OFDM QPSK	5 MHz	All RBs / All RBs
<b>Test Settings for DC_1A-20A_n78A Configuration – Note 3</b>												
1	1	DL 2120 MHz			20	UL 835 / DL 794 MHz			n78	3790 MHz		
	N/A	QPSK	5 MHz	All RBs / 0	QPSK	QPSK	5 MHz	All RBs / All RBs	DFT-s-OFDM QPSK	CP-OFDM QPSK	10 MHz	All RBs / All RBs
2	1	UL 1950 / DL 2140 MHz			20	DL 810 MHz			n78	3330 MHz		
	QPSK	QPSK	5 MHz	All RBs / All RBs	N/A	QPSK	5 MHz	All RBs / 0	DFT-s-OFDM QPSK	CP-OFDM QPSK	10 MHz	All RBs / All RBs
<b>Test Settings for DC_1A-21A_n78A Configuration (PC2 &amp; PC3) – Note 3</b>												
1 <sup>11</sup>	1	DL 2154.6 MHz			21	UL1450.4 / DL 1498.4 MHz			n78	3605 MHz		
	N/A	QPSK	5 MHz	All RBs / 0	QPSK	QPSK	5 MHz	All RBs / All RBs	DFT-s-OFDM QPSK	CP-OFDM QPSK	10 MHz	All RBs / All RBs
2 <sup>11</sup>	1	DL 2154.6 MHz			21	UL1450.4 / DL 1498.4 MHz			n78	3647 MHz		

	N/A	QPSK	5 MHz	All RBs / 0	QPSK	QPSK	5 MHz	All RBs / All RBs	DFT-s-OFDM QPSK	CP-OFDM QPSK	10 MHz	All RBs / All RBs
3 <sup>11</sup>	1	UL 1950 / DL 2140 MHz			21	DL 1500 MHz			n78	3450 MHz		
	QPSK	QPSK	5 MHz	All RBs / All RBs	N/A	QPSK	5 MHz	All RBs / 0	DFT-s-OFDM QPSK	CP-OFDM QPSK	10 MHz	All RBs / All RBs
4 <sup>11</sup>	1	UL 1950 / DL 2140 MHz			21	DL 1500 MHz			n78	3675 MHz		
	QPSK	QPSK	5 MHz	All RBs / All RBs	N/A	QPSK	5 MHz	All RBs / 0	DFT-s-OFDM QPSK	CP-OFDM QPSK	10 MHz	All RBs / All RBs
<b>Test Settings for DC_1A-28A_n3A – Note 3</b>												
1	1	DL 2139 MHz			28	UL 710.5 / DL 765.5 MHz			n3	UL 1780 / DL 1875 MHz		
	N/A	QPSK	5 MHz	All RBs / 0	QPSK	QPSK	5 MHz	All RBs / All RBs	DFT-s-OFDM QPSK	CP-OFDM QPSK	5 MHz	All RBs / All RBs
<b>Test Settings for DC_1A_n28A-n78A – Note 3</b>												
1	1	UL 1950 / DL 2140 MHz			n78	3416 MHz			n28	UL 733 / DL 788 MHz		
	QPSK	QPSK	5 MHz	All RBs / All RBs	N/A	CP-OFDM QPSK	10 MHz	All RBs / 0	DFT-s-OFDM QPSK	CP-OFDM QPSK	5 MHz	All RBs / All RBs
2	1	UL 1950 / DL 2140 MHz			n28	DL 790 MHz			n78	3320 MHz		
	QPSK	QPSK	5 MHz	All RBs / All RBs	N/A	CP-OFDM QPSK	5 MHz	All RBs / 0	DFT-s-OFDM QPSK	CP-OFDM QPSK	10 MHz	All RBs / All RBs
<b>Test Settings for DC_1A-28A_n78A – Note 3</b>												
1	28	UL 740 / DL 795 MHz			1	DL 2150 MHz			n78	3630 MHz		
	QPSK	QPSK	5 MHz	All RBs / All RBs	N/A	QPSK	5 MHz	All RBs / 0	DFT-s-OFDM QPSK	CP-OFDM QPSK	10 MHz	All RBs / All RBs
2	1	UL 1970 / DL 2160			28	DL 794 MHz			n78	3352 MHz		

	QPSK	QPSK	5 MHz	All RBs / All RBs	N/A	QPSK	5 MHz	All RBs / 0	DFT-s-OFDM QPSK	CP-OFDM QPSK	10 MHz	All RBs / All RBs
<b>Test Settings for DC_1A-41A_n77A (PC2 &amp; PC3) – Note 3</b>												
1	1	UL 1970 / DL 2160 MHz			41	2510 MHz			n77	3400 MHz		
	QPSK	QPSK	5 MHz	All RBs / All RBs	N/A	QPSK	5 MHz	All RBs / 0	DFT-s-OFDM QPSK	CP-OFDM QPSK	10 MHz	All RBs / All RBs
2	1	DL 2140 MHz			41	2640 MHz			n77	3710 MHz		
	N/A	QPSK	5 MHz	All RBs / 0	QPSK	QPSK	5 MHz	All RBs / All RBs	DFT-s-OFDM QPSK	CP-OFDM QPSK	10 MHz	All RBs / All RBs
3	1	UL 1930 / DL 2120 MHz			41	2510 MHz			n77	4150 MHz		
	QPSK	QPSK	5 MHz	All RBs / All RBs	N/A	QPSK	5 MHz	All RBs / 0	DFT-s-OFDM QPSK	CP-OFDM QPSK	10 MHz	All RBs / All RBs
<b>Test Settings for DC_1A-41A_n28A – Note 3</b>												
1	1	UL 1935 / DL 2125 MHz			41	2653 MHz			n28	UL 718 / DL 773 MHz		
	QPSK	QPSK	5 MHz	All RBs / All RBs	N/A	QPSK	10 MHz	All RBs / 0	DFT-s-OFDM QPSK	CP-OFDM QPSK	5 MHz	All RBs / All RBs
<b>Test Settings for DC_1A-42A_n79A (PC3) – Note 3</b>												
1	1	UL 1977.5 / DL 2167.5 MHz			42	DL 3490 MHz			n79			
	QPSK	QPSK	5 MHz	All RBs / All RBs	N/A	QPSK	5 MHz	All RBs / 0	DFT-s-OFDM QPSK	CP-OFDM QPSK	40 MHz	All RBs / All RBs
<b>Test Settings for DC_1A-42A_n79A (PC2) – Note 3</b>												
1	1	UL 1977.5 / DL 2167.5 MHz			42	DL 3490 MHz			n79			
	QPSK	QPSK	5 MHz	All RBs / All RBs	N/A	QPSK	5 MHz	All RBs / 0	DFT-s-OFDM QPSK	CP-OFDM QPSK	10 MHz	All RBs / All RBs
<b>Test Settings for DC_1A_n78A-n79A (PC2) – Note 3</b>												

1	1	UL 1950 / DL 2140 MHz			n78	3410 MHz			n79	4870 MHz		
	QPSK	QPSK	5 MHz	All RBs / All RBs	DFT-s-OFDM QPSK	QPSK	10 MHz	All RBs / All RBs	N/A	CP-OFDM QPSK	10 MHz	All RBs / 0
2	1	UL 1950 / DL 2140 MHz			n78	3490 MHz			n79	4670 MHz		
	QPSK	QPSK	5 MHz	All RBs / All RBs	N/A	QPSK	10 MHz	All RBs / 0	DFT-s-OFDM QPSK	CP-OFDM QPSK	10 MHz	All RBs / All RBs
<b>Test Settings for DC_1A_n78A-n79A (PC3) – Note 3</b>												
1	1	UL 1950 / DL 2140 MHz			n78	3410 MHz			n79	4870 MHz		
	QPSK	QPSK	5 MHz	All RBs / All RBs	DFT-s-OFDM QPSK	QPSK	10 MHz	All RBs / All RBs	N/A	CP-OFDM QPSK	40 MHz	All RBs / 0
2	1	UL 1950 / DL 2140 MHz			n78	3490 MHz			n79	4670 MHz		
	QPSK	QPSK	5 MHz	All RBs / All RBs	N/A	QPSK	10 MHz	All RBs / 0	DFT-s-OFDM QPSK	CP-OFDM QPSK	40 MHz	All RBs / All RBs
<b>Test Settings for DC_2A_n5A-n77A – Note 3</b>												
1	2	UL 1880 / DL 1960 MHz			n5	UL 830 / DL 875 MHz			n77	3540 MHz		
	QPSK	QPSK	5 MHz	All RBs / All RBs	QPSK	QPSK	5 MHz	All RBs / All RBs	N/A	CP-OFDM QPSK	10 MHz	All RBs / 0
<b>Test Settings for DC_2A-5A_n77A – Note 3</b>												
1	2	UL 1907,5 / DL 1987,5 MHz			5	DL 887,5 MHz			n77	3305 MHz		
	QPSK	QPSK	5 MHz	All RBs / All RBs	N/A	QPSK	5 MHz	All RBs / 0	CP-OFDM QPSK	CP-OFDM QPSK	10 MHz	All RBs / All RBs
2	2	DL 1987 MHz			5	UL 846,5 / DL 891,5 MHz			n77	3680 MHz		
	N/A	QPSK	5 MHz	All RBs / 0	QPSK	QPSK	5 MHz	All RBs / All RBs	CP-OFDM QPSK	CP-OFDM QPSK	10 MHz	All RBs / All RBs
<b>Test Settings for DC_2A-13A_n77A – Note 3</b>												

1 <sup>11</sup>	2	DL 1944 MHz			13	UL 783 / DL 752 MHz			n77	3510 MHz		
	N/A	QPSK	5 MHz	All RBs / 0	QPSK	QPSK	5 MHz	All RBs / All RBs	DFT-s-OFDM QPSK	CP-OFDM QPSK	10 MHz	All RBs / All RBs
<b>Test Settings for DC_2A-14A_n77A – Note 3</b>												
1	2	DL 1954 MHz			14	UL 793 / DL 763 MHz			n77	3540 MHz		
	N/A	QPSK	5 MHz	All RBs / 0	QPSK	QPSK	5 MHz	All RBs / All RBs	DFT-s-OFDM QPSK	CP-OFDM QPSK	10 MHz	All RBs / All RBs
<b>Test Settings for DC_2A-66A_n2A – Note 3</b>												
1	2	UL 1900 / DL 1980 MHz			66	UL 1730 / DL 2130 MHz			n2	UL 1855 / DL 1935 MHz		
	QPSK	QPSK	5 MHz	All RBs / 0	QPSK	QPSK	5 MHz	All RBs / All RBs	DFT-s-OFDM QPSK	CP-OFDM QPSK	5 MHz	All RBs / All RBs
<b>Test Settings for DC_2A-66A_n5A – Note 3</b>												
1	2	UL 1900 / DL 1980 MHz			66	UL 1740 / DL 2140 MHz			n5	UL 830 / DL 875 MHz		
	QPSK	QPSK	5 MHz	All RBs / All RBs	QPSK	QPSK	5 MHz	All RBs / 0	DFT-s-OFDM QPSK	CP-OFDM QPSK	5 MHz	All RBs / All RBs
<b>Test Settings for DC_2A-66A_n41A – Note 3</b>												
1	2	UL 1860 / DL 1940 MHz			66	UL 1715 / DL 2115 MHz			n41	2685 MHz		
	QPSK	QPSK	5 MHz	All RBs / 0	QPSK	QPSK	5 MHz	All RBs / All RBs	DFT-s-OFDM QPSK	CP-OFDM QPSK	5 MHz	All RBs / All RBs
<b>Test Settings for DC_2A-66A_n77A – Note 3</b>												
1 <sup>11</sup>	2	UL 1855 / DL 1935 MHz			66	DL 2115 MHz			n77	3970 MHz		
	QPSK	QPSK	5 MHz	All RBs / All RBs	N/A	QPSK	5 MHz	All RBs / 0	DFT-s-OFDM QPSK	CP-OFDM QPSK	10 MHz	All RBs / All RBs
2 <sup>11</sup>	2	UL 1880 / DL 1960 MHz			66	DL 2140 MHz			n77	3500 MHz		
	QPSK	QPSK	5 MHz	All RBs / All RBs	N/A	QPSK	5 MHz	All RBs / 0	DFT-s-OFDM QPSK	CP-OFDM QPSK	10 MHz	All RBs / All RBs



3	2	UL 1860 / DL 1940 MHz			66	DL 2175 MHz			n77	3915 MHz		
	QPSK	QPSK	5 MHz	All RBs / All RBs	N/A	QPSK	5 MHz	All RBs / All RBs	DFT-s- OFDM QPSK	CP-OFDM QPSK	10 MHz	All RBs / All RBs
4 <sup>11</sup>	2	DL 1960 MHz			66	UL 1760 / DL 2160 MHz			n77	3720 MHz		
	N/A	QPSK	5 MHz	All RBs / 0	QPSK	QPSK	5 MHz	All RBs / All RBs	DFT-s- OFDM QPSK	CP-OFDM QPSK	10 MHz	All RBs / All RBs
<b>Test Settings for DC_3A-7A_n5A – Note 3</b>												
1	3	UL 1780/ DL 1875 MHz			7	DL 2625 MHz			n5	UL 845 / DL 890 MHz		
	QPSK	QPSK	10 MHz	All RBs / All RBs	N/A	QPSK	10 MHz	All RBs / 0	DFT-s- OFDM QPSK	CP-OFDM QPSK	5 MHz	All RBs / All RBs
<b>Test Settings for DC_3A-7A_n8A – Note 3</b>												
1	3	UL 1780/ DL 1875 MHz			7	DL 2670 MHz			n8	UL 890 / DL 935 MHz		
	QPSK	QPSK	5 MHz	All RBs / All RBs	N/A	QPSK	10 MHz	All RBs / 0	DFT-s- OFDM QPSK	CP-OFDM QPSK	5 MHz	All RBs / All RBs
<b>Test Settings for DC_3A-7A_n28A – Note 3</b>												
1	3	UL 1712.5 / DL 1807.5 MHz			7	DL 2682 MHz			n28	UL 743 / DL 798 MHz		
	QPSK	QPSK	5 MHz	All RBs / All RBs	N/A	QPSK	10 MHz	All RBs / 0	DFT-s- OFDM QPSK	CP-OFDM QPSK	5 MHz	All RBs / All RBs
2	7	UL 2543 / DL 2663 MHz			3	DL 1832.5 MHz			n28	UL 710.5 / DL 765.5 MHz		
	QPSK	QPSK	10 MHz	All RBs / All RBs	N/A	QPSK	5 MHz	All RBs / 0	DFT-s- OFDM QPSK	CP-OFDM QPSK	5 MHz	All RBs / All RBs
<b>Test Settings for DC_3A-7A_n78A Configuration – Note 3</b>												
1	3	DL 1820 MHz			7	UL 2565 / DL 2685 MHz			n78	3310 MHz		

	N/A	QPSK	5 MHz	All RBs / 0	QPSK	QPSK	5 MHz	All RBs / All RBs	DFT-s-OFDM QPSK	CP-OFDM QPSK	10 MHz	All RBs / All RBs
2	3	DL 1820 MHz			7	UL 2565 / DL 2685 MHz			n78	3475 MHz		
	N/A	QPSK	5 MHz	All RBs / 0	QPSK	QPSK	5 MHz	All RBs / All RBs	DFT-s-OFDM QPSK	CP-OFDM QPSK	10 MHz	All RBs / All RBs
<b>Test Settings for DC_3A-8A_n78A Configuration – Note 3</b>												
1	3	DL 1820 MHz			8	UL 910 / DL 955 MHz			n78	3640 MHz		
	N/A	QPSK	5 MHz	All RBs / 0	QPSK	QPSK	5 MHz	All RBs / All RBs	DFT-s-OFDM QPSK	CP-OFDM QPSK	10 MHz	All RBs / All RBs
<b>Test Settings for DC_3A-18A_n77A Configuration (PC2) – Note 3</b>												
1	3	DL 1865 MHz			18	UL 820 / DL 865 MHz			n77	3505 MHz		
	N/A	QPSK	5 MHz	All RBs / 0	QPSK	QPSK	5 MHz	All RBs / All RBs	DFT-s-OFDM QPSK	CP-OFDM QPSK	10 MHz	All RBs / All RBs
<b>Test Settings for DC_3A-19A_n78A Configuration (PC2 &amp; PC3)– Note 3</b>												
1 <sup>11</sup>	3	DL 1850 MHz			8	UL 835 / DL 880 MHz			n78	3520 MHz		
	N/A	QPSK	5 MHz	All RBs / 0	QPSK	QPSK	5 MHz	All RBs / All RBs	DFT-s-OFDM QPSK	CP-OFDM QPSK	10 MHz	All RBs / All RBs
<b>Test Settings for DC_3A-19A_n79A Configuration (PC2 &amp; PC3) – Note 3</b>												
1 <sup>11</sup>	3	UL 1775 / DL 1870 MHz			19	DL 885 MHz			n79	4435 MHz		
	QPSK	QPSK	5 MHz	All RBs / All RBs	N/A	QPSK	5 MHz	All RBs / 0	DFT-s-OFDM QPSK	CP-OFDM QPSK	40 MHz	All RBs / All RBs
2 <sup>11</sup>	3	DL 1877.5 MHz			19	UL 842.5 / DL887.5 MHz			n79	4420 MHz		
	N/A	QPSK	5 MHz	All RBs / 0	QPSK	QPSK	5 MHz	All RBs / All RBs	DFT-s-OFDM QPSK	CP-OFDM QPSK	40 MHz	All RBs / All RBs
<b>Test Settings for DC_3A-20A_n8A Configuration – Note 3</b>												
1	3	DL 1860 MHz			20	UL 840 MHz / DL 799			n8	UL 900 / DL 945 MHz		

	N/A	QPSK	5 MHz	All RBs / All RBs	QPSK	QPSK	5 MHz	All RBs / 0	DFT-s-OFDM QPSK	CP-OFDM QPSK	5 MHz	All RBs / All RBs
<b>Test Settings for DC_3A-20A_n28A Configuration – Note 3</b>												
1	3	DL 1828 MHz			20	UL 852 / DL 811 MHz			n28	UL 728 / DL 783 MHz		
	N/A	QPSK	5 MHz	All RBs / 0	QPSK	QPSK	5 MHz	All RBs / All RBs	DFT-s-OFDM QPSK	CP-OFDM QPSK	5 MHz	All RBs / All RBs
<b>Test Settings for DC_3A-20A_n78A Configuration – Note 3</b>												
1	3	DL 1820 MHz			20	UL 845 / DL 804 MHz			n78	3510 MHz		
	N/A	QPSK	5 MHz	All RBs / 0	QPSK	QPSK	5 MHz	All RBs / All RBs	DFT-s-OFDM QPSK	CP-OFDM QPSK	10 MHz	All RBs / All RBs
<b>Test Settings for DC_3A-21A_n78A Configuration (PC3) – Note 3</b>												
1	3	UL 1767.5 / DL 1862.5 MHz			21	DL 1507.5 MHz			n78	3795 MHz		
	QPSK	QPSK	5 MHz	All RBs / All RBs	N/A	QPSK	5 MHz	All RBs / 0	DFT-s-OFDM QPSK	CP-OFDM QPSK	10 MHz	All RBs / All RBs
2	3	DL 1862.5			21	UL 1459.5 / DL 1507.5 MHz			n78	3322 MHz		
	N/A	QPSK	5 MHz	All RBs / 0	QPSK	QPSK	5 MHz	All RBs / All RBs	DFT-s-OFDM QPSK	CP-OFDM QPSK	10 MHz	All RBs / All RBs
<b>Test Settings for DC_3A-21A_n78A Configuration (PC2) – Note 3</b>												
1	3	UL 1767.5 / DL 1862.5 MHz			21	DL 1507.5 MHz			n78	3795 MHz		
	QPSK	QPSK	5 MHz	All RBs / All RBs	N/A	QPSK	5 MHz	All RBs / 0	DFT-s-OFDM QPSK	CP-OFDM QPSK	10 MHz	All RBs / All RBs
2	3	DL 1862.5			21	UL 1459.5 / DL 1507.5 MHz			n78	3322 MHz		
	N/A	QPSK	5 MHz	All RBs / 0	QPSK	QPSK	5 MHz	All RBs / All RBs	DFT-s-OFDM QPSK	CP-OFDM QPSK	10 MHz	All RBs / All RBs

3	3	UL 1767.5 / DL 1862.5 MHz			21	DL 1503.5 MHz			n78	3403 MHz		
	QPSK	QPSK	5 MHz	All RBs / All RBs	N/A	QPSK	5 MHz	All RBs / 0	DFT-s-OFDM QPSK	CP-OFDM QPSK	10 MHz	All RBs / All RBs
<b>Test Settings for DC_3A-21A_n79A Configuration (PC3) – Note 3</b>												
1	3	DL 1869.2 MHz			21	UL 1450.4 / DL 1498.4 MHz			n79	4770 MHz		
	N/A	QPSK	5 MHz	All RBs / 0	QPSK	QPSK	5 MHz	All RBs / All RBs	DFT-s-OFDM QPSK	CP-OFDM QPSK	40 MHz	All RBs / All RBs
<b>Test Settings for DC_3A-21A_n79A Configuration (PC2) – Note 3</b>												
1	3	DL 1869.2 MHz			21	UL 1450.4 / DL 1498.4 MHz			n79	4770 MHz		
	N/A	QPSK	5 MHz	All RBs / 0	QPSK	QPSK	5 MHz	All RBs / All RBs	DFT-s-OFDM QPSK	CP-OFDM QPSK	10 MHz	All RBs / All RBs
<b>Test Settings for DC_3A-28A_n78A Configuration – Note 3</b>												
1	28	UL 740 / DL 760 MHz			3	UL 1775 / DL 1870 MHz			n78	3350 MHz		
	QPSK	QPSK	5 MHz	All RBs / All RBs	N/A	QPSK	5 MHz	All RBs / 0	DFT-s-OFDM QPSK	CP-OFDM QPSK	10 MHz	All RBs / All RBs
<b>Test Settings for DC_3A_n28A-n78A Configuration – Note 3</b>												
1	3	UL 1750 / DL 1845 MHz			n78	3764 MHz			n28	UL 743 / DL 798 MHz		
	QPSK	QPSK	5 MHz	All RBs / All RBs	N/A	CP-OFDM QPSK	10 MHz	All RBs / 0	DFT-s-OFDM QPSK	CP-OFDM QPSK	5 MHz	All RBs / All RBs

Test Settings for DC_3A-40A_n1A Configuration – Note 3, 6												
1	3	UL 1735 / DL 1830 MHz			40	DL 2380 MHz			n1A	UL 1950 / DL 2140 MHz		
	QPSK	QPSK	5 MHz	All RBs / All RBs	N/A	QPSK	5 MHz	All RBs / 0	DFT-s-OFDM QPSK	CP-OFDM QPSK	5 MHz	All RBs / All RBs
Test Settings for DC_3A-41A_n28A – Note 3												
1	3	DL 1832.5 MHz			41	2543 MHz			n28	UL 710.5 / DL 765.5 MHz		
	N/A	QPSK	5 MHz	All RBs / 0	QPSK	QPSK	10 MHz	All RBs / All RBs	DFT-s-OFDM QPSK	CP-OFDM QPSK	5 MHz	All RBs / All RBs
2	3	UL 1780 / DL 1875 MHz			41	2518 MHz			n28	UL 738 / DL 793 MHz		
	QPSK	QPSK	5 MHz	All RBs / All RBs	N/A	QPSK	5 MHz	All RBs / 0	DFT-s-OFDM QPSK	CP-OFDM QPSK	5 MHz	All RBs / All RBs
3	3	UL 1715 / DL 1810 MHz			41	2687 MHz			n28	UL 743 / DL 798 MHz		
	QPSK	QPSK	5 MHz	All RBs / All RBs	QPSK	QPSK	5 MHz	All RBs / 0	DFT-s-OFDM QPSK	CP-OFDM QPSK	5 MHz	All RBs / All RBs
Test Settings for DC_3A-41A_n77A Configuration (PC3) – Note 3												
1	3	UL 1720 / DL 1815 MHz			41	2640 MHz			n77	3900 MHz		
	QPSK	QPSK	5 MHz	All RBs / All RBs	N/A	QPSK	5 MHz	All RBs / 0	DFT-s-OFDM QPSK	CP-OFDM QPSK	10 MHz	All RBs / All RBs
2	3	DL 1840 MHz			41	2620 MHz			n77	3400 MHz		
	QPSK	QPSK	5 MHz	All RBs / 0	N/A	QPSK	5 MHz	All RBs / All RBs	DFT-s-OFDM QPSK	CP-OFDM QPSK	10 MHz	All RBs / All RBs
Test Settings for DC_3A-41A_n77A Configuration (PC2) – Note 3												
1	3	UL 1720 / DL 1815 MHz			41	2640 MHz			n77	3900 MHz		
	QPSK	QPSK	5 MHz	All RBs / All RBs	N/A	QPSK	5 MHz	All RBs / 0	DFT-s-OFDM QPSK	CP-OFDM QPSK	10 MHz	All RBs / All RBs
Test Settings for DC_3A_n78A-n79A (PC2) – Note 3												

1	3	UL 1770 / DL 1865 MHz			n78	3340 MHz			n79	4910 MHz		
	QPSK	QPSK	5 MHz	All RBs / All RBs	DFT-s- OFDM QPSK	QPSK	10 MHz	All RBs / All RBs	N/A	CP-OFDM QPSK	10 MHz	All RBs / 0
2	3	UL 1770 / DL 1865 MHz			n78	3710 MHz			n79	4510 MHz		
	QPSK	QPSK	5 MHz	All RBs / All RBs	N/A	QPSK	10 MHz	All RBs / 0	DFT-s- OFDM QPSK	CP-OFDM QPSK	10 MHz	All RBs / All RBs
<b>Test Settings for DC_3A_n78A-n79A (PC3) – Note 3</b>												
1	3	UL 1770 / DL 1865 MHz			n78	3340 MHz			n79	4910 MHz		
	QPSK	QPSK	5 MHz	All RBs / All RBs	DFT-s- OFDM QPSK	QPSK	10 MHz	All RBs / All RBs	N/A	CP-OFDM QPSK	40 MHz	All RBs / 0
2	3	UL 1770 / DL 1865 MHz			n78	3710 MHz			n79	4510 MHz		
	QPSK	QPSK	5 MHz	All RBs / All RBs	N/A	QPSK	10 MHz	All RBs / 0	DFT-s- OFDM QPSK	CP-OFDM QPSK	40 MHz	All RBs / All RBs
<b>Test Settings for DC_5A-7A_n78A Configuration – Note 3</b>												
1	5	UL 844 / DL 889 MHz			7	DL 2645 MHz			n78	3489 MHz		
	QPSK	QPSK	5 MHz	All RBs / All RBs	N/A	QPSK	5 MHz	All RBs / 0	DFT-s- OFDM QPSK	CP-OFDM QPSK	10 MHz	All RBs / All RBs
2	5	DL 879 MHz			7	UL 2550 / DL 2670 MHz			n78	3429 MHz		
	N/A	QPSK	5 MHz	All RBs / 0	QPSK	QPSK	5 MHz	All RBs / All RBs	DFT-s- OFDM QPSK	CP-OFDM QPSK	10 MHz	All RBs / All RBs
3	5	DL 875 MHz			7	UL 2525 / DL 2645 MHz			n78	3350 MHz		
	N/A	QPSK	5 MHz	All RBs / 0	QPSK	QPSK	5 MHz	All RBs / All RBs	DFT-s- OFDM QPSK	CP-OFDM QPSK	10 MHz	All RBs / All RBs
<b>Test Settings for DC_5A-66A_n2A Configuration – Note 3</b>												

1	5	UL 834 / DL 879 MHz			66	DL 2132 MHz			n2	UL 1900 / DL 1980 MHz		
	QPSK	QPSK	5 MHz	All RBs / All RBs	N/A	QPSK	5 MHz	All RBs / 0	DFT-s-OFDM QPSK	CP-OFDM QPSK	5 MHz	All RBs / All RBs
<b>Test Settings for DC_5A-66A_n77A Configuration – Note 3</b>												
1	5	UL 826.5 / DL 871.5 MHz			66	DL 2142 MHz			n77	3795 MHz		
	QPSK	QPSK	5 MHz	All RBs / All RBs	N/A	QPSK	5 MHz	All RBs / 0	DFT-s-OFDM QPSK	CP-OFDM QPSK	10 MHz	All RBs / All RBs
<b>Test Settings for DC_7A-8A_n3A Configuration – Note 3</b>												
1	7	UL 2530 / DL 2650 MHz			8	DL 940 MHz			n3	UL 1735 / DL 1830 MHz		
	QPSK	QPSK	10 MHz	All RBs / All RBs	N/A	QPSK	5 MHz	All RBs / 0	DFT-s-OFDM QPSK	CP-OFDM QPSK	5 MHz	All RBs / All RBs
2	7	DL 2670 MHz			8	UL 890 / DL 935 MHz			n3	UL 1780 / DL 1875 MHz		
	N/A	QPSK	10 MHz	All RBs / 0	QPSK	QPSK	5 MHz	All RBs / All RBs	DFT-s-OFDM QPSK	CP-OFDM QPSK	5 MHz	All RBs / All RBs
<b>Test Settings for DC_7A-20A_n1A Configuration – Note 3</b>												
1	7	UL 2510 / DL 2630 MHz			20	800 MHz			n1	UL 1940 / DL 2130 MHz		
	N/A	QPSK	10 MHz	All RBs / 0	QPSK	QPSK	10 MHz	All RBs / All RBs	DFT-s-OFDM QPSK	CP-OFDM QPSK	5 MHz	All RBs / All RBs
<b>Test Settings for DC_7A-20A_n3A Configuration – Note 3</b>												
1	7	UL 2543 / DL 2663 MHz			20	DL 806 MHz			n3	UL 1737 / DL 1832 MHz		
	QPSK	QPSK	10 MHz	All RBs / All RBs	N/A	QPSK	10 MHz	All RBs / 0	DFT-s-OFDM QPSK	CP-OFDM QPSK	5 MHz	All RBs / All RBs
2	7	DL 2630 MHz			20	UL 855 / DL 896 MHz			n3	UL 1775 / DL 1870 MHz		
	N/A	QPSK	10 MHz	All RBs / 0	QPSK	QPSK	5 MHz	All RBs / All RBs	DFT-s-OFDM QPSK	CP-OFDM QPSK	10 MHz	All RBs / All RBs

Test Settings for DC_7A-20A_n8A Configuration – Note 3												
1	7	UL 2565 / DL 2685 MHz			20	DL 795 MHz			n8	UL 885 / DL 930 MHz		
	QPSK	QPSK	5 MHz	All RBs / All RBs	N/A	QPSK	5 MHz	All RBs / 0	DFT-s- OFDM QPSK	CP-OFDM QPSK	5 MHz	All RBs / All RBs
2	7	DL 2640 MHz			20	UL 840 / DL 799 MHz			n8	UL 900 / DL 945 MHz		
	N/A	QPSK	5 MHz	All RBs / 0	QPSK	QPSK	5 MHz	All RBs / All RBs	DFT-s- OFDM QPSK	CP-OFDM QPSK	5 MHz	All RBs / All RBs
3	7	DL 2624 MHz			20	UL 857 / DL 816 MHz			n8	UL 910 / DL 955 MHz		
	N/A	QPSK	5 MHz	All RBs / 0	QPSK	QPSK	5 MHz	All RBs / All RBs	DFT-s- OFDM QPSK	CP-OFDM QPSK	5 MHz	All RBs / All RBs
Test Settings for DC_7A-20A_n28A Configuration – Note 3												
1	20	UL 842/ DL 801 MHz			7	DL 2640 MHz			n28	UL 728 / DL 783 MHz		
	QPSK	QPSK	5 MHz	All RBs / All RBs	N/A	QPSK	10 MHz	All RBs / 0	DFT-s- OFDM QPSK	CP-OFDM QPSK	5 MHz	All RBs / All RBs



Test Settings for DC_7A-20A_n78A Configuration – Note 3												
1	7	UL 2560 / DL 2680 MHz			20	DL 810 MHz			n78	3370 MHz		
	QPSK	QPSK	5 MHz	All RBs / All RBs	N/A	QPSK	5 MHz	All RBs / 0	DFT-s- OFDM QPSK	CP-OFDM QPSK	10 MHz	All RBs / All RBs
2	7	UL 2560 / DL 2680 MHz			20	DL 810 MHz			n78	3435 MHz		
	QPSK	QPSK	5 MHz	All RBs / All RBs	N/A	QPSK	5 MHz	All RBs / 0	DFT-s- OFDM QPSK	CP-OFDM QPSK	10 MHz	All RBs / All RBs
3	7	DL 2675 MHz			20	UL 845 / DL 804 MHz			n78	3520 MHz		
	N/A	QPSK	5 MHz	All RBs / 0	QPSK	QPSK	5 MHz	All RBs / All RBs	DFT-s- OFDM QPSK	CP-OFDM QPSK	10 MHz	All RBs / All RBs
Test Settings for DC_7A-28A_n3A Configuration – Note 3												
1	7	UL 2543 / DL 2663 MHz			28	DL 796 MHz			n3	1842 MHz		
	QPSK	QPSK	5 MHz	All RBs / All RBs	N/A	QPSK	5 MHz	All RBs / 0	DFT-s- OFDM QPSK	CP-OFDM QPSK	5 MHz	All RBs / All RBs
2	7	DL 2685 MHz			28	UL 745 / DL 800 MHz			n3	1810 MHz		
	N/A	QPSK	5 MHz	All RBs / 0	QPSK	QPSK	5 MHz	All RBs / All RBs	DFT-s- OFDM QPSK	CP-OFDM QPSK	5 MHz	All RBs / All RBs
Test Settings for DC_7A-28A_n5A Configuration – Note 3												
1	7	UL 2540 / DL 2660 MHz			28	DL 776 MHz			n5	UL 829 / DL 874 MHz		
	QPSK	QPSK	5 MHz	All RBs / All RBs	N/A	QPSK	5 MHz	All RBs / 0	DFT-s- OFDM QPSK	CP-OFDM QPSK	5 MHz	All RBs / All RBs
2	7	DL 2630 MHz			28	UL 730 / DL 785 MHz			n5	UL 840 / DL 874 MHz		
	N/A	QPSK	5 MHz	All RBs / 0	QPSK	QPSK	5 MHz	All RBs / All RBs	DFT-s- OFDM QPSK	CP-OFDM QPSK	5 MHz	All RBs / All RBs
Test Settings for DC_7A-28A_n78A Configuration – Note 3												

1	7	UL 2567.5 / DL 2687.5 MHz			28	DL 782.5 MHz			n78	3350 MHz		
	QPSK	QPSK	5 MHz	All RBs / All RBs	N/A	QPSK	5 MHz	All RBs / 0	DFT-s-OFDM QPSK	CP-OFDM QPSK	10 MHz	All RBs / All RBs
2	7	UL 2567.5 / DL 2687.5 MHz			28	DL 782.5 MHz			n78	3460 MHz		
	QPSK	QPSK	5 MHz	All RBs / All RBs	N/A	QPSK	5 MHz	All RBs / 0	DFT-s-OFDM QPSK	CP-OFDM QPSK	10 MHz	All RBs / All RBs
3	7	DL 2650 MHz			28	UL 740 / DL 795 MHz			n78	3390 MHz		
	N/A	QPSK	5 MHz	All RBs / 0	QPSK	QPSK	5 MHz	All RBs / All RBs	DFT-s-OFDM QPSK	CP-OFDM QPSK	10 MHz	All RBs / All RBs
<b>Test Settings for DC_7A_n28A-n78A Configuration – Note 3</b>												
1	7	UL 2565/ DL 2685 MHz			n78	3310 MHz			n28	UL 745 / DL 800 MHz		
	QPSK	QPSK	5 MHz	All RBs / All RBs	N/A	CP-OFDM QPSK	10 MHz	All RBs / 0	DFT-s-OFDM QPSK	CP-OFDM QPSK	5 MHz	All RBs / All RBs
2	7	UL 2565/ DL 2685 MHz			n28	DL 800 MHz			n78	3365 MHz		
	QPSK	QPSK	5 MHz	All RBs / All RBs	N/A	CP-OFDM QPSK	5 MHz	All RBs / 0	DFT-s-OFDM QPSK	CP-OFDM QPSK	10 MHz	All RBs / All RBs

Test Settings for DC_2A-14A_n66A Configuration – Note 3												
1	2	DL 1954 MHz			14	UL 793 / DL 763 MHz			n66	UL 1770 / DL 2170 MHz		
	N/A	QPSK	5 MHz	All RBs / 0	QPSK	QPSK	5 MHz	All RBs / All RBs	DFT-s-OFDM QPSK	CP-OFDM QPSK	5 MHz	All RBs / All RBs
Test Settings for DC_13A_n2A-n77A Configuration – Note 3												
1	13	UL 782 / DL 751 MHz			n2	UL 1896 / DL 1976 MHz			n77	3460 MHz		
	QPSK	QPSK	5 MHz	All RBs / All RBs	QPSK	QPSK	5 MHz	All RBs / All RBs	N/A	CP-OFDM QPSK	10 MHz	All RBs / 0
2 <sup>11</sup>	13	UL 782 / DL 751 MHz			n2	DL 1960 MHz			n77	3524 MHz		
	QPSK	QPSK	5 MHz	All RBs / All RBs	N/A	QPSK	5 MHz	All RBs / 0	CP-OFDM QPSK	CP-OFDM QPSK	10 MHz	All RBs / All RBs
Test Settings for DC_13A-66A_n2A Configuration – Note 3												
1	13	UL 782 / DL 751 MHz			66	DL 2156 MHz			n2	UL 1860 / DL 1940 MHz		
	QPSK	QPSK	5 MHz	All RBs / All RBs	N/A	QPSK	5 MHz	All RBs / 0	DFT-s-OFDM QPSK	CP-OFDM QPSK	5 MHz	All RBs / All RBs
Test Settings for DC_13A-66A_n77A Configuration – Note 3												
1 <sup>11</sup>	13	UL 782 / DL 751 MHz			66	DL 2156 MHz			n77	3720 MHz		
	QPSK	QPSK	5 MHz	All RBs / All RBs	N/A	QPSK	5 MHz	All RBs / 0	DFT-s-OFDM QPSK	CP-OFDM QPSK	10 MHz	All RBs / All RBs
Test Settings for DC_14A-66A_n2A Configuration – Note 3												
1	14	DL 763 MHz			66	UL 1762 / DL 2162 MHz			n2	UL 1874 / DL 1954 MHz		
	QPSK	QPSK	5 MHz	All RBs / All RBs	N/A	QPSK	5 MHz	All RBs / 0	DFT-s-OFDM QPSK	CP-OFDM QPSK	5 MHz	All RBs / All RBs
Test Settings for DC_14A-66A_n77A Configuration – Note 3												
1	14	DL 763 MHz			66	UL 1712.5 / DL 2112.5 MHz			n77	4188 MHz		

	N/A	QPSK	5 MHz	All RBs / 0	QPSK	QPSK	5 MHz	All RBs / All RBs	DFT-s-OFDM QPSK	CP-OFDM QPSK	5 MHz	All RBs / All RBs
2	14	UL 793 / DL 762 MHz			66	DL 2155 MHz			n77	3741 MHz		
	QPSK	QPSK	5 MHz	All RBs / All RBs	N/A	QPSK	5 MHz	All RBs / 0	DFT-s-OFDM QPSK	CP-OFDM QPSK	5 MHz	All RBs / All RBs
<b>Test Settings for DC_18A-41A_n77A Configuration – Note 3</b>												
1	18	DL 865 MHz			41	2640 MHz			n77	3527.5 MHz		
	QPSK	QPSK	5 MHz	All RBs / 0	QPSK	QPSK	5MHz	All RBs / All RBs	DFT-s-OFDM QPSK	CP-OFDM QPSK	10MHz	All RBs / All RBs
<b>Test Settings for DC_18A-41A_n78A Configuration – Note 3</b>												
1	18	DL 865 MHz			41	2640 MHz			n78	3527.5 MHz		
	QPSK	QPSK	5 MHz	All RBs / 0	QPSK	QPSK	5MHz	All RBs / All RBs	DFT-s-OFDM QPSK	CP-OFDM QPSK	10MHz	All RBs / All RBs
<b>Test Settings for DC_19A-21A_n78A Configuration (PC2 &amp; PC3) – Note 3</b>												
1 <sup>11</sup>	19	DL 882.5 MHz			21	UL 1450.4 / DL 1498.4 MHz			n78	3783.3		
	N/A	QPSK	5 MHz	All RBs / 0	QPSK	QPSK	5 MHz	All RBs / All RBs	DFT-s-OFDM QPSK	CP-OFDM QPSK	10MHz	All RBs / All RBs
2 <sup>11</sup>	19	DL 882.5 MHz			21	UL 1450.4 / DL 1498.4 MHz			n78	3468.7		
	N/A	QPSK	5 MHz	All RBs / 0	QPSK	QPSK	5 MHz	All RBs / All RBs	DFT-s-OFDM QPSK	CP-OFDM QPSK	10MHz	All RBs / All RBs
<b>Test Settings for DC_19A-21A_n79A Configuration (PC3) – Note 3</b>												
1	19	UL 837.5 / DL 882.2 MHz			21	DL 1500 MHz			n79	4850		
	QPSK	QPSK	5 MHz	All RBs / All RBs	N/A	QPSK	5 MHz	All RBs / 0	DFT-s-OFDM QPSK	CP-OFDM QPSK	40MHz	All RBs / All RBs
<b>Test Settings for DC_19A-21A_n79A Configuration (PC2) – Note 3</b>												
1	19	UL 837.5 / DL 882.2 MHz			21	DL 1500 MHz			n79	4850		

	QPSK	QPSK	5 MHz	All RBs / All RBs	N/A	QPSK	5 MHz	All RBs / 0	DFT-s-OFDM QPSK	CP-OFDM QPSK	40MHz	All RBs / All RBs
<b>Test Settings for DC_19A_n78A-n79A (PC2) – Note 3</b>												
1	19	UL 835/ DL 880 MHz			n78	3680 MHz			n79	4515 MHz		
	QPSK	QPSK	5 MHz	All RBs / All RBs	DFT-s-OFDM QPSK	QPSK	10 MHz	All RBs / All RBs	N/A	CP-OFDM QPSK	40 MHz	All RBs / 0
2	19	UL 835/ DL 880 MHz			n78	3715 MHz			n79	4550 MHz		
	QPSK	QPSK	5 MHz	All RBs / All RBs	N/A	QPSK	10 MHz	All RBs / 0	DFT-s-OFDM QPSK	CP-OFDM QPSK	40 MHz	All RBs / All RBs
<b>Test Settings for DC_19A_n78A-n79A (PC3) – Note 3</b>												
1	19	UL 835/ DL 880 MHz			n78	3680 MHz			n79	4515 MHz		
	QPSK	QPSK	5 MHz	All RBs / All RBs	DFT-s-OFDM QPSK	QPSK	10 MHz	All RBs / All RBs	N/A	CP-OFDM QPSK	40 MHz	All RBs / 0
2	19	UL 835/ DL 880 MHz			n78	3715 MHz			n79	4550 MHz		
	QPSK	QPSK	5 MHz	All RBs / All RBs	N/A	QPSK	10 MHz	All RBs / 0	DFT-s-OFDM QPSK	CP-OFDM QPSK	40 MHz	All RBs / All RBs
<b>Test Settings for DC_20A_n28A-n78A Configuration – Note 3</b>												
1	20	UL 857 / DL 816 MHz			n78	3314 MHz			n28	UL 743 / DL 798 MHz		
	QPSK	QPSK	5 MHz	All RBs / All RBs	N/A	CP-OFDM QPSK	10MHz	All RBs / 0	DFT-s-OFDM QPSK	CP-OFDM QPSK	5 MHz	All RBs / All RBs
2	20	UL 837 / DL 796 MHz			n28	UL 744 / DL 799 MHz			n78	3310 MHz		
	QPSK	QPSK	5 MHz	All RBs / All RBs	N/A	CP-OFDM QPSK	5MHz	All RBs / 0	DFT-s-OFDM QPSK	CP-OFDM QPSK	10MHz	All RBs / All RBs
<b>Test Settings for DC_20A_n28A-n75A Configuration</b>												
1	20	Mid			n28	High			n75	DL 1476MHz		

	QPSK	QPSK	20MHz	All RBs / 0	DFT-s-OFDM QPSK	CP-OFDM QPSK	20MHz	All RBs / REFSEN S_ENDC_1	N/A	CP-OFDM QPSK	20MHz	All RBs / N/A
2 <sup>N</sup> ote 8	20	Mid			n28	Low			n75	High		
	QPSK	QPSK	20MHz	All RBs / 0	DFT-s-OFDM QPSK	CP-OFDM QPSK	20MHz	All RBs / REFSEN S_ENDC_1	N/A	CP-OFDM QPSK	20MHz	All RBs / N/A
<b>Test Settings for DC_21A_n78A-n79A (PC2) – Note 3</b>												
1	21	UL 1453/ DL 1501 MHz			n78	3420 MHz			n79	4873 MHz		
	QPSK	QPSK	5 MHz	All RBs / All RBs	DFT-s-OFDM QPSK	QPSK	10 MHz	All RBs / All RBs	N/A	CP-OFDM QPSK	10 MHz	All RBs / 0
2	21	UL 1453/ DL 1501 MHz			n78	3487 MHz			n79	4940 MHz		
	QPSK	QPSK	5 MHz	All RBs / All RBs	N/A	QPSK	10 MHz	All RBs / 0	DFT-s-OFDM QPSK	CP-OFDM QPSK	10 MHz	All RBs / All RBs
<b>Test Settings for DC_21A_n78A-n79A (PC3) – Note 3</b>												
1	21	UL 1453/ DL 1510 MHz			n78	3420 MHz			n79	4873 MHz		
	QPSK	QPSK	5 MHz	All RBs / All RBs	DFT-s-OFDM QPSK	QPSK	10 MHz	All RBs / All RBs	N/A	CP-OFDM QPSK	40 MHz	All RBs / 0
2	21	UL 1453/ DL 1510 MHz			n78	3487 MHz			n79	4940 MHz		
	QPSK	QPSK	5 MHz	All RBs / All RBs	N/A	QPSK	10 MHz	All RBs / 0	DFT-s-OFDM QPSK	CP-OFDM QPSK	40 MHz	All RBs / All RBs
<b>Test Settings for DC_28A_n7A-n78A Configuration – Note 3</b>												
1	28	UL 745 / DL 8005 MHz			n78	3310 MHz			n7	UL 2565 / DL 2685 MHz		
	QPSK	QPSK	5 MHz	All RBs / All RBs	N/A	CP-OFDM QPSK	10 MHz	All RBs / 0	DFT-s-OFDM QPSK	CP-OFDM QPSK	5 MHz	All RBs / All RBs
2	28	UL 745 / DL 8005 MHz			n7	DL 2650 MHz			n78	3390 MHz		

	QPSK	QPSK	5 MHz	All RBs / All RBs	N/A	CP-OFDM QPSK	5 MHz	All RBs / 0	DFT-s- OFDM QPSK	CP-OFDM QPSK	10 MHz	All RBs / All RBs
<b>Test Settings for DC_66A_n2A-n77A Configuration – Note 3</b>												
1 <sup>11</sup>	66	UL 1760 / DL 2160 MHz			n2	DL 1960 MHz			n77	3720 MHz		
	QPSK	QPSK	5 MHz	All RBs / All RBs	N/A	QPSK	5 MHz	All RBs / 0	CP- OFDM QPSK	CP-OFDM QPSK	10 MHz	All RBs / All RBs
<b>Test Settings for DC_66A_n5A-n77A Configuration – Note 3</b>												
1	66	UL 1770 / DL 2170 MHz			n5	UL 845 / DL 890 MHz			n77	3460 MHz		
	QPSK	QPSK	5 MHz	All RBs / All RBs	QPSK	QPSK	5 MHz	All RBs / All RBs	N/A	CP-OFDM QPSK	10 MHz	All RBs / 0
<p>Note 1: Void</p> <p>Note 2: Void</p> <p>Note 3: EN-DC configuration affected by 2UL intermodulation exception. The exceptions always apply for a certain UL configuration.</p> <p>Note 4: LTE CA fallback to 1CC is sufficient to test, unless both LTE cells are part of the exception requirement in which case the configuration need to be tested (using configuration specific test settings and not default).</p> <p>Note 5: In an E-UTRA band or FR1 band where UE supports 4Rx, the test shall be performed only with 4Rx antennas ports connected.</p> <p>Note 6: Test only applicable for to UEs not supporting UE capability <i>singleUL-Transmission</i> for the correspondent uplink configuration.</p> <p>Note 7: NR CA fallback to 1CC is sufficient to test, unless both NR cells are part of the exception requirement in which case the configuration need to be tested (using configuration specific test settings and not default).</p> <p>Note 8: Test ID with UL harmonic exception avoided.</p> <p>Note 9: REFSSENS_LTE refers to the single carrier Uplink RB allocation for reference sensitivity according to table 7.3.3-2 of TS 36.521-1 [10]. REFSENS_NR refers to the single carrier Uplink RB allocation for reference sensitivity according to table 7.3.2.4.1-3 of TS 38.521-1 [8]. REFSENS_ENDC_1 refers to the Uplink RB allocation for reference sensitivity exceptions due to UL harmonic interference according to table 7.3B.2.0.3.1-2. REFSENS_ENDC_2 refers to the Uplink RB allocation for reference sensitivity exceptions due to receiver harmonic mixing according to table 7.3B.2.0.3.2-2. REFSENS_ENDC_3 refers to the Uplink RB allocation for reference sensitivity exceptions due to cross band isolation according to table 7.3B.2.0.3.4-2. REFSENS_ENDC_4 refers to the Uplink RB allocation for reference sensitivity exceptions due to dual uplink operation for ENDC according to table 7.3B.2.0.3.5.1-1 for PC3 and table 7.3B.2.0.3.5.1-1a for PC2.</p> <p>NOTE 10: If the NR frequency does not match to a valid NR-ARFCN, apply the closest NR frequency with a valid NR-ARFCN.</p> <p>NOTE 11: This test ID is for both UL PC3 and PC2.</p>												

## 7.3B.2.3\_1.1.4.2 Test procedure

Same as in clause 7.3B.2.3.4.2.

## 7.3B.2.3\_1.1.4.3 Message contents

Message contents are according to TS 38.508-1 [6] clause 4.6 Table 4.6.3-118 with condition TRANSFORM\_PRECODER\_ENABLED for NR band.

Message contents exceptions for E-UTRA band are according to TS 36.521-1 [10] clause 7.3.4.3 for each network signalling value. Message contents exceptions for NR band are according to TS 38.521-1 [8] clause 7.3.2.4.3 for each network signalling value.

For test points with Note 3 in Table 7.3B.2.3\_1.1.4.1-1, the following message exception applies:

**Table 7.3B.2.3.4.2.3-1: RRCConnectionReconfiguration: nr-Config-r15**

Derivation Path: TS 36.508 [11], Table 4.6.1-8			
Information Element	Value/remark	Comment	Condition
p-MaxEUTRA-r15	23		Power Class 2 UE
	20		Power Class 3 UE

**Table 7.3B.2.3.4.2.3-2: PhysicalCellGroupConfig**

Derivation Path: TS 38.508-1 [6] Table 4.6.3-106			
Information Element	Value/remark	Comment	Condition
p-NR-FR1	23		Power Class 2 UE
	20		Power Class 3 UE

## 7.3B.2.3\_1.1.5 Test requirement

Reference sensitivity test requirements for EN-DC configurations affected by 3 band 2UL intermodulation interference, are specified in Table 7.3B.2.3\_1.1.5-1 and Table 7.3B.2.3\_1.1.5-2 with uplink configuration specified in Table 7.3B.2.3\_1.1.4.1-1.

Reference sensitivity test requirements for test points in Table 7.3B.2.3\_1.1.4.1-1, are specified in Table 7.3.2.5-1 in TS 38.521-1 [8] for the NR CC.



**Table 7.3B.2.3\_1.1.5-1: Reference sensitivity exceptions for Scell due to dual uplink operation for PC3 EN-DC in NR FR1 (three bands)**

EN-DC Configuration	Test ID	EUTRA/ NR band	SCS (kHz)	5 MHz (dBm)	10 MHz (dBm)	20 MHz (dBm)	40 MHz (dBm)	Duplex mode	IMD order	
DC_1A-3A_n28A	1	1	N/A	REFSENS	-	-	-	FDD	N/A	
		n28	15	REFSENS	-	-	-		N/A	
		3	N/A	-92.3	-	-	-		IMD5	
	2	3	N/A	REFSENS	-	-	-	FDD	N/A	
		n28	15	REFSENS	-	-	-		N/A	
		1	N/A	-88.3	-	-	-		IMD4	
DC_1A-7A_n28A	1	1	N/A	REFSENS	-	-	-	FDD	N/A	
		n28	15	REFSENS	-	-	-		N/A	
		7	N/A	-	-64.3	-	-		IMD2	
DC_1A-3A_n77A	1	1	N/A	REFSENS	-	-	-	FDD	N/A	
		3	N/A	-64.8	-	-	-		IMD2	
		n77	15	-	REFSENS	-	-		TDD	N/A
	2	1	N/A	REFSENS	-	-	-	FDD	N/A	
		3	N/A	-87.8	-	-	-		IMD4	
		n77	15	-	REFSENS	-	-		TDD	N/A
	3	1	N/A	-68.3	-	-	-	FDD	IMD2	
		3	N/A	REFSENS	-	-	-		N/A	
		n77	15	-	REFSENS	-	-		TDD	N/A
DC_1A-3A_n78A DC_1A-3C_n78A	1	1	N/A	REFSENS	-	-	-	FDD	N/A	
		3	N/A	-65.1	-	-	-		IMD2	
		n78	15	-	REFSENS	-	-		TDD	N/A
	2	1	N/A	-96.5	-	-	-	FDD	IMD5	
		3	N/A	REFSENS	-	-	-		N/A	
		n78	15	-	REFSENS	-	-		TDD	N/A
DC_1A_n3A-n78A	1	1	N/A	REFSENS	-	-	-	FDD	N/A	
		n3	15	REFSENS	-	-	-		N/A	
		n78	15	-	-65.9	-	-		TDD	IMD2
	2	1	N/A	REFSENS	-	-	-	FDD	N/A	
n78		15	-	REFSENS	-	-	TDD		N/A	
n3		15	-68.2	-	-	-	FDD		IMD2	
DC_1A-3A_n79A	1	1	N/A	-95.7	-	-	-	FDD	IMD5	
		3	N/A	REFSENS	-	-	-		FDD	N/A
		n79	15	-	-	-	REFSENS		TDD	N/A
DC_1A-5A_n78A	1	1	N/A	-91.0	-	-	-	FDD	IMD4	
		5	N/A	REFSENS	-	-	-		FDD	N/A
		n78	15	-	REFSENS	-	-		TDD	N/A
	2	1	N/A	REFSENS	-	-	-	FDD	N/A	
		5	N/A	-89.0	-	-	-		FDD	IMD4
		n78	15	-	REFSENS	-	-		TDD	N/A
	3	1	N/A	-81.2	-	-	-	FDD	IMD3	
		5	N/A	REFSENS	-	-	-		FDD	N/A
		n78	15	-	REFSENS	-	-		TDD	N/A
	4	1	N/A	REFSENS	-	-	-	FDD	N/A	
		5	N/A	-94.2	-	-	-		FDD	IMD5
		n78	15	-	REFSENS	-	-		TDD	N/A
DC_1A-7A_n78A	1	1	N/A	REFSENS	-	-	-	FDD	N/A	
		7	N/A	-88.2	-	-	-		FDD	IMD4
		n78	15	-	REFSENS	-	-		TDD	N/A
	2	1	N/A	-90.6	-	-	-	FDD	IMD4	
7		N/A	-	REFSENS	-	-	FDD		N/A	
n78		15	-	REFSENS	-	-	TDD		N/A	
DC_1A-18A_n77A	1	1	N/A	-82.9	-	-	-	FDD	IMD3	
		18	N/A	REFSENS	-	-	-		FDD	N/A

EN-DC Configuration	Test ID	EUTRA/ NR band	SCS (kHz)	5 MHz (dBm)	10 MHz (dBm)	20 MHz (dBm)	40 MHz (dBm)	Duplex mode	IMD order
DC_1A-19A_n78A	1	n77	15	-	REFSENS	-	-	TDD	N/A
		1	N/A	-81.5	-	-	-	FDD	IMD3
		19	N/A	REFSENS	-	-	-	FDD	N/A
	2	n78	15	-	REFSENS	-	-	TDD	N/A
		1	N/A	REFSENS	-	-	-	FDD	N/A
		19	N/A	-94.2	-	-	-	FDD	IMD5
DC_1A-19A_n79A	1	n78	15	-	REFSENS	-	-	TDD	N/A
		1	N/A	REFSENS	-	-	-	FDD	N/A
		19	N/A	-81.0	-	-	-	FDD	IMD3
	2	n79	15	-	-	-	REFSENS	TDD	N/A
		1	N/A	-91.2	-	-	-	FDD	IMD4
		19	N/A	REFSENS	-	-	-	FDD	N/A
DC_1A-20A_n8A	1	n79	15	-	-	-	REFSENS	TDD	N/A
		1	N/A	REFSENS	-	-	-	FDD	N/A
		20	N/A	-87.8	-	-	-	FDD	IMD4
	2	n8	15	REFSENS	-	-	-	FDD	N/A
		1	N/A	-79.0	-	-	-	FDD	IMD3
		20	N/A	REFSENS	-	-	-	FDD	N/A
DC_1A-20A_n78A	1	n78	15	-	REFSENS	-	-	TDD	N/A
		1	N/A	REFSENS	-	-	-	FDD	N/A
		20	N/A	-93.3	-	-	-	FDD	IMD5
	2	n78	15	-	REFSENS	-	-	TDD	N/A
		1	N/A	REFSENS	-	-	-	FDD	N/A
		20	N/A	-93.3	-	-	-	FDD	IMD5
DC_1A-21A_n78A	1	n78	15	-	REFSENS	-	-	TDD	N/A
		1	N/A	-68.7	-	-	-	FDD	IMD2
		21	N/A	REFSENS	-	-	-	FDD	N/A
	2	n78	15	-	REFSENS	-	-	TDD	N/A
		1	N/A	-95.7	-	-	-	FDD	IMD5
		21	N/A	REFSENS	-	-	-	FDD	N/A
	3	n78	15	-	REFSENS	-	-	TDD	N/A
		1	N/A	REFSENS	-	-	-	FDD	N/A
		21	N/A	-67.8	-	-	-	FDD	IMD2
	4	n78	15	-	REFSENS	-	-	TDD	N/A
		1	N/A	REFSENS	-	-	-	FDD	N/A
		21	N/A	-96.4	-	-	-	FDD	IMD5
DC_1A-28A_n3A	1	n78	15	-	REFSENS	-	-	TDD	N/A
		28	N/A	REFSENS	-	-	-	FDD	N/A
		n3	15	REFSENS	-	-	-	FDD	N/A
DC_1A_n28A-n78A	1	1	N/A	-88.3	-	-	-	FDD	IMD4
		n28	15	REFSENS	-	-	-	FDD	N/A
		n78	15	-	-79.1	-	-	TDD	IMD3
	2	n28	15	-94.5	-	-	-	FDD	IMD5
		n78	15	-	REFSENS	-	-	TDD	N/A
		1	N/A	REFSENS	-	-	-	FDD	N/A
DC_1A-28A_n78A	1	1	N/A	-83.6	-	-	-	FDD	IMD3
		28	N/A	REFSENS	-	-	-	FDD	N/A
		n78	15	-	REFSENS	-	-	TDD	N/A
	2	1	N/A	REFSENS	-	-	-	FDD	N/A
		28	N/A	-93.6	-	-	-	FDD	IMD5
		n78	15	-	REFSENS	-	-	TDD	N/A
DC_1A-41A_n28A	1	1	N/A	REFSENS	-	-	-	FDD	N/A
		41	N/A	-	-64.3	-	-	TDD	IMD2
		n28	15	REFSENS	-	-	-	FDD	N/A

EN-DC Configuration	Test ID	EUTRA/ NR band	SCS (kHz)	5 MHz (dBm)	10 MHz (dBm)	20 MHz (dBm)	40 MHz (dBm)	Duplex mode	IMD order
DC_1A-41A_n77A	1	1	N/A	REFSENS	-	-	-	FDD	N/A
		41	N/A	-86.3	-	-	-	TDD	IMD4
		n77	15	-	REFSENS	-	-	TDD	N/A
	2	1	N/A	-90.0	-	-	-	FDD	IMD4
		41	N/A	REFSENS	-	-	-	TDD	N/A
		n77	15	-	REFSENS	-	-	TDD	N/A
	3	1	N/A	REFSENS	-	-	-	FDD	N/A
		41	N/A	-93.7	-	-	-	TDD	IMD5
		n77	15	-	REFSENS	-	-	TDD	N/A
DC_1A-42A_n79A	1	1	N/A	REFSENS	-	-	-	FDD	N/A
		n79	15	-	-	-	REFSENS	TDD	N/A
		42	N/A	-93.2	-	-	-	TDD	IMD5
DC_1A_n78A-n79A	1	1	N/A	REFSENS	-	-	-	FDD	N/A
		n78	15	-	REFSENS	-	-	TDD	N/A
		n79	15	-	-	-	-73.7+TT	TDD	IMD3
	2	1	N/A	REFSENS	-	-	-	FDD	N/A
		n78	15	-	-91.2+TT	-	-	TDD	IMD5
		n79	15	-	-	-	REFSENS	TDD	N/A
DC_2A_5A-n77A	1	2	N/A	REFSENS	-	-	-	FDD	N/A
		5	N/A	-93.5	-	-	-	FDD	IMD5
		n77	15	-	REFSENS	-	-	TDD	N/A
	2	2	N/A	-80.8	-	-	-	FDD	IMD3
		5	N/A	REFSENS	-	-	-	FDD	N/A
		n77	15	-	REFSENS	-	-	TDD	N/A
DC_2A_n5A-n77A	1	2	N/A	REFSENS	-	-	-	FDD	N/A
		n5	N/A	REFSENS	-	-	-	FDD	N/A
		n77	15	-	-78.3	-	-	TDD	IMD3
DC_2A-13A_n77A	1	2	N/A	-81.3	-	-	-	FDD	IMD3
		13	N/A	REFSENS	-	-	-	FDD	N/A
		n77	15	-	REFSENS	-	-	TDD	N/A
DC_2A-14A_n66A	1	2	N/A	-90.1	-	-	-	FDD	IMD4
		14	N/A	REFSENS	-	-	-	FDD	N/A
		n66	15	REFSENS	-	-	-	FDD	N/A
DC_2A-14A_n77A	1	2	N/A	-80,8	-	-	-	FDD	IMD3
		14	N/A	REFSENS	-	-	-	FDD	N/A
		n77	15	-	REFSENS	-	-	TDD	N/A
DC_2A-66A_n2A	1	2	N/A	-77.3				FDD	IMD3
		66	N/A	REFSENS				FDD	N/A
		n2	15	REFSENS				FDD	N/A
DC_2A-66A_n5A	1	2	N/A	REFSENS	-	-	-	FDD	N/A
		66	N/A	-91.6	-	-	-	FDD	IMD4
		n5	15	REFSENS	-	-	-	FDD	N/A
DC_2A-66A_n41A	1	2	N/A	-74.4	-	-	-	FDD	IMD4
		66	N/A	REFSENS	-	-	-	FDD	N/A
		n41	15	REFSENS	-	-	-	TDD	N/A
DC_2A-66A_n77A	1	2	N/A	REFSENS	-	-	-	FDD	N/A
		66	N/A	-69.6	-	-	-	FDD	IMD2
		n77	15	-	REFSENS	-	-	TDD	N/A
	2	2	N/A	REFSENS	-	-	-	FDD	N/A
		66	N/A	-88.4	-	-	-	FDD	IMD4
		n77	15	-	REFSENS	-	-	TDD	N/A
	3	2	N/A	REFSENS	-	-	-	FDD	N/A
		66	N/A	-94.8	-	-	-	FDD	IMD5
		n77	15	-	REFSENS	-	-	TDD	N/A
	4	2	N/A	-65.2	-	-	-	FDD	IMD2

EN-DC Configuration	Test ID	EUTRA/ NR band	SCS (kHz)	5 MHz (dBm)	10 MHz (dBm)	20 MHz (dBm)	40 MHz (dBm)	Duplex mode	IMD order
		66	N/A	REFSENS	-	-	-	FDD	N/A
		n77	15	-	REFSENS	-	-	TDD	N/A
DC_3A-5A_n78A	1	3	N/A	REFSENS	-	-	-	FDD	N/A
		5	N/A	-89.0	-	-	-	FDD	IMD4
	2	n78	15	-	REFSENS	-	-	TDD	N/A
		3	N/A	-70.3	-	-	-	FDD	IMD2
	3	5	N/A	REFSENS	-	-	-	FDD	N/A
		n78	15	-	REFSENS	-	-	TDD	N/A
		n78	15	-	REFSENS	-	-	TDD	N/A
		3	N/A	-88.3	-	-	-	FDD	IMD4
			[TBD]			10.7 <sup>5</sup>			
DC_3A-7A_n5A	1	3	N/A	-	REFSENS	-	-	FDD	N/A
		7	N/A	-	-64.3	-	-	FDD	IMD2 <sup>xx</sup>
		n5	15	REFSENS	-	-	-	FDD	N/A
DC_3A-7A_n28A	1	3	N/A	REFSENS	-	-	-	FDD	N/A
		n28	15	REFSENS	-	-	-		N/A
		7	N/A	-	-77.4	-	-		IMD3
	2	7	N/A	-	REFSENS	-	-	FDD	N/A
		n28	15	REFSENS	-	-	-		N/A
		3	N/A	-70.3	-	-	-		IMD2
DC_3A-7A_n78A DC_3C-7A_n78A DC_3C-7C_n78A	1	3	N/A	-78.7	-	-	-	FDD	IMD3
		7	N/A	REFSENS	-	-	-	FDD	N/A
		n78	15	-	REFSENS	-	-	TDD	N/A
	2	3	N/A	-87.7	-	-	-	FDD	IMD4
		7	N/A	REFSENS	-	-	-	FDD	N/A
		n78	15	-	REFSENS	-	-	TDD	N/A
DC_3A-8A_n78A	1	3	N/A	-79.8	-	-	-	FDD	IMD3
		8	N/A	REFSENS	-	-	-	FDD	N/A
		n78	15	-	REFSENS	-	-	TDD	N/A
DC_3A-19A_n78A	1	3	N/A	-82.0	-	-	-	FDD	IMD3
		19	N/A	REFSENS	-	-	-	FDD	N/A
		n78	15	-	REFSENS	-	-	TDD	N/A
DC_3A-19A_n79A	1	3	N/A	REFSENS	-	-	-	FDD	N/A
		19	N/A	-80.8	-	-	-	FDD	IMD3
		n79	15	-	-	-	REFSENS	TDD	N/A
	2	3	N/A	-90.8	-	-	-	FDD	IMD4
		19	N/A	REFSENS	-	-	-	FDD	N/A
		n79	15	-	-	-	REFSENS	TDD	N/A
DC_3A-20A_n28A	1	20	N/A	REFSENS	-	-	-	FDD	N/A
		n28	15	REFSENS	-	-	-	FDD	N/A
		3	N/A	-86.9	-	-	-	FDD	IMD4
DC_3A-20A_n78A	1	3	N/A	-79.0	-	-	-	FDD	IMD3
		20	N/A	REFSENS	-	-	-	FDD	N/A
		n78	15	-	REFSENS	-	-	TDD	N/A
DC_3A-21A_n78A	1	3	N/A	REFSENS	-	-	-	FDD	N/A
		21	N/A	-90.5	-	-	-	FDD	IMD4
		n78	15	-	REFSENS	-	-	TDD	N/A
	2	3	N/A	-65.5	-	-	-	FDD	IMD2
		21	N/A	REFSENS	-	-	-	FDD	N/A
		n78	15	-	REFSENS	-	-	TDD	N/A
DC_3A-21A_n79A	1	3	N/A	-78.5	-	-	-	FDD	IMD3
		21	N/A	REFSENS	-	-	-	FDD	N/A
		n79	15	-	-	-	REFSENS	TDD	N/A
DC_3A_n28A-n78A	1	3	N/A	REFSENS	-	-	-	FDD	N/A

EN-DC Configuration	Test ID	EUTRA/ NR band	SCS (kHz)	5 MHz (dBm)	10 MHz (dBm)	20 MHz (dBm)	40 MHz (dBm)	Duplex mode	IMD order
		n28	15	REFSENS	-	-	-	FDD	N/A
		n78	15	-	-90.3	-	-	TDD	IMD5
DC_3A-28A_n78A	1	3	N/A	-79	-	-	-	FDD	IMD3
		28	N/A	REFSENS	-	-	-	FDD	N/A
		n78	15	-	REFSENS	-	-	TDD	N/A
DC_3A-40A_n1A	1	n1	15	REFSENS	-	-	-	FDD	N/A
		3	N/A	REFSENS	-	-	-	FDD	N/A
		40	N/A	-91.3	-	-	-	TDD	IMD5
DC_3A-41A_n28A	1	3	N/A	-70.3	-	-	-	FDD	IMD2
		41	N/A	REFSENS	-	-	-	TDD	N/A
	2	n28	15	-	REFSENS	-	-	TDD	N/A
		3	N/A	REFSENS	-	-	-	FDD	N/A
		41	N/A	-69.9	-	-	-	TDD	IMD2
	3	n28	15	REFSENS	-	-	-	TDD	N/A
		3	N/A	REFSENS	-	-	-	FDD	N/A
		41	N/A	-81.4	-	-	-	TDD	IMD3
		n28	15	REFSENS	-	-	-	TDD	N/A
DC_3A-41A_n77A	1	3	N/A	REFSENS	-	-	-	FDD	N/A

EN-DC Configuration	Test ID	EUTRA/ NR band	SCS (kHz)	5 MHz (dBm)	10 MHz (dBm)	20 MHz (dBm)	40 MHz (dBm)	Duplex mode	IMD order
DC_3A-41C_n77A DC_3A-41A_n77(2A)	2	n77	15	-	REFSENS	-	-	TDD	N/A
		41	N/A	-92	-	-	-	TDD	IMD5
		41	N/A	REFSENS	-	-	-	TDD	N/A
		n77	15	-	REFSENS	-	-	TDD	N/A
		3	N/A	-79.9	-	-	-	FDD	IMD3
DC_3A_n78A-n79A	1	3	N/A	REFSENS	-	-	-	FDD	N/A
		n78	15	-	REFSENS	-	-	TDD	N/A
		n79	15	-	-	-	-73.3+TT	TDD	IMD3
	2	3	N/A	REFSENS	-	-	-	FDD	N/A
		n78	15	-	-91.6+TT	-	-	TDD	IMD5
		n79	15	-	-	-	REFSENS	TDD	N/A
DC_5A-7A_n78A	1	5	N/A	-89.0	-	-	-	FDD	IMD4
		7	N/A	REFSENS	-	-	-	FDD	N/A
		n78	15	-	REFSENS	-	-	TDD	N/A
	2	5	N/A	REFSENS	-	-	-	FDD	N/A
		7	N/A	-67.2	-	-	-	FDD	N/A
		n78	15	-	REFSENS	-	-	TDD	N/A
	3	5	N/A	-67.1	-	-	-	FDD	IMD2
		7	N/A	REFSENS	-	-	-	FDD	N/A
		n78	15	-	REFSENS	-	-	TDD	N/A
	4	5	N/A	-94.0	-	-	-	FDD	IMD5
		7	N/A	REFSENS	-	-	-	FDD	N/A
		n78	15	-	REFSENS	-	-	TDD	N/A
DC_5A-66A_n2A	1	5	N/A	REFSENS	-	-	-	FDD	N/A
		66	N/A	-91.6	-	-	-	FDD	IMD4
		n2	N/A	REFSENS	-	-	-	FDD	N/A
DC_5A-66A_n77A	1	5	N/A	REFSENS	-	-	-	FDD	N/A
		66	N/A	-85.6	-	-	-	FDD	IMD3
		n77	15	-	REFSENS	-	-	TDD	N/A
DC_7A-8A_n3A	1	7	N/A	-	REFSENS	-	-	FDD	N/A
		8	N/A	-78.3	-	-	-	FDD	IMD3
		n3	15	REFSENS	-	-	-	FDD	N/A
	2	7	N/A	-	-65.3	-	-	FDD	IMD2+ IMD3 <sup>YY</sup>
		8	N/A	REFSENS	-	-	-	FDD	N/A
n3		15	REFSENS	-	-	-	FDD	N/A	
DC_7A-20A_n1A	1	7			REFSENS			FDD	N/A
		20			-88.8			FDD	IMD5
		n1			REFSENS			FDD	N/A
DC_7A-20A_n3A	1	7	N/A	-	REFSENS	-	-	FDD	N/A
		20	N/A	-	-82.8	-	-	FDD	IMD2
		n3	15	REFSENS	-	-	-	FDD	N/A
	2	7	N/A	-	-68.3	-	-	FDD	IMD2
		20	N/A	REFSENS	-	-	-	FDD	N/A
		n3	15	-	REFSENS	-	-	FDD	N/A
DC_7A-20A_n8A	1	7	N/A	REFSENS	-	-	-	FDD	N/A
		20	N/A	-78.9	-	-	-	FDD	IMD3
		n8	15	REFSENS	-	-	-	FDD	N/A
	2	7	N/A	-76.2	-	-	-	FDD	IMD3
		20	N/A	REFSENS	-	-	-	FDD	N/A
		n8	15	REFSENS	-	-	-	FDD	N/A
	3	7	N/A	-78.5	-	-	-	FDD	IMD3
		20	N/A	REFSENS	-	-	-	FDD	N/A
		n8	15	REFSENS	-	-	-	FDD	N/A
DC_7A-20A_n28A	1	7	N/A	-	-91.4	-	-	FDD	IMD5
		20	N/A	REFSENS	-	-	-	FDD	N/A
		n28	15	REFSENS	-	-	-	FDD	N/A

EN-DC Configuration	Test ID	EUTRA/ NR band	SCS (kHz)	5 MHz (dBm)	10 MHz (dBm)	20 MHz (dBm)	40 MHz (dBm)	Duplex mode	IMD order
DC_7A-20A_n78A	1	7	N/A	REFSENS	-	-	-	FDD	N/A
		20	N/A	-65.8	-	-	-	FDD	IMD2
		n78	15	-	REFSENS	-	-	TDD	N/A
	2	7	N/A	REFSENS	-	-	-	FDD	N/A
		20	N/A	-93.3	-	-	-	FDD	IMD5
		n78	15	-	REFSENS	-	-	TDD	N/A
	3	7	N/A	-66.5	-	-	-	FDD	IMD2
		20	N/A	REFSENS	-	-	-	FDD	N/A
		n78	15	-	REFSENS	-	-	TDD	N/A
DC_7A-28A_n3A	1	7	N/A	REFSENS	-	-	-	FDD	N/A
		28	N/A	-77.8	-	-	-	FDD	IMD2
		n3	15	REFSENS	-	-	-	FDD	N/A
	2	7	N/A	-79.3	-	-	-	FDD	IMD3
		28	N/A	REFSENS	-	-	-	FDD	N/A
		n3	15	REFSENS	-	-	-	FDD	N/A
DC_7A-28A_n5A	1	7	N/A	REFSENS	-	-	-	FDD	N/A
		28	N/A	-93.4	-	-	-	FDD	IMD5
		n5	15	REFSENS	-	-	-	FDD	N/A
	2	7	N/A	-91.9	-	-	-	FDD	IMD5
		28	N/A	REFSENS	-	-	-	FDD	N/A
		n5	15	REFSENS	-	-	-	FDD	N/A
DC_7A-28A_n78A	1	7	N/A	REFSENS	-	-	-	FDD	N/A
		28	N/A	-89.5	-	-	-	FDD	IMD2
		n78	15	-	REFSENS	-	-	TDD	N/A
	2	7	N/A	REFSENS	-	-	-	FDD	N/A
		28	N/A	-94.8	-	-	-	FDD	IMD5
		n78	15	-	REFSENS	-	-	TDD	N/A
	3	7	N/A	-66.8	-	-	-	FDD	IMD2
		28	N/A	REFSENS	-	-	-	FDD	N/A
		n78	15	-	REFSENS	-	-	TDD	N/A
DC_7A_n28A-n78A	1	7	N/A	REFSENS	-	-	-	FDD	N/A
		n28	15	REFSENS	-	-	-	FDD	N/A
		n78	15	-	-65.1	-	-	TDD	IMD2
	2	7	N/A	REFSENS	-	-	-	FDD	N/A
		n28	15	-69.0	-	-	-	FDD	IMD2
		n78	15	-	REFSENS	-	-	TDD	N/A
DC_13A_n2A-n77A	1	13	N/A	REFSENS	-	-	-	FDD	N/A
		n2	15	REFSENS	-	-	-	FDD	N/A
		n77	15	-	-77	-	-	TDD	IMD3
	2	13	N/A	REFSENS	-	-	-	FDD	N/A
		n2	15	-81	-	-	-	FDD	IMD3
		n77	15	-	REFSENS	-	-	TDD	N/A
DC_13A-66A_n2A	1	13	N/A	REFSENS	-	-	-	FDD	N/A
		66	N/A	-91.3	-	-	-	FDD	IMD4
		n2	15	REFSENS	-	-	-	FDD	N/A
DC_13A-66A_n77A	1	13	N/A	REFSENS	-	-	-	FDD	N/A
		66	N/A	-81.4	-	-	-	FDD	IMD3
		n77	15	-	REFSENS	-	-	FDD	N/A
DC_14A-66A_n77A	1	13	N/A	-81.1	-	-	-	FDD	IMD3
		66	N/A	REFSENS	-	-	-	FDD	N/A
		n77	15	-	REFSENS	-	-	TDD	N/A
	2	13	N/A	REFSENS	-	-	-	FDD	N/A
		66	N/A	-85.6	-	-	-	FDD	IMD3
		n77	15	REFSENS	REFSENS	-	-	TDD	N/A
DC_18A-41A_n77A DC_18A-41C_n77A	1	18	N/A	-95.9	-	-	-	FDD	IMD5
		n77	15	-	REFSENS	-	-	TDD	N/A
		41	N/A	REFSENS	-	-	-	TDD	N/A
DC_18A-41A_n78A	1	18	N/A	-95.9	-	-	-	FDD	IMD5



EN-DC Configuration	Test ID	EUTRA/ NR band	SCS (kHz)	5 MHz (dBm)	10 MHz (dBm)	20 MHz (dBm)	40 MHz (dBm)	Duplex mode	IMD order
DC_18A-41C_n78A		n78	15	-	REFSENS	-	-	TDD	N/A
		41	N/A	REFSENS	-	-	-	TDD	N/A
DC_19A-21A_n78A	1	19	N/A	-80.6	-	-	-	FDD	IMD3
		21	N/A	REFSENS	-	-	-	FDD	N/A
		n78	15	-	REFSENS	-	-	TDD	N/A
	2	19	N/A	-86.1	-	-	-	FDD	IMD4
		21	N/A	REFSENS	-	-	-	FDD	N/A
		n78	15	-	REFSENS	-	-	TDD	N/A
DC_19A-21A_n79A	1	19	N/A	REFSENS	-	-	-	FDD	N/A
		21	N/A	-95.5	-	-	-	FDD	IMD5
		n79	15	-	-	-	REFSENS	TDD	N/A
DC_19A_n78A-n79A	1	19	N/A	REFSENS	-	-	-	FDD	N/A
		n78	15	-	REFSENS	-	-	TDD	N/A
		n79	15	-	-	-	-60.3+TT	TDD	IMD2
	2	19	N/A	REFSENS	-	-	-	FDD	N/A
		n78	15	-	-67.0+TT	-	-	TDD	IMD2
		n79	15	-	-	-	REFSENS	TDD	N/A
DC_20A_n28A-n78A	1	20	N/A	REFSENS	-	-	-	FDD	N/A
		n28	15	REFSENS	-	-	-	FDD	N/A
		n78	15	-	-86.1	-	-	TDD	IMD4
	2	20	N/A	REFSENS	-	-	-	FDD	N/A
		n78	15	-	REFSENS	-	-	TDD	N/A
		n28	15	-89.1+TT	-	-	-	FDD	IMD4
DC_21A_n78A-n79A	1	21	N/A	REFSENS	-	-	-	FDD	N/A
		n78	15	-	REFSENS	-	-	TDD	N/A
		n79	15	-	-	-	-59.5+TT	TDD	IMD2
	2	21	N/A	REFSENS	-	-	-	FDD	N/A
		n78	15	-	-66.0+TT	-	-	TDD	IMD2
		n79	15	-	-	-	REFSENS	TDD	N/A
DC_28A_n7A-n78A	1	28	N/A	REFSENS	-	-	-	FDD	N/A
		n7	15	REFSENS	-	-	-	FDD	N/A
		n78	15	-	-65.1	-	-	TDD	IMD2
	2	28	N/A	REFSENS	-	-	-	FDD	N/A
		n7	15	-66.8	-	-	-	FDD	IMD2
		n78	15	-	REFSENS	-	-	TDD	N/A
DC_14A-66A_n2A	1	14	N/A	REFSENS	-	-	-	FDD	N/A
		66	N/A	-91.2	-	-	-	FDD	IMD4
		n2	15	REFSENS	-	-	-	FDD	N/A
DC_66A_n2A-n77A	1	n2	15	-65.2	-	-	-	FDD	IMD2
		66	N/A	REFSENS	-	-	-	FDD	N/A
		n77	15	-	REFSENS	-	-	TDD	N/A
DC_66A_n5A-n77A	1	66	N/A	REFSENS	-	-	-	FDD	N/A
		n5	15	REFSENS	-	-	-	FDD	N/A
		n77	15	-	-77.7	-	-	TDD	IMD3 <sup>9</sup>

NOTE 1: E-UTRA carrier shall be set to min(+20 dBm,  $P_{CMAX\_L\_E-UTRA,c}$ ) and NR carrier shall be set to min(+20 dBm,  $P_{CMAX\_L\_f,c,NR}$ ) defined in clause 6.2B.4.1.3.

NOTE 2:  $RB_{START} = 0$

NOTE 3: Void

NOTE 4: This band is subject to IMD5 also which MSD is not specified.

NOTE 5: The symbol "REFSENS" in this table refers to the reference sensitivity values for single carrier specified in Table 7.3.5-1 TS 36.521-1 [10] for 2 antenna port E-UTRA band, Table 7.3\_1.5-1 of TS 36.521-1 [10] for 4 antenna port E-UTRA band 7.3.2.5-1 for 2 antenna port NR band and Table 7.3.2.5-2 for 4 antenna port NR band.

NOTE 6: No requirements apply when there is at least one individual RE within the intermodulation generated by the dual uplink in the downlink transmission bandwidth of the Band 46. The reference sensitivity should only be verified when this is not the case (the requirements for Band 46 specified in the CA\_7A-46A in clause 7.3.1 of TS 36.101 [5] apply).

NOTE 7: This band is subject to IMD3 also which MSD is not specified.

NOTE 8: This MSD requirement apply with both IMD2 and IMD3 products should be generated.

NOTE 9: This band is subject to IMD4 also which MSD is not specified.

**Table 7.3B.2.3\_1.1.5-1a: Reference sensitivity exceptions for SCell due to dual uplink operation for PC2 EN-DC in NR FR1 (three bands)**

EN-DC Configuration	Test ID	EUTRA/ NR band	SCS (kHz)	5 MHz (dBm)	10 MHz (dBm)	20 MHz (dBm)	40 MHz (dBm)	Duplex mode	IMD order
DC_1A-3A_n77A	1	1	N/A	REFSENS	-	-	-	FDD	N/A
		3	N/A	-58.8	-	-	-	FDD	IMD2 <sup>3</sup>
		n77	15	-	REFSENS	-	-	TDD	N/A
	2	1	N/A	REFSENS	-	-	-	FDD	N/A
		3	N/A	-75.8	-	-	-	FDD	IMD4 <sup>3</sup>
		n77	15	-	REFSENS	-	-	TDD	N/A
	3	1	N/A	-62.3	-	-	-	FDD	IMD2 <sup>3</sup>
		3	N/A	REFSENS	-	-	-	FDD	N/A
		n77	15	-	REFSENS	-	-	TDD	N/A
DC_1A-3A_n78A	1	1	N/A	REFSENS	-	-	-	FDD	N/A
		3	N/A	-59.1	-	-	-	FDD	IMD2
		n78	15	-	REFSENS	-	-	TDD	N/A
	2	1	N/A	-81.5	-	-	-	FDD	IMD5
		3	N/A	REFSENS	-	-	-	FDD	N/A
		n78	15	-	REFSENS	-	-	TDD	N/A
DC_1A-3A_n79A	1	1	N/A	-74.7	-	-	-	FDD	IMD5
		3	N/A	REFSENS	-	-	-	FDD	N/A
		n79	15	-	REFSENS	-	-	TDD	N/A
DC_1A-18A_n77A	1	1	N/A	REFSENS	-	-	-	FDD	N/A
		18	N/A	-83.5	-	-	-	FDD	IMD5
		n77	15	-	REFSENS	-	-	TDD	N/A
	2	1	N/A	-74.3	-	-	-	FDD	IMD3
		18	N/A	REFSENS	-	-	-	FDD	N/A
		n77	15	-	REFSENS	-	-	TDD	N/A
DC_1A-19A_n78A	1	1	N/A	-72.6	-	-	-	FDD	IMD3
		19	N/A	REFSENS	-	-	-	FDD	N/A
		n78	15	-	REFSENS	-	-	TDD	N/A
	2	1	N/A	REFSENS	-	-	-	FDD	N/A
		19	N/A	-80.8	-	-	-	FDD	IMD5
		n78	15	-	REFSENS	-	-	TDD	N/A
DC_1A-19A_n79A	1	1	N/A	REFSENS	-	-	-	FDD	N/A
		19	N/A	-66.0	-	-	-	FDD	IMD3
		n79	15	-	REFSENS	-	-	TDD	N/A
	2	1	N/A	-73.2	-	-	-	FDD	IMD4
		19	N/A	REFSENS	-	-	-	FDD	N/A
		n79	15	-	REFSENS	-	-	TDD	N/A
DC_1A-21A_n78A	1	1	N/A	-62.7	-	-	-	FDD	IMD2
		21	N/A	REFSENS	-	-	-	FDD	N/A
		n78	15	-	REFSENS	-	-	TDD	N/A
	2	1	N/A	-83.1	-	-	-	FDD	IMD5
		21	N/A	REFSENS	-	-	-	FDD	N/A
		n78	15	-	REFSENS	-	-	TDD	N/A
	3	1	N/A	REFSENS	-	-	-	FDD	N/A
		21	N/A	-61.8	-	-	-	FDD	IMD2
		n78	15	-	REFSENS	-	-	TDD	N/A
	4	1	N/A	REFSENS	-	-	-	FDD	N/A
		21	N/A	-84.4	-	-	-	FDD	IMD5
		n78	15	-	REFSENS	-	-	TDD	N/A
DC_1A-41A_n77A	1	1	N/A	REFSENS	-	-	-	FDD	N/A
		41	N/A	-74.8	-	-	-	FDD	IMD4
		n77	15	-	REFSENS	-	-	TDD	N/A
	2	1	N/A	REFSENS	-	-	-	FDD	N/A
		41	N/A	-81.7	-	-	-	FDD	IMD5
		n77	15	-	REFSENS	-	-	TDD	N/A
1	1	N/A	REFSENS	-	-	-	FDD	N/A	
	n78	15	-	REFSENS	-	-	TDD	N/A	

EN-DC Configuration	Test ID	EUTRA/ NR band	SCS (kHz)	5 MHz (dBm)	10 MHz (dBm)	20 MHz (dBm)	40 MHz (dBm)	Duplex mode	IMD order
DC_1A-n78A-n79A	2	n79	15	-	+TT	-	-	TDD	IMD3
		1	N/A	REFSENS	-	-	-	FDD	N/A
		n78	15	-	+TT	-	-	TDD	IMD5
		n79	15	-	REFSENS	-	-	TDD	N/A
DC_1A-42A-n79A	1	1	N/A	REFSENS	-	-	-	FDD	N/A
		42	N/A	-72.2	-	-	-	TDD	IMD5
		n79	15	-	REFSENS	-	-	TDD	N/A
DC_2A-5A-n77A	1	2	N/A	REFSENS	-	-	-	FDD	N/A
		5	N/A	-83.7	-	-	-	FDD	IMD5
		n77	15	-	REFSENS	-	-	TDD	N/A
	2	2	N/A	-72.5	-	-	-	FDD	IMD3
		5	N/A	REFSENS	-	-	-	FDD	N/A
		n77	15	-	REFSENS	-	-	TDD	N/A
DC_2A-13A-n77A	1	2	N/A	-98.0 +TT+24.2	-	-	-	FDD	IMD3
		13	N/A	REFSENS	-	-	-	FDD	N/A
		n77	15	-	REFSENS	-	-	TDD	N/A
DC_2A-14A-n77A	1	2	N/A	-82.5	-	-	-	FDD	IMD3
		14	N/A	REFSENS	-	-	-	FDD	N/A
		n77	15	REFSENS	-	-	-	FDD	N/A
DC_2A-66A-n77A	1	2	N/A	REFSENS	-	-	-	FDD	N/A
		66	N/A	-99.5 +TT+34.7	-	-	-	FDD	IMD2
		n77	15	-	REFSENS	-	-	TDD	N/A
	2	2	N/A	REFSENS	-	-	-	FDD	N/A
		66	N/A	-99.5 +TT+21.1	-	-	-	FDD	IMD4 <sup>3</sup>
		n77	15	-	REFSENS	-	-	TDD	N/A
	4	2	N/A	-98.0 +TT+37.6	-	-	-	FDD	IMD2
		66	N/A	REFSENS	-	-	-	FDD	N/A
		n77	15	-	REFSENS	-	-	TDD	N/A
DC_3A-18A-n77A	1	3	N/A	-72.1	-	-	-	FDD	IMD3
		18	N/A	REFSENS	-	-	-	FDD	N/A
		n77	15	-	REFSENS	-	-	TDD	N/A
DC_3A-19A-n78A	1	3	N/A	-70.0	-	-	-	FDD	IMD3
		19	N/A	REFSENS	-	-	-	FDD	N/A
		n78	15	-	REFSENS	-	-	TDD	N/A
DC_3A-19A-n79A	1	3	N/A	REFSENS	-	-	-	FDD	N/A
		19	N/A	-71.8	-	-	-	FDD	IMD3
		n79	15	-	-	-	REFSENS	TDD	N/A
	2	3	N/A	-80.1	-	-	-	FDD	IMD4
		19	N/A	REFSENS	-	-	-	FDD	N/A
		n79	15	-	-	-	REFSENS	TDD	N/A
DC_3A-21A-n78A	1	3	N/A	REFSENS	-	-	-	FDD	N/A
		21	N/A	-76.1	-	-	-	FDD	IMD4
		n78	15	-	REFSENS	-	-	TDD	N/A
	2	3	N/A	-59.7	-	-	-	FDD	IMD2
		21	N/A	REFSENS	-	-	-	FDD	N/A
		n78	15	-	REFSENS	-	-	TDD	N/A
	3	3	N/A	REFSENS	-	-	-	FDD	N/A
		21	N/A	-89.8	-	-	-	FDD	IMD5
		n78	15	-	REFSENS	-	-	TDD	N/A
DC_3A-21A-n79A	1	3	N/A	-66.5	-	-	-	FDD	IMD3
		21	N/A	REFSENS	-	-	-	FDD	N/A
		n79	15	-	REFSENS	-	-	TDD	N/A

EN-DC Configuration	Test ID	EUTRA/ NR band	SCS (kHz)	5 MHz (dBm)	10 MHz (dBm)	20 MHz (dBm)	40 MHz (dBm)	Duplex mode	IMD order
DC_3A-41A_n77A	1	3	N/A	REFSENS	-	-	-	FDD	N/A
		41	N/A	-84.3	-	-	-	TDD	IMD5
		n77	15	-	REFSENS	-	-	TDD	N/A
DC_3A_n78A-n79A	1	3	N/A	REFSENS	-	-	-	FDD	N/A
		n78	15	-	REFSENS	-	-	TDD	N/A
		n79	15	-	-70.5+TT	-	-	TDD	IMD3
	2	3	N/A	REFSENS	-	-	-	FDD	N/A
		n78	15	-	-70.6+TT	-	-	TDD	IMD5
		n79	15	-	REFSENS	-	-	TDD	N/A
DC_5A-66A_n77A	1	5	N/A	REFSENS	-	-	-	FDD	N/A
		66	N/A	-76.6	-	-	-	FDD	IMD3
		n77	15	-	REFSENS	-	-	TDD	N/A
DC_13A_n2A-n77A	2	13	N/A	REFSENS	-	-	-	FDD	N/A
		n2	15	-98.0 +TT+25.0	-	-	-	FDD	IMD3
		n77	15	-	REFSENS	-	-	TDD	N/A
DC_13A-66A_n77A	1	13	N/A	REFSENS	-	-	-	FDD	N/A
		66	N/A	-99.5+ TT+25.3	-	-	-	FDD	IMD3
		n77	15	-	REFSENS	-	-	FDD	N/A
DC_14A-66A_n77A	1	13	N/A	-72.8	-	-	-	FDD	IMD3
		66	N/A	REFSENS	-	-	-	FDD	N/A
		n77	15	-	REFSENS	-	-	TDD	N/A
	2	13	N/A	REFSENS	-	-	-	FDD	N/A
		66	N/A	-77.4	-	-	-	FDD	IMD3
		n77	15	REFSENS	REFSENS	-	-	TDD	N/A
DC_19A-21A_n78A	1	19	N/A	-71.6	-	-	-	FDD	IMD3
		21	N/A	REFSENS	-	-	-	FDD	N/A
		n78	15	-	REFSENS	-	-	TDD	N/A
	2	19	N/A	-74.1	-	-	-	FDD	IMD4
		21	N/A	REFSENS	-	-	-	FDD	N/A
		n78	15	-	REFSENS	-	-	TDD	N/A
DC_19A-21A_n79A	1	19	N/A	REFSENS	-	-	-	FDD	N/A
		21	N/A	-74.5	-	-	-	FDD	IMD5
		n79	15	-	REFSENS	-	-	TDD	N/A
DC_19A_n78A-n79A	1	19	N/A	REFSENS	-	-	-	FDD	N/A
		n78	15	-	REFSENS	-	-	TDD	N/A
		n79	15	-	-	-	-60.5+TT	TDD	IMD2
	2	19	N/A	REFSENS	-	-	-	FDD	N/A
		n78	15	-	-	-	-61.0+TT	TDD	IMD2
		n79	15	-	REFSENS	-	-	TDD	N/A
DC_21A_n78A-n79A	1	21	N/A	REFSENS	-	-	-	FDD	N/A
		n78	15	-	REFSENS	-	-	TDD	N/A
		n79	15	-	-59.7+TT	-	-	TDD	IMD2
	2	21	N/A	REFSENS	-	-	-	FDD	N/A
		n78	15	-	-57.0+TT	-	-	TDD	IMD2
		n79	15	-	REFSENS	-	-	TDD	N/A
DC_66A_n2A-n77A	1	n2	15	-98.0+ TT+37.6	-	-	-	FDD	IMD2
		66	N/A	REFSENS	-	-	-	FDD	N/A
		n77	15	-	REFSENS	-	-	TDD	N/A

EN-DC Configuration	Test ID	EUTRA/ NR band	SCS (kHz)	5 MHz (dBm)	10 MHz (dBm)	20 MHz (dBm)	40 MHz (dBm)	Duplex mode	IMD order
NOTE 1: E-UTRA carrier shall be set to min(+23 dBm, $P_{\text{CMAX\_L,E-UTRA,c}}$ ) and NR carrier shall be set to min(+23 dBm, $P_{\text{CMAX\_L,f,c,NR}}$ ) defined in clause 6.2B.4.1.3.									
NOTE 2: $\text{RB}_{\text{START}} = 0$									
NOTE 3: This band is subject to IMD5 also which MSD is not specified.									
NOTE 4: The symbol "REFSENS" in this table refers to the reference sensitivity values for single carrier specified in Table 7.3.5-1 TS 36.521-1 [10] for 2 antenna port E-UTRA band, Table 7.3_1.5-1 of TS 36.521-1 [10] for 4 antenna port E-UTRA band 7.3.2.5-1 for 2 antenna port NR band and Table 7.3.2.5-2 for 4 antenna port NR band.									
NOTE 5: For UEs only indicating support of Single UL, this requirement is verified with non-simultaneous uplink transmissions on 1 UTRA and NR CGs.									
NOTE 6: TT is the same as defined in Table 7.3B.2.3.5-1a.									

**Table 7.3B.2.3\_1.1.5-2: Reference sensitivity exceptions for Scell due to dual uplink operation for EN-DC in NR FR1 (two bands)**

EN-DC Configuration	EUTRA/ NR band	SCS (kHz)	5 MHz (dBm)	10 MHz (dBm)	20 MHz (dBm)	40 MHz (dBm)	Duplex mode	IMD order	Single UL allowed
FFS	FFS	FFS	FFS	FFS	FFS	FFS	FFS	FFS	FFS
NOTE 1: Both of the transmitters shall be set min (+20 dBm, $P_{\text{CMAX\_L,c}}$ ) as defined in clause 6.2.5A. In case Single UL is allowed and the UE only indicates support of "Single UL" the output power of the active UL shall be set at $P_{\text{CMAX\_L,c}}$ or set to the maximum output power according to the UE power scaling capability.									
NOTE 2: $\text{RB}_{\text{START}} = 0$									

Test tolerance is the same as given in Table 7.3B.2.3.5-2.

**7.3B.2.3\_1.2 Reference sensitivity for EN-DC within FR1 (4 CCs)**

**7.3B.2.3\_1.2.1 Test purpose**

Same as in clause 7.3B.2.3.1.

**7.3B.2.3\_1.2.2 Test applicability**

This test applies to all types of NR UE release 15 and forward supporting 4 CCs EN-DC.

**7.3B.2.3\_1.2.3 Minimum conformance requirements**

The minimum conformance requirements are defined in clause 7.3B.2.0.

For EN-DC combinations with no exception requirements applicable to NR or E-UTRA, LTE anchor agnostic approach is applied.

For EN-DC combinations with exceptional requirements, LTE anchor agnostic approach is not applied.

**7.3B.2.3\_1.2.4 Test description**

**7.3B.2.3\_1.2.4.1 Initial conditions**

Initial conditions are a set of test configurations the UE needs to be tested in and the steps for the SS to take with the UE to reach the correct measurement state.

The initial test configurations for E-UTRA consist of the test frequency based on E-UTRA operating band and test channel bandwidth as specified in Table 4.6-1, with the exception that the E-UTRA channel bandwidth is the lowest supported value in Table 5.3B.1.3-1 for the EN-DC non-contiguous configuration under test.

The initial test configurations consist of environmental conditions, test frequencies, test channel bandwidths and sub-carrier spacing based on NR operating bands specified in Table 5.5B.2-1. The 4CC EN-DC configurations listed in table 7.3B.2.3\_1.2.4.1-0 shall not be tested according to TR 38.905 [7] test point analysis. The other 4CC configurations shall be tested with applicable test parameters for each combination of test channel bandwidth and sub-carrier spacing,

and are shown in Tables 7.3B.2.3.4.2.1-0 to 7.3B.2.3.4.2.1-1 for NR band. The details of the uplink reference measurement channels (RMCs) are specified in Annex A.2. Configurations of PDSCH and PDCCH before measurement are specified in TS 38.521-1 [8] Annex C2.

**Table 7.3B.2.3\_1.2.4.1-0: 4CC EN-DC configurations that shall not be tested**

EN-DC type	E-UTRA CA	NR CA	Notation
Intra-band non-contiguous EN-DC (1 band)	Yes (cont)	No	DC_XD_nXA
	Yes (non-cont)	No	Note 4
Inter-band EN-DC	Yes (all types)	No	DC_XD_nYA, DC_XA-YC_nZA, DC_XA-XA-YA_nZA, DC_XA-YA-ZA_nRA
	Yes (all types)	Yes (cont)	DC_XC_nYC, DC_XA-XA_nYC, DC_XA-YA_nYC
		Yes (non-cont)	DC_XC_nY(2A), DC_XA-YA_nY(2A)
		Yes (inter)	DC_XC_nYA-nZA, DC_XA-XA_nYA-nZA, DC_XA-YA_nZA-nRA
	Inter-band + Intra-band contiguous EN-DC (2-3 band)	Yes	No
Yes		Yes	DC_(n)XCA-nYA
Intra-band non contiguous EN-DC (2-3 band)	Yes	No	DC_XA-YA-ZA_nZA
	Yes	Yes	DC_XA-YA_nYA-nZA
NOTE 1: X, Y and Z in this table correspond to different bands i.e. X != Y != Z.			
NOTE 2: The table apply to all band numbers, i.e. all values of X, Y and Z defined in TS38.101-3			
NOTE 3: The band combinations with difference appearance order of bands/sub-blocks in the band combination string are not distinguished. E.g. DC_YA-(n)XAA represents the set of DC_YA-(n)XAA and DC_(n)XAA-YA.			
NOTE 4: No such config in TS 38.101-3 [7] V16.5.0x			

**Table 7.3B.2.3\_1.2.4.1-1: Test Configuration Table for all EN-DC configurations for FR1 non-exception requirements**



Initial Conditions									
Test Environment as specified in TS 38.508-1 [6] clause 4.1					Normal, TL/VL, TL/VH, TH/VL, TH/VH				
Test Frequencies as specified in TS 38.508-1 [6] clause 4.3.1 for different EN-DC bandwidth classes					DC_(n)XDA: Low range, High Range  DC_XA_nYA-nZC: Mid range for X and nY Low range, High Range for nY  DC_XA_nY(2A)-nZA: Mid range for X, nY, nZ				
Test EN-DC bandwidth combination as specified in Table 5.3B.1.2-1 across bandwidth combination sets supported by the UE					Refer to "NR N <sub>RB</sub> " and "E-UTRA N <sub>RB</sub> " columns				
NR Test SCS as specified in Table 5.3.5-1 in TS 38.521-1 [8]					Lowest SCS per Channel Bandwidth				
Network signalling value					NS_01 by default Unless given by Table 7.3.3-3 in TS 36.521-1 [10] for the E-UTRA band and Table 7.3.2.3-4 in TS 38.521-1 [8] for the NR band.				
Test Parameters for EN-DC Configurations									
ID	CC (NOTE1)	Band	SCS	N <sub>RB</sub>	Range/Wgap	UL MOD	DL MOD	UL Alloc	DL Alloc
Default Test Settings for a DC_(n)XDA Configuration – Note 5									
1 (Note 6)	PCC(M)	X		Highest N <sub>RB</sub>	default	QPSK	QPSK	REFSENS_LTE	All RBs
	SCC1(M)	X		Highest N <sub>RB</sub>	Default	N/A	QPSK	N/A	All RBs
	SCC2(M)	X		Highest N <sub>RB</sub>	Default	N/A	QPSK	N/A	All RBs
	PCC(S)	nX		Highest N <sub>RB</sub>	default	DFT-s-OFDM QPSK	CP-OFDM QPSK	REFSENS_NR	All RBs
2 (Note 7)	PCC(M)	X		Highest N <sub>RB</sub>	default	N/A	QPSK	0	All RBs
	SCC1(M)	X		Highest N <sub>RB</sub>	Default	N/A	QPSK	N/A	All RBs
	SCC2(M)	X		Highest N <sub>RB</sub>	Default	N/A	QPSK	N/A	All RBs
	PCC(S)	nX		Highest N <sub>RB</sub>	default	DFT-s-OFDM QPSK	CP-OFDM QPSK	REFSENS_NR	All RBs
Default Test Settings for a DC_XA_nY(2A)-nZA Configuration – Note 4									
1	PCC(M)	X		5 MHz	default	N/A	QPSK	0	All RBs
	SCC1(S)	nY		Highest N <sub>RB</sub>	default	N/A	QPSK	N/A	All RBs
	SCC2(S)	nZ		Highest N <sub>RB</sub>	default	N/A	QPSK	N/A	All RBs
	PCC(S)	nY		Highest N <sub>RB</sub>	default	DFT-s-OFDM QPSK	CP-OFDM QPSK	REFSENS_NR	All RBs
2	PCC(M)	X		5 MHz	default	N/A	QPSK	0	All RBs
	SCC1(S)	nY		Highest N <sub>RB</sub>	default	N/A	QPSK	N/A	All RBs
	SCC2(S)	nY		Highest N <sub>RB</sub>	default	N/A	QPSK	N/A	All RBs
	PCC(S)	nZ		Highest N <sub>RB</sub>	default	DFT-s-OFDM QPSK	CP-OFDM QPSK	REFSENS_NR	All RBs
Default Test Settings for a DC_XA_nYA-nZC Configuration– Note 4									
1	PCC(M)	X		5 MHz	default	N/A	QPSK	0	All RBs
	SCC1(S)	nZ		Highest N <sub>RB</sub>	default	N/A	QPSK	N/A	All RBs
	SCC2(S)	nZ		Highest N <sub>RB</sub>	default	N/A	QPSK	N/A	All RBs

	PCC(S)	nY		Highest N <sub>RB</sub>	default	DFT-s- OFDM QPSK	CP-OFDM QPSK	REFSENS_NR	All RBs
2	PCC(M)	X		5 MHz	default	N/A	QPSK	0	All RBs
	SCC1(S)	nZ		Highest N <sub>RB</sub>	default	N/A	QPSK	N/A	All RBs
	SCC2(S)	nY		Highest N <sub>RB</sub>	default	N/A	QPSK	N/A	All RBs
	PCC(S)	nZ		Highest N <sub>RB</sub>	default	DFT-s- OFDM QPSK	CP-OFDM QPSK	REFSENS	All RBs

NOTE 1: (M) and (S) indicate MCG and SCG respectively.  
NOTE 2: X, Y and Z in this table correspond to different bands i.e. X != Y != Z.  
NOTE 3: The band combinations with difference appearance order of bands/sub-blocks in the band combination string are not distinguished. E.g. DC\_YA-(n)XAA represents the set of DC\_YA-(n)XAA and DC\_(n)XAA-YA.  
NOTE 4: LTE anchor agnostic configuration  
NOTE 5: Not LTE anchor agnostic configuration due to exception requirement for intra-band contiguous CA in clause 7.4B, 7.5B, 7.6B.2, 7.6B.3, 7.6B.4, 7.7B, 7.8B, 7.9B test cases  
NOTE 6: Test point for UE supporting dual UL  
NOTE 7: Test point for UE supporting single UL  
NOTE 8: In a FR1 band where UE supports 4Rx, the test shall be performed only with 4Rx antennas ports connected.  
NOTE 9: UE supporting multiple EN-DC configurations with the same NR CA combination, only one EN-DC configuration is tested.  
NOTE 10: REFSENS\_LTE refers to the single carrier Uplink RB allocation for reference sensitivity according to table 7.3.3-2 of TS 36.521-1 [10].  
REFSENS\_NR refers to the single carrier Uplink RB allocation for reference sensitivity according to table 7.3.2.4.1-3 of TS 38.521-1 [8].

For 4CC EN-DC configurations affected by exceptions, exception testing can be covered by 2CC or 3CC fallback configurations. No exception test points are needed in this test case.

#### Table 7.3B.2.3\_1.2.4.1-2: Void

#### Table 7.3B.2.3\_1.2.4.1-3: Void

1. Connect the SS to the UE antenna connectors as shown in TS 38.508-1 [6] Annex A, Figure A.3.1.1.1 for TE diagram and clause A.3.2 for UE diagram.
2. The parameter settings for NR cell are set up according to TS 38.508-1 [6] clause 4.4.3.
3. The parameter settings for E-UTRA cell are set up according to TS 36.508 [11] clause 4.4.3.
4. NR downlink signals are initially set up according to Annex C.0, C.1, C.2, C.3.1, and uplink signals according to Annex G.0, G.1, G.2, and G.3.1 of TS 38.521-1 [8].
5. E-UTRA downlink signals are initially set up according to Annex C.0, C.1 and C.3.0, and uplink signals according to Annex H.1 and H.3.0 of TS 36.521-1 [10].
6. The DL and UL Reference Measurement channels are set according to Tables 7.3B.2.3.4.2.1-0 to 7.3B.2.3.4.2.1-6 for E-UTRA CG and NR CG.
7. NR propagation conditions are set according to Annex B.0 of TS 38.521-1 [8]. E-UTRA propagation conditions are set according to Annex B.0 of TS 36.521-1 [10].
8. Ensure the UE is in state RRC\_CONNECTED with generic procedure parameters Connectivity EN-DC, DC bearer MCG and SCG, Connected without release *On* according to TS 38.508-1 [6] clause 4.5. Message contents are defined in clause 7.3B.2.3\_1.2.4.3.
9. On the E-UTRA carrier, disable periodic and aperiodic CQI reports, disable SRS, set *TimeAlignmentTimerDedicated* IE to infinity and disable downlink and uplink scheduling, all as per Table 4.6-1 under clause 4.6.

### 7.3B.2.3\_1.2.4.2 Test procedure

1. NR SS transmits PDSCH via PDCCH DCI format 1\_1 for C\_RNTI to transmit the DL RMC according to Table 7.3B.2.3\_1.2.4.2.1-1 on the NR CC. The NR SS sends downlink MAC padding bits on the DL RMC.
2. NR SS sends uplink scheduling information for each UL HARQ process via PDCCH DCI format 0\_1 for C\_RNTI to schedule the UL RMC according to Table 7.3B.2.3\_1.2.4.2.1-1. Since the UL has no payload and no loopback data to send the UE sends uplink MAC padding bits on the UL RMC.
3. Set the Downlink signal level to the appropriate REFSSENS value defined in TS 38.521-1 [8], Table 7.3.2.5-1 for NR band. Send continuously uplink power control "up" commands in the uplink scheduling information to NR carrier to ensure the UE transmits PUMAX level for at least the duration of the Throughput measurement.
4. Measure the average throughput of the NR carrier for a duration sufficient to achieve statistical significance according to Annex H.2 of TS 38.521-1 [8] for NR band.

### 7.3B.2.3\_1.2.4.3 Message contents

Message contents are according to TS 38.508-1 [6] clause 4.6 Table 4.6.3-118 with condition TRANSFORM\_PRECODER\_ENABLED for NR band.

Message contents exceptions for E-UTRA band are according to TS 36.521-1 [10] clause 7.3.4.3 for each network signalling value. Message contents exceptions for NR band are according to TS 38.521-1 [8] clause 7.3.2.4.3 for each network signalling value.

### 7.3B.2.3\_1.2.5 Test Requirement

Reference sensitivity test requirements for EN-DC configurations are specified in Table 7.3.5-1 in TS 36.521-1 [10] for the LTE CC, and Table 7.3.2.5-1 in TS 38.521-1 [8] for the NR CC.

#### **Table 7.3B.2.3\_1.2.5-1: Reference sensitivity exceptions for Scell due to dual uplink operation for EN-DC in NR FR1 (two bands)**

FFS

#### **Table 7.3B.2.3\_1.2.5-2: Reference sensitivity exceptions for Scell due to dual uplink operation for EN-DC in NR FR1 (three bands)**

FFS

### 7.3B.2.3\_1.3 Reference sensitivity for EN-DC within FR1 (5 CCs)

#### 7.3B.2.3\_1.3.1 Test purpose

Same as in clause 7.3B.2.3.1.

#### 7.3B.2.3\_1.3.2 Test applicability

This test applies to all types of NR UE release 15 and forward supporting 5 CCs inter-band EN-DC.

#### 7.3B.2.3\_1.3.3 Minimum conformance requirements

The minimum conformance requirements are defined in clause 7.3B.2.0

Exception requirements for both NR and E-UTRA are defined for this test and therefore LTE anchor agnostic approach is not applied. E-UTRA test point analysis is included and E-UTRA measurements are performed.

#### 7.3B.2.3\_1.3.4 Test description

##### 7.3B.2.3\_1.3.4.1 Initial conditions

Same initial conditions as in clause 7.3B.2.3.4.1 with following exceptions:

The initial test configurations for E-UTRA band and NR band consist of environmental conditions, test frequencies, and channel bandwidths and RB allocations for exceptional test scenarios are specified in Table 7.3B.2.3\_1.3.4.1-1 and Table 7.3B.2.3\_1.3.4.1-2

**Table 7.3B.2.3\_1.3.4.1-1: Test Configuration Table Reference sensitivity exceptions due to dual uplink operation for EN-DC in NR FR1 (four bands)**

Initial Conditions									
Test Environment as specified in TS 38.508-1 [6] clause 4.1				Normal, TL/VL, TL/VH, TH/VL, TH/VH					
Test Frequencies as specified in TS 38.508-1 [6] clause 4.3.1 for different EN-DC bandwidth classes				For test frequencies refer to "Range" columns. For mapping within Band refer to "CC" columns					
Test EN-DC bandwidth combination as specified in Table 5.3B.1.2-1 across bandwidth combination sets supported by the UE				Refer to "N <sub>RB</sub> " column					
NR Test SCS as specified in Table 5.3.5-1 in TS 38.521-1 [8]				Refer to "SCS" column					
Network signalling value				NS_01 by default, exceptions listed in Table 7.3.3-3, dependent on PCC Band					
Test Parameters for EN-DC Configurations									
ID	CC (NOTE1)	Band	SCS	N <sub>RB</sub>	Range/Wgap	UL MOD	DL MOD	UL Alloc	DL Alloc
Default Test Settings for a DC_XA-YA_ZC_nRA Configuration									
1	PCC(M)	X	N/A	Highest N <sub>RB</sub>	Mid	QPSK	QPSK	REFSENS	All RBs
	SCC1(M)	Y	N/A	Highest N <sub>RB</sub>	Mid	N/A	QPSK	N/A	All RBs
	SCC2(M)	Z	N/A	Highest N <sub>RB</sub>	Mid	N/A	QPSK	N/A	All RBs
	SCC3(M)	Z	N/A	Highest N <sub>RB</sub>	Mid	N/A	QPSK	N/A	All RBs
	PCC(S)	R	15 kHz	Highest N <sub>RB</sub>	Mid	DFT-s-OFDM QPSK	CP-OFDM QPSK	REFSENS	All RBs
NOTE 1: (M) and (S) indicate MCG and SCG respectively.									
NOTE 2: X, Y and Z in this table correspond to different bands i.e. X != Y != Z									
NOTE 3: The band combinations with difference appearance order of bands/sub-blocks in the band combination string are not distinguished. E.g. DC_YA-(n)XAA represents the set of DC_YA-(n)XAA and DC_(n)XAA-YA									

**Table 7.3B.2.3\_1.3.4.1-2: Test Configuration Table Reference sensitivity exceptions due to dual uplink operation for EN-DC in NR FR1 (five bands)**

Initial Conditions									
Test Environment as specified in TS 38.508-1 [6] clause 4.1				Normal, TL/VL, TL/VH, TH/VL, TH/VH					
Test Frequencies as specified in TS 38.508-1 [6] clause 4.3.1 for different EN-DC bandwidth classes				For test frequencies refer to "Range" columns. For mapping within Band refer to "CC" columns					
Test EN-DC bandwidth combination as specified in Table 5.3B.1.2-1 across bandwidth combination sets supported by the UE				Refer to "N <sub>RB</sub> " column					
NR Test SCS as specified in Table 5.3.5-1 in TS 38.521-1 [8]				Refer to "SCS" column					
Network signalling value				NS_01 by default, exceptions listed in Table 7.3.3-3, dependent on PCC Band					
Test Parameters for EN-DC Configurations									
ID	CC (NOTE1)	Band	SCS	N <sub>RB</sub>	Range/Wgap	UL MOD	DL MOD	UL Alloc	DL Alloc
Default Test Settings for a DC_XA-YA-ZA-SA_nRA Configuration									
1	PCC(M)	X	N/A	Highest N <sub>RB</sub>	Mid	QPSK	QPSK	REFSENS	All RBs
	SCC1(M)	Y	N/A	Highest N <sub>RB</sub>	Mid	N/A	QPSK	N/A	All RBs
	SCC2(M)	Z	N/A	Highest N <sub>RB</sub>	Mid	N/A	QPSK	N/A	All RBs
	SCC3(M)	S	N/A	Highest N <sub>RB</sub>	Mid	N/A	QPSK	N/A	All RBs
	PCC(S)	R	15 kHz	Highest N <sub>RB</sub>	Mid	DFT-s-OFDM QPSK	CP-OFDM QPSK	REFSENS	All RBs
NOTE 1: (M) and (S) indicate MCG and SCG respectively. NOTE 2: X, Y and Z in this table correspond to different E-UTRA bands i.e. X != Y != Z, R corresponds to NR band. NOTE 3: For inter-band EN-DC 4CCs configuration with four bands, if there is no additional exceptional test point is defined besides the requirement for default uplink EN-DC configurations defined in Table 5.5B.4.3-1, testing for 4CC with four band can be skipped.									

**7.3B.2.3\_1.3.4.2 Test procedure**

Same as in clause 7.3B.2.3.4.2.

**7.3B.2.3\_1.3.4.3 Message contents**

Message contents are according to TS 38.508-1 [6] clause 4.6.

**7.3B.2.3\_1.3.5 Test requirement**

For inter-band EN-DC configurations, the throughput of each CG shall be  $\geq 95\%$  of the maximum throughput of the reference measurement channels as specified in Annex A.3.2 with reference receive power level specified in Tables Table 7.3.2.5-1 in TS 38.521-1 [8] and parameters specified Tables 7.3.2.4.1-1, Tables 7.3.2.4.1-2 and Tables 7.3.2.4.1-3 in TS 38.521-1 [8] for NR band.

Each EN-DC combination defined in Table 5.5B.4.3-1 shall be tested in anchor-agnostic mode as described in this clause. If a test point is overlapped with uplink EN-DC combo MSD test points, the requirement with MSD shall apply.

For the UE which supports inter-band EN-DC, the minimum requirement for reference sensitivity in Table 7.3.2.5-1 of TS 38.521-1 [8] for NR band and Table 7.3.5-1 of TS 36.521-1 [10] for EUTRA band, shall be increased by the amount given in  $\Delta R_{B,c}$  defined in clause 7.3B.3.3 for the applicable for two, three, four and five bands operation.

Reference sensitivity exceptions for intermodulation interference due to dual uplink operation for EN-DC in NR FR1, are specified in Table 7.3B.2.3\_1.3.5-1 for four bands and Table 7.3B.2.3\_1.3.5-2 for five bands with uplink configuration specified in Table 7.3B.2.3\_1.3.4.1-1 for four bands and 7.3B.2.3\_1.3.4.1-2 for five bands, respectively.

For a given inter-band EN-DC 5CCs configuration defined in Table 5.5B.4.3-1 and Table 5.5B.4.4-1, if there is no additional exceptional test point is defined besides the requirement for default uplink EN-DC configurations defined in Table 5.5B.4.3-1 and Table 5.5B.4.4-1, the test requirement for default fallback uplink EN-DC configurations defined in Table 5.5B.4.3-1 applies.

**Table 7.3B.2.3\_1.3.5-1 Reference sensitivity exceptions for Scell due to dual uplink operation for EN-DC in NR FR1 (four bands)**

TBD

**Table 7.3B.2.3\_1.3.5-2 Reference sensitivity exceptions for Scell due to dual uplink operation for EN-DC in NR FR1 (five bands)**

TBD

7.3B.2.3\_1.4 Reference sensitivity for EN-DC within FR1 (6 CCs)

TBD

7.3B.2.4 Reference sensitivity for Inter-band EN-DC including FR2 (1 NR CC)

**Editor's note: The following aspects are either missing or not yet determined:**

- **Measurement Uncertainties and Test Tolerances are FFS for power class other than 1, 3, 5, 6 and 7.**

7.3B.2.4.1 Test purpose

Same test purpose as in clause 7.3.2.1 in TS 38.521-2 [9] for the NR carrier.

7.3B.2.4.2 Test applicability

This test case applies to all types of E-UTRA UE release 15 and forward, supporting inter-band EN-DC including FR2 with 1 NR DL CC.

7.3B.2.4.3 Minimum conformance requirements

Same minimum conformance requirements as in clause 7.3B.2.0.4 TS 3.

No exception requirements applicable to NR or E-UTRA. LTE anchor agnostic approach is applied.

The normative reference for this requirement is TS 38.101-3 [4] clause 7.3B.2.4.

7.3B.2.4.4 Test description

7.3B.2.4.4.1 Initial conditions

Same test description as in clause 7.3.2.4 in TS 38.521-2 [9] for the NR carrier with the following exception:

The initial test configurations for E-UTRA band consist of environmental conditions, test frequencies, and channel bandwidths based on E-UTRA bands specified in Table 4.7-1. For Initial conditions as in clause 7.3.2.4.1 in TS 38.521-2 [9], the following steps will be added to configure E-UTRA component:

- 2.1. The parameter settings for E-UTRA cell are set up according to TS 36.508 [11] clause 4.4.3.
- 3.1. The E-UTRA downlink signal level, uplink signal level are set according to Table 4.7-1 and propagation conditions are set according to Annex B.0 of TS 36.521-1 [10].

Step 6 of Initial conditions as in clause 7.3.2.4.1 in TS 38.521-2 [9] is replaced by:

6. Ensure the UE is in state RRC\_CONNECTED with generic procedure parameters Connectivity EN-DC, DC bearer MCG and SCG, Connected without release On according to TS 38.508-1 [6] clause 4.5.

Same test procedure as in clause 7.3.2.4.2 in TS 38.521-2 [9] with the following steps added for E-UTRA component:

- 1.1 On the E-UTRA carrier, disable periodic and aperiodic CQI reports, disable SRS, set *TimeAlignmentTimerDedicated* IE to infinity and disable downlink and uplink scheduling, all as per Table 4.7-1 under clause 4.7.

#### 7.3B.2.4.5 Test requirement

Same test requirement as in clause 7.3.2.5 in TS 38.521-2 [9] for the NR carrier.

### 7.3B.2.4\_1 Reference sensitivity for Inter-band EN-DC including FR2 (>1 NR CC)

#### 7.3B.2.4\_1.1 Reference sensitivity for Inter-band EN-DC including FR2 (2 NR CCs)

**Editor's note: The following aspects are either missing or not yet determined:**

- **Measurement Uncertainties and Test Tolerances for intra-band contiguous CA supporting aggregated BW > 400MHz and for intra-band non-contiguous CA are TBD.**
- **Measurement Uncertainties and Test Tolerances are FFS for power class 1, 2 and 4.**
- **In case of frequency separation larger than 800 MHz and in case the device manufacturer does not explicitly declare that the beam peak for a reference (frequency band, CBW) or (frequency band combination, CA BW class) is applicable for a group of other intra-band contiguous combinations and CA BW classes, according to Table A.4.3.9-6 in 38.508-2, following aspect of beam peak search procedures for CA is FFS: RB allocation, power level, channel bandwidth configuration, per CC approach or all CC combined approach, etc**
- **Testing of extreme conditions for FR2 is FFS.**

#### 7.3B.2.4\_1.1.1 Test purpose

Same test purpose as in clause 7.3B.2.4.1.

#### 7.3B.2.4\_1.1.2 Test applicability

This test case applies to all types of E-UTRA UE release 15 and forward, supporting EN-DC including FR2 with 2 NR DL CCs in either intra-band contiguous or intra-band non-contiguous configuration.

#### 7.3B.2.4\_1.1.3 Minimum conformance requirements

Same minimum conformance requirements as in clause 7.3B.1.

No exception requirements applicable to NR or E-UTRA. LTE anchor agnostic approach is applied.

#### 7.3B.2.4\_1.1.4 Test description

For inter-band EN-DC including FR2 UE configured as 2 NR DL CCs and 1 LTE DL CC, the test description of 2DL FR2 CA for reference sensitivity is the same as in corresponding clause of clause 7.3A.2.1.4 in TS 38.521-2 [9] with the exceptions described below.

#### 7.3B.2.4\_1.1.4.1 Initial conditions

Initial conditions are a set of test configurations the UE needs to be tested in and the steps for the SS to take with the UE to reach the correct measurement state.

The initial test configurations consist of environmental conditions, test frequencies and channel bandwidths based on EN-DC operating bands specified in clause 5.5B.5.1, channel bandwidths and sub-carrier spacings for the NR cell specified in TS 38.521-2 [9] clause 5.3A and channel bandwidth for the E-UTRA cell are specified in TS 36.521-1 [10] clause 5.4.2 or clause 5.4.2A. All valid configurations shall be tested with applicable test parameters for inter-band EN-DC including FR2 configuration specified in clause 5.5B.5, and the configuration for NR carrier are shown in TS 38.521-2 [9] Table 7.3A.2.1.4.1-1.

For Initial conditions as in clause 7.3A.2.1.4.1 in TS 38.521-2 [9], the following steps will be added to configure E-UTRA component:

- 2.1. The parameter settings for E-UTRA cell are set up according to TS 36.508 [11] clause 4.4.3.

- 3.1. The E-UTRA downlink signal level, uplink signal level are configured as per clause 4.7 with parameters set according to Table 4.7-1 and propagation conditions set according to Annex B.0 of TS 36.521-1 [10].

Step 6 of Initial conditions as in clause 7.3A.2.1.4.1 in TS 38.521-2 [9] is replaced by:

6. Ensure the UE is in state RRC\_CONNECTED with generic procedure parameters Connectivity EN-DC, DC bearer MCG and SCG, Connected without release On according to TS 38.508-1 [6] clause 4.5.

#### 7.3B.2.4\_1.1.4.2 Test Procedure

Same test procedure as in clause 7.3A.2.1.4.2 in TS 38.521-2 [9] with the following steps added for E-UTRA component:

1.1 On the E-UTRA carrier, disable periodic and aperiodic CQI reports, disable SRS, set *TimeAlignmentTimerDedicated* IE to infinity and disable downlink and uplink scheduling, all as per Table 4.7-1 under clause 4.7.

#### 7.3B.2.4\_1.1.4.3 Message contents

Message contents are according to TS 38.508-1 [6] clause 4.6.1.

#### 7.3B.2.4\_1.1.5 Test requirement

For each NR component carrier, the test requirement is the same as in clause 7.3A.2.1.5 in TS 38.521-2 [9].

#### 7.3B.2.4\_1.2 Reference sensitivity for Inter-band EN-DC including FR2 (3 NR CCs)

**Editor's note: The following aspects are either missing or not yet determined:**

- **Measurement Uncertainties and Test Tolerances for intra-band contiguous CA supporting aggregated BW > 400MHz and for intra-band non-contiguous CA are TBD.**
- **Measurement Uncertainties and Test Tolerances are FFS for power class 1, 2 and 4.**
- **In case of frequency separation larger than 800 MHz and in case the device manufacturer does not explicitly declare that the beam peak for a reference (frequency band, CBW) or (frequency band combination, CA BW class) is applicable for a group of other intra-band contiguous combinations and CA BW classes, according to Table A.4.3.9-6 in 38.508-2, following aspect of beam peak search procedures for CA is FFS: RB allocation, power level, channel bandwidth configuration, per CC approach or all CC combined approach, etc**
- **Testing of extreme conditions for FR2 is FFS.**

#### 7.3B.2.4\_1.2.1 Test purpose

Same test purpose as in clause 7.3B.2.4\_1.1.1.

#### 7.3B.2.4\_1.2.2 Test applicability

This test case applies to all types of E-UTRA UE release 15 and forward, supporting EN-DC including FR2 with 3 NR DL CCs in either intra-band contiguous or intra-band non-contiguous configuration.

#### 7.3B.2.4\_1.2.3 Minimum conformance requirements

Same minimum conformance requirements as in clause 7.3B.2.4\_1.1.3.

No exception requirements applicable to NR or E-UTRA. LTE anchor agnostic approach is applied.

#### 7.3B.2.4\_1.2.4 Test description

For inter-band EN-DC including FR2 UE configured as 3 NR DL CCs and 1 LTE DL CC, the test description of 3DL FR2 CA for reference sensitivity is the same as in corresponding clause of clause 7.3A.2.2.4 in TS 38.521-2 [9], with the exceptions described in clause 7.3B.2.4\_1.1.4.1 and clause 7.3B.2.4\_1.1.4.2.



#### 7.3B.2.4\_1.2.5 Test requirement

For each NR component carrier, the test requirement is the same as in clause 7.3A.2.1.5 in TS 38.521-2 [9].

#### 7.3B.2.4\_1.3 Reference sensitivity for Inter-band EN-DC including FR2 (4 NR CCs)

**Editor's note:** The following aspects are either missing or not yet determined:

- Measurement Uncertainties and Test Tolerances for intra-band contiguous CA supporting aggregated BW > 400MHz and for intra-band non-contiguous CA are TBD.
- Measurement Uncertainties and Test Tolerances are FFS for power class 1, 2 and 4.
- In case of frequency separation larger than 800 MHz and in case the device manufacturer does not explicitly declare that the beam peak for a reference (frequency band, CBW) or (frequency band combination, CA BW class) is applicable for a group of other intra-band contiguous combinations and CA BW classes, according to Table A.4.3.9-6 in 38.508-2, following aspect of beam peak search procedures for CA is FFS: RB allocation, power level, channel bandwidth configuration, per CC approach or all CC combined approach, etc
- Testing of extreme conditions for FR2 is FFS.

#### 7.3B.2.4\_1.3.1 Test purpose

Same test purpose as in clause 7.3B.2.4\_1.1.1.

#### 7.3B.2.4\_1.3.2 Test applicability

This test case applies to all types of E-UTRA UE release 15 and forward, supporting EN-DC including FR2 with 4 NR DL CCs in either intra-band contiguous or intra-band non-contiguous configuration.

#### 7.3B.2.4\_1.3.3 Minimum conformance requirements

Same minimum conformance requirements as in clause 7.3B.2.4\_1.1.3.

No exception requirements applicable to NR or E-UTRA. LTE anchor agnostic approach is applied.

#### 7.3B.2.4\_1.3.4 Test description

For inter-band EN-DC including FR2 UE configured as 4 NR DL CCs and 1 LTE DL CC, the test description of 4DL FR2 CA for reference sensitivity is the same as in corresponding clause of clause 7.3A.2.3.4 in TS 38.521-2 [9], with the exceptions described in clause 7.3B.2.4\_1.1.4.1 and clause 7.3B.2.4\_1.1.4.2.

#### 7.3B.2.4\_1.3.5 Test requirement

For each NR component carrier, the test requirement is the same as in clause 7.3A.2.1.5 in TS 38.521-2 [9].

#### 7.3B.2.4\_1.4 Reference sensitivity for Inter-band EN-DC including FR2 (5 NR CCs)

**Editor's note:** This clause is incomplete. The following aspects are either missing or not yet determined:

- Measurement Uncertainties and Test Tolerances are FFS.
- In case of frequency separation larger than 800 MHz and in case the device manufacturer does not explicitly declare that the beam peak for a reference (frequency band, CBW) or (frequency band combination, CA BW class) is applicable for a group of other intra-band contiguous combinations and CA BW classes, according to Table A.4.3.9-6 in 38.508-2, following aspect of beam peak search procedures for CA is FFS: RB allocation, power level, channel bandwidth configuration, per CC approach or all CC combined approach, etc
- Testing of extreme conditions for FR2 is FFS.

#### 7.3B.2.4\_1.4.1 Test purpose

Same test purpose as in clause 7.3B.2.4\_1.1.1.

#### 7.3B.2.4\_1.4.2 Test applicability

This test case applies to all types of E-UTRA UE release 15 and forward, supporting EN-DC including FR2 with 5 NR DL CCs in either intra-band contiguous or intra-band non-contiguous configuration.

#### 7.3B.2.4\_1.4.3 Minimum conformance requirements

Same minimum conformance requirements as in clause 7.3B.2.4\_1.1.3.

No exception requirements applicable to NR or E-UTRA. LTE anchor agnostic approach is applied.

#### 7.3B.2.4\_1.4.4 Test description

For inter-band EN-DC including FR2 configured as 5 NR DL CCs and 1 LTE DL CC, the test description of 5DL FR2 CA for reference sensitivity is the same as in corresponding clause of clause 7.3A.2.4.4 in TS 38.521-2 [9], with the exceptions described in clause 7.3B.2.4\_1.1.4.1 and clause 7.3B.2.4\_1.1.4.2.

#### 7.3B.2.4\_1.4.5 Test requirement

For each NR component carrier, the test requirement is the same as in clause 7.3A.2.1.5 in TS 38.521-2 [9].

#### 7.3B.2.4\_1.5 Reference sensitivity for Inter-band EN-DC including FR2 (6 NR CCs)

**Editor's note: This clause is incomplete. The following aspects are either missing or not yet determined:**

- **Measurement Uncertainties and Test Tolerances are FFS.**
- **In case of frequency separation larger than 800 MHz and in case the device manufacturer does not explicitly declare that the beam peak for a reference (frequency band, CBW) or (frequency band combination, CA BW class) is applicable for a group of other intra-band contiguous combinations and CA BW classes, according to Table A.4.3.9-6 in 38.508-2, following aspect of beam peak search procedures for CA is FFS: RB allocation, power level, channel bandwidth configuration, per CC approach or all CC combined approach, etc**
- **Testing of extreme conditions for FR2 is FFS.**

#### 7.3B.2.4\_1.5.1 Test purpose

Same test purpose as in clause 7.3B.2.4\_1.1.1.

#### 7.3B.2.4\_1.5.2 Test applicability

This test case applies to all types of E-UTRA UE release 15 and forward, supporting EN-DC including FR2 with 6 NR DL CCs in either intra-band contiguous or intra-band non-contiguous configuration.

#### 7.3B.2.4\_1.5.3 Minimum conformance requirements

Same minimum conformance requirements as in clause 7.3B.2.4\_1.1.3.

No exception requirements applicable to NR or E-UTRA. LTE anchor agnostic approach is applied.

#### 7.3B.2.4\_1.5.4 Test description

For inter-band EN-DC including FR2 configured as 6 NR DL CCs and 1 LTE DL CC, the test description of 6DL FR2 CA for reference sensitivity is the same as in corresponding clause of clause 7.3A.2.5.4 in TS 38.521-2 [9], with the exceptions described in clause 7.3B.2.4\_1.1.4.1 and clause 7.3B.2.4\_1.1.4.2.

#### 7.3B.2.4\_1.5.5 Test requirement

For each NR component carrier, the test requirement is the same as in clause 7.3A.2.1.5 in TS 38.521-2 [9].

#### 7.3B.2.4\_1.6 Reference sensitivity for Inter-band EN-DC including FR2 (7 NR CCs)

**Editor's note: This clause is incomplete. The following aspects are either missing or not yet determined:**

- Measurement Uncertainties and Test Tolerances are FFS.
- In case of frequency separation larger than 800 MHz and in case the device manufacturer does not explicitly declare that the beam peak for a reference (frequency band, CBW) or (frequency band combination, CA BW class) is applicable for a group of other intra-band contiguous combinations and CA BW classes, according to Table A.4.3.9-6 in 38.508-2, following aspect of beam peak search procedures for CA is FFS: RB allocation, power level, channel bandwidth configuration, per CC approach or all CC combined approach, etc
- Testing of extreme conditions for FR2 is FFS.

#### 7.3B.2.4\_1.6.1 Test purpose

Same test purpose as in clause 7.3B.2.4\_1.1.1.

#### 7.3B.2.4\_1.6.2 Test applicability

This test case applies to all types of E-UTRA UE release 15 and forward, supporting EN-DC including FR2 with 7 NR DL CCs in either intra-band contiguous or intra-band non-contiguous configuration.

#### 7.3B.2.4\_1.6.3 Minimum conformance requirements

Same minimum conformance requirements as in clause 7.3B.2.4\_1.1.3.

No exception requirements applicable to NR or E-UTRA. LTE anchor agnostic approach is applied.

#### 7.3B.2.4\_1.6.4 Test description

For inter-band EN-DC including FR2 configured as 7 NR DL CCs and 1 LTE DL CC, the test description of 7 DL FR2 CA for reference sensitivity is the same as in corresponding clause of clause 7.3A.2.6.4 in TS 38.521-2 [9], with the exceptions described in clause 7.3B.2.4\_1.1.4.1 and clause 7.3B.2.4\_1.1.4.2.

#### 7.3B.2.4\_1.6.5 Test requirement

For each NR component carrier, the test requirement is the same as in clause 7.3A.2.1.5 in TS 38.521-2 [9].

#### 7.3B.2.4\_1.7 Reference sensitivity for Inter-band EN-DC including FR2 (8 NR CCs)

**Editor's note: This clause is incomplete. The following aspects are either missing or not yet determined:**

- Measurement Uncertainties and Test Tolerances are FFS.
- In case of frequency separation larger than 800 MHz and in case the device manufacturer does not explicitly declare that the beam peak for a reference (frequency band, CBW) or (frequency band combination, CA BW class) is applicable for a group of other intra-band contiguous combinations and CA BW classes, according to Table A.4.3.9-6 in 38.508-2, following aspect of beam peak search procedures for CA is FFS: RB allocation, power level, channel bandwidth configuration, per CC approach or all CC combined approach, etc
- Testing of extreme conditions for FR2 is FFS.

#### 7.3B.2.4\_1.7.1 Test purpose

Same test purpose as in clause 7.3B.2.4\_1.1.1.

#### 7.3B.2.4\_1.7.2 Test applicability

This test case applies to all types of E-UTRA UE release 15 and forward, supporting EN-DC including FR2 with 8 NR DL CCs in intra-band contiguous configuration.

#### 7.3B.2.4\_1.7.3 Minimum conformance requirements

Same minimum conformance requirements as in clause 7.3B.2.4\_1.1.3.

No exception requirements applicable to NR or E-UTRA. LTE anchor agnostic approach is applied.

#### 7.3B.2.4\_1.7.4 Test description

For inter-band EN-DC including FR2 configured as 8 NR DL CCs and 1 LTE DL CC, the test description of 8DL FR2 CA for reference sensitivity is the same as in corresponding clause of clause 7.3A.2.7.4 in TS 38.521-2 [9], with the exceptions described in clause 7.3B.2.4\_1.1.4.1 and clause 7.3B.2.4\_1.1.4.2.

#### 7.3B.2.4\_1.7.5 Test requirement

For each NR component carrier, the test requirement is the same as in clause 7.3A.2.1.5 in TS 38.521-2 [9].

### 7.3B.2.4D Reference sensitivity for inter-band EN-DC including FR2 for UL MIMO

No exception requirements applicable to NR or LTE. LTE anchor agnostic approach can be applied and only NR carriers need to be tested.

No test case details are specified. Given UE's Rx performance would not be impacted by the Tx configuration in NR FR2 TDD bands, the requirements in this test case can be well covered in 7.3B.2.4 and 7.3B.2.4\_1 and don't need to be tested again.

### 7.3B.2.5 Reference sensitivity for Inter-band EN-DC including FR1 and FR2 (3 CCs)

#### 7.3B.2.5.1 Test purpose

Same test purpose as in 7.3B.2 in TS 38.521-1 [8] for NR FR1 carrier(s) and 7.3.2 in TS 38.521-2 [9] for NR FR2 carrier(s).

#### 7.3B.2.5.2 Test applicability

The requirements in this test are not testable due to issues with combined testing of NR FR1 and E-UTRA in conducted mode with NR FR2 in radiated mode. Therefore, the conducted and radiated requirements are tested separately.

No test case details are specified. The EN-DC requirements for reference sensitivity apply and are tested as part of the EN-DC within FR1 and EN-DC including FR2 test cases in clause 7.3B.

### 7.3B.2.5D Reference sensitivity for inter-band EN-DC including FR1 and FR2 for UL MIMO

#### 7.3B.2.5D.1 Test purpose

Same test purpose as in clause 7.3D in TS 38.521-1 [8] for NR FR1 carrier and 7.3D in TS 38.521-2 [9] for NR FR2 carrier.

#### 7.3B.2.5D.2 Test applicability

The requirements in this test are not testable due to issues with combined testing of NR FR1 and E-UTRA in conducted mode with NR FR2 in radiated mode. Therefore, the conducted and radiated requirements are tested separately.

No test case details are specified. The EN-DC requirements for reference sensitivity apply and are tested as part of the EN-DC within FR1 as in clause 7.3 in TS 38.521-1 [8] and EN-DC within FR2 as in clause 7.3 in TS 38.521-2 [9].

7.3B.2.6 Void

7.3B.3  $\Delta R_{IB,c}$   $\Delta R_{IBNC}$  for DC

7.3B.3.0 General

For the UE which supports inter-band EN-DC or NE-DC configuration, the minimum requirement for reference sensitivity in Table 7.3.1-1 and Table 7.3.1-1a in TS.36101 [5], clause 7.3.2, 7.3A.2, 7.3C.2 in TS 38.101-1 [2] and clause 7.3.2, 7.3A.2 in TS 38.101-2 [3] shall be increased by the amount given in  $\Delta R_{IB,c}$   $\Delta R_{IBNC}$  in Tables below where unless otherwise stated, the same  $\Delta R_{IB,c}$ ,  $\Delta R_{IBNC}$  are applicable to NR band(s) part for DC configurations which have the same NR operating band combination. Unless otherwise stated,  $\Delta R_{IB,c}$  or  $\Delta R_{IBNC}$  is set to zero.

In case the UE supports more than one of band combinations for CA, SUL or DC, and an operating band belongs to more than one band combinations then

- When the operating band frequency range is  $\leq 1$  GHz, the applicable additional  $\Delta R_{IB,c}$  shall be the average value for all band combinations defined in clause 7.3A, 7.3B, 7.3C in TS 38.101-1 [2] and 7.3A, 7.3B in TS 38.101-3 [4], truncated to one decimal place that apply for that operating band among the supported band combinations. In case there is a harmonic relation between low band UL and high band DL, then the maximum  $\Delta R_{IB,c}$  among the different supported band combinations involving such band shall be applied.
- When the operating band frequency range is  $> 1$  GHz, the applicable additional  $\Delta R_{IB,c}$  shall be the maximum value for all band combinations defined in clause 7.3A, 7.3B, 7.3C in TS 38.101-1 [2] and 7.3A, 7.3B in TS 38.101-3 [4] for the applicable operating bands.

Unless  $\Delta R_{IB,c}$  is specified for the NE-DC configuration, the specified  $\Delta R_{IB,c}$  for the EN-DC configuration including same bands as the corresponding NE-DC configuration is applicable for the NE-DC configuration.

The normative reference for this requirement is TS 38.101-3 [4] clause 7.3B.3.

7.3B.3.1 Reference sensitivity  $\Delta R_{IB,c}$  for Intra-band Contiguous EN-DC

FFS

7.3B.3.2 Reference sensitivity  $\Delta R_{IB,c}$  for Intra-band non-contiguous EN-DC

**Table 7.3B.3.2-1: Intra-band non-contiguous EN-DC with one uplink configuration on E-UTRA for reference sensitivity**

DC configuration	Aggregated channel bandwidth (LTE+NR)		$W_{gap}$ / (MHz)	UL E-UTRA allocation	$\Delta R_{IBNC}$ (dB)	Duplex mode
	E-UTRA	NR				

7.3B.3.3  $\Delta R_{IB,c}$  for Inter-band EN-DC within FR1

7.3B.3.3.1  $\Delta R_{IB,c}$  for EN-DC in two bands

**Table 7.3B.3.3.1-1:  $\Delta R_{IB,c}$  due to EN-DC(two bands)**

Inter-band EN-DC configuration	E-UTRA or NR Band	$\Delta R_{IB,c}$ (dB)
DC_1_n28	n28	0.2
DC_1_n41	1	0
	n41	0
DC_1_n77	1	0.2
	n77	0.5
DC_1_n78	n78	0.5
DC_2_n66	2	0.3
	n66	0.3
DC_2_n77	2	0.2
DC_2-2_n77	n77	0.5
DC_2_n78	2	0.2
	n78	0.5
DC_3_n41	n41	0 <sup>3</sup>
		0.5 <sup>4</sup>
DC_3_n77	3	0.2
	n77	0.5
DC_3_n78	3	0.2
	n78	0.5
DC_5_n78	5	0.2
	n78	0.5
DC_7_n8	n8	0.2
DC_7_n66	7	0.5
	n66	0.5
DC_7_n71	n71	0.2
DC_7_n77	n77	0.5
DC_7_n78, DC_7-7_n78	n78	0.5
DC_8_n77	8	0.2
	n77	0.5
DC_8_n78	8	0.2
	n78	0.5
DC_11_n77	n77	0.5
DC_11_n78	n78	0.5
DC_12_n5	12	0.3
	n5	0.5
DC_12_n66	12	0.5
DC_12_n77	12	0.2
	n77	0.5
DC_12_n78	12	0.2
	n78	0.5
DC_14_n77	14	0.2
	n77	0.5
DC_18_n77	n77	0.5
DC_19_n77	n77	0.5
DC_19_n78	n78	0.5
DC_20_n78	n78	0.5
DC_21_n77	n77	0.5
DC_21_n78	n78	0.5
DC_25_n41	n41	0 <sup>1</sup>
		0.5 <sup>2</sup>
DC_26_n77	n77	0.5
DC_26_n78	n78	0.5
DC_28_n51	n51	0.2
DC_28_n77	28	0.2
	n77	0.5
DC_28_n78	28	0.2
	n78	0.5
DC_30_n66	30	0.5
	n66	0.4
DC_30_n77	n77	0.5
DC_38_n78	38	0.4
	n78	0.5
DC_39-n41	39	0.2
	n41	0.2

DC_39_n79	n79	0.5
DC_40_n78	40	0.4 <sup>5</sup>
	n78	0.5 <sup>5</sup>
DC_40_n79	n79	0.5
DC_41_n28	41	0
	n28	0
DC_41_n77	n77	0.5
DC_41_n78	n78	0.5
DC_41_n79	n79	0.5
DC_48_n66	48	0.5
	n66	0.2
DC_66_n2	66	0.3
	n2	0.3
DC_66_n25	66	0.3
	n25	0.3
DC_66_n41	66	0.5
	n41	0.5 <sup>1</sup> 1 <sup>2</sup>
DC_66_n77	66	0.2
DC_66-66_n77	n77	0.5
DC_66_n78	66	0.2
	n78	0.5
<p>NOTE 1: The requirement is applied for UE transmitting on the frequency range of 2545-2690MHz.  NOTE 2: The requirement is applied for UE transmitting on the frequency range of 2496-2545MHz.  NOTE 3: Applicable for the frequency range of 2515-2690 MHz.  NOTE 4: Applicable for the frequency range of 2496-2515 MHz.  NOTE 5: Only applicable for UE supporting inter-band carrier aggregation with uplink in one E-UTRA band and without simultaneous Rx/Tx.</p>		



7.3B.3.3.2  $\Delta R_{IB,c}$  for EN-DC in three bands

**Table 7.3B.3.3.2-1:  $\Delta R_{IB,c}$  due to EN-DC (three bands)**

Inter-band EN-DC configuration	E-UTRA or NR Band	$\Delta R_{IB,c}$ (dB)
DC_1-3_n28	n28	0.2
DC_1-3_n41	n41	0 <sup>3</sup>
DC_1-3_n77	1	0.2
	3	0.2
	n77	0.5
DC_1-3_n78	1	0.2
	3	0.2
	n78	0.5
DC_1_n3-n78	1	0.2
	n3	0.2
	n78	0.5
DC_1-5_n78	1	0.2
	5	0.2
	n78	0.5
DC_1-7_n28	n28	0.2
DC_1-7_n78	1	0.2
	7 or n7	0.2
	n78	0.5
	8	0.2
	n77	0.5
DC_1-8_n77	8	0.2
	n77	0.5
DC_1-8_n78	8	0.2
	n78	0.5
DC_1-18_n77	n77	0.5
DC_1-19_n77	n77	0.5
DC_1-19_n78	n78	0.5
DC_1-19_n79	1	0.3
	19	0.3
DC_1-20_n28	20	0.2
	n28	0.2
DC_1-20_n78	n78	0.5
DC_1-21_n77	n77	0.5
DC_1-21_n78	1	0.2
	n78	0.5
DC_1-28_n78	28 or n28	0.2
DC_1_n28-n78	n78	0.5
DC_1_n28-n79	1	0.3
	28	0.3
DC_1-41_n28	n28	0.2
DC_1-41_n41	1	0
	41	0
	n41	0
DC_1-41_n77	n77	0.5
DC_1-41_n78	n78	0.5
DC_1-42_n77	1	0.2
	42	0.5
	n77	0.5
DC_1-42_n78	1	0.2
	42	0.5
	n78	0.5
DC_1-42_n79	42	0.5
DC_1_n77-n79	1	0.2
	n77	0.5
DC_1_n78-n79	n78	0.5
DC_2-5_n66	2	0.3
DC_2-2-5_n66	n66	0.3
DC_2-5_n77	2	0.2
	5	0.2
	n77	0.5
DC_2_n5-n77	2	0.2
	n77	0.5
	2	0.3

DC_2-13_n66 DC_2-2-13_n66	n66	0.3		
DC_2-13_n77	2	0.2		
	13	0.2		
	n77	0.5		
DC_2-14_n77 DC_2-2-14_n77	2	0.2		
	14	0.2		
	n77	0.5		
DC_2-29_n260	2	0		
DC_2-14_n66 DC_2-2-14_n66	2	0.3		
	n66	0.3		
DC_2-30_n5, DC_2-2-30_n5	2	0.4		
	30	0.5		
DC_2-30_n66	2	0.4		
	30	0.5		
	n66	0.4		
DC_2-66_n2 DC_2-66-66_n2	2	0.3		
	66	0.3		
	n2	0.3		
DC_2-66_n5 DC_2-2-66_n5 DC_2-66-66_n5 DC_2-2-66-66_n5	2	0.3		
	66	0.3		
			2	0.3
			66	0.3
DC_2-66_n41	2	0.3		
	66	0.5		
	n41	0.5 <sup>1</sup> 1 <sup>2</sup>		
DC_2-66_n66 DC_2-2-66_n66 DC_2-66-66_n66	2	0.3		
	66	0.3		
	n66	0.3		
DC_2-66_n71B	2	0.3		
	66	0.3		
DC_2-66_n77 DC_2-2-66_n77 DC_2-66-66_n77 DC_2-2-66-66_n77	2	0.2		
	66	0.2		
			n77	0.5
			2	0.3
DC_2-66_n78	66	0.3		
	n78	0.5		
	3	0.2		
DC_3_n1-n77	n1	0.2		
	n77	0.5		
	3	0.2		
DC_3_n1-n78	n1	0.2		
	n78	0.5		
	3	0.2		
DC_3-5_n78	5	0.2		
	n78	0.5		
	n8	0.2		
DC_3-7_n8 DC_3-7-7_n78	3	0.2		
	7 or n7	0.2		
	n78	0.5		
DC_3-8_n28	8	0.2		
	n28	0.1		
DC_3-8_n77	3	0.2		
	8	0.2		
	n77	0.5		
DC_3-8_n78	3	0.2		
	8	0.2		
	n78	0.5		
DC_3-18_n77	3	0.2		
	n77	0.5		

DC_3-18_n78	3	0.2
	n78	0.5
DC_3-19_n77	3	0.2
	n77	0.5
DC_3-19_n78	3	0.2
	n78	0.5
DC_3-20_n28	20	0.1
	n28	0.1
DC_3-20_n78	3	0.2
	n78	0.5
DC_3-21_n77	3	0.3
	21	0.5
	n77	0.5
DC_3-21_n78	3	0.3
	21	0.5
	n78	0.5
DC_3-21_n79	3	0.3
	21	0.5
	28	0.1
	n5	0.1
	n41	0 <sup>1</sup> /0.5 <sup>2</sup>
DC_3-28_n78 DC_3_n28-n78	3	0.2
	n78	0.5
DC_3-41_n28	3	0
	41	0 <sup>1</sup> /0.5 <sup>2</sup>
	n28	0
DC_3-41_n41	41	0 <sup>3</sup>
		0.5 <sup>4</sup>
	n41	0 <sup>3</sup>
		0.5 <sup>4</sup>
DC_3-41_n77	3	0.2
	41	0 <sup>1</sup>
	n77	0.5 <sup>2</sup>
DC_3-42_n77	3	0.2
	42	0.5
	n77	0.5
DC_3-42_n78	3	0.2
	42	0.5
	n78	0.5
DC_3-42_n79	3	0.2
	42	0.5
DC_3_n77-n79	3	0.2
	n77	0.5
DC_3_n78-n79	3	0.2
	n78	0.5
DC_5-7_n78	5	0.2
	7	0.2
	n78	0.5 <sup>2</sup>
DC_5-30_n66	30	0.5
	n66	0.4
DC_5-66_n2 DC_5-66-66_n2	66	0.3
	n2	0.3
DC_5-66_n77 DC_5-66-66_n77	5	0.2
	66	0.2
	n77	0.5
DC_7_n1-n78	7	0.2
	n1	0.2
	n78	0.5
DC_7-8_n3	8	0.2
DC_7-20_n28	20	0.2
	n28	0.2
DC_7-20_n78	n78	0.5
DC_7-28_n78	n78	0.5
DC_7_n28-n78	n78	0.5

DC_13_n2-n77	n2	0.2
	n77	0.5
DC_13-66_n2	66	0.3
	n2	0.3
DC_13-66_n77	13	0.3
	66	0.3
	n77	0.5
DC_14-66_n2	66	0.3
DC_14-66-66_n2	n2	0.3
DC_14-66_n77 DC_14-66-66_n77	14	0.2
	66	0.5
	n77	0.5
DC_18-41_n77	n77	0.5
DC_18-41_n78	n78	0.5
DC_19-21_n77	n77	0.5
DC_19-21_n78	n78	0.5
DC_19-42_n77	42	0.5
	n77	0.5
DC_19-42_n78	42	0.5
	n78	0.5
DC_19-42_n79	42	0.5
DC_19_n77-n79	n77	0.5
DC_19_n78-n79	n78	0.5
DC_20_n3-n78	n3	0.2
	n78	0.5
DC_20_n28-n78	20	0.2
	n28	0.2
	n78	0.5
DC_20-38_n78	38	0.4
	n78	0.5
DC_20_n76-n78	n78	0.5
DC_21-42_n77	42	0.5
	n77	0.5
DC_21-42_n78	42	0.5
	n78	0.5
DC_21-42_n79	42	0.5
DC_21_n77-n79	n77	0.5
DC_21_n78-n79	n78	0.5
DC_28_n7-n78	n78	0.5
DC_28-41_n78	28	0.2
	n78	0.5
	n79	0.5
DC_28-42_n78	28	0.2
	42	0.5
	n78	0.5
DC_66_n5	66	0.4
	n5	0.5
DC_41-42_n78	42	0.5
	n78	0.5
DC_66_n2-n77	66	0.3
	n2	0.3
	n77	0.5
DC_66_n5-n77	66	0.2
	n77	0.5

NOTE 1: The requirement is applied for UE transmitting on the frequency range of 2545-2690MHz.

NOTE 2: The requirement is applied for UE transmitting on the frequency range of 2496-2545MHz.

NOTE 3: The requirement is applied for UE transmitting on the frequency range of 2515 – 2690 MHz.

NOTE 4: The requirement is applied for UE transmitting on the frequency range of 2496 – 2515 MHz.

NOTE 5: Only applicable for UE supporting inter-band carrier aggregation with uplink in one NR band and without simultaneous Rx/Tx.

7.3B.3.3.3  $\Delta R_{IB,c}$  for EN-DC in four bandsTable 7.3B.3.3.3-1:  $\Delta R_{IB,c}$  due to EN-DC (four bands)

Inter-band EN-DC configuration	E-UTRA or NR Band	$\Delta R_{IB,c}$ (dB)
DC_1-3-7_n28	n28	0.2
DC_1-3-7_n78	1	0.3
	3	0.3
	7 or n7	0.3
	n78	0.5
DC_1-3-8_n77	1	0.2
	3	0.2
	8	0.2
	n77	0.5
DC_1-3-8_n78	1	0.2
	3	0.2
	8	0.2
	n78	0.5
DC_1-3-19_n78	1	0.2
	3	0.2
	n78	0.5
DC_1-3-20_n28	20	0.2
	n28	0.2
DC_1-3-20_n78	1	0.2
	3	0.2
	n78	0.5
DC_1-3-21_n77	1	0.2
	3	0.3
	21	0.5
	n77	0.5
DC_1-3-21_n78	1	0.2
	3	0.3
	21	0.5
	n78	0.5
DC_1-3-21_n79	3	0.3
	21	0.5
DC_1-3-28_n78 DC_1-3_n28-n78	1	0.2
	3	0.2
	28 or n28	0.2
	n78	0.5

DC_1-3-42_n78	1	0.2
	3	0.2
	42	0.5
	n78	0.5
DC_1-3-42_n79	1	0.2
	3	0.2
	42	0.5
DC_1-3_n77-n79	1	0.2
	3	0.2
	n77	0.5
DC_1-3_n78-n79	1	0.2
	3	0.2
	n78	0.5
DC_1-3_SUL_n78-n80	1	0.2
	3	0.2
	n78	0.5
DC_1-7-20_n28	20	0.2
	n28	0.2
DC_1-7-20_n78	1	0.2
	7	0.2
	20	0.2
	n78	0.5
DC_1-7-28_n78	1	0.2
	7	0.2
	28	0.2
	n78	0.5
DC_1-7_n28-n78	1	0.2
	7	0.2
	n28	0.2
	n78	0.5
DC_1-19-42_n77	1	0.2
	42	0.5
	n77	0.5
DC_1-19-42_n78	42	0.5
	n78	0.5
DC_1-19-42_n79	42	0.5
DC_1-19_n77-n79	1	0.3
	19	0.3
	n77	0.5
DC_1-19_n78-n79	1	0.3
	19	0.3
	n78	0.5
DC_1-20_n28-n78	20	0.2
	n28	0.2
	n78	0.5
DC_1-21-42_n77	1	0.2
	42	0.5
	n77	0.5
DC_1-21-42_n78	42	0.5
	n78	0.5
DC_1-21-42_n79	42	0.5
DC_1-21_n77-n79	n77	0.5
DC_1-21_n78-n79	n78	0.5
DC_1-42_n77-n79	1	0.2
	42	0.5
	n77	0.5
DC_1-42_n78-n79	1	0.2
	42	0.5
	n78	0.5
DC_2-7-13_n66	2	0.3
	7	0.5
	n66	0.5
DC_2-7-66_n66	2	0.3
	7	0.5
DC_2-7-7-66_n66	66	0.5

	n66	
DC_2-7-66_n78 DC_2-7-7-66_n78	2	0.6
	7	0.5
	66	0.6
	n78	0.8
DC_2-13-66_n77	2	0.3
	66	0.3
	n77	0.5
DC_2-14-66_n2 DC_2-14-66-66_n2	2	0.3
	66	0.3
	n2	0.3
DC_2-14-66_n66 DC_2-2-14-66_n66	2	0.3
	66	0.3
	n66	0.3
DC_2-30-66_n5	2	0.4
	30	0.5
	66	0.4
DC_2-66_n5-n77	2	0.3
	66	0.3
	n77	0.5
DC_2-66-(n)71	2	0.3
	66	0.3
DC_3-7_n1-n78	3	0.3
	7	0.3
	n1	0.3
	n78	0.5
DC_3-7-20_n28	20	0.2
	n28	0.1
DC_3-7-20_n78	3	0.2
	7	0.2
	n78	0.5
DC_3-7-28_n78 DC_3-7_n28-n78	3	0.2
	7	0.2
	28 or n28	0.2
	n78	0.5
DC_3-19-21_n78	3	0.3
	21	0.5
	n78	0.5
DC_3-19-21_n79	3	0.3
	21	0.5
DC_3-19-42_n77	3	0.2
	42	0.5
	n77	0.5
DC_3-19-42_n78	3	0.2
	42	0.5
	n78	0.5
DC_3-19-42_n79	3	0.2
	42	0.5
DC_3-19_n78-n79	3	0.2
	n78	0.5
DC_3-20_n28-n78	3	0.2
	20	0.2
	n28	0.2
	n78	0.5
DC_3-21_n77-n79	3	0.3
	21	0.5
	n77	0.5
DC_3-21_n78-n79	3	0.3
	21	0.5
	n78	0.5
DC_3-41-42_n77	3	0.5
	41	0 <sup>1</sup> /0.5 <sup>2</sup>
	42	0.5
	n77	0.5
DC_3-41-42_n78	3	0.5



	41	0 <sup>1</sup> /0.5 <sup>2</sup>
	42	0.5
	n78	0.5
DC_3-41-42_n79	3	0.5
	41	0 <sup>1</sup> /0.5 <sup>2</sup>
	42	0.5
DC_3-42_n77-n79	3	0.2
	42	0.5
	n77	0.5
DC_3-42_n78-n79	3	0.2
	42	0.5
	n78	0.5
DC_7-20_n28-n78	20	0.2
	n28	0.2
	n78	0.5
DC_12-30-66_n260	12	0.5
	30	0.5
	66	0.4
DC_13-66_n2-n77	66	0.2
	n2	0.2
	n77	0.5
DC_19-21-42_n77	42	0.5
	n77	0.5
DC_19-21-42_n78	42	0.5
	n78	0.5
DC_19-21-42_n79	42	0.5
DC_19-21_n77-n79	n77	0.5
DC_19-21_n78-n79	n78	0.5
DC_19-42_n77-n79	42	0.5
	n77	0.5
DC_19-42_n78-n79	42	0.5
	n78	0.5
DC_21-42_n77-n79	42	0.5
	n77	0.5
DC_21-42_n78-n79	42	0.5
	n78	0.5
NOTE 1: The requirement is applied for UE transmitting on the frequency range of 2545 - 2690 MHz.		
NOTE 2: The requirement is applied for UE transmitting on the frequency range of 2496 - 2545 MHz.		
NOTE 3: The requirement is applied for UE transmitting on the frequency range of 2515 - 2690 MHz.		
NOTE 4: The requirement is applied for UE transmitting on the frequency range of 2496 - 2515 MHz.		

7.3B.3.3.4  $\Delta R_{IB,c}$  for EN-DC in five bands**Table 7.3B.3.3.4-1:  $\Delta R_{IB,c}$  due to EN-DC (five bands)**

Inter-band EN-DC configuration	E-UTRA or NR Band	$\Delta R_{IB,c}$ (dB)
DC_1-3-7-20_n28	20	0.2
	n28	0.2
DC_1-3-7-20_n78	1	0.2
	3	0.2
	7	0.2
	n78	0.5
DC_1-3-7-28_n78	1	0.2
	3	0.2
	7	0.2
	28	0.2
	n78	0.5
DC_1-3-7_n28-n78	1	0.2
	3	0.2
	7	0.2
	n78	0.5
DC_1-3-19-42_n79	1	0.2
	3	0.2
	42	0.5
DC_1-3-20_n28-n78	1	0.2
	3	0.2
	20	0.2
	n28	0.2
	n78	0.5
DC_1-3-21-42_n78	1	0.2
	3	0.3
	21	0.5
	42	0.5
	n78	0.2
DC_1-3-21-42_n79	1	0.2
	3	0.3
	21	0.5
	42	0.5
	n79	0.0
DC_1-7-20_n28-n78	1	0.2
	7	0.2
	20	0.2
	n28	0.2
	n78	0.5
DC_1-19-21-42_n78	42	0.5
DC_1-19-21-42_n79	n78	0.5
DC_1-19-42_n77-n79	42	0.5
	n77	0.5
	n79	0.5
DC_1-19-42_n78-n79	42	0.5
	n78	0.5
DC_1-21-42_n77-n79	1	0.2
	21	0.2
	42	0.5
	n77	0.5
DC_1-21-42_n78-n79	21	0.2
	42	0.5
	n78	0.5
DC_3-7-20_n28-n78	3	0.2
	7	0.2
	20	0.2
	n28	0.2
DC_3-19-21-42_n78	3	0.3
	21	0.5
	42	0.5
	n78	0.5
DC_3-19-21-42_n79	3	0.3
	21	0.5

	42	0.5
DC_19-21-42_n77-n79	42	0.5
	n77	0.5
DC_19-21-42_n78-n79	42	0.5
	n78	0.5
NOTE 1: The requirement is applied for UE transmitting on the frequency range of 2545 – 2690 MHz.		
NOTE 2: The requirement is applied for UE transmitting on the frequency range of 2496 – 2545 MHz.		

### 7.3B.3.3.5 $\Delta R_{IB,c}$ for EN-DC six bands

**Table 7.3B.3.3.5-1:  $\Delta R_{IB,c}$  due to EN-DC (six bands)**

Inter-band EN-DC configuration	E-UTRA or NR Band	$\Delta R_{IB,c}$ (dB)
DC_1-3-7-20_n28-n78	1	0.2
	3	0.2
	7	0.2
	20	0.2
	n28	0.2
	n78	0.5

### 7.3B.3.3a $\Delta R_{IB,c}$ for Inter-band NE-DC within FR1

Unless  $\Delta R_{IB,c}$  is specified in this clause, the value of  $\Delta R_{IB,c}$  for the correspondingly specified EN-DC configuration in clause 7.3B.3.3 is applicable.

### 7.3B.3.4 Reference sensitivity for $\Delta R_{IB,c}$ Inter-band EN-DC including FR2

The  $\Delta R_{IB,c}$  for NR FR2 band of inter-band CA defined in tables 5.5B.5.1-1 to 5.5B.5.5-1 is set to zero.

### 7.3B.3.5 Reference sensitivity for $\Delta R_{IB,c}$ Inter-band EN-DC including both FR1 and FR2

The  $\Delta R_{IB,c}$  for NR FR2 band of inter-band CA defined in tables 5.5B.6.2-1 to 5.5B.6.5-1 is set to zero and  $\Delta R_{IB,c}$  for constituent E-UTRA and NR FR1 bands is the same as those for the corresponding inter band EN-DC configuration without the NR FR2 bands specified in 7.3B.3.3.

## 7.3B.4 EIS Spherical Coverage for Inter-band EN-DC including FR2 (1 NR CC)

**Editor's note: The following aspects are either missing or not yet determined:**

- **Measurement Uncertainties and Test Tolerances are FFS for power class other than 1, 3, 5 and 7.**

### 7.3B.4.1 Test purpose

Same test purpose as in clause 7.3.4.1 in TS 38.521-2 [9] for the NR carrier.

### 7.3B.4.2 Test applicability

This test case applies to all types of E-UTRA UE release 15 and forward, supporting inter-band EN-DC including FR2 with 1 NR DL CC.

### 7.3B.4.3 Minimum conformance requirements

Same minimum conformance requirements as in clause 7.3.4.3 in TS 38.521-2 [9] for the NR carrier.

No exception requirements applicable to NR or E-UTRA. LTE anchor agnostic approach is applied.

The normative reference for this requirement is TS 38.101-2 [9] clause 7.3.4.

#### 7.3B.4.4 Test description

##### 7.3B.4.4.1 Initial conditions

Same test description as in clause 7.3.4.4 in TS 38.521-2 [9] for the NR carrier with the following exception:

The initial test configurations for E-UTRA band consist of environmental conditions, test frequencies, and channel bandwidths based on E-UTRA bands specified in Table 4.7-1. For Initial conditions as in clause 7.3.4.4.1 in TS 38.521-2 [9], the following steps will be added to configure E-UTRA component:

- 2.1. The parameter settings for E-UTRA cell are set up according to TS 36.508 [11] clause 4.4.3.
- 3.1. The E-UTRA downlink signal level, uplink signal level are set according to Table 4.7-1 and propagation conditions are set according to Annex B.0 of TS 36.521-1 [10].

Step 6 of Initial conditions as in clause 7.3.4.4.1 in TS 38.521-2 [9] is replaced by:

6. Ensure the UE is in state RRC\_CONNECTED with generic procedure parameters Connectivity EN-DC, DC bearer MCG and SCG, Connected without release On according to TS 38.508-1 [6] clause 4.5.

Same test procedure as in clause 7.3.4.4.2 in TS 38.521-2 [9] with the following steps added for E-UTRA component:

- 1.1 On the E-UTRA carrier, disable periodic and aperiodic CQI reports, disable SRS, set *TimeAlignmentTimerDedicated* IE to infinity and disable downlink and uplink scheduling, all as per Table 4.7-1 under clause 4.7.

#### 7.3B.4.5 Test requirement

Same test requirement as in clause 7.3.4.5 in TS 38.521-2 [9] for the NR carrier.

## 7.4 Void

### 7.4A Maximum Input Level for CA

#### 7.4A.1 Test purpose

Same test purpose as in clause 7.4 in TS 38.521-1 [8] for NR FR1 carrier(s) and clause 7.4 in TS 38.521-2 [9] for NR FR2 carrier(s).

#### 7.4A.2 Test applicability

The requirements in this test are not testable due to issues with combined testing of NR FR1 conducted mode with NR FR2 in radiated mode. Therefore, the conducted and radiated requirements are tested separately.

No test case details are specified. The NR/5GC requirements for maximum input level apply and are tested in TS 38.521-1 [8] clause 7.4 and 7.4A and TS 38.521-2 [9] clauses 7.4 and 7.4A.

### 7.4B Maximum Input Level for DC

#### 7.4B.0 Minimum conformance requirement

##### 7.4B.0.1 Intra-band contiguous EN-DC

Intra-band contiguous EN-DC maximum input level requirement and parameters are defined in Table 7.4B.0.1-1.

**Table 7.4B.0.1-1: Maximum Input**

Power in Largest CC, E-UTRA or NR, dBm	X <sup>1</sup>
--	----------------

Power in each other CC, dBm	$X^1 - 10 \cdot \log_{10}(N_x \text{SCS}_x / N_y \text{SCS}_y)$
NOTE 1: Power in Largest E-UTRA or NR bandwidth CC, listed in Table 7.4-1 [2]	
NOTE 2: $N_x, \text{SCS}_x$ is the number of RB's and Sub carrier spacing in the largest carrier bandwidth and could be LTE or NR carrier	
NOTE 3: $N_y, \text{SCS}_y$ is the number of RB's in any other carrier.	
NOTE 4: For NR carrier, the transmitter shall be set to 4dB below $P_{\text{CMAX\_L}}$ at the minimum uplink configuration specified in Table 7.3.2-3 [2] with $P_{\text{CMAX\_L}}$ as defined in clause 6.2B.4.	
NOTE 5: For E-UTRA carrier, the transmitter shall be set to 29dB below $P_{\text{CMAX\_L}}$ at the minimum uplink configuration specified in Table 7.3.1-2 [5] with $P_{\text{CMAX\_L}}$ as defined in clause 6.2B.4.	

### 7.4B.0.2 Intra-band non-contiguous EN-DC

For the E-UTRA sub-block containing one or multiple CC's, the requirement is defined in clause 7.4.1 for single carrier operation and in clause 7.4.1A for CA in TS 36.101 [5].

For the NR sub-block, the requirement is defined in clause 7.4 in TS 38.101-1 [2].

### 7.4B.0.3 Inter-band EN-DC within FR1

Maximum input level requirement for E-UTRA single carrier and CA operation specified in clauses 7.4.1 and 7.4.1A of TS 36.101 [5] and for NR single carrier and CA operation specified in clauses 7.4 and 7.4A of TS 38.101-1 [2] apply.

### 7.4B.0.4 Inter-band EN-DC including FR2

Maximum input level requirement for E-UTRA single carrier and CA operation specified in clauses 7.4.1 and 7.4.1A of TS 36.101 [5] and for NR single carrier and CA operation specified in clauses 7.4 and 7.4A of TS 38.101-2 [3] apply.

### 7.4B.0.5 Inter-band EN-DC including both FR1 and FR2

Maximum input level requirement for E-UTRA single carrier and CA operation specified in clauses 7.4.1 and 7.4.1A of TS 36.101 [5] and for NR single carrier and CA operation specified in clauses 7.4 and 7.4A of TS 38.101-1 [2] and TS 38.101-2 [3] apply.

The normative reference for this requirement is TS 38.101-3 [4] clause 7.4B.

## 7.4B.1 Maximum Input Level for Intra-Band Contiguous EN-DC (2 CCs)

### 7.4B.1.1 Test purpose

Maximum input level for intra-band contiguous EN-DC tests the UE's ability to receive data with a given average throughput for a specified reference measurement channel, under conditions of high signal level, ideal propagation and no added noise.

A UE unable to meet the throughput requirement under these conditions will decrease the coverage area near to an e-NodeB or a gNB.

### 7.4B.1.2 Test applicability

This test applies to all types of E-UTRA UE release 15 and forward, supporting intra-band contiguous EN-DC in FR1 with 2 DL CCs.

### 7.4B.1.3 Minimum conformance requirements

Refer to Clause 7.4B.0.1 for the intra-band contiguous EN-DC maximum input level requirement.

Exception requirements are defined for this test, therefore LTE agnostic approach is not applied. E-UTRA test point analysis is included and E-UTRA measurements are performed.

The normative reference for this requirement is TS 38.101-3 [4] Clause 7.4B.1.

7.4B.1.4 Test Description

7.4B.1.4.1 Initial Condition

Initial conditions are a set of test configurations the UE needs to be tested in and the steps for the SS to take with the UE to reach the correct measurement state.

The initial test configurations consist of environmental conditions, test frequencies and channel bandwidths based on EN-DC operating bands specified in table 5.5B.2-1, channel bandwidths and sub-carrier spacings for the NR cell specified in TS 38.521-1 [8] clause 5.3 and channel bandwidth for the E-UTRA cell are specified in TS 36.521-1 [10] clause 5.4.2. All of these configurations shall be tested with applicable test parameters for each intra-band contiguous EN-DC configuration specified in clause 5.3B.1.2, and are shown in table 7.4B.1.4.1-1. The details of the uplink reference measurement channels (RMCs) are specified in Annex A.2 for E-UTRA RMC for TDD, TS 36.521-1 [10] Annex A.2 for E-UTRA RMC for FDD, and TS 38.521-1 [8] Annex A.2 for NR RMC Configurations of PDSCH and PDCCH before measurement are specified in TS 36.521-1 [10] Annex C.2 and in TS 38.521-1 [8] Annex C.2 for E-UTRA CG and NR CG respectively.

**Table 7.4B.1.4.1-1: Test configuration table**

Initial Conditions								
Test Environment as specified in TS 38.508-1 [6] clause 4.1						Normal		
Test Frequencies as specified in TS 38.508-1 [6] clause 4.3.1						Mid range		
Test EN-DC bandwidth combination as specified in Table 5.3B.1.2-1 across bandwidth combination sets supported by the UE						Lowest N <sub>RB_agg</sub> , Highest N <sub>RB_agg</sub> (NOTE 5)		
Test SCS for the NR cell as specified in TS 38.521-1 [8] Table 5.3.5-1						Lowest		
Test Parameters for Intra-band Contiguous EN-DC Configuration								
Downlink Configuration					Uplink Configuration			
Test ID	NR Modulation	NR RB allocation	E-UTRA Modulation	E-UTRA RB allocation	NR Modulation	NR RB allocation	E-UTRA Modulation	E-UTRA RB allocation
1	CP-OFDM 64QAM	Full RB (NOTE 1)	CP-OFDM 64QAM	Full RB	DFT-s-OFDM QPSK	NOTE 2	QPSK	NOTE 3
2	CP-OFDM 256QAM	Full RB (NOTE 1)	CP-OFDM 256QAM	Full RB	DFT-s-OFDM QPSK	NOTE 2	QPSK	NOTE 3
NOTE 1: Full RB allocation shall be used per each SCS and channel BW as specified in Table 7.3.2.4.1-2 of TS 38.521-1 [8].								
NOTE 2: Same RB allocation shall be used per each SCS and channel BW as specified in Table 7.3.2.4.1-2 of TS 38.521-1 [8].								
NOTE 3: Same RB allocation shall be used per the E-UTRA band and channel BW as specified in Table 7.3.3-2 of TS 36.521 [10].								
NOTE 4: In an E-UTRA band or FR1 band where UE supports 4Rx, the test shall be performed only with 4Rx antennas ports connected.								
NOTE5: If the UE supports multiple CC combinations in the EN-DC configuration with the same N <sub>RB_agg</sub> , select the combination to test as follows:								
- Lowest ENBW: NR component with lowest NRB is tested.								
- Highest ENBW: NR component with highest NRB is tested.								

1. Connect the SS to the UE antenna connectors as shown in [6] TS 38.508-1 A.3.1.1 for SS diagram and A.3.2 for UE diagram.
2. The parameter settings for the E-UTRA cell are set up according to TS 36.508 [11] clause 4.4.3, and the parameter settings for the NR cell are set up according to TS 38.508-1 [6] clause 4.4.3.
3. Downlink signals are initially set up according to TS 36.521-1 [10] Annex C.0, C.1,C.2,C3.1 and TS 38.521-1 [8] Annex C.0,C.1,C.2,C3.1 for E-UTRA CG and NR CG respectively, and uplink signals according to TS 36.521-1 [10] Annex H.0,H.1,H.2,H.3.1 and TS 38.521-1 [8] Annex G.0,G.1,G.2,G.3.1 for E-UTRA CG and NR CG respectively.

4. The UL Reference Measurement channels are TS 36.521-1 [10] Annex A.2 and TS 38.521-1 [8] Annex A.2 for E-UTRA CG and NR CG respectively.
5. Propagation conditions are set according to TS 36.521-1 [10] Annex B.0 and TS 38.521-1 [8] Annex B.0 for E-UTRA CG and NR CG respectively.
6. Ensure the UE is in state RRC\_CONNECTED with generic procedure parameters Connectivity EN-DC, DC bearer *MCG* and *SCG*, Connected without release *On* according to TS 38.508-1 [6] clause 4.5. Message contents are defined in clause 7.4B.1.4.3.
7. When E-UTRA and NR bands are TDD, ensure the same uplink-downlink configuration by giving SCG a delay of 3 E-UTRA subframes, or by giving MCG a delay of 2 subframes.

#### 7.4B.1.4.2 Test Procedure

1. SS transmits PDSCH via PDCCH DCI format 1A and PDCCH DCI format 1\_1 for C\_RNTI to transmit the DL RMC according to Tables 7.4B.1.4.1 on the E-UTRA CC and NR CC. The SS sends downlink MAC padding bits on the DL RMC.
2. SS sends uplink scheduling information for each UL HARQ process via PDCCH DCI format 0 and PDCCH DCI format 0\_1 for C\_RNTI to schedule the UL RMC according to Table 7.4B.1.4.1-1 on the E-UTRA CC and NR CC. Since the UL has no payload and no loopback data to send the UE sends uplink MAC padding bits on the UL RMC.
3. SS sets the Downlink signal level for the E-UTRA CC and NR CC to the value defined in Table 7.4B.1.5-1. For NR CC and E-UTRA CC, send uplink power control commands to the UE using 1dB power step size to ensure that the UE output power measured by the test system is within the Uplink power control window, defined as  $-(\text{MU} + \text{Uplink power control window size})$  dB of the target power level in Table 7.4B.1.5-1 for at least the duration of the Throughput measurement, where:
  - MU is the test system uplink power measurement uncertainty and is specified in Table F.1.3-1 for the carrier frequency  $f$  and the channel bandwidth BW
  - For NR CC, Uplink power control window size = 1dB (UE power step size) + 0.7dB (UE power step tolerance) + (Test system relative power measurement uncertainty), where, the UE power step tolerance is specified in TS 38.101-1 [2], Table 6.3.4.3-1 and is 0.7dB for 1dB power step size, and the Test system relative power measurement uncertainty is specified in Table F.1.2-1.
  - For E-UTRA CC, Uplink power control window size = 1dB (UE power step size) + 1.0dB (UE power step tolerance) + (Test system relative power measurement uncertainty), where, the UE power step tolerance is specified in TS 36.101 [5], Table 6.3.5.2.1-1 and is 1.0dB for 1dB power step size, and the Test system relative power measurement uncertainty is specified in Table F.1.2-1 of TS 36.521-1 [10].
4. Measure the average throughput for each component carrier for duration sufficient to achieve statistical significance according to Annex H.2 in TS 38.521-1 [8] for NR band, and Annex G.2 of TS 36.521-1 [10] for EUTRA band.

NOTE: The purpose of the Uplink power control window is to ensure that the actual UE output power is no greater than the target power level, and as close as possible to the target power level. The relationship between the Uplink power control window, the target power level and the corresponding possible actual UE Uplink power window is illustrated in Annex F, clause F.4.

#### Table 7.4B.1.4.2-1: Void

#### 7.4B.1.4.3 Message Contents

Message contents are according to TS 36.508-1 [11] clause 4.6.1 and TS 38.508-1 [6] clause 4.6 Table 4.6.3-118 with condition TRANSFORM\_PRECODER\_ENABLED with the following exceptions.



**Table 7.4B.1.4.3-1: PhysicalCellGroupConfig**

Derivation Path: TS 38.508-1 [6], Table 4.6.3-106			
Information Element	Value/remark	Comment	Condition
p-NR-FR1	20		Power Class 3 UE
	23		Power Class 2 UE

**Table 7.4B.1.4.3-2: RRCConnectionReconfiguration**

Derivation Path: TS 36.508 [11], Table 4.6.1-8			
Information Element	Value/remark	Comment	Condition
nonCriticalExtension SEQUENCE {		RRCCConnectionReconfiguration-v1530-IEs	
p-MaxEUTRA-r15	20		Power Class 3 UE
	23		Power Class 2 UE
}			

#### 7.4B.1.5 Test Requirement

The throughput measurement of each CC derived in test procedure shall be  $\geq 95\%$  of the maximum throughput of the reference measurement channels with parameters specified in Table 7.4B.1.5-1

**Table 7.4B.1.5-1: Maximum input level requirement for each CC**

Channel bandwidth of Largest BW CC	Rx Parameter			
	Power in the Largest CC	Power in the other CC	Power in the Largest CC	Power in the other CC
5 MHz	$-25^2 - TT$	$10 \cdot \log_{10}(N_x SCS_x / N_y SCS_y) - TT$	$-27^3 - TT$	$-27^3 - 10 \cdot \log_{10}(N_x SCS_x / N_y SCS_y) - TT$
10 MHz	$-25^2 - TT$	$10 \cdot \log_{10}(N_x SCS_x / N_y SCS_y) - TT$	$-27^3 - TT$	$-27^3 - 10 \cdot \log_{10}(N_x SCS_x / N_y SCS_y) - TT$
15 MHz	$-25^2 - TT$	$10 \cdot \log_{10}(N_x SCS_x / N_y SCS_y) - TT$	$-27^3 - TT$	$-27^3 - 10 \cdot \log_{10}(N_x SCS_x / N_y SCS_y) - TT$
20 MHz	$-25^2 - TT$	$10 \cdot \log_{10}(N_x SCS_x / N_y SCS_y) - TT$	$-27^3 - TT$	$-27^3 - 10 \cdot \log_{10}(N_x SCS_x / N_y SCS_y) - TT$
25 MHz	$-24^2 - TT$	$10 \cdot \log_{10}(N_x SCS_x / N_y SCS_y) - TT$	$-26^3 - TT$	$-26^3 - 10 \cdot \log_{10}(N_x SCS_x / N_y SCS_y) - TT$
30 MHz	$-23^2 - TT$	$10 \cdot \log_{10}(N_x SCS_x / N_y SCS_y) - TT$	$-25^3 - TT$	$-25^3 - 10 \cdot \log_{10}(N_x SCS_x / N_y SCS_y) - TT$
40 MHz	$-22^2 - TT$	$10 \cdot \log_{10}(N_x SCS_x / N_y SCS_y) - TT$	$-24^3 - TT$	$-24^3 - 10 \cdot \log_{10}(N_x SCS_x / N_y SCS_y) - TT$
50 MHz	$-21^2 - TT$	$10 \cdot \log_{10}(N_x SCS_x / N_y SCS_y) - TT$	$-23^3 - TT$	$-23^3 - 10 \cdot \log_{10}(N_x SCS_x / N_y SCS_y) - TT$
60 MHz	$-20^2 - TT$	$10 \cdot \log_{10}(N_x SCS_x / N_y SCS_y) - TT$	$-22^3 - TT$	$-22^3 - 10 \cdot \log_{10}(N_x SCS_x / N_y SCS_y) - TT$
80 MHz	$-20^2 - TT$	$10 \cdot \log_{10}(N_x SCS_x / N_y SCS_y) - TT$	$-22^3 - TT$	$-22^3 - 10 \cdot \log_{10}(N_x SCS_x / N_y SCS_y) - TT$
90 MHz	$-20^2 - TT$	$10 \cdot \log_{10}(N_x SCS_x / N_y SCS_y) - TT$	$-22^3 - TT$	$-22^3 - 10 \cdot \log_{10}(N_x SCS_x / N_y SCS_y) - TT$
100 MHz	$-20^2 - TT$	$10 \cdot \log_{10}(N_x SCS_x / N_y SCS_y) - TT$	$-22^3 - TT$	$-22^3 - 10 \cdot \log_{10}(N_x SCS_x / N_y SCS_y) - TT$

NOTE 1:  $N_x, SCS_x$  is the number of RB's and Sub carrier spacing in the largest carrier bandwidth and could be LTE or NR carrier.  
 NOTE 2: Reference measurement channel refers to Clauses A.3.2.3 or A.3.3.3 in TS 38.521-1 [8] for 64-QAM NR Carrier, and to Tables A.3.2-3, A.3.2-4 for 64QAM in TS 36.521-1 [10] for E-UTRA Carrier.  
 NOTE 3: Reference measurement channel refers to Clauses A.3.2.4 or A.3.3.4 in TS 38.521-1 [8] for 256QAM NR Carrier, and Tables A.3.2-5, A.3.2-6 in TS 36.521-1 [10] for 256QAM E-UTRA Carrier.  
 NOTE 4:  $N_y, SCS_y$  is the number of RB's in any other carrier  
 NOTE 5: For NR carrier, the transmitter shall be set to 4dB below PCMAX\_L at the minimum uplink configuration specified in Table 7.3.2-3 in TS 38.101-1 [2] with PCMAX\_L as defined in clause 6.2B.4.  
 NOTE 6: For E-UTRA carrier, the transmitter shall be set to 29dB below PCMAX\_L at the minimum uplink configuration specified in Table 7.3.1-2 in TS 38.101-3 [4] with PCMAX\_L as defined in clause 6.2B.4 for single carrier.  
 NOTE 7: TT for each frequency is specified in Table 7.4B.1.5-2

**Table 7.4B.1.5-2: Test Tolerance (Maximum input level)**

$f \leq 3.0\text{GHz}$	$3.0\text{GHz} < f \leq 6.0\text{GHz}$
0.7 dB	1.0 dB

## 7.4B.2 Maximum Input Level for Intra-Band Non-Contiguous EN-DC (2 CCs)

### 7.4B.2.1 Test purpose

Maximum input level for intra-band non-contiguous EN-DC tests the UE's ability to receive data with a given average throughput for a specified reference measurement channel, under conditions of high signal level, ideal propagation and no added noise.

A UE unable to meet the throughput requirement under these conditions will decrease the coverage area near to an e-NodeB or a gNB.

### 7.4B.2.2 Test applicability

This test applies to all types of E-UTRA UE release 15 and forward, supporting intra-band non-contiguous EN-DC in FR1 with 2 DL CCs.

### 7.4B.2.3 Minimum conformance requirements

Refer to Clause 7.4B.0.2 for the intra-band non-contiguous EN-DC maximum input level requirement.

The normative reference for this requirement is TS 38.101-3 [4] clause 7.4B.2, and TS 38.101-1 [2] clause 7.4, and TS 38.101-2 [3] clauses 7.4 and 7.4A

No exception requirements for E-UTRA CG and NR CG, LTE agnostic approach applies.

### 7.4B.2.4 Test Description

Same test description as in clause 7.4.4 in TS 38.521-1 [8] for the NR carrier with the following exceptions in the initial test configuration.

- The initial test configurations consist of environmental conditions, test frequencies and channel bandwidths based on EN-DC operating bands specified in clause 5.5B.3, all of these configurations shall be tested with applicable test parameters for each intra-band non-contiguous EN-DC configuration specified in clause 5.3B.1.3, and are shown in table 7.4B.2.4.1-1.

**Table 7.4B.2.4.1-1: Test configuration table**

Initial Conditions								
Test Environment as specified in TS 38.508-1 [6] clause 4.1					Normal			
Test Frequencies as specified in TS 38.508-1 [6] clause 4.3.1					MaxWGap for intra-band non-contiguous EN-DC			
Test EN-DC bandwidth combination as specified in Table 5.3B.1.3-1 across bandwidth combination sets supported by the UE					Lowest, Mid, Highest of Channel BW for NR CC			
Test SCS for the NR cell as specified in TS 38.521-1 [8] Table 5.3.5-1					Lowest			
Test Parameters for EN-DC Configuration								
Downlink Configuration					Uplink Configuration			
Test ID	NR Modulation	NR RB allocation	E-UTRA Modulation	E-UTRA RB allocation	NR Modulation	NR RB allocation	E-UTRA Modulation	E-UTRA RB allocation
1	CP-OFDM 64QAM	NOTE 1	NOTE 2	NOTE 2	DFT-s-OFDM QPSK	NOTE 1	NOTE 2	NOTE 2
2	CP-OFDM 256QAM	NOTE 1	NOTE 2	NOTE 2	DFT-s-OFDM QPSK	NOTE 1	NOTE 2	NOTE 2
NOTE 1: Same RB allocation shall be used per modulation as specified in Table 7.4.4.1-1 of TS 38.521-1 [8].								
NOTE 2: Modulation and RB allocation for E-UTRA CC refers to the Table 4.6-2.								
NOTE 3: In a FR1 band where UE supports 4Rx, the test shall be performed only with 4Rx antennas ports connected.								

The initial test configurations for E-UTRA band consist of environmental conditions, test frequencies, and channel bandwidths based on E-UTRA bands specified in Table 4.6-1 with the exception that

- E-UTRA test frequency are specified in Table 7.4B.2.4.1-1 based on intra-band non-contiguous EN-DC configuration specified in clause 5.3B.1.3.

For Initial conditions as in clause 7.4.4.1 in TS 38.521-1 [8] with the following steps will be added to configure E-UTRA component:

- 2.1. The parameter settings for E-UTRA cell are set up according to TS 36.508 [11] clause 4.4.3.
- 3.1. The E-UTRA downlink signal level, uplink signal level are set according to Table 4.6-1 and propagation conditions are set according to Annex B.0 of TS 36.521-1 [10].

Step 6 of Initial conditions as in clause 6.4.1.4.1 in TS 38.521-1 [8] is replaced by the following three steps:

6. Ensure the UE is in state RRC\_CONNECTED with generic procedure parameters Connectivity EN-DC, DC bearer MCG and SCG according to TS 38.508 [6] clause 4.5.
7. On the E-UTRA carrier, disable periodic and aperiodic CQI reports, disable SRS, set TimeAlignmentTimerDedicated IE to infinity and disable downlink and uplink scheduling, all as per Table 4.6-1 under clause 4.6.
8. When E-UTRA and NR bands are TDD, ensure the same uplink-downlink configuration by giving SCG a delay of 3 E-UTRA subframes, or by giving MCG a delay of 2 subframes.

#### 7.4B.2.5 Test Requirement

Same test requirement as in clause 7.4.5 in TS 38.521-1 [8] for NR carrier.

### 7.4B.3 Maximum Input Level for Inter-band EN-DC within FR1 (1 NR CC)

#### 7.4B.3.1 Test purpose

Same test purpose as in clause 7.4.1 in TS 38.521-1 [8] for the NR carrier.

#### 7.4B.3.2 Test applicability

This test applies to all types of E-UTRA UE release 15 and forward, supporting inter-band EN-DC within FR1 with 1 NR DL CC.

#### 7.4B.3.3 Minimum conformance requirements

Same minimum conformance requirements as in clause 7.4.3 in TS 38.521-1 [8] for the NR carrier.

The normative reference for this requirement is TS 38.101-3 [4] clause 7.4B.3.

No exception requirements applicable to NR or E-UTRA. LTE anchor agnostic approach is applied.

#### 7.4B.3.4 Test Description

Same test description as in clause 7.4.4 in TS 38.521-1 [8] for the NR carrier with the following exceptions:

For band n28 / 28 used in EN-DC configurations with NOTE 8 of Table 5.5B.4.1-1, test channel bandwidth of 20MHz or more is tested with Low range test frequency.

The initial test configurations for E-UTRA consist of test frequency based on E-UTRA operating band and test channel bandwidth as specified in Table 4.6-1.

For Initial conditions as in clause 7.4.4.1 in TS 38.521-1 [8], the following steps will be added to configure E-UTRA component:

- 2.1. The parameter settings for the cell are set up according to TS 36.508 [11] clause 4.4.3.
- 3.1. The E-UTRA downlink signal level, uplink signal level are set according to Table 4.6-1 and propagation conditions are set according to Annex B, clause B.0 of TS 36.521-1 [10].

Step 6 of Initial conditions as in clause 7.4.4.1 in TS 38.521-1 [8] is replaced by:

6. Ensure the UE is in state RRC\_CONNECTED with generic procedure parameters Connectivity EN-DC, DC bearer MCG and SCG, Connected without release On according to TS 38.508 [6] clause 4.5.
7. On the E-UTRA carrier, disable periodic and aperiodic CQI reports, disable SRS, set *TimeAlignmentTimerDedicated* IE to infinity and disable downlink and uplink scheduling, all as per Table 4.6-1 under clause 4.6.

#### 7.4B.3.5 Test Requirement

Same test requirement as in clause 7.4.5 in TS 38.521-1 [8] for the NR carrier.

### 7.4B.3\_1 Maximum Input Level for EN-DC within FR1 (>2 CCs)

#### 7.4B.3\_1.1 Maximum Input Level for EN-DC within FR1 (3 CCs)

**Editor's note: The following aspects are either missing or not yet determined:**

- Only inter-band EN-DC and intra-band non-contiguous EN-DC within FR1 are considered. Testing of intra-band contiguous EN-DC is FFS.

##### 7.4B.3\_1.1.1 Test purpose

Same test purpose as in clause 7.4B.3.1.

#### 7.4B.3\_1.1.2 Test applicability

This test applies to all types of E-UTRA UE release 15 and forward, supporting inter-band or intra-band non-contiguous EN-DC within FR1 with 2 NR DL CCs and one or more E-UTRA DL CC(s).

#### 7.4B.3\_1.1.3 Minimum conformance requirements

Refer to Clause 7.4B.0.2 for the intra-band non-contiguous EN-DC and Clause 7.4B.0.3 for the inter-band EN-DC within FR1 maximum input level requirement.

No exception requirements applicable to NR or E-UTRA. LTE anchor agnostic approach is applied.

#### 7.4B.3\_1.1.4 Test Description

Same test description as in clause 7.4A.1.4 in TS 38.521-1 [8] for the NR carrier with the following exceptions:

The initial test configurations for E-UTRA consist of test frequency based on E-UTRA operating band and test channel bandwidth as specified in Table 4.6-1.

For Initial conditions as in clause 7.4A.1.4.1 in TS 38.521-1 [8], the following steps will be added to configure E-UTRA component:

2.1. The parameter settings for the cell are set up according to TS 36.508 [11] subclause 4.4.3.

3.1. The E-UTRA downlink signal level, uplink signal level are set according to Table 4.6-1 and propagation conditions are set according to Annex B.0 of TS 36.521-1 [10].

Step 6 of Initial conditions as in clause 7.4A.1.4.1 in TS 38.521-1 [8] is replaced by:

6. Ensure the UE is in state RRC\_CONNECTED with generic procedure parameters Connectivity EN-DC, DC bearer MCG and SCG, Connected without release *On* according to TS 38.508 [6] clause 4.5.

7. On the E-UTRA carrier, disable periodic and aperiodic CQI reports, disable SRS, set TimeAlignmentTimerDedicated IE to infinity and disable downlink and uplink scheduling, all as per Table 4.6-1 under clause 4.6.

#### 7.4B.3\_1.1.5 Test Requirement

Same test requirement as specified in TS 38.521-1 [8] clause 7.4A.1.5 for the NR carrier(s).

### 7.4B.3\_1.2 Maximum Input Level for EN-DC within FR1 (4 CCs)

**Editor's note: The following aspects are either missing or not yet determined:**

- Only inter-band EN-DC and intra-band non-contiguous EN-DC within FR1 are considered. Testing of intra-band contiguous EN-DC is FFS.

#### 7.4B.3\_1.2.1 Test purpose

Same test purpose as in clause 7.4B.3.1.

#### 7.4B.3\_1.2.2 Test applicability

This test applies to all types of E-UTRA UE release 15 and forward, supporting inter-band or intra-band non-contiguous EN-DC within FR1 with 3 NR DL CCs and one or more E-UTRA DL CC(s).

#### 7.4B.3\_1.2.3 Minimum conformance requirements

Refer to Clause 7.4B.0.2 for the intra-band non-contiguous EN-DC and 7.4B.0.3 for the inter-band EN-DC within FR1 maximum input level requirement.

No exception requirements applicable to NR or E-UTRA. LTE anchor agnostic approach is applied.

#### 7.4B.3\_1.2.4 Test Description

Same test description as in clause 7.4A.2.4 in TS 38.521-1 [8] for the NR carrier with the following exceptions:

The initial test configurations for E-UTRA consist of test frequency based on E-UTRA operating band and test channel bandwidth as specified in Table 4.6-1.

For Initial conditions as in clause 7.4A.2.4.1 in TS 38.521-1 [8], the following steps will be added to configure E-UTRA component:

2.1. The parameter settings for the cell are set up according to TS 36.508 [11] subclause 4.4.3.

3.1. The E-UTRA downlink signal level, uplink signal level are set according to Table 4.6-1 and propagation conditions are set according to Annex B.0 of TS 36.521-1 [10].

Step 6 of Initial conditions as in clause 7.4A.2.4.1 in TS 38.521-1 [8] is replaced by:

6. Ensure the UE is in state RRC\_CONNECTED with generic procedure parameters Connectivity EN-DC, DC bearer MCG and SCG, Connected without release *On* according to TS 38.508 [6] clause 4.5.

7. On the E-UTRA carrier, disable periodic and aperiodic CQI reports, disable SRS, set TimeAlignmentTimerDedicated IE to infinity and disable downlink and uplink scheduling, all as per Table 4.6-1 under clause 4.6.

#### 7.4B.3\_1.2.5 Test Requirement

Same test requirement as specified in TS 38.521-1 [8] clause 7.4A.2.5 for the NR carriers.

### 7.4B.3\_1.3 Maximum Input Level for EN-DC within FR1 (5 CCs)

**Editor's note: The following aspects are either missing or not yet determined:**

- Only inter-band EN-DC and intra-band non-contiguous EN-DC within FR1 are considered. Testing of intra-band contiguous EN-DC is FFS.

#### 7.4B.3\_1.3.1 Test purpose

Same test purpose as in clause 7.4B.3.1.

#### 7.4B.3\_1.3.2 Test applicability

This test applies to all types of E-UTRA UE release 15 and forward, supporting inter-band or intra-band non-contiguous EN-DC within FR1 with 4 NR DL CCs and one or more E-UTRA DL CC(s).

#### 7.4B.3\_1.3.3 Minimum conformance requirements

Refer to Clause 7.4B.0.2 for the intra-band non-contiguous EN-DC and Clause 7.4B.0.3 for the inter-band EN-DC within FR1 maximum input level requirement.

No exception requirements applicable to NR or E-UTRA. LTE anchor agnostic approach is applied.

#### 7.4B.3\_1.3.4 Test Description

Same test description as in clause 7.4A.3.4 in TS 38.521-1 [8] for the NR carrier with the following exceptions:

The initial test configurations for E-UTRA consist of test frequency based on E-UTRA operating band and test channel bandwidth as specified in Table 4.6-1.

For Initial conditions as in clause 7.4A.3.4.1 in TS 38.521-1 [8], the following steps will be added to configure E-UTRA component:

2.1. The parameter settings for the cell are set up according to TS 36.508 [11] subclause 4.4.3.

3.1. The E-UTRA downlink signal level, uplink signal level are set according to Table 4.6-1 and propagation conditions are set according to Annex B.0 of TS 36.521-1 [10].

Step 6 of Initial conditions as in clause 7.4A.3.4.1 in TS 38.521-1 [8] is replaced by:

6. Ensure the UE is in state RRC\_CONNECTED with generic procedure parameters Connectivity EN-DC, DC bearer MCG and SCG, Connected without release *On* according to TS 38.508 [6] clause 4.5.

7. On the E-UTRA carrier, disable periodic and aperiodic CQI reports, disable SRS, set TimeAlignmentTimerDedicated IE to infinity and disable downlink and uplink scheduling, all as per Table 4.6-1 under clause 4.6.

#### 7.4B.3\_1.3.5 Test Requirement

Same test requirement as specified in TS 38.521-1 [8] clause 7.4A.3.5 for the NR carrier(s).

#### 7.4B.3\_1.4 Maximum Input Level for EN-DC within FR1 (6 CCs)

**Editor's note: The test case in this clause is incomplete, the following aspects are either missing or not yet determined:**

- Only inter-band EN-DC and intra-band non-contiguous EN-DC within FR1 are considered. Testing of intra-band contiguous EN-DC is FFS.
- The referred test case 7.4A.4 in TS 38.521-1 [8] is incomplete.

#### 7.4B.3\_1.4.1 Test purpose

Same test purpose as in clause 7.4B.3.1.

#### 7.4B.3\_1.4.2 Test applicability

This test applies to all types of E-UTRA UE release 15 and forward, supporting inter-band or intra-band non-contiguous EN-DC within FR1 with 5 NR DL CCs and one or more E-UTRA DL CC(s).

#### 7.4B.3\_1.4.3 Minimum conformance requirements

Refer to Clause 7.4B.0.2 for the intra-band non-contiguous EN-DC and Clause 7.4B.0.3 for the inter-band EN-DC within FR1 maximum input level requirement.

No exception requirements applicable to NR or E-UTRA. LTE anchor agnostic approach is applied.

#### 7.4B.3\_1.4.4 Test Description

Same test description as in clause [7.4A.4.4] in TS 38.521-1 [8] for the NR carrier with the following exceptions:

The initial test configurations for E-UTRA consist of test frequency based on E-UTRA operating band and test channel bandwidth as specified in Table 4.6-1.

For Initial conditions as in clause [7.4A.4.4.1] in TS 38.521-1 [8], the following steps will be added to configure E-UTRA component:

2.1. The parameter settings for the cell are set up according to TS 36.508 [11] subclause 4.4.3.

3.1. The E-UTRA downlink signal level, uplink signal level are set according to Table 4.6-1 and propagation conditions are set according to Annex B.0 of TS 36.521-1 [10].

Step 6 of Initial conditions as in clause [7.4A.4.4.1] in TS 38.521-1 [8] is replaced by:

6. Ensure the UE is in state RRC\_CONNECTED with generic procedure parameters Connectivity EN-DC, DC bearer MCG and SCG, Connected without release *On* according to TS 38.508 [6] clause 4.5.



7. On the E-UTRA carrier, disable periodic and aperiodic CQI reports, disable SRS, set TimeAlignmentTimerDedicated IE to infinity and disable downlink and uplink scheduling, all as per Table 4.6-1 under clause 4.6.

#### 7.4B.3\_1.4.5 Test Requirement

Same test requirement as specified in TS 38.521-1 [8] clause [7.4A.4.5] for the NR carrier(s).

### 7.4B.3a Maximum Input Level for inter-band NE-DC within FR1 (2 CCs)

No exception requirements applicable to NR or E-UTRA.

No test case details are specified. The requirements for NR carrier(s) in this test case are tested in 7.4 and 7.4A of TS 38.521-1 [8], and the requirements for LTE carrier(s) in this test case are tested in 7.4 and 7.4A of TS 36.521-1 [10]. Neither NR carrier(s) nor LTE carrier(s) needs to be tested again.

### 7.4B.4 Maximum Input Level for inter-band EN-DC including FR2 (1 NR CC)

**Editor's note: The following aspects are either missing or not yet determined:**

- The referred test case 7.4 in TS 38.521-2 is incomplete.

#### 7.4B.4.1 Test purpose

Same test purpose as in clause 7.4 in TS 38.521-2 [9] for the NR carrier.

#### 7.4B.4.2 Test applicability

This test case applies to all types of E-UTRA UE release 15 and forward, supporting inter-band EN-DC including FR2 with 1 NR DL CC.

The minimum conformance requirements of NR FR2 carrier in this test case are not testable due to maximum input level unachievable in IFF OTA test setup. Other test setups have not been analysed. Thus the test case will not be tested as part of UE conformance testing.

**NOTE:** As a result TC 7.4B.4 has not been included in the test case applicability table 4.1.3-1, TS 38.522. This does not preclude the test from being used for R&D or other purposes if deemed useful to all types of NR UE release 15 and forward.

#### 7.4B.4.3 Minimum conformance requirements

Refer to Clause 7.4B.0.4 for the inter-band EN-DC including FR2 maximum input level requirement.

No exception requirements applicable to NR or E-UTRA. LTE anchor agnostic approach is applied.

#### 7.4B.4.4 Test description

Same test description as in clause 7.4.4 in TS 38.521-2 [9] for the NR carrier with the following exception:

The initial test configurations for E-UTRA band consist of environmental conditions, test frequencies, and channel bandwidths based on E-UTRA bands specified in Table 4.7-1.

For initial conditions as in clause 7.4.4.1 in TS 38.521-2 [9], the following steps will be added to configure E-UTRA component:

2.1 The parameter settings for E-UTRA cell are set up according to TS 36.508 [11] subclause 4.4.3.

3.1 The E-UTRA downlink signal level, uplink signal level are set according to Table 4.7-1 and propagation conditions are set according to Annex B.0 of TS36.521-1 [10].

Step 6 of Initial conditions as in clause 7.4.4.1 in TS 38.521-2 [9] is replaced by:

6. Ensure the UE is in state RRC\_CONNECTED with generic procedure parameters Connectivity EN-DC, DC bearer MCG and SCG, Connected without release On according to TS 38.508-1 [6] clause 4.5.

Same test procedure as in clause 7.4.4.2 in TS 38.521-2 [9] with the following steps added for E-UTRA component:

- 1.1 On the E-UTRA carrier, disable periodic and aperiodic CQI reports, disable SRS, set TimeAlignmentTimerDedicated IE to infinity and disable downlink and uplink scheduling, all as per Table 4.7-1 under clause 4.7.

#### 7.4B.4.5 Test requirement

Same test requirement as in clause 7.4.5 in TS 38.521-2 [9] for the NR carrier.

### 7.4B.4\_1 Maximum Input Level for inter-band EN-DC including FR2 (>1 NR CC)

#### 7.4B.4\_1.1 Maximum Input Level for Inter-Band EN-DC including FR2 (2 NR CCs)

**Editor's note: This clause is incomplete. The following aspects are either missing or not yet determined:**

- The referred test case 7.4A.1 in TS 38.521-2 is incomplete.

##### 7.4B.4\_1.1.1 Test purpose

Same test purpose as in clause 7.4 in TS 38.521-2 [9] for the NR carrier.

##### 7.4B.4\_1.1.2 Test applicability

This test case applies to all types of E-UTRA UE release 15 and forward, supporting inter-band EN-DC including FR2 with 2 NR DL CCs.

The minimum conformance requirements of NR FR2 carrier in this test case are not testable due to maximum input level unachievable in IFF OTA test setup. Other test setups have not been analysed. Thus the test case will not be tested as part of UE conformance testing.

**NOTE:** As a result TC 7.4B.4\_1.1 has not been included in the test case applicability table 4.1.3-1, TS 38.522. This does not preclude the test from being used for R&D or other purposes if deemed useful to all types of NR UE release 15 and forward.

##### 7.4B.4\_1.1.3 Minimum conformance requirements

Same minimum conformance requirements as in clause 7.4B.4.3.

##### 7.4B.4\_1.1.4 Test description

Same test description as in 7.4A.1.4 in TS 38.521-2 [9] for the NR carrier with the following exception:

The initial test configurations for E-UTRA band consist of environmental conditions, test frequencies, and channel bandwidths based on E-UTRA bands specified in Table 4.7-1.

For initial conditions as in 7.4A.1.4.1 in TS 38.521-2 [9], the following steps will be added to configure E-UTRA component:

- 2.1 The parameter settings for E-UTRA cell are set up according to TS 36.508 [11] subclause 4.4.3.
- 3.1 The E-UTRA downlink signal level, uplink signal level are set according to Table 4.7-1 and propagation conditions are set according to Annex B.0 of TS36.521-1 [10].

Step 6 of Initial conditions as in 7.4A.1.4.1 in TS 38.521-2 [9] is replaced by:

6. Ensure the UE is in state RRC\_CONNECTED with generic procedure parameters Connectivity EN-DC, DC bearer MCG and SCG, Connected without release On according to TS 38.508-1 [6] clause 4.5.

Same test procedure as in 7.4A.1.4.2 in TS 38.521-2 [9] with the following steps added for E-UTRA component:

- 1.1 On the E-UTRA carrier, disable periodic and aperiodic CQI reports, disable SRS, set TimeAlignmentTimerDedicated IE to infinity and disable downlink and uplink scheduling, all as per Table 4.7-1 under clause 4.7.

#### 7.4B.4\_1.1.5 Test Requirements

Same test requirement as in 7.4A.1.5 in TS 38.521-2 [9] for the NR carrier(s).

#### 7.4B.4\_1.2 Maximum Input Level for Inter-Band EN-DC including FR2 (3 NR CCs)

**Editor's note: This clause is incomplete. The following aspects are either missing or not yet determined:**

- The referred test case 7.4A.1 and 7.4A.2 in TS 38.521-2 is incomplete.

##### 7.4B.4\_1.2.1 Test purpose

Same test purpose as in clause 7.4 in TS 38.521-2 [9] for the NR carrier.

##### 7.4B.4\_1.2.2 Test applicability

This test case applies to all types of E-UTRA UE release 15 and forward, supporting inter-band EN-DC including FR2 with 3 NR DL CCs.

The minimum conformance requirements of NR FR2 carrier in this test case are not testable due to maximum input level unachievable in IFF OTA test setup. Other test setups have not been analysed. Thus the test case will not be tested as part of UE conformance testing.

- NOTE: As a result TC 7.4B.4\_1.2 has not been included in the test case applicability table 4.1.3-1, TS 38.522. This does not preclude the test from being used for R&D or other purposes if deemed useful to all types of NR UE release 15 and forward.

##### 7.4B.4\_1.2.3 Minimum conformance requirements

Same minimum conformance requirements as in clause 7.4B.4.3.

##### 7.4B.4\_1.2.4 Test description

Same test description as in 7.4A.2.4 in TS 38.521-2 [9] for the NR carrier with the following exception:

The initial test configurations for E-UTRA band consist of environmental conditions, test frequencies, and channel bandwidths based on E-UTRA bands specified in Table 4.7-1.

For initial conditions as in clause 7.4A.2.4.1 in TS 38.521-2 [9], the following steps will be added to configure E-UTRA component:

- 2.1 The parameter settings for E-UTRA cell are set up according to TS 36.508 [11] subclause 4.4.3.
- 3.1 The E-UTRA downlink signal level, uplink signal level are set according to Table 4.7-1 and propagation conditions are set according to Annex B.0 of TS36.521-1 [10].

Step 6 of Initial conditions as in 7.4A.2.4.1 in TS 38.521-2 [9] is replaced by:

6. Ensure the UE is in state RRC\_CONNECTED with generic procedure parameters Connectivity EN-DC, DC bearer MCG and SCG, Connected without release On according to TS 38.508-1 [6] clause 4.5.

Same test procedure as in 7.4A.2.4.2 in TS 38.521-2 [9] with the following steps added for E-UTRA component:

- 1.1 On the E-UTRA carrier, disable periodic and aperiodic CQI reports, disable SRS, set TimeAlignmentTimerDedicated IE to infinity and disable downlink and uplink scheduling, all as per Table 4.7-1 under clause 4.7.

#### 7.4B.4\_1.2.5 Test Requirements

Same test requirement as in clause 7.4A.2.5 in TS 38.521-2 [9] for the *NR* carrier(s).

#### 7.4B.4\_1.3 Maximum Input Level for Inter-Band EN-DC including FR2 (4 NR CCs)

**Editor's note: This clause is incomplete. The following aspects are either missing or not yet determined:**

- The referred test case 7.4A.1, 7.4A.2 and 7.4A.3 in TS 38.521-2 is incomplete.

##### 7.4B.4\_1.3.1 Test purpose

Same test purpose as in clause 7.4 in TS 38.521-2 [9] for the *NR* carrier.

##### 7.4B.4\_1.3.2 Test applicability

This test case applies to all types of E-UTRA UE release 15 and forward, supporting inter-band EN-DC including FR2 with 4 NR DL CCs.

The minimum conformance requirements of *NR* FR2 carrier in this test case are not testable due to maximum input level unachievable in IFF OTA test setup. Other test setups have not been analysed. Thus the test case will not be tested as part of UE conformance testing.

NOTE: As a result TC 7.4B.4\_1.3 has not been included in the test case applicability table 4.1.3-1, TS 38.522. This does not preclude the test from being used for R&D or other purposes if deemed useful to all types of *NR* UE release 15 and forward.

##### 7.4B.4\_1.3.3 Minimum conformance requirements

Same minimum conformance requirements as in clause 7.4B.4.3.

##### 7.4B.4\_1.3.4 Test description

Same test description as in 7.4A.3.4 in TS 38.521-2 [9] for the *NR* carrier with the following exception:

The initial test configurations for E-UTRA band consist of environmental conditions, test frequencies, and channel bandwidths based on E-UTRA bands specified in Table 4.7-1.

For initial conditions as in 7.4A.3.4.1 in TS 38.521-2 [9], the following steps will be added to configure E-UTRA component:

2.1 The parameter settings for E-UTRA cell are set up according to TS 36.508 [11] subclause 4.4.3.

3.1 The E-UTRA downlink signal level, uplink signal level are set according to Table 4.7-1 and propagation conditions are set according to Annex B.0 of TS36.521-1 [10].

Step 6 of Initial conditions as in 7.4A.3.4.1 in TS 38.521-2 [9] is replaced by:

6. Ensure the UE is in state `RRC_CONNECTED` with generic procedure parameters Connectivity EN-DC, DC bearer MCG and SCG, Connected without release On according to TS 38.508-1 [6] clause 4.5.

Same test procedure as in 7.4A.3.4.2 in TS 38.521-2 [9] with the following steps added for E-UTRA component:

1.1 On the E-UTRA carrier, disable periodic and aperiodic CQI reports, disable SRS, set `TimeAlignmentTimerDedicated` IE to infinity and disable downlink and uplink scheduling, all as per Table 4.7-1 under clause 4.7.

#### 7.4B.4\_1.2.5 Test Requirements

Same test requirement as in 7.4A.3.5 in TS 38.521-2 [9] for the *NR* carrier(s).

## 7.4B.4\_1.4 Maximum Input Level for Inter-Band EN-DC including FR2 (5 NR CCs)

**Editor's note: This clause is incomplete. The following aspects are either missing or not yet determined:**

- The referred test case 7.4A.4 in TS 38.521-2 is incomplete.

### 7.4B.4\_1.4.1 Test purpose

Same test purpose as in clause 7.4 in TS 38.521-2 [9] for the NR carrier.

### 7.4B.4\_1.4.2 Test applicability

This test case applies to all types of E-UTRA UE release 15 and forward, supporting inter-band EN-DC including FR2 with 5 NR DL CCs.

The minimum conformance requirements of NR FR2 carrier in this test case are not testable due to maximum input level unachievable in IFF OTA test setup. Other test setups have not been analysed. Thus the test case will not be tested as part of UE conformance testing.

NOTE: As a result TC 7.4B.4\_1.4 has not been included in the test case applicability table 4.1.3-1, TS 38.522. This does not preclude the test from being used for R&D or other purposes if deemed useful to all types of NR UE release 15 and forward.

### 7.4B.4\_1.4.3 Minimum conformance requirements

Same minimum conformance requirements as in clause 7.4B.4.3.

### 7.4B.4\_1.4.4 Test description

Same test description as in 7.4A.4.4 in TS 38.521-2 [9] for the NR carrier with the following exception:

The initial test configurations for E-UTRA band consist of environmental conditions, test frequencies, and channel bandwidths based on E-UTRA bands specified in Table 4.7-1.

For initial conditions as in 7.4A.4.4.1 in TS 38.521-2 [9], the following steps will be added to configure E-UTRA component:

- 2.1 The parameter settings for E-UTRA cell are set up according to TS 36.508 [11] subclause 4.4.3.
- 3.1 The E-UTRA downlink signal level, uplink signal level are set according to Table 4.7-1 and propagation conditions are set according to Annex B.0 of TS36.521-1 [10].

Step 6 of Initial conditions as in clause 7.4A.4.4.1 in TS 38.521-2 [9] is replaced by:

6. Ensure the UE is in state RRC\_CONNECTED with generic procedure parameters Connectivity EN-DC, DC bearer MCG and SCG, Connected without release On according to TS 38.508-1 [6] clause 4.5.

Same test procedure as in clause 7.4A.4.4.2 in TS 38.521-2 [9] with the following steps added for E-UTRA component:

- 1.1 On the E-UTRA carrier, disable periodic and aperiodic CQI reports, disable SRS, set TimeAlignmentTimerDedicated IE to infinity and disable downlink and uplink scheduling, all as per Table 4.7-1 under clause 4.7.

### 7.4B.4\_1.4.5 Test Requirements

Same test requirement as in 7.4A.4.5 in TS 38.521-2 [9] for the NR carrier(s).

## 7.4B.4D Maximum Input Level for inter-band EN-DC including FR2 for UL MIMO

No exception requirements applicable to NR or E-UTRA. LTE anchor agnostic approach can be applied and only NR carriers need to be tested.

No test case details are specified. Given UE's Rx performance would not be impacted by the Tx configuration in NR FR2 TDD bands, the requirements in this test case can be well covered in 7.4B.4 and 7.4B.4\_1 and don't need to be tested again.

## 7.4B.5 Maximum Input Level for inter-band EN-DC including both FR1 and FR2

### 7.4B.5.1 Test purpose

Same test purpose as in clause 7.4.1 in TS 38.521-1 [8] for NR FR1 carrier and 7.4.1 in TS 38.521-2 [9] for NR FR2 carrier.

### 7.4B.5.2 Test applicability

The requirements in this test are not testable due to issues with combined testing of NR FR1 and E-UTRA in conducted mode with NR FR2 in radiated mode. Therefore, the conducted and radiated requirements are tested separately.

No test case details are specified. The EN-DC requirements for maximum input level apply and are tested as part of the EN-DC within FR1 and EN-DC including FR2 test cases in clause 7.4B.

## 7.4B.5D Maximum Input Level for inter-band EN-DC including FR1 and FR2 for UL MIMO

### 7.4B.5D.1 Test purpose

Same test purpose as in clause 7.4D.1 in TS 38.521-1 [8] for NR FR1 carrier and 7.4D.1 in TS 38.521-2 [9] for NR FR2 carrier.

### 7.4B.5D.2 Test applicability

The requirements in this test are not testable due to issues with combined testing of NR FR1 and E-UTRA in conducted mode with NR FR2 in radiated mode. Therefore, the conducted and radiated requirements are tested separately.

No test case details are specified. The EN-DC requirements for maximum input level apply and are tested as part of the EN-DC within FR1 and EN-DC including FR2 test cases in clause 7.4B.

## 7.5 Void

## 7.5A Adjacent Channel Selectivity for CA

### 7.5A.0 Test purpose

Same test purpose as in clauses 7.5 and 7.5A in TS 38.521-1 [8] for NR FR1 carrier(s) and clauses 7.5 and 7.5A in TS 38.521-2 [9] for NR FR2 carrier(s).

### 7.5A.1 Test applicability

The requirements in this test are not testable due to issues with combined testing of NR FR1 conducted mode with NR FR2 in radiated mode. Therefore, the conducted and radiated requirements are tested separately.

No test case details are specified. The NR/5GC requirements for adjacent channel selectivity apply and are tested in clauses 7.5 and 7.5A in TS 38.521-1 [8] and clauses 7.5 and 7.5A in TS 38.521-2 [9].

## 7.5B Adjacent channel selectivity for DC

### 7.5B.0 Minimum Conformance Requirements

#### 7.5B.0.1 Intra-band contiguous EN-DC

Intra-band contiguous EN-DC ACS requirement and parameters are defined for test case 1 in Table 7.5B.0.1-1 and for test case 2 in Table 7.5B.0.1-2.

**Table 7.5B.0.1-1: ACS test case 1**

EN-DC Aggregated Bandwidth, MHz	≤100	>100, ≤120	>120, ≤140	>140, ≤160
ACS, dB	X <sup>1</sup>	19.2	18.5	17.9
P <sub>interferer</sub> , dBm	P <sub>i</sub> <sup>2</sup>	Aggregated power + 17.7 dB	Aggregated power + 17 dB	Aggregated power + 16.4 dB
P <sub>w</sub> in Transmission BW configuration, per CC, dBm	REFSENS +14dB			
NOTE 1: X is ACS level at the specified EN-DC aggregated Bandwidth from Table 7.5.1A-1 in TS 36.101 [5]				
NOTE 2: P <sub>i</sub> is from Table 7.5.1A-2 in TS 36.101 [5]				
NOTE 3: Jammer BW and offset is from Table 7.5.1A-2 in TS 36.101 [5] and is applied from the lowest edge of the lowest carrier and the highest edge of the highest carrier				
NOTE 4: For NR carrier, the transmitter shall be set to 4dB below P <sub>CMAX_L,f,c,NR</sub> at the minimum uplink configuration specified in Table 7.3.2-3 in TS 38.101-1 [2] with P <sub>CMAX_L,f,c,NR</sub> as defined in clause 6.2B.4 from TS 38.101-3 [4].				
NOTE 5: For E-UTRA carrier, the transmitter shall be set to 4dB below P <sub>CMAX_L,E-UTRA,c</sub> at the minimum uplink configuration specified in Table 7.3.1-2 in TS 36.101 [5] with P <sub>CMAX_L,E-UTRA,c</sub> as defined in clause 6.2B.4 from TS 38.101-3 [4] for single carrier.				

**Table 7.5B.0.1-2: ACS test case 2**

EN-DC Aggregated Bandwidth, ENBW, MHz	≤100	>100, ≤120	>120, ≤140	>140, ≤160
P <sub>w</sub> in Transmission Bandwidth Configuration, perCC, dBm	P <sub>w</sub> <sup>1</sup>	-42.7 +10log <sub>10</sub> (N <sub>RB,c</sub> /N <sub>NRB_agg</sub> )	-42 +10log <sub>10</sub> (N <sub>RB,c</sub> /N <sub>NRB_agg</sub> )	-41.4 +10log <sub>10</sub> (N <sub>RB,c</sub> /N <sub>NRB_agg</sub> )
P <sub>interferer</sub> , dBm	-25			
NOTE 1: P <sub>w</sub> is wanted signal power level at the specified EN-DC aggregated Bandwidth from Table 7.5.1A-3 in TS 36.101 [5]				
NOTE 2: Jammer BW and offset is from Table 7.5.1A-3 in TS 36.101 [5] and is applied from the lowest edge of the lowest carrier and the highest edge of the highest carrier				
NOTE 3: For NR carrier, the transmitter shall be set to 4dB below P <sub>CMAX_L,f,c,NR</sub> at the minimum uplink configuration specified in Table 7.3.2-3 in TS 38.101-1 [2] with P <sub>CMAX_L,f,c,NR</sub> as defined in clause 6.2B.4 from TS 38.101-3 [4].				
NOTE 4: For E-UTRA carrier, the transmitter shall be set to 29dB below P <sub>CMAX_L,E-UTRA,c</sub> at the minimum uplink configuration specified in Table 7.3.1-2 in TS 36.101 [5] with P <sub>CMAX_L,E-UTRA,c</sub> as defined in clause 6.2B.4 from TS 38.101-3 [4] for single carrier.				

#### 7.5B.0.2 Intra-band non-contiguous EN-DC

For the E-UTRA sub-block containing one or multiple CC's, the requirement is defined in clause 7.5.1 for single carrier operation and in clause 7.5.1A for CA in TS 36.101 [5].

For the NR sub-block, the requirement is defined in clause 7.5 in TS 38.101-1 [2].

The blocker configuration is defined in the general clause 7.1 in TS 38.101-3 [4].

### 7.5B.0.3 Inter-band EN-DC within FR1

Adjacent channel selectivity requirement for E-UTRA single carrier and CA operation specified in clauses 7.5.1 and 7.5.1A of TS 36.101 [5] and for NR single carrier and CA operation specified in clauses 7.5 and 7.5A of TS 38.101-1 [2] apply.

### 7.5B.0.3a Inter-band NE-DC within FR1

Adjacent channel selectivity requirement for E-UTRA single carrier and CA operation specified in subclauses 7.5.1 and 7.5.1A of TS 36.101 [5] and for NR single carrier and CA operation specified in subclauses 7.5 and 7.5A of TS 38.101-1 [2] apply.

### 7.5B.0.4 Inter-band EN-DC including FR2

Adjacent channel selectivity requirement for E-UTRA single carrier and CA operation specified in clauses 7.5.1 and 7.5.1A of TS 36.101 [5] and for NR single carrier and CA operation specified in clauses 7.5 and 7.5A of TS 38.101-2 [3] apply.

### 7.5B.0.4a Inter-band NE-DC including FR2

Adjacent channel selectivity requirement for E-UTRA single carrier and CA operation specified in clauses 7.5.1 and 7.5.1A of TS 36.101 [5] and for NR single carrier and CA operation specified in clauses 7.5 and 7.5A of TS 38.101-2 [3] apply.

### 7.5B.0.5 Inter-band EN-DC including both FR1 and FR2

Adjacent channel selectivity requirement for E-UTRA single carrier and CA operation specified in clauses 7.5.1 and 7.5.1A of TS 36.101 [5] and for NR single carrier and CA operation specified in clauses 7.5 and 7.5A of TS 38.101-1 [2] and TS 38.101-2 [3] apply.

The normative reference for this requirement is TS 38.101-3 [4] clause 7.5B.1, 7.5B.2, 7.5B.3, 7.5B.3a, 7.5B.4, 7.5B.4a, and 7.5B.5.

## 7.5B.1 Adjacent Channel Selectivity for intra-band contiguous EN-DC (2 CCs)

### 7.5B.1.1 Test purpose

Adjacent channel selectivity (ACS) is a measure of a receiver's ability to receive an NR and E-UTRA signal at its assigned channel frequency in the presence of an adjacent channel signal at a given frequency offset from the centre frequency of the assigned channel. ACS is the ratio of the receive filter attenuation on the assigned channel frequency to the receive filter attenuation on the adjacent channel(s).

### 7.5B.1.2 Test applicability

This test case applies to all types of E-UTRA UE release 15 and forward, supporting intra-band contiguous EN-DC in FR1 with 2 DL CCs.

### 7.5B.1.3 Minimum conformance requirements

Refer to Clause 7.5B.0.1 for the intra-band contiguous EN-DC in FR1.

Exception requirements are applicable for NR, therefore LTE anchor agnostic approach is not applied. E-UTRA test points are defined and measurements performed over the aggregated EN-DC bandwidth.



7.5B.1.4 Test description

7.5B.1.4.1 Initial Condition

Initial conditions are a set of test configurations the UE needs to be tested in and the steps for the SS to take with the UE to reach the correct measurement state.

The initial test configurations consist of environmental conditions, test frequencies and channel bandwidths based on EN-DC operating bands specified in table 5.5B.2-1, channel bandwidths and sub-carrier spacings for the NR cell specified in TS 38.521-1 [8] clause 5.3 and channel bandwidth for the E-UTRA cell are specified in TS 36.521-1 [10] clause 5.4.2. All of these configurations shall be tested with applicable test parameters for each intra-band contiguous EN-DC configuration specified in clause 5.5B.2, and are shown in Table 7.5B.1.4.1-1.

In an E-UTRA band or FR1 band where UE supports 4Rx, the test shall be performed only with 4Rx antennas ports connected and 4Rx REFSENS requirement (TS 38.521-1 [8] Table 7.3.2.5-2) is used in the test requirements.

The details of the uplink reference measurement channels (RMCs) are specified in Annex A.2 for E-UTRA RMC for TDD, TS 36.521-1 [10] Annex A.2 for E-UTRA RMC for FDD, TS 38.521-1 [8] Annex A.2 for NR UL RMC and TS 38.521-1 [8] Annex A.3 for NR DL RMC. Configurations of PDSCH and PDCCH before measurement are specified in TS 36.521-1 [10] Annex C.2 and in TS 38.521-1 [8] Annex C.2 for E-UTRA CG and NR CG respectively.

**Table 7.5B.1.4.1-1: Test Configuration Table**

Initial Conditions								
Test Environment as specified in TS 38.508-1 [6] clause 4.1				Normal				
Test Frequencies as specified in TS 38.508-1 [6] clause 4.3.1 for different EN-DC bandwidth classes				Mid range				
Test EN-DC bandwidth combination as specified in Table 5.3B.1.2-1 across bandwidth combination sets supported by the UE				Lowest $N_{RB\_agg}$ , Highest $N_{RB\_agg}$ (NOTE 3)				
NR Test SCS as specified in Table 5.3.5-1 in TS 38.521-1 [8]				Lowest supported SCS				
NR/E-UTRA Test Parameters								
Test ID	Downlink Configuration				Uplink Configuration			
	NR Modulation	NR RB allocation	E-UTRA Modulation	E-UTRA RB allocation	NR Modulation	NR RB allocation	E-UTRA Modulation	E-UTRA RB allocation
1	CP-OFDM QPSK	Full RB (NOTE 1)	QPSK	Full RB	DFT-s-OFDM QPSK	REFSENS_NR	QPSK	REFSENS_LTE
NOTE 1: Full RB allocation shall be used per each SCS and channel BW as specified in Table 7.3.2.4.1-2 of TS 38.521-1 [8].								
NOTE 2: Test Channel Bandwidths are checked separately for each EN-DC band, which applicable channel bandwidths are specified in Table 5.3B.1.2-1.								
NOTE 3: If the UE supports multiple CC Combinations in the EN-DC Configuration with the same $N_{RB\_agg}$ , only the combination with the highest $N_{RB\_SCG}$ is tested.								
NOTE 4: REFSENS_NR and REFSENS_LTE refer to Uplink configuration in Table 7.3.2.4.1-1 in TS 38.521-1 [8] and Table 7.3.4.1-1 in TS 36.521 [10] for NR and E-UTRA CC respectively.								
NOTE 5: In an E-UTRA band or FR1 band where UE supports 4Rx, the test shall be performed only with 4Rx antennas ports connected and 4Rx REFSENS requirement (TS 38.521-1 [8] Table 7.3.2.5-2) is used in the test requirements.								

1. Connect the SS to the UE antenna connectors as shown in A.3.1.1 for SS diagram and A.3.2 for UE diagram in TS 38.508-1 [6].
2. The parameter settings for the E-UTRA cell are set up according to TS 36.508 [11] clause 4.4.3, and parameter settings for the NR cell are set up according to TS 38.508-1 [6] clause 4.4.3.
3. Downlink signals are initially set up according to TS 36.521-1 [10] Annex C.0 and TS 38.521-1 [8] Annex C.0 for E-UTRA CG and NR CG respectively, and uplink signals according to TS 36.521-1 [10] Annex H and TS 38.521-1 [8] Annex G for E-UTRA CG and NR CG respectively.

4. The UL Reference Measurement channels are TS 36.521-1 [10] Annex A.2 and TS 38.521-1 [8] Annex A.2 for E-UTRA CG and NR CG respectively.
5. Propagation conditions are set according to TS 36.521-1 [10] Annex B.0 and TS 38.521-1 [8] Annex B.0 for E-UTRA CG and NR CG respectively.
6. Ensure the UE is in state RRC\_CONNECTED with generic procedure parameters Connectivity EN-DC, DC bearer *MCG* and *SCG*, Connected without release *On* according to TS 38.508-1 [6] clause 4.5. Message contents are defined in clause 7.5B.1.4.3.
7. When E-UTRA and NR bands are TDD, ensure the same uplink-downlink configuration by giving SCG a delay of 3 E-UTRA subframes, or by giving MCG a delay of 2 subframes.

#### 7.5B.1.4.2 Test Procedure

1. SS transmits PDSCH via PDCCH DCI format 1A and PDCCH DCI format 1\_1 for C\_RNTI to transmit the DL RMC according to Table 7.5B.1.4.1-1 on the E-UTRA CC and NR CC, respectively. The SS sends downlink MAC padding bits on the DL RMC.
2. SS sends uplink scheduling information for each UL HARQ process via PDCCH DCI format 0 and PDCCH DCI format 0\_1 for C\_RNTI to schedule the UL RMC according to Table 7.5B.1.4.1-1 on the E-UTRA CC and NR CC. Since the UE has no payload data to send, the UE transmits uplink MAC padding bits on the UL RMC.
3. Set the Downlink signal level to the value as defined in Table 7.5B.0.1-1 (Case 1). For NR CC and E-UTRA CC, send uplink power control commands to the UE using 1dB power step size to ensure that the UE output power measured by the test system is within the Uplink power control window, defined as  $-(\text{MU} + \text{Uplink power control window size})$  dB of the target power level in Table 7.5B.0.1-1 for at least the duration of the Throughput measurement, where:
  - MU is the test system uplink power measurement uncertainty and is specified in Table F.1.3-1 for the carrier frequency  $f$  and the channel bandwidth BW.
  - For NR CC, Uplink power control window size = 1dB (UE power step size) + 0.7dB (UE power step tolerance) + (Test system relative power measurement uncertainty), where, the UE power step tolerance is specified in TS 38.101-1 [2], Table 6.3.4.3-1 and is 0.7dB for 1dB power step size, and the Test system relative power measurement uncertainty is specified in Table F.1.2-1.
  - For E-UTRA CC, Uplink power control window size = 1dB (UE power step size) + 1.0dB (UE power step tolerance) + (Test system relative power measurement uncertainty), where, the UE power step tolerance is specified in TS 36.101 [5], Table 6.3.5.2.1-1 and is 1.0dB for 1dB power step size, and the Test system relative power measurement uncertainty is specified in Table F.1.2-1 of TS 36.521-1 [10].
4. Set the Interferer signal level to the value as defined in Table 7.5B.0.1-1 (Case 1) and frequency below the aggregated component carriers, using a modulated interferer bandwidth as defined in Annex D.
5. Measure the average throughput for a duration sufficient to achieve statistical significance according to Annex H.2 in TS 38.521-1 [8] for NR band, and Annex G.2 of TS 36.521-1 [10] for EUTRA band.
6. Repeat steps from 3 to 5, using an interfering signal above the aggregated component carriers in Case 1 at step 4.
7. Set the Downlink signal level to the value as defined in Table 7.5B.0.1-2 (Case 2). For NR CC and E-UTRA CC, send uplink power control commands to the UE using 1dB power step size to ensure that the UE output power measured by the test system is within the Uplink power control window, defined as  $-(\text{MU} + \text{Uplink power control window size})$  dB of the target power level in Table 7.5B.0.1-2 for at least the duration of the Throughput measurement, where MU and Uplink power control window size are defined above.
8. Set the Interferer signal level to the value as defined in Table 7.5B.0.1-2 (Case 2) and frequency below the aggregated component carriers, using a modulated interferer bandwidth as defined in Annex D.
9. Measure the average throughput for a duration sufficient to achieve statistical significance according to Annex H.2 in TS 38.521-1 [8] for NR band, and Annex G.2 of TS 36.521-1 [10] for EUTRA band.
10. Repeat steps from 7 to 9, using an interfering signal above the aggregated component carriers in Case 2 at step 8.
11. Repeat for applicable channel bandwidths and operating band combinations in both Case 1 and Case 2.

NOTE: The purpose of the Uplink power control window is to ensure that the actual UE output power is no greater than the target power level, and as close as possible to the target power level. The relationship between the Uplink power control window, the target power level and the corresponding possible actual UE Uplink power window is illustrated in Annex F, clause F.4.

#### 7.5B.1.4.3 Message Contents

Message contents are according to TS 38.508-1 [6] clause 4.6 Table 4.6.3-118 with condition TRANSFORM\_PRECODER\_ENABLED.

Message contents exceptions are according to TS 36.521-1 [10] clause 7.3.4.3 for each network signalling value with the following exceptions.

**Table 7.5B.1.4.3-1: PhysicalCellGroupConfig**

Derivation Path: TS 38.508-1 [6], Table 4.6.3-106			
Information Element	Value/remark	Comment	Condition
p-NR-FR1	20		Power Class 3 UE
	23		Power Class 2 UE

**Table 7.5B.1.4.3-2: RRCConnectionReconfiguration**

Derivation Path: TS 36.508 [11], Table 4.6.1-8			
Information Element	Value/remark	Comment	Condition
nonCriticalExtension SEQUENCE {		RRCConnectionReconfiguration-v1530-IEs	
p-MaxEUTRA-r15	20		Power Class 3 UE
	23		Power Class 2 UE
}			

#### 7.5B.1.5 Test requirement

The throughput measurement of each CG derived in test procedure shall be  $\geq 95\%$  of the maximum throughput of the reference measurement channels as specified in TS 36.521-1 [10] Annex A.3 and TS 38.521-1 [8] Annex A.3 for E-UTRA CG and NR CG respectively under the conditions specified in Table 7.5B.0.1-1, and also under the conditions specified in Table 7.5B.0.1-2.

## 7.5B.2 Adjacent Channel Selectivity for intra-band non-contiguous EN-DC (2 CCs)

#### 7.5B.2.1 Test purpose

Same test purpose as clause 7.5B.1.1

#### 7.5B.2.2 Test applicability

This test case applies to all types of E-UTRA UE release 15 and forward, supporting intra-band non-contiguous EN-DC in FR1 with 2 DL CCs.

#### 7.5B.2.3 Minimum conformance requirements

The minimum conformance requirements are defined in clause 7.5B.0.2.

No exception requirements applicable to NR or E-UTRA. LTE anchor agnostic approach is applied.

#### 7.5B.2.4 Test description

Same test description as in subclause 7.5.4 in TS 38.521-1 [8] for the NR carrier with the following exceptions:

**Table 7.5B.2.4.1-1: Test Configuration Table**

Initial Conditions	
Test Frequencies as specified in TS 38.508-1 [6] clause 4.3.1 for different DC bandwidth classes	Low with maxWgap, High with maxWgap
Test EN-DC bandwidth combination as specified in Table 5.3B.1.3-1 across bandwidth combination sets supported by the UE	Highest $N_{RB\_agg}$ (NOTE 1)
NOTE 1: If the UE supports multiple CC Combinations in the EN-DC Configuration with the same $N_{RB\_agg}$ , only the combination with the highest $N_{RB\_SCG}$ is tested.	

The initial test configurations for E-UTRA as specified in Table 4.6-1 except for the parameters specified in Table 7.5B.2.4.1-1.

For initial conditions as in clause 7.5.4.1 in TS 38.521-1 [8], the following steps are added to configure E-UTRA component:

- 2.1. The parameter settings for E-UTRA cell are set up according to TS 36.508 [11] clause 4.4.3. The E-UTRA downlink signal level, uplink signal level are set according to Table 4.6-1 and propagation conditions are set according to Annex B.0 of TS 36.521-1 [10].
7. On the E-UTRA carrier, disable periodic and aperiodic CQI reports, disable SRS, set *TimeAlignmentTimerDedicated* IE to infinity and disable downlink and uplink scheduling, all as per Table 4.6-1 under clause 4.6.

Step 6 of Initial conditions as in clause 7.5.4.1 in TS 38.521-1 [8] is replaced by the following two steps:

6. Ensure the UE is in state RRC\_CONNECTED with generic procedure parameters Connectivity EN-DC, DC bearer MCG and SCG, Connected without release *On* according to TS 38.508-1 [6] clause 4.5.
7. When E-UTRA and NR bands are TDD, ensure the same uplink-downlink configuration by giving SCG a delay of 3 E-UTRA subframes, or by giving MCG a delay of 2 subframes.

Step 3 of Test procedure as in clause 7.6.2.4.2 in TS 38.521-1 [8] shall treat the in-gap tests as below: For intra-band non-contiguous EN-DC of two sub-blocks with channel bandwidth larger than or equal to 5 MHz, the existing requirements apply for in-gap tests only if the corresponding interferer frequency offsets satisfy the following condition in relation to the sub-block gap size  $W_{gap}$ , so that the interferer frequency position does not change the nature of the core requirement tested:

$$W_{gap} \geq 2 \cdot |F_{Interferer}(\text{offset})| - BW_{Channel}$$

Same test procedure as specified in clause 7.5.4.2 in TS 38.521-1 [8].

#### 7.5B.2.5 Test requirement

Same test requirement as specified in TS 38.521-1 [8] Clause 7.5.5.

### 7.5B.3 Adjacent Channel Selectivity for inter-band EN-DC within FR1 (1 NR CC)

#### 7.5B.3.1 Test purpose

Same test purpose as in clause 7.5B.1.1.

#### 7.5B.3.2 Test applicability

This test case applies to all types of E-UTRA UE release 15 and forward, supporting inter-band EN-DC within FR1 with 1 NR DL CC.

#### 7.5B.3.3 Minimum conformance requirements

The minimum conformance requirements are defined in clause 7.5B.0.3.

No exception requirements applicable to NR or E-UTRA. LTE anchor agnostic approach is applied.

#### 7.5B.3.4 Test description

Same test description as in clause 7.5.4.2 in TS 38.521-1 [8] for the NR carrier with the following exceptions:

For band n28 / 28 used in EN-DC configurations with NOTE 8 of Table 5.5B.4.1-1, test channel bandwidth of 20MHz or more is tested with Low range test frequency.

The initial test configurations for E-UTRA consist of test frequency based on E-UTRA operating band and test channel bandwidth as specified in Table 4.6-1.

For Initial conditions as in clause 7.5.4.1 in TS 38.521-1 [8], add step 2.1 and step 3.1 as follows:

- 2.1. The parameter settings for E-UTRA cell are set up according to TS 36.508 [11] clause 4.4.3.
- 3.1. The E-UTRA downlink signal level, uplink signal level are set according to Table 4.6-1 and propagation conditions are set according to Annex B.0 of TS 36.521-1 [10].

Step 6 of Initial conditions as in clause 7.5.4.1 in TS 38.521-1 [8] is replaced by:

6. Ensure the UE is in state RRC\_CONNECTED with generic procedure parameters Connectivity EN-DC, DC bearer MCG and SCG, Connected without release *On* according to TS 38.508 [6] clause 4.5.

Add step 7 to Initial conditions in clause 7.5.4.1 in TS 38.521-1 [8] as follows:

7. On the E-UTRA carrier, disable periodic and aperiodic CQI reports, disable SRS, set *TimeAlignmentTimerDedicated* IE to infinity and disable downlink and uplink scheduling, all as per Table 4.6-1 under clause 4.6.

#### 7.5B.3.5 Test requirement

Same test requirement as specified in TS 38.521-1 [8] Clause 7.5.5.

### 7.5B.3\_1 Adjacent Channel Selectivity for EN-DC within FR1 (>2 CCs)

**Editor's note: The following aspects are either missing or not yet determined:**

- **The ACS for EN-DC within FR1 (2 NR CCs) test cases below cover only inter-band and intra-band non-contiguous EN-DC. Testing of intra-band contiguous EN-DC is FFS.**

#### 7.5B.3\_1.1 Adjacent Channel Selectivity for EN-DC within FR1 (2 NR CCs)

##### 7.5B.3\_1.1.1 Test purpose

Same test purpose as in clause 7.5B.1.1.

##### 7.5B.3\_1.1.2 Test applicability

This test applies to all types of E-UTRA UE release 15 and forward, supporting intra-band non-contiguous or inter-band EN-DC within FR1 with 2 NR DL CCs.

##### 7.5B.3\_1.1.3 Minimum conformance requirements

The minimum conformance requirements for intra-band non-contiguous or inter-band EN-DC within FR1 are defined in clause 7.5B.0.2 and 7.5B.0.3 respectively.

No exception requirements applicable to NR or E-UTRA. LTE anchor agnostic approach is applied.

##### 7.5B.3\_1.1.4 Test description

Same test description as in clause 7.5A.1.4 in TS 38.521-1 [8] for the NR carrier with the following exceptions:

The initial test configurations for E-UTRA consist of test frequency based on E-UTRA operating band and test channel bandwidth as specified in Table 4.6-1.

For Initial conditions as in clause 7.5A.1.4.1 in TS 38.521-1 [8], add step 2.1 and step 3.1 as follows:

- 2.1. The parameter settings for E-UTRA cell are set up according to TS 36.508 [11] clause 4.4.3.
- 3.1. The E-UTRA downlink signal level, uplink signal level are set according to Table 4.6-1 and propagation conditions are set according to Annex B.0 of TS 36.521-1 [10].

Step 6 of Initial conditions as in clause 7.5.4.1 or 7.5A.1.4.1 in TS 38.521-1 [8] is replaced by:

6. Ensure the UE is in state RRC\_CONNECTED with generic procedure parameters Connectivity EN-DC, DC bearer MCG and SCG, Connected without release *On* according to TS 38.508 [6] clause 4.5.

Add step 7 to Initial conditions in clause 7.5A.1.4.1 in TS 38.521-1 [8] as follows:

7. On the E-UTRA carrier, disable periodic and aperiodic CQI reports, disable SRS, set *TimeAlignmentTimerDedicated* IE to infinity and disable downlink and uplink scheduling, all as per Table 4.6-1 under clause 4.6.

#### 7.5B.3\_1.1.5 Test requirement

Same test requirement as specified in TS 38.521-1 [8] Clause 7.5A.1.5 for the NR carrier(s).

#### 7.5B.3\_1.2 Adjacent Channel Selectivity for EN-DC within FR1 (3 NR CCs)

**Editor's note: The following aspects are either missing or not yet determined:**

- **The ACS for EN-DC within FR1 (3 NR CCs) test cases below cover only inter-band and intra-band non-contiguous EN-DC. Testing of intra-band contiguous EN-DC is FFS.**

##### 7.5B.3\_1.2.1 Test purpose

Same test purpose as in clause 7.5B.1.1.

##### 7.5B.3\_1.2.2 Test applicability

This test applies to all types of E-UTRA UE release 15 and forward, supporting intra-band non-contiguous or inter-band EN-DC within FR1 with 3 NR DL CCs.

##### 7.5B.3\_1.2.3 Minimum conformance requirements

The minimum conformance requirements for intra-band non-contiguous and inter-band EN-DC within FR1 are defined in clause 7.5B.0.2 and 7.5B.0.3 respectively.

No exception requirements applicable to NR or E-UTRA. LTE anchor agnostic approach is applied.

##### 7.5B.3\_1.2.4 Test description

Same test description as in clause 7.5A.2.4 in TS 38.521-1 [8] for the NR carrier with the following exceptions:

The initial test configurations for E-UTRA consist of test frequency based on E-UTRA operating band and test channel bandwidth as specified in Table 4.6-1.

For Initial conditions as in clause 7.5A.2.4.1 in TS 38.521-1 [8], add step 2.1 and step 3.1 as follows:

- 2.1. The parameter settings for E-UTRA cell are set up according to TS 36.508 [11] clause 4.4.3.
- 3.1. The E-UTRA downlink signal level, uplink signal level are set according to Table 4.6-1 and propagation conditions are set according to Annex B.0 of TS 36.521-1 [10].

Step 6 of Initial conditions as in clause 7.5A.2.4.1 in TS 38.521-1 [8] is replaced by:

6. Ensure the UE is in state RRC\_CONNECTED with generic procedure parameters Connectivity EN-DC, DC bearer MCG and SCG, Connected without release *On* according to TS 38.508 [6] clause 4.5.

Add step 7 to Initial conditions in clause 7.5A.2.4.1 in TS 38.521-1 [8] as follows:

7. On the E-UTRA carrier, disable periodic and aperiodic CQI reports, disable SRS, set *TimeAlignmentTimerDedicated* IE to infinity and disable downlink and uplink scheduling, all as per Table 4.6-1 under clause 4.6.

#### 7.5B.3\_1.2.5 Test requirement

Same test requirement as specified in TS 38.521-1 [8] Clause 7.5A.2.5 for the NR carrier(s).

#### 7.5B.3\_1.3 Adjacent Channel Selectivity for EN-DC within FR1 (4 NR CCs)

**Editor's note: The following aspects are either missing or not yet determined:**

- **The ACS for EN-DC within FR1 (4 NR CCs) test cases below cover only inter-band and intra-band non-contiguous EN-DC. Testing of intra-band contiguous EN-DC is FFS.**

#### 7.5B.3\_1.3.1 Test purpose

Same test purpose as in clause 7.5B.1.1.

#### 7.5B.3\_1.3.2 Test applicability

This test applies to all types of E-UTRA UE release 15 and forward, supporting intra-band non-contiguous or inter-band EN-DC within FR1 with 4 NR DL CCs.

#### 7.5B.3\_1.3.3 Minimum conformance requirements

The minimum conformance requirements for intra-band non-contiguous and inter-band EN-DC within FR1 are defined in clause 7.5B.0.2 and 7.5B.0.3 respectively.

No exception requirements applicable to NR or E-UTRA. LTE anchor agnostic approach is applied.

#### 7.5B.3\_1.3.4 Test description

Same test description as in clause 7.5A.3.4 in TS 38.521-1 [8] for the NR carrier with the following exceptions:

The initial test configurations for E-UTRA consist of test frequency based on E-UTRA operating band and test channel bandwidth as specified in Table 4.6-1.

For Initial conditions as in clause 7.5A.3.4.1 in TS 38.521-1 [8], add step 2.1 and step 3.1 as follows:

- 2.1. The parameter settings for E-UTRA cell are set up according to TS 36.508 [11] clause 4.4.3.
- 3.1. The E-UTRA downlink signal level, uplink signal level are set according to Table 4.6-1 and propagation conditions are set according to Annex B.0 of TS 36.521-1 [10].

Step 6 of Initial conditions as in clause 7.5A.3.4.1 in TS 38.521-1 [8] is replaced by:

6. Ensure the UE is in state RRC\_CONNECTED with generic procedure parameters Connectivity EN-DC, DC bearer MCG and SCG, Connected without release *On* according to TS 38.508 [6] clause 4.5.

Add step 7 to Initial conditions in clause 7.5A.3.4.1 in TS 38.521-1 [8] as follows:

7. On the E-UTRA carrier, disable periodic and aperiodic CQI reports, disable SRS, set *TimeAlignmentTimerDedicated* IE to infinity and disable downlink and uplink scheduling, all as per Table 4.6-1 under clause 4.6.

#### 7.5B.3\_1.3.5 Test requirement

Same test requirement as specified in TS 38.521-1 [8] Clause 7.5A.3.5 for the NR carriers.

### 7.5B.3\_1.4 Adjacent Channel Selectivity for EN-DC within FR1 (5 NR CCs)

**Editor's note: The test cases in this clause are incomplete. The following aspects are either missing or not yet determined:**

- The ACS for EN-DC within FR1 (5 NR CCs) test cases below cover only inter-band and intra-band non-contiguous EN-DC. Testing of intra-band contiguous EN-DC is FFS.
- The referred clauses [7.5A.4.4], [7.5A.4.4.1] and [7.5A.4.5] have not been defined in TS 38.521-1 [8] yet.

#### 7.5B.3\_1.4.1 Test purpose

Same test purpose as in clause 7.5B.1.1.

#### 7.5B.3\_1.4.2 Test applicability

This test applies to all types of E-UTRA UE release 15 and forward, supporting intra-band non-contiguous or inter-band EN-DC within FR1 with 5 NR DL CCs.

#### 7.5B.3\_1.4.3 Minimum conformance requirements

The minimum conformance requirements for intra-band non-contiguous and inter-band EN-DC within FR1 are defined in clause 7.5B.0.2 and 7.5B.0.3 respectively.

No exception requirements applicable to NR or E-UTRA. LTE anchor agnostic approach is applied.

#### 7.5B.3\_1.4.4 Test description

Same test description as in clause [7.5A.4.4] in TS 38.521-1 [8] for the NR carrier with the following exceptions:

The initial test configurations for E-UTRA consist of test frequency based on E-UTRA operating band and test channel bandwidth as specified in Table 4.6-1.

For Initial conditions as in clause [7.5A.4.4.1] in TS 38.521-1 [8], add step 2.1 and step 3.1 as follows:

- 2.1. The parameter settings for E-UTRA cell are set up according to TS 36.508 [11] clause 4.4.3.
- 3.1. The E-UTRA downlink signal level, uplink signal level are set according to Table 4.6-1 and propagation conditions are set according to Annex B.0 of TS 36.521-1 [10].

Step 6 of Initial conditions as in clause [7.5A.4.4.1] in TS 38.521-1 [8] is replaced by:

6. Ensure the UE is in state RRC\_CONNECTED with generic procedure parameters Connectivity EN-DC, DC bearer MCG and SCG, Connected without release *On* according to TS 38.508 [6] clause 4.5.

Add step 7 to Initial conditions in clause [7.5A.4.4.1] in TS 38.521-1 [8] as follows:

7. On the E-UTRA carrier, disable periodic and aperiodic CQI reports, disable SRS, set *TimeAlignmentTimerDedicated* IE to infinity and disable downlink and uplink scheduling, all as per Table 4.6-1 under clause 4.6.

#### 7.5B.3\_1.4.5 Test requirement

Same test requirement as specified in TS 38.521-1 [8] Clause [7.5A.4.5] for the NR carriers.

### 7.5B.3a Adjacent Channel Selectivity for inter-band NE-DC within FR1 (2 CCs)

No exception requirements applicable to NR or E-UTRA.



No test case details are specified. The requirements for NR carrier(s) in this test case are tested in 7.5 and 7.5A of TS 38.521-1 [8], and the requirements for LTE carrier(s) in this test case are tested in 7.5 and 7.5A of TS 36.521-1 [10]. Neither NR carrier(s) nor LTE carrier(s) needs to be tested again.

## 7.5B.4 Adjacent Channel Selectivity for inter-band EN-DC including FR2 (1 NR CC)

**Editor's note:** Following aspects are either missing or not yet determined:

- Measurement Uncertainty is FFS for power class other than 1, 3, 5 and 6.
- The minimum conformance requirements for Case 2 in this test case are not testable due to maximum input level unachievable in IFF OTA test setup. Other test setups have not been analysed.

### 7.5B.4.1 Test purpose

Same test purpose as in clause 7.5B.1.1.

### 7.5B.4.2 Test applicability

This test case applies to all types of E-UTRA UE release 15 and forward, supporting inter-band EN-DC including FR2 with 1 NR DL CC.

### 7.5B.4.3 Minimum conformance requirements

The minimum conformance requirements are defined in clause 7.5B.0.4.

No exception requirements applicable to NR or E-UTRA. LTE anchor agnostic approach is applied.

### 7.5B.4.4 Test description

#### 7.5B.4.4.1 Initial Condition

Initial conditions are a set of test configurations the UE needs to be tested in and the steps for the SS to take with the UE to reach the correct measurement state.

The initial test configurations consist of environmental conditions, test frequencies and channel bandwidths based on EN-DC operating bands specified in clause 5.5B.5.1, channel bandwidths and sub-carrier spacings for the NR cell specified in TS 38.521-2 [9] clause 5.3 and channel bandwidth for the E-UTRA cell are specified in TS 36.521-1 [10] clause 5.4.2. All of these configurations shall be tested with applicable test parameters for each inter-band EN-DC including FR2 configuration specified in clause 5.5B.5.1, and the configuration for NR carrier are shown in TS 38.521-2 [9] Table 7.5.4.1-1.

For initial conditions as in clause 7.5.4.1 in TS 38.521-2 [9], the following steps are added to configure E-UTRA component:

- 2.1. The parameter settings for E-UTRA cell are set up according to TS 36.508 [11] clause 4.4.3. The E-UTRA downlink signal level, uplink signal level are set according to Table 4.7-1 and propagation conditions are set according to Annex B.0 of TS 36.521-1 [10].
7. On the E-UTRA carrier, disable periodic and aperiodic CQI reports, disable SRS, set *TimeAlignmentTimerDedicated* IE to infinity and disable downlink and uplink scheduling, all as per Table 4.7-1 under clause 4.7.

Step 6 of initial conditions as in clause 7.5.4.1 in TS 38.521-2 [9] is replaced by:

6. Ensure the UE is in state RRC\_CONNECTED with generic procedure parameters Connectivity EN-DC, DC bearer MCG and SCG, Connected without release On according to TS 38.508-1 [6] clause 4.5.

#### 7.5B.4.4.2 Test Procedure

Same test procedure as specified in clause 7.5.4.2 in TS 38.521-2 [9] with the following exceptions for E-UTRA anchor

On the E-UTRA carrier, disable periodic and aperiodic CQI reports, disable SRS, set *TimeAlignmentTimerDedicated* IE to infinity and disable downlink and uplink scheduling, all as per Table 4.7-1 under clause 4.7.

#### 7.5B.4.4.3 Message contents

Message contents are according to TS 38.508-1 [6] clause 4.6.1.

#### 7.5B.4.5 Test requirement

Same test requirement as specified in clause 7.5.5 of TS 38.521-2 [9] for the NR carrier(s).

### 7.5B.4\_1 Adjacent Channel Selectivity for inter-band EN-DC including FR2 (>1 NR CC)

#### 7.5B.4\_1.1 Adjacent Channel Selectivity for inter-band EN-DC including FR2 (2 NR CCs)

**Editor's note:** This test case is not complete. Following aspects are either missing or not yet determined:

- Working assumption: to avoid LTE CA testing in inter-band EN-DC including FR2 and only PCC band is configured.
- MU and TT are FFS.
- [Table 7.5A.1.4.1-1] in TS 38.521-2 [9] where the configuration for NR CA carriers are shown is FFS.
- [clause 7.5A.1.4.1] in TS 38.521-2 [9] where the initial conditions for NR CA is FFS.
- [clause 7.5A.1.4.2] in TS 38.521-2 [9] where the test procedure for NR CA is FFS.
- [Clause 7.5A.1.5] in TS 38.521-2 [9] where the test requirements for NR CA is FFS.
- [Clause 7.5A.1.4] in TS 38.521-2 [9] where the test description for NR CA is FFS.
- How to choose the LTE anchor when LTE CA is implemented is FFS.

##### 7.5B.4\_1.1.1 Test purpose

Same test purpose as in clause 7.5B.1.1.

##### 7.5B.4\_1.1.2 Test applicability

This test case applies to all types of E-UTRA UE release 15 and forward, supporting inter-band EN-DC including FR2 with 2 NR DL CCs.

##### 7.5B.4\_1.1.3 Minimum conformance requirements

The minimum conformance requirements are defined in clause 7.5B.0.4.

No exception requirements applicable to NR or E-UTRA. LTE anchor agnostic approach is applied.

##### 7.5B.4\_1.1.4 Test description

For inter-band EN-DC including FR2 UE configured as "2 NR DL CCs and 1 LTE DL CC", the test description of 2DL FR2 CA for adjacent channel selectivity is the same as in corresponding clause 7.5A.1.4 in TS 38.521-2 [9] for FR2 with the exceptions described below.

##### 7.5B.4\_1.1.4.1 Initial Condition

Initial conditions are a set of test configurations the UE needs to be tested in and the steps for the SS to take with the UE to reach the correct measurement state.

The initial test configurations consist of environmental conditions, test frequencies and channel bandwidths based on EN-DC operating bands specified in clause 5.5B.5.2, channel bandwidths and sub-carrier spacings for the NR cell specified in TS 38.521-2 [9] clause 5.3A and channel bandwidth for the E-UTRA cell are specified in TS 36.521-1 [10] clause 5.4.2. All of these configurations shall be tested with applicable test parameters for each inter-band EN-DC including FR2 configuration specified in clause 5.5B.5.2, and the configuration for NR carriers are shown in TS 38.521-2 [9] [Table 7.5A.1.4.1-1].

For initial conditions as in [clause 7.5A.1.4.1] in TS 38.521-2 [9], the following steps are added to configure E-UTRA component:

- 2.1. The parameter settings for E-UTRA cell are set up according to TS 36.508 [11] clause 4.4.3. The E-UTRA downlink signal level, uplink signal level are set according to Table 4.7-1 and propagation conditions are set according to Annex B.0 of TS 36.521-1 [10].
7. On the E-UTRA carrier, disable periodic and aperiodic CQI reports, disable SRS, set *TimeAlignmentTimerDedicated* IE to infinity and disable downlink and uplink scheduling, all as per Table 4.7-1 under clause 4.7.

Step 6 of initial conditions as in [clause 7.5A.1.4.1] in TS 38.521-2 [9] is replaced by:

6. Ensure the UE is in state RRC\_CONNECTED with generic procedure parameters Connectivity EN-DC, DC bearer MCG and SCG, Connected without release On according to TS 38.508-1 [6] clause 4.5.

#### 7.5B.4\_1.1.4.2 Test Procedure

Same test procedure as specified in [clause 7.5A.1.4.2] in TS 38.521-2 [9] with the following exceptions for E-UTRA anchor

On the E-UTRA carrier, disable periodic and aperiodic CQI reports, disable SRS, set *TimeAlignmentTimerDedicated* IE to infinity and disable downlink and uplink scheduling, all as per Table 4.7-1 under clause 4.7.

#### 7.5B.4\_1.1.4.3 Message contents

Message contents are according to TS 38.508-1 [6] clause 4.6.1.

#### 7.5B.4\_1.1.5 Test requirement

Same test requirement as specified in TS 38.521-2 [9] [Clause 7.5A.1.5].

#### 7.5B.4\_1.2 Void

#### 7.5B.4\_1.3 Void

#### 7.5B.4\_1.4 Void

### 7.5B.4D Adjacent Channel Selectivity for inter-band EN-DC including FR2 for UL MIMO

No exception requirements applicable to NR or E-UTRA. LTE anchor agnostic approach can be applied and only NR carriers need to be tested.

No test case details are specified. Given UE's Rx performance would not be impacted by the Tx configuration in NR FR2 TDD bands, the requirements in this test case can be well covered in 7.5B.4 and 7.5B.4\_1 and don't need to be tested again.

## 7.5B.5 Adjacent Channel Selectivity for inter-band EN-DC including both FR1 and FR2

### 7.5B.5.1 Test purpose

Same test purpose as in 7.5.1 in TS 38.521-1 [8] for NR FR1 carrier and 7.5.1 in TS 38.521-2 [9] for NR FR2 carrier.

### 7.5B.5.2 Test applicability

The requirements in this test are not testable due to issues with combined testing of NR FR1 and E-UTRA in conducted mode with NR FR2 in radiated mode. Therefore, the conducted and radiated requirements are tested separately.

No test case details are specified. The EN-DC requirements for adjacent channel selectivity apply and are tested as part of the EN-DC within FR1 and EN-DC including FR2 test cases in clause 7.5B.

## 7.5B.5D Adjacent Channel Selectivity for inter-band EN-DC including FR1 and FR2 for UL MIMO

### 7.5B.5D.1 Test purpose

Same test purpose as in 7.5D in TS 38.521-1 [8] for NR FR1 carrier and 7.5D in TS 38.521-2 [9] for NR FR2 carrier.

### 7.5B.5D.2 Test applicability

The requirements in this test are not testable due to issues with combined testing of NR FR1 and E-UTRA in conducted mode with NR FR2 in radiated mode. Therefore, the conducted and radiated requirements are tested separately.

No test case details are specified. The EN-DC requirements for adjacent channel selectivity apply and are tested as part of the EN-DC within FR1 and EN-DC including FR2 test cases in clause 7.5B.

## 7.6 Void

## 7.6A Blocking characteristics for CA

### 7.6A.1 Test purpose

Same test purpose as in clause 7.6 in TS 38.521-1 [8] for NR FR1 carrier(s) and clause 7.6 in TS 38.521-2 [9] for NR FR2 carrier(s).

### 7.6A.2 Test applicability

The requirements in this test are not testable due to issues with combined testing of NR FR1 conducted mode with NR FR2 in radiated mode. Therefore, the conducted and radiated requirements are tested separately.

No test case details are specified. The NR/5GC requirements for blocking characteristics apply and are tested in TS 38.521-1 [8] clause 7.6 and 7.6A and TS 38.521-2 [9] clauses 7.6 and 7.6A.

## 7.6B Blocking characteristics for DC

### 7.6B.1 General

The blocking characteristic for EN-DC in FR1 is a measure of the receiver's ability of an UE that support EN-DC in FR1 to receive a wanted signal at its assigned channel frequency in the presence of an unwanted interferer on frequencies other than those of the spurious response or the adjacent channels, without this unwanted input signal causing a degradation of the performance of the receiver beyond a specified limit. The blocking performance shall apply at all frequencies except those at which a spurious response occur.

## 7.6B.2 Inband blocking for DC

### 7.6B.2.0 Minimum Conformance Requirements

#### 7.6B.2.0.1 Intra-band contiguous EN-DC

Intra-band contiguous EN-DC in-band blocking requirement and parameters are defined in Table 7.6B.2.0.1-1.

**Table 7.6B.2.0.1-1: In-band blocking for intra-band contiguous EN-DC**

EN-DC Aggregated Bandwidth, MHz	≤100	>100, ≤120	>120, ≤140	>140, ≤160
P <sub>w</sub> in Transmission Bandwidth Configuration, per CC, dBm	REFSENS + Aggregated BW specific value below			
	P <sub>w</sub> <sup>1</sup>	16.8	17.5	18
NOTE 1: P <sub>w</sub> is wanted signal power level at the specified EN-DC aggregated Bandwidth from Table 7.6.1.1A-1 in TS 36.101 [5].				
NOTE 2: Interferer values are specified from Table 7.6.1.1A-2 in TS 36.101 [5].				
NOTE 3: Jammer BW and offset is from Table 7.6.1.1A-1 in TS 36.101 [5] and is applied from the lowest edge of the lowest carrier and the highest edge of the highest carrier.				
NOTE 4: For NR carrier, the transmitter shall be set to 4dB below P <sub>C<sub>MAX</sub>_L,f,c,NR</sub> at the minimum uplink configuration specified in Table 7.3.2-3 [2] with P <sub>C<sub>MAX</sub>_L,f,c,NR</sub> as defined in clause 6.2B.4.				
NOTE 5: For E-UTRA carrier, the transmitter shall be set to 29dB below P <sub>C<sub>MAX</sub>_L,E-UTRA,c</sub> at the minimum uplink configuration specified in Table 7.3.1-2 in TS 36.101 [5] with P <sub>C<sub>MAX</sub>_L,E-UTRA,c</sub> as defined in clause 6.2B.4 for single carrier.				

The normative reference for this requirement is TS 38.101-3 [4] clause 7.6B.2.1.

#### 7.6B.2.0.2 Intra-band non-contiguous EN-DC

For the E-TRA sub-block containing one or multiple CC's, the requirement is defined in clause 7.6.1.1 for single carrier operation and in clause 7.6.1.1A for CA in TS 36.101 [5].

For the NR sub-block, the requirement is defined in clause 7.6.2 in TS 38.101-1 [2].

The blocker configuration is defined in the general clause 7.1.

The normative reference for this requirement is TS 38.101-3 [4] clause 7.6B.2.2.

#### 7.6B.2.0.3 Inter-band EN-DC within FR1

Inband blocking requirement for E-UTRA single carrier and CA operation specified in clauses 7.6.1.1 and 7.6.1.1A of TS 36.101 [5] and for NR single carrier and CA operation specified in clauses 7.6.2 and 7.6A.2 of TS 38.101-1 [2] apply.

The normative reference for this requirement is TS 38.101-3 [4] clause 7.6B.2.3.

#### 7.6B.2.0.3a Inter-band NE-DC within FR1

Inband blocking requirement for E-UTRA single carrier and CA operation specified in clauses 7.6.1.1 and 7.6.1.1A of TS 36.101 [5] and for NR single carrier and CA operation specified in clauses 7.6.2 and 7.6A.2 of TS 38.101-1 [2] apply.

The normative reference for this requirement is TS 38.101-3 [4] clause 7.6B.2.3a.

#### 7.6B.2.0.4 Inter-band EN-DC including FR2

Inband blocking requirement for E-UTRA single carrier and CA operation specified in clauses 7.6.1.1 and 7.6.1.1A of TS 36.101 [5] and for NR single carrier and CA operation specified in clauses 7.6.2 and 7.6A.2 of TS 38.101-2 [3] apply.

The normative reference for this requirement is TS 38.101-3 [4] clause 7.6B.2.4.

#### 7.6B.2.0.5 Inter-band EN-DC including both FR1 and FR2

Inband blocking requirement for E-UTRA single carrier and CA operation specified in clauses 7.6.1.1 and 7.6.1.1A of TS 36.101 [5] and for NR single carrier and CA operation specified in clauses 7.6.2 and 7.6A.2 of TS 38.101-1 [2] and TS 38.101-2 [3] apply.

The normative reference for this requirement is TS 38.101-3 [4] clause 7.6B.2.5.

### 7.6B.2.1 Inband blocking for intra-band contiguous EN-DC (2 CCs)

#### 7.6B.2.1.1 Test Purpose

In-band blocking is defined for an unwanted interfering signal falling into the range from 15MHz below to 15MHz above the UE receive band, at which the relative throughput shall meet or exceed the requirement for the specified measurement channels. The lack of in-band blocking ability will decrease the coverage area when other NodeB transmitters exist (except in the adjacent channels and spurious response).

#### 7.6B.2.1.2 Test Applicability

This test case applies to all types of E-UTRA UE release 15 and forward, supporting intra-band contiguous EN-DC in FR1 with 2 DL CCs.

#### 7.6B.2.1.3 Minimum Conformance Requirements

The minimum conformance requirements are defined in clause 7.6 B.2.0.1.

Exception requirements for both NR and E-UTRA are defined for this test and therefore LTE anchor agnostic approach is not applied. E-UTRA test point analysis is included and E-UTRA measurements are performed.

#### 7.6B.2.1.4 Test Description

##### 7.6 B.2.1.4.1 Initial condition

Initial conditions are a set of test configurations the UE needs to be tested in and the steps for the SS to take with the UE to reach the correct measurement state.

The initial test configurations consist of environmental conditions, test frequencies and channel bandwidths based on EN-DC operating bands specified in clause 5.3B.1.2, channel bandwidths and sub-carrier spacings for the NR cell specified in TS 38.521-1 [8] clause 5.3 and channel bandwidth for the E-UTRA cell are specified in TS 36.521-1 [10] clause 5.4.2. All of these configurations shall be tested with applicable test parameters for each EN-DC configuration specified in clause 5.3B.1.2 and are shown in Table 7.6B.2.1.4.1-1. The details of the uplink and downlink reference measurement channels (RMCs) are specified in Annex A.2 and A.3 respectively. The details of the OCNG patterns used are specified in TS 36.521-1 [10] Annex A.5 and in TS 38.521-1 [8] Annex A.5 for E-UTRA CG and NR CG respectively. Configurations of PDSCH and PDCCH before measurement are specified in TS 36.521-1 [10] Annex C.2 and in TS 38.521-1 [8] Annex C.2 for E-UTRA CG and NR CG respectively.

Table 7.6B.2.1.4.1-1: Test configuration table

Initial Conditions							
Test Environment as specified in TS 38.508-1 [6] clause 4.1				Normal			
Test Frequencies as specified in TS 38.508-1 [6] clause 4.3.1 for different EN-DC bandwidth classes				Mid range			
Test EN-DC bandwidth combination as specified in Table 5.3B.1.2-1 across bandwidth combination sets supported by the UE				Lowest $N_{RB\_agg}$ , Highest $N_{RB\_agg}$ (NOTE 3)			
NR Test SCS as specified in Table 5.3.5-1 in TS 38.521-1 [8]				Lowest			
NR/E-UTRA Test Parameters							
Downlink Configuration				Uplink Configuration			
NR Modulation	NR RB allocation	E-UTRA Modulation	E-UTRA RB allocation	NR Modulation	NR RB allocation	E-UTRA Modulation	E-UTRA RB allocation
CP-OFDM QPSK	Full RB (NOTE 1)	QPSK	Full RB	DFT-s-OFDM QPSK	REFSENS	QPSK	REFSENS
NOTE 1: Full RB allocation shall be used per each SCS and channel BW as specified in Table 7.3.2.4.1-2 of TS 38.521-1 [8].							
NOTE 2: Test Channel Bandwidths are checked separately for each EN-DC band, which applicable channel bandwidths are specified in Table 5.3B.1.2-1.							
NOTE 3: If the UE supports multiple CC Combinations in the EN-DC Configuration with the same $N_{RB\_agg}$ , only the combination with the highest $N_{RB\_SCG}$ is tested.							
NOTE 4: REFSENS refers to Uplink configuration in Table 7.3.2.3-3 in [8] and Table 7.3.3-2 in [10] for NR and E-UTRA CC respectively.							
NOTE 5: In an E-UTRA band or FR1 band where UE supports 4Rx, the test shall be performed only with 4Rx antennas ports connected and 4Rx REFSENS requirement (TS 38.521-1 [8] Table 7.3.2.5-2) is used in the test requirements.							

1. Connect the SS to the UE antenna connectors as shown in [6] TS 38.508-1 Annex A, in Figure A.3.1.4.1 for SS diagram and clause A.3.2 for UE diagram.
2. The parameter settings for the E-UTRA cell are set up according to TS 36.508 [11] clause 4.4.3, and the parameter settings for the NR cell are set up according to TS 38.508-1 [6] clause 4.4.3.
3. Downlink signals are initially set up according to TS 36.521-1 [10] Annex C and TS 38.521-1 [8] Annex C for E-UTRA CG and NR CG respectively, and uplink signals according to TS 36.521-1 [10] Annex H and TS 38.521-1 [8] Annex G for E-UTRA CG and NR CG respectively.
4. The UL and DL Reference Measurement channels are TS 36.521-1 [10] Annex A.2, A.3 and TS 38.521-1 [8] Annex A.2, A.3 for E-UTRA CG and NR CG respectively.
5. Propagation conditions are set according to TS 36.521-1 [10] Annex B.0 and TS 38.521-1 [8] Annex B.0 for E-UTRA CG and NR CG respectively.
6. Ensure the UE is in state RRC\_CONNECTED with generic procedure parameters Connectivity EN-DC, DC bearer *MCG* and *SCG*, Connected without release *On* according to TS 38.508-1 [6] clause 4.5. Message contents are defined in clause 7.6B.2.1.4.3.
7. When E-UTRA and NR bands are TDD, ensure the same uplink-downlink configuration by giving SCG a delay of 3 E-UTRA subframes, or by giving MCG a delay of 2 subframes.

#### 7.6B.2.1.4.2 Test procedure

1. SS transmits PDSCH via PDCCH DCI format 1A and PDCCH DCI format 1\_1 for C\_RNTI to transmit the DL RMC according to Table 7.6B.2.1.4.1-1 on E-UTRA CC and NR CC respectively. The SS sends downlink MAC padding bits on the DL RMC.
2. SS sends uplink scheduling information for each UL HARQ process via PDCCH DCI format 0 and DCI format 0\_1 for C\_RNTI to schedule the UL RMC according to Table 7.6B.2.1.4.1-1 on E-UTRA CC and NR CC

respectively. Since the UL has no payload and no loopback data to send the UE sends uplink MAC padding bits on the UL RMC.

3. Set the Downlink signal level to the value as defined in Table 7.6B.2.1.5-1. For NR CC and E-UTRA CC, send uplink power control commands to the UE using 1dB power step size to ensure that the UE output power measured by the test system is within the Uplink power control window, defined as  $-(\text{MU} + \text{Uplink power control window size})$  dB of the target power level in Table 7.6B.2.1.5-1 for at least the duration of the Throughput measurement, where:
  - MU is the test system uplink power measurement uncertainty and is specified in Table F.1.3-1 for the carrier frequency  $f$  and the channel bandwidth BW
  - For NR CC, Uplink power control window size = 1dB (UE power step size) + 0.7dB (UE power step tolerance) + (Test system relative power measurement uncertainty), where, the UE power step tolerance is specified in TS 38.101-1 [2], Table 6.3.4.3-1 and is 0.7dB for 1dB power step size, and the Test system relative power measurement uncertainty is specified in Table F.1.2-1.
  - For E-UTRA CC, Uplink power control window size = 1dB (UE power step size) + 1.0dB (UE power step tolerance) + (Test system relative power measurement uncertainty), where, the UE power step tolerance is specified in TS 36.101 [5], Table 6.3.5.2.1-1 and is 1.0dB for 1dB power step size, and the Test system relative power measurement uncertainty is specified in Table F.1.2-1 of TS 36.521-1 [10].
4. Set the parameters of the signal generator for an interfering signal below the aggregated component carriers in Case 1 according to Table 7.6B.2.1.5-1.
5. Measure the average throughput for a duration sufficient to achieve statistical significance according to Annex H.2.
6. Repeat steps from 4 to 5, using an interfering signal above the aggregated component carriers in Case 1 at step 4.
7. Repeat steps from 4 to 6, using interfering signals in Case 2 at steps 4 and 6.

NOTE: The purpose of the Uplink power control window is to ensure that the actual UE output power is no greater than the target power level, and as close as possible to the target power level. The relationship between the Uplink power control window, the target power level and the corresponding possible actual UE Uplink power window is illustrated in Annex F, clause F.4.

#### 7.6B.2.1.4.3 Message contents

Message contents are according to TS 38.508-1 [6] clause 4.6 Table 4.6.3-118 with condition TRANSFORM\_PRECODER\_ENABLED with the following exceptions.

**Table 7.6B.1.4.3-1: PhysicalCellGroupConfig**

Derivation Path: TS 38.508-1 [6], Table 4.6.3-106			
Information Element	Value/remark	Comment	Condition
p-NR-FR1	20		Power Class 3 UE
	23		Power Class 2 UE

**Table 7.6B.1.4.3-2: RRCConnectionReconfiguration**

Derivation Path: TS 36.508 [11], Table 4.6.1-8			
Information Element	Value/remark	Comment	Condition
nonCriticalExtension SEQUENCE {		RRCConnectionReconfiguration-v1530-IEs	
p-MaxEUTRA-r15	20		Power Class 3 UE
	23		Power Class 2 UE
}			



## 7.6B.2.1.5 Test Requirement

The throughput shall be  $\geq 95\%$  of the maximum throughput of the reference measurement channels as specified in TS 36.521-1 [10] Annex A.3 and TS 38.521-1 [8] Annex A.3 for E-UTRA CG and NR CG respectively with parameters specified in Table 7.6B.2.1.5-1 for the specified wanted signal mean power in the presence of interfering signals.

**Table 7.6B.2.1.5-1: In-band blocking for intra-band contiguous EN-DC**

EN-DC Aggregated Bandwidth, MHz	$\leq 100$	$>100, \leq 120$	$>120, \leq 140$	$>140, \leq 160$
Pw in Transmission Bandwidth Configuration, perCC, dBm	REFSENS + Aggregated BW specific value below			
	$P_w^1$	16.8	17.5	18
NOTE 1: $P_w$ is wanted signal power level at the specified EN-DC aggregated Bandwidth from Table 7.6.1.1A-1 in TS 36.101 [5].				
NOTE 2: Interferer values are specified from Table 7.6.1.1A-2 in TS 36.101 [5].				
NOTE 3: Jammer BW and offset is from Table 7.6.1.1A-1 in TS 36.101 [5] and is applied from the lowest edge of the lowest carrier and the highest edge of the highest carrier.				
NOTE 4: For NR carrier, the transmitter shall be set to 4dB below $P_{\text{CMAX\_L,f,c,NR}}$ at the minimum uplink configuration specified in TS 38.101-1 [2], Table 7.3.2-3 with $P_{\text{CMAX\_L,f,c,NR}}$ as defined in clause 6.2B.4.				
NOTE 5: For E-UTRA carrier, the transmitter shall be set to 29dB below $P_{\text{CMAX\_L,E-UTRA,c}}$ at the minimum uplink configuration specified in TS 36.101 [5], Table 7.3.1-2 with $P_{\text{CMAX\_L,E-UTRA,c}}$ as defined in clause 6.2B.4 for single carrier.				

**Table 7.6B.2.1.5-2: Void****Table 7.6B.2.1.5-3: Void**

## 7.6B.2.2 Inband blocking for intra-band non-contiguous EN-DC (2 CCs)

## 7.6B.2.2.1 Test Purpose

Same test purpose as in clause 7.6.2.1 in TS 38.521-1 [8] for the NR carrier.

## 7.6B.2.2.2 Test Applicability

This test case applies to all types of E-UTRA UE release 15 and forward, supporting intra-band non-contiguous EN-DC in FR1 with 2 DL CCs.

## 7.6B.2.2.3 Minimum Conformance Requirements

The minimum conformance requirements are defined in clause 7.6B.2.0.2.

No exception requirements applicable to NR or E-UTRA. LTE anchor agnostic approach is applied.

## 7.6B.2.2.4 Test Description

Same test description as in clause 7.6.2.4 in TS 38.521-1 [8] for the NR carrier with the following exceptions:

**Table 7.6B.2.2.4-1: Test Configuration Table**

Initial Conditions	
Test Frequencies as specified in TS 38.508-1 [6] clause 4.3.1 for different EN-DC bandwidth classes	High range with maxWGap
Test EN-DC bandwidth combination as specified in Table 5.3B.1.2-1 across bandwidth combination sets supported by the UE	Highest N <sub>RB_agg</sub> (NOTE 1)
NOTE 1: If the UE supports multiple CC Combinations in the EN-DC Configuration with the same N <sub>RB_agg</sub> , only the combination with the highest N <sub>RB_SCG</sub> is tested.	

The initial test configurations for E-UTRA consist of test frequency based on E-UTRA operating band and test channel bandwidth as specified in Table 4.6-1 except for the parameters specified in Table 7.6B.2.2.4-1.

For Initial conditions as in clause 7.6.2.4.1 in TS 38.521-1 [8], add step 2.1 and step 3.1 as follows:

- 2.1. The parameter settings for E-UTRA cell are set up according to TS 36.508 [11] clause 4.4.3.
- 3.1. The E-UTRA downlink signal level, uplink signal level are set according to Table 4.6-1 and propagation conditions are set according to Annex B.0 of TS 36.521-1 [10].

Step 6 of Initial conditions as in clause 7.6.2.4.1 in TS 38.521-1 [8] is replaced by:

6. Ensure the UE is in state RRC\_CONNECTED with generic procedure parameters Connectivity EN-DC, DC bearer MCG and SCG, Connected without release *On* according to TS 38.508 [6] clause 4.5.

Add steps 7 and 8 to Initial conditions in clause 7.6.2.4.1 in TS 38.521-1 [8] as follows:

7. On the E-UTRA carrier, disable periodic and aperiodic CQI reports, disable SRS, set *TimeAlignmentTimerDedicated* IE to infinity and disable downlink and uplink scheduling, all as per Table 4.6-1 under clause 4.6.
8. When E-UTRA and NR bands are TDD, ensure the same uplink-downlink configuration by giving SCG a delay of 3 E-UTRA subframes, or by giving MCG a delay of 2 subframes.

Step 3 of Test procedure as in clause 7.6.2.4.2 in TS 38.521-1 [8] shall treat the in-gap tests as below: For intra-band non-contiguous EN-DC of two sub-blocks with channel bandwidth larger than or equal to 5 MHz, the existing requirements apply for in-gap tests only if the corresponding interferer frequency offsets satisfy the following condition in relation to the sub-block gap size  $W_{gap}$ , so that the interferer frequency position does not change the nature of the core requirement tested:

$$W_{gap} \geq 2 \cdot |F_{Interferer}(\text{offset})| - BW_{Channel}$$

Step 4 of Test procedure as in clause 7.6.2.4.2 in TS 38.521-1 [8] is replaced by:

4. Set the downlink signal level for NR CC according to the Table 7.6.2.5-1 or 7.6.2.5-3 in TS 38.521-1 [8] as appropriate. For NR CC and E-UTRA CC, send uplink power control commands to the UE using 1dB power step size to ensure that the UE output power measured by the test system is within the Uplink power control window, defined as  $-MU$  to  $-(MU + \text{Uplink power control window size})$  dB of 4dB below  $P_{CMAX\_L,f,c}$  for NR CC for at least the duration of the Throughput measurement, where:
  - $MU$  is the test system uplink power measurement uncertainty and is specified in Table F.1.3-1 for the carrier frequency  $f$  and the channel bandwidth  $BW$
  - For NR CC, Uplink power control window size = 1dB (UE power step size) + 0.7dB (UE power step tolerance) + (Test system relative power measurement uncertainty), where, the UE power step tolerance is specified in TS 38.101-1 [2], Table 6.3.4.3-1 and is 0.7dB for 1dB power step size, and the Test system relative power measurement uncertainty is specified in Table F.1.2-1.

#### 7.6B.2.2.5 Test Requirement

Same test requirement as in clause 7.6.2.5 in TS 38.521-1 [8].

## 7.6B.2.3 Inband blocking for inter-band EN-DC within FR1 (1 NR CC)

### 7.6B.2.3.1 Test Purpose

Same test purpose as in clause 7.6.2.1 in TS 38.521-1 [8] for the NR carrier.

### 7.6B.2.3.2 Test Applicability

This test case applies to all types of E-UTRA UE release 15 and forward, supporting inter-band EN-DC within FR1 with 1 NR DL CC.

### 7.6B.2.3.3 Minimum Conformance Requirements

The minimum conformance requirements are defined in clause 7.6B.2.0.3.

No exception requirements applicable to NR or E-UTRA. LTE anchor agnostic approach is applied.

### 7.6B.2.3.4 Test Description

Same test description as in clause 7.6.2.4 in TS 38.521-1 [8] for the NR carrier with the following exceptions:

For band n28 / 28 used in EN-DC configurations with NOTE 8 of Table 5.5B.4.1-1, test channel bandwidth of 20MHz or more is tested with Low range test frequency.

The initial test configurations for E-UTRA consist of test frequency based on E-UTRA operating band and test channel bandwidth as specified in Table 4.6-1.

For Initial conditions as in clause 7.6.2.4.1 in TS 38.521-1 [8], add step 2.1 and step 3.1 as follows:

- 2.1. The parameter settings for E-UTRA cell are set up according to TS 36.508 [11] clause 4.4.3.
- 3.1. The E-UTRA downlink signal level, uplink signal level are set according to Table 4.6-1 and propagation conditions are set according to Annex B.0 of TS 36.521-1 [10].

Step 6 of Initial conditions as in clause 7.6.2.4.1 in TS 38.521-1 [8] is replaced by:

6. Ensure the UE is in state RRC\_CONNECTED with generic procedure parameters Connectivity EN-DC, DC bearer MCG and SCG, Connected without release *On* according to TS 38.508 [6] clause 4.5.

Add step 7 to Initial conditions in clause 7.6.2.4.1 in TS 38.521-1 [8] as follows:

7. On the E-UTRA carrier, disable periodic and aperiodic CQI reports, disable SRS, set *TimeAlignmentTimerDedicated* IE to infinity and disable downlink and uplink scheduling, all as per Table 4.6-1 under clause 4.6.

### 7.6B.2.3.5 Test Requirement

Same test requirement as in clause 7.6.2.5 in TS 38.521-1 [8].

## 7.6B.2.3\_1 Inband blocking for EN-DC within FR1 (>2 CCs)

### 7.6B.2.3\_1.1 Inband blocking for EN-DC within FR1 (3 CCs)

#### 7.6B.2.3\_1.1.1 Test Purpose

For intra-band contiguous EN-DC within FR1 with 3 DL CCs: In-band blocking is defined for an unwanted interfering signal falling into the range from 15MHz below to 15MHz above the UE receive band, at which the relative throughput shall meet or exceed the requirement for the specified measurement channels. The lack of in-band blocking ability will decrease the coverage area when other NodeB transmitters exist (except in the adjacent channels and spurious response).

For inter-band EN-DC within FR1 with 3 DL CCs (2NR DL CCs): Same test purpose as in clause 7.6A.2.1.1 in TS 38.521-1 [8].

#### 7.6B.2.3\_1.1.2 Test Applicability

This test case applies to all types of E-UTRA UE release 15 and forward, supporting intra-band contiguous EN-DC within FR1 with 3 DL CCs or inter-band EN-DC within FR1 with 3 DL CCs (2NR DL CCs).

#### 7.6B.2.3\_1.1.3 Minimum Conformance Requirements

For intra-band contiguous EN-DC within FR1 with 3 DL CCs: The minimum conformance requirements are defined in clause 7.6 B.2.0.1. Exception requirements for both NR and E-UTRA are defined and therefore LTE anchor agnostic approach is not applied. E-UTRA test point analysis is included and E-UTRA measurements are performed.

For inter-band EN-DC within FR1 with 3 DL CCs (2NR DL CCs): The minimum conformance requirements are defined in clause 7.6B.2.0.3.

No exception requirements applicable to NR or E-UTRA. LTE anchor agnostic approach is applied.

#### 7.6B.2.3\_1.1.4 Test Description

##### 7.6B.2.3\_1.1.4.1 Intra-band contiguous EN-DC within FR1 with 3 DL CCs

##### 7.6B.2.3\_1.1.4.1.1 Initial condition

Initial conditions are a set of test configurations the UE needs to be tested in and the steps for the SS to take with the UE to reach the correct measurement state.

The initial test configurations consist of environmental conditions, test frequencies and channel bandwidths based on EN-DC operating bands specified in clause 5.3B.1.2, channel bandwidths and sub-carrier spacings for the NR cell specified in TS 38.521-1 [8] clause 5.3 and channel bandwidth for the E-UTRA cell are specified in TS 36.521-1 [10] clause 5.4.2. All of these configurations shall be tested with applicable test parameters for each EN-DC configuration specified in clause 5.3B.1.2 and are shown in Table 7.6B.2.3\_1.1.4.1.1-1. The details of the uplink and downlink reference measurement channels (RMCs) are specified in Annex A.2 and A.3 respectively. The details of the OCN patterns used are specified in TS 36.521-1 [10] Annex A.5 and in TS 38.521-1 [8] Annex A.5 for E-UTRA CG and NR CG respectively. Configurations of PDSCH and PDCCH before measurement are specified in TS 36.521-1 [10] Annex C.2 and in TS 38.521-1 [8] Annex C.2 for E-UTRA CG and NR CG respectively.

**Table 7.6B.2.3\_1.1.4.1.1-1: Test configuration table**

Initial Conditions					
Test Environment as specified in TS 38.508-1 [6] clause 4.1			Normal		
Test Frequencies as specified in TS 38.508-1 [6] clause 4.3.1 for different EN-DC bandwidth classes			Mid range		
Test EN-DC bandwidth combination as specified in Table 5.3B.1.2-1 across bandwidth combination sets supported by the UE			Lowest $N_{RB\_agg}$ , Highest $N_{RB\_agg}$ (NOTE 3)		
NR Test SCS as specified in Table 5.3.5-1 in TS 38.521-1 [8]			Lowest		
NR/E-UTRA Test Parameters					
PCC – E-UTRA		SCC – EUTRA		NR	
UL/DL Modulation	UL/DL allocation	UL/DL Modulation	UL/DL allocation	UL/DL Modulation	UL/DL allocation
QPSK/QPSK	REFSENS/Full RB	NA/QPSK	NA/Full RB	DFT-s-OFDM QPSK/CP-OFDM QPSK	REFSENS/Full RB (NOTE 1)
NOTE 1: Full RB allocation shall be used per each SCS and channel BW as specified in Table 7.3.2.4.1-2 of TS 38.521-1 [8].					
NOTE 2: Test Channel Bandwidths are checked separately for each EN-DC band, which applicable channel bandwidths are specified in Table 5.3B.1.2-1.					
NOTE 3: If the UE supports multiple CC Combinations in the EN-DC Configuration with the same $N_{RB\_agg}$ , only the combination with the highest $N_{RB\_SCG}$ is tested.					
NOTE 4: REFSENS refers to Uplink configuration in Table 7.3.2.3-3 in [8] and Table 7.3.3-2 in [10] for NR and E-UTRA CC respectively.					
NOTE 5: In a FR1 band where UE supports 4Rx, the test shall be performed only with 4Rx antennas ports connected and 4Rx REFSENS requirement (TS 38.521-1 [8] Table 7.3.2.5-2) is used in the test requirements.					

1. Connect the SS to the UE antenna connectors as shown in [6] TS 38.508-1 Annex A, in Figure A.3.1.4.1 for SS diagram and clause A.3.2 for UE diagram.
2. The parameter settings for the E-UTRA cell are set up according to TS 36.508 [11] clause 4.4.3, and the parameter settings for the NR cell are set up according to TS 38.508-1 [6] clause 4.4.3.
3. Downlink signals are initially set up according to TS 36.521-1 [10] Annex C and TS 38.521-1 [8] Annex C for E-UTRA CG and NR CG respectively, and uplink signals according to TS 36.521-1 [10] Annex H and TS 38.521-1 [8] Annex G for E-UTRA CG and NR CG respectively.
4. The UL and DL Reference Measurement channels are TS 36.521-1 [10] Annex A.2, A.3 and TS 38.521-1 [8] Annex A.2, A.3 for E-UTRA CG and NR CG respectively.
5. Propagation conditions are set according to TS 36.521-1 [10] Annex B.0 and TS 38.521-1 [8] Annex B.0 for E-UTRA CG and NR CG respectively.
6. Ensure the UE is in state RRC\_CONNECTED with generic procedure parameters Connectivity EN-DC, DC bearer *MCG* and *SCG*, Connected without release *On* according to TS 38.508-1 [6] clause 4.5. Message contents are defined in clause 7.6B.2.3\_1.1.4.1.3.

#### 7.6B.2.3\_1.1.4.1.2 Test procedure

1. SS transmits PDSCH via PDCCH DCI format 1A and PDCCH DCI format 1\_1 for C\_RNTI to transmit the DL RMC according to Table 7.6B.2.3\_1.1.4.1.1-1 on E-UTRA CC and NR CC respectively. The SS sends downlink MAC padding bits on the DL RMC.
2. SS sends uplink scheduling information for each UL HARQ process via PDCCH DCI format 0 and DCI format 0\_1 for C\_RNTI to schedule the UL RMC according to Table 7.6B.2.3\_1.1.4.1.1-1 on E-UTRA CC and NR CC respectively. Since the UL has no payload and no loopback data to send the UE sends uplink MAC padding bits on the UL RMC.

3. Set the Downlink signal level to the value as defined in Table 7.6B.2.1.5-1. For NR CC and E-UTRA CC, send uplink power control commands to the UE using 1dB power step size to ensure that the UE output power measured by the test system is within the Uplink power control window, defined as  $-(\text{MU} + \text{Uplink power control window size})$  dB of the target power level in Table 7.6B.2.1.5-1 +  $(10\log(S_{\text{L\_CRB}}/N_{\text{RB\_alloc}}))$  for NR CC,  $(10\log(P_{\text{L\_CRB}}/N_{\text{RB\_alloc}}))$  for E-UTRA CC) for at least the duration of the Throughput measurement, where:
  - MU is the test system uplink power measurement uncertainty and is specified in Table F.1.3-1 for the carrier frequency  $f$  and the channel bandwidth BW
  - For NR CC, Uplink power control window size = 1dB (UE power step size) + 0.7dB (UE power step tolerance) + (Test system relative power measurement uncertainty), where, the UE power step tolerance is specified in TS 38.101-1 [2], Table 6.3.4.3-1 and is 0.7dB for 1dB power step size, and the Test system relative power measurement uncertainty is specified in Table F.1.2-1.
  - For E-UTRA CC, Uplink power control window size = 1dB (UE power step size) + 1.0dB (UE power step tolerance) + (Test system relative power measurement uncertainty), where, the UE power step tolerance is specified in TS 36.101 [5], Table 6.3.5.2.1-1 and is 1.0dB for 1dB power step size, and the Test system relative power measurement uncertainty is specified in Table F.1.2-1 of TS 36.521-1 [10].
4. Set the parameters of the signal generator for an interfering signal below the aggregated component carriers in Case 1 according to Table 7.6B.2.1.5-1.
5. Measure the average throughput for a duration sufficient to achieve statistical significance according to Annex H.2.
6. Repeat steps from 4 to 5, using an interfering signal above the aggregated component carriers in Case 1 at step 4.
7. Repeat steps from 4 to 6, using interfering signals in Case 2 at steps 4 and 6.

NOTE: The purpose of the Uplink power control window is to ensure that the actual UE output power is no greater than the target power level, and as close as possible to the target power level. The relationship between the Uplink power control window, the target power level and the corresponding possible actual UE Uplink power window is illustrated in Annex F, clause F.4.

#### 7.6B.2.3\_1.1.4.1.3 Message contents

Message contents are according to TS 38.508-1 [6] clause 4.6 Table 4.6.3-118 with condition TRANSFORM\_PRECODER\_ENABLED.

#### 7.6B.2.3\_1.1.4.2 Inter-band EN-DC within FR1 with 3 DL CCs (2NR DL CCs)

Same test description as in clause 7.6A.2.1.4 in TS 38.521-1 [8] for the NR carrier with the following exceptions:

The initial test configurations for E-UTRA consist of test frequency based on E-UTRA operating band and test channel bandwidth as specified in Table 4.6-1.

For Initial conditions as in clause 7.6A.2.1.4.1 in TS 38.521-1 [8], add step 2.1 and step 3.1 as follows:

- 2.1. The parameter settings for E-UTRA cell are set up according to TS 36.508 [11] clause 4.4.3.
- 3.1. The E-UTRA downlink signal level, uplink signal level are set according to Table 4.6-1 and propagation conditions are set according to Annex B.0 of TS 36.521-1 [10].

Step 6 of Initial conditions as in clause 7.6A.2.1.4.1 in TS 38.521-1 [8] is replaced by:

6. Ensure the UE is in state RRC\_CONNECTED with generic procedure parameters Connectivity EN-DC, DC bearer MCG and SCG, Connected without release *On* according to TS 38.508 [6] clause 4.5.

Add step 7 to Initial conditions in clause 7.6A.2.1.4.1 in TS 38.521-1 [8] as follows:

7. On the E-UTRA carrier, disable periodic and aperiodic CQI reports, disable SRS, set *TimeAlignmentTimerDedicated* IE to infinity and disable downlink and uplink scheduling, all as per Table 4.6-1 under clause 4.6.

### 7.6B.2.3\_1.1.5 Test Requirement

For intra-band contiguous EN-DC within FR1 with 3 DL CCs: Same test requirement as in clause 7.6B.2.1.5.

For inter-band EN-DC within FR1 with 3 DL CCs (2NR DL CCs): Same test requirement as in clause 7.6A.2.1.5 in TS 38.521-1 [8].

### 7.6B.2.3\_1.2 Inband blocking for EN-DC within FR1 (4 CCs)

#### 7.6B.2.3\_1.2.1 Test Purpose

For intra-band contiguous EN-DC within FR1 with 4 DL CCs: In-band blocking is defined for an unwanted interfering signal falling into the range from 15MHz below to 15MHz above the UE receive band, at which the relative throughput shall meet or exceed the requirement for the specified measurement channels. The lack of in-band blocking ability will decrease the coverage area when other NodeB transmitters exist (except in the adjacent channels and spurious response).

For inter-band EN-DC within FR1 with 4 DL CCs (3NR DL CCs): Same test purpose as in clause 7.6A.2.2.1 in TS 38.521-1 [8].

#### 7.6B.2.3\_1.2.2 Test Applicability

This test case applies to all types of E-UTRA UE release 15 and forward, supporting intra-band contiguous EN-DC within FR1 with 4 DL CCs or inter-band EN-DC within FR1 with 4 DL CCs (3NR DL CCs).

#### 7.6B.2.3\_1.2.3 Minimum Conformance Requirements

For intra-band contiguous EN-DC within FR1 with 4 DL CCs: The minimum conformance requirements are defined in clause 7.6 B.2.0.1. Exception requirements for both NR and E-UTRA are defined and therefore LTE anchor agnostic approach is not applied. E-UTRA test point analysis is included and E-UTRA measurements are performed.

For inter-band EN-DC within FR1 with 4 DL CCs (3NR DL CCs): The minimum conformance requirements are defined in clause 7.6B.2.0.3.

No exception requirements applicable to NR or E-UTRA. LTE anchor agnostic approach is applied.

#### 7.6B.2.3\_1.2.4 Test Description

##### 7.6B.2.3\_1.2.4.1 Intra-band contiguous EN-DC within FR1 with 4 DL CCs

###### 7.6B.2.3\_1.2.4.1.1 Initial condition

Initial conditions are a set of test configurations the UE needs to be tested in and the steps for the SS to take with the UE to reach the correct measurement state.

The initial test configurations consist of environmental conditions, test frequencies and channel bandwidths based on EN-DC operating bands specified in clause 5.3B.1.2, channel bandwidths and sub-carrier spacings for the NR cell specified in TS 38.521-1 [8] clause 5.3 and channel bandwidth for the E-UTRA cell are specified in TS 36.521-1 [10] clause 5.4.2. All of these configurations shall be tested with applicable test parameters for each EN-DC configuration specified in clause 5.3B.1.2 and are shown in Table 7.6B.2.3\_1.2.4.1.1-1. The details of the uplink and downlink reference measurement channels (RMCs) are specified in Annex A.2 and A.3 respectively. The details of the OCN patterns used are specified in TS 36.521-1 [10] Annex A.5 and in TS 38.521-1 [8] Annex A.5 for E-UTRA CG and NR CG respectively. Configurations of PDSCH and PDCCH before measurement are specified in TS 36.521-1 [10] Annex C.2 and in TS 38.521-1 [8] Annex C.2 for E-UTRA CG and NR CG respectively.

**Table 7.6B.2.3\_1.2.4.1.1-1: Test configuration table**

Initial Conditions					
Test Environment as specified in TS 38.508-1 [6] clause 4.1			Normal		
Test Frequencies as specified in TS 38.508-1 [6] clause 4.3.1 for different EN-DC bandwidth classes			Mid range		
Test EN-DC bandwidth combination as specified in Table 5.3B.1.2-1 across bandwidth combination sets supported by the UE			Lowest $N_{RB\_agg}$ , Highest $N_{RB\_agg}$ (NOTE 3)		
NR Test SCS as specified in Table 5.3.5-1 in TS 38.521-1 [8]			Lowest		
NR/E-UTRA Test Parameters					
PCC – E-UTRA		SCC1 – EUTRA and SCC2 – EUTRA		NR	
UL/DL Modulation	UL/DL allocation	UL/DL Modulation	UL/DL allocation	UL/DL Modulation	UL/DL allocation
QPSK/QPSK	REFSENS/Full RB	NA/QPSK	NA/Full RB	DFT-s-OFDM QPSK/CP-OFDM QPSK	REFSENS/Full RB (NOTE 1)
NOTE 1: Full RB allocation shall be used per each SCS and channel BW as specified in Table 7.3.2.4.1-2 of TS 38.521-1 [8].					
NOTE 2: Test Channel Bandwidths are checked separately for each EN-DC band, which applicable channel bandwidths are specified in Table 5.3B.1.2-1.					
NOTE 3: If the UE supports multiple CC Combinations in the EN-DC Configuration with the same $N_{RB\_agg}$ , only the combination with the highest $N_{RB\_SCG}$ is tested.					
NOTE 4: REFSENS refers to Uplink configuration in Table 7.3.2.3-3 in [8] and Table 7.3.3-2 in [10] for NR and E-UTRA CC respectively.					
NOTE 5: In a FR1 band where UE supports 4Rx, the test shall be performed only with 4Rx antennas ports connected and 4Rx REFSENS requirement (TS 38.521-1 [8] Table 7.3.2.5-2) is used in the test requirements.					

1. Connect the SS to the UE antenna connectors as shown in [6] TS 38.508-1 Annex A, in Figure A.3.1.4.1 for SS diagram and clause A.3.2 for UE diagram.
2. The parameter settings for the E-UTRA cell are set up according to TS 36.508 [11] clause 4.4.3, and the parameter settings for the NR cell are set up according to TS 38.508-1 [6] clause 4.4.3.
3. Downlink signals are initially set up according to TS 36.521-1 [10] Annex C and TS 38.521-1 [8] Annex C for E-UTRA CG and NR CG respectively, and uplink signals according to TS 36.521-1 [10] Annex H and TS 38.521-1 [8] Annex G for E-UTRA CG and NR CG respectively.
4. The UL and DL Reference Measurement channels are TS 36.521-1 [10] Annex A.2, A.3 and TS 38.521-1 [8] Annex A.2, A.3 for E-UTRA CG and NR CG respectively.
5. Propagation conditions are set according to TS 36.521-1 [10] Annex B.0 and TS 38.521-1 [8] Annex B.0 for E-UTRA CG and NR CG respectively.
6. Ensure the UE is in state RRC\_CONNECTED with generic procedure parameters Connectivity EN-DC, DC bearer *MCG* and *SCG*, Connected without release *On* according to TS 38.508-1 [6] clause 4.5. Message contents are defined in clause 7.6B.2.3\_1.2.4.1.3.

#### 7.6B.2.3\_1.2.4.1.2 Test procedure

1. SS transmits PDSCH via PDCCH DCI format 1A and PDCCH DCI format 1\_1 for C\_RNTI to transmit the DL RMC according to Table 7.6B.2.3\_1.2.4.1.1-1 on E-UTRA CC and NR CC respectively. The SS sends downlink MAC padding bits on the DL RMC.
2. SS sends uplink scheduling information for each UL HARQ process via PDCCH DCI format 0 and DCI format 0\_1 for C\_RNTI to schedule the UL RMC according to Table 7.6B.2.3\_1.2.4.1.1-1 on E-UTRA CC and NR CC respectively. Since the UL has no payload and no loopback data to send the UE sends uplink MAC padding bits on the UL RMC.



3. Set the Downlink signal level to the value as defined in Table 7.6B.2.1.5-1. For NR CC and E-UTRA CC, send uplink power control commands to the UE using 1dB power step size to ensure that the UE output power measured by the test system is within the Uplink power control window, defined as  $-(\text{MU} + \text{Uplink power control window size})$  dB of the target power level in Table 7.6B.2.1.5-1 +  $(10\log(S_{\text{LCRB}}/N_{\text{RB\_alloc}}))$  for NR CC,  $(10\log(P_{\text{LCRB}}/N_{\text{RB\_alloc}}))$  for E-UTRA CC) for at least the duration of the Throughput measurement, where:
  - MU is the test system uplink power measurement uncertainty and is specified in Table F.1.3-1 for the carrier frequency  $f$  and the channel bandwidth BW
  - For NR CC, Uplink power control window size = 1dB (UE power step size) + 0.7dB (UE power step tolerance) + (Test system relative power measurement uncertainty), where, the UE power step tolerance is specified in TS 38.101-1 [2], Table 6.3.4.3-1 and is 0.7dB for 1dB power step size, and the Test system relative power measurement uncertainty is specified in Table F.1.2-1.
  - For E-UTRA CC, Uplink power control window size = 1dB (UE power step size) + 1.0dB (UE power step tolerance) + (Test system relative power measurement uncertainty), where, the UE power step tolerance is specified in TS 36.101 [5], Table 6.3.5.2.1-1 and is 1.0dB for 1dB power step size, and the Test system relative power measurement uncertainty is specified in Table F.1.2-1 of TS 36.521-1 [10].
4. Set the parameters of the signal generator for an interfering signal below the aggregated component carriers in Case 1 according to Table 7.6B.2.1.5-1.
5. Measure the average throughput for a duration sufficient to achieve statistical significance according to Annex H.2.
6. Repeat steps from 4 to 5, using an interfering signal above the aggregated component carriers in Case 1 at step 4.
7. Repeat steps from 4 to 6, using interfering signals in Case 2 at steps 4 and 6.

NOTE: The purpose of the Uplink power control window is to ensure that the actual UE output power is no greater than the target power level, and as close as possible to the target power level. The relationship between the Uplink power control window, the target power level and the corresponding possible actual UE Uplink power window is illustrated in Annex F, clause F.4.

#### 7.6B.2.3\_1.2.4.1.3 Message contents

Message contents are according to TS 38.508-1 [6] clause 4.6 Table 4.6.3-118 with condition TRANSFORM\_PRECODER\_ENABLED.

#### 7.6B.2.3\_1.2.4.2 Inter-band EN-DC within FR1 with 4 DL CCs (3NR DL CCs)

Same test description as in clause 7.6A.2.2.4 in TS 38.521-1 [8] for the NR carrier with the following exceptions:

The initial test configurations for E-UTRA consist of test frequency based on E-UTRA operating band and test channel bandwidth as specified in Table 4.6-1.

For Initial conditions as in clause 7.6A.2.2.4.1 in TS 38.521-1 [8], add step 2.1 and step 3.1 as follows:

- 2.1. The parameter settings for E-UTRA cell are set up according to TS 36.508 [11] clause 4.4.3.
- 3.1. The E-UTRA downlink signal level, uplink signal level are set according to Table 4.6-1 and propagation conditions are set according to Annex B.0 of TS 36.521-1 [10].

Step 6 of Initial conditions as in clause 7.6A.2.2.4.1 in TS 38.521-1 [8] is replaced by:

6. Ensure the UE is in state RRC\_CONNECTED with generic procedure parameters Connectivity EN-DC, DC bearer MCG and SCG, Connected without release *On* according to TS 38.508 [6] clause 4.5.

Add step 7 to Initial conditions in clause 7.6A.2.2.4.1 in TS 38.521-1 [8] as follows:

7. On the E-UTRA carrier, disable periodic and aperiodic CQI reports, disable SRS, set *TimeAlignmentTimerDedicated* IE to infinity and disable downlink and uplink scheduling, all as per Table 4.6-1 under clause 4.6.

### 7.6B.2.3\_1.2.5 Test Requirement

For intra-band contiguous EN-DC within FR1 with 4 DL CCs: Same test requirement as in clause 7.6B.2.1.5.

For inter-band EN-DC within FR1 with 4 DL CCs (3NR DL CCs): Same test requirement as in clause 7.6A.2.2.5 in TS 38.521-1 [8].

### 7.6B.2.3\_1.3 Inband blocking for EN-DC within FR1 (5 CCs)

#### 7.6B.2.3\_1.3.1 Test Purpose

Same test purpose as in clause 7.6B.2.3.1.

#### 7.6B.2.3\_1.3.2 Test Applicability

This test case applies to all types of E-UTRA UE release 16 and forward, supporting inter-band EN-DC within FR1 with 5 DL CCs (4 NR DL CCs).

#### 7.6B.2.3\_1.3.3 Minimum Conformance Requirements

The minimum conformance requirements are defined in clause 7.6B.2.0.3.

No exception requirements applicable to NR or E-UTRA. LTE anchor agnostic approach is applied.

#### 7.6B.2.3\_1.3.4 Test Description

Same test description as in clause 7.6A.2.3.4 in TS 38.521-1 [8] for the NR carrier with the following exceptions:

The initial test configurations for E-UTRA consist of test frequency based on E-UTRA operating band and test channel bandwidth as specified in Table 4.6-1.

For Initial conditions as in clause 7.6A.2.3.4.1 in TS 38.521-1 [8], add step 2.1 and step 3.1 as follows:

- 2.1. The parameter settings for E-UTRA cell are set up according to TS 36.508 [11] clause 4.4.3.
- 3.1. The E-UTRA downlink signal level, uplink signal level are set according to Table 4.6-1 and propagation conditions are set according to Annex B.0 of TS 36.521-1 [10].

Step 6 of Initial conditions as in clause 7.6A.2.3.4.1 in TS 38.521-1 [8] is replaced by:

6. Ensure the UE is in state RRC\_CONNECTED with generic procedure parameters Connectivity EN-DC, DC bearer MCG and SCG, Connected without release *On* according to TS 38.508 [6] clause 4.5.

Add step 7 to Initial conditions in clause 7.6A.2.3.4.1 in TS 38.521-1 [8] as follows:

7. On the E-UTRA carrier, disable periodic and aperiodic CQI reports, disable SRS, set *TimeAlignmentTimerDedicated* IE to infinity and disable downlink and uplink scheduling, all as per Table 4.6-1 under clause 4.6.

### 7.6B.2.3\_1.3.5 Test Requirement

Same test requirement as in clause 7.6A.2.3.5 in TS 38.521-1 [8].

### 7.6B.2.3\_1.4 Void

### 7.6B.2.3a In-band blocking for inter-band NE-DC within FR1 (2 CCs)

No exception requirements applicable to NR or E-UTRA.

No test case details are specified. The requirements for NR carrier(s) in this test case are tested in 7.6.2 and 7.6A.2 of TS 38.521-1 [8], and the requirements for LTE carrier(s) in this test case are tested in 7.6.1 and 7.6.1A of TS 36.521-1 [10]. Neither NR carrier(s) nor LTE carrier(s) needs to be tested again.

## 7.6B.2.4 Inband blocking for inter-band EN-DC including FR2 (1 NR CC)

**Editor's note:** The following aspects are either missing or not yet determined:

- Measurement uncertainty is FFS for power class other than 1, 3, 5 and 6.

### 7.6B.2.4.1 Test Purpose

Same test purpose as in clause 7.6.2.1 in TS 38.521-2 [9] for the NR carrier.

### 7.6B.2.4.2 Test Applicability

This test case applies to all types of E-UTRA UE release 15 and forward, supporting inter-band EN-DC including FR2 with 1 NR DL CC.

### 7.6B.2.4.3 Minimum Conformance Requirements

The minimum conformance requirements are defined in clause 7.6B.2.0.4.

No exception requirements applicable to NR or E-UTRA. LTE anchor agnostic approach is applied.

### 7.6B.2.4.4 Test Description

Same test description as in clause 7.6.2.4 in TS 38.521-2 [9] for the NR carrier with the following exceptions:

The initial test configurations for E-UTRA consist of test frequency based on E-UTRA operating band and test channel bandwidth as specified in Table 4.7-1.

For Initial conditions as in clause 7.6.2.4.1 in TS 38.521-2 [9], add step 2.1 and step 3.1 as follows:

- 2.1. The parameter settings for E-UTRA cell are set up according to TS 36.508 [11] clause 4.4.3.
- 3.1. The E-UTRA downlink signal level, uplink signal level are set according to Table 4.7-1 and propagation conditions are set according to Annex B.0 of TS 36.521-1 [10].

Step 6 of Initial conditions as in clause 7.6.2.4.1 in TS 38.521-2 [9] is replaced by:

6. Ensure the UE is in state RRC\_CONNECTED with generic procedure parameters Connectivity EN-DC, DC bearer MCG and SCG, Connected without release *On* according to TS 38.508 [6] clause 4.5.

Add step 7 to Initial conditions in clause 7.6.2.4.1 in TS 38.521-2 [9] as follows:

7. On the E-UTRA carrier, disable periodic and aperiodic CQI reports, disable SRS, set *TimeAlignmentTimerDedicated* IE to infinity and disable downlink and uplink scheduling, all as per Table 4.6-1 under clause 4.7.

### 7.6B.2.4.5 Test Requirement

Same test requirement as in clause 7.6.2.5 in TS 38.521-2 [9].

## 7.6B.2.4\_1 Inband blocking for inter-band EN-DC including FR2 (>1 NR CC)

### 7.6B.2.4\_1.1 Inband blocking for inter-band EN-DC including FR2 (2 NR CCs)

**Editor's note:** This clause is incomplete. The following aspects are either missing or not yet determined:

- The referred test case 7.6A.2.1 in TS 38.521-2 is incomplete.

#### 7.6B.2.4\_1.1.1 Test Purpose

Same test purpose as in clause 7.6B.2.4.1.

#### 7.6B.2.4\_1.1.2 Test Applicability

This test case applies to all types of E-UTRA UE release 15 and forward, supporting inter-band EN-DC including FR2 and FR2 inter-band 2DL CA.

#### 7.6B.2.4\_1.1.3 Minimum Conformance Requirements

Same minimum conformance requirements as in clause 7.4B.2.4.3

#### 7.6B.2.4\_1.1.4 Test Description

Same test description as in clause 7.6A.2.1.4 in TS 38.521-2 [9] for the NR carrier with the following exceptions:

The initial test configurations for E-UTRA consist of test frequency based on E-UTRA operating band and test channel bandwidth as specified in Table 4.7-1.

For Initial conditions as in clause 7.6A.2.1.4.1 in TS 38.521-2 [9], add step 2.1 and step 3.1 as follows:

- 2.1. The parameter settings for E-UTRA cell are set up according to TS 36.508 [11] clause 4.4.3.
- 3.1. The E-UTRA downlink signal level, uplink signal level are set according to Table 4.7-1 and propagation conditions are set according to Annex B.0 of TS 36.521-1 [10].

Step 6 of Initial conditions as in clause 7.6A.2.1.4.1 in TS 38.521-2 [9] is replaced by:

6. Ensure the UE is in state RRC\_CONNECTED with generic procedure parameters Connectivity EN-DC, DC bearer MCG and SCG, Connected without release *On* according to TS 38.508 [6] clause 4.5.

Add step 7 to Initial conditions in clause 7.6A.2.1.4.1 in TS 38.521-2 [9] as follows:

7. On the E-UTRA carrier, disable periodic and aperiodic CQI reports, disable SRS, set *TimeAlignmentTimerDedicated* IE to infinity and disable downlink and uplink scheduling, all as per Table 4.6-1 under clause 4.7.

#### 7.6B.2.4\_1.1.5 Test Requirement

Same test requirement as in clause 7.6A.2.1.5 in TS 38.521-2 [9].

#### 7.6B.2.4\_1.2 Void

#### 7.6B.2.4\_1.3 Void

#### 7.6B.2.4\_1.4 Void

### 7.6B.2.4D Inband blocking for inter-band EN-DC including FR2 for UL MIMO

No exception requirements applicable to NR or E-UTRA. LTE anchor agnostic approach can be applied and only NR carriers need to be tested.

No test case details are specified. Given UE's Rx performance would not be impacted by the Tx configuration in NR FR2 TDD bands, the requirements in this test case can be well covered in clauses 7.6B.2.4 and 7.6B.2.4\_1, and don't need to be tested again.

### 7.6B.2.5 Inband blocking for inter-band EN-DC including both FR1 and FR2

#### 7.6B.2.5.1 Test purpose

Same test purpose as in clause 7.6.2.1 in TS 38.521-1 [8] for NR FR1 carrier and clause 7.6.2.1 in TS 38.521-2 [9] for NR FR2 carrier.

### 7.6B.2.5.2 Test applicability

The requirements in this test are not testable due to issues with combined testing of NR FR1 and E-UTRA in conducted mode with NR FR2 in radiated mode. Therefore, the conducted and radiated requirements are tested separately.

No test case details are specified. The EN-DC requirements for Inband blocking apply and are tested as part of the EN-DC within FR1 and EN-DC including FR2 test cases in clause 7.6B.2.

## 7.6B.2.5D Inband blocking for inter-band EN-DC including FR1 and FR2 for UL MIMO

### 7.6B.2.5D.1 Test purpose

Same test purpose as in clause 7.6D.2 in TS 38.521-1 [8] for NR FR1 carrier and clause 7.6D in TS 38.521-2 [9] for NR FR2 carrier.

### 7.6B.2.5D.2 Test applicability

The requirements in this test are not testable due to issues with combined testing of NR FR1 and E-UTRA in conducted mode with NR FR2 in radiated mode. Therefore, the conducted and radiated requirements are tested separately.

No test case details are specified. The EN-DC requirements for Inband blocking apply and are tested as part of the EN-DC within FR1 and EN-DC including FR2 test cases in clause 7.6B.2.

## 7.6B.3 Out-of-band blocking for DC

### 7.6B.3.0 Minimum Conformance Requirements

#### 7.6B.3.0.1 Intra-band contiguous EN-DC

Intra-band contiguous EN-DC out-of-band requirement and parameters are defined in Table 7.6B.3.0.1-1.

**Table 7.6B.3.0.1-1: Out-of-band blocking for intra-band contiguous EN-DC**

EN-DC Aggregated Bandwidth, MHz	≤100	>100, ≤120	>120, ≤140	>140, ≤160
Pw in Transmission Bandwidth Configuration, perCC, dBm	REFSENS + Aggregated BW specific value below			
	9			
NOTE 1: Interferer values and offsets are specified from Table 7.6.2.1A-2 in TS 36.101 [5]. For inter-band combinations where the intra-band requirements are applicable, in which the E-UTRA band is a subset of an NR-only band, the NR band interferer values and offsets specified from Table 7.6A.3-2 in TS 38.101-1 [2] apply to both E-UTRA and NR carriers.				
NOTE 2: For NR carrier, the transmitter shall be set to 4dB below $P_{\text{CMAX\_L,f,c,NR}}$ at the minimum uplink configuration specified in Table 7.3.2-3 [2] with $P_{\text{CMAX\_L,f,c,NR}}$ as defined in clause 6.2B.4.				
NOTE 3: For E-UTRA carrier, the transmitter shall be set to 29dB below $P_{\text{CMAX\_L\_E-UTRA,c}}$ at the minimum uplink configuration specified in Table 7.3.1-2 [5] with $P_{\text{CMAX\_L\_E-UTRA,c}}$ as defined in clause 6.2B.4 for single carrier.				

For Table 7.6.2.1A-2 from TS 36.101 [4] in frequency range 1, 2 and 3, up to  $\max(24,6 \cdot \lceil N_{RB} / 6 \rceil)$  exceptions are allowed for spurious response frequencies in each assigned frequency channel when measured using a 1MHz step size. For these exceptions the requirements of subclause 7.7B.1 Spurious response are applicable.

The normative reference for this requirement is TS 38.101-3 [4] clause 7.6B.3.1.

#### 7.6B.3.0.2 Intra-band non-contiguous EN-DC

For the E-UTRA sub-block containing one or multiple CC's, the requirement is defined in clause 7.6.2.1 for single carrier operation and in clause 7.6.2.1A for CA in TS 36.101 [5].

For the NR sub-block, the requirement is defined in clause 7.6.3 in TS 38.101-1 [2].

The normative reference for this requirement is TS 38.101-3 [4] clause 7.6B.3.2.

### 7.6B.3.0.3 Inter-band EN-DC within FR1

Out-of-band blocking requirements for E-UTRA single carrier and CA operation specified in clauses 7.6.2.1 and 7.6.2.1A of TS 36.101 [5] and for NR single carrier and CA operation specified in clauses 7.6.3 and 7.6A.3 of TS 38.101-1 [2] apply for lowest level EN-DC fallbacks (two bands) in clause 5.5B.4.1 with following conditions:

- one E-UTRA uplink carrier with the output power set to 4dB below  $P_{\text{CMAX\_L,c}}$  and the NR band whose downlink is being tested has its uplink carrier output power set to 29 dB below  $P_{\text{CMAX\_L,f,c}}$ .
- one NR uplink carrier with the output power set to 4dB below  $P_{\text{CMAX\_L,f,c}}$  on the NR band with both E-UTRA and NR downlinks being tested with E-UTRA output power set to 29 dB below  $P_{\text{CMAX\_L,c}}$ .

If CW interferer falls in a gap between  $F_{\text{DL\_high}}$  of the E-UTRA or NR band and  $F_{\text{DL\_low}}$  of the NR or EUTRA band, where the corresponding OOB ranges 1 and 2 overlap, then the lower level interferer limit of the overlapping OOB ranges applies.

If  $F_{\text{DL\_high}}$  of the lower E-UTRA or NR band is greater than or equal to the  $F_{\text{DL\_low}}$  of the upper NR or E-UTRA band as in overlapping RX frequency ranges, then the OOB range shall start from the  $F_{\text{DL\_low}}$  of the lower E-UTRA or NR band, and from the  $F_{\text{DL\_high}}$  of the upper NR or E-UTRA band.

For EN-DC combination listed in Table 7.6B.3.0.3-1 under the first test condition above, exceptions to the requirement specified in Table 7.6B.3.0.3-2 are allowed when the second order intermodulation product of the lower frequency band UL carrier and the CW interfering signal fully or partially overlaps with the higher frequency band DL carrier.

**Table 7.6B.3.0.3-1: EN-DC combination with exceptions allowed**

EN-DC combination
DC_5_n78
DC_8_n77
DC_8_n78
DC_11_n77
DC_18_n77
DC_18_n78
DC_18_n79
DC_19_n77
DC_19_n78
DC_19_n79
DC_20_n78
DC_21_n77
DC_26_n77
DC_26_n78
DC_26_n79
DC_28_n77
DC_28_n78
DC_28_n79

**Table 7.6B.3.0.3-2: Exceptions allowed**

Parameter	Unit	Level
$P_{\text{Interferer}}$ (CW)	dBm	-44 <sup>1</sup>
NOTE 1: The requirement applies when $ f_{\text{Interferer}} \pm f_{\text{UL}}^{\text{LB}} - f_{\text{DL}}^{\text{HB}}  \leq (BW_{\text{UL}}^{\text{LB}} + BW_{\text{DL}}^{\text{HB}})/2$ , where $f_{\text{UL}}^{\text{LB}}$ and $f_{\text{DL}}^{\text{HB}}$ are the carrier frequencies for lower frequency band UL and higher frequency band DL, respectively. $BW_{\text{UL}}^{\text{LB}}$ and $BW_{\text{DL}}^{\text{HB}}$ are the channel bandwidths configured for lower frequency band UL carrier and higher frequency band DL carrier in MHz, respectively.		

For each of the two test cases in clauses 7.6.2.1 and 7.6.2.1A of [5] and for NR single carrier and CA operation specified in clauses 7.6.3 and 7.6A.3 of TS 38.101-1 [2] for all interferer frequency ranges a maximum of

$$\lfloor \max \{24,6 \cdot \lceil n \cdot N_{\text{RB}} / 6 \rceil / \min \{ \lfloor n \cdot N_{\text{RB}} / 10 \rfloor, 5 \} \rfloor$$

exceptions are allowed for spurious response frequencies in each assigned frequency channel when measured using a step size of  $\min(\lfloor CBW / 2 \rfloor, 5)$  MHz with  $N_{\text{RB}}$  the number of resource blocks in the downlink transmission bandwidth configuration,  $CBW$  the bandwidth of the frequency channel in MHz and  $n = 1, 2, 3$  for SCS = 15, 30, 60 kHz, respectively. For these exceptions, the requirements in clause 7.7 apply.

The normative reference for this requirement is TS 38.101-3 [4] clause 7.6B.3.3.

#### 7.6B.3.0.3a Inter-band NE-DC within FR1

Out-of-band blocking requirements for E-UTRA single carrier and CA operation specified in clauses 7.6.2.1 and 7.6.2.1A of TS 36.101 [5] and for NR single carrier and CA operation specified in clauses 7.6.3 and 7.6A.3 of TS 38.101-1 [2] apply for lowest level NE-DC fallbacks (two bands) in clause 5.5B.4a.1 with following conditions:

- one E-UTRA uplink carrier with the output power set to 4 dB below  $P_{\text{CMAX\_L,c}}$  and the NR band whose downlink is being tested has its uplink carrier output power set to 29 dB below  $P_{\text{CMAX\_L,f,c}}$ .
- one NR uplink carrier with the output power set to 4 dB below  $P_{\text{CMAX\_L,f,c}}$  on the NR band with both E-UTRA and NR downlinks being tested with E-UTRA output power set to 29 dB below  $P_{\text{CMAX\_L,c}}$ .

The normative reference for this requirement is TS 38.101-3 [4] clause 7.6B.3.3a.

#### 7.6B.3.0.4 Inter-band EN-DC including FR2

Out-of-band blocking requirements specified for E-UTRA single carrier and CA operation specified in clauses 7.6.2.1 and 7.6.2.1A of TS 36.101 [5] apply for lowest level EN-DC fallbacks (two bands) in clause 5.5B.5.1 with only E-UTRA UL with output power as in TS 36.101 [5] (4dB below  $P_{\text{CMAX\_L}}$ ).

The normative reference for this requirement is TS 38.101-3 [4] clause 7.6B.3.4.

#### 7.6B.3.0.5 Inter-band EN-DC including both FR1 and FR2

Out-of-band blocking requirements specified for E-UTRA single carrier and CA operation specified in clauses 7.6.2.1 and 7.6.2.1A of TS 36.101 [5] and for NR single carrier and CA operation specified in clauses 7.6.3 and 7.6A.3 of TS 38.101-1 [2] apply for lowest level EN-DC fallbacks (three bands) in clause 5.5B.6.2 with only E-UTRA UL with output power as in TS 36.101 [5] (4dB below  $P_{\text{CMAX\_L}}$ ).

The normative reference for this requirement is TS 38.101-3 [4] clause 7.6B.3.5.

### 7.6B.3.1 Out-of-band blocking for intra-band contiguous EN-DC (2 CCs)

#### 7.6B.3.1.1 Test Purpose

Out-of-band band blocking is defined for an unwanted CW interfering signal falling more than 15 MHz below or above the UE receive band, at which a given average throughput shall meet or exceed the requirement for the specified measurement channels.

For the first 15 MHz below or above the UE receive band the appropriate in-band blocking or adjacent channel selectivity in clause 7.6B.2.1 and clause 7.5B.1 shall be applied.

The lack of out-of-band blocking ability will decrease the coverage area when other NodeB transmitters exist (except in the adjacent channels and spurious response).

#### 7.6B.3.1.2 Test Applicability

This test case applies to all types of E-UTRA UE release 15 and forward, supporting intra-band contiguous EN-DC in FR1 with 2 DL CCs.

#### 7.6B.3.1.3 Minimum Conformance Requirements

The minimum conformance requirements are defined in clause 7.6B.3.0.1.

Exception requirements for both NR and E-UTRA are defined for this test and therefore LTE anchor agnostic approach is not applied. E-UTRA test point analysis is included and E-UTRA measurements are performed.

#### 7.6B.3.1.4 Test Description

##### 7.6B.3.1.4.1 Initial condition

Initial conditions are a set of test configurations the UE needs to be tested in and the steps for the SS to take with the UE to reach the correct measurement state.

The initial test configurations consist of environmental conditions, test frequencies and channel bandwidths based on EN-DC operating bands specified in clause 5.3B.1.2, channel bandwidths and sub-carrier spacings for the NR cell specified in TS 38.521-1 [8] clause 5.3 and channel bandwidth for the E-UTRA cell are specified in TS 36.521-1 [10] clause 5.4.2. All of these configurations shall be tested with applicable test parameters for each EN-DC configuration specified in clause 5.3B.1.2 and are shown in Table 7.6B.3.1.4.1-1. The details of the uplink and downlink reference measurement channels (RMCs) are specified in Annex A.2 and A.3 respectively. The details of the OCNG patterns used are specified in TS 36.521-1 [10] Annex A.5 and in TS 38.521-1 [8] Annex A.5 for E-UTRA CG and NR CG respectively. Configurations of PDSCH and PDCCH before measurement are specified in TS 36.521-1 [10] Annex C.2 and in TS 38.521-1 [8] Annex C.2 for E-UTRA CG and NR CG respectively.



Table 7.6B.3.1.4.1-1: Test configuration table

Initial Conditions							
Test Environment as specified in TS 38.508-1 [6] clause 4.1				Normal			
Test Frequencies as specified in TS 38.508-1 [6] clause 4.3.1 for different EN-DC bandwidth classes				Mid range			
Test EN-DC bandwidth combination as specified in Table 5.3B.1.2-1 across bandwidth combination sets supported by the UE				Highest $N_{RB\_agg}$ (NOTE 3)			
NR Test SCS as specified in Table 5.3.5-1 in TS 38.521-1 [8]				Lowest			
NR/E-UTRA Test Parameters							
Downlink Configuration				Uplink Configuration			
NR Modulation	NR RB allocation	E-UTRA Modulation	E-UTRA RB allocation	NR Modulation	NR RB allocation	E-UTRA Modulation	E-UTRA RB allocation
CP-OFDM QPSK	Full RB (NOTE 1)	QPSK	Full RB	DFT-s-OFDM QPSK	REFSENS_NR	QPSK	REFSENS_LTE
NOTE 1: Full RB allocation shall be used per each SCS and channel BW as specified in Table 7.3.2.4.1-2 of TS 38.521-1 [8].							
NOTE 2: Test Channel Bandwidths are checked separately for each EN-DC band, which applicable channel bandwidths are specified in Table 5.3B.1.2-1.							
NOTE 3: If the UE supports multiple CC Combinations in the EN-DC Configuration with the same $N_{RB\_agg}$ , only the combination with the highest $N_{RB\_SCG}$ is tested.							
NOTE 4: REFSENS_NR and REFSENS_LTE refers to Uplink configuration in Table 7.3.2.4.1-3 in 38.521-1 [8] and Table 7.3.4.1-1 in 36.521 [10] for NR and E-UTRA CC respectively.							
NOTE 5: In an E-UTRA band or FR1 band where UE supports 4Rx, the test shall be performed only with 4Rx antennas ports connected and 4Rx REFSENS requirement (TS 38.521-1 [8] Table 7.3.2.5-2) is used in the test requirements.							

1. Connect the SS to the UE antenna connectors as shown in [6] TS 38.508-1 Annex A, in Figure A.3.1.4.2 for SS diagram and clause A.3.2 for UE diagram.
2. The parameter settings for the cell are set up according to TS 38.508-1 [6] clause 4.4.3.
3. Downlink signals are initially set up according to TS 36.521-1 [10] Annex C and TS 38.521-1 [8] Annex C for E-UTRA CG and NR CG respectively, and uplink signals according to TS 36.521-1 [10] Annex H and TS 38.521-1 [8] Annex G for E-UTRA CG and NR CG respectively.
4. The UL and DL Reference Measurement channels are TS 36.521-1 [10] Annex A.2, A.3 and TS 38.521-1 [8] Annex A.2, A.3 for E-UTRA CG and NR CG respectively.
5. Propagation conditions are set according to TS 36.521-1 [10] Annex B.0 and TS 38.521-1 [8] Annex B.0 for E-UTRA CG and NR CG respectively.
6. Ensure the UE is in state RRC\_CONNECTED with generic procedure parameters Connectivity EN-DC, DC bearer MCG and SCG, Connected without release *On* according to TS 38.508-1 [6] clause 4.5. Message contents are defined in clause 7.6B.3.1.4.3.
7. When E-UTRA and NR bands are TDD, ensure the same uplink-downlink configuration by giving SCG a delay of 3 E-UTRA subframes, or by giving MCG a delay of 2 subframes.

#### 7.6B.3.1.4.2 Test procedure

1. SS transmits PDSCH via PDCCH DCI format 1A and PDCCH DCI format 1\_1 for C\_RNTI to transmit the DL RMC according to Table 7.6B.3.1.4.1-1 on E-UTRA CC and NR CC respectively. The SS sends downlink MAC padding bits on the DL RMC.
2. SS sends uplink scheduling information for each UL HARQ process via PDCCH DCI format 0 and DCI format 0\_1 for C\_RNTI to schedule the UL RMC according to Table 7.6B.3.1.4.1-1 on E-UTRA CC and NR CC respectively. Since the UL has no payload and no loopback data to send the UE sends uplink MAC padding bits on the UL RMC.

3. Set the Downlink signal level to the value as defined in Table 7.6B.3.1.5-1. For NR CC and E-UTRA CC, send uplink power control commands to the UE using 1dB power step size to ensure that the UE output power measured by the test system is within the Uplink power control window, defined as  $-(\text{MU} - \text{Uplink power control window size})$  dB of the target power level in Table 7.6B.3.1.5-1 for at least the duration of the Throughput measurement, where:
  - MU is the test system uplink power measurement uncertainty and is specified in Table F.1.3-1 for the carrier frequency  $f$  and the channel bandwidth BW
  - For NR CC, Uplink power control window size = 1dB (UE power step size) + 0.7dB (UE power step tolerance) + (Test system relative power measurement uncertainty), where, the UE power step tolerance is specified in TS 38.101-1 [2], Table 6.3.4.3-1 and is 0.7dB for 1dB power step size, and the Test system relative power measurement uncertainty is specified in Table F.1.2-1.
  - For E-UTRA CC, Uplink power control window size = 1dB (UE power step size) + 1.0dB (UE power step tolerance) + (Test system relative power measurement uncertainty), where, the UE power step tolerance is specified in TS 36.101 [5], Table 6.3.5.2.1-1 and is 1.0dB for 1dB power step size, and the Test system relative power measurement uncertainty is specified in Table F.1.2-1 of TS 36.521-1 [10].
4. Set the parameters of the CW signal generator for an interfering signal below the aggregated component carriers according to Table 7.6B.3.1.5-1. The frequency step size is 1MHz.
5. Measure the average throughput for a duration sufficient to achieve statistical significance according to Annex H.2 in TS 38.521-1 [8] for NR band, and Annex G.2 of TS 36.521-1 [10] for EUTRA band.
6. Record the frequencies for which the throughput doesn't meet the requirements.
7. Repeat steps from 4 to 6, using an interfering signal above the aggregated component carriers at step 4.

NOTE: The purpose of the Uplink power control window is to ensure that the actual UE output power is no greater than the target power level, and as close as possible to the target power level. The relationship between the Uplink power control window, the target power level and the corresponding possible actual UE Uplink power window is illustrated in Annex F, clause F.4.

#### 7.6B.3.1.4.3 Message contents

Message contents are according to TS 36.508 [11] clause 4.6.1 and TS 38.508-1 [6] clause 4.6 Table 4.6.3-118 with condition TRANSFORM\_PRECODER\_ENABLED with the following exceptions.

**Table 7.6B.3.1.4.3-1: PhysicalCellGroupConfig**

Derivation Path: TS 38.508-1 [6], Table 4.6.3-106			
Information Element	Value/remark	Comment	Condition
p-NR-FR1	20		Power Class 3 UE
	23		Power Class 2 UE

**Table 7.6B.3.1.4.3-2: RRCConnectionReconfiguration**

Derivation Path: TS 36.508 [11], Table 4.6.1-8			
Information Element	Value/remark	Comment	Condition
nonCriticalExtension SEQUENCE {		RRCConnectionReconfiguration-v1530-IEs	
p-MaxEUTRA-r15	20		Power Class 3 UE
	23		Power Class 2 UE
}			

#### 7.6B.3.1.5 Test Requirement

Except for the spurious response frequencies recorded in step 6 of test procedure, the throughput shall be  $\geq 95\%$  of the maximum throughput of the reference measurement channels as specified in TS 36.521-1 [10] Annex A.3 and

TS 38.521-1 [8] Annex A.3 for E-UTRA CG and NR CG respectively with parameters specified in Table 7.6B.3.1.5-1 for the specified wanted signal mean power in the presence of interfering signals.

The number of spurious response frequencies recorded in step 6 of test procedure shall not exceed  $\max(24,6 \cdot \lceil N_{RB} \cdot /6 \rceil)$  exceptions in each assigned frequency channel when measured using a 1MHz step size. For these exceptions the requirements of clause 7.7B Spurious Response are applicable.

**Table 7.6B.3.1.5-1: Out-of-band blocking for intra-band contiguous EN-DC**

EN-DC Aggregated Bandwidth, MHz	≤100	>100, ≤120	>120, ≤140	>140, ≤160
Pw in Transmission Bandwidth Configuration, perCC, dBm	REFSENS + Aggregated BW specific value below			
	9			
<p>NOTE 1: Interferer values and offsets are specified from Table 7.6.2.1A-2 in TS 36.101 [5]. For inter-band combinations where the intra-band requirements are applicable, in which the E-UTRA band is a subset of an NR-only band, the NR band interferer values and offsets specified from Table 7.6A.3-2 in TS 38.101-1 [2] apply to both E-UTRA and NR carriers.</p> <p>NOTE 2: For NR carrier, the transmitter shall be set to 4dB below <math>P_{\text{CMAX\_L,f,c,NR}}</math> at the minimum uplink configuration specified in Table 7.3.2-3 in TS 38.101-1 [2] with <math>P_{\text{CMAX\_L,f,c,NR}}</math> as defined in clause 6.2B.4.</p> <p>NOTE 3: For E-UTRA carrier, the transmitter shall be set to 29dB below <math>P_{\text{CMAX\_L\_E-UTRA,c}}</math> at the minimum uplink configuration specified in Table 7.3.1-2 in TS 36.101 [5] with <math>P_{\text{CMAX\_L\_E-UTRA,c}}</math> as defined in clause 6.2B.4 for single carrier.</p>				

**Table 7.6B.3.1.5-2: Void**

**Table 7.6B.3.1.5-3: Void**

## 7.6B.3.2 Out-of-band blocking for intra-band non-contiguous EN-DC (2 CCs)

### 7.6B.3.2.1 Test Purpose

Same test purpose as in clause 7.6.3.1 in TS 38.521-1 [8] for the NR carrier.

### 7.6B.3.2.2 Test Applicability

This test case applies to all types of E-UTRA UE release 15 and forward, supporting intra-band non-contiguous EN-DC in FR1 with 2 DL CCs.

### 7.6B.3.2.3 Minimum Conformance Requirements

The minimum conformance requirements are defined in clause 7.6B.3.0.2.

No exception requirements applicable to NR or E-UTRA. LTE anchor agnostic approach is applied.

### 7.6B.3.2.4 Test Description

Same test description as in clause 7.6.3.4 in TS 38.521-1 [8] for the NR carrier with the following exceptions:

**Table 7.6B.3.2.4-1: Test Configuration Table**

Initial Conditions	
Test Frequencies as specified in TS 38.508-1 [6] clause 4.3.1 for different EN-DC bandwidth classes	High range with maxWGap
Test EN-DC bandwidth combination as specified in Table 5.3B.1.2-1 across bandwidth combination sets supported by the UE	Highest $N_{RB\_agg}$ (NOTE 1)
NOTE 1: If the UE supports multiple CC Combinations in the EN-DC Configuration with the same $N_{RB\_agg}$ , only the combination with the highest $N_{RB\_SCG}$ is tested.	

The initial test configurations for E-UTRA consist of test frequency based on E-UTRA operating band and test channel bandwidth as specified in Table 4.6-1 except for the parameters specified in Table 7.6B.3.2.4-1.

For Initial conditions as in clause 7.6.3.4.1 in TS 38.521-1 [8], add step 2.1 and step 3.1 as follows:

- 2.1. The parameter settings for E-UTRA cell are set up according to TS 36.508 [11] clause 4.4.3.
- 3.1. The E-UTRA downlink signal level, uplink signal level are set according to Table 4.6-1 and propagation conditions are set according to Annex B.0 of TS 36.521-1 [10].

Step 6 of Initial conditions as in clause 7.6.3.4.1 in TS 38.521-1 [8] is replaced by:

6. Ensure the UE is in state RRC\_CONNECTED with generic procedure parameters Connectivity EN-DC, DC bearer MCG and SCG, Connected without release *On* according to TS 38.508 [6] clause 4.5.

Add steps 7 and 8 to Initial conditions in clause 7.6.3.4.1 in TS 38.521-1 [8] as follows:

7. On the E-UTRA carrier, disable periodic and aperiodic CQI reports, disable SRS, set *TimeAlignmentTimerDedicated* IE to infinity and disable downlink and uplink scheduling, all as per Table 4.6-1 under clause 4.6.
8. When E-UTRA and NR bands are TDD, ensure the same uplink-downlink configuration by giving SCG a delay of 3 E-UTRA subframes, or by giving MCG a delay of 2 subframes.

Step 4 of Test procedure as in clause 7.6.3.4.2 in TS 38.521-1 [8] is replaced by:

4. Set the downlink signal level for NR CC according to the Table 7.6.3.5-1 or 7.6.3.5-3 in TS 38.521-1 [8] as appropriate. For NR CC and E-UTRA CC, send uplink power control commands to the UE using 1dB power step size to ensure that the UE output power measured by the test system is within the Uplink power control window, defined as  $-(MU)$  to  $-(MU + \text{Uplink power control window size})$  dB of 4dB below  $P_{CMAX\_L,f,c}$  for NR CC for at least the duration of the Throughput measurement, where:
  - $MU$  is the test system uplink power measurement uncertainty and is specified in Table F.1.3-1 for the carrier frequency  $f$  and the channel bandwidth  $BW$
  - For NR CC, Uplink power control window size = 1dB (UE power step size) + 0.7dB (UE power step tolerance) + (Test system relative power measurement uncertainty), where, the UE power step tolerance is specified in TS 38.101-1 [2], Table 6.3.4.3-1 and is 0.7dB for 1dB power step size, and the Test system relative power measurement uncertainty is specified in Table F.1.2-1.

#### 7.6B.3.2.5 Test Requirement

Same test requirement as in clause 7.6.3.5 in TS 38.521-1 [8].

### 7.6B.3.3 Out-of-band blocking for inter-band EN-DC within FR1 (2 CCs)

#### 7.6B.3.3.1 Test Purpose

Out-of-band band blocking is defined for an unwanted CW interfering signal falling more than 15 MHz or  $3 \cdot CBW$  below or above the UE receive band, at which a given average throughput shall meet or exceed the requirement for the specified measurement channels.

For the first 15 MHz or 3\*CBW below or above the UE receive band the appropriate in-band blocking or adjacent channel selectivity in clause 7.6B.2.3 and clause 7.5B.3 shall be applied.

The lack of out-of-band blocking ability will decrease the coverage area when other NodeB transmitters exist (except in the adjacent channels and spurious response).

#### 7.6B.3.3.2 Test Applicability

This test case applies to all types of E-UTRA UE release 15 and forward, supporting inter-band EN-DC within FR1 with 2 DL CCs.

#### 7.6B.3.3.3 Minimum Conformance Requirements

The minimum conformance requirements are defined in clause 7.6B.3.0.3.

Exception requirements for both NR and E-UTRA are defined for this test and therefore LTE anchor agnostic approach is not applied. E-UTRA test point analysis is included and E-UTRA measurements are performed.

#### 7.6B.3.3.4 Test Description

##### 7.6B.3.3.4.1 Initial Conditions

Initial conditions are a set of test configurations the UE needs to be tested in and the steps for the SS to take with the UE to reach the correct measurement state.

The initial test configurations consist of environmental conditions, test frequencies, DC configuration specified in clause 5.5B.4 and test channel bandwidths specified in TS 36.508 [11] clause 4.3.1 and TS 38.508-1 [6] clause 4.3.1, and sub-carrier spacing based on NR operating bands specified in TS 38.521-1 [8] clause 5.3. All of these configurations shall be tested with applicable test parameters for each EN-DC configuration, and are shown in Table 7.6B.3.3.4.1-1. The details of the uplink and downlink reference measurement channels (RMCs) and OCNG patterns are specified in TS 36.521-1 [10] Annex A for E-UTRA, and TS 38.521-1 [8] Annex A for NR. Configurations of PDSCH and PDCCH before measurement are specified in TS 36.521-1 [10] Annex C and in TS 38.521-1 [8] Annex C for E-UTRA CG and NR CG respectively.

Table 7.6B.3.3.4.1-1: Test configuration table

Initial Conditions							
Test Environment as specified in TS 38.508-1 [6] clause 4.1				Normal			
NR Test Frequencies as specified in TS 38.508-1 [6] clause 4.3.1 E-UTRA Test Frequencies as specified in TS 36.508-1 [11] clause 4.3.1				Mid range for E-UTRA and Mid range for NR (NOTE 3)			
NR Test Channel Bandwidths as specified in TS 38.508-1 [6] clause 4.3.1 E-UTRA Test Channel Bandwidths as specified in TS 36.508 [11] clause 4.3.1				Highest for E-UTRA and Highest for NR			
NR Test SCS as specified in TS 38.508-1 [6] Table 5.3.5-1				Lowest			
Test Parameters							
Downlink Configuration				Uplink Configuration			
E-UTRA Cell		NR Cell		E-UTRA Cell		NR Cell	
Modulation	RB allocation	Modulation	RB allocation	Modulation	RB allocation	Modulation	RB allocation
QPSK	NOTE 1	CP-OFDM QPSK	NOTE 1	QPSK	NOTE 1	DFT-s-OFDM QPSK	NOTE 1
NOTE 1: The specific configuration of uplink and downlink are defined in Table 7.3B.2.3.4.2.1-1. NOTE 2: In an E-UTRA band or FR1 band where UE supports 4Rx, the test shall be performed only with 4Rx antennas ports connected and 4Rx REFSENS requirement (TS 38.521-1 [8] Table 7.3.2.5-2) is used in the test requirements. NOTE 3: For NR band n28, 30MHz test channel bandwidth is tested with Low range test frequency. NOTE 4: For band n28 / 28 used in EN-DC configurations with NOTE 8 of Table 5.5B.4.1-1, test channel bandwidth of 20MHz or more is tested with Low range test frequency.							

1. Connect the SS to the UE antenna connectors as shown in [6] TS 38.508-1 Annex A, in Figure A.3.1.4.2 for SS diagram and clause A.3.2 for UE diagram.
2. The parameter settings for the cell are set up according to TS 38.508-1 [6] clause 4.4.3.
3. Downlink signals are initially set up according to TS 36.521-1 [10] Annex C and TS 38.521-1 [8] Annex C for E-UTRA CG and NR CG respectively, and uplink signals according to TS 36.521-1 [10] Annex H and TS 38.521-1 [8] Annex G for E-UTRA CG and NR CG respectively.
4. The UL and DL Reference Measurement channels are TS 36.521-1 [10] Annex A.2, A.3 and TS 38.521-1 [8] Annex A.2 , A.3 for E-UTRA CG and NR CG respectively.
5. Propagation conditions are set according to TS 36.521-1 [10] Annex B.0 and TS 38.521-1 [8] Annex B.0 for E-UTRA CG and NR CG respectively.
6. Ensure the UE is in state RRC\_CONNECTED with generic procedure parameters Connectivity EN-DC, DC bearer MCG and SCG, Connected without release *On* according to TS 38.508-1 [6] clause 4.5. Message contents are defined in clause 7.6B.3.3.4.3.

#### 7.6B.3.3.4.2 Test procedure

1. SS transmits PDSCH via PDCCH DCI format 1A and PDCCH DCI format 1\_1 for C\_RNTI to transmit the DL RMC according to Table 7.6B.3.3.4.1-1 on E-UTRA CC and NR CC respectively. The SS sends downlink MAC padding bits on the DL RMC.
2. SS sends uplink scheduling information for each UL HARQ process via PDCCH DCI format 0 and DCI format 0\_1 for C\_RNTI to schedule the UL RMC according to Table 7.6B.3.3.4.1-1 on E-UTRA CC and NR CC respectively. Since the UL has no payload and no loopback data to send the UE sends uplink MAC padding bits on the UL RMC.
3. Set the Downlink signal level to the value as defined in Table 7.6B.3.3.5-1, Table 7.6B.3.3.5-3, or Table 7.6B.3.3.5-5 for E-UTRA CC and NR CC respectively. For NR CC and E-UTRA CC, send uplink power control commands to the UE using 1dB power step size to ensure that the UE output power measured by the test system is within the Uplink power control window, defined as -MU to -(MU + Uplink power control window size) dB

of ( $P_{\text{CMAX\_L,c}} - 4\text{dB}$ ) for E-UTRA CC, and of 29 dB below  $P_{\text{CMAX\_L,f,c}}$  for NR CC for at least the duration of the Throughput measurement, where:

- MU is the test system uplink power measurement uncertainty and is specified in Table F.1.3-1 for the carrier frequency  $f$  and the channel bandwidth BW
- For NR CC, Uplink power control window size = 1dB (UE power step size) + 0.7dB (UE power step tolerance) + (Test system relative power measurement uncertainty), where, the UE power step tolerance is specified in TS 38.101-1 [2], Table 6.3.4.3-1 and is 0.7dB for 1dB power step size, and the Test system relative power measurement uncertainty is specified in Table F.1.2-1.
- For E-UTRA CC, Uplink power control window size = 1dB (UE power step size) + 1.0dB (UE power step tolerance) + (Test system relative power measurement uncertainty), where, the UE power step tolerance is specified in TS 36.101 [5], Table 6.3.5.2.1-1 and is 1.0dB for 1dB power step size, and the Test system relative power measurement uncertainty is specified in Table F.1.2-1 of TS 36.521-1 [10].

4. Set the parameters of the CW signal generator for an interfering signal below the aggregated component carriers according to Table 7.6B.3.3.5-4 or Table 7.6B.3.3.5-6. The frequency step size is  $\min(\lfloor CBW / 2 \rfloor, 5)$  MHz.

If CW interferer falls in a gap between  $F_{\text{DL\_high}}$  of the E-UTRA or NR band and  $F_{\text{DL\_low}}$  of the NR or EUTRA band, where the corresponding OOB ranges 1 and 2 in Table 7.6B.3.3.5-2 and Table 7.6B.3.3.5-4 or Table 7.6B.3.3.5-6 overlap, then the lower level interferer limit of the overlapping OOB ranges applies. CW interferer is eliminated from  $F_{\text{DL\_low}} - 15\text{MHz}$  to  $F_{\text{DL\_high}} + 15\text{MHz}$  of E-UTRA carrier.

If  $F_{\text{DL\_high}}$  of the lower E-UTRA or NR band is greater than or equal to the  $F_{\text{DL\_low}}$  of the upper NR or E-UTRA band as in overlapping RX frequency ranges, then the OOB range shall start from the  $F_{\text{DL\_low}}$  of the lower E-UTRA or NR band, and from the  $F_{\text{DL\_high}}$  of the upper NR or E-UTRA band.

For EN-DC combination listed in Table 7.6B.3.3.5-7, exceptions to the requirement specified in Table 7.6B.3.3.5-8 are allowed when the second order intermodulation product of the lower frequency band UL carrier and the CW interfering signal fully or partially overlaps with the higher frequency band DL carrier.

5. Measure the average throughput of NR CC for a duration sufficient to achieve statistical significance according to Annex H.2. Record the frequencies for which the throughput doesn't meet the requirements.
6. Repeat steps from 4 to 5, using an interfering signal above the aggregated component carriers at step 4.
7. Set the Downlink signal level to the value as defined in Table 7.6B.3.3.5-1, Table 7.6B.3.3.5-3, or Table 7.6B.3.3.5-5 for E-UTRA CC and NR CC respectively. For NR CC and E-UTRA CC, send uplink power control commands to the UE using 1dB power step size to ensure that the UE output power measured by the test system is within the Uplink power control window, defined as  $-(\text{MU} + \text{Uplink power control window size})$  dB of ( $P_{\text{CMAX\_L,f,c}} - 4\text{dB}$ ) for NR CC, and of 29 dB below  $P_{\text{CMAX\_L,c}}$  for E-UTRA CC for at least the duration of the Throughput measurement, where:

- MU is the test system uplink power measurement uncertainty and is specified in Table F.1.3-1 for the carrier frequency  $f$  and the channel bandwidth BW
- For NR CC, Uplink power control window size = 1dB (UE power step size) + 0.7dB (UE power step tolerance) + (Test system relative power measurement uncertainty), where, the UE power step tolerance is specified in TS 38.101-1 [2], Table 6.3.4.3-1 and is 0.7dB for 1dB power step size, and the Test system relative power measurement uncertainty is specified in Table F.1.2-1.
- For E-UTRA CC, Uplink power control window size = 1dB (UE power step size) + 1.0dB (UE power step tolerance) + (Test system relative power measurement uncertainty), where, the UE power step tolerance is specified in TS 36.101 [5], Table 6.3.5.2.1-1 and is 1.0dB for 1dB power step size, and the Test system relative power measurement uncertainty is specified in Table F.1.2-1 of TS 36.521-1 [10].

8. Set the parameters of the CW signal generator for an interfering signal below the aggregated component carriers according to Table 7.6B.3.3.5-2, Table 7.6B.3.3.5-4 or Table 7.6B.3.3.5-6 for E-UTRA CC and NR CC testing respectively. The frequency step size is  $\min(\lfloor CBW / 2 \rfloor, 5)$  MHz.

If CW interferer falls in a gap between  $F_{\text{DL\_high}}$  of the E-UTRA or NR band and  $F_{\text{DL\_low}}$  of the NR or EUTRA band, where the corresponding OOB ranges 1 and 2 in Table 7.6B.3.3.5-2 and Table 7.6B.3.3.5-4 or Table

7.6B.3.3.5-6 overlap, then the lower level interferer limit of the overlapping OOB ranges applies. CW interferer is eliminated from  $F_{DL\_low} - 15\text{MHz}$  to  $F_{DL\_high} + 15\text{MHz}$  of E-UTRA and NR carriers.

If  $F_{DL\_high}$  of the lower E-UTRA or NR band is greater than or equal to the  $F_{DL\_low}$  of the upper NR or E-UTRA band as in overlapping RX frequency ranges, then the OOB range shall start from the  $F_{DL\_low}$  of the lower E-UTRA or NR band, and from the  $F_{DL\_high}$  of the upper NR or E-UTRA band.

9. Measure the average throughput of E-UTRA CC and NR CC respectively for a duration sufficient to achieve statistical significance according to Annex H.2. Record the frequencies for which the throughput doesn't meet the requirements.

10. Repeat steps from 8 to 9, using an interfering signal above the aggregated component carriers at step 8.

NOTE: The purpose of the Uplink power control window is to ensure that the actual UE output power is no greater than the target power level, and as close as possible to the target power level. The relationship between the Uplink power control window, the target power level and the corresponding possible actual UE Uplink power window is illustrated in Annex F, clause F.4.

#### 7.6B.3.3.4.3 Message contents

Message contents are according to TS 36.508 [11] clause 4.6.1 and TS 38.508-1 [6] clause 4.6 with the following exceptions.

**Table 7.6B.3.3.4.3-1: PhysicalCellGroupConfig**

Derivation Path: TS 38.508-1 [6], Table 4.6.3-106			
Information Element	Value/remark	Comment	Condition
p-NR-FR1	20		Power Class 3 UE
	23		Power Class 2 UE

**Table 7.6B.3.3.4.3-2: RRCConnectionReconfiguration**

Derivation Path: TS 36.508 [11], Table 4.6.1-8			
Information Element	Value/remark	Comment	Condition
p-MaxEUTRA-r15	20		Power Class 3 UE
	23		Power Class 2 UE

#### 7.6B.3.3.5 Test Requirement

For E-UTRA bands, except for the spurious response frequencies recorded in test procedure, the throughput measurement derived in test procedure shall be  $\geq 95\%$  of the maximum throughput of the reference measurement channels as specified in Annex A.3.2 of TS 36.521-1 [10] with parameters specified in Tables 7.6B.3.3.5-1 and 7.6B.3.3.5-2.

For NR bands with  $F_{DL\_high} < 2700\text{ MHz}$  and  $F_{UL\_high} < 2700\text{ MHz}$ , except for the spurious response frequencies recorded in test procedure, the throughput measurement derived in test procedure shall be  $\geq 95\%$  of the maximum throughput of the reference measurement channels as specified in Annex A.3.2 and A.3.3 of TS 38.521-1 [8] with parameters specified in Tables 7.6B.3.3.5-3 and 7.6B.3.3.5-4.

For NR bands with  $F_{DL\_low} \geq 3300\text{ MHz}$  and  $F_{UL\_low} \geq 3300\text{ MHz}$ , except for the spurious response frequencies recorded in test procedure, the throughput measurement derived in test procedure shall be  $\geq 95\%$  of the maximum throughput of the reference measurement channels as specified in Annex A.3.2 and A.3.3 of TS 38.521-1 [8] with parameters specified in Tables 7.6B.3.3.5-5 and 7.6B.3.3.5-6.

If CW interferer falls in a gap between  $F_{DL\_high}$  of the E-UTRA or NR band and  $F_{DL\_low}$  of the NR or EUTRA band, where the corresponding OOB ranges 1 and 2 in Table 7.6B.3.3.5-2 and Table 7.6B.3.3.5-4 or Table 7.6B.3.3.5-6 overlap, then the lower level interferer limit of the overlapping OOB ranges applies.



If  $F_{DL\_high}$  of the lower E-UTRA or NR band is greater than or equal to the  $F_{DL\_low}$  of the upper NR or E-UTRA band as in overlapping RX frequency ranges, then the OOB range shall start from the  $F_{DL\_low}$  of the lower E-UTRA or NR band, and from the  $F_{DL\_high}$  of the upper NR or E-UTRA band.

For EN-DC combination listed in Table 7.6B.3.3.5-7 under the first test condition above, exceptions to the requirement specified in Table 7.6B.3.3.5-8 are allowed when the second order intermodulation product of the lower frequency band UL carrier and the CW interfering signal fully or partially overlaps with the higher frequency band DL carrier.

For all interferer frequency ranges a maximum of

$$\lfloor \max \{24,6 \cdot \lceil n \cdot N_{RB} / 6 \rceil \} / \min \{ \lfloor n \cdot N_{RB} / 10 \rfloor, 5 \} \rfloor$$

exceptions are allowed for spurious response frequencies in each assigned frequency channel when measured using a step size of  $\min(\lfloor CBW / 2 \rfloor, 5)$  MHz with  $N_{RB}$  the number of resource blocks in the downlink transmission bandwidth configuration,  $CBW$  the bandwidth of the frequency channel in MHz and  $n = 1, 2, 3$  for SCS = 15, 30, 60 kHz, respectively. For these exceptions, the requirements in clause 7.7B.3 apply.

**Table 7.6B.3.3.5-1: Out-of-band blocking parameters for E-UTRA bands**

Rx Parameter	Units	Channel bandwidth					
		1.4 MHz	3 MHz	5 MHz	10 MHz	15 MHz	20 MHz
Power in Transmission Bandwidth Configuration	dBm	REFSENS + channel bandwidth specific value below					
		6	6	6	6	7	9
Note 1: The reference measurement channel is specified in Annex A.3.2 of TS 36.521-1 [10] with one sided dynamic OCNG Pattern OP.1 FDD/TDD as described in Annex A.5.1.1/A.5.2.1 of TS 36.521-1 [10]. Note 2: The REFSENS power level is specified in Table 7.3.3-1 of TS 36.521-1 [10] for two and four antenna ports, respectively.							

**Table 7.6B.3.3.5-2: Out of band blocking for E-UTRA bands**

E-UTRA band	Parameter	Units	Frequency			
			range 1	range 2	range 3	range 4
	$P_{Interferer}$	dBm	-44	-30	-15	-15
1, 2, 3, 4, 5, 6, 7, 8, 9, 10, 11, 12, 13, 14, 17, 18, 19, 20, 21, 22, 23, 24, 25, 26, 27, 28, 30, 31, 33, 34, 35, 36, 37, 38, 39, 40, 41, 42 (Note 3), 43 (Note 3), 44, 45, 53, 65, 66, 68, 70, 71, 72, 73, 74	$F_{Interferer}$ (CW)	MHz	$F_{DL\_low} -15$ to $F_{DL\_low} -60$	$F_{DL\_low} -60$ to $F_{DL\_low} -85$	$F_{DL\_low} -85$ to 1 MHz	-
			$F_{DL\_high} +15$ to $F_{DL\_high} +60$	$F_{DL\_high} +60$ to $F_{DL\_high} +85$	$F_{DL\_high} +85$ to +12750 MHz	-
2, 5, 12, 17	$F_{Interferer}$	MHz	-	-	-	$F_{UL\_low} - F_{UL\_high}$
Note 1: Range 3 shall be tested only with the highest channel bandwidth. Note 2: For the UE which supports both Band 11 and Band 21 the out of blocking is FFS. Note 3: The power level of the interferer ( $P_{Interferer}$ ) for Range 3 shall be modified to -20 dBm for $F_{Interferer} > 2800$ MHz and $F_{Interferer} < 4400$ MHz. Note 4: For the UE that supports both Band 4 and Band 66, the out-of-blocking frequency range for Band 4 is defined relative to $F_{DL\_low}$ and $F_{DL\_high}$ of Band 66.						

**Table 7.6B.3.3.5-3: Out-of-band blocking parameters for NR bands with  $F_{DL\_high} < 2700$  MHz and  $F_{UL\_high} < 2700$  MHz**

RX parameter	Units	Channel bandwidth				
		5 MHz	10 MHz	15 MHz	20 MHz	25 MHz
Power in transmission bandwidth configuration	dBm	REFSENS + channel bandwidth specific value below				
	dB	6	6	7	9	10
RX parameter	Units	Channel bandwidth				
		30 MHz	40 MHz	50 MHz	60 MHz	80 MHz
Power in transmission bandwidth configuration	dBm	REFSENS + channel bandwidth specific value below				
	dB	11	12	13	14	15
RX parameter	Units	Channel bandwidth				
		90 MHz	100 MHz			
Power in transmission bandwidth configuration	dBm	REFSENS + channel bandwidth specific value below				
	dB	15.5	16			
NOTE: The transmitter shall be at the minimum UL configuration specified in Table 7.3.2.3-3 of TS 38.521-1 [8].						

**Table 7.6B.3.3.5-4: Out of-band blocking for NR bands with  $F_{DL\_high} < 2700$  MHz and  $F_{UL\_high} < 2700$  MHz**

NR band	Parameter	Unit	Range 1	Range 2	Range 3
n1, n2, n3, n5, n7, n8, n12, n20, n25, n28, n34, n38, n39, n40, n41, n50, n51, n65, n66, n70, n71, n74, n75, n76	$P_{interferer}$	dBm	-44	-30	-15
	$F_{interferer}$ (CW)	MHz	$-60 < f - F_{DL\_low} < -15$ or $15 < f - F_{DL\_high} < 60$	$-85 < f - F_{DL\_low} \leq -60$ or $60 \leq f - F_{DL\_high} < 85$	$1 \leq f \leq F_{DL\_low} - 85$ or $F_{DL\_high} + 85 \leq f \leq 12750$
NOTE 1: The power level of the interferer ( $P_{interferer}$ ) for Range 3 shall be modified to -20 dBm for $F_{interferer} > 6000$ MHz.					
NOTE 2: For band 51 the $F_{DL\_high}$ of band 50 is applied as $F_{DL\_high}$ for band 51. For band 50, the $F_{DL\_low}$ of band 51 is applied as $F_{DL\_low}$ for band 50.					
NOTE 3: For band 76 the $F_{DL\_high}$ of band 75 is applied as $F_{DL\_high}$ for band 76. For band 75, the $F_{DL\_low}$ of band 76 is applied as $F_{DL\_low}$ for band 75.					
NOTE 4: For UEs supporting both bands 38 and 41, the $F_{DL\_high}$ and $F_{DL\_low}$ of band 41 is applied as $F_{DL\_high}$ and $F_{DL\_low}$ for band 38.					

**Table 7.6B.3.3.5-5: Out-of-band blocking parameters for NR bands with  $F_{DL\_low} \geq 3300$  MHz and  $F_{UL\_low} \geq 3300$  MHz**

RX parameter	Units	Channel bandwidth				
		10 MHz	15 MHz	20 MHz	40 MHz	50 MHz
Power in transmission bandwidth configuration	dBm	REFSENS + channel bandwidth specific value below				
	dB	6	7	9	9	9
RX parameter	Units	Channel bandwidth				
		60 MHz	80 MHz	90 MHz	100 MHz	
Power in transmission bandwidth configuration	dBm	REFSENS + channel bandwidth specific value below				
	dB	9	9	9	9	
NOTE: The transmitter shall be at the minimum UL configuration specified in Table 7.3.2.3-3 of TS 38.521-1 [8].						

**Table 7.6B.3.3.5-6: Out of-band blocking for NR bands with  $F_{DL\_low} \geq 3300$  MHz and  $F_{UL\_low} \geq 3300$  MHz**

NR band	Parameter	Unit	Range1	Range 2	Range 3
n77, n78 (NOTE 3)	$P_{interferer}$	dBm	-44	-30	-15
	$F_{interferer}$ (CW)	MHz	$-60 < f - F_{DL\_low} \leq -3CBW$ or $3CBW \leq f - F_{DL\_high} < 60$	$-200 < f - F_{DL\_low} \leq -MAX(60,3CBW)$ or $MAX(60,3CBW) \leq f - F_{DL\_high} < 200$	$1 \leq f \leq F_{DL\_low} - MAX(200,3CBW)$ or $F_{DL\_high} + MAX(200,3CBW) \leq f \leq 12750$
n79 (NOTE 4)	$F_{interferer}$ (CW)	MHz	N/A	$-150 < f - F_{DL\_low} \leq -MAX(60,3CBW)$ or $MAX(60,3CBW) \leq f - F_{DL\_high} < 150$	$1 \leq f \leq F_{DL\_low} - MAX(150,3CBW)$ or $F_{DL\_high} + MAX(150,3CBW) \leq f \leq 12750$
<p>NOTE 1: The power level of the interferer (<math>P_{interferer}</math>) for Range 3 shall be modified to -20 dBm for <math>F_{interferer} &gt; 6000</math> MHz.</p> <p>NOTE 2: CBW denotes the channel bandwidth of the wanted signal</p> <p>NOTE 3: The power level of the interferer (<math>P_{interferer}</math>) for Range 3 shall be modified to -20 dBm, for <math>F_{interferer} &gt; 2700</math> MHz and <math>F_{interferer} &lt; 4800</math> MHz. For <math>CBW &gt; 15</math> MHz, the requirement for Range 1 is not applicable and Range 2 applies from the frequency offset of 3CBW from the band edge. For CBW larger than 60 MHz, the requirement for Range 2 is not applicable and Range 3 applies from the frequency offset of 3CBW from the band edge.</p> <p>NOTE 4: The power level of the interferer (<math>P_{interferer}</math>) for Range 3 shall be modified to -20 dBm, for <math>F_{interferer} &gt; 3650</math> MHz and <math>F_{interferer} &lt; 5750</math> MHz. For <math>CBW \geq 40</math> MHz, the requirement for Range 2 is not applicable and Range 3 applies from the frequency offset of 3CBW from the band edge.</p>					

**Table 7.6B.3.3.5-7: EN-DC combination with exceptions allowed**

EN-DC combination
DC_5_n78
DC_8_n77
DC_8_n78
DC_11_n77
DC_18_n77
DC_18_n78
DC_18_n79
DC_19_n77
DC_19_n78
DC_19_n79
DC_20_n78
DC_21_n77
DC_26_n77
DC_26_n78
DC_26_n79
DC_28_n77
DC_28_n78
DC_28_n79

Table 7.6B.3.3.5-8: Exceptions allowed

Parameter	Unit	Level
$P_{\text{Interferer}}$ (CW)	dBm	-44 <sup>1</sup>
NOTE 1: The requirement applies when $ f_{\text{interferer}} \pm f_{\text{UL}} - f_{\text{DL}}  \leq (BW_{\text{UL}} + BW_{\text{DL}})/2$ , where $f_{\text{UL}}$ and $f_{\text{DL}}$ are the carrier frequencies for lower frequency band UL and higher frequency band DL, respectively. $BW_{\text{UL}}$ and $BW_{\text{DL}}$ are the channel bandwidths configured for lower frequency band UL carrier and higher frequency band DL carrier in MHz, respectively.		

### 7.6B.3.3\_1 Out-of-band blocking for EN-DC within FR1 (>2 CCs)

#### 7.6B.3.3\_1.1 Out-of-band blocking for EN-DC within FR1 (3 CCs)

##### 7.6B.3.3\_1.1.1 Test Purpose

Out-of-band band blocking is defined for an unwanted CW interfering signal falling more than 15 MHz below or above the UE receive band, at which a given average throughput shall meet or exceed the requirement for the specified measurement channels.

For the first 15 MHz below or above the UE receive band the appropriate in-band blocking or adjacent channel selectivity in clause 7.6B.2.1 and clause 7.5B.1 shall be applied.

The lack of out-of-band blocking ability will decrease the coverage area when other NodeB transmitters exist (except in the adjacent channels and spurious response).

##### 7.6B.3.3\_1.1.2 Test Applicability

This test case applies to all types of E-UTRA UE release 15 and forward, supporting intra-band contiguous EN-DC within FR1 with 3 DL CCs.

##### 7.6B.3.3\_1.1.3 Minimum Conformance Requirements

The minimum conformance requirements are defined in clause 7.6B.3.0.1.

Exception requirements for both NR and E-UTRA are defined for this test and therefore LTE anchor agnostic approach is not applied. E-UTRA test point analysis is included and E-UTRA measurements are performed.

##### 7.6B.3.3\_1.1.4 Test Description

###### 7.6B.3.3\_1.1.4.1 Initial condition

Initial conditions are a set of test configurations the UE needs to be tested in and the steps for the SS to take with the UE to reach the correct measurement state.

The initial test configurations consist of environmental conditions, test frequencies and channel bandwidths based on EN-DC operating bands specified in clause 5.3B.1.2, channel bandwidths and sub-carrier spacings for the NR cell specified in TS 38.521-1 [8] clause 5.3 and channel bandwidth for the E-UTRA cell are specified in TS 36.521-1 [10] clause 5.4.2. All of these configurations shall be tested with applicable test parameters for each EN-DC configuration specified in clause 5.3B.1.2 and are shown in Table 7.6B.3.3\_1.1.4.1-1. The details of the uplink and downlink reference measurement channels (RMCs) are specified in Annex A.2 and A.3 respectively. The details of the OCN patterns used are specified in TS 36.521-1 [10] Annex A.5 and in TS 38.521-1 [8] Annex A.5 for E-UTRA CG and NR CG respectively. Configurations of PDSCH and PDCCH before measurement are specified in TS 36.521-1 [10] Annex C.2 and in TS 38.521-1 [8] Annex C.2 for E-UTRA CG and NR CG respectively.

Table 7.6B.3.3\_1.1.4.1-1: Test configuration table

Initial Conditions					
Test Environment as specified in TS 38.508-1 [6] clause 4.1			Normal		
Test Frequencies as specified in TS 38.508-1 [6] clause 4.3.1 for different EN-DC bandwidth classes			Mid range		
Test EN-DC bandwidth combination as specified in Table 5.3B.1.2-1 across bandwidth combination sets supported by the UE			Highest $N_{RB\_agg}$ (NOTE 3)		
NR Test SCS as specified in Table 5.3.5-1 in TS 38.521-1 [8]			Lowest		
NR/E-UTRA Test Parameters					
PCC – E-UTRA		SCC – EUTRA		NR	
UL/DL Modulation	UL/DL allocation	UL/DL Modulation	UL/DL allocation	UL/DL Modulation	UL/DL allocation
QPSK/QPSK	REFSENS/Full RB	NA/QPSK	NA/Full RB	DFT-s-OFDM QPSK/CP-OFDM QPSK	REFSENS/Full RB (NOTE 1)
NOTE 1: Full RB allocation shall be used per each SCS and channel BW as specified in Table 7.3.2.4.1-2 of TS 38.521-1 [8].					
NOTE 2: Test Channel Bandwidths are checked separately for each EN-DC band, which applicable channel bandwidths are specified in Table 5.3B.1.2-1.					
NOTE 3: If the UE supports multiple CC Combinations in the EN-DC Configuration with the same $N_{RB\_agg}$ , only the combination with the highest $N_{RB\_SCG}$ is tested.					
NOTE 4: REFSENS refers to Uplink configuration in Table 7.3.2.3-3 in [8] and Table 7.3.3-2 in [10] for NR and E-UTRA CC respectively.					
NOTE 5: In an E-UTRA band or FR1 band where UE supports 4Rx, the test shall be performed only with 4Rx antennas ports connected and 4Rx REFSENS requirement (TS 38.521-1 [8] Table 7.3.2.5-2) is used in the test requirements.					

1. Connect the SS to the UE antenna connectors as shown in [6] TS 38.508-1 Annex A, in Figure A.3.1.4.2 for SS diagram and clause A.3.2 for UE diagram.
2. The parameter settings for the cell are set up according to TS 38.508-1 [6] clause 4.4.3.
3. Downlink signals are initially set up according to TS 36.521-1 [10] Annex C and TS 38.521-1 [8] Annex C for E-UTRA CG and NR CG respectively, and uplink signals according to TS 36.521-1 [10] Annex H and TS 38.521-1 [8] Annex G for E-UTRA CG and NR CG respectively.
4. The UL and DL Reference Measurement channels are TS 36.521-1 [10] Annex A.2, A.3 and TS 38.521-1 [8] Annex A.2, A.3 for E-UTRA CG and NR CG respectively.
5. Propagation conditions are set according to TS 36.521-1 [10] Annex B.0 and TS 38.521-1 [8] Annex B.0 for E-UTRA CG and NR CG respectively.
6. Ensure the UE is in state RRC\_CONNECTED with generic procedure parameters Connectivity EN-DC, DC bearer MCG and SCG, Connected without release *On* according to TS 38.508-1 [6] clause 4.5. Message contents are defined in clause 7.6B.3.3\_1.1.4.3.

#### 7.6B.3.3\_1.1.4.2 Test procedure

1. SS transmits PDSCH via PDCCH DCI format 1A and PDCCH DCI format 1\_1 for C\_RNTI to transmit the DL RMC according to Table 7.6B.3.3\_1.1.4.1-1 on E-UTRA CC and NR CC respectively. The SS sends downlink MAC padding bits on the DL RMC.
2. SS sends uplink scheduling information for each UL HARQ process via PDCCH DCI format 0 and DCI format 0\_1 for C\_RNTI to schedule the UL RMC according to Table 7.6B.3.3\_1.1.4.1-1 on E-UTRA CC and NR CC respectively. Since the UL has no payload and no loopback data to send the UE sends uplink MAC padding bits on the UL RMC.

3. Set the Downlink signal level to the value as defined in Table 7.6B.3.3\_1.1.5-1. For NR CC and E-UTRA CC, send uplink power control commands to the UE using 1dB power step size to ensure that the UE output power measured by the test system is within the Uplink power control window, defined as  $-(\text{MU} + \text{Uplink power control window size})$  dB of the target power level in Table 7.6B.3.3\_1.1.5-1  $+( [10\log(S_{\text{L\_CRB}}/N_{\text{RB\_alloc}})]$  for NR CC,  $[10\log(P_{\text{L\_CRB}}/N_{\text{RB\_alloc}})]$  for E-UTRA CC) for at least the duration of the Throughput measurement, where:
  - MU is the test system uplink power measurement uncertainty and is specified in Table F.1.3-1 for the carrier frequency  $f$  and the channel bandwidth BW
  - For NR CC, Uplink power control window size = 1dB (UE power step size) + 0.7dB (UE power step tolerance) + (Test system relative power measurement uncertainty), where, the UE power step tolerance is specified in TS 38.101-1 [2], Table 6.3.4.3-1 and is 0.7dB for 1dB power step size, and the Test system relative power measurement uncertainty is specified in Table F.1.2-1.
  - For E-UTRA CC, Uplink power control window size = 1dB (UE power step size) + 1.0dB (UE power step tolerance) + (Test system relative power measurement uncertainty), where, the UE power step tolerance is specified in TS 36.101 [5], Table 6.3.5.2.1-1 and is 1.0dB for 1dB power step size, and the Test system relative power measurement uncertainty is specified in Table F.1.2-1 of TS 36.521-1 [10].
4. Set the parameters of the CW signal generator for an interfering signal below the aggregated component carriers according to Table 7.6B.3.3\_1.1.5-1. The frequency step size is 1MHz.
5. Measure the average throughput for a duration sufficient to achieve statistical significance according to Annex H.2.
6. Repeat steps from 4 to 5, using an interfering signal above the aggregated component carriers at step 4.

NOTE: The purpose of the Uplink power control window is to ensure that the actual UE output power is no greater than the target power level, and as close as possible to the target power level. The relationship between the Uplink power control window, the target power level and the corresponding possible actual UE Uplink power window is illustrated in Annex F, clause F.4.

7.6B.3.3\_1.1.4.3 Message contents

Message contents are according to TS 36.508 [11] clause 4.6.1 and TS 38.508-1 [6] clause 4.6 Table 4.6.3-118 with condition TRANSFORM\_PRECODER\_ENABLED with the following exceptions.

**Table 7.6B.3.3\_1.1.4.3-1: PhysicalCellGroupConfig**

Derivation Path: TS 38.508-1 [6], Table 4.6.3-106			
Information Element	Value/remark	Comment	Condition
p-NR-FR1	20		Power Class 3 UE
	23		Power Class 2 UE

**Table 7.6B.3.3\_1.1.4.3-2: RRCConnectionReconfiguration**

Derivation Path: TS 36.508 [11], Table 4.6.1-8			
Information Element	Value/remark	Comment	Condition
p-MaxEUTRA-r15	20		Power Class 3 UE
	23		Power Class 2 UE

7.6B.3.3\_1.1.5 Test Requirement

The throughput shall be  $\geq 95\%$  of the maximum throughput of the reference measurement channels as specified in TS 36.521-1 [10] Annex A.3 and TS 38.521-1 [8] Annex A.3 for E-UTRA CG and NR CG respectively with parameters specified in Table 7.6B.3.3\_1.1.5-1 for the specified wanted signal mean power in the presence of interfering signals.

**Table 7.6B.3.3\_1.1.5-1: Out-of-band blocking for intra-band contiguous EN-DC**

EN-DC Aggregated Bandwidth, MHz	≤100	>100, ≤120	>120, ≤140	>140, ≤160
Pw in Transmission Bandwidth Configuration, perCC, dBm	REFSENS + Aggregated BW specific value below			
	9			
NOTE 1: Interferer values and offsets are specified from Table 7.6.2.1A-2 in TS 36.101 [5]. For inter-band combinations where the intra-band requirements are applicable, in which the E-UTRA band is a subset of an NR-only band, the NR band interferer values and offsets specified from Table 7.6A.3-2 in TS 38.101-1 [2] apply to both E-UTRA and NR carriers.				
NOTE 2: For NR carrier, the transmitter shall be set to 4dB below $P_{\text{CMAX\_L,f,c,NR}}$ at the minimum uplink configuration specified in Table 7.3.2-3 in TS 38.101-1 [2] with $P_{\text{CMAX\_L,f,c,NR}}$ as defined in clause 6.2B.4.				
NOTE 3: For E-UTRA carrier, the transmitter shall be set to 4dB below $P_{\text{CMAX\_L,E-UTRA,c}}$ at the minimum uplink configuration specified in Table 7.3.1-2 in TS 36.101 [5] with $P_{\text{CMAX\_L,E-UTRA,c}}$ as defined in clause 6.2B.4 for single carrier.				

### 7.6B.3.3\_1.2 Out-of-band blocking for EN-DC within FR1 (4 CCs)

#### 7.6B.3.3\_1.2.1 Test Purpose

Out-of-band band blocking is defined for an unwanted CW interfering signal falling more than 15 MHz below or above the UE receive band, at which a given average throughput shall meet or exceed the requirement for the specified measurement channels.

For the first 15 MHz below or above the UE receive band the appropriate in-band blocking or adjacent channel selectivity in clause 7.6B.2.1 and clause 7.5B.1 shall be applied.

The lack of out-of-band blocking ability will decrease the coverage area when other NodeB transmitters exist (except in the adjacent channels and spurious response).

#### 7.6B.3.3\_1.2.2 Test Applicability

This test case applies to all types of E-UTRA UE release 15 and forward, supporting intra-band contiguous EN-DC within FR1 with 4 DL CCs.

#### 7.6B.3.3\_1.2.3 Minimum Conformance Requirements

The minimum conformance requirements are defined in clause 7.6B.3.0.1.

Exception requirements for both NR and E-UTRA are defined for this test and therefore LTE anchor agnostic approach is not applied. E-UTRA test point analysis is included and E-UTRA measurements are performed.

#### 7.6B.3.3\_1.2.4 Test Description

##### 7.6B.3.3\_1.2.4.1 Initial condition

Initial conditions are a set of test configurations the UE needs to be tested in and the steps for the SS to take with the UE to reach the correct measurement state.

The initial test configurations consist of environmental conditions, test frequencies and channel bandwidths based on EN-DC operating bands specified in clause 5.3B.1.2, channel bandwidths and sub-carrier spacings for the NR cell specified in TS 38.521-1 [8] clause 5.3 and channel bandwidth for the E-UTRA cell are specified in TS 36.521-1 [10] clause 5.4.2. All of these configurations shall be tested with applicable test parameters for each EN-DC configuration specified in clause 5.3B.1.2 and are shown in Table 7.6B.3.3\_1.2.4.1-1. The details of the uplink and downlink reference measurement channels (RMCs) are specified in Annex A.2 and A.3 respectively. The details of the OCN patterns used are specified in TS 36.521-1 [10] Annex A.5 and in TS 38.521-1 [8] Annex A.5 for E-UTRA CG and NR CG respectively. Configurations of PDSCH and PDCCH before measurement are specified in TS 36.521-1 [10] Annex C.2 and in TS 38.521-1 [8] Annex C.2 for E-UTRA CG and NR CG respectively.

Table 7.6B.3.3\_1.2.4.1-1: Test configuration table

Initial Conditions					
Test Environment as specified in TS 38.508-1 [6] clause 4.1			Normal		
Test Frequencies as specified in TS 38.508-1 [6] clause 4.3.1 for different EN-DC bandwidth classes			Mid range		
Test EN-DC bandwidth combination as specified in Table 5.3B.1.2-1 across bandwidth combination sets supported by the UE			Highest $N_{RB\_agg}$ (NOTE 3)		
NR Test SCS as specified in Table 5.3.5-1 in TS 38.521-1 [8]			Lowest		
NR/E-UTRA Test Parameters					
PCC – E-UTRA		SCC1 – EUTRA and SCC2 – EUTRA		NR	
UL/DL Modulation	UL/DL allocation	UL/DL Modulation	UL/DL allocation	UL/DL Modulation	UL/DL allocation
QPSK/QPSK	REFSENS/Full RB	NA/QPSK	NA/Full RB	DFT-s-OFDM QPSK/CP-OFDM QPSK	REFSENS/Full RB (NOTE 1)
NOTE 1: Full RB allocation shall be used per each SCS and channel BW as specified in Table 7.3.2.4.1-2 of TS 38.521-1 [8].					
NOTE 2: Test Channel Bandwidths are checked separately for each EN-DC band, which applicable channel bandwidths are specified in Table 5.3B.1.2-1.					
NOTE 3: If the UE supports multiple CC Combinations in the EN-DC Configuration with the same $N_{RB\_agg}$ , only the combination with the highest $N_{RB\_SCG}$ is tested.					
NOTE 4: REFSENS refers to Uplink configuration in Table 7.3.2.3-3 in [8] and Table 7.3.3-2 in [10] for NR and E-UTRA CC respectively.					
NOTE 5: In an E-UTRA band or FR1 band where UE supports 4Rx, the test shall be performed only with 4Rx antennas ports connected and 4Rx REFSENS requirement (TS 38.521-1 [8] Table 7.3.2.5-2) is used in the test requirements.					

1. Connect the SS to the UE antenna connectors as shown in [6] TS 38.508-1 Annex A, in Figure A.3.1.4.2 for SS diagram and clause A.3.2 for UE diagram.
2. The parameter settings for the cell are set up according to TS 38.508-1 [6] clause 4.4.3.
3. Downlink signals are initially set up according to TS 36.521-1 [10] Annex C and TS 38.521-1 [8] Annex C for E-UTRA CG and NR CG respectively, and uplink signals according to TS 36.521-1 [10] Annex H and TS 38.521-1 [8] Annex G for E-UTRA CG and NR CG respectively.
4. The UL and DL Reference Measurement channels are TS 36.521-1 [10] Annex A.2, A.3 and TS 38.521-1 [8] Annex A.2, A.3 for E-UTRA CG and NR CG respectively.
5. Propagation conditions are set according to TS 36.521-1 [10] Annex B.0 and TS 38.521-1 [8] Annex B.0 for E-UTRA CG and NR CG respectively.
6. Ensure the UE is in state RRC\_CONNECTED with generic procedure parameters Connectivity EN-DC, DC bearer *MCG* and *SCG*, Connected without release *On* according to TS 38.508-1 [6] clause 4.5. Message contents are defined in clause 7.6B.3.3\_1.2.4.3.

#### 7.6B.3.3\_1.2.4.2 Test procedure

1. SS transmits PDSCH via PDCCH DCI format 1A and PDCCH DCI format 1\_1 for C\_RNTI to transmit the DL RMC according to Table 7.6B.3.3\_1.2.4.1-1 on E-UTRA CC and NR CC respectively. The SS sends downlink MAC padding bits on the DL RMC.
2. SS sends uplink scheduling information for each UL HARQ process via PDCCH DCI format 0 and DCI format 0\_1 for C\_RNTI to schedule the UL RMC according to Table 7.6B.3.3\_1.2.4.1-1 on E-UTRA CC and NR CC respectively. Since the UL has no payload and no loopback data to send the UE sends uplink MAC padding bits on the UL RMC.
3. Set the Downlink signal level to the value as defined in Table 7.6B.3.3\_1.2.5-1. For NR CC and E-UTRA CC, send uplink power control commands to the UE using 1dB power step size to ensure that the UE output power



measured by the test system is within the Uplink power control window, defined as  $-(\text{MU} + \text{Uplink power control window size})$  dB of the target power level in Table 7.6B.3.3\_1.2.5-1  $+( [10\log(S_{\text{LCRB}}/N_{\text{RB\_alloc}})]$  for NR CC,  $[10\log(P_{\text{LCRB}}/N_{\text{RB\_alloc}})]$  for E-UTRA CC) for at least the duration of the Throughput measurement, where:

- MU is the test system uplink power measurement uncertainty and is specified in Table F.1.3-1 for the carrier frequency  $f$  and the channel bandwidth BW
  - For NR CC, Uplink power control window size = 1dB (UE power step size) + 0.7dB (UE power step tolerance) + (Test system relative power measurement uncertainty), where, the UE power step tolerance is specified in TS 38.101-1 [2], Table 6.3.4.3-1 and is 0.7dB for 1dB power step size, and the Test system relative power measurement uncertainty is specified in Table F.1.2-1.
  - For E-UTRA CC, Uplink power control window size = 1dB (UE power step size) + 1.0dB (UE power step tolerance) + (Test system relative power measurement uncertainty), where, the UE power step tolerance is specified in TS 36.101 [5], Table 6.3.5.2.1-1 and is 1.0dB for 1dB power step size, and the Test system relative power measurement uncertainty is specified in Table F.1.2-1 of TS 36.521-1 [10].
4. Set the parameters of the CW signal generator for an interfering signal below the aggregated component carriers according to Table 7.6B.3.3\_1.2.5-1. The frequency step size is 1MHz.
  5. Measure the average throughput for a duration sufficient to achieve statistical significance according to Annex H.2.
  6. Repeat steps from 4 to 5, using an interfering BW signal above the aggregated component carriers at step 4.

NOTE: The purpose of the Uplink power control window is to ensure that the actual UE output power is no greater than the target power level, and as close as possible to the target power level. The relationship between the Uplink power control window, the target power level and the corresponding possible actual UE Uplink power window is illustrated in Annex F, clause F.4.

#### 7.6B.3.3\_1.2.4.3 Message contents

Message contents are according to TS 36.508 [11] clause 4.6.1 and TS 38.508-1 [6] clause 4.6 Table 4.6.3-118 with condition TRANSFORM\_PRECODER\_ENABLED with the following exceptions.

**Table 7.6B.3.3\_1.2.4.3-1: PhysicalCellGroupConfig**

Derivation Path: TS 38.508-1 [6], Table 4.6.3-106			
Information Element	Value/remark	Comment	Condition
p-NR-FR1	20		Power Class 3 UE
	23		Power Class 2 UE

**Table 7.6B.3.3\_1.2.4.3-2: RRCConnectionReconfiguration**

Derivation Path: TS 36.508 [11], Table 4.6.1-8			
Information Element	Value/remark	Comment	Condition
p-MaxEUTRA-r15	20		Power Class 3 UE
	23		Power Class 2 UE

#### 7.6B.3.3\_1.2.5 Test Requirement

The throughput shall be  $\geq 95\%$  of the maximum throughput of the reference measurement channels as specified in TS 36.521-1 [10] Annex A.3 and TS 38.521-1 [8] Annex A.3 for E-UTRA CG and NR CG respectively with parameters specified in Table 7.6B.3.3\_1.2.5-1 for the specified wanted signal mean power in the presence of interfering signals.

**Table 7.6B.3.3\_1.2.5-1: Out-of-band blocking for intra-band contiguous EN-DC**

EN-DC Aggregated Bandwidth, MHz	≤100	>100, ≤120	>120, ≤140	>140, ≤160
Pw in Transmission Bandwidth Configuration, perCC, dBm	REFSENS + Aggregated BW specific value below			
	9			
NOTE 1: Interferer values and offsets are specified from Table 7.6.2.1A-2 in TS 36.101 [5]. For inter-band combinations where the intra-band requirements are applicable, in which the E-UTRA band is a subset of an NR-only band, the NR band interferer values and offsets specified from Table 7.6A.3-2 in TS 38.101-1 [2] apply to both E-UTRA and NR carriers.				
NOTE 2: For NR carrier, the transmitter shall be set to 4dB below $P_{\text{CMAX\_L,f,c,NR}}$ at the minimum uplink configuration specified in Table 7.3.2-3 in TS 38.101-1 [2] with $P_{\text{CMAX\_L,f,c,NR}}$ as defined in clause 6.2B.4.				
NOTE 3: For E-UTRA carrier, the transmitter shall be set to 4dB below $P_{\text{CMAX\_L,E-UTRA,c}}$ at the minimum uplink configuration specified in Table 7.3.1-2 in TS 36.101 [5] with $P_{\text{CMAX\_L,E-UTRA,c}}$ as defined in clause 6.2B.4 for single carrier.				

## 7.6B.4 Narrow band blocking for DC

### 7.6B.4.0 Minimum Conformance Requirements

#### 7.6B.4.0.1 Intra-band contiguous EN-DC

Intra-band contiguous EN-DC narrow band blocking requirement and parameters are defined in Table 7.6B.4.0.1-1.

**Table 7.6B.4.0.1-1: Narrow band blocking parameters for intra-band contiguous EN-DC**

EN-DC Aggregated Bandwidth, MHz	≤100	>100, ≤120	>120, ≤140	>140, ≤160
Pw in Transmission Bandwidth Configuration, perCC, dBm	REFSENS + Aggregated BW specific value below			
	16			
P <sub>UW</sub> , dBm (CW)	-55			
NOTE 1: Jammer offset is from Table 7.6.3.1A-1 in TS 36.101 [5] and is applied from the lowest edge of the lowest carrier and the highest edge of the highest carrier.				
NOTE 2: For NR carrier, the transmitter shall be set to 4dB below $P_{\text{CMAX\_L,f,c,NR}}$ at the minimum uplink configuration specified in Table 7.3.2-3 [2] with $P_{\text{CMAX\_L,f,c,NR}}$ as defined in clause 6.2B.4.				
NOTE 3: For E-UTRA carrier, the transmitter shall be set to 29dB below $P_{\text{CMAX\_L,E-UTRA,c}}$ at the minimum uplink configuration specified in Table 7.3.1-2 [5] with $P_{\text{CMAX\_L,E-UTRA,c}}$ as defined in clause 6.2B.4 for single carrier.				
NOTE 4: If NR carrier BW > 40 MHz, no narrow band blocking requirements apply when blocker is applied at the edge of the NR carrier.				

The normative reference for this requirement is TS 38.101-3 [4] clause 7.6B.4.1.

#### 7.6B.4.0.2 Intra-band non-contiguous EN-DC

For the E-TRA sub-block containing one or multiple CC's, the requirement is defined in clause 7.6.3.1 for single carrier operation and in clause 7.6.3.1A for CA in TS 36.101 [5].

For the NR sub-block, the requirement is defined in clause 7.6.4 in TS 38.101-1 [2].

The blocker configuration is defined in the general clause 7.1.

The normative reference for this requirement is TS 38.101-3 [4] clause 7.6B.4.2.

### 7.6B.4.0.3 Inter-band EN-DC within FR1

Narrow band blocking requirement for E-UTRA single carrier and CA operation specified in clauses 7.6.3.1 and 7.6.3.1A of TS 36.101 [5] and for NR single carrier and CA operation specified in clauses 7.6.4 and 7.6A.4 of TS 38.101-1 [2] apply.

The normative reference for this requirement is TS 38.101-3 [4] clause 7.6B.4.3.

### 7.6B.4.0.3a Inter-band NE-DC within FR1

Narrow band blocking requirement for E-UTRA single carrier and CA operation specified in clauses 7.6.3.1 and 7.6.3.1A of TS 36.101 [5] and for NR single carrier and CA operation specified in clauses 7.6.4 and 7.6A.4 of TS 38.101-1 [2] apply.

The normative reference for this requirement is TS 38.101-3 [4] clause 7.6B.4.3a.

### 7.6B.4.0.4 Inter-band EN-DC including FR2

Narrow band blocking requirement for E-UTRA single carrier and CA operation specified in clauses 7.6.3.1 and 7.6.3.1A of TS 36.101 [5] apply.

The normative reference for this requirement is TS 38.101-3 [4] clause 7.6B.4.4.

### 7.6B.4.0.5 Inter-band EN-DC including both FR1 and FR2

Narrow band blocking requirement for E-UTRA single carrier and CA operation specified in clauses 7.6.3.1 and 7.6.3.1A of TS 36.101 [5] and for NR single carrier and CA operation specified in clauses 7.6.4 and 7.6A.4 of TS 38.101-1 [2] apply.

The normative reference for this requirement is TS 38.101-3 [4] clause 7.6B.4.5.

## 7.6B.4.1 Narrow band blocking for intra-band contiguous EN-DC (2 CCs)

### 7.6B.4.1.1 Test Purpose

Verifies a receiver's ability to receive EN-DC signals at its assigned channel frequencies in the presence of an unwanted narrow band CW interferer at a frequency, which is less than the nominal channel spacing.

The lack of narrow-band blocking ability will decrease the coverage area when other NodeB transmitters exist (except in the adjacent channels and spurious response).

### 7.6B.4.1.2 Test Applicability

This test case applies to all types of E-UTRA UE release 15 and forward, supporting intra-band contiguous EN-DC in FR1 with 2 DL CCs.

### 7.6B.4.1.3 Minimum Conformance Requirements

The minimum conformance requirements are defined in clause 7.6B.4.0.1.

Exception requirements for both NR and E-UTRA are defined for this test and therefore LTE anchor agnostic approach is not applied. E-UTRA test point analysis is included and E-UTRA measurements are performed.

### 7.6B.4.1.4 Test Description

#### 7.6B.4.1.4.1 Initial condition

Initial conditions are a set of test configurations the UE needs to be tested in and the steps for the SS to take with the UE to reach the correct measurement state.

The initial test configurations consist of environmental conditions, test frequencies and channel bandwidths based on EN-DC operating bands specified in clause 5.3B.1.2, channel bandwidths and sub-carrier spacings for the NR cell

specified in TS 38.521-1 [8] clause 5.3 and channel bandwidth for the E-UTRA cell are specified in TS 36.521-1 [10] clause 5.4.2. All of these configurations shall be tested with applicable test parameters for each EN-DC configuration specified in clause 5.3B.1.2 and are shown in Table 7.6B.4.1.4.1-1. The details of the uplink and downlink reference measurement channels (RMCs) are specified in Annex A.2 and A.3 respectively. The details of the OCN patterns used are specified in TS 36.521-1 [10] Annex A.5 and in TS 38.521-1 [8] Annex A.5 for E-UTRA CG and NR CG respectively. Configurations of PDSCH and PDCCH before measurement are specified in TS 36.521-1 [10] Annex C.2 and in TS 38.521-1 [8] Annex C.2 for E-UTRA CG and NR CG respectively.

**Table 7.6B.4.1.4.1-1: Test configuration table**

Initial Conditions							
Test Environment as specified in TS 38.508-1 [6] clause 4.1				Normal			
Test Frequencies as specified in TS 38.508-1 [6] clause 4.3.1 for different EN-DC bandwidth classes				Mid range			
Test EN-DC bandwidth combination as specified in Table 5.3B.1.2-1 across bandwidth combination sets supported by the UE				Lowest $N_{RB\_agg}$ , Highest $N_{RB\_agg}$ (NOTE 3)			
NR Test SCS as specified in Table 5.3.5-1 in TS 38.521-1 [8]				Lowest			
NR/E-UTRA Test Parameters							
Downlink Configuration				Uplink Configuration			
NR Modulation	NR RB allocation	E-UTRA Modulation	E-UTRA RB allocation	NR Modulation	NR RB allocation	E-UTRA Modulation	E-UTRA RB allocation
CP-OFDM QPSK	Full RB (NOTE 1)	QPSK	Full RB	DFT-s-OFDM QPSK	REFSENS	QPSK	REFSENS
NOTE 1: Full RB allocation shall be used per each SCS and channel BW as specified in Table 7.3.2.4.1-2 of TS 38.521-1 [8].							
NOTE 2: Test Channel Bandwidths are checked separately for each EN-DC band, which applicable channel bandwidths are specified in Table 5.3B.1.2-1.							
NOTE 3: If the UE supports multiple CC Combinations in the EN-DC Configuration with the same $N_{RB\_agg}$ , only the combination with the highest $N_{RB\_SCG}$ is tested.							
NOTE 4: REFSENS refers to Uplink configuration in Table 7.3.2.3-3 in [8] and Table 7.3.3-2 in [10] for NR and E-UTRA CC respectively.							
NOTE 5: In an E-UTRA band or FR1 band where UE supports 4Rx, the test shall be performed only with 4Rx antennas ports connected and 4Rx REFSENS requirement (TS 38.521-1 [8] Table 7.3.2.5-2) is used in the test requirements.							

1. Connect the SS to the UE antenna connectors as shown in [6] TS 38.508-1 Annex A, in Figure A.3.1.4.2 for SS diagram and clause A.3.2 for UE diagram.
2. The parameter settings for the E-UTRA cell are set up according to TS 36.508 [11] clause 4.4.3, and the parameter settings for the NR cell are set up according to TS 38.508-1 [6] clause 4.4.3.
3. Downlink signals are initially set up according to TS 36.521-1 [10] Annex C and TS 38.521-1 [8] Annex C for E-UTRA CG and NR CG respectively, and uplink signals according to TS 36.521-1 [10] Annex H and TS 38.521-1 [8] Annex G for E-UTRA CG and NR CG respectively.
4. The UL and DL Reference Measurement channels are TS 36.521-1 [10] Annex A.2, A.3 and TS 38.521-1 [8] Annex A.2, A.3 for E-UTRA CG and NR CG respectively.
5. Propagation conditions are set according to TS 36.521-1 [10] Annex B.0 and TS 38.521-1 [8] Annex B.0 for E-UTRA CG and NR CG respectively.
6. Ensure the UE is in state RRC\_CONNECTED with generic procedure parameters Connectivity EN-DC, DC bearer MCG and SCG, Connected without release *On* according to TS 38.508-1 [6] clause 4.5. Message contents are defined in clause 7.6B.4.1.4.3.
7. When E-UTRA and NR bands are TDD, ensure the same uplink-downlink configuration by giving SCG a delay of 3 E-UTRA subframes, or by giving MCG a delay of 2 subframes.

7.6B.4.1.4.2 Test procedure

1. SS transmits PDSCH via PDCCH DCI format 1A and PDCCH DCI format 1\_1 for C\_RNTI to transmit the DL RMC according to Table 7.6B.4.1.4.1-1 on E-UTRA CC and NR CC respectively. The SS sends downlink MAC padding bits on the DL RMC.
2. SS sends uplink scheduling information for each UL HARQ process via PDCCH DCI format 0 and DCI format 0\_1 for C\_RNTI to schedule the UL RMC according to Table 7.6B.4.1.4.1-1 on E-UTRA CC and NR CC respectively. Since the UL has no payload and no loopback data to send the UE sends uplink MAC padding bits on the UL RMC.
3. Set the Downlink signal level to the value as defined in Table 7.6B.4.1.5-1. For NR CC and E-UTRA CC, send uplink power control commands to the UE using 1dB power step size to ensure that the UE output power measured by the test system is within the Uplink power control window, defined as  $-(\text{MU} + \text{Uplink power control window size})$  dB of the target power level in Table 7.6B.4.1.5-1 for at least the duration of the Throughput measurement, where:
  - MU is the test system uplink power measurement uncertainty and is specified in Table F.1.3-1 for the carrier frequency  $f$  and the channel bandwidth BW
  - For NR CC, Uplink power control window size = 1dB (UE power step size) + 0.7dB (UE power step tolerance) = 1.7dB, where, the UE power step tolerance is specified in TS 38.101-1 [2], Table 6.3.4.3-1 and is 0.7dB for 1dB power step size.
  - For E-UTRA CC, Uplink power control window size = 1dB (UE power step size) + 1.0dB (UE power step tolerance) = 2.0dB, where, the UE power step tolerance is specified in TS 36.101 [5], Table 6.3.5.2.1-1 and is 1.0dB for 1dB power step size.
4. Set the parameters of the CW signal generator for an interfering signal below the aggregated component carriers according to Table 7.6B.4.1.5-1.
5. Measure the average throughput for a duration sufficient to achieve statistical significance according to Annex H.2.
6. Repeat steps from 4 to 5, using an interfering signal above the aggregated component carriers at step 4.

NOTE: The purpose of the Uplink power control window is to ensure that the actual UE output power is no greater than the target power level, and as close as possible to the target power level. The relationship between the Uplink power control window, the target power level and the corresponding possible actual UE Uplink power window is illustrated in Annex F, clause F.4.

7.6B.4.1.4.3 Message contents

Message contents are according to TS 36.508 [11] clause 4.6.1 and TS 38.508-1 [6] clause 4.6 Table 4.6.3-118 with condition TRANSFORM\_PRECODER\_ENABLED with the following exceptions.

**Table 7.6B.4.1.4.3-1: PhysicalCellGroupConfig**

Derivation Path: TS 38.508-1 [6], Table 4.6.3-106			
Information Element	Value/remark	Comment	Condition
p-NR-FR1	20		Power Class 3 UE
	23		Power Class 2 UE

**Table 7.6B.4.1.4.3-2: RRCConnectionReconfiguration**

Derivation Path: TS 36.508 [11], Table 4.6.1-8			
Information Element	Value/remark	Comment	Condition
nonCriticalExtension SEQUENCE {		RRCConnectionReconfiguration-v1530-IEs	
p-MaxEUTRA-r15	20		Power Class 3 UE
	23		Power Class 2 UE
}			

7.6B.4.1.5 Test Requirement

The throughput shall be  $\geq 95\%$  of the maximum throughput of the reference measurement channels as specified in TS 36.521-1 [10] Annex A.3 and TS 38.521-1 [8] Annex A.3 for E-UTRA CG and NR CG respectively with parameters specified in Table 7.6B.4.1.5-1 for the specified wanted signal mean power in the presence of interfering signals.

**Table 7.6B.4.1.5-1: Narrow band blocking for intra-band contiguous EN-DC**

EN-DC Aggregated Bandwidth, MHz	$\leq 100$	$>100, \leq 120$	$>120, \leq 140$	$>140, \leq 160$
Pw in Transmission Bandwidth Configuration, perCC, dBm	REFSENS + Aggregated BW specific value below			
P <sub>uw</sub> , dBm (CW)	16			
	-55			
NOTE 1: Jammer offset is from Table 7.6.3.1A-1 in TS 36.101 [5] and is applied from the lowest edge of the lowest carrier and the highest edge of the highest carrier.				
NOTE 2: For NR carrier, the transmitter shall be set to 4dB below P <sub>CMAX_L,f,c,NR</sub> at the minimum uplink configuration specified in Table 7.3.2-3 in TS 38.101-1 [2] with P <sub>CMAX_L,f,c,NR</sub> as defined in clause 6.2B.				
NOTE 3: For E-UTRA carrier, the transmitter shall be set to 29dB below P <sub>CMAX_L,E-UTRA,c</sub> at the minimum uplink configuration specified in Table 7.3.1-2 in TS 36.101 [5] with P <sub>CMAX_L,E-UTRA,c</sub> as defined in clause 6.2B.4 for single carrier.				
NOTE 4: If NR carrier BW > 40 MHz, no narrow band blocking requirements apply when blocker is applied at the edge of the NR carrier.				

**Table 7.6B.4.1.5-2: Void**

**Table 7.6B.4.1.5-3: Void**

7.6B.4.2 Narrow band blocking for intra-band non-contiguous EN-DC (2 CCs)

7.6B.4.2.1 Test Purpose

Same test purpose as in clause 7.6.4.1 in TS 38.521-1 [8] for the NR carrier.

7.6B.4.2.2 Test Applicability

This test case applies to all types of E-UTRA UE release 15 and forward, supporting intra-band non-contiguous EN-DC in FR1 with 2 DL CCs.

7.6B.4.2.3 Minimum Conformance Requirements

The minimum conformance requirements are defined in clause 7.6B.4.0.2.

No exception requirements applicable to NR or E-UTRA. LTE anchor agnostic approach is applied.

## 7.6B.4.2.4 Test Description

Same test description as in clause 7.6.4.4 in TS 38.521-1 [8] for the NR carrier with the following exceptions:

**Table 7.6B.4.2.4-1: Test Configuration Table**

Initial Conditions	
Test Frequencies as specified in TS 38.508-1 [6] clause 4.3.1 for different EN-DC bandwidth classes	High range with maxWGap
Test EN-DC bandwidth combination as specified in Table 5.3B.1.2-1 across bandwidth combination sets supported by the UE	Highest $N_{RB\_agg}$ (NOTE 1)
NOTE 1: If the UE supports multiple CC Combinations in the EN-DC Configuration with the same $N_{RB\_agg}$ , only the combination with the highest $N_{RB\_SCG}$ is tested.	

The initial test configurations for E-UTRA consist of test frequency based on E-UTRA operating band and test channel bandwidth as specified in Table 4.6-1 except for the parameters specified in Table 7.6B.4.2.4-1.

For Initial conditions as in clause 7.6.4.4.1 in TS 38.521-1 [8], add step 2.1 and step 3.1 as follows:

- 2.1. The parameter settings for E-UTRA cell are set up according to TS 36.508 [11] clause 4.4.3.
- 3.1. The E-UTRA downlink signal level, uplink signal level are set according to Table 4.6-1 and propagation conditions are set according to Annex B.0 of TS 36.521-1 [10].

Step 6 of Initial conditions as in clause 7.6.4.4.1 in TS 38.521-1 [8] is replaced by:

6. Ensure the UE is in state RRC\_CONNECTED with generic procedure parameters Connectivity EN-DC, DC bearer MCG and SCG, Connected without release  $On$  according to TS 38.508 [6] clause 4.5.

Add steps 7 and 8 to Initial conditions in clause 7.6.4.4.1 in TS 38.521-1 [8] as follows:

7. On the E-UTRA carrier, disable periodic and aperiodic CQI reports, disable SRS, set *TimeAlignmentTimerDedicated* IE to infinity and disable downlink and uplink scheduling, all as per Table 4.6-1 under clause 4.6.
8. When E-UTRA and NR bands are TDD, ensure the same uplink-downlink configuration by giving SCG a delay of 3 E-UTRA subframes, or by giving MCG a delay of 2 subframes.

Step 3 of Test procedure as in clause 7.6.4.4.2 in TS 38.521-1 [8] shall treat the in-gap tests as below: For intra-band non-contiguous EN-DC of two sub-blocks with channel bandwidth larger than or equal to 5 MHz, the existing requirements apply for in-gap tests only if the corresponding interferer frequency offsets satisfy the following condition in relation to the sub-block gap size  $W_{gap}$ , so that the interferer frequency position does not change the nature of the core requirement tested:

$$W_{gap} \geq 2 \cdot |F_{Interferer}(\text{offset})| - BW_{Channel}$$

Step 4 of Test procedure as in clause 7.6.4.4.2 in TS 38.521-1 [8] is replaced by:

4. Set the downlink signal level for NR CC according to the Table 7.6.4.5-1 in TS 38.521-1 [8] as appropriate. For NR CC and E-UTRA CC, send uplink power control commands to the UE using 1dB power step size to ensure that the UE output power measured by the test system is within the Uplink power control window, defined as  $-(MU) - (MU + \text{Uplink power control window size})$  dB of 4dB below  $P_{C_{MAX\_L,f,c}}$  for NR CC for at least the duration of the Throughput measurement, where:
  - MU is the test system uplink power measurement uncertainty and is specified in Table F.1.3-1 for the carrier frequency  $f$  and the channel bandwidth BW
  - For NR CC, Uplink power control window size = 1dB (UE power step size) + 0.7dB (UE power step tolerance) + (Test system relative power measurement uncertainty), where, the UE power step tolerance is specified in TS 38.101-1 [2], Table 6.3.4.3-1 and is 0.7dB for 1dB power step size, and the Test system relative power measurement uncertainty is specified in Table F.1.2-1.

#### 7.6B.4.2.5 Test Requirement

Same test requirement as in clause 7.6.4.5 in TS 38.521-1 [8].

### 7.6B.4.3 Narrow band blocking for inter-band EN-DC within FR1 (1 NR CC)

#### 7.6B.4.3.1 Test Purpose

Same test purpose as in clause 7.6.4.1 in TS 38.521-1 [8] for the NR carrier.

#### 7.6B.4.3.2 Test Applicability

This test case applies to all types of E-UTRA UE release 15 and forward, supporting inter-band EN-DC within FR1 with 1 NR DL CC.

#### 7.6B.4.3.3 Minimum Conformance Requirements

The minimum conformance requirements are defined in clause 7.6B.4.0.3.

No exception requirements applicable to NR or E-UTRA. LTE anchor agnostic approach is applied.

#### 7.6B.4.3.4 Test Description

Same test description as in clause 7.6.4.4 in TS 38.521-1 [8] for the NR carrier with the following exceptions:

The initial test configurations for E-UTRA consist of test frequency based on E-UTRA operating band and test channel bandwidth as specified in Table 4.6-1.

For Initial conditions as in clause 7.6.4.4.1 in TS 38.521-1 [8], add step 2.1 and step 3.1 as follows:

- 2.1. The parameter settings for E-UTRA cell are set up according to TS 36.508 [11] clause 4.4.3.
- 3.1. The E-UTRA downlink signal level, uplink signal level are set according to Table 4.6-1 and propagation conditions are set according to Annex B.0 of TS 36.521-1 [10].

Step 6 of Initial conditions as in clause 7.6.4.4.1 in TS 38.521-1 [8] is replaced by:

6. Ensure the UE is in state RRC\_CONNECTED with generic procedure parameters Connectivity EN-DC, DC bearer MCG and SCG, Connected without release *On* according to TS 38.508 [6] clause 4.5.

Add step 7 to Initial conditions in clause 7.6.4.4.1 in TS 38.521-1 [8] as follows:

7. On the E-UTRA carrier, disable periodic and aperiodic CQI reports, disable SRS, set *TimeAlignmentTimerDedicated* IE to infinity and disable downlink and uplink scheduling, all as per Table 4.6-1 under clause 4.6.

#### 7.6B.4.3.5 Test Requirement

Same test requirement as in clause 7.6.4.5 in TS 38.521-1 [8].

### 7.6B.4.3\_1 Narrow band blocking for EN-DC within FR1 (>2 CCs)

#### 7.6B.4.3\_1.1 Narrow band blocking for EN-DC within FR1 (3 CCs)

##### 7.6B.4.3\_1.1.1 Test Purpose

Verifies a receiver's ability to receive EN-DC signals at its assigned channel frequencies in the presence of an unwanted narrow band CW interferer at a frequency, which is less than the nominal channel spacing.

The lack of narrow-band blocking ability will decrease the coverage area when other NodeB transmitters exist (except in the adjacent channels and spurious response).



#### 7.6B.4.3\_1.1.2 Test Applicability

This test case applies to all types of E-UTRA UE release 15 and forward, supporting intra-band contiguous EN-DC within FR1 with 3 DL CCs or inter-band EN-DC within FR1 with 3 DL CCs (2NR DL CCs).

#### 7.6B.4.3\_1.1.3 Minimum Conformance Requirements

For intra-band contiguous EN-DC within FR1 with 3 DL CCs: The minimum conformance requirements are defined in clause 7.6B.4.0.1. Exception requirements for both NR and E-UTRA are defined for this test and therefore LTE anchor agnostic approach is not applied. E-UTRA test point analysis is included and E-UTRA measurements are performed.

For inter-band EN-DC within FR1 with 3 DL CCs (2NR DL CCs): The minimum conformance requirements are defined in clause 7.6B.4.0.3. No exception requirements applicable to NR or E-UTRA. LTE anchor agnostic approach is applied.

#### 7.6B.4.3\_1.1.4 Test Description

##### 7.6B.4.3\_1.1.4.1 Intra-band contiguous EN-DC within FR1 with 3 DL CCs

##### 7.6B.4.3\_1.1.4.1.1 Initial condition

Initial conditions are a set of test configurations the UE needs to be tested in and the steps for the SS to take with the UE to reach the correct measurement state.

The initial test configurations consist of environmental conditions, test frequencies and channel bandwidths based on EN-DC operating bands specified in clause 5.3B.1.2, channel bandwidths and sub-carrier spacings for the NR cell specified in TS 38.521-1 [8] clause 5.3 and channel bandwidth for the E-UTRA cell are specified in TS 36.521-1 [10] clause 5.4.2. All of these configurations shall be tested with applicable test parameters for each EN-DC configuration specified in clause 5.3B.1.2 and are shown in Table 7.6B.4.3\_1.1.4.1.1-1. The details of the uplink and downlink reference measurement channels (RMCs) are specified in Annex A.2 and A.3 respectively. The details of the OCN patterns used are specified in TS 36.521-1 [10] Annex A.5 and in TS 38.521-1 [8] Annex A.5 for E-UTRA CG and NR CG respectively. Configurations of PDSCH and PDCCH before measurement are specified in TS 36.521-1 [10] Annex C.2 and in TS 38.521-1 [8] Annex C.2 for E-UTRA CG and NR CG respectively.

**Table 7.6B.4.3\_1.1.4.1.1-1: Test configuration table**

Initial Conditions					
Test Environment as specified in TS 38.508-1 [6] clause 4.1			Normal		
Test Frequencies as specified in TS 38.508-1 [6] clause 4.3.1 for different EN-DC bandwidth classes			Mid range		
Test EN-DC bandwidth combination as specified in Table 5.3B.1.2-1 across bandwidth combination sets supported by the UE			Lowest $N_{RB\_agg}$ , Highest $N_{RB\_agg}$ (NOTE 3)		
NR Test SCS as specified in Table 5.3.5-1 in TS 38.521-1 [8]			Lowest		
NR/E-UTRA Test Parameters					
PCC – E-UTRA		SCC – EUTRA		NR	
UL/DL Modulation	UL/DL allocation	UL/DL Modulation	UL/DL allocation	UL/DL Modulation	UL/DL allocation
QPSK/QPSK	REFSENS/Full RB	NA/QPSK	NA/Full RB	DFT-s-OFDM QPSK/CP-OFDM QPSK	REFSENS/Full RB (NOTE 1)
NOTE 1: Full RB allocation shall be used per each SCS and channel BW as specified in Table 7.3.2.4.1-2 of TS 38.521-1 [8].					
NOTE 2: Test Channel Bandwidths are checked separately for each EN-DC band, which applicable channel bandwidths are specified in Table 5.3B.1.2-1.					
NOTE 3: If the UE supports multiple CC Combinations in the EN-DC Configuration with the same $N_{RB\_agg}$ , only the combination with the highest $N_{RB\_SCG}$ is tested.					
NOTE 4: REFSENS refers to Uplink configuration in Table 7.3.2.3-3 in [8] and Table 7.3.3-2 in [10] for NR and E-UTRA CC respectively.					
NOTE 5: In a FR1 band where UE supports 4Rx, the test shall be performed only with 4Rx antennas ports connected and 4Rx REFSENS requirement (TS 38.521-1 [8] Table 7.3.2.5-2) is used in the test requirements.					

1. Connect the SS to the UE antenna connectors as shown in [6] TS 38.508-1 Annex A, in Figure A.3.1.4.2 for SS diagram and clause A.3.2 for UE diagram.
2. The parameter settings for the E-UTRA cell are set up according to TS 36.508 [11] clause 4.4.3, and the parameter settings for the NR cell are set up according to TS 38.508-1 [6] clause 4.4.3.
3. Downlink signals are initially set up according to TS 36.521-1 [10] Annex C and TS 38.521-1 [8] Annex C for E-UTRA CG and NR CG respectively, and uplink signals according to TS 36.521-1 [10] Annex H and TS 38.521-1 [8] Annex G for E-UTRA CG and NR CG respectively.
4. The UL and DL Reference Measurement channels are TS 36.521-1 [10] Annex A.2, A.3 and TS 38.521-1 [8] Annex A.2, A.3 for E-UTRA CG and NR CG respectively.
5. Propagation conditions are set according to TS 36.521-1 [10] Annex B.0 and TS 38.521-1 [8] Annex B.0 for E-UTRA CG and NR CG respectively.
6. Ensure the UE is in state RRC\_CONNECTED with generic procedure parameters Connectivity EN-DC, DC bearer *MCG* and *SCG*, Connected without release *On* according to TS 38.508-1 [6] clause 4.5. Message contents are defined in clause 7.6B.4.3\_1.1.4.1.3.

#### 7.6B.4.3\_1.1.4.1.2 Test procedure

1. SS transmits PDSCH via PDCCH DCI format 1A and PDCCH DCI format 1\_1 for C\_RNTI to transmit the DL RMC according to Table 7.6B.4.3\_1.1.4.1.1-1 on E-UTRA CC and NR CC respectively. The SS sends downlink MAC padding bits on the DL RMC.
2. SS sends uplink scheduling information for each UL HARQ process via PDCCH DCI format 0 and DCI format 0\_1 for C\_RNTI to schedule the UL RMC according to Table 7.6B.4.3\_1.1.4.1.1-1 on E-UTRA CC and NR CC respectively. Since the UL has no payload and no loopback data to send the UE sends uplink MAC padding bits on the UL RMC.

3. Set the Downlink signal level to the value as defined in Table 7.6B.4.1.5-1. For NR CC and E-UTRA CC, send uplink power control commands to the UE using 1dB power step size to ensure that the UE output power measured by the test system is within the Uplink power control window, defined as  $-\text{MU}$  to  $-(\text{MU} + \text{Uplink power control window size})$  dB of the target power level in Table 7.6B.4.1.5-1 +  $([10\log(S_{\text{LCRB}}/N_{\text{RB\_alloc}})]$  for NR CC,  $[10\log(P_{\text{LCRB}}/N_{\text{RB\_alloc}})]$  for E-UTRA CC) for at least the duration of the Throughput measurement, where:
  - MU is the test system uplink power measurement uncertainty and is specified in Table F.1.3-1 for the carrier frequency  $f$  and the channel bandwidth BW
  - For NR CC, Uplink power control window size = 1dB (UE power step size) + 0.7dB (UE power step tolerance) + (Test system relative power measurement uncertainty), where, the UE power step tolerance is specified in TS 38.101-1 [2], Table 6.3.4.3-1 and is 0.7dB for 1dB power step size, and the Test system relative power measurement uncertainty is specified in Table F.1.2-1.
  - For E-UTRA CC, Uplink power control window size = 1dB (UE power step size) + 1.0dB (UE power step tolerance) + (Test system relative power measurement uncertainty), where, the UE power step tolerance is specified in TS 36.101 [5], Table 6.3.5.2.1-1 and is 1.0dB for 1dB power step size, and the Test system relative power measurement uncertainty is specified in Table F.1.2-1 of TS 36.521-1 [10].
4. Set the parameters of the CW signal generator for an interfering signal below the aggregated component carriers according to Table 7.6B.4.1.5-1.
5. Measure the average throughput for a duration sufficient to achieve statistical significance according to Annex H.2.
6. Repeat steps from 4 to 5, using an interfering signal above the aggregated component carriers at step 4.

NOTE: The purpose of the Uplink power control window is to ensure that the actual UE output power is no greater than the target power level, and as close as possible to the target power level. The relationship between the Uplink power control window, the target power level and the corresponding possible actual UE Uplink power window is illustrated in Annex F, clause F.4.

#### 7.6B.4.3\_1.1.4.1.3 Message contents

Message contents are according to TS 38.508-1 [6] clause 4.6 Table 4.6.3-118 with condition TRANSFORM\_PRECODER\_ENABLED.

#### 7.6B.4.3\_1.1.4.2 Inter-band EN-DC within FR1 with 3 DL CCs (2NR DL CCs)

Same test description as in clause 7.6.4.4 or 7.6A.4.1.4 in TS 38.521-1 [8] for the NR carrier with the following exceptions:

The initial test configurations for E-UTRA consist of test frequency based on E-UTRA operating band and test channel bandwidth as specified in Table 4.6-1.

For Initial conditions as in clause 7.6A.4.1.4.1 in TS 38.521-1 [8], add step 2.1 and step 3.1 as follows:

- 2.1. The parameter settings for E-UTRA cell are set up according to TS 36.508 [11] clause 4.4.3.
- 3.1. The E-UTRA downlink signal level, uplink signal level are set according to Table 4.6-1 and propagation conditions are set according to Annex B.0 of TS 36.521-1 [10].

Step 6 of Initial conditions as in clause 7.6A.4.1.4.1 in TS 38.521-1 [8] is replaced by:

6. Ensure the UE is in state RRC\_CONNECTED with generic procedure parameters Connectivity EN-DC, DC bearer MCG and SCG, Connected without release  $On$  according to TS 38.508 [6] clause 4.5.

Add step 7 to Initial conditions in clause 7.6A.4.1.4.1 in TS 38.521-1 [8] as follows:

7. On the E-UTRA carrier, disable periodic and aperiodic CQI reports, disable SRS, set *TimeAlignmentTimerDedicated* IE to infinity and disable downlink and uplink scheduling, all as per Table 4.6-1 under clause 4.6.

### 7.6B.4.3\_1.1.5 Test Requirement

For intra-band contiguous EN-DC within FR1 with 3 DL CCs: Same test requirement as in clause 7.6B.4.1.5.

For inter-band EN-DC within FR1 with 3 DL CCs (2NR DL CCs): Same test requirement as in clause 7.6A.4.1.5 in TS 38.521-1 [8].

### 7.6B.4.3\_1.2 Narrow band blocking for EN-DC within FR1 (4 CCs)

#### 7.6B.4.3\_1.2.1 Test Purpose

Verifies a receiver's ability to receive EN-DC signals at its assigned channel frequencies in the presence of an unwanted narrow band CW interferer at a frequency, which is less than the nominal channel spacing.

The lack of narrow-band blocking ability will decrease the coverage area when other NodeB transmitters exist (except in the adjacent channels and spurious response).

#### 7.6B.4.3\_1.2.2 Test Applicability

This test case applies to all types of E-UTRA UE release 15 and forward, supporting intra-band contiguous EN-DC within FR1 with 4 DL CCs or inter-band EN-DC within FR1 with 4 DL CCs (3NR DL CCs).

#### 7.6B.4.3\_1.2.3 Minimum Conformance Requirements

For intra-band contiguous EN-DC within FR1 with 4 DL CCs: The minimum conformance requirements are defined in clause 7.6B.4.0.1. Exception requirements for both NR and E-UTRA are defined for this test and therefore LTE anchor agnostic approach is not applied. E-UTRA test point analysis is included and E-UTRA measurements are performed.

For inter-band EN-DC within FR1 with 4 DL CCs (3NR DL CCs): The minimum conformance requirements are defined in clause 7.6B.4.0.3. No exception requirements applicable to NR or E-UTRA. LTE anchor agnostic approach is applied.

#### 7.6B.4.3\_1.2.4 Test Description

##### 7.6B.4.3\_1.2.4.1 Intra-band contiguous EN-DC within FR1 with 4 DL CCs

##### 7.6B.4.3\_1.2.4.1.1 Initial condition

Initial conditions are a set of test configurations the UE needs to be tested in and the steps for the SS to take with the UE to reach the correct measurement state.

The initial test configurations consist of environmental conditions, test frequencies and channel bandwidths based on EN-DC operating bands specified in clause 5.3B.1.2, channel bandwidths and sub-carrier spacings for the NR cell specified in TS 38.521-1 [8] clause 5.3 and channel bandwidth for the E-UTRA cell are specified in TS 36.521-1 [10] clause 5.4.2. All of these configurations shall be tested with applicable test parameters for each EN-DC configuration specified in clause 5.3B.1.2 and are shown in Table 7.6B.4.3\_1.2.4.1.1-1. The details of the uplink and downlink reference measurement channels (RMCs) are specified in Annex A.2 and A.3 respectively. The details of the OCN patterns used are specified in TS 36.521-1 [10] Annex A.5 and in TS 38.521-1 [8] Annex A.5 for E-UTRA CG and NR CG respectively. Configurations of PDSCH and PDCCH before measurement are specified in TS 36.521-1 [10] Annex C.2 and in TS 38.521-1 [8] Annex C.2 for E-UTRA CG and NR CG respectively.

**Table 7.6B.4.3\_1.2.4.1.1-1: Test configuration table**

Initial Conditions					
Test Environment as specified in TS 38.508-1 [6] clause 4.1			Normal		
Test Frequencies as specified in TS 38.508-1 [6] clause 4.3.1 for different EN-DC bandwidth classes			Mid range		
Test EN-DC bandwidth combination as specified in Table 5.3B.1.2-1 across bandwidth combination sets supported by the UE			Lowest $N_{RB\_agg}$ , Highest $N_{RB\_agg}$ (NOTE 3)		
NR Test SCS as specified in Table 5.3.5-1 in TS 38.521-1 [8]			Lowest		
NR/E-UTRA Test Parameters					
PCC – E-UTRA		SCC1 – EUTRA and SCC2 – EUTRA		NR	
UL/DL Modulation	UL/DL allocation	UL/DL Modulation	UL/DL allocation	UL/DL Modulation	UL/DL allocation
QPSK/QPSK	REFSENS/Full RB	NA/QPSK	NA/Full RB	DFT-s-OFDM QPSK/CP-OFDM QPSK	REFSENS/Full RB (NOTE 1)
NOTE 1: Full RB allocation shall be used per each SCS and channel BW as specified in Table 7.3.2.4.1-2 of TS 38.521-1 [8].					
NOTE 2: Test Channel Bandwidths are checked separately for each EN-DC band, which applicable channel bandwidths are specified in Table 5.3B.1.2-1.					
NOTE 3: If the UE supports multiple CC Combinations in the EN-DC Configuration with the same $N_{RB\_agg}$ , only the combination with the highest $N_{RB\_SCG}$ is tested.					
NOTE 4: REFSENS refers to Uplink configuration in Table 7.3.2.3-3 in [8] and Table 7.3.3-2 in [10] for NR and E-UTRA CC respectively.					
NOTE 5: In a FR1 band where UE supports 4Rx, the test shall be performed only with 4Rx antennas ports connected and 4Rx REFSENS requirement (TS 38.521-1 [8] Table 7.3.2.5-2) is used in the test requirements.					

1. Connect the SS to the UE antenna connectors as shown in [6] TS 38.508-1 Annex A, in Figure A.3.1.4.2 for SS diagram and clause A.3.2 for UE diagram.
2. The parameter settings for the E-UTRA cell are set up according to TS 36.508 [11] clause 4.4.3, and the parameter settings for the NR cell are set up according to TS 38.508-1 [6] clause 4.4.3.
3. Downlink signals are initially set up according to TS 36.521-1 [10] Annex C and TS 38.521-1 [8] Annex C for E-UTRA CG and NR CG respectively, and uplink signals according to TS 36.521-1 [10] Annex H and TS 38.521-1 [8] Annex G for E-UTRA CG and NR CG respectively.
4. The UL and DL Reference Measurement channels are TS 36.521-1 [10] Annex A.2, A.3 and TS 38.521-1 [8] Annex A.2, A.3 for E-UTRA CG and NR CG respectively.
5. Propagation conditions are set according to TS 36.521-1 [10] Annex B.0 and TS 38.521-1 [8] Annex B.0 for E-UTRA CG and NR CG respectively.
6. Ensure the UE is in state RRC\_CONNECTED with generic procedure parameters Connectivity EN-DC, DC bearer *MCG* and *SCG*, Connected without release *On* according to TS 38.508-1 [6] clause 4.5. Message contents are defined in clause 7.6B.4.3\_1.2.4.1.3.

#### 7.6B.4.3\_1.2.4.1.2 Test procedure

1. SS transmits PDSCH via PDCCH DCI format 1A and PDCCH DCI format 1\_1 for  $C\_RNTI$  to transmit the DL RMC according to Table 7.6B.4.3\_1.2.4.1.1-1 on E-UTRA CC and NR CC respectively. The SS sends downlink MAC padding bits on the DL RMC.
2. SS sends uplink scheduling information for each UL HARQ process via PDCCH DCI format 0 and DCI format 0\_1 for  $C\_RNTI$  to schedule the UL RMC according to Table 7.6B.4.3\_1.2.4.1.1-1 on E-UTRA CC and NR CC respectively. Since the UL has no payload and no loopback data to send the UE sends uplink MAC padding bits on the UL RMC.

3. Set the Downlink signal level to the value as defined in Table 7.6B.4.1.5-1. For NR CC and E-UTRA CC, send uplink power control commands to the UE using 1dB power step size to ensure that the UE output power measured by the test system is within the Uplink power control window, defined as  $-(\text{MU} + \text{Uplink power control window size})$  dB of the target power level in Table 7.6B.4.1.5-1 +  $([10\log(S_{\text{LCRB}}/N_{\text{RB\_alloc}})]$  for NR CC,  $[10\log(P_{\text{LCRB}}/N_{\text{RB\_alloc}})]$  for E-UTRA CC) for at least the duration of the Throughput measurement, where:
  - MU is the test system uplink power measurement uncertainty and is specified in Table F.1.3-1 for the carrier frequency  $f$  and the channel bandwidth BW
  - For NR CC, Uplink power control window size = 1dB (UE power step size) + 0.7dB (UE power step tolerance) + (Test system relative power measurement uncertainty), where, the UE power step tolerance is specified in TS 38.101-1 [2], Table 6.3.4.3-1 and is 0.7dB for 1dB power step size, and the Test system relative power measurement uncertainty is specified in Table F.1.2-1.
  - For E-UTRA CC, Uplink power control window size = 1dB (UE power step size) + 1.0dB (UE power step tolerance) + (Test system relative power measurement uncertainty), where, the UE power step tolerance is specified in TS 36.101 [5], Table 6.3.5.2.1-1 and is 1.0dB for 1dB power step size, and the Test system relative power measurement uncertainty is specified in Table F.1.2-1 of TS 36.521-1 [10].
4. Set the parameters of the CW signal generator for an interfering signal below the aggregated component carriers according to Table 7.6B.4.1.5-1.
5. Measure the average throughput for a duration sufficient to achieve statistical significance according to Annex H.2.
6. Repeat steps from 4 to 5, using an interfering signal above the aggregated component carriers at step 4.

NOTE: The purpose of the Uplink power control window is to ensure that the actual UE output power is no greater than the target power level, and as close as possible to the target power level. The relationship between the Uplink power control window, the target power level and the corresponding possible actual UE Uplink power window is illustrated in Annex F, clause F.4.

#### 7.6B.4.3\_1.2.4.1.3 Message contents

Message contents are according to TS 38.508-1 [6] clause 4.6 Table 4.6.3-118 with condition TRANSFORM\_PRECODER\_ENABLED.

#### 7.6B.4.3\_1.2.4.2 Inter-band EN-DC within FR1 with 4 DL CCs (3NR DL CCs)

Same test description as in clause 7.6A.4.2.4 in TS 38.521-1 [8] for the NR carrier with the following exceptions:

The initial test configurations for E-UTRA consist of test frequency based on E-UTRA operating band and test channel bandwidth as specified in Table 4.6-1.

For Initial conditions as in clause 7.6A.4.2.4.1 in TS 38.521-1 [8], add step 2.1 and step 3.1 as follows:

- 2.1. The parameter settings for E-UTRA cell are set up according to TS 36.508 [11] clause 4.4.3.
- 3.1. The E-UTRA downlink signal level, uplink signal level are set according to Table 4.6-1 and propagation conditions are set according to Annex B.0 of TS 36.521-1 [10].

Step 6 of Initial conditions as in clause 7.6A.4.2.4.1 in TS 38.521-1 [8] is replaced by:

6. Ensure the UE is in state RRC\_CONNECTED with generic procedure parameters Connectivity EN-DC, DC bearer MCG and SCG, Connected without release  $On$  according to TS 38.508 [6] clause 4.5.

Add step 7 to Initial conditions in clause 7.6A.4.2.4.1 in TS 38.521-1 [8] as follows:

7. On the E-UTRA carrier, disable periodic and aperiodic CQI reports, disable SRS, set *TimeAlignmentTimerDedicated* IE to infinity and disable downlink and uplink scheduling, all as per Table 4.6-1 under clause 4.6.

#### 7.6B.4.3\_1.2.5 Test Requirement

For intra-band contiguous EN-DC within FR1 with 4 DL CCs: Same test requirement as in clause 7.6B.4.1.5.

For inter-band EN-DC within FR1 with 4 DL CCs (3NR DL CCs): Same test requirement as in clause 7.6A.4.2.5 in TS 38.521-1 [8].

#### 7.6B.4.3\_1.3 Narrow band blocking for EN-DC within FR1 (5 CCs)

##### 7.6B.4.3\_1.3.1 Test Purpose

Same test purpose as in clause 7.6B.4.3.1.

##### 7.6B.4.3\_1.3.2 Test Applicability

This test case applies to all types of E-UTRA UE release 16 and forward, supporting inter-band EN-DC within FR1 with 5 DL CCs (4 NR DL CCs).

##### 7.6B.4.3\_1.3.3 Minimum Conformance Requirements

The minimum conformance requirements are defined in clause 7.6B.4.0.3.

No exception requirements applicable to NR or E-UTRA. LTE anchor agnostic approach is applied.

##### 7.6B.4.3\_1.3.4 Test Description

Same test description as in clause 7.6A.4.3.4 in TS 38.521-1 [8] for the NR carrier with the following exceptions:

The initial test configurations for E-UTRA consist of test frequency based on E-UTRA operating band and test channel bandwidth as specified in Table 4.6-1.

For Initial conditions as in clause 7.6A.4.3.4.1 in TS 38.521-1 [8], add step 2.1 and step 3.1 as follows:

- 2.1. The parameter settings for E-UTRA cell are set up according to TS 36.508 [11] clause 4.4.3.
- 3.1. The E-UTRA downlink signal level, uplink signal level are set according to Table 4.6-1 and propagation conditions are set according to Annex B.0 of TS 36.521-1 [10].

Step 6 of Initial conditions as in clause 7.6A.4.3.4.1 in TS 38.521-1 [8] is replaced by:

6. Ensure the UE is in state RRC\_CONNECTED with generic procedure parameters Connectivity EN-DC, DC bearer MCG and SCG, Connected without release *On* according to TS 38.508 [6] clause 4.5.

Add step 7 to Initial conditions in clause 7.6A.4.3.4.1 in TS 38.521-1 [8] as follows:

7. On the E-UTRA carrier, disable periodic and aperiodic CQI reports, disable SRS, set *TimeAlignmentTimerDedicated* IE to infinity and disable downlink and uplink scheduling, all as per Table 4.6-1 under clause 4.6.

##### 7.6B.4.3\_1.3.5 Test Requirement

Same test requirement as in clause 7.6A.4.3.5 in TS 38.521-1 [8].

##### 7.6B.4.3\_1.4 Void

#### 7.6B.4.3a Narrow band blocking for inter-band NE-DC within FR1 (2 CCs)

No exception requirements applicable to NR or E-UTRA.

No test case details are specified. The requirements for NR carrier(s) in this test case are tested in 7.6.4 and 7.6A.4 of TS 38.521-1 [8], and the requirements for LTE carrier(s) in this test case are tested in 7.6.3 and 7.6.3A of TS 36.521-1 [10]. Neither NR carrier(s) nor LTE carrier(s) needs to be tested again.

## 7.6E Blocking characteristics for V2X in FR1

### 7.6E.0 Minimum conformance requirements

For intra-band V2X operation, the blocking characteristics specified in clause 7.6.1.1G in TS 36.101 [5] and specified in clause 7.6E in TS 38.101-1 [2] apply when all SL reception CCs are activated at same time.

For inter-band con-current NR V2X operation, the blocking characteristics requirements shall be applied per each component carrier. The in-band blocking and out of band blocking requirement specified in clause 7.6E in TS 38.101-1 [2] shall apply on NR V2X carrier and the requirement specified in clause 7.6 in TS 36.101 [5] shall apply for the E-UTRA downlink reception in licensed band while all downlink carriers are active. The requirements specified in subclause 7.6.1.1G and 7.6.2.1G of TS 36.101 [5] shall apply for the E-UTRA sidelink reception and the requirements specified in subclause 7.6 of TS 38.101-1 [2] shall apply for the NR downlink reception while all downlink carriers are active.  $P_{\text{Interferer}}$  power is increased by  $\Delta R_{\text{IB,c}}$  in the requirement.

No narrow band blocking requirement applied for NR V2X carrier.

The normative reference for this requirement is TS 38.101-3 [4] clause 7.6E.

### 7.6E.1 In-band blocking for V2X operation

#### 7.6E.1.1 Test purpose

In-band blocking is defined for an unwanted interfering signal falling into the frequency range (see clause 7.6.1 and 7.6.1G of TS 36.521-1 [10] and clause 7.6.2 and 7.6E.2 of TS 38.521-1 [8]), at which the relative throughput shall meet or exceed the requirement for the specified measurement channels.

The lack of in-band blocking ability will decrease the coverage area when other transmitters exist (except in the adjacent channels and spurious response).

#### 7.6E.1.2 Test applicability

No exception requirements applicable to NR V2X operation or E-UTRA V2X operation. The requirements in this test case can be well covered in clause 7.6.1 and 7.6.1G of TS 36.521-1 [10] and clause 7.6.2 and 7.6E.2 of TS 38.521-1 [8] and don't need to be tested again.

### 7.6E.2 Out-of-band blocking for V2X operation

#### 7.6E.2.1 Test purpose

Out-of-band blocking for V2X is defined for an unwanted CW interfering signal falling into the frequency range ( see clause 7.6.2 and 7.6.2G of TS 36.521-1 [10] and clause 7.6.3 and 7.6E.3 of TS 38.521-1 [8] ), at which a given average throughput shall meet or exceed the requirement for the specified measurement channels in aggregated signals.

The lack of out-of-band blocking ability will decrease the coverage area when other transmitters exist (except in the adjacent channels and spurious response).

#### 7.6E.2.2 Test applicability

No exception requirements applicable to NR V2X operation or E-UTRA V2X operation. The requirements in this test case can be well covered in clause 7.6.2 and 7.6.2G of TS 36.521-1 [10] and clause 7.6.3 and 7.6E.3 of TS 38.521-1 [8] and don't need to be tested again.



## 7.7 Void

### 7.7A Spurious response for CA

#### 7.7A.1 Test purpose

Same test purpose as in clause 7.7 in TS 38.521-1 [8] for NR FR1 carrier(s).

#### 7.7A.2 Test applicability

The requirements are only for FR1. Therefore, only the conducted requirements are tested.

No test case details are specified. The NR/5GC requirements for Spurious response apply and are tested in TS 38.521-1 [8] clause 7.7 and 7.7A.

### 7.7B Spurious response for DC

#### 7.7B.0 Minimum Conformance Requirements

##### 7.7B.0.1 Intra-band contiguous EN-DC

Intra-band contiguous EN-DC spurious response requirement and parameters are defined in Table 7.7B.0.1-1.

**Table 7.7B.0.1-1: Spurious Response Parameters for intra-band contiguous EN-DC**

EN-DC Aggregated Bandwidth, MHz	≤100	>100, ≤120	>120, ≤140	>140, ≤160
P <sub>w</sub> in Transmission Bandwidth Configuration, perCC, dBm	REFSENS + Aggregated BW specific value below			
	9			
P <sub>interferer</sub> , dBm (CW)	-44			
NOTE 1: For NR carrier, the transmitter shall be set to 4dB below P <sub>C<sub>MAX</sub>L<sub>f,c</sub>NR</sub> at the minimum uplink configuration specified in Table 7.3.2-3 in TS 38.101-1 [2] with P <sub>C<sub>MAX</sub>L<sub>f,c</sub>NR</sub> as defined in clause 6.2B.4.				
NOTE 2: For E-UTRA carrier, the transmitter shall be set to 29dB below P <sub>C<sub>MAX</sub>L<sub>E-UTRA,c</sub></sub> at the minimum uplink configuration specified in Table 7.3.1-2 in TS 36.101 [5] with P <sub>C<sub>MAX</sub>L<sub>E-UTRA,c</sub></sub> as defined in clause 6.2B.4 for single carrier.				

The normative reference for this requirement is TS 38.101-3 [4] clause 7.7B.1.

##### 7.7B.0.2 Intra-band non-contiguous EN-DC

For the E-UTRA sub-block containing one or multiple CC's, the requirement is defined in clause 7.7.1 for single carrier operation and in clause 7.7.1A for CA in TS 36.101 [5].

For the NR sub-block, the requirement is defined in clause 7.7 in TS 38.101-1 [2].

The normative reference for this requirement is TS 38.101-3 [4] clause 7.7B.2.

##### 7.7B.0.3 Inter-band EN-DC within FR1

Spurious response requirement for E-UTRA single carrier and CA operation specified in clauses 7.7.1 and 7.7.1A of TS 36.101 [5] and for NR single carrier and CA operation specified in clauses 7.7 and 7.7A of TS 38.101-1 [2] apply for lowest level EN-DC fallbacks (two bands) in clause 5.5B.4.1 with following conditions:

- one E-UTRA uplink carrier with the output power set to 4 dB below P<sub>C<sub>MAX</sub>L<sub>c</sub></sub> and the NR band whose downlink is being tested has its uplink carrier output power set to 29 dB below P<sub>C<sub>MAX</sub>L<sub>f,c</sub></sub>.

- one NR uplink carrier with the output power set to 4 dB below  $P_{\text{CMAX\_L,f,c}}$  on the NR band with both E-UTRA and NR downlinks being tested with E-UTRA output power set to 29 dB below  $P_{\text{CMAX\_L,c}}$ .

The normative reference for this requirement is TS 38.101-3 [4] clause 7.7B.3.

### 7.7B.0.3a Inter-band NE-DC within FR1

Spurious response requirement for E-UTRA single carrier and CA operation specified in clauses 7.7.1 and 7.7.1A of TS 36.101 [5] and for NR single carrier and CA operation specified in clauses 7.7 and 7.7A of TS 38.101-1 [2] apply for lowest level NE-DC fallbacks (two bands) in clause 5.5B.4a.1 with following conditions:

- one E-UTRA uplink carrier with the output power set to 4 dB below  $P_{\text{CMAX\_L,c}}$  and the NR band whose downlink is being tested has its uplink carrier output power set to 29 dB below  $P_{\text{CMAX\_L,f,c}}$ .
- one NR uplink carrier with the output power set to 4 dB below  $P_{\text{CMAX\_L,f,c}}$  on the NR band with both E-UTRA and NR downlinks being tested with E-UTRA output power set to 29 dB below  $P_{\text{CMAX\_L,c}}$ .

The normative reference for this requirement is TS 38.101-3 [4] clause 7.7B.3a.

### 7.7B.0.4 Inter-band EN-DC including FR2

Spurious response requirement for E-UTRA single carrier and CA operation specified in clauses 7.7.1 and 7.7.1A of TS 36.101 [5] apply for lowest level EN-DC fallbacks (two bands) in clause 5.5B.5.1 with only E-UTRA UL with output power as in TS 36.101 [5] (4 dB below  $P_{\text{CMAX\_L}}$ ).

The normative reference for this requirement is TS 38.101-3 [4] clause 7.7B.4.

### 7.7B.0.5 Inter-band EN-DC including both FR1 and FR2

Spurious response requirement for E-UTRA single carrier and CA operation specified in clauses 7.7.1 and 7.7.1A of TS 36.101 [5] and for NR single carrier and CA operation specified in clauses 7.7 and 7.7A of TS 38.101-1 [2] apply for lowest level EN-DC fallbacks (three bands) in clause 5.5B.6.2 with only E-UTRA UL with output power as in TS 36.101 [5] (4 dB below  $P_{\text{CMAX\_L}}$ ).

The normative reference for this requirement is TS 38.101-3 [4] clause 7.7B.5.

## 7.7B.1 Spurious Response for intra-band contiguous EN-DC (2 CCs)

### 7.7B.1.1 Test Purpose

Spurious response for EN-DC verifies the receiver's ability to receive a wanted aggregated signal on its assigned channel frequency without exceeding a given degradation due to the presence of an unwanted CW interfering signal at any other frequency at which a response is obtained i.e. for which the out of band blocking limit as specified in clause 7.6B.3.1 is not met.

The lack of the spurious response ability decreases the coverage area when other unwanted interfering signal exists at any other frequency.

### 7.7B.1.2 Test Applicability

This test case applies to all types of E-UTRA UE release 15 and forward, supporting intra-band contiguous EN-DC in FR1 with 2 DL CCs.

### 7.7B.1.3 Minimum Conformance Requirements

The minimum conformance requirements are defined in clause 7.7B.0.1.

Exception requirements for both NR and E-UTRA are defined for this test and therefore LTE anchor agnostic approach is not applied. E-UTRA test point analysis is included and E-UTRA measurements are performed.

## 7.7B.1.4 Test Description

## 7.7B.1.4.1 Initial condition

The initial conditions shall be the same as in clause 7.6B.3.1.4.1 in order to test spurious responses obtained in clause 7.6B.3.1 under the same conditions.

## 7.7B.1.4.2 Test procedure

1. SS transmits PDSCH via PDCCH DCI format 1A and PDCCH DCI format 1\_1 for C\_RNTI to transmit the DL RMC according to Table 7.6B.3.1.4.1-1 on E-UTRA CC and NR CC respectively. The SS sends downlink MAC padding bits on the DL RMC.
2. SS sends uplink scheduling information for each UL HARQ process via PDCCH DCI format 0 and DCI format 0\_1 for C\_RNTI to schedule the UL RMC according to Table 7.6B.3.1.4.1-1 on E-UTRA CC and NR CC respectively. Since the UL has no payload and no loopback data to send the UE sends uplink MAC padding bits on the UL RMC.
3. Set the Downlink signal level to the value as defined in Table 7.7B.1.5-1. For NR CC and E-UTRA CC, send uplink power control commands to the UE using 1dB power step size to ensure that the UE output power measured by the test system is within the Uplink power control window, defined as  $-(\text{MU} + \text{Uplink power control window size})$  dB of the target power level in Table 7.7B.1.5-1 for at least the duration of the Throughput measurement, where:
  - MU is the test system uplink power measurement uncertainty and is specified in Table F.1.3-1 for the carrier frequency  $f$  and the channel bandwidth BW.
  - For NR CC, Uplink power control window size = 1dB (UE power step size) + 0.7dB (UE power step tolerance) + (Test system relative power measurement uncertainty), where, the UE power step tolerance is specified in TS 38.101-1 [2], Table 6.3.4.3-1 and is 0.7dB for 1dB power step size, and the Test system relative power measurement uncertainty is specified in Table F.1.2-1.
  - For E-UTRA CC, Uplink power control window size = 1dB (UE power step size) + 1.0dB (UE power step tolerance) + (Test system relative power measurement uncertainty), where, the UE power step tolerance is specified in TS 36.101 [5], Table 6.3.5.2.1-1 and is 1.0dB for 1dB power step size, and the Test system relative power measurement uncertainty is specified in Table F.1.2-1 of TS 36.521-1 [10].
4. Set the parameters of the CW signal generator for an interfering signal according to Table 7.7B.1.5-1. The spurious frequencies are taken from records in the final step of test procedures in clause 7.6B.3.1.4.2.
5. For each spurious frequency, Measure the average throughput for a duration sufficient to achieve statistical significance according to Annex H.2.

NOTE: The purpose of the Uplink power control window is to ensure that the actual UE output power is no greater than the target power level, and as close as possible to the target power level. The relationship between the Uplink power control window, the target power level and the corresponding possible actual UE Uplink power window is illustrated in Annex F, clause F.4.

## 7.7B.1.4.3 Message contents

Message contents are according to TS 36.508 [11] clause 4.6.1 and TS 38.508-1 [6] clause 4.6 Table 4.6.3-118 with condition TRANSFORM\_PRECODER\_ENABLED with the following exceptions.

**Table 7.7B.1.4.3-1: PhysicalCellGroupConfig**

Derivation Path: TS 38.508-1 [6], Table 4.6.3-106			
Information Element	Value/remark	Comment	Condition
p-NR-FR1	20		Power Class 3 UE
	23		Power Class 2 UE

**Table 7.7B.1.4.3-2: RRCConnectionReconfiguration**

Derivation Path: TS 36.508 [11], Table 4.6.1-8			
Information Element	Value/remark	Comment	Condition
nonCriticalExtension SEQUENCE {		RRCConnectionReconfiguration-v1530-IEs	
p-MaxEUTRA-r15	20		Power Class 3 UE
	23		Power Class 2 UE
}			

**7.7B.1.5 Test Requirement**

The throughput shall be  $\geq 95\%$  of the maximum throughput of the reference measurement channels as specified in TS 36.521-1 [10] Annex A.3 and TS 38.521-1 [8] Annex A.3 for E-UTRA CG and NR CG respectively with parameters specified in Table 7.7B.1.5-1 for the specified wanted signal mean power in the presence of interfering signals.

**Table 7.7B.1.5-1: Spurious Response for intra-band contiguous EN-DC**

EN-DC Aggregated Bandwidth, MHz	$\leq 100$	$>100, \leq 120$	$>120, \leq 140$	$>140, \leq 160$
Pw in Transmission Bandwidth Configuration, perCC, dBm	REFSENS + Aggregated BW specific value below			
	9			
P <sub>interferer</sub> , dBm (CW)	-44			
NOTE 1: For NR carrier, the transmitter shall be set to 4dB below P <sub>CMAX_L,f,c,NR</sub> at the minimum uplink configuration specified in Table 7.3.2-3 in TS 38.101-1 [2] with P <sub>CMAX_L,f,c,NR</sub> as defined in clause 6.2B.4.				
NOTE 2: For E-UTRA carrier, the transmitter shall be set to 29dB below P <sub>CMAX_L,E-UTRA,c</sub> at the minimum uplink configuration specified in Table 7.3.1-2 in TS 36.101 [5] with P <sub>CMAX_L,E-UTRA,c</sub> as defined in clause 6.2B.4 for single carrier.				

**Table 7.7B.1.5-2: Void****Table 7.7B.1.5-3: Void****7.7B.2 Spurious Response for intra-band non-contiguous EN-DC (2 CCs)****7.7B.2.1 Test Purpose**

Same test purpose as in clause 7.7.1 in TS 38.521-1 [8] for the NR carrier.

**7.7B.2.2 Test Applicability**

This test case applies to all types of E-UTRA UE release 15 and forward, supporting intra-band non-contiguous EN-DC in FR1 with 2 DL CCs.

**7.7B.2.3 Minimum Conformance Requirements**

The minimum conformance requirements are defined in clause 7.7B.0.2.

No exception requirements applicable to NR or E-UTRA. LTE anchor agnostic approach is applied.

**7.7B.2.4 Test Description**

Same test description as in clause 7.7.4 in TS 38.521-1 [8] for the NR carrier with the following exceptions:

The initial conditions shall be the same as the initial conditions in clause 7.6B.3.2.4 in order to test spurious responses obtained in clause 7.6B.3.2 under the same conditions.

Step 4 of Test procedure as in clause 7.7.4.2 in TS 38.521-1 [8] is replaced by:

4. Set the downlink signal level for NR CC according to the Table 7.7.5-1 or 7.7.5-1a in TS 38.521-1 [8] as appropriate. For NR CC and E-UTRA CC, send uplink power control commands to the UE using 1dB power step size to ensure that the UE output power measured by the test system is within the Uplink power control window, defined as  $-\text{MU}$  to  $-(\text{MU} + \text{Uplink power control window size})$  dB of 4dB below  $P_{\text{CMAX\_L,f,c}}$  for NR CC for at least the duration of the Throughput measurement, where:
  - MU is the test system uplink power measurement uncertainty and is specified in Table F.1.3-1 for the carrier frequency  $f$  and the channel bandwidth BW
  - For NR CC, Uplink power control window size = 1dB (UE power step size) + 0.7dB (UE power step tolerance) + (Test system relative power measurement uncertainty), where, the UE power step tolerance is specified in TS 38.101-1 [2], Table 6.3.4.3-1 and is 0.7dB for 1dB power step size, and the Test system relative power measurement uncertainty is specified in Table F.1.2-1.

#### 7.7B.2.5 Test Requirement

Same test requirement as in clause 7.7.5 in TS 38.521-1 [8].

### 7.7B.3 Spurious Response for inter-band EN-DC within FR1 (2 CCs)

#### 7.7B.3.1 Test Purpose

Spurious response is a measure of the ability of the receiver to receive a wanted signal on its assigned channel frequency without exceeding a given degradation due to the presence of an unwanted CW interfering signal at any other frequency for which a response is obtained, i.e. for which the out-of-band blocking limit as specified in subclause 7.6B.3.3 is not met.

The lack of the spurious response ability decreases the coverage area when other unwanted interfering signal exists at any other frequency.

#### 7.7B.3.2 Test Applicability

This test case applies to all types of E-UTRA UE release 15 and forward, supporting inter-band EN-DC within FR1 with 2 DL CCs.

#### 7.7B.3.3 Minimum Conformance Requirements

The minimum conformance requirements are defined in clause 7.7B.0.3.

Exception requirements for both NR and E-UTRA are defined for this test and therefore LTE anchor agnostic approach is not applied. E-UTRA test point analysis is included and E-UTRA measurements are performed.

#### 7.7B.3.4 Test Description

##### 7.7B.3.4.1 Initial Conditions

The initial conditions shall be the same as in clause 7.6B.3.3.4.1 in order to test spurious responses obtained in clause 7.6B.3.3 under the same conditions.

##### 7.7B.3.4.2 Test procedure

1. SS transmits PDSCH via PDCCH DCI format 1A and PDCCH DCI format 1\_1 for C\_RNTI to transmit the DL RMC according to Table 7.6B.3.3.4.1-1 on E-UTRA CC and NR CC respectively. The SS sends downlink MAC padding bits on the DL RMC.
2. SS sends uplink scheduling information for each UL HARQ process via PDCCH DCI format 0 and DCI format 0\_1 for C\_RNTI to schedule the UL RMC according to Table 7.6B.3.3.4.1-1 on E-UTRA CC and NR CC respectively. Since the UL has no payload and no loopback data to send the UE sends uplink MAC padding bits on the UL RMC.

3. Set the Downlink signal level to the value as defined in Table 7.7B.3.5-1, Table 7.7B.3.5-3, or Table 7.7B.3.5-4 for E-UTRA CC and NR CC respectively. For NR CC and E-UTRA CC, send uplink power control commands to the UE using 1dB power step size to ensure that the UE output power measured by the test system is within the Uplink power control window, defined as  $-(\text{MU} + \text{Uplink power control window size})$  dB of  $(P_{\text{CMAX,L,c}} - 4\text{dB})$  for E-UTRA CC, and of 29 dB below  $P_{\text{CMAX,L,f,c}}$  for NR CC for at least the duration of the Throughput measurement, where:
  - MU is the test system uplink power measurement uncertainty and is specified in Table F.1.3-1 for the carrier frequency  $f$  and the channel bandwidth BW
  - For NR CC, Uplink power control window size = 1dB (UE power step size) + 0.7dB (UE power step tolerance) + (Test system relative power measurement uncertainty), where, the UE power step tolerance is specified in TS 38.101-1 [2], Table 6.3.4.3-1 and is 0.7dB for 1dB power step size, and the Test system relative power measurement uncertainty is specified in Table F.1.2-1.
  - For E-UTRA CC, Uplink power control window size = 1dB (UE power step size) + 1.0dB (UE power step tolerance) + (Test system relative power measurement uncertainty), where, the UE power step tolerance is specified in TS 36.101 [5], Table 6.3.5.2.1-1 and is 1.0dB for 1dB power step size, and the Test system relative power measurement uncertainty is specified in Table F.1.2-1 of TS 36.521-1 [10].
4. Set the parameters of the CW signal generator for an interfering signal according to Table 7.7B.3.5-2. The spurious frequencies are taken from records in test procedures in clause 7.6B.3.3.4.2.
5. For the spurious frequency, measure the average throughput of NR CC for a duration sufficient to achieve statistical significance according to Annex H.2.
6. Set the Downlink signal level to the value as defined in Table 7.7B.3.5-1, Table 7.7B.3.5-3, or Table 7.7B.3.5-4 for E-UTRA CC and NR CC respectively. For NR CC and E-UTRA CC, send uplink power control commands to the UE using 1dB power step size to ensure that the UE output power measured by the test system is within the Uplink power control window, defined as  $-(\text{MU} + \text{Uplink power control window size})$  dB of  $(P_{\text{CMAX,L,f,c}} - 4\text{dB})$  for NR CC, and of 29 dB below  $P_{\text{CMAX,L,c}}$  for E-UTRA CC for at least the duration of the Throughput measurement, where:
  - MU is the test system uplink power measurement uncertainty and is specified in Table F.1.3-1 for the carrier frequency  $f$  and the channel bandwidth BW
  - For NR CC, Uplink power control window size = 1dB (UE power step size) + 0.7dB (UE power step tolerance) + (Test system relative power measurement uncertainty), where, the UE power step tolerance is specified in TS 38.101-1 [2], Table 6.3.4.3-1 and is 0.7dB for 1dB power step size, and the Test system relative power measurement uncertainty is specified in Table F.1.2-1.
  - For E-UTRA CC, Uplink power control window size = 1dB (UE power step size) + 1.0dB (UE power step tolerance) + (Test system relative power measurement uncertainty), where, the UE power step tolerance is specified in TS 36.101 [5], Table 6.3.5.2.1-1 and is 1.0dB for 1dB power step size, and the Test system relative power measurement uncertainty is specified in Table F.1.2-1 of TS 36.521-1 [10].
7. Set the parameters of the CW signal generator for an interfering signal according to Table 7.7B.3.5-2. The spurious frequencies are taken from records in test procedures in clause 7.6B.3.3.4.2 for E-UTRA CC and NR CC testing respectively..
8. For the spurious frequency, measure the average throughput of E-UTRA CC and NR CC respectively for a duration sufficient to achieve statistical significance according to Annex H.2.

NOTE: The purpose of the Uplink power control window is to ensure that the actual UE output power is no greater than the target power level, and as close as possible to the target power level. The relationship between the Uplink power control window, the target power level and the corresponding possible actual UE Uplink power window is illustrated in Annex F, clause F.4.

#### 7.7B.3.4.3 Message contents

Message contents are according to TS 36.508 [11] clause 4.6.1 and TS 38.508-1 [6] clause 4.6 with the following exceptions.

**Table 7.7B.3.4.3-1: PhysicalCellGroupConfig**

Derivation Path: TS 38.508-1 [6], Table 4.6.3-106			
Information Element	Value/remark	Comment	Condition
p-NR-FR1	20		Power Class 3 UE
	23		Power Class 2 UE

**Table 7.7B.3.4.3-2: RRCConnectionReconfiguration**

Derivation Path: TS 36.508 [11], Table 4.6.1-8			
Information Element	Value/remark	Comment	Condition
p-MaxEUTRA-r15	20		Power Class 3 UE
	23		Power Class 2 UE

### 7.7B.3.5 Test Requirement

For E-UTRA bands, the throughput measurement derived in test procedure shall be  $\geq 95\%$  of the maximum throughput of the reference measurement channels as specified in Annex A.3.2 of TS 36.521-1 [10] with parameters specified in Tables 7.7B.3.5-1 and 7.7B.3.5-2.

For NR bands with  $F_{DL\_high} < 2700$  MHz and  $F_{UL\_high} < 2700$  MHz, the throughput measurement derived in test procedure shall be  $\geq 95\%$  of the maximum throughput of the reference measurement channels as specified in Annex A.3.2 and A.3.3 of TS 38.521-1 [8] with parameters specified in Tables 7.7B.3.5-3 and 7.7B.3.5-2.

For NR bands with  $F_{DL\_low} \geq 3300$  MHz and  $F_{UL\_low} \geq 3300$  MHz, the throughput measurement derived in test procedure shall be  $\geq 95\%$  of the maximum throughput of the reference measurement channels as specified in Annex A.3.2 and A.3.3 of TS 38.521-1 [8] with parameters specified in Tables 7.7B.3.5-4 and 7.7B.3.5-2.

**Table 7.7B.3.5-1: Spurious response parameters for E-UTRA bands**

Rx Parameter	Units	Channel bandwidth					
		1.4 MHz	3 MHz	5 MHz	10 MHz	15 MHz	20 MHz
Power in Transmission Bandwidth Configuration	dBm	REFSENS + channel bandwidth specific value below					
		6	6	6	6	7	9
Note 1: The reference measurement channel is specified in Annex A.3.2 of TS 36.521-1 [10] with one sided dynamic OCNB Pattern OP.1 FDD/TDD as described in Annex A.5.1.1/A.5.2.1 of TS 36.521-1 [10].							
Note 2: The REFSENS power level is specified in Table 7.3.3-1 of TS 36.521-1 [10] for two and four antenna ports, respectively.							

**Table 7.7B.3.5-2: Spurious Response for E-UTRA bands and NR bands**

Parameter	Unit	Level
$P_{Interferer}$ (CW)	dBm	-44
$F_{Interferer}$	MHz	Spurious response frequencies

**Table 7.7B.3.5-3: Spurious response parameters for NR bands with  $F_{DL\_high} < 2700$  MHz and  $F_{UL\_high} < 2700$  MHz**

RX parameter	Units	Channel bandwidth				
		5 MHz	10 MHz	15 MHz	20 MHz	25 MHz
Power in transmission bandwidth configuration	dBm	REFSENS + channel bandwidth specific value below				
	dB	6	6	7	9	10
RX parameter	Units	Channel bandwidth				
		30 MHz	40 MHz	50 MHz	60 MHz	80 MHz
Power in transmission bandwidth configuration	dBm	REFSENS + channel bandwidth specific value below				
	dB	11	12	13	14	15
RX parameter	Units	Channel bandwidth				
		90 MHz	100 MHz			
Power in transmission bandwidth configuration	dBm	REFSENS + channel bandwidth specific value below				
	dB	15.5	16			
NOTE: The transmitter shall be at the minimum UL configuration specified in Table 7.3.2.3-3 of TS 38.521-1 [8].						

**Table 7.7B.3.5-4: Spurious response parameters for NR bands with  $F_{DL\_low} \geq 3300$  MHz and  $F_{UL\_low} \geq 3300$  MHz**

RX parameter	Units	Channel bandwidth				
		10 MHz	15 MHz	20 MHz	40 MHz	50 MHz
Power in transmission bandwidth configuration	dBm	REFSENS + channel bandwidth specific value below				
	dB	6	7	9	9	9
RX parameter	Units	Channel bandwidth				
		60 MHz	80 MHz	90 MHz	100 MHz	
Power in transmission bandwidth configuration	dBm	REFSENS + channel bandwidth specific value below				
	dB	9	9	9	9	
NOTE: The transmitter shall be at the minimum UL configuration specified in Table 7.3.2.3-3 of TS 38.521-1 [8].						

## 7.7B.3\_1 Spurious Response for EN-DC within FR1 (>2 CCs)

### 7.7B.3\_1.1 Spurious Response for EN-DC within FR1 (3 CCs)

#### 7.7B.3\_1.1.1 Test Purpose

Spurious response for EN-DC verifies the receiver's ability to receive a wanted aggregated signal on its assigned channel frequency without exceeding a given degradation due to the presence of an unwanted CW interfering signal at any other frequency at which a response is obtained i.e. for which the out of band blocking limit as specified in clause 7.6B.3.3\_1.1 is not met.

The lack of the spurious response ability decreases the coverage area when other unwanted interfering signal exists at any other frequency.

#### 7.7B.3\_1.1.2 Test Applicability

This test case applies to all types of E-UTRA UE release 15 and forward, supporting intra-band contiguous EN-DC in FR1 with 3 DL CCs.



### 7.7B.3\_1.1.3 Minimum Conformance Requirements

The minimum conformance requirements are defined in clause 7.7B.0.1.

Exception requirements for both NR and E-UTRA are defined for this test and therefore LTE anchor agnostic approach is not applied. E-UTRA test point analysis is included and E-UTRA measurements are performed.

### 7.7B.3\_1.1.4 Test Description

#### 7.7B.3\_1.1.4.1 Initial condition

The initial conditions shall be the same as in clause 7.6B.3.3\_1.1.4.1 in order to test spurious responses obtained in clause 7.6B.3.3\_1.1 under the same conditions.

#### 7.7B.3\_1.1.4.2 Test procedure

1. SS transmits PDSCH via PDCCH DCI format 1A and PDCCH DCI format 1\_1 for C\_RNTI to transmit the DL RMC according to Table 7.6B.3.3\_1.1.4.1-1 on E-UTRA CC and NR CC respectively. The SS sends downlink MAC padding bits on the DL RMC.
2. SS sends uplink scheduling information for each UL HARQ process via PDCCH DCI format 0 and DCI format 0\_1 for C\_RNTI to schedule the UL RMC according to Table 7.6B.3.3\_1.1.4.1-1 on E-UTRA CC and NR CC respectively. Since the UL has no payload and no loopback data to send the UE sends uplink MAC padding bits on the UL RMC.
3. Set the Downlink signal level to the value as defined in Table 7.7B.3\_1.1.5-1. For NR CC and E-UTRA CC, send uplink power control commands to the UE using 1dB power step size to ensure that the UE output power measured by the test system is within the Uplink power control window, defined as  $-(\text{MU} + \text{Uplink power control window size})$  dB of the target power level in Table 7.7B.3\_1.1.5-1 +  $([10\log(S_{\text{LCRB}}/N_{\text{RB\_alloc}})])$  for NR CC,  $[10\log(P_{\text{LCRB}}/N_{\text{RB\_alloc}})]$  for E-UTRA CC) for at least the duration of the Throughput measurement, where:
  - MU is the test system uplink power measurement uncertainty and is specified in Table F.1.3-1 for the carrier frequency  $f$  and the channel bandwidth BW.
  - For NR CC, Uplink power control window size = 1dB (UE power step size) + 0.7dB (UE power step tolerance) + (Test system relative power measurement uncertainty), where, the UE power step tolerance is specified in TS 38.101-1 [2], Table 6.3.4.3-1 and is 0.7dB for 1dB power step size, and the Test system relative power measurement uncertainty is specified in Table F.1.2-1.
  - For E-UTRA CC, Uplink power control window size = 1dB (UE power step size) + 1.0dB (UE power step tolerance) + (Test system relative power measurement uncertainty), where, the UE power step tolerance is specified in TS 36.101 [5], Table 6.3.5.2.1-1 and is 1.0dB for 1dB power step size, and the Test system relative power measurement uncertainty is specified in Table F.1.2-1 of TS 36.521-1 [10].
4. Set the parameters of the CW signal generator for an interfering signal according to Table 7.7B.3\_1.1.5-1. The spurious frequencies are taken from records in the final step of test procedures in clause 7.6B.3.3\_1.1.4.2.
5. For each spurious frequency, Measure the average throughput for a duration sufficient to achieve statistical significance according to Annex H.2.

NOTE: The purpose of the Uplink power control window is to ensure that the actual UE output power is no greater than the target power level, and as close as possible to the target power level. The relationship between the Uplink power control window, the target power level and the corresponding possible actual UE Uplink power window is illustrated in Annex F, clause F.4.

#### 7.7B.3\_1.1.4.3 Message contents

Message contents are according to TS 36.508 [11] clause 4.6.1 and TS 38.508-1 [6] clause 4.6 Table 4.6.3-118 with condition TRANSFORM\_PRECODER\_ENABLED with the following exceptions.

**Table 7.7B.3\_1.1.4.3-1: PhysicalCellGroupConfig**

Derivation Path: TS 38.508-1 [6], Table 4.6.3-106			
Information Element	Value/remark	Comment	Condition
p-NR-FR1	20		Power Class 3 UE
	23		Power Class 2 UE

**Table 7.7B.3\_1.1.4.3-2: RRCConnectionReconfiguration**

Derivation Path: TS 36.508 [11], Table 4.6.1-8			
Information Element	Value/remark	Comment	Condition
p-MaxEUTRA-r15	20		Power Class 3 UE
	23		Power Class 2 UE

### 7.7B.3\_1.1.5 Test Requirement

The throughput shall be  $\geq 95\%$  of the maximum throughput of the reference measurement channels as specified in TS 36.521-1 [10] Annex A.3 and TS 38.521-1 [8] Annex A.3 for E-UTRA CG and NR CG respectively with parameters specified in Table 7.7B.3\_1.1.5-1 for the specified wanted signal mean power in the presence of interfering signals.

**Table 7.7B.3\_1.1.5-1: Spurious Response for intra-band contiguous EN-DC**

EN-DC Aggregated Bandwidth, MHz	$\leq 100$	$>100, \leq 120$	$>120, \leq 140$	$>140, \leq 160$
Pw in Transmission Bandwidth Configuration, perCC, dBm	REFSENS + Aggregated BW specific value below			
	9			
$P_{\text{interferer}}$ , dBm (CW)	-44			
NOTE 1: For NR carrier, the transmitter shall be set to 4dB below $P_{\text{CMAX\_L,f,c,NR}}$ at the minimum uplink configuration specified in Table 7.3.2-3 in TS 38.101-1 [2] with $P_{\text{CMAX\_L,f,c,NR}}$ as defined in clause 6.2B.4.				
NOTE 2: For E-UTRA carrier, the transmitter shall be set to 4dB below $P_{\text{CMAX\_L,E-UTRA,c}}$ at the minimum uplink configuration specified in Table 7.3.1-2 in TS 36.101 [5] with $P_{\text{CMAX\_L,E-UTRA,c}}$ as defined in clause 6.2B.4 for single carrier.				

### 7.7B.3\_1.2 Spurious Response for EN-DC within FR1 (4 CCs)

#### 7.7B.3\_1.2.1 Test Purpose

Spurious response for EN-DC verifies the receiver's ability to receive a wanted aggregated signal on its assigned channel frequency without exceeding a given degradation due to the presence of an unwanted CW interfering signal at any other frequency at which a response is obtained i.e. for which the out of band blocking limit as specified in clause 7.6B.3.3\_1.2 is not met.

The lack of the spurious response ability decreases the coverage area when other unwanted interfering signal exists at any other frequency.

#### 7.7B.3\_1.2.2 Test Applicability

This test case applies to all types of E-UTRA UE release 15 and forward, supporting intra-band contiguous EN-DC in FR1 with 4 DL CCs.

#### 7.7B.3\_1.2.3 Minimum Conformance Requirements

The minimum conformance requirements are defined in clause 7.7B.0.1.

Exception requirements for both NR and E-UTRA are defined for this test and therefore LTE anchor agnostic approach is not applied. E-UTRA test point analysis is included and E-UTRA measurements are performed.

#### 7.7B.3\_1.2.4 Test Description

##### 7.7B.3\_1.2.4.1 Initial condition

The initial conditions shall be the same as in clause 7.6B.3.3\_1.2.4.1 in order to test spurious responses obtained in clause 7.6B.3.3\_1.2 under the same conditions.

##### 7.7B.3\_1.2.4.2 Test procedure

1. SS transmits PDSCH via PDCCH DCI format 1A and PDCCH DCI format 1\_1 for C\_RNTI to transmit the DL RMC according to Table 7.6B.3.3\_1.2.4.1-1 on E-UTRA CC and NR CC respectively. The SS sends downlink MAC padding bits on the DL RMC.
2. SS sends uplink scheduling information for each UL HARQ process via PDCCH DCI format 0 and DCI format 0\_1 for C\_RNTI to schedule the UL RMC according to Table 7.6B.3.3\_1.2.4.1-1 on E-UTRA CC and NR CC respectively. Since the UL has no payload and no loopback data to send the UE sends uplink MAC padding bits on the UL RMC.
3. Set the Downlink signal level to the value as defined in Table 7.7B.3\_1.2.5-1. For NR CC and E-UTRA CC, send uplink power control commands to the UE using 1dB power step size to ensure that the UE output power measured by the test system is within the Uplink power control window, defined as  $-(\text{MU} + \text{Uplink power control window size})$  dB of the target power level in Table 7.7B.3\_1.2.5-1  $+( [10\log(S_{\text{LCRB}}/N_{\text{RB\_alloc}})]$  for NR CC,  $[10\log(P_{\text{LCRB}}/N_{\text{RB\_alloc}})]$  for E-UTRA CC) for at least the duration of the Throughput measurement, where:
  - MU is the test system uplink power measurement uncertainty and is specified in Table F.1.3-1 for the carrier frequency  $f$  and the channel bandwidth BW.
  - For NR CC, Uplink power control window size = 1dB (UE power step size) + 0.7dB (UE power step tolerance) + (Test system relative power measurement uncertainty), where, the UE power step tolerance is specified in TS 38.101-1 [2], Table 6.3.4.3-1 and is 0.7dB for 1dB power step size, and the Test system relative power measurement uncertainty is specified in Table F.1.2-1.
  - For E-UTRA CC, Uplink power control window size = 1dB (UE power step size) + 1.0dB (UE power step tolerance) + (Test system relative power measurement uncertainty), where, the UE power step tolerance is specified in TS 36.101 [5], Table 6.3.5.2.1-1 and is 1.0dB for 1dB power step size, and the Test system relative power measurement uncertainty is specified in Table F.1.2-1 of TS 36.521-1 [10].
4. Set the parameters of the CW signal generator for an interfering signal according to Table 7.7B.3\_1.2.5-1. The spurious frequencies are taken from records in the final step of test procedures in clause 7.6B.3.3\_1.2.4.2.
5. For each spurious frequency, Measure the average throughput for a duration sufficient to achieve statistical significance according to Annex H.2.

NOTE: The purpose of the Uplink power control window is to ensure that the actual UE output power is no greater than the target power level, and as close as possible to the target power level. The relationship between the Uplink power control window, the target power level and the corresponding possible actual UE Uplink power window is illustrated in Annex F, clause F.4.

##### 7.7B.3\_1.2.4.3 Message contents

Message contents are according to TS 36.508 [11] clause 4.6.1 and TS 38.508-1 [6] clause 4.6 Table 4.6.3-118 with condition TRANSFORM\_PRECODER\_ENABLED with the following exceptions.

**Table 7.7B.3\_1.2.4.3-1: PhysicalCellGroupConfig**

Derivation Path: TS 38.508-1 [6], Table 4.6.3-106			
Information Element	Value/remark	Comment	Condition
p-NR-FR1	20		Power Class 3 UE
	23		Power Class 2 UE

**Table 7.7B.3\_1.2.4.3-2: RRCConnectionReconfiguration**

Derivation Path: TS 36.508 [11], Table 4.6.1-8			
Information Element	Value/remark	Comment	Condition
p-MaxEUTRA-r15	20		Power Class 3 UE
	23		Power Class 2 UE

### 7.7B.3\_1.2.5 Test Requirement

The throughput shall be  $\geq 95\%$  of the maximum throughput of the reference measurement channels as specified in TS 36.521-1 [10] Annex A.3 and TS 38.521-1 [8] Annex A.3 for E-UTRA CG and NR CG respectively with parameters specified in Table 7.7B.3\_1.2.5-1 for the specified wanted signal mean power in the presence of interfering signals.

**Table 7.7B.3\_1.2.5-1: Spurious Response for intra-band contiguous EN-DC**

EN-DC Aggregated Bandwidth, MHz	$\leq 100$	$>100, \leq 120$	$>120, \leq 140$	$>140, \leq 160$
Pw in Transmission Bandwidth Configuration, perCC, dBm	REFSENS + Aggregated BW specific value below			
	9			
$P_{\text{interferer}}$ , dBm (CW)	-44			
NOTE 1: For NR carrier, the transmitter shall be set to 4dB below $P_{\text{CMAX\_L,f,c,NR}}$ at the minimum uplink configuration specified in Table 7.3.2-3 in TS 38.101-1 [2] with $P_{\text{CMAX\_L,f,c,NR}}$ as defined in clause 6.2B.4.				
NOTE 2: For E-UTRA carrier, the transmitter shall be set to 4dB below $P_{\text{CMAX\_L,E-UTRA,c}}$ at the minimum uplink configuration specified in Table 7.3.1-2 in TS 36.101 [5] with $P_{\text{CMAX\_L,E-UTRA,c}}$ as defined in clause 6.2B.4 for single carrier.				

## 7.7E Spurious response for V2X in FR1

### 7.7E.0 Minimum conformance requirements

For intra-band V2X operation, the spurious response specified in clause 7.7.1G in TS 36.101 [5] and specified in clause 7.7E in TS 38.101-1 [2] apply when all SL reception CCs are activated at same time.

For the inter-band con-current NR V2X operation, the spurious response requirements shall be applied per each component carrier. The requirements specified in subclause 7.7E of TS 38.101-1 [2] shall apply for the NR sidelink reception in Band n47 and the requirements specified in subclause 7.7.1 of TS 36.101 [5] shall apply for the E-UTRA downlink reception in licensed band while all downlink carriers are active. The requirements specified in subclause 7.7.1G of TS 36.101 [5] shall apply for the E-UTRA sidelink reception and the requirements specified in subclause 7.7 of TS 38.101-1 [2] shall apply for the NR downlink reception while all downlink carriers are active.

The normative reference for this requirement is TS 38.101-3 [4] clause 7.7E.

## 7.7E.1 Spurious response for V2X operation

### 7.7E.1.1 Test purpose

Spurious response verifies the receiver's ability to receive a wanted signal on its assigned channel frequency without exceeding a given degradation due to the presence of an unwanted CW interfering signal at any other frequency at which a response is obtained i.e. for which the out of band blocking limit as specified in sub-clause 7.6E.2 is not met.

The lack of the spurious response ability decreases the coverage area when other unwanted interfering signal exists at any other frequency.

### 7.7E.1.2 Test applicability

No exception requirements applicable to NR V2X operation or E-UTRA V2X operation. The requirements in this test case can be well covered in clause 7.7 and 7.7G of TS 36.521-1 [10] and clause 7.7 and 7.7E of TS 38.521-1 [8] and don't need to be tested again.

## 7.8 Void

## 7.8B Intermodulation characteristics for DC

### 7.8B.1 General

### 7.8B.2 Wide band Intermodulation

#### 7.8B.2.0 Minimum Conformance Requirements

##### 7.8B.2.0.1 Intra-band contiguous EN-DC

Intra-band contiguous EN-DC wide band intermodulation requirement and parameters are defined in Table 7.8B.2.0.1-1.

**Table 7.8B.2.0.1-1: Wide band intermodulation**

EN-DC Aggregated Bandwidth, MHz	≤100	>100, ≤120	>120, ≤140	>140, ≤160
P <sub>w</sub> in Transmission Bandwidth Configuration, perCC, dBm	P <sub>w</sub> <sup>1</sup>	16.8	17.5	18.0
P <sub>interferer 1</sub> , dBm (CW) <sup>2</sup>	-46			
P <sub>interferer 2</sub> , dBm (Modulated) <sup>2</sup>	-46			
NOTE 1: P <sub>w</sub> is wanted signal power level from Table 7.8.1A-1 in TS 36.101 [5]				
NOTE 2: Jammer BW and offsets is from Table 7.8.1A-1 [5] and is applied from the lowest edge of the lowest carrier and the highest edge of the highest carrier				
NOTE 3: For NR carrier, the transmitter shall be set to 4dB below P <sub>C<sub>MAX</sub>L,f,c</sub> at the minimum uplink configuration specified in Table 7.3-3 with P <sub>C<sub>MAX</sub>L,f,c</sub> as defined in clause 6.2B.4.				
NOTE 4: For E-UTRA carrier, the transmitter shall be set to 29dB below P <sub>C<sub>MAX</sub>L,c</sub> at the minimum uplink configuration specified in Table 7.3-1-2 with P <sub>C<sub>MAX</sub>L,c</sub> as defined in clause 6.2B.4 for single carrier.				

The normative reference for this requirement is TS 38.101-3 [4] clause 7.8B.2.1.

##### 7.8B.2.0.2 Intra-band non-contiguous EN-DC

For the E-UTRA sub-block containing one or multiple CC's, the requirement is defined in clause 7.8.1 for single carrier operation and in clause 7.8.1A for CA in TS 36.101 [5].

For the NR sub-block, the requirement is defined in clause 7.8.2 in TS 38.101-1 [2].

The blocker configuration is defined in the general clause 7.1 and the requirement only apply for out of gap interferers.

The normative reference for this requirement is TS 38.101-3 [4] clause 7.8B.2.2.

#### 7.8B.2.0.3 Inter-band EN-DC within FR1

Wide band Intermodulation requirement for E-UTRA single carrier and CA operation specified in clauses 7.8.1 and 7.8.1A of TS 36.101 [5] and for NR single carrier and CA operation specified in clauses 7.8.2 and 7.8A.2 of TS 38.101-1 [2] apply.

The normative reference for this requirement is TS 38.101-3 [4] clause 7.8B.2.3.

#### 7.8B.2.0.4 Inter-band EN-DC including FR2

Wide band Intermodulation requirement for E-UTRA single carrier and CA operation specified in clauses 7.8.1 and 7.8.1A of TS 36.101 [5] apply.

The normative reference for this requirement is TS 38.101-3 [4] clause 7.8B.2.4.

#### 7.8B.2.0.5 Inter-band EN-DC including both FR1 and FR2

Wide band Intermodulation requirement for E-UTRA single carrier and CA operation specified in clauses 7.8.1 and 7.8.1A of TS 36.101 [5] and for NR single carrier and CA operation specified in clauses 7.8.2 and 7.8A.2 of TS 38.101-1 [2] apply.

The normative reference for this requirement is TS 38.101-3 [4] clause 7.8B.2.5.

### 7.8B.2.1 Wideband Intermodulation for intra-band contiguous EN-DC (2 CCs)

**Editor's note: This clause is incomplete. The following aspects are either missing or not yet determined:**

- **UL Power configuration is TBD**

#### 7.8B.2.1.1 Test Purpose

Intermodulation response tests the UE's ability to receive data with a given average throughput for a specified reference measurement channel, in the presence of two or more interfering signals which have a specific frequency relationship to the wanted signal, under conditions of ideal propagation and no added noise.

A UE unable to meet the throughput requirement under these conditions will decrease the coverage area when two or more interfering signals exist which have a specific frequency relationship to the wanted signal.

#### 7.8B.2.1.2 Test Applicability

This test case applies to all types of E-UTRA UE release 15 and forward, supporting intra-band contiguous EN-DC in FR1 with 2 DL CCs.

#### 7.8B.2.1.3 Minimum Conformance Requirements

The minimum conformance requirements are defined in clause 7.8B.2.0.1.

Exception requirements for both NR and E-UTRA are defined for this test and therefore LTE anchor agnostic approach is not applied. E-UTRA test point analysis is included and E-UTRA measurements are performed.

#### 7.8B.2.1.4 Test Description

##### 7.8B.2.1.4.1 Initial condition

Initial conditions are a set of test configurations the UE needs to be tested in and the steps for the SS to take with the UE to reach the correct measurement state.

The initial test configurations consist of environmental conditions, test frequencies and channel bandwidths based on EN-DC operating bands specified in clause 5.3B.1.2, channel bandwidths and sub-carrier spacings for the NR cell specified in TS 38.521-1 [8] clause 5.3 and channel bandwidth for the E-UTRA cell are specified in TS 36.521-1 [10] clause 5.4.2. All of these configurations shall be tested with applicable test parameters for each EN-DC configuration specified in clause 5.3B.1.2 and are shown in table 7.8B.2.1.4.1-1. The details of the uplink reference measurement channels (RMCs) are specified in Annex A.2. Configurations of PDSCH and PDCCH before measurement are specified in TS 36.521-1 [10] Annex C.2 and in TS 38.521-1 [8] Annex C.2 for E-UTRA CG and NR CG respectively.

**Table 7.8B.2.1.4.1-1: Test configuration table**

Initial Conditions							
Test Environment as specified in TS 38.508-1 [6] clause 4.1				Normal			
Test Frequencies as specified in TS 38.508-1 [6] clause 4.3.1 for different EN-DC bandwidth classes				Mid range			
Test EN-DC bandwidth combination as specified in Table 5.3B.1.2-1 across bandwidth combination sets supported by the UE				Lowest $N_{RB\_agg}$ , Highest $N_{RB\_agg}$ (NOTE 3)			
NR Test SCS as specified in Table 5.3.5-1 in TS 38.521-1 [8]				Highest			
NR/E-UTRA Test Parameters							
Downlink Configuration				Uplink Configuration			
NR Modulation	NR RB allocation	E-UTRA Modulation	E-UTRA RB allocation	NR Modulation	NR RB allocation	E-UTRA Modulation	E-UTRA RB allocation
CP-OFDM QPSK	Full RB (NOTE 1)	QPSK	Full RB	DFT-s-OFDM QPSK	REFSENS	QPSK	REFSENS
NOTE 1: Full RB allocation shall be used per each SCS and channel BW as specified in Table 7.3.2.4.1-2 of TS 38.521-1 [8].							
NOTE 2: Test Channel Bandwidths are checked separately for each E-UTRA band, which applicable channel bandwidths are specified in Table 5.3B.1.2-1.							
NOTE 3: If the UE supports multiple CC Combinations in the EN-DC Configuration with the same $N_{RB\_agg}$ , only the combination with the highest $N_{RB\_SCG}$ is tested.							
NOTE 4: REFSENS refers to Uplink configuration in Table 7.3.2-3 in [8] and Table 7.3.3-2 in [10] for NR and E-UTRA CC respectively.							
NOTE 5: In an E-UTRA band or NR FR1 band where UE supports 4Rx, the test shall be performed only with 4Rx antennas ports connected and 4Rx REFSENS requirement (TS 38.521-1 [8] Table 7.3.2.5-2) is used in the test requirements.							

1. Connect the SS to the UE antenna connectors as shown in [6] TS 38.508-1 A.3.1.2.1 for SS diagram and A.3.2 for UE diagram.
2. The parameter settings for the E-UTRA cell are set up according to TS 36.508 [11] clause 4.4.3, and the parameter settings for the NR cell are set up according to TS 38.508-1 [6] clause 4.4.3.
3. Downlink signals are initially set up according to TS 36.521-1 [10] Annex C.0 and TS 38.521-1 [8] Annex C.0 for E-UTRA CG and NR CG respectively, and uplink signals according to TS 36.521-1 [10] Annex H and TS 38.521-1 [8] Annex G for E-UTRA CG and NR CG respectively.
4. The UL Reference Measurement channels are TS 36.521-1 [10] Annex A.2 and TS 38.521-1 [8] Annex A.2 for E-UTRA CG and NR CG respectively.
5. Propagation conditions are set according to TS 36.521-1 [10] Annex B.0 and TS 38.521-1 [8] Annex B.0 for E-UTRA CG and NR CG respectively.
6. Ensure the UE is in state RRC\_CONNECTED with generic procedure parameters Connectivity EN-DC, DC bearer *MCG* and *SCG*, Connected without release *On* according to TS 38.508-1 [6] clause 4.5. Message contents are defined in clause 6.2B.1.1.4.3.
7. When E-UTRA and NR bands are TDD, ensure the same uplink-downlink configuration by giving SCG a delay of 3 E-UTRA subframes, or by giving MCG a delay of 2 subframes.

## 7.8B.2.1.4.2 Test procedure

1. SS sends uplink scheduling information for each UL HARQ process via PDCCH DCI format 0 and DCI format 0\_1 for C\_RNTI to schedule the UL RMC according to table 7.8B.2.1.4.1-1 on E-UTRA CC and NR CC respectively. Since the UL has no payload and no loopback data to send the UE sends uplink MAC padding bits on the UL RMC.
2. Set the Downlink signal level to the value as defined in Table 7.8B.2.1.5-1. For NR CC and E-UTRA CC, send uplink power control commands to the UE using 1dB power step size to ensure that the UE output power measured by the test system is within the Uplink power control window, defined as  $-(\text{MU} + \text{Uplink power control window size})$  dB of the target power level in Table 7.8B.2.1.5-1 for at least the duration of the Throughput measurement, where:
  - MU is the test system uplink power measurement uncertainty and is specified in Table F.1.3-1 for the carrier frequency  $f$  and the channel bandwidth BW.
  - For NR CC, Uplink power control window size = 1dB (UE power step size) + 0.7dB (UE power step tolerance) + (Test system relative power measurement uncertainty), where, the UE power step tolerance is specified in TS 38.101-1 [2], Table 6.3.4.3-1 and is 0.7dB for 1dB power step size. and the Test system relative power measurement uncertainty is specified in Table F.1.2-1.
  - For E-UTRA CC, Uplink power control window size = 1dB (UE power step size) + 1.0dB (UE power step tolerance) + (Test system relative power measurement uncertainty), where, the UE power step tolerance is specified in TS 36.101 [5], Table 6.3.5.2.1-1 and is 1.0dB for 1dB power step size, and the Test system relative power measurement uncertainty is specified in Table F.1.2-1 of TS 36.521-1 [10].
3. Set the Interfering signal levels to the values as defined in Table 7.8B.2.1.5-1 and frequency below the wanted signal
4. Measure the average throughput for a duration sufficient to achieve statistical significance according to Annex G.2.
5. Repeat steps from 2 to 4, using an interfering signal above the wanted signal at step 3.

NOTE: The purpose of the Uplink power control window is to ensure that the actual UE output power is no greater than the target power level, and as close as possible to the target power level. The relationship between the Uplink power control window, the target power level and the corresponding possible actual UE Uplink power window is illustrated in Annex F, clause F.4.

## 7.8B.2.1.4.3 Message contents

Message contents are according to TS 38.508-1 [5] clause 4.6 with DFT-s-OFDM condition in Table 4.6.3-118 PUSCH-Config.

## 7.8B.2.1.5 Test Requirement

The throughput shall be  $\geq 95\%$  of the maximum throughput of the reference measurement channels as specified in Annex A.3.2 with parameters specified in Table 7.8B.2.1.5-1 for the specified wanted signal mean power in the presence of two interfering signals.

**Table 7.8B.2.1.5-1: Wide band intermodulation**

EN-DC Aggregated Bandwidth, MHz	$\leq 100$	$>100, \leq 120$	$>120, \leq 140$	$>140, \leq 160$
P <sub>w</sub> in Transmission Bandwidth Configuration, perCC, dBm	P <sub>w</sub> <sup>1</sup>	16.8	17.5	18.0
P <sub>interferer 1</sub> , dBm (CW) <sup>2</sup>	-46			
P <sub>interferer 2</sub> , dBm (Modulated) <sup>2</sup>	-46			
NOTE 1: P <sub>w</sub> is wanted signal power level from Table 7.8.1A-1 in TS 36.101 [5]				



NOTE 2: Jammer BW and offsets is from Table 7.8.1A-1 in TS 36.101 [5] and is applied from the lowest edge of the lowest carrier and the highest edge of the highest carrier

NOTE 3: For NR carrier, the transmitter shall be set to 4dB below  $P_{CMAX\_L,f,c}$  at the minimum uplink configuration specified in Table 7.3-3 with  $P_{CMAX\_L,f,c}$  as defined in clause 6.2.4 from [2].

NOTE 4: For E-UTRA carrier, the transmitter shall be set to 29dB below  $P_{CMAX\_L,c}$  at the minimum uplink configuration specified in Table 7.3-1-2 with  $P_{CMAX\_L,c}$  as defined in clause 6.2.5 for single carrier and in Table 7.3-1A-1 with  $P_{CMAX\_L}$  as defined in clause 6.2.5A for LTE-CA from TS 36.101 [5].

**Table 7.8B.2.1.5-2: Void**

**7.8B.2.2 Wideband Intermodulation for intra-band non-contiguous EN-DC (2 CCs)**

**7.8B.2.2.1 Test Purpose**

Same test purpose as in clause 7.8.2.1 in TS 38.521-1 [8] for the NR carrier.

**7.8B.2.2.2 Test Applicability**

This test case applies to all types of E-UTRA UE release 15 and forward, supporting intra-band non-contiguous EN-DC in FR1 with 2 DL CCs.

**7.8B.2.2.3 Minimum Conformance Requirements**

The minimum conformance requirements are defined in clause 7.8B.2.0.2.

No exception requirements applicable to NR or E-UTRA. LTE anchor agnostic approach is applied.

**7.8B.2.2.4 Test Description**

Same test description as in clause 7.8.2.4 in TS 38.521-1 [8] with the following exceptions:

**Table 7.8B.2.2.4-1: Test Configuration Table**

Initial Conditions	
Test Frequencies as specified in TS 38.508-1 [6] clause 4.3.1 for different EN-DC bandwidth classes	High range with maxWGap
Test EN-DC bandwidth combination as specified in Table 5.3B.1.2-1 across bandwidth combination sets supported by the UE	Highest $N_{RB\_agg}$ (NOTE 1)
NOTE 1: If the UE supports multiple CC Combinations in the EN-DC Configuration with the same $N_{RB\_agg}$ , only the combination with the highest $N_{RB\_SCG}$ is tested.	

The initial test configurations for E-UTRA as specified in Table 4.6-1 except for the parameters specified in Table 7.9B.2.4-1.

For Initial conditions as in clause 7.8.2.4.1 in TS 38.521-1 [8], the following steps are added to configure E-UTRA component:

- 2.1. The parameter settings for E-UTRA cell are set up according to TS 36.508 [11] clause 4.4.3. The E-UTRA downlink signal level, uplink signal level are set according to Table 4.6-1 and propagation conditions are set according to Annex B.0 of TS 36.521-1 [10].7. On the E-UTRA carrier, disable periodic and aperiodic CQI reports, disable SRS, set *TimeAlignmentTimerDedicated* IE to infinity and disable downlink and uplink scheduling, all as per Table 4.6-1 under clause 4.6.

Step 6 of Initial conditions as in clause 7.8.2.4.2 in TS 38.521-1 [8] is replaced by the following two steps:

6. Ensure the UE is in state RRC\_CONNECTED with generic procedure parameters Connectivity EN-DC, DC bearer MCG and SCG, Connected without release *On* according to TS 38.508 [6] clause 4.5.
7. When E-UTRA and NR bands are TDD, ensure the same uplink-downlink configuration by giving SCG a delay of 3 E-UTRA subframes, or by giving MCG a delay of 2 subframes.

Step 4 of Test procedure is replaced by:

4. Set the Interfering signal levels to the values as defined in Table 7.8.2.5-1 and frequency at the out-of-gap of the sub-blocks.

Step 6 of Test procedure is removed.

#### 7.8B.2.2.5 Test Requirement

Same test requirement as in clause 7.8.2.5 in TS 38.521-1 [8].

### 7.8B.2.3 Wideband Intermodulation for inter-band EN-DC within FR1 (2 CCs)

#### 7.8B.2.3.1 Test Purpose

Same test purpose as in clause 7.8.2.1 in TS 38.521-1 [8] for the NR carrier.

#### 7.8B.2.3.2 Test Applicability

This test case applies to all types of E-UTRA UE release 15 and forward, supporting inter-band EN-DC within FR1 with 2 DL CCs.

#### 7.8B.2.3.3 Minimum Conformance Requirements

The minimum conformance requirements are defined in clause 7.8B.2.0.3.

No exception requirements applicable to NR or LTE. LTE anchor agnostic approach is applied.

#### 7.8B.2.3.4 Test Description

Same test description as in clause 7.8.2.4 in TS 38.521-1 [8] for the NR carrier with the following exceptions:

For band n28 / 28 used in EN-DC configurations with NOTE 8 of Table 5.5B.4.1-1, test channel bandwidth of 20MHz or more is tested with Low range test frequency.

The initial test configurations for E-UTRA consist of test frequency based on E-UTRA operating band and test channel bandwidth as specified in Table 4.6-1.

For Initial conditions as in clause 7.8.2.4.1 in TS 38.521-1 [8], the following steps are added to configure E-UTRA component:

- 2.1. The parameter settings for E-UTRA cell are set up according to TS 36.508 [11] clause 4.4.3. The E-UTRA downlink signal level, uplink signal level are set according to Table 4.6-1 and propagation conditions are set according to Annex B.0 of TS 36.521-1 [10].
7. On the E-UTRA carrier, disable periodic and aperiodic CQI reports, disable SRS, set *TimeAlignmentTimerDedicated* IE to infinity and disable downlink and uplink scheduling, all as per Table 4.6-1 under clause 4.6.

Step 6 of Initial conditions as in clause 7.8.2.4.2 in TS 38.521-1 [8] is replaced by:

6. Ensure the UE is in state RRC\_CONNECTED with generic procedure parameters Connectivity EN-DC, DC bearer MCG and SCG, Connected without release *On* according to TS 38.508 [6] clause 4.5.

#### 7.8B.2.3.5 Test Requirement

Same test requirement as in clause 7.8.2.5 in TS 38.521-1 [8].

## 7.8B.2.3\_1 Wideband Intermodulation for EN-DC within FR1 (>2 CCs)

### 7.8B.2.3\_1.1 Wideband Intermodulation for EN-DC within FR1 (3 CCs)

**Editor's note:** The following aspects are either missing or not yet determined:

- Test configuration for DC\_(n)XAA-nYA, DC\_XA-(n)YAA, DC\_XA-nXA-nYA, DC\_XA-YA\_nYA is missing in Table 7.8B.2.3\_1.1.4.1-1.

#### 7.8B.2.3\_1.1.1 Test Purpose

Intermodulation response tests the UE's ability to receive data with a given average throughput for a specified reference measurement channel, in the presence of two or more interfering signals which have a specific frequency relationship to the wanted signal, under conditions of ideal propagation and no added noise.

A UE unable to meet the throughput requirement under these conditions will decrease the coverage area when two or more interfering signals exist which have a specific frequency relationship to the wanted signal.

#### 7.8B.2.3\_1.1.2 Test Applicability

This test case applies to all types of E-UTRA UE release 15 and forward, supporting EN-DC within FR1 (3 CCs).

#### 7.8B.2.3\_1.1.3 Minimum Conformance Requirements

The minimum conformance requirements are defined in clause 7.8B.2.0.

#### 7.8B.2.3\_1.1.4 Test Description

##### 7.8B.2.3\_1.1.4.1 Initial condition

Initial conditions are a set of test configurations the UE needs to be tested in and the steps for the SS to take with the UE to reach the correct measurement state.

The initial test configurations consist of environmental conditions, test frequencies and channel bandwidths based on EN-DC operating bands specified in clause 5.5B.2, 5.5B.3, and 5.5B.4, channel bandwidths and sub-carrier spacings for the NR cell specified in TS 38.521-1 [8] clause 5.3 and channel bandwidth for the E-UTRA cell are specified in TS 36.521-1 [10] clause 5.4.2. All of these configurations shall be tested with applicable test parameters for each EN-DC configuration specified in clause 5.5B.2, 5.5B.3, and 5.5B.4 and are shown in table 7.8B.2.3\_1.1.4.1-1. The details of the uplink reference measurement channels (RMCs) are specified in Annex A.2. Configurations of PDSCH and PDCCH before measurement are specified in TS 36.521-1 [10] Annex C.2 and in TS 38.521-1 [8] Annex C.2 for E-UTRA CG and NR CG respectively.

Table 7.8B.2.3\_1.1.4.1-1: Test configuration table

Initial Conditions					
Test Environment as specified in TS 38.508-1 [6] clause 4.1					Normal
Test Frequencies as specified in TS 38.508-1 [6] clause 4.3.1 for different EN-DC bandwidth classes					Mid range
Test EN-DC bandwidth combination as specified in Table 5.3B.1.2-1 across bandwidth combination sets supported by the UE					Highest $N_{RB\_agg}$
NR Test SCS as specified in Table 5.3.5-1 in TS 38.521-1 [8]					Highest
Network signalling value					NS_01 by default
Test Parameters for EN-DC Configurations					
EN-DC Configurations	Environment	Frequency	Bandwidth Combination	SCS	Other Parameter Settings
DC_(n)XCA	Default	Default	Default	Default	As per DC_(n)XCA in Table 7.3B.2.3_1.1.4.1-0
DC_XC-nXA	-	-	-	-	No test required (LTE 1CC fallback is tested in 7.8B.2.2)
DC_XA_XA-nXA	-	-	-	-	No test required (LTE 1CC fallback is tested in 7.8B.2.2)
DC_XA_nYC	Default	Default	Default	Default	As per DC_XA_nYC in Table 7.3B.2.3_1.14.1-0
DC_XA_nY(2A)	Default	Default	Default	Default	As per DC_XA_nY(2A) in Table 7.3B.2.3_1.14.1-0
DC_XA_nYA-nZA	Default	Default	Default	Default	As per DC_XA_nYA-nZA in Table 7.3B.2.3_1.14.1-0
DC_XC_nYA	-	-	-	-	No test required (LTE 1CC fallback is tested in 7.8B.2.3)
DC_XA-XA_nYA	-	-	-	-	No test required (LTE 1CC fallback is tested in 7.8B.2.3)
DC_XA-YA_nZA	-	-	-	-	No test required (LTE 1CC fallback is tested in 7.8B.2.3)
NOTE 1: Void					
NOTE 2: Void					
NOTE 3: Void					
NOTE 4: X, Y and Z in this table correspond to different bands i.e. X != Y != Z					
NOTE 5: The band combinations with difference appearance order of bands/sub-blocks in the band combination string are not distinguished. E.g. DC_YA-(n)XAA represents the set of DC_YA-(n)XAA and DC_(n)XAA-YA					
NOTE 6: In a FR1 band where UE supports 4Rx, the test shall be performed only with 4Rx antennas ports connected and 4Rx REFSENS requirement (TS 38.521-1 [8] Table 7.3.2.5-2) is used in the test requirements.					

1. Connect the SS to the UE antenna connectors as shown in [6] TS 38.508-1 A.3.1.2.1 for SS diagram and A.3.2 for UE diagram.
2. The parameter settings for the E-UTRA cell are set up according to TS 36.508 [11] clause 4.4.3, and the parameter settings for the NR cell are set up according to TS 38.508-1 [6] clause 4.4.3.
3. Downlink signals are initially set up according to TS 36.521-1 [10] Annex C.0 and TS 38.521-1 [8] Annex C.0 for E-UTRA CG and NR CG respectively, and uplink signals according to TS 36.521-1 [10] Annex H and TS 38.521-1 [8] Annex G for E-UTRA CG and NR CG respectively.
4. The UL Reference Measurement channels are TS 36.521-1 [10] Annex A.2 and TS 38.521-1 [8] Annex A.2 for E-UTRA CG and NR CG respectively.
5. Propagation conditions are set according to TS 36.521-1 [10] Annex B.0 and TS 38.521-1 [8] Annex B.0 for E-UTRA CG and NR CG respectively.
6. Ensure the UE is in state RRC\_CONNECTED with generic procedure parameters Connectivity EN-DC, DC bearer MCG and SCG, Connected without release *On* according to TS 38.508-1 [6] clause 4.5. Message contents are defined in clause 6.2B.1.1.4.3.
7. For the E-UTRA CC(s) where anchor agnostic apply according to NOTE 1 in Table 7.3B.2.3\_1.1.4.1-0, downlink signal level and uplink signal level are set according to Table 4.6-1 and propagation conditions are set according to Annex B, clause B.0 of TS 36.521-1 [10]. Disable periodic and aperiodic CQI reports, disable SRS, set *TimeAlignmentTimerDedicated* IE to infinity and disable downlink and uplink scheduling, all as per Table 4.6-1 under clause 4.6.

## 7.8B.2.3\_1.1.4.2 Test procedure

1. SS sends uplink scheduling information for each UL HARQ process via PDCCH DCI format 0 and DCI format 0\_1 for C\_RNTI to schedule the UL RMC according to table 7.8B.2.3\_1.1.4.2-1 on E-UTRA CC and NR CC respectively. Since the UL has no payload and no loopback data to send the UE sends uplink MAC padding bits on the UL RMC.
2. Set the Downlink signal level to the value as defined in Table 7.8B.2.3\_1.1.4.2-1. For E-UTRA CC and NR CC where uplink is allocated according to Table 7.8B.2.3\_1.1.4.1-1, send uplink power control commands to the UE using 1dB power step size to ensure that the UE output power measured by the test system is within the Uplink power control window, defined as  $-MU$  to  $-(MU + \text{Uplink power control window size})$  dB of the 4dB below PCMAX\_L with PCMAX\_L as defined in clause 6.2B.4 for at least the duration of the Throughput measurement.
  - MU is the test system uplink power measurement uncertainty and is specified in Table F.1.3-1 for the carrier frequency  $f$  and the channel bandwidth BW.
  - For NR CC, Uplink power control window size = 1dB (UE power step size) + 0.7dB (UE power step tolerance) + (Test system relative power measurement uncertainty), where, the UE power step tolerance is specified in TS 38.101-1 [2], Table 6.3.4.3-1 and is 0.7dB for 1dB power step size, and the Test system relative power measurement uncertainty is specified in Table F.1.2-1.
  - For E-UTRA CC, Uplink power control window size = 1dB (UE power step size) + 1.0dB (UE power step tolerance) + (Test system relative power measurement uncertainty), where, the UE power step tolerance is specified in TS 36.101 [5], Table 6.3.5.2.1-1 and is 1.0dB for 1dB power step size, and the Test system relative power measurement uncertainty is specified in Table F.1.2-1 of TS 36.521-1 [10].

NOTE: The purpose of the Uplink power control window is to ensure that the actual UE output power is no greater than, or no less than the target power level, and as close as possible to the target power level. The relationship between the Uplink power control window, the target power level and the corresponding possible actual UE uplink power window is illustrated in Annex F, clause F.4.

3. Set the Interfering signal levels to the values as defined in Table 7.8B.2.3\_1.1.4.2-1 and frequency below the wanted signal.
4. Measure the average throughput for a duration sufficient to achieve statistical significance according to Annex G, clause G.2.
5. Repeat steps from 2 to 4, using an interfering signal above the wanted signal at step 3.
6. Repeat steps 2 to 5 for component carriers listed in Table 7.8B.2.3\_1.1.4.2-1.

**Table 7.8B.2.3\_1.1.4.2-1: Test repetition and measurement configuration**

DC configuration	Test parameters to select (NOTE 2)
DC_(n)XCA	7.8B.2.1.5
DC_XA_nYC	7.8B.2.3.5
DC_XA_nY(2A)	
DC_XA_nYA-nZA	
NOTE 1: Void	
NOTE 2: The reference for the placement of the interferer signals is the centre frequency of the carrier closest to the interferer among the carriers throughput is measured on.	
NOTE 3: Measure throughput on DL allocated CC. Where there are multiple rows for a single Test point ID, the test is repeated for each row.	

## 7.8B.2.3\_1.1.4.3 Message contents

Message contents are according to TS 38.508-1 [5] clause 4.6 with DFT-s-OFDM condition in Table 4.6.3-118 PUSCH-Config.

### 7.8B.2.3\_1.1.5 Test Requirement

The throughput shall be  $\geq 95\%$  of the maximum throughput of the reference measurement channels as specified in Annex A, clause A.3.2 with parameters specified in Table 7.8B.2.3\_1.1.4.2-1 for the specified wanted signal mean power in the presence of two interfering signals.

## 7.8B.2.3\_1.2 Wideband Intermodulation for EN-DC within FR1 (4 CCs)

### 7.8B.2.3\_1.2.1 Test Purpose

Intermodulation response tests the UE's ability to receive data with a given average throughput for a specified reference measurement channel, in the presence of two or more interfering signals which have a specific frequency relationship to the wanted signal, under conditions of ideal propagation and no added noise.

A UE unable to meet the throughput requirement under these conditions will decrease the coverage area when two or more interfering signals exist which have a specific frequency relationship to the wanted signal.

### 7.8B.2.3\_1.2.2 Test Applicability

This test case applies to all types of E-UTRA UE release 15 and forward, supporting EN-DC within FR1 (4 CCs).

### 7.8B.2.3\_1.2.3 Minimum Conformance Requirements

The minimum conformance requirements are defined in clause 7.8B.2.0.

### 7.8B.2.3\_1.2.4 Test Description

#### 7.8B.2.3\_1.2.4.1 Initial condition

Initial conditions are a set of test configurations the UE needs to be tested in and the steps for the SS to take with the UE to reach the correct measurement state.

The initial test configurations consist of environmental conditions, test frequencies and channel bandwidths based on EN-DC operating bands specified in clause 5.5B.2, 5.5B.3, and 5.5B.4, channel bandwidths and sub-carrier spacings for the NR cell specified in TS 38.521-1 [8] clause 5.3 and channel bandwidth for the E-UTRA cell are specified in TS 36.521-1 [10] clause 5.4.2. All of these configurations shall be tested with applicable test parameters for each EN-DC configuration specified in clause 5.3B.1.2 and are shown in table 7.8B.2.3\_1.2.4.1-1. The details of the uplink reference measurement channels (RMCs) are specified in Annex A.2. Configurations of PDSCH and PDCCH before measurement are specified in TS 36.521-1 [10] Annex C.2 and in TS 38.521-1 [8] Annex C.2 for E-UTRA CG and NR CG respectively.

Table 7.8B.2.3\_1.2.4.1-1: Test configuration table

Initial Conditions					
Test Environment as specified in TS 38.508-1 [6] clause 4.1					Normal
Test Frequencies as specified in TS 38.508-1 [6] clause 4.3.1 for different EN-DC bandwidth classes					Mid range
Test EN-DC bandwidth combination as specified in Table 5.3B.1.2-1 across bandwidth combination sets supported by the UE					Highest N <sub>RB_agg</sub>
NR Test SCS as specified in Table 5.3.5-1 in TS 38.521-1 [8]					Highest
Network signalling value					NS_01 by default
Test Parameters for EN-DC Configurations					
EN-DC Configurations	Environment	Frequency	Bandwidth Combination	SCS	Other Parameter Settings
DC_(n)XDA	Default	Default	Default	Default	As per DC_(n)XDA in Table 7.3B.2.3_1.2.4.1-1
DC_XD_nXA	-	-	-	-	No test required (LTE 2CC fallback is tested in 7.8B.2.2)
DC_XA-XC_nXA	-	-	-	-	No test required (LTE 2CC fallback is tested in 7.8B.2.2)
DC_XA_nY(2A)-nZA	Default	Default	Default	Default	As per DC_XA_nY(2A)-nZA in Table 7.3B.2.3_1.2.4.1-1
DC_XA_nYA-nZC	Default	Default	Default	Default	As per DC_XA_nYA-nZC in Table 7.3B.2.3_1.2.4.1-1
DC_XD_nYA DC_XA-YC_nZA DC_XA-XA-YA_nZA DC_XA-YA-ZA_nRA	-	-	-	-	No test required (LTE 2CC fallback is tested in 7.8B.2.2)
DC_XC_nYC DC_XA-XA_nYC DC_XA-YA_nYC	-	-	-	-	No test required (LTE 1CC fallback is tested in 7.8B.2.3_1.1)
DC_XC_nY(2A) DC_XA-XA_nY(2A) DC_XA-YA_nY(2A)	-	-	-	-	No test required (LTE 1CC fallback is tested in 7.8B.2.3_1.1)
DC_XC_nYA-nZA DC_XA-XA_nYA-nZA DC_XA-YA_nZA-nRA	-	-	-	-	No test required (LTE 1CC fallback is tested in 7.8B.2.3_1.1)
DC_XA-YA_(n)ZAA DC_XC_(n)YAA	-	-	-	-	No test required (LTE 2CC fallback is tested in 7.8B.2.2)
DC_(n)XCA-nYA	-	-	-	-	No test required (LTE 1CC fallback is tested in 7.8B.2.3_1.1)
DC_XA-YA-ZA_nZA	-	-	-	-	No test required (LTE 2CC fallback is tested in 7.8B.2.2)
DC_XA-YA_nYA-nZA	-	-	-	-	No test required (LTE 1CC fallback is tested in 7.8B.2.3_1.1)
NOTE 1: X, Y, Z and R in this table correspond to different bands i.e. X != Y != Z != R					
NOTE 2: The band combinations with difference appearance order of bands/sub-blocks in the band combination string are not distinguished. E.g. DC_YA-(n)XAA represents the set of DC_YA-(n)XAA and DC_(n)XAA-YA					
NOTE 3: In a FR1 band where UE supports 4Rx, the test shall be performed only with 4Rx antennas ports connected and 4Rx REFSENS requirement (TS 38.521-1 [8] Table 7.3.2.5-2) is used in the test requirements.					

1. Connect the SS to the UE antenna connectors as shown in [6] TS 38.508-1 A.3.1.2.1 for SS diagram and A.3.2 for UE diagram.
2. The parameter settings for the E-UTRA cell are set up according to TS 36.508 [11] clause 4.4.3, and the parameter settings for the NR cell are set up according to TS 38.508-1 [6] clause 4.4.3.
3. Downlink signals are initially set up according to TS 36.521-1 [10] Annex C.0 and TS 38.521-1 [8] Annex C.0 for E-UTRA CG and NR CG respectively, and uplink signals according to TS 36.521-1 [10] Annex H and TS 38.521-1 [8] Annex G for E-UTRA CG and NR CG respectively.
4. The UL Reference Measurement channels are TS 36.521-1 [10] Annex A.2 and TS 38.521-1 [8] Annex A.2 for E-UTRA CG and NR CG respectively.
5. Propagation conditions are set according to TS 36.521-1 [10] Annex B.0 and TS 38.521-1 [8] Annex B.0 for E-UTRA CG and NR CG respectively.

6. Ensure the UE is in state RRC\_CONNECTED with generic procedure parameters Connectivity EN-DC, DC bearer *MCG* and *SCG*, Connected without release *On* according to TS 38.508-1 [6] clause 4.5. Message contents are defined in clause 6.2B.1.1.4.3.
7. For the E-UTRA CC(s) where anchor agnostic apply according to NOTE 4 in Table 7.3B.2.3\_1.2.4.1-1, downlink signal level and uplink signal level are set according to Table 4.6-1 and propagation conditions are set according to Annex B, clause B.0 of TS 36.521-1 [10]. Disable periodic and aperiodic CQI reports, disable SRS, set *TimeAlignmentTimerDedicated* IE to infinity and disable downlink and uplink scheduling, all as per Table 4.6-1 under clause 4.6.

#### 7.8B.2.3\_1.2.4.2 Test procedure

1. SS sends uplink scheduling information for each UL HARQ process via PDCCH DCI format 0 and DCI format 0\_1 for C\_RNTI to schedule the UL RMC according to table 7.8B.2.3\_1.2.4.2-1 on E-UTRA CC and NR CC respectively. Since the UL has no payload and no loopback data to send the UE sends uplink MAC padding bits on the UL RMC.
2. Set the Downlink signal level to the value as defined in Table 7.8B.2.3\_1.2.4.2-1. For E-UTRA CC and NR CC where uplink is allocated according to Table 7.8B.2.3\_1.2.4.1-1, send uplink power control commands to the UE using 1dB power step size to ensure that the UE output power measured by the test system is within the Uplink power control window, defined as  $-MU$  to  $-(MU + \text{Uplink power control window size})$  dB of the 4dB below PCMAX\_L with PCMAX\_L as defined in clause 6.2B.4 for at least the duration of the Throughput measurement.
  - MU is the test system uplink power measurement uncertainty and is specified in Table F.1.3-1 for the carrier frequency  $f$  and the channel bandwidth BW.
  - For NR CC, Uplink power control window size = 1dB (UE power step size) + 0.7dB (UE power step tolerance) + (Test system relative power measurement uncertainty), where, the UE power step tolerance is specified in TS 38.101-1 [2], Table 6.3.4.3-1 and is 0.7dB for 1dB power step size, and the Test system relative power measurement uncertainty is specified in Table F.1.2-1.
  - For E-UTRA CC, Uplink power control window size = 1dB (UE power step size) + 1.0dB (UE power step tolerance) + (Test system relative power measurement uncertainty), where, the UE power step tolerance is specified in TS 36.101 [5], Table 6.3.5.2.1-1 and is 1.0dB for 1dB power step size, and the Test system relative power measurement uncertainty is specified in Table F.1.2-1 of TS 36.521-1 [10].

NOTE: The purpose of the Uplink power control window is to ensure that the actual UE output power is no greater than, or no less than the target power level, and as close as possible to the target power level. The relationship between the Uplink power control window, the target power level and the corresponding possible actual UE Uplink power window is illustrated in Annex F, clause F.4.

3. Set the Interfering signal levels to the values as defined in Table 7.8B.2.3\_1.2.4.2-1 and frequency below the wanted signal.
4. Measure the average throughput for a duration sufficient to achieve statistical significance according to Annex G, clause G.2.
5. Repeat steps from 2 to 4, using an interfering signal above the wanted signal at step 3.
6. Repeat steps 2 to 5 for component carriers listed in Table 7.8B.2.3\_1.2.4.2-1.

**Table 7.8B.2.3\_1.2.4.2-1: Test repetition and measurement configuration**

DC configuration	Test parameters to select (NOTE 1)
DC_(n)XDA	7.8B.2.1.5
DC_XA_nY(2A)-nZA	7.8B.2.3.5
DC_XA_nYA-nZC	
NOTE 1: The reference for the placement of the interferer signals is the centre frequency of the carrier closest to the interferer among the carriers throughput is measured on.	
NOTE 2: Measure throughput on DL allocated CC. Where there are multiple rows for a single Test point ID, the test is repeated for each row.	



#### 7.8B.2.3\_1.2.4.3 Message contents

Message contents are according to TS 38.508-1 [5] clause 4.6 with DFT-s-OFDM condition in Table 4.6.3-118 PUSCH-Config.

#### 7.8B.2.3\_1.2.5 Test Requirement

The throughput shall be  $\geq 95\%$  of the maximum throughput of the reference measurement channels as specified in Annex A, clause A.3.2 with parameters specified in Table 7.8B.2.3\_1.2.4.2-1 for the specified wanted signal mean power in the presence of two interfering signals.

#### 7.8B.2.3\_1.3 Wideband Intermodulation for EN-DC within FR1 (5 CCs)

**Editor's note: The Table 7.8B.2.3\_1.3.4.2-1 are either missing or not yet determined.**

##### 7.8B.2.3\_1.3.1 Test Purpose

Intermodulation response tests the UE's ability to receive data with a given average throughput for a specified reference measurement channel, in the presence of two or more interfering signals which have a specific frequency relationship to the wanted signal, under conditions of ideal propagation and no added noise.

A UE unable to meet the throughput requirement under these conditions will decrease the coverage area when two or more interfering signals exist which have a specific frequency relationship to the wanted signal.

##### 7.8B.2.3\_1.3.2 Test Applicability

This test case applies to all types of E-UTRA UE release 15 and forward, supporting EN-DC within FR1 (5 CCs).

##### 7.8B.2.3\_1.3.3 Minimum Conformance Requirements

The minimum conformance requirements are defined in clause 7.8B.2.0.

##### 7.8B.2.3\_1.3.4 Test Description

###### 7.8B.2.3\_1.3.4.1 Initial condition

Initial conditions are a set of test configurations the UE needs to be tested in and the steps for the SS to take with the UE to reach the correct measurement state.

The initial test configurations consist of environmental conditions, test frequencies and channel bandwidths based on EN-DC operating bands specified in clause 5.5B.2, 5.5B.3, and 5.5B.4, channel bandwidths and sub-carrier spacings for the NR cell specified in TS 38.521-1 [8] clause 5.3 and channel bandwidth for the E-UTRA cell are specified in TS 36.521-1 [10] clause 5.4.2. All of these configurations shall be tested with applicable test parameters for each EN-DC configuration specified in clause 5.3B.1.2 and are shown in table 7.8B.2.3\_1.3.4.1-1. The details of the uplink reference measurement channels (RMCs) are specified in Annex A.2. Configurations of PDSCH and PDCCH before measurement are specified in TS 36.521-1 [10] Annex C.2 and in TS 38.521-1 [8] Annex C.2 for E-UTRA CG and NR CG respectively.

Table 7.8B.2.3\_1.3.4.1-1: Test configuration table

Initial Conditions					
Test Environment as specified in TS 38.508-1 [6] clause 4.1					Normal
Test Frequencies as specified in TS 38.508-1 [6] clause 4.3.1 for different EN-DC bandwidth classes					Mid range
Test EN-DC bandwidth combination as specified in Table 5.3B.1.2-1 across bandwidth combination sets supported by the UE					Highest $N_{RB\_agg}$
NR Test SCS as specified in Table 5.3.5-1 in TS 38.521-1 [8]					Highest
Network signalling value					NS_01 by default
Test Parameters for EN-DC Configurations					
EN-DC Configurations	Environment	Frequency	Bandwidth Combination	SCS	Other Parameter Settings
DC_XA-XA-YC_nZA	-	-	-	-	No test required (LTE 1CC fallback is tested in 7.8B.2.3_1.2)
DC_XA-YC_nZ(2A)	-	-	-	-	No test required (LTE 1CC fallback is tested in 7.8B.2.3_1.2)
NOTE 1: X, Y, Z and R in this table correspond to different bands i.e. X != Y != Z != R					
NOTE 2: The band combinations with difference appearance order of bands/sub-blocks in the band combination string are not distinguished. E.g. DC_YA-(n)XAA represents the set of DC_YA-(n)XAA and DC_(n)XAA-YA					
NOTE 3: In a FR1 band where UE supports 4Rx, the test shall be performed only with 4Rx antennas ports connected and 4Rx REFSSENS requirement (TS 38.521-1 [8] Table 7.3.2.5-2) is used in the test requirements.					

1. Connect the SS to the UE antenna connectors as shown in [6] TS 38.508-1 A.3.1.2.1 for SS diagram and A.3.2 for UE diagram.
2. The parameter settings for the E-UTRA cell are set up according to TS 36.508 [11] clause 4.4.3, and the parameter settings for the NR cell are set up according to TS 38.508-1 [6] clause 4.4.3.
3. Downlink signals are initially set up according to TS 36.521-1 [10] Annex C.0 and TS 38.521-1 [8] Annex C.0 for E-UTRA CG and NR CG respectively, and uplink signals according to TS 36.521-1 [10] Annex H and TS 38.521-1 [8] Annex G for E-UTRA CG and NR CG respectively.
4. The UL Reference Measurement channels are TS 36.521-1 [10] Annex A.2 and TS 38.521-1 [8] Annex A.2 for E-UTRA CG and NR CG respectively.
5. Propagation conditions are set according to TS 36.521-1 [10] Annex B.0 and TS 38.521-1 [8] Annex B.0 for E-UTRA CG and NR CG respectively.
6. Ensure the UE is in state RRC\_CONNECTED with generic procedure parameters Connectivity EN-DC, DC bearer *MCG* and *SCG*, Connected without release *On* according to TS 38.508-1 [6] clause 4.5. Message contents are defined in clause 6.2B.1.1.4.3.
7. For the E-UTRA CC(s) where anchor agnostic apply according to NOTE 4 in Table 7.3B.2.3\_1.2.4.1-1, downlink signal level and uplink signal level are set according to Table 4.6-1 and propagation conditions are set according to Annex B, clause B.0 of TS 36.521-1 [10]. Disable periodic and aperiodic CQI reports, disable SRS, set *TimeAlignmentTimerDedicated* IE to infinity and disable downlink and uplink scheduling, all as per Table 4.6-1 under clause 4.6.

#### 7.8B.2.3\_1.3.4.2 Test procedure

1. SS sends uplink scheduling information for each UL HARQ process via PDCCH DCI format 0 and DCI format 0\_1 for C\_RNTI to schedule the UL RMC according to table 7.8B.2.3\_1.3.4.2-1 on E-UTRA CC and NR CC respectively. Since the UL has no payload and no loopback data to send the UE sends uplink MAC padding bits on the UL RMC.
2. Set the Downlink signal level to the value as defined in Table 7.8B.2.3\_1.3.4.2-1. For E-UTRA CC and NR CC where uplink is allocated according to Table 7.8B.2.3\_1.3.4.1-1, send uplink power control commands to the UE using 1dB power step size to ensure that the UE output power measured by the test system is within the Uplink power control window, defined as -MU to -(MU + Uplink power control window size) dB of the 4dB below PCMAX\_L with PCMAX\_L as defined in clause 6.2B.4 for at least the duration of the Throughput measurement.

- MU is the test system uplink power measurement uncertainty and is specified in Table F.1.3-1 for the carrier frequency  $f$  and the channel bandwidth BW.
- For NR CC, Uplink power control window size = 1dB (UE power step size) + 0.7dB (UE power step tolerance) + (Test system relative power measurement uncertainty), where, the UE power step tolerance is specified in TS 38.101-1 [2], Table 6.3.4.3-1 and is 0.7dB for 1dB power step size, and the Test system relative power measurement uncertainty is specified in Table F.1.2-1.
- For E-UTRA CC, Uplink power control window size = 1dB (UE power step size) + 1.0dB (UE power step tolerance) + (Test system relative power measurement uncertainty), where, the UE power step tolerance is specified in TS 36.101 [5], Table 6.3.5.2.1-1 and is 1.0dB for 1dB power step size, and the Test system relative power measurement uncertainty is specified in Table F.1.2-1 of TS 36.521-1 [10].

NOTE: The purpose of the Uplink power control window is to ensure that the actual UE output power is no greater than, or no less than the target power level, and as close as possible to the target power level. The relationship between the Uplink power control window, the target power level and the corresponding possible actual UE Uplink power window is illustrated in Annex F, clause F.4.

3. Set the Interfering signal levels to the values as defined in Table 7.8B.2.3\_1.3.4.2-1 and frequency below the wanted signal.
4. Measure the average throughput for a duration sufficient to achieve statistical significance according to Annex G, clause G.2.
5. Repeat steps from 2 to 4, using an interfering signal above the wanted signal at step 3.
6. Repeat steps 2 to 5 for component carriers listed in Table 7.8B.2.3\_1.3.4.2-1.

#### **Table 7.8B.2.3\_1.3.4.2-1: Test repetition and measurement configuration**

FFS

#### **7.8B.2.3\_1.3.4.3 Message contents**

Message contents are according to TS 38.508-1 [5] clause 4.6 with DFT-s-OFDM condition in Table 4.6.3-118 PUSCH-Config.

#### **7.8B.2.3\_1.3.5 Test Requirement**

The throughput shall be  $\geq 95\%$  of the maximum throughput of the reference measurement channels as specified in Annex A, clause A.3.2 with parameters specified in Table 7.8B.2.3\_1.3.4.2-1 for the specified wanted signal mean power in the presence of two interfering signals.

#### **7.8B.2.3\_1.4 Wideband Intermodulation for EN-DC within FR1 (6 CCs)**

TBD

#### **7.8B.2.3a Wideband Intermodulation for inter-band NE-DC within FR1 (2 CCs)**

No exception requirements applicable to NR or E-UTRA.

No test case details are specified. The requirements for NR carrier(s) in this test case are tested in 7.8.2 and 7.8A.2 of TS 38.521-1 [8], and the requirements for LTE carrier(s) in this test case are tested in 7.8.1 and 7.8.1A of TS 36.521-1 [10]. Neither NR carrier(s) nor LTE carrier(s) needs to be tested again.

7.8B.2.4 to 7.8B.2.9 Void

## 7.8E Intermodulation characteristics for V2X operation in FR1

### 7.8E.1 Wide band Intermodulation for V2X

#### 7.8E.1.0 Minimum conformance requirements

For intra-band V2X operation, the intermodulation characteristics specified in clause 7.8.1G in TS 36.101 [5] and specified in clause 7.8E in TS 38.101-1 [2] apply when all SL reception CCs are activated at same time.

For inter-band NR V2X con-current operation, the intermodulation characteristics requirements shall be applied per each component carrier. The wideband inter-modulation requirement specified in clause 7.8E in TS 38.101-1 [2] shall apply on NR V2X carrier and the requirement specified in clause 7.8.1 in TS 36.101 [5] shall apply on E-UTRA downlink reception in licensed band while all downlink carriers are active. The requirements specified in subclause 7.8.1G of TS 36.101 [5] shall apply for the E-UTRA sidelink reception and the requirements specified in subclause 7.8 of TS 38.101-1 [2] shall apply for the NR downlink reception while all downlink carriers are active.  $P_{\text{Interferer}}$  power is increased by  $\Delta R_{\text{B,c}}$  in the requirement.

#### 7.8E.1.1 Wide band Intermodulation for V2X operation

##### 7.8E.1.1.1 Test purpose

Intermodulation response tests the UE's ability to receive data with a given average throughput for a specified reference measurement channel, in the presence of two or more interfering signals which have a specific frequency relationship to the wanted signal, under conditions of ideal propagation and no added noise.

A UE unable to meet the throughput requirement under these conditions will decrease the coverage area when two or more interfering signals exist which have a specific frequency relationship to the wanted signal.

##### 7.8E.1.1.2 Test applicability

No exception requirements applicable to NR V2X operation or E-UTRA V2X operation. The requirements in this test case can be well covered in clause 7.8.1 and 7.8.1G of TS 36.521-1 [10] and clause 7.8.2 and 7.8E.2 of TS 38.521-1 [8] and don't need to be tested again.

## 7.9 Void

### 7.9B Spurious emissions for DC

#### 7.9B.0 Minimum Conformance Requirements

##### 7.9B.0.1 Intra-band contiguous EN-DC

The requirement is defined in clause 7.9A.1 in TS 38.101-1 [2].

The normative reference for this requirement is TS 38.101-3 [4] clause 7.9B.1.

##### 7.9B.0.2 Intra-band non-contiguous EN-DC

Spurious emissions requirement for E-UTRA single carrier and CA operation specified in clauses 7.9.1 and 7.9.1A of TS 36.101 [5] and for NR single carrier and CA operation specified in clauses 7.9 and 7.9A of TS 38.101-1 [2] apply.

The normative reference for this requirement is TS 38.101-3 [4] clause 7.9B.2.

### 7.9B.0.3 Inter-band EN-DC within FR1

E-UTRA requirements from TS 36.101 [5] and NR requirements from TS 38.101-1 [2] apply.

The normative reference for this requirement is TS 38.101-3 [4] clause 7.9B.3.

### 7.9B.0.4 Inter-band EN-DC including FR2

Spurious emissions requirement for E-UTRA single carrier and CA operation specified in clauses 7.9.1 and 7.9.1A of TS 36.101 [5] and for NR single carrier and CA operation specified in clause 7.9 of TS 38.101-2 [3] apply.

The normative reference for this requirement is TS 38.101-3 [4] clause 7.9B.4.

### 7.9B.0.5 Inter-band EN-DC including both FR1 and FR2

Spurious emissions requirement for E-UTRA single carrier and CA operation specified in clauses 7.9.1 and 7.9.1A of TS 36.101 [5] and for NR single carrier and CA operation specified in clauses 7.9 and 7.9A of TS 38.101-1 [2] and TS 38.101-2 [3] apply.

The normative reference for this requirement is TS 38.101-3 [4] clause 7.9B.5.

## 7.9B.1 Spurious Emissions for intra-band contiguous EN-DC (2 CCs)

### 7.9B.1.1 Test purpose

Same test purpose as in clause 7.9.1 in TS 38.521-1 [8] for the NR carrier.

### 7.9B.1.2 Test applicability

This test case applies to all types of E-UTRA UE release 15 and forward, supporting intra-band contiguous EN-DC in FR1 with 2 DL CCs.

### 7.9B.1.3 Minimum conformance requirements

The minimum conformance requirements are defined in clause 7.9B.0.3.

No exception requirements applicable to NR or E-UTRA. LTE anchor agnostic approach is applied.

### 7.9B.1.4 Test description

Same test description as in clause 7.9.4 in TS 38.521-1 [8] with the following exceptions:

**Table 7.9B.1.4-1: Test Configuration Table**

Initial Conditions	
Test Frequencies as specified in TS 38.508-1 [6] clause 4.3.1 for different DC bandwidth classes.	Mid range
Test EN-DC bandwidth combination as specified in Table 5.3B.1.2-1 across bandwidth combination sets supported by the UE	Highest $N_{RB\_agg}$ (NOTE 1)
NOTE 1: If the UE supports multiple CC Combinations in the EN-DC Configuration with the same $N_{RB\_agg}$ , only the combination with the highest $N_{RB\_SCG}$ is tested.	

The initial test configurations for E-UTRA as specified in Table 4.6-1 except for the parameters specified in Table 7.9B.1.4-1.

For Initial conditions as in clause 7.9.4.1 in TS 38.521-1 [8], the following steps are added to configure E-UTRA component:

2.1. The parameter settings for E-UTRA cell are set up according to TS 36.508 [11] clause 4.4.3. The E-UTRA downlink signal level, uplink signal level are set according to Table 4.6-1 and propagation conditions are set according to Annex B.0 of TS 36.521-1 [10].

7. On the E-UTRA carrier, disable periodic and aperiodic CQI reports, disable SRS, set *TimeAlignmentTimerDedicated* IE to infinity and disable downlink and uplink scheduling, all as per Table 4.6-1 under clause 4.6.

Step 6 of Initial conditions as in clause 7.9.4.1 in TS 38.521-1 [8] is replaced by the following two steps:

6. Ensure the UE is in state RRC\_CONNECTED with generic procedure parameters Connectivity EN-DC, DC bearer MCG and SCG, Connected without release *On* according to TS 38.508 [6] clause 4.5.

7. When E-UTRA and NR bands are TDD, ensure the same uplink-downlink configuration by giving SCG a delay of 3 E-UTRA subframes, or by giving MCG a delay of 2 subframes.

#### 7.9B.1.5 Test requirement

Same test requirement as in clause 7.9.5 in TS 38.521-1 [8].

### 7.9B.2 Spurious Emissions for intra-band non-contiguous EN-DC (2 CCs)

#### 7.9B.2.1 Test purpose

Same test purpose as in clause 7.9.1 in TS 38.521-1 [8] for the NR carrier.

#### 7.9B.2.2 Test applicability

This test case applies to all types of E-UTRA UE release 15 and forward, supporting intra-band non-contiguous in FR1 with 2 DL CCs.

#### 7.9B.2.3 Minimum conformance requirements

The minimum conformance requirements are defined in clause 7.9B.0.3.

No exception requirements applicable to NR or LTE. LTE anchor agnostic approach is applied.

#### 7.9B.2.4 Test description

Same test description as in clause 7.9.4 in TS 38.521-1 [8] with the following exceptions:

**Table 7.9B.2.4-1: Test Configuration Table**

Initial Conditions	
Test Frequencies as specified in TS 38.508-1 [6] clause 4.3.1 for different DC bandwidth classes	MaxWGap
Test EN-DC bandwidth combination as specified in Table 5.3B.1.2-1 across bandwidth combination sets supported by the UE	Highest $N_{RB\_agg}$ (NOTE 1)
NOTE 1: If the UE supports multiple CC Combinations in the EN-DC Configuration with the same $NRB\_agg$ , only the combination with the highest $NRB\_SCG$ is tested.	

The initial test configurations for E-UTRA as specified in Table 4.6-1 except for the parameters specified in Table 7.9B.2.4-1.

For Initial conditions as in clause 7.9.4.1 in TS 38.521-1 [8], the following steps are added to configure E-UTRA component:

2.1. The parameter settings for E-UTRA cell are set up according to TS 36.508 [11] clause 4.4.3. The E-UTRA downlink signal level, uplink signal level are set according to Table 4.6-1 and propagation conditions are set according to Annex B.0 of TS 36.521-1 [10].

7. On the E-UTRA carrier, disable periodic and aperiodic CQI reports, disable SRS, set *TimeAlignmentTimerDedicated* IE to infinity and disable downlink and uplink scheduling, all as per Table 4.6-1 under clause 4.6.

Step 6 of Initial conditions as in clause 7.9.4.1 in TS 38.521-1 [8] is replaced by the following two steps:

6. Ensure the UE is in state RRC\_CONNECTED with generic procedure parameters Connectivity EN-DC, DC bearer MCG and SCG, Connected without release *On* according to TS 38.508 [6] clause 4.5.
7. When E-UTRA and NR bands are TDD, ensure the same uplink-downlink configuration by giving SCG a delay of 3 E-UTRA subframes, or by giving MCG a delay of 2 subframes.

#### 7.9B.2.5 Test requirement

Same test requirement as in clause 7.9.5 in TS 38.521-1 [8].

### 7.9B.3 Spurious Emissions for inter-band EN-DC within FR1 (1 NR CC)

#### 7.9B.3.1 Test purpose

Same test purpose as in clause 7.9.1 in TS 38.521-1 [8] for the NR carrier.

#### 7.9B.3.2 Test applicability

This test case applies to all types of E-UTRA UE release 15 and forward, supporting inter-band EN-DC within FR1 with 1 NR DL CC.

#### 7.9B.3.3 Minimum conformance requirements

The minimum conformance requirements are defined in clause 7.9B.0.3.

No exception requirements applicable to NR or E-UTRA. LTE anchor agnostic approach is applied.

#### 7.9B.3.4 Test description

Same test description as in clause 7.9.4 in TS 38.521-1 [8] for the NR carrier with the following exceptions:

The initial test configurations for E-UTRA consist of test frequency based on E-UTRA operating band and test channel bandwidth as specified in Table 4.6-1.

For Initial conditions as in clause 7.9.4.1 in TS 38.521-1 [8], the following steps are added to configure E-UTRA component:

- 2.1. The parameter settings for E-UTRA cell are set up according to TS 36.508 [11] clause 4.4.3. The E-UTRA downlink signal level, uplink signal level are set according to Table 4.6-1 and propagation conditions are set according to Annex B.0 of TS 36.521-1 [10].
7. On the E-UTRA carrier, disable periodic and aperiodic CQI reports, disable SRS, set *TimeAlignmentTimerDedicated* IE to infinity and disable downlink and uplink scheduling, all as per Table 4.6-1 under clause 4.6.

Step 6 of Initial conditions as in clause 7.9.4.1 in TS 38.521-1 [8] is replaced by:

6. Ensure the UE is in state RRC\_CONNECTED with generic procedure parameters Connectivity EN-DC, DC bearer MCG and SCG, Connected without release *On* according to TS 38.508 [6] clause 4.5.

#### 7.9B.3.5 Test requirement

Same test requirement as in clause 7.9.5 in TS 38.521-1 [8].

## 7.9B.3\_1 Spurious Emissions for EN-DC within FR1 (>2 CCs)

### 7.9B.3\_1.1 Spurious Emissions for EN-DC within FR1 (3 CCs)

#### 7.9B.3\_1.1.1 Test purpose

Same test purpose as in clause 7.9B.1.

#### 7.9B.3\_1.1.2 Test applicability

This test applies to all types of E-UTRA UE release 15 and forward, supporting EN-DC within FR1 with 3CCs(1 LTE CC + 2 Inter-band NR CCs with a DL-only NR band).

#### 7.9B.3\_1.1.3 Minimum conformance requirements

The minimum conformance requirements are defined in clause 7.9B.0.3.

No exception requirements applicable to NR or E-UTRA. LTE anchor agnostic approach is applied.

#### 7.9B.3\_1.1.4 Test description

Same test description as in clause 7.9.4 or 7.9.A.1.4 in TS 38.521-1 [8] with the following exceptions:

**Table 7.9B.1.4-1: Test Configuration Table**

Initial Conditions	
Test Frequencies as specified in TS 38.508-1 [6] clause 4.3.1 for different DC bandwidth classes.	Mid range
Test EN-DC bandwidth combination as specified in Table 5.3B.1.2-1 across bandwidth combination sets supported by the UE	Highest $N_{RB\_agg}$ (NOTE 1)
NOTE 1: If the UE supports multiple CC Combinations in the EN-DC Configuration with the same $N_{RB\_agg}$ , only the combination with the highest $N_{RB\_SCG}$ is tested.	

The initial test configurations for E-UTRA as specified in Table 4.6-1 except for the parameters specified in Table 7.9B.1.4-1.

For Initial conditions as in clause 7.9.4.1 or 7.9A.1.4.1 in TS 38.521-1 [8], the following steps are added to configure E-UTRA component:

- 2.1. The parameter settings for E-UTRA cell are set up according to TS 36.508 [11] clause 4.4.3. The E-UTRA downlink signal level, uplink signal level are set according to Table 4.6-1 and propagation conditions are set according to Annex B.0 of TS 36.521-1 [10].
7. On the E-UTRA carrier, disable periodic and aperiodic CQI reports, disable SRS, set *TimeAlignmentTimerDedicated* IE to infinity and disable downlink and uplink scheduling, all as per Table 4.6-1 under clause 4.6.

Step 6 of Initial conditions as in clause 7.9.4.1 or 7.9A.1.4.1 in TS 38.521-1 [8] is replaced by:

6. Ensure the UE is in state RRC\_CONNECTED with generic procedure parameters Connectivity EN-DC, DC bearer MCG and SCG, Connected without release *On* according to TS 38.508 [6] clause 4.5.

#### 7.9B.3\_1.1.5 Test requirement

Same test requirement as in clause 7.9.5 in TS 38.521-1 [8].

## 7.9B.3a Spurious Emissions for inter-band NE-DC within FR1 (2 CCs)

No exception requirements applicable to NR or E-UTRA.



No test case details are specified. The requirements for NR carrier(s) in this test case are tested in 7.9 and 7.9A of TS 38.521-1 [8], and the requirements for LTE carrier(s) in this test case are tested in 7.9 and 7.9A of TS 36.521-1 [10]. Neither NR carrier(s) nor LTE carrier(s) needs to be tested again.

## 7.9B.4 Spurious Emissions for inter-band EN-DC including FR2 (1 NR CC)

**Editor's note:** The following aspects are either missing or not yet determined:

- The testability of this test case is pending further analysis on relaxation of the requirement for band other than n257, n258, n259, n260 and n261.
- TRP Measurement uncertainty is TBD for above 87 GHz.
- Measurement Uncertainties and Test Tolerances are FFS for power class other than PC1, PC3 and PC5.

### 7.9B.4.1 Test purpose

Same test purpose as in clause 7.9.1 in TS 38.521-2 [9] for the *NR* carrier.

### 7.9B.4.2 Test applicability

This test applies to all types of E-UTRA UE release 15 and forward, supporting inter-band EN-DC including FR2 with 1 NR DL CC.

### 7.9B.4.3 Minimum conformance requirements

Same minimum conformance requirements as in clause 7.9.3 in TS 38.521-2 [9] for the *NR* carrier.

No exception requirements applicable to NR or E-UTRA. LTE anchor agnostic approach is applied.

The normative reference for this requirement is TS 38.101-3 [4] clause 7.9B.4.

### 7.9B.4.4 Test description

Same test description as in clause 7.9.4 in TS 38.521-2 [9] for the *NR* carrier with the following exception:

The initial test configurations for E-UTRA band consist of environmental conditions, test frequencies, and channel bandwidths based on E-UTRA bands specified in Table 4.7-1.

For initial conditions as in clause 7.9.4.1 in TS 38.521-2 [9], the following steps will be added to configure E-UTRA component:

- 2.1. The parameter settings for E-UTRA cell are set up according to TS 36.508 [11] clause 4.4.3.
- 3.1. The E-UTRA downlink signal level, uplink signal level are set according to Table 4.7-1 and propagation conditions are set according to Annex B.0 of TS 36.521-1 [10].

Step 6 of Initial conditions as in clause 7.9.4.1 in TS 38.521-2 [9] is replaced by:

6. Ensure the UE is in state `RRC_CONNECTED` with generic procedure parameters Connectivity EN-DC, DC bearer MCG and SCG, Connected without release On according to TS 38.508-1 [6] clause 4.5.

Same test procedure as in clause 7.9.4.1 in TS 38.521-2 [9] with the following steps added for E-UTRA component:

- 1.1 On the E-UTRA carrier, disable periodic and aperiodic CQI reports, disable SRS, set *TimeAlignmentTimerDedicated* IE to infinity and disable downlink and uplink scheduling, all as per Table 4.7-1 under clause 4.7.

### 7.9B.4.5 Test requirements

Same test requirement as in clause 7.9.5 in TS 38.521-2 [9] for the *NR* carrier.

## 7.9B.5 Spurious Emissions for inter-band EN-DC including both FR1 and FR2 (3 CCs)

TBD

---

## Annex A (normative): Measurement Channels

Please refer to Annex A in TS 38.521-1 [8] and 38.521-2 [9] for appropriate details as needed for test cases in this test specification. EN-DC exceptions will be added.

---

### A.1 General

The throughput values defined in the measurement channels specified in Annex A, are calculated and are valid per datastream (codeword). For multi-stream (more than one codeword) transmissions, the throughput referenced in the minimum requirements is the sum of throughputs of all datastreams (codewords).

The UE category entry in the definition of the reference measurement channel in Annex A is only informative and reveals the UE categories, which can support the corresponding measurement channel. Whether the measurement channel is used for testing a certain UE category or not is specified in the individual minimum requirements.

---

### A.2 UL reference measurement channels for E-UTRA TDD Config 2

#### A.2.1 General

The measurement channels in the following clauses are defined to derive the requirements in clause 6 (Transmitter Characteristics) and clause 7 (Receiver Characteristics). The measurement channels represent example configurations of physical channels for different data rates.

## A.2.2 Reference measurement channels for E-UTRA

### A.2.2.1 Full RB allocation

#### A.2.2.1.1 QPSK

**Table A.2.2.1.1-1: Reference Channels for QPSK with full RB allocation**

Parameter	Unit	Value					
		1.4	3	5	10	15	20
Channel bandwidth	MHz	1.4	3	5	10	15	20
Allocated resource blocks		6	15	25	50	75	100
Uplink-Downlink Configuration (Note 2)		2	2	2	2	2	2
Special subframe configuration (Note 3)		7	7	7	7	7	7
DFT-OFDM Symbols per Sub-Frame		12	12	12	12	12	12
Modulation		QPSK	QPSK	QPSK	QPSK	QPSK	QPSK
Target Coding rate		1/3	1/3	1/3	1/3	1/5	1/6
Payload size							
For Sub-Frame 2,7	Bits	600	1544	2216	5160	4392	4584
Transport block CRC	Bits	24	24	24	24	24	24
Number of code blocks per Sub-Frame (Note 1)							
For Sub-Frame 2,7		1	1	1	1	1	1
Total number of bits per Sub-Frame							
For Sub-Frame 2,7	Bits	1728	4320	7200	14400	21600	28800
Total symbols per Sub-Frame							
For Sub-Frame 2,7		864	2160	3600	7200	10800	14400
UE Category		≥ 1	≥ 1	≥ 1	≥ 1	≥ 1	≥ 1
Note 1:	If more than one Code Block is present, an additional CRC sequence of L = 24 Bits is attached to each Code Block (otherwise L = 0 Bit)						
Note 2:	As per Table 4.2-2 in TS 36.211 [13]						
Note 3:	As per Table 4.2-1 in TS 36.211 [13]						

#### A.2.2.1.2 16-QAM

**Table A.2.2.1.2-1: Reference Channels for 16-QAM with full RB allocation**

Parameter	Unit	Value					
		1.4	3	5	10	15	20
Channel bandwidth	MHz	1.4	3	5	10	15	20
Allocated resource blocks		6	15	25	50	75	100
Uplink-Downlink Configuration (Note 2)		2	2	2	2	2	2
Special subframe configuration (Note 3)		7	7	7	7	7	7
DFT-OFDM Symbols per Sub-Frame		12	12	12	12	12	12
Modulation		16QAM	16QAM	16QAM	16QAM	16QAM	16QAM
Target Coding rate		3/4	1/2	1/3	3/4	1/2	1/3
Payload size							
For Sub-Frame 2,7	Bits	2600	4264	4968	21384	21384	19848
Transport block CRC	Bits	24	24	24	24	24	24
Number of code blocks per Sub-Frame (Note 1)							
For Sub-Frame 2,7		1	1	1	4	4	4
Total number of bits per Sub-Frame							
For Sub-Frame 2,7	Bits	3456	8640	14400	28800	43200	57600
Total symbols per Sub-Frame							
For Sub-Frame 2,7		864	2160	3600	7200	10800	14400
UE Category		≥ 1	≥ 1	≥ 1	≥ 2	≥ 2	≥ 2
Note 1:	If more than one Code Block is present, an additional CRC sequence of L = 24 Bits is attached to each Code Block (otherwise L = 0 Bit)						
Note 2:	As per Table 4.2-2 in TS 36.211 [13]						
Note 3:	As per Table 4.2-1 in TS 36.211 [13]						

## A.2.2.1.3 64-QAM

Table A.2.2.1.3-1: Reference Channels for 64-QAM with full RB allocation

Parameter	Unit	Value					
Channel bandwidth	MHz	1.4	3	5	10	15	20
Allocated resource blocks		6	15	25	50	75	100
Uplink-Downlink Configuration (Note 2)		2	2	2	2	2	2
Special subframe configuration (Note 3)		7	7	7	7	7	7
DFT-OFDM Symbols per Sub-Frame		12	12	12	12	12	12
Modulation		64QAM	64QAM	64QAM	64QAM	64QAM	64QAM
Target Coding rate		3/4	3/4	3/4	3/4	3/4	3/4
Payload size							
For Sub-Frame 2,7	Bits	3752	9528	15840	31704	46888	63776
Transport block CRC	Bits	24	24	24	24	24	24
Number of code blocks per Sub-Frame (Note 1)							
For Sub-Frame 2,7		1	2	3	6	8	11
Total number of bits per Sub-Frame							
For Sub-Frame 2,7	Bits	5184	12960	21600	43200	64800	86400
Total symbols per Sub-Frame							
For Sub-Frame 2,7		864	2160	3600	7200	10800	14400
UE Category (Note 4)		5, 8	5, 8	5, 8	5, 8	5, 8	5, 8
UE UL Category (Note 4)		5, 8, 13, 14	5, 8, 13, 14	5, 8, 13, 14	5, 8, 13, 14	5, 8, 13, 14	5, 8, 13, 14
<p>Note 1: If more than one Code Block is present, an additional CRC sequence of L = 24 Bits is attached to each Code Block (otherwise L = 0 Bit)</p> <p>Note 2: As per Table 4.2-2 in TS 36.211 [13]</p> <p>Note 3: As per Table 4.2-1 in TS 36.211 [13]</p> <p>Note 4: If UE does not report UE UL category, then the applicability of reference channel is determined by UE category. If UE reports UE UL category, then the applicability of reference channel is determined by UE UL category.</p>							

## A.2.2.1.4 256 QAM

Table A.2.2.1.4-1: Reference Channels for 256 QAM with full RB allocation

Parameter	Unit	Value					
		1.4	3	5	10	15	20
Channel bandwidth	MHz	1.4	3	5	10	15	20
Allocated resource blocks		6	15	25	50	75	100
Uplink-Downlink Configuration (Note 2)		2	2	2	2	2	2
Special subframe configuration (Note 3)		7	7	7	7	7	7
DFT-OFDM Symbols per Sub-Frame		12	12	12	12	12	12
Modulation		256QAM	256QAM	256QAM	256QAM	256QAM	256QAM
Target Coding rate		3/4	3/4	3/4	3/4	3/4	3/4
Payload size							
For Sub-Frame 2,7	Bits	5160	12960	21384	42368	63776	84760
Transport block CRC	Bits	24	24	24	24	24	24
Number of code blocks per Sub-Frame (Note 1)							
For Sub-Frame 2,7		1	3	4	8	11	15
Total number of bits per Sub-Frame							
For Sub-Frame 2,7	Bits	6912	17280	28800	57600	86400	115200
Total symbols per Sub-Frame							
For Sub-Frame 2,7		864	2160	3600	7200	10800	14400
UE UL Category		≥ 15	≥ 15	≥ 15	≥ 15	≥ 15	≥ 15
Note 1: If more than one Code Block is present, an additional CRC sequence of L = 24 Bits is attached to each Code Block (otherwise L = 0 Bit)							
Note 2: As per Table 4.2-2 in TS 36.211 [13]							
Note 3: As per Table 4.2-1 in TS 36.211 [13]							

## A.2.2.2 Partial RB allocation

### A.2.2.2.1 QPSK

**Table A.2.2.2.1-1: Reference Channels for QPSK with partial RB allocation**

Parameter	Ch BW	Allocated RBs	UL-DL Configuration (Note 2)	Special subframe configuration (Note 3)	DFT-OFDM Symbols per Sub-Frame	Mod'n	Target Coding rate	Payload size for Sub-Frame 2, 7	Transport block CRC	Number of code blocks per Sub-Frame (Note 1)	Total number of bits per Sub-Frame for Sub-Frame 2, 7	Total symbols per Sub-Frame for Sub-Frame 2, 7	UE Category
Unit	MHz							Bits	Bits		Bits		
	1.4 - 20	1	2	7	12	QPSK	1/3	72	24	1	288	144	≥ 1
	1.4 - 20	2	2	7	12	QPSK	1/3	176	24	1	576	288	≥ 1
	1.4 - 20	3	2	7	12	QPSK	1/3	256	24	1	864	432	≥ 1
	1.4 - 20	4	2	7	12	QPSK	1/3	392	24	1	1152	576	≥ 1
	1.4 - 20	5	2	7	12	QPSK	1/3	424	24	1	1440	720	≥ 1
	3-20	6	2	7	12	QPSK	1/3	600	24	1	1728	864	≥ 1
	3-20	8	2	7	12	QPSK	1/3	808	24	1	2304	1152	≥ 1
	3-20	9	2	7	12	QPSK	1/3	776	24	1	2592	1296	≥ 1
	3-20	10	2	7	12	QPSK	1/3	872	24	1	2880	1440	≥ 1
	3-20	12	2	7	12	QPSK	1/3	1224	24	1	3456	1728	≥ 1
	5-20	15	2	7	12	QPSK	1/3	1320	24	1	4320	2160	≥ 1
	5-20	16	2	7	12	QPSK	1/3	1384	24	1	4608	2304	≥ 1
	5-20	18	2	7	12	QPSK	1/3	1864	24	1	5184	2592	≥ 1
	5-20	20	2	7	12	QPSK	1/3	1736	24	1	5760	2880	≥ 1
	5-20	24	2	7	12	QPSK	1/3	2472	24	1	6912	3456	≥ 1
	10-20	25	2	7	12	QPSK	1/3	2216	24	1	7200	3600	≥ 1
	10-20	27	2	7	12	QPSK	1/3	2792	24	1	7776	3888	≥ 1
	10-20	30	2	7	12	QPSK	1/3	2664	24	1	8640	4320	≥ 1
	10-20	32	2	7	12	QPSK	1/3	2792	24	1	9216	4608	≥ 1
	10-20	36	2	7	12	QPSK	1/3	3752	24	1	10368	5184	≥ 1
	10-20	40	2	7	12	QPSK	1/3	4136	24	1	11520	5760	≥ 1
	10-20	45	2	7	12	QPSK	1/3	4008	24	1	12960	6480	≥ 1
	10-20	48	2	7	12	QPSK	1/3	4264	24	1	13824	6912	≥ 1
	15 - 20	50	2	7	12	QPSK	1/3	5160	24	1	14400	7200	≥ 1
	15 - 20	54	2	7	12	QPSK	1/3	4776	24	1	15552	7776	≥ 1
	15 - 20	60	2	7	12	QPSK	1/4	4264	24	1	17280	8640	≥ 1
	15 - 20	64	2	7	12	QPSK	1/4	4584	24	1	18432	9216	≥ 1
	15 - 20	72	2	7	12	QPSK	1/4	5160	24	1	20736	10368	≥ 1
	20	75	2	7	12	QPSK	1/5	4392	24	1	21600	10800	≥ 1
	20	80	2	7	12	QPSK	1/5	4776	24	1	23040	11520	≥ 1
	20	81	2	7	12	QPSK	1/5	4776	24	1	23328	11664	≥ 1
	20	90	2	7	12	QPSK	1/6	4008	24	1	25920	12960	≥ 1
	20	96	2	7	12	QPSK	1/6	4264	24	1	27648	13824	≥ 1

Note 1: If more than one Code Block is present, an additional CRC sequence of L = 24 Bits is attached to each Code Block (otherwise L = 0 Bit)

Note 2: As per Table 4.2-2 in TS 36.211 [13]

Note 3: As per Table 4.2-1 in TS 36.211 [13]





A.2.2.2.2 16-QAM

**Table A.2.2.2.2-1: Reference Channels for 16QAM with partial RB allocation**

Parameter	Ch BW	Allocated RBs	UL-DL Configuration (Note 2)	Special subframe configuration (Note 3)	DFT-OFDM Symbols per Sub-Frame	Mod'n	Target Coding rate	Payload size for Sub-Frame 2, 7	Transport block CRC	Number of code blocks per Sub-Frame (Note 1)	Total number of bits per Sub-Frame for Sub-Frame 2, 7	Total symbols per Sub-Frame for Sub-Frame 2, 7	UE Category
Unit	MHz							Bits	Bits		Bits		
	1.4-20	1	2	7	12	16QAM	3/4	408	24	1	576	144	≥ 1
	1.4-20	2	2	7	12	16QAM	3/4	840	24	1	1152	288	≥ 1
	1.4-20	3	2	7	12	16QAM	3/4	1288	24	1	1728	432	≥ 1
	1.4-20	4	2	7	12	16QAM	3/4	1736	24	1	2304	576	≥ 1
	1.4-20	5	2	7	12	16QAM	3/4	2152	24	1	2880	720	≥ 1
	3-20	6	2	7	12	16QAM	3/4	2600	24	1	3456	864	≥ 1
	3-20	8	2	7	12	16QAM	3/4	3496	24	1	4608	1152	≥ 1
	3-20	9	2	7	12	16QAM	3/4	3880	24	1	5184	1296	≥ 1
	3-20	10	2	7	12	16QAM	3/4	4264	24	1	5760	1440	≥ 1
	3-20	12	2	7	12	16QAM	3/4	5160	24	1	6912	1728	≥ 1
	5-20	15	2	7	12	16QAM	1/2	4264	24	1	8640	2160	≥ 1
	5-20	16	2	7	12	16QAM	1/2	4584	24	1	9216	2304	≥ 1
	5-20	18	2	7	12	16QAM	1/2	5160	24	1	10368	2592	≥ 1
	5-20	20	2	7	12	16QAM	1/3	4008	24	1	11520	2880	≥ 1
	5-20	24	2	7	12	16QAM	1/3	4776	24	1	13824	3456	≥ 1
	10-20	25	2	7	12	16QAM	1/3	4968	24	1	14400	3600	≥ 1
	10-20	27	2	7	12	16QAM	1/3	4776	24	1	15552	3888	≥ 1
	10-20	30	2	7	12	16QAM	3/4	12960	24	3	17280	4320	≥ 2
	10-20	32	2	7	12	16QAM	3/4	13536	24	3	18432	4608	≥ 2
	10-20	36	2	7	12	16QAM	3/4	15264	24	3	20736	5184	≥ 2
	10-20	40	2	7	12	16QAM	3/4	16992	24	3	23040	5760	≥ 2
	10-20	45	2	7	12	16QAM	3/4	19080	24	4	25920	6480	≥ 2
	10-20	48	2	7	12	16QAM	3/4	20616	24	4	27648	6912	≥ 2
	15-20	50	2	7	12	16QAM	3/4	21384	24	4	28800	7200	≥ 2
	15-20	54	2	7	12	16QAM	3/4	22920	24	4	31104	7776	≥ 2
	15-20	60	2	7	12	16QAM	2/3	23688	24	4	34560	8640	≥ 2
	15-20	64	2	7	12	16QAM	2/3	25456	24	4	36864	9216	≥ 2

	15 - 20	72	2	7	12	16QA M	1/2	20616	24	4	41472	10368	$\geq 2$
	20	75	2	7	12	16QA M	1/2	21384	24	4	43200	10800	$\geq 2$
	20	80	2	7	12	16QA M	1/2	22920	24	4	46080	11520	$\geq 2$
	20	81	2	7	12	16QA M	1/2	22920	24	4	46656	11664	$\geq 2$
	20	90	2	7	12	16QA M	2/5	20616	24	4	51840	12960	$\geq 2$
	20	96	2	7	12	16QA M	2/5	22152	24	4	55296	13824	$\geq 2$
Note 1:	If more than one Code Block is present, an additional CRC sequence of L = 24 Bits is attached to each Code Block (otherwise L = 0 Bit)												
Note 2:	As per Table 4.2-2 in TS 36.211 [13]												
Note 3:	As per Table 4.2-1 in TS 36.211 [13]												

### A.2.2.2.3 64-QAM

**Table A.2.2.2.3-1: Reference Channels for 64-QAM with partial RB allocation**

Parameter	ChBW	Allocated RBs	UL-DL Configuration (Note 2)	Special subframe configuration (Note 3)	DFT-OFDM Symbols per Sub-Frame	Mod'n	Target Coding rate	Payload size for Sub-Frame 2, 7	Transport block CRC	Number of code blocks per Sub-Frame (Note 1)	Total number of bits per Sub-Frame for Sub-Frame 2, 7	Total symbols per Sub-Frame for Sub-Frame 2, 7	UE Category (Note 4)	UE UL Category (Note 4)
Unit	MHz							Bits	Bits		Bits			
	1.4-20	1	2	7	12	64QAM	3/4	616	24	1	864	144	5,8	5, 8, 13, 14
	1.4-20	2	2	7	12	64QAM	3/4	1256	24	1	1728	288	5,8	5, 8, 13, 14
	1.4-20	3	2	7	12	64QAM	3/4	1864	24	1	2592	432	5,8	5, 8, 13, 14
	1.4-20	4	2	7	12	64QAM	3/4	2536	24	1	3456	576	5,8	5, 8, 13, 14
	1.4-20	5	2	7	12	64QAM	3/4	3112	24	1	4320	720	5,8	5, 8, 13, 14
	3-20	6	2	7	12	64QAM	3/4	3752	24	1	5184	864	5,8	5, 8, 13, 14
	3-20	8	2	7	12	64QAM	3/4	5160	24	1	6912	1152	5,8	5, 8, 13, 14
	3-20	9	2	7	12	64QAM	3/4	5736	24	1	7776	1296	5,8	5, 8, 13, 14
	3-20	10	2	7	12	64QAM	3/4	6200	24	2	8640	1440	5,8	5, 8, 13, 14
	3-20	12	2	7	12	64QAM	3/4	7480	24	2	10368	1728	5,8	5, 8, 13, 14
	5-20	15	2	7	12	64QAM	3/4	9528	24	2	12960	2160	5,8	5, 8, 13, 14
	5-20	16	2	7	12	64QAM	3/4	10296	24	2	13824	2304	5,8	5, 8, 13, 14
	5-20	18	2	7	12	64QAM	3/4	11448	24	2	15552	2592	5,8	5, 8, 13, 14
	5-20	20	2	7	12	64QAM	3/4	12576	24	3	17280	2880	5,8	5, 8, 13, 14
	5-20	24	2	7	12	64QAM	3/4	15264	24	3	20736	3456	5,8	5, 8, 13, 14
	10-20	25	2	7	12	64QAM	3/4	15840	24	3	21600	3600	5,8	5, 8, 13, 14

	10 - 20	27	2	7	12	64Q AM	3/4	169 92	24	3	233 28	3888	5,8	5, 8, 13, 14
	10 - 20	30	2	7	12	64Q AM	3/4	190 80	24	4	259 20	4320	5,8	5, 8, 13, 14
	10 - 20	32	2	7	12	64Q AM	3/4	206 16	24	4	276 48	4608	5,8	5, 8, 13, 14
	10 - 20	36	2	7	12	64Q AM	3/4	229 20	24	4	311 04	5184	5,8	5, 8, 13, 14
	10 - 20	40	2	7	12	64Q AM	3/4	254 56	24	5	345 60	5760	5,8	5, 8, 13, 14
	10 - 20	45	2	7	12	64Q AM	3/4	283 36	24	5	388 80	6480	5,8	5, 8, 13, 14
	10 - 20	48	2	7	12	64Q AM	3/4	305 76	24	5	414 72	6912	5,8	5, 8, 13, 14
	15 - 20	50	2	7	12	64Q AM	3/4	317 04	24	6	432 00	7200	5,8	5, 8, 13, 14
	15 - 20	54	2	7	12	64Q AM	3/4	340 08	24	6	466 56	7776	5,8	5, 8, 13, 14
	15 - 20	60	2	7	12	64Q AM	3/4	378 88	24	7	518 40	8640	5,8	5, 8, 13, 14
	15 - 20	64	2	7	12	64Q AM	3/4	405 76	24	7	552 96	9216	5,8	5, 8, 13, 14
	15 - 20	72	2	7	12	64Q AM	3/4	453 52	24	8	622 08	1036 8	5,8	5, 8, 13, 14
	20	75	2	7	12	64Q AM	3/4	468 88	24	8	648 00	1080 0	5,8	5, 8, 13, 14
	20	80	2	7	12	64Q AM	3/4	510 24	24	9	691 20	1152 0	5,8	5, 8, 13, 14
	20	81	2	7	12	64Q AM	3/4	510 24	24	9	699 84	1166 4	5,8	5, 8, 13, 14
	20	90	2	7	12	64Q AM	3/4	510 24	24	9	777 60	1296 0	5,8	5, 8, 13, 14
	20	96	2	7	12	64Q AM	3/4	616 64	24	11	829 44	1382 4	5,8	5, 8, 13, 14

Note 1: If more than one Code Block is present, an additional CRC sequence of L = 24 Bits is attached to each Code Block (otherwise L = 0 Bit)

Note 2: As per Table 4.2-2 in TS 36.211 [13]

Note 3: As per Table 4.2-1 in TS 36.211 [13]

Note 4: If UE does not report UE UL category, then the applicability of reference channel is determined by UE category. If UE reports UE UL category, then the applicability of reference channel is determined by UE UL category

A.2.2.2.4 256 QAM

Table A.2.2.2.4-1: Reference Channels for 256 QAM with partial RB allocation

Parameter	Ch BW	Allocated RBs	UL-DL Configuration (Note 2)	Special Slot Configuration (Note 3)	DFT-OFDM Symbols per Sub-Frame	Mod'n	Target Coding rate	Payload size for Sub-Frame 2, 7	Transport block CRC	Number of code blocks per Sub-Frame (Note 1)	Total number of bits per Sub-Frame for Sub-Frame 2, 7	Total symbols per Sub-Frame for Sub-Frame 2, 7	UE Category
Unit	MHz							Bits	Bits		Bits		
	1.4 - 20	1	2	7	12	256QAM	3/4	840	24	1	1152	144	≥ 14
	1.4 - 20	2	2	7	12	256QAM	3/4	1672	24	1	2304	288	≥ 14
	1.4 - 20	3	2	7	12	256QAM	3/4	2536	24	1	3456	432	≥ 14
	1.4 - 20	4	2	7	12	256QAM	3/4	3368	24	1	4608	576	≥ 14
	1.4 - 20	5	2	7	12	256QAM	3/4	4264	24	1	5760	720	≥ 14
	3-20	6	2	7	12	256QAM	3/4	5160	24	1	6912	864	≥ 14
	3-20	8	2	7	12	256QAM	3/4	6712	24	2	9216	1152	≥ 14
	3-20	9	2	7	12	256QAM	3/4	7736	24	2	10368	1296	≥ 14
	3-20	10	2	7	12	256QAM	3/4	8504	24	2	11520	1440	≥ 14
	3-20	12	2	7	12	256QAM	3/4	10296	24	2	13824	1728	≥ 14
	5-20	15	2	7	12	256QAM	3/4	12960	24	3	17280	2160	≥ 14
	5-20	16	2	7	12	256QAM	3/4	13536	24	3	18432	2304	≥ 14
	5-20	18	2	7	12	256QAM	3/4	15264	24	3	20736	2592	≥ 14
	5-20	20	2	7	12	256QAM	3/4	16992	24	3	23040	2880	≥ 14
	5-20	24	2	7	12	256QAM	3/4	20616	24	4	27648	3456	≥ 14
	10-20	25	2	7	12	256QAM	3/4	21384	24	4	28800	3600	≥ 14
	10-20	27	2	7	12	256QAM	3/4	22920	24	4	31104	3888	≥ 14
	10-20	30	2	7	12	256QAM	3/4	25456	24	5	34560	4320	≥ 14
	10-20	32	2	7	12	256QAM	3/4	27376	24	5	36864	4608	≥ 14
	10-20	36	2	7	12	256QAM	3/4	30576	24	6	41472	5184	≥ 14
	10-20	40	2	7	12	256QAM	3/4	34008	24	6	46080	5760	≥ 14
	10-20	45	2	7	12	256QAM	3/4	37888	24	7	51840	6480	≥ 14
	10-20	48	2	7	12	256QAM	3/4	40576	24	8	55296	6912	≥ 14
	15 - 20	50	2	7	12	256QAM	3/4	42368	24	8	57600	7200	≥ 14
	15 - 20	54	2	7	12	256QAM	3/4	46888	24	8	62208	7776	≥ 14
	15 - 20	60	2	7	12	256QAM	3/4	51024	24	9	69120	8640	≥ 14
	15 - 20	64	2	7	12	256QAM	3/4	55056	24	9	73728	9216	≥ 14
	15 - 20	72	2	7	12	256QAM	3/4	61664	24	11	82944	10368	≥ 14
	20	75	2	7	12	256QAM	3/4	63776	24	11	86400	10800	≥ 14
	20	80	2	7	12	256QAM	3/4	68808	24	12	92160	11520	≥ 14
	20	81	2	7	12	256QAM	3/4	68808	24	12	93312	11664	≥ 14
	20	90	2	7	12	256QAM	3/4	76208	24	13	103680	12960	≥ 14
	20	96	2	7	12	256QAM	3/4	81176	24	14	110592	13824	≥ 14

Note 1: If more than one Code Block is present, an additional CRC sequence of L = 24 Bits is attached to each Code Block (otherwise L = 0 Bit)

Note 2: As per Table 4.2-2 in TS 36.211 [13]

Note 3: As per Table 4.2-1 in TS 36.211 [13]

## A.3 DL reference measurement channels for E-UTRA

### A.3.1 General

The number of available channel bits varies across the sub-frames due to PBCH and PSS/SSS overhead. The payload size per sub-frame is varied in order to keep the code rate constant throughout a frame.

Unless otherwise stated, no user data is scheduled on subframes #5 in order to facilitate the transmission of system information blocks (SIB).

The algorithm for determining the payload size  $A$  is as follows; given a desired coding rate  $R$  and radio block allocation  $N_{RB}$

1. Calculate the number of channel bits  $N_{ch}$  that can be transmitted during the first transmission of a given sub-frame.
2. Find  $A$  such that the resulting coding rate is as close to  $R$  as possible, that is,

$$\min |R - (A + 24 * (N_{CB} + 1)) / N_{ch}|, \text{ where } N_{CB} = \begin{cases} 0, & \text{if } C = 1 \\ C, & \text{if } C > 1 \end{cases}$$

subject to

- a)  $A$  is a valid TB size according to clause 7.1.7 of TS 36.213 [6] assuming an allocation of  $N_{RB}$  resource blocks.
- b)  $C$  is the number of Code Blocks calculated according to clause 5.1.2 of TS 36.212 [5].
3. If there is more than one  $A$  that minimizes the equation above, then the larger value is chosen per default and the chosen code rate should not exceed 0.93.
4. For TDD, the measurement channel is based on DL/UL configuration ratio of 3DL+DwPTS (10 OFDM symbol SSF7): 1UL.

**Table A.3.1-1: PUCCH-ConfigDedicated-v1020-DEFAULT: Additional Configuration for LTE TDD 1CC**

Derivation Path: 36.508 [11] clause 4.6.3, Table 4.6.3-9A: PUCCH-ConfigDedicated-v1020-DEFAULT			
Information Element	Value/remark	Comment	Condition
PUCCH-ConfigDedicated-v1020 ::= SEQUENCE {			
pucch-Format-r10 CHOICE {			UL_RB_allocation=0
channelSelection-r10 SEQUENCE {			
n1PUCCH-AN-CS-r10 CHOICE {			
setup SEQUENCE {			
n1PUCCH-AN-CS-List-r10 SEQUENCE{	2		
N1PUCCH-AN-CS-r10	4		
	101		
	102		
	103		
	104		
N1PUCCH-AN-CS-r10	4		
	105		
	106		
	107		
	108		
}			
}			
}			
}			
}			



Condition	Explanation
UL_RB_allocation=0	TC is tested with no or N/A UL RB allocation (no PUSCH)

**Table A.3.1-2: RadioResourceConfigCommonSIB-DEFAULT: Additional Configuration for LTE TDD 1CC**

Derivation Path: 36.508 [11] clause 4.6.3, Table 4.6.3-14: RadioResourceConfigCommonSIB-DEFAULT			
Information Element	Value/remark	Comment	Condition
RadioResourceConfigCommonSIB-DEFAULT ::= SEQUENCE {			
uplinkPowerControlCommon-v1020	UplinkPowerControlCommon-v1020-DEFAULT: Additional Configuration for LTE TDD 1CC	Table A.3.1-3	UL_RB_allocation=0
}			

Condition	Explanation
UL_RB_allocation=0	TC is tested with no or N/A UL RB allocation (no PUSCH)

**Table A.3.1-3: UplinkPowerControlCommon-v1020-DEFAULT: Additional Configuration for LTE TDD 1CC**

Derivation Path: 36.508 [11] clause 4.6.3, Table 4.6.3-25AA: UplinkPowerControlCommon-v1020-DEFAULT			
Information Element	Value/remark	Comment	Condition
UplinkPowerControlCommon-v1020-DEFAULT ::= SEQUENCE {			UL_RB_allocation=0
deltaF-PUCCH-Format1bCS-r10	deltaF1		
}			

Condition	Explanation
UL_RB_allocation=0	TC is tested with no or N/A UL RB allocation (no PUSCH)

## A.3.1.1 QPSK

Table A.3.1.1-1: Fixed Reference Channel for Receiver Requirements (TDD)

Parameter	Unit	Value					
		1.4	3	5	10	15	20
Channel Bandwidth	MHz	1.4	3	5	10	15	20
Allocated resource blocks		6	15	25	50	75	100
Uplink-Downlink Configuration (NOTE 5)		2	2	2	2	2	2
Special subframe configuration (NOTE 6)		7	7	7	7	7	7
Allocated subframes per Radio Frame (D+S)		3	3+2	3+2	3+2	3+2	3+2
Number of HARQ Processes	Processes	7	7	7	7	7	7
Maximum number of HARQ transmission		1	1	1	1	1	1
Modulation		QPSK	QPSK	QPSK	QPSK	QPSK	QPSK
Target coding rate		1/3	1/3	1/3	1/3	1/3	1/3
Information Bit Payload per Sub-Frame	Bits						
For Sub-Frame 3, 4, 8, 9		408	1320	2216	4392	6712	8760
For Sub-Frame 1, 6		N/A	776	1288	2664	4008	5352
For Sub-Frame 5		N/A	N/A	N/A	N/A	N/A	N/A
For Sub-Frame 0		208	1064	1800	4392	6712	8760
Transport block CRC	Bits	24	24	24	24	24	24
Number of Code Blocks per Sub-Frame (NOTE 4)							
For Sub-Frame 3, 4, 8, 9		1	1	1	1	2	2
For Sub-Frame 1, 6		N/A	1	1	1	1	1
For Sub-Frame 5		N/A	N/A	N/A	N/A	N/A	N/A
For Sub-Frame 0		1	1	1	1	2	2
Binary Channel Bits Per Sub-Frame	Bits						
For Sub-Frame 3, 4, 8, 9		1368	3780	6300	13800	20700	27600
For Sub-Frame 1, 6		N/A	2616	4456	9056	13656	18256
For Sub-Frame 5		N/A	N/A	N/A	N/A	N/A	N/A
For Sub-Frame 0		672	3084	5604	13104	20004	26904
Max. Throughput averaged over 1 frame	kbps	102.4	564	932	1965.6	3007.2	3970.4
UE Category		≥ 1	≥ 1	≥ 1	≥ 1	≥ 1	≥ 1
NOTE 1: For normal subframes(0,3,4,5,8,9), 2 symbols allocated to PDCCH for 20 MHz, 15 MHz and 10 MHz channel BW; 3 symbols allocated to PDCCH for 5 MHz and 3 MHz; 4 symbols allocated to PDCCH for 1.4 MHz. For special subframe (1&6), only 2 OFDM symbols are allocated to PDCCH for all BWs.							
NOTE 2: For 1.4MHz, no data shall be scheduled on special subframes(1&6) to avoid problems with insufficient PDCCH performance							
NOTE 3: Reference signal, Synchronization signals and PBCH allocated as per TS 36.211 [7]							
NOTE 4: If more than one Code Block is present, an additional CRC sequence of L = 24 Bits is attached to each Code Block (otherwise L = 0 Bit).							
NOTE 5: As per Table 4.2-2 in TS 36.211 [7]							
NOTE 6: As per Table 4.2-1 in TS 36.211 [7]							

## A.3.1.2 64-QAM

Table A.3.1.2-1: Fixed Reference Channel for Maximum input level for UE Categories  $\geq 3$  (TDD)

Parameter	Unit	Value					
		1.4	3	5	10	15	20
Channel bandwidth	MHz	1.4	3	5	10	15	20
Allocated resource blocks		6	15	25	50	75	100
Subcarriers per resource block		12	12	12	12	12	12
Uplink-Downlink Configuration (NOTE 5)		2	2	2	2	2	2
Special subframe configuration (NOTE 6)		7	7	7	7	7	7
Allocated subframes per Radio Frame		2	3+2	3+2	3+2	3+2	3+2
Modulation		64QAM	64QAM	64QAM	64QAM	64QAM	64QAM
Target Coding Rate		$\frac{3}{4}$	$\frac{3}{4}$	$\frac{3}{4}$	$\frac{3}{4}$	$\frac{3}{4}$	$\frac{3}{4}$
Number of HARQ Processes	Processes	7	7	7	7	7	7
Maximum number of HARQ transmissions		1	1	1	1	1	1
Information Bit Payload per Sub-Frame							
For Sub-Frames 3, 4, 8, 9	Bits	2984	8504	14112	30576	46888	61664
For Sub-Frames 1,6	Bits	N/A	5544	9528	19848	30576	40576
For Sub-Frame 5	Bits	N/A	N/A	N/A	N/A	N/A	N/A
For Sub-Frame 0	Bits	N/A	6968	12576	30576	45352	61664
Transport block CRC	Bits	24	24	24	24	24	24
Number of Code Blocks per Sub-Frame (NOTE 4)							
For Sub-Frames 3, 4, 8, 9		1	2	3	5	8	11
For Sub-Frames 1,6		N/A	2	2	4	6	8
For Sub-Frame 5		N/A	N/A	N/A	N/A	N/A	N/A
For Sub-Frame 0		N/A	2	3	5	8	11
Binary Channel Bits per Sub-Frame							
For Sub-Frames 3, 4, 8, 9	Bits	4104	11340	18900	41400	62100	82800
For Sub-Frames 1,6		N/A	7848	13368	27168	40968	54768
For Sub-Frame 5	Bits	N/A	N/A	N/A	N/A	N/A	N/A
For Sub-Frame 0	Bits	N/A	9252	16812	39312	60012	80712
Max. Throughput averaged over 1 frame	kbps	596.8	3791.2	6369.6	13910	20945	27877
NOTE 1: For normal subframes(0,3,4,5,8,9), 2 symbols allocated to PDCCH for 20 MHz, 15 MHz and 10 MHz channel BW; 3 symbols allocated to PDCCH for 5 MHz and 3 MHz; 4 symbols allocated to PDCCH for 1.4 MHz. For special subframe (1&6), only 2 OFDM symbols are allocated to PDCCH for all BWs.							
NOTE 2: For 1.4MHz, no data shall be scheduled on special subframes(1&6) to avoid problems with insufficient PDCCH performance.							
NOTE 3: Reference signal, Synchronization signals and PBCH allocated as per TS 36.211 [7].							
NOTE 4: If more than one Code Block is present, an additional CRC sequence of L = 24 Bits is attached to each Code Block (otherwise L = 0 Bit).							
NOTE 5: As per Table 4.2-2 in TS 36.211 [7].							
NOTE 6: As per Table 4.2-1 in TS 36.211 [7]							

## A.3.1.3 256-QAM

Table A.3.1.3-1: Fixed Reference Channel for Maximum input level for UE Categories 11/12 and UE DL categories  $\geq 11$  (TDD)

Parameter	Unit	Value					
		1.4	3	5	10	15	20
Channel bandwidth	MHz	1.4	3	5	10	15	20
Allocated resource blocks		6	15	25	50	75	100
Subcarriers per resource block		12	12	12	12	12	12
Uplink-Downlink Configuration (NOTE 5)		2	2	2	2	2	2
Special subframe configuration (NOTE 6)		7	7	7	7	7	7
Allocated subframes per Radio Frame		2	3+2	3+2	3+2	3+2	3+2
Modulation		256QAM	256QAM	256QAM	256QAM	256QAM	256QAM
Target Coding Rate		4/5	4/5	4/5	4/5	4/5	4/5
Number of HARQ Processes	Processes	7	7	7	7	7	7
Maximum number of HARQ transmissions		1	1	1	1	1	1
Information Bit Payload per Sub-Frame							
For Sub-Frames 3,4,8,9	Bits	4392	12216	19848	42368	63776	84760
For Sub-Frames 1,6	Bits	N/A	10464	17824	36224	54624	73024
For Sub-Frame 5	Bits	N/A	N/A	N/A	N/A	N/A	N/A
For Sub-Frame 0	Bits	N/A	9912	17568	42368	63776	84760
Transport block CRC	Bits	24	24	24	24	24	24
Number of Code Blocks per Sub-Frame (NOTE 4)							
For Sub-Frames 3,4,8,9		1	2	4	7	11	14
For Sub-Frames 1,6		N/A	2	3	6	9	13
For Sub-Frame 5		N/A	N/A	N/A	N/A	N/A	N/A
For Sub-Frame 0		N/A	2	3	7	11	14
Binary Channel Bits per Sub-Frame							
For Sub-Frames 3,4,8,9	Bits	5472	15120	25200	55200	82800	110400
For Sub-Frames 1,6		N/A	8248	13536	27376	40576	55056
For Sub-Frame 5	Bits	N/A	N/A	N/A	N/A	N/A	N/A
For Sub-Frame 0	Bits	N/A	12336	22416	52416	80016	107616
Max. Throughput averaged over 1 frame	kbps	878.4	5570.4	9240	20049.6	30144	40503.2
NOTE 1: For normal subframes(0,3,4,5,8,9), 2 symbols allocated to PDCCH for 20 MHz, 15 MHz and 10 MHz channel BW; 3 symbols allocated to PDCCH for 5 MHz and 3 MHz; 4 symbols allocated to PDCCH for 1.4 MHz. For special subframe (1&6), only 2 OFDM symbols are allocated to PDCCH for all BWs.							
NOTE 2: For 1.4MHz, no data shall be scheduled on special subframes(1&6) to avoid problems with insufficient PDCCH performance.							
NOTE 3: Reference signal, Synchronization signals and PBCH allocated as per TS 36.211 [7].							
NOTE 4: If more than one Code Block is present, an additional CRC sequence of L = 24 Bits is attached to each Code Block (otherwise L = 0 Bit).							
NOTE 5: As per Table 4.2-2 in TS 36.211 [7].							
NOTE 6: As per Table 4.2-1 in TS 36.211 [7]							

---

## Annex B (normative): Propagation Conditions

Please refer to Annex B in TS 38.521-1 [8] and 38.521-2 [9] for appropriate details as needed for test cases in this test specification. EN-DC exceptions will be added,

---

## Annex C (normative): Downlink Physical Channels

Please refer to Annex C in TS 38.521-1 [8] and 38.521-2 [9] for appropriate details as needed for test cases in this test specification. EN-DC exceptions will be added,

---

## Annex D (normative): Characteristics of the Interfering Signal

Please refer to Annex D in TS 38.521-1 [8] and 38.521-2 [9] for appropriate details as needed for test cases in this test specification. EN-DC exceptions will be added,

---

## Annex E (normative): Global In-Channel Tx Test

Please refer to Annex E in TS 38.521-1 [8] and 38.521-2 [9] for appropriate details as needed for test cases in this test specification. EN-DC exceptions will be added,

---

## Annex F (informative): Measurement uncertainties and Test Tolerances

### F.1 Acceptable uncertainty of Test System (normative)

#### F.1.0 General

##### F.1.0.1 Conducted Measurements

Same as F.1.0 in TS 38.521-1 [8].

##### F.1.0.2 Radiated Measurements

Same as F.1.0 in TS 38.521-2 [9].

#### F.1.1 Measurement of test environments

##### F.1.1.1 Conducted Measurements

Same as F.1.1 in TS 38.521-1 [8].

##### F.1.1.2 Radiated Measurements

Same as F.1.1 in TS 38.521-2 [9].



## F.1.2 Measurement of transmitter

**Table F.1.2-1: Maximum Test System Uncertainty for transmitter tests**

Clause	Maximum Test System Uncertainty	Derivation of Test System Uncertainty
6.2B.1.1 UE Maximum Output Power for Intra-Band Contiguous EN-DC	$f \leq 3.0\text{GHz}$ $\pm 0.7\text{ dB}, \text{BW} \leq 40\text{MHz}$ $\pm 1.4\text{ dB}, 40\text{MHz} < \text{BW} \leq 100\text{MHz}$  $3.0\text{GHz} < f \leq 4.2\text{GHz}$ $\pm 1.0\text{ dB}, \text{BW} \leq 40\text{MHz}$ $\pm 1.6\text{ dB}, 40\text{MHz} < \text{BW} \leq 100\text{MHz}$  $4.2\text{GHz} < f \leq 6.0\text{GHz}$ $\pm 1.3\text{ dB}, \text{BW} \leq 20\text{MHz}$ $\pm 1.5\text{ dB}, 20\text{MHz} < \text{BW} \leq 40\text{MHz}$ $\pm 1.6\text{ dB}, 40\text{MHz} < \text{BW} \leq 100\text{MHz}$	
6.2B.1.2 UE Maximum Output Power for Intra-Band Non-Contiguous EN-DC	MAX ( $\text{MU}_{\text{LTE}}, \text{MU}_{\text{SA}}$ )  $\text{MU}_{\text{LTE}}$ $\pm 0.7\text{ dB}, f \leq 3.0\text{GHz}$ $\pm 1.0\text{ dB}, 3.0\text{GHz} < f \leq 4.2\text{GHz}$  $\text{MU}_{\text{SA}}$ $f \leq 3.0\text{GHz}$ $\pm 0.7\text{ dB}, \text{BW} \leq 40\text{MHz}$ $\pm 1.4\text{ dB}, 40\text{MHz} < \text{BW} \leq 100\text{MHz}$  $3.0\text{GHz} < f \leq 4.2\text{GHz}$ $\pm 1.0\text{ dB}, \text{BW} \leq 40\text{MHz}$ $\pm 1.6\text{ dB}, 40\text{MHz} < \text{BW} \leq 100\text{MHz}$  $4.2\text{GHz} < f \leq 6.0\text{GHz}$ $\pm 1.3\text{ dB}, \text{BW} \leq 20\text{MHz}$ $\pm 1.5\text{ dB}, 20\text{MHz} < \text{BW} \leq 40\text{MHz}$ $\pm 1.6\text{ dB}, 40\text{MHz} < \text{BW} \leq 100\text{MHz}$	$\text{MU}_{\text{LTE}}$ is MU of LTE specified in clause 6.2.2 in TS 36.521-1 [10].  $\text{MU}_{\text{SA}}$ is MU of FR1 SA specified in clause 6.2.1 in TS 38.521-1 [8].
6.2B.1.3 UE Maximum Output Power for Inter-Band EN-DC within FR1 (1 E-UTRA CC, 1 NR CC)	MAX ( $\text{MU}_{\text{LTE}}, \text{MU}_{\text{SA}}$ )  $\text{MU}_{\text{LTE}}$ $\pm 0.7\text{ dB}, f \leq 3.0\text{GHz}$ $\pm 1.0\text{ dB}, 3.0\text{GHz} < f \leq 4.2\text{GHz}$  $\text{MU}_{\text{SA}}$ $f \leq 3.0\text{GHz}$ $\pm 0.7\text{ dB}, \text{BW} \leq 40\text{MHz}$ $\pm 1.4\text{ dB}, 40\text{MHz} < \text{BW} \leq 100\text{MHz}$  $3.0\text{GHz} < f \leq 4.2\text{GHz}$ $\pm 1.0\text{ dB}, \text{BW} \leq 40\text{MHz}$ $\pm 1.6\text{ dB}, 40\text{MHz} < \text{BW} \leq 100\text{MHz}$  $4.2\text{GHz} < f \leq 6.0\text{GHz}$ $\pm 1.3\text{ dB}, \text{BW} \leq 20\text{MHz}$ $\pm 1.5\text{ dB}, 20\text{MHz} < \text{BW} \leq 40\text{MHz}$ $\pm 1.6\text{ dB}, 40\text{MHz} < \text{BW} \leq 100\text{MHz}$	$\text{MU}_{\text{LTE}}$ is MU of LTE specified in clause 6.2.2 in TS 36.521-1 [10].  $\text{MU}_{\text{SA}}$ is MU of FR1 SA specified in clause 6.2.1 in TS 38.521-1 [8].
6.2B.1.3_1 UE Maximum Output Power for Inter-Band EN-DC within FR1 (2 E-UTRA CCs, 1 NR CC)	Same as 6.2B.1.3	
6.2B.1.4.1 UE Maximum Output Power for Inter-Band EN-DC including FR2 (1 NR CC) - EIRP and TRP	Same as clause 6.2.1.1 in TS 38.521-2 [9]	
6.2B.1.4.2 UE Maximum Output Power for Inter-Band EN-DC including FR2 (1 NR CC) - Spherical Coverage	Same as clause 6.2.1.2 in TS 38.521-2 [9]	

6.2B.1.4_1.1.1 UE Maximum Output Power for Inter-Band EN-DC including FR2 (2 NR CCs) - EIRP and TRP	Same as clause 6.2A.1.1.1 in TS 38.521-2 [9]	
6.2B.1.4_1.1.2 UE Maximum Output Power for Inter-Band EN-DC including FR2 (2 NR CCs) - Spherical Coverage	Same as clause 6.2A.1.2.1 in TS 38.521-2 [9]	
6.2B.1.4_1.2.1 UE Maximum Output Power for Inter-Band EN-DC including FR2 (3 NR CCs) - EIRP and TRP	Same as clause 6.2A.1.1.2 in TS 38.521-2 [9]	
6.2B.1.4_1.2.2 UE Maximum Output Power for Inter-Band EN-DC including FR2 (3 NR CCs) -Spherical Coverage	Same as clause 6.2A.1.2.2 in TS 38.521-2 [9]	
6.2B.1.4_1.3.1 UE Maximum Output Power for Inter-Band EN-DC including FR2 (4 NR CCs) - EIRP and TRP	Same as clause 6.2A.1.1.3 in TS 38.521-2 [9]	
6.2B.1.4_1.3.2 UE Maximum Output Power for Inter-Band EN-DC including FR2 (4 NR CCs) –Spherical Coverage	Same as clause 6.2A.1.2.3 in TS 38.521-2 [9]	
6.2B.1.4_1.4.1 UE Maximum Output Power for Inter-Band EN-DC including FR2 (5 NR CCs) - EIRP and TRP	Same as clause 6.2A.1.1.4 in TS 38.521-2 [9]	
6.2B.1.4_1.4.2 UE Maximum Output Power for Inter-Band EN-DC including FR2 (5 NR CCs) –Spherical Coverage	Same as clause 6.2A.1.2.4 in TS 38.521-2 [9]	
6.2B.1.4_1.5.1 UE Maximum Output Power for Inter-Band EN-DC including FR2 (6 NR CCs) - EIRP and TRP	Same as clause 6.2A.1.1.5 in TS 38.521-2 [9]	
6.2B.1.4_1.5.2 UE Maximum Output Power for Inter-Band EN-DC including FR2 (6 NR CCs) –Spherical Coverage	Same as clause 6.2A.1.2.5 in TS 38.521-2 [9]	
6.2B.1.4_1.6.1 UE Maximum Output Power for Inter-Band EN-DC including FR2 (7 NR CCs) - EIRP and TRP	Same as clause 6.2A.1.1.6 in TS 38.521-2 [9]	
6.2B.1.4_1.6.2 UE Maximum Output Power for Inter-Band EN-DC including FR2 (7 NR CCs) –Spherical Coverage	Same as clause 6.2A.1.2.6 in TS 38.521-2 [9]	
6.2B.1.6 UE Maximum Output Power for Inter-Band EN-DC including FR2 (1 NR CC) - EIRP with UL Gaps	Same as clause 6.2.5 in TS 38.521-2	
6.2B.1.4D.1 UE Maximum Output Power for Inter-Band EN-DC including FR2 for UL MIMO	Same as clause 6.2D.1.1 in TS 38.521-2 [9]	

6.2B.1.4D.2 UE Maximum Output Power for Inter-Band EN-DC including FR2 for UL MIMO- Spherical coverage	Same as clause 6.2D.1.2 in TS 38.521-2 [9]	
6.2B.2.1 UE Maximum Output Power reduction for Intra-Band Contiguous EN-DC	Same as clause 6.2B.1.1	
6.2B.2.2 UE Maximum Output Power reduction for Intra-Band Non-Contiguous EN-DC	Same as clause 6.2B.1.2	
6.2B.2.3 UE Maximum Output Power reduction for Inter-Band EN-DC within FR1	Same as clause 6.2B.1.3	
6.2B.2.4 UE Maximum Output Power reduction for Inter-Band EN-DC including FR2	Same as clause 6.2.2 in TS 38.521-2 [9]	
6.2B.2.4a UE Maximum Output Power reduction enhancements for Inter-Band EN-DC including FR2 (1 NR CC)	Same as clause 6.2.2_1 in TS 38.521-2 [9]	
6.2B.2.4_1.1 UE Maximum Output Power reduction for Inter-Band EN-DC including FR2 (2 NR CCs)	Same as clause 6.2A.2.1 in TS 38.521-2 [9]	
6.2B.2.4_1.2 UE Maximum Output Power reduction for Inter-Band EN-DC including FR2 (3 NR CCs)	Same as clause 6.2A.2.2 in TS 38.521-2 [9]	
6.2B.2.4_1.3 UE Maximum Output Power reduction for Inter-Band EN-DC including FR2 (4 NR CCs)	Same as clause 6.2A.2.3 in TS 38.521-2 [9]	
6.2B.2.4D UE Maximum Output Power reduction for Inter-Band EN-DC including FR2 (1 NR CC)	Same as clause 6.2D.2 in TS 38.521-2 [9]	
6.2B.3.1 UE Additional Maximum Output Power reduction for Intra-band contiguous EN-DC	Same as clause 6.2B.1.1	
6.2B.3.2 UE Additional Maximum Output Power reduction for Intra-Band Non-Contiguous EN-DC	Same as clause 6.2B.1.2	
6.2B.3.3 UE Additional Maximum Output Power reduction for Inter-Band EN-DC within FR1	Same as clause 6.2B.1.3	
6.2B.3.4 UE Additional Maximum Output Power reduction for Inter-Band EN-DC including FR2 (1 NR CC)	Same as clause 6.2.3 in TS 38.521-2 [9]	
6.2B.3.4_1.1 UE Additional Maximum Output power reduction for inter-band EN-DC including FR2 (2 NR CCs)	Same as clause 6.2A.3.1 in TS 38.521-2 [9]	
6.2B.3.4_1.2 UE Additional Maximum Output power reduction for inter-band EN-DC including FR2 (3 NR CCs)	Same as clause 6.2A.3.2 in TS 38.521-2 [9]	

6.2B.3.4_1.3 UE Additional Maximum Output power reduction for inter-band EN-DC including FR2 (4 NR CCs)	Same as clause 6.2A.3.3 in TS 38.521-2 [9]	
6.2B.3.4D UE Additional Maximum Output Power reduction for Inter-Band EN-DC including FR2 (1 NR CC) for UL MIMO	Same as clause 6.2D.3 in TS 38.521-2 [9]	
6.2B.4.1.1 Configured Output Power Level for Intra-Band Contiguous EN-DC	MAX ( $MU_{LTE}$ , $MU_{SA}$ )	$MU_{LTE}$ is MU of LTE specified in clause 6.2.4 in TS 36.521-1 [10].  $MU_{SA}$ is MU of FR1 SA specified in clause 6.2.4 in TS 38.521-1 [8].
6.2B.4.1.2 Configured Output Power for Intra-Band Non-Contiguous EN-DC	MAX ( $MU_{LTE}$ , $MU_{SA}$ )	$MU_{LTE}$ is MU of LTE specified in clause 6.2.4 in TS 36.521-1 [10].  $MU_{SA}$ is MU of FR1 SA specified in clause 6.2.4 in TS 38.521-1 [8].
6.2B.4.1.3 Configured Output Power for Inter-Band EN-DC within FR1 (1 E-UTRA CC, 1 NR CC)	MAX ( $MU_{LTE}$ , $MU_{SA}$ )	$MU_{LTE}$ is MU of LTE specified in clause 6.2.4 in TS 36.521-1 [10].  $MU_{SA}$ is MU of FR1 SA specified in clause 6.2.4 in TS 38.521-1 [8].
6.2B.4.1.3_1 Configured Output Power for Inter-Band EN-DC within FR1 (2 E-UTRA CCs, 1 NR CC)	MAX ( $MU_{LTE}$ , $MU_{SA}$ )	$MU_{LTE}$ is MU of LTE specified in clause 6.2.4 in TS 36.521-1 [10].  $MU_{SA}$ is MU of FR1 SA specified in clause 6.2.4 in TS 38.521-1 [8].
6.2B.4.1.4_1 Configured Output Power with Power Boost for Inter-Band EN-DC including FR2 (1 NR CC)	Same as clause 6.2.4_1 in TS 38.521-2 [9]	
6.2H.1.3 UE maximum output power for inter-band EN-DC with UL MIMO	MAX ( $MU_{LTE}$ , $MU_{SA}$ )	$MU_{LTE}$ is MU of LTE specified in clause 6.2.2 in TS 36.521-1 [10].  $MU_{SA}$ is MU of FR1 SA specified in clause 6.2.1 in TS 38.521-1 [8] for the sum of power at each of UE antenna connector.
6.2H.2.3 UE maximum output power reduction for inter-band EN-DC with UL MIMO within FR1	Same as clause 6.2D.2 in TS 38.521-1 [8]	
6.2H.3.3 UE additional maximum output power reduction for inter-band EN-DC with UL MIMO within FR1	Same as clause 6.2D.3 in TS 38.521-1 [8]	
6.2H.4.3 Configured output power level for inter-band EN-DC with UL MIMO within FR1	Same as clause 6.2D.4 in TS 38.521-1 [8]	

6.2L.1.3 UE maximum output power for inter-band EN-DC with Tx Diversity	MAX (M <sub>ULTE</sub> , M <sub>USA</sub> )	M <sub>ULTE</sub> is MU of LTE specified in clause 6.2.2 in TS 36.521-1 [10].  M <sub>USA</sub> is MU of FR1 SA specified in clause 6.2.1 in TS 38.521-1 [8] for the sum of power at each of UE antenna connector.
6.2L.2.3 UE maximum output power reduction for inter-band EN-DC with Tx Diversity within FR1	Same as clause 6.2G.2 in TS 38.521-1 [8]	
6.2L.3.3 UE additional maximum output power reduction for inter-band EN-DC with Tx Diversity within FR1	Same as clause 6.2G.3 in TS 38.521-1 [8]	
6.2L.4.3 Configured output power level for inter-band EN-DC with Tx Diversity within FR1	Same as clause 6.2G.4 in TS 38.521-1 [8]	
6.3B.1.1 Minimum Output Power for intra-band contiguous EN-DC	Same as clause 6.3.1 in TS 38.521-1 [8]	
6.3B.1.2 Minimum output power for intra-band non-contiguous EN-DC	Same as clause 6.3.1 in TS 38.521-1 [8]	
6.3B.1.3 Minimum output power for inter-band EN-DC within FR1	Same as clause 6.3.1 in TS 38.521-1 [8]	
6.3B.1.4 Minimum Output Power for EN-DC Interband including FR2	Same as clause 6.3.1 in TS 38.521-2 [9]	
6.3B.1.4_1.1 Minimum output power for inter-band EN-DC including FR2 (3 CCs)	Same as 6.3A.1.1 in TS 38.521-2 [9]	
6.3B.1.4_1.2 Minimum output power for inter-band EN-DC including FR2 (4 CCs)	Same as 6.3A.1.2 in TS 38.521-2 [9]	
6.3B.1.4_1.3 Minimum output power for inter-band EN-DC including FR2 (5 CCs)	Same as 6.3A.1.3 in TS 38.521-2 [9]	
6.3B.1.4D Minimum output power for inter-band EN-DC including FR2 for UL MIMO	Same as 6.3D.1 in TS 38.521-2 [9]	
6.3B.2.1 Transmit OFF Power for intra-band contiguous EN-DC	Same as clause 6.3.2 in TS 38.521-1 [8]	
6.3B.2.2 Transmit OFF Power for intra-band non-contiguous EN-DC	Same as clause 6.3.2 in TS 38.521-1 [8]	
6.3B.2.3 Transmit OFF Power for inter-band EN-DC within FR1	Same as clause 6.3.2 in TS 38.521-1 [8]	
6.3B.2.4 Transmit OFF Power for inter-band EN-DC including FR2	Same as clause 6.3.2 in TS 38.521-2 [9]	
6.3B.2.4D Transmit OFF Power for inter-band EN-DC including FR2 for UL-MIMO	Same as 6.3D.2 in TS 38.521-2 [9]	
6.3B.3.1 Tx ON/OFF time mask for intra-band contiguous EN-DC	Same as clause 6.3.3.2 in TS 38.521-1 [8]	

6.3B.3_1.1 E-UTRA and NR switching time mask for switching between two uplink carriers for inter-band EN-DC	MAX (MU <sub>LTE</sub> , MU <sub>NR</sub> )  MU <sub>LTE</sub> is MU of LTE specified in clause 6.2.3 in TS 36.521-1 [10].  MU <sub>NR</sub> is MU of FR1 NR specified in clause 6.2D.2 in TS 38.521-1 [8].	
6.3B.2.4_1.1 Transmit OFF Power for Inter-band EN-DC including FR2 (3 CCs)	Same as clause 6.3A.2.1 in TS 38.521-2 [9]	
6.3B.2.4_1.2 Transmit OFF Power for Inter-band EN-DC including FR2 (4 CCs)	Same as clause 6.3A.2.2 in TS 38.521-2 [9]	
6.3B.2.4_1.3 Transmit OFF Power for Inter-band EN-DC including FR2 (5 CCs)	Same as clause 6.3A.2.3 in TS 38.521-2 [9]	
6.3B.3.2 Tx ON/OFF time mask for intra-band non-contiguous EN-DC	Same as clause 6.3.3.2 in TS 38.521-1 [8]	
6.3B.3.3 Tx ON/OFF time mask for inter-band EN-DC within FR1	Same as clause 6.3.3.2 in TS 38.521-1 [8]	
6.3B.3.4 Transmit ON/OFF time mask for inter-band EN-DC including FR2	Same as clause 6.3.3.2 in TS 38.521-2 [9]	
6.3B.3.4_1.1 Transmit ON/OFF time mask for inter-band EN-DC including FR2 (2 NR CCs)	Same as clause 6.3A.3.1.1 in TS 38.521-2 [9]	
6.3B.3.4_1.2 Transmit ON/OFF time mask for inter-band EN-DC including FR2 (3 NR CCs)	Same as clause 6.3A.3.1.2 in TS 38.521-2 [9]	
6.3B.3.4_1.3 Transmit ON/OFF time mask for inter-band EN-DC including FR2 (4 NR CCs)	Same as clause 6.3A.3.1.3 in TS 38.521-2 [9]	
6.3B.4.3 PRACH Time Mask for inter-band EN-DC within FR1	Same as clause 6.3.3.4 in TS 38.521-1 [8]	
6.3B.8.1.1 Absolute power tolerance for intra-band contiguous EN-DC	Same as clause 6.3.4.2 in TS 38.521-1 [8]	
6.3B.8.1.2 Absolute power tolerance for intra-band non-contiguous EN-DC	Same as clause 6.3.4.2 in TS 38.521-1 [8]	
6.3B.8.1.3 Absolute power tolerance for inter-band EN-DC within FR1	Same as clause 6.3.4.2 in TS 38.521-1 [8]	
6.3B.8.1.4 Absolute power tolerance for inter-band EN-DC including FR2	Same as clause 6.3.4.2 in TS 38.521-2 [9]	
6.3B.8.1.4_1.1 Absolute power tolerance for inter-band EN-DC including FR2 (2 NR CC)	Same as clause 6.3A.4.2.1 in TS 38.521-2 [9]	
6.3B.8.1.4_1.2 Absolute power tolerance for inter-band EN-DC including FR2 (3 NR CC)	Same as clause 6.3A.4.2.2 in TS 38.521-2 [9]	
6.3B.8.1.4_1.3 Absolute power tolerance for inter-band EN-DC including FR2 (4 NR CC)	Same as clause 6.3A.4.2.3 in TS 38.521-2 [9]	
6.3B.8.2.1 Relative power tolerance for intra-band contiguous EN-DC	Same as clause 6.3.4.3 in TS 38.521-1 [8]	

6.3B.8.2.2 Relative power tolerance for intra-band non-contiguous EN-DC	Same as clause 6.3.4.3 in TS 38.521-1 [8]	
6.3B.8.2.3 Relative power tolerance for inter-band EN-DC within FR1	Same as clause 6.3.4.3 in TS 38.521-1 [8]	
6.3B.8.2.4 Relative power tolerance for inter-band EN-DC including FR2	Same as clause 6.3.4.3 in TS 38.521-2 [9]	
6.3B.8.3.1 Aggregate power tolerance for intra-band contiguous EN-DC	Same as clause 6.3.4.4 in TS 38.521-1 [8]	
6.3B.8.3.2 Aggregate power tolerance for intra-band non-contiguous EN-DC	Same as clause 6.3.4.4 in TS 38.521-1 [8]	
6.3B.8.3.3 Aggregate power tolerance for inter-band EN-DC within FR1	Same as clause 6.3.4.4 in TS 38.521-1 [8]	
6.3B.8.3.4 Aggregate power tolerance for inter-band EN-DC including FR2	Same as clause 6.3.4.4 in TS 38.521-2 [9]	
6.3B.8.3.4_1.1 Aggregate power tolerance for inter-band EN-DC including FR2 (2 NR CC)	Same as clause 6.3A.4.4.1 in TS 38.521-2 [9]	
6.3B.8.3.4_1.2 Aggregate power tolerance for inter-band EN-DC including FR2 (3 NR CC)	Same as clause 6.3A.4.4.2 in TS 38.521-2 [9]	
6.3B.8.3.4_1.3 Aggregate power tolerance for inter-band EN-DC including FR2 (4 NR CC)	Same as clause 6.3A.4.4.3 in TS 38.521-2 [9]	
6.3H.3.1 Minimum output power for inter-band EN-DC with UL MIMO within FR1	Same as clause 6.3D.1 in TS 38.521-1 [8]	
6.3H.3.2 Transmit OFF Power for inter-band EN-DC with UL MIMO within FR1	Same as clause 6.3D.2 in TS 38.521-1 [8]	
6.3H.3.3 Transmit ON/OFF time mask for inter-band EN-DC with UL MIMO within FR1	Same as clause 6.3D.3 in TS 38.521-1 [8]	
6.3H.3.4.1 Absolute power tolerance for inter-band EN-DC with UL MIMO within FR1	Same as clause 6.3D.4.1 in TS 38.521-1 [8]	
6.3H.3.4.2 Relative power tolerance for inter-band EN-DC with UL MIMO within FR1	Same as clause 6.3D.4.2 in TS 38.521-1 [8]	
6.3H.3.4.3 Aggregate power tolerance for inter-band EN-DC with UL MIMO within FR1	Same as clause 6.3D.4.3 in TS 38.521-1 [8]	
6.3L.3.1 Minimum output power for inter-band EN-DC with Tx Diversity within FR1	Same as clause 6.3G.1 in TS 38.521-1 [8]	
6.3L.3.2 Transmit OFF Power for inter-band EN-DC with Tx Diversity within FR1	Same as clause 6.3G.2 in TS 38.521-1 [8]	
6.3L.3.3.1 General ON/OFF time mask for inter-band EN-DC with Tx Diversity within FR1	Same as clause 6.3G.3.1 in TS 38.521-1 [8]	
6.3L.3.3.2 PRACH time mask for inter-band EN-DC with Tx Diversity within FR1	Same as clause 6.3G.3.2 in TS 38.521-1 [8]	



6.3L.3.3.3 SRS time mask for inter-band EN-DC with Tx Diversity within FR1	Same as clause 6.3G.3.3 in TS 38.521-1 [8]	
6.3L.3.4.1 Absolute power tolerance for inter-band EN-DC with Tx Diversity within FR1	Same as clause 6.3G.4.1 in TS 38.521-1 [8]	
6.3L.3.4.2 Relative power tolerance for inter-band EN-DC with Tx Diversity within FR1	Same as clause 6.3G.4.2 in TS 38.521-1 [8]	
6.3L.3.4.3 Aggregate power tolerance for inter-band EN-DC with Tx Diversity within FR1	Same as clause 6.3G.4.3 in TS 38.521-1 [8]	
6.4B.1.1 Frequency Error for intra-band contiguous EN-DC	TBD	
6.4B.1.2 Frequency Error for intra-band non-contiguous EN-DC	TBD	
6.4B.1.3 Frequency Error for inter-band EN-DC within FR1	Same as clause 6.4.1 in TS 38.521-1 [8]	
6.4B.1.4 Frequency Error for inter-band EN-DC including FR2	Same as clause 6.4.1 in TS 38.521-2 [9]	
6.4B.1.4_1.1 Frequency Error for Inter-band EN-DC including FR2 (2 CCs)	Same as clause 6.4A.1.1 in TS 38.521-2 [9]	
6.4B.1.4_1.2 Frequency Error for Inter-band EN-DC including FR2 (3 CCs)	Same as clause 6.4A.1.2 in TS 38.521-2 [9]	
6.4B.1.4_1.3 Frequency Error for Inter-band EN-DC including FR2 (4 CCs)	Same as clause 6.4A.1.3 in TS 38.521-2 [9]	
6.4B.1.4_1.4 Frequency Error for Inter-band EN-DC including FR2 (5 CCs)	Same as clause 6.4A.1.4 in TS 38.521-2 [9]	
6.4B.1.4_1.5 Frequency Error for Inter-band EN-DC including FR2 (6 CCs)	Same as clause 6.4A.1.5 in TS 38.521-2 [9]	
6.4B.1.4_1.6 Frequency Error for Inter-band EN-DC including FR2 (7 CCs)	Same as clause 6.4A.1.6 in TS 38.521-2 [9]	
6.4B.1.4_1.7 Frequency Error for Inter-band EN-DC including FR2 (8 CCs)	Same as clause 6.4A.1.7 in TS 38.521-2 [9]	
6.4B.1.4D Frequency error for inter-band EN-DC including FR2 for UL-MIMO	Same as clause 6.4D.1 in TS 38.521-2 [9]	
6.4B.2.1.1 Error Vector Magnitude for intra-band contiguous EN-DC	Same as clause 6.4.2.1 in TS 38.521-1 [8] Uplink power measurement same as 6.3B.1.1.	
6.4B.2.1.2 Carrier Leakage for intra-band contiguous EN-DC	Same as clause 6.4.2.2 in TS 38.521-1 [8]	
6.4B.2.1.3 In-band Emissions for intra-band contiguous EN-DC	Same as clause 6.4.2.3 in TS 38.521-1 [8] for ENBW $\leq 100$ MHz. Uplink power measurement for steps 2 and 8 same as 6.2B.1.1. Uplink power measurement for steps 4, 6, 10, and 12 same as 6.3B.1.1.	
6.4B.2.1.4 EVM Equalizer Flatness for intra-band contiguous EN-DC	Same as clause 6.4.2.4 in TS 38.521-1 [8]	

6.4B.2.2.1 Error Vector Magnitude for intra-band non-contiguous EN-DC	Same as clause 6.4.2.1 in TS 38.521-1 [8] Uplink power measurement same as 6.3B.1.2.	
6.4B.2.2.2 Carrier Leakage for intra-band non-contiguous EN-DC	Same as clause 6.4.2.2 in TS 38.521-1 [8] Uplink power measurement for step 2 and step 4 same as 6.2B.1.2. Uplink power measurement for step 6 and step 8 same as 6.3B.1.2.	
6.4B.2.2.3 In-band Emissions for intra-band non-contiguous EN-DC	Same as clause 6.4.2.3 in TS 38.521-1 [8] Uplink power measurement for steps 2 and 8 same as 6.2B.1.2. Uplink power measurement for steps 4, 6, 10, and 12 same as 6.3B.1.2.	
6.4B.2.2.4 EVM Equalizer Flatness for intra-band non-contiguous EN-DC	Same as clause 6.4.2.4 in TS 38.521-1 [8]	
6.4B.2.3.1 Error Vector Magnitude for inter-band EN-DC within FR1	Same as clause 6.4.2.1 in TS 38.521-1 [8] Uplink power measurement same as 6.3B.1.3.	
6.4B.2.3.2 Carrier Leakage for inter-band EN-DC within FR1	Same as clause 6.4.2.2 in TS 38.521-1 [8] Uplink power measurement for step 2 and step 4 same as 6.2B.1.3. Uplink power measurement for step 6 and step 8 same as 6.3B.1.3.	
6.4B.2.3.3 In-band Emissions for inter-band EN-DC within FR1	Same as clause 6.4.2.3 in TS 38.521-1 [8] Uplink power measurement for steps 1.2, 1.4, 2.2, and 2.4 same as 6.2B.1.3. Uplink power measurement for steps 1.6, 1.8, 2.6, and 2.8 same as 6.3B.1.3.	
6.4B.2.3.4 EVM Equalizer Flatness for inter-band EN-DC within FR1	Same as clause 6.4.2.4 in TS 38.521-1 [8]	
6.4B.2.4.1 Error Vector Magnitude for inter-band EN-DC including FR2	Same as clause 6.4.2.1 in TS 38.521-2 [9]	
6.4B.2.4.1a Error Vector Magnitude with Power Boost for inter-band EN-DC including FR2 (1 NR CC)	Same as clause 6.4.2.1_1 in TS 38.521-2 [9]	
6.4B.2.4.2 Carrier Leakage for inter-band EN-DC including FR2	Same as clause 6.4.2.2 in TS 38.521-2 [9]	
6.4B.2.4.3 In-band Emissions for inter-band EN-DC including FR2	Same as clause 6.4.2.3 in TS 38.521-2 [9]	
6.4B.2.4.4 EVM Equalizer Flatness for inter-band EN-DC including FR2	Same as clause 6.4.2.4 in TS 38.521-2 [9]	
6.4B.2.4.5 EVM spectral flatness for pi/2 BPSK modulation for inter-band EN-DC including FR2 (1 NR CC)	Same as clause 6.4.2.5 in TS 38.521-2 [9]	
6.4H.1.3 Frequency error for inter-band EN-DC with UL MIMO within FR1	Same as clause 6.4D.1 in TS 38.521-1 [8]	
6.4H.2.3.1 Error Vector Magnitude for inter-band EN-DC with UL MIMO within FR1	Same as clause 6.4D.2.1 in TS 38.521-1 [8]	
6.4H.2.3.2 Carrier leakage for inter-band EN-DC with UL MIMO within FR1	Same as clause 6.4D.2.2 in TS 38.521-1 [8]	
6.4H.2.3.3 In-band emissions for inter-band EN-DC with UL MIMO within FR1	Same as clause 6.4D.2.3 in TS 38.521-1 [8]	

6.4L.1.3 Frequency error for inter-band EN-DC with Tx Diversity within FR1	Same as clause 6.4G.1 in TS 38.521-1 [8]	
6.4L.2.3.1 Error Vector Magnitude for inter-band EN-DC with Tx Diversity within FR1	Same as clause 6.4G.2.1 in TS 38.521-1 [8]	
6.4L.2.3.2 Carrier leakage for inter-band EN-DC with Tx Diversity within FR1	Same as clause 6.4G.2.2 in TS 38.521-1 [8]	
6.4H.2.3.3 In-band emissions for inter-band EN-DC with Tx Diversity within FR1	Same as clause 6.4G.2.3 in TS 38.521-1 [8]	
6.5B.1.1 Occupied bandwidth for Intra-Band Contiguous EN-DC	1.5% of aggregated channel bandwidth	
6.5B.1.2 Occupied bandwidth for Intra-Band Non-Contiguous EN-DC	Same as clause 6.5.1 in TS 38.521-1 [8]	
6.5B.1.3 Occupied bandwidth for Inter-Band EN-DC within FR1	Same as clause 6.5.1 in TS 38.521-1 [8]	
6.5B.1.4 Occupied bandwidth for Inter-Band EN-DC including FR2	Same as clause 6.5.1 in TS 38.521-2 [9]	
6.5B.1.4_1.1 Occupied bandwidth for Inter-band EN-DC including FR2 (2 CCs)	Same as clause 6.5A.1.1 in TS 38.521-2 [9]	
6.5B.1.4_1.2 Occupied bandwidth for Inter-band EN-DC including FR2 (3 CCs)	Same as clause 6.5A.1.2 in TS 38.521-2 [9]	
6.5B.1.4_1.3 Occupied bandwidth for Inter-band EN-DC including FR2 (4 CCs)	Same as clause 6.5A.1.3 in TS 38.521-2 [9]	
6.5B.1.4_1.4 Occupied bandwidth for Inter-band EN-DC including FR2 (5 CCs)	Same as clause 6.5A.1.4 in TS 38.521-2 [9]	
6.5B.1.4_1.5 Occupied bandwidth for Inter-band EN-DC including FR2 (6 CCs)	Same as clause 6.5A.1.5 in TS 38.521-2 [9]	
6.5B.1.4_1.6 Occupied bandwidth for Inter-band EN-DC including FR2 (7 CCs)	Same as clause 6.5A.1.6 in TS 38.521-2 [9]	
6.5B.1.4_1.7 Occupied bandwidth for Inter-band EN-DC including FR2 (8 CCs)	Same as clause 6.5A.1.7 in TS 38.521-2 [9]	
6.5B.1.4D Occupied bandwidth for inter-band EN-DC including FR2 for UL MIMO	Same as clause 6.5D.1 in TS 38.521-2 [9]	
6.5B.2.1.1 Spectrum emissions mask for intra-band contiguous EN-DC	Same as clause 6.5.2.2 in TS 38.521-1 [8]	
6.5B.2.1.2 Additional spectrum emissions mask for intra-band contiguous EN-DC	Same as clause 6.5.2.3 in TS 38.521-1 [8]	
6.5B.2.1.3 Adjacent channel leakage ratio for intra-band contiguous EN-DC	Same as clause 6.5.2.4.1 in TS 38.521-1 [8]	

6.5B.2.2.1 Spectrum emissions mask for intra-band non-contiguous EN-DC	Same as clause 6.5.2.2 in TS 38.521-1 [8]	
6.5B.2.2.2 Additional Spectrum emissions mask for intra-band non-contiguous EN-DC	Same as clause 6.5.2.3 in TS 38.521-1 [8]	
6.5B.2.2.3 Adjacent channel leakage ratio for intra-band non-contiguous EN-DC	TBD	
6.5B.2.3.1 Spectrum emissions mask for Inter-band EN-DC within FR1	Same as clause 6.5.2.2 in TS 38.521-1 [8]	
6.5B.2.3.2 Additional Spectrum emissions mask for Inter-band EN-DC within FR1	Same as clause 6.5.2.3 in TS 38.521-1 [8]	
6.5B.2.3.3.1NR - Adjacent channel leakage ratio for inter-band EN-DC within FR1 (1 NR CC)	Same as clause 6.5.2.4.1 in TS 38.521-1 [8]	
6.5B.2.3.3.2 UTRA - Adjacent channel leakage ratio for inter-band EN-DC within FR1 (1 NR CC)	Same as clause 6.5.2.4.2 in TS 38.521-1 [8]	
6.5B.2.4.1 Spectrum emissions mask for Inter-band EN-DC including FR2	Same as clause 6.5.2.1 in TS 38.521-2 [9]	
6.5B.2.4.1a Spectrum emissions mask with Power Boost for Inter-band EN-DC including FR2 (1 NR CC)	Same as clause 6.5.2.1.1_1 in TS 38.521-2 [9]	
6.5B.2.4.1_1.1 Spectrum emissions mask for Inter-band EN-DC including FR2 (2 NR CCs)	Same as clause 6.5A.2.1.1 in TS 38.521-2 [9]	
6.5B.2.4.1_1.2 Spectrum emissions mask for Inter-band EN-DC including FR2 (3 NR CCs)	Same as clause 6.5A.2.1.2 in TS 38.521-2 [9]	
6.5B.2.4.1_1.3 Spectrum emissions mask for Inter-band EN-DC including FR2 (4 NR CCs)	Same as clause 6.5A.2.1.3 in TS 38.521-2 [9]	
6.5B.2.4.1_1.4 Spectrum emissions mask for Inter-band EN-DC including FR2 (5 NR CCs)	Same as clause 6.5A.2.1.4 in TS 38.521-2 [9]	
6.5B.2.4.1_1.5 Spectrum emissions mask for Inter-band EN-DC including FR2 (6 NR CCs)	Same as clause 6.5A.2.1.5 in TS 38.521-2 [9]	
6.5B.2.4.1_1.6 Spectrum emissions mask for Inter-band EN-DC including FR2 (7 NR CCs)	Same as clause 6.5A.2.1.6 in TS 38.521-2 [9]	
6.5B.2.4.1_1.7 Spectrum emissions mask for Inter-band EN-DC including FR2 (8 NR CCs)	Same as clause 6.5A.2.1.7 in TS 38.521-2 [9]	
6.5B.2.4.1D Spectrum emissions mask for inter-band EN-DC including FR2 for UL MIMO	Same as clause 6.5D.2.1 in TS 38.521-2 [9]	
6.5B.2.4.3 Adjacent channel leakage ratio for Inter-band EN-DC including FR2	Same as clause 6.5.2.3 in TS 38.521-2 [9]	

6.5B.2.4.3_1.1 Adjacent channel leakage ratio for Inter-band EN-DC including FR2 (2 NR CCs)	Same as clause 6.5A.2.2.1 in TS 38.521-2 [9]	
6.5B.2.4.3_1.2 Adjacent channel leakage ratio for Inter-band EN-DC including FR2 (3 NR CCs)	Same as clause 6.5A.2.2.2 in TS 38.521-2 [9]	
6.5B.2.4.3_1.3 Adjacent channel leakage ratio for Inter-band EN-DC including FR2 (4 NR CCs)	Same as clause 6.5A.2.2.3 in TS 38.521-2 [9]	
6.5B.2.4.3_1.4 Adjacent channel leakage ratio for Inter-band EN-DC including FR2 (5 NR CCs)	Same as clause 6.5A.2.2.4 in TS 38.521-2 [9]	
6.5B.2.4.3_1.5 Adjacent channel leakage ratio for Inter-band EN-DC including FR2 (6 NR CCs)	Same as clause 6.5A.2.2.5 in TS 38.521-2 [9]	
6.5B.2.4.3_1.6 Adjacent channel leakage ratio for Inter-band EN-DC including FR2 (7 NR CCs)	Same as clause 6.5A.2.2.6 in TS 38.521-2 [9]	
6.5B.2.4.3_1.7 Adjacent channel leakage ratio for Inter-band EN-DC including FR2 (8 NR CCs)	Same as clause 6.5A.2.2.7 in TS 38.521-2 [9]	
6.5B.2.4D.3 Adjacent channel leakage ratio for inter-band EN-DC including FR2 for UL MIMO	Same as clause 6.5D.2.2 in TS 38.521-2 [9]	
6.5B.3.1.1 General spurious emissions for intra-band contiguous EN-DC	Same as clause 6.5.3.1 in TS 38.521-1 [8]	
6.5B.3.1.2 Spurious emission band UE co-existence for intra-band contiguous EN-DC	Same as clause 6.5.3.1 in TS 38.521-1 [8]	
6.5B.3.2.1 General spurious emissions for Intra-band non-contiguous EN-DC	Same as clause 6.5.3.1 in TS 38.521-1 [8]	
6.5B.3.2.2 Spurious Emission band UE co-existence for intra-band non-contiguous EN-DC	Same as clause 6.5.3.2 in TS 38.521-1 [8]	
6.5B.3.3.1 General spurious emissions for Inter-band EN-DC within FR1	<p>MAX (<math>MU_{LTE}</math>, <math>MU_{SA}</math>)</p> <p><math>MU_{LTE}</math>  <math>9\text{kHz} &lt; f \leq 4\text{GHz}</math>: <math>\pm 2.0</math> dB  <math>4\text{GHz} &lt; f \leq 19\text{GHz}</math>: <math>\pm 4.0</math> dB</p> <p><math>MU_{SA}</math>  for results <math>&gt; -60</math> dBm:  <math>\pm 2.0</math> dB, <math>9\text{kHz} &lt; f \leq 3\text{GHz}</math>  <math>\pm 2.5</math> dB, <math>3\text{GHz} &lt; f \leq 4\text{GHz}</math>  <math>\pm 4.0</math> dB, <math>4\text{GHz} &lt; f \leq 19\text{GHz}</math>  <math>\pm 6.0</math> dB, <math>19\text{GHz} &lt; f \leq 26\text{GHz}</math></p>	<p><math>MU_{LTE}</math> is MU of LTE specified in clause 6.6.3.1 in TS 36.521-1 [10].</p> <p><math>MU_{SA}</math> is MU of FR1 SA specified in clause 6.5.3.1 in TS 38.521-1 [8].</p>

6.5B.3.3.2 Spurious emission band UE co-existence for Inter-band within FR1	<p>MAX (MU<sub>LTE</sub>, MU<sub>SA</sub>)</p> <p>MU<sub>LTE</sub>  <math>\pm 2.0</math> dB for results <math>&gt; -60</math> dBm, <math>f \leq 3.0</math>GHz  <math>\pm 2.5</math> dB, <math>3.0</math>GHz <math>&lt; f \leq 4.2</math>GHz  <math>\pm 3.0</math> dB for results <math>\leq -60</math> dBm, <math>f \leq 3.0</math>GHz  <math>\pm 3.6</math> dB, <math>3.0</math>GHz <math>&lt; f \leq 4.2</math>GHz</p> <p>MU<sub>SA</sub>  for results <math>&gt; -60</math> dBm:  <math>\pm 2.0</math> dB, <math>9</math>kHz <math>&lt; f \leq 3</math>GHz  <math>\pm 2.5</math> dB, <math>3</math>GHz <math>&lt; f \leq 4</math>GHz  <math>\pm 4.0</math> dB, <math>4</math>GHz <math>&lt; f \leq 19</math>GHz  <math>\pm 6.0</math> dB, <math>19</math>GHz <math>&lt; f \leq 26</math>GHz</p>	<p>MU<sub>LTE</sub> is MU of LTE specified in clause 6.6.3.2 in TS 36.521-1 [10].</p> <p>MU<sub>SA</sub> is MU of FR1 SA specified in clause 6.5.3.2 in TS 38.521-1 [8].</p>
6.5B.3.4.1 General Spurious Emissions for Inter-band including FR2 (2 CCs)	Same as clause 6.5.3.1 in TS 38.521-2 [9]	
6.5B.3.4.1a General Spurious Emissions with Power Boost for Inter-band including FR2 (1 NR CC)	Same as clause 6.5.3.1_1 in TS 38.521-2 [9]	
6.5B.3.4.1_1.1 General Spurious Emissions for Inter-band including FR2 (2 NR CCs)	Same as clause 6.5A.3.1.1 in TS 38.521-2 [9]	
6.5B.3.4.1_1.2 General Spurious Emissions for Inter-band including FR2 (3 NR CCs)	Same as clause 6.5A.3.1.2 in TS 38.521-2 [9]	
6.5B.3.4.1_1.3 General Spurious Emissions for Inter-band including FR2 (4 NR CCs)	Same as clause 6.5A.3.1.3 in TS 38.521-2 [9]	
6.5B.3.4.1_1.4 General Spurious Emissions for Inter-band including FR2 (5 NR CCs)	Same as clause 6.5A.3.1.4 in TS 38.521-2 [9]	
6.5B.3.4.1_1.5 General Spurious Emissions for Inter-band including FR2 (6 NR CCs)	Same as clause 6.5A.3.1.5 in TS 38.521-2 [9]	
6.5B.3.4.1_1.6 General Spurious Emissions for Inter-band including FR2 (7 NR CCs)	Same as clause 6.5A.3.1.6 in TS 38.521-2 [9]	
6.5B.3.4.1_1.7 General Spurious Emissions for Inter-band including FR2 (8 NR CCs)	Same as clause 6.5A.3.1.7 in TS 38.521-2 [9]	
6.5B.3.4.1D General Spurious Emissions for inter-band EN-DC including FR2 for UL MIMO	Same as clause 6.5D.3.1 in TS 38.521-2 [9]	
6.5B.3.4.2 Spurious emission band UE co-existence for Inter-band including FR2	Same as clause 6.5.3.2 in TS 38.521-2 [9]	
6.5B.3.4.2a Spurious emission band UE co-existence with Power Boost for Inter-band including FR2 (1 NR CC)	Same as clause 6.5.3.2_1 in TS 38.521-2 [9]	
6.5B.3.4.2_1.1 Spurious emission band UE co-existence for Inter-band EN-DC including FR2 (2 NR CCs)	Same as clause 6.5A.3.2.1 in TS 38.521-2 [9]	

6.5B.3.4.2_1.2 Spurious emission band UE co-existence for Inter-band EN-DC including FR2 (3 NR CCs)	Same as clause 6.5A.3.2.2 in TS 38.521-2 [9]	
6.5B.3.4.2_1.3 Spurious emission band UE co-existence for Inter-band EN-DC including FR2 (4 NR CCs)	Same as clause 6.5A.3.2.3 in TS 38.521-2 [9]	
6.5B.3.4.2D Spurious emission band UE co-existence for inter-band EN-DC including FR2 for UL MIMO	Same as clause 6.5D.3.2 in TS 38.521-2 [9]	
6.5B.4.1 Additional Spurious Emissions for Intra-band contiguous EN-DC	Same as clause 6.5.3.3 in TS 38.521-1 [8]	
6.5B.4.2 Additional Spurious Emissions for Intra-band non-contiguous EN-DC	Same as clause 6.5.3.3 in TS 38.521-1 [8]	
6.5B.4.3 Additional Spurious Emissions for Inter-band EN-DC within FR1	Same as clause 6.5.3.3 in TS 38.521-1 [8]	
6.5B.4.4 Additional Spurious Emissions for Inter-band including FR2 (1 NR CC)	Same as clause 6.5.3.3 in TS 38.521-2 [9]	
6.5B.4.4a Additional Spurious Emissions with Power Boost for Inter-band including FR2 (1 NR CC)	Same as clause 6.5.3.3_1 in TS 38.521-2 [9]	
6.5B.4.4_1.1 Additional Spurious Emissions for Inter-band including FR2 (2 NR CC)	Same as clause 6.5A.3.3.1 in TS 38.521-2 [9]	
6.5B.4.4_1.2 Additional Spurious Emissions for Inter-band including FR2 (3 NR CC)	Same as clause 6.5A.3.3.2 in TS 38.521-2 [9]	
6.5B.4.4_1.3 Additional Spurious Emissions for Inter-band including FR2 (4 NR CC)	Same as clause 6.5A.3.3.3 in TS 38.521-2 [9]	
6.5B.4.4D Additional Spurious Emissions for Inter-band including FR2 for UL MIMO	Same as clause 6.5D.3.3 in TS 38.521-2 [9]	
6.5B.5.3 Transmit intermodulation for Inter-band EN-DC within FR1	Same as clause 6.5.4.3 in TS 38.521-1 [8]	
6.5H.3.3.1 General spurious emissions for inter-band EN-DC with UL MIMO within FR1	Same as clause 6.6.3.1 in TS 36.521-1 [10] for E-UTRA CC Same as clause 6.5D.3.1 in TS 38.521-1 [8] for NR CC	
6.5H.3.3.2 Spurious emissions for UE co-existence for inter-band EN-DC with UL MIMO within FR1	Same as clause 6.6.3.2 in TS 36.521-1 [10] for E-UTRA CC Same as clause 6.5D.3.2 in TS 38.521-1 [8] for NR CC	
6.5L.3.3.1 General spurious emissions for inter-band EN-DC with Tx Diversity within FR1	Same as clause 6.6.3.1 in TS 36.521-1 [10] for E-UTRA CC Same as clause 6.5G.3.1 in TS 38.521-1 [8] for NR CC	
6.5L.3.3.2 Spurious emissions for UE co-existence for inter-band EN-DC with Tx Diversity within FR1	Same as clause 6.6.3.2 in TS 36.521-1 [10] for E-UTRA CC Same as clause 6.5G.3.2 in TS 38.521-1 [8] for NR CC	

6.6B.4 Beam Correspondence for inter- band EN-DC including FR2 (1 NR CC) - EIRP	Same as clause 6.6.1 in TS 38.521-2 [9]	
6.6B.5 Enhanced Beam Correspondence for inter- band EN-DC including FR2 (1 NR CC) - EIRP	Same as clause 6.6.2 in TS 38.521-2 [9]	



## F.1.3 Measurement of receiver

**Table F.1.3-1: Maximum Test System Uncertainty for receiver tests**

Clause	Maximum Test System Uncertainty	Derivation of Test System Uncertainty
7.3B.2.1 Reference sensitivity for Intra-band Contiguous EN-DC (2 CCs)	Same as clause 7.3.2 in TS 38.521-1 [8]	
7.3B.2.2 Reference sensitivity for Intra-band non-contiguous EN-DC (2 CCs)	Same as clause 7.3.2 in TS 38.521-1 [8]	
7.3B.2.3 Reference sensitivity for Inter-band EN-DC within FR1 (2 CCs)	Same as clause 7.3.2 in TS 38.521-1 [8]	
7.3B.2.3_1.1 Reference sensitivity for Inter-band EN-DC within FR1 (3 CCs)	Same as clause 7.3A.1 in TS 38.521-1 [8]	
7.3B.2.4 Reference sensitivity for Inter-band EN-DC including FR2 (1 NR CC)	Same as clause 7.3.2 in TS 38.521-2 [9]	
7.3B.2.4_1.1 Reference sensitivity for Inter-band EN-DC including FR2 (2 NR CCs)	Same as clause 7.3A.2.1 in TS 38.521-2 [9]	
7.3B.2.4_1.2 Reference sensitivity for Inter-band EN-DC including FR2 (3 NR CCs)	Same as clause 7.3A.2.2 in TS 38.521-2 [9]	
7.3B.2.4_1.3 Reference sensitivity for Inter-band EN-DC including FR2 (4 NR CCs)	Same as clause 7.3A.2.3 in TS 38.521-2 [9]	
7.3B.2.4_1.4 Reference sensitivity for Inter-band EN-DC including FR2 (5 NR CCs)	Same as clause 7.3A.2.4 in TS 38.521-2 [9]	
7.3B.4 EIS Spherical Coverage for Inter-band EN-DC including FR2 (1 NR CC)	Same as clause 7.3.4 in TS 38.521-2 [9]	
7.4B.1 Maximum Input Level for Intra-Band Contiguous EN-DC (2 CCs)	MU for NR CC downlink power same as clause 7.4 in TS 38.521-1 [8]. Uplink power measurement same as 6.2B.1.1.	
7.4B.2 Maximum Input Level for Intra-Band Non-Contiguous EN-DC (2 CCs)	Same as clause 7.4 in TS 38.521-1 [8] Uplink power measurement same as 6.2B.1.2.	
7.4B.3 Maximum Input Level for Inter-band EN-DC within FR1 (2 CCs)	Same as clause 7.4 in TS 38.521-1 [8] Uplink power measurement same as 6.2B.1.3.	
7.4B.3_1.1 Maximum Input Level for Inter-band EN-DC within FR1 (3 CCs)	Same as clause 7.4A.1 in TS 38.521-1 [8] Uplink power measurement same as 6.2B.1.3.	
7.5B.1 Adjacent Channel Selectivity for intra-band contiguous EN-DC (2 CCs)	Same as clause 7.5 in TS 38.521-1 [8] for NR CC Same as clause 7.5 in TS 36.521 [10] Uplink power measurement same as 6.2B.1.1.	
7.5B.2 Adjacent Channel Selectivity for intra-band non-contiguous EN-DC (2 CCs)	Same as clause 7.5 in TS 38.521-1 [8] Uplink power measurement same as 6.2B.1.2.	
7.5B.3 Adjacent Channel Selectivity for inter-band EN-DC within FR1 (2 CCs)	Same as clause 7.5 in TS 38.521-1 [8] Uplink power measurement same as 6.2B.1.3.	
7.5B.3_1.1 Adjacent Channel Selectivity for EN-DC within FR1 (3 CCs)	Same as clause 7.5A in TS 38.521-1 [8] Uplink power measurement same as 6.2B.1.3.	
7.5B.3_1.2 Adjacent Channel Selectivity for EN-DC within FR1 (4 CCs)	Same as clause 7.5A in TS 38.521-1 [8] Uplink power measurement same as 6.2B.1.3.	

7.5B.3_1.3 Adjacent Channel Selectivity for EN-DC within FR1 (5 CCs)	Same as clause 7.5A in TS 38.521-1 [8] Uplink power measurement same as 6.2B.1.3.	
7.5B.3_1.4 Adjacent Channel Selectivity for EN-DC within FR1 (6 CCs)	Same as clause 7.5A in TS 38.521-1 [8] Uplink power measurement same as 6.2B.1.3.	
7.5B.4 Adjacent Channel Selectivity for inter-band EN-DC including FR2 FR2 (1 NR CC)	Same as clause 7.5 in TS 38.521-2 [9]	
7.5B.4_1.1 Adjacent Channel Selectivity for inter-band EN-DC including FR2 (2 NR CCs)	Same as clause 7.5A in TS 38.521-2 [9]	
7.6B.2.1 Inband blocking for intra-band contiguous EN-DC in FR1 (2 CCs)	MU for NR CC downlink power same as clause 7.6.2 in TS 38.521-1 [8]. Uplink power measurement same as 6.2B.1.1.	
7.6B.2.2 Inband blocking for intra-band non-contiguous EN-DC in FR1 (2 CCs)	Same as clause 7.6.2 in TS 38.521-1 [8] Uplink power measurement same as 6.2B.1.2.	
7.6B.2.3 Inband blocking for inter-band EN-DC within FR1 (2 CCs)	Same as clause 7.6.2 in TS 38.521-1 [8] Uplink power measurement same as 6.2B.1.3.	
7.6B.2.3_1.1 Inband blocking for EN-DC within FR1 (3 CCs)	Same as clause 7.6A.2.1 in TS 38.521-1 [8] Uplink power measurement same as 6.2B.1.3.	
7.6B.2.3_1.2 Inband blocking for EN-DC within FR1 (4 CCs)	Same as clause 7.6.2 in TS 38.521-1 [8] for each component carrier. Uplink power measurement same as 6.2B.1.3.	
7.6B.2.3_1.3 Inband blocking for EN-DC within FR1 (5 CCs)	Same as clause 7.6.2 in TS 38.521-1 [8] for each component carrier. Uplink power measurement same as 6.2B.1.3.	
7.6B.2.4 Inband blocking for inter-band EN-DC including FR2 (1 NR CC)	Same as 7.6.2 in TS 38.521-2 [9]	
7.6B.2.4_1.1 Inband blocking for inter-band EN-DC including FR2 (2 NR CCs)	TBD	
7.6B.3.1 Out-of-band blocking for intra-band contiguous EN-DC in FR1 (2 CCs)	MU for NR CC downlink power same as clause 7.6.3 in TS 38.521-1 [8]. Uplink power measurement same as 6.2B.1.1.	
7.6B.3.2 Out-of-band blocking for intra-band non-contiguous EN-DC in FR1 (2 CCs)	Same as clause 7.6.3 in TS 38.521-1 [8] Uplink power measurement same as 6.2B.1.2.	
7.6B.3.3 Out-of-band blocking for inter-band EN-DC within FR1 (2 CCs)	Same as clause 7.6.3 in TS 38.521-1 [8]. Uplink power measurement same as 6.2B.1.3.	
7.6B.3.3_1.1 Out-of-band blocking for EN-DC within FR1 (3 CCs)	Same as clause 7.6A.3.1 in TS 38.521-1 [8]. Uplink power measurement same as 6.2B.1.3.	
7.6B.4.1 Narrow band blocking for intra-band contiguous EN-DC in FR1 (2 CCs)	MU for NR CC downlink power same as clause 7.6.4 in TS 38.521-1 [8]. Uplink power measurement same as 6.2B.1.1.	
7.6B.4.2 Narrow band blocking for intra-band non-contiguous EN-DC in FR1 (2 CCs)	Same as clause 7.6.4 in TS 38.521-1 [8] Uplink power measurement same as 6.2B.1.2.	
7.6B.4.3 Narrow band blocking for inter-band EN-DC within FR1 (2 CCs)	Same as clause 7.6.4 in TS 38.521-1 [8] Uplink power measurement same as 6.2B.1.3.	
7.6B.4.3_1.1 Narrow band blocking for EN-DC within FR1 (3 CCs)	Same as clause 7.6A.4.1 in TS 38.521-1 [8] Uplink power measurement same as 6.2B.1.3.	

7.6B.4.3_1.2 Narrow band blocking for EN-DC within FR1 (4 CCs)	Same as clause 7.6.4 in TS 38.521-1 [8] for each component carrier. Uplink power measurement same as 6.2B.1.3.	
7.6B.4.3_1.3 Narrow band blocking for EN-DC within FR1 (5 CCs)	Same as clause 7.6.4 in TS 38.521-1 [8] for each component carrier. Uplink power measurement same as 6.2B.1.3.	
7.7B.1 Spurious Response for intra-band contiguous EN-DC in FR1 (2 CCs)	MU for NR CC downlink power same as clause 7.7 in TS 38.521-1 [8]. Uplink power measurement same as 6.2B.1.1.	
7.7B.2 Spurious Response for intra-band non-contiguous EN-DC in FR1 (2 CCs)	Same as clause 7.7 in TS 38.521-1 [8] Uplink power measurement same as 6.2B.1.2.	
7.7B.3 Spurious Response for inter-band EN-DC within FR1 (2 CCs)	Same as clause 7.7 in TS 38.521-1 [8]. Uplink power measurement same as 6.2B.1.3.	
7.7B.3_1.1 Spurious Response for EN-DC within FR1 (3 CCs)	Same as clause 7.7 in TS 38.521-1 [8] for each component carrier. Uplink power measurement same as 6.2B.1.2.	
7.7B.3_1.2 Spurious Response for EN-DC within FR1 (4 CCs)	Same as clause 7.7 in TS 38.521-1 [8] for each component carrier. Uplink power measurement same as 6.2B.1.2.	
7.8B.2.1 Wideband Intermodulation for intra-band contiguous EN-DC in FR1	MU for NR CC downlink power same as clause 7.8.2 in TS 38.521-1 [8]. Uplink power measurement same as 6.2B.1.1.	
7.8B.2.2 Wideband Intermodulation for intra-band non-contiguous EN-DC in FR1	Same as clause 7.8.2 in TS 38.521-1 [8] Uplink power measurement for same as 6.2B.1.2.	
7.8B.2.3 Wideband Intermodulation for inter-band EN-DC in FR1	Same as clause 7.8.2 in TS 38.521-1 [8] Uplink power measurement for same as 6.2B.1.3.	
7.8B.2.3_1.1 Wideband Intermodulation for EN-DC within FR1 (3 CCs)	Same as clause 7.8A.2.1 in TS 38.521-1 [8] Uplink power measurement for same as 6.2B.1.3.	
7.8B.2.3_1.2 Wideband Intermodulation for EN-DC within FR1 (4 CCs)	Same as clause 7.8A.2 in TS 38.521-1 [8] Uplink power measurement for same as 6.2B.1.3.	
7.8B.2.3_1.3 Wideband Intermodulation for EN-DC within FR1 (5 CCs)	Same as clause 7.8A.2 in TS 38.521-1 [8] Uplink power measurement for same as 6.2B.1.3.	
7.8B.2.3_1.4 Wideband Intermodulation for EN-DC within FR1 (6 CCs)	Same as clause 7.8A.2 in TS 38.521-1 [8] Uplink power measurement for same as 6.2B.1.3.	
7.9B.1 Spurious Emissions for intra-band contiguous EN-DC within FR1 (2 CCs)	Same as clause 7.9 in TS 38.521-1 [8]	
7.9B.2 Spurious Emissions for intra-band non-contiguous EN-DC within FR1 (2 CCs)	Same as clause 7.9 in TS 38.521-1 [8]	
7.9B.3 Spurious Emissions for inter-band EN-DC within FR1 (2 CCs)	Same as clause 7.9 in TS 38.521-1 [8]	
7.9B.3_1.1 Spurious Emissions for EN-DC within FR1 (3 CCs)	Same as clause 7.9A.1 in TS 38.521-1 [8]	
7.9B.4 Spurious Emissions for inter-band EN-DC including FR2 (1 NR CC)	Same as clause 7.9 in TS 38.521-2 [9]	

---

## F.2 Interpretation of measurement results (normative)

TBD

---

## F.3 Test Tolerance and Derivation of Test Requirements (informative)

TBD

### F.3.1 Measurement of test environments

TBD

## F.3.2 Measurement of transmitter

Table F.3.2-1: Derivation of Test Requirements (Transmitter tests)

Sub clause	Test Tolerance (TT)	Formula for test requirement
6.2B.1.1 UE Maximum Output Power for Intra-Band Contiguous EN-DC	Same as 6.2.1 in TS 38.521-1 [8]	
6.2B.1.2 UE Maximum Output Power for Intra-Band Non-Contiguous EN-DC	<p>MAX (TT<sub>LTE</sub>, TT<sub>SA</sub>)</p> <p>TT<sub>LTE</sub>  0.7 dB, <math>f \leq 3.0\text{GHz}</math>  1.0 dB, <math>3.0\text{GHz} &lt; f \leq 4.2\text{GHz}</math></p> <p>TT<sub>SA</sub>  <math>f \leq 3.0\text{GHz}</math>  0.7 dB, <math>\text{BW} \leq 40\text{MHz}</math>  1.0 dB, <math>40\text{MHz} &lt; \text{BW} \leq 100\text{MHz}</math>  <math>3.0\text{GHz} &lt; f \leq 6.0\text{GHz}</math>  1.0 dB, <math>\text{BW} \leq 100\text{MHz}</math></p>	<p>TT<sub>LTE</sub> is TT of LTE specified in 6.2.2 in TS 36.521-1 [10].</p> <p>TT<sub>SA</sub> is TT of FR1 SA specified in 6.2.1 in TS 38.521-1 [8].</p>
6.2B.1.3 UE Maximum Output Power for Inter-Band EN-DC within FR1 (1 E-UTRA CC, 1 NR CC)	<p>MAX (TT<sub>LTE</sub>, TT<sub>SA</sub>)</p> <p>TT<sub>LTE</sub>  0.7 dB, <math>f \leq 3.0\text{GHz}</math>  1.0 dB, <math>3.0\text{GHz} &lt; f \leq 4.2\text{GHz}</math></p> <p>TT<sub>SA</sub>  <math>f \leq 3.0\text{GHz}</math>  0.7 dB, <math>\text{BW} \leq 40\text{MHz}</math>  1.0 dB, <math>40\text{MHz} &lt; \text{BW} \leq 100\text{MHz}</math>  <math>3.0\text{GHz} &lt; f \leq 6.0\text{GHz}</math>  1.0 dB, <math>\text{BW} \leq 100\text{MHz}</math></p>	<p>TT<sub>LTE</sub> is TT of LTE specified in 6.2.3 in TS 36.521-1 [10].</p> <p>TT<sub>SA</sub> is TT of FR1 SA specified in 6.2.2 in TS 38.521-1 [8].</p>
6.2B.1.3_1 UE Maximum Output Power for Inter-Band EN-DC within FR1 (2 E-UTRA CCs, 1 NR CC)	Same as 6.2B.1.3	
6.2B.1.4 UE Maximum Output Power for Inter-Band EN-DC including FR2	Same as 6.2.1 in TS 38.521-2 [9]	
6.2B.1.4.1 UE Maximum Output Power for Inter-Band EN-DC including FR2 (1 NR CC) - EIRP and TR	Same as 6.2.1.1 in TS 38.521-2 [9]	
6.2B.1.4.2 UE Maximum Output Power for Inter-Band EN-DC including FR2 (1 NR CC) - Spherical Coverage	Same as 6.2.1.2 in TS 38.521-2 [9]	
6.2B.1.4_1.1.1 UE Maximum Output Power for Inter-Band EN-DC including FR2 (2 NR CCs) - EIRP and TRP	Same as 6.2A.1.1.1 in TS 38.521-2 [9]	
6.2B.1.4_1.1.2 UE Maximum Output Power for Inter-Band EN-DC including FR2 (2 NR CCs) - Spherical Coverage	Same as 6.2A.1.2.1 in TS 38.521-2 [9]	
6.2B.1.4_1.2.1 UE Maximum Output Power for Inter-Band EN-DC including FR2 (3 NR CCs) - EIRP and TRP	Same as clause 6.2A.1.1.2 in TS 38.521-2 [9]	
6.2B.1.4_1.2.2 UE Maximum Output Power for Inter-Band EN-DC including FR2 (3 NR CCs) - Spherical Coverage	Same as clause 6.2A.1.2.2 in TS 38.521-2 [9]	
6.2B.1.4_1.3.1 UE Maximum Output Power for Inter-Band EN-DC including FR2 (4 NR CCs) - EIRP and TRP	Same as clause 6.2A.1.1.3 in TS 38.521-2 [9]	

6.2B.1.4_1.3.2 UE Maximum Output Power for Inter-Band EN-DC including FR2 (4 NR CCs) – Spherical Coverage	Same as clause 6.2A.1.2.3 in TS 38.521-2 [9]	
6.2B.1.4_1.4.1 UE Maximum Output Power for Inter-Band EN-DC including FR2 (5 NR CCs) - EIRP and TRP	Same as clause 6.2A.1.1.4 in TS 38.521-2 [9]	
6.2B.1.4_1.4.2 UE Maximum Output Power for Inter-Band EN-DC including FR2 (5 NR CCs) – Spherical Coverage	Same as clause 6.2A.1.2.4 in TS 38.521-2 [9]	
6.2B.1.4_1.5.1 UE Maximum Output Power for Inter-Band EN-DC including FR2 (6 NR CCs) - EIRP and TRP	Same as clause 6.2A.1.1.5 in TS 38.521-2 [9]	
6.2B.1.4_1.5.2 UE Maximum Output Power for Inter-Band EN-DC including FR2 (6 NR CCs) – Spherical Coverage	Same as clause 6.2A.1.2.5 in TS 38.521-2 [9]	
6.2B.1.4_1.6.1 UE Maximum Output Power for Inter-Band EN-DC including FR2 (7 NR CCs) - EIRP and TRP	Same as clause 6.2A.1.1.6 in TS 38.521-2 [9]	
6.2B.1.4_1.6.2 UE Maximum Output Power for Inter-Band EN-DC including FR2 (7 NR CCs) – Spherical Coverage	Same as clause 6.2A.1.2.6 in TS 38.521-2 [9]	
6.2B.1.6 UE Maximum Output Power for Inter-Band EN-DC including FR2 (1 NR CC) - EIRP with UL Gaps	Same as clause 6.2.5 in TS 38.521-2	
6.2B.1.4D.1 UE Maximum Output Power for Inter-Band EN-DC including FR2 for UL MIMO	Same as clause 6.2D.1.1 in TS 38.521-2 [9]	
6.2B.1.4D.2 UE Maximum Output Power for Inter-Band EN-DC including FR2 for UL MIMO- Spherical coverage	Same as clause 6.2D.1.2 in TS 38.521-2 [9]	
6.2B.2.1 UE Maximum Output Power reduction for Intra-Band Contiguous EN-DC	Same as 6.2.2 in TS 38.521-1 [8]	
6.2B.2.2 UE Maximum Output Power reduction for Intra-Band Non-Contiguous EN-DC	Same as 6.2B.1.2	
6.2B.2.3 UE Maximum Output Power reduction for Inter-Band EN-DC within FR1	Same as 6.2B.1.3	
6.2B.2.4 UE Maximum Output Power reduction for Inter-Band EN-DC including FR2	Same as clause 6.2.2 and 6.2A.2.1 in TS 38.521-2 [9]	
6.2B.2.4a UE Maximum Output Power reduction enhancements for Inter-Band EN-DC including FR2 (1 NR CC)	Same as clause 6.2.2_1 in TS 38.521-2 [9]	



6.2B.2.4_1.1 UE Maximum Output Power reduction for Inter-Band EN-DC including FR2 (2 NR CCs)	Same as clause 6.2A.2.1 in TS 38.521-2 [9]	
6.2B.2.4_1.2 UE Maximum Output Power reduction for Inter-Band EN-DC including FR2 (3 NR CCs)	Same as clause 6.2A.2.2 in TS 38.521-2 [9]	
6.2B.2.4_1.3 UE Maximum Output Power reduction for Inter-Band EN-DC including FR2 (4 NR CCs)	Same as clause 6.2A.2.3 in TS 38.521-2 [9]	
6.2B.2.4D UE Maximum Output Power reduction for Inter-Band EN-DC including FR2 (1 NR CC)	Same as clause 6.2D.2 in TS 38.521-2 [9]	
6.2B.3.1 UE Additional Maximum Output Power reduction for Intra-band contiguous EN-DC	Same as 6.2.3 in TS 38.521-1 [8]	
6.2B.3.2 UE Additional Maximum Output Power reduction for Intra-Band Non-Contiguous EN-DC	Same as 6.2B.1.2	
6.2B.3.3 UE Additional Maximum Output Power reduction for Inter-Band EN-DC within FR1	Same as 6.2B.1.3	
6.2B.3.4 UE Additional Maximum Output Power reduction for Inter-Band EN-DC including FR2 (1 NR CC)	Same as clause 6.2.3 in TS 38.521-2 [9]	
6.2B.3.4_1.1 UE Additional Maximum Output power reduction for inter-band EN-DC including FR2 (2 NR CCs)	Same as clause 6.2A.3.1 in TS 38.521-2 [9]	
6.2B.3.4_1.2 UE Additional Maximum Output power reduction for inter-band EN-DC including FR2 (3 NR CCs)	Same as clause 6.2A.3.2 in TS 38.521-2 [9]	
6.2B.3.4_1.3 UE Additional Maximum Output power reduction for inter-band EN-DC including FR2 (4 NR CCs)	Same as clause 6.2A.3.3 in TS 38.521-2 [9]	
6.2B.3.4D UE Additional Maximum Output Power reduction for Inter-Band EN-DC including FR2 (1 NR CC) for UL MIMO	Same as clause 6.2D.3 in TS 38.521-2 [9]	
6.2B.4.1.1 Configured Output Power Level for Intra-Band Contiguous EN-DC	MAX ( $TT_{LTE}$ , $TT_{SA}$ )	$TT_{LTE}$ is TT of LTE specified in 6.2.4 in TS 36.521-1 [10]. $TT_{SA}$ is TT of FR1 SA specified in 6.2.4 in TS 38.521-1 [8].
6.2B.4.1.2 Configured Output Power for Intra-Band Non-Contiguous EN-DC	MAX ( $TT_{LTE}$ , $TT_{SA}$ )	$TT_{LTE}$ is TT of LTE specified in 6.2.4 in TS 36.521-1 [10]. $TT_{SA}$ is TT of FR1 SA specified in 6.2.4 in TS 38.521-1 [8].
6.2B.4.1.3 Configured Output Power for Inter-Band EN-DC within FR1 (1 E-UTRA CC, 1 NR CC)	MAX ( $TT_{LTE}$ , $TT_{SA}$ )	$TT_{LTE}$ is TT of LTE specified in 6.2.4 in TS 36.521-1 [10]. $TT_{SA}$ is TT of FR1 SA specified in 6.2.4 in TS 38.521-1 [8].

6.2B.4.1.3_1 Configured Output Power for Inter-Band EN-DC within FR1 (2 E-UTRA CCs, 1 NR CC)	MAX ( $TT_{LTE}$ , $TT_{SA}$ )	$TT_{LTE}$ is TT of LTE specified in 6.2.4 in TS 36.521-1 [10].  $TT_{SA}$ is TT of FR1 SA specified in 6.2.4 in TS 38.521-1 [8].
6.2B.4.1.4_1 Configured Output Power with Power Boost for Inter-Band EN-DC including FR2 (1 NR CC)	Same as clause 6.2.4_1 in TS 38.521-2 [9]	
6.2H.1.3 UE maximum output power for inter-band EN-DC with UL MIMO	MAX ( $TT_{LTE}$ , $TT_{SA}$ )	$TT_{LTE}$ is TT of LTE specified in 6.2.2 in TS 36.521-1 [10].  $TT_{SA}$ is TT of FR1 SA specified in 6.2.1 in TS 38.521-1 [8] for the sum of power at each of UE antenna connector.
6.2H.2.3 UE maximum output power reduction for inter-band EN-DC with UL MIMO within FR1	Same as clause 6.2D.2 in TS 38.521-1 [8]	
6.2H.3.3 UE additional maximum output power reduction for inter-band EN-DC with UL MIMO within FR1	Same as clause 6.2D.3 in TS 38.521-1 [8]	
6.2H.4.3 Configured output power level for inter-band EN-DC with UL MIMO within FR1	Same as clause 6.2D.4 in TS 38.521-1 [8]	
6.2L.1.3 UE maximum output power for inter-band EN-DC with Tx Diversity	MAX ( $TT_{LTE}$ , $TT_{SA}$ )	$TT_{LTE}$ is TT of LTE specified in 6.2.2 in TS 36.521-1 [10].  $TT_{SA}$ is TT of FR1 SA specified in 6.2.1 in TS 38.521-1 [8] for the sum of power at each of UE antenna connector.
6.2L.2.3 UE maximum output power reduction for inter-band EN-DC with Tx Diversity within FR1	Same as clause 6.2G.2 in TS 38.521-1 [8]	
6.2L.3.3 UE additional maximum output power reduction for inter-band EN-DC with Tx Diversity within FR1	Same as clause 6.2G.3 in TS 38.521-1 [8]	
6.2L.4.3 Configured output power level for inter-band EN-DC with Tx Diversity within FR1	Same as clause 6.2G.4 in TS 38.521-1 [8]	
6.3B.1.1 Minimum Output Power for intra-band contiguous EN-DC	Same as 6.3.1 in TS 38.521-1 [8]	
6.3B.1.2 Minimum output power for intra-band non-contiguous EN-DC	Same as 6.3.1 in TS 38.521-1 [8]	
6.3B.1.3 Minimum output power for inter-band EN-DC within FR1	Same as 6.3.1 in TS 38.521-1 [8]	
6.3B.1.4 Minimum Output Power for EN-DC Interband including FR2	Same as 6.3.1 in TS 38.521-2 [9]	
6.3B.1.4_1.1 Minimum output power for inter-band EN-DC including FR2 (3 CCs)	Same as 6.3A.1.1 in TS 38.521-2 [9]	
6.3B.1.4_1.2 Minimum output power for inter-band EN-DC including FR2 (4 CCs)	Same as 6.3A.1.2 in TS 38.521-2 [9]	

6.3B.1.4_1.3 Minimum output power for inter-band EN-DC including FR2 (5 CCs)	Same as 6.3A.1.3 in TS 38.521-2 [9]	
6.3B.1.4D Minimum output power for inter-band EN-DC including FR2 for UL MIMO	Same as 6.3D.1 in TS 38.521-2 [9]	
6.3B.2.1 Transmit OFF Power for intra-band contiguous EN-DC	Same as 6.3.2 in TS 38.521-1 [8]	
6.3B.2.2 Transmit OFF Power for intra-band non-contiguous EN-DC	Same as 6.3.2 in TS 38.521-1 [8]	
6.3B.2.3 Transmit OFF Power for inter-band EN-DC within FR1	Same as 6.3.2 in TS 38.521-1 [8]	
6.3B.2.4 Transmit OFF Power for inter-band EN-DC including FR2	Same as 6.3.2 in TS 38.521-2 [9]	
6.3B.2.4D Transmit OFF Power for inter-band EN-DC including FR2 for UL-MIMO	Same as 6.3D.2 in TS 38.521-2 [9]	
6.3B.3.1 Tx ON/OFF time mask for intra-band contiguous EN-DC	Same as 6.3.3.2 in TS 38.521-1 [8]	
6.3B.3_1.1 E-UTRA and NR switching time mask for switching between two uplink carriers for inter-band EN-DC	MAX (TT <sub>LTE</sub> , TT <sub>NR</sub> )  TT <sub>LTE</sub> is TT of LTE specified in clause 6.2.3 in TS 36.521-1 [10].  TT <sub>NR</sub> is TT of FR1 NR specified in clause 6.2D.2 in TS 38.521-1 [8].	
6.3B.2.4_1.1 Transmit OFF Power for Inter-band EN-DC including FR2 (3 CCs)	Same as 6.3A.2.1 in TS 38.521-2 [9]	
6.3B.2.4_1.2 Transmit OFF Power for Inter-band EN-DC including FR2 (4 CCs)	Same as 6.3A.2.2 in TS 38.521-2 [9]	
6.3B.2.4_1.3 Transmit OFF Power for Inter-band EN-DC including FR2 (5 CCs)	Same as 6.3A.2.3 in TS 38.521-2 [9]	
6.3B.3.2 Tx ON/OFF time mask for intra-band non-contiguous EN-DC	Same as 6.3.3.2 in TS 38.521-1 [8]	
6.3B.3.3 Tx ON/OFF time mask for inter-band EN-DC within FR1	Same as 6.3.3.2 in TS 38.521-1 [8]	
6.3B.3.4 Transmit ON/OFF time mask for inter-band EN-DC including FR2	Same as 6.3.3.2 in TS 38.521-2 [9]	
6.3B.3.4_1.1 Transmit ON/OFF time mask for inter-band EN-DC including FR2 (2 NR CCs)	Same as clause 6.3A.3.1.1 in TS 38.521-2 [9]	
6.3B.3.4_1.2 Transmit ON/OFF time mask for inter-band EN-DC including FR2 (3 NR CCs)	Same as clause 6.3A.3.1.2 in TS 38.521-2 [9]	
6.3B.3.4_1.3 Transmit ON/OFF time mask for inter-band EN-DC including FR2 (4 NR CCs)	Same as clause 6.3A.3.1.2 in TS 38.521-2 [9]	
6.3B.4.3 PRACH Time Mask for inter-band EN-DC within FR1	Same as 6.3.3.4 in TS 38.521-1 [8]	

6.3B.8.1.1 Absolute power tolerance for intra-band contiguous EN-DC	Same as 6.3.4.2 in TS 38.521-1 [8]	
6.3B.8.1.2 Absolute power tolerance for intra-band non-contiguous EN-DC	Same as 6.3.4.2 in TS 38.521-1 [8]	
6.3B.8.1.3 Absolute power tolerance for inter-band EN-DC within FR1	Same as 6.3.4.2 in TS 38.521-1 [8]	
6.3B.8.1.4 Absolute power tolerance for inter-band EN-DC including FR2	Same as 6.3.4.2 in TS 38.521-2 [9]	
6.3B.8.1.4_1.1 Absolute power tolerance for inter-band EN-DC including FR2 (2 NR CC)	Same as 6.3A.4.2.1 in TS 38.521-2 [9]	
6.3B.8.1.4_1.2 Absolute power tolerance for inter-band EN-DC including FR2 (3 NR CC)	Same as 6.3A.4.2.2 in TS 38.521-2 [9]	
6.3B.8.1.4_1.3 Absolute power tolerance for inter-band EN-DC including FR2 (4 NR CC)	Same as 6.3A.4.2.3 in TS 38.521-2 [9]	
6.3B.8.2.1 Relative power tolerance for intra-band contiguous EN-DC	Same as 6.3.4.3 in TS 38.521-1 [8]	
6.3B.8.2.2 Relative power tolerance for intra-band non-contiguous EN-DC	Same as 6.3.4.3 in TS 38.521-1 [8]	
6.3B.8.2.3 Relative power tolerance for inter-band EN-DC within FR1	Same as 6.3.4.3 in TS 38.521-1 [8]	
6.3B.8.2.4 Relative power tolerance for inter-band EN-DC including FR2	Same as 6.3.4.3 in TS 38.521-2 [9]	
6.3B.8.3.1 Aggregate power tolerance for intra-band contiguous EN-DC	Same as 6.3.4.4 in TS 38.521-1 [8]	
6.3B.8.3.2 Aggregate power tolerance for intra-band non-contiguous EN-DC	Same as 6.3.4.4 in TS 38.521-1 [8]	
6.3B.8.3.3 Aggregate power tolerance for inter-band EN-DC within FR1	Same as 6.3.4.4 in TS 38.521-1 [8]	
6.3B.8.3.4 Aggregate power tolerance for inter-band EN-DC including FR2	Same as 6.3.4.4 in TS 38.521-2 [9]	
6.3B.8.3.4_1.1 Aggregate power tolerance for inter-band EN-DC including FR2 (2 NR CC)	Same as 6.3A.4.4.1 in TS 38.521-2 [9]	
6.3B.8.3.4_1.2 Aggregate power tolerance for inter-band EN-DC including FR2 (3 NR CC)	Same as 6.3A.4.4.2 in TS 38.521-2 [9]	
6.3B.8.3.4_1.3 Aggregate power tolerance for inter-band EN-DC including FR2 (4 NR CC)	Same as 6.3A.4.4.3 in TS 38.521-2 [9]	
6.3H.3.1 Minimum output power for inter-band EN-DC with UL MIMO within FR1	Same as clause 6.3D.1 in TS 38.521-1 [8]	
6.3H.3.2 Transmit OFF Power for inter-band EN-DC with UL MIMO within FR1	Same as clause 6.3D.2 in TS 38.521-1 [8]	

6.3H.3.3 Transmit ON/OFF time mask for inter-band EN-DC with UL MIMO within FR1	Same as clause 6.3D.3 in TS 38.521-1 [8]	
6.3H.3.4.1 Absolute power tolerance for inter-band EN-DC with UL MIMO within FR1	Same as clause 6.3D.4.1 in TS 38.521-1 [8]	
6.3H.3.4.2 Relative power tolerance for inter-band EN-DC with UL MIMO within FR1	Same as clause 6.3D.4.2 in TS 38.521-1 [8]	
6.3H.3.4.3 Aggregate power tolerance for inter-band EN-DC with UL MIMO within FR1	Same as clause 6.3D.4.3 in TS 38.521-1 [8]	
6.3L.3.1 Minimum output power for inter-band EN-DC with Tx Diversity within FR1	Same as clause 6.3G.1 in TS 38.521-1 [8]	
6.3L.3.2 Transmit OFF Power for inter-band EN-DC with Tx Diversity within FR1	Same as clause 6.3G.2 in TS 38.521-1 [8]	
6.3L.3.3.1 General ON/OFF time mask for inter-band EN-DC with Tx Diversity within FR1	Same as clause 6.3G.3.1 in TS 38.521-1 [8]	
6.3L.3.3.2 PRACH time mask for inter-band EN-DC with Tx Diversity within FR1	Same as clause 6.3G.3.2 in TS 38.521-1 [8]	
6.3L.3.3.3 SRS time mask for inter-band EN-DC with Tx Diversity within FR1	Same as clause 6.3G.3.3 in TS 38.521-1 [8]	
6.3L.3.4.1 Absolute power tolerance for inter-band EN-DC with Tx Diversity within FR1	Same as clause 6.3G.4.1 in TS 38.521-1 [8]	
6.3L.3.4.2 Relative power tolerance for inter-band EN-DC with Tx Diversity within FR1	Same as clause 6.3G.4.2 in TS 38.521-1 [8]	
6.3L.3.4.3 Aggregate power tolerance for inter-band EN-DC with Tx Diversity within FR1	Same as clause 6.3G.4.3 in TS 38.521-1 [8]	
6.4B.1.1 Frequency Error for intra-band contiguous EN-DC	Same as 6.4.1 in TS 38.521-1 [8]	
6.4B.1.2 Frequency Error for intra-band non-contiguous EN-DC	Same as 6.4.1 in TS 38.521-1 [8]	
6.4B.1.3 Frequency Error for inter-band EN-DC within FR1	Same as 6.4.1 in TS 38.521-1 [8]	
6.4B.1.4 Frequency Error for inter-band EN-DC including FR2	Same as 6.4.1 in TS 38.521-2 [9]	
6.4B.1.4_1.1 Frequency Error for Inter-band EN-DC including FR2 (2 CCs)	Same as 6.4A.1.1 in TS 38.521-2 [9]	
6.4B.1.4_1.2 Frequency Error for Inter-band EN-DC including FR2 (3 CCs)	Same as 6.4A.1.2 in TS 38.521-2 [9]	
6.4B.1.4_1.3 Frequency Error for Inter-band EN-DC including FR2 (4 CCs)	Same as 6.4A.1.3 in TS 38.521-2 [9]	
6.4B.1.4_1.4 Frequency Error for Inter-band EN-DC including FR2 (5 CCs)	Same as 6.4A.1.4 in TS 38.521-2 [9]	
6.4B.1.4_1.5 Frequency Error for Inter-band EN-DC including FR2 (6 CCs)	Same as 6.4A.1.5 in TS 38.521-2 [9]	

6.4B.1.4_1.6 Frequency Error for Inter-band EN-DC including FR2 (7 CCs)	Same as 6.4A.1.6 in TS 38.521-2 [9]	
6.4B.1.4_1.7 Frequency Error for Inter-band EN-DC including FR2 (8 CCs)	Same as 6.4A.1.7 in TS 38.521-2 [9]	
6.4B.1.4D Frequency error for inter-band EN-DC including FR2 for UL-MIMO	Same as 6.4D.1 in TS 38.521-2 [9]	
6.4B.2.1.1 Error Vector Magnitude for intra-band contiguous EN-DC	Same as 6.4.2.1 in TS 38.521-1 [8]	
6.4B.2.1.2 Carrier Leakage for intra-band contiguous EN-DC	Same as 6.4.2.2 in TS 38.521-1 [8]	
6.4B.2.1.3 In-band Emissions for intra-band contiguous EN-DC	Same as 6.4.2.3 in TS 38.521-1 [8]	
6.4B.2.1.4 EVM Equalizer Flatness for intra-band contiguous EN-DC	Same as 6.4.2.4 in TS 38.521-1 [8]	
6.4B.2.2.1 Error Vector Magnitude for intra-band non-contiguous EN-DC	Same as 6.4.2.1 in TS 38.521-1 [8]	
6.4B.2.2.2 Carrier Leakage for intra-band non-contiguous EN-DC	Same as 6.4.2.2 in TS 38.521-1 [8]	
6.4B.2.2.3 In-band Emissions for intra-band non-contiguous EN-DC	Same as 6.4.2.3 in TS 38.521-1 [8]	
6.4B.2.2.4 EVM Equalizer Flatness for intra-band non-contiguous EN-DC	Same as 6.4.2.4 in TS 38.521-1 [8]	
6.4B.2.3.1 Error Vector Magnitude for inter-band EN-DC within FR1	Same as 6.4.2.1 in TS 38.521-1 [8]	
6.4B.2.3.2 Carrier Leakage for inter-band EN-DC within FR1	Same as 6.4.2.2 in TS 38.521-1 [8]	
6.4B.2.3.3 In-band Emissions for inter-band EN-DC within FR1	Same as 6.4.2.3 in TS 38.521-1 [8]	
6.4B.2.3.4 EVM Equalizer Flatness for inter-band EN-DC within FR1	Same as 6.4.2.4 in TS 38.521-1 [8]	
6.4B.2.4.1 Error Vector Magnitude for inter-band EN-DC including FR2	Same as 6.4.2.1 in TS 38.521-2 [9]	
6.4B.2.4.1a Error Vector Magnitude with Power Boost for inter-band EN-DC including FR2 (1 NR CC)	Same as clause 6.4.2.1_1 in TS 38.521-2 [9]	
6.4B.2.4.2 Carrier Leakage for inter-band EN-DC including FR2	Same as 6.4.2.2 in TS 38.521-2 [9]	
6.4B.2.4.3 In-band Emissions for inter-band EN-DC including FR2	Same as 6.4.2.3 in TS 38.521-2 [9]	
6.4B.2.4.4 EVM Equalizer Flatness for inter-band EN-DC including FR2	Same as 6.4.2.4 in TS 38.521-2 [9]	
6.4B.2.4.5 EVM spectral flatness for $\pi/2$ BPSK modulation for inter-band EN-DC including FR2 (1 NR CC)	Same as 6.4.2.5 in TS 38.521-2 [9]	

6.4H.1.3 Frequency error for inter-band EN-DC with UL MIMO within FR1	Same as clause 6.4D.1 in TS 38.521-1 [8]	
6.4H.2.3.1 Error Vector Magnitude for inter-band EN-DC with UL MIMO within FR1	Same as clause 6.4D.2.1 in TS 38.521-1 [8]	
6.4H.2.3.2 Carrier leakage for inter-band EN-DC with UL MIMO within FR1	Same as clause 6.4D.2.2 in TS 38.521-1 [8]	
6.4H.2.3.3 In-band emissions for inter-band EN-DC with UL MIMO within FR1	Same as clause 6.4D.2.3 in TS 38.521-1 [8]	
6.4L.1.3 Frequency error for inter-band EN-DC with Tx Diversity within FR1	Same as clause 6.4G.1 in TS 38.521-1 [8]	
6.4L.2.3.1 Error Vector Magnitude for inter-band EN-DC with Tx Diversity within FR1	Same as clause 6.4G.2.1 in TS 38.521-1 [8]	
6.4L.2.3.2 Carrier leakage for inter-band EN-DC with Tx Diversity within FR1	Same as clause 6.4G.2.2 in TS 38.521-1 [8]	
6.4H.2.3.3 In-band emissions for inter-band EN-DC with Tx Diversity within FR1	Same as clause 6.4G.2.3 in TS 38.521-1 [8]	
6.5B.1.1 Occupied bandwidth for Intra-Band Contiguous EN-DC	Same as 6.5.1 in TS 38.521-1 [8]	
6.5B.1.2 Occupied bandwidth for Intra-Band Non-Contiguous EN-DC	Same as 6.5.1 in TS 38.521-1 [8]	
6.5B.1.3 Occupied bandwidth for Inter-Band EN-DC within FR1	Same as 6.5.1 in TS 38.521-1 [8]	
6.5B.1.4 Occupied bandwidth for Inter-Band EN-DC including FR2	Same as 6.5.1 in TS 38.521-2 [9]	
6.5B.1.4_1.1 Occupied bandwidth for Inter-band EN-DC including FR2 (2 CCs)	Same as clause 6.5A.1.1 in TS 38.521-2 [9]	
6.5B.1.4_1.2 Occupied bandwidth for Inter-band EN-DC including FR2 (3 CCs)	Same as clause 6.5A.1.2 in TS 38.521-2 [9]	
6.5B.1.4_1.3 Occupied bandwidth for Inter-band EN-DC including FR2 (4 CCs)	Same as clause 6.5A.1.3 in TS 38.521-2 [9]	
6.5B.1.4_1.4 Occupied bandwidth for Inter-band EN-DC including FR2 (5 CCs)	Same as clause 6.5A.1.4 in TS 38.521-2 [9]	
6.5B.1.4_1.5 Occupied bandwidth for Inter-band EN-DC including FR2 (6 CCs)	Same as clause 6.5A.1.5 in TS 38.521-2 [9]	
6.5B.1.4_1.6 Occupied bandwidth for Inter-band EN-DC including FR2 (7 CCs)	Same as clause 6.5A.1.6 in TS 38.521-2 [9]	
6.5B.1.4_1.7 Occupied bandwidth for Inter-band EN-DC including FR2 (8 CCs)	Same as clause 6.5A.1.7 in TS 38.521-2 [9]	
6.5B.1.4D Occupied bandwidth for inter-band EN-DC including FR2 for UL MIMO	Same as 6.5D.1 in TS 38.521-2 [9]	
6.5B.2.1.1 Spectrum emissions mask for intra-band contiguous EN-DC	Same as 6.5.2.2 in TS 38.521-1 [8]	

6.5B.2.1.2 Additional spectrum emissions mask for intra-band contiguous EN-DC	Same as 6.5.2.3 in TS 38.521-1 [8]	
6.5B.2.1.3 Adjacent channel leakage ratio for intra-band contiguous EN-DC	Same as 6.5.2.4.1 in TS 38.521-1 [8]	
6.5B.2.2.1 Spectrum emissions mask for intra-band non-contiguous EN-DC	Same as 6.5.2.2 in TS 38.521-1 [8]	
6.5B.2.2.2 Additional Spectrum emissions mask for intra-band non-contiguous EN-DC	Same as 6.5.2.3 in TS 38.521-1 [8]	
6.5B.2.2.3 Adjacent channel leakage ratio for intra-band non-contiguous EN-DC	Same as 6.5.2.4.1 in TS 38.521-1 [8]	
6.5B.2.3.1 Spectrum emissions mask for Inter-band EN-DC within FR1	Same as 6.5.2.2 in TS 38.521-1 [8]	
6.5B.2.3.2 Additional Spectrum emissions mask for Inter-band EN-DC within FR1	Same as 6.5.2.3 in TS 38.521-1 [8]	
6.5B.2.3.3.1 NR - Adjacent channel leakage ratio for inter-band EN-DC within FR1 (1 NR CC)	Same as 6.5.2.4.1 in TS 38.521-1 [8]	
6.5B.2.3.3.2 UTRA - Adjacent channel leakage ratio for inter-band EN-DC within FR1 (1 NR CC)	Same as 6.5.2.4.2 in TS 38.521-1 [8]	
6.5B.2.4.1 Spectrum emissions mask for Inter-band EN-DC including FR2	Same as 6.5.2.1 in TS 38.521-2 [9]	
6.5B.2.4.1a Spectrum emissions mask with Power Boost for Inter-band EN-DC including FR2 (1 NR CC)	Same as clause 6.5.2.1.1_1 in TS 38.521-2 [9]	
6.5B.2.4.1_1.1 Spectrum emissions mask for Inter-band EN-DC including FR2 (2 NR CCs)	Same as clause 6.5A.2.1.1 in TS 38.521-2 [9]	
6.5B.2.4.1_1.2 Spectrum emissions mask for Inter-band EN-DC including FR2 (3 NR CCs)	Same as clause 6.5A.2.1.2 in TS 38.521-2 [9]	
6.5B.2.4.1_1.3 Spectrum emissions mask for Inter-band EN-DC including FR2 (4 NR CCs)	Same as clause 6.5A.2.1.3 in TS 38.521-2 [9]	
6.5B.2.4.1_1.4 Spectrum emissions mask for Inter-band EN-DC including FR2 (5 NR CCs)	Same as clause 6.5A.2.1.4 in TS 38.521-2 [9]	
6.5B.2.4.1_1.5 Spectrum emissions mask for Inter-band EN-DC including FR2 (6 NR CCs)	Same as clause 6.5A.2.1.5 in TS 38.521-2 [9]	
6.5B.2.4.1_1.6 Spectrum emissions mask for Inter-band EN-DC including FR2 (7 NR CCs)	Same as clause 6.5A.2.1.6 in TS 38.521-2 [9]	
6.5B.2.4.1_1.7 Spectrum emissions mask for Inter-band EN-DC including FR2 (8 NR CCs)	Same as clause 6.5A.2.1.7 in TS 38.521-2 [9]	



6.5B.2.4.1D Spectrum emissions mask for inter-band EN-DC including FR2 for UL MIMO	Same as clause 6.5D.2.1 in TS 38.521-2 [9]	
6.5B.2.4.3 Adjacent channel leakage ratio for Inter-band EN-DC including FR2	Same as 6.5.2.3 in TS 38.521-2 [9]	
6.5B.2.4.3_1.1 Adjacent channel leakage ratio for Inter-band EN-DC including FR2 (3 CCs)	Same as clause 6.5A.2.2.1 in TS 38.521-2 [9]	
6.5B.2.4.3_1.2 Adjacent channel leakage ratio for Inter-band EN-DC including FR2 (4 CCs)	Same as clause 6.5A.2.2.2 in TS 38.521-2 [9]	
6.5B.2.4.3_1.3 Adjacent channel leakage ratio for Inter-band EN-DC including FR2 (5 CCs)	Same as clause 6.5A.2.2.3 in TS 38.521-2 [9]	
6.5B.2.4.3_1.4 Adjacent channel leakage ratio for Inter-band EN-DC including FR2 (5 NR CCs)	Same as clause 6.5A.2.2.4 in TS 38.521-2 [9]	
6.5B.2.4.3_1.5 Adjacent channel leakage ratio for Inter-band EN-DC including FR2 (6 NR CCs)	Same as clause 6.5A.2.2.5 in TS 38.521-2 [9]	
6.5B.2.4.3_1.6 Adjacent channel leakage ratio for Inter-band EN-DC including FR2 (7 NR CCs)	Same as clause 6.5A.2.2.6 in TS 38.521-2 [9]	
6.5B.2.4.3_1.7 Adjacent channel leakage ratio for Inter-band EN-DC including FR2 (8 NR CCs)	Same as clause 6.5A.2.2.7 in TS 38.521-2 [9]	
6.5B.2.4D.3 Adjacent channel leakage ratio for inter-band EN-DC including FR2 for UL MIMO	Same as clause 6.5D.2.2 in TS 38.521-2 [9]	
6.5B.3.1.1 General spurious emissions for intra-band contiguous EN-DC	Same as 6.5.3.1 in TS 38.521-1 [8]	
6.5B.3.1.2 Spurious emission band UE co-existence for intra-band contiguous EN-DC	Same as 6.5.3.2 in TS 38.521-1 [8]	
6.5B.3.2.1 General spurious emissions for Intra-band non-contiguous EN-DC	Same as 6.5.3.1 in TS 38.521-1 [8]	
6.5B.3.2.2 Spurious Emission band UE co-existence for intra-band non-contiguous EN-DC	Same as 6.5.3.2 in TS 38.521-1 [8]	
6.5B.3.3.1 General spurious emissions for Inter-band EN-DC within FR1	Same as 6.5.3.1 in TS 38.521-1 [8] for NR CC Same as 6.6.3.1 in TS 36.521-1 [10] for E-UTRA CC	
6.5B.3.3.2 Spurious emission band UE co-existence for Inter-band within FR1	Same as 6.5.3.2 in TS 38.521-1 [8] for NR CC Same as 6.6.3.2 in TS 36.521-1 [10] for E-UTRA CC	
6.5B.3.4.1 General Spurious Emissions for Inter-band including FR2 (1 NR CC)	Same as 6.5.3.1 in TS 38.521-2 [9]	
6.5B.3.4.1a General Spurious Emissions with Power Boost for Inter-band including FR2 (1 NR CC)	Same as clause 6.5.3.1_1 in TS 38.521-2 [9]	

6.5B.3.4.1_1.1 General Spurious Emissions for Inter-band including FR2 (2 NR CCs)	Same as clause 6.5A.3.1.1 in TS 38.521-2 [9]	
6.5B.3.4.1_1.2 General Spurious Emissions for Inter-band including FR2 (3 NR CCs)	Same as clause 6.5A.3.1.2 in TS 38.521-2 [9]	
6.5B.3.4.1_1.3 General Spurious Emissions for Inter-band including FR2 (4 NR CCs)	Same as clause 6.5A.3.1.3 in TS 38.521-2 [9]	
6.5B.3.4.1_1.4 General Spurious Emissions for Inter-band including FR2 (5 NR CCs)	Same as clause 6.5A.3.1.4 in TS 38.521-2 [9]	
6.5B.3.4.1_1.5 General Spurious Emissions for Inter-band including FR2 (6 NR CCs)	Same as clause 6.5A.3.1.5 in TS 38.521-2 [9]	
6.5B.3.4.1_1.6 General Spurious Emissions for Inter-band including FR2 (7 NR CCs)	Same as clause 6.5A.3.1.6 in TS 38.521-2 [9]	
6.5B.3.4.1_1.7 General Spurious Emissions for Inter-band including FR2 (8 NR CCs)	Same as clause 6.5A.3.1.7 in TS 38.521-2 [9]	
6.5B.3.4.1D General Spurious Emissions for inter-band EN-DC including FR2 for UL MIMO	Same as clause 6.5D.3.1 in TS 38.521-2 [9]	
6.5B.3.4.2 Spurious emission band UE co-existence for Inter-band including FR2	Same as clause 6.5.3.2 in TS 38.521-2 [9]	
6.5B.3.4.2a Spurious emission band UE co-existence with Power Boost for Inter-band including FR2 (1 NR CC)	Same as clause 6.5.3.2_1 in TS 38.521-2 [9]	
6.5B.3.4.2_1.1 Spurious emission band UE co-existence for Inter-band EN-DC including FR2 (2 NR CCs)	Same as clause 6.5A.3.2.1 in TS 38.521-2 [9]	
6.5B.3.4.2_1.2 Spurious emission band UE co-existence for Inter-band EN-DC including FR2 (3 NR CCs)	Same as clause 6.5A.3.2.2 in TS 38.521-2 [9]	
6.5B.3.4.2_1.3 Spurious emission band UE co-existence for Inter-band EN-DC including FR2 (4 NR CCs)	Same as clause 6.5A.3.2.3 in TS 38.521-2 [9]	
6.5B.3.4.2D Spurious emission band UE co-existence for inter-band EN-DC including FR2 for UL MIMO	Same as clause 6.5D.3.2 in TS 38.521-2 [9]	
6.5B.4.1 Additional Spurious Emissions for Intra-band contiguous EN-DC	Same as clause 6.5.3.3 in TS 38.521-1 [8]	
6.5B.4.2 Additional Spurious Emissions for Intra-band non-contiguous EN-DC	Same as clause 6.5.3.3 in TS 38.521-1 [8]	

6.5B.4.3 Additional Spurious Emissions for Inter-band EN-DC within FR1	Same as clause 6.5.3.3 in TS 38.521-1 [8]	
6.5B.4.4 Additional Spurious Emissions for Inter-band including FR2 (1 NR CC)	Same as clause 6.5.3.3 in TS 38.521-2 [9]	
6.5B.4.4a Additional Spurious Emissions with Power Boost for Inter-band including FR2 (1 NR CC)	Same as clause 6.5.3.3_1 in TS 38.521-2 [9]	
6.5B.4.4_1.1 Additional Spurious Emissions for Inter-band including FR2 (2 NR CC)	Same as clause 6.5A.3.3.1 in TS 38.521-2 [9]	
6.5B.4.4_1.2 Additional Spurious Emissions for Inter-band including FR2 (3 NR CC)	Same as clause 6.5A.3.3.2 in TS 38.521-2 [9]	
6.5B.4.4_1.3 Additional Spurious Emissions for Inter-band including FR2 (4 NR CC)	Same as clause 6.5A.3.3.3 in TS 38.521-2 [9]	
6.5B.4.4D Additional Spurious Emissions for Inter-band including FR2 for UL MIMO	Same as clause 6.5D.3.3 in TS 38.521-2 [9]	
6.5B.5.3 Transmit intermodulation for Inter-band EN-DC within FR1	Same as 6.5.4 in TS 38.521-1 [8]	
6.5H.3.3.1 General spurious emissions for inter-band EN-DC with UL MIMO within FR1	Same as clause 6.6.3.1 in TS 36.521-1 [10] for E-UTRA CC Same as clause 6.5D.3.1 in TS 38.521-1 [8] for NR CC	
6.5H.3.3.2 Spurious emissions for UE co-existence for inter-band EN-DC with UL MIMO within FR1	Same as clause 6.6.3.2 in TS 36.521-1 [10] for E-UTRA CC Same as clause 6.5D.3.2 in TS 38.521-1 [8] for NR CC	
6.5L.3.3.1 General spurious emissions for inter-band EN-DC with Tx Diversity within FR1	Same as clause 6.6.3.1 in TS 36.521-1 [10] for E-UTRA CC Same as clause 6.5G.3.1 in TS 38.521-1 [8] for NR CC	
6.5L.3.3.2 Spurious emissions for UE co-existence for inter-band EN-DC with Tx Diversity within FR1	Same as clause 6.6.3.2 in TS 36.521-1 [10] for E-UTRA CC Same as clause 6.5G.3.2 in TS 38.521-1 [8] for NR CC	
6.6B.4 Beam Correspondence for inter-band EN-DC including FR2 (1 NR CC) - EIRP	Same as clause 6.6.1 in TS 38.521-2 [9]	
6.6B.5 Enhanced Beam Correspondence for inter-band EN-DC including FR2 (1 NR CC) - EIRP	Same as clause 6.6.2 in TS 38.521-2 [9]	

## F.3.3 Measurement of receiver

**Table F.3.3-1: Derivation of Test Requirements (Receiver tests)**

Sub clause	Test Tolerance (TT)	Formula for test requirement
7.3B.2.1 Reference sensitivity for Intra-band Contiguous EN-DC (2 CCs)	Same as 7.3.2 in TS 38.521-1 [8]	
7.3B.2.2 Reference sensitivity for Intra-band non-contiguous EN-DC (2 CCs)	Same as 7.3.2 in TS 38.521-1 [8]	
7.3B.2.3 Reference sensitivity for Inter-band EN-DC within FR1 (2 CCs)	Same as 7.3.2 in TS 38.521-1 [8]	
7.3B.2.3_1.1 Reference sensitivity for Inter-band EN-DC within FR1 (3 CCs)	Same as 7.3A.1 in TS 38.521-1 [8]	
7.3B.2.4 Reference sensitivity for Inter-band EN-DC including FR2 (1 NR CC)	Same as 7.3.2 in TS 38.521-2 [9]	
7.3B.2.4_1.1 Reference sensitivity for Inter-band EN-DC including FR2 (2 NR CCs)	Same as 7.3A.2.1 in TS 38.521-2 [9]	
7.3B.2.4_1.2 Reference sensitivity for Inter-band EN-DC including FR2 (3 NR CCs)	Same as 7.3A.2.2 in TS 38.521-2 [9]	
7.3B.2.4_1.3 Reference sensitivity for Inter-band EN-DC including FR2 (4 NR CCs)	Same as 7.3A.2.3 in TS 38.521-2 [9]	
7.3B.2.4_1.4 Reference sensitivity for Inter-band EN-DC including FR2 (5 NR CCs)	Same as 7.3A.2.4 in TS 38.521-2 [9]	
7.3B.4 EIS Spherical Coverage for Inter-band EN-DC including FR2 (1 NR CC)	Same as 7.3.4 in TS 38.521-2 [9]	
7.4B.1 Maximum Input Level for Intra-Band Contiguous EN-DC (2 CCs)	Same as 7.4 in TS 38.521-1 [8]	
7.4B.2 Maximum Input Level for Intra-Band Non-Contiguous EN-DC (2 CCs)	Same as 7.4 in TS 38.521-1 [8]	
7.4B.3 Maximum Input Level for Inter-band EN-DC within FR1 (2 CCs)	Same as 7.4 in TS 38.521-1 [8]	
7.4B.3_1.1 Maximum Input Level for Inter-band EN-DC within FR1 (3 CCs)	Same as 7.4A.1 in TS 38.521-1 [8]	
7.5B.1 Adjacent Channel Selectivity for intra-band contiguous EN-DC (2 CCs)	Same as 7.5 in TS 38.521-1 [8]	
7.5B.2 Adjacent Channel Selectivity for intra-band non-contiguous EN-DC (2 CCs)	Same as 7.5 in TS 38.521-1 [8]	
7.5B.3 Adjacent Channel Selectivity for inter-band EN-DC within FR1 (2 CCs)	Same as 7.5 in TS 38.521-1 [8]	
7.5B.3_1.1 Adjacent Channel Selectivity for EN-DC within FR1 (3 CCs)	Same as 7.5A.1 in TS 38.521-1 [8]	
7.5B.3_1.2 Adjacent Channel Selectivity for EN-DC within FR1 (4 CCs)	Same as 7.5 in TS 38.521-1 [8]	
7.5B.4 Adjacent Channel Selectivity for inter-band EN-DC including FR2 (1 NR CC)	Same as clause 7.5 in TS 38.521-2 [9]	

7.6B.2.1 Inband blocking for intra-band contiguous EN-DC in FR1 (2 CCs)	Same as 7.6.2 in TS 38.521-1 [8]	
7.6B.2.2 Inband blocking for intra-band non-contiguous EN-DC in FR1 (2 CCs)	Same as 7.6.2 in TS 38.521-1 [8]	
7.6B.2.3 Inband blocking for inter-band EN-DC within FR1 (2 CCs)	Same as 7.6.2 in TS 38.521-1 [8]	
7.6B.2.3_1.1 Inband blocking for EN-DC within FR1 (3 CCs)	<u>0 dB</u>	Wanted signal power + TT Interferer signal power unchanged T-put limit unchanged
7.6B.2.3_1.2 Inband blocking for EN-DC within FR1 (4 CCs)	<u>0 dB</u>	Wanted signal power + TT Interferer signal power unchanged T-put limit unchanged
7.6B.2.3_1.3 Inband blocking for EN-DC within FR1 (5 CCs)	<u>0 dB</u>	Wanted signal power + TT Interferer signal power unchanged T-put limit unchanged
7.6B.2.4 Inband blocking for inter-band EN-DC including FR2 (1 NR CC)	Same as 7.6.2 in TS 38.521-2 [9]	
7.6B.2.4_1.1 Inband blocking for inter-band EN-DC including FR2 (2 NR CCs)	<u>0 dB</u>	Wanted signal power + TT T-put limit unchanged
7.6B.3.1 Out-of-band blocking for intra-band contiguous EN-DC in FR1 (2 CCs)	Same as 7.6.3 in TS 38.521-1 [8]	
7.6B.3.2 Out-of-band blocking for intra-band non-contiguous EN-DC in FR1 (2 CCs)	Same as 7.6.3 in TS 38.521-1 [8]	
7.6B.3.3 Out-of-band blocking for inter-band EN-DC within FR1 (2 CCs)	Same as 7.6.3 in TS 38.521-1 [8]	
7.6B.3.3_1.1 Out-of-band blocking for EN-DC within FR1 (3 CCs)	0 dB	Wanted signal power + TT Interferer signal power unchanged T-put limit unchanged
7.6B.3.3_1.2 Out-of-band blocking for EN-DC within FR1 (4 CCs)	0 dB	Wanted signal power + TT Interferer signal power unchanged T-put limit unchanged
7.6B.4.1 Narrow band blocking for intra-band contiguous EN-DC in FR1 (2 CCs)	Same as 7.6.4 in TS 38.521-1 [8]	
7.6B.4.2 Narrow band blocking for intra-band non-contiguous EN-DC in FR1 (2 CCs)	Same as 7.6.4 in TS 38.521-1 [8]	
7.6B.4.3 Narrow band blocking for inter-band EN-DC within FR1 (2 CCs)	Same as 7.6.4 in TS 38.521-1 [8]	
7.6B.4.3_1.1 Narrow band blocking for EN-DC within FR1 (3 CCs)	<u>0 dB</u>	Wanted signal power + TT Interferer signal power unchanged T-put limit unchanged
7.6B.4.3_1.2 Narrow band blocking for EN-DC within FR1 (4 CCs)	<u>0 dB</u>	Wanted signal power + TT Interferer signal power unchanged T-put limit unchanged
7.6B.4.3_1.3 Narrow band blocking for EN-DC within FR1 (5 CCs)	<u>0 dB</u>	Wanted signal power + TT Interferer signal power unchanged T-put limit unchanged
7.7B.1 Spurious Response for intra-band contiguous EN-DC in FR1 (2 CCs)	Same as 7.7 in TS 38.521-1 [8]	
7.7B.2 Spurious Response for intra-band non-contiguous EN-DC in FR1 (2 CCs)	Same as 7.7 in TS 38.521-1 [8]	

7.7B.3 Spurious Response for inter-band EN-DC within FR1 (2 CCs)	Same as 7.7 in TS 38.521-1 [8]	
7.6B.3.3_1.1 Out-of-band blocking for EN-DC within FR1 (3 CCs)	0 dB	Wanted signal power + TT Interferer signal power unchanged T-put limit unchanged
7.6B.3.3_1.2 Out-of-band blocking for EN-DC within FR1 (4 CCs)	0 dB	Wanted signal power + TT Interferer signal power unchanged T-put limit unchanged
7.8B.2.1 Wideband Intermodulation for intra-band contiguous EN-DC in FR1	Same as 7.8.2 in TS 38.521-1 [8]	
7.8B.2.2 Wideband Intermodulation for intra-band non-contiguous EN-DC in FR1	Same as 7.8.2 in TS 38.521-1 [8]	
7.8B.2.3 Wideband Intermodulation for inter-band EN-DC in FR1	Same as 7.8.2 in TS 38.521-1 [8]	
7.8B.2.3_1.1 Wideband Intermodulation for EN-DC within FR1 (3 CCs)	Same as 7.8A.2.1 in TS 38.521-1 [8]	
7.8B.2.3_1.2 Wideband Intermodulation for EN-DC within FR1 (4 CCs)	Same as 7.8A.2 in TS 38.521-1 [8]	
7.8B.2.3_1.3 Wideband Intermodulation for EN-DC within FR1 (5 CCs)	Same as 7.8A.2 in TS 38.521-1 [8]	
7.8B.2.3_1.4 Wideband Intermodulation for EN-DC within FR1 (6 CCs)	Same as 7.8A.2 in TS 38.521-1 [8]	
7.9B.1 Spurious Emissions for intra-band contiguous EN-DC within FR1 (2 CCs)	Same as 7.9 in TS 38.521-1 [8]	
7.9B.2 Spurious Emissions for intra-band non-contiguous EN-DC within FR1 (2 CCs)	Same as 7.9 in TS 38.521-1 [8]	
7.9B.3 Spurious Emissions for inter-band EN-DC within FR1 (2 CCs)	Same as 7.9 in TS 38.521-1 [8]	
7.9B.3_1.1 Spurious Emissions for EN-DC within FR1 (3 CCs)	Same as 7.9A.1 in TS 38.521-1 [8]	
7.9B.4 Spurious Emissions for inter-band EN-DC including FR2 (1 NR CC)	Same as 7.9 in TS 38.521-2 [9]	

## F.4 Uplink power window

### F.4.1 Introduction

A number of Tx and Rx Test cases set the UE uplink power to be within a defined window to ensure the test is carried out in the intended conditions. This clause gives the method for calculating the uplink power window used in Tx test cases and Rx Test cases.

## F.4.2 Setting the power window above a requirement

### F.4.2.1 NR FR1

Information from the core requirements in TS 38.101-1 [2], TS 38.213 [19] and the uncertainties in Annex F applicable to the Test case are used to derive the uplink power window. There are 4 stages:

- Find the uplink power target value.
- Determine how closely the uplink power can be set to the target value.
- Include the effect of test system uncertainty.
- Position the Uplink power window to ensure UE is not tested outside Core requirements.

This process is shown in the diagram below, using values for  $f \leq 3\text{GHz}$  and  $\text{BW} \leq 40\text{MHz}$  and taking an example where the target value is 0dBm (lower end of a UE Core requirement side condition range of  $0\text{ dBm} \leq \text{Output power} \leq 10\text{ dBm}$ ):

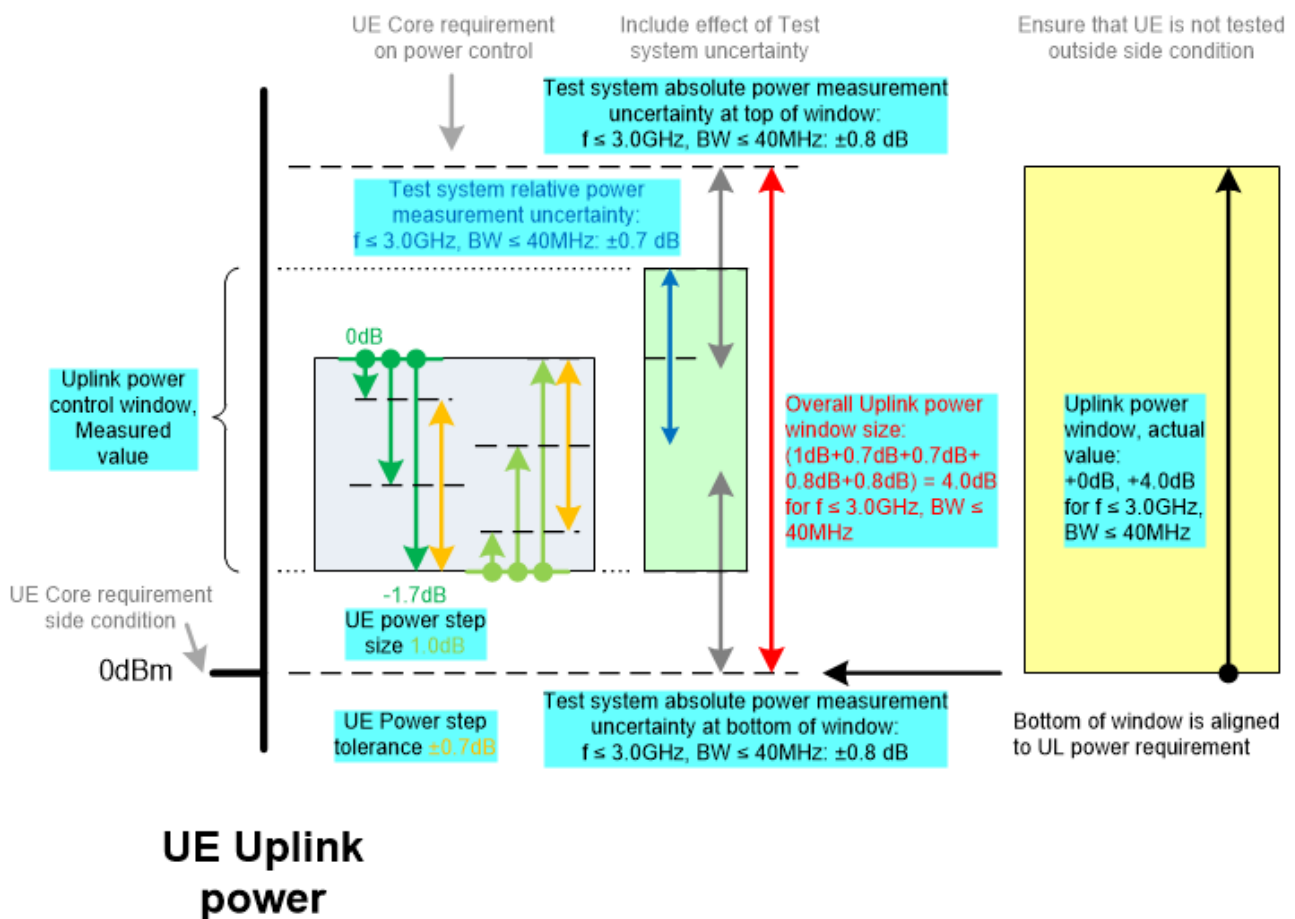

Figure F.4.2.1-1: Example NR FR1 uplink power setting to be above a requirement

The smallest UE Power step size is defined in TS 38.213 [9] Table 7.1.1-1, for absolute  $\delta_{\text{PUSCH},f,c}$ .

The UE Power step size tolerance is defined in TS 38.101-1 [2] Table 6.3.4.3-1, for PUSCH to PUSCH transitions with the allocated resource blocks fixed in frequency and no transmission gaps other than those generated by downlink subframes, DwPTS fields or Guard Periods, and for a power step  $\Delta P \leq 1\text{ dB}$ .

The Test system uncertainties are defined in Annex F of the present document.



To ensure that the actual UE uplink power is within the Uplink power window, UE uplink power measured by the test system should remain within the smaller Uplink power control window shown in Figure F.4.2.1-1.

### F.4.2.2 NR FR2

Information from the core requirements in TS 38.101-2 [3], TS 38.213 [19] and the uncertainties in Annex F applicable to the Test case are used to derive the uplink power window. There are 4 stages:

- Find the uplink power target value.
- Determine how closely the uplink power can be set to the target value.
- Include the effect of test system uncertainty.
- Position the Uplink power window to ensure UE is not tested outside Core requirements.

This process is shown in the diagram below, using values for FR2a and  $P_{MAX} \geq P > P_{int}$  and taking an example where the target value is  $P_{int}$ :

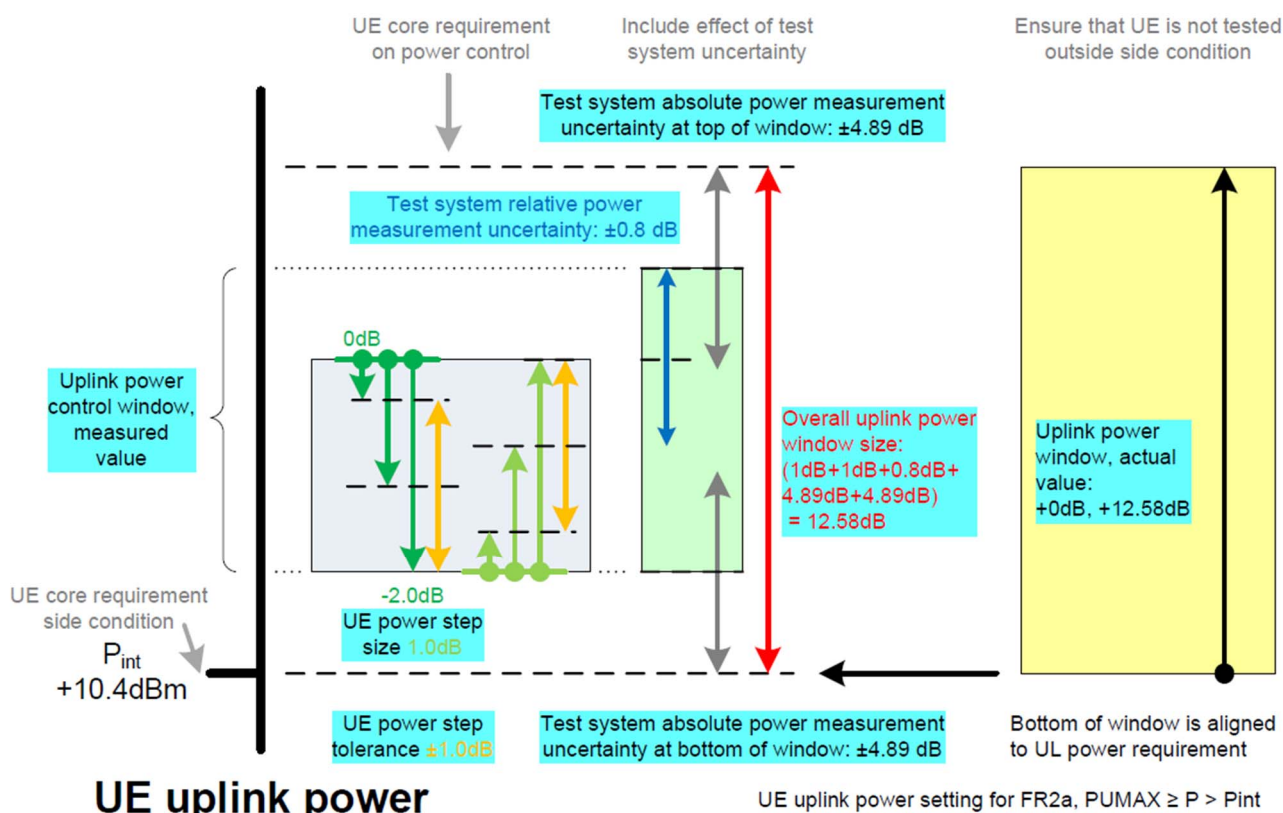

Figure F.4.2.2-1: Example NR FR2 uplink power setting to be above a requirement

The smallest UE Power step size is defined in TS 38.213 [9] Table 7.1.1-1, for absolute  $\delta_{PUSCH,f,c}$ .

The UE Power step size tolerance is defined in TS 38.101-2 [3] Table 6.3.4.3-1 and Table 6.3.4.3-2, for PUSCH to PUSCH transitions with the allocated resource blocks fixed in frequency and no transmission gaps other than those generated by downlink subframes, Guard Periods, and for a power step  $\Delta P = 1$  dB.

The Test system uncertainties are defined in Annex F of the present document.

To ensure that the actual UE uplink power is within the Uplink power window, UE uplink power measured by the test system should remain within the smaller Uplink power control window shown in Figure F.4.2.2-1.

### F.4.2.3 E-UTRA

Information from the core requirements in TS 36.101 [5], TS 36.213 [20] and the uncertainties in Annex F applicable to the Test case are used to derive the uplink power window. There are 4 stages:

- Find the uplink power target value.
- Determine how closely the uplink power can be set to the target value.
- Include the effect of test system uncertainty.
- Position the Uplink power window to ensure UE is not tested outside Core requirements.

This process is shown in the diagram below, using values for  $f \leq 3\text{GHz}$  and  $\text{BW} \leq 40\text{MHz}$  and taking an example where the target value is 0dBm (lower end of a UE Core requirement side condition range of  $0\text{ dBm} \leq \text{Output power} \leq 10\text{ dBm}$ ):

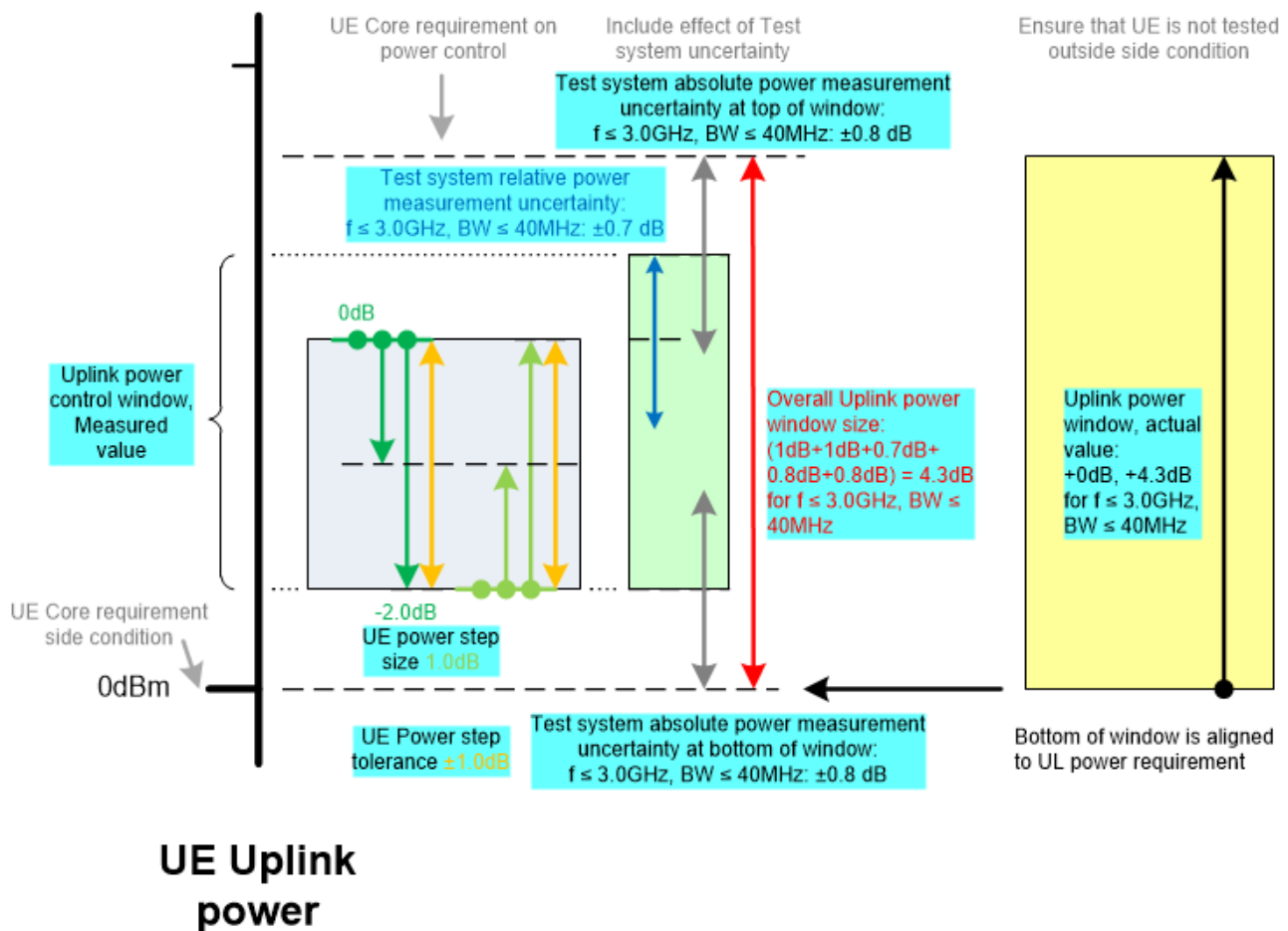

Figure F.4.2.3-1: Example E-UTRA uplink power setting to be above a requirement

The smallest UE Power step size is defined in TS 36.213 [20] Table 5.1.1.1-2, for absolute  $\delta_{\text{PUSCH}}$ .

The UE Power step size tolerance is defined in TS 36.101 [5] Table 6.3.5.2.1-1, for PUSCH to PUSCH transitions with the allocated resource blocks fixed in frequency and no transmission gaps other than those generated by downlink subframes, DwPTS fields or Guard Periods, and for a power step  $\Delta P \leq 1\text{ dB}$ .

The Test system uncertainties are defined in Annex F of the present document.

To ensure that the actual UE uplink power is within the Uplink power window, UE uplink power measured by the test system should remain within the smaller Uplink power control window shown in Figure F.4.2.3-1.

### F.4.3 Setting the power window below a requirement

#### F.4.3.1 NR FR1

Information from the core requirements in TS 38.101-1 [2], TS 38.213 [19] and the uncertainties in Annex F applicable to the Test case are used to derive the uplink power window. There are 4 stages:

- Find the uplink power target value.
- Determine how closely the uplink power can be set to the target value.
- Include the effect of test system uncertainty.
- Position the Uplink power window to ensure UE is not tested outside Core requirements.

This process is shown in the diagram below, using values for  $f \leq 3\text{GHz}$  and  $\text{BW} \leq 40\text{MHz}$  and taking an example where the target value is 4dB below PCMAX\_L (UE Core requirement side condition):

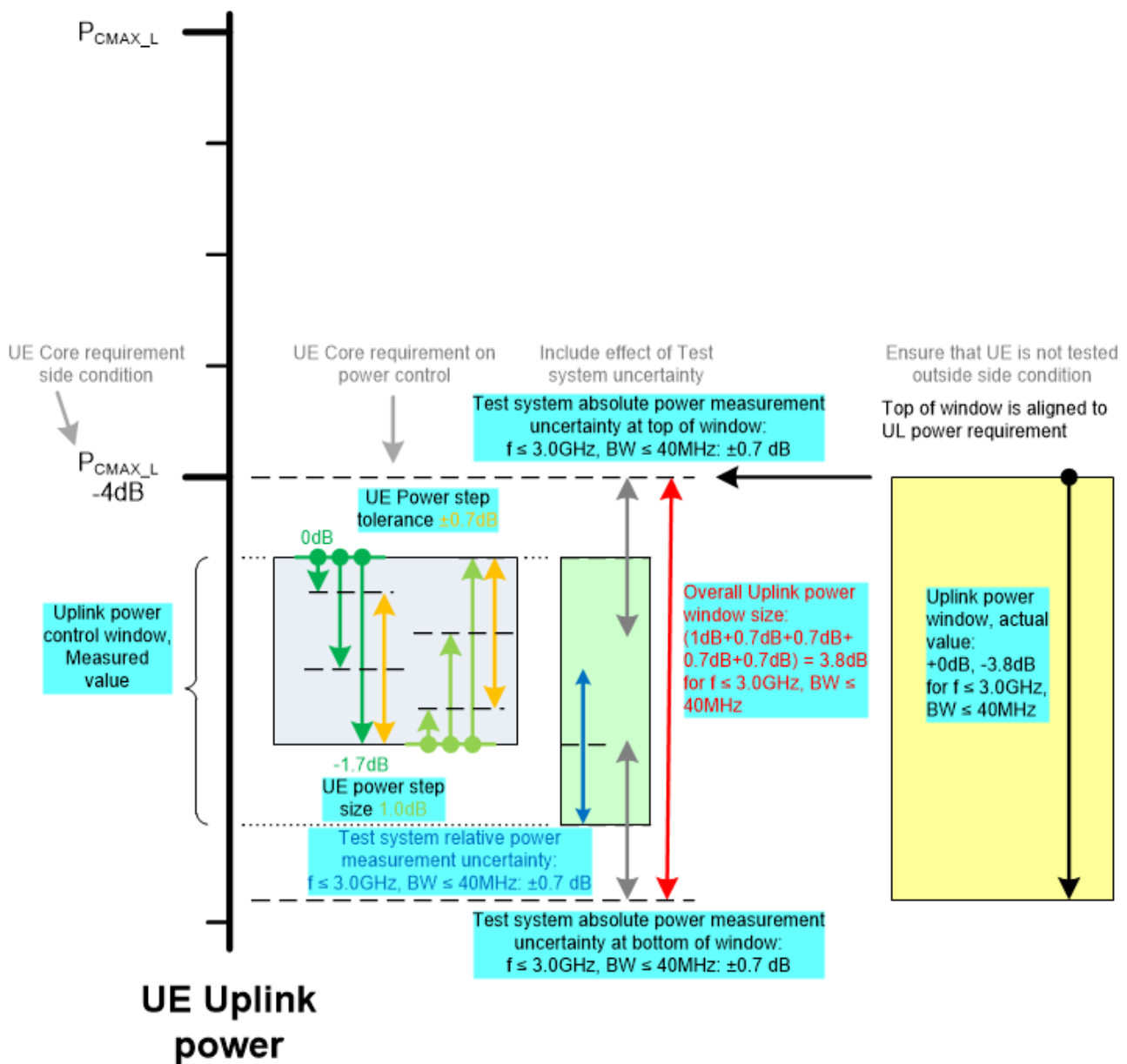

Figure F.4.3.1-1: Example NR FR1 uplink power setting to be below a requirement

The smallest UE Power step size is defined in TS 38.213 [19] Table 7.1.1-1, for absolute  $\delta_{PUSCH,f,c}$ .

The UE Power step size tolerance is defined in TS 38.101-1 [5] Table 6.3.4.3-1, for PUSCH to PUSCH transitions with the allocated resource blocks fixed in frequency and no transmission gaps other than those generated by downlink subframes, DwPTS fields or Guard Periods, and for a power step  $\Delta P \leq 1$  dB.

The Test system uncertainties are defined in Annex F of the present document.

To ensure that the actual UE uplink power is within the Uplink power window, UE uplink power measured by the test system should remain within the smaller Uplink power control window shown in Figure F.4.3.1-1.

### F.4.3.2 NR FR2

Information from the core requirements in TS 38.101-2 [3], TS 38.213 [19] and the uncertainties in Annex F applicable to the Test case are used to derive the uplink power window. There are 4 stages:

- Find the uplink power target value.
- Determine how closely the uplink power can be set to the target value.
- Include the effect of test system uncertainty.
- Position the Uplink power window to ensure UE is not tested outside Core requirements.

This process is shown in the diagram below, using values for FR2a and  $P_{UMAX} \geq P > P_{int}$  and taking an example where the target value is  $P_{UMAX}$ :

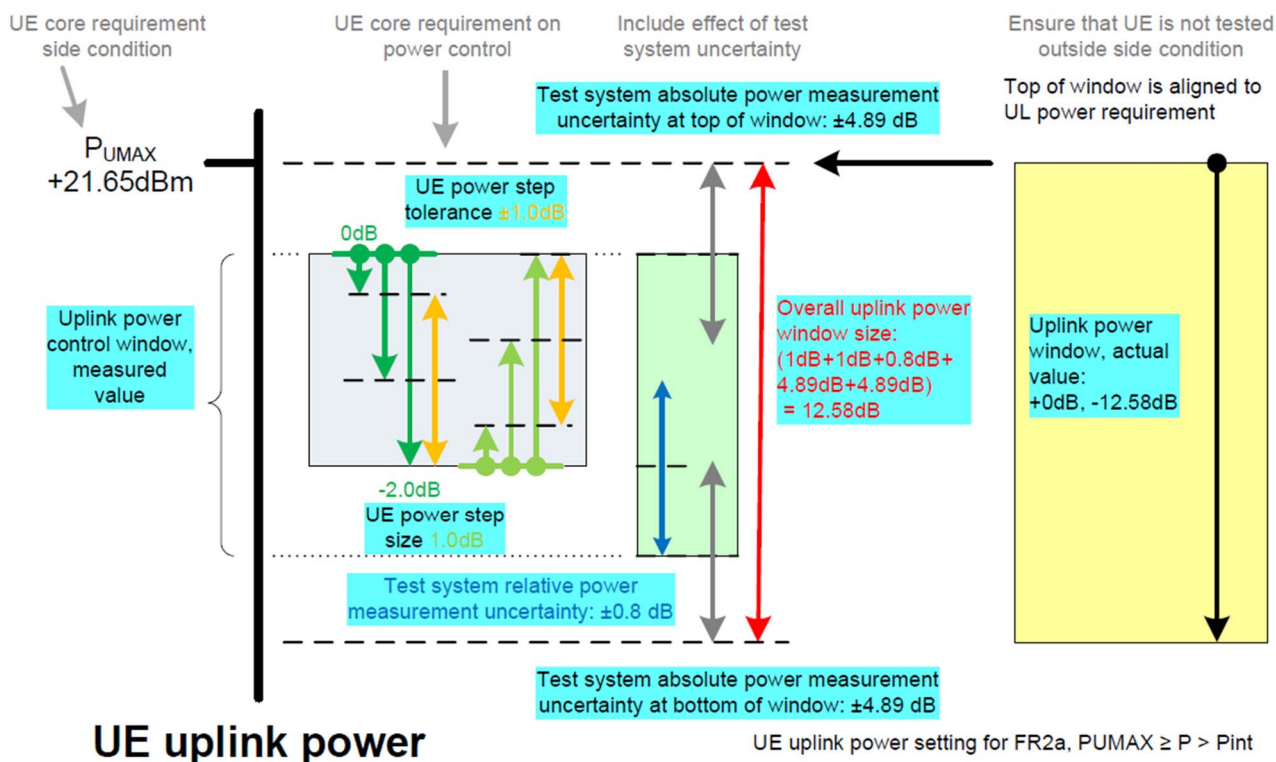

Figure F.4.3.2-1: Example NR FR2 uplink power setting to be below a requirement

The smallest UE Power step size is defined in TS 38.213 [19] Table 7.1.1-1, for absolute  $\delta_{PUSCH,f,c}$ .

The UE Power step size tolerance is defined in TS 38.101-1 [3] Table 6.3.4.3-1 and Table 6.3.4.3-2, for PUSCH to PUSCH transitions with the allocated resource blocks fixed in frequency and no transmission gaps other than those generated by downlink subframes, Guard Periods, and for a power step  $\Delta P = 1$  dB.

The Test system uncertainties are defined in Annex F of the present document.

To ensure that the actual UE uplink power is within the Uplink power window, UE uplink power measured by the test system should remain within the smaller Uplink power control window shown in Figure F.4.3.2-1.

### F.4.3.3 E-UTRA

Information from the core requirements in TS 36.101 [5], TS 36.213 [20] and the uncertainties in Annex F applicable to the Test case are used to derive the uplink power window. There are 4 stages:

- Find the uplink power target value.
- Determine how closely the uplink power can be set to the target value.
- Include the effect of test system uncertainty.
- Position the Uplink power window to ensure UE is not tested outside Core requirements.

This process is shown in the diagram below, using values for  $f \leq 3\text{GHz}$  and  $\text{BW} \leq 40\text{MHz}$  and taking an example where the target value is 4dB below  $P_{\text{CMAX\_L}}$  (UE Core requirement side condition):

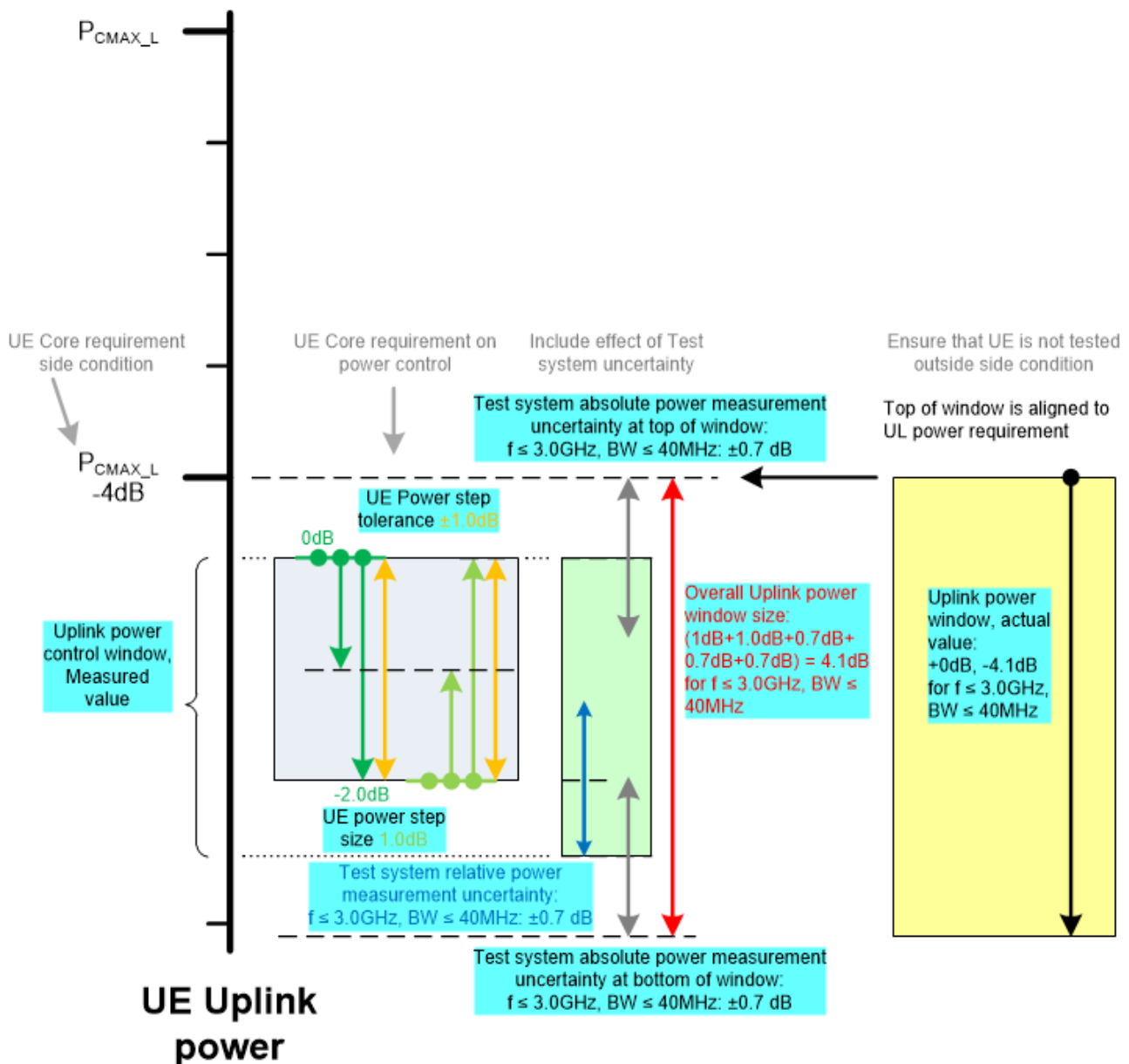

Figure F.4.3.3-1: Example E-UTRA uplink power setting to be below a requirement

The smallest UE Power step size is defined in TS 36.213 [20] Table 5.1.1.1-2, for absolute  $\delta_{\text{PUSCH}}$ .

The UE Power step size tolerance is defined in TS 36.101 [5] Table 6.3.5.2.1-1, for PUSCH to PUSCH transitions with the allocated resource blocks fixed in frequency and no transmission gaps other than those generated by downlink subframes, DwPTS fields or Guard Periods, and for a power step  $\Delta P \leq 1$  dB.

The Test system uncertainties are defined in Annex F of the present document.

To ensure that the actual UE uplink power is within the Uplink power window, UE uplink power measured by the test system should remain within the smaller Uplink power control window shown in Figure F.4.3.3-1.

## F.4.4 Setting the power window centred on a target value

### F.4.4.1 NR FR1

Information from the core requirements in TS 38.101-1 [2], TS 38.213 [19] and the uncertainties in Annex F applicable to the Test case are used to derive the uplink power window. There are 4 stages:

- Find the uplink power target value.
- Determine how closely the uplink power can be set to the target value.
- Include the effect of test system uncertainty.
- Position the Uplink power window centred on the target value.

This process is shown in the diagram below, using values for  $f \leq 3\text{GHz}$  and  $\text{BW} \leq 40\text{MHz}$  and taking an example where the target value is +10dBm:



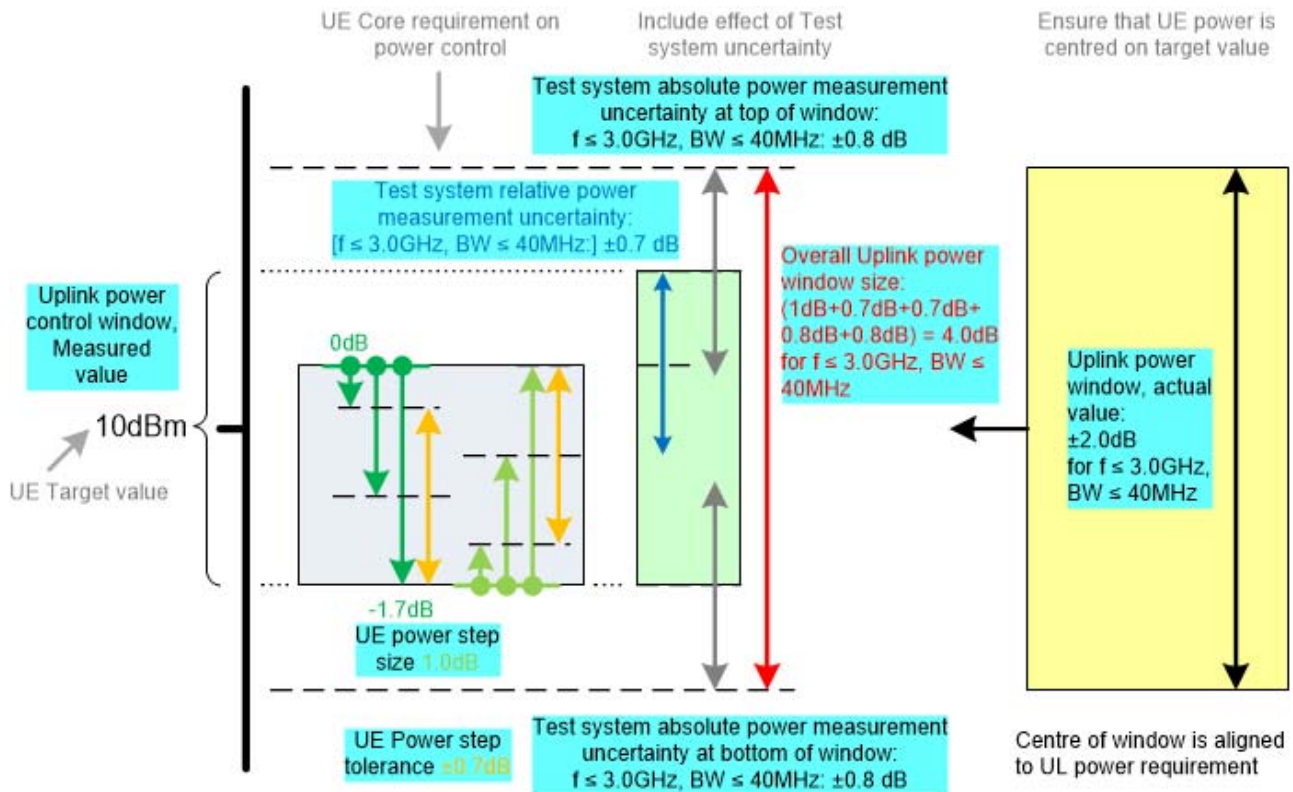

## UE Uplink power

Figure F.4.4.1-1: Example NR FR1 uplink power setting centred on a target value

The smallest UE Power step size is defined in TS 38.213 [9] Table 7.1.1-1, for absolute  $\delta_{\text{PUSCH},f,c}$ .

The UE Power step size tolerance is defined in TS 38.101-1 [2] Table 6.3.4.3-1, for PUSCH to PUSCH transitions with the allocated resource blocks fixed in frequency and no transmission gaps other than those generated by downlink subframes, DwPTS fields or Guard Periods, and for a power step  $\Delta P \leq 1\text{ dB}$ .

The Test system uncertainties are defined in Annex F of the present document.

To ensure that the actual UE uplink power is centred on the target value, UE uplink power measured by the test system should remain within the smaller Uplink power control window shown in Figure F.4.4.1-1.

### F.4.4.2 NR FR2

Information from the core requirements in TS 38.101-2 [3], TS 38.213 [19] and the uncertainties in Annex F applicable to the Test case are used to derive the uplink power window. There are 4 stages:

- Find the uplink power target value.
- Determine how closely the uplink power can be set to the target value.
- Include the effect of test system uncertainty.
- Position the Uplink power window centred on the target value.

This process is shown in the diagram below, using values for FR2a and  $P_{\text{UMAX}} \geq P > P_{\text{int}}$  and taking an example where the target value is +15dBm:

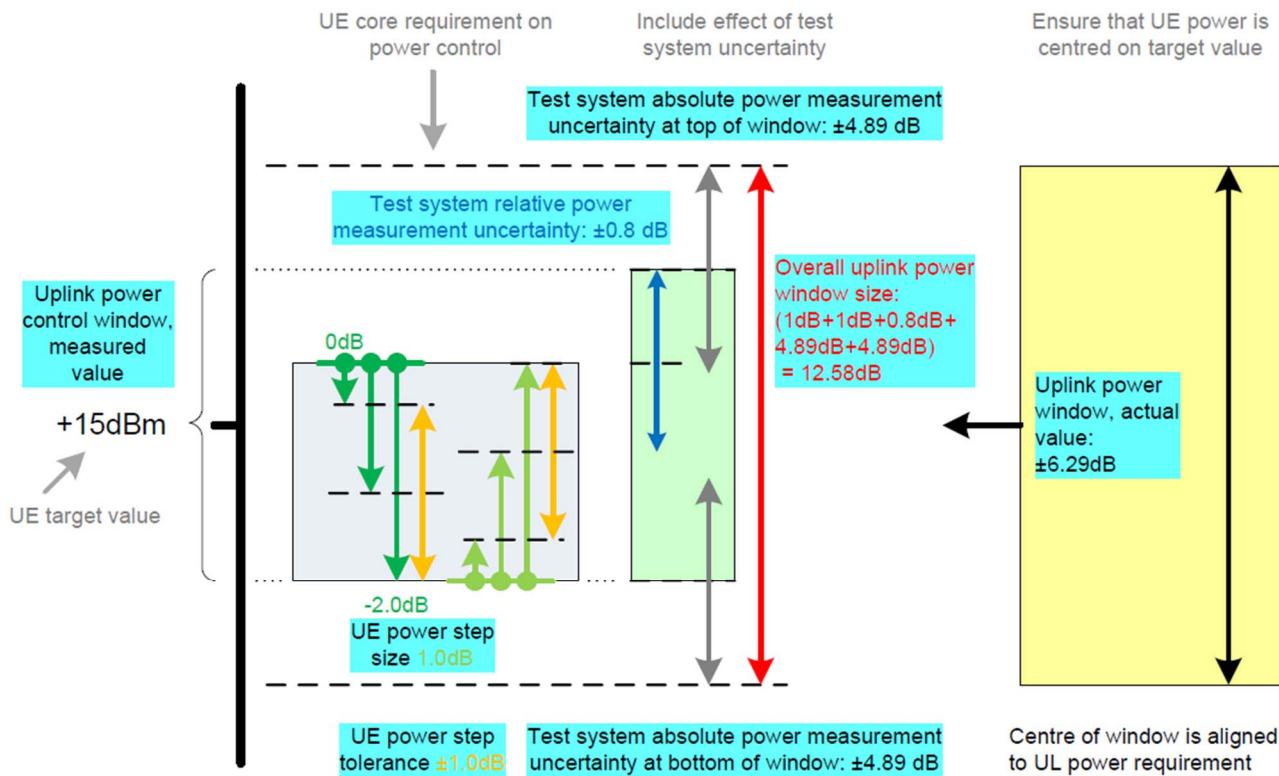

## UE uplink power

UE uplink power setting for FR2a,  $P_{UMAX} \geq P > P_{int}$

Figure F.4.4.2-1: Example NR FR2 uplink power setting centred on a target value

The smallest UE Power step size is defined in TS 38.213 [9] Table 7.1.1-1, for absolute  $\delta_{PUSCH,f,c}$ .

The UE Power step size tolerance is defined in TS 38.101-2 [3] Table 6.3.4.3-1 and Table 6.3.4.3-2, for PUSCH to PUSCH transitions with the allocated resource blocks fixed in frequency and no transmission gaps other than those generated by downlink subframes, Guard Periods, and for a power step  $\Delta P = 1$  dB.

The Test system uncertainties are defined in Annex F of the present document.

To ensure that the actual UE uplink power is centred on the target value, UE uplink power measured by the test system should remain within the smaller Uplink power control window shown in Figure F.4.4.2-1.

### F.4.4.3 E-UTRA

Information from the core requirements in TS 36.101 [5], TS 36.213 [20] and the uncertainties in Annex F applicable to the Test case are used to derive the uplink power window. There are 4 stages:

- Find the uplink power target value.
- Determine how closely the uplink power can be set to the target value.
- Include the effect of test system uncertainty.
- Position the Uplink power window centred on the target value.

This process is shown in the diagram below, using values for  $f \leq 3$ GHz and  $BW \leq 40$ MHz and taking an example where the target value is -10dBm:



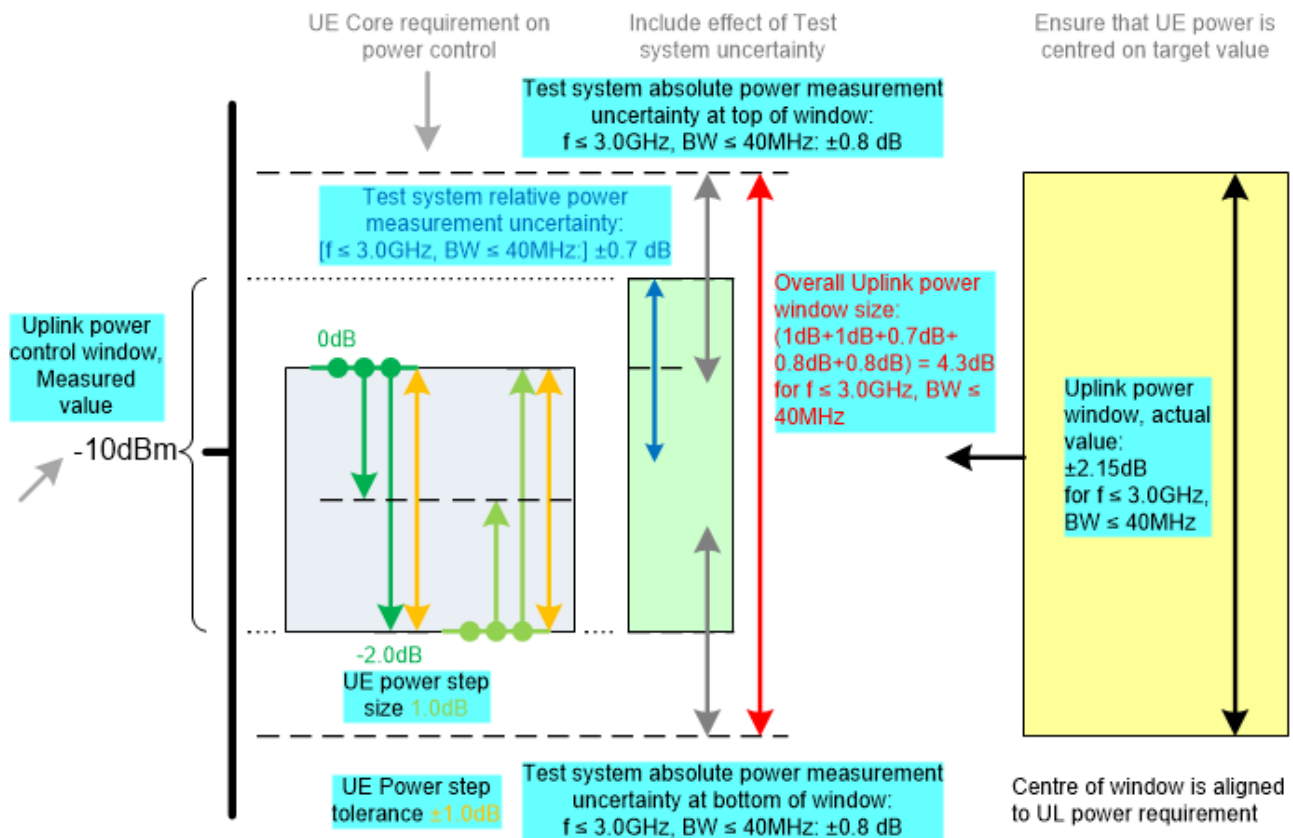

## UE Uplink power

Figure F.4.4.3-1: Example E-UTRA uplink power setting centred on a target value

The smallest UE Power step size is defined in TS 36.213 [20] Table 5.1.1.1-2, for absolute  $\delta_{\text{PUSCH}}$ .

The UE Power step size tolerance is defined in TS 36.101 [5] Table 6.3.5.2.1-1, for PUSCH to PUSCH transitions with the allocated resource blocks fixed in frequency and no transmission gaps other than those generated by downlink subframes, DwPTS fields or Guard Periods, and for a power step  $\Delta P \leq 1$  dB.

The Test system uncertainties are defined in Annex F of the present document.

To ensure that the actual UE uplink power is centred on the target value, UE uplink power measured by the test system should remain within the smaller Uplink power control window shown in Figure F.4.4.3-1.

---

## Annex G (normative): Uplink Physical Channels

Please refer to Annex G in TS 38.521-1 [8] and TS 38.521-2 [9] for appropriate details as needed for test cases in this test specification. EN-DC exceptions will be added,

---

# Annex H (normative): Statistical Testing

## Editor's Note:

- Further investigate the technical details behind this statistical method to ensure that this is applicable for FR2 radiated test cases.

## H.1 General

This annex specifies mapping throughput to error ratio, pass fail limits and pass fail decision rules that are needed for measuring average throughput for a duration sufficient to achieve statistical significance for testing receiver characteristics.

## H.2 Statistical testing of receiver characteristics

### H.2.1 General

The test of receiver characteristics is twofold.

1. A signal or a combination of signals is offered to the RX port(s) of the receiver.
2. The ability of the receiver to demodulate /decode this signal is verified by measuring the throughput.

In (2) is the statistical aspect of the test and is treated here.

The minimum requirement for all receiver tests is >95% of the maximum throughput.

All receiver tests are performed in static propagation conditions. No fading conditions are applied.

### H.2.2 Mapping throughput to error ratio

- a) The measured information bit throughput  $R$  is defined as the sum (in kilobits) of the information bit payloads successfully received during the test interval, divided by the duration of the test interval (in seconds).
- b) In measurement practice the UE indicates successfully received information bit payload by signalling an ACK to the SS.  
If payload is received, but damaged and cannot be decoded, the UE signals a NACK.
- c) Only the ACK and NACK signals, not the data bits received, are accessible to the SS.  
The number of bits is known in the SS from knowledge of what payload was sent.
- d) For the reference measurement channel, applied for testing, the number of bits is different in different slots, however in a radio frame it is fixed during one test.
- e) The time in the measurement interval is composed of successfully received slots (ACK), unsuccessfully received slots (NACK) and no reception at all (DTX-slots).
- f) DTX-slots may occur regularly according the applicable reference measurement channel (regDTX).  
In real live networks this is the time when other UEs are served. In TDD these are the UL and special slots.  
regDTX vary from test to test but are fixed within the test.
- g) Additional DTX-slots occur statistically when the UE is not responding ACK or NACK where it should.  
(statDTX)  
This may happen when the UE was not expecting data or decided that the data were not intended for it.

The pass / fail decision is done by observing the:

- number of NACKs

- number of ACKs and
- number of statDTXs (regDTX is implicitly known to the SS)

The ratio  $(NACK + statDTX) / (NACK + statDTX + ACK)$  is the Error Ratio (ER). Taking into account the time consumed by the ACK, NACK, and DTX-TTIs (regular and statistical), ER can be mapped unambiguously to throughput for any single reference measurement channel test.

### H.2.3 Design of the test

The test is defined by the following design principles (see clause H.x, Theory...):

1. The early decision concept is applied.
2. A second limit is introduced: Bad DUT factor  $M > 1$
3. To decide the test pass:
  - Supplier risk is applied based on the Bad DUT quality
  - To decide the test fail
  - Customer Risk is applied based on the specified DUT quality

The test is defined by the following parameters:

1. Limit ER = 0.05 (Throughput limit = 95%)
2. Bad DUT factor  $M = 1.5$  (selectivity)
3. Confidence level CL = 95% (for specified DUT and Bad DUT-quality)

## H.2.4 Numerical definition of the pass fail limits

Table H.2.4-1: pass fail limits

ne	ns <sub>p</sub>	ns <sub>f</sub>	ne	ns <sub>p</sub>	ns <sub>f</sub>	ne	ns <sub>p</sub>	ns <sub>f</sub>	ne	ns <sub>p</sub>	ns <sub>f</sub>
0	67	NA	39	763	500	78	1366	1148	117	1951	1828
1	95	NA	40	778	516	79	1381	1166	118	1965	1845
2	119	NA	41	794	532	80	1396	1183	119	1980	1863
3	141	NA	42	810	548	81	1412	1200	120	1995	1881
4	162	NA	43	826	564	82	1427	1217	121	2010	1899
5	183	NA	44	842	580	83	1442	1234	122	2025	1916
6	202	NA	45	858	596	84	1457	1252	123	2039	1934
7	222	NA	46	873	612	85	1472	1269	124	2054	1952
8	241	NA	47	889	629	86	1487	1286	125	2069	1969
9	259	NA	48	905	645	87	1502	1303	126	2084	1987
10	278	76	49	920	661	88	1517	1321	127	2099	2005
11	296	88	50	936	678	89	1532	1338	128	2113	2023
12	314	100	51	952	694	90	1547	1355	129	2128	2040
13	332	113	52	967	711	91	1562	1373	130	2143	2058
14	349	126	53	983	727	92	1577	1390	131	2158	2076
15	367	140	54	998	744	93	1592	1407	132	2172	2094
16	384	153	55	1014	760	94	1607	1425	133	2187	2111
17	401	167	56	1029	777	95	1623	1442	134	2202	2129
18	418	181	57	1045	793	96	1637	1459	135	2217	2147
19	435	195	58	1060	810	97	1652	1477	136	2231	2165
20	452	209	59	1076	827	98	1667	1494	137	2246	2183
21	469	224	60	1091	844	99	1682	1512	138	2261	2201
22	486	238	61	1106	860	100	1697	1529	139	2275	2218
23	503	253	62	1122	877	101	1712	1547	140	2290	2236
24	519	268	63	1137	894	102	1727	1564	141	2305	2254
25	536	283	64	1153	911	103	1742	1582	142	2320	2272
26	552	298	65	1168	928	104	1757	1599	143	2334	2290
27	569	313	66	1183	944	105	1772	1617	144	2349	2308
28	585	328	67	1199	961	106	1787	1634	145	2364	2326
29	602	343	68	1214	978	107	1802	1652	146	2378	2344
30	618	359	69	1229	995	108	1817	1669	147	2393	2361
31	634	374	70	1244	1012	109	1832	1687	148	2408	2379
32	650	389	71	1260	1029	110	1847	1704	149	2422	2397
33	667	405	72	1275	1046	111	1861	1722	150	2437	2415
34	683	421	73	1290	1063	112	1876	1740	151	2452	2433
35	699	436	74	1305	1080	113	1891	1757	152	2466	2451
36	715	452	75	1321	1097	114	1906	1775	153*)	NA	2469
37	731	468	76	1336	1114	115	1921	1793			
38	747	484	77	1351	1131	116	1936	1810	*) note 2 in H.2.5		

NOTE 1: The first column is the number of errors (ne = number of NACK + statDTX)

NOTE 2: The second column is the number of samples for the pass limit (ns<sub>p</sub>, ns=Number of Samples= number of NACK + statDTX + ACK)

NOTE 3: The third column is the number of samples for the fail limit (ns<sub>f</sub>)

## H.2.5 Pass fail decision rules

The pass fail decision rules apply for a single test, comprising one component in the test vector. The over all Pass /Fail conditions are defined in clause H.2.6 and H.2A.6

Having observed 0 errors, pass the test at 67+ samples, otherwise continue

Having observed 1 error, pass the test at 95+ otherwise continue

Having observed 2 errors, pass the test at 119+ samples, fail the test at 2- samples, otherwise continue

Etc. etc.

Having observed 151 errors, pass the test at 2452+ samples, fail the test at 2433- samples, otherwise continue

Having observed 152 errors, pass the test at 2466+ samples, fail the test at 2451- samples.

Where x+ means: x or more, x- means x or less

NOTE 1: an ideal DUT passes after 67 samples. The maximum test time is 2466 samples.

NOTE 2: It is allowed to deviate from the early decision concept by postponing the decision (pass/fail or continue). Postponing the decision to or beyond the end of Table H.2.4-1 requires a pass fail decision against the test limit: pass the DUT for  $ER < 0.0618$ , otherwise fail.

Annex I (normative):  
Void

---

## Annex J (normative): Test applicability per permitted test method

Please refer to Annex J in TS 38.521-1 [8] and 38.521-2 [9] for appropriate details as needed for test cases in this test specification. Exceptions for EN-DC may be added as needed.



---

## Annex K (normative): EIRP, TRP, and EIS measurement procedures

Please refer to Annex K in 38.521-2 [9] for appropriate details as needed for test cases in this test specification. Exceptions for EN-DC may be added as needed.

Annex L (normative):  
Void

## Annex M (normative): Dual uplink interferer

UE is mandated to support operation in dual and triple uplink mode for EN-DC configuration in NR FR1 listed in Table 5.5B.2-1, Table 5.5B.3-1, and Table 5.5B.4.1-1 and indicated by column single uplink allowed, Table 7.3B.2.0.3.5.1-1, Table 7.3B.2.0.3.5.2-0, Table 7.3B.2.0.3.5.2-1 or NE-DC configuration in NR FR1 listed in Table 5.5B.4a.1-1 and indicated by column single uplink allowed if the intermodulation products caused by the dual uplink operation do not interfere with its own primary downlink transmission channel bandwidth. For intermodulation products falling into LTE secondary downlink channel bandwidth, UE single UL capability is not considered.

Formula for determining if the EN-DC in NR FR1 configuration with dual uplink operation interferes with its own downlink reception.

Interference bandwidth:  $IBW = |a| * CBW1 + |b| * CBW2$

- $|a| + |b| = 2$  (or 3)
- CBW1 and CBW2 are the transmission bandwidth configurations of the UL channels

Center frequency of IBW:  $f_{IBW} = |a * f1 + b * f2|$

- f1 and f2 are center frequency of the transmission bandwidth configurations of each UL channel

The range of IMD 2 (or 3):  $[f_{IBW} - IBW/2, f_{IBW} + IBW/2]$

NOTE 1: UE shall be able to apply operations which are configured by RRC reconfiguration and corresponding HARQ timing on the transmission bandwidth.

NOTE 2: For identified difficult band combination, during two adjacent RRC reconfiguration, the changing of transmission bandwidth should not introduce IM2 and IM3, which will result in UE changing from 2Tx to 1Tx. Otherwise, UE behavior is not specified.

For DC\_3A\_n3A intra-band non-contiguous EN-DC combination, only single switched UL is supported in Rel-15.

For DC\_2A\_n2A, DC\_66A\_n66A intra-band non-contiguous EN-DC combination, only single switched UL is supported.

---

## Annex N (normative): Modified MPR behaviour

The definitions of the bits in the modifiedMPRbehavior field have been moved to Annex I of TS 38.521-1 [8] noting there are only few cases with explicit definitions for EN-DC configurations.

## Annex O (informative): Change history

Change history							
Date	Meeting	TDoc	CR	R ev	Cat	Subject/Comment	New version
2017-08	RAN5#76	R5-174710	-	-	-	Draft skeleton	0.0.1
2018-01	RAN5#1-5G-NR Adhoc	R5-180086	-	-	-	TP to add clause 6.2B.3.3 UE A-MPR intra-band EN-DC to 38.521-3	0.1.0
2018-01	RAN5#1-5G-NR Adhoc	R5-180087	-	-	-	TP to add clause 6.5B.2.1.2 Additional Spectrum emissions mask (contiguous sub-blocks) for intra-band EN-DC to 38.521-3	0.1.0
2018-02	RAN5#78	R5-181509	-	-	-	Updated 38.521-3 for new Annex A Dual uplink interferer information	0.2.0
2018-02	RAN5#78	R5-181690	-	-	-	Updated 38.521-3 for channel bandwidth information	0.2.0
2018-03	RAN5#2-5G-NR Adhoc	R5-181760	-	-	-	Draft TS 38.521-3 0.3.0	0.3.0
2018-04	RAN5#2-5G-NR Adhoc	R5-182035	-	-	-	5G-NR Text Proposal to add spurious emissions test case to 38.521-3	0.4.0
2018-04	RAN5#2-5G-NR Adhoc	R5-182016	-	-	-	TP for new test case: 6.5B.2.1.3, Adjacent channel leakage ratio for intra-band contiguous EN-DC	0.4.0
2018-04	RAN5#2-5G-NR Adhoc	R5-182017	-	-	-	TP to update clause 6.2B.3.1 UE A-MPR intra-band EN-DC to 38.521-3	0.4.0
2018-04	RAN5#2-5G-NR Adhoc	R5-182018	-	-	-	TP to update clause 6.5B.2.1.2 Additional spectrum emission mask to 38.521-3	0.4.0
2018-04	RAN5#2-5G-NR Adhoc	R5-181807	-	-	-	Update to Operating bands of 38.521-3	0.4.0
2018-04	RAN5#2-5G-NR Adhoc	R5-181808	-	-	-	Update to clause 3 and clause 4 of 38.521-3	0.4.0
2018-04	RAN5#2-5G-NR Adhoc	R5-181828	-	-	-	Updated 38.521-3 for channel bandwidth information with new structure	0.4.0
2018-07	RAN5#79	R5-183961	-	-	-	5G_FR1_EN_DC_RF_sensitivity_for_DC	0.5.0
2018-07	RAN5#79	R5-183962	-	-	-	Introduction of TC 6.2B.1.3 for EN-DC	0.5.0
2018-07	RAN5#79	R5-183949	-	-	-	Statistical Testing Annex for 38.521-3	0.5.0
2018-07	RAN5#79	<a href="#">R5-182995</a>	-	-	-	Corrections annex for EIRP and TRP metric definition in TS 38.521-3	0.5.0
2018-07	RAN5#79	<a href="#">R5-183707</a>	-	-	-	TP for updating test case 6.2B.2.1, UE Maximum Output Power reduction for Intra-Band Contiguous EN-DC	0.5.0
2018-07	RAN5#79	<a href="#">R5-183708</a>	-	-	-	Updated clause 5.5B Configuration for DC to 38.521-3	0.5.0
2018-07	RAN5#79	<a href="#">R5-183709</a>	-	-	-	TP to add Occupied BW EN-DC test case	0.5.0
2018-07	RAN5#79	<a href="#">R5-183710</a>	-	-	-	TP to add SEM EN-DC test case	0.5.0
2018-07	RAN5#79	<a href="#">R5-183711</a>	-	-	-	TP to add ACLR EN-DC test case	0.5.0
2018-09	RAN5#80	<a href="#">R5-185563</a>	-	-	-	FR2_StoreTxRxBeamPeakCoordinates_38.521-3	1.0.0
2018-09	RAN5#80	R5-185520	-	-	-	Addition of TRx MU and TT in TS 38.521-3 Annex	1.0.0
2018-09	RAN5#80	R5-185503	-	-	-	Add Clause 7.5B.1 into TS 38.521-3	1.0.0
2018-09	RAN5#80	R5-185504	-	-	-	Add Clause 7.5B.2 into TS 38.521-3	1.0.0
2018-09	RAN5#80	R5-185505	-	-	-	Add Clause 7.5B.3 into TS 38.521-3	1.0.0
2018-09	RAN5#80	<a href="#">R5-184579</a>	-	-	-	Updated EN-DC configuration information in clause 5	1.0.0
2018-09	RAN5#80	<a href="#">R5-184580</a>	-	-	-	TIB value add for EN-DC band in 38.521-3	1.0.0
2018-09	RAN5#80	<a href="#">R5-184671</a>	-	-	-	Update of References in clause 2 of 38.521-3 spec	1.0.0
2018-09	RAN5#80	<a href="#">R5-184672</a>	-	-	-	Updates to Operating Bands in clause 5.2	1.0.0
2018-09	RAN5#80	<a href="#">R5-184737</a>	-	-	-	Dual uplink interferer updated to 38.521-3	1.0.0
2018-09	RAN5#80	<a href="#">R5-184737</a>	-	-	-	Dual uplink interferer updated to 38.521-3	1.0.0
2018-09	RAN5#80	<a href="#">R5-185332</a>	-	-	-	Addition of 6.2B.4.1.1 Configured OP for Intra-Band Contiguous EN-DC	1.0.0
2018-09	RAN5#80	<a href="#">R5-185333</a>	-	-	-	Addition of 6.2B.4.1.2 Configured OP for Intra-Band Non-Contiguous EN-DC	1.0.0
2018-09	RAN5#80	<a href="#">R5-185507</a>	-	-	-	Addition of 6.2B.4.1.3 Configured OP for Inter-Band within FR1	1.0.0
2018-09	RAN5#80	R5-185198	-	-	-	Addition of 6.2B.4.1.4 Configured OP for Inter-Band EN-DC including FR2	1.0.0
2018-09	RAN5#80	R5-185199	-	-	-	Addition of 6.2B.4.1.5 Configured OP for Inter-Band EN-DC including both FR1 and FR2	1.0.0
2018-09	RAN5#80	R5-185469	-	-	-	TP for updating test case 6.2B.3.1 UE AMPR for Intra-band contiguous EN-DC	1.0.0
2018-09	RAN5#80	R5-185470	-	-	-	TP for updating test case 6.2B.3.2 UE AMPR for Intra-band non-contiguous EN-DC	1.0.0
2018-09	RAN5#80	R5-185200	-	-	-	TP for updating test case 6.5B.2.1.2 Additional spectrum emission mask for intra-band contiguous EN-DC	1.0.0

2018-09	RAN5#80	<a href="#">R5-185556</a>	-	-	-	FR2_UE_BeamlockInvoke_38.521-3	1.0.0
2018-09	RAN5#80	<a href="#">R5-185472</a>	-	-	-	Update of TC 6.2B.1.1	1.0.0
2018-09	RAN5#80	<a href="#">R5-185473</a>	-	-	-	Introduction of TC 6.2B.1.2	1.0.0
2018-09	RAN5#80	<a href="#">R5-185474</a>	-	-	-	Update of 6.2B.1.3	1.0.0
2018-09	RAN5#80	R5-185201	-	-	-	Introduction of TC 7.4B.1	1.0.0
2018-09	RAN5#80	R5-185202	-	-	-	Introduction of 7.4B.2	1.0.0
2018-09	RAN5#80	R5-185203	-	-	-	Introduction of 7.4B.3	1.0.0
2018-09	RAN5#80	<a href="#">R5-185479</a>	-	-	-	Update Occupied Bandwidth for interband EN-DC within FR1	1.0.0
2018-09	RAN5#80	<a href="#">R5-185480</a>	-	-	-	Update SEM interband EN-DC within FR1	1.0.0
2018-09	RAN5#80	<a href="#">R5-185481</a>	-	-	-	Update ACLR for interband EN-DC within FR1	1.0.0
2018-09	RAN5#80	R5-185204	-	-	-	5G NR_EN_DC with FR1_Text update for RX sensitivity	1.0.0
2018-09	RAN5#80	R5-185205	-	-	-	5G NR_EN_DC with FR1_Text_proposal for_TX_Spurious_emission	1.0.0
2018-09	RAN5#80	<a href="#">R5-185422</a>	-	-	-	Alignment of Annex numbering with core spec	1.0.0
2018-09	RAN5#80	<a href="#">R5-184897</a>	-	-	-	Updates to Channel Arrangement clause in 38.521-3	1.0.0
2018-09	RAN5#80	R5-185206	-	-	-	Addition of TC6.3B.1.1 Minimum Output power for intra-band contiguous EN-DC	1.0.0
2018-09	RAN5#80	R5-185207	-	-	-	Addition of TC6.3B.1.2 Minimum output power for intra-band non-contiguous EN-DC	1.0.0
2018-09	RAN5#80	R5-185208	-	-	-	Addition of TC6.3B.1.3 Minimum output power for inter-band EN-DC within FR1	1.0.0
2018-09	RAN5#80	<a href="#">R5-185351</a>	-	-	-	Update across EN-DC RF test cases in TS 38.521-3	1.0.0
2018-09	RAN#81	-	-	-	-	raised to v15.0.0 with editorial changes only	15.0.0
2018-12	RAN#82	R5-186503	0033	-	F	FR2 Spurious Emission test case updates	15.1.0
2018-12	RAN#82	R5-186506	0034	-	F	Update Text on Store Beam Peak Coordinate	15.1.0
2018-12	RAN#82	R5-186507	0035	-	F	38.521-3 Applicability Rules	15.1.0
2018-12	RAN#82	R5-186601	0039	-	F	5G NR_EN_DC with FR1_Text update for Intra-Band Contiguous RX sensitivity	15.1.0
2018-12	RAN#82	R5-186602	0040	-	F	5G NR_Text update for TX spurious emission intra-band contiguous EN-DC	15.1.0
2018-12	RAN#82	R5-186608	0042	-	F	Spurious emission band UE co-existence for Inter-band EN-DC within FR1	15.1.0
2018-12	RAN#82	R5-186672	0044	-	F	Updating test case 6.2B.3.1 Additional Maximum Output Power reduction for Intra-band contiguous EN-DC	15.1.0
2018-12	RAN#82	R5-186673	0045	-	F	Updating test case 6.5B.2.1.2 Additional spectrum emissions mask for intra-band contiguous EN-DC	15.1.0
2018-12	RAN#82	R5-186681	0046	-	F	Updates to EN-DC test case 6.2B.2.1, UE Maximum Output Power reduction for Intra-Band Contiguous EN-DC	15.1.0
2018-12	RAN#82	R5-186684	0047	-	F	Updates to test case 6.2B.2.3, UE Maximum Output Power reduction for Inter-Band EN-DC within FR1	15.1.0
2018-12	RAN#82	R5-186788	0049	-	F	Minor update OBW, SEM and ACLR inter-band FR1 test cases	15.1.0
2018-12	RAN#82	R5-187153	0061	-	F	Updated EN-DC configuration information in clause 5	15.1.0
2018-12	RAN#82	R5-187371	0076	-	F	Addition of TC6.3B.2.1 Transmit OFF Power for intra-band contiguous EN-DC	15.1.0
2018-12	RAN#82	R5-187372	0077	-	F	Addition of TC6.3B.2.3 Transmit OFF Power for inter-band EN-DC within FR1	15.1.0
2018-12	RAN#82	R5-187373	0078	-	F	Addition of TC6.3B.2.2 Transmit OFF Power for intra-band non-contiguous EN-DC	15.1.0
2018-12	RAN#82	R5-187552	0083	-	F	Updates to TS 38.521-3 common sections 1-4 to align with core spec	15.1.0
2018-12	RAN#82	R5-187559	0084	-	F	Updates to TS 38.521-3 clause 5 to align with core spec	15.1.0
2018-12	RAN#82	R5-187562	0085	-	F	Update to TC6.5B.3.2.1 - General Spurious Emissions for intra-band non-contiguous EN-DC	15.1.0
2018-12	RAN#82	R5-187563	0086	-	F	Update to 7.3B.2.2 - REFSENS for Intra-band Non-Contiguous EN-DC	15.1.0
2018-12	RAN#82	R5-187565	0087	-	F	Updates to TS 38.521-3 clause 4 with LTE anchor details	15.1.0
2018-12	RAN#82	R5-187614	0094	-	F	Updates to EN-DC test case 6.2B.2.2, UE Maximum Output Power reduction for Intra-Band Non-Contiguous EN-DC	15.1.0
2018-12	RAN#82	R5-187816	0048	1	F	Adding test case 6.2B.2.4, UE Maximum Output Power reduction for Inter-Band EN-DC including FR2	15.1.0
2018-12	RAN#82	R5-187819	0053	1	F	Update general parameter Connection without release in initial conditions in TS 38.521-3	15.1.0
2018-12	RAN#82	R5-187820	0043	1	F	Updates to test case 6.5B.2.1.3, Adjacent channel leakage ratio for intra-band contiguous EN-DC	15.1.0
2018-12	RAN#82	R5-187821	0052	1	F	Addition OBW intraband non contiguous EN-DC	15.1.0
2018-12	RAN#82	R5-187822	0055	1	F	Introduction of New test case 6.4B.2.2.1 Error Vector Magnitude for intra-band non-contiguous EN-DC	15.1.0
2018-12	RAN#82	R5-187823	0056	1	F	Introduction of New test case 6.4B.2.2.2 Carrier Leakage for intra-band non-contiguous EN-DC	15.1.0
2018-12	RAN#82	R5-187825	0058	1	F	Introduction of New test case 6.4B.2.3.1 Error Vector Magnitude for inter-band EN-DC within FR1	15.1.0
2018-12	RAN#82	R5-187826	0059	1	F	Introduction of New test case 6.4B.2.3.2 Carrier Leakage for inter-band EN-DC within FR1	15.1.0

2018-12	RAN#82	R5-187827	0060	1	F	Introduction of New test case 6.4B.2.3.3 In-band Emissions for inter-band EN-DC within FR1	15.1.0
2018-12	RAN#82	R5-187828	0070	1	F	Introduction of Error Vector Magnitude for intra-band contiguous EN-DC	15.1.0
2018-12	RAN#82	R5-187829	0071	1	F	Introduction of Carrier Leakage for intra-band contiguous EN-DC	15.1.0
2018-12	RAN#82	R5-187831	0088	1	F	FR2 General Spurious Emission test case update	15.1.0
2018-12	RAN#82	R5-187832	0089	1	F	FR2 Reference Sensitivity test case update	15.1.0
2018-12	RAN#82	R5-187833	0092	1	F	Updates to clause 7.3B.3.4 in TS 38.521-3	15.1.0
2018-12	RAN#82	R5-187834	0090	1	F	Updates to sections 1-4 in TS 38.521-3 to align with core spec	15.1.0
2018-12	RAN#82	R5-187835	0091	1	F	Updates to Clause 5 in TS 38.521-3	15.1.0
2018-12	RAN#82	R5-187913	0067	1	F	Addition of notes to clarify test point selection into general clause of TS 38.521-3	15.1.0
2018-12	RAN#82	R5-188012	0057	1	F	Introduction of New test case 6.4B.2.2.3 In-band Emissions for intra-band non-contiguous EN-DC	15.1.0
2018-12	RAN#82	R5-188013	0050	1	F	Addition OBW intra-band contiguous EN-DC	15.1.0
2018-12	RAN#82	R5-188014	0051	1	F	Addition SEM intra-band contiguous EN-DC	15.1.0
2018-12	RAN#82	R5-188015	0064	1	F	Additional Spurious Emissions for Intra-band contiguous EN-DC	15.1.0
2018-12	RAN#82	R5-188016	0065	1	F	Additional Spurious Emissions for Intra-band non-contiguous EN-DC	15.1.0
2018-12	RAN#82	R5-188017	0066	1	F	Additional Spurious emission for inter-band EN-DC	15.1.0
2018-12	RAN#82	R5-188018	0068	1	F	Spurious emission band UE co-existence for intra-band non-contiguous EN-DC	15.1.0
2018-12	RAN#82	R5-188019	0072	1	F	Introduction of In-band Emissions for intra-band contiguous EN-DC	15.1.0
2018-12	RAN#82	R5-188020	0073	1	F	Addition of TC6.3B.3.1 Tx ON/OFF time mask for intra-band contiguous EN-DC	15.1.0
2018-12	RAN#82	R5-188021	0074	1	F	Addition of TC6.3B.3.2 Tx ON/OFF time mask for intra-band non-contiguous EN-DC	15.1.0
2018-12	RAN#82	R5-188022	0075	1	F	Addition of TC6.3B.3.3 Tx ON/OFF time mask for inter-band EN-DC within FR1	15.1.0
2018-12	RAN#82	R5-188023	0080	1	F	Update of test case 6.5B.2.1.2 Additional spectrum emission mask for intra-band contiguous EN-DC for NS_04	15.1.0
2018-12	RAN#82	R5-188024	0081	1	F	Update of test case 6.2B.3.1 UE A-MPR for Intra-band contiguous EN-DC for NS_04	15.1.0
2018-12	RAN#82	R5-188025	0038	1	F	Update Clause 7.5B.3 in TS 38.521-3	15.1.0
2018-12	RAN#82	R5-188026	0041	1	F	5G NR_EN_DC with FR1_Text update for Inter-Band RX sensitivity	15.1.0
2018-12	RAN#82	R5-188027	0082	1	F	Update TC 7.4B.3	15.1.0
2018-12	RAN#82	R5-188028	0036	1	F	Updates of MU in TS 38.521-3 Annex F during RAN5#81	15.1.0
2018-12	RAN#82	R5-188029	0037	1	F	Updates of TT in TS 38.521-3 Annex F during RAN5#81	15.1.0
2018-12	RAN#82	R5-188039	0093	1	F	LTE Anchor Link configuration for FR2	15.1.0
2018-12	RAN#82	R5-188219	0062	1	F	Introduction of receiver spurious emission tests for FR1 inter-band EN-DC	15.1.0
2018-12	RAN#82	R5-188220	0063	1	F	Introduction of wideband intermodulation tests for FR1 inter-band EN-DC	15.1.0
2018-12	RAN#82	R5-188221	0054	1	F	LTE TDD configuration for UE Tx test in EN-DC	15.1.0
2018-12	RAN#82	R5-188222	0069	1	F	Core alignment CR to capture TS 38.101-3 updates during RAN4#89	15.1.0
2019-03	RAN#83	R5-191057	0165	-	F	Introduction of TC 7.5B.0	15.2.0
2019-03	RAN#83	R5-191157	0174	-	F	Updated EN-DC configuration information in clause 5	15.2.0
2019-03	RAN#83	R5-191231	0175	-	F	Adding missing reference to 38.521-3	15.2.0
2019-03	RAN#83	R5-191336	0176	-	F	Updates to EN-DC test case 6.2B.2.1, UE Maximum Output Power reduction for Intra-Band Contiguous EN-DC	15.2.0
2019-03	RAN#83	R5-191339	0177	-	F	Updates to EN-DC test case 6.2B.2.2, UE Maximum Output Power reduction for Intra-Band Non-Contiguous EN-DC	15.2.0
2019-03	RAN#83	R5-191340	0178	-	F	Adding test case 6.5A.2.3, Adjacent channel leakage ratio for CA without EN-DC	15.2.0
2019-03	RAN#83	R5-191510	0183	-	F	Shared Risk clarification in TS 38.521-3	15.2.0
2019-03	RAN#83	R5-191637	0193	-	F	Updates of TT in TS 38.521-3 Annex F during RAN5#NR4	15.2.0
2019-03	RAN#83	R5-191845	0200	-	F	Text update for 7.3B.3 deltaRIB,c deltaRIBNC for EN-DC	15.2.0
2019-03	RAN#83	R5-191867	0205	-	F	Addition of 7.3B.2.0 Reference sensitivity Minimum Conformance Requirements for EN-DC	15.2.0
2019-03	RAN#83	R5-192004	0215	-	F	Update of TC 6.2B.1.1	15.2.0
2019-03	RAN#83	R5-192005	0216	-	F	Update of TC 6.2B.1.2	15.2.0
2019-03	RAN#83	R5-192006	0217	-	F	Update of TC 6.2B.1.3	15.2.0
2019-03	RAN#83	R5-192176	0224	-	F	TIB,c updated for CA and EN-DC cases	15.2.0
2019-03	RAN#83	R5-192177	0225	-	F	Updated to Annex M Dual uplink interferer	15.2.0
2019-03	RAN#83	R5-192206	0228	-	F	38.521-3 Common clause updates to clarify leverage across architecture options	15.2.0
2019-03	RAN#83	R5-192207	0229	-	F	Formatting updates and index correction in TS 38.521-3	15.2.0
2019-03	RAN#83	R5-192208	0230	-	F	38.521-1 Common clause updates to clarify leverage across architecture options	15.2.0
2019-03	RAN#83	R5-192209	0231	-	F	38.521-2 Common clause updates to clarify leverage across architecture options	15.2.0



2019-03	RAN#83	R5-192242	0237	-	F	Update of test case 6.2B.3.1 UE A-MPR for Intra-band contiguous EN-DC	15.2.0
2019-03	RAN#83	R5-192243	0238	-	F	Update of test case 6.2B.3.4 UE A-MPR for Inter-Band EN-DC including FR2	15.2.0
2019-03	RAN#83	R5-192244	0239	-	F	Update of test case 6.5B.2.1.2 UE Additional spectrum emissions mask for intra-band contiguous EN-DC	15.2.0
2019-03	RAN#83	R5-192423	0157	1	F	Update of TC 7.5B.1	15.2.0
2019-03	RAN#83	R5-192424	0159	1	F	Introduction of TC 7.5B.4	15.2.0
2019-03	RAN#83	R5-192425	0166	1	F	Update of TC 7.5B.3	15.2.0
2019-03	RAN#83	R5-192427	0180	1	F	Introduction of NSA FR1 7.6B.2.1 Inband blocking for intra-band contiguous EN-DC in FR1	15.2.0
2019-03	RAN#83	R5-192428	0182	1	F	Introduction of NSA FR1 7.6B.2.3 Inband blocking for inter-band EN-DC within FR1	15.2.0
2019-03	RAN#83	R5-192429	0184	1	F	Introduction of NSA FR1 7.6B.3.1 Out-of-band blocking for intra-band contiguous EN-DC in FR1	15.2.0
2019-03	RAN#83	R5-192430	0185	1	F	Introduction of NSA FR1 7.6B.3.2 Out-of-band blocking for intra-band non-contiguous EN-DC in FR1	15.2.0
2019-03	RAN#83	R5-192431	0186	1	F	Introduction of NSA FR1 7.6B.3.3 Out-of-band blocking for inter-band EN-DC within FR1	15.2.0
2019-03	RAN#83	R5-192432	0187	1	F	Introduction of NSA FR1 7.6B.4.1 Narrow band blocking for intra-band contiguous EN-DC in FR1	15.2.0
2019-03	RAN#83	R5-192433	0188	1	F	Introduction of NSA FR1 7.6B.4.2 Narrow band blocking for intra-band non-contiguous EN-DC in FR1	15.2.0
2019-03	RAN#83	R5-192434	0189	1	F	Introduction of NSA FR1 7.6B.4.3 Narrow band blocking for inter-band EN-DC within FR1	15.2.0
2019-03	RAN#83	R5-192435	0190	1	F	Introduction of NSA FR1 7.7B.1 Spurious Response for intra-band contiguous EN-DC in FR1	15.2.0
2019-03	RAN#83	R5-192436	0191	1	F	Introduction of NSA FR1 7.7B.2 Spurious Response for intra-band non-contiguous EN-DC in FR1	15.2.0
2019-03	RAN#83	R5-192437	0192	1	F	Introduction of NSA FR1 7.7B.3 Spurious Response for inter-band EN-DC within FR1	15.2.0
2019-03	RAN#83	R5-192438	0207	1	F	Text Update for 7.3B.2.2 Reference sensitivity for Intra-band non-contiguous EN-DC	15.2.0
2019-03	RAN#83	R5-192439	0234	1	F	TS 38.521-3 corrections and clean-up to TC categories within Clause 7	15.2.0
2019-03	RAN#83	R5-192440	0179	1	F	Editorial: Band combinations for Inter-band CA between FR1 and FR2	15.2.0
2019-03	RAN#83	R5-192441	0232	1	F	TS 38.521-3 clause 5 updates to align with core specification	15.2.0
2019-03	RAN#83	R5-192442	0195	1	F	Addition of TC6.3B.4.3 PRACH Time Mask for inter-band EN-DC within FR1	15.2.0
2019-03	RAN#83	R5-192443	0220	1	F	Update of EN-DC 6.2B.4.1.3 Configured transmitted power inter-band within FR1	15.2.0
2019-03	RAN#83	R5-192445	0233	1	F	TS 38.521-3 corrections and clean-up to TC categories within Clause 6	15.2.0
2019-03	RAN#83	R5-192453	0198	1	F	FR2 NSA Spurious Emission Coexistence test case	15.2.0
2019-03	RAN#83	R5-192454	0199	1	F	FR2 NSA Frequency Error test case	15.2.0
2019-03	RAN#83	R5-192455	0221	1	F	Addition of transmit modulation quality test cases for inter-band EN-DC including FR2	15.2.0
2019-03	RAN#83	R5-192456	0222	1	F	Introduction 6.5B.1.4 OBW interband EN-DC including FR2	15.2.0
2019-03	RAN#83	R5-192457	0223	1	F	Introduction 6.5B.2.4.1 SEM interband EN-DC including FR2	15.2.0
2019-03	RAN#83	R5-192458	0226	1	F	Introduction 6.5B.2.4.3 ACLR interband EN-DC including FR2	15.2.0
2019-03	RAN#83	R5-192459	0236	1	F	Addition of TC6.3B.1.4 - Minimum Output Power for EN-DC Interband including FR2	15.2.0
2019-03	RAN#83	R5-192535	0194	1	F	Clean up of occupied bandwidth for EN-DC within FR1	15.2.0
2019-03	RAN#83	R5-192600	0196	1	F	Addition of TC6.3B.4.1 PRACH Time Mask for intra-band contiguous EN-DC	15.2.0
2019-03	RAN#83	R5-192601	0197	1	F	Addition of TC6.3B.4.2 PRACH Time Mask for intra-band non-contiguous EN-DC	15.2.0
2019-03	RAN#83	R5-192603	0201	1	F	Text Update for 6.5B.3.2 Spurious Emissions for intra-band non-contiguous EN-DC	15.2.0
2019-03	RAN#83	R5-192604	0202	1	F	Text Update for 6.5B.3.1 Spurious Emissions for intra-band contiguous EN-DC	15.2.0
2019-03	RAN#83	R5-192605	0203	1	F	Text Update for 6.5B.3.3 Spurious Emissions for Inter-band EN-DC within FR1	15.2.0
2019-03	RAN#83	R5-192606	0204	1	F	Text Update for 6.5B.4 Additional Spurious Emissions for EN-DC	15.2.0
2019-03	RAN#83	R5-192607	0209	1	F	Update to Carrier Leakage for intra-band contiguous EN-DC	15.2.0
2019-03	RAN#83	R5-192608	0210	1	F	Introduction of Error Vector Magnitude for intra-band contiguous EN-DC	15.2.0
2019-03	RAN#83	R5-192609	0211	1	F	Update to In-band Emissions for intra-band contiguous EN-DC	15.2.0
2019-03	RAN#83	R5-192610	0227	1	F	Clarification on UL slots in OBW, SEM and ACLR in TS 38.521-3	15.2.0
2019-03	RAN#83	R5-192611	0158	1	F	Update of TC 7.5B.2	15.2.0
2019-03	RAN#83	R5-192617	0167	1	F	Introducing Wideband Intermodulation for intra-band EN-DC in FR1	15.2.0
2019-03	RAN#83	R5-192618	0168	1	F	Introducing receiver spurious emission for intra-band EN-DC in FR1	15.2.0

2019-03	RAN#83	R5-192619	0181	1	F	Introduction of NSA FR1 7.6B.2.2 Inband blocking for intra-band non-contiguous EN-DC in FR1	15.2.0
2019-03	RAN#83	R5-192620	0206	1	F	Text Update for 7.3B.2.1 Reference sensitivity for Intra-band Contiguous EN-DC	15.2.0
2019-03	RAN#83	R5-192622	0170	1	F	Updates of MU in TS 38.521-3 Annex F during RAN5#82	15.2.0
2019-03	RAN#83	R5-192623	0171	1	F	Updates of TT in TS 38.521-3 Annex F during RAN5#82	15.2.0
2019-03	RAN#83	R5-192626	0214	1	F	Update of TC 7.4B.2	15.2.0
2019-03	RAN#83	R5-192681	0235	1	F	Addition of TC6.2B.1.4 - Max Output Power for EN-DC Interband including FR2	15.2.0
2019-03	RAN#83	R5-192689	0218	1	F	Update of 6.2B.4.1.1 Configured output power Intra-band contiguous EN-DC	15.2.0
2019-03	RAN#83	R5-192690	0219	1	F	Update of EN-DC 6.2B.4.1.2 Configured transmitted power Intra-band non-contiguous	15.2.0
2019-03	RAN#83	R5-192844	0213	2	F	Update of TC 7.4B.1	15.2.0
2019-03	RAN#83	R5-192847	0212	1	F	Addition of 7.4B.0	15.2.0
2019-03	RAN#83	R5-192863	0172	1	F	Introduction of TxIM (inter-band EN-DC within FR1)	15.2.0
2019-03	RAN#83	-	-	-	-	Editorial correction of references to TS 38.508-1 clause 4.6 tables	15.2.0
2019-06	RAN#84	R5-193539	0294	-	F	Adding missing reference in 38.521-3	15.3.0
2019-06	RAN#84	R5-193546	0295	-	F	Updates to 6.2B.2.3, UE Maximum Output power reduction for inter-band EN-DC within FR1	15.3.0
2019-06	RAN#84	R5-193547	0296	-	F	Adding test case 6.2B.2.5, UE Maximum Output power reduction for inter-band EN-DC including both FR1 and FR2	15.3.0
2019-06	RAN#84	R5-193548	0297	-	F	Update of test case 6.2B.2.1, UE Maximum Output Power reduction for Intra-Band Contiguous EN-DC	15.3.0
2019-06	RAN#84	R5-193714	0309	-	F	Update of Clause 5.5B Configuration for DC	15.3.0
2019-06	RAN#84	R5-193719	0311	-	F	Update of TC 7.5B.2 ACS for intra-band non-contiguous 2CC	15.3.0
2019-06	RAN#84	R5-193720	0312	-	F	Update of TC 7.5B.3 ACS for inter-band FR1 2CC	15.3.0
2019-06	RAN#84	R5-193722	0314	-	F	Update of TC 7.5B.4.1 ACS for inter-band FR2 2CC	15.3.0
2019-06	RAN#84	R5-193724	0316	-	F	Introduction of TC 7.5B.4.3 ACS for inter-band FR2 4CC	15.3.0
2019-06	RAN#84	R5-193725	0317	-	F	Introduction of TC 7.5B.4.4 ACS for inter-band FR2 5CC	15.3.0
2019-06	RAN#84	R5-193726	0318	-	F	Introduction of TC 7.5B.4.5 ACS for inter-band FR2 6CC	15.3.0
2019-06	RAN#84	R5-193727	0319	-	F	Introduction of TC 7.5B.5 inter-band FR1 FR2 3CC	15.3.0
2019-06	RAN#84	R5-193886	0320	-	F	Introduction of NSA FR2 7.6B.2.4.1	15.3.0
2019-06	RAN#84	R5-193888	0322	-	F	Update of NSA FR1 7.6B.2.0	15.3.0
2019-06	RAN#84	R5-193896	0324	-	F	Update of NSA FR1 7.6B.2.2	15.3.0
2019-06	RAN#84	R5-193899	0326	-	F	Update of NSA FR1 7.6B.3.1	15.3.0
2019-06	RAN#84	R5-193900	0327	-	F	Update of NSA FR1 7.6B.3.2	15.3.0
2019-06	RAN#84	R5-193901	0328	-	F	Update of NSA FR1 7.6B.4.0	15.3.0
2019-06	RAN#84	R5-193902	0329	-	F	Update of NSA FR1 7.6B.4.1	15.3.0
2019-06	RAN#84	R5-193903	0330	-	F	Update of NSA FR1 7.6B.4.2	15.3.0
2019-06	RAN#84	R5-193904	0331	-	F	Update of NSA FR1 7.7B.0	15.3.0
2019-06	RAN#84	R5-193905	0332	-	F	Update of NSA FR1 7.7B.1	15.3.0
2019-06	RAN#84	R5-193906	0333	-	F	Update of NSA FR1 7.7B.2	15.3.0
2019-06	RAN#84	R5-193947	0343	-	F	Removing invalid test IDs from test case 6.5B.2.1.3	15.3.0
2019-06	RAN#84	R5-194016	0344	-	F	38.521-3 Annex re-alignment	15.3.0
2019-06	RAN#84	R5-194128	0347	-	F	Addition SEM intraband non-contiguous EN-DC in TS 38.521-3	15.3.0
2019-06	RAN#84	R5-194129	0348	-	F	Addition ACLR intraband non-contiguous EN-DC in TS 38.521-3	15.3.0
2019-06	RAN#84	R5-194164	0351	-	F	Update of test case 6.2B.3.1 UE A-MPR for Intra-band contiguous EN-DC	15.3.0
2019-06	RAN#84	R5-194166	0353	-	F	Update of test case 6.2B.3.3 UE A-MPR for Inter-Band EN-DC within FR1	15.3.0
2019-06	RAN#84	R5-194317	0359	-	F	Text Update for 7.3B.2.3 Reference sensitivity for Inter-band EN-DC within FR1	15.3.0
2019-06	RAN#84	R5-194318	0360	-	F	Text Update for 7.3B.2.1 Ref sensitivity for Intra-band Contiguous EN-DC	15.3.0
2019-06	RAN#84	R5-194319	0361	-	F	Text Update for 6.5B.4 Additional Spurious Emissions for EN-DC	15.3.0
2019-06	RAN#84	R5-194320	0362	-	F	Text Update for 7.3B.3	15.3.0
2019-06	RAN#84	R5-194374	0366	-	F	Text Update for 6.5B.3.3.2 Spurious emission band UE co-existence for Inter-band EN-DC within FR1	15.3.0
2019-06	RAN#84	R5-194375	0367	-	F	Text Update for 7.3B.2.2 Ref sensitivity for Intra-band Non-Contiguous EN-DC	15.3.0
2019-06	RAN#84	R5-194376	0368	-	F	Text Update for 7.3B.2.0 Min Requirements of Ref sensitivity for EN-DC	15.3.0
2019-06	RAN#84	R5-194400	0372	-	F	Update to Carrier Leakage and In-band Emissions for intra-band contiguous EN-DC	15.3.0
2019-06	RAN#84	R5-194463	0378	-	F	Update to 6.2.3 A-MPR FR2 NSA	15.3.0
2019-06	RAN#84	R5-194484	0380	-	F	Update EN-DC Transmit modulation quality test cases	15.3.0
2019-06	RAN#84	R5-194621	0381	-	F	Update of transmit modulation quality test cases for inter-band EN-DC including FR2	15.3.0

2019-06	RAN#84	R5-194706	0382	-	F	TS 38.521-3 clause 5 updates to align with core specification	15.3.0
2019-06	RAN#84	R5-194707	0383	-	F	TS 38.521-3 updates across clause 6 test cases	15.3.0
2019-06	RAN#84	R5-194708	0384	-	F	TS 38.521-3 updates across clause 7 test cases	15.3.0
2019-06	RAN#84	R5-194725	0388	-	F	Update to clarify number of LTE CCs config for anchor agnostic EN-DC RF tests	15.3.0
2019-06	RAN#84	R5-194934	0334	1	F	Update of NSA FR1 RF 6.2B.1.1 MOP	15.3.0
2019-06	RAN#84	R5-194935	0335	1	F	Update of NSA FR1 RF 6.2B.1.2 MOP	15.3.0
2019-06	RAN#84	R5-194936	0337	1	F	Update of NSA FR1 RF 7.4B.1	15.3.0
2019-06	RAN#84	R5-194937	0338	1	F	Update of NSA FR1 RF 7.4B.2	15.3.0
2019-06	RAN#84	R5-194938	0298	1	F	Adding test case 6.5A.2.2, Additional Spectrum emissions mask for CA without EN-DC	15.3.0
2019-06	RAN#84	R5-194941	0350	1	F	Introduction of New test case 6.4B.2.3.4 EVM Equalizer Flatness for inter-band EN-DC within FR1	15.3.0
2019-06	RAN#84	R5-194942	0373	1	F	Update of test case 6.2A.2.1, UE maximum output power reduction for inter-band NR CA between FR1 and FR2 without EN-DC	15.3.0
2019-06	RAN#84	R5-194943	0374	1	F	Update of 6.2B.3.1 A-MPR Intra-band contiguous for NS_35	15.3.0
2019-06	RAN#84	R5-194944	0375	1	F	Update of 6.2B.3.2 A-MPR for Intra-band non-contiguous with additional test frequencies	15.3.0
2019-06	RAN#84	R5-194945	0376	1	F	Correction of editorial note in 6.5B.2.1.2	15.3.0
2019-06	RAN#84	R5-194946	0377	1	F	Update to 6.2.3 A-MPR FR1 and FR2	15.3.0
2019-06	RAN#84	R5-194947	0389	1	F	Updates to E-UTRA, FR1,FR2 IW tests in line with agreed way forward	15.3.0
2019-06	RAN#84	R5-194948	0369	1	F	Addition of msg content in TC 6.3B.4.1	15.3.0
2019-06	RAN#84	R5-194949	0370	1	F	Addition of msg content in TC 6.3B.4.2	15.3.0
2019-06	RAN#84	R5-194950	0371	1	F	Addition of msg content in TC 6.3B.4.3	15.3.0
2019-06	RAN#84	R5-194951	0310	1	F	Update of TC 7.5B.0 ACS for EN-DC	15.3.0
2019-06	RAN#84	R5-194952	0321	1	F	Introduction of NSA FR2 7.6B.2.5	15.3.0
2019-06	RAN#84	R5-194953	0323	1	F	Update of NSA FR1 7.6B.2.1	15.3.0
2019-06	RAN#84	R5-194954	0363	1	F	Updated to EN-DC band and TIB information	15.3.0
2019-06	RAN#84	R5-194955	0385	1	F	TS 38.521-3 clause 5 updates to align with core specification	15.3.0
2019-06	RAN#84	R5-194975	0315	1	F	Introduction of TC 7.5B.4.2 ACS for inter-band FR2 3CC	15.3.0
2019-06	RAN#84	R5-195046	0356	1	F	Update to Wideband Intermodulation for EN-DC in FR1- 2CCs	15.3.0
2019-06	RAN#84	R5-195047	0379	1	F	Update to 6.2.3 A-MPR FR1 and FR2 NSA	15.3.0
2019-06	RAN#84	R5-195049	0357	1	F	Correction to 6.5B.3.3.2 Spurious emission band UE co-existence for Inter-band within FR1	15.3.0
2019-06	RAN#84	R5-195050	0358	1	F	Introducing Wideband Intermodulation for EN-DC including FR1 - 3 CCs	15.3.0
2019-06	RAN#84	R5-195051	0391	-	F	Update of 6.5B.3.3.2 spurious co-existence inter-band EN-DC FR1	15.3.0
2019-06	RAN#84	R5-195091	0392	1	F	Update of EN-DC ON_ON time mask test cases	15.3.0
2019-06	RAN#84	R5-195162	0349	1	F	Introduction of New test case 6.4B.2.2.4 EVM Equalizer Flatness for intra-band non-contiguous EN-DC	15.3.0
2019-06	RAN#84	R5-195163	0364	1	F	Clean up FR2 Inter-band EN-DC test cases	15.3.0
2019-06	RAN#84	R5-195164	0390	1	F	Update to UE Maximum Output Power for Inter-Band EN-DC within FR1	15.3.0
2019-06	RAN#84	R5-195165	0325	1	F	Update of NSA FR1 7.6B.3.0	15.3.0
2019-06	RAN#84	R5-195411	0386	1	F	TS 38.521-3 updates across clause 6 test cases	15.3.0
2019-06	RAN#84	R5-195412	0387	1	F	TS 38.521-3 updates across clause 7 test cases	15.3.0
2019-06	RAN#84	R5-195419	0393	1	F	EN-DC implementation of FR2 UL demod OTA tests using single pol Rx TE	15.3.0
2019-06	RAN#84	R5-195436	0336	1	F	Update of NSA FR1 RF 6.2B.1.3 MOP	15.3.0
2019-06	RAN#84	R5-195437	0299	1	F	Updates of MU and TT in TS 38.521-3	15.3.0
2019-06	RAN#84	R5-195446	0394	1	F	Introduction of Tx test cases for FR2 NSA UL CA	15.3.0
2019-06	RAN#84	R5-193922	0340	-	F	Update of 6.2B.1.3 MOP inter-band adding Rel-16 EN-DC configurations	16.0.0
2019-06	RAN#84	R5-193923	0341	-	F	Update of 7.3B.2.3 REFSENS inter-band adding Rel-16 EN-DC configurations	16.0.0
2019-06	RAN#84	R5-194059	0345	-	F	Update of general sections adding Rel-16 EN-DC configurations, Editorial	16.0.0
2019-06	RAN#84	R5-195054	0342	1	F	Update of 6.5B.3.3.2 spurious co-existence inter-band adding Rel-16 EN-DC configurations	16.0.0
2019-09	RAN#85	R5-197441	0397	1	F	Correction of test case numbering for UL CA	16.1.0
2019-09	RAN#85	R5-197346	0398	1	F	Update of UE A_MPR intra band contiguous EN DC test case in 6.2B.3.1	16.1.0
2019-09	RAN#85	R5-197347	0399	1	F	Update of UE A_MPR intra band non contiguous EN DC test case in 6.2B.3.2	16.1.0
2019-09	RAN#85	R5-197348	0401	1	F	Addition of test case 6.5B.2.1.2 Additional Spectrum emissions mask for intra band contiguous EN DC	16.1.0
2019-09	RAN#85	R5-197349	0402	1	F	Addition of test case 6.5B.2.2.2 Additional Spectrum emissions mask for intra band non contiguous EN DC	16.1.0
2019-09	RAN#85	R5-197350	0403	1	F	Addition of test case 6.5B.2.3.2 Additional Spectrum emissions mask for Inter band EN DC within FR1	16.1.0
2019-09	RAN#85	R5-197561	0404	1	F	Refsens test case updates	16.1.0

2019-09	RAN#85	R5-197351	0405	1	F	Spurious test case updates	16.1.0
2019-09	RAN#85	R5-197331	0406	1	F	Correction to ACLR inter-band EN-DC FR1 test case	16.1.0
2019-09	RAN#85	R5-196160	0407	-	F	Clean up test cases 6.4B.2.2 Transmit Modulation Quality	16.1.0
2019-09	RAN#85	R5-196161	0408	-	F	Update to Annex F for Tx modulation quality test cases	16.1.0
2019-09	RAN#85	R5-196200	0409	-	F	Correction of uplink power setting for NSA transmitter test cases	16.1.0
2019-09	RAN#85	R5-197516	0410	1	F	Correction of uplink power setting for NSA receiver test cases	16.1.0
2019-09	RAN#85	R5-196241	0411	-	F	Correction to FR1 Transmit OFF Power	16.1.0
2019-09	RAN#85	R5-197646	0412	1	F	Correction to NR power control in FR1 Out-of-band blocking	16.1.0
2019-09	RAN#85	R5-197352	0414	1	F	Correction to FR1 PRACH time mask for EN-DC	16.1.0
2019-09	RAN#85	R5-197353	0415	1	F	Correction of NR uplink RB allocation for FR1 Inter-Band EN-DC MOP	16.1.0
2019-09	RAN#85	R5-196290	0416	-	F	Add Annex F.4 Uplink Power window explanation for interworking test cases	16.1.0
2019-09	RAN#85	R5-196296	0417	-	F	Addition of Clause 7.5A in TS 38.521-3	16.1.0
2019-09	RAN#85	R5-197549	0418	1	F	Update of 6.2B.1.1 MOP for Intra-band contiguous EN-DC	16.1.0
2019-09	RAN#85	R5-197550	0419	1	F	Update of 6.2B.1.2 MOP for Intra-band non-contiguous EN-DC	16.1.0
2019-09	RAN#85	R5-196446	0421	-	F	Editorial update of general sections adding Rel-16 EN-DC configurations	16.1.0
2019-09	RAN#85	R5-196449	0422	-	F	Correction to description of Table 4.5.1-2	16.1.0
2019-09	RAN#85	R5-197354	0423	1	F	Update for 6.5B.3.1.2 Spurious emission band UE co-existence for intra-band contiguous EN-DC	16.1.0
2019-09	RAN#85	R5-197553	0424	1	F	Update for 6.5B.3.3.2 Spurious emission band UE co-existence for Inter-band within FR1	16.1.0
2019-09	RAN#85	R5-197333	0425	1	F	Update for 7.3B.2.0 Minimum Conformance Requirements of Reference sensitivity for EN-DC	16.1.0
2019-09	RAN#85	R5-197636	0426	2	F	Update for 7.3B.2.3 Ref sensitivity for Inter-band EN-DC within FR1	16.1.0
2019-09	RAN#85	R5-197359	0427	1	F	Update for 7.3B.2.1 Reference sensitivity for Intra-band Contiguous EN-DC	16.1.0
2019-09	RAN#85	R5-197334	0428	1	F	Update for 7.3B.3.2	16.1.0
2019-09	RAN#85	R5-197335	0429	1	F	Update for 7.3B.3	16.1.0
2019-09	RAN#85	R5-197337	0430	1	F	Update for 7.3B.3.3	16.1.0
2019-09	RAN#85	R5-197338	0431	1	F	Updated to EN-DC band information	16.1.0
2019-09	RAN#85	R5-197336	0433	1	F	Update of TCs in 7.6B and 7.7B	16.1.0
2019-09	RAN#85	R5-197554	0434	1	F	Updates to 6.2B.2.1, UE Maximum Output Power reduction for Intra-Band Contiguous EN-DC	16.1.0
2019-09	RAN#85	R5-197555	0435	1	F	Update of TC 6.3B.1.1 Minimum Output Power for intra-band contiguous EN-DC	16.1.0
2019-09	RAN#85	R5-197556	0436	1	F	Update of TC 6.3B.1.2 Minimum output power for intra-band non-contiguous EN-DC	16.1.0
2019-09	RAN#85	R5-197340	0437	1	F	Update of TC 6.3B.2.1 Transmit OFF Power for intra-band contiguous EN-DC	16.1.0
2019-09	RAN#85	R5-197341	0438	1	F	Update of TC 6.3B.2.2 Transmit OFF Power for intra-band non-contiguous EN-DC	16.1.0
2019-09	RAN#85	R5-197342	0440	1	F	Update of TC 6.4B.1.1 Frequency error for Intra-band contiguous EN-DC	16.1.0
2019-09	RAN#85	R5-197557	0441	1	F	Update of TC 6.4B.1.2 Frequency error for Intra-band non-contiguous EN-DC	16.1.0
2019-09	RAN#85	R5-197343	0442	1	F	Update of TC 6.4B.1.3 Frequency error for Inter-band EN-DC within FR1	16.1.0
2019-09	RAN#85	R5-197647	0443	1	F	Correction to 7.8B.2.6 Wideband Intermodulation for EN-DC including FR1 - 3 CCs	16.1.0
2019-09	RAN#85	R5-197562	0448	1	F	Corrections to Reference sensitivity for EN-DC	16.1.0
2019-09	RAN#85	R5-196842	0449	-	F	Editorial corrections to Additional Spurious Emission test case	16.1.0
2019-09	RAN#85	R5-197360	0450	1	F	Correction to test case 7.4B.3	16.1.0
2019-09	RAN#85	R5-197558	0452	1	F	Correction to EN-DC Spurious Emissions	16.1.0
2019-09	RAN#85	R5-197345	0456	1	F	Update OBW EN-DC FR2 test case	16.1.0
2019-09	RAN#85	R5-197339	0457	1	F	TS 38.521-3 Section 5 updates to align with core specification (Covered by CR0431R1)	16.1.0
2019-09	RAN#85	R5-197542	0458	1	F	TS 38.521-3 updates across section 6 test cases	16.1.0
2019-09	RAN#85	R5-197563	0459	1	F	TS 38.521-3 updates across section 7 test cases	16.1.0
2019-09	RAN#85	R5-197559	0460	1	F	Updates to 6.2B.2.4, UE Maximum Output Power reduction for Inter-Band EN-DC including FR2	16.1.0
2019-09	RAN#85	R5-196946	0461	-	F	Corrections on UE maximum output power for DC in 38.521-3	16.1.0
2019-09	RAN#85	R5-197332	0462	1	F	Corrections on Minimum conformance requirements of A-MPR in 38.521-3	16.1.0
2019-09	RAN#85	R5-196948	0463	-	F	Corrections on clause 5 in 38.521-3	16.1.0
2019-09	RAN#85	R5-196949	0464	-	F	Corrections on clause 2-4 in 38.521-3	16.1.0
2019-09	RAN#85	R5-197633	0465	-	F	Removing test points for CP-OFDM PI/2 BPSK in test case 6.5B.2.1.1	16.1.0
2019-12	RAN#86	R5-197940	0472	-	F	Addition of 6.2B.1.5 MOP for Inter-Band EN-DC including FR1 and FR2	16.2.0

2019-12	RAN#86	R5-197944	0475	-	F	Update of 6.2B.4.1.4 configured transmitted power for Inter-Band EN-DC including FR2	16.2.0
2019-12	RAN#86	R5-197945	0476	-	F	Update of 6.2B.4.1.5 configured transmitted power for Inter-Band EN-DC including FR1 and FR2	16.2.0
2019-12	RAN#86	R5-197946	0477	-	F	Addition of 7.4A Maximum Input Level for FR1-FR2 CA	16.2.0
2019-12	RAN#86	R5-197949	0480	-	F	Addition of 7.4B.5 Maximum Input Level for inter-band EN-DC including FR1 and FR2	16.2.0
2019-12	RAN#86	R5-198045	0485	-	F	Update of TC 7.5B.0 ACS for EN-DC	16.2.0
2019-12	RAN#86	R5-198046	0486	-	F	Update of TC 7.5B.1 ACS for intra-band contiguous EN-DC 2CCs	16.2.0
2019-12	RAN#86	R5-198172	0488	-	F	Updating incorrect note in test procedure	16.2.0
2019-12	RAN#86	R5-198280	0490	-	F	Introduction of New TC 6.4B.2.1.4 EVM Equalizer Flatness for intra-band contiguous EN-DC	16.2.0
2019-12	RAN#86	R5-198403	0501	-	F	Correction to TC 6.4B.1.3 test description	16.2.0
2019-12	RAN#86	R5-198404	0502	-	F	Correction to Additional Spurious Emissions for Inter-band EN-DC within FR1	16.2.0
2019-12	RAN#86	R5-198406	0504	-	F	Correction to Spurious emission band UE co-existence for Inter-band within FR1	16.2.0
2019-12	RAN#86	R5-198537	0509	-	F	Updates to 6.2B.3.1, UE A-MPR for Intra-band Contig EN-DC	16.2.0
2019-12	RAN#86	R5-198538	0510	-	F	Updates to 6.2B.3.2, UE A-MPR for Intra-band Non-Contig EN-DC	16.2.0
2019-12	RAN#86	R5-198539	0511	-	F	Updates to 6.5B.2.1.2, Additional spectrum emission mask for intra-band Contig EN-DC	16.2.0
2019-12	RAN#86	R5-198559	0512	-	F	Updated to EN-DC band information Rel-16	16.2.0
2019-12	RAN#86	R5-198637	0513	-	F	Updated to EN-DC General clause and band information Rel-15	16.2.0
2019-12	RAN#86	R5-198685	0515	-	F	Update single allowed info and MPR test description to EN-DC configuration in 38.521-3	16.2.0
2019-12	RAN#86	R5-198686	0516	-	F	Corrections on delta TIB for EN-DC configurations in 38.521-3	16.2.0
2019-12	RAN#86	R5-198722	0519	-	F	Update for 7.3B.1 General	16.2.0
2019-12	RAN#86	R5-198734	0523	-	F	Update for 6.5B.3.3.1 General spurious emissions for Inter-band EN-DC within FR1	16.2.0
2019-12	RAN#86	R5-198735	0524	-	F	Update for 6.5B.3.3.2 Spurious emission band UE co-existence for Inter-band within FR1	16.2.0
2019-12	RAN#86	R5-199088	0466	1	F	Updates of MU and TT in TS 38.521-3	16.2.0
2019-12	RAN#86	R5-199342	0483	1	F	Updates to test case 6.2B.2.1, UE Maximum Output Power reduction for Intra-Band Contiguous EN-DC	16.2.0
2019-12	RAN#86	R5-199343	0487	1	F	Editorial correction of test description in TC 6.4B.2.3.3	16.2.0
2019-12	RAN#86	R5-199344	0478	1	F	Addition of 7.4B.3 Maximum Input Level for inter-band EN-DC within FR1	16.2.0
2019-12	RAN#86	R5-199345	0491	1	F	Update of minimum conformance requirements of 7.6B.3 and editorial correction in 7.6B and 7.7B	16.2.0
2019-12	RAN#86	R5-199346	0492	1	F	Addition of 7.6A Blocking Characteristics for CA	16.2.0
2019-12	RAN#86	R5-199347	0493	1	F	Addition of 7.6B.2.3_1 Inband blocking for EN-DC within FR1 (>2 CCs)	16.2.0
2019-12	RAN#86	R5-199348	0495	1	F	Addition of 7.6B.4.3_1 Narrow band blocking for EN-DC within FR1 (>2 CCs)	16.2.0
2019-12	RAN#86	R5-199349	0468	1	F	Add Uplink Power window explanation when centred on a target	16.2.0

2019-12	RAN#86	R5-199350	0489	1	F	Correction and addition of uplink power measurement MUs for NSA FR1 TCs	16.2.0
2019-12	RAN#86	R5-199351	0508	1	F	Addition of MU and TT for NSA 7.6B.2.3_1, 7.6B.2.4, 7.6B.2.4_1 and 7.6B.4.3_1 TCs in F.1.3 and F.3.3	16.2.0
2019-12	RAN#86	R5-199352	0529	1	F	TS 38.521-3 Section 1-5 and Annex updates to align with core specification	16.2.0
2019-12	RAN#86	R5-199377	0471	1	F	Update of 6.2B.1.4 MOP for Inter-Band EN-DC including FR2	16.2.0
2019-12	RAN#86	R5-199378	0479	1	F	Addition of 7.4B.4 Maximum Input Level for inter-band EN-DC including FR2	16.2.0
2019-12	RAN#86	R5-199413	0482	1	F	Addition of 2A-7A-7A-66A_n66A	16.2.0
2019-12	RAN#86	R5-199498	0500	1	F	Correction to minimum output power for intra-band EN-DC	16.2.0
2019-12	RAN#86	R5-199506	0496	1	F	Removal of 7.7A Spurious Response for CA	16.2.0
2019-12	RAN#86	R5-199508	0484	1	F	Updates to test case 6.2B.2.2, UE Maximum Output Power reduction for Intra-Band Non-Contiguous EN-DC	16.2.0
2019-12	RAN#86	R5-199514	0469	1	F	Update of 6.2B.1.1 MOP for Intra-Band contiguous EN-DC	16.2.0
2019-12	RAN#86	R5-199518	0467	1	F	Updates of test procedure for MOP and co-existence tests	16.2.0
2019-12	RAN#86	R5-199519	0517	1	F	Update for 6.5B.3.1.1 General spurious emissions for intra-band contiguous EN-DC	16.2.0
2019-12	RAN#86	R5-199520	0518	1	F	Update for 6.5B.3.2.1 General spurious emissions for Intra-band non-contiguous EN-DC	16.2.0
2019-12	RAN#86	R5-199521	0527	1	F	Update for Additional Spurious Emissions for Intra-band contiguous EN-DC	16.2.0
2019-12	RAN#86	R5-199522	0530	1	F	TS 38.521-3 updates across section 6 test cases	16.2.0
2019-12	RAN#86	R5-199523	0526	1	F	Update for 7.3B.2.0 Minimum Conformance Requirements of Reference sensitivity for EN-DC	16.2.0
2019-12	RAN#86	R5-199524	0531	1	F	TS 38.521-3 updates across section 7 test cases	16.2.0
2019-12	RAN#86	R5-199543	0520	1	F	Correction of E-UTRA Mid channel bandwidth	16.2.0
2019-12	RAN#86	R5-199546	0498	1	F	Corrections to DC Config and dual UL interferer	16.2.0
2019-12	RAN#86	R5-199547	0499	1	F	Corrections to EN-DC and NE-DC Configurations	16.2.0
2019-12	RAN#86	R5-199566	0494	1	F	Addition of 7.6B.2.4_1 Inband blocking for inter-band EN-DC including FR2 (>2 CCs)	16.2.0
2019-12	RAN#86	R5-199567	0522	1	F	Update to test case 7.3B.2.3	16.2.0
2019-12	RAN#86	R5-199568	0525	1	F	Update for 7.3B.2.3 Reference sensitivity for Inter-band EN-DC within FR1	16.2.0
2019-12	RAN#86	R5-199569	0528	1	F	Update 4.5 Applicability and test coverage rules	16.2.0
2020-03	RAN#87	R5-200351	0538	-	F	Updated to EN-DC band information Rel-16	16.3.0
2020-03	RAN#87	R5-200446	0549	-	F	Correction to FR1 EN-DC Spurious Test Case	16.3.0
2020-03	RAN#87	R5-200448	0551	-	F	Correction to LTE specialSubframePatterns in Maximum Output Power Test Case	16.3.0
2020-03	RAN#87	R5-200449	0552	-	F	Correction to tdm-PatternConfig in FR1 EN-DC Maximum Output Power Test Case	16.3.0
2020-03	RAN#87	R5-200599	0553	-	F	Update of 6.2B.1.3 on inter-band EN-DC MOP in 38.521-3	16.3.0
2020-03	RAN#87	R5-200651	0558	-	F	Updates to 6.2B.2.1, UE Maximum Output Power reduction for Intra-Band Contiguous EN-DC	16.3.0

2020-03	RAN#87	R5-200653	0559	-	F	Updates to 6.2B.2.2, UE Maximum Output Power reduction for Intra-Band Non-Contiguous EN-DC	16.3.0
2020-03	RAN#87	R5-200657	0560	-	F	Updates to 6.2B.2.3 and 6.2B.3.3	16.3.0
2020-03	RAN#87	R5-200668	0561	-	F	Correction of reference clause for 7.3B.2.3 Reference Sensitivity Test Procedure	16.3.0
2020-03	RAN#87	R5-200670	0563	-	F	Update reference in Test Requirement section of 6.5B.4.3.5	16.3.0
2020-03	RAN#87	R5-200728	0568	-	F	Correction of test cases in 7.6B.2 Inband blocking for DC	16.3.0
2020-03	RAN#87	R5-200730	0569	-	F	Correction to reference table number for TC 6.2B.2.3 and TC 6.2B.2.4	16.3.0
2020-03	RAN#87	R5-200731	0570	-	F	Correction of test cases in 7.6B.3 Out-of-band blocking for DC	16.3.0
2020-03	RAN#87	R5-200732	0571	-	F	Correction of test cases in 7.6B.4 Narrow band blocking for DC	16.3.0
2020-03	RAN#87	R5-200733	0572	-	F	Correction of test cases in 7.7B Spurious response for DC	16.3.0
2020-03	RAN#87	R5-200776	0576	-	F	TS 38.521-3 Section 1-5 and Annex updates to align with core specification	16.3.0
2020-03	RAN#87	R5-200801	0577	-	F	Update of Non-Standalone FR2 A-MPR test case	16.3.0
2020-03	RAN#87	R5-200814	0579	-	F	Correction to Test Case 6.5B.3.3.2	16.3.0
2020-03	RAN#87	R5-200913	0534	1	F	Update of Clause 4 in TS 38.521-3	16.3.0
2020-03	RAN#87	R5-200925	0541	1	F	Adding common uplink configuration of E-UTRA carrier for EN-DC testing	16.3.0
2020-03	RAN#87	R5-200926	0543	1	F	Updating configured output power for inter-band EN-DC	16.3.0
2020-03	RAN#87	R5-200927	0545	1	F	Updating configured output power for intra-band contiguous EN-DC	16.3.0
2020-03	RAN#87	R5-200928	0547	1	F	Updating configured output power for intra-band non-contiguous EN-DC	16.3.0
2020-03	RAN#87	R5-200929	0567	1	F	Core spec alignment of EN-DC MOP and configured output power	16.3.0
2020-03	RAN#87	R5-200963	0536	1	F	Update of TC 7.5B.2 ACS for intra-band non-contiguous EN-DC 2CCs	16.3.0
2020-03	RAN#87	R5-200964	0535	1	F	Update of TC 7.5B.1 ACS for intra-band contiguous EN-DC 2CCs	16.3.0
2020-03	RAN#87	R5-200982	0557	1	F	Updates to 6.5B.2.1.3, Adjacent channel leakage ratio for intra-band contiguous EN-DC	16.3.0
2020-03	RAN#87	R5-200983	0575	1	F	Corrections to 6.2B.3.1, UE A_MPR for Intra-band Contig EN_DC	16.3.0
2020-03	RAN#87	R5-200984	0533	1	F	Addition of Clause 7.5B.0.3a	16.3.0
2020-03	RAN#87	R5-200995	0578	1	F	Correction of Reference Sensitivity Test Case 7.3B.2.3	16.3.0
2020-03	RAN#87	R5-201019	0555	1	F	Update of general sections on EN-DC configurations in 38.521-3	16.3.0
2020-03	RAN#87	R5-201055	0542	1	F	Updating MOP for inter-band EN-DC	16.3.0
2020-03	RAN#87	R5-201066	0564	1	F	Add TX test for Rel16_DC_2_n41 and 66_n41	16.3.0
2020-03	RAN#87	R5-201067	0565	1	F	Add RX test for Rel16_DC_2_n41 and 66_n41	16.3.0
2020-03	RAN#87	R5-201165	0574	1	F	Correction of REFSENS for inter-band EN-DC	16.3.0
2020-03	RAN#87	R5-201187	0548	1	F	Addition of a few R16 EN-DC configurations	16.3.0
2020-03	RAN#87	R5-201193	0532	1	F	Updates of MU and TT in TS 38.521-3	16.3.0
2020-03	RAN#87	R5-201198	0556	1	F	Correcting usage of modifiedMPR-Behaviour	16.3.0
2020-06	RAN#88	R5-201721	0587	-	F	Update Annex F.4 Uplink Power window explanation	16.4.0

2020-06	RAN#88	R5-201855	0594	-	F	Update of 6.2B.1.3 MOP for inter-band EN-DC	16.4.0
2020-06	RAN#88	R5-201859	0596	-	F	Updating A-SE to align test points with A-MPR	16.4.0
2020-06	RAN#88	R5-201870	0598	-	F	Update of test configuration in 6.5B.3.3.2 for UE co-existence	16.4.0
2020-06	RAN#88	R5-201942	0605	-	F	Updated to EN-DC Rel-16 band information in clause 5	16.4.0
2020-06	RAN#88	R5-202032	0611	-	F	Correction of Initial condition for OOB in-band contiguous EN-DC 2 CCs in FR1 in TC 7.6B.3.1 R15	16.4.0
2020-06	RAN#88	R5-202293	0626	-	F	Correction to 7.3B.2.3 test configuration for EN-DC 26_n79	16.4.0
2020-06	RAN#88	R5-202294	0627	-	F	Correction to Frequency error for Intra-band contiguous EN-DC	16.4.0
2020-06	RAN#88	R5-202295	0628	-	F	Correction to PRACH configuration for intra-band EN-DC tests	16.4.0
2020-06	RAN#88	R5-202393	0630	-	F	Addition of Intra-band non-contiguous EN-DC combination	16.4.0
2020-06	RAN#88	R5-202421	0633	-	F	Update Uplink power control window size for NSA TX TCs	16.4.0
2020-06	RAN#88	R5-202429	0637	-	F	Update for 7.3A.3 for CA without EN-DC	16.4.0
2020-06	RAN#88	R5-202475	0638	-	F	TS 38.521-3 Section 1-5 and Annex updates to align with core specification	16.4.0
2020-06	RAN#88	R5-202725	0585	1	F	Correction on the channel bandwidth to use in section 6.5B.3.3	16.4.0
2020-06	RAN#88	R5-202726	0586	1	F	Setting p-MaxEUTRA to avoid limiting NR power in section 6.5B	16.4.0
2020-06	RAN#88	R5-202727	0590	1	F	Correction to TC 6.2B.4.1.3	16.4.0
2020-06	RAN#88	R5-202728	0595	1	F	Updating 6.2B.4.x configured output power test cases for FR1 EN-DC	16.4.0
2020-06	RAN#88	R5-202729	0614	1	F	correction 6.3B.1.3 to include anchor agnostic approach applies	16.4.0
2020-06	RAN#88	R5-202730	0616	1	F	Clarification of disabling Tx diversity for FR2 UE for NSA FR2 testing	16.4.0
2020-06	RAN#88	R5-202731	0618	1	F	Updation of 6.5B.3.3.1	16.4.0
2020-06	RAN#88	R5-202732	0639	1	F	Addition of UL-MIMO EN-DC tests in Clause 6	16.4.0
2020-06	RAN#88	R5-202733	0641	1	F	Common updates across tests in Clause 6	16.4.0
2020-06	RAN#88	R5-202734	0640	1	F	Addition of UL-MIMO EN-DC tests in Clause 7	16.4.0
2020-06	RAN#88	R5-202735	0642	1	F	Common updates across tests in Clause 7	16.4.0
2020-06	RAN#88	R5-202782	0635	1	F	Update Rx TC for 5 Rel_16_DC_combos	16.4.0
2020-06	RAN#88	R5-202809	0632	1	F	Receiver characteristics testing update to 38.521-3	16.4.0
2020-06	RAN#88	R5-202829	0601	1	F	Addition of 6.2B.1.5D UE Maximum Output Power for Inter-Band EN-DC including both FR1 and FR2 for UL-MIMO	16.4.0
2020-06	RAN#88	R5-202830	0602	1	F	Addition of 6.2B.5.1.1 Configured Output Power Level for Inter-band NR-DC between FR1 and FR2	16.4.0
2020-06	RAN#88	R5-202901	0631	1	F	Power control for EN-DC	16.4.0
2020-06	RAN#88	R5-202902	0588	1	F	Updated structure for RefSens for EN-DC within FR1 more than 2CCs	16.4.0
2020-06	RAN#88	R5-202903	0597	1	F	Updating REFSSENS for 1A_n78A and 3A_n78A	16.4.0
2020-06	RAN#88	R5-202904	0613	1	F	Introduction of Rx test cases for EN-DC within FR1 3CCs	16.4.0
2020-06	RAN#88	R5-202905	0629	1	F	Update to NSA FR2 Receiver Spurious Emission Test Case	16.4.0
2020-06	RAN#88	R5-202906	0636	1	F	Add 7.3B.2.3_1.2 Reference sensitivity for EN-DC within FR1v - 4 CCs	16.4.0
2020-06	RAN#88	R5-202907	0624	1	F	Updates of FR2 MU and TT in TS 38.521-3	16.4.0



2020-06	RAN#88	R5-202925	0634	1	F	Update Tx TC for 5 Rel_16_DC_combos	16.4.0
2020-06	RAN#88	R5-202934	0604	1	F	Addition of TDD-TDD PC2 inter-band EN-DC	16.4.0
2020-06	RAN#88	R5-202945	0592	1	F	Updating 6.2B.1.1 MOP for intra-band contiguous EN-DC	16.4.0
2020-06	RAN#88	R5-202946	0593	1	F	Updating 6.2B.1.2 MOP for intra-band non-contiguous EN-DC	16.4.0
2020-06	RAN#88	R5-202947	0606	1	F	Updates to 6.2B.2.1, UE Maximum Output Power reduction for Intra-Band Contiguous EN-DC	16.4.0
2020-06	RAN#88	R5-202948	0607	1	F	Updates to 6.5B.2.1.1, Spectrum emissions mask for intra-band contiguous EN-DC	16.4.0
2020-06	RAN#88	R5-202949	0608	1	F	Updates to 6.5B.2.1.3, Adjacent channel leakage ratio for intra-band contiguous EN-DC	16.4.0
2020-06	RAN#88	R5-202959	0620	1	F	Updates of Tx test cases for EN-DC including FR2	16.4.0
2020-06	RAN#88	R5-202964	0622	1	F	Update to configured output power relaxation due to inter-band EN-DC in 38.521-3	16.4.0
2020-06	RAN#88	R5-202965	0623	1	F	Update to REFSENS relaxation due to inter-band EN-DC in 38.521-3	16.4.0
2020-06	RAN#88	R5-202991	0609	1	F	Completion of TC 7.6B.3.3 OOB Inter-band EN-DC 2CCs within FR1 R15	16.4.0
2020-06	RAN#88	R5-202992	0610	1	F	Completion of TC 7.7B.3 Spurious Response Inter-band EN-DC 2CCs within FR1 R15	16.4.0
2020-06	RAN#88	R5-202993	0612	1	F	Alignment of requirements in 7.6B and 7.7B with core spec for Intra-band contiguous EN-DC in FR1 R15	16.4.0
2020-09	RAN#89	R5-203227	0644	-	F	Adding receiver requirements for Rel-16 inter-band EN-DC FR1 band combinations	16.5.0
2020-09	RAN#89	R5-203294	0645	-	F	Correction of MU definition for test case 6.5B.2.1.3	16.5.0
2020-09	RAN#89	R5-203295	0646	-	F	definition of MU and TT for test case 6.3B.4.3	16.5.0
2020-09	RAN#89	R5-203296	0647	-	F	definition of MU and TT for test case 6.5B.4.3	16.5.0
2020-09	RAN#89	R5-203297	0648	-	F	Definition of MU and TT for test case 7.3B.2.4	16.5.0
2020-09	RAN#89	R5-203492	0650	-	F	In-band Blocking FR2 MU updates in 38.521-3	16.5.0
2020-09	RAN#89	R5-203515	0651	-	F	Editorial correction of test case 6.5B.3.3.1	16.5.0
2020-09	RAN#89	R5-203637	0655	-	F	Introduction of additional Rel-16 EN-DC inter-band configurations to EN-DC MOP test case 6.2B.1.3	16.5.0
2020-09	RAN#89	R5-203753	0660	-	F	Update test procedure to 6.5B.3.3.1	16.5.0
2020-09	RAN#89	R5-203763	0661	-	F	Editorial correction of referenced clause (6.2.3) in test case 6.2B.2.1.2	16.5.0
2020-09	RAN#89	R5-203872	0668	-	F	Adding RRCCONNECTIONRECONFIGURATION Table for E-UTRA on FDD band and UE does not support dynamic power sharing in 6.5B.3.3.1 and 6.5B.3.3.2	16.5.0
2020-09	RAN#89	R5-203907	0669	-	F	Corrections on delta RIB due to Rel-16 EN-DC configurations	16.5.0
2020-09	RAN#89	R5-203941	0674	-	F	Addition of the test description to apply LTE agnostic approach in 7.4B.2 MIL	16.5.0
2020-09	RAN#89	R5-203960	0680	-	F	Correction to additional test points for spurious emission UE co-existence for a few Rel-15 inter-band EN-DC	16.5.0
2020-09	RAN#89	R5-203973	0684	-	F	Cleaning up of delta_TIB	16.5.0
2020-09	RAN#89	R5-204154	0693	-	F	Updated to Annex M for EN-DC Rel-16 configuration requirement	16.5.0

2020-09	RAN#89	R5-204170	0697	-	F	Update for TC 7.5B.0 Minimum Conformance Requirements of ACS for DC	16.5.0
2020-09	RAN#89	R5-204176	0703	-	F	Update for TC 7.5B.4 ACS for inter-band EN-DC including FR2 2CCs	16.5.0
2020-09	RAN#89	R5-204177	0704	-	F	Update for TC 7.5B.4_1.1 ACS for inter-band EN-DC including FR2 3CCs	16.5.0
2020-09	RAN#89	R5-204178	0705	-	F	Update for TC 7.5B.4_1.2 ACS for inter-band EN-DC including FR2 4CCs	16.5.0
2020-09	RAN#89	R5-204179	0706	-	F	Update for TC 7.5B.4_1.3 ACS for inter-band EN-DC including FR2 5CCs	16.5.0
2020-09	RAN#89	R5-204180	0707	-	F	Update for TC 7.5B.4_1.4 ACS for inter-band EN-DC including FR2 6CCs	16.5.0
2020-09	RAN#89	R5-204198	0713	-	F	Update for 7.3B.2.0	16.5.0
2020-09	RAN#89	R5-204199	0714	-	F	Update for Spurious Emissions for intra-band EN-DC	16.5.0
2020-09	RAN#89	R5-204209	0717	-	F	Update Uplink power control window size for NSA RX TCs	16.5.0
2020-09	RAN#89	R5-204210	0718	-	F	Update Tx TC for Rel-16 DC combos	16.5.0
2020-09	RAN#89	R5-204250	0721	-	F	FR2 Minimum output power measurement period definition	16.5.0
2020-09	RAN#89	R5-204296	0726	-	F	Addition of test case 6.4B.2.4.1D	16.5.0
2020-09	RAN#89	R5-204297	0727	-	F	Addition of test case 6.4B.2.4.2D	16.5.0
2020-09	RAN#89	R5-204298	0728	-	F	Addition of test case 6.4B.2.4.3D	16.5.0
2020-09	RAN#89	R5-204299	0729	-	F	Addition of test case 6.4B.2.4.4D	16.5.0
2020-09	RAN#89	R5-204310	0730	-	F	Update of test case 6.2B.3.1 UE Additional Maximum Output Power reduction for Intra-band contiguous EN-DC	16.5.0
2020-09	RAN#89	R5-204313	0733	-	F	TS 38.521-3 Section 1-5 and Annex updates to align with core specification	16.5.0
2020-09	RAN#89	R5-204322	0736	-	F	Update for TC 7.5B.5 ACS for inter-band EN-DC including both FR1 and FR2	16.5.0
2020-09	RAN#89	R5-204349	0738	-	F	Editorial correction of Rx spurious emissions for FR1 EN-DC	16.5.0
2020-09	RAN#89	R5-204705	0739	-	F	Addition of test configuration for 71AA in 6.2B.1.1 MOP	16.5.0
2020-09	RAN#89	R5-204707	0740	-	F	Addition of MOP testing for DC_28A_n3A in 6.2B.1.3	16.5.0
2020-09	RAN#89	R5-204719	0715	1	F	Update for 7.3B.2.3_1.3 Reference sensitivity for EN-DC within FR1 5CCs	16.5.0
2020-09	RAN#89	R5-204724	0662	1	F	Updated to clause 6 for EN-DC Rel-16 band requirement	16.5.0
2020-09	RAN#89	R5-204766	0665	1	F	Spurious inter-band EN-DC FR2 UL MIMO test cases	16.5.0
2020-09	RAN#89	R5-204767	0673	1	F	Addition of test requirement of dropped NR carrier for non-DPS UE in 6.2B.4.x	16.5.0
2020-09	RAN#89	R5-204768	0678	1	F	Addition of additional test points for spurious emission UE co-existence for a few Rel-15 inter-band EN-DC	16.5.0
2020-09	RAN#89	R5-204769	0723	1	F	Editorial correction to EN-DC co-existence requirements	16.5.0
2020-09	RAN#89	R5-204770	0664	1	F	FR2 RefSens inter-band EN-DC UL MIMO test cases	16.5.0
2020-09	RAN#89	R5-204771	0670	1	F	Update of 7.3B.3.3 for REFSSENS relaxation due to inter-band EN-DC within FR1	16.5.0
2020-09	RAN#89	R5-204772	0676	1	F	Addition of new test case 7.4B.5D MIL for inter-band EN-DC including FR1 and FR2 for UL-MIMO	16.5.0

2020-09	RAN#89	R5-204773	0709	1	F	Addition of TC 7.5B.5D ACS for inter-band EN-DC including FR1 and FR2 for UL-MIMO	16.5.0
2020-09	RAN#89	R5-204809	0643	1	F	Adding transmitter requirements for Rel-16 inter-band EN-DC FR1 band combinations	16.5.0
2020-09	RAN#89	R5-204810	0654	1	F	Editorial correction to spurious emission test case 6.5B.3.3.2	16.5.0
2020-09	RAN#89	R5-204811	0656	1	F	Introduction of dTIBc for additional Rel-16 EN-DC inter-band configurations	16.5.0
2020-09	RAN#89	R5-204812	0657	1	F	Introduction of Rel-16 EN-DC configuration DC_40A_n1A to spurious emission test case 6.5B.3.3.2	16.5.0
2020-09	RAN#89	R5-204813	0658	1	F	Introduction of Rel-16 EN-DC configuration DC_40A_n78A to spurious emission test case 6.5B.3.3.2	16.5.0
2020-09	RAN#89	R5-204814	0679	1	F	Addition of additional test points for spurious emission UE co-existence for a few Rel-16 inter-band EN-DC	16.5.0
2020-09	RAN#89	R5-204815	0694	1	F	Updated to clause 6 for EN-DC Rel-16 configuration test requirement	16.5.0
2020-09	RAN#89	R5-204816	0692	1	F	Updated to EN-DC Rel-16 Configuration information in clause 5	16.5.0
2020-09	RAN#89	R5-204840	0696	1	F	Updated to EN-DC general clauses for NRSL eV2X	16.5.0
2020-09	RAN#89	R5-204866	0689	1	F	CR to update MU and TT in 38.521-3	16.5.0
2020-09	RAN#89	R5-204867	0716	1	F	Update for 6.5B.3.3.2 Spurious emission band UE co-existence	16.5.0
2020-09	RAN#89	R5-204869	0649	1	F	Adjacent Channel Selectivity FR2 MU and TT updates in 38.521-3	16.5.0
2020-09	RAN#89	R5-204924	0666	1	F	Update of Test applicability for some Inter-Band EN-DC including FR2 TCs	16.5.0
2020-09	RAN#89	R5-204925	0687	1	F	Clean up complete status for EN-DC test cases	16.5.0
2020-09	RAN#89	R5-204926	0731	1	F	Addition of pending UL-MIMO tests (FR2) in Clause 6	16.5.0
2020-09	RAN#89	R5-204928	0681	1	F	Update of NSA Rx test cases for 4Rx UEs	16.5.0
2020-09	RAN#89	R5-204929	0700	1	F	Addition of TC 7.5B.3_1.2 ACS for EN-DC within FR1 4CC	16.5.0
2020-09	RAN#89	R5-204930	0711	1	F	Addition of TC 7.6B.2.5D Inband blocking for inter-band EN-DC including FR1 and FR2 for UL-MIMO	16.5.0
2020-09	RAN#89	R5-204931	0712	1	F	Update for 7.3B.2.3 Ref sense for Inter-band EN-DC within FR1-2 CCs	16.5.0
2020-09	RAN#89	R5-204932	0719	1	F	Re-organization of EN-DC refsens test cases	16.5.0
2020-09	RAN#89	R5-204957	0695	1	F	Updated to clause 7 for EN-DC Rel-16 configuration test requirement	16.5.0
2020-09	RAN#89	R5-204958	0737	1	F	Add Rx TC for 2Rel 16 DC combos	16.5.0
2020-09	RAN#89	R5-205005	0741	-	F	Update of OOB and Spurious Response of Inter-band EN-DC within FR1	16.5.0
2020-09	RAN#89	R5-205006	0690	1	F	Update Refsense exceptions for EN-DC including n78	16.5.0
2020-12	RAN#90	R5-205489	0749	-	F	Correction to Reference Sensitivity for Inter-band EN-DC	16.6.0
2020-12	RAN#90	R5-205500	0750	-	F	Minor correction of section 6.1	16.6.0
2020-12	RAN#90	R5-205501	0751	-	F	Correction of spec style in section 7.6B and 7.7B and correction of table number in 7.6B.3.3.4.1	16.6.0
2020-12	RAN#90	R5-205502	0752	-	F	Addition of intra-band contiguous EN-DC testing and update of inter-band EN-DC testing for 7.6B.2.3_1.1 Inband blocking for EN-DC within FR1 3 CCs	16.6.0

2020-12	RAN#90	R5-205503	0753	-	F	Addition of intra-band contiguous EN-DC testing and update of inter-band EN-DC testing for 7.6B.2.3_1.2 Inband blocking for EN-DC within FR1 4 CCs	16.6.0
2020-12	RAN#90	R5-205505	0755	-	F	Addition of new test case 7.6B.3.3_1.1 Out-of-band blocking for EN-DC within FR1 3 CCs	16.6.0
2020-12	RAN#90	R5-205506	0756	-	F	Addition of new test case 7.6B.3.3_1.2 Out-of-band blocking for EN-DC within FR1 4 CCs	16.6.0
2020-12	RAN#90	R5-205507	0757	-	F	Addition of intra-band contiguous EN-DC testing and update of inter-band EN-DC testing for 7.6B.4.3_1.1 Narrow band blocking for EN-DC within FR1 3 CCs	16.6.0
2020-12	RAN#90	R5-205508	0758	-	F	Addition of intra-band contiguous EN-DC testing and update of inter-band EN-DC testing for 7.6B.4.3_1.2 Narrow band blocking for EN-DC within FR1 4 CCs	16.6.0
2020-12	RAN#90	R5-205510	0760	-	F	Addition of new test case 7.7B.3_1.1 Spurious Response for EN-DC within FR1 3 CCs	16.6.0
2020-12	RAN#90	R5-205511	0761	-	F	Addition of new test case 7.7B.3_1.2 Spurious Response for EN-DC within FR1 4 CCs	16.6.0
2020-12	RAN#90	R5-205515	0763	-	F	Correction of section 7.1 and update of 7.6B.3.0.3A and 7.7B.0.3A as per RAN4 spec	16.6.0
2020-12	RAN#90	R5-205516	0764	-	F	Correction of uplink power and in gap test requirement for 7.6B.2.2, 7.6B.3.2, 7.6B.4.2 and 7.7B.2	16.6.0
2020-12	RAN#90	R5-205534	0768	-	F	Editorial, removing duplication of text in test case	16.6.0
2020-12	RAN#90	R5-205568	0776	-	F	Introduction of DC_3A-40A_n1A to reference sensitivity test	16.6.0
2020-12	RAN#90	R5-205678	0778	-	F	Addition of Clause 7.5B.4D ACS for inter-band EN-DC including FR2 for UL-MIMO	16.6.0
2020-12	RAN#90	R5-205679	0779	-	F	Addition of Clause 7.6B.2.4D Inband blocking for inter-band EN-DC including FR2 for UL-MIMO	16.6.0
2020-12	RAN#90	R5-205696	0782	-	F	Editorial correction to EN-DC test cases 6.5B.2.3	16.6.0
2020-12	RAN#90	R5-205775	0785	-	F	Adding delta TIB for a few Rel-16 inter-band EN-DC configurations within FR1	16.6.0
2020-12	RAN#90	R5-205776	0786	-	F	Adding refsens exceptions for DC_3_n78 due to receiver harmonic mixing	16.6.0
2020-12	RAN#90	R5-205778	0788	-	F	Adding delta RIB for DC_2-7-66_n78	16.6.0
2020-12	RAN#90	R5-205784	0790	-	F	Update of UE co-existence spurious emissions for Rel-16 inter-band EN-DC DC_13_n66	16.6.0
2020-12	RAN#90	R5-205788	0792	-	F	Correction to UE co-existence spurious emissions for inter-band EN-DC within FR1	16.6.0
2020-12	RAN#90	R5-205803	0793	-	F	Introduction of New TC 6.4B.2.4.2_1.1 Carrier Leakage for inter-band EN-DC including FR2 with 3 CCs	16.6.0
2020-12	RAN#90	R5-205804	0794	-	F	Introduction of New TC 6.4B.2.4.2_1.2 Carrier Leakage for inter-band EN-DC including FR2 with 4 CCs	16.6.0
2020-12	RAN#90	R5-205806	0795	-	F	Introduction of New TC 6.4B.2.4.2_1.3 Carrier Leakage for inter-band EN-DC including FR2 with 5 CCs	16.6.0
2020-12	RAN#90	R5-205855	0798	-	F	Correction of channel bandwidth for EN-DC MOP TC 6.2B.1.3	16.6.0
2020-12	RAN#90	R5-205911	0803	-	F	Introduction of DC_3A-20A_n78A to reference sensitivity test	16.6.0
2020-12	RAN#90	R5-205934	0805	-	F	Update of DC_1A-7A_n78A to reference sensitivity test	16.6.0
2020-12	RAN#90	R5-205935	0806	-	F	Update DC_7A-20A_n78A to reference sensitivity test	16.6.0
2020-12	RAN#90	R5-205994	0808	-	F	Updates to Reference sensitivity for EN-DC within FR1 3CC	16.6.0

2020-12	RAN#90	R5-206018	0811	-	F	Correction of 7.3B.3.3 for delta RIB with inter-band EN-DC configurations	16.6.0
2020-12	RAN#90	R5-206029	0813	-	F	Update spurious emission band UE co-existence for DC_2_n41 and DC_66_n41	16.6.0
2020-12	RAN#90	R5-206236	0832	-	F	Correction to Rel-16 EN-DC configuration DC_40A_n1A and DC_40A_n78 in spurious emission test case 6.5B.3.3.2	16.6.0
2020-12	RAN#90	R5-206237	0833	-	F	Introduction of Rel-16 EN-DC configuration DC_1A_n3A to spurious emission test case 6.5B.3.3.2	16.6.0
2020-12	RAN#90	R5-206238	0834	-	F	Introduction of Rel-16 EN-DC configuration DC_20A_n3A to spurious emission test case 6.5B.3.3.2	16.6.0
2020-12	RAN#90	R5-206255	0835	-	F	Update for 6.5B.3.2.2 Spurious emission band UE co-existence for intra-band non-contiguous EN-DC	16.6.0
2020-12	RAN#90	R5-206648	0766	1	F	Addition of TC6.3B.1.4D Minimum output power for inter-band EN-DC including FR2 for UL-MIMO	16.6.0
2020-12	RAN#90	R5-206649	0767	1	F	Addition of TC6.3B.3.4 Transmit ON/OFF time mask for inter-band EN-DC including FR2	16.6.0
2020-12	RAN#90	R5-206650	0777	1	F	Update on Transmit OFF power for EN-DC including FR2	16.6.0
2020-12	RAN#90	R5-206651	0789	1	F	Update of UE co-existence spurious emissions for a few Rel-15 inter-band EN-DC configurations	16.6.0
2020-12	RAN#90	R5-206652	0796	1	F	Addition of 6.5B.2.4D.3 Adjacent channel leakage ratio for inter-band EN-DC including FR2 for UL-MIMO	16.6.0
2020-12	RAN#90	R5-206653	0799	1	F	Update of 6.2B.1.4_1 MOP for Inter-Band EN-DC including FR2	16.6.0
2020-12	RAN#90	R5-206654	0821	1	F	Update for 6.5B.3.1.2 Spurious emission band UE co-existence for intra-band contiguous EN-DC	16.6.0
2020-12	RAN#90	R5-206655	0822	1	F	Update for 6.5B.3.3.2 Spurious emission band UE co-existence for Inter-band within FR1	16.6.0
2020-12	RAN#90	R5-206656	0780	1	F	Update for Clause F.1.3 Measurement of receiver	16.6.0
2020-12	RAN#90	R5-206657	0810	1	F	Correction of 7.3B.3.3 for allowed reference sensitivity relaxation	16.6.0
2020-12	RAN#90	R5-206658	0819	1	F	Update the interferer range for OOB and Spurious Response of Inter-band EN-DC within FR1	16.6.0
2020-12	RAN#90	R5-206659	0823	1	F	Update for 7.3B.2.0 Minimum Conformance Requirements of Reference sensitivity for EN-DC	16.6.0
2020-12	RAN#90	R5-206660	0826	1	F	Editor's notes updates for FR1 inter-band 3CC DL CA	16.6.0
2020-12	RAN#90	R5-206661	0762	1	F	Addition of measurement uncertainties and test tolerance for blocking test cases for EN-DC within FR1 with 3CCs, 4CCs and 5CCs and correction of some spec styles	16.6.0
2020-12	RAN#90	R5-206662	0817	1	F	6.4B.2.1.1 Error Vector Magnitude for intra-band contiguous EN DC Measurement Uncertainty update	16.6.0
2020-12	RAN#90	R5-206663	0818	1	F	6.4B.2.1.2 Carrier Leakage for intra-band contiguous EN-DC Measurement Uncertainty update	16.6.0
2020-12	RAN#90	R5-206664	0820	1	F	FR1 Intra-band CA General Tx ON OFF time mask measurement uncertainties and test tolerances corrections	16.6.0
2020-12	RAN#90	R5-206665	0836	1	F	TS 38.521-3 Section 1-5 and Annex updates to align with core specification	16.6.0
2020-12	RAN#90	R5-206720	0742	1	F	Introduction of New test case 6.3B.1.4_1.1 Minimum output power for inter-band EN-DC including FR2 - 3 CCs	16.6.0
2020-12	RAN#90	R5-206721	0743	1	F	Introduction of New test case 6.3B.1.4_1.2 Minimum output power for inter-band EN-DC including FR2 - 4 CCs	16.6.0

2020-12	RAN#90	R5-206722	0744	1	F	Introduction of New test case 6.3B.1.4_1.3 Minimum output power for inter-band EN-DC including FR2 - 5 CCs	16.6.0
2020-12	RAN#90	R5-206723	0745	1	F	Introduction of New test case 6.4B.2.4.1_1.1 Error Vector Magnitude for inter-band EN-DC including FR2 - 3 CCs	16.6.0
2020-12	RAN#90	R5-206724	0746	1	F	Introduction of New test case 6.4B.2.4.1_1.2 Error Vector Magnitude for inter-band EN-DC including FR2 - 4 CCs	16.6.0
2020-12	RAN#90	R5-206725	0747	1	F	Introduction of New test case 6.4B.2.4.1_1.3 Error Vector Magnitude for inter-band EN-DC including FR2 - 5 CCs	16.6.0
2020-12	RAN#90	R5-206727	0787	1	F	Adding refsens exceptions for DC_3_n1 due to cross band isolation	16.6.0
2020-12	RAN#90	R5-206728	0783	1	F	Update to EN-DC R16 Configuration information in clause 5	16.6.0
2020-12	RAN#90	R5-206772	0781	1	F	Addition of PC2 Tx requirements for DC_3A_n41A	16.6.0
2020-12	RAN#90	R5-206773	0801	1	F	Addition of PC2 Tx requirements for DC_3A_n78A	16.6.0
2020-12	RAN#90	R5-206784	0802	1	F	Updating Rel-16 EN-DC PC2 MOP to add UE power class capability for NR part	16.6.0
2020-12	RAN#90	R5-206827	0829	1	F	Minimum output power editor's notes	16.6.0
2020-12	RAN#90	R5-206828	0828	1	F	Update FR2 TRx MU and TT in 38.521-3	16.6.0
2020-12	RAN#90	R5-206869	0809	1	F	Updates to Reference sensitivity for EN-DC within FR1 4CC restructuring test configuration tables	16.6.0
2020-12	RAN#90	R5-206870	0825	1	F	Measurement uncertainties and test tolerances updates for FR1 inter-band 3CC DL CA	16.6.0
2020-12	RAN#90	R5-206883	0772	1	F	Introduction of DC_3A_n1A to reference sensitivity test	16.6.0
2020-12	RAN#90	R5-206884	0773	1	F	Introduction of DC_1A_n3A to reference sensitivity test	16.6.0
2020-12	RAN#90	R5-206885	0774	1	F	Introduction of DC_20A_n3A to reference sensitivity test	16.6.0
2020-12	RAN#90	R5-206886	0775	1	F	Introduction of DC_40A_n78A to reference sensitivity test	16.6.0
2020-12	RAN#90	R5-206902	0769	1	F	Moving test configurations table for EN-DC 20_n78 to a general test configuration table for 2CC reference sensitivity exceptions	16.6.0
2020-12	RAN#90	R5-206903	0770	1	F	Introduction of DC_1A_n78A to reference sensitivity test	16.6.0
2020-12	RAN#90	R5-206904	0771	1	F	Introduction of DC_3A_n78A to reference sensitivity test	16.6.0
2020-12	RAN#90	R5-206913	0754	1	F	Update of 7.6B.2.3_1.3 Inband blocking for EN-DC within FR1 5 CCs and removal of 7.6B.2.3_1.4 Inband blocking for EN-DC within FR1 6 CCs	16.6.0
2020-12	RAN#90	R5-206914	0759	1	F	Update of 7.6B.4.3_1.3 Narrow band blocking for EN-DC within FR1 5 CCs and removal of 7.6B.4.3_1.4 Narrow band blocking for EN-DC within FR1 6 CCs	16.6.0
2020-12	RAN#90	R5-206915	0807	1	F	Updates to Reference sensitivity for EN-DC within FR1 2CC for UE supporting single UL	16.6.0
2020-12	RAN#90	R5-206916	0827	1	F	Update for 7.3B.3.2	16.6.0
2020-12	RAN#90	R5-206918	0804	1	F	Addition of PC2 Rx requirements for DC_3A_n41A	16.6.0
2020-12	RAN#90	R5-206919	0814	1	F	Addition of PC2 ENDC DC_3A-n78A into TC7.3B.2.3	16.6.0
2021-03	RAN#91	R5-210093	0842	-	F	Introduction of DC_7A-20A_n3A to reference sensitivity test	16.7.0
2021-03	RAN#91	R5-210301	0847	-	F	Completion of OBW intra-band non-contiguous test 6.5B.1.2	16.7.0
2021-03	RAN#91	R5-210302	0848	-	B	Addition of new test case 6.5B.1.4D OBW for inter-band EN-DC FR2 UL MIMO	16.7.0
2021-03	RAN#91	R5-210387	0857	-	F	Correction to EN-DC OoB emissions	16.7.0

2021-03	RAN#91	R5-210415	0858	-	F	Addition of new test case 6.4B.2.4.3_1.1 In-band Emissions for inter-band EN-DC including FR2 with 3 CCs	16.7.0
2021-03	RAN#91	R5-210416	0859	-	F	Addition of new test case 6.4B.2.4.3_1.2 In-band Emissions for inter-band EN-DC including FR2 with 4 CCs	16.7.0
2021-03	RAN#91	R5-210417	0860	-	F	Addition of new test case 6.4B.2.4.3_1.3 In-band Emissions for inter-band EN-DC including FR2 with 5 CCs	16.7.0
2021-03	RAN#91	R5-210497	0861	-	F	Correction of test frequencies for NR band n28 30MHz test channel bandwidth of 6.2B.1.3	16.7.0
2021-03	RAN#91	R5-210498	0862	-	F	Addition of editor note to the incomplete test cases	16.7.0
2021-03	RAN#91	R5-210499	0863	-	F	Correction of test applicability of 6.5B.5.3	16.7.0
2021-03	RAN#91	R5-210500	0864	-	F	Correction of test configuration tables in section 6	16.7.0
2021-03	RAN#91	R5-210501	0865	-	F	Completion of 7.6B.2.3_1.3 Inband blocking for EN-DC within FR1 5 CCs	16.7.0
2021-03	RAN#91	R5-210502	0866	-	F	Correction of test frequencies for NR band n28 30MHz test channel bandwidth of 7.6B.3.3	16.7.0
2021-03	RAN#91	R5-210548	0872	-	F	Default message exceptions for LTE carriers in EN-DC	16.7.0
2021-03	RAN#91	R5-210725	0874	-	F	Omitting of NSA Rx cases with UL-MIMO on TDD bands	16.7.0
2021-03	RAN#91	R5-210909	0882	-	F	Editorial correction to test case 6.2B.4.1.3	16.7.0
2021-03	RAN#91	R5-210943	0883	-	F	Adding delta TIB and delta RIB for DC_2-7-7-66_n78	16.7.0
2021-03	RAN#91	R5-210989	0889	-	F	Update for 7.3B.2.0 Minimum Conformance Requirements of Reference sensitivity for EN-DC	16.7.0
2021-03	RAN#91	R5-211005	0893	-	F	Update to EN-DC R16 Configuration information in clause 5	16.7.0
2021-03	RAN#91	R5-211010	0895	-	F	Update of reference sensitivity for intra-band contiguous EN-DC	16.7.0
2021-03	RAN#91	R5-211014	0899	-	F	Adding in-gap tests to ACS for intra-band non-contiguous EN-DC	16.7.0
2021-03	RAN#91	R5-211017	0901	-	F	Update of test coverage for reference sensitivity for 3CC EN-DC	16.7.0
2021-03	RAN#91	R5-211020	0902	-	F	Adding EN-DC configurations DC_1A-28A_n3A and DC_7A-28A_n3A to clause 5.5B.4.2	16.7.0
2021-03	RAN#91	R5-211099	0917	-	F	Correction to editors note about number of E-UTRA carriers	16.7.0
2021-03	RAN#91	R5-211111	0921	-	F	Corrections to subclauses in 38.521-3 with appropriate subclause level and heading styles	16.7.0
2021-03	RAN#91	R5-211125	0922	-	F	Update of 5.3B for UE channel bandwidth for EN-DC	16.7.0
2021-03	RAN#91	R5-211240	0934	-	F	Introduction of DC_7A-20A_n1A to reference sensitivity test	16.7.0
2021-03	RAN#91	R5-211241	0935	-	F	Introduction of DC_7A- 28A_n3A to referce sensitivity test	16.7.0
2021-03	RAN#91	R5-211694	0844	1	F	Spectrum emissions mask for intra-band non-contiguous EN-DC Test Definition	16.7.0
2021-03	RAN#91	R5-211695	0849	1	F	ACLR for intra-band non-contiguous EN-DC Test Definition	16.7.0
2021-03	RAN#91	R5-211696	0856	1	F	Update Test description of 6.5B.1.1	16.7.0
2021-03	RAN#91	R5-211697	0871	1	F	EN-DC FR2 UL CA Frequency error test cases update	16.7.0
2021-03	RAN#91	R5-211698	0876	1	F	Correction of test requirements for EN-DC configured output power	16.7.0
2021-03	RAN#91	R5-211699	0906	1	F	Introduction of Rel-15 EN-DC configuration DC_8A_n77A to spurious emission test case 6.5B.3.3.2	16.7.0
2021-03	RAN#91	R5-211700	0907	1	F	Introduction of Rel-15 EN-DC configuration DC_11A_n77A to spurious emission test case 6.5B.3.3.2	16.7.0

2021-03	RAN#91	R5-211701	0908	1	F	Introduction of Rel-15 EN-DC configuration DC_11A_n78A to spurious emission test case 6.5B.3.3.2	16.7.0
2021-03	RAN#91	R5-211702	0909	1	F	Introduction of Rel-15 EN-DC configuration DC_11A_n79A to spurious emission test case 6.5B.3.3.2	16.7.0
2021-03	RAN#91	R5-211703	0910	1	F	Introduction of Rel-15 EN-DC configuration DC_25A_n41A to spurious emission test case 6.5B.3.3.2	16.7.0
2021-03	RAN#91	R5-211704	0911	1	F	Introduction of Rel-15 EN-DC configuration DC_26A_n41A to spurious emission test case 6.5B.3.3.2	16.7.0
2021-03	RAN#91	R5-211705	0912	1	F	Introduction of Rel-15 EN-DC configuration DC_26A_n77A to spurious emission test case 6.5B.3.3.2	16.7.0
2021-03	RAN#91	R5-211706	0913	1	F	Introduction of Rel-15 EN-DC configuration DC_26A_n78A to spurious emission test case 6.5B.3.3.2	16.7.0
2021-03	RAN#91	R5-211707	0914	1	F	Introduction of Rel-15 EN-DC configuration DC_26A_n79A to spurious emission test case 6.5B.3.3.2	16.7.0
2021-03	RAN#91	R5-211708	0915	1	F	Introduction of Rel-15 EN-DC configuration DC_41A_n77A to spurious emission test case 6.5B.3.3.2	16.7.0
2021-03	RAN#91	R5-211709	0916	1	F	Introduction of Rel-15 EN-DC configuration DC_41A_n78A to spurious emission test case 6.5B.3.3.2	16.7.0
2021-03	RAN#91	R5-211710	0853	1	F	Correction of MSD test point on Table 7.3B.2.0.3.5.2-1 DC_1A-8A_n78A	16.7.0
2021-03	RAN#91	R5-211711	0854	1	F	Update of 7.3B.2.3_1.1 RefSens DC_3A-8A_n78A	16.7.0
2021-03	RAN#91	R5-211712	0855	1	F	Addition of new test case 7.3B.4 for EIS Spherical Coverage	16.7.0
2021-03	RAN#91	R5-211713	0867	1	F	Editorial correction for errors in 7.6B.4.3_1	16.7.0
2021-03	RAN#91	R5-211714	0868	1	F	Correction of test configuration tables in section 7	16.7.0
2021-03	RAN#91	R5-211715	0877	1	F	Clarification of tested Rx antenna numbers on E-UTRA band	16.7.0
2021-03	RAN#91	R5-211766	0837	1	F	Introduction of Rel-16 EN-DC configuration DC_7A_n3A to spurious emission test case 6.5B.3.3.2	16.7.0
2021-03	RAN#91	R5-211767	0838	1	F	Introduction of Rel-16 EN-DC configuration DC_8A_n3A to spurious emission test case 6.5B.3.3.2	16.7.0
2021-03	RAN#91	R5-211768	0839	1	F	Introduction of Rel-16 EN-DC configuration DC_20A_n1A to spurious emission test case 6.5B.3.3.2	16.7.0
2021-03	RAN#91	R5-211769	0887	1	F	Update for 6.5B.3.3.2 Spurious emission band UE co-existence_Rel16	16.7.0
2021-03	RAN#91	R5-211770	0903	1	F	Adding Delta TIB,c for DC_1A-28A_n3A, DC_7A-20A_n1A and DC_7A-28A_n3A to clause 6.2B.4.2.3.3	16.7.0
2021-03	RAN#91	R5-211771	0840	1	F	Introduction of DC_7A_n3A to reference sensitivity test	16.7.0
2021-03	RAN#91	R5-211772	0841	1	F	Introduction of DC_8A_n1A and DC_8A_n3A to reference sensitivity test	16.7.0
2021-03	RAN#91	R5-211773	0869	1	F	Adding Inter-band EN-DC combination within FR1	16.7.0
2021-03	RAN#91	R5-211840	0878	1	F	Updating Rel-16 EN-DC PC2 MOP to include powerClassNRPart-r16	16.7.0
2021-03	RAN#91	R5-211841	0879	1	F	Updating Rel-16 EN-DC PC2 MPR to include powerClassNRPart-r16	16.7.0
2021-03	RAN#91	R5-211842	0880	1	F	Updating Rel-16 EN-DC PC2 A-MPR to include powerClassNRPart-r16	16.7.0
2021-03	RAN#91	R5-211843	0881	1	F	Updating Rel-16 EN-DC PC2 configured output power to include powerClassNRPart-r16	16.7.0
2021-03	RAN#91	R5-211852	0888	1	F	Update for 6.5B.3.3.2 Spurious emission band UE co-existence	16.7.0



2021-03	RAN#91	R5-211854	0890	1	F	Correction to EN-DC Wideband Intermodulation tests	16.7.0
2021-03	RAN#91	R5-211870	0843	1	F	Editorial addition of editors notes in 6.3B.8.1.4, 6.3B.8.2.4 and 6.3B.8.3.4	16.7.0
2021-03	RAN#91	R5-211871	0875	1	F	Correcting EN-DC A-MPR test requirements for non-overlapping test points	16.7.0
2021-03	RAN#91	R5-211872	0886	1	F	Correction to the TDM pattern configuration for EN-DC Tx test cases	16.7.0
2021-03	RAN#91	R5-211873	0918	1	F	Correction to MOP and MPR test procedures for PC2 in TC 6.2B.1.3 and 6.2B.2.1	16.7.0
2021-03	RAN#91	R5-211874	0845	1	F	Correction of LTE frequency for 19-n79 combo in 7.3B.2.3	16.7.0
2021-03	RAN#91	R5-211875	0870	1	F	Update to EN-DC Reference Sensitivity	16.7.0
2021-03	RAN#91	R5-211876	0896	1	F	Update of reference sensitivity for intra-band non-contiguous EN-DC	16.7.0
2021-03	RAN#91	R5-211877	0897	1	F	Update of reference sensitivity for inter-band 2CC EN-DC	16.7.0
2021-03	RAN#91	R5-211878	0898	1	F	Correction to refsens test requirements for DC_1A-7A_n78A	16.7.0
2021-03	RAN#91	R5-211879	0900	1	F	Update of test configuration for inter-band 2CC EN-DC configurations affected by reference sensitivity exceptions	16.7.0
2021-03	RAN#91	R5-211880	0924	1	F	Update of 2CC refsens test case 7.3B.2.3	16.7.0
2021-03	RAN#91	R5-211881	0925	1	F	Update of 3CC refsens test case 7.3B.2.3_1.1	16.7.0
2021-03	RAN#91	R5-211882	0926	1	F	Correction of configurations not to be tested in 4CC refsens test case 7.3B.2.3_1.2	16.7.0
2021-03	RAN#91	R5-211883	0927	1	F	Addition of DC_8A_n77A in test case 7.3B.2.3	16.7.0
2021-03	RAN#91	R5-211884	0928	1	F	Addition of DC_11A_n79A in test case 7.3B.2.3	16.7.0
2021-03	RAN#91	R5-211885	0929	1	F	Addition of DC_26A_n41A in test case 7.3B.2.3	16.7.0
2021-03	RAN#91	R5-211886	0930	1	F	Addition of DC_26A_n77A and DC_26A_n78A in test case 7.3B.2.3	16.7.0
2021-03	RAN#91	R5-211887	0931	1	F	Addition of DC_26A_n79A in test case 7.3B.2.3	16.7.0
2021-03	RAN#91	R5-211888	0932	1	F	Addition of DC_41A_n77A and DC_41A_n78A in test case 7.3B.2.3	16.7.0
2021-03	RAN#91	R5-211905	0933	1	F	Introduction of DC_1A-28A_n3A to reference sensitivity test	16.7.0
2021-03	RAN#91	R5-211926	0851	1	F	MU definition for UE MOP for Inter-Band EN-DC including FR2 (3CCs)	16.7.0
2021-03	RAN#91	R5-211927	0852	1	F	MU and TT definition for REFSENS EN-DC including FR2 up to 5CCs	16.7.0
2021-03	RAN#91	R5-211928	0920	1	F	Update FR2 MU and TT in 38.521-3	16.7.0
2021-03	RAN#91	-	-	-	-	Administrative release upgrade to match the release of TS 38.508-1, TS 38.508-2 and TS 38.521-1 which were upgraded at RAN#91 to Rel-17 due to Rel-17 relevant CRs	17.0.0
2021-06	RAN#92	R5-212345	0944	-	F	Define MU and TT for test case 7.9B.3_1.1	17.1.0
2021-06	RAN#92	R5-212349	0948	-	F	Update MU and TT in 38.521-3 for Transmit OFF Power FR2 CA tests	17.1.0
2021-06	RAN#92	R5-212350	0949	-	F	ACS and IBB - FR2 MU definition in 38.521-3	17.1.0
2021-06	RAN#92	R5-212531	0954	-	F	Update for 6.5B.3.3.2 Spurious emission band UE co-existence for Rel 16	17.1.0
2021-06	RAN#92	R5-212646	0976	-	F	Correcting test case title in 6.5B.2.2.2	17.1.0
2021-06	RAN#92	R5-212734	0977	-	F	Update UL-MIMO to UL MIMO in clause 6 to align with other specs	17.1.0
2021-06	RAN#92	R5-212735	0978	-	F	Update UL-MIMO to UL MIMO in clause 7 to align with other specs	17.1.0

2021-06	RAN#92	R5-212736	0979	-	F	Update UL-MIMO to UL MIMO in Common and Annexes to align with other specs	17.1.0
2021-06	RAN#92	R5-212749	0983	-	F	Update to EN-DC R15 common section	17.1.0
2021-06	RAN#92	R5-212824	0986	-	F	Correction of 6.2B.1.2 for test of UE maximum output power for intra-band non-contiguous EN-DC	17.1.0
2021-06	RAN#92	R5-212825	0987	-	F	Correction of 6.2B.1.3 for test of UE maximum output power for EN-DC within FR1	17.1.0
2021-06	RAN#92	R5-212867	0992	-	F	Correction of the section order in 7.9B	17.1.0
2021-06	RAN#92	R5-212869	0994	-	F	Unify the SCS definitions in the test configuration tables	17.1.0
2021-06	RAN#92	R5-212976	0996	-	F	Updating H.2.2 for NR NSA testing	17.1.0
2021-06	RAN#92	R5-213018	0998	-	F	Update of E-UTRA TDD configuration for overlapping UL transmission	17.1.0
2021-06	RAN#92	R5-213019	0999	-	F	Update of TDM pattern configuration in EN-DC MOP and A-MPR cases	17.1.0
2021-06	RAN#92	R5-213020	1000	-	F	Update of EN-DC Tx cases to enable DFT-s-OFDM modulation for NR uplink carrier	17.1.0
2021-06	RAN#92	R5-213045	1006	-	F	Correction to reference sensitivity for DC_41A_n77A and DC_41A_n78A	17.1.0
2021-06	RAN#92	R5-213046	1007	-	F	Correction to reference sensitivity for a few Rel-16 EN-DC combinations	17.1.0
2021-06	RAN#92	R5-213047	1008	-	F	Correction to test description in 7.3B.2 refsens for EN-DC within FR1	17.1.0
2021-06	RAN#92	R5-213048	1009	-	F	Update of test requirements for exception avoiding test points in 7.3B.2.3 refsens for inter-band EN-DC	17.1.0
2021-06	RAN#92	R5-213059	1011	-	F	Update of 6.4B.2.2.3 In-band Emissions for intra-band non-contiguous EN-DC	17.1.0
2021-06	RAN#92	R5-213060	1012	-	F	Correction of 7.4B.3_1 Maximum Input Level for EN-DC within FR1 with more than 2 CCs	17.1.0
2021-06	RAN#92	R5-213200	1015	-	F	Correction to EN-DC FR1 TC6.3B.1.1	17.1.0
2021-06	RAN#92	R5-213377	1028	-	F	Correcting test procedure and test requirement for MPR Intra-Band Contiguous EN-DC	17.1.0
2021-06	RAN#92	R5-213843	0971	1	F	Correction of power control in 38.521-3	17.1.0
2021-06	RAN#92	R5-213844	1020	1	F	FR2 Inter-band Carrier Aggregation Minimum Output power updates	17.1.0
2021-06	RAN#92	R5-213845	1010	1	F	Adding refsens testing per band for all inter-band 2CC EN-DC FR1 non-exception requirements	17.1.0
2021-06	RAN#92	R5-213846	1019	1	F	Measurement uncertainties and test tolerances for FR2 Inter-band Carrier Aggregation Minimum Output power	17.1.0
2021-06	RAN#92	R5-213905	0947	1	F	Update 6.2B.1.1 according to core requirements	17.1.0
2021-06	RAN#92	R5-213906	0952	1	F	Update for 6.5B.3.3.2 Spurious emission band UE co-existence for Rel 15 DC_2A_n71A	17.1.0
2021-06	RAN#92	R5-213907	0955	1	F	Update for 6.5B.3.3.2 for Rel 15 requirement	17.1.0
2021-06	RAN#92	R5-213908	0975	1	F	References to voided clause 5.2B.2 corrected	17.1.0
2021-06	RAN#92	R5-213909	0990	1	F	Removal of test cases in 6.3B.2.4_1	17.1.0
2021-06	RAN#92	R5-213910	0997	1	F	Correction of test frequencies for NR band n28 30MHz test channel bandwidth in 6.2B.4.1.3	17.1.0
2021-06	RAN#92	R5-213911	1001	1	F	Update of EN-DC Tx test cases with LTE anchor agnostic approach applied	17.1.0

2021-06	RAN#92	R5-213912	1023	1	F	Updates to Frequency Error for Inter-band EN-DC including FR2 (>2 CCs)	17.1.0
2021-06	RAN#92	R5-213913	1025	1	F	Addition of missing EN-DC Beam Correspondence requirements	17.1.0
2021-06	RAN#92	R5-213914	0963	1	F	Addition of 7.5B.3_1.3 ACS for EN-DC within FR1 5 CCs	17.1.0
2021-06	RAN#92	R5-213915	0964	1	F	Addition of 7.5B.3_1.4 ACS for EN-DC within FR1 6 CCs	17.1.0
2021-06	RAN#92	R5-213916	0973	1	F	Update of FR1 EN-DC intermodulation with 4CC in TC 7.8B.2.3_1.2	17.1.0
2021-06	RAN#92	R5-213917	1029	1	F	Correction to EN-DC Rx test case and format	17.1.0
2021-06	RAN#92	R5-213918	0967	1	F	Update of Annex F.1.3 for ACS for EN-DC within FR1 5CCs and 6CCs	17.1.0
2021-06	RAN#92	R5-213973	0942	1	F	Correction to EN-DC configuration DC_7A_n3A spurious emission test requirement	17.1.0
2021-06	RAN#92	R5-213974	0953	1	F	Update for 6.5B.3.3.2 Spurious emission band UE co-existence for Rel 16 DC_66A_n2A	17.1.0
2021-06	RAN#92	R5-213975	0988	1	F	Update of 6.5B.3.3 for spurious emission for DC_2_n41	17.1.0
2021-06	RAN#92	R5-213976	0956	1	F	Correction for DC_7A-20A_n3A reference sensitivity test	17.1.0
2021-06	RAN#92	R5-214008	1018	1	F	Update of PC2 ENDC DC_3A-n78A into 38.521-3 TC7.3B.2.3	17.1.0
2021-06	RAN#92	R5-214030	1014	1	F	Addition of PC2 ENDC DC_1A-n78A into 38.521-3 TC7.3B.2.3	17.1.0
2021-06	RAN#92	R5-214041	0972	1	F	Correction of ON OFF time mask in 38.521-3	17.1.0
2021-06	RAN#92	R5-214052	0993	1	F	Correction of for further study notes about FR2 ETC testing	17.1.0
2021-06	RAN#92	R5-214053	1002	1	F	Correction to UE co-existence spurious emissions for intra-band contiguous EN-DC	17.1.0
2021-06	RAN#92	R5-214054	1003	1	F	Correction to UE co-existence spurious emissions for intra-band non-contiguous EN-DC	17.1.0
2021-06	RAN#92	R5-214055	1004	1	F	Correction to test configuration for general spurious emissions for inter-band EN-DC	17.1.0
2021-06	RAN#92	R5-214056	1005	1	F	Updating test requirements for general spurious emissions for inter-band EN-DC	17.1.0
2021-06	RAN#92	R5-214057	1024	1	F	Update of Spurious emission band UE co-existence test case	17.1.0
2021-06	RAN#92	R5-214072	0950	1	F	Update of 6.5B.3.3.2 for Rel-16 combo DC_14A_n2A and DC_14A_n66A	17.1.0
2021-06	RAN#92	R5-214079	0958	1	F	Update of Applicability for Tx inter-band EN-DC including FR2 under R15 WI	17.1.0
2021-06	RAN#92	R5-214080	0974	1	F	Editor's note for Wgap can be removed in 6.5B.4.2	17.1.0
2021-06	RAN#92	R5-214081	0980	1	F	Update of applicability for EN-DC Tx tests within FR1	17.1.0
2021-06	RAN#92	R5-214082	0959	1	F	Update of Applicability for Rx inter-band EN-DC including FR2	17.1.0
2021-06	RAN#92	R5-214083	0961	1	F	Correction of 7.5B.3_1.1 ACS for EN-DC within FR1 3 CCs	17.1.0
2021-06	RAN#92	R5-214084	0962	1	F	Correction of 7.5B.3_1.2 ACS for EN-DC within FR1 4 CCs	17.1.0
2021-06	RAN#92	R5-214085	0966	1	F	Update of Applicability for 7.5B.3 ACS for inter-band EN-DC within FR1 2 CCs	17.1.0
2021-06	RAN#92	R5-214086	0981	1	F	Update of applicability for EN-DC Rx tests within FR1	17.1.0
2021-06	RAN#92	R5-214087	0982	1	F	Correction to EN-DC inter-band FR2 test cases 7.3B.2.4_1.x	17.1.0
2021-06	RAN#92	R5-214094	0957	1	F	Update of Applicability for Tx inter-band EN-DC including FR2 under R16 WI	17.1.0

2021-06	RAN#92	R5-214095	0984	1	F	Update to EN-DC R16 common section	17.1.0
2021-09	RAN#93	R5-214188	1030	-	F	Update of R17 CADC configurations into TS38.521-3 clause 5	17.2.0
2021-09	RAN#93	R5-214280	1032	-	F	Introduction of Rel-15 EN-DC DC_1A_n77A to spurious emission test cases	17.2.0
2021-09	RAN#93	R5-214281	1033	-	F	Introduction of Rel-15 EN-DC DC_1A_n79A to spurious emission test cases	17.2.0
2021-09	RAN#93	R5-214282	1034	-	F	Introduction of Rel-15 EN-DC DC_3A_n28A to spurious emission test cases	17.2.0
2021-09	RAN#93	R5-214283	1035	-	F	Introduction of Rel-15 EN-DC DC_3A_n77A to spurious emission test cases	17.2.0
2021-09	RAN#93	R5-214290	1042	-	F	Introduction of Rel-15 EN-DC DC_21A_n77A to spurious emission test cases	17.2.0
2021-09	RAN#93	R5-214291	1043	-	F	Introduction of Rel-15 EN-DC DC_21A_n78A to spurious emission test cases	17.2.0
2021-09	RAN#93	R5-214292	1044	-	F	Introduction of Rel-15 EN-DC DC_21A_n79A to spurious emission test cases	17.2.0
2021-09	RAN#93	R5-214293	1045	-	F	Introduction of Rel-15 EN-DC DC_28A_n77A to spurious emission test cases	17.2.0
2021-09	RAN#93	R5-214296	1048	-	F	Introduction of Rel-15 EN-DC DC_42A_n77A to spurious emission test cases	17.2.0
2021-09	RAN#93	R5-214298	1050	-	F	Update of Rel-15 EN-DC DC_3A_n79A in spurious emission test cases	17.2.0
2021-09	RAN#93	R5-214299	1051	-	F	Update of Rel-15 EN-DC DC_5A_n66A in spurious emission test cases	17.2.0
2021-09	RAN#93	R5-214301	1053	-	F	Update of Rel-15 EN-DC DC_7A_n78A in spurious emission test cases	17.2.0
2021-09	RAN#93	R5-214302	1054	-	F	Update of Rel-15 EN-DC DC_11A_n77A in spurious emission test cases	17.2.0
2021-09	RAN#93	R5-214303	1055	-	F	Update of Rel-15 EN-DC DC_11A_n78A in spurious emission test cases	17.2.0
2021-09	RAN#93	R5-214304	1056	-	F	Update of Rel-15 EN-DC DC_11A_n79A in spurious emission test cases	17.2.0
2021-09	RAN#93	R5-214307	1059	-	F	Update of Rel-15 EN-DC DC_26A_n78A in spurious emission test cases	17.2.0
2021-09	RAN#93	R5-214308	1060	-	F	Update of Rel-15 EN-DC DC_39A_n79A in spurious emission test cases	17.2.0
2021-09	RAN#93	R5-214309	1061	-	F	Update of Rel-15 EN-DC DC_41A_n77A in spurious emission test cases	17.2.0
2021-09	RAN#93	R5-214310	1062	-	F	Update of Rel-15 EN-DC DC_41A_n78A in spurious emission test cases	17.2.0
2021-09	RAN#93	R5-214311	1063	-	F	Update of Rel-15 EN-DC DC_41A_n79A in spurious emission test cases	17.2.0
2021-09	RAN#93	R5-214312	1064	-	F	Update of Rel-15 EN-DC DC_66A_n5A in spurious emission test cases	17.2.0
2021-09	RAN#93	R5-214313	1065	-	F	Update of Rel-15 EN-DC DC_66A_n78A in spurious emission test cases	17.2.0
2021-09	RAN#93	R5-214318	1067	-	F	Update of Rel-16 EN-DC DC_40A_n78A in spurious emission test cases	17.2.0
2021-09	RAN#93	R5-214384	1070	-	F	Update clause 7 for R17 DC RX characteristics in TS 38.521-3	17.2.0

2021-09	RAN#93	R5-214481	1071	-	F	Update of Applicability and Titles for ACS for EN-DC within FR1	17.2.0
2021-09	RAN#93	R5-214483	1072	-	F	Clarification on NSA Option 3 Tx test cases	17.2.0
2021-09	RAN#93	R5-214484	1073	-	F	Clarification on NSA Option 3 Rx test cases	17.2.0
2021-09	RAN#93	R5-214846	1094	-	F	Correction to EN-DC receiver spurious emission test cases	17.2.0
2021-09	RAN#93	R5-215047	1096	-	F	Correcting references in EN-DC TX test cases	17.2.0
2021-09	RAN#93	R5-215061	1098	-	F	Update of REFSENS for inter-band EN-DC 2CC adding DC_28A_n78A	17.2.0
2021-09	RAN#93	R5-215062	1099	-	F	Update of REFSENS for inter-band EN-DC 3CC adding DC_1A-28A_n78A	17.2.0
2021-09	RAN#93	R5-215063	1100	-	F	Update of REFSENS for inter-band EN-DC 3CC adding DC_3A-28A_n78A	17.2.0
2021-09	RAN#93	R5-215194	1108	-	F	Correction to 6.2B.2.1 MPR for intra-band contiguous EN-DC	17.2.0
2021-09	RAN#93	R5-215195	1109	-	F	Correction to 6.2B.2.2 MPR for intra-band non-contiguous EN-DC	17.2.0
2021-09	RAN#93	R5-215209	1113	-	F	Correction to 6.5B.2.1.1 SEM for intra-band contiguous EN-DC	17.2.0
2021-09	RAN#93	R5-215210	1114	-	F	Correction to 6.5B.2.1.3 ACLR for intra-band contiguous EN-DC	17.2.0
2021-09	RAN#93	R5-215223	1118	-	F	Correction to 6.5B.3.1.2 and 6.5B.3.2.2 UE co-existence spurious emissions	17.2.0
2021-09	RAN#93	R5-215228	1119	-	F	Correction to 6.4B.2 in-band emission for intra-band contiguous EN-DC	17.2.0
2021-09	RAN#93	R5-215230	1120	-	F	Addition of test case body to 6.5B.5 transmit intermodulation	17.2.0
2021-09	RAN#93	R5-215232	1122	-	F	Addition of reference sensitivity testing for DC_1A_n28A-n78A	17.2.0
2021-09	RAN#93	R5-215233	1123	-	F	Addition of reference sensitivity testing for DC_1A-3A_n28A	17.2.0
2021-09	RAN#93	R5-215234	1124	-	F	Addition of reference sensitivity testing for DC_1A-7A_n28A	17.2.0
2021-09	RAN#93	R5-215235	1125	-	F	Addition of reference sensitivity testing for DC_3A-7A_n28A	17.2.0
2021-09	RAN#93	R5-215254	1126	-	F	Update of reference sensitivity test requirements for DC_41A_n77A and DC_41A_n78A	17.2.0
2021-09	RAN#93	R5-215255	1127	-	F	Correction to reference sensitivity test configuration for 3CC EN-DC	17.2.0
2021-09	RAN#93	R5-215257	1129	-	F	Update of reference sensitivity test coverage for 4CC EN-DC configurations	17.2.0
2021-09	RAN#93	R5-215266	1130	-	F	Added refsens deltaRIB test case for EN-DC including FR1 and FR2	17.2.0
2021-09	RAN#93	R5-215292	1135	-	F	Updating 7.3B.2.3 REFSENS testing for DC_3A-20A_n28A	17.2.0
2021-09	RAN#93	R5-215294	1136	-	F	Updating 7.3B.2.3 REFSENS testing for DC_7A-20A_n28A	17.2.0
2021-09	RAN#93	R5-215296	1137	-	F	Editorial correction to clause 7.3B.2.0.3	17.2.0
2021-09	RAN#93	R5-215323	1138	-	F	Correction of power control in 38.521-3	17.2.0
2021-09	RAN#93	R5-215337	1140	-	F	Correction of test CBW for n28 in 6.2B.1.3	17.2.0
2021-09	RAN#93	R5-215376	1142	-	F	Update to EN-DC R15 common section	17.2.0
2021-09	RAN#93	R5-215378	1144	-	F	Update to EN-DC R17 common section	17.2.0
2021-09	RAN#93	R5-215379	1145	-	F	Update of R15 EN-DC Tx tests	17.2.0
2021-09	RAN#93	R5-215380	1146	-	F	Update of applicability and title for R16 EN-DC Tx tests	17.2.0
2021-09	RAN#93	R5-215381	1147	-	F	Updated to title of clause 6.5B.5.x	17.2.0

2021-09	RAN#93	R5-215460	1155	-	F	Correction of 5.4B.1 for channel spacing for intra-band EN-DC carriers	17.2.0
2021-09	RAN#93	R5-215521	1160	-	F	Updates to Editors note for spurious emission CA test case	17.2.0
2021-09	RAN#93	R5-215668	1179	-	F	Correcting references in EN-DC RX test cases	17.2.0
2021-09	RAN#93	R5-215673	1180	-	F	EN-DC including FR2 DL CA up to 8 NR CCs REFSENS measurement uncertainties	17.2.0
2021-09	RAN#93	R5-215804	1181	-	F	Update of 6.5B.2.3 out of band emissions for inter-band EN-DC	17.2.0
2021-09	RAN#93	R5-215832	1162	1	F	EN-DC including FR2 DL CA up to 8 NR CCs REFSENS test cases addition	17.2.0
2021-09	RAN#93	R5-215833	1169	1	F	Measurement Uncertainties and test tolerances for NSA FR2 CA Maximum Output Power and Spectrum Emission Mask	17.2.0
2021-09	RAN#93	R5-215864	1038	1	F	Introduction of Rel-15 EN-DC DC_19A_n78A to spurious emission test cases	17.2.0
2021-09	RAN#93	R5-215865	1039	1	F	Introduction of Rel-15 EN-DC DC_19A_n79A to spurious emission test cases	17.2.0
2021-09	RAN#93	R5-215866	1041	1	F	Introduction of Rel-15 EN-DC DC_20A_n78A to spurious emission test cases	17.2.0
2021-09	RAN#93	R5-215867	1047	1	F	Introduction of Rel-15 EN-DC DC_28A_n79A to spurious emission test cases	17.2.0
2021-09	RAN#93	R5-215868	1052	1	F	Update of Rel-15 EN-DC DC_5A_n78A in spurious emission test cases	17.2.0
2021-09	RAN#93	R5-215869	1057	1	F	Update of Rel-15 EN-DC DC_25A_n41A in spurious emission test cases	17.2.0
2021-09	RAN#93	R5-215870	1069	1	F	Clarification of SA and NSA support in the UE	17.2.0
2021-09	RAN#93	R5-215871	1074	1	F	Addition of 6.4B.1.3A Frequency Error for inter-band NE-DC within FR1	17.2.0
2021-09	RAN#93	R5-215872	1075	1	F	Addition of 6.4B.2.3A.1 Error Vector Magnitude for inter-band NE-DC within FR1	17.2.0
2021-09	RAN#93	R5-215873	1076	1	F	Addition of 6.4B.2.3A.2 Carrier Leakage for inter-band NE-DC within FR1	17.2.0
2021-09	RAN#93	R5-215874	1077	1	F	Addition of 6.4B.2.3A.3 In-band Emissions for inter-band NE-DC within FR1	17.2.0
2021-09	RAN#93	R5-215875	1079	1	F	Addition of 6.5B.2.3A.1 Spectrum emissions mask for Inter-band NE-DC within FR1	17.2.0
2021-09	RAN#93	R5-215876	1080	1	F	Addition of 6.5B.2.3A.2 Additional Spectrum emissions mask for Inter-band NE-DC within FR1	17.2.0
2021-09	RAN#93	R5-215877	1081	1	F	Addition of 6.5B.2.3A.3 Adjacent channel leakage ratio for inter-band NE-DC within FR1	17.2.0
2021-09	RAN#93	R5-215878	1082	1	F	Addition of 6.5B.3.3A.1 General Spurious Emissions for Inter-band NE-DC within FR1	17.2.0
2021-09	RAN#93	R5-215879	1084	1	F	Addition of 6.5B.5.3A Transmit Intermodulation for Inter-band NE-DC within FR1	17.2.0
2021-09	RAN#93	R5-215880	1095	1	F	Editorial correction to test applicability in 6.2B.1.4_1.1.1	17.2.0
2021-09	RAN#93	R5-215881	1097	1	F	Addition of spurious emission for DC 1A_n78A and 20A_n78A and 28A_n78A	17.2.0
2021-09	RAN#93	R5-215882	1104	1	F	Addition of TC6.3B.2.4D Transmit OFF Power for inter-band EN-DC including FR2 for UL-MIMO	17.2.0

2021-09	RAN#93	R5-215883	1106	1	F	Addition of TC6.3B.3.4D Transmit ON/OFF time mask for inter-band EN-DC including FR2 for UL-MIMO	17.2.0
2021-09	RAN#93	R5-215884	1107	1	F	Addition of TC6.3B.4.4 PRACH Time Mask for inter-band EN-DC including FR2	17.2.0
2021-09	RAN#93	R5-215885	1110	1	F	Update of test applicability for 6.2B.2 MPR and 6.2B.3 A-MPR for inter-band EN-DC	17.2.0
2021-09	RAN#93	R5-215886	1121	1	F	Update of MOP requirements for DC_3A_n3A	17.2.0
2021-09	RAN#93	R5-215887	1131	1	F	Updated EN-DC spur emissions including FR2 editor notes	17.2.0
2021-09	RAN#93	R5-215888	1156	1	F	Addition of test case 6.4B.2.4.5	17.2.0
2021-09	RAN#93	R5-215889	1167	1	F	Message content updates for intra-band contiguous EN-DC additional spectrum emission mask test	17.2.0
2021-09	RAN#93	R5-215890	1168	1	F	Message contents addition for intra-band non-contiguous EN-DC SEM, A-SEM and ACLR test cases	17.2.0
2021-09	RAN#93	R5-215891	1086	1	F	Addition of 7.4B.3A Maximum Input Level for inter-band NE-DC within FR1	17.2.0
2021-09	RAN#93	R5-215892	1087	1	F	Addition of 7.5B.3A ACS for inter-band NE-DC within FR1	17.2.0
2021-09	RAN#93	R5-215893	1088	1	F	Addition of 7.6B.2.3A In-band blocking for inter-band NE-DC within FR1	17.2.0
2021-09	RAN#93	R5-215894	1089	1	F	Addition of 7.6B.4.3A Narrow band blocking for inter-band NE-DC within FR1	17.2.0
2021-09	RAN#93	R5-215895	1090	1	F	Addition of 7.8B.2.3A Wide band Intermodulation for inter-band NE-DC within FR1	17.2.0
2021-09	RAN#93	R5-215896	1091	1	F	Addition of 7.9B.3A Spurious Emissions for inter-band NE-DC within FR1	17.2.0
2021-09	RAN#93	R5-215897	1093	1	F	Addition of 7.5B.0.4a Inter-band NE-DC including FR2	17.2.0
2021-09	RAN#93	R5-215898	1133	1	F	Updating 7.3B.2.3 REFSSENS testing for DC_3A_n28A-n78A	17.2.0
2021-09	RAN#93	R5-215899	1134	1	F	Updating 7.3B.2.3 REFSSENS testing for DC_7A_n28A-n78A	17.2.0
2021-09	RAN#93	R5-215900	1141	1	F	Editors note correction to reference sensitivity for inter-band EN-DC including FR2	17.2.0
2021-09	RAN#93	R5-215926	1161	1	F	Spurious co-existence corrections for band combo DC_8_n41	17.2.0
2021-09	RAN#93	R5-215927	1173	1	F	Update for 6.5B.3.3.1 for Rel 16 combos	17.2.0
2021-09	RAN#93	R5-215928	1143	1	F	Update to EN-DC R16 common section	17.2.0
2021-09	RAN#93	R5-216007	1031	1	F	Introduction of Rel-15 EN-DC DC_1A_n28A to spurious emission test cases	17.2.0
2021-09	RAN#93	R5-216008	1036	1	F	Introduction of Rel-15 EN-DC DC_7A_n28A to spurious emission test cases	17.2.0
2021-09	RAN#93	R5-216009	1040	1	F	Introduction of Rel-15 EN-DC DC_20A_n28A to spurious emission test cases	17.2.0
2021-09	RAN#93	R5-216010	1058	1	F	Update of Rel-15 EN-DC DC_26A_n77A in spurious emission test cases	17.2.0
2021-09	RAN#93	R5-216011	1111	1	F	Cleanup for TS 38.521-3 spurious emission for UE co-existence table for Rel-15	17.2.0
2021-09	RAN#93	R5-216012	1112	1	F	Cleanup for TS 38.521-3 spurious emission for UE co-existence table Rel-16	17.2.0
2021-09	RAN#93	R5-216013	1170	1	F	Update for 6.5B.3.3.1 for Rel 15 combos	17.2.0

2021-09	RAN#93	R5-216015	1117	1	F	Update of general spurious emissions test requirements for Rel-16 inter-band EN-DC	17.2.0
2021-09	RAN#93	R5-216016	1154	1	F	Update of 6.5B.3.3.2.3 for the requirements of spurious emission band UE co-existence limits for Rel-16	17.2.0
2021-09	RAN#93	R5-216038	1049	1	F	Update of Rel-15 EN-DC DC_1A_n78A in spurious emission test cases	17.2.0
2021-09	RAN#93	R5-216039	1182	1	F	Addition of cl 6.2B.1.3A for RF	17.2.0
2021-09	RAN#93	R5-216093	1132	1	F	Updated editors note to indicate missing LO retrieval RRC framework	17.2.0
2021-09	RAN#93	R5-216094	1128	1	F	Update of reference sensitivity test coverage for 3CC EN-DC configurations	17.2.0
2021-09	RAN#93	R5-216095	1178	1	F	Update to Rel.15 EN-DC FR2 Band Combination Tables	17.2.0
2021-09	RAN#93	R5-216108	1171	1	F	Update for reference sensitivity for DC_48A_n66A	17.2.0
2021-09	RAN#93	R5-216119	1115	1	F	Correction to 6.5B.2.2.1 SEM for intra-band non-contiguous EN-DC	17.2.0
2021-09	RAN#93	R5-216120	1116	1	F	Correction to 6.5B.2.2.3 ACLR for intra-band non-contiguous EN-DC	17.2.0
2021-09	RAN#93	R5-216131	1159	1	F	Spurious co-existence core requirement updates for Dual connectivity including band n28 and other core requirement alignments	17.2.0
2021-12	RAN#94	R5-216518	1184	-	F	6.5B.2.2.1 SEM IBNC update as per TP analysis update	17.3.0
2021-12	RAN#94	R5-216519	1185	-	F	6.5B.2.2.3 ACLR IBNC update as per TP analysis update	17.3.0
2021-12	RAN#94	R5-216919	1189	-	F	Addition of TC6.4B.1.4D Frequency error for inter-band EN-DC including FR2 for UL-MIMO	17.3.0
2021-12	RAN#94	R5-217094	1191	-	F	Update of Reference Sensitivity Test Cases for EN-DC with FR2	17.3.0
2021-12	RAN#94	R5-217116	1192	-	F	FR2 EN-DC Refsens 6 to 8 NR CCs - Editorial correction	17.3.0
2021-12	RAN#94	R5-217117	1193	-	F	UL modulation correction in 7.3B.2.3_1.1	17.3.0
2021-12	RAN#94	R5-217176	1195	-	F	Adding Power Class 1.5 for LTE Band 41and NR Band n41 to Annex N.1 Indication of modified MPR behaviour	17.3.0
2021-12	RAN#94	R5-217232	1199	-	F	Tx Spurious emission-Editorial corrections	17.3.0
2021-12	RAN#94	R5-217295	1202	-	F	Update of 6.5B.2.1.1 SEM test configuration for intra-band contiguous EN-DC	17.3.0
2021-12	RAN#94	R5-217296	1203	-	F	Update of 6.2B.2.1 MPR for intra-band contiguous EN-DC	17.3.0
2021-12	RAN#94	R5-217300	1204	-	F	Addition of reference sensitivity testing for DC_20A_n28A-n78A	17.3.0
2021-12	RAN#94	R5-217305	1206	-	F	Addition of 4Rx reference sensitivity test requirements for DC_3A_n41A	17.3.0
2021-12	RAN#94	R5-217382	1211	-	F	Addition of 6.2E.1.1 MOP for intra-band contiguous V2X operation	17.3.0
2021-12	RAN#94	R5-217383	1212	-	F	Addition of 6.2E.1.2 MOP for intra-band non-contiguous V2X operation	17.3.0
2021-12	RAN#94	R5-217384	1213	-	F	Addition of 6.2E.1.3.1 MOP for inter-band E-UTRA Uu and NR Sidelink operation	17.3.0
2021-12	RAN#94	R5-217385	1214	-	F	Addition of 6.2E.1.3.2 MOP for inter-band NR Uu and E-UTRA V2X Sidelink operation	17.3.0
2021-12	RAN#94	R5-217386	1215	-	F	Addition of 6.2E.2.1 MPR for intra-band V2X operation	17.3.0
2021-12	RAN#94	R5-217387	1216	-	F	Addition of 6.2E.2.2.1 MPR for inter-band E-UTRA Uu and NR Sidelink operation	17.3.0



2021-12	RAN#94	R5-217388	1217	-	F	Addition of 6.2E.2.2.2 MPR for inter-band NR Uu and E-UTRA V2X Sidelink operation	17.3.0
2021-12	RAN#94	R5-217389	1218	-	F	Addition of 6.3E Output power dynamics for V2X	17.3.0
2021-12	RAN#94	R5-217428	1220	-	F	Correction to note of DC_1_n3 and DC_3_n1 in 6.5B.3.3.2	17.3.0
2021-12	RAN#94	R5-217554	1228	-	F	Correction of Reference Sensitivity for DC_28A_n41A	17.3.0
2021-12	RAN#94	R5-217562	1229	-	F	Update of modulation quality for inter-band EN-DC with FR2	17.3.0
2021-12	RAN#94	R5-217610	1230	-	F	Correction to 5G V2X common sections	17.3.0
2021-12	RAN#94	R5-217615	1231	-	F	Addition of R15 EN-DC configurations in clause 5	17.3.0
2021-12	RAN#94	R5-217616	1232	-	F	Correction to EN-DC Tx test cases	17.3.0
2021-12	RAN#94	R5-217617	1233	-	F	Correction to title and test applicability to EN-DC Rx test cases	17.3.0
2021-12	RAN#94	R5-217705	1237	-	F	38.521-3 Beam correspondence Measurement Uncertainties	17.3.0
2021-12	RAN#94	R5-217720	1238	-	F	Introduction of EN-DC FR2 Beam Correspondence Test Case	17.3.0
2021-12	RAN#94	R5-217724	1239	-	F	Update to Rel.17 EN-DC FR2 Band Combination Tables	17.3.0
2021-12	RAN#94	R5-217726	1241	-	F	Update to Rel.15 EN-DC FR2 Band Combination Tables	17.3.0
2021-12	RAN#94	R5-217740	1242	-	F	Correction to DC_1A_n79A spurious emission test case 6.5B.3.3.2	17.3.0
2021-12	RAN#94	R5-217741	1243	-	F	Correction of spurious emission test case 6.5B.3.3.2 for DC_5A-n66A, DC_25A-n41A and DC_19A_n77A	17.3.0
2021-12	RAN#94	R5-218211	1250	-	F	Adding new test case spurious UE coex for inter-band EN-DC including FR2 and editors note updates	17.3.0
2021-12	RAN#94	R5-218243	1207	1	F	Update of 6.5B.3.3.1 general spurious emissions test requirements for inter-band EN-DC	17.3.0
2021-12	RAN#94	R5-218244	1205	1	F	Addition of 4Rx reference sensitivity test requirements for DC_3A_n78A	17.3.0
2021-12	RAN#94	R5-218245	1221	1	F	Correction to test configuration of DC_41A_n78A in 7.3B.2.3	17.3.0
2021-12	RAN#94	R5-218246	1188	1	F	Handling of fallbacks for FR2 CA for EN-DC	17.3.0
2021-12	RAN#94	R5-218247	1210	1	F	Correction of clause 4 for minimum requirements and test applicability rules	17.3.0
2021-12	RAN#94	R5-218271	1197	1	F	Update for 6.5B.3.3.2 Spurious emission band UE co-existence	17.3.0
2021-12	RAN#94	R5-218273	1249	1	F	Adding RX requirements for Rel-16 FR1 EN-DC band combinations	17.3.0
2021-12	RAN#94	R5-218274	1234	1	F	Addition of R16 EN-DC configurations in clause 5	17.3.0
2021-12	RAN#94	R5-218275	1240	1	F	Update to Rel.16 EN-DC FR2 Band Combination Tables	17.3.0
2021-12	RAN#94	R5-218293	1208	1	F	Adding UL switching time mask test for inter-band EN-DC	17.3.0
2021-12	RAN#94	R5-218433	1183	1	F	6.2B.2.2 MPR IBNC update as per TP analysis update	17.3.0
2021-12	RAN#94	R5-218434	1236	1	F	Update of test case 6.2B.3.4 EN-DC A-MPR for FR2	17.3.0
2021-12	RAN#94	R5-218455	1200	1	F	Update for EN_DC reference sensitivity_r16	17.3.0
2021-12	RAN#94	R5-218472	1227	1	F	Updating 6.2B.1.3 UE Maximum Output Power for Rel-17 NR inter-band EN-DC configurations	17.3.0
2021-12	RAN#94	R5-218473	1226	1	F	Updating Rel-17 NR inter-band EN-DC configurations	17.3.0
2021-12	RAN#94	R5-218485	1225	1	F	Clarification on cl 4.5.1 test coverage across 5G NR architecture options for RF	17.3.0
2022-03	RAN#95	R5-220063	1251	-	F	Correction of Test applicability of 6.2B.2.3	17.4.0

2022-03	RAN#95	R5-220068	1254	-	F	Correction of test config table for 6.3B.3_1.1	17.4.0
2022-03	RAN#95	R5-220069	1255	-	F	Correction of reference section numbers in 6.4B.2.4.5.4.1	17.4.0
2022-03	RAN#95	R5-220070	1256	-	F	Correction of Editor Note and reference section numbers in 6.5B.3.4.2_1	17.4.0
2022-03	RAN#95	R5-220087	1257	-	F	Introduction of new V2X test cases in 7.6E	17.4.0
2022-03	RAN#95	R5-220088	1258	-	F	Introduction of new V2X test cases in 7.7E	17.4.0
2022-03	RAN#95	R5-220089	1259	-	F	Introduction of new V2X test cases in 7.8E	17.4.0
2022-03	RAN#95	R5-220260	1260	-	F	FR1 NSA IBC - ACLR clean up to leverage MPR test definition	17.4.0
2022-03	RAN#95	R5-220275	1261	-	F	Clarifications on 5G NR connectivity options for RF FR1 and FR2	17.4.0
2022-03	RAN#95	R5-220314	1264	-	F	Introduction of Output power requirements for Rel-16 inter-band EN-DC FR1 two band combinations	17.4.0
2022-03	RAN#95	R5-220315	1265	-	F	Introduction of General Spurious emissions requirements for Rel-16 inter-band EN-DC FR1 two band combinations	17.4.0
2022-03	RAN#95	R5-220322	1267	-	F	Adding Reference sensitivity exceptions and MSD test points for Rel-16 inter-band EN-DC FR1 two band combinations	17.4.0
2022-03	RAN#95	R5-220323	1268	-	F	Adding reference sensitivity requirements for Rel-16 inter-band EN-DC FR1 two band combinations	17.4.0
2022-03	RAN#95	R5-220369	1270	-	F	Update general spurious emissions 6.5B.3.3.1 for 4 Rel-17 ENDC combos	17.4.0
2022-03	RAN#95	R5-220371	1271	-	F	Update for 6.5B.3.3.2 Spurious emission band UE co-existence for 4 Rel-17 combos	17.4.0
2022-03	RAN#95	R5-220380	1273	-	F	Introduction of DC_1A-n5A reference sensitivity test requirements	17.4.0
2022-03	RAN#95	R5-220382	1274	-	F	Introduction of DC_3A-n5A reference sensitivity test requirements	17.4.0
2022-03	RAN#95	R5-220384	1275	-	F	Introduction of DC_7A-n5A reference sensitivity test requirements	17.4.0
2022-03	RAN#95	R5-220387	1276	-	F	Introduction of DC_7A-n78A reference sensitivity test requirements	17.4.0
2022-03	RAN#95	R5-220390	1277	-	F	Introduction of DC_28A_n7A-n78A reference sensitivity test requirements	17.4.0
2022-03	RAN#95	R5-220431	1280	-	F	Update to R16 Configuration for DC	17.4.0
2022-03	RAN#95	R5-220432	1281	-	F	Update to R17 Configuration for DC	17.4.0
2022-03	RAN#95	R5-220538	1282	-	F	Correction on test requirements for TC 6.5B.3.3.2	17.4.0
2022-03	RAN#95	R5-220539	1283	-	F	Addition of 6.4E.1 Frequency error for V2X	17.4.0
2022-03	RAN#95	R5-220540	1284	-	F	Addition of 6.4E.2.1 Error Vector Magnitude for V2X	17.4.0
2022-03	RAN#95	R5-220655	1286	-	F	Adding RIB,c for Inter-band NE-DC	17.4.0
2022-03	RAN#95	R5-221698	1289	1	F	Updating on 6.5B.3.3.2 Spurious emission for UE co-existence for inter-band within FR1 including n1	17.4.0
2022-03	RAN#95	R5-220759	1290	-	F	Introduction of maximum output power test requirements for DC_1A_n5A, DC_1A_n7A, DC_3A_n5A, DC_7A_n5A and DC_28A_n7A	17.4.0
2022-03	RAN#95	R5-220766	1291	-	F	Update Tx test cases for DC_n28A_3A, DC_n28A_3C, DC_n28A_39A, DC_n28A_39C	17.4.0
2022-03	RAN#95	R5-220896	1296	-	F	Definition of MTSU for 7.6B.3.3_1.1	17.4.0
2022-03	RAN#95	R5-220902	1298	-	F	Correction to measurement timing for EN-DC combination with FDD and TDD	17.4.0
2022-03	RAN#95	R5-220904	1299	-	F	Correction to test frequency of EN-DC 28_n51 in 7.3B.2.3	17.4.0

2022-03	RAN#95	R5-220961	1301	-	F	Addition of common uplink configuration for E-UTRA intra-band contiguous CA	17.4.0
2022-03	RAN#95	R5-220967	1305	-	F	Update of 6.2B.1.3 Maximum Output Power for Inter-Band EN-DC	17.4.0
2022-03	RAN#95	R5-220968	1306	-	F	Update of 6.2B.4.1.3 Configured Output Power for Inter-Band EN-DC	17.4.0
2022-03	RAN#95	R5-220976	1308	-	F	Correction to reference sensitivity for intra-band contiguous EN-DC	17.4.0
2022-03	RAN#95	R5-220977	1309	-	F	Correction to Maximum Input Level for intra-band contiguous EN-DC	17.4.0
2022-03	RAN#95	R5-220978	1310	-	F	Correction to Adjacent Channel Selectivity for intra-band contiguous EN-DC	17.4.0
2022-03	RAN#95	R5-220979	1311	-	F	Update of Adjacent Channel Selectivity for intra-band non-contiguous EN-DC	17.4.0
2022-03	RAN#95	R5-220980	1312	-	F	Correction to out-of-band blocking for intra-band contiguous EN-DC	17.4.0
2022-03	RAN#95	R5-220981	1313	-	F	Update of Annex F for Adjacent Channel Selectivity for intra-band EN-DC	17.4.0
2022-03	RAN#95	R5-221053	1314	-	F	Correction of 6.2B.1.1 for intra-band contiguous EN-DC maximum output power	17.4.0
2022-03	RAN#95	R5-221170	1316	-	F	Addition of 6.2B.2.3a MPR for inter-band NE-DC within FR1	17.4.0
2022-03	RAN#95	R5-221171	1317	-	F	Addition of 6.4B.2.3a.4 EVM Equalizer Flatness for inter-band NE-DC within FR1	17.4.0
2022-03	RAN#95	R5-221172	1318	-	F	Addition of 6.2B.4.2.3a TIB,c for Inter-band NE-DC within FR1	17.4.0
2022-03	RAN#95	R5-221268	1323	-	F	Update of E-UTRA configuration	17.4.0
2022-03	RAN#95	R5-221317	1326	-	F	Update for 6.5B.4.2 Additional Spurious Emissions for Intra-band non-contiguous EN-DC	17.4.0
2022-03	RAN#95	R5-221321	1327	-	F	Update for reference sensitivity for EN_DC_r15	17.4.0
2022-03	RAN#95	R5-221325	1328	-	F	Editorial Update for 6.2B.4.2.3.1	17.4.0
2022-03	RAN#95	R5-221329	1330	-	F	Update Ref sense for r16 DC combos	17.4.0
2022-03	RAN#95	R5-221337	1332	-	F	Addition of PC2 ENDC 4 combos into 38.521-3 TC7.3B.2	17.4.0
2022-03	RAN#95	R5-221693	1252	1	F	Correction of Test applicability of 6.2B.3.3	17.4.0
2022-03	RAN#95	R5-221694	1253	1	F	Correction of 6.5B.2.3.3 to include 6.5.2.4.2 of 38.521-1	17.4.0
2022-03	RAN#95	R5-221695	1262	1	F	Update MOP for inter-band NE-DC within FR1	17.4.0
2022-03	RAN#95	R5-221696	1269	1	F	FR2 NSA EVM test case editor notes update	17.4.0
2022-03	RAN#95	R5-221697	1287	1	F	Clarification on clause number of NE-DC for Tx test cases	17.4.0
2022-03	RAN#95	R5-221699	1293	1	F	Correction of ON OFF time mask for inter-band EN-DC including FR2	17.4.0
2022-03	RAN#95	R5-221700	1294	1	F	Definition of MTSU and TT for Intra-band EN-DC additional spurious emissions test cases	17.4.0
2022-03	RAN#95	R5-221701	1295	1	F	Correction to test procedure of FR1 EN-DC Spurious test for EN-DC only capable UE	17.4.0
2022-03	RAN#95	R5-221702	1324	1	F	Editorial correction for 6.5B.3.3 Spurious emission	17.4.0
2022-03	RAN#95	R5-221703	1288	1	F	Clarification on clause number of NE-DC for Rx test cases	17.4.0
2022-03	RAN#95	R5-221704	1331	1	F	Update for 7.3B.2	17.4.0
2022-03	RAN#95	R5-221705	1278	1	F	Regrouping DC Configuration in clause 5	17.4.0
2022-03	RAN#95	R5-221706	1315	1	F	Update of 3.2 and 3.3 on symbols and abbreviations	17.4.0

2022-03	RAN#95	R5-221767	1266	1	F	Introduction of Spurious emissions band UE co-existence requirements for Rel-16 inter-band EN-DC FR1 two band combinations	17.4.0
2022-03	RAN#95	R5-221768	1297	1	F	Correction to test requirement of DC_xxA_n41A in 6.5B.3.3.1	17.4.0
2022-03	RAN#95	R5-221769	1300	1	F	Correction of General Spurious emissions requirements for Rel-16 inter-band EN-DC FR1 two band combinations	17.4.0
2022-03	RAN#95	R5-221770	1320	1	F	Introduction of DC_1A_n5A, DC_1A_n7A, DC_3A_n5A, DC_7A_n5A, DC_28A_n7A to general spurious emission test case	17.4.0
2022-03	RAN#95	R5-221771	1321	1	F	Introduction of DC_1A_n5A, DC_1A_n7A, DC_3A_n5A, DC_7A_n5A, DC_28A_n7A to UE co-existence spurious emission test case	17.4.0
2022-03	RAN#95	R5-221772	1322	1	F	Addition of new CADC MPR TC 6.2B.2.4_1.1	17.4.0
2022-03	RAN#95	R5-221773	1329	1	F	Update for 7.3B.2.0 Min Requirements of Ref sensitivity for EN-DC	17.4.0
2022-03	RAN#95	R5-221883	1272	1	F	Update Tx TC for 4 Rel-17 combos	17.4.0
2022-03	RAN#95	R5-221884	1325	1	F	Update Rx Requirements for 4 Rel-17 ENDC combos	17.4.0
2022-03	RAN#95	R5-221885	1333	1	F	MSD test configurations modification for US inter-band EN-DC combinations with n77	17.4.0
2022-03	RAN#95	R5-221886	1285	1	F	Update NE-DC configurations for DC_n28A_3A, DC_n28A_3C, DC_n28A_39A, DC_n28A_39C	17.4.0
2022-03	RAN#95	R5-221892	1292	1	F	Update of MOP TC for PC2 ENDC configurations	17.4.0
2022-03	RAN#95	R5-221908	1302	1	F	Addition of new test case 6.2B.1.3_1 for Maximum Output Power for inter-band EN-DC with 3 uplink	17.4.0
2022-03	RAN#95	R5-221909	1303	1	F	Addition of new test case 6.2B.4.1.3_1 for Configured Output Power for inter-band EN-DC with 3 uplink	17.4.0
2022-03	RAN#95	R5-221910	1304	1	F	Addition of annex F for test cases for EN-DC configurations with 3 uplink	17.4.0
2022-03	RAN#95	R5-221931	1307	1	F	Addition of transmit power configuration for EN-DC reference sensitivity	17.4.0
2022-06	RAN#96	R5-222192	1335	-	F	Correction of minimum requirement and test requirement of 6.2B.1.3	17.5.0
2022-06	RAN#96	R5-222194	1337	-	F	Correction of reference section numbers in 6.4E and title of 6.4E.2.1.2	17.5.0
2022-06	RAN#96	R5-222195	1338	-	F	Correction of test requirement of 6.2B.2.1	17.5.0
2022-06	RAN#96	R5-222196	1339	-	F	Separation of 6.2B.1.4D into two test cases	17.5.0
2022-06	RAN#96	R5-222197	1340	-	F	Correction of clause numbers in 6.2B.1.3a	17.5.0
2022-06	RAN#96	R5-222344	1353	-	F	6.6B.4 Beam Correspondence test case editor note update	17.5.0
2022-06	RAN#96	R5-222345	1354	-	F	MU and TT definition and clean up in 38.521-3 annex F	17.5.0
2022-06	RAN#96	R5-222421	1355	-	F	Addition of 6.5E.1 Occupied bandwidth for V2X	17.5.0
2022-06	RAN#96	R5-222422	1356	-	F	Addition of 6.5E.2 Out of band emission for V2X	17.5.0
2022-06	RAN#96	R5-222473	1359	-	F	Addition Delta TIB,c for FR1 EN-DC	17.5.0
2022-06	RAN#96	R5-222484	1362	-	F	Editorial correction in 6.2B.4.1.3	17.5.0
2022-06	RAN#96	R5-222486	1363	-	F	Correction about test configuration in 6.5B.3.3.2	17.5.0
2022-06	RAN#96	R5-222487	1364	-	F	Correction to title of 7.6B.2.4 and editorial correction for Rx test cases	17.5.0
2022-06	RAN#96	R5-222543	1365	-	F	Correction of Refsens CA test case	17.5.0

2022-06	RAN#96	R5-222700	1367	-	F	Editorial correction to EN-DC test cases	17.5.0
2022-06	RAN#96	R5-222702	1368	-	F	Update to R15 common part and DC configurations in clause 5	17.5.0
2022-06	RAN#96	R5-222703	1369	-	F	Update to R16 Configuration for DC	17.5.0
2022-06	RAN#96	R5-222743	1379	-	F	Update for 7.3B.2.0 Min Requirements of Ref sensitivity for EN-DC	17.5.0
2022-06	RAN#96	R5-222748	1381	-	F	Update 6.5B.3.3.2 for R17 DC_14_n2 and DC_14_n66	17.5.0
2022-06	RAN#96	R5-222829	1382	-	F	Update of 6.2B.1.3_1 UE Maximum Output Power for inter-Band EN-DC with 2 E-UTRA CCs and 1 NR CC	17.5.0
2022-06	RAN#96	R5-222830	1383	-	F	Update of 6.2B.4.1.3_1 Configured Output Power for inter-Band EN-DC with 2 E-UTRA CCs and 1 NR CC	17.5.0
2022-06	RAN#96	R5-222884	1386	-	F	Addition of 6.4E.2.3 In-band emissions for V2X	17.5.0
2022-06	RAN#96	R5-223061	1387	-	F	Addition of 6.5B.3.3.1 requirements for NR inter-band EN-DC configurations including n1	17.5.0
2022-06	RAN#96	R5-223231	1389	-	F	Correction to 6.2B.1.3 for UE capability IE for inter-band EN-DC UE maximum output power	17.5.0
2022-06	RAN#96	R5-223245	1391	-	F	Add delta RIBc for inter-band DC_28A_n7A-n78A	17.5.0
2022-06	RAN#96	R5-223658	1341	1	F	Introduction of Output power requirements for DC_1A_n8A, DC_7A_n8A and DC_8A_n28A	17.5.0
2022-06	RAN#96	R5-223659	1342	1	F	Introduction of Allowed maximum configured output power relaxation for DC_1_n5, DC_1_n8, DC_3_n5, DC_7_n5, DC_7_n8 and DC_8_n28	17.5.0
2022-06	RAN#96	R5-223660	1343	1	F	Introduction of General Spurious emissions requirements for DC_1A_n8A, DC_7A_n8A, DC_8A_n28A and DC_20A_n8A	17.5.0
2022-06	RAN#96	R5-223661	1344	1	F	Introduction of Spurious emissions band UE co-existence limits Rel-16 for DC_1A_n8A, DC_7A_n8A, DC_8A_n28A and DC_20A_n8A	17.5.0
2022-06	RAN#96	R5-223662	1345	1	F	Introduction of Spurious emissions band UE co-existence Test description for DC_1A_n8A, DC_7A_n5A, DC_7A_n8A, DC_8A_n28A and DC_20A_n8A	17.5.0
2022-06	RAN#96	R5-223663	1346	1	F	Introduction of Spurious emissions band UE co-existence Rel-16 Test requirements for DC_1A_n8A, DC_7A_n8A, DC_8A_n28A and DC_20A_n8A	17.5.0
2022-06	RAN#96	R5-223664	1366	1	F	Addition of new CADC MOP TC	17.5.0
2022-06	RAN#96	R5-223665	1371	1	F	Addition of ACLR Test Case for Inter-band EN-DC including FR2 5 NR CCs	17.5.0
2022-06	RAN#96	R5-223666	1372	1	F	Addition of ACLR Test Case for Inter-band EN-DC including FR2 6 NR CCs	17.5.0
2022-06	RAN#96	R5-223667	1373	1	F	Addition of ACLR Test Case for Inter-band EN-DC including FR2 7 NR CCs	17.5.0
2022-06	RAN#96	R5-223668	1374	1	F	Addition of ACLR Test Case for Inter-band EN-DC including FR2 8 NR CCs	17.5.0
2022-06	RAN#96	R5-223669	1375	1	F	Addition of General Spurious Emissions Test Case for Inter-band EN-DC including FR2 5 NR CCs	17.5.0
2022-06	RAN#96	R5-223670	1376	1	F	Addition of General Spurious Emissions Test Case for Inter-band EN-DC including FR2 6 NR CCs	17.5.0
2022-06	RAN#96	R5-223671	1377	1	F	Addition of General Spurious Emissions Test Case for Inter-band EN-DC including FR2 7 NR CCs	17.5.0
2022-06	RAN#96	R5-223672	1378	1	F	Addition of General Spurious Emissions Test Case for Inter-band EN-DC including FR2 8 NR CCs	17.5.0
2022-06	RAN#96	R5-223673	1380	1	F	Update 6.5B.3.3.2 for R16 DC_14_n2 and DC_14_n66	17.5.0

2022-06	RAN#96	R5-223674	1390	1	F	Add delta TIBc for inter-band DC_28A_n7A-n78A	17.5.0
2022-06	RAN#96	R5-223675	1393	1	F	Introduction of Allowed reference sensitivity relaxation for DC_3A-8A_n28A	17.5.0
2022-06	RAN#96	R5-223676	1347	1	F	Introduction of DC_1A-20A_n8A reference sensitivity test requirements	17.5.0
2022-06	RAN#96	R5-223677	1348	1	F	Introduction of DC_3A-7A_n5A reference sensitivity test requirements	17.5.0
2022-06	RAN#96	R5-223678	1349	1	F	Introduction of DC_7A-8A_n3A reference sensitivity test requirements	17.5.0
2022-06	RAN#96	R5-223679	1350	1	F	Introduction of DC_7A-20A_n8A reference sensitivity test requirements	17.5.0
2022-06	RAN#96	R5-223680	1351	1	F	Introduction of DC_7A-28A_n5A reference sensitivity test requirements	17.5.0
2022-06	RAN#96	R5-223681	1360	1	F	Addition Minimum Conformance Requests of REFSSENS for FR1 EN-DC	17.5.0
2022-06	RAN#96	R5-223703	1385	1	F	Addition of 6.4E.2.2 Carrier leakage for V2X	17.5.0
2022-06	RAN#96	R5-223744	1370	1	F	Update to R17 Configuration for DC	17.5.0
2022-06	RAN#96	R5-223833	1336	1	F	Correction of Transmitter power test requirements for EN-DC within FR1	17.5.0
2022-06	RAN#96	R5-223834	1357	1	F	Editorial correction for 6.3B.8 Power control for EN-DC	17.5.0
2022-06	RAN#96	R5-223835	1358	1	F	Clarifications on Common Uplink Configuration updates	17.5.0
2022-06	RAN#96	R5-223836	1384	1	F	Adding missing configurations in SE co-ex Rel-17 table	17.5.0
2022-09	RAN#97	R5-224152	1398	-	F	Introduction of Allowed maximum configured output power relaxation for DC_3_n8	17.6.0
2022-09	RAN#97	R5-224153	1399	-	F	Introduction of General Spurious emissions requirements for DC_3A_n8A	17.6.0
2022-09	RAN#97	R5-224154	1400	-	F	Introduction of Spurious emissions band UE co-existence limits Rel-16 for DC_3A_n8A	17.6.0
2022-09	RAN#97	R5-224156	1402	-	F	Introduction of Spurious emissions band UE co-existence Rel-16 Test requirements for DC_3A_n8A	17.6.0
2022-09	RAN#97	R5-224159	1403	-	F	Introduction of DC_3A-7A-20A_n8A reference sensitivity 2-band fallback test requirements	17.6.0
2022-09	RAN#97	R5-224160	1404	-	F	Introduction of DC_3A-7A-20A_n8A reference sensitivity 3-band fallback test requirements	17.6.0
2022-09	RAN#97	R5-224161	1405	-	F	Introduction of Allowed reference sensitivity relaxation for DC_3A-7A-20A_n8A	17.6.0
2022-09	RAN#97	R5-224308	1408	-	F	FR2 NSA EVM test case editor notes update	17.6.0
2022-09	RAN#97	R5-224437	1412	-	F	Addition of new CADC MOP TC	17.6.0
2022-09	RAN#97	R5-224622	1413	-	F	Addition of test requirement for E-UTRA cell of PC2 UE in 6.2B.4.1	17.6.0
2022-09	RAN#97	R5-224626	1414	-	F	Correction to test frequency definition for DC combination including n28	17.6.0
2022-09	RAN#97	R5-224629	1415	-	F	Correction to E-UTRA output power in intra-band contiguous EN-DC Rx test cases	17.6.0
2022-09	RAN#97	R5-224653	1417	-	F	Correction of reference to test configuration table for intra band contiguous EN-DC test case	17.6.0
2022-09	RAN#97	R5-224809	1418	-	F	Editorial correction for 6.2B.1.3 Maximum output power for Inter-band EN-DC within FR1	17.6.0

2022-09	RAN#97	R5-224936	1423	-	F	Corrections on test configuration table in spurious emission band UE co-existence for Rel-15 inter-band EN-DC configuration	17.6.0
2022-09	RAN#97	R5-224939	1425	-	F	Introduction of DC_2A-66A_n41A reference sensitivity test requirements	17.6.0
2022-09	RAN#97	R5-224942	1426	-	F	Corrections on general spurious emission test requirements for DC_2A_n5A	17.6.0
2022-09	RAN#97	R5-224943	1427	-	F	Update of Rel-16 EN-DC configuration DC_2A_n41A in spurious emission test cases	17.6.0
2022-09	RAN#97	R5-224946	1428	-	F	Update of DC_8A_n41A, DC_3A_n41A, DC_25A_n41A, DC_26A_n41A, DC_39A_n41A and DC_40A_n41A in spurious emission test cases	17.6.0
2022-09	RAN#97	R5-224950	1429	-	F	Update of Rel-16 EN-DC configuration DC_48A_n5A in spurious emission test cases	17.6.0
2022-09	RAN#97	R5-224952	1430	-	F	Update of Rel-16 EN-DC configuration DC_48A_n66A in spurious emission test cases	17.6.0
2022-09	RAN#97	R5-224954	1431	-	F	Update of Rel-16 EN-DC configuration DC_66A_n41A in spurious emission test cases	17.6.0
2022-09	RAN#97	R5-225000	1434	-	F	Update to R16 Configuration for DC	17.6.0
2022-09	RAN#97	R5-225001	1435	-	F	Update to R17 Configuration for DC	17.6.0
2022-09	RAN#97	R5-225005	1436	-	F	Editorial correction to reference table ID to TC6.2B.1.3	17.6.0
2022-09	RAN#97	R5-225006	1437	-	F	Update to test case 6.5B.3.3.2	17.6.0
2022-09	RAN#97	R5-225031	1438	-	F	Add EN-DC Enhanced Beam Correspondence Test Case	17.6.0
2022-09	RAN#97	R5-225661	1394	1	F	New test case addition: 6.2B.4.1.4_1 Configured Output Power with Power Boost for Inter-Band EN-DC including FR2 (1 NR CC).	17.6.0
2022-09	RAN#97	R5-225662	1395	1	F	Measurement uncertainties and test tolerances for test case 6.2B.4.1.4_1 Configured Output Power with Power Boost for Inter-Band EN-DC including FR2 (1 NR CC)	17.6.0
2022-09	RAN#97	R5-225668	1409	1	F	PC1 MU - General Editor notes update in 38.521-3 FR2 Rx tests	17.6.0
2022-09	RAN#97	R5-225669	1396	1	F	Rel-15 Beam correspondence test tolerance definition	17.6.0
2022-09	RAN#97	R5-225678	1410	1	F	Update of FR2 5CC to 8CCs Transmission Test Cases	17.6.0
2022-09	RAN#97	R5-225705	1397	1	F	Introduction of Output power requirements for DC_3A_n8A	17.6.0
2022-09	RAN#97	R5-225706	1401	1	F	Introduction of Spurious emissions band UE co-existence Test description for DC_3A_n8A	17.6.0
2022-09	RAN#97	R5-225707	1419	1	F	Update 6.5B.3.3.2 for DC_5A_n2A	17.6.0
2022-09	RAN#97	R5-225708	1424	1	F	Corrections on test configuration table in spurious emission band UE co-existence for Rel-16 inter-band EN-DC configuration	17.6.0
2022-09	RAN#97	R5-225709	1421	1	F	Update for reference sensitivity for DC_48A_n66A	17.6.0
2022-09	RAN#97	R5-225736	1422	1	F	Update for reference sensitivity for DC_5A_n77A	17.6.0
2022-09	RAN#97	R5-225799	1406	1	F	Correction of Power Class 2 test requirements in 6.2B.1.3.5 for Interband EN-DC FDD and TDD Duplex-mode	17.6.0
2022-09	RAN#97	R5-225800	1411	1	F	Replacing the word LTE by E-UTRA in description of exception requirement	17.6.0
2022-09	RAN#97	R5-225801	1439	1	F	Removal of brackets for DCI format for Tx test cases	17.6.0
2022-09	RAN#97	R5-225802	1445	1	F	Introduction of test section for UL MIMO EN-DC MPR with FR1 and FR2	17.6.0

2022-09	RAN#97	R5-225803	1446	1	F	Introduction of test section for UL MIMO EN-DC A-MPR with FR1 and FR2	17.6.0
2022-09	RAN#97	R5-225804	1447	1	F	Introduction of test tase for UL MIMO EN-DC MPR in FR2	17.6.0
2022-09	RAN#97	R5-225805	1448	1	F	Introduction of test tase for UL MIMO EN-DC A-MPR in FR2	17.6.0
2022-09	RAN#97	R5-225806	1449	1	F	P-MaxUE-FR1-r15 correction for PC2 ENDC test cases	17.6.0
2022-09	RAN#97	R5-225807	1420	1	F	Update for ref sensitivity for R15_combos	17.6.0
2022-09	RAN#97	R5-225808	1441	1	F	Correction of reference sensitivity test case	17.6.0
2022-09	RAN#97	R5-225881	1440	1	F	Addition of new test case additional spurious for FR2	17.6.0
2022-12	RAN#98	R5-226296	1451		F	Move 6.5B.4.4 which is in front of 6.5B.3.5 to be after 6.5B.4.3	17.7.0
2022-12	RAN#98	R5-226297	1452		F	Clause styles and clause number correction in 6.6B.5	17.7.0
2022-12	RAN#98	R5-226480	1454		F	Introduction of reference sensitivity for three bands within FR1	17.7.0
2022-12	RAN#98	R5-226744	1462		F	Clean-up pending R15 configurations in clause 5.3	17.7.0
2022-12	RAN#98	R5-226746	1464		F	Clean-up pending R16 configurations in clause 5	17.7.0
2022-12	RAN#98	R5-226747	1465		F	Clean-up pending R17 configurations in clause 5	17.7.0
2022-12	RAN#98	R5-226749	1467		F	Clean-up pending R16 configurations in clause 6	17.7.0
2022-12	RAN#98	R5-226750	1468		F	Clean-up pending R17 configurations in clause 6	17.7.0
2022-12	RAN#98	R5-226751	1469		F	Clean-up pending R15 configurations in clause 7	17.7.0
2022-12	RAN#98	R5-226752	1470		F	Clean-up pending R16 configurations in clause 7	17.7.0
2022-12	RAN#98	R5-226754	1471		F	Editorial correction to the wording used for NR FRx	17.7.0
2022-12	RAN#98	R5-226761	1472		F	Editorial correction to editor note of completed TC6.3B.1.4_1.x minimum output power for EN-DC FR2	17.7.0
2022-12	RAN#98	R5-226815	1473		F	Update of FR2 Test Case 6.4B.2.4.4	17.7.0
2022-12	RAN#98	R5-226886	1474		F	New test case addition: 6.4B.2.4.1a Error Vector Magnitude with Power Boost for inter-band EN-DC including FR2 (1 NR CC)	17.7.0
2022-12	RAN#98	R5-226887	1475		F	New test case addition: 6.5B.2.4.1a Spectrum emissions mask with Power Boost for Inter-band EN-DC including FR2 (1 NR CC)	17.7.0
2022-12	RAN#98	R5-226888	1476		F	New test case addition: 6.5B.3.4.1a General Spurious Emissions with Power Boost for Inter-band including FR2 (1 NR CC)	17.7.0
2022-12	RAN#98	R5-226889	1477		F	New test case addition: 6.5B.3.4.2a Spurious emission band UE co-existence with Power Boost for Inter-band including FR2 (1 NR CC)	17.7.0
2022-12	RAN#98	R5-226890	1478		F	New test case addition: 6.5B.4.4a Additional Spurious Emissions with Power Boost for Inter-band including FR2 (1 NR CC)	17.7.0
2022-12	RAN#98	R5-226939	1479		F	New test case addition: 6.2B.2.4a UE maximum output power reduction enhancements for Inter-Band EN-DC including FR2 (1 NR CC)	17.7.0
2022-12	RAN#98	R5-226941	1480		F	Measurement uncertainties and test tolerances for mpr-PowerBoost tests 6.4B.2.4.1a, 6.5B.2.4.1a, 6.5B.3.4.1a, 6.5B.3.4.2a and 6.5B.4.4a	17.7.0
2022-12	RAN#98	R5-226994	1481		F	Measurement uncertainties and test tolerances for test 6.2B.2.4a UE maximum output power reduction enhancements for Inter-Band EN-DC including FR2 (1 NR CC)	17.7.0
2022-12	RAN#98	R5-227085	1495		F	Correction to test description of 6.2B.1.4D.1	17.7.0
2022-12	RAN#98	R5-227284	1498		F	Corrections on reference sensitivity test requirements for EN-DC configurations	17.7.0



2022-12	RAN#98	R5-227285	1499		F	Corrections on reference sensitivity test requirements on TT for DC_28A_n7A-n78A	17.7.0
2022-12	RAN#98	R5-227286	1500		F	Corrections on reference sensitivity test requirements on TT for R15 EN-DC configurations	17.7.0
2022-12	RAN#98	R5-227287	1501		F	Corrections on REFSEN for inter-band CA configurations	17.7.0
2022-12	RAN#98	R5-227289	1503		F	Corrections on test configuration table in spurious emission band UE co-existence for Rel-17 inter-band EN-DC configuration	17.7.0
2022-12	RAN#98	R5-227290	1504		F	Corrections on general description for MSD test frequencies	17.7.0
2022-12	RAN#98	R5-227786	1456	1	F	7.3B.2 cleaning up_R16	17.7.0
2022-12	RAN#98	R5-227787	1466	1	F	Clean-up pending R15 configurations in clause 6	17.7.0
2022-12	RAN#98	R5-227788	1458	1	F	Update Ref sense for R15 combos	17.7.0
2022-12	RAN#98	R5-227789	1507	1	F	Updated to clause 5 for simultaneous RxTx clarification	17.7.0
2022-12	RAN#98	R5-227790	1453	1	F	Update some frequency selections in test configuration table	17.7.0
2022-12	RAN#98	R5-227791	1482	1	F	Addition of new test case 6.3B.1.4_1.4 Minimum output power for inter-band EN-DC including FR2 - 5 NR CCs	17.7.0
2022-12	RAN#98	R5-227792	1483	1	F	Addition of new test case 6.3B.1.4_1.5 Minimum output power for inter-band EN-DC including FR2 - 6 NR CCs	17.7.0
2022-12	RAN#98	R5-227793	1484	1	F	Addition of new test case 6.3B.1.4_1.6 Minimum output power for inter-band EN-DC including FR2 - 7 NR CCs	17.7.0
2022-12	RAN#98	R5-227794	1485	1	F	Addition of new test case 6.3B.1.4_1.7 Minimum output power for inter-band EN-DC including FR2 - 8 NR CCs	17.7.0
2022-12	RAN#98	R5-227795	1486	1	F	Addition of new test case 6.4B.2.4.1_1.4 Error Vector Magnitude for inter-band EN-DC including FR2 - 5 NR CCs	17.7.0
2022-12	RAN#98	R5-227796	1487	1	F	Addition of new test case 6.4B.2.4.1_1.5 Error Vector Magnitude for inter-band EN-DC including FR2 - 6 NR CCs	17.7.0
2022-12	RAN#98	R5-227797	1488	1	F	Addition of new test case 6.4B.2.4.1_1.6 Error Vector Magnitude for inter-band EN-DC including FR2 - 7 NR CCs	17.7.0
2022-12	RAN#98	R5-227798	1489	1	F	Addition of new test case 6.4B.2.4.1_1.7 Error Vector Magnitude for inter-band EN-DC including FR2 - 8 NR CCs	17.7.0
2022-12	RAN#98	R5-227799	1490	1	F	Addition of new test case 6.4B.2.4.2_1.4 Carrier Leakage for inter-band EN-DC including FR2 - 5 NR CCs	17.7.0
2022-12	RAN#98	R5-227800	1491	1	F	Addition of new test case 6.4B.2.4.2_1.5 Carrier Leakage for inter-band EN-DC including FR2 - 6 NR CCs	17.7.0
2022-12	RAN#98	R5-227801	1492	1	F	Addition of new test case 6.4B.2.4.2_1.6 Carrier Leakage for inter-band EN-DC including FR2 - 7 NR CCs	17.7.0
2022-12	RAN#98	R5-227802	1493	1	F	Addition of new test case 6.4B.2.4.2_1.7 Carrier Leakage for inter-band EN-DC including FR2 - 8 NR CCs	17.7.0
2022-12	RAN#98	R5-227803	1455	1	F	Introduction of spurious emissions test cases for 18A_n77A and 18A_n78A	17.7.0
2022-12	RAN#98	R5-227804	1497	1	F	Corrections on MOP band edge relaxation for intra-band contiguous and non-contiguous EN-DC band combinations	17.7.0
2022-12	RAN#98	R5-227952	1508	1	F	Updates to EN-DC Enhanced Beam Corr test 6.6B.5	17.7.0
2022-12	RAN#98	R5-227966	1450	1	F	PC1 FR2 - Editor notes updates in 38.521-3	17.7.0
2022-12	RAN#98	R5-228032	1496	1	F	Additions to the clarification on intra-band contiguous and non-contiguous EN-DC configurations	17.7.0
2022-12	RAN#98	R5-228046	1461	1	F	Clean-up pending R15 configurations in clause 5.2	17.7.0

2022-12	RAN#98	R5-228047	1463	1	F	Clean-up pending R15 configurations in clause 5.5	17.7.0
2023-03	RAN#99	R5-230181	1511	-	F	Missing MU and TT in annex F for Spurious co-existence EN-DC FR2 CA tests	17.8.0
2023-03	RAN#99	R5-230246	1527	-	F	Addition of reference sensitivity for new EN-DC comb within FR1	17.8.0
2023-03	RAN#99	R5-230313	1532	-	F	Editorial - missing reference to 38.101 in section 7.3B	17.8.0
2023-03	RAN#99	R5-230568	1534	-	F	Correction of test tolerance for Tx power test cases	17.8.0
2023-03	RAN#99	R5-230569	1535	-	F	Move 6.4B.2.4.4D to be after 6.4B.2.4.4	17.8.0
2023-03	RAN#99	R5-230570	1536	-	F	Move 6.5B.4.4a to be after 6.5B.4.4	17.8.0
2023-03	RAN#99	R5-230571	1537	-	F	Editorial correction for content style in 6.6B.5.5	17.8.0
2023-03	RAN#99	R5-230573	1539	-	F	Addition of F.1.0 and F.1.1	17.8.0
2023-03	RAN#99	R5-230574	1540	-	F	Addition of 6.2B.2.1 in F.3.2	17.8.0
2023-03	RAN#99	R5-230659	1541	-	F	Addition of 6.5E.3.1 General Spurious emissions for V2X	17.8.0
2023-03	RAN#99	R5-230883	1544	-	F	Update Configured Output Power Level for inter-band EN-DC	17.8.0
2023-03	RAN#99	R5-230892	1545	-	F	Update 6.2B.4.2.3.1 for DC_71A_n66A and DC_12A_n2A	17.8.0
2023-03	RAN#99	R5-230893	1546	-	F	Update 6.2B.4.2.3.1 for DC_71A_n2A	17.8.0
2023-03	RAN#99	R5-230895	1547	-	F	Update 6.2B.1.3 for R17 combo DC_71A_n2A	17.8.0
2023-03	RAN#99	R5-230899	1548	-	F	Update for reference sensitivity for DC_48A_n66A	17.8.0
2023-03	RAN#99	R5-230901	1550	-	F	Remove pending combo from 7.2B.2.3	17.8.0
2023-03	RAN#99	R5-230906	1554	-	F	Update ref sense min requirement for DC_71A_n2A	17.8.0
2023-03	RAN#99	R5-230907	1555	-	F	Update ref sense min requirement for DC_71A_n66A	17.8.0
2023-03	RAN#99	R5-230940	1560	-	F	Correction to reference sensitivity test configuration for DC_1A_n28A	17.8.0
2023-03	RAN#99	R5-230941	1561	-	F	Correction to reference sensitivity test configuration for DC_8A_n41A	17.8.0
2023-03	RAN#99	R5-230943	1563	-	F	Addition of reference sensitivity for DC_2A-66A_n5A	17.8.0
2023-03	RAN#99	R5-230948	1564	-	F	Correction to reference sensitivity requirements for EN-DC with 4 Rx support	17.8.0
2023-03	RAN#99	R5-230949	1565	-	F	Correction to NR test SCS for DC_(n)71AA across clause 6	17.8.0
2023-03	RAN#99	R5-230959	1567	-	F	Update 6.2B.1.3 for R16 combos DC_71A_n66A and DC_12A_n2A	17.8.0
2023-03	RAN#99	R5-230978	1569	-	F	Correction to the MOP measurement for simultaneous transmission	17.8.0
2023-03	RAN#99	R5-231058	1573	-	F	Introduction of reference sensitivity for 21A_n28A	17.8.0
2023-03	RAN#99	R5-231180	1576	-	F	Add editors note to TC6.2B.3.4D with incomplete state	17.8.0
2023-03	RAN#99	R5-231182	1578	-	F	Update to R16 Configuration for DC	17.8.0
2023-03	RAN#99	R5-231294	1583	-	F	Corrections on test requirements for reference sensitivity exceptions for DC_7A-20A_n1A	17.8.0
2023-03	RAN#99	R5-231301	1584	-	F	Correction of maximum output power test case	17.8.0
2023-03	RAN#99	R5-231312	1586	-	F	Update of 7.3B.2.3 Reference sensitivity for Inter-band EN-DC within FR1 (2 CCs) for DC_25A_n41A	17.8.0
2023-03	RAN#99	R5-231670	1585	1	F	Editorial correction of E-UTRA reference for FR2 test cases	17.8.0
2023-03	RAN#99	R5-231671	1526	1	F	Addition of delta TIBc for new EN-DC comb within FR1	17.8.0

2023-03	RAN#99	R5-231672	1523	1	F	Addition of delta TIBc for new 3CC EN-DC comb within FR1	17.8.0
2023-03	RAN#99	R5-231673	1524	1	F	Addition of reference sensitivity for new 3CC EN-DC comb within FR1	17.8.0
2023-03	RAN#99	R5-231674	1542	1	F	Addition of MOP and spurious emissions for new 2CC EN-DC comb within FR1	17.8.0
2023-03	RAN#99	R5-231675	1543	1	F	Updating spurious coex for inter-band EN-DC CA to add 5 to 8 CCs	17.8.0
2023-03	RAN#99	R5-231676	1558	1	F	Update Tx spurious co-exist for DC_71A_n66A and DC_12A_n2A	17.8.0
2023-03	RAN#99	R5-231677	1559	1	F	General SE for DC_71A_n66A and DC_12A_n2A	17.8.0
2023-03	RAN#99	R5-231678	1549	1	F	Remove pending combo from 7.2B.2.3	17.8.0
2023-03	RAN#99	R5-231679	1552	1	F	Update 7.3B.2.3 for DC_71A_n66A and DC_12A_n2A	17.8.0
2023-03	RAN#99	R5-231680	1556	1	F	Update Tx spurious co-exist for DC_71A_n2A	17.8.0
2023-03	RAN#99	R5-231681	1557	1	F	General SE for DC_71A_n2A	17.8.0
2023-03	RAN#99	R5-231682	1553	1	F	Update 7.3B.2.3 for DC_71_n2A	17.8.0
2023-03	RAN#99	R5-231684	1562	1	F	Correction to reference sensitivity test configuration for DC_12A_n78A	17.8.0
2023-03	RAN#99	R5-231685	1579	1	F	Update to R17 Configuration for DC	17.8.0
2023-03	RAN#99	R5-231686	1577	1	F	Update to R15 Configuration for DC	17.8.0
2023-03	RAN#99	R5-231687	1572	1	F	Introduction of spurious emissions test cases for 21A_n28A	17.8.0
2023-03	RAN#99	R5-231688	1574	1	F	Introduction of DC_28A_n78A PC2 MOP test requirements	17.8.0
2023-03	RAN#99	R5-231689	1529	1	F	Updates for Table 7.3B.2.3.4.2.1-6 due to frequency selections in test configuration table partly non-implementable	17.8.0
2023-03	RAN#99	R5-231690	1520	1	F	Update of MOP TC for PC2 ENDC configurations	17.8.0
2023-03	RAN#99	R5-231691	1521	1	F	Addition of PC2 ENDC combo into 38.521-3 TC 7.3B.2	17.8.0
2023-03	RAN#99	R5-231692	1587	1	F	Introduction of EIRP with UL-Gaps test for EN-DC with FR2	17.8.0
2023-03	RAN#99	R5-231693	1568	1	F	Correction to time offset for TDD intra-band EN-DC	17.8.0
2023-03	RAN#99	R5-231694	1582	1	F	Corrections on reference sensitivity for configuration DC_66A_n41A	17.8.0
2023-03	RAN#99	R5-231695	1580	1	F	Corrections on applicability of minimum requirements for intra-band EN-DC	17.8.0
2023-03	RAN#99	R5-231783	1519	1	F	Update of editors note for PC1	17.8.0
2023-03	RAN#99	R5-231840	1509	1	F	Update switching time mask for UL tx switching for EN-DC	17.8.0
2023-03	RAN#99	R5-231847	1510	1	F	PC1 FR2 - Editor notes updates in 38.521-3	17.8.0
2023-03	RAN#99	R5-231860	1551	1	F	Ref sensitivity correction for DC_1A_n77A and DC_21_n79A	17.8.0
2023-03	RAN#99	R5-231864	1566	1	F	Update of EN-DC reference sensitivity to handle simultaneous Rx/Tx capability	17.8.0
2023-03	RAN#99	R5-231876	1570	1	F	Clarification on power class of LTE band in 6.2B.4.1.3	17.8.0
2023-03	RAN#99	R5-231887	1538	1	F	Correction of referenced clause numbers in 7.5B.4_1	17.8.0
2023-03	RAN#99	R5-231892	1528	1	F	Corrections of test requirement tables for spurious emission for UE co-existence for EN-DC	17.8.0
2023-03	RAN#99	R5-231965	1581	1	F	Corrections on intra-band EN-DC configuration for DC_n41	17.8.0
2023-06	RAN#100	R5-232349	1594	-	F	Editorial update Tx spurious co-existence for DC_71A_n2A	17.9.0
2023-06	RAN#100	R5-232365	1596	-	F	Correction to spurious emissions test cases for 21A_n28A	17.9.0

2023-06	RAN#100	R5-232383	1598	-	F	Correction of the DC_28A_n78A PC2 MOP test requirements	17.9.0
2023-06	RAN#100	R5-232514	1601	-	F	Update the Initial Conditions of four 6.2B.x TCs	17.9.0
2023-06	RAN#100	R5-232609	1603	-	F	Update Ref sense for DC_7A_n66A DC_7A_n71A DC_7A_n77A and DC_66A_n25A	17.9.0
2023-06	RAN#100	R5-232623	1604	-	F	Adding SE Coex Inter band ENDC FR2 UL-MIMO test case	17.9.0
2023-06	RAN#100	R5-232700	1605	-	F	Addition of 6.5E.4 Transmit intermodulation for V2X	17.9.0
2023-06	RAN#100	R5-232754	1607	-	F	Correction to test ID for PC2 fallback PC3 testing	17.9.0
2023-06	RAN#100	R5-232772	1608	-	F	Addition of reference sensitivity for 21A_n28A	17.9.0
2023-06	RAN#100	R5-232840	1610	-	F	Update of PC2 UE configured output power for inter-band EN-DC configurations	17.9.0
2023-06	RAN#100	R5-232841	1611	-	F	Update of PC2 UE maximum output power for inter-band EN-DC configurations	17.9.0
2023-06	RAN#100	R5-233001	1612	-	F	Correction to reference of RMC for E-UTRA TDD in FR1 EN-DC test cases	17.9.0
2023-06	RAN#100	R5-233002	1613	-	F	Correction to 6.2B.4.1.3 and editorial correction to Tx test cases	17.9.0
2023-06	RAN#100	R5-233025	1615	-	F	Adding time delay to intra-band EN-DC test cases	17.9.0
2023-06	RAN#100	R5-233157	1617	-	F	Update 7.3B.3.3.1 for R16 DC combos	17.9.0
2023-06	RAN#100	R5-233168	1618	-	F	Addition of Additional Spurious Emissions FR2 CA test cases	17.9.0
2023-06	RAN#100	R5-233175	1619	-	F	Update of in-band blocking for CA test cases	17.9.0
2023-06	RAN#100	R5-233182	1620	-	F	Update to R15 Configuration for DC	17.9.0
2023-06	RAN#100	R5-233183	1621	-	F	Update to R16 Configuration for DC	17.9.0
2023-06	RAN#100	R5-233190	1623	-	F	Additional editors note to Power Boost relevant test cases	17.9.0
2023-06	RAN#100	R5-233520	1602	1	F	Update Ref sense for DC_38A_n78A, DC_18A_n77A and DC_19A_n77A	17.9.0
2023-06	RAN#100	R5-233545	1616	1	F	Clarification of spurious emission testing configuration - Part 3	17.9.0
2023-06	RAN#100	R5-233563	1599	1	F	Addition of new CADC MOP TC	17.9.0
2023-06	RAN#100	R5-233564	1600	1	F	Addition of new CADC TC 6.3B.3.4_1.1	17.9.0
2023-06	RAN#100	R5-233576	1625	1	F	Corrections on test requirements for MSD due to dual uplink for EN-DC	17.9.0
2023-06	RAN#100	R5-233577	1624	1	F	Corrections on higher power class indication for EN-DC configuration	17.9.0
2023-06	RAN#100	R5-233638	1589	1	F	FR2 MUs - Editor notes updates in 38.521-3	17.9.0
2023-06	RAN#100	R5-233703	1590	1	F	Update PC2 MSD minimum requirements and test requirements for DC_2A_n77A, DC_13A_n77A, and DC_66A_n77A	17.9.0
2023-06	RAN#100	R5-233724	1595	1	F	NSA beam correspondence test applicability inconsistent with SA test	17.9.0
2023-06	RAN#100	R5-233725	1606	1	F	Correction to 6.2B.4.1.3 configured output power for EN-DC	17.9.0
2023-09	RAN#101	R5-234040	1629	-	F	Correction to ref sense configuration for DC_71A_n2A	17.10.0
2023-09	RAN#101	R5-234054	1632	-	F	Update 6.2B.4.2.3.1 for DC_48A_n46	17.10.0
2023-09	RAN#101	R5-234055	1633	-	F	Update 6.2B.1.3 for DC_48A_n46A	17.10.0
2023-09	RAN#101	R5-234057	1634	-	F	Update Ch5 for DC_48A_n46A	17.10.0
2023-09	RAN#101	R5-234117	1637	-	F	Correction of reference sensitivity test point for DC_48A_n66A	17.10.0

2023-09	RAN#101	R5-234182	1642	-	F	Correction for NSA band combo DC_7A_n71A in 7.3B.2.3	17.10.0
2023-09	RAN#101	R5-234185	1645	-	F	Correction for NSA band combos DC_19A_n77A and DC_1A_n77A in 7.3B.2.3	17.10.0
2023-09	RAN#101	R5-234227	1646	-	F	Update the Initial Conditions of 6.3B.x and 6.4B.x TCs	17.10.0
2023-09	RAN#101	R5-234564	1647	-	F	Update to R15 Configuration for DC	17.10.0
2023-09	RAN#101	R5-234777	1651	-	F	Addition of new test case 6.4B.2.4.3_1.4 In-band Emissions for inter-band EN-DC including FR2 (5 NR CCs)	17.10.0
2023-09	RAN#101	R5-234778	1652	-	F	Addition of new test case 6.4B.2.4.3_1.5 In-band Emissions for inter-band EN-DC including FR2 (6 NR CCs)	17.10.0
2023-09	RAN#101	R5-234790	1653	-	F	Update of higher power limit requirements for inter-band EN-DC	17.10.0
2023-09	RAN#101	R5-234912	1655	-	F	Correction to message exception in EVM test case for intra-band EN-DC	17.10.0
2023-09	RAN#101	R5-234913	1656	-	F	Editorial correction to Reference sensitivity for EN-DC	17.10.0
2023-09	RAN#101	R5-235069	1658	-	F	Correction to referred clause number of CADC MOP TCs	17.10.0
2023-09	RAN#101	R5-235141	1661	-	F	Correction of Refsens FR1 EN-DC	17.10.0
2023-09	RAN#101	R5-235148	1663	-	F	Editorial correction of Refsens for Rel-16 configuration	17.10.0
2023-09	RAN#101	R5-235202	1664	-	F	Correction to title of 6.2B.1.4D.1	17.10.0
2023-09	RAN#101	R5-235203	1665	-	F	Updated to editors note for EN-DC FR2 TC completion status	17.10.0
2023-09	RAN#101	R5-235623	1662	1	F	Editorial correction of UE co-existence Inter-band FR1	17.10.0
2023-09	RAN#101	R5-235672	1643	1	F	Correction for NSA band combo DC_14A_n77A in 7.3B.2.3	17.10.0
2023-09	RAN#101	R5-235673	1659	1	F	Corrections on cross-band isolation MSD for the more than 2 bands configuration	17.10.0
2023-09	RAN#101	R5-235674	1660	1	F	Corrections on test requirements for MSD due to dual uplink for R15 EN-DC configurations	17.10.0
2023-09	RAN#101	R5-235675	1648	1	F	Update to R16 Configuration for DC	17.10.0
2023-09	RAN#101	R5-235676	1630	1	F	Update 7.3B.2.0 for DC_48A_n46A	17.10.0
2023-09	RAN#101	R5-235677	1666	1	F	Update of EIRP with UL-Gaps test for EN-DC with FR2	17.10.0
2023-09	RAN#101	R5-235750	1628	1	F	FR2 MUs - Editor notes updates in 38.521-3	17.10.0
2023-09	RAN#101	R5-235820	1657	1	F	Addition of new CADC MOP TC for 8 NR CCs	17.10.0
2023-09	RAN#101	R5-235870	1654	1	F	Clarification of unwanted emission testing configuration - Part 3	17.10.0
2023-09	RAN#101	R5-235958	1636	1	F	Correction of 7.3B.2.3 for exception and no exception requirements	17.10.0
2023-09	RAN#101	R5-235959	1638	1	F	Correction of 6.5B.3.3.1 for exception and non-exception requirements	17.10.0
2023-09	RAN#101	R5-235960	1639	1	F	Correction of requirements of Spurious emissions for UE co-existence of intra band ENDC	17.10.0
2023-09	RAN#101	R5-235961	1640	1	F	Correction of 6.5B.3.3.2 for exception and non-exception requirements	17.10.0
2023-09	RAN#101	R5-234097	1635	-	F	Introduction of DC for n78 and n79 PC2 MOP test requirements	18.0.0
2023-09	RAN#101	R5-235618	1650	1	F	Updates to spurious emissions UE coexistence test cases as part of introduction of LTE Band 54	18.0.0
2023-12	RAN#102	R5-236067	1667		F	FR2 MUs - Editor notes updates for Tx test cases in 38.521-3	18.1.0
2023-12	RAN#102	R5-236328	1672		F	Missing notes for DC_1A_n41A test IDs in 7.3B.2.3 test configuration table	18.1.0

2023-12	RAN#102	R5-236339	1676		F	Defined MU and TT for EUTRA and NR UL Switching test case 6.3B.3_1.1	18.1.0
2023-12	RAN#102	R5-236340	1677		F	Editorial correction in test procedure of NSA ACLR test 6.5B.2.1.3	18.1.0
2023-12	RAN#102	R5-236351	1679		F	Addition of max power requirements for several EN-DC combos	18.1.0
2023-12	RAN#102	R5-236352	1680		F	Addition of spurious emissions test for several EN-DC combos	18.1.0
2023-12	RAN#102	R5-236369	1681		F	Update minimum requirements for additional ENDC configurations	18.1.0
2023-12	RAN#102	R5-236370	1682		F	Update test configurations and test requirements for additional three band ENDC configurations	18.1.0
2023-12	RAN#102	R5-236461	1685		F	New addition of RF Rel-16 Test Case 6.2B.2.4_1.2 UE Maximum Output power reduction for inter-band EN-DC including FR2 (3 NR CCs)	18.1.0
2023-12	RAN#102	R5-236467	1687		F	Addition of new test case 6.4B.2.4.3_1.6 In-band Emissions for inter-band EN-DC including FR2 (7 NR CCs)	18.1.0
2023-12	RAN#102	R5-236468	1688		F	Addition of new test case 6.4B.2.4.3_1.7 In-band Emissions for inter-band EN-DC including FR2 (8 NR CCs)	18.1.0
2023-12	RAN#102	R5-236502	1691		F	Addition of REFSSENS for 2CC EN-DC for n79 in PC2	18.1.0
2023-12	RAN#102	R5-236545	1693		F	Update to R15 common section	18.1.0
2023-12	RAN#102	R5-236661	1697		F	Updating FR2 MOP for 5UL-8UL CA test cases	18.1.0
2023-12	RAN#102	R5-236816	1702		F	Correction to DL RMC for TDD E-UTRA	18.1.0
2023-12	RAN#102	R5-236846	1704		F	New addition of RF Rel-16 Test Case 6.2B.2.4_1.3 UE Maximum Output power reduction for inter-band EN-DC including FR2 (4 NR CCs)	18.1.0
2023-12	RAN#102	R5-236946	1705		F	Corrections to 7.3A.3 and 7.3B.3 on delta RIB value for CA and DC in REFSSENS requirement	18.1.0
2023-12	RAN#102	R5-237261	1709		F	Editorial correction of FR2 spurious emissions test cases	18.1.0
2023-12	RAN#102	R5-237636	1690	1	F	Update of REFSSENS for 3CC EN-DC for n78 and n79	18.1.0
2023-12	RAN#102	R5-237663	1694	1	F	Update to R16 Configuration for DC	18.1.0
2023-12	RAN#102	R5-237664	1678	1	F	Addition of reference sensitivity test for several EN-DC combos	18.1.0
2023-12	RAN#102	R5-237665	1695	1	F	Update to R17 Configuration for DC	18.1.0
2023-12	RAN#102	R5-237666	1700	1	F	Correction to test condition for test frequency restriction of DC_xA_n28A	18.1.0
2023-12	RAN#102	R5-237667	1711		F	Correction to message contents in Rx test cases for inter-band EN-DC with FR1	18.1.0
2023-12	RAN#102	R5-237668	1708	1	F	Correction of Refsens EN-DC within FR1	18.1.0
2023-12	RAN#102	R5-237669	1710	1	F	Update to Table 7.3B.2.3.4.2.1-6: Test Configuration Table for EN-DC configurations	18.1.0
2023-12	RAN#102	R5-237732	1707	1	F	Editors notes update in FR2 UL MIMO test cases	18.1.0
2023-12	RAN#102	R5-237733	1668	1	F	FR2 MUs - Editor notes updates for Rx test cases in 38.521-3	18.1.0
2023-12	RAN#102	R5-237784	1689	1	F	Adding DeltaTIB for DC_1-3-7-28_n78 and DC_1-7_28-n78	18.1.0
2023-12	RAN#102	R5-237862	1706	1	F	Corrections to spurious emissions co-existence for 2 UL Inter-band CA (38.521-3)	18.1.0
2023-12	RAN#102	R5-237955	1692	1	F	Correction to 6.5B.3.3.2	18.1.0
2023-12	RAN#102	R5-237963	1703	1	F	Clarifications for FR2 testing with NR-DC and NR-CA	18.1.0

2024-03	RAN#103	R5-240305	1715	-	F	Correction to test configuration for non-exception REFSENS testing for 3CC EN-DC	18.2.0
2024-03	RAN#103	R5-240331	1716	-	F	Addition of UE maximum output power for new PC2 EN-DC combos within FR1	18.2.0
2024-03	RAN#103	R5-240338	1718	-	F	Update of MOP test configuration for DC_20A_n28A	18.2.0
2024-03	RAN#103	R5-240339	1719	-	F	Correction to H3 title for clauses including NE-DC test cases	18.2.0
2024-03	RAN#103	R5-240627	1722	-	F	Minimum requirements update for DC_5A_n78A	18.2.0
2024-03	RAN#103	R5-240879	1723	-	F	Addition of general spurious emissions test for EN-DC combos DC_2A_n66A and DC_30A_n66A	18.2.0
2024-03	RAN#103	R5-240884	1724	-	F	Addition of many EN-DC PC2 combos to Ch 5	18.2.0
2024-03	RAN#103	R5-240885	1725	-	F	Addition of test requirements for EN-DC PC2 combos DC_12A_n77A, DC_14A_n77A and DC_30A_n77A max power test	18.2.0
2024-03	RAN#103	R5-240934	1729	-	F	Update to R16 Configuration for DC	18.2.0
2024-03	RAN#103	R5-241062	1738	-	F	Addition and correction of REFSENS for 2CC EN-DC in PC2	18.2.0
2024-03	RAN#103	R5-241072	1742	-	F	Update to FR1 EN-DC Configurations for n78 and n79	18.2.0
2024-03	RAN#103	R5-241108	1748	-	F	Correction to Reference sensitivity for DC_21A_n28A	18.2.0
2024-03	RAN#103	R5-241109	1749	-	F	Correction to note application in Table 7.3B.2.0.3.4-2	18.2.0
2024-03	RAN#103	R5-241110	1750	-	F	Correction to p-Max value in Rx test cases for FR1 intra-band contiguous EN-DC	18.2.0
2024-03	RAN#103	R5-241111	1751	-	F	Correction to UL power control for FR1 intra-band non-contiguous EN-DC	18.2.0
2024-03	RAN#103	R5-241725	1720	1	F	Addition of new test case 6.2H.2.3 MPR for inter-band EN-DC with UL MIMO	18.2.0
2024-03	RAN#103	R5-241784	1733	1	F	Clarification of trace mode in emission testing_lw	18.2.0
2024-03	RAN#103	R5-241789	1732	1	F	Correct clause 6.2B.4.1.2 initial conditions	18.2.0
2024-03	RAN#103	R5-241790	1753	1	F	Editorial correction to FR1 inter-band co-existence	18.2.0
2024-03	RAN#103	R5-241861	1747	1	F	Update for FR2c MU	18.2.0
2024-03	RAN#103	R5-241904	1717	1	F	Addition of reference sensitivity for new PC2 EN-DC combos within FR1	18.2.0
2024-03	RAN#103	R5-241905	1713	1	F	Correction of applicability and test coverage rules for SA and NSA capable devices	18.2.0
2024-03	RAN#103	R5-241923	1714	1	F	Correction of applicability for test with LTE anchor agnostic approach in 6.5B.3.3.1	18.2.0
2024-03	RAN#103	R5-241924	1752	1	F	Correction to p-Max value in out of band test cases for FR1 inter-band EN-DC	18.2.0
2024-03	RAN#103	R5-241989	1741	1	F	Addition of REFSENS for 3CC EN-DC in PC2	18.2.0
2024-03	RAN#103	R5-241991	1712	1	F	Removal of LTE anchor agnostic approach testing in 6.5B.3.3.2	18.2.0
2024-03	RAN#103	R5-241992	1740	1	F	Update of REFSENS for DC_19A_n77A and DC_19A_n78A in PC3	18.2.0
2024-03	RAN#103	R5-242027	1755	1	F	Updates to 6.2B.1.6 UE Maximum Output Power for Inter-Band EN-DC including FR2 (1 NR CC) - EIRP with UL Gaps test case	18.2.0
2024-03	RAN#103	R5-242028	1754	1	F	Updates to Annex F for 6.2B.1.6 UE Maximum Output Power for Inter-Band EN-DC including FR2 (1 NR CC) - EIRP with UL Gaps test case	18.2.0
2024-06	RAN#104	R5-242252	1756	-	F	Addition of UE maximum output power for new PC2 EN-DC combs within FR1	18.3.0

2024-06	RAN#104	R5-242254	1758	-	F	Addition and correction of reference sensitivity exceptions for PC2 EN-DC combos	18.3.0
2024-06	RAN#104	R5-242452	1760	-	F	Update for additional ENDC band configurations	18.3.0
2024-06	RAN#104	R5-242711	1762	-	F	Addition of DC_66A_n66 BCS1, DC_66A-66A_n66A, DC_2A-2A_n66A, DC_66A-66A-66A_n77A, DC_66A-66A-66A_n77(2A) and DC_66A-66A_n2A to Ch5	18.3.0
2024-06	RAN#104	R5-242724	1768	-	F	Correct typo for clause 6.5B.3.2.1.4 and 6.5B.3.4.1.4.1	18.3.0
2024-06	RAN#104	R5-242785	1769	-	F	Correction to IE name higherPowerLimit used in test cases	18.3.0
2024-06	RAN#104	R5-242790	1770	-	F	Clarification On Beam Correspondence requirement for EN-DC	18.3.0
2024-06	RAN#104	R5-242796	1771	-	F	Update to FR1 EN-DC Configurations for n78 and n79	18.3.0
2024-06	RAN#104	R5-242928	1777	-	F	Addition of new test case 6.2H.1.3 MOP for inter-band EN-DC with MIMO	18.3.0
2024-06	RAN#104	R5-242929	1778	-	F	Addition of new test cases 6.2H.x.3 for inter-band EN-DC with MIMO	18.3.0
2024-06	RAN#104	R5-242930	1779	-	F	Addition of new test case 6.2L.1.3 MOP for inter-band EN-DC with TxD	18.3.0
2024-06	RAN#104	R5-242931	1780	-	F	Addition of new test cases 6.2L.x.3 for inter-band EN-DC with TxD	18.3.0
2024-06	RAN#104	R5-243015	1782	-	F	Correction to notes for FR1 EN-DC Spurious emission band UE co-existence	18.3.0
2024-06	RAN#104	R5-243106	1784	-	F	Update of status of FR2 CA and UL MIMO test cases	18.3.0
2024-06	RAN#104	R5-243108	1785	-	F	Addition of power tolerance CA test cases for FR2	18.3.0
2024-06	RAN#104	R5-243204	1786	-	F	Updating description in test configuration table of test case 7.3B.2.3_1.1	18.3.0
2024-06	RAN#104	R5-243220	1787	-	F	Addition of MU and TT analysis for 3Tx EN-DC test cases	18.3.0
2024-06	RAN#104	R5-243221	1788	-	F	Addition of general information for 3Tx EN-DC	18.3.0
2024-06	RAN#104	R5-243615	1757	1	F	Addition of reference sensitivity for new PC2 EN-DC combs within FR1	18.3.0
2024-06	RAN#104	R5-243665	1761	1	F	Core requirements alignment for UE co-existence of Inter-band within FR1	18.3.0
2024-06	RAN#104	R5-243666	1789	1	F	Addition of delta TIBc for R16 inter-band EN-DC within FR1	18.3.0
2024-06	RAN#104	R5-243667	1790	1	F	Addition of delta RIBc for R16 inter-band EN-DC within FR1	18.3.0
2024-06	RAN#104	R5-243668	1791	1	F	Addition of minimum requirements of reference sensitivity exceptions for R16 inter-band EN-DC within FR1	18.3.0
2024-06	RAN#104	R5-243669	1792	1	F	Update of R16 Configuration for inter-band EN-DC	18.3.0
2024-06	RAN#104	R5-243670	1763	1	F	Correction of Reference Sensitivity test for DC_30A-n77A	18.3.0
2024-06	RAN#104	R5-243671	1793	1	F	Corrections on 6.2B.1.3 for UE MOP for configuration DC_38A_n78A	18.3.0
2024-06	RAN#104	R5-243672	1774	1	F	Update of 7.3B.2 reference sensitivity for inter-band EN-DC	18.3.0
2024-06	RAN#104	R5-243728	1759	1	F	PC5 FR2 MU - Updates in 38.521-3	18.3.0
2024-06	RAN#104	R5-243825	1772	1	F	Addition of REFSSENS for 3CC EN-DC for n78A and n79A in PC3	18.3.0
2024-06	RAN#104	R5-243828	1773	1	F	Addition of REFSSENS for 3CC EN-DC for n78A and n79A in PC2	18.3.0
2024-06	RAN#104	R5-243840	1783	1	F	Correction to Inter-band EN-DC spurious emission requirements	18.3.0
2024-09	RAN#105	R5-244092	1797	-	F	Addition of UE maximum output power for new PC2 2CC EN-DC comb within FR1	18.4.0



2024-09	RAN#105	R5-244413	1802	-	F	Undoing the Correction of 7.3B.2.3 for exception and no exception requirements	18.4.0
2024-09	RAN#105	R5-244533	1803	-	F	Addition of new test case 6.4B.1.4_1.4 Frequency Error for Inter-band EN-DC including FR2 for 5 NR CCs	18.4.0
2024-09	RAN#105	R5-244534	1804	-	F	Addition of new test case 6.4B.1.4_1.5 Frequency Error for Inter-band EN-DC including FR2 for 6 NR CCs	18.4.0
2024-09	RAN#105	R5-244535	1805	-	F	Addition of new test case 6.4B.1.4_1.6 Frequency Error for Inter-band EN-DC including FR2 for 7 NR CCs	18.4.0
2024-09	RAN#105	R5-244536	1806	-	F	Addition of new test case 6.4B.1.4_1.7 Frequency Error for Inter-band EN-DC including FR2 for 8 NR CCs	18.4.0
2024-09	RAN#105	R5-244542	1807	-	F	Addition of many EN-DC combos to Ch5	18.4.0
2024-09	RAN#105	R5-244543	1808	-	F	Addition of configured output power requirements for several EN-DC 3 band combos	18.4.0
2024-09	RAN#105	R5-244593	1810	-	F	Addition of DC_66A-66A-66A_n77A PC2 and DC_66A-66A-66A_n77(2A) PC2 to Ch5	18.4.0
2024-09	RAN#105	R5-244800	1811	-	F	Update of Transmit OFF power for inter-band EN-DC including FR2	18.4.0
2024-09	RAN#105	R5-244827	1812	-	F	Addition of DC_1A_n3A_n78A to Reference sensitivity	18.4.0
2024-09	RAN#105	R5-244863	1814	-	F	Correction to REFSENS test points for DC_12A_n66A	18.4.0
2024-09	RAN#105	R5-244903	1816	-	F	Editorial correction in Annex F for FR2 absolute power tolerance	18.4.0
2024-09	RAN#105	R5-244906	1817	-	F	Addition of new test case for FR2 additional spurious emissions for UL MIMO	18.4.0
2024-09	RAN#105	R5-244909	1818	-	F	Addition of new test cases for FR2 A-MPR with CA	18.4.0
2024-09	RAN#105	R5-245122	1823	-	F	Update of R16 Configuration for inter-band EN-DC	18.4.0
2024-09	RAN#105	R5-245157	1826	-	F	Addition of new test case 6.5H.3.3.1 for inter-band EN-DC with UL MIMO	18.4.0
2024-09	RAN#105	R5-245158	1827	-	F	Addition of new test case 6.5H.3.3.2 for inter-band EN-DC with UL MIMO	18.4.0
2024-09	RAN#105	R5-245159	1828	-	F	Addition of new test case 6.5L.3.3.1 for inter-band EN-DC with TxD	18.4.0
2024-09	RAN#105	R5-245160	1829	-	F	Addition of new test case 6.5L.3.3.2 for inter-band EN-DC with TxD	18.4.0
2024-09	RAN#105	R5-245162	1831	-	F	Addition of Rx requirements for inter-band EN-DC with 3Tx	18.4.0
2024-09	RAN#105	R5-245167	1832	-	F	Update of simultaneous RxTx capability indication for DC_39_n41 and DC_40_n41	18.4.0
2024-09	RAN#105	R5-245168	1833	-	F	Addition of TIB value for DC_40_n41 with simultaneous RxTx capability	18.4.0
2024-09	RAN#105	R5-245723	1825	2	F	Correction to clause 5 for 3Tx inter-band EN-DC configurations	18.4.0
2024-09	RAN#105	R5-245815	1830	1	F	Addition of Annex F for spurious emissions test cases for inter-band EN-DC with 3Tx	18.4.0
2024-09	RAN#105	R5-245818	1798	1	F	Addition of reference sensitivity for new PC2 2CC and 3CC EN-DC combs within FR1	18.4.0
2024-09	RAN#105	R5-245829	1836	-	F	Addition of RX tests for several EN-DC 3 band combos	18.4.0
2024-09	RAN#105	R5-245834	1796	1	F	Correction of reference sensitivity for PC3 DC_18A_n77A and DC_18A_n78A	18.4.0
2024-09	RAN#105	R5-245850	1819	1	F	Corrections on 7.3B.2.0.3 for harmonic mixing MSD valid test point notes	18.4.0
2024-09	RAN#105	R5-245851	1822	1	F	Addition of MSD test points for R16 inter-band EN-DC within FR1	18.4.0

2024-09	RAN#105	R5-245852	1800	1	F	Remove Editors Note which is no longer needed	18.4.0
2024-09	RAN#105	R5-245853	1813	1	F	Correction to note for 2UL intermodulation exception in 7.3B.2.3	18.4.0
2024-09	RAN#105	R5-245949	1799	1	F	FR2 MU - General Updates in 38.521-3	18.4.0
2024-09	RAN#105	R5-245950	1815	1	F	Update of status of FR2 CA and UL MIMO test cases	18.4.0
2024-09	RAN#105	R5-245986	1821	1	F	Addition of test requirement for Inter-band EN-DC FR1 configurations with three bands	18.4.0
2024-09	RAN#105	R5-245987	1794	1	F	Correction of reference sensitivity for PC2 EN-DC combs within FR1	18.4.0
2024-09	RAN#105	R5-245988	1801	1	F	Modified MPR behaviour correction in 38.521-3	18.4.0
2024-09	RAN#105	R5-246019	1824	1	F	Correction to Annex F for inter-band EN-DC spurious emissions test cases	18.4.0
2024-09	RAN#105	R5-246039	1834	1	F	Addition of reference sensitivity for EN-DC configurations with simultaneous RxTx	18.4.0
2024-12	RAN#106	R5-246126	1838	-	F	Addition of reference sensitivity for new PC2 3CC EN-DC combos within FR1	18.5.0
2024-12	RAN#106	R5-246246	1839	-	F	FR2 MU - General Updates in 38.521-3 Tx test cases	18.5.0
2024-12	RAN#106	R5-246247	1840	-	F	FR2 MU - General Updates in 38.521-3 Rx test cases	18.5.0
2024-12	RAN#106	R5-246395	1841	-	F	Editorial correction to Annex F.1.3 and Annex F.3.3 of 38.521-3	18.5.0
2024-12	RAN#106	R5-246620	1842	-	F	Correct initial conditions of clause 7.3B.2.4 and 7.3B.4	18.5.0
2024-12	RAN#106	R5-246648	1843	-	F	Addition of new TC 6.5B.1.4_1.4 Occupied bandwidth for Inter-band EN-DC including FR2 for 5 NR CCs	18.5.0
2024-12	RAN#106	R5-246649	1844	-	F	Addition of new TC 6.5B.1.4_1.5 Occupied bandwidth for Inter-band EN-DC including FR2 for 6 NR CCs	18.5.0
2024-12	RAN#106	R5-246650	1845	-	F	Addition of new TC 6.5B.1.4_1.6 Occupied bandwidth for Inter-band EN-DC including FR2 for 7 NR CCs	18.5.0
2024-12	RAN#106	R5-246651	1846	-	F	Addition of new TC 6.5B.1.4_1.7 Occupied bandwidth for Inter-band EN-DC including FR2 for 8 NR CCs	18.5.0
2024-12	RAN#106	R5-246653	1847	-	F	Addition of new TC 6.5B.2.4.1_1.4 Spectrum emissions mask for Inter-band EN-DC including FR2 for 5 NR CCs	18.5.0
2024-12	RAN#106	R5-246654	1848	-	F	Addition of new TC 6.5B.2.4.1_1.5 Spectrum emissions mask for Inter-band EN-DC including FR2 for 6 NR CCs	18.5.0
2024-12	RAN#106	R5-246655	1849	-	F	Addition of new TC 6.5B.2.4.1_1.6 Spectrum emissions mask for Inter-band EN-DC including FR2 for 7 NR CCs	18.5.0
2024-12	RAN#106	R5-246656	1850	-	F	Addition of new TC 6.5B.2.4.1_1.7 Spectrum emissions mask for Inter-band EN-DC including FR2 for 8 NR CCs	18.5.0
2024-12	RAN#106	R5-246657	1851	-	F	Update to Annex F of 38.521-3 for transmitter tests	18.5.0
2024-12	RAN#106	R5-246780	1852	-	F	Addition of many EN-DC combos to Ch5	18.5.0
2024-12	RAN#106	R5-246781	1853	-	F	Addition of configured output power requirements for many EN-DC combos	18.5.0
2024-12	RAN#106	R5-246782	1854	-	F	Addition of Rx requirements for many EN-DC combos	18.5.0
2024-12	RAN#106	R5-246789	1856	-	F	Addition of many PC2 EN-DC combos to Ch5	18.5.0
2024-12	RAN#106	R5-246790	1857	-	F	Addition of many PC2 EN-DC combos reference sensitivity test	18.5.0
2024-12	RAN#106	R5-246916	1858	-	F	Addition of new test cases 6.3H.3.x for inter-band EN-DC with UL MIMO	18.5.0
2024-12	RAN#106	R5-246917	1859	-	F	Addition of new test cases 6.3L.3.x for inter-band EN-DC with TxD	18.5.0

2024-12	RAN#106	R5-246918	1860	-	F	Addition of new test cases 6.4H.x for inter-band EN-DC with UL MIMO	18.5.0
2024-12	RAN#106	R5-246919	1861	-	F	Addition of new test cases 6.4L.x for inter-band EN-DC with TxD	18.5.0
2024-12	RAN#106	R5-246920	1862	-	F	Addition of Annex F for 3Tx inter-band EN-DC new test cases	18.5.0
2024-12	RAN#106	R5-247005	1865	-	F	Updating REFSENS testing for DC_26A_n41A	18.5.0
2024-12	RAN#106	R5-247008	1866	-	F	Updating test coverage rules for NSA band configuration Spurious emission UE co-ex testing	18.5.0
2024-12	RAN#106	R5-247074	1867	-	F	Removing n38 from V2X Tx test cases	18.5.0
2024-12	RAN#106	R5-247180	1869	-	F	Correction to PC2 requirement level in 7.3B.2.3	18.5.0
2024-12	RAN#106	R5-247181	1870	-	F	Correction to test configuration of 6.5B.3.3.2 for Rel-16 EN-DC configuration	18.5.0
2024-12	RAN#106	R5-247182	1871	-	F	Correction to test configuration of 6.5B.3.3.2 for Rel-17 EN-DC configuration	18.5.0
2024-12	RAN#106	R5-247183	1872	-	F	Correction to note of test configuration table in 6.5B.3.3.2	18.5.0
2024-12	RAN#106	R5-247395	1874	-	F	Addition of UE maximum output power for PC2 DC_2A_n41A	18.5.0
2024-12	RAN#106	R5-247445	1877	-	F	Editorial Correction to 6.2B.1.4D.x title and reference clauses	18.5.0
2024-12	RAN#106	R5-247780	1875	1	F	Addition of reference sensitivity for PC2 DC_2A_n41A	18.5.0
2024-12	RAN#106	R5-247781	1876	1	F	Update the rules of high power applicability for high order combinations	18.5.0
2024-12	RAN#106	R5-247837	1868	1	F	Update of MU for FR1 configured output power	18.5.0
2024-12	RAN#106	R5-247857	1873	1	F	Update of status of FR2 SISO and UL MIMO test cases	18.5.0
2024-12	RAN#106	R5-247973	1863	1	F	Addition of Transmit ON/OFF time mask for Inter-Band EN-DC including FR2 (3 NR CCs)	18.5.0
2024-12	RAN#106	R5-247974	1864	1	F	Addition of Transmit ON/OFF time mask for Inter-Band EN-DC including FR2 (4 NR CCs)	18.5.0

---

# History

<b>Document history</b>		
V18.2.0	May 2024	Publication
V18.3.0	August 2024	Publication
V18.4.0	October 2024	Publication
V18.5.0	February 2025	Publication