

# ETSI TS 138 523-1 V15.1.0 (2018-10)



**5G;  
5GS;  
UE conformance specification;  
Part 1: Protocol  
(3GPP TS 38.523-1 version 15.1.0 Release 15)**



---

Reference

RTS/TSGR-0538523-1v10

---

Keywords

5G

**ETSI**

650 Route des Lucioles  
F-06921 Sophia Antipolis Cedex - FRANCE

Tel.: +33 4 92 94 42 00 Fax: +33 4 93 65 47 16

Siret N° 348 623 562 00017 - NAF 742 C  
Association à but non lucratif enregistrée à la  
Sous-Préfecture de Grasse (06) N° 7803/88

---

**Important notice**

The present document can be downloaded from:

<http://www.etsi.org/standards-search>

The present document may be made available in electronic versions and/or in print. The content of any electronic and/or print versions of the present document shall not be modified without the prior written authorization of ETSI. In case of any existing or perceived difference in contents between such versions and/or in print, the only prevailing document is the print of the Portable Document Format (PDF) version kept on a specific network drive within ETSI Secretariat.

Users of the present document should be aware that the document may be subject to revision or change of status.

Information on the current status of this and other ETSI documents is available at

<https://portal.etsi.org/TB/ETSIDeliverableStatus.aspx>

If you find errors in the present document, please send your comment to one of the following services:

<https://portal.etsi.org/People/CommiteeSupportStaff.aspx>

---

**Copyright Notification**

No part may be reproduced or utilized in any form or by any means, electronic or mechanical, including photocopying and microfilm except as authorized by written permission of ETSI.

The content of the PDF version shall not be modified without the written authorization of ETSI.

The copyright and the foregoing restriction extend to reproduction in all media.

© ETSI 2018.

All rights reserved.

**DECT™**, **PLUGTESTS™**, **UMTS™** and the ETSI logo are trademarks of ETSI registered for the benefit of its Members.

**3GPP™** and **LTE™** are trademarks of ETSI registered for the benefit of its Members and of the 3GPP Organizational Partners.

**oneM2M** logo is protected for the benefit of its Members.

**GSM®** and the GSM logo are trademarks registered and owned by the GSM Association.

---

# Intellectual Property Rights

## Essential patents

IPRs essential or potentially essential to normative deliverables may have been declared to ETSI. The information pertaining to these essential IPRs, if any, is publicly available for **ETSI members and non-members**, and can be found in ETSI SR 000 314: *"Intellectual Property Rights (IPRs); Essential, or potentially Essential, IPRs notified to ETSI in respect of ETSI standards"*, which is available from the ETSI Secretariat. Latest updates are available on the ETSI Web server (<https://ipr.etsi.org/>).

Pursuant to the ETSI IPR Policy, no investigation, including IPR searches, has been carried out by ETSI. No guarantee can be given as to the existence of other IPRs not referenced in ETSI SR 000 314 (or the updates on the ETSI Web server) which are, or may be, or may become, essential to the present document.

## Trademarks

The present document may include trademarks and/or tradenames which are asserted and/or registered by their owners. ETSI claims no ownership of these except for any which are indicated as being the property of ETSI, and conveys no right to use or reproduce any trademark and/or tradename. Mention of those trademarks in the present document does not constitute an endorsement by ETSI of products, services or organizations associated with those trademarks.

---

# Foreword

This Technical Specification (TS) has been produced by ETSI 3rd Generation Partnership Project (3GPP).

The present document may refer to technical specifications or reports using their 3GPP identities, UMTS identities or GSM identities. These should be interpreted as being references to the corresponding ETSI deliverables.

The cross reference between GSM, UMTS, 3GPP and ETSI identities can be found under <http://webapp.etsi.org/key/queryform.asp>.

---

# Modal verbs terminology

In the present document "**shall**", "**shall not**", "**should**", "**should not**", "**may**", "**need not**", "**will**", "**will not**", "**can**" and "**cannot**" are to be interpreted as described in clause 3.2 of the [ETSI Drafting Rules](#) (Verbal forms for the expression of provisions).

"**must**" and "**must not**" are **NOT** allowed in ETSI deliverables except when used in direct citation.

# Contents

Intellectual Property Rights .....	2
Foreword.....	2
Modal verbs terminology.....	2
Foreword.....	8
1 Scope .....	9
2 References .....	9
3 Definitions, symbols and abbreviations .....	10
3.1 Definitions .....	10
3.2 Symbols.....	11
3.3 Abbreviations .....	11
4 Overview .....	11
4.1 Test methodology .....	11
4.1.1 Testing of optional functions and procedures .....	11
4.1.2 Test interfaces and facilities.....	11
4.2 Implicit testing.....	11
4.3 Repetition of tests.....	11
4.4 Handling of differences between conformance requirements in different releases of core specifications .....	12
5 Reference conditions and generic setup procedures.....	12
5.1 Reference conditions .....	12
5.2 Generic setup procedures .....	12
6 Idle mode operations .....	12
6.1 NR idle mode operations.....	12
7 Layer 2.....	12
7.1 NR Layer 2.....	12
7.1.0 Common test case specific values for Layer 2.....	12
7.1.1 MAC.....	13
7.1.1.0 Default Pre-Test Conditions for all MAC test cases .....	13
7.1.1.1 Random Access Procedures .....	14
7.1.1.1.1 Correct selection of RACH parameters / Random access preamble and PRACH resource explicitly signalled to the UE by RRC / contention free random access procedure .....	14
7.1.1.1.1a Correct selection of RACH parameters / Random access preamble and PRACH resource explicitly signalled to the UE by PDCCH Order / contention free random access procedure.....	19
7.1.1.1.2 Random access procedure / Successful / C-RNTI Based / Preamble selected by MAC itself.....	24
7.1.1.2 Downlink Data Transfer.....	38
7.1.1.2.1 Correct Handling of DL MAC PDU / Assignment / HARQ process .....	38
7.1.1.2.2 Correct Handling of DL HARQ process PDSCH Aggregation.....	46
7.1.1.3 Uplink Data Transfer.....	52
7.1.1.3.1 Correct Handling of UL MAC PDU / Assignment / HARQ process .....	52
7.1.1.3.2 Logical channel prioritization handling.....	59
7.1.1.3.3 Correct handling of MAC control information / Scheduling requests.....	63
7.1.1.3.4 Correct handling of MAC control information / Buffer status / UL data arrive in the UE Tx buffer / Regular BSR.....	68
7.1.1.3.5 Correct handling of MAC control information / Buffer Status / UL resources are allocated / Padding BSR .....	78
7.1.1.3.6 Correct handling of MAC control information / Buffer status / Periodic BSR timer expires.....	87
7.1.1.3.7 UE power headroom reporting / Periodic reporting / DL pathloss change reporting .....	94
7.1.1.3.8 UE power headroom reporting / SCell activation / DL pathloss change reporting.....	105
7.1.1.4 Transport Size Selection .....	115
7.1.1.4.1 DL-SCH Transport Block Size Selection .....	115
7.1.1.4.1.1 DL-SCH Transport Block Size selection / DCI format 1_0.....	115
7.1.1.4.1.2 DL-SCH Transport Block Size selection / DCI format 1_0 / 256QAM .....	123

7.1.1.4.1.3	DL-SCH transport block size selection / DCI format 1_1 / RA type 0/RA Type 1 / 2 Codewords enabled .....	132
7.1.1.4.1.4	DL-SCH transport block size selection / DCI format 1_1 / RA type 0/RA Type 1 / 2 Codewords enabled / 256QAM.....	144
7.1.1.4.2	UL-SCH Transport Block Size Selection .....	157
7.1.1.4.2.1	UL-SCH Transport Block Size selection / DCI format 0_0 / Transform precoding disabled .....	157
7.1.1.4.2.2	UL-SCH Transport Block Size selection / DCI format 0_0 / 256QAM / Transform precoding disabled .....	168
7.1.1.4.2.3	UL-SCH transport block size selection / DCI format 0_1 / RA type 0/RA Type 1 / Transform precoding disabled .....	178
7.1.1.4.2.4	UL-SCH transport block size selection / DCI format 0_1 / RA type 0/RA Type 1 / 256QAM / Transform precoding disabled .....	194
7.1.1.4.2.5	UL-SCH Transport Block Size selection / DCI format 0_0 / Transform precoding and 64QAM.....	209
7.1.1.5	Discontinuous reception .....	220
7.1.1.5.1	DRX operation / Short cycle not configured / Parameters configured by RRC .....	220
7.1.1.5.2	DRX operation / Short cycle not configured / Long DRX command MAC control element reception .....	228
7.1.1.5.3	DRX operation / Short cycle configured / Parameters configured by RRC .....	236
7.1.1.5.4	DRX Operation / Short cycle configured / DRX command MAC control element reception.....	244
7.1.1.6	Semi-Persistent Scheduling.....	252
7.1.1.6.1	Correct handling of DL assignment / Semi-persistent case .....	252
7.1.1.6.2	Correct handling of UL grant / configured grant Type 1.....	261
7.1.1.6.3	Correct handling of UL grant / configured grant Type 2.....	271
7.1.1.7	Activation/Deactivation of Scells.....	281
7.1.1.7.1	Activation/Deactivation of SCells / Activation/Deactivation MAC control element reception / sCellDeactivationTimer.....	281
7.1.1.7.1.1	Activation/Deactivation of SCells / Activation/Deactivation MAC control element reception / sCellDeactivationTimer / Intra-band non-Contiguous CA .....	281
7.1.1.7.1.2	Activation/Deactivation of SCells / Activation/Deactivation MAC control element reception / sCellDeactivationTimer / Inter-Band CA .....	286
7.1.1.7.1.3	Activation/Deactivation of SCells / Activation/Deactivation MAC control element reception / sCellDeactivationTimer / Intra-band non-Contiguous CA .....	287
7.1.1.8	287	
7.1.1.9	MAC Reconfiguration and Reset .....	287
7.1.1.9.1	MAC Reset.....	287
7.1.2	RLC .....	292
7.1.2.1	Default Pre-Test Conditions for all RLC test cases.....	292
7.1.2.1.1	Default Pre-Test Conditions for AM RLC test cases.....	292
7.1.2.1.2	Default Pre-Test Conditions for UM RLC test cases.....	293
7.1.2.2	RLC Unacknowledged mode .....	294
7.1.2.2.1	UM RLC / Segmentation and reassembly / 6-bit SN / Segmentation Info (SI) field.....	294
7.1.2.2.2	UM RLC / Segmentation and reassembly / 12-bit SN / Segmentation Info (SI) field.....	298
7.1.2.2.3	UM RLC / 6-bit SN / Correct use of sequence numbering.....	300
7.1.2.2.4	UM RLC / 12-bit SN / Correct use of sequence numbering.....	304
7.1.2.2.5	UM RLC / Receive Window operation and t-Reassembly expiry.....	308
7.1.2.2.6	UM RLC / RLC re-establishment procedure.....	311
7.1.2.3	RLC Acknowledged Mode .....	314
7.1.2.3.1	AM RLC / 12-bit SN / Segmentation and reassembly / Segmentation Info (SI) field.....	314
7.1.2.3.2	AM RLC / 18-bit SN / Segmentation and reassembly / Segmentation Info (SI) field.....	317
7.1.2.3.3	AM RLC / 12-bit SN / Correct use of sequence numbering .....	319
7.1.2.3.4	AM RLC / 18-bit SN / Correct use of sequence numbering .....	324
7.1.2.3.5	AM RLC / Control of transmit window/Control of receive window.....	329
7.1.2.3.6	AM RLC / Polling for status.....	333
7.1.2.3.7	AM RLC / Receiver status triggers .....	338
7.1.2.3.8	AM RLC / Reconfiguration of RLC parameters by upper layers.....	344
7.1.2.3.9	AM RLC / Reassembling of AMD PDUs .....	349
7.1.2.3.10	AM RLC / Re-transmission of RLC PDU with and without re-segmentation .....	356
7.1.2.3.11	AM RLC / RLC re-establishment procedure.....	364
7.1.3	PDCP .....	370
7.1.3.0	Default Pre-Test Conditions for all PDCP test cases .....	370

7.1.3.1	Maintenance of PDCP sequence numbers for radio bearers .....	371
7.1.3.1.1	Maintenance of PDCP sequence numbers / User plane / 12 bit SN .....	371
7.1.3.1.2	Maintenance of PDCP sequence numbers / User plane / 18 bit SN .....	375
7.1.3.2	PDCP integrity protection .....	376
7.1.3.2.1	Integrity protection / Correct functionality of encryption algorithm SNOW3G / SRB / DRB .....	376
7.1.3.2.2	Integrity protection / Correct functionality of encryption algorithm AES / SRB / DRB .....	380
7.1.3.2.3	Integrity protection / Correct functionality of encryption algorithm ZUC / SRB / DRB .....	381
7.1.3.3	PDCP Ciphering and deciphering .....	382
7.1.3.3.1	Ciphering and deciphering / Correct functionality of encryption algorithm SNOW3G / SRB / DRB .....	382
7.1.3.3.2	Ciphering and deciphering / Correct functionality of encryption algorithm AES / SRB / DRB .....	385
7.1.3.3.3	Ciphering and deciphering / Correct functionality of encryption algorithm ZUC / SRB / DRB .....	386
7.1.3.4	PDCP Handover .....	386
7.1.3.4.1	PDCP handover / Lossless handover / PDCP sequence number maintenance / PDCP status report to convey the information on missing or acknowledged PDCP SDUs at handover / In-order delivery and duplicate elimination in the downlink .....	386
7.1.3.4.2	PDCP handover / Non-lossless handover / PDCP sequence number maintenance .....	398
7.1.3.5	PDCP other .....	400
7.1.3.5.1	PDCP Discard .....	400
7.1.3.5.2	PDCP Uplink Routing / Split DRB .....	403
7.1.3.5.3	PDCP Data Recovery .....	405
7.1.3.5.4	PDCP reordering / Maximum re-ordering delay below t-Reordering / t-Reordering timer operations .....	409
7.1.4	SDAP .....	414
7.1.4.1	SDAP Data Transfer and PDU Header Handling UL/DL .....	414
7.1.4.1.1	Test Purpose (TP) .....	414
7.1.4.2	SDAP Data Transfer handling without Header UL/DL .....	420
8	RRC .....	424
8.1	NR RRC .....	424
8.2	MR-DC RRC .....	425
8.2.1	UE Capability transfer / RRC Others .....	425
8.2.1.1	UE capability transfer / Success .....	425
8.2.1.1.1	UE capability transfer / Success / EN-DC .....	425
8.2.1.2	BandwidthPart Configuration / SCG .....	441
8.2.1.2.1	BandwidthPart Configuration / SCG / EN-DC .....	441
8.2.2	Radio Bearer Addition, Modification and Release .....	444
8.2.2.1	Radio Bearer Addition, Modification and Release / SRB .....	444
8.2.2.1.1	SRB3 Establishment, Reconfiguration and Release / NR addition, modification and release / EN-DC .....	444
8.2.2.2	Split SRB Establishment and Release .....	450
8.2.2.2.1	Split SRB Establishment and Release / EN-DC .....	450
8.2.2.3	Simultaneous SRB3 and Split SRB / Sequential message flow on SRB3 and Split SRB .....	457
8.2.2.3.1	Simultaneous SRB3 and Split SRB / Sequential message flow on SRB3 and Split SRB / EN-DC .....	457
8.2.2.4	PSCell addition, modification and release / SCG DRB .....	466
8.2.2.4.1	PSCell addition, modification and release / SCG DRB / EN-DC .....	466
8.2.2.5	PSCell addition, modification and release / Split DRB .....	475
8.2.2.5.1	PSCell addition, modification and release / Split DRB / EN-DC .....	475
8.2.2.6	Bearer Modification / MCG DRB .....	484
8.2.2.6.1	Bearer Modification / MCG DRB / SRB / PDCP version change / EN-DC .....	484
8.2.2.7	Bearer Modification / Handling for bearer type change without security key change .....	496
8.2.2.7.1	Bearer Modification / Handling for bearer type change without security key change / EN-DC .....	496
8.2.2.8	Bearer Modification / Handling for bearer type change with security key change .....	514
8.2.2.8.1	Bearer Modification / Handling for bearer type change with security key change / EN-DC .....	514
8.2.2.9	Bearer Modification / Uplink data path / Split DRB Reconfiguration .....	543
8.2.2.9.1	Bearer Modification / Uplink data path / Split DRB Reconfiguration / EN-DC .....	543
8.2.3	Measurement Configuration Control and Reporting / Handovers .....	550
8.2.3.1	Measurement configuration control and reporting / Inter-RAT measurements / Event B1 / Measurement of NR cells .....	550
8.2.3.1.1	Measurement configuration control and reporting / Inter-RAT measurements / Event B1 / Measurement of NR cells / EN-DC .....	550

8.2.3.2	Measurement configuration control and reporting / Inter-RAT measurements / Event B1 / Measurement of NR cells / RSRQ based measurements.....	557
8.2.3.2.1	Measurement configuration control and reporting / Inter-RAT measurements / Event B1 / Measurement of NR cells / RSRQ based measurements / EN-DC.....	557
8.2.3.3	Measurement configuration control and reporting / Inter-RAT measurements / Periodic reporting / Measurement of NR cells.....	566
8.2.3.3.1	Measurement configuration control and reporting / Inter-RAT measurements / Periodic reporting / Measurement of NR cells / EN-DC .....	566
8.2.3.4	Measurement configuration control and reporting / Event A1 / Measurement of NR PSCell .....	577
8.2.3.4.1	Measurement configuration control and reporting / Event A1 / Measurement of NR PSCell / EN-DC .....	577
8.2.3.5	Measurement configuration control and reporting / Event A2 / Measurement of NR PSCell .....	585
8.2.3.5.1	Measurement configuration control and reporting / Event A2 / Measurement of NR PSCell / EN-DC.....	585
8.2.3.6	Measurement configuration control and reporting / Event A3 (intra-frequency, inter-frequency and inter-band measurements) / Measurement of Neighbour NR cells.....	593
8.2.3.6.1	Measurement configuration control and reporting / Event A3 (intra-frequency, inter-frequency and inter-band measurements) / Measurement of Neighbour NR cells / EN-DC .....	593
8.2.3.7	Measurement configuration control and reporting / Event A4 (intra-frequency, inter-frequency and inter-band measurements) / Measurement of Neighbour NR cell .....	605
8.2.3.7.1	Measurement configuration control and reporting / Event A4 (intra-frequency, inter-frequency and inter-band measurements) / Measurement of Neighbour NR cell / EN-DC.....	605
8.2.3.8	Measurement configuration control and reporting / Event A5 (intra-frequency, inter-frequency and inter-band measurements) / Measurement of Neighbour NR cell .....	616
8.2.3.8.1	Measurement configuration control and reporting / Event A5 (intra-frequency, inter-frequency and inter-band measurements) / Measurement of Neighbour NR cell / EN-DC.....	616
8.2.3.9	Measurement configuration control and reporting / SS/PBCH block based / CSI-RS based intra-frequency measurements / Measurement of Neighbour NR cell.....	633
8.2.3.9.1	Measurement configuration control and reporting / SS/PBCH block based beam measurements of Intra-frequency NR Neighbour PSCell / EN-DC .....	633
8.2.3.10	Measurement configuration control and reporting / SS/PBCH block based / CSI-RS based inter-frequency measurements / Measurement of Neighbour NR cell.....	645
8.2.3.10.1	Measurement configuration control and reporting / SS/PBCH block based beam measurements of Inter-frequency NR Neighbour PSCell / EN-DC .....	645
8.2.3.11	Measurement Gaps patterns Related .....	657
8.2.3.11.1	Measurement Gaps patterns Related / LTE/NR FR1 / EN-DC .....	657
8.2.3.11.2	Measurement Gaps patterns Related / LTE/NR FR2 / EN-DC .....	657
8.2.3.12	Measurement configuration control and reporting / Inter-RAT measurements / Event B2 / Measurement of NR cells.....	657
8.2.3.12.1	Measurement configuration control and reporting / Inter-RAT measurements / Event B2 / Measurement of NR cells / EN-DC .....	657
8.2.3.13	PCell Handover with SCG change / Reconfiguration with sync / SCG DRB .....	666
8.2.3.13.1	PCell Handover with SCG change / Reconfiguration with sync / SCG DRB / EN-DC .....	666
8.2.3.14	SCG change / Reconfiguration with sync / Split DRB.....	671
8.2.3.14.1	SCG change / Reconfiguration with sync / Split DRB / EN-DC.....	671
8.2.4	Carrier Aggregation .....	676
8.2.4.1	NR CA / NR SCell addition / modification / release / Success .....	676
8.2.4.1.1	NR CA / NR SCell addition / modification / release / Success / EN-DC .....	676
8.2.4.1.1.1	NR CA / NR SCell addition / modification / release / Success / EN-DC / Intra-band Contiguous CA .....	676
8.2.4.1.1.2	NR CA / NR SCell addition / modification / release / Success / EN-DC / Intra-band non-Contiguous CA .....	686
8.2.4.1.1.3	NR CA / NR SCell addition / modification / release / Success / EN-DC / Inter-band CA .....	686
8.2.4.2	NR CA / Simultaneous PSCell and SCell addition / PSCell and SCell change / CA Deconfiguration .....	687
8.2.4.2.1	NR CA / Simultaneous PSCell and SCell addition / PSCell and SCell change / CA Deconfiguration / EN-DC.....	687
8.2.4.2.1.1	NR CA / Simultaneous PSCell and SCell addition / PSCell and SCell change / CA Release / EN-DC / Intra-band Contiguous CA .....	687
8.2.4.2.1.2	NR CA / Simultaneous PSCell and SCell addition / PSCell and SCell change / CA Release / EN-DC / Intra-band non-Contiguous CA .....	699

8.2.4.2.1.3	NR CA / Simultaneous PSCell and SCell addition / PSCell and SCell change / CA Release / EN-DC / Inter-band CA.....	699
8.2.4.3	NR CA / SCell change / Intra-NR measurement event A6 / SRB3.....	700
8.2.4.3.1	NR CA / SCell change / Intra-NR measurement event A6 / SRB3 / EN-DC.....	700
8.2.4.3.1.1	NR CA / SCell change / Intra-NR measurement event A6 / SRB3 / EN-DC / Intra-band Contiguous CA.....	700
8.2.4.3.1.2	NR CA / SCell change / Intra-NR measurement event A6 / SRB3 / EN-DC / Intra-band non-Contiguous CA.....	710
8.2.4.3.1.3	NR CA / SCell change / Intra-NR measurement event A6 / SRB3 / EN-DC / Inter-band CA.....	710
8.2.5	Reconfiguration Failure / Radio link failure.....	711
8.2.5.1	Radio link failure / PSCell addition failure.....	711
8.2.5.1.1	Radio link failure / PSCell addition failure - random access problem / EN-DC.....	711
8.2.5.2	Radio link failure / PSCell out of sync indication.....	715
8.2.5.2.1	Radio link failure / PSCell out of sync indication / EN-DC.....	715
8.2.5.3	Radio link failure / RLC-MaxNumRetx failure.....	718
8.2.5.3.1	Radio link failure / RLC-MaxNumRetx failure / EN-DC.....	718
8.2.5.4	Reconfiguration failure / SCG change failure.....	720
8.2.5.4.1	Reconfiguration failure / SCG change failure / EN-DC.....	720
8.2.5.5	Reconfiguration failure / SCG Reconfiguration failure / SRB3.....	724
8.2.5.5.1	Reconfiguration failure / SCG Reconfiguration Failure / SRB3 / EN-DC.....	724
8.2.5.6	Reconfiguration failure / SCG Reconfiguration failure / SRB1.....	728
8.2.5.6.1	Reconfiguration failure / SCG Reconfiguration Failure / SRB1 / EN-DC.....	728
9	Mobility management.....	733
9.1	5GS Mobility Management.....	733
9.1.5	Registration.....	733
9.1.5.1	Initial Registration.....	733
9.1.5.1.12	Initial registration / Rejected / Congestion / Abnormal cases / T3346.....	733
10	Session management.....	737
10.1	5GS session management.....	737
10.2	EN-DC session management.....	737
10.2.1	Network initiated procedures.....	737
10.2.1.1	Default EPS bearer context activation.....	737
10.2.1.2	Dedicated EPS bearer context activation.....	745
10.2.2	UE initiated procedures.....	749
10.2.2.1	EPS bearer resource allocation / modification.....	749
<b>Annex A (informative):</b>	<b>Change history.....</b>	<b>758</b>
History.....		765



---

# Foreword

This Technical Specification has been produced by the 3rd Generation Partnership Project (3GPP).

The contents of the present document are subject to continuing work within the TSG and may change following formal TSG approval. Should the TSG modify the contents of the present document, it will be re-released by the TSG with an identifying change of release date and an increase in version number as follows:

Version x.y.z

where:

- x the first digit:
  - 1 presented to TSG for information;
  - 2 presented to TSG for approval;
  - 3 or greater indicates TSG approved document under change control.
- y the second digit is incremented for all changes of substance, i.e. technical enhancements, corrections, updates, etc.
- z the third digit is incremented when editorial only changes have been incorporated in the document.

The present document is part 1 of a multi-part deliverable covering the 5G System (5GS) User Equipment (UE) protocol conformance specification, as identified below:

- **3GPP TS 38.523-1: "5GS; User Equipment (UE) conformance specification; Part 1: Protocol"** (the present document).
- 3GPP TS 38.523-2 [2]: "5GS; User Equipment (UE) conformance specification; Part 2: Applicability of protocol test cases".
- 3GPP TS 38.523-3 [3]: "5GS; User Equipment (UE) conformance specification; Part 3: Protocol Test Suites".

---

# 1 Scope

The present document specifies the protocol conformance testing for the 3GPP UE connecting to the 5G System (5GS) via its radio interface(s).

The following information can be found in the present document (first part of a multi-part test specification):

- the overall test structure;
- the test configurations;
- the conformance requirement and references to the core specifications;
- the test purposes; and
- a brief description of the test procedure, the specific test requirements and short message exchange table.

The applicability of the individual test cases is specified in the ICS proforma specification (3GPP TS 38.523-2 [2]). The Test Suites are specified in part 3 (3GPP TS 38.523-3 [3]).

The present document is valid for UE implemented according to 3GPP Releases starting from Release 15 up to the Release indicated on the cover page of the present document.

---

# 2 References

The following documents contain provisions which, through reference in this text, constitute provisions of the present document.

- References are either specific (identified by date of publication, edition number, version number, etc.) or non-specific.
- For a specific reference, subsequent revisions do not apply.
- For a non-specific reference, the latest version applies. In the case of a reference to a 3GPP document (including a GSM document), a non-specific reference implicitly refers to the latest version of that document *in the same Release as the present document*.

- [1] 3GPP TR 21.905: "Vocabulary for 3GPP Specifications".
- [2] 3GPP TS 38.523-2: "5GS; UE conformance specification; Part 2: Implementation Conformance Statement (ICS) proforma specification".
- [3] 3GPP TS 38.523-3: "5GS; User Equipment (UE) conformance specification; Part 3: Protocol Test Suites".
- [4] 3GPP TS 38.508-1: "5GS; User Equipment (UE) conformance specification; Part 1: Common test environment".
- [5] 3GPP TS 38.508-2: "5GS; User Equipment (UE) conformance specification; Part 2: Common Implementation Conformance Statement (ICS) proforma".
- [6] 3GPP TS 38.509: "5GS; Special conformance testing functions for User Equipment (UE)".
- [7] 3GPP TS 36.508: "Evolved Universal Terrestrial Radio Access (E-UTRA) and Evolved Universal Terrestrial Radio Access (E-UTRAN); Common Test Environments for User Equipment (UE) Conformance Testing".
- [8] 3GPP TS 36.509: "Evolved Universal Terrestrial Radio Access (E-UTRA) and Evolved Universal Terrestrial Radio Access Network (E-UTRAN); Special conformance testing functions for User Equipment (UE)".
- [9] 3GPP TS 38.113: "New Radio (NR); Requirements for support of radio resource management".

- [10] 3GPP TS 36.133: "Evolved Universal Terrestrial Radio Access (E-UTRA); Requirements for support of radio resource management".
- [11] 3GPP TS 36.331: "Evolved Universal Terrestrial Radio Access (E-UTRA); Radio Resource Control (RRC); Protocol specification".
- [12] 3GPP TS 38.331: "NR; Radio Resource Control (RRC) protocol specification".
- [13] 3GPP TS 36.523-1: "Evolved Universal Terrestrial Radio Access (E-UTRA) and Evolved Packet Core (EPC); User Equipment (UE) conformance specification; Part 1: Protocol conformance specification".
- [14] 3GPP TS 38.212: "NR; Multiplexing and channel coding".
- [15] 3GPP TS 38.214: "NR; Physical layer procedures for data".
- [16] 3GPP TS 38.101-1: "NR; User Equipment (UE) radio transmission and reception; Part 1: Range 1 Standalone".
- [17] 3GPP TS 38.101-2: "NR; User Equipment (UE) radio transmission and reception; Part 2: Range 2 Standalone".
- [18] 3GPP TS 38.321: "NR; Medium Access Control (MAC) protocol specification".
- [19] 3GPP TS 38.323: "NR; Packet Data Convergence Protocol (PDCP) specification".
- [20] 3GPP TS 33.501: "Security Architecture and Procedures for 5G System".
- [21] 3GPP TS 24.301: "Non-Access-Stratum (NAS) protocol for Evolved Packet System (EPS); Stage 3".
- [22] 3GPP TS 24.501: "Non-Access-Stratum (NAS) protocol for 5G System (5GS); Stage 3".
- [23] 3GPP TS 38.306: "NR: User Equipment (UE) radio access capabilities"[24] 3GPP TS 38.211: "NR; Physical channels and modulation".
- [25] 3GPP TS 36.523-3: "Evolved Universal Terrestrial Radio Access (E-UTRA) and Evolved Universal Terrestrial Radio Access (E-UTRAN); User Equipment (UE) conformance specification; Part 3: Abstract Test Suites (ATS)".
- [26] 3GPP TS 38.300: "NR; NR and NG-RAN Overall Description; Stage 2".
- [27] 3GPP TS 38.322: "NR; Radio Link Control (RLC) protocol specification".
- [28] 3GPP TS 37.340: "NR; Multi-connectivity; Overall description; Stage-2".

---

## 3 Definitions, symbols and abbreviations

### 3.1 Definitions

For the purposes of the present document, the terms and definitions given in 3GPP TR 21.905 [1], specifications referred to in the tests' Conformance requirements subclauses and the following apply. A term defined in the present document takes precedence.

**Floor:** Floor(x) is the largest integer smaller than or equal to x.

**Ceil:** Ceil (x) is the smallest integer larger than or equal to x.

## 3.2 Symbols

For the purposes of the present document, symbols defined in specifications referred to in the tests' Conformance requirements subclauses and the following apply. A symbol defined in the present document takes precedence

None.

## 3.3 Abbreviations

For the purposes of the present document, the abbreviations given in 3GPP TR 21.905 [1]], specifications referred to in the tests' Conformance requirements subclauses and the following apply. An abbreviation defined in the present document takes precedence.

ICS	Implementation Conformance Statement
FFS	For Further Study

---

# 4 Overview

## 4.1 Test methodology

### 4.1.1 Testing of optional functions and procedures

Any function or procedure which is optional, as indicated in the present document may be subject to a conformance test if it is implemented in the UE.

A declaration by the apparatus supplier (ICS) is used to determine whether an optional function/procedure has been implemented.

### 4.1.2 Test interfaces and facilities

Detailed descriptions of the UE test interfaces and special facilities for testing are provided in 3GPP TS 38.509 [6].

## 4.2 Implicit testing

For some 3GPP signalling and protocol features conformance is not verified explicitly in the present document. This does not imply that correct functioning of these features is not essential, but that these are implicitly tested to a sufficient degree in other tests.

Implicit testing of 5GS requirements may be done also in tests specified in other 3GPP conformance test specifications. For clarity these are listed below:

- Indication for support of EN-DC: if the UE supports E-UTRA-NR dual connectivity, then the UE shall set the DCNR bit to "dual connectivity with NR supported" in the UE network capability IE of the ATTACH REQUEST/TRACKING AREA UPDATE REQUEST message; verified implicitly (the setting of the DCNR bit to 1) by tests specified in TS 36.523-1 [13].

NOTE 1: It is assumed that an UE supporting EN-DC will support EPS (legacy LTE) and therefore it will be tested against all relevant legacy LTE tests.

## 4.3 Repetition of tests

As a general rule, the test cases specified in the present document are highly reproducible and don't need to be repeated unless otherwise stated. However, the rate of correct UE behaviour such as cell re-selection, measurement and handover is specified statistically, e.g. "at least 90%" [8], [9]. Additionally, in some of the test cases, presented in TS 38.523-3

[3], HARQ retransmissions are not tolerated, because of characteristics of the test case. In such cases a repetition of test may be required. Details are FFS.

## 4.4 Handling of differences between conformance requirements in different releases of core specifications

The conformance requirements which determine the scope of each test case are explicitly copy-pasted from relevant core specifications in the especially dedicated for this section of each test with the title 'Conformance requirements'.

NOTE: When in the copy/pasted text there are references to other specifications the reference numbers will not match the reference numbers used in the present document. This approach has been taken in order to allow easy copy and then search for conformance requirements in those specifications.

When differences between conformance requirements in different releases of the cores specifications have impact on the Pre-test conditions, Test procedure sequence or/and the Specific message contents, the Conformance requirements related to different releases are specified separately with clear indication of the Release of the spec from which they were copied.

When there is no Release indicated for a conformance requirement text, this should be understood either as the Conformance requirements in the latest version of the spec with release = the TC Applicability release (which can be found in the column 'Release' for the relevant for the test case entry in the tables in TS 38.523-2 [2], subclause 4.1, or, as the Conformance requirements in the latest version of the spec of the release when the feature was introduced to the core specs.

---

# 5 Reference conditions and generic setup procedures

## 5.1 Reference conditions

The reference environments used by all signalling and protocol tests will be specified in TS 38.508-1 [4]. If a test requires an environment that is different, this will be specified in the test itself.

## 5.2 Generic setup procedures

A set of basic generic procedures for radio resource signalling, and generic setup procedures for layer 3 NAS signalling will be described in TS 38.508-1 [4]. These procedures will be used in numerous test cases throughout the present document.

---

# 6 Idle mode operations

## 6.1 NR idle mode operations

*Editor's note: Intended to capture tests of Idle Mode behaviour defined in TS 38.304*

FFS

---

# 7 Layer 2

## 7.1 NR Layer 2

### 7.1.0 Common test case specific values for Layer 2

For all layer 2 test cases, default values for periodicBSR-Timer, retxBSR-Timer and phr-Config shall be taken according to the table 7.1.0-1 unless test case specific values are given in the test case.

**Table 7.1.0-1: MAC-CellGroupConfig**

Derivation Path: TS 38.308 [6], clause Table 4.6.3-49			
Information Element	Value/remark	Comment	Condition
MAC-CellGroupConfig ::= SEQUENCE {			
bsr-Config SEQUENCE {			
periodicBSR-Timer	infinity		
retxBSR-Timer	sf10240		
}			
phr-Config CHOICE {			
release	NULL		
}			
}			

## 7.1.1 MAC

### 7.1.1.0 Default Pre-Test Conditions for all MAC test cases

The following pre-test conditions shall be applied in all MAC test cases until the test case explicitly over writes these conditions

System Simulator:

- The SS configures the test environment in accordance to the execution conditions in Table 7.1.1.0-1.

UE:

- None

Preamble:

- The SS performs the generic procedure in [4] to get UE in state RRC\_CONNECTED in accordance to the execution conditions in Table 7.1.1.0-2 and using the message condition UE TEST LOOP MODE A to return one PDCP SDU per DL PDCP SDU.

**Table 7.1.1.0-1: Test environment**

Execution Condition	Cell configuration	System Information Combination ([4] clause FFS)
IF [pc_nrFDD] or [pc_nrTDD]	NR Cell 1	FFS
ELSE IF [pc_EN_DC]	E-UTRA Cell 1 is PCell, NR Cell 1 is PSCell	EUTRA: System information Combination 1 NR: N/A
ELSE IF [pc_NGEN_DC]	NG-RAN E-UTRA Cell 1 is PCell, NR Cell 1 is PSCell	EUTRA: System information Combination 1 NR: N/A

Table 7.1.1.0-2: Preamble parameters

Execution Condition	Multi-PDN Condition	Generic Procedure Parameters	Primary DRB used for Data testing
IF [pc_nrFDD] or [pc_nrTDD]s	FALSE	Connectivity(NR), Test loop function(On) One DRB	DRB on NR Cell
	TRUE	Connectivity(NR), Test loop function(On) Two DRB	
ELSE IF [pc_EN_DC]	FALSE	Connectivity(EN-DC), DC bearer(One MN Terminated MCG bearer and One SN terminated SCG bearer), Test loop function(On)	SN Terminated SCG bearer unless explicitly specified in test case
	TRUE	Connectivity(EN-DC), DC bearer(Two MN Terminated MCG bearer and One SN terminated SCG bearer), Test loop function(On)	
ELSE IF [pc_NGEN_DC]	FALSE	Connectivity(NGEN-DC), DC bearer(One MN Terminated MCG bearer and One SN terminated SCG bearer), Test loop function(On)	SN Terminated SCG bearer unless explicitly specified in test case
	TRUE	Connectivity(EN-DC), DC bearer(Two MN Terminated MCG bearer and One SN terminated SCG bearer), Test loop function(On)	

Table 7.1.1.0-3: Message conditions

Execution Condition	Message condition exceptions
IF [pc_nrFDD] or [pc_nrTDD]	FFS
ELSE IF [pc_EN_DC]	message condition MCG_and_SCG with condition AM is used for step 7 in 4.5.4.2 according to [4]
ELSE IF [pc_NGEN_DC]	message condition MCG_and_SCG with condition AM is used for step 7 in 4.5.4.2 according to [4]

### 7.1.1.1 Random Access Procedures

#### 7.1.1.1.1 Correct selection of RACH parameters / Random access preamble and PRACH resource explicitly signalled to the UE by RRC / contention free random access procedure

##### 7.1.1.1.1.1 Test Purpose (TP)

(1)

```
with { UE in RRC_Connected }
ensure that {
  when { SS sends an RRCReconfiguration message including RACH-ConfigDedicated information element }
  then { UE sends a prach preamble given in the RACH-ConfigDedicated on the target cell }
}
```

(2)

```
with { UE in RRC_Connected state after transmission of a PRACH preamble on NR SpCell received in RACH-ConfigDedicated on the target cell }
ensure that {
  when { UE does not receive a matching Random Access response in ra-ResponseWindowSize (hence considers RACH attempt as failed) and PREAMBLE_TRANSMISSION_COUNTER is less than PREAMBLE_TRANS_MAX }
}
```

```

then { UE retransmits a PRACH preamble received in RACH-ConfigDedicated on the target cell }
}

```

#### 7.1.1.1.1.2 Conformance requirements

References: The conformance requirements covered in the present test case are specified in: TS 38.321, clauses 5.1.2, 5.1.4. Unless otherwise stated these are Rel-15 requirements.

[TS 38.321, clause 5.1.2]

The MAC entity shall:

...

1> else if the *ra-PreambleIndex* has been explicitly provided by either PDCCH or RRC; and

1> if the *ra-PreambleIndex* is not 0b000000; and

1> if contention-free Random Access Resource associated with SSBs or CSI-RS have not been explicitly provided by RRC:

2> set the *PREAMBLE\_INDEX* to the signalled *ra-PreambleIndex*.

...

1> if an SSB is selected above and an association between PRACH occasions and SSBs is configured:

2> determine the next available PRACH occasion from the PRACH occasions corresponding to the selected SSB permitted by the restrictions given by the *ra-ssb-OccasionMaskIndex* if configured (the MAC entity may take into account the possible occurrence of measurement gaps when determining the next available PRACH occasion corresponding to the selected SSB).

1> else if a CSI-RS is selected above and an association between PRACH occasions and CSI-RSs is configured:

2> determine the next available PRACH occasion from the PRACH occasions in *ra-OccasionList* corresponding to the selected CSI-RS (the MAC entity may take into account the possible occurrence of measurement gaps when determining the next available PRACH occasion corresponding to the selected CSI-RS).

1> else:

2> determine the next available PRACH occasion (the MAC entity may take into account the possible occurrence of measurement gaps when determining the next available PRACH occasion).

1> perform the Random Access Preamble transmission procedure (see subclause 5.1.3).

[TS 38.321, clause 5.1.4]

Once the Random Access Preamble is transmitted and regardless of the possible occurrence of a measurement gap, the MAC entity shall:

...

1> else:

2> start the *ra-ResponseWindow* configured in *RACH-ConfigCommon* at the first PDCCH occasion as specified in TS 38.213 [6] from the end of the Random Access Preamble transmission;

2> monitor the PDCCH of the SpCell for Random Access Response(s) identified by the RA-RNTI while the *ra-ResponseWindow* is running.

1> if notification of a reception of a PDCCH transmission is received from lower layers; and

1> if PDCCH transmission is addressed to the C-RNTI; and

...



- 1> else if a downlink assignment has been received on the PDCCH for the RA-RNTI and the received TB is successfully decoded:
    - 2> if the Random Access Response contains a Backoff Indicator subheader:
      - 3> set the *PREAMBLE\_BACKOFF* to value of the BI field of the Backoff Indicator subheader using Table 7.2-1.
    - 2> else:
      - 3> set the *PREAMBLE\_BACKOFF* to 0 ms.
    - 2> if the Random Access Response contains a Random Access Preamble identifier corresponding to the transmitted *PREAMBLE\_INDEX* (see subclause 5.1.3):
      - 3> consider this Random Access Response reception successful.
    - 2> if the Random Access Response reception is considered successful:
      - 3> if the Random Access Response includes RAPID only:
        - 4> consider this Random Access procedure successfully completed;
        - 4> indicate the reception of an acknowledgement for the SI request to upper layers.
      - 3> else:
        - 4> apply the following actions for the Serving Cell where the Random Access Preamble was transmitted:
          - 5> process the received Timing Advance Command (see subclause 5.2);
          - 5> indicate the *preambleReceivedTargetPower* and the amount of power ramping applied to the latest Random Access Preamble transmission to lower layers (i.e.  $(PREAMBLE\_POWER\_RAMPING\_COUNTER - 1) \times preamblePowerRampingStep$ );
          - 5> if the Serving Cell for the Random Access procedure is SRS-only SCell:
            - 6> ignore the received UL grant.
        - 5> else:
          - 6> process the received UL grant value and indicate it to the lower layers.
      - 4> if the Random Access Preamble was not selected by the MAC entity among the contention-based Random Access Preamble(s):
        - 5> consider the Random Access procedure successfully completed.
- ...
- 1> if *ra-ResponseWindow* configured in *RACH-ConfigCommon* expires, and if the Random Access Response containing Random Access Preamble identifiers that matches the transmitted *PREAMBLE\_INDEX* has not been received; or:
    - 1> if *ra-ResponseWindow* configured in *BeamFailureRecoveryConfig* expires and if the PDCCH addressed to the C-RNTI has not been received:
      - 2> consider the Random Access Response reception not successful;
      - 2> increment *PREAMBLE\_TRANSMISSION\_COUNTER* by 1;
      - 2> if *PREAMBLE\_TRANSMISSION\_COUNTER* = *preambleTxMax* + 1:
        - 3> if the Random Access Preamble is transmitted on the SpCell:
          - 4> indicate a Random Access problem to upper layers.
        - 3> else if the Random Access Preamble is transmitted on a SCell:

- 4> consider the Random Access procedure unsuccessfully completed.
- 2> if in this Random Access procedure, the Random Access Preamble was selected by MAC among the contention-based Random Access Preambles:
- 3> select a random backoff time according to a uniform distribution between 0 and the *PREAMBLE\_BACKOFF*;
- 3> delay the subsequent Random Access Preamble transmission by the backoff time.
- 2> perform the Random Access Resource selection procedure (see subclause 5.1.2).

The MAC entity may stop *ra-ResponseWindow* (and hence monitoring for Random Access Response(s)) after successful reception of a Random Access Response containing Random Access Preamble identifiers that matches the transmitted *PREAMBLE\_INDEX*.

HARQ operation is not applicable to the Random Access Response transmission.

#### 7.1.1.1.1.3 Test description

##### 7.1.1.1.1.3.1 Pre-test conditions

Same Pre-test conditions as in clause 7.1.3.0 except the following:

- 2 NR cells (NR Cell 1 and NR Cell 2) are configured with SN terminated SCG bearers in RLC AM mode.

##### 7.1.1.1.1.3.2 Test procedure sequence

**Table 7.1.1.1.1.3.2-1: Main behaviour**

St	Procedure	Message Sequence		TP	Verdict
		U - S	Message		
1	The SS transmits an <i>RRConnectionReconfiguration</i> message containing NR <i>RRCReconfiguration</i> message i to handover source PSCell NR Cell 1 to target NR Cell 2, including RACH-ConfigDedicated information element	<--	<i>RRConnectionReconfiguration</i> ( <i>RRCReconfiguration</i> )	-	-
2	Check: Does the UE transmit an <i>RRConnectionReconfigurationComplete</i> message containing NR <i>RRCReconfigurationComplete</i> message?	-->	<i>RRConnectionReconfigurationC</i> <i>omplete</i> ( <i>RRCReconfigurationComplete</i> )	-	-
3	Check: Does the UE transmit Preamble on PRACH corresponding to <i>ra-PreambleIndex</i> in step 1?	-->	(PRACH Preamble)	1	P
4	Check: Does the UE re-transmits Preamble on PRACH corresponding to <i>ra-PreambleIndex</i> in step 1?	-->	(PRACH Preamble)	2	P
5	The SS transmits Random Access Response on NR cell 2, with RAPID corresponding to <i>ra-PreambleIndex</i> in step 1	<--	Random Access Response	-	-

7.1.1.1.1.3.3 Specific message contents

**Table 7.1.1.1.1.3.3-1: RRCConnectionReconfiguration (step 1, Table 7.1.1.1.1.3.2-1)**

Derivation Path: 36.508 [7], Table 4.6.1-8			
Information Element	Value/remark	Comment	Condition
RRCConnectionReconfiguration ::= SEQUENCE {			
criticalExtensions CHOICE {			
c1 CHOICE {			
rrcConnectionReconfiguration-r8 ::= SEQUENCE {			
nonCriticalExtension SEQUENCE {			
nonCriticalExtension SEQUENCE {			
nonCriticalExtension SEQUENCE {			
nonCriticalExtension SEQUENCE {			
nonCriticalExtension SEQUENCE {			
nonCriticalExtension SEQUENCE {			
nonCriticalExtension SEQUENCE {			
nr-Config-r15 CHOICE {			
setup SEQUENCE {			
nr-SecondaryCellGroupConfig-r15	OCTET STRING including the RRCReconfiguration message containing the IE secondaryCellGroup		
}			
nonCriticalExtension ::= SEQUENCE {}			
}			
}			
}			
}			
}			
}			
}			
}			
}			
}			
}			
}			
}			
}			
}			
}			
}			
}			
}			

**Table 7.1.1.1.1.3.3-2: RRCReconfiguration (Table 7.1.1.1.1.3.3-1)**

Derivation Path: 38.508-1 [4], Table [4.6.1-3]			
Information Element	Value/remark	Comment	Condition
RRCReconfiguration ::= SEQUENCE {			
criticalExtensions CHOICE {			
rrcReconfiguration ::= SEQUENCE {			
secondaryCellGroup	CellGroupConfig		
}			
}			
}			
}			

Table 7.1.1.1.3.3-3 CellGroupConfig (Table 7.1.1.1.3.3-2)

Derivation Path: 38.508-1 [4], Table [4.6.3-13] with conditions EN-DC, SCG and RECONFWITHSYNC			
Information Element	Value/remark	Comment	Condition
CellGroupConfig ::= SEQUENCE {			
spCellConfig SEQUENCE {			
servCellIndex	1		
reconfigurationWithSync SEQUENCE {			
rach-ConfigDedicated CHOICE {			
uplink	RACH-ConfigDedicated		
}			
}			
}			
}			

Table 7.1.1.1.3.3-4: RACH-ConfigDedicated (Table 7.1.1.1.3.3-3)

Derivation Path: TS 38.331 [6], clause 6.3.2			
Information Element	Value/remark	Comment	Condition
RACH-ConfigDedicated ::= SEQUENCE {			
cfra-Resources CHOICE {			
ssb SEQUENCE {			
ssb-ResourceList SEQUENCE (SIZE(1..maxRA-SSB-Resources)) OF SEQUENCE {	1 entry		
ssb	0		
ra-PreambleIndex	52	Randomly selected	
}			
ra-ssb-OccasionMaskIndex	0		
}			
cfra-Occasions	Not present		
}			

7.1.1.1.1a Correct selection of RACH parameters / Random access preamble and PRACH resource explicitly signalled to the UE by PDCCH Order / contention free random access procedure

7.1.1.1.1a.1 Test Purpose (TP)

(1)

```
with { UE in RRC_Connected }
ensure that {
  when { PDCCH control command is received in NR PsCell providing Random Access Preamble }
  then { UE sends a PRACH preamble given in the PDCCH Order in NR PsCell }
}
```

(2)

```
with { UE in RRC_Connected state after transmission of a PRACH preamble on NR SpCell received in
PDCCH control command on NR PsCell }
ensure that {
  when { UE does not receive a matching Random Access response in ra-ResponseWindowSize (hence
considers RACH attempt as failed) and PREAMBLE_TRANSMISSION_COUNTER is less than PREAMBLE_TRANS_MAX
}
  then { UE retransmits a PRACH preamble received in PDCCH control command on NR PsCell }
}
```

7.1.1.1.1a.2 Conformance requirements

References: The conformance requirements covered in the present test case are specified in: TS 38.321, clauses 5.1.2, 5.1.4 and TS 38.212 clause 7.3.1.2.1. Unless otherwise stated these are Rel-15 requirements.

[TS 38.321, clause 5.1.2]

The MAC entity shall:

...

1> else if the *ra-PreambleIndex* has been explicitly provided by either PDCCH or RRC; and

1> if the *ra-PreambleIndex* is not 0b000000; and

1> if contention-free Random Access Resource associated with SSBs or CSI-RS have not been explicitly provided by RRC:

2> set the *PREAMBLE\_INDEX* to the signalled *ra-PreambleIndex*.

...

1> if an SSB is selected above and an association between PRACH occasions and SSBs is configured:

2> determine the next available PRACH occasion from the PRACH occasions corresponding to the selected SSB permitted by the restrictions given by the *ra-ssb-OccasionMaskIndex* if configured (the MAC entity may take into account the possible occurrence of measurement gaps when determining the next available PRACH occasion corresponding to the selected SSB).

1> else if a CSI-RS is selected above and an association between PRACH occasions and CSI-RSs is configured:

2> determine the next available PRACH occasion from the PRACH occasions in *ra-OccasionList* corresponding to the selected CSI-RS (the MAC entity may take into account the possible occurrence of measurement gaps when determining the next available PRACH occasion corresponding to the selected CSI-RS).

1> else:

2> determine the next available PRACH occasion (the MAC entity may take into account the possible occurrence of measurement gaps when determining the next available PRACH occasion).

1> perform the Random Access Preamble transmission procedure (see subclause 5.1.3).

[TS 38.321, clause 5.1.4]

Once the Random Access Preamble is transmitted and regardless of the possible occurrence of a measurement gap, the MAC entity shall:

...

1> else:

2> start the *ra-ResponseWindow* configured in *RACH-ConfigCommon* at the first PDCCH occasion as specified in TS 38.213 [6] from the end of the Random Access Preamble transmission;

2> monitor the PDCCH of the SpCell for Random Access Response(s) identified by the RA-RNTI while the *ra-ResponseWindow* is running.

1> if notification of a reception of a PDCCH transmission is received from lower layers; and

1> if PDCCH transmission is addressed to the C-RNTI; and

...

1> else if a downlink assignment has been received on the PDCCH for the RA-RNTI and the received TB is successfully decoded:

2> if the Random Access Response contains a Backoff Indicator subheader:

3> set the *PREAMBLE\_BACKOFF* to value of the BI field of the Backoff Indicator subheader using Table 7.2-1.

2> else:

3> set the *PREAMBLE\_BACKOFF* to 0 ms.

- 2> if the Random Access Response contains a Random Access Preamble identifier corresponding to the transmitted *PREAMBLE\_INDEX* (see subclause 5.1.3):
    - 3> consider this Random Access Response reception successful.
  - 2> if the Random Access Response reception is considered successful:
    - 3> if the Random Access Response includes RAPID only:
      - 4> consider this Random Access procedure successfully completed;
      - 4> indicate the reception of an acknowledgement for the SI request to upper layers.
    - 3> else:
      - 4> apply the following actions for the Serving Cell where the Random Access Preamble was transmitted:
        - 5> process the received Timing Advance Command (see subclause 5.2);
        - 5> indicate the *preambleReceivedTargetPower* and the amount of power ramping applied to the latest Random Access Preamble transmission to lower layers (i.e.  $(PREAMBLE\_POWER\_RAMPING\_COUNTER - 1) \times preamblePowerRampingStep$ );
        - 5> if the Serving Cell for the Random Access procedure is SRS-only SCell:
          - 6> ignore the received UL grant.
        - 5> else:
          - 6> process the received UL grant value and indicate it to the lower layers.
      - 4> if the Random Access Preamble was not selected by the MAC entity among the contention-based Random Access Preamble(s):
        - 5> consider the Random Access procedure successfully completed.
- ...
- 1> if *ra-ResponseWindow* configured in *RACH-ConfigCommon* expires, and if the Random Access Response containing Random Access Preamble identifiers that matches the transmitted *PREAMBLE\_INDEX* has not been received; or:
  - 1> if *ra-ResponseWindow* configured in *BeamFailureRecoveryConfig* expires and if the PDCCH addressed to the C-RNTI has not been received:
    - 2> consider the Random Access Response reception not successful;
    - 2> increment *PREAMBLE\_TRANSMISSION\_COUNTER* by 1;
    - 2> if *PREAMBLE\_TRANSMISSION\_COUNTER* = *preambleTxMax* + 1:
      - 3> if the Random Access Preamble is transmitted on the SpCell:
        - 4> indicate a Random Access problem to upper layers.
      - 3> else if the Random Access Preamble is transmitted on a SCell:
        - 4> consider the Random Access procedure unsuccessfully completed.
    - 2> if in this Random Access procedure, the Random Access Preamble was selected by MAC among the contention-based Random Access Preambles:
      - 3> select a random backoff time according to a uniform distribution between 0 and the *PREAMBLE\_BACKOFF*;
      - 3> delay the subsequent Random Access Preamble transmission by the backoff time.
    - 2> perform the Random Access Resource selection procedure (see subclause 5.1.2).

The MAC entity may stop *ra-ResponseWindow* (and hence monitoring for Random Access Response(s)) after successful reception of a Random Access Response containing Random Access Preamble identifiers that matches the transmitted *PREAMBLE\_INDEX*.

HARQ operation is not applicable to the Random Access Response transmission.

[TS 38.212, 7.3.1.2.1]

If the CRC of the DCI format 1\_0 is scrambled by C-RNTI and the "Frequency domain resource assignment" field are of all ones, the DCI format 1\_0 is for random access procedure initiated by a PDCCH order, with all remaining fields set as follows:

- Random Access Preamble index – 6 bits according to *ra-PreambleIndex* in Subclause 5.1.2 of [8, TS38.321]
- UL/SUL indicator – 1 bit. If the value of the "Random Access Preamble index" is not all zeros and if the UE is configured with SUL in the cell, this field indicates which UL carrier in the cell to transmit the PRACH according to Table 7.3.1.1.1-1; otherwise, this field is reserved
- SS/PBCH index – 6 bits. If the value of the "Random Access Preamble index" is not all zeros, this field indicates the SS/PBCH that shall be used to determine the RACH occasion for the PRACH transmission; otherwise, this field is reserved.
- PRACH Mask index – 4 bits. If the value of the "Random Access Preamble index" is not all zeros, this field indicates the RACH occasion associated with the SS/PBCH indicated by "SS/PBCH index" for the PRACH transmission, according to Subclause 5.1.1 of [8, TS38.321]; otherwise, this field is reserved
- Reserved bits – 10 bits

7.1.1.1.1a.3 Test description

7.1.1.1.1a.3.1 Pre-test conditions

Same Pre-test conditions as in clause 7.1.3.0.

7.1.1.1.1a.3.2 Test procedure sequence

**Table 7.1.1.1.1a.3.2-1: Main behaviour**

St	Procedure	Message Sequence		TP	Verdict
		U - S	Message		
1	The SS transmits a PDCCH order providing Random Access Preamble on NR SpCell.	<--	(PDCCH Order)	-	-
2	Check: Does the UE transmit Preamble on PRACH corresponding to <i>ra-PreambleIndex</i> in step 1?	-->	(PRACH Preamble)	1	P
3	Check: Does the UE re-transmits Preamble on PRACH corresponding to <i>ra-PreambleIndex</i> in step 1?	-->	(PRACH Preamble)	2	P
4	Check: Does the UE transmit Preamble on PRACH corresponding to <i>ra-PreambleIndex</i> in step 1?	-->	(PRACH Preamble)	2	P
5	Check: Does the UE re-transmits Preamble on PRACH corresponding to <i>ra-PreambleIndex</i> in step 1?	-->	(PRACH Preamble)	2	P
6	The SS transmits Random Access Response on NR SpCell, with RAPID corresponding to <i>ra-PreambleIndex</i> in step 1	<--	Random Access Response	-	-

## 7.1.1.1.1a.3.3 Specific message contents

**Table 7.1.1.1.1a.3.3-1: RRCReconfiguration (Preamble, step 7, Table 4.5.4.2-1)**

Derivation Path: TS 38.508-1 [4], Table 4.6.1-3			
Information Element	Value/remark	Comment	Condition
RRCReconfiguration ::= SEQUENCE {			
rrc-TransactionIdentifier	RRC-TransactionIdentifier	Table [4.6.5-1].	
criticalExtensions CHOICE {			
rrcReconfiguration ::= SEQUENCE {			
secondaryCellGroup	CellGroupConfig	OCTET STRING (CONTAINING CellGroupConfig)	EN-DC
}			
}			
}			

**Table 7.1.1.1.1a.3.3-2: CellGroupConfig (Table 7.1.1.1.1a.3.3-1)**

Derivation Path: TS 38.508-1 [4], Table 4.6.3-13			
Information Element	Value/remark	Comment	Condition
CellGroupConfig ::= SEQUENCE {			
spCellConfig SEQUENCE {			
reconfigurationWithSync SEQUENCE {			
spCellConfigCommon	ServingCellConfigCommon		
newUE-Identity	RNTI-Value		
t304	ms2000		
rach-ConfigDedicated CHOICE {			
uplink	Not Present	CFRA resources not available	
supplementaryUplink	Not Present		
}			
}			
}			

**Table 7.1.1.1.1a.3.3-3: ServingCellConfigCommon (Table 7.1.1.1.1a.3.3-2)**

Derivation Path: TS 38.508-1 [4], Table 4.6.3-129			
Information Element	Value/remark	Comment	Condition
ServingCellConfigCommon ::= SEQUENCE {			
uplinkConfigCommon SEQUENCE {			
initialUplinkBWP	BWP-UplinkCommon		
}			
}			

**Table 7.1.1.1.1a.3.3-4: BWP-UplinkCommon (Table 7.1.1.1.1a.3.3-3)**

Derivation Path: TS 38.508-1 [4], Table 4.6.3-6			
Information Element	Value/remark	Comment	Condition
BWP-UplinkCommon ::= SEQUENCE {			
rach-ConfigCommon CHOICE {			
setup	RACH-ConfigCommon		
}			
}			



**Table 7.1.1.1a.3.3-5: RACH-ConfigCommon (Table 7.1.1.1a.3.3-4)**

Derivation Path: TS 38.508-1 [4], Table 4.6.3-97			
Information Element	Value/remark	Comment	Condition
RACH-ConfigCommon ::= SEQUENCE {			
rach-ConfigGeneric	RACH-ConfigGeneric		
}			

**Table 7.1.1.1a.3.3-6: RACH-ConfigGeneric (Table 7.1.1.1a.3.3-5)**

Derivation Path: TS 38.508-1 [4], Table 4.6.3-98			
Information Element	Value/remark	Comment	Condition
RACH-ConfigGeneric ::= SEQUENCE {			
preambleTransMax	n4		
}			

### 7.1.1.1.2 Random access procedure / Successful / C-RNTI Based / Preamble selected by MAC itself

#### 7.1.1.1.2.1 Test Purpose (TP)

(1)

```
with { UE in RRC_Connected NR SpCell TimeAlignmentTimer expired, and has UL Data to send }
ensure that {
  when { the UL MAC PDU Size is less than messageSizeGroupA }
    then { UE transmits a random access preamble using a preamble in group A of random access
preambles }
}
```

(2)

```
with { UE in RRC_Connected state after transmission of a PRACH preamble on NR SpCell }
ensure that {
  when { SS does not answer with a matching Random Access Response within ra-ResponseWindowSize }
    then { UE retransmits a PRACH preamble from same group }
}
```

(3)

```
with { UE in RRC_Connected state after transmission of a PRACH preamble on NR SpCell }
ensure that {
  when { UE receives while ra-ResponseWindowSizeTimer is running MAC PDU containing multiple RARs
but none of the subheaders contains a RAPID corresponding to the UE }
    then { UE retransmits a PRACH preamble from same group }
}
```

(4)

```
with { UE in RRC_Connected state after transmission of a PRACH preamble on NR SpCell }
ensure that {
  when { SS sends a Random Access Response including a Backoff Indicator and the Random Access
Preamble identifier is different from the value received from the UE }
    then { UE triggers RA preamble after a random time between 0 and the indicated Backoff parameter
from same group }
}
```

(5)

```
with { UE in RRC_Connected state after transmission of a PRACH preamble on NR SpCell }
ensure that {
  when { UE receives while ra-ResponseWindowSizeTimer is running MAC PDU containing multiple RARs
and one of the subheaders contains a RAPID corresponding to the UE and containing Backoff Indicator
}
    then { UE stores Backoff Indicator UE transmits RACH procedure MSG3 }
}
```

(6)

```

with { UE in RRC_Connected state after transmission of Msg3 on NR SpCell without dedicated preamble
}
ensure that {
  when { The SS does not schedule any PDCCH transmission addressed to UE C-RNTI before Contention
  resolution timer expiry }
  then { UE transmits a random access preamble using a preamble in the same group of random access
  preambles as used for the first transmission of Msg3 }
}

```

(7)

```

with { UE in RRC_Connected state after transmission of Msg3 on NR SpCell without dedicated preamble
}
ensure that {
  when { UE receive PDCCH transmission addressed to its C-RNTI before Contention resolution timer
  expiry }
  then { UE considers RACH procedure as complete }
}

```

(8)

```

with { UE in RRC_Connected NR SpCell TimeAlignmentTimer expired, and has UL Data to send }
ensure that {
  when { the UL MAC PDU Size is greater than messageSizeGroupA }
  then { UE transmits a random access preamble using a preamble in group B of random access
  preambles }
}

```

(9)

```

with { UE in RRC_Connected state and having initiated a random access procedure in NR SpCell }
ensure that {
  when { The SS transmits a Timing Advance Command in a Random Access Response message }
  then { the UE applies the received Timing Advance value in the next transmitted MAC PDU }
}

```

#### 7.1.1.1.2.2 Conformance requirements

**Editor's Note: The conformance requirements are based on running RAN2 CRs**

References: The conformance requirements covered in the present test case are specified in: TS 38.321, clauses 5.1.2, 5.1.3, 5.1.4, 5.1.5, 5.2, 6.1.3.2, 6.1.5 and 6.2.3. Unless otherwise stated these are Rel-15 requirements.

[TS 38.321, clause 5.1.2]

The MAC entity shall:

...

1> else:

2> if at least one of the SSBs with SS-RSRP above *rsrp-ThresholdSSB* is available:

3> select an SSB with SS-RSRP above *rsrp-ThresholdSSB*.

2> else:

3> select any SSB.

2> if Msg3 has not yet been transmitted:

3> if Random Access Preambles group B is configured:

4> if the potential Msg3 size (UL data available for transmission plus MAC header and, where required, MAC CEs) is greater than *ra-Msg3SizeGroupA* and the pathloss is less than *PCMAX* (of the Serving Cell performing the Random Access Procedure)  $- preambleReceivedTargetPower - msg3-DeltaPreamble - messagePowerOffsetGroupB$ ; or

- 4> if the Random Access procedure was initiated for the CCCH logical channel and the CCCH SDU size plus MAC subheader is greater than *ra-Msg3SizeGroupA*:5> select the Random Access Preambles group B.
- 4> else:
  - 5> select the Random Access Preambles group A.
- 3> else:
  - 4> select the Random Access Preambles group A.
- 2> else (i.e. Msg3 is being retransmitted):
  - 3> select the same group of Random Access Preambles as was used for the Random Access Preamble transmission attempt corresponding to the first transmission of Msg3.
- 2> if the association between Random Access Preambles and SSBs is configured:
  - 3> select a *ra-PreambleIndex* randomly with equal probability from the Random Access Preambles associated with the selected SSB and the selected Random Access Preambles group.
- 2> else:
  - 3> select a *ra-PreambleIndex* randomly with equal probability from the Random Access Preambles within the selected Random Access Preambles group.
- 2> set the *PREAMBLE\_INDEX* to the selected *ra-PreambleIndex*.
- ...
- 1> else:
  - 2> determine the next available PRACH occasion (the MAC entity shall select a PRACH occasion randomly with equal probability amongst the PRACH occasions occurring simultaneously but on different subcarriers; the MAC entity may take into account the possible occurrence of measurement gaps when determining the next available PRACH occasion).
- 1> perform the Random Access Preamble transmission procedure (see subclause 5.1.3).

[TS 38.321, clause 5.1.3]

The MAC entity shall, for each Random Access Preamble:

- 1> if *PREAMBLE\_TRANSMISSION\_COUNTER* is greater than one; and
- 1> if the notification of suspending power ramping counter has not been received from lower layers; and
- 1> if SSB selected is not changed (i.e. same as the previous Random Access Preamble transmission):
  - 2> increment *PREAMBLE\_POWER\_RAMPING\_COUNTER* by 1.
- 1> select the value of *DELTA\_PREAMBLE* according to subclause 7.3;
- 1> set *PREAMBLE\_RECEIVED\_TARGET\_POWER* to  $\text{preambleReceivedTargetPower} + \text{DELTA\_PREAMBLE} + (\text{PREAMBLE\_POWER\_RAMPING\_COUNTER} - 1) \times \text{PREAMBLE\_POWER\_RAMPING\_STEP}$ ;
- 1> except for contention-free Random Access Preamble for beam failure recovery request, compute the RA-RNTI associated with the PRACH occasion in which the Random Access Preamble is transmitted;
- 1> instruct the physical layer to transmit the Random Access Preamble using the selected PRACH, corresponding RA-RNTI (if available), *PREAMBLE\_INDEX* and *PREAMBLE\_RECEIVED\_TARGET\_POWER*.

The RA-RNTI associated with the PRACH in which the Random Access Preamble is transmitted, is computed as:

$$\text{RA-RNTI} = 1 + \text{s\_id} + 14 \times \text{t\_id} + 14 \times 80 \times \text{f\_id} + 14 \times 80 \times 8 \times \text{ul\_carrier\_id}$$

where  $s\_id$  is the index of the first OFDM symbol of the specified PRACH ( $0 \leq s\_id < 14$ ),  $t\_id$  is the index of the first slot of the specified PRACH in a system frame ( $0 \leq t\_id < 80$ ),  $f\_id$  is the index of the specified PRACH in the frequency domain ( $0 \leq f\_id < 8$ ), and  $ul\_carrier\_id$  is the UL carrier used for Msg1 transmission (0 for NUL carrier, and 1 for SUL carrier).

[TS 38.321, clause 5.1.4]

Once the Random Access Preamble is transmitted and regardless of the possible occurrence of a measurement gap, the MAC entity shall:

...

1> else:

2> start the *ra-ResponseWindow* configured in *RACH-ConfigCommon* at the first PDCCH occasion as specified in TS 38.213 [6] from the end of the Random Access Preamble transmission;

2> monitor the PDCCH of the SpCell for Random Access Response(s) identified by the RA-RNTI while the *ra-ResponseWindow* is running.

1> if notification of a reception of a PDCCH transmission is received from lower layers; and

1> if PDCCH transmission is addressed to the C-RNTI; and

1> if the contention-free Random Access Preamble for beam failure recovery request was transmitted by the MAC entity:

2> consider the Random Access procedure successfully completed.

1> else if a downlink assignment has been received on the PDCCH for the RA-RNTI and the received TB is successfully decoded:

2> if the Random Access Response contains a MAC subPDU with Backoff Indicator:

3> set the *PREAMBLE\_BACKOFF* to value of the BI field of the MAC subPDU using Table 7.2-1, multiplied with *SCALING\_FACTOR\_BI*.

2> else:

3> set the *PREAMBLE\_BACKOFF* to 0 ms.

2> if the Random Access Response contains a MAC subPDU with Random Access Preamble identifier corresponding to the transmitted *PREAMBLE\_INDEX* (see subclause 5.1.3):

3> consider this Random Access Response reception successful.

2> if the Random Access Response reception is considered successful:

3> if the Random Access Response includes RAPID only:

4> consider this Random Access procedure successfully completed;

4> indicate the reception of an acknowledgement for the SI request to upper layers.

3> else:

4> apply the following actions for the Serving Cell where the Random Access Preamble was transmitted:

5> process the received Timing Advance Command (see subclause 5.2);

5> indicate the *preambleReceivedTargetPower* and the amount of power ramping applied to the latest Random Access Preamble transmission to lower layers (i.e.  $(PREAMBLE\_POWER\_RAMPING\_COUNTER - 1) \times preamblePowerRampingStep$ ).

5> if the Serving Cell for the Random Access procedure is SRS-only SCell:

6> ignore the received UL grant.

- 5> else:
  - 6> process the received UL grant value and indicate it to the lower layers.
- 4> if the Random Access Preamble was not selected by the MAC entity among the contention-based Random Access Preamble(s):
  - 5> consider the Random Access procedure successfully completed.
- 4> else:
  - 5> set the *TEMPORARY\_C-RNTI* to the value received in the Random Access Response;
- ...
- 1> if *ra-ResponseWindow* configured in *RACH-ConfigCommon* expires, and if the Random Access Response containing Random Access Preamble identifiers that matches the transmitted *PREAMBLE\_INDEX* has not been received; or
  - 1> if *ra-ResponseWindow* configured in *BeamFailureRecoveryConfig* expires and if the PDCCH addressed to the C-RNTI has not been received:2> consider the Random Access Response reception not successful;
  - 2> increment *PREAMBLE\_TRANSMISSION\_COUNTER* by 1;
  - 2> if *PREAMBLE\_TRANSMISSION\_COUNTER* = *preambleTxMax* + 1:
    - 3> if the Random Access Preamble is transmitted on the SpCell:
      - 4> indicate a Random Access problem to upper layers.
      - 4> if this Random Access procedure was triggered for SI request:
        - 5> consider the Random Access procedure unsuccessfully completed.
    - > else if the Random Access Preamble is transmitted on a SCell:
      - 4> consider the Random Access procedure unsuccessfully completed.
  - 2> if the Random Access procedure is not completed:
    - 3> if in this Random Access procedure, the Random Access Preamble was selected by MAC among the contention-based Random Access Preambles:
      - 4> select a random backoff time according to a uniform distribution between 0 and the *PREAMBLE\_BACKOFF*;
      - 4> delay the subsequent Random Access Preamble transmission by the backoff time.
  - 3> perform the Random Access Resource selection procedure (see subclause 5.1.2).

The MAC entity may stop *ra-ResponseWindow* (and hence monitoring for Random Access Response(s)) after successful reception of a Random Access Response containing Random Access Preamble identifiers that matches the transmitted *PREAMBLE\_INDEX*.

HARQ operation is not applicable to the Random Access Response transmission.[TS 38.321, clause 5.1.5]

Contention Resolution is based on either C-RNTI on PDCCH of the SpCell or UE Contention Resolution Identity on DL-SCH.

Once Msg3 is transmitted, the MAC entity shall:

- 1> start the *ra-ContentionResolutionTimer* and restart the *ra-ContentionResolutionTimer* at each HARQ retransmission in the first symbol after the end of the Msg3 transmission;
- 1> monitor the PDCCH while the *ra-ContentionResolutionTimer* is running regardless of the possible occurrence of a measurement gap;
- 1> if notification of a reception of a PDCCH transmission is received from lower layers:

- 2> if the C-RNTI MAC CE was included in Msg3:
  - 3> if the Random Access procedure was initiated by the MAC sublayer itself or by the RRC sublayer and the PDCCH transmission is addressed to the C-RNTI and contains a UL grant for a new transmission; or
  - 3> if the Random Access procedure was initiated by a PDCCH order and the PDCCH transmission is addressed to the C-RNTI; or
  - 3> if the Random Access procedure was initiated by a beam failure indication from lower layer and the PDCCH transmission is addressed to the C-RNTI:
    - 4> consider this Contention Resolution successful;
    - 4> stop *ra-ContentionResolutionTimer*;
    - 4> discard the *TEMPORARY\_C-RNTI*;
    - 4> consider this Random Access procedure successfully completed.

...

- 1> if *ra-ContentionResolutionTimer* expires:
  - 2> discard the *TEMPORARY\_C-RNTI*;
  - 2> consider the Contention Resolution not successful.
- 1> if the Contention Resolution is considered not successful:
  - 2> flush the HARQ buffer used for transmission of the MAC PDU in the Msg3 buffer;
  - 2> increment *PREAMBLE\_TRANSMISSION\_COUNTER* by 1;
  - 2> if *PREAMBLE\_TRANSMISSION\_COUNTER* = *preambleTxMax* + 1:
    - 3> indicate a Random Access problem to upper layers.
    - 3> if this Random Access procedure was triggered for SI request:
      - 4> consider the Random Access procedure unsuccessfully completed. 2> if the Random Access procedure is not completed:
        - 3> select a random backoff time according to a uniform distribution between 0 and the *PREAMBLE\_BACKOFF*;
        - 3> delay the subsequent Random Access Preamble transmission by the backoff time;
        - 3> perform the Random Access Resource selection procedure (see subclause 5.1.2).

[TS 38.321, clause 5.2]

RRC configures the following parameters for the maintenance of UL time alignment:

- *timeAlignmentTimer* (per TAG) which controls how long the MAC entity considers the Serving Cells belonging to the associated TAG to be uplink time aligned.

The MAC entity shall:

- 1> when a Timing Advance Command MAC CE is received, and if a  $N_{TA}$  (as defined in TS 38.211 [8]) has been maintained with the indicated TAG:
  - 2> apply the Timing Advance Command for the indicated TAG;
  - 2> start or restart the *timeAlignmentTimer* associated with the indicated TAG.

...

- 1> when a *timeAlignmentTimer* expires:

- 2> if the *timeAlignmentTimer* is associated with the pTAG:
  - 3> flush all HARQ buffers for all Serving Cells;
  - 3> notify RRC to release PUCCH for all Serving Cells, if configured;
  - 3> notify RRC to release SRS for all Serving Cells, if configured;
  - 3> clear any configured downlink assignments and configured uplink grants;
  - 3> consider all running *timeAlignmentTimers* as expired;
  - 3> maintain  $N_{TA}$  (defined in TS 38.211 [8]) of all TAGs.
- 2> else if the *timeAlignmentTimer* is associated with an sTAG, then for all Serving Cells belonging to this TAG:
  - 3> flush all HARQ buffers;
  - 3> notify RRC to release PUCCH, if configured;
  - 3> notify RRC to release SRS, if configured;
  - 3> clear any configured downlink assignments and configured uplink grants;
  - 3> maintain  $N_{TA}$  (defined in TS 38.211 [8]) of this TAG.

When the MAC entity stops uplink transmissions for an SCell due to the fact that the maximum uplink transmission timing difference between TAGs of the MAC entity or the maximum uplink transmission timing difference between TAGs of any MAC entity of the UE is exceeded, the MAC entity considers the *timeAlignmentTimer* associated with the SCell as expired.

The MAC entity shall not perform any uplink transmission on a Serving Cell except the Random Access Preamble transmission when the *timeAlignmentTimer* associated with the TAG to which this Serving Cell belongs is not running. Furthermore, when the *timeAlignmentTimer* associated with the pTAG is not running, the MAC entity shall not perform any uplink transmission on any Serving Cell except the Random Access Preamble transmission on the SpCell.

[TS 38.321, clause 6.1.3.2]

The C-RNTI MAC CE is identified by MAC PDU subheader with LCID as specified in Table 6.2.1-2.

It has a fixed size and consists of a single field defined as follows (Figure 6.1.3.2-1):

- C-RNTI: This field contains the C-RNTI of the MAC entity. The length of the field is 16 bits.

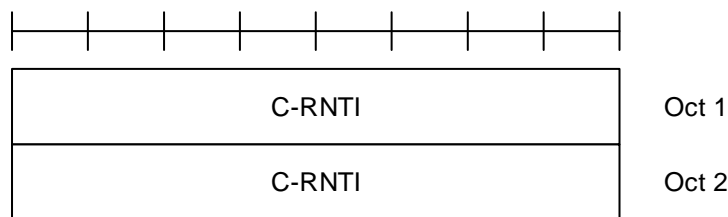

**Figure 6.1.3.2-1: C-RNTI MAC CE**

[TS 38.321, clause 6.1.5]

A MAC PDU consists of one or more MAC subPDUs and optionally padding. Each MAC subPDU consists one of the following:

- a MAC subheader with Backoff Indicator only;
- a MAC subheader with RAPID only (i.e. acknowledgment for SI request);
- a MAC subheader with RAPID and MAC RAR.

A MAC subheader with Backoff Indicator consists of five header fields E/T/R/R/BI as described in Figure 6.1.5-1. A MAC subPDU with Backoff Indicator only is placed at the beginning of the MAC PDU, if included. 'MAC subPDU(s) with RAPID only' and 'MAC subPDU(s) with RAPID and MAC RAR' can be placed anywhere between MAC subPDU with Backoff Indicator only (if any) and padding (if any).

A MAC subheader with RAPID consists of three header fields E/T/RAPID as described in Figure 6.1.5-2.

Padding is placed at the end of the MAC PDU if present. Presence and length of padding is implicit based on TB size, size of MAC subPDU(s).

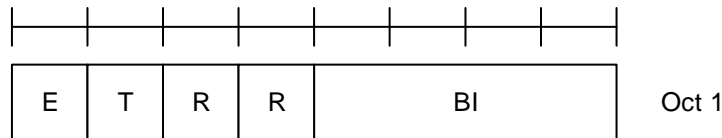

Figure 6.1.5-1: E/T/R/R/BI MAC subheader

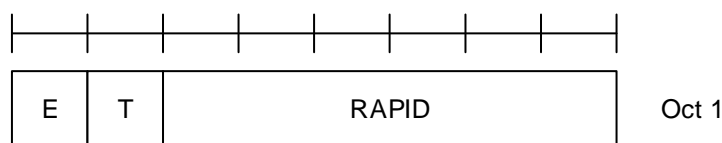

Figure 6.1.5-2: E/T/RAPID MAC subheader

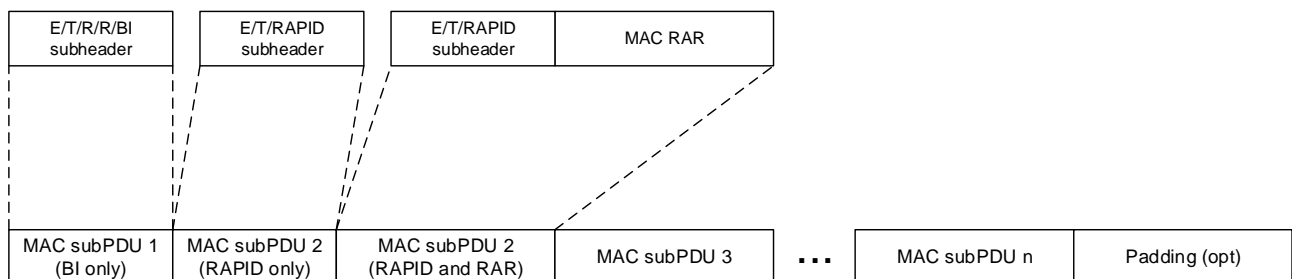

Figure 6.1.5-3: Example of MAC PDU consisting of MAC RARs

[TS 38.321, clause 6.2.3]

The MAC RAR is of fixed size as depicted in Figure 6.2.3-1, and consists of the following fields:

- R: Reserved bit, set to "0";
- Timing Advance Command: The Timing Advance Command field indicates the index value  $T_A$  used to control the amount of timing adjustment that the MAC entity has to apply in TS 38.213 [6]. The size of the Timing Advance Command field is 12 bits;
- UL Grant: The Uplink Grant field indicates the resources to be used on the uplink in TS 38.213 [6]. The size of the UL Grant field is 20 bits;
- Temporary C-RNTI: The Temporary C-RNTI field indicates the temporary identity that is used by the MAC entity during Random Access. The size of the Temporary C-RNTI field is 16 bits.

The MAC RAR is octet aligned.

Figure 6.2.3-1: MAC RAR



7.1.1.1.2.3 Test description

7.1.1.1.2.3.1 Pre-test conditions

Same Pre-test conditions as in clause 7.1.1.0.

7.1.1.1.2.3.2 Test procedure sequence

**Table 7.1.1.1.2.3.2-1: Main behaviour**

St	Procedure	Message Sequence		TP	Verdict
		U - S	Message		
1	SS transmits Timing Advance command to SpCell. SS does not send any subsequent timing alignments. Start Timer_T1 = Time Alignment timer value on SS.	<--	MAC PDU (Timing Advance Command MAC Control Element)	-	-
2	40 to 50 TTI before Timer_T1 expires the SS transmits a MAC PDU containing a PDCP SDU of size 56 bits, less than ra-Msg3SizeGroupA(208 bits) on SpCell. (Note 1)	<--	MAC PDU	-	-
3	The SS ignores scheduling requests and does not allocate any uplink grant.	-	-	-	-
4	Check: Does the UE transmit preamble on PRACH using a preamble in group A defined in nr-SecondaryCellGroupConfig in RRCConnectionReconfiguration (totalNumberOfRA-Preambles, ssb-perRACH-OccasionAndCB-PreamblesPerSSB and numberOfRA-PreamblesGroupA) on SpCell in frame number X meeting condition $n_{SFN} \bmod 8 = 1$ , subframe number 2,6,9 (FDD FR1) 4,9 (FR1 TDD) and frame number X and Slot number 0,1,2...39 (FR2)?	-->	PRACH Preamble	1	P
5	Check: does the UE transmit a preamble on PRACH, in frame number X+1 or X+2 subframe number 2,5,8 (FDD FR1)/ 7,8,9 (FR1 TDD) and frame number X and slot number 0,1,2...39 (FR2) using the same group A?	-->	PRACH Preamble	2	P
6	The SS transmits a MAC PDU addressed to UE RA-RNTI, containing multiple RARs but none of the MAC sub headers contains a matching RAPID on SpCell	<--	Random Access Response	-	-
-	EXCEPTION: In parallel with step 7, parallel behaviour defined in table 7.1.1.1.2.3.2-2 is executed	-	-	-	-
7	Check: Does the UE re-transmit a preamble on PRACH on SpCell using the same group A?	-->	PRACH Preamble	3	P
8	The SS transmits a Random Access Response with the back off parameter set to value Index field 'x' and with the Random Access Preamble identifier different from the value received from the UE in the Random Access Preamble. The SS sets Timer_T2 to the Back off value 'y' associated with the Index value 'x' and starts Timer_T2.	<--	Random Access Response(BI, RAPID)	-	-
9	Check: Does UE send a Random Access Preamble on SpCell while Timer_T2 is running ?	-->	Random Access Preamble	4	P
10	SS sends Random Access Response with an UL Grant of 56-bits, a back off parameter set to value Index field 'x' and the Random Access Preamble identifier value set to the same value as received from the UE in the Random Access Preamble. (Note 2)	<--	Random Access Response(BI, RAPID)	-	-
11	Check: Does UE send a msg3 in the grant associated to the Random Access Response received in step 10 on SpCell?	-->	msg3 (C-RNTI MAC CONTROL ELEMENT)	5	P
12	SS Does not schedule any PDCCH transmission for UE C-RNTI. The SS sets Timer_T3 to the Back off value 'y' associated with the Index value 'x' plus Contention Resolution Timer and starts Timer_T3.	-	-	-	-
13	Check: Does the UE transmit preamble on PRACH using a preamble belonging to group A for time equal to Timer_T3 on SpCell?	-->	PRACH Preamble	6	P

14	The SS transmits Random Access Response with an UL Grant of 56-bits and RAPID corresponding to the transmitted Preamble in step 13, including T-CRNTI.	<--	Random Access Response	-	-
15	UE sends a msg3 using the grant associated to the Random Access Response received in step 14 on SpCell?	-->	msg3 (C-RNTI MAC CONTROL ELEMENT)	-	-
16	SS schedules PDCCH transmission for UE C_RNTI and allocate uplink grant.	<--	Contention Resolution	-	-
-	EXCEPTION: In parallel with step 17, parallel behaviour defined in table 7.1.1.1.2.3.2-3 is executed	-	-	-	-
17	The UE transmits a MAC PDU with C-RNTI containing looped back PDCP SDU	-->	MAC PDU	7	P
18	SS transmits Timing Advance command to SpCell. SS does not send any subsequent timing alignments. Start Timer_T4 = Time Alignment timer value on SS	<--	MAC PDU (Timing Advance Command MAC Control Element)	-	-
19	40 to 50 TTI before Timer_T4 expires the SS transmits a MAC PDU containing a PDCP SDU of size > ra-Msg3SizeGroupA(208 bits)	<--	MAC PDU	-	-
20	The SS ignores scheduling requests and does not allocate any uplink grant.	-	-	-	-
21	Check: Does the UE transmit preamble on PRACH using a preamble in group B defined in nr-SecondaryCellGroupConfig in RRCConnectionReconfiguration ( ssb-perRACH-OccasionAndCB-PreamblesPerSSB, numberOfRA-PreamblesGroupA and numberOfRA-Preambles) on SpCell?	-->	PRACH Preamble	8	P
22	The SS transmits Random Access Response with an UL Grant of 56-bits and RAPID corresponding to the transmitted Preamble in step 21, including T-CRNTI.	<--	Random Access Response	-	-
23	UE sends a msg3 using the grant associated to the Random Access Response received in step 22 on SpCell?	-->	msg3 (C-RNTI MAC CONTROL ELEMENT)	-	-
23	SS schedules PDCCH transmission for UE C_RNTI and allocate uplink grant.	<--	Contention Resolution	-	-
24	The UE transmits a MAC PDU with C-RNTI containing looped back PDCP SDU	-->	MAC PDU	9	P
Note 1: MAC PDU size of 56bits is selected to allow UE send status PDU and still stays below the limit of ra-Msg3SizeGroupA.					
Note 2: UL grant of 56bits is to make UE not send any loopback data in uplink with msg3.					

Table 7.1.1.1.2.3.2-2: Parallel behaviour

St	Procedure	Message Sequence		TP	Verdict
		U - S	Message		
1	Check: Does the UE transmit msg3 message on SpCell.	-->	msg3 (C-RNTI MAC CONTROL ELEMENT)	-	F

Table 7.1.1.1.2.3.2-3: Parallel behaviour

St	Procedure	Message Sequence		TP	Verdict
		U - S	Message		
1	Check: Does the UE transmit an PRACH preamble or msg3 on SpCell?	-->	PRACH Preamble OR msg3 (C-RNTI MAC CONTROL ELEMENT)	-	F

## 7.1.1.1.2.3.3 Specific message contents

**Table 7.1.1.1.2.3.3-1: RRCReconfiguration (Preamble, step 7, Table 4.5.4.2-1)**

Derivation Path: TS 38.508-1 [4], Table 4.6.1-3			
Information Element	Value/remark	Comment	Condition
RRCReconfiguration ::= SEQUENCE {			
rrc-TransactionIdentifier	RRC-TransactionIdentifier	Table [4.6.5-1].	
criticalExtensions CHOICE {			
rrcReconfiguration ::= SEQUENCE {			
secondaryCellGroup	CellGroupConfig	OCTET STRING (CONTAINING CellGroupConfig)	EN-DC
}			
}			
}			

**Table 7.1.1.1.2.3.3-2: CellGroupConfig (Table 7.1.1.1.2.3.3-1)**

Derivation Path: TS 38.508-1 [4], Table 4.6.3-13			
Information Element	Value/remark	Comment	Condition
CellGroupConfig ::= SEQUENCE {			
spCellConfig SEQUENCE {			
reconfigurationWithSync SEQUENCE {			
spCellConfigCommon	ServingCellConfigCommon		
newUE-Identity	RNTI-Value		
t304	ms2000		
rach-ConfigDedicated CHOICE {			
uplink	Not Present	CFRA resources not available	
supplementaryUplink	Not Present		
}			
}			
}			

**Table 7.1.1.1.2.3.3-3: ServingCellConfigCommon (Table 7.1.1.1.2.3.3-1)**

Derivation Path: TS 38.508-1 [4], Table 4.6.3-129			
Information Element	Value/remark	Comment	Condition
ServingCellConfigCommon ::= SEQUENCE {			
uplinkConfigCommon SEQUENCE {			
initialUplinkBWP	BWP-UplinkCommon		
}			
}			

**Table 7.1.1.1.2.3.3-4: BWP-UplinkCommon (Table 7.1.1.1.2.3.3-1)**

Derivation Path: TS 38.508-1 [4], Table 4.6.3-6			
Information Element	Value/remark	Comment	Condition
BWP-UplinkCommon ::= SEQUENCE {			
rach-ConfigCommon CHOICE {			
setup	RACH-ConfigCommon		
}			
}			

**Table 7.1.1.1.2.3.3-5: RACH-ConfigCommon (Table 7.1.1.1.2.3.3-1)**

Derivation Path: TS 38.508-1 [4], Table 4.6.3-97			
Information Element	Value/remark	Comment	Condition
RACH-ConfigCommon ::= SEQUENCE {			
rach-ConfigGeneric	RACH-ConfigGeneric		
totalNumberOfRA-Preambles	42		
ssb-perRACH-OccasionAndCB-PreamblesPerSSB			
CHOICE {			
One	n32		
}			
groupBconfigured SEQUENCE {			
ra-Msg3SizeGroupA	b208		
messagePowerOffsetGroupB	minusinfinity		
numberOfRA-PreamblesGroupA	28		
}			
ra-ContentionResolutionTimer	sf48		
}			

Table 7.1.1.1.2.3.3-6: RACH-ConfigGeneric (Table 7.1.1.1.2.3.3-1)

Derivation Path: TS 38.508-1 [4], Table 4.6.3-98			
Information Element	Value/remark	Comment	Condition
RACH-ConfigGeneric ::= SEQUENCE { prach-ConfigurationIndex	119	As per Table 6.3.3.2-2: of TS 38.211 [24], this results in PRACH preamble transmission in a radio frame meeting $n_{SFN} \bmod 8 = 1$ , subframe number 2, 6, 9 and starting symbol 0 using preamble Format A2.	FR1 FDD
prach-ConfigurationIndex	94	As per Table 6.3.3.2-3: of TS 38.211 [24], this results in PRACH preamble transmission in a radio frame meeting $n_{SFN} \bmod 8 = 1$ , subframe number 4, 9 and starting symbol 0 using preamble Format A2.	FR1 TDD
prach-ConfigurationIndex	6	As per Table 6.3.3.2-4: of TS 38.211 [24], this results in PRACH preamble transmission start in any radio frame number, slot number 0,1,2,...,39 and starting symbol 0.	FR2
preambleReceivedTargetPower	dBm-104		
preambleTransMax	n10		
powerRampingStep	dB2		
ra-ResponseWindow	sl8		
}			

## 7.1.1.2 Downlink Data Transfer

### 7.1.1.2.1 Correct Handling of DL MAC PDU / Assignment / HARQ process

#### 7.1.1.2.1.1 Test Purpose (TP)

(1)

```
with { UE in RRC_CONNECTED state }
ensure that {
  when { UE receives downlink assignment on the PDCCH for the UE's C-RNTI and receives data in the
associated Slot and UE performs HARQ operation }
  then { UE sends a HARQ feedback on the HARQ process }
}
```

(2)

```
with { UE in RRC_CONNECTED state }
```

```

ensure that {
  when { SS transmits downlink assignment on the PDCCH with a C-RNTI unknown by the UE and data is
    available in the associated Slot }
    then { UE does not send any HARQ feedback on the HARQ process }
}

```

(3)

```

with { UE in RRC_CONNECTED state }
ensure that {
  when { the UE receives a MAC PDU addressed to its C-RNTI and decode fails in the associated Slot }
    then { the UE transmits a NACK for the corresponding HARQ process }
}

```

(4)

```

with { UE in RRC_CONNECTED state }
ensure that {
  when { the UE receives a MAC PDU retransmission addressed to its C-RNTI, and results in successful
    decode in the associated Slot }
    then { the UE transmits an ACK for the corresponding HARQ process and forward to higher layer }
}

```

(5)

```

with { UE in RRC_CONNECTED state }
ensure that {
  when { UE receives a MAC PDU containing multiple MAC sub PDUs each containing a MAC SDU that is
    larger than 256 bytes (16 bits L field used) with padding MAC sub PDU at the end }
    then { UE successfully decodes the MAC PDU and forward to higher layer }
}

```

(6)

```

with { UE in RRC_CONNECTED state }
ensure that {
  when { UE receives a MAC PDU containing multiple MAC sub PDUs each containing a MAC SDU that is
    smaller than 256 bytes (8 bits L field used) with padding MAC sub PDU at the end }
    then { UE successfully decodes the MAC PDU and forward to higher layer }
}

```

(7)

```

with { UE in RRC_CONNECTED state }
ensure that {
  when { UE receives a MAC PDU containing MAC sub PDU containing a MAC SDU and no padding MAC sub
    PDU }
    then { UE successfully decodes the MAC PDU and forward to higher layer }
}

```

(8)

```

with { UE in RRC_CONNECTED state }
ensure that {
  when { UE receives a MAC PDU containing MAC sub PDU containing a MAC SDU that is smaller than 256
    bytes (8 bits L field used) plus MAC sub PDU containing a MAC SDU that is greater than 256 bytes (16
    bits L field used) and no padding }
    then { UE successfully decodes the MAC PDU and forwards the AMD PDUs to higher layer }
}

```

#### 7.1.1.2.1.2 Conformance requirements

References: The conformance requirements covered in the present TC are specified in: TS 38.321, clauses 5.3.1, 5.3.2.1, 5.3.2.2 and 6.1.2. Unless otherwise stated these are Rel-15 requirements.

[TS 38.321, clause 5.3.1]

Downlink assignments received on the PDCCH both indicate that there is a transmission on a DL-SCH for a particular MAC entity and provide the relevant HARQ information.



When the MAC entity has a C-RNTI, Temporary C-RNTI, or CS-RNTI, the MAC entity shall for each PDCCH occasion during which it monitors PDCCH and for each Serving Cell:

- 1> if a downlink assignment for this PDCCH occasion and this Serving Cell has been received on the PDCCH for the MAC entity's C-RNTI, or Temporary C-RNTI:
  - 2> if this is the first downlink assignment for this Temporary C-RNTI:
    - 3> consider the NDI to have been toggled.
  - 2> if the downlink assignment is for the MAC entity's C-RNTI, and if the previous downlink assignment indicated to the HARQ entity of the same HARQ process was either a downlink assignment received for the MAC entity's CS-RNTI or a configured downlink assignment:
    - 3> consider the NDI to have been toggled regardless of the value of the NDI.
  - 2> indicate the presence of a downlink assignment and deliver the associated HARQ information to the HARQ entity.
- 1> else if a downlink assignment for this PDCCH occasion has been received for this Serving Cell on the PDCCH for the MAC entity's CS-RNTI:
  - 2> if the NDI in the received HARQ information is 1:
    - 3> consider the NDI for the corresponding HARQ process not to have been toggled;
    - 3> indicate the presence of a downlink assignment for this Serving Cell and deliver the associated HARQ information to the HARQ entity.
  - 2> if the NDI in the received HARQ information is 0:
    - 3> if PDCCH contents indicate SPS deactivation:
      - 4> clear the configured downlink assignment for this Serving Cell (if any);
      - 4> if the timeAlignmentTimer associated with the PTAG is running:
        - 5> indicate a positive acknowledgement for the SPS deactivation to the physical layer.
    - 3> else if PDCCH content indicates SPS activation:
      - 4> store the downlink assignment for this Serving Cell and the associated HARQ information as configured downlink assignment;
      - 4> initialise or re-initialise the configured downlink assignment for this Serving Cell to start in the associated PDSCH duration and to recur according to rules in subclause 5.8.1;
      - 4> set the HARQ Process ID to the HARQ Process ID associated with this PDSCH duration;
      - 4> consider the NDI bit for the corresponding HARQ process to have been toggled;
      - 4> indicate the presence of a configured downlink assignment for this Serving Cell and deliver the stored HARQ information to the HARQ entity.

For each Serving Cell and each configured downlink assignment, if configured and activated, the MAC entity shall:

- 1> if the PDSCH duration of the configured downlink assignment does not overlap with the PDSCH duration of a downlink assignment received on the PDCCH for this Serving Cell:
  - 2> instruct the physical layer to receive, in this PDSCH duration, transport block on the DL-SCH according to the configured downlink assignment and to deliver it to the HARQ entity;
  - 2> set the HARQ Process ID to the HARQ Process ID associated with this PDSCH duration;
  - 2> consider the NDI bit to have been toggled;

- 2> indicate the presence of a configured downlink assignment and deliver the stored HARQ information to the HARQ entity.

For configured downlink assignments, the HARQ Process ID associated with the slot where the DL transmission starts is derived from the following equation:

$$\text{HARQ Process ID} = [\text{floor}(\text{CURRENT\_slot} \times 10 / (\text{numberOfSlotsPerFrame} \times \text{semiPersistSchedIntervalDL}))] \bmod \text{nrofHARQ-Processes}$$

where  $\text{CURRENT\_slot} = [(\text{SFN} \times \text{numberOfSlotsPerFrame}) + \text{slot number in the frame}]$  and  $\text{numberOfSlotsPerFrame}$  refers to the number of consecutive slots per frame as specified in TS 38.211 [8].

When the MAC entity needs to read BCCH, the MAC entity may, based on the scheduling information from RRC:

- 1> if a downlink assignment for this PDCCH occasion has been received on the PDCCH for the SI-RNTI;
- 2> indicate a downlink assignment and redundancy version for the dedicated broadcast HARQ process to the HARQ entity.

[TS 38.321, clause 5.3.2.2]

When a transmission takes place for the HARQ process, one or more (in case of downlink spatial multiplexing) TBs and the associated HARQ information are received from the HARQ entity.

For each received TB and associated HARQ information, the HARQ process shall:

- 1> if the NDI, when provided, has been toggled compared to the value of the previous received transmission corresponding to this TB; or
- 1> if the HARQ process is equal to the broadcast process, and this is the first received transmission for the TB according to the system information schedule indicated by RRC; or
- 1> if this is the very first received transmission for this TB (i.e. there is no previous NDI for this TB):
  - 2> consider this transmission to be a new transmission.
- 1> else:
  - 2> consider this transmission to be a retransmission.

The MAC entity then shall:

- 1> if this is a new transmission:
  - 2> attempt to decode the received data.
- 1> else if this is a retransmission:
  - 2> if the data for this TB has not yet been successfully decoded:
    - 3> instruct the physical layer to combine the received data with the data currently in the soft buffer for this TB and attempt to decode the combined data.
- 1> if the data which the MAC entity attempted to decode was successfully decoded for this TB; or
- 1> if the data for this TB was successfully decoded before:
  - 2> if the HARQ process is equal to the broadcast process:
    - 3> deliver the decoded MAC PDU to upper layers.
  - 2> else if this is the first successful decoding of the data for this TB:
    - 3> deliver the decoded MAC PDU to the disassembly and demultiplexing entity.
- 1> else:

- 2> instruct the physical layer to replace the data in the soft buffer for this TB with the data which the MAC entity attempted to decode;
- 1> if the HARQ process is associated with a transmission indicated with a Temporary C-RNTI and the Contention Resolution is not yet successful (see subclause 5.1.5); or
- 1> if the HARQ process is equal to the broadcast process; or
- 1> if the *timeAlignmentTimer*, associated with the TAG containing the Serving Cell on which the HARQ feedback is to be transmitted, is stopped or expired:
  - 2> not instruct the physical layer to generate acknowledgement(s) of the data in this TB.
- 1> else:
  - 2> instruct the physical layer to generate acknowledgement(s) of the data in this TB.

The MAC entity shall ignore NDI received in all downlink assignments on PDCCH for its Temporary C-RNTI when determining if NDI on PDCCH for its C-RNTI has been toggled compared to the value in the previous transmission.

[TS 38.321, clause 6.1.2]

A MAC PDU consists of one or more MAC subPDUs. Each MAC subPDU consists of one of the following:

- A MAC subheader only (including padding);
- A MAC subheader and a MAC SDU;
- A MAC subheader and a MAC CE;
- A MAC subheader and padding.

The MAC SDUs are of variable sizes.

Each MAC subheader corresponds to either a MAC SDU, a MAC CE, or padding.

A MAC subheader except for fixed sized MAC CE and padding consists of the four header fields R/F/LCID/L. A MAC subheader for fixed sized MAC CE and padding consists of the two header fields R/LCID.

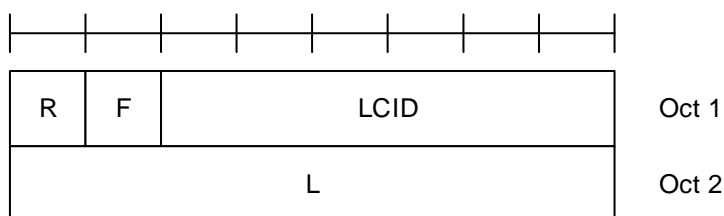

**Figure 6.1.2-1: R/F/LCID/L MAC subheader with 8-bit L field**

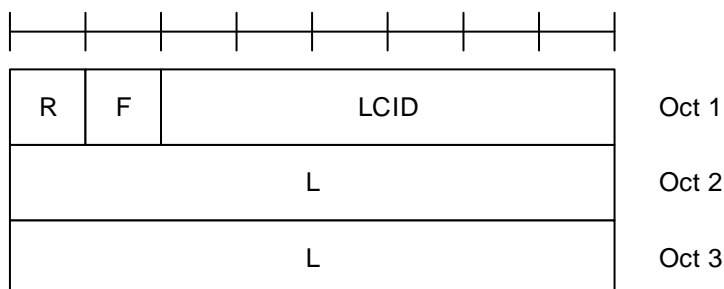

**Figure 6.1.2-2: R/F/LCID/L MAC subheader with 16-bit L field**

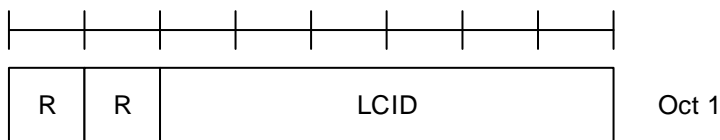

Figure 6.1.2-3: R/LCID MAC subheader

MAC CEs are placed together. DL MAC subPDU(s) with MAC CE(s) is placed before any MAC subPDU with MAC SDU and MAC subPDU with padding as depicted in Figure 6.1.2-4. UL MAC subPDU(s) with MAC CE(s) is placed after all the MAC subPDU(s) with MAC SDU and before the MAC subPDU with padding in the MAC PDU as depicted in Figure 6.1.2-5. The size of padding can be zero.

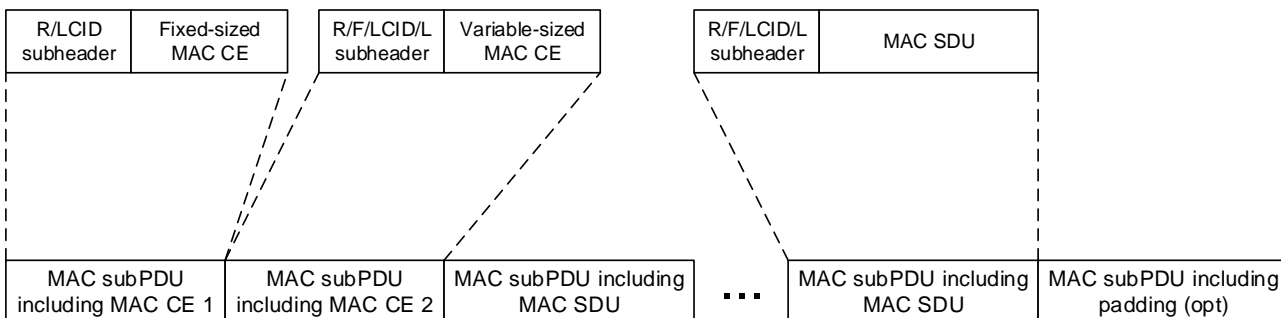

Figure 6.1.2-4: Example of a DL MAC PDU

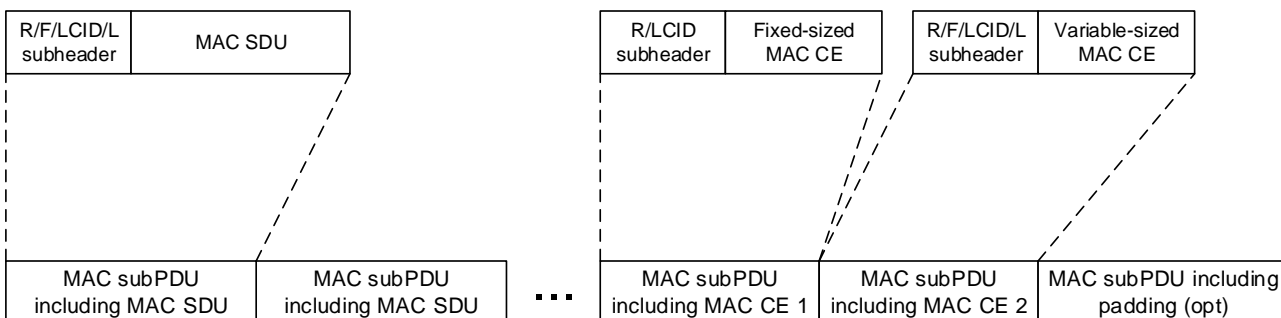

Figure 6.1.2-5: Example of a UL MAC PDU

A maximum of one MAC PDU can be transmitted per TB per MAC entity.

7.1.1.2.1.3 Test description

7.1.1.2.1.3.1 Pre-test conditions

Same Pre-test conditions as in clause 7.1.1.0 except that set to return no data in uplink and parameters as in Table 7.1.1.2.1.3.1-1.

Table 7.1.1.2.1.3.1-1: MAC Parameters

nrofHARQ-ProcessesForPDSCH	n16
----------------------------	-----

7.1.1.2.1.3.2 Test procedure sequence

**Table 7.1.1.2.1.3.2-1: Main behaviour**

St	Procedure	Message Sequence		TP	Verdict
		U - S	Message		
1	SS transmits a downlink assignment addressed to the C-RNTI assigned to the UE	<--	(PDCCH (C-RNTI))	-	-
2	SS transmits in the indicated downlink assignment a MAC PDU including a RLC PDU with poll bit not set.	<--	MAC PDU	-	-
3	Check: Does the UE transmit an HARQ ACK on PUCCH?	-->	HARQ ACK	1	P
4	SS transmits a downlink assignment to including a C-RNTI different from the assigned to the UE	<--	(PDCCH (unknown C-RNTI))	-	-
5	SS transmits in the indicated downlink assignment a RLC PDU in a MAC PDU including a RLC PDU with poll bit not set.	<--	MAC PDU	-	-
6	Check: Does the UE send any HARQ ACK/NACK on PUCCH?	-->	HARQ ACK/NACK	2	F
-	EXCEPTION: Steps 7 to 10 are run repeated using test parameter values as given for each iteration in table 7.1.1.2.1.3.2.-2.	-	-	-	-
7	The SS indicates a new transmission on PDCCH and transmits a MAC PDU including a RLC PDU with poll bit not set, with content set so that UE could not successfully decode the data from its soft buffer. (Note 1)	<--	MAC PDU	-	-
8	Check: Does the UE transmit a HARQ NACK?	-->	HARQ NACK	3	P
-	EXCEPTION: Step 9 shall be repeated till HARQ ACK is received at step 10 or until HARQ retransmission count = 4 is reached for MAC PDU at step 9 (Note 2).	-	-	-	-
9	The SS indicates a retransmission on PDCCH and transmits the same MAC PDU like step 7 (Note 1).	<--	MAC PDU	-	-
-	EXCEPTION: Up to [3] HARQ NACK from the UE should be allowed at step 10 (Note 2).	-	-	-	-
10	Check: Does the UE send a HARQ ACK?	-->	HARQ ACK	4	P
11	The SS transmits a MAC PDU containing three MAC sub PDUs each containing a MAC SDU(RLC PDU) that is of 260 bytes (16 bits L field used) and a padding MAC sub PDU at the end. The third RLC PDU contained will have poll bit set.	<--	MAC PDU	-	-
12	Check: Does the UE transmit a MAC PDU containing an RLC STATUS PDU acknowledging the reception of all the AMD PDUs in step 11?	-->	MAC PDU (RLC STATUS PDU )	5	P
13	The SS transmits a MAC PDU containing three MAC sub PDUs each containing a MAC SDU(RLC PDU) that is of 128 bytes (8 bits L field used) and a padding MAC sub PDU at the end. The third RLC PDU contained will have poll bit set.	<--	MAC PDU	-	-
14	Check: Does the UE transmit a MAC PDU containing an RLC STATUS PDU acknowledging the reception of all the AMD PDUs in step 13?	-->	MAC PDU (RLC STATUS PDU )	6	P
15	The SS transmits a MAC PDU containing one MAC sub PDU containing a MAC SDU(RLC PDU) that is of [128] bytes (8 bits L field used) and no padding MAC sub PDU at the end. The RLC PDU contained will have poll bit set.	<--	MAC PDU	-	-
16	Check: Does the UE transmit a MAC PDU containing an RLC STATUS PDU acknowledging the reception of the AMD PDU in step 15?	-->	MAC PDU (RLC STATUS PDU )	7	P

17	The SS transmits a MAC PDU containing one MAC sub PDU containing a MAC SDU(RLC PDU) that is of [128] bytes (8 bits L field used), one MAC sub PDU containing a MAC SDU(RLC PDU) that is of [260] bytes (16 bits L field used) and no padding MAC sub PDU at the end. The second RLC PDU contained will have poll bit set.	<--	MAC PDU	-	-
18	Check: Does the UE transmit a MAC PDU containing an RLC STATUS PDU acknowledging the reception of all the AMD PDUs in step 17?	-->	MAC PDU (RLC STATUS PDU )	8	P
<p>Note 1: SS should transmit this PDU so as to ensure at least one NACK.</p> <p>Note 2: The value 4 for the maximum number of HARQ retransmissions has been chosen based on an assumption that, given the radio conditions used in this test case, a UE soft combiner implementation should have sufficient retransmissions to be able to successfully decode the data in its soft buffer.</p>					

Table 7.1.1.2.1.3.2-2: Test Parameters

Iteration	DL HARQ process (X)
K=1 to 16	X=K-1

## 7.1.1.2.1.3.3 Specific message contents

None.

## 7.1.1.2.2 Correct Handling of DL HARQ process PDSCH Aggregation

## 7.1.1.2.2.1 Test Purpose (TP)

(1)

```

with { UE in RRC_CONNECTED state and pdsch-AggragationFactor > 1 }
ensure that {
  when { UE receives downlink assignment on the PDCCH for the UE's C-RNTI and receives data in the
associated slot and successive pdsch-AggragationFactor - 1 HARQ retransmissions within a bundle and
UE performs HARQ operation }
  then { UE sends a HARQ feedback on the HARQ process }
}

```

## 7.1.1.2.2.2 Conformance requirements

References: The conformance requirements covered in the current TC are specified in: TS 38.321, clauses 5.3.1, 5.3.2.1 and 5.3.2.2, TS 38.214, clause 5.1.2.1.

[TS 38.321, clause 5.3.1]

Downlink assignments received on the PDCCH both indicate that there is a transmission on a DL-SCH for a particular MAC entity and provide the relevant HARQ information.

When the MAC entity has a C-RNTI, Temporary C-RNTI, or CS-RNTI, the MAC entity shall for each PDCCH occasion during which it monitors PDCCH and for each Serving Cell:

- 1> if a downlink assignment for this PDCCH occasion and this Serving Cell has been received on the PDCCH for the MAC entity's C-RNTI, or Temporary C-RNTI:
  - 2> if this is the first downlink assignment for this Temporary C-RNTI:
    - 3> consider the NDI to have been toggled.
  - 2> if the downlink assignment is for the MAC entity's C-RNTI, and if the previous downlink assignment indicated to the HARQ entity of the same HARQ process was either a downlink assignment received for the MAC entity's CS-RNTI or a configured downlink assignment:
    - 3> consider the NDI to have been toggled regardless of the value of the NDI.

- 2> indicate the presence of a downlink assignment and deliver the associated HARQ information to the HARQ entity.
- 1> else if a downlink assignment for this PDCCH occasion has been received for this Serving Cell on the PDCCH for the MAC entity's CS-RNTI:
  - 2> if the NDI in the received HARQ information is 1:
    - 3> consider the NDI for the corresponding HARQ process not to have been toggled;
    - 3> indicate the presence of a downlink assignment for this Serving Cell and deliver the associated HARQ information to the HARQ entity.
  - 2> if the NDI in the received HARQ information is 0:
    - 3> if PDCCH contents indicate SPS deactivation:
      - 4> clear the configured downlink assignment for this Serving Cell (if any);
      - 4> if the timeAlignmentTimer associated with the PTAG is running:
        - 5> indicate a positive acknowledgement for the SPS deactivation to the physical layer.
    - 3> else if PDCCH content indicates SPS activation:
      - 4> store the downlink assignment for this Serving Cell and the associated HARQ information as configured downlink assignment;
      - 4> initialise or re-initialise the configured downlink assignment for this Serving Cell to start in the associated PDSCH duration and to recur according to rules in subclause 5.8.1;
      - 4> set the HARQ Process ID to the HARQ Process ID associated with this PDSCH duration;
      - 4> consider the NDI bit for the corresponding HARQ process to have been toggled;
      - 4> indicate the presence of a configured downlink assignment for this Serving Cell and deliver the stored HARQ information to the HARQ entity.

For each Serving Cell and each configured downlink assignment, if configured and activated, the MAC entity shall:

- 1> if the PDSCH duration of the configured downlink assignment does not overlap with the PDSCH duration of a downlink assignment received on the PDCCH for this Serving Cell:
  - 2> instruct the physical layer to receive, in this PDSCH duration, transport block on the DL-SCH according to the configured downlink assignment and to deliver it to the HARQ entity;
  - 2> set the HARQ Process ID to the HARQ Process ID associated with this PDSCH duration;
  - 2> consider the NDI bit to have been toggled;
  - 2> indicate the presence of a configured downlink assignment and deliver the stored HARQ information to the HARQ entity.

For configured downlink assignments, the HARQ Process ID associated with the slot where the DL transmission starts is derived from the following equation:

$$\text{HARQ Process ID} = [\text{floor}(\text{CURRENT\_slot} \times 10 / (\text{numberOfSlotsPerFrame} \times \text{periodicity}))] \text{ modulo } n_{\text{rofHARQ-Processes}}$$

where  $\text{CURRENT\_slot} = [(\text{SFN} \times \text{numberOfSlotsPerFrame}) + \text{slot number in the frame}]$  and  $\text{numberOfSlotsPerFrame}$  refers to the number of consecutive slots per frame as specified in TS 38.211 [8].

When the MAC entity needs to read BCCH, the MAC entity may, based on the scheduling information from RRC:

- 1> if a downlink assignment for this PDCCH occasion has been received on the PDCCH for the SI-RNTI;



- 2> indicate a downlink assignment and redundancy version for the dedicated broadcast HARQ process to the HARQ entity.

[TS 38.321, clause 5.3.2.1]

The MAC entity includes a HARQ entity for each Serving Cell, which maintains a number of parallel HARQ processes. Each HARQ process is associated with a HARQ process identifier. The HARQ entity directs HARQ information and associated TBs received on the DL-SCH to the corresponding HARQ processes (see subclause 5.3.2.2).

The number of parallel DL HARQ processes per HARQ entity is specified in TS 38.214 [7]. The dedicated broadcast HARQ process is used for BCCH.

The HARQ process supports one TB when the physical layer is not configured for downlink spatial multiplexing. The HARQ process supports one or two TBs when the physical layer is configured for downlink spatial multiplexing.

When the MAC entity is configured with *pdsch-AggregationFactor* > 1, the parameter *pdsch-AggregationFactor* provides the number of transmissions of a TB within a bundle of the dynamic downlink assignment. Bundling operation relies on the HARQ entity for invoking the same HARQ process for each transmission that is part of the same bundle. After the initial transmission, *pdsch-AggregationFactor* – 1 HARQ retransmissions follow within a bundle.

The MAC entity shall:

- 1> if a downlink assignment has been indicated:
  - 2> allocate the TB(s) received from the physical layer and the associated HARQ information to the HARQ process indicated by the associated HARQ information.
- 1> if a downlink assignment has been indicated for the broadcast HARQ process:
  - 2> allocate the received TB to the broadcast HARQ process.

[TS 38.321, clause 5.3.2.2]

When a transmission takes place for the HARQ process, one or two (in case of downlink spatial multiplexing) TBs and the associated HARQ information are received from the HARQ entity.

For each received TB and associated HARQ information, the HARQ process shall:

- 1> if the NDI, when provided, has been toggled compared to the value of the previous received transmission corresponding to this TB; or
- 1> if the HARQ process is equal to the broadcast process, and this is the first received transmission for the TB according to the system information schedule indicated by RRC; or
- 1> if this is the very first received transmission for this TB (i.e. there is no previous NDI for this TB):
  - 2> consider this transmission to be a new transmission.
- 1> else:
  - 2> consider this transmission to be a retransmission.

The MAC entity then shall:

- 1> if this is a new transmission:
  - 2> attempt to decode the received data.
- 1> else if this is a retransmission:
  - 2> if the data for this TB has not yet been successfully decoded:
    - 3> instruct the physical layer to combine the received data with the data currently in the soft buffer for this TB and attempt to decode the combined data.
- 1> if the data which the MAC entity attempted to decode was successfully decoded for this TB; or

- 1> if the data for this TB was successfully decoded before:
  - 2> if the HARQ process is equal to the broadcast process:
    - 3> deliver the decoded MAC PDU to upper layers.
  - 2> else if this is the first successful decoding of the data for this TB:
    - 3> deliver the decoded MAC PDU to the disassembly and demultiplexing entity.
- 1> else:
  - 2> instruct the physical layer to replace the data in the soft buffer for this TB with the data which the MAC entity attempted to decode.
- 1> if the HARQ process is associated with a transmission indicated with a Temporary C-RNTI and the Contention Resolution is not yet successful (see subclause 5.1.5); or
- 1> if the HARQ process is equal to the broadcast process; or
- 1> if the *timeAlignmentTimer*, associated with the TAG containing the Serving Cell on which the HARQ feedback is to be transmitted, is stopped or expired:
  - 2> not instruct the physical layer to generate acknowledgement(s) of the data in this TB.
- 1> else:
  - 2> instruct the physical layer to generate acknowledgement(s) of the data in this TB.

The MAC entity shall ignore NDI received in all downlink assignments on PDCCH for its Temporary C-RNTI when determining if NDI on PDCCH for its C-RNTI has been toggled compared to the value in the previous transmission.

[TS 38.214, clause 5.1.2.1]

When the UE is scheduled to receive PDSCH by a DCI, the *Time domain resource assignment* field value  $m$  of the DCI provides a row index  $m + 1$  to an allocation table. The determination of the used resource allocation table is defined in sub-clause 5.1.2.1.1. The indexed row defines the slot offset  $K_0$ , the start and length indicator *SLIV*, or directly the start symbol  $S$  and the allocation length  $L$ , and the PDSCH mapping type to be assumed in the PDSCH reception.

Given the parameter values of the indexed row:

- The slot allocated for the PDSCH is  $\left\lfloor n \cdot \frac{2^{\mu_{\text{PDSCH}}}}{2^{\mu_{\text{PDCCH}}}} \right\rfloor + K_0$ , where  $n$  is the slot with the scheduling DCI, and  $K_0$  is based on the numerology of PDSCH, and  $\mu_{\text{PDSCH}}$  and  $\mu_{\text{PDCCH}}$  are the subcarrier spacing configurations for PDSCH and PDCCH, respectively, and
- The starting symbol  $S$  relative to the start of the slot, and the number of consecutive symbols  $L$  counting from the symbol  $S$  allocated for the PDSCH are determined from the start and length indicator *SLIV*:
  - if  $(L-1) \leq 7$  then
 
$$SLIV = 14 \cdot (L-1) + S$$
  - else
 
$$SLIV = 14 \cdot (14-L+1) + (14-1-S)$$
  - where  $0 < L \leq 14 - S$ , and
- The PDSCH mapping type is set to Type A or Type B as defined in sub-clause 7.4.1.1.2 of [4, TS 38.211].

The UE shall consider the  $S$  and  $L$  combinations defined in table 5.1.2.1-1 as valid PDSCH allocations:

Table 5.1.2.1-1: Valid *S* and *L* combinations

PDSCH mapping type	Normal cyclic prefix			Extended cyclic prefix		
	<i>S</i>	<i>L</i>	<i>S+L</i>	<i>S</i>	<i>L</i>	<i>S+L</i>
Type A	{0,1,2,3} (Note 1)	{3,...,14}	{3,...,14}	{0,1,2,3} (Note 1)	{3,...,12}	{3,...,12}
Type B	{0,...,12}	{2,4,7}	{2,...,14}	{0,...,10}	{2,4,6}	{2,...,12}

Note 1: *S* = 3 is applicable only if *dmrs-TypeA-Position* = 3

When the UE is configured with *aggregationFactorDL* > 1, the same symbol allocation is applied across the *aggregationFactorDL* consecutive slots. The UE may expect that the TB is repeated within each symbol allocation among each of the *aggregationFactorDL* consecutive slots and the PDSCH is limited to a single transmission layer. The redundancy version to be applied on the *n*<sup>th</sup> transmission occasion of the TB is determined according to table 5.1.2.1-2.

Table 5.1.2.1-2: Applied redundancy version when *aggregationFactorDL* > 1

<i>rvid</i> indicated by the DCI scheduling the PDSCH	<i>rvid</i> to be applied to <i>n</i> <sup>th</sup> transmission occasion			
	<i>n mod 4</i> = 0	<i>n mod 4</i> = 1	<i>n mod 4</i> = 2	<i>n mod 4</i> = 3
0	0	2	3	1
2	2	3	1	0
3	3	1	0	2
1	1	0	2	3

If the UE procedure for determining slot configuration as defined in Subclause 11.1 of [6, TS 38.213] determines symbol of a slot allocated for PDSCH as uplink symbols, the transmission on that slot is omitted for multi-slot PDSCH transmission.

The UE is not expected to receive a PDSCH with mapping type A in a slot, if the PDCCH scheduling the PDSCH was received in the same slot and was not contained within the first three symbols of the slot.

The UE is not expected to receive a PDSCH with mapping type B in a slot, if the first symbol of the PDCCH scheduling the PDSCH was received in a later symbol than the first symbol indicated in the PDSCH time domain resource allocation.

7.1.1.2.2.3 Test description

7.1.1.2.2.3.1 Pre-test conditions

Same Pre-test conditions as in clause 7.1.1.0 except that set to return no data in uplink and parameters as in Table 7.1.1.2.2.3.1-1.

Table 7.1.1.2.2.3.1-1: MAC Parameters

<i>nrofHARQ-ProcessesForPDSCH</i>	n16
-----------------------------------	-----

7.1.1.2.2.3.2 Test procedure sequence

**Table 7.1.1.2.2.3.2-1: Main behaviour**

St	Procedure	Message Sequence		TP	Verdict
		U - S	Message		
1	SS transmits in the indicated downlink assignment an RRCReconfiguration.	<--	-	-	-
2	UE transmits RRCReconfigurationComplete message to the SS.	-->	-	-	-
3	The SS transmits a downlink assignment addressed to the C-RNTI assigned to the UE, the rv_idx is 0.	<--	-	-	-
4	The SS transmits in the indicated downlink assignment a MAC PDU including a RLC PDU, The CRC is calculated in such a way, it will result in CRC error on UE side.	<--	MAC PDU	-	-
5	In the following 3 consecutive slots, the SS transmits on the same downlink assignment a MAC PDU including a RLC PDU, The CRC is calculated in such a way, it will result in CRC error on UE side. (Note 1)	<--	MAC PDU	-	-
6	Check: Does the UE transmit a HARQ NACK?	-->	HARQ NACK	1	P
7	The SS transmits a downlink assignment addressed to the C-RNTI assigned to the UE, the rv_idx is 0.	<--	-	-	-
8	The SS transmits in the indicated downlink assignment a MAC PDU including a RLC PDU, The CRC is calculated in such a way, it will result in CRC pass on UE side.	<--	MAC PDU	-	-
9	In the following 3 consecutive slots, the SS transmits on the same downlink assignment a MAC PDU including a RLC PDU, The CRC is calculated in such a way, it will result in CRC pass on UE side. (Note 1)	<--	MAC PDU	-	-
10	Check: Does the UE transmit a HARQ ACK?	-->	HARQ ACK	1	P
Note 1: For <i>aggregationFactorDL</i> =4, the PDSCH will repeat in following 4-1=3 slots with same resource allocation but different redundancy version.					

7.1.1.2.2.3.3 Specific message contents

**Table 7.1.1.2.2.3.3-1: RRCReconfiguration (step 1, Table 7.1.1.2.2.3.2-1)**

Derivation Path: 38.508-1 [4], Table [4.6.1-3]			
Information Element	Value/remark	Comment	Condition
RRCReconfiguration ::= SEQUENCE {			
criticalExtensions CHOICE {			
rrcReconfiguration SEQUENCE {			
secondaryCellGroup	CellGroupConfig	OCTET STRING (CONTAINING CellGroupConfig)	SA
}			
}			
}			

Table 7.1.1.2.2.3.3-2: cellGroupConfig (Table 7.1.1.2.2.3.3-1: RRCReconfiguration)

Derivation Path: 38.508-1 [4], Table [4.6.3-13]			
Information Element	Value/remark	Comment	Condition
cellGroupConfig ::= SEQUENCE {			
cellGroupId	1		
spCellConfig SEQUENCE {			
spCellConfigDedicated SEQUENCE {			
servingCellConfig SEQUENCE {			
initialDownlinkBWP SEQUENCE {			
pdsch-Config SEQUENCE {			
pdsch-AggregationFactor	n4		
}			
}			
}			
}			
}			

### 7.1.1.3 Uplink Data Transfer

#### 7.1.1.3.1 Correct Handling of UL MAC PDU / Assignment / HARQ process

##### 7.1.1.3.1.1 Test Purpose (TP)

(1)

```
with { UE in RRC_CONNECTED state }
ensure that {
  when { UE receives for a Slot an uplink grant with valid C-RNTI }
  then { UE transmits data and associated HARQ information to the HARQ entity for this Slot }
}
```

(2)

```
with { UE in RRC_CONNECTED state }
ensure that {
  when { SS transmits for a Slot an uplink grant with not allocated C-RNTI }
  then { UE does not transmits data and associated HARQ information to the HARQ entity for this Slot }
}
```

(3)

```
with { UE in RRC_CONNECTED state }
ensure that {
  when { UE receives an UL Grant with toggled NDI and has data available for transmission }
  then { UE transmits a new MAC PDU }
}
```

(4)

```
with { UE in RRC_CONNECTED state and having transmitted a MAC PDU on a HARQ process }
ensure that {
  when { UE receives an uplink grant on PDCCH for the next Slot corresponding to the HARQ process with old NDI not toggled }
  then { UE performs an adaptive retransmission of the MAC PDU with redundancy version as received on PDCCH }
}
```

(5)

```
with { UE in E-UTRA RRC_CONNECTED state }
ensure that {
  when { UE receives an uplink grant on PDCCH for the next Slot corresponding to the HARQ process with toggled NDI, and data is not available for transmission }
  then { UE transmits any MAC Padding PDU }
}
```

(6)

```

with { UE in RRC_CONNECTED state }
ensure that {
  when { UE has a MAC SDU to be transmitted that is smaller or equal to 256 bytes }
  then { UE sets F field to 0 and includes 8 bit L field in the MAC sub PDU }
}

```

(7)

```

with { UE in RRC_CONNECTED state }
ensure that {
  when { UE has a MAC SDU to be transmitted that is larger than 256 bytes }
  then { UE sets F field to 1 and includes 16 bit L field in the MAC sub PDU }
}

```

(8)

```

with { UE in E-UTRA RRC_CONNECTED state }
ensure that {
  when { UE has to insert padding in a MAC PDU }
  then { UE inserts the last MAC sub PDU as a padding sub PDU }
}

```

#### 7.1.1.3.1.2 Conformance requirements

References: The conformance requirements covered in the present TC are specified in: TS 38.321, clauses 5.4.1, 5.4.2.1, 5.4.2.2 and 6.1.2. Unless otherwise stated these are Rel-15 requirements.

[TS 38.322, clause 5.4.1]

Uplink grant is either received dynamically on the PDCCH, in a Random Access Response, or configured semi-persistently by RRC. The MAC entity shall have an uplink grant to transmit on the UL-SCH. To perform the requested transmissions, the MAC layer receives HARQ information from lower layers.

If the MAC entity has a C-RNTI, a Temporary C-RNTI or CS-RNTI, the MAC entity shall for each PDCCH occasion and for each Serving Cell belonging to a TAG that has a running *timeAlignmentTimer* and for each grant received for this PDCCH occasion:

- 1> if an uplink grant for this Serving Cell has been received on the PDCCH for the MAC entity's C-RNTI or Temporary C-RNTI; or
- 1> if an uplink grant has been received in a Random Access Response:
  - 2> if the uplink grant is for MAC entity's C-RNTI and if the previous uplink grant delivered to the HARQ entity for the same HARQ process was either an uplink grant received for the MAC entity's CS-RNTI or a configured uplink grant:
    - 3> consider the NDI to have been toggled for the corresponding HARQ process regardless of the value of the NDI.
    - 2> deliver the uplink grant and the associated HARQ information to the HARQ entity.
- 1> else if an uplink grant for this PDCCH occasion has been received for this serving cell on the PDCCH for the MAC entity's CS-RNTI:
  - 2> if the NDI in the received HARQ information is 1:
    - 3> consider the NDI for the corresponding HARQ process not to have been toggled;
    - 3> stop the *ConfiguredGrantTimer* for the corresponding HARQ process, if running;
    - 3> deliver the uplink grant and the associated HARQ information to the HARQ entity.
  - 2> else if the NDI in the received HARQ information is 0:
    - 3> if PDCCH contents indicate configured grant Type 2 deactivation:

- 4> trigger configured grant confirmation.
- 3> else if PDCCH contents indicate configured grant Type 2 activation:
  - 4> trigger configured grant confirmation;
  - 4> store the uplink grant for this serving cell and the associated HARQ information as configured uplink grant;
  - 4> initialise or re-initialise the configured uplink grant for this serving cell to start in the associated PUSCH duration and to recur according to rules in subclause 5.8.2;
  - 4> set the HARQ Process ID to the HARQ Process ID associated with this PUSCH duration;
  - 4> consider the NDI bit for the corresponding HARQ process to have been toggled;
  - 4> stop the *ConfiguredGrantTimer* for the corresponding HARQ process, if running;
  - 4> deliver the configured uplink grant and the associated HARQ information to the HARQ entity.

For each Serving Cell and each configured uplink grant, if configured and activated, the MAC entity shall:

- 1> set the HARQ Process ID to the HARQ Process ID associated with this PUSCH duration;
- 1> if the *ConfiguredGrantTimer* for the corresponding HARQ process is not running:
  - 2> consider the NDI bit for the corresponding HARQ process to have been toggled;
  - 2> deliver the configured uplink grant and the associated HARQ information to the HARQ entity.

NOTE 1: For the same serving cell, an uplink grant addressed to C-RNTI shall override a configured uplink grant in case of overlap in time domain.

For configured uplink grants, the HARQ Process ID associated with this symbol is derived from the following equation:

$$\text{HARQ Process ID} = [\text{floor}(\text{CURRENT\_symbol}/\text{periodicity})] \text{ modulo } \text{numberOfConfGrant-Processes}$$

where  $\text{CURRENT\_symbol} = (\text{SFN} * \text{numberOfSlotsPerFrame} * \text{numberOfSymbolsPerSlot} + \text{slot number in the frame} * \text{numberOfSymbolsPerSlot} + \text{symbol number in the slot})$ , and *numberOfSlotsPerFrame* and *numberOfSymbolsPerSlot* refer to the number of consecutive slots per frame and the number of consecutive symbols per slot, respectively as specified in TS 38.211 [8].

NOTE 2: *CURRENT\_symbol* refers to the symbol index of the first transmission of a repetition bundle that takes place. [TS 36.322, clause 5.4.2.1]

The MAC entity includes a HARQ entity for each Serving Cell with configured uplink (including the case when it is configured with *supplementaryUplink*), which maintains a number of parallel HARQ processes.

The number of parallel UL HARQ processes per HARQ entity is specified in TS 38.214 [7].

Each HARQ process supports one TB.

Each HARQ process is associated with a HARQ process identifier. For UL transmission with UL grant in RA Response, HARQ process identifier 0 is used.

When repetition is configured with  $\text{repK} > 1$ , the parameter *repK* provides the number of repetitions of a TB within a bundle. Repetition operation relies on the HARQ entity for invoking the same HARQ process for each transmission that is part of the same bundle. Within a bundle HARQ retransmissions are non-adaptive and triggered without waiting for feedback from previous transmissions according to *repK*.

For each uplink grant, the HARQ entity shall:

- 1> identify the HARQ process(es) associated with this grant, and for each identified HARQ process:
  - 2> if the received grant was not addressed to a Temporary C-RNTI on PDCCH, and the NDI provided in the associated HARQ information has been toggled compared to the value in the previous transmission of this TB of this HARQ process; or

- 2> if the uplink grant was received on PDCCH for the C-RNTI and the HARQ buffer of the identified process is empty; or
- 2> if the uplink grant was received in a Random Access Response:
  - 3> if there is a MAC PDU in the Msg3 buffer and the uplink grant was received in a Random Access Response:
    - 4> obtain the MAC PDU to transmit from the Msg3 buffer.
  - 3> else:
    - 4> obtain the MAC PDU to transmit from the "Multiplexing and assembly" entity, if any;
  - 3> if a MAC PDU to transmit has been obtained:
    - 4> deliver the MAC PDU and the uplink grant and the HARQ information of the TB to the identified HARQ process;
    - 4> instruct the identified HARQ process to trigger a new transmission.
    - 4> if the uplink grant is addressed to CS-RNTI or the uplink grant is a configured uplink grant:
      - 5> start or restart the *ConfiguredGrantTimer*, if configured, for the corresponding HARQ process when the transmission is performed.
- 2> else:
  - 3> if the uplink grant received on PDCCH was addressed to CS-RNTI and if the HARQ buffer of the identified process is empty:
    - 4> ignore the uplink grant.
  - 3> else:
    - 4> deliver the uplink grant and the HARQ information (redundancy version) of the TB to the identified HARQ process;
    - 4> instruct the identified HARQ process to trigger a retransmission;
    - 4> if the uplink grant is addressed to CS-RNTI or the uplink grant is a configured uplink grant:
      - 5> start or restart the *ConfiguredGrantTimer*, if configured, for the corresponding HARQ process when the transmission is performed.

When determining if NDI has been toggled compared to the value in the previous transmission the MAC entity shall ignore NDI received in all uplink grants on PDCCH for its Temporary C-RNTI.

[TS 38.322, clause 5.4.2.2]

Each HARQ process is associated with a HARQ buffer.

New transmissions are performed on the resource and with the MCS indicated on either PDCCH, Random Access Response, or RRC. Retransmissions are performed on the resource and, if provided, with the MCS indicated on PDCCH.

If the HARQ entity requests a new transmission for a TB, the HARQ process shall:

- 1> store the MAC PDU in the associated HARQ buffer;
- 1> store the uplink grant received from the HARQ entity;
- 1> generate a transmission as described below.

If the HARQ entity requests a retransmission for a TB, the HARQ process shall:

- 1> store the uplink grant received from the HARQ entity;



1> generate a transmission as described below.

To generate a transmission for a TB, the HARQ process shall:

1> if the MAC PDU was obtained from the Msg3 buffer; or

1> if there is no measurement gap at the time of the transmission and, in case of retransmission, the retransmission does not collide with a transmission for a MAC PDU obtained from the Msg3 buffer:

2> instruct the physical layer to generate a transmission according to the stored uplink grant.

[TS 38.322, clause 6.1.2]

A MAC PDU consists of one or more MAC subPDUs. Each MAC subPDU consists of one of the following:

- A MAC subheader only (including padding);
- A MAC subheader and a MAC SDU;
- A MAC subheader and a MAC CE;
- A MAC subheader and padding.

The MAC SDUs are of variable sizes.

Each MAC subheader corresponds to either a MAC SDU, a MAC CE, or padding.

A MAC subheader except for fixed sized MAC CE and padding consists of the four header fields R/F/LCID/L. A MAC subheader for fixed sized MAC CE and padding consists of the two header fields R/LCID.

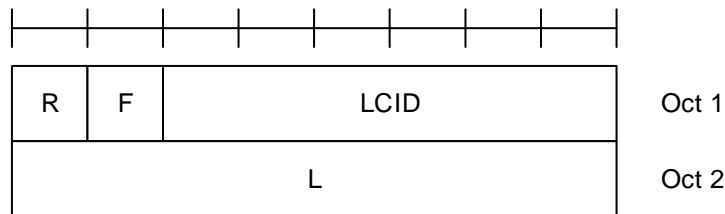

**Figure 6.1.2-1: R/F/LCID/L MAC subheader with 8-bit L field**

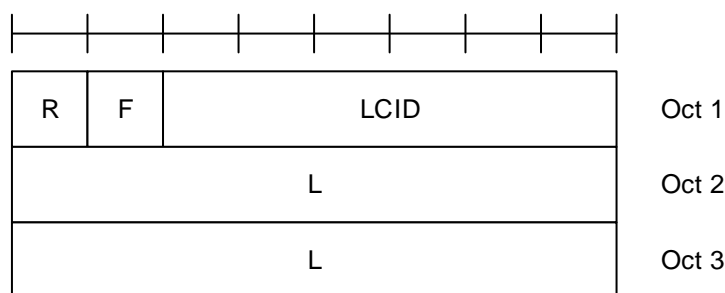

**Figure 6.1.2-2: R/F/LCID/L MAC subheader with 16-bit L field**

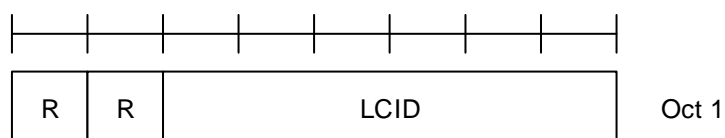

**Figure 6.1.2-3: R/LCID MAC subheader**

MAC CEs are placed together. DL MAC subPDU(s) with MAC CE(s) is placed before any MAC subPDU with MAC SDU and MAC subPDU with padding as depicted in Figure 6.1.2-4. UL MAC subPDU(s) with MAC CE(s) is placed after all the MAC subPDU(s) with MAC SDU and before the MAC subPDU with padding in the MAC PDU as depicted in Figure 6.1.2-5. The size of padding can be zero.

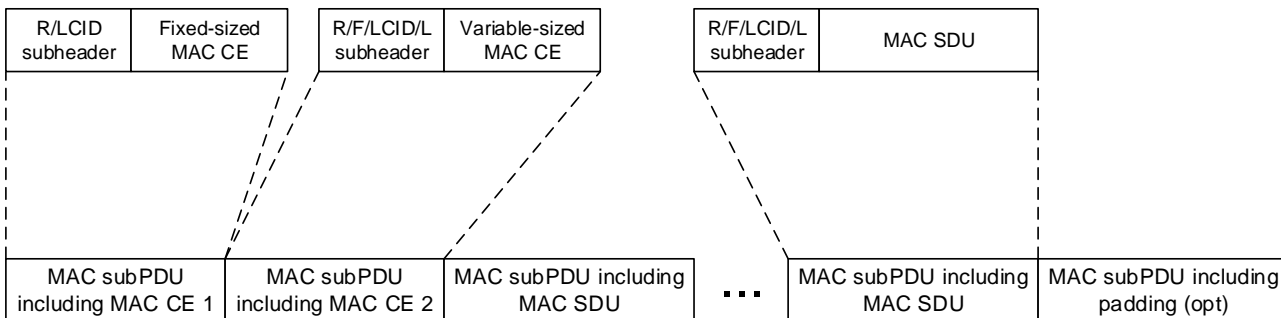

Figure 6.1.2-4: Example of a DL MAC PDU

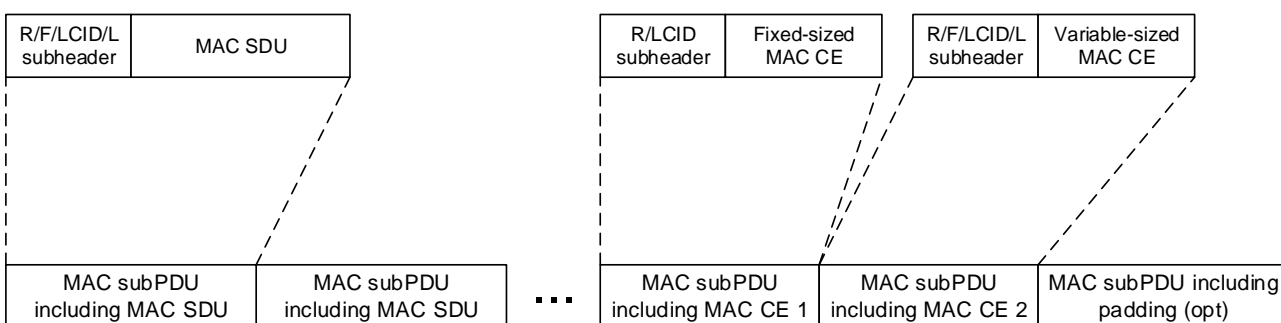

Figure 6.1.2-5: Example of a UL MAC PDU

A maximum of one MAC PDU can be transmitted per TB per MAC entity.

7.1.1.3.1.3 Test description

7.1.1.3.1.3.1 Pre-test conditions

Same Pre-test conditions as in clause 7.1.1.0.

## 7.1.1.3.1.3.2 Test procedure sequence

Table 7.1.1.3.1.3.2-1: Main behaviour

St	Procedure	Message Sequence		TP	Verdict
		U - S	Message		
1	The SS ignores scheduling requests and does not allocate any uplink grant.	-	-	-	-
2	SS transmits a MAC PDU including a RLC SDU	<--	MAC PDU	-	-
-	EXCEPTION: Step 3 runs in parallel with behaviour in table 7.1.1.3.1.3.2-2	-	-	-	-
3	For 400 ms SS transmits an UL Grant every 10 ms , allowing the UE to return the RLC SDU as received in step 2, on PDCCH, but with the C-RNTI different from the C-RNTI assigned to the UE.	<--	(UL Grant (unknown C-RNTI))	-	-
4	Check: Does the UE transmit a MAC PDU corresponding to grant in step 3?	-->	MAC PDU	2	F
5	SS transmits an UL Grant, allowing the UE to return the RLC SDU as received in step 2, on PDCCH with the C-RNTI assigned to the UE.	<--	(UL Grant (C-RNTI))	-	-
6	Check: Does the UE transmit a MAC PDU corresponding to grant in step 6?	-->	MAC PDU	1	P
7	The SS Transmits a valid MAC PDU containing RLC PDU	<--	MAC PDU	-	-
8	The SS allocates an UL Grant for one HARQ process X, sufficient for one RLC SDU to be looped back in a Slot, and NDI indicates new transmission redundancy version to be used as 0	<--	Uplink Grant	-	-
9	Check: Does the UE transmit a MAC PDU including one RLC SDU, in HARQ process X?	-->	MAC PDU	3	P
10	The SS transmits an UL grant corresponding to slot for HARQ process X, with NDI not toggled and redundancy version to be used as 1	<--	Uplink Grant	-	-
11	Check: Does the UE retransmit the MAC PDU in for HARQ process X, using redundancy version1?	-->	MAC PDU	4	P
12	The SS transmits an UL grant corresponding to SLOT for HARQ process X, with NDI toggled and redundancy version to be used as 2	<--	Uplink Grant	-	-
13	Check: Does the UE retransmit the MAC PDU containing padding for HARQ process X, using redundancy version 2?	-->	MAC PDU	5	P
14	SS transmits a MAC PDU including a RLC PDU of size 128 bytes	<--	MAC PDU	-	-
15	The SS transmits an UL Grant, allowing the UE to return the RLC SDU as received in step 14 and padding.	<--	(UL Grant (C-RNTI))	-	-
16	Check: Does the UE transmit a MAC PDU corresponding to grant in step 14 with F field set to 0 and includes 8 bit L field in the MAC sub PDU and includes a padding sub PDU at end?	-->	MAC PDU	6,8	P
17	SS transmits a MAC PDU including a RLC PDU of size 512 bytes	<--	MAC PDU	-	-
18	The SS transmits an UL Grant, allowing the UE to return the RLC SDU as received in step 17 and padding.	<--	(UL Grant (C-RNTI))	-	-
19	Check: Does the UE transmit a MAC PDU corresponding to grant in step 17 with F field set to 1 and includes 8 bit L field in the MAC sub PDU and includes a padding sub PDU at end?	-->	MAC PDU	7,8	P

**Table 7.1.1.3.1.3.2-2: Parallel behaviour**

St	Procedure	Message Sequence		TP	Verdict
		U - S	Message		
1	UE transmits a Scheduling Request.	-->	(SR)	-	-

## 7.1.1.3.1.3.3 Specific message contents

**Table 7.1.1.3.1.3.3-1: MAC-CellGroupConfig (preamble)**

Derivation Path: TS 38.508-1 [4], Table 4.6.3-49			
Information Element	Value/remark	Comment	Condition
MAC-CellGroupConfig ::= SEQUENCE {			
tag-ToAddModList SEQUENCE (SIZE (1..maxNrofTAGs)) OF SEQUENCE {	1 entry		
timeAlignmentTimer	infinity		
}			
}			

## 7.1.1.3.2 Logical channel prioritization handling

## 7.1.1.3.2.1 Test Purpose (TP)

(1)

```

with {UE in RRC_CONNECTED state}
ensure that {
  when { UE is sending data on the uplink }
    then { UE serves the logical channels according to their priority and configured PBR }
}

```

## 7.1.1.3.1.2 Conformance requirements

References: The conformance requirements covered in the present TC are specified in: TS 38.321, clause 5.4.3.1.1, 5.4.3.1.2, 5.4.3.1.3. Unless otherwise stated these are Rel-15 requirements.

[TS 38.321, clause 5.4.3.1.1]

The Logical Channel Prioritization procedure is applied whenever a new transmission is performed.

RRC controls the scheduling of uplink data by signalling for each logical channel per MAC entity:

- *priority* where an increasing priority value indicates a lower priority level;
- *prioritisedBitRate* which sets the Prioritized Bit Rate (PBR);
- *bucketSizeDuration* which sets the Bucket Size Duration (BSD).

RRC additionally controls the LCP procedure by configuring mapping restrictions for each logical channel:

- *allowedSCS-List* which sets the allowed Subcarrier Spacing(s) for transmission;
- *maxPUSCH-Duration* which sets the maximum PUSCH duration allowed for transmission;
- *configuredGrantType1Allowed* which sets whether a Configured Grant Type 1 can be used for transmission;
- *allowedServingCells* which sets the allowed cell(s) for transmission.

The following UE variable is used for the Logical channel prioritization procedure:

- *B<sub>j</sub>* which is maintained for each logical channel *j*.

The MAC entity shall initialize *B<sub>j</sub>* of the logical channel to zero when the logical channel is established.

For each logical channel  $j$ , the MAC entity shall:

- 1> increment  $B_j$  by the product  $PBR \times T$  before every instance of the LCP procedure, where  $T$  is the time elapsed since  $B_j$  was last updated;
- 1> if the value of  $B_j$  is greater than the bucket size (i.e.  $PBR \times BSD$ ):
  - 2> set  $B_j$  to the bucket size.

NOTE: The exact moment(s) when the UE updates  $B_j$  between LCP procedures is up to UE implementation, as long as  $B_j$  is up to date at the time when a grant is processed by LCP.

[TS 38.321, clause 5.4.3.1.2]

The MAC entity shall, when a new transmission is performed:

- 1> select the logical channels for each UL grant that satisfy all the following conditions:
  - 2> the set of allowed Subcarrier Spacing index values in *allowedSCS-List*, if configured, includes the Subcarrier Spacing index associated to the UL grant; and
  - 2> *maxPUSCH-Duration*, if configured, is larger than or equal to the PUSCH transmission duration associated to the UL grant; and
  - 2> *configuredGrantType1Allowed*, if configured, is set to TRUE in case the UL grant is a Configured Grant Type 1; and
  - 2> *allowedServingCells*, if configured, includes the Cell information associated to the UL grant.

NOTE: The Subcarrier Spacing index, PUSCH transmission duration and Cell information are included in Uplink transmission information received from lower layers for the corresponding scheduled uplink transmission.

[TS 38.321, clause 5.4.3.1.3]

The MAC entity shall, when a new transmission is performed:

- 1> allocate resources to the logical channels as follows:
  - 2> logical channels selected in subclause 5.4.3.1.2 for the UL grant with  $B_j > 0$  are allocated resources in a decreasing priority order. If the PBR of a logical channel is set to "infinity", the MAC entity shall allocate resources for all the data that is available for transmission on the logical channel before meeting the PBR of the lower priority logical channel(s);
  - 2> decrement  $B_j$  by the total size of MAC SDUs served to logical channel  $j$  above;

NOTE: The value of  $B_j$  can be negative.

- 2> if any resources remain, all the logical channels selected in subclause 5.4.3.1.2 are served in a strict decreasing priority order (regardless of the value of  $B_j$ ) until either the data for that logical channel or the UL grant is exhausted, whichever comes first. Logical channels configured with equal priority should be served equally.

The UE shall also follow the rules below during the scheduling procedures above:

- the UE should not segment an RLC SDU (or partially transmitted SDU or retransmitted RLC PDU) if the whole SDU (or partially transmitted SDU or retransmitted RLC PDU) fits into the remaining resources of the associated MAC entity;
- if the UE segments an RLC SDU from the logical channel, it shall maximize the size of the segment to fill the grant of the associated MAC entity as much as possible;
- the UE should maximise the transmission of data;
- if the MAC entity is given an UL grant size that is equal to or larger than 8 bytes while having data available for transmission, the MAC entity shall not transmit only padding BSR and/or padding.

The MAC entity shall not generate a MAC PDU for the HARQ entity if the following conditions are satisfied:

- the MAC entity is configured with *skipUplinkTxDynamic* and the grant indicated to the HARQ entity was addressed to a C-RNTI, or the grant indicated to the HARQ entity is a configured uplink grant; and
- the MAC PDU includes zero MAC SDUs; and
- the MAC PDU includes only the periodic BSR and there is no data available for any LCG, or the MAC PDU includes only the padding BSR.

Logical channels shall be prioritised in accordance with the following order (highest priority listed first):

- MAC CE for C-RNTI or data from UL-CCCH;
- MAC CE for SPS confirmation;
- MAC CE for BSR, with exception of BSR included for padding;
- MAC CE for single entry PHR or multiple entry PHR;
- data from any Logical Channel, except data from UL-CCCH;
- MAC CE for BSR included for padding.

#### 7.1.1.3.2.3 Test description

##### 7.1.1.3.2.3.1 Pre-test conditions

Same Pre-test conditions as in clause 7.1.1.0 except the conditions mentioned in this section.

#### System Simulator

- The Table 7.1.2.1.2-1, mentioned in default pre-test conditions for UM RLC test cases section, needs to be replaced with the Table 7.1.1.3.2.3.1-1

**Table 7.1.1.3.2.3.1-1: Message conditions**

Execution Condition	Message condition exceptions
IF [pc_nrFDD] or [pc_nrTDD]	FFS
ELSE IF [pc_EN_DC]	message condition SCG-DRB(0,3) is used for step 7 in 4.5.4.2 according to [4]
ELSE IF [pc_NGEN_DC]	message condition SCG-DRB(0,3) is used for step 7 in 4.5.4.2 according to [4]

- The 3 UM DRBs are configured according to Table 7.1.1.3.2.3.1-2.

**Table 7.1.1.3.2.3.1-2: Priority, PBR and Bucket Delay settings**

DRB	priority	prioritizedBitRate (kbytes/s)	bucketSizeDuration (ms)
DRB1	6	8	100
DRB2	7	16	100
DRB3	8	32	100

**Table 7.1.1.3.2.3.1-3: PDCP Settings**

Parameter	Value
Discard_Timer	ms1500

## 7.1.1.3.2.3.2 Test procedure sequence

**Table 7.1.1.3.2.3.2-1: Main behaviour**

St	Procedure	Message Sequence		TP	Verdict
		U - S	Message		
-	EXCEPTION: Steps 1 to 3 are run 4 times using the parameters specified for each run in table 7.1.1.3.2.3.2-3.	-	-	-	-
1	The SS transmits N1 320-octet RLC SDUs on DRB1, N2 320-octet RLC SDUs on DRB2, and N3 320-octet RLC SDUs on DRB3.	<--	(RLC SDUs)	-	-
-	EXCEPTION: In parallel to the event described in step 2 the events specified in Table 7.1.1.3.2.3.2-2 shall take place.	-	-	-	-
2	The SS is configured for Uplink Grant Allocation Type 2 as defined in TS 38.523-3 [3]. 150 ms after Step 1 (Note1), for a duration of T2, the SS transmits an UL grant of D octets every T1.	<--	(UL grants)	-	-
3	Check: Are the total number of octets of the UL RLC SDUs received at the SS for each DRB as follows: - total number of octets received for DRB1 is D1 octets +/- 10% - total number of octets received for DRB2 is D2 octets +/- 10% - total number of octets received for DRB3 is D3 octets +/- 10% ?	-	-	1	P
Note 1: This wait time will ensure that a) all octets have been completely received by the UE on all 3 DRBs before the first UL grant is received and b) the Bjs for each logical channel have reached their maximum value i.e. the bucket size of the corresponding logical channel before the first UL grant is received.					

**Table 7.1.1.3.2.3.2-2: Parallel behaviour**

St	Procedure	Message Sequence		TP	Verdict
		U - S	Message		
1	Check: Does the UE transmit the RLC SDUs back to the SS?	-->	-	1	P

**Table 7.1.1.3.2.3.2-3: Test parameter values**

Parameter	First run	Second run	Third run	Fourth run
N1 (SDUs)	13	13	7	104
N2 (SDUs)	25	25	50	25
N3 (SDUs)	50	50	50	50
D (octets)	1143	573	1143	1143
T1 (ms)	20	20	20	10
T2 (ms)	500	700	500	500
D1 (octets)	4160	4160	2240	33000 (Note 1)
D2 (octets)	8000	8000	10260 (Note 1)	8000
D3 (octets)	16000	7790 (Note 1)	16000	16000
Note 1: Calculated using the following equation for the case of the least header size: $(D1 + D2 + D3) = (D - 3) * T2 / T1$				

NOTE: The Test parameter values above and the test procedure assume that the UE has a loopback buffer of at least 57280 octets.

## 7.1.1.3.2.3.3 Specific message contents

**Table 7.1.1.3.2.3.3-1: SchedulingRequest-Config (Preamble)**

Derivation Path: 36.508 [7], Table 4.6.3-20			
Information Element	Value/remark	Comment	Condition
sr-TransMax	n16		

## 7.1.1.3.3 Correct handling of MAC control information / Scheduling requests

## 7.1.1.3.3.1 Test Purpose (TP)

(1)

```
with { UE in RRC_CONNECTED state with SR resource on PUCCH is configured }
ensure that {
  when { UE has UL data available for transmission and UE has no UL-SCH resources available and
SR_COUNTER is less than sr-TransMax }
    then { the UE transmits a SR on every available PUCCH until resources are granted }
}
```

(2)

```
with { UE in RRC_CONNECTED state with SR resource on PUCCH is configured }
ensure that {
  when { UE receives an UL grant for a new transmission }
    then { UE cancels all pending SR(s) }
}
```

(3)

```
with { UE in RRC_CONNECTED state with SR resource on PUCCH is configured }
ensure that {
  when { UE has UL data available for transmission and UE has no UL-SCH resources available or
SR_COUNTER becomes equal to sr-TransMax }
    then { the UE transmits a PRACH Preamble to initiate a Random Access procedure }
}
```

(4)

```
with { UE in RRC_CONNECTED state with SR resource on PUCCH is configured and logicaChannelSR-
DelayTimer is configured }
ensure that {
  when { UE has UL data available for transmission on LCH for which logicaChannelSR-DelayTimer is
configured and UE has no UL-SCH resources available and SR_COUNTER is less than sr-TransMax }
    then { the UE delays transmission of SR until logicaChannelSR-DelayTimer expires }
}
```

(5)

```
with { UE in RRC_CONNECTED state with SR resource on PUCCH is configured and logicaChannelSR-
DelayTimer is running }
ensure that {
  when { UE has UL data available for transmission for transmission on LCH for which
logicaChannelSR-DelayTimer is not configured and UE has no UL-SCH resources available and SR_COUNTER
is less than sr-TransMax }
    then { the UE transmits a SR on every available PUCCH until resources are granted }
}
```

## 7.1.1.3.3.2 Conformance requirements

References: The conformance requirements covered in the present TC are specified in: TS 38.321, clauses 5.4.4 and 5.4.5. Unless otherwise stated these are Rel-15 requirements.

[TS 38.321, clause 5.4.4]

The Scheduling Request (SR) is used for requesting UL-SCH resources for new transmission.



The MAC entity may be configured with zero, one, or more SR configurations. An SR configuration consists of a set of PUCCH resources for SR across different BWPs and cells. For a logical channel, at most one PUCCH resource for SR is configured per BWP.

Each SR configuration corresponds to one or more logical channels. Each logical channel may be mapped to zero or one SR configuration, which is configured by RRC. The SR configuration of the LCH that triggered the BSR (subclause 5.4.5) (if such a configuration exists) is considered as corresponding SR configuration for the triggered SR. For BSR triggered by *retxBSR-Timer* expiry, the corresponding SR configuration for the triggered SR is that of the highest priority LCH (if such a configuration exists) that has data available for transmission at the time the BSR is triggered.

RRC configures the following parameters for the scheduling request procedure:

- *sr-ProhibitTimer* (per SR configuration);
- *sr-TransMax* (per SR configuration);
- *sr-ConfigIndex*.

The following UE variables are used for the scheduling request procedure:

- *SR\_COUNTER* (per SR configuration).

If an SR is triggered and there are no other SRs pending corresponding to the same SR configuration, the MAC entity shall set the *SR\_COUNTER* of the corresponding SR configuration to 0.

When an SR is triggered, it shall be considered as pending until it is cancelled. All pending SR(s) shall be cancelled and each respective *sr-ProhibitTimer* shall be stopped when a MAC PDU is assembled and this PDU includes a BSR which contains buffer status up to (and including) the last event that triggered a BSR (see subclause 5.4.5), or when the UL grant(s) can accommodate all pending data available for transmission.

Only PUCCH resources on a BWP which is active at the time of SR transmission occasion are considered valid.

As long as at least one SR is pending, the MAC entity shall for each pending SR:

- 1> if the MAC entity has no valid PUCCH resource configured for the pending SR:
  - 2> initiate a Random Access procedure (see subclause 5.1) on the SpCell and cancel the pending SR.
- 1> else, for the SR configuration corresponding to the pending SR:
  - 2> when the MAC entity has an SR transmission occasion on the valid PUCCH resource for SR configured; and
  - 2> if *sr-ProhibitTimer* is not running at the time of the SR transmission occasion; and
  - 2> if the PUCCH resource for the SR transmission occasion does not overlap with a measurement gap; and
  - 2> if the PUCCH resource for the SR transmission occasion does not overlap with a UL-SCH resource:
    - 3> if *SR\_COUNTER* < *sr-TransMax*:
      - 4> increment *SR\_COUNTER* by 1;
      - 4> instruct the physical layer to signal the SR on one valid PUCCH resource for SR;
      - 4> start the *sr-ProhibitTimer*.
    - 3> else:
      - 4> notify RRC to release PUCCH for all serving cells;
      - 4> notify RRC to release SRS for all serving cells;
      - 4> clear any configured downlink assignments and uplink grants;
      - 4> initiate a Random Access procedure (see subclause 5.1) on the SpCell and cancel all pending SRs.

NOTE: The selection of which valid PUCCH resource for SR to signal SR on when the MAC entity has more than one overlapping valid PUCCH resource for the SR transmission occasion is left to UE implementation.

[TS 38.321, clause 5.4.5]

For Regular BSR, the MAC entity shall:

- 1> if the BSR is triggered for a logical channel for which *logicalChannelSR-Delay* is configured by upper layers:
  - 2> start or restart the *logicalChannelSR-DelayTimer*.
- 1> else:
  - 2> if running, stop the *logicalChannelSR-DelayTimer*.

...

The MAC entity shall:

- 1> if the Buffer Status reporting procedure determines that at least one BSR has been triggered and not cancelled:
  - 2> if UL-SCH resources are available for a new immediate transmission:
    - 3> instruct the Multiplexing and Assembly procedure to generate the BSR MAC CE(s);
    - 3> start or restart *periodicBSR-Timer* except when all the generated BSRs are long or short Truncated BSRs;
    - 3> start or restart *retxBSR-Timer*.
  - 2> else if a Regular BSR has been triggered and *logicalChannelSR-DelayTimer* is not running:
    - 3> if an uplink grant is not a configured grant; or
    - 3> if the Regular BSR was not triggered for a logical channel for which logical channel SR masking (*logicalChannelSR-Mask*) is setup by upper layers:
      - 4> trigger a Scheduling Request.

7.1.1.3.3.3 Test description

7.1.1.3.3.3.1 Pre-test conditions

Same Pre-test conditions as in clause 7.1.1.0 with the exception of 2 AM DRBs configured according to Table 7.1.1.3.3.3.1-1.

**Table 7.1.1.3.3.3.1-1: Logical Channel Configuration Settings**

Parameter	DRB1	DRB2
LogicalChannel-Identity	4	5
Priority	7	6
prioritizedBitRate	0kbs	0kbs
logicalChannelGroup	2 (LCG ID#2)	1 (LCG ID#1)
logicalChannelSR-DelayTimerApplied	False	True
logicaChannelSR-DelayTimer	Not Present	sf512

7.1.1.3.3.3.2 Test procedure sequence

**Table 7.1.1.3.3.3.2-1: Main behaviour**

St	Procedure	Message Sequence		TP	Verdict
		U - S	Message		
1	The SS transmits a MAC PDU containing A MAC Sub PDU containing a RLC SDU on LCH 5	<--	MAC PDU (containing 1 MAC sub PDU)	-	-
2	Check: Does the UE transmit Scheduling Requests for logicaChannelSR-DelayTimer (sf512) from step 1?	-->	(SR)	4	F
3	Check: Does the UE transmit [x] Scheduling Requests separately on [x] consecutively available PUCCHs after logicaChannelSR-DelayTimer expiry? (Note 1)	-->	(SR)	1,4	P
4	The SS transmits an UL grant to allocate UL-SCH resources that are enough to transmit looped back PDU	<--	(UL Grant )	-	-
5	Check: Does the UE transmit a MAC PDU containing MAC Sub PDU containing a RLC SDU?	-->	MAC PDU (containing 1 MAC sub PDU containing RLC SDU)	1	P
6	The SS transmits a MAC PDU containing A MAC Sub PDU containing a RLC SDU on LCH 5	<--	MAC PDU (containing 1 MAC sub PDU)	-	-
7	Check: Does the UE transmit Scheduling Requests for logicaChannelSR-DelayTimer /2 (sf512/2) from step 5	-->	(SR)	4	F
8	After logicaChannelSR-DelayTimer /2 (sf512/2) from step 5, the SS transmits a MAC PDU containing A MAC Sub PDU containing a RLC SDU on LCH 4	<--	MAC PDU (containing 1 MAC sub PDU)	-	-
9	Check: Does the UE transmit Scheduling Requests separately on [x] consecutively available PUCCHs? (Note 1)	-->	(SR)	1,5	P
10	The SS transmits an UL grant to allocate UL-SCH resources that are enough to transmit looped back PDU	<--	(UL Grant )	-	-
11	Check: Does the UE transmit a MAC PDU containing MAC Sub PDU containing a RLC SDU?	-->	MAC PDU (containing 1 MAC sub PDU containing RLC SDU)	1	P
12	Check: For 1 second, does the UE transmit a Scheduling Request?	-->	(SR)	1,2	F
13	The SS transmits a MAC PDU containing a Timing Advance Command MAC Control Element, but does not send any subsequent alignments.	<--	MAC PDU (Timing Advance Command)	-	-
14	The SS transmits a MAC PDU containing a MAC SDU on LCH 4	<--	MAC PDU (MAC SDU)	-	-
-	EXCEPTION: Step 13 is repeated less than [64] times (sr-TransMax)	-	-	-	-
15	The UE may transmit Scheduling Requests before time alignment timer expires. The SS shall not respond to the Scheduling Requests in this step. (Note 2)	-->	(SR)	-	-
16	Check: does the UE transmit a preamble on PRACH? (Note 3)	-->	(PRACH Preamble)	3	P
17	The SS transmits a Random Access Response including an UL grant to enable UE to transmit C-RNTI MAC Control Element and the MAC SDU as received in step 12.	<--	Random Access Response	-	-
18	The UE transmit a MAC PDU including a C-RNTI MAC Control Element and a MAC SDU. (Note 4)	-->	MAC PDU (MAC Sub PDU containing C-RNTI control element, MAC sub PDU containing MAC SDU)	-	-
19	The SS sends PDCCH transmission for UE C-RNTI	<--	-	-	-

Note 1:	[FFS] The UE repeats the scheduling requests on every available PUCCH as long as $SR\_COUNTER < dsr-TransMax$ and there is UL data available for transmission and there are no resources available to transmit it. At the reception of first Scheduling Request from the UE, SS will be scheduled to transmit a grant after 100ms. Hence SS will receive 6 Scheduling Requests as $sr-ConfigIndex = 30$ .
Note 2:	In step 8, SR repetition of [63] times ( $sr-TransMax (64)$ ) will take at least $[63 \times 20 = 1260]$ ms which is much larger than TA timer [750ms].
Note 3:	When UL time alignment timer expires in the UE then "UL synchronization" is lost and the UE initiates a Random Access Procedure.
Note 4:	The UE transmission of the MAC PDU ensures that the random access procedure was successful.

#### 7.1.1.3.3.3 Specific message contents

None

#### 7.1.1.3.4 Correct handling of MAC control information / Buffer status / UL data arrive in the UE Tx buffer / Regular BSR

##### 7.1.1.3.4.1 Test Purpose (TP)

(1)

```
with { UE in RRC_CONNECTED state }
ensure that {
  when { UL data arrives in the UE transmission buffer and the data belongs to a logical channel
with higher priority than those for which data is already available for transmission and the new
logical channel and the existing logical channels belongs to the different LCG }
  then { UE Reports a Long Buffer Status Reporting (BSR) }
}
```

(2)

```
with { UE in RRC_CONNECTED state }
ensure that {
  when { UL data arrives in the UE transmission buffer and there is no data available for
transmission for any of the logical channels which belong to a LCG }
  then { UE Reports a Short Buffer Status Reporting (BSR) }
}
```

(3)

```
with { UE in RRC_CONNECTED state }
ensure that {
  when { UL data arrives in the UE transmission buffer and the data belongs to a logical channel
with higher priority than those for which data is already available for transmission and the new
logical channel and existing logical channels belong to the same LCG }
  then { UE Reports a Short Buffer Status Reporting (BSR) }
}
```

(4)

```
with { UE in RRC_CONNECTED state }
ensure that {
  when { retxBSR-Timer expires and only one LCG has data available for transmission }
  then { UE triggers a regular BSR and Reports a Short Buffer Status Reporting (BSR) }
}
```

(5)

```
with { UE in RRC_CONNECTED state }
ensure that {
  when { a Regular BSR has been triggered and UE has pending data for transmission and UE has only
resources to send either BSR report or data }
  then { UE transmits the BSR report }
}
```

(6)

```
with { UE in E-UTRA RRC_CONNECTED state }
ensure that {
```

```

when { UE determines that a BSR has been triggered since the last transmission of a BSR and UE has
no UL resources allocated for new transmission for this TTI }
  then { UE transmits a scheduling request }
}

```

(7)

```

with { UE in RRC_CONNECTED state }
ensure that {
  when { a Regular BSR has been triggered and UE has pending data on several logical channels for
transmission and UE has only UL resources to send all pending data available for transmission, but
UL grant is not sufficient to additionally accommodate the BSR MAC control element }
    then { UE cancels the triggered BSR report and transmits the UL data }
}

```

(8)

```

with { UE in RRC_CONNECTED state }
ensure that {
  when { a Regular BSR has been triggered and UE has pending data on several logical channels for
transmission and UE has UL resources to send all pending data including BSR }
    then { UE transmits the UL data and reports buffer status reporting (BSR) that indicates there
is no more data in the buffer }
}

```

#### 7.1.1.3.4.2 Conformance requirements

References: The conformance requirements covered in the present TC are specified in: TS 38.321, clauses 5.4.5, 6.1.3.1, 6.2.1 and TS 38.323 clause 5.6. Unless otherwise stated these are Rel-15 requirements.

[TS 38.321, clause 5.4.5]

The Buffer Status reporting (BSR) procedure is used to provide the serving gNB with information about UL data volume in the MAC entity.

RRC configures the following parameters to control the BSR:

- *periodicBSR-Timer*;
- *retxBSR-Timer*;
- *logicalChannelSR-Delay*;
- *logicalChannelSR-DelayTimer*;
- *logicalChannelGroup*.

Each logical channel may be allocated to an LCG using the *logicalChannelGroup*. The maximum number of LCGs is eight.

The MAC entity determines the amount of UL data available for a logical channel according to the data volume calculation procedure in TSs 38.322 and 38.323 [3] [4].

A BSR shall be triggered if any of the following events occur:

- the MAC entity has new UL data available for a logical channel which belongs to an LCG; and either
  - the new UL data belongs to a logical channel with higher priority than the priority of any logical channel containing available UL data which belong to any LCG; or
  - none of the logical channels which belong to an LCG contains any available UL data.

in which case the BSR is referred below to as 'Regular BSR';

- UL resources are allocated and number of padding bits is equal to or larger than the size of the Buffer Status Report MAC CE plus its subheader, in which case the BSR is referred below to as 'Padding BSR';
- *retxBSR-Timer* expires, and at least one of the logical channels which belong to an LCG contains UL data, in which case the BSR is referred below to as 'Regular BSR';

- *periodicBSR-Timer* expires, in which case the BSR is referred below to as 'Periodic BSR'.

For Regular BSR, the MAC entity shall:

- 1> if the BSR is triggered for a logical channel for which *logicalChannelSR-Delay* is configured by upper layers:
  - 2> start or restart the *logicalChannelSR-DelayTimer*.
- 1> else:
  - 2> if running, stop the *logicalChannelSR-DelayTimer*.

For Regular and Periodic BSR, the MAC entity shall:

- 1> if more than one LCG has data available for transmission when the BSR is to be transmitted:
  - 2> report Long BSR for all LCGs which have data available for transmission.
- 1> else:
  - 2> report Short BSR.

For Padding BSR:

- 1> if the number of padding bits is equal to or larger than the size of the Short BSR plus its subheader but smaller than the size of the Long BSR plus its subheader:
  - 2> if more than one LCG has data available for transmission when the BSR is to be transmitted:
    - 3> if the number of padding bits is equal to the size of the Short BSR plus its subheader:
      - 4> report Short Truncated BSR of the LCG with the highest priority logical channel with data available for transmission.
    - 3> else:
      - 4> report Long Truncated BSR of the LCG(s) with the logical channels having data available for transmission following a decreasing order of priority, and in case of equal priority, in increasing order of LCGID.
  - 2> else:
    - 3> report Short BSR;
- 1> else if the number of padding bits is equal to or larger than the size of the Long BSR plus its subheader:
  - 2> report Long BSR for all LCGs which have data available for transmission.

The MAC entity shall:

- 1> if the Buffer Status reporting procedure determines that at least one BSR has been triggered and not cancelled:
  - 2> if UL-SCH resources are available for a new immediate transmission:
    - 3> instruct the Multiplexing and Assembly procedure to generate the BSR MAC CE(s);
    - 3> start or restart *periodicBSR-Timer* except when all the generated BSRs are long or short Truncated BSRs;
    - 3> start or restart *retxBSR-Timer*.
  - 2> else if a Regular BSR has been triggered and *logicalChannelSR-DelayTimer* is not running:
    - 3> if an uplink grant is not a configured grant; or
    - 3> if the Regular BSR was not triggered for a logical channel for which logical channel SR masking (*logicalChannelSR-Mask*) is setup by upper layers:
      - 4> trigger a Scheduling Request.

A MAC PDU shall contain at most one BSR MAC CE, even when multiple events have triggered a BSR by the time. The Regular BSR and the Periodic BSR shall have precedence over the padding BSR.

The MAC entity shall restart *retxBSR-Timer* upon reception of a grant for transmission of new data on any UL-SCH.

All triggered BSRs may be cancelled when the UL grant(s) can accommodate all pending data available for transmission but is not sufficient to additionally accommodate the BSR MAC control element plus its subheader. All triggered BSRs shall be cancelled when a BSR is included in a MAC PDU for transmission.

The MAC entity shall transmit at most one BSR in one MAC PDU. Padding BSR shall not be included when the MAC PDU contains a Regular or Periodic BSR.

[TS 38.322, clause 6.1.3.1]

Buffer Status Report (BSR) MAC CEs consist of either:

- Short BSR format (fixed size); or
- Long BSR format (variable size); or
- Short Truncated BSR format (fixed size); or
- Long Truncated BSR format (variable size).

The BSR formats are identified by MAC PDU subheaders with LCIDs as specified in Table 6.2.1-2.

The fields in the BSR MAC CE are defined as follows:

- LCG ID: The Logical Channel Group ID field identifies the group of logical channel(s) whose buffer status is being reported. The length of the field is 3 bits;
- LCG<sub>i</sub>: For the Long BSR format, this field indicates the presence of the Buffer Size field for the logical channel group i. The LCG<sub>i</sub> field set to "1" indicates that the Buffer Size field for the logical channel group i is reported. The LCG<sub>i</sub> field set to "0" indicates that the Buffer Size field for the logical channel group i is not reported. For the Long Truncated BSR format, this field indicates whether logical channel group i has data available. The LCG<sub>i</sub> field set to "1" indicates that logical channel group i has data available. The LCG<sub>i</sub> field set to "0" indicates that logical channel group i does not have data available;
- Buffer Size: The Buffer Size field identifies the total amount of data available according to the data volume calculation procedure in TSs 38.322 and 38.323 [3] [4] across all logical channels of a logical channel group after the MAC PDU has been built (i.e. after the logical channel prioritization procedure, which may result the value of the Buffer Size field to zero). The amount of data is indicated in number of bytes. The size of the RLC and MAC headers are not considered in the buffer size computation. The length of this field for the Short BSR format and the Short Truncated BSR format is 5 bits. The length of this field for the Long BSR format and the Long Truncated BSR format is 8 bits. The values for the 5-bit and 8-bit Buffer Size fields are shown in Tables 6.1.3.1-1 and 6.1.3.1-2, respectively. For the Long BSR format and the Long Truncated BSR format, the Buffer Size fields are included in ascending order based on the LCG<sub>i</sub>. For the Long Truncated BSR format the number of Buffer Size fields included is maximised, while not exceeding the number of padding bits.

NOTE: The number of the Buffer Size fields in the Long Truncated BSR format can be zero.

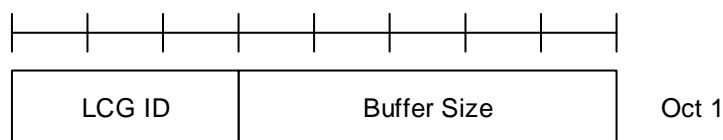

Figure 6.1.3.1-1: Short BSR and Short Truncated BSR MAC CE



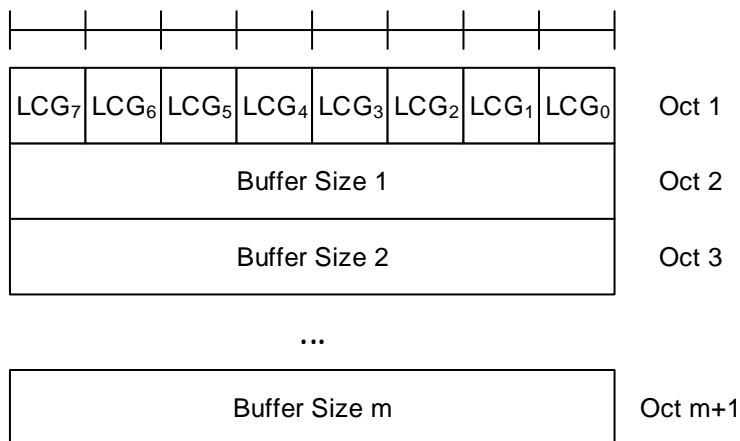

Figure 6.1.3.1-2: Long BSR and Long Truncated BSR MAC CE

Table 6.1.3.1-1: Buffer size levels (in bytes) for 5-bit Buffer Size field

Index	BS value	Index	BS value	Index	BS value	Index	BS value
0	0	8	≤ 102	16	≤ 1446	24	≤ 20516
1	≤ 10	9	≤ 142	17	≤ 2014	25	≤ 28581
2	≤ 14	10	≤ 198	18	≤ 2806	26	≤ 39818
3	≤ 20	11	≤ 276	19	≤ 3909	27	≤ 55474
4	≤ 28	12	≤ 384	20	≤ 5446	28	≤ 77284
5	≤ 38	13	≤ 535	21	≤ 7587	29	≤ 107669
6	≤ 53	14	≤ 745	22	≤ 10570	30	≤ 150000
7	≤ 74	15	≤ 1038	23	≤ 14726	31	> 150000

**Table 6.1.3.1-2: Buffer size levels (in bytes) for 8-bit Buffer Size field**

Index	BS value	Index	BS value	Index	BS value	Index	BS value
0	0	64	≤ 526	128	≤ 29431	192	≤ 1647644
1	≤ 10	65	≤ 560	129	≤ 31342	193	≤ 1754595
2	≤ 11	66	≤ 597	130	≤ 33376	194	≤ 1868488
3	≤ 12	67	≤ 635	131	≤ 35543	195	≤ 1989774
4	≤ 13	68	≤ 677	132	≤ 37850	196	≤ 2118933
5	≤ 13	69	≤ 720	133	≤ 40307	197	≤ 2256475
6	≤ 14	70	≤ 767	134	≤ 42923	198	≤ 2402946
7	≤ 15	71	≤ 817	135	≤ 45709	199	≤ 2558924
8	≤ 16	72	≤ 870	136	≤ 48676	200	≤ 2725027
9	≤ 17	73	≤ 926	137	≤ 51836	201	≤ 2901912
10	≤ 18	74	≤ 987	138	≤ 55200	202	≤ 3090279
11	≤ 19	75	≤ 1051	139	≤ 58784	203	≤ 3290873
12	≤ 20	76	≤ 1119	140	≤ 62599	204	≤ 3504487
13	≤ 22	77	≤ 1191	141	≤ 66663	205	≤ 3731968
14	≤ 23	78	≤ 1269	142	≤ 70990	206	≤ 3974215
15	≤ 25	79	≤ 1351	143	≤ 75598	207	≤ 4232186
16	≤ 26	80	≤ 1439	144	≤ 80505	208	≤ 4506902
17	≤ 28	81	≤ 1532	145	≤ 85730	209	≤ 4799451
18	≤ 30	82	≤ 1631	146	≤ 91295	210	≤ 5110989
19	≤ 32	83	≤ 1737	147	≤ 97221	211	≤ 5442750
20	≤ 34	84	≤ 1850	148	≤ 103532	212	≤ 5796046
21	≤ 36	85	≤ 1970	149	≤ 110252	213	≤ 6172275
22	≤ 38	86	≤ 2098	150	≤ 117409	214	≤ 6572925
23	≤ 40	87	≤ 2234	151	≤ 125030	215	≤ 6999582
24	≤ 43	88	≤ 2379	152	≤ 133146	216	≤ 7453933
25	≤ 46	89	≤ 2533	153	≤ 141789	217	≤ 7937777
26	≤ 49	90	≤ 2698	154	≤ 150992	218	≤ 8453028
27	≤ 52	91	≤ 2873	155	≤ 160793	219	≤ 9001725
28	≤ 55	92	≤ 3059	156	≤ 171231	220	≤ 9586039
29	≤ 59	93	≤ 3258	157	≤ 182345	221	≤ 10208280
30	≤ 62	94	≤ 3469	158	≤ 194182	222	≤ 10870913
31	≤ 66	95	≤ 3694	159	≤ 206786	223	≤ 11576557
32	≤ 71	96	≤ 3934	160	≤ 220209	224	≤ 12328006
33	≤ 75	97	≤ 4189	161	≤ 234503	225	≤ 13128233
34	≤ 80	98	≤ 4461	162	≤ 249725	226	≤ 13980403
35	≤ 85	99	≤ 4751	163	≤ 265935	227	≤ 14887889
36	≤ 91	100	≤ 5059	164	≤ 283197	228	≤ 15854280
37	≤ 97	101	≤ 5387	165	≤ 301579	229	≤ 16883401
38	≤ 103	102	≤ 5737	166	≤ 321155	230	≤ 17979324
39	≤ 110	103	≤ 6109	167	≤ 342002	231	≤ 19146385
40	≤ 117	104	≤ 6506	168	≤ 364202	232	≤ 20389201
41	≤ 124	105	≤ 6928	169	≤ 387842	233	≤ 21712690
42	≤ 132	106	≤ 7378	170	≤ 413018	234	≤ 23122088
43	≤ 141	107	≤ 7857	171	≤ 439827	235	≤ 24622972
44	≤ 150	108	≤ 8367	172	≤ 468377	236	≤ 26221280
45	≤ 160	109	≤ 8910	173	≤ 498780	237	≤ 27923336
46	≤ 170	110	≤ 9488	174	≤ 531156	238	≤ 29735875
47	≤ 181	111	≤ 10104	175	≤ 565634	239	≤ 31666069
48	≤ 193	112	≤ 10760	176	≤ 602350	240	≤ 33721553
49	≤ 205	113	≤ 11458	177	≤ 641449	241	≤ 35910462
50	≤ 218	114	≤ 12202	178	≤ 683087	242	≤ 38241455
51	≤ 233	115	≤ 12994	179	≤ 727427	243	≤ 40723756
52	≤ 248	116	≤ 13838	180	≤ 774645	244	≤ 43367187
53	≤ 264	117	≤ 14736	181	≤ 824928	245	≤ 46182206
54	≤ 281	118	≤ 15692	182	≤ 878475	246	≤ 49179951
55	≤ 299	119	≤ 16711	183	≤ 935498	247	≤ 52372284
56	≤ 318	120	≤ 17795	184	≤ 996222	248	≤ 55771835
57	≤ 339	121	≤ 18951	185	≤ 1060888	249	≤ 59392055
58	≤ 361	122	≤ 20181	186	≤ 1129752	250	≤ 63247269
59	≤ 384	123	≤ 21491	187	≤ 1203085	251	≤ 67352729
60	≤ 409	124	≤ 22885	188	≤ 1281179	252	≤ 71724679
61	≤ 436	125	≤ 24371	189	≤ 1364342	253	≤ 76380419
62	≤ 464	126	≤ 25953	190	≤ 1452903	254	≤ 81338368
63	≤ 494	127	≤ 27638	191	≤ 1547213	255	> 81338368

[TS 38.321, clause 6.2.1]

**Table 6.2.1-2 Values of LCID for UL-SCH**

Index	LCID values
000000	CCCH
000001–100000	Identity of the logical channel
100001–110110	Reserved
110111	Configured Grant Confirmation
111000	Multiple Entry PHR
111001	Single Entry PHR
111010	C-RNTI
111011	Short Truncated BSR
111100	Long Truncated BSR
111101	Short BSR
111110	Long BSR
111111	Padding

[TS 38.323, clause 5.6]

For the purpose of MAC buffer status reporting, the transmitting PDCP entity shall consider the following as PDCP data volume:

- the PDCP SDUs for which no PDCP Data PDUs have been constructed;
- the PDCP Data PDUs that have not been submitted to lower layers;
- the PDCP Control PDUs;
- for AM DRBs, the PDCP SDUs to be retransmitted according to subclause 5.1.2;
- for AM DRBs, the PDCP Data PDUs to be retransmitted according to subclause 5.5.

7.1.1.3.4.3 Test description

7.1.1.3.4.3.1 Pre-test conditions

Same Pre-test conditions as in clause 7.1.1.0 with the exception of 3 AM SN terminated SCG bearers configured according to Table 7.1.1.3.4.3.1-1.

**Table 7.1.1.3.4.3.1-1: Logical Channel Configuration Settings**

Parameter	Value DRB1	Value DRB2	Value DRB3
LogicalChannel-Identity	4	5	6
Priority	8	7	6
prioritizedBitRate	0 kB/s	0 kB/s	0 kB/s
logicalChannelGroup	2 (LCG ID#2)	2 (LCG ID#2)	1 (LCG ID#1)

7.1.1.3.4.3.2 Test procedure sequence

**Table 7.1.1.3.4.3.2-1: Main behaviour**

St	Procedure	Message Sequence		TP	Verdict
		U - S	Message		
1	The SS ignores scheduling requests and does not allocate any uplink grant.	-	-	-	-
2	The SS transmits a MAC PDU containing two RLC SDUs of size 12 bytes on LC 4	<--	MAC PDU (2 RLC SDUs on LC 4)	-	-
3	SS allocates an UL Grant of 32 bits. (Note 1)	<--	(UL Grant, 32 bits)	-	-
4	Check: Does the UE transmit a Short BSR with 'LCG ID' field set to '2' and 'Buffer size' field set to value '4' or bigger? (Note 2)	-->	MAC PDU (MAC Short BSR (LCG ID='2', Buffer Size='4' or bigger))	2,5	P
5	Wait for retxBSR-Timer expiry on UE side.	-	-	-	-
6	Check: Does the UE transmit a scheduling request?	-->	(SR)	6	P
7	The SS respond to the scheduling request in step 6 by an UL Grant of 32 bits. (Note 1)	<--	(UL Grant, 32 bits)	-	-
8	Check: Does the UE transmit a Short BSR with 'LCG ID' field set to '2' and 'Buffer size' field set to value '4' or bigger? (Note 2)	-->	MAC PDU (MAC Short BSR (LCG ID='2', Buffer Size='4' or bigger))	4,5	P
9	The SS transmits a MAC PDU containing one RLC SDUs of size 12 bytes on LC 5	<--	MAC PDU (1 RLC SDUs on LC 5)	-	-
10	Check: Does the UE transmit a scheduling request?	-->	(SR)	6	P
11	The SS respond to the scheduling request in step 10 by an UL Grant of 32 bits. (Note 1)	<--	(UL Grant, 32 bits)	-	-
12	Check: Does the UE transmit a Short BSR with 'LCG ID' field set to '2' and 'Buffer size#1' field set to value '5' or bigger? (Note 2)	-->	MAC PDU (MAC Short BSR (LCG ID='2', Buffer Size='5' or bigger))	3,5	P
13	The SS transmits a MAC PDU containing two RLC SDUs of size 8 bytes on LC 6	<--	MAC PDU (2 RLC SDUs on LC 6)	-	-
14	Check: Does the UE transmit a scheduling request?	-->	(SR)	6	P
15	The SS respond to the scheduling request in step 14 by one UL Grant of 40 bits. (Note 1)	<--	(UL Grant, 40 bits)	-	-
16	Check: Does the UE transmit a Long BSR with 'Buffer size#1' field set to value '3', 'Buffer size#2' field set to value '21' or bigger? (Note 3)	-->	MAC PDU (MAC Long BSR (Buffer size#1='8' or bigger, Buffer size#2='21' or bigger))	1,5	P
17	Wait for retxBSR-Timer expiry on the UE side.	-	-	-	-
18	Check: Does the UE transmit a scheduling request?	-->	(SR)	6	P
19	SS allocates an UL Grant of 576 bits. (Note 4)	<--	(UL Grant, 576 bits)	-	-
20	Check: Does the UE transmit a MAC PDU including five RLC SDUs and not including any BSR? (Note 5)	-->	MAC PDU (16 Byte 2 MAC sub PDU from LC 4, 16 Byte 1 MAC sub PDU from LC 5 and 01 Byte 2 MAC Sub PDU from LC 6)	7	P
21	SS transmits an RLC STATUS PDU to acknowledge correctly received data(LCID='000100')	<--	RLC STATUS PDU (ACK_SN=2)	-	-
22	SS transmits an RLC STATUS PDU to acknowledge correctly received data(LCID='000101')	<--	RLC STATUS PDU (ACK_SN=1)	-	-
23	SS transmits an RLC STATUS PDU to acknowledge correctly received data(LCID='000110')	<--	RLC STATUS PDU (ACK_SN=2)	-	-
24	The SS transmits a MAC PDU containing two MAC SDUs, the first containing a 8 byte RLC SDU with LCID set to 4 and the second containing a 7 byte RLC SDU with LCID set to 6.	<--	MAC PDU	-	-
25	The UE sends Scheduling Request	-->	(SR)	-	-
26	The SS transmits an uplink grant of size 256 bits. (Note 6)	<--	(UL grant)	-	-

27	Check: Does the UE return a MAC PDU of length 256 bits including 2 RLC SDUs, Padding and Short BSR or LongBSR with Buffer size(s) set to '0'? (Note 5)	-->	MAC PDU (12 Byte MAC Sub PDU from LC 4 and 11 Byte MAC Sub PDU from LC 6 and 5 Byte MAC Sub PDU containing Long BSR and 4 Byte MAC Sub PDU containing Padding) Or MAC PDU (12 Byte MAC Sub PDU from LC 4 and 11 Byte MAC Sub PDU from LC 6 and 2 Byte MAC Sub PDU containing short BSR and 7 Byte MAC Sub PDU containing Padding)	8	P
28	SS transmits an RLC STATUS PDU to acknowledge correctly received data(LCID='000100')	<--	RLC STATUS PDU (ACK_SN=3)	-	-
29	SS transmits an RLC STATUS PDU to acknowledge correctly received data(LCID='000110')	<--	RLC STATUS PDU (ACK_SN=3)	-	-
<p>Note 1: 40 bits enables UE to transmit a MAC PDU with a 1 byte MAC BSR header and a Short BSR (1 bytes) or a 2 byte MAC BSR header and a Long BSR (3 byte with 2 LCG configured).</p> <p>Note 2: UE triggers a Short BSR of type "Regular BSR" to report buffer status for one LCG for that TTI. The UE should not send any of the received RLC SDUs (segmented) due to Regular BSR has higher priority than U-plane logical channels.</p> <p>Note 3: UE triggers and transmit a Long BSR of type "Regular BSR". The UL grant would be enough for UE to transmit one RLC SDU as received in step 8, but Regular BSR has higher priority than U-plane logical channels.</p> <p>Note 4: The UE has 48 bytes of RLC SDU data (received in steps 2, 9 and 13) in the transmission buffer. 544 bits enables UE to transmit user data in MAC PDU 2 RLC SDU of 12 byte on LC 4, each 2 Byte RLC Header and 2 Byte MAC Header resulting in 2 MAC Sub PDU of 16 Bytes Each. Similarly one 16 Byte MAC Sub PDU for 12 Byte RLC SDU on LC 5. Two 8 Byte RLC SDUs on LC 6 with 2 Byte RLC header each and 2 Byte MAC header each, will result in 2 MAC sub PDUs of 10 bytes each. Total comes to 16+16+16+12+12 =72 Bytes.</p> <p>Note 5: The MAC SDUs for the different logical channels may be in any order in the MAC PDU.</p> <p>Note 6: UL grant of 256 bits (<math>L_{RBS}</math> &amp; <math>I_{MCS}</math> as per 38.523-3[3] annex B) is chosen to enable UE to transmit two MAC SDUs of size 10 and 9 bytes in a MAC PDU (8 bytes RLC SDU + 2 bytes AMD PDU header + 2 Byte MAC sub Header + 7 bytes RLC SDU+ 2 bytes AMD PDU header+2 Byte MAC sub Header + 2 Byte Long BSR MAC Sub Header + 3 Byte Long BSR + 4 Byte MAC Padding Sub PDU) or (8 bytes RLC SDU + 2 bytes AMD PDU header + 2 Byte MAC sub Header + 7 bytes RLC SDU+ 2 bytes AMD PDU header+2 Byte MAC sub Header + 1 Byte Short BSR MAC Sub Header + 1 Byte Short BSR + 7 Byte MAC Padding Sub PDU) = 32 Bytes</p>					

#### 7.1.1.3.4.3.3 Specific message contents

None

#### 7.1.1.3.5 Correct handling of MAC control information / Buffer Status / UL resources are allocated / Padding BSR

##### 7.1.1.3.5.1 Test Purpose (TP)

(1)

```

with { UE in RRC_CONNECTED state }
ensure that {
  when { UE transmits a MAC PDU and the number of padding bits is equal to the size of a Short BSR
plus its subheader and the UE has available data for transmission from more than one LCG in the TTI
where the BSR is transmitted }
  then { UE reports a Truncated short BSR of the LCG with the highest priority logical channel
with data available for transmission }
}

```

(2)

```

with { UE in E-UTRA RRC_CONNECTED state }
ensure that {

```

```

when { UE transmits a MAC PDU and the number of padding bits is larger than the size of a Short
BSR plus its subheader but smaller than the size of a Long BSR plus its subheader and the UE has
available data for transmission from more than one LCG in the TTI where the BSR is transmitted }
  then { UE reports a Truncated long BSR }
}

```

(3)

```

with { UE in RRC_CONNECTED state }
ensure that {
  when { UE transmits a MAC PDU and the number of padding bits is equal to or larger than the size
of a Short BSR plus its subheader but smaller than the size of a Long BSR plus its subheader and the
UE has available data for transmission from only one LCG in the TTI where the BSR is transmitted }
    then { UE reports a Short BSR }
}

```

(4)

```

with { UE in RRC_CONNECTED state }
ensure that {
  when { UE transmits a MAC PDU and the number of padding bits is equal to or larger than the size
of a Long BSR plus its subheader }
    then { UE reports a long BSR }
}

```

#### 7.1.1.3.5.2 Conformance requirements

References: The conformance requirements covered in the present TC are specified in: TS 38.321, clauses 5.4.5, 6.1.3.1 and 6.2.1. Unless otherwise stated these are Rel-15 requirements.

[TS 38.321, clause 5.4.5]

The Buffer Status reporting (BSR) procedure is used to provide the serving gNB with information about UL data volume in the MAC entity.

RRC configures the following parameters to control the BSR:

- *periodicBSR-Timer*;
- *retxBSR-Timer*;
- *logicalChannelSR-Delay*;
- *logicalChannelSR-DelayTimer*;
- *logicalChannelGroup*.

Each logical channel may be allocated to an LCG using the *logicalChannelGroup*. The maximum number of LCGs is eight.

The MAC entity determines the amount of UL data available for a logical channel according to the data volume calculation procedure in TSs 38.322 and 38.323 [3] [4].

A BSR shall be triggered if any of the following events occur:

- the MAC entity has new UL data available for a logical channel which belongs to an LCG; and either
  - the new UL data belongs to a logical channel with higher priority than the priority of any logical channel containing available UL data which belong to any LCG; or
  - none of the logical channels which belong to an LCG contains any available UL data.

in which case the BSR is referred below to as 'Regular BSR';

- UL resources are allocated and number of padding bits is equal to or larger than the size of the Buffer Status Report MAC CE plus its subheader, in which case the BSR is referred below to as 'Padding BSR';
- *retxBSR-Timer* expires, and at least one of the logical channels which belong to an LCG contains UL data, in which case the BSR is referred below to as 'Regular BSR';



- *periodicBSR-Timer* expires, in which case the BSR is referred below to as 'Periodic BSR'.

For Regular BSR, the MAC entity shall:

- 1> if the BSR is triggered for a logical channel for which *logicalChannelSR-Delay* is configured by upper layers:
  - 2> start or restart the *logicalChannelSR-DelayTimer*.
- 1> else:
  - 2> if running, stop the *logicalChannelSR-DelayTimer*.

For Regular and Periodic BSR, the MAC entity shall:

- 1> if more than one LCG has data available for transmission when the BSR is to be transmitted:
  - 2> report Long BSR for all LCGs which have data available for transmission.
- 1> else:
  - 2> report Short BSR.

For Padding BSR:

- 1> if the number of padding bits is equal to or larger than the size of the Short BSR plus its subheader but smaller than the size of the Long BSR plus its subheader:
  - 2> if more than one LCG has data available for transmission when the BSR is to be transmitted:
    - 3> if the number of padding bits is equal to the size of the Short BSR plus its subheader:
      - 4> report Short Truncated BSR of the LCG with the highest priority logical channel with data available for transmission.
    - 3> else:
      - 4> report Long Truncated BSR of the LCG(s) with the logical channels having data available for transmission following a decreasing order of priority, and in case of equal priority, in increasing order of LCGID.
  - 2> else:
    - 3> report Short BSR;
- 1> else if the number of padding bits is equal to or larger than the size of the Long BSR plus its subheader:
  - 2> report Long BSR for all LCGs which have data available for transmission.

The MAC entity shall:

- 1> if the Buffer Status reporting procedure determines that at least one BSR has been triggered and not cancelled:
  - 2> if UL-SCH resources are available for a new immediate transmission:
    - 3> instruct the Multiplexing and Assembly procedure to generate the BSR MAC CE(s);
    - 3> start or restart *periodicBSR-Timer* except when all the generated BSRs are long or short Truncated BSRs;
    - 3> start or restart *retxBSR-Timer*.
  - 2> else if a Regular BSR has been triggered and *logicalChannelSR-DelayTimer* is not running:
    - 3> if an uplink grant is not a configured grant; or
    - 3> if the Regular BSR was not triggered for a logical channel for which logical channel SR masking (*logicalChannelSR-Mask*) is setup by upper layers:
      - 4> trigger a Scheduling Request.

A MAC PDU shall contain at most one BSR MAC CE, even when multiple events have triggered a BSR by the time. The Regular BSR and the Periodic BSR shall have precedence over the padding BSR.

The MAC entity shall restart *retxBSR-Timer* upon reception of a grant for transmission of new data on any UL-SCH.

All triggered BSRs may be cancelled when the UL grant(s) can accommodate all pending data available for transmission but is not sufficient to additionally accommodate the BSR MAC control element plus its subheader. All triggered BSRs shall be cancelled when a BSR is included in a MAC PDU for transmission.

The MAC entity shall transmit at most one BSR in one MAC PDU. Padding BSR shall not be included when the MAC PDU contains a Regular or Periodic BSR.

[TS 38.322, clause 6.1.3.1]

Buffer Status Report (BSR) MAC CEs consist of either:

- Short BSR format (fixed size); or
- Long BSR format (variable size); or
- Short Truncated BSR format (fixed size); or
- Long Truncated BSR format (variable size).

The BSR formats are identified by MAC PDU subheaders with LCIDs as specified in Table 6.2.1-2.

The fields in the BSR MAC CE are defined as follows:

- LCG ID: The Logical Channel Group ID field identifies the group of logical channel(s) whose buffer status is being reported. The length of the field is 3 bits;
- LCG<sub>i</sub>: For the Long BSR format, this field indicates the presence of the Buffer Size field for the logical channel group i. The LCG<sub>i</sub> field set to "1" indicates that the Buffer Size field for the logical channel group i is reported. The LCG<sub>i</sub> field set to "0" indicates that the Buffer Size field for the logical channel group i is not reported. For the Long Truncated BSR format, this field indicates whether logical channel group i has data available. The LCG<sub>i</sub> field set to "1" indicates that logical channel group i has data available. The LCG<sub>i</sub> field set to "0" indicates that logical channel group i does not have data available;
- Buffer Size: The Buffer Size field identifies the total amount of data available according to the data volume calculation procedure in TSs 38.322 and 38.323 [3] [4] across all logical channels of a logical channel group after the MAC PDU has been built (i.e. after the logical channel prioritization procedure, which may result the value of the Buffer Size field to zero). The amount of data is indicated in number of bytes. The size of the RLC and MAC headers are not considered in the buffer size computation. The length of this field for the Short BSR format and the Short Truncated BSR format is 5 bits. The length of this field for the Long BSR format and the Long Truncated BSR format is 8 bits. The values for the 5-bit and 8-bit Buffer Size fields are shown in Tables 6.1.3.1-1 and 6.1.3.1-2, respectively. For the Long BSR format and the Long Truncated BSR format, the Buffer Size fields are included in ascending order based on the LCG<sub>i</sub>. For the Long Truncated BSR format the number of Buffer Size fields included is maximised, while not exceeding the number of padding bits.

NOTE: The number of the Buffer Size fields in the Long Truncated BSR format can be zero.

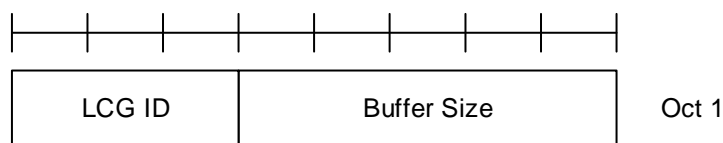
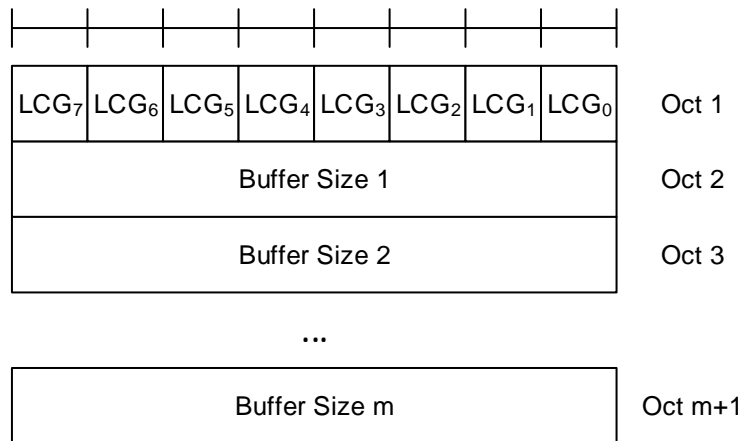

Figure 6.1.3.1-1: Short BSR and Short Truncated BSR MAC CE



**Figure 6.1.3.1-2: Long BSR and Long Truncated BSR MAC CE**

**Table 6.1.3.1-1: Buffer size levels (in bytes) for 5-bit Buffer Size field**

Index	BS value	Index	BS value	Index	BS value	Index	BS value
0	0	8	≤ 102	16	≤ 1446	24	≤ 20516
1	≤ 10	9	≤ 142	17	≤ 2014	25	≤ 28581
2	≤ 14	10	≤ 198	18	≤ 2806	26	≤ 39818
3	≤ 20	11	≤ 276	19	≤ 3909	27	≤ 55474
4	≤ 28	12	≤ 384	20	≤ 5446	28	≤ 77284
5	≤ 38	13	≤ 535	21	≤ 7587	29	≤ 107669
6	≤ 53	14	≤ 745	22	≤ 10570	30	≤ 150000
7	≤ 74	15	≤ 1038	23	≤ 14726	31	> 150000

**Table 6.1.3.1-2: Buffer size levels (in bytes) for 8-bit Buffer Size field**

Index	BS value	Index	BS value	Index	BS value	Index	BS value
0	0	64	≤ 526	128	≤ 29431	192	≤ 1647644
1	≤ 10	65	≤ 560	129	≤ 31342	193	≤ 1754595
2	≤ 11	66	≤ 597	130	≤ 33376	194	≤ 1868488
3	≤ 12	67	≤ 635	131	≤ 35543	195	≤ 1989774
4	≤ 13	68	≤ 677	132	≤ 37850	196	≤ 2118933
5	≤ 13	69	≤ 720	133	≤ 40307	197	≤ 2256475
6	≤ 14	70	≤ 767	134	≤ 42923	198	≤ 2402946
7	≤ 15	71	≤ 817	135	≤ 45709	199	≤ 2558924
8	≤ 16	72	≤ 870	136	≤ 48676	200	≤ 2725027
9	≤ 17	73	≤ 926	137	≤ 51836	201	≤ 2901912
10	≤ 18	74	≤ 987	138	≤ 55200	202	≤ 3090279
11	≤ 19	75	≤ 1051	139	≤ 58784	203	≤ 3290873
12	≤ 20	76	≤ 1119	140	≤ 62599	204	≤ 3504487
13	≤ 22	77	≤ 1191	141	≤ 66663	205	≤ 3731968
14	≤ 23	78	≤ 1269	142	≤ 70990	206	≤ 3974215
15	≤ 25	79	≤ 1351	143	≤ 75598	207	≤ 4232186
16	≤ 26	80	≤ 1439	144	≤ 80505	208	≤ 4506902
17	≤ 28	81	≤ 1532	145	≤ 85730	209	≤ 4799451
18	≤ 30	82	≤ 1631	146	≤ 91295	210	≤ 5110989
19	≤ 32	83	≤ 1737	147	≤ 97221	211	≤ 5442750
20	≤ 34	84	≤ 1850	148	≤ 103532	212	≤ 5796046
21	≤ 36	85	≤ 1970	149	≤ 110252	213	≤ 6172275
22	≤ 38	86	≤ 2098	150	≤ 117409	214	≤ 6572925
23	≤ 40	87	≤ 2234	151	≤ 125030	215	≤ 6999582
24	≤ 43	88	≤ 2379	152	≤ 133146	216	≤ 7453933
25	≤ 46	89	≤ 2533	153	≤ 141789	217	≤ 7937777
26	≤ 49	90	≤ 2698	154	≤ 150992	218	≤ 8453028
27	≤ 52	91	≤ 2873	155	≤ 160793	219	≤ 9001725
28	≤ 55	92	≤ 3059	156	≤ 171231	220	≤ 9586039
29	≤ 59	93	≤ 3258	157	≤ 182345	221	≤ 10208280
30	≤ 62	94	≤ 3469	158	≤ 194182	222	≤ 10870913
31	≤ 66	95	≤ 3694	159	≤ 206786	223	≤ 11576557
32	≤ 71	96	≤ 3934	160	≤ 220209	224	≤ 12328006
33	≤ 75	97	≤ 4189	161	≤ 234503	225	≤ 13128233
34	≤ 80	98	≤ 4461	162	≤ 249725	226	≤ 13980403
35	≤ 85	99	≤ 4751	163	≤ 265935	227	≤ 14887889
36	≤ 91	100	≤ 5059	164	≤ 283197	228	≤ 15854280
37	≤ 97	101	≤ 5387	165	≤ 301579	229	≤ 16883401
38	≤ 103	102	≤ 5737	166	≤ 321155	230	≤ 17979324
39	≤ 110	103	≤ 6109	167	≤ 342002	231	≤ 19146385
40	≤ 117	104	≤ 6506	168	≤ 364202	232	≤ 20389201
41	≤ 124	105	≤ 6928	169	≤ 387842	233	≤ 21712690
42	≤ 132	106	≤ 7378	170	≤ 413018	234	≤ 23122088
43	≤ 141	107	≤ 7857	171	≤ 439827	235	≤ 24622972
44	≤ 150	108	≤ 8367	172	≤ 468377	236	≤ 26221280
45	≤ 160	109	≤ 8910	173	≤ 498780	237	≤ 27923336
46	≤ 170	110	≤ 9488	174	≤ 531156	238	≤ 29735875
47	≤ 181	111	≤ 10104	175	≤ 565634	239	≤ 31666069
48	≤ 193	112	≤ 10760	176	≤ 602350	240	≤ 33721553
49	≤ 205	113	≤ 11458	177	≤ 641449	241	≤ 35910462
50	≤ 218	114	≤ 12202	178	≤ 683087	242	≤ 38241455
51	≤ 233	115	≤ 12994	179	≤ 727427	243	≤ 40723756
52	≤ 248	116	≤ 13838	180	≤ 774645	244	≤ 43367187
53	≤ 264	117	≤ 14736	181	≤ 824928	245	≤ 46182206
54	≤ 281	118	≤ 15692	182	≤ 878475	246	≤ 49179951
55	≤ 299	119	≤ 16711	183	≤ 935498	247	≤ 52372284
56	≤ 318	120	≤ 17795	184	≤ 996222	248	≤ 55771835
57	≤ 339	121	≤ 18951	185	≤ 1060888	249	≤ 59392055
58	≤ 361	122	≤ 20181	186	≤ 1129752	250	≤ 63247269
59	≤ 384	123	≤ 21491	187	≤ 1203085	251	≤ 67352729
60	≤ 409	124	≤ 22885	188	≤ 1281179	252	≤ 71724679
61	≤ 436	125	≤ 24371	189	≤ 1364342	253	≤ 76380419
62	≤ 464	126	≤ 25953	190	≤ 1452903	254	≤ 81338368
63	≤ 494	127	≤ 27638	191	≤ 1547213	255	> 81338368

[TS 38.321, clause 6.2.1]

**Table 6.2.1-2 Values of LCID for UL-SCH**

Index	LCID values
000000	CCCH
000001–100000	Identity of the logical channel
100001–110110	Reserved
110111	Configured Grant Confirmation
111000	Multiple Entry PHR
111001	Single Entry PHR
111010	C-RNTI
111011	Short Truncated BSR
111100	Long Truncated BSR
111101	Short BSR
111110	Long BSR
111111	Padding

7.1.1.3.5.3 Test description

7.1.1.3.5.3.1 Pre-test conditions

Same Pre-test conditions as in clause 7.1.1.0 with the exception of 2 AM SN terminated SCG bearers configured according to Table 7.1.1.3.5.3.1-1.

**Table 7.1.1.3.5.3.1-1: Logical Channel Configuration Settings**

Parameter	DRB1	DRB2
LogicalChannel-Identity	4	5
Priority	7	6
prioritizedBitRate	0kbs	0kbs
logicalChannelGroup	2 (LCG ID#2)	1 (LCG ID#1)

## 7.1.1.3.5.3.2 Test procedure sequence

Table 7.1.1.3.5.3.2-1: Main behaviour

St	Procedure	Message Sequence		TP	Verdict
		U - S	Message		
1	The SS ignores scheduling requests and does not allocate any uplink grant.	-	-	-	-
-	EXCEPTION: Step 2 shall be repeated for 3 times	-	-	-	-
2	The SS transmits a MAC PDU including an RLC SDU of size 12 bytes on logical channel 5.	<--	MAC PDU (RLC SDU on LC 5)	-	-
3	The SS transmits a MAC PDU including an RLC SDU of size 12 bytes on logical channel 4.	<--	MAC PDU (RLC SDU on LC 4)	-	-
4	UE transmits a Scheduling Request on PUCCH.	-->	(SR)	-	-
5	The SS sends an uplink grant of size 40 bits. (Note 1)	<--	(UL grant)	-	-
6	The UE transmit a Long BSR report.	-->	MAC PDU (Long BSR header (LCID='111110'), Long BSR)	-	-
7	The SS sends an uplink grant of size 128 bits. (Note 2)	<--	(UL grant)	-	-
8	Check: Does UE transmit a MAC PDU containing an RLC SDU and a short truncated BSR indicating pending data ('Buffer size' field > '0') for logicalChannelGroup 1 ('LCG ID' field set to '01')?	-->	MAC PDU (MAC sub PDU for RLC PDU, short truncated BSR header (LCID='111011'), short truncatedBSR(LCG ID ='01', Buffer size>'0'),)	1	P
9	The SS sends an uplink grant of size 136 bits. (Note 3)	<--	(UL grant)	-	-
10	Check: Does UE transmit a MAC PDU containing an RLC SDU and a long truncated BSR indicating pending data ('Buffer size' field > '0') for logicalChannelGroup 1 ('LCG ID' field set to '01')?	-->	MAC PDU (MAC sub PDU for RLC PDU, long truncated BSR header (LCID='111100'), long truncatedBSR(LCG ID ='01', Buffer size>'0'),)	2	P
11	The SS sends an uplink grant of size 136 bits. (Note 4)	<--	(UL grant)	-	-
12	Check: Does UE transmit a MAC PDU containing an RLC SDU and with a Short BSR indicating pending data ('Buffer size' field > '0') for logicalChannelGroup 2 ('LCG ID' field ='10')?	-->	MAC PDU (Short BSR header(LCID='11101'), Short BSR(LCG ID ='10',Buffer size>'0'), RLC SDU)	3	P
13	The SS sends an uplink grant of size 152 bits. (Note 5)	<--	(UL grant)	-	-
14	Check: Does UE transmit a MAC PDU containing a RLC SDU and a Long BSR?	-->	MAC PDU (Long BSR header (LCID='111110'), Long BSR), RLC SDU)	4	P
Note 1:	40 bits (L <sub>RBs</sub> & I <sub>MCS</sub> as per 38.523-3[3] annex B) enables UE to transmit a MAC PDU with a MAC BSR header (1 byte) and a Short BSR (1 bytes) or a MAC BSR header (2 byte) a Long BSR (3 byte when 2 LCG configured).				
Note 2:	UE triggers a truncated Short BSR of type "Padding BSR" to report buffer status for one LCG for that TTI. (2 Byte MAC Data sub PDU header + 12 Byte MAC SDU + 1 Byte Short truncated BSR sub header + 1 Byte short truncated BSR)				
Note 3:	UE triggers a truncated Long BSR of type "Padding BSR" to report buffer status for one LCG for that TTI. (2 Byte MAC Data sub PDU header + 12 Byte MAC SDU + 1 Byte Short truncated BSR sub header + 2 Byte long truncated BSR)				
Note 4:	UE triggers a Short BSR of type "Padding BSR" to report buffer status for one LCG for that TTI. (2 Byte MAC Data sub PDU header + 12 Byte MAC SDU + 1 Byte Short BSR sub header + 1 Byte short BSR)				
Note 5:	UE triggers a long BSR of type "Padding BSR" to report buffer status for one LCG for that TTI. (2 Byte MAC Data sub PDU header + 12 Byte MAC SDU + 2 Byte long BSR sub header + 3 Byte long BSR)				

## 7.1.1.3.5.3.3 Specific message contents

None

### 7.1.1.3.6 Correct handling of MAC control information / Buffer status / Periodic BSR timer expires

#### 7.1.1.3.6.1 Test Purpose (TP)

(1)

```
with { UE in RRC_CONNECTED state }
ensure that {
  when { periodicBSR-Timer expires and more than one LCG has buffered data }
  then { UE triggers a Periodic BSR and reports Long BSR and restarts the periodicBSR-Timer }
}
```

(2)

```
with { UE in E-UTRA RRC_CONNECTED state }
ensure that {
  when { periodicBSR-Timer expires and one LCG has buffered data }
  then { UE triggers a Periodic BSR and reports Short BSR and restarts the periodicBSR-Timer }
}
```

#### 7.1.1.3.6.2 Conformance requirements

References: The conformance requirements covered in the present TC are specified in: TS 38.321, clauses 5.4.5, 6.1.3.1 and 6.2.1. Unless otherwise stated these are Rel-15 requirements.

[TS 38.321, clause 5.4.5]

The Buffer Status reporting (BSR) procedure is used to provide the serving gNB with information about UL data volume in the MAC entity.

RRC configures the following parameters to control the BSR:

- *periodicBSR-Timer*;
- *retxBSR-Timer*;
- *logicalChannelSR-Delay*;
- *logicalChannelSR-DelayTimer*;
- *logicalChannelGroup*.

Each logical channel may be allocated to an LCG using the *logicalChannelGroup*. The maximum number of LCGs is eight.

The MAC entity determines the amount of UL data available for a logical channel according to the data volume calculation procedure in TSs 38.322 and 38.323 [3] [4].

A BSR shall be triggered if any of the following events occur:

- the MAC entity has new UL data available for a logical channel which belongs to an LCG; and either
  - the new UL data belongs to a logical channel with higher priority than the priority of any logical channel containing available UL data which belong to any LCG; or
  - none of the logical channels which belong to an LCG contains any available UL data.

in which case the BSR is referred below to as 'Regular BSR';

- UL resources are allocated and number of padding bits is equal to or larger than the size of the Buffer Status Report MAC CE plus its subheader, in which case the BSR is referred below to as 'Padding BSR';
- *retxBSR-Timer* expires, and at least one of the logical channels which belong to an LCG contains UL data, in which case the BSR is referred below to as 'Regular BSR';
- *periodicBSR-Timer* expires, in which case the BSR is referred below to as 'Periodic BSR'.



For Regular BSR, the MAC entity shall:

- 1> if the BSR is triggered for a logical channel for which *logicalChannelSR-Delay* is configured by upper layers:
  - 2> start or restart the *logicalChannelSR-DelayTimer*.
- 1> else:
  - 2> if running, stop the *logicalChannelSR-DelayTimer*.

For Regular and Periodic BSR, the MAC entity shall:

- 1> if more than one LCG has data available for transmission when the BSR is to be transmitted:
  - 2> report Long BSR for all LCGs which have data available for transmission.
- 1> else:
  - 2> report Short BSR.

For Padding BSR:

- 1> if the number of padding bits is equal to or larger than the size of the Short BSR plus its subheader but smaller than the size of the Long BSR plus its subheader:
  - 2> if more than one LCG has data available for transmission when the BSR is to be transmitted:
    - 3> if the number of padding bits is equal to the size of the Short BSR plus its subheader:
      - 4> report Short Truncated BSR of the LCG with the highest priority logical channel with data available for transmission.
    - 3> else:
      - 4> report Long Truncated BSR of the LCG(s) with the logical channels having data available for transmission following a decreasing order of priority, and in case of equal priority, in increasing order of LCGID.
  - 2> else:
    - 3> report Short BSR;
- 1> else if the number of padding bits is equal to or larger than the size of the Long BSR plus its subheader:
  - 2> report Long BSR for all LCGs which have data available for transmission.

The MAC entity shall:

- 1> if the Buffer Status reporting procedure determines that at least one BSR has been triggered and not cancelled:
  - 2> if UL-SCH resources are available for a new immediate transmission:
    - 3> instruct the Multiplexing and Assembly procedure to generate the BSR MAC CE(s);
    - 3> start or restart *periodicBSR-Timer* except when all the generated BSRs are long or short Truncated BSRs;
    - 3> start or restart *retxBSR-Timer*.
  - 2> else if a Regular BSR has been triggered and *logicalChannelSR-DelayTimer* is not running:
    - 3> if an uplink grant is not a configured grant; or
    - 3> if the Regular BSR was not triggered for a logical channel for which logical channel SR masking (*logicalChannelSR-Mask*) is setup by upper layers:
      - 4> trigger a Scheduling Request.

A MAC PDU shall contain at most one BSR MAC CE, even when multiple events have triggered a BSR by the time. The Regular BSR and the Periodic BSR shall have precedence over the padding BSR.

The MAC entity shall restart *retxBSR-Timer* upon reception of a grant for transmission of new data on any UL-SCH.

All triggered BSRs may be cancelled when the UL grant(s) can accommodate all pending data available for transmission but is not sufficient to additionally accommodate the BSR MAC control element plus its subheader. All triggered BSRs shall be cancelled when a BSR is included in a MAC PDU for transmission.

The MAC entity shall transmit at most one BSR in one MAC PDU. Padding BSR shall not be included when the MAC PDU contains a Regular or Periodic BSR.

[TS 38.322, clause 6.1.3.1]

Buffer Status Report (BSR) MAC CEs consist of either:

- Short BSR format (fixed size); or
- Long BSR format (variable size); or
- Short Truncated BSR format (fixed size); or
- Long Truncated BSR format (variable size).

The BSR formats are identified by MAC PDU subheaders with LCIDs as specified in Table 6.2.1-2.

The fields in the BSR MAC CE are defined as follows:

- LCG ID: The Logical Channel Group ID field identifies the group of logical channel(s) whose buffer status is being reported. The length of the field is 3 bits;
- LCG<sub>i</sub>: For the Long BSR format, this field indicates the presence of the Buffer Size field for the logical channel group i. The LCG<sub>i</sub> field set to "1" indicates that the Buffer Size field for the logical channel group i is reported. The LCG<sub>i</sub> field set to "0" indicates that the Buffer Size field for the logical channel group i is not reported. For the Long Truncated BSR format, this field indicates whether logical channel group i has data available. The LCG<sub>i</sub> field set to "1" indicates that logical channel group i has data available. The LCG<sub>i</sub> field set to "0" indicates that logical channel group i does not have data available;
- Buffer Size: The Buffer Size field identifies the total amount of data available according to the data volume calculation procedure in TSs 38.322 and 38.323 [3] [4] across all logical channels of a logical channel group after the MAC PDU has been built (i.e. after the logical channel prioritization procedure, which may result the value of the Buffer Size field to zero). The amount of data is indicated in number of bytes. The size of the RLC and MAC headers are not considered in the buffer size computation. The length of this field for the Short BSR format and the Short Truncated BSR format is 5 bits. The length of this field for the Long BSR format and the Long Truncated BSR format is 8 bits. The values for the 5-bit and 8-bit Buffer Size fields are shown in Tables 6.1.3.1-1 and 6.1.3.1-2, respectively. For the Long BSR format and the Long Truncated BSR format, the Buffer Size fields are included in ascending order based on the LCG<sub>i</sub>. For the Long Truncated BSR format the number of Buffer Size fields included is maximised, while not exceeding the number of padding bits.

NOTE: The number of the Buffer Size fields in the Long Truncated BSR format can be zero.

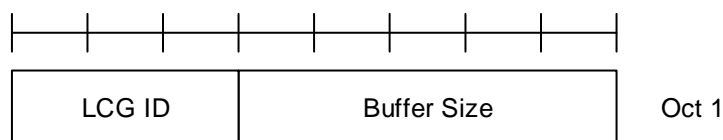

Figure 6.1.3.1-1: Short BSR and Short Truncated BSR MAC CE

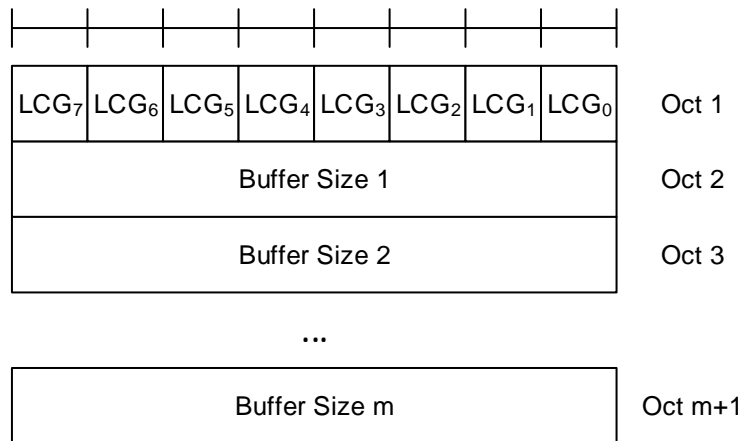

Figure 6.1.3.1-2: Long BSR and Long Truncated BSR MAC CE

Table 6.1.3.1-1: Buffer size levels (in bytes) for 5-bit Buffer Size field

Index	BS value	Index	BS value	Index	BS value	Index	BS value
0	0	8	≤ 102	16	≤ 1446	24	≤ 20516
1	≤ 10	9	≤ 142	17	≤ 2014	25	≤ 28581
2	≤ 14	10	≤ 198	18	≤ 2806	26	≤ 39818
3	≤ 20	11	≤ 276	19	≤ 3909	27	≤ 55474
4	≤ 28	12	≤ 384	20	≤ 5446	28	≤ 77284
5	≤ 38	13	≤ 535	21	≤ 7587	29	≤ 107669
6	≤ 53	14	≤ 745	22	≤ 10570	30	≤ 150000
7	≤ 74	15	≤ 1038	23	≤ 14726	31	> 150000

**Table 6.1.3.1-2: Buffer size levels (in bytes) for 8-bit Buffer Size field**

Index	BS value	Index	BS value	Index	BS value	Index	BS value
0	0	64	≤ 526	128	≤ 29431	192	≤ 1647644
1	≤ 10	65	≤ 560	129	≤ 31342	193	≤ 1754595
2	≤ 11	66	≤ 597	130	≤ 33376	194	≤ 1868488
3	≤ 12	67	≤ 635	131	≤ 35543	195	≤ 1989774
4	≤ 13	68	≤ 677	132	≤ 37850	196	≤ 2118933
5	≤ 13	69	≤ 720	133	≤ 40307	197	≤ 2256475
6	≤ 14	70	≤ 767	134	≤ 42923	198	≤ 2402946
7	≤ 15	71	≤ 817	135	≤ 45709	199	≤ 2558924
8	≤ 16	72	≤ 870	136	≤ 48676	200	≤ 2725027
9	≤ 17	73	≤ 926	137	≤ 51836	201	≤ 2901912
10	≤ 18	74	≤ 987	138	≤ 55200	202	≤ 3090279
11	≤ 19	75	≤ 1051	139	≤ 58784	203	≤ 3290873
12	≤ 20	76	≤ 1119	140	≤ 62599	204	≤ 3504487
13	≤ 22	77	≤ 1191	141	≤ 66663	205	≤ 3731968
14	≤ 23	78	≤ 1269	142	≤ 70990	206	≤ 3974215
15	≤ 25	79	≤ 1351	143	≤ 75598	207	≤ 4232186
16	≤ 26	80	≤ 1439	144	≤ 80505	208	≤ 4506902
17	≤ 28	81	≤ 1532	145	≤ 85730	209	≤ 4799451
18	≤ 30	82	≤ 1631	146	≤ 91295	210	≤ 5110989
19	≤ 32	83	≤ 1737	147	≤ 97221	211	≤ 5442750
20	≤ 34	84	≤ 1850	148	≤ 103532	212	≤ 5796046
21	≤ 36	85	≤ 1970	149	≤ 110252	213	≤ 6172275
22	≤ 38	86	≤ 2098	150	≤ 117409	214	≤ 6572925
23	≤ 40	87	≤ 2234	151	≤ 125030	215	≤ 6999582
24	≤ 43	88	≤ 2379	152	≤ 133146	216	≤ 7453933
25	≤ 46	89	≤ 2533	153	≤ 141789	217	≤ 7937777
26	≤ 49	90	≤ 2698	154	≤ 150992	218	≤ 8453028
27	≤ 52	91	≤ 2873	155	≤ 160793	219	≤ 9001725
28	≤ 55	92	≤ 3059	156	≤ 171231	220	≤ 9586039
29	≤ 59	93	≤ 3258	157	≤ 182345	221	≤ 10208280
30	≤ 62	94	≤ 3469	158	≤ 194182	222	≤ 10870913
31	≤ 66	95	≤ 3694	159	≤ 206786	223	≤ 11576557
32	≤ 71	96	≤ 3934	160	≤ 220209	224	≤ 12328006
33	≤ 75	97	≤ 4189	161	≤ 234503	225	≤ 13128233
34	≤ 80	98	≤ 4461	162	≤ 249725	226	≤ 13980403
35	≤ 85	99	≤ 4751	163	≤ 265935	227	≤ 14887889
36	≤ 91	100	≤ 5059	164	≤ 283197	228	≤ 15854280
37	≤ 97	101	≤ 5387	165	≤ 301579	229	≤ 16883401
38	≤ 103	102	≤ 5737	166	≤ 321155	230	≤ 17979324
39	≤ 110	103	≤ 6109	167	≤ 342002	231	≤ 19146385
40	≤ 117	104	≤ 6506	168	≤ 364202	232	≤ 20389201
41	≤ 124	105	≤ 6928	169	≤ 387842	233	≤ 21712690
42	≤ 132	106	≤ 7378	170	≤ 413018	234	≤ 23122088
43	≤ 141	107	≤ 7857	171	≤ 439827	235	≤ 24622972
44	≤ 150	108	≤ 8367	172	≤ 468377	236	≤ 26221280
45	≤ 160	109	≤ 8910	173	≤ 498780	237	≤ 27923336
46	≤ 170	110	≤ 9488	174	≤ 531156	238	≤ 29735875
47	≤ 181	111	≤ 10104	175	≤ 565634	239	≤ 31666069
48	≤ 193	112	≤ 10760	176	≤ 602350	240	≤ 33721553
49	≤ 205	113	≤ 11458	177	≤ 641449	241	≤ 35910462
50	≤ 218	114	≤ 12202	178	≤ 683087	242	≤ 38241455
51	≤ 233	115	≤ 12994	179	≤ 727427	243	≤ 40723756
52	≤ 248	116	≤ 13838	180	≤ 774645	244	≤ 43367187
53	≤ 264	117	≤ 14736	181	≤ 824928	245	≤ 46182206
54	≤ 281	118	≤ 15692	182	≤ 878475	246	≤ 49179951
55	≤ 299	119	≤ 16711	183	≤ 935498	247	≤ 52372284
56	≤ 318	120	≤ 17795	184	≤ 996222	248	≤ 55771835
57	≤ 339	121	≤ 18951	185	≤ 1060888	249	≤ 59392055
58	≤ 361	122	≤ 20181	186	≤ 1129752	250	≤ 63247269
59	≤ 384	123	≤ 21491	187	≤ 1203085	251	≤ 67352729
60	≤ 409	124	≤ 22885	188	≤ 1281179	252	≤ 71724679
61	≤ 436	125	≤ 24371	189	≤ 1364342	253	≤ 76380419
62	≤ 464	126	≤ 25953	190	≤ 1452903	254	≤ 81338368
63	≤ 494	127	≤ 27638	191	≤ 1547213	255	> 81338368

[TS 38.321, clause 6.2.1]

**Table 6.2.1-2 Values of LCID for UL-SCH**

Index	LCID values
000000	CCCH
000001–100000	Identity of the logical channel
100001–110110	Reserved
110111	Configured Grant Confirmation
111000	Multiple Entry PHR
111001	Single Entry PHR
111010	C-RNTI
111011	Short Truncated BSR
111100	Long Truncated BSR
111101	Short BSR
111110	Long BSR
111111	Padding

7.1.1.3.6.3 Test description

7.1.1.3.6.3.1 Pre-test conditions

Same Pre-test conditions as in clause 7.1.1.0 with the exception of 2 SN terminated SCG bearers configured according to Table 7.1.1.3.6.3.1-1.

**Table 7.1.1.3.6.3.1-1: Logical Channel Configuration Settings**

Parameter	DRB1	DRB2
LogicalChannel-Identity	4	5
Priority	7	6
prioritizedBitRate	0kbs	0kbs
logicalChannelGroup	2 (LCG ID#2)	1 (LCG ID#1)

## 7.1.1.3.6.3.2 Test procedure sequence

Table 7.1.1.3.6.3.2-1: Main behaviour

St	Procedure	Message Sequence		TP	Verdict
		U - S	Message		
1	The SS ignores scheduling requests and does not allocate any uplink grant.	-	-	-	-
2	The SS transmits a MAC PDU containing an RLC PDU on logical channel 4 (LCG ID 2), which contains 1 RLC SDU of size 14 bytes.	<--	MAC PDU (RLC PDU)		
3	The SS sends an uplink grant of size 32 bits. (Note 1)	<--	(UL grant)	-	-
4	The UE transmits a short BSR report and restarts <i>periodicBSR-Timer</i>	-->	MAC PDU ((LCID='111101', LCG ID='10', Buffer size index > 0)	-	-
-	EXCEPTION: Steps 5 to 7 shall be repeated two times (Note 2)	-	-	-	-
5	Wait for <i>periodicBSR-Timer</i> expiry.	-	-	-	-
6	The SS sends an uplink grant of size 32 bits	-	-	-	-
7	Check: Does UE transmit a MAC PDU containing a Short BSR with 'LCG ID' field set to '10' (logicalChannelGroup 2) and Buffer Size Index > 0?	-->	MAC PDU (LCID='111101', LCG ID='10', Buffer Size index > 0)	2	P
8	The SS transmits a MAC PDU containing an RLC PDU on logical channel 5 (LCG ID 1), which contains 1 RLC SDU of size 14 bytes.	<--	MAC PDU (RLC PDU)	-	-
9	The SS sends an uplink grant of size 40 bits (Note 3)	<--	(UL grant)	-	-
10	The UE transmits a long BSR report with 'Buffer size#1' (LCG ID=1) and 'Buffer size#2' (LCG ID=2) fields set to value > '0'	-->	MAC PDU (( 'Buffer size#1 index' > 0, 'Buffer size#2 index=' >0')	-	-
-	EXCEPTION: Step 11 to 13 shall be repeated twice. (Note 4)	-	-	-	-
11	Wait for <i>periodicBSR-Timer</i> expiry.	-	-	-	-
12	The SS sends an uplink grant of size 40 bits	-	-	-	-
13	Check: Does UE transmit a MAC PDU containing a Long BSR with 'Buffer size#1' (LCG ID=1) and 'Buffer size#2' (LCG ID=2) fields set to value > '0'?	-->	MAC PDU	1	P
14	The SS transmits 1 UL grant of size 328 bits to enable the UE to loopback RLC SDU on LCG 4 and LCG 5.			-	-
15	The UE transmits MAC PDU containing the remaining RLC SDUs as sent by the SS in steps 2 and 8.	-->	MAC PDU	-	-
<p>Note 1: SS transmits an UL grant of 32 bits(L<sub>RBs</sub> &amp; M<sub>Cs</sub> as per 38.523-3[3] annex B) to allow UE to transmit a Regular BSR triggered by the new data received logicalChannelGroup 1 in step 2.</p> <p>Note 2: One short BSR due to first expiry of <i>periodicBSR-Timer</i> and one short BSR due to second expiry of <i>periodicBSR-Timer</i>.</p> <p>Note 3: SS transmits an UL grant of 40 bits(L<sub>RBs</sub> &amp; M<sub>Cs</sub> as per 38.523-3[3] annex B) to allow UE to transmit a Regular BSR triggered by the new data received on higher priority logicalChannelGroup 1 in step 8.</p> <p>Note 4: One long BSR due to expiry of <i>periodicBSR-Timer</i> and one long BSR due to second expiry of <i>periodicBSR-Timer</i>.</p>					

## 7.1.1.3.6.3.3 Specific message contents

None

## 7.1.1.3.7 UE power headroom reporting / Periodic reporting / DL pathloss change reporting

## 7.1.1.3.7.1 Test Purpose (TP)

(1)

```
with { UE in RRC_CONNECTED state }
ensure that {
  when { phr-PeriodicTimer is configured in UE }
```

```

    then { UE transmits a MAC PDU containing Power Headroom MAC Control Element }
  }

```

(2)

```

with { UE in RRC_CONNECTED state with periodic power headroom reporting configured }
ensure that {
  when { phr-PeriodicTimer expires and UL resources allocated for new transmission }
  then { UE transmits a MAC PDU containing Power Headroom MAC Control Element }
}

```

(3)

```

with { UE in RRC_CONNECTED state with periodic power headroom reporting configured }
ensure that {
  when { power headroom reporting is disabled }
  then { UE stops transmitting Power Headroom MAC Control Element }
}

```

(4)

```

with { UE in RRC_Connected state with Power headroom reporting for phr-Tx-PowerFactorChange
configured }
ensure that {
  when { the DL Pathloss has changed more than phr-Tx-PowerFactorChange dB and phr-ProhibitTimer is
running }
  then { UE does not transmit a MAC PDU containing Power Headroom MAC Control Element }
}

```

(5)

```

with { UE in RRC_Connected state with Power headroom reporting for phr-Tx-PowerFactorChange
configured }
ensure that {
  when { phr-ProhibitTimer expires and power headroom report is triggered due to DL Pathloss change
}
  then { UE transmits a MAC PDU containing Power Headroom MAC Control Element }
}

```

#### 7.1.1.3.7.2 Conformance requirements

References: The conformance requirements covered in the current TC are specified in: TS 38.321 clause 5.4.6 and 6.1.3.8. Unless otherwise stated these are Rel-15 requirements.

[TS 38.321, clause 5.4.6]

The Power Headroom reporting procedure is used to provide the serving gNB with information about the difference between the nominal UE maximum transmit power and the estimated power for UL-SCH transmission per activated Serving Cell and also with information about the difference between the nominal UE maximum power and the estimated power for UL-SCH and PUCCH transmission on SpCell and PUCCH SCell.

RRC controls Power Headroom reporting by configuring the following parameters:

- *phr-PeriodicTimer*;
- *phr-ProhibitTimer*;
- *phr-Tx-PowerFactorChange*;
- *phr-Type2PCell*;
- *phr-Type2OtherCell*;
- *phr-ModeOtherCG*;
- *multiplePHR*.

A Power Headroom Report (PHR) shall be triggered if any of the following events occur:



- *phr-ProhibitTimer* expires or has expired and the path loss has changed more than *phr-Tx-PowerFactorChange* dB for at least one activated Serving Cell of any MAC entity which is used as a pathloss reference since the last transmission of a PHR in this MAC entity when the MAC entity has UL resources for new transmission;
- *phr-PeriodicTimer* expires;
- upon configuration or reconfiguration of the power headroom reporting functionality by upper layers, which is not used to disable the function;
- activation of an SCell of any MAC entity with configured uplink;
- addition of the PSCell;
- *phr-ProhibitTimer* expires or has expired, when the MAC entity has UL resources for new transmission, and the following is true for any of the activated Serving Cells of any MAC entity with configured uplink:
  - there are UL resources allocated for transmission or there is a PUCCH transmission on this cell, and the required power backoff due to power management (as allowed by  $P\text{-MPR}_c$  as specified in TS 38.101 [10]) for this cell has changed more than *phr-Tx-PowerFactorChange* dB since the last transmission of a PHR when the MAC entity had UL resources allocated for transmission or PUCCH transmission on this cell.

NOTE: The MAC entity should avoid triggering a PHR when the required power backoff due to power management decreases only temporarily (e.g. for up to a few tens of milliseconds) and it should avoid reflecting such temporary decrease in the values of  $P_{\text{CMAX},c}/\text{PH}$  when a PHR is triggered by other triggering conditions.

If the MAC entity has UL resources allocated for new transmission the MAC entity shall:

- 1> if it is the first UL resource allocated for a new transmission since the last MAC reset:
  - 2> start *periodicPHR-Timer*;
- 1> if the Power Headroom reporting procedure determines that at least one PHR has been triggered and not cancelled, and;
- 1> if the allocated UL resources can accommodate the MAC CE for PHR which the MAC entity is configured to transmit, plus its subheader, as a result of logical channel prioritization:
  - 2> if *multiplePHR* is configured:
    - 3> for each activated Serving Cell with configured uplink associated with any MAC entity:
      - 4> obtain the value of the Type 1 or Type 3 power headroom for the corresponding uplink carrier;
      - 4> if this MAC entity has UL resources allocated for transmission on this Serving Cell; or
      - 4> if the other MAC entity, if configured, has UL resources allocated for transmission on this Serving Cell and *phr-ModeOtherCG* is set to real by upper layers:
        - 5> obtain the value for the corresponding  $P_{\text{CMAX},c}$  field from the physical layer.
    - 3> if *phr-Type2PCell* is configured:
      - 4> obtain the value of the Type 2 power headroom for the PCell;
      - 4> obtain the value for the corresponding  $P_{\text{CMAX},c}$  field from the physical layer.
    - 3> if *phr-Type2OtherCell* is configured:
      - 4> if PUCCH SCell is configured:
        - 5> obtain the value of the Type 2 power headroom for the PUCCH SCell.
      - 4> else (i.e. other CG is configured):
        - 5> obtain the value of the Type 2 power headroom for the SpCell of the other MAC entity.

- 4> obtain the value for the corresponding  $P_{\text{CMAX},c}$  field from the physical layer.
- 3> instruct the Multiplexing and Assembly procedure to generate and transmit a PHR MAC CE according to configured *ServCellIndex* and the PUCCH(s) for the MAC entity as defined in subclause 6.1.3.9 based on the values reported by the physical layer.
- 2> else (i.e. Single Entry PHR format is used):
  - 3> obtain the value of the Type 1 or Type 3 power headroom from the physical layer for the corresponding uplink carrier of the PCell;
  - 3> obtain the value for the corresponding  $P_{\text{CMAX},c}$  field from the physical layer;
  - 3> instruct the Multiplexing and Assembly procedure to generate and transmit a PHR MAC CE as defined in subclause 6.1.3.8 based on the value reported by the physical layer.
- 2> start or restart *periodicPHR-Timer*;
- 2> start or restart *prohibitPHR-Timer*;
- 2> cancel all triggered PHR(s).

[TS 38.321, clause 6.1.3.8]

The Single Entry PHR MAC CE is identified by a MAC PDU subheader with LCID as specified in Table 6.2.1-2. It has a fixed size and consists of two octet defined as follows (figure 6.1.3.8-1):

- R: reserved bit, set to "0";
- Power Headroom (PH): this field indicates the power headroom level. The length of the field is 6 bits. The reported PH and the corresponding power headroom levels are shown in Table 6.1.3.8-1 below (the corresponding measured values in dB are specified in TS 38.133 [11]);
- $P_{\text{CMAX},c}$ : this field indicates the  $P_{\text{CMAX},c}$  (as specified in TS 38.213 [6]) used for calculation of the preceding PH field. The reported  $P_{\text{CMAX},c}$  and the corresponding nominal UE transmit power levels are shown in Table 6.1.3.8-2 (the corresponding measured values in dB are specified in TS 38.133 [11]).

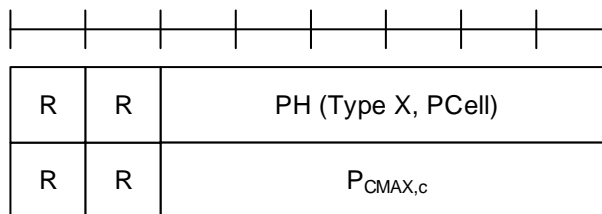

**Figure 6.1.3.8-1: Single Entry PHR MAC CE**

**Table 6.1.3.8-1: Power Headroom levels for PHR**

PH	Power Headroom Level
0	POWER_HEADROOM_0
1	POWER_HEADROOM_1
2	POWER_HEADROOM_2
3	POWER_HEADROOM_3
...	...
60	POWER_HEADROOM_60
61	POWER_HEADROOM_61
62	POWER_HEADROOM_62
63	POWER_HEADROOM_63

**Table 6.1.3.8-2: Nominal UE transmit power level for PHR**

$P_{\text{CMAX},c}$	Nominal UE transmit power level
0	PCMAX_C_00
1	PCMAX_C_01
2	PCMAX_C_02
...	...
61	PCMAX_C_61
62	PCMAX_C_62
63	PCMAX_C_63

7.1.1.3.7.3 Test description

7.1.1.3.7.3.1 Pre-test conditions

Same Pre-test conditions as in clause 7.1.1.0 except that set to return no data in uplink.

7.1.1.3.7.3.2 Test procedure sequence

**Table 7.1.1.3.7.3.2-1: Main behaviour**

St	Procedure	Message Sequence		TP	Verdict
		U - S	Message		
1	The SS transmits UL grant to the UE at every 10ms in PDCCH occasion.	<--	-	-	-
2	SS transmits <i>RRCCONNECTIONRECONFIGURATION</i> message containing <i>nr-SecondaryCellGroupConfig-r15</i> to configure specific Power Headroom parameters for PSCell.	<--	-	-	-
3	Check: does the UE transmit a MAC PDU containing Power Headroom MAC Control Element? (Note 1)	-->	MAC PDU	1	P
4	The UE transmits an <i>RRCCONNECTIONRECONFIGURATIONCOMPLETE</i> message to confirm the setup of Power Headroom parameters. (Note 1)	-->	-	-	-
5	Check: does the UE transmit a MAC PDU containing Power Headroom MAC Control Element 200ms after step 3?	-->	MAC PDU	2	P
6	The SS transmits an <i>RRCCONNECTIONRECONFIGURATION</i> message containing <i>nr-SecondaryCellGroupConfig-r15</i> to disable Power Headroom reporting.	<--	-	-	-
7	The UE transmits an <i>RRCCONNECTIONRECONFIGURATIONCOMPLETE</i> message to confirm the disabling of Power Headroom parameters.	-->	-	-	-
8	Check: for 2 seconds, does the UE transmit a MAC PDU containing Power Headroom MAC Control Element?	-->	MAC PDU	3	F
9	SS transmits <i>RRCCONNECTIONRECONFIGURATION</i> message containing <i>nr-SecondaryCellGroupConfig-r15</i> to configure specific Power Headroom parameters for PSCell.	<--	-	-	-
10	Check: does the UE transmit a MAC PDU containing Power Headroom MAC Control Element? (Note 2)	-->	MAC PDU	1	P
11	The UE transmits an <i>RRCCONNECTIONRECONFIGURATIONCOMPLETE</i> message to confirm the setup of Power Headroom parameters. (Note 2)	-->	-	-	-
12	Wait for $T1 = 10\%$ of <i>prohibitPHR-Timer</i> .	-	-	-	-
13	Reduce SS power level for NR Cell so as to cause a <i>DL_Pathloss</i> change at UE by 5dB.	-	-	-	-
14	Check: for 80% of <i>prohibitPHR-Timer</i> since step 10, does the UE transmit a MAC PDU containing Power Headroom MAC Control Element?	-->	MAC PDU	4	F
15	Check: after <i>prohibitPHR-Timer</i> after step 10, does the UE transmit a MAC PDU containing Power Headroom MAC Control Element?	-->	MAC PDU	5	P
16	Increase SS power level for NR Cell so as to cause a <i>DL_Pathloss</i> change at UE by 5dB.	-	-	-	-
17	Check: for 80% of <i>prohibitPHR-Timer</i> since step 15, does the UE transmit a MAC PDU containing Power Headroom MAC Control Element?	-->	MAC PDU	4	F
18	Check: after <i>prohibitPHR-Timer</i> after step 15, does the UE transmit a MAC PDU containing Power Headroom MAC Control Element?	-->	MAC PDU	5	P
Note 1: Steps 3 and 4 can happen in any order.					
Note 2: Steps 10 and 11 can happen in any order.					

7.1.1.3.7.3.3 Specific message contents

**Table 7.1.1.3.7.3.3-1: RRCConnectionReconfiguration (step 2, Table 7.1.1.3.7.3.2-1)**

Derivation Path: 36.508 [7], Table 4.6.1-8			
Information Element	Value/remark	Comment	Condition
RRCConnectionReconfiguration ::= SEQUENCE {			
criticalExtensions CHOICE {			
c1 CHOICE {			
rrcConnectionReconfiguration-r8 SEQUENCE {			
nonCriticalExtension SEQUENCE {			
nonCriticalExtension SEQUENCE {			
nonCriticalExtension SEQUENCE {			
nonCriticalExtension SEQUENCE {			
nonCriticalExtension SEQUENCE {			
nonCriticalExtension SEQUENCE {			
nonCriticalExtension SEQUENCE {			
nr-Config-r15 CHOICE {			
setup SEQUENCE {			
nr-SecondaryCellGroupConfig-r15	<i>RRCReconfiguration</i>	OCTET STRING including the <i>RRCReconfiguration</i>	
}			
}			
}			
}			
}			
}			
}			
}			
}			
}			
}			
}			

**Table 7.1.1.3.7.3.3-2: RRCReconfiguration (Table 7.1.1.3.7.3.3-1)**

Derivation Path: 38.508-1 [4], Table 4.6.1-3			
Information Element	Value/remark	Comment	Condition
RRCReconfiguration ::= SEQUENCE {			
criticalExtensions CHOICE {			
rrcReconfiguration SEQUENCE {			
secondaryCellGroup	CellGroupConfig	OCTET STRING (CONTAINING CellGroupConfig)	EN-DC
}			
}			

**Table 7.1.1.3.7.3.3-3: CellGroupConfig (Table 7.1.1.3.7.3.3-2)**

Derivation Path: 38.508-1 [4], Table 4.6.3-13			
Information Element	Value/remark	Comment	Condition
cellGroupConfig ::= SEQUENCE {			
cellGroupId	1		
mac-CellGroupConfig SEQUENCE {			
phr-Config CHOICE {			
setup SEQUENCE {			
phr-PeriodicTimer	sf200		
phr-ProhibitTimer	sf1000		
phr-Tx-PowerFactorChange	infinity		
multiplePHR	false		
phr-Type2PCell	false		
phr-Type2OtherCell	false		
phr-ModeOtherCG	real		
}			
}			
}			
}			

**Table 7.1.1.3.7.3.3-4: RRCConnectionReconfiguration (step 6, Table 7.1.1.3.7.3.2-1)**

Derivation Path: 36.508 [7], Table 4.6.1-8			
Information Element	Value/remark	Comment	Condition
RRCConnectionReconfiguration ::= SEQUENCE {			
criticalExtensions CHOICE {			
c1 CHOICE {			
rrcConnectionReconfiguration-r8 SEQUENCE {			
nonCriticalExtension SEQUENCE {			
nonCriticalExtension SEQUENCE {			
nonCriticalExtension SEQUENCE {			
nonCriticalExtension SEQUENCE {			
nonCriticalExtension SEQUENCE {			
nonCriticalExtension SEQUENCE {			
nonCriticalExtension SEQUENCE {			
nr-Config-r15 CHOICE {			
setup SEQUENCE {			
nr-SecondaryCellGroupConfig-r15	<i>RRCReconfiguration</i>	OCTET STRING including the <i>RRCReconfiguration</i>	
}			
}			
}			
}			
}			
}			
}			
}			
}			
}			
}			

**Table 7.1.1.3.7.3.3-5: RRCReconfiguration (Table 7.1.1.3.7.3.3-4)**

Derivation Path: 38.508-1 [4], Table 4.6.1-3			
Information Element	Value/remark	Comment	Condition
RRCReconfiguration ::= SEQUENCE {			
criticalExtensions CHOICE {			
rrcReconfiguration SEQUENCE {			
secondaryCellGroup	CellGroupConfig	OCTET STRING (CONTAINING CellGroupConfig)	EN-DC
}			
}			
}			

**Table 7.1.1.3.7.3.3-6: CellGroupConfig (Table 7.1.1.3.7.3.3-5)**

Derivation Path: 38.508-1 [4], Table 4.6.3-13			
Information Element	Value/remark	Comment	Condition
cellGroupConfig ::= SEQUENCE {			
cellGroupId	1		
mac-CellGroupConfig SEQUENCE {			
phr-Config CHOICE {			
release	NULL		
}			
}			
}			



**Table 7.1.1.3.7.3.3-7: RRCConnectionReconfiguration (step 9, Table 7.1.1.3.7.3.2-1)**

Derivation Path: 36.508 [7], Table 4.6.1-8			
Information Element	Value/remark	Comment	Condition
RRCConnectionReconfiguration ::= SEQUENCE {			
criticalExtensions CHOICE {			
c1 CHOICE{			
rrcConnectionReconfiguration-r8 ::= SEQUENCE			
{			
nonCriticalExtension SEQUENCE {			
nonCriticalExtension SEQUENCE {			
nonCriticalExtension SEQUENCE {			
nonCriticalExtension SEQUENCE {			
nonCriticalExtension SEQUENCE {			
nonCriticalExtension SEQUENCE {			
nonCriticalExtension SEQUENCE {			
nr-Config-r15 CHOICE {			
setup SEQUENCE {			
nr-SecondaryCellGroupConfig-r15	<i>RRCReconfiguration</i>	OCTET STRING including the <i>RRCReconfiguration</i>	
}			
}			
}			
}			
}			
}			
}			
}			
}			
}			
}			
}			

**Table 7.1.1.3.7.3.3-8: RRCReconfiguration (Table 7.1.1.3.7.3.3-7)**

Derivation Path: 38.508-1 [4], Table 4.6.1-3			
Information Element	Value/remark	Comment	Condition
RRCReconfiguration ::= SEQUENCE {			
criticalExtensions CHOICE {			
rrcReconfiguration SEQUENCE {			
secondaryCellGroup	CellGroupConfig	OCTET STRING (CONTAINING CellGroupConfig)	EN-DC
}			
}			
}			

Table 7.1.1.3.7.3.3-9: CellGroupConfig (Table 7.1.1.3.7.3.3-8)

Derivation Path: 38.508-1 [4], Table 4.6.3-13			
Information Element	Value/remark	Comment	Condition
cellGroupConfig ::= SEQUENCE {			
cellGroupId	1		
mac-CellGroupConfig SEQUENCE {			
phr-Config CHOICE {			
setup SEQUENCE {			
phr-PeriodicTimer	infinity		
phr-ProhibitTimer	sf1000		
phr-Tx-PowerFactorChange	3dB		
multiplePHR	false		
phr-Type2PCell	false		
phr-Type2OtherCell	false		
phr-ModeOtherCG	real		
}			
}			
}			
}			

### 7.1.1.3.8 UE power headroom reporting / SCell activation / DL pathloss change reporting

#### 7.1.1.3.8.1 Test Purpose (TP)

(1)

```
with { UE in RRC_Connected state with Power headroom reporting with phr-Type2SpCell and phr-
Type2OtherCell and an SCell with uplink is configured }
ensure that {
  when { UE receives an Activation MAC Control Element activating the SCell }
  then { UE transmits a MAC PDU containing Power Headroom Report MAC Control Element including PH
type2 for SpCell and SCell }
}
```

(2)

```
with { UE in RRC_Connected state with Power headroom reporting for phr-dl-PathlossChange, phr-
Type2SpCell and phr-Type2OtherCell configured }
ensure that {
  when { the DL Pathloss changes and phr-ProhibitTimer is running }
  then { UE does not transmit a MAC PDU containing Power Headroom Report MAC Control Element
including PH type2 for SpCell and SCell }
}
```

(3)

```
with { UE in RRC_Connected state with Power headroom reporting for phr-dl-PathlossChange, phr-
Type2SpCell and phr-Type2OtherCell configured }
ensure that {
  when { phr-ProhibitTimer expires and extended power headroom report is triggered due to DL
Pathloss change }
  then { UE transmits a MAC PDU containing Power Headroom Report MAC Control Element including PH
type2 for SpCell and SCell }
}
```

#### 7.1.1.3.8.2 Conformance requirements

References: The conformance requirements covered in the current TC are specified in: TS 38.321 clause 5.4.6 and 6.1.3.8. Unless otherwise stated these are Rel-15 requirements.

[TS 38.321, clause 5.4.6]

The Power Headroom reporting procedure is used to provide the serving gNB with information about the difference between the nominal UE maximum transmit power and the estimated power for UL-SCH transmission or SRS transmission per activated Serving Cell and also with information about the difference between the nominal UE maximum power and the estimated power for UL-SCH and PUCCH transmission on SpCell and PUCCH SCell.

RRC controls Power Headroom reporting by configuring the following parameters:

- *phr-PeriodicTimer*;
- *phr-ProhibitTimer*;
- *phr-Tx-PowerFactorChange*;
- *phr-Type2SpCell*;
- *phr-Type2OtherCell*;
- *phr-ModeOtherCG*;
- *multiplePHR*.

A Power Headroom Report (PHR) shall be triggered if any of the following events occur:

- *phr-ProhibitTimer* expires or has expired and the path loss has changed more than *phr-Tx-PowerFactorChange* dB for at least one activated Serving Cell of any MAC entity which is used as a pathloss reference since the last transmission of a PHR in this MAC entity when the MAC entity has UL resources for new transmission;

NOTE 1: The path loss variation for one cell assessed above is between the pathloss measured at present time on the current pathloss reference and the pathloss measured at the transmission time of the last transmission of PHR on the pathloss reference in use at that time, irrespective of whether the pathloss reference has changed in between.

- *phr-PeriodicTimer* expires;
- upon configuration or reconfiguration of the power headroom reporting functionality by upper layers, which is not used to disable the function;
- activation of an SCell of any MAC entity with configured uplink;
- addition of the PSCell (i.e. PSCell is newly added or changed);
- *phr-ProhibitTimer* expires or has expired, when the MAC entity has UL resources for new transmission, and the following is true for any of the activated Serving Cells of any MAC entity with configured uplink:
  - there are UL resources allocated for transmission or there is a PUCCH transmission on this cell, and the required power backoff due to power management (as allowed by  $P\text{-MPR}_c$  as specified in TS 38.101 [10]) for this cell has changed more than *phr-Tx-PowerFactorChange* dB since the last transmission of a PHR when the MAC entity had UL resources allocated for transmission or PUCCH transmission on this cell.

NOTE 2: The MAC entity should avoid triggering a PHR when the required power backoff due to power management decreases only temporarily (e.g. for up to a few tens of milliseconds) and it should avoid reflecting such temporary decrease in the values of  $P_{\text{CMAX},f,c}/\text{PH}$  when a PHR is triggered by other triggering conditions.

If the MAC entity has UL resources allocated for a new transmission the MAC entity shall:

- 1> if it is the first UL resource allocated for a new transmission since the last MAC reset:
  - 2> start *phr-PeriodicTimer*;
- 1> if the Power Headroom reporting procedure determines that at least one PHR has been triggered and not cancelled, and;
  - 1> if the allocated UL resources can accommodate the MAC CE for PHR which the MAC entity is configured to transmit, plus its subheader, as a result of logical channel prioritization:
    - 2> if *multiplePHR* is configured:
      - 3> for each activated Serving Cell with configured uplink associated with any MAC entity:
        - 4> obtain the value of the Type 1 or Type 3 power headroom for the corresponding uplink carrier;

- 4> if this MAC entity has UL resources allocated for transmission on this Serving Cell; or
- 4> if the other MAC entity, if configured, has UL resources allocated for transmission on this Serving Cell and *phr-ModeOtherCG* is set to real by upper layers:
  - 5> obtain the value for the corresponding  $P_{\text{CMAX},f,c}$  field from the physical layer.
- 3> if *phr-Type2SpCell* is configured:
  - 4> obtain the value of the Type 2 power headroom for the SpCell of this MAC entity;
  - 4> obtain the value for the corresponding  $P_{\text{CMAX},f,c}$  field from the physical layer.
- 3> if *phr-Type2OtherCell* is configured:
  - 4> if other CG is configured:
    - 5> obtain the value of the Type 2 power headroom for the SpCell of the other MAC entity;
    - 5> if *phr-ModeOtherCG* is set to real by upper layers:
      - 6> obtain the value for the corresponding  $P_{\text{CMAX},f,c}$  field for the SpCell of the other MAC entity from the physical layer.
  - 4> else if PUCCH SCell is configured and activated:
    - 5> obtain the value of the Type 2 power headroom for the PUCCH SCell;
    - 5> obtain the value for the corresponding  $P_{\text{CMAX},f,c}$  field from the physical layer.
- 3> instruct the Multiplexing and Assembly procedure to generate and transmit a PHR MAC CE according to configured *ServCellIndex* and the PUCCH(s) for the MAC entity as defined in subclause 6.1.3.9 based on the values reported by the physical layer.
- 2> else (i.e. Single Entry PHR format is used):
  - 3> obtain the value of the Type 1 power headroom from the physical layer for the corresponding uplink carrier of the PCell;
  - 3> obtain the value for the corresponding  $P_{\text{CMAX},f,c}$  field from the physical layer;
  - 3> instruct the Multiplexing and Assembly procedure to generate and transmit a PHR MAC CE as defined in subclause 6.1.3.8 based on the value reported by the physical layer.
- 2> start or restart *phr-PeriodicTimer*;
- 2> start or restart *phr-ProhibitTimer*;
- 2> cancel all triggered PHR(s).

[TS 38.321, clause 6.1.3.9]

The Multiple Entry PHR MAC CE is identified by a MAC PDU subheader with LCID as specified in Table 6.2.1-2.

It has a variable size, and includes the bitmap, a Type 2 PH field and an octet containing the associated  $P_{\text{CMAX},f,c}$  field (if reported) for the SpCell of this MAC entity, a Type 2 PH field and an octet containing the associated  $P_{\text{CMAX},f,c}$  field (if reported) for either SpCell of the other MAC entity or PUCCH SCell, a Type 1 PH field and an octet containing the associated  $P_{\text{CMAX},f,c}$  field (if reported) for the PCell. It further includes, in ascending order based on the *ServCellIndex*, one or multiple of Type X PH fields and octets containing the associated  $P_{\text{CMAX},f,c}$  fields (if reported) for Serving Cells other than PCell indicated in the bitmap. X is either 1 or 3 according to TS 38.213 [6].

The presence of Type 2 PH field for SpCell of this MAC entity is configured by *phr-Type2SpCell*, and the presence of Type 2 PH field for either SpCell of the other MAC entity or for PUCCH SCell of this MAC entity is configured by *phr-Type2OtherCell*.

A single octet bitmap is used for indicating the presence of PH per Serving Cell when the highest *ServCellIndex* of Serving Cell with configured uplink is less than 8, otherwise four octets are used.

UE determines whether PH value for an activated Serving Cell is based on real transmission or a reference format by considering the downlink control information which has been received until and including the PDCCH occasion in which the first UL grant for a new transmission is received since a PHR has been triggered.

The PHR MAC CEs are defined as follows:

- $C_i$ : This field indicates the presence of a PH field for the Serving Cell with *ServCellIndex*  $i$  as specified in TS 38.331 [5]. The  $C_i$  field set to "1" indicates that a PH field for the Serving Cell with *ServCellIndex*  $i$  is reported. The  $C_i$  field set to "0" indicates that a PH field for the Serving Cell with *ServCellIndex*  $i$  is not reported;
- R: Reserved bit, set to "0";
- V: This field indicates if the PH value is based on a real transmission or a reference format. For Type 1 PH,  $V=0$  indicates real transmission on PUSCH and  $V=1$  indicates that a PUSCH reference format is used. For Type 2 PH,  $V=0$  indicates real transmission on PUCCH and  $V=1$  indicates that a PUCCH reference format is used. For Type 3 PH,  $V=0$  indicates real transmission on SRS and  $V=1$  indicates that an SRS reference format is used. Furthermore, for Type 1, Type 2, and Type 3 PH,  $V=0$  indicates the presence of the octet containing the associated  $P_{CMAX,f,c}$  field, and  $V=1$  indicates that the octet containing the associated  $P_{CMAX,f,c}$  field is omitted;
- Power Headroom (PH): This field indicates the power headroom level. The length of the field is 6 bits. The reported PH and the corresponding power headroom levels are shown in Table 6.1.3.8-1 (the corresponding measured values in dB for the NR Serving Cell are specified in TS 38.133 [11] while the corresponding measured values in dB for the E-UTRA Serving Cell are specified in TS 36.133 [12]);
- P: This field indicates whether the MAC entity applies power backoff due to power management. The MAC entity shall set  $P=1$  if the corresponding  $P_{CMAX,f,c}$  field would have had a different value if no power backoff due to power management had been applied;
- $P_{CMAX,f,c}$ : If present, this field indicates the  $P_{CMAX,f,c}$  or  $\tilde{P}_{CMAX,f,c}$  (as specified in TS 38.213 [6]) used for calculation of the preceding PH field. The reported  $P_{CMAX,f,c}$  and the corresponding nominal UE transmit power levels are shown in Table 6.1.3.8-2 (the corresponding measured values in dBm for the NR Serving Cell are specified in TS 38.133 [11] while the corresponding measured values in dBm for the E-UTRA Serving Cell are specified in TS 36.133 [12]).

C <sub>7</sub>	C <sub>6</sub>	C <sub>5</sub>	C <sub>4</sub>	C <sub>3</sub>	C <sub>2</sub>	C <sub>1</sub>	R
P	V	PH (Type 2, SpCell of this MAC entity)					
R	R	P <sub>C<sub>MAX,f,c</sub> 1</sub>					
P	V	PH (Type 2, SpCell of the other MAC entity or PUCCH SCell)					
R	R	P <sub>C<sub>MAX,f,c</sub> 2</sub>					
P	V	PH (Type 1, PCell)					
R	R	P <sub>C<sub>MAX,f,c</sub> 3</sub>					
P	V	PH (Type X, Serving Cell 1)					
R	R	P <sub>C<sub>MAX,f,c</sub> 4</sub>					
...							
P	V	PH (Type X, Serving Cell n)					
R	R	P <sub>C<sub>MAX,f,c</sub> m</sub>					

**Figure 6.1.3.9-1: Multiple Entry PHR MAC CE with the highest *ServCellIndex* of Serving Cell with configured uplink is less than 8**

C <sub>7</sub>	C <sub>6</sub>	C <sub>5</sub>	C <sub>4</sub>	C <sub>3</sub>	C <sub>2</sub>	C <sub>1</sub>	R
C <sub>15</sub>	C <sub>14</sub>	C <sub>13</sub>	C <sub>12</sub>	C <sub>11</sub>	C <sub>10</sub>	C <sub>9</sub>	C <sub>8</sub>
C <sub>23</sub>	C <sub>22</sub>	C <sub>21</sub>	C <sub>20</sub>	C <sub>19</sub>	C <sub>18</sub>	C <sub>17</sub>	C <sub>16</sub>
C <sub>31</sub>	C <sub>30</sub>	C <sub>29</sub>	C <sub>28</sub>	C <sub>27</sub>	C <sub>26</sub>	C <sub>25</sub>	C <sub>24</sub>
P	V	PH (Type 2, SpCell of this MAC entity)					
R	R	$P_{\text{CMAX},f,c} 1$					
P	V	PH (Type 2, SpCell of the other MAC entity or PUCCH SCell)					
R	R	$P_{\text{CMAX},f,c} 2$					
P	V	PH (Type 1, PCell)					
R	R	$P_{\text{CMAX},f,c} 3$					
P	V	PH (Type X, Serving Cell 1)					
R	R	$P_{\text{CMAX},f,c} 4$					
...							
P	V	PH (Type X, Serving Cell n)					
R	R	$P_{\text{CMAX},f,c} m$					

**Figure 6.1.3.9-2: Multiple Entry PHR MAC CE with the highest ServCellIndex of Serving Cell with configured uplink is equal to or higher than 8**

7.1.1.3.8.3 Test description

7.1.1.3.8.3.1 Pre-test conditions

Same Pre-test conditions as in clause 7.1.1.0 and in addition NR Cell 3 (intra band CA) or Cell 10(inter band CA) is configured as NR Active Scell.

## 7.1.1.3.8.3.2 Test procedure sequence

**Table 7.1.1.3.8.3.2-0: Cell configuration power level changes over time**

	Parameter	Unit	NR Cell 1	NR Cell 3/10	Remarks
<b>T0</b>	Cell-specific RS EPRE	dBm/15k Hz	[-82]	[-82]	
<b>T1</b>	Cell-specific RS EPRE	dBm/15k Hz	[-89]	[-82]	
<b>T2</b>	Cell-specific RS EPRE	dBm/15k Hz	[-82]	[-82]	
<b>T3</b>	Cell-specific RS EPRE	dBm/15k Hz	[-82]	[-89]	
<b>T4</b>	Cell-specific RS EPRE	dBm/15k Hz	[-82]	[-82]	



**Table 7.1.1.3.8.3.2-1: Main behaviour**

St	Procedure	Message Sequence		TP	Verdict
		U - S	Message		
1	SS transmits an RRCReconfiguration message to configure SCell (NR Cell 3 or Cell 10). Note 1	<--	(RRCReconfiguration)	-	-
2	The UE transmits RRCReconfigurationComplete message. Note 2	-->	(RRCReconfigurationComplete)	-	-
3	The SS is configured for Uplink Grant Allocation Type 2. SS is configured to transmit UL grant for UE at every 10 ms.	-	-	-	-
4	SS transmits an RRCReconfiguration message to provide Power Headroom parameters. Note 1	<--	(RRCReconfiguration)	-	-
	EXCEPTION: In parallel with step 5, UE executes parallel behaviour defined in Table 7.1.1.3.8.3.2-2	-	-	-	-
5	The UE transmits RRCReconfigurationComplete message to confirm the setup of Power Headroom parameters	-->	(RRCReconfigurationComplete)	-	-
6	The SS transmits an Activation MAC control element to activate SCell.	<--	MAC PDU (SCell Activation/Deactivation MAC CE of one octet (C <sub>1</sub> =1))	-	-
7	Check: Does the UE transmit a MAC PDU containing Multiple Entry PHR MAC CE containing Type 2 PH of NR SpCell and Scell?	-->	MAC PDU	1	P
8	Wait for T1= 10% of <i>prohibitPHR-Timer</i> .	-	-	-	-
9	SS adjusts cell levels according to row T1 of Table 7.1.1.3.8.3.2-0.	-	-	-	-
10	Check: For 80% of <i>prohibitPHR-Timer</i> since step 7, does the UE transmit a MAC PDU containing Multiple Entry PHR MAC CE?	-->	MAC PDU	2	F
11	Check: After <i>prohibitPHR-Timer</i> after step 7, does the UE transmit a MAC PDU containing Multiple Entry PHR MAC CE containing Type 2 PH of NR SpCell and Scell?	-->	MAC PDU	3	P
12	SS adjusts cell levels according to row T2 of Table 7.1.1.3.8.3.2-0..	-	-	-	-
13	Check: For 80% of <i>prohibitPHR-Timer</i> since step 11, does the UE transmit a MAC PDU containing Multiple Entry PHR MAC CE ?	-->	MAC PDU	2	F
14	Check: After <i>prohibitPHR-Timer</i> after step 11, does the UE transmit a MAC PDU containing Multiple Entry PHR MAC CE containing Type 2 PH of NR SpCell and Scell?	-->	MAC PDU	3	P
15	SS adjusts cell levels according to row T3 of Table 7.1.1.3.8.3.2-0.	-	-	-	-
16	Check: For 80% of <i>prohibitPHR-Timer</i> since step 14, does the UE transmit a MAC PDU containing Multiple Entry PHR MAC CE containing?	-->	MAC PDU	2	F
17	Check: After <i>prohibitPHR-Timer</i> after step 14, does the UE transmit a MAC PDU containing Multiple Entry PHR MAC CE containing Type 2 PH of NR SpCell and Scell?	-->	MAC PDU	3	P
18	SS adjusts cell levels according to row T4 of Table 7.1.1.3.8.3.2-0.	-	-	-	-
19	Check: For 80% of <i>prohibitPHR-Timer</i> since step 17, does the UE transmit a MAC PDU containing Multiple Entry PHR MAC CE?	-->	MAC PDU	2	F
20	Check: After <i>prohibitPHR-Timer</i> after step 17, does the UE transmit a MAC PDU containing Multiple Entry PHR MAC CE containing Type 2 PH of NR SpCell and Scell?	-->	MAC PDU	3	P

Note 1: for EN-DC the NR *RRCReconfiguration* message is contained in *RRCConnectionReconfiguration*.  
 Note 2: for EN-DC the NR *RRCReconfigurationComplete* message is contained in *RRCConnectionReconfigurationComplete*.

Table 7.1.1.3.8.3.2-2: Parallel behaviour

St	Procedure	Message Sequence		TP	Verdict
		U - S	Message		
1	The UE transmits a MAC PDU containing Multiple Entry PHR MAC CE containing Type 2 PH of NR SpCell.	-->	MAC PDU	-	-

## 7.1.1.3.8.3.3 Specific message contents

Table 7.1.1.3.8.3.3-1: *RRCReconfiguration* (step 1, Table 7.1.1.3.8.3.2-1)

Derivation Path: TS 38.508-1 [4], Table 4.6.1-3.			
Information Element	Value/remark	Comment	Condition
<i>RRCReconfiguration</i> ::= SEQUENCE {			
criticalExtensions CHOICE {			
c1 CHOICE {			
<i>rrcReconfiguration</i> ::= SEQUENCE {			
radioBearerConfig	RadioBearerConfig	TS 38.508-1 [4] table 4.6.3-100 condition SRB3	
secondaryCellGroup	CellGroupConfig		
}			
}			
}			
}			

Table 7.1.1.3.8.3.3-2: *CellGroupConfig* (Table 7.1.1.3.8.3.3-1)

Derivation Path: TS 38.508-1 [4], Table 4.6.3-13.			
Information Element	Value/remark	Comment	Condition
<i>CellGroupConfig</i> ::= SEQUENCE {			
sCellToAddModList SEQUENCE (SIZE (1..maxMeasId)) OF SEQUENCE {			
sCellIndex[1]	1		
sCellConfigCommon[1]	ServingCellConfigCommon		
sCellConfigDedicated[1]	ServingCellConfig		
}			
}			

Table 7.1.1.3.8.3.3-3: *ServingCellConfigCommon* (Table 7.1.1.3.8.3.3-2)

Derivation Path: TS 38.508-1 [4], Table 4.6.3-129.			
Information Element	Value/remark	Comment	Condition
<i>ServingCellConfigCommon</i> ::= SEQUENCE {			
physCellId	Physical Cell Identity of NR Cell 3/Cell 10		
}			

Table 7.1.1.3.8.3.3-3A: *ServingCellConfig* (Table 7.1.1.3.8.3.3-2)

Derivation Path: TS 38.508-1 [4], Table 4.6.3-128.			
Information Element	Value/remark	Comment	Condition
<i>ServingCellConfig</i> ::= SEQUENCE {			
sCellDeactivationTimer	ms320		
}			

**Table 7.1.1.3.8.3.3-4: RRCReconfiguration ( Step 4, Table 7.1.1.3.8.3.2-1)**

Derivation Path: 38.508-1 [4], Table [4.6.1-3]			
Information Element	Value/remark	Comment	Condition
RRCReconfiguration ::= SEQUENCE {			
criticalExtensions CHOICE {			
rrcReconfiguration SEQUENCE {			
secondaryCellGroup	CellGroupConfig	OCTET STRING (CONTAINING CellGroupConfig)	EN-DC
}			
}			
}			

**Table 7.1.1.3.8.3.3-5: CellGroupConfig (Table 7.1.1.3.8.3.3-4)**

Derivation Path: 38.508-1 [4], Table [4.6.3-13]			
Information Element	Value/remark	Comment	Condition
CellGroupConfig ::= SEQUENCE {			
cellGroupId	1		
mac-CellGroupConfig SEQUENCE {			
phr-Config CHOICE {			
setup SEQUENCE {			
phr-PeriodicTimer	sf200		
phr-ProhibitTimer	sf500		
phr-Tx-PowerFactorChange	infinity		
multiplePHR	true		
phr-Type2SpCell	true		
phr-Type2OtherCell	true		
phr-ModeOtherCG	real		
}			
}			
}			
}			

#### 7.1.1.4 Transport Size Selection

##### 7.1.1.4.1 DL-SCH Transport Block Size Selection

###### 7.1.1.4.1.1 DL-SCH Transport Block Size selection / DCI format 1\_0

###### 7.1.1.4.1.1.1 Test Purpose (TP)

(1)

```

with { UE in RRC_CONNECTED state }
ensure that {
  when { UE on PDCCH receives DCI format 1_0 indicating a resource block assignment correspondent to
physical resource blocks , Time domain resource assignment and a modulation and coding }
  then { UE decodes the received transport block of size correspondent as per Modulation Coding
scheme, time domain resource allocation and PRB's and forwards it to higher layers }
}

```

###### 7.1.1.4.1.1.2 Conformance requirements

References: The conformance requirements covered in the present TC are specified in: TS 38.212 clause 7.3.1.2.1, TS 38.214 clause 5.1.2.1, 5.1.2.2, 5.1.2.2.2, 5.1.3, 5.1.3.1 and 5.1.3.2. Unless otherwise stated these are Rel-15 requirements.

[TS 38.212, clause 7.3.1.2.1]

DCI format 1\_0 is used for the scheduling of PDSCH in one DL cell.

The following information is transmitted by means of the DCI format 1\_0 with CRC scrambled by C-RNTI or CS-RNTI or new-RNTI:

- Identifier for DCI formats – 1 bits
  - The value of this bit field is always set to 1, indicating a DL DCI format
- Frequency domain resource assignment –  $\lceil \log_2(N_{RB}^{DL,BWP}(N_{RB}^{DL,BWP} + 1)/2) \rceil$  bits
  - $N_{RB}^{DL,BWP}$  is the size of the active DL bandwidth part in case DCI format 1\_0 is monitored in the UE specific search space and satisfying
    - the total number of different DCI sizes monitored per slot is no more than 4 for the cell, and
    - the total number of different DCI sizes with C-RNTI monitored per slot is no more than 3 for the cell
  - otherwise,  $N_{RB}^{DL,BWP}$  is the size of the initial DL bandwidth part.

If the CRC of the DCI format 1\_0 is scrambled by C-RNTI and the “Frequency domain resource assignment” field are of all ones, the DCI format 1\_0 is for random access procedure initiated by a PDCCH order, with all remaining fields set as follows:

- Random Access Preamble index – 6 bits according to *ra-PreambleIndex* in Subclause 5.1.2 of [8, TS38.321]
- UL/SUL indicator – 1 bit. If the value of the “Random Access Preamble index” is not all zeros and if the UE is configured with SUL in the cell, this field indicates which UL carrier in the cell to transmit the PRACH according to Table 7.3.1.1.1-1; otherwise, this field is reserved
- SS/PBCH index – 6 bits. If the value of the “Random Access Preamble index” is not all zeros, this field indicates the SS/PBCH that shall be used to determine the RACH occasion for the PRACH transmission; otherwise, this field is reserved.
- PRACH Mask index – 4 bits. If the value of the “Random Access Preamble index” is not all zeros, this field indicates the RACH occasion associated with the SS/PBCH indicated by “SS/PBCH index” for the PRACH transmission, according to Subclause 5.1.1 of [8, TS38.321]; otherwise, this field is reserved
- Reserved bits – 10 bits

Otherwise, all remaining fields are set as follows:

- Time domain resource assignment – 4 bits as defined in Subclause 5.1.2.1 of [6, TS38.214]
- VRB-to-PRB mapping – 1 bit according to Table 7.3.1.1.2-33
- Modulation and coding scheme – 5 bits as defined in Subclause 5.1.3 of [6, TS38.214]
- New data indicator – 1 bit
- Redundancy version – 2 bits as defined in Table 7.3.1.1.1-2
- HARQ process number – 4 bits
- Downlink assignment index – 2 bits as defined in Subclause 9.1.3 of [5, TS38.213], as counter DAI
- TPC command for scheduled PUCCH – 2 bits as defined in Subclause 7.2.1 of [5, TS38.213]
- PUCCH resource indicator – 3 bits as defined in Subclause 9.2.3 of [5, TS38.213]
- PDSCH-to-HARQ\_feedback timing indicator – 3 bits as defined in Subclause 9.2.3 of [5, TS38.213]

[TS 38.214, clause 5.1.2.1]

When the UE is scheduled to receive PDSCH by a DCI, the *Time domain resource assignment* field value  $m$  of the DCI provides a row index  $m + 1$  to an allocation table. The determination of the used resource allocation table is defined in sub-clause 5.1.2.1.1. The indexed row defines the slot offset  $K_0$ , the start and length indicator  $SLIV$ , or directly the start symbol  $S$  and the allocation length  $L$ , and the PDSCH mapping type to be assumed in the PDSCH reception.

Given the parameter values of the indexed row:

- The slot allocated for the PDSCH is  $\left\lfloor n \cdot \frac{2^{\mu_{\text{PDSCH}}}}{2^{\mu_{\text{PDCCH}}}} \right\rfloor + K_0$ , where  $n$  is the slot with the scheduling DCI, and  $K_0$  is based on the numerology of PDSCH, and  $\mu_{\text{PDSCH}}$  and  $\mu_{\text{PDCCH}}$  are the subcarrier spacing configurations for PDSCH and PDCCH, respectively, and
- The starting symbol  $S$  relative to the start of the slot, and the number of consecutive symbols  $L$  counting from the symbol  $S$  allocated for the PDSCH are determined from the start and length indicator  $SLIV$ :
  - if  $(L-1) \leq 7$  then
 
$$SLIV = 14 \cdot (L-1) + S$$
  - else
 
$$SLIV = 14 \cdot (14 - L + 1) + (14 - 1 - S)$$
  - where  $0 < L \leq 14 - S$ , and
- The PDSCH mapping type is set to Type A or Type B as defined in sub-clause 7.4.1.1.2 of [4, TS 38.211].

The UE shall consider the  $S$  and  $L$  combinations defined in table 5.1.2.1-1 as valid PDSCH allocations:

**Table 5.1.2.1-1: Valid  $S$  and  $L$  combinations**

PDSCH mapping type	Normal cyclic prefix			Extended cyclic prefix		
	$S$	$L$	$S+L$	$S$	$L$	$S+L$
Type A	{0,1,2,3} (Note 1)	{3,...,14}	{3,...,14}	{0,1,2,3} (Note 1)	{3,...,12}	{3,...,12}
Type B	{0,...,12}	{2,4,7}	{2,...,14}	{0,...,10}	{2,4,6}	{2,...,12}

[38.214 clause 5.1.2.2]

Two downlink resource allocation schemes, type 0 and type 1, are supported. The UE shall assume that when the scheduling grant is received with DCI format 1\_0, then downlink resource allocation type 1 is used.

[38.214 clause 5.1.2.2.2]

In downlink resource allocation of type 1, the resource block assignment information indicates to a scheduled UE a set of contiguously allocated non-interleaved or interleaved virtual resource blocks within the active bandwidth part of size  $N_{\text{BWP}}^{\text{size}}$  PRBs except for the case when DCI format 1\_0 is decoded in any common search space in CORESET 0 in which case the initial bandwidth part of size  $N_{\text{BWP},0}^{\text{size}}$  shall be used.

A downlink type 1 resource allocation field consists of a resource indication value ( $RIV$ ) corresponding to a starting virtual resource block ( $RB_{\text{start}}$ ) and a length in terms of contiguously allocated resource blocks  $L_{\text{RBs}}$ . The resource indication value is defined by

if  $(L_{\text{RBs}} - 1) \leq \lfloor N_{\text{BWP}}^{\text{size}} / 2 \rfloor$  then

$$RIV = N_{\text{BWP}}^{\text{size}} (L_{\text{RBs}} - 1) + RB_{\text{start}}$$

else

$$RIV = N_{\text{BWP}}^{\text{size}} (N_{\text{BWP}}^{\text{size}} - L_{\text{RBs}} + 1) + (N_{\text{BWP}}^{\text{size}} - 1 - RB_{\text{start}})$$

where  $L_{\text{RBs}} \geq 1$  and shall not exceed  $N_{\text{BWP}}^{\text{size}} - RB_{\text{start}}$ .

[TS 38.214, clause 5.1.3]

To determine the modulation order, target code rate, and transport block size(s) in the physical downlink shared channel, the UE shall first

- read the 5-bit *modulation and coding scheme* field ( $I_{MCS}$ ) in the DCI to determine the modulation order ( $Q_m$ ) and target code rate ( $R$ ) based on the procedure defined in Subclause 5.1.3.1, and
- read *redundancy version* field ( $rv$ ) in the DCI to determine the redundancy version..

and second

- the UE shall use the number of layers ( $v$ ), the total number of allocated PRBs before rate matching ( $n_{PRB}$ ) to determine to the transport block size based on the procedure defined in Subclause 5.1.3.2.

The UE may skip decoding a transport block in an initial transmission if the effective channel code rate is higher than 0.95, where the effective channel code rate is defined as the number of downlink information bits (including CRC bits) divided by the number of physical channel bits on PDSCH. If the UE skips decoding, the physical layer indicates to higher layer that the transport block is not successfully decoded.

[TS 38.214, clause 5.1.3.1]

For the PDSCH scheduled by a PDCCH with DCI format 1\_0 or format 1\_1 with CRC scrambled by C-RNTI, new-RNTI, TC-RNTI, CS-RNTI, SI-RNTI, RA-RNTI, or P-RNTI,

if the higher layer parameter *mcs-Table* given by *PDSCH-Config* is set to 'qam256', and the PDSCH is scheduled by a PDCCH with a DCI format 1\_1 and the CRC is scrambled by C-RNTI or CS-RNTI

- the UE shall use  $I_{MCS}$  and Table 5.1.3.1-2 to determine the modulation order ( $Q_m$ ) and Target code rate ( $R$ ) used in the physical downlink shared channel.

elseif the UE is not configured with new-RNTI, the higher layer parameter *mcs-Table* given by *PDSCH-Config* is set to 'qam64LowSE', and the PDSCH is scheduled with C-RNTI, and the PDSCH is assigned by a PDCCH in a UE-specific search space

- the UE shall use  $I_{MCS}$  and Table 5.1.3.1-3 to determine the modulation order ( $Q_m$ ) and Target code rate ( $R$ ) used in the physical downlink shared channel.

elseif the UE is configured with new-RNTI, and the PDSCH is scheduled with new-RNTI

- the UE shall use  $I_{MCS}$  and Table 5.1.3.1-3 to determine the modulation order ( $Q_m$ ) and Target code rate ( $R$ ) used in the physical downlink shared channel.

elseif the UE is not configured with the higher layer parameter *mcs-Table* given by *SPS-config*, the higher layer parameter *mcs-Table* given by *PDSCH-Config* is set to 'qam256', the PDSCH is scheduled with CS-RNTI, and the PDSCH is assigned by a PDCCH with DCI format 1\_1

- the UE shall use  $I_{MCS}$  and Table 5.1.3.1-2 to determine the modulation order ( $Q_m$ ) and Target code rate ( $R$ ) used in the physical downlink shared channel.

elseif the UE is configured with the higher layer parameter *mcs-Table* given by *SPS-config* set to 'qam64LowSE', and the PDSCH is scheduled with CS-RNTI

- the UE shall use  $I_{MCS}$  and Table 5.1.3.1-3 to determine the modulation order ( $Q_m$ ) and Target code rate ( $R$ ) used in the physical downlink shared channel.

else

- the UE shall use  $I_{MCS}$  and Table 5.1.3.1-1 to determine the modulation order ( $Q_m$ ) and Target code rate ( $R$ ) used in the physical downlink shared channel.

End

The UE is not expected to decode a PDSCH scheduled with P-RNTI, RA-RNTI, SI-RNTI and  $Q_m > 2$

Table 5.1.3.1-1: MCS index table 1 for PDSCH

MCS Index $I_{MCS}$	Modulation Order $Q_m$	Target code Rate $R \times [1024]$	Spectral efficiency
0	2	120	0.2344
1	2	157	0.3066
2	2	193	0.3770
3	2	251	0.4902
4	2	308	0.6016
5	2	379	0.7402
6	2	449	0.8770
7	2	526	1.0273
8	2	602	1.1758
9	2	679	1.3262
10	4	340	1.3281
11	4	378	1.4766
12	4	434	1.6953
13	4	490	1.9141
14	4	553	2.1602
15	4	616	2.4063
16	4	658	2.5703
17	6	438	2.5664
18	6	466	2.7305
19	6	517	3.0293
20	6	567	3.3223
21	6	616	3.6094
22	6	666	3.9023
23	6	719	4.2129
24	6	772	4.5234
25	6	822	4.8164
26	6	873	5.1152
27	6	910	5.3320
28	6	948	5.5547
29	2	reserved	
30	4	reserved	
31	6	reserved	

[TS 38.214, clause 5.1.3.2]

In case the higher layer parameter *maxNrofCodeWordsScheduledByDCI* indicates that two codeword transmission is enabled, then a transport block is disabled by DCI format 1\_1 if  $I_{MCS} = 26$  and if  $rv_{id} = 1$  for the corresponding transport block, otherwise the transport block is enabled. If both transport blocks are enabled, transport block 1 and 2 are mapped to codeword 0 and 1 respectively. If only one transport block is enabled, then the enabled transport block is always mapped to the first codeword.

For the PDSCH assigned by a PDCCH with DCI format 1\_0 or format 1\_1 with CRC scrambled by C-RNTI, new-RNTI, TC-RNTI, CS-RNTI, or SI-RNTI, if Table 5.1.3.1-2 is used and  $0 \leq I_{MCS} \leq 27$ , or a table other than Table 5.1.3.1-2 is used and  $0 \leq I_{MCS} \leq 28$ , the UE shall, except if the transport block is disabled in DCI format 1\_1, first determine the TBS as specified below:

1) The UE shall first determine the number of REs ( $N_{RE}$ ) within the slot.

- A UE first determines the number of REs allocated for PDSCH within a PRB ( $N'_{RE}$ ) by

$$N'_{RE} = N_{sc}^{RB} \cdot N_{symp}^{sh} - N_{DMRS}^{PRB} - N_{oh}^{PRB}, \text{ where } N_{sc}^{RB} = 12 \text{ is the number of subcarriers in a physical resource}$$

block,  $N_{symp}^{sh}$  is the number of symbols of the PDSCH allocation within the slot,  $N_{DMRS}^{PRB}$  is the number of REs for DM-RS per PRB in the scheduled duration including the overhead of the DM-RS CDM groups without data, as indicated by DCI format 1\_1 or as described for format 1\_0 in Subclause 5.1.6.2, and  $N_{oh}^{PRB}$  is the overhead configured by higher layer parameter *xOverhead* in *PDSCH-ServingCellConfig*. If the *xOverhead* in *PDSCH-ServingCellConfig* is not configured (a value from 0, 6, 12, or 18), the  $N_{oh}^{PRB}$  is set to



0. If the PDSCH is scheduled by PDCCH with a CRC scrambled by SI-RNTI, RA-RNTI or P-RNTI,  $N_{oh}^{PRB}$  is assumed to be 0.

- A UE determines the total number of REs allocated for PDSCH ( $N_{RE}$ ) by  $N_{RE} = \min(156, N_{RE}^{\prime}) \cdot n_{PRB}$ , where  $n_{PRB}$  is the total number of allocated PRBs for the UE.

2) Intermediate number of information bits ( $N_{info}$ ) is obtained by  $N_{info} = N_{RE} \cdot R \cdot Q_m \cdot \nu$ .

If  $N_{info} \leq 3824$

Use step 3 as the next step of the TBS determination

else

Use step 4 as the next step of the TBS determination

end if

3) When  $N_{info} \leq 3824$ , TBS is determined as follows

- quantized intermediate number of information bits  $N_{info}^{\prime} = \max\left(24, 2^n \cdot \left\lfloor \frac{N_{info}}{2^n} \right\rfloor\right)$ , where  $n = \max(3, \lfloor \log_2(N_{info}) \rfloor - 6)$ .
- use Table 5.1.3.2-2 find the closest TBS that is not less than  $N_{info}^{\prime}$ .

**Table 5.1.3.2-2: TBS for  $N_{info} \leq 3824$**

Index	TBS	Index	TBS	Index	TBS	Index	TBS
1	24	31	336	61	1288	91	3624
2	32	32	352	62	1320	92	3752
3	40	33	368	63	1352	93	3824
4	48	34	384	64	1416		
5	56	35	408	65	1480		
6	64	36	432	66	1544		
7	72	37	456	67	1608		
8	80	38	480	68	1672		
9	88	39	504	69	1736		
10	96	40	528	70	1800		
11	104	41	552	71	1864		
12	112	42	576	72	1928		
13	120	43	608	73	2024		
14	128	44	640	74	2088		
15	136	45	672	75	2152		
16	144	46	704	76	2216		
17	152	47	736	77	2280		
18	160	48	768	78	2408		
19	168	49	808	79	2472		
20	176	50	848	80	2536		
21	184	51	888	81	2600		
22	192	52	928	82	2664		
23	208	53	984	83	2728		
24	224	54	1032	84	2792		
25	240	55	1064	85	2856		
26	256	56	1128	86	2976		
27	272	57	1160	87	3104		
28	288	58	1192	88	3240		
29	304	59	1224	89	3368		
30	320	60	1256	90	3496		

4) When  $N_{info} > 3824$ , TBS is determined as follows.

- quantized intermediate number of information bits  $N'_{info} = \max\left(3840, 2^n \times \text{round}\left(\frac{N_{info} - 24}{2^n}\right)\right)$ , where  $n = \lfloor \log_2(N_{info} - 24) \rfloor - 5$  and ties in the round function are broken towards the next largest integer.

- if  $R \leq 1/4$

$$TBS = 8 \cdot C \cdot \left\lceil \frac{N'_{info} + 24}{8 \cdot C} \right\rceil - 24, \text{ where } C = \left\lceil \frac{N'_{info} + 24}{3816} \right\rceil$$

else

if  $N'_{info} > 8424$

$$TBS = 8 \cdot C \cdot \left\lceil \frac{N'_{info} + 24}{8 \cdot C} \right\rceil - 24, \text{ where } C = \left\lceil \frac{N'_{info} + 24}{8424} \right\rceil$$

else

$$TBS = 8 \cdot \left\lceil \frac{N'_{info} + 24}{8} \right\rceil - 24$$

end if

end if

7.1.1.4.1.1.3 Test description

7.1.1.4.1.1.3.1 Pre-test conditions

Same Pre-test conditions as in clause 7.1.1.0 except set the NR Cell bandwidth and applicable BWP to maximum for the NR Band under test as specified in Table 5.3.5-1 in TS 38.101-1 [16] / TS 38.101-2 [17] (to enable testing of  $n_{PRB}$  up to maximum value).

7.1.1.4.1.1.3.2 Test procedure sequence

**Table 7.1.1.4.1.1.3.2-1: Maximum TBS for different UE categories**

UE Category	Maximum number of bits of a UL-SCH transport block received within a TTI
TS 38.306 [23] clause 4.1.2 require UE without <i>ue-CategoryDL</i> and <i>ue-CategoryUL</i> , to support Max TBS achievable based on max bandwidth of the Band under test.	

**Table 7.1.1.4.1.1.3.2-2: Number of downlink PDCP SDUs and PDCP SDU size used as test data**

TBS [bits]	Number of PDCP SDUs	PDCP SDU size [bits] (Note 1)
$132 \leq \text{TBS} \leq 12128$ note 2	1	$8 * \text{FLOOR}((\text{TBS} - 128)/8)$
$12129 \leq \text{TBS} \leq 24200$	2	$8 * \text{FLOOR}((\text{TBS} - 200)/16)$
$24201 \leq \text{TBS} \leq 36272$	3	$8 * \text{FLOOR}((\text{TBS} - 272)/24)$
$36273 \leq \text{TBS} \leq 48344$	4	$8 * \text{FLOOR}((\text{TBS} - 344)/32)$
$48345 \leq \text{TBS} \leq 60416$	5	$8 * \text{FLOOR}((\text{TBS} - 416)/40)$
$60417 \leq \text{TBS} \leq 72488$	6	$8 * \text{FLOOR}((\text{TBS} - 488)/48)$
$72489 \leq \text{TBS} \leq 84560$	7	$8 * \text{FLOOR}((\text{TBS} - 560)/56)$
$84561 \leq \text{TBS} \leq 96632$	8	$8 * \text{FLOOR}((\text{TBS} - 632)/64)$
$96633 < \text{TBS} \leq 108704$	9	$8 * \text{FLOOR}((\text{TBS} - 704)/72)$
$10705 \leq \text{TBS} \leq 120776$	10	$8 * \text{FLOOR}((\text{TBS} - 776)/80)$
$120777 \leq \text{TBS} \leq 132848$	11	$8 * \text{FLOOR}((\text{TBS} - 848)/88)$
$132849 \leq \text{TBS} \leq 144920$	12	$8 * \text{FLOOR}((\text{TBS} - 920)/96)$
$\text{TBS} > 144920$	13	$8 * \text{FLOOR}((\text{TBS} - 992)/112)$

Note 1: Each PDCP SDU is limited to 1500 octets (to keep below maximum SDU size of ESM as specified in TS 24.301 [21] clause 9.9.4.12).

The PDCP SDU size of each PDCP SDU is

PDCP SDU size = (TBS – N\*PDCP header size – N\*AMD PDU header size – N\*MAC header size – Size of Timing Advance – RLC Status PDU size- MAC header for RLC Status PDU) / N, where

PDCP header size is 24 bits for the RLC AM and 18-bit SN case;  
AMD PDU header size is 24 bits with 18 bit SN;

MAC header size for AMD PDU = 16 or 24 bits depending on L=8 or 16 bits. Worst case 24 is taken.

Size of Timing Advance MAC CE with header is 16 bits (if no Timing Advance and/or RLC status needs to be sent, padding will occur instead).

RLC Status PDU size = 24 bits with 1 ACK\_SN, With a MAC header of 16 bits.

This gives:

PDCP SDU size =  $8 * \text{FLOOR}((\text{TBS} - N * 24 - N * 24 - N * 24 - 56) / (8 * N))$  bits.

Note 2: According to the final PDCP SDU size formula in Note 1, the smallest TBS that can be tested is 136 bits.

**Table 7.1.1.4.1.1.3.2-3: Specific Parameters**

Parameter	Value	Comment
PDSCH mappingType	typeA	
starting symbol S	0 Or 3 to avoid clash with PDCCH symbols	
number of consecutive symbols L	3..14-S	
k0	0 or 1 (if S=0)	
number of layers (v)	1	
mcs-Table	qam64	
xoh-PDSCH	Not Present	Results in value 0(xoh0)
dmrs-AdditionalPosition	pos0	Results in 1 DMRS symbol per two carrier ( $N_{DMRS}^{PRB}$ ) for Duration in symbols $\geq 3$ (TS 38.211 [24], table 7.4.1.1.2-3)

Table 7.1.1.4.1.1.3.2-4: Main behaviour

St	Procedure	Message Sequence		TP	Verdict
		U - S	Message		
-	EXCEPTION: Steps 1 to 5 are repeated for allowed values of $N_{PRB}$ 1 to $N_{RB}^{DL,BWP}$ in BWP, time domain resource length L 3 to 14- S and $I_{MCS}$ from 0 to 28.	-	-	-	-
1	The SS calculates or looks up TBS in TS 38.214 [15] based on the value of S, L, $I_{MCS}$ and $n_{PRB}$ .	-	-	-	-
-	EXCEPTION: Steps 2 to 5 are performed if TBS is less than or equal to UE capability "Maximum number of DL-SCH transport block bits received within a TTI" as specified in Table 7.1.1.4.1.1.3.2-1 and larger than or equal to 132 bits as specified in Table 7.1.1.4.1.1.3.2-2	-	-	-	-
2	The SS creates one or more PDCP SDUs, depending on TBS, in accordance with Table 7.1.1.4.1.1.3.2-2.	-	-	-	-
3	The SS transmits the PDCP SDUs concatenated into a MAC PDU and indicates on PDCCH DCI Format 1_0 and values of S, L, $I_{MCS}$ and $n_{PRB}$ .	<--	MAC PDU (NxPDCP SDUs) DCI: (DCI Format 1_0, S, L, $I_{MCS}$ and $n_{PRB}$ )	-	-
4	At the reception of scheduling request the SS transmits UL Grant for transmitting loop back PDCP SDUs.	<--	(UL Grant)	-	-
5	CHECK: Does UE return the same number of PDCP SDUs with same content as transmitted by the SS in step 3?	-->	(NxPDCP SDUs)	1	P

## 7.1.1.4.1.1.3.3 Specific message contents

[None].

## 7.1.1.4.1.2 DL-SCH Transport Block Size selection / DCI format 1\_0 / 256QAM

## 7.1.1.4.1.2.1 Test Purpose (TP)

(1)

```

with { UE in RRC_CONNECTED state and mcs-Table is set as 'qam256' }
ensure that {
  when { UE on PDCCH receives DCI format 1_0 indicating a resource block assignment correspondent to physical resource blocks , Time domain resource assignment and a modulation and coding }
  then { UE decodes the received transport block of size correspondent as per Modulation Coding scheme, time domain resource allocation and PRB's and forwards it to higher layers }
}

```

## 7.1.1.4.1.2.2 Conformance requirements

References: The conformance requirements covered in the present TC are specified in: TS 38.212 clause 7.3.1.2.1, TS 38.214 clause 5.1.2.1, 5.1.2.2, 5.1.2.2.2, 5.1.3, 5.1.3.1 and 5.1.3.2. Unless otherwise stated these are Rel-15 requirements.

[TS 38.212, clause 7.3.1.2.1]

DCI format 1\_0 is used for the scheduling of PDSCH in one DL cell.

The following information is transmitted by means of the DCI format 1\_0 with CRC scrambled by C-RNTI or CS-RNTI or new-RNTI:

- Identifier for DCI formats – 1 bits
  - The value of this bit field is always set to 1, indicating a DL DCI format
- Frequency domain resource assignment –  $\lceil \log_2(N_{RB}^{DL,BWP}(N_{RB}^{DL,BWP} + 1)/2) \rceil$  bits
  - $N_{RB}^{DL,BWP}$  is the size of the active DL bandwidth part in case DCI format 1\_0 is monitored in the UE specific search space and satisfying
    - the total number of different DCI sizes monitored per slot is no more than 4 for the cell, and
    - the total number of different DCI sizes with C-RNTI monitored per slot is no more than 3 for the cell

otherwise,  $N_{RB}^{DL,BWP}$  is the size of the initial DL bandwidth part.

If the CRC of the DCI format 1\_0 is scrambled by C-RNTI and the “Frequency domain resource assignment” field are of all ones, the DCI format 1\_0 is for random access procedure initiated by a PDCCH order, with all remaining fields set as follows:

- Random Access Preamble index – 6 bits according to *ra-PreambleIndex* in Subclause 5.1.2 of [8, TS38.321]
- UL/SUL indicator – 1 bit. If the value of the “Random Access Preamble index” is not all zeros and if the UE is configured with SUL in the cell, this field indicates which UL carrier in the cell to transmit the PRACH according to Table 7.3.1.1.1-1; otherwise, this field is reserved
- SS/PBCH index – 6 bits. If the value of the “Random Access Preamble index” is not all zeros, this field indicates the SS/PBCH that shall be used to determine the RACH occasion for the PRACH transmission; otherwise, this field is reserved.
- PRACH Mask index – 4 bits. If the value of the “Random Access Preamble index” is not all zeros, this field indicates the RACH occasion associated with the SS/PBCH indicated by “SS/PBCH index” for the PRACH transmission, according to Subclause 5.1.1 of [8, TS38.321]; otherwise, this field is reserved
- Reserved bits – 10 bits

Otherwise, all remaining fields are set as follows:- Time domain resource assignment – 4 bits as defined in Subclause 5.1.2.1 of [6, TS38.214]

- VRB-to-PRB mapping – 1 bit according to Table 7.3.1.1.2-33
- Modulation and coding scheme – 5 bits as defined in Subclause 5.1.3 of [6, TS38.214]
- New data indicator – 1 bit
- Redundancy version – 2 bits as defined in Table 7.3.1.1.1-2
- HARQ process number – 4 bits
- Downlink assignment index – 2 bits as defined in Subclause 9.1.3 of [5, TS38.213], as counter DAI
- TPC command for scheduled PUCCH – 2 bits as defined in Subclause 7.2.1 of [5, TS38.213]
- PUCCH resource indicator – 3 bits as defined in Subclause 9.2.3 of [5, TS38.213]
- PDSCH-to-HARQ\_feedback timing indicator – 3 bits as defined in Subclause 9.2.3 of [5, TS38.213]

[TS 38.214, clause 5.1.2.1]

When the UE is scheduled to receive PDSCH by a DCI, the *Time domain resource assignment* field value  $md$  of the DCI provides a row index  $m + 1$  to an allocation table. The determination of the used resource allocation table is defined in

sub-clause 5.1.2.1.1. The indexed row defines the slot offset  $K_0$ , the start and length indicator  $SLIV$ , or directly the start symbol  $S$  and the allocation length  $L$ , and the PDSCH mapping type to be assumed in the PDSCH reception.

Given the parameter values of the indexed row:

- The slot allocated for the PDSCH is  $\left\lfloor n \cdot \frac{2^{\mu_{\text{PDSCH}}}}{2^{\mu_{\text{PDCCH}}}} \right\rfloor + K_0$ , where  $n$  is the slot with the scheduling DCI, and  $K_0$  is based on the numerology of PDSCH, and  $\mu_{\text{PDSCH}}$  and  $\mu_{\text{PDCCH}}$  are the subcarrier spacing configurations for PDSCH and PDCCH, respectively, and
- The starting symbol  $S$  relative to the start of the slot, and the number of consecutive symbols  $L$  counting from the symbol  $S$  allocated for the PDSCH are determined from the start and length indicator  $SLIV$ :
  - if  $(L-1) \leq 7$  then
 
$$SLIV = 14 \cdot (L-1) + S$$
  - else
 
$$SLIV = 14 \cdot (14 - L + 1) + (14 - 1 - S)$$
  - where  $0 < L \leq 14 - S$ , and
- The PDSCH mapping type is set to Type A or Type B as defined in sub-clause 7.4.1.1.2 of [4, TS 38.211].

The UE shall consider the  $S$  and  $L$  combinations defined in table 5.1.2.1-1 as valid PDSCH allocations:

**Table 5.1.2.1-1: Valid  $S$  and  $L$  combinations**

PDSCH mapping type	Normal cyclic prefix			Extended cyclic prefix		
	$S$	$L$	$S+L$	$S$	$L$	$S+L$
Type A	{0,1,2,3} (Note 1)	{3,...,14}	{3,...,14}	{0,1,2,3} (Note 1)	{3,...,12}	{3,...,12}
Type B	{0,...,12}	{2,4,7}	{2,...,14}	{0,...,10}	{2,4,6}	{2,...,12}

[38.214 clause 5.1.2.2]

Two downlink resource allocation schemes, type 0 and type 1, are supported. The UE shall assume that when the scheduling grant is received with DCI format 1<sub>0</sub>, then downlink resource allocation type 1 is used.

[38.214 clause 5.1.2.2.2]

In downlink resource allocation of type 1, the resource block assignment information indicates to a scheduled UE a set of contiguously allocated non-interleaved or interleaved virtual resource blocks within the active bandwidth part of size  $N_{\text{BWP}}^{\text{size}}$  PRBs except for the case when DCI format 1<sub>0</sub> is decoded in any common search space in CORESET 0 in which case the initial bandwidth part of size  $N_{\text{BWP},0}^{\text{size}}$  shall be used.

A downlink type 1 resource allocation field consists of a resource indication value ( $RIV$ ) corresponding to a starting virtual resource block ( $RB_{\text{start}}$ ) and a length in terms of contiguously allocated resource blocks  $L_{\text{RBs}}$ . The resource indication value is defined by

if  $(L_{\text{RBs}} - 1) \leq \lfloor N_{\text{BWP}}^{\text{size}} / 2 \rfloor$  then

$$RIV = N_{\text{BWP}}^{\text{size}} (L_{\text{RBs}} - 1) + RB_{\text{start}}$$

else

$$RIV = N_{\text{BWP}}^{\text{size}} (N_{\text{BWP}}^{\text{size}} - L_{\text{RBs}} + 1) + (N_{\text{BWP}}^{\text{size}} - 1 - RB_{\text{start}})$$

where  $L_{RBs} \geq 1$  and shall not exceed  $N_{BWP}^{size} - RB_{start}$ .

[TS 38.214, clause 5.1.3]

To determine the modulation order, target code rate, and transport block size(s) in the physical downlink shared channel, the UE shall first

- read the 5-bit *modulation and coding scheme* field ( $I_{MCS}$ ) in the DCI to determine the modulation order ( $Q_m$ ) and target code rate ( $R$ ) based on the procedure defined in Subclause 5.1.3.1, and
- read *redundancy version* field ( $rv$ ) in the DCI to determine the redundancy version.

and second

- the UE shall use the number of layers ( $v$ ), the total number of allocated PRBs before rate matching ( $n_{PRB}$ ) to determine to the transport block size based on the procedure defined in Subclause 5.1.3.2.

The UE may skip decoding a transport block in an initial transmission if the effective channel code rate is higher than 0.95, where the effective channel code rate is defined as the number of downlink information bits (including CRC bits) divided by the number of physical channel bits on PDSCH. If the UE skips decoding, the physical layer indicates to higher layer that the transport block is not successfully decoded.

[TS 38.214, clause 5.1.3.1]

For the PDSCH scheduled by a PDCCH with DCI format 1\_0 or format 1\_1 with CRC scrambled by C-RNTI, new-RNTI, TC-RNTI, CS-RNTI, SI-RNTI, RA-RNTI, or P-RNTI,

if the higher layer parameter *mcs-Table* given by *PDSCH-Config* is set to 'qam256', and the PDSCH is scheduled by a PDCCH with a DCI format 1\_1 and the CRC is scrambled by C-RNTI or CS-RNTI

- the UE shall use  $I_{MCS}$  and Table 5.1.3.1-2 to determine the modulation order ( $Q_m$ ) and Target code rate ( $R$ ) used in the physical downlink shared channel.

elseif the UE is not configured with new-RNTI, the higher layer parameter *mcs-Table* given by *PDSCH-Config* is set to 'qam64LowSE', and the PDSCH is scheduled with C-RNTI, and the PDSCH is assigned by a PDCCH in a UE-specific search space

- the UE shall use  $I_{MCS}$  and Table 5.1.3.1-3 to determine the modulation order ( $Q_m$ ) and Target code rate ( $R$ ) used in the physical downlink shared channel.

elseif the UE is configured with new-RNTI, and the PDSCH is scheduled with new-RNTI

- the UE shall use  $I_{MCS}$  and Table 5.1.3.1-3 to determine the modulation order ( $Q_m$ ) and Target code rate ( $R$ ) used in the physical downlink shared channel.

elseif the UE is not configured with the higher layer parameter *mcs-Table* given by *SPS-config*, the higher layer parameter *mcs-Table* given by *PDSCH-Config* is set to 'qam256', the PDSCH is scheduled with CS-RNTI, and the PDSCH is assigned by a PDCCH with DCI format 1\_1

- the UE shall use  $I_{MCS}$  and Table 5.1.3.1-2 to determine the modulation order ( $Q_m$ ) and Target code rate ( $R$ ) used in the physical downlink shared channel.

elseif the UE is configured with the higher layer parameter *mcs-Table* given by *SPS-config* set to 'qam64LowSE', and the PDSCH is scheduled with CS-RNTI

- the UE shall use  $I_{MCS}$  and Table 5.1.3.1-3 to determine the modulation order ( $Q_m$ ) and Target code rate ( $R$ ) used in the physical downlink shared channel.

else

- the UE shall use  $I_{MCS}$  and Table 5.1.3.1-1 to determine the modulation order ( $Q_m$ ) and Target code rate ( $R$ ) used in the physical downlink shared channel.

End

The UE is not expected to decode a PDSCH scheduled with P-RNTI, RA-RNTI, SI-RNTI and  $Q_m > 2$

Table 5.1.3.1-2: MCS index table 2 for PDSCH

MCS Index $I_{MCS}$	Modulation Order $Q_m$	Target code Rate $R \times [1024]$	Spectral efficiency
0	2	120	0.2344
1	2	193	0.3770
2	2	308	0.6016
3	2	449	0.8770
4	2	602	1.1758
5	4	378	1.4766
6	4	434	1.6953
7	4	490	1.9141
8	4	553	2.1602
9	4	616	2.4063
10	4	658	2.5703
11	6	466	2.7305
12	6	517	3.0293
13	6	567	3.3223
14	6	616	3.6094
15	6	666	3.9023
16	6	719	4.2129
17	6	772	4.5234
18	6	822	4.8164
19	6	873	5.1152
20	8	682.5	5.3320
21	8	711	5.5547
22	8	754	5.8906
23	8	797	6.2266
24	8	841	6.5703
25	8	885	6.9141
26	8	916.5	7.1602
27	8	948	7.4063
28	2	reserved	
29	4	reserved	
30	6	reserved	
31	8	reserved	

[TS 38.214, clause 5.1.3.2]

In case the higher layer parameter *maxNrofCodeWordsScheduledByDCI* indicates that two codeword transmission is enabled, then a transport block is disabled by DCI format 1\_1 if  $I_{MCS} = 26$  and if  $rv_{id} = 1$  for the corresponding transport block, otherwise the transport block is enabled. If both transport blocks are enabled, transport block 1 and 2 are mapped to codeword 0 and 1 respectively. If only one transport block is enabled, then the enabled transport block is always mapped to the first codeword.

For the PDSCH assigned by a PDCCH with DCI format 1\_0 or format 1\_1 with CRC scrambled by C-RNTI, new-RNTI, TC-RNTI, CS-RNTI, or SI-RNTI, if Table 5.1.3.1-2 is used and  $0 \leq I_{MCS} \leq 27$ , or a table other than Table 5.1.3.1-2 is used and  $0 \leq I_{MCS} \leq 28$ , the UE shall, except if the transport block is disabled in DCI format 1\_1, first determine the TBS as specified below:

1) The UE shall first determine the number of REs ( $N_{RE}$ ) within the slot.

- A UE first determines the number of REs allocated for PDSCH within a PRB ( $N'_{RE}$ ) by

$$N'_{RE} = N_{sc}^{RB} \cdot N_{symb}^{sh} - N_{DMRS}^{PRB} - N_{oh}^{PRB}, \text{ where } N_{sc}^{RB} = 12 \text{ is the number of subcarriers in a physical resource}$$

block,  $N_{symb}^{sh}$  is the number of symbols of the PDSCH allocation within the slot,  $N_{DMRS}^{PRB}$  is the number of REs for DM-RS per PRB in the scheduled duration including the overhead of the DM-RS CDM groups without data, as indicated by DCI format 1\_1 or as described for format 1\_0 in Subclause 5.1.6.2, and  $N_{oh}^{PRB}$  is the overhead configured by higher layer parameter *xOverhead* in *PDSCH-ServingCellConfig*. If the



$\alpha$ Overhead in *PDSCH-ServingCellconfig* is not configured (a value from 0, 6, 12, or 18), the  $N_{oh}^{PRB}$  is set to 0. If the PDSCH is scheduled by PDCCH with a CRC scrambled by SI-RNTI, RA-RNTI or P-RNTI,  $N_{oh}^{PRB}$  is assumed to be 0.

- A UE determines the total number of REs allocated for PDSCH ( $N_{RE}$ ) by  $N_{RE} = \min(156, N_{RE}')$  ·  $n_{PRB}$ , where  $n_{PRB}$  is the total number of allocated PRBs for the UE.

2) Intermediate number of information bits ( $N_{info}$ ) is obtained by  $N_{info} = N_{RE} \cdot R \cdot Q_m \cdot \nu$ .

If  $N_{info} \leq 3824$

Use step 3 as the next step of the TBS determination

else

Use step 4 as the next step of the TBS determination

end if

3) When  $N_{info} > 3824$ , TBS is determined as follows

- quantized intermediate number of information bits  $N'_{info} = \max\left(24, 2^n \cdot \left\lfloor \frac{N_{info}}{2^n} \right\rfloor\right)$ , where  $n = \max(3, \lfloor \log_2(N_{info}) \rfloor - 6)$ .
- use Table 5.1.3.2-2 find the closest TBS that is not less than  $N'_{info}$ .

Table 5.1.3.2-2: TBS for  $N_{info} \leq 3824$ 

Index	TBS	Index	TBS	Index	TBS	Index	TBS
1	24	31	336	61	1288	91	3624
2	32	32	352	62	1320	92	3752
3	40	33	368	63	1352	93	3824
4	48	34	384	64	1416		
5	56	35	408	65	1480		
6	64	36	432	66	1544		
7	72	37	456	67	1608		
8	80	38	480	68	1672		
9	88	39	504	69	1736		
10	96	40	528	70	1800		
11	104	41	552	71	1864		
12	112	42	576	72	1928		
13	120	43	608	73	2024		
14	128	44	640	74	2088		
15	136	45	672	75	2152		
16	144	46	704	76	2216		
17	152	47	736	77	2280		
18	160	48	768	78	2408		
19	168	49	808	79	2472		
20	176	50	848	80	2536		
21	184	51	888	81	2600		
22	192	52	928	82	2664		
23	208	53	984	83	2728		
24	224	54	1032	84	2792		
25	240	55	1064	85	2856		
26	256	56	1128	86	2976		
27	272	57	1160	87	3104		
28	288	58	1192	88	3240		
29	304	59	1224	89	3368		
30	320	60	1256	90	3496		

4) When  $N_{info} > 3824$ , TBS is determined as follows.

- quantized intermediate number of information bits  $N'_{info} = \max\left(3840, 2^n \times \text{round}\left(\frac{N_{info} - 24}{2^n}\right)\right)$ , where  $n = \lfloor \log_2(N_{info} - 24) \rfloor - 5$  and ties in the round function are broken towards the next largest integer.
- if  $R \leq 1/4$

$$TBS = 8 \cdot C \cdot \left\lceil \frac{N'_{info} + 24}{8 \cdot C} \right\rceil - 24, \text{ where } C = \left\lceil \frac{N'_{info} + 24}{3816} \right\rceil$$

else

if  $N'_{info} > 8424$

$$TBS = 8 \cdot C \cdot \left\lceil \frac{N'_{info} + 24}{8 \cdot C} \right\rceil - 24, \text{ where } C = \left\lceil \frac{N'_{info} + 24}{8424} \right\rceil$$

else

$$TBS = 8 \cdot \left\lceil \frac{N'_{info} + 24}{8} \right\rceil - 24$$

end if

end if

7.1.1.4.1.2.3 Test description

7.1.1.4.1.2.3.1 Pre-test conditions

Same Pre-test conditions as in clause 7.1.1.0 except set the NR Cell bandwidth and applicable BWP to maximum for the NR Band under test as specified in Table 5.3.5-1 in TS 38.101-1 [16] / TS 38.101-2 [17] (to enable testing of  $n_{PRB}$  up to maximum value).

7.1.1.4.1.2.3.2 Test procedure sequence

**Table 7.1.1.4.1.2.3.2-1: Maximum TBS for different UE categories**

UE Category	Maximum number of bits of a UL-SCH transport block received within a TTI
TS 38.306 [23] clause 4.1.2 require UE without <i>ue-CategoryDL</i> and <i>ue-CategoryUL</i> , to support Max TBS achievable based on max bandwidth of the Band under test.	

**Table 7.1.1.4.1.2.3.2-2: Number of downlink PDCP SDUs and PDCP SDU size used as test data**

TBS [bits]	Number of PDCP SDUs	PDCP SDU size [bits] (Note 1)
$132 \leq TBS \leq 12128$ note 2	1	$8 * \text{FLOOR}((TBS - 128) / 8)$
$12129 \leq TBS \leq 24200$	2	$8 * \text{FLOOR}((TBS - 200) / 16)$
$24201 \leq TBS \leq 36272$	3	$8 * \text{FLOOR}((TBS - 272) / 24)$
$36273 \leq TBS \leq 48344$	4	$8 * \text{FLOOR}((TBS - 344) / 32)$
$48345 \leq TBS \leq 60416$	5	$8 * \text{FLOOR}((TBS - 416) / 40)$
$60417 \leq TBS \leq 72488$	6	$8 * \text{FLOOR}((TBS - 488) / 48)$
$72489 \leq TBS \leq 84560$	7	$8 * \text{FLOOR}((TBS - 560) / 56)$
$84561 \leq TBS \leq 96632$	8	$8 * \text{FLOOR}((TBS - 632) / 64)$
$96633 < TBS \leq 108704$	9	$8 * \text{FLOOR}((TBS - 704) / 72)$
$10705 \leq TBS \leq 120776$	10	$8 * \text{FLOOR}((TBS - 776) / 80)$
$120777 \leq TBS \leq 132848$	11	$8 * \text{FLOOR}((TBS - 848) / 88)$
$132849 \leq TBS \leq 144920$	12	$8 * \text{FLOOR}((TBS - 920) / 96)$
$TBS > 144920$	13	$8 * \text{FLOOR}((TBS - 992) / 112)$

Note 1: Each PDCP SDU is limited to 1500 octets (to keep below maximum SDU size of ESM as specified in TS 24.301 clause 9.9.4.12).

The PDCP SDU size of each PDCP SDU is

PDCP SDU size = (TBS – N\*PDCP header size – N\*AMD PDU header size – N\*MAC header size – Size of Timing Advance – RLC Status PDU size- MAC header for RLC Status PDU) / N, where

PDCP header size is 24 bits for the RLC AM and 18-bit SN case;  
 AMD PDU header size is 24 bits with 18 bit SN;

MAC header size for AMD PDU = 16 or 24 bits depending on L=8 or 16 bits. Worst case 24 is taken.

Size of Timing Advance MAC CE with header is 16 bits (if no Timing Advance and/or RLC status needs to be sent, padding will occur instead).

RLC Status PDU size = 24 bits with 1 ACK\_SN, With a MAC header of 16 bits.

This gives:

PDCP SDU size =  $8 * \text{FLOOR}((TBS - N * 24 - N * 24 - N * 24 - 56) / (8 * N))$  bits.

Note 2: According to the final PDCP SDU size formula in Note 1, the smallest TBS that can be tested is 136 bits.

**Table 7.1.1.4.1.2.3.2-3: Specific Parameters**

Parameter	Value	Comments
PDSCH mappingType	typeA	
starting symbol S	0 Or 3 to avoid clash with PDCCH symbols	
number of consecutive symbols L	3..14-S]	
k0	0 or 1 (if S=0)	
number of layers (v)	1	
mcs-Table	qam256	
xoh-PDSCH	Not Present	Results in value 0(xoh0)
dmrs-AdditionalPosition	pos0	Results in 1 DMRS symbol per two carrier ( $N_{DMRS}^{PRB}$ ) for Duration in symbols $\geq 3$ (TS 38.211 [24], table 7.4.1.1.2-3)

**Table 7.1.1.4.1.2.3.2-4: Main behaviour**

St	Procedure	Message Sequence		TP	Verdict
		U - S	Message		
-	EXCEPTION: Steps 1 to 5 are repeated for allowed values of $N_{PRB}$ 1 to $N_{RB}^{DL,BWP}$ in BWP, time domain resource length L from 3 to 14-S and $I_{MCS}$ from 0 to 27.	-	-	-	-
1	The SS calculates or looks up TBS in TS 38.214 [15] clause 5.3.1 based on the value of S, L, $I_{MCS}$ and $n_{PRB}$ .	-	-	-	-
-	EXCEPTION: Steps 2 to 5 are performed if TBS is less than or equal to UE capability "Maximum number of DL-SCH transport block bits received within a TTI" as specified in Table 7.1.1.4.1.2.3.2-1 and larger than or equal to 132 bits as specified in Table 7.1.1.4.1.2.3.2-2.	-	-	-	-
2	The SS creates one or more PDCP SDUs, depending on TBS, in accordance with Table 7.1.1.4.1.2.3.2-2.	-	-	-	-
3	The SS transmits the PDCP SDUs concatenated into a MAC PDU and indicates on PDCCH DCI Format 1_0 and values of S, L, $I_{MCS}$ and $n_{PRB}$ .	<--	MAC PDU (NxPDCP SDUs) DCI: (DCI Format 1_0, S, L, $I_{MCS}$ and $n_{PRB}$ )	-	-
4	At the reception of scheduling request the SS transmits UL Grant for transmitting loop back PDCP SDUs.	<--	(UL Grant)	-	-
5	CHECK: Does UE return the same number of PDCP SDUs with same content as transmitted by the SS in step 3?	-->	(NxPDCP SDUs)	1	P

7.1.1.4.1.2.3.3 Specific message contents

[None].

### 7.1.1.4.1.3 DL-SCH transport block size selection / DCI format 1\_1 / RA type 0/RA Type 1 / 2 Codewords enabled

#### 7.1.1.4.1.3.1 Test Purpose (TP)

(1)

```
with { UE in RRC_CONNECTED state and maxNrofCodeWordsScheduledByDCI set to 'n2' }
ensure that {
  when { UE on PDCCH receives DCI format 1_1 indicating resource allocation type 0 a resource block
assignment correspondent to physical resource blocks , Time domain resource assignment and a
modulation and coding }
  then { UE decodes the received transport block of size correspondent as per Modulation Coding
scheme, time domain resource allocation and PRB's and forwards it to higher layers }
}
```

(2)

```
with { UE in RRC_CONNECTED state and maxNrofCodeWordsScheduledByDCI set to 'n2' }
ensure that {
  when { UE on PDCCH receives DCI format 1_1 indicating resource allocation type 1 a resource block
assignment correspondent to physical resource blocks , Time domain resource assignment and a
modulation and coding }
  then { UE decodes the received transport block of size correspondent as per Modulation Coding
scheme, time domain resource allocation and PRB's and forwards it to higher layers }
}
```

#### 7.1.1.4.1.3.2 Conformance requirements

References: The conformance requirements covered in the present TC are specified in: TS 38.212 clause 7.3.1.2.2, TS 38.214 clause 5.1.2.1, 5.1.2.2.1, 5.1.2.2.2, 5.1.3, 5.1.3.1 and 5.1.3.2. Unless otherwise stated these are Rel-15 requirements.

[TS 38.212, clause 7.3.1.2.2]

DCI format 1\_1 is used for the scheduling of PDSCH in one cell.

The following information is transmitted by means of the DCI format 1\_1 with CRC scrambled by C-RNTI or CS-RNTI or new-RNTI:

- Identifier for DCI formats – 1 bits
- The value of this bit field is always set to 1, indicating a DL DCI format
  - Carrier indicator – 0 or 3 bits as defined in Subclause 10.1 of [5, TS38.213].
  - Bandwidth part indicator – 0, 1 or 2 bits as determined by the number of DL BWPs  $n_{\text{BWP,RRC}}$  configured by higher layers, excluding the initial DL bandwidth part. The bit width for this field is determined as  $\lceil \log_2(n_{\text{BWP}}) \rceil$  bits, where
    - $n_{\text{BWP}} = n_{\text{BWP,RRC}} + 1$  if  $n_{\text{BWP,RRC}} \leq 3$ , in which case the bandwidth part indicator is equivalent to the higher layer parameter *BWP-Id*;
    - otherwise  $n_{\text{BWP}} = n_{\text{BWP,RRC}}$ , in which case the bandwidth part indicator is defined in Table 7.3.1.1.2-1;

If a UE does not support active BWP change via DCI, the UE ignores this bit field.

- Frequency domain resource assignment – number of bits determined by the following, where  $N_{\text{RB}}^{\text{DL,BWP}}$  is the size of the active DL bandwidth part:
  - $N_{\text{RBG}}$  bits if only resource allocation type 0 is configured, where  $N_{\text{RBG}}$  is defined in Subclause 5.1.2.2.1 of [6, TS38.214],
  - $\lceil \log_2(N_{\text{RB}}^{\text{DL,BWP}}(N_{\text{RB}}^{\text{DL,BWP}} + 1)/2) \rceil$  bits if only resource allocation type 1 is configured, or

- $\max \left( \left\lceil \log_2 \left( N_{RB}^{DL,BWP} (N_{RB}^{DL,BWP} + 1) / 2 \right) \right\rceil, N_{RBG} \right) + 1$  bits if both resource allocation type 0 and 1 are configured.
- If both resource allocation type 0 and 1 are configured, the MSB bit is used to indicate resource allocation type 0 or resource allocation type 1, where the bit value of 0 indicates resource allocation type 0 and the bit value of 1 indicates resource allocation type 1.
- For resource allocation type 0, the  $N_{RBG}$  LSBs provide the resource allocation as defined in Subclause 5.1.2.2.1 of [6, TS38.214].
- For resource allocation type 1, the  $\left\lceil \log_2 \left( N_{RB}^{DL,BWP} (N_{RB}^{DL,BWP} + 1) / 2 \right) \right\rceil$  LSBs provide the resource allocation as defined in Subclause 5.1.2.2.2 of [6, TS38.214]

If “Bandwidth part indicator” field indicates a bandwidth part other than the active bandwidth part and if both resource allocation type 0 and 1 are configured for the indicated bandwidth part, the UE assumes resource allocation type 0 for the indicated bandwidth part if the bit width of the “Frequency domain resource assignment” field of the active bandwidth part is smaller than the bit width of the “Frequency domain resource assignment” field of the indicated bandwidth part.

- Time domain resource assignment – 0, 1, 2, 3, or 4 bits as defined in Subclause 5.1.2.1 of [6, TS38.214]. The bit width for this field is determined as  $\lceil \log_2(I) \rceil$  bits, where  $I$  is the number of entries in the higher layer parameter *pusch-AllocationList*.
- VRB-to-PRB mapping – 0 or 1 bit
  - 0 bit if only resource allocation type 0 is configured;
  - 1 bit according to Table 7.3.1.1.2-33 otherwise, only applicable to resource allocation type 1, as defined in Subclause 7.3.1.6 of [4, TS38.211].
- PRB bundling size indicator – 0 bit if the higher layer parameter *prb-BundlingType* is not configured or is set to ‘static’, or 1 bit if the higher layer parameter *prb-BundlingType* is set to ‘dynamic’, according to Subclause 5.1.2.3 of [6, TS38.214].
- Rate matching indicator – 0, 1, or 2 bits according to higher layer parameter *rateMatchPattern*.
- ZP CSI-RS trigger – 0, 1, or 2 bits as defined in Subclause 5.1.4.2 of [6, TS38.214]. The bit width for this field is determined as  $\lceil \log_2(n_{ZP} + 1) \rceil$  bits, where  $n_{ZP}$  is the number of ZP CSI-RS resource sets in the higher layer parameter *zp-CSI-RS-Resource*.

For transport block 1:

- Modulation and coding scheme – 5 bits as defined in Subclause 5.1.3.1 of [6, TS38.214]
- New data indicator – 1 bit
- Redundancy version – 2 bits as defined in Table 7.3.1.1.1-2

For transport block 2 (only present if *maxNrofCodeWordsScheduledByDCI* equals 2

- Modulation and coding scheme – 5 bits as defined in Subclause 5.1.3.1 of [6, TS38.214]
- New data indicator – 1 bit
- Redundancy version – 2 bits as defined in Table 7.3.1.1.1-2

If “Bandwidth part indicator” field indicates a bandwidth part other than the active bandwidth part and the value of *maxNrofCodeWordsScheduledByDCI* for the indicated bandwidth part equals 2 and the value of *maxNrofCodeWordsScheduledByDCI* for the active bandwidth part equals 1, the UE assumes zeros are padded when interpreting the “Modulation and coding scheme”, “New data indicator”, and “Redundancy version” fields of transport block 2 according to Subclause 12 of [5, TS38.213], and the UE ignores the “Modulation and coding scheme”, “New data indicator”, and “Redundancy version” fields of transport block 2 for the indicated bandwidth part.

- HARQ process number – 4 bits
- Downlink assignment index – number of bits as defined in the following
  - 4 bits if more than one serving cell are configured in the DL and the higher layer parameter *pdsch-HARQ-ACK-Codebook=dynamic*, where the 2 MSB bits are the counter DAI and the 2 LSB bits are the total DAI;
  - 2 bits if only one serving cell is configured in the DL and the higher layer parameter *pdsch-HARQ-ACK-Codebook=dynamic*, where the 2 bits are the counter DAI;
  - 0 bits otherwise.
- TPC command for scheduled PUCCH – 2 bits as defined in Subclause 7.2.1 of [5, TS38.213]
- PUCCH resource indicator – 3 bits as defined in Subclause 9.2.3 of [5, TS38.213]
- PDSCH-to-HARQ\_feedback timing indicator – 3 0, 1, 2, or bits as defined in Subclause 9.2.3 of [5, TS38.213]. The bit width for this field is determined as  $\lceil \log_2(I) \rceil$  bits, where  $I$  is the number of entries in the higher layer parameter *dl-DataToUL-ACK*.

- Antenna port(s) – 4, 5, or 6 bits as defined by Tables 7.3.1.2.2-1/2/3/4, where the number of CDM groups without data of values 1, 2, and 3 refers to CDM groups {0}, {0,1}, and {0, 1,2} respectively. The antenna ports  $\{p_0, \dots, p_{v-1}\}$  shall be determined according to the ordering of DMRS port(s) given by Tables 7.3.1.2.2-1/2/3/4.

If a UE is configured with both *dmrs-DownlinkForPDSCH-MappingTypeA* and *dmrs-DownlinkForPDSCH-MappingTypeB*, the bit width of this field equals  $\max\{x_A, x_B\}$ , where  $x_A$  is the “Antenna ports” bit width derived according to *dmrs-DownlinkForPDSCH-MappingTypeA* and  $x_B$  is the “Antenna ports” bit width derived according to *dmrs-DownlinkForPDSCH-MappingTypeB*. A number of  $|x_A - x_B|$  zeros are padded in the MSB of this field, if the mapping type of the PDSCH corresponds to the smaller value of  $x_A$  and  $x_B$ .

- Transmission configuration indication – 0 bit if higher layer parameter *tci-PresentInDCI* is not enabled; otherwise 3 bits as defined in Subclause 5.1.5 of [6, TS38.214].

If “Bandwidth part indicator” field indicates a bandwidth part other than the active bandwidth part and the “Transmission configuration indication” field is not present in the DCI format 1\_1, the UE assumes *tci-PresentInDCI* is not enabled for the indicated bandwidth part.

- SRS request – 2 bits as defined by Table 7.3.1.1.2-24 for UEs not configured with SUL in the cell; 3 bits for UEs configured SUL in the cell where the first bit is the non-SUL/SUL indicator as defined in Table 7.3.1.1.1-1 and the second and third bits are defined by Table 7.3.1.1.2-24. This bit field may also indicate the associated CSI-RS according to Subclause 6.1.1.2 of [6, TS 38.214].
- CBG transmission information (CBGTI) – 0, 2, 4, 6, or 8 bits as defined in Subclause 5.1.7 of [6, TS38.214], determined by the higher layer parameters *maxCodeBlockGroupsPerTransportBlock* and *Number-MCS-HARQ-DL-DCI* for the PDSCH.
- CBG flushing out information (CBGFI) – 0 or 1 bit as defined in Subclause 5.1.7 of [6, TS38.214], determined by higher layer parameter *codeBlockGroupFlushIndicator*.
- DMRS sequence initialization – 1 bit if both *scramblingID0* and *scramblingID1* are configured in *DMRS-DownlinkConfig* for  $n_{\text{SCID}}$  selection defined in Subclause 7.4.1.1.1 of [4, TS38.211]; 0 bit otherwise.

[TS 38.214, clause 5.1.2.1]

When the UE is scheduled to receive PDSCH by a DCI, the *Time domain resource assignment* field value  $m$  of the DCI provides a row index  $m + 1$  to an allocation table. The determination of the used resource allocation table is defined in sub-clause 5.1.2.1.1. The indexed row defines the slot offset  $K_0$ , the start and length indicator *SLIV*, or directly the start symbol  $S$  and the allocation length  $L$ , and the PDSCH mapping type to be assumed in the PDSCH reception.

Given the parameter values of the indexed row:

- The slot allocated for the PDSCH is  $\left\lfloor n \cdot \frac{2^{\mu_{\text{PDSCH}}}}{2^{\mu_{\text{PDCCH}}}} \right\rfloor + K_0$ , where  $n$  is the slot with the scheduling DCI, and  $K_0$  is based on the numerology of PDSCH, and  $\mu_{\text{PDSCH}}$  and  $\mu_{\text{PDCCH}}$  are the subcarrier spacing configurations for PDSCH and PDCCH, respectively, and
- The starting symbol  $S$  relative to the start of the slot, and the number of consecutive symbols  $L$  counting from the symbol  $S$  allocated for the PDSCH are determined from the start and length indicator  $SLIV$ :
  - if  $(L-1) \leq 7$  then
 
$$SLIV = 14 \cdot (L-1) + S$$
  - else
 
$$SLIV = 14 \cdot (14 - L + 1) + (14 - 1 - S)$$
  - where  $0 < L \leq 14 - S$ , and
- The PDSCH mapping type is set to Type A or Type B as defined in sub-clause 7.4.1.1.2 of [4, TS 38.211].

The UE shall consider the  $S$  and  $L$  combinations defined in table 5.1.2.1-1 as valid PDSCH allocations:

**Table 5.1.2.1-1: Valid  $S$  and  $L$  combinations**

PDSCH mapping type	Normal cyclic prefix			Extended cyclic prefix		
	$S$	$L$	$S+L$	$S$	$L$	$S+L$
Type A	{0,1,2,3} (Note 1)	{3,...,14}	{3,...,14}	{0,1,2,3} (Note 1)	{3,...,12}	{3,...,12}
Type B	{0,...,12}	{2,4,7}	{2,...,14}	{0,...,10}	{2,4,6}	{2,...,12}

Note 1:  $S = 3$  is applicable only if  $dms\text{-}TypeA\text{-}Position = 3$

[TS 38.214, clause 5.1.2.2.1]

In downlink resource allocation of type 0, the resource block assignment information includes a bitmap indicating the Resource Block Groups (RBGs) that are allocated to the scheduled UE where a RBG is a set of consecutive virtual resource blocks defined by higher layer parameter  $rbg\text{-}Size$  configured for PDSCH and the size of the carrier bandwidth part as defined in Table 5.1.2.2.1-1.

**Table 5.1.2.2.1-1: Nominal RBG size  $P$**

Bandwidth Part Size	Configuration 1	Configuration 2
1 – 36	2	4
37 – 72	4	8
73 – 144	8	16
145 – 275	16	16

The total number of RBGs ( $N_{\text{RBG}}$ ) for a downlink carrier bandwidth part  $i$  of size  $N_{\text{BWP},i}^{\text{size}}$  PRBs is given by

$$N_{\text{RBG}} = \left\lfloor \left( N_{\text{BWP},i}^{\text{size}} + \left( N_{\text{BWP},i}^{\text{start}} \bmod P \right) \right) / P \right\rfloor, \text{ where}$$

- the size of the first RBG is  $RBG_0^{\text{size}} = P - N_{\text{BWP},i}^{\text{start}} \bmod P$ ,
- the size of last RBG is  $RBG_{\text{last}}^{\text{size}} = \left( N_{\text{BWP},i}^{\text{start}} + N_{\text{BWP},i}^{\text{size}} \right) \bmod P$  if  $\left( N_{\text{BWP},i}^{\text{start}} + N_{\text{BWP},i}^{\text{size}} \right) \bmod P > 0$  and  $P$  otherwise,
- the size of all other RBGs is  $P$ .

The bitmap is of size  $N_{\text{RBG}}$  bits with one bitmap bit per RBG such that each RBG is addressable. The RBGs shall be indexed in the order of increasing frequency and starting at the lowest frequency of the carrier bandwidth part. The



order of RBG bitmap is such that RBG 0 to RBG  $N_{\text{RBG}} - 1$  are mapped from MSB to LSB. The RBG is allocated to the UE if the corresponding bit value in the bitmap is 1, the RBG is not allocated to the UE otherwise.

[TS 38.214, clause 5.1.2.2.2]

In downlink resource allocation of type 1, the resource block assignment information indicates to a scheduled UE a set of contiguously allocated localized or distributed virtual resource blocks within the active carrier bandwidth part of size  $N_{\text{BWP}}^{\text{size}}$  PRBs except for the case when DCI format 1\_0 is decoded in the common search space in CORESET 0 in which case the initial bandwidth part of size  $N_{\text{BWP}}^{\text{size}}$  shall be used.

A downlink type 1 resource allocation field consists of a resource indication value ( $RIV$ ) corresponding to a starting virtual resource block ( $RB_{\text{start}}$ ) and a length in terms of contiguously allocated resource blocks  $L_{\text{RBs}}$ . The resource indication value is defined by

if  $(L_{\text{RBs}} - 1) \leq \lfloor N_{\text{BWP}}^{\text{size}} / 2 \rfloor$  then

$$RIV = N_{\text{BWP}}^{\text{size}} (L_{\text{RBs}} - 1) + RB_{\text{start}}$$

else

$$RIV = N_{\text{BWP}}^{\text{size}} (N_{\text{BWP}}^{\text{size}} - L_{\text{RBs}} + 1) + (N_{\text{BWP}}^{\text{size}} - 1 - RB_{\text{start}})$$

where  $L_{\text{RBs}} \geq 1$  and shall not exceed  $N_{\text{BWP}}^{\text{size}} - RB_{\text{start}}$ .

[TS 38.214, clause 5.1.3]

To determine the modulation order, target code rate, and transport block size(s) in the physical downlink shared channel, the UE shall first

- read the 5-bit *modulation and coding scheme* field ( $I_{\text{MCS}}$ ) in the DCI to determine the modulation order ( $Q_m$ ) and target code rate ( $R$ ) based on the procedure defined in Subclause 5.1.3.1, and
- read *redundancy version* field ( $rv$ ) in the DCI to determine the redundancy version.

and second

- the UE shall use the number of layers ( $v$ ), the total number of allocated PRBs before rate matching ( $n_{\text{PRB}}$ ) to determine the transport block size based on the procedure defined in Subclause 5.1.3.2.

The UE may skip decoding a transport block in an initial transmission if the effective channel code rate is higher than 0.95, where the effective channel code rate is defined as the number of downlink information bits (including CRC bits) divided by the number of physical channel bits on PDSCH. If the UE skips decoding, the physical layer indicates to higher layer that the transport block is not successfully decoded.

[TS 38.214, clause 5.1.3.1]

For the PDSCH scheduled by a PDCCH with DCI format 1\_0 or format 1\_1 with CRC scrambled by C-RNTI, new-RNTI, TC-RNTI, CS-RNTI, SI-RNTI, RA-RNTI, or P-RNTI,

if the higher layer parameter *mcs-Table* given by *PDSCH-Config* is set to 'qam256', and the PDSCH is scheduled by a PDCCH with a DCI format 1\_1 and the CRC is scrambled by C-RNTI or CS-RNTI

- the UE shall use  $I_{\text{MCS}}$  and Table 5.1.3.1-2 to determine the modulation order ( $Q_m$ ) and Target code rate ( $R$ ) used in the physical downlink shared channel.

elseif the UE is not configured with new-RNTI, the higher layer parameter *mcs-Table* given by *PDSCH-Config* is set to 'qam64LowSE', and the PDSCH is scheduled with C-RNTI, and the PDSCH is assigned by a PDCCH in a UE-specific search space

- the UE shall use  $I_{\text{MCS}}$  and Table 5.1.3.1-3 to determine the modulation order ( $Q_m$ ) and Target code rate ( $R$ ) used in the physical downlink shared channel.

elseif the UE is configured with new-RNTI, and the PDSCH is scheduled with new-RNTI

- the UE shall use  $I_{MCS}$  and Table 5.1.3.1-3 to determine the modulation order ( $Q_m$ ) and Target code rate ( $R$ ) used in the physical downlink shared channel.

elseif the UE is not configured with the higher layer parameter *mcs-Table* given by *SPS-config*, the higher layer parameter *mcs-Table* given by *PDSCH-Config* is set to 'qam256', the PDSCH is scheduled with CS-RNTI, and the PDSCH is assigned by a PDCCH with DCI format 1\_1

- the UE shall use  $I_{MCS}$  and Table 5.1.3.1-2 to determine the modulation order ( $Q_m$ ) and Target code rate ( $R$ ) used in the physical downlink shared channel.

elseif the UE is configured with the higher layer parameter *mcs-Table* given by *SPS-config* set to 'qam64LowSE', and the PDSCH is scheduled with CS-RNTI

- the UE shall use  $I_{MCS}$  and Table 5.1.3.1-3 to determine the modulation order ( $Q_m$ ) and Target code rate ( $R$ ) used in the physical downlink shared channel.

else

- the UE shall use  $I_{MCS}$  and Table 5.1.3.1-1 to determine the modulation order ( $Q_m$ ) and Target code rate ( $R$ ) used in the physical downlink shared channel.

End

The UE is not expected to decode a PDSCH scheduled with P-RNTI, RA-RNTI, SI-RNTI and  $Q_m > 2$

**Table 5.1.3.1-1: MCS index table 1 for PDSCH**

MCS Index $I_{MCS}$	Modulation Order $Q_m$	Target code Rate $R \times [1024]$	Spectral efficiency
0	2	120	0.2344
1	2	157	0.3066
2	2	193	0.3770
3	2	251	0.4902
4	2	308	0.6016
5	2	379	0.7402
6	2	449	0.8770
7	2	526	1.0273
8	2	602	1.1758
9	2	679	1.3262
10	4	340	1.3281
11	4	378	1.4766
12	4	434	1.6953
13	4	490	1.9141
14	4	553	2.1602
15	4	616	2.4063
16	4	658	2.5703
17	6	438	2.5664
18	6	466	2.7305
19	6	517	3.0293
20	6	567	3.3223
21	6	616	3.6094
22	6	666	3.9023
23	6	719	4.2129
24	6	772	4.5234
25	6	822	4.8164
26	6	873	5.1152
27	6	910	5.3320
28	6	948	5.5547
29	2	reserved	
30	4	reserved	
31	6	reserved	

[TS 38.214, clause 5.1.3.2]

In case the higher layer parameter *maxNrofCodeWordsScheduledByDCI* indicates that two codeword transmission is enabled, then a transport block is disabled by DCI format 1\_1 if  $I_{MCS} = 26$  and if  $rv_{id} = 1$  for the corresponding transport block, otherwise the transport block is enabled. If both transport blocks are enabled, transport block 1 and 2 are mapped to codeword 0 and 1 respectively. If only one transport block is enabled, then the enabled transport block is always mapped to the first codeword.

For the PDSCH assigned by a PDCCH with DCI format 1\_0 or format 1\_1 with CRC scrambled by C-RNTI, new-RNTI, TC-RNTI, CS-RNTI, or SI-RNTI, if Table 5.1.3.1-2 is used and  $0 \leq I_{MCS} \leq 27$ , or a table other than Table 5.1.3.1-2 is used and  $0 \leq I_{MCS} \leq 28$ , the UE shall, except if the transport block is disabled in DCI format 1\_1, first determine the TBS as specified below:

- 1) The UE shall first determine the number of REs ( $N_{RE}$ ) within the slot.
  - A UE first determines the number of REs allocated for PDSCH within a PRB ( $N'_{RE}$ ) by
 
$$N'_{RE} = N_{sc}^{RB} \cdot N_{symp}^{sh} - N_{DMRS}^{PRB} - N_{oh}^{PRB}$$
, where  $N_{sc}^{RB} = 12$  is the number of subcarriers in a physical resource block,  $N_{symp}^{sh}$  is the number of symbols of the PDSCH allocation within the slot,  $N_{DMRS}^{PRB}$  is the number of REs for DM-RS per PRB in the scheduled duration including the overhead of the DM-RS CDM groups without data, as indicated by DCI format 1\_1 or as described for format 1\_0 in Subclause 5.1.6.2, and  $N_{oh}^{PRB}$  is the overhead configured by higher layer parameter *xOverhead* in *PDSCH-ServingCellConfig*. If the *xOverhead* in *PDSCH-ServingCellconfig* is not configured (a value from 0, 6, 12, or 18), the  $N_{oh}^{PRB}$  is set to 0. If the PDSCH is scheduled by PDCCH with a CRC scrambled by SI-RNTI, RA-RNTI or P-RNTI,  $N_{oh}^{PRB}$  is assumed to be 0.
  - A UE determines the total number of REs allocated for PDSCH ( $N_{RE}$ ) by  $N_{RE} = \min(156, N'_{RE}) \cdot n_{PRB}$ , where  $n_{PRB}$  is the total number of allocated PRBs for the UE.

- 2) Intermediate number of information bits ( $N_{info}$ ) is obtained by  $N_{info} = N_{RE} \cdot R \cdot Q_m \cdot \nu$ .

If  $N_{info} \leq 3824$

Use step 3 as the next step of the TBS determination

else

Use step 4 as the next step of the TBS determination

end if

- 3) When  $N_{info} \leq 3824$ , TBS is determined as follows

- quantized intermediate number of information bits  $N'_{info} = \max\left(24, 2^n \cdot \left\lfloor \frac{N_{info}}{2^n} \right\rfloor\right)$ , where
 
$$n = \max(3, \lfloor \log_2(N_{info}) \rfloor - 6).$$
- use Table 5.1.3.2-2 find the closest TBS that is not less than  $N'_{info}$ .

Table 5.1.3.2-2: TBS for  $N_{info} \leq 3824$ 

Index	TBS	Index	TBS	Index	TBS	Index	TBS
1	24	31	336	61	1288	91	3624
2	32	32	352	62	1320	92	3752
3	40	33	368	63	1352	93	3824
4	48	34	384	64	1416		
5	56	35	408	65	1480		
6	64	36	432	66	1544		
7	72	37	456	67	1608		
8	80	38	480	68	1672		
9	88	39	504	69	1736		
10	96	40	528	70	1800		
11	104	41	552	71	1864		
12	112	42	576	72	1928		
13	120	43	608	73	2024		
14	128	44	640	74	2088		
15	136	45	672	75	2152		
16	144	46	704	76	2216		
17	152	47	736	77	2280		
18	160	48	768	78	2408		
19	168	49	808	79	2472		
20	176	50	848	80	2536		
21	184	51	888	81	2600		
22	192	52	928	82	2664		
23	208	53	984	83	2728		
24	224	54	1032	84	2792		
25	240	55	1064	85	2856		
26	256	56	1128	86	2976		
27	272	57	1160	87	3104		
28	288	58	1192	88	3240		
29	304	59	1224	89	3368		
30	320	60	1256	90	3496		

4) When  $N_{info} > 3824$ , TBS is determined as follows.

- quantized intermediate number of information bits  $N'_{info} = \max\left(3840, 2^n \times \text{round}\left(\frac{N_{info} - 24}{2^n}\right)\right)$ , where  $n = \lfloor \log_2(N_{info} - 24) \rfloor - 5$  and ties in the round function are broken towards the next largest integer.
- if  $R \leq 1/4$

$$TBS = 8 \cdot C \cdot \left\lceil \frac{N'_{info} + 24}{8 \cdot C} \right\rceil - 24, \text{ where } C = \left\lceil \frac{N'_{info} + 24}{3816} \right\rceil$$

else

if  $N'_{info} > 8424$

$$TBS = 8 \cdot C \cdot \left\lceil \frac{N'_{info} + 24}{8 \cdot C} \right\rceil - 24, \text{ where } C = \left\lceil \frac{N'_{info} + 24}{8424} \right\rceil$$

else

$$TBS = 8 \cdot \left\lceil \frac{N'_{info} + 24}{8} \right\rceil - 24$$

end if

end if

7.1.1.4.1.3.3 Test description

7.1.1.4.1.3.3.1 Pre-test conditions

Same Pre-test conditions as in clause 7.1.1.0 except set the NR Cell bandwidth and applicable BWP to maximum for the NR Band under test as specified in Table 5.3.5-1 in TS 38.101-1 [16] / TS 38.101-2 [17] (to enable testing of  $n_{PRB}$  up to maximum value).

7.1.1.4.1.3.3.2 Test procedure sequence

**Table 7.1.1.4.1.3.3.2-1: Maximum TBS for different UE categories**

UE Category	Maximum number of bits of a UL-SCH transport block received within a TTI
TS 38.306 [23] clause 4.1.2 require UE without <i>ue-CategoryDL</i> and <i>ue-CategoryUL</i> , to support Max TBS achievable based on max bandwidth of the Band under test.	

**Table 7.1.1.4.1.3.3.2-2: Number of downlink PDCP SDUs and PDCP SDU size used as test data**

TBS [bits]	Number of PDCP SDUs	PDCP SDU size [bits] (Note 1)
$192 \leq TBS \leq 12184$ note 2	1	$8 * \text{FLOOR}((TBS - 184)/8)$
$12185 \leq TBS \leq 24256$	2	$8 * \text{FLOOR}((TBS - 256)/16)$
$24257 \leq TBS \leq 36328$	3	$8 * \text{FLOOR}((TBS - 328)/24)$
$36329 \leq TBS \leq 48400$	4	$8 * \text{FLOOR}((TBS - 400)/32)$
$48401 \leq TBS \leq 60472$	5	$8 * \text{FLOOR}((TBS - 472)/40)$
$60473 \leq TBS \leq 72544$	6	$8 * \text{FLOOR}((TBS - 544)/48)$
$72545 \leq TBS \leq 84616$	7	$8 * \text{FLOOR}((TBS - 616)/56)$
$84617 \leq TBS \leq 96688$	8	$8 * \text{FLOOR}((TBS - 688)/64)$
$96689 < TBS \leq 108760$	9	$8 * \text{FLOOR}((TBS - 760)/72)$
$108761 \leq TBS \leq 120832$	10	$8 * \text{FLOOR}((TBS - 832)/80)$
$120833 \leq TBS \leq 132904$	11	$8 * \text{FLOOR}((TBS - 904)/88)$
$132905 \leq TBS \leq 144976$	12	$8 * \text{FLOOR}((TBS - 976)/96)$
$TBS > 144976$	13	$8 * \text{FLOOR}((TBS - 1048)/112)$

Note 1: Each PDCP SDU is limited to 1500 octets (to keep below maximum SDU size of ESM as specified in TS 24.301 [21] clause 9.9.4.12).

The PDCP SDU size of each PDCP SDU is

PDCP SDU size = (TBS – N\*PDCP header size – N\*AMD PDU header size – N\*MAC header size – Size of Timing Advance – RLC Status PDU size- MAC header for RLC Status PDU – 32 bit Additional RLC header with SO if one RLC SDU gets split in 2 TBS and 24 bit MAC header for this additional PDU) / N, where

PDCP header size is 24 bits for the RLC AM and 18-bit SN case;  
AMD PDU header size is 24 bits with 18 bit SN;

MAC header size for AMD PDU = 16 or 24 bits depending on L=8 or 16 bits. Worst case 24 is taken.

Size of Timing Advance MAC CE with header is 16 bits (if no Timing Advance and/or RLC status needs to be sent, padding will occur instead).  
IF RLC SDU does not get split the 32 bits additional padding gets added instead

RLC Status PDU size = 24 bits with 1 ACK\_SN, With a MAC header of 16 bits.

This gives:

PDCP SDU size =  $8 * \text{FLOOR}((TBS - N*24 - N*24 - N*24 - 112) / (8*N))$  bits.

Note 2: According to the final PDCP SDU size formula in Note 1, the smallest TBS that can be tested is 192 bits.

**Table 7.1.1.4.1.3.3.2-2A: Bandwidth part Dependent Parameters for Resource allocation 0 with start of BWP assumed as 0**

$N_{RB}^{DL,BWP} = N_{BWP,i}^{size}$	Nominal RBG size $P$ (Configuration1)	Size of last RBG	Allowed $N_{PRB}$ Values
11	2	1	All 1...11
18	2	2	2,4,6,8,10,12,16,18
24	2	2	2,4,6,8,10,12,16,18,20,22,24
25	2	1	All 1...25
31	2	1	All 1...31
32	2	2	2,4,6,8,10,12,16,18,20,22,24,26,28,30,32
38	4	2	2,4,6,8,10,12,16,18,20,22,24,26,28,30,32,34,36,38
51	4	3	3,4,7,8,11,12,15,16,19,20,23,24,27,28,31,32,35,36,39,40,43,44,47,48,51
52	4	4	4,8,12,16,20,24,28,32,36,40,44,48,52
65	4	1	1,4,5,8,9,12,13,16,17,20,21,24,25,28,29,32,33,36,37,40,41,44,45,48,49,52,53,56,57,60,61,64,65
66	4	2	2,4,6,8,10,12,16,18,20,22,24,26,28,30,32,34,36,38,40,42,44,46,48,50,52,54,56,58,60,62,64,66
79	8	7	7,8,15,16,23,24,31,32,39,40,47,48,55,56,63,64,71,72,79
106	8	2	2,8,10,16,18,24,26,32,34,40,42,48,50,56,58,64,66,72,74,80,82,88,90,96,92,104,106
107	8	3	3,8,11,16,19,24,27,32,35,40,43,48,51,56,59,64,67,72,75,80,83,88,91,96,99,104,107
132	8	4	4,8,12,16,20,24,28,32,36,40,44,48,52,56,60,64,68,72,76,80,84,88,92,96,100,104,108,112,116,120,124,128,132
133	8	5	5,8,13,16,21,24,29,32,37,40,45,48,53,56,61,64,69,72,77,80,85,88,93,96,101,104,109,112,117,120,125,128,133
135	8	7	7,8,15,16,23,24,31,32,39,40,47,48,55,56,63,64,71,72,79,80,87,88,95,96,103,104,111,112,119,120,127,128,135
216	16	8	8,16,24,32,40,48,56,64,72,80,88,96,104,112,120,128,136,144,152,160,168,176,184,192,200,208,216
217	16	9	9,16,25,32,41,48,57,64,73,80,89,96,105,112,121,128,137,144,153,160,169,176,185,192,201,208,217
264	16	8	8,16,24,32,40,48,56,64,72,80,88,96,104,112,120,128,136,144,160,168,176,184,192,200,208,216,224,232,240,248,256,264
270	16	14	14,16,30,32,46,44,62,64,78,80,94,96,110,112,126,128,142,144,158,160,174,176,190,192,206,208,222,224,238,240,254,256,270
273	16	1	1,16,17,32,33,48,49,64,65,80,81,96,97,112,113,128,129,144,145,160,161,176,171,192,193,208,209,224,225,240,241,256,257,272,273

**Table 7.1.1.4.1.3.3.2-3: Specific Parameter**

Parameter	Value	Comments
PDSCH mappingType	typeA	
starting symbol $S$	0 or 3 to avoid clash with PDCCH symbols	
number of consecutive symbols $L$	3..14- $S$	
$k_0$	0 or 1 (if $S=0$ )	
number of layers ( $v$ )	1	
mcs-Table	qam64	
$xoh$ -PDSCH	Not present	Results in value 0( $xoh$ 0)
dmrs-AdditionalPosition	pos0	Results in 1 DMRS symbol per two carrier ( $N_{DMRS}^{PRB}$ ) for Duration in symbols $\geq 3$ (TS 38.211 [24], table 7.4.1.1.2-3)
resourceAllocation	dynamicSwitch	
maxNrofCodeWordsScheduledByDCI	n2	both codewords enabled
$rbg$ -Size	Not present	configuration 1 applicable
$N_{BWP}^{start}$	0	

**Table 7.1.1.4.1.3.3.2-4: Main behaviour**

St	Procedure	Message Sequence		TP	Verdict
		U - S	Message		
-	EXCEPTION: Steps 1 to 5 are repeated for allowed values of $N_{PRB}$ as per table 7.1.1.4.1.3.3.2-2A in BWP, time domain resource length L 3 to 14-S and $I_{MCS}$ from 0 to 28.	-	-	-	-
1	SS calculates or looks up TBS in TS 38.214 [15] based on the value of S, L, $I_{MCS}$ and $n_{PRB}$ . The SS uses the same $I_{MCS}$ and TBS for both transport blocks:  $I_{MCS\#1} = I_{MCS\#2} = I_{MCS}$ TBS 1= TBS 2= TBS	-	-	-	-
-	EXCEPTION: Steps 2 to 5 are performed if TBS1 + TBS2 is less than or equal to UE capability "Maximum number of DL-SCH transport block bits received within a TTI" as specified in Table 7.1.1.4.1.3.3.2-1 and larger than or equal to 192 bits as specified in Table 7.1.1.4.1.3.3.2-2.	-	-	-	-
2	SS creates one or more PDCP SDUs for transport block 1 and 2 depending on TBS1, and TBS2 in accordance with Table 7.1.1.4.1.3.3.2-2.	-	-	-	-
3	SS transmits the PDCP SDUs concatenated into a MAC PDU and indicates on PDCCH DCI Format 1_1 resource allocation 0 and values of S, L, $I_{MCS\#1}$ , $I_{MCS\#2}$ and $n_{PRB}$ .	<--	Transport block 1: MAC PDU Transport block 2: MAC PDU DCI: (DCI Format 1_1, S, L, $I_{MCS\#1}$ , $I_{MCS\#2}$ and $n_{PRB}$ .)	-	-
4	At the reception of scheduling request the SS transmits UL Grant for transmitting loop back PDCP SDUs.	<--	(UL Grant)	-	-
5	CHECK: Does UE return the same number of PDCP SDUs with same content as transmitted by the SS in step 3?	-->	(NxPDCP SDUs)	1	P
-	EXCEPTION: Steps 6 to 10 are repeated for allowed values of $N_{PRB}$ 1 to $N_{RB}^{DL,BWP}$ in BWP, time domain resource length L 3 to 14-S and $I_{MCS}$ from 0 to 28.	-	-	-	-
6	SS calculates or looks up TBS in TS 38.214 [15] based on the value of S, L, $I_{MCS}$ and $n_{PRB}$ . The SS uses the same $I_{MCS}$ and TBS for both transport blocks:  $I_{MCS\#1} = I_{MCS\#2} = I_{MCS}$ TBS 1= TBS 2= TBS	-	-	-	-
-	EXCEPTION: Steps 7 to 10 are performed if TBS1 + TBS2 is less than or equal to UE capability "Maximum number of DL-SCH transport block bits received within a TTI" as specified in Table 7.1.1.4.1.3.3.2-1 and larger than or equal to 192 bits as specified in Table 7.1.1.4.1.3.3.2-2.	-	-	-	-



7	SS creates one or more PDCP SDUs for transport block 1 and 2 depending on TBS1, and TBS2 in accordance with Table 7.1.1.4.1.3.3.2-2.	-	-	-	-
8	SS transmits the PDCP SDUs concatenated into a MAC PDU and indicates on PDCCH DCI Format 1_1 resource allocation 1 and values of S, L, $I_{MCS\#1}$ , $I_{MCS\#2}$ and $n_{PRB}$ .	<--	Transport block 1: MAC PDU Transport block 2: MAC PDU DCI: (DCI Format 1_1, S, L, $I_{MCS\#1}$ , $I_{MCS\#2}$ and $n_{PRB}$ )	-	-
9	At the reception of scheduling request the SS transmits UL Grant for transmitting loop back PDCP SDUs.	<--	(UL Grant)	-	-
10	CHECK: Does UE return the same number of PDCP SDUs with same content as transmitted by the SS in step 3?	-->	(NxPDCP SDUs)	2	P

#### 7.1.1.4.1.3.3.3 Specific message contents

[None].

#### 7.1.1.4.1.4 DL-SCH transport block size selection / DCI format 1\_1 / RA type 0/RA Type 1 / 2 Codewords enabled / 256QAM

##### 7.1.1.4.1.4.1 Test Purpose (TP)

(1)

```
with { UE in RRC_CONNECTED state, maxNrofCodeWordsScheduledByDCI set to 'n2' and mcs-Table is set as 'qam256' }
ensure that {
  when { UE on PDCCH receives DCI format 1_1 indicating resource allocation type 0 a resource block assignment correspondent to physical resource blocks, Time domain resource assignment and a modulation and coding }
  then { UE decodes the received transport block of size correspondent as per Modulation Coding scheme, time domain resource allocation and PRB's and forwards it to higher layers }
}
```

(2)

```
with { UE in RRC_CONNECTED state, maxNrofCodeWordsScheduledByDCI set to 'n2' and mcs-Table is set as 'qam256' }
ensure that {
  when { UE on PDCCH receives DCI format 1_1 indicating resource allocation type 1 a resource block assignment correspondent to physical resource blocks, Time domain resource assignment and a modulation and coding }
  then { UE decodes the received transport block of size correspondent as per Modulation Coding scheme, time domain resource allocation and PRB's and forwards it to higher layers }
}
```

##### 7.1.1.4.1.4.2 Conformance requirements

References: The conformance requirements covered in the present TC are specified in: TS 38.212 clause 7.3.1.2.2, TS 38.214 clauses 5.1.2.1, 5.1.2.2.1, 5.1.2.2.2, 5.1.3, 5.1.3.1 and 5.1.3.2. Unless otherwise stated these are Rel-15 requirements.

[TS 38.212, clause 7.3.1.2.2]

DCI format 1\_1 is used for the scheduling of PDSCH in one cell.

The following information is transmitted by means of the DCI format 1\_1 with CRC scrambled by C-RNTI or CS-RNTI or new-RNTI:

- Identifier for DCI formats – 1 bits
- The value of this bit field is always set to 1, indicating a DL DCI format
- Carrier indicator – 0 or 3 bits as defined in Subclause 10.1 of [5, TS38.213].

- Bandwidth part indicator – 0, 1 or 2 bits as determined by the number of DL BWPs  $n_{\text{BWP,RRC}}$  configured by higher layers, excluding the initial DL bandwidth part. The bit width for this field is determined as  $\lceil \log_2(n_{\text{BWP}}) \rceil$  bits, where
  - $n_{\text{BWP}} = n_{\text{BWP,RRC}} + 1$  if  $n_{\text{BWP,RRC}} \leq 3$ , in which case the bandwidth part indicator is equivalent to the higher layer parameter *BWP-Id*;
  - otherwise  $n_{\text{BWP}} = n_{\text{BWP,RRC}}$ , in which case the bandwidth part indicator is defined in Table 7.3.1.1.2-1;

If a UE does not support active BWP change via DCI, the UE ignores this bit field.

- Frequency domain resource assignment – number of bits determined by the following, where  $N_{\text{RB}}^{\text{DL,BWP}}$  is the size of the active DL bandwidth part:
  - $N_{\text{RB}}$  bits if only resource allocation type 0 is configured, where  $N_{\text{RB}}$  is defined in Subclause 5.1.2.2.1 of [6, TS38.214],
  - $\lceil \log_2(N_{\text{RB}}^{\text{DL,BWP}}(N_{\text{RB}}^{\text{DL,BWP}} + 1)/2) \rceil$  bits if only resource allocation type 1 is configured, or
  - $\max(\lceil \log_2(N_{\text{RB}}^{\text{DL,BWP}}(N_{\text{RB}}^{\text{DL,BWP}} + 1)/2) \rceil, N_{\text{RB}}) + 1$  bits if both resource allocation type 0 and 1 are configured.
  - If both resource allocation type 0 and 1 are configured, the MSB bit is used to indicate resource allocation type 0 or resource allocation type 1, where the bit value of 0 indicates resource allocation type 0 and the bit value of 1 indicates resource allocation type 1.
  - For resource allocation type 0, the  $N_{\text{RB}}$  LSBs provide the resource allocation as defined in Subclause 5.1.2.2.1 of [6, TS38.214].
  - For resource allocation type 1, the  $\lceil \log_2(N_{\text{RB}}^{\text{DL,BWP}}(N_{\text{RB}}^{\text{DL,BWP}} + 1)/2) \rceil$  LSBs provide the resource allocation as defined in Subclause 5.1.2.2.2 of [6, TS38.214]

If “Bandwidth part indicator” field indicates a bandwidth part other than the active bandwidth part and if both resource allocation type 0 and 1 are configured for the indicated bandwidth part, the UE assumes resource allocation type 0 for the indicated bandwidth part if the bit width of the “Frequency domain resource assignment” field of the active bandwidth part is smaller than the bit width of the “Frequency domain resource assignment” field of the indicated bandwidth part.

- Time domain resource assignment – 0, 1, 2, 3, or 4 bits as defined in Subclause 5.1.2.1 of [6, TS38.214]. The bit width for this field is determined as  $\lceil \log_2(I) \rceil$  bits, where  $I$  is the number of entries in the higher layer parameter *pusch-AllocationList*.
- VRB-to-PRB mapping – 0 or 1 bit
  - 0 bit if only resource allocation type 0 is configured;
  - 1 bit according to Table 7.3.1.1.2-33 otherwise, only applicable to resource allocation type 1, as defined in Subclause 7.3.1.6 of [4, TS38.211].
- PRB bundling size indicator – 0 bit if the higher layer parameter *prb-BundlingType* is not configured or is set to ‘static’, or 1 bit if the higher layer parameter *prb-BundlingType* is set to ‘dynamic’, according to Subclause 5.1.2.3 of [6, TS38.214].
- Rate matching indicator – 0, 1, or 2 bits according to higher layer parameter *rateMatchPattern*.
- ZP CSI-RS trigger – 0, 1, or 2 bits as defined in Subclause 5.1.4.2 of [6, TS38.214]. The bit width for this field is determined as  $\lceil \log_2(n_{\text{ZP}} + 1) \rceil$  bits, where  $n_{\text{ZP}}$  is the number of ZP CSI-RS resource sets in the higher layer parameter *zp-CSI-RS-Resource*.

For transport block 1:

- Modulation and coding scheme – 5 bits as defined in Subclause 5.1.3.1 of [6, TS38.214]
- New data indicator – 1 bit
- Redundancy version – 2 bits as defined in Table 7.3.1.1.1-2

For transport block 2 (only present if *maxNrofCodeWordsScheduledByDCI* equals 2

- Modulation and coding scheme – 5 bits as defined in Subclause 5.1.3.1 of [6, TS38.214]
- New data indicator – 1 bit
- Redundancy version – 2 bits as defined in Table 7.3.1.1.1-2

If “Bandwidth part indicator” field indicates a bandwidth part other than the active bandwidth part and the value of *maxNrofCodeWordsScheduledByDCI* for the indicated bandwidth part equals 2 and the value of *maxNrofCodeWordsScheduledByDCI* for the active bandwidth part equals 1, the UE assumes zeros are padded when interpreting the “Modulation and coding scheme”, “New data indicator”, and “Redundancy version” fields of transport block 2 according to Subclause 12 of [5, TS38.213], and the UE ignores the “Modulation and coding scheme”, “New data indicator”, and “Redundancy version” fields of transport block 2 for the indicated bandwidth part.

- HARQ process number – 4 bits
- Downlink assignment index – number of bits as defined in the following
  - 4 bits if more than one serving cell are configured in the DL and the higher layer parameter *pdsch-HARQ-ACK-Codebook=dynamic*, where the 2 MSB bits are the counter DAI and the 2 LSB bits are the total DAI;
  - 2 bits if only one serving cell is configured in the DL and the higher layer parameter *pdsch-HARQ-ACK-Codebook=dynamic*, where the 2 bits are the counter DAI;
  - 0 bits otherwise.
- TPC command for scheduled PUCCH – 2 bits as defined in Subclause 7.2.1 of [5, TS38.213]
- PUCCH resource indicator – 3 bits as defined in Subclause 9.2.3 of [5, TS38.213]
- PDSCH-to-HARQ\_feedback timing indicator – 0, 1, 2, or 3 bits as defined in Subclause 9.2.3 of [5, TS38.213]. The bit width for this field is determined as  $\lceil \log_2(I) \rceil$  bits, where  $I$  is the number of entries in the higher layer parameter *dl-DataToUL-ACK*.
- Antenna port(s) – 4, 5, or 6 bits as defined by Tables 7.3.1.2.2-1/2/3/4, where the number of CDM groups without data of values 1, 2, and 3 refers to CDM groups {0}, {0,1}, and {0, 1,2} respectively. The antenna ports  $\{p_0, \dots, p_{v-1}\}$  shall be determined according to the ordering of DMRS port(s) given by Tables 7.3.1.2.2-1/2/3/4.

If a UE is configured with both *dmrs-DownlinkForPDSCH-MappingTypeA* and *dmrs-DownlinkForPDSCH-MappingTypeB*, the bit width of this field equals  $\max\{x_A, x_B\}$ , where  $x_A$  is the “Antenna ports” bit width derived according to *dmrs-DownlinkForPDSCH-MappingTypeA* and  $x_B$  is the “Antenna ports” bit width derived according to *dmrs-DownlinkForPDSCH-MappingTypeB*. A number of  $|x_A - x_B|$  zeros are padded in the MSB of this field, if the mapping type of the PDSCH corresponds to the smaller value of  $x_A$  and  $x_B$ .

- Transmission configuration indication – 0 bit if higher layer parameter *tcj-PresentInDCI* is not enabled; otherwise 3 bits as defined in Subclause 5.1.5 of [6, TS38.214].

If “Bandwidth part indicator” field indicates a bandwidth part other than the active bandwidth part and the “Transmission configuration indication” field is not present in the DCI format 1\_1, the UE assumes *tcj-PresentInDCI* is not enabled for the indicated bandwidth part.

- SRS request – 2 bits as defined by Table 7.3.1.1.2-24 for UEs not configured with SUL in the cell; 3 bits for UEs configured SUL in the cell where the first bit is the non-SUL/SUL indicator as defined in Table 7.3.1.1.1-1 and the second and third bits are defined by Table 7.3.1.1.2-24. This bit field may also indicate the associated CSI-RS according to Subclause 6.1.1.2 of [6, TS 38.214].

- CBG transmission information (CBGTI) – 0, 2, 4, 6, or 8 bits as defined in Subclause 5.1.7 of [6, TS38.214], determined by the higher layer parameters *maxCodeBlockGroupsPerTransportBlock* and *Number-MCS-HARQ-DL-DCI* for the PDSCH.
- CBG flushing out information (CBGFI) – 0 or 1 bit as defined in Subclause 5.1.7 of [6, TS38.214], determined by higher layer parameter *codeBlockGroupFlushIndicator*.
- DMRS sequence initialization – 1 bit if both *scramblingID0* and *scramblingID1* are configured in *DMRS-DownlinkConfig* for  $n_{\text{SCID}}$  selection defined in Subclause 7.4.1.1.1 of [4, TS38.211]; 0 bit otherwise.

[TS 38.214, clause 5.1.2.1]

When the UE is scheduled to receive PDSCH by a DCI, the *Time domain resource assignment* field value  $m$  of the DCI provides a row index  $m + 1$  to an allocation table. The determination of the used resource allocation table is defined in sub-clause 5.1.2.1.1. The indexed row defines the slot offset  $K_0$ , the start and length indicator *SLIV*, or directly the start symbol  $S$  and the allocation length  $L$ , and the PDSCH mapping type to be assumed in the PDSCH reception.

Given the parameter values of the indexed row:

- The slot allocated for the PDSCH is  $\left\lceil n \cdot \frac{2^{\mu_{\text{PDSCH}}}}{2^{\mu_{\text{PDCCH}}}} \right\rceil + K_0$ , where  $n$  is the slot with the scheduling DCI, and  $K_0$  is based on the numerology of PDSCH, and  $\mu_{\text{PDSCH}}$  and  $\mu_{\text{PDCCH}}$  are the subcarrier spacing configurations for PDSCH and PDCCH, respectively, and
- The starting symbol  $S$  relative to the start of the slot, and the number of consecutive symbols  $L$  counting from the symbol  $S$  allocated for the PDSCH are determined from the start and length indicator *SLIV*:

if  $(L-1) \leq 7$  then

$$SLIV = 14 \cdot (L-1) + S$$

else

$$SLIV = 14 \cdot (14 - L + 1) + (14 - 1 - S)$$

where  $0 < L \leq 14 - S$ , and

- The PDSCH mapping type is set to Type A or Type B as defined in sub-clause 7.4.1.1.2 of [4, TS 38.211].

The UE shall consider the  $S$  and  $L$  combinations defined in table 5.1.2.1-1 as valid PDSCH allocations:

**Table 5.1.2.1-1: Valid  $S$  and  $L$  combinations**

PDSCH mapping type	Normal cyclic prefix			Extended cyclic prefix		
	$S$	$L$	$S+L$	$S$	$L$	$S+L$
Type A	{0,1,2,3 (Note 1)}	{3,...,14}	{3,...,14}	{0,1,2,3 (Note 1)}	{3,...,12}	{3,...,12}
Type B	{0,...,12}	{2,4,7}	{2,...,14}	{0,...,10}	{2,4,6}	{2,...,12}

Note 1:  $S = 3$  is applicable only if *dmrs-TypeA-Position* = 3

[TS 38.214, clause 5.1.2.2.1]

In downlink resource allocation of type 0, the resource block assignment information includes a bitmap indicating the Resource Block Groups (RBGs) that are allocated to the scheduled UE where a RBG is a set of consecutive virtual resource blocks defined by higher layer parameter *rbg-Size* configured for PDSCH and the size of the carrier bandwidth part as defined in Table 5.1.2.2.1-1.

Table 5.1.2.2.1-1: Nominal RBG size  $P$ 

Bandwidth Part Size	Configuration 1	Configuration 2
1 – 36	2	4
37 – 72	4	8
73 – 144	8	16
145 – 275	16	16

The total number of RBGs ( $N_{\text{RBG}}$ ) for a downlink carrier bandwidth part  $i$  of size  $N_{\text{BWP},i}^{\text{size}}$  PRBs is given by

$$N_{\text{RBG}} = \left\lfloor \left( N_{\text{BWP},i}^{\text{size}} + \left( N_{\text{BWP},i}^{\text{start}} \bmod P \right) \right) / P \right\rfloor, \text{ where}$$

- the size of the first RBG is  $\text{RBG}_0^{\text{size}} = P - N_{\text{BWP},i}^{\text{start}} \bmod P$ ,
- the size of last RBG is  $\text{RBG}_{\text{last}}^{\text{size}} = \left( N_{\text{BWP},i}^{\text{start}} + N_{\text{BWP},i}^{\text{size}} \right) \bmod P$  if  $\left( N_{\text{BWP},i}^{\text{start}} + N_{\text{BWP},i}^{\text{size}} \right) \bmod P > 0$  and  $P$  otherwise,
- the size of all other RBGs is  $P$ .

The bitmap is of size  $N_{\text{RBG}}$  bits with one bitmap bit per RBG such that each RBG is addressable. The RBGs shall be indexed in the order of increasing frequency and starting at the lowest frequency of the carrier bandwidth part. The order of RBG bitmap is such that RBG 0 to RBG  $N_{\text{RBG}} - 1$  are mapped from MSB to LSB. The RBG is allocated to the UE if the corresponding bit value in the bitmap is 1, the RBG is not allocated to the UE otherwise.

[TS 38.214, clause 5.1.2.2.2]

In downlink resource allocation of type 1, the resource block assignment information indicates to a scheduled UE a set of contiguously allocated localized or distributed virtual resource blocks within the active carrier bandwidth part of size  $N_{\text{BWP}}^{\text{size}}$  PRBs except for the case when DCI format 1\_0 is decoded in the common search space in CORESET 0 in which case the initial bandwidth part of size  $N_{\text{BWP}}^{\text{size}}$  shall be used.

A downlink type 1 resource allocation field consists of a resource indication value ( $RIV$ ) corresponding to a starting virtual resource block ( $RB_{\text{start}}$ ) and a length in terms of contiguously allocated resource blocks  $L_{\text{RBs}}$ . The resource indication value is defined by

if  $(L_{\text{RBs}} - 1) \leq \lfloor N_{\text{BWP}}^{\text{size}} / 2 \rfloor$  then

$$RIV = N_{\text{BWP}}^{\text{size}} (L_{\text{RBs}} - 1) + RB_{\text{start}}$$

else

$$RIV = N_{\text{BWP}}^{\text{size}} (N_{\text{BWP}}^{\text{size}} - L_{\text{RBs}} + 1) + (N_{\text{BWP}}^{\text{size}} - 1 - RB_{\text{start}})$$

where  $L_{\text{RBs}} \geq 1$  and shall not exceed  $N_{\text{BWP}}^{\text{size}} - RB_{\text{start}}$ .

[TS 38.214, clause 5.1.3]

To determine the modulation order, target code rate, and transport block size(s) in the physical downlink shared channel, the UE shall first

- read the 5-bit *modulation and coding scheme* field ( $I_{\text{MCS}}$ ) in the DCI to determine the modulation order ( $Q_m$ ) and target code rate ( $R$ ) based on the procedure defined in Subclause 5.1.3.1, and
- read *redundancy version* field ( $rv$ ) in the DCI to determine the redundancy version..

and second

- the UE shall use the number of layers ( $v$ ), the total number of allocated PRBs before rate matching ( $n_{\text{PRB}}$ ) to determine to the transport block size based on the procedure defined in Subclause 5.1.3.2.

The UE may skip decoding a transport block in an initial transmission if the effective channel code rate is higher than 0.95, where the effective channel code rate is defined as the number of downlink information bits (including CRC bits) divided by the number of physical channel bits on PDSCH. If the UE skips decoding, the physical layer indicates to higher layer that the transport block is not successfully decoded.

[TS 38.214, clause 5.1.3.1]

For the PDSCH scheduled by a PDCCH with DCI format 1\_0 or format 1\_1 with CRC scrambled by C-RNTI, new-RNTI, TC-RNTI, CS-RNTI, SI-RNTI, RA-RNTI, or P-RNTI,

if the higher layer parameter *mcs-Table* given by *PDSCH-Config* is set to 'qam256', and the PDSCH is scheduled by a PDCCH with a DCI format 1\_1 and the CRC is scrambled by C-RNTI or CS-RNTI

- the UE shall use  $I_{MCS}$  and Table 5.1.3.1-2 to determine the modulation order ( $Q_m$ ) and Target code rate ( $R$ ) used in the physical downlink shared channel.

elseif the UE is not configured with new-RNTI, the higher layer parameter *mcs-Table* given by *PDSCH-Config* is set to 'qam64LowSE', and the PDSCH is scheduled with C-RNTI, and the PDSCH is assigned by a PDCCH in a UE-specific search space

- the UE shall use  $I_{MCS}$  and Table 5.1.3.1-3 to determine the modulation order ( $Q_m$ ) and Target code rate ( $R$ ) used in the physical downlink shared channel.

elseif the UE is configured with new-RNTI, and the PDSCH is scheduled with new-RNTI

- the UE shall use  $I_{MCS}$  and Table 5.1.3.1-3 to determine the modulation order ( $Q_m$ ) and Target code rate ( $R$ ) used in the physical downlink shared channel.

elseif the UE is not configured with the higher layer parameter *mcs-Table* given by *SPS-config*, the higher layer parameter *mcs-Table* given by *PDSCH-Config* is set to 'qam256', the PDSCH is scheduled with CS-RNTI, and the PDSCH is assigned by a PDCCH with DCI format 1\_1

- the UE shall use  $I_{MCS}$  and Table 5.1.3.1-2 to determine the modulation order ( $Q_m$ ) and Target code rate ( $R$ ) used in the physical downlink shared channel.

elseif the UE is configured with the higher layer parameter *mcs-Table* given by *SPS-config* set to 'qam64LowSE', and the PDSCH is scheduled with CS-RNTI

- the UE shall use  $I_{MCS}$  and Table 5.1.3.1-3 to determine the modulation order ( $Q_m$ ) and Target code rate ( $R$ ) used in the physical downlink shared channel.

else

- the UE shall use  $I_{MCS}$  and Table 5.1.3.1-1 to determine the modulation order ( $Q_m$ ) and Target code rate ( $R$ ) used in the physical downlink shared channel.

End

The UE is not expected to decode a PDSCH scheduled with P-RNTI, RA-RNTI, SI-RNTI and  $Q_m > 2$

...

Table 5.1.3.1-2: MCS index table 2 for PDSCH

MCS Index $I_{MCS}$	Modulation Order $Q_m$	Target code Rate $R \times [1024]$	Spectral efficiency
0	2	120	0.2344
1	2	193	0.3770
2	2	308	0.6016
3	2	449	0.8770
4	2	602	1.1758
5	4	378	1.4766
6	4	434	1.6953
7	4	490	1.9141
8	4	553	2.1602
9	4	616	2.4063
10	4	658	2.5703
11	6	466	2.7305
12	6	517	3.0293
13	6	567	3.3223
14	6	616	3.6094
15	6	666	3.9023
16	6	719	4.2129
17	6	772	4.5234
18	6	822	4.8164
19	6	873	5.1152
20	8	682.5	5.3320
21	8	711	5.5547
22	8	754	5.8906
23	8	797	6.2266
24	8	841	6.5703
25	8	885	6.9141
26	8	916.5	7.1602
27	8	948	7.4063
28	2	reserved	
29	4	reserved	
30	6	reserved	
31	8	reserved	

[TS 38.214, clause 5.1.3.2]

In case the higher layer parameter *maxNrofCodeWordsScheduledByDCI* indicates that two codeword transmission is enabled, then a transport block is disabled by DCI format 1\_1 if  $I_{MCS} = 26$  and if  $rv_{id} = 1$  for the corresponding transport block, otherwise the transport block is enabled. If both transport blocks are enabled, transport block 1 and 2 are mapped to codeword 0 and 1 respectively. If only one transport block is enabled, then the enabled transport block is always mapped to the first codeword.

For the PDSCH assigned by a PDCCH with DCI format 1\_0 or format 1\_1 with CRC scrambled by C-RNTI, new-RNTI, TC-RNTI, CS-RNTI, or SI-RNTI, if Table 5.1.3.1-2 is used and  $0 \leq I_{MCS} \leq 27$ , or a table other than Table 5.1.3.1-2 is used and  $0 \leq I_{MCS} \leq 28$ , the UE shall, except if the transport block is disabled in DCI format 1\_1, first determine the TBS as specified below:

1) The UE shall first determine the number of REs ( $N_{RE}$ ) within the slot.

- A UE first determines the number of REs allocated for PDSCH within a PRB ( $N'_{RE}$ ) by

$$N'_{RE} = N_{sc}^{RB} \cdot N_{symb}^{sh} - N_{DMRS}^{PRB} - N_{oh}^{PRB}, \text{ where } N_{sc}^{RB} = 12 \text{ is the number of subcarriers in a physical resource}$$

block,  $N_{symb}^{sh}$  is the number of symbols of the PDSCH allocation within the slot,  $N_{DMRS}^{PRB}$  is the number of REs for DM-RS per PRB in the scheduled duration including the overhead of the DM-RS CDM groups without data, as indicated by DCI format 1\_1 or as described for format 1\_0 in Subclause 5.1.6.2, and  $N_{oh}^{PRB}$  is the overhead configured by higher layer parameter *xOverhead* in *PDSCH-ServingCellConfig*. If the *xOverhead* in *PDSCH-ServingCellConfig* is not configured (a value from 0, 6, 12, or 18), the  $N_{oh}^{PRB}$  is set to

0. If the PDSCH is scheduled by PDCCH with a CRC scrambled by SI-RNTI, RA-RNTI or P-RNTI,  $N_{oh}^{PRB}$  is assumed to be 0.

- A UE determines the total number of REs allocated for PDSCH ( $N_{RE}$ ) by  $N_{RE} = \min(156, N_{RE}^{\prime}) \cdot n_{PRB}$ , where  $n_{PRB}$  is the total number of allocated PRBs for the UE.

2) Intermediate number of information bits ( $N_{info}$ ) is obtained by  $N_{info} = N_{RE} \cdot R \cdot Q_m \cdot \nu$ .

If  $N_{info} \leq 3824$

Use step 3 as the next step of the TBS determination

else

Use step 4 as the next step of the TBS determination

end if

3) When  $N_{info} \leq 3824$ , TBS is determined as follows

- quantized intermediate number of information bits  $N_{info}^{\prime} = \max\left(24, 2^n \cdot \left\lfloor \frac{N_{info}}{2^n} \right\rfloor\right)$ , where  $n = \max(3, \lfloor \log_2(N_{info}) \rfloor - 6)$ .
- use Table 5.1.3.2-2 find the closest TBS that is not less than  $N_{info}^{\prime}$ .

**Table 5.1.3.2-2: TBS for  $N_{info} \leq 3824$**

Index	TBS	Index	TBS	Index	TBS	Index	TBS
1	24	31	336	61	1288	91	3624
2	32	32	352	62	1320	92	3752
3	40	33	368	63	1352	93	3824
4	48	34	384	64	1416		
5	56	35	408	65	1480		
6	64	36	432	66	1544		
7	72	37	456	67	1608		
8	80	38	480	68	1672		
9	88	39	504	69	1736		
10	96	40	528	70	1800		
11	104	41	552	71	1864		
12	112	42	576	72	1928		
13	120	43	608	73	2024		
14	128	44	640	74	2088		
15	136	45	672	75	2152		
16	144	46	704	76	2216		
17	152	47	736	77	2280		
18	160	48	768	78	2408		
19	168	49	808	79	2472		
20	176	50	848	80	2536		
21	184	51	888	81	2600		
22	192	52	928	82	2664		
23	208	53	984	83	2728		
24	224	54	1032	84	2792		
25	240	55	1064	85	2856		
26	256	56	1128	86	2976		
27	272	57	1160	87	3104		
28	288	58	1192	88	3240		
29	304	59	1224	89	3368		
30	320	60	1256	90	3496		



4) When  $N_{info} > 3824$ , TBS is determined as follows.

- quantized intermediate number of information bits  $N'_{info} = \max\left(3840, 2^n \times \text{round}\left(\frac{N_{info} - 24}{2^n}\right)\right)$ , where  $n = \lfloor \log_2(N_{info} - 24) \rfloor - 5$  and ties in the round function are broken towards the next largest integer.

- if  $R \leq 1/4$

$$TBS = 8 \cdot C \cdot \left\lceil \frac{N'_{info} + 24}{8 \cdot C} \right\rceil - 24, \text{ where } C = \left\lceil \frac{N'_{info} + 24}{3816} \right\rceil$$

else

if  $N'_{info} > 8424$

$$TBS = 8 \cdot C \cdot \left\lceil \frac{N'_{info} + 24}{8 \cdot C} \right\rceil - 24, \text{ where } C = \left\lceil \frac{N'_{info} + 24}{8424} \right\rceil$$

else

$$TBS = 8 \cdot \left\lceil \frac{N'_{info} + 24}{8} \right\rceil - 24$$

end if

end if

7.1.1.4.1.4.3 Test description

7.1.1.4.1.4.3.1 Pre-test conditions

Same Pre-test conditions as in clause 7.1.1.0 except set the NR Cell bandwidth and applicable BWP to maximum for the NR Band under test as specified in Table 5.3.5-1 in TS 38.101-1 [16] / TS 38.101-2 [17] (to enable testing of  $n_{PRB}$  up to maximum value).

7.1.1.4.1.4.3.2 Test procedure sequence

**Table 7.1.1.4.1.4.3.2-1: Maximum TBS for different UE categories**

UE Category	Maximum number of bits of a UL-SCH transport block received within a TTI
TS 38.306 [23] clause 4.1.2 require UE without ue-CategoryDL and ue-CategoryUL, to support Max TBS achievable based on max bandwidth of the Band under test.	

Table 7.1.1.4.1.4.3.2-2: Number of downlink PDCP SDUs and PDCP SDU size used as test data

TBS [bits]	Number of PDCP SDUs	PDCP SDU size [bits] (Note 1)
$192 \leq \text{TBS} \leq 12184$ note 2	1	$8 * \text{FLOOR}((\text{TBS} - 184)/8)$
$12185 \leq \text{TBS} \leq 24256$	2	$8 * \text{FLOOR}((\text{TBS} - 256)/16)$
$24257 \leq \text{TBS} \leq 36328$	3	$8 * \text{FLOOR}((\text{TBS} - 328)/24)$
$36329 \leq \text{TBS} \leq 48400$	4	$8 * \text{FLOOR}((\text{TBS} - 400)/32)$
$48401 \leq \text{TBS} \leq 60472$	5	$8 * \text{FLOOR}((\text{TBS} - 472)/40)$
$60473 \leq \text{TBS} \leq 72544$	6	$8 * \text{FLOOR}((\text{TBS} - 544)/48)$
$72545 \leq \text{TBS} \leq 84616$	7	$8 * \text{FLOOR}((\text{TBS} - 616)/56)$
$84617 \leq \text{TBS} \leq 96688$	8	$8 * \text{FLOOR}((\text{TBS} - 688)/64)$
$96689 < \text{TBS} \leq 108760$	9	$8 * \text{FLOOR}((\text{TBS} - 760)/72)$
$108761 \leq \text{TBS} \leq 120832$	10	$8 * \text{FLOOR}((\text{TBS} - 832)/80)$
$120833 \leq \text{TBS} \leq 132904$	11	$8 * \text{FLOOR}((\text{TBS} - 904)/88)$
$132905 \leq \text{TBS} \leq 144976$	12	$8 * \text{FLOOR}((\text{TBS} - 976)/96)$
$144785 \leq \text{TBS} \leq 157048$	13	$8 * \text{FLOOR}((\text{TBS} - 1048)/56)$
$157049 \leq \text{TBS} \leq 169120$	14	$8 * \text{FLOOR}((\text{TBS} - 1120)/64)$
$169121 < \text{TBS} \leq 181192$	15	$8 * \text{FLOOR}((\text{TBS} - 1192)/72)$
$181193 \leq \text{TBS} \leq 193336$	16	$8 * \text{FLOOR}((\text{TBS} - 1264)/80)$
$193337 \leq \text{TBS} \leq 205408$	17	$8 * \text{FLOOR}((\text{TBS} - 1336)/88)$
$205409 \leq \text{TBS} \leq 217480$	18	$8 * \text{FLOOR}((\text{TBS} - 1408)/96)$
$\text{TBS} > 217480$	19	$8 * \text{FLOOR}((\text{TBS} - 1480)/112)$

Note 1: Each PDCP SDU is limited to 1500 octets (to keep below maximum SDU size of ESM as specified in TS 24.301 [21] clause 9.9.4.12).

The PDCP SDU size of each PDCP SDU is

PDCP SDU size = (TBS – N\*PDCP header size – N\*AMD PDU header size – N\*MAC header size – Size of Timing Advance – RLC Status PDU size- MAC header for RLC Status PDU – 32 bit Additional RLC header with SO if one RLC SDU gets split in 2 TBS and 24 bit MAC header for this additional PDU) / N, where

PDCP header size is 24 bits for the RLC AM and 18-bit SN case;  
AMD PDU header size is 24 bits with 18 bit SN;

MAC header size for AMD PDU = 16 or 24 bits depending on L=8 or 16 bits. Worst case 24 is taken.

Size of Timing Advance MAC CE with header is 16 bits (if no Timing Advance and/or RLC status needs to be sent, padding will occur instead).  
IF RLC SDU does not get split the 32 bits additional padding gets added instead

RLC Status PDU size = 24 bits with 1 ACK\_SN, With a MAC header of 16 bits.

This gives:

PDCP SDU size =  $8 * \text{FLOOR}((\text{TBS} - N * 24 - N * 24 - N * 24 - 112) / (8 * N))$  bits.

Note 2: According to the final PDCP SDU size formula in Note 1, the smallest TBS that can be tested is 192 bits.

**Table 7.1.1.4.1.4.3.2-2A: Bandwidth part Dependent Parameters for Resource allocation 0 with start of BWP assumed as 0**

$N_{RB}^{DL,BWP} = N_{BWP,i}^{size}$	Nominal RBG size $P$ (Configuration1)	Size of last RBG	Allowed $N_{PRB}$ Values
11	2	1	All 1...11
18	2	2	2,4,6,8,10,12,16,18
24	2	2	2,4,6,8,10,12,16,18,20,22,24
25	2	1	All 1...25
31	2	1	All 1...31
32	2	2	2,4,6,8,10,12,16,18,20,22,24,26,28,30,32
38	4	2	2,4,6,8,10,12,16,18,20,22,24,26,28,30,32,34,36,38
51	4	3	3,4,7,8,11,12,15,16,19,20,23,24,27,28,31,32,35,36,39,40,43,44,47,48,51
52	4	4	4,8,12,16,20,24,28,32,36,40,44,48,52
65	4	1	1,4,5,8,9,12,13,16,17,20,21,24,25,28,29,32,33,36,37,40,41,44,45,48,49,52,53,56,57,60,61,64,65
66	4	2	2,4,6,8,10,12,16,18,20,22,24,26,28,30,32,34,36,38,40,42,44,46,48,50,52,54,56,58,60,62,64,66
79	8	7	7,8,15,16,23,24,31,32,39,40,47,48,55,56,63,64,71,72,79
106	8	2	2,8,10,16,18,24,26,32,34,40,42,48,50,56,58,64,66,72,74,80,82,88,90,96,92,104,106
107	8	3	3,8,11,16,19,24,27,32,35,40,43,48,51,56,59,64,67,72,75,80,83,88,91,96,99,104,107
132	8	4	4,8,12,16,20,24,28,32,36,40,44,48,52,56,60,64,68,72,76,80,84,88,92,96,100,104,108,112,116,120,124,128,132
133	8	5	5,8,13,16,21,24,29,32,37,40,45,48,53,56,61,64,69,72,77,80,85,88,93,96,101,104,109,112,117,120,125,128,133
135	8	7	7,8,15,16,23,24,31,32,39,40,47,48,55,56,63,64,71,72,79,80,87,88,95,96,103,104,111,112,119,120,127,128,135
216	16	8	8,16,24,32,40,48,56,64,72,80,88,96,104,112,120,128,136,144,152,160,168,176,184,192,200,208,216
217	16	9	9,16,25,32,41,48,57,64,73,80,89,96,105,112,121,128,137,144,153,160,169,176,185,192,201,208,217
264	16	8	8,16,24,32,40,48,56,64,72,80,88,96,104,112,120,128,136,144,160,168,176,184,192,200,208,216,224,232,240,248,256,264
270	16	14	14,16,30,32,46,44,62,64,78,80,94,96,110,112,126,128,142,144,158,160,174,176,190,192,206,208,222,224,238,240,254,256,270
273	16	1	1,16,17,32,33,48,49,64,65,80,81,96,97,112,113,128,129,144,145,160,161,176,171,192,193,208,209,224,225,240,241,256,257,272,273

**Table 7.1.1.4.1.4.3.2-3: Specific Parameter**

Parameter	Value	Comments
PDSCH mappingType	typeA	
starting symbol $S$	0 Or 3 to avoid clash with PDCCH symbols	
number of consecutive symbols $L$	3..14- $S$	
$k_0$	0 or 1 (if $S=0$ )	
number of layers ( $v$ )	1	
mcs-Table	qam256	
<i>xoh-PDSCH</i>	Not present	Results in value 0( <i>xoh</i> 0)
dms-AdditionalPosition	pos0	Results in 1 DMRS symbol per two carrier ( $N_{DMRS}^{PRB}$ ) for Duration in symbols $\geq 3$ (TS 38.211 [24], table 7.4.1.1.2-3)
resourceAllocation	dynamicSwitch	
maxNrofCodeWordsScheduledByDCI	n2	both codewords enabled
<i>rbg-Size</i>	Not present	configuration 1 applicable
$N_{BWP}^{start}$	0	

**Table 7.1.1.4.1.4.3.2-4: Main behaviour**

St	Procedure	Message Sequence		TP	Verdict
		U - S	Message		
-	EXCEPTION: Steps 1 to 5 are repeated for allowed values of $N_{PRB}$ as per Table 7.1.1.4.1.4.3.2-2A in BWP, time domain resource length L 3 to 14-S and $I_{MCS}$ from 0 to 27.	-	-	-	-
1	SS calculates or looks up TBS in TS 38.214 [15] based on the value of S, L, $I_{MCS}$ and $n_{PRB}$ . The SS uses the same $I_{MCS}$ and TBS for both transport blocks:  $I_{MCS\#1} = I_{MCS\#2} = I_{MCS}$ TBS 1= TBS 2= TBS	-	-	-	-
-	EXCEPTION: Steps 2 to 5 are performed if TBS1 + TBS2 is less than or equal to UE capability "Maximum number of DL-SCH transport block bits received within a TTI" as specified in Table 7.1.1.4.1.4.3.2-1 and larger than or equal to 192 bits as specified in Table 7.1.1.4.1.4.3.2-2.	-	-	-	-
2	SS creates one or more PDCP SDUs for transport block 1 and 2 depending on TBS1, and TBS2 in accordance with Table 7.1.1.4.1.4.3.2-2.	-	-	-	-
3	SS transmits the PDCP SDUs concatenated into a MAC PDU and indicates on PDCCH DCI Format 1_1 resource allocation 0 and values of S, L, $I_{MCS\#1}$ , $I_{MCS\#2}$ and $n_{PRB}$ .	<--	Transport block 1: MAC PDU Transport block 2: MAC PDU DCI: (DCI Format 1_1, S, L, $I_{MCS\#1}$ , $I_{MCS\#2}$ and $n_{PRB}$ .)	-	-
4	At the reception of scheduling request the SS transmits UL Grant for transmitting loop back PDCP SDUs.	<--	(UL Grant)	-	-
5	CHECK: Does UE return the same number of PDCP SDUs with same content as transmitted by the SS in step 3?	-->	(NxPDCP SDUs)	1	P
-	EXCEPTION: Steps 6 to 10 are repeated for allowed values of $N_{PRB}$ 1 to $N_{RB}^{DL,BWP}$ in BWP, time domain resource length L 3 to 14-S and $I_{MCS}$ from 0 to 27.	-	-	-	-
6	SS calculates or looks up TBS in TS 38.214 [15] based on the value of S, L, $I_{MCS}$ and $n_{PRB}$ . The SS uses the same $I_{MCS}$ and TBS for both transport blocks:  $I_{MCS\#1} = I_{MCS\#2} = I_{MCS}$ TBS 1= TBS 2= TBS	-	-	-	-
-	EXCEPTION: Steps 7 to 10 are performed if TBS1 + TBS2 is less than or equal to UE capability "Maximum number of DL-SCH transport block bits received within a TTI" as specified in Table 7.1.1.4.1.4.3.2-1 and larger than or equal to 192 bits as specified in Table 7.1.1.4.1.4.3.2-2	-	-	-	-
7	SS creates one or more PDCP SDUs for transport block 1 and 2 depending on TBS1, and TBS2 in accordance with Table 7.1.1.4.1.4.3.2-2.	-	-	-	-

8	SS transmits the PDCP SDUs concatenated into a MAC PDU and indicates on PDCCH DCI Format 1_1 resource allocation 1 and values of S, L, $I_{MCS\#1}$ , $I_{MCS\#2}$ and $nPRB$ .	<--	Transport block 1: MAC PDU Transport block 2: MAC PDU DCI: (DCI Format 1_1, S, L, $I_{MCS\#1}$ , $I_{MCS\#2}$ and $nPRB$ .)	-	-
9	At the reception of scheduling request the SS transmits UL Grant for transmitting loop back PDCP SDUs.	<--	(UL Grant)	-	-
10	CHECK: Does UE return the same number of PDCP SDUs with same content as transmitted by the SS in step 3?	-->	(NxPDCP SDUs)	2	P

#### 7.1.1.4.1.4.3.3 Specific message contents

[None].

#### 7.1.1.4.2 UL-SCH Transport Block Size Selection

##### 7.1.1.4.2.1 UL-SCH Transport Block Size selection / DCI format 0\_0 / Transform precoding disabled

##### 7.1.1.4.2.1.1 Test Purpose (TP)

(1)

```
with { UE in RRC_CONNECTED state }
ensure that {
  when { UE has pending data for transmission and receives on PDCCH DCI format 0_0 indicating a
resource block assignment correspondent to physical resource blocks , Time domain resource
assignment and modulation and coding }
  then { UE transmits MAC PDU on PUSCH as per Modulation Coding scheme, time domain resource
allocation and PRB's }
}
```

##### 7.1.1.4.2.1.2 Conformance requirements

References: The conformance requirements covered in the present TC are specified in: TS 38.212 clause 7.3.1.1.1, TS 38.214 clause 6.1.2.1, 6.1.2.2, 6.1.2.2.2, 6.1.4.1, 5.1.3.1, 6.1.4.2 and 5.1.3.2. Unless otherwise stated these are Rel-15 requirements.

[TS 38.212, clause 7.3.1.1.1]

DCI format 0\_0 is used for the scheduling of PUSCH in one cell.

The following information is transmitted by means of the DCI format 0\_0 with CRC scrambled by C-RNTI or CS-RNTI or new-RNTI:

- Identifier for DCI formats – 1 bit
  - The value of this bit field is always set to 0, indicating an UL DCI format
- Frequency domain resource assignment –  $\left\lceil \log_2(N_{RB}^{UL,BWP}(N_{RB}^{UL,BWP} + 1)/2) \right\rceil$  bits where
  - $N_{RB}^{UL,BWP}$  is the size of the active UL bandwidth part in case DCI format 0\_0 is monitored in the UE specific search space and satisfying
    - the total number of different DCI sizes monitored per slot is no more than 4 for the cell, and
    - the total number of different DCI sizes with C-RNTI monitored per slot is no more than 3 for the cell
    - otherwise,  $N_{RB}^{UL,BWP}$  is the size of the initial UL bandwidth part.
- For PUSCH hopping with resource allocation type 1:

- $N_{UL\_hop}$  MSB bits are used to indicate the frequency offset according to Subclause 6.3 of [6, TS 38.214], where  $N_{UL\_hop} = 1$  if the higher layer parameter *frequencyHoppingOffsetLists* contains two offset values and  $N_{UL\_hop} = 2$  if the higher layer parameter *frequencyHoppingOffsetLists* contains four offset values
- $\lceil \log_2(N_{RB}^{UL,BWP}(N_{RB}^{UL,BWP} + 1)/2) \rceil - N_{UL\_hop}$  bits provides the frequency domain resource allocation according to Subclause 6.1.2.2.2 of [6, TS 38.214]
- For non-PUSCH hopping with resource allocation type 1:
  - $\lceil \log_2(N_{RB}^{UL,BWP}(N_{RB}^{UL,BWP} + 1)/2) \rceil$  bits provides the frequency domain resource allocation according to Subclause 6.1.2.2.2 of [6, TS 38.214]
- Time domain resource assignment – 4 bits as defined in Subclause 6.1.2.1 of [6, TS 38.214]
- Frequency hopping flag – 1 bit.
- Modulation and coding scheme – 5 bits as defined in Subclause 6.1.3 of [6, TS 38.214]
- New data indicator – 1 bit
- Redundancy version – 2 bits as defined in Table 7.3.1.1.1-2
- HARQ process number – 4 bits
- TPC command for scheduled PUSCH – 2 bits as defined in Subclause 7.1.1 of [5, TS 38.213]
- Padding bits, if required.
- UL/SUL indicator – 1 bit for UEs configured with SUL in the cell as defined in Table 7.3.1.1.1-1 and the number of bits for DCI format 1\_0 before padding is larger than the number of bits for DCI format 0\_0 before padding; 0 bit otherwise. The UL/SUL indicator, if present, locates in the last bit position of DCI format 0\_0, after the padding bit(s).
  - If the UL/SUL indicator is present in DCI format 0\_0 and the higher layer parameter *pusch-Config* is not configured on both UL and SUL the UE ignores the UL/SUL indicator field in DCI format 0\_0, and the corresponding PUSCH scheduled by the DCI format 0\_0 is for the UL or SUL for which high layer parameter *pucch-Config* is configured;
  - If the UL/SUL indicator is not present in DCI format 0\_0, the corresponding PUSCH scheduled by the DCI format 0\_0 is for the UL or SUL for which high layer parameter *pucch-Config* is configured.

The following information is transmitted by means of the DCI format 0\_0 with CRC scrambled by TC-RNTI:

- Identifier for DCI formats – 1 bit
  - The value of this bit field is always set to 0, indicating an UL DCI format
- Frequency domain resource assignment –  $\lceil \log_2(N_{RB}^{UL,BWP}(N_{RB}^{UL,BWP} + 1)/2) \rceil$  bits where
  - $N_{RB}^{UL,BWP}$  is the size of the initial UL bandwidth part.
  - For PUSCH hopping with resource allocation type 1:
    - $N_{UL\_hop}$  MSB bits are used to indicate the frequency offset according to Subclause 6.3 of [6, TS 38.214], where  $N_{UL\_hop} = 1$  if  $N_{RB}^{UL,BWP} < 50$  and  $N_{UL\_hop} = 2$  otherwise
    - $\lceil \log_2(N_{RB}^{UL,BWP}(N_{RB}^{UL,BWP} + 1)/2) \rceil - N_{UL\_hop}$  bits provides the frequency domain resource allocation according to Subclause 6.1.2.2.2 of [6, TS 38.214]
  - For non-PUSCH hopping with resource allocation type 1:

- $\lceil \log_2(N_{RB}^{UL,BWP}(N_{RB}^{UL,BWP} + 1)/2) \rceil$  bits provides the frequency domain resource allocation according to Subclause 6.1.2.2.2 of [6, TS 38.214]
- Time domain resource assignment – 4 bits as defined in Subclause 6.1.2.1 of [6, TS 38.214]
- Frequency hopping flag – 1 bit.
- Modulation and coding scheme – 5 bits as defined in Subclause 6.1.3 of [6, TS 38.214], using Table 5.1.3.1-1
- New data indicator – 1 bit, reserved
- Redundancy version – 2 bits as defined in Table 7.3.1.1.1-2
- HARQ process number – 4 bits, reserved
- TPC command for scheduled PUSCH – 2 bits as defined in Subclause 7.1.1 of [5, TS 38.213]
- Padding bits, if required.
- UL/SUL indicator – 1 bit if the cell has two ULs and the number of bits for DCI format 1\_0 before padding is larger than the number of bits for DCI format 0\_0 before padding; 0 bit otherwise. The UL/SUL indicator, if present, locates in the last bit position of DCI format 0\_0, after the padding bit(s).
  - If 1 bit, reserved, and the corresponding PUSCH is always on the same UL carrier as the previous transmission of the same TB

If DCI format 0\_0 is monitored in common search space and if the number of information bits in the DCI format 0\_0 prior to padding is less than the payload size of the DCI format 1\_0 monitored in common search space for scheduling the same serving cell, zeros shall be appended to the DCI format 0\_0 until the payload size equals that of the DCI format 1\_0.

If DCI format 0\_0 is monitored in common search space and if the number of information bits in the DCI format 0\_0 prior to padding is larger than the payload size of the DCI format 1\_0 monitored in common search space for scheduling the same serving cell, the bit width of the frequency domain resource allocation field in the DCI format 0\_0 is reduced by truncating the first few most significant bits such that the size of DCI format 0\_0 equals to the size of the DCI format 1\_0.

If DCI format 0\_0 is monitored in UE specific search space but does not satisfy at least one of the following

- the total number of different DCI sizes monitored per slot is no more than 4 for the cell, and
- the total number of different DCI sizes with C-RNTI monitored per slot is no more than 3 for the cell

and if the number of information bits in the DCI format 0\_0 prior to padding is less than the payload size of the DCI format 1\_0 monitored in common search space for scheduling the same serving cell, zeros shall be appended to the DCI format 0\_0 until the payload size equals that of the DCI format 1\_0.

If DCI format 0\_0 is monitored in UE specific search space but does not satisfy at least one of the following

- the total number of different DCI sizes monitored per slot is no more than 4 for the cell, and
- the total number of different DCI sizes with C-RNTI monitored per slot is no more than 3 for the cell

and if the number of information bits in the DCI format 0\_0 prior to padding is larger than the payload size of the DCI format 1\_0 monitored in common search space for scheduling the same serving cell, the bit width of the frequency domain resource allocation field in the DCI format 0\_0 is reduced by truncating the first few most significant bits such that the size of DCI format 0\_0 equals to the size of the DCI format 1\_0.

If DCI format 0\_0 is monitored in UE specific search space and satisfies both of the following

- the total number of different DCI sizes monitored per slot is no more than 4 for the cell, and
- the total number of different DCI sizes with C-RNTI monitored per slot is no more than 3 for the cell



and if the number of information bits in the DCI format 0\_0 prior to padding is less than the payload size of the DCI format 1\_0 monitored in UE specific search space for scheduling the same serving cell, zeros shall be appended to the DCI format 0\_0 until the payload size equals that of the DCI format 1\_0.

[TS 38.214, clause 6.1.2.1]

When the UE is scheduled to transmit a transport block and no CSI report, or the UE is scheduled to transmit a transport block and a CSI report on PUSCH by a DCI, the *Time domain resource assignment* field value  $m$  of the DCI provides a row index  $m + 1$  to an allocated table. The determination of the used resource allocation table is defined in sub-clause 6.1.2.1.1. The indexed row defines the slot offset  $K_2$ , the start and length indicator  $SLIV$ , or directly the start symbol  $S$  and the allocation length  $L$ , and the PUSCH mapping type to be applied in the PUSCH transmission.

When the UE is scheduled to transmit a PUSCH with no transport block and with a CSI report by a *CSI request* field on a DCI, the *Time-domain resource assignment* field value  $m$  of the DCI provides a row index  $m + 1$  to an allocated table. The determination of the applied resource allocation table is defined in sub-clause 6.1.2.1.1. The indexed row defines the start and length indicator  $SLIV$ , or directly the start symbol  $S$  and the allocation length  $L$ , and the PUSCH mapping type to be applied in the PUSCH transmission and  $K_2$  is determined based on the corresponding list entries  $Y_j, j = 0, \dots, N_{\text{Rep}} - 1$  of the higher layer parameter *reportSlotConfig* in *CSI-ReportConfig* for the  $N_{\text{Rep}}$  triggered CSI Reporting Settings. The  $i$ th codepoint of  $K_2$  s determined as  $K_2 = \max_j Y_j(i)$  where  $Y_j(i)$  is the  $i$ th codepoint of  $Y_j$ .

- The slot where the UE shall transmit the PUSCH is determined by  $K_2$  as  $\left\lfloor n \cdot \frac{2^{\mu_{\text{PUSCH}}}}{2^{\mu_{\text{PDCCH}}}} \right\rfloor + K_2$  where  $n$  is the slot with the scheduling DCI,  $K_2$  is based on the numerology of PUSCH, and  $\mu_{\text{PUSCH}}$  and  $\mu_{\text{PDCCH}}$  are the subcarrier spacing configurations for PUSCH and PDCCH, respectively, and
- The starting symbol  $S$  relative to the start of the slot, and the number of consecutive symbols  $L$  counting from the symbol  $S$  allocated for the PUSCH are determined from the start and length indicator  $SLIV$  of the indexed row:

if  $(L-1) \leq 7$  then

$$SLIV = 14 \cdot (L-1) + S$$

else

$$SLIV = 14 \cdot (14 - L + 1) + (14 - 1 - S)$$

where  $0 < L \leq 14 - S$ , and

- The PUSCH mapping type is set to Type A or Type B as defined in Subclause 6.4.1.1.3 of [4, TS 38.211] as given by the indexed row.

The UE shall consider the  $S$  and  $L$  combinations defined in table 6.1.2.1-1 as valid PUSCH allocations

**Table 6.1.2.1-1: Valid S and L combinations**

PUSCH mapping type	Normal cyclic prefix			Extended cyclic prefix		
	S	L	S+L	S	L	S+L
Type A	0	{4,...,14}	{4,...,14}	0	{4,...,12}	{4,...,12}
Type B	{0,...,13}	{1,...,14}	{1,...,14}	{0,...,12}	{1,...,12}	{1,...,12}

When the UE is configured with  $aggregationFactorUL > 1$ , the same symbol allocation is applied across the  $aggregationFactorUL$  consecutive slots and the PUSCH is limited to a single transmission layer. The UE shall repeat the TB across the  $aggregationFactorUL$  consecutive slots applying the same symbol allocation in each slot. The redundancy version to be applied on the  $n^{\text{th}}$  transmission occasion of the TB is determined according to table 6.1.2.1-2.

Table 6.1.2.1-2: Redundancy version when *aggregationFactorUL* > 1

<i>rvid</i> indicated by the DCI scheduling the PUSCH	<i>rvid</i> to be applied to <i>n</i> <sup>th</sup> transmission occasion			
	<i>n mod 4 = 0</i>	<i>n mod 4 = 1</i>	<i>n mod 4 = 2</i>	<i>n mod 4 = 3</i>
0	0	2	3	1
2	2	3	1	0
3	3	1	0	2
1	1	0	2	3

If the UE procedure for determining slot configuration, as defined in subclause 11.1 of [6, TS 38.213], determines symbols of a slot allocated for PUSCH as downlink symbols, the transmission on that slot is omitted for multi-slot PUSCH transmission.

[38.214 clause 6.1.2.2]

The UE shall determine the resource block assignment in frequency domain using the resource allocation field in the detected PDCCH DCI. Two uplink resource allocation schemes type 0 and type 1 are supported. Uplink resource allocation scheme type 0 is supported for PUSCH only when transform precoding is disabled. Uplink resource allocation scheme type 1 is supported for PUSCH for both cases when transform precoding is enabled or disabled.

If the scheduling DCI is configured to indicate the uplink resource allocation type as part of the *Frequency domain resource* assignment field by setting a higher layer parameter *resourceAllocation* in *pusch-Config* to ‘dynamicswitch’, the UE shall use uplink resource allocation type 0 or type 1 as defined by this DCI field. Otherwise the UE shall use the uplink frequency resource allocation type as defined by the higher layer parameter *resourceAllocation*.

The UE shall assume that when the scheduling PDCCH is received with DCI format 0\_0, then uplink resource allocation type 1 is used.

If a bandwidth part indicator field is not configured in the scheduling DCI, the RB indexing for uplink type 0 and type 1 resource allocation is determined within the UE's active bandwidth part. If a bandwidth part indicator field is configured in the scheduling DCI, the RB indexing for uplink type 0 and type 1 resource allocation is determined within the UE's bandwidth part indicated by bandwidth part indicator field value in the DCI, except for the case when DCI format 0\_0 is decoded in any PDCCH common search space in CORESET 0 in which case the initial bandwidth part shall be used. The UE shall upon detection of PDCCH intended for the UE determine first the uplink bandwidth part and then the resource allocation within the bandwidth part.

[38.214 clause 6.1.2.2.2]

In uplink resource allocation of type 1, the resource block assignment information indicates to a scheduled UE a set of contiguously allocated non-interleaved virtual resource blocks within the active carrier bandwidth part of size  $N_{BWP}^{size}$  PRBs except for the case when DCI format 0\_0 is decoded in the Type0-PDCCH common search space in CORESET 0 in which case the initial bandwidth part of size  $N_{BWP}^{size}$  shall be used.

An uplink type 1 resource allocation field consists of a resource indication value (*RIV*) corresponding to a starting virtual resource block ( $RB_{start}$ ) and a length in terms of contiguously allocated resource blocks  $L_{RBs}$ . The resource indication value is defined by

if  $(L_{RBs} - 1) \leq \lfloor N_{BWP}^{size} / 2 \rfloor$  then

$$RIV = N_{BWP}^{size} (L_{RBs} - 1) + RB_{start}$$

else

$$RIV = N_{BWP}^{size} (N_{BWP}^{size} - L_{RBs} + 1) + (N_{BWP}^{size} - 1 - RB_{start})$$

where  $L_{RBs} \geq 1$  and shall not exceed  $N_{BWP}^{size} - RB_{start}$ .

[TS 38.214, clause 6.1.4.1]

For the PUSCH assigned by a DCI format 0\_0/0\_1 with CRC scrambled by C-RNTI, new-RNTI, TC-RNTI, or SP-CSI-RNTI, the transform precoding is enabled if *transformPrecoder* in *PUSCH-Config* is set to 'enabled', or if *transformPrecoder* in *PUSCH-Config* is not configured and *msg3-transformPrecoding* in *rach-ConfigCommon* is set to 'enabled'; otherwise the transform precoding is disabled.

For the PUSCH assigned by a DCI format 0\_0/0\_1 with CRC scrambled by CS-RNTI, or the PUSCH with configured grant using CS-RNTI, the transform precoding is enabled if *transformPrecoder* in *ConfiguredGrantConfig* is set to 'enabled'; otherwise the transform precoding is disabled.

For a PUSCH scheduled by RAR UL grant or for a PUSCH scheduled by a DCI format 0\_0/0\_1 with CRC scrambled by C-RNTI, TC-RNTI, or CS-RNTI, or SP-CSI-RNTI, or for a PUSCH with configured grant using CS-RNTI,

if *transformPrecoder* is disabled for this PUSCH transmission

- if *mcs-Table* in *PUSCH-Config* is set to 'qam256', and PUSCH is scheduled with C-RNTI or SP-CSI-RNTI, and PUSCH is assigned by DCI format 0\_1,
  - the UE shall use  $I_{MCS}$  and Table 5.1.3.1-2 to determine the modulation order ( $Q_m$ ) and Target code rate ( $R$ ) used in the physical uplink shared channel.
- elseif the UE is not configured with new-RNTI, *mcs-Table* in *PUSCH-Config* is set to 'qam64LowSE', the PUSCH is scheduled with C-RNTI, or SP-CSI-RNTI, and the PUSCH is assigned by a PDCCH in a UE-specific search space,
  - the UE shall use  $I_{MCS}$  and Table 5.1.3.1-3 to determine the modulation order ( $Q_m$ ) and Target code rate ( $R$ ) used in the physical uplink shared channel.
- elseif the UE is configured with new-RNTI, and the PUSCH is scheduled with new-RNTI,
  - the UE shall use  $I_{MCS}$  and Table 5.1.3.1-3 to determine the modulation order ( $Q_m$ ) and Target code rate ( $R$ ) used in the physical uplink shared channel.
- elseif *mcs-Table* in *ConfiguredGrantConfig* is set to 'qam256', and PUSCH is scheduled with CS-RNTI,
  - the UE shall use  $I_{MCS}$  and Table 5.1.3.1-2 to determine the modulation order ( $Q_m$ ) and Target code rate ( $R$ ) used in the physical uplink shared channel.
- elseif *mcs-Table* in *ConfiguredGrantConfig* is set to 'qam64LowSE', and PUSCH is scheduled with CS-RNTI,
  - the UE shall use  $I_{MCS}$  and Table 5.1.3.1-3 to determine the modulation order ( $Q_m$ ) and Target code rate ( $R$ ) used in the physical uplink shared channel.
- else
  - the UE shall use  $I_{MCS}$  and Table 5.1.3.1-1 to determine the modulation order ( $Q_m$ ) and Target code rate ( $R$ ) used in the physical uplink shared channel.

[TS 38.214, clause 5.1.3.1]

Table 5.1.3.1-1: MCS index table 1 for PDSCH

MCS Index $I_{MCS}$	Modulation Order $Q_m$	Target code Rate $R \times [1024]$	Spectral efficiency
0	2	120	0.2344
1	2	157	0.3066
2	2	193	0.3770
3	2	251	0.4902
4	2	308	0.6016
5	2	379	0.7402
6	2	449	0.8770
7	2	526	1.0273
8	2	602	1.1758
9	2	679	1.3262
10	4	340	1.3281
11	4	378	1.4766
12	4	434	1.6953
13	4	490	1.9141
14	4	553	2.1602
15	4	616	2.4063
16	4	658	2.5703
17	6	438	2.5664
18	6	466	2.7305
19	6	517	3.0293
20	6	567	3.3223
21	6	616	3.6094
22	6	666	3.9023
23	6	719	4.2129
24	6	772	4.5234
25	6	822	4.8164
26	6	873	5.1152
27	6	910	5.3320
28	6	948	5.5547
29	2	reserved	
30	4	reserved	
31	6	reserved	

[TS 38.214, clause 6.1.4.2]

For a PUSCH scheduled by RAR UL grant or for a PUSCH scheduled by a DCI format 0\_0/0\_1 with CRC scrambled by C-RNTI, new-RNTI, TC-RNTI, CS-RNTI, or SP-CSI-RNTI.

if

- $0 \leq I_{MCS} \leq 27$  and transform precoding is disabled and Table 5.1.3.1-2 is used, or
- $0 \leq I_{MCS} \leq 28$  and transform precoding is disabled and a table other than Table 5.1.3.1-2 is used, or
- $0 \leq I_{MCS} \leq 27$  and transform precoding is enabled and , the UE shall first determine the TBS as specified below:

The UE shall first determine the number of REs ( $N_{RE}$ ) within the slot:

- A UE first determines the number of REs allocated for PUSCH within a PRB ( $N'_{RE}$ ) by
- $N'_{RE} = N_{sc}^{RB} * N_{ymb}^{sh} - N_{DMRS}^{PRB} - N_{oh}^{PRB}$ , where  $N_{sc}^{RB} = 12$  is the number of subcarriers in the frequency domain in a physical resource block,  $N_{ymb}^{sh}$  is the number of symbols of the PUSCH allocation within the slot,  $N_{DMRS}^{PRB}$  is the number of REs for DM-RS per PRB in the scheduled duration including the overhead of the DM-RS CDM groups without data, as indicated by DCI format 0\_1 or as described for DCI format 0\_0 in Subclause 6.2.2, and  $N_{oh}^{PRB}$  is the overhead configured by higher layer parameter  $xOverhead$  in PUSCH-

*ServingCellConfig*. If the  $N_{oh}^{PRB}$  is not configured (a value from 0, 6, 12, or 18), the  $N_{oh}^{PRB}$  is assumed to be 0. For MSG3 transmission the  $N_{oh}^{PRB}$  is always set to 0..

- A UE determines the total number of REs allocated for PUSCH ( $N_{RE}$ ) by  $N_{RE} = \min(156, N_{RE}') \cdot n_{PRB}$  where  $n_{PRB}$  is the total number of allocated PRBs for the UE.
- Next, proceed with steps 2-5 as defined in Subclause 5.1.3.2

else if

- $28 \leq I_{MCS} \leq 31$  and transform precoding is disabled and Table 5.1.3.1-2 is used, or
- $28 \leq I_{MCS} \leq 31$  and transform precoding is enabled,
- the TBS is assumed to be as determined from the DCI transported in the latest PDCCH for the same transport block using  $0 \leq I_{MCS} \leq 27$ . If there is no PDCCH for the same transport block using  $0 \leq I_{MCS} \leq 27$ , and if the initial PUSCH for the same transport block is transmitted with configured grant, the TBS shall be determined from the most recent configured scheduling PDCCH.

else

- the TBS is assumed to be as determined from the DCI transported in the latest PDCCH for the same transport block using  $0 \leq I_{MCS} \leq 28$ . If there is no PDCCH for the same transport block using  $0 \leq I_{MCS} \leq 28$ , and if the initial PUSCH for the same transport block is transmitted with configured grant, the TBS shall be determined from the most recent configured scheduling PDCCH.

[TS 38.214, clause 5.1.3.2]

2 Intermediate number of information bits ( $N_{info}$ ) is obtained by  $N_{info} = N_{RE} \cdot R \cdot Q_m \cdot \nu$ .

If  $N_{info} \leq 3824$

Use step 3 as the next step of the TBS determination

else

Use step 4 as the next step of the TBS determination

end if

3) When  $N_{info} \leq 3824$ , TBS is determined as follows

- quantized intermediate number of information bits  $N_{info}' = \max\left(24, 2^n \cdot \left\lfloor \frac{N_{info}}{2^n} \right\rfloor\right)$ , where  $n = \max(3, \lfloor \log_2(N_{info}) \rfloor - 6)$ .
- use Table 5.1.3.2-2 find the closest TBS that is not less than  $N_{info}'$ .

Table 5.1.3.2-2: TBS for  $N_{info} \leq 3824$ 

Index	TBS	Index	TBS	Index	TBS	Index	TBS
1	24	31	336	61	1288	91	3624
2	32	32	352	62	1320	92	3752
3	40	33	368	63	1352	93	3824
4	48	34	384	64	1416		
5	56	35	408	65	1480		
6	64	36	432	66	1544		
7	72	37	456	67	1608		
8	80	38	480	68	1672		
9	88	39	504	69	1736		
10	96	40	528	70	1800		
11	104	41	552	71	1864		
12	112	42	576	72	1928		
13	120	43	608	73	2024		
14	128	44	640	74	2088		
15	136	45	672	75	2152		
16	144	46	704	76	2216		
17	152	47	736	77	2280		
18	160	48	768	78	2408		
19	168	49	808	79	2472		
20	176	50	848	80	2536		
21	184	51	888	81	2600		
22	192	52	928	82	2664		
23	208	53	984	83	2728		
24	224	54	1032	84	2792		
25	240	55	1064	85	2856		
26	256	56	1128	86	2976		
27	272	57	1160	87	3104		
28	288	58	1192	88	3240		
29	304	59	1224	89	3368		
30	320	60	1256	90	3496		

4) When  $N_{info} > 3824$ , TBS is determined as follows.

- quantized intermediate number of information bits  $N'_{info} = \max\left(3840, 2^n \times \text{round}\left(\frac{N_{info} - 24}{2^n}\right)\right)$ , where  $n = \lfloor \log_2(N_{info} - 24) \rfloor - 5$  and ties in the round function are broken towards the next largest integer.
- if  $R \leq 1/4$

$$TBS = 8 \cdot C \cdot \left\lceil \frac{N'_{info} + 24}{8 \cdot C} \right\rceil - 24, \text{ where } C = \left\lceil \frac{N'_{info} + 24}{3816} \right\rceil$$

else

if  $N'_{info} > 8424$

$$TBS = 8 \cdot C \cdot \left\lceil \frac{N'_{info} + 24}{8 \cdot C} \right\rceil - 24, \text{ where } C = \left\lceil \frac{N'_{info} + 24}{8424} \right\rceil$$

else

$$TBS = 8 \cdot \left\lceil \frac{N'_{info} + 24}{8} \right\rceil - 24$$

end if

end if

7.1.1.4.2.1.3 Test description

7.1.1.4.2.1.3.1 Pre-test conditions

Same Pre-test conditions as in clause 7.1.1.0 except set the NR Cell bandwidth and applicable BWP to maximum for the NR Band under test as specified in Table 5.3.5-1 in TS 38.101-1 [16] / TS 38.101-2 [17] (to enable testing of  $n_{PRB}$  up to maximum value).

7.1.1.4.2.1.3.2 Test procedure sequence

**Table 7.1.1.4.2.1.3.2-1: Maximum TBS for different UE categories**

UE Category	Maximum number of bits of a UL-SCH transport block received within a TTI
TS 38.306 [23] clause 4.1.2 require UE without ue-CategoryDL and ue-CategoryUL, to support Max TBS achievable based on max bandwidth of the Band under test.	

**Table 7.1.1.4.2.1.3.2-2: Number of uplink PDCP SDUs and PDCP SDU size used as test data**

TBS [bits]	Number of PDCP SDUs	PDCP SDU size [bits] (Note 1)
$132 \leq TBS \leq 12128$ note 2	1	$8 * \text{FLOOR}((TBS - 128) / 8)$
$12129 \leq TBS \leq 24200$	2	$8 * \text{FLOOR}((TBS - 200) / 16)$
$24201 \leq TBS \leq 36272$	3	$8 * \text{FLOOR}((TBS - 272) / 24)$
$36273 \leq TBS \leq 48344$	4	$8 * \text{FLOOR}((TBS - 344) / 32)$
$48345 \leq TBS \leq 60416$	5	$8 * \text{FLOOR}((TBS - 416) / 40)$
$60417 \leq TBS \leq 72488$	6	$8 * \text{FLOOR}((TBS - 488) / 48)$
$72489 \leq TBS \leq 84560$	7	$8 * \text{FLOOR}((TBS - 560) / 56)$
$84561 \leq TBS \leq 96632$	8	$8 * \text{FLOOR}((TBS - 632) / 64)$
$96633 < TBS \leq 108704$	9	$8 * \text{FLOOR}((TBS - 704) / 72)$
$10705 \leq TBS \leq 120776$	10	$8 * \text{FLOOR}((TBS - 776) / 80)$
$120777 \leq TBS \leq 132848$	11	$8 * \text{FLOOR}((TBS - 848) / 88)$
$132849 \leq TBS \leq 144920$	12	$8 * \text{FLOOR}((TBS - 920) / 96)$
$TBS > 144920$	13	$8 * \text{FLOOR}((TBS - 992) / 112)$

Note 1: Each PDCP SDU is limited to 1500 octets (to keep below maximum SDU size of ESM as specified in TS 24.301 [21] clause 9.9.4.12).

The PDCP SDU size of each PDCP SDU is

$\text{PDCP SDU size} = (TBS - N * \text{PDCP header size} - N * \text{AMD PDU header size} - N * \text{MAC header size} - \text{Size of Timing Advance} - \text{RLC Status PDU size} - \text{MAC header for RLC Status PDU}) / N$ , where

PDCP header size is 24 bits for the RLC AM and 18-bit SN case;  
 AMD PDU header size is 24 bits with 18 bit SN;

MAC header size for AMD PDU = 16 or 24 bits depending on L=8 or 16 bits. Worst case 24 is taken.

Size of Timing Advance MAC CE with header is 16 bits (if no Timing Advance and/or RLC status needs to be sent, padding will occur instead).

RLC Status PDU size = 24 bits with 1 ACK\_SN, With a MAC header of 16 bits.

This gives:

$\text{PDCP SDU size} = 8 * \text{FLOOR}((TBS - N * 24 - N * 24 - N * 24 - 56) / (8 * N))$  bits.

Note 2: According to the final PDCP SDU size formula in Note 1, the smallest TBS that can be tested is 136 bits.

Table 7.1.1.4.2.1.3.2-3: Specific Parameters

Parameter	Value	Comment
PUSCH mappingType	typeA	
starting symbol S	0	
number of consecutive symbols L	4..14	
$K_2$	Not present	UE applies the value 01 when PUSCH SCS is 15/30KHz; 2 when PUSCH SCS is 60KHz and 3 when PUSCH SCS is 120KHz
number of layers (v)	1	
mcs-Table	gam64	
$xoh\text{-PUSCH}(N_{oh}^{PRB})$	Not present	Results in value 0(xoh0)
dmrs-AdditionalPosition	pos0	Results in 1 DMRS symbol per two carrier ( $N_{DMRS}^{PRB}$ ) for Duration in symbols $\geq 4$

Table 7.1.1.4.2.1.3.2-4: Main behaviour

St	Procedure	Message Sequence		TP	Verdict
		U - S	Message		
-	EXCEPTION: Steps 1 to 5 are repeated for allowed values of $N_{PRB}$ 1 to $N_{RB}^{UL,BWP}$ in BWP, time domain resource length L 4 to 14- S and $I_{MCS}$ from 0 to 28.	-	-	-	-
1	The SS calculates or looks up TBS in TS 38.214 [15] based on the value of S, L, $I_{MCS}$ and $n_{PRB}$ .	-	-	-	-
-	EXCEPTION: Steps 2 to 5 are performed if TBS is less than or equal to UE capability "Maximum number of UL-SCH transport block bits received within a TTI" as specified in Table 7.1.1.4.2.1.3.2-1 and larger than or equal to 136 bits as specified in Table 7.1.1.4.2.1.3.2-2	-	-	-	-
2	The SS creates one or more PDCP SDUs, depending on TBS, in accordance with Table 7.1.1.4.2.1.3.2-2.	-	-	-	-
3	After 300ms, the SS transmits all PDCP SDUs ( $N_{SDUs}$ ) as created in step 2 in a MAC PDU.	<--	MAC PDU (N x PDCP SDUs)	-	-
4	After 60ms of step 3, SS transmits UL Grant DCI 0_0, and values of S, L, $I_{MCS}$ and $n_{PRB}$ .	<--	(UL Grant) (DCI Format 0_0, S, L, $I_{MCS}$ and $n_{PRB}$ .)	-	-
5	CHECK: Does UE return the same number of PDCP SDUs with same content as transmitted by the SS in step 3 using Time, frequency Resources and modulation and coding scheme as configured by the SS in step 4?	-->	MAC PDU (N x PDCP SDU)	1	P

## 7.1.1.4.2.1.3.3 Specific message contents

[None].



#### 7.1.1.4.2.2 UL-SCH Transport Block Size selection / DCI format 0\_0 / 256QAM / Transform precoding disabled

##### 7.1.1.4.2.2.1 Test Purpose (TP)

(1)

```
with { UE in RRC_CONNECTED state and mcs-Table is set as 'qam256' }
ensure that {
  when { UE has pending data for transmission and receives on PDCCH DCI format 0_0 indicating a
resource block assignment correspondent to physical resource blocks , Time domain resource
assignment and modulation and coding }
  then { UE transmits MAC PDU on PUSCH as per Modulation Coding scheme, time domain resource
allocation and PRB's }
}
```

##### 7.1.1.4.2.2.2 Conformance requirements

References: The conformance requirements covered in the present TC are specified in: TS 38.212 clause 7.3.1.1.1, TS 38.214 clause 6.1.2.1, 6.1.2.2, 6.1.2.2.2, 6.1.4.1, 5.1.3.1, 6.1.4.2 and 5.1.3.2. Unless otherwise stated these are Rel-15 requirements.

[TS 38.212, clause 7.3.1.1.1]

DCI format 0\_0 is used for the scheduling of PUSCH in one cell.

The following information is transmitted by means of the DCI format 0\_0 with CRC scrambled by C-RNTI or CS-RNTI or new-RNTI:

- Identifier for DCI formats – 1 bit
  - The value of this bit field is always set to 0, indicating an UL DCI format
- Frequency domain resource assignment –  $\lceil \log_2(N_{RB}^{UL,BWP}(N_{RB}^{UL,BWP} + 1)/2) \rceil$  bits where
  - $N_{RB}^{UL,BWP}$  is the size of the active UL bandwidth part in case DCI format 0\_0 is monitored in the UE specific search space and satisfying
    - the total number of different DCI sizes monitored per slot is no more than 4 for the cell, and
    - the total number of different DCI sizes with C-RNTI monitored per slot is no more than 3 for the cell
  - otherwise,  $N_{RB}^{UL,BWP}$  is the size of the initial UL bandwidth part.
- For PUSCH hopping with resource allocation type 1:
  - $N_{UL\_hop}$  MSB bits are used to indicate the frequency offset according to Subclause 6.3 of [6, TS 38.214], where  $N_{UL\_hop} = 1$  if the higher layer parameter *frequencyHoppingOffsetLists* contains two offset values and  $N_{UL\_hop} = 2$  if the higher layer parameter *frequencyHoppingOffsetLists* contains four offset values
  - $\lceil \log_2(N_{RB}^{UL,BWP}(N_{RB}^{UL,BWP} + 1)/2) \rceil - N_{UL\_hop}$  bits provides the frequency domain resource allocation according to Subclause 6.1.2.2.2 of [6, TS 38.214]
- For non-PUSCH hopping with resource allocation type 1:
  - $\lceil \log_2(N_{RB}^{UL,BWP}(N_{RB}^{UL,BWP} + 1)/2) \rceil$  bits provides the frequency domain resource allocation according to Subclause 6.1.2.2.2 of [6, TS 38.214]
- Time domain resource assignment – 4 bits as defined in Subclause 6.1.2.1 of [6, TS 38.214]
- Frequency hopping flag – 1 bit.
- Modulation and coding scheme – 5 bits as defined in Subclause 6.1.3 of [6, TS 38.214]

- New data indicator – 1 bit
- Redundancy version – 2 bits as defined in Table 7.3.1.1.1-2
- HARQ process number – 4 bits
- TPC command for scheduled PUSCH – 2 bits as defined in Subclause 7.1.1 of [5, TS 38.213]
- Padding bits, if required.
- UL/SUL indicator – 1 bit for UEs configured with SUL in the cell as defined in Table 7.3.1.1.1-1 and the number of bits for DCI format 1\_0 before padding is larger than the number of bits for DCI format 0\_0 before padding; 0 bit otherwise. The UL/SUL indicator, if present, locates in the last bit position of DCI format 0\_0, after the padding bit(s).
  - If the UL/SUL indicator is present in DCI format 0\_0 and the higher layer parameter *pusch-Config* is not configured on both UL and SUL the UE ignores the UL/SUL indicator field in DCI format 0\_0, and the corresponding PUSCH scheduled by the DCI format 0\_0 is for the UL or SUL for which high layer parameter *pucch-Config* is configured;
  - If the UL/SUL indicator is not present in DCI format 0\_0, the corresponding PUSCH scheduled by the DCI format 0\_0 is for the UL or SUL for which high layer parameter *pucch-Config* is configured.

The following information is transmitted by means of the DCI format 0\_0 with CRC scrambled by TC-RNTI:

- Identifier for DCI formats – 1 bit
  - The value of this bit field is always set to 0, indicating an UL DCI format
- Frequency domain resource assignment –  $\lceil \log_2(N_{RB}^{UL,BWP}(N_{RB}^{UL,BWP} + 1)/2) \rceil$  bits where
  - $N_{RB}^{UL,BWP}$  is the size of the initial UL bandwidth part.
  - For PUSCH hopping with resource allocation type 1:
    - $N_{UL\_hop}$  MSB bits are used to indicate the frequency offset according to Subclause 6.3 of [6, TS 38.214], where  $N_{UL\_hop} = 1$  if  $N_{RB}^{UL,BWP} < 50$  and  $N_{UL\_hop} = 2$  otherwise
    - $\lceil \log_2(N_{RB}^{UL,BWP}(N_{RB}^{UL,BWP} + 1)/2) \rceil - N_{UL\_hop}$  bits provides the frequency domain resource allocation according to Subclause 6.1.2.2.2 of [6, TS 38.214]
  - For non-PUSCH hopping with resource allocation type 1:
    - $\lceil \log_2(N_{RB}^{UL,BWP}(N_{RB}^{UL,BWP} + 1)/2) \rceil$  bits provides the frequency domain resource allocation according to Subclause 6.1.2.2.2 of [6, TS 38.214]
- Time domain resource assignment – 4 bits as defined in Subclause 6.1.2.1 of [6, TS 38.214]
- Frequency hopping flag – 1 bit.
- Modulation and coding scheme – 5 bits as defined in Subclause 6.1.3 of [6, TS 38.214], using Table 5.1.3.1-1
- New data indicator – 1 bit, reserved
- Redundancy version – 2 bits as defined in Table 7.3.1.1.1-2
- HARQ process number – 4 bits, reserved
- TPC command for scheduled PUSCH – 2 bits as defined in Subclause 7.1.1 of [5, TS 38.213]
- Padding bits, if required.

- UL/SUL indicator – 1 bit if the cell has two ULs and the number of bits for DCI format 1\_0 before padding is larger than the number of bits for DCI format 0\_0 before padding; 0 bit otherwise. The UL/SUL indicator, if present, locates in the last bit position of DCI format 0\_0, after the padding bit(s).
- If 1 bit, reserved, and the corresponding PUSCH is always on the same UL carrier as the previous transmission of the same TB

If DCI format 0\_0 is monitored in common search space and if the number of information bits in the DCI format 0\_0 prior to padding is less than the payload size of the DCI format 1\_0 monitored in common search space for scheduling the same serving cell, zeros shall be appended to the DCI format 0\_0 until the payload size equals that of the DCI format 1\_0.

If DCI format 0\_0 is monitored in common search space and if the number of information bits in the DCI format 0\_0 prior to padding is larger than the payload size of the DCI format 1\_0 monitored in common search space for scheduling the same serving cell, the bit width of the frequency domain resource allocation field in the DCI format 0\_0 is reduced by truncating the first few most significant bits such that the size of DCI format 0\_0 equals to the size of the DCI format 1\_0.

If DCI format 0\_0 is monitored in UE specific search space but does not satisfy at least one of the following

- the total number of different DCI sizes monitored per slot is no more than 4 for the cell, and
- the total number of different DCI sizes with C-RNTI monitored per slot is no more than 3 for the cell

and if the number of information bits in the DCI format 0\_0 prior to padding is less than the payload size of the DCI format 1\_0 monitored in common search space for scheduling the same serving cell, zeros shall be appended to the DCI format 0\_0 until the payload size equals that of the DCI format 1\_0.

If DCI format 0\_0 is monitored in UE specific search space but does not satisfy at least one of the following

- the total number of different DCI sizes monitored per slot is no more than 4 for the cell, and
- the total number of different DCI sizes with C-RNTI monitored per slot is no more than 3 for the cell

and if the number of information bits in the DCI format 0\_0 prior to padding is larger than the payload size of the DCI format 1\_0 monitored in common search space for scheduling the same serving cell, the bit width of the frequency domain resource allocation field in the DCI format 0\_0 is reduced by truncating the first few most significant bits such that the size of DCI format 0\_0 equals to the size of the DCI format 1\_0.

If DCI format 0\_0 is monitored in UE specific search space and satisfies both of the following

- the total number of different DCI sizes monitored per slot is no more than 4 for the cell, and
- the total number of different DCI sizes with C-RNTI monitored per slot is no more than 3 for the cell

and if the number of information bits in the DCI format 0\_0 prior to padding is less than the payload size of the DCI format 1\_0 monitored in UE specific search space for scheduling the same serving cell, zeros shall be appended to the DCI format 0\_0 until the payload size equals that of the DCI format 1\_0.

[TS 38.214, clause 6.1.2.1]

When the UE is scheduled to transmit a transport block and no CSI report, or the UE is scheduled to transmit a transport block and a CSI report on PUSCH by a DCI, the *Time domain resource assignment* field value  $m$  of the DCI provides a row index  $m + 1$  to an allocated table. The determination of the used resource allocation table is defined in sub-clause 6.1.2.1.1. The indexed row defines the slot offset  $K_2$ , the start and length indicator *SLIV*, or directly the start symbol  $S$  and the allocation length  $L$ , and the PUSCH mapping type to be applied in the PUSCH transmission.

When the UE is scheduled to transmit a PUSCH with no transport block and with a CSI report by a *CSI request* field on a DCI, the *Time-domain resource assignment* field value  $m$  of the DCI provides a row index  $m + 1$  to an allocated table. The determination of the applied resource allocation table is defined in sub-clause 6.1.2.1.1. The indexed row defines the start and length indicator *SLIV*, or directly the start symbol  $S$  and the allocation length  $L$ , and the PUSCH mapping type to be applied in the PUSCH transmission and  $K_2$  is determined based on the corresponding list entries  $Y_j, j = 0, \dots, N_{\text{Rep}} - 1$  of the higher layer parameter *reportSlotConfig* in *CSI-ReportConfig* for the  $N_{\text{Rep}}$  triggered CSI Reporting Settings. The  $i$ th codepoint of  $K_2$  is determined as  $K_2 = \max_j Y_j(i)$  where  $Y_j(i)$  is the  $i$ th codepoint of  $Y_j$ .

- The slot where the UE shall transmit the PUSCH is determined by  $K_2$  as  $\left\lfloor n \cdot \frac{2^{\mu_{\text{PUSCH}}}}{2^{\mu_{\text{PDCCH}}}} \right\rfloor + K_2$  where  $n$  is the slot with the scheduling DCI,  $K_2$  is based on the numerology of PUSCH, and  $\mu_{\text{PUSCH}}$  and  $\mu_{\text{PDCCH}}$  are the subcarrier spacing configurations for PUSCH and PDCCH, respectively, and
- The starting symbol  $S$  relative to the start of the slot, and the number of consecutive symbols  $L$  counting from the symbol  $S$  allocated for the PUSCH are determined from the start and length indicator  $SLIV$  of the indexed row:

if  $(L-1) \leq 7$  then

$$SLIV = 14 \cdot (L-1) + S$$

else

$$SLIV = 14 \cdot (14 - L + 1) + (14 - 1 - S)$$

where  $0 < L \leq 14 - S$ , and

- The PUSCH mapping type is set to Type A or Type B as defined in Subclause 6.4.1.1.3 of [4, TS 38.211] as given by the indexed row.

The UE shall consider the  $S$  and  $L$  combinations defined in table 6.1.2.1-1 as valid PUSCH allocations

**Table 6.1.2.1-1: Valid  $S$  and  $L$  combinations**

PUSCH mapping type	Normal cyclic prefix			Extended cyclic prefix		
	$S$	$L$	$S+L$	$S$	$L$	$S+L$
Type A	0	{4,...,14}	{4,...,14}	0	{4,...,12}	{4,...,12}
Type B	{0,...,13}	{1,...,14}	{1,...,14}	{0,...,12}	{1,...,12}	{1,...,12}

When the UE is configured with  $aggregationFactorUL > 1$ , the same symbol allocation is applied across the  $aggregationFactorUL$  consecutive slots and the PUSCH is limited to a single transmission layer. The UE shall repeat the TB across the  $aggregationFactorUL$  consecutive slots applying the same symbol allocation in each slot. The redundancy version to be applied on the  $n^{\text{th}}$  transmission occasion of the TB is determined according to table 6.1.2.1-2.

**Table 6.1.2.1-2: Redundancy version when  $aggregationFactorUL > 1$**

$r_{vid}$ indicated by the DCI scheduling the PUSCH	$r_{vid}$ to be applied to $n^{\text{th}}$ transmission occasion			
	$n \bmod 4 = 0$	$n \bmod 4 = 1$	$n \bmod 4 = 2$	$n \bmod 4 = 3$
0	0	2	3	1
2	2	3	1	0
3	3	1	0	2
1	1	0	2	3

If the UE procedure for determining slot configuration, as defined in subclause 11.1 of [6, TS 38.213], determines symbols of a slot allocated for PUSCH as downlink symbols, the transmission on that slot is omitted for multi-slot PUSCH transmission.

[38.214 clause 6.1.2.2]

The UE shall determine the resource block assignment in frequency domain using the resource allocation field in the detected PDCCH DCI. Two uplink resource allocation schemes type 0 and type 1 are supported. Uplink resource allocation scheme type 0 is supported for PUSCH only when transform precoding is disabled. Uplink resource allocation scheme type 1 is supported for PUSCH for both cases when transform precoding is enabled or disabled.

If the scheduling DCI is configured to indicate the uplink resource allocation type as part of the *Frequency domain resource* assignment field by setting a higher layer parameter *resourceAllocation* in *pusch-Config* to ‘dynamicswitch’, the UE shall use uplink resource allocation type 0 or type 1 as defined by this DCI field. Otherwise the UE shall use the uplink frequency resource allocation type as defined by the higher layer parameter *resourceAllocation*.

The UE shall assume that when the scheduling PDCCH is received with DCI format 0\_0, then uplink resource allocation type 1 is used.

If a bandwidth part indicator field is not configured in the scheduling DCI, the RB indexing for uplink type 0 and type 1 resource allocation is determined within the UE's active bandwidth part. If a bandwidth part indicator field is configured in the scheduling DCI, the RB indexing for uplink type 0 and type 1 resource allocation is determined within the UE's bandwidth part indicated by bandwidth part indicator field value in the DCI, except for the case when DCI format 0\_0 is decoded in any PDCCH common search space in CORESET 0 in which case the initial bandwidth part shall be used. The UE shall upon detection of PDCCH intended for the UE determine first the uplink bandwidth part and then the resource allocation within the bandwidth part.

[38.214 clause 6.1.2.2.2]

In uplink resource allocation of type 1, the resource block assignment information indicates to a scheduled UE a set of contiguously allocated non-interleaved virtual resource blocks within the active carrier bandwidth part of size  $N_{BWP}^{size}$  PRBs except for the case when DCI format 0\_0 is decoded in the Type0-PDCCH common search space in CORESET 0 in which case the initial bandwidth part of size  $N_{BWP}^{size}$  shall be used.

An uplink type 1 resource allocation field consists of a resource indication value ( $RIV$ ) corresponding to a starting virtual resource block ( $RB_{start}$ ) and a length in terms of contiguously allocated resource blocks  $L_{RBs}$ . The resource indication value is defined by

if  $(L_{RBs} - 1) \leq \lfloor N_{BWP}^{size} / 2 \rfloor$  then

$$RIV = N_{BWP}^{size} (L_{RBs} - 1) + RB_{start}$$

else

$$RIV = N_{BWP}^{size} (N_{BWP}^{size} - L_{RBs} + 1) + (N_{BWP}^{size} - 1 - RB_{start})$$

where  $L_{RBs} \geq 1$  and shall not exceed  $N_{BWP}^{size} - RB_{start}$ .

[TS 38.214, clause 6.1.4.1]

For the PUSCH assigned by a DCI format 0\_0/0\_1 with CRC scrambled by C-RNTI, new-RNTI, TC-RNTI, or SP-CSI-RNTI, the transform precoding is enabled if *transformPrecoder* in *PUSCH-Config* is set to 'enabled', or if *transformPrecoder* in *PUSCH-Config* is not configured and *msg3-transformPrecoding* in *rach-ConfigCommon* is set to 'enabled'; otherwise the transform precoding is disabled.

For the PUSCH assigned by a DCI format 0\_0/0\_1 with CRC scrambled by CS-RNTI, or the PUSCH with configured grant using CS-RNTI, the transform precoding is enabled if *transformPrecoder* in *ConfiguredGrantConfig* is set to 'enabled'; otherwise the transform precoding is disabled.

For a PUSCH scheduled by RAR UL grant or for a PUSCH scheduled by a DCI format 0\_0/0\_1 with CRC scrambled by C-RNTI, TC-RNTI, or CS-RNTI, or SP-CSI-RNTI, or for a PUSCH with configured grant using CS-RNTI,

if *transformPrecoder* is disabled for this PUSCH transmission

- if *mcs-Table* in *PUSCH-Config* is set to 'qam256', and PUSCH is scheduled with C-RNTI or SP-CSI-RNTI, and PUSCH is assigned by DCI format 0\_1,
  - the UE shall use  $I_{MCS}$  and Table 5.1.3.1-2 to determine the modulation order ( $Q_m$ ) and Target code rate ( $R$ ) used in the physical uplink shared channel.
- elseif the UE is not configured with new-RNTI, *mcs-Table* in *PUSCH-Config* is set to 'qam64LowSE', the PUSCH is scheduled with C-RNTI, or SP-CSI-RNTI, and the PUSCH is assigned by a PDCCH in a UE-specific search space,
  - the UE shall use  $I_{MCS}$  and Table 5.1.3.1-3 to determine the modulation order ( $Q_m$ ) and Target code rate ( $R$ ) used in the physical uplink shared channel.
- elseif the UE is configured with new-RNTI, and the PUSCH is scheduled with new-RNTI,

- the UE shall use  $I_{MCS}$  and Table 5.1.3.1-3 to determine the modulation order ( $Q_m$ ) and Target code rate ( $R$ ) used in the physical uplink shared channel.
- elseif *mcs-Table* in *ConfiguredGrantConfig* is set to 'qam256', and PUSCH is scheduled with CS-RNTI,
  - the UE shall use  $I_{MCS}$  and Table 5.1.3.1-2 to determine the modulation order ( $Q_m$ ) and Target code rate ( $R$ ) used in the physical uplink shared channel.
- elseif *mcs-Table* in *ConfiguredGrantConfig* is set to 'qam64LowSE', and PUSCH is scheduled with CS-RNTI,
  - the UE shall use  $I_{MCS}$  and Table 5.1.3.1-3 to determine the modulation order ( $Q_m$ ) and Target code rate ( $R$ ) used in the physical uplink shared channel.
- else
  - the UE shall use  $I_{MCS}$  and Table 5.1.3.1-1 to determine the modulation order ( $Q_m$ ) and Target code rate ( $R$ ) used in the physical uplink shared channel.

[TS 38.214, clause 5.1.3.1]

**Table 5.1.3.1-2: MCS index table 2 for PDSCH**

MCS Index $I_{MCS}$	Modulation Order $Q_m$	Target code Rate $R \times [1024]$	Spectral efficiency
0	2	120	0.2344
1	2	193	0.3770
2	2	308	0.6016
3	2	449	0.8770
4	2	602	1.1758
5	4	378	1.4766
6	4	434	1.6953
7	4	490	1.9141
8	4	553	2.1602
9	4	616	2.4063
10	4	658	2.5703
11	6	466	2.7305
12	6	517	3.0293
13	6	567	3.3223
14	6	616	3.6094
15	6	666	3.9023
16	6	719	4.2129
17	6	772	4.5234
18	6	822	4.8164
19	6	873	5.1152
20	8	682.5	5.3320
21	8	711	5.5547
22	8	754	5.8906
23	8	797	6.2266
24	8	841	6.5703
25	8	885	6.9141
26	8	916.5	7.1602
27	8	948	7.4063
28	2	reserved	
29	4	reserved	
30	6	reserved	
31	8	reserved	

[TS 38.214, clause 6.1.4.2]

For a PUSCH scheduled by RAR UL grant or for a PUSCH scheduled by a DCI format 0\_0/0\_1 with CRC scrambled by C-RNTI, new-RNTI, TC-RNTI, CS-RNTI, or SP-CSI-RNTI.

if

- $0 \leq I_{MCS} \leq 27$  and transform precoding is disabled and Table 5.1.3.1-2 is used, or

- $0 \leq I_{MCS} \leq 28$  and transform precoding is disabled and a table other than Table 5.1.3.1-2 is used, or
- $0 \leq I_{MCS} \leq 27$  and transform precoding is enabled, the UE shall first determine the TBS as specified below:

The UE shall first determine the number of REs ( $N_{RE}$ ) within the slot:

- A UE first determines the number of REs allocated for PUSCH within a PRB ( $N'_{RE}$ ) by
- $N'_{RE} = N_{sc}^{RB} * N_{symbol}^{sh} - N_{DMRS}^{PRB} - N_{oh}^{PRB}$ , where  $N_{sc}^{RB} = 12$  is the number of subcarriers in the frequency domain in a physical resource block,  $N_{symbol}^{sh}$  is the number of symbols of the PUSCH allocation within the slot,  $N_{DMRS}^{PRB}$  is the number of REs for DM-RS per PRB in the scheduled duration including the overhead of the DM-RS CDM groups without data, as indicated by DCI format 0\_1 or as described for DCI format 0\_0 in Subclause 6.2.2, and  $N_{oh}^{PRB}$  is the overhead configured by higher layer parameter  $xOverhead$  in *PUSCH-ServingCellConfig*.
- A UE determines the total number of REs allocated for PUSCH ( $N_{RE}$ ) by  $N_{RE} = \min(156, N'_{RE}) \cdot n_{PRB}$  where  $n_{PRB}$  is the total number of allocated PRBs for the UE.
- Next, proceed with steps 2-4 as defined in Subclause 5.1.3.2

else if

- $28 \leq I_{MCS} \leq 31$  and transform precoding is disabled and Table 5.1.3.1-2 is used, or
- $28 \leq I_{MCS} \leq 31$  and transform precoding is enabled,
- the TBS is assumed to be as determined from the DCI transported in the latest PDCCH for the same transport block using  $0 \leq I_{MCS} \leq 27$ . If there is no PDCCH for the same transport block using  $0 \leq I_{MCS} \leq 27$ , and if the initial PUSCH for the same transport block is transmitted with configured grant, the TBS shall be determined from the most recent configured scheduling PDCCH.

else

- the TBS is assumed to be as determined from the DCI transported in the latest PDCCH for the same transport block using  $0 \leq I_{MCS} \leq 28$ . If there is no PDCCH for the same transport block using  $0 \leq I_{MCS} \leq 28$ , and if the initial PUSCH for the same transport block is transmitted with configured grant, the TBS shall be determined from the most recent configured scheduling PDCCH.

[TS 38.214, clause 5.1.3.2]

- 2) Intermediate number of information bits ( $N_{info}$ ) is obtained by  $N_{info} = N_{RE} \cdot R \cdot Q_m \cdot \nu$ .

If  $N_{info} \leq 3824$

Use step 3 as the next step of the TBS determination

else

Use step 4 as the next step of the TBS determination

end if

- 3) When  $N_{info} \leq 3824$ , TBS is determined as follows

- quantized intermediate number of information bits  $N'_{info} = \max\left(24, 2^n \cdot \left\lfloor \frac{N_{info}}{2^n} \right\rfloor\right)$ , where  
 $n = \max(3, \lfloor \log_2(N_{info}) \rfloor - 6)$ .

- use Table 5.1.3.2-2 find the closest TBS that is not less than  $N'_{info}$ .

**Table 5.1.3.2-2: TBS for  $N_{info} \leq 3824$**

Index	TBS	Index	TBS	Index	TBS	Index	TBS
1	24	31	336	61	1288	91	3624
2	32	32	352	62	1320	92	3752
3	40	33	368	63	1352	93	3824
4	48	34	384	64	1416		
5	56	35	408	65	1480		
6	64	36	432	66	1544		
7	72	37	456	67	1608		
8	80	38	480	68	1672		
9	88	39	504	69	1736		
10	96	40	528	70	1800		
11	104	41	552	71	1864		
12	112	42	576	72	1928		
13	120	43	608	73	2024		
14	128	44	640	74	2088		
15	136	45	672	75	2152		
16	144	46	704	76	2216		
17	152	47	736	77	2280		
18	160	48	768	78	2408		
19	168	49	808	79	2472		
20	176	50	848	80	2536		
21	184	51	888	81	2600		
22	192	52	928	82	2664		
23	208	53	984	83	2728		
24	224	54	1032	84	2792		
25	240	55	1064	85	2856		
26	256	56	1128	86	2976		
27	272	57	1160	87	3104		
28	288	58	1192	88	3240		
29	304	59	1224	89	3368		
30	320	60	1256	90	3496		

4) When  $N_{info} > 3824$ , TBS is determined as follows.

- quantized intermediate number of information bits  $N'_{info} = \max\left(3840, 2^n \times \text{round}\left(\frac{N_{info} - 24}{2^n}\right)\right)$ , where  $n = \lfloor \log_2(N_{info} - 24) \rfloor - 5$  and ties in the round function are broken towards the next largest integer.
- if  $R \leq 1/4$

$$TBS = 8 \cdot C \cdot \left\lceil \frac{N'_{info} + 24}{8 \cdot C} \right\rceil - 24, \text{ where } C = \left\lceil \frac{N'_{info} + 24}{3816} \right\rceil$$

else

if  $N'_{info} > 8424$

$$TBS = 8 \cdot C \cdot \left\lceil \frac{N'_{info} + 24}{8 \cdot C} \right\rceil - 24, \text{ where } C = \left\lceil \frac{N'_{info} + 24}{8424} \right\rceil$$

else



$$TBS = 8 \left\lceil \frac{N_{info}' + 24}{8} \right\rceil - 24$$

end if

end if

7.1.1.4.2.2.3 Test description

7.1.1.4.2.2.3.1 Pre-test conditions

Same Pre-test conditions as in clause 7.1.1.0 except set the NR Cell bandwidth and applicable BWP to maximum for the NR Band under test as specified in Table 5.3.5-1 in TS 38.101-1 [16] / TS 38.101-2 [17] (to enable testing of  $n_{PRB}$  up to maximum value).

7.1.1.4.2.2.3.2 Test procedure sequence

**Table 7.1.1.4.2.2.3.2-1: Maximum TBS for different UE categories**

UE Category	Maximum number of bits of a UL-SCH transport block received within a TTI
<i>TS 38.306 [23] clause 4.1.2 require UE without ue-CategoryDL and ue-CategoryUL, to support Max TBS achievable based on max bandwidth of the Band under test.</i>	

**Table 7.1.1.4.2.3.2-2: Number of downlink PDCP SDUs and PDCP SDU size used as test data**

TBS [bits]	Number of PDCP SDUs	PDCP SDU size [bits] (Note 1)
$132 \leq TBS \leq 12128$ note 2	1	$8 * \text{FLOOR}((TBS - 128) / 8)$
$12129 \leq TBS \leq 24200$	2	$8 * \text{FLOOR}((TBS - 200) / 16)$
$24201 \leq TBS \leq 36272$	3	$8 * \text{FLOOR}((TBS - 272) / 24)$
$36273 \leq TBS \leq 48344$	4	$8 * \text{FLOOR}((TBS - 344) / 32)$
$48345 \leq TBS \leq 60416$	5	$8 * \text{FLOOR}((TBS - 416) / 40)$
$60417 \leq TBS \leq 72488$	6	$8 * \text{FLOOR}((TBS - 488) / 48)$
$72489 \leq TBS \leq 84560$	7	$8 * \text{FLOOR}((TBS - 560) / 56)$
$84561 \leq TBS \leq 96632$	8	$8 * \text{FLOOR}((TBS - 632) / 64)$
$96633 < TBS \leq 108704$	9	$8 * \text{FLOOR}((TBS - 704) / 72)$
$10705 \leq TBS \leq 120776$	10	$8 * \text{FLOOR}((TBS - 776) / 80)$
$120777 \leq TBS \leq 132848$	11	$8 * \text{FLOOR}((TBS - 848) / 88)$
$132849 \leq TBS \leq 144920$	12	$8 * \text{FLOOR}((TBS - 920) / 96)$
$TBS > 144920$	13	$8 * \text{FLOOR}((TBS - 992) / 112)$

Note 1: Each PDCP SDU is limited to 1500 octets (to keep below maximum SDU size of ESM as specified in TS 24.301 [21] clause 9.9.4.12).

The PDCP SDU size of each PDCP SDU is

PDCP SDU size = (TBS – N\*PDCP header size – N\*AMD PDU header size – N\*MAC header size – Size of Timing Advance – RLC Status PDU size- MAC header for RLC Status PDU) / N, where

PDCP header size is 24 bits for the RLC AM and 18-bit SN case;  
 AMD PDU header size is 24 bits with 18 bit SN;

MAC header size for AMD PDU = 16 or 24 bits depending on L=8 or 16 bits. Worst case 24 is taken.

Size of Timing Advance MAC CE with header is 16 bits (if no Timing Advance and/or RLC status needs to be sent, padding will occur instead).

RLC Status PDU size = 24 bits with 1 ACK\_SN, With a MAC header of 16 bits.

This gives:

PDCP SDU size =  $8 * \text{FLOOR}((TBS - N * 24 - N * 24 - N * 24 - 56) / (8 * N))$  bits.

Note 2: According to the final PDCP SDU size formula in Note 1, the smallest TBS that can be tested is 136 bits.

**Table 7.1.1.4.2.3.2-3: Specific Parameters**

Parameter	Value	Comment
PUSCH mappingType	typeA	
starting symbol S	0	
number of consecutive symbols L	4..14	
K <sub>2</sub>	Not present	UE applies the value 01 when PUSCH SCS is 15/30KHz; 2 when PUSCH SCS is 60KHz and 3 when PUSCH SCS is 120KHz
number of layers (v)	1	
mcs-Table	qam256	
xoh-PUSCH(N <sup>PRB</sup> <sub>oh</sub> )	Not present	Results in value 0(xoh0)
dmrs-AdditionalPosition	pos0	Results in 1 DMRS symbol per two carrier (N <sup>PRB</sup> <sub>DMRS</sub> ) for Duration in symbols >=4

**Table 7.1.1.4.2.3.2-4: Main behaviour**

St	Procedure	Message Sequence		TP	Verdict
		U - S	Message		

-	EXCEPTION: Steps 1 to 5 are repeated for allowed values of $N_{PRB}$ 1 to $N_{RB}^{UL,BWP}$ in BWP, time domain resource length L 4 to 14-S and $I_{MCS}$ from 0 to 27.	-	-	-	-
1	The SS calculates or looks up TBS in TS 38.214 [15] based on the value of S, L, $I_{MCS}$ and $n_{PRB}$ .	-	-	-	-
-	EXCEPTION: Steps 2 to 5 are performed if TBS is less than or equal to UE capability "Maximum number of UL-SCH transport block bits received within a TTI" as specified in Table 7.1.1.4.2.2.3.2-1 and larger than or equal to 136 bits as specified in Table 7.1.1.4.2.2.3.2-2	-	-	-	-
2	The SS creates one or more PDCP SDUs, depending on TBS, in accordance with Table 7.1.1.4.2.2.3.2-2.	-	-	-	-
3	After 300ms, the SS transmits all PDCP SDUs ( $N_{SDUs}$ ) as created in step 2 in a MAC PDU.	<--	MAC PDU (NxPDCP SDUs)	-	-
4	After 60ms of step 3, SS transmits UL Grant DCI 0_0, and values of S, L, $I_{MCS}$ and $n_{PRB}$ .	<--	(UL Grant) (DCI: (DCI Format 0_0, S, L, $I_{MCS}$ and $n_{PRB}$ ))	-	-
5	CHECK: Does UE return the same number of PDCP SDUs with same content as transmitted by the SS in step 3 using Time, frequency Resources and modulation and coding scheme as configured by the SS in step 4?	-->	MAC PDU (N x PDCP SDU)	1	P

### 7.1.1.4.2.2.3.3 Specific message contents

[None].

### 7.1.1.4.2.3 UL-SCH transport block size selection / DCI format 0\_1 / RA type 0/RA Type 1 / Transform precoding disabled

#### 7.1.1.4.2.3.1 Test Purpose (TP)

(1)

```
with { UE in RRC_CONNECTED state }
ensure that {
  when { UE has pending data for transmission and receives DCI format 0_1 indicating resource allocation type 0 a resource block assignment correspondent to physical resource blocks , Time domain resource assignment and a modulation and coding }
  then { UE transmits MAC PDU's on PUSCH as per Modulation Coding scheme, time domain resource allocation and PRB's }
}
```

(2)

```
with { UE in RRC_CONNECTED state }
ensure that {
  when { UE has pending data for transmission and receives DCI format 0_1 indicating resource allocation type 1 a resource block assignment correspondent to physical resource blocks , Time domain resource assignment and a modulation and coding }
  then { UE transmits MAC PDU's on PUSCH as per Modulation Coding scheme, time domain resource allocation and PRB's }
}
```

## 7.1.1.4.2.3.2 Conformance requirements

References: The conformance requirements covered in the present TC are specified in: TS 38.212 clause 7.3.1.1.1, TS 38.214 clause 6.1.2.1, 6.1.2.2, 6.1.2.2.1, 6.1.2.2.2, 6.1.4.1, 5.1.3.1, 6.1.4.2 and 5.1.3.2. Unless otherwise stated these are Rel-15 requirements.

[TS 38.212, clause 7.3.1.1.2]

DCI format 0\_1 is used for the scheduling of PUSCH in one cell.

The following information is transmitted by means of the DCI format 0\_1 with CRC scrambled by C-RNTI or CS-RNTI or SP-CSI-RNTI or new-RNTI:

- Identifier for DCI formats – 1 bit
- The value of this bit field is always set to 0, indicating an UL DCI format
- Carrier indicator – 0 or 3 bits, as defined in Subclause 10.1 of [5, TS38.213].
- UL/SUL indicator – 0 bit for UEs not configured with SUL in the cell or UEs configured with SUL in the cell but only PUCCH carrier in the cell is configured for PUSCH transmission; 1 bit for UEs configured with SUL in the cell as defined in Table 7.3.1.1.1-1.
- Bandwidth part indicator – 0, 1 or 2 bits as determined by the number of UL BWPs  $n_{\text{BWP,RRC}}$  configured by higher layers, excluding the initial UL bandwidth part. The bit width for this field is determined as  $\lceil \log_2(n_{\text{BWP}}) \rceil$  bits, where
  - $n_{\text{BWP}} = n_{\text{BWP,RRC}} + 1$  if , in which case the bandwidth part indicator is equivalent to the higher layer parameter *BWP-Id*;
  - otherwise  $n_{\text{BWP}} = n_{\text{BWP,RRC}}$ , in which case the bandwidth part indicator is defined in Table 7.3.1.1.2-1;

If a UE does not support active BWP change via DCI, the UE ignores this bit field.

- Frequency domain resource assignment – number of bits determined by the following, where  $N_{\text{RB}}^{\text{UL,BWP}}$  is the size of the active UL bandwidth part:
  - $N_{\text{RB}}$  bits if only resource allocation type 0 is configured, where  $N_{\text{RB}}$  is defined in Subclause 6.1.2.2.1 of [6, TS 38.214],
  - $\lceil \log_2(N_{\text{RB}}^{\text{UL,BWP}}(N_{\text{RB}}^{\text{UL,BWP}} + 1)/2) \rceil$  bits if only resource allocation type 1 is configured, or  $\max(\lceil \log_2(N_{\text{RB}}^{\text{UL,BWP}}(N_{\text{RB}}^{\text{UL,BWP}} + 1)/2) \rceil, N_{\text{RB}}) + 1$  bits if both resource allocation type 0 and 1 are configured.
  - If both resource allocation type 0 and 1 are configured, the MSB bit is used to indicate resource allocation type 0 or resource allocation type 1, where the bit value of 0 indicates resource allocation type 0 and the bit value of 1 indicates resource allocation type 1.
  - For resource allocation type 0, the  $N_{\text{RB}}$  LSBs provide the resource allocation as defined in Subclause 6.1.2.2.1 of [6, TS 38.214].
  - For resource allocation type 1, the  $\lceil \log_2(N_{\text{RB}}^{\text{UL,BWP}}(N_{\text{RB}}^{\text{UL,BWP}} + 1)/2) \rceil$  LSBs provide the resource allocation as follows:
    - For PUSCH hopping with resource allocation type 1:
      - $N_{\text{UL\_hop}}$  MSB bits are used to indicate the frequency offset according to Subclause 6.3 of [6, TS 38.214], where  $N_{\text{UL\_hop}} = 1$  if the higher layer parameter *frequencyHoppingOffsetLists* contains two offset values and  $N_{\text{UL\_hop}} = 2$  if the higher layer parameter *frequencyHoppingOffsetLists* contains four offset values

- $\left\lceil \log_2(N_{RB}^{UL,BWP}(N_{RB}^{UL,BWP} + 1)/2) \right\rceil - N_{UL\_hop}$  bits provides the frequency domain resource allocation according to Subclause 6.1.2.2.2 of [6, TS 38.214]

If "Bandwidth part indicator" field indicates a bandwidth part other than the active bandwidth part and if both resource allocation type 0 and 1 are configured for the indicated bandwidth part, the UE assumes resource allocation type 0 for the indicated bandwidth part if the bit width of the "Frequency domain resource assignment" field of the active bandwidth part is smaller than the bit width of the "Frequency domain resource assignment" field of the indicated bandwidth part.

- For non-PUSCH hopping with resource allocation type 1:
  - $\left\lceil \log_2(N_{RB}^{UL,BWP}(N_{RB}^{UL,BWP} + 1)/2) \right\rceil$  bits provides the frequency domain resource allocation according to Subclause 6.1.2.2.2 of [6, TS 38.214]
- Time domain resource assignment – 0, 1, 2, 3, or 4 bits as defined in Subclause 6.1.2.1 of [6, TS38.214]. The bit width for this field is determined as  $\left\lceil \log_2(I) \right\rceil$  bits, where  $I$  the number of entries in the higher layer parameter *pusch-AllocationList*.
- Frequency hopping flag – 0 or 1 bit:
  - 0 bit if only resource allocation type 0 is configured or if the higher layer parameter *frequencyHopping* is not configured;
  - 1 bit according to Table 7.3.1.1.2-34 otherwise, only applicable to resource allocation type 1, as defined in Subclause 6.3 of [6, TS 38.214].
- Modulation and coding scheme – 5 bits as defined in Subclause 6.1.4.1 of [6, TS 38.214]
- New data indicator – 1 bit
- Redundancy version – 2 bits as defined in Table 7.3.1.1.1-2
- HARQ process number – 4 bits
- 1<sup>st</sup> downlink assignment index – 1 or 2 bits:
  - 1 bit for semi-static HARQ-ACK codebook;
  - 2 bits for dynamic HARQ-ACK codebook.
- 2<sup>nd</sup> downlink assignment index – 0 or 2 bits:
  - 2 bits for dynamic HARQ-ACK codebook with two HARQ-ACK sub-codebooks;
  - 0 bit otherwise.
- TPC command for scheduled PUSCH – 2 bits as defined in Subclause 7.1.1 of [5, TS38.213]
- SRS resource indicator –  $\left\lceil \log_2 \left( \sum_{k=1}^{\min\{L_{max}^{PUSCH}, N_{SRS}\}} \binom{N_{SRS}}{k} \right) \right\rceil$  or  $\left\lceil \log_2(N_{SRS}) \right\rceil$  bits, where  $N_{SRS}$  is the number of configured SRS resources in the SRS resource set associated with the higher layer parameter *usage* of value 'codeBook' or 'nonCodeBook', and  $L_{max}^{PUSCH}$  is the maximum number of supported layers for the PUSCH.
  - $\left\lceil \log_2 \left( \sum_{k=1}^{\min\{L_{max}^{PUSCH}, N_{SRS}\}} \binom{N_{SRS}}{k} \right) \right\rceil$  bits according to Tables 7.3.1.1.2-28/29/30/31 if the higher layer parameter *txConfig* = *nonCodebook*, where  $N_{SRS}$  is the number of configured SRS resources in the SRS resource set associated with the higher layer parameter *usage* of value 'nonCodeBook';

- $\lceil \log_2(N_{\text{SRS}}) \rceil$  bits according to Tables 7.3.1.1.2-32 if the higher layer parameter  $txConfig = codebook$ , where  $N_{\text{SRS}}$  is the number of configured SRS resources in the SRS resource set associated with the higher layer parameter  $usage$  of value 'codeBook'.
- Precoding information and number of layers – number of bits determined by the following:
  - 0 bits if the higher layer parameter  $txConfig = nonCodeBook$ ;
  - 0 bits for 1 antenna port and if the higher layer parameter  $txConfig = codebook$ ;
  - 4, 5, or 6 bits according to Table 7.3.1.1.2-2 for 4 antenna ports, if  $txConfig = codebook$ , and according to the values of higher layer parameters  $transformPrecoder$ ,  $maxRank$ , and  $codebookSubset$ ;
  - 2, 4, or 5 bits according to Table 7.3.1.1.2-3 for 4 antenna ports, if  $txConfig = codebook$ , and according to the values of higher layer parameters  $transformPrecoder$ ,  $maxRank$ , and  $codebookSubset$ ;
  - 2 or 4 bits according to Table 7.3.1.1.2-4 for 2 antenna ports, if  $txConfig = codebook$ , and according to the values of higher layer parameters  $maxRank$  and  $codebookSubset$ ;
  - 1 or 3 bits according to Table 7.3.1.1.2-5 for 2 antenna ports, if  $txConfig = codebook$  and according to the values of higher layer parameters  $maxRank$  and  $codebookSubset$ .
- Antenna ports – number of bits determined by the following
  - 2 bits as defined by Tables 7.3.1.1.2-6, if  $transformPrecoder=enabled$ ,  $dmrs-Type=1$ , and  $maxLength=1$ ;
  - 4 bits as defined by Tables 7.3.1.1.2-7, if  $transformPrecoder=enabled$ ,  $dmrs-Type=1$ , and  $maxLength=2$ ;
  - 3 bits as defined by Tables 7.3.1.1.2-8/9/10/11, if  $transformPrecoder=disabled$ ,  $dmrs-Type=1$ , and  $maxLength=1$ , and the value of rank is determined according to the SRS resource indicator field if the higher layer parameter  $txConfig = nonCodebook$  and according to the Precoding information and number of layers field if the higher layer parameter  $txConfig = codebook$ ;
  - 4 bits as defined by Tables 7.3.1.1.2-12/13/14/15, if  $transformPrecoder=disabled$ ,  $dmrs-Type=1$ , and  $maxLength=2$ , and the value of rank is determined according to the SRS resource indicator field if the higher layer parameter  $txConfig = nonCodebook$  and according to the Precoding information and number of layers field if the higher layer parameter  $txConfig = codebook$ ;
  - 4 bits as defined by Tables 7.3.1.1.2-16/17/18/19, if  $transformPrecoder=disabled$ ,  $dmrs-Type=2$ , and  $maxLength=1$ , and the value of rank is determined according to the SRS resource indicator field if the higher layer parameter  $txConfig = nonCodebook$  and according to the Precoding information and number of layers field if the higher layer parameter  $txConfig = codebook$ ;
  - 5 bits as defined by Tables 7.3.1.1.2-20/21/22/23, if  $transformPrecoder=disabled$ ,  $dmrs-Type=2$ , and  $maxLength=2$ , and the value of rank is determined according to the SRS resource indicator field if the higher layer parameter  $txConfig = nonCodebook$  and according to the Precoding information and number of layers field if the higher layer parameter  $txConfig = codebook$ .

where the number of CDM groups without data of values 1, 2, and 3 in Tables 7.3.1.1.2-6 to 7.3.1.1.2-23 refers to CDM groups {0}, {0,1}, and {0, 1,2} respectively.

If a UE is configured with both  $dmrs-UplinkForPUSCH-MappingTypeA$  and  $dmrs-UplinkForPUSCH-MappingTypeB$ , the bit width of this field equals  $\max\{x_A, x_B\}$ , where  $x_A$  is the “Antenna ports” bit width derived according to  $dmrs-UplinkForPUSCH-MappingTypeA$  and  $x_B$  is the “Antenna ports” bit width derived according to  $dmrs-UplinkForPUSCH-MappingTypeB$ . A number of  $|x_A - x_B|$  zeros are padded in the MSB of this field, if the mapping type of the PUSCH corresponds to the smaller value of  $x_A$  and  $x_B$ .

- SRS request – 2 bits as defined by Table 7.3.1.1.2-24 for UEs not configured with SUL in the cell; 3 bits for UEs configured SUL in the cell where the first bit is the non-SUL/SUL indicator as defined in Table 7.3.1.1.1-1 and the second and third bits are defined by Table 7.3.1.1.2-24. This bit field may also indicate the associated CSI-RS according to Subclause 6.1.1.2 of [6, TS 38.214].

- CSI request – 0, 1, 2, 3, 4, 5, or 6 bits determined by higher layer parameter *reportTriggerSize*.
- CBG transmission information (CBGTI) – 0, 2, 4, 6, or 8 bits determined by higher layer parameter *maxCodeBlockGroupsPerTransportBlock* for PUSCH.
- PTRS-DMRS association – number of bits determined as follows
  - 0 bit if *PTRS-UplinkConfig* is not configured and *transformPrecoder=disabled*, or if *transformPrecoder=enabled*, or if *maxRank=1*;
  - 2 bits otherwise, where Table 7.3.1.1.2-25 and 7.3.1.1.2-26 are used to indicate the association between PTRS port(s) and DMRS port(s) for transmission of one PT-RS port and two PT-RS ports respectively, and the DMRS ports are indicated by the Antenna ports field.

If “Bandwidth part indicator” field indicates a bandwidth part other than the active bandwidth part and the “PTRS-DMRS association” field is present for the indicated bandwidth part but not present for the active bandwidth part, the UE assumes the “PTRS-DMRS association” field is not present for the indicated bandwidth part. *betaOffsets = semiStatic*

- beta\_offset indicator – 0 if the higher layer parameter ; otherwise 2 bits as defined by Table 9.3-3 in [5, TS 38.213].
- DMRS sequence initialization – 0 if the higher layer parameter *transformPrecoder=enabled*; 1 bit if the higher layer parameter *transformPrecoder=disabled* and both *scramblingID0* and *scramblingID1* are configured in *DMRS-UplinkConfig*, for  $n_{\text{SCID}}$  selection defined in Subclause 6.4.1.1.1.1 of [4, TS 38.211].
- UL-SCH indicator – 1 bit. A value of “1” indicates UL-SCH shall be transmitted on the PUSCH and a value of “0” indicates UL-SCH shall not be transmitted on the PUSCH.

For a UE configured with SUL in a cell, if PUSCH is configured to be transmitted on both the SUL and the non-SUL of the cell and if the number of information bits in format 0\_1 for the SUL is not equal to the number of information bits in format 0\_1 for the non-SUL, zeros shall be appended to smaller format 0\_1 until the payload size equals that of the larger format 0\_1.

**Table 7.3.1.1.2-1: Bandwidth part indicator**

Value of BWP indicator field	Bandwidth part
2 bits	
00	First bandwidth part configured by higher layers
01	Second bandwidth part configured by higher layers
10	Third bandwidth part configured by higher layers
11	Fourth bandwidth part configured by higher layers

**Table 7.3.1.1.2-2: Precoding information and number of layers, for 4 antenna ports, if *transformPrecoder=disabled* and *maxRank = 2 or 3 or 4***

Bit field mapped to index	<i>codebookSubset = fullyAndPartialAndNonCoherent</i>	Bit field mapped to index	<i>codebookSubset = partialAndNonCoherent</i>	Bit field mapped to index	<i>codebookSubset=nonCoherent</i>
0	1 layer: TPMI=0	0	1 layer: TPMI=0	0	1 layer: TPMI=0
1	1 layer: TPMI=1	1	1 layer: TPMI=1	1	1 layer: TPMI=1
...	...	...	...	...	...
3	1 layer: TPMI=3	3	1 layer: TPMI=3	3	1 layer: TPMI=3
4	2 layers: TPMI=0	4	2 layers: TPMI=0	4	2 layers: TPMI=0
...	...	...	...	...	...
9	2 layers: TPMI=5	9	2 layers: TPMI=5	9	2 layers: TPMI=5
10	3 layers: TPMI=0	10	3 layers: TPMI=0	10	3 layers: TPMI=0
11	4 layers: TPMI=0	11	4 layers: TPMI=0	11	4 layers: TPMI=0
12	1 layer: TPMI=4	12	1 layer: TPMI=4	12-15	reserved
...	...	...	...		
19	1 layer: TPMI=11	19	1 layer: TPMI=11		
20	2 layers: TPMI=6	20	2 layers: TPMI=6		
...	...	...	...		
27	2 layers: TPMI=13	27	2 layers: TPMI=13		
28	3 layers: TPMI=1	28	3 layers: TPMI=1		
29	3 layers: TPMI=2	29	3 layers: TPMI=2		
30	4 layers: TPMI=1	30	4 layers: TPMI=1		
31	4 layers: TPMI=2	31	4 layers: TPMI=2		
32	1 layers: TPMI=12				
...	...				
47	1 layers: TPMI=27				
48	2 layers: TPMI=14				
...	...				
55	2 layers: TPMI=21				
56	3 layers: TPMI=3				
...	...				
59	3 layers: TPMI=6				
60	4 layers: TPMI=3				
61	4 layers: TPMI=4				
62-63	reserved				

**Table 7.3.1.1.2-3: Precoding information and number of layers for 4 antenna ports, if *transformPrecoder= enabled*, or if *transformPrecoder=disabled* and *maxRank = 1***

Bit field mapped to index	<i>codebookSubset = fullyAndPartialAndNonCoherent</i>	Bit field mapped to index	<i>codebookSubset=partialAndNonCoherent</i>	Bit field mapped to index	<i>codebookSubset = nonCoherent</i>
0	1 layer: TPMI=0	0	1 layer: TPMI=0	0	1 layer: TPMI=0
1	1 layer: TPMI=1	1	1 layer: TPMI=1	1	1 layer: TPMI=1
...	...	...	...	...	...
3	1 layer: TPMI=3	3	1 layer: TPMI=3	3	1 layer: TPMI=3
4	1 layer: TPMI=4	4	1 layer: TPMI=4		
...	...	...	...		
11	1 layer: TPMI=11	11	1 layer: TPMI=11		
12	1 layers: TPMI=12	12-15	reserved		
...	...				
27	1 layers: TPMI=27				
28-31	reserved				



**Table 7.3.1.1.2-4: Precoding information and number of layers, for 2 antenna ports, if  $transformPrecoder=disabled$  and  $maxRank = 2$**

Bit field mapped to index	<i>codebookSubset = fullyAndPartialAndNonCoherent</i>	Bit field mapped to index	<i>codebookSubset = nonCoherent</i>
0	1 layer: TPMI=0	0	1 layer: TPMI=0
1	1 layer: TPMI=1	1	1 layer: TPMI=1
2	2 layers: TPMI=0	2	2 layers: TPMI=0
3	1 layer: TPMI=2	3	reserved
4	1 layer: TPMI=3		
5	1 layer: TPMI=4		
6	1 layer: TPMI=5		
7	2 layers: TPMI=1		
8	2 layers: TPMI=2		
9-15	reserved		

**Table 7.3.1.1.2-5: Precoding information and number of layers, for 2 antenna ports, if  $transformPrecoder=enabled$ , or if  $transformPrecoder=disabled$  and  $maxRank = 1$**

Bit field mapped to index	<i>codebookSubset = fullyAndPartialAndNonCoherent</i>	Bit field mapped to index	<i>codebookSubset = nonCoherent</i>
0	1 layer: TPMI=0	0	1 layer: TPMI=0
1	1 layer: TPMI=1	1	1 layer: TPMI=1
2	1 layer: TPMI=2		
3	1 layer: TPMI=3		
4	1 layer: TPMI=4		
5	1 layer: TPMI=5		
6-7	reserved		

...

**Table 7.3.1.1.2-33: VRB-to-PRB mapping**

Bit field mapped to index	VRB-to-PRB mapping
0	Non-interleaved
1	Interleaved

[TS 38.214, clause 6.1.2.1]

When the UE is scheduled to transmit a transport block and no CSI report, or the UE is scheduled to transmit a transport block and a CSI report on PUSCH by a DCI, the *Time domain resource assignment* field value  $m$  of the DCI provides a row index  $m + 1$  to an allocated table. The determination of the used resource allocation table is defined in sub-clause 6.1.2.1.1. The indexed row defines the slot offset  $K_2$ , the start and length indicator  $SLIV$ , or directly the start symbol  $S$  and the allocation length  $L$ , and the PUSCH mapping type to be applied in the PUSCH transmission.

When the UE is scheduled to transmit a PUSCH with no transport block and with a CSI report by a *CSI request* field on a DCI, the *Time-domain resource assignment* field value  $m$  of the DCI provides a row index  $m + 1$  to an allocated table. The determination of the applied resource allocation table is defined in sub-clause 6.1.2.1.1. The indexed row defines the start and length indicator  $SLIV$ , or directly the start symbol  $S$  and the allocation length  $L$ , and the PUSCH mapping type to be applied in the PUSCH transmission and  $K_2$  is determined based on the corresponding list entries  $Y_j, j = 0, \dots, N_{Rep} - 1$  of the higher layer parameter *reportSlotConfig* in *CSI-ReportConfig* for the  $N_{Rep}$  triggered CSI Reporting Settings. The  $i$ th codepoint of  $K_2$  is determined as  $K_2 = \max_j Y_j(i)$  where  $Y_j(i)$  is the  $i$ th codepoint of  $Y_j$ .

- The slot where the UE shall transmit the PUSCH is determined by  $K_2$  as  $\left\lfloor n \cdot \frac{2^{\mu_{\text{PUSCH}}}}{2^{\mu_{\text{PDCCH}}}} \right\rfloor + K_2$  where  $n$  is the slot with the scheduling DCI,  $K_2$  is based on the numerology of PUSCH, and  $\mu_{\text{PUSCH}}$  and  $\mu_{\text{PDCCH}}$  are the subcarrier spacing configurations for PUSCH and PDCCH, respectively, and
- The starting symbol  $S$  relative to the start of the slot, and the number of consecutive symbols  $L$  counting from the symbol  $S$  allocated for the PUSCH are determined from the start and length indicator  $SLIV$  of the indexed row:

if  $(L-1) \leq 7$  then

$$SLIV = 14 \cdot (L-1) + S$$

else

$$SLIV = 14 \cdot (14 - L + 1) + (14 - 1 - S)$$

where  $0 < L \leq 14 - S$ , and

- The PUSCH mapping type is set to Type A or Type B as defined in Subclause 6.4.1.1.3 of [4, TS 38.211] as given by the indexed row.

The UE shall consider the  $S$  and  $L$  combinations defined in table 6.1.2.1-1 as valid PUSCH allocations

**Table 6.1.2.1-1: Valid  $S$  and  $L$  combinations**

PUSCH mapping type	Normal cyclic prefix			Extended cyclic prefix		
	S	L	S+L	S	L	S+L
Type A	0	{4,...,14}	{4,...,14}	0	{4,...,12}	{4,...,12}
Type B	{0,...,13}	{1,...,14}	{1,...,14}	{0,...,12}	{1,...,12}	{1,...,12}

When the UE is configured with  $aggregationFactorUL > 1$ , the same symbol allocation is applied across the  $aggregationFactorUL$  consecutive slots and the PUSCH is limited to a single transmission layer. The UE shall repeat the TB across the  $aggregationFactorUL$  consecutive slots applying the same symbol allocation in each slot. The redundancy version to be applied on the  $n^{\text{th}}$  transmission occasion of the TB is determined according to table 6.1.2.1-2.

**Table 6.1.2.1-2: Redundancy version when  $aggregationFactorUL > 1$**

$r_{vid}$ indicated by the DCI scheduling the PUSCH	$r_{vid}$ to be applied to $n^{\text{th}}$ transmission occasion			
	$n \bmod 4 = 0$	$n \bmod 4 = 1$	$n \bmod 4 = 2$	$n \bmod 4 = 3$
0	0	2	3	1
2	2	3	1	0
3	3	1	0	2
1	1	0	2	3

If the UE procedure for determining slot configuration, as defined in subclause 11.1 of [6, TS 38.213], determines symbols of a slot allocated for PUSCH as downlink symbols, the transmission on that slot is omitted for multi-slot PUSCH transmission.

[38.214 clause 6.1.2.2]

The UE shall determine the resource block assignment in frequency domain using the resource allocation field in the detected PDCCH DCI. Two uplink resource allocation schemes type 0 and type 1 are supported. Uplink resource allocation scheme type 0 is supported for PUSCH only when transform precoding is disabled. Uplink resource allocation scheme type 1 is supported for PUSCH for both cases when transform precoding is enabled or disabled.

If the scheduling DCI is configured to indicate the uplink resource allocation type as part of the *Frequency domain resource* assignment field by setting a higher layer parameter *resourceAllocation* in *pusch-Config* to ‘dynamicswitch’, the UE shall use uplink resource allocation type 0 or type 1 as defined by this DCI field. Otherwise the UE shall use the uplink frequency resource allocation type as defined by the higher layer parameter *resourceAllocation*.

The UE shall assume that when the scheduling PDCCH is received with DCI format 0\_0, then uplink resource allocation type 1 is used.

If a bandwidth part indicator field is not configured in the scheduling DCI, the RB indexing for uplink type 0 and type 1 resource allocation is determined within the UE's active bandwidth part. If a bandwidth part indicator field is configured in the scheduling DCI, the RB indexing for uplink type 0 and type 1 resource allocation is determined within the UE's bandwidth part indicated by bandwidth part indicator field value in the DCI, except for the case when DCI format 0\_0 is decoded in any PDCCH common search space in CORESET 0 in which case the initial bandwidth part shall be used. The UE shall upon detection of PDCCH intended for the UE determine first the uplink bandwidth part and then the resource allocation within the bandwidth part.

[38.214 clause 6.1.2.2.1]

In uplink resource allocation of type 0, the resource block assignment information includes a bitmap indicating the Resource Block Groups (RBGs) that are allocated to the scheduled UE where a RBG is a set of consecutive virtual resource blocks defined by higher layer parameter *rbg-Size* configured for PUSCH and the size of the carrier bandwidth part as defined in Table 6.1.2.2.1-1.

**Table 6.1.2.2.1-1: Nominal RBG size  $P$**

Carrier Bandwidth Part Size	Configuration 1	Configuration 2
1 – 36	2	4
37 – 72	4	8
73 – 144	8	16
145 – 275	16	16

The total number of RBGs ( $N_{\text{RBG}}$ ) for a uplink carrier bandwidth part  $i$  of size  $N_{\text{BWP},i}^{\text{size}}$  PRBs is given by

$$N_{\text{RBG}} = \left\lfloor \left( N_{\text{BWP},i}^{\text{size}} + \left( N_{\text{BWP},i}^{\text{start}} \bmod P \right) \right) / P \right\rfloor \text{ where}$$

- the size of the first RBG is  $\text{RBG}_0^{\text{size}} = P - N_{\text{BWP},i}^{\text{start}} \bmod P$ ,
- the size of the last RBG is  $\text{RBG}_{\text{last}}^{\text{size}} = \left( N_{\text{BWP},i}^{\text{start}} + N_{\text{BWP},i}^{\text{size}} \right) \bmod P$  if  $\left( N_{\text{BWP},i}^{\text{start}} + N_{\text{BWP},i}^{\text{size}} \right) \bmod P > 0$  and  $P$  otherwise.
- the size of all other RBG is  $P$ .

The bitmap is of size  $N_{\text{RBG}}$  bits with one bitmap bit per RBG such that each RBG is addressable. The RBGs shall be indexed in the order of increasing frequency of the carrier bandwidth part and starting at the lowest frequency. The order of RBG bitmap is such that RBG 0 to RBG  $N_{\text{RBG}} - 1$  are mapped from MSB to LSB of the bitmap. The RBG is allocated to the UE if the corresponding bit value in the bitmap is 1, the RBG is not allocated to the UE otherwise.

[38.214 clause 6.1.2.2.2]

In uplink resource allocation of type 1, the resource block assignment information indicates to a scheduled UE a set of contiguously allocated non-interleaved virtual resource blocks within the active carrier bandwidth part of size  $N_{\text{BWP}}^{\text{size}}$  PRBs except for the case when DCI format 0\_0 is decoded in the Type0-PDCCH common search space in CORESET 0 in which case the initial bandwidth part of size  $N_{\text{BWP}}^{\text{size}}$  shall be used.

An uplink type 1 resource allocation field consists of a resource indication value (*RIV*) corresponding to a starting virtual resource block ( $\text{RB}_{\text{start}}$ ) and a length in terms of contiguously allocated resource blocks  $L_{\text{RBs}}$ . The resource indication value is defined by

$$\text{if } (L_{\text{RBs}} - 1) \leq \left\lfloor N_{\text{BWP}}^{\text{size}} / 2 \right\rfloor \text{ then}$$

$$RIV = N_{\text{BWP}}^{\text{size}} (L_{\text{RBs}} - 1) + \text{RB}_{\text{start}}$$

else

$$RIV = N_{BWP}^{size} (N_{BWP}^{size} - L_{RBs} + 1) + (N_{BWP}^{size} - 1 - RB_{start})$$

where  $L_{RBs} \geq 1$  and shall not exceed  $N_{BWP}^{size} - RB_{start}$ .

[TS 38.214, clause 6.1.4.1]

For the PUSCH assigned by a DCI format 0\_0/0\_1 with CRC scrambled by C-RNTI, new-RNTI, TC-RNTI, or SP-CSI-RNTI, the transform precoding is enabled if *transformPrecoder* in *PUSCH-Config* is set to 'enabled', or if *transformPrecoder* in *PUSCH-Config* is not configured and *msg3-transformPrecoding* in *rach-ConfigCommon* is set to 'enabled'; otherwise the transform precoding is disabled.

For the PUSCH assigned by a DCI format 0\_0/0\_1 with CRC scrambled by CS-RNTI, or the PUSCH with configured grant using CS-RNTI, the transform precoding is enabled if *transformPrecoder* in *ConfiguredGrantConfig* is set to 'enabled'; otherwise the transform precoding is disabled.

For a PUSCH scheduled by RAR UL grant or for a PUSCH scheduled by a DCI format 0\_0/0\_1 with CRC scrambled by C-RNTI, TC-RNTI, or CS-RNTI, or SP-CSI-RNTI, or for a PUSCH with configured grant using CS-RNTI,

if *transformPrecoder* is disabled for this PUSCH transmission

- if *mcs-Table* in *PUSCH-Config* is set to 'qam256', and PUSCH is scheduled with C-RNTI or SP-CSI-RNTI, and PUSCH is assigned by DCI format 0\_1,
  - the UE shall use  $I_{MCS}$  and Table 5.1.3.1-2 to determine the modulation order ( $Q_m$ ) and Target code rate ( $R$ ) used in the physical uplink shared channel.
- elseif the UE is not configured with new-RNTI, *mcs-Table* in *PUSCH-Config* is set to 'qam64LowSE', the PUSCH is scheduled with C-RNTI, or SP-CSI-RNTI, and the PUSCH is assigned by a PDCCH in a UE-specific search space,
  - the UE shall use  $I_{MCS}$  and Table 5.1.3.1-3 to determine the modulation order ( $Q_m$ ) and Target code rate ( $R$ ) used in the physical uplink shared channel.
- elseif the UE is configured with new-RNTI, and the PUSCH is scheduled with new-RNTI,
  - the UE shall use  $I_{MCS}$  and Table 5.1.3.1-3 to determine the modulation order ( $Q_m$ ) and Target code rate ( $R$ ) used in the physical uplink shared channel.
- elseif *mcs-Table* in *ConfiguredGrantConfig* is set to 'qam256', and PUSCH is scheduled with CS-RNTI,
  - the UE shall use  $I_{MCS}$  and Table 5.1.3.1-2 to determine the modulation order ( $Q_m$ ) and Target code rate ( $R$ ) used in the physical uplink shared channel.
- elseif *mcs-Table* in *ConfiguredGrantConfig* is set to 'qam64LowSE', and PUSCH is scheduled with CS-RNTI,
  - the UE shall use  $I_{MCS}$  and Table 5.1.3.1-3 to determine the modulation order ( $Q_m$ ) and Target code rate ( $R$ ) used in the physical uplink shared channel.
- else
  - the UE shall use  $I_{MCS}$  and Table 5.1.3.1-1 to determine the modulation order ( $Q_m$ ) and Target code rate ( $R$ ) used in the physical uplink shared channel.

[TS 38.214, clause 5.1.3.1]

Table 5.1.3.1-1: MCS index table 1 for PDSCH

MCS Index $I_{MCS}$	Modulation Order $Q_m$	Target code Rate $R \times [1024]$	Spectral efficiency
0	2	120	0.2344
1	2	157	0.3066
2	2	193	0.3770
3	2	251	0.4902
4	2	308	0.6016
5	2	379	0.7402
6	2	449	0.8770
7	2	526	1.0273
8	2	602	1.1758
9	2	679	1.3262
10	4	340	1.3281
11	4	378	1.4766
12	4	434	1.6953
13	4	490	1.9141
14	4	553	2.1602
15	4	616	2.4063
16	4	658	2.5703
17	6	438	2.5664
18	6	466	2.7305
19	6	517	3.0293
20	6	567	3.3223
21	6	616	3.6094
22	6	666	3.9023
23	6	719	4.2129
24	6	772	4.5234
25	6	822	4.8164
26	6	873	5.1152
27	6	910	5.3320
28	6	948	5.5547
29	2	reserved	
30	4	reserved	
31	6	reserved	

[TS 38.214, clause 6.1.4.2]

For a PUSCH scheduled by RAR UL grant or for a PUSCH scheduled by a DCI format 0\_0/0\_1 with CRC scrambled by C-RNTI, new-RNTI, TC-RNTI, CS-RNTI, or SP-CSI-RNTI.

if

- $0 \leq I_{MCS} \leq 27$  and transform precoding is disabled and Table 5.1.3.1-2 is used, or
- $0 \leq I_{MCS} \leq 28$  and transform precoding is disabled and a table other than Table 5.1.3.1-2 is used, or
- $0 \leq I_{MCS} \leq 27$  and transform precoding is enabled, the UE shall first determine the TBS as specified below:

The UE shall first determine the number of REs ( $N_{RE}$ ) within the slot:

- A UE first determines the number of REs allocated for PUSCH within a PRB ( $N'_{RE}$ ) by
- $N'_{RE} = N_{sc}^{RB} * N_{symb}^{sh} - N_{DMRS}^{PRB} - N_{oh}^{PRB}$ , where  $N_{sc}^{RB} = 12$  is the number of subcarriers in the frequency domain in a physical resource block,  $N_{symb}^{sh}$  is the number of symbols of the PUSCH allocation within the slot,  $N_{DMRS}^{PRB}$  is the number of REs for DM-RS per PRB in the scheduled duration including the overhead of the DM-RS CDM groups without data, as indicated by DCI format 0\_1 or as described for DCI format 0\_0 in Subclause 6.2.2, and  $N_{oh}^{PRB}$  is the overhead configured by higher layer parameter  $xOverhead$  in *PUSCH*-

*ServingCellConfig*. If the  $N_{oh}^{PRB}$  is not configured (a value from 0, 6, 12, or 18), the  $N_{oh}^{PRB}$  is assumed to be 0. For MSG3 transmission the  $N_{oh}^{PRB}$  is always set to 0..

- A UE determines the total number of REs allocated for PUSCH ( $N_{RE}$ ) by  $N_{RE} = \min(156, N_{RE}') \cdot n_{PRB}$  where  $n_{PRB}$  is the total number of allocated PRBs for the UE.
- Next, proceed with steps 2-4 as defined in Subclause 5.1.3.2

else if

- $28 \leq I_{MCS} \leq 31$  and transform precoding is disabled and Table 5.1.3.1-2 is used, or
- $28 \leq I_{MCS} \leq 31$  and transform precoding is enabled,
- the TBS is assumed to be as determined from the DCI transported in the latest PDCCH for the same transport block using  $0 \leq I_{MCS} \leq 27$ . If there is no PDCCH for the same transport block using  $0 \leq I_{MCS} \leq 27$ , and if the initial PUSCH for the same transport block is transmitted with configured grant, the TBS shall be determined from the most recent configured scheduling PDCCH.

else

- the TBS is assumed to be as determined from the DCI transported in the latest PDCCH for the same transport block using  $0 \leq I_{MCS} \leq 28$ . If there is no PDCCH for the same transport block using  $0 \leq I_{MCS} \leq 28$ , and if the initial PUSCH for the same transport block is transmitted with configured grant, the TBS shall be determined from the most recent configured scheduling PDCCH.

[TS 38.214, clause 5.1.3.2]

2) Intermediate number of information bits ( $N_{info}$ ) is obtained by  $N_{info} = N_{RE} \cdot R \cdot Q_m \cdot \nu$ .

If  $N_{info} \leq 3824$

Use step 3 as the next step of the TBS determination

else

Use step 4 as the next step of the TBS determination

end if

3) When  $N_{info} \leq 3824$ , TBS is determined as follows

- quantized intermediate number of information bits  $N_{info}' = \max\left(24, 2^n \cdot \left\lfloor \frac{N_{info}}{2^n} \right\rfloor\right)$ , where  $n = \max(3, \lfloor \log_2(N_{info}) \rfloor - 6)$ .
- use Table 5.1.3.2-2 find the closest TBS that is not less than  $N_{info}'$ .

Table 5.1.3.2-2: TBS for  $N_{info} \leq 3824$ 

Index	TBS	Index	TBS	Index	TBS	Index	TBS
1	24	31	336	61	1288	91	3624
2	32	32	352	62	1320	92	3752
3	40	33	368	63	1352	93	3824
4	48	34	384	64	1416		
5	56	35	408	65	1480		
6	64	36	432	66	1544		
7	72	37	456	67	1608		
8	80	38	480	68	1672		
9	88	39	504	69	1736		
10	96	40	528	70	1800		
11	104	41	552	71	1864		
12	112	42	576	72	1928		
13	120	43	608	73	2024		
14	128	44	640	74	2088		
15	136	45	672	75	2152		
16	144	46	704	76	2216		
17	152	47	736	77	2280		
18	160	48	768	78	2408		
19	168	49	808	79	2472		
20	176	50	848	80	2536		
21	184	51	888	81	2600		
22	192	52	928	82	2664		
23	208	53	984	83	2728		
24	224	54	1032	84	2792		
25	240	55	1064	85	2856		
26	256	56	1128	86	2976		
27	272	57	1160	87	3104		
28	288	58	1192	88	3240		
29	304	59	1224	89	3368		
30	320	60	1256	90	3496		

4) When  $N_{info} > 3824$ , TBS is determined as follows.

- quantized intermediate number of information bits  $N'_{info} = \max\left(3840, 2^n \times \text{round}\left(\frac{N_{info} - 24}{2^n}\right)\right)$ , where  $n = \lfloor \log_2(N_{info} - 24) \rfloor - 5$  and ties in the round function are broken towards the next largest integer.
- if  $R \leq 1/4$

$$TBS = 8 \cdot C \cdot \left\lceil \frac{N'_{info} + 24}{8 \cdot C} \right\rceil - 24, \text{ where } C = \left\lceil \frac{N'_{info} + 24}{3816} \right\rceil$$

else

if  $N'_{info} > 8424$

$$TBS = 8 \cdot C \cdot \left\lceil \frac{N'_{info} + 24}{8 \cdot C} \right\rceil - 24, \text{ where } C = \left\lceil \frac{N'_{info} + 24}{8424} \right\rceil$$

else

$$TBS = 8 \cdot \left\lceil \frac{N'_{info} + 24}{8} \right\rceil - 24$$

end if

end if

7.1.1.4.2.3.3 Test description

7.1.1.4.2.3.3.1 Pre-test conditions

Same Pre-test conditions as in clause 7.1.1.0 except set the NR Cell bandwidth and applicable BWP to maximum for the NR Band under test as specified in Table 5.3.5-1 in TS 38.101-1 [16] / TS 38.101-2 [17] (to enable testing of  $n_{PRB}$  up to maximum value).

7.1.1.4.2.3.3.2 Test procedure sequence

**Table 7.1.1.4.2.3.3.2-1: Maximum TBS for different UE categories**

UE Category	Maximum number of bits of a UL-SCH transport block received within a TTI
TS 38.306 [23] clause 4.1.2 require UE without ue-CategoryDL and ue-CategoryUL, to support Max TBS achievable based on max bandwidth of the Band under test.	

**Table 7.1.1.4.2.3.3.2-2: Number of downlink PDCP SDUs and PDCP SDU size used as test data**

TBS [bits]	Number of PDCP SDUs	PDCP SDU size [bits] (Note 1)
$132 \leq TBS \leq 12128$ note 2	1	$8 * \text{FLOOR}((TBS - 128) / 8)$
$12129 \leq TBS \leq 24200$	2	$8 * \text{FLOOR}((TBS - 200) / 16)$
$24201 \leq TBS \leq 36272$	3	$8 * \text{FLOOR}((TBS - 272) / 24)$
$36273 \leq TBS \leq 48344$	4	$8 * \text{FLOOR}((TBS - 344) / 32)$
$48345 \leq TBS \leq 60416$	5	$8 * \text{FLOOR}((TBS - 416) / 40)$
$60417 \leq TBS \leq 72488$	6	$8 * \text{FLOOR}((TBS - 488) / 48)$
$72489 \leq TBS \leq 84560$	7	$8 * \text{FLOOR}((TBS - 560) / 56)$
$84561 \leq TBS \leq 96632$	8	$8 * \text{FLOOR}((TBS - 632) / 64)$
$96633 < TBS \leq 108704$	9	$8 * \text{FLOOR}((TBS - 704) / 72)$
$10705 \leq TBS \leq 120776$	10	$8 * \text{FLOOR}((TBS - 776) / 80)$
$120777 \leq TBS \leq 132848$	11	$8 * \text{FLOOR}((TBS - 848) / 88)$
$132849 \leq TBS \leq 144920$	12	$8 * \text{FLOOR}((TBS - 920) / 96)$
$TBS > 144920$	13	$8 * \text{FLOOR}((TBS - 992) / 112)$

Note 1: Each PDCP SDU is limited to 1500 octets (to keep below maximum SDU size of ESM as specified in TS 24.301 [21] clause 9.9.4.12).

The PDCP SDU size of each PDCP SDU is

$\text{PDCP SDU size} = (TBS - N * \text{PDCP header size} - N * \text{AMD PDU header size} - N * \text{MAC header size} - \text{Size of Timing Advance} - \text{RLC Status PDU size} - \text{MAC header for RLC Status PDU}) / N$ , where

PDCP header size is 24 bits for the RLC AM and 18-bit SN case;  
 AMD PDU header size is 24 bits with 18 bit SN;

MAC header size for AMD PDU = 16 or 24 bits depending on L=8 or 16 bits. Worst case 24 is taken.

Size of Timing Advance MAC CE with header is 16 bits (if no Timing Advance and/or RLC status needs to be sent, padding will occur instead).

RLC Status PDU size = 24 bits with 1 ACK\_SN, With a MAC header of 16 bits.

This gives:

$\text{PDCP SDU size} = 8 * \text{FLOOR}((TBS - N * 24 - N * 24 - N * 24 - 56) / (8 * N))$  bits.

Note 2: According to the final PDCP SDU size formula in Note 1, the smallest TBS that can be tested is 136 bits.



**Table 7.1.1.4.2.3.3.2-2A: Bandwidth part Dependent Parameters for Resource allocation 0 with start of BWP assumed as 0**

$N_{RB}^{DL,BWP} = N_{BWP,i}^{size}$	Nominal RBG size $P$ (Configuration1)	Size of last RBG	Allowed $N_{PRB}$ Values
11	2	1	All 1...11
18	2	2	2,4,6,8,10,12,16,18
24	2	2	2,4,6,8,10,12,16,18,20,22,24
25	2	1	All 1...25
31	2	1	All 1...31
32	2	2	2,4,6,8,10,12,16,18,20,22,24,26,28,30,32
38	4	2	2,4,6,8,10,12,16,18,20,22,24,26,28,30,32,34,36,38
51	4	3	3,4,7,8,11,12,15,16,19,20,23,24,27,28,31,32,35,36,39,40,43,44,47,48,51
52	4	4	4,8,12,16,20,24,28,32,36,40,44,48,52
65	4	1	1,4,5,8,9,12,13,16,17,20,21,24,25,28,29,32,33,36,37,40,41,44,45,48,49,52,53,56,57,60,61,64,65
66	4	2	2,4,6,8,10,12,16,18,20,22,24,26,28,30,32,34,36,38,40,42,44,46,48,50,52,54,56,58,60,62,64,66
79	8	7	7,8,15,16,23,24,31,32,39,40,47,48,55,56,63,64,71,72,79
106	8	2	2,8,10,16,18,24,26,32,34,40,42,48,50,56,58,64,66,72,74,80,82,88,90,96,92,104,106
107	8	3	3,8,11,16,19,24,27,32,35,40,43,48,51,56,59,64,67,72,75,80,83,88,91,96,99,104,107
132	8	4	4,8,12,16,20,24,28,32,36,40,44,48,52,56,60,64,68,72,76,80,84,88,92,96,100,104,108,112,116,120,124,128,132
133	8	5	5,8,13,16,21,24,29,32,37,40,45,48,53,56,61,64,69,72,77,80,85,88,93,96,101,104,109,112,117,120,125,128,133
135	8	7	7,8,15,16,23,24,31,32,39,40,47,48,55,56,63,64,71,72,79,80,87,88,95,96,103,104,111,112,119,120,127,128,135
216	16	8	8,16,24,32,40,48,56,64,72,80,88,96,104,112,120,128,136,144,152,160,168,176,184,192,200,208,216
217	16	9	9,16,25,32,41,48,57,64,73,80,89,96,105,112,121,128,137,144,153,160,169,176,185,192,201,208,217
264	16	8	8,16,24,32,40,48,56,64,72,80,88,96,104,112,120,128,136,144,160,168,176,184,192,200,208,216,224,232,240,248,256,264
270	16	14	14,16,30,32,46,44,62,64,78,80,94,96,110,112,126,128,142,144,158,160,174,176,190,192,206,208,222,224,238,240,254,256,270
273	16	1	1,16,17,32,33,48,49,64,65,80,81,96,97,112,113,128,129,144,145,160,161,176,171,192,193,208,209,224,225,240,241,256,257,272,273

**Table 7.1.1.4.2.3.3.2-3: Specific Parameter**

Parameter	Value	Comment
PUSCH mappingType	typeA	
starting symbol $S$	0	
number of consecutive symbols $L$	4..14	
$K_2$	Not present	UE applies the value 01 when PUSCH SCS is 15/30KHz; 2 when PUSCH SCS is 60KHz and 3 when PUSCH SCS is 120KHz
number of layers ( $v$ )	1	
mcs-Table	qam64	
$xoh$ -PUSCH ( $N_{oh}^{PRB}$ )	Not present	Results in value 0(xoh0)
dmrs-AdditionalPosition	pos0	Results in 1 DMRS symbol per two carrier ( $N_{DMRS}^{PRB}$ ) for Duration in symbols $\geq 4$
resourceAllocation	dynamicSwitch	
$rbg$ -Size	Not present	configuration 1 applicable
$N_{BWP}^{start}$	0	

Table 7.1.1.4.2.3.3.2-4: Main behaviour

St	Procedure	Message Sequence		TP	Verdict
		U - S	Message		
-	EXCEPTION: Steps 1 to 5 are repeated for allowed values of $N_{PRB}$ as per table 7.1.1.4.2.3.3.2-2A in BWP, time domain resource length L 3 to 14-S and $I_{MCS}$ from 0 to 28.	-	-	-	-
1	SS calculates or looks up TBS in TS 38.214 [15] based on the value of S, L, $I_{MCS}$ and $n_{PRB}$ .	-	-	-	-
-	EXCEPTION: Steps 2 to 5 are performed if TBS is less than or equal to UE capability "Maximum number of UL-SCH transport block bits received within a TTI" as specified in Table 7.1.1.4.2.3.3.2-1 and larger than or equal to 136 bits as specified in Table 7.1.1.4.2.3.3.2-2	-	-	-	-
2	SS creates one or more PDCP SDUs depending on TBS in accordance with Table 7.1.1.4.2.3.3.2-2.	-	-	-	-
3	After 300ms, the SS transmits all PDCP SDUs ( $N_{SDUs}$ ) as created in step 2 in a MAC PDU.	<--	MAC PDU (NxPDCP SDUs)	-	-
4	After 60ms of step 3 SS transmits UL Grant DCI 0_1, and values of S, L, $I_{MCS}$ and $n_{PRB}$ .	<--	(UL Grant) (DCI: (DCI Format 0_1, S, L, $I_{MCS}$ and $n_{PRB}$ ))	-	-
5	CHECK: Does UE return the same number of PDCP SDUs with same content as transmitted by the SS in step 3 using Time, frequency Resources and modulation and coding scheme as configured by the SS in step 4?	-->	(NxPDCP SDUs)	1	P
-	EXCEPTION: Steps 6 to 10 are repeated for allowed values of $N_{PRB}$ 1 to $N_{RB}^{UL,BWP}$ in BWP, time domain resource length L 3 to 14-S and $I_{MCS}$ from 0 to 28.	-	-	-	-
6	SS calculates or looks up TBS in TS 38.214 [15] based on the value of S, L, $I_{MCS}$ and $n_{PRB}$ .	-	-	-	-
-	EXCEPTION: Steps 7 to 10 are performed if TBS1 + TBS2 is less than or equal to UE capability "Maximum number of UL-SCH transport block bits received within a TTI" as specified in Table 7.1.1.4.2.3.3.2-1 and larger than or equal to 136 bits as specified in Table 7.1.1.4.2.3.3.2-2.	-	-	-	-
7	SS creates one or more PDCP SDUs depending on TBS in accordance with Table 7.1.1.4.2.3.3.2-2.	-	-	-	-
8	After 300ms, the SS transmits all PDCP SDUs ( $N_{SDUs}$ ) as created in step 7 in a MAC PDU.	<--	MAC PDU (NxPDCP SDUs)	-	-
9	After 60ms of step 8 SS transmits UL Grant DCI 0_1, and values of S, L, $I_{MCS}$ and $n_{PRB}$ .	<--	(UL Grant) (DCI: (DCI Format 0_1, S, L, $I_{MCS}$ and $n_{PRB}$ ))	-	-
10	CHECK: Does UE return the same number of PDCP SDUs with same content as transmitted by the SS in step 8 using Time, frequency Resources and modulation and	-->	(NxPDCP SDUs)	2	P

	coding scheme as configured by the SS in step 9?				
--	--	--	--	--	--

#### 7.1.1.4.2.3.3 Specific message contents

[None].

#### 7.1.1.4.2.4 UL-SCH transport block size selection / DCI format 0\_1 / RA type 0/RA Type 1 / 256QAM / Transform precoding disabled

##### 7.1.1.4.2.4.1 Test Purpose (TP)

(1)

```
with { UE in RRC_CONNECTED state and mcs-Table is set as 'qam256' }
ensure that {
  when { UE has pending data for transmission and receives DCI format 1_1 indicating resource
allocation type 0 a resource block assignment correspondent to physical resource blocks , Time
domain resource assignment and a modulation and coding }
  then { UE transmits MAC PDU's on PUSCH as per Modulation Coding scheme, time domain resource
allocation and PRB's }
}
```

(2)

```
with { UE in RRC_CONNECTED state and mcs-Table is set as 'qam256' }
ensure that {
  when { UE has pending data for transmission and receives DCI format 1_1 indicating resource
allocation type 1 a resource block assignment correspondent to physical resource blocks , Time
domain resource assignment and a modulation and coding }
  then { UE transmits MAC PDU's on PUSCH as per Modulation Coding scheme, time domain resource
allocation and PRB's }
}
```

##### 7.1.1.4.2.4.2 Conformance requirements

References: The conformance requirements covered in the present TC are specified in: TS 38.212 clause 7.3.1.1.1, TS 38.214 clause 6.1.2.1, 6.1.2.2, 6.1.2.2.1, 6.1.2.2.2, 6.1.4.1, 5.1.3.1, 6.1.4.2 and 5.1.3.2. Unless otherwise stated these are Rel-15 requirements.

[TS 38.212, clause 7.3.1.1.2]

DCI format 0\_1 is used for the scheduling of PUSCH in one cell.

The following information is transmitted by means of the DCI format 0\_1 with CRC scrambled by C-RNTI or CS-RNTI or SP-CSI-RNTI or new-RNTI:

- Identifier for DCI formats – 1 bit
- The value of this bit field is always set to 0, indicating an UL DCI format
  - Carrier indicator – 0 or 3 bits, as defined in Subclause 10.1 of [5, TS38.213].
  - UL/SUL indicator – 0 bit for UEs not configured with SUL in the cell or UEs configured with SUL in the cell but only PUCCH carrier in the cell is configured for PUSCH transmission; 1 bit for UEs configured with SUL in the cell as defined in Table 7.3.1.1.1-1.
  - Bandwidth part indicator – 0, 1 or 2 bits as determined by the number of UL BWPs  $n_{\text{BWP,RRC}}$  configured by higher layers, excluding the initial UL bandwidth part. The bit width for this field is determined as  $\lceil \log_2(n_{\text{BWP}}) \rceil$  bits, where
    - $n_{\text{BWP}} = n_{\text{BWP,RRC}} + 1$  if  $n_{\text{BWP,RRC}} \leq 3$ , in which case the bandwidth part indicator is equivalent to the higher layer parameter *BWP-Id*;
    - otherwise  $n_{\text{BWP}} = n_{\text{BWP,RRC}}$ , in which case the bandwidth part indicator is defined in Table 7.3.1.1.2-1;

If a UE does not support active BWP change via DCI, the UE ignores this bit field.

- Frequency domain resource assignment – number of bits determined by the following, where  $N_{RB}^{UL,BWP}$  is the size of the active UL bandwidth part:
  - $N_{RBG}$  bits if only resource allocation type 0 is configured, where  $N_{RBG}$  is defined in Subclause 6.1.2.2.1 of [6, TS 38.214],
  - $\lceil \log_2(N_{RB}^{UL,BWP}(N_{RB}^{UL,BWP} + 1)/2) \rceil$  bits if only resource allocation type 1 is configured, or  $\max(\lceil \log_2(N_{RB}^{UL,BWP}(N_{RB}^{UL,BWP} + 1)/2) \rceil, N_{RBG}) + 1$  bits if both resource allocation type 0 and 1 are configured.
- If both resource allocation type 0 and 1 are configured, the MSB bit is used to indicate resource allocation type 0 or resource allocation type 1, where the bit value of 0 indicates resource allocation type 0 and the bit value of 1 indicates resource allocation type 1.
- For resource allocation type 0, the  $N_{RBG}$  LSBs provide the resource allocation as defined in Subclause 6.1.2.2.1 of [6, TS 38.214].
- For resource allocation type 1, the  $\lceil \log_2(N_{RB}^{UL,BWP}(N_{RB}^{UL,BWP} + 1)/2) \rceil$  LSBs provide the resource allocation as follows:
  - For PUSCH hopping with resource allocation type 1:
    - $N_{UL\_hop}$  MSB bits are used to indicate the frequency offset according to Subclause 6.3 of [6, TS 38.214], where  $N_{UL\_hop} = 1$  if the higher layer parameter *frequencyHoppingOffsetLists* contains two offset values and  $N_{UL\_hop} = 2$  if the higher layer parameter *frequencyHoppingOffsetLists* contains four offset values
    - $\lceil \log_2(N_{RB}^{UL,BWP}(N_{RB}^{UL,BWP} + 1)/2) \rceil - N_{UL\_hop}$  bits provides the frequency domain resource allocation according to Subclause 6.1.2.2.2 of [6, TS 38.214]
  - For non-PUSCH hopping with resource allocation type 1:
    - $\lceil \log_2(N_{RB}^{UL,BWP}(N_{RB}^{UL,BWP} + 1)/2) \rceil$  bits provides the frequency domain resource allocation according to Subclause 6.1.2.2.2 of [6, TS 38.214]

If "Bandwidth part indicator" field indicates a bandwidth part other than the active bandwidth part and if both resource allocation type 0 and 1 are configured for the indicated bandwidth part, the UE assumes resource allocation type 0 for the indicated bandwidth part if the bit width of the "Frequency domain resource assignment" field of the active bandwidth part is smaller than the bit width of the "Frequency domain resource assignment" field of the indicated bandwidth part.

- Time domain resource assignment – 0, 1, 2, 3, or 4 bits as defined in Subclause 6.1.2.1 of [6, TS38.214]. The bit width for this field is determined as  $\lceil \log_2(I) \rceil$  bits, where  $I$  the number of entries in the higher layer parameter *pusch-AllocationList*.
- Frequency hopping flag – 0 or 1 bit:
  - 0 bit if only resource allocation type 0 is configured or if the higher layer parameter *frequencyHopping* is not configured;
  - 1 bit according to Table 7.3.1.1.2-34 otherwise, only applicable to resource allocation type 1, as defined in Subclause 6.3 of [6, TS 38.214].
- Modulation and coding scheme – 5 bits as defined in Subclause 6.1.4.1 of [6, TS 38.214]
- New data indicator – 1 bit
- Redundancy version – 2 bits as defined in Table 7.3.1.1.1-2

- HARQ process number – 4 bits
- 1<sup>st</sup> downlink assignment index – 1 or 2 bits:
  - 1 bit for semi-static HARQ-ACK codebook;
  - 2 bits for dynamic HARQ-ACK codebook.
- 2<sup>nd</sup> downlink assignment index – 0 or 2 bits:
  - 2 bits for dynamic HARQ-ACK codebook with two HARQ-ACK sub-codebooks;
  - 0 bit otherwise.
- TPC command for scheduled PUSCH – 2 bits as defined in Subclause 7.1.1 of [5, TS38.213]
- SRS resource indicator –  $\left\lceil \log_2 \left( \sum_{k=1}^{\min\{L_{\max}^{\text{PUSCH}}, N_{\text{SRS}}\}} \binom{N_{\text{SRS}}}{k} \right) \right\rceil$  or  $\lceil \log_2(N_{\text{SRS}}) \rceil$  bits, where  $N_{\text{SRS}}$  is the number of configured SRS resources in the SRS resource set associated with the higher layer parameter *usage* of value 'codeBook' or 'nonCodeBook', and  $L_{\max}^{\text{PUSCH}}$  is the maximum number of supported layers for the PUSCH.
  - $\left\lceil \log_2 \left( \sum_{k=1}^{\min\{L_{\max}^{\text{PUSCH}}, N_{\text{SRS}}\}} \binom{N_{\text{SRS}}}{k} \right) \right\rceil$  bits according to Tables 7.3.1.1.2-28/29/30/31 if the higher layer parameter *txConfig* = *nonCodebook*, where  $N_{\text{SRS}}$  is the number of configured SRS resources in the SRS resource set associated with the higher layer parameter *usage* of value 'nonCodeBook';
  - $\lceil \log_2(N_{\text{SRS}}) \rceil$  bits according to Tables 7.3.1.1.2-32 if the higher layer parameter *txConfig* = *codebook*, where  $N_{\text{SRS}}$  is the number of configured SRS resources in the SRS resource set associated with the higher layer parameter *usage* of value 'codeBook'.
- Precoding information and number of layers – number of bits determined by the following:
  - 0 bits if the higher layer parameter *txConfig* = *nonCodeBook*;
  - 0 bits for 1 antenna port and if the higher layer parameter *txConfig* = *codebook*;
  - 4, 5, or 6 bits according to Table 7.3.1.1.2-2 for 4 antenna ports, if *txConfig* = *codebook*, and according to the values of higher layer parameters *transformPrecoder*, *maxRank*, and *codebookSubset*;
  - 2, 4, or 5 bits according to Table 7.3.1.1.2-3 for 4 antenna ports, if *txConfig* = *codebook*, and according to the values of higher layer parameters *transformPrecoder*, *maxRank*, and *codebookSubset*;
  - 2 or 4 bits according to Table 7.3.1.1.2-4 for 2 antenna ports, if *txConfig* = *codebook*, and according to the values of higher layer parameters *maxRank* and *codebookSubset*;
  - 1 or 3 bits according to Table 7.3.1.1.2-5 for 2 antenna ports, if *txConfig* = *codebook*, and according to the values of higher layer parameters *maxRank* and *codebookSubset*.
- Antenna ports – number of bits determined by the following
  - 2 bits as defined by Tables 7.3.1.1.2-6, if *transformPrecoder*=*enabled*, *dmrs-Type*=1, and *maxLength*=1;
  - 4 bits as defined by Tables 7.3.1.1.2-7, if *transformPrecoder*=*enabled*, *dmrs-Type*=1, and *maxLength*=2;
  - 3 bits as defined by Tables 7.3.1.1.2-8/9/10/11, if *transformPrecoder*=*disabled*, *dmrs-Type*=1, and *maxLength*=1, and the value of rank is determined according to the SRS resource indicator field if the higher layer parameter *txConfig* = *nonCodebook* and according to the Precoding information and number of layers field if the higher layer parameter *txConfig* = *codebook*;
  - 4 bits as defined by Tables 7.3.1.1.2-12/13/14/15, if *transformPrecoder*=*disabled*, *dmrs-Type*=1, and *maxLength*=2, and the value of rank is determined according to the SRS resource indicator field if the higher

layer parameter  $txConfig = nonCodebook$  and according to the Precoding information and number of layers field if the higher layer parameter  $txConfig = codebook$ ;

- 4 bits as defined by Tables 7.3.1.1.2-16/17/18/19, if  $transformPrecoder=disabled$ ,  $dmrs-Type=2$ , and  $maxLength=1$ , and the value of rank is determined according to the SRS resource indicator field if the higher layer parameter  $txConfig = nonCodebook$  and according to the Precoding information and number of layers field if the higher layer parameter  $txConfig = codebook$ ;
- 5 bits as defined by Tables 7.3.1.1.2-20/21/22/23, if  $transformPrecoder=disabled$ ,  $dmrs-Type=2$ , and  $maxLength=2$ , and the value of rank is determined according to the SRS resource indicator field if the higher layer parameter  $txConfig = nonCodebook$  and according to the Precoding information and number of layers field if the higher layer parameter  $txConfig = codebook$ .

where the number of CDM groups without data of values 1, 2, and 3 in Tables 7.3.1.1.2-6 to 7.3.1.1.2-23 refers to CDM groups  $\{0\}$ ,  $\{0,1\}$ , and  $\{0, 1,2\}$  respectively.

If a UE is configured with both  $dmrs-UplinkForPUSCH-MappingTypeA$  and  $dmrs-UplinkForPUSCH-MappingTypeB$ , the bit width of this field equals  $\max\{x_A, x_B\}$ , where  $x_A$  is the “Antenna ports” bit width derived according to  $dmrs-UplinkForPUSCH-MappingTypeA$  and  $x_B$  is the “Antenna ports” bit width derived according to  $dmrs-UplinkForPUSCH-MappingTypeB$ . A number of  $|x_A - x_B|$  zeros are padded in the MSB of this field, if the mapping type of the PUSCH corresponds to the smaller value of  $x_A$  and  $x_B$ .

- SRS request – 2 bits as defined by Table 7.3.1.1.2-24 for UEs not configured with SUL in the cell; 3 bits for UEs configured SUL in the cell where the first bit is the non-SUL/SUL indicator as defined in Table 7.3.1.1.1-1 and the second and third bits are defined by Table 7.3.1.1.2-24. This bit field may also indicate the associated CSI-RS according to Subclause 6.1.1.2 of [6, TS 38.214].
- CSI request – 0, 1, 2, 3, 4, 5, or 6 bits determined by higher layer parameter  $reportTriggerSize$ .
- CBG transmission information (CBGTI) – 0, 2, 4, 6, or 8 bits determined by higher layer parameter  $maxCodeBlockGroupsPerTransportBlock$  for PUSCH.
- PTRS-DMRS association – number of bits determined as follows
  - 0 bit if  $PTRS-UplinkConfig$  is not configured and  $transformPrecoder=disabled$ , or if  $transformPrecoder=enabled$ , or if  $maxRank=1$ ;
  - 2 bits otherwise, where Table 7.3.1.1.2-25 and 7.3.1.1.2-26 are used to indicate the association between PTRS port(s) and DMRS port(s) for transmission of one PT-RS port and two PT-RS ports respectively, and the DMRS ports are indicated by the Antenna ports field.

If “Bandwidth part indicator” field indicates a bandwidth part other than the active bandwidth part and the “PTRS-DMRS association” field is present for the indicated bandwidth part but not present for the active bandwidth part, the UE assumes the “PTRS-DMRS association” field is not present for the indicated bandwidth part.

- beta\_offset indicator – 0 if the higher layer parameter  $betaOffsets = semiStatic$ ; otherwise 2 bits as defined by Table 9.3-3 in [5, TS 38.213].
- DMRS sequence initialization – 0 if the higher layer parameter  $transformPrecoder=enabled$ ; 1 bit if the higher layer parameter  $transformPrecoder=disabled$  and both  $scramblingID0$  and  $scramblingID1$  are configured in  $DMRS-UplinkConfig$ , for  $n_{SCID}$  selection defined in Subclause 6.4.1.1.1.1 of [4, TS 38.211].
- UL-SCH indicator – 1 bit. A value of “1” indicates UL-SCH shall be transmitted on the PUSCH and a value of “0” indicates UL-SCH shall not be transmitted on the PUSCH.

For a UE configured with SUL in a cell, if PUSCH is configured to be transmitted on both the SUL and the non-SUL of the cell and if the number of information bits in format 0\_1 for the SUL is not equal to the number of information bits in format 0\_1 for the non-SUL, zeros shall be appended to smaller format 0\_1 until the payload size equals that of the larger format 0\_1.

**Table 7.3.1.1.2-1: Bandwidth part indicator**

Value of BWP indicator field 2 bits	Bandwidth part
00	First bandwidth part configured by higher layers
01	Second bandwidth part configured by higher layers
10	Third bandwidth part configured by higher layers
11	Fourth bandwidth part configured by higher layers

**Table 7.3.1.1.2-2: Precoding information and number of layers, for 4 antenna ports, if *transformPrecoder=disabled* and *maxRank = 2 or 3 or 4***

Bit field mapped to index	<i>codebookSubset = fullyAndPartialAndNonCoherent</i> <i>t</i>	Bit field mapped to index	<i>codebookSubset = partialAndNonCoherent</i> <i>t</i>	Bit field mapped to index	<i>codebookSubset = nonCoherent</i>
0	1 layer: TPMI=0	0	1 layer: TPMI=0	0	1 layer: TPMI=0
1	1 layer: TPMI=1	1	1 layer: TPMI=1	1	1 layer: TPMI=1
...	...	...	...	...	...
3	1 layer: TPMI=3	3	1 layer: TPMI=3	3	1 layer: TPMI=3
4	2 layers: TPMI=0	4	2 layers: TPMI=0	4	2 layers: TPMI=0
...	...	...	...	...	...
9	2 layers: TPMI=5	9	2 layers: TPMI=5	9	2 layers: TPMI=5
10	3 layers: TPMI=0	10	3 layers: TPMI=0	10	3 layers: TPMI=0
11	4 layers: TPMI=0	11	4 layers: TPMI=0	11	4 layers: TPMI=0
12	1 layer: TPMI=4	12	1 layer: TPMI=4	12-15	reserved
...	...	...	...		
19	1 layer: TPMI=11	19	1 layer: TPMI=11		
20	2 layers: TPMI=6	20	2 layers: TPMI=6		
...	...	...	...		
27	2 layers: TPMI=13	27	2 layers: TPMI=13		
28	3 layers: TPMI=1	28	3 layers: TPMI=1		
29	3 layers: TPMI=2	29	3 layers: TPMI=2		
30	4 layers: TPMI=1	30	4 layers: TPMI=1		
31	4 layers: TPMI=2	31	4 layers: TPMI=2		
32	1 layers: TPMI=12				
...	...				
47	1 layers: TPMI=27				
48	2 layers: TPMI=14				
...	...				
55	2 layers: TPMI=21				
56	3 layers: TPMI=3				
...	...				
59	3 layers: TPMI=6				
60	4 layers: TPMI=3				
61	4 layers: TPMI=4				
62-63	reserved				

**Table 7.3.1.1.2-3: Precoding information and number of layers for 4 antenna ports, if *transformPrecoder= enabled*, or if *transformPrecoder=disabled* and *maxRank = 1***

Bit field mapped to index	<i>codebookSubset = fullyAndPartialAndNonCoherent</i> <i>t</i>	Bit field mapped to index	<i>codebookSubset= partialAndNonCoherent</i> <i>t</i>	Bit field mapped to index	<i>codebookSubset = nonCoherent</i>
0	1 layer: TPMI=0	0	1 layer: TPMI=0	0	1 layer: TPMI=0
1	1 layer: TPMI=1	1	1 layer: TPMI=1	1	1 layer: TPMI=1
...	...	...	...	...	...
3	1 layer: TPMI=3	3	1 layer: TPMI=3	3	1 layer: TPMI=3
4	1 layer: TPMI=4	4	1 layer: TPMI=4		
...	...	...	...		
11	1 layer: TPMI=11	11	1 layer: TPMI=11		
12	1 layers: TPMI=12	12-15	reserved		
...	...				
27	1 layers: TPMI=27				
28-31	reserved				

**Table 7.3.1.1.2-4: Precoding information and number of layers, for 2 antenna ports, if *transformPrecoder=disabled* and *maxRank = 2***

Bit field mapped to index	<i>codebookSubset = fullyAndPartialAndNonCoherent</i>	Bit field mapped to index	<i>codebookSubset = nonCoherent</i>
0	1 layer: TPMI=0	0	1 layer: TPMI=0
1	1 layer: TPMI=1	1	1 layer: TPMI=1
2	2 layers: TPMI=0	2	2 layers: TPMI=0
3	1 layer: TPMI=2	3	reserved
4	1 layer: TPMI=3		
5	1 layer: TPMI=4		
6	1 layer: TPMI=5		
7	2 layers: TPMI=1		
8	2 layers: TPMI=2		
9-15	reserved		

**Table 7.3.1.1.2-5: Precoding information and number of layers, for 2 antenna ports, if *transformPrecoder= enabled*, or if *transformPrecoder= disabled* and *maxRank = 1***

Bit field mapped to index	<i>codebookSubset = fullyAndPartialAndNonCoherent</i>	Bit field mapped to index	<i>codebookSubset = nonCoherent</i>
0	1 layer: TPMI=0	0	1 layer: TPMI=0
1	1 layer: TPMI=1	1	1 layer: TPMI=1
2	1 layer: TPMI=2		
3	1 layer: TPMI=3		
4	1 layer: TPMI=4		
5	1 layer: TPMI=5		
6-7	reserved		

...

**Table 7.3.1.1.2-33: VRB-to-PRB mapping**

Bit field mapped to index	VRB-to-PRB mapping
0	Non-interleaved
1	Interleaved

[TS 38.214, clause 6.1.2.1]



When the UE is scheduled to transmit a transport block and no CSI report, or the UE is scheduled to transmit a transport block and a CSI report on PUSCH by a DCI, the *Time domain resource assignment* field value  $m$  of the DCI provides a row index  $m + 1$  to an allocated table. The determination of the used resource allocation table is defined in sub-clause 6.1.2.1.1. The indexed row defines the slot offset  $K_2$ , the start and length indicator *SLIV*, or directly the start symbol  $S$  and the allocation length  $L$ , and the PUSCH mapping type to be applied in the PUSCH transmission.

When the UE is scheduled to transmit a PUSCH with no transport block and with a CSI report by a *CSI request* field on a DCI, the *Time-domain resource assignment* field value  $m$  of the DCI provides a row index  $m + 1$  to an allocated table. The determination of the applied resource allocation table is defined in sub-clause 6.1.2.1.1. The indexed row defines the start and length indicator *SLIV*, or directly the start symbol  $S$  and the allocation length  $L$ , and the PUSCH mapping type to be applied in the PUSCH transmission and  $K_2$  is determined based on the corresponding list entries  $Y_j, j = 0, \dots, N_{\text{Rep}} - 1$  of the higher layer parameter *reportSlotConfig* in *CSI-ReportConfig* for the  $N_{\text{Rep}}$  triggered CSI Reporting Settings. The  $i$ th codepoint of  $K_2$  is determined as  $K_2 = \max_j Y_j(i)$  where  $Y_j(i)$  is the  $i$ th codepoint of  $Y_j$ .

- The slot where the UE shall transmit the PUSCH is determined by  $K_2$  as  $\left\lfloor n \cdot \frac{2^{\mu_{\text{PUSCH}}}}{2^{\mu_{\text{PDCCH}}}} \right\rfloor + K_2$  where  $n$  is the slot with the scheduling DCI,  $K_2$  is based on the numerology of PUSCH, and  $\mu_{\text{PUSCH}}$  and  $\mu_{\text{PDCCH}}$  are the subcarrier spacing configurations for PUSCH and PDCCH, respectively, and

- The starting symbol  $S$  relative to the start of the slot, and the number of consecutive symbols  $L$  counting from the symbol  $S$  allocated for the PUSCH are determined from the start and length indicator *SLIV* of the indexed row:

if  $(L-1) \leq 7$  then

$$SLIV = 14 \cdot (L-1) + S$$

else

$$SLIV = 14 \cdot (14-L+1) + (14-1-S)$$

where  $0 < L \leq 14 - S$ , and

- The PUSCH mapping type is set to Type A or Type B as defined in Subclause 6.4.1.1.3 of [4, TS 38.211] as given by the indexed row.

The UE shall consider the  $S$  and  $L$  combinations defined in table 6.1.2.1-1 as valid PUSCH allocations

**Table 6.1.2.1-1: Valid  $S$  and  $L$  combinations**

PUSCH mapping type	Normal cyclic prefix			Extended cyclic prefix		
	$S$	$L$	$S+L$	$S$	$L$	$S+L$
Type A	0	{4,...,14}	{4,...,14}	0	{4,...,12}	{4,...,12}
Type B	{0,...,13}	{1,...,14}	{1,...,14}	{0,...,12}	{1,...,12}	{1,...,12}

When the UE is configured with  $aggregationFactorUL > 1$ , the same symbol allocation is applied across the  $aggregationFactorUL$  consecutive slots and the PUSCH is limited to a single transmission layer. The UE shall repeat the TB across the  $aggregationFactorUL$  consecutive slots applying the same symbol allocation in each slot. The redundancy version to be applied on the  $n^{\text{th}}$  transmission occasion of the TB is determined according to table 6.1.2.1-2.

**Table 6.1.2.1-2: Redundancy version when  $aggregationFactorUL > 1$**

$rvid$ indicated by the DCI scheduling the PUSCH	$rvid$ to be applied to $n^{\text{th}}$ transmission occasion			
	$n \bmod 4 = 0$	$n \bmod 4 = 1$	$n \bmod 4 = 2$	$n \bmod 4 = 3$
0	0	2	3	1
2	2	3	1	0
3	3	1	0	2
1	1	0	2	3

If the UE procedure for determining slot configuration, as defined in subclause 11.1 of [6, TS 38.213], determines symbols of a slot allocated for PUSCH as downlink symbols, the transmission on that slot is omitted for multi-slot PUSCH transmission.

[38.214 clause 6.1.2.2]

The UE shall determine the resource block assignment in frequency domain using the resource allocation field in the detected PDCCH DCI. Two uplink resource allocation schemes type 0 and type 1 are supported. Uplink resource allocation scheme type 0 is supported for PUSCH only when transform precoding is disabled. Uplink resource allocation scheme type 1 is supported for PUSCH for both cases when transform precoding is enabled or disabled.

If the scheduling DCI is configured to indicate the uplink resource allocation type as part of the *Frequency domain resource* assignment field by setting a higher layer parameter *resourceAllocation* in *pusch-Config* to 'dynamicswitch', the UE shall use uplink resource allocation type 0 or type 1 as defined by this DCI field. Otherwise the UE shall use the uplink frequency resource allocation type as defined by the higher layer parameter *resourceAllocation*.

The UE shall assume that when the scheduling PDCCH is received with DCI format 0\_0, then uplink resource allocation type 1 is used.

If a bandwidth part indicator field is not configured in the scheduling DCI, the RB indexing for uplink type 0 and type 1 resource allocation is determined within the UE's active bandwidth part. If a bandwidth part indicator field is configured in the scheduling DCI, the RB indexing for uplink type 0 and type 1 resource allocation is determined within the UE's bandwidth part indicated by bandwidth part indicator field value in the DCI, except for the case when DCI format 0\_0 is decoded in any PDCCH common search space in CORESET 0 in which case the initial bandwidth part shall be used. The UE shall upon detection of PDCCH intended for the UE determine first the uplink bandwidth part and then the resource allocation within the bandwidth part.

[38.214 clause 6.1.2.2.1]

In uplink resource allocation of type 0, the resource block assignment information includes a bitmap indicating the Resource Block Groups (RBGs) that are allocated to the scheduled UE where a RBG is a set of consecutive virtual resource blocks defined by higher layer parameter *rbg-Size* configured for PUSCH and the size of the carrier bandwidth part as defined in Table 6.1.2.2.1-1.

**Table 6.1.2.2.1-1: Nominal RBG size  $P$**

Carrier Bandwidth Part Size	Configuration 1	Configuration 2
1 – 36	2	4
37 – 72	4	8
73 – 144	8	16
145 – 275	16	16

The total number of RBGs ( $N_{\text{RBG}}$ ) for a uplink carrier bandwidth part  $i$  of size  $N_{\text{BWP},i}^{\text{size}}$  PRBs is given by

$$N_{\text{RBG}} = \left\lfloor \left( N_{\text{BWP},i}^{\text{size}} + \left( N_{\text{BWP},i}^{\text{start}} \bmod P \right) \right) / P \right\rfloor \text{ where}$$

- the size of the first RBG is  $\text{RBG}_0^{\text{size}} = P - N_{\text{BWP},i}^{\text{start}} \bmod P$ ,
- the size of the last RBG is  $\text{RBG}_{\text{last}}^{\text{size}} = \left( N_{\text{BWP},i}^{\text{start}} + N_{\text{BWP},i}^{\text{size}} \right) \bmod P$  if  $\left( N_{\text{BWP},i}^{\text{start}} + N_{\text{BWP},i}^{\text{size}} \right) \bmod P > 0$  and  $P$  otherwise.
- the size of all other RBG is  $P$ .

The bitmap is of size  $N_{\text{RBG}}$  bits with one bitmap bit per RBG such that each RBG is addressable. The RBGs shall be indexed in the order of increasing frequency of the carrier bandwidth part and starting at the lowest frequency. The order of RBG bitmap is such that RBG 0 to RBG  $N_{\text{RBG}} - 1$  are mapped from MSB to LSB of the bitmap. The RBG is allocated to the UE if the corresponding bit value in the bitmap is 1, the RBG is not allocated to the UE otherwise.

[38.214 clause 6.1.2.2.2]

In uplink resource allocation of type 1, the resource block assignment information indicates to a scheduled UE a set of contiguously allocated non-interleaved virtual resource blocks within the active carrier bandwidth part of size  $N_{\text{BWP}}^{\text{size}}$

PRBs except for the case when DCI format 0\_0 is decoded in the Type0-PDCCH common search space in CORESET 0 in which case the initial bandwidth part of size  $N_{BWP}^{size}$  shall be used.

An uplink type 1 resource allocation field consists of a resource indication value ( $RIV$ ) corresponding to a starting virtual resource block ( $RB_{start}$ ) and a length in terms of contiguously allocated resource blocks  $L_{RBs}$ . The resource indication value is defined by

if  $(L_{RBs} - 1) \leq \lfloor N_{BWP}^{size} / 2 \rfloor$  then

$$RIV = N_{BWP}^{size} (L_{RBs} - 1) + RB_{start}$$

else

$$RIV = N_{BWP}^{size} (N_{BWP}^{size} - L_{RBs} + 1) + (N_{BWP}^{size} - 1 - RB_{start})$$

where  $L_{RBs} \geq 1$  and shall not exceed  $N_{BWP}^{size} - RB_{start}$ .

[TS 38.214, clause 6.1.4.1]

For the PUSCH assigned by a DCI format 0\_0/0\_1 with CRC scrambled by C-RNTI, new-RNTI, TC-RNTI, or SP-CSI-RNTI, the transform precoding is enabled if *transformPrecoder* in *PUSCH-Config* is set to 'enabled', or if *transformPrecoder* in *PUSCH-Config* is not configured and *msg3-transformPrecoding* in *rach-ConfigCommon* is set to 'enabled'; otherwise the transform precoding is disabled.

For the PUSCH assigned by a DCI format 0\_0/0\_1 with CRC scrambled by CS-RNTI, or the PUSCH with configured grant using CS-RNTI, the transform precoding is enabled if *transformPrecoder* in *ConfiguredGrantConfig* is set to 'enabled'; otherwise the transform precoding is disabled.

For a PUSCH scheduled by RAR UL grant or for a PUSCH scheduled by a DCI format 0\_0/0\_1 with CRC scrambled by C-RNTI, TC-RNTI, or CS-RNTI, or SP-CSI-RNTI, or for a PUSCH with configured grant using CS-RNTI,

if *transformPrecoder* is disabled for this PUSCH transmission

- if *mcs-Table* in *PUSCH-Config* is set to 'qam256', and PUSCH is scheduled with C-RNTI or SP-CSI-RNTI, and PUSCH is assigned by DCI format 0\_1,
  - the UE shall use  $I_{MCS}$  and Table 5.1.3.1-2 to determine the modulation order ( $Q_m$ ) and Target code rate ( $R$ ) used in the physical uplink shared channel.
- elseif the UE is not configured with new-RNTI, *mcs-Table* in *PUSCH-Config* is set to 'qam64LowSE', the PUSCH is scheduled with C-RNTI, or SP-CSI-RNTI, and the PUSCH is assigned by a PDCCH in a UE-specific search space,
  - the UE shall use  $I_{MCS}$  and Table 5.1.3.1-3 to determine the modulation order ( $Q_m$ ) and Target code rate ( $R$ ) used in the physical uplink shared channel.
- elseif the UE is configured with new-RNTI, and the PUSCH is scheduled with new-RNTI,
  - the UE shall use  $I_{MCS}$  and Table 5.1.3.1-3 to determine the modulation order ( $Q_m$ ) and Target code rate ( $R$ ) used in the physical uplink shared channel.
- elseif *mcs-Table* in *ConfiguredGrantConfig* is set to 'qam256', and PUSCH is scheduled with CS-RNTI,
  - the UE shall use  $I_{MCS}$  and Table 5.1.3.1-2 to determine the modulation order ( $Q_m$ ) and Target code rate ( $R$ ) used in the physical uplink shared channel.
- elseif *mcs-Table* in *ConfiguredGrantConfig* is set to 'qam64LowSE', and PUSCH is scheduled with CS-RNTI,
  - the UE shall use  $I_{MCS}$  and Table 5.1.3.1-3 to determine the modulation order ( $Q_m$ ) and Target code rate ( $R$ ) used in the physical uplink shared channel.
- else

- the UE shall use  $I_{MCS}$  and Table 5.1.3.1-1 to determine the modulation order ( $Q_m$ ) and Target code rate ( $R$ ) used in the physical uplink shared channel.

[TS 38.214, clause 5.1.3.1]

**Table 5.1.3.1-2: MCS index table 2 for PDSCH**

MCS Index $I_{MCS}$	Modulation Order $Q_m$	Target code Rate $R \times [1024]$	Spectral efficiency
0	2	120	0.2344
1	2	193	0.3770
2	2	308	0.6016
3	2	449	0.8770
4	2	602	1.1758
5	4	378	1.4766
6	4	434	1.6953
7	4	490	1.9141
8	4	553	2.1602
9	4	616	2.4063
10	4	658	2.5703
11	6	466	2.7305
12	6	517	3.0293
13	6	567	3.3223
14	6	616	3.6094
15	6	666	3.9023
16	6	719	4.2129
17	6	772	4.5234
18	6	822	4.8164
19	6	873	5.1152
20	8	682.5	5.3320
21	8	711	5.5547
22	8	754	5.8906
23	8	797	6.2266
24	8	841	6.5703
25	8	885	6.9141
26	8	916.5	7.1602
27	8	948	7.4063
28	2	reserved	
29	4	reserved	
30	6	reserved	
31	8	reserved	

[TS 38.214, clause 6.1.4.2]

For a PUSCH scheduled by RAR UL grant or for a PUSCH scheduled by a DCI format 0\_0/0\_1 with CRC scrambled by C-RNTI, new-RNTI, TC-RNTI, CS-RNTI, or SP-CSI-RNTI.

if

- $0 \leq I_{MCS} \leq 27$  and transform precoding is disabled and Table 5.1.3.1-2 is used, or
- $0 \leq I_{MCS} \leq 28$  and transform precoding is disabled and a table other than Table 5.1.3.1-2 is used, or
- $0 \leq I_{MCS} \leq 27$  and transform precoding is enabled, the UE shall first determine the TBS as specified below:

The UE shall first determine the number of REs ( $N_{RE}$ ) within the slot:

- A UE first determines the number of REs allocated for PUSCH within a PRB ( $N'_{RE}$ ) by
- $N'_{RE} = N_{sc}^{RB} * N_{symp}^{sh} - N_{DMRS}^{PRB} - N_{oh}^{PRB}$ , where  $N_{sc}^{RB} = 12$  is the number of subcarriers in the frequency domain in a physical resource block,  $N_{symp}^{sh}$  is the number of symbols of the PUSCH allocation within the

slot,  $N_{DMRS}^{PRB}$  is the number of REs for DM-RS per PRB in the scheduled duration including the overhead of the DM-RS CDM groups without data, as indicated by DCI format 0\_1 or as described for DCI format 0\_0 in Subclause 6.2.2, and  $N_{oh}^{PRB}$  is the overhead configured by higher layer parameter  $xOverhead$  in *PUSCH-ServingCellConfig*. If the  $N_{oh}^{PRB}$  is not configured (a value from 0, 6, 12, or 18), the  $N_{oh}^{PRB}$  is assumed to be 0. For MSG3 transmission the  $N_{oh}^{PRB}$  is always set to 0..

- A UE determines the total number of REs allocated for PUSCH ( $N_{RE}$ ) by  $N_{RE} = \min(156, N_{RE}') \cdot n_{PRB}$  where  $n_{PRB}$  is the total number of allocated PRBs for the UE.
- Next, proceed with steps 2-4 as defined in Subclause 5.1.3.2

else if

- $28 \leq I_{MCS} \leq 31$  and transform precoding is disabled and Table 5.1.3.1-2 is used, or
- $28 \leq I_{MCS} \leq 31$  and transform precoding is enabled,
- the TBS is assumed to be as determined from the DCI transported in the latest PDCCH for the same transport block using  $0 \leq I_{MCS} \leq 27$ . If there is no PDCCH for the same transport block using  $0 \leq I_{MCS} \leq 27$ , and if the initial PUSCH for the same transport block is transmitted with configured grant, the TBS shall be determined from the most recent configured scheduling PDCCH.

else

- the TBS is assumed to be as determined from the DCI transported in the latest PDCCH for the same transport block using  $0 \leq I_{MCS} \leq 28$ . If there is no PDCCH for the same transport block using  $0 \leq I_{MCS} \leq 28$ , and if the initial PUSCH for the same transport block is transmitted with configured grant, the TBS shall be determined from the most recent configured scheduling PDCCH.

[TS 38.214, clause 5.1.3.2]

2) Intermediate number of information bits ( $N_{info}$ ) is obtained by  $N_{info} = N_{RE} \cdot R \cdot Q_m \cdot \nu$ .

If  $N_{info} \leq 3824$

Use step 3 as the next step of the TBS determination

else

Use step 4 as the next step of the TBS determination

end if

3) When  $N_{info} \leq 3824$ , TBS is determined as follows

- quantized intermediate number of information bits  $N_{info}' = \max\left(24, 2^n \cdot \left\lfloor \frac{N_{info}}{2^n} \right\rfloor\right)$ , where  $n = \max(3, \lfloor \log_2(N_{info}) \rfloor - 6)$ .
- use Table 5.1.3.2-2 find the closest TBS that is not less than  $N_{info}'$ .

Table 5.1.3.2-2: TBS for  $N_{info} \leq 3824$ 

Index	TBS	Index	TBS	Index	TBS	Index	TBS
1	24	31	336	61	1288	91	3624
2	32	32	352	62	1320	92	3752
3	40	33	368	63	1352	93	3824
4	48	34	384	64	1416		
5	56	35	408	65	1480		
6	64	36	432	66	1544		
7	72	37	456	67	1608		
8	80	38	480	68	1672		
9	88	39	504	69	1736		
10	96	40	528	70	1800		
11	104	41	552	71	1864		
12	112	42	576	72	1928		
13	120	43	608	73	2024		
14	128	44	640	74	2088		
15	136	45	672	75	2152		
16	144	46	704	76	2216		
17	152	47	736	77	2280		
18	160	48	768	78	2408		
19	168	49	808	79	2472		
20	176	50	848	80	2536		
21	184	51	888	81	2600		
22	192	52	928	82	2664		
23	208	53	984	83	2728		
24	224	54	1032	84	2792		
25	240	55	1064	85	2856		
26	256	56	1128	86	2976		
27	272	57	1160	87	3104		
28	288	58	1192	88	3240		
29	304	59	1224	89	3368		
30	320	60	1256	90	3496		

4) When  $N_{info} > 3824$ , TBS is determined as follows.

- quantized intermediate number of information bits  $N'_{info} = \max\left(3840, 2^n \times \text{round}\left(\frac{N_{info} - 24}{2^n}\right)\right)$ , where  $n = \lfloor \log_2(N_{info} - 24) \rfloor - 5$  and ties in the round function are broken towards the next largest integer.
- if  $R \leq 1/4$

$$TBS = 8 \cdot C \cdot \left\lceil \frac{N'_{info} + 24}{8 \cdot C} \right\rceil - 24, \text{ where } C = \left\lceil \frac{N'_{info} + 24}{3816} \right\rceil$$

else

if  $N'_{info} > 8424$

$$TBS = 8 \cdot C \cdot \left\lceil \frac{N'_{info} + 24}{8 \cdot C} \right\rceil - 24, \text{ where } C = \left\lceil \frac{N'_{info} + 24}{8424} \right\rceil$$

else

$$TBS = 8 \cdot \left\lceil \frac{N'_{info} + 24}{8} \right\rceil - 24$$

end if

end if

7.1.1.4.2.4.3 Test description

7.1.1.4.2.4.3.1 Pre-test conditions

Same Pre-test conditions as in clause 7.1.1.0 except set the NR Cell bandwidth and applicable BWP to maximum for the NR Band under test as specified in Table 5.3.5-1 in TS 38.101-1 [16] / TS 38.101-2 [17] (to enable testing of  $n_{PRB}$  up to maximum value).

7.1.1.4.2.4.3.2 Test procedure sequence

**Table 7.1.1.4.2.4.3.2-1: Maximum TBS for different UE categories**

UE Category	Maximum number of bits of a UL-SCH transport block received within a TTI
TS 38.306 [23] clause 4.1.2 require UE without ue-CategoryDL and ue-CategoryUL, to support Max TBS achievable based on max bandwidth of the Band under test.	

**Table 7.1.1.4.2.4.3.2-2: Number of downlink PDCP SDUs and PDCP SDU size used as test data**

TBS [bits]	Number of PDCP SDUs	PDCP SDU size [bits] (Note 1)
$132 \leq TBS \leq 12128$ note 2	1	$8 * \text{FLOOR}((TBS - 128) / 8)$
$12129 \leq TBS \leq 24200$	2	$8 * \text{FLOOR}((TBS - 200) / 16)$
$24201 \leq TBS \leq 36272$	3	$8 * \text{FLOOR}((TBS - 272) / 24)$
$36273 \leq TBS \leq 48344$	4	$8 * \text{FLOOR}((TBS - 344) / 32)$
$48345 \leq TBS \leq 60416$	5	$8 * \text{FLOOR}((TBS - 416) / 40)$
$60417 \leq TBS \leq 72488$	6	$8 * \text{FLOOR}((TBS - 488) / 48)$
$72489 \leq TBS \leq 84560$	7	$8 * \text{FLOOR}((TBS - 560) / 56)$
$84561 \leq TBS \leq 96632$	8	$8 * \text{FLOOR}((TBS - 632) / 64)$
$96633 < TBS \leq 108704$	9	$8 * \text{FLOOR}((TBS - 704) / 72)$
$10705 \leq TBS \leq 120776$	10	$8 * \text{FLOOR}((TBS - 776) / 80)$
$120777 \leq TBS \leq 132848$	11	$8 * \text{FLOOR}((TBS - 848) / 88)$
$132849 \leq TBS \leq 144920$	12	$8 * \text{FLOOR}((TBS - 920) / 96)$
$TBS > 144920$	13	$8 * \text{FLOOR}((TBS - 992) / 112)$

Note 1: Each PDCP SDU is limited to 1500 octets (to keep below maximum SDU size of ESM as specified in TS 24.301 [21] clause 9.9.4.12).

The PDCP SDU size of each PDCP SDU is

$$\text{PDCP SDU size} = (TBS - N * \text{PDCP header size} - N * \text{AMD PDU header size} - N * \text{MAC header size} - \text{Size of Timing Advance} - \text{RLC Status PDU size} - \text{MAC header for RLC Status PDU}) / N$$
, where

PDCP header size is 24 bits for the RLC AM and 18-bit SN case;  
 AMD PDU header size is 24 bits with 18 bit SN;

MAC header size for AMD PDU = 16 or 24 bits depending on L=8 or 16 bits. Worst case 24 is taken.

Size of Timing Advance MAC CE with header is 16 bits (if no Timing Advance and/or RLC status needs to be sent, padding will occur instead).

RLC Status PDU size = 24 bits with 1 ACK\_SN, With a MAC header of 16 bits.

This gives:

$$\text{PDCP SDU size} = 8 * \text{FLOOR}((TBS - N * 24 - N * 24 - N * 24 - 56) / (8 * N))$$
 bits.

Note 2: According to the final PDCP SDU size formula in Note 1, the smallest TBS that can be tested is 136 bits.

**Table 7.1.1.4.2.4.3.2-2A: Bandwidth part Dependent Parameters for Resource allocation 0 with start of BWP assumed as 0**

$N_{RB}^{DL,BWP} = N_{BWP,i}^{size}$	Nominal RBG size $P$ (Configuration1)	Size of last RBG	Allowed $N_{PRB}$ Values
11	2	1	All 1...11
18	2	2	2,4,6,8,10,12,16,18
24	2	2	2,4,6,8,10,12,16,18,20,22,24
25	2	1	All 1...25
31	2	1	All 1...31
32	2	2	2,4,6,8,10,12,16,18,20,22,24,26,28,30,32
38	4	2	2,4,6,8,10,12,16,18,20,22,24,26,28,30,32,34,36,38
51	4	3	3,4,7,8,11,12,15,16,19,20,23,24,27,28,31,32,35,36,39,40,43,44,47,48,51
52	4	4	4,8,12,16,20,24,28,32,36,40,44,48,52
65	4	1	1,4,5,8,9,12,13,16,17,20,21,24,25,28,29,32,33,36,37,40,41,44,45,48,49,52,53,56,57,60,61,64,65
66	4	2	2,4,6,8,10,12,16,18,20,22,24,26,28,30,32,34,36,38,40,42,44,46,48,50,52,54,56,58,60,62,64,66
79	8	7	7,8,15,16,23,24,31,32,39,40,47,48,55,56,63,64,71,72,79
106	8	2	2,8,10,16,18,24,26,32,34,40,42,48,50,56,58,64,66,72,74,80,82,88,90,96,92,104,106
107	8	3	3,8,11,16,19,24,27,32,35,40,43,48,51,56,59,64,67,72,75,80,83,88,91,96,99,104,107
132	8	4	4,8,12,16,20,24,28,32,36,40,44,48,52,56,60,64,68,72,76,80,84,88,92,96,100,104,108,112,116,120,124,128,132
133	8	5	5,8,13,16,21,24,29,32,37,40,45,48,53,56,61,64,69,72,77,80,85,88,93,96,101,104,109,112,117,120,125,128,133
135	8	7	7,8,15,16,23,24,31,32,39,40,47,48,55,56,63,64,71,72,79,80,87,88,95,96,103,104,111,112,119,120,127,128,135
216	16	8	8,16,24,32,40,48,56,64,72,80,88,96,104,112,120,128,136,144,152,160,168,176,184,192,200,208,216
217	16	9	9,16,25,32,41,48,57,64,73,80,89,96,105,112,121,128,137,144,153,160,169,176,185,192,201,208,217
264	16	8	8,16,24,32,40,48,56,64,72,80,88,96,104,112,120,128,136,144,160,168,176,184,192,200,208,216,224,232,240,248,256,264
270	16	14	14,16,30,32,46,44,62,64,78,80,94,96,110,112,126,128,142,144,158,160,174,176,190,192,206,208,222,224,238,240,254,256,270
273	16	1	1,16,17,32,33,48,49,64,65,80,81,96,97,112,113,128,129,144,145,160,161,176,171,192,193,208,209,224,225,240,241,256,257,272,273

**Table 7.1.1.4.2.4.3.2-3: Specific Parameter**

Parameter	Value	Comment
PUSCH mappingType	typeA	
starting symbol $S$	0	
number of consecutive symbols $L$	4..14	
$K_2$	Not present	UE applies the value 01 when PUSCH SCS is 15/30KHz; 2 when PUSCH SCS is 60KHz and 3 when PUSCH SCS is 120KHz
number of layers ( $v$ )	1	
mcs-Table	qam256	
$xoh$ -PUSCH ( $N_{oh}^{PRB}$ )	Not present	Results in value 0(xoh0)
dmrs-AdditionalPosition	pos0	Results in 1 DMRS symbol per two carrier ( $N_{DMRS}^{PRB}$ ) for Duration in symbols $\geq 4$
resourceAllocation	dynamicSwitch	
$rbg$ -Size	Not present	configuration 1 applicable
$N_{BWP}^{start}$	0	



Table 7.1.1.4.2.4.3.2-4: Main behaviour

St	Procedure	Message Sequence		TP	Verdict
		U - S	Message		
-	EXCEPTION: Steps 1 to 5 are repeated for allowed values of $N_{PRB}$ as per Table 7.1.1.4.2.4.3.2-2A in BWP, time domain resource length L 3 to 14-S and $I_{MCS}$ from 0 to 27.	-	-	-	-
1	SS calculates or looks up TBS in TS 38.214 [15] based on the value of S, L, $I_{MCS}$ and $n_{PRB}$ .	-	-	-	-
-	EXCEPTION: Steps 2 to 5 are performed if TBS is less than or equal to UE capability "Maximum number of UL-SCH transport block bits received within a TTI" as specified in Table 7.1.1.4.2.4.3.2-1 and larger than or equal to 136 bits as specified in Table 7.1.1.4.2.4.3.2-2.	-	-	-	-
2	SS creates one or more PDCP SDUs depending on TBS in accordance with Table 7.1.1.4.2.4.3.2-2.	-	-	-	-
3	After 300ms, the SS transmits all PDCP SDUs ( $N_{SDUs}$ ) as created in step 2 in a MAC PDU.	<--	MAC PDU (NxPDCP SDUs)	-	-
4	After 60ms of step 3 SS transmits UL Grant DCI 0_1, and values of S, L, $I_{MCS}$ and $n_{PRB}$ .	<--	(UL Grant) (DCI: (DCI Format 0_1, S, L, $I_{MCS}$ and $n_{PRB}$ ))	-	-
5	CHECK: Does UE return the same number of PDCP SDUs with same content as transmitted by the SS in step 3 using Time, frequency Resources and modulation and coding scheme as configured by the SS in step 4?	-->	(NxPDCP SDUs)	1	P
-	EXCEPTION: Steps 6 to 10 are repeated for allowed values of $N_{PRB}$ 1 to $N_{RB}^{DL,BWP}$ in BWP, time domain resource length L 3 to 14-S and $I_{MCS}$ from 0 to 27.	-	-	-	-
6	SS calculates or looks up TBS in TS 38.214 [15] based on the value of S, L, $I_{MCS}$ and $n_{PRB}$ .	-	-	-	-
-	EXCEPTION: Steps 7 to 10 are performed if TBS is less than or equal to UE capability "Maximum number of UL-SCH transport block bits received within a TTI" as specified in Table 7.1.1.4.2.4.3.2-1 and larger than or equal to 136 bits as specified in Table 7.1.1.4.2.4.3.2-2.	-	-	-	-
7	SS creates one or more PDCP SDUs depending on TBS in accordance with Table 7.1.1.4.2.4.3.2-2.	-	-	-	-
8	After 300ms, the SS transmits all PDCP SDUs ( $N_{SDUs}$ ) as created in step 7 in a MAC PDU.	<--	MAC PDU (NxPDCP SDUs)	-	-
9	After 60ms of step 8 SS transmits UL Grant DCI 0_1, and values of S, L, $I_{MCS}$ and $n_{PRB}$ .	<--	(UL Grant) (DCI: (DCI Format 0_1, S, L, $I_{MCS}$ and $n_{PRB}$ ))	-	-
10	CHECK: Does UE return the same number of PDCP SDUs with same content as transmitted by the SS in step 8 using Time, frequency Resources and modulation and coding scheme as configured by the SS in step 4?	-->	(NxPDCP SDUs)	2	P

## 7.1.1.4.2.4.3.3 Specific message contents

[None].

## 7.1.1.4.2.5 UL-SCH Transport Block Size selection / DCI format 0\_0 / Transform precoding and 64QAM

## 7.1.1.4.2.5.1 Test Purpose (TP)

(1)

```
with { UE in RRC_CONNECTED state and transform precoding enabled}
ensure that {
  when { UE has pending data for transmission and receives on PDCCH DCI format 0_0 indicating a
resource block assignment correspondent to physical resource blocks , Time domain resource
assignment and modulation and coding }
  then { UE transmits MAC PDU on PUSCH as per Modulation Coding scheme, time domain resource
allocation and PRB's }
}
```

## 7.1.1.4.2.5.2 Conformance requirements

References: The conformance requirements covered in the present TC are specified in: TS 38.212 clause 7.3.1.1.1, TS 38.214 clause 6.1.2.1, 6.1.2.2, 6.1.2.2.2, 6.1.4.1, 5.1.3.1, 6.1.4.2 and 5.1.3.2. Unless otherwise stated these are Rel-15 requirements.

[TS 38.212, clause 7.3.1.1.1]

DCI format 0\_0 is used for the scheduling of PUSCH in one cell.

The following information is transmitted by means of the DCI format 0\_0 with CRC scrambled by C-RNTI or CS-RNTI or new-RNTI:

- Identifier for DCI formats – 1 bit
  - The value of this bit field is always set to 0, indicating an UL DCI format
- Frequency domain resource assignment –  $\lceil \log_2(N_{RB}^{UL,BWP}(N_{RB}^{UL,BWP} + 1)/2) \rceil$  bits where
  - $N_{RB}^{UL,BWP}$  is the size of the active UL bandwidth part in case DCI format 0\_0 is monitored in the UE specific search space and satisfying
    - the total number of different DCI sizes monitored per slot is no more than 4 for the cell, and
    - the total number of different DCI sizes with C-RNTI monitored per slot is no more than 3 for the cell
  - otherwise,  $N_{RB}^{UL,BWP}$  is the size of the initial UL bandwidth part.
- For PUSCH hopping with resource allocation type 1:
  - $N_{UL\_hop}$  MSB bits are used to indicate the frequency offset according to Subclause 6.3 of [6, TS 38.214], where  $N_{UL\_hop} = 1$  if the higher layer parameter *frequencyHoppingOffsetLists* contains two offset values and  $N_{UL\_hop} = 2$  if the higher layer parameter *frequencyHoppingOffsetLists* contains four offset values
  - $\lceil \log_2(N_{RB}^{UL,BWP}(N_{RB}^{UL,BWP} + 1)/2) \rceil - N_{UL\_hop}$  bits provides the frequency domain resource allocation according to Subclause 6.1.2.2.2 of [6, TS 38.214]
- For non-PUSCH hopping with resource allocation type 1:
  - $\lceil \log_2(N_{RB}^{UL,BWP}(N_{RB}^{UL,BWP} + 1)/2) \rceil$  bits provides the frequency domain resource allocation according to Subclause 6.1.2.2.2 of [6, TS 38.214]
- Time domain resource assignment – 4 bits as defined in Subclause 6.1.2.1 of [6, TS 38.214]

- Frequency hopping flag – 1 bit.
- Modulation and coding scheme – 5 bits as defined in Subclause 6.1.3 of [6, TS 38.214]
- New data indicator – 1 bit
- Redundancy version – 2 bits as defined in Table 7.3.1.1.1-2
- HARQ process number – 4 bits
- TPC command for scheduled PUSCH – 2 bits as defined in Subclause 7.1.1 of [5, TS 38.213]
- Padding bits, if required.
- UL/SUL indicator – 1 bit for UEs configured with SUL in the cell as defined in Table 7.3.1.1.1-1 and the number of bits for DCI format 1\_0 before padding is larger than the number of bits for DCI format 0\_0 before padding; 0 bit otherwise. The UL/SUL indicator, if present, locates in the last bit position of DCI format 0\_0, after the padding bit(s).
  - If the UL/SUL indicator is present in DCI format 0\_0 and the higher layer parameter *pusch-Config* is not configured on both UL and SUL the UE ignores the UL/SUL indicator field in DCI format 0\_0, and the corresponding PUSCH scheduled by the DCI format 0\_0 is for the UL or SUL for which high layer parameter *pucch-Config* is configured;
  - If the UL/SUL indicator is not present in DCI format 0\_0, the corresponding PUSCH scheduled by the DCI format 0\_0 is for the UL or SUL for which high layer parameter *pucch-Config* is configured.

The following information is transmitted by means of the DCI format 0\_0 with CRC scrambled by TC-RNTI:

- Identifier for DCI formats – 1 bit
  - The value of this bit field is always set to 0, indicating an UL DCI format
- Frequency domain resource assignment –  $\lceil \log_2(N_{RB}^{UL,BWP}(N_{RB}^{UL,BWP} + 1)/2) \rceil$  bits where
  - $N_{RB}^{UL,BWP}$  is the size of the initial UL bandwidth part.
  - For PUSCH hopping with resource allocation type 1:
    - $N_{UL\_hop}$  MSB bits are used to indicate the frequency offset according to Subclause 6.3 of [6, TS 38.214], where  $N_{UL\_hop} = 1$  if  $N_{RB}^{UL,BWP} < 50$  and  $N_{UL\_hop} = 2$  otherwise
    - $\lceil \log_2(N_{RB}^{UL,BWP}(N_{RB}^{UL,BWP} + 1)/2) \rceil - N_{UL\_hop}$  bits provides the frequency domain resource allocation according to Subclause 6.1.2.2.2 of [6, TS 38.214]
  - For non-PUSCH hopping with resource allocation type 1:
    - $\lceil \log_2(N_{RB}^{UL,BWP}(N_{RB}^{UL,BWP} + 1)/2) \rceil$  bits provides the frequency domain resource allocation according to Subclause 6.1.2.2.2 of [6, TS 38.214]
- Time domain resource assignment – 4 bits as defined in Subclause 6.1.2.1 of [6, TS 38.214]
- Frequency hopping flag – 1 bit.
- Modulation and coding scheme – 5 bits as defined in Subclause 6.1.3 of [6, TS 38.214], using Table 5.1.3.1-1
- New data indicator – 1 bit, reserved
- Redundancy version – 2 bits as defined in Table 7.3.1.1.1-2
- HARQ process number – 4 bits, reserved
- TPC command for scheduled PUSCH – 2 bits as defined in Subclause 7.1.1 of [5, TS 38.213]
- Padding bits, if required.

- UL/SUL indicator – 1 bit if the cell has two ULs and the number of bits for DCI format 1\_0 before padding is larger than the number of bits for DCI format 0\_0 before padding; 0 bit otherwise. The UL/SUL indicator, if present, locates in the last bit position of DCI format 0\_0, after the padding bit(s).
- If 1 bit, reserved, and the corresponding PUSCH is always on the same UL carrier as the previous transmission of the same TB

If DCI format 0\_0 is monitored in common search space and if the number of information bits in the DCI format 0\_0 prior to padding is less than the payload size of the DCI format 1\_0 monitored in common search space for scheduling the same serving cell, zeros shall be appended to the DCI format 0\_0 until the payload size equals that of the DCI format 1\_0.

If DCI format 0\_0 is monitored in common search space and if the number of information bits in the DCI format 0\_0 prior to padding is larger than the payload size of the DCI format 1\_0 monitored in common search space for scheduling the same serving cell, the bit width of the frequency domain resource allocation field in the DCI format 0\_0 is reduced by truncating the first few most significant bits such that the size of DCI format 0\_0 equals to the size of the DCI format 1\_0.

If DCI format 0\_0 is monitored in UE specific search space but does not satisfy at least one of the following

- the total number of different DCI sizes monitored per slot is no more than 4 for the cell, and
- the total number of different DCI sizes with C-RNTI monitored per slot is no more than 3 for the cell

and if the number of information bits in the DCI format 0\_0 prior to padding is less than the payload size of the DCI format 1\_0 monitored in common search space for scheduling the same serving cell, zeros shall be appended to the DCI format 0\_0 until the payload size equals that of the DCI format 1\_0.

If DCI format 0\_0 is monitored in UE specific search space but does not satisfy at least one of the following

- the total number of different DCI sizes monitored per slot is no more than 4 for the cell, and
- the total number of different DCI sizes with C-RNTI monitored per slot is no more than 3 for the cell

and if the number of information bits in the DCI format 0\_0 prior to padding is larger than the payload size of the DCI format 1\_0 monitored in common search space for scheduling the same serving cell, the bit width of the frequency domain resource allocation field in the DCI format 0\_0 is reduced by truncating the first few most significant bits such that the size of DCI format 0\_0 equals to the size of the DCI format 1\_0.

If DCI format 0\_0 is monitored in UE specific search space and satisfies both of the following

- the total number of different DCI sizes monitored per slot is no more than 4 for the cell, and
- the total number of different DCI sizes with C-RNTI monitored per slot is no more than 3 for the cell

and if the number of information bits in the DCI format 0\_0 prior to padding is less than the payload size of the DCI format 1\_0 monitored in UE specific search space for scheduling the same serving cell, zeros shall be appended to the DCI format 0\_0 until the payload size equals that of the DCI format 1\_0.

[TS 38.214, clause 6.1.2.1]

When the UE is scheduled to transmit a transport block and no CSI report, or the UE is scheduled to transmit a transport block and a CSI report on PUSCH by a DCI, the *Time domain resource assignment* field value  $m$  of the DCI provides a row index  $m + 1$  to an allocated table. The determination of the used resource allocation table is defined in sub-clause 6.1.2.1.1. The indexed row defines the slot offset  $K_2$ , the start and length indicator *SLIV*, or directly the start symbol  $S$  and the allocation length  $L$ , and the PUSCH mapping type to be applied in the PUSCH transmission.

When the UE is scheduled to transmit a PUSCH with no transport block and with a CSI report by a *CSI request* field on a DCI, the *Time-domain resource assignment* field value  $m$  of the DCI provides a row index  $m + 1$  to an allocated table. The determination of the applied resource allocation table is defined in sub-clause 6.1.2.1.1. The indexed row defines the start and length indicator *SLIV*, or directly the start symbol  $S$  and the allocation length  $L$ , and the PUSCH mapping type to be applied in the PUSCH transmission and  $K_2$  is determined based on the corresponding list entries  $Y_j, j = 0, \dots, N_{\text{Rep}} - 1$  of the higher layer parameter *reportSlotConfig* in *CSI-ReportConfig* for the  $N_{\text{Rep}}$  triggered CSI Reporting Settings. The  $i$ th codepoint of  $K_2$  is determined as  $K_2 = \max_j Y_j(i)$  where  $Y_j(i)$  is the  $i$ th codepoint of  $Y_j$ .

- The slot where the UE shall transmit the PUSCH is determined by  $K_2$  as  $\left\lceil n \cdot \frac{2^{\mu_{\text{PUSCH}}}}{2^{\mu_{\text{PDCCH}}}} \right\rceil + K_2$  where  $n$  is the slot with the scheduling DCI,  $K_2$  is based on the numerology of PUSCH, and  $\mu_{\text{PUSCH}}$  and  $\mu_{\text{PDCCH}}$  are the subcarrier spacing configurations for PUSCH and PDCCH, respectively, and
- The starting symbol  $S$  relative to the start of the slot, and the number of consecutive symbols  $L$  counting from the symbol  $S$  allocated for the PUSCH are determined from the start and length indicator  $SLIV$  of the indexed row:
 

if  $(L-1) \leq 7$  then

$$SLIV = 14 \cdot (L-1) + S$$

else

$$SLIV = 14 \cdot (14-L+1) + (14-1-S)$$

where  $0 < L \leq 14 - S$ , and
- The PUSCH mapping type is set to Type A or Type B as defined in Subclause 6.4.1.1.3 of [4, TS 38.211] as given by the indexed row.

The UE shall consider the  $S$  and  $L$  combinations defined in table 6.1.2.1-1 as valid PUSCH allocations

**Table 6.1.2.1-1: Valid  $S$  and  $L$  combinations**

PUSCH mapping type	Normal cyclic prefix			Extended cyclic prefix		
	$S$	$L$	$S+L$	$S$	$L$	$S+L$
Type A	0	{4,...,14}	{4,...,14}	0	{4,...,12}	{4,...,12}
Type B	{0,...,13}	{1,...,14}	{1,...,14}	{0,...,12}	{1,...,12}	{1,...,12}

When the UE is configured with  $aggregationFactorUL > 1$ , the same symbol allocation is applied across the  $aggregationFactorUL$  consecutive slots and the PUSCH is limited to a single transmission layer. The UE shall repeat the TB across the  $aggregationFactorUL$  consecutive slots applying the same symbol allocation in each slot. The redundancy version to be applied on the  $n^{\text{th}}$  transmission occasion of the TB is determined according to table 6.1.2.1-2.

**Table 6.1.2.1-2: Redundancy version when  $aggregationFactorUL > 1$**

$r_{vid}$ indicated by the DCI scheduling the PUSCH	$r_{vid}$ to be applied to $n^{\text{th}}$ transmission occasion			
	$n \bmod 4 = 0$	$n \bmod 4 = 1$	$n \bmod 4 = 2$	$n \bmod 4 = 3$
0	0	2	3	1
2	2	3	1	0
3	3	1	0	2
1	1	0	2	3

If the UE procedure for determining slot configuration, as defined in subclause 11.1 of [6, TS 38.213], determines symbols of a slot allocated for PUSCH as downlink symbols, the transmission on that slot is omitted for multi-slot PUSCH transmission.

[38.214 clause 6.1.2.2]

The UE shall determine the resource block assignment in frequency domain using the resource allocation field in the detected PDCCH DCI. Two uplink resource allocation schemes type 0 and type 1 are supported. Uplink resource allocation scheme type 0 is supported for PUSCH only when transform precoding is disabled. Uplink resource allocation scheme type 1 is supported for PUSCH for both cases when transform precoding is enabled or disabled.

If the scheduling DCI is configured to indicate the uplink resource allocation type as part of the *Frequency domain resource* assignment field by setting a higher layer parameter *resourceAllocation* in *pusch-Config* to ‘dynamicswitch’, the UE shall use uplink resource allocation type 0 or type 1 as defined by this DCI field. Otherwise the UE shall use the uplink frequency resource allocation type as defined by the higher layer parameter *resourceAllocation*.

The UE shall assume that when the scheduling PDCCH is received with DCI format 0\_0, then uplink resource allocation type 1 is used.

If a bandwidth part indicator field is not configured in the scheduling DCI, the RB indexing for uplink type 0 and type 1 resource allocation is determined within the UE's active bandwidth part. If a bandwidth part indicator field is configured in the scheduling DCI, the RB indexing for uplink type 0 and type 1 resource allocation is determined within the UE's bandwidth part indicated by bandwidth part indicator field value in the DCI, except for the case when DCI format 0\_0 is decoded in any PDCCH common search space in CORESET 0 in which case the initial bandwidth part shall be used. The UE shall upon detection of PDCCH intended for the UE determine first the uplink bandwidth part and then the resource allocation within the bandwidth part.

[38.214 clause 6.1.2.2.2]

n uplink resource allocation of type 1, the resource block assignment information indicates to a scheduled UE a set of contiguously allocated non-interleaved virtual resource blocks within the active carrier bandwidth part of size  $N_{BWP}^{size}$  PRBs except for the case when DCI format 0\_0 is decoded in the Type0-PDCCH common search space in CORESET 0 in which case the initial bandwidth part of size  $N_{BWP}^{size}$  shall be used.

An uplink type 1 resource allocation field consists of a resource indication value ( $RIV$ ) corresponding to a starting virtual resource block ( $RB_{start}$ ) and a length in terms of contiguously allocated resource blocks  $L_{RBs}$ . The resource indication value is defined by

if  $(L_{RBs} - 1) \leq \lfloor N_{BWP}^{size} / 2 \rfloor$  then

$$RIV = N_{BWP}^{size} (L_{RBs} - 1) + RB_{start}$$

else

$$RIV = N_{BWP}^{size} (N_{BWP}^{size} - L_{RBs} + 1) + (N_{BWP}^{size} - 1 - RB_{start})$$

where  $L_{RBs} \geq 1$  and shall not exceed  $N_{BWP}^{size} - RB_{start}$ .

[TS 38.214, clause 6.1.4.1]

For the PUSCH assigned by a DCI format 0\_0/0\_1 with CRC scrambled by C-RNTI, new-RNTI, TC-RNTI, or SP-CSI-RNTI, the transform precoding is enabled if *transformPrecoder* in *PUSCH-Config* is set to 'enabled', or if *transformPrecoder* in *PUSCH-Config* is not configured and *msg3-transformPrecoding* in *rach-ConfigCommon* is set to 'enabled'; otherwise the transform precoding is disabled.

For the PUSCH assigned by a DCI format 0\_0/0\_1 with CRC scrambled by CS-RNTI, or the PUSCH with configured grant using CS-RNTI, the transform precoding is enabled if *transformPrecoder* in *ConfiguredGrantConfig* is set to 'enabled'; otherwise the transform precoding is disabled.

For a PUSCH scheduled by RAR UL grant or for a PUSCH scheduled by a DCI format 0\_0/0\_1 with CRC scrambled by C-RNTI, TC-RNTI, or CS-RNTI, or for a PUSCH with configured grant using CS-RNTI,

if *transformPrecoder* is disabled for this PUSCH transmission

...

else

- if *mcs-TableTransformPrecoder* in *PUSCH-Config* is set to 'qam256', and the PUSCH is scheduled with C-RNTI or SP-CSI-RNTI, and PUSCH is assigned by DCI format 0\_1,
- the UE shall use  $I_{MCS}$  and Table 5.1.3.1.-2 to determine the modulation order ( $Q_m$ ) and Target code rate ( $R$ ) used in the physical uplink shared channel.
- elseif the UE is not configured with new-RNTI, *mcs-TableTransformPrecoder* in *PUSCH-Config* is set to 'qam64LowSE', and the PUSCH is scheduled with C-RNTI, or SP-CSI-RNTI, and the PUSCH is assigned by a PDCCH in a UE-specific search space,

- the UE shall use  $I_{MCS}$  and Table 6.1.4.1-2 to determine the modulation order ( $Q_m$ ) and Target code rate ( $R$ ) used in the physical uplink shared channel.
- elseif the UE is configured with new-RNTI, and the PUSCH is scheduled with new-RNTI,
  - the UE shall use  $I_{MCS}$  and Table 6.1.4.1-2 to determine the modulation order ( $Q_m$ ) and Target code rate ( $R$ ) used in the physical uplink shared channel.
- elseif *mcs-TableTransformPrecoder* in *ConfiguredGrantConfig* is set to 'qam256', and PUSCH is scheduled with CS-RNTI,
  - the UE shall use  $I_{MCS}$  and Table 5.1.3.1-2 to determine the modulation order ( $Q_m$ ) and Target code rate ( $R$ ) used in the physical uplink shared channel.
- elseif *mcs-TableTransformPrecoder* in *ConfiguredGrantConfig* is set to 'qam64LowSE', and PUSCH is scheduled with CS-RNTI,
  - the UE shall use  $I_{MCS}$  and Table 6.1.4.1-2 to determine the modulation order ( $Q_m$ ) and Target code rate ( $R$ ) used in the physical uplink shared channel.
- else
  - the UE shall use  $I_{MCS}$  and Table 6.1.4.1-1 to determine the modulation order ( $Q_m$ ) and Target code rate ( $R$ ) used in the physical uplink shared channel.

end

For Table 6.1.4.1-1 and Table 6.1.4.1-2, if higher layer parameter *PUSCH-tp-pi2BPSK* is configured,  $q = 1$  otherwise  $q=2$ .

Table 6.1.4.1-1: MCS index table for PUSCH with transform precoding and 64QAM

MCS Index $I_{MCS}$	Modulation Order $Q_m$	Target code Rate R x 1024	Spectral efficiency
0	q	240/ q	0.2344
1	q	314/ q	0.3066
2	2	193	0.3770
3	2	251	0.4902
4	2	308	0.6016
5	2	379	0.7402
6	2	449	0.8770
7	2	526	1.0273
8	2	602	1.1758
9	2	679	1.3262
10	4	340	1.3281
11	4	378	1.4766
12	4	434	1.6953
13	4	490	1.9141
14	4	553	2.1602
15	4	616	2.4063
16	4	658	2.5703
17	6	466	2.7305
18	6	517	3.0293
19	6	567	3.3223
20	6	616	3.6094
21	6	666	3.9023
22	6	719	4.2129
23	6	772	4.5234
24	6	822	4.8164
25	6	873	5.1152
26	6	910	5.3320
27	6	948	5.5547
28	q	reserved	
29	2	reserved	
30	4	reserved	
31	6	reserved	

[TS 38.214, clause 6.1.4.2]

For a PUSCH scheduled by RAR UL grant or for a PUSCH scheduled by a DCI format 0\_0/0\_1 with CRC scrambled by C-RNTI, new-RNTI, TC-RNTI, CS-RNTI, or SP-CSI-RNTI.

if

- $0 \leq I_{MCS} \leq 27$  and transform precoding is disabled and Table 5.1.3.1-2 is used, or
- $0 \leq I_{MCS} \leq 28$  and transform precoding is disabled and a table other than Table 5.1.3.1-2 is used, or
- $0 \leq I_{MCS} \leq 27$  and transform precoding is enabled, the UE shall first determine the TBS as specified below:

The UE shall first determine the number of REs ( $N_{RE}$ ) within the slot:

- A UE first determines the number of REs allocated for PUSCH within a PRB ( $N'_{RE}$ ) by
- $N'_{RE} = N_{sc}^{RB} * N_{symp}^{sh} - N_{DMRS}^{PRB} - N_{oh}^{PRB}$ , where  $N_{sc}^{RB} = 12$  is the number of subcarriers in the frequency domain in a physical resource block,  $N_{symp}^{sh}$  is the number of symbols of the PUSCH allocation within the slot,  $N_{DMRS}^{PRB}$  is the number of REs for DM-RS per PRB in the scheduled duration including the overhead of the DM-RS CDM groups without data, as indicated by DCI format 0\_1 or as described for DCI format 0\_0 in Subclause 6.2.2, and  $N_{oh}^{PRB}$  is the overhead configured by higher layer parameter  $xOverhead$  in PUSCH-



*ServingCellConfig*. If the  $N_{oh}^{PRB}$  is not configured (a value from 0, 6, 12, or 18), the  $N_{oh}^{PRB}$  is assumed to be 0. For MSG3 transmission the  $N_{oh}^{PRB}$  is always set to 0..

- A UE determines the total number of REs allocated for PUSCH ( $N_{RE}$ ) by  $N_{RE} = \min(156, N_{RE}') \cdot n_{PRB}$  where  $n_{PRB}$  is the total number of allocated PRBs for the UE.
- Next, proceed with steps 2-4 as defined in Subclause 5.1.3.2

else if

- $28 \leq I_{MCS} \leq 31$  and transform precoding is disabled and Table 5.1.3.1-2 is used, or
- $28 \leq I_{MCS} \leq 31$  and transform precoding is enabled,
- the TBS is assumed to be as determined from the DCI transported in the latest PDCCH for the same transport block using  $0 \leq I_{MCS} \leq 27$ . If there is no PDCCH for the same transport block using  $0 \leq I_{MCS} \leq 27$ , and if the initial PUSCH for the same transport block is transmitted with configured grant, the TBS shall be determined from the most recent configured scheduling PDCCH.

else

- the TBS is assumed to be as determined from the DCI transported in the latest PDCCH for the same transport block using  $0 \leq I_{MCS} \leq 28$ . If there is no PDCCH for the same transport block using  $0 \leq I_{MCS} \leq 28$ , and if the initial PUSCH for the same transport block is transmitted with configured grant, the TBS shall be determined from the most recent configured scheduling PDCCH.

[TS 38.214, clause 5.1.3.2]

2) Intermediate number of information bits ( $N_{info}$ ) is obtained by  $N_{info} = N_{RE} \cdot R \cdot Q_m \cdot \nu$ .

If  $N_{info} \leq 3824$

Use step 3 as the next step of the TBS determination

else

Use step 4 as the next step of the TBS determination

end if

3) When  $N_{info} \leq 3824$ , TBS is determined as follows

- quantized intermediate number of information bits  $N_{info}' = \max\left(24, 2^n \cdot \left\lfloor \frac{N_{info}}{2^n} \right\rfloor\right)$ , where  $n = \max(3, \lfloor \log_2(N_{info}) \rfloor - 6)$ .
- use Table 5.1.3.2-2 find the closest TBS that is not less than  $N_{info}'$ .

Table 5.1.3.2-2: TBS for  $N_{info} \leq 3824$ 

Index	TBS	Index	TBS	Index	TBS	Index	TBS
1	24	31	336	61	1288	91	3624
2	32	32	352	62	1320	92	3752
3	40	33	368	63	1352	93	3824
4	48	34	384	64	1416		
5	56	35	408	65	1480		
6	64	36	432	66	1544		
7	72	37	456	67	1608		
8	80	38	480	68	1672		
9	88	39	504	69	1736		
10	96	40	528	70	1800		
11	104	41	552	71	1864		
12	112	42	576	72	1928		
13	120	43	608	73	2024		
14	128	44	640	74	2088		
15	136	45	672	75	2152		
16	144	46	704	76	2216		
17	152	47	736	77	2280		
18	160	48	768	78	2408		
19	168	49	808	79	2472		
20	176	50	848	80	2536		
21	184	51	888	81	2600		
22	192	52	928	82	2664		
23	208	53	984	83	2728		
24	224	54	1032	84	2792		
25	240	55	1064	85	2856		
26	256	56	1128	86	2976		
27	272	57	1160	87	3104		
28	288	58	1192	88	3240		
29	304	59	1224	89	3368		
30	320	60	1256	90	3496		

4) When  $N_{info} > 3824$ , TBS is determined as follows.

- quantized intermediate number of information bits  $N'_{info} = \max\left(3840, 2^n \times \text{round}\left(\frac{N_{info} - 24}{2^n}\right)\right)$ , where  $n = \lfloor \log_2(N_{info} - 24) \rfloor - 5$  and ties in the round function are broken towards the next largest integer.
- if  $R \leq 1/4$

$$TBS = 8 \cdot C \cdot \left\lceil \frac{N'_{info} + 24}{8 \cdot C} \right\rceil - 24, \text{ where } C = \left\lceil \frac{N'_{info} + 24}{3816} \right\rceil$$

else

if  $N'_{info} > 8424$

$$TBS = 8 \cdot C \cdot \left\lceil \frac{N'_{info} + 24}{8 \cdot C} \right\rceil - 24, \text{ where } C = \left\lceil \frac{N'_{info} + 24}{8424} \right\rceil$$

else

$$TBS = 8 \cdot \left\lceil \frac{N'_{info} + 24}{8} \right\rceil - 24$$

end if

end if

7.1.1.4.2.5.3 Test description

7.1.1.4.2.5.3.1 Pre-test conditions

Same Pre-test conditions as in clause 7.1.1.0 except set the NR Cell bandwidth and applicable BWP to maximum for the NR Band under test as specified in Table 5.3.5-1 in TS 38.101-1 [16] / TS 38.101-2 [17] (to enable testing of  $n_{PRB}$  up to maximum value).

7.1.1.4.2.5.3.2 Test procedure sequence

**Table 7.1.1.4.2.5.3.2-1: Maximum TBS for different UE categories**

UE Category	Maximum number of bits of a UL-SCH transport block received within a TTI
TS 38.306 [23] clause 4.1.2 require UE without <i>ue-CategoryDL</i> and <i>ue-CategoryUL</i> , to support Max TBS achievable based on max bandwidth of the Band under test.	

**Table 7.1.1.4.2.5.3.2-2: Number of uplink PDCP SDUs and PDCP SDU size used as test data**

TBS [bits]	Number of PDCP SDUs	PDCP SDU size [bits] (Note 1)
$132 \leq TBS \leq 12128$ note 2	1	$8 * \text{FLOOR}((TBS - 128)/8)$
$12129 \leq TBS \leq 24200$	2	$8 * \text{FLOOR}((TBS - 200)/16)$
$24201 \leq TBS \leq 36272$	3	$8 * \text{FLOOR}((TBS - 272)/24)$
$36273 \leq TBS \leq 48344$	4	$8 * \text{FLOOR}((TBS - 344)/32)$
$48345 \leq TBS \leq 60416$	5	$8 * \text{FLOOR}((TBS - 416)/40)$
$60417 \leq TBS \leq 72488$	6	$8 * \text{FLOOR}((TBS - 488)/48)$
$72489 \leq TBS \leq 84560$	7	$8 * \text{FLOOR}((TBS - 560)/56)$
$84561 \leq TBS \leq 96632$	8	$8 * \text{FLOOR}((TBS - 632)/64)$
$96633 < TBS \leq 108704$	9	$8 * \text{FLOOR}((TBS - 704)/72)$
$10705 \leq TBS \leq 120776$	10	$8 * \text{FLOOR}((TBS - 776)/80)$
$120777 \leq TBS \leq 132848$	11	$8 * \text{FLOOR}((TBS - 848)/88)$
$132849 \leq TBS \leq 144920$	12	$8 * \text{FLOOR}((TBS - 920)/96)$
$TBS > 144920$	13	$8 * \text{FLOOR}((TBS - 992)/112)$

Note 1: Each PDCP SDU is limited to 1500 octets (to keep below maximum SDU size of ESM as specified in TS 24.301 [21] clause 9.9.4.12).

The PDCP SDU size of each PDCP SDU is

PDCP SDU size = (TBS – N\*PDCP header size – N\*AMD PDU header size – N\*MAC header size – Size of Timing Advance – RLC Status PDU size- MAC header for RLC Status PDU) / N, where

PDCP header size is 24 bits for the RLC AM and 18-bit SN case;  
AMD PDU header size is 24 bits with 18 bit SN;

MAC header size for AMD PDU = 16 or 24 bits depending on L=8 or 16 bits. Worst case 24 is taken.

Size of Timing Advance MAC CE with header is 16 bits (if no Timing Advance and/or RLC status needs to be sent, padding will occur instead).

RLC Status PDU size = 24 bits with 1 ACK\_SN, With a MAC header of 16 bits.

This gives:

PDCP SDU size =  $8 * \text{FLOOR}((TBS - N * 24 - N * 24 - N * 24 - 56) / (8 * N))$  bits.

Note 2: According to the final PDCP SDU size formula in Note 1, the smallest TBS that can be tested is 136 bits.

**Table 7.1.1.4.2.5.3.2-3: Specific Parameters**

Parameter	Value	Comment
PUSCH mappingType	typeA	
starting symbol S	0	
number of consecutive symbols L	4..14	
K <sub>2</sub>	Not present	UE applies the value 01 when PUSCH SCS is 15/30KHz; 2 when PUSCH SCS is 60KHz and 3 when PUSCH SCS is 120KHz
number of layers (v)	1	
transformPrecoder	enabled	
xoh-PUSCH( $N_{oh}^{PRB}$ )	Not present	Results in value 0(xoh0)
dmrs-AdditionalPosition	pos0	Results in 1 DMRS symbol per two carrier ( $N_{DMRS}^{PRB}$ ) for Duration in symbols $\geq 4$

**Table 7.1.1.4.2.5.3.2-4: Main behaviour**

St	Procedure	Message Sequence		TP	Verdict
		U - S	Message		
-	EXCEPTION: Steps 1 to 5 are repeated for allowed values of $N_{PRB}$ 1 to $N_{RB}^{UL,BWP}$ in BWP, time domain resource length L 4 to 14- S and $I_{MCS}$ from 0 to 28.	-	-	-	-
1	The SS calculates or looks up TBS in TS 38.214 [15] based on the value of S, L, $I_{MCS}$ and $n_{PRB}$ .	-	-	-	-
-	EXCEPTION: Steps 2 to 5 are performed if TBS is less than or equal to UE capability "Maximum number of UL-SCH transport block bits received within a TTI" as specified in Table 7.1.1.4.2.5.3.2-1 and larger than or equal to 136 bits as specified in Table 7.1.1.4.2.5.3.2-2	-	-	-	-
2	The SS creates one or more PDCP SDUs, depending on TBS, in accordance with Table 7.1.1.4.2.5.3.2-2.	-	-	-	-
3	After 300ms, the SS transmits all PDCP SDUs ( $N_{SDUs}$ ) as created in step 2 in a MAC PDU.	<--	MAC PDU (N x PDCP SDUs)	-	-
4	After 60ms of step 3, SS transmits UL Grant DCI 0_0, and values of S, L, $I_{MCS}$ and $n_{PRB}$ .	<--	(UL Grant) (DCI Format 0_0, S, L, $I_{MCS}$ and $n_{PRB}$ .)	-	-
5	CHECK: Does UE return the same number of PDCP SDUs with same content as transmitted by the SS in step 3 using Time, frequency Resources and modulation and coding scheme as configured by the SS in step 4?	-->	MAC PDU (N x PDCP SDU)	1	P

7.1.1.4.2.5.3.3 Specific message contents

[None]

### 7.1.1.5 Discontinuous reception

#### 7.1.1.5.1 DRX operation / Short cycle not configured / Parameters configured by RRC

(1)

```
with { UE in RRC_CONNECTED state }
ensure that {
  when { Long DRX cycle is configured and [(SFN * 10) + subframe number] modulo (drx-LongCycle) =
drx-StartOffset }
  then { UE starts the OnDurationTimer and monitors the PDCCH for OnDurationTimer PDCCH-Occasions}
}
```

(2)

```
with { UE in RRC_CONNECTED state }
ensure that {
  when { Long DRX cycle is configured and a new DL transmission is indicated on the PDCCH during
Active Time }
  then { UE starts or restarts the Drx-InactivityTimer and monitors the PDCCH for Drx-
InactivityTimer PDCCH occasions starting from the next PDCCH occasion of the PDCCH occasion where
the DL new transmission was indicated }
}
```

(3)

```
with { UE in RRC_CONNECTED state }
ensure that {
  when { Long DRX cycle is configured and if a HARQ RTT Timer expires in this PDCCH Occasion and the
data in the soft buffer of the corresponding HARQ process was not successfully decoded }
  then { UE starts the drx-RetransmissionTimer-DL for the corresponding HARQ process and monitors
the PDCCH for drx-RetransmissionTimer consecutive PDCCH Occasion }
}
```

(4)

```
with { UE in RRC_CONNECTED state }
ensure that {
  when { Long DRX cycle is configured and an uplink grant for a pending HARQ retransmission can
occur in this PDCCH occasion}
  then { UE monitors the PDCCH in this PDCCH occasion }
}
```

#### 7.1.1.5.1.2 Conformance requirements

References: The conformance requirements covered in the present TC are specified in: TS 38.321, clause 5.7. Unless otherwise stated these are Rel-15 requirements.

[TS 38.321, clause 5.7]

The MAC entity may be configured by RRC with a DRX functionality that controls the UE's PDCCH monitoring. When in RRC\_CONNECTED, if DRX is configured, the MAC entity may monitor the PDCCH discontinuously using the DRX operation specified in this subclause; otherwise the MAC entity shall monitor the PDCCH continuously. When using DRX operation, the MAC entity shall monitor PDCCH according to requirements found in this specification.

RRC controls DRX operation by configuring the following timers:

- *drx-onDurationTimer*: the duration at the beginning of a DRX Cycle;
- *drx-SlotOffset*: the delay in slots before starting the *drx-onDurationTimer*;
- *drx-InactivityTimer*: the duration after the PDCCH occasion in which a PDCCH indicates an initial UL or DL user data transmission for the MAC entity;
- *drx-RetransmissionTimerDL* (per DL HARQ process): the maximum duration until a DL retransmission is received;
- *drx-RetransmissionTimerUL* (per UL HARQ process): the maximum duration until a grant for UL retransmission is received;

- *drx-LongCycle*: the Long DRX cycle;
- *drx-ShortCycle* (optional): the Short DRX cycle;
- *drx-ShortCycleTimer* (optional): the duration the UE shall follow the Short DRX cycle;
- *drx-HARQ-RTT-TimerDL* (per DL HARQ process): the minimum duration before a DL assignment for HARQ retransmission is expected by the MAC entity;
- *drx-HARQ-RTT-TimerUL* (per UL HARQ process): the minimum duration before a UL HARQ retransmission grant is expected by the MAC entity.

When a DRX cycle is configured, the Active Time includes the time while:

- *drx-onDurationTimer* or *drx-InactivityTimer* or *drx-RetransmissionTimerDL* or *drx-RetransmissionTimerUL* or *ra-ContentionResolutionTimer* (as described in subclause 5.1.5) is running; or
- a Scheduling Request is sent on PUCCH and is pending (as described in subclause 5.4.4); or
- a PDCCH indicating a new transmission addressed to the C-RNTI of the MAC entity has not been received after successful reception of a Random Access Response for the preamble not selected by the MAC entity (as described in subclause 5.1.4).

When DRX is configured, the MAC entity shall:

- 1> if a *drx-HARQ-RTT-TimerDL* expires:
  - 2> if the data of the corresponding HARQ process was not successfully decoded:
    - 3> start the *drx-RetransmissionTimerDL* for the corresponding HARQ process.
- 1> if an *drx-HARQ-RTT-TimerUL* expires:
  - 2> start the *drx-RetransmissionTimerUL* for the corresponding HARQ process.
- 1> if a DRX Command MAC CE or a Long DRX Command MAC CE is received:
  - 2> stop *drx-onDurationTimer*;
  - 2> stop *drx-InactivityTimer*.
- 1> if *drx-InactivityTimer* expires or a DRX Command MAC CE is received:
  - 2> if the Short DRX cycle is configured:
    - 3> start or restart *drx-ShortCycleTimer*;
    - 3> use the Short DRX Cycle.
  - 2> else:
    - 3> use the Long DRX cycle.
- 1> if *drx-ShortCycleTimer* expires:
  - 2> use the Long DRX cycle.
- 1> if a Long DRX Command MAC CE is received:
  - 2> stop *drx-ShortCycleTimer*;
  - 2> use the Long DRX cycle.
- 1> if the Short DRX Cycle is used, and  $[(\text{SFN} * 10) + \text{subframe number}] \bmod (\text{drx-ShortCycle}) = (\text{drx-StartOffset}) \bmod (\text{drx-ShortCycle})$ ; or
- 1> if the Long DRX Cycle is used, and  $[(\text{SFN} * 10) + \text{subframe number}] \bmod (\text{drx-LongCycle}) = \text{drx-StartOffset}$ :

2> if *drx-SlotOffset* is configured:

3> start *drx-onDurationTimer* after *drx-SlotOffset*.

2> else:

3> start *drx-onDurationTimer*.

1> if the MAC entity is in Active Time:

2> monitor the PDCCH;

2> if the PDCCH indicates a DL transmission or if a DL assignment has been configured:

3> start the *drx-HARQ-RTT-TimerDL* for the corresponding HARQ process immediately after the corresponding PUCCH transmission;

3> stop the *drx-RetransmissionTimerDL* for the corresponding HARQ process.

2> if the PDCCH indicates a UL transmission or if a UL grant has been configured:

3> start the *drx-HARQ-RTT-TimerUL* for the corresponding HARQ process immediately after the first repetition of the corresponding PUSCH transmission;

3> stop the *drx-RetransmissionTimerUL* for the corresponding HARQ process.

2> if the PDCCH indicates a new transmission (DL or UL):

3> start or restart *drx-InactivityTimer*.

1> else (i.e. not part of the Active Time):

2> not report CQI/PMI/RI on PUCCH.

#### 7.1.1.5.1.3 Test description

##### 7.1.1.5.1.3.1 Pre-test conditions

Same Pre-test conditions as in clause 7.1.1.0 except that set to return no data in uplink.

##### 7.1.1.5.1.3.2 Test procedure sequence

For FDD,  $NormalSLT(\text{current SFN}, \text{current subframe}, \text{current slot}, y) = y$ ; For TDD,  $NormalSLT(\text{current SFN}, \text{current slot}, y)$  counts the minimum number of normal slots needed to cover  $y$  number of PDCCH-occasions(slots) until next PDCCH-occasion(slot) available, starting from current slot on current subframe.

**Table 7.1.1.5.1.3.2-1: Main behaviour**



St	Procedure	Message Sequence		TP	Verdict
		U - S	Message		
1	SS transmits RRCConnectionReconfiguration to configure specific DRX parameters.	<--	-	-	-
2	The UE transmits RRCConnectionReconfigurationComplete	-->	-	-	-
3	In the first PDCCH occasion when the <i>Drx-onDurationTimer</i> is running, the SS indicates the transmission of a DL MAC PDU on the PDCCH.  i.e., on the PDCCH occasion <i>csn1</i> within the subframe number = $(\text{csfn1} + \text{floor}([\text{csn1} + \text{NormalSLT}(\text{SFN1}, \text{csfn1}, \text{csn1}, 0)] / \text{numberofslotswithin subframe})) \bmod 10$ , and system frame number = $\text{SFN1} + \text{floor}([\text{csn1} + \text{NormalSLT}(\text{SFN1}, \text{csfn1}, \text{csn1}, 0)] / \text{numberofslotswithin subframe} / 10)$ ; where $[(\text{SFN1} * 10) + \text{csfn1}] \bmod (\text{LongDRX-Cycle}) = \text{drx-StartOffset}$ ; $\text{csn1} = \text{drx-slotoffset}$ .	<--	MAC PDU	-	-
4	Check: Does the UE transmit a HARQ ACK for the DL MAC PDU in Step 3?	-->	HARQ ACK	1	P
5	At least <i>drx-InactivityTimer</i> PDCCH occasions after the transmission of the MAC PDU in Step 3 has been indicated (This means the next DRX cycle or later after Step 2) in the last PDCCH occasion while the <i>drx-onDurationTimer</i> is still running, the SS indicates the transmission a DL MAC PDU on the PDCCH. (Note 4).  i.e., on the PDCCH occasion = $[\text{csn2} + \text{NormalSLT}(\text{SFN2}, \text{csfn2}, \text{csn2}, \text{drx-onDurationTimer-1})] \bmod \text{numberofslotswithin subframe}$ within the subframe number = $(\text{csfn2} + \text{floor}([\text{csn2} + \text{NormalSLT}(\text{SFN2}, \text{csfn2}, \text{csn2}, \text{drx-onDurationTimer-1})] / \text{numberofslotswithin subframe})) \bmod 10$ , and system frame number = $\text{SFN2} + \text{floor}([\text{csn2} + \text{NormalSLT}(\text{SFN2}, \text{csfn2}, \text{drx-onDurationTimer-1})] / \text{numberofslotspersubframe} / 10)$ ; where $[(\text{SFN2} * 10) + \text{csfn2}] \bmod (\text{LongDRX-Cycle}) = \text{drx-StartOffset}$ and $\text{csn2} = \text{drx-slotoffset}$ . (Note 5)	<--	MAC PDU	-	-
6	Check: Does the UE transmit a HARQ ACK for the DL MAC PDU in Step 5?	-->	HARQ ACK	1	P
7	<i>drx-InactivityTimer</i> PDCCH-occasions after the transmission of the MAC PDU transmitted in step 5 was indicated on the PDCCH, the SS indicates the transmission of a DL MAC PDU on the PDCCH. (Note 4)  i.e. on the PDCCH occasion = $[\text{csn2} + \text{NormalSLT}(\text{SFN2}, \text{csfn2}, \text{csn2}, \text{drx-onDurationTimer} + \text{drx-InactivityTimer-1})] \bmod \text{numberofslotswithin subframe}$ within the subframe number = $(\text{csfn2} + \text{floor}([\text{csn2} + \text{NormalSLT}(\text{SFN2}, \text{csfn2}, \text{csn2}, \text{drx-onDurationTimer} + \text{drx-InactivityTimer-1})] / \text{numberofslotswithin subframe})) \bmod 10$ , and system frame number = $\text{SFN2} + \text{floor}([\text{csn2} + \text{NormalSLT}(\text{SFN2}, \text{csfn2}, \text{drx-onDurationTimer} + \text{drx-InactivityTimer-1})] / \text{numberofslotspersubframe} / 10)$	<--	MAC PDU	-	-
8	Check: Does the UE transmit a HARQ ACK for the DL MAC PDU in Step 7?	-->	HARQ ACK	2	P

9	<p>At least drx-InactivityTimer PDCCH occasions after the transmission of the MAC PDU in Step 7 has been indicated (This means the next DRX cycle or later after Step 5) and 1 PDCCH occasion before the <i>Drx-onDurationTimer</i> expires, the SS indicates the transmission of a DL MAC PDU on the PDCCH. The DL MAC PDU transmitted is invalid. (Note 1, Note 4)</p> <p>i.e. on the PDCCH occasion = <math>[\text{csn3} + \text{NormalSLT}(\text{SFN3}, \text{csfn3}, \text{csn3}, \text{drx-onDurationTimer} - 2)]</math> modulo numberofslotswithin subframe within the subframe number = <math>(\text{csfn3} + \text{floor}([\text{csn3} + \text{NormalSLT}(\text{SFN3}, \text{csfn3}, \text{csn3}, \text{drx-onDurationTimer} - 2)] / \text{numberofslotswithin subframe}))</math> modulo 10, and system frame number = <math>\text{SFN3} + \text{floor}([\text{csfn3} + \text{floor}([\text{csn3} + \text{NormalSLT}(\text{SFN3}, \text{csfn3}, \text{drx-onDurationTimer} - 2)] / \text{numberofslotspersubframe})] / 10)</math>; where <math>[(\text{SFN3} * 10) + \text{csfn3}]</math> modulo (LongDRX-Cycle) = drxStartOffset and csn3=drx-slotoffset.</p>	<--	Invalid MAC PDU	-	-
10	Check: Does the UE transmit a HARQ NACK for the DL MAC PDU in Step 9?	-->	HARQ NACK	1	P
11	<p>In the first PDCCH occasion when the <i>Drx-RetransmissionTimerDL</i> for the MAC PDU in Step 9 is started, the SS indicates the transmission of a DL MAC PDU on the PDCCH.</p> <p>i.e., on the PDCCH occasion with the subframe number = <math>(\text{csfn4} + \text{floor}([\text{csn4} + \text{NormalSLT}(\text{SFN4}, \text{csfn4}, 0)] / \text{numberofslotswithin subframe}))</math> modulo 10, and system frame number = <math>\text{SFN4} + \text{floor}([\text{csfn4} + \text{floor}([\text{csn4} + \text{NormalSLT}(\text{SFN4}, \text{csfn4}, 0)] / \text{numberofslotswithin subframe})] / 10)</math>; where <math>\text{csn4} = [\text{csn3} + \text{NormalSLT}(\text{SFN3}, \text{csfn3}, \text{drx-onDurationTimer} - 2) + \text{drx-HARQ-RTT-TimerDL timer}]</math> modulo numberofslotswithin subframe within the <math>\text{csfn4} = (\text{csfn3} + \text{floor}([\text{csn3} + \text{NormalSLT}(\text{SFN3}, \text{csfn3}, \text{drx-onDurationTimer} - 2) + \text{drx-HARQ-RTT-TimerDL timer}] / \text{numberofslotswithin subframe}))</math> modulo 10, and <math>\text{SFN4} = \text{SFN3} + \text{floor}([\text{csfn3} + \text{floor}([\text{csn3} + \text{NormalSLT}(\text{SFN3}, \text{csfn3}, \text{drx-onDurationTimer} - 2) + \text{drx-HARQ-RTT-TimerDL timer}] / \text{numberofslotspersubframe})] / 10)</math>.</p>	<--	MAC PDU	-	-
12	Check: Does the UE transmit a HARQ ACK for the DL MAC PDU in Step 11?	-->	HARQ ACK	3	P

13	<p>At least drx-InactivityTimer PDCCH occasions after the transmission of the DL MAC PDU in Step 11 has been indicated (This means the next DRX cycle or later after Step 11) and 1 subframe before the <i>Drx-onDurationTimer</i> expires, the SS indicates the transmission of DL MAC PDU on the PDCCH. The DL MAC PDU transmitted is invalid. (Note 1, Note 4)</p> <p>i.e. on the PDCCH occasion = <math>[\text{csn5} + \text{NormalSLT}(\text{SFN5}, \text{csfn5}, \text{csn5}, \text{drx-onDurationTimer}-1)] \text{ modulo } \text{numberofslotswithinsubframe}</math> within the subframe number = <math>(\text{csfn5} + \text{floor}([\text{csn5} + \text{NormalSLT}(\text{SFN5}, \text{csfn5}, \text{csn5}, \text{drx-onDurationTimer} + \text{drx-onDurationTimer}-2)] / \text{numberofslotswithinsubframe})) \text{ modulo } 10</math>, and system frame number = <math>\text{SFN5} + \text{floor}([\text{csfn5} + \text{floor}([\text{csn5} + \text{NormalSLT}(\text{SFN5}, \text{csfn5}, \text{csn5}, \text{drx-onDurationTimer}-2)] / \text{numberofslotspersubframe})] / 10)</math>; where <math>[(\text{SFN5} * 10) + \text{csfn5}] \text{ modulo } (\text{LongDRX-Cycle}) = \text{drxStartOffset}</math> and <math>\text{csn5} = \text{drx-slotoffset}</math>.</p>	<--	Invalid MAC PDU	-	-
14	Check: Does the UE transmit a HARQ NACK for the DL MAC PDU in Step 13?	-->	HARQ NACK	1	P
15	<p>In the last PDCCH occasion when the drx-RetransmissionTimerDL for MAC PDU in Step 13 is still running, the SS indicates the transmission of a DL MAC PDU on the PDCCH.</p> <p>i.e., on the PDCCH occasion with the subframe number = <math>\text{csfn6} + \text{floor}([\text{csn6} + \text{NormalSLT}(\text{SFN6}, \text{csfn6}, \text{drx-RetransmissionTimerDL} - 1)] / \text{numberofslotswithinsubframe})</math>, and system frame number = <math>\text{SFN6} + \text{floor}([\text{csfn6} + \text{floor}([\text{csn6} + \text{NormalSLT}(\text{SFN6}, \text{csfn6}, \text{drx-RetransmissionTimerDL} - 1)] / \text{numberofslotswithinsubframe})] / 10)</math>; where <math>\text{csn6} = [\text{csn5} + \text{NormalSLT}(\text{SFN5}, \text{csfn5}, \text{drx-onDurationTimer}-2 + \text{drx-HARQ-RTT-TimerDL})] \text{ modulo } \text{numberofslotswithinsubframe}</math> within <math>\text{csfn6} = (\text{csfn5} + \text{floor}([\text{csn5} + \text{NormalSLT}(\text{SFN5}, \text{csfn5}, \text{drx-onDurationTimer}-2 + \text{drx-HARQ-RTT-TimerDL})] / \text{numberofslotswithinsubframe})) \text{ modulo } 10</math>, and <math>\text{SFN6} = \text{SFN5} + \text{floor}([\text{csfn5} + \text{floor}([\text{csn5} + \text{NormalSLT}(\text{SFN5}, \text{csfn5}, \text{csn5}, \text{drx-onDurationTimer}-2 + \text{drx-HARQ-RTT-TimerDL})] / \text{numberofslotspersubframe})] / 10)</math>.</p>	<--	MAC PDU	-	-
16	Check: Does the UE transmit a HARQ ACK for the DL MAC PDU in Step 15?	-->	HARQ ACK	3	P

17	<p>The SS is configured for Uplink Grant Allocation Type [0]. At least drx-InactivityTimer PDCCH subframes after the transmission of the DL MAC PDU in Step 15 has been indicated in the last subframe when the onDurationTimer is still running (This means the next DRX cycle or later after Step 9), the SS indicates an UL grant to the UE on the PDCCH. (Note 4)</p> <p>i.e. on the PDCCH occasion = <math>[csn7 + NormalSLT(SFN7, csn7, csn7, drx-onDurationTimer-1)]</math> modulo numberofslotswithin subframe within the subframe number = <math>(csn7 + floor([csn7 + NormalSLT(SFN7, csn7, csn7, drx-onDurationTimer + drx-onDurationTimer-1)] / numberofslotswithin subframe))</math> modulo 10, and system frame number = <math>SFN7 + floor([csn7 + floor([csn7 + NormalSLT(SFN7, csn7, csn7, drx-onDurationTimer-1)] / numberofslotspersubframe)] / 10)</math>; where <math>[(SFN7 * 10) + csn7]</math> modulo (LongDRX-Cycle) = drxStartOffset and <math>csn7 = drx-slotoffset</math>.</p>	<--	UL grant on PDCCH	-	-
18	Check: Does the UE transmit a Buffer Status Report on the UL indicating an empty buffer?	-->	Buffer Status Report MAC control element	1	P
19	<p>In the last PDCCH occasion when the drx-RetransmissionTimer-UL for MAC PDU from Step 17 is still running, the SS indicates the transmission of a DL MAC PDU on the PDCCH.</p> <p>i.e., on the PDCCH occasion with the subframe number = <math>csfn8 + floor([csn8 + NormalSLT(SFN8, csn8, drx-RetransmissionTimerUL - 1)] / numberofslotswithin subframe)</math>, and system frame number = <math>SFN8 + floor([csn8 + floor([csn8 + NormalSLT(SFN8, csn8, drx-RetransmissionTimerUL - 1)] / numberofslotswithin subframe)] / 10)</math>; where <math>csn8 = [csn7 + NormalSLT(SFN7, csn7, drx-onDurationTimer-2 + drx-HARQ-RTT-TimerDL)]</math> modulo numberofslotswithin subframe within <math>csfn8 = (csn7 + floor([csn7 + NormalSLT(SFN7, csn7, drx-onDurationTimer-2 + drx-HARQ-RTT-TimerDL)] / numberofslotswithin subframe))</math> modulo 10, and <math>SFN8 = SFN7 + floor([csn7 + floor([csn7 + NormalSLT(SFN7, csn7, csn7, drx-onDurationTimer-1 + drx-HARQ-RTT-TimerUL)] / numberofslotspersubframe)] / 10)</math>.</p>	<--	MAC PDU	-	-
20	Check: Does the UE transmit a HARQ ACK for the DL MAC PDU in Step 19?	-->	HARQ ACK	4	P
<p>Note 1: Invalid MAC PDU is a MAC PDU that fails the CRC check.</p> <p>Note 2: All the DL MAC PDU are transmitted with the NDI set on the PDCCH.</p> <p>Note 3: Timer tolerances for the MAC DRX related timers measured in PDCCH occasions is 0. These timers are: drx-InactivityTimer, drx-RetransmissionTimerDL, drx-RetransmissionTimerUL, drx-HARQ-RTT-TimerDL and drx-HARQ-RTT-TimerUL.</p> <p>Note 4: The drx-InactivityTimer is started in the next PDCCH occasion of the PDCCH occasion where DL new transmission is indicated.</p> <p>Note 5: The timer values expressed in number of slots.</p>					

## 7.1.1.5.1.3.3 Specific message contents

Table 7.1.1.5.1.3.3-1: *RRCConnectionReconfiguration* (step 1, Table 7.1.1.5.1.3.2-1)

Derivation Path: 38.508-1 [4], Table [value]			
Information Element	Value/remark	Comment	Condition
RRCReconfiguration-IEs ::= SEQUENCE {			
secondaryCellGroupToAddModList SEQUENCE	[1 entry]		
(SIZE (1..maxSCellGroups)) OF SEQUENCE {			
cellGroupConfig [value] ::= SEQUENCE {			
mac-CellGroupConfig ::= SEQUENCE {			
drx-Config CHOICE {			
setup ::= SEQUENCE {			
drx-onDurationTimer	ms20		
drx-InactivityTimer	ms6		
drx-HARQ-RTT-TimerDL	56	Number of slots=4 due to number of symbol per slot=14	$\mu$ =0,1,2,3,4 ( 2 with normal CP)
drx-HARQ-RTT-TimerDL	48	Number of slots=4 due to number of symbol per slot=12	$\mu$ = 2 with external CP
drx-HARQ-RTT-TimerUL	56	Number of slots=4 due to number of symbol per slot=14	$\mu$ =0,1,2,3,4 ( 2 with normal CP)
drx-HARQ-RTT-TimerUL	48	Number of slots=4 due to number of symbol per slot=12	$\mu$ = 2 with external CP
drx-RetransmissionTimerDL	s12		
drx-RetransmissionTimerUL	s12		
drx-LongCycleStartOffset CHOICE {			
ms640	4		
}			
shortDRX	Not present		
drx-SlotOffset	ms0		
}			
}			
}			
}			
}			

## 7.1.1.5.2 DRX operation / Short cycle not configured / Long DRX command MAC control element reception

## 7.1.1.5.2.1 Test Purpose (TP)

(1)

```

with { UE in CONNECTED mode }
ensure that {
  when { long DRX cycle is configured and a DRX Command MAC control element is received }
  then { UE successfully decodes the MAC control PDU }
}

```

(2)

```

with { UE in CONNECTED mode }
ensure that {
  when { long DRX cycle is configured and the HARQ RTT Timer is running and a DRX Command MAC control element is received }
  then { UE continues running the HARQ RTT timer }
}

```

(3)

```

with { UE in CONNECTED mode }
ensure that {
  when { long DRX cycle is configured and the drx-RetransmissionTimer is running and a DRX Command
  MAC control element is received }
  then { UE continues running the drx-RetransmissionTimer and monitors the PDCCH }
}

```

#### 7.1.1.5.2.2 Conformance requirements

References: The conformance requirements covered in the present TC are specified in: TS 38.321, clause 5.7. Unless otherwise stated these are Rel-15 requirements.

[TS 38.321, clause 5.7]

The MAC entity may be configured by RRC with a DRX functionality that controls the UE's PDCCH monitoring. When in RRC\_CONNECTED, if DRX is configured, the MAC entity may monitor the PDCCH discontinuously using the DRX operation specified in this subclause; otherwise the MAC entity shall monitor the PDCCH continuously. When using DRX operation, the MAC entity shall monitor PDCCH according to requirements found in this specification.

RRC controls DRX operation by configuring the following timers:

- *drx-onDurationTimer*: the duration at the beginning of a DRX Cycle;
- *drx-SlotOffset*: the delay in slots before starting the *drx-onDurationTimer*;
- *drx-InactivityTimer*: the duration after the PDCCH occasion in which a PDCCH indicates an initial UL or DL user data transmission for the MAC entity;
- *drx-RetransmissionTimerDL* (per DL HARQ process): the maximum duration until a DL retransmission is received;
- *drx-RetransmissionTimerUL* (per UL HARQ process): the maximum duration until a grant for UL retransmission is received;
- *drx-LongCycle*: the Long DRX cycle;
- *drx-ShortCycle* (optional): the Short DRX cycle;
- *drx-ShortCycleTimer* (optional): the duration the UE shall follow the Short DRX cycle;
- *drx-HARQ-RTT-TimerDL* (per DL HARQ process): the minimum duration before a DL assignment for HARQ retransmission is expected by the MAC entity;
- *drx-HARQ-RTT-TimerUL* (per UL HARQ process): the minimum duration before a UL HARQ retransmission grant is expected by the MAC entity.

When a DRX cycle is configured, the Active Time includes the time while:

- *drx-onDurationTimer* or *drx-InactivityTimer* or *drx-RetransmissionTimerDL* or *drx-RetransmissionTimerUL* or *ra-ContentionResolutionTimer* (as described in subclause 5.1.5) is running; or
- a Scheduling Request is sent on PUCCH and is pending (as described in subclause 5.4.4); or
- a PDCCH indicating a new transmission addressed to the C-RNTI of the MAC entity has not been received after successful reception of a Random Access Response for the preamble not selected by the MAC entity (as described in subclause 5.1.4).

When DRX is configured, the MAC entity shall:

- 1> if a *drx-HARQ-RTT-TimerDL* expires:
- 2> if the data of the corresponding HARQ process was not successfully decoded:
- 3> start the *drx-RetransmissionTimerDL* for the corresponding HARQ process.

- 1> if an *drx-HARQ-RTT-TimerUL* expires:
  - 2> start the *drx-RetransmissionTimerUL* for the corresponding HARQ process.
- 1> if a DRX Command MAC CE or a Long DRX Command MAC CE is received:
  - 2> stop *drx-onDurationTimer*;
  - 2> stop *drx-InactivityTimer*.
- 1> if *drx-InactivityTimer* expires or a DRX Command MAC CE is received:
  - 2> if the Short DRX cycle is configured:
    - 3> start or restart *drx-ShortCycleTimer*;
    - 3> use the Short DRX Cycle.
  - 2> else:
    - 3> use the Long DRX cycle.
- 1> if *drx-ShortCycleTimer* expires:
  - 2> use the Long DRX cycle.
- 1> if a Long DRX Command MAC CE is received:
  - 2> stop *drx-ShortCycleTimer*;
  - 2> use the Long DRX cycle.
- 1> if the Short DRX Cycle is used, and  $[(SFN * 10) + \text{subframe number}] \bmod (drx-ShortCycle) = (drx-StartOffset) \bmod (drx-ShortCycle)$ ; or
- 1> if the Long DRX Cycle is used, and  $[(SFN * 10) + \text{subframe number}] \bmod (drx-LongCycle) = drx-StartOffset$ :
  - 2> if *drx-SlotOffset* is configured:
    - 3> start *drx-onDurationTimer* after *drx-SlotOffset*.
  - 2> else:
    - 3> start *drx-onDurationTimer*.
- 1> if the MAC entity is in Active Time:
  - 2> monitor the PDCCH;
  - 2> if the PDCCH indicates a DL transmission or if a DL assignment has been configured:
    - 3> start the *drx-HARQ-RTT-TimerDL* for the corresponding HARQ process immediately after the corresponding PUCCH transmission;
    - 3> stop the *drx-RetransmissionTimerDL* for the corresponding HARQ process.
  - 2> if the PDCCH indicates a UL transmission or if a UL grant has been configured:
    - 3> start the *drx-HARQ-RTT-TimerUL* for the corresponding HARQ process immediately after the first repetition of the corresponding PUSCH transmission;
    - 3> stop the *drx-RetransmissionTimerUL* for the corresponding HARQ process.
  - 2> if the PDCCH indicates a new transmission (DL or UL):
    - 3> start or restart *drx-InactivityTimer*.
- 1> else (i.e. not part of the Active Time):

2> not report CQI/PMI/RI on PUCCH.

7.1.1.5.2.3 Test description

7.1.1.5.2.3.1 Pre-test conditions

Same Pre-test conditions as in clause 7.1.1.0 except that set to return no data in uplink.

7.1.1.5.2.3.2 Test procedure sequence

For FDD,  $NormalSLT(current\ SFN, current\ sub-frame, current\ slot, y) = y$ ; For TDD,  $NormalSLT(current\ SFN, current\ slot, y)$  counts the minimum number of normal slots needed to cover  $y$  number of PDCCH-occasions(slots) until next PDCCH-occasion(slot) available, starting from current slot on current SFN.



**Table 7.1.1.5.2.3.2-1: Main behaviour**

St	Procedure	Message Sequence		TP	Verdict
		U - S	Message		
1	SS transmits RRCConnectionReconfiguration to configure specific DRX parameters.	<--	-	-	-
2	The UE transmits RRCConnectionReconfigurationComplete.	-->	-	-	-
3	<p>In a PDCCH occasion which is X PDCCH sub frames before the PDCCH occasion in which the <i>onDurationTimer</i> expires, with <math>\text{drx-InactivityTimer} &lt; X &lt; \text{the number of PDCCH occasions encapsulated by Drx-HARQ-RTT-TimerDL}</math>, the SS indicates the transmission of a DL MAC PDU on the PDCCH. The SS transmits an invalid MAC PDU. (Note 1)</p> <p>i.e., on the PDCCH occasion <math>\text{csn2} = [\text{csn1} + \text{NormalSLT}(\text{SFN1}, \text{csfn1}, \text{csn1}, \text{drx-onDurationTimer} - 1 - X)] \text{ modulo } \text{numberofslotswithin subframe}</math> within the subframe number <math>\text{csfn2} = (\text{csfn1} + \text{floor}([\text{csn1} + \text{NormalSLT}(\text{SFN1}, \text{csfn1}, \text{csn1}, \text{drx-onDurationTimer} - 1 - X)] / \text{numberofslotswithin subframe})) \text{ modulo } 10</math>, and system frame number <math>\text{SFN2} = \text{SFN1} + \text{floor}([\text{csfn1} + \text{floor}([\text{csn1} + \text{NormalSLT}(\text{SFN1}, \text{csfn1}, \text{csn1}, \text{drx-onDurationTimer} - 1 - X)] / \text{numberofslotswithin subframe}) / 10])</math>; where <math>[(\text{SFN1} * 10) + \text{csfn1}] \text{ modulo } (\text{LongDRX-Cycle}) = \text{drx-StartOffset}</math>; <math>\text{csn1} = \text{drx-slotoffset}</math>.</p>	<--	MAC PDU	-	-
4	Check: Does the UE transmit a HARQ NACK for the DL MAC PDU in Step 1?	-->	HARQ NACK	1	P
5	<p>In a PDCCH sub frames before the <i>drx-onDurationTimer</i> expires, the SS indicates the transmission of a DL MAC PDU on the PDCCH. The SS transmits a DL MAC PDU with DRX MAC Control element. UE successfully decodes the MAC PDU.</p> <p>i.e., on the PDCCH occasion = <math>[\text{csn1} + \text{NormalSLT}(\text{SFN1}, \text{csfn1}, \text{csn1}, \text{drx-onDurationTimer} - 1 - X + Y)] \text{ modulo } \text{numberofslotswithin subframe}</math> within the subframe number = <math>(\text{csfn1} + \text{floor}([\text{csn1} + \text{NormalSLT}(\text{SFN1}, \text{csfn1}, \text{csn1}, \text{drx-onDurationTimer} - 1 - X + Y)] / \text{numberofslotswithin subframe})) \text{ modulo } 10</math>, and system frame number = <math>\text{SFN1} + \text{floor}([\text{csfn1} + \text{floor}([\text{csn1} + \text{NormalSLT}(\text{SFN1}, \text{csfn1}, \text{csn1}, \text{drx-onDurationTimer} - 1 - X + Y)] / \text{numberofslotswithin subframe}) / 10])</math>; and <math>0 &lt; Y &lt; X</math>.</p>	<--	MAC PDU(DRX MAC Control element)	-	-
6	Check: Does the UE transmit a HARQ ACK for the DL MAC PDU in Step 3?	-->	HARQ ACK	1	P

7	<p>In the PDCCH sub frame when the drx-RetransmissionTimer for the MAC PDU indicated in Step 1 on the PDCCH is started the SS indicates the transmission of a DL MAC PDU. The SS transmits an invalid MAC PDU. (Note 1)</p> <p>i.e., on the PDCCH occasion with <math>csn5 = csn4</math> the subframe number = <math>(csfn4 + \text{floor}([\text{csn4} + \text{NormalSLT}(\text{SFN4}, \text{csfn4}, 0)] / \text{numberofslotswithin subframe})) \text{ modulo } 10</math>, and system frame number = <math>\text{SFN4} + \text{floor}([\text{csfn4} + \text{floor}([\text{csn4} + \text{NormalSLT}(\text{SFN4}, \text{csfn4}, 0)] / \text{numberofslotswithin subframe})] / 10)</math>; where <math>csn4 = [\text{csn2} + \text{NormalSLT}(\text{SFN2}, \text{csfn2}, \text{numberofslotswithin subframe} + \text{Drx-HARQ-RTT-TimerDL})] \text{ modulo } \text{numberofslotswithin subframe}</math> within the <math>csfn4 = (\text{csfn2} + \text{floor}([\text{csn2} + \text{NormalSLT}(\text{SFN2}, \text{csfn2}, \text{Drx-HARQ-RTT-TimerDL})] / \text{numberofslotswithin subframe})) \text{ modulo } 10</math>, and <math>\text{SFN4} = \text{SFN2} + \text{floor}([\text{csfn2} + \text{floor}([\text{csn2} + \text{NormalSLT}(\text{SFN2}, \text{csfn2}, \text{numberofslotswithin subframe} + \text{Drx-HARQ-RTT-TimerDL})] / \text{numberofslotswithin subframe})] / 10)</math>;</p>	<--	MAC PDU	-	-
8	<p>Check: Does the UE transmit a HARQ NACK for the DL MAC PDU in Step 5?</p>	-->	HARQ NACK	2,3	P
9	<p>Z PDCCH sub frames, where <math>Z &gt; \text{drx-InactivityTimer}</math>, before the PDCCH sub-frame in which the drx-RetransmissionTimer for the DL MAC PDU in Step 5 expires, the SS indicates the transmission of a DL MAC PDU. The SS transmits a DL MAC PDU with DRX MAC Control element.</p> <p>i.e., on the PDCCH occasion = <math>csn6</math> within subframe = <math>(\text{csfn6} + \text{floor}([\text{csn6} + \text{NormalSLT}(\text{SFN6}, \text{csfn6}, \text{csn6}, \text{drx-RetransmissionTimer} - Z)] / \text{numberofslotswithin subframe})) \text{ modulo } 10</math> and the system frame number = <math>\text{SFN6} + \text{floor}([\text{csfn6} + \text{NormalSLT}(\text{SFN6}, \text{csfn6}, 0)] / 10 * \text{numberofslotswithin subframe})</math>; where PDCCH occasion <math>csn6 = \text{floor}([\text{csn5} + \text{NormalSLT}(\text{SFN5}, \text{csfn5}, \text{csn5}, \text{Drx-HARQ-RTT-TimerDL})] \text{ modulo } \text{numberofslotswithin subframe}</math>, <math>csfn6 = (\text{csfn5} + \text{floor}([\text{csn5} + \text{NormalSLT}(\text{SFN5}, \text{csfn5}, \text{csn5}, \text{Drx-HARQ-RTT-TimerDL})] / \text{numberofslotswithin subframe})) \text{ modulo } 10</math>, and the <math>\text{SFN6} = \text{SFN5} + \text{floor}([\text{csfn5} + \text{floor}([\text{csn5} + \text{NormalSLT}(\text{SFN5}, \text{csfn5}, \text{csn5}, \text{Drx-HARQ-RTT-TimerDL})] / \text{numberofslotswithin subframe})] / 10)</math>;</p>	<--	MAC PDU(DRX MAC Control element)	-	-
10	<p>Check: Does the UE transmit a HARQ ACK for the DL MAC PDU in Step 7?</p>	-->	HARQ ACK	2,3,1	P

11	<p>In the last sub frame when the Drx-RetransmissionTimer for the DL MAC PDU indicated on the PDCCH in Step 5 is still running, the SS indicates the transmission of a DL MAC PDU.</p> <p>i.e., on the PDCCH occasion within subframe number = <math>(\text{csfn6} + \text{floor}([\text{csn6} + \text{NormalSLT}(\text{SFN6}, \text{csfn6}, \text{csn6}, \text{drx-RetransmissionTimer} - 1)] / \text{numberofslotswithinsubframe})) \bmod 10</math>, and the system frame number = <math>\text{SFN6} + \text{floor}([\text{csfn6} + \text{floor}([\text{csn6} + \text{NormalSLT}(\text{SFN6}, \text{csfn6}, \text{csn6}, \text{drx-RetransmissionTimer} - 1)] / \text{numberofslotswithinsubframe}) / 10)</math>;</p>	<--	MAC PDU	-	-
12	Check: Does the UE transmit a HARQ ACK for the DL MAC PDU in Step 9?	-->	HARQ ACK	2,3	P
<p>Note 1: Invalid MAC PDU is a MAC PDU that fails the CRC check.</p> <p>Note 2: All DL MAC PDUs are transmitted with the NDI set on the PDCCH.</p> <p>Note 3: Timer tolerances for the MAC DRX related timers measured in PDCCH occasions(slots). These timers are: drx-InactivityTimer, drx-RetransmissionTimer, Drx-HARQ-RTT-TimerDL.</p>					

## 7.1.1.5.2.3.3 Specific message contents

Table 7.1.1.5.2.3.3-1: *RRCConnectionReconfiguration* (step 1, Table 7.1.1.5.2.3.2-1)

Derivation Path: 38.508-1 [4], Table [4.6.1-3]			
Information Element	Value/remark	Comment	Condition
RRCReconfiguration-IEs ::= SEQUENCE {			
secondaryCellGroupToAddModList SEQUENCE (SIZE (1..maxSCellGroups)) OF SEQUENCE {	[1 entry]		
cellGroupConfig ::= SEQUENCE {			
mac-CellGroupConfig ::= SEQUENCE {			
drx-Config CHOICE {			
setup ::= SEQUENCE {			
drx-onDurationTimer	ms20		
drx-InactivityTimer	ms6		
drx-HARQ-RTT-TimerDL	56	Number of slots=4 due to number of symbol per slot=14	$\mu = 0,1,2,3,4$ (2 with normal CP)
drx-HARQ-RTT-TimerDL	48	Number of slots=4 due to number of symbol per slot=12	$\mu = 2$ with external CP
drx-HARQ-RTT-TimerUL	56	Number of slots=4 due to number of symbol per slot=14	$\mu = 0,1,2,3,4$ (2 with normal CP)
drx-HARQ-RTT-TimerDL	48	Number of slots=4 due to number of symbol per slot=12	$\mu = 2$ with external CP
drx-RetransmissionTimerDL	s12		
drx-RetransmissionTimerUL	s12		
drx-LongCycleStartOffset CHOICE {			
ms640	4		
}			
shortDRX	Not present		
drx-SlotOffset	ms0		
}			
}			
}			
}			
}			
}			

## 7.1.1.5.3 DRX operation / Short cycle configured / Parameters configured by RRC

## 7.1.1.5.3.1 Test Purpose (TP)

(1)

```

with { UE in RRC_CONNECTED state }
ensure that {
  when { Short DRX cycle and drx-SlotOffset is configured and [(SFN * 10) + subframe number] modulo
drx-ShortCycle) = (drx-StartOffset) modulo (drx-ShortCycle) }
  then { UE starts the OnDurationTimer after drx-SlotOffset and monitors the PDCCH for
OnDurationTimer PDCCH-subframes }
}

```

(2)

```

with { UE in RRC_CONNECTED state }
ensure that {
  when { drxShortCycleTimer is expired and [(SFN * 10) + subframe number] modulo (drx-LongCycle) =
drx-StartOffset: }
}

```

```

    then { UE starts the OnDurationTimer after drx-SlotOffset and monitors the PDCCH for
OnDurationTimer PDCCH-subframes }
}

```

### 7.1.1.5.3.2 Conformance requirements

Editor's Note: The conformance requirements are based on running RAN2 CR

References: The conformance requirements covered in the present test case are specified in: TS 38.321, clause 5.7. Unless otherwise stated these are Rel-15 requirements.

[TS 38.321, clause 5.7]

The MAC entity may be configured by RRC with a DRX functionality that controls the UE's PDCCH monitoring activity for the MAC entity's C-RNTI, CS-RNTI, INT-RNTI, SFI-RNTI, SP-CSI-RNTI, TPC-PUCCH-RNTI, TPC-PUSCH-RNTI, and TPC-SRS-RNTI. When using DRX operation, the MAC entity shall also monitor PDCCH according to requirements found in other subclauses of this specification. When in RRC\_CONNECTED, if DRX is configured, the MAC entity may monitor the PDCCH discontinuously using the DRX operation specified in this subclause; otherwise the MAC entity shall monitor the PDCCH continuously.

RRC controls DRX operation by configuring the following parameters:

- *drx-onDurationTimer*: the duration at the beginning of a DRX Cycle;
- *drx-SlotOffset*: the delay before starting the *drx-onDurationTimer*;
- *drx-StartOffset*: the subframe where the DRX Cycle starts;
- *drx-InactivityTimer*: the duration after the PDCCH occasion in which a PDCCH indicates a new UL or DL transmission for the MAC entity;
- *drx-RetransmissionTimerDL* (per DL HARQ process): the maximum duration until a DL retransmission is received;
- *drx-RetransmissionTimerUL* (per UL HARQ process): the maximum duration until a grant for UL retransmission is received;
- *drx-LongCycle*: the Long DRX cycle;
- *drx-ShortCycle* (optional): the Short DRX cycle;
- *drx-ShortCycleTimer* (optional): the duration the UE shall follow the Short DRX cycle;
- *drx-HARQ-RTT-TimerDL* (per DL HARQ process): the minimum duration before a DL assignment for HARQ retransmission is expected by the MAC entity;
- *drx-HARQ-RTT-TimerUL* (per UL HARQ process): the minimum duration before a UL HARQ retransmission grant is expected by the MAC entity.

When a DRX cycle is configured, the Active Time includes the time while:

- *drx-onDurationTimer* or *drx-InactivityTimer* or *drx-RetransmissionTimerDL* or *drx-RetransmissionTimerUL* or *ra-ContentionResolutionTimer* (as described in subclause 5.1.5) is running; or
- a Scheduling Request is sent on PUCCH and is pending (as described in subclause 5.4.4); or
- a PDCCH indicating a new transmission addressed to the C-RNTI of the MAC entity has not been received after successful reception of a Random Access Response for the Random Access Preamble not selected by the MAC entity among the contention-based Random Access Preamble (as described in subclause 5.1.4).

When DRX is configured, the MAC entity shall:

- 1> if a MAC PDU is transmitted in a configured uplink grant:

- 2> start the *drx-HARQ-RTT-TimerUL* for the corresponding HARQ process in the first symbol after the end of the first repetition of the corresponding PUSCH transmission;
- 2> stop the *drx-RetransmissionTimerUL* for the corresponding HARQ process
- 1> if a *drx-HARQ-RTT-TimerDL* expires:
  - 2> if the data of the corresponding HARQ process was not successfully decoded:
    - 3> start the *drx-RetransmissionTimerDL* for the corresponding HARQ process in the first symbol after the expiry of *drx-HARQ-RTT-TimerDL*.
- 1> if an *drx-HARQ-RTT-TimerUL* expires:
  - 2> start the *drx-RetransmissionTimerUL* for the corresponding HARQ process in the first symbol after the expiry of *drx-HARQ-RTT-TimerUL*.
- 1> if a DRX Command MAC CE or a Long DRX Command MAC CE is received:
  - 2> stop *drx-onDurationTimer*;
  - 2> stop *drx-InactivityTimer*.
- 1> if *drx-InactivityTimer* expires or a DRX Command MAC CE is received:
  - 2> if the Short DRX cycle is configured:
    - 3> start or restart *drx-ShortCycleTimer* in the first symbol after the expiry of *drx-InactivityTimer* or in the first symbol after the end of DRX Command MAC CE reception;
    - 3> use the Short DRX Cycle.
  - 2> else:
    - 3> use the Long DRX cycle.
- 1> if *drx-ShortCycleTimer* expires:
  - 2> use the Long DRX cycle.
- 1> if a Long DRX Command MAC CE is received:
  - 2> stop *drx-ShortCycleTimer*;
  - 2> use the Long DRX cycle.
- 1> if the Short DRX Cycle is used, and  $[(\text{SFN} \times 10) + \text{subframe number}] \bmod (\text{drx-ShortCycle}) = (\text{drx-StartOffset}) \bmod (\text{drx-ShortCycle})$ ; or
- 1> if the Long DRX Cycle is used, and  $[(\text{SFN} \times 10) + \text{subframe number}] \bmod (\text{drx-LongCycle}) = \text{drx-StartOffset}$ :
  - 2> start *drx-onDurationTimer* after *drx-SlotOffset* from the beginning of the subframe.
- 1> if the MAC entity is in Active Time:
  - 2> monitor the PDCCH;
  - 2> if the PDCCH indicates a DL transmission or if a DL assignment has been configured:
    - 3> start the *drx-HARQ-RTT-TimerDL* for the corresponding HARQ process immediately after the corresponding PUCCH transmission;
    - 3> stop the *drx-RetransmissionTimerDL* for the corresponding HARQ process.
  - 2> if the PDCCH indicates a UL transmission:

- 3> start the *drx-HARQ-RTT-TimerUL* for the corresponding HARQ process in the first symbol after the end of the first repetition of the corresponding PUSCH transmission;
- 3> stop the *drx-RetransmissionTimerUL* for the corresponding HARQ process.
- 2> if the PDCCH indicates a new transmission (DL or UL):
  - 3> start or restart *drx-InactivityTimer* in the first symbol after the end of the PDCCH reception.
- 1> else (i.e. not part of the Active Time):
  - 2> not transmit type-0-triggered SRS defined in TS 38.214 [7].
- 1> if CQI masking (*cqi-Mask*) is setup by upper layers:
  - 2> if *drx-onDurationTimer* is not running:
    - 3> not report CSI on PUCCH.
- 1> else:
  - 2> if the MAC entity is not in Active Time:
    - 3> not report CSI on PUCCH.

Regardless of whether the MAC entity is monitoring PDCCH or not, the MAC entity transmits HARQ feedback and type-1-triggered SRS defined in TS 38.214 [7] when such is expected.

The MAC entity needs not to monitor the PDCCH if it is not a complete PDCCH occasion (e.g. the Active Time starts or expires in the middle of a PDCCH occasion).

#### 7.1.1.5.3.3 Test description

##### 7.1.1.5.3.3.1 Pre-test conditions

Same Pre-test conditions as in clause 7.1.1.0 except that set to return no data in uplink.

##### 7.1.1.5.3.3.2 Test procedure sequence

For FDD, *NormalSLT* (current SFN, current sub-frame, current slot,  $y$ ) =  $y$ ; For TDD, *NormalSLT* (current SFN, current slot,  $y$ ) counts the minimum number of normal slots needed to cover  $y$  number of PDCCH-occasions(slots) until next PDCCH-occasion(slot) available, starting from current slot on current Subframe.



**Table 7.1.1.5.3.3.2-1: Main behaviour**

St	Procedure	Message Sequence		TP	Verdict
		U – S	Message		
1	SS transmits RRCConnectionReconfiguration message containing nr-SecundaryCellGroupConfig-r15 to configure specific DRX parameters for PSCell	<--	-	-	-
2	The UE transmits RRCConnectionReconfigurationComplete message containing scg-ConfigResponseNR-r15	-->	-	-	-
3	In the first PDCCH occasion, after the <i>drx-SlotOffset</i> when the <i>drx-onDurationTimer</i> is running, the SS indicates the transmission of a DL MAC PDU on the PDCCH.  i.e., on the PDCCH occasion <i>csn1</i> within the subframe number = ( <i>csfn1</i> + floor([ <i>csn1</i> + <i>NormalSLT</i> ( <i>SFN1</i> , <i>csfn1</i> , <i>csn1</i> , 0)] / <i>numberofslotswithinframe</i> )) modulo 10, and system frame number = <i>SFN1</i> + floor([ <i>csn1</i> + floor([ <i>csn1</i> + <i>NormalSLT</i> ( <i>SFN1</i> , <i>csfn1</i> , <i>csn1</i> , 0)] / <i>numberofslotswithinframe</i> )/10); where [( <i>SFN1</i> * 10) + <i>csfn1</i> ] modulo ( <i>ShortDRX-Cycle</i> ) = <i>drx-StartOffset</i> modulo ( <i>ShortDRX-Cycle</i> ); <i>csn1</i> = <i>drx-slotoffset</i>	<--	MAC PDU	-	-
4	Check: Does the UE transmit a HARQ ACK for the DL MAC PDU in Step 3?	-->	HARQ ACK	1	P
5	At least <i>drx-InactivityTimer</i> PDCCH occasions after the transmission of the MAC PDU in Step 3 has been indicated (This means the next DRX cycle or later after Step 1) in the last PDCCH occasion while the <i>drx-onDurationTimer</i> is still running, the SS indicates the transmission a DL MAC PDU on the PDCCH. (Note).  i.e., on the PDCCH occasion = [ <i>csn2</i> + <i>NormalSLT</i> ( <i>SFN2</i> , <i>csfn2</i> , <i>csn2</i> , <i>drx-onDurationTimer-1</i> )] modulo <i>numberofslotswithinframe</i> within the subframe number = ( <i>csfn2</i> + floor([ <i>csn2</i> + <i>NormalSLT</i> ( <i>SFN2</i> , <i>csfn2</i> , <i>csn2</i> , <i>drx-onDurationTimer-1</i> )] / <i>numberofslotswithinframe</i> )) modulo 10, and system frame number = <i>SFN2</i> + floor([ <i>csfn2</i> + floor([ <i>csn2</i> + <i>NormalSLT</i> ( <i>SFN2</i> , <i>csfn2</i> , <i>drx-onDurationTimer-1</i> )] / <i>numberofslotspersubframe</i> )/10); where [( <i>SFN2</i> * 10) + <i>csfn2</i> ] modulo ( <i>ShortDRX-Cycle</i> ) = <i>drx-StartOffset</i> modulo ( <i>ShortDRX-Cycle</i> ) and <i>csn2</i> = <i>drx-slotoffset</i> .	<--	MAC PDU	-	-
6	Check: Does the UE transmit a HARQ ACK for the DL MAC PDU in Step 5?	-->	HARQ ACK	1	P
7	UE waits for <i>drx-ShortCycleTimer</i> expire.	-	-	-	-

8	<p>In the first PDCCH occasion after the <i>drx-SlotOffset</i> when the <i>drx-onDurationTimer</i> of <i>drx-LongCycle</i> is running, the SS indicates the transmission of a DL MAC PDU on the PDCCH.</p> <p>i.e., on the PDCCH occasion <i>csn1</i> within the subframe number = (<i>csfn1</i> + floor([ <i>csn1</i>+ <i>NormalSLT</i>(<i>SFN1</i>, <i>csfn1</i>,<i>csn1</i>, 0)] / <i>numberofslotswithinframe</i>)) modulo 10, and system frame number = <i>SFN1</i> + floor([<i>csfn1</i> + floor([<i>csn1</i>+ <i>NormalSLT</i>(<i>SFN1</i>, <i>csfn1</i>,<i>csn1</i>, 0)]/ <i>numberofslotswithinframe</i>)/10); where [(<i>SFN1</i> * 10) + <i>csfn1</i>] modulo (<i>LongDRX-Cycle</i>) = <i>drx-StartOffset</i>; <i>csn1</i>=<i>drx-slotoffset</i></p>	<--	MAC PDU	-	-
9	<p>Check: Does the UE transmit a HARQ ACK for the DL MAC PDU in Step 8?</p>	-->	HARQ ACK	2	P
10	<p>At least <i>drx-InactivityTimer</i> PDCCH occasions after the transmission of the MAC PDU in Step 8 has been indicated (This means the next DRX cycle or later after Step 5) in the last PDCCH occasion while the <i>drx-onDurationTimer</i> is still running, the SS indicates the transmission a DL MAC PDU on the PDCCH. (Note).</p> <p>i.e., on the PDCCH occasion = [<i>csn2</i> + <i>NormalSLT</i>(<i>SFN2</i>,<i>csfn2</i>,<i>csn2</i>,<i>drx-onDurationTimer-1</i>)] modulo <i>numberofslotswithinframe</i> within the subframe number = (<i>csfn2</i>+ floor([<i>csn2</i> + <i>NormalSLT</i>(<i>SFN2</i>,<i>csfn2</i>,<i>csn2</i>,<i>drx-onDurationTimer-1</i>)] / <i>numberofslotswithinframe</i>)) modulo 10, and system frame number = <i>SFN2</i> + floor([<i>csfn2</i> + floor([<i>csn2</i>+ <i>NormalSLT</i>(<i>SFN2</i>,<i>csfn2</i>,<i>drx-onDurationTimer-1</i>)] /<i>numberofslotspersubframe</i>)]/10); where [(<i>SFN2</i> * 10) + <i>csfn2</i>] modulo (<i>LongDRX-Cycle</i>) = <i>drx-StartOffset</i> and <i>csn2</i>=<i>drx-slotoffset</i>.</p>	<--	MAC PDU	-	-
11	<p>Check: Does the UE transmit a HARQ ACK for the DL MAC PDU in Step 10?</p>	-->	HARQ ACK	2	P
<p>Note: The <i>drx-InactivityTimer</i> is started in the next PDCCH occasion of the PDCCH occasion where DL new transmission is indicated.</p>					

7.1.1.5.3.3.3 Specific message contents

**Table 7.1.1.5.3.3.3-1: RRCConnectionReconfiguration (step1, Table 7.1.1.5.3.3.2-1)**

Derivation Path: 36.508 [7], Table 4.6.1-8			
Information Element	Value/remark	Comment	Condition
RRCConnectionReconfiguration ::= SEQUENCE {			
criticalExtensions CHOICE {			
c1 CHOICE {			
rrcConnectionReconfiguration-r8 ::= SEQUENCE			
{			
nonCriticalExtension ::= SEQUENCE {			
nonCriticalExtension ::= SEQUENCE {			
nonCriticalExtension ::= SEQUENCE {			
nonCriticalExtension ::= SEQUENCE {			
nonCriticalExtension ::= SEQUENCE {			
nonCriticalExtension ::= SEQUENCE {			
nonCriticalExtension ::= SEQUENCE {			
nonCriticalExtension ::= SEQUENCE {			
nr-Config-r15 CHOICE {			
setup SEQUENCE {			
nr-SecondaryCellGroupConfig-r15	OCTET STRING including the <i>RRCReconfiguration</i> message and the IE <i>secondaryCellGroup</i> .		
}			
}			
}			
}			
}			
}			
}			
}			
}			
}			
}			

**Table 7.1.1.5.3.3.3-2: RRCReconfiguration (Table 7.1.1.5.3.3.3-1)**

Derivation Path: 38.508-1 [4], Table 4.6.1-3			
Information Element	Value/remark	Comment	Condition
RRCReconfiguration ::= SEQUENCE {			
criticalExtensions CHOICE {			
rrcReconfiguration ::= SEQUENCE {			
secondaryCellGroup	CellGroupConfig		
}			
}			
}			

Table 7.1.1.5.3.3-3: CellGroupConfig (Table 7.1.1.5.3.3-2)

Derivation Path: 38.508-1 [4], Table 4.6.3-13			
Information Element	Value/remark	Comment	Condition
cellGroupConfig ::= SEQUENCE {			
cellGroupId	[value]		
mac-CellGroupConfig SEQUENCE {			
drx-Config CHOICE {			
setup SEQUENCE {			
drx-onDurationTimer	ms20		
drx-InactivityTimer	ms6		
drx-LongCycleStartOffset CHOICE {			
ms640	4		
}			
shortDRX SEQUENCE {			
drx-ShortCycle	ms64		
drx-ShortCycleTimer	4		
}			
drx-SlotOffset	ms0		
}			
}			
}			

#### 7.1.1.5.4 DRX Operation / Short cycle configured / DRX command MAC control element reception

##### 7.1.1.5.4.1 Test Purpose (TP)

(1)

```
with { UE in RRC_CONNECTED state }
ensure that {
  when { Short DRX cycle is configured and a DRX Command MAC control element is received }
  then { UE successfully decodes the MAC control PDU }
}
```

(2)

```
with { UE in RRC_CONNECTED state }
ensure that {
  when { Short DRX cycle is configured and the HARQ RTT Timer is running and a DRX Command MAC control element is received }
  then { UE continues running the HARQ RTT timer }
}
```

(3)

```
with { UE in RRC_CONNECTED state }
ensure that {
  when { Short DRX cycle is configured and the drx-RetransmissionTimer-DL is running and a DRX Command MAC control element is received }
  then { UE continues running the drx-RetransmissionTimer-DL and monitors the PDCCH }
}
```

##### 7.1.1.5.4.2 Conformance requirements

References: The conformance requirements covered in the present TC are specified in: TS 38.321, clause 5.7. Unless otherwise stated these are Rel-15 requirements.

[TS 38.321, clause 5.7]

The MAC entity may be configured by RRC with a DRX functionality that controls the UE's PDCCH monitoring activity for the MAC entity's C-RNTI, CS-RNTI, TPC-PUCCH-RNTI, TPC-PUSCH-RNTI, and TPC-SRS-RNTI. When using DRX operation, the MAC entity shall also monitor PDCCH according to requirements found in other subclauses of this specification. When in RRC\_CONNECTED, if DRX is configured, the MAC entity may monitor the

PDCCH discontinuously using the DRX operation specified in this subclause; otherwise the MAC entity shall monitor the PDCCH continuously.

RRC controls DRX operation by configuring the following parameters:

- *drx-onDurationTimer*: the duration at the beginning of a DRX Cycle;
- *drx-SlotOffset*: the delay in slots before starting the *drx-onDurationTimer*;
- *drx-StartOffset*: the subframe where the DRX Cycle starts;
- *drx-InactivityTimer*: the duration after the PDCCH occasion in which a PDCCH indicates an initial UL or DL user data transmission for the MAC entity;
- *drx-RetransmissionTimerDL* (per DL HARQ process): the maximum duration until a DL retransmission is received;
- *drx-RetransmissionTimerUL* (per UL HARQ process): the maximum duration until a grant for UL retransmission is received;
- *drx-LongCycle*: the Long DRX cycle;
- *drx-ShortCycle* (optional): the Short DRX cycle;
- *drx-ShortCycleTimer* (optional): the duration the UE shall follow the Short DRX cycle;
- *drx-HARQ-RTT-TimerDL* (per DL HARQ process): the minimum duration before a DL assignment for HARQ retransmission is expected by the MAC entity;
- *drx-HARQ-RTT-TimerUL* (per UL HARQ process): the minimum duration before a UL HARQ retransmission grant is expected by the MAC entity.

When a DRX cycle is configured, the Active Time includes the time while:

- *drx-onDurationTimer* or *drx-InactivityTimer* or *drx-RetransmissionTimerDL* or *drx-RetransmissionTimerUL* or *ra-ContentionResolutionTimer* (as described in subclause 5.1.5) is running; or
- a Scheduling Request is sent on PUCCH and is pending (as described in subclause 5.4.4); or
- a PDCCH indicating a new transmission addressed to the C-RNTI of the MAC entity has not been received after successful reception of a Random Access Response for the Random Access Preamble not selected by the MAC entity among the contention-based Random Access Preamble (as described in subclause 5.1.4).

When DRX is configured, the MAC entity shall:

- 1> if a MAC PDU is transmitted in a configured uplink grant:
  - 2> start the *drx-HARQ-RTT-TimerUL* for the corresponding HARQ process immediately after the first repetition of the corresponding PUSCH transmission;
  - 2> stop the *drx-RetransmissionTimerUL* for the corresponding HARQ process.
- 1> if a *drx-HARQ-RTT-TimerDL* expires:
  - 2> if the data of the corresponding HARQ process was not successfully decoded:
    - 3> start the *drx-RetransmissionTimerDL* for the corresponding HARQ process.
- 1> if a *drx-HARQ-RTT-TimerUL* expires:
  - 2> start the *drx-RetransmissionTimerUL* for the corresponding HARQ process.
- 1> if a DRX Command MAC CE or a Long DRX Command MAC CE is received:
  - 2> stop *drx-onDurationTimer*;
  - 2> stop *drx-InactivityTimer*.

- 1> if *drx-InactivityTimer* expires or a DRX Command MAC CE is received:
  - 2> if the Short DRX cycle is configured:
    - 3> start or restart *drx-ShortCycleTimer*;
    - 3> use the Short DRX Cycle.
  - 2> else:
    - 3> use the Long DRX cycle.
- 1> if *drx-ShortCycleTimer* expires:
  - 2> use the Long DRX cycle.
- 1> if a Long DRX Command MAC CE is received:
  - 2> stop *drx-ShortCycleTimer*;
  - 2> use the Long DRX cycle.
- 1> if the Short DRX Cycle is used, and  $[(\text{SFN} \times 10) + \text{subframe number}] \bmod (\text{drx-ShortCycle}) = (\text{drx-StartOffset}) \bmod (\text{drx-ShortCycle})$ ; or
- 1> if the Long DRX Cycle is used, and  $[(\text{SFN} \times 10) + \text{subframe number}] \bmod (\text{drx-LongCycle}) = \text{drx-StartOffset}$ :
  - 2> if *drx-SlotOffset* is configured:
    - 3> start *drx-onDurationTimer* after *drx-SlotOffset*.
  - 2> else:
    - 3> start *drx-onDurationTimer*.
- 1> if the MAC entity is in Active Time:
  - 2> monitor the PDCCH;
  - 2> if the PDCCH indicates a DL transmission or if a DL assignment has been configured:
    - 3> start the *drx-HARQ-RTT-TimerDL* for the corresponding HARQ process immediately after the corresponding PUCCH transmission;
    - 3> stop the *drx-RetransmissionTimerDL* for the corresponding HARQ process.
  - 2> if the PDCCH indicates a UL transmission:
    - 3> start the *drx-HARQ-RTT-TimerUL* for the corresponding HARQ process immediately after the first repetition of the corresponding PUSCH transmission;
    - 3> stop the *drx-RetransmissionTimerUL* for the corresponding HARQ process.
  - 2> if the PDCCH indicates a new transmission (DL or UL):
    - 3> start or restart *drx-InactivityTimer*.
- 1> else (i.e. not part of the Active Time):
  - 2> not transmit type-0-triggered SRS defined in TS 38.214 [7].
- 1> if CQI masking (*cqi-Mask*) is setup by upper layers:
  - 2> if *drx-onDurationTimer* is not running:
    - 3> not report CSI on PUCCH.
- 1> else:

2> if the MAC entity is not in Active Time:

3> not report CSI on PUCCH.

Regardless of whether the MAC entity is monitoring PDCCH or not, the MAC entity transmits HARQ feedback and type-1-triggered SRS defined in TS 38.214 [7] when such is expected.

The MAC entity needs not to monitor the PDCCH if it is not a complete PDCCH occasion (e.g. the Active Time starts or expires in the middle of a PDCCH occasion).

7.1.1.5.4.3 Test description

7.1.1.5.4.3.1 Pre-test conditions

Same Pre-test conditions as in clause 7.1.1.0 except that set to return no data in uplink.

7.1.1.5.4.3.2 Test procedure sequence

For FDD,  $NormalSLT(current\ SFN, current\ subframe, current\ slot, y)=y$ ; For TDD,  $NormalSLT(current\ SFN, current\ subframe, current\ slot, y)$  counts the minimum number of normal slots needed to cover  $y$  number of PDCCH-occasions (slots) until next PDCCH-occasion (slot) available, starting from current slot on current SFN.



**Table 7.1.1.5.4.3.2-1: Main behaviour**

St	Procedure	Message Sequence		TP	Verdict
		U - S	Message		
1	SS transmits RRCConnectionReconfiguration message containing nr-SecondaryCellGroupConfig-r15 to configure specific DRX parameters for PSCell.	<--	RRCConnectionReconfiguration	-	-
2	The UE transmits RRCConnectionReconfigurationComplete message containing scg-ConfigResponseNR-r15.	-->	RRCConnectionReconfigurationComplete	-	-
3	In a PDCCH occasion which is X subframes before the PDCCH occasion in which the <i>drx-onDurationTimer</i> expires, with <i>drx-InactivityTimer</i> < X < <i>drx-onDurationTimer</i> -1, the SS indicates the transmission of a DL MAC PDU on the PDCCH. The SS transmits an invalid MAC PDU. (Note 1)  i.e., on the PDCCH occasion $csn2 = [csn1 + NormalSLT(SFN1, csfn1, csn1, drx-onDurationTimer-1-X)]$ modulo <i>numberofslotswithinsubframe</i> within the subframe number $csfn2 = (csfn1 + floor([csn1 + NormalSLT(SFN1, csfn1, csn1, drx-onDurationTimer-1-X)] / numberofslotswithinsubframe))$ modulo 10, and system frame number $SFN2 = SFN1 + floor([csfn1 + floor([csn1 + NormalSLT(SFN1, csfn1, csn1, drx-onDurationTimer-1-X)] / numberofslotswithinsubframe)/10)$ ; where $[(SFN1 * 10) + csfn1]$ modulo ( <i>drx-ShortCycle</i> ) = ( <i>drx-StartOffset</i> ) modulo ( <i>drx-ShortCycle</i> ), <i>csn1</i> = <i>drx-SlotOffset</i> .	<--	MAC PDU	-	-
4	Check: Does the UE transmit a HARQ NACK for the DL MAC PDU in Step 3?	-->	HARQ NACK	1	P
5	In a PDCCH occasion before the <i>drx-onDurationTimer</i> expires, the SS indicates the transmission of a DL MAC PDU on the PDCCH. The SS transmits a DL MAC PDU with DRX MAC Control element. UE successfully decodes the MAC PDU.  i.e., on the PDCCH occasion = $[csn1 + NormalSLT(SFN1, csfn1, csn1, drx-onDurationTimer-1-X+Y)]$ modulo <i>numberofslotswithinsubframe</i> within the subframe number = $(csfn1 + floor([csn1 + NormalSLT(SFN1, csfn1, csn1, drx-onDurationTimer-1-X+Y)] / numberofslotswithinsubframe))$ modulo 10, and system frame number = $SFN1 + floor([csfn1 + floor([csn1 + NormalSLT(SFN1, csfn1, csn1, drx-onDurationTimer-1-X+Y)] / numberofslotswithinsubframe)/10)$ ; and $K < Y < \min\{K + drx-HARQ-RTT\_TimerDL, drx-InactivityTimer\}$ . (Note 4)	<--	MAC PDU (DRX MAC Control element)	-	-
6	Check: Does the UE transmit a HARQ ACK for the DL MAC PDU in Step 5?	-->	HARQ ACK	1	P

7	<p>In the first PDCCH slot when the <i>drx-RetransmissionTimerDL</i> for the MAC PDU indicated in Step 3 on the PDCCH is started, the SS indicates the transmission of a DL MAC PDU. The SS transmits an invalid MAC PDU. (Note 1)</p> <p>i.e., on the PDCCH occasion <math>csn3 = [csn2 + NormalSLT(SFN2, csn2, csn2, K + drx-HARQ-RTT\_TimerDL)] \text{ modulo } \text{numberofslotswithinsubframe}</math> within the subframe number <math>csfn3 = (csfn2 + \text{floor}([csn2 + NormalSLT(SFN2, csn2, csn2, K + drx-HARQ-RTT\_TimerDL)] / \text{numberofslotswithinsubframe})) \text{ modulo } 10</math>, and system frame number <math>SFN3 = SFN2 + \text{floor}([csfn2 + \text{floor}([csn2 + NormalSLT(SFN2, csn2, csn2, K + drx-HARQ-RTT\_TimerDL)] / \text{numberofslotswithinsubframe}) / 10)</math>;</p>	<--	MAC PDU	-	-
8	Check: Does the UE transmit a HARQ NACK for the DL MAC PDU in Step 7?	-->	HARQ NACK	2,3	P
9	<p>In a PDCCH occasion which is Z slots before the PDCCH slot in which the <i>drx-RetransmissionTimerDL</i> for the DL MAC PDU in Step 7 expires, with <math>1 &lt; Z &lt; drx-RetransmissionTimerDL</math>, the SS indicates the transmission of a DL MAC PDU. The SS transmits a DL MAC PDU with DRX MAC Control element.</p> <p>i.e., on the PDCCH occasion <math>csn4 = \text{floor}([csn3 + NormalSLT(SFN3, csn3, csn3, K + drx-HARQ-RTT-TimerDL + drx-RetransmissionTimerDL - Z)] \text{ modulo } \text{numberofslotswithinsubframe}</math>, <math>csfn4 = (csfn3 + \text{floor}([csn3 + NormalSLT(SFN3, csn3, csn3, K + drx-HARQ-RTT-TimerDL + drx-RetransmissionTimerDL - Z)] / \text{numberofslotswithinsubframe})) \text{ modulo } 10</math>, and the <math>SFN4 = SFN3 + \text{floor}([csfn3 + \text{floor}([csn3 + NormalSLT(SFN3, csn3, csn3, K + drx-HARQ-RTT-TimerDL + drx-RetransmissionTimerDL - Z)] / \text{numberofslotswithinsubframe}) / 10)</math>;</p>	<--	MAC PDU(DRX MAC Control element)	-	-
10	Check: Does the UE transmit a HARQ ACK for the DL MAC PDU in Step 9?	-->	HARQ ACK	2,3,1	P
11	<p>In the last PDCCH slot when the <i>drx-RetransmissionTimerDL</i> for the DL MAC PDU indicated on the PDCCH in Step 7 is still running, the SS indicates the transmission of a DL MAC PDU.</p> <p>i.e., on the PDCCH occasion <math>csn5 = \text{floor}([csn3 + NormalSLT(SFN3, csn3, csn3, K + drx-HARQ-RTT-TimerDL + drx-RetransmissionTimerDL - 1)] \text{ modulo } \text{numberofslotswithinsubframe}</math>, <math>csfn5 = (csfn3 + \text{floor}([csn3 + NormalSLT(SFN3, csn3, csn3, K + drx-HARQ-RTT-TimerDL + drx-RetransmissionTimerDL - 1)] / \text{numberofslotswithinsubframe})) \text{ modulo } 10</math>, and the <math>SFN5 = SFN3 + \text{floor}([csfn3 + \text{floor}([csn3 + NormalSLT(SFN3, csn3, csn3, K + drx-HARQ-RTT-TimerDL + drx-RetransmissionTimerDL - 1)] / \text{numberofslotswithinsubframe}) / 10)</math>.</p>	<--	MAC PDU	-	-
12	Check: Does the UE transmit a HARQ ACK for the DL MAC PDU in Step 11?	-->	HARQ ACK	2,3	P

Note 1: Invalid MAC PDU is a MAC PDU that fails the CRC check.  
 Note 2: All DL MAC PDUs are transmitted with the NDI set on the PDCCH.  
 Note 3: Timer tolerances for the MAC DRX related timers measured in PDCCH occasions (slots). These timers are: *drx-InactivityTimer*, *drx-RetransmissionTimer*, *Drx-HARQ-RTT-TimerDL*.  
 Note 4: K is the time for given PDSCH to HARQ feedback of PUCCH and shall be shorter than *drx-InactivityTimer*. In this TC, the DCI format should be configured to not include the PDSCH-to-HARQ-timing-indicator field. When the UE schedules a PDSCH reception over a number of symbols where the last symbol is within slot n-k, the UE shall provide corresponding HARQ-ACK information in a PUCCH transmission within slot n-k+4 according to TS 38.321 clause 9.2.3. Thus, the maximum value of K is 4 slots in this test case.

7.1.1.5.4.3.3 Specific message contents

**Table 7.1.1.5.4.3.3-1: RRCConnectionReconfiguration (step 1, Table 7.1.1.5.4.3.2-1)**

Derivation Path: 36.508 [7], Table 4.6.1-8			
Information Element	Value/remark	Comment	Condition
RRCConnectionReconfiguration ::= SEQUENCE {			
criticalExtensions CHOICE {			
c1 CHOICE {			
rrcConnectionReconfiguration-r8 SEQUENCE {			
nonCriticalExtension SEQUENCE {			
nonCriticalExtension SEQUENCE {			
nonCriticalExtension SEQUENCE {			
nonCriticalExtension SEQUENCE {			
nonCriticalExtension SEQUENCE {			
nonCriticalExtension SEQUENCE {			
nonCriticalExtension SEQUENCE {			
nr-Config-r15 CHOICE {			
setup SEQUENCE {			
nr-SecondaryCellGroupConfig-r15	<i>RRCReconfiguration</i>	OCTET STRING including the <i>RRCReconfiguration</i>	
}			
}			
}			
}			
}			
}			
}			
}			
}			

**Table 7.1.1.5.4.3.3-2: RRCReconfiguration (Table 7.1.1.5.4.3.3-1)**

Derivation Path: 38.508-1 [4], Table 4.6.1-3			
Information Element	Value/remark	Comment	Condition
RRCReconfiguration ::= SEQUENCE {			
criticalExtensions CHOICE {			
rrcReconfiguration SEQUENCE {			
secondaryCellGroup	CellGroupConfig	OCTET STRING (CONTAINING CellGroupConfig)	EN-DC
}			
}			
}			

Table 7.1.1.5.4.3.3-3: CellGroupConfig (Table 7.1.1.5.4.3.3-2)

Derivation Path: 38.508-1 [4], Table 4.6.3-n			
Information Element	Value/remark	Comment	Condition
cellGroupConfig ::= SEQUENCE {			
cellGroupId	[value]		
mac-CellGroupConfig SEQUENCE {			
drx-Config CHOICE {			
setup SEQUENCE {			
drx-onDurationTimer	ms20		
drx-InactivityTimer	ms6		
drx-HARQ-RTT-TimerDL	56		
drx-HARQ-RTT-TimerUL	56		
drx-RetransmissionTimerDL	sl12		
drx-RetransmissionTimerUL	sl12		
drx-LongCycleStartOffset CHOICE {			
ms640	4		
}			
shortDRX SEQUENCE {			
drx-ShortCycle	ms64		
drx-ShortCycleTimer	10		
}			
drx-SlotOffset	ms0		
}			
}			
}			

## 7.1.1.6 Semi-Persistent Scheduling

### 7.1.1.6.1 Correct handling of DL assignment / Semi-persistent case

#### 7.1.1.6.1.1 Test Purpose (TP)

(1)

```
with { UE in RRC_Connected state with DRB established and sps-Configuration in DL is enabled }
ensure that {
  when { UE receives a DL assignment addressed to its stored CS-RNTI in slot y and with NDI set as 0 }
  then { UE starts receiving DL MAC PDU in slots y+n*[semiPersistSchedIntervalDL] where 'n' is positive integer starting at zero }
}
```

(2)

```
with { UE in RRC_Connected state with DRB established and stored DL SPS assignment to receive MAC PDU in slot y+n*[semiPersistSchedIntervalDL] }
ensure that {
  when { UE receives a DL assignment addressed to its CS-RNTI in slot p and with NDI set as 0, where p!= y+n*[semiPersistSchedIntervalDL] }
  then { UE starts receiving DL MAC PDU in slots p+n*[semiPersistSchedIntervalDL] and stops receiving DL MAC PDU at slots y+n*[semiPersistSchedIntervalDL] where 'n' is positive integer starting at zero }
}
```

(3)

```
with { UE in RRC_Connected state with DRB established and stored DL SPS assignment to receive MAC PDU at slot p+n*[semiPersistSchedIntervalDL] }
ensure that {
  when { UE receives a DL assignment [for retransmission] addressed to its CS-RNTI in Slot z and with NDI set as 1, where z!= p+n*[semiPersistSchedIntervalDL] }
  then { UE receives MAC PDU as per the retransmission grant for CS-RNTI }
}
```

(4)

```

with { UE in RRC_Connected state with DRB established and stored DL SPS assignment to receive MAC
PDU at slot y+n*[semiPersistSchedIntervalDL] }
ensure that {
  when { UE receives a DL assignment addressed to its C-RNTI in Slot p, such that p=
y+n*[semiPersistSchedIntervalDL] }
  then { UE receives MAC PDU as per assignment addressed to its C-RNTI }
}

```

(5)

```

with { UE in RRC_Connected state with DRB established and stored DL SPS grant to receive MAC PDU at
slot z+n*[semiPersistSchedIntervalDL] }
ensure that {
  when { UE receives a RRC Message including sps-Configuration with sps-ConfigurationDL set as
'disable' and hence resulting in DL SPS grant deactivation }
  then { UE deletes the stored sps-Configuration DL parameters and stops receiving DL MAC PDU's as
per stored SPS assignment in slot z+n*[semiPersistSchedIntervalDL] }
}

```

#### 7.1.1.6.1.2 Conformance requirements

References: The conformance requirements covered in the present TC are specified in TS 38.321, clause 5.3.1, 5.8.1 and TS 38.300, clause 10.2. Unless otherwise stated these are Rel-15 requirements.

[TS 38.321, clause 5.3.1]

Downlink assignments received on the PDCCH both indicate that there is a transmission on a DL-SCH for a particular MAC entity and provide the relevant HARQ information.

When the MAC entity has a C-RNTI, Temporary C-RNTI, or CS-RNTI, the MAC entity shall for each PDCCH occasion during which it monitors PDCCH and for each Serving Cell:

- 1> if a downlink assignment for this PDCCH occasion and this Serving Cell has been received on the PDCCH for the MAC entity's C-RNTI, or Temporary C-RNTI:
  - 2> if this is the first downlink assignment for this Temporary C-RNTI:
    - 3> consider the NDI to have been toggled.
  - 2> if the downlink assignment is for the MAC entity's C-RNTI, and if the previous downlink assignment indicated to the HARQ entity of the same HARQ process was either a downlink assignment received for the MAC entity's CS-RNTI or a configured downlink assignment:
    - 3> consider the NDI to have been toggled regardless of the value of the NDI.
  - 2> indicate the presence of a downlink assignment and deliver the associated HARQ information to the HARQ entity.
- 1> else if a downlink assignment for this PDCCH occasion has been received for this Serving Cell on the PDCCH for the MAC entity's CS-RNTI:
  - 2> if the NDI in the received HARQ information is 1:
    - 3> consider the NDI for the corresponding HARQ process not to have been toggled;
    - 3> indicate the presence of a downlink assignment for this Serving Cell and deliver the associated HARQ information to the HARQ entity.
  - 2> if the NDI in the received HARQ information is 0:
    - 3> if PDCCH contents indicate SPS deactivation:
      - 4> clear the configured downlink assignment for this Serving Cell (if any);
      - 4> if the timeAlignmentTimer associated with the PTAG is running:
        - 5> indicate a positive acknowledgement for the SPS deactivation to the physical layer.

3> else if PDCCH content indicates SPS activation:

- 4> store the downlink assignment for this Serving Cell and the associated HARQ information as configured downlink assignment;
- 4> initialise or re-initialise the configured downlink assignment for this Serving Cell to start in the associated PDSCH duration and to recur according to rules in subclause 5.8.1;
- 4> set the HARQ Process ID to the HARQ Process ID associated with this PDSCH duration;
- 4> consider the NDI bit for the corresponding HARQ process to have been toggled;
- 4> indicate the presence of a configured downlink assignment for this Serving Cell and deliver the stored HARQ information to the HARQ entity.

For each Serving Cell and each configured downlink assignment, if configured and activated, the MAC entity shall:

- 1> if the PDSCH duration of the configured downlink assignment does not overlap with the PDSCH duration of a downlink assignment received on the PDCCH for this Serving Cell:
  - 2> instruct the physical layer to receive, in this PDSCH duration, transport block on the DL-SCH according to the configured downlink assignment and to deliver it to the HARQ entity;
  - 2> set the HARQ Process ID to the HARQ Process ID associated with this PDSCH duration;
  - 2> consider the NDI bit to have been toggled;
  - 2> indicate the presence of a configured downlink assignment and deliver the stored HARQ information to the HARQ entity.

For configured downlink assignments, the HARQ Process ID associated with the slot where the DL transmission starts is derived from the following equation:

$$\text{HARQ Process ID} = [\text{floor}(\text{CURRENT\_slot} \times 10 / (\text{numberOfSlotsPerFrame} \times \text{semiPersistSchedIntervalDL}))] \text{ modulo } \text{nrofHARQ-Processes}$$

where  $\text{CURRENT\_slot} = [(\text{SFN} \times \text{numberOfSlotsPerFrame}) + \text{slot number in the frame}]$  and  $\text{numberOfSlotsPerFrame}$  refers to the number of consecutive slots per frame as specified in TS 38.211 [8].

[TS 38.321, clause 5.8.1]

Semi-Persistent Scheduling (SPS) is configured by RRC per Serving Cell and per BWP. Multiple configurations can be active simultaneously only on different Serving Cells. Activation and deactivation of the DL SPS are independent among the Serving Cells.

For the DL SPS, a DL assignment is provided by PDCCH, and stored or cleared based on L1 signalling indicating SPS activation or deactivation.

RRC configures the following parameters when SPS is configured:

- *cs-RNTI*: CS-RNTI for activation, deactivation, and retransmission;
- *nrofHARQ-Processes*: the number of configured HARQ processes for SPS;
- *periodicity*: Interval of SPS.

When SPS is released by upper layers, all the corresponding configurations shall be released.

After a downlink assignment is configured for SPS, the MAC entity shall consider sequentially that the  $N^{\text{th}}$  downlink assignment occurs in the slot for which:

$$[(\text{numberOfSlotsPerFrame} \times \text{SFN} + \text{slot number in the frame}) = (\text{numberOfSlotsPerFrame} \times \text{SFN}_{\text{start time}} + \text{slot}_{\text{start time}}) + N \times \text{semiPersistSchedIntervalDL} \times \text{numberOfSlotsPerFrame} / 10] \text{ modulo } (1024 \times \text{numberOfSlotsPerFrame})$$

where  $\text{SFN}_{\text{start time}}$  and  $\text{slot}_{\text{start time}}$  are the SFN and slot, respectively, of the first transmission of PDSCH where the configured downlink assignment was (re-)initialised.

[TS 38.300, clause 10.2]

In the downlink, the gNB can dynamically allocate resources to UEs via the C-RNTI on PDCCH(s). A UE always monitors the PDCCH(s) in order to find possible assignments when its downlink reception is enabled (activity governed by DRX when configured). When CA is configured, the same C-RNTI applies to all serving cells.

In addition, with Semi-Persistent Scheduling (SPS), the gNB can allocate downlink resources for the initial HARQ transmissions to UEs: RRC defines the periodicity of the configured downlink assignments while PDCCH addressed to CS-RNTI can either signal and activate the configured downlink assignment, or deactivate it; i.e. a PDCCH addressed to CS-RNTI indicates that the downlink assignment can be implicitly reused according to the periodicity defined by RRC, until deactivated.

NOTE: when required, retransmissions are explicitly scheduled on PDCCH(s).

When a configured downlink assignment is active, if the UE cannot find its C-RNTI on the PDCCH(s), a downlink transmission according to the configured downlink assignment is assumed. Otherwise, if the UE finds its C-RNTI on the PDCCH(s), the PDCCH allocation overrides the configured downlink assignment.

7.1.1.6.1.3 Test description

7.1.1.6.1.3.1 Pre-test conditions

Same Pre-test conditions as in clause 7.1.1.0 except that set to return no data in uplink.



7.1.1.6.1.3.2 Test procedure sequence

**Table 7.1.1.6.1.3.2-1: Main behaviour**

St	Procedure	Message Sequence		TP	Verdict
		U - S	Message		
1	The SS transmits a DL assignment using UE's CS-RNTI in Slot 'Y', NDI=0.	<--	(DL SPS Grant)	-	-
2	The SS transmits in Slot 'Y', a DL MAC PDU containing a RLC PDU (DL-SQN=0) on UM DRB.	<--	MAC PDU	-	-
3	Check: Does the UE transmit a HARQ ACK?	-->	HARQ ACK	1	P
4	The SS transmits in Slot 'Y+X', a DL MAC PDU containing a RLC PDU (DL-SQN=1) on DRB. (Note 1)	<--	MAC PDU	-	-
5	Check: Does the UE transmit a HARQ ACK?	-->	HARQ ACK	1	P
6	The SS transmits a DL assignment using UE's CS-RNTI in Slot 'P', NDI=0; (Where $Y+X < P < Y+2X$ )	<--	(DL SPS Grant)	-	-
7	The SS transmits in Slot 'P', a DL MAC PDU containing a RLC PDU (DL-SQN=2) on UM DRB.	<--	MAC PDU	-	-
8	Check: Does the UE transmit a HARQ ACK?	-->	HARQ ACK	2	P
9	The SS transmits in Slot 'Y+2X', a DL MAC PDU containing a RLC PDU (DL-SQN=3) on UM DRB.	<--	MAC PDU	-	-
10	Check: Does the UE transmit a HARQ Feedback?	-->	HARQ ACK/NACK	2	F
11	The SS transmits a DL assignment using UE's C-RNTI in Slot 'P+X', NDI=0.	<--	(DL Grant)	-	-
12	The SS transmits in Slot 'P+X', a DL MAC PDU containing a RLC PDU (DL-SQN=3) on UM DRB. (Note 2)	<--	MAC PDU	-	-
13	Check: Does the UE transmit a HARQ ACK?	-->	HARQ ACK	4	P
14	The SS transmits in Slot 'P+2X', a DL MAC PDU containing a RLC PDU (DL-SQN=4) on UM DRB.	<--	MAC PDU	-	-
15	Check: Does the UE transmit a HARQ ACK?	-->	HARQ ACK	1	P
16	The SS transmits a DL assignment using UE's CS-RNTI in Slot 'P+3X', NDI=0.	<--	(DL SPS Grant)	-	-
17	The SS transmits in Slot 'P+3X', a DL MAC PDU containing 1 RLC PDU's (DL-SQN=5) on UM DRB; CRC is calculated in such a way will result in CRC error in UE.	<--	MAC PDU	-	-
18	Check: Does the UE transmit a HARQ NACK?	-->	HARQ NACK	-	-
-	EXCEPTION: Step 19 and 20 shall be repeated until HARQ retransmission count = 3 is reached for MAC PDU at step 17. (Note 3)	-	-	-	-
19	The SS transmits a DL assignment using UE's CS-RNTI in Slot 'Z', NDI=1; Where $(P+3X < Z < P+4X)$ ; The DL HARQ process is same as in step 18.	<--	(DL SPS Grant)	-	-
20	The SS re-transmits in Slot 'Z', a DL MAC PDU containing a RLC PDU (DL-SQN=5) on UM DRB.	<--	MAC PDU	-	-
-	EXCEPTION: Up to 3 HARQ NACK from the UE should be allowed at step 21 (Note 3).	-	-	-	-
21	Check: Does the UE transmit a HARQ ACK?	-->	HARQ ACK	3	P
22	SS transmits RRCConnectionReconfiguration to disable SPS-ConfigurationDL.	<--	RRCConnectionReconfiguration	-	-
23	The UE transmits RRCConnectionReconfigurationComplete.	-->	RRCConnectionReconfigurationComplete	-	-
24	The SS transmits in Slot 'P+5X', a DL MAC PDU containing 1 RLC PDU's (DL-SQN=7) on UM DRB;	<--	MAC PDU	-	-
25	Check: Does the UE transmit a HARQ Feedback?	-->	HARQ ACK/NACK	5	F

Note 1: X is equal to semiPersistSchedIntervalDL in this document.  
 Note 2: The DL assignment for C-RNTI and hence the size of MAC PDU is different in size than stored CS-RNTI DL assignment in step 6. This assures UE is receiving DSCH data as per DL assignment for C-RNTI and not as per stored grant for CS-RNTI.  
 Note 3: The value 4 for the maximum number of HARQ retransmissions has been chosen based on an assumption that, given the radio conditions used in this test case, a UE soft combiner implementation should have sufficient retransmissions to be able to successfully decode the data in its soft buffer.

7.1.1.6.1.3.3 Specific message contents

**Table 7.1.1.6.1.3.3-1: RRCConnectionReconfiguration (Preamble)**

Derivation path: 36.508 [7], Table 4.6.1-8			
Information Element	Value/remark	Comment	Condition
RRCConnectionReconfiguration ::= SEQUENCE {			
criticalExtensions CHOICE {			
c1 CHOICE {			
rrcConnectionReconfiguration-r8 SEQUENCE {			
nonCriticalExtension SEQUENCE {			
nonCriticalExtension SEQUENCE {			
nonCriticalExtension SEQUENCE {			
nonCriticalExtension SEQUENCE {			
nonCriticalExtension SEQUENCE {			
nonCriticalExtension SEQUENCE {			
nonCriticalExtension SEQUENCE {			
nr-Config-r15 CHOICE {			
setup SEQUENCE {			
nr-SecondaryCellGroupConfig-r15	<i>RRCReconfiguration</i>	OCTET STRING including the <i>RRCReconfiguration</i>	
}			
}			
}			
}			
}			
}			
}			
}			
}			
}			
}			
}			

**Table 7.1.1.6.1.3.3-2: RRCReconfiguration (Table 7.1.1.6.1.3.3-1)**

Derivation path: 38.508-1 [4], Table 4.6.1-3			
Information Element	Value/remark	Comment	Condition
RRCReconfiguration ::= SEQUENCE {			
criticalExtensions CHOICE {			
rrcReconfiguration SEQUENCE {			
secondaryCellGroup	CellGroupConfig	OCTET STRING (CONTAINING CellGroupConfig)	EN-DC
}			
}			

**Table 7.1.1.6.1.3.3-3: CellGroupConfig (Table 7.1.1.6.1.3.3-2)**

Derivation path: 38.508-1 [4], Table 4.6.3-13			
Information Element	Value/remark	Comment	Condition
CellGroupConfig ::= SEQUENCE {			
spCellConfig SEQUENCE {			
servCellIndex	1		
spCellConfigDedicated SEQUENCE {			
initialDownlinkBWP SEQUENCE {			
sps-Config CHOICE {			
setup SEQUENCE {			
periodicity	ms40		
nrofHARQ-Processes	8		
n1PUCCH-AN SEQUENCE{			
pucch-ResourceId	0		
}			
}			
}			
}			
}			
mac-CellGroupConfig SEQUENCE {			
cs-RNTI CHOICE {			
setup SEQUENCE{			
RNTI-Value	'FFE0'H		
}			
}			
}			
}			

**Table 7.1.1.6.1.3.3-4: RRCConnectionReconfiguration (step 22, Table 7.1.1.6.1.3.2-1)**

Derivation path: 36.508 [7], Table 4.6.1-8			
Information Element	Value/remark	Comment	Condition
RRCConnectionReconfiguration ::= SEQUENCE {			
criticalExtensions CHOICE {			
c1 CHOICE{			
rrcConnectionReconfiguration-r8 SEQUENCE {			
nonCriticalExtension SEQUENCE {			
nonCriticalExtension SEQUENCE {			
nonCriticalExtension SEQUENCE {			
nonCriticalExtension SEQUENCE {			
nonCriticalExtension SEQUENCE {			
nonCriticalExtension SEQUENCE {			
nonCriticalExtension SEQUENCE {			
nr-Config-r15 CHOICE {			
setup SEQUENCE {			
nr-SecondaryCellGroupConfig-r15	<i>RRCReconfiguration</i>	OCTET STRING including the <i>RRCReconfiguration</i>	
}			
}			
}			
}			
}			
}			
}			
}			
}			
}			
}			
}			

**Table 7.1.1.6.1.3.3-5: RRCReconfiguration (Table 7.1.1.6.1.3.3-4)**

Derivation path: 38.508-1 [4], Table 4.6.1-3			
Information Element	Value/remark	Comment	Condition
RRCReconfiguration ::= SEQUENCE {			
criticalExtensions CHOICE {			
rrcReconfiguration SEQUENCE {			
secondaryCellGroup	CellGroupConfig	OCTET STRING (CONTAINING CellGroupConfig)	EN-DC
}			
}			

Table 7.1.1.6.1.3.3-6: *CellGroupConfig* (Table 7.1.1.6.1.3.3-5)

Derivation path: 38.508-1 [4], Table 4.6.3-13			
Information Element	Value/remark	Comment	Condition
<i>CellGroupConfig</i> ::= SEQUENCE {			
<i>spCellConfig</i> SEQUENCE {			
<i>servCellIndex</i>	1		
<i>spCellConfigDedicated</i> SEQUENCE {			
<i>initialDownlinkBWP</i> SEQUENCE {			
<i>sps-Config</i> CHOICE {			
<i>release</i>	Null		
}			
}			
}			
}			
}			

### 7.1.1.6.2 Correct handling of UL grant / configured grant Type 1

#### 7.1.1.6.2.1 Test Purpose (TP)

(1)

```
with { UE in RRC_Connected state with DRB established and sps-Configuration in UL is enabled with
Configured grant type 1 }
ensure that {
  when { The symbol in which equation  $[(SFN \times \text{numberOfSlotsPerFrame} \times \text{numberOfSymbolsPerSlot}) +
(\text{slot number in the frame} \times \text{numberOfSymbolsPerSlot}) + \text{symbol number in the slot}] =
(\text{timeDomainOffset} \times \text{numberOfSymbolsPerSlot} + S + N \times \text{periodicity}) \text{ modulo } (1024 \times
\text{numberOfSlotsPerFrame} \times \text{numberOfSymbolsPerSlot})$  is satisfied }
  then { UE starts transmitting UL MAC PDU periodically in the symbol associated with the new re-
configured grant }
}
```

(2)

```
with { UE in RRC_Connected state with DRB established and configured UL grant type 1 }
ensure that {
  when { UE receives a new UL grant type 1 in an RRC message }
  then { UE starts transmitting UL MAC PDU periodically in the symbol associated with the new re-
configured grant }
}
```

(3)

```
with { UE in RRC_Connected state with DRB established and configured UL grant type 1 }
ensure that {
  when { UE receives a RRC message including sps-Configuration with rrcConfiguredUplinkGrant set as
'release' }
  then { UE deletes the stored configured UL Grant type 1 parameters and stops transmitting UL MAC
PDU's as per configured UL grant type 1 }
}
```

#### 7.1.1.6.2.2 Conformance requirements

References: The conformance requirements covered in the present TC are specified in: 3GPP TS 38.321 clauses 5.4.1 and 5.8.2, 3GPP TS 38.300 clause 10.3. Unless otherwise stated these are Rel-15 requirements.

[TS 38.321, clause 5.4.1]

Uplink grant is either received dynamically on the PDCCH, in a Random Access Response, or configured semi-persistently by RRC. The MAC entity shall have an uplink grant to transmit on the UL-SCH. To perform the requested transmissions, the MAC layer receives HARQ information from lower layers.

If the MAC entity has a C-RNTI, a Temporary C-RNTI, or CS-RNTI, the MAC entity shall for each PDCCH occasion and for each Serving Cell belonging to a TAG that has a running *timeAlignmentTimer* and for each grant received for this PDCCH occasion:

- 1> if an uplink grant for this Serving Cell has been received on the PDCCH for the MAC entity's C-RNTI or Temporary C-RNTI; or
- 1> if an uplink grant has been received in a Random Access Response:
  - 2> if the uplink grant is for MAC entity's C-RNTI and if the previous uplink grant delivered to the HARQ entity for the same HARQ process was either an uplink grant received for the MAC entity's CS-RNTI or a configured uplink grant:
    - 3> consider the NDI to have been toggled for the corresponding HARQ process regardless of the value of the NDI.
  - 2> if the uplink grant is for MAC entity's C-RNTI, and the identified HARQ process is configured for a configured grant:
    - 3> start or restart the *configuredGrantTimer* for the corresponding HARQ process, if configured.
  - 2> deliver the uplink grant and the associated HARQ information to the HARQ entity.
- 1> else if an uplink grant for this PDCCH occasion has been received for this Serving Cell on the PDCCH for the MAC entity's CS-RNTI:
  - 2> if the NDI in the received HARQ information is 1:
    - 3> consider the NDI for the corresponding HARQ process not to have been toggled;
    - 3> start or restart the *configuredGrantTimer* for the corresponding HARQ process, if configured;
    - 3> deliver the uplink grant and the associated HARQ information to the HARQ entity.
  - 2> else if the NDI in the received HARQ information is 0:
    - 3> if PDCCH contents indicate configured grant Type 2 deactivation:
      - 4> trigger configured grant confirmation.
    - 3> else if PDCCH contents indicate configured grant Type 2 activation:
      - 4> trigger configured grant confirmation;
      - 4> store the uplink grant for this Serving Cell and the associated HARQ information as configured uplink grant;
      - 4> initialise or re-initialise the configured uplink grant for this Serving Cell to start in the associated PUSCH duration and to recur according to rules in subclause 5.8.2;
      - 4> set the HARQ Process ID to the HARQ Process ID associated with this PUSCH duration;
      - 4> consider the NDI bit for the corresponding HARQ process to have been toggled;
      - 4> stop the *configuredGrantTimer* for the corresponding HARQ process, if running;
      - 4> deliver the configured uplink grant and the associated HARQ information to the HARQ entity.

For each Serving Cell and each configured uplink grant, if configured and activated, the MAC entity shall:

- 1> if the PUSCH duration of the configured uplink grant does not overlap with the PUSCH duration of an uplink grant received on the PDCCH for this Serving Cell:
  - 2> set the HARQ Process ID to the HARQ Process ID associated with this PUSCH duration;
- 2> if the *configuredGrantTimer* for the corresponding HARQ process is not running:
  - 3> consider the NDI bit for the corresponding HARQ process to have been toggled;
  - 3> deliver the configured uplink grant and the associated HARQ information to the HARQ entity.

For configured uplink grants, the HARQ Process ID associated with the first symbol of a UL transmission is derived from the following equation:

$$\text{HARQ Process ID} = [\text{floor}(\text{CURRENT\_symbol}/\text{periodicity})] \text{ modulo } n\text{rofHARQ-Processes}$$

where  $\text{CURRENT\_symbol} = (\text{SFN} \times \text{numberOfSlotsPerFrame} \times \text{numberOfSymbolsPerSlot} + \text{slot number in the frame} \times \text{numberOfSymbolsPerSlot} + \text{symbol number in the slot})$ , and  $\text{numberOfSlotsPerFrame}$  and  $\text{numberOfSymbolsPerSlot}$  refer to the number of consecutive slots per frame and the number of consecutive symbols per slot, respectively as specified in TS 38.211 [8].

NOTE 1:  $\text{CURRENT\_symbol}$  refers to the symbol index of the first transmission occasion of a repetition bundle that takes place.

NOTE 2: A HARQ process is configured for a configured grant if the configured grant is activated and the associated HARQ process ID is less than  $n\text{rofHARQ-Processes}$ .

[TS 38.321, clause 5.8.2]

There are two types of transmission without dynamic grant:

- configured grant Type 1 where an uplink grant is provided by RRC, and stored as configured uplink grant;
- configured grant Type 2 where an uplink grant is provided by PDCCH, and stored or cleared as configured uplink grant based on L1 signalling indicating configured grant activation or deactivation.

Type 1 and Type 2 are configured by RRC per Serving Cell and per BWP. Multiple configurations can be active simultaneously only on different Serving Cells. For Type 2, activation and deactivation are independent among the Serving Cells. For the same Serving Cell, the MAC entity is configured with either Type 1 or Type 2.

RRC configures the following parameters when the configured grant Type 1 is configured:

- *cs-RNTI*: CS-RNTI for retransmission;
- *periodicity*: periodicity of the configured grant Type 1;
- *timeDomainOffset*: Offset of a resource with respect to  $\text{SFN}=0$  in time domain;
- *timeDomainAllocation*: Allocation of configured grant in time domain which contains *startSymbolAndLength* (i.e. *SLIV* in TS 38.214 [7]);
- *nrofHARQ-Processes*: the number of HARQ processes.

RRC configures the following parameters when the configured grant Type 2 is configured:

- *cs-RNTI*: CS-RNTI for both activation, deactivation, and retransmission;
- *periodicity*: periodicity of the configured grant Type 2;
- *nrofHARQ-Processes*: the number of HARQ processes.

Upon configuration of a configured grant Type 1 for a Serving Cell by upper layers, the MAC entity shall:

- 1> store the uplink grant provided by upper layers as a configured uplink grant for the indicated Serving Cell;
- 1> initialise or re-initialise the configured uplink grant to start in the symbol according to *timeDomainOffset* and  $S$  (derived from *SLIV* as specified in TS 38.214 [7]), and to reoccur with *periodicity*.

After an uplink grant is configured for a configured grant Type 1, the MAC entity shall consider sequentially that the  $N^{\text{th}}$  uplink grant occurs associated with the symbol for which:

$$[(\text{SFN} \times \text{numberOfSlotsPerFrame} \times \text{numberOfSymbolsPerSlot}) + (\text{slot number in the frame} \times \text{numberOfSymbolsPerSlot}) + \text{symbol number in the slot}] = (\text{timeDomainOffset} \times \text{numberOfSymbolsPerSlot} + S + N \times \text{periodicity}) \text{ modulo } (1024 \times \text{numberOfSlotsPerFrame} \times \text{numberOfSymbolsPerSlot})$$

After an uplink grant is configured for a configured grant Type 2, the MAC entity shall consider sequentially that the  $N^{\text{th}}$  uplink grant occurs associated with the symbol for which:



$$\begin{aligned} &[(SFN \times \text{numberOfSlotsPerFrame} \times \text{numberOfSymbolsPerSlot}) + (\text{slot number in the frame} \times \\ &\quad \text{numberOfSymbolsPerSlot}) + \text{symbol number in the slot}] = \\ &[(SFN_{\text{start time}} \times \text{numberOfSlotsPerFrame} \times \text{numberOfSymbolsPerSlot} + \text{slot}_{\text{start time}} \times \text{numberOfSymbolsPerSlot} + \\ &\quad \text{symbol}_{\text{start time}}) + N \times \text{periodicity}] \text{ modulo } (1024 \times \text{numberOfSlotsPerFrame} \times \text{numberOfSymbolsPerSlot}) \end{aligned}$$

where  $SFN_{\text{start time}}$ ,  $\text{slot}_{\text{start time}}$ , and  $\text{symbol}_{\text{start time}}$  are the SFN, slot, and symbol, respectively, of the first transmission of PUSCH where the configured uplink grant was (re-)initialised.

When a configured grant is released by upper layers, all the corresponding configurations shall be released and all corresponding uplink grants shall be cleared immediately.

The MAC entity shall:

- 1> if the configured grant confirmation has been triggered and not cancelled; and
- 1> if the MAC entity has UL resources allocated for new transmission:
  - 2> instruct the Multiplexing and Assembly procedure to generate an Configured Grant Confirmation MAC CE as defined in subclause 6.1.3.7;
  - 2> cancel the triggered configured grant confirmation.

For a configured grant Type 2, the MAC entity shall clear the configured uplink grant immediately after first transmission of Configured Grant Confirmation MAC CE triggered by the configured grant deactivation.

Retransmissions except for repetition of configured grants use uplink grants addressed to CS-RNTI.

[TS 38.300, clause 10.3]

In the uplink, the gNB can dynamically allocate resources to UEs via the C-RNTI on PDCCH(s). A UE always monitors the PDCCH(s) in order to find possible grants for uplink transmission when its downlink reception is enabled (activity governed by DRX when configured). When CA is configured, the same C-RNTI applies to all serving cells.

In addition, with Configured Grants, the gNB can allocate uplink resources for the initial HARQ transmissions to UEs. Two types of configured uplink grants are defined:

- With Type 1, RRC directly provides the configured uplink grant (including the periodicity).
- With Type 2, RRC defines the periodicity of the configured uplink grant while PDCCH addressed to CS-RNTI can either signal and activate the configured uplink grant, or deactivate it; i.e. a PDCCH addressed to CS-RNTI indicates that the uplink grant can be implicitly reused according to the periodicity defined by RRC, until deactivated.

When a configured uplink grant is active, if the UE cannot find its C-RNTI/CS-RNTI on the PDCCH(s), an uplink transmission according to the configured uplink grant can be made. Otherwise, if the UE finds its C-RNTI/CS-RNTI on the PDCCH(s), the PDCCH allocation overrides the configured uplink grant.

Retransmissions other than repetitions are explicitly allocated via PDCCH(s).

When CA is configured, at most one configured uplink grant can be signalled per serving cell. When BA is configured, at most one configured uplink grant can be signalled per BWP. On each serving cell, there can be only one configured uplink grant active at a time. A configured uplink grant for one serving cell can either be of Type 1 or Type 2. For Type 2, activation and deactivation of configured uplink grants are independent among the serving cells. When SUL is configured, a configured uplink grant can only be signalled for one of the 2 ULs of the cell.

7.1.1.6.2.3 Test description

7.1.1.6.2.3.1 Pre-test conditions

Same Pre-test conditions as in clause 7.1.1.0 and UM DRB should be established on NR Cell 1.

7.1.1.6.2.3.2 Test procedure sequence

**Table 7.1.1.6.2.3.2-1: Main behaviour**

St	Procedure	Message Sequence		TP	Verdict
		U - S	Message		
1	SS transmits <i>RRCReconfiguration</i> to configure UL configured grant type 1 in SFN 900, <i>timeDomainOffset</i> is set to 5.	<--	<i>RRCReconfiguration</i>	-	-
2	The UE transmits <i>RRCReconfigurationComplete</i> .	-->	<i>RRCReconfigurationComplete</i>	-	-
3	SS transmits a DL MAC PDU containing 4 RLC SDUs of size 96 bytes in SFN 1022 on UM DRB. (Note 1)	<--	MAC PDU (four RLC SDUs)	-	-
4	Check: Does the UE transmit a MAC PDU containing one RLC SDU in Symbol 'x0', Slot y0', SFN 'z0' after the SFN in step 4 wraps around? Where $[(z0 \times \text{numberOfSlotsPerFrame} \times \text{numberOfSymbolsPerSlot}) + (y0 \times \text{numberOfSymbolsPerSlot}) + x0] = (5 \times \text{numberOfSymbolsPerSlot} + S + 0 \times \text{periodicity}) \text{ modulo } (1024 \times \text{numberOfSlotsPerFrame} \times \text{numberOfSymbolsPerSlot}).$ (Note 2)	-->	MAC PDU (one RLC SDU)	1	P
5	Check: Does the UE transmit a MAC PDU containing one RLC SDU in Symbol 'x1', Slot y1', SFN 'z1'? Where $[(z1 \times \text{numberOfSlotsPerFrame} \times \text{numberOfSymbolsPerSlot}) + (y1 \times \text{numberOfSymbolsPerSlot}) + x1] = (5 \times \text{numberOfSymbolsPerSlot} + S + 1 \times \text{periodicity}) \text{ modulo } (1024 \times \text{numberOfSlotsPerFrame} \times \text{numberOfSymbolsPerSlot}).$	-->	MAC PDU (one RLC SDU)	1	P
6	SS transmits <i>RRCReconfiguration</i> to configure UL configured grant type 1 in SFN 'z1 + 1', <i>timeDomainOffset</i> is set to 35.	<--	<i>RRCReconfiguration</i>	-	-
7	The UE transmits <i>RRCReconfigurationComplete</i> .	-->	<i>RRCReconfigurationComplete</i>	-	-
8	Check: Does the UE transmit a MAC PDU containing one RLC SDU received in step 4 in Symbol 'x2', Slot y2', SFN 'z2'? Where $[(z2 \times \text{numberOfSlotsPerFrame} \times \text{numberOfSymbolsPerSlot}) + (y2 \times \text{numberOfSymbolsPerSlot}) + x2] = (5 \times \text{numberOfSymbolsPerSlot} + S + N \times \text{periodicity}) \text{ modulo } (1024 \times \text{numberOfSlotsPerFrame} \times \text{numberOfSymbolsPerSlot}), N \geq 2.$	-->	MAC PDU (one RLC SDU)	2	F
9	Check: Does the UE transmit a MAC PDU containing one RLC SDU in Symbol 'x3', Slot y3', SFN 'z3' after the SFN in step 8 wraps around? Where $[(z3 \times \text{numberOfSlotsPerFrame} \times \text{numberOfSymbolsPerSlot}) + (y3 \times \text{numberOfSymbolsPerSlot}) + x3] = (35 \times \text{numberOfSymbolsPerSlot} + S + 0 \times \text{periodicity}) \text{ modulo } (1024 \times \text{numberOfSlotsPerFrame} \times \text{numberOfSymbolsPerSlot}).$	-->	MAC PDU (one RLC SDU)	2	P

10	Check: Does the UE transmit a MAC PDU containing one RLC SDU in Symbol 'x4', Slot y4', SFN 'z4'? Where $[(z4 \times \text{numberOfSlotsPerFrame} \times \text{numberOfSymbolsPerSlot}) + (y4 \times \text{numberOfSymbolsPerSlot}) + x4] = (35 \times \text{numberOfSymbolsPerSlot} + S + 1 \times \text{periodicity}) \text{ modulo } (1024 \times \text{numberOfSlotsPerFrame} \times \text{numberOfSymbolsPerSlot})$ .	-->	MAC PDU (one RLC SDU)	2	P
11	After step 10, SS transmits <i>RRCReconfiguration</i> to release UL configured grant type 1 in SFN 'z4 + 1'.	<--	<i>RRCReconfiguration</i>	-	-
12	The UE transmits <i>RRCReconfigurationComplete</i> .	-->	<i>RRCReconfigurationComplete</i>	-	-
13	SS transmits a DL MAC PDU containing one RLC SDU of size 96 bytes in SFN 'z4 + 10'.	<--	MAC PDU (one RLC SDU)		
14	Check: Does the UE transmit a MAC PDU containing one RLC SDU in Symbol 'x5', Slot y5', SFN 'z5'? Where $[(z5 \times \text{numberOfSlotsPerFrame} \times \text{numberOfSymbolsPerSlot}) + (y5 \times \text{numberOfSymbolsPerSlot}) + x5] = (35 \times \text{numberOfSymbolsPerSlot} + S + 4 \times \text{periodicity}) \text{ modulo } (1024 \times \text{numberOfSlotsPerFrame} \times \text{numberOfSymbolsPerSlot})$ .	-->	MAC PDU (one RLC SDU)	3	F
<p>Note 1: According to the setting parameters in Table 7.1.1.6.2.3.3-2, TB size for configured grant type 1 is 808 bits, which is enough to allow the UE to transmit one PDU at a time (96 bytes RLC SDU + 1 byte UM RLC Header + 2 bytes MAC Sub PDU header + 2 bytes for short BSR or padding).</p> <p>Note 2: S is the starting symbol relative to the slot of the first PUSCH transmission for new configured grant type 1. The value of S can be obtained from TS 38.508-1 Table 4.6.3-93.</p>					

7.1.1.6.2.3.3 Specific message contents

**Table 7.1.1.6.2.3.3-1: *RRCReconfiguration* (step 1 and step 6, Table 7.1.1.6.2.3.2-1)**

Derivation path: 38.508-1 [4], Table 4.6.1-3			
Information Element	Value/remark	Comment	Condition
<i>RRCReconfiguration</i> ::= SEQUENCE {			
criticalExtensions CHOICE {			
rrcReconfiguration SEQUENCE {			
secondaryCellGroup	CellGroupConfig	OCTET STRING (CONTAINING CellGroupConfig)	SA
}			
}			
}			

**Table 7.1.1.6.2.3.3-2: *CellGroupConfig* (Table 7.1.1.6.2.3.3-2: *RRCReconfiguration*)**

Derivation path: 38.331 [12], clause 6.3.2			
Information Element	Value/remark	Comment	Condition
CellGroupConfig ::= SEQUENCE {			
cellGroupld	1		
spCellConfig SEQUENCE{			
spCellConfigDedicated SEQUENCE{			
uplinkConfig SEQUENCE {			
initialUplink SEQUENCE {			
pucch-Config CHOICE {			
setup SEQUENCE {			
schedulingRequestResourceToAddModList {			
schedulingRequestResourceId	1		
schedulingRequestID	0		
periodicityAndOffset CHOICE {			
sl20	10		
}			
}			
}			
}			
}			
configuredGrantConfig CHOICE {			
setup SEQUENCE {			
cg-DMRS-Configuration	DMRS-UplinkConfig	Reference TS 38.508-1[4], Table 4.6.3-37	
uci-OnPUSCH CHOICE {			
setup SEQUENCE {			
semiStatic SEQUENCE {	BetaOffsets		
betaOffsetACK-Index1	9		
betaOffsetACK-Index2	9		
betaOffsetACK-Index3	9		
betaOffsetCSI-Part1-Index1	6		
betaOffsetCSI-Part1-Index2	6		
betaOffsetCSI-Part2-Index1	6		
betaOffsetCSI-Part2-Index2	6		
}			
}			
}			
}			
resourceAllocation	ResourceAllocationType 1		
powerControlLoopToUse	n0		
p0-PUSCH-Alpha	1		
nrofHARQ-Processes	16		
repK	n1		
periodicity	Sym40x14		15kHz
periodicity	Sym80x14		30kHz
periodicity	Sym160x14		60kHz
periodicity	Sym320x14		120kHz
rrc-ConfiguredUplinkGrant SEQUENCE{			
timeDomainOffset	5		For Step 1
	35		For Step 6
timeDomainAllocation	0	Reference TS 38.508 [4], Table 4.6.3-93	
frequencyDomainAllocation	FFS	BIT STRING (SIZE(18), Equal to NBWPsize * (LRB-1) + RBstart), where LRB = 2 PRB, RBstart (FFS), NBWPsize (FFS)	FR1_FDD, FR1_TDD

frequencyDomainAllocation	FFS	BIT STRING (SIZE(18), Equal to NBWPsize * (LRB-1) + RBstart), where LRB=9 PRB, RBstart (FFS), NBWPsize (FFS)	FR2_TDD
antennaPort	FFS		
precodingAndNumberOfLayers	0		
srs-ResourceIndicator	FFS		
mcsAndTBS	18		FR1_FDD, FR1_TDD
	25		FR2_TDD
pathlossReferenceIndex	0		
}			
}			
}			
}			
}			
}			
physicalCellGroupConfig SEQUENCE {			
cs-RNTI CHOICE {			
setup SEQUENCE{			
RNTI-Value	'FFE0'H		
}			
}			
}			
macCellGroupConfig SEQUENCE {			
drx-Config	Not Present		
}			
}			

**Table 7.1.1.6.2.3.3-3: RRCReconfiguration (step 11, Table 7.1.1.6.2.3.2-1)**

Derivation path: 38.508-1 [4], Table 4.6.1-3			
Information Element	Value/remark	Comment	Condition
RRCReconfiguration ::= SEQUENCE {			
criticalExtensions CHOICE {			
rrcReconfiguration SEQUENCE {			
FFS	FFS	OCTET STRING (CONTAINING CellGroupConfig)	SA
}			
}			
}			

**Table 7.1.1.6.2.3.3-4: CellGroupConfig (Table 7.1.1.6.2.3.3-3: RRCReconfiguration)**

Derivation path: 38.331 [12], clause 6.3.2			
Information Element	Value/remark	Comment	Condition
CellGroupConfig ::= SEQUENCE {			
cellGroupId	1		
spCellConfig SEQUENCE{			
spCellConfigDedicated SEQUENCE{			
uplinkConfig SEQUENCE {			
initialUplink SEQUENCE {			
configuredGrantConfig CHOICE {			
release	Null		
}			
}			
}			
}			
}			
}			

### 7.1.1.6.3 Correct handling of UL grant / configured grant Type 2

#### 7.1.1.6.3.1 Test Purpose (TP)

(1)

```
with { UE in RRC_Connected state with DRB established and sps-Configuration in UL is enabled }
ensure that {
  when { UE receives a UL configured grant type 2 addressed to its stored CS-CRNTI with NDI set as 0 }
  then { UE starts transmitting UL MAC PDU periodically in the symbol associated with the configured grant }
}
```

(2)

```
with { UE in RRC_Connected state with DRB established and configured UL grant type 2 }
ensure that {
  when {UE receives a UL grant addressed to its CS-CRNTI with NDI set as 0 }
  then { UE starts transmitting UL MAC PDU periodically in the symbol associated with the new re-configured grant }
}
```

(3)

```
with { UE in RRC_Connected state with DRB established and configured UL grant type 2 }
ensure that {
  when { UE receives a UL grant addressed to its CS-CRNTI with NDI set as 1 for retransmission }
  then { UE re-transmits MAC PDU as per the new grant }
}
```

(4)

```
with{ UE in RRC_Connected state with DRB established and configured UL grant type 2 }
ensure that {
  when { UE receives a UL grant addressed to its C-RNTI resulting in UL transmission overlap in time domain as configured grante type 2 }
  then { UE transmits MAC PDU as per grant addressed to its C-RNTI }
}
```

(5)

```
with { UE in RRC_Connected state with DRB established and configured UL grant type 2 }
ensure that {
  when {UE receives a RRC message including sps-Configuration with sps-ConfigurationUL set as 'disable' and hence resulting in UL SPS grant deactivation }
  then { UE deletes the stored sps-Configuration UL parameters and stops transmitting UL MAC PDU's as per configured UL grant type 2 }
}
```



(6)

```

with{ UE in RRC_Connected state with DRB established and configured UL grant type 2 }
ensure that {
  when{ If in the symbol in which UL Configured Grant type 2 is available but the HARQ buffer is
empty (no data for transmission) }
    then{ UE ignores the UL configured grant type 2 and does not send any MAC PDU }
}

```

#### 7.1.1.6.3.2 Conformance requirements

References: The conformance requirements covered in the present TC are specified in: 3GPP TS 38.321 clauses 5.4.1 and 5.8.2, 3GPP TS 38.300 clauses 10.3. Unless otherwise stated these are Rel-15 requirements.

[TS 38.321, clause 5.4.1]

Uplink grant is either received dynamically on the PDCCH, in a Random Access Response, or configured semi-persistently by RRC. The MAC entity shall have an uplink grant to transmit on the UL-SCH. To perform the requested transmissions, the MAC layer receives HARQ information from lower layers.

If the MAC entity has a C-RNTI, a Temporary C-RNTI, or CS-RNTI, the MAC entity shall for each PDCCH occasion and for each Serving Cell belonging to a TAG that has a running *timeAlignmentTimer* and for each grant received for this PDCCH occasion:

- 1> if an uplink grant for this Serving Cell has been received on the PDCCH for the MAC entity's C-RNTI or Temporary C-RNTI; or
- 1> if an uplink grant has been received in a Random Access Response:
  - 2> if the uplink grant is for MAC entity's C-RNTI and if the previous uplink grant delivered to the HARQ entity for the same HARQ process was either an uplink grant received for the MAC entity's CS-RNTI or a configured uplink grant:
    - 3> consider the NDI to have been toggled for the corresponding HARQ process regardless of the value of the NDI.
  - 2> if the uplink grant is for MAC entity's C-RNTI, and the identified HARQ process is configured for a configured grant:
    - 3> start or restart the *configuredGrantTimer* for the corresponding HARQ process, if configured.
  - 2> deliver the uplink grant and the associated HARQ information to the HARQ entity.
- 1> else if an uplink grant for this PDCCH occasion has been received for this Serving Cell on the PDCCH for the MAC entity's CS-RNTI:
  - 2> if the NDI in the received HARQ information is 1:
    - 3> consider the NDI for the corresponding HARQ process not to have been toggled;
    - 3> start or restart the *configuredGrantTimer* for the corresponding HARQ process, if configured;
    - 3> deliver the uplink grant and the associated HARQ information to the HARQ entity.
  - 2> else if the NDI in the received HARQ information is 0:
    - 3> if PDCCH contents indicate configured grant Type 2 deactivation:
      - 4> trigger configured grant confirmation.
    - 3> else if PDCCH contents indicate configured grant Type 2 activation:
      - 4> trigger configured grant confirmation;
      - 4> store the uplink grant for this Serving Cell and the associated HARQ information as configured uplink grant;

- 4> initialise or re-initialise the configured uplink grant for this Serving Cell to start in the associated PUSCH duration and to recur according to rules in subclause 5.8.2;
- 4> set the HARQ Process ID to the HARQ Process ID associated with this PUSCH duration;
- 4> consider the NDI bit for the corresponding HARQ process to have been toggled;
- 4> stop the *configuredGrantTimer* for the corresponding HARQ process, if running;
- 4> deliver the configured uplink grant and the associated HARQ information to the HARQ entity.

For each Serving Cell and each configured uplink grant, if configured and activated, the MAC entity shall:

- 1> if the PUSCH duration of the configured uplink grant does not overlap with the PUSCH duration of an uplink grant received on the PDCCH for this Serving Cell:
  - 2> set the HARQ Process ID to the HARQ Process ID associated with this PUSCH duration;
- 2> if the *configuredGrantTimer* for the corresponding HARQ process is not running:
  - 3> consider the NDI bit for the corresponding HARQ process to have been toggled;
  - 3> deliver the configured uplink grant and the associated HARQ information to the HARQ entity.

For configured uplink grants, the HARQ Process ID associated with the first symbol of a UL transmission is derived from the following equation:

$$\text{HARQ Process ID} = [\text{floor}(\text{CURRENT\_symbol}/\text{periodicity})] \text{ modulo } n\text{rofHARQ-Processes}$$

where  $\text{CURRENT\_symbol} = (\text{SFN} \times \text{numberOfSlotsPerFrame} \times \text{numberOfSymbolsPerSlot} + \text{slot number in the frame} \times \text{numberOfSymbolsPerSlot} + \text{symbol number in the slot})$ , and *numberOfSlotsPerFrame* and *numberOfSymbolsPerSlot* refer to the number of consecutive slots per frame and the number of consecutive symbols per slot, respectively as specified in TS 38.211 [8].

NOTE 1: *CURRENT\_symbol* refers to the symbol index of the first transmission occasion of a repetition bundle that takes place.

NOTE 2: A HARQ process is configured for a configured grant if the configured grant is activated and the associated HARQ process ID is less than *nrofHARQ-Processes*.

[TS 38.321, clause 5.8.2]

There are two types of transmission without dynamic grant:

- configured grant Type 1 where an uplink grant is provided by RRC, and stored as configured uplink grant;
- configured grant Type 2 where an uplink grant is provided by PDCCH, and stored or cleared as configured uplink grant based on L1 signalling indicating configured grant activation or deactivation.

Type 1 and Type 2 are configured by RRC per Serving Cell and per BWP. Multiple configurations can be active simultaneously only on different Serving Cells. For Type 2, activation and deactivation are independent among the Serving Cells. For the same Serving Cell, the MAC entity is configured with either Type 1 or Type 2.

RRC configures the following parameters when the configured grant Type 1 is configured:

- *cs-RNTI*: CS-RNTI for retransmission;
- *periodicity*: periodicity of the configured grant Type 1;
- *timeDomainOffset*: Offset of a resource with respect to SFN=0 in time domain;
- *timeDomainAllocation*: Allocation of configured grant in time domain which contains *startSymbolAndLength* (i.e. *SLIV* in TS 38.214 [7]);
- *nrofHARQ-Processes*: the number of HARQ processes.

RRC configures the following parameters when the configured grant Type 2 is configured:

- *cs-RNTI*: CS-RNTI for both activation, deactivation, and retransmission;
- *periodicity*: periodicity of the configured grant Type 2;
- *nrofHARQ-Processes*: the number of HARQ processes.

Upon configuration of a configured grant Type 1 for a Serving Cell by upper layers, the MAC entity shall:

- 1> store the uplink grant provided by upper layers as a configured uplink grant for the indicated Serving Cell;
- 1> initialise or re-initialise the configured uplink grant to start in the symbol according to *timeDomainOffset* and *S* (derived from *SLIV* as specified in TS 38.214 [7]), and to reoccur with *periodicity*.

After an uplink grant is configured for a configured grant Type 1, the MAC entity shall consider sequentially that the  $N^{\text{th}}$  uplink grant occurs associated with the symbol for which:

$$\begin{aligned} &[(\text{SFN} \times \text{numberOfSlotsPerFrame} \times \text{numberOfSymbolsPerSlot}) + (\text{slot number in the frame} \times \\ &\quad \text{numberOfSymbolsPerSlot}) + \text{symbol number in the slot}] = \\ &(\text{timeDomainOffset} \times \text{numberOfSymbolsPerSlot} + S + N \times \text{periodicity}) \text{ modulo } (1024 \times \text{numberOfSlotsPerFrame} \times \\ &\quad \text{numberOfSymbolsPerSlot}) \end{aligned}$$

After an uplink grant is configured for a configured grant Type 2, the MAC entity shall consider sequentially that the  $N^{\text{th}}$  uplink grant occurs associated with the symbol for which:

$$\begin{aligned} &[(\text{SFN} \times \text{numberOfSlotsPerFrame} \times \text{numberOfSymbolsPerSlot}) + (\text{slot number in the frame} \times \\ &\quad \text{numberOfSymbolsPerSlot}) + \text{symbol number in the slot}] = \\ &[(\text{SFN}_{\text{start time}} \times \text{numberOfSlotsPerFrame} \times \text{numberOfSymbolsPerSlot} + \text{slot}_{\text{start time}} \times \text{numberOfSymbolsPerSlot} + \\ &\quad \text{symbol}_{\text{start time}}) + N \times \text{periodicity}] \text{ modulo } (1024 \times \text{numberOfSlotsPerFrame} \times \text{numberOfSymbolsPerSlot}) \end{aligned}$$

where  $\text{SFN}_{\text{start time}}$ ,  $\text{slot}_{\text{start time}}$ , and  $\text{symbol}_{\text{start time}}$  are the SFN, slot, and symbol, respectively, of the first transmission of PUSCH where the configured uplink grant was (re-)initialised.

When a configured grant is released by upper layers, all the corresponding configurations shall be released and all corresponding uplink grants shall be cleared immediately.

The MAC entity shall:

- 1> if the configured grant confirmation has been triggered and not cancelled; and
- 1> if the MAC entity has UL resources allocated for new transmission:
  - 2> instruct the Multiplexing and Assembly procedure to generate an Configured Grant Confirmation MAC CE as defined in subclause 6.1.3.7;
  - 2> cancel the triggered configured grant confirmation.

For a configured grant Type 2, the MAC entity shall clear the configured uplink grant immediately after first transmission of Configured Grant Confirmation MAC CE triggered by the configured grant deactivation.

Retransmissions except for repetition of configured grants use uplink grants addressed to CS-RNTI.

[TS 38.300, clause 10.3]

In the uplink, the gNB can dynamically allocate resources to UEs via the C-RNTI on PDCCH(s). A UE always monitors the PDCCH(s) in order to find possible grants for uplink transmission when its downlink reception is enabled (activity governed by DRX when configured). When CA is configured, the same C-RNTI applies to all serving cells.

In addition, with Configured Grants, the gNB can allocate uplink resources for the initial HARQ transmissions to UEs. Two types of configured uplink grants are defined:

- With Type 1, RRC directly provides the configured uplink grant (including the periodicity).
- With Type 2, RRC defines the periodicity of the configured uplink grant while PDCCH addressed to CS-RNTI can either signal and activate the configured uplink grant, or deactivate it; i.e. a PDCCH addressed to CS-RNTI indicates that the uplink grant can be implicitly reused according to the periodicity defined by RRC, until deactivated.

When a configured uplink grant is active, if the UE cannot find its C-RNTI/CS-RNTI on the PDCCH(s), an uplink transmission according to the configured uplink grant can be made. Otherwise, if the UE finds its C-RNTI/CS-RNTI on the PDCCH(s), the PDCCH allocation overrides the configured uplink grant.

Retransmissions other than repetitions are explicitly allocated via PDCCH(s).

When CA is configured, at most one configured uplink grant can be signalled per serving cell. When BA is configured, at most one configured uplink grant can be signalled per BWP. On each serving cell, there can be only one configured uplink grant active at a time. A configured uplink grant for one serving cell can either be of Type 1 or Type 2. For Type 2, activation and deactivation of configured uplink grants are independent among the serving cells. When SUL is configured, a configured uplink grant can only be signalled for one of the 2 ULs of the cell.

#### 7.1.1.6.3.3 Test description

##### 7.1.1.6.3.3.1 Pre-test conditions

Same Pre-test conditions as in clause 7.1.1.0 and UM DRB should be established on NR Cell 1. The loop back size is set to accommodate one RLC SDU in UL of same size as one RLC SDU in DL and 1 byte MAC subheader for Configured Grant Confirmation MAC CE.

7.1.1.6.3.3.2 Test procedure sequence

**Table 7.1.1.6.3.3.2-1: Main behaviour**

St	Procedure	Message Sequence		TP	Verdict
		U - S	Message		
1	SS transmits <i>RRCReconfiguration</i> to configure UL configured grant type 2.	<--	<i>RRCReconfiguration</i>	-	-
2	The UE transmits <i>RRCReconfigurationComplete</i> .	-->	<i>RRCReconfigurationComplete</i>	-	-
3	SS transmits a DL MAC PDU containing 6 RLC SDUs on UM DRB.	<--	MAC PDU	-	-
4	The UE transmits a Scheduling Request, indicating that loop back SDUs are ready for transmission in UL RLC.	-->	(SR)	-	-
5	SS transmits a UL configured grant type 2 addressed to UE's stored CS-RNTI in Slot 'n' of PDCCH, NDI=0, allowing the UE to transmit one loop back SDU and 1 byte MAC subheader for Configured Grant Confirmation MAC CE.	<--	(UL SPS Grant)	-	-
6	Check: Does the UE transmit a MAC PDU containing one RLC SDU and a Configured Grant Confirmation MAC CE in Symbol 'S' of Slot 'y' of PUSCH as per grant in step 5?  i.e., in the PUSCH slot $y = \text{floor}(n * (\text{PUSCH}_{\text{scs}} / \text{PDCCH}_{\text{scs}})) + K_2$ . (Note 1)	-->	MAC PDU	1	P
7	Check: Does the UE transmit a MAC PDU containing one RLC SDU in Symbol 'S' of Slot 'y + x' of PUSCH as per grant in step 5? (Note 2)	-->	MAC PDU	1	P
8	SS transmits a UL configured grant type 2 addressed to UE's stored CS-RNTI in Slot 'p' of PDCCH ( $p = \text{floor}(p_0 * (\text{PDCCH}_{\text{scs}} / \text{PUSCH}_{\text{scs}}))$ ), NDI = 0, allowing the UE to transmit one loop back SDU and 1 byte MAC subheader for Configured Grant Confirmation MAC CE, Where $p_0$ is the slot of PUSCH with $y + x < p_0 < y + 2x - K_2$ .	<--	(UL SPS Grant)	-	-
9	Check: Does the UE transmit a MAC PDU containing one RLC SDU and 1 byte MAC subheader for Configured Grant Confirmation MAC CE in Symbol 'S' of Slot 'z' of PUSCH as per grant in step 8?  i.e., in the PUSCH slot $z = \text{floor}(p * (\text{PUSCH}_{\text{scs}} / \text{PDCCH}_{\text{scs}})) + K_2$ . (Note 1)	-->	MAC PDU	2	P
10	Check: Does the UE transmit a MAC PDU containing one RLC SDU in Symbol 'S' of Slot 'y + 2x' as per grant in step 5?	-->	MAC PDU	2	F
11	Check: Does the UE transmit a MAC PDU containing one RLC SDU in Symbol 'S' of Slot 'z + x' of PUSCH as per grant in step 8?	-->	MAC PDU	2	P
12	SS transmits a UL configured grant type 2 addressed to UE's stored CS-RNTI in Slot 'q' of PDCCH ( $q = \text{floor}(q_0 * (\text{PDCCH}_{\text{scs}} / \text{PUSCH}_{\text{scs}}))$ ), NDI = 1; allowing the UE to transmit one loop back SDU. The UL HARQ process is the same as in step 11, Where $q_0$ is the slot of PUSCH with $z + x < q_0 < z + 2x - K_2$ .	<--	(UL SPS Grant)	-	-
13	Check: Does the UE transmit a MAC PDU containing the same RLC SDU as in step 11 in Symbol 'S' of Slot 'w' of PUSCH?  i.e., in the PUSCH slot $w = \text{floor}(q * (\text{PUSCH}_{\text{scs}} / \text{PDCCH}_{\text{scs}})) + K_2$ . (Note 1)	-->	MAC PDU	3	P
14	Check: Does the UE transmit a MAC PDU containing one RLC SDU in Symbol 'S' of Slot 'z + 2x' of PUSCH as per grant in step 8?	-->	MAC PDU	1	P

15	SS transmits a UL Grant using UE's C-RNTI in in Slot 'r' of PDCCH allowing UE to transmit a MAC PDU containing one RLC SDU, where $r = \text{floor}((z + 3x - K_2) * (\text{PDCCH}_{\text{SCS}} / \text{PUSCH}_{\text{SCS}}))$ .	<--	(UL Grant)	-	-
16	Check: Does the UE transmit a MAC PDU containing one RLC SDU in Symbol 'S' of Slot 'z + 3x' of PUSCH as per grant in step 8?	-->	MAC PDU	4	P
17	Check: Does the UE transmit a MAC PDU in Slot 'z + 4x' as per grant in containing zero MAC SDU? (Note 3)	-->	MAC PDU	6	F
18	SS transmits a DL MAC PDU containing 1 RLC SDU on UM DRB after step 17.	<--	MAC PDU		
19	Check: Does the UE transmit a MAC PDU containing one RLC SDU in Symbol 'S' of Slot 'z + 5x' of PUSCH as per grant in step 8?	-->	MAC PDU	1	P
20	SS transmits <i>RRCReconfiguration</i> to disable UL configured grant type 2.	<--	<i>RRCReconfiguration</i>	-	-
21	The UE transmits <i>RRCReconfigurationComplete</i> .	-->	<i>RRCReconfigurationComplete</i>	-	-
22	SS transmits a DL MAC PDU containing 1 RLC SDU.	<--	MAC PDU	-	-
23	Check: Does the UE transmit a MAC PDU in Symbol 'S' of Slot 'z + 6x' of PUSCH as per grant in step 8.	-->	MAC PDU	5	F

Note 1:  $y$  is the slot where the UE shall transmit the PUSCH and is determined by  $K_2$  as  $\left\lceil n \cdot \frac{2^{\mu_{\text{PUSCH}}}}{2^{\mu_{\text{PDCCH}}}} \right\rceil + K_2$   
 where  $n$  is the slot with the scheduling DCI,  $K_2$  is based on the numerology of PUSCH.  $S$  is the starting symbol relative to the start of the slot  $y$  according to TS 38.214 clause 6.1.2.1.  
 Note 2:  $x$  is equal to *periodicity* / 14 in this test case.  
 Note 3: If the MAC entity does not generate a MAC PDU, one of the conditions which shall be satisfied is that there is no aperiodic CSI requested for this PUSCH transmission as specified in TS 38.321 clause 5.4.3.1.3.

7.1.1.6.3.3.3 Specific message contents

**Table 7.1.1.6.3.3.3-1: RRCReconfiguration (step 1, Table 7.1.1.6.3.3.2-1)**

Derivation path: 38.508-1 [4], Table 4.6.1-3			
Information Element	Value/remark	Comment	Condition
RRCReconfiguration ::= SEQUENCE {			
criticalExtensions CHOICE {			
rrcReconfiguration SEQUENCE {			
FFS	FFS	OCTET STRING (CONTAINING CellGroupConfig)	SA
}			
}			
}			

**Table 7.1.1.6.3.3.3-2: *CellGroupConfig* (Table 7.1.1.6.3.3.3-1: *RRCReconfiguration*)**



Derivation path: 38.331 [12], clause 6.3.2			
Information Element	Value/remark	Comment	Condition
CellGroupConfig ::= SEQUENCE {			
cellGroupld	1		
spCellConfig SEQUENCE{			
spCellConfigDedicated SEQUENCE{			
uplinkConfig SEQUENCE {			
initialUplinkBWP SEQUENCE {			
pucch-Config CHOICE {			
setup SEQUENCE {			
schedulingRequestResourceToAddModList {			
schedulingRequestResourceId	1		
schedulingRequestID	0		
periodicityAndOffset CHOICE {			
sl20	10		
}			
}			
}			
}			
}			
configuredGrantConfig CHOICE {			
setup SEQUENCE {			
cg-DMRS-Configuration	DMRS-UplinkConfig	Reference TS 38.508-1 [4], Table 4.6.3-37	
uci-OnPUSCH CHOICE {			
setup SEQUENCE {			
semiStatic SEQUENCE {	BetaOffsets		
betaOffsetACK-Index1	9		
betaOffsetACK-Index2	9		
betaOffsetACK-Index3	9		
betaOffsetCSI-Part1-Index1	6		
betaOffsetCSI-Part1-Index2	6		
betaOffsetCSI-Part2-Index1	6		
betaOffsetCSI-Part2-Index2	6		
}			
}			
}			
resourceAllocation	ResourceAllocationType1		
powerControlLoopToUse	n0		
p0-PUSCH-Alpha	1		
nrofHARQ-Processes	16		
repK	n1		
periodicity	Sym40x14		15kHz
periodicity	Sym80x14		30kHz
periodicity	Sym160x14		60kHz
periodicity	Sym320x14		120kHz
}			
}			
pusch-Config CHOICE {			
setup SEQUENCE {			
PUSCH-TimeDomainResourceAllocationList SEQUENCE {			
k2	n8		FR1 and FR2
mappingType	typeB		
startSymbolAndLength	0011011		FR1
startSymbolAndLength	0001110		FR2
}			
}			
}			
}			

}			
}			
physicalCellGroupConfig SEQUENCE {			
cs-RNTI CHOICE {			
setup SEQUENCE{			
RNTI-Value	'FFE0'H		
}			
}			
}			
macCellGroupConfig SEQUENCE {			
drx-Config	Not Present		
}			
}			

**Table 7.1.1.6.3.3.3-3: RRCReconfiguration (step 20 of Table 7.1.1.6.3.3.2-1)**

Derivation path: 38.508-1 [4], Table 4.6.1-3			
Information Element	Value/remark	Comment	Condition
RRCReconfiguration ::= SEQUENCE {			
criticalExtensions CHOICE {			
rrcReconfiguration SEQUENCE {			
FFS	FFS	OCTET STRING (CONTAINING CellGroupConfig)	SA
}			
}			
}			

**Table 7.1.1.6.3.3.3-4: CellGroupConfig (Table 7.1.1.6.3.3.3-3: RRCReconfiguration)**

Derivation path: 38.331 [12], clause 6.3.2			
Information Element	Value/remark	Comment	Condition
CellGroupConfig ::= SEQUENCE {			
cellGroupId	1		
spCellConfig SEQUENCE{			
spCellConfigDedicated SEQUENCE{			
uplinkConfig SEQUENCE {			
initialUplink SEQUENCE {			
configuredGrantConfig CHOICE {			
release	Null		
}			
}			
}			
}			
}			

**7.1.1.7 Activation/Deactivation of Scells**

7.1.1.7.1 Activation/Deactivation of SCells / Activation/Deactivation MAC control element reception / sCellDeactivationTimer

7.1.1.7.1.1 Activation/Deactivation of SCells / Activation/Deactivation MAC control element reception / sCellDeactivationTimer / Intra-band non-Contiguous CA

7.1.1.7.1.1.1 Test Purpose (TP)

(1)

```
with { UE in RRC_CONNECTED state with SCell configured }
ensure that {
  when { the UE receives an SCell Activation/Deactivation MAC CE activating the Scell }
  then { the UE starts monitoring PDCCH on activated Scell }
```

```
    }
```

(2)

```
with(UE in RRC_CONNECTED state with SCell activated)
ensure that {
  when{ the UE receives a DL assignment on SCell PDCCH }
  then { the UE restarts the sCellDeactivationTimer }
}
```

(3)

```
with ( UE in RRC_CONNECTED state with SCell activated)
ensure that {
  when{ the UE sCellDeactivationTimer expires }
  then { the UE deactivates the SCell and stops monitoring PDCCH on SCell }
}
```

(4)

```
with (UE in RRC_CONNECTED state with SCell activated )
ensure that {
  when{ the UE receives a SCell Activation/Deactivation MAC CE deactivating the SCell }
  then { the UE deactivates the SCell and stops monitoring PDCCH on SCell }
}
```

#### 7.1.1.7.1.1.2 Conformance requirements

References: The conformance requirements covered in the present TC are specified in: TS 38.321, clauses 5.9 and TS 38.331 clause 5.3.5.5.2. Unless otherwise stated these are Rel-15 requirements.

[TS 38.321, clause 5.9]

If the MAC entity is configured with one or more SCells, the network may activate and deactivate the configured SCells. Upon configuration of an SCell, the SCell is deactivated.

The configured SCell(s) is activated and deactivated by:

- receiving the SCell Activation/Deactivation MAC CE described in subclause 6.1.3.10;
- configuring *sCellDeactivationTimer* timer per configured SCell (except the SCell configured with PUCCH, if any): the associated SCell is deactivated upon its expiry.

The MAC entity shall for each configured SCell:

- 1> if an SCell Activation/Deactivation MAC CE is received activating the SCell:
  - 2> activate the SCell according to the timing defined in TS 38.213 [6]; i.e. apply normal SCell operation including:
    - 3> SRS transmissions on the SCell;
    - 3> CSI reporting for the SCell;
    - 3> PDCCH monitoring on the SCell;
    - 3> PDCCH monitoring for the SCell;
    - 3> PUCCH transmissions on the SCell, if configured.
  - 2> start or restart the *sCellDeactivationTimer* associated with the SCell in the slot when the SCell Activation/Deactivation MAC CE was received;
  - 2> (re-)initialize any suspended configured uplink grants of configured grant Type 1 associated with this SCell according to the stored configuration, if any, and to start in the symbol according to rules in subclause 5.8.2;
  - 2> trigger PHR according to subclause 5.4.6.

- 1> else if an SCell Activation/Deactivation MAC CE is received deactivating the SCell; or
- 1> if the *sCellDeactivationTimer* associated with the activated SCell expires:
  - 2> deactivate the SCell according to the timing defined in TS 38.213 [6];
  - 2> stop the *sCellDeactivationTimer* associated with the SCell;
  - 2> stop the *bwp-InactivityTimer* associated with the SCell;
  - 2> clear any configured downlink assignment and any configured uplink grant Type 2 associated with the SCell respectively;
  - 2> suspend any configured uplink grant Type 1 associated with the SCell;
  - 2> flush all HARQ buffers associated with the SCell.
- 1> if PDCCH on the activated SCell indicates an uplink grant or downlink assignment; or
- 1> if PDCCH on the Serving Cell scheduling the activated SCell indicates an uplink grant or a downlink assignment for the activated SCell; or
- 1> if a MAC PDU is transmitted in a configured uplink grant or received in a configured downlink assignment:
  - 2> restart the *sCellDeactivationTimer* associated with the SCell.
- 1> if the SCell is deactivated:
  - 2> not transmit SRS on the SCell;
  - 2> not report CSI for the SCell;
  - 2> not transmit on UL-SCH on the SCell;
  - 2> not transmit on RACH on the SCell;
  - 2> not monitor the PDCCH on the SCell;
  - 2> not monitor the PDCCH for the SCell;
  - 2> not transmit PUCCH on the SCell.

HARQ feedback for the MAC PDU containing SCell Activation/Deactivation MAC CE shall not be impacted by PCell, PSCell and PUCCH SCell interruptions due to SCell activation/deactivation in TS 38.133 [11].

When SCell is deactivated, the ongoing Random Access procedure on the SCell, if any, is aborted.

[TS 38.321, clause 6.1.3.10]

The SCell Activation/Deactivation MAC CE of one octet is identified by a MAC PDU subheader with LCID as specified in Table 6.2.1-1. It has a fixed size and consists of a single octet containing seven C-fields and one R-field. The SCell Activation/Deactivation MAC CE with one octet is defined as follows (Figure 6.1.3.10-1).

The SCell Activation/Deactivation MAC CE of four octets is identified by a MAC PDU subheader with LCID as specified in Table 6.2.1-1. It has a fixed size and consists of four octets containing 31 C-fields and one R-field. The SCell Activation/Deactivation MAC CE of four octets is defined as follows (Figure 6.1.3.10-2).

For the case with no Serving Cell with a *ServCellIndex* as specified in TS 38.331 [8] larger than 7, SCell Activation/Deactivation MAC CE of one octet is applied, otherwise SCell Activation/Deactivation MAC CE of four octets is applied.

- C<sub>i</sub>: If there is an SCell configured for the MAC entity with *SCellIndex* *i* as specified in TS 38.331 [8], this field indicates the activation/deactivation status of the SCell with *SCellIndex* *i*, else the MAC entity shall ignore the C<sub>i</sub> field. The C<sub>i</sub> field is set to "1" to indicate that the SCell with *SCellIndex* *i* shall be activated. The C<sub>i</sub> field is set to "0" to indicate that the SCell with *SCellIndex* *i* shall be deactivated;
- R: Reserved bit, set to "0".

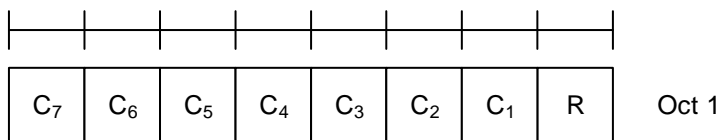

**Figure 6.1.3.10-1: SCell Activation/Deactivation MAC CE of one octet**

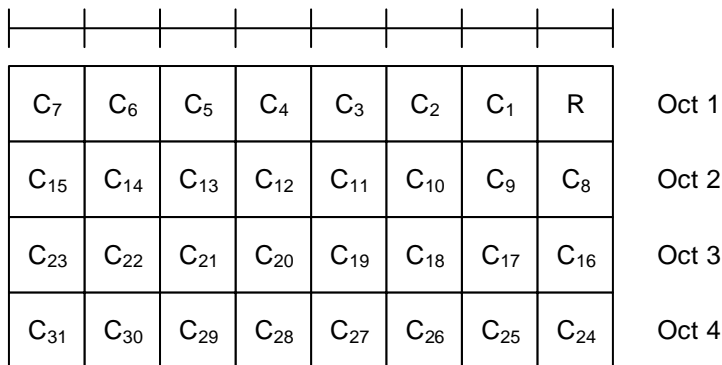

**Figure 6.1.3.10-2: SCell Activation/Deactivation MAC CE of four octets**

7.1.1.7.1.1.3 Test description

7.1.1.7.1.1.3.1 Pre-test conditions

Same Pre-test conditions as in clause 7.1.1.0 with the additional NR Cell 3 (intra band CA) or Cell 10(inter band CA) is configured as NR Active Scell.

7.1.1.7.1.1.3.2 Test procedure sequence

**Table 7.1.1.7.1.1.3.2-1: Time instances of cell power level and parameter changes**

	Parameter	Unit	NR Cell 1	NR Cell 3 or 10
T0	Cell-specific RS EPRE	dBm/15k Hz	-85	-85

Table 7.1.1.7.1.1.3.2-2: Main behaviour

St	Procedure	Message Sequence		TP	Verdict
		U - S	Message		
1	SS transmits an RRCReconfiguration message to configure SCell (NR Cell 3 or Cell 10). Note 1	<--	(RRCReconfiguration)	-	-
2	The UE transmits RRCReconfigurationComplete message. Note 2	-->	(RRCReconfigurationComplete)	-	-
3	The SS transmits Activation MAC control element to activate SCell on NR SpCell.	<--	MAC PDU (SCell Activation/Deactivation MAC CE of one octet (C <sub>1</sub> =1))	-	-
4	200 ms after step 3, the SS indicates a new transmission on PDCCH of SCell and transmits a MAC PDU (containing an RLC PDU )	<--	MAC PDU	-	-
5	Check: Does the UE transmit a Scheduling Request on PUCCH?	-->	(SR)	1	P
6	The SS sends an UL grant suitable for transmitting loop back PDU on NRSpCell.	<--	(UL Grant)	-	-
7	The UE transmit a MAC PDU containing the loop back PDU corresponding to step 4.	-->	MAC PDU	-	-
8	The SS transmits a MAC PDU containing RLC status PDU acknowledging reception of RLC PDU in step 7 on NR SpCell	<--	MAC PDU	-	-
9	400 ms after step 4, the SS indicates a new transmission on PDCCH of NR Scell and transmits a MAC PDU (containing an RLC PDU )	<--	MAC PDU	-	-
10	Check: Does the UE transmit a Scheduling Request on PUCCH in next 1 second?	-->	(SR)	2	F
11	The SS transmits Activation MAC control element to activate SCell on NR SpCell.	<--	MAC PDU ((SCell Activation/Deactivation MAC CE of one octet (C <sub>1</sub> =1))	-	-
12	200 ms after step 11 The SS indicates a new transmission on PDCCH of NR Scell and transmits a MAC PDU (containing just padding or RLC status PDU, but no RLC data PDU)	<--	MAC PDU	-	-
13	400 ms after step 11 the SS indicates a new transmission on PDCCH of NR Scell and transmits a MAC PDU (containing an RLC PDU )	<--	MAC PDU	-	-
14	Check: Does the UE transmit a Scheduling Request on PUCCH?	-->	(SR)	1,3	P
15	The SS sends an UL grant suitable for transmitting loop back PDU on NR SpCell.	<--	(UL Grant)	-	-
16	The UE transmits a MAC PDU containing the loop back PDU corresponding to step 12	-->	MAC PDU	-	-
17	The SS transmits a MAC PDU containing RLC status PDU acknowledging reception of RLC PDU in step 16	<--	MAC PDU	-	-
18	The SS transmits Deactivation MAC control element to de-activate SCell.	<--	MAC PDU (SCell Activation/Deactivation MAC CE of one octet (C <sub>1</sub> =0))	-	-
19	The SS indicates a new transmission on PDCCH of NR Scell and transmits a MAC PDU (containing an RLC PDU )	<--	MAC PDU	-	-
20	Check: Does the UE transmit a Scheduling Request on PUCCH in next 1 second?	-->	(SR)	4	F

Note 1: for EN-DC the NR *RRCReconfiguration* message is contained in *RRCConnectionReconfiguration*.  
Note 2: for EN-DC the NR *RRCReconfigurationComplete* message is contained in *RRCConnectionReconfigurationComplete*.

## 7.1.1.7.1.1.3.3 Specific message contents

**Table 7.1.1.7.1.1.3.3-1: RRCReconfiguration (step 1, Table 7.1.1.7.1.1.3.2-2)**

Derivation Path: TS 38.508-1 [4], Table 4.6.1-3.			
Information Element	Value/remark	Comment	Condition
RRCReconfiguration ::= SEQUENCE {			
criticalExtensions CHOICE {			
c1 CHOICE {			
rrcReconfiguration ::= SEQUENCE {			
radioBearerConfig	RadioBearerConfig	TS 38.508-1 [4] table 4.6.3-100 condition SRB3	
secondaryCellGroup	CellGroupConfig		
}			
}			
}			
}			

**Table 7.1.1.7.1.1.3.3-2: CellGroupConfig (Table 7.1.1.7.1.1.3.3-1)**

Derivation Path: TS 38.508-1 [4], Table 4.6.3-13.			
Information Element	Value/remark	Comment	Condition
CellGroupConfig ::= SEQUENCE {			
sCellToAddModList SEQUENCE (SIZE (1..maxMeasId)) OF SEQUENCE {			
sCellIndex[1]	1		
sCellConfigCommon[1]	ServingCellConfigCommon		
sCellConfigDedicated[1]	ServingCellConfig		
}			
}			

**Table 7.1.1.7.1.1.3.3-3: ServingCellConfigCommon (Table 7.1.1.7.1.1.3.3-2)**

Derivation Path: TS 38.508-1 [4], Table 4.6.3-129.			
Information Element	Value/remark	Comment	Condition
ServingCellConfigCommon ::= SEQUENCE {			
physCellId	Physical Cell Identity of NR Cell 3/Cell 10		
}			

**Table 7.1.1.7.1.1.3.3-4: ServingCellConfig (Table 7.1.1.7.1.1.3.3-2)**

Derivation Path: TS 38.508-1 [4], Table 4.6.3-128.			
Information Element	Value/remark	Comment	Condition
ServingCellConfig ::= SEQUENCE {			
sCellDeactivationTimer	ms320		
}			

## 7.1.1.7.1.2 Activation/Deactivation of SCells / Activation/Deactivation MAC control element reception / sCellDeactivationTimer / Inter-Band CA

The scope and description of the present TC is the same as test case 7.1.1.7.1.1 with the following differences:

- CA configuration: Inter-band CA replaces Intra-band Contiguous CA
- Cells configuration: NR Cell 10 replaces NR Cell 3

### 7.1.1.7.1.3 Activation/Deactivation of SCells / Activation/Deactivation MAC control element reception / sCellDeactivationTimer / Intra-band non-Contiguous CA

The scope and description of the present TC is the same as test case 7.1.1.7.1.1 with the following differences:

- CA configuration: Intra-band non-Contiguous CA replaces Intra-band Contiguous CA

### 7.1.1.8

### 7.1.1.9 MAC Reconfiguration and Reset

#### 7.1.1.9.1 MAC Reset

##### 7.1.1.9.1.1 Test Purpose (TP)

(1)

```
with { UE in RRC_CONNECTED state }
ensure that {
  when { UE MAC is reset, due to reconfiguration with sync on same cell }
  then { UE flushes DL HARQ buffer }
}
```

(2)

```
with { UE in RRC_CONNECTED state }
ensure that {
  when { UE MAC is reset, due to reconfiguration with sync on same cell }
  then { UE considers the next transmission for each DL HARQ process as very first }
}
```

(3)

```
with(UE in RRC_CONNECTED state, with Scheduling Request procedure triggered)
ensure that {
  when { UE MAC is reset, due to reconfiguration with sync on same cell }
  then { UE cancels Scheduling Request procedure }
}
```

(4)

```
with ( UE in RRC_CONNECTED state )
ensure that {
  when { UE MAC is reset, due to reconfiguration with sync on same cell }
  then { UE flushes UL HARQ buffer }
}
```

(5)

```
with (UE in RRC_CONNECTED state )
ensure that {
  when { UE MAC is reset, due to reconfiguration with sync on same cell }
  then { UE Considers the next transmission for each UL HARQ process as very first }
}
```

##### 7.1.1.9.1.2 Conformance requirements

References: The conformance requirements covered in the present TC are specified in: TS 38.321, clauses 5.12 and TS 38.331 clause 5.3.5.5.2. Unless otherwise stated these are Rel-15 requirements.

[TS 38.321, clause 5.12]

If a reset of the MAC entity is requested by upper layers, the MAC entity shall:

- 1> initialize  $B_j$  for each logical channel to zero;
- 1> stop (if running) all timers;
- 1> consider all *timeAlignmentTimers* as expired and perform the corresponding actions in subclause 5.2;



- 1> set the NDIs for all uplink HARQ processes to the value 0;
- 1> stop, if any, ongoing RACH procedure;
- 1> discard explicitly signalled contention-free Random Access Resources, if any;
- 1> flush Msg3 buffer;
- 1> cancel, if any, triggered Scheduling Request procedure;
- 1> cancel, if any, triggered Buffer Status Reporting procedure;
- 1> cancel, if any, triggered Power Headroom Reporting procedure;
- 1> flush the soft buffers for all DL HARQ processes;
- 1> for each DL HARQ process, consider the next received transmission for a TB as the very first transmission;
- 1> release, if any, Temporary C-RNTI;
- 1> reset *BFI\_COUNTER*.

[TS 38.331, clause 5.3.5.5.2]

The UE shall perform the following actions to execute a reconfiguration with sync.

- 1> stop timer T310 for the corresponding SpCell, if running;
- 1> start timer T304 for the corresponding SpCell with the timer value set to *t304*, as included in the *reconfigurationWithSync*;
- 1> if the *frequencyInfoDL* is included:
  - 2> consider the target SpCell to be one on the frequency indicated by the *frequencyInfoDL* with a physical cell identity indicated by the *physCellId*;
- 1> else:
  - 2> consider the target SpCell to be one on the frequency of the source SpCell with a physical cell identity indicated by the *physCellId*;
- 1> start synchronising to the DL of the target SpCell and acquire the *MIB* of the target SpCell as specified in 5.2.2.3.1;

NOTE: The UE should perform the reconfiguration with sync as soon as possible following the reception of the RRC message triggering the reconfiguration with sync, which could be before confirming successful reception (HARQ and ARQ) of this message.

- 1> reset the MAC entity of this cell group;
- 1> consider the SCell(s) of this cell group, if configured, to be in deactivated state;
- 1> apply the value of the *newUE-Identity* as the C-RNTI for this cell group;

**Editor's Note: Verify that this does not configure some common parameters which are later discarded due to e.g. SCell release or due to LCH release.**

- 1> configure lower layers in accordance with the received *spCellConfigCommon*;
- 1> consider the bandwidth part indicated in *firstActiveUplinkBWP-Id* to be the active uplink bandwidth part;
- 1> consider the bandwidth part indicated in *firstActiveDownlinkBWP-Id* to be the active downlink bandwidth part;
- 1> configure lower layers in accordance with any additional fields, not covered in the previous, if included in the received *reconfigurationWithSync*.

7.1.1.9.1.3 Test description

7.1.1.9.1.3.1 Pre-test conditions

Same Pre-test conditions as in clause 7.1.1.0 with the exception that the AM DRB PDCP is configured according to Table 7.1.9.1.3.1-1

**Table 7.1.1.9.1.3.1-1: PDCP parameters**

discardTimer	ms60
--------------	------

7.1.1.9.1.3.2 Test procedure sequence

**Table 7.1.1.9.1.3.2-1: Main behaviour**

St	Procedure	Message Sequence		TP	Verdict
		U - S	Message		
1	The SS transmits a MAC PDU containing one RLC SDU on DRB, but the CRC is calculated in such a way that it will result in CRC error on UE side.	<--	MAC PDU (1 RLC SDU of 40 bytes on DRB)	-	-
2	The UE transmits a HARQ NACK	-->	HARQ NACK	-	-
3	The SS transmits NR <i>RRCReconfiguration</i> message to perform SCG change with reconfigurationWithSync with the same PSCell. Note 1	<--	(RRCReconfiguration)	-	-
4	The UE transmits an NR <i>RRCReconfigurationComplete</i> message. Note 2		(RRCReconfigurationComplete)	-	-
5	Check: For 100 ms, does the UE transmit any HARQ NACK?	-->	HARQ NACK	1	F
6	The SS transmits a MAC PDU containing RLC SDU on DRB. The HARQ Process and NDI on PDCCH is same as in step 1. The SS shall ensure that the HARQ process used at step 1 will not be used in between steps 3 and 5.	<--	MAC PDU (1 RLC SDU of 40 bytes on DRB)	-	-
7	Check: Does the UE transmit a scheduling request?	-->	(SR)	2	P
8	The SS allocates UL Grant sufficient for one RLC SDU to be loop backed in a TTI, and NDI indicates new transmission	<--	Uplink Grant	-	-
9	The UE transmits a MAC PDU including one RLC SDU	-->	MAC PDU	-	-
10	The SS ignores scheduling requests and does not allocate any uplink grant.	-	-	-	-
11	The SS transmits a MAC PDU containing one RLC SDU on DRB	<--	MAC PDU (1 RLC SDU of 40 bytes on DRB)	-	-
12	The UE transmit a scheduling request	-->	(SR)	-	-
13	Wait for 60ms (Discard timer to expire at UE).	-	-	-	-
14	The SS transmits NR <i>RRCReconfiguration</i> message to perform SCG change with reconfigurationWithSync with the same PSCell. Note 1	<--	(RRCReconfiguration)	-	-
15	The UE transmits an NR <i>RRCReconfigurationComplete</i> message. Note 2		(RRCReconfigurationComplete)	-	-
16	Check: For 100 ms seconds, if UE transmits a scheduling request?	-->	(SR)	3	F
17	The SS transmits a MAC PDU containing RLC SDU on DRB	<--	MAC PDU (1 RLC SDU of 40 bytes on DRB)	-	-
18	The UE transmits a scheduling request	-->	(SR)	-	-
19	The SS allocate UL Grant sufficient for one RLC SDU to be loop backed in a TTI, and NDI indicates new transmission	<--	Uplink Grant	-	-
20	The UE transmit a MAC PDU including one RLC SDU	-->	MAC PDU	-	-
21	The SS transmits a NACK	<--	HARQ NACK	-	-
22	The SS transmits NR <i>RRCReconfiguration</i> message to perform SCG change with reconfigurationWithSync with the same PSCell. Note 1	<--	(RRCReconfiguration)	-	-
23	The UE transmits an NR <i>RRCReconfigurationComplete</i> message. Note 2		(RRCReconfigurationComplete)	-	-
24	Check: For 2 seconds, does UE transmit MAC PDU containing Loop Back PDU?	-->	MAC PDU (1 RLC SDU of 40 bytes on DRB)	4	F
25	The SS transmits a MAC PDU containing RLC SDU on DRB	<--	MAC PDU (1 RLC SDU of 40 bytes on DRB)	-	-
26	The UE transmits a scheduling request	-->	(SR)	-	-
27	The SS allocates UL Grant sufficient for one RLC SDU to be loop backed in a TTI, and NDI indicates new transmission	<--	Uplink Grant	-	-

28	Check: Does UE transmit a MAC PDU including one RLC SDU?	-->	MAC PDU	5	P
Note 1: for EN-DC the NR <i>RRCReconfiguration</i> message is contained in <i>RRCConnectionReconfiguration</i> . Note 2: for EN-DC the NR <i>RRCReconfigurationComplete</i> message is contained in <i>RRCConnectionReconfigurationComplete</i> .					

7.1.1.9.1.3.3 Specific message contents

**Table 7.1.1.9.1.3.3-3: RRCReconfiguration (steps 3, 14 & 22 of Table 7.1.1.9.1.3.2-1)**

Derivation Path: 38.508-1 [4], Table 4.6.1-3			
Information Element	Value/remark	Comment	Condition
RRCReconfiguration ::= SEQUENCE {			
criticalExtensions CHOICE {			
rrcReconfiguration ::= SEQUENCE {			
secondaryCellGroup	CellGroupConfig		
}			
}			
}			

**Table 7.1.1.9.1.3.3-4: CellGroupConfig (Table 7.1.1.9.1.3.3-1)**

Derivation Path: 38.508-1 [4], Table 4.6.3-13 with condition EN-DC
--

7.1.2 RLC

*Editor’s note: Intended to capture tests of RLC Layer behaviour defined in TS 38.322*

7.1.2.1 Default Pre-Test Conditions for all RLC test cases

The following pre-test conditions shall be applied in all RLC test cases until the test case explicitly over writes these conditions.

7.1.2.1.1 Default Pre-Test Conditions for AM RLC test cases

System Simulator:

- The SS configures the test environment in accordance to the execution conditions in Table 7.1.2.1.1-1.

UE:

- None

Preamble:

- The SS performs the generic procedure in [4] to get UE in state RRC\_CONNECTED in accordance to the execution conditions in Table 7.1.2.1.1-2 and the message condition UE TEST LOOP MODE A to return one UL PDCP SDU per DL PDCP SDU.

**Table 7.1.2.1.1-1: Test environment**

Execution Condition	Cell configuration	System Information Combination ([4] clause FFS)
IF [pc_nrFDD] or [pc_nrTDD]	NR Cell 1	FFS
ELSE IF [pc_EN_DC]	E-UTRA Cell 1 is PCell, NR Cell 1 is PSCell	EUTRA: System information Combination 1 NR: N/A
ELSE IF [pc_NGEN_DC]	NG-RAN E-UTRA Cell 1 is PCell, NR Cell 1 is PSCell	EUTRA: System information Combination 1 NR: N/A

Table 7.1.2.1.1-2: Preamble parameters

Execution Condition	Multi-PDN Condition	Generic Procedure Parameters	Primary DRB used for Data testing
IF [pc_nrFDD] or [pc_nrTDD]s	FALSE	Connectivity(NR), Test loop function(On) One DRB	DRB on NR Cell
	TRUE	Connectivity(NR), Test loop function(On) Two DRB	
ELSE IF [pc_EN_DC]	FALSE	Connectivity(EN-DC), DC bearer(One MN Terminated MCG bearer and One SN terminated SCG bearer), Test loop function(On)	SN Terminated SCG bearer unless explicitly specified in test case
	TRUE	Connectivity(EN-DC), DC bearer(Two MN Terminated MCG bearer and One SN terminated SCG bearer), Test loop function(On)	
ELSE IF [pc_NGEN_DC]	FALSE	Connectivity(NGEN-DC), DC bearer(One MN Terminated MCG bearer and One SN terminated SCG bearer), Test loop function(On)	SN Terminated SCG bearer unless explicitly specified in test case
	TRUE	Connectivity(EN-DC), DC bearer(Two MN Terminated MCG bearer and One SN terminated SCG bearer), Test loop function(On)	

Table 7.1.2.1.1-3: Message conditions

Execution Condition	Message condition exceptions
IF [pc_nrFDD] or [pc_nrTDD]	FFS
ELSE IF [pc_EN_DC]	message condition MCG_and_SCG with condition AM is used for step 7 in 4.5.4.2 according to [4]
ELSE IF [pc_NGEN_DC]	message condition MCG_and_SCG with condition AM is used for step 7 in 4.5.4.2 according to [4]

## 7.1.2.1.2 Default Pre-Test Conditions for UM RLC test cases

Same Pre-test conditions as in clause 7.1.2.1.1 with the exceptions in Table 7.1.2.1.2-1.

Table 7.1.2.1.2-1: Message conditions

Execution Condition	Message condition exceptions
IF [pc_nrFDD] or [pc_nrTDD]	FFS
ELSE IF [pc_EN_DC]	message condition MCG_and_SCG with condition UM-DRB(0,1) is used for step 7 in 4.5.4.2 according to [4]
ELSE IF [pc_NGEN_DC]	message condition MCG_and_SCG with condition UM-DRB(0,1) is used for step 7 in 4.5.4.2 according to [4]

## 7.1.2.2 RLC Unacknowledged mode

### 7.1.2.2.1 UM RLC / Segmentation and reassembly / 6-bit SN / Segmentation Info (SI) field

#### 7.1.2.2.1.1 Test Purpose (TP)

(1)

```
with { UE in RRC_CONNECTED state configured for 6 bit SN in RLC UM }
ensure that {
  when { UE receives UMD PDU containing a SI field set to 00 }
  then { UE correctly decodes the received UMD PDU }
}
```

(2)

```
with { UE in RRC_CONNECTED state configured for 6 bit SN in RLC UM }
ensure that {
  when { UE receives a 6 bit SN configured UMD PDU containing a SI field set to 01 }
  then { UE correctly decodes the received UMD PDU }
}
```

(3)

```
with { UE in RRC_CONNECTED state configured for 6 bit SN in RLC UM }
ensure that {
  when { UE receives a 6 bit SN configured UMD PDU containing a SI field set to 11 and SO field }
  then { UE correctly decodes the received UMD PDU }
}
```

(4)

```
with { UE in RRC_CONNECTED state configured for 6 bit SN in RLC UM }
ensure that {
  when { UE receives a 6 bit SN configured UMD PDU containing a SI field set to 10 and SO field }
  then { UE correctly decodes the received UMD PDU }
}
```

(5)

```
with { UE in RRC_CONNECTED state configured for 6 bit SN in RLC UM }
ensure that {
  when { UE has UL SDU to send and UL grant available is sufficient to send whole SDU in one PDU }
  then { UE transmits RLC SDU containing a SI field set to 00 }
}
```

(6)

```
with { UE in RRC_CONNECTED state configured for 6 bit SN in RLC UM }
ensure that {
  when { UE has UL SDU to send and UL grant available is not sufficient to send whole SDU in one PDU }
  then { UE transmits first RLC SDU segment containing a SI field set to 01 and including 6 bit SN }
}
```

(7)

```
with { UE in RRC_CONNECTED state configured for 6 bit SN in RLC UM }
ensure that {
  when { UE has UL SDU to send and UL grant available is not sufficient to send whole SDU in one PDU }
  then { UE transmits middle RLC SDU segment containing a SI field set to 11, including SO field
and including 6 bit SN }
}
```

(8)

```
with { UE in RRC_CONNECTED state configured for 6 bit SN in RLC UM }
ensure that {
```

```

when { UE has UL SDU to send and UL grant available is not sufficient to send whole SDU in one PDU
}
then { UE transmits last RLC SDU segment containing a SI field set to 10, including SO field and
including 6 bit SN }
}

```

#### 7.1.2.2.1.2 Conformance requirements

References: The conformance requirements covered in the present TC are specified in: TS 38.322, clauses 5.2.2.2.1, 5.2.2.2.2, 6.2.3.4 and 6.2.2.3. Unless otherwise stated these are Rel-15 requirements.

[TS 38.322, clause 5.2.2.2.1]

The receiving UM RLC entity shall maintain a reassembly window according to state variable *RX\_Next\_Highest* as follows:

- a SN falls within the reassembly window if  $(RX\_Next\_Highest - UM\_Window\_Size) \leq SN < RX\_Next\_Highest$ ;
- a SN falls outside of the reassembly window otherwise.

When receiving an UMD PDU from lower layer, the receiving UM RLC entity shall:

- either deliver the UMD PDU after removing the RLC header, discard the received UMD PDU, or place it in the reception buffer (see sub clause 5.2.2.2.2);
- if the received UMD PDU was placed in the reception buffer:
  - update state variables, reassemble and deliver RLC SDUs to upper layer and start/stop *t-Reassembly* as needed (see sub clause 5.2.2.2.3).

When *t-Reassembly* expires, the receiving UM RLC entity shall:

- update state variables, discard RLC SDU segments and start *t-Reassembly* as needed (see sub clause 5.2.2.2.4).

[TS 38.322, clause 5.2.2.2.2]

When an UMD PDU is received from lower layer, the receiving UM RLC entity shall:

- if the UMD PDU header does not contain an SN:
  - remove the RLC header and deliver the RLC SDU to upper layer.
- else if  $(RX\_Next\_Highest - UM\_Window\_Size) \leq SN < RX\_Next\_Reassembly$ :
  - discard the received UMD PDU.
- else:
  - place the received UMD PDU in the reception buffer.

[TS 38.322, clause 6.2.2.3]

UMD PDU consists of a Data field and an UMD PDU header. The UMD PDU header is byte aligned

When an UMD PDU contains a complete RLC SDU, the UMD PDU header only contains the SI and R fields.

An UM RLC entity is configured by RRC to use either a 6 bit SN or a 12 bit SN. An UMD PDU header contains the SN field only when the corresponding RLC SDU is segmented. An UMD PDU carrying the first segment of an RLC SDU does not carry the SO field in its header. The length of the SO field is 16 bits.



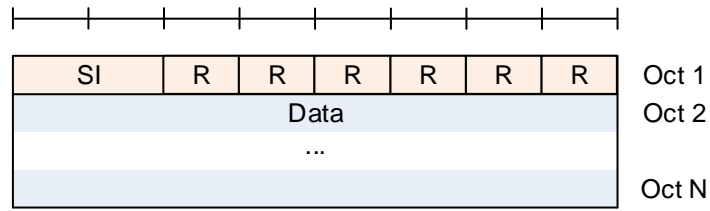

Figure 6.2.2.3-1: UMD PDU containing a complete RLC SDU

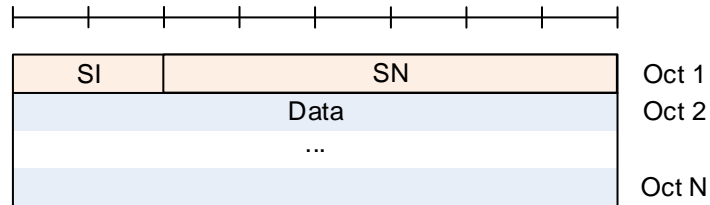

Figure 6.2.2.3-2: UMD PDU with 6 bit SN (No SO)

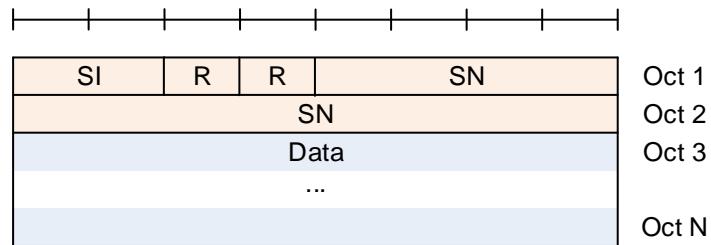

Figure 6.2.2.3-3: UMD PDU with 12 bit SN (No SO)

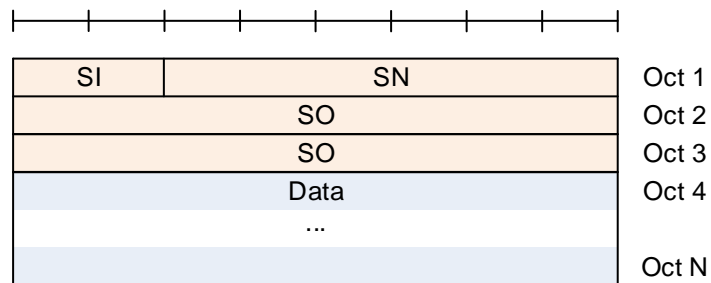
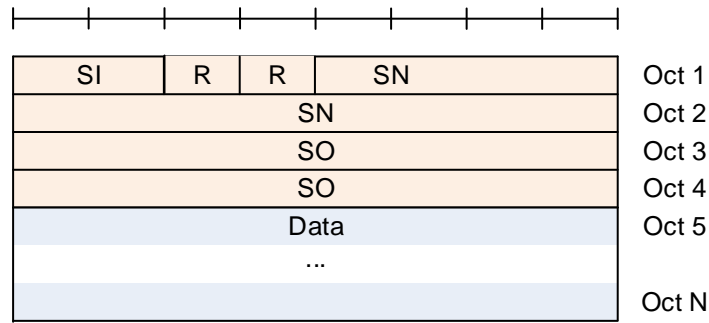

Figure 6.2.2.3-4: UMD PDU with 6 bit SN and with SO



**Figure 6.2.2.3-5: UMD PDU with 12 bit SN and with SO**

[TS 38.322, clause 6.2.3.4]

Length: 2 bits.

The SI field indicates whether a RLC PDU contains a complete RLC SDU or the first, middle, last segment of a RLC SDU.

**Table 6.2.2.6-1: SI field interpretation**

Value	Description
00	Data field contains all bytes of a RLC SDU
01	Data field contains the first segment of a RLC SDU
10	Data field contains the last segment of a RLC SDU
11	Data field contains neither the first nor last segment of a RLC SDU

7.1.2.2.1.3 Test description

7.1.2.2.1.3.1 Pre-test conditions

Same Pre-test conditions as in clause 7.1.2.1.2 with the exception for the UM DRB is configured according to Table 7.1.2.2.1.3.1-1.

**Table 7.1.2.2.1.3.1-1: RLC parameters**

Uplink UM RLC sn-FieldLength	size6
Downlink UM RLC sn-FieldLength	size6

## 7.1.2.2.1.3.2 Test procedure sequence

Table 7.1.2.2.1.3.2-1: Main behaviour

St	Procedure	Message Sequence		TP	Verdict
		U - S	Message		
1	The SS transmits UMD PDU#1 containing a complete RLC SDU#1 (SI field = 00).	<--	UMD PDU#1	-	-
2	SS allocates an UL grant sufficient to loop back RLC SDU#1 in one RLC/MAC PDU	<--	UL Grant	-	-
3	Check: Does the UE transmit RLC SDU#1?	-->	(RLC SDU#1)	1,5	P
3A	The SS stops allocating any UL grant.	-	-	-	-
4	The SS transmits UMD PDU#2 containing the first segment of RLC SDU#2 (SI field = 01). Note 2	<--	UMD PDU#2	-	-
5	The SS transmits UMD PDU#3 containing the second segment of RLC SDU#2 (SI field = 11) and including SO field. Note 2	<--	UMD PDU#3	-	-
6	The SS transmits UMD PDU#4 containing the last segment of RLC SDU#2 (SI field = 10) and including SO field. Note 2	<--	UMD PDU#4	-	-
7	SS allocates 3 UL grants at an interval of 20 ms so as to loop back RLC SDU#2 in 3 RLC/MAC PDUs. Note 1 & 2	<--	UL Grants	-	-
8	Check: Does the UE transmit UMD PDU#2 containing the first segment of RLC SDU#2 (SI field = 01)?	-->	(RLC SDU#2, first segment)	2,3, 4,6	P
9	Check: Does the UE transmit UMD PDU#3 containing the second segment of RLC SDU#2 (SI field = 11) and including SO field?	-->	(RLC SDU#2, second segment)	2,3, 4,7	P
10	Check: Does the UE transmit UMD PDU#4 containing the last segment of RLC SDU#2 (SI field = 10) and including SO field?	-->	(RLC SDU#2, last segment)	2,3, 4,8	P
<p>Note 1: The UL grants for step 8,9,10 are sufficiently small (240 bits, <math>L_{RBS}</math> &amp; <math>l_{MCS}</math> as per 38.523-3[3] annex B) that UE transmits RLC SDU#2 in 3 UL RLC PDUs by segmenting.</p> <p>Note 2: The RLC PDU containing segment shall be of size 224 bits and a MAC sub PDU header of 16 bits resulting in a MAC PDU of size 240 bits. The data part in step 4 first segment not including SO is 216 bits (27 Bytes). Step 5, second segment <math>SO=27</math> and data is 200 bits (25 bytes). Step 6, third segment <math>SO=27+25=52</math> and data is 200 bits (25 bytes).</p>					

## 7.1.2.2.1.3.3 Specific message contents

None.

## 7.1.2.2.2 UM RLC / Segmentation and reassembly / 12-bit SN / Segmentation Info (SI) field

## 7.1.2.2.2.1 Test Purpose (TP)

(1)

```
with { UE in RRC_CONNECTED state configured for 12 bit SN in RLC UM }
ensure that {
  when { UE receives UMD PDU containing a SI field set to 00 }
  then { UE correctly decodes the received UMD PDU }
}
```

(2)

```
with { UE in RRC_CONNECTED state configured for 12 bit SN in RLC UM }
ensure that {
  when { UE receives a 12 bit SN configured UMD PDU containing a SI field set to 01 }
  then { UE correctly decodes the received UMD PDU }
}
```

(3)

```

with { UE in RRC_CONNECTED state configured for 12 bit SN in RLC UM }
ensure that {
  when { UE receives a 12 bit SN configured UMD PDU containing a SI field set to 11 and SO field }
  then { UE correctly decodes the received UMD PDU }
}

```

(4)

```

with { UE in RRC_CONNECTED state configured for 12 bit SN in RLC UM }
ensure that {
  when { UE receives a 12 bit SN configured UMD PDU containing a SI field set to 10 and SO field }
  then { UE correctly decodes the received UMD PDU }
}

```

(5)

```

with { UE in RRC_CONNECTED state configured for 12 bit SN in RLC UM }
ensure that {
  when { UE has UL SDU to send and UL grant available is sufficient to send whole SDU in one PDU }
  then { UE transmits RLC SDU containing a SI field set to 00 }
}

```

(6)

```

with { UE in RRC_CONNECTED state configured for 12 bit SN in RLC UM }
ensure that {
  when { UE has UL SDU to send and UL grant available is not sufficient to send whole SDU in one PDU }
}
then { UE transmits first RLC SDU segment containing a SI field set to 01 and including 12 bit SN }
}

```

(7)

```

with { UE in RRC_CONNECTED state configured for 12 bit SN in RLC UM }
ensure that {
  when { UE has UL SDU to send and UL grant available is not sufficient to send whole SDU in one PDU }
}
then { UE transmits middle RLC SDU segment containing a SI field set to 11, including SO field and including 12 bit SN }
}

```

(8)

```

with { UE in RRC_CONNECTED state configured for 12 bit SN in RLC UM }
ensure that {
  when { UE has UL SDU to send and UL grant available is not sufficient to send whole SDU in one PDU }
}
then { UE transmits last RLC SDU segment containing a SI field set to 10, including SO field and including 12 bit SN }
}

```

#### 7.1.2.2.2.2 Conformance requirements

Same conformance requirements as clause 7.1.2.2.1.2

#### 7.1.2.2.2.3 Test description

##### 7.1.2.2.2.3.1 Pre-test conditions

Same Pre-test conditions as in clause 7.1.2.1.2 with the exception for the UM DRB is configured according to Table 7.1.2.2.2.3.1-1.

**Table 7.1.2.2.2.3.1-1: RLC parameters**

Uplink UM RLC sn-FieldLength	size12
Downlink UM RLC sn-FieldLength	size12

### 7.1.2.2.3.2 Test procedure sequence

Same test procedure sequence as 7.1.2.2.1.3.2 except that RLC UM SN is 12 bit and the data part in step 4 first segment not including SO is 208 bits (26 Bytes). Step 5, second segment SO=26 and data is 192 bits (24 bytes). Step 6, third segment SO=26+24=50 and data is 192 bits (24 bytes).

### 7.1.2.2.3.3 Specific message contents

None.

## 7.1.2.2.3 UM RLC / 6-bit SN / Correct use of sequence numbering

### 7.1.2.2.3.1 Test Purpose (TP)

(1)

```
with { UE in RRC_CONNECTED state with UM RLC 6 bit SN }
ensure that {
  when { UE transmits the first PDU which is segmented }
  then { UE includes the SN field equal to 0 in each RLC segment }
}
```

(2)

```
with { UE in RRC_CONNECTED state with UM RLC 6 bit SN }
ensure that {
  when { UE transmit subsequent segmented PDUs }
  then { UE includes the SN field incremented by 1 for each segmented PDU of one RLC SDU }
}
```

(3)

```
with { UE in RRC_CONNECTED state with UM RLC 6 bit SN }
ensure that {
  when { UE transmit segments belonging to more than 64 SDUs }
  then { UE wraps the SN after transmitting the segments of 64 SDUs }
}
```

(4)

```
with { UE in RRC_CONNECTED state with UM RLC 6 bit SN }
ensure that {
  when { segments of more than 64 SDUs are sent to UE }
  then { UE accepts PDUs with SNs that wrap around every 64 segmented SDUs }
}
```

### 7.1.2.2.3.2 Conformance requirements

References: The conformance requirements covered in the present TC are specified in: 3GPP TS 38.322, clause 5.2.2.1.1, 5.2.2.2, 6.2.2.3, 6.2.3.3 and 7.1. Unless otherwise stated these are Rel-15 requirements.

[TS 38.322, clause 5.2.2.1.1]

When submitting a UMD PDU to lower layer, the transmitting UM RLC entity shall:

- if the UMD PDU contains a segment of an RLC SDU, set the SN of the UMD PDU to TX\_Next;
- if the UMD PDU contains a segment that maps to the last byte of an RLC SDU, then increment TX\_Next by one.

[TS 38.322, clause 5.2.2.2]

The receiving UM RLC entity shall maintain a reassembly window according to state variable RX\_Next\_Highest as follows:

- a SN falls within the reassembly window if  $(RX\_Next\_Highest - UM\_Window\_Size) \leq SN < RX\_Next\_Highest$ ;
- a SN falls outside of the reassembly window otherwise.

When receiving an UMD PDU from lower layer, the receiving UM RLC entity shall:

- either deliver the UMD PDU after removing the RLC header, discard the received UMD PDU, or place it in the reception buffer (see sub clause 5.2.2.2.2);
- if the received UMD PDU was placed in the reception buffer:
  - update state variables, reassemble and deliver RLC SDUs to upper layer and start/stop *t-Reassembly* as needed (see sub clause 5.2.2.2.3).

...

When an UMD PDU is received from lower layer, the receiving UM RLC entity shall:

- if the UMD PDU header does not contain an SN:
  - remove the RLC header and deliver the RLC SDU to upper layer.
- else if  $(RX\_Next\_Highest - UM\_Window\_Size) \leq SN < RX\_Next\_Reassembly$ :
  - discard the received UMD PDU.
- else:
  - place the received UMD PDU in the reception buffer.

...

When an UMD PDU with  $SN = x$  is placed in the reception buffer, the receiving UM RLC entity shall:

- if all byte segments with  $SN = x$  are received:
  - reassemble the RLC SDU from all byte segments with  $SN = x$ , remove RLC headers and deliver the reassembled RLC SDU to upper layer;
  - if  $x = RX\_Next\_Reassembly$ :
    - update  $RX\_Next\_Reassembly$  to the SN of the first  $SN > current\ RX\_Next\_Reassembly$  that has not been reassembled and delivered to upper layer.
- else if  $x$  falls outside of the reassembly window:
  - update  $RX\_Next\_Highest$  to  $x + 1$ ;
  - discard any UMD PDUs with SN that falls outside of the reassembly window;
  - if  $RX\_Next\_Reassembly$  falls outside of the reassembly window:
    - set  $RX\_Next\_Reassembly$  to the SN of the first  $SN \geq (RX\_Next\_Highest - UM\_Window\_Size)$  that has not been reassembled and delivered to upper layer.

[TS 38.322, clause 6.2.2.3]

An UM RLC entity is configured by RRC to use either a 6 bit SN or a 12 bit SN. An UMD PDU header contains the SN field only when the corresponding RLC SDU is segmented.

[TS 38.322, clause 6.2.3.3]

The SN field indicates the sequence number of the corresponding RLC SDU. .... For RLC UM, the sequence number is incremented by one for every segmented RLC SDU..

[TS 38.322, clause 7.1]

All state variables and all counters are non-negative integers.

...

All state variables related to UM data transfer can take values from 0 to 63 for 6 bit SN or from 0 to 4095 for 12 bit SN. All arithmetic operations contained in the present document on state variables related to UM data transfer are affected by the UM modulus (i.e. final value = [value from arithmetic operation] modulo 64 for 6 bit SN and 4096 for 12 bit SN).

...

Each transmitting UM RLC entity shall maintain the following state variables:

a) TX\_Next

This state variable holds the value of the SN to be assigned for the next newly generated UMD PDU with segment. It is initially set to 0, and is updated after the UM RLC entity submits a UMD PDU including the last segment of an RLC SDU to lower layers.

Each receiving UM RLC entity shall maintain the following state variables and constant:

b) RX\_Next\_Reassembly – UM receive state variable

This state variable holds the value of the earliest SN that is still considered for reassembly. It is initially set to 0.

c) RX\_Timer\_Trigger – UM *t-Reassembly* state variable

This state variable holds the value of the SN following the SN which triggered *t-Reassembly*.

d) RX\_Next\_Highest– UM receive state variable

This state variable holds the value of the SN following the SN of the UMD PDU with the highest SN among received UMD PDUs. It serves as the higher edge of the reassembly window. It is initially set to 0.

7.1.2.2.3.3 Test description

7.1.2.2.3.3.1 Pre-test conditions

Same Pre-test conditions as in clause 7.1.2.1.2 with the exception for the UM DRB is configured according to Table 7.1.2.2.3.3.1-1.

**Table 7.1.2.2.3.3.1-1: RLC parameters**

Uplink UM RLC sn-FieldLength	size6
Downlink UM RLC sn-FieldLength	size6

## 7.1.2.2.3.3.2 Test procedure sequence

Table 7.1.2.2.3.3.2-1: Main behaviour

St	Procedure	Message Sequence		TP	Verdict
		U - S	Message		
1	The SS transmits UMD PDU#1 with 6 bit SN = 0 containing the first segment of RLC SDU#1 (SI field = 01).	<--	UMD PDU#1	-	-
2	The SS transmits UMD PDU#2 with 6 bit SN=0 containing the last segment of RLC SDU#1 (SI field = 10) and including SO field.	<--	UMD PDU#2	-	-
3	SS allocates 2 UL grants at an interval of 20 ms so as to loop back RLC SDU#1 in 2 RLC/MAC PDUs. (Note 1)	<--	UL Grants	-	-
4	Check: Does the UE transmit UMD PDU#1 with 6 bit SN = 0 containing the first segment of RLC SDU#1 (SI field = 01)?	-->	(RLC SDU#1, first segment)	1	P
5	Check: Does the UE transmit UMD PDU#2 with 6 bit SN = 0 containing the last segment of RLC SDU#1 (SI field = 10)?	-->	(RLC SDU#1, last segment)	1	P
-	EXCEPTION: Steps 6 to 10 are executed 63 times, the initial value of k = 1, it is incremented by one for each iteration.	-	-	-	-
6	The SS transmits UMD PDU#(2*k+1) with 6 bit SN = k containing the first segment of RLC SDU#(k+1) (SI field = 01).	<--	UMD PDU#(2*k+1)	-	-
7	The SS transmits UMD PDU#(2*(k+1)) with 6 bit SN=k containing the last segment of RLC SDU#(k+1) (SI field = 10)	<--	UMD PDU#(2*(k+1))	-	-
8	SS allocates 2 UL grants at an interval of 20 ms so as to loop back RLC SDU#(k+1) in 2 RLC/MAC PDUs. (Note 1)	<--	UL Grants	-	-
9	Check: Does the UE transmit UMD PDU#(2*k+1) with 6 bit SN = k containing the first segment of RLC SDU#(k+1) (SI field = 01)? (Note 2)	-->	(RLC SDU#(k+1), first segment)	2	P
10	Check: Does the UE transmit UMD PDU#(2*(k+1)) with 6 bit SN = k containing the last segment of RLC SDU#(k+1) (SI field = 10) and including SO field? (Note 2)	-->	(RLC SDU#(k+1), last segment)	2	P
11	The SS transmits UMD PDU#129 with 6 bit SN = 0 containing the first segment of RLC SDU#4 (SI field = 01).	<--	UMD PDU#129	-	-
12	The SS transmits UMD PDU#130 with 6 bit SN= 0 containing the last segment of RLC SDU#65 (SI field = 10) and including SO field	<--	UMD PDU#130	-	-
13	SS allocates 2 UL grants at an interval of 20 ms so as to loop back RLC SDU#65 in 2 RLC/MAC PDUs. (Note 1)	<--	UL Grants	-	-
14	Check: Does the UE transmit UMD PDU#129 with 6 bit SN = 0 containing the first segment of RLC SDU#65 (SI field = 01)?	-->	(RLC SDU#65, first segment)	3,4	P
15	Check: Does the UE transmit UMD PDU#130 with 6 bit SN = 0 containing the last segment of RLC SDU#65 (SI field = 10) and including SO field?	-->	(RLC SDU#65, last segment)	3,4	P
Note 1: The RLC SDU size shall be 12 octets which are segmented into 7 and 5 octets. With 2 octets of MAC header and 1 octet of RLC header (without SO) the first segment consists of 80 bits and a TBS of this size shall be allocated. With 2 octets of MAC header and 3 octets of RLC header (with SO) the second segment consists of 80 bits and a TBS of this size shall be allocated. (L <sub>RBS</sub> & I <sub>MCS</sub> as per 38.523-3[3] annex B)					
Note 2: The verdict shall be provided each if k mod 16 = 0, k is the received SN.					

## 7.1.2.2.3.3.3 Specific message contents

None.



#### 7.1.2.2.4 UM RLC / 12-bit SN / Correct use of sequence numbering

##### 7.1.2.2.4.1 Test Purpose (TP)

(1)

```
with { UE in RRC_CONNECTED state with UM RLC 12 bit SN }
ensure that {
  when { UE transmits the first PDU which is segmented }
  then { UE includes the SN field equal to 0 in each RLC segment }
}
```

(2)

```
with { UE in RRC_CONNECTED state with UM RLC 12 bit SN }
ensure that {
  when { UE transmit subsequent segmented PDUs }
  then { UE includes the SN field incremented by 1 for each segmented PDU of one RLC SDU }
}
```

(3)

```
with { UE in RRC_CONNECTED state with UM RLC 12 bit SN }
ensure that {
  when { UE transmit segments belonging to more than 4096 SDUs }
  then { UE wraps the SN after transmitting the segments of 4096 SDUs }
}
```

(4)

```
with { UE in RRC_CONNECTED state with UM RLC 12 bit SN }
ensure that {
  when { segments of more than 4096 SDUs are sent to UE }
  then { UE accepts PDUs with SNs that wrap around every 4096 segmented SDUs }
}
```

##### 7.1.2.2.4.2 Conformance requirements

References: The conformance requirements covered in the present TC are specified in: 3GPP TS 38.322, clause 5.2.2.1.1, 5.2.2.2, 6.2.2.3, 6.2.3.3 and 7.1. Unless otherwise stated these are Rel-15 requirements.

[TS 38.322, clause 5.2.2.1.1]

When submitting a UMD PDU to lower layer, the transmitting UM RLC entity shall:

- if the UMD PDU contains a segment of an RLC SDU, set the SN of the UMD PDU to TX\_Next;
- if the UMD PDU contains a segment that maps to the last byte of an RLC SDU, then increment TX\_Next by one.

[TS 38.322, clause 5.2.2.2]

The receiving UM RLC entity shall maintain a reassembly window according to state variable RX\_Next\_Highest as follows:

- a SN falls within the reassembly window if  $(RX\_Next\_Highest - UM\_Window\_Size) \leq SN < RX\_Next\_Highest$ ;
- a SN falls outside of the reassembly window otherwise.

When receiving an UMD PDU from lower layer, the receiving UM RLC entity shall:

- either deliver the UMD PDU after removing the RLC header, discard the received UMD PDU, or place it in the reception buffer (see sub clause 5.2.2.2.2);
- if the received UMD PDU was placed in the reception buffer:
  - update state variables, reassemble and deliver RLC SDUs to upper layer and start/stop *t-Reassembly* as needed (see sub clause 5.2.2.2.3).

...

When an UMD PDU is received from lower layer, the receiving UM RLC entity shall:

- if the UMD PDU header does not contain an SN:
  - remove the RLC header and deliver the RLC SDU to upper layer.
- else if  $(RX\_Next\_Highest - UM\_Window\_Size) \leq SN < RX\_Next\_Reassembly$ :
  - discard the received UMD PDU.
- else:
- place the received UMD PDU in the reception buffer.

...

When an UMD PDU with SN = x is placed in the reception buffer, the receiving UM RLC entity shall:

- if all byte segments with SN = x are received:
  - reassemble the RLC SDU from all byte segments with SN = x, remove RLC headers and deliver the reassembled RLC SDU to upper layer;
  - if  $x = RX\_Next\_Reassembly$ :
    - update  $RX\_Next\_Reassembly$  to the SN of the first  $SN > current\ RX\_Next\_Reassembly$  that has not been reassembled and delivered to upper layer.
- else if x falls outside of the reassembly window:
  - update  $RX\_Next\_Highest$  to  $x + 1$ ;
  - discard any UMD PDUs with SN that falls outside of the reassembly window;
  - if  $RX\_Next\_Reassembly$  falls outside of the reassembly window:
    - set  $RX\_Next\_Reassembly$  to the SN of the first  $SN \geq (RX\_Next\_Highest - UM\_Window\_Size)$  that has not been reassembled and delivered to upper layer.

[TS 38.322, clause 6.2.2.3]

An UM RLC entity is configured by RRC to use either a 6 bit SN or a 12 bit SN. An UMD PDU header contains the SN field only when the corresponding RLC SDU is segmented.

[TS 38.322, clause 6.2.3.3]

The SN field indicates the sequence number of the corresponding RLC SDU. ... For RLC UM, the sequence number is incremented by one for every segmented RLC SDU.

[TS 38.322, clause 7.1]

All state variables and all counters are non-negative integers.

...

All state variables related to UM data transfer can take values from 0 to 63 for 6 bit SN or from 0 to 4095 for 12 bit SN. All arithmetic operations contained in the present document on state variables related to UM data transfer are affected by the UM modulus (i.e. final value = [value from arithmetic operation] modulo 64 for 6 bit SN and 4096 for 12 bit SN).

...

Each transmitting UM RLC entity shall maintain the following state variables:

a) TX\_Next

This state variable holds the value of the SN to be assigned for the next newly generated UMD PDU with segment. It is initially set to 0, and is updated after the UM RLC entity submits a UMD PDU including the last segment of an RLC SDU to lower layers.

Each receiving UM RLC entity shall maintain the following state variables and constant:

b) RX\_Next\_Reassembly – UM receive state variable

This state variable holds the value of the earliest SN that is still considered for reassembly. It is initially set to 0.

c) RX\_Timer\_Trigger – UM *t-Reassembly* state variable

This state variable holds the value of the SN following the SN which triggered *t-Reassembly*.

d) RX\_Next\_Highest– UM receive state variable

This state variable holds the value of the SN following the SN of the UMD PDU with the highest SN among received UMD PDUs. It serves as the higher edge of the reassembly window. It is initially set to 0.

7.1.2.2.4.3 Test description

7.1.2.2.4.3.1 Pre-test conditions

Same Pre-test conditions as in clause 7.1.2.1.2 with the exception for the UM DRB is configured according to Table 7.1.2.2.4.3.1-1.

**Table 7.1.2.2.4.3.1-1: RLC parameters**

Uplink RLC sn-FieldLength	size12
Downlink RLC sn-FieldLength	size12

## 7.1.2.2.4.3.2 Test procedure sequence

Table 7.1.2.2.4.3.2-1: Main behaviour

St	Procedure	Message Sequence		TP	Verdict
		U - S	Message		
1	The SS transmits UMD PDU#1 with 12 bit SN = 0 containing the first segment of RLC SDU#1 (SI field = 01).	<--	UMD PDU#1	-	-
2	The SS transmits UMD PDU#2 with 12 bit SN=0 containing the last segment of RLC SDU#1 (SI field = 10) and including SO field	<--	UMD PDU#2	-	-
3	SS allocates 2 UL grants at an interval of 20 ms so as to loop back RLC SDU#1 in 2 RLC/MAC PDUs. (Note 1)	<--	UL Grants	-	-
4	Check: Does the UE transmit UMD PDU#1 with 12 bit SN = 0 containing the first segment of RLC SDU#1 (SI field = 01)?	-->	(RLC SDU#1, first segment)	1	P
5	Check: Does the UE transmit UMD PDU#2 with 12 bit SN = 0 containing the last segment of RLC SDU#1 (SI field = 10)?	-->	(RLC SDU#1, last segment)	1	P
-	EXCEPTION: Steps 6 to 10 are executed 4095 times, the initial value of k = 1, it is incremented by one for each iteration.	-	-	-	-
6	The SS transmits UMD PDU#(2*k+1) with 12 bit SN = k containing the first segment of RLC SDU#(k+1) (SI field = 01).	<--	UMD PDU#(2*k+1)	-	-
7	The SS transmits UMD PDU#(2*(k+1)) with 12 bit SN=k containing the last segment of RLC SDU#(k+1) (SI field = 10)	<--	UMD PDU#(2*(k+1))	-	-
8	SS allocates 2 UL grants at an interval of 20 ms so as to loop back RLC SDU#(k+1) in 2 RLC/MAC PDUs. (Note 1)	<--	UL Grants	-	-
9	Check: Does the UE transmit UMD PDU#(2*k+1) with 12 bit SN = k containing the first segment of RLC SDU#(k+1) (SI field = 01)? (Note 2)	-->	(RLC SDU#(k+1), first segment)	2	P
10	Check: Does the UE transmit UMD PDU#(2*(k+1)) with 12 bit SN = k containing the last segment of RLC SDU#(k+1) (SI field = 10) and including SO field? (Note 2)	-->	(RLC SDU#(k+1), last segment)	2	P
11	The SS transmits UMD PDU#8193 with 12 bit SN = 0 containing the first segment of RLC SDU#4097 (SI field = 01).	<--	UMD PDU#8193	-	-
12	The SS transmits UMD PDU#8194 with 12 bit SN= 0 containing the last segment of RLC SDU#4097 (SI field = 10) and including SO field	<--	UMD PDU#8194	-	-
13	SS allocates 2 UL grants at an interval of 20 ms so as to loop back RLC SDU#4097 in 2 RLC/MAC PDUs. (Note 1)	<--	UL Grants	-	-
14	Check: Does the UE transmit UMD PDU#8193 with 12 bit SN = 0 containing the first segment of RLC SDU#4097 (SI field = 01)?	-->	(RLC SDU#4097, first segment)	3,4	P
15	Check: Does the UE transmit UMD PDU#8194 with 12 bit SN = 0 containing the last segment of RLC SDU#4097 (SI field = 10) and including SO field?	-->	(RLC SDU#4097, last segment)	3,4	P
Note 1:	The RLC SDU size shall be 12 octets which are segmented into 7 and 5 octets. With 2 octets of MAC header and 2 octets of RLC header (without SO) the first segment consists of 88 bits and a TBS of this size shall be allocated. With 2 octets of MAC header and 4 octets of RLC header (with SO) the second segment consists of 88 bits and a TBS of this size shall be allocated. (L <sub>RBs</sub> & I <sub>MCS</sub> as per 38.523-3[3] annex B)				
Note 2:	The verdict shall be provided each if k mod 256 = 0, k is the received SN.				

## 7.1.2.2.4.3.3 Specific message contents

None.

### 7.1.2.2.5 UM RLC / Receive Window operation and t-Reassembly expiry

#### 7.1.2.2.5.1 Test Purpose (TP)

(1)

```
with { UE in RRC_CONNECTED state and using UM RLC }
ensure that {
  when { UE receives a RLC PDU including SN and does not fall in UM receive window '(RX_Next_Highest -
  - UM_Window_Size) <= SN < RX_Next_Reassembly' }
  then { UE discards the PDU }
}
```

(2)

```
with { UE in RRC_CONNECTED state and using UM RLC }
ensure that {
  when { UE receives a RLC PDU including SN and fall in UM receive window '(RX_Next_Highest -
  - UM_Window_Size) <= SN < RX_Next_Reassembly' }
  then { UE stores the PDU in receive buffer }
}
```

(3)

```
with { UE in RRC_CONNECTED state and using UM RLC }
ensure that {
  when { UE receives a RLC PDU including SN and in UM receive window '(RX_Next_Highest -
  - UM_Window_Size) <= SN < RX_Next_Reassembly' and all bytes of SN are received }
  then { UE delivers the reassembled SDU to upper layers and updates the RX variables and discard
  any stored UMD PDUs with SN that falls outside of the updated reassembly window }
}
```

(4)

```
with { UE in RRC_CONNECTED state and using UM RLC }
ensure that {
  when { t-Reassembly expires }
  then { UE discards the corresponding PDU segments and updates RX variables }
}
```

#### 7.1.2.2.5.2 Conformance requirements

References: The conformance requirements covered in the present TC are specified in: TS 38.322, clauses 5.2.2.2.1, 5.2.2.2.2, 5.2.2.2.3 and 5.2.2.2.4. Unless otherwise stated these are Rel-15 requirements.

[TS 38.322, clause 5.2.2.2.1]

The receiving UM RLC entity shall maintain a reassembly window according to state variable `RX_Next_Highest` as follows:

- a SN falls within the reassembly window if  $(RX\_Next\_Highest - UM\_Window\_Size) \leq SN < RX\_Next\_Highest$ ;
- a SN falls outside of the reassembly window otherwise.

When receiving an UMD PDU from lower layer, the receiving UM RLC entity shall:

- either deliver the UMD PDU after removing the RLC header, discard the received UMD PDU, or place it in the reception buffer (see sub clause 5.2.2.2.2);
- if the received UMD PDU was placed in the reception buffer:
  - update state variables, reassemble and deliver RLC SDUs to upper layer and start/stop *t-Reassembly* as needed (see sub clause 5.2.2.2.3).

When *t-Reassembly* expires, the receiving UM RLC entity shall:

- update state variables, discard RLC SDU segments and start *t-Reassembly* as needed (see sub clause 5.2.2.2.4).

[TS 38.322, clause 5.2.2.2.2]

When an UMD PDU is received from lower layer, the receiving UM RLC entity shall:

- if the UMD PDU header does not contain an SN:
  - remove the RLC header and deliver the RLC SDU to upper layer.
- else if  $(RX\_Next\_Highest - UM\_Window\_Size) \leq SN < RX\_Next\_Reassembly$ :
  - discard the received UMD PDU.
- else:
  - place the received UMD PDU in the reception buffer.

[TS 38.322, clause 5.2.2.2.3]

When an UMD PDU with SN = x is placed in the reception buffer, the receiving UM RLC entity shall:

- if all byte segments with SN = x are received:
  - reassemble the RLC SDU from all byte segments with SN = x, remove RLC headers and deliver the reassembled RLC SDU to upper layer;
  - if  $x = RX\_Next\_Reassembly$ :
    - update  $RX\_Next\_Reassembly$  to the SN of the first  $SN > current\ RX\_Next\_Reassembly$  that has not been reassembled and delivered to upper layer.
- else if x falls outside of the reassembly window:
  - update  $RX\_Next\_Highest$  to  $x + 1$ ;
  - discard any UMD PDUs with SN that falls outside of the reassembly window;
  - if  $RX\_Next\_Reassembly$  falls outside of the reassembly window:
    - set  $RX\_Next\_Reassembly$  to the SN of the first  $SN \geq (RX\_Next\_Highest - UM\_Window\_Size)$  that has not been reassembled and delivered to upper layer.
- if *t-Reassembly* is running:
  - if  $RX\_Timer\_Trigger \leq RX\_Next\_Reassembly$ ; or
  - if  $RX\_Timer\_Trigger$  falls outside of the reassembly window and  $RX\_Timer\_Trigger$  is not equal to  $RX\_Next\_Highest$ ; or
  - if  $RX\_Next\_Highest = RX\_Next\_Reassembly + 1$  and there is no missing byte segment of the RLC SDU associated with SN =  $RX\_Next\_Reassembly$  before the last byte of all received segments of this RLC SDU:
    - stop and reset *t-Reassembly*.
- if *t-Reassembly* is not running (includes the case when *t-Reassembly* is stopped due to actions above):
  - if  $RX\_Next\_Highest > RX\_Next\_Reassembly + 1$ ; or
  - if  $RX\_Next\_Highest = RX\_Next\_Reassembly + 1$  and there is at least one missing byte segment of the RLC SDU associated with SN =  $RX\_Next\_Reassembly$  before the last byte of all received segments of this RLC SDU:
    - start *t-Reassembly*;
    - set  $RX\_Timer\_Trigger$  to  $RX\_Next\_Highest$ .

[TS 38.322, clause 5.2.2.2.4]

When *t-Reassembly* expires, the receiving UM RLC entity shall:

- update RX\_Next\_Reassembly to the SN of the first SN  $\geq$  RX\_Timer\_Trigger that has not been reassembled;
- discard all segments with SN  $<$  updated RX\_Next\_Reassembly;
- if RX\_Next\_Highest  $>$  RX\_Next\_Reassembly + 1; or
- if RX\_Next\_Highest = RX\_Next\_Reassembly + 1 and there is at least one missing byte segment of the RLC SDU associated with SN = RX\_Next\_Reassembly before the last byte of all received segments of this RLC SDU:
  - start t-Reassembly;
  - set RX\_Timer\_Trigger to RX\_Next\_Highest.

#### 7.1.2.2.5.3 Test description

##### 7.1.2.2.5.3.1 Pre-test conditions

Same Pre-test conditions as in clause 7.1.2.1.1 with the exception that the UM DRB is configured according to Table 7.1.2.2.5.3.1-1.

**Table 7.1.2.2.5.3.1-1: RLC parameters**

t-Reassembly	ms200
Uplink UM RLC sn-FieldLength	IF (pc_Um_WithShortSN ) size6 ELSE size12
Downlink UM RLC sn-FieldLength	F (pc_Um_WithShortSN ) size6 ELSE size12

##### 7.1.2.2.5.3.2 Test procedure sequence

**Table 7.1.2.2.5.3.2-1: Main behaviour**

St	Procedure	Message Sequence		TP	Verdict
		U - S	Message		
1	The SS transmits UMD PDU#1 containing first segment of RLC SDU#1, SN=0.	<--	UMD PDU#1	-	-
2	The SS transmits UMD PDU#3 containing first segment of RLC SDU#2, SN=1.	<--	UMD PDU#3	-	-
3	The SS transmits UMD PDU#4 containing last segment of RLC SDU#2, SN=1.	<--	UMD PDU#4	-	-
4	Check: Does the UE transmit RLC SDU#2?	-->	(RLC SDU#2)	2,3	P
5	The SS transmits UMD PDU#2 last segment of RLC SDU#1, SN=0.	<--	UMD PDU#2	-	-
6	Check: For 1 sec after step 6, Does the UE transmit RLC SDU#1?	-->	(RLC SDU#1)	1	F
7	The SS transmits UMD PDU#5 containing first segment of RLC SDU#3., SN=5.	<--	UMD PDU#5	-	-
8	Wait for 200 ms to ensure that t- Reassembly for the UMD PDU#5 expires.	-	-	-	-
9	The SS transmits UMD PDU#6 containing last segment of RLC SDU#3. SN=5.	<--	UMD PDU#6	-	-
10	Check: For 1 sec after step 6, does the UE transmit RLC SDU#3?	-->	(RLC SDU#3)	4	F
11	The SS transmits UMD PDU#7 containing first segment of RLC SDU#4, SN=8.	<--	UMD PDU#7	-	-
12	The SS transmits UMD PDU#8 containing last segment of RLC SDU#4, SN=8.	<--	UMD PDU#8	-	-
13	Check: Does the UE transmit RLC SDU#4?	-->	(RLC SDU#4)	2,3	P

##### 7.1.2.2.5.3.3 Specific message contents

None

### 7.1.2.2.6 UM RLC / RLC re-establishment procedure

#### 7.1.2.2.6.1 Test Purpose (TP)

(1)

```
with { UE in RRC_CONNECTED state and using UM RLC }
ensure that {
  when { RLC re-establishment is performed upon request by RRC }
  then { The UE discards all UMD PDUs where no RLC SDUs can be reassembled }
}
```

(2)

```
with { UE in RRC_CONNECTED state and using UM RLC }
ensure that {
  when { RLC re-establishment is performed upon request by RRC }
  then { The UE resets variable TX_Next, RX_Next_Reassembly, and RX_Next_Highest to its initial value of 0 }
}
```

#### 7.1.2.2.6.2 Conformance requirements

References: The conformance requirements covered in the present TC are specified in: TS 38.322, clauses 5.1.2 and 7.1, TS 38.331 clause 5.3.5.5.4. Unless otherwise stated these are Rel-15 requirements.

[TS 38.322, clause 5.1.2]

When upper layers request an RLC entity re-establishment, the UE shall:

- discard all RLC SDUs, RLC SDU segments, and RLC PDUs, if any;
- stop and reset all timers;
- reset all state variables to their initial values.

[TS 38.322, clause 7.1]

##### d) RX\_Next\_Highest – Highest received state variable

This state variable holds the value of the SN following the SN of the RLC SDU with the highest SN among received RLC SDUs. It is initially set to 0.

Each transmitting UM RLC entity shall maintain the following state variables:

##### a) TX\_Next

This state variable holds the value of the SN to be assigned for the next newly generated UMD PDU with segment. It is initially set to 0, and is updated after the UM RLC entity submits a UMD PDU including the last segment of an RLC SDU to lower layers.

Each receiving UM RLC entity shall maintain the following state variables and constant:

##### b) RX\_Next\_Reassembly – UM receive state variable

This state variable holds the value of the earliest SN that is still considered for reassembly. It is initially set to 0.

##### c) RX\_Timer\_Trigger – UM *t-Reassembly* state variable

This state variable holds the value of the SN following the SN which triggered *t-Reassembly*.

##### d) RX\_Next\_Highest– UM receive state variable

This state variable holds the value of the SN following the SN of the UMD PDU with the highest SN among received UMD PDUs. It serves as the higher edge of the reassembly window. It is initially set to 0.

[TS 38.331, clause 5.3.5.5.4]

For each *RLC-Bearer-Config* received in the *rlc-BearerToAddModList* IE the UE shall:



- 1> if the UE's current configuration contains a RLC bearer with the received *logicalChannelIdentity*:
  - 2> if *reestablishRLC* is received:
    - 3> re-establish the RLC entity as specified in TS 38.322 [4];
  - 2> reconfigure the RLC entity or entities in accordance with the received *rlc-Config*;
  - 2> reconfigure the logical channel in accordance with the received *mac-LogicalChannelConfig*;

NOTE: The network does not re-associate an already configured logical channel with another radio bearer. Hence *servedRadioBearer* is not present in this case.

#### 7.1.2.2.6.3 Test description

##### 7.1.2.2.6.3.1 Pre-test conditions

Same Pre-test conditions as in clause 7.1.2.1.1 with the exception that the UM DRB is configured according to Table 7.1.2.2.6.3.1-1.

**Table 7.1.2.2.6.3.1-1: RLC parameters**

t-Reassembly	ms200
Uplink UM RLC sn-FieldLength	IF (pc_Um_WithShortSN ) size6 ELSE size12
Downlink UM RLC sn-FieldLength	IF (pc_Um_WithShortSN ) size6 ELSE size12

## 7.1.2.2.6.3.2 Test procedure sequence

Table 7.1.2.2.6.3.2-1: Main behaviour

St	Procedure	Message Sequence		TP	Verdict
		U - S	Message		
1	The SS transmits UMD PDU#1. Header of UMD PDU#1. This PDU carries RLC SDU#1.	<--	UMD PDU#1	-	-
2	The UE transmits RLC SDU#1.	-->	(RLC SDU#1)	-	-
3	The SS transmits UMD PDU#2. Header of UMD PDU#2 contains SN=0. This PDU carries the first segment of SDU#2.	<--	UMD PDU#2	-	-
4	The SS performs a RRCReconfiguration procedure including the secondaryCellGroup containing CellGroupConfig IE, including rlc-BearerToAddModList containing RLC-Bearer-Config for DRB with reestablishRLC set as true triggering RLC re-establishment.	-	-	-	-
5	The SS transmits UMD PDU#3. Header of UMD PDU#3 contains SN=0. This PDU carries the last segment of RLC SDU#2. The UE starts t- Reassembly.	<--	UMD PDU#3	-	-
6	Check: Does the UE transmit RLC SDU#2?	-->	(RLC SDU#2)	1	F
7	300 ms (1.5 * t-Reordering) after step 5 the SS transmits UMD PDU#4. This PDU carries the first segment of RLC SDU#3.SN=1.	<--	UMD PDU#4	-	-
8	The SS transmits UMD PDU#5. This PDU carries the second and last segment of RLC SDU#3.SN=1.	<--	UMD PDU#5	-	-
9	Check: Does the UE transmit first segment of RLC SDU#3? Header of UMD PDU contains SN=0.	-->	(RLC SDU#3 first segment)	2	P
10	Check: Does the UE transmit second and last segment of RLC SDU#3? Header of UMD PDU contains SN=0.	-->	(RLC SDU#3 last segment)	2	P
11	The SS performs a RRCReconfiguration procedure including the secondaryCellGroup containing CellGroupConfig IE, including rlc-BearerToAddModList containing RLC-Bearer-Config for DRB with reestablishRLC set as true triggering RLC re-establishment.	-	-	-	-
12	The SS transmits UMD PDU#6. Header of UMD PDU#6 contains SN=0. This PDU carries the first segment of SDU#4.	<--	UMD PDU#6	-	-
13	The SS transmits UMD PDU#7. Header of UMD PDU#6 contains SN=0. This PDU carries the second segment of SDU#4.	<--	UMD PDU#7	-	-
14	Check: Does the UE transmit first segment of RLC SDU#3? Header of UMD PDU contains SN=0.	-->	(RLC SDU#4 first segment)	2	P
15	Check: Does the UE transmit second and last segment of RLC SDU#3? Header of UMD PDU contains SN=0.	-->	(RLC SDU#4 last segment)	2	P

## 7.1.2.2.6.3.3 Specific message contents

**Table 7.1.2.2.6.3.3-1: RLC-Bearer-Config (steps 4, 11, Table 7.1.2.2.6.3.2-1)**

Derivation Path: 38.508-1 [4], Table 4.6.3-110			
Information Element	Value/remark	Comment	Condition
RLC-Bearer-Config ::= SEQUENCE {			
logicalChannelIdentity	Set to LCID of the DRB under test		
servedRadioBearer	Not present		
reestablishRLC	true		
rlc-Config	Not present		
mac-LogicalChannelConfig	Not present		
}			

## 7.1.2.3 RLC Acknowledged Mode

## 7.1.2.3.1 AM RLC / 12-bit SN / Segmentation and reassembly / Segmentation Info (SI) field

## 7.1.2.3.1.1 Test Purpose (TP)

(1)

```
with { UE in RRC_CONNECTED state }
ensure that {
  when { UE receives a 12 bit SN configured AMD PDU containing a SI field set to 00 }
  then { UE correctly decodes the received AMD PDU }
}
```

(2)

```
with { UE in RRC_CONNECTED state }
ensure that {
  when { UE receives a 12 bit SN configured AMD PDU containing a SI field set to 01 }
  then { UE correctly decodes the received AMD PDU }
}
```

(3)

```
with { UE in RRC_CONNECTED state }
ensure that {
  when { UE receives a 12 bit SN configured AMD PDU containing a SI field set to 11 and SO field }
  then { UE correctly decodes the received AMD PDU }
}
```

(4)

```
with { UE in RRC_CONNECTED state }
ensure that {
  when { UE receives a 12 bit SN configured AMD PDU containing a SI field set to 10 and SO field }
  then { UE correctly decodes the received AMD PDU }
}
```

(5)

```
with { UE in RRC_CONNECTED state }
ensure that {
  when { UE has UL RLC SDU to send and the UL Grant is sufficient to send complete PDU }
  then { UE transmits AMD PDU containing a complete AMD SDU and SI field set to 00 }
}
```

(6)

```
with { UE in RRC_CONNECTED state }
ensure that {
  when { UE has UL RLC SDU to send and the UL Grant is sufficient to send first segment only }
  then { UE transmits AMD PDU containing first segment of AMD SDU and SI field set to 01 }
}
```

(7)

```
with { UE in RRC_CONNECTED state }
ensure that {
  when { UE has UL RLC SDU to send and the UL Grant is sufficient to send middle segment only }
  then { UE transmits AMD PDU containing middle segment of AMD SDU and SI field set to 11,
including SO field }
}
```

(8)

```
with { UE in RRC_CONNECTED state }
ensure that {
  when { UE has UL RLC SDU to send and the UL Grant is sufficient to send last segment only }
  then { UE transmits AMD PDU containing last segment of AMD SDU and SI field set to 10, including
SO field }
}
```

7.1.2.3.1.2 Conformance requirements

References: The conformance requirements covered in the present TC are specified in: TS 38.322, clauses 6.2.2.4 and 6.2.3.4. Unless otherwise stated these are Rel-15 requirements.

[TS 38.322, clause 6.2.2.4]

AMD PDU consists of a Data field and an AMD PDU header. The AMD PDU header is byte aligned.

An AM RLC entity is configured by RRC to use either a 12 bit SN or a 18 bit SN. The length of the AMD PDU header is two and three bytes respectively.

An AMD PDU header contains a D/C, a P, a SI, and a SN. An AMD PDU header contains the SO field only when the Data field consists of an RLC SDU segment which is not the first segment, in which case a 16 bit SO is present.

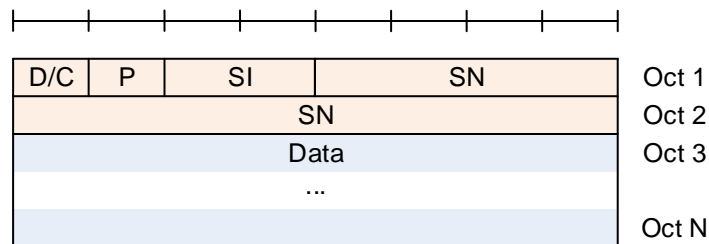

Figure 6.2.2.4-1: AMD PDU with 12 bit SN (No SO)

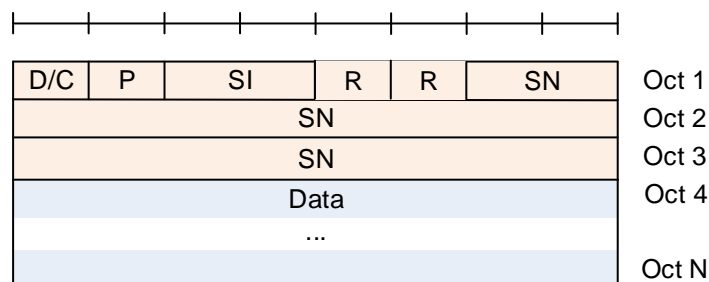

Figure 6.2.2.4-2: AMD PDU with 18 bit SN (No SO)

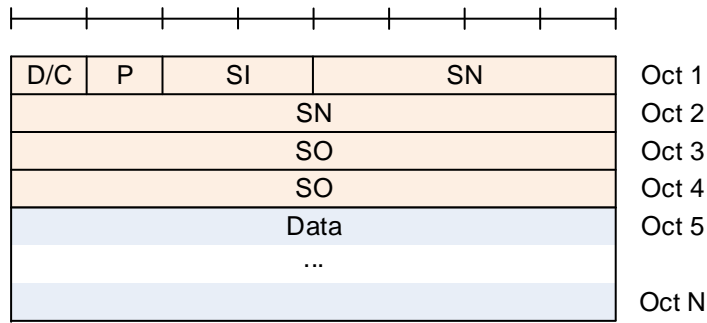

Figure 6.2.2.4-3: AMD PDU with 12 bit SN with SO

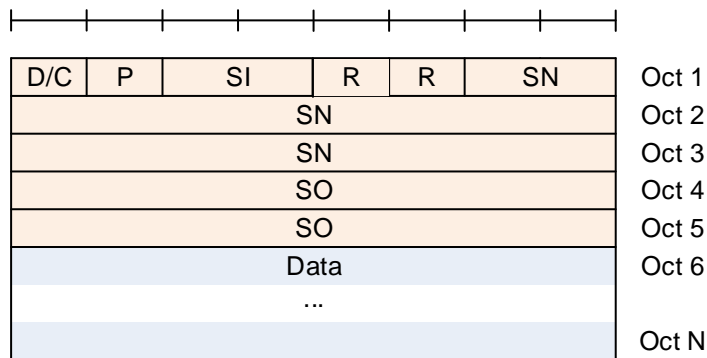

Figure 6.2.2.4-4: AMD PDU with 18 bit SN with SO

[TS 38.322, clause 6.2.3.4]

Length: 2 bits.

The SI field indicates whether an RLC PDU contains a complete RLC SDU or the first, middle, last segment of an RLC SDU.

Table 6.2.3.4-1: SI field interpretation

Value	Description
00	Data field contains all bytes of an RLC SDU
01	Data field contains the first segment of an RLC SDU
10	Data field contains the last segment of an RLC SDU
11	Data field contains neither the first nor last segment of an RLC SDU

7.1.2.3.1.3 Test description

7.1.2.3.1.3.1 Pre-test conditions

Same Pre-test conditions as in clause 7.1.2.1.1 with the exception that the AM DRB is configured according to Table 7.1.2.3.1.3.1-1.

Table 7.1.2.3.1.3.1-1: RLC parameters

Uplink SN-FieldLength-AM	size12
Downlink SN-FieldLength-AM	size12

## 7.1.2.3.1.3.2 Test procedure sequence

Table 7.1.2.3.1.3.2-1: Main behaviour

St	Procedure	Message Sequence		TP	Verdict
		U - S	Message		
1	The SS transmits AMD PDU#1 containing a complete RLC SDU#1 (SI field = 00).	<--	AMD PDU#1	-	-
2	Check: Does the UE transmit AMD PDU#1 containing a complete RLC SDU#1 (SI field = 00)?	-->	(RLC SDU#1)	1,5	P
3	The SS transmits a STATUS PDU.	<--	STATUS PDU (ACK SN=1)	-	-
3A	The SS stops allocating any UL grant.	-	-	-	-
4	The SS transmits AMD PDU#2 containing the first segment of RLC SDU#2 (SI field = 01). Note 2	<--	AMD PDU#2	-	-
5	The SS transmits AMD PDU#3 containing the second segment of RLC SDU#2 (SI field = 11) and including SO field. Note 2	<--	AMD PDU#3	-	-
6	The SS transmits AMD PDU#4 containing the last segment of RLC SDU#2 (SI field = 10) and including SO field.	<--	AMD PDU#4	-	-
6A	SS allocates 3 UL grants at an interval of 20 ms so as to loop back RLC SDU#2 in 3 RLC/MAC PDUs. (Note 1 and Note 2)	<--	UL Grants	-	-
7	Check: Does the UE transmits AMD PDU#2 containing the first segment of RLC SDU#2 (SI field = 01)?	-->	(RLC SDU#2)	2,3, 4,6	P
8	Check: Does the UE transmits AMD PDU#3 containing the middle segment of RLC SDU#2 (SI field = 11) and including SO field?	-->	(RLC SDU#2)	2,3, 4,7	P
9	Check: Does the UE transmits AMD PDU#4 containing the last segment of RLC SDU#2 (SI field = 10) and including SO field?	-->	(RLC SDU#2)	2,3, 4,8	P
10	The SS transmits a STATUS PDU.	<--	STATUS PDU (ACK SN=2)	-	-
Note 1: The UL grants for step 7,8,9 are sufficiently small (240 bits, L <sub>RBs</sub> & I <sub>MCS</sub> as per 38.523-3[3] annex B L <sub>RBs</sub> & I <sub>MCS</sub> as per 38.523-3[3] annex B) that UE transmits RLC SDU#2 in 3 UL RLC PDUs by segmenting. Note 2: The RLC PDU containing segment shall be of size 224 bits and a MAC sub PDU header of 16 bits resulting in a MAC PDU of size 240 bits. The data part in step 4 first segment not including SO is 208 bits (26 Bytes). Step 5, second segment SO=26 and data is 192 bits (24 bytes). Step 6, third segment SO=26+24=50 and data is 192 bits (24 bytes).					

## 7.1.2.3.1.3.3 Specific message contents

None

## 7.1.2.3.2 AM RLC / 18-bit SN / Segmentation and reassembly / Segmentation Info (SI) field

## 7.1.2.3.2.1 Test Purpose (TP)

(1)

```

with { UE in RRC_CONNECTED state }
ensure that {
  when { UE receives a 18 bit SN configured AMD PDU containing a SI field set to 00 }
  then { UE correctly decodes the received AMD PDU or AMD PDU segment }
}

```

(2)

```

with { UE in RRC_CONNECTED state }
ensure that {
  when { UE receives a 18 bit SN configured AMD PDU containing a SI field set to 01 }
  then { UE correctly decodes the received AMD PDU or AMD PDU segment }
}

```

(3)

```

with { UE in RRC_CONNECTED state }
ensure that {
  when { UE receives a 18 bit SN configured AMD PDU containing a SI field set to 11 and SO field }
  then { UE correctly decodes the received AMD PDU or AMD PDU segment }
}

```

(4)

```

with { UE in RRC_CONNECTED state }
ensure that {
  when { UE receives a 18 bit SN configured AMD PDU containing a SI field set to 10 and SO field }
  then { UE correctly decodes the received AMD PDU or AMD PDU segment }
}

```

(5)

```

with { UE in RRC_CONNECTED state }
ensure that {
  when { UE has UL RLC SDU to send and the UL Grant is sufficient to send complete PDU }
  then { UE transmits AMD PDU containing a complete AMD SDU and SI field set to 00 }
}

```

(6)

```

with { UE in RRC_CONNECTED state }
ensure that {
  when { UE has UL RLC SDU to send and the UL Grant is sufficient to send first segment only }
  then { UE transmits AMD PDU containing first segment of AMD SDU and SI field set to 01 }
}

```

(7)

```

with { UE in RRC_CONNECTED state }
ensure that {
  when { UE has UL RLC SDU to send and the UL Grant is sufficient to send middle segment only }
  then { UE transmits AMD PDU containing middle segment of AMD SDU and SI field set to 11,
including SO field }
}

```

(8)

```

with { UE in RRC_CONNECTED state }
ensure that {
  when { UE has UL RLC SDU to send and the UL Grant is sufficient to send last segment only }
  then { UE transmits AMD PDU containing last segment of AMD SDU and SI field set to 10, including
SO field }
}

```

#### 7.1.2.3.2.2 Conformance requirements

Same conformance requirements as in clause 7.1.2.3.1.2

#### 7.1.2.3.2.3 Test description

##### 7.1.2.3.2.3.1 Pre-test conditions

Same Pre-test conditions as in clause 7.1.2.1.1 with the exception that the AM DRB is configured according to Table 7.1.2.3.2.3.1-1.

Table 7.1.2.3.2.3.1-1: RLC parameters

Uplink SN-FieldLength-AM	size18
Downlink SN-FieldLength-AM	size18

#### 7.1.2.3.2.3.2 Test procedure sequence

Same test procedure as in clause 7.1.2.3.1.3.2 except that SN is 18 bit and the data part in step 4 first segment not including SO is 200 bits (25 Bytes). Step 5, second segment SO=25 and data is 184 bits (23 bytes). Step 6, third segment SO=25+23=48 and data is 184 bits (23 bytes).

#### 7.1.2.3.2.3.3 Specific message contents

None

### 7.1.2.3.3 AM RLC / 12-bit SN / Correct use of sequence numbering

#### 7.1.2.3.3.1 Test Purpose (TP)

(1)

```
with { UE in RRC_CONNECTED state with AM RLC 12 bit SN }
ensure that {
  when { UE transmits the PDU corresponding to first SDU }
  then { UE includes the SN field equal to 0 in PDU }
}
```

(2)

```
with { UE in RRC_CONNECTED state with AM RLC 12 bit SN }
ensure that {
  when { UE transmits subsequent SDUs }
  then { UE includes the SN field incremented by 1 per SDU of each PDU transmitted }
}
```

(3)

```
with { UE in RRC_CONNECTED state with AM RLC 12 bit SN }
ensure that {
  with { UE transmits more than 4096 SDUs }
  then { UE wraps the SN after transmitting the 4096 SDUs }
}
```

(4)

```
with { UE in RRC_CONNECTED state with AM RLC 12 bit SN }
ensure that {
  with { more than 4096 SDUs are sent to UE }
  then { UE accepts PDUs with SNs that wrap around every 4096 SDUs }
}
```

#### 7.1.2.3.3.2 Conformance requirements

References: The conformance requirements covered in the present TC are specified in: TS 38.322, clauses 5.2.3.1.1, 5.2.3.2.1, 5.2.3.2.2, 6.2.2.4 and 7.1. Unless otherwise stated these are Rel-15 requirements.

[TS 38.322, clause 5.2.3.2.1]

The receiving side of an AM RLC entity shall maintain a receiving window according to the state variable RX\_Next as follows:

- a SN falls within the receiving window if  $RX\_Next \leq SN < RX\_Next + AM\_Window\_Size$ ;
- a SN falls outside of the receiving window otherwise.

When receiving an AMD PDU from lower layer, the receiving side of an AM RLC entity shall:

- either discard the received AMD PDU or place it in the reception buffer (see sub clause 5.2.3.2.2);



- if the received AMD PDU was placed in the reception buffer:
  - update state variables, reassemble and deliver RLC SDUs to upper layer and start/stop *t-Reassembly* as needed (see sub clause 5.2.3.2.3).

When *t-Reassembly* expires, the receiving side of an AM RLC entity shall:

- update state variables and start *t-Reassembly* as needed (see sub clause 5.2.3.2.4).

[TS 38.322, clause 5.2.3.2.2]

When an AMD PDU is received from lower layer, where the AMD PDU contains byte segment numbers y to z of an RLC SDU with SN = x, the receiving side of an AM RLC entity shall:

- if x falls outside of the receiving window; or
- if byte segment numbers y to z of the RLC SDU with SN = x have been received before:
  - discard the received AMD PDU.
- else:
  - place the received AMD PDU in the reception buffer;
  - if some byte segments of the RLC SDU contained in the AMD PDU have been received before:
    - discard the duplicate byte segments.

[TS 38.322, clause 6.2.2.4]

AMD PDU consists of a Data field and an AMD PDU header. The AMD PDU header is byte aligned.

An AM RLC entity is configured by RRC to use either a 12 bit SN or a 18 bit SN. The length of the AMD PDU header is two and three bytes respectively.

An AMD PDU header contains a D/C, a P, a SI, and a SN. An AMD PDU header contains the SO field only when the Data field consists of an RLC SDU segment which is not the first segment, in which case a 16 bit SO is present.

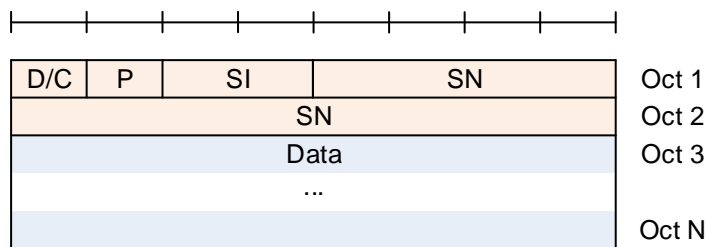

**Figure 6.2.2.4-1: AMD PDU with 12 bit SN (No SO)**

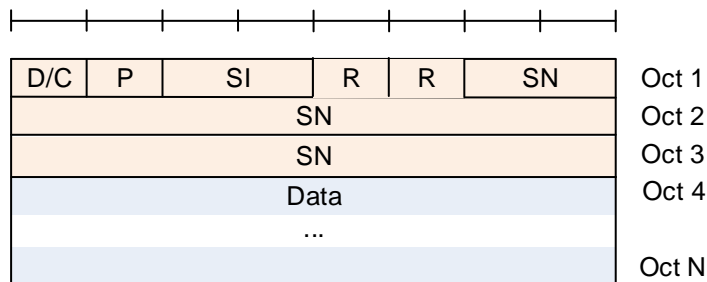

**Figure 6.2.2.4-2: AMD PDU with 18 bit SN (No SO)**

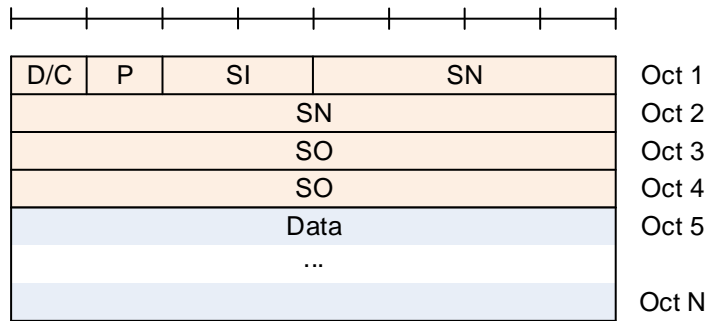

Figure 6.2.2.4-3: AMD PDU with 12 bit SN with SO

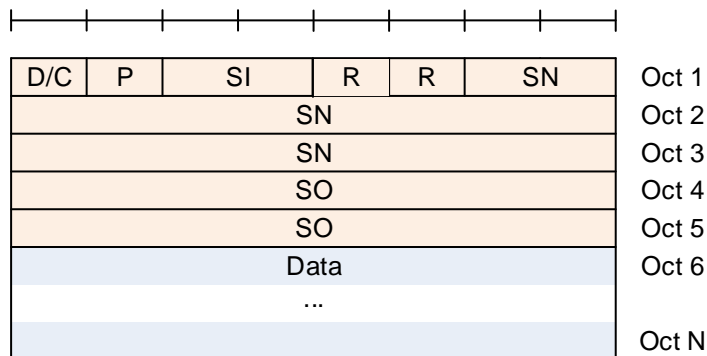

Figure 6.2.2.4-4: AMD PDU with 18 bit SN with SO

[TS 38.322, clause 7.1]

c) RETX\_COUNT – Counter

This counter counts the number of retransmissions of an RLC SDU or RLC SDU segment (see subclause 5.3.2). There is one RETX\_COUNT counter maintained per RLC SDU.

The receiving side of each AM RLC entity shall maintain the following state variables:

a) RX\_Next – Receive state variable

This state variable holds the value of the SN following the last in-sequence completely received RLC SDU, and it serves as the lower edge of the receiving window. It is initially set to 0, and is updated whenever the AM RLC entity receives an RLC SDU with SN = RX\_Next.

b) RX\_Next\_Status\_Trigger – *t-Reassembly* state variable

This state variable holds the value of the SN following the SN of the RLC SDU which triggered *t-Reassembly*.

c) RX\_Highest\_Status – Maximum STATUS transmit state variable

This state variable holds the highest possible value of the SN which can be indicated by "ACK\_SN" when a STATUS PDU needs to be constructed. It is initially set to 0.

d) RX\_Next\_Highest – Highest received state variable

This state variable holds the value of the SN following the SN of the RLC SDU with the highest SN among received RLC SDUs. It is initially set to 0.

Each transmitting UM RLC entity shall maintain the following state variables:

a) TX\_Next

This state variable holds the value of the SN to be assigned for the next newly generated UMD PDU with segment. It is initially set to 0, and is updated after the UM RLC entity submits a UMD PDU including the last segment of an RLC SDU to lower layers.

Each receiving UM RLC entity shall maintain the following state variables and constant:

b) RX\_Next\_Reassembly – UM receive state variable

This state variable holds the value of the earliest SN that is still considered for reassembly. It is initially set to 0.

c) RX\_Timer\_Trigger – UM *t-Reassembly* state variable

This state variable holds the value of the SN following the SN which triggered *t-Reassembly*.

d) RX\_Next\_Highest– UM receive state variable

This state variable holds the value of the SN following the SN of the UMD PDU with the highest SN among received UMD PDUs. It serves as the higher edge of the reassembly window. It is initially set to 0.

7.1.2.3.3.3 Test description

7.1.2.3.3.3.1 Pre-test conditions

Same Pre-test conditions as in clause 7.1.2.3.3 with the exception that the AM DRB is configured according to Table 7.1.2.3.3.3.1-1.

**Table 7.1.2.3.3.3.1-1: RLC parameters**

Uplink SN-FieldLength-AM	size12
Downlink SN-FieldLength-AM	size12
pollPDU	infinity
pollByte	infinity

## 7.1.2.3.3.3.2 Test procedure sequence

Table 7.1.2.3.3.3.2-1: Main behaviour

St	Procedure	Message Sequence		TP	Verdict
		U - S	Message/PDU/SDU		
-	During the whole test sequence, the SS should not allocate UL grants unless when explicitly stated so in the procedure.	-	-	-	-
-	EXCEPTION: The SS is configured 500ms in advance for step 1 and 2. Step 1 is executed 2048 times such that 1 AMD PDU is transmitted every second radio frame. (Note 1). Step 2 is started 60 ms after the first DL AMD PDU has been transmitted in step 1 (Note 1,3).	-	-	-	-
-	EXCEPTION: In parallel to steps 1 and 2, the behaviour described in Table 7.1.2.3.3.3.2-2 is running.	-	-	-	-
1	The SS transmits an AMD PDU to the UE. SN equals 0 and is incremented for each PDU transmitted (Note 1,3).	<--	AMD PDU	-	-
2	The SS transmits 1 UL grant (UL grant allocation type [2]) in every second radio frame to enable the UE to return each received AMD PDU in one looped back AMD PDU (Note 1,3).	<--	(UL grants)	-	-
3	The SS does not allocate any uplink grant.	-	-	-	-
-	EXCEPTION: The SS is configured 500ms in advance for step 4 and 5. Step 4 is executed 2048 times such that 1 AMD PDU is transmitted every second radio frame. (Note 1). Step 5 is started 60 ms after the first DL AMD PDU has been transmitted in step 4 (Note 1,3).	-	-	-	-
-	EXCEPTION: In parallel to steps 4 and 5, the behaviour described in Table 7.1.2.3.3.3.2-3 is running.	-	-	-	-
4	The SS transmits an AMD PDU to the UE. SN equals 2048 and is incremented for each PDU transmitted.	<--	AMD PDU	-	-
5	The SS transmits 1 UL grant (UL grant allocation type [2]) in every second radio frame to enable the UE to return each received AMD PDU in one looped back AMD PDU (Note 1,3).	<--	(UL grants)	-	-
6	The SS transmits an AMD PDU to the UE. SN equals 0.	<--	AMD PDU	-	-
7	The SS starts the UL default grant transmission.	-	-	-	-
8	Check: Does the UE transmit an AMD PDU with SN=0?	-->	AMD PDU	3,4	P
9	The SS transmits a STATUS PDU with ACK_SN = 1.	<--	STATUS PDU	-	-
Note 1:	20 ms gap between transmissions both in DL and UL respectively allows TTCN to tolerate one HARQ retransmission (FDD/TDD) per transport block, if such happen (TS 38.523-3 [3]).				
Note 2:	Delaying first UL grant for 60 ms, ensures that UE UL buffer does not become empty every time one UL AMD PDU is sent, i.e. the UE does not enable polling for every UL AMD PDU. The SS continuously transmits the grants until it has received all PDUs in UL.				
Note 3:	The RLC SDU size shall be 13 octets. With 2 octets of MAC header and 2 octets of RLC header (without SO) the RLC PDU consists of 120 bits and a TBS of 136 bits shall be allocated				

Table 7.1.2.3.3.2-2: Parallel behaviour

St	Procedure	Message Sequence		TP	Verdict
		U - S	Message		
1	Check: Does the UE transmit an AMD PDU with SN = 0?	-->	AMD PDU	1	P
-	EXCEPTION: Steps 2 and 3a1 are executed 2047 times.	-	-	-	-
2	Check: Does the UE transmit an AMD PDU with SN increased by 1 compared with the previous one?(Note1)	-->	AMD PDU	2	P
Note 1: The verdict shall be provided each if $k \bmod 2048 = 0$ , and k shall be explicitly stated . k is the received SN+1.					

Table 7.1.2.3.3.2-3: Parallel behaviour

St	Procedure	Message Sequence		TP	Verdict
		U - S	Message		
-	EXCEPTION: Steps 1 and 2a1 are executed 2048 times.	-	-	-	-
1	Check: Does the UE transmit an AMD PDU with SN increased by 1 compared with the previous one?(Note1)	-->	AMD PDU	2	P
Note 1: The verdict shall be provided each if $k \bmod 2048 = 0$ , and k shall be explicitly stated . k is the received SN+1.					

## 7.1.2.3.3.3 Specific message contents

None.

## 7.1.2.3.4 AM RLC / 18-bit SN / Correct use of sequence numbering

## 7.1.2.3.4.1 Test Purpose (TP)

(1)

```
with { UE in RRC_CONNECTED state with AM RLC 18 bit SN }
ensure that {
  when { UE transmits the PDU corresponding to first SDU }
  then { UE includes the SN field equal to 0 in PDU }
}
```

(2)

```
with { UE in RRC_CONNECTED state with AM RLC 18 bit SN }
ensure that {
  when { UE transmits subsequent SDUs }
  then { UE includes the SN field incremented by 1 per SDU of each PDU transmitted }
}
```

(3)

```
with { UE in RRC_CONNECTED state with AM RLC 18 bit SN }
ensure that {
  with { UE transmits more than 262144 SDUs }
  then { UE wraps the SN after transmitting the 262144 SDUs }
}
```

(4)

```
with { UE in RRC_CONNECTED state with AM RLC 18 bit SN }
ensure that {
  with { more than 262144 SDUs are sent to UE }
  then { UE accepts PDUs with SNs that wrap around every 262144 SDUs }
}
```

7.1.2.3.4.2 Conformance requirements

References: The conformance requirements covered in the present TC are specified in: TS 38.322, clause 5.2.3.1.1, 5.2.3.2.1, 5.2.3.2.2, 6.2.2.4, 7.1. Unless otherwise stated these are Rel-15 requirements.

[TS 38.322, clause 5.2.3.2.1]

The receiving side of an AM RLC entity shall maintain a receiving window according to the state variable RX\_Next as follows:

- a SN falls within the receiving window if  $RX\_Next \leq SN < RX\_Next + AM\_Window\_Size$ ;
- a SN falls outside of the receiving window otherwise.

When receiving an AMD PDU from lower layer, the receiving side of an AM RLC entity shall:

- either discard the received AMD PDU or place it in the reception buffer (see sub clause 5.2.3.2.2);
- if the received AMD PDU was placed in the reception buffer:
  - update state variables, reassemble and deliver RLC SDUs to upper layer and start/stop *t-Reassembly* as needed (see sub clause 5.2.3.2.3).

When *t-Reassembly* expires, the receiving side of an AM RLC entity shall:

- update state variables and start *t-Reassembly* as needed (see sub clause 5.2.3.2.4).

[TS 38.322, clause 5.2.3.2.2]

When an AMD PDU is received from lower layer, where the AMD PDU contains byte segment numbers y to z of an RLC SDU with SN = x, the receiving side of an AM RLC entity shall:

- if x falls outside of the receiving window; or
- if byte segment numbers y to z of the RLC SDU with SN = x have been received before:
  - discard the received AMD PDU.
- else:
  - place the received AMD PDU in the reception buffer;
  - if some byte segments of the RLC SDU contained in the AMD PDU have been received before:
    - discard the duplicate byte segments.

[TS 38.322, clause 6.2.2.4]

AMD PDU consists of a Data field and an AMD PDU header. The AMD PDU header is byte aligned.

An AM RLC entity is configured by RRC to use either a 12 bit SN or a 18 bit SN. The length of the AMD PDU header is two and three bytes respectively.

An AMD PDU header contains a D/C, a P, a SI, and a SN. An AMD PDU header contains the SO field only when the Data field consists of an RLC SDU segment which is not the first segment, in which case a 16 bit SO is present.

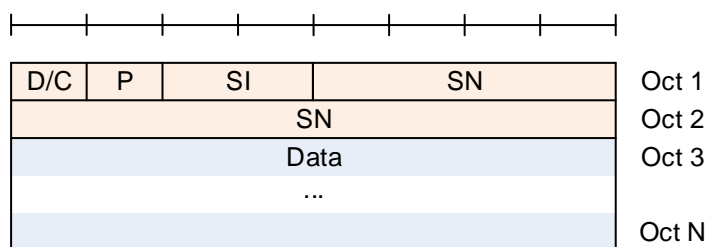

Figure 6.2.2.4-1: AMD PDU with 12 bit SN (No SO)

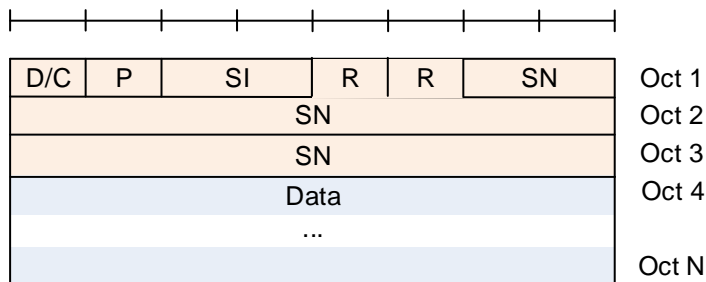

Figure 6.2.2.4-2: AMD PDU with 18 bit SN (No SO)

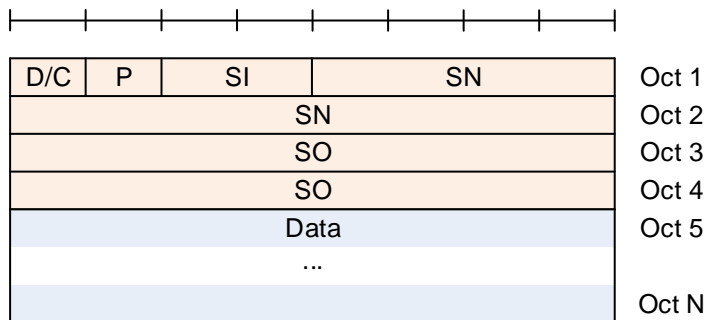

Figure 6.2.2.4-3: AMD PDU with 12 bit SN with SO

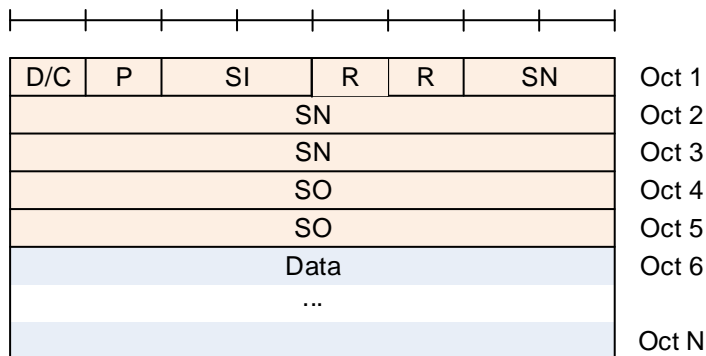

Figure 6.2.2.4-4: AMD PDU with 18 bit SN with SO

[TS 38.322, clause 7.1]

c) RETX\_COUNT – Counter

This counter counts the number of retransmissions of an RLC SDU or RLC SDU segment (see subclause 5.3.2). There is one RETX\_COUNT counter maintained per RLC SDU.

The receiving side of each AM RLC entity shall maintain the following state variables:

a) RX\_Next – Receive state variable

This state variable holds the value of the SN following the last in-sequence completely received RLC SDU, and it serves as the lower edge of the receiving window. It is initially set to 0, and is updated whenever the AM RLC entity receives an RLC SDU with SN = RX\_Next.

b) RX\_Next\_Status\_Trigger – *t-Reassembly* state variable

This state variable holds the value of the SN following the SN of the RLC SDU which triggered *t-Reassembly*.

c) RX\_Highest\_Status – Maximum STATUS transmit state variable

This state variable holds the highest possible value of the SN which can be indicated by "ACK\_SN" when a STATUS PDU needs to be constructed. It is initially set to 0.

d) RX\_Next\_Highest – Highest received state variable

This state variable holds the value of the SN following the SN of the RLC SDU with the highest SN among received RLC SDUs. It is initially set to 0.

Each transmitting UM RLC entity shall maintain the following state variables:

a) TX\_Next

This state variable holds the value of the SN to be assigned for the next newly generated UMD PDU with segment. It is initially set to 0, and is updated after the UM RLC entity submits a UMD PDU including the last segment of an RLC SDU to lower layers.

Each receiving UM RLC entity shall maintain the following state variables and constant:

b) RX\_Next\_Reassembly – UM receive state variable

This state variable holds the value of the earliest SN that is still considered for reassembly. It is initially set to 0.

c) RX\_Timer\_Trigger – UM *t-Reassembly* state variable

This state variable holds the value of the SN following the SN which triggered *t-Reassembly*.

d) RX\_Next\_Highest– UM receive state variable

This state variable holds the value of the SN following the SN of the UMD PDU with the highest SN among received UMD PDUs. It serves as the higher edge of the reassembly window. It is initially set to 0.

7.1.2.3.4.3 Test description

7.1.2.3.4.3.1 Pre-test conditions

Same Pre-test conditions as in clause 7.1.2.3.4 with the exception that the AM DRB is configured according to Table 7.1.2.3.4.3.1-1.

**Table 7.1.2.3.4.3.1-1: RLC parameters**

Uplink SN-FieldLength-AM	size18
Downlink SN-FieldLength-AM	size18



## 7.1.2.3.4.3.2 Test procedure sequence

Table 7.1.2.3.4.3.2-1: Main behaviour

St	Procedure	Message Sequence		TP	Verdict
		U - S	Message/PDU/SDU		
-	During the whole test sequence, the SS should not allocate UL grants unless when explicitly stated so in the procedure.	-	-	-	-
-	EXCEPTION: The SS is configured 500ms in advance for step 1 and 2. Step 1 is executed 131072 times such that 1 AMD PDU is transmitted every second radio frame. (Note 1). Step 2 is started 60 ms after the first DL AMD PDU has been transmitted in step 1 (Note 1,3).	-	-	-	-
-	EXCEPTION: In parallel to steps 1 and 2, the behaviour described in Table 7.1.2.3.4.3.2-2 is running.	-	-	-	-
1	The SS transmits an AMD PDU to the UE. SN equals 0 and is incremented for each PDU transmitted (Note 1,3).	<--	AMD PDU	-	-
2	The SS transmits 1 UL grant (UL grant allocation type [2]) in every second radio frame to enable the UE to return each received AMD PDU in one looped back AMD PDU (Note 1,3).	<--	(UL grants)	-	-
3	The SS does not allocate any uplink grant.	-	-	-	-
-	EXCEPTION: The SS is configured 500ms in advance for step 4 and 5. Step 4 is executed 131072 times such that 1 AMD PDU is transmitted every second radio frame. (Note 1). Step 5 is started 60 ms after the first DL AMD PDU has been transmitted in step 4 (Note 1,3).	-	-	-	-
-	EXCEPTION: In parallel to steps 4 and 5, the behaviour described in Table 7.1.2.3.4.3.2-3 is running.	-	-	-	-
4	The SS transmits an AMD PDU to the UE. SN equals 131072 and is incremented for each PDU transmitted.	<--	AMD PDU	-	-
5	The SS transmits 1 UL grant (UL grant allocation type [2]) in every second radio frame to enable the UE to return each received AMD PDU in one looped back AMD PDU (Note 1,3).	<--	(UL grants)	-	-
6	The SS transmits an AMD PDU to the UE. SN equals 0.	<--	AMD PDU	-	-
7	The SS starts the UL default grant transmission.	-	-	-	-
8	Check: Does the UE transmit an AMD PDU with SN=0?	-->	AMD PDU	3,4	P
9	The SS transmits a STATUS PDU with ACK_SN = 1.	<--	STATUS PDU	-	-
Note 1:	20 ms gap between transmissions both in DL and UL respectively allows TTCN to tolerate one HARQ retransmission (FDD/TDD) per transport block, if such happen (TS 38.523-3 [3]).				
Note 2:	Delaying first UL grant for 60 ms, ensures that UE UL buffer does not become empty every time one UL AMD PDU is sent, i.e. the UE does not enable polling for every UL AMD PDU. The SS continuously transmits the grants until it has received all PDUs in UL.				
Note 3:	The RLC SDU size shall be 10 octets. With 2 octets of MAC header and 3 octets of RLC header (without SO) the RLC PDU consists of 120 bits and a TBS of 136 bits shall be allocated				

Table 7.1.2.3.4.3.2-2: Parallel behaviour

St	Procedure	Message Sequence		TP	Verdict
		U - S	Message		
1	Check: Does the UE transmit an AMD PDU with SN = 0?	-->	AMD PDU	1	P
-	EXCEPTION: Steps 2 and 3a1 are executed 131071 times.	-	-	-	-
2	Check: Does the UE transmit an AMD PDU with SN increased by 1 compared with the previous one? (Note1)	-->	AMD PDU	2	P
-	EXCEPTION: Step 3a1 describes behaviour that depends on the contents of the AMD PDU transmitted at Step 2.	-	-	-	-
3a1	IF the UE has set the poll bit in the AMD PDU transmitted at Step 2 THEN the SS transmits a Status Report.	<--	STATUS PDU	-	-

Table 7.1.2.3.4.3.2-3: Parallel behaviour

St	Procedure	Message Sequence		TP	Verdict
		U - S	Message		
-	EXCEPTION: Steps 1 and 2a1 are executed 131072 times.	-	-	-	-
1	Check: Does the UE transmit an AMD PDU with SN increased by 1 compared with the previous one? (Note1)	-->	AMD PDU	2	P
-	EXCEPTION: Step 2a1 describes behaviour that depends on the contents of the AMD PDU transmitted at Step 1.	-	-	-	-
2a1	IF the UE has set the poll bit in the AMD PDU transmitted at Step 1 THEN the SS transmits a Status Report.	<--	STATUS PDU	-	-

## 7.1.2.3.4.3.3 Specific message contents

None.

## 7.1.2.3.5 AM RLC / Control of transmit window/Control of receive window

## 7.1.2.3.5.1 Test Purpose (TP)

(1)

```
with { UE in RRC_CONNECTED state and using AM RLC and pending uplink data for transmission }
ensure that {
  when { AMD PDUs in transmission buffer fall outside TX_Next_Ack <= SN < TX_Next_Ack +
AM_Window_Size }
  then { UE does not transmit these AMD PDUs }
}
```

(2)

```
with { UE in RRC_CONNECTED state and using AM RLC and pending uplink data for transmission }
ensure that {
  when { receiving a STATUS PDU where ACK_SN acknowledges at least one AMD PDU not yet acknowledged }
  then { UE transmits AMD PDUs within updated window range }
}
```

(3)

```
with { UE in RRC_CONNECTED state and using AM RLC }
ensure that {
  when { the UE receives AMD PDUs with SN outside the upper boundary of the receive window }
  then { the UE discards these AMD PDUs }
}
```

(4)

```

with { UE in RRC_CONNECTED state and using AM RLC }
ensure that {
  when { the receive window has been moved }
  then { UE continues accepting AMD PDUs within updated window range }
}

```

#### 7.1.2.3.5.2 Conformance requirements

References: The conformance requirements covered in the present TC are specified in: TS 38.322, clauses 5.2.3.2.1, 5.2.3.2.2, 5.2.3.2.3 and 7.2. Unless otherwise stated these are Rel-15 requirements.

[TS 38.322, clause 5.2.3.2.2]

When an AMD PDU is received from lower layer, where the AMD PDU contains byte segment numbers  $y$  to  $z$  of an RLC SDU with  $SN = x$ , the receiving side of an AM RLC entity shall:

- if  $x$  falls outside of the receiving window; or
- if byte segment numbers  $y$  to  $z$  of the RLC SDU with  $SN = x$  have been received before:
  - discard the received AMD PDU.
- else:
  - place the received AMD PDU in the reception buffer;
  - if some byte segments of the RLC SDU contained in the AMD PDU have been received before:
    - discard the duplicate byte segments.

[TS 38.322, clause 5.2.3.2.3]

When an AMD PDU with  $SN = x$  is placed in the reception buffer, the receiving side of an AM RLC entity shall:

- if  $x \geq RX\_Next\_Highest$ 
  - update  $RX\_Next\_Highest$  to  $x + 1$ .
- if all bytes of the RLC SDU with  $SN = x$  are received:
  - reassemble the RLC SDU from AMD PDU(s) with  $SN = x$ , remove RLC headers when doing so and deliver the reassembled RLC SDU to upper layer;
  - if  $x = RX\_Highest\_Status$ ,
    - update  $RX\_Highest\_Status$  to the SN of the first RLC SDU with  $SN > current\ RX\_Highest\_Status$  for which not all bytes have been received.
  - if  $x = RX\_Next$ :
    - update  $RX\_Next$  to the SN of the first RLC SDU with  $SN > current\ RX\_Next$  for which not all bytes have been received.
- if  $t\text{-Reassembly}$  is running:
  - if  $RX\_Next\_Status\_Trigger = RX\_Next$ ; or
  - if  $RX\_Next\_Status\_Trigger = RX\_Next + 1$  and there is no missing byte segment of the SDU associated with  $SN = RX\_Next$  before the last byte of all received segments of this SDU; or
  - if  $RX\_Next\_Status\_Trigger$  falls outside of the receiving window and  $RX\_Next\_Status\_Trigger$  is not equal to  $RX\_Next + AM\_Window\_Size$ :
    - stop and reset  $t\text{-Reassembly}$ .

- if *t-Reassembly* is not running (includes the case *t-Reassembly* is stopped due to actions above):
  - if  $RX\_Next\_Highest > RX\_Next + 1$ ; or
  - if  $RX\_Next\_Highest = RX\_Next + 1$  and there is at least one missing byte segment of the SDU associated with  $SN = RX\_Next$  before the last byte of all received segments of this SDU:
    - start *t-Reassembly*;
    - set  $RX\_Next\_Status\_Trigger$  to  $RX\_Next\_Highest$ .

[TS 38.322, clause 7.2]

#### a) AM\_Window\_Size

This constant is used by both the transmitting side and the receiving side of each AM RLC entity.  $AM\_Window\_Size = 2048$  when a 12 bit SN is used,  $AM\_Window\_Size = 131072$  when an 18 bit SN is used.

### 7.1.2.3.5.3 Test description

#### 7.1.2.3.5.3.1 Pre-test conditions

Same Pre-test conditions as in clause 7.1.2.1.1 with the exception that the AM DRB is configured according to Table 7.1.2.3.5.3.1-1.

**Table 7.1.2.3.5.3.1-1: RLC parameters**

t-PollRetransmit	ms300
pollPDU	infinity
pollByte	infinity
sn-FieldLength(UL-AM-RLC)	IF (pc_am_WithShortSN ) size12 ELSE size18
sn-FieldLength(DL-AM-RLC)	IF (pc_am_WithShortSN ) size12 ELSE size18

## 7.1.2.3.5.3.2 Test procedure sequence

Table 7.1.2.3.5.3.2-1: Main behaviour

St	Procedure	Message Sequence		TP	Verdict
		U - S	Message		
-	The SS does not allocate any uplink grant.	-	-	-	-
-	EXCEPTION: The SS is configured for step 1 and 2 500ms in advance. Step 1 is repeated $W+1$ times, where $W = AM\_Window\_Size$ . The transmission is performed every second radio frame. (Note 2). Step 2 is started 100 ms after the first DL AMD PDU has been transmitted in step 1.	-	-	-	-
-	EXCEPTION: In parallel to steps 1 and 2, the behaviour described in Table 7.1.2.3.5.3.2-2 is running.	-	-	-	-
1	The SS transmits an AMD PDU containing a SDU to the UE.	<--	AMD PDU	-	-
2	In the following steps the SS transmits 1 UL grant in every second radio frame to enable the UE to return each received AMD PDU in one looped back AMD PDU. (Note 2)	<--	(UL grants)	-	-
3	Check: Does the UE transmit an AMD PDU with the Poll bit set and with the contents of the SDU?	-->	AMD PDU(SN=W-1), Poll	1	P
4	The SS starts the UL default grant transmission.	-	-	-	-
5	Check: Does the UE transmit an AMD PDU within $t\_PollRetransmit/2$ ?	-->	AMD PDU	1	F
6	The SS transmits a STATUS PDU to acknowledge the $W$ uplink AMD PDUs with SN=0 to SN=W-1. ACK_SN = W.	<--	STATUS PDU	-	-
7	Check: Does the UE transmit an AMD PDU with the Poll bit set and with the contents of the SDU?	-->	AMD PDU(SN=W), Poll	2	P
8	The SS transmits a STATUS PDU with ACK_SN = W+1.	<--	STATUS PDU	-	-
9	The SS transmits the (W+1)th AMD PDU containing a SDU to the UE with the Sequence Number field set to $((2W+1 \bmod 4096) = 1)$ and the Polling bit set.	<--	AMD PDU	-	-
10	Check: Does the UE transmit a STATUS PDU acknowledging W+1 SDUs? (ACK_SN = W+1). (Note 1)	-->	STATUS PDU	3	P
11	The SS transmits the (W+2)th AMD PDU to the UE with the Sequence Number field set to W+1 and the Polling bit set.	<--	AMD PDU	-	-
-	EXCEPTION: Steps 12 and 13 can happen in any order.				
12	Check: Does the UE transmit a STATUS PDU acknowledging W +1 PDUs? (ACK_SN field = W+1). (Note 2)	-->	STATUS PDU	4	P
13	The UE transmits an AMD PDU with the same data as received in the corresponding DL AMD PDU in step 11.	-->	AMD PDU	4	P
Note 1: SDUs are numbered 1,2, ..., W+1.					
Note 2: 20 ms gap between transmissions both in DL and UL respectively allows TTCN to tolerate one HARQ retransmission (FDD/TDD) per transport block,					

Table 7.1.2.3.5.3.2-2: Parallel behaviour

St	Procedure	Message Sequence		TP	Verdict
		U - S	Message		
-	EXCEPTION: Step 1 is executed W-1 times.	-	-	-	-
1	The UE transmits an AMD PDU with the same data as received in the corresponding DL AMD PDU.	-->	AMD PDU	4	P

## 7.1.2.3.5.3.3 Specific message contents

None

## 7.1.2.3.6 AM RLC / Polling for status

## 7.1.2.3.6.1 Test Purpose (TP)

(1)

```
with { UE in RRC_CONNECTED state and using AM RLC }
ensure that {
  when { last data in the UL buffer is being transmitted }
  then { UE transmits a Poll }
}
```

(2)

```
with { UE in RRC_CONNECTED state and using AM RLC }
ensure that {
  when { the t-PollRetransmit timer expires }
  then { UE transmits a Poll }
}
```

(3)

```
with { UE in RRC_CONNECTED state and using AM RLC }
ensure that {
  when { PDU_WITHOUT_POLL >= pollPDU }
  then { UE transmits a Poll }
}
```

(4)

```
with { UE in RRC_CONNECTED state and using AM RLC }
ensure that {
  when { BYTE_WITHOUT_POLL >= pollByte }
  then { UE transmits a Poll }
}
```

## 7.1.2.3.6.2 Conformance requirements

References: The conformance requirements covered in the present TC are specified in: TS 38.322, clauses 5.3.3.2, 7.3 and 7.4. Unless otherwise stated these are Rel-15 requirements.

[TS 38.322, clause 5.3.3.2]

Upon notification of a transmission opportunity by lower layer, for each AMD PDU submitted for transmission such that the AMD PDU contains either a not previously transmitted RLC SDU or an RLC SDU segment containing not previously transmitted byte segment, the transmitting side of an AM RLC entity shall:

- increment PDU\_WITHOUT\_POLL by one;
- increment BYTE\_WITHOUT\_POLL by every new byte of Data field element that it maps to the Data field of the AMD PDU;
- if PDU\_WITHOUT\_POLL >= pollPDU; or
- if BYTE\_WITHOUT\_POLL >= pollByte:

- include a poll in the AMD PDU as described below.

Upon notification of a transmission opportunity by lower layer, for each AMD PDU submitted for transmission, the transmitting side of an AM RLC entity shall:

- if both the transmission buffer and the retransmission buffer becomes empty (excluding transmitted RLC SDUs or RLC SDU segments awaiting acknowledgements) after the transmission of the AMD PDU; or
- if no new RLC SDU can be transmitted after the transmission of the AMD PDU (e.g. due to window stalling);
- include a poll in the AMD PDU as described below.

NOTE: Empty RLC buffer (excluding transmitted RLC SDUs or RLC SDU segments awaiting acknowledgements) should not lead to unnecessary polling when data awaits in the upper layer. Details are left up to UE implementation.

To include a poll in an AMD PDU, the transmitting side of an AM RLC entity shall:

- set the P field of the AMD PDU to "1";
- set PDU\_WITHOUT\_POLL to 0;
- set BYTE\_WITHOUT\_POLL to 0.

After submitting an AMD PDU including a poll to lower layer and after incrementing of TX\_Next if necessary, the transmitting side of an AM RLC entity shall:

- set POLL\_SN to TX\_Next – 1;
- if *t-PollRetransmit* is not running:
  - start *t-PollRetransmit*.
- else:
  - restart *t-PollRetransmit*.

[TS 38.322, clause 5.3.3.4]

Upon expiry of *t-PollRetransmit*, the transmitting side of an AM RLC entity shall:

- if both the transmission buffer and the retransmission buffer are empty (excluding transmitted RLC SDU or RLC SDU segment awaiting acknowledgements); or
- if no new RLC SDU or RLC SDU segment can be transmitted (e.g. due to window stalling):
  - consider the RLC SDU with SN = TX\_Next – 1 for retransmission; or
  - consider any RLC SDU which has not been positively acknowledged for retransmission.
- include a poll in an AMD PDU as described in section 5.3.3.2.

[TS 38.322, clause 7.3]

#### a) *t-PollRetransmit*

This timer is used by the transmitting side of an AM RLC entity in order to retransmit a poll (see sub clause 5.3.3).

[TS 38.322, clause 7.4]

#### b) pollPDU

This parameter is used by the transmitting side of each AM RLC entity to trigger a poll for every pollPDU PDUs (see subclause 5.3.3).

#### c) pollByte

This parameter is used by the transmitting side of each AM RLC entity to trigger a poll for every pollByte bytes (see subclause 5.3.3).

7.1.2.3.6.3 Test description

7.1.2.3.6.3.1 Pre-test conditions

Same Pre-test conditions as in clause 7.1.2.1.1 with the exception that the AM DRB is configured according to Table 7.1.2.3.6.3.1-1.

**Table 7.1.2.3.6.3.1-1: RLC parameters**

t-PollRetransmit	ms400
pollPDU	p256
pollByte	kB25



7.1.2.3.6.3.2 Test procedure sequence

**Table 7.1.2.3.6.3.2-1: Main behaviour**

St	Procedure	Message Sequence		TP	Verdict
		U - S	Message		
1	During the whole test sequence, the SS should not allocate UL grants unless when explicitly stated so in the procedure.	-	-	-	-
2	The SS transmits 4 AMD PDUs such that 1 AMD PDU is sent every two radio frame, each containing an RLC SDU of 976 bits. (Note 2)	<--	AMD PDU (SN=0) AMD PDU (SN=1) AMD PDU (SN=2) AMD PDU (SN=3)	-	-
-	EXCEPTION: In parallel to the events described in step 3, the step specified in Table 7.1.2.3.6.3.2-2 should take place.	-	-	-	-
3	The SS waits for 100 ms after the first DL AMD PDU has been transmitted in step 2, then starts assigning UL grants in every second radio frame of size 1032 bits. (Note 1) (Note 2)	-	-	-	-
4	Check 1: Does the UE transmit an AMD PDU with a SN in range 0 to 3 and P=1? Record time $T_B$ . Check 2: Is $(T_B - T_A) = t\text{-PollRetransmit?}$	-->	AMD PDU	2	P
5	The SS starts the UL default grant transmission on reception of SR.	-	-	-	-
6	The SS transmits an RLC Status Report ACKing reception of PDU's 0-3.	<--	STATUS PDU	-	-
7	Check: Does the UE retransmit an AMD PDU within 1 sec?	-->	AMD PDU	2	F
8	The SS performs an RRCReconfiguration procedure changing <i>pollPDU</i> to p4.	-	-	-	-
9	The SS stops allocating any UL grant.	-	-	-	-
10	The SS transmits 8 AMD PDUs such that 1 AMD PDU is sent every second radio frame, each containing an RLC SDU of 976 bits. (Note 2)	<--	AMD PDU (SN=4) AMD PDU (SN=5) ... AMD PDU (SN=11)	-	-
-	EXCEPTION: In parallel to the events described in step 11, the step specified in Table 7.1.2.3.6.3.2-3 should take place.	-	-	-	-
11	The SS waits for 100 ms after the first DL AMD PDU has been transmitted in step 10, then starts assigning UL grants (UL grant allocation type 2) in every second radio frame of size 1032 bits. (Note 1) (Note 2)	-	-	-	-
12	The SS transmits a Status Report with ACK_SN=12, NACK_SN=4, NACK_SN=5, NACK_SN=6 (constructed by NACK_SN Range), NACK_SN=8 and NACK_SN=9 (constructed by NACK_SN Range).	<--	STATUS PDU	-	-
13	Check: Does the UE transmit AMD PDUs with the following SN and P values? AMD PDU, SN=4, P=0 AMD PDU, SN=5, P=0 AMD PDU, SN=6, P=0 AMD PDU, SN=8, P=0 AMD PDU, SN=9, P=1	-->	AMD PDU (SN=4, P=0) AMD PDU (SN=5, P=0) AMD PDU (SN=6, P=0) AMD PDU (SN=8, P=0) AMD PDU (SN=9, P=1)	2	P
14	The SS starts the UL default grant transmission.	-	-	-	-
15	The SS transmits a Status Report with ACK_SN=12 and no NACK_SN.	<--	STATUS PDU	-	-
16	The SS performs an RRCReconfiguration procedure changing <i>pollPDU</i> to p256.	-	-	-	-
17	The SS does not allocate any UL grant.	-	-	-	-
18	After 500 ms the SS transmits 412 AMD PDUs such that 1 AMD PDU is sent every second radio frame, each containing an RLC SDU of size 976 bits. (Note 2)	<--	AMD PDU (SN=12) AMD PDU (SN=13) ... AMD PDU (SN=423)	-	-
-	EXCEPTION: In parallel to the events described in step 19, the steps specified in Table 7.1.2.3.6.3.2-4 should take place.	-	-	-	-

19	The SS waits for 100 ms after the first DL AMD PDU has been transmitted in step 10, then starts assigning UL grants (UL grant allocation type 2) in every second radio frame of size 1032 bits. (Note 1) (Note 2)	-	-	-	-
20	The SS starts the UL default grant transmission	-	-	-	-
<p>Note 1: UL grant of 1032 bits (<i>index 54 of TS 38.214 [15] Table 5.1.3.2-2, L<sub>RBs</sub> &amp; l<sub>MCS</sub> as per 38.523-3[3] annex B</i>) is chosen to allow the UE to loop back one SDU of size 976 bits and one short BSR (16 bits) into each MAC PDU sent in the uplink (1032 bits - 24 bit AMD PDU header - 16 bit MAC BSR CE- 16 bit MAC PDU subheader). The UE will include an SDU of size 976 bits and one short BSR in the looped back MAC PDU.</p> <p>Note 2: 20ms gap between transmissions both in DL and UL respectively allows TTCN to tolerate one HARQ retransmission (FDD/TDD) per transport block, if such happen (TS 36.523-3 [25]).</p>					

Table 7.1.2.3.6.3.2-2: Parallel behaviour

St	Procedure	Message Sequence		TP	Verdict
		U - S	Message		
1	Check: Does the UE transmit 4 AMD PDUs, with only the last one having the poll bit set? Record time T <sub>A</sub> when the PDU with the poll bit set is received at the SS.	-->	AMD PDUs	1	P

Table 7.1.2.3.6.3.2-3: Parallel behaviour

St	Procedure	Message Sequence		TP	Verdict
		U - S	Message		
1	Check: Does the UE transmit 8 AMD PDUs, with the poll bit set only in the 4 <sup>th</sup> and the 8 <sup>th</sup> PDUs?	-->	AMD PDUs	3	P

Table 7.1.2.3.6.3.2-4: Parallel behaviour

St	Procedure	Message Sequence		TP	Verdict
		U - S	Message		
1	Check: Does the UE transmit 205 AMD PDUs, with the poll bit set only in the last (205 <sup>th</sup> ) one? (Note 1)	-->	AMD PDUs	4	P
2	The SS transmits an RLC Status Report.	<--	STATUS PDU	-	-
3	Check: Does the UE transmit 205 AMD PDUs, with the poll bit set only in the last (410 <sup>th</sup> ) one? (Note 1)	-->	AMD PDUs	4	P
4	The SS transmits an RLC Status Report.	<--	STATUS PDU	-	-
5	Check: Does the UE transmit 2 AMD PDUs, with the poll bit set only in the last (412 <sup>th</sup> ) one?	-->	AMD PDUs	1	P
6	The SS transmits an RLC Status Report.	<--	STATUS PDU	-	-
Note 1: (976 bits x 205PDUs) / 8 = 25010 > 25 KB, with 1 kB = 1000 bytes (TS 38.331 [12], clause 3.2)					

## 7.1.2.3.6.3.3 Specific message contents

None

## 7.1.2.3.7 AM RLC / Receiver status triggers

## 7.1.2.3.7.1 Test Purpose (TP)

(1)

```

with { UE in RRC_CONNECTED state and using AM RLC }
ensure that {
  when { Reception failure of an RLC data PDU is detected and t-Reassembly expires }
  then { UE initiates Status Reporting }
}

```

(2)

```

with { UE in RRC_CONNECTED state and using AM RLC }
ensure that {
  when { Status Reporting is triggered and t-StatusProhibit is running }
  then { UE wait until t-StatusProhibit has expired to send Status Report }
}

```

(3)

```

with { UE in RRC_CONNECTED state and using AM RLC }
ensure that {
  when { Polling from peer AM RLC entity is detected and the sequence number 'x' of the PDU that
  carries the Poll satisfies  $x < RX\_Highest\_Status$  or  $x \geq RX\_Next + AM\_Window\_Size$  }
  then { UE initiates Status Reporting }
}

```

(4)

```

with { UE in RRC_CONNECTED state and using AM RLC }
ensure that {
  when { Polling from peer AM RLC entity is detected and the sequence number 'x' of the PDU that
  carries the Poll does not satisfies  $x < RX\_Highest\_Status$  or  $x \geq RX\_Next + AM\_Window\_Size$  }
  then { UE waits until ' $x < RX\_Highest\_Status$  or  $x \geq RX\_Next + AM\_Window\_Size$ ' before initiating
  Status Reporting }
}

```

(5)

```

with { UE in RRC_CONNECTED state and using AM RLC }
ensure that {
  when { the UE needs to send a Status Report and the UL grant is not large enough to accommodate
  the whole report }
  then { UE includes as many NACK_SNs in the Status Report as allowed by the UL grant }
}

```

(6)

```

with { UE in RRC_CONNECTED state and using AM RLC }
ensure that {
  when { the UE needs to send a Status Report and continuous sequence of RLC SDUs that have not been
  received yet }
  then { UE includes NACK_SN with NACK range }
}

```

### 7.1.2.3.7.2 Conformance requirements

References: The conformance requirements covered in the present TC are specified in: TS 38.322, clause 5.3.4. Unless otherwise stated these are Rel-15 requirements.

[TS 38.322, clause 5.3.4]

An AM RLC entity sends STATUS PDUs to its peer AM RLC entity in order to provide positive and/or negative acknowledgements of RLC SDUs (or portions of them).

Triggers to initiate STATUS reporting include:

- Polling from its peer AM RLC entity:
  - When an AMD PDU with SN = x and the P field set to "1" is received from lower layer, the receiving side of an AM RLC entity shall:
    - if the AMD PDU is to be discarded as specified in subclause 5.2.3.2.2; or
    - if  $x < RX\_Highest\_Status$  or  $x \geq RX\_Next + AM\_Window\_Size$ :
      - trigger a STATUS report.

- else:
  - delay triggering the STATUS report until  $x < \text{RX\_Highest\_Status}$  or  $x \geq \text{RX\_Next} + \text{AM\_Window\_Size}$ .

NOTE 1: This ensures that the RLC Status report is transmitted after HARQ reordering.

- Detection of reception failure of an AMD PDU
  - The receiving side of an AM RLC entity shall trigger a STATUS report when *t-Reassembly* expires.

NOTE 2: The expiry of *t-Reassembly* triggers both *RX\_Highest\_Status* to be updated and a STATUS report to be triggered, but the STATUS report shall be triggered after *RX\_Highest\_Status* is updated.

When STATUS reporting has been triggered, the receiving side of an AM RLC entity shall:

- if *t-StatusProhibit* is not running:
  - at the first transmission opportunity indicated by lower layer, construct a STATUS PDU and submit it to lower layer.
- else:
  - at the first transmission opportunity indicated by lower layer after *t-StatusProhibit* expires, construct a single STATUS PDU even if status reporting was triggered several times while *t-StatusProhibit* was running and submit it to lower layer.

When a STATUS PDU has been submitted to lower layer, the receiving side of an AM RLC entity shall:

- start *t-StatusProhibit*.

When constructing a STATUS PDU, the AM RLC entity shall:

- for the RLC SDUs with SN such that  $\text{RX\_Next} \leq \text{SN} < \text{RX\_Highest\_Status}$  that has not been completely received yet, in increasing SN order of RLC SDUs and increasing byte segment order within RLC SDUs, starting with  $\text{SN} = \text{RX\_Next}$  up to the point where the resulting STATUS PDU still fits to the total size of RLC PDU(s) indicated by lower layer:
  - for an RLC SDU for which no byte segments have been received yet:
    - include in the STATUS PDU a *NACK\_SN* which is set to the SN of the RLC SDU.
  - for a continuous sequence of byte segments of a partly received RLC SDU that have not been received yet:
    - include in the STATUS PDU a set of *NACK\_SN*, *SOstart* and *SOend*.
  - for a continuous sequence of RLC SDUs that have not been received yet:
    - include in the STATUS PDU a set of *NACK\_SN* and *NACK range*;
    - include in the STATUS PDU, if required, a pair of *SOstart* and *SOend*.
- set the *ACK\_SN* to the SN of the next not received RLC SDU which is not indicated as missing in the resulting STATUS PDU.

7.1.2.3.7.3 Test description

7.1.2.3.7.3.1 Pre-test conditions

Same Pre-test conditions as in clause 7.1.2.1.1 with the exception that the AM DRB is configured according to Table 7.1.2.3.7.3.1-1.

**Table 7.1.2.3.7.3.1-1: RLC parameters**

t-Reassembly	ms150
t-StatusProhibit	ms300
t-PollRetransmit	ms500

7.1.2.3.7.3.2 Test procedure sequence

**Table 7.1.2.3.7.3.2-1: Main behaviour**

St	Procedure	Message Sequence		TP	Verdict
		U - S	Message		
-	The SS ignores scheduling requests and does not allocate any uplink grant.	-	-	-	-
1	The SS transmits 4 AMD PDUs with SN=0, 1, 2, and 4. The SS sets the P field of all the AMD PDUs to 0. Record time $T_A$ when the AMD PDU with SN=4 is sent.	<--	AMD PDU (SN=0, P=0) AMD PDU (SN=1, P=0) AMD PDU (SN=2, P=0) AMD PDU (SN=4, P=0)	-	-
2	The SS waits for 30 ms after the transmission of the last AMD PDU to ensure UE RLC has all the required SDUs available and then assigns 3 UL grants (UL grant allocation type 2) with a time spacing of 10 ms of size 848 bits (UL Grant Allocation type 2). (Note 1)	<--	(UL grants, 848 bits)	-	-
3	The UE transmits RLC SDU#1.	-->	(RLC SDU#1)	-	-
4	The UE transmits RLC SDU#2.	-->	(RLC SDU#2)	-	-
5	The UE transmits RLC SDU#3.	-->	(RLC SDU#3)	-	-
6	The SS transmits a STATUS PDU	<--	STATUS PDU	-	-
7	The SS starts the UL default grant transmission.	-	-	-	-
8	Check 1: Does the UE transmit a Status Report with NACK_SN=3 and ACK_SN=5? Record time $T_B$ Check 2: $(T_B - T_A) = t\text{-Reassembly}$	-->	STATUS PDU	1	P
9	100 ms after the Status Report is received at Step 8, the SS transmits 4 AMD PDUs with SN=5, 6, 8 and 9. The SS sets the P field of all the AMD PDUs to 0.	<--	AMD PDU (SN=5, P=0) AMD PDU (SN=6, P=0) AMD PDU (SN=8, P=0) AMD PDU (SN=9, P=0)	-	-
10	Check 1: Does the UE transmit a Status Report with NACK_SN=3, NACK_SN=7, ACK_SN=10? Record time $T_C$ Check 2: $(T_C - T_B) = t\text{-StatusProhibit}$	-->	STATUS PDU	2	P
11	The SS ignores scheduling requests unless otherwise specified and does not allocate any uplink grant and is configured for Uplink Grant Allocation Type 3.	-	-	-	-
12	After 300 ms the SS transmits 2 AMD PDUs with SN=3, SN=7. The SS sets the P field of all the AMD PDUs to 0 except for that of the AMD PDU with SN=7.	<--	AMD PDU (SN=3, P=0) AMD PDU (SN=7, P=1)	-	-
13	The SS waits for 50 ms after the transmission of the last AMD PDU to ensure UE RLC has all the required SDUs available and then assigns 1 UL grant (UL grant allocation type 3) of size 80 bits. (Note 2)	<--	(UL grant, 80 bits)	-	-
14	Check: Does the UE transmit a Status Report with no NACK_SN and ACK_SN = 10?	-->	STATUS PDU	3	P
15	In the frame following the one scheduled in step 13 the SS assigns 7 UL grants (UL grant allocation type 2) with a time spacing of 10 ms of size 848 bits. (Note 1)	<--	(UL grant, 848 bits)	-	-
16	The UE transmits RLC SDU#4.	-->	(RLC SDU#4)	-	-
17	The UE transmits RLC SDU#5.	-->	(RLC SDU#5)	-	-
18	The UE transmits RLC SDU#6.	-->	(RLC SDU#6)	-	-
19	The UE transmits RLC SDU#7.	-->	(RLC SDU#7)	-	-
20	The UE transmits RLC SDU#8.	-->	(RLC SDU#8)	-	-
21	The UE transmits RLC SDU#9.	-->	(RLC SDU#9)	-	-
22	The UE transmits RLC SDU#10.	-->	(RLC SDU#10)	-	-
23	The SS transmits a STATUS PDU	<--	STATUS PDU	-	-
24	After 300 ms the SS transmits an AMD PDU with SN=11 and P=0, and an AMD PDU with SN=12 and P=1.	<--	AMD PDU (SN=11, P=0) AMD PDU (SN=12, P=1)	-	-
25	Check: Does the UE transmit a scheduling request within $t\text{-Reassembly}/2$ ms?	-->	(SR)	4	F

26	Within <i>t-Reassembly</i> / 2 ms after the transmission of the first AMD PDU of Step 24, the SS transmits an AMD PDU with SN=10 and P=0.	<--	AMD PDU (SN=10, P=0)	-	-
27	The SS waits for 60 ms to ensure UE RLC has all the required SDUs available and then assigns 1 UL grant (UL grant allocation type 3) of size 80 bits. (Note 2)	<--	(UL grants, 80 bits)	-	-
28	Check: Does the UE transmit a Status Report with no NACK_SN and ACK_SN=13?	-->	STATUS PDU	4	P
29	The SS assigns 3 UL grants (UL grant allocation type 2) with a time spacing of 10 ms of size 848 bits. (Note 1)	<--	(UL grant, 848 bits)	-	-
30	The UE transmit RLC SDU#11.	-->	(RLC SDU#11)	-	-
31	The UE transmit RLC SDU#12.	-->	(RLC SDU#12)	-	-
32	The UE transmit RLC SDU#13.	-->	(RLC SDU#13)	-	-
33	The SS transmits a STATUS PDU.	<--	STATUS PDU	-	-
34	After 300 ms the SS transmits an AMD PDU with SN=17 and P=0, and an AMD PDU with SN=19 and P=1.	<--	AMD PDU (SN=17, P=0) AMD PDU (SN=19, P=1)	-	-
35	The SS waits for <i>t-Reassembly</i> ms to ensure expiry.	-	-	-	-
36	60 ms after step 15 the SS assigns an UL grant (UL grant allocation type 3) of size 88 bits. (Note 3)	<--	(UL Grant)	-	-
37	Check: Does the UE transmit a Status Report with ACK_SN=18 and NACK_SN: 13 including NACK Range 4 (SN 13, 14, 15, 16)	-->	STATUS PDU	5,6	P
38	After 300 ms the SS transmits an AMD PDU with SN=16 and P=1.	<--	AMD PDU (SN=16, P=1)	-	-
39	60 ms after step 38 the SS assigns an UL grant (UL grant allocation type 3) of size 112 bits. (Note 4)	<--	(UL Grant)	-	-
40	Check: Does the UE transmit a Status Report with ACK_SN=20 and NACK_SN: 13 including NACK Range 3 (SN 13, 14, 15) and NACK_SN=18 without NACK Range,	-->	STATUS PDU	5,6	P
41	60 ms after step 40 the SS transmits 5 AMD PDU with SN=13, 14, 15 and 18.	<--	AMD PDU (SN=13, P=0) AMD PDU (SN=14, P=0) AMD PDU (SN=15, P=0) AMD PDU (SN=18, P=0)	-	-
42	30 ms after the transmission of the last AMD PDU the SS assigns 7 UL grant (UL grant allocation type 3 with a time spacing of 10 ms of size 848 bits. (Note 1)	<--	(UL grant, 848 bits)	-	-
43	The UE loops back the complete RLC SDU.	-->	(RLC SDU#14)	-	-
44	The UE loops back the complete RLC SDU.	-->	(RLC SDU#15)	-	-
45	The UE loops back the complete RLC SDU.	-->	(RLC SDU#16)	-	-
46	The UE loops back the complete RLC SDU.	-->	(RLC SDU#17)	-	-
47	The UE loops back the complete RLC SDU.	-->	(RLC SDU#18)	-	-
48	The UE loops back the complete RLC SDU.	-->	(RLC SDU#19)	-	-
49	The UE loops back the complete RLC SDU.	-->	(RLC SDU#20)	-	-
50	The SS transmits a STATUS PDU.	<--	STATUS PDU	-	-
Note 1:	UL grant of 848 bits ( <i>index 50 of TS 38.214 [15] Table 5.1.3.2-2, L<sub>RBs</sub> &amp; I<sub>MCS</sub> as per 38.523-3[3] annex B</i> ) is chosen to allow the UE to transmit one PDU at a time.				
Note 2:	UL grant of 80 bits ( <i>index 8 of TS 38.214 [15] Table 5.1.3.2-2, L<sub>RBs</sub> &amp; I<sub>MCS</sub> as per 38.523-3[3] annex B</i> ) is chosen to allow the UE to transmit a Status Report with ACK_SN(3 byte) + 2 byte MAC PDU subheader and (2 byte short BSR). 3 Bytes additional space provided to confirm UE does not include NACK_SN and conformant UE instead will include MAC Padding.				
Note 3:	UL grant of 88 bits ( <i>index 9 of TS 38.214 [15] Table 5.1.3.2-2, L<sub>RBs</sub> &amp; I<sub>MCS</sub> as per 38.523-3[3] annex B</i> ) is chosen to allow the UE to transmit (a Status Report with ACK_SN (3 Bytes)and 1 NACK_SNs with NACK Range(4 Bytes) + MAC PDU subheader (2 Bytes) + Short BSR (2 Byte).				
Note 4:	UL grant of 112 bits ( <i>index 12 of TS 38.214 [15] Table 5.1.3.2-2, L<sub>RBs</sub> &amp; I<sub>MCS</sub> as per 38.523-3[3] annex B</i> ) is chosen to allow the UE to transmit (a Status Report with ACK_SN (3 Bytes)and 1 NACK_SNs with NACK Range(4 Bytes) +NACK SN (3 Bytes) + MAC PDU subheader (2 Bytes) + Short BSR (2 Byte).				



## 7.1.2.3.7.3.3 Specific message contents

None

## 7.1.2.3.8 AM RLC / Reconfiguration of RLC parameters by upper layers

## 7.1.2.3.8.1 Test Purpose (TP)

(1)

```
with { UE in RRC_CONNECTED state and using AM RLC }
ensure that {
  when { t-PollRetransmit value is changed during reconfiguration of RLC parameters by upper layers }
  then { UE starts using new t-PollRetransmit value }
}
```

(2)

```
with { UE in RRC_CONNECTED state and using AM RLC }
ensure that {
  when { t-Reassembly value is changed during reconfiguration of RLC parameters by upper layers }
  then { UE starts using new t-Reassembly value }
}
```

(3)

```
with { UE in RRC_CONNECTED state and using AM RLC }
ensure that {
  when { t-StatusProhibit value is changed during reconfiguration of RLC parameters by upper layers }
  then { UE starts using new t-StatusProhibit value }
}
```

## 7.1.2.3.8.2 Conformance requirements

References: The conformance requirements covered in the present TC are specified in: TS 38.322, clauses 5.3.3.1, 5.3.3.2, 5.3.3.3, 5.3.4 and 7.3. TS 38.331 clause 5.3.5.5.4. Unless otherwise stated these are Rel-15 requirements.

[TS 38.322, clause 5.3.3.1]

An AM RLC entity can poll its peer AM RLC entity in order to trigger STATUS reporting at the peer AM RLC entity.

[TS 38.322, clause 5.3.3.2]

Upon notification of a transmission opportunity by lower layer, for each AMD PDU submitted for transmission such that the AMD PDU contains either a not previously transmitted RLC SDU or an RLC SDU segment containing not previously transmitted byte segment, the transmitting side of an AM RLC entity shall:

- increment PDU\_WITHOUT\_POLL by one;
- increment BYTE\_WITHOUT\_POLL by every new byte of Data field element that it maps to the Data field of the AMD PDU;
- if PDU\_WITHOUT\_POLL >= pollPDU; or
- if BYTE\_WITHOUT\_POLL >= pollByte:
  - include a poll in the AMD PDU as described below.

Upon notification of a transmission opportunity by lower layer, for each AMD PDU submitted for transmission, the transmitting side of an AM RLC entity shall:

- if both the transmission buffer and the retransmission buffer becomes empty (excluding transmitted RLC SDUs or RLC SDU segments awaiting acknowledgements) after the transmission of the AMD PDU; or
- if no new RLC SDU can be transmitted after the transmission of the AMD PDU (e.g. due to window stalling);
  - include a poll in the AMD PDU as described below.

NOTE: Empty RLC buffer (excluding transmitted RLC SDUs or RLC SDU segments awaiting acknowledgements) should not lead to unnecessary polling when data awaits in the upper layer. Details are left up to UE implementation.

To include a poll in an AMD PDU, the transmitting side of an AM RLC entity shall:

- set the P field of the AMD PDU to "1";
- set PDU\_WITHOUT\_POLL to 0;
- set BYTE\_WITHOUT\_POLL to 0.

After submitting an AMD PDU including a poll to lower layer and after incrementing of TX\_Next if necessary, the transmitting side of an AM RLC entity shall:

- set POLL\_SN to TX\_Next – 1;
- if *t-PollRetransmit* is not running:
  - start *t-PollRetransmit*.
- else:
  - restart *t-PollRetransmit*.

[TS 38.322, clause 5.3.3.3]

Upon reception of a STATUS report from the receiving RLC AM entity the transmitting side of an AM RLC entity shall:

- if the STATUS report comprises a positive or negative acknowledgement for the RLC SDU with sequence number equal to POLL\_SN:
  - if *t-PollRetransmit* is running:
    - stop and reset *t-PollRetransmit*.

[TS 38.322, clause 5.3.4]

Upon expiry of *t-PollRetransmit*, the transmitting side of an AM RLC entity shall:

- if both the transmission buffer and the retransmission buffer are empty (excluding transmitted RLC SDU or RLC SDU segment awaiting acknowledgements); or
- if no new RLC SDU or RLC SDU segment can be transmitted (e.g. due to window stalling):
  - consider the RLC SDU with SN = TX\_Next – 1 for retransmission; or
  - consider any RLC SDU which has not been positively acknowledged for retransmission.
- include a poll in an AMD PDU as described in section 5.3.3.2.

[TS 38.322, clause 7.3]

The following timers are configured by 3GPP TS 38.331 [5]:

a) *t-PollRetransmit*

This timer is used by the transmitting side of an AM RLC entity in order to retransmit a poll (see sub clause 5.3.3).

b) *t-Reassembly*

This timer is used by the receiving side of an AM RLC entity and receiving UM RLC entity in order to detect loss of RLC PDUs at lower layer (see sub clauses 5.2.2.2 and 5.2.3.2). If *t-Reassembly* is running, *t-Reassembly* shall not be started additionally, i.e. only one *t-Reassembly* per RLC entity is running at a given time.

c) *t-StatusProhibit*

This timer is used by the receiving side of an AM RLC entity in order to prohibit transmission of a STATUS PDU (see sub clause 5.3.4).

[TS 38.331, clause 5.3.5.5.4]

For each RLC-Bearer-Config received in the rlc-BearerToAddModList IE the UE shall:

- 1> if the UE's current configuration contains a RLC bearer with the received *logicalChannelIdentity*:
  - 2> if *reestablishRLC* is received:
    - 3> re-establish the RLC entity as specified in TS 38.322 [4];
  - 2> reconfigure the RLC entity or entities in accordance with the received *rlc-Config*;
  - 2> reconfigure the logical channel in accordance with the received *mac-LogicalChannelConfig*;

NOTE: The network does not re-associate an already configured logical channel with another radio bearer. Hence *servedRadioBearer* is not present in this case.

### 7.1.2.3.8.3 Test description

#### 7.1.2.3.8.3.1 Pre-test conditions

Same Pre-test conditions as in clause 7.1.2.1.1 with the exception that the AM DRB is configured according to Table 7.1.2.3.8.3.1-1.

**Table 7.1.2.3.8.3.1-1: RLC parameters**

Parameter	Value
t-Reassembly	ms150
t-StatusProhibit	ms300
t-PollRetransmit	ms400
pollPDU	infinity
pollByte	infinity

#### 7.1.2.3.8.3.2 Test procedure sequence

**Table 7.1.2.3.8.3.2-1: Main behaviour**

St	Procedure	Message Sequence		TP	Verdict
		U - S	Message/PDU/SDU		
1-29	Same expected sequence as in Table 7.1.2.3.8.3.2-2 with (X=0, t-Reassembly = ms150, t-StatusProhibit = ms300, t-PollRetransmit=ms400) Note 1.	-	-	1,2,3	-
30	The SS reconfigures RLC in the UE and sets: - t-Reassembly to ms200, - t-StatusProhibit to ms400, - t-PollRetransmit to ms500. (Note 1)	-	-	-	-
31-59	Same expected sequence as in Table 7.1.2.3.8.3.2-2 with (X=11, t-Reassembly = ms200, t-StatusProhibit = ms400, t-PollRetransmit=ms500).	-	-	1,2,3	-
Note 1: The RRC Reconfiguration procedure is performed.					

**Table 7.1.2.3.8.3.2-2: Behaviour Sequence (X, t-Reassembly, t-StatusProhibit,t-PollRetransmit)**

St	Procedure	Message Sequence		TP	Verdict
		U - S	Message/PDU/SDU		
1	The SS ignores scheduling requests and does not allocate any uplink grant.	-	-	-	-
2	The SS transmits 4 AMD PDUs with P=0 and SN=X, X+1, X+2 and X+4. The SS record time $T_A$ when AMD PDU#5 (with SN= X+4) is sent.	<--	AMD PDU#1 (SN=X, P=0) AMD PDU#2 (SN=X+1, P=0) AMD PDU#3 (SN= X+2, P=0) AMD PDU#5 (SN= X+4, P=0)	-	-
3	The SS waits for 60 ms after the transmission of the first AMD PDU to ensure UE RLC has all the required SDUs available and then assigns 3 UL grants of size 848 bits with a time spacing of 10 ms. (Note 1)	<--	(UL grants, 848 bits)	-	-
4	The UE transmits RLC SDU#1.	-->	(RLC SDU#1)	-	-
5	The UE transmits RLC SDU#2.	-->	(RLC SDU#2)	-	-
6	The UE transmits RLC SDU#3.	-->	(RLC SDU#3)	-	-
7	The SS transmits a STATUS PDU.	<--	STATUS PDU	-	-
8	The SS starts the UL default grant transmission.	-	-	-	-
9	Check 1: Does the UE transmit a STATUS PDU with NACK_SN= X+3 and ACK_SN= X+5? Record time $T_B$ . Check 2: Is $(T_B - T_A) = t\text{-Reassembly?}$	-->	STATUS PDU	2	P
10	100 ms after the Status Report received at Step 9, the SS sends 4 AMD PDUs with P=0 and SN= X+5, X+6, X+8 and X+9.	<--	AMD PDU#6 (SN= X+5, P=0) AMD PDU#7 (SN= X+6, P=0) AMD PDU#9 (SN= X+8, P=0) AMD PDU#10 (SN= X+9, P=0)	-	-
11	Check 1: Does the UE transmit a Status Report with NACK_SN= X+3, NACK_SN= X+7 and ACK_SN= X+10? Record time $T_C$ Check 2: $(T_C - T_B) = t\text{-StatusProhibit?}$	-->	STATUS PDU	3	P
12	The SS ignores scheduling requests and does not allocate any uplink grant.	-	-	-	-
13	After 300 ms the SS transmits 3 AMD PDUs with SN= X+3, X+7 and X+9. The SS sets the P field of all the AMD PDUs to 0 except for that of the AMD PDU with SN= X+9.	<--	AMD PDU#4 (SN= X+3, P=0) AMD PDU#8 (SN= X+7, P=0) AMD PDU#10 (SN= X+9, P=1)	-	-
14	The SS waits for 60 ms to ensure UE RLC has all the required SDUs available and then assigns 1 UL grant of size 80 bits (UL Grant Allocation type 3). (Note 2)	<--	(UL grant, 80 bits)	-	-
15	The UE transmits a Status Report with no NACK_SN and ACK_SN = X+10.	-->	STATUS PDU	-	-
16	In the subframe following the one scheduled in step 7A the SS assigns 7 UL grants of size 848 bits (UL Grant Allocation type 2) with a time spacing of 10 ms. (Note 1)	<--	(UL grants, 848 bits)	-	-
17	The UE transmits RLC SDU#4.	-->	(RLC SDU#4)	-	-
18	The UE transmits RLC SDU#5.	-->	(RLC SDU#5)	-	-
19	The UE transmits RLC SDU#6.	-->	(RLC SDU#6)	-	-
20	The UE transmits RLC SDU#7.	-->	(RLC SDU#7)	-	-
21	The UE transmits RLC SDU#8.	-->	(RLC SDU#8)	-	-
22	The UE transmits RLC SDU#9.	-->	(RLC SDU#9)	-	-
23	The UE transmits RLC SDU#10.	-->	(RLC SDU#10)	-	-
24	The SS transmits a STATUS PDU.	<--	STATUS PDU	-	-
25	The SS transmits an AMD PDU to the UE.	<--	AMD PDU#11 (SN= X+10, P=0)	-	-
26	The SS starts the UL default grant transmission.	-	-	-	-
27	The UE transmits an AMD PDU with the same data as received in the corresponding DL AMD PDU. Record time $T_D$ .	-->	AMD PDU#11 (SN= X+10, P=1)	-	-
28	Check 1: Does the UE set the poll bit as both the transmission and retransmission buffers become empty? Record time $T_E$ . Check 2: Is $(T_E - T_D) = t\text{-PollRetransmit?}$	-->	AMD PDU#11 (SN= X+10, P=1)	1	P
29	The SS transmits a STATUS PDU	<--	STATUS PDU	-	-

Note 1:	UL grant of 848 bits ( <i>index 50 of TS 38.214 [15] Table 5.1.3.2-2, LRBs &amp; IMCS as per 38.523-3[3] annex B</i> ) is chosen to allow the UE to transmit one PDU at a time.
Note 2:	UL grant of 80 bits ( <i>index 8 of TS 38.214 [15] Table 5.1.3.2-2, LRBs &amp; IMCS as per 38.523-3[3] annex B</i> ) is chosen to allow the UE to transmit a Status Report with ACK_SN(3 byte) + 2 byte MAC PDU subheader and (2 byte short BSR). 3 Bytes additional space provided to confirm UE does not include NACK_SN and conformant UE instead will include MAC Padding.
Note 3:	Every DL AMD PDU contains 1 RLC SDU size of 100 bytes.

### 7.1.2.3.8.3.3 Specific message contents

None

### 7.1.2.3.9 AM RLC / Reassembling of AMD PDUs

#### 7.1.2.3.9.1 Test Purpose (TP)

(1)

```
with { UE in RRC_CONNECTED state }
ensure that {
  when { UE receives AMD PDUs, and all bytes of the RLC SDU(s) with SN = x are received }
  then { UE reassembles the RLC SDU(s) from AMD PDU(s) with SN = x }
}
```

(2)

```
with { UE in RRC_CONNECTED state }
ensure that {
  when { t-Reassembly expires }
  then { update RX_Highest_Status to the SN of the first RLC SDU with SN >= RX_Next_Status_Trigger
for which not all bytes have been received }
}
```

(3)

```
with { UE in RRC_CONNECTED state }
ensure that {
  when { UE receives AM PDU segments }
  then { UE delivers reassembled RLC SDU to upper layer }
}
```

(4)

```
with { UE in RRC_CONNECTED state }
ensure that {
  when { UE receives duplicate RLC AM PDU segments }
  then { UE discards duplicate RLC AMD PDU segments }
}
```

(5)

```
with { UE in RRC_CONNECTED state }
ensure that {
  when { UE receives RLC AMD PDU segments with segments lost }
  then { UE transmits STATUS PDU to request retransmission of missing segments }
}
```

(6)

```
with { UE in RRC_CONNECTED state }
ensure that {
  when { UE receives overlapping RLC AMD PDU segments }
  then { UE discards duplicate RLC AMD PDU byte segments }
}
```

(7)

```
with { UE in RRC_CONNECTED state }
```

```

ensure that {
  when { UE receives an AMD PDU with a SN gap }
  then { UE sends STATUS PDU to request retransmissions of PDUs in the SN gap }
}

```

#### 7.1.2.3.9.2 Conformance requirements

References: The conformance requirements covered in the present TC are specified in: 3GPP TS 38.322 clauses 4.2.1.3.3, 5.2.3.2.1, 5.2.3.2.2, 5.2.3.2.3, 5.2.3.2.4 and 5.3.4. Unless otherwise stated these are Rel-15 requirements.

[TS 38.322, clause 4.2.1.3.3]

When the receiving side of an AM RLC entity receives AMD PDUs, it shall:

- detect whether or not the AMD PDUs have been received in duplication, and discard duplicated AMD PDUs;
- detect the loss of AMD PDUs at lower layers and request retransmissions to its peer AM RLC entity;
- reassemble RLC SDUs from the received AMD PDUs and deliver the RLC SDUs to upper layer as soon as they are available.

[TS 38.322, clause 5.2.3.2.1]

The receiving side of an AM RLC entity shall maintain a receiving window according to the state variable `RX_Next` as follows:

- a SN falls within the receiving window if  $RX\_Next \leq SN < RX\_Next + AM\_Window\_Size$ ;
- a SN falls outside of the receiving window otherwise.

When receiving an AMD PDU from lower layer, the receiving side of an AM RLC entity shall:

- either discard the received AMD PDU or place it in the reception buffer (see sub clause 5.2.3.2.2);
- if the received AMD PDU was placed in the reception buffer:
  - update state variables, reassemble and deliver RLC SDUs to upper layer and start/stop t-Reassembly as needed (see sub clause 5.2.3.2.3).

When t-Reassembly expires, the receiving side of an AM RLC entity shall:

- update state variables and start t-Reassembly as needed (see sub clause 5.2.3.2.4).

[TS 38.322, clause 5.2.3.2.2]

When an AMD PDU is received from lower layer, where the AMD PDU contains byte segment numbers `y` to `z` of an RLC SDU with `SN = x`, the receiving side of an AM RLC entity shall:

- if `x` falls outside of the receiving window; or
- if byte segment numbers `y` to `z` of the RLC SDU with `SN = x` have been received before:
  - discard the received AMD PDU.
- else:
  - place the received AMD PDU in the reception buffer;
  - if some byte segments of the RLC SDU contained in the AMD PDU have been received before:
    - discard the duplicate byte segments.

[TS 38.322, clause 5.2.3.2.3]

When an AMD PDU with `SN = x` is placed in the reception buffer, the receiving side of an AM RLC entity shall:

- if  $x \geq RX\_Next\_Highest$

- update RX\_Next\_Highest to x+ 1.
- if all bytes of the RLC SDU with SN = x are received:
  - reassemble the RLC SDU from AMD PDU(s) with SN = x, remove RLC headers when doing so and deliver the reassembled RLC SDU to upper layer;
  - if x = RX\_Highest\_Status,
    - update RX\_Highest\_Status to the SN of the first RLC SDU with SN > current RX\_Highest\_Status for which not all bytes have been received.
  - if x = RX\_Next:
    - update RX\_Next to the SN of the first RLC SDU with SN > current RX\_Next for which not all bytes have been received.
- if t-Reassembly is running:
  - if RX\_Next\_Status\_Trigger = RX\_Next; or
  - if RX\_Next\_Status\_Trigger = RX\_Next + 1 and there is no missing byte segment of the SDU associated with SN = RX\_Next before the last byte of all received segments of this SDU; or
  - if RX\_Next\_Status\_Trigger falls outside of the receiving window and RX\_Next\_Status\_Trigger is not equal to RX\_Next + AM\_Window\_Size:
    - stop and reset t-Reassembly.
- if t-Reassembly is not running (includes the case t-Reassembly is stopped due to actions above):
  - if RX\_Next\_Highest > RX\_Next + 1; or
  - if RX\_Next\_Highest = RX\_Next + 1 and there is at least one missing byte segment of the SDU associated with SN = RX\_Next before the last byte of all received segments of this SDU:
    - start t-Reassembly;
    - set RX\_Next\_Status\_Trigger to RX\_Next\_Highest.

[TS 38.322, clause 5.2.3.2.4]

When t-Reassembly expires, the receiving side of an AM RLC entity shall:

- update RX\_Highest\_Status to the SN of the first RLC SDU with SN >= RX\_Next\_Status\_Trigger for which not all bytes have been received;
- if RX\_Next\_Highest > RX\_Highest\_Status + 1: or
- if RX\_Next\_Highest = RX\_Highest\_Status + 1 and there is at least one missing byte segment of the SDU associated with SN = RX\_Highest\_Status before the last byte of all received segments of this SDU:
  - start t-Reassembly;
  - set RX\_Next\_Status\_Trigger to RX\_Next\_Highest.

[TS 38.322, clause 5.3.4]

An AM RLC entity sends STATUS PDUs to its peer AM RLC entity in order to provide positive and/or negative acknowledgements of RLC SDUs (or portions of them).

Triggers to initiate STATUS reporting include:

- Polling from its peer AM RLC entity:
  - When an AMD PDU with SN = x and the P field set to "1" is received from lower layer, the receiving side of an AM RLC entity shall:



- if the AMD PDU is to be discarded as specified in subclause 5.2.3.2.2; or
- if  $x < \text{RX\_Highest\_Status}$  or  $x \geq \text{RX\_Next} + \text{AM\_Window\_Size}$ :
  - trigger a STATUS report.
- else:
  - delay triggering the STATUS report until  $x < \text{RX\_Highest\_Status}$  or  $x \geq \text{RX\_Next} + \text{AM\_Window\_Size}$ .

NOTE 1: This ensures that the RLC Status report is transmitted after HARQ reordering.

- Detection of reception failure of an AMD PDU
  - The receiving side of an AM RLC entity shall trigger a STATUS report when t-Reassembly expires.

NOTE 2: The expiry of t-Reassembly triggers both  $\text{RX\_Highest\_Status}$  to be updated and a STATUS report to be triggered, but the STATUS report shall be triggered after  $\text{RX\_Highest\_Status}$  is updated.

#### 7.1.2.3.9.3 Test description

##### 7.1.2.3.9.3.1 Pre-test conditions

Same Pre-test conditions as in clause 7.1.2.1.1.

7.1.2.3.9.3.2 Test procedure sequence

**Table 7.1.2.3.9.3.2-1: Main behaviour**

St	Procedure	Message Sequence		TP	Verdict
		U - S	Message/PDU/SDU		
1	The SS transmits AMD PDU#1 containing a complete RLC SDU#4 (90 bytes and SI field = 00).	<--	AMD PDU#1 (SN=3)	-	-
2	The SS transmits AMD PDU#2 containing the last segment (45 bytes) of RLC SDU#1 (SI field =10, SO=45).	<--	AMD PDU#2 (SN=0) segment 2	-	-
3	The SS transmits AMD PDU#3 containing the last segment (45 bytes) of RLC SDU#2 (SI field =10, SO=45).	<--	AMD PDU#3 (SN=1) segment 2	-	-
4	The SS transmits AMD PDU#4 containing the first segment (45 bytes) of RLC SDU#2 (SI field =01).	<--	AMD PDU#4 (SN=1) segment 1	-	-
5	The SS transmits AMD PDU#5 containing the first segment (45 bytes) of RLC SDU#1 (SI field =01).	<--	AMD PDU#5 (SN=0) segment 1	-	-
6	The SS waits for 60 ms then SS transmits 3 uplink grants with a time spacing of 20ms. (Note 1)	<--	UL Grants	-	-
7	Check: Does the UE transmit an AMD PDU containing RLC SDU#4 in its data field?	-->	AMD PDU (RLC SDU#4)	1,3	P
8	Check: Does the UE transmit an AMD PDU containing RLC SDU#2 in its data field?	-->	AMD PDU (RLC SDU#2)	1,3	P
9	Check: Does the UE transmit an AMD PDU containing RLC SDU#1 in its data field?	-->	AMD PDU (RLC SDU#1)	1,3	P
10	Wait for t-reassembly of UE side to expire. Check: Does the UE transmit an RLC STATUS PDU with NACK_SN=2 and ACK_SN=4 to correctly to inform SS of missing RLC SDU#3?	-->	STATUS PDU (ACK_SN=4, NACK_SN=2)	2,7	P
11	The SS transmits AMD PDU#6 containing the complete RLC SDU#3(90 bytes and SI field = 00).	<--	AMD PDU#6 (SN=2, P=1)	-	-
12	The SS waits for 100 ms then SS transmits one uplink grant (Note 1).	<--	UL Grant	-	-
13	Check: Does the UE transmit an AMD PDU containing RLC SDU#3 in its data field?	-->	AMD PDU (RLC SDU#3)	1,3,4	P
14	Check: Does the UE transmit an RLC STATUS PDU with ACK_SN=4?	-->	STATUS PDU (ACK_SN=4)	1,3,4	P
15	The SS transmits AMD PDU#6 containing the complete RLC SDU#3 again (90 bytes and SI field = 00).	<--	AMD PDU#6 (SN=2, P=1)	-	-
16	Check: Does the UE transmit an AMD PDU containing RLC SDU#3 in its data field?	-->	AMD PDU (RLC SDU#3)	1,3,4	F
17	The SS transmits AMD PDU#7 containing the last segment (45 bytes) of RLC SDU#5 (SI field =10, SO=45).	<--	AMD PDU#7 (SN=4) segment 2	-	-

18	Wait for t-reassembly of UE side to expire. Check: Does the UE transmit an RLC STATUS PDU with ACK_SN=5, NACK_SN=4 with SOStart=0 and SOEnd=44?	-->	STATUS PDU (ACK_SN=5, NACK_SN=4 with SOStart=0 /SOEnd=44)	2,5	P
19	The SS transmits AMD PDU#8 containing the first segment (45 bytes) of RLC SDU#5 (SI field =01).	<--	AMD PDU#8 (SN=4, P=1) segment 1	-	-
20	The SS waits for 100 ms then SS transmits one uplink grant. (Note 1)	<--	UL Grant	-	-
21	Check: Does the UE transmit an AMD PDU containing RLC SDU#5 in its data field?	-->	AMD PDU (RLC SDU#5)	1,3,5	P
22	Check: Does the UE transmit an RLC STATUS PDU with ACK_SN=5?	-->	STATUS PDU (ACK_SN=5)	1,3,5	P
23	The SS transmits AMD PDU#9 containing the last 30 bytes of RLC SDU#6 (SI field =10, SO=60).	<--	AMD PDU#9 (SN=5) segment 3	-	-
24	Wait for t-reassembly of UE side to expire. Check: Does the UE transmit an RLC STATUS PDU with ACK_SN=6, NACK_SN=5 with SOStart=0 and SOEnd=59?	-->	STATUS PDU (ACK_SN=6, NACK_SN=5 with SOStart=0 / SOEnd=59)	2,6	P
25	The SS transmits AMD PDU#10 containing the last 50 byte of RLC SDU#6 (SI field =10, SO=40).	<--	AMD PDU#10 (SN=5) segment 2	-	-
26	Wait for t-reassembly of UE side to expire. Check: Does the UE transmit an RLC STATUS PDU with ACK_SN=6, NACK_SN=5 with SOStart=0 and SOEnd=39?	-->	STATUS PDU (ACK_SN=6, NACK_SN=5 with SOStart=0 / SOEnd=39)	2,6	P
27	The SS transmits AMD PDU#11 containing the first 40 bytes of RLC SDU#6 (SI field =01).	<--	AMD PDU#11 (SN=5, P=1) segment 1	-	-
28	The SS waits for 100 ms then SS transmits one uplink grant. (Note 1)	<--	UL Grant	-	-
29	Check: Does the UE transmit an AMD PDU containing RLC SDU#6 in its data field?	-->	AMD PDU (RLC SDU#6)	1,3,6	P
30	Check: Does the UE transmit an RLC STATUS PDU with ACK_SN=5, thus acknowledging the reception of RLC SDUs with SN=0 to SN=5, and no NACK_SN provided?	-->	STATUS PDU (ACK_SN=6)	1,3,6	P
Note 1: UL grant of 768 bits(index 48 of TS 38.214 [15] Table 5.1.3.2-2, L <sub>RBS</sub> & I <sub>MCS</sub> as per 38.523-3[3] annex B) is chosen to allow the UE to transmit one PDU at a time( 90 bytes RLC SDU + 2 bytes RLC Header + 2 bytes MAC Sub PDU header + 2 bytes for short BSR or padding).					

## 7.1.2.3.9.3.3 Specific message contents

None.

### 7.1.2.3.10 AM RLC / Re-transmission of RLC PDU with and without re-segmentation

#### 7.1.2.3.10.1 Test Purpose (TP)

(1)

```
with { UE in RRC_CONNECTED state }
ensure that {
  when { UE receives a STATUS PDU including a NACK_SN for missing AMD PDUs and missing AMD PDUs can
  be transmitted as indicated by lower layer at the particular transmission opportunity }
  then { UE successfully retransmits missing AMD PDUs without re-segmentation }
}
```

(2)

```
with { UE in RRC_CONNECTED state }
ensure that {
  when { NACK received for missing AMD PDUs and RETX_COUNT < maxRetxThreshold }
  then { UE retransmits AMD PDUs }
}
```

(3)

```
with { UE in RRC_CONNECTED state }
ensure that {
  when { AMD PDU to be retransmitted does not fit in new allocated TBS }
  then { UE segments AMD PDU }
}
```

(4)

```
with { UE in RRC_CONNECTED state }
ensure that {
  when { AMD PDU segment to be retransmitted does not fit in new allocated TBS }
  then { UE re-segments AMD PDU segment to fit TBS }
}
```

#### 7.1.2.3.10.2 Conformance requirements

References: The conformance requirements covered in the present test case are specified in: TS 38.322, clauses 5.3.2, 6.2.2.5, 6.2.3.3, 6.2.3.4, 6.2.3.5, 6.2.3.7, 6.2.3.10, 6.2.3.12, 6.2.3.14 and 6.2.3.15. Unless otherwise stated these are Rel-15 requirements.

[TS 38.322, clause 5.3.2]

The transmitting side of an AM RLC entity can receive a negative acknowledgement (notification of reception failure by its peer AM RLC entity) for an RLC SDU or an RLC SDU segment by the following:

- STATUS PDU from its peer AM RLC entity.

When receiving a negative acknowledgement for an RLC SDU or an RLC SDU segment by a STATUS PDU from its peer AM RLC entity, the transmitting side of the AM RLC entity shall:

- if the SN of the corresponding RLC SDU falls within the range  $TX\_Next\_Ack \leq SN < TX\_Next$ :
  - consider the RLC SDU or the RLC SDU segment for which a negative acknowledgement was received for retransmission.

When an RLC SDU or an RLC SDU segment is considered for retransmission, the transmitting side of the AM RLC entity shall:

- if the RLC SDU or RLC SDU segment is considered for retransmission for the first time:
  - set the RETX\_COUNT associated with the RLC SDU to zero.
- else, if it (the RLC SDU or the RLC SDU segment that is considered for retransmission) is not pending for retransmission already and the RETX\_COUNT associated with the RLC SDU has not been incremented due to another negative acknowledgment in the same STATUS PDU:

- increment the RETX\_COUNT.
- if RETX\_COUNT = *maxRetxThreshold*:
  - indicate to upper layers that max retransmission has been reached.

When retransmitting an RLC SDU or an RLC SDU segment, the transmitting side of an AM RLC entity shall:

- if needed, segment the RLC SDU or the RLC SDU segment;
- form a new AMD PDU which will fit within the total size of AMD PDU(s) indicated by lower layer at the particular transmission opportunity;
- submit the new AMD PDU to lower layer.

When forming a new AMD PDU, the transmitting side of an AM RLC entity shall:

- only map the original RLC SDU or RLC SDU segment to the Data field of the new AMD PDU;
- modify the header of the new AMD PDU in accordance with the description in sub clause 6.2.2.4;
- set the P field according to sub clause 5.3.3.

[TS 38.322, clause 6.2.2.4]

AMD PDU consists of a Data field and an AMD PDU header. The AMD PDU header is byte aligned.

An AM RLC entity is configured by RRC to use either a 12 bit SN or a 18 bit SN. The length of the AMD PDU header is two and three bytes respectively.

An AMD PDU header contains a D/C, a P, a SI, and a SN. An AMD PDU header contains the SO field only when the Data field consists of an RLC SDU segment which is not the first segment, in which case a 16 bit SO is present.

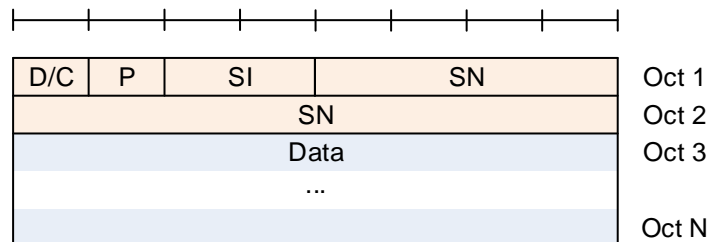

**Figure 6.2.2.4-1: AMD PDU with 12 bit SN (No SO)**

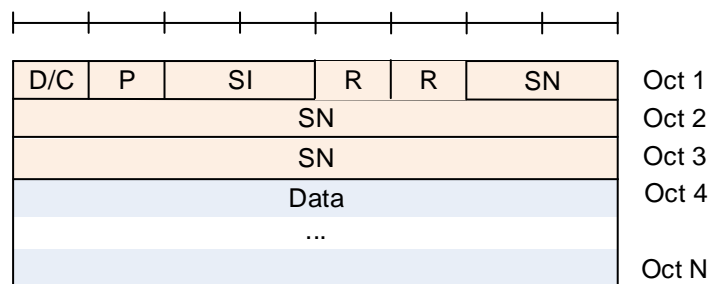

**Figure 6.2.2.4-2: AMD PDU with 18 bit SN (No SO)**

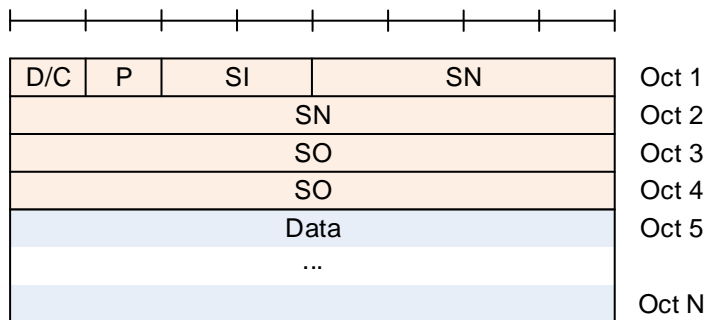

Figure 6.2.2.4-3: AMD PDU with 12 bit SN with SO

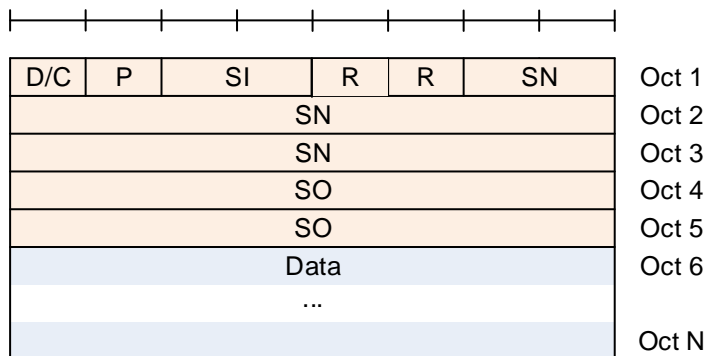

Figure 6.2.2.4-4: AMD PDU with 18 bit SN with SO

[TS 38.322, clause 6.2.2.5]

STATUS PDU consists of a STATUS PDU payload and an RLC control PDU header.

RLC control PDU header consists of a D/C and a CPT field.

The STATUS PDU payload starts from the first bit following the RLC control PDU header, and it consists of one ACK\_SN and one E1, zero or more sets of a NACK\_SN, an E1, an E2 and an E3, and possibly a pair of a SOstart and a SOend or a NACK range field for each NACK\_SN.

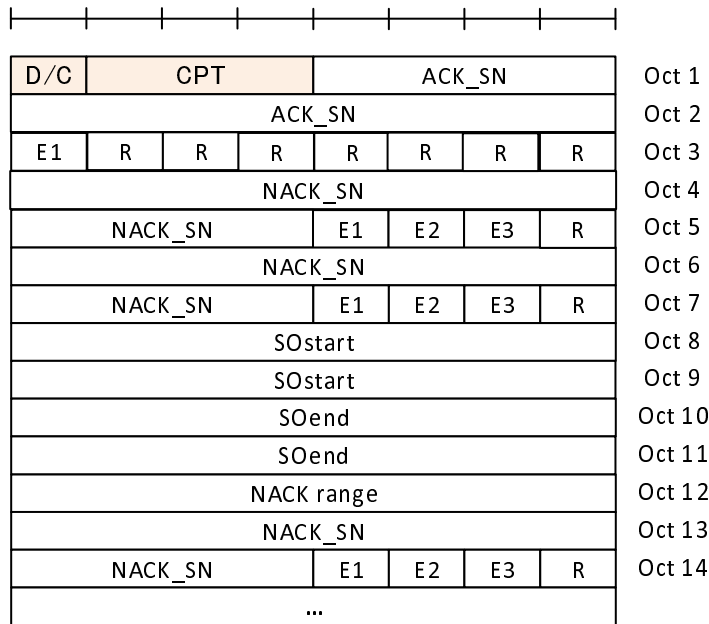

Figure 6.2.2.5-1: STATUS PDU with 12 bit SN

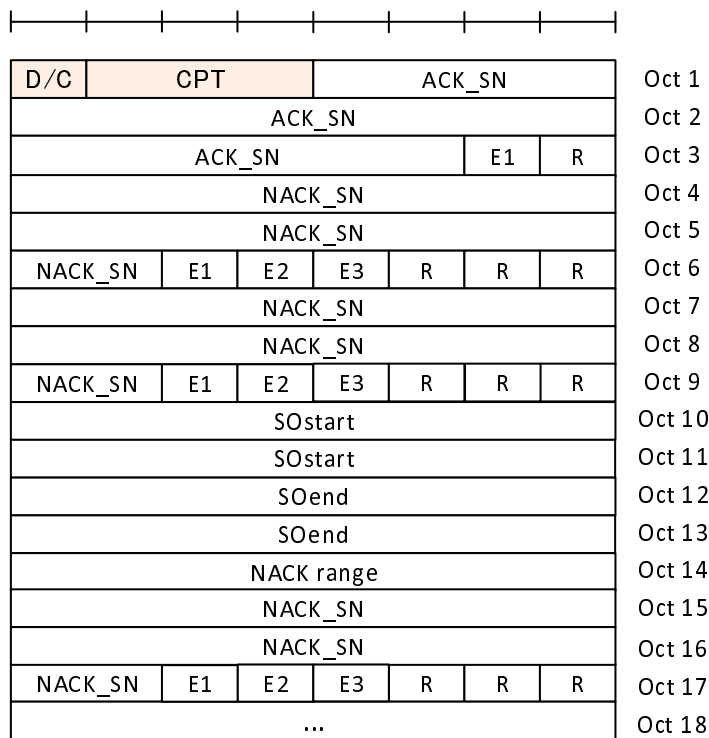

Figure 6.2.2.5-2: STATUS PDU with 18 bit SN

[TS 38.322, clause 6.2.3.3]

Length: 12 bits or 18 bits (configurable) for AMD PDU. 6 bits or 12 bits (configurable) for UMD PDU.

The SN field indicates the sequence number of the corresponding RLC SDU. For RLC AM, the sequence number is incremented by one for every RLC SDU. For RLC UM, the sequence number is incremented by one for every segmented RLC SDU.

[TS 38.322, clause 6.2.3.4]



Length: 2 bits.

The SI field indicates whether an RLC PDU contains a complete RLC SDU or the first, middle, last segment of an RLC SDU.

**Table 6.2.3.4-1: SI field interpretation**

Value	Description
00	Data field contains all bytes of an RLC SDU
01	Data field contains the first segment of an RLC SDU
10	Data field contains the last segment of an RLC SDU
11	Data field contains neither the first nor last segment of an RLC SDU

[TS 38.322, clause 6.2.3.5]

Length: 16 bits

The SO field indicates the position of the RLC SDU segment in bytes within the original RLC SDU. Specifically, the SO field indicates the position within the original RLC SDU to which the first byte of the RLC SDU segment in the Data field corresponds. The first byte of the original RLC SDU is referred by the SO field value "0000000000000000", i.e., numbering starts at zero.

[TS 38.322, clause 6.2.3.7]

Length: 1 bit.

The P field indicates whether or not the transmitting side of an AM RLC entity requests a STATUS report from its peer AM RLC entity. The interpretation of the P field is provided in Table 6.2.3.7-1.

**Table 6.2.3.7-1: P field interpretation**

Value	Description
0	Status report not requested
1	Status report is requested

[TS 38.322, clause 6.2.3.10]

Length: 12 bits or 18 bits (configurable).

The ACK\_SN field indicates the SN of the next not received RLC SDU which is not reported as missing in the STATUS PDU. When the transmitting side of an AM RLC entity receives a STATUS PDU, it interprets that all RLC SDUs up to but not including the RLC SDU with SN = ACK\_SN have been received by its peer AM RLC entity, excluding those RLC SDUs indicated in the STATUS PDU with NACK\_SN, portions of RLC SDUs indicated in the STATUS PDU with NACK\_SN, SOstart and SOend, RLC SDUs indicated in the STATUS PDU with NACK\_SN and NACK\_range, and portions of RLC SDUs indicated in the STATUS PDU with NACK\_SN, NACK range, SOstart and SOend.

[TS 38.322, clause 6.2.3.12]

Length: 12 bits or 18 bits (configurable).

The NACK\_SN field indicates the SN of the RLC SDU (or RLC SDU segment) that has been detected as lost at the receiving side of the AM RLC entity.

[TS 38.322, clause 6.2.3.14]

Length: 16 bits.

The SOstart field (together with the SOend field) indicates the portion of the RLC SDU with SN = NACK\_SN (the NACK\_SN for which the SOstart is related to) that has been detected as lost at the receiving side of the AM RLC entity. Specifically, the SOstart field indicates the position of the first byte of the portion of the RLC SDU in bytes within the original RLC SDU. The first byte of the original RLC SDU is referred by the SOstart field value "0000000000000000", i.e., numbering starts at zero.

[TS 38.322, clause 6.2.3.15]

Length: 16 bits.

When E3 is 0, the SOend field (together with the SOstart field) indicates the portion of the RLC SDU with SN = NACK\_SN (the NACK\_SN for which the SOend is related to) that has been detected as lost at the receiving side of the AM RLC entity. Specifically, the SOend field indicates the position of the last byte of the portion of the RLC SDU in bytes within the original RLC SDU. The first byte of the original RLC SDU is referred by the SOend field value "0000000000000000", i.e., numbering starts at zero. The special SOend value "1111111111111111" is used to indicate that the missing portion of the RLC SDU includes all bytes to the last byte of the RLC SDU.

When E3 is 1, the SOend field indicates the portion of the RLC SDU with SN = NACK\_SN + NACK range - 1 that has been detected as lost at the receiving side of the AM RLC entity. Specifically, the SOend field indicates the position of the last byte of the portion of the RLC SDU in bytes within the original RLC SDU. The first byte of the original RLC SDU is referred by the SOend field value "0000000000000000", i.e., numbering starts at zero. The special SOend value "1111111111111111" is used to indicate that the missing portion of the RLC SDU includes all bytes to the last byte of the RLC SDU.

7.1.2.3.10.3 Test description

7.1.2.3.10.3.1 Pre-test conditions

Same Pre-test conditions as in clause 7.1.2.1.1 with the exception for the AM DRB is configured according to Table 7.1.2.3.10.3.1-1.

**Table 7.1.2.3.10.3.1-1: PDCP-Config-DRB-AM**

Parameter	Value
statusReportRequired	FALSE

**Table 7.1.2.3.10.3.1-2: RLC settings**

Parameter	Value
t-PollRetransmit	ms150

7.1.2.3.10.3.2 Test procedure sequence

**Table 7.1.2.3.10.3.2-1: Main behaviour**

St	Procedure	Message Sequence		TP	Verdict
		U - S	Message		
1	The SS transmits one AMD PDU containing SDU#1 (100 bytes) in its data field.	<--	AMD PDU#1	-	-
2	The UE transmits one AMD PDU containing SDU#1 in its data field.	-->	AMD PDU#1 (SN=0)	-	-
3	The SS transmits one AMD PDU containing SDU#2 (100 bytes) in its data field.	<--	AMD PDU#2	-	-
4	The UE transmits one AMD PDU containing SDU#2 in its data field.	-->	AMD PDU#2 (SN=1)	-	-
5	The SS transmits a RLC STATUS PDU. ACK_SN=2, NACK_SN=0.	<--	STATUS PDU	-	-
6	Check: Does the UE transmit the AMD PDU not yet acknowledged?	-->	AMD PDU#1 (SN=0)	1	P
7	The SS transmits a RLC STATUS PDU. ACK_SN=2.	<--	STATUS PDU	-	-
8	The SS transmits one AMD PDU containing SDU#3 (100 bytes) in its data field.	<--	AMD PDU#3	-	-
9	The UE transmits an AMD PDU containing SDU#3 in its data field.	-->	AMD PDU#3 (SN=2)	-	-
-	EXCEPTION: Steps 10 to 11 shall be repeated until RETX_COUNT = maxRetxThreshold-1.	-	-	-	-
10	The SS transmits a RLC STATUS PDU. ACK_SN =3 and NACK_SN =2.	<--	STATUS PDU	-	-
11	Check: Does the UE retransmit the AMD PDU not yet acknowledged?	-->	AMD PDU#3 (SN=2)	2	P
12	The SS transmits a RLC STATUS PDU. ACK_SN =3.	<--	STATUS PDU	-	-
13	The SS stops the UL grant transmission.	-	-	-	-
14	The SS transmits one AMD PDU containing SDU#4 (100 bytes) in its data field.	<--	AMD PDU#4 (SN=3)	-	-
15	The SS waits for 60ms and allocates UL grant of size 872 bits. (Note 1)	<--	(UL grant, 872 bits)	-	-
16	The UE transmits an AMD PDU with the same data contents as received in the corresponding part of SDU#4?	-->	AMD PDU#4 (SN=3)	-	-
17	The SS transmits a STATUS PDU. This PDU nacks the AMD PDU with SN=3. ACK_SN=4 and NACK_SN=3.	<--	STATUS PDU	-	-
18	The SS waits for 20 ms and then allocates 2 UL grants of size 472 bits such that there is 20 ms gap between UL grants (Note 2, Note 5)	<--	(UL grants, 472 bits)	-	-
19	Check: Does the UE transmit an SDU segment with SI=01 and the <x-1> data contents at the received positions as in the original SDU#4?	-->	SDU#4 segment 1 (SN=3)	3	P
20	Check: Does the UE transmit an SDU segment with SI=10 and SO=<x> and the same data contents at the received positions as in the original SDU#4? (Note 4)	-->	SDU#4 segment 2 (SN=3)	3	P
21	After 100 ms SS transmits a STATUS PDU. This PDU nacks the SDU with SN=3. NACK_SN=3, SOStart=0, SOEnd=<x-1> and ACK_SN=4 (Note 4, Note 6)	<--	STATUS PDU	-	-
22	The SS waits for 20 ms and then allocates 2 UL grants (UL grant allocation type 2) of size 328 bits such that there is 20 ms gap between UL grants (Note 3) (Note 5)	<--	(UL grants, 328 bits)	-	-
23	Check: Does the UE transmit an AMD PDU segment with SI=01 and the <y-1> data contents at the received positions as in the original SDU#4?	-->	SDU#4 segment 1, first part (SN=3)	4	P
24	Check: Does the UE transmit an AMD PDU segment with SI=10, SO=<y> and the same data contents at the received positions as in the original SDU#4? (Note 6)	-->	SDU#4 segment 1, second part (SN=3)	4	P

25	The SS transmits a STATUS PDU. This PDU acks the AMD PDUs with SN=3. ACK_SN=4.	<--	STATUS PDU	-	-
Note 1:	UL grant of 872 bits=109 bytes ( <i>index 51 of TS 38.214 [15] Table 5.1.3.2-2, L<sub>RBs</sub> &amp; I<sub>MCS</sub> as per 38.523-3[3] annex B</i> ) is chosen to allow the UE to transmit one PDU at a time.				
Note 2:	UL grant of 472 bits ( <i>index 38 of TS 38.214 [15] Table 5.1.3.2-2, L<sub>RBs</sub> &amp; I<sub>MCS</sub> as per 38.523-3[3] annex B</i> ) is chosen such that UE will segment into 2 AMD PDUs. MAC PDU of 472 bits=59 bytes fit an AMD PDU payload of >= 50 bytes + 3 bytes for the first segment of the AMD PDU header OR 5 bytes for the second segment of the AMD PDU header +? bytes spare for MAC header and possible RLC STATUS PDU and BSR report.				
Note 3:	UL grant of 328 bits ( <i>index 31 of TS 38.214 [15] Table 5.1.3.2-2, L<sub>RBs</sub> &amp; I<sub>MCS</sub> as per 38.523-3[3] annex B</i> ) is chosen such that UE will segment into 2 AMD PDUs. MAC PDU of 328 bits=41 bytes fit an AMD PDU payload of >= 25 bytes + 3 bytes for the first segment of the AMD PDU header OR 5 bytes for the second segment of the AMD PDU header +? bytes spare for MAC header and possible RLC STATUS PDU and BSR report.				
Note 4:	The values x and y depend upon the need of the UE to add RLC STATUS PDU and BSR report. The TBS has been chosen to ensure that the PDUs to be resegmented can be carried in 2 segments.				
Note 5:	20 ms gap between transmissions both in DL and UL respectively allows TTCN to tolerate one HARQ retransmission (FDD/TDD) per transport block, if such happen (TS 38.523-3 [3]).				
Note 6:	As <x> becomes available in step 20 only the transmission in step 21 can be scheduled afterwards. This requires a 100 ms activation time.				
<b>Editor's Note: Note 5 needs to be defined in 38.523-3 which is FFS..</b>					

### 7.1.2.3.10.3.3 Specific message contents

None.

### 7.1.2.3.11 AM RLC / RLC re-establishment procedure

#### 7.1.2.3.11.1 Test Purpose (TP)

(1)

```
with { UE in RRC_CONNECTED state }
ensure that {
  when { RLC re-establishment is performed upon request by RRC }
  then { The UE discards all RLC SDUs, RLC SDU segments, and RLC PDUs, if any }
}
```

(2)

```
with { UE in RRC_CONNECTED state }
ensure that {
  when { RLC re-establishment is performed upon request by RRC }
  then { The UE reset all state variables to their initial values }
}
```

#### 7.1.2.3.11.2 Conformance requirements

**Editor's Note: The conformance requirements are based on running RAN2 CRs**

References:

The conformance requirements covered in the present test case are specified in: TS 38.322, clauses 5.1.2, 5.3.11 and 7.1. Unless otherwise stated these are Rel-15 requirements.

[TS 38.322, clause 5.1.2]

When upper layers request an RLC entity re-establishment, the UE shall:

- discard all RLC SDUs, RLC SDU segments, and RLC PDUs, if any;
- stop and reset all timers;
- reset all state variables to their initial values.

[TS 38.322, clause 7.1]

This sub clause describes the state variables used in AM and UM entities in order to specify the RLC protocol. The state variables defined in this subclause are normative.

All state variables and all counters are non-negative integers.

All state variables related to AM data transfer can take values from 0 to 4095 for 12 bit SN or from 0 to 262143 for 18 bit SN. All arithmetic operations contained in the present document on state variables related to AM data transfer are affected by the AM modulus (i.e. final value = [value from arithmetic operation] modulo 4096 for 12 bit SN and 262144 for 18 bit SN).

All state variables related to UM data transfer can take values from 0 to 63 for 6 bit SN or from 0 to 4095 for 12 bit SN. All arithmetic operations contained in the present document on state variables related to UM data transfer are affected by the UM modulus (i.e. final value = [value from arithmetic operation] modulo 64 for 6 bit SN and 4096 for 12 bit SN).

When performing arithmetic comparisons of state variables or SN values, a modulus base shall be used.

TX\_Next\_Ack and RX\_Next shall be assumed as the modulus base at the transmitting side and receiving side of an AM RLC entity, respectively. This modulus base is subtracted from all the values involved, and then an absolute comparison is performed (e.g.  $RX\_Next \leq SN < RX\_Next + AM\_Window\_Size$  is evaluated as  $[RX\_Next - RX\_Next] \bmod 2^{sn-FieldLength} \leq [SN - RX\_Next] \bmod 2^{sn-FieldLength} < [RX\_Next + AM\_Window\_Size - RX\_Next] \bmod 2^{sn-FieldLength}$ ), where *sn-FieldLength* is 12 or 18 for 12 bit SN and 18 bit SN, respectively.

$RX\_Next\_Highest - UM\_Window\_Size$  shall be assumed as the modulus base at the receiving side of an UM RLC entity. This modulus base is subtracted from all the values involved, and then an absolute comparison is performed (e.g.  $(RX\_Next\_Highest - UM\_Window\_Size) \leq SN < RX\_Next\_Highest$  is evaluated as  $[(RX\_Next\_Highest - UM\_Window\_Size) - (RX\_Next\_Highest - UM\_Window\_Size)] \bmod 2^{sn-FieldLength} \leq [SN - (RX\_Next\_Highest - UM\_Window\_Size)] \bmod 2^{sn-FieldLength} < [RX\_Next\_Highest - (RX\_Next\_Highest - UM\_Window\_Size)] \bmod 2^{sn-FieldLength}$ ), where *sn-FieldLength* is 6 or 12 for 6 bit SN and 12 bit SN, respectively.

The transmitting side of each AM RLC entity shall maintain the following state variables:

a) TX\_Next\_Ack – Acknowledgement state variable

This state variable holds the value of the SN of the next RLC SDU for which a positive acknowledgment is to be received in-sequence, and it serves as the lower edge of the transmitting window. It is initially set to 0, and is updated whenever the AM RLC entity receives a positive acknowledgment for an RLC SDU with SN = TX\_Next\_Ack.

b) TX\_Next – Send state variable

This state variable holds the value of the SN to be assigned for the next newly generated AMD PDU. It is initially set to 0, and is updated whenever the AM RLC entity constructs an AMD PDU with SN = TX\_Next and contains an RLC SDU or the last segment of a RLC SDU.

c) POLL\_SN – Poll send state variable

This state variable holds the value of the highest SN of the AMD PDU among the AMD PDUs submitted to lower layer when POLL\_SN is set according to sub clause 5.3.3.2. It is initially set to 0.

The transmitting side of each AM RLC entity shall maintain the following counters:

a) PDU\_WITHOUT\_POLL – Counter

This counter is initially set to 0. It counts the number of AMD PDUs sent since the most recent poll bit was transmitted.

b) BYTE\_WITHOUT\_POLL – Counter

This counter is initially set to 0. It counts the number of data bytes sent since the most recent poll bit was transmitted.

c) RETX\_COUNT – Counter

This counter counts the number of retransmissions of an RLC SDU or RLC SDU segment (see subclause 5.3.2). There is one RETX\_COUNT counter maintained per RLC SDU.

The receiving side of each AM RLC entity shall maintain the following state variables:

## a) RX\_Next – Receive state variable

This state variable holds the value of the SN following the last in-sequence completely received RLC SDU, and it serves as the lower edge of the receiving window. It is initially set to 0, and is updated whenever the AM RLC entity receives an RLC SDU with SN = RX\_Next.

b) RX\_Next\_Status\_Trigger – *t-Reassembly* state variable

This state variable holds the value of the SN following the SN of the RLC SDU which triggered *t-Reassembly*.

## c) RX\_Highest\_Status – Maximum STATUS transmit state variable

This state variable holds the highest possible value of the SN which can be indicated by "ACK\_SN" when a STATUS PDU needs to be constructed. It is initially set to 0.

## d) RX\_Next\_Highest – Highest received state variable

This state variable holds the value of the SN following the SN of the RLC SDU with the highest SN among received RLC SDUs. It is initially set to 0.

Each transmitting UM RLC entity shall maintain the following state variables:

## a) TX\_Next

This state variable holds the value of the SN to be assigned for the next newly generated UMD PDU with segment. It is initially set to 0, and is updated after the UM RLC entity submits a UMD PDU including the last segment of an RLC SDU to lower layers.

Each receiving UM RLC entity shall maintain the following state variables and constant:

## b) RX\_Next\_Reassembly – UM receive state variable

This state variable holds the value of the earliest SN that is still considered for reassembly. It is initially set to 0.

c) RX\_Timer\_Trigger – UM *t-Reassembly* state variable

This state variable holds the value of the SN following the SN which triggered *t-Reassembly*.

## d) RX\_Next\_Highest – UM receive state variable

This state variable holds the value of the SN following the SN of the UMD PDU with the highest SN among received UMD PDUs. It serves as the higher edge of the reassembly window. It is initially set to 0.

[TS 38.331, clause 5.3.11]

**Editor's Note: Targeted for completion in Sept 2018.**

UE shall:

1> reset MAC;

1> stop all timers that are running except T320 and T325;

1> discard any stored AS context, *fullI-RNTI*, *shortIRNTI*, *ran-PagingCycle* and *ran-NotificationAreaInfo*;

1> discard the security context including the  $K_{RRcenc}$  key, the  $K_{RRcint}$ , the  $K_{UPint}$  key and the  $K_{UPenc}$  key, if stored;

1> release all radio resources, including release of the RLC entity, the MAC configuration and the associated PDCP entity for all established RBs;

1> indicate the release of the RRC connection to upper layers together with the release cause;

1> enter RRC\_IDLE and perform procedures as specified in TS 38.304 [21], except if going to RRC\_IDLE was triggered by reception of the *MobilityFromNRCommand* message or by selecting an inter-RAT cell while T311 was running;

7.1.2.3.11.3 Test description

7.1.2.3.11.3.1 Pre-test conditions

Same Pre-test conditions as in clause 7.1.2.1.1 with the exception for the AM DRB is configured according to Table 7.1.2.3.11.3.1-1.

**Table 7.1.2.3.11.3.1-1: RLC parameters**

Parameter	Value
<i>t-Reassembly</i>	ms150
<i>t-PollRetransmit</i>	ms150

**Table 7.1.2.3.11.3.1-2: PDCP parameters**

Parameter	Value
<i>t-Reordering</i>	ms150



## 7.1.2.3.11.3.2 Test procedure sequence

Table 7.1.2.3.11.3.2-1: Main behaviour

St	Procedure	Message Sequence		TP	Verdict
		U - S	Message		
-	The SS ignores scheduling requests and does not allocate any uplink grant.	-	-	-	-
1	The SS creates 2 RLC SDUs of size 40 bytes segmented into two AMD PDUs each. AMD PDU#1 and AMD PDU#2 belong to RLC SDU#1, AMD PDU#3 and #4 belong to RLC SDU#2. SS transmits AMD PDU#1 (SN=0), AMD PDU#2 (SN=0) and AMD PDU#4 (SN=1).	<--	AMD PDU#1 AMD PDU#2 AMD PDU#4	-	-
2	60 ms after step 1 the SS allocates 1 UL grant of default size.	<--	(UL grant)	-	-
3	The UE returns RLC SDU#1.	-->	(RLC SDU#1)	-	-
4	The SS does not acknowledge the reception of RLC SDU#1.	-	-	-	-
5	90 ms after step 1, the SS transmits <i>RRCCONNECTIONRECONFIGURATION</i> message containing NR RRCreconfiguration message to trigger RLC re-establishment on SCG DRB. (Note 1)	<--	<i>RRCCONNECTIONRECONFIGURATION</i> ( <i>RRCCONNECTIONRECONFIGURATION</i> )	-	-
6	The UE transmits a <i>RRCCONNECTIONRECONFIGURATIONCOMPLETE</i> message containing NR <i>RRCCONNECTIONRECONFIGURATIONCOMPLETE</i> message. (Note2)	-->	<i>RRCCONNECTIONRECONFIGURATIONCOMPLETE</i> ( <i>RRCCONNECTIONRECONFIGURATIONCOMPLETE</i> )	-	-
7	The SS starts the UL default grant transmissions	-	-	-	-
8	The UE retransmits RLC SDU #1. (Note 3)	-->	(RLC SDU#1)	-	-
9	SS transmits a STATUS PDU (ACK_SN = 1).	<--	STATUS PDU	-	-
10	SS transmits AMD PDU#3 with SN=0 and the P field set to "1"	<--	AMD PDU#3	-	-
11	Check: Does the UE transmit a STATUS PDU?	-->	STATUS PDU (ACK_SN = 1)	2	P
12	Check: Does the UE return RLC SDU#2 (Note 4)	-->	(RLC SDU#2)	1	F
13	SS transmits AMD PDU#4 with SN=1	<--	AMD PDU#4	-	-
14	Check: Does the UE return RLC SDU#2 with its first AMD PDU set to SN=1?	-->	(RLC SDU#2)	2	P
<p>Note 1: Upon a RLC re-establishment a conformant UE discards any remaining AMD PDUs in the receiver and transmitter side, stops and resets all timers and resets all state variables to their initial values.</p> <p>Note 2: UE will perform RACH procedure on NR Cell 1 which will happen in parallel to step 6.</p> <p>Note 3: The UE will retransmit the PDCP SDU associated with RLC SDU#1 in accordance to TS 38.323 clause 5.1.2</p> <p>Note 4: AMD PDU#4 is discarded by a conformant UE in step 5.</p>					

7.1.2.3.11.3.3 Specific message contents

**Table 7.1.2.3.11.3.3-1: RRCConnectionReconfiguration (step 5, Table 7.1.2.3.11.3.2-1)**

Derivation Path: 36.508 [7], Table 4.6.1-8			
Information Element	Value/remark	Comment	Condition
RRCConnectionReconfiguration ::= SEQUENCE {			
criticalExtensions CHOICE {			
c1 CHOICE {			
rrcConnectionReconfiguration-r8 ::= SEQUENCE {			
nonCriticalExtension SEQUENCE {			
nonCriticalExtension SEQUENCE {			
nonCriticalExtension SEQUENCE {			
nonCriticalExtension SEQUENCE {			
nonCriticalExtension SEQUENCE {			
nonCriticalExtension SEQUENCE {			
nr-Config-r15 CHOICE {			
setup ::= SEQUENCE {			
nr-SecondaryCellGroupConfig-r15	OCTET STRING including the RRCReconfiguration message and the IE secondaryCellGroup.	NR Cell 1	
}			
}			
}			
}			
}			
}			
}			
}			
}			
}			
}			
}			

**Table 7.1.2.3.11.3.3-2: RRCReconfiguration (Table 7.1.2.3.11.3.3-1)**

Derivation Path: 38.508-1 [4], Table 4.6.1-3			
Information Element	Value/remark	Comment	Condition
RRCReconfiguration ::= SEQUENCE {			
criticalExtensions CHOICE {			
rrcReconfiguration ::= SEQUENCE {			
secondaryCellGroup	CellGroupConfig		
}			
}			

**Table 7.1.2.3.11.3.3-3: CellGroupConfig (Table 7.1.2.3.11.3.3-2)**

Derivation Path: 38.508-1 [4], Table 4.6.3-13			
Information Element	Value/remark	Comment	Condition
CellGroupConfig ::= SEQUENCE {			
rlc-BearerToAddModList SEQUENCE (SIZE (1..maxLCH)) OF SEQUENCE {	1 entry		EN-DC
servedRadioBearer CHOICE {			
drb-Identity	2	SCG DRB Id	
}			
reestablishRLC	True		
}			
}			

## 7.1.3 PDCP

**Editor's note: Intended to capture tests of PDCP Layer behaviour defined in TS 38.323. E.g. testing of PDCP lossless operation for single SCG bearer is handled here.**

### 7.1.3.0 Default Pre-Test Conditions for all PDCP test cases

The following pre-test conditions shall be applied in all PDCP test cases until the test case explicitly over writes these conditions

System Simulator:

- The SS configures the test environment in accordance to the execution conditions in Table 7.1.3.0-1.

UE:

- None

Preamble:

- The SS performs the generic procedure in [4] to get UE in state RRC\_CONNECTED in accordance to the execution conditions in Table 7.1.3.0-2 and using the message condition UE TEST LOOP MODE A to return one UL PDCP SDU per DL PDCP SDU.

**Table 7.1.3.0-1: Test environment**

Execution Condition	Cell configuration	System Information Combination ([4] clause FFS)
IF [pc_nrFDD] or [pc_nrTDD]	NR Cell 1	FFS
ELSE IF [pc_EN_DC]	E-UTRA Cell 1 is PCell, NR Cell 1 is PSCell	EUTRA: System information Combination 1 NR: N/A
ELSE IF [pc_NGEN_DC]	NG-RAN E-UTRA Cell 1 is PCell, NR Cell 1 is PSCell	EUTRA: System information Combination 1 NR: N/A

**Table 7.1.3.0-2: Preamble parameters**

Execution Condition	Multi-PDN Condition	Generic Procedure Parameters	Primary DRB used for Data testing
IF [pc_nrFDD] or [pc_nrTDD]s	FALSE	Connectivity(NR), Test loop function(On) One DRB	DRB on NR Cell
	TRUE	Connectivity(NR), Test loop function(On) Two DRB	
ELSE IF [pc_EN_DC]	FALSE	Connectivity(EN-DC), DC bearer(One MN Terminated MCG bearer and One SN terminated SCG bearer), Test loop function(On)	SN Terminated SCG bearer unless explicitly specified in test case
	TRUE	Connectivity(EN-DC), DC bearer(Two MN Terminated MCG bearer and One SN terminated SCG bearer), Test loop function(On)	
ELSE IF [pc_NGEN_DC]	FALSE	Connectivity(NGEN-DC), DC bearer(One MN Terminated MCG bearer and One SN terminated SCG bearer), Test loop function(On)	SN Terminated SCG bearer unless explicitly specified in test case
	TRUE	Connectivity(EN-DC), DC bearer(Two MN Terminated MCG bearer and One SN terminated SCG bearer), Test loop function(On)	

**Table 7.1.3.0-3: Message conditions**

Execution Condition	Message condition exceptions
IF [pc_nrFDD] or [pc_nrTDD]	FFS
ELSE IF [pc_EN_DC]	message condition MCG_and_SCG with condition AM is used for step 7 in 4.5.4.2 according to [4]
ELSE IF [pc_NGEN_DC]	message condition MCG_and_SCG with condition AM is used for step 7 in 4.5.4.2 according to [4]

**7.1.3.1 Maintenance of PDCP sequence numbers for radio bearers**

**7.1.3.1.1 Maintenance of PDCP sequence numbers / User plane / 12 bit SN**

**7.1.3.1.1.1 Test Purpose (TP)**

(1)

```
with { UE in RRC_CONNECTED state with PDCP configured for 12 bit SN }
ensure that {
  when { UE transmits a PDCP Data SDU on a DRB }
  then { UE increments SN with 1 for each transmitted PDU for SN=0 to Maximum_PDCP_SN (2[pdcp-SN-Size] - 1) }
}
```

(2)

```
with { UE in E-UTRA RRC_CONNECTED state with PDCP configured for 12 bit SN }
ensure that {
  when { UE transmits a PDCP Data SDU on a DRB and, after incrementation, TX_NEXT is larger than the Maximum_PDCP_SN(2[pdcp-SN-Size] - 1) }
  then { UE sets SN to 0 in the next transmitted PDCP SDU }
}
```

## 7.1.3.1.1.2 Conformance requirements

References: The conformance requirements covered in the present TC are specified in: TS 38.323, clauses 5.2.1, 5.2.2.1 and 6.2.2.2. Unless otherwise stated these are Rel-15 requirements.

[TS 38.323, clause 5.2.1]

At reception of a PDCP SDU from upper layers, the transmitting PDCP entity shall:

- start the *discardTimer* associated with this PDCP SDU (if configured).

For a PDCP SDU received from upper layers, the transmitting PDCP entity shall:

- associate the COUNT value corresponding to TX\_NEXT to this PDCP SDU;

NOTE 1: Associating more than half of the PDCP SN space of contiguous PDCP SDUs with PDCP SNs, when e.g., the PDCP SDUs are discarded or transmitted without acknowledgement, may cause HFN desynchronization problem. How to prevent HFN desynchronization problem is left up to UE implementation.

- perform header compression of the PDCP SDU as specified in the subclause 5.7.4;
- perform integrity protection, and ciphering using the TX\_NEXT as specified in the subclause 5.9 and 5.8, respectively;
- set the PDCP SN of the PDCP Data PDU to TX\_NEXT modulo  $2^{[pdc\text{-}SN\text{-}Size]}$ ;
- increment TX\_NEXT by one;
- submit the resulting PDCP Data PDU to lower layer as specified below.

When submitting a PDCP Data PDU to lower layer, the transmitting PDCP entity shall:

- if the transmitting PDCP entity is associated with one RLC entity:
  - submit the PDCP Data PDU to the associated RLC entity.
- else, if the transmitting PDCP entity is associated with two RLC entities:
  - if *pdcplDuplication* is configured and activated:
    - duplicate the PDCP Data PDU and submit the PDCP Data PDU to both associated RLC entities.
  - else, if *pdcplDuplication* is configured but not activated:
    - submit the PDCP Data PDU to the primary RLC entity.
  - else:
    - if the total amount of PDCP data volume and RLC data volume pending for initial transmission (as specified in TS 36.322 [5]) in the two associated RLC entities is less than *ul-DataSplitThreshold*:
      - submit the PDCP Data PDU to the primary RLC entity.
    - else:
      - submit the PDCP Data PDU to either the primary RLC entity or the secondary RLC entity.

NOTE 2: If the transmitting PDCP entity is associated with two RLC entities, the UE should minimize the amount of PDCP PDUs submitted to lower layers before receiving request from lower layers and minimize the PDCP SN gap between PDCP PDUs submitted to two associated RLC entities to minimize PDCP reordering delay in the receiving PDCP entity.

[TS 38.323, clause 5.2.2.1]

In this section, following definitions are used:

- HFN(State Variable): the HFN part (i.e. the number of most significant bits equal to HFN length) of the State Variable;
- SN(State Variable): the SN part (i.e. the number of least significant bits equal to PDCP SN length) of the State Variable;
- RCVD\_SN: the PDCP SN of the received PDCP Data PDU, included in the PDU header;
- RCVD\_HFN: the HFN of the received PDCP Data PDU, calculated by the receiving PDCP entity;
- RCVD\_COUNT: the COUNT of the received PDCP Data PDU = [RCVD\_HFN, RCVD\_SN]

At reception of a PDCP Data PDU from lower layers, the receiving PDCP entity shall determine the COUNT value of the received PDCP Data PDU, i.e. RCVD\_COUNT, as follows:

- if  $RCVD\_SN < SN(RX\_DELIV) - Window\_Size$ :
  - $RCVD\_HFN = HFN(RX\_DELIV) + 1$ .
- else if  $RCVD\_SN \geq SN(RX\_DELIV) + Window\_Size$ :
  - $RCVD\_HFN = HFN(RX\_DELIV) - 1$ .
- else:
  - $RCVD\_HFN = HFN(RX\_DELIV)$ ;
  - $RCVD\_COUNT = [RCVD\_HFN, RCVD\_SN]$ .

After determining the COUNT value of the received PDCP Data PDU = RCVD\_COUNT, the receiving PDCP entity shall:

- if  $RCVD\_COUNT < RX\_DELIV$ ; or
- if the PDCP Data PDU with COUNT = RCVD\_COUNT has been received before:
  - perform deciphering and integrity verification of the PDCP Data PDU using COUNT = RCVD\_COUNT;
  - if integrity verification fails:
    - indicate the integrity verification failure to upper layer;
  - discard the PDCP Data PDU.
- else:
  - perform deciphering and integrity verification of the PDCP Data PDU using COUNT = RCVD\_COUNT;
  - if integrity verification fails:
    - indicate the integrity verification failure to upper layer;
    - discard the PDCP Data PDU.

If the received PDCP Data PDU with COUNT value = RCVD\_COUNT is not discarded above, the receiving PDCP entity shall:

- store the resulting PDCP SDU in the reception buffer;
- if  $RCVD\_COUNT \geq RX\_NEXT$ :
  - update RX\_NEXT to RCVD\_COUNT + 1.
- if *outOfOrderDelivery* is configured:
  - deliver the resulting PDCP SDU to upper layers.
- if  $RCVD\_COUNT = RX\_DELIV$ :

- deliver to upper layers in ascending order of the associated COUNT value after performing header decompression, if not decompressed before;
  - all stored PDCP SDU(s) with consecutively associated COUNT value(s) starting from COUNT = RX\_DELIV;
- update RX\_DELIV to the COUNT value of the first PDCP SDU which has not been delivered to upper layers, with COUNT value > RX\_DELIV;
- if *t-Reordering* is running, and if RX\_DELIV >= RX\_REORD:
  - stop and reset *t-Reordering*.
- if *t-Reordering* is not running (includes the case when *t-Reordering* is stopped due to actions above), and RX\_DELIV < RX\_NEXT:
  - update RX\_REORD to RX\_NEXT;
  - start *t-Reordering*.

[TS 38.322, clause 6.2.2.2]

Figure 6.2.2.2-1 shows the format of the PDCP Data PDU with 12 bits PDCP SN. This format is applicable for UM DRBs and AM DRBs.

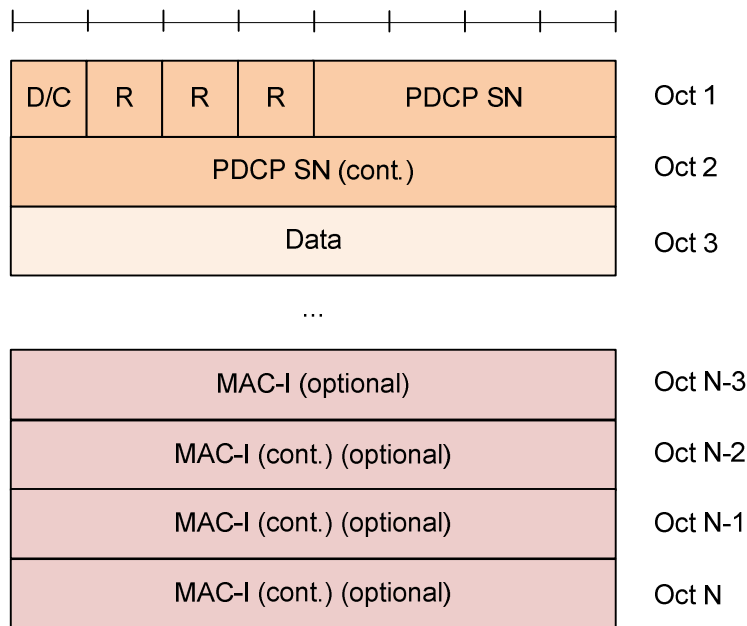

**Figure 6.2.2.2-1: PDCP Data PDU format with 12 bits PDCP SN**

7.1.3.1.1.3 Test description

7.1.3.1.1.3.1 Pre-test conditions

Same Pre-test conditions as in clause 7.1.3.0 exception of PDCP parameters according to Table 7.1.3.1.1.3.1-1.

**Table 7.1.3.1.1.3.1-1: PDCP parameters**

PDCP-Config pdcp-SN-SizeUL	len12bits
PDCP-Config pdcp-SN-SizeDL	len12bits

7.1.3.1.1.3.2 Test procedure sequence

**Table 7.1.3.1.1.3.2-1: Main behaviour**

St	Procedure	Message Sequence		TP	Verdict
		U - S	Message		
-	EXCEPTION: Steps 1 and 2 shall be repeated for k=0 to Maximum_PDCP_SN (increment=1).	-	-	-	-
1	SS transmits a PDCP Data PDU containing one PDCP SDU without header compression.	<--	PDCP Data PDU (SN = k)		
2	CHECK: Does UE transmit a PDCP Data PDU with SN=0 for the first iteration and then incremented by 1 at each iteration?	-->	PDCP Data PDU (SN = k)	1	P
3	SS transmits a PDCP Data PDU containing one PDCP SDU without header compression.	<--	PDCP Data PDU (SN = 0)		
4	CHECK: Does UE transmit a PDCP Data PDU with SN=0?	-->	PDCP Data PDU (SN = 0)	2	P
5	SS sends a PDCP Data PDU containing one PDCP SDU without header compression.	<--	PDCP Data PDU (SN = 1)		
6	CHECK: Does UE transmit a PDCP Data PDU with SN=1?	-->	PDCP Data PDU (SN = 1)	1	P
Note 1: Maximum_PDCP_SN = 2 <sup>[pdcpsn-size]</sup> - 1.					

7.1.3.1.1.3.3 Specific message contents

None.

7.1.3.1.2 Maintenance of PDCP sequence numbers / User plane / 18 bit SN

7.1.3.1.2.1 Test Purpose (TP)

(1)

```
with { UE in RRC_CONNECTED state with PDCP configured for 18 bit SN }
ensure that {
  when { UE transmits a PDCP Data SDU on a DRB }
  then { UE increments SN with 1 for each transmitted PDU for SN=0 to Maximum_PDCP_SN (2[pdcpsn-size] - 1) }
}
```

(2)

```
with { UE in E-UTRA RRC_CONNECTED state with PDCP configured for 18 bit SN }
ensure that {
  when { UE transmits a PDCP Data SDU on a DRB and, after incrementation, TX_Next is larger than the Maximum_PDCP_SN (2[pdcpsn-size] - 1) }
  then { UE sets SN to 0 in the next transmitted PDCP SDU }
}
```

7.1.3.1.2.2 Conformance requirements

Same as conformance requirements in clause 7.1.3.1.1.2

7.1.3.1.2.3 Test description

7.1.3.1.2.3.1 Pre-test conditions

Same Pre-test conditions as in clause 7.1.3.0 exception of PDCP parameters according to Table 7.1.3.1.2.3.1-1.

**Table 7.1.3.1.2.3.1-1: PDCP parameters**

PDCP-Config pdcpsn-sizeUL	len18bits
PDCP-Config pdcpsn-sizeDL	len18bits

7.1.3.1.2.3.2 Test procedure sequence

Same as test procedure in clause 7.1.3.1.1.3.2



## 7.1.3.1.2.3.3 Specific message contents

None.

## 7.1.3.2 PDCP integrity protection

## 7.1.3.2.1 Integrity protection / Correct functionality of encryption algorithm SNOW3G / SRB / DRB

**Editor's Note: The Test sequence is currently defined for EN-DC. Enhancements for other options is FFS**

(1)

```
with { UE in RRC_CONNECTED state and SRB is configured with NR-PDCP }
ensure that {
  when { Functionality of integrity algorithms with SNOW3G is taken into use on SRB }
  then { UE performs correct integrity protection function in NR-PDCP entities associated with SRB }
}
```

(2)

```
with { UE in RRC_CONNECTED state and NOT EN-DC }
ensure that {
  when { Functionality of integrity algorithms with SNOW3G is taken into use on DRB }
  then { UE performs correct integrity protection function in PDCP entities associated with DRB }
}
```

(3)

```
with { UE in RRC_CONNECTED state and SRB3 is configured }
ensure that {
  when { message on SRB 3 is received and fails the integrity protection check }
  then { UE transmits SCGFailureInformationNR message with failure type as srb3-IntegrityFailure }
}
```

NOTE: TP2 (integrity on DRB) is not applicable to EN-DC as per 38.331 clause 6.3.2, the IE *PDCP-Config.drb.integrityProtection* is 'Cond ConnectedTo5GC'.

## 7.1.3.2.1.2 Conformance requirements

References: The conformance requirements covered in the present TC are specified in: TS 38.323, clauses 5.9, 5.2.2.1, TS 33.501 clauses 5.6.2, D.3.1 and TS 38.331 clauses 5.7.3.1, 5.7.3.2, 5.7.3.3. Unless otherwise stated these are Rel-15 requirements.

[TS 38.323, clause 5.9]

The integrity protection function includes both integrity protection and integrity verification and is performed in PDCP, if configured. The data unit that is integrity protected is the PDU header and the data part of the PDU before ciphering. The integrity protection is always applied to PDCP Data PDUs of SRBs. The integrity protection is applied to PDCP Data PDUs of DRBs for which integrity protection is configured. The integrity protection is not applicable to PDCP Control PDUs.

The integrity protection algorithm and key to be used by the PDCP entity are configured by upper layers TS 38.331 [3] and the integrity protection method shall be applied as specified in TS 33.501 [6].

The integrity protection function is activated by upper layers TS 38.331 [3]. When security is activated, the integrity protection function shall be applied to all PDUs including and subsequent to the PDU indicated by upper layers TS 38.331 [3] for the downlink and the uplink, respectively.

NOTE: As the RRC message which activates the integrity protection function is itself integrity protected with the configuration included in this RRC message, this message needs first be decoded by RRC before the integrity protection verification could be performed for the PDU in which the message was received.

For downlink and uplink integrity protection and verification, the parameters that are required by PDCP for integrity protection are defined in TS 33.501 [6] and are input to the integrity protection algorithm. The required inputs to the integrity protection function include the COUNT value, and DIRECTION (direction of the transmission: set as

specified in TS 33.501 [6]). The parameters required by PDCP which are provided by upper layers TS 38.331 [3] are listed below:

- BEARER (defined as the radio bearer identifier in TS 33.501 [6]. It will use the value RB identity –1 as in TS 38.331 [3]);
- KEY (the integrity protection keys for the control plane and for the user plane are  $K_{RRCint}$  and  $K_{UPint}$ , respectively).

At transmission, the UE computes the value of the MAC-I field and at reception it verifies the integrity of the PDCP Data PDU by calculating the X-MAC based on the input parameters as specified above. If the calculated X-MAC corresponds to the received MAC-I, integrity protection is verified successfully.

[TS 38.323, clause 5.2.2.1]

At reception of a PDCP Data PDU from lower layers, the receiving PDCP entity shall determine the COUNT value of the received PDCP Data PDU, i.e. RCVD\_COUNT, as follows:

- if  $RCVD\_SN < SN(RX\_DELIV) - Window\_Size$ :
  - $RCVD\_HFN = HFN(RX\_DELIV) + 1$ .
- else if  $RCVD\_SN \geq SN(RX\_DELIV) + Window\_Size$ :
  - $RCVD\_HFN = HFN(RX\_DELIV) - 1$ .
- else:
  - $RCVD\_HFN = HFN(RX\_DELIV)$ ;
  - $RCVD\_COUNT = [RCVD\_HFN, RCVD\_SN]$ .

After determining the COUNT value of the received PDCP Data PDU = RCVD\_COUNT, the receiving PDCP entity shall:

- perform deciphering and integrity verification of the PDCP Data PDU using COUNT = RCVD\_COUNT;
  - if integrity verification fails:
    - indicate the integrity verification failure to upper layer;
    - discard the PDCP Data PDU;
- if  $RCVD\_COUNT < RX\_DELIV$ ; or
- if the PDCP Data PDU with COUNT = RCVD\_COUNT has been received before:
  - discard the PDCP Data PDU;

[TS 33.501, clause 5.6.2]

All Identifiers and names specified in the present subclause are for 5G.

Each Integrity Algorithm used for 5G will be assigned a 4-bit identifier. The following values for integrity algorithms are defined:

"0000 <sub>2</sub> "	NIA0	Null Integrity Protection algorithm;
"0001 <sub>2</sub> "	128-NIA1	128-bit SNOW 3G based algorithm;
"0010 <sub>2</sub> "	128-NIA2	128-bit AES based algorithm; and
"0011 <sub>2</sub> "	128-NIA3	128-bit ZUC based algorithm.

128-NIA1 is based on SNOW 3G (see TS35.215 [14]).

128-NIA2 is based on 128-bit AES [15] in CMAC mode [17].

128-NIA3 is based on 128-bit ZUC (see TS35.221 [18]).

Full details of the algorithms are specified in Annex D.

[TS 33.501, clause D.3.1.1]

The input parameters to the integrity algorithm are a 128-bit integrity key named KEY, a 32-bit COUNT, a 5-bit bearer identity called BEARER, the 1-bit direction of the transmission i.e. DIRECTION, and the message itself i.e. MESSAGE. The DIRECTION bit shall be 0 for uplink and 1 for downlink. The bit length of the MESSAGE is LENGTH.

Figure D.3.1.1-1 illustrates the use of the integrity algorithm NIA to authenticate the integrity of messages.

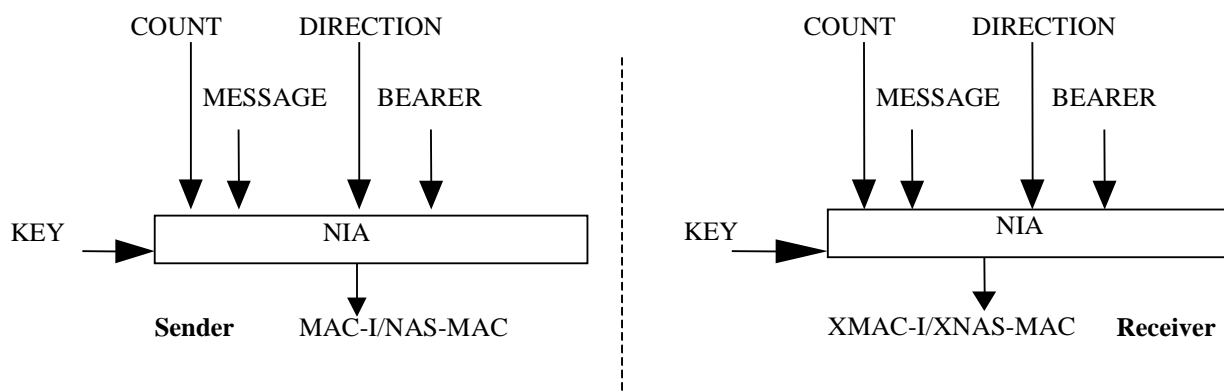

**Figure D.3.1.1-1: Derivation of MAC-I/NAS-MAC (or XMAC-I/XNAS-MAC)**

Based on these input parameters the sender computes a 32-bit message authentication code (MAC-I/NAS-MAC) using the integrity algorithm NIA. The message authentication code is then appended to the message when sent. For integrity protection algorithms, the receiver computes the expected message authentication code (XMAC-I/XNAS-MAC) on the message received in the same way as the sender computed its message authentication code on the message sent and verifies the data integrity of the message by comparing it to the received message authentication code, i.e. MAC-I/NAS-MAC.

[TS 38.331, clause 5.7.3.1]

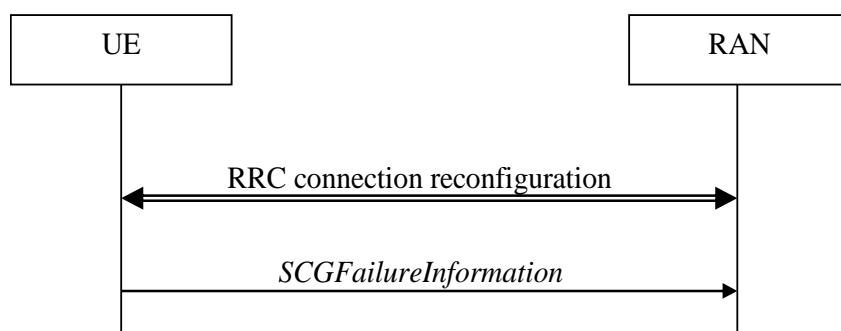

**Figure 5.7.3.1-1: SCG failure information**

The purpose of this procedure is to inform EUTRAN or NR MN about an SCG failure the UE has experienced i.e. SCG radio link failure, e failure of SCG reconfiguration with sync, SCG configuration failure for RRC message on SRB3, SCG integrity check failure and exceeding the maximum uplink transmission timing difference.

[TS 38.331, clause 5.7.3.2]

A UE initiates the procedure to report SCG failures when SCG transmission is not suspended and when one of the following conditions is met:

- 1> upon detecting radio link failure for the SCG, in accordance with subclause 5.3.10.3;
- 1> upon reconfiguration with sync failure of the SCG, in accordance with subclause 5.3.5.9.3;

1> upon SCG configuration failure, in accordance with subclause 5.3.5.9.2;

1> upon integrity check failure indication from SCG lower layers, in accordance with subclause 5.3.5.9.1.

Upon initiating the procedure, the UE shall:

1> suspend SCG transmission for all SRBs and DRBs;

1> reset SCG-MAC;

1> stop T304, if running;

1> if the UE is operating in EN-DC:

2> initiate transmission of the *SCGFailureInformationNR* message as specified in TS 36.331 [10, 5.6.13a].

[TS 38.331, clause 5.7.3.3]

The UE shall set the SCG failure type as follows:

1> if the UE initiates transmission of the *SCGFailureInformationNR* message to provide SCG radio link failure information:

2> set the failureType as scg-RadioLinkFailure;

1> else if the UE initiates transmission of the *SCGFailureInformationNR* message to provide reconfiguration with sync failure information for an SCG:

2> set the failureType as scg-ChangeFailure;

**Editor's Note: FFS whether to change scg-ChangeFailure to synchronousReconfigurationFailure-SCG.**

1> else, if the UE initiates transmission of the *SCGFailureInformationNR* message due to SRB3 IP check failure:

2> set the failureType as srb3-IntegrityFailure;

1> else, if the UE initiates transmission of the *SCGFailureInformationNR* message due to Reconfiguration failure of NR RRC reconfiguration message:

2> set the failureType as scg-reconfigFailure.

7.1.3.2.1.3 Test description

7.1.3.2.1.3.1 Pre-test conditions

Same Pre-test conditions as in clause 7.1.3.0 with the exception that integrity protection algorithm 'eia1 (SNOW3G)' is configured. NR PDCP is configured on SRB1 and SRB2. if pc\_srb3 SRB3 is configured.

7.1.3.2.1.3.2 Test procedure sequence

**Table 7.1.3.2.1.3.2-1: Main behaviour**

St	Procedure	Message Sequence		TP	Verdict
		U - S	Message		
1	The SS sends <i>UECapabilityEnquiry</i> message to the UE integrity protected.	<--	<i>UECapabilityEnquiry</i>	-	-
2	Check: Does the UE send a <i>UECapabilityInformation</i> message integrity protected?	-->	<i>UECapabilityInformation</i>	1	P
-	EXCEPTION: steps 3a1-3a4 depends on UE configuration, executed if UE supports SRB3	-	-	-	-
3a1	If <i>pc_srb3</i> then the SS transmits an <i>RRCReconfiguration</i> message to reconfigure NR MAC sent on SRB3 integrity protected.	<--	<i>RRCReconfiguration</i>	-	-
3a2	Check: Does the UE transmit an <i>RRCReconfigurationComplete</i> message on SRB3 integrity protected?	-->	<i>RRCReconfigurationComplete</i>	1	P
3a3	The SS sends <i>RRCReconfiguration</i> message to the UE integrity protected on SRB3. The MAC-I is corrupted so as to result in integrity failure at UE.	<--	<i>RRCReconfiguration</i>	-	-
3a4	Check: Does the UE send <i>SCGFailureInformationNR</i> with <i>failureType</i> as <i>srb3-IntegrityFailure</i> on SRB1.	-->	<i>SCGFailureInformationNR</i>	3	P
-	EXCEPTION: steps 4a1-4a2 depends if 5GC is being emulated	-	-	-	-
4a1	If (NOT <i>pc_EN_DC</i> ) then the SS transmits PDCP PDU on DRB integrity protected.	<--	PDCP PDU	-	-
4a2	Check: Does the UE transmit looped back PDCP PDU integrity protected on DRB?	-->	PDCP PDU	2	P

7.1.3.2.1.3.3 Specific message contents

**Table 7.1.3.2.1.3.3-1: *SCGFailureInformationNR* message (step 4, Table 7.1.3.2.1.3.2-1)**

Derivation Path: 38.508-1 [4], Table xxx			
Information Element	Value/remark	Comment	Condition
<i>SCGFailureInformationNR</i> -r15::= SEQUENCE {			
criticalExtensions CHOICE {			
c1 CHOICE {			
scgFailureInformationNR-r15 SEQUENCE {			
failureReportSCG-NR-r15 SEQUENCE {			
failureType-r15	srb3-IntegrityFailure		
measResultFreqListNR-r15	Not checked		
measResultSCG-r15	Not checked		
}			
nonCriticalExtension SEQUENCE {}			
}			
}			
}			
}			

7.1.3.2.2 Integrity protection / Correct functionality of encryption algorithm AES / SRB / DRB

**Editor’s Note: The Test sequence is currently defined for EN-DC. Enhancements for other options is FFS**

7.1.3.2.2.1 Test Purpose (TP)

(1)

**with** { UE in RRC\_CONNECTED state and SRB is configured with NR-PDCP }  
**ensure that** {

```

when { Functionality of integrity algorithms with AES is taken into use on SRB }
  then { UE performs correct integrity protection function in NR-PDCP entity associated with SRB }
}

```

(2)

```

with { UE in RRC_CONNECTED state and NOT EN-DC }
ensure that {
  when { Functionality of integrity algorithms with AES is taken into use on DRB }
    then { UE performs correct integrity protection function in PDCP entities associated with DRB }
}

```

(3)

```

with { UE in RRC_CONNECTED state and SRB3 is configured }
ensure that {
  when { message on SRB 3 is received and fails the integrity protection check }
    then { UE transmits SCGFailureInformationNR message with failure type as srb3-IntegrityFailure }
}

```

NOTE: TP2 (integrity on DRB) is not applicable to EN-DC as per TS 38.331 [12] clause 6.3.2, the IE *PDCP-Config.drb.integrityProtection* is 'Cond ConnectedTo5GC'.

#### 7.1.3.2.2.2 Conformance requirements

Same conformance requirements as in clause 7.1.3.2.1.2

#### 7.1.3.2.2.3 Test description

##### 7.1.3.2.2.3.1 Pre-test conditions

Same Pre-test conditions as in clause 7.1.3.2.1.3.1 except that integrity protection algorithm 'eia2 (AES)' is configured.

##### 7.1.3.2.2.3.2 Test procedure sequence

Same test procedure sequence as in clause 7.1.3.2.1.3.2.

##### 7.1.3.2.2.3.3 Specific message contents

Same specific message contents as in clause 7.1.3.2.1.3.3 except for integrity protection algorithm 'eia2 (AES)'.

#### 7.1.3.2.3 Integrity protection / Correct functionality of encryption algorithm ZUC / SRB / DRB

**Editor's Note: The Test sequence is currently defined for EN-DC. Enhancements for other options is FFS**

(1)

```

with { UE in RRC_CONNECTED state and SRB is configured with NR-PDCP }
ensure that {
  when { Functionality of integrity algorithms with ZUC is taken into use on SRB }
    then { UE performs correct integrity protection function in NR-PDCP entities associated with SRB }
}

```

(2)

```

with { UE in RRC_CONNECTED state and NOT EN-DC }
ensure that {
  when { Functionality of integrity algorithms with ZUC is taken into use on DRB }
    then { UE performs correct integrity protection function in PDCP entities associated with DRB }
}

```

(3)

```

with { UE in RRC_CONNECTED state and SRB3 is configured }
ensure that {
  when { message on SRB 3 is received and fails the integrity protection check }
    then { UE transmits SCGFailureInformationNR message with failure type as srb3-IntegrityFailure }
}

```

}

NOTE: TP2 (integrity on DRB) is not applicable to EN-DC as per TS 38.331 [12] clause 6.3.2, the IE *PDCP-Config.drb.integrityProtection* is 'Cond ConnectedTo5GC'.

#### 7.1.3.2.3.2 Conformance requirements

Same conformance requirements as in clause 7.1.3.2.1.2.

#### 7.1.3.2.3.3 Test description

##### 7.1.3.2.3.3.1 Pre-test conditions

Same Pre-test conditions as in clause 7.1.3.2.1.3.1 except that integrity protection algorithm 'eia3 (ZUC)' is configured.

##### 7.1.3.2.3.3.2 Test procedure sequence

Same test procedure sequence as in clause 7.1.3.2.1.3.2.

##### 7.1.3.2.3.3.3 Specific message contents

Same specific message contents as in clause 7.1.3.2.1.3.3 except integrity protection algorithm 'eia3 (ZUC)'.

### 7.1.3.3 PDCP Ciphery and deciphering

#### 7.1.3.3.1 Ciphery and deciphering / Correct functionality of encryption algorithm SNOW3G / SRB / DRB

##### 7.1.3.3.1.1 Test Purpose (TP)

(1)

(1)

```
with { UE in RRC_CONNECTED state and SRB is configured with NR-PDCP }
ensure that {
  when { Functionality of encryption algorithms with SNOW3G is taken into use on SRB }
  then { UE performs correct ciphery/deciphering function in NR-PDCP entity associated with SRB }
}
```

(2)

```
with { UE in RRC_CONNECTED state }
ensure that {
  when { Functionality of encryption algorithms with SNOW3G is taken into use on DRB }
  then { UE performs correct ciphery/deciphering function in NR-PDCP entity associated with DRB }
}
```

##### 7.1.3.3.1.2 Conformance requirements

References: The conformance requirements covered in the present TC are specified in: TS 38.323 clause 5.8, TS 33.501 clauses 5.6.1, D.2.1.1 and TS 36.331 clause 6.3.2. Unless otherwise stated these are Rel-15 requirements.

[TS 38.323, clause 5.8]

The ciphery function includes both ciphery and deciphering and is performed in PDCP, if configured. The data unit that is ciphered is the data part of the PDCP Data PDU (see subclause 6.3.3) except the SDAP header if included in the PDCP SDU, and the MAC-I (see subclause 6.3.4). The ciphery is not applicable to PDCP Control PDUs.

The ciphery algorithm and key to be used by the PDCP entity are configured by upper layers TS 38.331 [3] and the ciphery method shall be applied as specified in TS 33.501 [6].

The ciphery function is activated by upper layers TS 38.331 [3]. When security is activated, the ciphery function shall be applied to all PDCP Data PDUs indicated by upper layers TS 38.331 [3] for the downlink and the uplink, respectively.

For downlink and uplink ciphering and deciphering, the parameters that are required by PDCP for ciphering are defined in TS 33.501 [6] and are input to the ciphering algorithm. The required inputs to the ciphering function include the COUNT value, and DIRECTION (direction of the transmission: set as specified in TS 33.501 [6]). The parameters required by PDCP which are provided by upper layers TS 38.331 [3] are listed below:

- BEARER (defined as the radio bearer identifier in TS 33.501 [6]. It will use the value RB identity –1 as in TS 38.331 [3]);
- KEY (the ciphering keys for the control plane and for the user plane are  $K_{RRCCenc}$  and  $K_{UPenc}$ , respectively).

[TS 33.501, clause 5.6.1]

All Identifiers and names specified in this subclause are for 5G.

Each Encryption Algorithm used for 5G will be assigned a 4-bit identifier. The following values for ciphering algorithms are defined:

"0000 <sub>2</sub> "	NEA0	Null ciphering algorithm;
"0001 <sub>2</sub> "	128-NEA1	128-bit SNOW 3G based algorithm;
"0010 <sub>2</sub> "	128-NEA2	128-bit AES based algorithm; and
"0011 <sub>2</sub> "	128-NEA3	128-bit ZUC based algorithm.

128-NEA1 is based on SNOW 3G (see TS35.215 [14]).

128-NEA2 is based on 128-bit AES [15] in CTR mode [16].

128-NEA3 is based on 128-bit ZUC (see TS35.221 [18]).

Full details of the algorithms are specified in Annex D.

[TS 33.501, clause D.2.1.1]

The input parameters to the ciphering algorithm are a 128-bit cipher key named KEY, a 32-bit COUNT, a 5-bit bearer identity BEARER, the 1-bit direction of the transmission i.e. DIRECTION, and the length of the keystream required i.e. LENGTH. The DIRECTION bit shall be 0 for uplink and 1 for downlink.

**Editor's Note: For NAS layer security, the inputs may need to change depending on the solution that is selected for having simultaneous NAS connections for 3GPP and non-3GPP.**

Figure D.2.1.1-1 illustrates the use of the ciphering algorithm NEA to encrypt plaintext by applying a keystream using a bit per bit binary addition of the plaintext and the keystream. The plaintext may be recovered by generating the same keystream using the same input parameters and applying a bit per bit binary addition with the ciphertext.



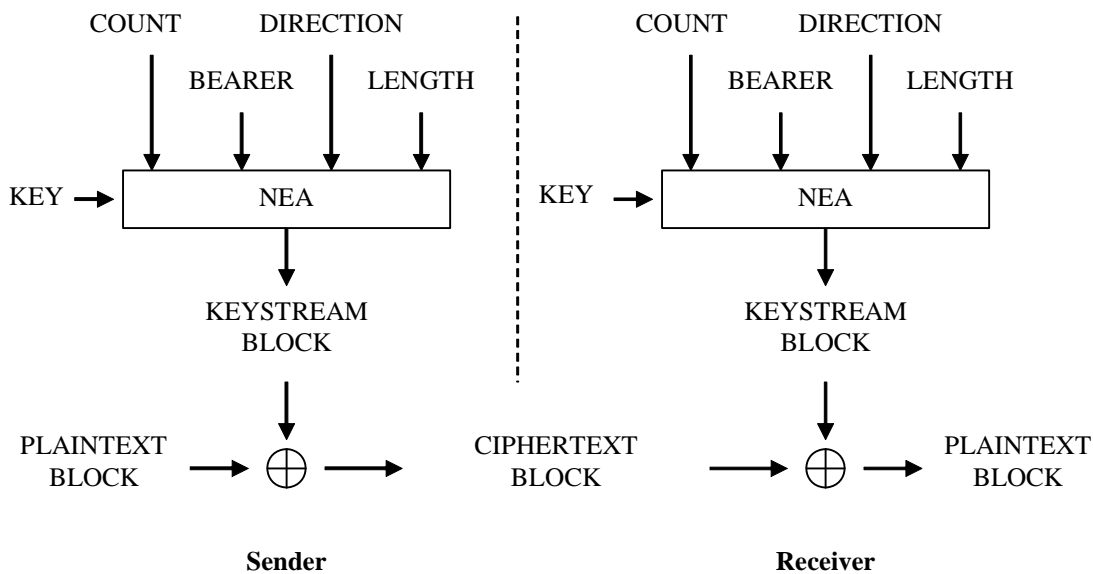

Figure D.2.1.1-1: Ciphering of data

Based on the input parameters the algorithm generates the output keystream block KEYSTREAM which is used to encrypt the input plaintext block PLAINTEXT to produce the output ciphertext block CIPHERTEXT.

The input parameter LENGTH shall affect only the length of the KEYSTREAM BLOCK, not the actual bits in it.

[TS 36.331, clause 6.3.3]

The IE *SecurityAlgorithmConfig* is used to configure AS integrity protection algorithm (SRBs) and AS ciphering algorithm (SRBs and DRBs).

...

SecurityAlgorithmConfig field descriptions	
<b>cipheringAlgorithm</b>	Indicates the ciphering algorithm to be used for SRBs and DRBs, as specified in TS 33.501 [11]. The algorithms nea0-nea3 are identical to the LTE algorithms eea0-3. For EN-DC, the algorithms configured for bearers using KeNB shall be the same as for all bearers using KeNB.
<b>integrityProtAlgorithm</b>	For EN-DC, this IE indicates the integrity protection algorithm to be used for SRBs, as specified in TS 33.501 [11]. The algorithms nia0-nia3 is identical to the LTE algorithms eia0-3. For EN-DC, the algorithms configured for SRBs using KeNB shall be the same as for all SRBs using KeNB.

7.1.3.3.1.3 Test description

7.1.3.3.1.3.1 Pre-test conditions

Same Pre-test conditions as in clause 7.1.3.0 with the exception that ciphering algorithm ‘nea1 (SNOW3G)’ is configured. NR PDCP is configured on SRBs and DRBs.

## 7.1.3.3.1.3.2 Test procedure sequence

**Table 7.1.3.3.1.3.2-1: Main behaviour**

St	Procedure	Message Sequence		TP	Verdict
		U - S	Message		
1	The SS sends <i>UECapabilityEnquiry</i> message to the UE.	<--	<i>UECapabilityEnquiry</i>	-	-
2	Check: Does the UE send a <i>UECapabilityInformation</i> message?	-->	<i>UECapabilityInformation</i>	1	P
3	SS transmits PDCP PDU on SCG DRB ciphered.	<--	PDCP PDU	-	-
4	Check: Does the UE transmit looped back PDCP PDU ciphered on SCG DRB?	-->	PDCP PDU	2	P
5	SS transmits PDCP PDU on MCG DRB ciphered.	<--	PDCP PDU	-	-
6	Check: Does the UE transmit looped back PDCP PDU ciphered on MCG DRB?	-->	PDCP PDU	2	P

## 7.1.3.3.1.3.3 Specific message contents

None

## 7.1.3.3.2 Ciphering and deciphering / Correct functionality of encryption algorithm AES / SRB / DRB

## 7.1.3.3.2.1 Test Purpose (TP)

(1)

```

with { UE in RRC_CONNECTED state and SRB is configured with NR-PDCP }
ensure that {
  when { Functionality of encryption algorithms with AES is taken into use on SRB }
  then { UE performs correct ciphering/deciphering function in NR-PDCP entity associated with SRB }
}

```

(2)

```

with { UE in RRC_CONNECTED state }
ensure that {
  when { Functionality of encryption algorithms with AES is taken into use on DRB }
  then { UE performs correct ciphering/deciphering function in NR-PDCP entity associated with DRB }
}

```

## 7.1.3.3.2.2 Conformance requirements

Same conformance requirement as in clause 7.1.3.3.1.2.

## 7.1.3.3.2.3 Test description

## 7.1.3.3.2.3.1 Pre-test conditions

Same Pre-test conditions as in clause 7.1.3.3.1.3.1 with the exception that ciphering algorithm 'nea2 (AES)' is configured.

## 7.1.3.3.2.3.2 Test procedure sequence

Same Test procedure sequence as in clause 7.1.3.3.1.3.2

## 7.1.3.3.2.3.3 Specific message contents

None

### 7.1.3.3.3 Ciphering and deciphering / Correct functionality of encryption algorithm ZUC / SRB / DRB

#### 7.1.3.3.3.1 Test Purpose (TP)

(1)

```
with { UE in RRC_CONNECTED state and SRB is configured with NR-PDCP }
ensure that {
  when { Functionality of encryption algorithms with ZUC is taken into use on SRB }
  then { UE performs correct ciphering/deciphering function in NR-PDCP entity associated with SRB }
}
```

(2)

```
with { UE in RRC_CONNECTED state and DRB is configured with NR-PDCP }
ensure that {
  when { Functionality of encryption algorithms with ZUC is taken into use on DRB }
  then { UE performs correct ciphering/deciphering function in NR-PDCP entity associated with DRB }
}
```

#### 7.1.3.3.3.2 Conformance requirements

Same conformance requirement as in clause 7.1.3.3.1.2.

#### 7.1.3.3.3.3 Test description

##### 7.1.3.3.3.3.1 Pre-test conditions

Same Pre-test conditions as in clause 7.1.3.3.1.3.1 with the exception that ciphering algorithm 'nea3 (ZUC)' is configured.

##### 7.1.3.3.3.3.2 Test procedure sequence

Same Test procedure sequence as in clause 7.1.3.3.1.3.2.

##### 7.1.3.3.3.3.3 Specific message contents

None

### 7.1.3.4 PDCP Handover

#### 7.1.3.4.1 PDCP handover / Lossless handover / PDCP sequence number maintenance / PDCP status report to convey the information on missing or acknowledged PDCP SDUs at handover / In-order delivery and duplicate elimination in the downlink

##### 7.1.3.4.1.1 Test Purpose (TP)

(1)

```
with { UE in RRC_CONNECTED state with default RB used RLC-AM mode }
ensure that {
  when { UE is requested to make a lossless handover by SS }
  then { UE creates a PDCP status report to SS }
}
```

(2)

```
with { UE in RRC_CONNECTED state with default RB used RLC-AM mode }
ensure that {
  when { UE is requested to make a lossless handover by SS }
  then { UE discards the corresponding PDCP PDU and PDCP SDU according to the PDCP status report from SS }
}
```

(3)

```

with { UE in RRC_CONNECTED state with default RB using RLC-AM }
ensure that {
  when { UE is requested to make a lossless handover by SS }
  then { UE retransmits the unacknowledged data }
}

```

(4)

```

with { UE in RRC_CONNECTED state with default RB using RLC-AM }
ensure that {
  when { UE is requested to make a lossless handover by SS }
  then { UE achieves in-order delivery and duplicate elimination in the downlink }
}

```

#### 7.1.3.4.1.2 Conformance requirements

References: The conformance requirements covered in the present test case are specified in: TS 38.323, clauses 5.1.2, 5.2.2.1, 5.3, 5.4.1, 5.4.2 and 7.1. Unless otherwise stated these are Rel-15 requirements.

[TS 38.323, clause 5.1.2]

When upper layers request a PDCP entity re-establishment, the UE shall additionally perform once the procedures described in this section. After performing the procedures in this section, the UE shall follow the procedures in subclause 5.2.

When upper layers request a PDCP entity re-establishment, the transmitting PDCP entity shall:

- for UM DRBs and AM DRBs, reset the header compression protocol for uplink and start with an IR state in U-mode (as defined in RFC 3095 [8] and RFC 4815 [9]) if *drb-ContinueROHC* is not configured in TS 38.331 [3];
- for UM DRBs and SRBs, set TX\_NEXT to the initial value;
- for SRBs, discard all stored PDCP SDUs and PDCP PDUs;
- apply the ciphering algorithm and key provided by upper layers during the PDCP entity re-establishment procedure;
- apply the integrity protection algorithm and key provided by upper layers during the PDCP entity re-establishment procedure;
- for UM DRBs, for each PDCP SDU already associated with a PDCP SN but for which a corresponding PDU has not previously been submitted to lower layers:
  - consider the PDCP SDUs as received from upper layer;
  - perform transmission of the PDCP SDUs in ascending order of the COUNT value associated to the PDCP SDU prior to the PDCP re-establishment without restarting the *discardTimer*;
- for AM DRBs, from the first PDCP SDU for which the successful delivery of the corresponding PDCP Data PDU has not been confirmed by lower layers, perform retransmission or transmission of all the PDCP SDUs already associated with PDCP SNs in ascending order of the COUNT values associated to the PDCP SDU prior to the PDCP entity re-establishment as specified below:
  - perform header compression of the PDCP SDU as specified in the subclause 5.7.4;
  - perform integrity protection and ciphering of the PDCP SDU using the COUNT value associated with this PDCP SDU as specified in the subclause 5.9 and 5.8;
  - submit the resulting PDCP Data PDU to lower layer.

When upper layers request a PDCP entity re-establishment, the receiving PDCP entity shall:

- process the PDCP Data PDUs that are received from lower layers due to the re-establishment of the lower layers, as specified in the subclause 5.2.2.1;
- for SRBs, discard all stored PDCP SDUs and PDCP PDUs;

- for SRBs and UM DRBs, if *t-Reordering* is running:
  - stop and reset *t-Reordering*;
  - for UM DRBs, deliver all stored PDCP SDUs to the upper layers in ascending order of associated COUNT values after performing header decompression;
- for AM DRBs, perform header decompression for all stored PDCP SDUs if *drb-ContinueROHC* is not configured in TS 38.331 [3];
- for UM DRBs and AM DRBs, reset the header compression protocol for downlink and start with NC state in U-mode (as defined in RFC 3095 [8] and RFC 4815 [9]) if *drb-ContinueROHC* is not configured in TS 38.331 [3];
- for UM DRBs and SRBs, set RX\_NEXT and RX\_DELIV to the initial value;
- apply the ciphering algorithm and key provided by upper layers during the PDCP entity re-establishment procedure;
- apply the integrity protection algorithm and key provided by upper layers during the PDCP entity re-establishment procedure.

[TS 38.323, clause 5.2.2.1]

In this section, following definitions are used:

- HFN(State Variable): the HFN part (i.e. the number of most significant bits equal to HFN length) of the State Variable;
- SN(State Variable): the SN part (i.e. the number of least significant bits equal to PDCP SN length) of the State Variable;
- RCVD\_SN: the PDCP SN of the received PDCP Data PDU, included in the PDU header;
- RCVD\_HFN: the HFN of the received PDCP Data PDU, calculated by the receiving PDCP entity;
- RCVD\_COUNT: the COUNT of the received PDCP Data PDU = [RCVD\_HFN, RCVD\_SN].

At reception of a PDCP Data PDU from lower layers, the receiving PDCP entity shall determine the COUNT value of the received PDCP Data PDU, i.e. RCVD\_COUNT, as follows:

- if  $RCVD\_SN < SN(RX\_DELIV) - Window\_Size$ :
  - $RCVD\_HFN = HFN(RX\_DELIV) + 1$ .
- else if  $RCVD\_SN \geq SN(RX\_DELIV) + Window\_Size$ :
  - $RCVD\_HFN = HFN(RX\_DELIV) - 1$ .
- else:
  - $RCVD\_HFN = HFN(RX\_DELIV)$ ;
- $RCVD\_COUNT = [RCVD\_HFN, RCVD\_SN]$ .

After determining the COUNT value of the received PDCP Data PDU = RCVD\_COUNT, the receiving PDCP entity shall:

- perform deciphering and integrity verification of the PDCP Data PDU using COUNT = RCVD\_COUNT;
  - if integrity verification fails:
    - indicate the integrity verification failure to upper layer;
    - discard the PDCP Data PDU;
- if  $RCVD\_COUNT < RX\_DELIV$ ; or
- if the PDCP Data PDU with COUNT = RCVD\_COUNT has been received before:

- discard the PDCP Data PDU;

If the received PDCP Data PDU with COUNT value = RCVD\_COUNT is not discarded above, the receiving PDCP entity shall:

- store the resulting PDCP SDU in the reception buffer;
- if RCVD\_COUNT >= RX\_NEXT:
  - update RX\_NEXT to RCVD\_COUNT + 1.
- if *outOfOrderDelivery* is configured:
  - deliver the resulting PDCP SDU to upper layers.
- if RCVD\_COUNT = RX\_DELIV:
  - deliver to upper layers in ascending order of the associated COUNT value after performing header decompression, if not decompressed before;
    - all stored PDCP SDU(s) with consecutively associated COUNT value(s) starting from COUNT = RX\_DELIV;
  - update RX\_DELIV to the COUNT value of the first PDCP SDU which has not been delivered to upper layers, with COUNT value > RX\_DELIV;
- if *t-Reordering* is running, and if RX\_DELIV >= RX\_REORD:
  - stop and reset *t-Reordering*.
- if *t-Reordering* is not running (includes the case when *t-Reordering* is stopped due to actions above), and RX\_DELIV < RX\_NEXT:
  - update RX\_REORD to RX\_NEXT;
- start *t-Reordering*.

[TS 38.323, clause 5.3]

When the *discardTimer* expires for a PDCP SDU, or the successful delivery of a PDCP SDU is confirmed by PDCP status report, the transmitting PDCP entity shall discard the PDCP SDU along with the corresponding PDCP Data PDU. If the corresponding PDCP Data PDU has already been submitted to lower layers, the discard is indicated to lower layers.

For SRBs, when upper layers request a PDCP SDU discard, the PDCP entity shall discard all stored PDCP SDUs and PDCP PDUs.

NOTE: Discarding a PDCP SDU already associated with a PDCP SN causes a SN gap in the transmitted PDCP Data PDUs, which increases PDCP reordering delay in the receiving PDCP entity. It is up to UE implementation how to minimize SN gap after SDU discard.

[TS 38.323, clause 5.4.1]

For AM DRBs configured by upper layers to send a PDCP status report in the uplink (*statusReportRequired* in TS 38.331 [3]), the receiving PDCP entity shall trigger a PDCP status report when:

- upper layer requests a PDCP entity re-establishment;
- upper layer requests a PDCP data recovery.

If a PDCP status report is triggered, the receiving PDCP entity shall:

- compile a PDCP status report as indicated below by:
  - setting the FMC field to RX\_DELIV;
  - if RX\_DELIV < RX\_NEXT:

- allocating a Bitmap field of length in bits equal to the number of COUNTs from and not including the first missing PDCP SDU up to and including the last out-of-sequence PDCP SDUs, rounded up to the next multiple of 8, or up to and including a PDCP SDU for which the resulting PDCP Control PDU size is equal to 9000 bytes, whichever comes first;
- setting in the bitmap field as '0' for all PDCP SDUs that have not been received, and optionally PDCP SDUs for which decompression have failed;
- setting in the bitmap field as '1' for all PDCP SDUs that have been received;
- submit the PDCP status report to lower layers as the first PDCP PDU for transmission.

[TS 38.323, clause 5.4.2]

For AM DRBs, when a PDCP status report is received in the downlink, the transmitting PDCP entity shall:

- consider for each PDCP SDU, if any, with the bit in the bitmap set to '1', or with the associated COUNT value less than the value of FMC field as successfully delivered, and discard the PDCP SDU as specified in the subclause 5.3.

[TS 38.323, clause 7.1]

This sub clause describes the state variables used in PDCP entities in order to specify the PDCP protocol. The state variables defined in this subclause are normative.

All state variables are non-negative integers, and take values from 0 to  $[2^{32} - 1]$ .

PDCP Data PDUs are numbered integer sequence numbers (SN) cycling through the field: 0 to  $[2^{[pdcip-SN-Size]} - 1]$ .

The transmitting PDCP entity shall maintain the following state variables:

a) TX\_NEXT

This state variable indicates the COUNT value of the next PDCP SDU to be transmitted. The initial value is 0.

The receiving PDCP entity shall maintain the following state variables:

a) RX\_NEXT

This state variable indicates the COUNT value of the next PDCP SDU expected to be received. The initial value is 0.

b) RX\_DELIV

This state variable indicates the COUNT value of the first PDCP SDU not delivered to the upper layers, but still waited for. The initial value is 0.

c) RX\_REORD

This state variable indicates the COUNT value following the COUNT value associated with the PDCP Data PDU which triggered *t-Reordering*.

7.1.3.4.1.3 Test description

7.1.3.4.1.3.1 Pre-test conditions

Same Pre-test conditions as in clause 7.1.3.0 except the following:

- 2 NR cells (NR Cell 1 and NR Cell 2) are configured with SN terminated SCG bearers in RLC AM mode.
- The cell power levels are configured as per the Table 7.1.3.4.1.3.1-1.

**Table 7.1.3.4.1.3.1-1: Time instances of cell power level**

IF [pc\_EN\_DC] or [pc\_NGEN\_DC] and FR1 FDD THEN

	Parameter	Unit	EUTRA Cell 1	NR Cell 1	NR Cell 2	Remark
T0	Cell-specific RS EPRE	dBm/15kHz	-85	-		
	SS/PBCH SSS EPRE	dBm/15kHz	-			
T1	Cell-specific RS EPRE	dBm/15kHz	-85	-		
	SS/PBCH SSS EPRE	dBm/15kHz	-	[-85]	[-79]	
T2	Cell-specific RS EPRE	dBm/15kHz	-85	-		
	SS/PBCH SSS EPRE	dBm/15kHz	-	[-79]	[-85]	

IF [pc\_EN\_DC] or [pc\_NGEN\_DC] and FR1 TDD THEN

	Parameter	Unit	NR Cell 1	NR Cell 2	Remark
T1	Cell-specific RS EPRE	dBm/15kHz	FFS	FFS	
T2	Cell-specific RS EPRE	dBm/15kHz	FFS	FFS	

IF [pc\_EN\_DC] or [pc\_NGEN\_DC] and FR2 THEN

	Parameter	Unit	NR Cell 1	NR Cell 2	Remark
T1	Cell-specific RS EPRE	dBm/15kHz	FFS	FFS	
T2	Cell-specific RS EPRE	dBm/15kHz	FFS	FFS	



7.1.3.4.1.3.2 Test procedure sequence

**Table 7.1.3.4.1.3.2-1: Main behaviour**

St	Procedure	Message Sequence		TP	Verdict
		U - S	Message		
1	The SS creates 5 PDCP Data PDUs and the TX_NEXT is set to "0".	-	-	-	-
-	EXCEPTION: Step 2 and 4 shall be repeated for k=0 to 1(increment=1).	-	-	-	-
2	The SS sends the PDCP Data PDU#k via RLC-AM RB with the following content to the UE: D/C field = 1 (PDCP Data PDU) and PDCP SN = k. After having sent a PDU, the SS set TX_NEXT = k+1.	<--	PDCP PDU DATA #k	-	-
3	The UE sends the PDCP Data PDU#k via RLC-AM RB with the following content to the UE: D/C field = 1 (PDCP Data PDU) and PDCP SN = k. Data is previously received data from PDU #k. (Note 1)	-->	PDCP PDU DATA #k	-	-
4	Wait for the expiry of t-PollRetransmit.	-	-	-	-
-	EXCEPTION: Step 5 and 6 shall be repeated for m=2 to 4 (increment=1).	-	-	-	-
5	The SS sends the PDCP Data PDU #m via RLC-AM RB with the following content to the UE: D/C field = 1 (PDCP Data PDU) and PDCP SN =m. After having sent a PDU, the SS set TX_NEXT = m+1.	<--	PDCP PDU DATA #m	-	-
6	The UE sends the PDCP Data PDU#m via RLC-AM RB with the following content to the UE: D/C field = 1 (PDCP Data PDU) and PDCP SN = m. Data is previously received data from PDU #m. (Note 2)	-->	PDCP PDU DATA #m	-	-
7	The SS changes NR Cell 2 parameters according to the row "T1" in table 7.1.3.4.1.3.2.0-1.	-	-	-	-
8	The SS requests UE to make a handover to NR Cell 2 with the <i>RRConnectionReconfiguration</i> message containing NR <i>RRCReconfiguration</i> message sent on NR Cell 1 with SCG key (S-KgNB) change.	<--	<i>RRConnectionReconfiguration</i>	-	-
9	The UE transmits a <i>RRConnectionReconfigurationComplete</i> message containing NR <i>RRCReconfigurationComplete</i> message. (Note 3)	-->	<i>RRConnectionReconfigurationComplete</i>	-	-
10	The SS assigns UL grant during the Random Access procedure on NR Cell 2 to allow the UE to send only PDCP status report.	-	-	-	-
11	Check: Does the UE send PDCP Control PDUs via RLC-AM RB with the following content to the SS: D/C field = 0 (PDCP control PDU) and PDU Type =000, FMC field = 5?	-->	PDCP STATUS REPORT	1	P
12	The SS generates a PDCP status report message and sends it to UE: D/C field = 0 (PDCP control PDU) and PDU Type =000, FMC field = 3.	<--	PDCP STATUS REPORT	-	-
13	Configure the SS to allocate Default UL grant to the UE in NR Cell 2.	-	-	-	-
14	Check: Does the UE send PDU#2? Note: This is to check if UE is discarding PDU#2 based on Status report from SS.	-->	PDCP DATA PDU#2	2	F

-	EXCEPTION: Step 15 shall be repeated for m=3 to 4 (increment=1).	-	-	-	-
15	Check: Does the UE send the PDCP Data PDU #m via RLC-AM RB with the following content to the SS: D/C field = 1 (PDCP Data PDU) and PDCP SN = m? Note: Data is previously received data from PDU #m.	-->	PDCP PDU DATA #m	3	P
16	The SS sends the PDCP Data PDU#5 via RLC-AM RB with the following content to the UE: PDCP Data PDU #5 ( D/C field = 1 (PDCP Data PDU) and PDCP SN=5).	<--	PDCP DATA PDU#5	-	-
17	The UE transmits a PDCP Data PDU via RLC-AM RB with the following content back to the SS: D/C field = 1 (PDCP Data PDU) and PDCP SN=5. Note: Data is previously received packet in PDCP Data PDU#5. (Note 1)	-->	PDCP DATA PDU #5	-	-
18	TX_NEXT is set to "6".  The SS creates a PDCP Data PDU#6 (not transmitted).	-	-	-	-
19	The TX_NEXT is set to "7". The SS creates a PDCP Data PDU #7.	-	-	-	-
20	The SS sends PDCP Data PDU#7 via RLC-AM RB with the following content to the UE: PDCP Data PDU#7; D/C field = 1 (PDCP Data PDU) and PDCP SN=7.	<--	PDCP DATA PDU #7	-	-
21	Check: Does the UE transmit a PDCP DATA PDU#7?	-->	PDCP DATA PDU#7	4	F
22	The SS changes NR Cell 1 and NR Cell 2 parameters according to row "T2" in Table 7.1.3.4.1.3.1-1.	-	-	-	-
23	The SS requests UE to make a handover to NR Cell 1 with the <i>RRConnectionReconfiguration</i> message containing NR <i>RRReconfiguration</i> sent on NR Cell 2 with SCG key (S-KgNB) change.	<--	<i>RRConnectionReconfiguration</i>	-	-
24	The UE transmits a <i>RRConnectionReconfigurationComplete</i> message containing NR <i>RRReconfigurationComplete</i> message. (Note 3)	-->	<i>RRConnectionReconfigurationComplete</i>	-	-
25	SS assigns UL grant during the Random Access procedure on NR Cell 1 to allow the UE to send only PDCP status report.	-	-	-	-
26	The UE sends PDCP Control PDUs via RLC-AM RB with the following content to the SS: D/C field = 0 (PDCP control PDU) and PDU Type =000, FMC field = 6, Bitmap = 0x80.	-->	PDCP STATUS REPORT	-	-
27	The SS generates a PDCP status report message and sends it to UE: D/C field = 0 (PDCP control PDU) and PDU Type =000, FMC field = 6.	<--	PDCP STATUS REPORT	-	-
28	Configure the SS to allocate Default UL grant to the UE in NR Cell 1	-	-	-	-
29	The SS sends the PDCP Data PDU#6 via RLC-AM RB with the following content to the UE: PDCP Data PDU#6 ( D/C field = 1 (PDCP Data PDU) and PDCP SN=6).	<--	PDCP DATA PDU #6	-	-

30	Check: Does the UE transmit a PDCP Data PDU via RLC-AM RB with the following content back to the SS? D/C field = 1 (PDCP Data PDU) and PDCP SN=6 Note: Data is previously received packet in PDCP Data PDU#6	-->	PDCP DATA PDU #6	4	P
31	Check: Does the UE transmit PDCP Data PDU via RLC-AM RB with the following content back to the SS? D/C field = 1 (PDCP Data PDU) and PDCP SN=7 Note: Data is previously received packet in PDCP Data PDU#7	-->	PDCP DATA PDU #7	4	P
<p>Note 1: The SS acknowledges the received data.</p> <p>Note 2: SS doesn't send the RLC ACK for this data.</p> <p>Note 3: UE will perform RACH procedure on NR Cell which will happen in parallel to steps 9 and 24</p>					

## 7.1.3.4.1.3.3 Specific message contents

**Table 7.1.3.4.1.3.3-0: SchedulingRequest-Config (Preamble)**

Derivation Path: 38.508-1 [4], Table: 4.6.3-117			
Information Element	Value/remark	Comment	Condition
sr-TransMax	n64		

**Table 7.1.3.4.1.3.3-1: RRCConnectionReconfiguration (steps 8, 23, Table 7.1.3.4.1.3.3-2)**

Derivation Path: 36.508 [7], Table 4.6.1-8			
Information Element	Value/remark	Comment	Condition
RRCConnectionReconfiguration ::= SEQUENCE {			
criticalExtensions CHOICE {			
c1 CHOICE {			
rrcConnectionReconfiguration-r8 ::= SEQUENCE			
{			
nonCriticalExtension ::= SEQUENCE {			
nonCriticalExtension ::= SEQUENCE {			
nonCriticalExtension ::= SEQUENCE {			
nonCriticalExtension ::= SEQUENCE {			
nonCriticalExtension ::= SEQUENCE {			
nonCriticalExtension ::= SEQUENCE {			
nonCriticalExtension ::= SEQUENCE {			
nonCriticalExtension ::= SEQUENCE {			
nr-Config-r15 CHOICE {			
setup SEQUENCE {			
nr-SecondaryCellGroupConfig-r15	OCTET STRING		
	including the		
	<i>RRCReconfiguration</i>		
	message and the IE		
	secondaryCellGroup.		
}			
}			
sk-Counter-r15	Different counter value		
	used before Handover.		
nr-RadioBearerConfig1-r15	OCTET STRING		
	including		
	RadioBearerConfig.		
}			
}			
}			

**Table 7.1.3.4.1.3.3-2: RRCReconfiguration (Table 7.1.3.4.1.3.3-1)**

Derivation Path: 38.508-1 [4], Table: 4.6.1-3			
Information Element	Value/remark	Comment	Condition
RRCReconfiguration ::= SEQUENCE {			
criticalExtensions CHOICE {			
rrcReconfiguration ::= SEQUENCE {			
secondaryCellGroup	CellGroupConfig		
}			
}			
}			

**Table 7.1.3.4.1.3.3-3: CellGroupConfig (Table 7.1.3.4.1.3.3-2)**

Derivation Path: 38.508-1 [4], Table: 4.6.3-1			
Information Element	Value/remark	Comment	Condition
CellGroupConfig ::= SEQUENCE {			
rlc-BearerToAddModList SEQUENCE (SIZE(1..maxLCH)) OF SEQUENCE {	1 entry		EN-DC
servedRadioBearer CHOICE {			
drb-Identity	2	SCG DRB Id	
}			
reestablishRLC	True		
}			
spCellConfig SEQUENCE {			
servCellIndex	Serving cell Index of NR Cell X	NR cell 2 at step 8 NR cell 1 at step 23	
ReconfigurationWithSync SEQUENCE {			
spCellConfigCommon	ServingcellInfocommon	NR cell 2 at step 8 NR cell 1 at step 23	
}			
}			
}			

**Table 7.1.3.4.1.3.3-4: ServingCellConfigCommon (Table 7.1.3.4.1.3.3-3)**

Derivation Path: 38.508-1 [4], Table: 4.6.3-12			
Information Element	Value/remark	Comment	Condition
ServingCellConfigCommon ::= SEQUENCE {			
physCellId	PhysCellId		
frequencyInfoDL	FrequencyInfoDL	NR cell 2 at step 8 NR cell 1 at step 23	
}			

**Table 7.1.3.4.1.3.3-5: RadioBearerConfig (Table 7.1.3.4.1.3.3-1)**

Derivation Path: 38.508-1 [4], Table: 4.6.3-100			
Information Element	Value/remark	Comment	Condition
RadioBearerConfig ::= SEQUENCE {			
drb-ToAddModList SEQUENCE (SIZE (1..maxDRB)) OF SEQUENCE {	1 entry		EN-DC
cnAssociation CHOICE {			
eps-BearerIdentity	6	Dedicated EPS bearer Id of SCG DRB	
}			
drb-Identity	2	SCG DRB Id	
reestablishPDCP	True		
pdcpc-Config	PDCP-Config		
}			
securityConfig SEQUENCE {			
keyToUse	s-KgNB		
}			
}			

**Table 7.1.3.4.1.3.3-6: PDCP-Config (Table 7.1.3.4.1.3.3-5)**

Derivation Path: 38.508-1 [4], Table: 4.6.3-74			
Information Element	Value/remark	Comment	Condition
PDCP-Config ::= SEQUENCE {			
drb SEQUENCE {			
statusReportRequired	True		
}			
}			

#### 7.1.3.4.2 PDCP handover / Non-lossless handover / PDCP sequence number maintenance

**Editor's Note:** The test case is specified to test the Connectivity options EN-DC and NGEN-DC only. Other Connectivity options are FFS

##### 7.1.3.4.2.1 Test Purpose (TP)

(1)

```
with { UE in RRC_CONNECTED state with default RB using RLC-UM }
ensure that {
  when { UE is requested to make a non-lossless handover by SS }
  then { UE transmits next PDCP Data PDU with SN value 0 }
}
```

(2)

```
with { UE in RRC_CONNECTED state with default RB using RLC-UM }
ensure that {
  when { UE is requested to make a non-lossless handover by SS }
  then { UE is able to receive next PDCP Data PDU with SN value 0 }
}
```

##### 7.1.3.4.2.2 Conformance requirements

References: The conformance requirements covered in the present TC are specified in: TS 38.323, clause 5.1.2. Unless otherwise stated these are Rel-15 requirements.

[TS 38.323, clause 5.1.2]

When upper layers request a PDCP entity re-establishment, the UE shall additionally perform once the procedures described in this section. After performing the procedures in this section, the UE shall follow the procedures in subclause 5.2.

When upper layers request a PDCP entity re-establishment, the transmitting PDCP entity shall:

- for UM DRBs and AM DRBs, reset the header compression protocol for uplink and start with an IR state in U-mode (as defined in RFC 3095 [8] and RFC 4815 [9]) if *drb-ContinueROHC* is not configured in TS 38.331 [3];
- for UM DRBs and SRBs, set TX\_NEXT to the initial value;
- for SRBs, discard all stored PDCP SDUs and PDCP PDUs;
- apply the ciphering algorithm and key provided by upper layers during the PDCP entity re-establishment procedure;
- apply the integrity protection algorithm and key provided by upper layers during the PDCP entity re-establishment procedure;
- for UM DRBs, for each PDCP SDU already associated with a PDCP SN but for which a corresponding PDU has not previously been submitted to lower layers:
  - consider the PDCP SDUs as received from upper layer;

- perform transmission of the PDCP SDUs in ascending order of the COUNT value associated to the PDCP SDU prior to the PDCP re-establishment without restarting the *discardTimer*.
- for AM DRBs, from the first PDCP SDU for which the successful delivery of the corresponding PDCP Data PDU has not been confirmed by lower layers, perform retransmission or transmission of all the PDCP SDUs already associated with PDCP SNs in ascending order of the COUNT values associated to the PDCP SDU prior to the PDCP entity re-establishment as specified below:
  - perform header compression of the PDCP SDU as specified in the subclause 5.7.4;
  - perform integrity protection and ciphering of the PDCP SDU using the COUNT value associated with this PDCP SDU as specified in the subclause 5.9 and 5.8;
- submit the resulting PDCP Data PDU to lower layer.

When upper layers request a PDCP entity re-establishment, the receiving PDCP entity shall:

- process the PDCP Data PDUs that are received from lower layers due to the re-establishment of the lower layers, as specified in the subclause 5.2.2.1;
- for SRBs, discard all stored PDCP SDUs and PDCP PDUs;
- for UM DRBs, if *t-Reordering* is running:
  - stop and reset *t-Reordering*;
  - deliver all stored PDCP SDUs to the upper layers in ascending order of associated COUNT values after performing header decompression.
- for AM DRBs, perform header decompression for all stored PDCP SDUs if *drb-ContinueROHC* is not configured in TS 38.331 [3];
- for UM DRBs and AM DRBs, reset the header compression protocol for downlink and start with NC state in U-mode (as defined in RFC 3095 [8] and RFC 4815 [9]) if *drb-ContinueROHC* is not configured in TS 38.331 [3];
- for UM DRBs and SRBs, set RX\_NEXT and RX\_DELIV to the initial value;
- apply the ciphering algorithm and key provided by upper layers during the PDCP entity re-establishment procedure;
- apply the integrity protection algorithm and key provided by upper layers during the PDCP entity re-establishment procedure.

#### 7.1.3.4.2.3 Test description

##### 7.1.3.4.2.3.1 Pre-test conditions

Same Pre-test conditions as in clause 7.1.3.0 except that SCG DRB is configured in RLC UM mode.



## 7.1.3.4.2.3.2 Test procedure sequence

Table 7.1.3.4.2.3.2-1: Main behaviour

St	Procedure	Message Sequence		TP	Verdict
		U - S	Message		
1	The SS creates 3 PDCP Data PDUs and the TX_NEXT is set to "0".	-	-	-	-
-	EXCEPTION: Step 2 and 3 shall be repeated for k=0 to 1 (increment=1).	-	-	-	-
2	The SS sends the PDCP Data PDU #k via RLC-UM RB with the following content to the UE: D/C field = 1 (PDCP Data PDU) and PDCP SN = k. After having sent a PDU, the SS set TX_NEXT= k+1.	<--	PDCP PDU DATA #k	-	-
3	The UE sends the PDCP Data PDU #k via RLC-UM RB with the following content to the SS: D/C field = 1 (PDCP Data PDU) and PDCP SN = k.	-->	PDCP PDU DATA #k	-	-
4	The SS transmits RRCConnectionReconfiguration message to trigger handover to the same PSCell with SCG key (S-KgNB) change	<--	-	-	-
5	The UE transmits a RRCConnectionReconfigurationComplete message.	-->	-	-	-
6	The SS sends the PDCP Data PDU #2 via RLC-UM RB with the following content to the UE: D/C field = 1 (PDCP Data PDU) and PDCP SN = 0. After having sent a PDU, the SS set TX_NEXT= 1.	<--	PDCP PDU DATA #2	-	-
7	Check: Does the UE send the PDCP Data PDU #2 via RLC-UM RB with the following content back to the SS: D/C field = 1 (PDCP Data PDU) and PDCP SN = 0?	-->	PDCP PDU DATA #2	1, 2	P

## 7.1.3.4.2.3 Specific message contents

None

## 7.1.3.5 PDCP other

## 7.1.3.5.1 PDCP Discard

## 7.1.3.5.1.1 Test Purpose (TP)

(1)

```

with { UE in RRC_CONNECTED state }
ensure that {
  when { the Discard Timer for a PDCP SDU expires }
  then { UE discards the corresponding PDCP SDU }
}

```

## 7.1.3.5.1.2 Conformance requirements

References: The conformance requirements covered in the present TC are specified in: TS 38.323, clause 5.3. Unless otherwise stated these are Rel-15 requirements.

[TS 38.323, clause 5.3]

When the *discardTimer* expires for a PDCP SDU, or the successful delivery of a PDCP SDU is confirmed by PDCP status report, the transmitting PDCP entity shall discard the PDCP SDU along with the corresponding PDCP Data PDU. If the corresponding PDCP Data PDU has already been submitted to lower layers, the discard is indicated to lower layers.

For SRBs, when upper layers request a PDCP SDU discard, the PDCP entity shall discard all stored PDCP SDUs and PDCP PDUs.

NOTE: Discarding a PDCP SDU already associated with a PDCP SN causes a SN gap in the transmitted PDCP Data PDUs, which increases PDCP reordering delay in the receiving PDCP entity. It is up to UE implementation how to minimize SN gap after SDU discard.

[TS 38.323, clause 7.1]

This sub clause describes the state variables used in PDCP entities in order to specify the PDCP protocol. The state variables defined in this subclause are normative.

All state variables are non-negative integers, and take values from 0 to  $[2^{32} - 1]$ .

PDCP Data PDUs are numbered integer sequence numbers (SN) cycling through the field: 0 to  $[2^{[pdcp-SN-Size]} - 1]$ .

The transmitting PDCP entity shall maintain the following state variables:

a) TX\_NEXT

This state variable indicates the COUNT value of the next PDCP SDU to be transmitted. The initial value is 0.

The receiving PDCP entity shall maintain the following state variables:

a) RX\_NEXT

This state variable indicates the COUNT value of the next PDCP SDU expected to be received. The initial value is 0.

b) RX\_DELIV

This state variable indicates the COUNT value of the first PDCP SDU not delivered to the upper layers, but still waited for. The initial value is 0.

c) RX\_REORD

This state variable indicates the COUNT value following the COUNT value associated with the PDCP Data PDU which triggered *t-Reordering*.

[TS 38.323, clause 6.3.5]

Length: 32 bits

The COUNT value is composed of a HFN and the PDCP SN. The size of the HFN part in bits is equal to 32 minus the length of the PDCP SN.



**Figure 6.3.5-1: Format of COUNT**

NOTE: COUNT does not wrap around.

7.1.3.5.1.3 Test description

7.1.3.5.1.3.1 Pre-test conditions

Same Pre-test conditions as in clause 7.1.3.0 with exceptions listed in Table 7.1.3.5.1.3.1-1 applicable for the configured UM DRB and Table 7.1.3.5.1.3.1-2 for SR configuration except that PDCP is configured for 12 bit SN.

The condition MCG DRB with UM in clause [4] according to [4].

**Table 7.1.3.5.1.3.1-1: PDCP Settings**

Parameter	Value
Discard_Timer	500 ms

## 7.1.3.5.1.3.2 Test procedure sequence

**Table 7.1.3.5.1.3.2-1: Main behaviour**

St	Procedure	Message Sequence		TP	Verdict
		U - S	Message		
-	EXCEPTION: The SS does not allocate UL grants unless when explicitly stated so in the procedure.	-	-	-	-
1	The SS creates 5 PDCP Data PDUs and the PDCP SN = "0" within TX_NEXT.		-	-	-
2	Void				
-	EXCEPTION: Step 3 shall be repeated for k=0 to 2 (increment=1) with the below specified PDU size sent to the UE: Data PDU#1 = 46 bytes for k=0 Data PDU#2 = 62 bytes for k=1 Data PDU#3 = 78 bytes for k=2	-	-	-	-
3	The SS sends a PDCP Data PDU via RLC-UM RB with the following content to the UE: D/C field = 1 (PDCP Data PDU) and PDCP SN = k After having sent a PDU, the SS sets PDCP SN is set to k+1 within TX_NEXT.	<--	PDCP DATA PDU (SN=k)	-	-
4	Wait for Discard_Timer to expire. Note: According to TS38.508-1, timer tolerance should be 10% of Discard_Timer or 5 x RTT, whichever is greater. RTT = 3 TTIs	-	-	-	-
-	EXCEPTION: Step 5 shall be repeated for k=3 to 4 (increment=1) with the below specified PDU size sent to the UE: Data PDU#4 = 94 bytes for k=3 Data PDU#5 = 110 bytes for k=4	-	-	-	-
5	The SS sends a PDCP Data PDU via RLC-UM RB with the following content to the UE: D/C field = 1 (PDCP Data PDU) and PDCP SN = k After having sent a PDU, the SS sets PDCP SN is set to k+1 within TX_NEXT.	<--	PDCP DATA PDU (SN=k)	-	-
6	The SS resumes normal UL grant allocation.	-	-	-	-
7	Check: Does UE transmit a PDCP Data PDU # 4 of size 94 bytes? (Note1)	-->	PDCP Data PDU # 4	1	P
8	Check: Does UE transmit a PDCP Data PDU # 5 of size 110 bytes? (Note1)	-->	PDCP Data PDU # 5	1	P
Note 1	PDCP Data PDU contents are checked to verify that the UL PDU is same as the DL PDU. According to the Note in TS 38.323 [19] clause 5.3 in case of PDCP SDUs being discarded it is up to the UE implementation which SN to be used and therefore the SN cannot be checked.				
Note 2	PDSCH-to-HARQ_feedback timing indicator is two slots as per 38.508-1[4] and 1 slot for PUSCH transmission				

## 7.1.3.5.1.3.3 Specific message contents

**Table 7.1.3.5.1.3.3-1: SchedulingRequest-Config (Preamble)**

Derivation Path: 38.508-1 [4], Table 4.6.3-117			
Information Element	Value/remark	Comment	Condition
sr-TransMax	n64		

### 7.1.3.5.2 PDCP Uplink Routing / Split DRB

#### 7.1.3.5.2.1 Test Purpose

(1)

```
with { UE in RRC_CONNECTED state with SCG activated with a Split DRB established and total amount of
PDCP data volume and not yet transmitted RLC data volume in the two associated RLC entities is less
than ul-DataSplitThreshold }
ensure that {
  when { UE has PDCP SDUs available for transmission }
  then { the UE transmits the PDCP SDUs on the Primary RLC entity }
}
```

(2)

```
with { UE in RRC_CONNECTED state with SCG activated with a Split DRB established pdcpDuplication and
total amount of PDCP data volume and not yet transmitted RLC data volume in the two associated RLC
entities is not less than ul-DataSplitThreshold }
ensure that {
  when { UE has PDCP SDUs available for transmission }
  then { the UE transmits the PDCP SDUs on the primary or secondary RLC entity }
}
```

#### 7.1.3.5.2.2 Conformance requirements

References: The conformance requirements covered in the present TC are specified in: TS 38.323, clause 5.2.1. Unless otherwise stated these are Rel-15 requirements.

[TS 38.323, clause 5.2.1]

At reception of a PDCP SDU from upper layers, the transmitting PDCP entity shall:

- start the *discardTimer* associated with this PDCP SDU (if configured).

For a PDCP SDU received from upper layers, the transmitting PDCP entity shall:

- associate the COUNT value corresponding to TX\_NEXT to this PDCP SDU;

NOTE 1: Associating more than half of the PDCP SN space of contiguous PDCP SDUs with PDCP SNs, when e.g., the PDCP SDUs are discarded or transmitted without acknowledgement, may cause HFN desynchronization problem. How to prevent HFN desynchronization problem is left up to UE implementation.

- perform header compression of the PDCP SDU as specified in the subclause 5.7.4;
- perform integrity protection, and ciphering using the TX\_NEXT as specified in the subclause 5.9 and 5.8, respectively;
- set the PDCP SN of the PDCP Data PDU to TX\_NEXT modulo  $2^{[pdcp-SN-Size]}$ ;
- increment TX\_NEXT by one;
- submit the resulting PDCP Data PDU to lower layer as specified below.

When submitting a PDCP Data PDU to lower layer, the transmitting PDCP entity shall:

- if the transmitting PDCP entity is associated with one RLC entity:
  - submit the PDCP Data PDU to the associated RLC entity.
- else, if the transmitting PDCP entity is associated with two RLC entities:
  - if *pdcpDuplication* is configured and activated:
    - duplicate the PDCP Data PDU and submit the PDCP Data PDU to both associated RLC entities.
  - else, if *pdcpDuplication* is configured but not activated:

- submit the PDCP Data PDU to the primary RLC entity.
- else:
  - if the total amount of PDCP data volume and RLC data volume pending for initial transmission (as specified in TS 36.322 [5]) in the two associated RLC entities is less than *ul-DataSplitThreshold*:
    - submit the PDCP Data PDU to the primary RLC entity.
  - else:
    - submit the PDCP Data PDU to either the primary RLC entity or the secondary RLC entity.

NOTE 2: If the transmitting PDCP entity is associated with two RLC entities, the UE should minimize the amount of PDCP PDUs submitted to lower layers before receiving request from lower layers and minimize the PDCP SN gap between PDCP PDUs submitted to two associated RLC entities to minimize PDCP reordering delay in the receiving PDCP entity.

### 7.1.3.5.2.3 Test description

#### 7.1.3.5.2.3.1 Pre-test conditions

Same Pre-test conditions as in clause 7.1.3.0 with exceptions listed in Table 7.1.3.5.2.3.1-1 and Generic procedure parameter DC bearer(MCG and *split*).

**Table 7.1.3.5.2.3.1-1: PDCP Settings**

Parameter	Value
Discard_Timer	500 ms
ul-DataSplitThreshold	b800

#### 7.1.3.5.2.3.2 Test procedure sequence

**Table 7.1.3.5.2.3.2-1: Main behaviour**

St	Procedure	Message Sequence		TP	Verdict
		U - S	Message		
1	The SS sends a PDCP Data PDU on the split DRB on NR Cell 1 (PSCell). Data PDU = 64 bytes.	<--	PDCP DATA PDU	-	-
-	EXCEPTION: In parallel with step 2, UE may execute parallel behaviour defined in table 7.1.3.5.2.3.2-2.	-	-	-	-
2	Check: Does UE transmit a PDCP Data PDU on the AM RLC entity configured for SCG on NR Cell 1 (PSCell)?	-->	PDCP DATA PDU	1	P
3	The SS sends a PDCP Data PDU on the split DRB on NR Cell 1 (PSCell). Data PDU = 164 bytes.	<--	PDCP DATA PDU	-	-
-	EXCEPTION: Steps 4a1 to 4b2 describe optional behaviour that depend on the UE uplink path	-	-	-	-
4a1	Check: Does UE transmit a PDCP Data PDU on the AM RLC entity configured for MCG on EUTRA Cell 1 (PCell)?	-->	PDCP DATA PDU	2	P
4a2	Check: Does UE transmit a PDCP Data PDU on the AM RLC entity configured for MCG on EUTRA Cell 1 (PSCell)?	-->	PDCP DATA PDU	2	F
4b1	Check: Does UE transmit a PDCP Data PDU on the AM RLC entity configured for SCG on EUTRA NR Cell 1 (PSCell)?	-->	PDCP DATA PDU	2	P
4b2	Check: Does UE transmit a PDCP Data PDU on the AM RLC entity configured for MCG on EUTRA Cell 1 (PCell)?	-->	PDCP DATA PDU	2	F

Table 7.1.3.5.2.3.2-2: Parallel behaviour

St	Procedure	Message Sequence		TP	Verdict
		U - S	Message		
1	Check: Does UE transmit a PDCP Data PDU on the AM RLC entity configured for MCG on EUTRA Cell 1 (PCell) in next two seconds? NOTE: Two seconds sufficient time to discard PDCP PDU.	-->	PDCP DATA PDU	1	F

## 7.1.3.5.2.3.3 Specific message contents

None

## 7.1.3.5.3 PDCP Data Recovery

## 7.1.3.5.3.1 Test Purpose (TP)

(1)

```

with { UE in RRC_CONNECTED state with SCG activated with a DRB established using RLC-AM }
ensure that {
  when { network requests reconfiguration and recovery of the DRB (without handover) }
  then { UE reconfigures the DRB and performs retransmission of all the PDCP PDUs previously
submitted to re-established AM RLC entity in ascending order of the associated COUNT values from the
first PDCP PDU for which the successful delivery has not been confirmed by lower layers }
}

```

## 7.1.3.5.3.1.2 Conformance requirements

References: The conformance requirements covered in the present TC are specified in: TS 38.323, clauses 5.2.1, 5.4.1 and 5.5; TS 38.331, clause 5.3.5.4.3. **Unless otherwise stated these are Rel-15 requirements.**

[TS 38.323, clause 5.2.1]

At reception of a PDCP SDU from upper layers, the transmitting PDCP entity shall:

- start the *discardTimer* associated with this PDCP SDU (if configured).

For a PDCP SDU received from upper layers, the transmitting PDCP entity shall:

- associate the COUNT value corresponding to TX\_NEXT to this PDCP SDU;

NOTE 1: Associating more than half of the PDCP SN space of contiguous PDCP SDUs with PDCP SNs, when e.g., the PDCP SDUs are discarded or transmitted without acknowledgement, may cause HFN desynchronization problem. How to prevent HFN desynchronization problem is left up to UE implementation.

- perform header compression of the PDCP SDU as specified in the subclause 5.7.4;
- perform integrity protection, and ciphering using the TX\_NEXT as specified in the subclause 5.9 and 5.8, respectively;
- set the PDCP SN of the PDCP Data PDU to TX\_NEXT modulo  $2^{[pdcp-SN-Size]}$ ;
- increment TX\_NEXT by one;
- submit the resulting PDCP Data PDU to lower layer as specified below.

When submitting a PDCP PDU to lower layer, the transmitting PDCP entity shall:

- if the transmitting PDCP entity is associated with one RLC entity:
  - submit the PDCP PDU to the associated RLC entity;
- else, if the transmitting PDCP entity is associated with two RLC entities:

- if *pdcp-Duplication* is configured and activated:
  - duplicate the PDCP Data PDU and submit the PDCP Data PDU to both associated RLC entities;
- else, if *pdcp-Duplication* is configured but not activated:
  - submit the PDCP Data PDU to the primary RLC entity;
- else:
  - if the total amount of PDCP data volume and RLC data volume pending for initial transmission (as specified in TS 38.322 [5]) in the two associated RLC entities is less than *ul-DataSplitThreshold*:
    - submit the PDCP PDU to the primary RLC entity;
  - else:
    - submit the PDCP PDU to either the primary RLC entity or the secondary RLC entity.

NOTE 2: If the transmitting PDCP entity is associated with two RLC entities, the UE should minimize the amount of PDCP PDUs submitted to lower layers before receiving request from lower layers and minimize the PDCP SN gap between PDCP PDUs submitted to two associated RLC entities to minimize PDCP reordering delay in the receiving PDCP entity.

[TS 38.323, clause 5.4.1]

For AM DRBs configured by upper layers to send a PDCP status report in the uplink (*statusReportRequired* in TS 38.331 [3]), the receiving PDCP entity shall trigger a PDCP status report when:

- upper layer requests a PDCP entity re-establishment;
- upper layer requests a PDCP data recovery.

If a PDCP status report is triggered, the receiving PDCP entity shall:

- compile a PDCP status report as indicated below by:
  - setting the FMC field to RX\_DELIV;
  - if  $RX\_DELIV < RX\_NEXT$ :
    - allocating a Bitmap field of length in bits equal to the number of COUNTs from and not including the first missing PDCP SDU up to and including the last out-of-sequence PDCP SDUs, rounded up to the next multiple of 8, or up to and including a PDCP SDU for which the resulting PDCP Control PDU size is equal to 9000 bytes, whichever comes first;
    - setting in the bitmap field as '0' for all PDCP SDUs that have not been received, and optionally PDCP SDUs for which decompression have failed;
    - setting in the bitmap field as '1' for all PDCP SDUs that have been received;
- submit the PDCP status report to lower layers as the first PDCP PDU for transmission.

[TS 38.323, clause 5.4.2]

For AM DRBs, when a PDCP status report is received in the downlink, the transmitting PDCP entity shall:

- consider for each PDCP SDU, if any, with the bit in the bitmap set to '1', or with the associated COUNT value less than the value of FMC field as successfully delivered, and discard the PDCP SDU as specified in the subclause 5.3.

[TS 38.323, clause 5.5]

For AM DRBs, when upper layers request a PDCP data recovery for a radio bearer, the transmitting PDCP entity shall:

- perform retransmission of all the PDCP Data PDUs previously submitted to re-established or released AM RLC entity in ascending order of the associated COUNT values for which the successful delivery has not been confirmed by lower layers.

After performing the above procedures, the transmitting PDCP entity shall follow the procedures in subclause 5.2.1.

### 7.1.3.5.3.3 Test description

#### 7.1.3.5.3.3.1 Pre-test conditions

Same Pre-test conditions as in clause 7.1.3.0 except that SCG DRB is configured in RLC AM mode.

#### 7.1.3.5.3.3.2 Test procedure sequence

**Table 7.1.3.5.3.3.2-1: Main behaviour**

St	Procedure	Message Sequence		TP	Verdict
		U - S	Message		
1	The SS is configured on NR Cell 1 (PSCell) to not send RLC acknowledgements (RLC ACKs) to the UE.	-	-	-	-
2	The SS creates 3 PDCP Data PDUs and the Next_PDCP_TX_SN is set to "0".	-	-	-	-
-	EXCEPTION: Steps 3 and 4 shall be repeated for k=0 to 2 (increment=1).	-	-	-	-
3	The SS sends the PDCP Data PDU #k on SCG DRB on NR Cell 1 (PSCell): D/C field = 1 (PDCP Data PDU) and PDCP SN = k. After having sent a PDU, the SS sets Next_PDCP_TX_SN= k+1.	<--	PDCP PDU DATA #k	-	-
4	The UE sends the PDCP Data PDU #k on the AM RLC entity configured for SCG on NR Cell 1 (PSCell): D/C field = 1 (PDCP Data PDU) and PDCP SN = k. Data is previously received data from PDU #k.	-->	PDCP PDU DATA #k	-	-
5	The SS transmits a <i>RRConnectionReconfiguration</i> message containing NR <i>RRReconfiguration</i> .	<--	<i>RRConnectionReconfiguration (RRReconfiguration)</i>	-	-
6	The UE transmits a <i>RRConnectionReconfigurationComplete</i> message containing NR <i>RRReconfigurationComplete</i> .	-->	<i>RRConnectionReconfigurationComplete (RRReconfigurationComplete)</i>	-	-
7	The SS assigns UL grant during the Random Access procedure on NR Cell 1 to allow the UE to send only PDCP status report.	-	-	-	-
8	The UE sends PDCP Control PDUs via RLC-AM RB with the following content to the SS: D/C field = 0 (PDCP control PDU) and PDU Type =000, FMC field = 3.	-->	PDCP STATUS REPORT	-	-
-	EXCEPTION: Step 9 shall be repeated for k=0 to 2 (increment=1).	-	-	-	-
9	Check: Does the UE send the PDCP Data PDU #k via the AM RLC entity configured for SCG on NR Cell 1 (PSCell): D/C field = 1 (PDCP Data PDU) and PDCP SN = k. Data is previously received data from PDU #k ?	-->	PDCP DATA PDU #k	1	P



7.1.3.5.3.3.3 Specific message contents

**Table 7.1.3.5.3.3.3-1: RRCConnectionReconfiguration (step 5, Table 7.1.3.5.3.3.2-1)**

Derivation Path: 36.508 [7], Table 4.6.1-8 with condition MCG_and_SCG			
Information Element	Value/remark	Comment	Condition
RRCConnectionReconfiguration ::= SEQUENCE {			
criticalExtensions CHOICE {			
c1 CHOICE{			
rrcConnectionReconfiguration-r8 ::= SEQUENCE			
{			
nonCriticalExtension SEQUENCE {			
nonCriticalExtension SEQUENCE {			
nonCriticalExtension SEQUENCE {			
nonCriticalExtension SEQUENCE {			
nonCriticalExtension SEQUENCE {			
nonCriticalExtension SEQUENCE {			
nonCriticalExtension SEQUENCE {			
nonCriticalExtension SEQUENCE {			
nr-Config-r15 CHOICE {			
setup SEQUENCE {			
nr-SecondaryCellGroupConfig-r15	RRCReconfiguration-PDCP		
}			
}			
}			
}			
}			
}			
}			
}			
}			
}			
}			
}			

**Table 7.1.3.5.3.3.3-2: RRCReconfiguration-PDCP (Table 7.1.3.5.3.3.3-1)**

Derivation Path: 38.508-1 [4], Table 4.6.1-3			
Information Element	Value/remark	Comment	Condition
RRCReconfiguration ::= SEQUENCE {			
criticalExtensions CHOICE {			
rrcReconfiguration SEQUENCE {			
radioBearerConfig	RadioBearerConfig-PDCP		
secondaryCellGroup	CellGroupConfig		EN-DC
measConfig	Not present		
}			
}			

**Table 7.1.3.5.3.3-3: RadioBearerConfig-PDCP (Table 7.1.3.5.3.3-2)**

Derivation Path: TS 38.508-1 [7], Table 4.6.1-n condition EN-DC			
Information Element	Value/remark	Comment	Condition
RadioBearerConfig ::= SEQUENCE {			
srb3-ToRelease	Not present		
drb-ToAddModList	Not present		
drb-ToAddModList SEQUENCE (SIZE (1..maxDRB)) OF SEQUENCE {	1 entry		EN-DC
cnAssociation CHOICE {			
eps-BearerIdentity	6		
sdap-Config	Not present		
}			
drb-Identity	2		
reestablishPDCP	Not present		
recoverPDCP	true		
pdcp-Config	PDCP-Config-Split		
}			
drb-ToReleaseList	Not present		
}			

**Table 7.1.3.5.3.3-4: PDCP-Config-Split (Table 7.1.3.5.3.3-3)**

Derivation Path: 38.508-1 [4], Table 4.6.1-n condition EN-DC			
Information Element	Value/remark	Comment	Condition
PDCP-Config ::= SEQUENCE {			
moreThanOneRLC SEQUENCE {			
primaryPath SEQUENCE {			
cellGroup	1		
}			
ul-DataSplitThreshold	infinity		
}			
}			

#### 7.1.3.5.4 PDCP reordering / Maximum re-ordering delay below t-Reordering / t-Reordering timer operations

##### 7.1.3.5.4.1 Test Purpose (TP)

(1)

```
with { UE in RRC_CONNECTED state using RLC-AM }
ensure that {
  when { a PDCP PDU is received from the lower layers and the COUNT value of the received PDCP Data
PDU is out of the re-ordering window }
    then { UE discards the PDCP PDU }
}
```

(2)

```
with { UE in RRC_CONNECTED state using RLC-AM }
ensure that {
  when { a PDCP PDU is received from the lower layers and the COUNT value of the received PDCP Data
PDU is within the re-ordering window }
    then { UE stores the resulting PDCP SDU }
}
```

(3)

```
with { UE in RRC_CONNECTED state using RLC-AM, and the RX_DELIV is not equal to the COUNT value of
the RX_NEXT (there is missing PDCP PDUs) }
ensure that {
  when { a PDCP PDU is received from the lower layers and the RCVD_COUNT = RX_DELIV }
    then { UE delivers the resulting PDCP SDU and all stored PDCP SDUs with consecutive COUNT value
to upper layer, in ascending order }
}
```

```
    }
```

(4)

```
with { UE in RRC_CONNECTED state using RLC-AM and the associated PDCP t-Reordering timer is running
}
ensure that {
  when { RX_DELIV >= RX_REORD }
  then { UE stops and resets t-Reordering timer }
}
```

(5)

```
with { UE in RRC_CONNECTED state using RLC-AM and the associated PDCP t-Reordering timer is running
}
ensure that {
  when { the t-Reordering timer expires }
  then { UE delivers all stored PDCP SDUs to upper layer }
}
```

(6)

```
with { UE in RRC_CONNECTED state using RLC-AM and the associated PDCP t-Reordering timer is running
}
ensure that {
  when { the t-Reordering is reconfigured by upper layers }
  then { UE stops and resets t-Reordering timer }
}
```

#### 7.1.3.5.4.2 Conformance requirements

References: The conformance requirements covered in the present test case are specified in: TS 38.323, clause 5.2.2.1, 5.2.2.2 and 5.2.2.3. Unless otherwise stated these are Rel-15 requirements.

[TS 38.323, clause 5.2.2.1]

In this section, following definitions are used:

- HFN(State Variable): the HFN part (i.e. the number of most significant bits equal to HFN length) of the State Variable;
- SN(State Variable): the SN part (i.e. the number of least significant bits equal to PDCP SN length) of the State Variable;
- RCVD\_SN: the PDCP SN of the received PDCP Data PDU, included in the PDU header;
- RCVD\_HFN: the HFN of the received PDCP Data PDU, calculated by the receiving PDCP entity;
- RCVD\_COUNT: the COUNT of the received PDCP Data PDU = [RCVD\_HFN, RCVD\_SN].

At reception of a PDCP Data PDU from lower layers, the receiving PDCP entity shall determine the COUNT value of the received PDCP Data PDU, i.e. RCVD\_COUNT, as follows:

- if  $RCVD\_SN < SN(RX\_DELIV) - Window\_Size$ :
  - $RCVD\_HFN = HFN(RX\_DELIV) + 1$ .
- else if  $RCVD\_SN \geq SN(RX\_DELIV) + Window\_Size$ :
  - $RCVD\_HFN = HFN(RX\_DELIV) - 1$ .
- else:
  - $RCVD\_HFN = HFN(RX\_DELIV)$ ;
  - $RCVD\_COUNT = [RCVD\_HFN, RCVD\_SN]$ .

After determining the COUNT value of the received PDCP Data PDU = RCVD\_COUNT, the receiving PDCP entity shall:

- perform deciphering and integrity verification of the PDCP Data PDU using COUNT = RCVD\_COUNT;
- if integrity verification fails:
  - indicate the integrity verification failure to upper layer;
  - discard the PDCP Data PDU;
- if RCVD\_COUNT < RX\_DELIV; or
- if the PDCP Data PDU with COUNT = RCVD\_COUNT has been received before:
  - discard the PDCP Data PDU;

If the received PDCP Data PDU with COUNT value = RCVD\_COUNT is not discarded above, the receiving PDCP entity shall:

- store the resulting PDCP SDU in the reception buffer;
- if RCVD\_COUNT >= RX\_NEXT:
  - update RX\_NEXT to RCVD\_COUNT + 1.
- if *outOfOrderDelivery* is configured:
  - deliver the resulting PDCP SDU to upper layers.
- if RCVD\_COUNT = RX\_DELIV:
  - deliver to upper layers in ascending order of the associated COUNT value after performing header decompression, if not decompressed before;
    - all stored PDCP SDU(s) with consecutively associated COUNT value(s) starting from COUNT = RX\_DELIV;
  - update RX\_DELIV to the COUNT value of the first PDCP SDU which has not been delivered to upper layers, with COUNT value > RX\_DELIV;
- if *t-Reordering* is running, and if RX\_DELIV >= RX\_REORD:
  - stop and reset *t-Reordering*.
- if *t-Reordering* is not running (includes the case when *t-Reordering* is stopped due to actions above), and RX\_DELIV < RX\_NEXT:
  - update RX\_REORD to RX\_NEXT;
  - start *t-Reordering*.

[TS 38.323, clause 5.2.2.2]

When *t-Reordering* expires, the receiving PDCP entity shall:

- deliver to upper layers in ascending order of the associated COUNT value after performing header decompression, if not decompressed before:
  - all stored PDCP SDU(s) with associated COUNT value(s) < RX\_REORD;
  - all stored PDCP SDU(s) with consecutively associated COUNT value(s) starting from RX\_REORD;
- update RX\_DELIV to the COUNT value of the first PDCP SDU which has not been delivered to upper layers, with COUNT value >= RX\_REORD;
- if RX\_DELIV < RX\_NEXT:
  - update RX\_REORD to RX\_NEXT;
  - start *t-Reordering*.

[TS 38.323, clause 5.2.2.3]

When the value of the *t-Reordering* is reconfigured by upper layers while the *t-Reordering* is running, the receiving PDCP entity shall:

- update RX\_REORD to RX\_NEXT;
- stop and restart *t-Reordering*.

7.1.3.5.4.3 Test description

7.1.3.5.4.3.1 Pre-test conditions

Same Pre-test conditions as in clause 7.1.3.0 exception of PDCP parameters according to Table 7.1.3.5.4.3.1-1.

**Table 7.1.3.5.4.3.1-1: PDCP parameters**

t-Reordering	ms300
--------------	-------

## 7.1.3.5.4.3.2 Test procedure sequence

Table 7.1.3.5.4.3.2-1: Main behaviour

St	Procedure	Message Sequence		TP	Verdict
		U - S	Message		
1	The SS sends the PDCP SDU #131072 D/C field = 1 (PDCP Data PDU) and PDCP SN = 131072. (Note 1)	<--	(PDCP SDU #131072)	-	-
2	Check: Does the UE transmit a PDCP SDU via the AM RLC entity in the next 1s?	-->	(PDCP SDU)	1	F
3	The SS sends the PDCP SDU #1 D/C field = 1 (PDCP Data PDU) and PDCP SN = 1. The UE starts <i>t-Reordering</i> .	<--	(PDCP SDU #1)	-	-
4	The SS sends the PDCP SDU #2 D/C field = 1 (PDCP Data PDU) and PDCP SN = 2.	<--	(PDCP SDU #2)	-	-
5	Wait for 100ms (< configured <i>t-Reordering</i> ).	-	-	-	-
6	The SS sends the PDCP SDU #0 D/C field = 1 (PDCP Data PDU) and PDCP SN = 0.	<--	(PDCP SDU #0)	-	-
7	Check: Does the UE transmit the PDCP SDU #0 via the AM RLC entity D/C field = 1 (PDCP Data PDU) and PDCP SN = 0?	-->	(PDCP SDU #0)	2, 3	P
8	Check: Does the UE transmit the PDCP SDU #1 via the AM RLC entity D/C field = 1 (PDCP Data PDU) and PDCP SN = 1?	-->	(PDCP SDU #1)	2, 3	P
9	Check: Does the UE transmit the PDCP SDU #2 via the AM RLC entity D/C field = 1 (PDCP Data PDU) and PDCP SN = 2?	-->	(PDCP SDU #2)	2, 3	P
10	The SS sends the PDCP SDU #4 D/C field = 1 (PDCP Data PDU) and PDCP SN = 4. The UE starts <i>t-Reordering</i> .	<--	(PDCP SDU #4)	-	-
11	Wait for 100ms (< configured <i>t-Reordering</i> )	-	-	-	-
12	The SS sends the PDCP SDU #7 D/C field = 1 (PDCP Data PDU) and PDCP SN = 7.	<--	(PDCP SDU #7)	-	-
13	The SS sends the PDCP SDU #3 D/C field = 1 (PDCP Data PDU) and PDCP SN = 3. The UE restarts <i>t-Reordering</i> timer. Note T <sub>1</sub>	<--	(PDCP SDU #3)	-	-
14	Check: Does the UE transmit the PDCP SDU #3 via the AM RLC entity?	-->	(PDCP SDU #3)	3	P
15	Check: Does the UE transmit the PDCP SDU #4 via the AM RLC entity?	-->	(PDCP SDU #4)	3	P
16	Check 1: Does the UE transmit the PDCP SDU #7 via the AM RLC entity after <i>t-Reordering</i> expiry? Note T <sub>2</sub> Check 2: Is $(T_2 - T_1) > t\text{-Reordering}$ ?	-->	(PDCP SDU #7)	4,5	P
17	The SS sends the PDCP SDU #9 D/C field = 1 (PDCP Data PDU) and PDCP SN = 9. The UE starts <i>t-Reordering</i> .	<--	(PDCP SDU #9)	-	-
18	Wait for 100ms (< configured <i>t-Reordering</i> )	-	-	-	-
19	The SS reconfigures the <i>t-Reordering</i> by sending a <i>RRCCONNECTIONRECONFIGURATION</i> message. The UE restarts <i>t-Reordering</i> timer. Note T <sub>3</sub>	<--	<i>RRCCONNECTIONRECONFIGURATION</i>	-	-
20	The UE transmits an <i>RRCCONNECTIONRECONFIGURATIONCOMPLETE</i> message.	-->	<i>RRCCONNECTIONRECONFIGURATIONCOMPLETE</i>	-	-
21	Check 1: Does the UE transmit the PDCP SDU #9 via the AM RLC entity after <i>t-Reordering</i> expiry? Note T <sub>4</sub> Check 2: Is $(T_4 - T_3) > t\text{-Reordering}$ ?	-->	(PDCP SDU #9)	6	P

Note 1: The Reordering Window size is 131072 when 18 bit SN length is used.

7.1.3.5.4.3.3 Specific message contents

**Table 7.1.3.5.4.3.3-1: RRCConnectionReconfiguration (step 19, Table 7.1.3.5.4.3.2-1)**

Derivation Path: 36.508 [7], Table 4.6.1-8			
Information Element	Value/remark	Comment	Condition
RRCConnectionReconfiguration ::= SEQUENCE {			
criticalExtensions CHOICE {			
c1 CHOICE {			
rrcConnectionReconfiguration-r8 ::= SEQUENCE {			
nonCriticalExtension ::= SEQUENCE {			
nonCriticalExtension ::= SEQUENCE {			
nonCriticalExtension ::= SEQUENCE {			
nonCriticalExtension ::= SEQUENCE {			
nonCriticalExtension ::= SEQUENCE {			
nonCriticalExtension ::= SEQUENCE {			
nonCriticalExtension ::= SEQUENCE {			
nonCriticalExtension ::= SEQUENCE {			
nonCriticalExtension ::= SEQUENCE {			
nr-RadioBearerConfig1-r15	OCTET STRING including RadioBearerConfig.		
}			
}			
}			
}			
}			
}			
}			
}			
}			
}			

**Table 7.1.3.5.4.3.3-2: RadioBearerConfig (Table 7.1.3.5.4.3.3-1)**

Derivation path: 38.508-1 [4], Table 4.6.3-100			
Information Element	Value/Remark	Comment	Condition
RadioBearerConfig ::= SEQUENCE {			
srb-ToAddModList ::= SEQUENCE (SIZE 1..2) OF SEQUENCE {			
pdcp-Config ::= SEQUENCE {			
drb SEQUENCE {			
outOfOrderDelivery	False		
}			
t-Reordering	ms750		
}			
}			
}			

7.1.4 SDAP

7.1.4.1 SDAP Data Transfer and PDU Header Handling UL/DL

7.1.4.1.1 Test Purpose (TP)

(1)

with { UE in RRC\_CONNECTED state with multiple DRB's established, each mapping more than one QoS flow }

```

ensure that {
  when { UE receives an SDAP PDU with SDAP header }
  then { UE SDAP entity retrieves the SDAP SDU from the SDAP PDU and delivers it to the QoS the
flow as indicated in the QFI field      }
}

```

(2)

```

with { UE in RRC_CONNECTED state with multiple DRB's established, each mapping more than one QoS
flow configured by RRC }
ensure that {
  when { UE has to transmit a SDAP PDU with header to be included }
  then {UE builds an SDAP PDU from the SDAP SDU including the header, and maps it to the DRB as
per stored DRB mapping rule for the QoS flow }
}

```

(3)

```

with { UE in RRC_CONNECTED state with multiple DRB's and QoS flows established }
ensure that {
  when { UE receives a SDAP PDU with SDAP header and RDI fields set to 1 }
  then {the UE stores the QoS flow to DRB mapping of the DL SDAP PDU as the QoS flow to DRB
mapping rule for the UL and uses it for further UL SDAP PDU transmissions }
}

```

(4)

```

with { UE in RRC_CONNECTED state with multiple DRB's and QoS flows established }
ensure that {
  when { UE receives a SDAP PDU with SDAP header and RDI field set to 1 and the stored QoS flow to
DRB mapping rule for the QoS flow is different from the QoS flow to DRB mapping of the DL SDAP data
PDU }
  then {the UE stores the QoS flow to DRB mapping of the DL SDAP PDU as the QoS flow to DRB
mapping rule for the UL, to be used for further UL SDAP PDU transmissions and transmits an end-
marker control PDU for the QoS flow on the old DRB }
}

```

(5)

```

with { UE in RRC_CONNECTED state with multiple DRB's and QoS flows established with QoS flow to DRB
mapping }
ensure that {
  when { RRC configures a new QoS flow to DRB mapping, different from the existing mapping } then
then { the UE stores the QoS flow to DRB mapping to be used for further UL SDAP PDU transmissions
and transmits an end-marker control PDU for the QoS flow on the old DRB }
}

```

#### 7.1.4.1.2 Conformance requirements

References: The conformance requirements covered in the present test case are specified in: TS 37.324, clauses 5.2.1, 5.2.2, 5.3.1, 5.3.2, 6.2.2.1, 6.2.2.2, 6.2.2.3, 6.2.3 and 6.3.4. Unless otherwise stated these are Rel-15 requirements.

[TS 37.324 clause 5.2.1]

At the reception of an SDAP SDU from upper layer for a QoS flow, the transmitting SDAP entity shall:

- if there is no stored QoS flow to DRB mapping rule for the QoS flow as specified in the subclause 5.3:
  - map the SDAP SDU to the default DRB;
- else:
  - map the SDAP SDU to the DRB according to the stored QoS flow to DRB mapping rule;
- if the DRB to which the SDAP SDU is mapped is configured by RRC [3] with the presence of SDAP header,
  - construct the UL SDAP data PDU as specified in the subclause 6.2.2.3;
- else:
  - construct the UL SDAP data PDU as specified in the subclause 6.2.2.1;



- submit the constructed UL SDAP data PDU to the lower layers.

NOTE: UE behaviour is not defined if there is neither a default DRB nor a stored QoS flow to DRB mapping rule for the QoS flow.

[TS 37.324 clause 5.2.2]

At the reception of an SDAP PDU from lower layers for a QoS flow, the receiving SDAP entity shall:

- if the DRB from which this SDAP PDU is received is configured by RRC [3] with the presence of SDAP header:
  - perform reflective QoS flow to DRB mapping as specified in the subclause 5.3.2;
  - perform RQI handling as specified in the subclause 5.4;
  - retrieves the SDAP SDU from the DL SDAP data PDU as specified in the subclause 6.2.2.2.
- else:
  - retrieve the SDAP SDU from the DL SDAP data PDU as specified in the subclause 6.2.2.1;
- deliver the retrieved SDAP SDU to the upper layer.

[TS 37.324 clause 5.3.1]

When RRC [3] configures an UL QoS flow to DRB mapping rule for a QoS flow, the SDAP entity shall:

- if the SDAP entity has already been establishment and there is no stored QoS flow to DRB mapping rule for the QoS flow and a default DRB is configured:
  - construct an end-marker control PDU, as specified in subclause 6.2.3, for the QoS flow;
  - map the end-marker control PDU to the default DRB;
  - submit the end-marker control PDU to the lower layers.
- if the stored UL QoS flow to DRB mapping rule is different from the configured QoS flow to DRB mapping rule for the QoS flow and the DRB according to the stored QoS flow to DRB mapping rule is configured by RRC [3] with the presence of SDAP header:
  - construct an end-marker control PDU, as specified in subclause 6.2.3, for the QoS flow;
  - map the end-marker control PDU to the DRB according to the stored QoS flow to DRB mapping rule;
  - submit the end-marker control PDU to the lower layers.
- store the configured UL QoS flow to DRB mapping rule for the QoS flow.

When RRC [3] releases an UL QoS flow to DRB mapping rule for a QoS flow, the SDAP entity shall:

- remove the UL QoS flow to DRB mapping rule for the QoS flow.

[TS 37.324 clause 5.3.2]

For each received DL SDAP PDU with RDI set to 1, the SDAP entity shall:

- process the QFI field in the SDAP header and determine the QoS flow;
- if there is no stored QoS flow to DRB mapping rule for the QoS flow and a default DRB is configured:
  - construct an end-marker control PDU, as specified in subclause 6.2.3, for the QoS flow;
  - map the end-marker control PDU to the default DRB;
  - submit the end-marker control PDU to the lower layers;

- if the stored QoS flow to DRB mapping rule for the QoS flow is different from the QoS flow to DRB mapping of the DL SDAP data PDU and the DRB according to the stored QoS flow to DRB mapping rule is configured by RRC [3] with the presence of SDAP header:
  - construct an end-marker control PDU, as specified in subclause 6.2.3, for the QoS flow;
  - map the end-marker control PDU to the DRB according to the stored QoS flow to DRB mapping rule;
  - submit the end-marker control PDU to the lower layers;
- store the QoS flow to DRB mapping of the DL SDAP data PDU as the QoS flow to DRB mapping rule for the UL.

[TS 37.324 clause 6.2.2.1]

An SDAP PDU consists only of a data field and does not consist of any SDAP header, as described in Figure 6.2.2.1-1.

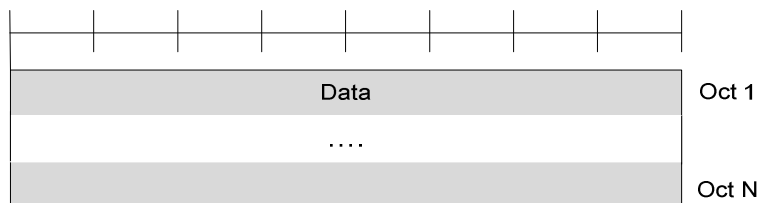

**Figure 6.2.2.1-1: SDAP Data PDU format without SDAP header**

[TS 37.324 clause 6.2.2.2]

Figure 6.2.2.2 – 1 shows the format of SDAP Data PDU of DL with SDAP header being configured.

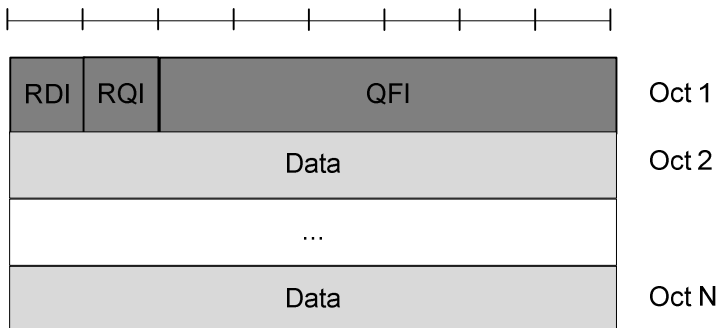

**Figure 6.2.2.2-1: DL SDAP Data PDU format with SDAP header**

[TS 37.324 clause 6.2.2.3]

Figure 6.2.2.3 – 1 shows the format of SDAP Data PDU of UL with SDAP header being configured.



Figure 6.2.2.3-1: UL SDAP Data PDU format with SDAP header

[TS 37.324 clause 6.2.3]

Figure 6.2.3 – 1 shows the format of End-Marker Control PDU.

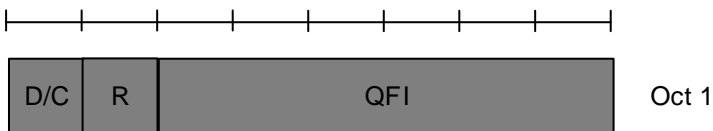

Figure 6.2.2.3-1: UL SDAP Data PDU format with SDAP header

[TS 37.324 clause 6.3.4]

Length: 6 bits

The QFI field indicates the ID of the QoS flow [4] to which the SDAP SDU belongs.

7.1.4.1.3 Test description

7.1.4.1.3.1 Pre-test conditions

The SS performs the generic procedure [FFS] in [4] to get UE into state RRC\_CONNECTED in accordance to the execution conditions in Table [FFS] and using the message condition UE TEST LOOP MODE J in [FFS] to return one SDAP SDU per DL SDAP SDU. 2 DRBs are configured where DRB 1 is defined as default DRB. QoS flows with QFI=5 and QFI=6 are mapped to DRB 1, QoS flows with QFI=1 and QFI=2 are mapped to DRB 2

## 7.1.4.1.3.2 Test procedure sequence

Table 7.1.4.1.3.2-1: Main behaviour

St	Procedure	Message Sequence		TP	Verdict
		U - S	Message		
1	The SS sends the SDAP Data PDU with SDAP header on DRB 2 and the following content to the UE: RDI=0, RQI=0, QFI=1.	<--	SDAP DL Data PDU	-	-
2	Check: Does the UE re-transmit SDAP Data PDU on DRB 2 with SDAP header as per the stored DRB mapping flow with QFI=1?	-->	SDAP UL Data PDU	1,2	P
3	The SS sends the SDAP Data PDU with SDAP header on DRB 2 and the following content to the UE: RDI=1, RQI=0, QFI=5.	<--	SDAP DL Data PDU	-	-
-	EXCEPTION: In parallel to the event described in step 4 the events specified in Table 7.1.4.1.3.2-2 shall take place.	-	-	-	-
4	Check: Does the UE re-transmit SDAP Data PDU on DRB 2 with SDAP header as per the stored DRB mapping Flow with QFI=5?	-->	SDAP UL Data PDU	3	P
5	The SS transmits an RRCReconfiguration message	<--	<i>RRCReconfiguration</i>	-	-
-	EXCEPTION: In parallel to the event described in step 6 the events specified in Table 7.1.4.1.3.2-3 shall take place.	-	-	-	-
6	The UE transmits an RRCReconfigurationComplete message.	-->	<i>RRCReconfigurationComplete</i>	-	-
7	The SS sends the SDAP Data PDU with SDAP header on DRB 2 and the following content to the UE: RDI=0, RQI=0, QFI=4.	<--	SDAP DL Data PDU	-	-
8	Check: Does the UE re-transmit SDAP Data PDU on DRB 2 with SDAP header as per the stored DRB mapping Flow with QFI=4?	-->	SDAP UL Data PDU	5	P

Table 7.1.4.1.3.2-2: Parallel behaviour

St	Procedure	Message Sequence		TP	Verdict
		U - S	Message		
1	Check: Does the UE transmit End-Marker Control PDU on DRB 1? [Content of End-Marker Control PDU is FFS]	-->	SDAP UL Control PDU	4	P

Table 7.1.4.1.3.3-2: Parallel behaviour

St	Procedure	Message Sequence		TP	Verdict
		U - S	Message		
1	Check: Does the UE transmit End-Marker Control PDU on DRB 1? [Content of End-Marker Control PDU is FFS]	-->	SDAP UL Control PDU	5	P

## 7.1.4.1.3.3 Specific message contents

**Table 7.1.4.1.3.3-1: RadioBearerConfig-DRB (step 7, Table 7.1.4.1.3.2-1)**

Derivation Path: TS 38.508-1, table 4.6.3-100 and condition FFS			
Information Element	Value/remark	Comment	Condition
RadioBearerConfig ::= SEQUENCE {	-	-	-
drb-ToAddModList SEQUENCE (SIZE (1..maxDRB))	2	BID is the total number of established DRBs in the UE, before applying the contents of this IE	-
OF SEQUENCE {			
cnAssociation[1] CHOICE {	-	-	-
sdap-Config ::= SEQUENCE {	-	-	-
pdu-Session -	1	-	-
sdap-HeaderDL	present	-	-
sdap-HeaderUL	present	-	-
defaultDRB	false	-	-
mappedQoS-FlowsToAdd ::= SEQUENCE {	-	-	-
QFI	4	-	-
}	-	-	-
}	-	-	-
drb-Identity	2	-	-
}	-	-	-
}	-	-	-
}	-	-	-

## 7.1.4.2 SDAP Data Transfer handling without Header UL/DL

## 7.1.4.2.1 Test Purpose (TP)

(1)

```
with { UE in RRC_CONNECTED state with multiple DRB's established. SDAP configured without header and no stored QoS flow mapping }
ensure that{
  when { UE receives a SDAP SDU from upper layers }
  then { UE SDAP entity transmits the SDAP PDU without header on default DRB }
```

(2)

```
with { UE in RRC_CONNECTED state with multiple DRB's established. SDAP configured without header and no stored QoS flow mapping }
ensure that {
  when { UE SDAP receives from RRC new QoS Flow mapping }
  then { UE SDAP entity transmits an end-marker control PDU for the QoS flow on default DRB }
}
```

(3)

```
with { UE in RRC_CONNECTED state with multiple DRB's established. SDAP configured without header and stored QoS flow mapping configured by RRC }
ensure that{
  when { UE receives a SDAP SDU from upper layers }
  then { UE SDAP entity transmits the SDAP PDU without header on DRB as per configured QoS flow mapping}
```

## 7.1.4.2.2 Conformance requirements

References: The conformance requirements covered in the present test case are specified in: TS 37.324, clauses 5.2.1, 5.2.2, 5.3.1, 6.2.2.1 and 6.2.3. Unless otherwise stated these are Rel-15 requirements.

[TS 37.324 clause 5.2.1]

At the reception of an SDAP SDU from upper layer for a QoS flow, the transmitting SDAP entity shall:

- if there is no stored QoS flow to DRB mapping rule for the QoS flow as specified in the subclause 5.3:
  - map the SDAP SDU to the default DRB;
- else:
  - map the SDAP SDU to the DRB according to the stored QoS flow to DRB mapping rule;
- if the DRB to which the SDAP SDU is mapped is configured by RRC [3] with the presence of SDAP header,
  - construct the UL SDAP data PDU as specified in the subclause 6.2.2.3;
- else:
  - construct the UL SDAP data PDU as specified in the subclause 6.2.2.1;
- submit the constructed UL SDAP data PDU to the lower layers.

NOTE: UE behaviour is not defined if there is neither a default DRB nor a stored QoS flow to DRB mapping rule for the QoS flow.

[TS 37.324 clause 5.2.2]

At the reception of an SDAP PDU from lower layers for a QoS flow, the receiving SDAP entity shall:

- if the DRB from which this SDAP PDU is received is configured by RRC [3] with the presence of SDAP header:
  - perform reflective QoS flow to DRB mapping as specified in the subclause 5.3.2;
  - perform RQI handling as specified in the subclause 5.4;
  - retrieves the SDAP SDU from the DL SDAP data PDU as specified in the subclause 6.2.2.2.
- else:
  - retrieve the SDAP SDU from the DL SDAP data PDU as specified in the subclause 6.2.2.1;
- deliver the retrieved SDAP SDU to the upper layer.

[TS 37.324 clause 5.3.1]

When RRC [3] configures an UL QoS flow to DRB mapping rule for a QoS flow, the SDAP entity shall:

- if the SDAP entity has already been established and there is no stored QoS flow to DRB mapping rule for the QoS flow and a default DRB is configured:
  - construct an end-marker control PDU, as specified in subclause 6.2.3, for the QoS flow;
  - map the end-marker control PDU to the default DRB;
  - submit the end-marker control PDU to the lower layers.
- if the stored UL QoS flow to DRB mapping rule is different from the configured QoS flow to DRB mapping rule for the QoS flow and the DRB according to the stored QoS flow to DRB mapping rule is configured by RRC [3] with the presence of SDAP header:
  - construct an end-marker control PDU, as specified in subclause 6.2.3, for the QoS flow;
  - map the end-marker control PDU to the DRB according to the stored QoS flow to DRB mapping rule;
  - submit the end-marker control PDU to the lower layers.
- store the configured UL QoS flow to DRB mapping rule for the QoS flow.

When RRC [3] releases an UL QoS flow to DRB mapping rule for a QoS flow, the SDAP entity shall:

- remove the UL QoS flow to DRB mapping rule for the QoS flow.

[TS 37.324 clause 6.2.2.1]

An SDAP PDU consists only of a data field and does not consist of any SDAP header, as described in Figure 6.2.2.1-1.

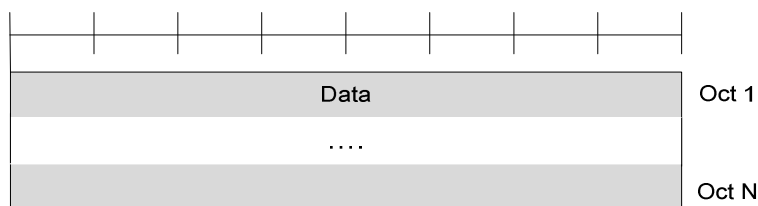

**Figure 6.2.2.1-1: SDAP Data PDU format without SDAP header**

[TS 37.324 clause 6.2.3]

Figure 6.2.3 – 1 shows the format of End-Marker Control PDU.



**Figure 6.2.3-1: End-Marker Control PDU**

7.1.4.2.3 Test description

7.1.4.2.3.1 Pre-test conditions

System Simulator:

- NR Cell 1
- System Information combination as defined in TS 38.508-1 [4] clause 4.4.3.1.1 is NR Cell 1.

UE:

- None.

Preamble:

The SS performs the generic procedure [FFS] in [4] to get UE in state RRC\_CONNECTED in accordance to the execution conditions in Table [FFS] and using the message condition UE TEST LOOP MODE J to return one UL SDAP SDU per DL SDAP SDU. 2 DRBs are configured where DRB1 is defined as default DRB. QoS flows QFI = 5 and QFI = 6 are mapped to DRB1, QoS flows QFI = 1 and QFI =2 are mapped to DRB2 at SM Layer. The 'mappedQoS-Flows' is empty for both DRB's for SDAP layer.

## 7.1.4.2.3.2 Test procedure sequence

Table 7.1.4.2.3.2-1: Main behaviour

St	Procedure	Message Sequence		TP	Verdict
		U - S	Message		
1	The SS sends the SDAP Data PDU without SDAP header on DRB 2 for QFI =2.	<--	SDAP DL Data PDU	-	-
2	Check: Does the UE transmits SDAP Data PDU on DRB 1 which is default DRB?	-->	SDAP UL Data PDU	1	P
3	The SS sends the SDAP Data PDU without SDAP header on DRB 1 for QFI 5.	<--	SDAP DL Data PDU	-	-
4	Check: Does the UE transmits SDAP Data PDU on DRB 1 which is default DRB?	-->	SDAP UL Data PDU	1	P
5	The SS sends the SDAP Data PDU without SDAP header on DRB 2 for QFI =1.	<--	SDAP DL Data PDU	-	-
6	Check: Does the UE transmits SDAP Data PDU on DRB 1 which is default DRB?	-->	SDAP UL Data PDU	1	P
7	The SS transmits an NR RRCReconfiguration message to configure QoS Flow rules	<--	<i>(RRCReconfiguration)</i>	-	-
-	EXCEPTION: In parallel to the event described in step 8 the events specified in Table 7.1.4.2.3.2-2 shall take place.			-	-
8	The UE transmit an NR <i>RRCReconfigurationComplete</i> message.	-->	<i>(RRCReconfigurationComplete)</i>	-	-
9	The SS sends the SDAP Data PDU without SDAP header on DRB 2 for QFI =2.	<--	SDAP DL Data PDU	-	-
10	Check: Does the UE transmits SDAP Data PDU on DRB 2?	-->	SDAP UL Data PDU	3	P
11	The SS sends the SDAP Data PDU without SDAP header on DRB 1 for QFI 5.	<--	SDAP DL Data PDU	-	-
12	Check: Does the UE transmits SDAP Data PDU on DRB 1?	-->	SDAP UL Data PDU	3	P
13	The SS sends the SDAP Data PDU without SDAP header on DRB 2 for QFI =1.	<--	SDAP DL Data PDU	-	-
14	Check: Does the UE transmits SDAP Data PDU on DRB 2?	-->	SDAP UL Data PDU	3	P

Table 7.1.4.2.3.2-2: Parallel behaviour

St	Procedure	Message Sequence		TP	Verdict
		U - S	Message		
1	Check: Does the UE transmits End-Marker Control PDU on DRB1?	-->	SDAP UL Control PDU	2	P



## 7.1.4.2.3.3 Specific message contents

**Table 7.1.4.2.3.3-1: RadioBearerConfig-DRB (step 7, Table 7.1.4.2.3.2-1)**

Derivation Path: TS 38.508-1, table 4.6.3-100 and condition FFS			
Information Element	Value/remark	Comment	Condition
RadioBearerConfig ::= SEQUENCE {			
drb-ToAddModList SEQUENCE (SIZE (1..maxDRB))	2 entries		
OF SEQUENCE {			
{			
cnAssociation[1] CHOICE {			
sdap-Config ::= SEQUENCE {			
pdu-Session	1		
sdap-HeaderDL	false		
sdap-HeaderUL	false		
defaultDRB	false		
mappedQoS-FlowsToAdd ::= SEQUENCE {			
QFI	1		
QFI	2		
}			
}			
}			
drb-Identity	2		
}			
{			
cnAssociation[2] CHOICE {			
sdap-Config ::= SEQUENCE {			
pdu-Session	1		
sdap-HeaderDL	false		
sdap-HeaderUL	false		
defaultDRB	false		
mappedQoS-FlowsToAdd ::= SEQUENCE {			
QFI	5		
}			
}			
}			
drb-Identity	1		
}			
}			
}			

## 8 RRC

Editor's note: Intended to capture tests of RRC Layer defined in TS 38.331 and capabilities defined in TS 38.306.

- a) SN Measurements and Reporting (various bearer options as in Impact#2)
- b) UE Capability Co-ordination (FFS in RAN2)
- c) SN Release (various bearer options as in Impact#2)
- d) SN Modifications including SCG SRBs
- e) Handover Scenarios (various bearer options as in Impact#2)
- f) Handovers with combination E-UTRA + NR (various bearer options as in Impact#2)
- g) Carrier Aggregation in NR
- h) Failure Handling with combinations of E-UTRA+NR (various bearer options as in Impact#2)
- i) SN System Information Handling

Non-Standalone resp. Standalone deployments may be handled in the following options sub-structure:

8.1 RRC 5G NR Standalone / Single Connectivity (Option 2, 5)

8.2 RRC 5G NR Non-Standalone / Dual Connectivity (Option 3, 4, 7)

### 8.1 NR RRC

Editor's note: Core Spec completion for Standalone NR (Option 2) to happen at RAN#80 and this section will be updated after RAN5#79 (August 2018).

## 8.2 MR-DC RRC

Editor's note: Editorial updates to test purposes and Preamble of all RRC test cases shall be updated to reflect as per generic procedure parameter for Bearers in TS 38.508-1 Table 4.5.1-1 for handling multi-PDN scenarios.

### 8.2.1 UE Capability transfer / RRC Others

#### 8.2.1.1 UE capability transfer / Success

##### 8.2.1.1.1 UE capability transfer / Success / EN-DC

###### 8.2.1.1.1.1 Test Purpose (TP)

(1)

```
with { UE in RRC_CONNECTED state with EN-DC, and, MCG (E-UTRA PDCP) only }
ensure that {
  when { UE receives an UECapabilityEnquiry message that includes eutra, eutra-nr and nr }
  then { UE transmits an UECapabilityInformation message including UE radio access capability
information corresponding to the ue-CapabilityRequest variable }
}
```

###### 8.2.1.1.1.2 Conformance requirements

References: The conformance requirements covered in the present TC are specified in: TS 36.331, clause 5.6.3.3. Unless otherwise stated these are Rel-15 requirements.

[TS 36.331, clause 5.6.3.3]

The UE shall:

- 1> for NB-IoT, set the contents of *UECapabilityInformation* message as follows:
  - 2> include the UE Radio Access Capability Parameters within the *ue-Capability-Container*;
  - 2> include *ue-RadioPagingInfo*;
  - 2> submit the *UECapabilityInformation* message to lower layers for transmission, upon which the procedure ends;
- 1> else, set the contents of *UECapabilityInformation* message as follows:
  - 2> if the *ue-CapabilityRequest* includes *eutra*:
    - 3> include the *UE-EUTRA-Capability* within a *ue-CapabilityRAT-Container* and with the *rat-Type* set to *eutra*;
    - 3> if the UE supports FDD and TDD:
      - 4> set all fields of *UECapabilityInformation*, except field *fdd-Add-UE-EUTRA-Capabilities* and *tdd-Add-UE-EUTRA-Capabilities* (including their sub-fields), to include the values applicable for both FDD and TDD (i.e. functionality supported by both modes);
      - 4> if (some of) the UE capability fields have a different value for FDD and TDD:
        - 5> if for FDD, the UE supports additional functionality compared to what is indicated by the previous fields of *UECapabilityInformation*:
          - 6> include field *fdd-Add-UE-EUTRA-Capabilities* and set it to include fields reflecting the additional functionality applicable for FDD;
        - 5> if for TDD, the UE supports additional functionality compared to what is indicated by the previous fields of *UECapabilityInformation*:
          - 6> include field *tdd-Add-UE-EUTRA-Capabilities* and set it to include fields reflecting the additional functionality applicable for TDD;

NOTE 1: The UE includes fields of *XDD-Add-UE-EUTRA-Capabilities* in accordance with the following:

- The field is included only if one or more of its sub-fields (or bits in the feature group indicators string) has a value that is different compared to the value signalled elsewhere within *UE-EUTRA-Capability*; (this value signalled elsewhere is also referred to as the *Common value* that is supported for both XDD modes)
- For the fields that are included in *XDD-Add-UE-EUTRA-Capabilities*, the UE sets:
  - the sub-fields (or bits in the feature group indicators string) that are not allowed to be different to the same value as the *Common value*;
  - the sub-fields (or bits in the feature group indicators string) that are allowed to be different to a value indicating at least the same functionality as indicated by the *Common value*;

3> else (UE supports single xDD mode):

4> set all fields of *UECapabilityInformation*, except field *fdd-Add-UE-EUTRA-Capabilities* and *tdd-Add-UE-EUTRA-Capabilities* (including their sub-fields), to include the values applicable for the xDD mode supported by the UE;

3> compile a list of band combinations, candidate for inclusion in the *UECapabilityInformation* message, comprising of band combinations supported by the UE according to the following priority order (i.e. listed in order of decreasing priority):

4> include all non-CA bands, regardless of whether UE supports carrier aggregation, only:

- if the UE includes *ue-Category-v1020* (i.e. indicating category 6 to 8); or
- if for at least one of the non-CA bands, the UE supports more MIMO layers with TM9 and TM10 than implied by the UE category; or
- if the UE supports TM10 with one or more CSI processes;

4> if the *UECapabilityEnquiry* message includes *requestedFrequencyBands* and UE supports *requestedFrequencyBands*:

5> include all 2DL+1UL CA band combinations, only consisting of bands included in *requestedFrequencyBands*;

5> include all other CA band combinations, only consisting of bands included in *requestedFrequencyBands*, and prioritized in the order of *requestedFrequencyBands*, (i.e. first include remaining band combinations containing the first-listed band, then include remaining band combinations containing the second-listed band, and so on);

4> else (no requested frequency bands):

5> include all 2DL+1UL CA band combinations;

5> include all other CA band combinations;

4> if UE supports *maximumCCsRetrieval* and if the *UECapabilityEnquiry* message includes the *requestedMaxCCsDL* and the *requestedMaxCCsUL* (i.e. both UL and DL maximums are given):

5> remove from the list of candidates the band combinations for which the number of CCs in DL exceeds the value indicated in the *requestedMaxCCsDL* or for which the number of CCs in UL exceeds the value indicated in the *requestedMaxCCsUL*;

5> indicate in *requestedCCsUL* the same value as received in *requestedMaxCCsUL*;

5> indicate in *requestedCCsDL* the same value as received in *requestedMaxCCsDL*;

4> else if UE supports *maximumCCsRetrieval* and if the *UECapabilityEnquiry* message includes the *requestedMaxCCsDL* (i.e. only DL maximum limit is given):

- 5> remove from the list of candidates the band combinations for which the number of CCs in DL exceeds the value indicated in the *requestedMaxCCsDL*;
- 5> indicate value in *requestedCCsDL* the same value as received in *requestedMaxCCsDL*;
- 4> else if UE supports *maximumCCsRetrieval* and if the *UECapabilityEnquiry* message includes the *requestedMaxCCsUL* (i.e. only UL maximum limit is given):
  - 5> remove from the list of candidates the band combinations for which the number of CCs in UL exceeds the value indicated in the *requestedMaxCCsUL*;
  - 5> indicate in *requestedCCsUL* the same value as received in *requestedMaxCCsUL*;
- 4> if the UE supports *reducedIntNonContComb* and the *UECapabilityEnquiry* message includes *requestReducedIntNonContComb*:
  - 5> set *reducedIntNonContCombRequested* to true;
  - 5> remove from the list of candidates the intra-band non-contiguous CA band combinations which support is implied by another intra-band non-contiguous CA band combination included in the list of candidates as specified in TS 36.306 [5, 4.3.5.21]:
- 4> if the UE supports *requestReducedFormat* and UE supports *skipFallbackCombinations* and *UECapabilityEnquiry* message includes *requestSkipFallbackComb*:
  - 5> set *skipFallbackCombRequested* to true;
  - 5> for each band combination included in the list of candidates (including 2DL+1UL CA band combinations), starting with the ones with the lowest number of DL and UL carriers, that concerns a fallback band combination of another band combination included in the list of candidates as specified in TS 36.306 [5]:
    - 6> remove the band combination from the list of candidates;
    - 6> include *differentFallbackSupported* in the band combination included in the list of candidates whose fallback concerns the removed band combination, if its capabilities differ from the removed band combination;
- 4> if the UE supports *requestReducedFormat* and *diffFallbackCombReport*, and *UECapabilityEnquiry* message includes *requestDiffFallbackCombList*:
  - 5> if the UE does not support *skipFallbackCombinations* or *UECapabilityEnquiry* message does not include *requestSkipFallbackComb*:
    - 6> remove all band combination from the list of candidates;
  - 5> for each CA band combination indicated in *requestDiffFallbackCombList*:
    - 6> include the CA band combination, if not already in the list of candidates;
    - 6> include the fallback combinations for which the supported UE capabilities are different from the capability of the CA band combination;
  - 5> include CA band combinations indicated in *requestDiffFallbackCombList* into *requestedDiffFallbackCombList*;
- 3> if the *UECapabilityEnquiry* message includes *requestReducedFormat* and UE supports *requestReducedFormat*:
  - 4> include in *supportedBandCombinationReduced* as many as possible of the band combinations included in the list of candidates, including the non-CA combinations, determined according to the rules and priority order defined above;
- 3> else
  - 4> if the *UECapabilityEnquiry* message includes *requestedFrequencyBands* and UE supports *requestedFrequencyBands*:

- 5> include in *supportedBandCombination* as many as possible of the band combinations included in the list of candidates, including the non-CA combinations and up to 5DL+5UL CA band combinations, determined according to the rules and priority order defined above;
- 5> include in *supportedBandCombinationAdd* as many as possible of the remaining band combinations included in the list of candidates, (i.e. the candidates not included in *supportedBandCombination*), up to 5DL+5UL CA band combinations, determined according to the rules and priority order defined above;
- 4> else
  - 5> include in *supportedBandCombination* as many as possible of the band combinations included in the list of candidates, including the non-CA combinations and up to 5DL+5UL CA band combinations, determined according to the rules defined above;
  - 5> if it is not possible to include in *supportedBandCombination* all the band combinations to be included according to the above, selection of the subset of band combinations to be included is left up to UE implementation;
- 3> indicate in *requestedBands* the same bands and in the same order as included in *requestedFrequencyBands*, if received;
- 3> if the UE is a category 0, M1 or M2 UE, or supports any UE capability information in *ue-RadioPagingInfo*, according to TS 36.306 [5]:
  - 4> include *ue-RadioPagingInfo* and set the fields according to TS 36.306 [5];
- 3> for each band combination the UE included in a field of the *UECapabilityInformation* message in accordance with the previous:
  - 4> include the baseband processing combination supported for the band combination into *basebandProcessingCombList*, unless it is already included;
  - 4> for each fallback baseband processing combination of this baseband processing combination, as specified in TS 36.306 [5], for which supported baseband capabilities are different from this baseband processing combination:
    - 5> include the fallback baseband processing combinations into *basebandProcessingCombList*;
- 2> if the *ue-CapabilityRequest* includes *geran-cs* and if the UE supports GERAN CS domain:
  - 3> include the UE radio access capabilities for GERAN CS within a *ue-CapabilityRAT-Container* and with the *rat-Type* set to *geran-cs*;
- 2> if the *ue-CapabilityRequest* includes *geran-ps* and if the UE supports GERAN PS domain:
  - 3> include the UE radio access capabilities for GERAN PS within a *ue-CapabilityRAT-Container* and with the *rat-Type* set to *geran-ps*;
- 2> if the *ue-CapabilityRequest* includes *utra* and if the UE supports UTRA:
  - 3> include the UE radio access capabilities for UTRA within a *ue-CapabilityRAT-Container* and with the *rat-Type* set to *utra*;
- 2> if the *ue-CapabilityRequest* includes *cdma2000-1XRTT* and if the UE supports CDMA2000 1xRTT:
  - 3> include the UE radio access capabilities for CDMA2000 within a *ue-CapabilityRAT-Container* and with the *rat-Type* set to *cdma2000-1XRTT*;
- 2> if the *ue-CapabilityRequest* includes *nr* and if the UE supports NR:
  - 3> include the UE radio access capabilities for NR within a *ue-CapabilityRAT-Container*, with the *rat-Type* set to *nr* and in accordance with *requestedFreqBandsNR-MRDC* and as specified in TS 38.331 [X2, 5.6.1].
- 2> if the *ue-CapabilityRequest* includes *eutra-nr* and if the UE supports EN-DC:

3> include the UE radio access capabilities for EUTRA-NR within a *ue-CapabilityRAT-Container*, with the *rat-Type* set to *eutra-nr* and in accordance with *requestedFreqBandsNR-MRDC* and as specified in TS 38.331 [82, 5.6.1].

1> submit the *UECapabilityInformation* message to lower layers for transmission, upon which the procedure ends;

8.2.1.1.1.3 Test description

8.2.1.1.1.3.1 Pre-test conditions

System Simulator:

- EUTRA Cell 1 is the PCell and NR Cell 1 is the PS Cell.

UE:

- None

Preamble:

- The UE is in state RRC\_CONNECTED in EN-DC mode according to TS 38.508-1 [4] clause 4.5.4.2 with MCG and SCG.

8.2.1.1.1.3.2 Test procedure sequence

**Table 8.2.1.1.1.3.2-1: Main behaviour**

St	Procedure	Message Sequence		TP	Verdict
		U - S	Message		
1	The SS transmits a <i>UECapabilityEnquiry</i> message including <i>eutra</i> , <i>eutra-nr</i> and <i>nr</i> .	<--	<i>UECapabilityEnquiry</i>	-	-
2	Check: Does the UE transmit a <i>UECapabilityInformation</i> message including UE radio access capability information as per the <i>ue-CapabilityRequest</i> variable?	-->	<i>UECapabilityInformation</i>	1	P

8.2.1.1.1.3.3 Specific message contents

**Table 8.2.1.1.1.3.3-1: UECapabilityEnquiry (step 1, Table 8.2.1.1.1.3.2-1)**

Derivation Path: 36.508 [7], Table 4.6.1-22			
Information Element	Value/remark	Comment	Condition
UECapabilityEnquiry ::= SEQUENCE {			
criticalExtensions CHOICE {			
c1 CHOICE{			
ueCapabilityEnquiry-r8 SEQUENCE {			
ue-CapabilityRequest SEQUENCE (SIZE (1..maxRAT-Capabilities)) OF RAT TYPE {			
RAT-Type [1]	eutra		pc_EUTRA
RAT-Type [2]	nr		pc_NR_FDD or pc_NR_TDD
RAT-Type [3]	eutra-nr		pc_EN_DC
}			
nonCriticalExtension SEQUENCE {			
nonCriticalExtension SEQUENCE {			
nonCriticalExtension SEQUENCE {			
nonCriticalExtension SEQUENCE {			
nonCriticalExtension SEQUENCE {			
requestedFreqBandsNR-MRDC-r15	OCTET STRING including the FreqBandList IE according to TS 38.508-1 [4] table [4.6.4-9]		pc_EN_DC or pc_NR_FDD or pc_NR_TDD
}			
}			
}			
}			
}			
}			
}			
}			
}			

Editor's Note: Based on ongoing RAN2 work on CR 100 for TS 38.331, R2-1812411 (CR 100r3).Frequency Bands to be reported by the UE in the UECapabilityInformation message are [FFS].

**Table 8.2.1.1.1.3.3-2: UECapabilityInformation (step 2, Table 8.2.1.1.1.3.2-1)**

Derivation Path: 36.508 [7], Table 4.6.1-23			
Information Element	Value/remark	Comment	Condition
UECapabilityInformation ::= SEQUENCE {			
criticalExtensions CHOICE {			
c1 CHOICE{			
ueCapabilityInformation-r8 SEQUENCE {			
ue-CapabilityRAT-ContainerList SEQUENCE			
(SIZE (1..maxRAT-Capabilities)) OF SEQUENCE {			
rat-Type[1]	eutra		pc_EUTRA
ueCapabilityRAT-Container [1] OCTET	UE-EUTRA-Capability	Encoded as per	pc_EUTRA
STRING {}		TS 36.331 [11]	
		clause 6.3.6	
rat-Type[2]	nr		pc_NR_FDD
			or
			pc_NR_TDD
ueCapabilityRAT-Container [2] OCTET	UE-NR-Capability	Encoded as per	pc_NR_FDD
STRING {}		TS 38.331 [12]	or
		clause 5.6.1	pc_NR_TDD
rat-Type[3]	eutra-nr		pc_EN_DC
ueCapabilityRAT-Container [3] OCTET	UE-MRDC-Capability	Encoded as per	pc_EN_DC
STRING {}		TS 38.331 [12]	
		clause 5.6.1	
}			
nonCriticalExtension SEQUENCE {}	Not present		
}			
}			
}			

**Table 8.2.1.1.1.3.3-3: UE-EUTRA-Capability (Table 8.2.1.1.1.3.3-2)**

Derivation Path: 36.331 [11], clause 6.3.6			
Information Element	Value/remark	Comment	Condition
UE-EUTRA-Capability	As per TS 36.523-1 [13] Table 8.5.4.1.3.3-2; details not checked in the scope of the present NR RRC TC 8.2.1.1.1		



**Table 8.2.1.1.1.3.3-4: *UE-NR-Capability* (Table 8.2.1.1.1.3.3-2)**

Derivation Path: 38.331 [12], clause 6.3.3			
Information Element	Value/remark	Comment	Condition
UE-NR-Capability ::= SEQUENCE {			
accessStratumRelease	AccessStratumRelease		
pdcp-Parameters SEQUENCE {			
supportedROHC-Profiles SEQUENCE {			
profile0x0000	[Not checked]		
profile0x0001	[Not checked]		
profile0x0002	[Not checked]		
profile0x0003	[Not checked]		
profile0x0004	[Not checked]		
profile0x0006	[Not checked]		
profile0x0101	[Not checked]		
profile0x0102	[Not checked]		
profile0x0103	[Not checked]		
profile0x0104	[Not checked]		
}			
maxNumberROHC-ContextSessions	[Not checked]		
uplinkOnlyROHC-Profiles	[Not checked]		
continueROHC-Context	[Not checked]		
outOfOrderDelivery	[Not checked]		
shortSN	[Not checked]		
}			
ric-Parameters SEQUENCE {			
am-WithShortSN	[Checked]		pc_am_With ShortSN
um-WithShortSN	[Checked]		pc_um_With ShortSN
um-WithLongSN	[Checked]		pc_um_With LongSN
}			
mac-Parameters SEQUENCE {			
mac-ParametersCommon SEQUENCE {			
lcp-Restriction	[Not checked]		
pucch-SpatialRelInfoMAC-CE	[Not checked]		
}			
mac-ParametersXDD-Diff SEQUENCE {			
skipUplinkTxDynamic	[Checked]		pc_skipUplinkTxDynamic
logicalChannelSR-DelayTimer	[Not checked]		
longDRX-Cycle	[Checked]		pc_longDRX_Cycle
shortDRX-Cycle	[Checked]		pc_shortDRX_Cycle
multipleSR-Configurations	[Not checked]		
multipleConfiguredGrants	[Not checked]		
}			
}			
phy-Parameters SEQUENCE {			
phy-ParametersCommon SEQUENCE {			
csi-RS-CFRA-ForHO	[Checked]		pc_csi_RS_CFRA_ForHO
dynamicPRB-BundlingDL	[Not checked]		
sp-CSI-ReportPUCCH	[Not checked]		
sp-CSI-ReportPUSCH	[Not checked]		
nzp-CSI-RS-IntefMgmt	[Not checked]		
type2-SP-CSI-Feedback-LongPUCCH	[Not checked]		
precoderGranularityCORESET	[Not checked]		
dynamicHARQ-ACK-Codebook	[Not checked]		
semiStaticHARQ-ACK-Codebook	[Not checked]		
spatialBundlingHARQ-ACK	[Not checked]		
dynamicBetaOffsetInd-HARQ-ACK-CSI	[Not checked]		
pucch-Repetition-F1-3-4	[Not checked]		
ra-Type0-PUSCH	[Checked]		pc_ra_Type0_PUSCH

dynamicSwitchRA-Type0-1-PDSCH	[Not checked]		
dynamicSwitchRA-Type0-1-PUSCH	[Not checked]		
pdsch-MappingTypeA	[Checked]		pc_pdsch_MappingTypeA
pdsch-MappingTypeB	[Checked]		pc_pdsch_MappingTypeB
interleavingVRB-ToPRB-PDSCH	[Not checked]		
interSlotFreqHopping-PUSCH	[Not checked]		
type1-PUSCH-RepetitionMultiSlots	[Not checked]		
type2-PUSCH-RepetitionMultiSlots	[Not checked]		
pusch-RepetitionMultiSlots	[Not checked]		
pdsch-RepetitionMultiSlots	[Not checked]		
downlinkSPS	[Checked]		pc_downlinkSPS
configuredUL-GrantType1	[Not checked]		
configuredUL-GrantType2	[Not checked]		
pre-EmptIndication-DL	[Not checked]		
cbg-TransIndication	[Not checked]		
cbq-TransIndication-UL	[Not checked]		
cbg-FlushIndication-DL	[Not checked]		
dynamicHARQ-ACK-CodeB-CBG-Retx-DL	[Not checked]		
rateMatchingResrcSetSemi-Static	[Not checked]		
rateMatchingResrcSetDynamic	[Not checked]		
rateMatchingLTE-CRS	[Not checked]		
bwp-SwitchingDelay	[Not checked]		
}			
phy-ParametersXDD-Diff SEQUENCE {			
dynamicSFI	[Not checked]		
twoPUCCH-F0-2-ConsecSymbols	[Not checked]		
twoDifferentTPC-Loop-PUSCH	[Not checked]		
twoDifferentTPC-Loop-PUCCH	[Not checked]		
}			
phy-ParametersFRX-Diff SEQUENCE {			
dynamicSFI	[Not checked]		
oneFL-DMRS-TwoAdditionalDMRS	[Not checked]		
twoFL-DMRS	[Not checked]		
twoFL-DMRS-TwoAdditionalDMRS	[Not checked]		
oneFL-DMRS-ThreeAdditionalDMRS	[Not checked]		
supportedDMRS-TypeDL	[Not checked]		
supportedDMRS-TypeUL	[Not checked]		
semiOpenLoopCSI	[Not checked]		
csi-ReportWithoutPMI	[Not checked]		
csi-ReportWithoutCQI	[Not checked]		
onePortsPTRS	[Not checked]		
twoPUCCH-F0-2-ConsecSymbols	[Not checked]		
pucch-F2-WithFH	[Not checked]		
pucch-F3-WithFH	[Not checked]		
pucch-F4-WithFH	[Not checked]		
freqHoppingPUCCH-F0-2	[Not checked]		
freqHoppingPUCCH-F1-3-4	[Not checked]		
mux-SR-HARQ-ACK-CSI-PUCCH	[Not checked]		
uci-CodeBlockSegmentation	[Not checked]		
onePUCCH-LongAndShortFormat	[Not checked]		
twoPUCCH-AnyOthersInSlot	[Not checked]		
intraSlotFreqHopping-PUSCH	[Not checked]		
pusch-LBRM	[Not checked]		
pdccch-BlindDetectionCA	[Not checked]		
tpc-PUSCH-RNTI	[Not checked]		
tpc-PUCCH-RNTI	[Not checked]		
tpc-SRS-RNTI	[Not checked]		
absoluteTPC-Command	[Not checked]		
twoDifferentTPC-Loop-PUSCH	[Not checked]		
twoDifferentTPC-Loop-PUCCH	[Not checked]		
pusch-HalfPi-BPSK	[Not checked]		

pucch-F3-4-HalfPi-BPSK	[Not checked]		
almostContiguousCP-OFDM-UL	[Not checked]		
sp-CSI-RS	[Not checked]		
sp-CSI-IM	[Not checked]		
tdd-MultiDL-UL-SwitchPerSlot	[Not checked]		
multipleCORESET	[Not checked]		
}			
phy-ParametersFR1 SEQUENCE {			
pdcchMonitoringSingleOccasion	[Not checked]		
scs-60kHz	[Not checked]		
pdsch-256QAM-FR1	[Checked]		pc_pdsch_2 56QAM_FR1
pdsch-RE-MappingFR1	[Not checked]		
}			
phy-ParametersFR2 SEQUENCE {			
calibrationGapPA	[Not checked]		
pdsch-RE-MappingFR2	[Not checked]		
}			
}			
rf-Parameters SEQUENCE {			
supportedBandListNR SEQUENCE (SIZE (1..maxBands)) OF SEQUENCE {	1 Entry		
bandNR[1]	FreqBandIndicatorNR		
modifiedMPR-Behaviour[1]	[Not checked]		
mimo-ParametersPerBand[1] SEQUENCE {			
timeDurationForQCL SEQUENCE {			
scs-60kHz	[Not checked]		
sch-120kHz	[Not checked]		
}			
maxNumberMIMO-LayersPDSCH	MIMO-LayersDL		
maxNumberMIMO-LayersCB-PUSCH	MIMO-LayersUL		
maxNumberMIMO-LayersNonCB-PUSCH	MIMO-LayersUL		
maxNumberConfiguredTCIstates	[Not checked]		
maxNumberActiveTCI-PerCC	[Not checked]		
pusch-TransCoherence	[Not checked]		
beamCorrespondence	[Not checked]		
periodicBeamReport	[Not checked]		
aperiodicBeamReport	[Not checked]		
sp-BeamReportPUCCH	[Not checked]		
sp-BeamReportPUSCH	[Not checked]		
beamManagementSSB-CSI-RS SEQUENCE {			
maxNumberSSB-CSI-RS-ResourceOneTx	[Not checked]		
maxNumberSSB-CSI-RS-ResourceTwoTx	[Not checked]		
supportedCSI-RS-Density	[Not checked]		
}			
maxNumberRxBeam	[Not checked]		
maxNumberRxTxBeamSwitchDL SEQUENCE {			
scs-15kHz	[Not checked]		
scs-30kHz	[Not checked]		
scs-60kHz	[Not checked]		
scs-120kHz	[Not checked]		
scs-240kHz	[Not checked]		
}			
maxNumberNonGroupBeamReporting	[Not checked]		
groupBeamReporting	[Not checked]		
uplinkBeamManagement SEQUENCE {			
maxNumberSRS-ResourcePerSet	[Not checked]		
maxNumberSRS-ResourceSet	[Not checked]		
}			
maxNumberCSI-RS-BFR	[Not checked]		
maxNumberSSB-BFR	[Not checked]		
maxNumberCSI-RS-SSB-BFR	[Not checked]		
twoPortsPTRS	[Not checked]		
supportedSRS-Resources SEQUENCE {			
maxNumberAperiodicSRS-PerBWP	[Not checked]		

maxNumberAperiodicSRS-PerBWP-PerSlot	[Not checked]		
maxNumberPeriodicSRS-PerBWP	[Not checked]		
maxNumberPeriodicSRS-PerBWP-PerSlot	[Not checked]		
maxNumberSemiPersistentSRS-PerBWP	[Not checked]		
maxNumberSP-SRS-PerBWP-PerSlot	[Not checked]		
maxNumberSRS-Ports-PerResource	[Not checked]		
}			
srs-TxSwitch SEQUENCE {			
supportedSRS-TxPortSwitch	[Not checked]		
txSwitchImpactToRx	[Not checked]		
}			
maxNumberSimultaneousSRS-PerCC	[Not checked]		
lowLatencyCSI-Feedback	[Not checked]		
}			
extendedCP[1]	[Not checked]		
multipleTCI[1]	[Not checked]		
bwp-WithoutRestriction[1]	[Not checked]		
bwp-SameNumerology[1]	[Not checked]		
bwp-DiffNumerology[1]	[Not checked]		
crossCarrierSchedulingDL-SameSCS[1]	[Not checked]		
crossCarrierSchedulingUL-SameSCS[1]			
pdsch-256QAM-FR2[1]	[Checked]		pc_pdsch_2 56QAM_FR2
pusch-256QAM[1]	[Checked]		pc_pusch_2 56QAM_FR1
ue-PowerClass[1]	[Not checked]		
rateMatchingLTE-CRS[1]	[Not checked]		
}			
supportedBandCombinationList	BandCombinationList		
appliedFreqBandListFilter	FreqBandList		
}			
measParameters SEQUENCE {			
measParametersCommon SEQUENCE {			
supportedGapPattern	[Not checked]		
}			
measParametersXDD-Diff SEQUENCE {			
intraAndInterF-MeasAndReport	[Not checked]		
eventA-MeasAndReport	[Not checked]		
}			
measParametersFRX-Diff SEQUENCE {			
ss-SINR-Meas	[Not checked]		
csi-RSRP-AndRSRQ-MeasWithSSB	[Not checked]		
csi-RSRP-AndRSRQ-MeasWithoutSSB	[Not checked]		
csi-SINR-Meas	[Not checked]		
csi-RS-RLM	[Not checked]		
}			
}			
fdd-Add-UE-NR-Capabilities SEQUENCE {			
phy-ParametersXDD-Diff SEQUENCE {			
dynamicSFI	[Not checked]		
twoPUCCH-F0-2-ConsecSymbols	[Not checked]		
twoDifferentTPC-Loop-PUSCH	[Not checked]		
twoDifferentTPC-Loop-PUCCH	[Not checked]		
}			
mac-ParametersXDD-Diff SEQUENCE {			
skipUplinkTxDynamic	[Not checked]		
logicalChannelSR-DelayTimer	[Not checked]		
longDRX-Cycle	[Not checked]		
shortDRX-Cycle	[Not checked]		
multipleSR-Configurations	[Not checked]		
multipleConfiguredGrants	[Not checked]		
}			
measParametersXDD-Diff SEQUENCE {			
intraAndInterF-MeasAndReport	[Not checked]		
eventA-MeasAndReport	[Not checked]		

}			
}			
tdd-Add-UE-NR-Capabilities SEQUENCE {			
phy-ParametersXDD-Diff SEQUENCE {			
dynamicSFI	[Not checked]		
twoPUCCH-F0-2-ConsecSymbols	[Not checked]		
twoDifferentTPC-Loop-PUSCH	[Not checked]		
twoDifferentTPC-Loop-PUCCH	[Not checked]		
}			
mac-ParametersXDD-Diff SEQUENCE {			
skipUplinkTxDynamic	[Not checked]		
logicalChannelSR-DelayTimer	[Not checked]		
longDRX-Cycle	[Not checked]		
shortDRX-Cycle	[Not checked]		
multipleSR-Configurations	[Not checked]		
multipleConfiguredGrants	[Not checked]		
}			
measParametersXDD-Diff SEQUENCE {			
intraAndInterF-MeasAndReport	[Not checked]		
eventA-MeasAndReport	[Not checked]		
}			
fr1-Add-UE-NR-Capabilities SEQUENCE {			
phy-ParametersFRX-Diff SEQUENCE {			
dynamicSFI	[Not checked]		
oneFL-DMRS-TwoAdditionalDMRS	[Not checked]		
twoFL-DMRS	[Not checked]		
twoFL-DMRS-TwoAdditionalDMRS	[Not checked]		
oneFL-DMRS-ThreeAdditionalDMRS	[Not checked]		
supportedDMRS-TypeDL	[Not checked]		
supportedDMRS-TypeUL	[Not checked]		
semiOpenLoopCSI	[Not checked]		
csi-ReportWithoutPMI	[Not checked]		
csi-ReportWithoutCQI	[Not checked]		
onePortsPTRS	[Not checked]		
twoPUCCH-F0-2-ConsecSymbols	[Not checked]		
pucch-F2-WithFH	[Not checked]		
pucch-F3-WithFH	[Not checked]		
pucch-F4-WithFH	[Not checked]		
freqHoppingPUCCH-F0-2	[Not checked]		
freqHoppingPUCCH-F1-3-4	[Not checked]		
mux-SR-HARQ-ACK-CSI-PUCCH	[Not checked]		
uci-CodeBlockSegmentation	[Not checked]		
onePUCCH-LongAndShortFormat	[Not checked]		
twoPUCCH-AnyOthersInSlot	[Not checked]		
intraSlotFreqHopping-PUSCH	[Not checked]		
pusch-LBRM	[Not checked]		
pdccch-BlindDetectionCA	[Not checked]		
tpc-PUSCH-RNTI	[Not checked]		
tpc-PUCCH-RNTI	[Not checked]		
tpc-SRS-RNTI	[Not checked]		
absoluteTPC-Command	[Not checked]		
twoDifferentTPC-Loop-PUSCH	[Not checked]		
twoDifferentTPC-Loop-PUCCH	[Not checked]		
pusch-HalfPi-BPSK	[Not checked]		
pucch-F3-4-HalfPi-BPSK	[Not checked]		
almostContiguousCP-OFDM-UL	[Not checked]		
sp-CSI-RS	[Not checked]		
sp-CSI-IM	[Not checked]		
tdd-MultiDL-UL-SwitchPerSlot	[Not checked]		
multipleCORESET	[Not checked]		
}			
measParametersFRX-Diff SEQUENCE {			
ss-SINR-Meas	[Not checked]		
csi-RSRP-AndRSRQ-MeasWithSSB	[Not checked]		
csi-RSRP-AndRSRQ-MeasWithoutSSB	[Not checked]		

csi-SINR-Meas	[Not checked]		
csi-RS-RLM	[Not checked]		
}			
}			
fr2-Add-UE-NR-Capabilities SEQUENCE {			
phy-ParametersFRX-Diff SEQUENCE {	[Not checked]		
dynamicSFI	[Not checked]		
oneFL-DMRS-TwoAdditionalDMRS	[Not checked]		
twoFL-DMRS	[Not checked]		
twoFL-DMRS-TwoAdditionalDMRS	[Not checked]		
oneFL-DMRS-ThreeAdditionalDMRS	[Not checked]		
supportedDMRS-TypeDL	[Not checked]		
supportedDMRS-TypeUL	[Not checked]		
semiOpenLoopCSI	[Not checked]		
csi-ReportWithoutPMI	[Not checked]		
csi-ReportWithoutCQI	[Not checked]		
onePortsPTRS	[Not checked]		
twoPUCCH-F0-2-ConsecSymbols	[Not checked]		
pucch-F2-WithFH	[Not checked]		
pucch-F3-WithFH	[Not checked]		
pucch-F4-WithFH	[Not checked]		
freqHoppingPUCCH-F0-2	[Not checked]		
freqHoppingPUCCH-F1-3-4	[Not checked]		
mux-SR-HARQ-ACK-CSI-PUCCH	[Not checked]		
uci-CodeBlockSegmentation	[Not checked]		
onePUCCH-LongAndShortFormat	[Not checked]		
twoPUCCH-AnyOthersInSlot	[Not checked]		
intraSlotFreqHopping-PUSCH	[Not checked]		
pusch-LBRM	[Not checked]		
pdcch-BlindDetectionCA	[Not checked]		
tpc-PUSCH-RNTI	[Not checked]		
tpc-PUCCH-RNTI	[Not checked]		
tpc-SRS-RNTI	[Not checked]		
absoluteTPC-Command	[Not checked]		
twoDifferentTPC-Loop-PUSCH	[Not checked]		
twoDifferentTPC-Loop-PUCCH	[Not checked]		
pusch-HalfPi-BPSK	[Not checked]		
pucch-F3-4-HalfPi-BPSK	[Not checked]		
almostContiguousCP-OFDM-UL	[Not checked]		
sp-CSI-RS	[Not checked]		
sp-CSI-IM	[Not checked]		
tdd-MultiDL-UL-SwitchPerSlot	[Not checked]		
multipleCORESET	[Not checked]		
}			
measParametersFRX-Diff SEQUENCE {			
ss-SINR-Meas	[Not checked]		
csi-RSRP-AndRSRQ-MeasWithSSB	[Not checked]		
csi-RSRP-AndRSRQ-MeasWithoutSSB	[Not checked]		
csi-SINR-Meas	[Not checked]		
csi-RS-RLM	[Not checked]		
}			
}			
featureSets	[Not checked]		
featureSetCombinations SEQUENCE (SIZE (1..maxFeatureSetCombinations)) OF FeatureSetCombination	[Not checked]		
lateNonCriticalExtension	[Not checked]		
nonCriticalExtension SEQUENCE {			
}			
}			

**Table 8.2.1.1.1.3.3-5: *UE-MRDC-Capability* (Table 8.2.1.1.1.3.3-2)**



Derivation Path: 38.331 [12], clause 6.3.3			
Information Element	Value/remark	Comment	Condition
UE-MRDC-Capability ::= SEQUENCE {			
measParametersMRDC SEQUENCE {			
measParametersMRDC-Common SEQUENCE {			
independentGapConfig	[Not checked]		
}			
measParametersMRDC-XDD-Diff SEQUENCE {			
sftd-MeasPSCell	[Not checked]		
sftd-MeasNR-Cell	[Not checked]		
}			
measParametersMRDC-FRX-Diff SEQUENCE {			
simultaneousRxDataSSB- DiffNumerology	[Not checked]		
}			
}			
rf-ParametersMRDC SEQUENCE {			
supportedBandCombinationList	BandCombinationList		
appliedFreqBandListFilter	FreqBandList		
}			
generalParametersMRDC SEQUENCE {			
splitSRB-WithOneUL-Path	[Checked]		pc_splitSRB_WithOneUL_Path
splitDRB-withUL-Both-MCG-SCG	[Checked]		pc_splitDRB_withUL_Both_MCG_SC G
srb3	[Checked]		pc_srb3
}			
fdd-Add-UE-MRDC-Capabilities SEQUENCE {			
measParametersMRDC-XDD-Diff SEQUENCE {			
sftd-MeasPSCell	[Not checked]		
sftd-MeasNR-Cell	[Not checked]		
}			
generalParametersMRDC-XDD-Diff SEQUENCE {			
splitSRB-WithOneUL-Path	[Not checked]		
splitDRB-withUL-Both-MCG-SCG	[Not checked]		
srb3	[Not checked]		
}			
}			
tdt-Add-UE-MRDC-Capabilities SEQUENCE {			
measParametersMRDC-XDD-Diff SEQUENCE {			
sftd-MeasPSCell	[Not checked]		
sftd-MeasNR-Cell	[Not checked]		
}			
generalParametersMRDC-XDD-Diff SEQUENCE {			
splitSRB-WithOneUL-Path	[Not checked]		
splitDRB-withUL-Both-MCG-SCG	[Not checked]		
srb3	[Not checked]		
}			
}			
fr1-Add-UE-MRDC-Capabilities SEQUENCE {			
measParametersMRDC-FRX-Diff SEQUENCE {			
simultaneousRxDataSSB-DiffNumerology	[Not checked]		
}			
}			
fr2-Add-UE-MRDC-Capabilities			
measParametersMRDC-FRX-Diff SEQUENCE {			
simultaneousRxDataSSB-DiffNumerology	[Not checked]		
}			
}			
featureSetCombinations SEQUENCE (SIZE (1.. maxFeatureSetCombinations)) OF FeatureSetCombination	[Not checked]		
lateNonCriticalExtension	[Not checked]		
nonCriticalExtension SEQUENCE {}	[Not checked]		

}		
---	--	--

## 8.2.1.2 BandwidthPart Configuration / SCG

### 8.2.1.2.1 BandwidthPart Configuration / SCG / EN-DC

#### 8.2.1.2.1.1 Test Purpose (TP)

(1)

```
with { UE in RRC_CONNECTED state with EN-DC, and, MCG (E-UTRA PDCP) and SCG }
ensure that {
  when { UE receives an RRCConnectionReconfiguration message to configure a BandwidthPart for SCG }
  then { UE configures BandwidthPart for SCG and transmits an RRCConnectionReconfigurationComplete
message }
}
```

#### 8.2.1.2.1.2 Conformance requirements

References: The conformance requirements covered in the present test case are specified in: TS 36.331, clause 5.3.5.3, TS 38.331, clauses 5.3.5.3, 5.3.5.5.1 and 5.3.5.5.7. Unless otherwise stated these are Rel-15 requirements.

[TS 36.331, clause 5.3.5.3]

If the *RRCConnectionReconfiguration* message does not include the *mobilityControlInfo* and the UE is able to comply with the configuration included in this message, the UE shall:

...

- 1> if the received *RRCConnectionReconfiguration* includes the *nr-Config* and it is set to *release*: or
- 1> if the received *RRCConnectionReconfiguration* includes *endc-ReleaseAndAdd* and it is set to *TRUE*:
  - 2> perform ENDC release as specified in TS38.331 [82, 5.3.5.10];
- 1> if the received *RRCConnectionReconfiguration* includes the *sk-Counter*:
  - 2> perform key update procedure as specified in TS 38.331 [82, 5.3.5.8];
- 1> if the received *RRCConnectionReconfiguration* includes the *nr-SecondaryCellGroupConfig*:
  - 2> perform NR RRC Reconfiguration as specified in TS 38.331 [82, 5.3.5.3];
- 1> if the received *RRCConnectionReconfiguration* includes the *nr-RadioBearerConfig1*:
  - 2> perform radio bearer configuration as specified in TS 38.331 [82, 5.3.5.6];
- 1> if the received *RRCConnectionReconfiguration* includes the *nr-RadioBearerConfig2*:
  - 2> perform radio bearer configuration as specified in TS 38.331 [82, 5.3.5.6];

...

- 1> set the content of *RRCConnectionReconfigurationComplete* message as follows:
  - 2> if the *RRCConnectionReconfiguration* message includes *perCC-GapIndicationRequest*:
    - 3> include *perCC-GapIndicationList* and *numFreqEffective*;
  - 2> if the frequencies are configured for reduced measurement performance:
    - 3> include *numFreqEffectiveReduced*;
  - 2> if the received *RRCConnectionReconfiguration* message included *nr-SecondaryCellGroupConfig*:
    - 3> include *scg-ConfigResponseNR* in accordance with TS 38.331 [82, 5.3.5.3];

- 1> submit the *RRCConnectionReconfigurationComplete* message to lower layers for transmission using the new configuration, upon which the procedure ends;

[TS 38.331, clause 5.3.5.3]

The UE shall perform the following actions upon reception of the *RRCReconfiguration*:

- 1> if the *RRCReconfiguration* includes the *secondaryCellGroup*:
  - 2> perform the cell group configuration for the SCG according to 5.3.5.5;
- 1> if the *RRCReconfiguration* message contains the *radioBearerConfig*:
  - 2> perform the radio bearer configuration according to 5.3.5.6;
- 1> if the *RRCReconfiguration* message includes the *measConfig*:
  - 2> perform the measurement configuration procedure as specified in 5.5.2;
- 1> set the content of *RRCReconfigurationComplete* message as follows:
  - 2> if the *RRCReconfiguration* includes the *masterCellGroup* containing the *reportUplinkTxDirectCurrent*, or;
  - 2> if the *RRCReconfiguration* includes the *secondaryCellGroup* containing the *reportUplinkTxDirectCurrent*:
  - 3> include the *uplinkTxDirectCurrentList*;
- 1> if the UE is configured with E-UTRA *nr-SecondaryCellGroupConfig* (MCG is E-UTRA):
  - 2> if *RRCReconfiguration* was received via SRB1:
    - 3> construct *RRCReconfigurationComplete* message and submit it via the EUTRA MCG embedded in E-UTRA RRC message *RRCConnectionReconfigurationComplete* as specified in TS 36.331 [10].
    - 3> if *reconfigurationWithSync* was included in *spCellConfig* of an SCG:
      - 4> initiate the random access procedure on the SpCell, as specified in TS 38.321 [3];
    - 3> else:
      - 4> the procedure ends;
  - 2> else (*RRCReconfiguration* was received via SRB3):
    - 3> submit the *RRCReconfigurationComplete* message via SRB3 to lower layers for transmission using the new configuration.

NOTE: For EN-DC, in the case of SRB1, the random access is triggered by RRC layer itself as there is not necessarily other UL transmission. In the case of SRB3, the random access is triggered by the MAC layer due to arrival of *RRCReconfigurationComplete*.

- 1 > else:
  - 2> submit the *RRCReconfigurationComplete* message via SRB1 to lower layers for transmission using the new configuration;
- 1> if *reconfigurationWithSync* was included in *spCellConfig* of an MCG or SCG, and when MAC of an NR cell group successfully completes a random access procedure triggered above;
  - 2> stop timer T304 for that cell group;
  - 2> apply the parts of the CQI reporting configuration, the scheduling request configuration and the sounding RS configuration that do not require the UE to know the SFN of the respective target SpCell, if any;

- 2> apply the parts of the measurement and the radio resource configuration that require the UE to know the SFN of the respective target SpCell (e.g. measurement gaps, periodic CQI reporting, scheduling request configuration, sounding RS configuration), if any, upon acquiring the SFN of that target SpCell;
- 2> if the *reconfigurationWithSync* was included in *spCellConfig* of an MCG:
  - 3> if the active downlink BWP, which is indicated by the *firstActiveDownlinkBWP-Id* for the target SpCell of the MCG, has a common search space configured or if the conditions defined in FFS\_Spec [X], section FFS\_Section are satisfied;
- 4> acquire the *SIB1* of the target SpCell of the MCG, as specified in 5.2.2.3.1;
- 2> the procedure ends;

NOTE: The UE is only required to acquire broadcasted *SIB1* if the UE can acquire it without disrupting unicast data reception, i.e. the broadcast and unicast beams are quasi co-located.

[TS 38.331, clause 5.3.5.5.1]

The network configures the UE with one Secondary Cell Group (SCG). For EN-DC, the MCG is configured as specified in TS 36.331 [10]. The network provides the configuration parameters for a cell group in the *CellGroupConfig* IE.

The UE performs the following actions based on a received *CellGroupConfig* IE:

...

- 1> if the *CellGroupConfig* contains the *spCellConfig*:
  - 2> configure the SpCell as specified in 5.3.5.5.7;

...

[TS 38.331, clause 5.3.5.5.7]

The UE shall:

- 1> if the *SpCellConfig* contains the *rlf-TimersAndConstants*:
  - 2> configure the RLF timers and constants for this cell group as specified in 5.3.5.5.6.
- 1> if the *SpCellConfig* contains *spCellConfigDedicated*:
  - 2> configure the SpCell in accordance with the *spCellConfigDedicated*.
  - 2> if the any of the reference signal(s) that are used for radio link monitoring are reconfigured by the received *spCellConfigDedicated*:
    - 3> stop timer T310 for the corresponding SpCell, if running;
    - 3> reset the counters N310 and N311.

8.2.1.2.1.3 Test description

8.2.1.2.1.3.1 Pre-test conditions

System Simulator:

- E-UTRA Cell 1 is the PCell and NR Cell 1 is the PSCell.

UE:

- None.

Preamble:

- The UE is in state RRC\_CONNECTED using generic procedure parameter Connectivity (EN-DC) with MCG(s) and SCG DRBs established according to [4].

## 8.2.1.2.1.3.2 Test procedure sequence

**Table 8.2.1.2.1.3.2-1: Main behaviour**

St	Procedure	Message Sequence		TP	Verdict
		U - S	Message		
1	The SS transmits an <i>RRCConnectionReconfiguration</i> message containing NR <i>RRCReconfiguration</i> message to configure bandwidth part (BWP).	<--	<i>RRCConnectionReconfiguration</i> ( <i>RRCReconfiguration</i> )	-	-
2	Check: Does the UE transmit an <i>RRCConnectionReconfigurationComplete</i> message containing NR <i>RRCReconfigurationComplete</i> message after configuring the new bandwidth part (BWP)?	-->	<i>RRCConnectionReconfigurationComplete</i> ( <i>RRCReconfigurationComplete</i> )	1	P

## 8.2.1.2.1.3.3 Specific message contents

**Table 8.2.1.2.1.3.3-1: *RRCConnectionReconfiguration* (step 1, Table 8.2.1.2.1.3.2-1)**

FFS

**8.2.2 Radio Bearer Addition, Modification and Release****8.2.2.1 Radio Bearer Addition, Modification and Release / SRB****8.2.2.1.1 SRB3 Establishment, Reconfiguration and Release / NR addition, modification and release / EN-DC****8.2.2.1.1.1 Test Purpose (TP)**

(1)

```

with { UE in E-UTRA RRC_CONNECTED state }
ensure that {
  when { UE receives an RRCConnectionReconfiguration message to add Primary Secondary Cell and SRB3 }
  then { UE configures the Primary Secondary Cell and establishes SRB3 and sends an RRCConnectionReconfigurationComplete message on SRB1 }
}

```

(2)

```

with { UE in RRC_CONNECTED state in EN-DC mode and SRB3 configured }
ensure that {
  when { UE receives an RRCReconfiguration message on SRB3 to reconfigure NR MAC }
  then { UE reconfigures NR MAC and sends RRCReconfigurationComplete message on SRB3 }
}

```

(3)

```

with { UE in RRC_CONNECTED state in EN-DC mode }
ensure that {
  when { UE receives an RRCConnectionReconfiguration message to release on SRB1 }
  then { UE releases SRB3 and sends an RRCConnectionReconfigurationComplete message on SRB1 }
}

```

**8.2.2.1.1.2 Conformance requirements**

References: The conformance requirements covered in the present test case are specified in: TS 36.331, clause 5.3.5.3, TS 38.331, clauses 5.3.5.3, 5.3.5.5.1, 5.3.5.5.3, 5.3.5.5.4, 5.3.5.5.8, 5.3.5.5.9, 5.3.5.6.1, 5.3.5.6.2 and 5.3.5.6.3. Unless otherwise stated these are Rel-15 requirements.

[TS 36.331, 5.3.5.3]

1> if the received *RRCConnectionReconfiguration* includes the *nr-Config* and it is set to *release*: or

- 1> if the received *RRCConnectionReconfiguration* includes *endc-ReleaseAndAdd*:
  - 2> perform ENDC release as specified in TS38.331 [82, 5.3.5.x];
  - ...
- 1> if the received *RRCConnectionReconfiguration* includes the *nr-SecondaryCellGroupConfig*:
  - 2> perform NR RRC Reconfiguration as specified in TS 38.331 [82, 5.3.5.3];
- 1> if the received *RRCConnectionReconfiguration* includes the *nr-RadioBearerConfig1*:
  - 2> perform radio bearer configuration as specified in TS 38.331 [82, 5.3.5.6];
- 1> if the received *RRCConnectionReconfiguration* includes the *nr-RadioBearerConfig2*:
  - 2> perform radio bearer configuration as specified in TS 38.331 [82, 5.3.5.6];
  - ...
- 1> set the content of *RRCConnectionReconfigurationComplete* message as follows:
  - 2> if the received *RRCConnectionReconfiguration* message included *nr-SecondaryCellGroupConfig*:
    - 3> include *scg-ConfigResponseNR* in accordance with TS 38.331 [82, 5.3.5.3];
- 1> submit the *RRCConnectionReconfigurationComplete* message to lower layers for transmission using the new configuration, upon which the procedure ends;

[TS 38.331, 5.3.5.3]

The UE shall perform the following actions upon reception of the *RRCReconfiguration*:

- 1> if the *RRCReconfiguration* includes the *secondaryCellGroup*:
    - 2> perform the cell group configuration for the SCG according to 5.3.5.5;
    - ...
  - 1> if the UE is configured with E-UTRA *nr-SecondaryCellGroupConfig* (MCG is E-UTRA):
    - 2> if *RRCReconfiguration* was received via SRB1:
      - 3> construct *RRCReconfigurationComplete* message and submit it via the EUTRA MCG embedded in E-UTRA RRC message *RRCConnectionReconfigurationComplete* as specified in TS 36.331 [10];
      - ...
    - 2> else (*RRCReconfiguration* was received via SRB3):
      - 3> submit the *RRCReconfigurationComplete* message via SRB3 to lower layers for transmission using the new configuration;
- NOTE: In the case of SRB1, the random access is triggered by RRC layer itself as there is not necessarily other UL transmission. In the case of SRB3, the random access is triggered by the MAC layer due to arrival of *RRCReconfigurationComplete*.

[TS 38.331, 5.3.5.5.1]

The UE performs the following actions based on a received *CellGroupConfig* IE:

- ...
- 1> if the *CellGroupConfig* contains the *rlc-BearerToReleaseList*:
  - 2> perform RLC bearer release as specified in 5.3.5.5.3;
- 1> if the *CellGroupConfig* contains the *rlc-BearerToAddModList*:

- 2> perform the RLC bearer addition/modification as specified in 5.3.5.5.4;
- 1> if the *CellGroupConfig* contains the *mac-CellGroupConfig*:
  - 2> configure the MAC entity of this cell group as specified in 5.3.5.5.5;
- 1> if the *CellGroupConfig* contains the *sCellToReleaseList*:
  - 2> perform SCell release as specified in 5.3.5.5.8;
- ...
- 1> if the *CellGroupConfig* contains the *sCellToAddModList*:
  - 2> perform SCell addition/modification as specified in 5.3.5.5.9.

[TS 38.331, 5.3.5.5.3]

- 1> for each *logicalChannellIdentity* value included in the *rlc-BearerToReleaseList* that is part of the current UE configuration (LCH release); or
- 1> for each *logicalChannellIdentity* value that is to be released as the result of an SCG release according to 5.3.5.4:
  - 2> release the RLC entity or entities (includes discarding all pending RLC PDUs and RLC SDUs);
  - 2> release the corresponding logical channel.

[TS 38.331, 5.3.5.5.4]

For each *RLC-Bearer-Config* received in the *rlc-BearerToAddModList* IE the UE shall:

- 1> if the UE's current configuration contains a RLC bearer with the received *logicalChannellIdentity*:
  - ...
  - 2> reconfigure the RLC entity or entities in accordance with the received *rlc-Config*;

[TS 38.331, 5.3.5.5.8]

The UE shall:

- 1> if the release is triggered by reception of the *sCellToReleaseList*:
  - 2> for each *sCellIndex* value included in the *sCellToReleaseList*:
    - 3> if the current UE configuration includes an SCell with value *sCellIndex*:
      - 4> release the SCell.

[TS 38.331, 5.3.5.5.9]

The UE shall:

- 1> for each *sCellIndex* value included in the *sCellToAddModList* that is not part of the current UE configuration (SCell addition):
  - 2> add the SCell, corresponding to the *sCellIndex*, in accordance with the *sCellConfigCommon* and *sCellConfigDedicated*;
  - 2> configure lower layers to consider the SCell to be in deactivated state;
  - ...
- 1> for each *sCellIndex* value included in the *sCellToAddModList* that is part of the current UE configuration (SCell modification):
  - 2> modify the SCell configuration in accordance with the *sCellConfigDedicated*.

[TS 38.331, 5.3.5.6.1]

The UE shall perform the following actions based on a received *RadioBearerConfig* IE:

1> if the *RadioBearerConfig* includes the *srb3-ToRelease* and set to true:

2> perform the SRB release as specified in 5.3.5.6.2;

1> if the *RadioBearerConfig* includes the *srb-ToAddModList*:

2> perform the SRB addition or reconfiguration as specified in 5.3.5.6.3;

[TS 38.331, 5.3.5.6.2]

The UE shall:

1> release the PDCP entity of the SRB3.

[TS 38.331, 5.3.5.6.3]

The UE shall:

1> for each *srb-Identity* value included in the *srb-ToAddModList* that is not part of the current UE configuration (SRB establishment or reconfiguration from E-UTRA PDCP to NR PDCP):

2> establish a PDCP entity and configure it with the security algorithms according to *securityConfig* and apply the keys ( $K_{\text{RRCenc}}$  and  $K_{\text{RRCint}}$ ) associated with the  $K_{\text{eNB/S}}-K_{\text{gNB}}$  as indicated in *keyToUse*, if applicable;

...

2> if the *pdcp-Config* is included:

3> configure the PDCP entity in accordance with the received *pdcp-Config*;

8.2.2.1.1.3 Test description

8.2.2.1.1.3.1 Pre-test conditions

System Simulator:

- E-UTRA Cell 1 is the PCell and NR Cell 1 is the PSCell
- System Information combination as defined in TS 38.508-1 [4] clause 4.4.3.1.1 is used in E-UTRA Cell 1 and NR Cell 1.

UE:

- None.

Preamble:

- The UE is in state RRC\_CONNECTED using generic procedure parameter Connectivity (*EN-DC*) and DC bearers (*MCG and SCG*) according to TS 38.508-1 [4], Table 4.5.1-1.



8.2.2.1.1.3.2 Test procedure sequence

**Table 8.2.2.1.1.3.2-1: Main behaviour**

St	Procedure	Message Sequence		TP	Verdict
		U - S	Message		
1	The SS transmits an <i>RRCConnectionReconfiguration</i> message containing NR <i>RRCReconfiguration</i> message to add PSCell with SRB3 sent on SRB1/E-UTRA Cell 1.	<--	<i>RRCConnectionReconfiguration</i> ( <i>RRCReconfiguration</i> )	-	-
2	Check: Does the UE transmit an <i>RRCConnectionReconfigurationComplete</i> message containing NR <i>RRCReconfigurationComplete</i> message on SRB1/E-UTRA Cell 1?	-->	<i>RRCConnectionReconfigurationComplete</i> ( <i>RRCReconfigurationComplete</i> )	1	P
3	The SS transmits an <i>RRCReconfiguration</i> message to reconfigure NR MAC sent on SRB3/NR Cell 1.	<--	<i>RRCReconfiguration</i>	-	-
4	Check: Does the UE transmit an <i>RRCReconfigurationComplete</i> message on SRB3/NR Cell 1?	-->	<i>RRCReconfigurationComplete</i>	2	P
5	The SS transmits an <i>RRCConnectionReconfiguration</i> message to release SRB3 sent on SRB1/E-UTRA Cell 1.	<--	<i>RRCConnectionReconfiguration</i>	-	-
6	Check: Does the UE transmit an <i>RRCConnectionReconfigurationComplete</i> message on SRB1/E-UTRA Cell 1?	-->	<i>RRCConnectionReconfigurationComplete</i>	3	P
7	The SS releases the RRC connection.	-	-	-	-

8.2.2.1.1.3.3 Specific message contents

**Table 8.2.2.1.1.3.3-1: *RRCConnectionReconfiguration* (step 1, Table 8.2.2.1.1.3.2-1)**

Derivation Path: 36.508 [7], Table 4.6.1-8 with condition SRB3

**Table 8.2.2.1.1.3.3-2: *RRCReconfiguration RECONFIG* (step 3, Table 8.2.2.1.1.3.2-1)**

Derivation Path: 38.508-1 [4], Table [4.6.1-3] with condition EN-DC			
Information Element	Value/remark	Comment	Condition
<i>RRCReconfiguration</i> ::= SEQUENCE {			
criticalExtensions CHOICE {			
rrcReconfiguration ::= SEQUENCE {			
secondaryCellGroup	OCTET STRING containing CellGroupConfig RECONFIG according to Table 8.2.2.1.1.3.3-4.		
}			
}			
}			

**Table 8.2.2.1.1.3.3-3: CellGroupConfig RECONFIG (Table 8.2.2.1.1.3.3-2)**

Derivation Path: 38.508-1 [4], Table [4.6.3-8] with condition EN-DC			
Information Element	Value/remark	Comment	Condition
CellGroupConfig ::= SEQUENCE {			
cellGroupId	1		
rlc-BearerToAddModList	Not present		
rlc-BearerToReleaseList	Not present		
mac-CellGroupConfig ::= SEQUENCE {			
drx-Config	Not present		
schedulingRequestConfig	Not present		
bsr-Config SEQUENCE {			
periodicBSR-Timer	[sf32]		
retxBSR-Timer	[sf160]		
logicalChannelSR-DelayTimer	[sf64]		
}			
}			
physicalCellGroupConfig	Not present		
spCellConfig	Not present		
sCellToAddModList	Not present		
sCellToReleaseList SEQUENCE (SIZE (1..maxNrofSCells)) OF SEQUENCE {			
sCellIndex[1]	SCellIndex	NR Cell 1	
}			
}			

**Table 8.2.2.1.1.3.3-4: RRCConnectionReconfiguration (step 5, Table 8.2.2.1.1.3.2-1)**

Derivation Path: 36.508 [7], Table 4.6.1-8 with condition EN-DC			
Information Element	Value/remark	Comment	Condition
RRCConnectionReconfiguration ::= SEQUENCE {			
criticalExtensions CHOICE {			
c1 CHOICE {			
rrcConnectionReconfiguration-r8 ::= SEQUENCE {			
nonCriticalExtension SEQUENCE {			
nonCriticalExtension SEQUENCE {			
nonCriticalExtension SEQUENCE {			
nonCriticalExtension SEQUENCE {			
nonCriticalExtension SEQUENCE {			
nonCriticalExtension SEQUENCE {			
nr-Config-r15 CHOICE {	Not present		
nr-RadioBearerConfig1-r15	RadioBearerConfig		
}			
}			
}			
}			
}			
}			
}			
}			
}			
}			
}			

Table 8.2.2.1.1.3.3-5: *RadioBearerConfig* (Table 8.2.2.1.1.3.3-4)

Derivation Path: 38.508-1 [4], Table [4.6.3-n] with condition EN-DC			
Information Element	Value/remark	Comment	Condition
<i>RadioBearerConfig</i> ::= SEQUENCE {			
<i>srb-ToAddModList</i>	Not present		
<i>srb3-ToRelease</i>	true		
<i>drb-ToAddModList</i>	Not present		
<i>drb-ToReleaseList</i>	Not present		
<i>securityConfig</i>	Not present		
}			

## 8.2.2.2 Split SRB Establishment and Release

### 8.2.2.2.1 Split SRB Establishment and Release / EN-DC

#### 8.2.2.2.1.1 Test Purpose (TP)

(1)

```
with { UE in RRC_CONNECTED state with EN-DC }
ensure that {
  when { UE receives an RRCConnectionReconfiguration message to configure Split SRB }
  then { UE configures the Split SRB establishing SRB1/SRB2 on LTE and SRB1S/ SRB2S on NR and
sends an RRCConnectionReconfigurationComplete message }
}
```

(2)

```
with { UE in RRC_CONNECTED state with EN-DC and Split SRB configured }
ensure that {
  when { UE receives an RRCConnectionReconfiguration message on SRB1S on NR to release Split SRB }
  then { UE releases Split SRB and sends an RRCConnectionReconfigurationComplete message }
}
```

#### 8.2.2.2.1.2 Conformance requirements

References: The conformance requirements covered in the present TC are specified in: TS 36.331, clause 5.3.5.3 and TS 38.331: clauses 5.3.5.3, 5.3.5.5, 5.3.5.5.3, 5.3.5.6, 5.3.5.6.2 and 5.3.5.6.3. Unless and otherwise stated these are Rel-15 requirements

[TS 36.331, clause 5.3.5.3]

If the *RRCConnectionReconfiguration* message does not include the *mobilityControlInfo* and the UE is able to comply with the configuration included in this message, the UE shall:

...

1> if the received *RRCConnectionReconfiguration* includes the *nr-SecondaryCellGroupConfig*:

2> perform NR RRC Reconfiguration as specified in TS 38.331 [82, 5.3.5.3];

1> if the received *RRCConnectionReconfiguration* includes the *nr-RadioBearerConfig1*:

2> perform radio bearer configuration as specified in TS 38.331 [82, 5.3.5.6];

1> if the received *RRCConnectionReconfiguration* includes the *nr-RadioBearerConfig2*:

2> perform radio bearer configuration as specified in TS 38.331 [82, 5.3.5.6];

...

1> set the content of *RRCConnectionReconfigurationComplete* message as follows:

...

2> if the received *RRCConnectionReconfiguration* message included *nr-SecondaryCellGroupConfig*:

3> include *scg-ConfigResponseNR* in accordance with TS 38.331 [82, 5.3.5.3];

1> submit the *RRCConnectionReconfigurationComplete* message to lower layers for transmission using the new configuration, upon which the procedure ends;

[TS 38.331, clause 5.3.5.3]

The UE shall perform the following actions upon reception of the *RRCReconfiguration*:

1> if the *RRCReconfiguration* includes the *secondaryCellGroup*:

2> perform the cell group configuration for the SCG according to 5.3.5.5;

1> if the *RRCReconfiguration* message contains the *radioBearerConfig*:

2> perform the radio bearer configuration according to 5.3.5.6;

...1> if the UE is configured with E-UTRA *nr-SecondaryCellGroupConfig* (MCG is E-UTRA):

2> if *RRCReconfiguration* was received via SRB1:

3> construct *RRCReconfigurationComplete* message and submit it via the EUTRA MCG embedded in E-UTRA RRC message *RRCConnectionReconfigurationComplete* as specified in TS 36.331 [10];

[TS 38.331, clause 5.3.5.6.1]

The UE shall perform the following actions based on a received *RadioBearerConfig* IE:

...

1> if the *RadioBearerConfig* includes the *srb-ToAddModList*:

2> perform the SRB addition or reconfiguration as specified in 5.3.5.6.3;

[TS 38.331, clause 5.3.5.6.3]

The UE shall:

1> for each *srb-Identity* value included in the *srb-ToAddModList* that is not part of the current UE configuration (SRB establishment or reconfiguration from E-UTRA PDCP to NR PDCP):

2> establish a PDCP entity and configure it with the security algorithms according to *securityConfig* and apply the keys ( $K_{\text{RRCenc}}$  and  $K_{\text{RRCint}}$ ) associated with the  $K_{\text{eNB/S}}-K_{\text{gNB}}$  as indicated in *keyToUse*, if applicable;

2> if the current UE configuration as configured by E-UTRA in TS 36.331 includes an SRB identified with the same *srb-Identity* value:

3> associate the E-UTRA RLC entity and DCCH of this SRB with the NR PDCP entity;

3> release the E-UTRA PDCP entity of this SRB;

2> if the *pdcp-Config* is included:

3> configure the PDCP entity in accordance with the received *pdcp-Config*;

2> else:

3> configure the PDCP entity in accordance with the default configuration defined in 9.2.1 for the corresponding SRB;

[TS 38.331, clause 5.3.5.5.3]

The UE shall:

1> for each *logicalChannelIdentity* value included in the *rlc-BearerToReleaseList* that is part of the current UE configuration (LCH release); or

1> for each *logicalChannelIdentity* value that is to be released as the result of an SCG release according to 5.3.5.4:

2> release the RLC entity or entities (includes discarding all pending RLC PDUs and RLC SDUs);

2> release the corresponding logical channel

8.2.2.2.1.3 Test description

8.2.2.2.1.3.1 Pre-test conditions

System Simulator:

- E-UTRA Cell 1 is the PCell and NR Cell 1 is the PSCell.

UE:

- None.

Preamble:

- The UE is in state RRC\_CONNECTED using generic procedure parameter Connectivity (*EN-DC*) on E-UTRA Cell 1 according to TS 38.508-1 [4], clause 4.5.4.

8.2.2.2.1.3.2 Test procedure sequence

**Table 8.2.2.1.3.2: Main behaviour**

St	Procedure	Message Sequence		TP	Verdict
		U - S	Message		
1	SS transmits <i>RRCConnectionReconfiguration</i> message containing NR <i>RRCReconfiguration</i> message to configure Split SRBs.	<--	<i>RRCConnectionReconfiguration</i> ( <i>RRCReconfiguration</i> )	-	-
2	Check: UE sends <i>RRCConnectionReconfigurationComplete</i> containing NR <i>RRCReconfigurationComplete</i> message?	-->	<i>RRCConnectionReconfigurationComplete</i> ( <i>RRCReconfigurationComplete</i> )	1	P
3	SS transmits <i>UECapabilityEnquiry</i> message for NR capabilities on SRB1.	<--	<i>UECapabilityEnquiry</i>	-	-
4	Check: Does the UE send <i>UECapabilityInformation</i> message including UE radio access capability information for NR on SRB1S?	-->	<i>UECapabilityInformation</i>	1	P
5	SS transmits <i>RRCConnectionReconfiguration</i> message containing NR <i>RRCReconfiguration</i> message on SRB1S to release Split SRB.	<--	<i>RRCConnectionReconfiguration</i> ( <i>RRCReconfiguration</i> )	-	-
6	Check: Does the UE send <i>RRCConnectionReconfigurationComplete</i> containing NR <i>RRCReconfigurationComplete</i> message?	-->	<i>RRCConnectionReconfigurationComplete</i> ( <i>RRCReconfigurationComplete</i> )	2	P

8.2.2.2.1.3.3 Specific message contents

**Table 8.2.2.2.1.3.3-1: RRCConnectionReconfiguration (steps 1, 5, Table 8.2.2.2.1.3.2-2)**

Derivation Path: 36.508 [7], Table 4.6.1-8 with condition MCG_and_split			
Information Element	Value/remark	Comment	Condition
RRCConnectionReconfiguration ::= SEQUENCE {			
criticalExtensions CHOICE {			
c1 CHOICE{			
rrcConnectionReconfiguration-r8 ::= SEQUENCE			
{			
nonCriticalExtension SEQUENCE {			
nonCriticalExtension SEQUENCE {			
nonCriticalExtension SEQUENCE {			
nonCriticalExtension SEQUENCE {			
nonCriticalExtension SEQUENCE {			
nonCriticalExtension SEQUENCE {			
nonCriticalExtension SEQUENCE {			
nonCriticalExtension SEQUENCE {			
nr-Config-r15 CHOICE {			
setup SEQUENCE {			
nr-SecondaryCellGroupConfig-r15	RRCReconfiguration-SplitSRB		
}			
}			
nr-RadioBearerConfig1-r15	RadioBearerConfig-SplitSRB		
}			
}			
}			
}			
}			
}			
}			
}			
}			
}			
}			
}			
}			
}			
}			

**Table 8.2.2.2.1.3.3-2: RRCReconfiguration-SplitSRB (Table 8.2.2.2.1.3.3-1)**

Derivation Path: 38.508-1 [4], Table 4.6.1-3 with condition EN-DC			
Information Element	Value/remark	Comment	Condition
RRCReconfiguration ::= SEQUENCE {			
criticalExtensions CHOICE {			
rrcReconfiguration SEQUENCE {			
secondaryCellGroup	CellGroupConfig-SplitSRB		
}			
}			
}			

**Table 8.2.2.2.1.3.3-3: CellGroupConfig-SplitSRB (Table 8.2.2.2.1.3.3-2)**

Derivation Path: 38.508-1 [4], Table 4.6.3-8			
Information Element	Value/remark	Comment	Condition
CellGroupConfig ::= SEQUENCE {			
cellGroupId	1		
rlc-BearerToAddModList SEQUENCE (SIZE(1..maxLCH)) OF SEQUENCE {	2 entries		
logicalChannelIdentity[1]	1		
servedRadioBearer[1] CHOICE {			
srb-Identity	1		
}			
reestablishRLC[1]	Not present		
RLC-Config[1]	Not present.		
mac-LogicalChannelConfig[1]	Not present		
logicalChannelIdentity[2]	2		
servedRadioBearer[1] CHOICE {			
srb-Identity	2		
}			
reestablishRLC[2]	Not present		
RLC-Config[2]	Not present		
mac-LogicalChannelConfig [2]	Not present		
}			
}			

**Table 8.2.2.2.1.3.3-4: RadioBearerConfig-SplitSRB (step 1, Table 8.2.2.2.1.3.3-1)**

Derivation Path: 38.508-1 [4], Table 4.6.3-30			
Information Element	Value/remark	Comment	Condition
RadioBearerConfig ::= SEQUENCE {			
srb-ToAddModList SEQUENCE (SIZE (1..2)) OF SEQUENCE {	2 entries		
srb-Identity[1]	1		
pdcp-Config[1]	PDCP-Config-SRB1		
srb-Identity[2]	2		
pdcp-Config[2]	PDCP-Config-SRB2		
}			
}			

**Table 8.2.2.2.1.3.3-5: PDCP-Config-SRB1 (Table 8.2.2.2.1.3.3-4)**

Derivation Path: 38.508-1 [4], Table 4.6.3-21			
Information Element	Value/remark	Comment	Condition
PDCP-Config ::= SEQUENCE {			
drb	Not present		
moreThanOneRLC SEQUENCE {			
primaryPath SEQUENCE {			
cellGroup	1		
logicalChannel	1		
}			
ul-DataSplitThreshold	infinity		
pdcp-Duplication	Not present		
}			
t-Reordering	Not present		
}			

Table 8.2.2.2.1.3.3-6: PDCP-Config-SRB2 (Table 8.2.2.2.1.3.3-4)

Derivation Path: 38.508-1 [4], Table 4.6.3-21			
Information Element	Value/remark	Comment	Condition
PDCP-Config ::= SEQUENCE {			
drb	Not present		
moreThanOneRLC SEQUENCE {			
primaryPath SEQUENCE {			
cellGroup	1		
logicalChannel	2		
}			
ul-DataSplitThreshold	infinity		
pdcg-Duplication	Not present		
}			
t-Reordering	Not present		
}			

Table 8.2.2.2.1.3.3-7: RRCConnectionReconfigurationComplete (steps 2, 6, Table 8.2.2.2.1.3.2-2)

Derivation Path: 36.508 [7], Table 4.6.1-9			
Information Element	Value/remark	Comment	Condition
RRCConnectionReconfigurationComplete ::= SEQUENCE {			
criticalExtensions CHOICE {			
rrcConnectionReconfigurationComplete-r8 SEQUENCE {			
nonCriticalExtension SEQUENCE {			
nonCriticalExtension SEQUENCE {			
nonCriticalExtension SEQUENCE {			
nonCriticalExtension SEQUENCE {			
nonCriticalExtension SEQUENCE {			
nonCriticalExtension SEQUENCE {			
scg-ConfigResponseNR-r15	Present		
}			
}			
}			
}			
}			
}			
}			
}			
}			

Table 8.2.2.2.1.3.3-8: UE Capability Enquiry (step 3, Table 8.2.2.2.1.3.2-2)

Derivation Path: 36.508 [7], Table 4.6.1-22			
Information Element	Value/remark	Comment	Condition
UECapabilityEnquiry ::= SEQUENCE {			
ue-CapabilityRequest SEQUENCE (SIZE (1.. maxRAT-Capabilities)) OF SEQUENCE {	1 entry		
RAT-Type[1]	nr		
}			
}			



**Table 8.2.2.2.1.3.3-9: UECapabilityInformation (step 4, Table 8.2.2.2.1.3.2-2)**

Derivation Path: 36.508 [7], Table 4.6.1-23			
Information Element	Value/remark	Comment	Condition
UECapabilityInformation ::= SEQUENCE {			
rrc-TransactionIdentifier	RRC-TransactionIdentifier-UL		
criticalExtensions CHOICE {			
c1 CHOICE{			
ueCapabilityInformation-r8 SEQUENCE {			
ue-CapabilityRAT-ContainerList SEQUENCE (SIZE (1..maxRAT-Capabilities)) OF SEQUENCE {	1 entry		
rat-Type	nr		
ueCapabilityRAT-Container	Not checked		
}			
}			
}			
}			
}			

**Table 8.2.2.2.1.3.3-10: RRCConnectionReconfiguration (step 5, Table 8.2.2.2.1.3.2-2)**

Derivation Path: 36.508 [7], Table 4.6.1-8 condition MCG_and_split			
Information Element	Value/remark	Comment	Condition
RRCConnectionReconfiguration ::= SEQUENCE {			
criticalExtensions CHOICE {			
c1 CHOICE{			
rrcConnectionReconfiguration-r8 SEQUENCE {			
nonCriticalExtension SEQUENCE {			
nonCriticalExtension SEQUENCE {			
nonCriticalExtension SEQUENCE {			
nonCriticalExtension SEQUENCE {			
nonCriticalExtension SEQUENCE {			
nonCriticalExtension SEQUENCE {			
nonCriticalExtension SEQUENCE {			
nr-Config-r15 CHOICE {			
setup SEQUENCE {			
nr-SecondaryCellGroupConfig-r15	<i>RRCReconfiguration-SplitSRBRelease</i>		
}			
}			
}			
}			
}			
}			
}			
}			
}			

Table 8.2.2.2.1.3.3-11: RRCReconfiguration-SplitSRBRelease (Table 8.2.2.2.1.3.3-10)

Derivation Path: 38.508-1 [4], Table 4.6.1-3			
Information Element	Value/remark	Comment	Condition
RRCReconfiguration ::= SEQUENCE {			
criticalExtensions CHOICE {			
c1 CHOICE{			
rrcReconfiguration SEQUENCE {			
radioBearerConfig	Not present		
secondaryCellGroup	CellGroupConfig-SplitSRB-Release		
measConfig	Not Present		
}			
}			
}			
}			

Table 8.2.2.2.1.3.3-12: CellGroupConfig-SplitSRB-Release (Table 8.2.2.2.1.3.3-11)

Derivation Path: 38.508-1 [4], Table 4.6.3-8			
Information Element	Value/remark	Comment	Condition
CellGroupConfig ::= SEQUENCE {			
cellGroupId	1		
rlc-BearerToReleaseList SEQUENCE (SIZE(1..maxLC-ID)) OF {	2 entries		
logicalChannelIdentity[1]	1		
logicalChannelIdentity[2]	2		
}			
}			

### 8.2.2.3 Simultaneous SRB3 and Split SRB / Sequential message flow on SRB3 and Split SRB

#### 8.2.2.3.1 Simultaneous SRB3 and Split SRB / Sequential message flow on SRB3 and Split SRB / EN-DC

##### 8.2.2.3.1.1 Test Purpose (TP)

(1)

```
with { UE in E-UTRA RRC_CONNECTED state in EN_DC mode and split SRB configured with uplink on SCG path }
ensure that {
  when { UE receives an RRCConnectionReconfiguration message on SRB1s on NR to modify MCG DRB }
  then { UE sends RRCConnectionReconfigurationComplete message on SRB1s }
}
```

(2)

```
with { UE in E-UTRA RRC_CONNECTED state in EN_DC mode and split SRB configured with uplink on SCG path }
ensure that {
  when { UE receives RRCReconfiguration message on SRB3 to modify SCG DRB }
  then { UE sends RRCReconfigurationComplete message on SRB3/SCG }
}
```

(3)

```
with { UE in RRC_CONNECTED state in EN-DC mode with Split SRB configured with uplink on SCG path }
ensure that {
  when { UE receives an RRCConnectionReconfiguration message on SRB1S on NR to release SRB3 }
  then { UE releases SRB3 and sends an RRCConnectionReconfigurationComplete message on SRB1s on SCG }
}
```

(4)

```

with { UE in RRC_CONNECTED state in EN-DC mode with Split SRB configured with uplink on SCG path }
ensure that {
  when { UE receives an RRCConnectionReconfiguration message to release SRB1s on SCG path }
  then { UE releases SRB1s and sends an RRCConnectionReconfigurationComplete message on SRB1/MCG
path }
}

```

#### 8.2.2.3.1.2 Conformance requirements

References: The conformance requirements covered in the present TC are specified in: TS 36.331, clauses 5.3.5.3 and TS 38.331:5.3.5.3, 5.3.5.5, 5.3.5.5.3, 5.3.5.6, 5.3.5.6.2 and 5.3.5.6.3. Unless and otherwise stated these are Rel-15 requirements

[TS 36.331, clause 5.3.5.3]

If the *RRCConnectionReconfiguration* message does not include the *mobilityControlInfo* and the UE is able to comply with the configuration included in this message, the UE shall:

...

1> if the received *RRCConnectionReconfiguration* includes the *nr-SecondaryCellGroupConfig*:

2> perform NR RRC Reconfiguration as specified in TS 38.331 [82, 5.3.5.3];

1> if the received *RRCConnectionReconfiguration* includes the *nr-RadioBearerConfig1*:

2> perform radio bearer configuration as specified in TS 38.331 [82, 5.3.5.6];

1> if the received *RRCConnectionReconfiguration* includes the *nr-RadioBearerConfig2*:

2> perform radio bearer configuration as specified in TS 38.331 [82, 5.3.5.6];

...

1> set the content of *RRCConnectionReconfigurationComplete* message as follows:

...

2> if the received *RRCConnectionReconfiguration* message included *nr-SecondaryCellGroupConfig*:

3> include *scg-ConfigResponseNR* in accordance with TS 38.331 [82, 5.3.5.3];

1> submit the *RRCConnectionReconfigurationComplete* message to lower layers for transmission using the new configuration, upon which the procedure ends;

[TS 38.331, clause 5.3.5.3]

The UE shall perform the following actions upon reception of the *RRCReconfiguration*:

1> if the *RRCReconfiguration* includes the *secondaryCellGroup*:

2> perform the cell group configuration for the SCG according to 5.3.5.5;

1> if the *RRCReconfiguration* message contains the *radioBearerConfig*:

2> perform the radio bearer configuration according to 5.3.5.6;

1> if the UE is configured with E-UTRA *nr-SecondaryCellGroupConfig* (MCG is E-UTRA):

2> if *RRCReconfiguration* was received via SRB1:

3> construct *RRCReconfigurationComplete* message and submit it via the EUTRA MCG embedded in E-UTRA RRC message *RRCConnectionReconfigurationComplete* as specified in TS 36.331 [10].

[TS 38.331, clause 5.3.5.6.1]

The UE shall perform the following actions based on a received *RadioBearerConfig* IE:

...

- 1> if the *RadioBearerConfig* includes the *srb-ToAddModList*:
  - 2> perform the SRB addition or reconfiguration as specified in 5.3.5.6.3;

[TS 38.331, clause 5.3.5.6.3]

The UE shall:

- 1> for each *srb-Identity* value included in the *srb-ToAddModList* that is not part of the current UE configuration (SRB establishment or reconfiguration from E-UTRA PDCP to NR PDCP):
  - 2> establish a PDCP entity and configure it with the security algorithms according to *securityConfig* and apply the keys ( $K_{RRCEnc}$  and  $K_{RRCint}$ ) associated with the  $K_{eNB}/S-K_{gNB}$  as indicated in *keyToUse*, if applicable;
- 2> if the current UE configuration as configured by E-UTRA in TS 36.331 includes an SRB identified with the same *srb-Identity* value:
  - 3> associate the E-UTRA RLC entity and DCCH of this SRB with the NR PDCP entity;
  - 3> release the E-UTRA PDCP entity of this SRB;
- 2> if the *pdcp-Config* is included:
  - 3> configure the PDCP entity in accordance with the received *pdcp-Config*;
- 2> else:
  - 3> configure the PDCP entity in accordance with the default configuration defined in 9.2.1 for the corresponding SRB;

[TS 38.331, clause 5.3.5.5.3]

The UE shall:

- 1> for each *logicalChannelIdentity* value included in the *rlc-BearerToReleaseList* that is part of the current UE configuration (LCH release); or
- 1> for each *logicalChannelIdentity* value that is to be released as the result of an SCG release according to 5.3.5.4:
  - 2> release the RLC entity or entities (includes discarding all pending RLC PDUs and RLC SDUs);
  - 2> release the corresponding logical channel

8.2.2.3.1.3 Test description

8.2.2.3.1.3.1 Pre-test conditions

System Simulator:

- E-UTRA Cell 1 is the PCell and NR Cell 1 is the PSCell.
- System Information combination as defined in TS 38.508-1 [4] clause 4.4.3.1.1 is used in E-UTRA Cell 1 and NR Cell 1.

UE:

- None.

Preamble:

- The UE is in state RRC\_CONNECTED using generic procedure parameter Connectivity (*EN-DC*) and DC bearers (*MCG and SCG*) according to TS 38.508-1 [4], table 4.5.1-1.

8.2.2.3.1.3.2 Test procedure sequence

**Table 8.2.2.3.1.3.2-1: Main behaviour**

St	Procedure	Message Sequence		TP	Verdict
		U - S	Message		
1	The SS transmits an <i>RRCCONNECTIONRECONFIGURATION</i> message to reconfigure MCG DRB on SRB1s over SCG path/NR Cell 1.	<--	<i>RRCCONNECTIONRECONFIGURATION</i>	-	-
2	Check: Does the UE transmits an <i>RRCCONNECTIONRECONFIGURATIONCOMPLETE</i> message on SRB1s over the SCG path/NR Cell 1?	-->	<i>RRCCONNECTIONRECONFIGURATIONCOMPLETE</i>	1	P
3	The SS transmits an NR <i>RRCRECONFIGURATION</i> message to reconfigure SCG DRB on SRB3/NR Cell 1.	<--	<i>RRCRECONFIGURATION</i>	-	-
4	Check: Does the UE transmit an NR <i>RRCRECONFIGURATIONCOMPLETE</i> message on SRB3/NR Cell 1?	-->	<i>RRCRECONFIGURATIONCOMPLETE</i>	2	P
5	The SS transmits an <i>RRCCONNECTIONRECONFIGURATION</i> message to release SRB3 over SRB1s SCG path/NR Cell 1.	<--	<i>RRCCONNECTIONRECONFIGURATION</i>	-	-
6	Check: Does the UE transmits an <i>RRCCONNECTIONRECONFIGURATIONCOMPLETE</i> message on SRB1s over the SCG path/NR Cell 1?	-->	<i>RRCCONNECTIONRECONFIGURATIONCOMPLETE</i>	3	P
7	The SS transmits an <i>RRCCONNECTIONRECONFIGURATION</i> message to release SRB1s over SRB1s/SCG path/NR Cell 1.	<--	<i>RRCCONNECTIONRECONFIGURATION</i>	-	-
8	Check: Does the UE transmits an <i>RRCCONNECTIONRECONFIGURATIONCOMPLETE</i> message on SRB1 over the MCG path/E-UTRA Cell 1?	-->	<i>RRCCONNECTIONRECONFIGURATIONCOMPLETE</i>	4	P

8.2.2.3.1.3.3 Specific message contents

**Table 8.2.2.3.1.3.3-1: *RRCCONNECTIONRECONFIGURATION* (step 1, Table 8.2.2.3.1.3.2-1)**

Derivation Path: 38.508-1 [4], Table 4.6.1-8			
Information Element	Value/remark	Comment	Condition
<i>RRCCONNECTIONRECONFIGURATION</i> ::= SEQUENCE {			
<i>criticalExtensions</i> CHOICE {			
c1 CHOICE {			
<i>rrcConnectionReconfiguration-r8</i> SEQUENCE {			
<i>radioResourceConfigDedicated</i>	RadioResourceConfigDedicated-RECONFIG	Table 8.2.2.3.1.3.3-2	
<i>nonCriticalExtension</i>	Not present		
}			
}			
}			
}			

**Table 8.2.2.3.1.3.3-2: RadioResourceConfigDedicated-RECONFIG (Table 8.2.2.3.1.3.3-1)**

Derivation Path: 36.331 [11], clause 6.3.2			
Information Element	Value/remark	Comment	Condition
RadioResourceConfigDedicated ::= SEQUENCE {			
srb-ToAddModList	SRB-ToAddModList-RECONFIG	TS 36.508 [7] Table 4.6.3-22A	
drb-ToAddModList	Not present		
drb-ToReleaseList	Not present		
mac-MainConfig CHOICE {			
explicitValue	MAC-MainConfig-RECONFIG	Table 8.2.2.3.1.3.3-3	
}			
sps-Config	Not present		
physicalConfigDedicated	Not present		
}			

**Table 8.2.2.3.1.3.3-3: MAC-MainConfig-RECONFIG (Table 8.2.2.3.1.3.3-2)**

Derivation Path: 36.508 [7], Table 4.8.2.1.5-1			
Information Element	Value/remark	Comment	Condition
MAC-MainConfig ::= SEQUENCE {			
ul-SCH-Config SEQUENCE {			
periodicBSR-Timer	sf32		
retxBSR-Timer	sf2560		
}			
pdr-Config CHOICE {			
setup SEQUENCE {			
periodicPHR-Timer	sf1000		
prohibitPHR-Timer	sf500		
}			
}			
}			

**Table 8.2.2.3.1.3.3-4: RRCReconfiguration RECONFIG (step 3, Table 8.2.2.3.1.3.2-1)**

Derivation Path: 38.508-1 [4], Table [4.6.1-3] with condition EN-DC			
Information Element	Value/remark	Comment	Condition
RRCReconfiguration ::= SEQUENCE {			
criticalExtensions CHOICE {			
rrcReconfiguration ::= SEQUENCE {			
secondaryCellGroup	OCTET STRING containing <i>CellGroupConfig RECONFIG</i> according to table 8.2.2.3.1.3.3-5.		
}			
}			
}			

**Table 8.2.2.3.1.3.3-5: CellGroupConfig RECONFIG (Table 8.2.2.3.1.3.3-4)**

Derivation Path: 38.508-1 [4], Table [4.6.3-8] with condition EN-DC			
Information Element	Value/remark	Comment	Condition
CellGroupConfig ::= SEQUENCE {			
cellGroupId	1		
rlc-BearerToAddModList	Not present		
rlc-BearerToReleaseList	Not present		
mac-CellGroupConfig ::= SEQUENCE {			
drx-Config	Not present		
schedulingRequestConfig	Not present		
bsr-Config ::= SEQUENCE {			
periodicBSR-Timer	[sf32]		
retxBSR-Timer	[sf160]		
logicalChannelSR-DelayTimer	[sf64]		
}			
}			
physicalCellGroupConfig	Not present		
spCellConfig	Not present		
sCellToAddModList	Not present		
sCellToReleaseList SEQUENCE (SIZE (1..maxNrofSCells)) OF SEQUENCE {			
sCellIndex[1]	SCellIndex	NR Cell 1	
}			
}			

**Table 8.2.2.3.1.3.3-6: RRCConnectionReconfiguration (step 5, Table 8.2.2.3.1.3.2-1)**

Derivation Path: 36.508 [7], Table 4.6.1-8 with condition EN-DC			
Information Element	Value/remark	Comment	Condition
RRCConnectionReconfiguration ::= SEQUENCE {			
criticalExtensions CHOICE {			
c1 CHOICE{			
rrcConnectionReconfiguration-r8 SEQUENCE {			
nonCriticalExtension SEQUENCE {			
nonCriticalExtension SEQUENCE {			
nonCriticalExtension SEQUENCE {			
nonCriticalExtension SEQUENCE {			
nonCriticalExtension SEQUENCE {			
nonCriticalExtension SEQUENCE {			
nr-Config-r15 CHOICE {			
setup SEQUENCE {			
nr-SecondaryCellGroupConfig-r15	OCTET STRING containing <i>RRCReconfiguration</i> <i>RELEASE SRB3</i> according to Table 8.2.2.3.1.3.3-7.		
}			
}			
}			
}			
}			
}			
}			
}			
}			
}			
}			
}			

**Table 8.2.2.3.1.3.3-7: RadioBearerConfig RELEASE SRB3 (Table 8.2.2.3.1.3.3-6)**

Derivation Path: 38.508-1 [4], Table [4.6.3-n] with condition EN-DC			
Information Element	Value/remark	Comment	Condition
RadioBearerConfig ::= SEQUENCE {			
srb-ToAddModList	Not present		
srb3-ToRelease	true		
drb-ToAddModList	Not present		
drb-ToReleaseList	Not present		
securityConfig	Not present		
}			



**Table 8.2.2.3.1.3.3-8: RRCReconfiguration RELEASE SRB3 (Table 8.2.2.3.1.3.3-6)**

Derivation Path: 38.508-1 [4], Table [4.6.1-3] with condition EN-DC			
Information Element	Value/remark	Comment	Condition
RRCReconfiguration ::= SEQUENCE {			
criticalExtensions CHOICE {			
rrcReconfiguration ::= SEQUENCE {			
secondaryCellGroup	OCTET STRING containing <i>CellGroupConfig RELEASE SRB3</i> according to table 8.2.2.1.1.3.3-8.		
}			
}			
}			

**Table 8.2.2.3.1.3.3-9: CellGroupConfig RELEASE SRB3 (Table 8.2.2.3.1.3.3-8)**

Derivation Path: 38.508-1 [4], Table [4.6.3-8] with condition EN-DC			
Information Element	Value/remark	Comment	Condition
CellGroupConfig ::= SEQUENCE {			
cellGroupId	1		
rlc-BearerToAddModList	Not present		
rlc-BearerToReleaseList SEQUENCE (SIZE (1.. maxLC-ID)) OF {	1 entry		
LogicalChannelIdentity	3		
}			
mac-CellGroupConfig	Not present		
physicalCellGroupConfig	Not present		
sCellToAddModList	Not present		
sCellToReleaseList SEQUENCE (SIZE (1..maxNrofSCells)) OF SEQUENCE {			
sCellIndex[1]	SCellIndex	NR Cell 1	
}			
}			

**Table 8.2.2.3.1.3.3-10: RRCConnectionReconfiguration (step 7, Table 8.2.2.3.1.3.2-1)**

Derivation Path: 36.508 [7], Table 4.6.1-8 with condition EN-DC			
Information Element	Value/remark	Comment	Condition
RRCConnectionReconfiguration ::= SEQUENCE {			
criticalExtensions CHOICE {			
c1 CHOICE {			
rrcConnectionReconfiguration-r8 SEQUENCE {			
nonCriticalExtension SEQUENCE {			
nonCriticalExtension SEQUENCE {			
nonCriticalExtension SEQUENCE {			
nonCriticalExtension SEQUENCE {			
nonCriticalExtension SEQUENCE {			
nonCriticalExtension SEQUENCE {			
nonCriticalExtension SEQUENCE {			
nr-Config-r15 CHOICE {			
setup SEQUENCE {			
nr-SecondaryCellGroupConfig-r15	OCTET STRING containing RRCReconfiguration RELEASE Split according to Table 8.2.2.3.1.3.3-11		
}			
}			
nr-RadioBearerConfig1-r15	Not present		
}			
}			
}			
}			
}			
}			
}			
}			
}			
}			
}			

**Table 8.2.2.3.1.3.3-11: RRCReconfiguration RELEASE Split (Table 8.2.2.3.1.3.2-10)**

Derivation Path: 38.508-1 [4], Table [4.6.1-3] with condition EN-DC			
Information Element	Value/remark	Comment	Condition
RRCReconfiguration ::= SEQUENCE {			
criticalExtensions CHOICE {			
rrcReconfiguration ::= SEQUENCE {			
radioBearerConfig	[FFS]		
secondaryCellGroup	OCTET STRING containing CellGroupConfig RELEASE Split according to Table 8.2.2.3.1.3.3-12.		
}			
}			

Table 8.2.2.3.1.3.3-12: *CellGroupConfig RELEASE Split* (Table 8.2.2.3.1.3.3-11)

Derivation Path: 38.508-1 [4], Table [4.6.3-8] with condition EN-DC			
Information Element	Value/remark	Comment	Condition
CellGroupConfig ::= SEQUENCE {			
cellGroupId	1		
rlc-BearerToAddModList	Not present		
rlc-BearerToReleaseList SEQUENCE (SIZE (1.. maxLC-ID)) OF {	2 entries		
LogicalChannelIdentity[1]	1		
LogicalChannelIdentity[2]	2		
}			
mac-CellGroupConfig	Not present		
physicalCellGroupConfig	Not present		
sCellToAddModList	Not present		
sCellToReleaseList	Not present		
}			

## 8.2.2.4 PSCell addition, modification and release / SCG DRB

### 8.2.2.4.1 PSCell addition, modification and release / SCG DRB / EN-DC

**Editor's Note:** The conformance requirements are based on running RAN2 CRs.

#### 8.2.2.4.1.1 Test Purpose (TP)

(1)

```
with { UE in RRC_CONNECTED state with EN-DC, and, MCG (E-UTRA PDCP) only }
ensure that {
  when { UE receives an RRCConnectionReconfiguration message to add PSCell with SCG DRB }
  then { UE configures the PSCell with SCG DRB and sends an RRCConnectionReconfigurationComplete
message }
}
```

(2)

```
with { UE in RRC_CONNECTED state with EN-DC, and, MCG (E-UTRA PDCP) and SCG }
ensure that {
  when { UE receives an RRCConnectionReconfiguration message to modify SCG DRB }
  then { UE reconfigures the SCG DRB and sends an RRCConnectionReconfigurationComplete message }
}
```

(3)

```
with { UE in RRC_CONNECTED state with EN-DC, and, MCG (E-UTRA PDCP) and SCG }
ensure that {
  when { UE receives an RRCConnectionReconfiguration message to release PSCell with SCG DRB }
  then { UE releases the PSCell and SCG DRB and sends an RRCConnectionReconfigurationComplete
message }
}
```

#### 8.2.2.4.1.2 Conformance requirements

References: The conformance requirements covered in the present test case are specified in: TS 36.331, clause 5.3.5.3, TS 38.331, clauses 5.3.5.3, 5.3.5.5.7, 5.3.5.6.4 and 5.3.5.6.5. Unless otherwise stated these are Rel-15 requirements.

[TS 36.331, clause 5.3.5.3]

If the *RRCCConnectionReconfiguration* message does not include the *mobilityControlInfo* and the UE is able to comply with the configuration included in this message, the UE shall:

...

1> if the received *RRCCConnectionReconfiguration* includes the *nr-Config* and it is set to release: or

1> if the received *RRCCConnectionReconfiguration* includes *endc-ReleaseAndAdd* and it is set to *TRUE*:

- 2> perform ENDC release as specified in TS38.331 [82, 5.3.5.10];
- 1> if the received *RRCConnectionReconfiguration* includes the *sk-Counter*:
  - 2> perform key update procedure as specified in TS 38.331 [82, 5.3.5.8];
- 1> if the received *RRCConnectionReconfiguration* includes the *nr-SecondaryCellGroupConfig*:
  - 2> perform NR RRC Reconfiguration as specified in TS 38.331 [82, 5.3.5.3];
- 1> if the received *RRCConnectionReconfiguration* includes the *nr-RadioBearerConfig1*:
  - 2> perform radio bearer configuration as specified in TS 38.331 [82, 5.3.5.6];
- 1> if the received *RRCConnectionReconfiguration* includes the *nr-RadioBearerConfig2*:
  - 2> perform radio bearer configuration as specified in TS 38.331 [82, 5.3.5.6];
- ...
- 1> set the content of *RRCConnectionReconfigurationComplete* message as follows:
  - 2> if the *RRCConnectionReconfiguration* message includes *perCC-GapIndicationRequest*:
    - 3> include *perCC-GapIndicationList* and *numFreqEffective*;
  - 2> if the frequencies are configured for reduced measurement performance:
    - 3> include *numFreqEffectiveReduced*;
  - 2> if the received *RRCConnectionReconfiguration* message included *nr-SecondaryCellGroupConfig*:
    - 3> include *scg-ConfigResponseNR* in accordance with TS 38.331 [82, 5.3.5.3];
- 1> submit the *RRCConnectionReconfigurationComplete* message to lower layers for transmission using the new configuration, upon which the procedure ends;

[TS 38.331, clause 5.3.5.3]

The UE shall perform the following actions upon reception of the *RRCReconfiguration*:

- 1> if the *RRCReconfiguration* includes the *secondaryCellGroup*:
  - 2> perform the cell group configuration for the SCG according to 5.3.5.5;
- 1> if the *RRCReconfiguration* message contains the *radioBearerConfig*:
  - 2> perform the radio bearer configuration according to 5.3.5.6;
- 1> if the *RRCReconfiguration* message includes the *measConfig*:
  - 2> perform the measurement configuration procedure as specified in 5.5.2;
- 1> set the content of *RRCReconfigurationComplete* message as follows:
  - 2> if the *RRCReconfiguration* includes the *masterCellGroup* containing the *reportUplinkTxDirectCurrent*, or;
  - 2> if the *RRCReconfiguration* includes the *secondaryCellGroup* containing the *reportUplinkTxDirectCurrent*:
  - 3> include the *uplinkTxDirectCurrentList*;
- 1> if the UE is configured with E-UTRA *nr-SecondaryCellGroupConfig* (MCG is E-UTRA):
  - 2> if *RRCReconfiguration* was received via SRB1:
    - 3> construct *RRCReconfigurationComplete* message and submit it via the EUTRA MCG embedded in E-UTRA RRC message *RRCConnectionReconfigurationComplete* as specified in TS 36.331 [10].
    - 3> if *reconfigurationWithSync* was included in *spCellConfig* of an SCG:

4> initiate the random access procedure on the SpCell, as specified in TS 38.321 [3];

3> else:

4> the procedure ends;

NOTE: The order the UE sends the *RRCConnectionReconfigurationComplete* message and performs the Random Access procedure towards the SCG is left to UE implementation.

2> else (*RRCReconfiguration* was received via SRB3):

3> submit the *RRCReconfigurationComplete* message via SRB3 to lower layers for transmission using the new configuration.

NOTE: For EN-DC, in the case of SRB1, the random access is triggered by RRC layer itself as there is not necessarily other UL transmission. In the case of SRB3, the random access is triggered by the MAC layer due to arrival of *RRCReconfigurationComplete*.

1 > else:

2> submit the *RRCReconfigurationComplete* message via SRB1 to lower layers for transmission using the new configuration;

1> if *reconfigurationWithSync* was included in *spCellConfig* of an MCG or SCG, and when MAC of an NR cell group successfully completes a random access procedure triggered above;

2> stop timer T304 for that cell group;

2> apply the parts of the CQI reporting configuration, the scheduling request configuration and the sounding RS configuration that do not require the UE to know the SFN of the respective target SpCell, if any;

2> apply the parts of the measurement and the radio resource configuration that require the UE to know the SFN of the respective target SpCell (e.g. measurement gaps, periodic CQI reporting, scheduling request configuration, sounding RS configuration), if any, upon acquiring the SFN of that target SpCell;

2> if the *reconfigurationWithSync* was included in *spCellConfig* of an MCG:

3> if the active downlink BWP, which is indicated by the *firstActiveDownlinkBWP-Id* for the target SpCell of the MCG, has a common search space configured or if the conditions defined in FFS\_Spec [X], section FFS\_Section are satisfied:

4> acquire the *SIB1* of the target SpCell of the MCG, as specified in 5.2.2.3.1;

2> the procedure ends;

[TS 38.331, clause 5.3.5.5.7]

The UE shall:

1> if the *SpCellConfig* contains the *rlf-TimersAndConstants*

2> configure the RLF timers for this cell group as specified in 5.3.5.5.6;

1> if the *SpCellConfig* contains *spCellConfigDedicated*:

2> configure the SpCell in accordance with the *spCellConfigDedicated*;

2> if the any of the reference signal(s) that are used for radio link monitoring are reconfigured by the received *spCellConfigDedicated*:

3> stop timer T310 for the corresponding SpCell, if running;

3> reset the counters N310 and N311.

[TS 38.331, clause 5.3.5.6.4]

Editor's Note: FFS / TODO: Add handling for the new QoS concept (mapping of flows; configuration of QFI-to-DRB mapping; reflective QoS...) but keep also EPS-Bearer handling for the EN-DC case

The UE shall:

- 1> for each *drb-Identity* value included in the *drb-ToReleaseList* that is part of the current UE configuration (DRB release):
  - 2> release the PDCP entity;
  - 2> indicate the release of the DRB to SDAP entity associated with this DRB.( TS 37.324 [xx] section 5.3.3);
  - 2> if the UE is operating in EN-DC:
    - 3> if a new bearer is not added either with NR or E-UTRA with same *eps-BearerIdentity*:
      - 4> if the procedure was triggered due to reconfiguration with sync:
        - 5> indicate the release of the DRB and the *eps-BearerIdentity* of the released DRB to upper layers after successful reconfiguration with sync;
      - 4> else:
        - 5> indicate the release of the DRB and the *eps-BearerIdentity* of the released DRB to upper layers immediately.

NOTE: The UE does not consider the message as erroneous if the *drb-ToReleaseList* includes any *drb-Identity* value that is not part of the current UE configuration.

NOTE: Whether or not the RLC and MAC entities associated with this PDCP entity are reset or released is determined by the *CellGroupConfig*.

[TS 38.331, clause 5.3.5.6.5]

The UE shall:

- 1> for each *drb-Identity* value included in the *drb-ToAddModList* that is not part of the current UE configuration (DRB establishment including the case when full configuration option is used):
  - ...
  - 2> establish a PDCP entity and configure it in accordance with the received *pdcp-Config*;
  - 2> if the PDCP entity of this DRB is not configured with *cipheringDisabled*:
    - 3>configure the PDCP entity with the ciphering algorithms according to *securityConfig* and apply the  $K_{UPenc}$  key associated with the master key ( $K_{eNB}/K_{gNB}$ ) or the secondary key ( $S-K_{gNB}$ ) as indicated in *keyToUse*;
  - 2> if the PDCP entity of this DRB is configured with *integrityProtection*:
    - 3> configure the PDCP entity with the integrity algorithms according to *securityConfig* and apply the  $K_{UPint}$  key associated with the master ( $K_{eNB}/K_{gNB}$ ) or the secondary key ( $S-K_{gNB}$ ) as indicated in *keyToUse*;
  - 2> if the UE is operating in EN-DC:
    - 3> if the DRB was configured with the same *eps-BearerIdentity* either by NR or E-UTRA prior to receiving this reconfiguration:
      - 4> associate the established DRB with the corresponding *eps-BearerIdentity*;
    - 3> else:
      - 4> indicate the establishment of the DRB(s) and the *eps-BearerIdentity* of the established DRB(s) to upper layers;
- 1> for each *drb-Identity* value included in the *drb-ToAddModList* that is part of the current UE configuration:

- 2> if an *sdap-Config* is included, reconfigure the SDAP entity in accordance with the received *sdap-Config* as specified in TS 37.324 [xx];
- 2> if the *reestablishPDCP* is set:
  - 3> if the PDCP entity of this DRB is not configured with *cipheringDisabled*:
    - 4> configure the PDCP entity with the ciphering algorithm and  $K_{UPenc}$  key associated with the master or secondary key ( $K_{eNB/S-K_{gNB}/K_{gNB}}$ ) as indicated in *keyToUse*, i.e. the ciphering configuration shall be applied to all subsequent PDCP PDUs received and sent by the UE;
  - 3> if the PDCP entity of this DRB is configured with *integrityProtection*:
    - 4> configure the PDCP entity with the integrity algorithms according to *securityConfig* and apply the  $K_{UPint}$  key associated with the master ( $K_{eNB}/K_{gNB}$ ) or the secondary key ( $S-K_{gNB}$ ) as indicated in *keyToUse*;
  - 3> re-establish the PDCP entity of this DRB as specified in 38.323 [5], section 5.1.2;
- 2> else, if the *recoverPDCP* is set:
  - 3> trigger the PDCP entity of this DRB to perform data recovery as specified in 38.323;
- 2> if the *pdcp-Config* is included:
  - 3> reconfigure the PDCP entity in accordance with the received *pdcp-Config*.

NOTE 1: Removal and addition of the same *drb-Identity* in a single *radioResourceConfig* is not supported. In case *drb-Identity* is removed and added due to reconfiguration with sync or re-establishment with the full configuration option, the network can use the same value of *drb-Identity*.

NOTE 2: When determining whether a *drb-Identity* value is part of the current UE configuration, the UE does not distinguish which *RadioBearerConfig* and *DRB-ToAddModList* that DRB was originally configured in. To re-associate a DRB with a different key ( $K_{eNB}$  to  $S-K_{eNB}$  or vice versa), the network provides the *drb-Identity* value in the (target) *drb-ToAddModList* and sets the *reestablishPDCP* flag. The network does not list the *drb-Identity* in the (source) *drb-ToReleaseList*.

NOTE 3: When setting the *reestablishPDCP* flag for a radio bearer, the network ensures that the RLC receiver entities do not deliver old PDCP PDUs to the re-established PDCP entity. It does that e.g. by triggering a reconfiguration with sync of the cell group hosting the old RLC entity or by releasing the old RLC entity.

NOTE 4: In this specification, UE configuration refers to the parameters configured by NR RRC unless otherwise stated.

NOTE 5: Ciphering and integrity protection can be enabled or disabled for a DRB. The enabling/disabling of ciphering or integrity protection can be changed only by releasing and adding the DRB.

8.2.2.4.1.3 Test description

8.2.2.4.1.3.1 Pre-test conditions

System Simulator:

- E-UTRA Cell 1 is the PCell and NR Cell 1 is the PSCell.

UE:

- None.

Preamble:

- If *pc\_IP\_Ping* is set to TRUE then, the UE is in state RRC\_CONNECTED using generic procedure parameter Connectivity (*EN-DC*), Bearers (*MCG(s) only*) established according to TS 38.508-1 [4], clause 4.5.4.
- Else, the UE is in state RRC\_CONNECTED using generic procedure parameter Connectivity (*EN-DC*), Bearers (*MCG(s) only*) established and Test Mode (*On*) associated with UE test loop mode B configured on E-UTRA Cell 1 according to TS 38.508-1 [4], clause 4.5.4.

## 8.2.2.4.1.3.2 Test procedure sequence

Table 8.2.2.4.1.3.2-1: Main behaviour

St	Procedure	Message Sequence		TP	Verdict
		U - S	Message		
1	The SS transmits an <i>RRCCONNECTIONRECONFIGURATION</i> message containing NR <i>RRCRECONFIGURATION</i> message to add NR <i>PSCell</i> with SCG DRB. <i>RRCCONNECTIONRECONFIGURATION</i> message contains the ACTIVATE DEDICATED EPS BEARER CONTEXT REQUEST message.	<--	<i>RRCCONNECTIONRECONFIGURATION (RRCRECONFIGURATION)</i>	-	-
2	Check: Does the UE transmit an <i>RRCCONNECTIONRECONFIGURATIONCOMPLETE</i> message containing NR <i>RRCRECONFIGURATIONCOMPLETE</i> message?	-->	<i>RRCCONNECTIONRECONFIGURATIONCOMPLETE (RRCRECONFIGURATIONCOMPLETE)</i>	1	P
3	The UE transmits an <i>ULINFORMATIONTRANSFER</i> message containing the ACTIVATE DEDICATED EPS BEARER CONTEXT ACCEPT message.	-->	<i>ULINFORMATIONTRANSFER</i>	-	-
-	EXCEPTION: Steps 4a1 to 4a2 describe behaviour that depends on the UE implementation; the "lower case letter" identifies a step sequence that take place depending on the UE implementation.	-	-	-	-
4a1	IF <i>pc_IP_Ping</i> = FALSE, then, the SS transmits a CLOSE UE TEST LOOP message.	<--	CLOSE UE TEST LOOP	-	-
4a2	The UE transmits a CLOSE UE TEST LOOP COMPLETE message.	-->	CLOSE UE TEST LOOP COMPLETE	-	-
5	Check: Does the test result of generic test procedure in TS 38.508-1 subclause 4.9.1 indicate that the UE is capable of exchanging IP data on SCG DRB#2?	-	-	1	P
66	The SS transmits one IP Packet to verify data path on SCG DRB.	-	-	-	-
7	Check: Does UE send the IP Packet on SCG DRB in the uplink?	-	-	1	P
	SS transmits <i>RRCCONNECTIONRECONFIGURATION</i> message containing NR <i>RADIOBEARERCONFIG</i> to modify PDCP discardTimer value of SCG DRB.	<--	<i>RRCCONNECTIONRECONFIGURATION</i>	-	-
7	Check: Does the UE transmit an <i>RRCCONNECTIONRECONFIGURATIONCOMPLETE</i> message?	-->	<i>RRCCONNECTIONRECONFIGURATIONCOMPLETE</i>	2	P
8	Check: Does the test result of generic test procedure in TS 38.508-1 subclause 4.9.1 indicate that the UE is capable of exchanging IP data on SCG DRB#2?	-	-	2	P
9	SS transmits <i>RRCCONNECTIONRECONFIGURATION</i> message containing <i>nr-Config-r15</i> and NR <i>RADIOBEARERCONFIG</i> to release <i>PSCell</i> and SCG DRB. <i>RRCCONNECTIONRECONFIGURATION</i> message contains the DEACTIVATE EPS BEARER CONTEXT REQUEST message.	<--	<i>RRCCONNECTIONRECONFIGURATION</i>	-	-
10	Check: Does the UE transmit an <i>RRCCONNECTIONRECONFIGURATIONCOMPLETE</i> message containing NR <i>RRCRECONFIGURATIONCOMPLETE</i> message?	-->	<i>RRCCONNECTIONRECONFIGURATIONCOMPLETE</i>	3	P
11	The UE transmits an <i>ULINFORMATIONTRANSFER</i> message containing the DEACTIVATE EPS BEARER CONTEXT ACCEPT message.	-->	<i>ULINFORMATIONTRANSFER</i>	-	-



8.2.2.4.1.3.3 Specific message contents

**Table 8.2.2.4.1.3.3-1: RRCConnectionReconfiguration (step 1, Table 8.2.2.4.1.3.2-1)**

Derivation Path: 36.508 [7], Table 4.6.1-8			
Information Element	Value/remark	Comment	Condition
RRCConnectionReconfiguration ::= SEQUENCE {			
criticalExtensions CHOICE {			
c1 CHOICE {			
rrcConnectionReconfiguration-r8 ::= SEQUENCE			
{			
nonCriticalExtension ::= SEQUENCE {			
nonCriticalExtension ::= SEQUENCE {			
nonCriticalExtension ::= SEQUENCE {			
nonCriticalExtension ::= SEQUENCE {			
nonCriticalExtension ::= SEQUENCE {			
nonCriticalExtension ::= SEQUENCE {			
nonCriticalExtension ::= SEQUENCE {			
nonCriticalExtension ::= SEQUENCE {			
nr-Config-r15 CHOICE {			
setup SEQUENCE {			
nr-SecondaryCellGroupConfig-r15	OCTET STRING including the RRCReconfiguration message and the IE secondaryCellGroup.		
}			
}			
}			
}			
}			
}			
}			
}			
}			
}			
}			
}			
}			
}			
}			

**Table 8.2.2.4.1.3.3-2: RRCReconfiguration (Table 8.2.2.4.1.3.3-1)**

Derivation Path: 38.508-1 [4], Table 4.6.1-3			
Information Element	Value/remark	Comment	Condition
RRCReconfiguration ::= SEQUENCE {			
criticalExtensions CHOICE {			
rrcReconfiguration ::= SEQUENCE {			
secondaryCellGroup	CellGroupConfig		
}			
}			
}			

**Table 8.2.2.4.1.3.3-3: CellGroupConfig (Table 8.2.2.4.1.3.3-2)**

Derivation Path: 38.508-1 [4], Table 4.6.3-13			
Information Element	Value/remark	Comment	Condition
CellGroupConfig ::= SEQUENCE {			
rlc-BearerToAddModList SEQUENCE (SIZE(1..maxLCH)) OF SEQUENCE {	1 entry		
servedRadioBearer CHOICE {			
drb-Identity	2	SCG DRB Id	
}			
}			
}			

**Table 8.2.2.4.1.3.3-4: RadioBearerConfig (Table 8.2.2.4.1.3.3-1)**

Derivation Path: 38.508-1 [4], Table 4.6.3-100			
Information Element	Value/remark	Comment	Condition
RadioBearerConfig ::= SEQUENCE {			
drb-ToAddModList SEQUENCE (SIZE (1..maxDRB)) OF SEQUENCE {	1 entry		
cnAssociation CHOICE {			
eps-BearerIdentity	6	Dedicated EPS bearer Id of SCG DRB	
}			
drb-Identity	2	SCG DRB Id	
}			
securityConfig SEQUENCE {			
keyToUse	s-KgNB		
}			
}			

**Table 8.2.2.4.1.3.3-5: RRCConnectionReconfiguration (step 6, Table 8.2.2.4.1.3.2-1)**

Derivation Path: 36.508 [7], Table 4.6.1-8			
Information Element	Value/remark	Comment	Condition
RRCConnectionReconfiguration ::= SEQUENCE {			
criticalExtensions CHOICE {			
c1 CHOICE{			
rrcConnectionReconfiguration-r8 ::= SEQUENCE			
{			
nonCriticalExtension ::= SEQUENCE {			
nonCriticalExtension ::= SEQUENCE {			
nonCriticalExtension ::= SEQUENCE {			
nonCriticalExtension ::= SEQUENCE {			
nonCriticalExtension ::= SEQUENCE {			
nonCriticalExtension ::= SEQUENCE {			
nonCriticalExtension ::= SEQUENCE {			
nonCriticalExtension ::= SEQUENCE {			
nr-RadioBearerConfig1-r15	OCTET STRING including RadioBearerConfig.		
}			
}			
}			
}			
}			

**Table 8.2.2.4.1.3.3-6: RadioBearerConfig (Table 8.2.2.4.1.3.3-5)**

Derivation Path: 38.508-1 [4], Table 4.6.3-100			
Information Element	Value/remark	Comment	Condition
RadioBearerConfig ::= SEQUENCE {			
drb-ToAddModList SEQUENCE (SIZE (1..maxDRB))	1 entry		
OF SEQUENCE {			
cnAssociation CHOICE {			
eps-BearerIdentity	6	Dedicated EPS bearer Id of SCG DRB	
}			
drb-Identity	2	SCG DRB Id	
pdcp-Config	PDCP-Config		
}			
}			

**Table 8.2.2.4.1.3.3-7: PDCP-Config (Table 8.2.2.4.1.3.3-6)**

Derivation Path: 38.508-1 [4], Table 4.6.3-74			
Information Element	Value/remark	Comment	Condition
PDCP-Config ::= SEQUENCE {			
drb SEQUENCE {			
discardTimer	ms500	Other than default value.	
}			
}			

**Table 8.2.2.4.1.3.3-8: RRCConnectionReconfiguration (step 9, Table 8.2.2.4.1.3.2-1)**

Derivation Path: 36.508 [7], Table 4.6.1-8			
Information Element	Value/remark	Comment	Condition
RRCConnectionReconfiguration ::= SEQUENCE {			
criticalExtensions CHOICE {			
c1 CHOICE {			
rrcConnectionReconfiguration-r8 ::= SEQUENCE			
{			
nonCriticalExtension ::= SEQUENCE {			
nonCriticalExtension ::= SEQUENCE {			
nonCriticalExtension ::= SEQUENCE {			
nonCriticalExtension ::= SEQUENCE {			
nonCriticalExtension ::= SEQUENCE {			
nonCriticalExtension ::= SEQUENCE {			
nonCriticalExtension ::= SEQUENCE {			
nr-Config-r15 CHOICE {			
release			
}			
nr-RadioBearerConfig1-r15	OCTET STRING		
}	including		
}	RadioBearerConfig.		
}			
}			

**Table 8.2.2.4.1.3.3-9: RadioBearerConfig (Table 8.2.2.4.1.3.3-8)**

Derivation Path: 38.508-1 [4], Table 4.6.3-100			
Information Element	Value/remark	Comment	Condition
RadioBearerConfig ::= SEQUENCE {			
drb-ToReleaseList	2	SCG DRB Id	
}			

## 8.2.2.5 PSCell addition, modification and release / Split DRB

### 8.2.2.5.1 PSCell addition, modification and release / Split DRB / EN-DC

#### 8.2.2.5.1.1 Test Purpose (TP)

(1)

```
with { UE in RRC_CONNECTED state with EN-DC, and, MCG (E-UTRA PDCP) only }
ensure that {
  when { UE receives an RRCConnectionReconfiguration message to add PSCell with Split DRB }
    then { UE configures the PSCell and sends an RRCConnectionReconfigurationComplete message }
}
```

(2)

```
with { UE in RRC_CONNECTED state with EN-DC, and, MCG (E-UTRA PDCP) and Split }
ensure that {
  when { UE receives an RRCConnectionReconfiguration message to modify Split DRB }
    then { UE reconfigures the Split DRB and sends an RRCConnectionReconfigurationComplete message }
}
```

(3)

```

with { UE in RRC_CONNECTED state with EN-DC, and, MCG (E-UTRA PDCP) and Split }
ensure that {
  when { UE receives an RRCConnectionReconfiguration message to release PSCell with Split DRB }
  then { UE releases the PSCell and Split DRB and sends an RRCConnectionReconfigurationComplete
message }
}

```

#### 8.2.2.5.1.2 Conformance requirements

References: The conformance requirements covered in the present TC are specified in: TS 36.331, clause 5.3.5.3, TS 38.331, clauses 5.3.5.3, 5.3.5.5.7, 5.3.5.6.4 and 5.3.5.6.5. Unless otherwise stated these are Rel-15 requirements.

[TS 36.331, clause 5.3.5.3]

If the *RRCConnectionReconfiguration* message does not include the *mobilityControlInfo* and the UE is able to comply with the configuration included in this message, the UE shall:

...

- 1> if the received *RRCConnectionReconfiguration* includes the *nr-Config* and it is set to release: or
- 1> if the received *RRCConnectionReconfiguration* includes *endc-ReleaseAndAdd* and it is set to *TRUE*:
  - 2> perform ENDC release as specified in TS38.331 [82, 5.3.5.10];
- 1> if the received *RRCConnectionReconfiguration* includes the *sk-Counter*:
  - 2> perform key update procedure as specified in TS 38.331 [82, 5.3.5.7];
- 1> if the received *RRCConnectionReconfiguration* includes the *nr-SecondaryCellGroupConfig*:
  - 2> perform NR RRC Reconfiguration as specified in TS 38.331 [82, 5.3.5.3];
- 1> if the received *RRCConnectionReconfiguration* includes the *nr-RadioBearerConfig1*:
  - 2> perform radio bearer configuration as specified in TS 38.331 [82, 5.3.5.6];
- 1> if the received *RRCConnectionReconfiguration* includes the *nr-RadioBearerConfig2*:
  - 2> perform radio bearer configuration as specified in TS 38.331 [82, 5.3.5.6];

...

- 1> set the content of *RRCConnectionReconfigurationComplete* message as follows:
  - 2> if the *RRCConnectionReconfiguration* message includes *perCC-GapIndicationRequest*:
    - 3> include *perCC-GapIndicationList* and *numFreqEffective*;
  - 2> if the frequencies are configured for reduced measurement performance:
    - 3> include *numFreqEffectiveReduced*;
  - 2> if the received *RRCConnectionReconfiguration* message included *nr-SecondaryCellGroupConfig*:
    - 3> include *scg-ConfigResponseNR* in accordance with TS 38.331 [82, 5.3.5.3];
- 1> submit the *RRCConnectionReconfigurationComplete* message to lower layers for transmission using the new configuration, upon which the procedure ends;

[TS 38.331, clause 5.3.5.3]

The UE shall perform the following actions upon reception of the *RRCReconfiguration*:

- 1> if the *RRCReconfiguration* includes the *fullConfig*:

- 2> perform the radio configuration procedure as specified in 5.3.5.11;
  - 1> if the *RRCReconfiguration* includes the *masterCellGroup*:
    - 2> perform the cell group configuration for the received *masterCellGroup* according to 5.3.5.5;
  - 1> if the *RRCReconfiguration* includes the *keyRefresh*:
    - 2> perform security key update procedure as specified in 5.3.5.7;
  - 1> if the *RRCReconfiguration* includes the *secondaryCellGroup*:
    - 2> perform the cell group configuration for the SCG according to 5.3.5.5;
  - 1> if the *RRCReconfiguration* message contains the *radioBearerConfig*:
    - 2> perform the radio bearer configuration according to 5.3.5.6;
  - 1> if the *RRCReconfiguration* message includes the *measConfig*:
    - 2> perform the measurement configuration procedure as specified in 5.5.2;
  - 1> set the content of *RRCReconfigurationComplete* message as follows:
    - 2> if the *RRCReconfiguration* includes the *masterCellGroup* containing the *reportUplinkTxDirectCurrent*, or;
    - 2> if the *RRCReconfiguration* includes the *secondaryCellGroup* containing the *reportUplinkTxDirectCurrent*:
      - 3> include the *uplinkTxDirectCurrentList*;
  - 1> if the UE is configured with E-UTRA *nr-SecondaryCellGroupConfig* (MCG is E-UTRA):
    - 2> if *RRCReconfiguration* was received via SRB1:
      - 3> submit the *RRCReconfigurationComplete* via the EUTRA MCG embedded in E-UTRA RRC message *RRCConnectionReconfigurationComplete* as specified in TS 36.331 [10];
      - 3> if *reconfigurationWithSync* was included in *spCellConfig* of an SCG:
        - 4> initiate the random access procedure on the SpCell, as specified in TS 38.321 [3];
      - 3> else:
        - 4> the procedure ends;
- NOTE: The order the UE sends the *RRCConnectionReconfigurationComplete* message and performs the Random Access procedure towards the SCG is left to UE implementation.
- 2> else (*RRCReconfiguration* was received via SRB3):
    - 3> submit the *RRCReconfigurationComplete* message via SRB3 to lower layers for transmission using the new configuration;
- NOTE: For EN-DC, in the case of SRB1, the random access is triggered by RRC layer itself as there is not necessarily other UL transmission. In the case of SRB3, the random access is triggered by the MAC layer due to arrival of *RRCReconfigurationComplete*.
- 1 > else:
    - 2> submit the *RRCReconfigurationComplete* message via SRB1 to lower layers for transmission using the new configuration;
  - 1> if *reconfigurationWithSync* was included in *spCellConfig* of an MCG or SCG, and when MAC of an NR cell group successfully completes a random access procedure triggered above;
    - 2> stop timer T304 for that cell group;

- 2> apply the parts of the CQI reporting configuration, the scheduling request configuration and the sounding RS configuration that do not require the UE to know the SFN of the respective target SpCell, if any;
- 2> apply the parts of the measurement and the radio resource configuration that require the UE to know the SFN of the respective target SpCell (e.g. measurement gaps, periodic CQI reporting, scheduling request configuration, sounding RS configuration), if any, upon acquiring the SFN of that target SpCell;
- 2> if the *reconfigurationWithSync* was included in *spCellConfig* of an MCG:
  - 3> if the active downlink BWP, which is indicated by the *firstActiveDownlinkBWP-Id* for the target SpCell of the MCG, has a common search space configured or if the conditions defined in FFS\_Spec [X], section FFS\_Section are satisfied:
    - 4> acquire the *SIB1* of the target SpCell of the MCG, as specified in 5.2.2.3.1;
- 2> the procedure ends.

NOTE: The UE is only required to acquire broadcasted *SIB1* if the UE can acquire it without disrupting unicast data reception, i.e. the broadcast and unicast beams are quasi co-located.

[TS 38.331, clause 5.3.5.5.7]

The UE shall:

- 1> if the *SpCellConfig* contains the *rlf-TimersAndConstants*
  - 2> configure the RLF timers for this cell group as specified in 5.3.5.5.6;
- 1> if the *SpCellConfig* contains *spCellConfigDedicated*:
  - 2> configure the SpCell in accordance with the *spCellConfigDedicated*;
  - 2> if the any of the reference signal(s) that are used for radio link monitoring are reconfigured by the received *spCellConfigDedicated*:
    - 3> stop timer T310 for the corresponding SpCell, if running;
  - 3> reset the counters N310 and N311.

[TS 38.331, clause 5.3.5.6.4]

**Editor's Note: FFS / TODO: Add handling for the new QoS concept (mapping of flows; configuration of QFI-to-DRB mapping; reflective QoS...) but keep also EPS-Bearer handling for the EN-DC case**

The UE shall:

- 1> for each *drb-Identity* value included in the *drb-ToReleaseList* that is part of the current UE configuration (DRB release):
  - 2> release the PDCP entity;
  - 2> indicate the release of the DRB to SDAP entity associated with this DRB.( TS 37.324 [xx] section 5.3.3);
  - 2> if the UE is operating in EN-DC:
- 1> if a new bearer is not added either with NR or E-UTRA with same *eps-BearerIdentity*:
  - 2> if the procedure was triggered due to reconfiguration with sync:
    - 3> indicate the release of the DRB and the *eps-BearerIdentity* of the released DRB to upper layers after successful reconfiguration with sync;
  - 2> else:
    - 3> indicate the release of the DRB and the *eps-BearerIdentity* of the released DRB to upper layers immediately;

NOTE: The UE does not consider the message as erroneous if the *drb-ToReleaseList* includes any *drb-Identity* value that is not part of the current UE configuration.

NOTE: Whether or not the RLC and MAC entities associated with this PDCP entity are reset or released is determined by the *CellGroupConfig*.

[TS 38.331, clause 5.3.5.6.5]

The UE shall:

- 1> for each *drb-Identity* value included in the *drb-ToAddModList* that is not part of the current UE configuration (DRB establishment including the case when full configuration option is used):
  - 2> if an *sdap-Config* is included:
    - 3> if an SDAP entity with the received *pdu-Session* does not exist:
      - 4> establish an SDAP entity as specified in TS 37.324 [xx] section 5.1.1;
    - 3> configure the SDAP entity in accordance with the received *sdap-Config* as specified in TS 37.324 [xx] and associate the DRB with the SDAP entity;
  - 2> establish a PDCP entity and configure it in accordance with the received *pdcp-Config*;
  - 2> if the PDCP entity of this DRB is not configured with *cipheringDisabled*:
    - 3> configure the PDCP entity with the ciphering algorithms according to *securityConfig* and apply the  $K_{UPenc}$  key associated with the master key ( $K_{eNB}/K_{gNB}$ ) or the secondary key (S- $K_{gNB}$ ) as indicated in *keyToUse*;
  - 2> if the PDCP entity of this DRB is configured with *integrityProtection*:
    - 3> configure the PDCP entity with the integrity algorithms according to *securityConfig* and apply the  $K_{UPint}$  key associated with the master ( $K_{eNB}/K_{gNB}$ ) or the secondary key (S- $K_{gNB}$ ) as indicated in *keyToUse*;
  - 2> if the UE is operating in EN-DC:
    - 3> if the DRB was configured with the same *eps-BearerIdentity* either by NR or E-UTRA prior to receiving this reconfiguration:
      - 4> associate the established DRB with the corresponding *eps-BearerIdentity*;
    - 3> else:
      - 4> indicate the establishment of the DRB(s) and the *eps-BearerIdentity* of the established DRB(s) to upper layers;
- 2> for each *drb-Identity* value included in the *drb-ToAddModList* that is part of the current UE configuration:
  - 2> if an *sdap-Config* is included, reconfigure the SDAP entity in accordance with the received *sdap-Config* as specified in TS 37.324 [xx];
  - 2> if the *reestablishPDCP* is set:
    - 3> if the PDCP entity of this DRB is not configured with *cipheringDisabled*:
      - 4> configure the PDCP entity with the ciphering algorithm and  $K_{UPenc}$  key associated with the master or secondary key ( $K_{eNB}/S-K_{gNB}/K_{gNB}$ ) as indicated in *keyToUse*, i.e. the ciphering configuration shall be applied to all subsequent PDCP PDUs received and sent by the UE;
    - 3> if the PDCP entity of this DRB is configured with *integrityProtection*:
      - 4> configure the PDCP entity with the integrity algorithms according to *securityConfig* and apply the  $K_{UPint}$  key associated with the master ( $K_{eNB}/K_{gNB}$ ) or the secondary key (S- $K_{gNB}$ ) as indicated in *keyToUse*;
    - 3> re-establish the PDCP entity of this DRB as specified in 38.323 [5], section 5.1.2;



2> else, if the *recoverPDCP* is set:

3> trigger the PDCP entity of this DRB to perform data recovery as specified in 38.323;

2> if the *pdcp-Config* is included:

3> reconfigure the PDCP entity in accordance with the received *pdcp-Config*.

NOTE 1: Removal and addition of the same *drb-Identity* in a single *radioResourceConfig* is not supported. In case *drb-Identity* is removed and added due to reconfiguration with sync or re-establishment with the full configuration option, the network can use the same value of *drb-Identity*.

NOTE 2: When determining whether a *drb-Identity* value is part of the current UE configuration, the UE does not distinguish which *RadioBearerConfig* and *DRB-ToAddModList* that DRB was originally configured in. To re-associate a DRB with a different key (KeNB to S-KeNB or vice versa), the network provides the *drb-Identity* value in the (target) *drb-ToAddModList* and sets the *reestablishPDCP* flag. The network does not list the *drb-Identity* in the (source) *drb-ToReleaseList*.

NOTE 3: When setting the *reestablishPDCP* flag for a radio bearer, the network ensures that the RLC receiver entities do not deliver old PDCP PDUs to the re-established PDCP entity. It does that e.g. by triggering a reconfiguration with sync of the cell group hosting the old RLC entity or by releasing the old RLC entity.

NOTE 4: In this specification, UE configuration refers to the parameters configured by NR RRC unless otherwise stated.

NOTE 5: Ciphering and integrity protection can be enabled or disabled for a DRB. The enabling/disabling of ciphering or integrity protection can be changed only by releasing and adding the DRB.

8.2.2.5.1.3 Test description

8.2.2.5.1.3.1 Pre-test conditions

System Simulator:

- E-UTRA Cell 1 is the PCell and NR Cell 1 is the PSCell.

UE:

- None.

Preamble:

- If *pc\_IP\_Ping* is set to TRUE then, the UE is in state RRC\_CONNECTED using generic procedure parameter Connectivity (*EN-DC*), Bearers (*MCG(s) only*) established according to TS 38.508-1 [4], clause 4.5.4.
- Else, the UE is in state RRC\_CONNECTED using generic procedure parameter Connectivity (*EN-DC*), Bearers (*MCG(s) only*) established and Test Mode (*On*) associated with UE test loop mode B configured on E-UTRA Cell 1 according to TS 38.508-1 [4], clause 4.5.4.

## 8.2.2.5.1.3.2 Test procedure sequence

Table 8.2.2.5.1.3.2-1: Main behaviour

St	Procedure	Message Sequence		TP	Verdict
		U - S	Message		
1	The SS transmits an <i>RRCCONNECTIONRECONFIGURATION</i> message containing NR <i>RRCRECONFIGURATION</i> message to add NR <i>PSCell</i> with Split DRB. <i>RRCCONNECTIONRECONFIGURATION</i> message contains the ACTIVATE DEDICATED EPS BEARER CONTEXT REQUEST message.	<--	<i>RRCCONNECTIONRECONFIGURATION (RRCRECONFIGURATION)</i>	-	-
2	Check: Does the UE transmit an <i>RRCCONNECTIONRECONFIGURATIONCOMPLETE</i> message containing NR <i>RRCRECONFIGURATIONCOMPLETE</i> message?	-->	<i>RRCCONNECTIONRECONFIGURATIONCOMPLETE (RRCRECONFIGURATIONCOMPLETE)</i>	1	P
3	The UE transmits an <i>ULINFORMATIONTRANSFER</i> message containing the ACTIVATE DEDICATED EPS BEARER CONTEXT ACCEPT message.	-->	<i>ULINFORMATIONTRANSFER</i>	-	-
-	EXCEPTION: Steps 4a1 to 4a2 describe behaviour that depends on the UE implementation; the "lower case letter" identifies a step sequence that take place depending on the UE implementation.	-	-	-	-
4a1	IF <i>pc_IP_Ping</i> = FALSE, then the SS transmits a CLOSE UE TEST LOOP message.	<--	CLOSE UE TEST LOOP	-	-
4a2	The UE transmits a CLOSE UE TEST LOOP COMPLETE message.	-->	CLOSE UE TEST LOOP COMPLETE	-	-
5	Check: Does the test result of generic test procedure in TS 38.508-1 subclause 4.9.1 indicate that the UE is capable of exchanging IP data on Split DRB#2 using NR radio path?	-	-	1	P
6	SS transmits <i>RRCCONNECTIONRECONFIGURATION</i> message containing NR <i>RADIOBEARERCONFIG</i> to modify PDCP discardTimer value of Split DRB.	<--	<i>RRCCONNECTIONRECONFIGURATION</i>	-	-
7	Check: Does the UE transmit an <i>RRCCONNECTIONRECONFIGURATIONCOMPLETE</i> message?	-->	<i>RRCCONNECTIONRECONFIGURATIONCOMPLETE</i>	2	P
8	Check: Does the test result of generic test procedure in TS 38.508-1 subclause 4.9.1 indicate that the UE is capable of exchanging IP data on the Split DRB#2 using NR radio path?	-	-	2	P
9	SS transmits <i>RRCCONNECTIONRECONFIGURATION</i> message containing <i>nr-Config-r15</i> and NR <i>RADIOBEARERCONFIG</i> to release <i>PSCell</i> and Split DRB. <i>RRCCONNECTIONRECONFIGURATION</i> message contains the DEACTIVATE EPS BEARER CONTEXT REQUEST message.	<--	<i>RRCCONNECTIONRECONFIGURATION</i>	-	-
10	Check: Does the UE transmit an <i>RRCCONNECTIONRECONFIGURATIONCOMPLETE</i> message containing NR <i>RRCRECONFIGURATIONCOMPLETE</i> message?	-->	<i>RRCCONNECTIONRECONFIGURATIONCOMPLETE</i>	3	P
11	The UE transmits an <i>ULINFORMATIONTRANSFER</i> message containing the DEACTIVATE EPS BEARER CONTEXT ACCEPT message.	-->	<i>ULINFORMATIONTRANSFER</i>	-	-

8.2.2.5.1.3.3 Specific message contents

**Table 8.2.2.5.1.3.3-1: RRCConnectionReconfiguration (step 1, Table 8.2.2.5.1.3.2-1)**

Derivation Path: 36.508 [7], Table 4.6.1-8			
Information Element	Value/remark	Comment	Condition
RRCConnectionReconfiguration ::= SEQUENCE {			
criticalExtensions CHOICE {			
c1 CHOICE {			
rrcConnectionReconfiguration-r8 ::= SEQUENCE			
{			
nonCriticalExtension ::= SEQUENCE {			
nonCriticalExtension ::= SEQUENCE {			
nonCriticalExtension ::= SEQUENCE {			
nonCriticalExtension ::= SEQUENCE {			
nonCriticalExtension ::= SEQUENCE {			
nonCriticalExtension ::= SEQUENCE {			
nonCriticalExtension ::= SEQUENCE {			
nonCriticalExtension ::= SEQUENCE {			
nr-Config-r15 CHOICE {			
setup SEQUENCE {			
nr-SecondaryCellGroupConfig-r15	OCTET STRING including the RRCReconfiguration message and the IE secondaryCellGroup.		
}			
}			
}			
}			
}			
}			
}			
}			
}			
}			
}			
}			
}			
}			
}			

**Table 8.2.2.5.1.3.3-2: RRCReconfiguration (Table 8.2.2.5.1.3.3-1)**

Derivation Path: 38.508-1 [4], Table 4.6.1-3, condition EN-DC

**Table 8.2.2.5.1.3.3-3: RadioBearerConfig (Table 8.2.2.5.1.3.3-1)**

Derivation Path: 38.508-1 [4], Table 4.6.3-100, condition EN-DC

**Table 8.2.2.5.1.3.3-4: PDCP-Config (Table 8.2.2.5.1.3.3-1)**

Derivation Path: 38.508-1 [4], Table 4.6.3-74, condition Split

**Table 8.2.2.5.1.3.3-5: RRCConnectionReconfiguration (step 6, Table 8.2.2.5.1.3.2-1)**

Derivation Path: 36.508 [7], Table 4.6.1-8			
Information Element	Value/remark	Comment	Condition
RRCConnectionReconfiguration ::= SEQUENCE {			
criticalExtensions CHOICE {			
c1 CHOICE{			
rrcConnectionReconfiguration-r8 ::= SEQUENCE			
{			
nonCriticalExtension ::= SEQUENCE {			
nonCriticalExtension ::= SEQUENCE {			
nonCriticalExtension ::= SEQUENCE {			
nonCriticalExtension ::= SEQUENCE {			
nonCriticalExtension ::= SEQUENCE {			
nonCriticalExtension ::= SEQUENCE {			
nonCriticalExtension ::= SEQUENCE {			
nonCriticalExtension ::= SEQUENCE {			
nr-RadioBearerConfig1-r15	OCTET STRING		
including	including		
RadioBearerConfig.	RadioBearerConfig.		
}			
}			
}			
}			
}			

**Table 8.2.2.5.1.3.3-6: RadioBearerConfig (Table 8.2.2.5.1.3.3-5)**

Derivation Path: 38.508-1 [4], Table 4.6.3-100, condition EN-DC
---

**Table 8.2.2.5.1.3.3-7: PDCP-Config (Table 8.2.2.5.1.3.3-6)**

Derivation Path: 38.508-1 [4], Table 4.6.3-74			
Information Element	Value/remark	Comment	Condition
PDCP-Config ::= SEQUENCE {			
drb SEQUENCE {			
discardTimer	ms500	Other than default value.	
}			
}			

**Table 8.2.2.5.1.3.3-8: RRCConnectionReconfiguration (step 9, Table 8.2.2.5.1.3.2-1)**

Derivation Path: 36.508 [7], Table 4.6.1-8			
Information Element	Value/remark	Comment	Condition
RRCConnectionReconfiguration ::= SEQUENCE {			
criticalExtensions CHOICE {			
c1 CHOICE{			
rrcConnectionReconfiguration-r8 ::= SEQUENCE			
{			
nonCriticalExtension ::= SEQUENCE {			
nonCriticalExtension ::= SEQUENCE {			
nonCriticalExtension ::= SEQUENCE {			
nonCriticalExtension ::= SEQUENCE {			
nonCriticalExtension ::= SEQUENCE {			
nonCriticalExtension ::= SEQUENCE {			
nonCriticalExtension ::= SEQUENCE {			
nr-Config-r15 CHOICE {			
release			
}			
nr-RadioBearerConfig1-r15	OCTET STRING including RadioBearerConfig.		
}			
}			
}			
}			
}			
}			
}			
}			
}			
}			

**Table 8.2.2.5.1.3.3-9: RadioBearerConfig (Table 8.2.2.5.1.3.3-8)**

Derivation Path: 38.508-1 [4], Table 4.6.3-100			
Information Element	Value/remark	Comment	Condition
RadioBearerConfig ::= SEQUENCE {			
drb-ToReleaseList	2	Split DRB Id	
}			

**8.2.2.6 Bearer Modification / MCG DRB**

**8.2.2.6.1 Bearer Modification / MCG DRB / SRB / PDCP version change / EN-DC**

**8.2.2.6.1.1 Test Purpose (TP)**

(1)

```
with { UE in RRC_CONNECTED state with EN-DC, and, MCG (E-UTRA PDCP) only }
ensure that {
  when { UE receives an RRCConnectionReconfiguration with mobility message to change PDCP version of the SRB1 and SRB2 from E-UTRA PDCP to NR PDCP }
  then { UE performs PDCP version change and sends an RRCConnectionReconfigurationComplete message }
}
```

(2)

```
with { UE in RRC_CONNECTED state with EN-DC, and, MCG (E-UTRA PDCP) only with SRB1 and SRB2 using NR PDCP }
ensure that {
```

```

when { UE receives an RRCConnectionReconfiguration with mobility message to change PDCP version of
the MCG DRB from E-UTRA PDCP to NR PDCP }
  then { UE performs PDCP version change and sends an RRCConnectionReconfigurationComplete message
}
}

```

(3)

```

with { UE in RRC_CONNECTED state with EN-DC, and, MCG (NR PDCP) only with SRB1 and SRB2 using NR
PDCP }
ensure that {
  when { UE receives an RRCConnectionReconfiguration with mobility message to change PDCP version of
the MCG DRB from NR PDCP to E-UTRA PDCP }
    then { UE performs PDCP version change and sends an RRCConnectionReconfigurationComplete message
}
}

```

(4)

```

with { UE in RRC_CONNECTED state with EN-DC, and, MCG (E-UTRA PDCP) only with SRB1 and SRB2 using NR
PDCP }
ensure that {
  when { UE receives an RRCConnectionReconfiguration with mobility message to change PDCP version of
the SRB1 and SRB2 from NR PDCP to E-UTRA PDCP }
    then { UE performs PDCP version change and sends an RRCConnectionReconfigurationComplete message
}
}

```

#### 8.2.2.6.1.2 Conformance requirements

References: The conformance requirements covered in the present TC are specified in: TS 36.331, clause 5.3.1.1, 5.3.5.4 and 5.3.10.3, TS 38.331, clauses 5.3.5.3, 5.3.5.5, 5.3.5.5.7, 5.3.5.6, 5.3.5.6.3 and 5.3.5.6.5. Unless otherwise stated these are Rel-15 requirements.

[TS 36.331, clause 5.3.1.1]

Change to NR PDCP or vice versa, for both SRBs and DRBs, can be performed using an *RRCConnectionReconfiguration* message including the *mobilityControlInfo* (handover) by release and addition of the concerned RB (for DRBs) or of the concerned PDCP entity (for SRBs). The same *RRCConnectionReconfiguration* message may be used to make changes regarding the CG(s) used for transmission. For SRBs, change from E-UTRA PDCP to NR PDCP type, may also be performed using an *RRCConnectionReconfiguration* message not including the *mobilityControlInfo*.

[TS 36.331, clause 5.3.5.4]

If the *RRCConnectionReconfiguration* message includes the *mobilityControlInfo* and the UE is able to comply with the configuration included in this message, the UE shall:

- 1> stop timer T310, if running;
- 1> stop timer T312, if running;
- 1> start timer T304 with the timer value set to *t304*, as included in the *mobilityControlInfo*;
- 1> stop timer T370, if running;
- 1> if the *carrierFreq* is included:
  - 2> consider the target PCell to be one on the frequency indicated by the *carrierFreq* with a physical cell identity indicated by the *targetPhysCellId*;
- 1> else:
  - 2> consider the target PCell to be one on the frequency of the source PCell with a physical cell identity indicated by the *targetPhysCellId*;
- 1> start synchronising to the DL of the target PCell;

NOTE 1: The UE should perform the handover as soon as possible following the reception of the RRC message triggering the handover, which could be before confirming successful reception (HARQ and ARQ) of this message.

- 1> reset MCG MAC and SCG MAC, if configured;
- 1> re-establish PDCP for all RBs configured with *pdcp-config* that are established;

NOTE 2: The handling of the radio bearers after the successful completion of the PDCP re-establishment, e.g. the re-transmission of unacknowledged PDCP SDUs (as well as the associated status reporting), the handling of the SN and the HFN, is specified in TS 36.323 [8].

- 1> re-establish MCG RLC and SCG RLC, if configured, for all RBs that are established;
- 1> configure lower layers to consider the SCell(s) other than the PSCell, if configured, to be in deactivated state;
- 1> apply the value of the *newUE-Identity* as the C-RNTI;
- 1> configure lower layers in accordance with the received *radioResourceConfigCommon*;
- 1> configure lower layers in accordance with any additional fields, not covered in the previous, if included in the received *mobilityControlInfo*;
- 1> if the *RRCCONNECTIONRECONFIGURATION* message includes the *radioResourceConfigDedicated*:
  - 2> perform the radio resource configuration procedure as specified in 5.3.10;
- 1> store the *nextHopChainingCount* value;
- 1> else:
  - 2> derive the  $K_{RRCint}$  key associated with the current integrity algorithm, as specified in TS 33.401 [32];
  - 2> if connected as an RN:
    - 3> derive the  $K_{UPint}$  key associated with the current integrity algorithm, as specified in TS 33.401 [32];
    - 2> derive the  $K_{RRCenc}$  key and the  $K_{UPenc}$  key associated with the current ciphering algorithm, as specified in TS 33.401 [32];
  - 1> configure lower layers to apply the integrity protection algorithm and the  $K_{RRCint}$  key, i.e. the integrity protection configuration shall be applied to all subsequent messages received and sent by the UE, including the message used to indicate the successful completion of the procedure;
  - 1> configure lower layers to apply the ciphering algorithm, the  $K_{RRCenc}$  key and the  $K_{UPenc}$  key, i.e. the ciphering configuration shall be applied to all subsequent messages received and sent by the UE, including the message used to indicate the successful completion of the procedure;
- 1> if the received *RRCCONNECTIONRECONFIGURATION* includes the *nr-RadioBearerConfig1*:
  - 2> perform radio bearer configuration as specified in TS 38.331 [82, 5.3.5.6];
- 1> set the content of *RRCCONNECTIONRECONFIGURATIONCOMPLETE* message as follows:
  - 2> else if the UE has logged measurements available for E-UTRA and if the RPLMN is included in *plmn-IdentityList* stored in *VarLogMeasReport*:
    - 3> include the *logMeasAvailable*;
  - 2> if the UE has connection establishment failure information available in *VarConnEstFailReport* and if the RPLMN is equal to *plmn-Identity* stored in *VarConnEstFailReport*:
    - 3> include *connEstFailInfoAvailable*;
  - 2> if the *RRCCONNECTIONRECONFIGURATION* message includes *perCC-GapIndicationRequest*:
    - 3> include *perCC-GapIndicationList* and *numFreqEffective*;

- 2> if the frequencies are configured for reduced measurement performance:
  - 3> include numFreqEffectiveReduced;
- 2> if the received RRCConnectionReconfiguration message included nr-SecondaryCellGroupConfig:
  - 3> include *scg-ConfigResponseNR* in accordance with TS 38.331 [82, 5.3.5.3];
- 1> submit the *RRCConnectionReconfigurationComplete* message to lower layers for transmission;
- 1> if MAC successfully completes the random access procedure; or

[TS 36.331, clause 5.3.10.3]

The UE shall:

- 1> for each *drb-Identity* value included in the *drb-ToAddModList* that is part of the current UE configuration (DRB reconfiguration):
  - 2> if *drb-ToAddModListSCG* is not received or does not include the *drb-Identity* value:
    - 3> if the DRB indicated by *drb-Identity* is an MCG DRB or configured with MCG RLC bearer in EN-DC (reconfigure MCG RLC bearer for EN-DC or reconfigure MCG DRB):
      - 4> if the *pdc-Config* is included:
        - 5> reconfigure the PDCP entity in accordance with the received *pdc-Config*;
      - 4> if the *rlc-Config* is included:
        - 5> if *reestablishRLC* is received, re-establish the RLC entity of this DRB;
        - 5> reconfigure the RLC entity or entities in accordance with the received *rlc-Config*;
      - 4> if the *logicalChannelConfig* is included:
        - 5> reconfigure the DTCH logical channel in accordance with the received *logicalChannelConfig*;

NOTE: Removal and addition of the same *drb-Identity* in a single *radioResourceConfigDedicated* is not supported. In case *drb-Identity* is removed and added due to handover or re-establishment with the full configuration option, the eNB can use the same value of *drb-Identity*.

[TS 38.331, clause 5.3.5.3]

The UE shall perform the following actions upon reception of the *RRCReconfiguration*:

- 1> if the *RRCReconfiguration* message contains the *radioBearerConfig*:
  - 2> perform the radio bearer configuration according to 5.3.5.6;
- 1> if the *RRCReconfiguration* message includes the *measConfig*:
  - 2> perform the measurement configuration procedure as specified in 5.5.2;
- 1> if the UE is configured with E-UTRA *nr-SecondaryCellGroupConfig* (MCG is E-UTRA):
  - 2> if *RRCReconfiguration* was received via SRB1:
    - 3> construct *RRCReconfigurationComplete* message and submit it via the EUTRA MCG embedded in E-UTRA RRC message *RRCConnectionReconfigurationComplete* as specified in TS 36.331 [10];
    - 3> if *reconfigurationWithSync* was included in *spCellConfig* of an SCG:
      - 4> initiate the random access procedure on the SpCell, as specified in TS 38.321 [3];
  - 2> else (*RRCReconfiguration* was received via SRB3):



- 3> submit the *RRCReconfigurationComplete* message via SRB3 to lower layers for transmission using the new configuration;

NOTE: In the case of SRB1, the random access is triggered by RRC layer itself as there is not necessarily other UL transmission. In the case of SRB3, the random access is triggered by the MAC layer due to arrival of *RRCReconfigurationComplete*.

- 1> if MAC of an NR cell group successfully completes a random access procedure triggered above;
  - 2> stop timer T304 for that cell group;
  - 2> apply the parts of the CQI reporting configuration, the scheduling request configuration and the sounding RS configuration that do not require the UE to know the SFN of the respective target SpCell, if any;
  - 2> apply the parts of the measurement and the radio resource configuration that require the UE to know the SFN of the respective target SpCell (e.g. measurement gaps, periodic CQI reporting, scheduling request configuration, sounding RS configuration), if any, upon acquiring the SFN of that target SpCell;
  - 2> the procedure ends.

[TS 38.331, clause 5.3.5.6.3]

The UE shall:

- 1> for each *srb-Identity* value included in the *srb-ToAddModList* that is not part of the current UE configuration (SRB establishment or reconfiguration from E-UTRA PDCP to NR PDCP):
  - 2> establish a PDCP entity and configure it with the security algorithms according to *securityConfig* and apply the keys ( $K_{\text{RRCenc}}$  and  $K_{\text{RRCint}}$ ) associated with the  $K_{\text{eNB/S-K}_{\text{gNB}}$  as indicated in *keyToUse*, if applicable;
  - 2> if the current UE configuration as configured by E-UTRA in TS 36.331 includes an SRB identified with the same *srb-Identity* value:
    - 3> associate the E-UTRA RLC entity and DCCH of this SRB with the NR PDCP entity;
    - 3> release the E-UTRA PDCP entity of this SRB;
  - 2> if the *pdcp-Config* is included:
    - 3> configure the PDCP entity in accordance with the received *pdcp-Config*;
  - 2> else:
    - 3> configure the PDCP entity in accordance with the default configuration defined in 9.2.1 for the corresponding SRB;
- 1> for each *srb-Identity* value included in the *srb-ToAddModList* that is part of the current UE configuration:
  - 2> if *reestablishPDCP* is set:
    - 3> configure the PDCP entity to apply the integrity protection algorithm and  $K_{\text{RRCint}}$  key associated with the  $K_{\text{eNB/S-K}_{\text{gNB}}$  as indicated in *keyToUse*, i.e. the integrity protection configuration shall be applied to all subsequent messages received and sent by the UE, including the message used to indicate the successful completion of the procedure;
    - 3> configure the PDCP entity to apply the ciphering algorithm and  $K_{\text{RRCenc}}$  key associated with the  $K_{\text{eNB/S-K}_{\text{gNB}}$  as indicated in *keyToUse*, i.e. the ciphering configuration shall be applied to all subsequent messages received and sent by the UE, including the message used to indicate the successful completion of the procedure;
    - 3> re-establish the PDCP entity of this SRB as specified in 38.323 [5];
  - 2> else, if *discardOnPDCP* is set:
    - 3> trigger the PDCP entity to perform SDU discard as specified in TS 38.323 [5];
  - 2> if the *pdcp-Config* is included:

3> reconfigure the PDCP entity in accordance with the received *pdcp-Config*.

[TS 38.331, clause 5.3.5.6.5]

The UE shall:

- 1> for each *drb-Identity* value included in the *drb-ToAddModList* that is not part of the current UE configuration (DRB establishment including the case when full configuration option is used):
  - 2> establish a PDCP entity and configure it in accordance with the received *pdcp-Config*;
  - 2> configure the PDCP entity with the security algorithms according to *securityConfig* and apply the keys ( $K_{UPenc}$ ) associated with the  $K_{eNB}/S-K_{gNB}$  as indicated in *keyToUse*;
  - 2> if the DRB was configured with the same *eps-BearerIdentity* either by NR or E-UTRA prior to receiving this reconfiguration:
    - 3> associate the established DRB with the corresponding *eps-BearerIdentity*;
  - 2> else:
    - 3> indicate the establishment of the DRB(s) and the *eps-BearerIdentity* of the established DRB(s) to upper layers;
- 1> for each *drb-Identity* value included in the *drb-ToAddModList* that is part of the current UE configuration:
  - 2> if *reestablishPDCP* is set:
    - 3> configure the PDCP entity of this *RadioBearerConfig* to apply the ciphering algorithm and  $K_{UPenc}$  key associated with the  $K_{eNB}/S-K_{gNB}$  as indicated in *keyToUse*, i.e. the ciphering configuration shall be applied to all subsequent PDCP PDUs received and sent by the UE;
    - 3> re-establish the PDCP entity of this DRB as specified in 38.323 [5], section 5.1.2;
  - 2> else, if *recoverPDCP* is set:
    - 3> trigger the PDCP entity of this DRB to perform data recovery as specified in 38.323;
  - 2> if the *pdcp-Config* is included:
    - 3> reconfigure the PDCP entity in accordance with the received *pdcp-Config*.

NOTE 1: Removal and addition of the same *drb-Identity* in a single *radioResourceConfig* is not supported. In case *drb-Identity* is removed and added due to reconfiguration with sync or re-establishment with the full configuration option, the network can use the same value of *drb-Identity*.

NOTE 2: When determining whether a *drb-Identity* value is part of the current UE configuration, the UE does not distinguish which *RadioBearerConfig* and *DRB-ToAddModList* that DRB was originally configured in. To re-associate a DRB with a different key ( $K_{eNB}$  to  $S-K_{eNB}$  or vice versa), the network provides the *drb-Identity* value in the (target) *drb-ToAddModList* and sets the *reestablishPDCP* flag. The network does not list the *drb-Identity* in the (source) *drb-ToReleaseList*.

NOTE 3: When setting the *reestablishPDCP* flag for a radio bearer, the network ensures that the RLC receiver entities do not deliver old PDCP PDUs to the re-established PDCP entity. It does that e.g. by triggering a reconfiguration with sync of the cell group hosting the old RLC entity or by releasing the old RLC entity.

NOTE 4: In this specification, UE configuration refers to the parameters configured by NR RRC unless otherwise stated.

8.2.2.6.1.3 Test description

8.2.2.6.1.3.1 Pre-test conditions

System Simulator:

- EUTRA Cell 1 is the PCell and NR Cell 1 is the PS Cell.

UE:

- None

Preamble:

- The UE is in state RRC\_CONNECTED using generic procedure parameter Connectivity (*EN-DC*), Bearers (*MCG only*) and Test Mode (*On*) associated with UE test loop mode A according to TS 38.508-1 [4], table 4.5.1-1.

## 8.2.2.6.1.3.2 Test procedure sequence

Table 8.2.2.6.1.3.2-1: Main behaviour

St	Procedure	Message Sequence		TP	Verdict
		U - S	Message		
1	The SS transmits an <i>RRCCONNECTIONRECONFIGURATION</i> message including <i>MobilityControlInfo</i> IE on E-UTRA Cell 1 to reconfigure SRB1 and SRB2 from E-UTRA PDCP to NR PDCP	<--	<i>RRCCONNECTIONRECONFIGURATION</i>	-	-
2	Check: Does the UE transmit an <i>RRCCONNECTIONRECONFIGURATIONCOMPLETE</i> message?	-->	<i>RRCCONNECTIONRECONFIGURATIONCOMPLETE</i>	1	P
3	The SS transmits a CLOSE UE TEST LOOP message.	<--	RRC: <i>DLInformationTransfer</i> TC: CLOSE UE TEST LOOP	-	-
4	The UE transmits a CLOSE UE TEST LOOP COMPLETE message. NOTE: <i>DLInformationTransfer</i> is transmitted using SRB2. This implicitly verifies SRB2 PDCP version change.	-->	RRC: <i>ULInformationTransfer</i> TC: CLOSE UE TEST LOOP COMPLETE	1	P
5	The SS transmits an <i>RRCCONNECTIONRECONFIGURATION</i> message including <i>MobilityControlInfo</i> IE on E-UTRA Cell 1 to reconfigure MCG DRB from E-UTRA PDCP to NR PDCP?	<--	<i>RRCCONNECTIONRECONFIGURATION</i>	-	-
6	Check: Does the UE transmit an <i>RRCCONNECTIONRECONFIGURATIONCOMPLETE</i> message? NOTE: <i>RRCCONNECTIONRECONFIGURATION</i> is transmitted using SRB1. This implicitly verifies SRB1 PDCP version change.	-->	<i>RRCCONNECTIONRECONFIGURATIONCOMPLETE</i>	1, 2	P
7	The SS transmits one IP packet to verify data path on MCG DRB.	<--	-	-	-
8	Check: Does the UE loop back the IP Packet on MCG DRB in uplink?	-->	-	2	P
9	The SS transmits an <i>RRCCONNECTIONRECONFIGURATION</i> message including <i>MobilityControlInfo</i> IE on E-UTRA Cell 1 to reconfigure MCG DRB from NR PDCP to E-UTRA PDCP?	<--	<i>RRCCONNECTIONRECONFIGURATION</i>	-	-
10	Check: Does the UE transmit an <i>RRCCONNECTIONRECONFIGURATIONCOMPLETE</i> message?	-->	<i>RRCCONNECTIONRECONFIGURATIONCOMPLETE</i>	3	P
11	The SS transmits one IP packet to verify data path on MCG DRB.	<--	-	-	-
12	Check: Does the UE loop back the IP Packet on MCG DRB in uplink?	-->	-	3	P
13	The SS transmits an <i>RRCCONNECTIONRECONFIGURATION</i> message including <i>MobilityControlInfo</i> IE on E-UTRA Cell 1 to reconfigure SRB1 and SRB2 from NR PDCP to E-UTRA PDCP.	<--	<i>RRCCONNECTIONRECONFIGURATION</i>	-	-
14	Check: Does the UE transmit an <i>RRCCONNECTIONRECONFIGURATIONCOMPLETE</i> message?	-->	<i>RRCCONNECTIONRECONFIGURATIONCOMPLETE</i>	4	P

8.2.2.6.1.3.3 Specific message contents

**Table 8.2.2.6.1.3.3-1: RRCConnectionReconfiguration (step 1, Table 8.2.2.6.1.3.2-1)**

Derivation Path: 36.508 [7], Table 4.6.1-8 with condition MCG_and_SCG and condition HO			
Information Element	Value/remark	Comment	Condition
RRCConnectionReconfiguration ::= SEQUENCE {			
criticalExtensions CHOICE {			
c1 CHOICE{			
rrcConnectionReconfiguration-r8 ::= SEQUENCE			
{			
mobilityControlInfo	MobilityControlInfo-HO-SameCell	As per Table 8.2.2.6.1.3.3-2	
nonCriticalExtension SEQUENCE {			
nonCriticalExtension SEQUENCE {			
nonCriticalExtension SEQUENCE {			
nonCriticalExtension SEQUENCE {			
nonCriticalExtension SEQUENCE {			
nonCriticalExtension SEQUENCE {			
nonCriticalExtension SEQUENCE {			
nr-Config-r15	Not present		
nr-RadioBearerConfig1-r15	OCTET STRING containing RadioBearerConfig-MCG-SRB	As per Table 8.2.2.6.1.3.3-3	
}			
}			
}			
}			
}			
}			
}			
}			
}			
}			

**Table 8.2.2.6.1.3.3-2: MobilityControlInfo-HO-SameCell (Table 8.2.2.6.1.3.3-1)**

Derivation Path: 36.508 [7], Table 4.6.5-1			
Information Element	Value/remark	Comment	Condition
MobilityControlInfo-HO ::= SEQUENCE {			
targetPhysCellId	PhysicalCellIdentity of E-UTRA Cell 1		
carrierFreq	Not present		
}			

**Table 8.2.2.6.1.3.3-3: RadioBearerConfig-MCG-SRB (Table 8.2.2.6.1.3.3-1)**

Derivation Path: 38.508-1 [4], Table [4.6.3-n]			
Information Element	Value/remark	Comment	Condition
RadioBearerConfig ::= SEQUENCE {			
srb-ToAddModList SEQUENCE (SIZE (1..2)) OF SEQUENCE {	2 entries		
srb-Identity[1]	Same as the srb-identity associated with SRB1		
pdcp-Config[1]	Same as TS 38.508-1 Table [4.6.374-]		
srb-Identity[2]	Same as the srb-identity associated with SRB2		
pdcp-Config[2]	Same as TS 38.508-1 Table [4.6.374-]		
}			
drb-ToAddModList	Not present		
securityConfig ::= SEQUENCE {			
keyToUse	KeNB		
securityAlgorithmConfig	Same as TS 38.508-1 Table [4.6.3-126]		
}			
}			

**Table 8.2.2.6.1.3.3-4: RRCConnectionReconfiguration (step 5, Table 8.2.2.6.1.3.2-1)**

Derivation Path: 38.508 [7], Table 4.6.1-8 with condition MCG_and_SCG and condition HO			
Information Element	Value/remark	Comment	Condition
RRCConnectionReconfiguration ::= SEQUENCE {			
criticalExtensions CHOICE {			
c1 CHOICE{			
rrcConnectionReconfiguration-r8 ::= SEQUENCE {			
mobilityControlInfo	MobilityControlInfo-HO-SameCell	As per Table 8.2.2.6.1.3.3-2	
radioResourceConfigDedicated	RadioResourceConfigDedicated-DRB-RELEASE	As per Table 8.2.2.6.1.3.3-5	
nonCriticalExtension SEQUENCE {			
nonCriticalExtension SEQUENCE {			
nonCriticalExtension SEQUENCE {			
nonCriticalExtension SEQUENCE {			
nonCriticalExtension SEQUENCE {			
nonCriticalExtension SEQUENCE {			
nonCriticalExtension SEQUENCE {			
nr-Config-r15	Not present		
nr-RadioBearerConfig1-r15	OCTET STRING containing RadioBearerConfig-MCG-DRB	As per Table 8.2.2.6.1.3.3-6	
}			
}			
}			
}			
}			
}			
}			
}			
}			

**Table 8.2.2.6.1.3.3-5: RadioResourceConfigDedicated-DRB-RELEASE (Table 8.2.2.6.1.3.3-4)**

Derivation Path: 36.508 [7], Table 4.6.3-18C			
Information Element	Value/remark	Comment	Condition
RadioResourceConfigDedicated ::= SEQUENCE {			
drb-ToReleaseListSEQUENCE (SIZE (1..maxDRB))	1 entry		
OF SEQUENCE {			
drb-Identity[1]	Same as the DRB identity associated with the default EPS bearer		
}			
}			

**Table 8.2.2.6.1.3.3-6: RadioBearerConfig-MCG-DRB (Table 8.2.2.6.1.3.3-4)**

Derivation Path: 38.508-1 [4], Table [4.6.3-n]			
Information Element	Value/remark	Comment	Condition
RadioBearerConfig ::= SEQUENCE {			
drb-ToAddModList SEQUENCE (SIZE (1.. maxDRB))	1 entry		
OF SEQUENCE {			
cnAssociation CHOICE {			
eps-BearerIdentity	Same as the default EPS bearer Identity		
}			
drb-Identity	Same as the DRB associated with the default EPS bearer		
pdcp-Config	Same as TS 38.508-1 Table [4.6.3-74]		
}			
securityConfig SEQUENCE {			
keyToUse	keNB		
securityAlgorithmConfig	Same as TS 38.508-1 Table [4.6.3-126]		
}			
}			

**Table 8.2.2.6.1.3.3-7: RRCConnectionReconfiguration (step 9, Table 8.2.2.6.1.3.2-1)**

Derivation Path: 36.508 [4], Table 4.6.1-8 with Condition MCG_and_SCG and condition HO			
Information Element	Value/remark	Comment	Condition
RRCConnectionReconfiguration ::= SEQUENCE {			
criticalExtensions CHOICE {			
c1 CHOICE {			
rrcConnectionReconfiguration-r8 ::= SEQUENCE {			
mobilityControllInfo	MobilityControllInfo-HO-SameCell	As per Table 8.2.2.6.1.3.3-2	
radioResourceConfigDedicated	RadioResourceConfigDedicated-DRB-AddMod	As per Table 8.2.2.6.1.3.3-8	
nonCriticalExtension ::= SEQUENCE {			
nonCriticalExtension ::= SEQUENCE {			
nonCriticalExtension ::= SEQUENCE {			
nonCriticalExtension ::= SEQUENCE {			
nonCriticalExtension ::= SEQUENCE {			
nonCriticalExtension ::= SEQUENCE {			
nonCriticalExtension ::= SEQUENCE {			
nonCriticalExtension ::= SEQUENCE {			
nr-Config-r15	Not present		
nr-RadioBearerConfig1-r15	OCTET STRING containing RadioBearerConfig-MCG-DRB-RELEASE	As per Table 8.2.2.6.1.3.3-9	
}			
}			
}			
}			
}			
}			
}			
}			
}			

**Table 8.2.2.6.1.3.3-8: RadioResourceConfigDedicated-DRB-AddMod (Table 8.2.2.6.1.3.3-7)**

Derivation Path: 36.508 [7], Table 4.6.3-17 using DRB configuration from Table 4.8.2.1.7-1			
Information Element	Value/remark	Comment	Condition
RadioResourceConfigDedicated-DRB ::= SEQUENCE {			
drb-ToAddModList SEQUENCE (SIZE (1..maxDRB)) OF SEQUENCE {			
drb-Identity[1]	Same as the DRB associated with the default EPS bearer		
pdcp-Config	Same as TS 38.508-1 Table [4.6.3-74]		
rlc-Config	Not present		
logicalChannelIdentity	Not present		
logicalChannelConfig	Not present		
}			
}			



**Table 8.2.2.6.1.3.3-9 RadioBearerConfig-MCG-DRB-RELEASE (Table 8.2.2.6.1.3.3-7)**

Derivation Path: 38.508-1 [4], Table [4.6.3-n]			
Information Element	Value/remark	Comment	Condition
RadioBearerConfig ::= SEQUENCE {			
drb-ToAddModList	Not present		
drb-ToReleaseList SEQUENCE (SIZE (1.. maxDRB))	1 entry		
OF SEQUENCE {			
drb-Identity[1]	Same as the DRB associated with the default EPS bearer		
}			
}			

**Table 8.2.2.6.1.3.3-10: RRCConnectionReconfiguration (step 13, Table 8.2.2.6.1.3.2-1)**

Derivation Path: 36.508 [7], Table 4.6.1-8 with Condition HO			
Information Element	Value/remark	Comment	Condition
RRCConnectionReconfiguration ::= SEQUENCE {			
criticalExtensions CHOICE {			
c1 CHOICE {			
rrcConnectionReconfiguration-r8 ::= SEQUENCE {			
mobilityControlInfo	MobilityControlInfo-HO-SameCell	As per Table 8.2.2.6.1.3.3-2	
radioResourceConfigDedicated	RadioResourceConfigDedicated-SRB-AddMod	As per Table 8.2.2.6.1.3.3-11	
}			
}			
}			
}			

**Table 8.2.2.6.1.3.3-11 RadioResourceConfigDedicated-SRB-AddMod (Table 8.2.2.6.1.3.3-10)**

Derivation Path: 36.331 [11], Table 6.3.2			
Information Element	Value/remark	Comment	Condition
RadioResourceConfigDedicated			
srb-ToAddModList SEQUENCE (SIZE (1..2)) OF SEQUENCE {			
srb-Identity[1]	Same as the SRB associated with SRB1		
pdcp-verChange-r15[1]	True		
srb-Identity[2]	Same as the SRB associated with SRB2		
pdcp-verChange-r15[2]	True		
}			

## 8.2.2.7 Bearer Modification / Handling for bearer type change without security key change

### 8.2.2.7.1 Bearer Modification / Handling for bearer type change without security key change / EN-DC

#### 8.2.2.7.1.1 Test Purpose (TP)

(1)

```

with { UE in RRC_CONNECTED state with EN-DC, and, MCG (E-UTRA PDCP) and SCG DRBs established }
ensure that {
  when { UE receives an RRCConnectionReconfiguration message to modify SCG DRB to Split DRB }
  then { UE reconfigures the DRB and sends an RRCConnectionReconfigurationComplete message }
}

```

(2)

```

with { UE in RRC_CONNECTED state with EN-DC, and, MCG (E-UTRA PDCP) and Split DRBs established }
ensure that {
  when { UE receives an RRCConnectionReconfiguration message to modify Split DRB to MCG DRB (NR PDCP) }
  then { UE reconfigures the DRB and sends an RRCConnectionReconfigurationComplete message }
}

```

(3)

```

with { UE in RRC_CONNECTED state with EN-DC, and, MCG (E-UTRA PDCP) and MCG (NR PDCP) DRBs established }
ensure that {
  when { UE receives an RRCConnectionReconfiguration message to modify MCG DRB (NR PDCP) to Split DRB }
  then { UE reconfigures the DRB and sends an RRCConnectionReconfigurationComplete message }
}

```

(4)

```

with { UE in RRC_CONNECTED state with EN-DC, and, MCG (E-UTRA PDCP) and Split DRBs established }
ensure that {
  when { UE receives an RRCConnectionReconfiguration message to modify Split DRB to SCG DRB }
  then { UE reconfigures the DRB and sends an RRCConnectionReconfigurationComplete message }
}

```

(5)

```

with { UE in RRC_CONNECTED state with EN-DC, and, MCG (E-UTRA PDCP) and SCG DRBs established }
ensure that {
  when { UE receives an RRCConnectionReconfiguration message to modify SCG DRB to MCG DRB (NR PDCP) }
  then { UE reconfigures the DRB and sends an RRCConnectionReconfigurationComplete message }
}

```

(6)

```

with { UE in RRC_CONNECTED state with EN-DC, and, MCG (E-UTRA PDCP) and MCG (NR PDCP) DRBs established }
ensure that {
  when { UE receives an RRCConnectionReconfiguration message to modify MCG DRB (NR PDCP) to SCG DRB }
  then { UE reconfigures the DRB and sends an RRCConnectionReconfigurationComplete message }
}

```

#### 8.2.2.7.1.2 Conformance requirements

References: The conformance requirements covered in the present TC are specified in TS 36.331, clauses 5.3.5.3 and TS 38.331: 5.3.5.3, 5.3.5.5.1, 5.3.5.6.1 and 5.3.5.6.5. Unless and otherwise stated these are Rel-15 requirements

[TS 36.331, clause 5.3.5.3]

If the *RRCConnectionReconfiguration* message does not include the *mobilityControlInfo* and the UE is able to comply with the configuration included in this message, the UE shall:

- 1> if this is the first *RRCConnectionReconfiguration* message after successful completion of the RRC connection re-establishment procedure:

...

- 1> else:

- 2> if the *RRCConnectionReconfiguration* message includes the *radioResourceConfigDedicated*:

- 3> perform the radio resource configuration procedure as specified in 5.3.10;

NOTE 3: If the *RRCConnectionReconfiguration* message includes the establishment of radio bearers other than SRB1, the UE may start using these radio bearers immediately, i.e. there is no need to wait for an outstanding acknowledgment of the *SecurityModeComplete* message.

...

1> if the received *RRCConnectionReconfiguration* includes the *nr-SecondaryCellGroupConfig*:

2> perform NR RRC Reconfiguration as specified in TS 38.331 [82, 5.3.5.3];

1> if the received *RRCConnectionReconfiguration* includes the *nr-RadioBearerConfig1*:

2> perform radio bearer configuration as specified in TS 38.331 [82, 5.3.5.6];

1> if the received *RRCConnectionReconfiguration* includes the *nr-RadioBearerConfig2*:

2> perform radio bearer configuration as specified in TS 38.331 [82, 5.3.5.6];

...

1> set the content of *RRCConnectionReconfigurationComplete* message as follows:

...

2> if the received *RRCConnectionReconfiguration* message included *nr-SecondaryCellGroupConfig*:

3> include *scg-ConfigResponseNR* in accordance with TS 38.331 [82, 5.3.5.3];

1> submit the *RRCConnectionReconfigurationComplete* message to lower layers for transmission using the new configuration, upon which the procedure ends;

[TS 38.331, clause 5.3.5.3]

The UE shall perform the following actions upon reception of the *RRCReconfiguration*:

...

1> if the *RRCReconfiguration* message contains the *radioBearerConfig*:

2> perform the radio bearer configuration according to 5.3.5.6;

...

1> if the UE is configured with E-UTRA *nr-SecondaryCellGroupConfig* (MCG is E-UTRA):

2> if *RRCReconfiguration* was received via SRB1:

3> construct *RRCReconfigurationComplete* message and submit it via the EUTRA MCG embedded in E-UTRA RRC message *RRCConnectionReconfigurationComplete* as specified in TS 36.331 [10];

[TS 38.331, clause 5.3.5.5.1]

The network configures the UE with one Secondary Cell Group (SCG). For EN-DC, the MCG is configured as specified in TS 36.331 [10]. The network provides the configuration parameters for a cell group in the *CellGroupConfig* IE.

The UE performs the following actions based on a received *CellGroupConfig* IE:

1> if the *CellGroupConfig* contains the *spCellConfig* with *reconfigurationWithSync*:

2> perform Reconfiguration with sync according to 5.3.5.5.2;

2> resume all suspended radio bearers and resume SCG transmission for all radio bearers, if suspended;

1> if the *CellGroupConfig* contains the *rlc-BearerToReleaseList*:

2> perform RLC bearer release as specified in 5.3.5.5.3;

1> if the *CellGroupConfig* contains the *rlc-BearerToAddModList*:

2> perform the RLC bearer addition/modification as specified in 5.3.5.5.4;

1> if the *CellGroupConfig* contains the *mac-CellGroupConfig*:

- 2> configure the MAC entity of this cell group as specified in 5.3.5.5.5;
- 1> if the *CellGroupConfig* contains the *sCellToReleaseList*:
  - 2> perform SCell release as specified in 5.3.5.5.8;
- 1> if the *CellGroupConfig* contains the *spCellConfig*:
  - 2> configure the SpCell as specified in 5.3.5.5.7;
- 1> if the *CellGroupConfig* contains the *sCellToAddModList*:
  - 2> perform SCell addition/modification as specified in 5.3.5.5.9

[TS 38.331, clause 5.3.5.6.1]

The UE shall perform the following actions based on a received *RadioBearerConfig* IE:

...

- 1> if the *RadioBearerConfig* includes the *drb-ToReleaseList*:
  - 2> perform DRB release as specified in 5.3.5.6.4;
- 1> if the *RadioBearerConfig* includes the *drb-ToAddModList*:
  - 2> perform DRB addition or reconfiguration as specified in 5.3.5.6.5.

[TS 38.331, clause 5.3.5.6.5]

The UE shall:

- 1> for each *drb-Identity* value included in the *drb-ToAddModList* that is not part of the current UE configuration (DRB establishment including the case when full configuration option is used):
  - 2> establish a PDCP entity and configure it in accordance with the received *pdcp-Config*;
  - 2> configure the PDCP entity with the security algorithms according to *securityConfig* and apply the keys ( $K_{UPenc}$ ) associated with the  $K_{eNB/S}$ - $K_{gNB}$  as indicated in *keyToUse*;
  - 2> if the DRB was configured with the same *eps-BearerIdentity* either by NR or E-UTRA prior to receiving this reconfiguration:
    - 3> associate the established DRB with the corresponding *eps-BearerIdentity*;
  - 2> else:
    - 3> indicate the establishment of the DRB(s) and the *eps-BearerIdentity* of the established DRB(s) to upper layers;
- 1> for each *drb-Identity* value included in the *drb-ToAddModList* that is part of the current UE configuration:
  - 2> if *reestablishPDCP* is set:
    - 3> configure the PDCP entity of this *RadioBearerConfig* to apply the ciphering algorithm and  $K_{UPenc}$  key associated with the  $K_{eNB/S}$ - $K_{gNB}$  as indicated in *keyToUse*, i.e. the ciphering configuration shall be applied to all subsequent PDCP PDUs received and sent by the UE;
    - 3> re-establish the PDCP entity of this DRB as specified in 38.323 [5], section 5.1.2;
  - 2> else, if *recoverPDCP* is set:
    - 3> trigger the PDCP entity of this DRB to perform data recovery as specified in 38.323;
  - 2> if the *pdcp-Config* is included:
    - 3> reconfigure the PDCP entity in accordance with the received *pdcp-Config*.

8.2.2.7.1.3 Test description

8.2.2.7.1.3.1 Pre-test conditions

System Simulator:

- E-UTRA Cell 1 is the PCell and NR Cell 1 is the PSCell.

UE:

None.

Preamble:

- The UE is in state RRC\_CONNECTED using generic procedure parameter Connectivity (*EN-DC*), Bearers (*MCG and SCG*) established and Test Loop Function (*On*) with UE test loop mode B according to TS 38.508-1 [4].

8.2.2.7.1.3.2 Test procedure sequence

**Table 8.2.2.7.1.2-1: Main behaviour**

St	Procedure	Message Sequence		TP	Verdict
		U - S	Message		
1	The SS transmits an <i>RRCCONNECTIONRECONFIGURATION</i> message containing NR <i>RADIOBEARERCONFIG</i> to modify SCG DRB to Split DRB.	<--	<i>RRCCONNECTIONRECONFIGURATION</i>	-	-
2	Check: Does the UE transmit an <i>RRCCONNECTIONRECONFIGURATIONCOMPLETE</i> message?	-->	<i>RRCCONNECTIONRECONFIGURATIONCOMPLETE</i>	1	P
3	The SS transmits one IP Packet to verify data path on Split DRB using NR radio path	-	-	-	-
4	Check: Does UE send the IP Packet on Split DRB in the uplink using NR radio path?	-	-	1	P
5	The SS transmits <i>RRCCONNECTIONRECONFIGURATION</i> message containing NR <i>RRCRECONFIGURATION</i> message to modify Split DRB to MCG DRB using NR PDCP.	<--	<i>RRCCONNECTIONRECONFIGURATION (RRCRECONFIGURATION)</i>	-	-
6	Check: Does the UE transmit an <i>RRCCONNECTIONRECONFIGURATIONCOMPLETE</i> message containing NR <i>RRCRECONFIGURATIONCOMPLETE</i> message?	-->	<i>RRCCONNECTIONRECONFIGURATIONCOMPLETE (RRCRECONFIGURATIONCOMPLETE)</i>	2	P
7	The SS transmits one IP Packet to verify data path on MCG DRB	-	-	-	-
8	Check: Does UE send the IP Packet on MCG DRB in the uplink?	-	-	2	P
9	The SS transmits an <i>RRCCONNECTIONRECONFIGURATION</i> message containing NR <i>RRCRECONFIGURATION</i> message to modify MCG DRB to Split DRB.	<--	<i>RRCCONNECTIONRECONFIGURATION (RRCRECONFIGURATION)</i>	-	-
10	Check: Does the UE transmit an <i>RRCCONNECTIONRECONFIGURATIONCOMPLETE</i> message containing NR <i>RRCRECONFIGURATIONCOMPLETE</i> message?	-->	<i>RRCCONNECTIONRECONFIGURATIONCOMPLETE (RRCRECONFIGURATIONCOMPLETE)</i>	3	P
11	The SS transmits one IP Packet to verify data path on Split DRB using NR radio path	-	-	-	-
12	Check: Does UE send the IP Packet on Split DRB in the uplink using NR radio path?	-	-	3	P
13	SS transmits <i>RRCCONNECTIONRECONFIGURATION</i> message containing NR <i>RADIOBEARERCONFIG</i> to modify Split DRB to SCG DRB.	<--	<i>RRCCONNECTIONRECONFIGURATION (RRCRECONFIGURATION)</i>	-	-
14	Check: Does the UE transmit an <i>RRCCONNECTIONRECONFIGURATIONCOMPLETE</i> message?	-->	<i>RRCCONNECTIONRECONFIGURATIONCOMPLETE</i>	4	P
15	The SS transmits one IP Packet to verify data path on SCG DRB.	-	-	-	-
16	Check: Does UE send the IP Packet on SCG DRB in the uplink?	-	-	4	P
17	SS transmits <i>RRCCONNECTIONRECONFIGURATION</i> message containing NR <i>RRCRECONFIGURATION</i> message to modify SCG DRB to MCG DRB.	<--	<i>RRCCONNECTIONRECONFIGURATION (RRCRECONFIGURATION)</i>	-	-
18	Check: Does the UE transmit an <i>RRCCONNECTIONRECONFIGURATIONCOMPLETE</i> message containing NR <i>RRCRECONFIGURATIONCOMPLETE</i> message?	-->	<i>RRCCONNECTIONRECONFIGURATIONCOMPLETE (RRCRECONFIGURATIONCOMPLETE)</i>	5	P
19	The SS transmits one IP Packet to verify data path on MCG DRB.	-	-	-	-
20	Check: Does UE send the IP Packet on MCG DRB in the uplink?	-	-	5	P
21	SS transmits <i>RRCCONNECTIONRECONFIGURATION</i> message containing NR <i>RRCRECONFIGURATION</i> message to modify MCG DRB to SCG DRB.	<--	<i>RRCCONNECTIONRECONFIGURATION (RRCRECONFIGURATION)</i>	-	-
22	Check: Does the UE transmit an <i>RRCCONNECTIONRECONFIGURATIONCOMPLETE</i> message containing NR <i>RRCRECONFIGURATIONCOMPLETE</i> message?	-->	<i>RRCCONNECTIONRECONFIGURATIONCOMPLETE (RRCRECONFIGURATIONCOMPLETE)</i>	6	P

23	The SS transmits one IP Packet to verify data path on SCG DRB.	-	-	-	-
24	Check: Does UE send the IP Packet on SCG DRB in the uplink?	-	-	6	P

8.2.2.7.1.3.3 Specific message contents

**Table 8.2.2.7.1.3.3-1: RRCConnectionReconfiguration (step 1, Table 8.2.2.7.1.3.2-1)**

Derivation Path: 36.508 [7], Table 4.6.1-8			
Information Element	Value/remark	Comment	Condition
RRCConnectionReconfiguration ::= SEQUENCE {			
criticalExtensions CHOICE {			
c1 CHOICE {			
rrcConnectionReconfiguration-r8 ::= SEQUENCE {			
radioResourceConfigDedicated	RadioResourceConfigDedicated-SCG-to-Split		
nonCriticalExtension ::= SEQUENCE {			
nonCriticalExtension ::= SEQUENCE {			
nonCriticalExtension ::= SEQUENCE {			
nonCriticalExtension ::= SEQUENCE {			
nonCriticalExtension ::= SEQUENCE {			
nonCriticalExtension ::= SEQUENCE {			
nonCriticalExtension ::= SEQUENCE {			
nr-RadioBearerConfig1-r15	OCTET STRING including RadioBearerConfig-SCG-to-Split.		
}			
}			
}			
}			
}			
}			
}			

**Table 8.2.2.7.1.3.3-2: RadioResourceConfigDedicated-SCG-to-Split (step 1, Table 8.2.2.7.1.3.2-1)**

Derivation Path: 36.508 [7], Table 4.6.3-27			
Information Element	Value/remark	Comment	Condition
RadioResourceConfigDedicated-DRB ::= SEQUENCE {			
drb-ToAddModList	DRB-ToAddModList-SCG-to-Split		
}			



**Table 8.2.2.7.1.3.3-3: DRB-ToAddModList-SCG-to-Split (step 1, Table 8.2.2.7.1.3.2-1)**

Derivation Path: 36.508 [7], Table 4.6.3-2A			
Information Element	Value/remark	Comment	Condition
DRB-ToAddModList ::= SEQUENCE (SIZE (1..maxDRB)) OF SEQUENCE {	1 Entry		
eps-BearerIdentity[1]	6	Dedicated EPS bearer Id of SCG DRB	
drb-Identity[1]	2	SCG DRB Id	
}			

**Table 8.2.2.7.1.3.3-4: RadioBearerConfig-SCG-to-Split (step 1, Table 8.2.2.7.1.3.2-1)**

Derivation Path: 38.508-1 [4], Table 4.6.3-100 with condition EN-DC			
Information Element	Value/remark	Comment	Condition
RadioBearerConfig ::= SEQUENCE {			
drb-ToAddModList SEQUENCE (SIZE (1..maxDRB)) OF SEQUENCE {	1 entry		
cnAssociation CHOICE {			
eps-BearerIdentity	6	Dedicated EPS bearer Id of SCG DRB	
}			
drb-Identity	2	SCG DRB Id	
pdcp-Config	PDCP-Config		
}			
}			
}			

**Table 8.2.2.7.1.3.3-5: PDCP-Config (step 1, Table 8.2.2.7.1.3.2-1)**

Derivation Path: 38.508-1 [4], Table 4.6.3-74			
Information Element	Value/remark	Comment	Condition
PDCP-Config ::= SEQUENCE {			
moreThanOneRLC SEQUENCE {			
primaryPath SEQUENCE {			
cellGroup	1		
}			
ul-DataSplitThreshold	infinity		
}			
}			

**Table 8.2.2.7.1.3.3-6: RRCConnectionReconfiguration (step 5, Table 8.2.2.7.1.3.2-1)**

Derivation Path: 36.508 [7], Table 4.6.1-8			
Information Element	Value/remark	Comment	Condition
RRCConnectionReconfiguration ::= SEQUENCE {			
criticalExtensions CHOICE {			
c1 CHOICE{			
rrcConnectionReconfiguration-r8 ::= SEQUENCE			
{			
radioResourceConfigDedicated	Not Present		
nonCriticalExtension ::= SEQUENCE {			
nonCriticalExtension ::= SEQUENCE {			
nonCriticalExtension ::= SEQUENCE {			
nonCriticalExtension ::= SEQUENCE {			
nonCriticalExtension ::= SEQUENCE {			
nonCriticalExtension ::= SEQUENCE {			
nonCriticalExtension ::= SEQUENCE {			
nr-Config-r15 CHOICE {			
setup SEQUENCE {			
nr-SecondaryCellGroupConfig-r15	OCTET STRING		
}	containing		
}	RRCReconfiguration-		
}	Split-to-MCG		
}			
}			
}			
}			
}			
}			
}			
}			
}			
}			
}			

**Table 8.2.2.7.1.3.3-7: RRCReconfiguration-Split-to-MCG (step 5, Table 8.2.2.7.1.3.2-1)**

Derivation Path: 38.508-1 [4], Table 4.6.1-3 with condition EN-DC			
Information Element	Value/remark	Comment	Condition
RRCReconfiguration ::= SEQUENCE {			
criticalExtensions CHOICE {			
c1 CHOICE{			
rrcReconfiguration SEQUENCE {			
radioBearerConfig	Not present		
secondaryCellGroup	OCTET STRING		
}	containing		
}	CellGroupConfig-Split-to-		
}	MCG		
}			
}			

**Table 8.2.2.7.1.3.3-8: CellGroupConfig-Split-to-MCG (step 5, Table 8.2.2.7.1.3.2-1)**

Derivation Path: 38.508-1 [4], Table 4.6.3-13			
Information Element	Value/remark	Comment	Condition
CellGroupConfig ::= SEQUENCE {			
rlc-BearerToAddModList	Not present		
rlc-BearerToReleaseList SEQUENCE (SIZE(1..maxLCH)) OF SEQUENCE {	1 entry		
logicalChannelIdentity[1]	Logical channel identity corresponding to split bearer		
}			
mac-CellGroupConfig	Not present		
physicalCellGroupConfig	Not present		
spCellConfig	Not present		
}			

**Table 8.2.2.7.1.3.3-9: RadioBearerConfig-Split-to-MCG (step 5, Table 8.2.2.7.1.3.2-1)**

Derivation Path: 38.508-1 [4], Table 4.6.3-100 with condition EN-DC			
Information Element	Value/remark	Comment	Condition
RadioBearerConfig ::= SEQUENCE {			
drb-ToAddModList SEQUENCE (SIZE (1..maxDRB)) OF SEQUENCE {	1 entry		
cnAssociation CHOICE {			
eps-BearerIdentity	6		
}			
drb-Identity	2		
recoverPDCP	true		
}			
}			

**Table 8.2.2.7.1.3.3-10: RRCConnectionReconfiguration (step 9, Table 8.2.2.7.1.3.2-1)**

Derivation Path: 36.508 [7], Table 4.6.1-8			
Information Element	Value/remark	Comment	Condition
RRCConnectionReconfiguration ::= SEQUENCE {			
criticalExtensions CHOICE {			
c1 CHOICE{			
rrcConnectionReconfiguration-r8 ::= SEQUENCE			
{			
radioResourceConfigDedicated	Not Present		
nonCriticalExtension ::= SEQUENCE {			
nonCriticalExtension ::= SEQUENCE {			
nonCriticalExtension ::= SEQUENCE {			
nonCriticalExtension ::= SEQUENCE {			
nonCriticalExtension ::= SEQUENCE {			
nonCriticalExtension ::= SEQUENCE {			
nonCriticalExtension ::= SEQUENCE {			
nr-Config-r15 CHOICE {			
setup SEQUENCE {			
nr-SecondaryCellGroupConfig-r15	OCTET STRING containing RRCReconfiguration-MCG-to-Split		
}			
}			
}			
}			
}			
}			
}			
}			
}			
}			
}			

**Table 8.2.2.4.3.3-11: RRCReconfiguration-MCG-to-Split (step 9, Table 8.2.2.7.1.3.2-1)**

Derivation Path: 38.508-1 [4], Table 4.6.1-3 with condition EN-DC			
Information Element	Value/remark	Comment	Condition
RRCReconfiguration ::= SEQUENCE {			
criticalExtensions CHOICE {			
c1 CHOICE{			
rrcReconfiguration SEQUENCE {			
radioBearerConfig	Not present		
secondaryCellGroup	OCTET STRING containing CellGroupConfig-MCG-to-Split		
}			
}			
}			
}			

**Table 8.2.2.7.1.3.3-12: CellGroupConfig-MCG-to-Split (step 9, Table 8.2.2.7.1.3.2-1)**

Derivation Path: 38.508-1 [4], Table 4.6.3-13 with condition EN-DC			
Information Element	Value/remark	Comment	Condition
CellGroupConfig ::= SEQUENCE {			
mac-CellGroupConfig	Not present		
physicalCellGroupConfig	Not present		
spCellConfig	Not present		
}			

**Table 8.2.2.7.1.3.3-13: RadioBearerConfig-MCG-to-Split (step 9, Table 8.2.2.7.1.3.2-1)**

Derivation Path: 38.508-1 [4], Table 4.6.3-100 with condition EN-DC			
Information Element	Value/remark	Comment	Condition
RadioBearerConfig ::= SEQUENCE {			
drb-ToAddModList SEQUENCE (SIZE (1..maxDRB))	1 entry		
OF SEQUENCE {			
cnAssociation CHOICE {			
eps-BearerIdentity	6		
}			
drb-Identity	2		
pdcp-Config	PDCP-Config		
}			
}			
}			

**Table 8.2.2.7.1.3.3-14: PDCP-Config (step 9, Table 8.2.2.7.1.3.2-1)**

Derivation Path: 38.508-1 [4], Table 4.6.3-74			
Information Element	Value/remark	Comment	Condition
PDCP-Config ::= SEQUENCE {			
moreThanOneRLC SEQUENCE {			
primaryPath SEQUENCE {			
cellGroup	1		
}			
ul-DataSplitThreshold	infinity		
}			
}			

**Table 8.2.2.7.1.3.3-15: RRCConnectionReconfiguration (step 13, Table 8.2.2.7.1.3.2-1)**

Derivation Path: 36.508 [7], Table 4.6.1-8			
Information Element	Value/remark	Comment	Condition
RRCConnectionReconfiguration ::= SEQUENCE {			
criticalExtensions CHOICE {			
c1 CHOICE{			
rrcConnectionReconfiguration-r8 ::= SEQUENCE			
{			
radioResourceConfigDedicated	RadioResourceConfigDe		
	dicated-DRB-REL(2)		
nonCriticalExtension ::= SEQUENCE {			
nonCriticalExtension ::= SEQUENCE {			
nonCriticalExtension ::= SEQUENCE {			
nonCriticalExtension ::= SEQUENCE {			
nonCriticalExtension ::= SEQUENCE {			
nonCriticalExtension ::= SEQUENCE {			
nonCriticalExtension ::= SEQUENCE {			
nr-RadioBearerConfig1-r15	OCTET STRING		
	including		
	RadioBearerConfig-Split-		
	to-SCG.		
}			
}			
}			
}			
}			
}			
}			
}			
}			
}			
}			

**Table 8.2.2.7.1.3.3-16: RadioResourceConfigDedicated-DRB-REL(bid) (step 13, Table 8.2.2.7.1.3.2-1)**

Derivation Path: 36.508 [7], Table 4.6.3-18C			
Information Element	Value/remark	Comment	Condition
RadioResourceConfigDedicated-DRB-REL(bid) ::= SEQUENCE {		bid is the bearer identity	
drb-ToReleaseList SEQUENCE (SIZE (1..maxDRB))	one entry		
OF			
DRB-Identity[1]	2	Split DRB Id	
}			

**Table 8.2.2.7.1.3.3-17: RadioBearerConfig-Split-to-SCG (step 13, Table 8.2.2.7.1.3.2-1)**

Derivation Path: 38.508-1 [4], Table 4.6.3-100 with condition EN-DC			
Information Element	Value/remark	Comment	Condition
RadioBearerConfig ::= SEQUENCE {			
drb-ToAddModList SEQUENCE (SIZE (1..maxDRB))	1 entry		
OF SEQUENCE {			
cnAssociation CHOICE {			
eps-BearerIdentity	6		
}			
drb-Identity	2		
recoverPDCP	true		
}			

**Table 8.2.2.7.1.3.3-18: RRCConnectionReconfiguration (step 17, Table 8.2.2.7.1.3.2-1)**

Derivation Path: 36.508 [7], Table 4.6.1-8			
Information Element	Value/remark	Comment	Condition
RRCConnectionReconfiguration ::= SEQUENCE {			
criticalExtensions CHOICE {			
c1 CHOICE {			
rrcConnectionReconfiguration-r8 ::= SEQUENCE			
{			
radioResourceConfigDedicated	<i>RadioResourceConfigDe</i> <i>dedicated-SCG-to-MCG</i>		
nonCriticalExtension ::= SEQUENCE {			
nonCriticalExtension ::= SEQUENCE {			
nonCriticalExtension ::= SEQUENCE {			
nonCriticalExtension ::= SEQUENCE {			
nonCriticalExtension ::= SEQUENCE {			
nonCriticalExtension ::= SEQUENCE {			
nonCriticalExtension ::= SEQUENCE {			
nr-Config-r15 CHOICE {			
setup SEQUENCE {			
nr-SecondaryCellGroupConfig-r15	OCTET STRING containing <i>RRCReconfiguration-</i> <i>SCG-to-MCG</i>		
}			
}			
}			
}			
}			
}			
}			
}			
}			
}			
}			
}			
}			
}			

**Table 8.2.2.7.1.3.3-19: RadioResourceConfigDedicated-SCG-to-MCG (step 17, Table 8.2.2.7.1.3.2-1)**

Derivation Path: 36.508 [7], Table 4.6.3-27			
Information Element	Value/remark	Comment	Condition
RadioResourceConfigDedicated-DRB ::= SEQUENCE {			
drb-ToAddModList	DRB-ToAddModList- SCG-to-MCG		
}			

**Table 8.2.2.7.1.3.3-20: DRB-ToAddModList-SCG-to-MCG (step 17, Table 8.2.2.7.1.3.2-1)**

Derivation Path: 36.508 [7], Table 4.6.3-2A			
Information Element	Value/remark	Comment	Condition
DRB-ToAddModList ::= SEQUENCE (SIZE (1..maxDRB)) OF SEQUENCE {	1 Entry		
eps-BearerIdentity[1]	6		
drb-Identity[1]	2		
}			

**Table 8.2.2.4.3.3-21: RRCReconfiguration-SCG-to-MCG (step 17, Table 8.2.2.7.1.3.2-1)**

Derivation Path: 38.508-1 [4], Table 4.6.1-3 with condition EN-DC			
Information Element	Value/remark	Comment	Condition
RRCReconfiguration ::= SEQUENCE {			
criticalExtensions CHOICE {			
c1 CHOICE{			
rrcReconfiguration SEQUENCE {			
radioBearerConfig	Not present		
secondaryCellGroup	OCTET STRING containing CellGroupConfig-SCG-to- MCG		
}			
}			
}			
}			

**Table 8.2.2.7.1.3.3-22: CellGroupConfig-SCG-to-MCG (step 17, Table 8.2.2.7.1.3.2-1)**

Derivation Path: 38.508-1 [4] Table 4.6.3-13			
Information Element	Value/remark	Comment	Condition
CellGroupConfig ::= SEQUENCE {			
rlc-BearerToAddModList	Not present		
rlc-BearerToReleaseList SEQUENCE (SIZE(1..maxLCH)) OF SEQUENCE {	1 entry		
logicalChannelIdentity[1]	Logical channel identity corresponding to SCG Bearer		
}			
mac-CellGroupConfig	Not present		
physicalCellGroupConfig	Not present		
spCellConfig	Not present		
}			
}			

**Table 8.2.2.7.1.3.3-23: RadioBearerConfig-SCG-to-MCG (step 17, Table 8.2.2.7.1.3.2-1)**

Derivation Path: 38.508-1 [4], Table 4.6.3-100 with condition EN-DC			
Information Element	Value/remark	Comment	Condition
RadioBearerConfig ::= SEQUENCE {			
drb-ToAddModList SEQUENCE (SIZE (1..maxDRB)) OF SEQUENCE {	1 entry		
cnAssociation CHOICE {			
eps-BearerIdentity	6		
}			
drb-Identity	2		
recoverPDCP	true		
}			
}			
}			



**Table 8.2.2.7.1.3.3-24: RRCConnectionReconfiguration (step 21, Table 8.2.2.7.1.3.2-1)**

Derivation Path: 36.508 [7], Table 4.6.1-8			
Information Element	Value/remark	Comment	Condition
RRCConnectionReconfiguration ::= SEQUENCE {			
criticalExtensions CHOICE {			
c1 CHOICE{			
rrcConnectionReconfiguration-r8 ::= SEQUENCE			
{			
radioResourceConfigDedicated	<i>RadioResourceConfigDe</i> <i>dedicated-DRB-REL(2)</i>		
nonCriticalExtension ::= SEQUENCE {			
nonCriticalExtension ::= SEQUENCE {			
nonCriticalExtension ::= SEQUENCE {			
nonCriticalExtension ::= SEQUENCE {			
nonCriticalExtension ::= SEQUENCE {			
nonCriticalExtension ::= SEQUENCE {			
nonCriticalExtension ::= SEQUENCE {			
nr-Config-r15 CHOICE {			
setup SEQUENCE {			
nr-SecondaryCellGroupConfig-r15	OCTET STRING		
	containing		
	<i>RRCReconfiguration-</i>		
	<i>MCG-to-SCG</i>		
}			
}			
nr-RadioBearerConfig1-r15	OCTET STRING		
	including		
	<i>RadioBearerConfig-</i>		
	<i>MCG-to-SCG.</i>		
}			
}			
}			
}			
}			

**Table 8.2.2.7.1.3.3-25: RadioResourceConfigDedicated-DRB-REL (bid) (step 13, Table 8.2.2.7.1.3.2-1)**

Derivation Path: 36.508 [7], Table 4.6.3-18C			
Information Element	Value/remark	Comment	Condition
RadioResourceConfigDedicated-DRB-REL(bid) ::= SEQUENCE {		bid is the bearer identity	
drb-ToReleaseList SEQUENCE (SIZE (1..maxDRB))	one entry		
OF			
DRB-Identity[1]	2		
}			

**Table 8.2.2.7.1.3.3-26: RRCReconfiguration-MCG-to-SCG (step 21, Table 8.2.2.7.1.3.2-1)**

Derivation Path: 38.508-1 [4], Table 4.6.1-3 with condition EN-DC			
Information Element	Value/remark	Comment	Condition
RRCReconfiguration ::= SEQUENCE {			
criticalExtensions CHOICE {			
c1 CHOICE{			
rrcReconfiguration SEQUENCE {			
radioBearerConfig	Not present		
secondaryCellGroup	OCTET STRING containing <i>CellGroupConfig-MCG-</i> <i>to-SCG</i>		
}			
}			
}			
}			

**Table 8.2.2.7.1.3.3-27: CellGroupConfig-MCG-to-SCG (step 21, Table 8.2.2.7.1.3.2-1)**

Derivation Path: 38.508-1 [4] Table 4.6.3-13 with condition EN-DC			
Information Element	Value/remark	Comment	Condition
CellGroupConfig ::= SEQUENCE {			
mac-CellGroupConfig	Not present		
physicalCellGroupConfig	Not present		
spCellConfig	Not present		
}			

**Table 8.2.2.7.1.3.3-28: RadioBearerConfig-MCG-to-SCG (step 21, Table 8.2.2.7.1.3.2-1)**

Derivation Path: 38.508-1 [4], Table 4.6.3-100 with condition EN-DC			
Information Element	Value/remark	Comment	Condition
RadioBearerConfig ::= SEQUENCE {			
drb-ToAddModList SEQUENCE (SIZE (1..maxDRB))	1 entry		
OF SEQUENCE {			
cnAssociation CHOICE {			
eps-BearerIdentity	6		
}			
drb-Identity	2		
recoverPDCP	true		
}			
}			

**Table 8.2.2.7.1.3.3-29: RRCConnectionReconfigurationComplete (steps 6, 10, 18, 22, Table 8.2.2.7.1.3.2-1)**

Derivation Path: 36.508 [7] Table 4.6.1-9			
Information Element	Value/remark	Comment	Condition
RRCConnectionReconfigurationComplete ::= SEQUENCE {			
criticalExtensions CHOICE {			
rrcConnectionReconfigurationComplete-r8 SEQUENCE {			
nonCriticalExtension SEQUENCE {			
nonCriticalExtension SEQUENCE {			
nonCriticalExtension SEQUENCE {			
nonCriticalExtension SEQUENCE {			
nonCriticalExtension SEQUENCE {			
scg-ConfigResponseNR-r15	Present		
}			
}			
}			
}			
}			
}			
}			
}			

## 8.2.2.8 Bearer Modification / Handling for bearer type change with security key change

### 8.2.2.8.1 Bearer Modification / Handling for bearer type change with security key change / EN-DC

**Editor's Note:** The conformance requirements are based on running RAN2 CRs.

#### 8.2.2.8.1.1 Test Purpose (TP)

(1)

```
with { UE in RRC_CONNECTED state with EN-DC, and, MCG (E-UTRA PDCP) and SCG }
ensure that {
  when { UE receives an RRCConnectionReconfiguration message to modify the SN terminated SCG DRB to
  MN terminated SCG DRB with security key change to keNB }
  then { UE reconfigures the DRB and sends an RRCConnectionReconfigurationComplete message }
}
```

(2)

```
with { UE in RRC_CONNECTED state with EN-DC, and, MCG (E-UTRA PDCP) and MN terminated SCG DRB
established with security key keNB }
ensure that {
  when { UE receives an RRCConnectionReconfiguration message to modify the MN terminated SCG DRB to
  SN terminated Split DRB with security key change to s-KgNB }
  then { UE reconfigures the DRB and sends an RRCConnectionReconfigurationComplete message }
}
```

(3)

```
with { UE in RRC_CONNECTED state with EN-DC, and, MCG (E-UTRA PDCP) and SN terminated Split DRB
established with security key s-KgNB }
ensure that {
  when { UE receives an RRCConnectionReconfiguration message to modify the SN terminated Split DRB
  to MN terminated Split DRB with security key change to keNB }
  then { UE reconfigures the DRB and sends an RRCConnectionReconfigurationComplete message }
}
```

(4)

```

with { UE in RRC_CONNECTED state with EN-DC, and, MCG (E-UTRA PDCP) and MN terminated Split DRB
established with security key keNB }
ensure that {
  when { UE receives an RRCConnectionReconfiguration message to modify the MN terminated Split DRB
to SN terminated MCG DRB (NR PDCP) with security key change to s-KgNB }
  then { UE reconfigures the DRB and sends an RRCConnectionReconfigurationComplete message }
}

```

(5)

```

with { UE in RRC_CONNECTED state with EN-DC, and, MCG (E-UTRA PDCP) and SN terminated MCG DRB (NR
PDCP) established with security key s-KgNB }
ensure that {
  when { UE receives an RRCConnectionReconfiguration message to modify the SN terminated MCG DRB (NR
PDCP) to MN terminated MCG DRB (NR PDCP) with security key change to keNB }
  then { UE reconfigures the DRB and sends an RRCConnectionReconfigurationComplete message }
}

```

(6)

```

with { UE in RRC_CONNECTED state with EN-DC, and, MCG (E-UTRA PDCP) and MN terminated MCG DRB (NR
PDCP) established with security key keNB }
ensure that {
  when { UE receives an RRCConnectionReconfiguration message to modify the MN terminated MCG DRB (NR
PDCP) to SN terminated Split DRB with security key change to s-KgNB }
  then { UE reconfigures the DRB and sends an RRCConnectionReconfigurationComplete message }
}

```

(7)

```

with { UE in RRC_CONNECTED state with EN-DC, and, MCG (E-UTRA PDCP) and SN terminated Split DRB
established with security key s-KgNB }
ensure that {
  when { UE receives an RRCConnectionReconfiguration message to modify the SN terminated Split DRB
to MN terminated SCG DRB with security key change to keNB }
  then { UE reconfigures the DRB and sends an RRCConnectionReconfigurationComplete message }
}

```

(8)

```

with { UE in RRC_CONNECTED state with EN-DC, and, MCG (E-UTRA PDCP) and MN terminated SCG DRB
established with security key keNB }
ensure that {
  when { UE receives an RRCConnectionReconfiguration message to modify the MN terminated SCG DRB to
SN terminated MCG DRB (NR PDCP) with security key change to s-KgNB }
  then { UE reconfigures the DRB and sends an RRCConnectionReconfigurationComplete message }
}

```

(9)

```

with { UE in RRC_CONNECTED state with EN-DC, and, MCG (E-UTRA PDCP) and SN terminated MCG DRB (NR
PDCP) established with security key s-KgNB }
ensure that {
  when { UE receives an RRCConnectionReconfiguration message to modify the SN terminated MCG DRB (NR
PDCP) to MN terminated SCG DRB with security key change to keNB }
  then { UE reconfigures the DRB and sends an RRCConnectionReconfigurationComplete message }
}

```

#### 8.2.2.8.1.2 Conformance requirements

References: The conformance requirements covered in the present test case are specified in: TS 36.331, clause 5.3.5.3, TS 38.331, clauses 5.3.5.3, 5.3.5.6.1 and 5.3.5.6.5, TS 37.340, clause Annex A: Table A-1: L2 handling for bearer type change with and without security key change. Unless otherwise stated these are Rel-15 requirements.

[TS 36.331, clause 5.3.5.3]

If the *RRCConnectionReconfiguration* message does not include the *mobilityControlInfo* and the UE is able to comply with the configuration included in this message, the UE shall:

...

- 1> if the received *RRCCConnectionReconfiguration* includes the *nr-Config* and it is set to *release*: or
- 1> if the received *RRCCConnectionReconfiguration* includes *endc-ReleaseAndAdd* and it is set to *TRUE*:
  - 2> perform ENDC release as specified in TS38.331 [82, 5.3.5.10];
- 1> if the received *RRCCConnectionReconfiguration* includes the *sk-Counter*:
  - 2> perform key update procedure as specified in TS 38.331 [82, 5.3.5.8];
- 1> if the received *RRCCConnectionReconfiguration* includes the *nr-SecondaryCellGroupConfig*:
  - 2> perform NR RRC Reconfiguration as specified in TS 38.331 [82, 5.3.5.3];
- 1> if the received *RRCCConnectionReconfiguration* includes the *nr-RadioBearerConfig1*:
  - 2> perform radio bearer configuration as specified in TS 38.331 [82, 5.3.5.6];
- 1> if the received *RRCCConnectionReconfiguration* includes the *nr-RadioBearerConfig2*:
  - 2> perform radio bearer configuration as specified in TS 38.331 [82, 5.3.5.6];
- 1> if this is the first *RRCCConnectionReconfiguration* message after successful completion of the RRC connection re-establishment procedure:
  - 2> resume SRB2 and all DRBs that are suspended, if any, including RBs configured with NR PDCP;

NOTE 4: The handling of the radio bearers after the successful completion of the PDCP re-establishment, e.g. the re-transmission of unacknowledged PDCP SDUs (as well as the associated status reporting), the handling of the SN and the HFN, is specified in TS 36.323 [8].

NOTE 5: The UE may discard SRB2 messages and data that it receives prior to completing the reconfiguration used to resume these bearers.

...

- 1> set the content of *RRCCConnectionReconfigurationComplete* message as follows:
  - 2> if the *RRCCConnectionReconfiguration* message includes *perCC-GapIndicationRequest*:
    - 3> include *perCC-GapIndicationList* and *numFreqEffective*;
  - 2> if the frequencies are configured for reduced measurement performance:
    - 3> include *numFreqEffectiveReduced*;
  - 2> if the received *RRCCConnectionReconfiguration* message included *nr-SecondaryCellGroupConfig*:
    - 3> include *scg-ConfigResponseNR* in accordance with TS 38.331 [82, 5.3.5.3];
- 1> submit the *RRCCConnectionReconfigurationComplete* message to lower layers for transmission using the new configuration, upon which the procedure ends;

[TS 38.331, clause 5.3.5.3]

The UE shall perform the following actions upon reception of the *RRCReconfiguration*:

- 1> if the *RRCReconfiguration* includes the *secondaryCellGroup*:
  - 2> perform the cell group configuration for the SCG according to 5.3.5.5;
- 1> if the *RRCReconfiguration* message contains the *radioBearerConfig*:
  - 2> perform the radio bearer configuration according to 5.3.5.6;
- 1> if the *RRCReconfiguration* message includes the *measConfig*:

- 2> perform the measurement configuration procedure as specified in 5.5.2;
- 1> set the content of *RRCReconfigurationComplete* message as follows:
  - 2> if the *RRCReconfiguration* includes the *masterCellGroup* containing the *reportUplinkTxDirectCurrent*, or;
  - 2> if the *RRCReconfiguration* includes the *secondaryCellGroup* containing the *reportUplinkTxDirectCurrent*:
  - 3> include the *uplinkTxDirectCurrentList*;
- 1> if the UE is configured with E-UTRA *nr-SecondaryCellGroupConfig* (MCG is E-UTRA):
  - 2> if *RRCReconfiguration* was received via SRB1:
    - 3> construct *RRCReconfigurationComplete* message and submit it via the EUTRA MCG embedded in E-UTRA RRC message *RRCConnectionReconfigurationComplete* as specified in TS 36.331 [10];
    - 3> if *reconfigurationWithSync* was included in *spCellConfig* of an SCG:
      - 4> initiate the random access procedure on the SpCell, as specified in TS 38.321 [3];
    - 3> else:
      - 4> the procedure ends;
  - NOTE: The order the UE sends the *RRCConnectionReconfigurationComplete* message and performs the Random Access procedure towards the SCG is left to UE implementation.
  - 2> else (*RRCReconfiguration* was received via SRB3):

- 3> submit the *RRCReconfigurationComplete* message via SRB3 to lower layers for transmission using the new configuration .

NOTE: For EN-DC, in the case of SRB1, the random access is triggered by RRC layer itself as there is not necessarily other UL transmission. In the case of SRB3, the random access is triggered by the MAC layer due to arrival of *RRCReconfigurationComplete*.

- 1 > else:
  - 2> submit the *RRCReconfigurationComplete* message via SRB1 to lower layers for transmission using the new configuration;
  - 1> if *reconfigurationWithSync* was included in *spCellConfig* of an MCG or SCG, and when MAC of an NR cell group successfully completes a random access procedure triggered above;
    - 2> stop timer T304 for that cell group;
    - 2> apply the parts of the CQI reporting configuration, the scheduling request configuration and the sounding RS configuration that do not require the UE to know the SFN of the respective target SpCell, if any;
    - 2> apply the parts of the measurement and the radio resource configuration that require the UE to know the SFN of the respective target SpCell (e.g. measurement gaps, periodic CQI reporting, scheduling request configuration, sounding RS configuration), if any, upon acquiring the SFN of that target SpCell;
    - 2> if the *reconfigurationWithSync* was included in *spCellConfig* of an MCG:
      - 3> if the active downlink BWP, which is indicated by the *firstActiveDownlinkBWP-Id* for the target SpCell of the MCG, has a common search space configured or if the conditions defined in FFS\_Spec [X], section FFS\_Section are satisfied:
    - 4> acquire the *SIB1* of the target SpCell of the MCG, as specified in 5.2.2.3.1;
    - 2> the procedure ends.

NOTE: The UE is only required to acquire broadcasted *SIB1* if the UE can acquire it without disrupting unicast data reception, i.e. the broadcast and unicast beams are quasi co-located.

[TS 38.331, clause 5.3.5.6.1]

The UE shall perform the following actions based on a received *RadioBearerConfig* IE:

...

- 1> if the *RadioBearerConfig* includes the *drb-ToAddModList*:
  - 2> perform DRB addition or reconfiguration as specified in 5.3.5.6.5.

[TS 38.331, clause 5.3.5.6.5]

The UE shall:

- 1> for each *drb-Identity* value included in the *drb-ToAddModList* that is not part of the current UE configuration (DRB establishment including the case when full configuration option is used):
  - 2> if an *sdap-Config* is included:
    - 3> if an SDAP entity with the received *pdu-Session* does not exist:
      - 4> establish an SDAP entity as specified in TS 37.324 [xx] section 5.1.1;
    - 3> configure the SDAP entity in accordance with the received *sdap-Config* as specified in TS 37.324 [xx] and associate the DRB with the SDAP entity;
  - 2> establish a PDCP entity and configure it in accordance with the received *pdcp-Config*;
  - 2> if the PDCP entity of this DRB is not configured with *cipheringDisabled*:
    - 3> configure the PDCP entity with the ciphering algorithms according to *securityConfig* and apply the  $K_{UPenc}$  key associated with the master key ( $K_{eNB}/K_{gNB}$ ) or the secondary key ( $S-K_{gNB}$ ) as indicated in *keyToUse*;
  - 2> if the PDCP entity of this DRB is configured with *integrityProtection*:
    - 3> configure the PDCP entity with the integrity algorithms according to *securityConfig* and apply the  $K_{UPint}$  key associated with the master ( $K_{eNB}/K_{gNB}$ ) or the secondary key ( $S-K_{gNB}$ ) as indicated in *keyToUse*;
  - 2> if the UE is operating in EN-DC:
    - 3> if the DRB was configured with the same *eps-BearerIdentity* either by NR or E-UTRA prior to receiving this reconfiguration:
      - 4> associate the established DRB with the corresponding *eps-BearerIdentity*;
    - 3> else:
      - 4> indicate the establishment of the DRB(s) and the *eps-BearerIdentity* of the established DRB(s) to upper layers;
- 3> for each *drb-Identity* value included in the *drb-ToAddModList* that is part of the current UE configuration:
  - 2> if an *sdap-Config* is included, reconfigure the SDAP entity in accordance with the received *sdap-Config* as specified in TS 37.324 [xx];
  - 2> if the *reestablishPDCP* is set:
    - 3> if the PDCP entity of this DRB is not configured with *cipheringDisabled*:
      - 4> configure the PDCP entity with the ciphering algorithm and  $K_{UPenc}$  key associated with the master or secondary key ( $K_{eNB}/S-K_{gNB}/K_{gNB}$ ) as indicated in *keyToUse*, i.e. the ciphering configuration shall be applied to all subsequent PDCP PDUs received and sent by the UE;
    - 3> if the PDCP entity of this DRB is configured with *integrityProtection*:

4> configure the PDCP entity with the integrity algorithms according to *securityConfig* and apply the  $K_{UPint}$  key associated with the master ( $K_{eNB}/K_{gNB}$ ) or the secondary key ( $S-K_{gNB}$ ) as indicated in *keyToUse*;

3> re-establish the PDCP entity of this DRB as specified in 38.323 [5], section 5.1.2;

2> else, if the *recoverPDCP* is set:

3> trigger the PDCP entity of this DRB to perform data recovery as specified in 38.323;

2> if the *pdcp-Config* is included:

3> reconfigure the PDCP entity in accordance with the received *pdcp-Config*.

NOTE 1: Removal and addition of the same *drb-Identity* in a single *radioResourceConfig* is not supported. In case *drb-Identity* is removed and added due to reconfiguration with sync or re-establishment with the full configuration option, the network can use the same value of *drb-Identity*.

NOTE 2: When determining whether a *drb-Identity* value is part of the current UE configuration, the UE does not distinguish which *RadioBearerConfig* and *DRB-ToAddModList* that DRB was originally configured in. To re-associate a DRB with a different key ( $K_{eNB}$  to  $S-K_{eNB}$  or vice versa), the network provides the *drb-Identity* value in the (target) *drb-ToAddModList* and sets the *reestablishPDCP* flag. The network does not list the *drb-Identity* in the (source) *drb-ToReleaseList*.

NOTE 3: When setting the *reestablishPDCP* flag for a radio bearer, the network ensures that the RLC receiver entities do not deliver old PDCP PDUs to the re-established PDCP entity. It does that e.g. by triggering a reconfiguration with sync of the cell group hosting the old RLC entity or by releasing the old RLC entity.

NOTE 4: In this specification, UE configuration refers to the parameters configured by NR RRC unless otherwise stated.

NOTE 5: Ciphering and integrity protection can be enabled or disabled for a DRB. The enabling/disabling of ciphering or integrity protection can be changed only by releasing and adding the DRB.

[TS 37.340, Annex A]

This subclause provides for information an overview on L2 handling for bearer type change in EN-DC, with and without security key change (from  $K_{eNB}$  to  $S-K_{gNB}$  and from  $S-K_{gNB}$  to  $K_{eNB}$ ), i.e. with and without a change of the termination point.



Table A-1: L2 handling for bearer type change with and without security key change

Bearer type change from row to col	MCG		Split		SCG	
	no key change	with key change (K <sub>eNB</sub> <-> S-K <sub>gNB</sub> )	no key change	with key change (K <sub>eNB</sub> <-> S-K <sub>gNB</sub> )	no key change	with key change (K <sub>eNB</sub> <-> S-K <sub>gNB</sub> )
MCG	N/A	PDCP: Re-establish MCG RLC: Re-establish MCG MAC: See Note SCG RLC: No action SCG MAC: No action	PDCP: Reconfigure MCG RLC: No action MCG MAC: No action SCG RLC: Establish SCG MAC: Reconfigure	PDCP: Re-establish MCG RLC: Re-establish MCG MAC: See Note SCG RLC: Establish SCG MAC: Reconfigure	PDCP: Recovery MCG RLC: Re-est+release MCG MAC: Reconfigure SCG RLC: Establish SCG MAC: Reconfigure	PDCP: Re-establish MCG RLC: Re-est+release MCG MAC: Reconfigure SCG RLC: Establish SCG MAC: Reconfigure
Split	PDCP: Recovery MCG RLC: No action MCG MAC: No action SCG RLC: Release SCG MAC: Reconfigure	PDCP: Re-establish MCG RLC: Re-establish MCG MAC: See Note SCG RLC: Release SCG MAC: Reconfigure	N/A	PDCP: Re-establish MCG RLC: Re-establish MCG MAC: Reset SCG RLC: Re-establish SCG MAC: Reset	PDCP: Recovery MCG RLC: Re-est+release MCG MAC: Reconfigure SCG RLC: No action SCG MAC: No action	PDCP: Re-establish MCG RLC: Re-est+release MCG MAC: Reconfigure SCG RLC: Re-establish SCG MAC: See Note
SCG	PDCP: Recovery MCG RLC: Establish MCG MAC: Reconfigure SCG RLC: Release SCG MAC: Reconfigure	PDCP: Re-establish MCG RLC: Establish MCG MAC: Reconfigure SCG RLC: Release SCG MAC: Reconfigure	PDCP: Reconfigure MCG RLC: Establish MCG MAC: Reconfigure SCG RLC: No action SCG MAC: No action	PDCP: Re-establish MCG RLC: Establish MCG MAC: Reconfigure SCG RLC: Re-establish SCG MAC: See Note	N/A	PDCP: Re-establish MCG RLC: No action MCG MAC: No action SCG RLC: Re-establish SCG MAC: See note

NOTE: MAC behaviour depends on the solution selected by the network, e.g. MAC reset, change of LCID, etc.

#### 8.2.2.8.1.3 Test description

##### 8.2.2.8.1.3.1 Pre-test conditions

System Simulator:

- E-UTRA Cell 1 is the PCell and NR Cell 1 is the PSCell.

UE:

- None.

Preamble:

- If pc\_IP\_Ping is set to TRUE then, the UE is in state RRC\_CONNECTED using generic procedure parameter Connectivity (EN-DC), Bearers (MCG(s) and SCG) established according to TS 38.508-1 [4], clause 4.5.4.
- Else, the UE is in state RRC\_CONNECTED using generic procedure parameter Connectivity (EN-DC), Bearers (MCG(s) and SCG) established and Test Loop Function (On) with UE test loop mode B according to TS 38.508-1 [4], clause 4.5.4.

8.2.2.8.1.3.2 Test procedure sequence

**Table 8.2.2.8.1.3.2-1: Main behaviour**

St	Procedure	Message Sequence		TP	Verdict
		U - S	Message		
1	The SS transmits an <i>RRCCONNECTIONRECONFIGURATION</i> message containing NR <i>RRCCONNECTIONRECONFIGURATION</i> message to modify SN terminated SCG DRB with security key s-KgNB to MN terminated SCG DRB with security key change to keNB.	<--	<i>RRCCONNECTIONRECONFIGURATION</i> ( <i>RRCCONNECTIONRECONFIGURATION</i> )	-	-
2	Check: Does the UE transmit an <i>RRCCONNECTIONRECONFIGURATIONCOMPLETE</i> message containing NR <i>RRCCONNECTIONRECONFIGURATIONCOMPLETE</i> message?	-->	<i>RRCCONNECTIONRECONFIGURATIONCOMPLETE</i> ( <i>RRCCONNECTIONRECONFIGURATIONCOMPLETE</i> )	1	P
3	Check: Does the test result of generic test procedure in TS 38.508-1 subclause 4.9.1 indicate that the UE is capable of exchanging IP data on SCG DRB#2?	-	-	1	P
4	The SS transmits an <i>RRCCONNECTIONRECONFIGURATION</i> message containing NR <i>RRCCONNECTIONRECONFIGURATION</i> message to modify MN terminated SCG DRB with security key keNB to SN terminated Split DRB with security key change to s-KgNB.	<--	<i>RRCCONNECTIONRECONFIGURATION</i> ( <i>RRCCONNECTIONRECONFIGURATION</i> )	-	-
5	Check: Does the UE transmit an <i>RRCCONNECTIONRECONFIGURATIONCOMPLETE</i> message containing NR <i>RRCCONNECTIONRECONFIGURATIONCOMPLETE</i> message?	-->	<i>RRCCONNECTIONRECONFIGURATIONCOMPLETE</i> ( <i>RRCCONNECTIONRECONFIGURATIONCOMPLETE</i> )	2	P
6	Check: Does the test result of generic test procedure in TS 38.508-1 subclause 4.9.1 indicate that the UE is capable of exchanging IP data on Split DRB#2 using NR radio path?	-	-	2	P
7	The SS transmits an <i>RRCCONNECTIONRECONFIGURATION</i> message containing NR <i>RRCCONNECTIONRECONFIGURATION</i> message to modify SN terminated Split DRB with security key s-KgNB to MN terminated Split DRB with security key change to keNB.	<--	<i>RRCCONNECTIONRECONFIGURATION</i> ( <i>RRCCONNECTIONRECONFIGURATION</i> )	-	-
8	Check: Does the UE transmit an <i>RRCCONNECTIONRECONFIGURATIONCOMPLETE</i> message containing NR <i>RRCCONNECTIONRECONFIGURATIONCOMPLETE</i> message?	-->	<i>RRCCONNECTIONRECONFIGURATIONCOMPLETE</i> ( <i>RRCCONNECTIONRECONFIGURATIONCOMPLETE</i> )	3	P
9	Check: Does the test result of generic test procedure in TS 38.508-1 subclause 4.9.1 indicate that the UE is capable of exchanging IP data on Split DRB#2 using NR radio path?	-	-	3	P
10	The SS transmits an <i>RRCCONNECTIONRECONFIGURATION</i> message containing NR <i>RRCCONNECTIONRECONFIGURATION</i> message to modify MN terminated Split DRB with security key keNB to SN terminated MCG DRB with security key change to s-KgNB.	<--	<i>RRCCONNECTIONRECONFIGURATION</i> ( <i>RRCCONNECTIONRECONFIGURATION</i> )	-	-
11	Check: Does the UE transmit an <i>RRCCONNECTIONRECONFIGURATIONCOMPLETE</i> message containing NR <i>RRCCONNECTIONRECONFIGURATIONCOMPLETE</i> message?	-->	<i>RRCCONNECTIONRECONFIGURATIONCOMPLETE</i> ( <i>RRCCONNECTIONRECONFIGURATIONCOMPLETE</i> )	4	P
12	Check: Does the test result of generic test procedure in TS 38.508-1 subclause 4.9.1 indicate that the UE is capable of exchanging IP data on MCG DRB#2?	-	-	4	P
13	The SS transmits an <i>RRCCONNECTIONRECONFIGURATION</i> message containing NR <i>RADIOBEARERCONFIG</i> to modify SN terminated MCG DRB with security key s-KgNB to MN terminated MCG DRB with security key change to keNB.	<--	<i>RRCCONNECTIONRECONFIGURATION</i>	-	-
14	Check: Does the UE transmit an <i>RRCCONNECTIONRECONFIGURATIONCOMPLETE</i> message?	-->	<i>RRCCONNECTIONRECONFIGURATIONCOMPLETE</i>	5	P

15	Check: Does the test result of generic test procedure in TS 38.508-1 subclause 4.9.1 indicate that the UE is capable of exchanging IP data on MCG DRB#2?	-	-	5	P
16	The SS transmits an <i>RRConnectionReconfiguration</i> message containing NR <i>RRCReconfiguration</i> message to modify MN terminated MCG DRB with security key keNB to SN terminated Split DRB with security key change to s-KgNB.	<--	<i>RRConnectionReconfiguration</i> ( <i>RRCReconfiguration</i> )	-	-
17	Check: Does the UE transmit an <i>RRConnectionReconfigurationComplete</i> message containing NR <i>RRCReconfigurationComplete</i> message?	-->	<i>RRConnectionReconfigurationComplete</i> ( <i>RRCReconfigurationComplete</i> )	6	P
18	Check: Does the test result of generic test procedure in TS 38.508-1 subclause 4.9.1 indicate that the UE is capable of exchanging IP data on Split DRB#2 using NR radio path?	-	-	6	P
19	The SS transmits an <i>RRConnectionReconfiguration</i> message containing NR <i>RRCReconfiguration</i> message to modify SN terminated Split DRB with security key s-KgNB to MN terminated SCG DRB with security key change to keNB.	<--	<i>RRConnectionReconfiguration</i> ( <i>RRCReconfiguration</i> )	-	-
20	Check: Does the UE transmit an <i>RRConnectionReconfigurationComplete</i> message containing NR <i>RRCReconfigurationComplete</i> message?	-->	<i>RRConnectionReconfigurationComplete</i> ( <i>RRCReconfigurationComplete</i> )	7	P
21	Check: Does the test result of generic test procedure in TS 38.508-1 subclause 4.9.1 indicate that the UE is capable of exchanging IP data on SCG DRB#2?	-	-	7	P
22	The SS transmits an <i>RRConnectionReconfiguration</i> message containing NR <i>RRCReconfiguration</i> message to modify MN terminated SCG DRB with security key keNB to SN terminated MCG DRB with security key change to s-KgNB.	<--	<i>RRConnectionReconfiguration</i> ( <i>RRCReconfiguration</i> )	-	-
23	Check: Does the UE transmit an <i>RRConnectionReconfigurationComplete</i> message containing NR <i>RRCReconfigurationComplete</i> message?	-->	<i>RRConnectionReconfigurationComplete</i> ( <i>RRCReconfigurationComplete</i> )	8	P
24	Check: Does the test result of generic test procedure in TS 38.508-1 subclause 4.9.1 indicate that the UE is capable of exchanging IP data on MCG DRB#2?	-	-	8	P
25	The SS transmits an <i>RRConnectionReconfiguration</i> message containing NR <i>RRCReconfiguration</i> message to modify SN terminated MCG DRB with security key s-KgNB to MN terminated SCG DRB with security key change to keNB.	<--	<i>RRConnectionReconfiguration</i> ( <i>RRCReconfiguration</i> )	-	-
26	Check: Does the UE transmit an <i>RRConnectionReconfigurationComplete</i> message containing NR <i>RRCReconfigurationComplete</i> message?	-->	<i>RRConnectionReconfigurationComplete</i> ( <i>RRCReconfigurationComplete</i> )	9	P
27	Check: Does the test result of generic test procedure in TS 38.508-1 subclause 4.9.1 indicate that the UE is capable of exchanging IP data on SCG DRB#2?	-	-	9	P

8.2.2.8.1.3.3 Specific message contents

**Table 8.2.2.8.1.3.3-1: RRCConnectionReconfiguration (step 1, Table 8.2.2.8.1.3.2-1)**

Derivation Path: 36.508 [7], Table 4.6.1-8			
Information Element	Value/remark	Comment	Condition
RRCConnectionReconfiguration ::= SEQUENCE {			
criticalExtensions CHOICE {			
c1 CHOICE {			
rrcConnectionReconfiguration-r8 ::= SEQUENCE			
{			
nonCriticalExtension ::= SEQUENCE {			
nonCriticalExtension ::= SEQUENCE {			
nonCriticalExtension ::= SEQUENCE {			
nonCriticalExtension ::= SEQUENCE {			
nonCriticalExtension ::= SEQUENCE {			
nonCriticalExtension ::= SEQUENCE {			
nonCriticalExtension ::= SEQUENCE {			
nonCriticalExtension ::= SEQUENCE {			
nr-Config-r15 CHOICE {			
setup SEQUENCE {			
nr-SecondaryCellGroupConfig-r15	OCTET STRING including the RRCReconfiguration message and the IE secondaryCellGroup.		
}			
}			
}			
}			
}			
}			
}			
}			
}			
}			
}			
}			
}			
}			
}			

**Table 8.2.2.8.1.3.3-2: RRCReconfiguration (Table 8.2.2.8.1.3.3-1)**

Derivation Path: 38.508-1 [4], Table 4.6.1-3			
Information Element	Value/remark	Comment	Condition
RRCReconfiguration ::= SEQUENCE {			
criticalExtensions CHOICE {			
rrcReconfiguration ::= SEQUENCE {			
secondaryCellGroup	CellGroupConfig		
}			
}			
}			

**Table 8.2.2.8.1.3.3-3: CellGroupConfig (Table 8.2.2.8.1.3.3-2)**

Derivation Path: 38.508-1 [4], Table 4.6.3-13			
Information Element	Value/remark	Comment	Condition
CellGroupConfig ::= SEQUENCE {			
rlc-BearerToAddModList SEQUENCE (SIZE(1..maxLCH)) OF SEQUENCE {	1 entry		
logicalChannelIdentity[1]	Logical channel identity corresponding to SCG DRB.		
reestablishRLC[1]	true		
}			
}			

**Table 8.2.2.8.1.3.3-4: RadioBearerConfig (Table 8.2.2.8.1.3.3-1)**

Derivation Path: 38.508-1 [4], Table 4.6.3-100			
Information Element	Value/remark	Comment	Condition
RadioBearerConfig ::= SEQUENCE {			
drb-ToAddModList SEQUENCE (SIZE (1..maxDRB)) OF SEQUENCE {	1 entry		
cnAssociation CHOICE {			
eps-BearerIdentity	6	Dedicated EPS bearer Id of SCG DRB	
}			
drb-Identity	2	SCG DRB Id	
reestablishPDCP	true		
}			
securityConfig SEQUENCE {			
keyToUse	keNB		
}			
}			

**Table 8.2.2.8.1.3.3-5: RRCConnectionReconfiguration (step 4, Table 8.2.2.8.1.3.2-1)**

Derivation Path: 36.508 [7], Table 4.6.1-8			
Information Element	Value/remark	Comment	Condition
RRCConnectionReconfiguration ::= SEQUENCE {			
criticalExtensions CHOICE {			
c1 CHOICE{			
rrcConnectionReconfiguration-r8 ::= SEQUENCE			
{			
radioResourceConfigDedicated	RadioResourceConfigDe dicated-MN_SCG-to- SN_Split		
nonCriticalExtension ::= SEQUENCE {			
nonCriticalExtension ::= SEQUENCE {			
nonCriticalExtension ::= SEQUENCE {			
nonCriticalExtension ::= SEQUENCE {			
nonCriticalExtension ::= SEQUENCE {			
nonCriticalExtension ::= SEQUENCE {			
nonCriticalExtension ::= SEQUENCE {			
nonCriticalExtension ::= SEQUENCE {			
nr-Config-r15 CHOICE {			
setup SEQUENCE {			
nr-SecondaryCellGroupConfig-r15	OCTET STRING including the <i>RRCReconfiguration</i> message and the IE secondaryCellGroup.		
}			
}			
nr-RadioBearerConfig1-r15	OCTET STRING including RadioBearerConfig.		
}			
}			
}			
}			
}			
}			
}			
}			
}			
}			
}			
}			
}			

**Table 8.2.2.8.1.3.3-6: RadioResourceConfigDedicated-MN\_SCG-to-SN\_Split (Table 8.2.2.8.1.3.3-5)**

Derivation Path: 36.508 [7], Table 4.6.3-19AAAAAB

**Table 8.2.2.8.1.3.3-7: RRCReconfiguration (Table 8.2.2.8.1.3.3-5)**

Derivation Path: 38.508-1 [4], Table 4.6.1-3			
Information Element	Value/remark	Comment	Condition
RRCReconfiguration ::= SEQUENCE {			
criticalExtensions CHOICE {			
rrcReconfiguration ::= SEQUENCE {			
secondaryCellGroup	CellGroupConfig		
}			
}			
}			

**Table 8.2.2.8.1.3.3-8: CellGroupConfig (Table 8.2.2.8.1.3.3-7)**

Derivation Path: 38.508-1 [4], Table 4.6.3-13			
Information Element	Value/remark	Comment	Condition
CellGroupConfig ::= SEQUENCE {			
rlc-BearerToAddModList SEQUENCE (SIZE(1..maxLCH)) OF SEQUENCE {	1 entry		
logicalChannelIdentity[1]	Logical channel identity corresponding to SCG DRB.		
reestablishRLC[1]	true		
}			
}			

**Table 8.2.2.8.1.3.3-9: RadioBearerConfig (Table 8.2.2.8.1.3.3-5)**

Derivation Path: 38.508-1 [4], Table 4.6.3-100			
Information Element	Value/remark	Comment	Condition
RadioBearerConfig ::= SEQUENCE {			
drb-ToAddModList SEQUENCE (SIZE (1..maxDRB)) OF SEQUENCE {	1 entry		
cnAssociation CHOICE {			
eps-BearerIdentity	6	Dedicated EPS bearer Id of SCG DRB	
}			
drb-Identity	2	SCG DRB Id	
reestablishPDCP	true		
pdcpc-Config	PDCP-Config		
}			
securityConfig SEQUENCE {			
keyToUse	s-KgNB		
}			
}			

**Table 8.2.2.8.1.3.3-10: PDCP-Config (Table 8.2.2.8.1.3.3-9)**

Derivation Path: 38.508-1 [4], Table 4.6.3-74			
Information Element	Value/remark	Comment	Condition
PDCP-Config ::= SEQUENCE {			
moreThanOneRLC SEQUENCE {			
primaryPath SEQUENCE {			
cellGroup	1		
}			
ul-DataSplitThreshold	infinity		
}			
}			



**Table 8.2.2.8.1.3.3-11: *RRCConnectionReconfiguration* (step 7, Table 8.2.2.8.1.3.2-1)**

Derivation Path: 36.508 [7], Table 4.6.1-8			
Information Element	Value/remark	Comment	Condition
RRCConnectionReconfiguration ::= SEQUENCE {			
criticalExtensions CHOICE {			
c1 CHOICE{			
rrcConnectionReconfiguration-r8 ::= SEQUENCE			
{			
radioResourceConfigDedicated	RadioResourceConfigDe dicated-SN_Split-to- MN_Split		
nonCriticalExtension ::= SEQUENCE {			
nonCriticalExtension ::= SEQUENCE {			
nonCriticalExtension ::= SEQUENCE {			
nonCriticalExtension ::= SEQUENCE {			
nonCriticalExtension ::= SEQUENCE {			
nonCriticalExtension ::= SEQUENCE {			
nonCriticalExtension ::= SEQUENCE {			
nonCriticalExtension ::= SEQUENCE {			
nr-Config-r15 CHOICE {			
setup SEQUENCE {			
nr-SecondaryCellGroupConfig-r15	OCTET STRING including the <i>RRCReconfiguration</i> message and the IE secondaryCellGroup.		
}			
}			
}			
}			
}			
}			
}			
}			
}			
}			
}			
}			
}			
}			
}			
}			

**Table 8.2.2.8.1.3.3-12: *RadioResourceConfigDedicated-SN\_Split-to-MN\_Split* (Table 8.2.2.8.1.3.3-11)**

Derivation Path: 36.508 [7], Table 4.6.3-27			
Information Element	Value/remark	Comment	Condition
RadioResourceConfigDedicated-DRB ::= SEQUENCE {			
drb-ToAddModList	DRB-ToAddModList- SN_Split-to-MN_Split		
}			

**Table 8.2.2.8.1.3.3-13: DRB-ToAddModList-SN\_Split-to-MN\_Split (Table 8.2.2.8.1.3.3-12)**

Derivation Path: 36.508 [7], Table 4.6.3-2A			
Information Element	Value/remark	Comment	Condition
DRB-ToAddModList ::= SEQUENCE (SIZE (1..maxDRB)) OF SEQUENCE {	1 Entry		
eps-BearerIdentity[1]	6	Dedicated EPS bearer Id of Split DRB	
drb-Identity[1]	2	Split DRB Id	
rlc-Config-v1510[1] ::= SEQUENCE {			
reestablishRLC-r15	true		
}			
}			

**Table 8.2.2.8.1.3.3-14: RRCReconfiguration (Table 8.2.2.8.1.3.3-11)**

Derivation Path: 38.508-1 [4], Table 4.6.1-3			
Information Element	Value/remark	Comment	Condition
RRCReconfiguration ::= SEQUENCE {			
criticalExtensions CHOICE {			
rrcReconfiguration ::= SEQUENCE {			
secondaryCellGroup	CellGroupConfig		
}			
}			
}			

**Table 8.2.2.8.1.3.3-15: CellGroupConfig (Table 8.2.2.8.1.3.3-14)**

Derivation Path: 38.508-1 [4], Table 4.6.3-13			
Information Element	Value/remark	Comment	Condition
CellGroupConfig ::= SEQUENCE {			
rlc-BearerToAddModList SEQUENCE (SIZE(1..maxLCH)) OF SEQUENCE {	1 entry		
logicalChannelIdentity[1]	Logical channel identity corresponding to Split DRB.		
reestablishRLC[1]	true		
}			
}			

**Table 8.2.2.8.1.3.3-16: RadioBearerConfig (Table 8.2.2.8.1.3.3-11)**

Derivation Path: 38.508-1 [4], Table 4.6.3-100			
Information Element	Value/remark	Comment	Condition
RadioBearerConfig ::= SEQUENCE {			
drb-ToAddModList SEQUENCE (SIZE (1..maxDRB)) OF SEQUENCE {	1 entry		
cnAssociation CHOICE {			
eps-BearerIdentity	6	Dedicated EPS bearer Id of Split DRB	
}			
drb-Identity	2	Split DRB Id	
reestablishPDCP	true		
pdcpc-Config	Not present		
}			
securityConfig SEQUENCE {			
keyToUse	keNB		
}			
}			

**Table 8.2.2.8.1.3.3-17: RRCConnectionReconfiguration (step 10, Table 8.2.2.8.1.3.2-1)**

Derivation Path: 36.508 [7], Table 4.6.1-8			
Information Element	Value/remark	Comment	Condition
RRCConnectionReconfiguration ::= SEQUENCE {			
criticalExtensions CHOICE {			
c1 CHOICE{			
rrcConnectionReconfiguration-r8 ::= SEQUENCE			
{			
radioResourceConfigDedicated	RadioResourceConfigDe dicated-MN_Split-to- SN_MCG		
nonCriticalExtension ::= SEQUENCE {			
nonCriticalExtension ::= SEQUENCE {			
nonCriticalExtension ::= SEQUENCE {			
nonCriticalExtension ::= SEQUENCE {			
nonCriticalExtension ::= SEQUENCE {			
nonCriticalExtension ::= SEQUENCE {			
nonCriticalExtension ::= SEQUENCE {			
nonCriticalExtension ::= SEQUENCE {			
nr-Config-r15 CHOICE {			
setup SEQUENCE {			
nr-SecondaryCellGroupConfig-r15	OCTET STRING including the <i>RRCReconfiguration</i> message and the IE secondaryCellGroup.		
}			
}			
nr-RadioBearerConfig1-r15	OCTET STRING including RadioBearerConfig.		
}			
}			
}			
}			
}			
}			
}			
}			
}			
}			
}			
}			
}			

**Table 8.2.2.8.1.3.3-18: RadioResourceConfigDedicated-MN\_Split-to-SN\_MCG (Table 8.2.2.8.1.3.3-17)**

Derivation Path: 36.508 [7], Table 4.6.3-27			
Information Element	Value/remark	Comment	Condition
RadioResourceConfigDedicated-DRB ::= SEQUENCE {			
drb-ToAddModList	DRB-ToAddModList- MN_Split-to-SN_MCG		
}			

**Table 8.2.2.8.1.3.3-19: DRB-ToAddModList-MN\_Split-to-SN\_MCG (Table 8.2.2.8.1.3.3-18)**

Derivation Path: 36.508 [7], Table 4.6.3-2A			
Information Element	Value/remark	Comment	Condition
DRB-ToAddModList ::= SEQUENCE (SIZE (1..maxDRB)) OF SEQUENCE {	1 Entry		
eps-BearerIdentity[1]	6	Dedicated EPS bearer Id of Split DRB	
drb-Identity[1]	2	Split DRB Id	
rlc-Config-v1510[1] ::= SEQUENCE {			
reestablishRLC-r15	true		
}			
}			

**Table 8.2.2.8.1.3.3-20: RRCReconfiguration (Table 8.2.2.8.1.3.3-17)**

Derivation Path: 38.508-1 [4], Table 4.6.1-3			
Information Element	Value/remark	Comment	Condition
RRCReconfiguration ::= SEQUENCE {			
criticalExtensions CHOICE {			
rrcReconfiguration ::= SEQUENCE {			
secondaryCellGroup	CellGroupConfig		
}			
}			
}			

**Table 8.2.2.8.1.3.3-21: CellGroupConfig (Table 8.2.2.8.1.3.3-20)**

Derivation Path: 38.508-1 [4] Table 4.6.3-13			
Information Element	Value/remark	Comment	Condition
CellGroupConfig ::= SEQUENCE {			
rlc-BearerToAddModList	Not present		
rlc-BearerToReleaseList SEQUENCE (SIZE(1..maxLCH)) OF SEQUENCE {	1 entry		
logicalChannelIdentity[1]	Logical channel identity corresponding to Split DRB.		
}			
mac-CellGroupConfig	Not present		
physicalCellGroupConfig	Not present		
spCellConfig	Not present		
}			

**Table 8.2.2.8.1.3.3-22: RadioBearerConfig (Table 8.2.2.8.1.3.3-17)**

Derivation Path: 38.508-1 [4], Table 4.6.3-100 with condition EN-DC			
Information Element	Value/remark	Comment	Condition
RadioBearerConfig ::= SEQUENCE {			
drb-ToAddModList SEQUENCE (SIZE (1..maxDRB)) OF SEQUENCE {	1 entry		
drb-Identity	2	Split DRB Id	
reestablishPDCCP	true		
}			
securityConfig SEQUENCE {			
keyToUse	s-KgNB		
}			
}			

**Table 8.2.2.8.1.3.3-23: RRCConnectionReconfiguration (step 13, Table 8.2.2.8.1.3.2-1)**

Derivation Path: 36.508 [7], Table 4.6.1-8			
Information Element	Value/remark	Comment	Condition
RRCConnectionReconfiguration ::= SEQUENCE {			
criticalExtensions CHOICE {			
c1 CHOICE{			
rrcConnectionReconfiguration-r8 ::= SEQUENCE			
{			
radioResourceConfigDedicated	RadioResourceConfigDe dicated-SN_MCG-to- MN_MCG		
nonCriticalExtension ::= SEQUENCE {			
nonCriticalExtension ::= SEQUENCE {			
nonCriticalExtension ::= SEQUENCE {			
nonCriticalExtension ::= SEQUENCE {			
nonCriticalExtension ::= SEQUENCE {			
nonCriticalExtension ::= SEQUENCE {			
nonCriticalExtension ::= SEQUENCE {			
nr-RadioBearerConfig1-r15	OCTET STRING including RadioBearerConfig.		
}			
}			
}			
}			
}			
}			
}			
}			
}			
}			
}			
}			

**Table 8.2.2.8.1.3.3-24: RadioResourceConfigDedicated-SN\_MCG-to-MN\_MCG (Table 8.2.2.8.1.3.3-23)**

Derivation Path: 36.508 [7], Table 4.6.3-27			
Information Element	Value/remark	Comment	Condition
RadioResourceConfigDedicated-DRB ::= SEQUENCE {			
drb-ToAddModList	DRB-ToAddModList- SN_MCG-to-MN_MCG		
}			

**Table 8.2.2.8.1.3.3-25: DRB-ToAddModList-SN\_MCG-to-MN\_MCG (Table 8.2.2.8.1.3.3-24)**

Derivation Path: 36.508 [7], Table 4.6.3-2A			
Information Element	Value/remark	Comment	Condition
DRB-ToAddModList ::= SEQUENCE (SIZE (1..maxDRB)) OF SEQUENCE {	1 Entry		
eps-BearerIdentity[1]	6	Dedicated EPS bearer Id of MCG DRB	
drb-Identity[1]	2	MCG DRB Id	
rlc-Config-v1510[1] ::= SEQUENCE {			
reestablishRLC-r15	true		
}			
}			

**Table 8.2.2.8.1.3.3-26: RadioBearerConfig (Table 8.2.2.8.1.3.3-23)**

Derivation Path: 38.508-1 [4], Table 4.6.3-100			
Information Element	Value/remark	Comment	Condition
RadioBearerConfig ::= SEQUENCE {			
drb-ToAddModList SEQUENCE (SIZE (1..maxDRB))	1 entry		
OF SEQUENCE {			
cnAssociation CHOICE {			
eps-BearerIdentity	6	Dedicated EPS bearer Id of MCG DRB	
}			
drb-Identity	2	MCG DRB Id	
reestablishPDCP	true		
pdcpc-Config	Not present		
}			
securityConfig SEQUENCE {			
keyToUse	keNB		
}			
}			

**Table 8.2.2.8.1.3.3-27: RRCConnectionReconfiguration (step 16, Table 8.2.2.8.1.3.2-1)**

Derivation Path: 36.508 [7], Table 4.6.1-8			
Information Element	Value/remark	Comment	Condition
RRCConnectionReconfiguration ::= SEQUENCE {			
criticalExtensions CHOICE {			
c1 CHOICE {			
rrcConnectionReconfiguration-r8 ::= SEQUENCE			
{			
radioResourceConfigDedicated	RadioResourceConfigDe dicated-MN_MCG-to- SN_Split		
nonCriticalExtension ::= SEQUENCE {			
nonCriticalExtension ::= SEQUENCE {			
nonCriticalExtension ::= SEQUENCE {			
nonCriticalExtension ::= SEQUENCE {			
nonCriticalExtension ::= SEQUENCE {			
nonCriticalExtension ::= SEQUENCE {			
nonCriticalExtension ::= SEQUENCE {			
nonCriticalExtension ::= SEQUENCE {			
nr-Config-r15 CHOICE {			
setup SEQUENCE {			
nr-SecondaryCellGroupConfig-r15	OCTET STRING including the <i>RRCReconfiguration</i> message and the IE secondaryCellGroup.		
}			
}			
nr-RadioBearerConfig1-r15	OCTET STRING including RadioBearerConfig.		
}			
}			
}			

**Table 8.2.2.8.1.3.3-28: RadioResourceConfigDedicated-MN\_MCG-to-SN\_Split (Table 8.2.2.8.1.3.3-27)**

Derivation Path: 36.508 [7], Table 4.6.3-27			
Information Element	Value/remark	Comment	Condition
RadioResourceConfigDedicated-DRB ::= SEQUENCE {			
drb-ToAddModList	DRB-ToAddModList- MN_MCG-to-SN_Split		
}			

**Table 8.2.2.8.1.3.3-29: DRB-ToAddModList-MN\_MCG-to-SN\_Split (Table 8.2.2.8.1.3.3-30)**

Derivation Path: 36.508 [7], Table 4.6.3-2A			
Information Element	Value/remark	Comment	Condition
DRB-ToAddModList ::= SEQUENCE (SIZE (1..maxDRB)) OF SEQUENCE {	1 Entry		
eps-BearerIdentity[1]	6	Dedicated EPS bearer Id of MCG DRB	
drb-Identity[1]	2	MCG DRB Id	
rlc-Config-v1510[1] ::= SEQUENCE {			
reestablishRLC-r15	true		
}			
}			

**Table 8.2.2.8.1.3.3-30: RRCReconfiguration (Table 8.2.2.8.1.3.3-27)**

Derivation Path: 38.508-1 [4], Table 4.6.1-3			
Information Element	Value/remark	Comment	Condition
RRCReconfiguration ::= SEQUENCE {			
criticalExtensions CHOICE {			
rrcReconfiguration ::= SEQUENCE {			
secondaryCellGroup	CellGroupConfig		
}			
}			
}			

**Table 8.2.2.8.1.3.3-31: CellGroupConfig (Table 8.2.2.8.1.3.3-30)**

Derivation Path: 38.508-1 [4], Table 4.6.3-13 with condition EN-DC			
Information Element	Value/remark	Comment	Condition
CellGroupConfig ::= SEQUENCE {			
rlc-BearerToAddModList SEQUENCE (SIZE(1..maxLCH)) OF SEQUENCE {	1 entry		
logicalChannelIdentity[1]	Logical channel identity corresponding to MCG DRB.		
servedRadioBearer[1] CHOICE {			
drb-Identity	2	MCG DRB Id	
}			
}			
mac-CellGroupConfig	Not present		
physicalCellGroupConfig	Not present		
spCellConfig	Not present		
}			



**Table 8.2.2.8.1.3.3-32: RadioBearerConfig (Table 8.2.2.8.1.3.3-27)**

Derivation Path: 38.508-1 [4], Table 4.6.3-100			
Information Element	Value/remark	Comment	Condition
RadioBearerConfig ::= SEQUENCE {			
drb-ToAddModList SEQUENCE (SIZE (1..maxDRB))	1 entry		
OF SEQUENCE {			
cnAssociation CHOICE {			
eps-BearerIdentity	6	Dedicated EPS bearer Id of MCG DRB	
}			
drb-Identity	2	MCG DRB Id	
reestablishPDCP	true		
pdcpc-Config	PDCP-Config		
}			
securityConfig SEQUENCE {			
keyToUse	s-KgNB		
}			
}			

**Table 8.2.2.8.1.3.3-33: PDCP-Config (Table 8.2.2.8.1.3.3-32)**

Derivation Path: 38.508-1 [4], Table 4.6.3-74			
Information Element	Value/remark	Comment	Condition
PDCP-Config ::= SEQUENCE {			
moreThanOneRLC SEQUENCE {			
primaryPath SEQUENCE {			
cellGroup	1		
}			
ul-DataSplitThreshold	infinity		
}			
}			

**Table 8.2.2.8.1.3.3-34: RRCConnectionReconfiguration (step 19, Table 8.2.2.8.1.3.2-1)**

Derivation Path: 36.508 [7], Table 4.6.1-8			
Information Element	Value/remark	Comment	Condition
RRCConnectionReconfiguration ::= SEQUENCE {			
criticalExtensions CHOICE {			
c1 CHOICE {			
rrcConnectionReconfiguration-r8 ::= SEQUENCE {			
radioResourceConfigDedicated	RadioResourceConfigDe- dedicated-DRB-REL(2)		
nonCriticalExtension ::= SEQUENCE {			
nonCriticalExtension ::= SEQUENCE {			
nonCriticalExtension ::= SEQUENCE {			
nonCriticalExtension ::= SEQUENCE {			
nonCriticalExtension ::= SEQUENCE {			
nonCriticalExtension ::= SEQUENCE {			
nonCriticalExtension ::= SEQUENCE {			
nr-Config-r15 CHOICE {			
setup SEQUENCE {			
nr-SecondaryCellGroupConfig-r15	OCTET STRING including the RRCReconfiguration message and the IE secondaryCellGroup.		
}			
}			
}			
}			
}			
}			
}			
}			
nr-RadioBearerConfig1-r15	OCTET STRING including RadioBearerConfig.		
}			
}			
}			
}			
}			
}			
}			
}			
}			
}			
}			
}			
}			
}			
}			
}			
}			
}			
}			
}			
}			
}			
}			

**Table 8.2.2.8.1.3.3-35: RRCReconfiguration (Table 8.2.2.8.1.3.3-34)**

Derivation Path: 38.508-1 [4], Table 4.6.1-3			
Information Element	Value/remark	Comment	Condition
RRCReconfiguration ::= SEQUENCE {			
criticalExtensions CHOICE {			
rrcReconfiguration ::= SEQUENCE {			
secondaryCellGroup	CellGroupConfig		
}			
}			
}			
}			

**Table 8.2.2.8.1.3.3-36: CellGroupConfig (Table 8.2.2.8.1.3.3-35)**

Derivation Path: 38.508-1 [4], Table 4.6.3-13			
Information Element	Value/remark	Comment	Condition
CellGroupConfig ::= SEQUENCE {			
rlc-BearerToAddModList SEQUENCE (SIZE(1..maxLCH)) OF SEQUENCE {	1 entry		
logicalChannelIdentity[1]	Logical channel identity corresponding to Split DRB.		
reestablishRLC[1]	true		
}			
}			

**Table 8.2.2.8.1.3.3-37: RadioBearerConfig (Table 8.2.2.8.1.3.3-34)**

Derivation Path: 38.508-1 [4], Table 4.6.3-100 with condition EN-DC			
Information Element	Value/remark	Comment	Condition
RadioBearerConfig ::= SEQUENCE {			
drb-ToAddModList SEQUENCE (SIZE (1..maxDRB)) OF SEQUENCE {	1 entry		
drb-Identity	2	Split DRB Id	
reestablishPDCP	true		
}			
securityConfig SEQUENCE {			
keyToUse	keNB		
}			
}			

**Table 8.2.2.8.1.3.3-38: RRCConnectionReconfiguration (step 22, Table 8.2.2.8.1.3.2-1)**

Derivation Path: 36.508 [7], Table 4.6.1-8			
Information Element	Value/remark	Comment	Condition
RRCConnectionReconfiguration ::= SEQUENCE {			
criticalExtensions CHOICE {			
c1 CHOICE {			
rrcConnectionReconfiguration-r8 ::= SEQUENCE			
{			
radioResourceConfigDedicated	RadioResourceConfigDe dicated-MN_SCG-to- SN_MCG		
nonCriticalExtension ::= SEQUENCE {			
nonCriticalExtension ::= SEQUENCE {			
nonCriticalExtension ::= SEQUENCE {			
nonCriticalExtension ::= SEQUENCE {			
nonCriticalExtension ::= SEQUENCE {			
nonCriticalExtension ::= SEQUENCE {			
nonCriticalExtension ::= SEQUENCE {			
nr-Config-r15 CHOICE {			
setup SEQUENCE {			
nr-SecondaryCellGroupConfig-r15	OCTET STRING including the <i>RRCReconfiguration</i> message and the IE secondaryCellGroup.		
}			
}			
}			
}			
}			
}			
}			
}			
}			
}			
}			
}			
}			
}			

**Table 8.2.2.8.1.3.3-39: RadioResourceConfigDedicated-MN\_SCG-to-SN\_MCG (Table 8.2.2.8.1.3.3-38)**

Derivation Path: 36.508 [7], Table 4.6.3-27			
Information Element	Value/remark	Comment	Condition
RadioResourceConfigDedicated-DRB ::= SEQUENCE {			
drb-ToAddModList	DRB-ToAddModList- MN_SCG-to-SN_MCG		
}			

**Table 8.2.2.8.1.3.3-40: DRB-ToAddModList-MN\_SCG-to-SN\_MCG (Table 8.2.2.8.1.3.3-39)**

Derivation Path: 36.508 [7], Table 4.6.3-2A			
Information Element	Value/remark	Comment	Condition
DRB-ToAddModList ::= SEQUENCE (SIZE (1..maxDRB)) OF SEQUENCE {	1 Entry		
eps-BearerIdentity[1]	6	Dedicated EPS bearer Id of SCG DRB	
drb-Identity[1]	2	SCG DRB Id	
}			

**Table 8.2.2.8.1.3.3-41: RRCReconfiguration (Table 8.2.2.8.1.3.3-40)**

Derivation Path: 38.508-1 [4], Table 4.6.1-3			
Information Element	Value/remark	Comment	Condition
RRCReconfiguration ::= SEQUENCE {			
criticalExtensions CHOICE {			
rrcReconfiguration ::= SEQUENCE {			
secondaryCellGroup	CellGroupConfig		
}			
}			
}			

**Table 8.2.2.8.1.3.3-42: CellGroupConfig (Table 8.2.2.8.1.3.3-43)**

Derivation Path: 38.508-1 [4] Table 4.6.3-13			
Information Element	Value/remark	Comment	Condition
CellGroupConfig ::= SEQUENCE {			
rlc-BearerToAddModList	Not present		
rlc-BearerToReleaseList SEQUENCE (SIZE(1..maxLCH)) OF SEQUENCE {	1 entry		
logicalChannelIdentity[1]	Logical channel identity corresponding to SCG DRB.		
}			
mac-CellGroupConfig	Not present		
physicalCellGroupConfig	Not present		
spCellConfig	Not present		
}			

**Table 8.2.2.8.1.3.3-43: RadioBearerConfig (Table 8.2.2.8.1.3.3-38)**

Derivation Path: 38.508-1 [4], Table 4.6.3-100			
Information Element	Value/remark	Comment	Condition
RadioBearerConfig ::= SEQUENCE {			
drb-ToAddModList SEQUENCE (SIZE (1..maxDRB)) OF SEQUENCE {	1 entry		
cnAssociation CHOICE {			
eps-BearerIdentity	6	Dedicated EPS bearer Id of SCG DRB	
}			
drb-Identity	2	SCG DRB Id	
reestablishPDCP	true		
pdcp-Config	Not present		
}			
securityConfig SEQUENCE {			
keyToUse	s-KgNB		
}			
}			



**Table 8.2.2.8.1.3.3-46: CellGroupConfig (Table 8.2.2.8.1.3.3-45)**

Derivation Path: 38.508-1 [4], Table 4.6.3-13 with condition EN-DC			
Information Element	Value/remark	Comment	Condition
CellGroupConfig ::= SEQUENCE {			
rlc-BearerToAddModList SEQUENCE (SIZE(1..maxLCH)) OF SEQUENCE {	1 entry		
logicalChannelIdentity[1]	Logical channel identity corresponding to MCG DRB.		
servedRadioBearer[1] CHOICE {			
drb-Identity	2	MCG DRB Id	
}			
}			
mac-CellGroupConfig	Not present		
physicalCellGroupConfig	Not present		
spCellConfig	Not present		
}			

**Table 8.2.2.8.1.3.3-47: RadioBearerConfig (Table 8.2.2.8.1.3.3-44)**

Derivation Path: 38.508-1 [4], Table 4.6.3-100			
Information Element	Value/remark	Comment	Condition
RadioBearerConfig ::= SEQUENCE {			
drb-ToAddModList SEQUENCE (SIZE (1..maxDRB)) OF SEQUENCE {	1 entry		
cnAssociation CHOICE {			
eps-BearerIdentity	6	Dedicated EPS bearer Id of MCG DRB	
}			
drb-Identity	2	MCG DRB Id	
reestablishPDCP	true		
pdcpc-Config	Not present		
}			
securityConfig SEQUENCE {			
keyToUse	keNB		
}			
}			

**Table 8.2.2.8.1.3.3-48: RRCConnectionReconfigurationComplete (steps 2, 5, 8, 11, 17, 20, 23, 26, Table 8.2.2.8.1.3.2-1)**

Derivation Path: 36.508 [7] Table 4.6.1-9			
Information Element	Value/remark	Comment	Condition
RRCConnectionReconfigurationComplete ::= SEQUENCE {			
criticalExtensions CHOICE {			
rrcConnectionReconfigurationComplete-r8 SEQUENCE {			
nonCriticalExtension SEQUENCE {			
nonCriticalExtension SEQUENCE {			
nonCriticalExtension SEQUENCE {			
nonCriticalExtension SEQUENCE {			
nonCriticalExtension SEQUENCE {			
scg-ConfigResponseNR-r15	Present		
}			
}			
}			
}			
}			
}			
}			
}			

## 8.2.2.9 Bearer Modification / Uplink data path / Split DRB Reconfiguration

### 8.2.2.9.1 Bearer Modification / Uplink data path / Split DRB Reconfiguration / EN-DC

**Editor's Note:** The conformance requirements are based on running RAN2 CRs.

#### 8.2.2.9.1.1 Test Purpose (TP)

(1)

```
with { UE in RRC_CONNECTED state with EN-DC, and, MCG (E-UTRA PDCP) and Split }
ensure that {
  when { UE receives an RRCConnectionReconfiguration message to change the primaryPath to E-UTRA
radio path from NR }
  then { UE changes the uplink data path to E-UTRA radio path and sends an
RRCConnectionReconfigurationComplete message }
}
```

(2)

```
with { UE in RRC_CONNECTED state with EN-DC, and, MCG (E-UTRA PDCP) and Split }
ensure that {
  when { UE receives an RRCConnectionReconfiguration message to change the primaryPath from E-UTRA
radio path to NR }
  then { UE changes the uplink data path to NR radio path and sends an
RRCConnectionReconfigurationComplete message }
}
```

#### 8.2.2.9.1.2 Conformance requirements

References: The conformance requirements covered in the present test case are specified in: TS 36.331, clause 5.3.5.3, TS 38.331, clauses 5.3.5.3 and 5.3.5.6.5. Unless otherwise stated these are Rel-15 requirements.

[TS 36.331, clause 5.3.5.3]

If the *RRCConnectionReconfiguration* message does not include the *mobilityControlInfo* and the UE is able to comply with the configuration included in this message, the UE shall:

...



- 1> if the received *RRCConnectionReconfiguration* includes the *nr-Config* and it is set to *release*: or
- 1> if the received *RRCConnectionReconfiguration* includes *endc-ReleaseAndAdd* and it is set to *TRUE*:
  - 2> perform ENDC release as specified in TS38.331 [82, 5.3.5.10];
- 1> if the received *RRCConnectionReconfiguration* includes the *sk-Counter*:
  - 2> perform key update procedure as specified in TS 38.331 [82, 5.3.5.8];
- 1> if the received *RRCConnectionReconfiguration* includes the *nr-SecondaryCellGroupConfig*:
  - 2> perform NR RRC Reconfiguration as specified in TS 38.331 [82, 5.3.5.3];
- 1> if the received *RRCConnectionReconfiguration* includes the *nr-RadioBearerConfig1*:
  - 2> perform radio bearer configuration as specified in TS 38.331 [82, 5.3.5.6];
- 1> if the received *RRCConnectionReconfiguration* includes the *nr-RadioBearerConfig2*:
  - 2> perform radio bearer configuration as specified in TS 38.331 [82, 5.3.5.6];
- ...
- 1> set the content of *RRCConnectionReconfigurationComplete* message as follows:
  - 2> if the *RRCConnectionReconfiguration* message includes *perCC-GapIndicationRequest*:
    - 3> include *perCC-GapIndicationList* and *numFreqEffective*;
  - 2> if the frequencies are configured for reduced measurement performance:
    - 3> include *numFreqEffectiveReduced*;
  - 2> if the received *RRCConnectionReconfiguration* message included *nr-SecondaryCellGroupConfig*:
    - 3> include *scg-ConfigResponseNR* in accordance with TS 38.331 [82, 5.3.5.3];
- 1> submit the *RRCConnectionReconfigurationComplete* message to lower layers for transmission using the new configuration, upon which the procedure ends;

[TS 38.331, clause 5.3.5.3]

The UE shall perform the following actions upon reception of the *RRCReconfiguration*:

- 1> if the *RRCReconfiguration* includes the *secondaryCellGroup*:
  - 2> perform the cell group configuration for the SCG according to 5.3.5.5;
- 1> if the *RRCReconfiguration* message contains the *radioBearerConfig*:
  - 2> perform the radio bearer configuration according to 5.3.5.6;
- 1> if the *RRCReconfiguration* message includes the *measConfig*:
  - 2> perform the measurement configuration procedure as specified in 5.5.2
- 1> set the content of *RRCReconfigurationComplete* message as follows:
  - 2> if the *RRCReconfiguration* includes the *masterCellGroup* containing the *reportUplinkTxDirectCurrent*, or;
  - 2> if the *RRCReconfiguration* includes the *secondaryCellGroup* containing the *reportUplinkTxDirectCurrent*:
    - 3> include the *uplinkTxDirectCurrentList*;
- 1> if the UE is configured with E-UTRA *nr-SecondaryCellGroupConfig* (MCG is E-UTRA):
  - 2> if *RRCReconfiguration* was received via SRB1:

3> construct *RRCReconfigurationComplete* message and submit it via the EUTRA MCG embedded in E-UTRA RRC message *RRCConnectionReconfigurationComplete* as specified in TS 36.331 [10];

3> if *reconfigurationWithSync* was included in *spCellConfig* of an SCG:

4> initiate the random access procedure on the SpCell, as specified in TS 38.321 [3];

3> else:

4> the procedure ends;

NOTE: The order the UE sends the *RRCConnectionReconfigurationComplete* message and performs the Random Access procedure towards the SCG is left to UE implementation.

2> else (*RRCReconfiguration* was received via SRB3):

3> submit the *RRCReconfigurationComplete* message via SRB3 to lower layers for transmission using the new configuration.

NOTE: For EN-DC, in the case of SRB1, the random access is triggered by RRC layer itself as there is not necessarily other UL transmission. In the case of SRB3, the random access is triggered by the MAC layer due to arrival of *RRCReconfigurationComplete*.

1 > else:

2> submit the *RRCReconfigurationComplete* message via SRB1 to lower layers for transmission using the new configuration;

1> if *reconfigurationWithSync* was included in *spCellConfig* of an MCG or SCG, and when MAC of an NR cell group successfully completes a random access procedure triggered above;

2> stop timer T304 for that cell group;

2> apply the parts of the CQI reporting configuration, the scheduling request configuration and the sounding RS configuration that do not require the UE to know the SFN of the respective target SpCell, if any;

2> apply the parts of the measurement and the radio resource configuration that require the UE to know the SFN of the respective target SpCell (e.g. measurement gaps, periodic CQI reporting, scheduling request configuration, sounding RS configuration), if any, upon acquiring the SFN of that target SpCell;

2> if the *reconfigurationWithSync* was included in *spCellConfig* of an MCG:

3> if the active downlink BWP, which is indicated by the *firstActiveDownlinkBWP-Id* for the target SpCell of the MCG, has a common search space configured or if the conditions defined in FFS\_Spec [X], section FFS\_Section are satisfied:

4> acquire the *SIB1* of the target SpCell of the MCG, as specified in 5.2.2.3.1; 2> the procedure ends.

NOTE: The UE is only required to acquire broadcasted *SIB1* if the UE can acquire it without disrupting unicast data reception, i.e. the broadcast and unicast beams are quasi co-located.

[TS 38.331, clause 5.3.5.6.5]

The UE shall:

1> for each *drb-Identity* value included in the *drb-ToAddModList* that is not part of the current UE configuration (DRB establishment including the case when full configuration option is used):

...

2> establish a PDCP entity and configure it in accordance with the received *pdcp-Config*;

2> if the PDCP entity of this DRB is not configured with *cipheringDisabled*:

- 3> configure the PDCP entity with the ciphering algorithms according to *securityConfig* and apply the K<sub>UPenc</sub> key associated with the master key (K<sub>eNB</sub>/K<sub>gNB</sub>) or the secondary key (S-K<sub>gNB</sub>) as indicated in *keyToUse*;
- 2> if the PDCP entity of this DRB is configured with *integrityProtection*:
  - 3> configure the PDCP entity with the integrity algorithms according to *securityConfig* and apply the K<sub>UPint</sub> key associated with the master (K<sub>eNB</sub>/K<sub>gNB</sub>) or the secondary key (S-K<sub>gNB</sub>) as indicated in *keyToUse*;
- 2> if the UE is operating in EN-DC:
  - 3> if the DRB was configured with the same *eps-BearerIdentity* either by NR or E-UTRA prior to receiving this reconfiguration:
    - 4> associate the established DRB with the corresponding *eps-BearerIdentity*;
  - 3> else:
    - 4> indicate the establishment of the DRB(s) and the *eps-BearerIdentity* of the established DRB(s) to upper layers;
- 4> for each *drb-Identity* value included in the *drb-ToAddModList* that is part of the current UE configuration:
  - 2> if an *sdap-Config* is included, reconfigure the SDAP entity in accordance with the received *sdap-Config* as specified in TS 37.324 [xx];
  - 2> if the *reestablishPDCP* is set:
    - 3> if the PDCP entity of this DRB is not configured with *cipheringDisabled*:
      - 4> configure the PDCP entity with the ciphering algorithm and K<sub>UPenc</sub> key associated with the master or secondary key (K<sub>eNB</sub>/S-K<sub>gNB</sub>/K<sub>gNB</sub>) as indicated in *keyToUse*, i.e. the ciphering configuration shall be applied to all subsequent PDCP PDUs received and sent by the UE;
    - 3> if the PDCP entity of this DRB is configured with *integrityProtection*:
      - 4> configure the PDCP entity with the integrity algorithms according to *securityConfig* and apply the K<sub>UPint</sub> key associated with the master (K<sub>eNB</sub>/K<sub>gNB</sub>) or the secondary key (S-K<sub>gNB</sub>) as indicated in *keyToUse*;
    - 3> re-establish the PDCP entity of this DRB as specified in 38.323 [5], section 5.1.2;
  - 2> else, if the *recoverPDCP* is set:
    - 3> trigger the PDCP entity of this DRB to perform data recovery as specified in 38.323;
  - 2> if the *pdcp-Config* is included:
    - 3> reconfigure the PDCP entity in accordance with the received *pdcp-Config*.

NOTE 1: Removal and addition of the same *drb-Identity* in a single *radioResourceConfig* is not supported. In case *drb-Identity* is removed and added due to reconfiguration with sync or re-establishment with the full configuration option, the network can use the same value of *drb-Identity*.

NOTE 2: When determining whether a *drb-Identity* value is part of the current UE configuration, the UE does not distinguish which *RadioBearerConfig* and *DRB-ToAddModList* that DRB was originally configured in. To re-associate a DRB with a different key (K<sub>eNB</sub> to S-K<sub>eNB</sub> or vice versa), the network provides the *drb-Identity* value in the (target) *drb-ToAddModList* and sets the *reestablishPDCP* flag. The network does not list the *drb-Identity* in the (source) *drb-ToReleaseList*.

NOTE 3: When setting the *reestablishPDCP* flag for a radio bearer, the network ensures that the RLC receiver entities do not deliver old PDCP PDUs to the re-established PDCP entity. It does that e.g. by triggering a reconfiguration with sync of the cell group hosting the old RLC entity or by releasing the old RLC entity.

NOTE 4: In this specification, UE configuration refers to the parameters configured by NR RRC unless otherwise stated.

NOTE 5: Ciphering and integrity protection can be enabled or disabled for a DRB. The enabling/disabling of ciphering or integrity protection can be changed only by releasing and adding the DRB.

### 8.2.2.9.1.3 Test description

#### 8.2.2.9.1.3.1 Pre-test conditions

System Simulator:

- E-UTRA Cell 1 is the PCell and NR Cell 1 is the PSCell.

UE:

- None.

Preamble:

- If `pc_IP_Ping` is set to TRUE then, the UE is in state `RRC_CONNECTED` using generic procedure parameter Connectivity (*EN-DC*), Bearers (*MCG(s) and Split*) established according to TS 38.508-1 [4], clause 4.5.4.
- Else, the UE is in state `RRC_CONNECTED` using generic procedure parameter Connectivity (*EN-DC*), Bearers (*MCG(s) and Split*) established and Test Loop Function (*On*) with UE test loop mode B according to TS 38.508-1 [4], clause 4.5.4.

#### 8.2.2.9.1.3.2 Test procedure sequence

**Table 8.2.2.9.1.3.2-1: Main behaviour**

St	Procedure	Message Sequence		TP	Verdict
		U - S	Message		
1	The SS transmits an <i>RRCCoNNECTIONReconfiguration</i> message containing NR <i>RadioBearerConfig</i> to change the <i>primaryPath</i> of the Split DRB to E-UTRA radio path from NR.	<--	<i>RRCCoNNECTIONReconfiguration</i>	-	-
2	Check: Does the UE transmit an <i>RRCCoNNECTIONReconfigurationComplete</i> message?	-->	<i>RRCCoNNECTIONReconfigurationComplete</i>	1	P
3	Check: Does the test result of generic test procedure in TS 38.508-1 subclause 4.9.1 indicate that the UE is capable of exchanging IP data on Split DRB#2 using E-UTRA radio path in the uplink?	-	-	1	P
4	The SS transmits an <i>RRCCoNNECTIONReconfiguration</i> message containing NR <i>RadioBearerConfig</i> to change the <i>primaryPath</i> of the Split DRB from E-UTRA radio path to NR.	<--	<i>RRCCoNNECTIONReconfiguration</i>	-	-
5	Check: Does the UE transmit an <i>RRCCoNNECTIONReconfigurationComplete</i> message?	-->	<i>RRCCoNNECTIONReconfigurationComplete</i>	2	P
6	Check: Does the test result of generic test procedure in TS 38.508-1 subclause 4.9.1 indicate that the UE is capable of exchanging IP data on the Split DRB#2 using NR radio path in the uplink?	-	-	2	P

8.2.2.9.1.3.3 Specific message contents

**Table 8.2.2.9.1.3.3-1: RRCConnectionReconfiguration (step 1, Table 8.2.2.9.1.3.2-1)**

Derivation Path: 36.508 [7], Table 4.6.1-8			
Information Element	Value/remark	Comment	Condition
RRCConnectionReconfiguration ::= SEQUENCE {			
criticalExtensions CHOICE {			
c1 CHOICE {			
rrcConnectionReconfiguration-r8 ::= SEQUENCE			
{			
nonCriticalExtension ::= SEQUENCE {			
nonCriticalExtension ::= SEQUENCE {			
nonCriticalExtension ::= SEQUENCE {			
nonCriticalExtension ::= SEQUENCE {			
nonCriticalExtension ::= SEQUENCE {			
nonCriticalExtension ::= SEQUENCE {			
nonCriticalExtension ::= SEQUENCE {			
nr-RadioBearerConfig1-r15	OCTET STRING including RadioBearerConfig.		
}			
}			
}			
}			
}			
}			
}			
}			
}			
}			

**Table 8.2.2.9.1.3.3-2: RadioBearerConfig (Table 8.2.2.9.1.3.3-1)**

Derivation Path: 38.508-1 [4], Table 4.6.3-100			
Information Element	Value/remark	Comment	Condition
RadioBearerConfig ::= SEQUENCE {			
drb-ToAddModList SEQUENCE (SIZE (1..maxDRB))	1 entry		
OF SEQUENCE {			
pdcp-Config	PDCP-Config		
}			
}			

**Table 8.2.2.9.1.3.3-3: PDCP-Config (Table 8.2.2.9.1.3.3-2)**

Derivation Path: 38.508-1 [4], Table 4.6.3-74			
Information Element	Value/remark	Comment	Condition
PDCP-Config ::= SEQUENCE {			
drb SEQUENCE {			
statusReportRequired	true		
}			
moreThanOneRLC SEQUENCE {			
primaryPath SEQUENCE {			
cellGroup	0		
}			
ul-DataSplitThreshold	infinity		
}			
}			

**Table 8.2.2.9.1.3.3-4: RRCConnectionReconfiguration (step 4, Table 8.2.2.9.1.3.2-1)**

Derivation Path: 36.508 [7], Table 4.6.1-8			
Information Element	Value/remark	Comment	Condition
RRCConnectionReconfiguration ::= SEQUENCE {			
criticalExtensions CHOICE {			
c1 CHOICE{			
rrcConnectionReconfiguration-r8 ::= SEQUENCE			
{			
nonCriticalExtension ::= SEQUENCE {			
nonCriticalExtension ::= SEQUENCE {			
nonCriticalExtension ::= SEQUENCE {			
nonCriticalExtension ::= SEQUENCE {			
nonCriticalExtension ::= SEQUENCE {			
nonCriticalExtension ::= SEQUENCE {			
nonCriticalExtension ::= SEQUENCE {			
nr-RadioBearerConfig1-r15	OCTET STRING		
including	including		
RadioBearerConfig.	RadioBearerConfig.		
}			
}			
}			
}			
}			
}			
}			
}			
}			

**Table 8.2.2.9.1.3.3-5: RadioBearerConfig (Table 8.2.2.9.1.3.3-4)**

Derivation Path: 38.508-1 [4], Table 4.6.3-100			
Information Element	Value/remark	Comment	Condition
RadioBearerConfig ::= SEQUENCE {			
drb-ToAddModList SEQUENCE (SIZE (1..maxDRB))	1 entry		
OF SEQUENCE {			
pdcp-Config	PDCCP-Config		
}			
}			

**Table 8.2.2.9.1.3.3-6: PDCCP-Config (Table 8.2.2.9.1.3.3-5)**

Derivation Path: 38.508-1 [4], Table 4.6.3-74			
Information Element	Value/remark	Comment	Condition
PDCCP-Config ::= SEQUENCE {			
drb SEQUENCE {			
statusReportRequired	true		
}			
moreThanOneRLC SEQUENCE {			
primaryPath SEQUENCE {			
cellGroup	1		
}			
ul-DataSplitThreshold	infinity		
}			
}			

## 8.2.3 Measurement Configuration Control and Reporting / Handovers

### 8.2.3.1 Measurement configuration control and reporting / Inter-RAT measurements / Event B1 / Measurement of NR cells

#### 8.2.3.1.1 Measurement configuration control and reporting / Inter-RAT measurements / Event B1 / Measurement of NR cells / EN-DC

**Editor's Note:** The conformance requirements are based on running RAN2 CRs.

##### 8.2.3.1.1.1 Test Purpose (TP)

(1)

```
with { UE in RRC_CONNECTED state with EN-DC, and, MCG (E-UTRA PDCP) only having completed the radio
bearer establishment and performed the inter RAT measurement for NR cell and not detected entering
condition for the event B1 is met }
ensure that {
  when { UE detects entering condition for the event B1 is not met }
  then { UE does not transmit any MeasurementReport }
}
```

(2)

```
with { UE in RRC_CONNECTED state with EN-DC, and, MCG (E-UTRA PDCP) only having completed the radio
bearer establishment and performed the inter RAT measurement for NR cell and not detected entering
condition for the event B1 is met }
ensure that {
  when { UE detects entering condition for the event B1 is met }
  then { UE transmits a MeasurementReport }
}
```

(3)

```
with { UE in RRC_CONNECTED state with EN-DC, and, MCG (E-UTRA PDCP) only having completed the radio
bearer establishment and performed the inter RAT measurement for NR cell and detected entering
condition for the event B1 is met }
ensure that {
  when { UE detects leaving condition for the event B1 is met }
  then { UE does not transmit any MeasurementReport }
}
```

##### 8.2.3.1.1.2 Conformance requirements

References: The conformance requirements covered in the present TC are specified in: TS 36.331, clauses 5.5.1, 5.5.4.1, 5.5.4.7, 5.5.5 and 5.5.5.3. Unless otherwise stated these are Rel-15 requirements.

[TS 36.331, clause 5.5.1]

The UE reports measurement information in accordance with the measurement configuration as provided by E-UTRAN. E-UTRAN provides the measurement configuration applicable for a UE in RRC\_CONNECTED by means of dedicated signalling, i.e. using the *RRCConnectionReconfiguration* or *RRCConnectionResume* message.

The UE can be requested to perform the following types of measurements:

- Intra-frequency measurements: measurements at the downlink carrier frequency(ies) of the serving cell(s).
- Inter-frequency measurements: measurements at frequencies that differ from any of the downlink carrier frequency(ies) of the serving cell(s).
- Inter-RAT measurements of NR frequencies.

...

The measurement configuration includes the following parameters:

1. **Measurement objects:** The objects on which the UE shall perform the measurements.

- For intra-frequency and inter-frequency measurements a measurement object is a single E-UTRA carrier frequency. Associated with this carrier frequency, E-UTRAN can configure a list of cell specific offsets, a list of 'blacklisted' cells and a list of 'whitelisted' cells. Blacklisted cells are not considered in event evaluation or measurement reporting.
- For inter-RAT NR measurements a measurement object is a single NR carrier frequency. Associated with this carrier frequency, E-UTRAN can configure a list of 'blacklisted' cells. Blacklisted cells are not considered in event evaluation or measurement reporting.

...

NOTE 1: Some measurements using the above mentioned measurement objects, only concern a single cell, e.g. measurements used to report neighbouring cell system information, PCell UE Rx-Tx time difference, or a pair of cells, e.g. SSTD measurements between the PCell and the PSCell.

2. **Reporting configurations:** A list of reporting configurations where each reporting configuration consists of the following:
  - Reporting criterion: The criterion that triggers the UE to send a measurement report. This can either be periodical or a single event description.
  - Reporting format: The quantities that the UE includes in the measurement report and associated information (e.g. number of cells to report).
3. **Measurement identities:** A list of measurement identities where each measurement identity links one measurement object with one reporting configuration. By configuring multiple measurement identities it is possible to link more than one measurement object to the same reporting configuration, as well as to link more than one reporting configuration to the same measurement object. The measurement identity is used as a reference number in the measurement report.
4. **Quantity configurations:** One quantity configuration is configured per RAT type. The quantity configuration defines the measurement quantities and associated filtering used for all event evaluation and related reporting of that measurement type. One filter can be configured per measurement quantity, except for NR where the network may configure up to 2 sets of quantity configurations each comprising per measurement quantity separate filters for cell and RS index measurement results. The quantity configuration set that applies for a given measurement is indicated within the NR measurement object.

[TS 36.331, clause 5.5.4.1]

The UE shall:

- 1> for each *measId* included in the *measIdList* within *VarMeasConfig*:
  - ...
  - 2> else:
    - ...
    - 3> else if the corresponding *measObject* concerns NR:
      - 4> if the *reportSFTD-Meas* is set to *pSCell* in the corresponding *reportConfigInterRAT*:
        - 5> consider the PSCell to be applicable;
      - 4> else if the *reportSFTD-Meas* is set to *neighborCells* in the corresponding *reportConfigInterRAT*:
        - 5> if *cellsForWhichToReportSFTD* is configured in the corresponding *measObjectNR*:6> consider any neighbouring NR cell on the associated frequency that is included in *cellsForWhichToReportSFTD* to be applicable;
    - 5> else:
      - 6> consider up to 3 strongest neighbouring NR cells detected on the associated frequency to be applicable when the concerned cell is not included in the *blackCellsToAddModList* defined within the *VarMeasConfig* for this *measId*;



4> else:

5> consider any neighbouring cell detected on the associated frequency to be applicable when the concerned cell is not included in the *blackCellsToAddModList* defined within the *VarMeasConfig* for this *measId*; [TS 36.331, clause 5.5.4.7]

The UE shall:

- 1> for UTRA and CDMA2000, only trigger the event for cells included in the corresponding measurement object;
- 1> consider the entering condition for this event to be satisfied when condition B1-1, as specified below, is fulfilled;
- 1> consider the leaving condition for this event to be satisfied when condition B1-2, as specified below, is fulfilled;

Inequality B1-1 (Entering condition)

$$Mn + Ofn - Hys > Thresh$$

Inequality B1-2 (Leaving condition)

$$Mn + Ofn + Hys < Thresh$$

The variables in the formula are defined as follows:

***Mn*** is the measurement result of the inter-RAT neighbour cell, not taking into account any offsets. For CDMA 2000 measurement result, *pilotStrength* is divided by -2.

***Ofn*** is the frequency specific offset of the frequency of the inter-RAT neighbour cell (i.e. *offsetFreq* as defined within the *measObject* corresponding to the frequency of the neighbour inter-RAT cell).

***Hys*** is the hysteresis parameter for this event (i.e. *hysteresis* as defined within *reportConfigInterRAT* for this event).

***Thresh*** is the threshold parameter for this event (i.e. *b1-Threshold* as defined within *reportConfigInterRAT* for this event). For CDMA2000, *b1-Threshold* is divided by -2.

***Mn*** is expressed in dBm or in dB, depending on the measurement quantity of the inter-RAT neighbour cell.

***Ofn*, *Hys*** are expressed in dB.

***Thresh*** is expressed in the same unit as ***Mn***.

[TS 36.331, clause 5.5.5]

The purpose of this procedure is to transfer measurement results from the UE to E-UTRAN. The UE shall initiate this procedure only after successful security activation.

For the *measId* for which the measurement reporting procedure was triggered, the UE shall set the *measResults* within the *MeasurementReport* message as follows:

- 1> set the *measId* to the measurement identity that triggered the measurement reporting;
- 1> set the *measResultPCell* to include the quantities of the PCell;
- 1> set the *measResultServFreqList* to include for each E-UTRA SCell that is configured, if any, within *measResultSCell* the quantities of the concerned SCell, if available according to performance requirements in [16], except if *purpose* for the *reportConfig* associated with the *measId* that triggered the measurement reporting is set to *reportLocation*;
- 1> if the *reportConfig* associated with the *measId* that triggered the measurement reporting includes *reportAddNeighMeas*:
  - 2> for each E-UTRA serving frequency for which *measObjectId* is referenced in the *measIdList*, other than the frequency corresponding with the *measId* that triggered the measurement reporting:
    - 3> set the *measResultServFreqList* to include within *measResultBestNeighCell* the *physCellId* and the quantities of the best non-serving cell, based on RSRP, on the concerned serving frequency;

- 1> if the *triggerType* is set to *event*; and if the corresponding *measObject* concerns NR; and if *eventId* is set to *eventB1* or *eventB2*; or
  - 1> if the *triggerType* is set to *event*; and if *eventId* is set to *eventA3* or *eventA4* or *eventA5*:
    - 2> if *purpose* for the *reportConfig* associated with the *measId* that triggered the measurement reporting is set to a value other than *reportLocation*:
      - 3> set the *measResultServFreqListNR* to include for each NR serving frequency, if any, the following:
        - 4> set *measResultSCell* to include the available results of the NR serving cell, as specified in 5.5.5.1;
        - 4> if the *reportConfig* associated with the *measId* that triggered the measurement reporting includes *reportAddNeighMeas*:
          - 5> set *measResultBestNeighCell* to include the available results, as specified in 5.5.5.1, of the best non-serving cell, ordered based on the quantity determined as specified in 5.5.5.2;
          - 5> for each (serving or neighbouring) cell for which the UE reports results according to the previous, additionally include available beam results according to the following:
            - 6> if *maxReportRS-Index* is configured, set *measResultCellRS-Index* to include available, as specified in 5.5.5.2, of up to *maxReportRS-Index* beams, ordered based on the quantity determined as specified in 5.5.5.3;
    - 1> if there is at least one applicable neighbouring cell to report:
      - 2> set the *measResultNeighCells* to include the best neighbouring cells up to *maxReportCells* in accordance with the following:
        - 3> if the *triggerType* is set to *event*:
          - 4> include the cells included in the *cellsTriggeredList* as defined within the *VarMeasReportList* for this *measId*;
        - 3> else:
          - 4> include the applicable cells for which the new measurement results became available since the last periodical reporting or since the measurement was initiated or reset;
- NOTE 1: The reliability of the report (i.e. the certainty it contains the strongest cells on the concerned frequency) depends on the measurement configuration i.e. the *reportInterval*. The related performance requirements are specified in TS 36.133 [16].
- 3> for each cell that is included in the *measResultNeighCells*, include the *physCellId*;
  - 3> if the *triggerType* is set to *event*; or the *purpose* is set to *reportStrongestCells* or to *reportStrongestCellsForSON*:
    - 4> for each included cell, include the layer 3 filtered measured results in accordance with the *reportConfig* for this *measId*, ordered as follows:
      - 5> if the *measObject* associated with this *measId* concerns E-UTRA:
        - 6> set the *measResult* to include the quantity(ies) indicated in the *reportQuantity* within the concerned *reportConfig* in order of decreasing *triggerQuantity*, i.e. the best cell is included first;
      - 5> if the *measObject* associated with this *measId* concerns NR:
        - 6> set the *measResultCell* to include the quantity(ies) indicated in the *reportQuantityCellNR* within the concerned *reportConfig* in order of decreasing quantity according to *bN-ThresholdYNR*, i.e. the best cell is included first;
        - 6> if *maxReportRS-Index* and *reportQuantityRS-IndexNR* are configured, set *measResultCellRS-Index* to include results of the best beam and the beams whose quantity is above *threshRS-Index* defined in the *VarMeasConfig* for the corresponding *measObject*, up to *maxReportRS-*

*Index* beams in total, and in order of decreasing quantity, same as used for cell reporting, and as follows:

7> order beams based on the sorting quantity determined as specified in 5.5.5.3;

7> include *ssbIndex*;

7> if *reportRS-IndexResultsNR* is configured, for each quantity indicated, include the corresponding measurement result;

...

[TS 36.331, clause 5.5.5.3]

When configured to report the best cells or beams, the UE shall determine the quantity, that is used to order and select as follows

1> consider the quantities the UE reports as candidate sorting quantities i.e. as follows:

2> for NR cells for which measurement reporting is triggered (i.e. NR cells included in *cellsTriggered*):

3> the quantities defined by *reportQuantityCellNR*, when used for sorting cells;

3> the quantities defined by *reportQuantityRS-IndexNR*, when used for sorting beams;

2> for cells on NR serving frequencies:

3> the available quantities of available NR measurement results as specified in 5.5.5.2;

1> if *reportType* is set to *eventTriggered*; and if *eventId* is set to *eventB1* or *eventB2*:

2> consider the trigger quantity to be the sorting quantity;

1> if *reportType* is set to *periodical*:

2> if there is a single candidate sorting quantity;

3> consider the concerned quantity to be the sorting quantity;

2> else:

3> if RSRP is one of the candidate sorting quantities;

4> consider RSRP to be the sorting quantity;

3> else:

4> consider RSRQ to be the sorting quantity;

8.2.3.1.1.3 Test description

8.2.3.1.1.3.1 Pre-test conditions

System Simulator:

- E-UTRA Cell 1 and NR Cell 1.

UE:

- None.

Preamble:

- The UE is in state RRC\_CONNECTED using generic procedure parameter Connectivity (*EN-DC*) and Bearers (*MCG only*) established according to TS 38.508-1 [4].

## 8.2.3.1.1.3.2 Test procedure sequence

Table 8.2.3.1.3.2-1 illustrates the downlink power levels and other changing parameters to be applied for the cells at various time instants of the test execution. Row marked "T0" denotes the initial conditions after preamble, while columns marked "T1" and "T2" are to be applied subsequently. The exact instants on which these values shall be applied are described in the texts in this clause.

**Table 8.2.3.1.1.3.2-1: Time instances of cell power level and parameter changes**

	Parameter	Unit	E-UTRA Cell 1	NR Cell 1	Remark
T0	Cell-specific RS EPRE	dBm/15 kHz	-85	-	The power level values are such that entering conditions for event B1 are not satisfied.
	SS/PBCH SSS EPRE	dBm/15 kHz	-	[-91]	
T1	Cell-specific RS EPRE	dBm/15 kHz	-85	-	The power level values are such that entering conditions for event B1 are satisfied.
	SS/PBCH SSS EPRE	dBm/15 kHz	-	[-79]	
T2	Cell-specific RS EPRE	dBm/15 kHz	-85	-	The power level values are such that leaving conditions for event B1 are satisfied.
	SS/PBCH SSS EPRE	dBm/15 kHz	-	[-91]	

**Table 8.2.3.1.1.3.2-2: Main behaviour**

St	Procedure	Message Sequence		TP	Verdict
		U - S	Message		
1	The SS transmits an <i>RRCCONNECTIONRECONFIGURATION</i> including measConfig to setup inter RAT measurements and reporting for NR Cell 1.	<--	<i>RRCCONNECTIONRECONFIGURATION</i>	-	-
2	The UE transmits an <i>RRCCONNECTIONRECONFIGURATIONCOMPLETE</i> message to confirm the setup of inter RAT measurements for NR Cell 1.	-->	<i>RRCCONNECTIONRECONFIGURATIONCOMPLETE</i>	-	-
3	Check: Does the UE transmit a <i>MEASUREMENTREPORT</i> message on E-UTRA Cell 1 to report the event B1 during the next 10s?	-->	<i>MEASUREMENTREPORT</i>	1	F
4	The SS changes NR Cell y parameters according to the row "T1" in Table 8.2.3.1.1.3.2-1.	-	-	-	-
5	Check: Does the UE transmit a <i>MEASUREMENTREPORT</i> message to report the event B1 for NR Cell 1?	-->	<i>MEASUREMENTREPORT</i>	2	P
6	The SS changes NR Cell y parameters according to the row "T2" in Table 8.2.3.1.1.3.2-1.	-	-	-	-
7	Wait and ignore <i>MEASUREMENTREPORT</i> messages for 15s to allow change of power levels and UE measurements for NR Cell 1.	-	-	-	-
8	Check: Does the UE transmit a <i>MEASUREMENTREPORT</i> message on E-UTRA Cell 1 to report the event B1 during the next 10s?	-->	<i>MEASUREMENTREPORT</i>	3	F

## 8.2.3.1.1.3.3 Specific message contents

**Table 8.2.3.1.1.3.3-1: *RRCCONNECTIONRECONFIGURATION* (step 1, Table 8.2.3.1.1.3.2-2)**

Derivation Path: 36.508 [7], Table 4.6.1-8, condition MEAS
--

Table 8.2.3.1.1.3.3-2: *MeasConfig* (Table 8.2.3.1.1.3.3-1)

Derivation Path: 36.508 [7], Table 4.6.6-1			
Information Element	Value/remark	Comment	Condition
MeasConfig ::= SEQUENCE {			
measObjectToAddModList SEQUENCE (SIZE (1..maxObjectId)) OF SEQUENCE {	1 entry		
measObjectId[1]	[IdMeasObject-NRf1]		
measObject[1]	MeasObjectNR-GENERIC (NRf1)		
}			
reportConfigToAddModList SEQUENCE (SIZE (1..maxReportConfigId)) OF SEQUENCE {	1 entry		
reportConfigId[1]	[IdReportConfig-B1-NR]		
reportConfig[1]	ReportConfig-B1-NR-r15(-85)		
}			
measIdToAddModList SEQUENCE (SIZE (1..maxMeasId)) OF SEQUENCE {	1 entry		
measId[1]	1		
measObjectId[1]	[IdMeasObject-NRf1]		
reportConfigId[1]	[IdReportConfig-B1-NR]		
}			
quantityConfig	QuantityConfig-DEFAULT		
}			

Table 8.2.3.1.1.3.3-3: *QuantityConfig-DEFAULT* (Table 8.2.3.1.1.3.3-2)

Derivation Path: 36.508 [7], Table 4.6.6-3A			
Information Element	Value/remark	Comment	Condition
QuantityConfig-DEFAULT ::= SEQUENCE {			
quantityConfigNRLList-r15 SEQUENCE ((SIZE (1..maxQuantSetsNR-r15)) OF SEQUENCE {			
measQuantityCellNR-r15 SEQUENCE {			
filterCoeff-RSRP-r15	fc0		
filterCoeff-RSRQ-r15	fc0		
filterCoefficient-SINR-r13	fc0		
}			
}			
}			

Table 8.2.3.1.1.3.3-4: *MeasObjectNR-GENERIC (NRf1)* (Table 8.2.3.1.1.3.3-2)

Derivation Path: 36.508 [7], Table 4.6.6-2B			
Information Element	Value/remark	Comment	Condition
MeasObjectNR-GENERIC(Freq) ::= SEQUENCE {			
carrierFreq-r15	Downlink carrier frequency of NR cell 1		
}			

Table 8.2.3.1.1.3.3-5: *ReportConfig-B1-NR-r15(-85)* (Table 8.2.3.1.1.3.3-2)

Derivation Path: 36.508 [7], Table 4.6.6-7AA			
Information Element	Value/remark	Comment	Condition
ReportConfig-B1-NR ::= SEQUENCE {			
triggerType CHOICE {			
reportAmount	infinity		
}			

Table 8.2.3.1.1.3.3-6: *MeasurementReport* (step 5, Table 8.2.3.1.1.3.2-2)

Derivation Path: 36.508 [7], Table 4.6.1-5			
Information Element	Value/remark	Comment	Condition
MeasurementReport ::= SEQUENCE {			
criticalExtensions CHOICE {			
c1 CHOICE{			
measurementReport-r8 SEQUENCE {			
measResults SEQUENCE {			
measId	1		
measResultPCell SEQUENCE {			
rsrpResult	(0..97)		
rsrqResult	(0..34)		
}			
measResultNeighCells CHOICE {			
measResultNeighCellListNR-r15 SEQUENCE	1 entry		
(SIZE (1..maxCellReport)) OF SEQUENCE {			
pci-r15 [1]	PhysicalCellIdentity of NR Cell 1		
measResultCell-r15 [1] SEQUENCE {			
rsrpResult-r15	(0..127)		
}			
}			
}			
}			
}			
}			
}			
}			

### 8.2.3.2 Measurement configuration control and reporting / Inter-RAT measurements / Event B1 / Measurement of NR cells / RSRQ based measurements

#### 8.2.3.2.1 Measurement configuration control and reporting / Inter-RAT measurements / Event B1 / Measurement of NR cells / RSRQ based measurements / EN-DC

##### 8.2.3.2.1.1 Test Purpose (TP)

(1)

```
with { UE in RRC_CONNECTED state with EN-DC, and, MCG (E-UTRA PDCP) only having completed the radio
bearer establishment and performed the inter RAT measurement for NR cell, configured b1-Threshold
set to threshold-RSRQ and not detected entering condition for the event B1 is met }
ensure that {
  when { UE detects entering condition for the event B1 is not met }
  then { UE does not transmit any MeasurementReport }
}
```

(2)

```
with { UE in RRC_CONNECTED state with EN-DC, and, MCG (E-UTRA PDCP) only having completed the radio
bearer establishment and performed the inter RAT measurement for NR cell, configured b1-Threshold
set to threshold-RSRQ and not detected entering condition for the event B1 is met }
ensure that {
  when { UE detects entering condition for the event B1 is met }
  then { UE transmits a MeasurementReport }
}
```

(3)

```
with { UE in RRC_CONNECTED state with EN-DC, and, MCG (E-UTRA PDCP) only having completed the radio
bearer establishment and performed the inter RAT measurement for NR cell, configured b1-Threshold
set to threshold-RSRQ and detected entering condition for the event B1 is met }
ensure that {
  when { UE detects leaving condition for the event B1 is met }
  then { UE does not transmit any MeasurementReport }
}
```

### 8.2.3.2.1.2 Conformance requirements

References: The conformance requirements covered in the present TC are specified in: TS 36.331, clauses 5.5.1, 5.5.4.1, 5.5.4.7, 5.5.5.1 and 5.5.5.3. Unless otherwise stated these are Rel-15 requirements.

[TS 36.331, clause 5.5.1]

The UE reports measurement information in accordance with the measurement configuration as provided by E-UTRAN. E-UTRAN provides the measurement configuration applicable for a UE in RRC\_CONNECTED by means of dedicated signalling, i.e. using the *RRCCONNECTIONRECONFIGURATION* or *RRCCONNECTIONRESUME* message.

The UE can be requested to perform the following types of measurements:

- Intra-frequency measurements: measurements at the downlink carrier frequency(ies) of the serving cell(s).
- Inter-frequency measurements: measurements at frequencies that differ from any of the downlink carrier frequency(ies) of the serving cell(s).
- Inter-RAT measurements of NR frequencies.
- ...

The measurement configuration includes the following parameters:

1. **Measurement objects:** The objects on which the UE shall perform the measurements.
  - For intra-frequency and inter-frequency measurements a measurement object is a single E-UTRA carrier frequency. Associated with this carrier frequency, E-UTRAN can configure a list of cell specific offsets, a list of 'blacklisted' cells and a list of 'whitelisted' cells. Blacklisted cells are not considered in event evaluation or measurement reporting.
  - For inter-RAT NR measurements a measurement object is a single NR carrier frequency. Associated with this carrier frequency, E-UTRAN can configure a list of 'blacklisted' cells. Blacklisted cells are not considered in event evaluation or measurement reporting.
  - ...

NOTE 1: Some measurements using the above mentioned measurement objects, only concern a single cell, e.g. measurements used to report neighbouring cell system information, PCell UE Rx-Tx time difference, or a pair of cells, e.g. SSTD measurements between the PCell and the PSCell.

2. **Reporting configurations:** A list of reporting configurations where each reporting configuration consists of the following:
  - Reporting criterion: The criterion that triggers the UE to send a measurement report. This can either be periodical or a single event description.
  - Reporting format: The quantities that the UE includes in the measurement report and associated information (e.g. number of cells to report).
3. **Measurement identities:** A list of measurement identities where each measurement identity links one measurement object with one reporting configuration. By configuring multiple measurement identities it is possible to link more than one measurement object to the same reporting configuration, as well as to link more than one reporting configuration to the same measurement object. The measurement identity is used as a reference number in the measurement report.
4. **Quantity configurations:** One quantity configuration is configured per RAT type. The quantity configuration defines the measurement quantities and associated filtering used for all event evaluation and related reporting of that measurement type. One filter can be configured per measurement quantity, except for NR where the network may configure up to 2 sets of quantity configurations each comprising per measurement quantity separate filters for cell and RS index measurement results. The quantity configuration set that applies for a given measurement is indicated within the NR measurement object.
5. **Measurement gaps:** Periods that the UE may use to perform measurements, i.e. no (UL, DL) transmissions are scheduled.

E-UTRAN only configures a single measurement object for a given frequency (except for WLAN and except for CBR measurements), i.e. it is not possible to configure two or more measurement objects for the same frequency with different associated parameters, e.g. different offsets and/ or blacklists. E-UTRAN may configure multiple instances of the same event e.g. by configuring two reporting configurations with different thresholds.

The UE maintains a single measurement object list, a single reporting configuration list, and a single measurement identities list. The measurement object list includes measurement objects, that are specified per RAT type, possibly including intra-frequency object(s) (i.e. the object(s) corresponding to the serving frequency(ies)), inter-frequency object(s) and inter-RAT objects. Similarly, the reporting configuration list includes E-UTRA and inter-RAT reporting configurations. Any measurement object can be linked to any reporting configuration of the same RAT type. Some reporting configurations may not be linked to a measurement object. Likewise, some measurement objects may not be linked to a reporting configuration.

[TS 36.331, clause 5.5.4.1]

If security has been activated successfully, the UE shall:

- 1> for each *measId* included in the *measIdList* within *VarMeasConfig*:
  - ...
  - 2> else:
    - ...
    - 3> else if the corresponding *measObject* concerns NR:
      - 4> if the *reportSFTD-Meas* is set to *pSCell* in the corresponding *reportConfigInterRAT*:
        - 5> consider the PSCell to be applicable;
      - 4> else if the *reportSFTD-Meas* is set to *neighborCells* in the corresponding *reportConfigInterRAT*:
        - 5> if *cellsForWhichToReportSFTD* is configured in the corresponding *measObjectNR*:
          - 6> consider any neighbouring NR cell on the associated frequency that is included in *cellsForWhichToReportSFTD* to be applicable;
        - 5> else:
          - 6> consider up to 3 strongest neighbouring NR cells detected on the associated frequency to be applicable when the concerned cells are not included in the *blackCellsToAddModList* defined within the *VarMeasConfig* for this *measId*;
    - ...
    - 2> else if the *purpose* is included and set to *reportStrongestCells*, *reportStrongestCellsForSON*, *reportLocation* or *sidelink* and if a (first) measurement result is available:
      - 3> include a measurement reporting entry within the *VarMeasReportList* for this *measId*;
      - 3> set the *numberOfReportsSent* defined within the *VarMeasReportList* for this *measId* to 0;
      - 3> if the *purpose* is set to *reportStrongestCells* and *reportStrongestCSI-RSs* is not included:
        - 4> if the *triggerType* is set to *periodical* and the corresponding *reportConfig* includes the *ul-DelayConfig*:
          - 5> initiate the measurement reporting procedure, as specified in 5.5.5, immediately after a first measurement result is provided by lower layers;
        - ...
        - 4> else if the *reportAmount* exceeds 1:
          - 5> initiate the measurement reporting procedure, as specified in 5.5.5, immediately after the quantity to be reported becomes available for the PCell;



4> else (i.e. the *reportAmount* is equal to 1):

5> initiate the measurement reporting procedure, as specified in 5.5.5, immediately after the quantity to be reported becomes available for the PCell and for the strongest cell among the applicable cells, or becomes available for the pair of PCell and the PSCell in case of SSTD measurements, or becomes available for each requested pair of PCell and NR cell or the maximal measurement reporting delay as specified in TS 38.133 [X, 8.17.2.3] in case of SFTD measurements;

...

3> else:

4> initiate the measurement reporting procedure, as specified in 5.5.5, when it has determined the strongest cells on the associated frequency;

2> upon expiry of the periodical reporting timer for this *measId*:

3> initiate the measurement reporting procedure, as specified in 5.5.5;

...

NOTE 2: The UE does not stop the periodical reporting with *triggerType* set to *event* or to *periodical* while the corresponding measurement is not performed due to the PCell RSRP being equal to or better than *s-Measure* or due to the measurement gap not being setup.

NOTE 3: If the UE is configured with DRX, the UE may delay the measurement reporting for event triggered and periodical triggered measurements until the Active Time, which is defined in TS 36.321 [6].

[TS 36.331, clause 5.5.4.7]

The UE shall:

1> for UTRA and CDMA2000, only trigger the event for cells included in the corresponding measurement object;

1> consider the entering condition for this event to be satisfied when condition B1-1, as specified below, is fulfilled;

1> consider the leaving condition for this event to be satisfied when condition B1-2, as specified below, is fulfilled;

Inequality B1-1 (Entering condition)

$$Mn + Ofn - Hys > Thresh$$

Inequality B1-2 (Leaving condition)

$$Mn + Ofn + Hys < Thresh$$

The variables in the formula are defined as follows:

***Mn*** is the measurement result of the inter-RAT neighbour cell, not taking into account any offsets. For CDMA 2000 measurement result, *pilotStrength* is divided by -2.

***Ofn*** is the frequency specific offset of the frequency of the inter-RAT neighbour cell (i.e. *offsetFreq* as defined within the *measObject* corresponding to the frequency of the neighbour inter-RAT cell).

***Hys*** is the hysteresis parameter for this event (i.e. *hysteresis* as defined within *reportConfigInterRAT* for this event).

***Thresh*** is the threshold parameter for this event (i.e. *b1-Threshold* as defined within *reportConfigInterRAT* for this event). For CDMA2000, *b1-Threshold* is divided by -2.

***Mn*** is expressed in dBm or in dB, depending on the measurement quantity of the inter-RAT neighbour cell.

***Ofn*, *Hys*** are expressed in dB.

***Thresh*** is expressed in the same unit as ***Mn***.

[TS 36.331, clause 5.5.5.1]

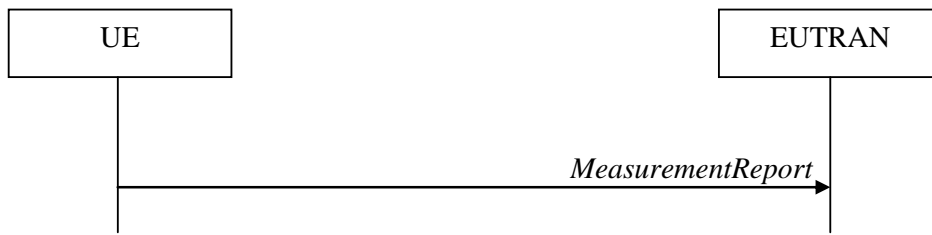

**Figure 5.5.5.1-1: Measurement reporting**

The purpose of this procedure is to transfer measurement results from the UE to E-UTRAN. The UE shall initiate this procedure only after successful security activation.

For the *measId* for which the measurement reporting procedure was triggered, the UE shall set the *measResults* within the *MeasurementReport* message as follows:

- 1> set the *measId* to the measurement identity that triggered the measurement reporting;
- 1> set the *measResultPCell* to include the quantities of the PCell;
- 1> set the *measResultServFreqList* to include for each E-UTRA SCell that is configured, if any, within *measResultSCell* the quantities of the concerned SCell, if available according to performance requirements in [16], except if *purpose* for the *reportConfig* associated with the *measId* that triggered the measurement reporting is set to *reportLocation*;
- 1> if the *reportConfig* associated with the *measId* that triggered the measurement reporting includes *reportAddNeighMeas*:
  - 2> for each E-UTRA serving frequency for which *measObjectId* is referenced in the *measIdList*, other than the frequency corresponding with the *measId* that triggered the measurement reporting:
    - 3> set the *measResultServFreqList* to include within *measResultBestNeighCell* the *physCellId* and the quantities of the best non-serving cell, based on RSRP, on the concerned serving frequency;
- 1> if the *triggerType* is set to *event*; and if the corresponding *measObject* concerns NR; and if *eventId* is set to *eventB1* or *eventB2*; or
- 1> if the *triggerType* is set to *event*; and if *eventId* is set to *eventA3* or *eventA4* or *eventA5*:
  - 2> if *purpose* for the *reportConfig* associated with the *measId* that triggered the measurement reporting is set to a value other than *reportLocation*:
    - 3> set the *measResultServFreqListNR* to include for each NR serving frequency, if any, the following:
      - 4> set *measResultSCell* to include the available results of the NR serving cell, as specified in 5.5.5.2;
      - 4> if the *reportConfig* associated with the *measId* that triggered the measurement reporting includes *reportAddNeighMeas*:
        - 5> set *measResultBestNeighCell* to include the available results, as specified in 5.5.5.2, of the best non-serving cell, ordered based on the quantity determined as specified in 5.5.5.3;
        - 5> for each (serving or neighbouring) cell for which the UE reports results according to the previous, additionally include available beam results according to the following:
          - 6> if *maxReportRS-Index* is configured, set *measResultCellRS-Index* to include available results, as specified in 5.5.5.2, of up to *maxRS-IndexReport* beams, ordered based on the quantity determined as specified in 5.5.5.3;
  - 1> if there is at least one applicable neighbouring cell to report:
    - 2> set the *measResultNeighCells* to include the best neighbouring cells up to *maxReportCells* in accordance with the following:

3> if the *triggerType* is set to *event*:

4> include the cells included in the *cellsTriggeredList* as defined within the *VarMeasReportList* for this *measId*;

3> else:

4> include the applicable cells for which the new measurement results became available since the last periodical reporting or since the measurement was initiated or reset;

NOTE 1: The reliability of the report (i.e. the certainty it contains the strongest cells on the concerned frequency) depends on the measurement configuration i.e. the *reportInterval*. The related performance requirements are specified in TS 36.133 [16].

3> for each cell that is included in the *measResultNeighCells*, include the *physCellId*;

3> if the *triggerType* is set to *event*; or the *purpose* is set to *reportStrongestCells* or to *reportStrongestCellsForSON*:

4> for each included cell, include the layer 3 filtered measured results in accordance with the *reportConfig* for this *measId*, ordered as follows:

5> if the *measObject* associated with this *measId* concerns E-UTRA:

6> set the *measResult* to include the quantity(ies) indicated in the *reportQuantity* within the concerned *reportConfig* in order of decreasing *triggerQuantity*, i.e. the best cell is included first;

5> if the *measObject* associated with this *measId* concerns NR:

6> set the *measResultCell* to include the quantity(ies) indicated in the *reportQuantityCellNR* within the concerned *reportConfig* in order of decreasing quantity according to *bN-ThresholdYNR*, i.e. the best cell is included first;

6> if *maxReportRS-Index* and *reportQuantityRS-IndexNR* are configured, set *measResultCellRS-Index* to include results of the best beam and the beams whose quantity is above *threshRS-Index* defined in the *VarMeasConfig* for the corresponding *measObject*, up to *maxReportRS-Index* beams in total, and in order of decreasing quantity, same as used for cell reporting, and as follows:

7> order beams based on the reporting quantity determined as specified in 5.5.5.2;

7> include *ssbIndex*;

7> if *reportQuantityRS-IndexNR* and *reportRS-IndexResultsNR* are configured, for each quantity indicated, include the corresponding measurement result;

[TS 36.331, clause 5.5.5.3]

When configured to report the best cells or beams, the UE shall determine the quantity, that is used to order and select as follows

1> consider the quantities the UE reports as candidate sorting quantities i.e. as follows:

2> for NR cells for which measurement reporting is triggered (i.e. NR cells included in *cellsTriggered*):

3> the quantities defined by *reportQuantityCellNR*, when used for sorting cells;

3> the quantities defined by *reportQuantityRS-IndexNR*, when used for sorting beams;

2> for cells on NR serving frequencies:

3> the available quantities of available NR measurement results as specified in 5.5.5.2;

1> if *reportType* is set to *eventTriggered*; and if *eventId* is set to *eventB1* or *eventB2*:

2> consider the trigger quantity to be the sorting quantity;

- 1> if *reportType* is set to *periodical*:
  - 2> if there is a single candidate sorting quantity;
    - 3> consider the concerned quantity to be the sorting quantity;
  - 2> else:
    - 3> if RSRP is one of the candidate sorting quantities;
      - 4> consider RSRP to be the sorting quantity;
    - 3> else:
      - 4> consider RSRQ to be the sorting quantity;

#### 8.2.3.2.1.3 Test description

##### 8.2.3.2.1.3.1 Pre-test conditions

##### System Simulator:

- E-UTRA Cell 1 and NR Cell 1.

##### UE:

- None.

##### Preamble:

- The UE is in state RRC\_CONNECTED using generic procedure parameter Connectivity (*EN-DC*), Bearers (*MCG(s) only*) established according to TS 38.508-1 [4], clause 4.5.4.

##### 8.2.3.2.1.3.2 Test procedure sequence

Table 8.2.3.2.1.3.2-1 illustrates the downlink power levels and other changing parameters to be applied for the cells at various time instants of the test execution. Row marked "T0" denotes the initial conditions after preamble, while columns marked "T1" and "T2" are to be applied subsequently. The exact instants on which these values shall be applied are described in the texts in this clause.

**Table 8.2.3.2.1.3.2-1: Time instances of cell power level and parameter changes**

	Parameter	Unit	E-UTRA Cell 1	NR Cell 1	Remark
T0	Cell-specific RS EPRE	dBm/15 kHz	-85	-	The power level values are such that entering conditions for event B1 are not satisfied.
	SS/PBCH SSS EPRE	dBm/15 kHz	-	[-91]	
T1	Cell-specific RS EPRE	dBm/15 kHz	-85	-	The power level values are such that entering conditions for event B1 are satisfied.
	SS/PBCH SSS EPRE	dBm/15 kHz	-	[-85]	
T2	Cell-specific RS EPRE	dBm/15 kHz	-85	-	The power level values are such that leaving conditions for event B1 are satisfied.
	SS/PBCH SSS EPRE	dBm/15 kHz	-	[-91]	

**Table 8.2.3.2.1.3.2-2: Main behaviour**

St	Procedure	Message Sequence		TP	Verdict
		U - S	Message		
1	The SS transmits an <i>RRCConnectionReconfiguration</i> including measConfig to setup inter RAT measurements and reporting for NR Cell 1.	<--	<i>RRCConnectionReconfiguration</i>	-	-
2	The UE transmits an <i>RRCConnectionReconfigurationComplete</i> message to confirm the setup of inter RAT measurements for NR Cell 1.	-->	<i>RRCConnectionReconfigurationComplete</i>	-	-
3	Check: Does the UE transmit a <i>MeasurementReport</i> message on E-UTRA Cell 1 to report the event B1 during the next 10s?	-->	<i>MeasurementReport</i>	1	F
4	The SS changes E-UTRA Cell 1 and NR Cell 1 parameters according to the row "T1" in table 8.2.3.2.1.3.2-1.	-	-	-	-
5	Check: Does the UE transmit a <i>MeasurementReport</i> message to report the event B1 for NR Cell 1?	-->	<i>MeasurementReport</i>	2	P
6	The SS changes E-UTRA Cell 1 and NR Cell 1 parameters according to the row "T2" in table 8.2.3.2.1.3.2-1.	-	-	-	-
7	Wait and ignore <i>MeasurementReport</i> messages for 15s to allow change of power levels and UE measurements for NR Cell 1.	-	-	-	-
8	Check: Does the UE transmit a <i>MeasurementReport</i> message on E-UTRA Cell 1 to report the event B1 during the next 10s?	-->	<i>MeasurementReport</i>	3	F

8.2.3.2.1.3.3 Specific message contents

**Table 8.2.3.2.1.3.3-1: *RRCConnectionReconfiguration* (step 1, Table 8.2.3.2.1.3.2-2)**

Derivation Path: 36.508 [7], Table 4.6.1-8, condition MEAS
--

Table 8.2.3.2.1.3.3-2: *MeasConfig* (Table 8.2.3.2.1.3.3-1)

Derivation Path: 36.508 [7], Table 4.6.6-1			
Information Element	Value/remark	Comment	Condition
MeasConfig ::= SEQUENCE {			
measObjectToAddModList SEQUENCE (SIZE (1..maxObjectld)) OF SEQUENCE {	2 entries		
measObjectld[1]	ldMeasObject-f1		
measObject{1}	MeasObjectEUTRA-GENERIC(f1)		
measObject{1}	MeasObjectEUTRA-GENERIC(maxEARFCN)		Band > 64
measObjectld[2]	[ldMeasObject-NRf1]		
measObject{2}	MeasObjectNR-GENERIC (NRf1)		
}			
reportConfigToAddModList SEQUENCE (SIZE (1..maxReportConfigld)) OF SEQUENCE {	1 entry		
reportConfigld[1]	[ldReportConfig-B1-NR]		
reportConfig{1}	ReportConfig-B1-NR-r15		
}			
measldToAddModList SEQUENCE (SIZE (1..maxMeasld)) OF SEQUENCE {	1 entry		
measld[1]	1		
measObjectld[2]	[ldMeasObject-NRf1]		
reportConfigld[1]	[ldReportConfig-B1-NR]		
}			
quantityConfig	QuantityConfig-DEFAULT		
}			

Table 8.2.3.2.1.3.3-3: *QuantityConfig-DEFAULT* (Table 8.2.3.2.1.3.3-2)

Derivation Path: 36.508 [7], Table 4.6.6-3A			
Information Element	Value/remark	Comment	Condition
QuantityConfig-DEFAULT SEQUENCE {			
quantityConfigNRList-r15 SEQUENCE ((SIZE (1..maxQuantSetsNR-r15)) OF SEQUENCE {			
measQuantityCellNR-r15 SEQUENCE {			
filterCoeff-RSRP-r15	fc0		
filterCoeff-RSRQ-r15	fc0		
}			
}			
}			

Table 8.2.3.2.1.3.3-4: *MeasObjectNR-GENERIC (NRf1)* (Table 8.2.3.2.1.3.3-2)

Derivation Path: 36.508 [7], Table 4.6.6-2B			
Information Element	Value/remark	Comment	Condition
MeasObjectNR-GENERIC(Freq) ::= SEQUENCE {			
carrierFreq-r15	Downlink carrier frequency of NR cell 1		
}			

**Table 8.2.3.2.1.3.3-5: ReportConfigInterRAT-B1-NR-r15 (Table 8.2.3.2.1.3.3-2)**

Derivation Path: 36.508 [7], Table 4.6.6-7C			
Information Element	Value/remark	Comment	Condition
ReportConfig-B1-NR ::= SEQUENCE {			
triggerType CHOICE {			
event SEQUENCE {			
eventId CHOICE {			
eventB1-NR-r15 SEQUENCE{			
b1-ThresholdNR-r15 CHOICE{			
nr-RSRQ-r15	[51]		
}			
}			
}			
}			
reportAmount	infinity		
}			

**Table 8.2.3.2.1.3.3-6: MeasurementReport (step 5, Table 8.2.3.2.1.3.2-2)**

Derivation Path: 36.508 [7], Table 4.6.1-5			
Information Element	Value/remark	Comment	Condition
MeasurementReport ::= SEQUENCE {			
criticalExtensions CHOICE {			
c1 CHOICE{			
measurementReport-r8 SEQUENCE {			
measResults SEQUENCE {			
measId	1		
measResultPCell SEQUENCE {			
rsrpResult	(0..97)		
rsrqResult	(0..34)		
}			
measResultNeighCells CHOICE {			
measResultNeighCellListNR-r15 SEQUENCE	1 entry		
(SIZE (1..maxCellReport)) OF SEQUENCE {			
pci-r15 [1]	PhysicalCellIdentity of NR Cell 1		
measResultCell-r15 [1] SEQUENCE {			
rsrqResult-r15	(0..127)		
}			
}			
}			
}			
}			
}			
}			
}			

**8.2.3.3 Measurement configuration control and reporting / Inter-RAT measurements / Periodic reporting / Measurement of NR cells**

**8.2.3.3.1 Measurement configuration control and reporting / Inter-RAT measurements / Periodic reporting / Measurement of NR cells / EN-DC**

**8.2.3.3.1.1 Test Purpose (TP)**

(1)

```

with { UE in RRC_CONNECTED state with EN-DC, and, MCG (E-UTRA PDCP) only having completed the radio
bearer establishment and performed the inter RAT measurement for NR cell }
ensure that {
  when { The UE receives reference signal power for cells on the NR frequencies where measurements
are configured }
  then { UE sends MeasurementReport message at regular intervals for these NR cells }
}
    
```

(2)

```

with { UE in RRC_CONNECTED state with EN-DC, and, MCG (E-UTRA PDCP) only and a MeasurementReport
message for a configured periodic measurement reporting of NR cells on a configured frequency were
sent }
ensure that {
  when { A previously reported cell become unavailable and the UE receives reference signal power on
a reported NR frequency for a cell which was previously not reported }
  then { UE sends MeasurementReport message at regular intervals for the available NR cells }
}

```

(3)

```

with { UE in RRC_CONNECTED state with EN-DC, and, MCG (E-UTRA PDCP) only and periodic measurement
reporting of NR cells ongoing }
ensure that {
  when { The UE receives a RRCConnectionReconfiguration message removing the measId of periodic
reporting of NR cells }
  then { UE stops sending MeasurementReport message for NR cells }
}

```

### 8.2.3.3.1.2 Conformance requirements

References: The conformance requirements covered in the present TC are specified in: TS 36.331, clauses 5.5.1, 5.5.4.1, 5.5.4.7 and 5.5.5.1. Unless otherwise stated these are Rel-15 requirements.

[TS 36.331, clause 5.5.1]

The UE reports measurement information in accordance with the measurement configuration as provided by E-UTRAN. E-UTRAN provides the measurement configuration applicable for a UE in RRC\_CONNECTED by means of dedicated signalling, i.e. using the *RRCConnectionReconfiguration* or *RRCConnectionResume* message.

The UE can be requested to perform the following types of measurements:

- Intra-frequency measurements: measurements at the downlink carrier frequency(ies) of the serving cell(s).
- Inter-frequency measurements: measurements at frequencies that differ from any of the downlink carrier frequency(ies) of the serving cell(s).
- Inter-RAT measurements of NR frequencies.

...

The measurement configuration includes the following parameters:

1. **Measurement objects:** The objects on which the UE shall perform the measurements.

- For intra-frequency and inter-frequency measurements a measurement object is a single E-UTRA carrier frequency. Associated with this carrier frequency, E-UTRAN can configure a list of cell specific offsets, a list of 'blacklisted' cells and a list of 'whitelisted' cells. Blacklisted cells are not considered in event evaluation or measurement reporting.
- For inter-RAT NR measurements a measurement object is a single NR carrier frequency. Associated with this carrier frequency, E-UTRAN can configure a list of 'blacklisted' cells. Blacklisted cells are not considered in event evaluation or measurement reporting.

...

NOTE 1: Some measurements using the above mentioned measurement objects, only concern a single cell, e.g. measurements used to report neighbouring cell system information, PCell UE Rx-Tx time difference, or a pair of cells, e.g. SSTD measurements between the PCell and the PSCell.

2. **Reporting configurations:** A list of reporting configurations where each reporting configuration consists of the following:

- Reporting criterion: The criterion that triggers the UE to send a measurement report. This can either be periodical or a single event description.



- Reporting format: The quantities that the UE includes in the measurement report and associated information (e.g. number of cells to report).
3. **Measurement identities:** A list of measurement identities where each measurement identity links one measurement object with one reporting configuration. By configuring multiple measurement identities it is possible to link more than one measurement object to the same reporting configuration, as well as to link more than one reporting configuration to the same measurement object. The measurement identity is used as a reference number in the measurement report.
  4. **Quantity configurations:** One quantity configuration is configured per RAT type. The quantity configuration defines the measurement quantities and associated filtering used for all event evaluation and related reporting of that measurement type. One filter can be configured per measurement quantity, except for NR where the network may configure up to 2 sets of quantity configurations each comprising per measurement quantity separate filters for cell and RS index measurement results. The quantity configuration set that applies for a given measurement is indicated within the NR measurement object.
  5. **Measurement gaps:** Periods that the UE may use to perform measurements, i.e. no (UL, DL) transmissions are scheduled.

E-UTRAN only configures a single measurement object for a given frequency (except for WLAN and except for CBR measurements), i.e. it is not possible to configure two or more measurement objects for the same frequency with different associated parameters, e.g. different offsets and/ or blacklists. E-UTRAN may configure multiple instances of the same event e.g. by configuring two reporting configurations with different thresholds.

The UE maintains a single measurement object list, a single reporting configuration list, and a single measurement identities list. The measurement object list includes measurement objects, that are specified per RAT type, possibly including intra-frequency object(s) (i.e. the object(s) corresponding to the serving frequency(ies)), inter-frequency object(s) and inter-RAT objects. Similarly, the reporting configuration list includes E-UTRA and inter-RAT reporting configurations. Any measurement object can be linked to any reporting configuration of the same RAT type. Some reporting configurations may not be linked to a measurement object. Likewise, some measurement objects may not be linked to a reporting configuration.

[TS 36.331, clause 5.5.4.1]

If security has been activated successfully, the UE shall:

- 1> for each *measId* included in the *measIdList* within *VarMeasConfig*:
  - ...
  - 2> else:
    - ...
    - 3> else if the corresponding *measObject* concerns NR:
      - 4> if the *reportSFTD-Meas* is set to *pSCell* in the corresponding *reportConfigInterRAT*:
        - 5> consider the PSCell to be applicable;
      - 4> else if the *reportSFTD-Meas* is set to *neighborCells* in the corresponding *reportConfigInterRAT*:
        - 5> if *cellsForWhichToReportSFTD* is configured in the corresponding *measObjectNR*:
          - 6> consider any neighbouring NR cell on the associated frequency that is included in *cellsForWhichToReportSFTD* to be applicable;
        - 5> else:
          - 6> consider up to 3 strongest neighbouring NR cells detected on the associated frequency to be applicable when the concerned cells are not included in the *blackCellsToAddModList* defined within the *VarMeasConfig* for this *measId*;
- ...

- 2> else if the *purpose* is included and set to *reportStrongestCells*, *reportStrongestCellsForSON*, *reportLocation* or *sidelink* and if a (first) measurement result is available:
- 3> include a measurement reporting entry within the *VarMeasReportList* for this *measId*;
  - 3> set the *numberOfReportsSent* defined within the *VarMeasReportList* for this *measId* to 0;
  - 3> if the *purpose* is set to *reportStrongestCells* and *reportStrongestCSI-RSs* is not included:
    - 4> if the *triggerType* is set to *periodical* and the corresponding *reportConfig* includes the *ul-DelayConfig*:
      - 5> initiate the measurement reporting procedure, as specified in 5.5.5, immediately after a first measurement result is provided by lower layers;
    - ...
    - 4> else if the *reportAmount* exceeds 1:
      - 5> initiate the measurement reporting procedure, as specified in 5.5.5, immediately after the quantity to be reported becomes available for the PCell;
    - 4> else (i.e. the *reportAmount* is equal to 1):
      - 5> initiate the measurement reporting procedure, as specified in 5.5.5, immediately after the quantity to be reported becomes available for the PCell and for the strongest cell among the applicable cells, or becomes available for the pair of PCell and the PSCell in case of SSTD measurements, or becomes available for each requested pair of PCell and NR cell or the maximal measurement reporting delay as specified in TS 38.133 [X, 8.17.2.3] in case of SFTD measurements;
    - ...
  - 3> else:
    - 4> initiate the measurement reporting procedure, as specified in 5.5.5, when it has determined the strongest cells on the associated frequency;
- 2> upon expiry of the periodical reporting timer for this *measId*:
- 3> initiate the measurement reporting procedure, as specified in 5.5.5;
  - ...

NOTE 2: The UE does not stop the periodical reporting with *triggerType* set to *event* or to *periodical* while the corresponding measurement is not performed due to the PCell RSRP being equal to or better than *s-Measure* or due to the measurement gap not being setup.

NOTE 3: If the UE is configured with DRX, the UE may delay the measurement reporting for event triggered and periodical triggered measurements until the Active Time, which is defined in TS 36.321 [6].

[TS 36.331, clause 5.5.5.1]

The purpose of this procedure is to transfer measurement results from the UE to E-UTRAN. The UE shall initiate this procedure only after successful security activation.

For the *measId* for which the measurement reporting procedure was triggered, the UE shall set the *measResults* within the *MeasurementReport* message as follows:

- 1> set the *measId* to the measurement identity that triggered the measurement reporting;
- 1> set the *measResultPCell* to include the quantities of the PCell;
- 1> set the *measResultServFreqList* to include for each E-UTRA SCell that is configured, if any, within *measResultSCell* the quantities of the concerned SCell, if available according to performance requirements in [16], except if *purpose* for the *reportConfig* associated with the *measId* that triggered the measurement reporting is set to *reportLocation*;

- 1> if the *reportConfig* associated with the *measId* that triggered the measurement reporting includes *reportAddNeighMeas*:
  - 2> for each E-UTRA serving frequency for which *measObjectId* is referenced in the *measIdList*, other than the frequency corresponding with the *measId* that triggered the measurement reporting:
    - 3> set the *measResultServFreqList* to include within *measResultBestNeighCell* the *physCellId* and the quantities of the best non-serving cell, based on RSRP, on the concerned serving frequency;
  - ...
- 1> if there is at least one applicable neighbouring cell to report:
  - 2> set the *measResultNeighCells* to include the best neighbouring cells up to *maxReportCells* in accordance with the following:
    - ...
  - 3> else:
    - 4> include the applicable cells for which the new measurement results became available since the last periodical reporting or since the measurement was initiated or reset;

NOTE 1: The reliability of the report (i.e. the certainty it contains the strongest cells on the concerned frequency) depends on the measurement configuration i.e. the *reportInterval*. The related performance requirements are specified in TS 36.133 [16].

- 3> for each cell that is included in the *measResultNeighCells*, include the *physCellId*;
- 3> if the *triggerType* is set to *event*; or the *purpose* is set to *reportStrongestCells* or to *reportStrongestCellsForSON*:
  - 4> for each included cell, include the layer 3 filtered measured results in accordance with the *reportConfig* for this *measId*, ordered as follows:
    - 5> if the *measObject* associated with this *measId* concerns E-UTRA:
      - 6> set the *measResult* to include the quantity(ies) indicated in the *reportQuantity* within the concerned *reportConfig* in order of decreasing *triggerQuantity*, i.e. the best cell is included first;
    - 5> if the *measObject* associated with this *measId* concerns NR:
      - 6> set the *measResultCell* to include the quantity(ies) indicated in the *reportQuantityCellNR* within the concerned *reportConfig* in order of decreasing quantity according to *bN-ThresholdYNR*, i.e. the best cell is included first;
      - 6> if *maxRS-IndexReport* is configured, set *measResultCellRS-Index* to include results of up to *maxRS-IndexReport* beams whose quantity is above *threshRS-Index* defined in the *VarMeasConfig* for the corresponding *measObject* and in order of decreasing quantity, same as used for cell reporting, and as follows:
        - 7> order beams based on the reporting quantity determined as specified in 5.5.5.2;
        - 7> include *ssbIndex*;
        - 7> if *reportQuantityRS-IndexNR* and *reportRS-IndexResultsNR* are configured, for each quantity indicated, include the corresponding measurement result;
  - 5> if the *measObject* associated with this *measId* concerns UTRA FDD and if *ReportConfigInterRAT* includes the *reportQuantityUTRA-FDD*:
    - 6> set the *measResult* to include the quantities indicated by the *reportQuantityUTRA-FDD* in order of decreasing *measQuantityUTRA-FDD* within the *quantityConfig*, i.e. the best cell is included first;

- 5> if the *measObject* associated with this *measId* concerns UTRA FDD and if *ReportConfigInterRAT* does not include the *reportQuantityUTRA-FDD*; or
- 5> if the *measObject* associated with this *measId* concerns UTRA TDD, GERAN or CDMA2000:
  - 6> set the *measResult* to the quantity as configured for the concerned RAT within the *quantityConfig* in order of either decreasing quantity for UTRA and GERAN or increasing quantity for CDMA2000 *pilotStrength*, i.e. the best cell is included first;
- 3> else if the *purpose* is set to *reportCGI*:
  - 4> if the mandatory present fields of the *cgi-Info* for the cell indicated by the *cellForWhichToReportCGI* in the associated *measObject* have been obtained:
    - 5> if the *includeMultiBandInfo* is configured:
      - 6> include the *freqBandIndicator*;
      - 6> if the cell broadcasts the *multiBandInfoList*, include the *multiBandInfoList*;
      - 6> if the cell broadcasts the *freqBandIndicatorPriority*, include the *freqBandIndicatorPriority*;
    - 5> if the cell broadcasts a CSG identity:
      - 6> include the *csg-Identity*;
      - 6> include the *csg-MemberStatus* and set it to *member* if the cell is a CSG member cell;
    - 5> if the *si-RequestForHO* is configured within the *reportConfig* associated with this *measId*:
      - 6> include the *cgi-Info* containing all the fields other than the *plmn-IdentityList* that have been successfully acquired;
      - 6> include, within the *cgi-Info*, the field *plmn-IdentityList* in accordance with the following:
        - 7> if the cell is a CSG member cell, determine the subset of the PLMN identities, starting from the second entry of PLMN identities in the broadcast information that meet the following conditions:
          - a) equal to the RPLMN or an EPLMN; and
          - b) the CSG whitelist of the UE includes an entry comprising of the concerned PLMN identity and the CSG identity broadcast by the cell;
        - 7> if the subset of PLMN identities determined according to the previous includes at least one PLMN identity, include the *plmn-IdentityList* and set it to include this subset of the PLMN identities;
        - 7> if the cell is a CSG member cell, include the *primaryPLMN-Suitable* if the primary PLMN meets conditions a) and b) specified above;
        - 7> if the cell does not broadcast *csg-Identity* and the UE is capable of reporting the *plmn-IdentityList* from cells not broadcasting *csg-Identity*:
          - 8> include in the *plmn-IdentityList* the list of identities starting from the second entry of PLMN identities in the broadcast information;
    - 5> else:
      - 6> include the *cgi-Info* containing all the fields that have been successfully acquired and in accordance with the following:
        - 7> include in the *plmn-IdentityList* the list of identities starting from the second entry of PLMN Identities in the broadcast information;
  - 1> for the cells included according to the previous (i.e. covering the PCell, the SCells, the best non-serving cells on serving frequencies as well as neighbouring EUTRA cells) include results according to the extended RSRQ if corresponding results are available according to the associated performance requirements defined in 36.133 [16];

- 1> if there is at least one applicable CSI-RS resource to report:
  - 2> set the *measResultCSI-RS-List* to include the best CSI-RS resources up to *maxReportCells* in accordance with the following:
    - 3> if the *triggerType* is set to *event*:
      - 4> include the CSI-RS resources included in the *csi-RS-TriggeredList* as defined within the *VarMeasReportList* for this *measId*;
    - 3> else:
      - 4> include the applicable CSI-RS resources for which the new measurement results became available since the last periodical reporting or since the measurement was initiated or reset;

NOTE 2: The reliability of the report (i.e. the certainty it contains the strongest CSI-RS resources on the concerned frequency) depends on the measurement configuration i.e. the *reportInterval*. The related performance requirements are specified in TS 36.133 [16].

...

- 1> increment the *numberOfReportsSent* as defined within the *VarMeasReportList* for this *measId* by 1;
- 1> stop the periodical reporting timer, if running;
- 1> if the *numberOfReportsSent* as defined within the *VarMeasReportList* for this *measId* is less than the *reportAmount* as defined within the corresponding *reportConfig* for this *measId*:
  - 2> start the periodical reporting timer with the value of *reportInterval* as defined within the corresponding *reportConfig* for this *measId*;
- 1> else:
  - 2> if the *triggerType* is set to *periodical*:
    - 3> remove the entry within the *VarMeasReportList* for this *measId*;
    - 3> remove this *measId* from the *measIdList* within *VarMeasConfig*;

...

- 1> submit the *MeasurementReport* message to lower layers for transmission, upon which the procedure ends;

#### 8.2.3.3.1.3 Test description

##### 8.2.3.3.1.3.1 Pre-test conditions

#### System Simulator:

- E-UTRA Cell 1, NR Cell 1 and NR Cell 2.

#### UE:

- None.

#### Preamble:

- The UE is in state RRC\_CONNECTED using generic procedure parameter Connectivity (*EN-DC*), Bearers (*MCG(s) only*) established according to TS 38.508-1 [4], clause 4.5.4.

##### 8.2.3.3.1.3.2 Test procedure sequence

Table 8.2.3.3.1.3.2-1 illustrates the downlink power levels and other changing parameters to be applied for the cells at various time instants of the test execution. Row marked "T0" denotes the initial conditions after preamble, while columns marked "T1", "T2" and "T3" are to be applied subsequently. The exact instants on which these values shall be applied are described in the texts in this clause.

**Table 8.2.3.3.1.3.2-1: Time instances of cell power level and parameter changes**

	Parameter	Unit	E-UTRA Cell 1	NR Cell 1	NR Cell 2	Remark
T0	Cell-specific RS EPRE	dBm/15 kHz	-85	-	-	The power level values are such that camping on E-UTRA Cell 1 is guarantee.
	SS/PBCH SSS EPRE	dBm/15 kHz	-	Off	Off	
T1	Cell-specific RS EPRE	dBm/15 kHz	-85	-	-	The power level values are such that NR Cell 1 is satisfied for periodic reporting.
	SS/PBCH SSS EPRE	dBm/15 kHz	-	FFS	FFS	
T2	Cell-specific RS EPRE	dBm/15 kHz	-85	-	-	The power level values are such that NR Cell 2 is satisfied for periodic reporting and NR Cell 1 become unavailable.
	SS/PBCH SSS EPRE	dBm/15 kHz	-	FFS	FFS	
T3	Cell-specific RS EPRE	dBm/15 kHz	-85	-	-	The power level values are such that NR Cell 1 and NR Cell 2 are satisfied for periodic reporting.
	SS/PBCH SSS EPRE	dBm/15 kHz	-	FFS	FFS	

Table 8.2.3.3.1.3.2-2: Main behaviour

St	Procedure	Message Sequence		TP	Verdict
		U - S	Message		
1	The SS transmits an <i>RRCCONNECTIONRECONFIGURATION</i> including measConfig to setup inter RAT measurements and reporting for NR Cell.	<--	<i>RRCCONNECTIONRECONFIGURATION</i>	-	-
2	The UE transmits an <i>RRCCONNECTIONRECONFIGURATIONCOMPLETE</i> message to confirm the setup of inter RAT measurements for NR Cell.	-->	<i>RRCCONNECTIONRECONFIGURATIONCOMPLETE</i>	-	-
3	The SS changes NR Cell y parameters according to the row "T1" in table 8.2.3.3.1.3.2-1.	-	-	-	-
4	Wait and ignore <i>MEASUREMENTREPORT</i> messages for 15s to allow change of power levels and UE measurements for NR Cell 1.	-	-	-	-
5	Check: Does the UE transmit a <i>MEASUREMENTREPORT</i> message on E-UTRA Cell 1 to perform periodical reporting for NR Cell 1?	-->	<i>MEASUREMENTREPORT</i>	1	P
6	The SS changes NR Cell y parameters according to the row "T2" in table 8.2.3.3.1.3.2-1.	-	-	-	-
7	Wait and ignore <i>MEASUREMENTREPORT</i> messages for 15s to allow change of power levels and UE measurements for NR Cell 2.	-	-	-	-
8	Check: Does the UE transmit a <i>MEASUREMENTREPORT</i> message on E-UTRA Cell 1 to perform periodical reporting for NR Cell 2?	-->	<i>MEASUREMENTREPORT</i>	2	P
9	The SS changes NR Cell y parameters according to the row "T3" in table 8.2.3.3.1.3.2-1.	-	-	-	-
10	Wait and ignore <i>MEASUREMENTREPORT</i> messages for 15s to allow change of power levels and UE measurements for NR Cell 1 and NR Cell 2.	-	-	-	-
11	The SS transmits an <i>RRCCONNECTIONRECONFIGURATION</i> including measConfig to remove inter RAT measurements and reporting for NR Cell.	<--	<i>RRCCONNECTIONRECONFIGURATION</i>	-	-
12	The UE transmits an <i>RRCCONNECTIONRECONFIGURATIONCOMPLETE</i> message to confirm the remove of inter RAT measurements for NR Cell.	-->	<i>RRCCONNECTIONRECONFIGURATIONCOMPLETE</i>	-	-
13	Check: Does the UE transmit a <i>MEASUREMENTREPORT</i> message on E-UTRA Cell 1 to perform periodical reporting for NR Cell 1 and NR Cell 2 during the next 10s?	-->	<i>MEASUREMENTREPORT</i>	3	F

## 8.2.3.3.1.3.3 Specific message contents

Table 8.2.3.3.1.3.3-1: *RRCCONNECTIONRECONFIGURATION* (step 1, Table 8.2.3.3.1.3.2-2)

Derivation Path: 36.508 [7], Table 4.6.1-8, condition MEAS
--

Table 8.2.3.3.1.3.3-2: *MeasConfig* (Table 8.2.3.3.1.3.3-1)

Derivation Path: 36.508 [7], Table 4.6.6-1			
Information Element	Value/remark	Comment	Condition
MeasConfig ::= SEQUENCE {			
measObjectToAddModList SEQUENCE (SIZE (1..maxObjectld)) OF SEQUENCE {	2 entries		
measObjectld[1]	ldMeasObject-f1		
measObject{1}	MeasObjectEUTRA-GENERIC(f1)		
measObject{1}	MeasObjectEUTRA-GENERIC(maxEARFCN)		Band > 64
measObjectld[2]	[ldMeasObject-NRf1]		
measObject{2}	MeasObjectNR-GENERIC (NRf1)		
}			
reportConfigToAddModList SEQUENCE (SIZE (1..maxReportConfigld)) OF SEQUENCE {	1 entry		
reportConfigld[1]	[ldReportConfig-NR]		
reportConfig{1}	ReportConfigInterRAT-PERIODICAL-NR		
}			
measldToAddModList SEQUENCE (SIZE (1..maxMeasld)) OF SEQUENCE {	1 entry		
measld[1]	1		
measObjectld[2]	[ldMeasObject-NRf1]		
reportConfigld[1]	[ldReportConfig-NR]		
}			
quantityConfig	QuantityConfig-DEFAULT		
}			

Table 8.2.3.3.1.3.3-3: *QuantityConfig-DEFAULT* (Table 8.2.3.3.1.3.3-2)

Derivation Path: 36.508 [7], Table 4.6.6-3A			
Information Element	Value/remark	Comment	Condition
QuantityConfig-DEFAULT SEQUENCE {			
quantityConfigNRList-r15 SEQUENCE ((SIZE (1..maxQuantSetsNR-r15)) OF SEQUENCE {			
measQuantityCellNR-r15 SEQUENCE {			
filterCoeff-RSRP-r15	fc0		
filterCoeff-RSRQ-r15	fc0		
}			
}			
}			

Table 8.2.3.3.1.3.3-4: *MeasObjectNR-GENERIC (NRf1)* (Table 8.2.3.3.1.3.3-2)

Derivation Path: 36.508 [7], Table 4.6.6-2B			
Information Element	Value/remark	Comment	Condition
MeasObjectNR-GENERIC(Freq) ::= SEQUENCE {			
carrierFreq-r15	Downlink carrier frequency of NR cell 1		
}			



**Table 8.2.3.3.1.3.3-5: ReportConfigInterRAT-PERIODICAL-NR (Table 8.2.3.2.3.3-2)**

Derivation path: 36.508 [7] FFS			
Information Element	Value/remark	Comment	Condition
ReportConfigInterRAT ReportConfigInterRAT-PERIODICAL-NR ::= SEQUENCE {			
maxReportCells	1		
reportAmount	Infinity		
}			

**Table 8.2.3.3.1.3.3-6: MeasurementReport (step 5, Table 8.2.3.3.1.3.2-2)**

Derivation Path: 36.508 [7], Table 4.6.1-5			
Information Element	Value/remark	Comment	Condition
MeasurementReport ::= SEQUENCE {			
criticalExtensions CHOICE {			
c1 CHOICE{			
measurementReport-r8 SEQUENCE {			
measResults SEQUENCE {			
measId	1		
measResultPCell SEQUENCE {			
rsrpResult	(0..97)		
rsrqResult	(0..34)		
}			
measResultNeighCells CHOICE {			
measResultNeighCellListNR-r15 SEQUENCE (SIZE (1..maxCellReport)) OF SEQUENCE {	1 entry		
pci-r15 [1]	PhysicalCellIdentity of NR Cell 1		
measResultCell-r15 [1] SEQUENCE {			
rsrpResult-r15	(0..127)		
rsrqResult-r15	(0..127)		
}			
}			
}			
}			
}			
}			
}			

**Table 8.2.3.3.1.3.3-7: MeasurementReport (step 8, Table 8.2.3.3.1.3.2-2)**

Derivation Path: 36.508 [7], Table 4.6.1-5			
Information Element	Value/remark	Comment	Condition
MeasurementReport ::= SEQUENCE {			
criticalExtensions CHOICE {			
c1 CHOICE{			
measurementReport-r8 SEQUENCE {			
measResults SEQUENCE {			
measId	1		
measResultPCell SEQUENCE {			
rsrpResult	(0..97)		
rsrqResult	(0..34)		
}			
measResultNeighCells CHOICE {			
measResultNeighCellListNR-r15 SEQUENCE (SIZE (1..maxCellReport)) OF SEQUENCE {	1 entry		
pci-r15 [1]	PhysicalCellIdentity of NR Cell 2		
measResultCell-r15 [1] SEQUENCE {			
rsrpResult-r15	(0..127)		
rsrqResult-r15	(0..127)		
}			
}			
}			
}			
}			
}			
}			

**Table 8.2.3.3.1.3.3-8: MeasConfig (step 11, Table 8.2.3.3.1.3.2-2)**

Derivation Path: 36.508 [7], Table 4.6.6-1			
Information Element	Value/remark	Comment	Condition
MeasConfig ::= SEQUENCE {			
measIdToRemoveList SEQUENCE (SIZE (1..maxMeasId)) OF SEQUENCE {	1 entry		
measId[1]	1		
}			
}			

#### 8.2.3.4 Measurement configuration control and reporting / Event A1 / Measurement of NR PSCell

##### 8.2.3.4.1 Measurement configuration control and reporting / Event A1 / Measurement of NR PSCell / EN-DC

###### 8.2.3.4.1.1 Test Purpose (TP)

(1)

```
with { UE in RRC_CONNECTED state in EN-DC, and, MCG (E-UTRA PDCP) and SCG and measurement configured for event A1 with event based periodical reporting }
ensure that {
  when { Serving NR cell becomes better than absolute threshold plus hysteresis }
    then { UE sends MeasurementReport message at regular intervals while entering condition for event A1 is satisfied }
}
```

(2)

```
with { UE in RRC_CONNECTED state in EN-DC, and, MCG (E-UTRA PDCP) and SCG and periodical measurement reporting triggered by event A1 ongoing }
ensure that {
```

```

when { Serving NR cell becomes worse than absolute threshold minus hysteresis }
  then {UE stops sending MeasurementReport message }
      }

```

#### 8.2.3.4.1.2 Conformance requirements

References: The conformance requirements covered in the present TC are specified in: TS 36.331:5.3.5.3; TS 38.331:5.3.5.3, 5.5.2, 5.5.4.1, 5.5.4.2 and 5.5.5.1. Unless otherwise stated these are Rel-15 requirements.

[TS 36.331, clause 5.3.5.3]

If the *RRCConnectionReconfiguration* message does not include the *mobilityControllInfo* and the UE is able to comply with the configuration included in this message, the UE shall:

...

- 1> if the received *RRCConnectionReconfiguration* includes the *nr-SecondaryCellGroupConfig*:
  - 2> perform NR RRC Reconfiguration as specified in TS 38.331 [82, 5.3.5.3];

[TS 38.331, clause 5.3.5.3]

The UE shall perform the following actions upon reception of the *RRCReconfiguration*:

...

- 1> if the *RRCReconfiguration* message includes the *measConfig*:
  - 2> perform the measurement configuration procedure as specified in 5.5.2.
- 1> set the content of *RRCReconfigurationComplete* message as follows:
  - 2> if the *RRCReconfiguration* includes the *masterCellGroup* containing the *reportUplinkTxDirectCurrent*, or;
  - 2> if the *RRCReconfiguration* includes the *secondaryCellGroup* containing the *reportUplinkTxDirectCurrent*:
  - 3> include the *uplinkTxDirectCurrentList*;
- 1> if the UE is configured with E-UTRA *nr-SecondaryCellGroupConfig* (MCG is E-UTRA):
  - 2> if *RRCReconfiguration* was received via SRB1:
    - 3> submit the *RRCReconfigurationComplete* via the EUTRA MCG embedded in E-UTRA RRC message *RRCConnectionReconfigurationComplete* as specified in TS 36.331 [10];
    - 3> if *reconfigurationWithSync* was included in *spCellConfig* of an SCG:
      - 4> initiate the random access procedure on the SpCell, as specified in TS 38.321 [3];
    - 3> else:
      - 4> the procedure ends;

NOTE: The order the UE sends the *RRCConnectionReconfigurationComplete* message and performs the Random Access procedure towards the SCG is left to UE implementation.

- 2> else (*RRCReconfiguration* was received via SRB3):

- 3> submit the *RRCReconfigurationComplete* message via SRB3 to lower layers for transmission using the new configuration;

NOTE: For EN-DC, in the case of SRB1, the random access is triggered by RRC layer itself as there is not necessarily other UL transmission. In the case of SRB3, the random access is triggered by the MAC layer due to arrival of *RRCReconfigurationComplete*.

- 1 > else:

- 2> submit the *RRCReconfigurationComplete* message via SRB1 to lower layers for transmission using the new configuration;

[TS 38.331, clause 5.5.2.3]

The network applies the procedure as follows:

- configure a *measId* only if the corresponding measurement object, the corresponding reporting configuration and the corresponding quantity configuration, are configured;

The UE shall:

- 1> for each *measId* included in the received *measIdToAddModList*:
  - 2> if an entry with the matching *measId* exists in the *measIdList* within the *VarMeasConfig*:
    - 3> replace the entry with the value received for this *measId*;
  - 2> else:
    - 3> add a new entry for this *measId* within the *VarMeasConfig*;
  - 2> remove the measurement reporting entry for this *measId* from the *VarMeasReportList*, if included;
  - 2> stop the periodical reporting timer and reset the associated information (e.g. *timeToTrigger*) for this *measId*;

[TS 38.331, clause 5.5.4.1]

If security has been activated successfully, the UE shall:

- 1> for each *measId* included in the *measIdList* within *VarMeasConfig*:
  - 2> if the corresponding *reportConfig* includes a *reportType* set to *eventTriggered* or *periodical*;
    - 3> if the corresponding *measObject* concerns NR;
      - 4> if the *eventA1* or *eventA2* is configured in the corresponding *reportConfig*;
        - 5> consider only the serving cell to be applicable;
  - ...
  - 2> upon expiry of the periodical reporting timer for this *measId*:
    - 3> initiate the measurement reporting procedure, as specified in 5.5.5;

[TS 38.331, clause 5.5.4.2]

The UE shall:

- 1> consider the entering condition for this event to be satisfied when condition A1-1, as specified below, is fulfilled;
- 1> consider the leaving condition for this event to be satisfied when condition A1-2, as specified below, is fulfilled;
- 1> for this measurement, consider the NR serving cell corresponding to the associated *measObjectNR* associated with this event.

Inequality A1-1 (Entering condition)

$$M_s - H_{ys} > Thres_i$$

Inequality A1-2 (Leaving condition)

$$M_s + H_{ys} < Thres_i$$

The variables in the formula are defined as follows:

*Ms* is the measurement result of the serving cell, not taking into account any offsets.

*Hys* is the hysteresis parameter for this event (i.e. *hysteresis* as defined within *reportConfigNR* for this event).

*Thresh* is the threshold parameter for this event (i.e. *a1-Threshold* as defined within *reportConfigNR* for this event).

*Ms* is expressed in dBm in case of RSRP, or in dB in case of RSRQ and RS-SINR.

*Hys* is expressed in dB.

*Thresh* is expressed in the same unit as *Ms*.

[TS 38.331, clause 5.5.5.1]



**Figure 5.5.5.1-1: Measurement reporting**

The purpose of this procedure is to transfer measurement results from the UE to the network. The UE shall initiate this procedure only after successful security activation.

For the *measId* for which the measurement reporting procedure was triggered, the UE shall set the *measResults* within the *MeasurementReport* message as follows:

- 1> set the *measId* to the measurement identity that triggered the measurement reporting;
- 1> set the *measResultServingCell* within *measResultServingMOList* to include RSRP, RSRQ and the available SINR for each configured serving cell derived based on the *rsType* indicated in the associated *reportConfig*;
- 1> set the *measResultServingCell* within *measResultServingMOList* to include for each NR serving cell that is configured, if any, the *servFreqId*;
- ...
- 1> increment the *numberOfReportsSent* as defined within the *VarMeasReportList* for this *measId* by 1;
- 1> stop the periodical reporting timer, if running;
- 1> if the *numberOfReportsSent* as defined within the *VarMeasReportList* for this *measId* is less than the *reportAmount* as defined within the corresponding *reportConfig* for this *measId*:
  - 2> start the periodical reporting timer with the value of *reportInterval* as defined within the corresponding *reportConfig* for this *measId*.
- 1> else:
  - 2> if the *reportType* is set to *periodical*:
    - 3> remove the entry within the *VarMeasReportList* for this *measId*;
    - 3> remove this *measId* from the *measIdList* within *VarMeasConfig*.
- 1> if the UE is configured with EN-DC:
  - 2> if SRB3 is configured:
    - 3> submit the *MeasurementReport* message via SRB3 to lower layers for transmission, upon which the procedure ends;
  - 2>else:

3> submit the *MeasurementReport* message via the EUTRA MCG embedded in E-UTRA RRC message *ULInformationTransferMRDC* as specified in TS 36.331 [10].

1> else:

2>submit the *MeasurementReport* message to lower layers for transmission, upon which the procedure ends.

#### 8.2.3.4.1.3 Test description

System Simulator:

- EUTRA Cell 1 is the PCell and NR Cell 1 is the PSCell.

UE:

- None

Preamble:

- The UE is in state RRC\_CONNECTED using generic procedure parameter Connectivity (*EN-DC*) and Bearers (*MCG(s) and SCG*) on E-UTRA Cell 1 according to TS 38.508-1 [4], clause 4.5.4.

#### 8.2.3.4.1.3.2 Test procedure sequence

Table 8.2.3.4.1.3.2-1 illustrates the downlink power levels to be applied for NR Cell 1 at various time instants of the test execution. Row marked "T0" denotes the conditions after the preamble, while rows marked "T1" and "T2" are to be applied subsequently. The exact instants on which these values shall be applied are described in the texts in this clause.

**Table 8.2.3.4.1.3.2-1: Time instances of cell power level and parameter changes**

	Parameter	Unit	E-UTRA Cell 1	NR Cell 1	Remark
T0	Cell-specific RS EPRE	dBm/15 kHz	-85	-	Power level is such that $M_s < Thresh + Hys$
	SS/PBCH SSS EPRE	dBm/15 kHz	-	[-91]	
T1	Cell-specific RS EPRE	dBm/15 kHz	-85	-	Power level is such that entry condition for event A1 is satisfied $M_s - Hys > Thresh$
	SS/PBCH SSS EPRE	dBm/15 kHz	-	[-79]	
T2	Cell-specific RS EPRE	dBm/15 kHz	-85	-	Power level is such that exit condition for event A1 is satisfied $M_s < Thresh + Hys$
	SS/PBCH SSS EPRE	dBm/15 kHz	-	[-91]	

Table 8.2.3.4.1.3.2-1: Main behaviour

St	Procedure	Message Sequence		TP	Verdict
		U - S	Message		
1	The SS transmits an <i>RRCConnectionReconfiguration</i> message including nr Config to setup intra NR measurement for NR Cell 1 and reporting for event A1	<--	<i>RRCConnectionReconfiguration</i>	-	-
2	Check: Does the UE transmit an <i>RRCConnectionReconfigurationComplete</i> message?	-->	<i>RRCConnectionReconfigurationComplete</i>	1	P
3	SS re-adjusts the cell-specific reference signal level according to row "T1" in table 8.2.3.4.1.3.2-1.	-	-	-	-
4	Check: Does the UE transmit a <i>MeasurementReport</i> encapsulated in <i>ULInformationTransferMRDC</i> message to report event A1 with the measured [Results] for NR Cell 1?	-->	<i>ULInformationTransferMRDC (MeasurementReport)</i>	1	P
-	EXCEPTION: Step 5 below is repeated until 3 <i>MeasurementReport</i> messages are received from the UE	-	-	-	-
5	Check: Does the UE transmit a <i>MeasurementReport</i> encapsulated in <i>ULInformationTransferMRDC</i> message, with the measured [Results] value for NR Cell 1?	-->	<i>ULInformationTransferMRDC (MeasurementReport)</i>	1	P
6	SS re-adjusts the cell-specific reference signal level according to row "T2" in table 8.2.3.4.1.3.2-1.	-	-	-	-
7	Wait and ignore <i>MeasurementReport</i> messages for 15 s to allow change of power levels for NR Cell 1 and UE measurement.	-	-	-	-
8	Check: Does the UE transmit a <i>MeasurementReport</i> encapsulated in <i>ULInformationTransferMRDC</i> message, with the measured [Results] value for NR Cell 1 within the next 10s?	-	<i>ULInformationTransferMRDC (MeasurementReport)</i>	2	F

8.2.3.4.1.3.3 Specific message contents

**Table 8.2.3.4.1.3.3-1: RRCConnectionReconfiguration (step 1, Table 8.2.3.4.1.3.2-2)**

Derivation Path: 36.508 [7], Table 4.6.1-8 with condition MCG_and_SCG			
Information Element	Value/remark	Comment	Condition
RRCConnectionReconfiguration ::= SEQUENCE {			
criticalExtensions CHOICE {			
c1 CHOICE {			
rrcConnectionReconfiguration-r8 ::= SEQUENCE			
{			
nonCriticalExtension SEQUENCE {			
nonCriticalExtension SEQUENCE {			
nonCriticalExtension SEQUENCE {			
nonCriticalExtension SEQUENCE {			
nonCriticalExtension SEQUENCE {			
nonCriticalExtension SEQUENCE {			
nonCriticalExtension SEQUENCE {			
nonCriticalExtension SEQUENCE {			
nr-Config-r15 CHOICE {			
setup SEQUENCE {			
nr-SecondaryCellGroupConfig-r15	OCTET STRING including the <i>RRCReconfiguration</i> message		
}			
}			
}			
}			
}			

**Table 8.2.3.4.1.3.3-2: RRCReconfiguration (Table 8.2.3.4.1.3.3-1)**

Derivation Path: TS 38.508-1 [4], Table [4.6.1-3]			
Information Element	Value/remark	Comment	Condition
RRCReconfiguration ::= SEQUENCE {			
rrc-TransactionIdentifier	RRC-TransactionIdentifier	Table [4.6.5-1].	
criticalExtensions CHOICE {			
c1 CHOICE {			
rrcReconfiguration ::= SEQUENCE {			
radioBearerConfig	Not present		
secondaryCellGroup	Not present		
measConfig	MeasConfig		
lateNonCriticalExtension	Not present		
nonCriticalExtension	Not present		
}			
}			
}			
}			



**Table 8.2.3.4.1.3.3-3: MeasConfig (Table 8.2.3.4.1.3.3-2)**

Derivation path: 38.508-1[4] Table 4.6.3-50			
Information Element	Value/Remark	Comment	Condition
measConfig ::= SEQUENCE {			
measObjectToAddModList SEQUENCE (SIZE (1..maxNrofObjectld)) OF SEQUENCE {	1 entry		
measObjectld[1]	MeasObjectld		
measObject CHOICE {			
measObjectNR[1]	MeasObjectNR-GENERIC(NRf1)		
}			
}			
reportConfigToAddModList SEQUENCE (SIZE (1..maxReportConfigld)) OF SEQUENCE {	1 entry		
reportConfigld[1]	ReportConfigld		
reportConfig[1]	ReportConfig-A1		
}			
measldToAddModList SEQUENCE (SIZE (1..maxNrofMeasld)) OF SEQUENCE {	1 entry		
measld[1]	Measld		
measObjectld[1]	MeasObjectld		
reportConfigld[1]	ReportConfigld		
}			
}			

**Table 8.2.3.4.1.3.3-4: MeasObjectNR-GENERIC(NRf1) (Table 8.2.3.4.1.3.3-3)**

Derivation Path: 38.508-1 [4], Table 4.6.3-56			
Information Element	Value/remark	Comment	Condition
MeasObjectNR-GENERIC(Freq) ::= SEQUENCE {			
ssbFrequency	Downlink carrier frequency of NR cell 1		
}			

**Table 8.2.3.4.1.3.3-5: ReportConfig-A1 (Table 8.2.3.4.1.3.3-3)**

Derivation Path: 38.508-1 [4], Table 4.6.3-107 with condition EVENT_A1			
Information Element	Value/remark	Comment	Condition
ReportConfigNR ::= SEQUENCE {			
reportType CHOICE {			
eventTriggered SEQUENCE {			
eventId CHOICE {			
eventA1 SEQUENCE {			
a1-Threshold CHOICE {			
rsrp	[51]		
}			
hysteresis	6	3dB	
}			
}			
reportAmount	Infinity		
}			
}			

**Table 8.2.3.4.1.3.3-6: RRCConnectionReconfigurationComplete (step 2, Table 8.2.3.4.1.3.2-2)**

Derivation Path: 36.508 [7], Table 4.6.1-9			
Information Element	Value/remark	Comment	Condition
RRCConnectionReconfigurationComplete ::= SEQUENCE {			
criticalExtensions CHOICE {			
rrcConnectionReconfigurationComplete-r8 SEQUENCE {			
nonCriticalExtension SEQUENCE {			
nonCriticalExtension SEQUENCE {			
nonCriticalExtension SEQUENCE {			
nonCriticalExtension SEQUENCE {			
nonCriticalExtension SEQUENCE {			
scg-ConfigResponseNR-r15	Present		
}			
}			
}			
}			
}			
}			
}			
}			

**Table 8.2.3.4.1.3.3-7: MeasurementReport (steps 4, 5, Table 8.2.3.4.1.3.2-2)**

Derivation Path: 38.508-1 [4], Table 4.6.1-2			
Information Element	Value/remark	Comment	Condition
MeasurementReport ::= SEQUENCE {			
criticalExtensions CHOICE {			
c1 CHOICE {			
measurementReport ::= SEQUENCE {			
measResults	(0..127)		
}			
}			
}			
}			

**8.2.3.5 Measurement configuration control and reporting / Event A2 / Measurement of NR PSCell**

**8.2.3.5.1 Measurement configuration control and reporting / Event A2 / Measurement of NR PSCell / EN-DC**

**8.2.3.5.1.1 Test Purpose (TP)**

(1)

```
with { UE in RRC_CONNECTED state in EN-DC mode and measurement configured for event A2 with event based periodical reporting }
ensure that {
  when { Serving NR cell becomes worse than absolute threshold minus hysteresis }
  then { UE sends MeasurementReport message at regular intervals while entering condition for event A2 is satisfied }
}
```

(2)

```
with { UE in RRC_CONNECTED state in EN-DC mode and periodical measurement reporting triggered by event A2 ongoing }
ensure that {
  when { Serving NR cell becomes better than absolute threshold plus hysteresis }
  then { UE stops sending MeasurementReport message }
```

}

### 8.2.3.5.1.2 Conformance requirements

References: The conformance requirements covered in the present TC are specified in: TS 36.331, clause 5.3.5.3, TS 38.331, clauses 5.3.5.3, 5.5.4.3. Unless otherwise stated these are Rel-15 requirements.

[TS 36.331, clause 5.3.5.3]

1> else:

2> if the *RRCCONNECTIONRECONFIGURATION* message includes the *radioResourceConfigDedicated*:

3> perform the radio resource configuration procedure as specified in 5.3.10;

NOTE 3: If the *RRCCONNECTIONRECONFIGURATION* message includes the establishment of radio bearers other than SRB1, the UE may start using these radio bearers immediately, i.e. there is no need to wait for an outstanding acknowledgment of the *SecurityModeComplete* message.

1> if the received *RRCCONNECTIONRECONFIGURATION* includes the *sCellToReleaseList*:

2> perform SCell release as specified in 5.3.10.3a;

1> if the received *RRCCONNECTIONRECONFIGURATION* includes the *sCellToAddModList*:

2> perform SCell addition or modification as specified in 5.3.10.3b;

1> if the received *RRCCONNECTIONRECONFIGURATION* includes the *scg-Configuration*; or

1> if the current UE configuration includes one or more split DRBs and the received *RRCCONNECTIONRECONFIGURATION* includes *radioResourceConfigDedicated* including *drb-ToAddModList*:

2> perform SCG reconfiguration as specified in 5.3.10.10;

1> if the received *RRCCONNECTIONRECONFIGURATION* includes the *systemInformationBlockType1Dedicated*:

2> perform the actions upon reception of the *SystemInformationBlockType1* message as specified in 5.2.2.7;

1> if the *RRCCONNECTIONRECONFIGURATION* message includes the *dedicatedInfoNASList*:

2> forward each element of the *dedicatedInfoNASList* to upper layers in the same order as listed;

1> if the *RRCCONNECTIONRECONFIGURATION* message includes the *measConfig*:

2> perform the measurement configuration procedure as specified in 5.5.2;

[TS 38.331, clause 5.3.5.3]

The UE shall perform the following actions upon reception of the *RRCRECONFIGURATION*:

**Editor's Note: For EN-DC, MCG configuration is not supported.**

1> if the received *RRCRECONFIGURATION* includes the *masterCellGroupConfig*:

2> perform the cell group configuration for the MCG according to 5.3.5.5.

**Editor's Note: For EN-DC, SCG release is not supported by *SecondaryCellGroupToReleaseList* (instead by field in 36.331). FFS how to capture**

1> if the received *RRCRECONFIGURATION* includes the *SecondaryCellGroupToReleaseList*:

2> perform the SCG release according to 5.3.5.4.

1> if the received *RRCRECONFIGURATION* includes the *secondaryCellGroup*:

2> perform the cell group configuration for the SCG according to 5.3.5.5.

1> if the *RRCRECONFIGURATION* message contains the *radioBearerConfig*:

2> perform the radio bearer configuration according to 5.3.5.6.

**Editor's Note:** *dedicatedInfoNASList* is not supported for EN-DC. FFS how to capture

1> if the *RRCReconfiguration* message includes the *dedicatedInfoNASList*:

2> forward each element of the *dedicatedInfoNASList* to upper layers in the same order as listed.

1> if the *RRCReconfiguration* message includes the *measConfig*:

2> perform the measurement configuration procedure as specified in 5.5.2.

**Editor's Note:** *otherConfig* is not supported for EN-DC. FFS how to capture

1> if the *RRCReconfiguration* message includes the *otherConfig*:

2> perform the other configuration procedure as specified in 5.3.10.9.

1> if the UE is operating in EN-DC mode (MCG is EUTRA):

2> if *RRCReconfiguration* was received via SRB1:

3> construct *RRCReconfigurationComplete* message and submit it via the EUTRA MCG as specified in TS 36.331 [10];

3> if *reconfigurationWithSync* was included in *spCellConfig* of an SCG:

4> initiate the random access procedure on the SpCell, as specified in TS 38.321 [3].

2> else (*RRCReconfiguration* was received via SRB3):

3> submit the *RRCReconfigurationComplete* message via SRB3 to lower layers for transmission using the new configuration.

[TS 38.331, clause 5.5.4.3]

The UE shall:

1> consider the entering condition for this event to be satisfied when condition A2-1, as specified below, is fulfilled;

1> consider the leaving condition for this event to be satisfied when condition A2-2, as specified below, is fulfilled;

1> for this measurement, consider the primary or secondary cell that is configured on the frequency indicated in the associated *measObjectNR* to be the serving cell;

Inequality A2-1 (Entering condition)

$$Ms + Hys < Thresh$$

Inequality A2-2 (Leaving condition)

$$Ms - Hys > Thresh$$

The variables in the formula are defined as follows:

***Ms*** is the measurement result of the serving cell, not taking into account any offsets.

***Hys*** is the hysteresis parameter for this event (i.e. *hysteresis* as defined within *reportConfigEUTRA* for this event).

***Thresh*** is the threshold parameter for this event (i.e. *a2-Threshold* as defined within *reportConfigEUTRA* for this event).

***Ms*** is expressed in dBm in case of RSRP, or in dB in case of RSRQ and RS-SINR.

***Hys*** is expressed in dB.

***Thresh*** is expressed in the same unit as ***Ms***.

8.2.3.5.1.3 Test description

8.2.3.5.1.3.1 Pre-test conditions

System Simulator:

- EUTRA Cell 1 is the PCell and NR Cell 1 is the PS Cell.

UE:

- None

Preamble:

- The UE is in state RRC\_CONNECTED using generic procedure parameter Connectivity (EN-DC) and DC Bearers (MCG and SCG) on E-UTRA Cell 1 according to TS 38.508-1, clause 4.5.4 [4].

8.2.3.5.1.3.2 Test procedure sequence

Table 8.2.3.5.1.3.2-1 illustrates the downlink power levels to be applied for NR Cell 1 at various time instants of the test execution. Row marked "T0" denotes the conditions after the preamble, while rows marked "T1" and "T2" are to be applied subsequently. The exact instants on which these values shall be applied are described in the texts in this clause.

**Table 8.2.3.5.1.3.2-1: Power levels**

	Parameter	Unit	EUTRA Cell 1	NR Cell 1	Remark
T0	Cell-specific RS EPRE	dBm/15 kHz	-85	-	
	SS/PBCH SSS EPRE	dBm/15 kHz	-	[-79]	Power level is such that $M_s > Thresh + Hys$
T1	Cell-specific RS EPRE	dBm/15 kHz	-85	-	
	SS/PBCH SSS EPRE	dBm/15 kHz	-	[-95]	Power level is such that entry condition for event A2 is satisfied $M_s + Hys < Thresh$
T2	Cell-specific RS EPRE	dBm/15 kHz	-85	-	
	SS/PBCH SSS EPRE	dBm/15 kHz	-	[-79]	Power level is such that exit condition for event A2 is satisfied $M_s > Thresh + Hys$

Table 8.2.3.5.1.3.2-2: Main behaviour

St	Procedure	Message Sequence		TP	Verdict
		U - S	Message		
1	The SS transmits an <i>RRConnectionReconfiguration</i> message including <i>measConfig</i> to setup intra NR measurement for PSCell and reporting for event A2	<--	<i>RRConnectionReconfiguration</i>	-	-
2	Check: Does the UE transmit an <i>RRConnectionReconfigurationComplete</i> message?	-->	<i>RRConnectionReconfigurationComplete</i>	1	P
3	SS re-adjusts the cell-specific reference signal level according to row "T1" in table 8.3.2.5.3.2-1.	-	-	-	-
4	Check: Does the UE transmit a <i>ULInformationTransferMRDC</i> message containing NR <i>MeasurementReport</i> message to report event A2 with the measured [Results] for NR Cell 1?	-->	<i>ULInformationTransferMRDC (MeasurementReport)</i>	1	P
-	EXCEPTION: Step 5 below is repeated until 3 <i>MeasurementReport</i> messages are received from the UE	-	-	-	-
5	Check: Does the UE transmit a <i>ULInformationTransferMRDC</i> message containing NR <i>MeasurementReport</i> message, with the measured [Results] value for NR Cell 1?	-->	<i>ULInformationTransferMRDC (MeasurementReport)</i>	1	P
6	SS re-adjusts the cell-specific reference signal level according to row "T2" in table 8.3.2.5.3.2-1.	-	-	-	-
7	Wait and ignore <i>MeasurementReport</i> messages for 15 s to allow change of power levels for NR Cell 1 and UE measurement.	-	-	-	-
8	Check: Does the UE attempt to transmit an uplink message within the next 10s?	-	-	2	F

8.2.3.5.1.3.3 Specific message contents

**Table 8.2.3.5.1.3.3-1: RRCConnectionReconfiguration (step 1, Table 8.2.3.5.1.3.2-2)**

Derivation Path: 36.508 [7], Table 4.6.1-8 with condition MCG_and_SCG			
Information Element	Value/remark	Comment	Condition
RRCConnectionReconfiguration ::= SEQUENCE {			
criticalExtensions CHOICE {			
c1 CHOICE {			
rrcConnectionReconfiguration-r8 ::= SEQUENCE			
{			
nonCriticalExtension SEQUENCE {			
nonCriticalExtension SEQUENCE {			
nonCriticalExtension SEQUENCE {			
nonCriticalExtension SEQUENCE {			
nonCriticalExtension SEQUENCE {			
nonCriticalExtension SEQUENCE {			
nonCriticalExtension SEQUENCE {			
nonCriticalExtension SEQUENCE {			
nr-Config-r15 CHOICE {			
setup SEQUENCE {			
nr-SecondaryCellGroupConfig-r15	OCTET STRING including the <i>RRCReconfiguration</i> message and the IE measConfig		
}			
}			
}			
}			
}			
}			
}			
}			
}			
}			
}			
}			

**Table 8.2.3.5.1.3.3-2: RRCReconfiguration (Table 8.2.3.5.1.3.3-1)**

Derivation Path: 38.508-1 [4], Table 4.6.1-3 with condition MEAS

**Table 8.2.3.5.1.3.3-3: MeasConfig (Table 8.2.3.5.1.3.3-2)**

Derivation Path: 38.508-1 [4], Table 4.6.3-50			
Information Element	Value/remark	Comment	Condition
MeasConfig ::= SEQUENCE {			
measObjectToAddModList	1 entry		
reportConfigToAddModList	1 entry		
measIdToAddModList	1 entry		
}			

**Table 8.2.3.5.1.3.3-4: MeasIdToAddModList (Table 8.2.3.5.1.3.3-3)**

Derivation Path: 38.508-1 [4], Table 4.6.3-50			
Information Element	Value/remark	Comment	Condition
MeasConfig ::= SEQUENCE {			
measObjectToAddModList	MeasObjectToAddModList		
reportConfigToAddModList	ReportConfig-A2		
measIdToAddModList	MeasIdToAddModList		
}			

**Table 8.2.3.5.1.3.3-5: MeasObjectToAddModList**

Derivation Path: 38.508-1 [4], Table 4.6.3-57			
Information Element	Value/remark	Comment	Condition
MeasObjectToAddModList ::= SEQUENCE (SIZE (1..maxNrofMeasId)) OF SEQUENCE {	1 entry		
measObjectId[1]	1		
measObject CHOICE {			
measObjectNR	MeasObjectNR-f1		
}			
}			

**Table 8.2.3.5.1.3.3-6: MeasObjectNR-f1**

Information Element	Value/remark	Comment	Condition
MeasObjectNR-GENERIC(Freq) ::= SEQUENCE {			
carrierFreq-r15	Downlink carrier frequency of NR cell 1		
}			

**Table 8.2.3.5.1.3.3-4: ReportConfig-A2 (Table 8.2.3.5.1.3.3-3)**

Derivation Path: 38.508-1 [4], Table 4.6.3-107 with condition EVENT_A2			
Information Element	Value/remark	Comment	Condition
ReportConfigNR ::= SEQUENCE {			
reportType CHOICE {			
eventTriggered SEQUENCE {			
eventId CHOICE {			
eventA2 SEQUENCE {			
a2-Threshold CHOICE {			
rsrp	[60]		
}			
hysteresis	6	3dB	
}			
}			
}			
}			
}			



**Table 8.2.3.5.1.3.3-3: MeasConfig (Table 8.2.3.5.1.3.3-2)**

Derivation path: 38.508-1[4], Table 4.6.3-50			
Information Element	Value/Remark	Comment	Condition
measConfig ::= SEQUENCE {			
measObjectToAddModList SEQUENCE (SIZE (1..maxNrofObjectId)) OF SEQUENCE {	1 entry		
measObjectId[1]	IdMeasObject-f1		
measObject CHOICE {			
measObjectNR[1]	MeasObjectNR-GENERIC(f1)		
}			
}			
reportConfigToAddModList SEQUENCE (SIZE (1..maxReportConfigId)) OF SEQUENCE {	1 entry		
reportConfigId[1]	IdReportConfig-A2		
reportConfig[1]	ReportConfig-A2-H		
}			
measIdToAddModList SEQUENCE (SIZE (1..maxMeasId)) OF SEQUENCE {	1 entry		
measId[1]	1		
measObjectId[1]	IdMeasObject-f1		
reportConfigId[1]	IdReportConfig-A2		
}			
}			

**Table 8.2.3.5.1.3.3-4: RRCConnectionReconfigurationComplete (step 2, Table 8.2.3.5.1.3.2-2)**

Derivation Path: 36.508 [7], Table 4.6.1-9			
Information Element	Value/remark	Comment	Condition
RRCConnectionReconfigurationComplete ::= SEQUENCE {			
criticalExtensions CHOICE {			
rrcConnectionReconfigurationComplete-r8 SEQUENCE {			
nonCriticalExtension SEQUENCE {			
nonCriticalExtension SEQUENCE {			
nonCriticalExtension SEQUENCE {			
nonCriticalExtension SEQUENCE {			
nonCriticalExtension SEQUENCE {			
scg-ConfigResponseNR-r15	Present		
}			
}			
}			
}			
}			
}			
}			
}			

Table 8.2.3.5.1.3.3-5: MeasurementReport (steps 4, 5, Table 8.2.3.5.1.3.2-2)

Derivation Path: TS 38.331 [6], clause 6.2.2			
Information Element	Value/remark	Comment	Condition
MeasurementReport ::= SEQUENCE {			
criticalExtensions CHOICE {			
c1 CHOICE {			
measurementReport ::= SEQUENCE {			
measResults SEQUENCE {			
measId			
measResultServingFreqList SEQUENCE {	1 entry		
servFreqId			
measResultServingCell SEQUENCE :			
physCellId	Physical CellID of the NR Cell 1		
cgi-Info	Not present		
measResult SEQUENCE {			
cellResults SEQUENCE {			
resultsSSB-Cell SEQUENCE {			
rsrp	Not checked		
rsrq	Not checked		
sinr	Not checked		
}			
}			
}			
}			
}			
}			
}			
}			
}			

### 8.2.3.6 Measurement configuration control and reporting / Event A3 (intra-frequency, inter-frequency and inter-band measurements) / Measurement of Neighbour NR cells

#### 8.2.3.6.1 Measurement configuration control and reporting / Event A3 (intra-frequency, inter-frequency and inter-band measurements) / Measurement of Neighbour NR cells / EN-DC

##### 8.2.3.6.1.1 Test Purpose (TP)

(1)

```
with { UE in RRC_CONNECTED state with EN-DC, and, MCG (E-UTRA PDCP) and SCG and measurements
configured for event A3 }
ensure that {
  when { Entry condition for event A3 is not met for neighbour NR cell }
  then { UE does not send MeasurementReport }
}
```

(2)

```
with { UE in RRC_CONNECTED state with EN-DC, and, MCG (E-UTRA PDCP) and SCG and measurements
configured for event A3 }
ensure that {
  when { Neighbour NR cell becomes offset better than serving NR PSCell }
  then { UE sends MeasurementReport with correct measId for event A3 }
}
```

##### 8.2.3.6.1.2 Conformance requirements

References: The conformance requirements covered in the present TC are specified in: TS 36.331, clause 5.3.5.3, TS 38.331, clauses 5.3.5.3, 5.5.2, 5.5.4.1, 5.5.4.4 and 5.5.5. Unless otherwise stated these are Rel-15 requirements.

[TS 36.331, clause 5.3.5.3]

If the *RRCCONNECTIONRECONFIGURATION* message does not include the *mobilityControlInfo* and the UE is able to comply with the configuration included in this message, the UE shall:

- 1> if the *RRCCONNECTIONRECONFIGURATION* message includes the *measConfig*:
  - 2> perform the measurement configuration procedure as specified in 5.5.2;
- 1> set the content of *RRCCONNECTIONRECONFIGURATIONCOMPLETE* message as follows:
  - 2> if the received *RRCCONNECTIONRECONFIGURATION* message included *nr-SecondaryCellGroupConfig*:
    - 3> include *scg-ConfigResponseNR* in accordance with TS 38.331 [82, 5.3.5.3];
- 1> submit the *RRCCONNECTIONRECONFIGURATIONCOMPLETE* message to lower layers for transmission using the new configuration, upon which the procedure ends;

[TS 38.331, clause 5.3.5.3]

The UE shall perform the following actions upon reception of the *RRCRECONFIGURATION*:

- 1> if the UE is configured with E-UTRA *nr-SecondaryCellGroupConfig* (MCG is E-UTRA):
  - 2> if *RRCRECONFIGURATION* was received via SRB1:
    - 3> construct *RRCRECONFIGURATIONCOMPLETE* message and submit it via the EUTRA MCG embedded in E-UTRA RRC message *RRCCONNECTIONRECONFIGURATIONCOMPLETE* as specified in TS 36.331 [10];
  - 3> if *reconfigurationWithSync* was included in *spCellConfig* of an SCG:
    - 4> initiate the random access procedure on the SpCell, as specified in TS 38.321 [3];

[TS 38.331, clause 5.5.2]

The UE shall:

- 1> if the received *measConfig* includes the *measObjectToAddModList*:
  - 2> perform the measurement object addition/modification procedure as specified in 5.5.2.5;
- 1> if the received *measConfig* includes the *reportConfigToAddModList*:
  - 2> perform the reporting configuration addition/modification procedure as specified in 5.5.2.7;
- 1> if the received *measConfig* includes the *measIdToAddModList*:
  - 2> perform the measurement identity addition/modification procedure as specified in 5.5.2.3;

[TS 38.331, clause 5.5.4.1]

If security has been activated successfully, the UE shall:

- 1> for each *measId* included in the *measIdList* within *VarMeasConfig*:
  - 2> if the corresponding *reportConfig* includes a *reportType* set to *eventTriggered* or *periodical*;
    - 3> if the corresponding *measObject* concerns NR;
      - 4> else:
        - 5> for events involving a serving cell on one frequency and neighbours on another frequency, consider any serving cell on the other frequency to be a neighbouring cell as well;
  - 2> if *reportType* is set to *periodical* and if a (first) measurement result is available:
    - 3> include a measurement reporting entry within the *VarMeasReportList* for this *measId*;
    - 3> set the *numberOfReportsSent* defined within the *VarMeasReportList* for this *measId* to 0;

- 4> if the *reportAmount* exceeds 1:
  - 5> initiate the measurement reporting procedure, as specified in 5.5.5, immediately after the quantity to be reported becomes available for the NR SpCell;
- 4> else (i.e. the *reportAmount* is equal to 1):
  - 5> initiate the measurement reporting procedure, as specified in 5.5.5, immediately after the quantity to be reported becomes available for the NR SpCell and for the strongest cell among the applicable cells;
- 2> upon expiry of the periodical reporting timer for this *measId*:
  - 3> initiate the measurement reporting procedure, as specified in 5.5.5.

[TS 38.331, clause 5.5.4.4]

The UE shall:

- 1> consider the entering condition for this event to be satisfied when condition A3-1, as specified below, is fulfilled;
- 1> consider the leaving condition for this event to be satisfied when condition A3-2, as specified below, is fulfilled;
- 1> use the PSCell for *Mp*, *Ofp* and *Ocp*.

NOTE The cell(s) that triggers the event is on the frequency indicated in the associated *measObjectNR* which may be different from the frequency used by the NR SpCell.

Inequality A3-1 (Entering condition)

$$Mn + Ofn + Ocn - Hys > Mp + Ofp + Ocp + Off$$

Inequality A3-2 (Leaving condition)

$$Mn + Ofn + Ocn + Hys < Mp + Ofp + Ocp + Off$$

The variables in the formula are defined as follows:

***Mn*** is the measurement result of the neighbouring cell, not taking into account any offsets.

***Ofn*** is the frequency specific offset of the frequency of the neighbour cell (i.e. *offsetFreq* as defined within *measObjectNR* corresponding to the frequency of the neighbour cell).

***Ocn*** is the cell specific offset of the neighbour cell (i.e. *cellIndividualOffset* as defined within *measObjectNR* corresponding to the frequency of the neighbour cell), and set to zero if not configured for the neighbour cell.

***Mp*** is the measurement result of the SpCell, not taking into account any offsets.

***Ofp*** is the frequency specific offset of the frequency of the SpCell (i.e. *offsetFreq* as defined within *measObjectNR* corresponding to the frequency of the SpCell).

***Ocp*** is the cell specific offset of the SpCell (i.e. *cellIndividualOffset* as defined within *measObjectNR* corresponding to the frequency of the SpCell), and is set to zero if not configured for the SpCell.

***Hys*** is the hysteresis parameter for this event (i.e. *hysteresis* as defined within *reportConfigNR* for this event).

***Off*** is the offset parameter for this event (i.e. *a3-Offset* as defined within *reportConfigNR* for this event).

***Mn*, *Mp*** are expressed in dBm in case of RSRP, or in dB in case of RSRQ and RS-SINR.

***Ofn*, *Ocn*, *Ofp*, *Ocp*, *Hys*, *Off*** are expressed in dB.

[TS 38.331, clause 5.5.5]

For the *measId* for which the measurement reporting procedure was triggered, the UE shall set the *measResults* within the *MeasurementReport* message as follows:

- 1> set the *measId* to the measurement identity that triggered the measurement reporting;

- 1> set the *measResultServingCell* within *measResultServingFreqList* to include RSRP, RSRQ and the available SINR for each configured serving cell derived based on the *rsType* indicated in the associated *reportConfig*;
- 1> set the *measResultServingCell* within *measResultServingFreqList* to include for each NR serving cell that is configured, if any, the *servFreqId*;
- 1> if the *reportConfig* associated with the *measId* that triggered the measurement reporting includes *reportQuantityRsIndexes* and *maxNrofRSIndexesToReport*:
  - 2> for each configured serving cell, include beam measurement information according to the associated *reportConfig* as described in 5.5.5.2;
- 1> if the *reportConfig* associated with the *measId* that triggered the measurement reporting includes *reportAddNeighMeas*:
  - 2>for each serving frequency for which *measObjectId* is referenced in the *measIdList*, other than the frequency corresponding with the *measId* that triggered the measurement reporting:
    - 3> set the *measResultBestNeighCell* within *measResultServingFreqList* to include the *physCellId* and the available measurement quantities based on the *reportQuantityCell* and *rsType* indicated in *reportConfig* of the non-serving cell on the concerned serving frequency with the highest measured RSRP if RSRP measurement results are available for cells on this frequency, otherwise with the highest measured RSRQ if RSRQ measurement results are available for cells on this frequency, otherwise with the highest measured SINR;
    - 3> if the *reportConfig* associated with the *measId* that triggered the measurement reporting includes *reportQuantityRsIndexes* and *maxNrofRSIndexesToReport*:
      - 4> for each best non-serving cell included in the measurement report:
        - 5>include beam measurement information according to the associated *reportConfig* as described in 5.5.5.2;
- 1> if there is at least one applicable neighbouring cell to report:
  - 2> set the *measResultNeighCells* to include the best neighbouring cells up to *maxReportCells* in accordance with the following:
    - 3> if the *reportType* is set to *eventTriggered*:
      - 4> include the cells included in the *cellsTriggeredList* as defined within the *VarMeasReportList* for this *measId*;
    - 3> else:
      - 4> include the applicable cells for which the new measurement results became available since the last periodical reporting or since the measurement was initiated or reset;
      - 4> if *reportQuantityRsIndexes* and *maxNrofRSIndexesToReport* are configured, include beam measurement information as described in 5.5.5.2;
  - 3> for each cell that is included in the *measResultNeighCells*, include the *physCellId*;
  - 3> if the *reportType* is set to *eventTriggered*:
    - 4> for each included cell, include the layer 3 filtered measured results in accordance with the *reportConfig* for this *measId*, ordered as follows:
      - 5> if the *measObject* associated with this *measId* concerns NR:
        - 6> if *rsType* in the associated *reportConfig* is set to *ssb*:
          - 7> set *resultsSSB-Cell* within the *measResult* to include the SS/PBCH block based quantity(ies) indicated in the *reportQuantityCell* within the concerned *reportConfig*, in order of decreasing trigger quantity, i.e. the best cell is included first;

- 8> if *reportQuantityRsIndexes* and *maxNrofRSIndexesToReport* are configured, include beam measurement information as described in 5.5.5.2;
- 6> else if *rsType* in the associated *reportConfig* is set to *csi-rs*:
  - 7> set *resultsCSI-RS-Cell* within the *measResult* to include the CSI-RS based quantity(ies) indicated in the *reportQuantityCell* within the concerned *reportConfig*, in order of decreasing trigger quantity, i.e. the best cell is included first:
    - 8> if *reportQuantityRsIndexes* and *maxNrofRSIndexesToReport* are, include beam measurement information as described in 5.5.5.2;
- 1> increment the *numberOfReportsSent* as defined within the *VarMeasReportList* for this *measId* by 1;
- 1> stop the periodical reporting timer, if running;
- 1> if the *numberOfReportsSent* as defined within the *VarMeasReportList* for this *measId* is less than the *reportAmount* as defined within the corresponding *reportConfig* for this *measId*:
  - 2> start the periodical reporting timer with the value of *reportInterval* as defined within the corresponding *reportConfig* for this *measId*;
- 1> else:
  - 2> if the *reportType* is set to *periodical*:
    - 3> remove the entry within the *VarMeasReportList* for this *measId*;
    - 3> remove this *measId* from the *measIdList* within *VarMeasConfig*;
- 1> if the UE is configured with EN-DC:
  - 2> if SRB3 is configured:
    - 3> submit the *MeasurementReport* message via SRB3 to lower layers for transmission, upon which the procedure ends;
  - 2>else:
    - 3> submit the *MeasurementReport* message via the EUTRA MCG embedded in E-UTRA RRC message *ULInformationTransferMRDC* as specified in TS 36.331 [10].
- 1> else:
  - 2>submit the *MeasurementReport* message to lower layers for transmission, upon which the procedure ends.

### 8.2.3.6.1.3 Test description

#### 8.2.3.6.1.3.1 Pre-test conditions

#### System Simulator:

- EUTRA Cell 1 is the PCell and NR Cell 1 is the PS Cell.
- NR Cell 2 is the intra-frequency neighbour cell.
- NR Cell 3 is the inter-frequency neighbour cell.
- NR Cell 10 is the inter-band neighbour cell.
- System information combination [xx] as defined in TS 38.508-1 [4] clause [xx] is used in E-UTRA Cell 1, NR Cell 1, NR Cell 2, NR Cell 3 and NR Cell 10.

#### UE:

- None

Preamble:

- The UE is in state RRC\_CONNECTED in EN-DC mode according to TS 38.508-1 [4].

#### 8.2.3.6.1.3.2 Test procedure sequence

Table 8.2.3.6.1.3.2-1 illustrates the downlink power levels to be applied for NR Cell 1, NR Cell 2, NR Cell 3 and NR Cell 10 at various time instants of the test execution. Row marked "T0" denotes the conditions after the preamble, while rows marked "T1", "T2" and "T3" are to be applied subsequently. The exact instants on which these values shall be applied are described in the texts in this clause.

**Table 8.2.3.6.1.3.2-1: Power levels**

	Parameter	Unit	EUTRA Cell 1	NR Cell 1	NR Cell 2	NR Cell 3	NR Cell 10	Remark
T0	Cell-specific RS EPRE	dBm/15 kHz	-85	-	-	-	-	Power levels are such that entry condition for event A3 is not satisfied for any of the neighbour NR cells:
	FFS	FFS	-	[FFS]	[FFS]	[FFS]	[FFS]	$Mn + Ofn + Ocn - Hys > Mp + Ofp + Ocp + Off$
T1	Cell-specific RS EPRE	dBm/15 kHz	-85	-	-	-	-	Power levels are such that entry condition for event A3 is satisfied for intra-frequency neighbour NR cell ( <i>measId 1</i> ):
	FFS	FFS	-	[FFS]	[FFS]	[FFS]	[FFS]	$Mn + Ofn + Ocn - Hys > Ms + OfS + Ocs + Off$
T2	Cell-specific RS EPRE	dBm/15 kHz	-85	-	-	-	-	Power levels are such that entry condition for event A3 is satisfied for inter-frequency neighbour NR cell ( <i>measId 2</i> ):
	FFS	FFS		[FFS]	[FFS]	[FFS]	[FFS]	$Mn + Ofn + Ocn - Hys > Ms + OfS + Ocs + Off$
T3	Cell-specific RS EPRE	dBm/15 kHz	-85	-	-	-	-	Power levels are such that entry condition for event A3 is satisfied for inter-band neighbour NR cell ( <i>measId 3</i> ):
	FFS	FFS	-	[FFS]	[FFS]	[FFS]	[FFS]	$Mn + Ofn + Ocn - Hys > Ms + OfS + Ocs + Off$

Table 8.2.3.6.1.3.2-2: Main behaviour

St	Procedure	Message Sequence		TP	Verdict
		U - S	Message		
1	The SS transmits an <i>RRCConnectionReconfiguration</i> message containing NR <i>RRCReconfiguration</i> to setup measurements for neighbour NR Cells and reporting for event A3	<--	<i>RRCConnectionReconfiguration</i> ( <i>RRCReconfiguration</i> )	-	-
2	Check: Does the UE transmit an <i>RRCConnectionReconfigurationComplete</i> message containing NR <i>RRCReconfigurationComplete</i> message?	-->	<i>RRCConnectionReconfigurationComplete</i> ( <i>RRCReconfigurationComplete</i> )	-	-
3	Check: Does the UE transmit an <i>ULInformationTransferMRDC</i> message containing NR <i>MeasurementReport</i> message within the next 10s to report event A3?	-->	<i>ULInformationTransferMRDC</i> ( <i>MeasurementReport</i> )	1	F
4	The SS re-adjusts the cell-specific reference signal level according to row "T1" in Table 8.3.2.6.1.3.2-1.	-	-	-	-
5	Check: Does the UE transmit an <i>ULInformationTransferMRDC</i> message containing NR <i>MeasurementReport</i> message to report event A3 ( <i>measId 1</i> ) with the measured value for NR Cell 2?	-->	<i>ULInformationTransferMRDC</i> ( <i>MeasurementReport</i> )	2	P
6	The SS re-adjusts the cell-specific reference signal level according to row "T2" in Table 8.3.2.6.1.3.2-1.	-	-	-	-
7	Check: Does the UE transmit an <i>ULInformationTransferMRDC</i> message containing NR <i>MeasurementReport</i> message to report event A3 ( <i>measId 2</i> ) with the measured value for NR Cell 3?	-->	<i>ULInformationTransferMRDC</i> ( <i>MeasurementReport</i> )	2	P
-	EXCEPTION: Steps 8a1-8a2 are executed if UE supports more than one NR band.	-	-	-	-
8a1	The SS re-adjusts the cell-specific reference signal level according to row "T3" in Table 8.3.2.6.1.3.2-1.	-	-	-	-
8a2	Check: Does the UE transmit an <i>ULInformationTransferMRDC</i> message containing NR <i>MeasurementReport</i> message to report event A3 ( <i>measId 3</i> ) with the measured value for NR Cell 10?	-->	<i>ULInformationTransferMRDC</i> ( <i>MeasurementReport</i> )	2	P



8.2.3.6.1.3.3 Specific message contents

**Table 8.2.3.6.1.3.3-1: RRCConnectionReconfiguration (step 1, Table 8.2.3.6.1.3.2-2)**

Derivation Path: 36.508 [7], Table 4.6.1-8 with condition MCG_and_SCG			
Information Element	Value/remark	Comment	Condition
RRCConnectionReconfiguration ::= SEQUENCE {			
criticalExtensions CHOICE {			
c1 CHOICE{			
rrcConnectionReconfiguration-r8 ::= SEQUENCE			
{			
nonCriticalExtension SEQUENCE {			
nonCriticalExtension SEQUENCE {			
nonCriticalExtension SEQUENCE {			
nonCriticalExtension SEQUENCE {			
nonCriticalExtension SEQUENCE {			
nonCriticalExtension SEQUENCE {			
nonCriticalExtension SEQUENCE {			
nonCriticalExtension SEQUENCE {			
nr-Config-r15 CHOICE {			
setup SEQUENCE {			
nr-SecondaryCellGroupConfig-r15	RRCReconfiguration-MEAS		
}			
}			
}			
}			
}			
}			
}			
}			
}			
}			
}			
}			

**Table 8.2.3.6.1.3.3-2: RRCReconfiguration-MEAS (Table 8.2.3.6.1.3.3-1)**

Derivation Path: 38.508-1 [4], Table 4.6.1-3			
Information Element	Value/remark	Comment	Condition
RRCReconfiguration ::= SEQUENCE {			
criticalExtensions CHOICE {			
rrcReconfiguration SEQUENCE {			
radioBearerConfig	Not Present		
secondaryCellGroup	Not Present		
measConfig	MeasConfig-A3		
}			
}			

Table 8.2.3.6.1.3.3-3: *MeasConfig-A3* (Table 8.2.3.6.1.3.3-2)

Derivation Path: 38.508-1 [4], Table 4.6.3-50			
Information Element	Value/remark	Comment	Condition
MeasConfig ::= SEQUENCE {			
measObjectToAddModList	MeasObjectNRAddMod		
ReportConfigToAddModList	Same as TS 38.508-1 Table 4.6.3-107 except for reportAmount set to 'r1'. Hystersis value should be set to 'FFS'		EVENT_A3
MeasIdToAddModList ::= SEQUENCE (SIZE (1..maxNrofMeasId)) OF SEQUENCE {	[3 entries]		
measId[1]	1		
measObjectId[1]	[1]		
reportConfigId[1]	1		
measId[2]	2		
measObjectId[2]	[2]		
reportConfigId[2]	1		
measId[3]	3		
measObjectId[3]	[3]		
reportConfigId[3]	1		
}			
}			

Table 8.2.3.6.1.3.3-4: *MeasObjectNRAddMod* (Table 8.2.3.6.1.3.3-3)

Derivation Path: 38.508-1 [4], Table 4.6.3-56			
Information Element	Value/remark	Comment	Condition
measObjectToAddModList ::= SEQUENCE (SIZE (1..maxNrofObjectId)) OF SEQUENCE {	[3 entries]		
measObjectId[1]	[1]		
measObject CHOICE {			
measObjectNR	Same as TS 38.508-1 Table 4.6.3-56 except for ssbFrequency IE equals the ARFCN for NR Cell 2		
}			
measObjectId[2]	[2]		
measObject CHOICE {			
measObjectNR	Same as TS 38.508-1 Table 4.6.3-56 except for ssbFrequency IE equals the ARFCN for NR Cell 3		
}			
measObjectId[3]	[3]		
measObject CHOICE {			
measObjectNR	Same as TS 38.508-1 Table 4.6.3-56 except for ssbFrequency IE equals the ARFCN for NR Cell 10		
}			
}			

**Table 8.2.3.6.1.3.3-5: RRCConnectionReconfigurationComplete (step 2, Table 8.2.3.6.1.3.2-2)**

Derivation Path: 36.508 [7], Table 4.6.1-9			
Information Element	Value/remark	Comment	Condition
RRCConnectionReconfigurationComplete ::= SEQUENCE {			
criticalExtensions CHOICE {			
rrcConnectionReconfigurationComplete-r8 SEQUENCE {			
nonCriticalExtension SEQUENCE {			
nonCriticalExtension SEQUENCE {			
nonCriticalExtension SEQUENCE {			
nonCriticalExtension SEQUENCE {			
nonCriticalExtension SEQUENCE {			
scg-ConfigResponseNR-r15	OCTET STRING including the RRCReconfigurationComplete message according to TS 38.508-1 [4], table 4.6.1-4		
}			
}			
}			
}			
}			
}			
}			
}			

**Table 8.2.3.6.1.3.3-6: ULInformationTransferMRDC (step 5, Table 8.2.3.6.1.3.2-2)**

Derivation Path: 36.508 [7], Table 4.6.1-27			
Information Element	Value/remark	Comment	Condition
ULInformationTransferMRDC ::= SEQUENCE {			
ul-DCCH-MessageNR-r15	OCTET STRING including the MeasurementReport message according to Table 8.2.3.6.1.3.3-7		
}			

**Table 8.2.3.8.1.3.3-7: MeasurementReport (Table 8.2.3.6.1.3.3-6)**

Derivation Path: 38.508-1 [4], Table 4.6.1-2			
Information Element	Value/remark	Comment	Condition
measurementReport ::= SEQUENCE {			
measResults ::= SEQUENCE {			
measId	1		
measResultServingMOList ::= SEQUENCE (SIZE (1..maxNrofServingCells)) {		Report NR Cell 1	
servCellId	Cell index corresponding to NR Cell 1		
measResultServingCell ::= SEQUENCE {			
physCellId	Phy cell id corresponding to NR Cell 1		
measResult SEQUENCE {			
cellResults SEQUENCE{			
resultsSSB-Cell ::= SEQUENCE {			
Rsrp	(0..127)		
Rsrq	(0..127)		
Sinr	(0..127)		
}			
}			
}			
measResultNeighCells ::= SEQUENCE (SIZE (1..maxCellReport)) {	1 entry	Report NR Cell 2	
measResultListNR ::= SEQUENCE {			
physCellId	Phy cell id corresponding to NR Cell 2		
measResult SEQUENCE {			
cellResults SEQUENCE{			
resultsSSB-Cell ::= SEQUENCE {			
Rsrp	(0..127)		
Rsrq	(0..127)		
Sinr	(0..127)		
}			
}			
}			
}			
}			

**Table 8.2.3.6.1.3.3-8: ULInformationTransferMRDC (step 7, Table 8.2.3.6.1.3.2-2)**

Derivation Path: 36.508 [7], Table 4.6.1-27			
Information Element	Value/remark	Comment	Condition
ULInformationTransferMRDC ::= SEQUENCE {			
ul-DCCH-MessageNR-r15	OCTET STRING including the MeasurementReport message according to Table 8.2.3.6.1.3.3-9		
}			

**Table 8.2.3.6.1.3.3-9: MeasurementReport (Table 8.2.3.6.1.3.3-8)**

Derivation Path: 38.508-1 [4], Table 4.6.1-2			
Information Element	Value/remark	Comment	Condition
measurementReport ::= SEQUENCE {			
measResults ::= SEQUENCE {			
measId	2		
measResultServingMOList ::= SEQUENCE (SIZE (1..maxNrofServingCells)) {		Report NR Cell 1	
servCellId	Cell index corresponding to NR Cell 1		
measResultServingCell ::= SEQUENCE {			
physCellId	Phy cell id corresponding to NR Cell 1		
measResult SEQUENCE {			
cellResults SEQUENCE{			
resultsSSB-Cell ::= SEQUENCE {			
Rsrp	(0..127)		
Rsrq	(0..127)		
Sinr	(0..127)		
}			
}			
}			
}			
measResultNeighCells ::= SEQUENCE (SIZE (1..maxCellReport)) {	1 entry	Report NR Cell 3	
measResultListNR ::= SEQUENCE {			
physCellId	Phy cell id corresponding to NR Cell 3		
measResult SEQUENCE {			
cellResults SEQUENCE{			
resultsSSB-Cell ::= SEQUENCE {			
Rsrp	(0..127)		
Rsrq	(0..127)		
Sinr	(0..127)		
}			
}			
}			
}			
}			

**Table 8.2.3.6.1.3.3-10: ULInformationTransferMRDC (step 8a2, Table 8.2.3.6.1.3.2-2)**

Derivation Path: 36.508 [7], Table 4.6.1-27			
Information Element	Value/remark	Comment	Condition
ULInformationTransferMRDC ::= SEQUENCE {			
ul-DCCH-MessageNR-r15	OCTET STRING including the MeasurementReport message according to Table 8.2.3.6.1.3.3-11		
}			

**Table 8.2.3.6.1.3.3-11: MeasurementReport (Table 8.2.3.6.1.3.3-10)**

Derivation Path: 38.508-1 [4], Table 4.6.1-2			
Information Element	Value/remark	Comment	Condition
measurementReport ::= SEQUENCE {			
measResults ::= SEQUENCE {			
measId	3		
measResultServingMOList ::= SEQUENCE (SIZE (1..maxNrofServingCells)) {		Report NR Cell 1	
servCellId	Cell index corresponding to NR Cell 1		
measResultServingCell ::= SEQUENCE {			
physCellId	Phy cell id corresponding to NR Cell 1		
measResult SEQUENCE {			
cellResults SEQUENCE{			
resultsSSB-Cell ::= SEQUENCE {			
Rsrp	(0..127)		
Rsrq	(0..127)		
Sinr	(0..127)		
}			
}			
}			
measResultNeighCells ::= SEQUENCE (SIZE (1..maxCellReport)) {	1 entry	Report NR Cell 10	
measResultListNR ::= SEQUENCE {			
physCellId	Phy cell id corresponding to NR Cell 10		
measResult SEQUENCE {			
cellResults SEQUENCE{			
resultsSSB-Cell ::= SEQUENCE {			
Rsrp	(0..127)		
Rsrq	(0..127)		
Sinr	(0..127)		
}			
}			
}			
}			
}			

**8.2.3.7 Measurement configuration control and reporting / Event A4 (intra-frequency, inter-frequency and inter-band measurements) / Measurement of Neighbour NR cell**

**8.2.3.7.1 Measurement configuration control and reporting / Event A4 (intra-frequency, inter-frequency and inter-band measurements) / Measurement of Neighbour NR cell / EN-DC**

**8.2.3.7.1.1 Test Purpose (TP)**

(1)

```

with { UE in RRC_CONNECTED state with EN-DC and measurement configured for event A4 with event based
periodical reporting }
ensure that {
  when { Neighbour NR cell becomes better than absolute threshold }
  then { UE sends MeasurementReport message at regular intervals while entering condition for
event A4 is satisfied }
}

```

(2)

```

with { UE in RRC_CONNECTED state with EN-DC and periodical measurement reporting triggered by event
A4 ongoing }
ensure that {
  when { Neighbour NR cell becomes worse than absolute threshold }
  then { UE stops sending MeasurementReport message }
}

```

### 8.2.3.7.1.2 Conformance requirements

References: The conformance requirements covered in the current TC are specified in: TS 36.331, clause 5.3.5.3, and TS 38.331, clause 5.3.5.3, 5.5.2.1, 5.5.4.1, 5.5.4.5 and 5.5.5.1. Unless otherwise stated these are Rel-15 requirements.

[TS 36.331, clause 5.3.5.3]

If the *RRCConnectionReconfiguration* message does not include the *mobilityControlInfo* and the UE is able to comply with the configuration included in this message, the UE shall:

...

1> if the received *RRCConnectionReconfiguration* includes the *nr-SecondaryCellGroupConfig*:

2> perform NR RRC Reconfiguration as specified in TS 38.331 [82, 5.3.5.3];

...

1> set the content of *RRCConnectionReconfigurationComplete* message as follows:

...

2> if the received *RRCConnectionReconfiguration* message included *nr-SecondaryCellGroupConfig*:

3> include *scg-ConfigResponseNR* in accordance with TS 38.331 [82, 5.3.5.3];

1> submit the *RRCConnectionReconfigurationComplete* message to lower layers for transmission using the new configuration, upon which the procedure ends;

[TS 38.331, clause 5.3.5.3]

The UE shall perform the following actions upon reception of the *RRCReconfiguration*:

1> if the *RRCReconfiguration* includes the *secondaryCellGroup*:

2> perform the cell group configuration for the SCG according to 5.3.5.5;

...1> if the *RRCReconfiguration* message includes the *measConfig*:

2> perform the measurement configuration procedure as specified in 5.5.2;

1> if the UE is configured with E-UTRA *nr-SecondaryCellGroupConfig* (MCG is E-UTRA):

2> if *RRCReconfiguration* was received via SRB1:

3> construct *RRCReconfigurationComplete* message and submit it via the EUTRA MCG embedded in E-UTRA RRC message *RRCConnectionReconfigurationComplete* as specified in TS 36.331 [10];

[TS 38.331, clause 5.5.2.1]

The network applies the procedure as follows:

- to ensure that, whenever the UE has a *measConfig*, it includes a *measObject* for each NR serving frequency.

**Editor's Note: FFS How the procedure is used for CGI reporting.**

The UE shall:

...

- 1> if the received *measConfig* includes the *measObjectToAddModList*:
  - 2> perform the measurement object addition/modification procedure as specified in 5.5.2.5;
  - ...
- 1> if the received *measConfig* includes the *reportConfigToAddModList*:
  - 2> perform the reporting configuration addition/modification procedure as specified in 5.5.2.7;
  - ...
- 1> if the received *measConfig* includes the *measIdToAddModList*:
  - 2> perform the measurement identity addition/modification procedure as specified in 5.5.2.3;
- 1> if the received *measConfig* includes the *measGapConfig*:
  - 2> perform the measurement gap configuration procedure as specified in 5.5.2.9;

[TS 38.331, clause 5.5.4.1]

If security has been activated successfully, the UE shall:

- 1> for each *measId* included in the *measIdList* within *VarMeasConfig*:
  - 2> if the corresponding *reportConfig* includes a *reportType* set to *eventTriggered* or *periodical*;
    - 3> if the corresponding *measObject* concerns NR;
      - 4> if the *eventA1* or *eventA2* is configured in the corresponding *reportConfig*:
        - 5> consider only the serving cell to be applicable;
      - 4> else:
        - 5> for events involving a serving cell on one frequency and neighbours on another frequency, consider any serving cell on the other frequency to be a neighbouring cell as well;
        - 5> if *useWhiteCellList* is set to TRUE:
          - 6> consider any neighbouring cell detected on the associated frequency to be applicable when the concerned cell is included in the *whiteCellsToAddModList* defined within the *VarMeasConfig* for this *measId*;
        - 5> else:
          - 6> consider any neighbouring cell detected on the associated frequency to be applicable when the concerned cell is not included in the *blackCellsToAddModList* defined within the *VarMeasConfig* for this *measId*;
  - 2> if the *reportType* is set to *eventTriggered* and if the entry condition applicable for this event, i.e. the event corresponding with the *eventId* of the corresponding *reportConfig* within *VarMeasConfig*, is fulfilled for one or more applicable cells for all measurements after layer 3 filtering taken during *timeToTrigger* defined for this event within the *VarMeasConfig*, while the *VarMeasReportList* does not include a measurement reporting entry for this *measId* (a first cell triggers the event):
    - 3> include a measurement reporting entry within the *VarMeasReportList* for this *measId*;
    - 3> set the *numberOfReportsSent* defined within the *VarMeasReportList* for this *measId* to 0;
    - 3> include the concerned cell(s) in the *cellsTriggeredList* defined within the *VarMeasReportList* for this *measId*;
    - 3> initiate the measurement reporting procedure, as specified in 5.5.5;
  - 2> if the *reportType* is set to *eventTriggered* and if the entry condition applicable for this event, i.e. the event corresponding with the *eventId* of the corresponding *reportConfig* within *VarMeasConfig*, is fulfilled for one



or more applicable cells not included in the *cellsTriggeredList* for all measurements after layer 3 filtering taken during *timeToTrigger* defined for this event within the *VarMeasConfig* (a subsequent cell triggers the event):

- 3> set the *numberOfReportsSent* defined within the *VarMeasReportList* for this *measId* to 0;
- 3> include the concerned cell(s) in the *cellsTriggeredList* defined within the *VarMeasReportList* for this *measId*;
- 3> initiate the measurement reporting procedure, as specified in 5.5.5;
- 2> if the *reportType* is set to *eventTriggered* and if the leaving condition applicable for this event is fulfilled for one or more of the cells included in the *cellsTriggeredList* defined within the *VarMeasReportList* for this *measId* for all measurements after layer 3 filtering taken during *timeToTrigger* defined within the *VarMeasConfig* for this event:
  - 3> remove the concerned cell(s) in the *cellsTriggeredList* defined within the *VarMeasReportList* for this *measId*;
  - 3> if *reportOnLeave* is set to *TRUE* for the corresponding reporting configuration:
    - 4> initiate the measurement reporting procedure, as specified in 5.5.5;
  - 3> if the *cellsTriggeredList* defined within the *VarMeasReportList* for this *measId* is empty:
    - 4> remove the measurement reporting entry within the *VarMeasReportList* for this *measId*;
    - 4> stop the periodical reporting timer for this *measId*, if running;
- 2> if *reportType* is set to *periodical* and if a (first) measurement result is available:
  - 3> include a measurement reporting entry within the *VarMeasReportList* for this *measId*;
  - 3> set the *numberOfReportsSent* defined within the *VarMeasReportList* for this *measId* to 0;
    - 4> if the *reportAmount* exceeds 1:
      - 5> initiate the measurement reporting procedure, as specified in 5.5.5, immediately after the quantity to be reported becomes available for the NR SpCell;
    - 4> else (i.e. the *reportAmount* is equal to 1):
      - 5> initiate the measurement reporting procedure, as specified in 5.5.5, immediately after the quantity to be reported becomes available for the NR SpCell and for the strongest cell among the applicable cells;
- 2> upon expiry of the periodical reporting timer for this *measId*:
  - 3> initiate the measurement reporting procedure, as specified in 5.5.5

[TS 38.331, clause 5.5.4.5]

The UE shall:

- 1> consider the entering condition for this event to be satisfied when condition A4-1, as specified below, is fulfilled;
- 1> consider the leaving condition for this event to be satisfied when condition A4-2, as specified below, is fulfilled.

Inequality A4-1 (Entering condition)

$$Mn + Ofn + Ocn - Hys > Thresh$$

Inequality A4-2 (Leaving condition)

$$Mn + Ofn + Ocn + Hys < Thresh$$

The variables in the formula are defined as follows:

**Mn** is the measurement result of the neighbouring cell, not taking into account any offsets.

**Ofn** is the frequency specific offset of the frequency of the neighbour cell (i.e. *offsetFreq* as defined within *measObjectNR* corresponding to the frequency of the neighbour cell).

**Ocn** is the cell specific offset of the neighbour cell (i.e. *cellIndividualOffset* as defined within *measObjectNR* corresponding to the frequency of the neighbour cell), and set to zero if not configured for the neighbour cell.

**Hys** is the hysteresis parameter for this event (i.e. *hysteresis* as defined within *reportConfigNR* for this event).

**Thresh** is the threshold parameter for this event (i.e. *a4-Threshold* as defined within *reportConfigNR* for this event).

**Mn** is expressed in dBm in case of RSRP, or in dB in case of RSRQ and RS-SINR.

**Ofn, Ocn, Hys** are expressed in dB.

**Thresh** is expressed in the same unit as **Mn**.

[TS 38.331, clause 5.5.5.1]

The purpose of this procedure is to transfer measurement results from the UE to the network. The UE shall initiate this procedure only after successful security activation.

For the *measId* for which the measurement reporting procedure was triggered, the UE shall set the *measResults* within the *MeasurementReport* message as follows:

- 1> set the *measId* to the measurement identity that triggered the measurement reporting;
- 1> set the *measResultServingCell* within *measResultServingFreqList* to include RSRP, RSRQ and the available SINR for each configured serving cell derived based on the *rsType* indicated in the associated *reportConfig*;
- 1> set the *measResultServingCell* within *measResultServingFreqList* to include for each NR serving cell that is configured, if any, the *servFreqId*;
- 1> if the *reportConfig* associated with the *measId* that triggered the measurement reporting includes *reportQuantityRsIndexes* and *maxNrofRSIndexesToReport*:
  - 2> for each configured serving cell, include beam measurement information according to the associated *reportConfig* as described in 5.5.5.2;
- 1> if the *reportConfig* associated with the *measId* that triggered the measurement reporting includes *reportAddNeighMeas*:
  - 2> for each serving frequency for which *measObjectId* is referenced in the *measIdList*, other than the frequency corresponding with the *measId* that triggered the measurement reporting:
    - 3> set the *measResultBestNeighCell* within *measResultServingFreqList* to include the *physCellId* and the available measurement quantities based on the *reportQuantityCell* and *rsType* indicated in *reportConfig* of the non-serving cell on the concerned serving frequency with the highest measured RSRP if RSRP measurement results are available for cells on this frequency, otherwise with the highest measured RSRQ if RSRQ measurement results are available for cells on this frequency, otherwise with the highest measured SINR;
    - 3> if the *reportConfig* associated with the *measId* that triggered the measurement reporting includes *reportQuantityRsIndexes* and *maxNrofRSIndexesToReport*:
      - 4> for each best non-serving cell included in the measurement report
        - 5> include beam measurement information according to the associated *reportConfig* as described in 5.5.5.2;
- 1> if there is at least one applicable neighbouring cell to report:
  - 2> set the *measResultNeighCells* to include the best neighbouring cells up to *maxReportCells* in accordance with the following:
    - 3> if the *reportType* is set to *eventTriggered*:

- 4> include the cells included in the *cellsTriggeredList* as defined within the *VarMeasReportList* for this *measId*;
- 3> else:
  - 4> include the applicable cells for which the new measurement results became available since the last periodical reporting or since the measurement was initiated or reset;
  - 4> if *reportQuantityRsIndexes* and *maxNrofRSIndexesToReport* are configured, include beam measurement information as described in 5.5.5.2;
- 3> for each cell that is included in the *measResultNeighCells*, include the *physCellId*;
- 3> if the *reportType* is set to *eventTriggered*:
  - 4> for each included cell, include the layer 3 filtered measured results in accordance with the *reportConfig* for this *measId*, ordered as follows:
    - 5> if the *measObject* associated with this *measId* concerns NR:
      - 6> if *rsType* in the associated *reportConfig* is set to *ssb*:
        - 7> set *resultsSSB-Cell* within the *measResult* to include the SS/PBCH block based quantity(ies) indicated in the *reportQuantityCell* within the concerned *reportConfig*, in order of decreasing trigger quantity, i.e. the best cell is included first;
        - 8> if *reportQuantityRsIndexes* and *maxNrofRSIndexesToReport* are configured, include beam measurement information as described in 5.5.5.2;
      - 6> else if *rsType* in the associated *reportConfig* is set to *csi-rs*:
        - 7> set *resultsCSI RS-Cell* within the *measResult* to include the CSI-RS based quantity(ies) indicated in the *reportQuantityCell* within the concerned *reportConfig*, in order of decreasing trigger quantity, i.e. the best cell is included first;
        - 8> if *reportQuantityRsIndexes* and *maxNrofRSIndexesToReport* are, include beam measurement information as described in 5.5.5.2;
- 1> increment the *numberOfReportsSent* as defined within the *VarMeasReportList* for this *measId* by 1;
- 1> stop the periodical reporting timer, if running;
- 1> if the *numberOfReportsSent* as defined within the *VarMeasReportList* for this *measId* is less than the *reportAmount* as defined within the corresponding *reportConfig* for this *measId*:
  - 2> start the periodical reporting timer with the value of *reportInterval* as defined within the corresponding *reportConfig* for this *measId*;
- 1> else:
  - 2> if the *reportType* is set to *periodical*:
    - 3> remove the entry within the *VarMeasReportList* for this *measId*;
    - 3> remove this *measId* from the *measIdList* within *VarMeasConfig*;
- 1> if the UE is configured with EN-DC:
  - 2> if SRB3 is configured:
    - 3> submit the *MeasurementReport* message via SRB3 to lower layers for transmission, upon which the procedure ends;
  - 2>else:
    - 3> submit the *MeasurementReport* message via the EUTRA MCG embedded in E-UTRA RRC message *ULInformationTransferMRDC* as specified in TS 36.331 [10];

## 8.2.3.7.1.3 Test description

## 8.2.3.7.1.3.1 Pre-test conditions

## System Simulator:

- E-UTRA Cell 1 is the PCell and NR Cell 1 is the PSCell
- NR Cell 2 is the intra-frequency neighbour cell of NR Cell 1.
- NR Cell 3 is the inter-frequency neighbour cell of NR Cell 1.
- NR Cell 10 is the inter-band neighbour cell of NR Cell 1

## UE:

- None

## Preamble:

- The UE is in state RRC\_CONNECTED using generic procedure parameter Connectivity (EN-DC) and DC Bearers (MCG and SCG) on E-UTRA Cell 1 according to TS 38.508-1 [4], clause 4.5.4.

## 8.2.3.7.1.3.2 Test procedure sequence

Table 8.2.3.7.1.3.2-1 illustrates the downlink power levels to be applied for NR Cell 2, NR Cell 3 and NR Cell 10 at various time instants of the test execution. Row marked "T0" denotes the conditions after the preamble, while rows marked "T1", "T2", "T3", "T4", "T5" and "T6" are to be applied subsequently. The exact instants on which these values shall be applied are described in the texts in this clause.

**Table 8.2.3.7.1.3.2-1: Time instances of cell power level and parameter changes**

	Parameter	Unit	NR Cell 2	NR Cell 3	NR Cell 10	Remark
T0	FFS	FFS	Off	Off	Off	The power level values are such that entry condition for event A4 is not satisfied
T1	FFS	FFS	FFS	Off	Off	The power level values are such that entry condition for event A4 is satisfied for intra-frequency neighbour NR Cell 2
T2	FFS	FFS	FFS	Off	Off	The power level values are such that entry conditions for event A4 is not satisfied for intra-frequency neighbour NR Cell 2
T3	FFS	FFS	Off	FFS	Off	The power level values are such that entry condition for event A4 is satisfied for inter-frequency neighbour NR Cell 3
T4	FFS	FFS	Off	FFS	Off	The power level values are such that entry conditions for event A4 is not satisfied for inter-frequency neighbour NR Cell 3
T5	FFS	FFS	Off	Off	FFS	The power level values are such that entry condition for event A4 is satisfied for inter-band neighbour NR Cell 10
T6	FFS	FFS	Off	Off	FFS	The power level values are such that entry conditions for event A4 is not satisfied for inter-band neighbour NR Cell 10

**Table 8.2.3.7.1.3.2-2: Main behaviour**

St	Procedure	Message Sequence		TP	Verdict
		U - S	Message		
1	The SS transmits an <i>RRCConnectionReconfiguration</i> message containing NR <i>RRCReconfiguration</i> message to setup NR measurement and reporting of event A4.	<--	<i>RRCConnectionReconfiguration (RRCReconfiguration)</i>	-	-
2	Check: Does the UE transmit an <i>RRCConnectionReconfigurationComplete</i> message containing NR <i>RRCReconfigurationComplete</i> message?	-->	<i>RRCConnectionReconfigurationComplete (RRCReconfigurationComplete)</i>	-	-
3	The SS re-adjusts the cell-specific reference signal level according to row "T1" in Table 8.2.3.7.1.3.2-1.	-	-	-	-
4	Check: Does the UE transmit <i>ULInformationTransferMRDC</i> message containing NR <i>MeasurementReport</i> message to report event A4 with the measured Results for NR Cell 2?	-->	<i>ULInformationTransferMRDC (MeasurementReport)</i>	1	P
-	EXCEPTION: Step 5 below is repeated until 3 <i>MeasurementReport</i> messages are received from the UE	-	-	-	-
5	Check: Does the UE transmit <i>ULInformationTransferMRDC</i> message containing NR <i>MeasurementReport</i> message to report event A4 with the measured Results for NR Cell 2?	-->	<i>ULInformationTransferMRDC (MeasurementReport)</i>	1	P
6	The SS re-adjusts the cell-specific reference signal level according to row "T2" in Table 8.2.3.7.1.3.2-1.	-	-	-	-
7	Wait and ignore <i>MeasurementReport</i> messages for 15 s to allow change of power levels for NR Cell 2 and UE measurement.	-	-	-	-
8	Check: Does the UE attempt to transmit an uplink message within the next 10s?	-	-	2	F
9	The SS re-adjusts the cell-specific reference signal level according to row "T3" in Table 8.2.3.7.1.3.2-1.	-	-	-	-
10	Check: Does the UE transmit <i>ULInformationTransferMRDC</i> message containing NR <i>MeasurementReport</i> message to report event A4 with the measured Results for NR Cell 3?	-->	<i>ULInformationTransferMRDC (MeasurementReport)</i>	1	P
-	EXCEPTION: Step 11 below is repeated until 3 <i>MeasurementReport</i> messages are received from the UE	-	-	-	-
11	Check: Does the UE transmit <i>ULInformationTransferMRDC</i> message containing NR <i>MeasurementReport</i> message to report event A4 with the measured Results for NR Cell 3?	-->	<i>ULInformationTransferMRDC (MeasurementReport)</i>	1	P
12	The SS re-adjusts the cell-specific reference signal level according to row "T4" in Table 8.2.3.7.1.3.2-1.	-	-	-	-
13	Wait and ignore <i>MeasurementReport</i> messages for 15 s to allow change of power levels for NR Cell 3 and UE measurement.	-	-	-	-
14	Check: Does the UE attempt to transmit an uplink message within the next 10s?	-	-	2	F
-	EXCEPTION: Steps 15 to 20 below are executed if UE supports more than one NR band	-	-	-	-
15	The SS re-adjusts the cell-specific reference signal level according to row "T5" in Table 8.2.3.7.1.3.2-1.	-	-	-	-

16	Check: Does the UE transmit ULInformationTransferMRDC message containing NR MeasurementReport message to report event A4 with the measured Results for NR Cell 10?	-->	ULInformationTransferMRDC (MeasurementReport)	1	P
-	EXCEPTION: Step 17 below is repeated until 3 MeasurementReport messages are received from the UE	-	-	-	-
17	Check: Does the UE transmit ULInformationTransferMRDC message containing NR MeasurementReport message to report event A4 with the measured Results for NR Cell 10?	-->	ULInformationTransferMRDC (MeasurementReport)	1	P
18	The SS re-adjusts the cell-specific reference signal level according to row "T6" in Table 8.2.3.7.1.3.2-1.	-	-	-	-
19	Wait and ignore MeasurementReport messages for 15 s to allow change of power levels for NR Cell 10 and UE measurement.	-	-	-	-
20	Check: Does the UE attempt to transmit an uplink message within the next 10s?	-	-	2	F

8.2.3.7.1.3.3 Specific message contents

**Table 8.2.3.7.1.3.3-1: RRCConnectionReconfiguration (step 1, Table 8.2.3.7.1.3.2-2)**

Derivation Path: 36.508 [7], Table 4.6.1-8 with condition MCG_and_SCG			
Information Element	Value/remark	Comment	Condition
RRCConnectionReconfiguration ::= SEQUENCE {			
criticalExtensions CHOICE {			
c1 CHOICE {			
rrcConnectionReconfiguration-r8 ::= SEQUENCE {			
nonCriticalExtension SEQUENCE {			
nonCriticalExtension SEQUENCE {			
nonCriticalExtension SEQUENCE {			
nonCriticalExtension SEQUENCE {			
nonCriticalExtension SEQUENCE {			
nonCriticalExtension SEQUENCE {			
nr-Config-r15 CHOICE {			
setup SEQUENCE {			
nr-SecondaryCellGroupConfig-r15	RRCReconfiguration-MEAS		
}			
}			
}			
}			
}			
}			
}			
}			
}			
}			
}			

**Table 8.2.3.7.1.3.3-2: RRCReconfiguration-MEAS (Table 8.2.3.7.1.3.3-1)**

Derivation Path: 38.508-1 [4], Table 4.6.1-3			
Information Element	Value/remark	Comment	Condition
RRCReconfiguration ::= SEQUENCE {			
criticalExtensions CHOICE {			
rrcReconfiguration SEQUENCE {			
radioBearerConfig	Not Present		
secondaryCellGroup	Not Present		
measConfig	MeasConfig-A4		
}			
}			
}			

**Table 8.2.3.7.1.3.3-3: MeasConfig-A4 (Table 8.2.3.7.1.3.3-2)**

Derivation Path: 38.508-1 [4], Table 4.6.3-12			
Information Element	Value/remark	Comment	Condition
MeasConfig ::= SEQUENCE {			
FFS		Inter-band measurement configuration is included only if UE supports more than one NR band	
}			

**Table 8.2.3.7.1.3.3-4: RRCConnectionReconfigurationComplete (step 2, Table 8.2.3.7.1.3.2-2)**

Derivation Path: 36.508 [7], Table 4.6.1-9			
Information Element	Value/remark	Comment	Condition
RRCConnectionReconfigurationComplete ::= SEQUENCE {			
criticalExtensions CHOICE {			
rrcConnectionReconfigurationComplete-r8 SEQUENCE {			
nonCriticalExtension SEQUENCE {			
nonCriticalExtension SEQUENCE {			
nonCriticalExtension SEQUENCE {			
nonCriticalExtension SEQUENCE {			
nonCriticalExtension SEQUENCE {			
scg-ConfigResponseNR-r15	Present		
}			
}			
}			
}			
}			
}			

**Table 8.2.3.7.1.3.3-5: ULInformationTransferMRDC (steps 4, 5, Table 8.2.3.7.1.3.2-2)**

Derivation Path: 36.508 [7], Table FFS			
Information Element	Value/remark	Comment	Condition
ULInformationTransferMRDC ::= SEQUENCE {			
FFS			
}			



**Table 8.2.3.7.1.3.3-6: ULInformationTransferMRDC (steps 10, 11, Table 8.2.3.7.1.3.2-2)**

Derivation Path: 36.508 [7], Table FFS			
Information Element	Value/remark	Comment	Condition
ULInformationTransferMRDC ::= SEQUENCE {			
FFS			
}			

**Table 8.2.3.7.1.3.3-7: ULInformationTransferMRDC (step 16 and 17, Table 8.2.3.7.1.3.2-2)**

Derivation Path: 36.508 [7], Table FFS			
Information Element	Value/remark	Comment	Condition
ULInformationTransferMRDC ::= SEQUENCE {			
FFS			
}			

### 8.2.3.8 Measurement configuration control and reporting / Event A5 (intra-frequency, inter-frequency and inter-band measurements) / Measurement of Neighbour NR cell

#### 8.2.3.8.1 Measurement configuration control and reporting / Event A5 (intra-frequency, inter-frequency and inter-band measurements) / Measurement of Neighbour NR cell / EN-DC

##### 8.2.3.8.1.1 Test Purpose (TP)

(1)

```
with { UE in RRC_CONNECTED state with EN-DC, and, MCG (E-UTRA PDCP) and SCG and measurement
configured for event A5 with event based periodical reporting }
ensure that {
  when { Serving NR PSCell becomes worse than absolute threshold1 and neighbour NR cell becomes
better than absolute threshold2 }
  then { UE sends MeasurementReport message at regular intervals while entering conditions for
event A5 are satisfied }
}
```

(2)

```
with { UE in RRC_CONNECTED state with EN-DC, and, MCG (E-UTRA PDCP) and SCG and periodical
measurement reporting triggered by event A5 ongoing }
ensure that {
  when { Serving NR PSCell becomes better than absolute threshold1 or neighbour NR cell becomes
worse than absolute threshold2 }
  then { UE stops sending MeasurementReport message }
}
```

##### 8.2.3.8.1.2 Conformance requirements

References: The conformance requirements covered in the present TC are specified in: TS 36.331, clause 5.3.5.3, TS 38.331, clauses 5.3.5.3, 5.5.2, 5.5.4.1 and 5.5.4.6. **Unless otherwise stated these are Rel-15 requirements.**

[TS 36.331, clause 5.3.5.3]

If the *RRCCONNECTIONRECONFIGURATION* message does not include the *mobilityControlInfo* and the UE is able to comply with the configuration included in this message, the UE shall:

- 1> if the *RRCCONNECTIONRECONFIGURATION* message includes the *measConfig*:
  - 2> perform the measurement configuration procedure as specified in 5.5.2;
- 1> set the content of *RRCCONNECTIONRECONFIGURATIONCOMPLETE* message as follows:
  - 2> if the received *RRCCONNECTIONRECONFIGURATION* message included *nr-SecondaryCellGroupConfig*:

3> include *scg-ConfigResponseNR* in accordance with TS 38.331 [82, 5.3.5.3];

1> submit the *RRCConnectionReconfigurationComplete* message to lower layers for transmission using the new configuration, upon which the procedure ends;

[TS 38.331, clause 5.3.5.3]

The UE shall perform the following actions upon reception of the *RRCReconfiguration*:

1> if the UE is configured with E-UTRA *nr-SecondaryCellGroupConfig* (MCG is E-UTRA):

2> if *RRCReconfiguration* was received via SRB1:

3> construct *RRCReconfigurationComplete* message and submit it via the EUTRA MCG embedded in E-UTRA RRC message *RRCConnectionReconfigurationComplete* as specified in TS 36.331 [10];

3> if *reconfigurationWithSync* was included in *spCellConfig* of an SCG:

4> initiate the random access procedure on the SpCell, as specified in TS 38.321 [3];

[TS 38.331, clause 5.5.2]

The UE shall:

1> if the received *measConfig* includes the *measObjectToAddModList*:

2> perform the measurement object addition/modification procedure as specified in 5.5.2.5;

1> if the received *measConfig* includes the *reportConfigToAddModList*:

2> perform the reporting configuration addition/modification procedure as specified in 5.5.2.7;

1> if the received *measConfig* includes the *measIdToAddModList*:

2> perform the measurement identity addition/modification procedure as specified in 5.5.2.3;

[TS 38.331, clause 5.5.4.1]

If security has been activated successfully, the UE shall:

1> for each *measId* included in the *measIdList* within *VarMeasConfig*:

2> if the corresponding *reportConfig* includes a *reportType* set to *eventTriggered* or *periodical*;

3> if the corresponding *measObject* concerns NR;

4> else:

5> for events involving a serving cell on one frequency and neighbours on another frequency, consider any serving cell on the other frequency to be a neighbouring cell as well;

2> if *reportType* is set to *periodical* and if a (first) measurement result is available:

3> include a measurement reporting entry within the *VarMeasReportList* for this *measId*;

3> set the *numberOfReportsSent* defined within the *VarMeasReportList* for this *measId* to 0;

4> if the *reportAmount* exceeds 1:

5> initiate the measurement reporting procedure, as specified in 5.5.5, immediately after the quantity to be reported becomes available for the NR SpCell;

4> else (i.e. the *reportAmount* is equal to 1):

5> initiate the measurement reporting procedure, as specified in 5.5.5, immediately after the quantity to be reported becomes available for the NR SpCell and for the strongest cell among the applicable cells;

2> upon expiry of the periodical reporting timer for this *measId*:

3> initiate the measurement reporting procedure, as specified in 5.5.5.

[TS 38.331, clause 5.5.4.6]

The UE shall:

1> consider the entering condition for this event to be satisfied when both condition A5-1 and condition A5-2, as specified below, are fulfilled;

1> consider the leaving condition for this event to be satisfied when condition A5-3 or condition A5-4, i.e. at least one of the two, as specified below, is fulfilled;

1> use the PSCell for *Mp*.

NOTE: The cell(s) that triggers the event is on the frequency indicated in the associated *measObjectNR* which may be different from the frequency used by the NR SpCell.

Inequality A5-1 (Entering condition 1)

$$M_p + H_{ys} < Thresh1$$

Inequality A5-2 (Entering condition 2)

$$M_n + Ofn + Ocn - H_{ys} > Thresh2$$

Inequality A5-3 (Leaving condition 1)

$$M_p - H_{ys} > Thresh1$$

Inequality A5-4 (Leaving condition 2)

$$M_n + Ofn + Ocn + H_{ys} < Thresh2$$

The variables in the formula are defined as follows:

*Mp* is the measurement result of the NR SpCell, not taking into account any offsets.

*Mn* is the measurement result of the neighbouring cell, not taking into account any offsets.

*Ofn* is the frequency specific offset of the frequency of the neighbour cell (i.e. *offsetFreq* as defined within *measObjectNR* corresponding to the frequency of the neighbour cell).

*Ocn* is the cell specific offset of the neighbour cell (i.e. *cellIndividualOffset* as defined within *measObjectNR* corresponding to the frequency of the neighbour cell), and set to zero if not configured for the neighbour cell.

*Hys* is the hysteresis parameter for this event (i.e. *hysteresis* as defined within *reportConfigNR* for this event).

*Thresh1* is the threshold parameter for this event (i.e. *a5-Threshold1* as defined within *reportConfigNR* for this event).

*Thresh2* is the threshold parameter for this event (i.e. *a5-Threshold2* as defined within *reportConfigNR* for this event).

*Mn*, *Mp* are expressed in dBm in case of RSRP, or in dB in case of RSRQ and RS-SINR.

*Ofn*, *Ocn*, *Hys* are expressed in dB.

*Thresh1* is expressed in the same unit as *Mp*.

*Thresh2* is expressed in the same unit as *Mn*.

[TS 38.331, clause 5.5.5]

For the *measId* for which the measurement reporting procedure was triggered, the UE shall set the *measResults* within the *MeasurementReport* message as follows:

- 1> set the *measId* to the measurement identity that triggered the measurement reporting;
- 1> set the *measResultServingCell* within *measResultServingFreqList* to include RSRP, RSRQ and the available SINR for each configured serving cell derived based on the *rsType* indicated in the associated *reportConfig*;
- 1> set the *measResultServingCell* within *measResultServingFreqList* to include for each NR serving cell that is configured, if any, the *servFreqId*;
- 1> if the *reportConfig* associated with the *measId* that triggered the measurement reporting includes *reportQuantityRsIndexes* and *maxNrofRSIndexesToReport*:
  - 2> for each configured serving cell, include beam measurement information according to the associated *reportConfig* as described in 5.5.5.2;
- 1> if the *reportConfig* associated with the *measId* that triggered the measurement reporting includes *reportAddNeighMeas*:
  - 2> for each serving frequency for which *measObjectId* is referenced in the *measIdList*, other than the frequency corresponding with the *measId* that triggered the measurement reporting:
    - 3> set the *measResultBestNeighCell* within *measResultServingFreqList* to include the *physCellId* and the available measurement quantities based on the *reportQuantityCell* and *rsType* indicated in *reportConfig* of the non-serving cell on the concerned serving frequency with the highest measured RSRP if RSRP measurement results are available for cells on this frequency, otherwise with the highest measured RSRQ if RSRQ measurement results are available for cells on this frequency, otherwise with the highest measured SINR;
    - 3> if the *reportConfig* associated with the *measId* that triggered the measurement reporting includes *reportQuantityRsIndexes* and *maxNrofRSIndexesToReport*:
      - 4> for each best non-serving cell included in the measurement report:
        - 5> include beam measurement information according to the associated *reportConfig* as described in 5.5.5.2;
- 1> if there is at least one applicable neighbouring cell to report:
  - 2> set the *measResultNeighCells* to include the best neighbouring cells up to *maxReportCells* in accordance with the following:
    - 3> if the *reportType* is set to *eventTriggered*:
      - 4> include the cells included in the *cellsTriggeredList* as defined within the *VarMeasReportList* for this *measId*;
    - 3> else:
      - 4> include the applicable cells for which the new measurement results became available since the last periodical reporting or since the measurement was initiated or reset;
      - 4> if *reportQuantityRsIndexes* and *maxNrofRSIndexesToReport* are configured, include beam measurement information as described in 5.5.5.2;
    - 3> for each cell that is included in the *measResultNeighCells*, include the *physCellId*;
    - 3> if the *reportType* is set to *eventTriggered*:
      - 4> for each included cell, include the layer 3 filtered measured results in accordance with the *reportConfig* for this *measId*, ordered as follows:
        - 5> if the *measObject* associated with this *measId* concerns NR:
          - 6> if *rsType* in the associated *reportConfig* is set to *ssb*:
            - 7> set *resultsSSB-Cell* within the *measResult* to include the SS/PBCH block based quantity(ies) indicated in the *reportQuantityCell* within the concerned *reportConfig*, in order of decreasing trigger quantity, i.e. the best cell is included first:

- 8> if *reportQuantityRsIndexes* and *maxNrofRSIndexesToReport* are configured, include beam measurement information as described in 5.5.5.2;
- 6> else if *rsType* in the associated *reportConfig* is set to *csi-rs*:
- 7> set *resultsCSI-RS-Cell* within the *measResult* to include the CSI-RS based quantity(ies) indicated in the *reportQuantityCell* within the concerned *reportConfig*, in order of decreasing trigger quantity, i.e. the best cell is included first:
- 8> if *reportQuantityRsIndexes* and *maxNrofRSIndexesToReport* are, include beam measurement information as described in 5.5.5.2;
- 1> increment the *numberOfReportsSent* as defined within the *VarMeasReportList* for this *measId* by 1;
- 1> stop the periodical reporting timer, if running;
- 1> if the *numberOfReportsSent* as defined within the *VarMeasReportList* for this *measId* is less than the *reportAmount* as defined within the corresponding *reportConfig* for this *measId*:
- 2> start the periodical reporting timer with the value of *reportInterval* as defined within the corresponding *reportConfig* for this *measId*;
- 1> else:
- 2> if the *reportType* is set to *periodical*:
- 3> remove the entry within the *VarMeasReportList* for this *measId*;
- 3> remove this *measId* from the *measIdList* within *VarMeasConfig*;
- 1> if the UE is configured with EN-DC:
- 2> if SRB3 is configured:
- 3> submit the *MeasurementReport* message via SRB3 to lower layers for transmission, upon which the procedure ends;
- 2>else:
- 3> submit the *MeasurementReport* message via the EUTRA MCG embedded in E-UTRA RRC message *ULInformationTransferMRDC* as specified in TS 36.331 [10].
- 1> else:
- 2>submit the *MeasurementReport* message to lower layers for transmission, upon which the procedure ends.

### 8.2.3.8.1.3 Test description

#### 8.2.3.8.1.3.1 Pre-test conditions

#### System Simulator:

- EUTRA Cell 1 is the PCell and NR Cell 1 is the Serving PS Cell.
- NR Cell 2 is the intra-frequency neighbour cell.
- NR Cell 3 is the inter-frequency neighbour cell.
- NR Cell 10 is the inter-band neighbour cell.
- System information combination [xx] as defined in TS 38.508-1 [4] clause [xx] is used in E-UTRA Cell 1 and NR Cell 1.

#### UE:

- None

Preamble:

- The UE is in state RRC\_CONNECTED in EN-DC mode according to TS 38.508-1 [4].

#### 8.2.3.8.1.3.2 Test procedure sequence

Table 8.2.3.8.1.3.2-1 illustrates the downlink power levels to be applied for NR Cell 1, NR Cell 2, NR Cell 3 and NR Cell 10 at various time instants of the test execution. Row marked "T0" denotes the conditions after the preamble, while rows marked "T1", "T2", "T3", "T4", "T5", "T6", "T7", "T8", "T9", "T10" and "T11" are to be applied subsequently. The exact instants on which these values shall be applied are described in the texts in this clause.

**Table 8.2.3.8.1.3.2-1: Power levels**

	Parameter	Unit	EUTRA Cell 1	NR Cell 1	NR Cell 2	NR Cell 3	NR Cell 10	Remark
T0	Cell-specific RS EPRE	dBm/15 kHz	-85	-	-	-	-	Power levels are such that entry condition for event A5 is not satisfied, i.e. condition A5-1 ( $Mp+Hys<Thresh$ ) is fulfilled but condition A5-2 ( $Mn+Ofn+Ocn-Hys>Thresh2$ ) is not fulfilled for intra-frequency neighbour NR Cell 2.
	FFS	FFS	-	[FFS]	[FFS]	[FFS]	[FFS]	
T1	Cell-specific RS EPRE	dBm/15 kHz	-85	-	-	-	-	Power levels are such that entry condition for event A5 is not satisfied, i.e. condition A5-1 ( $Mp+Hys<Thresh$ ) is not fulfilled but condition A5-2 ( $Mn+Ofn+Ocn-Hys>Thresh2$ ) is fulfilled for intra-frequency neighbour NR Cell 2.
	FFS	FFS	-	[FFS]	[FFS]	[FFS]	[FFS]	
T2	Cell-specific RS EPRE	dBm/15 kHz	-85	-	-	-	-	Power levels are such that entry condition for event A5 is satisfied, i.e. condition A5-1 ( $Mp+Hys<Thresh$ ) and condition A5-2 ( $Mn+Ofn+Ocn-Hys>Thresh2$ ) are fulfilled for intra-frequency neighbour NR Cell 2 (i.e. periodical reporting for event A5 starts).
	FFS	FFS	-	[FFS]	[FFS]	[FFS]	[FFS]	
T3	Cell-specific RS EPRE	dBm/15 kHz	-85	-	-	-	-	Power levels are such that leaving condition for event A5 is satisfied, i.e. condition A5-3 ( $Mp-Hys>Thresh$ ) is satisfied but condition A5-4 ( $Mn+Ofn+Ocn+Hys<Thresh2$ ) is not satisfied for intra-frequency neighbour NR Cell 2 (i.e. periodical reporting for event A5 stops).
	FFS	FFS	-	[FFS]	[FFS]	[FFS]	[FFS]	
T4	Cell-specific RS EPRE	dBm/15 kHz	-85	-	-	-	-	Power levels are such that entry condition for event A5 is satisfied, i.e. condition A5-1 ( $Mp+Hys<Thresh$ ) and condition A5-2 ( $Mn+Ofn+Ocn-Hys>Thresh2$ ) are fulfilled for intra-frequency neighbour NR Cell 2 (i.e. periodical reporting for event A5 starts).
	FFS	FFS	-	[FFS]	[FFS]	[FFS]	[FFS]	
T5	Cell-specific RS EPRE	dBm/15 kHz	-85	-	-	-	-	Power levels are such that leaving condition for event A5 is satisfied, i.e. condition A5-3 ( $Mp-Hys>Thresh$ ) is not satisfied but condition A5-4 ( $Mn+Ofn+Ocn+Hys<Thresh2$ ) is satisfied for intra-frequency neighbour NR Cell 2 (i.e. periodical reporting for event A5 stops).
	FFS	FFS	-	[FFS]	[FFS]	[FFS]	[FFS]	
T6	Cell-specific RS EPRE	dBm/15 kHz	-85	-	-	-	-	Power levels are such that entry condition for event A5 is not satisfied, i.e. condition A5-1 ( $Mp+Hys<Thresh$ ) is fulfilled but condition A5-2 ( $Mn+Ofn+Ocn-Hys>Thresh2$ ) is not fulfilled for inter-frequency neighbour NR Cell 3 and inter-band neighbour NR Cell 10.
	FFS	FFS	-	[FFS]	[FFS]	[FFS]	[FFS]	
T7	Cell-specific RS EPRE	dBm/15 kHz	-85	-	-	-	-	Power levels are such that entry condition for event A5 is not satisfied, i.e. condition A5-1 ( $Mp+Hys<Thresh$ ) is not fulfilled but condition A5-2 ( $Mn+Ofn+Ocn-Hys>Thresh2$ ) is fulfilled for inter-frequency neighbour NR Cell 3 and inter-band neighbour NR Cell 10.
	FFS	FFS	-	[FFS]	[FFS]	[FFS]	[FFS]	
T8	Cell-specific RS EPRE	dBm/15 kHz	-85	-	-	-	-	



	FFS	FFS	-	[FFS]	[FFS]	[FFS]	[FFS]	Power levels are such that entry condition for event A5 is satisfied, i.e. condition A5-1 ( $Mp+Hys<Thresh$ ) and condition A5-2 ( $Mn+Ofn+Ocn-Hys>Thresh2$ ) are fulfilled for inter-frequency neighbour NR Cell 3 and inter-band neighbour NR Cell 10.
T9	Cell-specific RS EPRE	dBm/15 kHz	-85	-	-	-	-	Power levels are such that leaving condition for event A5 is satisfied, i.e. condition A5-3 ( $Mp-Hys>Thresh$ ) is satisfied but condition A5-4 ( $Mn+Ofn+Ocn+Hys<Thresh2$ ) is not satisfied for inter-frequency neighbour NR Cell 3 and inter-band neighbour NR Cell 10.
	FFS	FFS	-	[FFS]	[FFS]	[FFS]	[FFS]	
T10	Cell-specific RS EPRE	dBm/15 kHz	-85	-	-	-	-	Power levels are such that entry condition for event A5 is satisfied, i.e. condition A5-1 ( $Mp+Hys<Thresh$ ) and condition A5-2 ( $Mn+Ofn+Ocn-Hys>Thresh2$ ) are fulfilled for inter-frequency neighbour NR Cell 3 and inter-band neighbour NR Cell 10.
	FFS	FFS	-	[FFS]	[FFS]	[FFS]	[FFS]	
T11	Cell-specific RS EPRE	dBm/15 kHz	-85	-	-	-	-	Power levels are such that leaving condition for event A5 is satisfied, i.e. condition A5-3 ( $Mp-Hys>Thresh$ ) is not satisfied but condition A5-4 ( $Mn+Ofn+Ocn+Hys<Thresh2$ ) is satisfied for inter-frequency neighbour NR Cell 3 and inter-band neighbour NR Cell 10.
	FFS	FFS	-	[FFS]	[FFS]	[FFS]	[FFS]	

**Table 8.2.3.8.1.3.2-2: Main behaviour**

St	Procedure	Message Sequence		TP	Verdict
		U - S	Message		
1	The SS transmits an <i>RRCConnectionReconfiguration</i> message containing NR <i>RRCReconfiguration</i> message to setup measurements for neighbour NR Cells and reporting for event A5.	<--	<i>RRCConnectionReconfiguration (RRCReconfiguration)</i>	-	-
2	Check: Does the UE transmit an <i>RRCConnectionReconfigurationComplete</i> message containing NR <i>RRCReconfigurationComplete</i> message?	-->	<i>RRCConnectionReconfigurationComplete (RRCReconfigurationComplete)</i>	-	-
3	Check: Does the UE transmit an <i>ULInformationTransferMRDC</i> message containing NR <i>MeasurementReport</i> message within the next 10s?	-->	<i>ULInformationTransferMRDC (MeasurementReport)</i>	1	F
4	The SS re-adjusts the cell-specific reference signal level according to row "T1" in Table 8.3.2.8.1.3.2-1.	-	-	-	-
5	Check: Does the UE transmit an <i>ULInformationTransferMRDC</i> message containing NR <i>MeasurementReport</i> message to report event A5 with the measured value for NR Cell 2?	-->	<i>ULInformationTransferMRDC (MeasurementReport)</i>	1	F
6	The SS re-adjusts the cell-specific reference signal level according to row "T2" in Table 8.3.2.8.1.3.2-1.	-	-	-	-
7	Check: Does the UE transmit an <i>ULInformationTransferMRDC</i> message containing NR <i>MeasurementReport</i> message to report event A5 with the measured value for NR Cell 2?	-->	<i>ULInformationTransferMRDC (MeasurementReport)</i>	1	P
-	EXCEPTION: Step 8 below is repeated until 3 <i>MeasurementReport</i> messages are received from the UE.	-	-	-	-
8	Check: Does the UE transmit an <i>ULInformationTransferMRDC</i> message containing NR <i>MeasurementReport</i> message, with the measured value for NR Cell 2?	-->	<i>ULInformationTransferMRDC (MeasurementReport)</i>	1	P
9	The SS re-adjusts the cell-specific reference signal level according to row "T3" in Table 8.3.2.8.1.3.2-1.	-	-	-	-
10	Wait and ignore NR <i>MeasurementReport</i> messages for 15 s to allow change of power levels for NR Cell 2 and UE measurements.	-	-	-	-
11	Check: Does the UE attempt to transmit an uplink message within the next 10s?	-->	<i>ULInformationTransferMRDC (MeasurementReport)</i>	2	F
12	The SS re-adjusts the cell-specific reference signal level according to row "T4" in Table 8.3.2.8.1.3.2-1.	-	-	-	-
13	Check: Does the UE transmit an <i>ULInformationTransferMRDC</i> message containing NR <i>MeasurementReport</i> message to report event A5 with the measured value for NR Cell 2?	-->	<i>ULInformationTransferMRDC (MeasurementReport)</i>	1	P
14	The SS re-adjusts the cell-specific reference signal level according to row "T5" in Table 8.3.2.8.1.3.2-1.	-	-	-	-
15	Wait and ignore NR <i>MeasurementReport</i> messages for 15 s to allow change of power levels for NR Cell 2 and UE measurements.	-	-	-	-
16	Check: Does the UE attempt to transmit an uplink message within the next 10s?	-->	<i>ULInformationTransferMRDC (MeasurementReport)</i>	2	F
17	The SS re-adjusts the cell-specific reference signal level according to row "T6" in Table 8.3.2.8.1.3.2-1.	-	-	-	-
18	Check: Does the UE transmit an <i>ULInformationTransferMRDC</i> message containing NR <i>MeasurementReport</i> message to report event A5 with the measured value for NR Cell 3 and - IF the UE supports more than one NR band - also for NR Cell 10?	-->	<i>ULInformationTransferMRDC (MeasurementReport)</i>	1	F
19	The SS re-adjusts the cell-specific reference signal level according to row "T7" in Table 8.3.2.8.1.3.2-1.	-	-	-	-

20	Check: Does the UE transmit an <i>ULInformationTransferMRDC</i> message containing NR <i>MeasurementReport</i> message to report event A5 with the measured value for NR Cell 3 and - IF the UE supports more than one NR band - also for NR Cell 10?	-->	<i>ULInformationTransferMRDC (MeasurementReport)</i>	1	F
21	The SS re-adjusts the cell-specific reference signal level according to row "T8" in Table 8.3.2.8.1.3.2-1.	-	-	-	-
22	Check: Does the UE transmit an <i>ULInformationTransferMRDC</i> message containing NR <i>MeasurementReport</i> message to report event A5 with the measured value for NR Cell 3 and - IF the UE supports more than one NR band - also for NR Cell 10?	-->	<i>ULInformationTransferMRDC (MeasurementReport)</i>	1	P
-	EXCEPTION: Step 23 below is repeated until 3 <i>MeasurementReport</i> messages are received from the UE.	-	-	-	-
23	Check: Does the UE transmit an <i>ULInformationTransferMRDC</i> message containing NR <i>MeasurementReport</i> message, with the measured value for NR Cell .3– Note : This step is repeated for NR Cell 10 IF the UE supports more than one NR band.	-->	<i>ULInformationTransferMRDC (MeasurementReport)</i>	1	P
24	The SS re-adjusts the cell-specific reference signal level according to row "T9" in Table 8.3.2.8.1.3.2-1.	-	-	-	-
25	Wait and ignore NR <i>MeasurementReport</i> messages for 15 s to allow change of power levels for NR Cell 3 and NR Cell 10 and UE measurements.	-	-	-	-
26	Check: Does the UE attempt to transmit an uplink message within the next 10s?	-->	<i>ULInformationTransferMRDC (MeasurementReport)</i>	2	F
27	The SS re-adjusts the cell-specific reference signal level according to row "T10" in Table 8.3.2.8.1.3.2-1.	-	-	-	-
28	Check: Does the UE transmit an <i>ULInformationTransferMRDC</i> message containing NR <i>MeasurementReport</i> message to report event A5 with the measured value for NR Cell 3.– Note : This step is repeated for NR Cell 10 IF the UE supports more than one NR band.	-->	<i>ULInformationTransferMRDC (MeasurementReport)</i>	1	P
29	The SS re-adjusts the cell-specific reference signal level according to row "T11" in Table 8.3.2.8.1.3.2-1.	-	-	-	-
30	Wait and ignore NR <i>MeasurementReport</i> messages for 15 s to allow change of power levels for NR Cell 3 and NR Cell 10 and UE measurements.	-	-	-	-
31	Check: Does the UE attempt to transmit an uplink message within the next 10s?	-->	<i>ULInformationTransferMRDC (MeasurementReport)</i>	2	F

8.2.3.8.1.3.3 Specific message contents

**Table 8.2.3.8.1.3.3-1: RRCConnectionReconfiguration (step 1, Table 8.2.3.8.1.3.2-2)**

Derivation Path: 36.508 [7], Table 4.6.1-8 with condition MCG_and_SCG			
Information Element	Value/remark	Comment	Condition
RRCConnectionReconfiguration ::= SEQUENCE {			
criticalExtensions CHOICE {			
c1 CHOICE{			
rrcConnectionReconfiguration-r8 ::= SEQUENCE			
{			
nonCriticalExtension SEQUENCE {			
nonCriticalExtension SEQUENCE {			
nonCriticalExtension SEQUENCE {			
nonCriticalExtension SEQUENCE {			
nonCriticalExtension SEQUENCE {			
nonCriticalExtension SEQUENCE {			
nonCriticalExtension SEQUENCE {			
nr-Config-r15 CHOICE {			
setup SEQUENCE {			
nr-SecondaryCellGroupConfig-r15	RRCReconfiguration-MEAS		
}			
}			
}			
}			
}			
}			
}			
}			
}			
}			
}			

**Table 8.2.3.8.1.3.3-2: RRCReconfiguration-MEAS (Table 8.2.3.8.1.3.3-1)**

Derivation Path: 38.508-1 [4], Table 4.6.1-3			
Information Element	Value/remark	Comment	Condition
RRCReconfiguration ::= SEQUENCE {			
criticalExtensions CHOICE {			
rrcReconfiguration SEQUENCE {			
radioBearerConfig	Not Present		
secondaryCellGroup	Not Present		
measConfig	MeasConfig-A5		
}			
}			

Table 8.2.3.8.1.3.3-3: MeasConfig-A5 (Table 8.2.3.8.1.3.3-2)

Derivation Path: 38.508-1 [4], Table 4.6.3-50			
Information Element	Value/remark	Comment	Condition
MeasConfig ::= SEQUENCE {			
measObjectToAddModList	MeasObjectNR		
ReportConfigToAddModList	Same as TS 38.508-1 Table 4.6.3-107 except for reportAmount set to 'infinity'. ReportInterval value is set to 'ms1024' and Hystersis value is set to 'FFS'		EVENT_A5
MeasIdToAddModList ::= SEQUENCE (SIZE (1..maxNrofMeasId)) OF SEQUENCE {	[3 entries]		
measId[1]	1		
measObjectId[1]	[1]		
reportConfigId[1]	1		
measId[2]	2		
measObjectId[2]	[2]		
reportConfigId[2]	1		
measId[3]	3		
measObjectId[3]	[3]		
reportConfigId[3]	1		
}			
}			

Table 8.2.3.8.1.3.3-4: MeasObjectNR (Table 8.2.3.8.1.3.3-3)

Derivation Path: 38.508-1 [4], Table 4.6.3-56			
Information Element	Value/remark	Comment	Condition
measObjectToAddModList ::= SEQUENCE (SIZE (1..maxNrofObjectId)) OF SEQUENCE {	[3 entries]		
measObjectId[1]	[1]		
measObject CHOICE {			
measObjectNR	Same as TS 38.508-1 Table 4.6.3-56 except for ssbFrequency IE equals the ARFCN for NR Cell 2		
}			
measObjectId[2]	[2]		
measObject CHOICE {			
measObjectNR	Same as TS 38.508-1 Table 4.6.3-56 except for ssbFrequency IE equals the ARFCN for NR Cell 3		
}			
measObjectId[3]	[3]		
measObject CHOICE {			
measObjectNR	Same as TS 38.508-1 Table 4.6.3-56 except for ssbFrequency IE equals the ARFCN for NR Cell 10		
}			
}			

**Table 8.2.3.8.1.3.3-5: RRCConnectionReconfigurationComplete (step 2, Table 8.2.3.8.1.3.2-2)**

Derivation Path: 36.508 [7], Table 4.6.1-9			
Information Element	Value/remark	Comment	Condition
RRCConnectionReconfigurationComplete ::= SEQUENCE {			
criticalExtensions CHOICE {			
rrcConnectionReconfigurationComplete-r8 SEQUENCE {			
nonCriticalExtension SEQUENCE {			
nonCriticalExtension SEQUENCE {			
nonCriticalExtension SEQUENCE {			
nonCriticalExtension SEQUENCE {			
nonCriticalExtension SEQUENCE {			
scg-ConfigResponseNR-r15	OCTET STRING including the RRCReconfigurationComplete message according to TS 38.508-1 [4], table 4.6.1-4		
}			
}			
}			
}			
}			
}			
}			
}			

**Table 8.2.3.8.1.3.3-6: ULInformationTransferMRDC (steps 7, 8, 13 Table 8.2.3.8.1.3.2-2)**

Derivation Path: 36.508 [7], Table 4.6.1-27			
Information Element	Value/remark	Comment	Condition
ULInformationTransferMRDC ::= SEQUENCE {			
ul-DCCH-MessageNR-r15	OCTET STRING including the MeasurementReport message according to Table 8.2.3.8.1.3.3-7		
}			

**Table 8.2.3.8.1.3.3-7: MeasurementReport (Table 8.2.3.8.1.3.3-6)**

Derivation Path: 38.508-1 [4], Table 4.6.1-2			
Information Element	Value/remark	Comment	Condition
measurementReport ::= SEQUENCE {			
measResults ::= SEQUENCE {			
measId	1		
measResultServingMOList ::= SEQUENCE (SIZE (1..maxNrofServingCells)) {		Report NR Cell 1	
servCellId	Cell index corresponding to NR Cell 1		
measResultServingCell ::= SEQUENCE {			
physCellId	Phy cell id corresponding to NR Cell 1		
measResult SEQUENCE {			
cellResults SEQUENCE{			
resultsSSB-Cell ::= SEQUENCE {			
rsrp	(0..127)		
rsrq	(0..127)		
sinr	(0..127)		
}			
}			
}			
measResultNeighCells ::= SEQUENCE (SIZE (1..maxCellReport)) {	1 entry	Report NR Cell 2	
measResultListNR ::= SEQUENCE {			
physCellId	Phy cell id corresponding to NR Cell 2		
measResult SEQUENCE {			
cellResults SEQUENCE{			
resultsSSB-Cell ::= SEQUENCE {			
rsrp	(0..127)		
rsrq	(0..127)		
sinr	(0..127)		
}			
}			
}			
}			
}			

**Table 8.2.3.8.1.3.3-8: ULInformationTransferMRDC (steps 22, 23, 28 Table 8.2.3.8.1.3.2-2)**

Derivation Path: 36.508 [7], Table 4.6.1-27			
Information Element	Value/remark	Comment	Condition
ULInformationTransferMRDC ::= SEQUENCE {			
ul-DCCH-MessageNR-r15	OCTET STRING including the MeasurementReport message according to Table 8.2.3.8.1.3.3-10	Measurement report for NR Cell 3	
}			



**Table 8.2.3.8.1.3.3-9: ULInformationTransferMRDC (steps 22, 23, 28 Table 8.2.3.8.1.3.2-2)**

Derivation Path: 36.508 [7], Table 4.6.1-27			
Information Element	Value/remark	Comment	Condition
ULInformationTransferMRDC ::= SEQUENCE {			This message is only sent IF UE supports more than one NR band
ul-DCCH-MessageNR-r15	OCTET STRING including the MeasurementReport message according to Table 8.2.3.8.1.3.3-11	Measurement report for NR Cell 10	
}			

**Table 8.2.3.8.1.3.3-10: MeasurementReport (Table 8.2.3.8.1.3.3-8)**

Derivation Path: 38.508-1 [4], Table 4.6.1-2			
Information Element	Value/remark	Comment	Condition
measurementReport ::= SEQUENCE {			
measResults ::= SEQUENCE {			
measId	2		
measResultServingMOList ::= SEQUENCE (SIZE (1..maxNrofServingCells)) {		Report NR Cell 1	
servCellId	Cell index corresponding to NR Cell 1		
measResultServingCell ::= SEQUENCE {			
physCellId	Phy cell id corresponding to NR Cell 1		
measResult SEQUENCE {			
cellResults SEQUENCE{			
resultsSSB-Cell ::= SEQUENCE {			
rsrp	(0..127)		
rsrq	(0..127)		
sinr	(0..127)		
}			
}			
}			
}			
measResultNeighCells ::= SEQUENCE (SIZE (1..maxCellReport)) {	1 entry	Report NR Cell 3	
measResultListNR ::= SEQUENCE {			
physCellId	Phy cell id corresponding to NR Cell 3		
measResult SEQUENCE {			
cellResults SEQUENCE{			
resultsSSB-Cell ::= SEQUENCE {			
rsrp	(0..127)		
rsrq	(0..127)		
sinr	(0..127)		
}			
}			
}			
}			
}			

**Table 8.2.3.8.1.3.3-11: MeasurementReport (Table 8.2.3.8.1.3.3-9)**

Derivation Path: 38.508-1 [4], Table 4.6.1-2			
Information Element	Value/remark	Comment	Condition
measurementReport ::= SEQUENCE {			
measResults ::= SEQUENCE {			
measId	3		
measResultServingMOList ::= SEQUENCE (SIZE (1..maxNrofServingCells)) {		Report NR Cell 1	
servCellId	Cell index corresponding to NR Cell 1		
measResultServingCell ::= SEQUENCE {			
physCellId	Phy cell id corresponding to NR Cell 1		
measResult SEQUENCE {			
cellResults SEQUENCE{			
resultsSSB-Cell ::= SEQUENCE {			
rsrp	(0..127)		
rsrq	(0..127)		
sinr	(0..127)		
}			
}			
}			
}			
measResultNeighCells ::= SEQUENCE (SIZE (1..maxCellReport)) {	1 entry	Report NR Cell 10	
measResultListNR ::= SEQUENCE {			
physCellId	Phy cell id corresponding to NR Cell 10		
measResult SEQUENCE {			
cellResults SEQUENCE{			
resultsSSB-Cell ::= SEQUENCE {			
rsrp	(0..127)		
rsrq	(0..127)		
sinr	(0..127)		
}			
}			
}			
}			
}			

8.2.3.9 Measurement configuration control and reporting / SS/PBCH block based / CSI-RS based intra-frequency measurements / Measurement of Neighbour NR cell

8.2.3.9.1 Measurement configuration control and reporting / SS/PBCH block based beam measurements of Intra-frequency NR Neighbour PSCell / EN-DC

8.2.3.9.1.1 Test Purpose (TP)

(1)

```

with { UE in RRC_CONNECTED state in EN-DC mode and measurement configured for SS/PBCH measurement reporting of intra-frequency on specified frequency }
ensure that {
  when { SS/PBCH block sorting quantity is above absThreshSS-BlocksConsolidation for each beam of NR Neighbour Cell }
  then { UE sends MeasurementReport message containing rsIndexResults with resultsSSB-Indexes }
}
    
```

(2)

```

with { UE in RRC_CONNECTED state in EN-DC mode and measurement configured for SS/PBCH measurement
reporting of intra-frequency on specified frequency }
ensure that {
  when { SS/PBCH block sorting quantity is below absThreshSS-BlocksConsolidation for one beam of NR
Neighbour Cell and another beam(s) is above absThreshSS-BlocksConsolidation }
  then { UE sends MeasurementReport message containing rsIndexResults with resultsSSB-Indexes
includes RsIndex above absThreshSS-BlocksConsolidation and excludes RsIndex below absThreshSS-
BlocksConsolidation }
}

```

(3)

```

with { UE in RRC_CONNECTED state in EN-DC mode and measurement configured for SS/PBCH measurement
reporting of intra frequency on specified frequency }
ensure that {
  when { CSI-RS sorting quantity is above absThreshCSI-RS-Consolidation for each beam of NR
Neighbour Cell }
  then { UE sends MeasurementReport message containing rsIndexResults with resultsSSB-Indexes }
}

```

(4)

```

with { UE in RRC_CONNECTED state in EN-DC mode and measurement configured for SS/PBCH measurement
reporting of intra frequency on specified frequency }
ensure that {
  when { CSI-RS sorting quantity is below absThreshCSI-RS-Consolidation for one beam of NR Neighbour
Cell and another beam(s) is above absThreshCSI-RS-Consolidation }
  then { UE sends MeasurementReport message containing rsIndexResults with resultsSSB-Indexes
includes RsIndex above absThreshCSI-RS-Consolidation and excludes RsIndex below absThreshCSI-RS-
Consolidation }
}

```

#### 8.2.3.9.1.2 Conformance requirements

References: The conformance requirements covered in the present TC are specified in: TS 38.331 clauses 5.5.5.1 and 5.5.5.2. Unless otherwise stated these are Rel-15 requirements.

[TS 38.331, clause 5.5.5.1]

The purpose of this procedure is to transfer measurement results from the UE to the network. The UE shall initiate this procedure only after successful security activation.

For the *measId* for which the measurement reporting procedure was triggered, the UE shall set the *measResults* within the *MeasurementReport* message as follows:

- 1> set the *measId* to the measurement identity that triggered the measurement reporting;
- 1> set the *measResultServingCell* within *measResultServingFreqList* to include RSRP, RSRQ and the available SINR for each configured serving cell derived based on the *rsType* indicated in the associated *reportConfig*;
- 1> set the *measResultServingCell* within *measResultServingFreqList* to include for each NR serving cell that is configured, if any, the *servFreqId*;
- 1> if the *reportConfig* associated with the *measId* that triggered the measurement reporting includes *reportQuantityRsIndexes* and *maxNrofRSIndexesToReport*:
  - 2> for each configured serving cell, include beam measurement information according to the associated *reportConfig* as described in 5.5.5.2;
- 1> if the *reportConfig* associated with the *measId* that triggered the measurement reporting includes *reportAddNeighMeas*:
  - 2> for each serving frequency for which *measObjectId* is referenced in the *measIdList*, other than the frequency corresponding with the *measId* that triggered the measurement reporting:
    - 3> set the *measResultBestNeighCell* within *measResultServingFreqList* to include the *physCellId* and the available measurement quantities based on the *reportQuantityCell* and *rsType* indicated in *reportConfig*

of the non-serving cell on the concerned serving frequency with the highest measured RSRP if RSRP measurement results are available for cells on this frequency, otherwise with the highest measured RSRQ if RSRQ measurement results are available for cells on this frequency, otherwise with the highest measured SINR;

- 3> if the *reportConfig* associated with the *measId* that triggered the measurement reporting includes *reportQuantityRsIndexes* and *maxNrofRSIndexesToReport*:
  - 4> for each best non-serving cell included in the measurement report:
    - 5> include beam measurement information according to the associated *reportConfig* as described in 5.5.5.2;
- 1> if there is at least one applicable neighbouring cell to report:
  - 2> set the *measResultNeighCells* to include the best neighbouring cells up to *maxReportCells* in accordance with the following:
    - 3> if the *reportType* is set to *eventTriggered*:
      - 4> include the cells included in the *cellsTriggeredList* as defined within the *VarMeasReportList* for this *measId*;
    - 3> else:
      - 4> include the applicable cells for which the new measurement results became available since the last periodical reporting or since the measurement was initiated or reset;
      - 4> if *reportQuantityRsIndexes* and *maxNrofRSIndexesToReport* are configured, include beam measurement information as described in 5.5.5.2;
  - 3> for each cell that is included in the *measResultNeighCells*, include the *physCellId*;
  - 3> if the *reportType* is set to *eventTriggered*:
    - 4> for each included cell, include the layer 3 filtered measured results in accordance with the *reportConfig* for this *measId*, ordered as follows:
      - 5> if the *measObject* associated with this *measId* concerns NR:
        - 6> if *rsType* in the associated *reportConfig* is set to *ssb*:
          - 7> set *resultsSSB-Cell* within the *measResult* to include the SS/PBCH block based quantity(ies) indicated in the *reportQuantityCell* within the concerned *reportConfig*, in order of decreasing trigger quantity, i.e. the best cell is included first;
          - 8> if *reportQuantityRsIndexes* and *maxNrofRSIndexesToReport* are configured, include beam measurement information as described in 5.5.5.2;
        - 6> else if *rsType* in the associated *reportConfig* is set to *csi-rs*:
          - 7> set *resultsCSI-RS-Cell* within the *measResult* to include the CSI-RS based quantity(ies) indicated in the *reportQuantityCell* within the concerned *reportConfig*, in order of decreasing trigger quantity, i.e. the best cell is included first;
          - 8> if *reportQuantityRsIndexes* and *maxNrofRSIndexesToReport* are, include beam measurement information as described in 5.5.5.2;
- 1> increment the *numberOfReportsSent* as defined within the *VarMeasReportList* for this *measId* by 1;
- 1> stop the periodical reporting timer, if running;
- 1> if the *numberOfReportsSent* as defined within the *VarMeasReportList* for this *measId* is less than the *reportAmount* as defined within the corresponding *reportConfig* for this *measId*:
  - 2> start the periodical reporting timer with the value of *reportInterval* as defined within the corresponding *reportConfig* for this *measId*;

- 1> else:
  - 2> if the *reportType* is set to *periodical*:
    - 3> remove the entry within the *VarMeasReportList* for this *measId*;
    - 3> remove this *measId* from the *measIdList* within *VarMeasConfig*;
- 1> if the UE is configured with EN-DC:
  - 2> if SRB3 is configured:
    - 3> submit the *MeasurementReport* message via SRB3 to lower layers for transmission, upon which the procedure ends;
  - 2>else:
    - 3> submit the *MeasurementReport* message via the EUTRA MCG embedded in E-UTRA RRC message *ULInformationTransferMRDC* as specified in TS 36.331 [10].
- 1> else:
  - 2>submit the *MeasurementReport* message to lower layers for transmission, upon which the procedure ends.

[TS 38.331, clause 5.5.5.2]

For beam measurement information to be included in a measurement report the UE shall:

- 1> if *reportType* is set to *eventTriggered*:
  - 2> consider the trigger quantity as the sorting quantity;
- 1> if *reportType* is set to *periodical*:
  - 2> if a single reporting quantity is set to TRUE in *reportQuantityRsIndexes*;
    - 3> consider the configured single quantity as the sorting quantity;
  - 2> else:
    - 3> if *rsrp* is set to TRUE;
      - 4> consider RSRP as the sorting quantity;
    - 3> else:
      - 4> consider RSRQ as the sorting quantity;
- 1> set *rsIndexResults* to include up to *maxNrofRsIndexesToReportSS/PBCH* block indexes or CSI-RS indexes in order of decreasing sorting quantity as follows:
  - 2> if the measurement information to be included is based on SS/PBCH block:
    - 3> include within *resultsSSB-Indexes* the index associated to the best beam for that SS/PBCH block sorting quantity and the remaining beams whose sorting quantity is above *absThreshSS-BlocksConsolidation* defined in the *VarMeasConfig* for the corresponding *measObject*;
    - 3> if *includeBeamMeasurements* is configured, include the SS/PBCH based measurement results for the quantities in *reportQuantityRsIndexes* set to TRUE for each SS/PBCH blockindex;2> else if the beam measurement information to be included is based on CSI-RS:
      - 3> include within *resultsCSI-RS-Indexes* the index associated to the best beam for that CSI-RS sorting quantity and the remaining beams whose sorting quantity is above *absThreshCSI-RS-Consolidation* defined in the *VarMeasConfig* for the corresponding *measObject*;
      - 3> if *includeBeamMeasurements* is configured, include the CSI-RS based measurement results for the quantities in *reportQuantityRsIndexes* set to TRUE for each CSI-RS index.

8.2.3.9.1.3 Test description

8.2.3.9.1.3.1 Pre-test conditions

System Simulator:

- EUTRA Cell 1 is the PCell and NR Cell 1 is the PS Cell and NR Cell 2 is the intra-frequency neighbour cell of NR Cell 1. NR Cell2 has two beams with index#0 and index#1.

UE:

- None

Preamble:

- The UE is in state RRC\_CONNECTED in EN-DC according to TS 38.508-1 [4].

8.2.3.9.1.3.2 Test procedure sequence

Table 8.2.3.9.1.3.2-1 illustrates the downlink power levels to be applied for NR Cell 1 and NR Cell 2 at various time instants of the test execution. Row marked "T0" denotes the conditions after the preamble, while rows marked "T1" and "T2" are to be applied subsequently. The exact instants on which these values shall be applied are described in the texts in this clause.

**Table 8.2.3.9.1.3.2-1: Power levels**

	Parameter	Unit	EUTRA Cell 1	NR Cell 1	NR Cell 2	NR Cell 2 Beam Index# 0	NR Cell 2 Beam Index# 1	Remark
T0	Cell-specific RS EPRE	dBm/15 kHz	-85	[-94]	[FFS]	[FFS]	[FFS]	
T1	Cell-specific RS EPRE	dBm/15 kHz	-85	[-100]	[FFS]	[FFS]	[FFS]	$Mn+Ofn+Ocn-Hys > Mp+Ofp+Ocp+Odf$ Power level is such that SS/PBCH quality of NR Cell 2, BeamIndex#0 and BeamIndex#1 is above <i>absThreshSS-BlocksConsolidation</i> .
T2	Cell-specific RS EPRE	dBm/15 kHz	-85	[-100]	[FFS]	[FFS]	[FFS]	Power level is such that SS/PBCH quality of NR Cell 2 is BeamIndex#0 is above <i>absThreshSS-BlocksConsolidation</i> and BeamIndex#1 is below <i>absThreshSS-BlocksConsolidation</i> .

Table 8.2.3.9.1.3.2-2: Main behaviour

St	Procedure	Message Sequence		TP	Verdict
		U - S	Message		
1	The SS transmits an <i>RRCCONNECTIONRECONFIGURATION</i> message containing NR <i>RRCRECONFIGURATION</i> including <i>measConfig</i> to setup SS/PBCH block based intra-frequency NR measurement for PSCell (NR Cell 1) and reporting for event A3.	<--	<i>RRCCONNECTIONRECONFIGURATION</i> ( <i>RRCRECONFIGURATION</i> )	-	-
2	The UE transmits an <i>RRCCONNECTIONRECONFIGURATIONCOMPLETE</i> message containing NR <i>RRCRECONFIGURATIONCOMPLETE</i> .	-->	<i>RRCCONNECTIONRECONFIGURATIONCOMPLETE</i> ( <i>RRCRECONFIGURATIONCOMPLETE</i> )	-	-
3	SS re-adjusts the cell-specific reference signal level according to row "T1" in Table 8.2.3.9.1.3.2-1.	-	-	-	-
4	Check: Does the UE transmit a <i>MEASUREMENTREPORT</i> message to report event A3 with the measured [Results] for NR Cell 2 with beam information containing <i>RsIndex</i> [0] and <i>RsIndex</i> [1]?	-->	<i>ULINFORMATIONTRANSFERMRDC</i> ( <i>MEASUREMENTREPORT</i> )	1	P
5	SS re-adjusts the cell-specific reference signal level according to row "T2" in Table 8.2.3.9.1.3.2-1.	-	-	-	-
6	Check: Does the UE transmit a <i>MEASUREMENTREPORT</i> message to report event A3 with the measured [Results] for NR Cell 2 with beam information containing <i>RsIndex</i> [0] and excludes <i>RsIndex</i> [1]?	-->	<i>ULINFORMATIONTRANSFERMRDC</i> ( <i>MEASUREMENTREPORT</i> )	2	P
7	The SS transmits an <i>RRCCONNECTIONRECONFIGURATION</i> message containing NR <i>RRCRECONFIGURATION</i> including <i>measConfig</i> to remove SS/PBCH block based intra-frequency NR measurement for PSCell (NR Cell 1) and reporting for event A3.	<--	<i>RRCCONNECTIONRECONFIGURATION</i> ( <i>RRCRECONFIGURATION</i> )	-	-
8	The UE transmits an <i>RRCCONNECTIONRECONFIGURATIONCOMPLETE</i> message containing NR <i>RRCRECONFIGURATIONCOMPLETE</i> .	-->	<i>RRCCONNECTIONRECONFIGURATIONCOMPLETE</i> ( <i>RRCRECONFIGURATIONCOMPLETE</i> )	-	-
9	The SS transmits an <i>RRCCONNECTIONRECONFIGURATION</i> message containing NR <i>RRCRECONFIGURATION</i> including <i>measConfig</i> to setup CSI-RS based intra-frequency NR measurement for PSCell (NR Cell 1) and reporting for event A3.	<--	<i>RRCCONNECTIONRECONFIGURATION</i> ( <i>RRCRECONFIGURATION</i> )	-	-
10	The UE transmits an <i>RRCCONNECTIONRECONFIGURATIONCOMPLETE</i> message containing NR <i>RRCCONFIGURATIONCOMPLETE</i> .	-->	<i>RRCCONNECTIONRECONFIGURATIONCOMPLETE</i> ( <i>RRCCONFIGURATIONCOMPLETE</i> )	-	-
11	SS re-adjusts the cell-specific reference signal level according to row "T1" in Table 8.2.3.11.3.2-1.	-	-	-	-
12	Check: Does the UE transmit a <i>MEASUREMENTREPORT</i> message to report event A3 with the measured [Results] for NR Cell 2 with beam information containing <i>RsIndex</i> [0] and <i>RsIndex</i> [1]?	-->	<i>ULINFORMATIONTRANSFERMRDC</i> ( <i>MEASUREMENTREPORT</i> )	1	P
13	SS re-adjusts the cell-specific reference signal level according to row "T2" in Table 8.2.3.11.3.2-1.	-	-	-	-
14	Check: Does the UE transmit a <i>MEASUREMENTREPORT</i> message to report event A3 with the measured [Results] for NR Cell 2 with beam information containing <i>RsIndex</i> [0] and excludes <i>RsIndex</i> [1]?	-->	<i>ULINFORMATIONTRANSFERMRDC</i> ( <i>MEASUREMENTREPORT</i> )	2	P

8.2.3.9.1.3.3 Specific message contents

**Table 8.2.3.9.1.3.3-1: RRCConnectionReconfiguration (steps 1, 7, 9 Table 8.2.3.9.1.3.2-2)**

Derivation Path: 36.508 [7], Table 4.6.1-8 with condition MCG_and_SCG			
Information Element	Value/remark	Comment	Condition
RRCConnectionReconfiguration ::= SEQUENCE {			
criticalExtensions CHOICE {			
c1 CHOICE {			
rrcConnectionReconfiguration-r8 ::= SEQUENCE			
{			
nonCriticalExtension SEQUENCE {			
nonCriticalExtension SEQUENCE {			
nonCriticalExtension SEQUENCE {			
nonCriticalExtension SEQUENCE {			
nonCriticalExtension SEQUENCE {			
nonCriticalExtension SEQUENCE {			
nonCriticalExtension SEQUENCE {			
nonCriticalExtension SEQUENCE {			
nr-Config-r15 CHOICE {			
setup SEQUENCE {			
nr-SecondaryCellGroupConfig-r15	OCTET STRING including the <i>RRCReconfiguration</i> message and the IE measConfig		
}			
}			
}			
}			
}			
}			
}			
}			
}			
}			
}			
}			

**Table 8.2.3.9.1.3.3-2: RRCReconfiguration (Table 8.2.3.9.1.3.3-1)**

Derivation Path: 38.508-1 [4], Table 4.6.1-3 with condition MEAS
--

**Table 8.2.3.9.1.3.3-3: MeasConfig (Table 8.2.3.9.1.3.3-2)**

Derivation Path: 38.508-1 [4], Table 4.6.3-50			
Information Element	Value/remark	Comment	Condition
MeasConfig ::= SEQUENCE {			
measObjectToAddModList	IdMeasObjectToAdd		
reportConfigToAddModList	IdReportConfigToAdd		
measIdToAddModList	IdMeasIdToAdd		
s-MeasureConfig CHOICE {			
ssb-rsrp	[45]		
}			
}			



**Table 8.2.3.9.1.3.3-4: IdMeasObjectToAdd (Table 8.2.3.9.1.3.3-3, Table 8.2.3.9.1.3.3-13)**

Derivation Path: TS 38.331 [6], clause 6.3.2			
Information Element	Value/remark	Comment	Condition
MeasObjectToAddModList ::= SEQUENCE (SIZE (1..maxNrofMeasId)) OF SEQUENCE {	[1 entry]		
measObjectId[1]	1		
measObject CHOICE {			
measObjectNR	Id-MeasObjectNR		
}			
}			

**Table 8.2.3.9.1.3.3-5: Id-MeasObjectNR (Table 8.2.3.9.1.3.3-4)**

Derivation Path: 38.508-1 [4], Table 4.6.3-56			
Information Element	Value/remark	Comment	Condition
MeasObjectNR ::= SEQUENCE {			
ssbFrequency	Downlink ARFCN of f1		
absThreshSS-BlocksConsolidation SEQUENCE {			
thresholdRSRP	[-90]		
}			
}			

**Table 8.2.3.9.1.3.3-6: IdReportConfigToAdd (Table 8.2.3.9.1.3.3-3, Table 8.2.3.9.1.3.3-13)**

Derivation Path: TS 38.331 [6], clause 6.3.2			
Information Element	Value/remark	Comment	Condition
ReportConfigToAddModList ::= SEQUENCE (SIZE (1..maxReportConfigId)) OF SEQUENCE {	1 entry		
reportConfigId[1]	1		
reportConfig[1] CHOICE {			
reportConfigNR	IdReportConfig-A3		
}			
}			

**Table 8.2.3.9.1.3.3-7: IdReportConfig-A3 (Table 8.2.3.9.1.3.3-6)**

Derivation Path: 38.508-1 [4], Table 4.6.3-107 with condition EVENT_A2			
Information Element	Value/remark	Comment	Condition
ReportConfigNR ::= SEQUENCE {			
reportType CHOICE {			
eventTriggered SEQUENCE {			
eventId CHOICE {			
eventA3 SEQUENCE {			
a3-Offset CHOICE {			
Rsrp	[2]		
}			
Hysteresis	6	3dB	
}			
}			
}			
}			
}			

**Table 8.2.3.9.1.3.3-8: IdMeasIdToAdd (Table 8.2.3.9.1.3.3-3, Table 8.2.3.9.1.3.3-13)**

Derivation Path: TS 38.331 [6], clause 6.3.2			
Information Element	Value/remark	Comment	Condition
MeasIdToAddModList ::= SEQUENCE (SIZE (1..maxNrofMeasId)) OF SEQUENCE {	[1 entry]		
measId[1]	1		
measObjectId[1]	1		
reportConfigId[1]	1		
}			

**Table 8.2.3.9.1.3.3-9: RRCConnectionReconfigurationComplete (steps 2, 8, 10, Table 8.2.3.9.1.3.2-2)**

Derivation Path: 36.508 [7], Table 4.6.1-9			
Information Element	Value/remark	Comment	Condition
RRCConnectionReconfigurationComplete ::= SEQUENCE {			
criticalExtensions CHOICE {			
rrcConnectionReconfigurationComplete-r8 SEQUENCE {			
nonCriticalExtension SEQUENCE {			
nonCriticalExtension SEQUENCE {			
nonCriticalExtension SEQUENCE {			
nonCriticalExtension SEQUENCE {			
nonCriticalExtension SEQUENCE {			
nonCriticalExtension SEQUENCE {			
scg-ConfigResponseNR-r15	Present		
}			
}			
}			
}			
}			
}			
}			

**Table 8.2.3.9.1.3.3-10: ULInformationTransferMRDC (steps 4, 5, Table 8.2.3.9.1.3.2-2)**

Derivation Path: 36.508 [7], Table 4.6.1-XX			
Information Element	Value/remark	Comment	Condition
ULInformationTransferMRDC-r15 ::= SEQUENCE {			
criticalExtensions CHOICE {			
c1 CHOICE {			
ulInformationTransferMRDC-r15 SEQUENCE {			
ul-DCCH-MessageNR-r15	OCTET STRING containing NR RRC MeasurementReport		
}			
}			
}			
}			

**Table 8.2.3.9.1.3.3-11: MeasurementReport (step 4, Table 8.2.3.9.1.3.2-2)**

Derivation Path: TS 38.331 [6], clause 6.2.2			
Information Element	Value/remark	Comment	Condition
MeasurementReport ::= SEQUENCE {			
criticalExtensions CHOICE {			
c1 CHOICE {			
measurementReport ::= SEQUENCE {			
measResults SEQUENCE {			
measId			
measResultServingFreqList SEQUENCE {	1 entry		
servFreqId			
measResultServingCell SEQUENCE :			
physCellId	Physical CellID of the NR Cell 2		
cgi-Info	Not present		
measResult SEQUENCE {			
cellResults SEQUENCE {			
resultsSSB-Cell SEQUENCE {			
rsrp	Not checked		
rsrq	Not checked		
sinr	Not checked		
}			
}			
rsIndexResults SEQUENCE {			
resultsSSB-Indexes	Contains SSB-Index for BeamIndex#0 and BeamIndex#1		
}			
}			
}			
}			
}			
}			
}			
}			

**Table 8.2.3.9.1.3.3-12: MeasurementReport (step 6, Table 8.2.3.9.1.3.2-2)**

Derivation Path: TS 38.331 [6], clause 6.2.2			
Information Element	Value/remark	Comment	Condition
MeasurementReport ::= SEQUENCE {			
criticalExtensions CHOICE {			
c1 CHOICE {			
measurementReport ::= SEQUENCE {			
measResults SEQUENCE {			
measId			
measResultServingFreqList SEQUENCE {	1 entry		
servFreqId			
measResultServingCell SEQUENCE :			
physCellId	Physical CellID of the NR Cell 2		
cgi-Info	Not present		
measResult SEQUENCE {			
cellResults SEQUENCE {			
resultsSSB-Cell SEQUENCE {			
rsrp	Not checked		
rsrq	Not checked		
sinr	Not checked		
}			
}			
rsIndexResults SEQUENCE {			
resultsSSB-Indexes	Contains SSB-Index for BeamIndex#0		
}			
}			
}			
}			
}			
}			

**Table 8.2.3.9.1.3.3-13: MeasConfig (step 7, Table 8.2.3.9.1.3.2-2)**

Derivation Path: 38.508-1 [4], Table 4.6.3-50			
Information Element	Value/remark	Comment	Condition
MeasConfig ::= SEQUENCE {			
measIdToRemoveList SEQUENCE (SIZE (1..maxMeasId)) OF SEQUENCE {	One entry		
Meas-Id[1]	1		
}			
}			

**Table 8.2.3.9.1.3.3-14: MeasConfig (step 9, Table 8.2.3.9.1.3.2-2)**

Derivation Path: 38.508-1 [4], Table 4.6.3-50			
Information Element	Value/remark	Comment	Condition
MeasConfig ::= SEQUENCE {			
measObjectToAddModList	IdMeasObjectToAdd		
reportConfigToAddModList	IdReportConfigToAdd		
measIdToAddModList	IdMeasIdToAdd		
s-MeasureConfig CHOICE {			
csi-rsrp	[45]		
}			
}			

**Table 8.2.3.9.1.3.3-15: MeasurementReport (step 12, Table 8.2.3.9.1.3.2-2)**

Derivation Path: TS 38.331 [6], clause 6.2.2			
Information Element	Value/remark	Comment	Condition
MeasurementReport ::= SEQUENCE {			
criticalExtensions CHOICE {			
c1 CHOICE {			
measurementReport ::= SEQUENCE {			
measResults SEQUENCE {			
measId			
measResultServingFreqList SEQUENCE {	1 entry		
servFreqId			
measResultServingCell SEQUENCE :			
physCellId	Physical CellID of the NR Cell 2		
cgi-Info	Not present		
measResult SEQUENCE {			
cellResults SEQUENCE {			
resultsSSB-Cell SEQUENCE {			
rsrp	Not checked		
rsrq	Not checked		
sinr	Not checked		
}			
}			
rsIndexResults SEQUENCE {			
resultsCSI-RS-Indexes	Contains SSB-Index for BeamIndex#0 and BeamIndex#1		
}			
}			
}			
}			
}			
}			
}			
}			

Table 8.2.3.9.1.3.3-16: MeasurementReport (step 14. Table 8.2.3.9.1.3.2-2)

Derivation Path: TS 38.331 [6], clause 6.2.2			
Information Element	Value/remark	Comment	Condition
MeasurementReport ::= SEQUENCE {			
criticalExtensions CHOICE {			
c1 CHOICE {			
measurementReport ::= SEQUENCE {			
measResults SEQUENCE {			
measId			
measResultServingFreqList SEQUENCE {	1 entry		
servFreqId			
measResultServingCell SEQUENCE :			
physCellId	Physical CellID of the NR Cell 2		
cgi-Info	Not present		
measResult SEQUENCE {			
cellResults SEQUENCE {			
resultsSSB-Cell SEQUENCE {			
rsrp	Not checked		
rsrq	Not checked		
sinr	Not checked		
}			
}			
rsIndexResults SEQUENCE {			
resultsCSI-RS-Indexes	Contains SSB-Index for BeamIndex#0		
}			
}			
}			
}			
}			
}			

### 8.2.3.10 Measurement configuration control and reporting / SS/PBCH block based / CSI-RS based inter-frequency measurements / Measurement of Neighbour NR cell

#### 8.2.3.10.1 Measurement configuration control and reporting / SS/PBCH block based beam measurements of Inter-frequency NR Neighbour PSCell / EN-DC

##### 8.2.3.10.1.1 Test Purpose (TP)

(1)

```
with { UE in RRC_CONNECTED state in EN-DC mode and measurement configured for SS/PBCH measurement reporting of inter frequency on specified frequency }
ensure that {
  when { SS/PBCH block sorting quantity is above absThreshSS-BlocksConsolidation for each beam of NR Neighbour Cell }
  then { UE sends MeasurementReport message containing rsIndexResults with resultsSSB-Indexes }
}
```

(2)

```
with { UE in RRC_CONNECTED state in EN-DC mode and measurement configured for SS/PBCH measurement reporting of inter frequency on specified frequency }
ensure that {
  when { SS/PBCH block sorting quantity is below absThreshSS-BlocksConsolidation for one beam of NR Neighbour Cell and another beam(s) is above absThreshSS-BlocksConsolidation }
  then { UE sends MeasurementReport message containing rsIndexResults with resultsSSB-Indexes includes RsIndex above absThreshSS-BlocksConsolidation and excludes RsIndex below absThreshSS-BlocksConsolidation }
}
```

(3)

```

with { UE in RRC_CONNECTED state in EN-DC mode and measurement configured for SS/PBCH measurement
reporting of inter frequency on specified frequency }
ensure that {
  when { CSI-RS sorting quantity is above absThreshCSI-RS-Consolidation for each beam of NR
  Neighbour Cell }
  then { UE sends MeasurementReport message containing rsIndexResults with resultsSSB-Indexes }
}

```

(4)

```

with { UE in RRC_CONNECTED state in EN-DC mode and measurement configured for SS/PBCH measurement
reporting of inter frequency on specified frequency }
ensure that {
  when { CSI-RS sorting quantity is below absThreshCSI-RS-Consolidation for one beam of NR Neighbour
  Cell and another beam(s) is above absThreshCSI-RS-Consolidation }
  then { UE sends MeasurementReport message containing rsIndexResults with resultsSSB-Indexes
  includes RsIndex above absThreshCSI-RS-Consolidation and excludes RsIndex below absThreshCSI-RS-
  Consolidation }
}

```

### 8.2.3.10.1.2 Conformance requirements

References: The conformance requirements covered in the present TC are specified in: TS 38.331 clauses 5.5.5.1 and 5.5.5.2. Unless otherwise stated these are Rel-15 requirements.

[TS 38.331, clause 5.5.5.1]

The purpose of this procedure is to transfer measurement results from the UE to the network. The UE shall initiate this procedure only after successful security activation.

For the *measId* for which the measurement reporting procedure was triggered, the UE shall set the *measResults* within the *MeasurementReport* message as follows:

- 1> set the *measId* to the measurement identity that triggered the measurement reporting;
- 1> set the *measResultServingCell* within *measResultServingFreqList* to include RSRP, RSRQ and the available SINR for each configured serving cell derived based on the *rsType* indicated in the associated *reportConfig*;
- 1> set the *measResultServingCell* within *measResultServingFreqList* to include for each NR serving cell that is configured, if any, the *servFreqId*;
- 1> if the *reportConfig* associated with the *measId* that triggered the measurement reporting includes *reportQuantityRsIndexes* and *maxNrofRSIndexesToReport*:
  - 2> for each configured serving cell, include beam measurement information according to the associated *reportConfig* as described in 5.5.5.2;
- 1> if the *reportConfig* associated with the *measId* that triggered the measurement reporting includes *reportAddNeighMeas*:
  - 2> for each serving frequency for which *measObjectId* is referenced in the *measIdList*, other than the frequency corresponding with the *measId* that triggered the measurement reporting:
    - 3> set the *measResultBestNeighCell* within *measResultServingFreqList* to include the *physCellId* and the available measurement quantities based on the *reportQuantityCell* and *rsType* indicated in *reportConfig* of the non-serving cell on the concerned serving frequency with the highest measured RSRP if RSRP measurement results are available for cells on this frequency, otherwise with the highest measured RSRQ if RSRQ measurement results are available for cells on this frequency, otherwise with the highest measured SINR;
    - 3> if the *reportConfig* associated with the *measId* that triggered the measurement reporting includes *reportQuantityRsIndexes* and *maxNrofRSIndexesToReport*:
      - 4> for each best non-serving cell included in the measurement report:

- 5> include beam measurement information according to the associated *reportConfig* as described in 5.5.5.2;
- 1> if there is at least one applicable neighbouring cell to report:
  - 2> set the *measResultNeighCells* to include the best neighbouring cells up to *maxReportCells* in accordance with the following:
    - 3> if the *reportType* is set to *eventTriggered*:
      - 4> include the cells included in the *cellsTriggeredList* as defined within the *VarMeasReportList* for this *measId*;
    - 3> else:
      - 4> include the applicable cells for which the new measurement results became available since the last periodical reporting or since the measurement was initiated or reset;
      - 4> if *reportQuantityRsIndexes* and *maxNrofRSIndexesToReport* are configured, include beam measurement information as described in 5.5.5.2;
    - 3> for each cell that is included in the *measResultNeighCells*, include the *physCellId*;
    - 3> if the *reportType* is set to *eventTriggered*:
      - 4> for each included cell, include the layer 3 filtered measured results in accordance with the *reportConfig* for this *measId*, ordered as follows:
        - 5> if the *measObject* associated with this *measId* concerns NR:
          - 6> if *rsType* in the associated *reportConfig* is set to *ssb*:
            - 7> set *resultsSSB-Cell* within the *measResult* to include the SS/PBCH block based quantity(ies) indicated in the *reportQuantityCell* within the concerned *reportConfig*, in order of decreasing trigger quantity, i.e. the best cell is included first;
            - 8> if *reportQuantityRsIndexes* and *maxNrofRSIndexesToReport* are configured, include beam measurement information as described in 5.5.5.2;
          - 6> else if *rsType* in the associated *reportConfig* is set to *csi-rs*:
            - 7> set *resultsCSI-RS-Cell* within the *measResult* to include the CSI-RS based quantity(ies) indicated in the *reportQuantityCell* within the concerned *reportConfig*, in order of decreasing trigger quantity, i.e. the best cell is included first;
            - 8> if *reportQuantityRsIndexes* and *maxNrofRSIndexesToReport* are, include beam measurement information as described in 5.5.5.2;
  - 1> increment the *numberOfReportsSent* as defined within the *VarMeasReportList* for this *measId* by 1;
  - 1> stop the periodical reporting timer, if running;
  - 1> if the *numberOfReportsSent* as defined within the *VarMeasReportList* for this *measId* is less than the *reportAmount* as defined within the corresponding *reportConfig* for this *measId*:
    - 2> start the periodical reporting timer with the value of *reportInterval* as defined within the corresponding *reportConfig* for this *measId*;
  - 1> else:
    - 2> if the *reportType* is set to *periodical*:
      - 3> remove the entry within the *VarMeasReportList* for this *measId*;
      - 3> remove this *measId* from the *measIdList* within *VarMeasConfig*;
  - 1> if the UE is configured with EN-DC:



2> if SRB3 is configured:

3> submit the *MeasurementReport* message via SRB3 to lower layers for transmission, upon which the procedure ends;

2>else:

3> submit the *MeasurementReport* message via the EUTRA MCG embedded in E-UTRA RRC message *ULInformationTransferMRDC* as specified in TS 36.331 [10].

1> else:

2>submit the *MeasurementReport* message to lower layers for transmission, upon which the procedure ends.

[TS 38.331, clause 5.5.5.2]

For beam measurement information to be included in a measurement report the UE shall:

1> if reportType is set to eventTriggered:

2> consider the trigger quantity as the sorting quantity;

1> if reportType is set to periodical:

2> if a single reporting quantity is set to TRUE in *reportQuantityRsIndexes*;

3> consider the configured single quantity as the sorting quantity;

2> else:

3> if *rsrp* is set to TRUE;

4> consider RSRP as the sorting quantity;

3> else:

4> consider RSRQ as the sorting quantity;

1> set *rsIndexResults* to include up to *maxNrofRsIndexesToReportSS/PBCH* block indexes or CSI-RS indexes in order of decreasing sorting quantity as follows:

2> if the measurement information to be included is based on SS/PBCH block:

3> include within *resultsSSB-Indexes* the index associated to the best beam for that SS/PBCH block sorting quantity and the remaining beams whose sorting quantity is above *absThreshSS-BlocksConsolidation* defined in the *VarMeasConfig* for the corresponding *measObject*;

3> if *includeBeamMeasurements* is configured, include the SS/PBCH based measurement results for the quantities in *reportQuantityRsIndexes* set to TRUE for each SS/PBCH blockindex;2> else if the beam measurement information to be included is based on CSI-RS:

3> include within *resultsCSI-RS-Indexes* the index associated to the best beam for that CSI-RS sorting quantity and the remaining beams whose sorting quantity is above *absThreshCSI-RS-Consolidation* defined in the *VarMeasConfig* for the corresponding *measObject*;

3> if *includeBeamMeasurements* is configured, include the CSI-RS based measurement results for the quantities in *reportQuantityRsIndexes* set to TRUE for each CSI-RS index.

8.2.3.10.1.3 Test description

8.2.3.10.1.3.1 Pre-test conditions

System Simulator:

- EUTRA Cell 1 is the PCell and NR Cell 1 is the PS Cell and NR Cell 3 is the inter-frequency neighbour cell of NR Cell 1. NR Cell 3 has two beams with index#0 and index#1.

UE:

- None

Preamble:

- The UE is in state RRC\_CONNECTED in EN-DC according to TS 38.508-1 [4].

8.2.3.10.1.3.2 Test procedure sequence

Table 8.2.3.10.1.3.2-1 illustrates the downlink power levels to be applied for NR Cell 1 and NR Cell 3 at various time instants of the test execution. Row marked "T0" denotes the conditions after the preamble, while rows marked "T1" and "T2" are to be applied subsequently. The exact instants on which these values shall be applied are described in the texts in this clause.

**Table 8.2.3.10.1.3.2-1: Power levels**

	Parameter	Unit	EUTRA Cell 1	NR Cell 1	NR Cell 3	NR Cell 3 Beam Index# 0	NR Cell 3 Beam Index #1	Remark
T0	Cell-specific RS EPRE	dBm/15 kHz	-85	[-94]	[FFS]	[FFS]	[FFS]	
T1	Cell-specific RS EPRE	dBm/15 kHz	-85	[-100]	[FFS]	[FFS]	[FFS]	$Mn + Ofn + Ocn - Hys > Mp + Ofp + Ocp + Off$ Power level is such that SS/PBCH quality of NR Cell 3, BeamIndex#0 and BeamIndex#1 is above <i>absThreshSS-BlocksConsolidation</i> .
T2	Cell-specific RS EPRE	dBm/15 kHz	-85	[-100]	[FFS]	[FFS]	[FFS]	Power level is such that SS/PBCH quality of NR Cell 3 is BeamIndex#0 is above <i>absThreshSS-BlocksConsolidation</i> and BeamIndex#1 is below <i>absThreshSS-BlocksConsolidation</i> .

Table 8.2.3.10.1.3.2-2: Main behaviour

St	Procedure	Message Sequence		TP	Verdict
		U - S	Message		
1	The SS transmits an <i>RRConnectionReconfiguration</i> message containing NR <i>RRReconfiguration</i> including <i>measConfig</i> to setup SS/PBCH block based inter-frequency NR measurement for PSCell (NR Cell 1) and reporting for A3.	<--	<i>RRConnectionReconfiguration</i> ( <i>RRReconfiguration</i> )	-	-
2	The UE transmits an <i>RRConnectionReconfigurationComplete</i> message containing NR <i>RRReconfigurationComplete</i> .	-->	<i>RRConnectionReconfigurationComplete</i> ( <i>RRReconfigurationComplete</i> )	-	-
3	The SS re-adjusts the cell-specific reference signal level according to row "T1" in Table 8.2.3.10.1.3.2-1.	-	-	-	-
4	Check: Does the UE transmit a <i>MeasurementReport</i> message to report event A3 with the measured [Results] for NR Cell 3 with beam information containing <i>RsIndex</i> [0] and <i>RsIndex</i> [1]?	-->	<i>ULInformationTransferMRDC</i> ( <i>MeasurementReport</i> )	1	P
5	The SS re-adjusts the cell-specific reference signal level according to row "T2" in Table 8.2.3.10.1.3.2-1.	-	-	-	-
6	Check: Does the UE transmit a <i>MeasurementReport</i> message to report event A3 with the measured [Results] for NR Cell 3 with beam information containing <i>RsIndex</i> [0] and excludes <i>RsIndex</i> [1]?	-->	<i>ULInformationTransferMRDC</i> ( <i>MeasurementReport</i> )	2	P
7	The SS transmits an <i>RRConnectionReconfiguration</i> message containing NR <i>RRReconfiguration</i> including <i>measConfig</i> to remove SS/PBCH block based intra-frequency NR measurement for PSCell (NR Cell 1) and reporting for event A3.	<--	<i>RRConnectionReconfiguration</i> ( <i>RRReconfiguration</i> )	-	-
8	The UE transmits an <i>RRConnectionReconfigurationComplete</i> message containing NR <i>RRReconfigurationComplete</i> .	-->	<i>RRConnectionReconfigurationComplete</i> ( <i>RRReconfigurationComplete</i> )	-	-
9	The SS transmits an <i>RRConnectionReconfiguration</i> message containing NR <i>RRReconfiguration</i> including <i>measConfig</i> to setup CSI-RS based inter-frequency NR measurement for PSCell (NR Cell 1) and event A3.	<--	<i>RRConnectionReconfiguration</i> ( <i>RRReconfiguration</i> )	-	-
10	The UE transmits an <i>RRConnectionReconfigurationComplete</i> message.	-->	<i>RRConnectionReconfigurationComplete</i> ( <i>RRReconfigurationComplete</i> )	-	-
11	The SS re-adjusts the cell-specific reference signal level according to row "T1" in Table 8.2.3.12.3.2-1.	-	-	-	-
12	Check: Does the UE transmit a <i>MeasurementReport</i> message to report event A3 with the measured [Results] for NR Cell 3 with beam information containing <i>RsIndex</i> [0] and <i>RsIndex</i> [1]?	-->	<i>ULInformationTransferMRDC</i> ( <i>MeasurementReport</i> )	1	P
13	The SS re-adjusts the cell-specific reference signal level according to row "T2" in Table 8.2.3.12.3.2-1.	-	-	-	-
14	Check: Does the UE transmit a <i>MeasurementReport</i> message to report event A3 with the measured [Results] for NR Cell 3 with beam information containing <i>RsIndex</i> [0] and excludes <i>RsIndex</i> [1]?	-->	<i>ULInformationTransferMRDC</i> ( <i>MeasurementReport</i> )	2	P

## 8.2.3.10.1.3.3 Specific message contents

Table 8.2.3.10.1.3.3-1: *RRConnectionReconfiguration* (steps 1, 7, 9. Table 8.2.3.10.1.3.2-2)

Derivation Path: 36.508 [7], Table 4.6.1-8 with condition MCG_and_SCG			
Information Element	Value/remark	Comment	Condition
RRCConnectionReconfiguration ::= SEQUENCE {			
criticalExtensions CHOICE {			
c1 CHOICE {			
rrcConnectionReconfiguration-r8 ::= SEQUENCE			
{			
nonCriticalExtension SEQUENCE {			
nonCriticalExtension SEQUENCE {			
nonCriticalExtension SEQUENCE {			
nonCriticalExtension SEQUENCE {			
nonCriticalExtension SEQUENCE {			
nonCriticalExtension SEQUENCE {			
nonCriticalExtension SEQUENCE {			
nr-Config-r15 CHOICE {			
setup SEQUENCE {			
nr-SecondaryCellGroupConfig-r15	OCTET STRING including the RRCReconfiguration message and the IE measConfig		
}			
}			
}			
}			
}			
}			
}			

**Table 8.2.3.10.1.3.3-2: RRCReconfiguration (Table 8.2.3.10.1.3.3-1)**

Derivation Path: 38.508-1 [4], Table 4.6.1-3 with condition MEAS

**Table 8.2.3.10.1.3.3-3: MeasConfig (Table 8.2.3.10.1.3.3-2,)**

Derivation Path: 38.508-1 [4], Table 4.6.3-50			
Information Element	Value/remark	Comment	Condition
MeasConfig ::= SEQUENCE {			
measObjectToAddModList	IdMeasObjectToAdd		
reportConfigToAddModList	IdReportConfigToAdd		
measIdToAddModList	IdMeasIdToAdd		
s-MeasureConfig CHOICE {			
ssb-rsrp	[45]		
}			
}			

**Table 8.2.3.10.1.3.3-4: IdMeasObjectToAdd (Table 8.2.3.10.1.3.3-3, Table 8.2.3.10.1.3.3-12)**

Derivation Path: TS 38.331 [6], clause 6.3.2			
Information Element	Value/remark	Comment	Condition
MeasObjectToAddModList ::= SEQUENCE (SIZE (1..maxNrofMeasId)) OF SEQUENCE {	[2 entry]		
measObjectId[1]	1		
measObject[1] CHOICE {			
measObjectNR	Id-MeasObjectNR-f1		
}			
measObjectId[2]	2		
measObject[2] CHOICE {			
measObjectNR	Id-MeasObjectNR-f2		
}			
}			

**Table 8.2.3.10.1.3.3-5: Id-MeasObjectNR-f1 (Table 8.2.3.10.1.3.3-4)**

Derivation Path: 38.508-1 [4], Table 4.6.3-56			
Information Element	Value/remark	Comment	Condition
MeasObjectNR ::= SEQUENCE {			
ssbFrequency	Downlink ARFCN of f1		
absThreshSS-BlocksConsolidation SEQUENCE {			
thresholdRSRP	[-90]		
}			
}			

**Table 8.2.3.10.1.3.3-5: Id-MeasObjectNR-f2 (Table 8.2.3.10.1.3.3-4)**

Derivation Path: 38.508-1 [4], Table 4.6.3-56			
Information Element	Value/remark	Comment	Condition
MeasObjectNR ::= SEQUENCE {			
ssbFrequency	Downlink ARFCN of f2		
absThreshSS-BlocksConsolidation SEQUENCE {			
thresholdRSRP	[-90]		
}			
}			

**Table 8.2.3.10.1.3.3-6: IdReportConfigToAdd (Table 8.2.3.10.1.3.3-3, Table 8.2.3.10.1.3.3-12)**

Derivation Path: TS 38.331 [6], clause 6.3.2			
Information Element	Value/remark	Comment	Condition
ReportConfigToAddModList ::= SEQUENCE(SIZE (1..maxReportConfigId)) OF SEQUENCE {	1 entry		
reportConfigId[1]	1		
reportConfig[1] CHOICE {			
reportConfigNR	IdReportConfig-A3		
}			
}			

**Table 8.2.3.10.1.3.3-7: IdReportConfig-A3 (Table 8.2.3.10.1.3.3-3)**

Derivation Path: 38.508-1 [4], Table 4.6.3-107 with condition EVENT_A2			
Information Element	Value/remark	Comment	Condition
ReportConfigNR ::= SEQUENCE {			
reportType CHOICE {			
eventTriggered SEQUENCE {			
eventId CHOICE {			
eventA3 SEQUENCE {			
a3-Offset CHOICE {			
Rsrp	[2]		
}			
Hysteresis	6	3dB	
}			
}			
}			
}			
}			

**Table 8.2.3.10.1.3.3-8: IdMeasIdToAdd (Table 8.2.3.10.1.3.3-3, Table 8.2.3.10.1.3.3-12)**

Derivation Path: TS 38.331 [6], clause 6.3.2			
Information Element	Value/remark	Comment	Condition
MeasIdToAddModList ::= SEQUENCE (SIZE (1..maxNrofMeasId)) OF SEQUENCE {	2 entries		
measId[1]	1		
measObjectId[1]	1		
reportConfigId[1]	1		
measId[2]	2		
measObjectId[2]	2		
reportConfigId[2]	1		
}			

**Table 8.2.3.10.1.3.3-9: RRCConnectionReconfigurationComplete (steps 2, 8, 10, Table 8.2.3.10.1.3.2-2)**

Derivation Path: 36.508 [7], Table 4.6.1-9			
Information Element	Value/remark	Comment	Condition
RRCConnectionReconfigurationComplete ::= SEQUENCE {			
criticalExtensions CHOICE {			
rrcConnectionReconfigurationComplete-r8 SEQUENCE {			
nonCriticalExtension SEQUENCE {			
nonCriticalExtension SEQUENCE {			
nonCriticalExtension SEQUENCE {			
nonCriticalExtension SEQUENCE {			
nonCriticalExtension SEQUENCE {			
scg-ConfigResponseNR-r15	Present		
}			
}			
}			
}			
}			
}			
}			

**Table 8.2.3.10.1.3.3-10: ULInformationTransferMRDC (steps 4, 5, Table 8.2.3.10.1.3.2-2)**

Derivation Path: 36.508 [7], Table 4.6.1-XX			
Information Element	Value/remark	Comment	Condition
ULInformationTransferMRDC-r15 ::= SEQUENCE {			
criticalExtensions CHOICE {			
c1 CHOICE {			
ulInformationTransferMRDC-r15 SEQUENCE {			
ul-DCCH-MessageNR-r15	OCTET STRING containing NR RRC MeasurementReport		
}			
}			
}			
}			

**Table 8.2.3.10.1.3.3-11: MeasurementReport (step 4, Table 8.2.3.10.1.3.2-2)**

Derivation Path: TS 38.331 [6], clause 6.2.2			
Information Element	Value/remark	Comment	Condition
MeasurementReport ::= SEQUENCE {			
criticalExtensions CHOICE {			
c1 CHOICE {			
measurementReport ::= SEQUENCE {			
measResults SEQUENCE {			
measId			
measResultServingFreqList SEQUENCE {	1 entry		
servFreqId			
measResultServingCell SEQUENCE {			
physCellId	Physical CellID of the NR Cell 2		
cgi-Info	Not present		
measResult SEQUENCE {			
cellResults SEQUENCE {			
resultsSSB-Cell SEQUENCE {			
rsrp	Not checked		
rsrq	Not checked		
sinr	Not checked		
}			
}			
rsIndexResults SEQUENCE {			
resultsSSB-Indexes	Contains SSB-Index for BeamIndex#0 and BeamIndex#1		
}			
}			
}			
}			
}			

**Table 8.2.3.10.1.3.3-12: MeasurementReport (step 6, Table 8.2.3.10.1.3.2-2)**

Derivation Path: TS 38.331 [6], clause 6.2.2			
Information Element	Value/remark	Comment	Condition
MeasurementReport ::= SEQUENCE {			
criticalExtensions CHOICE {			
c1 CHOICE {			
measurementReport ::= SEQUENCE {			
measResults SEQUENCE {			
measId			
measResultServingFreqList SEQUENCE {	1 entry		
servFreqId			
measResultServingCell SEQUENCE {			
physCellId	Physical CellID of the NR Cell 2		
cgi-Info	Not present		
measResult SEQUENCE {			
cellResults SEQUENCE {			
resultsSSB-Cell SEQUENCE {			
rsrp	Not checked		
rsrq	Not checked		
sinr	Not checked		
}			
}			
rsIndexResults SEQUENCE {			
resultsSSB-Indexes	Contains SSB-Index for BeamIndex#0		
}			
}			
}			
}			
}			
}			
}			
}			

**Table 8.2.3.10.1.3.3-13: MeasConfig (step 7, Table 8.2.3.10.1.3.3-2)**

Derivation Path: 38.508-1 [4], Table 4.6.3-50			
Information Element	Value/remark	Comment	Condition
MeasConfig ::= SEQUENCE {			
measIdToRemoveList SEQUENCE (SIZE (1..maxMeasId)) OF SEQUENCE {	1 entry		
Meas-Id[1]	1		
Meas-Id[1]	1		
}			
}			

**Table 8.2.3.10.1.3.3-14: MeasConfig (step 9, Table 8.2.3.10.1.3.3-2)**

Derivation Path: 38.508-1 [4], Table 4.6.3-50			
Information Element	Value/remark	Comment	Condition
MeasConfig ::= SEQUENCE {			
measObjectToAddModList	IdMeasObjectToAdd		
reportConfigToAddModList	IdReportConfigToAdd		
measIdToAddModList	IdMeasIdToAdd		
s-MeasureConfig CHOICE {			
csi-rsrp	[45]		
}			
}			



**Table 8.2.3.10.1.3.3-15: MeasurementReport (step 12, Table 8.2.3.10.1.3.2-2)**

Derivation Path: TS 38.331 [6], clause 6.2.2			
Information Element	Value/remark	Comment	Condition
MeasurementReport ::= SEQUENCE {			
criticalExtensions CHOICE {			
c1 CHOICE {			
measurementReport ::= SEQUENCE {			
measResults SEQUENCE {			
measId			
measResultServingFreqList SEQUENCE {	1 entry		
servFreqId			
measResultServingCell SEQUENCE {			
physCellId	Physical CellID of the NR Cell 2		
cgi-Info	Not present		
measResult SEQUENCE {			
cellResults SEQUENCE {			
resultsSSB-Cell SEQUENCE {			
rsrp	Not checked		
rsrq	Not checked		
sinr	Not checked		
}			
}			
rsIndexResults SEQUENCE {			
resultsCSI-RS-Indexes	Contains SSB-Index for BeamIndex#0 and BeamIndex#1		
}			
}			
}			
}			
}			
}			

Table 8.2.3.10.1.3.3-16: MeasurementReport (step 14, Table 8.2.3.10.1.3.2-2)

Derivation Path: TS 38.331 [6], clause 6.2.2			
Information Element	Value/remark	Comment	Condition
MeasurementReport ::= SEQUENCE {			
criticalExtensions CHOICE {			
c1 CHOICE {			
measurementReport ::= SEQUENCE {			
measResults SEQUENCE {			
measId			
measResultServingFreqList SEQUENCE {	1 entry		
servFreqId			
measResultServingCell SEQUENCE {			
physCellId	Physical CellID of the NR Cell 2		
cgi-Info	Not present		
measResult SEQUENCE {			
cellResults SEQUENCE {			
resultsSSB-Cell SEQUENCE {			
rsrp	Not checked		
rsrq	Not checked		
sinr	Not checked		
}			
}			
rsIndexResults SEQUENCE {			
resultsCSI-RS-Indexes	Contains SSB-Index for BeamIndex#0		
}			
}			
}			
}			
}			
}			
}			
}			

### 8.2.3.11 Measurement Gaps patterns Related

#### 8.2.3.11.1 Measurement Gaps patterns Related / LTE/NR FR1 / EN-DC

FFS

#### 8.2.3.11.2 Measurement Gaps patterns Related / LTE/NR FR2 / EN-DC

FFS

### 8.2.3.12 Measurement configuration control and reporting / Inter-RAT measurements / Event B2 / Measurement of NR cells

#### 8.2.3.12.1 Measurement configuration control and reporting / Inter-RAT measurements / Event B2 / Measurement of NR cells / EN-DC

##### 8.2.3.12.1.1 Test Purpose (TP)

(1)

**with** { UE in RRC\_CONNECTED state with EN-DC, and, MCG (E-UTRA PDCP) only having completed the radio bearer establishment and performed the inter RAT measurement for NR cell and not detected entering condition for the event B2 is met }

**ensure that** {

**when** { UE detects entering condition for the event B2 is not met }

**then** { UE does not transmit any MeasurementReport }

}

(2)

```

with { UE in RRC_CONNECTED state with EN-DC, and, MCG (E-UTRA PDCP) only having completed the radio
bearer establishment and performed the inter RAT measurement for NR cell and not detected entering
condition for the event B2 is met }
ensure that {
  when { UE detects entering condition for the event B2 is met }
  then { UE transmits a MeasurementReport }
}

```

(3)

```

with { UE in RRC_CONNECTED state with EN-DC, and, MCG (E-UTRA PDCP) only having completed the radio
bearer establishment and performed the inter RAT measurement for NR cell and detected entering
condition for the event B2 is met }
ensure that {
  when { UE detects leaving condition for the event B2 is met }
  then { UE does not transmit any MeasurementReport }
}

```

### 8.2.3.12.1.2 Conformance requirements

References: The conformance requirements covered in the present TC are specified in: TS 36.331, clauses 5.5.1, 5.5.4.1, 5.5.4.8, 5.5.5 and 5.5.5.3. Unless otherwise stated these are Rel-15 requirements.

[TS 36.331, clause 5.5.1]

The UE reports measurement information in accordance with the measurement configuration as provided by E-UTRAN. E-UTRAN provides the measurement configuration applicable for a UE in RRC\_CONNECTED by means of dedicated signalling, i.e. using the *RRCConnectionReconfiguration* or *RRCConnectionResume* message.

The UE can be requested to perform the following types of measurements:

- Intra-frequency measurements: measurements at the downlink carrier frequency(ies) of the serving cell(s).
- Inter-frequency measurements: measurements at frequencies that differ from any of the downlink carrier frequency(ies) of the serving cell(s).
- Inter-RAT measurements of NR frequencies.

...

The measurement configuration includes the following parameters:

1. **Measurement objects:** The objects on which the UE shall perform the measurements.

- For intra-frequency and inter-frequency measurements a measurement object is a single E-UTRA carrier frequency. Associated with this carrier frequency, E-UTRAN can configure a list of cell specific offsets, a list of 'blacklisted' cells and a list of 'whitelisted' cells. Blacklisted cells are not considered in event evaluation or measurement reporting.
- For inter-RAT NR measurements a measurement object is a single NR carrier frequency. Associated with this carrier frequency, E-UTRAN can configure a list of 'blacklisted' cells. Blacklisted cells are not considered in event evaluation or measurement reporting.

...

NOTE 1: Some measurements using the above mentioned measurement objects, only concern a single cell, e.g. measurements used to report neighbouring cell system information, PCell UE Rx-Tx time difference, or a pair of cells, e.g. SSTD measurements between the PCell and the PSCell.

2. **Reporting configurations:** A list of reporting configurations where each reporting configuration consists of the following:

- Reporting criterion: The criterion that triggers the UE to send a measurement report. This can either be periodical or a single event description.

- Reporting format: The quantities that the UE includes in the measurement report and associated information (e.g. number of cells to report).
3. **Measurement identities:** A list of measurement identities where each measurement identity links one measurement object with one reporting configuration. By configuring multiple measurement identities it is possible to link more than one measurement object to the same reporting configuration, as well as to link more than one reporting configuration to the same measurement object. The measurement identity is used as a reference number in the measurement report.
  4. **Quantity configurations:** One quantity configuration is configured per RAT type. The quantity configuration defines the measurement quantities and associated filtering used for all event evaluation and related reporting of that measurement type. One filter can be configured per measurement quantity, except for NR where the network may configure up to 2 sets of quantity configurations each comprising per measurement quantity separate filters for cell and RS index measurement results. The quantity configuration set that applies for a given measurement is indicated within the NR measurement object.

[TS 36.331, clause 5.5.4.1]

The UE shall:

- 1> for each *measId* included in the *measIdList* within *VarMeasConfig*:
  - ...
  - 2> else:
    - ...
    - 3> else if the corresponding *measObject* concerns NR:
      - 4> if the *reportSFTD-Meas* is set to *pSCell* in the corresponding *reportConfigInterRAT*:
        - 5> consider the PSCell to be applicable;
      - 4> else if the *reportSFTD-Meas* is set to *neighborCells* in the corresponding *reportConfigInterRAT*:
        - 5> if *cellsForWhichToReportSFTD* is configured in the corresponding *measObjectNR*:
          - 6> consider any neighbouring NR cell on the associated frequency that is included in *cellsForWhichToReportSFTD* to be applicable;
        - 5> else:
          - 6> consider up to 3 strongest neighbouring NR cells detected on the associated frequency to be applicable when the concerned cells are not included in the *blackCellsToAddModList* defined within the *VarMeasConfig* for this *measId*;
      - 4> else:
        - 5> consider any neighbouring cell detected on the associated frequency to be applicable when the concerned cell is not included in the *blackCellsToAddModList* defined within the *VarMeasConfig* for this *measId*;

[TS 36.331, clause 5.5.4.8]

The UE shall:

- 1> for UTRA and CDMA2000, only trigger the event for cells included in the corresponding measurement object;
- 1> consider the entering condition for this event to be satisfied when both condition B2-1 and condition B2-2, as specified below, are fulfilled;
- 1> consider the leaving condition for this event to be satisfied when condition B2-3 or condition B2-4, i.e. at least one of the two, as specified below, is fulfilled;

Inequality B2-1 (Entering condition 1)

$$M_p + H_{ys} < Thresh1$$

Inequality B2-2 (Entering condition 2)

$$M_n + Ofn - H_{ys} > Thresh2$$

Inequality B2-3 (Leaving condition 1)

$$M_p - H_{ys} > Thresh1$$

Inequality B2-4 (Leaving condition 2)

$$M_n + Ofn + H_{ys} < Thresh2$$

The variables in the formula are defined as follows:

***M<sub>p</sub>*** is the measurement result of the PCell, not taking into account any offsets.

***M<sub>n</sub>*** is the measurement result of the inter-RAT neighbour cell, not taking into account any offsets. For CDMA2000 measurement result, *pilotStrength* is divided by -2.

***Ofn*** is the frequency specific offset of the frequency of the inter-RAT neighbour cell (i.e. *offsetFreq* as defined within the *measObject* corresponding to the frequency of the inter-RAT neighbour cell).

***H<sub>ys</sub>*** is the hysteresis parameter for this event (i.e. *hysteresis* as defined within *reportConfigInterRAT* for this event).

***Thresh1*** is the threshold parameter for this event (i.e. *b2-Threshold1* as defined within *reportConfigInterRAT* for this event).

***Thresh2*** is the threshold parameter for this event (i.e. *b2-Threshold2* as defined within *reportConfigInterRAT* for this event). For CDMA2000, *b2-Threshold2* is divided by -2.

***M<sub>p</sub>*** is expressed in dBm in case of RSRP, or in dB in case of RSRQ.

***M<sub>n</sub>*** is expressed in dBm or dB, depending on the measurement quantity of the inter-RAT neighbour cell.

***Ofn***, ***H<sub>ys</sub>*** are expressed in dB.

***Thresh1*** is expressed in the same unit as ***M<sub>p</sub>***.

***Thresh2*** is expressed in the same unit as ***M<sub>n</sub>***.

[TS 36.331, clause 5.5.5]

The purpose of this procedure is to transfer measurement results from the UE to E-UTRAN. The UE shall initiate this procedure only after successful security activation.

For the *measId* for which the measurement reporting procedure was triggered, the UE shall set the *measResults* within the *MeasurementReport* message as follows:

- 1> set the *measId* to the measurement identity that triggered the measurement reporting;
- 1> set the *measResultPCell* to include the quantities of the PCell;
- 1> set the *measResultServFreqList* to include for each E-UTRA SCell that is configured, if any, within *measResultSCell* the quantities of the concerned SCell, if available according to performance requirements in [16], except if *purpose* for the *reportConfig* associated with the *measId* that triggered the measurement reporting is set to *reportLocation*;
- 1> if the *reportConfig* associated with the *measId* that triggered the measurement reporting includes *reportAddNeighMeas*:
  - 2> for each E-UTRA serving frequency for which *measObjectId* is referenced in the *measIdList*, other than the frequency corresponding with the *measId* that triggered the measurement reporting:
    - 3> set the *measResultServFreqList* to include within *measResultBestNeighCell* the *physCellId* and the quantities of the best non-serving cell, based on RSRP, on the concerned serving frequency;

1> if the *triggerType* is set to *event*; and if the corresponding *measObject* concerns NR; and if *eventId* is set to *eventB1* or *eventB2*; or

...

2> if *purpose* for the *reportConfig* associated with the *measId* that triggered the measurement reporting is set to a value other than *reportLocation*:

3> set the *measResultServFreqListNR* to include for each NR serving frequency, if any, the following:

4> set *measResultSCell* to include the available results of the NR serving cell, as specified in 5.5.5.1; 4> if the *reportConfig* associated with the *measId* that triggered the measurement reporting includes *reportAddNeighMeas*:

5> set *measResultBestNeighCell* to include the available results, as specified in 5.5.5.1, of the best non-serving cell, ordered based on the quantity determined as specified in 5.5.5.2;

5> for each (serving or neighbouring) cell for which the UE reports results according to the previous, additionally include available beam results according to the following:

6> if *maxReportRS-Index* is configured, set *measResultCellRS-Index* to include results, as specified in 5.5.5.2, of up to *maxReportRS-Index* beams, ordered based on the quantity determined as specified in 5.5.5.3;

1> if there is at least one applicable neighbouring cell to report:

2> set the *measResultNeighCells* to include the best neighbouring cells up to *maxReportCells* in accordance with the following:

3> if the *triggerType* is set to *event*:

4> include the cells included in the *cellsTriggeredList* as defined within the *VarMeasReportList* for this *measId*;

3> else:

4> include the applicable cells for which the new measurement results became available since the last periodical reporting or since the measurement was initiated or reset;

NOTE 1: The reliability of the report (i.e. the certainty it contains the strongest cells on the concerned frequency) depends on the measurement configuration i.e. the *reportInterval*. The related performance requirements are specified in TS 36.133 [16].

3> for each cell that is included in the *measResultNeighCells*, include the *physCellId*;

3> if the *triggerType* is set to *event*; or the *purpose* is set to *reportStrongestCells* or to *reportStrongestCellsForSON*:

4> for each included cell, include the layer 3 filtered measured results in accordance with the *reportConfig* for this *measId*, ordered as follows:

5> if the *measObject* associated with this *measId* concerns E-UTRA:

6> set the *measResult* to include the quantity(ies) indicated in the *reportQuantity* within the concerned *reportConfig* in order of decreasing *triggerQuantity*, i.e. the best cell is included first;

5> if the *measObject* associated with this *measId* concerns NR:

6> set the *measResultCell* to include the quantity(ies) indicated in the *reportQuantityCellNR* within the concerned *reportConfig* in order of decreasing quantity according to *bN-ThresholdYNR*, i.e. the best cell is included first;

6> if *maxReportRS-Index* and *reportQuantityRS-IndexNR* are configured, set *measResultCellRS-Index* to include results of the best beam and the beams whose quantity is above *threshRS-Index* defined in the *VarMeasConfig* for the corresponding *measObject*, up to *maxReportRS-*

*Index* beams in total, and in order of decreasing quantity, same as used for cell reporting, and as follows:

- 7> order beams based on the sorting quantity determined as specified in 5.5.5.3;
- 7> include *ssbIndex*;
- 7> if *reportRS-IndexResultsNR* is configured, for each quantity indicated, include the corresponding measurement result;

[TS 36.331, clause 5.5.5.3]

When configured to report the best cells or beams, the UE shall determine the quantity that is used to order and select as follows:

- 1> consider the quantities the UE reports as candidate sorting quantities i.e. as follows:
  - 2> for NR cells for which measurement reporting is triggered (i.e. NR cells included in *cellsTriggered*):
    - 3> the quantities defined by *reportQuantityCellNR*, when used for sorting cells;
    - 3> the quantities defined by *reportQuantityRS-IndexNR*, when used for sorting beams;
  - 2> for cells on NR serving frequencies:
    - 3> the available quantities of available NR measurement results as specified in 5.5.5.2;
- 1> if *reportType* is set to *eventTriggered*; and if *eventId* is set to *eventB1* or *eventB2*:
  - 2> consider the trigger quantity to be the sorting quantity;
- 1> if *reportType* is set to *periodical*:
  - 2> if there is a single candidate sorting quantity;
    - 3> consider the concerned quantity to be the sorting quantity;
  - 2> else:
    - 3> if RSRP is one of the candidate sorting quantities;
      - 4> consider RSRP to be the sorting quantity;
    - 3> else:
      - 4> consider RSRQ to be the sorting quantity;

8.2.3.12.1.3 Test description

8.2.3.12.1.3.1 Pre-test conditions

System Simulator:

- E-UTRA Cell 1 and NR Cell 1.

UE:

- None.

Preamble:

- The UE is in state RRC\_CONNECTED using generic procedure parameter Connectivity (*EN-DC*) with MCG only established according to [4].

8.2.3.12.1.3.2 Test procedure sequence

Table 8.2.3.12.1.3.2-1 illustrates the downlink power levels and other changing parameters to be applied for the cells at various time instants of the test execution. Row marked "T0" denotes the initial conditions after preamble, while

columns marked "T1" and "T2" are to be applied subsequently. The exact instants on which these values shall be applied are described in the texts in this clause.

**Table 8.2.3.12.1.3.2-1: Time instances of cell power level and parameter changes**

	Parameter	Unit	E-UTRA Cell 1	NR Cell 1	Remark
T0	Cell-specific RS EPRE	dBm/15 kHz	-60	-	The power level values are such that entering conditions for event B2 are not satisfied.
	SS/PBCH SSS EPRE	FFS	-	[-91]	
T1	Cell-specific RS EPRE	dBm/15 kHz	-84	-	The power level values are such that entering conditions for event B2 are satisfied.
	SS/PBCH SSS EPRE	FFS	-	[-79]	
T2	Cell-specific RS EPRE	dBm/15 kHz	-60	-	The power level values are such that leaving conditions for event B2 are satisfied.
	SS/PBCH SSS EPRE	FFS	-	[-91]	

**Table 8.2.3.12.1.3.2-2: Main behaviour**

St	Procedure	Message Sequence		TP	Verdict
		U – S	Message		
1	The SS transmits an <i>RRCCONNECTIONRECONFIGURATION</i> including <i>measConfig</i> to setup inter RAT measurements and reporting for NR Cell 1.	<--	<i>RRCCONNECTIONRECONFIGURATION</i>	-	-
2	The UE transmits an <i>RRCCONNECTIONRECONFIGURATIONCOMPLETE</i> message to confirm the setup of inter RAT measurements for NR Cell 1.	-->	<i>RRCCONNECTIONRECONFIGURATIONCOMPLETE</i>	-	-
3	Check: Does the UE transmit a <i>MEASUREMENTREPORT</i> message on E-UTRA Cell 1 to report the event B2 during the next 10s?	-->	<i>MEASUREMENTREPORT</i>	1	F
4	The SS changes NR Cell 1 and E-UTRA Cell 1 parameters according to the row "T1" in table 8.2.3.12.1.3.2-1.	-	-	-	-
5	Check: Does the UE transmit a <i>MEASUREMENTREPORT</i> message to report the event B2 for NR Cell 1?	-->	<i>MEASUREMENTREPORT</i>	2	P
6	The SS changes NR Cell 1 and E-UTRA Cell 1 parameters according to the row "T2" in table 8.2.3.12.1.3.2-1.	-	-	-	-
7	Wait and ignore <i>MEASUREMENTREPORT</i> messages for 15s to allow change of power levels and UE measurements for NR Cell 1 and E-UTRA Cell 1.	-	-	-	-
8	Check: Does the UE transmit a <i>MEASUREMENTREPORT</i> message on E-UTRA Cell 1 to report the event B2 during the next 10s?	-->	<i>MEASUREMENTREPORT</i>	3	F

### 8.2.3.12.1.3.3 Specific message contents

**Table 8.2.3.12.1.3.3-1: *RRCCONNECTIONRECONFIGURATION* (step 1, Table 8.2.3.12.1.3.2-2)**

Derivation Path: 36.508 [7], Table 4.6.1-8, condition MEAS
--



**Table 8.2.3.12.1.3.3-2: MeasConfig (Table 8.2.3.12.1.3.3-1)**

Derivation Path: 36.508 [7], Table 4.6.6-1			
Information Element	Value/remark	Comment	Condition
MeasConfig ::= SEQUENCE {			
measObjectToAddModList SEQUENCE (SIZE (1..maxObjectld)) OF SEQUENCE {	1 entries		
measObjectld[1]	[ldMeasObject-NRf1]		
measObject[1]	MeasObjectNR-GENERIC (NRf1)		
}			
reportConfigToAddModList SEQUENCE (SIZE (1..maxReportConfigld)) OF SEQUENCE {	1 entry		
reportConfigld[1]	[ldReportConfig-B2-NR]		
reportConfig[1]	[ReportConfig-B2-NR-r15(FFS)]		
}			
measldToAddModList SEQUENCE (SIZE (1..maxMeasld)) OF SEQUENCE {	1 entry		
measld[1]	1		
measObjectld[1]	[ldMeasObject-NRf1]		
reportConfigld[1]	[ldReportConfig-B2-NR]		
}			
quantityConfig	QuantityConfig-DEFAULT		
}			

**Table 8.2.3.12.1.3.3-3: QuantityConfig-DEFAULT (Table 8.2.3.12.1.3.3-2)**

Derivation Path: 36.508 [7], Table 4.6.6-3A			
Information Element	Value/remark	Comment	Condition
QuantityConfig-DEFAULT ::= SEQUENCE {			
quantityConfigNRLList-r15 SEQUENCE ((SIZE (1..maxQuantSetsNR-r15)) OF SEQUENCE {			
measQuantityCellNR-r15 SEQUENCE {			
filterCoeff-RSRP-r15	fc0		
filterCoeff-RSRQ-r15	fc0		
}			
}			
}			

**Table 8.2.3.12.1.3.3-4: MeasObjectNR-GENERIC (NRf1) (Table 8.2.3.12.1.3.3-2)**

Derivation Path: 36.508 [7], Table 4.6.6-2B			
Information Element	Value/remark	Comment	Condition
MeasObjectNR-GENERIC(Freq) ::= SEQUENCE {			
carrierFreq-r15	Downlink carrier frequency of NR cell 1		
}			

**Table 8.2.3.12.1.3.3-5: ReportConfigInterRAT-B2-NR-r15 (FFS) (Table 8.2.3.12.1.3.3-2)**

Derivation Path: 36.508 [7], Table 4.6.6-8			
Information Element	Value/remark	Comment	Condition
ReportConfig-B2-NR ::= SEQUENCE {			
triggerType CHOICE {			
event SEQUENCE {			
eventId CHOICE {			
eventB2-NR-r15 SEQUENCE{			
b2-Threshold1-r15 CHOICE{			
threshold-RSRP	FFS	EUTRA Thres is actual threshold value in dBm	
}			
b2-Threshold2NR-r15 CHOICE{			
nr-RSRP-r15	FFS	NR Thres is actual threshold value in dBm	
}			
}			
}			
}			
}			
reportAmount	infinity		
}			

**Table 8.2.3.12.1.3.3-6: MeasurementReport (step 5, Table 8.2.3.12.1.3.2-2)**

Derivation Path: 36.508 [7], Table 4.6.1-5			
Information Element	Value/remark	Comment	Condition
MeasurementReport ::= SEQUENCE {			
criticalExtensions CHOICE {			
c1 CHOICE{			
measurementReport-r8 SEQUENCE {			
measResults SEQUENCE {			
measId	1		
measResultPCell SEQUENCE {			
rsrpResult	(0..97)		
rsrqResult	(0..34)		
}			
measResultNeighCells CHOICE {			
measResultNeighCellListNR-r15 SEQUENCE (SIZE (1..maxCellReport)) OF SEQUENCE {	1 entry		
pci-r15 [1]	PhysicalCellIdentity of NR Cell 1		
measResultCell-r15 [1] SEQUENCE {			
rsrpResult-r15	(0..127)		
}			
}			
}			
}			
}			
}			
}			

### 8.2.3.13 PCell Handover with SCG change / Reconfiguration with sync / SCG DRB

#### 8.2.3.13.1 PCell Handover with SCG change / Reconfiguration with sync / SCG DRB / EN-DC

##### 8.2.3.13.1.1 Test Purpose (TP)

(1)

```
with { UE in RRC_CONNECTED state in EN-DC mode, and, MCG (E-UTRA PDCP) and SCG DRB established }
ensure that {
  when { UE receives an RRCConnectionReconfiguration message containing mobilityControlInfo to
handover to target E-UTRAN PCell involving SCG change with reconfigurationWithSync on the same
PSCell }
    then { UE sends an RRCConnectionReconfigurationComplete message }
}
```

##### 8.2.3.13.1.2 Conformance requirements

References: The conformance requirements covered in the present TC are specified in: TS 36.331, clause 5.3.5.4, TS 38.331, clauses 5.3.5.3, 5.3.5.5.1 and 5.3.5.5.2. Unless otherwise stated these are Rel-15 requirements.

[TS 36.331, clause 5.3.5.4]

If the *RRCConnectionReconfiguration* message includes the *mobilityControlInfo* and the UE is able to comply with the configuration included in this message, the UE shall:

- 1> stop timer T310, if running;
- 1> stop timer T312, if running;
- 1> start timer T304 with the timer value set to *t304*, as included in the *mobilityControlInfo*;
- 1> stop timer T370, if running;
- 1> if the *carrierFreq* is included:
  - 2> consider the target PCell to be one on the frequency indicated by the *carrierFreq* with a physical cell identity indicated by the *targetPhysCellId*;
- 1> else:
  - 2> consider the target PCell to be one on the frequency of the source PCell with a physical cell identity indicated by the *targetPhysCellId*;
- 1> start synchronising to the DL of the target PCell;

NOTE 1: The UE should perform the handover as soon as possible following the reception of the RRC message triggering the handover, which could be before confirming successful reception (HARQ and ARQ) of this message.

...

- 1> if the received *RRCConnectionReconfiguration* includes the *nr-SecondaryCellGroupConfig*:

- 2> perform NR RRC Reconfiguration as specified in TS 38.331 [82, 5.3.5.5].

...

- 1> set the content of *RRCConnectionReconfigurationComplete* message as follows:

...

- 2> if the received *RRCConnectionReconfiguration* message included *nr-SecondaryCellGroupConfig*:

- 3> include *scg-ConfigResponseNR* in accordance with TS 38.331 [82, 5.3.5.3];

[TS 38.331, clause 5.3.5.3]

The UE shall perform the following actions upon reception of the *RRCReconfiguration*:

- 1> if the *RRCReconfiguration* includes the *secondaryCellGroup*:
  - 2> perform the cell group configuration for the SCG according to 5.3.5.5;
- 1> if the *RRCReconfiguration* message contains the *radioBearerConfig*:
  - 2> perform the radio bearer configuration according to 5.3.5.6;
- 1> if the *RRCReconfiguration* message includes the *measConfig*:
  - 2> perform the measurement configuration procedure as specified in 5.5.2;
- 1> if the UE is configured with E-UTRA *nr-SecondaryCellGroupConfig* (MCG is E-UTRA):
  - 2> if *RRCReconfiguration* was received via SRB1:
    - 3> construct *RRCReconfigurationComplete* message and submit it via the EUTRA MCG embedded in E-UTRA RRC message *RRCConnectionReconfigurationComplete* as specified in TS 36.331 [10].
    - 3> if *reconfigurationWithSync* was included in *spCellConfig* of an SCG:
      - 4> initiate the random access procedure on the SpCell, as specified in TS 38.321 [3];
    - 3> else:
      - 4> the procedure ends;
  - 2> else (*RRCReconfiguration* was received via SRB3):
    - 3> if *reconfigurationWithSync* was included in *spCellConfig* of an SCG:
      - 4> initiate the random access procedure on the SpCell, as specified in TS 38.321 [3];
    - 3> submit the *RRCReconfigurationComplete* message via SRB3 to lower layers for transmission using the new configuration and the procedure ends;

NOTE: In the case of SRB1, the random access is triggered by RRC layer itself as there is not necessarily other UL transmission. In the case of SRB3, the random access is triggered by the MAC layer due to arrival of *RRCReconfigurationComplete*.

- 1> if MAC of an NR cell group successfully completes a random access procedure triggered above:
  - 2> stop timer T304 for that cell group;
  - 2> apply the parts of the CQI reporting configuration, the scheduling request configuration and the sounding RS configuration that do not require the UE to know the SFN of the respective target SpCell, if any;
  - 2> apply the parts of the measurement and the radio resource configuration that require the UE to know the SFN of the respective target SpCell (e.g. measurement gaps, periodic CQI reporting, scheduling request configuration, sounding RS configuration), if any, upon acquiring the SFN of that target SpCell;
  - 2> the procedure ends;

[TS 38.331, clause 5.3.5.5.1]

The network configures the UE with one Secondary Cell Group (SCG). For EN-DC, the MCG is configured as specified in TS 36.331 [10]. The network provides the configuration parameters for a cell group in the *CellGroupConfig* IE.

The UE performs the following actions based on a received *CellGroupConfig* IE:

- 1> if the *CellGroupConfig* contains the *spCellConfig* with *reconfigurationWithSync*:
  - 2> perform Reconfiguration with sync according to 5.3.5.5.2;
  - 2> resume all suspended radio bearers and resume SCG transmission for all radio bearers, if suspended;

- 1> if the *CellGroupConfig* contains the *rlc-BearerToReleaseList*:
  - 2> perform RLC bearer release as specified in 5.3.5.5.3;
- 1> if the *CellGroupConfig* contains the *rlc-BearerToAddModList*:
  - 2> perform the RLC bearer addition/modification as specified in 5.3.5.5.4;
- 1> if the *CellGroupConfig* contains the *mac-CellGroupConfig*:
  - 2> configure the MAC entity of this cell group as specified in 5.3.5.5.5;
- 1> if the *CellGroupConfig* contains the *sCellToReleaseList*:
  - 2> perform SCell release as specified in 5.3.5.5.8;
- 1> if the *CellGroupConfig* contains the *spCellConfig*:
  - 2> configure the SpCell as specified in 5.3.5.5.7;
- 1> if the *CellGroupConfig* contains the *sCellToAddModList*:
  - 2> perform SCell addition/modification as specified in 5.3.5.5.9.

[TS 38.331, clause 5.3.5.5.2]

The UE shall perform the following actions to execute a reconfiguration with sync.

- 1> stop timer T310 for the corresponding SpCell, if running;
- 1> start timer T304 for the corresponding SpCell with the timer value set to *t304*, as included in the *reconfigurationWithSync*;
- 1> if the *frequencyInfoDL* is included:
  - 2> consider the target SpCell to be one on the frequency indicated by the *frequencyInfoDL* with a physical cell identity indicated by the *physCellId*;
- 1> else:
  - 2> consider the target SpCell to be one on the frequency of the source SpCell with a physical cell identity indicated by the *physCellId*;
- 1> start synchronising to the DL of the target SpCell and acquire the *MIB* of the target SpCell as specified in 5.2.2.3.1;

NOTE: The UE should perform the reconfiguration with sync as soon as possible following the reception of the RRC message triggering the reconfiguration with sync, which could be before confirming successful reception (HARQ and ARQ) of this message.

- 1> reset the MAC entity of this cell group;
- 1> consider the SCell(s) of this cell group, if configured, to be in deactivated state;
- 1> apply the value of the *newUE-Identity* as the C-RNTI for this cell group;

**Editor's Note: Verify that this does not configure some common parameters which are later discarded due to e.g. SCell release or due to LCH release.**

- 1> configure lower layers in accordance with the received *spCellConfigCommon*;
- 1> consider the initial bandwidth part to be the active bandwidth part where random access is performed;
- 1> configure lower layers in accordance with any additional fields, not covered in the previous, if included in the received *reconfigurationWithSync*.

## 8.2.3.13.1.3 Test description

## 8.2.3.13.1.3.1 Pre-test conditions

## System Simulator:

- E-UTRA Cell 1 is the PCell, E-UTRA Cell 2 is the target PCell and NR Cell 1 is the PSCell.

## UE:

- None.

## Preamble:

- The UE is in state RRC\_CONNECTED using generic procedure parameter Connectivity (EN-DC), Bearers (MCG, SCG) and Test Mode (On) associated with UE test loop mode B according to TS 38.508-1 [4], table 4.5.1-1.

## 8.2.3.13.1.3.2 Test procedure sequence

Table 8.2.3.13.1.3.2-1 illustrates the downlink power levels and other changing parameters to be applied for the cells at various time instants of the test execution. Row marked "T0" denotes the initial conditions after preamble, while columns marked "T1" is to be applied subsequently. The exact instants on which these values shall be applied are described in the texts in this clause.

**Table 8.2.3.13.1.3.2-1: Time instances of cell power level and parameter changes**

	Parameter	Unit	E-UTRA Cell 1	E-UTRA Cell 2	NR Cell 1	Remark
T0	Cell-specific RS EPRE	dBm/15kHz	-85	-91	-	
	SS/PBCH SSS EPRE	dBm/15kHz	-	-	[-94]	
T1	Cell-specific RS EPRE	dBm/15kHz	-85	-79	-	
	SS/PBCH SSS EPRE	dBm/15kHz	-	-	[-94]	

**Table 8.2.3.13.1.3.2-2: Main behaviour**

St	Procedure	Message Sequence		TP	Verdict
		U - S	Message		
1	SS re-adjusts the cell-specific reference signal level according to row "T1" in table 8.2.3.13.1.3.2-1.	-	-	-	-
2	The SS transmits an <i>RRCConnectionReconfiguration</i> message containing <i>mobilityControlInfo</i> to handover to E-UTRA Cell 2 and NR <i>RRCReconfiguration</i> message to perform SCG change with <i>reconfigurationWithSync</i> with the same PSCell.	<--	<i>RRCConnectionReconfiguration (RRCReconfiguration)</i>	-	-
3	Check: Does the UE transmit an <i>RRCConnectionReconfigurationComplete</i> message containing NR <i>RRCReconfigurationComplete</i> message on E-UTRA Cell 2?	-->	<i>RRCConnectionReconfigurationComplete (RRCReconfigurationComplete)</i>	1	P
4	The SS transmits one IP Packet each to verify data path on SCG DRB.	-	-	-	-
5	Check: Does UE send the IP Packet on SCG DRB in the uplink?	-	-	1	P

8.2.3.13.1.3.3 Specific message contents

**Table 8.2.3.13.1.3.3-1: *RRCConnectionReconfiguration* (step 1, Table 8.2.3.13.1.3.2-2)**

Derivation Path: 36.508 [7], Table 4.6.1-8			
Information Element	Value/remark	Comment	Condition
RRCConnectionReconfiguration ::= SEQUENCE {			
criticalExtensions CHOICE {			
c1 CHOICE {			
rrcConnectionReconfiguration-r8 ::= SEQUENCE {			
mobilityControllInfo	MobilityControllInfo-HO		HO, HO-TO-EUTRA
nonCriticalExtension SEQUENCE {			
nonCriticalExtension SEQUENCE {			
nonCriticalExtension SEQUENCE {			
nonCriticalExtension SEQUENCE {			
nonCriticalExtension SEQUENCE {			
nonCriticalExtension SEQUENCE {			
nonCriticalExtension SEQUENCE {			
nr-Config-r15 CHOICE {			
setup SEQUENCE {			
nr-SecondaryCellGroupConfig-r15	OCTET STRING including the <i>RRCReconfiguration</i> message containing the IE secondaryCellGroup	reconfigurationwithsync is present in spCellConfig IE in the secondaryCellGroup IE	
}			
nonCriticalExtension ::= SEQUENCE {}			
}			
}			
}			
}			
}			
}			
}			
}			
}			
}			
}			
}			
}			
}			
}			
}			
}			

**Table 8.2.3.13.1.3.3-2: *MobilityControllInfo* (Table 8.2.3.13.1.3.3-1)**

Derivation Path: 36.508 [7], Table 4.6.5-1			
Information Element	Value/remark	Comment	Condition
MobilityControllInfo-HO ::= SEQUENCE {			
targetPhysCellId	PhysicalCellId of E-UTRA Cell 2		
carrierFreq SEQUENCE {			
dl-CarrierFreq	Same downlink EARFCN as used for E-UTRA Cell 2		
}			
carrierFreq SEQUENCE {}	Not present		Band > 64
carrierFreq-v9e0 SEQUENCE {			Band > 64
dl-CarrierFreq-v9e0	Same downlink EARFCN as used for E-UTRA Cell 2		
}			
}			

**Table 8.2.3.13.1.3.3-3: RRCReconfiguration (Table 8.2.3.13.1.3.3-1)**

Derivation Path: 38.508-1 [4], Table [4.6.1-3]			
Information Element	Value/remark	Comment	Condition
RRCReconfiguration ::= SEQUENCE {			
criticalExtensions CHOICE {			
rrcReconfiguration ::= SEQUENCE {			
secondaryCellGroup	CellGroupConfig		
}			
}			
}			

**Table 8.2.3.13.1.3.3-4: CellGroupConfig (Table 8.2.3.13.1.3.3-3)**

Derivation Path: 38.508-1 [4], Table [4.6.3-13] with condition EN-DC
--

## 8.2.3.14 SCG change / Reconfiguration with sync / Split DRB

### 8.2.3.14.1 SCG change / Reconfiguration with sync / Split DRB / EN-DC

#### 8.2.3.14.1.1 Test Purpose (TP)

(1)

```
with { UE in RRC_CONNECTED state with EN-DC, and, MCG (E-UTRA PDCP) and Split }
ensure that {
  when { UE receives an RRCConnectionReconfiguration message to handover from NR PSCell involving
  SCG change with reconfigurationWithSync to the target NR cell with Split DRB }
  then { UE sends an RRCConnectionReconfigurationComplete message }
}
```

#### 8.2.3.14.1.2 Conformance requirements

References: The conformance requirements covered in the present TC are specified in: TS 36.331, clause 5.3.5.3, TS 38.331, clauses 5.3.5.3, 5.3.5.5.1 and 5.3.5.5.2. Unless otherwise stated these are Rel-15 requirements.

[TS 36.331, clause 5.3.5.3]

If the *RRCConnectionReconfiguration* message does not include the *mobilityControlInfo* and the UE is able to comply with the configuration included in this message, the UE shall:

...

- 1> if the received *RRCConnectionReconfiguration* includes the *nr-Config* and it is set to *release*: or
- 1> if the received *RRCConnectionReconfiguration* includes *endc-ReleaseAndAdd* and it is set to *TRUE*:
  - 2> perform ENDC release as specified in TS38.331 [82, 5.3.5.x];
- 1> if the received *RRCConnectionReconfiguration* includes the *sk-Counter*:
  - 2> perform key update procedure as specified in TS 38.331 [82, 5.3.5.8];
- 1> if the received *RRCConnectionReconfiguration* includes the *nr-SecondaryCellGroupConfig*:
  - 2> perform NR RRC Reconfiguration as specified in TS 38.331 [82, 5.3.5.3];
- 1> if the received *RRCConnectionReconfiguration* includes the *nr-RadioBearerConfig1*:
  - 2> perform radio bearer configuration as specified in TS 38.331 [82, 5.3.5.6];
- 1> if the received *RRCConnectionReconfiguration* includes the *nr-RadioBearerConfig2*:
  - 2> perform radio bearer configuration as specified in TS 38.331 [82, 5.3.5.6];

...



- 1> set the content of *RRCConnectionReconfigurationComplete* message as follows:
  - 2> if the *RRCConnectionReconfiguration* message includes *perCC-GapIndicationRequest*:
    - 3> include *perCC-GapIndicationList* and *numFreqEffective*;
  - 2> if the frequencies are configured for reduced measurement performance:
    - 3> include *numFreqEffectiveReduced*;
  - 2> if the received *RRCConnectionReconfiguration* message included *nr-SecondaryCellGroupConfig*:
    - 3> include *scg-ConfigResponseNR* in accordance with TS 38.331 [82, 5.3.5.3];
- 1> submit the *RRCConnectionReconfigurationComplete* message to lower layers for transmission using the new configuration, upon which the procedure ends;

[TS 38.331, clause 5.3.5.3]

The UE shall perform the following actions upon reception of the *RRCReconfiguration*:

- 1> if the *RRCReconfiguration* includes the *secondaryCellGroup*:
  - 2> perform the cell group configuration for the SCG according to 5.3.5.5;
- 1> if the *RRCReconfiguration* message contains the *radioBearerConfig*:
  - 2> perform the radio bearer configuration according to 5.3.5.6;
- 1> if the *RRCReconfiguration* message includes the *measConfig*:
  - 2> perform the measurement configuration procedure as specified in 5.5.2;
- 1> if the UE is configured with E-UTRA *nr-SecondaryCellGroupConfig* (MCG is E-UTRA):
  - 2> if *RRCReconfiguration* was received via SRB1:
    - 3> construct *RRCReconfigurationComplete* message and submit it via the EUTRA MCG embedded in E-UTRA RRC message *RRCConnectionReconfigurationComplete* as specified in TS 36.331 [10];
    - 3> if *reconfigurationWithSync* was included in *spCellConfig* of an SCG:
      - 4> initiate the random access procedure on the SpCell, as specified in TS 38.321 [3];
    - 3> else:
      - 4> the procedure ends;
  - 2> else (*RRCReconfiguration* was received via SRB3):
    - 3> if *reconfigurationWithSync* was included in *spCellConfig* of an SCG:
      - 4> initiate the random access procedure on the SpCell, as specified in TS 38.321 [3];
    - 3> submit the *RRCReconfigurationComplete* message via SRB3 to lower layers for transmission using the new configuration, and the procedure ends;

NOTE: In the case of SRB1, the random access is triggered by RRC layer itself as there is not necessarily other UL transmission. In the case of SRB3, the random access is triggered by the MAC layer due to arrival of *RRCReconfigurationComplete*.

- 1> if MAC of an NR cell group successfully completes a random access procedure triggered above:
  - 2> stop timer T304 for that cell group;
  - 2> apply the parts of the CQI reporting configuration, the scheduling request configuration and the sounding RS configuration that do not require the UE to know the SFN of the respective target SpCell, if any;

2> apply the parts of the measurement and the radio resource configuration that require the UE to know the SFN of the respective target SpCell (e.g. measurement gaps, periodic CQI reporting, scheduling request configuration, sounding RS configuration), if any, upon acquiring the SFN of that target SpCell;

2> the procedure ends.

[TS 38.331, clause 5.3.5.5.1]

The network configures the UE with one Secondary Cell Group (SCG). For EN-DC, the MCG is configured as specified in TS 36.331 [10]. The network provides the configuration parameters for a cell group in the *CellGroupConfig* IE.

The UE performs the following actions based on a received *CellGroupConfig* IE:

- 1> if the *CellGroupConfig* contains the *spCellConfig* with *reconfigurationWithSync*:
  - 2> perform Reconfiguration with sync according to 5.3.5.5.2;
  - 2> resume all suspended radio bearers and resume SCG transmission for all radio bearers, if suspended;
- 1> if the *CellGroupConfig* contains the *rlc-BearerToReleaseList*:
  - 2> perform RLC bearer release as specified in 5.3.5.5.3;
- 1> if the *CellGroupConfig* contains the *rlc-BearerToAddModList*:
  - 2> perform the RLC bearer addition/modification as specified in 5.3.5.5.4;
- 1> if the *CellGroupConfig* contains the *mac-CellGroupConfig*:
  - 2> configure the MAC entity of this cell group as specified in 5.3.5.5.5;
- 1> if the *CellGroupConfig* contains the *sCellToReleaseList*:
  - 2> perform SCell release as specified in 5.3.5.5.8;
- 1> if the *CellGroupConfig* contains the *spCellConfig*:
  - 2> configure the SpCell as specified in 5.3.5.5.7;
- 1> if the *CellGroupConfig* contains the *sCellToAddModList*:
  - 2> perform SCell addition/modification as specified in 5.3.5.5.9.

[TS 38.331, clause 5.3.5.5.2]

The UE shall perform the following actions to execute a reconfiguration with sync.

- 1> stop timer T310 for the corresponding SpCell, if running;
- 1> start timer T304 for the corresponding SpCell with the timer value set to *t304*, as included in the *reconfigurationWithSync*;
- 1> if the *frequencyInfoDL* is included:
  - 2> consider the target SpCell to be one on the frequency indicated by the *frequencyInfoDL* with a physical cell identity indicated by the *physCellId*;
- 1> else:
  - 2> consider the target SpCell to be one on the frequency of the source SpCell with a physical cell identity indicated by the *physCellId*;
- 1> start synchronising to the DL of the target SpCell and acquire the *MIB* of the target SpCell as specified in 5.2.2.3.1;

NOTE: The UE should perform the reconfiguration with sync as soon as possible following the reception of the RRC message triggering the reconfiguration with sync, which could be before confirming successful reception (HARQ and ARQ) of this message.

1> reset the MAC entity of this cell group;

1> consider the SCell(s) of this cell group, if configured, to be in deactivated state;

1> apply the value of the *newUE-Identity* as the C-RNTI for this cell group;

**Editor's Note: Verify that this does not configure some common parameters which are later discarded due to e.g. SCell release or due to LCH release.**

1> configure lower layers in accordance with the received *spCellConfigCommon*;

1> consider the initial bandwidth part to be the active bandwidth part where random access is performed;

1> configure lower layers in accordance with any additional fields, not covered in the previous, if included in the received *reconfigurationWithSync*.

### 8.2.3.14.1.3 Test description

#### 8.2.3.14.1.3.1 Pre-test conditions

System Simulator:

- E-UTRA Cell 1 is the PCell, NR Cell 1 is the source PSCell and NR Cell 2 is the target PSCell.

UE:

- None.

Preamble:

- The UE is in state RRC\_CONNECTED using generic procedure parameter Connectivity (*EN-DC*), Bearers (MCG and Split) and Test Mode (On) associated with UE test loop mode B according to TS 38.508-1 [4], table 4.5.4.2-1.

#### 8.2.3.14.1.3.2 Test procedure sequence

**Table 8.2.3.14.1.3.2-1: Main behaviour**

St	Procedure	Message Sequence		TP	Verdict
		U - S	Message		
1	The SS transmits an <i>RRConnectionReconfiguration</i> message containing NR <i>RRReconfiguration</i> message including <i>reconfigurewithsync</i> to handover source PSCell NR Cell 1 to target NR Cell 2 with Split DRB	<--	<i>RRConnectionReconfiguration (RRReconfiguration)</i>	-	-
2	Check: Does the UE transmit an <i>RRConnectionReconfigurationComplete</i> message containing NR <i>RRReconfigurationComplete</i> message?	-->	<i>RRConnectionReconfigurationComplete (RRReconfigurationComplete)</i>	1	P
3	The SS transmits one IP Packet to verify data path on Split DRB using NR radio path.	-	-	-	-
4	Check: Does UE send the IP Packet on Split DRB in the uplink using NR radio path?	-	-	1	P

8.2.3.14.1.3.3 Specific message contents

**Table 8.2.3.14.1.3.3-1: RRCConnectionReconfiguration (step 1, Table 8.2.3.14.1.3.2-1)**

Derivation Path: 36.508 [7], Table 4.6.1-8			
Information Element	Value/remark	Comment	Condition
RRCConnectionReconfiguration ::= SEQUENCE {			
criticalExtensions CHOICE {			
c1 CHOICE {			
rrcConnectionReconfiguration-r8 ::= SEQUENCE {			
nonCriticalExtension SEQUENCE {			
nonCriticalExtension SEQUENCE {			
nonCriticalExtension SEQUENCE {			
nonCriticalExtension SEQUENCE {			
nonCriticalExtension SEQUENCE {			
nonCriticalExtension SEQUENCE {			
nonCriticalExtension SEQUENCE {			
nr-Config-r15 CHOICE {			
setup SEQUENCE {			
nr-SecondaryCellGroupConfig-r15	OCTET STRING including the RRCReconfiguration message containing the IE secondaryCellGroup	reconfigurewiths ync is present in spCellConfig IE in the secondaryCellGroup IE	
}			
}			
sk-Counter-r15	Different counter value used before Handover than what was used for initial Split bearer configuration.		
}			
}			
}			
}			
}			
}			
}			
}			
}			
}			
}			
}			
}			
}			

**Table 8.2.3.14.1.3.3-2: RRCReconfiguration (Table 8.2.3.14.1.3.3-1)**

Derivation Path: 38.508-1 [4], Table [4.6.1-3]			
Information Element	Value/remark	Comment	Condition
RRCReconfiguration ::= SEQUENCE {			
criticalExtensions CHOICE {			
rrcReconfiguration ::= SEQUENCE {			
secondaryCellGroup	CellGroupConfig		
}			
}			
}			

Table 8.2.3.14.1.3.3-3 CellGroupConfig (Table 8.2.3.14.1.3.3-2)

Derivation Path: 38.508-1 [4], Table [4.6.3-13] with condition EN-DC			
Information Element	Value/remark	Comment	Condition
CellGroupConfig ::= SEQUENCE {			
spCellConfig SEQUENCE {			
servCellIndex	1		
reconfigurationWithSync SEQUENCE {			
spCellConfigCommon SEQUENCE {			
physCellId	102		
}			
newUE-Identity	'4148'H		
}			
}			

## 8.2.4 Carrier Aggregation

### 8.2.4.1 NR CA / NR SCell addition / modification / release / Success

#### 8.2.4.1.1 NR CA / NR SCell addition / modification / release / Success / EN-DC

##### 8.2.4.1.1.1 NR CA / NR SCell addition / modification / release / Success / EN-DC / Intra-band Contiguous CA

*Editor's Note: The conformance requirements are based on running RAN2 CRs.*

##### 8.2.4.1.1.1.1 Test Purpose (TP)

(1)

```
with { UE in RRC_CONNECTED state with EN-DC, and, MCG (E-UTRA PDCP) and SCG with initial AS security
activated }
ensure that {
  when { UE receives an RRCConnectionReconfiguration message with nr-Config IE including NR
RRCReconfiguration message containing sCellToAddModList with an sCellIndex set to the configured
SCell }
  then { UE adds the new SCell, configures lower layers to consider the SCell to be in deactivated
state and sends an RRCConnectionReconfigurationComplete message }
}
```

(2)

```
with { UE in RRC_CONNECTED state with EN-DC, and, MCG (E-UTRA PDCP) and SCG with SCell(s)
configured }
ensure that {
  when { UE receives an RRCConnectionReconfiguration message with nr-Config IE including NR
RRCReconfiguration message containing sCellToAddModList with an sCellIndex matching one of the
current UE SCell configuration }
  then {UE modifies the affected SCell dedicated configurations and sends an
RRCConnectionReconfigurationComplete message }
}
```

(3)

```
with { UE in RRC_CONNECTED state with EN-DC, and, MCG (E-UTRA PDCP) and SCG with SCell(s)
configured }
ensure that {
  when { UE receives an RRCConnectionReconfiguration message with nr-Config IE including NR
RRCReconfiguration message containing sCellToReleaseList with an sCellIndex matching one of the
current UE SCell configuration }
  then {UE releases the SCell and sends an RRCConnectionReconfigurationComplete message }
}
```

## 8.2.4.1.1.1.2 Conformance requirements

References: The conformance requirements covered in the present TC are specified in: TS 36.331: 5.3.5.3; TS 38.331: 5.3.5.3, 5.3.5.5.8, 5.3.5.5.9. **Unless otherwise stated these are Rel-15 requirements.**

[TS 36.331, clause 5.3.5.3]

If the *RRCCConnectionReconfiguration* message does not include the *mobilityControlInfo* and the UE is able to comply with the configuration included in this message, the UE shall:

- 1> if this is the first *RRCCConnectionReconfiguration* message after successful completion of the RRC connection re-establishment procedure:
  - 2> re-establish PDCP for SRB2 configured with E-UTRA PDCP entity and for all DRBs that are established and configured with E-UTRA PDCP, if any;
  - 2> re-establish RLC for SRB2 and for all DRBs that are established and configured with E-UTRA RLC, if any;
  - 2> if the *RRCCConnectionReconfiguration* message includes the *fullConfig*:
    - 3> perform the radio configuration procedure as specified in 5.3.5.8;
  - 2> if the *RRCCConnectionReconfiguration* message includes the *radioResourceConfigDedicated*:
    - 3> perform the radio resource configuration procedure as specified in 5.3.10;

NOTE 1: Void

NOTE 2: Void

1> else:

- 2> if the *RRCCConnectionReconfiguration* message includes the *radioResourceConfigDedicated*:
  - 3> perform the radio resource configuration procedure as specified in 5.3.10;

NOTE 3: If the *RRCCConnectionReconfiguration* message includes the establishment of radio bearers other than SRB1, the UE may start using these radio bearers immediately, i.e. there is no need to wait for an outstanding acknowledgment of the *SecurityModeComplete* message.

- 1> if the received *RRCCConnectionReconfiguration* includes the *sCellToReleaseList*:
  - 2> perform SCell release as specified in 5.3.10.3a;
- 1> if the received *RRCCConnectionReconfiguration* includes the *sCellToAddModList*:
  - 2> perform SCell addition or modification as specified in 5.3.10.3b;
- 1> if the received *RRCCConnectionReconfiguration* includes the *scg-Configuration*; or
- 1> if the current UE configuration includes one or more split DRBs configured with *pdcp-Config* and the received *RRCCConnectionReconfiguration* includes *radioResourceConfigDedicated* including *drb-ToAddModList*:
  - 2> perform SCG reconfiguration as specified in 5.3.10.10;
- 1> if the received *RRCCConnectionReconfiguration* includes the *nr-Config* and it is set to *release*: or
- 1> if the received *RRCCConnectionReconfiguration* includes *endc-ReleaseAndAdd* and it is set to *TRUE*:
  - 2> perform ENDC release as specified in TS 38.331 [82, 5.3.5.10];
- 1> if the received *RRCCConnectionReconfiguration* includes the *sk-Counter*:
  - 2> perform key update procedure as specified in TS 38.331 [82, 5.3.5.7];
- 1> if the received *RRCCConnectionReconfiguration* includes the *nr-SecondaryCellGroupConfig*:
  - 2> perform NR RRC Reconfiguration as specified in TS 38.331 [82, 5.3.5.3];

- 1> if the received *RRCCConnectionReconfiguration* includes the *nr-RadioBearerConfig1*:
  - 2> perform radio bearer configuration as specified in TS 38.331 [82, 5.3.5.6];
- 1> if the received *RRCCConnectionReconfiguration* includes the *nr-RadioBearerConfig2*:
  - 2> perform radio bearer configuration as specified in TS 38.331 [82, 5.3.5.6];
- 1> if this is the first *RRCCConnectionReconfiguration* message after successful completion of the RRC connection re-establishment procedure:
  - 2> resume SRB2 and all DRBs that are suspended, if any, including RBs configured with NR PDCP;

NOTE 4: The handling of the radio bearers after the successful completion of the PDCP re-establishment, e.g. the re-transmission of unacknowledged PDCP SDUs (as well as the associated status reporting), the handling of the SN and the HFN, is specified in TS 36.323 [8].

NOTE 5: The UE may discard SRB2 messages and data that it receives prior to completing the reconfiguration used to resume these bearers.

- 1> if the received *RRCCConnectionReconfiguration* includes the *systemInformationBlockType1Dedicated*:
  - 2> perform the actions upon reception of the *SystemInformationBlockType1* message as specified in 5.2.2.7;
- 1> if the *RRCCConnectionReconfiguration* message includes the *dedicatedInfoNASList*:
  - 2> forward each element of the *dedicatedInfoNASList* to upper layers in the same order as listed;
- 1> if the *RRCCConnectionReconfiguration* message includes the *measConfig*:
  - 2> perform the measurement configuration procedure as specified in 5.5.2;
- 1> perform the measurement identity autonomous removal as specified in 5.5.2.2a;
- 1> if the *RRCCConnectionReconfiguration* message includes the *otherConfig*:
  - 2> perform the other configuration procedure as specified in 5.3.10.9;
- 1> if the *RRCCConnectionReconfiguration* message includes the *sl-DiscConfig* or *sl-CommConfig*:
  - 2> perform the sidelink dedicated configuration procedure as specified in 5.3.10.15;
- 1> if the *RRCCConnectionReconfiguration* message includes the *sl-V2X-ConfigDedicated*:
  - 2> perform the V2X sidelink communication dedicated configuration procedure as specified in 5.3.10.15a;
- 1> if the *RRCCConnectionReconfiguration* message includes *wlan-OffloadInfo*:
  - 2> perform the dedicated WLAN offload configuration procedure as specified in 5.6.12.2;
- 1> if the *RRCCConnectionReconfiguration* message includes *rclwi-Configuration*:
  - 2> perform the WLAN traffic steering command procedure as specified in 5.6.16.2;
- 1> if the *RRCCConnectionReconfiguration* message includes *lwa-Configuration*:
  - 2> perform the LWA configuration procedure as specified in 5.6.14.2;
- 1> if the *RRCCConnectionReconfiguration* message includes *lwip-Configuration*:
  - 2> perform the LWIP reconfiguration procedure as specified in 5.6.17.2;
- 1> upon RRC connection establishment, if UE does not need UL gaps during continuous uplink transmission:
  - 2> configure lower layers to stop using UL gaps during continuous uplink transmission in FDD for *RRCCConnectionReconfigurationComplete* message and subsequent uplink transmission in RRC\_CONNECTED except for UL transmissions as specified in TS36.211 [21];

- 1> set the content of *RRCConnectionReconfigurationComplete* message as follows:
  - 2> if the *RRCConnectionReconfiguration* message includes *perCC-GapIndicationRequest*:
    - 3> include *perCC-GapIndicationList* and *numFreqEffective*;
  - 2> if the frequencies are configured for reduced measurement performance:
    - 3> include *numFreqEffectiveReduced*;
  - 2> if the received *RRCConnectionReconfiguration* message included *nr-SecondaryCellGroupConfig*:
    - 3> include *scg-ConfigResponseNR* in accordance with TS 38.331 [82, 5.3.5.3];
- 1> submit the *RRCConnectionReconfigurationComplete* message to lower layers for transmission using the new configuration, upon which the procedure ends;

[TS 38.331, clause 5.3.5.3]

The UE shall perform the following actions upon reception of the *RRCReconfiguration*:

- 1> if the *RRCReconfiguration* includes the *fullConfig*:
  - 2> perform the radio configuration procedure as specified in 5.3.5.11;
- 1> if the *RRCReconfiguration* includes the *masterCellGroup*:
  - 2> perform the cell group configuration for the received *masterCellGroup* according to 5.3.5.5;
- 1> if the *RRCReconfiguration* includes the *keyRefresh*:
  - 2> perform security key update procedure as specified in 5.3.5.7;
- 1> if the *RRCReconfiguration* includes the *secondaryCellGroup*:
  - 2> perform the cell group configuration for the SCG according to 5.3.5.5;
- 1> if the *RRCReconfiguration* message contains the *radioBearerConfig*:
  - 2> perform the radio bearer configuration according to 5.3.5.6;
- 1> if the *RRCReconfiguration* message includes the *measConfig*:
  - 2> perform the measurement configuration procedure as specified in 5.5.2;
- 1> set the content of *RRCReconfigurationComplete* message as follows:
  - 2> if the *RRCReconfiguration* includes the *masterCellGroup* containing the *reportUplinkTxDirectCurrent*, or;
  - 2> if the *RRCReconfiguration* includes the *secondaryCellGroup* containing the *reportUplinkTxDirectCurrent*:
    - 3> include the *uplinkTxDirectCurrentList*;
- 1> if the UE is configured with E-UTRA *nr-SecondaryCellGroupConfig* (MCG is E-UTRA):
  - 2> if *RRCReconfiguration* was received via SRB1:
    - 3> submit the *RRCReconfigurationComplete* via the EUTRA MCG embedded in E-UTRA RRC message *RRCConnectionReconfigurationComplete* as specified in TS 36.331 [10];
    - 3> if *reconfigurationWithSync* was included in *spCellConfig* of an SCG:
      - 4> initiate the random access procedure on the SpCell, as specified in TS 38.321 [3];
    - 3> else:
      - 4> the procedure ends;



NOTE: The order the UE sends the *RRCConnectionReconfigurationComplete* message and performs the Random Access procedure towards the SCG is left to UE implementation.

2> else (*RRCReconfiguration* was received via SRB3):

3> submit the *RRCReconfigurationComplete* message via SRB3 to lower layers for transmission using the new configuration;

NOTE: For EN-DC, in the case of SRB1, the random access is triggered by RRC layer itself as there is not necessarily other UL transmission. In the case of SRB3, the random access is triggered by the MAC layer due to arrival of *RRCReconfigurationComplete*.

1 > else:

2> submit the *RRCReconfigurationComplete* message via SRB1 to lower layers for transmission using the new configuration;

1> if *reconfigurationWithSync* was included in *spCellConfig* of an MCG or SCG, and when MAC of an NR cell group successfully completes a random access procedure triggered above;

2> stop timer T304 for that cell group;

2> apply the parts of the CQI reporting configuration, the scheduling request configuration and the sounding RS configuration that do not require the UE to know the SFN of the respective target SpCell, if any;

2> apply the parts of the measurement and the radio resource configuration that require the UE to know the SFN of the respective target SpCell (e.g. measurement gaps, periodic CQI reporting, scheduling request configuration, sounding RS configuration), if any, upon acquiring the SFN of that target SpCell;

2> if the *reconfigurationWithSync* was included in *spCellConfig* of an MCG:

3> if the active downlink BWP, which is indicated by the *firstActiveDownlinkBWP-Id* for the target SpCell of the MCG, has a common search space configured or if the conditions defined in FFS\_Spec [X], section FFS\_Section are satisfied:

4> acquire the *SIB1* of the target SpCell of the MCG, as specified in 5.2.2.3.1;

2> the procedure ends.

NOTE: The UE is only required to acquire broadcasted *SIB1* if the UE can acquire it without disrupting unicast data reception, i.e. the broadcast and unicast beams are quasi co-located.

[TS 38.331, clause 5.3.5.5.8]

The UE shall:

1> if the release is triggered by reception of the *sCellToReleaseList*:

2> for each *sCellIndex* value included in the *sCellToReleaseList*:

3> if the current UE configuration includes an SCell with value *sCellIndex*:

4> release the SCell.

[TS 38.331, clause 5.3.5.5.9]

The UE shall:

1> for each *sCellIndex* value included in the *sCellToAddModList* that is not part of the current UE configuration (SCell addition):

2> add the SCell, corresponding to the *sCellIndex*, in accordance with the *sCellConfigCommon* and *sCellConfigDedicated*;

2> configure lower layers to consider the SCell to be in deactivated state;

**Editor's Note: FFS Check automatic measurement handling for SCells.**

2> for each *measId* included in the *measIdList* within *VarMeasConfig*:

3> if SCells are not applicable for the associated measurement; and

3> if the concerned SCell is included in *cellsTriggeredList* defined within the *VarMeasReportList* for this *measId*:

4> remove the concerned SCell from *cellsTriggeredList* defined within the *VarMeasReportList* for this *measId*;

1> for each *sCellIndex* value included in the *sCellToAddModList* that is part of the current UE configuration (SCell modification):

2> modify the SCell configuration in accordance with the *sCellConfigDedicated*.

8.2.4.1.1.1.3 Test description

8.2.4.1.1.1.3.1 Pre-test conditions

System Simulator:

- E-UTRA Cell 1 is the PCell. NR Cell 1 is the PSCell and NR Cell 2 is the SCell.

UE:

- None.

Preamble:

- The UE is in state RRC\_CONNECTED using generic procedure parameter Connectivity (*EN-DC*), Bearers (*MCG(s) and SCG*) established according to TS 38.508-1 [4].

8.2.4.1.1.1.3.2 Test procedure sequence

**Table 8.2.4.1.1.1.3.2-1: Main behaviour**

St	Procedure	Message Sequence		TP	Verdict
		U - S	Message		
1	The SS transmits a <i>RRCConnectionReconfiguration</i> message including NR <i>RRCReconfiguration</i> message to configure the NR SCell	<--	<i>RRCConnectionReconfiguration</i> ( <i>RRCReconfiguration</i> )	-	-
2	Check: Does the UE transmit a <i>RRCConnectionReconfigurationComplete</i> message containing <i>RRCReconfigurationComplete</i> message?	-->	<i>RRCConnectionReconfigurationComplete</i> ( <i>RRCReconfigurationComplete</i> )	1	P
3	The SS transmits a <i>RRCConnectionReconfiguration</i> message including NR <i>RRCReconfiguration</i> message to modify the BWP-Id of the NR SCell	<--	<i>RRCConnectionReconfiguration</i> ( <i>RRCReconfiguration</i> )	-	-
4	Check: Does the UE transmit a <i>RRCConnectionReconfigurationComplete</i> message containing NR <i>RRCReconfigurationComplete</i> message?	-->	<i>RRCConnectionReconfigurationComplete</i> ( <i>RRCReconfigurationComplete</i> )	2	P
5	The SS transmits a <i>RRCConnectionReconfiguration</i> message including NR <i>RRCReconfiguration</i> message to release the NR SCell	<--	<i>RRCConnectionReconfiguration</i> ( <i>RRCReconfiguration</i> )	-	-
6	Check: Does the UE release SCell and sends a <i>RRCConnectionReconfigurationComplete</i> message containing NR <i>RRCReconfigurationComplete</i> message?	-->	<i>RRCConnectionReconfigurationComplete</i> ( <i>RRCReconfigurationComplete</i> )	3	P

8.2.4.1.1.3.3 Specific message contents

**Table 8.2.4.1.1.3.3-1: RRCConnectionReconfiguration (step 1, Table 8.2.4.1.1.3.2-1)**

Derivation Path: 36.508 [7], Table 4.6.1-8			
Information Element	Value/remark	Comment	Condition
RRCConnectionReconfiguration ::= SEQUENCE {			
criticalExtensions CHOICE {			
c1 CHOICE {			
rrcConnectionReconfiguration-r8 ::= SEQUENCE			
{			
nonCriticalExtension ::= SEQUENCE {			
nonCriticalExtension ::= SEQUENCE {			
nonCriticalExtension ::= SEQUENCE {			
nonCriticalExtension ::= SEQUENCE {			
nonCriticalExtension ::= SEQUENCE {			
nonCriticalExtension ::= SEQUENCE {			
nonCriticalExtension ::= SEQUENCE {			
nonCriticalExtension ::= SEQUENCE {			
nr-Config-r15 CHOICE {			
setup SEQUENCE {			
nr-SecondaryCellGroupConfig-r15	OCTET STRING including the <i>RRCReconfiguration</i> message and the IE <i>secondaryCellGroup</i> .		
}			
}			
}			
}			
}			
}			
}			
}			
}			
}			
}			
}			
}			

**Table 8.2.4.1.1.3.3-2: RRCReconfiguration (Table 8.2.4.1.1.3.3-1)**

Derivation Path: 38.508-1 [4], Table 4.6.1-3			
Information Element	Value/remark	Comment	Condition
RRCReconfiguration ::= SEQUENCE {			
criticalExtensions CHOICE {			
rrcReconfiguration ::= SEQUENCE {			
secondaryCellGroup	CellGroupConfig		
}			
}			
}			

**Table 8.2.4.1.1.3.3-3: CellGroupConfig (Table 8.2.4.1.1.3.3-2)**

Derivation Path: TS 38.508-1 [4], Table 4.6.3-13.			
Information Element	Value/remark	Comment	Condition
CellGroupConfig ::= SEQUENCE {			
sCellToAddModList SEQUENCE (SIZE (1..maxMeasId)) OF SEQUENCE {			
sCellIndex[1]	1		
sCellConfigCommon[1]	ServingCellConfigCommon		
sCellConfigDedicated[1]	ServingCellConfig	TS 38.508-1 [4] table 4.6.3-128	
}			
}			

**Table 8.2.4.1.1.3.3-4: ServingCellConfigCommon (Table 8.2.4.1.1.3.3-3)**

Derivation Path: TS 38.508-1 [4], Table 4.6.3-129.			
Information Element	Value/remark	Comment	Condition
ServingCellConfigCommon ::= SEQUENCE {			
PhysCellId	Physical Cell Identity of NR Cell 2		
}			

**Table 8.2.4.1.1.3.3-5: RRCConnectionReconfiguration (step 3, Table 8.2.4.1.1.3.2-1)**

Derivation Path: 36.508 [7], Table 4.6.1-8			
Information Element	Value/remark	Comment	Condition
RRCConnectionReconfiguration ::= SEQUENCE {			
criticalExtensions CHOICE {			
c1 CHOICE {			
rrcConnectionReconfiguration-r8 ::= SEQUENCE {			
nonCriticalExtension ::= SEQUENCE {			
nonCriticalExtension ::= SEQUENCE {			
nonCriticalExtension ::= SEQUENCE {			
nonCriticalExtension ::= SEQUENCE {			
nonCriticalExtension ::= SEQUENCE {			
nonCriticalExtension ::= SEQUENCE {			
nonCriticalExtension ::= SEQUENCE {			
nr-Config-r15 CHOICE {			
setup SEQUENCE {			
nr-SecondaryCellGroupConfig-r15	OCTET STRING including the <i>RRCReconfiguration</i> message and the IE <i>secondaryCellGroup</i> .		
}			
}			
}			
}			
}			
}			
}			
}			
}			

**Table 8.2.4.1.1.3.3-6: RRCReconfiguration (Table 8.2.4.1.1.3.3-5)**

Derivation Path: 38.508-1 [4], Table 4.6.1-3			
Information Element	Value/remark	Comment	Condition
RRCReconfiguration ::= SEQUENCE {			
criticalExtensions CHOICE {			
rrcReconfiguration ::= SEQUENCE {			
secondaryCellGroup	CellGroupConfig		
}			
}			
}			

**Table 8.2.4.1.1.3.3-7: CellGroupConfig (Table 8.2.4.1.1.3.3-6)**

Derivation Path: 38.508-1 [4], Table 4.6.3-13			
Information Element	Value/remark	Comment	Condition
CellGroupConfig ::= SEQUENCE {			
sCellToAddModList SEQUENCE	1 entry		
(SIZE(1..maxNrofSCells)) OF SEQUENCE {			
sCellConfigDedicated	ServingCellConfig		
}			
}			

**Table 8.2.4.1.1.3.3-8: ServingCellConfig (Table 8.2.4.1.1.3.3-7)**

Derivation Path: TS 38.508-1 [4], Table 4.6.3-128			
Information Element	Value/remark	Comment	Condition
ServingCellConfig ::= SEQUENCE {			
initialDownlinkBWP	BWP-DownlinkDedicated		
}			

**Table 8.2.4.1.1.3.3-9: BWP-DownlinkDedicated (Table 8.2.4.1.1.3.3-8)**

Derivation Path: TS 38.508-1 [4], Table 4.6.3-10			
Information Element	Value/remark	Comment	Condition
BWP-DownlinkDedicated ::= SEQUENCE {			
pdcch-Config CHOICE {			
setup	PDCCH-Config		
}			
}			

**Table 8.2.4.1.1.3.3-10: PDCCH-Config (Table 8.2.4.1.1.3.3-9)**

Derivation Path: TS 38.508-1 [4], Table 4.6.3-75			
Information Element	Value/remark	Comment	Condition
PDCCH-Config ::= SEQUENCE {			
tpc-SRS SetupRelease {			
setup	SRS-TPC-CommandConfig		
}			
}			

**Table 8.2.4.1.1.3.3-11: SRS-TPC-CommandConfig (Table 8.2.4.1.1.3.3-10)**

Derivation Path: TS 38.508-1 [4], Table 4.6.3-137			
Information Element	Value/remark	Comment	Condition
SRS-TPC-CommandConfig ::= SEQUENCE {			
FFS			
}			

**Table 8.2.4.1.1.3.3-12: RRCConnectionReconfiguration (step 5, Table 8.2.4.1.1.3.2-1)**

Derivation Path: 36.508 [7], Table 4.6.1-8			
Information Element	Value/remark	Comment	Condition
RRCConnectionReconfiguration ::= SEQUENCE {			
criticalExtensions CHOICE {			
c1 CHOICE {			
rrcConnectionReconfiguration-r8 ::= SEQUENCE			
{			
nonCriticalExtension ::= SEQUENCE {			
nonCriticalExtension ::= SEQUENCE {			
nonCriticalExtension ::= SEQUENCE {			
nonCriticalExtension ::= SEQUENCE {			
nonCriticalExtension ::= SEQUENCE {			
nonCriticalExtension ::= SEQUENCE {			
nonCriticalExtension ::= SEQUENCE {			
nonCriticalExtension ::= SEQUENCE {			
nr-Config-r15 CHOICE {			
setup SEQUENCE {			
nr-SecondaryCellGroupConfig-r15	OCTET STRING		
	including the		
	<i>RRCReconfiguration</i>		
	message and the IE		
	secondaryCellGroup.		
}			
}			
}			
}			
}			

**Table 8.2.4.1.1.3.3-13: RRCReconfiguration (Table 8.2.4.1.1.3.3-12)**

Derivation Path: 38.508-1 [4], Table 4.6.1-3			
Information Element	Value/remark	Comment	Condition
RRCReconfiguration ::= SEQUENCE {			
criticalExtensions CHOICE {			
rrcReconfiguration ::= SEQUENCE {			
secondaryCellGroup	CellGroupConfig		
}			
}			
}			

**Table 8.2.4.1.1.3.3-14: CellGroupConfig (Table 8.2.4.1.1.3.3-13)**

Derivation Path: 38.508-1 [4], Table 4.6.3-13			
Information Element	Value/remark	Comment	Condition
CellGroupConfig ::= SEQUENCE {			
sCellToReleaseList SEQUENCE	1 entry		
(SIZE(1..maxNrofSCells)) OF SEQUENCE {			
sCellIndex	1		
}			
}			

#### 8.2.4.1.1.2 NR CA / NR SCell addition / modification / release / Success / EN-DC / Intra-band non-Contiguous CA

##### 8.2.4.1.1.2.1 Test Purpose (TP)

Same as TC 8.2.4.1.1.1 but applied to Intra-band non-Contiguous CA.

##### 8.2.4.1.1.2.2 Conformance requirements

Same as TC 8.2.4.1.1.1 but applied to Intra-band non-Contiguous CA.

##### 8.2.4.1.1.2.3 Test description

###### 8.2.4.1.1.2.3.1 Pre-test conditions

Same as TC 8.2.4.1.1.1 with the following differences:

- CA configuration: Intra-band non-Contiguous CA replaces Intra-band Contiguous CA
- Cells configuration: NR Cell 3 replaces NR Cell 2

###### 8.2.4.1.1.2.3.2 Test procedure sequence

Same as TC 8.2.4.1.1.1 with the following differences:

- CA configuration: Intra-band non-Contiguous CA replaces Intra-band Contiguous CA
- Cells configuration: NR Cell 3 replaces NR Cell 2

#### 8.2.4.1.1.3 NR CA / NR SCell addition / modification / release / Success / EN-DC / Inter-band CA

##### 8.2.4.1.1.3.1 Test Purpose (TP)

Same as TC 8.2.4.1.1.1 but applied to Inter-band CA

##### 8.2.4.1.1.3.2 Conformance requirements

Same as TC 8.2.4.1.1.1 but applied to Inter-band CA

##### 8.2.4.1.1.3.3 Test description

###### 8.2.4.1.1.3.3.1 Pre-test conditions

Same as TC 8.2.4.1.1.1 with the following differences:

- CA configuration: Inter-band CA replaces Intra-band Contiguous CA
- Cells configuration: NR Cell 10 replaces NR Cell 2

###### 8.2.4.1.1.3.3.2 Test procedure sequence

Same as TC 8.2.4.1.1.1 with the following differences:

- CA configuration: Inter-band CA replaces Intra-band Contiguous CA
- Cells configuration: NR Cell 10 replaces NR Cell 2

## 8.2.4.2 NR CA / Simultaneous PSCell and SCell addition / PSCell and SCell change / CA Deconfiguration

### 8.2.4.2.1 NR CA / Simultaneous PSCell and SCell addition / PSCell and SCell change / CA Deconfiguration / EN-DC

#### 8.2.4.2.1.1 NR CA / Simultaneous PSCell and SCell addition / PSCell and SCell change / CA Release / EN-DC / Intra-band Contiguous CA

##### 8.2.4.2.1.1.1 Test Purpose (TP)

(1)

```
with { UE in RRC_CONNECTED state with E-UTRA }
ensure that {
  when { UE receives an RRCConnectionReconfiguration message with nr-Config IE including NR
RRCReconfiguration message to configure NR PSCell and sCellToAddModList with an sCellIndex set to
the configured SCell }
  then { UE sends an RRCConnectionReconfigurationComplete message indicating the addition of
PSCell and configures lower layers to consider the SCell to be in deactivated state }
}
```

(2)

```
with { UE in RRC_CONNECTED state with EN-DC, and, MCG (E-UTRA PDCP) and SCG with SCell(s) configured
}
ensure that {
  when { UE receives an RRCConnectionReconfiguration message with nr-Config IE including NR
RRCReconfiguration message to perform both PSCell and SCell change to the configured target PSCell
and SCell }
  then { UE sends an RRCConnectionReconfigurationComplete message and configures new PSCell and
configures lower layers to consider the SCell to be in deactivated state }
}
```

(3)

```
with { UE in RRC_CONNECTED state with EN-DC, and, MCG (E-UTRA PDCP) and SCG with SCell(s) configured
}
ensure that {
  when { UE receives an RRCConnectionReconfiguration message with nr-Config IE including NR
RRCReconfiguration message to perform PSCell change to one of the SCell equaling to one of the
current UE SCell configuration }
  then { UE sends an RRCConnectionReconfigurationComplete message and reconfigures the current NR
Scell to PSCell }
}
```

##### 8.2.4.2.1.1.2 Conformance requirements

References: The conformance requirements covered in the present TC are specified in: TS 36.331: 5.3.5.3; TS 38.331: 5.3.5.3, 5.3.5.5.7, 5.3.5.5.8, 5.3.5.5.9, 5.3.5.6.4 and 5.3.5.6.5. Unless otherwise stated these are Rel-15 requirements.

[TS 36.331, clause 5.3.5.3]

If the *RRCConnectionReconfiguration* message does not include the *mobilityControlInfo* and the UE is able to comply with the configuration included in this message, the UE shall:

- 1> if this is the first *RRCConnectionReconfiguration* message after successful completion of the RRC connection re-establishment procedure:
  - 2> re-establish PDCP for SRB2 configured with E-UTRA PDCP entity and for all DRBs that are established and configured with E-UTRA PDCP, if any;
  - 2> re-establish RLC for SRB2 and for all DRBs that are established and configured with E-UTRA RLC, if any;
- 2> if the *RRCConnectionReconfiguration* message includes the *fullConfig*:
  - 3> perform the radio configuration procedure as specified in 5.3.5.8;
- 2> if the *RRCConnectionReconfiguration* message includes the *radioResourceConfigDedicated*:



3> perform the radio resource configuration procedure as specified in 5.3.10;

NOTE 1: Void

NOTE 2: Void

1> else:

2> if the *RRCCConnectionReconfiguration* message includes the *radioResourceConfigDedicated*:

3> perform the radio resource configuration procedure as specified in 5.3.10;

NOTE 3: If the *RRCCConnectionReconfiguration* message includes the establishment of radio bearers other than SRB1, the UE may start using these radio bearers immediately, i.e. there is no need to wait for an outstanding acknowledgment of the *SecurityModeComplete* message.

1> if the received *RRCCConnectionReconfiguration* includes the *sCellToReleaseList*:

2> perform SCell release as specified in 5.3.10.3a;

1> if the received *RRCCConnectionReconfiguration* includes the *sCellToAddModList*:

2> perform SCell addition or modification as specified in 5.3.10.3b;

1> if the received *RRCCConnectionReconfiguration* includes the *scg-Configuration*; or

1> if the current UE configuration includes one or more split DRBs configured with *pdcp-Config* and the received *RRCCConnectionReconfiguration* includes *radioResourceConfigDedicated* including *drb-ToAddModList*:

2> perform SCG reconfiguration as specified in 5.3.10.10;

1> if the received *RRCCConnectionReconfiguration* includes the *nr-Config* and it is set to *release*: or

1> if the received *RRCCConnectionReconfiguration* includes *endc-ReleaseAndAdd*:

2> perform ENDC release as specified in TS38.331 [82, 5.3.5.x];

1> if the received *RRCCConnectionReconfiguration* includes the *sk-Counter*:

2> perform key update procedure as specified in TS 38.331 [82, 5.3.5.8];

1> if the received *RRCCConnectionReconfiguration* includes the *nr-SecondaryCellGroupConfig*:

2> perform NR RRC Reconfiguration as specified in TS 38.331 [82, 5.3.5.3];

1> if the received *RRCCConnectionReconfiguration* includes the *nr-RadioBearerConfig1*:

2> perform radio bearer configuration as specified in TS 38.331 [82, 5.3.5.6];

1> if the received *RRCCConnectionReconfiguration* includes the *nr-RadioBearerConfig2*:

2> perform radio bearer configuration as specified in TS 38.331 [82, 5.3.5.6];

1> if this is the first *RRCCConnectionReconfiguration* message after successful completion of the RRC connection re-establishment procedure:

2> resume SRB2 and all DRBs that are suspended, if any, including RBs configured with NR PDCP;

NOTE 4: The handling of the radio bearers after the successful completion of the PDCP re-establishment, e.g. the re-transmission of unacknowledged PDCP SDUs (as well as the associated status reporting), the handling of the SN and the HFN, is specified in TS 36.323 [8].

NOTE 5: The UE may discard SRB2 messages and data that it receives prior to completing the reconfiguration used to resume these bearers.

1> if the received *RRCCConnectionReconfiguration* includes the *systemInformationBlockType1Dedicated*:

2> perform the actions upon reception of the *SystemInformationBlockType1* message as specified in 5.2.2.7;

- 1> if the *RRCCONNECTIONRECONFIGURATION* message includes the *dedicatedInfoNASList*:
  - 2> forward each element of the *dedicatedInfoNASList* to upper layers in the same order as listed;
- 1> if the *RRCCONNECTIONRECONFIGURATION* message includes the *measConfig*:
  - 2> perform the measurement configuration procedure as specified in 5.5.2;
- 1> perform the measurement identity autonomous removal as specified in 5.5.2.2a;
- 1> if the *RRCCONNECTIONRECONFIGURATION* message includes the *otherConfig*:
  - 2> perform the other configuration procedure as specified in 5.3.10.9;
- 1> if the *RRCCONNECTIONRECONFIGURATION* message includes the *sl-DiscConfig* or *sl-CommConfig*:
  - 2> perform the sidelink dedicated configuration procedure as specified in 5.3.10.15;
- 1> if the *RRCCONNECTIONRECONFIGURATION* message includes the *sl-V2X-ConfigDedicated*:
  - 2> perform the V2X sidelink communication dedicated configuration procedure as specified in 5.3.10.15a;
- 1> if the *RRCCONNECTIONRECONFIGURATION* message includes *wlan-OffloadInfo*:
  - 2> perform the dedicated WLAN offload configuration procedure as specified in 5.6.12.2;
- 1> if the *RRCCONNECTIONRECONFIGURATION* message includes *rclwi-Configuration*:
  - 2> perform the WLAN traffic steering command procedure as specified in 5.6.16.2;
- 1> if the *RRCCONNECTIONRECONFIGURATION* message includes *lwa-Configuration*:
  - 2> perform the LWA configuration procedure as specified in 5.6.14.2;
- 1> if the *RRCCONNECTIONRECONFIGURATION* message includes *lwip-Configuration*:
  - 2> perform the LWIP reconfiguration procedure as specified in 5.6.17.2;
- 1> upon RRC connection establishment, if UE does not need UL gaps during continuous uplink transmission:
  - 2> configure lower layers to stop using UL gaps during continuous uplink transmission in FDD for *RRCCONNECTIONRECONFIGURATIONCOMPLETE* message and subsequent uplink transmission in RRC\_CONNECTED except for UL transmissions as specified in TS36.211 [21];
- 1> set the content of *RRCCONNECTIONRECONFIGURATIONCOMPLETE* message as follows:
  - 2> if the *RRCCONNECTIONRECONFIGURATION* message includes *perCC-GapIndicationRequest*:
    - 3> include *perCC-GapIndicationList* and *numFreqEffective*;
  - 2> if the frequencies are configured for reduced measurement performance:
    - 3> include *numFreqEffectiveReduced*;
  - 2> if the received *RRCCONNECTIONRECONFIGURATION* message included *nr-SecondaryCellGroupConfig*:
    - 3> include *scg-ConfigResponseNR* in accordance with TS 38.331 [82, 5.3.5.3];
- 1> submit the *RRCCONNECTIONRECONFIGURATIONCOMPLETE* message to lower layers for transmission using the new configuration, upon which the procedure ends;

[TS 38.331, clause 5.3.5.3]

The UE shall perform the following actions upon reception of the *RRCReconfiguration*:

- 1> if the *RRCReconfiguration* includes the *secondaryCellGroup*:
  - 2> perform the cell group configuration for the SCG according to 5.3.5.5;

- 1> if the *RRCReconfiguration* message contains the *radioBearerConfig*:
  - 2> perform the radio bearer configuration according to 5.3.5.6;
- 1> if the *RRCReconfiguration* message includes the *measConfig*:
  - 2> perform the measurement configuration procedure as specified in 5.5.2;
- 1> if the UE is configured with E-UTRA *nr-SecondaryCellGroupConfig* (MCG is E-UTRA):
  - 2> if *RRCReconfiguration* was received via SRB1:
    - 3> construct *RRCReconfigurationComplete* message and submit it via the EUTRA MCG embedded in E-UTRA RRC message *RRCConnectionReconfigurationComplete* as specified in TS 36.331 [10];
    - 3> if *reconfigurationWithSync* was included in *spCellConfig* of an SCG:
      - 4> initiate the random access procedure on the SpCell, as specified in TS 38.321 [3];
  - 2> else (*RRCReconfiguration* was received via SRB3):
    - 3> submit the *RRCReconfigurationComplete* message via SRB3 to lower layers for transmission using the new configuration;

NOTE: In the case of SRB1, the random access is triggered by RRC layer itself as there is not necessarily other UL transmission. In the case of SRB3, the random access is triggered by the MAC layer due to arrival of *RRCReconfigurationComplete*.

- 1> if MAC of an NR cell group successfully completes a random access procedure triggered above;
  - 2> stop timer T304 for that cell group;
  - 2> apply the parts of the CQI reporting configuration, the scheduling request configuration and the sounding RS configuration that do not require the UE to know the SFN of the respective target SpCell, if any;
  - 2> apply the parts of the measurement and the radio resource configuration that require the UE to know the SFN of the respective target SpCell (e.g. measurement gaps, periodic CQI reporting, scheduling request configuration, sounding RS configuration), if any, upon acquiring the SFN of that target SpCell;
  - 2> the procedure ends.

[TS 38.331, clause 5.3.5.5.7]

The UE shall:

- 1> if the *SpCellConfig* contains the *rlf-TimersAndConstants*:
  - 2> configure the RLF timers and constants for this cell group as specified in 5.3.5.5.6.
- 1> if the *SpCellConfig* contains *spCellConfigDedicated*:
  - 2> configure the SpCell in accordance with the *spCellConfigDedicated*.

[TS 38.331, clause 5.3.5.5.8]

The UE shall:

- 1> if the release is triggered by reception of the *sCellToReleaseList*:
  - 2> for each *sCellIndex* value included in the *sCellToReleaseList*:
    - 3> if the current UE configuration includes an SCell with value *sCellIndex*:
      - 4> release the SCell.

[TS 38.331, clause 5.3.5.5.9]

The UE shall:

- 1> for each *sCellIndex* value included in the *sCellToAddModList* that is not part of the current UE configuration (SCell addition):
  - 2> add the SCell, corresponding to the *sCellIndex*, in accordance with the *sCellConfigCommon* and *sCellConfigDedicated*;
  - 2> configure lower layers to consider the SCell to be in deactivated state;

**Editor's Note: FFS Check automatic measurement handling for SCells.**

- 2> for each *measId* included in the *measIdList* within *VarMeasConfig*:
  - 3> if SCells are not applicable for the associated measurement; and
  - 3> if the concerned SCell is included in *cellsTriggeredList* defined within the *VarMeasReportList* for this *measId*:
    - 4> remove the concerned SCell from *cellsTriggeredList* defined within the *VarMeasReportList* for this *measId*;
- 1> for each *sCellIndex* value included in the *sCellToAddModList* that is part of the current UE configuration (SCell modification):
  - 2> modify the SCell configuration in accordance with the *sCellConfigDedicated*.

[TS 38.331, clause 5.3.5.5.9]

The UE shall:

- 1> for each *sCellIndex* value included in the *sCellToAddModList* that is not part of the current UE configuration (SCell addition):
  - 2> add the SCell, corresponding to the *sCellIndex*, in accordance with the *sCellConfigCommon* and *sCellConfigDedicated*;
  - 2> configure lower layers to consider the SCell to be in deactivated state;

**Editor's Note: FFS Check automatic measurement handling for SCells.**

- 2> for each *measId* included in the *measIdList* within *VarMeasConfig*:
  - 3> if SCells are not applicable for the associated measurement; and
  - 3> if the concerned SCell is included in *cellsTriggeredList* defined within the *VarMeasReportList* for this *measId*:
    - 4> remove the concerned SCell from *cellsTriggeredList* defined within the *VarMeasReportList* for this *measId*;
- 1> for each *sCellIndex* value included in the *sCellToAddModList* that is part of the current UE configuration (SCell modification):
  - 2> modify the SCell configuration in accordance with the *sCellConfigDedicated*.

[TS 38.331, clause 5.3.5.6.4]

The UE shall:

- 1> for each *drb-Identity* value included in the *drb-ToReleaseList* that is part of the current UE configuration (DRB release), or
- 1> for each *drb-identity* value that is to be released as the result of full configuration option according to 5.3.5.7:
  - 2> release the PDCP entity;
- 1> if a new bearer is not added either with NR or E-UTRA with same *eps-BearerIdentity*:
  - 2> if the procedure was triggered due to reconfiguration with sync:

3> indicate the release of the DRB and the *eps-BearerIdentity* of the released DRB to upper layers after successful reconfiguration with sync;

2> else:

3> indicate the release of the DRB and the *eps-BearerIdentity* of the released DRB to upper layers immediately.

NOTE 1: The UE does not consider the message as erroneous if the *drb-ToReleaseList* includes any *drb-Identity* value that is not part of the current UE configuration.

NOTE 2: Whether or not the RLC and MAC entities associated with this PDCP entity are reset or released is determined by the *CellGroupConfig*.

[TS 38.331, clause 5.3.5.6.5]

The UE shall:

1> for each *drb-Identity* value included in the *drb-ToAddModList* that is not part of the current UE configuration (DRB establishment including the case when full configuration option is used):

2> establish a PDCP entity and configure it in accordance with the received *pdcp-Config*;

2> configure the PDCP entity with the security algorithms according to *securityConfig* and apply the keys ( $K_{UPenc}$ ) associated with the  $K_{eNB}/S-K_{gNB}$  as indicated in *keyToUse*;

2> if the DRB was configured with the same *eps-BearerIdentity* either by NR or E-UTRA prior to receiving this reconfiguration:

3> associate the established DRB with the corresponding *eps-BearerIdentity*;

2> else:

3> indicate the establishment of the DRB(s) and the *eps-BearerIdentity* of the established DRB(s) to upper layers;

1> for each *drb-Identity* value included in the *drb-ToAddModList* that is part of the current UE configuration:

2> if *reestablishPDCP* is set:

3> configure the PDCP entity of this *RadioBearerConfig* to apply the ciphering algorithm and  $K_{UPenc}$  key associated with the  $K_{eNB}/S-K_{gNB}$  as indicated in *keyToUse*, i.e. the ciphering configuration shall be applied to all subsequent PDCP PDUs received and sent by the UE;

3> re-establish the PDCP entity of this DRB as specified in 38.323 [5], section 5.1.2;

2> else, if *recoverPDCP* is set:

3> trigger the PDCP entity of this DRB to perform data recovery as specified in 38.323;

2> if the *pdcp-Config* is included:

3> reconfigure the PDCP entity in accordance with the received *pdcp-Config*.

NOTE 1: Removal and addition of the same *drb-Identity* in a single *radioResourceConfig* is not supported. In case *drb-Identity* is removed and added due to reconfiguration with sync or re-establishment with the full configuration option, the network can use the same value of *drb-Identity*.

NOTE 2: When determining whether a *drb-Identity* value is part of the current UE configuration, the UE does not distinguish which *RadioBearerConfig* and *DRB-ToAddModList* that DRB was originally configured in. To re-associate a DRB with a different key ( $K_{eNB}$  to  $S-K_{eNB}$  or vice versa), the network provides the *drb-Identity* value in the (target) *drb-ToAddModList* and sets the *reestablishPDCP* flag. The network does not list the *drb-Identity* in the (source) *drb-ToReleaseList*.

NOTE 3: When setting the *reestablishPDCP* flag for a radio bearer, the network ensures that the RLC receiver entities do not deliver old PDCP PDUs to the re-established PDCP entity. It does that e.g. by triggering a reconfiguration with sync of the cell group hosting the old RLC entity or by releasing the old RLC entity.

NOTE 4: In this specification, UE configuration refers to the parameters configured by NR RRC unless otherwise stated.

8.2.4.2.1.1.3 Test description

8.2.4.2.1.1.3.1 Pre-test conditions

System Simulator:

- E-UTRA Cell 1 is the PCell, NR Cell 1 is the PSCell to be added, and NR Cell 3 is Scell to be added. NR Cell 2 and NR Cell 12 are the target PSCell and SCell.
- NR Cell 1 and NR Cell 3 are Intra-band Contiguous. NR Cell 2 and NR Cell 12 are Intra-band Contiguous.

UE:

None

Preamble:

- The UE is in state RRC\_CONNECTED using generic procedure parameter Connectivity (*EN-DC*) according to TS 38.508-1 [4].

8.2.4.2.1.1.3.2 Test procedure sequence

Table 8.2.4.2.1.1.3.2-1 illustrates the downlink power levels to be applied for EUTRA Cell 1, NR Cell 1, NR Cell 3, NR Cell 2 and NR Cell 12 at various time instants of the test execution. Row marked "T0" denotes the conditions after the preamble, while rows marked "T1" are to be applied subsequently. The exact instants on which these values shall be applied are described in the texts in this clause.

**Table 8.2.4.2.1.1.3.2-1: Power levels**

	Parameter	Unit	E-UTRA Cell 1	NR Cell 1	NR Cell 3	NR Cell 2	NR Cell 12	Remark
T0	Cell-specific RS EPRE	dBm/1 5kHz	-85	-	-	-	-	EUTRA Cell 1, NR Cell 1 and NR Cell 3 are available. NR Cell 2 and NR Cell 12 are not available.
	SS/PBCH SSS EPRE	dBm/1 5kHz	-	[-85]	[-85]	off	off	
T1	Cell-specific RS EPRE	dBm/1 5kHz	-85	-	-	-	-	EUTRA Cell 1, NR Cell 1, NR Cell 3, NR Cell 2 and NR Cell 12 are available.
	SS/PBCH SSS EPRE	dBm/1 5kHz	-	[-85]	[-85]	[-85]	[-85]	

Table 8.2.4.2.1.1.3.2-2: Main behaviour

St	Procedure	Message Sequence		TP	Verdict
		U – S	Message		
1	The SS changes Cell parameters according to the row "T0" in table 8.2.4.2.1.1.3.2-1.	-	-	-	-
2	The SS transmits an <i>RRCCONNECTIONRECONFIGURATION</i> message with nr-Config IE including NR RRCReconfiguration message to configure NR Cell 1 as the NR PSCell and sCellToAddModList with an sCellIndex set to NR Cell 3 as the configured Scell.	<--	<i>RRCCONNECTIONRECONFIGURATION</i>	-	-
3	Check: Does the UE transmit an <i>RRCCONNECTIONRECONFIGURATIONCOMPLETE</i> message?	-->	<i>RRCCONNECTIONRECONFIGURATIONCOMPLETE</i>	1	P
4	The SS changes NR Cell 2 and NR Cell 12 parameters according to the row "T1" in table 8.2.4.2.1.1.3.2-1.	-	-	-	-
5	The SS transmits an <i>RRCCONNECTIONRECONFIGURATION</i> message with nr-Config IE including NR RRCReconfiguration message to perform both NR Cell 1 and NR Cell 3 changed to the configured target NR Cell 2 and NR Cell 12.	<--	<i>RRCCONNECTIONRECONFIGURATION</i>	-	-
6	Check: Does the UE transmit an <i>RRCCONNECTIONRECONFIGURATIONCOMPLETE</i> message configuring the new PSCell and SCell and configure lower layers to consider the SCell to be in deactivated state?	-->	<i>RRCCONNECTIONRECONFIGURATIONCOMPLETE</i>	2	P
7	The SS transmits an <i>RRCCONNECTIONRECONFIGURATION</i> message with nr-Config IE including NR RRCReconfiguration message to change the current PSCell (NR Cell 2) to NR Cell 12 equaling to one of the current UE SCell configuration.	<--	<i>RRCCONNECTIONRECONFIGURATION</i>	-	-
8	Check: Does the UE send an <i>RRCCONNECTIONRECONFIGURATIONCOMPLETE</i> message and reconfigure the current NR Scell to PSCell?	-->	<i>RRCCONNECTIONRECONFIGURATIONCOMPLETE</i>	3	P

8.2.4.2.1.1.3.3 Specific message contents

**Table 8.2.4.2.1.1.3.3-1: RRCConnectionReconfiguration (step 2, Table 8.2.4.2.1.1.3.2-2)**

Derivation Path: 36.508 [7], Table 4.6.1-8			
Information Element	Value/remark	Comment	Condition
RRCConnectionReconfiguration ::= SEQUENCE {			
criticalExtensions CHOICE {			
c1 CHOICE{			
rrcConnectionReconfiguration-r8 SEQUENCE {			
nonCriticalExtension SEQUENCE {			
nonCriticalExtension SEQUENCE {			
nonCriticalExtension SEQUENCE {			
nonCriticalExtension SEQUENCE {			
nonCriticalExtension SEQUENCE {			
nonCriticalExtension SEQUENCE {			
nonCriticalExtension SEQUENCE {			
nr-Config-r15 CHOICE {			
setup SEQUENCE {			
nr-SecondaryCellGroupConfig-r15	RRCReconfiguration	OCTET STRING including the RRCReconfiguration	
}			
}			
}			
}			
}			
}			
}			
}			
}			
}			
}			
}			
}			
}			
}			
}			
}			
}			
}			
}			

**Table 8.2.4.2.1.1.3.3-2: RRCReconfiguration (Table 8.2.4.2.1.1.3.3-1: RRCConnectionReconfiguration)**

Derivation Path: 38.508-1 [4], Table 4.6.1-3			
Information Element	Value/remark	Comment	Condition
RRCReconfiguration ::= SEQUENCE {			
criticalExtensions CHOICE {			
rrcReconfiguration SEQUENCE {			
secondaryCellGroup	CellGroupConfig	OCTET STRING (CONTAINING CellGroupConfig)	EN-DC
}			
}			
}			



**Table 8.2.4.2.1.1.3.3-3: CellGroupConfig (Table 8.2.4.2.1.1.3.3-2: RRCReconfiguration)**

Derivation Path: 38.508-1 [4], Table 4.6.3-13			
Information Element	Value/remark	Comment	Condition
CellGroupConfig ::= SEQUENCE {			
spCellConfig SEQUENCE {			
servCellIndex	1		
reconfigurationWithSync SEQUENCE {			EN-DC
spCellConfigCommon ::= SEQUENCE {			
physCellId	Physical Cell Identity of NR Cell 1		
}			
}			
sCellToAddModList SEQUENCE (SIZE (1..maxNrofSCells)) OF SEQUENCE {	1 entry		
sCellIndex[1]	1		
sCellConfigCommon[1] SEQUENCE {			
physCellId	Physical Cell Identity of NR Cell 3		
}			
}			
sCellToReleaseList	Not present		
}			

**Table 8.2.4.2.1.1.3.3-4: RRCConnectionReconfigurationComplete (step 3, step 6 and step 8, Table 8.2.4.2.1.1.3.2-2)**

Derivation Path: 36.508 [7], Table 4.6.1-9			
Information Element	Value/remark	Comment	Condition
RRCConnectionReconfigurationComplete ::= SEQUENCE {			
criticalExtensions CHOICE {			
rrcConnectionReconfigurationComplete-r8 SEQUENCE {			
nonCriticalExtension SEQUENCE {			
nonCriticalExtension SEQUENCE {			
nonCriticalExtension SEQUENCE {			
nonCriticalExtension SEQUENCE {			
nonCriticalExtension SEQUENCE {			
nonCriticalExtension SEQUENCE {			
scg-ConfigResponseNR-r15	Present		
}			
}			
}			
}			
}			

**Table 8.2.4.2.1.1.3.3-5: RRCConnectionReconfiguration (step 5, Table 8.2.4.2.1.1.3.2-2)**

Derivation Path: 36.508 [7], Table 4.6.1-8			
Information Element	Value/remark	Comment	Condition
RRCConnectionReconfiguration ::= SEQUENCE {			
criticalExtensions CHOICE {			
c1 CHOICE{			
rrcConnectionReconfiguration-r8 SEQUENCE {			
nonCriticalExtension SEQUENCE {			
nonCriticalExtension SEQUENCE {			
nonCriticalExtension SEQUENCE {			
nonCriticalExtension SEQUENCE {			
nonCriticalExtension SEQUENCE {			
nonCriticalExtension SEQUENCE {			
nr-Config-r15 CHOICE {			
setup SEQUENCE {			
endc-ReleaseAndAdd	True		
nr-SecondaryCellGroupConfig-r15	RRCReconfiguration	OCTET STRING including the RRCReconfiguration	
}			
}			
}			
}			
}			
}			
}			
}			

**Table 8.2.4.2.1.1.3.3-6: RRCReconfiguration (Table 8.2.4.2.1.1.3.3-5: RRCConnectionReconfiguration)**

Derivation Path: 38.508-1 [4], Table 4.6.1-3			
Information Element	Value/remark	Comment	Condition
RRCReconfiguration ::= SEQUENCE {			
criticalExtensions CHOICE {			
rrcReconfiguration SEQUENCE {			
secondaryCellGroup	CellGroupConfig	OCTET STRING (CONTAINING CellGroupConfig)	EN-DC
}			
}			
}			

**Table 8.2.4.2.1.1.3.3-7: CellGroupConfig (Table 8.2.4.2.1.1.3.3-6: RRCReconfiguration)**

Derivation Path: 38.508-1 [4], Table 4.6.3-13			
Information Element	Value/remark	Comment	Condition
CellGroupConfig ::= SEQUENCE {			
spCellConfig SEQUENCE {			
servCellIndex	1		
reconfigurationWithSync SEQUENCE {			EN-DC
spCellConfigCommon ::= SEQUENCE {			
physCellId	Physical Cell Identity of NR Cell 2		
}			
}			
}			
sCellToAddModList SEQUENCE (SIZE (1..maxNrofSCells)) OF SEQUENCE {	1 entry		
sCellIndex[1]	1		
sCellConfigCommon[1] SEQUENCE {			
physCellId	Physical Cell Identity of NR Cell 12		
}			
}			
sCellToReleaseList	Not present		
}			

**Table 8.2.4.2.1.1.3.3-8: RRCConnectionReconfiguration (step 7, Table 8.2.4.2.1.1.3.2-2)**

Derivation Path: 36.508 [7], Table 4.6.1-8			
Information Element	Value/remark	Comment	Condition
RRCConnectionReconfiguration ::= SEQUENCE {			
criticalExtensions CHOICE {			
c1 CHOICE {			
rrcConnectionReconfiguration-r8 SEQUENCE {			
nonCriticalExtension SEQUENCE {			
nonCriticalExtension SEQUENCE {			
nonCriticalExtension SEQUENCE {			
nonCriticalExtension SEQUENCE {			
nonCriticalExtension SEQUENCE {			
nonCriticalExtension SEQUENCE {			
nonCriticalExtension SEQUENCE {			
nr-Config-r15 CHOICE {			
setup SEQUENCE {			
endc-ReleaseAndAdd	True		
nr-SecondaryCellGroupConfig-r15	RRCReconfiguration	OCTET STRING including the RRCReconfiguration	
}			
}			
}			
}			
}			
}			

**Table 8.2.4.2.1.1.3.3-9: RRCReconfiguration (Table 8.2.4.2.1.1.3.3-8: RRCConnectionReconfiguration)**

Derivation Path: 38.508-1 [4], Table 4.6.1-3			
Information Element	Value/remark	Comment	Condition
RRCReconfiguration ::= SEQUENCE {			
criticalExtensions CHOICE {			
rrcReconfiguration SEQUENCE {			
secondaryCellGroup	CellGroupConfig	OCTET STRING (CONTAINING CellGroupConfig)	EN-DC
}			
}			
}			

**Table 8.2.4.2.1.1.3.3-10: CellGroupConfig (Table 8.2.4.2.1.1.3.3-10: RRCReconfiguration)**

Derivation Path: 38.508-1 [4], Table 4.6.3-13			
Information Element	Value/remark	Comment	Condition
CellGroupConfig ::= SEQUENCE {			
spCellConfig SEQUENCE {			
servCellIndex	1		
reconfigurationWithSync SEQUENCE {			EN-DC
spCellConfigCommon ::= SEQUENCE {			
physCellId	Physical Cell Identity of NR Cell 12		
}			
}			
}			
sCellToAddModList	Not present		
sCellToReleaseList	Not present		
}			

#### 8.2.4.2.1.2 NR CA / Simultaneous PSCell and SCell addition / PSCell and SCell change / CA Release / EN-DC / Intra-band non-Contiguous CA

##### 8.2.4.2.1.2.1 Test Purpose (TP)

Same as TC 8.2.4.2.1.1 but applied to Intra-band non-Contiguous CA.

##### 8.2.4.2.1.2.2 Conformance requirements

Same as TC 8.2.4.2.1.1 but applied to Intra-band non-Contiguous CA.

##### 8.2.4.2.1.2.3 Test description

###### 8.2.4.2.1.2.3.1 Pre-test conditions

Same as TC 8.2.4.2.1.1 with the following differences:

- CA configuration: Intra-band non-Contiguous CA replaces Intra-band Contiguous CA

###### 8.2.4.2.1.2.3.2 Test procedure sequence

Same as TC 8.2.4.2.1.1 with the following differences:

- CA configuration: Intra-band non-Contiguous CA replaces Intra-band Contiguous CA

#### 8.2.4.2.1.3 NR CA / Simultaneous PSCell and SCell addition / PSCell and SCell change / CA Release / EN-DC / Inter-band CA

##### 8.2.4.2.1.3.1 Test Purpose (TP)

Same as TC 8.2.4.2.1.1 but applied to Inter-band CA.

## 8.2.4.2.1.3.2 Conformance requirements

Same as TC 8.2.4.2.1.1 but applied to Inter-band CA.

## 8.2.4.2.1.3.3 Test description

## 8.2.4.2.1.3.3.1 Pre-test conditions

Same as TC 8.2.4.2.1.1 with the following differences:

- CA configuration: Inter-band CA replaces Intra-band Contiguous CA

## 8.2.4.2.1.2.3.2 Test procedure sequence

Same as TC 8.2.4.2.1.1 with the following differences:

- CA configuration: Inter-band CA replaces Intra-band Contiguous CA
- Cells configuration: NR Cell 10 replaces NR Cell 3, NR Cell 30 replaces NR Cell 10

## 8.2.4.3 NR CA / SCell change / Intra-NR measurement event A6 / SRB3

## 8.2.4.3.1 NR CA / SCell change / Intra-NR measurement event A6 / SRB3 / EN-DC

## 8.2.4.3.1.1 NR CA / SCell change / Intra-NR measurement event A6 / SRB3 / EN-DC / Intra-band Contiguous CA

## 8.2.4.3.1.1.1 Test Purpose (TP)

(1)

```
with { UE in RRC_CONNECTED state with EN-DC, and MCG (E-UTRA PDCP) and SCG with SCell(s) configured
and SRB3 configured and Intra-NR measurement configured for event A6 }
ensure that {
  when { Neighbour becomes offset better than NR SCell }
  then { UE sends a Measurement Report message on SRB3 While entering condition for event A6 is
satisfied }
}
```

(2)

```
with { UE in RRC_CONNECTED state with EN-DC, and MCG (E-UTRA PDCP) and SCG with SCell(s) configured
and received event A6 triggered measurement report }
ensure that {
  when { UE receives an RRCReconfiguration message containing sCellToReleaseList with an sCellIndex
equalling to one of the current UE SCell configuration and sCellToAddModList with an sCellIndex set
to the configured target SCell }
  then { UE sends an RRCReconfigurationComplete message and changes the SCell }
}
```

## 8.2.4.3.1.1.2 Conformance requirements

References: The conformance requirements covered in the present test case are specified in: TS 36.331, clause 5.3.5.3, TS 38.331, clauses 5.3.5.3, 5.3.5.5.8, 5.3.5.5.9, 5.5.4.7 and 5.5.5. Unless otherwise stated these are Rel-15 requirements.

[TS 36.331, clause 5.3.5.3]

If the *RRCCONNECTIONRECONFIGURATION* message does not include the *mobilityControlInfo* and the UE is able to comply with the configuration included in this message, the UE shall:

...

1> if the received *RRCCONNECTIONRECONFIGURATION* includes the *nr-Config* and it is set to *release*: or

1> if the received *RRCCONNECTIONRECONFIGURATION* includes *endc-ReleaseAndAdd*:

2> perform ENDC release as specified in TS38.331 [82, 5.3.5.10];

1> if the received *RRCCONNECTIONRECONFIGURATION* includes the *sk-Counter*:

- 2> perform key update procedure as specified in TS 38.331 [82, 5.3.5.8];
- 1> if the received *RRCConnectionReconfiguration* includes the *nr-SecondaryCellGroupConfig*:
  - 2> perform NR RRC Reconfiguration as specified in TS 38.331 [82, 5.3.5.5];
- 1> if the received *RRCConnectionReconfiguration* includes the *nr-RadioBearerConfig1*:
  - 2> perform radio bearer configuration as specified in TS 38.331 [82, 5.3.5.6];
- 1> if the received *RRCConnectionReconfiguration* includes the *nr-RadioBearerConfig2*:
  - 2> perform radio bearer configuration as specified in TS 38.331 [82, 5.3.5.6];
- ...
- 1> set the content of *RRCConnectionReconfigurationComplete* message as follows:
  - 2> if the *RRCConnectionReconfiguration* message includes *perCC-GapIndicationRequest*:
    - 3> include *perCC-GapIndicationList* and *numFreqEffective*;
  - 2> if the frequencies are configured for reduced measurement performance:
    - 3> include *numFreqEffectiveReduced*;
  - 2> if the received *RRCConnectionReconfiguration* message included *nr-SecondaryCellGroupConfig*:
    - 3> include *scg-ConfigResponseNR*;
- 1> submit the *RRCConnectionReconfigurationComplete* message to lower layers for transmission using the new configuration, upon which the procedure ends;

[TS 38.331, clause 5.3.5.3]

The UE shall perform the following actions upon reception of the *RRCReconfiguration*:

- 1> if the *RRCReconfiguration* includes the *secondaryCellGroup*:
  - 2> perform the cell group configuration for the SCG according to 5.3.5.5;
- 1> if the *RRCReconfiguration* message contains the *radioBearerConfig*:
  - 2> perform the radio bearer configuration according to 5.3.5.6;
- 1> if the *RRCReconfiguration* message includes the *measConfig*:
  - 2> perform the measurement configuration procedure as specified in 5.5.2;
- 1> if the UE is configured with E-UTRA *nr-SecondaryCellGroupConfig* (MCG is E-UTRA):
  - 2> if *RRCReconfiguration* was received via SRB1:
    - 3> construct *RRCReconfigurationComplete* message and submit it via the EUTRA MCG embedded in E-UTRA RRC message *RRCConnectionReconfigurationComplete* as specified in TS 36.331 [10].
    - 3> if *reconfigurationWithSync* was included in *spCellConfig* of an SCG:
      - 4> initiate the random access procedure on the SpCell, as specified in TS 38.321 [3];
  - 2> else (*RRCReconfiguration* was received via SRB3):
    - 3> submit the *RRCReconfigurationComplete* message via SRB3 to lower layers for transmission using the new configuration;

NOTE: In the case of SRB1, the random access is triggered by RRC layer itself as there is not necessarily other UL transmission. In the case of SRB3, the random access is triggered by the MAC layer due to arrival of *RRCReconfigurationComplete*.

- 1> if MAC of an NR cell group successfully completes a random access procedure triggered above;
  - 2> stop timer T304 for that cell group;
  - 2> apply the parts of the CQI reporting configuration, the scheduling request configuration and the sounding RS configuration that do not require the UE to know the SFN of the respective target SpCell, if any;
  - 2> apply the parts of the measurement and the radio resource configuration that require the UE to know the SFN of the respective target SpCell (e.g. measurement gaps, periodic CQI reporting, scheduling request configuration, sounding RS configuration), if any, upon acquiring the SFN of that target SpCell;
  - 2> the procedure ends;

[TS 38.331, clause 5.3.5.5.8]

The UE shall:

- 1> if the release is triggered by reception of the *sCellToReleaseList*:
  - 2> for each *sCellIndex* value included in the *sCellToReleaseList*:
    - 3> if the current UE configuration includes an SCell with value *sCellIndex*:
      - 4> release the SCell;

[TS 38.331, clause 5.3.5.5.9]

The UE shall:

- 1> for each *sCellIndex* value included in the *sCellToAddModList* that is not part of the current UE configuration (SCell addition):
  - 2> add the SCell, corresponding to the *sCellIndex*, in accordance with the *sCellConfigCommon* and *sCellConfigDedicated*;
  - 2> configure lower layers to consider the SCell to be in deactivated state;

**Editor's Note: FFS Check automatic measurement handling for SCells.**

- 2> for each *measId* included in the *measIdList* within *VarMeasConfig*:
  - 3> if SCells are not applicable for the associated measurement; and
  - 3> if the concerned SCell is included in *cellsTriggeredList* defined within the *VarMeasReportList* for this *measId*:
    - 4> remove the concerned SCell from *cellsTriggeredList* defined within the *VarMeasReportList* for this *measId*;
- 1> for each *sCellIndex* value included in the *sCellToAddModList* that is part of the current UE configuration (SCell modification):
  - 2> modify the SCell configuration in accordance with the *sCellConfigDedicated*;

[TS 38.331, clause 5.5.4.7]

The UE shall:

- 1> consider the entering condition for this event to be satisfied when condition A6-1, as specified below, is fulfilled;
- 1> consider the leaving condition for this event to be satisfied when condition A6-2, as specified below, is fulfilled;
- 1> for this measurement, consider the (secondary) cell that is configured on the frequency indicated in the associated *measObjectNR* to be the serving cell.

NOTE: The neighbour(s) is on the same frequency as the SCell i.e. both are on the frequency indicated in the associated *measObjectNR*.

Inequality A6-1 (Entering condition)

$$M_n + O_{cn} - H_{ys} > M_s + O_{cs} + Off$$

Inequality A6-2 (Leaving condition)

$$M_n + O_{cn} + H_{ys} < M_s + O_{cs} + Off$$

The variables in the formula are defined as follows:

***M<sub>n</sub>*** is the measurement result of the neighbouring cell, not taking into account any offsets.

***O<sub>cn</sub>*** is the cell specific offset of the neighbour cell (i.e. *cellIndividualOffset* as defined within *measObjectNR* corresponding to the frequency of the neighbour cell), and set to zero if not configured for the neighbour cell.

***M<sub>s</sub>*** is the measurement result of the serving cell, not taking into account any offsets.

***O<sub>cs</sub>*** is the cell specific offset of the serving cell (i.e. *cellIndividualOffset* as defined within *measObjectNR* corresponding to the serving frequency), and is set to zero if not configured for the serving cell.

***H<sub>ys</sub>*** is the hysteresis parameter for this event (i.e. *hysteresis* as defined within *reportConfigNR* for this event).

***Off*** is the offset parameter for this event (i.e. *a6-Offset* as defined within *reportConfigNR* for this event).

***M<sub>n</sub>***, ***M<sub>s</sub>*** are expressed in dBm in case of RSRP, or in dB in case of RSRQ and RS-SINR.

***O<sub>cn</sub>***, ***O<sub>cs</sub>***, ***H<sub>ys</sub>***, ***Off*** are expressed in dB.

[TS 38.331, clause 5.5.5]



**Figure 5.5.5.1-1: Measurement reporting**

The purpose of this procedure is to transfer measurement results from the UE to the network. The UE shall initiate this procedure only after successful security activation.

For the *measId* for which the measurement reporting procedure was triggered, the UE shall set the *measResults* within the *MeasurementReport* message as follows:

- 1> set the *measId* to the measurement identity that triggered the measurement reporting;
- 1> set the *measResultServingCell* within *measResultServingFreqList* to include RSRP, RSRQ and the available SINR for each configured serving cell derived based on the *rsType* indicated in the associated *reportConfig*;
- 1> set the *measResultServingCell* within *measResultServingFreqList* to include for each NR serving cell that is configured, if any, the *servFreqId*;
- 1> if the *reportConfig* associated with the *measId* that triggered the measurement reporting includes *reportQuantityRsIndexes* and *maxNrofRSIndexesToReport*:
  - 2> for each configured serving cell, include beam measurement information according to the associated *reportConfig* as described in 5.5.5.2;



- 1> if the *reportConfig* associated with the *measId* that triggered the measurement reporting includes *reportAddNeighMeas*:
  - 2> for each serving frequency for which *measObjectId* is referenced in the *measIdList*, other than the frequency corresponding with the *measId* that triggered the measurement reporting:
    - 3> set the *measResultBestNeighCell* within *measResultServingFreqList* to include the *physCellId* and the available measurement quantities based on the *reportQuantityCell* and *rsType* indicated in *reportConfig* of the non-serving cell on the concerned serving frequency with the highest measured RSRP if RSRP measurement results are available for cells on this frequency, otherwise with the highest measured RSRQ if RSRQ measurement results are available for cells on this frequency, otherwise with the highest measured SINR;
    - 3> if the *reportConfig* associated with the *measId* that triggered the measurement reporting includes *reportQuantityRsIndexes* and *maxNrofRSIndexesToReport*:
      - 4> for each best non-serving cell included in the measurement report:
        - 5> include beam measurement information according to the associated *reportConfig* as described in 5.5.5.2;
  - 1> if there is at least one applicable neighbouring cell to report:
    - 2> set the *measResultNeighCells* to include the best neighbouring cells up to *maxReportCells* in accordance with the following:
      - 3> if the *reportType* is set to *eventTriggered*:
        - 4> include the cells included in the *cellsTriggeredList* as defined within the *VarMeasReportList* for this *measId*;
      - 3> else:
        - 4> include the applicable cells for which the new measurement results became available since the last periodical reporting or since the measurement was initiated or reset;
        - 4> if *reportQuantityRsIndexes* and *maxNrofRSIndexesToReport* are configured, include beam measurement information as described in 5.5.5.2;
      - 3> for each cell that is included in the *measResultNeighCells*, include the *physCellId*;
      - 3> if the *reportType* is set to *eventTriggered*:
        - 4> for each included cell, include the layer 3 filtered measured results in accordance with the *reportConfig* for this *measId*, ordered as follows:
          - 5> if the *measObject* associated with this *measId* concerns NR:
            - 6> if *rsType* in the associated *reportConfig* is set to *ssb*:
              - 7> set *resultsSSB-Cell* within the *measResult* to include the SS/PBCH block based quantity(ies) indicated in the *reportQuantityCell* within the concerned *reportConfig*, in order of decreasing trigger quantity, i.e. the best cell is included first;
              - 8> if *reportQuantityRsIndexes* and *maxNrofRSIndexesToReport* are configured, include beam measurement information as described in 5.5.5.2;
            - 6> else if *rsType* in the associated *reportConfig* is set to *csi-rs*:
              - 7> set *resultsCSI-RS-Cell* within the *measResult* to include the CSI-RS based quantity(ies) indicated in the *reportQuantityCell* within the concerned *reportConfig*, in order of decreasing trigger quantity, i.e. the best cell is included first;
              - 8> if *reportQuantityRsIndexes* and *maxNrofRSIndexesToReport* are, include beam measurement information as described in 5.5.5.2;
    - 1> increment the *numberOfReportsSent* as defined within the *VarMeasReportList* for this *measId* by 1;

- 1> stop the periodical reporting timer, if running;
- 1> if the *numberOfReportsSent* as defined within the *VarMeasReportList* for this *measId* is less than the *reportAmount* as defined within the corresponding *reportConfig* for this *measId*:
  - 2> start the periodical reporting timer with the value of *reportInterval* as defined within the corresponding *reportConfig* for this *measId*;
- 1> else:
  - 2> if the *reportType* is set to *periodical*:
    - 3> remove the entry within the *VarMeasReportList* for this *measId*;
    - 3> remove this *measId* from the *measIdList* within *VarMeasConfig*;
- 1> if the UE is configured with EN-DC:
  - 2> if SRB3 is configured:
    - 3> submit the *MeasurementReport* message via SRB3 to lower layers for transmission, upon which the procedure ends;
  - 2> else:
    - 3> submit the *MeasurementReport* message via the EUTRA MCG embedded in E-UTRA RRC message *ULInformationTransferMRDC* as specified in TS 36.331 [10].
- 1> else:
  - 2> submit the *MeasurementReport* message to lower layers for transmission, upon which the procedure ends.

#### 8.2.4.3.1.1.3 Test description

##### 8.2.4.3.1.1.3.1 Pre-test conditions

##### System Simulator:

- E-UTRA Cell 1 is the PCell. NR Cell 1 is the PSCell and NR Cell 3 is the SCell to be added, NR Cell 12 is the intra-frequency neighbour cell of NR Cell 3.
- System Information combination [xx] as defined in TS 38.508-1 [4] clause 4.4.3.1.1 is used in E-UTRA Cell 1 and NR Cell 1 and NR Cell 3 and NR Cell 12.

##### UE:

None.

##### Preamble:

- The UE is in state RRC\_CONNECTED using generic procedure parameter Connectivity (*EN-DC*) and DC bearers (*MCG and SCG*) according to TS 38.508-1 [4], table 4.5.4.

##### 8.2.4.3.1.1.3.2 Test procedure sequence

Table 8.2.4.3.1.1.3.2-1 illustrates the downlink power levels to be applied for E-UTRA Cell 1, NR Cell 1, NR Cell 3 and NR Cell 12 at various time instants of the test execution. Row marked "T0" denotes the conditions after the preamble, while the configuration marked "T1" is applied at the point indicated in the Main behaviour description in Table 8.2.4.3.1.1.3.2-2.

Table 8.2.4.3.1.1.3.2-1: Power levels

	Parameter	Unit	E-UTRA Cell 1	NR Cell 1	NR Cell 3	NR Cell 12	Remark
T0	Cell-specific RS EPRE	dBm/15 kHz	-79	-	-	-	Power levels are such that entry condition for event A6 is not satisfied: $Mn + Ocn + Hys < Ms + Ocs + Off$
	SS/PBCH SSS EPRE	dBm/15 kHz	-	[-79]	[-85]	[-97]	
T1	Cell-specific RS EPRE	dBm/15 kHz	-79	-	-	-	Power levels are such that entry condition for event A6 is satisfied: $Mn + Ocn - Hys > Ms + Ocs + Off$
	SS/PBCH SSS EPRE	dBm/15 kHz	-	[-79]	[-97]	[-85]	

Table 8.2.4.3.1.1.3.2-2: Main behaviour

St	Procedure	Message Sequence		TP	Verdict
		U – S	Message		
1	SS transmits an <i>RRCConnectionReconfiguration</i> message containing <i>RRCReconfiguration</i> message to <i>configure SCell (NR Cell 3) and SRB3</i> .	<--	<i>RRCConnectionReconfiguration(RRCReconfiguration)</i>	-	-
2	The UE transmits an <i>RRCConnectionReconfigurationComplete</i> message containing <i>RRCReconfigurationComplete</i> message.	-->	<i>RRCConnectionReconfigurationComplete(RRCReconfigurationComplete)</i>	-	-
3	SS transmits an <i>RRCConnectionReconfiguration</i> message containing <i>RRCReconfiguration</i> message including <i>measConfig</i> to setup intra NR measurement and reporting for event A6	<--	<i>RRCConnectionReconfiguration(RRCReconfiguration)</i>	-	-
4	The UE transmits an <i>RRCConnectionReconfigurationComplete</i> message containing <i>RRCReconfigurationComplete</i> message.	-->	<i>RRCConnectionReconfigurationComplete(RRCReconfigurationComplete)</i>	-	-
5	SS re-adjusts the cell-specific reference signal level according to row "T1" in table 8.2.4.3.1.1.3.2-1.	-	-	-	-
6	Check: Does the UE transmit a <i>MeasurementReport</i> message via SRB3 to report event A6 with the measured RSRP and RSRQ value for NR Cell 12?	-->	<i>MeasurementReport</i>	1	P
7	The SS transmits an <i>RRCReconfiguration</i> message including <i>sCellToReleaseList</i> with NR Cell 3 as SCell release and <i>sCellToAddModList</i> with NR Cell 12 as SCell addition via SRB3.	<--	<i>RRCReconfiguration</i>	-	-
8	Check: Does the UE transmit an <i>RRCConnectionReconfigurationComplete</i> message on NR Cell 1?	-->	<i>RRCReconfigurationComplete</i>	2	P

## 8.2.4.3.1.1.3.3 Specific message contents

Table 8.2.4.3.1.1.3.3-1: *RRCConnectionReconfiguration* (step 1, Table 8.2.4.3.1.1.3.2-2)

Derivation Path: TS 36.508 [7], Table 4.6.1-8 condition MCG_and_SCG.
--

**Table 8.2.4.3.1.1.3.3-2: RRCReconfiguration (step 1, Table 8.2.4.3.1.1.3.2-2)**

Derivation Path: TS 38.508-1 [4], Table 4.6.1-3.			
Information Element	Value/remark	Comment	Condition
RRCReconfiguration ::= SEQUENCE {			
criticalExtensions CHOICE {			
c1 CHOICE {			
rrcReconfiguration ::= SEQUENCE {			
RadioBearerConfig	RadioBearerConfig	TS 38.508-1 [4] table 4.6.3-100 condition SRB3	
SecondaryCellGroup	CellGroupConfig		
}			
}			
}			
}			

**Table 8.2.4.3.1.1.3.3-3: CellGroupConfig (Table 8.2.4.3.1.1.3.3-2)**

Derivation Path: TS 38.508-1 [4], Table 4.6.3-13.			
Information Element	Value/remark	Comment	Condition
CellGroupConfig ::= SEQUENCE {			
sCellToAddModList SEQUENCE (SIZE (1..maxMeasId)) OF SEQUENCE {			
sCellIndex[1]	1		
sCellConfigCommon[1]	ServingCellConfigCommon		
sCellConfigDedicated[1]	ServingCellConfig	TS 38.508-1 [4] table 4.6.3-128	
}			
}			

**Table 8.2.4.3.1.1.3.3-4: ServingCellConfigCommon (Table 8.2.4.3.1.1.3.3-3)**

Derivation Path: TS 38.508-1 [4], Table 4.6.3-129.			
Information Element	Value/remark	Comment	Condition
ServingCellConfigCommon ::= SEQUENCE {			
PhysCellId	Physical Cell Identity of NR Cell 3		
}			

**Table 8.2.4.3.1.1.3.3-5: RRCReconfiguration (step 3, Table 8.2.4.3.1.1.3.2-2)**

Derivation Path: TS 38.508-1 [4], Table 4.6.1-3.			
Information Element	Value/remark	Comment	Condition
RRCReconfiguration ::= SEQUENCE {			
criticalExtensions CHOICE {			
c1 CHOICE {			
rrcReconfiguration ::= SEQUENCE {			
measConfig	MeasConfig		
}			
}			
}			
}			

Table 8.2.4.3.1.1.3.3-6: *MeasConfig* (Table 8.2.4.3.1.1.3.3-5)

Derivation path: TS 38.508-1 [4], Table 4.6.3-50.			
Information Element	Value/Remark	Comment	Condition
measConfig ::= SEQUENCE {			
measObjectToAddModList SEQUENCE (SIZE (1..maxNrofObjectId)) OF SEQUENCE {	2 entry		
measObjectId[1]	IdMeasObject-NRf1	NR Cell 1	
measObject[1] CHOICE {			
measObjectNR	MeasObjectNR-GENERIC(NRf1)		
}			
measObjectId[2]	IdMeasObject-NRf2	NR Cell 3	
measObject[2] CHOICE {			
measObjectNR	MeasObjectNR-GENERIC(NRf2)		
}			
}			
reportConfigToAddModList SEQUENCE (SIZE (1..maxReportConfigId)) OF SEQUENCE {	1 entry		
reportConfigId[1]	IdReportConfig-A6		
reportConfig[1] CHOICE {			
reportConfigNR	ReportConfigNR	TS 38.508-1 [4] table 4.6.3-107 condition EVENT_A6	
}			
}			
measIdToAddModList SEQUENCE (SIZE (1..maxMeasId)) OF SEQUENCE {	1 entry		
measId[1]	1		
measObjectId[1]	IdMeasObject-NRf2		
reportConfigId[1]	IdReportConfig-A6		
}			
}			

**Table 8.2.4.3.1.1.3.3-7: MeasurementReport (step 6, Table 8.2.4.3.1.1.3.2-2)**

Derivation Path: TS 38.508-1 [4], Table 4.6.1-2.			
Information Element	Value/remark	Comment	Condition
MeasurementReport ::= SEQUENCE {			
criticalExtensions CHOICE {			
c1 CHOICE {			
measurementReport ::= SEQUENCE {			
measResults ::= SEQUENCE {			
measId	1		
measResultServingMOList ::=SEQUENCE(SIZE (1..maxNrofServingCells)) OF SEQUENCE {			
servCellId[1]	1		
measResultServingCell[1] :=SEQUENCE(SIZE (1.. maxCellReport)) OF SEQUENCE {		Report NR Cell 3	
physCellId	physCellId of NR Cell 3		
measResult SEQUENCE {			
cellResults SEQUENCE {			
resultsSSB-Cell SEQUENCE {			
rsrp	(0..127)		
rsrq	(0..127)		
sinr	(0..127)		
}			
}			
}			
}			
measResultBestNeighCell[1] :=SEQUENCE (SIZE (1.. maxCellReport)) OF SEQUENCE {		Report NR Cell 12	
physCellId	physCellId of NR Cell 12		
measResult SEQUENCE {			
cellResults SEQUENCE {			
resultsSSB-Cell SEQUENCE {			
rsrp	(0..127)		
rsrq	(0..127)		
sinr	(0..127)		
}			
}			
}			
}			
}			

**Table 8.2.4.3.1.1.3.3-8: RRCReconfiguration (step 7, Table 8.2.4.3.1.1.3.2-2)**

Derivation Path: 38.508-1 [4], Table 4.6.1-3.			
Information Element	Value/remark	Comment	Condition
RRCReconfiguration ::= SEQUENCE {			
criticalExtensions CHOICE {			
c1 CHOICE {			
rrcReconfiguration ::= SEQUENCE {			
SecondaryCellGroup	CellGroupConfig		
}			
}			
}			
}			

**Table 8.2.4.3.1.1.3.3-9: CellGroupConfig (Table 8.2.4.3.1.1.3.3-8)**

Derivation Path: 38.508-1 [4], Table 4.6.3-13.			
Information Element	Value/remark	Comment	Condition
CellGroupConfig ::= SEQUENCE {			
sCellToAddModList SEQUENCE (SIZE (1.. maxNrofSCells)) OF SEQUENCE {			
sCellIndex[1]	2		
sCellConfigCommon[1]	ServingCellConfigCommon		
sCellConfigDedicated[1]	ServingCellConfig	TS 38.508-1 [4] table 4.6.3-128	
}			
sCellToReleaseList SEQUENCE (SIZE (1.. maxNrofSCells)) OF {	1 entry		
sCellIndex[1]	1		
}			
}			

**Table 8.2.4.3.1.1.3.3-10: ServingCellConfigCommon (Table 8.2.4.3.1.1.3.3-9)**

Derivation Path: TS 38.508-1 [4], Table 4.6.3-129.			
Information Element	Value/remark	Comment	Condition
ServingCellConfigCommon ::= SEQUENCE {			
PhysCellId	Physical Cell Identity of NR Cell 12		
}			

8.2.4.3.1.2 NR CA / SCell change / Intra-NR measurement event A6 / SRB3 / EN-DC / Intra-band non-Contiguous CA

The scope and description of the present TC is the same as test case 8.2.4.3.1.1 with the following differences:

- CA configuration: Intra-band non-contiguous CA replaces Intra-band Contiguous CA

8.2.4.3.1.3 NR CA / SCell change / Intra-NR measurement event A6 / SRB3 / EN-DC / Inter-band CA

8.2.4.3.1.3.1 Test Purpose (TP)

Same as TC 8.2.4.3.1.1 but applied to Inter-band CA case.

8.2.4.3.1.3.2 Conformance requirements

Same as TC 8.2.4.3.1.1.

8.2.4.3.1.3.3 Test description

8.2.4.3.1.3.3.1 Pre-test conditions

Same as test case 8.2.4.3.1.1 with the following differences:

- Cells configuration: NR Cell 10 replaces NR Cell 3, NR Cell 30 replaces NR Cell 12

8.2.4.3.1.3.3.2 Test procedure sequence

Same as test case 8.2.4.3.1.1 with the following differences:

- Cells configuration: NR Cell 10 replaces NR Cell 3, NR Cell 30 replaces NR Cell 12

## 8.2.4.3.1.3.3.3 Specific message contents

**Table 8.2.4.3.1.3.3.3-1: MeasConfig (Table 8.2.4.3.1.1.3.3-6)**

Derivation path: TS 38.508-1 [4], Table 4.6.3-50.			
Information Element	Value/Remark	Comment	Condition
measConfig ::= SEQUENCE {			
measObjectToAddModList SEQUENCE (SIZE (1..maxNrofObjectId)) OF SEQUENCE {	2 entry		
measObjectId[1]	IdMeasObject-NRf1	NR Cell 1	
measObject[1] CHOICE {			
measObjectNR	MeasObjectNR-GENERIC(NRf1)		
}			
measObjectId[2]	IdMeasObject-NRf5	NR Cell 10	
measObject[2] CHOICE {			
measObjectNR	MeasObjectNR-GENERIC(NRf5)		
}			
}			
reportConfigToAddModList SEQUENCE (SIZE (1..maxReportConfigId)) OF SEQUENCE {	1 entry		
reportConfigId[1]	IdReportConfig-A6		
reportConfig[1] CHOICE {			
ReportConfigNR	ReportConfigNR	TS 38.508-1 [4] table 4.6.3-107 condition EVENT_A6	
}			
}			
measIdToAddModList SEQUENCE (SIZE (1..maxMeasId)) OF SEQUENCE {	1 entry		
measId[1]	1		
measObjectId[1]	IdMeasObject-NRf5		
reportConfigId[1]	IdReportConfig-A6		
}			
}			

## 8.2.5 Reconfiguration Failure / Radio link failure

### 8.2.5.1 Radio link failure / PSCell addition failure

#### 8.2.5.1.1 Radio link failure / PSCell addition failure - random access problem / EN-DC

##### 8.2.5.1.1.1 Test Purpose (TP)

(1)

```

with { UE in RRC_CONNECTED state with EN-DC, and, MCG (E-UTRA PDCP) only }
ensure that {
  when { UE receives an RRCConnectionReconfiguration message with nr-Config IE containing NR
RRCReconfiguration message to add PSCell and UE fails RACH procedure on PSCell }
  then { UE initiates the NR SCG failure information procedure to report SCGFailureInformationNR
with failure type randomAccessProblem }
}

```

##### 8.2.5.1.1.2 Conformance requirements

References: The conformance requirements covered in the present TC are specified in: TS 36.331, clauses 5.6.13a.3, TS 38.331, clauses 5.3.10.3, 5.7.3.2, 5.7.3.3. Unless otherwise stated these are Rel-15 requirements.

[TS 36.331, clause 5.6.13a.3]

The UE shall set the contents of the *SCGFailureInformationNR* message as follows:



- 1> include *failureType* within *failureReportSCG-NR* and set it to indicate the SCG failure in accordance with TS 38.331 [82, 5.7.3.3];

...

The UE shall submit the *SCGFailureInformationNR* message to lower layers for transmission.

[TS 38.331, clause 5.3.10.3]

The UE shall:

...

- 1> upon random access problem indication from SCG MAC; or

...

- 2> consider radio link failure to be detected for the SCG i.e. SCG-RLF;
- 2> initiate the SCG failure information procedure as specified in 5.7.3 to report SCG radio link failure.

[TS 38.331, clause 5.7.3.2]

A UE initiates the procedure to report SCG failures when SCG transmission is not suspended and when one of the following conditions is met:

...

- 1> upon SCG configuration failure, in accordance with subclause 5.3.5.8.2;

...

Upon initiating the procedure, the UE shall:

- 1> suspend SCG transmission for all SRBs and DRBs;
- 1> reset SCG-MAC;
- 1> stop T304, if running;
- 1> if the UE is operating in EN-DC:
  - 2> initiate transmission of the *SCGFailureInformationNR* message as specified in TS 36.331 [10, 5.6.13a].

[TS 38.331, clause 5.7.3.3]

The UE shall set the SCG failure type as follows:

- 1> else if the UE initiates transmission of the *SCGFailureInformationNR* message to provide random access problem indication from SCG MAC:
  - 2> set the *failureType* as *randomAccessProblem*;

8.2.5.1.1.3 Test description

8.2.5.1.1.3.1 Pre-test conditions

System Simulator:

- E-UTRA Cell 1 is the PCell and NR Cell 1 is the PSCell.

UE:

- None.

Preamble:

- The UE is in state RRC\_CONNECTED using generic procedure parameter Connectivity (*EN-DC*) and Bearers (*MCG only*) established on E-UTRA Cell 1 according to TS 38.508-1 [4], clause 4.5.4.

## 8.2.5.1.1.3.2 Test procedure sequence

Table 8.2.5.1.1.3.2-1: Main behaviour

St	Procedure	Message Sequence		TP	Verdict
		U - S	Message		
1	The SS transmits an <i>RRCCONNECTIONRECONFIGURATION</i> message containing NR <i>RRCRECONFIGURATION</i> message to add NR <i>PSCell</i> with SCG DRB. <i>RRCCONNECTIONRECONFIGURATION</i> message contains the ACTIVATE DEDICATED EPS BEARER CONTEXT REQUEST message.	<--	<i>RRCCONNECTIONRECONFIGURATION</i> ( <i>RRCRECONFIGURATION</i> )	-	-
2	Void.	-	-	-	-
-	EXCEPTION: In parallel to the events described in steps 3-4 the events described in Table 8.2.5.1.1.3.2-2 take place.	-	-	-	-
-	EXCEPTION: Step 3 is repeated <i>preambleTransMax</i> times. The SS shall not send Random Access Response thereby simulating a random access problem. NOTE: <i>preambleTransMax</i> is configured by <i>RACH-ConfigGeneric</i> .	-	-	-	-
3	The UE transmits a preamble on PRACH to initiate the NR <i>PSCell</i> addition.	-->	( <i>PRACH Preamble</i> )	-	-
4	Check: Does the UE transmit in the next 5 sec (arbitrary value) a <i>SCGFAILUREINFORMATIONNR</i> message with <i>failureType</i> set to ' <i>randomAccessProblem</i> '?	-->	<i>SCGFAILUREINFORMATIONNR</i>	1	P
5	The SS transmits a <i>DLINFORMATIONTRANSFER</i> message containing the DEACTIVATE EPS BEARER CONTEXT REQUEST message to deactivate the SCG bearer.	<--	<i>DLINFORMATIONTRANSFER</i>	-	-
6	The UE transmits an <i>ULINFORMATIONTRANSFER</i> message containing the DEACTIVATE EPS BEARER CONTEXT ACCEPT message.	-->	<i>ULINFORMATIONTRANSFER</i>	-	-

Table 8.2.5.1.1.3.2-2: Parallel behaviour

St	Procedure	Message Sequence		TP	Verdict
		U - S	Message		
0	The UE transmits an <i>RRCCONNECTIONRECONFIGURATIONCOMPLETE</i> message containing NR <i>RRCRECONFIGURATIONCOMPLETE</i> message.	-->	<i>RRCCONNECTIONRECONFIGURATIONCOMPLETE</i> ( <i>RRCRECONFIGURATIONCOMPLETE</i> )	-	-
1	The UE transmits an <i>ULINFORMATIONTRANSFER</i> message containing the ACTIVATE DEDICATED EPS BEARER CONTEXT ACCEPT message.	-->	<i>ULINFORMATIONTRANSFER</i>	-	-

Table 8.2.5.1.1.3.2-3: Void

8.2.5.1.1.3.3 Specific message contents

**Table 8.2.5.1.1.3.3-1: RRCConnectionReconfiguration (step 1, Table 8.2.5.1.1.3.2-1)**

Derivation Path: 36.508 [7], Table 4.6.1-8			
Information Element	Value/remark	Comment	Condition
RRCConnectionReconfiguration ::= SEQUENCE {			
criticalExtensions CHOICE {			
c1 CHOICE {			
rrcConnectionReconfiguration-r8 ::= SEQUENCE			
{			
nonCriticalExtension ::= SEQUENCE {			
nonCriticalExtension ::= SEQUENCE {			
nonCriticalExtension ::= SEQUENCE {			
nonCriticalExtension ::= SEQUENCE {			
nonCriticalExtension ::= SEQUENCE {			
nonCriticalExtension ::= SEQUENCE {			
nonCriticalExtension ::= SEQUENCE {			
nonCriticalExtension ::= SEQUENCE {			
nr-Config-r15 CHOICE {			
setup SEQUENCE {			
nr-SecondaryCellGroupConfig-r15	OCTET STRING including the RRCReconfiguration message and the IE secondaryCellGroup.		
}			
}			
}			
}			
}			
}			
}			
}			
}			
}			
}			
}			
}			
}			
}			

**Table 8.2.5.1.1.3.3-2: RRCReconfiguration (Table 8.2.5.1.1.3.3-1)**

Derivation Path: 38.508-1 [4], Table 4.6.1-3			
Information Element	Value/remark	Comment	Condition
RRCReconfiguration ::= SEQUENCE {			
criticalExtensions CHOICE {			
rrcReconfiguration ::= SEQUENCE {			
secondaryCellGroup	CellGroupConfig		
}			
}			
}			

**Table 8.2.5.1.1.3.3-3: CellGroupConfig (Table 8.2.5.1.1.3.3-2)**

Derivation Path: 38.508-1 [4], Table 4.6.3-13			
Information Element	Value/remark	Comment	Condition
CellGroupConfig ::= SEQUENCE {			
rlc-BearerToAddModList SEQUENCE (SIZE(1..maxLCH)) OF SEQUENCE {	1 entry		
servedRadioBearer CHOICE {			
drb-Identity	2	SCG DRB Id	
}			
}			
}			

**Table 8.2.5.1.1.3.3-4: RadioBearerConfig (Table 8.2.5.1.1.3.3-1)**

Derivation Path: 38.508-1 [4], Table 4.6.3-100			
Information Element	Value/remark	Comment	Condition
RadioBearerConfig ::= SEQUENCE {			
drb-ToAddModList SEQUENCE (SIZE (1..maxDRB)) OF SEQUENCE {	1 entry		
cnAssociation CHOICE {			
eps-BearerIdentity	6	Dedicated EPS bearer Id of SCG DRB	
}			
drb-Identity	2	SCG DRB Id	
}			
}			

**Table 8.2.5.1.1.3.3-5: SCGFailureInformationNR (step 4, Table 8.2.5.1.1.3.2-1)**

Derivation Path: 36.508 [7], Table 4.6.1-18AA			
Information Element	Value/remark	Comment	Condition
SCGFailureInformationNR-r15 ::= SEQUENCE {			
criticalExtensions CHOICE {			
c1 CHOICE {			
scgFailureInformationNR-r15 SEQUENCE {			
failureReportSCG-NR-r15 SEQUENCE {			
failureType-r15	randomAccessProblem		
measResultFreqListNR-r15	Not checked		
measResultSCG-r15	Not checked		
}			
nonCriticalExtension SEQUENCE {}			
}			
}			
}			

## 8.2.5.2 Radio link failure / PSCell out of sync indication

### 8.2.5.2.1 Radio link failure / PSCell out of sync indication / EN-DC

#### 8.2.5.2.1.1 Test Purpose (TP)

(1)

```

with { UE in RRC_CONNECTED state with EN-DC, and, MCG (E-UTRA PDCP) and SCG DRB established }
ensure that {
  when { UE receives N310 consecutive "out-of-sync" indications for the SpCell from lower layers due to radio link failure }
  then { UE starts timer T310 for the corresponding SpCell, and, upon timer expiry initiates the NR SCG failure information procedure to report SCGFailureInformationNR with failure type set to 't310-Expiry' }
}

```

## 8.2.5.2.1.2 Conformance requirements

References: The conformance requirements covered in the present test case are specified in: TS 36.331, clause 5.6.13a.3, TS 38.331, clauses 5.3.10.1, 5.3.10.3, 5.7.3.2, 5.7.3.3. Unless otherwise stated these are Rel-15 requirements.

[TS 36.331, clause 5.6.13a.3]

The UE shall set the contents of the *SCGFailureInformationNR* message as follows:

- 1> include *failureType* within *failureReportSCG-NR* and set it to indicate the SCG failure in accordance with TS 38.331 [82, 5.7.3.3];

...

The UE shall submit the *SCGFailureInformationNR* message to lower layers for transmission.

[TS 38.331, clause 5.3.10.1]

The UE shall:

- 1> upon receiving N310 consecutive "out-of-sync" indications for the SpCell from lower layers while T311 is not running;
- 2> start timer T310 for the corresponding SpCell.

[TS 38.331, clause 5.3.10.3]

The UE shall:

- 1> upon T310 expiry in PSCell; or

...

- 2> initiate the SCG failure information procedure as specified in 5.7.3 to report SCG radio link failure.

[TS 38.331, clause 5.7.3.2]

A UE initiates the procedure to report SCG failures when SCG transmission is not suspended and when one of the following conditions is met:

- 1> upon detecting radio link failure for the SCG, in accordance with subclause 5.3.10.3;

...

Upon initiating the procedure, the UE shall:

- 1> suspend SCG transmission for all SRBs and DRBs;
- 1> reset SCG-MAC;
- 1> stop T304, if running;
- 1> if the UE is operating in EN-DC:
  - 2> initiate transmission of the *SCGFailureInformationNR* message as specified in TS 36.331 [10, 5.6.13a].

[TS 38.331, clause 5.7.3.3]

The UE shall set the SCG failure type as follows:

- 1> if the UE initiates transmission of the *SCGFailureInformationNR* message due to T310 expiry:
  - 2> set the *failureType* as t310-Expiry;

8.2.5.2.1.3 Test description

8.2.5.2.1.3.1 Pre-test conditions

System Simulator:

- E-UTRA Cell 1 is the PCell and NR Cell 1 is the PSCell.

UE:

- None.

Preamble:

- The UE is in state RRC\_CONNECTED using generic procedure parameter Connectivity (EN-DC) and DC Bearers (MCG and SCG) on E-UTRA Cell 1 according to TS 38.508-1 [4], clause 4.5.4.

8.2.5.2.1.3.2 Test procedure sequence

**Table 8.2.5.2.1.3.2-1: Main behaviour**

St	Procedure	Message Sequence		TP	Verdict
		U - S	Message		
1	The SS changes NR Cell 1 parameter to non-suitable "Off" in order to simulate radio link failure.	-	-	-	-
2	Void.	-	-	-	-
3	Check: Does the UE transmit in the next 5 sec (NOTE 1) a <i>SCGFailureInformationNR</i> message with <i>failureType</i> set to 't310-Expiry'?	-->	<i>SCGFailureInformationNR</i>	1	P

NOTE 1: The time of 5 sec is chosen arbitrary. When the UE will send the Failure report depends on (1) the values pre-set for N310 and T310 (see TS 38.508-1 [4], *RLF-TimersAndConstants* - set at the moment to 'n1' and 'ms1000' respectively), and, (2) the time it will take for the SS to complete step 1 and the UE to notice the change and perform internally all relevant to it actions. Because of the uncertainties associated with (2), and, the lower values used in typical network setting for (1), testing if the UE obeys the exact values of (1) is unreliable.

8.2.5.2.1.3.3 Specific message contents

**Table 8.2.5.2.1.3.3-1: *SCGFailureInformationNR* (step 3, Table 8.2.5.2.1.3.2-1)**

Derivation Path: 36.508 [7], Table 4.6.1-18AA			
Information Element	Value/remark	Comment	Condition
<i>SCGFailureInformationNR-r15</i> ::= SEQUENCE {			
<i>criticalExtensions</i> CHOICE {			
c1 CHOICE {			
<i>scgFailureInformationNR-r15</i> SEQUENCE {			
<i>failureReportSCG-NR-r15</i> SEQUENCE {			
<i>failureType-r15</i>	t310-Expiry		
<i>measResultFreqListNR-r15</i>	Not checked		
<i>measResultSCG-r15</i>	Not present		
}			
<i>nonCriticalExtension</i> SEQUENCE {}			
}			
}			
}			

### 8.2.5.3 Radio link failure / RLC-MaxNumRetx failure

#### 8.2.5.3.1 Radio link failure / RLC-MaxNumRetx failure / EN-DC

##### 8.2.5.3.1.1 Test Purpose (TP)

(1)

```
with { UE in RRC_CONNECTED state with EN-DC, and, MCG (E-UTRA PDCP) and SCG DRB established }
ensure that {
  when { an indication from SCG RLC that the maximum number of retransmissions has been reached for
a SCG DRB }
  then { the UE shall transmit a SCGFailureInformationNR message with failureType set to 'rlc-
MaxNumRetx' }
}
```

##### 8.2.5.3.1.2 Conformance requirements

References: The conformance requirements covered in the present test case are specified in: TS 36.331, clause 5.6.13a.3, TS 38.331, clauses 5.3.10.3, 5.7.3.2, 5.7.3.3. Unless otherwise stated these are Rel-15 requirements.

[TS 36.331, clause 5.6.13a.3]

The UE shall set the contents of the *SCGFailureInformationNR* message as follows:

- 1> include *failureType* within *failureReportSCG-NR* and set it to indicate the SCG failure in accordance with TS 38.331 [82, 5.7.3.3];

The UE shall submit the *SCGFailureInformationNR* message to lower layers for transmission.

[TS 38.331, clause 5.3.10.3]

The UE shall:

...

- 1> upon indication from SCG RLC that the maximum number of retransmissions has been reached:
- 2> consider radio link failure to be detected for the SCG i.e. SCG-RLF;

**Editor's Note: FFS: How to handle RLC failure in CA duplication for SCG DRB and SRB.**

- 2> initiate the SCG failure information procedure as specified in 5.7.3 to report SCG radio link failure.

[TS 38.331, clause 5.7.3.2]

A UE initiates the procedure to report SCG failures when SCG transmission is not suspended and when one of the following conditions is met:

- 1> upon detecting radio link failure for the SCG, in accordance with subclause 5.3.10.3;

...

Upon initiating the procedure, the UE shall:

- 1> suspend SCG transmission for all SRBs and DRBs;
- 1> reset SCG-MAC;
- 1> stop T304, if running;
- 1> if the UE is operating in EN-DC:
  - 2> initiate transmission of the *SCGFailureInformationNR* message as specified in TS 36.331 [10, 5.6.13a].

[TS 38.331, clause 5.7.3.3]

The UE shall set the SCG failure type as follows:

...

1> else if the UE initiates transmission of the *SCGFailureInformationNR* message to provide indication from SCG RLC that the maximum number of retransmissions has been reached:

2> set the failureType as rlc-MaxNumRetx;

8.2.5.3.1.3 Test description

8.2.5.3.1.3.1 Pre-test conditions

System Simulator:

- E-UTRA Cell 1 is the PCell and NR Cell 1 is the PSCell.

UE:

- None.

Preamble:

- The UE is in state RRC\_CONNECTED using generic procedure parameter Connectivity (*EN-DC*), Bearers (*MCG and SCG*) established and Test Loop Function (*On*) with UE test loop mode A (message condition UE TEST LOOP MODE A to return one UL PDCP SDU per DL PDCP SDU) according to TS 38.508-1 [4].
- The RLC Acknowledged Mode is enabled

8.2.5.3.1.3.2 Test procedure sequence

**Table 8.2.5.3.1.3.2-1: Main behaviour**

St	Procedure	Message Sequence		TP	Verdict
		U - S	Message		
1	The SS transmits AMD PDU#1 containing a complete RLC SDU#1 (on the SCG bearer).	<--	AMD PDU#1	-	-
2	SS allocates an UL grant sufficient to loop back RLC SDU#1 in one RLC/MAC PDU	<--	UL Grant	-	-
-	EXCEPTION: Step 3 is repeated <i>maxRetxThreshold</i> times - the SS does not acknowledge the reception of RLC SDU#1. NOTE: <i>maxRetxThreshold</i> is configured by <i>RLC-Config</i> .	-	-	-	-
3	The UE transmits RLC SDU#1 (on the SCG bearer). NOTE: SS RLC shall not ack the UL RLC PDU.	-->	(RLC SDU#1)	-	-
4	Check: Does the UE transmit in the next 5 sec (arbitrary value) a <i>SCGFailureInformationNR</i> message with <i>failureType</i> set to ' <i>rlc-MaxNumRetx</i> '?	-->	<i>SCGFailureInformationNR</i>	1	P



## 8.2.5.3.1.3.3 Specific message contents

**Table 8.2.5.3.1.3.3-1: SCGFailureInformationNR (step 4, Table 8.2.5.3.1.3.2-1)**

Derivation Path: 36.508 [7], Table 4.6.1-18AA			
Information Element	Value/remark	Comment	Condition
SCGFailureInformationNR-r15 ::= SEQUENCE {			
criticalExtensions CHOICE {			
c1 CHOICE {			
scgFailureInformationNR-r15 SEQUENCE {			
failureReportSCG-NR-r15 SEQUENCE {			
failureType-r15	rlc-MaxNumRetx		
measResultFreqListNR-r15	Not checked		
measResultSCG-r15	Not checked		
}			
nonCriticalExtension SEQUENCE {}			
}			
}			
}			
}			

## 8.2.5.4 Reconfiguration failure / SCG change failure

## 8.2.5.4.1 Reconfiguration failure / SCG change failure / EN-DC

## 8.2.5.4.1.1 Test Purpose (TP)

(1)

```

with { UE in RRC_CONNECTED state with EN-DC, and, MCG (E-UTRA PDCP) and SCG DRB established }
ensure that {
  when { UE receives an RRCConnectionReconfiguration message with nr-Config IE containing NR
RRCReconfiguration message with reconfigurationWithSync for configured PSCell and if T304 of a
secondary cell group expires }
  then { UE initiates the NR SCG failure information procedure to report SCGFailureInformationNR
with failure type set to 'scg-ChangeFailure' }
}

```

## 8.2.5.4.1.2 Conformance requirements

References: The conformance requirements covered in the present test case are specified in: TS 36.331, clause 5.6.13a.3, TS 38.331, clauses 5.3.5.3, 5.3.5.5.1, 5.3.5.5.2, 5.3.5.8.3, 5.7.3.2 and 5.7.3.3. Unless otherwise stated these are Rel-15 requirements.

[TS 36.331, clause 5.6.13a.3]

The UE shall set the contents of the *SCGFailureInformationNR* message as follows:

- 1> include *failureType* within *failureReportSCG-NR* and set it to indicate the SCG failure in accordance with TS 38.331 [82, 5.7.3.3];

...

The UE shall submit the *SCGFailureInformationNR* message to lower layers for transmission.

[TS 38.331, clause 5.3.5.3]

The UE shall perform the following actions upon reception of the *RRCReconfiguration*:

- 1> if the *RRCReconfiguration* includes the *secondaryCellGroup*:
  - 2> perform the cell group configuration for the SCG according to 5.3.5.5;

...

- 1> if the UE is configured with E-UTRA *nr-SecondaryCellGroupConfig* (MCG is E-UTRA):

2> if *RRCReconfiguration* was received via SRB1:

3> construct *RRCReconfigurationComplete* message and submit it via the EUTRA MCG embedded in E-UTRA RRC message *RRCConnectionReconfigurationComplete* as specified in TS 36.331 [10];

3> if *reconfigurationWithSync* was included in *spCellConfig* of an SCG:

4> initiate the random access procedure on the SpCell, as specified in TS 38.321 [3];

...

2> else (*RRCReconfiguration* was received via SRB3):

3> if *reconfigurationWithSync* was included in *spCellConfig* of an SCG:

4> initiate the random access procedure on the SpCell, as specified in TS 38.321 [3];

3> submit the *RRCReconfigurationComplete* message via SRB3 to lower layers for transmission using the new configuration, and the procedure ends;

NOTE: In the case of SRB1, the random access is triggered by RRC layer itself as there is not necessarily other UL transmission. In the case of SRB3, the random access is triggered by the MAC layer due to arrival of *RRCReconfigurationComplete*.

[TS 38.331, clause 5.3.5.5.1]

The network configures the UE with one Secondary Cell Group (SCG). For EN-DC, the MCG is configured as specified in TS 36.331 [10]. The network provides the configuration parameters for a cell group in the *CellGroupConfig* IE.

The UE performs the following actions based on a received *CellGroupConfig* IE:

1> if the *CellGroupConfig* contains the *spCellConfig* with *reconfigurationWithSync*:

2> perform Reconfiguration with sync according to 5.3.5.5.2;

[TS 38.331, clause 5.3.5.5.2]

The UE shall perform the following actions to execute a reconfiguration with sync.

1> stop timer T310 for the corresponding SpCell, if running;

1> start timer T304 for the corresponding SpCell with the timer value set to *t304*, as included in the *reconfigurationWithSync*;

1> start synchronising to the DL of the target SpCell and acquire the *MIB* of the target SpCell as specified in 5.2.2.3.1;

NOTE: The UE should perform the reconfiguration with sync as soon as possible following the reception of the RRC message triggering the reconfiguration with sync, which could be before confirming successful reception (HARQ and ARQ) of this message.

1> reset the MAC entity of this cell group;

1> consider the SCell(s) of this cell group, if configured, to be in deactivated state;

1> apply the value of the *newUE-Identity* as the C-RNTI for this cell group;

**Editor's Note: Verify that this does not configure some common parameters which are later discarded due to e.g. SCell release or due to LCH release.**

1> configure lower layers in accordance with the received *spCellConfigCommon*;

1> consider the initial bandwidth part to be the active bandwidth part where random access is performed;

1> configure lower layers in accordance with any additional fields, not covered in the previous, if included in the received *reconfigurationWithSync*.

[TS 38.331, clause 5.3.5.8.3]

The UE shall:

- 1> if T304 of a secondary cell group expires:
  - 2> release rach-ConfigDedicated;
  - 2> initiate the SCG failure information procedure as specified in subclause 5.7.3 to report SCG reconfiguration with sync failure, upon which the RRC reconfiguration procedure ends.

[TS 38.331, clause 5.7.3.2]

A UE initiates the procedure to report SCG failures when SCG transmission is not suspended and when one of the following conditions is met:

...

- 1> upon reconfiguration with sync failure of the SCG, in accordance with subclause 5.3.5.8.3;

...

Upon initiating the procedure, the UE shall:

- 1> suspend SCG transmission for all SRBs and DRBs;
- 1> reset SCG-MAC;
- 1> stop T304, if running;
- 1> if the UE is operating in EN-DC:
  - 2> initiate transmission of the *SCGFailureInformationNR* message as specified in TS 36.331 [10, 5.6.13a].

[TS 38.331, clause 5.7.3.3]

The UE shall set the SCG failure type as follows:

...

- 1> else if the UE initiates transmission of the *SCGFailureInformationNR* message to provide reconfiguration with sync failure information for an SCG:
  - 2> set the failureType as scg-ChangeFailure;

**Editor's Note:** FFS whether to change scg-ChangeFailure to synchronousReconfigurationFailure-SCG.

8.2.5.4.1.3 Test description

8.2.5.4.1.3.1 Pre-test conditions

System Simulator:

- E-UTRA Cell 1 is the PCell and NR Cell 1 is the PSCell.

UE:

- None.

Preamble:

- The UE is in state RRC\_CONNECTED using generic procedure parameter Connectivity (EN-DC) and DC Bearers (MCG and SCG) on E-UTRA Cell 1 according to TS 38.508-1 [4], clause 4.5.4.

8.2.5.4.1.3.2 Test procedure sequence

**Table 8.2.5.4.1.3.2-1: Main behaviour**

St	Procedure	Message Sequence		TP	Verdict
		U – S	Message		
1	The SS transmits an <i>RRCCoReonfiguration</i> message containing NR <i>RRCCoReonfiguration</i> message to perform SCG change with <i>reconfigurationWithSync</i> with the same PSCell.	<--	<i>RRCCoReonfiguration (RRCCoReonfiguration)</i>	-	-
-	EXCEPTION: In parallel to the event described in step 2 the event described in Table 8.2.5.4.1.3.2-2 takes place.	-	-	-	-
2	Wait for t304 ms to ensure that T304 expires (the value is defined in <i>CellGroupConfig</i> ). NOTE: SS does not respond to the UE transmitted RACH preambles on NR Cell 1	-	-	-	-
3	Check: Does the UE transmit in the next 5 sec (arbitrary value) a <i>SCGFailureInformationNR</i> message with <i>failureType</i> set to 'scg-ChangeFailure'?	-->	<i>SCGFailureInformationNR</i>	1	P

**Table 8.2.5.4.1.3.2-2: Parallel behaviour**

St	Procedure	Message Sequence		TP	Verdict
		U – S	Message		
1	The UE transmits an <i>RRCCoReonfigurationComplete</i> message containing NR <i>RRCCoReonfigurationComplete</i> message on E-UTRA Cell 1.	-->	<i>RRCCoReonfigurationComplete (RRCCoReonfigurationComplete)</i>	-	-

8.2.5.4.1.3.3 Specific message contents

**Table 8.2.5.4.1.3.3-1: CellGroupConfig (step 1, Table 8.2.5.4.1.3.2-1)**

Derivation Path: 38.508-1 [4], Table [4.6.3-13] with condition EN-DC

**Table 8.2.5.4.1.3.3-2: SCGFailureInformationNR (step 3, Table 8.2.5.4.1.3.2-1)**

Derivation Path: 36.508 [7], Table 4.6.1-18AA			
Information Element	Value/remark	Comment	Condition
SCGFailureInformationNR-r15 ::= SEQUENCE {			
criticalExtensions CHOICE {			
c1 CHOICE {			
scgFailureInformationNR-r15 SEQUENCE {			
failureReportSCG-NR-r15 SEQUENCE {			
failureType-r15	scg-ChangeFailure	FFS	
measResultFreqListNR-r15	Not checked		
measResultSCG-r15	Not checked		
}			
nonCriticalExtension SEQUENCE {}			
}			
}			
}			
}			

## 8.2.5.5 Reconfiguration failure / SCG Reconfiguration failure / SRB3

### 8.2.5.5.1 Reconfiguration failure / SCG Reconfiguration Failure / SRB3 / EN-DC

**Editor's Note:** The test procedure defined simulates a non 3GPP complaint network behaviour and needs to be explored to find more realistic test procedure.

#### 8.2.5.5.1.1 Test Purpose (TP)

(1)

```
with { UE in RRC_CONNECTED state with EN-DC, and, MCG (E-UTRA PDCP) and SCG and SRB3 established }
ensure that {
  when { UE receives an RRCReconfiguration message over SRB3 to reconfigure SCG and UE fails to
  comply with the configuration received }
  then { UE will initiate the NR SCG failure information procedure to report
  SCGFailureInformationNR with failure type as scg-reconfigFailure and continue using the
  configuration used prior to the reception of RRCReconfiguration message }
}
```

#### 8.2.5.5.1.2 Conformance requirements

References: The conformance requirements covered in the present test case are specified in: TS 36.331, clause 5.6.13a.3, TS 38.331, clauses 5.3.5.8.2, 5.7.3.2, 5.7.3.3. Unless otherwise stated these are Rel-15 requirements.

[TS 36.331, clause 5.6.13a.3]

The UE shall set the contents of the *SCGFailureInformationNR* message as follows:

- 1> include *failureType* within *failureReportSCG-NR* and set it to indicate the SCG failure in accordance with TS 38.331 [82, 5.7.3.3];

...

The UE shall submit the *SCGFailureInformationNR* message to lower layers for transmission.

[TS 38.331, clause 5.3.5.8.2]

The UE shall:

- 1> if the UE is operating in EN-DC:
  - 2> if the UE is unable to comply with (part of) the configuration included in the *RRCReconfiguration* message received over SRB3;
  - 3> continue using the configuration used prior to the reception of *RRCReconfiguration* message;
  - 3> initiate the SCG failure information procedure as specified in subclause 5.7.3 to report SCG reconfiguration error, upon which the connection reconfiguration procedure ends;

[TS 38.331, clause 5.7.3.2]

A UE initiates the procedure to report SCG failures when SCG transmission is not suspended and when one of the following conditions is met:

...

- 1> upon SCG configuration failure, in accordance with subclause 5.3.5.8.2;

...

Upon initiating the procedure, the UE shall:

- 1> suspend SCG transmission for all SRBs and DRBs;
- 1> reset SCG-MAC;
- 1> stop T304, if running;

1> if the UE is operating in EN-DC:

2> initiate transmission of the *SCGFailureInformationNR* message as specified in TS 36.331 [10, 5.6.13a].

[TS 38.331, clause 5.7.3.3]

The UE shall set the SCG failure type as follows:

...

1> else, if the UE initiates transmission of the *SCGFailureInformationNR* message due to Reconfiguration failure of NR RRC reconfiguration message:

2> set the failureType as scg-reconfigFailure.

**Editor's Note: FFS: whether to include *rrc-TransactionIdentifier* information.**

8.2.5.5.1.3 Test description

8.2.5.5.1.3.1 Pre-test conditions

System Simulator:

- E-UTRA Cell 1 is the PCell and NR Cell 1 is the PSCell.

UE:

- None.

Preamble:

- The UE is in state RRC\_CONNECTED using generic procedure parameter Connectivity (*EN-DC*), Bearers (*MCG and SCG*) established according to TS 38.508-1 [4].

8.2.5.5.1.3.2 Test procedure sequence

**Table 8.2.5.5.1.3.2-1: Main behaviour**

St	Procedure	Message Sequence		TP	Verdict
		U - S	Message		
1	The SS transmits an <i>RRCCoReconnectionReconfiguration</i> message containing NR <i>RRCCoReconfiguration</i> message to configure SRB3 on NR PSCell with SCG DRB.	<--	<i>RRCCoReconnectionReconfiguration</i> ( <i>RRCCoReconfiguration</i> )	-	-
2	The UE transmits an <i>RRCCoReconnectionReconfigurationComplete</i> message containing NR <i>RRCCoReconfigurationComplete</i> message.	-->	<i>RRCCoReconnectionReconfigurationC</i> <i>omplete</i> ( <i>RRCCoReconfigurationComplete</i> )	-	-
3	The SS transmits NR <i>RRCCoReconfiguration</i> message on SRB3 to add SCell without physCellId.	<--	<i>RRCCoReconfiguration</i>	-	-
4	Check: Does the UE transmit an <i>SCGFailureInformationNR</i> message with <i>failureType</i> set to 'scg-reconfigfailure' on E-UTRA Cell 1 when UE fails to comply with the configuration received?	-->	<i>SCGFailureInformationNR</i>	1	P
5	The SS transmits NR <i>RRCCoReconfiguration</i> message on SRB3 to modify PSCell RLF timer t310 value.	<--	<i>RRCCoReconfiguration</i>	-	-
6	Check: Does the UE transmit an <i>RRCCoReconfigurationComplete</i> message on NR Cell 1?	-->	<i>RRCCoReconfigurationComplete</i>	1	P

8.2.5.5.1.3.3 Specific message contents

**Table 8.2.5.5.1.3.3-1: RRCConnectionReconfiguration (step 1, Table 8.2.5.5.1.3.2-1)**

Derivation Path: 36.508 [7], Table 4.6.1-8			
Information Element	Value/remark	Comment	Condition
RRCConnectionReconfiguration ::= SEQUENCE {			
criticalExtensions CHOICE {			
c1 CHOICE {			
rrcConnectionReconfiguration-r8 ::= SEQUENCE			
{			
nonCriticalExtension ::= SEQUENCE {			
nonCriticalExtension ::= SEQUENCE {			
nonCriticalExtension ::= SEQUENCE {			
nonCriticalExtension ::= SEQUENCE {			
nonCriticalExtension ::= SEQUENCE {			
nonCriticalExtension ::= SEQUENCE {			
nonCriticalExtension ::= SEQUENCE {			
nonCriticalExtension ::= SEQUENCE {			
nr-Config-r15 CHOICE {			
setup SEQUENCE {			
nr-SecondaryCellGroupConfig-r15	OCTET STRING including the RRCReconfiguration message and the IE secondaryCellGroup.		
}			
}			
}			
}			
}			
}			
}			
}			
}			
}			
}			
}			
}			
}			
}			

**Table 8.2.5.5.1.3.3-2: RRCReconfiguration (Table 8.2.5.5.1.3.3-1)**

Derivation Path: 38.508-1 [4], Table 4.6.1-3			
Information Element	Value/remark	Comment	Condition
RRCReconfiguration ::= SEQUENCE {			
criticalExtensions CHOICE {			
rrcReconfiguration ::= SEQUENCE {			
secondaryCellGroup	CellGroupConfig		
}			
}			
}			

**Table 8.2.5.5.1.3.3-3: CellGroupConfig (Table 8.2.5.5.1.3.3-2)**

Derivation Path: 38.508-1 [4], Table 4.6.3-13			
Information Element	Value/remark	Comment	Condition
CellGroupConfig ::= SEQUENCE {			
rlc-BearerToAddModList SEQUENCE	1 entry		
(SIZE(1..maxLCH) OF SEQUENCE {			
servedRadioBearer CHOICE {			
srb-Identity	3		
}			
}			
}			

**Table 8.2.5.5.1.3.3-4: RadioBearerConfig (Table 8.2.5.5.1.3.3-1)**

Derivation Path: 38.508-1 [4], Table 4.6.3-100			
Information Element	Value/remark	Comment	Condition
RadioBearerConfig ::= SEQUENCE {			
srb-ToAddModList SEQUENCE (SIZE (1..2)) OF			
SEQUENCE {			
srb-Identity	3		
}			
}			

**Table 8.2.5.5.1.3.3-5: RRCReconfiguration (step 3, Table 8.2.5.5.1.3.2-1)**

Derivation Path: 38.508-1 [4], Table 4.6.1-3			
Information Element	Value/remark	Comment	Condition
RRCReconfiguration ::= SEQUENCE {			
criticalExtensions CHOICE {			
rrcReconfiguration ::= SEQUENCE {			
secondaryCellGroup	CellGroupConfig		
}			
}			
}			

**Table 8.2.5.5.1.3.3-6: CellGroupConfig (Table 8.2.5.5.1.3.3-5)**

Derivation Path: 38.508-1 [4], Table 4.6.3-13			
Information Element	Value/remark	Comment	Condition
CellGroupConfig ::= SEQUENCE {			
sCellToAddModList SEQUENCE (SIZE			
(1..maxNrofSCells)) OF SEQUENCE {			
sCellIndex	1		
sCellConfigCommon SEQUENCE {			
physCellId	Not present.		
}			
}			
}			



**Table 8.2.5.5.1.3.3-7: SCGFailureInformationNR (step 4, Table 8.2.5.5.1.3.2-1)**

Derivation Path: 36.508 [7], Table 4.6.1-18AA			
Information Element	Value/remark	Comment	Condition
SCGFailureInformationNR-r15 ::= SEQUENCE {			
criticalExtensions CHOICE {			
c1 CHOICE {			
scgFailureInformationNR-r15 SEQUENCE {			
failureReportSCG-NR-r15 SEQUENCE {			
failureType-r15	scg-reconfigFailure		
measResultFreqListNR-r15	Not checked		
measResultSCG-r15	Not checked		
}			
nonCriticalExtension SEQUENCE {}			
}			
}			
}			

**Table 8.2.5.5.1.3.3-8: RRCReconfiguration (step 5, Table 8.2.5.5.1.3.2-1)**

Derivation Path: 38.508-1 [4], Table 4.6.1-3			
Information Element	Value/remark	Comment	Condition
RRCReconfiguration ::= SEQUENCE {			
criticalExtensions CHOICE {			
rrcReconfiguration ::= SEQUENCE {			
secondaryCellGroup	CellGroupConfig		
}			
}			
}			

**Table 8.2.5.5.1.3.3-9: CellGroupConfig (Table 8.2.5.5.1.3.3-8)**

Derivation Path: 38.508-1 [4], Table 4.6.3-13			
Information Element	Value/remark	Comment	Condition
CellGroupConfig ::= SEQUENCE {			
spCellConfig SEQUENCE {			
rf-TimersAndConstants SEQUENCE {			
t310	ms1000		
}			
}			
}			

8.2.5.6 Reconfiguration failure / SCG Reconfiguration failure / SRB1

8.2.5.6.1 Reconfiguration failure / SCG Reconfiguration Failure / SRB1 / EN-DC

**Editor’s Note:** The test procedure defined simulates a non 3GPP complaint network behaviour and needs to be explored to find more realistic test procedure.

8.2.5.6.1.1 Test Purpose (TP)

(1)

```

with { UE in RRC_CONNECTED state with EN-DC, and, MCG (E-UTRA PDCP) and SCG DRB established }
ensure that {
  when { UE receives an RRCConnectionReconfiguration message with nr-Config IE containing NR
RRCReconfiguration message to reconfigure SCG and UE fails to comply with the configuration received
}
  then { UE will initiate the RRC Connection Re-establishment procedure }
}
    
```

### 8.2.5.6.1.2 Conformance requirements

References: The conformance requirements covered in the present test case are specified in: TS 38.331, clause 5.3.5.8.2. Unless otherwise stated these are Rel-15 requirements.

[TS 38.331, clause 5.3.5.8.2]

The UE shall:

1> if the UE is operating in EN-DC:

...

2> else, if the UE is unable to comply with (part of) the configuration included in the *RRCReconfiguration* message received over MCG SRB1;

3> continue using the configuration used prior to the reception of *RRCReconfiguration* message;

3> initiate the connection re-establishment procedure as specified in TS 36.331 [10, 5.3.7], upon which the connection reconfiguration procedure ends.

...

NOTE 2: If the UE is unable to comply with part of the configuration, it does not apply any part of the configuration, i.e. there is no partial success/failure.

### 8.2.5.6.1.3 Test description

#### 8.2.5.6.1.3.1 Pre-test conditions

System Simulator:

- E-UTRA Cell 1 is the PCell and NR Cell 1 is the PSCell.

UE:

- None.

Preamble:

- The UE is in state RRC\_CONNECTED using generic procedure parameter Connectivity (EN-DC), Bearers (*MCG and SCG*) established according to TS 38.508-1 [4].

## 8.2.5.6.1.3.2 Test procedure sequence

Table 8.2.5.6.1.3.2-1: Main behaviour

St	Procedure	Message Sequence		TP	Verdict
		U - S	Message		
1	The SS transmits an <i>RRCCONNECTIONRECONFIGURATION</i> message containing NR <i>RRCRECONFIGURATION</i> message to configure a second SCG DRB on PSCell. <i>RRCCONNECTIONRECONFIGURATION</i> message contains the ACTIVATE DEDICATED EPS BEARER CONTEXT REQUEST message.	<--	<i>RRCCONNECTIONRECONFIGURATION (RRCRECONFIGURATION)</i>	-	-
2	Check: Does the UE transmit an <i>RRCCONNECTIONREESTABLISHMENTREQUEST</i> message with <i>reestablishmentCause</i> set to <i>reconfigurationFailure</i> on EUTRA Cell 1 when UE fails to comply with the configuration received?	-->	<i>RRCCONNECTIONREESTABLISHMENTREQUEST</i>	1	P
3	The SS transmits an <i>RRCCONNECTIONREESTABLISHMENT</i> message to resume SRB1 operation on EUTRA Cell 1.	<--	<i>RRCCONNECTIONREESTABLISHMENT</i>	-	-
4	The UE transmit an <i>RRCCONNECTIONREESTABLISHMENTCOMPLETE</i> message.	-->	<i>RRCCONNECTIONREESTABLISHMENTCOMPLETE</i>	-	-

8.2.5.6.1.3.3 Specific message contents

**Table 8.2.5.6.1.3.3-1: RRCConnectionReconfiguration (step 1, Table 8.2.5.6.1.3.2-1)**

Derivation Path: 36.508 [7], Table 4.6.1-8			
Information Element	Value/remark	Comment	Condition
RRCConnectionReconfiguration ::= SEQUENCE {			
criticalExtensions CHOICE {			
c1 CHOICE {			
rrcConnectionReconfiguration-r8 ::= SEQUENCE			
{			
nonCriticalExtension ::= SEQUENCE {			
nonCriticalExtension ::= SEQUENCE {			
nonCriticalExtension ::= SEQUENCE {			
nonCriticalExtension ::= SEQUENCE {			
nonCriticalExtension ::= SEQUENCE {			
nonCriticalExtension ::= SEQUENCE {			
nonCriticalExtension ::= SEQUENCE {			
nonCriticalExtension ::= SEQUENCE {			
nr-Config-r15 CHOICE {			
setup SEQUENCE {			
nr-SecondaryCellGroupConfig-r15	OCTET STRING including the RRCReconfiguration message and the IE secondaryCellGroup.		
}			
}			
}			
}			
}			
}			
}			
}			
}			
}			
}			
}			
}			
}			
}			

**Table 8.2.5.6.1.3.3-2: RRCReconfiguration (Table 8.2.5.6.1.3.3-1)**

Derivation Path: 38.508-1 [4], Table 4.6.1-3			
Information Element	Value/remark	Comment	Condition
RRCReconfiguration ::= SEQUENCE {			
criticalExtensions CHOICE {			
rrcReconfiguration ::= SEQUENCE {			
secondaryCellGroup	CellGroupConfig		
}			
}			
}			

**Table 8.2.5.6.1.3.3-3: CellGroupConfig (Table 8.2.5.6.1.3.3-2)**

Derivation Path: 38.508-1 [4], Table 4.6.3-13			
Information Element	Value/remark	Comment	Condition
CellGroupConfig ::= SEQUENCE {			
rlc-BearerToAddModList SEQUENCE (SIZE(1..maxLCH)) OF SEQUENCE {	1 entry		
servedRadioBearer CHOICE {			
drb-Identity	3	Second SCG DRB Id	
}			
}			
}			
}			

**Table 8.2.5.6.1.3.3-4: RadioBearerConfig (Table 8.2.5.6.1.3.3-1)**

Derivation Path: 38.508-1 [4], Table 4.6.3-100			
Information Element	Value/remark	Comment	Condition
RadioBearerConfig ::= SEQUENCE {			
drb-ToAddModList SEQUENCE (SIZE (1..maxDRB)) OF SEQUENCE {	1 entry		
cnAssociation CHOICE {			
eps-BearerIdentity	7	Dedicated EPS bearer Id of second SCG DRB	
}			
drb-Identity	3	Second SCG DRB Id	
pdcp-Config	PDCP-Config		
}			
}			

**Table 8.2.5.6.1.3.3-5: PDCP-Config (Table 8.2.5.6.1.3.3-4)**

Derivation Path: 38.508-1 [4], Table 4.6.3-74			
Information Element	Value/remark	Comment	Condition
PDCP-Config ::= SEQUENCE {			
drb SEQUENCE {			
pdcp-SN-SizeUL	Not present		
pdcp-SN-SizeDL	Not present		
}			
}			

**Table 8.2.5.6.1.3.3-6: RRCConnectionReestablishmentRequest (step 2, Table 8.2.5.6.1.3.2-1)**

Derivation Path: 36.508 [7], Table 4.6.1-13			
Information Element	Value/remark	Comment	Condition
RRCConnectionReestablishmentRequest ::= SEQUENCE {			
criticalExtensions CHOICE {			
rrcConnectionReestablishmentRequest-r8 SEQUENCE {			
reestablishmentCause	reconfigurationFailure		
}			
}			
}			

## 9 Mobility management

Editor's note: Intended to capture tests of  
5G Core Network behaviour defined in TS 24.301, TS 24.501 et.al.

Multi-RAT Dual Connectivity behaviour defined in TS 37.340.

Possible configurations may be handled in the following sub-structure:

- a) E-UTRA–NR DC via EPC with E-UTRA as master (also referred to EN-DC, option 3, 3a, 3x)
- b) E-UTRA–NR DC via 5GC
  - with E-UTRA as master (also referred to NGEN-DC, option 7, 7a, 7x)
  - with NR as master (also referred to NE-DC, option 4, 4A)

### 9.1 5GS Mobility Management

#### 9.1.5 Registration

##### 9.1.5.1 Initial Registration

##### 9.1.5.1.12 Initial registration / Rejected / Congestion / Abnormal cases / T3346

##### 9.1.5.1.12.1 Test Purpose (TP)

(1)

```
with { The UE has sent initial REGISTRAION REQUEST message }
ensure that {
  when { UE receives a REGISTRATION REJECT with cause #22 (Congestion) with T3346 included and the
  UE is NOT configured for High Priority Access in the selected PLMN }
  then { UE starts the Initial registration until T3346 expires }
}
```

(2)

```
with { The UE has received initial REGISTRATION REJECT with T3346 included }
ensure that {
  when { upon expiry of T3346 }
  then { UE starts the Initial registration procedure }
}
```

(3)

```
with { The UE has received initial REGISTRATION REJECT with T3346 included }
ensure that {
  when { the timer T3346 is running and the UE needs to perform initial registration for emergency
  services }
  then { UE starts the Initial registration procedure }
}
```

(4)

```
with { The UE has received initial REGISTRATION REJECT with T3346 included }
ensure that {
  when { the timer T3346 is running and the UE detects a cell better than serving cell (S criterion
  for detected cell > S criterion for serving cell )
  then { UE starts the Initial registration procedure on the detected cell }
}
```

##### 9.1.5.1.12.2 Conformance requirements

References: The conformance requirements covered in the present TC are specified in: TS 24.501, clauses 5.5.1.2.5 and 5.5.1.2.7. Unless otherwise stated these are Rel-15 requirements.

[TS 24.501, clause 5.5.1.2.5]

If the initial registration request cannot be accepted by the network, the AMF shall send a REGISTRATION REJECT message to the UE including an appropriate 5GMM cause value.

If the initial registration request is rejected due to general NAS level mobility management congestion control, the network shall set the 5GMM cause value to #22 "congestion" and assign a back-off timer T3346.

The UE shall take the following actions depending on the 5GMM cause value received in the REGISTRATION REJECT message.

#3 (Illegal UE);

#6 (Illegal ME); or

....

#22 (Congestion).

If the T3346 value IE is present in the REGISTRATION REJECT message and the value indicates that this timer is neither zero nor deactivated, the UE shall proceed as described below; otherwise it shall be considered as an abnormal case and the behaviour of the UE for this case is specified in subclause 5.5.1.2.7.

The UE shall abort the initial registration procedure, set the 5GS update status to 5U2 NOT UPDATED and enter state 5GMM-DEREGISTERED.ATTEMPTING-REGISTRATION.

The UE shall stop timer T3346 if it is running.

If the REGISTRATION REJECT message is integrity protected, the UE shall start timer T3346 with the value provided in the T3346 value IE.

If the REGISTRATION REJECT message is not integrity protected, the UE shall start timer T3346 with a random value from the default range specified in 3GPP TS 24.008 [12].

The UE stays in the current serving cell and applies the normal cell reselection process. The initial registration procedure is started if still needed when timer T3346 expires or is stopped.

#27 (N1 mode not allowed).

The UE capable of S1 mode shall disable the N1 mode capability for both 3GPP access and non-3GPP access (see subclause 4.9).

Other values are considered as abnormal cases. The behaviour of the UE in those cases is specified in subclause 5.5.1.2.7.

[TS 24.501, clause 5.5.1.2.7]

The following abnormal cases can be identified:

a) Timer T3346 is running.

The UE shall not start the registration procedure for initial registration unless:

- 1) the UE is a UE configured for high priority access in selected PLMN; or
- 2) the UE needs to perform the registration procedure for initial registration for emergency services.

The UE stays in the current serving cell and applies the normal cell reselection process.

NOTE 1: It is considered an abnormal case if the UE needs to initiate a registration procedure for initial registration while timer T3346 is running independent on whether timer T3346 was started due to an abnormal case or a non-successful case.

9.1.5.1.12.3 Test description

9.1.5.1.12.3.1 Pre test conditions

System Simulator:

- 2 NR cells, default system information [38.508 cl. 4.4.3.1.2, FFS]
- NR cell 1 "Serving cell" [38.508 Table 6.2.2.1-3], PLMN1, TAI-1

- NR cell 12 "Non-Suitable cell" [38.508 Table 6.2.2.1-3], PLMN2, TAI-3

UE:

None.

Preamble:

- The UE is in state Switched OFF [State as per 38.508-1 is FFS].



## 9.1.5.1.12.3.2 Test procedure sequence

Table 9.1.5.1.12.3.2-1: Main behaviour

St	Procedure	Message Sequence		TP	Verdict
		U - S	Message		
	The SS configures <ul style="list-style-type: none"> <li>- NR Cell 1 as the serving cell</li> <li>- NR Cell 12 as non-suitable neighbouring cell</li> </ul>	-	-	-	-
	The following messages are observed on NR Cell 1 unless explicitly stated otherwise	-	-	-	-
1	The UE is switched on	-	-	-	-
2	The UE transmits an <i>RRCSetupRequest</i> message	-->	[ <i>RRCSetupRequest</i> ]	-	-
3	The network transmits an <i>RRCSetup</i> message to the UE	<--	[ <i>RRCSetup</i> ]	-	-
4	The UE transmits an <i>RRCSetupComplete</i> message to the network	-->	[ <i>RRCSetupComplete</i> ]	-	-
5	The UE transmits a REGISTRATION REQUEST with IE 5GS registration type set to "initial registration" (Note 1)	-->	REGISTRATION REQUEST	-	-
6	The SS transmits an AUTHENTICATION REQUEST (Note 2)	<--	AUTHENTICATION REQUEST	-	-
7	The UE transmits an AUTHENTICATION RESPONSE message and establishes mutual authentication.	-->	AUTHENTICATION RESPONSE	-	-
8	The SS transmits a SECURITY MODE COMMAND message	<--	SECURITY MODE COMMAND	-	-
9	The UE transmits a SECURITY MODE COMPLETE	-->	SECURITY MODE COMPLETE	-	-
10	The AMF transmits a REGISTRATION REJECT with cause #22 (Congestion) and T3346 set to 3 minutes.	<--	REGISTRATION REJECT	-	-
11	The SS releases the RRC connection	<--	[ <i>RRCConnectionRelease</i> ]	-	-
12	Check: Does the UE transmit an <i>RRCSetupRequest</i> in the next 3 minutes? (Note 3)	-	-	1	F
13-20	Steps 2-9 above are repeated	-	-	2	-
21	The AMF transmits a REGISTRATION REJECT with cause #22 (Congestion) and T3346 set to 5 minutes.	<--	REGISTRATION REJECT	-	-
22	The SS releases the RRC connection	<--	[ <i>RRCConnectionRelease</i> ]	-	-
23	The SS configures <ul style="list-style-type: none"> <li>- NR Cell 1 as non-suitable neighbouring cell</li> <li>- NR Cell 12 as the serving cell</li> </ul>	-	-	-	-
	The following messages are observed on NR Cell 12 unless explicitly stated otherwise	-	-	-	-
24-33	Steps 2-11 above are repeated	-	-	4	-
34	The operator initiates an emergency call by MMI or by AT command	-	-	-	-
35	Check: Does the UE transmit an <i>RRCSetupRequest</i> in the next 3 minutes?	-->	[ <i>RRCSetupRequest</i> ]	3	F
36	The SS transmits an <i>RRCReject</i>	<--	[ <i>RRCReject</i> ]	-	-
37	The UE is Switched/Powered OFF	-	-	-	-
<p>Note 1: Whether this REGISTRATION REQ is piggybacked with <i>RRCSetupComplete</i> or not is FFS</p> <p>Note 2: This could be either EAP based primary authentication and key agreement procedure (24.501 cl. 5.4.1.2) , or 5G AKA based primary authentication and key agreement based on non-3gpp access or 3gpp access for RRC Connection Establishment. This is FFS.</p> <p>Note 3: The actual timer could be 3 minutes less tolerance</p>					

## 9.1.5.1.12.3.3 Specific message contents

**Table 9.1.5.1.12.3.3-1: REGISTRATION REJECT (step 10 Table 9.1.5.1.12.3.2-1)**

Derivation Path: 38.508-1 [4], FFS			
Information Element	Value/remark	Comment	Condition
5GMM cause	FFS	Cause #22 (Congestion)	
T3346 Value	'00100011'B	3 minutes	

**Table 9.1.5.1.12.3.3-1: REGISTRATION REJECT (step 21 Table 9.1.5.1.12.3.2-1)**

Derivation Path: 38.508 [4], FFS			
Information Element	Value/remark	Comment	Condition
5GMM cause	FFS	Cause #22 (Congestion)	
T3346 Value	'00100101'B	5 minutes	

---

## 10 Session management

### 10.1 5GS session management

*Editor's note: Intended to capture tests of 5G Core Network behaviour defined in TS 24.301, TS 24.501 et.al. (TR 24.890).*

FFS.

### 10.2 EN-DC session management

#### 10.2.1 Network initiated procedures

##### 10.2.1.1 Default EPS bearer context activation

###### 10.2.1.1.1 Test Purpose (TP)

(1)

```

with { UE has sent a PDN CONNECTIVITY REQUEST message }
ensure that {
  when { UE receives an RRCConnectionReconfiguration message including an ACTIVATE DEFAULT EPS
  BEARER CONTEXT REQUEST message with IE Procedure transaction identity matching the PDN CONNECTIVITY
  REQUEST message and including the Extended QoS and Extended APN-AMBR IEs }
  then { UE transmits an ACTIVATE DEFAULT EPS BEARER CONTEXT ACCEPT message and enters BEARER
  CONTEXT ACTIVE state }
}

```

###### 10.2.1.1.2 Conformance requirements

References: The conformance requirements covered in the present TC are specified in: TS 24.301, clause 6.4.1.3, 8.3.6.17, 8.3.6.18, 9.9.4.29 and 9.9.4.30. Unless otherwise stated these are Rel-15 requirements.

[TS 24.301, clause 6.4.1.3]

Upon receipt of the ACTIVATE DEFAULT EPS BEARER CONTEXT REQUEST message, if the UE provided an APN for the establishment of the PDN connection, the UE shall stop timer T3396 if it is running for the APN provided by the UE. If the UE did not provide an APN for the establishment of the PDN connection and the request type was different from "emergency" and from "handover of emergency bearer services", the UE shall stop the timer T3396 associated with no APN if it is running. If the ACTIVATE DEFAULT EPS BEARER CONTEXT REQUEST message was received in response to a request for an emergency PDN connection, the UE shall not stop the timer T3396 associated with no APN if it is running. For any case, the UE shall then send an ACTIVATE DEFAULT EPS BEARER CONTEXT ACCEPT message and enter the state BEARER CONTEXT ACTIVE. When the default bearer is activated as part of the attach procedure, the UE shall send the ACTIVATE DEFAULT EPS BEARER CONTEXT ACCEPT

message together with ATTACH COMPLETE message. When the default bearer is activated as the response to the stand-alone PDN CONNECTIVITY REQUEST message, the UE shall send the ACTIVATE DEFAULT EPS BEARER CONTEXT ACCEPT message alone.

If a WLAN offload indication information element is included in the ACTIVATE DEFAULT EPS BEARER CONTEXT REQUEST message, the UE shall store the WLAN offload acceptability values for this PDN connection and use the E-UTRAN offload acceptability value to determine whether this PDN connection is offloadable to WLAN or not.

The UE checks the PTI in the ACTIVATE DEFAULT EPS BEARER CONTEXT REQUEST message to identify the UE requested PDN connectivity procedure to which the default bearer context activation is related (see subclause 6.5.1).

If the UE receives a serving PLMN rate control IE in the ACTIVATE DEFAULT EPS BEARER CONTEXT REQUEST message, the UE shall store the serving PLMN rate control IE value and use the stored serving PLMN rate control value as the maximum allowed limit of uplink User data container IEs included in ESM DATA TRANSPORT messages for the corresponding PDN connection in accordance with 3GPP TS 23.401 [10].

If the UE receives an APN rate control parameters container in the protocol configuration options IE or extended protocol configuration options IE in the ACTIVATE DEFAULT EPS BEARER CONTEXT REQUEST message, the UE shall store the APN rate control parameters value and use the stored APN rate control parameters value as the maximum allowed limit of uplink user data related to the APN indicated in the ACTIVATE DEFAULT EPS BEARER CONTEXT REQUEST message in accordance with 3GPP TS 23.401 [10]. If the UE has a previously stored APN rate control parameters value for this APN, the UE shall replace the stored APN rate control parameters value for this APN with the received APN rate control parameters value.

If the UE receives an additional APN rate control parameters for exception data container in the protocol configuration options IE or extended protocol configuration options IE in the ACTIVATE DEFAULT EPS BEARER CONTEXT REQUEST message, the UE shall store the additional APN rate control parameters for exception data value and use the stored additional APN rate control parameters for exception data value as the maximum allowed limit of uplink exception data related to the APN indicated in the ACTIVATE DEFAULT EPS BEARER CONTEXT REQUEST message in accordance with 3GPP TS 23.401 [10]. If the UE has a previously stored additional APN rate control parameters for exception data value for this APN, the UE shall replace the stored additional APN rate control parameters for exception data value for this APN with the received additional APN rate control parameters for exception data value.

If the UE receives non-IP Link MTU parameter or IPv4 Link MTU parameter of the protocol configuration options IE in the ACTIVATE DEFAULT EPS BEARER CONTEXT REQUEST message, the UE shall pass the received Non-IP Link MTU or IPv4 Link MTU to the upper layer.

**NOTE:** The Non-IP Link MTU and the IPv4 Link MTU size correspond to the maximum length of user data that can be sent either in the user data container in the ESM DATA TRANSPORT message or via S1-U interface.

If the UE receives a session-AMBR and QoS rule(s), which correspond to the default EPS bearer of the PDN connectivity being activated, in the protocol configuration options IE or the extended protocol configuration options IE in the ACTIVATE DEFAULT EPS BEARER CONTEXT REQUEST message, the UE stores the session-AMBR and QoS rule(s) for use during inter-system change from S1 mode to N1 mode.

Upon receipt of the ACTIVATE DEFAULT EPS BEARER CONTEXT ACCEPT message, the MME shall enter the state BEARER CONTEXT ACTIVE and stop the timer T3485, if the timer is running. If the PDN CONNECTIVITY REQUEST message included a low priority indicator set to "MS is configured for NAS signalling low priority", the MME shall store the NAS signalling low priority indication within the default EPS bearer context.

[TS 24.301, clause 8.3.6.17]

This IE shall be included in the message only if the network wishes to transmit the APN-AMBR values to the UE for possible uplink policy enforcement and at least one of the values to be transmitted exceeds the maximum value specified in the APN aggregate maximum bit rate information element in subclause 9.9.4.2.

[TS 24.301, clause 8.3.6.18]

This IE shall be included in the message only if the network wishes to transmit the maximum and guaranteed bit rate values to the UE and at least one of the values to be transmitted exceeds the maximum value specified in the EPS quality of service information element in subclause 9.9.4.3.

[TS 24.301, clause 9.9.4.29]

The purpose of the extended APN aggregate maximum bit rate information element is to indicate the initial subscribed APN-AMBR with a value higher than 65280 Mbps when the UE establishes a PDN connection or to indicate the new APN-AMBR with a value higher than 65280 Mbps if it is changed by the network.

The receiving entity shall ignore the bit rate values which are included in the extended APN aggregate maximum bit rate information element and not higher than 65280 Mbps.

The extended APN aggregate maximum bit rate information element is coded as shown in figure 9.9.4.29.1 and table 9.9.4.29.1.

The extended APN aggregate maximum bit rate is a type 4 information element with a length of 8 octets.

8	7	6	5	4	3	2	1	
Extended APN aggregate maximum bit rate IEI								octet 1
Length of extended APN aggregate maximum bit rate contents								octet 2
Unit for extended APN-AMBR for downlink								octet 3
Extended APN-AMBR for downlink								octet 4
Extended APN-AMBR for downlink (continued)								octet 5
Unit for extended APN-AMBR for uplink								octet 6
Extended APN-AMBR for uplink								octet 7
Extended APN-AMBR for uplink (continued)								octet 8

**Figure 9.9.4.29.1: Extended APN aggregate maximum bit rate information element**

**Table 9.9.4.29.1: Extended APN aggregate maximum bit rate information element**

Unit for extended APN-AMBR for downlink (octet 3)	
0 0 0 0 0 0 0 0	value is not used
0 0 0 0 0 0 0 1	value is not used
0 0 0 0 0 0 1 0	value is not used
0 0 0 0 0 0 1 1	value is incremented in multiples of 4 Mbps
0 0 0 0 0 1 0 0	value is incremented in multiples of 16 Mbps
0 0 0 0 0 1 0 1	value is incremented in multiples of 64 Mbps
0 0 0 0 0 1 1 0	value is incremented in multiples of 256 Mbps
0 0 0 0 0 1 1 1	value is incremented in multiples of 1 Gbps
0 0 0 0 1 0 0 0	value is incremented in multiples of 4 Gbps
0 0 0 0 1 0 0 1	value is incremented in multiples of 16 Gbps
0 0 0 0 1 0 1 0	value is incremented in multiples of 64 Gbps
0 0 0 0 1 0 1 1	value is incremented in multiples of 256 Gbps
0 0 0 0 1 1 0 0	value is incremented in multiples of 1 Tbps
0 0 0 0 1 1 0 1	value is incremented in multiples of 4 Tbps
0 0 0 0 1 1 1 0	value is incremented in multiples of 16 Tbps
0 0 0 0 1 1 1 1	value is incremented in multiples of 64 Tbps
0 0 0 1 0 0 0 0	value is incremented in multiples of 256 Tbps
0 0 0 1 0 0 0 1	value is incremented in multiples of 1 Pbps
0 0 0 1 0 0 1 0	value is incremented in multiples of 4 Pbps
0 0 0 1 0 0 1 1	value is incremented in multiples of 16 Pbps
0 0 0 1 0 1 0 0	value is incremented in multiples of 64 Pbps
0 0 0 1 0 1 0 1	value is incremented in multiples of 256 Pbps
Other values shall be interpreted as multiples of 256 Pbps in this version of the protocol.	
Extended APN-AMBR for downlink (octets 4 and 5)	
Octets 4 and 5 represent the binary coded value of extended APN-AMBR for downlink in units defined by octet 3	
Unit for extended APN-AMBR for uplink (octet 6)	
The coding is identical to that of the unit for extended APN-AMBR for downlink (octet 3)	
Extended APN-AMBR for uplink (octets 7 and 8)	
Octets 7 and 8 represent the binary coded value of extended APN-AMBR for uplink in units defined by octet 6.	

[TS 24.301, clause 9.9.4.30]

The purpose of the Extended quality of service information element is to indicate for an EPS bearer context the maximum bit rates for uplink and downlink and the guaranteed bit rates for uplink and downlink, if at least one of the bit rates has a value higher than 10 Gbps.

The Extended quality of service information element is coded as shown in figure 9.9.4.30.1 and table 9.9.4.30.1. For uplink and downlink, if the sending entity only has to indicate one bit rate (i.e., with a value higher than 10 Gbps), it shall encode the other bit rate (i.e., with a value smaller or equal to 10 Gbps) as "00000000". The receiving entity shall ignore a bit rate which is included in the extended quality of service information element and has a value smaller or equal to 10 Gbps.

The Extended quality of service is a type 4 information element with a length of 12 octets.

8	7	6	5	4	3	2	1	
Extended quality of service IEI								octet 1
Length of Extended quality of service contents								octet 2
Unit for maximum bit rate								octet 3
Maximum bit rate for uplink								octet 4
Maximum bit rate for uplink (continued)								octet 5
Maximum bit rate for downlink								octet 6
Maximum bit rate for downlink (continued)								octet 7
Unit for guaranteed bit rate								octet 8
Guaranteed bit rate for uplink								octet 9
Guaranteed bit rate for uplink (continued)								octet 10
Guaranteed bit rate for downlink								octet 11
Guaranteed bit rate for downlink (continued)								octet 12

**Figure 9.9.4.30.1: Extended quality of service information element**

**Table 9.9.4.30.1: Extended quality of service information element**

Unit for maximum bit rate (octet 3)	
0 0 0 0 0 0 0 0	value is not used
0 0 0 0 0 0 0 1	value is incremented in multiples of 200 kbps
0 0 0 0 0 0 1 0	value is incremented in multiples of 1 Mbps
0 0 0 0 0 0 1 1	value is incremented in multiples of 4 Mbps
0 0 0 0 0 1 0 0	value is incremented in multiples of 16 Mbps
0 0 0 0 0 1 0 1	value is incremented in multiples of 64 Mbps
0 0 0 0 0 1 1 0	value is incremented in multiples of 256 Mbps
0 0 0 0 0 1 1 1	value is incremented in multiples of 1 Gbps
0 0 0 0 1 0 0 0	value is incremented in multiples of 4 Gbps
0 0 0 0 1 0 0 1	value is incremented in multiples of 16 Gbps
0 0 0 0 1 0 1 0	value is incremented in multiples of 64 Gbps
0 0 0 0 1 0 1 1	value is incremented in multiples of 256 Gbps
0 0 0 0 1 1 0 0	value is incremented in multiples of 1 Tbps
0 0 0 0 1 1 0 1	value is incremented in multiples of 4 Tbps
0 0 0 0 1 1 1 0	value is incremented in multiples of 16 Tbps
0 0 0 0 1 1 1 1	value is incremented in multiples of 64 Tbps
0 0 0 1 0 0 0 0	value is incremented in multiples of 256 Tbps
0 0 0 1 0 0 0 1	value is incremented in multiples of 1 Pbps
0 0 0 1 0 0 1 0	value is incremented in multiples of 4 Pbps
0 0 0 1 0 0 1 1	value is incremented in multiples of 16 Pbps
0 0 0 1 0 1 0 0	value is incremented in multiples of 64 Pbps
0 0 0 1 0 1 0 1	value is incremented in multiples of 256 Pbps
Other values shall be interpreted as multiples of 256 Pbps in this version of the protocol.	
Maximum bit rate for uplink (octets 4 and 5)	
Octets 4 and 5 represent the binary coded value of maximum bit rate for uplink in units defined by octet 3.	
Maximum bit rate for downlink (octets 6 and 7)	
Octets 6 and 7 represent the binary coded value of maximum bit rate for downlink in units defined by octet 3.	
Unit for guaranteed bit rate (octet 8)	
The coding is identical to that of the unit for maximum bit rate (octet 3).	
Guaranteed bit rate for uplink (octets 9 and 10)	
Octets 9 and 10 represent the binary coded value of guaranteed bit rate for uplink in units defined by octet 8.	
Guaranteed bit rate for downlink (octets 11 and 12)	
Octets 11 and 12 represent the binary coded value of guaranteed bit rate for downlink in units defined by octet 8.	

10.2.1.1.3 Test description

10.2.1.1.3.1 Pre-test conditions

System Simulator:

- E-UTRA Cell 1 is the PCell and NR Cell 1 is the PSCell.

UE:

None.

Preamble:

- The UE is in RRC\_IDLE state on E-UTRA Cell 1 using generic procedure parameter Connectivity (*EN-DC*) and Bearers (*MCG only*) established according to TS 38.508-1 [4].

#### 10.2.1.1.3.2 Test procedure sequence

**Table 10.2.1.1.3.2-1: Main behaviour**

St	Procedure	Message Sequence		TP	Verdict
		U - S	Message		
1	Cause the UE to request connectivity to an additional PDN (see Note 1)	-	-	-	-
2	UE transmit an <i>RRCCONNECTIONREQUEST</i> message with <i>establishmentCause</i> set to 'mo-Data' followed by a SERVICE REQUEST message.	-->	SERVICE REQUEST	-	-
3	The SS establishes SRB2 and DRB associated with default EPS bearer context (a first PDN obtained during the attach procedure).	-	-	-	-
4	The UE transmit a PDN CONNECTIVITY REQUEST message as specified to request an additional PDN.	-->	PDN CONNECTIVITY REQUEST	-	-
5	The SS transmits an <i>RRCCONNECTIONRECONFIGURATION</i> message containing NR <i>RRCRECONFIGURATION</i> message to add NR <i>PSCell</i> with SCG DRB. The <i>RRCCONNECTIONRECONFIGURATION</i> message contains ACTIVATE DEFAULT EPS BEARER CONTEXT REQUEST message containing Extended QoS IE and Extended APN-AMBR IEs.	<--	RRC: <i>RRCCONNECTIONRECONFIGURATION</i> (( <i>RRCRECONFIGURATION</i> ) NAS: ACTIVATE DEFAULT EPS BEARER CONTEXT REQUEST	-	-
6	The UE transmits an <i>RRCCONNECTIONRECONFIGURATIONCOMPLETE</i> message to confirm the establishment of default bearer.	-->	RRC: <i>RRCCONNECTIONRECONFIGURATIONCOMPLETE</i> ( <i>RRCRECONFIGURATIONCOMPLETE</i> )	-	-
-	EXCEPTION: In parallel to the event described in step 7 below, if initiated by the UE the generic procedure for IP address allocation in the U-plane specified in TS 36.508 subclause 4.5A.1 takes place performing IP address allocation in the U-plane.	-	-	-	-
7	The UE transmits ACTIVATE DEFAULT EPS BEARER CONTEXT ACCEPT message.	-->	RRC: <i>ULINFORMATIONTRANSFER</i> NAS: ACTIVATE DEFAULT EPS BEARER CONTEXT ACCEPT	1	P

Note 1: The request of connectivity to an additional PDN may be performed by MMI or AT command.

#### 10.2.1.1.3.3 Specific message contents

**Table 10.2.1.1.3.3-1: PDN CONNECTIVITY REQUEST (step 4, Table 10.2.1.1.3.2-1)**

Derivation Path: 36.508 [7], Table 4.7.3-20			
Information Element	Value/remark	Comment	Condition
Protocol discriminator	ESM		
EPS bearer identity	'0000'B	No EPS bearer identity assigned	
Procedure transaction identity	PTI-1	UE assigns a particular PTI not yet used between 1 and 254	
Access point name	APN-1(New PDN name)	The requested PDN is different from default PDN	



**Table 10.2.1.1.3.3-2: ACTIVATE DEFAULT EPS BEARER CONTEXT REQUEST (step 5, Table 10.2.1.1.3.2-1)**

Derivation Path: TS 36.508 [7], Table 4.7.3-6			
Information Element	Value/remark	Comment	Condition
Protocol discriminator	ESM		
EPS bearer identity	'0110'B		
Procedure transaction identity	PTI-1	SS re-uses the particular PTI defined by UE for this present additional PDN connectivity request procedure.	
EPS QoS			
QCI	8		
Maximum bit rate for uplink	384 kbps		
Maximum bit rate for downlink	'11111110'B (8640 kbps)		
Guaranteed bit rate for uplink	128 kbps		
Guaranteed bit rate for downlink	128 kbps		
Maximum bit rate for uplink (extended)	0		
Maximum bit rate for downlink (extended)	'11111010'B (256 Mbps)		
Guaranteed bit rate for uplink (extended)	0		
Guaranteed bit rate for downlink (extended)	0		
Maximum bit rate for uplink (extended-2)	0		
Maximum bit rate for downlink (extended-2)	'11110110'B (10 Gbps)		
Guaranteed bit rate for uplink (extended-2)	0		
Guaranteed bit rate for downlink (extended-2)	0		
APN-AMBR			
APN-AMBR for downlink	'11111110'B (8640 kbps)		
APN-AMBR for uplink	'11111110'B (8640 kbps)		
APN-AMBR for downlink (extended)	'11111010' B(256 Mbps)		
APN-AMBR for uplink (extended)	'11111010' B(256 Mbps)		
APN-AMBR for downlink (extended-2)	'11111110'B (65280 Mbps)		
APN-AMBR for uplink (extended-2)	0		
Access point name	APN-1	SS re-uses the particular APN defined by UE for this present additional PDN connectivity request procedure	
Extended APN-AMBR			
Unit for extended APN-AMBR for downlink	'00000111'B (value is incremented in multiples of 1 Gbps)		
Extended APN-AMBR for downlink	'0000000010000000' (128 Gbps)		
Unit for extended APN-AMBR for uplink	0		
Extended APN-AMBR for uplink	0		
Extended EPS QoS			
Unit for maximum bit rate	'00000111' (value is incremented in multiples of 1 Gbps)		
Maximum bit rate for uplink	'00000000'B		
Maximum bit rate for downlink	'0000000000001100'		
Unit for guaranteed bit rate	'00000000'B		
Guaranteed bit rate for uplink	'00000000'B		
Guaranteed bit rate for downlink	'00000000'B		

## 10.2.1.2 Dedicated EPS bearer context activation

### 10.2.1.2.1 Test Purpose (TP)

(1)

```
with { UE in EMM-REGISTERED state }
ensure that {
  when { UE receives an ACTIVATE DEDICATED EPS BEARER CONTEXT REQUEST message, including the
Extended EPS QoS IE, linked to the existing default EPS bearer }
    then { UE transmits an ACTIVATE DEDICATED EPS BEARER CONTEXT ACCEPT }
}
```

(2)

```
with { the UE in BEARER CONTEXT ACTIVE STATE and in EMM-CONNECTED mode }
ensure that {
  when { the UE receives a MODIFY EPS BEARER CONTEXT REQUEST message including the Extended EPS QoS
and Extended APN-AMBR IEs }
    then { UE transmits a MODIFY EPS BEARER CONTEXT ACCEPT }
}
```

### 10.2.1.2.2 Conformance requirements

References: The conformance requirements covered in the present TC are specified in: TS 24.301, clauses 6.4.2.3, 6.4.3.1, 6.4.3.2, 6.4.3.3, 8.3.3.11, 9.9.4.29 and 9.9.4.30. Unless otherwise stated these are Rel-15 requirements.

[TS 24.301, clause 6.4.2.3]

Upon receipt of the ACTIVATE DEDICATED EPS BEARER CONTEXT REQUEST message, if the UE provided an APN for the establishment of the PDN connection, the UE shall stop timer T3396, if it is running for the APN provided by the UE. If the UE did not provide an APN for the establishment of the PDN connection and the request type was different from "emergency" and from "handover of emergency bearer services", the UE shall stop the timer T3396 associated with no APN if it is running. If the ACTIVATE DEDICATED EPS BEARER CONTEXT REQUEST message was received for an emergency PDN connection, the UE shall not stop the timer T3396 associated with no APN if it is running. For any case, the UE shall then check the received TFT before taking it into use, send an ACTIVATE DEDICATED EPS BEARER CONTEXT ACCEPT message and enter the state BEARER CONTEXT ACTIVE. The ACTIVATE DEDICATED EPS BEARER CONTEXT ACCEPT message shall include the EPS bearer identity.

The linked EPS bearer identity included in the ACTIVATE DEDICATED EPS BEARER CONTEXT REQUEST message indicates to the UE to which default bearer, IP address and PDN the dedicated bearer is linked.

If the ACTIVATE DEDICATED EPS BEARER CONTEXT REQUEST message contains a PTI value other than "no procedure transaction identity assigned" and "reserved" (see 3GPP TS 24.007 [12]), the UE uses the PTI to identify the UE requested bearer resource allocation procedure or the UE requested bearer resource modification procedure to which the dedicated bearer context activation is related.

[TS 24.301, clause 6.4.3.1]

The purpose of the EPS bearer context modification procedure is to modify an EPS bearer context with a specific QoS and TFT, or re-negotiate header compression configuration associated to an EPS bearer context. The EPS bearer context modification procedure is initiated by the network, but it may also be initiated as part of the UE requested bearer resource allocation procedure or the UE requested bearer resource modification procedure.

The network may also initiate the EPS bearer context modification procedure to update the APN-AMBR of the UE, for instance after an inter-system handover. See 3GPP TS 23.401 [10] annex E.

[TS 24.301, clause 6.4.3.2]

The MME shall initiate the EPS bearer context modification procedure by sending a MODIFY EPS BEARER CONTEXT REQUEST message to the UE, starting the timer T3486, and entering the state BEARER CONTEXT MODIFY PENDING (see example in figure 6.4.3.2.1).

The MME shall include an EPS bearer identity that identifies the EPS bearer context to be modified in the MODIFY EPS BEARER CONTEXT REQUEST message.

[TS 24.301, clause 6.4.3.3]

Upon receipt of the MODIFY EPS BEARER CONTEXT REQUEST message, if the UE provided an APN for the establishment of the PDN connection, the UE shall stop timer T3396, if it is running for the APN provided by the UE. If the UE did not provide an APN for the establishment of the PDN connection and the request type was different from "emergency" and from "handover of emergency bearer services", the UE shall stop the timer T3396 associated with no APN if it is running. If the MODIFY EPS BEARER CONTEXT REQUEST message was received for an emergency PDN connection, the UE shall not stop the timer T3396 associated with no APN if it is running. For any case, the UE shall then check the received TFT before taking it into use and send a MODIFY EPS BEARER CONTEXT ACCEPT message to the MME.

If the MODIFY EPS BEARER CONTEXT REQUEST message contains a PTI value other than "no procedure transaction identity assigned" and "reserved" (see 3GPP TS 24.007 [12]), the UE uses the PTI to identify the UE requested bearer resource allocation procedure or the UE requested bearer resource modification procedure to which the EPS bearer context modification is related (see subclause 6.5.3 and subclause 6.5.4).

If the MODIFY EPS BEARER CONTEXT REQUEST message contains a PTI value other than "no procedure transaction identity assigned" and "reserved" (see 3GPP TS 24.007 [12]) and the PTI is associated to a UE requested bearer resource allocation procedure or a UE requested bearer resource modification procedure, the UE shall release the traffic flow aggregate description associated to the PTI value provided.

...

Upon receipt of the MODIFY EPS BEARER CONTEXT ACCEPT message, the MME shall stop the timer T3486 and enter the state BEARER CONTEXT ACTIVE.

[TS 24.301, clause 8.3.3.11]

This IE shall be included in the message only if the network wishes to transmit the maximum and guaranteed bit rate values to the UE and at least one of the values to be transmitted exceeds the maximum value specified in the EPS quality of service information element in subclause 9.9.4.3

[TS 24.301, clause 9.9.4.29]

The purpose of the extended APN aggregate maximum bit rate information element is to indicate the initial subscribed APN-AMBR with a value higher than 65280 Mbps when the UE establishes a PDN connection or to indicate the new APN-AMBR with a value higher than 65280 Mbps if it is changed by the network.

The receiving entity shall ignore the bit rate values which are included in the extended APN aggregate maximum bit rate information element and not higher than 65280 Mbps.

The extended APN aggregate maximum bit rate information element is coded as shown in figure 9.9.4.29.1 and table 9.9.4.29.1.

The extended APN aggregate maximum bit rate is a type 4 information element with a length of 8 octets

[TS 24.301, clause 9.9.4.30]

The purpose of the Extended EPS quality of service information element is to indicate for an EPS bearer context the maximum bit rates for uplink and downlink and the guaranteed bit rates for uplink and downlink, if at least one of the bit rates has a value higher than 10 Gbps.

The Extended EPS quality of service information element is coded as shown in figure 9.9.4.30.1 and table 9.9.4.30.1. For uplink and downlink, if sending entity only has to indicate one bit rate (i.e., with a value higher than 10 Gbps), it shall encode the other bit rate (i.e., with a value smaller or equal to 10 Gbps) as "00000000". The receiving entity shall ignore the bit rate which is included in the extended quality of service information element and has a value smaller or equal to 10 Gbps.

10.2.1.2.3 Test description

10.2.1.2.3.1 Pre-test conditions

System Simulator:

- E-UTRA Cell 1 is the PCell and NR Cell 1 is the PSCell.

UE:

- None.

Preamble:

- The UE is in RRC\_IDLE state on E-UTRA Cell 1 using generic procedure parameter Connectivity (EN-DC) according to TS 38.508-1 [4].

#### 10.2.1.2.3.2 Test procedure sequence

**Table 10.2.1.2.3.2-1: Main behaviour**

St	Procedure	Message Sequence		TP	Verdict
		U - S	Message		
1-6	Steps 1 to 6 of generic procedure defined in clause 4.5.4 in TS 38.508-1 [4].	-	-	-	-
7	The SS configures a dedicated EPS bearer associated with the default EPS bearer context by sending ACTIVATE DEDICATED EPS BEARER CONTEXT REQUEST including the Extended QoS IE. (See Note 1 and Note 2).	<--	NAS: ACTIVATE DEDICATED EPS BEARER CONTEXT REQUEST	-	-
8	Check: Does the UE transmit an ACTIVATE DEDICATED EPS BEARER CONTEXT ACCEPT message as specified?	-->	ACTIVATE DEDICATED EPS BEARER CONTEXT ACCEPT	1	P
9	The SS transmits a MODIFY EPS BEARER CONTEXT REQUEST message with Extended EPS QoS and Extended APN-AMBR IEs. This message is included in a DLInformationTransfer message.	<--	MODIFY EPS BEARER CONTEXT REQUEST	-	-
10	Check: Does the UE transmit a MODIFY EPS BEARER CONTEXT ACCEPT message?	-->	MODIFY EPS BEARER CONTEXT ACCEPT	2	P
Note 1: The ACTIVATE DEDICATED EPS BEARER CONTEXT REQUEST message is included in a <i>RRCConnectionReconfiguration</i> message including a DRB setup for the same EPS bearer ID.					
Note 2: The <i>RRCConnectionReconfiguration</i> uses the condition for DC bearer MCG and SCG					

## 10.2.1.2.3.3 Specific message contents

**Table 10.2.1.2.3.3-1: ACTIVATE DEDICATED EPS BEARER CONTEXT REQUEST (step 7, Table 10.2.1.2.3.2-1)**

Derivation Path: TS 38.508-1[4], Table 4.5.4.3-1			
Information Element	Value/remark	Comment	Condition
Protocol discriminator	ESM		
EPS bearer identity	6		
Procedure transaction identity	'0000 0000'B	No procedure transaction identity assigned	
EPS QoS			
QCI	8		
Maximum bit rate for uplink	'01101000'B (384) kbps		
Maximum bit rate for downlink	'11111110'B (8640) kbps		
Guaranteed bit rate for uplink	'01001000'B (128) kbps		
Guaranteed bit rate for downlink	'01001000'B (128) kbps		
Maximum bit rate for uplink (extended)	0		
Maximum bit rate for downlink (extended)	'11111010'B (256) Mbps		
Guaranteed bit rate for uplink (extended)	0		
Guaranteed bit rate for downlink (extended)	0		
Maximum bit rate for uplink (extended-2)	0		
Maximum bit rate for downlink (extended-2)	'11110110'B (10) Gbps		
Guaranteed bit rate for uplink (extended-2)	0		
Guaranteed bit rate for downlink (extended-2)	0		
Extended EPS QoS			
Unit for maximum bit rate	'00000111' (value is incremented in multiples of 1 Gbps)		
Maximum bit rate for uplink	'0000000000000000'B		
Maximum bit rate for downlink	'000000000001100'B (12) Gbps		
Unit for guaranteed bit rate	'00000000'B		
Guaranteed bit rate for uplink	'00000000'B		
Guaranteed bit rate for downlink	'00000000'B		

Table 10.2.1.2.3.3-2: MODIFY EPS BEARER CONTEXT REQUEST (step 9, Table 10.2.1.2.3.2-1)

Derivation path: 36.508 [7], Table 4.7.3-18			
Information Element	Value/Remark	Comment	Condition
New EPS QoS			
QCI	8		
Maximum bit rate for uplink	'01101000'B (384 kbps)		
Maximum bit rate for downlink	'11111110'B (8640 kbps)		
Guaranteed bit rate for uplink	'01001000'B (128 kbps)		
Guaranteed bit rate for downlink	'01001000'B (128 kbps)		
Maximum bit rate for uplink (extended)	0		
Maximum bit rate for downlink (extended)	'11111010'B (256 Mbps)		
Guaranteed bit rate for uplink (extended)	0		
Guaranteed bit rate for downlink (extended)	0		
Maximum bit rate for uplink (extended-2)	0		
Maximum bit rate for downlink (extended-2)	'11110110'B (10 Gbps)		
Guaranteed bit rate for uplink (extended-2)	0		
Guaranteed bit rate for downlink (extended-2)	0		
APN-AMBR			
APN-AMBR for downlink	'11111110'B (8640 kbps)		
APN-AMBR for uplink	'11111110'B (8640 kbps)		
APN-AMBR for downlink (extended)	'11111010' B(256 Mbps)		
APN-AMBR for uplink (extended)	'11111010' B(256 Mbps)		
APN-AMBR for downlink (extended-2)	'11111110'B (65280 Mbps)		
APN-AMBR for uplink (extended-2)	0		
Extended APN-AMBR			
Unit for extended APN-AMBR for downlink	'00000111'B (value is incremented in multiples of 1 Gbps)		
Extended APN-AMBR for downlink	'0000000010000000' (128 Gbps)		
Unit for extended APN-AMBR for uplink	0		
Extended APN-AMBR for uplink	0		
Extended EPS QoS			
Unit for maximum bit rate	'00000111' (value is incremented in multiples of 1 Gbps)		
Maximum bit rate for uplink	'0000000000000000'B		
Maximum bit rate for downlink	'0000000000001110'B		
Unit for guaranteed bit rate	'00000000'B		
Guaranteed bit rate for uplink	'00000000'B		
Guaranteed bit rate for downlink	'00000000'B		

## 10.2.2 UE initiated procedures

### 10.2.2.1 EPS bearer resource allocation / modification

#### 10.2.2.1.1 Test Purpose (TP)

(1)

```
with { UE in PROCEDURE TRANSACTION INACTIVE state and in EMM-IDLE mode }
ensure that {
  when { UE is requested to allocate bearer resource using Extended EPS QoS }
  then { UE sends a BEARER RESOURCE ALLOCATION REQUEST including the Extended EPS QoS IE }
}
```

(2)

```
with { UE has sent the BEARER RESOURCE ALLOCATION REQUEST message }
ensure that {
  when { UE receives an ACTIVATE DEDICATED EPS BEARER CONTEXT REQUEST message with the procedure
transaction identity (PTI) indicated in the BEARER RESOURCE ALLOCATION REQUEST message }
  then { UE sends an ACTIVATE DEDICATED EPS BEARER CONTEXT ACCEPT message }
}
```

(3)

```

with { UE in PROCEDURE TRANSACTION INACTIVE state and in EMM-CONNECTED mode }
ensure that {
  when { UE is requested to modify of bearer resource corresponding to the dedicated bearer using
Extended EPS QoS }
    then { UE sends a BEARER RESOURCE MODIFICATION REQUEST message including the Extended EPS QoS IE
}
}

```

(4)

```

with { UE having sent the BEARER RESOURCE MODIFICATION REQUEST message }
ensure that {
  when { UE receives an MODIFY EPS BEARER CONTEXT REQUEST message with the procedure transaction
identity (PTI) indicated in the BEARER RESOURCE MODIFICATION REQUEST message }
    then { UE sends a MODIFY EPS BEARER CONTEXT ACCEPT message }
}

```

#### 10.2.2.1.2 Conformance requirements

References: The conformance requirements covered in the present TC are specified in: TS 24.301, clauses 6.4.2.3, 6.5.3.2, 6.5.3.3, 6.5.4.2, 6.5.4.3, 8.3.8, 8.3.10 and 9.9.4.30. Unless otherwise stated these are Rel-15 requirements.

[TS 24.301, clause 6.4.2.3]

The linked EPS bearer identity included in the ACTIVATE DEDICATED EPS BEARER CONTEXT REQUEST message indicates to the UE to which default bearer, IP address and PDN the dedicated bearer is linked.

If the ACTIVATE DEDICATED EPS BEARER CONTEXT REQUEST message contains a PTI value other than "no procedure transaction identity assigned" and "reserved" (see 3GPP TS 24.007 [12]), the UE uses the PTI to identify the UE requested bearer resource allocation procedure or the UE requested bearer resource modification procedure to which the dedicated bearer context activation is related.

[TS 24.301, clause 6.5.3.2]

In order to request the allocation of bearer resources for one traffic flow aggregate, the UE shall send a BEARER RESOURCE ALLOCATION REQUEST message to the MME, start timer T3480 and enter the state PROCEDURE TRANSACTION PENDING (see example in figure 6.5.3.2.1).

The UE shall include the EPS bearer identity of the default EPS bearer associated with the requested bearer resource in the Linked EPS bearer identity IE. The UE shall set the TFT operation code in the Traffic flow aggregate IE to "Create new TFT". The packet filters in the Traffic flow aggregate IE shall include at least one packet filter applicable for the uplink direction. In the Required traffic flow QoS IE, the UE shall indicate a QCI and, if the UE also includes a GBR, the additional GBR required for the traffic flow aggregate.

[TS 24.301, clause 6.5.3.3]

If the bearer resource allocation requested is accepted by the network, the MME shall initiate either a dedicated EPS bearer context activation procedure or an EPS bearer context modification procedure. Upon receipt of an ACTIVATE DEDICATED EPS BEARER CONTEXT REQUEST or MODIFY EPS BEARER CONTEXT REQUEST message with a PTI which matches the value used for the BEARER RESOURCE ALLOCATION REQUEST message, the UE shall stop timer T3480 and enter the state PROCEDURE TRANSACTION INACTIVE. The UE should ensure that the procedure transaction identity (PTI) assigned to this procedure is not released immediately. The way to achieve this is implementation dependent. While the PTI value is not released, the UE regards any received ACTIVATE DEDICATED EPS BEARER CONTEXT REQUEST or MODIFY EPS BEARER CONTEXT REQUEST message with the same PTI value as a network retransmission (see subclause 7.3.1).

If the ACTIVATE DEDICATED EPS BEARER CONTEXT REQUEST message is received, the UE shall verify that the EPS bearer identity given in the EPS bearer identity IE is not already used by any EPS bearer context. The UE shall then proceed as described in subclause 6.4.2.3 or subclause 6.4.2.4.

[TS 24.301, clause 6.5.4.2]

In order to request the modification of bearer resources for one traffic flow aggregate, the UE shall send a BEARER RESOURCE MODIFICATION REQUEST message to the MME, start timer T3481 and enter the state PROCEDURE TRANSACTION PENDING (see example in figure 6.5.4.2.1).

[TS 24.301, clause 6.5.4.3]

Upon receipt of the BEARER RESOURCE MODIFICATION REQUEST message, the MME checks whether the resources requested by the UE can be established, modified or released by verifying the EPS bearer identity given in the EPS bearer identity for packet filter IE.

If the bearer resource modification requested is accepted by the network, the MME shall initiate either a dedicated EPS bearer context activation procedure, an EPS bearer context modification procedure or an EPS bearer context deactivation procedure.

...

Upon receipt of an ACTIVATE DEDICATED EPS BEARER CONTEXT REQUEST, MODIFY EPS BEARER CONTEXT REQUEST or DEACTIVATE EPS BEARER CONTEXT REQUEST message with a PTI which matches the value used for the BEARER RESOURCE MODIFICATION REQUEST message, the UE shall stop timer T3481 and enter the state PROCEDURE TRANSACTION INACTIVE. The UE should ensure that the procedure transaction identity (PTI) assigned to this procedure is not released immediately. The way to achieve this is implementation dependent. While the PTI value is not released, the UE regards any received ACTIVATE DEDICATED EPS BEARER CONTEXT REQUEST or MODIFY EPS BEARER CONTEXT REQUEST message with the same PTI value as a network retransmission (see subclause 7.3.1).

- i) If the ACTIVATE DEDICATED EPS BEARER CONTEXT REQUEST message is received, the UE shall verify that the EPS bearer identity given in the EPS bearer identity IE is not already used by any EPS bearer context. The UE shall then proceed as described in subclause 6.4.2.3 or subclause 6.4.2.4.

[TS 24.301, clause 8.3.8]

This IE shall be included in the message only if the UE wishes to transmit the maximum and guaranteed bit rate values to the network and at least one of the values to be transmitted exceeds the maximum value specified in the EPS quality of service information element in subclause 9.9.4.3.

[TS 24.301, clause 8.3.10]

This IE shall be included in the message only if the UE wishes to transmit the maximum and guaranteed bit rate values to the network and at least one of the values to be transmitted exceeds the maximum value specified in the EPS quality of service information element in subclause 9.9.4.3.

[TS 24.301, clause 9.9.4.30]

The purpose of the Extended quality of service information element is to indicate for an EPS bearer context the maximum bit rates for uplink and downlink and the guaranteed bit rates for uplink and downlink, if at least one of the bit rates has a value higher than 10 Gbps.

The Extended quality of service information element is coded as shown in figure 9.9.4.30.1 and table 9.9.4.30.1. For uplink and downlink, if the sending entity only has to indicate one bit rate (i.e., with a value higher than 10 Gbps), it shall encode the other bit rate (i.e., with a value smaller or equal to 10 Gbps) as "00000000". The receiving entity shall ignore a bit rate which is included in the extended quality of service information element and has a value smaller or equal to 10 Gbps.

The Extended quality of service is a type 4 information element with a length of 12 octets.



8	7	6	5	4	3	2	1	
Extended quality of service IEI								octet 1
Length of Extended quality of service contents								octet 2
Unit for maximum bit rate								octet 3
Maximum bit rate for uplink								octet 4
Maximum bit rate for uplink (continued)								octet 5
Maximum bit rate for downlink								octet 6
Maximum bit rate for downlink (continued)								octet 7
Unit for guaranteed bit rate								octet 8
Guaranteed bit rate for uplink								octet 9
Guaranteed bit rate for uplink (continued)								octet 10
Guaranteed bit rate for downlink								octet 11
Guaranteed bit rate for downlink (continued)								octet 12

**Figure 9.9.4.30.1: Extended quality of service information element**

**Table 9.9.4.30.1: Extended quality of service information element**

Unit for maximum bit rate (octet 3)	
0 0 0 0 0 0 0 0	value is not used
0 0 0 0 0 0 0 1	value is incremented in multiples of 200 kbps
0 0 0 0 0 0 1 0	value is incremented in multiples of 1 Mbps
0 0 0 0 0 0 1 1	value is incremented in multiples of 4 Mbps
0 0 0 0 0 1 0 0	value is incremented in multiples of 16 Mbps
0 0 0 0 0 1 0 1	value is incremented in multiples of 64 Mbps
0 0 0 0 0 1 1 0	value is incremented in multiples of 256 Mbps
0 0 0 0 0 1 1 1	value is incremented in multiples of 1 Gbps
0 0 0 0 1 0 0 0	value is incremented in multiples of 4 Gbps
0 0 0 0 1 0 0 1	value is incremented in multiples of 16 Gbps
0 0 0 0 1 0 1 0	value is incremented in multiples of 64 Gbps
0 0 0 0 1 0 1 1	value is incremented in multiples of 256 Gbps
0 0 0 0 1 1 0 0	value is incremented in multiples of 1 Tbps
0 0 0 0 1 1 0 1	value is incremented in multiples of 4 Tbps
0 0 0 0 1 1 1 0	value is incremented in multiples of 16 Tbps
0 0 0 0 1 1 1 1	value is incremented in multiples of 64 Tbps
0 0 0 1 0 0 0 0	value is incremented in multiples of 256 Tbps
0 0 0 1 0 0 0 1	value is incremented in multiples of 1 Pbps
0 0 0 1 0 0 1 0	value is incremented in multiples of 4 Pbps
0 0 0 1 0 0 1 1	value is incremented in multiples of 16 Pbps
0 0 0 1 0 1 0 0	value is incremented in multiples of 64 Pbps
0 0 0 1 0 1 0 1	value is incremented in multiples of 256 Pbps
Other values shall be interpreted as multiples of 256 Pbps in this version of the protocol.	
Maximum bit rate for uplink (octets 4 and 5)	
Octets 4 and 5 represent the binary coded value of maximum bit rate for uplink in units defined by octet 3.	
Maximum bit rate for downlink (octets 6 and 7)	
Octets 6 and 7 represent the binary coded value of maximum bit rate for downlink in units defined by octet 3.	
Unit for guaranteed bit rate (octet 8)	
The coding is identical to that of the unit for maximum bit rate (octet 3).	
Guaranteed bit rate for uplink (octets 9 and 10)	
Octets 9 and 10 represent the binary coded value of guaranteed bit rate for uplink in units defined by octet 8.	
Guaranteed bit rate for downlink (octets 11 and 12)	
Octets 11 and 12 represent the binary coded value of guaranteed bit rate for downlink in units defined by octet 8.	

10.2.2.1.3 Test description

10.2.2.1.3.1 Pre-test conditions

System Simulator:

- E-UTRA Cell 1 and NR Cell 1.

UE:

- None.

Preamble:

- The UE is in state RRC\_IDLE using generic procedure parameter Connectivity (*EN-DC*) according to [4].

#### 10.2.2.1.3.2 Test procedure sequence

**Table 10.2.2.1.3.2-1: Main behaviour**

St	Procedure	Message Sequence		TP	Verdict
		U - S	Message		
1	Cause the UE to request bearer resource allocation of dedicated EPS bearer associated with non-IMS PDN connectivity if pc_MULTI_PDN=TRUE else first PDN connectivity. (Note 1).	-	-	-	-
2	The UE transmits a SERVICE REQUEST message.	-->	SERVICE REQUEST	-	-
3	The SS establishes SRB2 and the MCG DRBs associated with the default EPS bearer context activated during the preamble.	-	-	-	-
4	Check: Does the UE transmit a BEARER RESOURCE ALLOCATION REQUEST message?	-->	BEARER RESOURCE ALLOCATION REQUEST	1	P
5	The SS transmits an ACTIVATE DEDICATED EPS BEARER CONTEXT REQUEST message and establishes a RLC-AM SCG DRB bearer using MCG_and_SCG condition.	<--	ACTIVATE DEDICATED EPS BEARER CONTEXT REQUEST	-	-
6	Check: Does the UE transmit an ACTIVATE DEDICATED EPS BEARER CONTEXT ACCEPT message?	-->	ACTIVATE DEDICATED EPS BEARER CONTEXT ACCEPT	2	P
7	Cause the UE to request bearer resource modification of dedicated EPS bearer associated with non-IMS PDN connectivity if pc_MULTI_PDN=TRUE else first PDN connectivity. (Note 2).	-	-	-	-
8	Check: Does the UE transmit a BEARER RESOURCE MODIFICATION REQUEST message?	-->	BEARER RESOURCE MODIFICATION REQUEST	3	P
9	The SS transmits an ACTIVATE DEDICATED EPS BEARER CONTEXT REQUEST message.	<--	MODIFY EPS BEARER CONTEXT REQUEST	-	-
10	Check: Does the UE transmit an ACTIVATE DEDICATED EPS BEARER CONTEXT ACCEPT message?	-->	MODIFY EPS BEARER CONTEXT ACCEPT	4	P
Note 1: The request is assumed to be triggered by AT command +CGDSCONT, and +CGACT (activated).					
Note 2: The request is assumed to be triggered by AT command +CGCMOD.					

## 10.2.2.1.3.3 Specific message contents

**Table 10.2.2.1.3.3-1: Message BEARER RESOURCE ALLOCATION REQUEST (step 4, Table 10.2.2.1.3.2-1)**

Derivation path: TS 36.508 [7], Table 4.7.3-6B			
Information Element	Value/Remark	Comment	Condition
Linked EPS bearer identity	12		
EPS QoS			
QCI	8		
Maximum bit rate for uplink	384 kbps		
Maximum bit rate for downlink	'11111110'B (8640 kbps)		
Guaranteed bit rate for uplink	128 kbps		
Guaranteed bit rate for downlink	128 kbps		
Maximum bit rate for uplink (extended)	0		
Maximum bit rate for downlink (extended)	'11111010'B (256 Mbps)		
Guaranteed bit rate for uplink (extended)	0		
Guaranteed bit rate for downlink (extended)	0		
Maximum bit rate for uplink (extended-2)	0		
Maximum bit rate for downlink (extended-2)	'11110110'B (10 Gbps)		
Guaranteed bit rate for uplink (extended-2)	0		
Guaranteed bit rate for downlink (extended-2)	0		
Extended EPS QoS			
Unit for maximum bit rate	'00000111' (value is incremented in multiples of 1 Gbps)		
Maximum bit rate for uplink	'00000000'B		
Maximum bit rate for downlink	'0000000000001100' B (12 Gbps)		
Unit for guaranteed bit rate	'00000000'B		
Guaranteed bit rate for uplink	'00000000'B		
Guaranteed bit rate for downlink	'00000000'B		

**Table 10.2.2.1.3.3-2: Message ACTIVATE DEDICATED EPS BEARER CONTEXT REQUEST (step 5, Table 10.2.2.1.3.2-1)**

Derivation path: TS 38.508-1 [4], Table 4.5.4.3-1 , condition UE-INITIATED			
Information Element	Value/Remark	Comment	Condition
EPS bearer identity	6		
EPS QoS			
QCI	8		
Maximum bit rate for uplink	384 kbps		
Maximum bit rate for downlink	'11111110'B (8640 kbps)		
Guaranteed bit rate for uplink	128 kbps		
Guaranteed bit rate for downlink	128 kbps		
Maximum bit rate for uplink (extended)	0		
Maximum bit rate for downlink (extended)	'11111010'B (256 Mbps)		
Guaranteed bit rate for uplink (extended)	0		
Guaranteed bit rate for downlink (extended)	0		
Maximum bit rate for uplink (extended-2)	0		
Maximum bit rate for downlink (extended-2)	'11110110'B (10 Gbps)		
Guaranteed bit rate for uplink (extended-2)	0		
Guaranteed bit rate for downlink (extended-2)	0		
Extended EPS QoS			
Unit for maximum bit rate	'00000111' (value is incremented in multiples of 1 Gbps)		
Maximum bit rate for uplink	'00000000'B		
Maximum bit rate for downlink	'0000000000001100' B (12 Gbps)		
Unit for guaranteed bit rate	'00000000'B		
Guaranteed bit rate for uplink	'00000000'B		
Guaranteed bit rate for downlink	'00000000'B		

**Table 10.2.2.1.3.3-3: Message BEARER RESOURCE MODIFICATION REQUEST (step 8, Table 10.2.2.1.3.2-1)**

Derivation path: TS 36.508 [7], Table 4.7.3-8			
Information Element	Value/Remark	Comment	Condition
EPS bearer identity for packet filter	6		
Required traffic flow QoS			
QCI	8		
Maximum bit rate for uplink	384 kbps		
Maximum bit rate for downlink	'11111110'B (8640 kbps)		
Guaranteed bit rate for uplink	128 kbps		
Guaranteed bit rate for downlink	128 kbps		
Maximum bit rate for uplink (extended)	0		
Maximum bit rate for downlink (extended)	'11111010'B (256 Mbps)		
Guaranteed bit rate for uplink (extended)	0		
Guaranteed bit rate for downlink (extended)	0		
Maximum bit rate for uplink (extended-2)	0		
Maximum bit rate for downlink (extended-2)	'11110110'B (10 Gbps)		
Guaranteed bit rate for uplink (extended-2)	0		
Guaranteed bit rate for downlink (extended-2)	0		
Extended EPS QoS			
Unit for maximum bit rate	'0000111' (value is incremented in multiples of 1 Gbps)		
Maximum bit rate for uplink	'00000000'B		
Maximum bit rate for downlink	'000000000010000'B (16 Gbps)		
Unit for guaranteed bit rate	'00000000'B		
Guaranteed bit rate for uplink	'00000000'B		
Guaranteed bit rate for downlink	'00000000'B		

**Table 10.2.2.1.3.3-4: Message MODIFY EPS BEARER CONTEXT REQUEST (step 7, Table 10.2.2.1.3.2-1)**

Derivation path: TS 36.508 [7], Table 4.7.3-18, condition UE-INITIATED			
Information Element	Value/Remark	Comment	Condition
EPS bearer identity	6		
Linked EPS bearer identity	12		
New EPS QoS			
QCI	8		
Maximum bit rate for uplink	384 kbps		
Maximum bit rate for downlink	'11111110'B (8640 kbps)		
Guaranteed bit rate for uplink	128 kbps		
Guaranteed bit rate for downlink	128 kbps		
Maximum bit rate for uplink (extended)	0		
Maximum bit rate for downlink (extended)	'11111010'B (256 Mbps)		
Guaranteed bit rate for uplink (extended)	0		
Guaranteed bit rate for downlink (extended)	0		
Maximum bit rate for uplink (extended-2)	0		
Maximum bit rate for downlink (extended-2)	'11110110'B (10 Gbps)		
Guaranteed bit rate for uplink (extended-2)	0		
Guaranteed bit rate for downlink (extended-2)	0		
APN-AMBR			
APN-AMBR for downlink	'11111110'B (8640 kbps)		
APN-AMBR for uplink	'11111110'B (8640 kbps)		
APN-AMBR for downlink (extended)	'11111010' B(256 Mbps)		
APN-AMBR for uplink (extended)	'11111010' B(256 Mbps)		
APN-AMBR for downlink (extended-2)	'11111110'B (65280 Mbps)		
APN-AMBR for uplink (extended-2)	0		
Extended APN-AMBR			
Unit for extended APN-AMBR for downlink	'00000111'B (value is incremented in multiples of 1 Gbps)		
Extended APN-AMBR for downlink	'0000000010000000' (128 Gbps)		
Unit for extended APN-AMBR for uplink	0		
Extended APN-AMBR for uplink	0		
Extended EPS QoS			
Unit for maximum bit rate	'00000111' (value is incremented in multiples of 1 Gbps)		
Maximum bit rate for uplink	'00000000'B		
Maximum bit rate for downlink	'000000000010000' B (16 Gbps)		
Unit for guaranteed bit rate	'00000000'B		
Guaranteed bit rate for uplink	'00000000'B		
Guaranteed bit rate for downlink	'00000000'B		

## Annex A (informative): Change history

Change history							
Date	Meeting	TDoc	CR	Rev	Cat	Subject/Comment	New version
2017-08	RAN5#76	R5-174427	-	-	-	Introduction of TS 38.523-1.	0.0.1
2017-12	RAN5#77	R5-176926	-	-	-	Addition of new NR PDCP test case 7.3.1.2	0.1.0
2017-12	RAN5#77	R5-176928	-	-	-	Addition of new NR MAC test case 7.1.3.1	0.1.0
2017-12	RAN5#77	R5-177072	-	-	-	Addition of new NR RLC UM test case 7.2.2.1	0.1.0
2017-12	RAN5#77	R5-177073	-	-	-	Addition of new NR RLC UM test case 7.2.2.2	0.1.0
2017-12	RAN5#77	R5-177074	-	-	-	Addition of new NR PDCP test case 7.3.1.1	0.1.0
2017-12	RAN5#77	R5-177075	-	-	-	Addition of new NR MAC test case 7.1.2.1	0.1.0
2018-03	RAN5#77	R5-181171	-	-	-	5GS RRC TC 8.2.2.2.1	0.2.0
2018-03	RAN5#77	R5-181172	-	-	-	5GS RRC TC 8.2.2.2.6	0.2.0
2018-03	RAN5#77	R5-181173	-	-	-	5GS RRC TC 8.2.3.1	0.2.0
2018-03	RAN5#77	R5-181174	-	-	-	5GS RRC TC 8.2.3.16	0.2.0
2018-03	RAN5#77	R5-181175	-	-	-	5GS RRC TC 8.2.5.1	0.2.0
2018-03	RAN5#77	R5-181176	-	-	-	5GS MAC Test case 7.1.1.2	0.2.0
2018-03	RAN5#77	R5-181177	-	-	-	Addition of new NR MAC test case 7.1.3.2	0.2.0
2018-03	RAN5#77	R5-181178	-	-	-	Addition of new NR MAC test case 7.1.3.3	0.2.0
2018-03	RAN5#77	R5-181179	-	-	-	Addition of new NR MAC test case 7.1.3.4	0.2.0
2018-03	RAN5#77	R5-181180	-	-	-	Addition of new NR MAC test case 7.1.3.5	0.2.0
2018-03	RAN5#77	R5-181181	-	-	-	Addition of new NR MAC test case 7.1.3.6	0.2.0
2018-03	RAN5#77	R5-181182	-	-	-	Addition of new NR RLC test case 7.2.3.1	0.2.0
2018-03	RAN5#77	R5-181183	-	-	-	Addition of new NR RLC test case 7.2.3.2	0.2.0
2018-03	RAN5#77	R5-181184	-	-	-	Addition of new NR PDCP test case 7.3.2.1	0.2.0
2018-03	RAN5#77	R5-181185	-	-	-	Addition of new NR PDCP test case 7.3.2.2	0.2.0
2018-03	RAN5#77	R5-181186	-	-	-	Addition of new NR PDCP test case 7.3.2.3	0.2.0
2018-03	RAN5#77	R5-181187	-	-	-	Addition of new NR PDCP test case 7.3.3.1	0.2.0
2018-03	RAN5#77	R5-181188	-	-	-	Addition of new NR PDCP test case 7.3.3.2	0.2.0
2018-03	RAN5#77	R5-181189	-	-	-	Addition of new NR PDCP test case 7.3.3.3	0.2.0
2018-03	RAN5#77	R5-181201	-	-	-	Addition of new NR MAC test case 7.1.5.1	0.2.0
2018-03	RAN5#77	R5-181202	-	-	-	Addition of new NR MAC test case 7.1.5.2	0.2.0
2018-03	RAN5#77	R5-181203	-	-	-	Addition of new NR PDCP test case 7.3.5.1	0.2.0
2018-03	RAN5#77	R5-181204	-	-	-	Addition of new NR RRC test case 8.2.2.2.5	0.2.0
2018-03	RAN5#77	R5-181205	-	-	-	Addition of new NR RRC test case 8.2.3.5	0.2.0
2018-03	RAN5#77	R5-181206	-	-	-	Update of NR MAC test cases	0.2.0
2018-03	RAN5#77	R5-181207	-	-	-	Update of NR RLC test cases	0.2.0
2018-03	RAN5#77	R5-181208	-	-	-	Update of NR PDCP test cases	0.2.0
2018-03	RAN5#77	R5-181209	-	-	-	5GS MAC Test case 7.1.5.3	0.2.0
2018-03	RAN5#77	R5-181312	-	-	-	Addition of new NR PDCP test case 7.3.5.2	0.2.0
2018-03	RAN5#77	R5-181334	-	-	-	Addition of new NR PDCP test case 7.3.4.2	0.2.0
2018-04	RAN5#2-5G-NR Adhoc	R5-181805	-	-	-	Corrections to RRC TC 8.2.3.1 Measurement configuration control and reporting / Inter-RAT measurements / Event B1 / Measurement of NR cells	0.3.0
2018-04	RAN5#2-5G-NR Adhoc	R5-181806	-	-	-	5GS RRC TC 8.2.1.2	0.3.0
2018-04	RAN5#2-5G-NR Adhoc	R5-181914	-	-	-	Addition of 5GS NR RRC test case 8.2.3.6	0.3.0
2018-04	RAN5#2-5G-NR Adhoc	R5-181951	-	-	-	Correction to RLC UM Test cases	0.3.0
2018-04	RAN5#2-5G-NR Adhoc	R5-181952	-	-	-	Correction to RLC AM Test cases	0.3.0
2018-04	RAN5#2-5G-NR Adhoc	R5-181967	-	-	-	Correction to PDCP ciphering test cases	0.3.0
2018-04	RAN5#2-5G-NR Adhoc	R5-181980	-	-	-	5GS RRC TC 8.2.2.2.9	0.3.0
2018-04	RAN5#2-5G-NR Adhoc	R5-181981	-	-	-	Corrections to RRC TC 8.2.3.16 Handover with PSCell release / SCG DRB	0.3.0
2018-04	RAN5#2-5G-NR Adhoc	R5-181982	-	-	-	5GS RRC TC 8.2.3.2	0.3.0
2018-04	RAN5#2-5G-NR Adhoc	R5-181983	-	-	-	5GS RRC TC 8.2.3.3	0.3.0
2018-04	RAN5#2-5G-NR Adhoc	R5-181984	-	-	-	5GS RRC TC 8.2.3.4	0.3.0



2018-04	RAN5#2-5G-NR Adhoc	R5-181986	-	-	-	Addition of new NR RRC test case 8.2.2.2.4	0.3.0
2018-04	RAN5#2-5G-NR Adhoc	R5-181988	-	-	-	Addition of new NR NAS test case for dedicated EPS bearer context activation	0.3.0
2018-04	RAN5#2-5G-NR Adhoc	R5-181991	-	-	-	Addition of text to clarify that 5GS requirements may be implicitly tested in other specs	0.3.0
2018-04	RAN5#2-5G-NR Adhoc	R5-181992	-	-	-	New NAS test case EPS bearer resource allocation / New EPS bearer context	0.3.0
2018-04	RAN5#2-5G-NR Adhoc	R5-181994	-	-	-	Addition of new NR MAC test case 7.1.4.1.1	0.3.0
2018-04	RAN5#2-5G-NR Adhoc	R5-181995	-	-	-	Addition of new NR MAC test case 7.1.4.1.2	0.3.0
2018-04	RAN5#2-5G-NR Adhoc	R5-181996	-	-	-	Addition of new NR MAC test case 7.1.4.1.3	0.3.0
2018-04	RAN5#2-5G-NR Adhoc	R5-181997	-	-	-	Addition of new NR MAC test case 7.1.4.1.4	0.3.0
2018-04	RAN5#2-5G-NR Adhoc	R5-181998	-	-	-	Addition of new NR RLC test case 7.2.2.6	0.3.0
2018-04	RAN5#2-5G-NR Adhoc	R5-181999	-	-	-	Addition of new NR RLC test case 7.2.3.5	0.3.0
2018-04	RAN5#2-5G-NR Adhoc	R5-182050	-	-	-	Addition of new NR RLC test case 7.2.2.5	0.3.0
2018-04	RAN5#2-5G-NR Adhoc	R5-182051	-	-	-	Addition of new NR RLC test case 7.2.3.6	0.3.0
2018-04	RAN5#2-5G-NR Adhoc	R5-182052	-	-	-	Addition of new NR RLC test case 7.2.3.7	0.3.0
2018-04	RAN5#2-5G-NR Adhoc	R5-182053	-	-	-	Addition of new NR RLC test case 7.2.3.8	0.3.0
2018-04	RAN5#2-5G-NR Adhoc	R5-182054	-	-	-	Addition of new NR RLC test case 7.2.3.3	0.3.0
2018-04	RAN5#2-5G-NR Adhoc	R5-182055	-	-	-	Addition of new NR RLC test case 7.2.3.4	0.3.0
2018-04	RAN5#2-5G-NR Adhoc	R5-182056	-	-	-	Addition of new NR RRC test case 8.2.3.9	0.3.0
2018-04	RAN5#2-5G-NR Adhoc	R5-182057	-	-	-	Addition of new NR RRC test case 8.2.3.10	0.3.0
2018-04	RAN5#2-5G-NR Adhoc	R5-182058	-	-	-	Addition of new NR RRC test case 8.2.3.11	0.3.0
2018-04	RAN5#2-5G-NR Adhoc	R5-182059	-	-	-	Addition of new NR RRC test case 8.2.3.12	0.3.0
2018-04	RAN5#2-5G-NR Adhoc	R5-182060	-	-	-	Correction to MAC test case 7.1.2.1	0.3.0
2018-04	RAN5#2-5G-NR Adhoc	R5-182061	-	-	-	Addition of new NR RRC test case 8.2.3.19	0.3.0
2018-04	RAN5#2-5G-NR Adhoc	R5-182076	-	-	-	5GS PDCP Test case 7.3.4.1	0.3.0
2018-04	RAN5#2-5G-NR Adhoc	R5-182077	-	-	-	5GS PDCP Test case 7.3.5.4	0.3.0
2018-04	RAN5#2-5G-NR Adhoc	R5-182078	-	-	-	5GS RLC test case 7.2.3.11	0.3.0

2018-04	RAN5#2-5G-NR Adhoc	R5-182079	-	-	-	5GS RLC test case 7.2.3.12	0.3.0
2018-04	RAN5#2-5G-NR Adhoc	R5-182080	-	-	-	Addition of new NR RRC test case 8.2.3.7	0.3.0
2018-04	RAN5#2-5G-NR Adhoc	R5-182081	-	-	-	Addition of new NR RLC test case 7.2.2.3	0.3.0
2018-04	RAN5#2-5G-NR Adhoc	R5-182082	-	-	-	Addition of new NR RLC test case 7.2.2.4	0.3.0
2018-04	RAN5#2-5G-NR Adhoc	R5-182083	-	-	-	Addition of new NR RRC test case 8.2.3.17	0.3.0
2018-04	RAN5#2-5G-NR Adhoc	R5-182085	-	-	-	Correction to PDCP integrity protection test cases	0.3.0
2018-04	RAN5#2-5G-NR Adhoc	R5-182089	-	-	-	5GS RRC TC 8.2.5.5	0.3.0
2018-04	RAN5#2-5G-NR Adhoc	R5-182100	-	-	-	5GS RRC TC 8.2.5.6	0.3.0
2018-04	RAN5#2-5G-NR Adhoc	R5-182101	-	-	-	5GS RRC TC 8.2.5.7	0.3.0
2018-04	RAN5#2-5G-NR Adhoc	R5-182102	-	-	-	5GS RRC TC 8.2.2.2.7	0.3.0
2018-04	RAN5#2-5G-NR Adhoc	R5-182103	-	-	-	Corrections to RRC TC 8.2.5.1 RRC connection reconfiguration / PSCell addition failure	0.3.0
2018-04	RAN5#2-5G-NR Adhoc	R5-182104	-	-	-	Corrections to RRC TC 8.2.2.2.1 PSCell addition, modification and release / SCG DRB	0.3.0
2018-04	RAN5#2-5G-NR Adhoc	R5-182105	-	-	-	Corrections to RRC TC 8.2.2.2.6 Bearer Modification / SCG DRB / Split DRB Reconfiguration	0.3.0
2018-04	RAN5#2-5G-NR Adhoc	R5-182106	-	-	-	Addition of new NR RRC test case 8.2.2.1.2	0.3.0
2018-04	RAN5#2-5G-NR Adhoc	R5-182115	-	-	-	Introduction of 5GS RRC TC 8.2.4.3.1	0.3.0
2018-04	RAN5#2-5G-NR Adhoc	R5-182116	-	-	-	Adding NR test case 8.2.2.1.1	0.3.0
2018-04	RAN5#2-5G-NR Adhoc	R5-182117	-	-	-	Adding NR test case 8.2.2.1.3	0.3.0
2018-04	post RAN5#2-5G-NR Adhoc	-	-	-	-	Editorial update to apply with the 3GPP drafting rules (styles)	0.3.1
2018-05	RAN5#79	<a href="#">R5-183094</a>	-	-	-	Addition of UE power headroom reporting test case 7.1.1.3.7	1.0.0
2018-05	RAN5#79	<a href="#">R5-183101</a>	-	-	-	Addition of DRX Operation test case 7.1.1.5.4	1.0.0
2018-05	RAN5#79	<a href="#">R5-183102</a>	-	-	-	Addition of Correct handling of DL assignment/Semi-persistent test case 7.1.1.6.1	1.0.0
2018-05	RAN5#79	<a href="#">R5-183103</a>	-	-	-	Addition of AM RLC test case 7.1.2.3.10	1.0.0
2018-05	RAN5#79	<a href="#">R5-183227</a>	-	-	-	Editorial updates to 38.523-1	1.0.0
2018-05	RAN5#79	<a href="#">R5-183229</a>	-	-	-	Correction to PDCP Test case - PDCP reordering/Maximum re-ordering delay below t-Reordering/ t-Reordering timer operations	1.0.0
2018-05	RAN5#79	<a href="#">R5-183109</a>	-	-	-	Update to MAC Test case - Random access procedure / Successful/ C-RNTI Based/Preamble selected by MAC itself	1.0.0
2018-05	RAN5#79	R5-183111	-	-	-	Update RLC test case - AM RLC / Re-transmission of RLC PDU with and without re-segmentation	1.0.0
2018-05	RAN5#79	R5-183112	-	-	-	Correction to MAC Test case - DRX operation / Short cycle configured / Parameters configured by RRC	1.0.0
2018-05	RAN5#79	R5-183113	-	-	-	Correction to PDCP Test case - PDCP handover / Lossless handover / PDCP sequence number maintenance/PDCP status report to convey the information on missing or acknowledged PDCP SDUs at handover/ In-order delivery and duplicate elimination in the downlink	1.0.0
2018-05	RAN5#79	R5-182497	-	-	-	Corrections to RRC TC - BandwidthPart Configuration / SCG	1.0.0

2018-05	RAN5#79	R5-183230	-	-	-	Corrections to RRC TC - PSCell addition, modification and release / SCG DRB	1.0.0
2018-05	RAN5#79	<a href="#">R5-183114</a>	-	-	-	Corrections to RRC TC - Bearer Modification / Handling for bearer type change with security key change	1.0.0
2018-05	RAN5#79	<a href="#">R5-183115</a>	-	-	-	Corrections to RRC TC - Bearer Modification / Uplink data path / Split DRB Reconfiguration	1.0.0
2018-05	RAN5#79	<a href="#">R5-183117</a>	-	-	-	Corrections to RRC TC - Measurement configuration control and reporting / Inter-RAT measurements / Event B1 / Measurement of NR cells	1.0.0
2018-05	RAN5#79	<a href="#">R5-183116</a>	-	-	-	Corrections to RRC TC - RRC connection reconfiguration / PSCell addition failure	1.0.0
2018-05	RAN5#79	<a href="#">R5-183231</a>	-	-	-	Corrections to RRC TC - NR SCG Failure Information / RLC-MaxNumRetx	1.0.0
2018-05	RAN5#79	<a href="#">R5-183118</a>	-	-	-	Corrections to RRC TC - SCG Reconfiguration Failure / SRB3	1.0.0
2018-05	RAN5#79	<a href="#">R5-183119</a>	-	-	-	Corrections to RRC TC - SCG Reconfiguration Failure / SRB1	1.0.0
2018-05	RAN5#79	<a href="#">R5-182508</a>	-	-	-	Void RRC TC - Handover with PSCell release / SCG DRB	1.0.0
2018-05	RAN5#79	<a href="#">R5-182509</a>	-	-	-	Void RRC TC - Bearer Modification / SCG DRB / Split DRB Reconfiguration	1.0.0
2018-05	RAN5#79	<a href="#">R5-183120</a>	-	-	-	Correction to NR RRC test case 8.2.3.17	1.0.0
2018-05	RAN5#79	<a href="#">R5-183121</a>	-	-	-	Correction to NR RRC test case 8.2.3.19	1.0.0
2018-05	RAN5#79	<a href="#">R5-183228</a>	-	-	-	Correction to NR MAC test case 7.1.1.3.2	1.0.0
2018-05	RAN5#79	<a href="#">R5-183122</a>	-	-	-	Correction to NR PDCP test case 7.1.3.4.2	1.0.0
2018-05	RAN5#79	<a href="#">R5-183123</a>	-	-	-	Addition of new NR RRC test case 8.2.5.2.1	1.0.0
2018-05	RAN5#79	<a href="#">R5-183124</a>	-	-	-	Addition of new NR RRC test case 8.2.5.4.1	1.0.0
2018-05	RAN5#79	<a href="#">R5-182601</a>	-	-	-	Removal of NR RRC test case 8.2.2.5	1.0.0
2018-05	RAN5#79	<a href="#">R5-183126</a>	-	-	-	Addition of new 5GS RRC TC 8.2.4.3.1.1	1.0.0
2018-05	RAN5#79	<a href="#">R5-183127</a>	-	-	-	Addition of new NR RRC test case - Bearer Modification / Handling for bearer type change without security key change / EN-DC	1.0.0
2018-05	RAN5#79	<a href="#">R5-182652</a>	-	-	-	Void RRC TC - Bearer Modification / MCG DRB / SCG DRB Reconfiguration	1.0.0
2018-05	RAN5#79	<a href="#">R5-182774</a>	-	-	-	Addition of 5GS NR RRC test case 8.2.3.8.1	1.0.0
2018-05	RAN5#79	<a href="#">R5-183130</a>	-	-	-	Removal of RRC TC 8.2.4.3.1	1.0.0
2018-05	RAN5#79	<a href="#">R5-182798</a>	-	-	-	Update of 5GS NR RRC test case 8.2.3.6	1.0.0
2018-05	RAN5#79	<a href="#">R5-183232</a>	-	-	-	Addition of 5GS NR RRC test case 8.2.2.6.1	1.0.0
2018-05	RAN5#79	<a href="#">R5-183233</a>	-	-	-	Addition of 5GS NR PDCP test case 7.1.3.5.3	1.0.0
2018-05	RAN5#79	<a href="#">R5-183132</a>	-	-	-	Update of NR RRC TC - Measurement configuration control and reporting / Inter-RAT measurements / Event B1 / Measurement of NR cells / RSRQ based measurements	1.0.0
2018-05	RAN5#79	<a href="#">R5-183133</a>	-	-	-	Update of NR RRC TC - Measurement configuration control and reporting / Inter-RAT measurements / Periodic reporting / Measurement of NR cells	1.0.0
2018-05	RAN5#79	<a href="#">R5-183134</a>	-	-	-	Update of NR RRC TC - Measurement configuration control and reporting / Event A1 / Measurement of NR PSCell	1.0.0
2018-05	RAN5#79	<a href="#">R5-183135</a>	-	-	-	Addition of NR RRC TC - PSCell addition, modification and release / Split DRB / EN-DC	1.0.0
2018-05	RAN5#79	<a href="#">R5-183137</a>	-	-	-	Addition of 5GS NR RRC test case 8.2.1.1.1	1.0.0
2018-05	RAN5#79	<a href="#">R5-183138</a>	-	-	-	Addition of new NR MAC UL TBS test case 7.1.1.4.2.1	1.0.0
2018-05	RAN5#79	<a href="#">R5-183139</a>	-	-	-	Addition of new NR MAC UL TBS test case 7.1.1.4.2.2	1.0.0
2018-05	RAN5#79	<a href="#">R5-183140</a>	-	-	-	Addition of new NR MAC UL TBS test case 7.1.1.4.2.3	1.0.0
2018-05	RAN5#79	<a href="#">R5-183141</a>	-	-	-	Addition of new NR MAC UL TBS test case 7.1.1.4.2.4	1.0.0
2018-05	RAN5#79	<a href="#">R5-183142</a>	-	-	-	Addition of Layer 2 test case specific parameters	1.0.0
2018-05	RAN5#79	<a href="#">R5-183143</a>	-	-	-	Correction to MAC Pre-test conditions	1.0.0
2018-05	RAN5#79	<a href="#">R5-183144</a>	-	-	-	Correction to RLC Pre-test conditions	1.0.0
2018-05	RAN5#79	<a href="#">R5-183145</a>	-	-	-	Correction to PDCP Pre-test conditions	1.0.0
2018-05	RAN5#79	<a href="#">R5-183146</a>	-	-	-	Correction to MAC RACH Test Cases	1.0.0
2018-05	RAN5#79	<a href="#">R5-182940</a>	-	-	-	Correction to MAC DL Data Transfer test cases	1.0.0
2018-05	RAN5#79	<a href="#">R5-183147</a>	-	-	-	Correction to MAC UL Data Transfer test cases	1.0.0
2018-05	RAN5#79	<a href="#">R5-183148</a>	-	-	-	Correction to MAC DL-SCH TBS test cases	1.0.0
2018-05	RAN5#79	<a href="#">R5-183149</a>	-	-	-	Correction to RLC UM Test cases	1.0.0
2018-05	RAN5#79	<a href="#">R5-183150</a>	-	-	-	Correction to RLC AM Test cases	1.0.0
2018-05	RAN5#79	<a href="#">R5-182945</a>	-	-	-	Corrections to PDCP sequence number test cases	1.0.0
2018-05	RAN5#79	<a href="#">R5-183151</a>	-	-	-	Correction to PDCP integrity protection test cases	1.0.0
2018-05	RAN5#79	<a href="#">R5-182947</a>	-	-	-	Correction to PDCP Ciphering test cases	1.0.0
2018-05	RAN5#79	<a href="#">R5-183152</a>	-	-	-	Corrections to PDCP other test cases	1.0.0
2018-05	RAN5#79	<a href="#">R5-183153</a>	-	-	-	Addition of new NR RACH test case 7.1.1.1.1	1.0.0
2018-05	RAN5#79	<a href="#">R5-182966</a>	-	-	-	Correction to NR RLC test case 7.1.2.3.4	1.0.0
2018-05	RAN5#79	<a href="#">R5-183154</a>	-	-	-	Correction to PDCP test case 7.1.3.5.2	1.0.0
2018-05	RAN5#79	<a href="#">R5-183155</a>	-	-	-	Correction to NR MAC DRX Test cases	1.0.0
2018-05	RAN5#79	<a href="#">R5-183156</a>	-	-	-	Correction to NR RRC intra frequency measurement Test case 8.2.3.9	1.0.0
2018-05	RAN5#79	<a href="#">R5-183157</a>	-	-	-	Correction to NR RRC inter frequency measurement Test case 8.2.3.10	1.0.0
2018-05	RAN5#79	<a href="#">R5-183016</a>	-	-	-	Removal of NR RRC test case 8.2.3.11	1.0.0

2018-05	RAN#79	<a href="#">R5-183017</a>	-	-	-	Removal of NR RRC test case 8.2.3.12	1.0.0
2018-05	RAN#79	<a href="#">R5-183129</a>	-	-	-	Addition of new 5GS RRC TC 8.2.3.13.1	1.0.0
2018-05	RAN#79	<a href="#">R5-183136</a>	-	-	-	Correction to NR RRC test case 8.2.3.5	1.0.0
2018-05	RAN#79	<a href="#">R5-183263</a>	-	-	-	Addition of new NR NAS test case Default EPS bearer context activation	1.0.0
2018-05	RAN#79	<a href="#">R5-183265</a>	-	-	-	Updates to session management TC 10.2.2.1	1.0.0
2018-06	RAN#80	RP-181210	-	-	-	put under revision control as v15.0.0 with small editorial changes	15.0.0
2018-09	RAN#81	R5-184226	001	-	F	Addition of Correct handling of Configured UL grant Type 1 test case 7.1.1.6.2	15.1.0
2018-09	RAN#81	R5-184227	001	-	F	Addition of Correct handling of Configured UL grant Type 2 test case 7.1.1.6.3	15.1.0
2018-09	RAN#81	R5-184228	001	-	F	CR of Correct handling of DL assignment Semi persistent test case 7.1.1.6.1	15.1.0
2018-09	RAN#81	R5-184229	001	-	F	CR of UE power headroom reporting test case 7.1.1.3.7	15.1.0
2018-09	RAN#81	R5-184343	002	-	F	Correction to 5GS PDCP Test case 7.1.3.4.1 PDCP handover / Lossless handover / PDCP sequence number maintenance / PDCP status report to convey the information on missing or acknowledged PDCP SDUs at handover / In-order delivery and duplicate elimination in the downlink	15.1.0
2018-09	RAN#81	R5-184344	002	-	F	Correction to 5GS PDCP Test case 7.1.3.5.4 PDCP reordering / Maximum re-ordering delay below t-Reordering / t-Reordering timer operations	15.1.0
2018-09	RAN#81	R5-184353	002	-	F	Corrections to RRC TC - BandwidthPart Configuration / SCG / EN-DC	15.1.0
2018-09	RAN#81	R5-184500	003	-	F	Addition of new 5GS RRC TC 8.2.4.3.1.3	15.1.0
2018-09	RAN#81	R5-184517	003	-	F	Correction to NR PDCP test case 7.1.3.4.2	15.1.0
2018-09	RAN#81	R5-184523	003	-	F	Corrections to MAC TBS test cases	15.1.0
2018-09	RAN#81	R5-184527	004	-	F	Addition of new MAC test case for Reset	15.1.0
2018-09	RAN#81	R5-184680	005	-	F	Update of RRC SCG failure TC 8.2.5.5.1	15.1.0
2018-09	RAN#81	R5-184681	005	-	F	Update of RRC SCG failure TC 8.2.5.6.1	15.1.0
2018-09	RAN#81	R5-184760	005	-	F	Correction to RRC TC - PSCell addition, modification and release / Split DRB / EN-DC	15.1.0
2018-09	RAN#81	R5-184761	006	-	F	Correction to RRC TC - Measurement configuration control and reporting / Inter-RAT measurements / Periodic reporting / Measurement of NR cells / EN-DC	15.1.0
2018-09	RAN#81	R5-184763	006	-	F	Correction to RRC TC - Measurement configuration control and reporting / Inter-RAT measurements / Event B1 / Measurement of NR cells / RSRQ based measurements / EN-DC	15.1.0
2018-09	RAN#81	R5-184769	006	-	F	Update of 5GS NR RRC test case 8.2.2.6.1	15.1.0
2018-09	RAN#81	R5-185059	000	1	F	Correction to NR MAC test case 7.1.1.3.2	15.1.0
2018-09	RAN#81	R5-185060	000	1	F	Addition of Correct Handling of DL HARQ process PDSCH Aggregation test case 7.1.1.2.2	15.1.0
2018-09	RAN#81	R5-185061	000	1	F	Addition of NR CA reconfiguration test case 8.2.4.2.1.1	15.1.0
2018-09	RAN#81	R5-185062	000	1	F	Addition of NR CA reconfiguration test case 8.2.4.2.1.2	15.1.0
2018-09	RAN#81	R5-185064	001	1	F	Addition of 5GS NR SDAP test case 7.1.4.1	15.1.0
2018-09	RAN#81	R5-185065	001	1	F	Correction to 5GS MAC Test case 7.1.1.1.2 Random access procedure / Successful / C-RNTI Based / Preamble selected by MAC itself	15.1.0
2018-09	RAN#81	R5-185066	001	1	F	Correction to 5GS MAC Test case 7.1.1.5.3 DRX operation / Short cycle configured / Parameters configured by RRC	15.1.0
2018-09	RAN#81	R5-185067	001	1	F	Correction to 5GS RLC Test case 7.1.2.3.10 AM RLC / Re-transmission of RLC PDU with and without re-segmentation	15.1.0
2018-09	RAN#81	R5-185068	001	1	F	Correction to 5GS RLC Test case 7.1.2.3.11 AM RLC / RLC re-establishment procedure	15.1.0
2018-09	RAN#81	R5-185069	002	1	F	Addition of NR CA / NR SCell addition / modification / release / Success test cases 8.2.4.1.1.1, 8.2.4.1.1.2 and 8.2.4.1.1.3	15.1.0
2018-09	RAN#81	R5-185070	002	1	F	Corrections to RRC TC - Measurement configuration control and reporting / Inter-RAT measurements / Event B1 / Measurement of NR cells / EN-DC	15.1.0
2018-09	RAN#81	R5-185071	002	1	F	Correction to 5GS RRC TC 8.2.4.3.1.1	15.1.0

2018-09	RAN#81	R5-185072	003 0	1	F	Addition of 5GS RRC TC 8.2.4.3.1.2	15.1.0
2018-09	RAN#81	R5-185073	003 3	1	F	Corrections to Layer 2 test cases	15.1.0
2018-09	RAN#81	R5-185074	003 4	1	F	Corrections to MAC test case 7.1.2.2.1	15.1.0
2018-09	RAN#81	R5-185075	003 5	1	F	Corrections to MAC test case 7.1.2.3.1	15.1.0
2018-09	RAN#81	R5-185076	003 7	1	F	Addition of new MAC RACH test case for PDCCH order	15.1.0
2018-09	RAN#81	R5-185077	003 9	1	F	Addition of new MAC test case for Scell Activation Deactivation	15.1.0
2018-09	RAN#81	R5-185078	004 1	1	F	Addition of new MAC UL TBS test case with transform precoding configured	15.1.0
2018-09	RAN#81	R5-185079	004 2	1	F	Correction to default pre-test conditions for UM RLC test cases	15.1.0
2018-09	RAN#81	R5-185080	004 3	1	F	New NAS test case 9.1.5.1.12	15.1.0
2018-09	RAN#81	R5-185082	004 5	1	F	Correction to NR PDCP test case 7.1.3.5.1	15.1.0
2018-09	RAN#81	R5-185083	004 6	1	F	Correction to NR RLC test case 7.1.2.3.3 and 7.1.2.3.4	15.1.0
2018-09	RAN#81	R5-185089	004 9	1	F	Corrections to RRC TC - Measurement configuration control and reporting / Inter-RAT measurements / Event B2 / Measurement of NR cells / EN-DC	15.1.0
2018-09	RAN#81	R5-185090	005 0	1	F	CR of AM RLC test case 7.1.2.3.10	15.1.0
2018-09	RAN#81	R5-185091	005 1	1	F	Update of RRC SCG failure TC 8.2.5.1.1	15.1.0
2018-09	RAN#81	R5-185092	005 2	1	F	Update of RRC SCG failure TC 8.2.5.2.1	15.1.0
2018-09	RAN#81	R5-185093	005 3	1	F	Update of RRC SCG failure TC 8.2.5.3.1	15.1.0
2018-09	RAN#81	R5-185094	005 4	1	F	Update of RRC SCG failure TC 8.2.5.4.1	15.1.0
2018-09	RAN#81	R5-185095	005 7	1	F	Addition of 5GS NR SDAP test case 7.1.4.2	15.1.0
2018-09	RAN#81	R5-185096	006 4	1	F	Update of 5GS NR RRC test case 8.2.3.6.1	15.1.0
2018-09	RAN#81	R5-185097	006 6	1	F	Update of 5GS NR RRC test case 8.2.3.8.1	15.1.0
2018-09	RAN#81	R5-185098	006 7	1	F	Update of 5GS NR RRC test case 8.2.1.1.1	15.1.0
2018-09	RAN#81	R5-185099	006 8	1	F	L2 Preamble Parameter Update for Multi-PDN configuration	15.1.0
2018-09	RAN#81	R5-185100	006 9	1	F	Correction to NR RLC test cases 7.1.2.2.3 and 7.1.2.2.4	15.1.0
2018-09	RAN#81	R5-185101	007 0	1	F	Correction to NR RRC test case 8.2.3.14.1	15.1.0
2018-09	RAN#81	R5-185148	000 7	1	F	Addition of NR CA reconfiguration test case 8.2.4.2.1.3	15.1.0
2018-09	RAN#81	R5-185149	002 4	1	F	Corrections to RRC TC - PSCell addition, modification and release / SCG DRB / EN-DC	15.1.0
2018-09	RAN#81	R5-185150	002 5	1	F	Corrections to RRC TC - Bearer Modification / Handling for bearer type change with security key change / EN-DC	15.1.0
2018-09	RAN#81	R5-185151	002 6	1	F	Corrections to RRC TC - Bearer Modification / Uplink data path / Split DRB Reconfiguration / EN-DC	15.1.0
2018-09	RAN#81	R5-185152	003 8	1	F	Addition of new MAC test case for Power Headroom report	15.1.0
2018-09	RAN#81	R5-185153	004 7	1	F	Addition of RRC Default Pre-test conditions for NSA	15.1.0
2018-09	RAN#81	R5-185154	005 8	1	F	Correction to RRC TC - Measurement configuration control and reporting / Event A1 / Measurement of NR PSCell / EN-DC	15.1.0
2018-09	RAN#81	R5-185155	006 2	1	F	Updates to NAS test case 10.2.1.2	15.1.0
2018-09	RAN#81	R5-185167	007 1	1	F	Update to EPS SM Test case for Multi-PDN	15.1.0

---

# History

<b>Document history</b>		
V15.0.0	July 2018	Publication
V15.1.0	October 2018	Publication