

ETSI TS 138 523-1 V15.4.0 (2019-07)



**5G;
5GS;
User Equipment (UE) conformance specification;
Part 1: Protocol
(3GPP TS 38.523-1 version 15.4.0 Release 15)**



Reference

RTS/TSGR-0538523-1v40

Keywords

5G

ETSI

650 Route des Lucioles
F-06921 Sophia Antipolis Cedex - FRANCE

Tel.: +33 4 92 94 42 00 Fax: +33 4 93 65 47 16

Siret N° 348 623 562 00017 - NAF 742 C
Association à but non lucratif enregistrée à la
Sous-Préfecture de Grasse (06) N° 7803/88

Important notice

The present document can be downloaded from:

<http://www.etsi.org/standards-search>

The present document may be made available in electronic versions and/or in print. The content of any electronic and/or print versions of the present document shall not be modified without the prior written authorization of ETSI. In case of any existing or perceived difference in contents between such versions and/or in print, the prevailing version of an ETSI deliverable is the one made publicly available in PDF format at www.etsi.org/deliver.

Users of the present document should be aware that the document may be subject to revision or change of status.

Information on the current status of this and other ETSI documents is available at

<https://portal.etsi.org/TB/ETSIDeliverableStatus.aspx>

If you find errors in the present document, please send your comment to one of the following services:

<https://portal.etsi.org/People/CommiteeSupportStaff.aspx>

Copyright Notification

No part may be reproduced or utilized in any form or by any means, electronic or mechanical, including photocopying and microfilm except as authorized by written permission of ETSI.

The content of the PDF version shall not be modified without the written authorization of ETSI.

The copyright and the foregoing restriction extend to reproduction in all media.

© ETSI 2019.

All rights reserved.

DECT™, **PLUGTESTS™**, **UMTS™** and the ETSI logo are trademarks of ETSI registered for the benefit of its Members.

3GPP™ and **LTE™** are trademarks of ETSI registered for the benefit of its Members and of the 3GPP Organizational Partners.

oneM2M™ logo is a trademark of ETSI registered for the benefit of its Members and of the oneM2M Partners.

GSM® and the GSM logo are trademarks registered and owned by the GSM Association.

Intellectual Property Rights

Essential patents

IPRs essential or potentially essential to normative deliverables may have been declared to ETSI. The information pertaining to these essential IPRs, if any, is publicly available for **ETSI members and non-members**, and can be found in ETSI SR 000 314: *"Intellectual Property Rights (IPRs); Essential, or potentially Essential, IPRs notified to ETSI in respect of ETSI standards"*, which is available from the ETSI Secretariat. Latest updates are available on the ETSI Web server (<https://ipr.etsi.org/>).

Pursuant to the ETSI IPR Policy, no investigation, including IPR searches, has been carried out by ETSI. No guarantee can be given as to the existence of other IPRs not referenced in ETSI SR 000 314 (or the updates on the ETSI Web server) which are, or may be, or may become, essential to the present document.

Trademarks

The present document may include trademarks and/or tradenames which are asserted and/or registered by their owners. ETSI claims no ownership of these except for any which are indicated as being the property of ETSI, and conveys no right to use or reproduce any trademark and/or tradename. Mention of those trademarks in the present document does not constitute an endorsement by ETSI of products, services or organizations associated with those trademarks.

Legal Notice

This Technical Specification (TS) has been produced by ETSI 3rd Generation Partnership Project (3GPP).

The present document may refer to technical specifications or reports using their 3GPP identities. These shall be interpreted as being references to the corresponding ETSI deliverables.

The cross reference between 3GPP and ETSI identities can be found under <http://webapp.etsi.org/key/queryform.asp>.

Modal verbs terminology

In the present document "**shall**", "**shall not**", "**should**", "**should not**", "**may**", "**need not**", "**will**", "**will not**", "**can**" and "**cannot**" are to be interpreted as described in clause 3.2 of the [ETSI Drafting Rules](#) (Verbal forms for the expression of provisions).

"**must**" and "**must not**" are **NOT** allowed in ETSI deliverables except when used in direct citation.

Contents

Intellectual Property Rights	2
Legal Notice	2
Modal verbs terminology.....	2
Foreword.....	14
1 Scope	15
2 References	15
3 Definitions, symbols and abbreviations	17
3.1 Definitions	17
3.2 Symbols.....	17
3.3 Abbreviations	17
4 Overview	17
4.1 Test methodology.....	17
4.1.1 Testing of optional functions and procedures	17
4.1.2 Test interfaces and facilities.....	17
4.2 Implicit testing.....	17
4.3 Repetition of tests.....	18
4.4 Handling of differences between conformance requirements in different releases of core specifications	18
5 Reference conditions and generic setup procedures.....	18
5.1 Reference conditions	18
5.2 Generic setup procedures	18
6 Idle mode operations	18
6.1 NR idle mode operations.....	18
6.1.1 NG-RAN Only PLMN Selection	19
6.1.1.1 PLMN selection of RPLMN, HPLMN/EHPLMN, UPLMN and OPLMN / Automatic mode	19
6.1.1.2 PLMN selection of "Other PLMN/access technology combinations" / Automatic mode.....	26
6.1.1.3 Cell reselection of ePLMN in manual mode	30
6.1.1.4 PLMN selection in shared network environment / Automatic mode	35
6.1.1.5 PLMN selection of RPLMN, HPLMN/EHPLMN, UPLMN and OPLMN / Automatic mode / User reselection	40
6.1.1.6 PLMN selection / Periodic reselection / MinimumPeriodicSearchTimer	45
6.1.1.7 PLMN selection of RPLMN or (E)HPLMN; Automatic mode	47
6.1.1.8 PLMN selection of RPLMN or (E)HPLMN; Manual mode	51
6.1.2 NG-RAN Only Cell Selection	54
6.1.2.1 Cell Selection/Qrxlevmin & Cell Reselection (Intra NR)	54
6.1.2.2 Cell Selection / Qqualmin/Intra NR / Serving cell becomes non-suitable (Srxlev > 0, Squal < 0).....	62
6.1.2.3 Cell selection / Intra NR/ Serving cell becomes non-suitable (S<0, MIB Indicated barred).....	70
6.1.2.4 Cell Reselection for interband operation.....	76
6.1.2.6	84
6.1.2.7 Cell reselection / Equivalent PLMN	84
6.1.2.8 Cell reselection / Equivalent PLMN / Single Frequency operation	88
6.1.2.9 Cell reselection using Qhyst, Qoffset and Treselection	92
6.1.2.10	100
6.1.2.11	100
6.1.2.12 Cell reselection using cell status and cell reservations / cellReservedForOtherUse	100
6.1.2.13 Cell reselection using cell status and cell reservations / Access Identity 1, 2 or 12 to 14 – cellReservedForOperatorUse	103
6.1.2.14 Cell reselection using cell status and cell reservations / Access Identity 11 or 15 - cellReservedForOperatorUse	106
6.1.2.15 Cell reselection in shared network environment	109
6.1.2.16	113
6.1.2.17 Cell reselection / Cell-specific reselection parameters provided by the network in a neighbouring cell list.....	113

6.1.2.18	116
6.1.2.19	116
6.1.2.20	Inter-frequency cell reselection according to cell reselection priority provided by SIBs.....	116
6.1.2.21	Cell reselection, SIntra SearchQ and SnonIntraSeqrchQ	121
6.1.2.22	Inter-frequency cell reselection based on common priority information with parameters ThreshX,HighQ, ThreshX,LowQ and ThreshServing,LowQ.....	131
6.2	Multi-mode environment.....	138
6.2.1	Inter-RAT PLMN selection	138
6.2.1.1	Inter-RAT PLMN Selection / Selection of correct RAT for OPLMN / Automatic mode.....	138
6.2.1.2	Inter-RAT PLMN Selection / Selection of correct RAT for UPLMN / Automatic mode.....	140
6.2.1.3	Inter-RAT PLMN Selection / Selection of correct PLMN and RAT in shared network environment / Automatic mode.....	142
6.2.1.4	Inter-RAT PLMN Selection / Selection of correct RAT from the OPLMN list / Manual mode.....	146
6.2.1.5	Inter-RAT Background HPLMN Search / Search for correct RAT for HPLMN / Automatic Mode	149
6.2.2	152
6.2.3	152
6.2.3.1	152
6.2.3.2	152
6.2.3.3	Inter-RAT cell reselection / From NR RRC_IDLE to E-UTRA_IDLE (lower priority & higher priority, Srxlev based).....	152
6.2.3.4	158
6.2.3.5	Inter-RAT cell reselection/From NR RRC_IDLE to E-UTRA_Idle according to RAT priority provided by dedicated signalling (RRCRelease).....	158
6.2.3.6	166
6.2.3.7	Inter-RAT cell reselection/From NR RRC_IDLE to E-UTRA RRC_IDLE, Snonintrasearch.....	166
6.3	5GS Steering of Roaming.....	171
6.3.1	Steering of Roaming	171
6.3.1.1	Steering of UE in roaming during registration/security check successful using List Type 1.....	171
6.3.1.2	Steering of UE in roaming during registration/security check successful but SOR Transparent container indicates ACK has been NOT been requested.....	176
6.4	182
6.4.1	182
6.4.1.1	182
6.4.1.2	Cell reselection of ePLMN in manual mode	182
6.4.2	Cell Selection/Qrxlevmin & Cell Reselection (Intra NR in RRC_INACTIVE state).....	189
6.4.2.1	Cell Selection/Qrxlevmin & Cell Reselection (Intra NR in RRC_INACTIVE state)	189
7	Layer 2.....	197
7.1	NR Layer 2	197
7.1.0	Common test case specific values for Layer 2.....	197
7.1.1	MAC	197
7.1.1.0	Default Pre-Test Conditions for all MAC test cases	197
7.1.1.1	Random Access Procedures	198
7.1.1.1.1	Correct selection of RACH parameters / Random access preamble and PRACH resource explicitly signalled to the UE by RRC / contention free random access procedure	198
7.1.1.1.1a	Correct selection of RACH parameters / Random access preamble and PRACH resource explicitly signalled to the UE by PDCCH Order / contention free random access procedure.....	203
7.1.1.1.2	Random access procedure / Successful / C-RNTI Based / Preamble selected by MAC itself.....	207
7.1.1.1.3	Random access procedure / Successful / SI request	222
7.1.1.1.4	Random access procedure / Successful / Beam Failure / Preamble selected by MAC itself / Non Contention Free RACH procedure	232
7.1.1.1.5	Random access procedure / Successful / Supplementary Uplink	246
7.1.1.1.6	Random access procedure / Successful/ Temporary C-RNTI Based / Preamble selected by MAC itself.....	251
7.1.1.2	Downlink Data Transfer.....	265
7.1.1.2.1	Correct Handling of DL MAC PDU / Assignment / HARQ process	265
7.1.1.2.2	Correct Handling of DL HARQ process PDSCH Aggregation	276
7.1.1.2.3	Correct HARQ process handling / CCCH	282
7.1.1.2.4	Correct HARQ process handling / BCCH	286
7.1.1.3	Uplink Data Transfer.....	289
7.1.1.3.1	Correct Handling of UL MAC PDU / Assignment / HARQ process	289

7.1.1.3.2	Logical channel prioritization handling.....	301
7.1.1.3.3	Correct handling of MAC control information / Scheduling requests.....	305
7.1.1.3.4	Correct handling of MAC control information / Buffer status / UL data arrive in the UE Tx buffer / Regular BSR.....	309
7.1.1.3.5	Correct handling of MAC control information / Buffer Status / UL resources are allocated / Padding BSR.....	320
7.1.1.3.6	Correct handling of MAC control information / Buffer status / Periodic BSR timer expires.....	328
7.1.1.3.7	UE power headroom reporting / Periodic reporting / DL pathloss change reporting.....	336
7.1.1.3.8	UE power headroom reporting / SCell activation / DL pathloss change reporting.....	344
7.1.1.3.9	Correct Handling of UL HARQ process / PUSCH Aggregation.....	354
7.1.1.4	Transport Size Selection.....	361
7.1.1.4.1	DL-SCH Transport Block Size Selection.....	361
7.1.1.4.2	UL-SCH Transport Block Size Selection.....	397
7.1.1.4.2.0	Common parameters for UL-SCH Transport Block Size Selection.....	397
7.1.1.4.2.1	UL-SCH Transport Block Size selection / DCI format 0_0 / Transform precoding disabled.....	398
7.1.1.5	Discontinuous reception.....	449
7.1.1.5.1	DRX operation / Short cycle not configured / Parameters configured by RRC.....	449
7.1.1.5.2	DRX operation / Short cycle not configured / Long DRX command MAC control element reception.....	458
7.1.1.5.3	DRX operation / Short cycle configured / Parameters configured by RRC.....	466
7.1.1.5.4	DRX Operation / Short cycle configured / DRX command MAC control element reception.....	472
7.1.1.6	Semi-Persistent Scheduling.....	480
7.1.1.6.1	Correct handling of DL assignment / Semi-persistent case.....	480
7.1.1.6.2	Correct handling of UL grant / configured grant Type 1.....	487
7.1.1.6.3	Correct handling of UL grant / configured grant Type 2.....	499
7.1.1.7	Activation/Deactivation of SCells.....	511
7.1.1.7.1	Activation/Deactivation of SCells / Activation/Deactivation MAC control element reception / sCellDeactivationTimer.....	511
7.1.1.8	Bandwidth Part (BWP) operation.....	516
7.1.1.8.1	Bandwidth Part (BWP) operation UL/DL.....	516
7.1.1.9	MAC Reconfiguration and Reset.....	532
7.1.1.9.1	MAC Reset.....	532
7.1.2	RLC.....	537
7.1.2.1	Default Pre-Test Conditions for all RLC test cases.....	537
7.1.2.1.1	Default Pre-Test Conditions for AM RLC test cases.....	537
7.1.2.1.2	Default Pre-Test Conditions for UM RLC test cases.....	539
7.1.2.2	RLC Unacknowledged mode.....	539
7.1.2.2.1	UM RLC / Segmentation and reassembly / 6-bit SN / Segmentation Info (SI) field.....	539
7.1.2.2.2	UM RLC / Segmentation and reassembly / 12-bit SN / Segmentation Info (SI) field.....	543
7.1.2.2.3	UM RLC / 6-bit SN / Correct use of sequence numbering.....	545
7.1.2.2.4	UM RLC / 12-bit SN / Correct use of sequence numbering.....	549
7.1.2.2.5	UM RLC / Receive Window operation and t-Reassembly expiry.....	553
7.1.2.2.6	UM RLC / RLC re-establishment procedure.....	558
7.1.2.3	RLC Acknowledged Mode.....	562
7.1.2.3.1	AM RLC / 12-bit SN / Segmentation and reassembly / Segmentation Info (SI) field.....	562
7.1.2.3.2	AM RLC / 18-bit SN / Segmentation and reassembly / Segmentation Info (SI) field.....	566
7.1.2.3.3	AM RLC / 12-bit SN / Correct use of sequence numbering.....	567
7.1.2.3.4	AM RLC / 18-bit SN / Correct use of sequence numbering.....	572
7.1.2.3.5	AM RLC / Control of transmit window/Control of receive window.....	577
7.1.2.3.6	AM RLC / Polling for status.....	581
7.1.2.3.7	AM RLC / Receiver status triggers.....	587
7.1.2.3.8	AM RLC / Reconfiguration of RLC parameters by upper layers.....	593
7.1.2.3.9	AM RLC / Reassembling of AMD PDUs.....	599
7.1.2.3.10	AM RLC / Re-transmission of RLC PDU with and without re-segmentation.....	607
7.1.2.3.11	AM RLC / RLC re-establishment procedure.....	616
7.1.3	PDCP.....	621
7.1.3.0	Default Pre-Test Conditions for all PDCP test cases.....	621
7.1.3.1	Maintenance of PDCP sequence numbers for radio bearers.....	622
7.1.3.1.1	Maintenance of PDCP sequence numbers / User plane / 12 bit SN.....	622
7.1.3.1.2	Maintenance of PDCP sequence numbers / User plane / 18 bit SN.....	626
7.1.3.2	PDCP integrity protection.....	627

7.1.3.2.1	Integrity protection / Correct functionality of encryption algorithm SNOW3G / SRB / DRB	627
7.1.3.2.2	Integrity protection / Correct functionality of encryption algorithm AES / SRB / DRB	634
7.1.3.2.3	Integrity protection / Correct functionality of encryption algorithm ZUC / SRB / DRB	635
7.1.3.3	PDCP Ciphering and deciphering	636
7.1.3.3.1	Ciphering and deciphering / Correct functionality of encryption algorithm SNOW3G / SRB / DRB	636
7.1.3.3.2	Ciphering and deciphering / Correct functionality of encryption algorithm AES / SRB / DRB ...	641
7.1.3.3.3	Ciphering and deciphering / Correct functionality of encryption algorithm ZUC / SRB / DRB ...	642
7.1.3.4	PDCP Handover	643
7.1.3.4.1	PDCP handover / Lossless handover / PDCP sequence number maintenance / PDCP status report to convey the information on missing or acknowledged PDCP SDUs at handover / In-order delivery and duplicate elimination in the downlink	643
7.1.3.4.2	PDCP handover / Non-lossless handover / PDCP sequence number maintenance	653
7.1.3.5	PDCP other	656
7.1.3.5.1	PDCP Discard.....	656
7.1.3.5.2	PDCP Uplink Routing / Split DRB	658
7.1.3.5.3	PDCP Data Recovery	661
7.1.3.5.4	PDCP reordering / Maximum re-ordering delay below t-Reordering / t-Reordering timer operations	665
7.1.3.5.5	PDCP Duplication	671
7.1.4	SDAP	675
7.1.4.1	SDAP Data Transfer and PDU Header Handling UL/DL	675
7.1.4.1.1	Test Purpose (TP)	675
7.1.4.1.2	Conformance requirements.....	675
7.1.4.2	SDAP Data Transfer handling without Header UL/DL	683
7.1.4.2.1	Test Purpose (TP)	683
7.1.4.2.2	Conformance requirements.....	684
7.1.4.2.3	Test description	686
8	RRC.....	690
8.1	NR RRC	690
8.1.1	RRC connection management procedures	690
8.1.1.1	Paging	690
8.1.1.1.1	RRC / Paging for connection / Multiple paging records.....	690
8.1.1.1.2	RRC / Paging for connection / Shared network environment.....	694
8.1.1.2	RRC connection establishment	700
8.1.1.2.1	RRC connection establishment / Return to idle state after T300 expiry.....	700
8.1.1.2.3	RRC connection establishment / RRC Reject with wait time.....	702
8.1.1.3	RRC release.....	704
8.1.1.3.1	RRC connection release / Redirection to another NR frequency.....	704
8.1.1.3.2	RRC connection release / Redirection from NR to E-UTRA	707
8.1.1.3.3	RRC connection release / Success / With priority information	709
8.1.1.3.4	RRC connection release / Success / With priority information / E-UTRA.....	715
8.1.1.3.5	RRC connection release / With priority information / T320 expiry	719
8.1.1.3.6	RRC connection release / With priority information / T320 expiry / E-UTRA.....	724
8.1.1.4	RRC resume	729
8.1.1.4.1	RRC resume / Suspend-Resume / Success	729
8.1.1.4.2	RRC resume / Suspend-Resume / RRC setup / T319 expiry.....	732
8.1.1.4.3	RRC resume / Suspend-Resume / RNA update / Success	736
8.1.2	RRC reconfiguration.....	739
8.1.2.1	Radio bearer establishment / reconfiguration / release.....	739
8.1.2.1.1	RRC reconfiguration / DRB / SRB / Establishment / Modification / Release / Success	739
8.1.2.1.2	748	
8.1.2.1.3	RRC reconfiguration / Radio resource reconfiguration / dedicatedSIB1-Delivery	748
8.1.3	Measurement configuration control and reporting.....	753
8.1.3.1	Intra NR measurements.....	753
8.1.3.1.1	Measurement configuration control and reporting / Intra NR measurements / Event A1 / Event A2.....	753
8.1.3.1.2	Measurement configuration control and reporting / Event A3 / Measurement of Neighbor NR cell / Intra-frequency measurements.....	765
8.1.3.1.3	Measurement configuration control and reporting / Event A3 / Measurement of Neighbour NR cell / Inter-frequency measurements	774

8.1.3.1.4	Measurement configuration control and reporting / Event A3 / Measurement of Neighbour NR cell / Inter-band measurements	777
8.1.3.1.5	Measurement configuration control and reporting / Event A4 / Measurement of Neighbour NR cell / Intra-frequency measurements	779
8.1.3.1.6	Measurement configuration control and reporting / Event A4 / Measurement of Neighbour NR cell / Inter-frequency measurements	787
8.1.3.1.7	Measurement configuration control and reporting / Event A4 / Measurement of Neighbour NR cell / Inter-band measurements	790
8.1.3.1.8	Measurement configuration control and reporting / Event A5 / Measurement of Neighbour NR cell / Intra-frequency measurements	792
8.1.3.1.9	Measurement configuration control and reporting / Event A5 / Measurement of Neighbour NR cell / Inter-frequency measurements	801
8.1.3.1.10	Measurement configuration control and reporting / Event A5 / Measurement of Neighbour NR cell / Inter-band measurements	804
8.1.3.1.11	Measurement configuration control and reporting / Intra NR measurements / Two simultaneous events A3 (intra and inter-frequency measurements) / RSRQ based measurements	806
8.1.3.1.12	Measurement configuration control and reporting / Intra NR measurements / Two simultaneous events A5 (intra and inter-frequency measurements) / SINR based measurements	816
8.1.3.1.13	Measurement configuration control and reporting / SS/PBCH block based / CSI-RS based intra-frequency measurements / Measurement of Neighbour NR cell.....	827
8.1.3.1.14	Void	833
8.1.3.1.14A	Measurement configuration control and reporting / SS/PBCH block based / CSI-RS based inter-frequency measurements / Measurement of Neighbour NR cell.....	833
8.1.3.1.15	Void	838
8.1.3.1.15A	Measurement configuration control and reporting / Intra NR measurements / Blacklisting	839
8.1.3.1.16	850	
8.1.3.1.17	NR CA / Measurement configuration control and reporting / Intra NR measurements / Event A6	850
8.1.3.1.17.1	NR CA / Measurement configuration control and reporting / Intra NR measurements / Event A6 / Intra-band Contiguous CA	850
8.1.3.1.17.2	NR CA / Measurement configuration control and reporting / Intra NR measurements / Event A6 / Inter-band CA	861
8.1.3.1.17.3	NR CA / Measurement configuration control and reporting / Intra NR measurements / Event A6 / Intra-band non Contiguous CA	862
8.1.3.1.18	NR CA / Measurement configuration control and reporting / Intra NR measurements / Additional measurement reporting	864
8.1.3.1.18.1	NR CA / Measurement configuration control and reporting / Intra NR measurements / Additional measurement reporting / Intra-band Contiguous CA	864
8.1.3.1.18.2	NR CA / Measurement configuration control and reporting / Intra NR measurements / Additional measurement reporting / Inter-band CA	875
8.1.3.1.18.3	NR CA / Measurement configuration control and reporting / Intra NR measurements / Additional measurement reporting / Intra-band non Contiguous CA	877
8.1.3.2	879	
8.1.3.2.1	Measurement configuration control and reporting / Inter-RAT measurements / Event B1 / Measurement of E-UTRA cells	879
8.1.3.2.2	Measurement configuration control and reporting / Inter-RAT measurements / Event B2 / Measurement of E-UTRA cells	888
8.1.3.2.3	Measurement configuration control and reporting / Inter-RAT measurements / Event B2 / Measurement of E-UTRA cells / RSRQ based measurements	899
8.1.3.2.5	Measurement configuration control and reporting / Inter-RAT measurements / Simultaneous A2 and B2 / Measurements of NR and E-UTRA cells	908
8.1.4	Handover	919
8.1.4.1	Intra NR handover	919
8.1.4.1.1	Intra NR handover / Success / Dedicated preamble / Common preamble / Intra-frequency	919
8.1.4.1.2	Intra NR handover / Success / Dedicated preamble / Common preamble / Inter-frequency	928
8.1.4.1.3	Intra NR handover / Success / Security key reconfiguration	940
8.1.4.1.4	Intra NR handover / Failure / Security key reconfiguration	942
8.1.4.1.5	Intra NR handover / Failure / Re-establishment successful	946
8.1.4.1.6	Intra NR handover / Failure / Re-establishment failure	953
8.1.4.1.7	958

8.1.4.1.8	958
8.1.4.1.9	NR CA / Intra NR handover / Failure / Re-establishment successful.....	958
8.1.4.1.9.1	NR CA / Intra NR handover / Failure / Re-establishment successful / Intra-band Contiguous CA	958
8.1.4.1.9.2	NR CA / Intra NR handover / Failure / Re-establishment successful / Inter-band CA	970
8.1.4.1.9.3	NR CA / Intra NR handover / Failure / Re-establishment successful / Intra-band non- contiguous CA	971
8.1.4.2	Inter-RAT handover	971
8.1.4.2.1	Inter-RAT handover from NR	971
8.1.4.2.1.1	Inter-RAT handover / From NR to E-UTRA / Success	971
8.1.4.2.2	977
8.1.4.2.2.1	Inter-RAT handover / From E-UTRA to NR / Success	977
8.1.5	RRC others.....	983
8.1.5.1	UE capability transfer	983
8.1.5.1.1	UE capability transfer / Success	983
8.1.5.2	SI change / On-demand SIB.....	1000
8.1.5.2.1	SI change / Notification of BCCH modification / Short message for SI update.....	1000
8.1.5.2.2	SI change / Notification of BCCH modification / Short message for SI update in NR RRC_CONNECTED state.....	1004
8.1.5.3	1007
8.1.5.3.1	PWS notification / PWS reception in NR RRC_IDLE state.....	1007
8.1.5.3.2	PWS notification / PWS reception in NR RRC_INACTIVE state	1010
8.1.5.3.3	PWS notification / PWS reception in NR RRC_CONNECTED state.....	1011
8.1.5.3.4	PWS notification / PWS reception using dedicatedSystemInformationDelivery	1012
8.1.5.4	Counter check	1017
8.1.5.4.1	Counter check / Reception of CounterCheck message by the UE.....	1017
8.1.5.5	Redirection to NR	1019
8.1.5.5.1	Redirection to NR / From E-UTRA / Success	1019
8.1.5.6	Radio link failure	1023
8.1.5.6.1	Radio link failure / RRC connection re-establishment success	1023
8.1.5.6.2	Radio link failure / T301 expiry	1028
8.1.5.6.3	Radio link failure / T311 expiry	1032
8.1.5.6.4	Radio link failure / Radio link recovery while T310 is running	1035
8.1.5.6.5	NR CA / No Radio Link Failure on SCell / RRC Connection Continues on Pcell.....	1037
8.1.5.6.5.1	NR CA / No Radio Link Failure on SCell / RRC Connection Continues on PCell / Intra- band Contiguous CA.....	1037
8.1.5.6.5.2	NR CA / No Radio Link Failure on SCell / RRC Connection Continues on PCell / Inter- band CA	1040
8.2	MR-DC RRC.....	1041
8.2.1	UE Capability	1041
8.2.1.1	UE capability transfer / Success	1041
8.2.1.1.1	UE capability transfer / Success / EN-DC	1041
8.2.1.2	Void.....	1073
8.2.2	Radio Bearer Addition, Modification and Release	1073
8.2.2.1	Radio Bearer Addition, Modification and Release / SRB	1073
8.2.2.1.1	SRB3 Establishment, Reconfiguration and Release / NR addition, modification and release / EN-DC.....	1073
8.2.2.2	Split SRB Establishment and Release	1082
8.2.2.2.1	Split SRB Establishment and Release / EN-DC	1082
8.2.2.3	Simultaneous SRB3 and Split SRB / Sequential message flow on SRB3 and Split SRB	1091
8.2.2.3.1	Simultaneous SRB3 and Split SRB / Sequential message flow on SRB3 and Split SRB / EN- DC	1091
8.2.2.4	PSCell addition, modification and release / SCG DRB	1101
8.2.2.4.1	PSCell addition, modification and release / SCG DRB / EN-DC.....	1101
8.2.2.5	PSCell addition, modification and release / Split DRB.....	1111
8.2.2.5.1	PSCell addition, modification and release / Split DRB / EN-DC.....	1111
8.2.2.6	Bearer Modification / MCG DRB	1121
8.2.2.6.1	Bearer Modification / MCG DRB / SRB / PDCP version change / EN-DC.....	1121
8.2.2.7	Bearer Modification / Handling for bearer type change without security key change	1133
8.2.2.7.1	Bearer Modification / Handling for bearer type change without security key change / EN-DC	1133
8.2.2.8	Bearer Modification / Handling for bearer type change with security key change	1151
8.2.2.8.1	Bearer Modification / Handling for bearer type change with security key change / EN-DC	1151

8.2.2.9	Bearer Modification / Uplink data path / Split DRB Reconfiguration	1181
8.2.2.9.1	Bearer Modification / Uplink data path / Split DRB Reconfiguration / EN-DC	1181
8.2.3	Measurement Configuration Control and Reporting / Handovers	1189
8.2.3.1	Measurement configuration control and reporting / Inter-RAT measurements / Event B1 / Measurement of NR cells.....	1189
8.2.3.1.1	Measurement configuration control and reporting / Inter-RAT measurements / Event B1 / Measurement of NR cells / EN-DC.....	1189
8.2.3.2	Measurement configuration control and reporting / Inter-RAT measurements / Event B1 / Measurement of NR cells / RSRQ based measurements.....	1198
8.2.3.2.1	Measurement configuration control and reporting / Inter-RAT measurements / Event B1 / Measurement of NR cells / RSRQ based measurements / EN-DC.....	1198
8.2.3.3	Measurement configuration control and reporting / Inter-RAT measurements / Periodic reporting / Measurement of NR cells.....	1209
8.2.3.3.1	Measurement configuration control and reporting / Inter-RAT measurements / Periodic reporting / Measurement of NR cells / EN-DC	1209
8.2.3.4	Measurement configuration control and reporting / Event A1 / Measurement of NR PSCell	1219
8.2.3.4.1	Measurement configuration control and reporting / Event A1 / Measurement of NR PSCell / EN-DC.....	1219
8.2.3.5	Measurement configuration control and reporting / Event A2 / Measurement of NR PSCell	1229
8.2.3.5.1	Measurement configuration control and reporting / Event A2 / Measurement of NR PSCell / EN-DC.....	1229
8.2.3.6	Measurement configuration control and reporting / Event A3 / Measurement of Neighbour NR cells	1239
8.2.3.6.1	Measurement configuration control and reporting / Event A3 / Measurement of Neighbour NR cells / Intra-frequency measurements / EN-DC	1239
8.2.3.6.1a	Measurement configuration control and reporting / Event A3 / Measurement of Neighbor NR cell / Inter-frequency measurements / EN-DC	1247
8.2.3.6.1b	Measurement configuration control and reporting / Event A3 / Measurement of Neighbor NR cell / Inter-band measurements / EN-DC.....	1250
8.2.3.7	Measurement configuration control and reporting / Event A4 (intra-frequency, inter-frequency and inter-band measurements) / Measurement of Neighbour NR cell	1252
8.2.3.7.1	Measurement configuration control and reporting / Event A4 / Measurement of Neighbour NR cell / Intra-frequency measurements / EN-DC.....	1252
8.2.3.7.1a	Measurement configuration control and reporting / Event A4 / Measurement of Neighbor NR cell / Inter-frequency measurements / EN-DC	1263
8.2.3.7.1b	Measurement configuration control and reporting / Event A4 / Measurement of Neighbor NR cell / Inter-band measurements / EN-DC.....	1274
8.2.3.8	Measurement configuration control and reporting / Event A5 / Measurement of Neighbour NR cell.....	1285
8.2.3.8.1	Measurement configuration control and reporting / Event A5 / Measurement of Neighbour NR cell / Intra-frequency measurements / EN-DC.....	1285
8.2.3.8.1a	Measurement configuration control and reporting / Event A5 / Measurement of Neighbor NR cell / Inter-frequency measurements / EN-DC	1296
8.2.3.8.1b	Measurement configuration control and reporting / Event A5 / Measurement of Neighbor NR cell / Inter-band measurements / EN-DC.....	1298
8.2.3.9	Measurement configuration control and reporting / SS/PBCH block based / CSI-RS based intra- frequency measurements / Measurement of Neighbour NR cell.....	1300
8.2.3.9.1	Measurement configuration control and reporting / SS/PBCH block based / CSI-RS based Intra-frequency measurements / Measurement of Neighbour NR Cell / EN-DC	1300
8.2.3.10	Measurement configuration control and reporting / SS/PBCH block based / CSI-RS based inter- frequency measurements / Measurement of Neighbour NR cell.....	1323
8.2.3.10.1	Measurement configuration control and reporting / SS/PBCH block based /CSI-RS based Inter-frequency measurements/ Measurement of Neighbour NR Cell / EN-DC	1323
8.2.3.11	Measurement configuration control and reporting / Measurement Gaps	1346
8.2.3.11.1	Measurement configuration control and reporting / Measurement Gaps / NR FR1 / EN-DC	1346
8.2.3.11.2	Measurement configuration control and reporting / Measurement Gaps / NR FR2 / EN-DC	1364
8.2.3.12	Measurement configuration control and reporting / Inter-RAT measurements / Event B2 / Measurement of NR cells.....	1374
8.2.3.12.1	Measurement configuration control and reporting / Inter-RAT measurements / Event B2 / Measurement of NR cells / EN-DC.....	1374
8.2.3.13	PCell Handover with SCG change / Reconfiguration with sync / SCG DRB	1386
8.2.3.13.1	PCell Handover with SCG change / Reconfiguration with sync / SCG DRB / EN-DC.....	1386

8.2.3.14	SCG change / Reconfiguration with sync / Split DRB.....	1391
8.2.3.14.1	SCG change / Reconfiguration with sync / Split DRB / EN-DC.....	1391
8.2.3.15	Measurement configuration control and reporting / Two simultaneous events A2 and A3 (intra-frequency measurements) / Measurement of Neighbour NR cells.....	1398
8.2.3.15.1	Measurement configuration control and reporting / Two simultaneous events A2 and A3 (intra-frequency measurements) / Measurement of Neighbour NR cells / EN-DC.....	1398
8.2.4	Carrier Aggregation.....	1410
8.2.4.1	NR CA / NR SCell addition / modification / release / Success.....	1410
8.2.4.1.1	NR CA / NR SCell addition / modification / release / Success / EN-DC.....	1410
8.2.4.1.1.1	NR CA / NR SCell addition / modification / release / Success / EN-DC / Intra-band Contiguous CA.....	1410
8.2.4.1.1.2	NR CA / NR SCell addition / modification / release / Success / EN-DC / Intra-band non-Contiguous CA.....	1420
8.2.4.1.1.3	NR CA / NR SCell addition / modification / release / Success / EN-DC / Inter-band CA.....	1420
8.2.4.2	NR CA / Simultaneous PSCell and SCell addition / PSCell and SCell change / CA Release.....	1421
8.2.4.2.1	NR CA / Simultaneous PSCell and SCell addition / PSCell and SCell change / CA Release/ EN-DC.....	1421
8.2.4.2.1.1	NR CA / Simultaneous PSCell and SCell addition / PSCell and SCell change / CA Release / EN-DC / Intra-band Contiguous CA.....	1421
8.2.4.3	NR CA / SCell change / Intra-NR measurement event A6 / SRB3.....	1435
8.2.4.3.1	NR CA / SCell change / Intra-NR measurement event A6 / SRB3 / EN-DC.....	1435
8.2.5	Reconfiguration Failure / Radio link failure.....	1448
8.2.5.1	Radio link failure / PSCell addition failure.....	1448
8.2.5.1.1	Radio link failure / Random access problem / EN-DC.....	1448
8.2.5.2	Radio link failure / PSCell out of sync indication.....	1451
8.2.5.2.1	Radio link failure / PSCell out of sync indication / EN-DC.....	1451
8.2.5.3	Radio link failure / rlc-MaxNumRetx failure.....	1454
8.2.5.3.1	Radio link failure / rlc-MaxNumRetx failure / EN-DC.....	1454
8.2.5.4	Reconfiguration failure / SCG change failure.....	1457
8.2.5.4.1	Reconfiguration failure / SCG change failure / EN-DC.....	1457
8.2.5.5	Reconfiguration failure / SCG Reconfiguration failure / SRB3.....	1462
8.2.5.5.1	Void.....	1462
8.2.5.6	Reconfiguration failure / SCG Reconfiguration failure / SRB1.....	1462
8.2.5.6.1	Void.....	1462
9	Mobility management.....	1462
9.1	5GS Mobility Management.....	1462
9.1.1	Primary authentication and key agreement.....	1462
9.1.1.1	EAP based primary authentication and key agreement / EAP-AKA' related procedures.....	1462
9.1.1.2	EAP based primary authentication and key agreement / Reject.....	1466
9.1.1.3	EAP based primary authentication and key agreement / EAP message transport / Abnormal.....	1469
9.1.1.4	1470
9.1.1.5	1470
9.1.1.6	5G AKA based primary authentication and key agreement / Abnormal.....	1470
9.1.2	Security mode control.....	1473
9.1.2.1	NAS security mode command.....	1473
9.1.2.2	Protection of initial NAS signalling messages.....	1477
9.1.3	Identification.....	1480
9.1.3.1	Identification procedure.....	1480
9.1.4	1485
9.1.4.1	Generic UE configuration update / New 5G-GUTI, NITZ, registration requested, Network slicing indication, New Allowed NSSAI / acknowledgement from the UE.....	1485
9.1.5	Registration.....	1495
9.1.5.1	Initial Registration.....	1495
9.1.5.1.1	Initial registration / Success / 5G-GUTI reallocation, Last visited TAI.....	1495
9.1.5.1.2	Initial registration / 5GS services / Equivalent PLMN list handling.....	1501
9.1.5.1.3	Initial registration / 5GS services / NSSAI handling.....	1507
9.1.5.1.4	Initial registration / 5GS services / MICO mode / TAI list handling.....	1517
9.1.5.1.5	Initial registration / Abnormal / Failure after 5 attempts.....	1521
9.1.5.1.6	Initial registration / Rejected / Illegal UE.....	1525
9.1.5.1.7	Void.....	1528
9.1.5.1.8	Initial registration / Rejected / Serving network not authorized.....	1528

9.1.5.1.9	Initial registration / Abnormal / Change of cell into a new tracking area.....	1529
9.1.5.1.10	Initial registration / Rejected / PLMN not allowed.....	1531
9.1.5.1.11	Initial registration / Rejected / Tracking area not allowed.....	1536
9.1.5.1.12	Initial registration / Rejected / Roaming not allowed in this tracking area.....	1542
9.1.5.1.13	Initial registration / Rejected / No suitable cells in tracking area.....	1549
9.1.5.1.14	Initial registration / Rejected / Congestion / Abnormal cases / T3346.....	1551
9.1.5.2	Mobility and periodic registration update	1555
9.1.5.2.1	Mobility registration update / TAI list handling.....	1555
9.1.5.2.2	Periodic registration update / Accepted.....	1561
9.1.5.2.3	1563
9.1.5.2.4	Mobility registration update / The lower layer requests NAS signalling connection recovery ...	1563
9.1.5.2.6	Mobility registration update / Registered slice(s) change.....	1567
9.1.5.2.7	Mobility and periodic registration update / Rejected / UE identity cannot be derived by the network.....	1567
9.1.5.2.8	Mobility and periodic registration update / Rejected / Implicitly de-registered	1569
9.1.5.2.9	Mobility and periodic registration update / Abnormal / Change of cell into a new tracking area, collision with generic UE configuration update procedure.....	1573
9.1.6	De-registration	1576
9.1.6.1	UE-initiated de-registration.....	1576
9.1.6.1.1	UE-initiated de-registration / Switch off / Abnormal / De-registration and 5GMM common procedure collision	1576
9.1.6.1.2	UE-initiated de-registration / Normal de-registration / Abnormal / Transmission failure without TAI change from lower layers, De-registration and 5GMM common procedure collision, T3521 timeout.....	1581
9.1.6.1.3	UE-initiated de-registration / Abnormal / Change of cell into a new tracking area.....	1585
9.1.6.1.4	UE-initiated de-registration / Abnormal / Transmission failure with TAI change from lower layers	1590
9.1.6.2	Network-initiated de-registration	1593
9.1.6.2.1	Network-initiated de-registration / De-registration for 3GPP access / Re-registration required .	1593
9.1.6.2.2	Network-initiated de-registration / De-registration for 3GPP access / Re-registration not required.....	1595
9.1.7	Service request.....	1598
9.1.7.1	Service request / IDLE mode uplink user data transport / Rejected / Restricted service area, Abnormal / T3517, T3525.....	1598
9.1.7.2	Service request / CONNECTED mode user data transport / Abnormal / T3517, T3525	1603
9.1.8	SMS over NAS	1608
9.1.8.1	SMS over NAS / MO and MT SMS over NAS - Idle mode	1608
9.2	5GS Non-3GPP Access Mobility Management	1616
9.2.1	Primary authentication and key agreement procedure	1616
9.2.2	Security Mode Control.....	1616
9.2.2.1	NAS security mode command.....	1616
9.2.2.2	Protection of initial NAS signalling messages	1620
9.2.3	Identification.....	1622
9.2.4	Generic UE configuration.....	1622
9.2.5	Registration.....	1622
9.2.5.1	Initial Registration.....	1622
9.2.5.1.1	Initial registration / Success / 5G-GUTI reallocation, Last visited TAI	1622
9.2.5.1.2	1624
9.2.5.1.3	1624
9.2.5.1.4	Initial registration / Rejected / Congestion / Abnormal cases / T3346.....	1624
9.2.6	De-registration	1628
9.2.6.1	UE-initiated de-registration.....	1628
9.2.6.1.1	UE-initiated de-registration / switch off.....	1628
9.2.6.2	Network-initiated de-registration	1633
9.2.6.2.1	Network-initiated de-registration / De-registration for Non-3GPP access / Re-registration required.....	1633
9.2.6.2.2	Network-initiated de-registration / De-registration for Non 3GPP access / Re-registration not required.....	1635
9.2.7	Service request.....	1639
9.2.8	SMS over NAS	1639
9.2.8.1	SMS over NAS / MO SMS over NAS - 5GMM-Idle mode.....	1639
9.3	Inter-system mobility	1642

9.3.1	5GS-EPC Inter-system mobility	1642
9.3.1.1	Mobility registration update / Single-registration mode with N26 / 5GMM-IDLE / 5GC to EPC ...	1642
9.3.1.2	Mobility registration update / Single-registration mode with N26 / 5GMM-IDLE / EPC to 5GC ...	1644
9.3.1.3	Mobility and periodic registration update / Rejected / Single-registration mode with N26 / Handling of EPC relevant parameters	1648
10	Session management	1650
10.1	5GS session management	1650
10.1.1	PDU session authentication and authorization	1651
10.1.1.1	PDU session authentication and authorization / during the UE-requested PDU session procedure..	1651
10.1.1.2	PDU session authentication and authorization / after the UE-requested PDU session procedure....	1657
10.1.2	Network-requested PDU session modification	1664
10.1.2.1	1664
10.1.2.2	Network-requested PDU session modification / Abnormal / PDU session in state PDU SESSION INACTIVE.....	1664
10.1.3	1667
10.1.3.1	1667
10.1.3.2	Network-requested PDU session release / Accepted / Insufficient resources / T3396, Accepted / Insufficient resources for specific slice and DNN / T3584, Abnormal / No PDU session context active for the received PDU session ID	1667
10.1.4	1678
10.1.5	UE-requested PDU session modification.....	1678
10.1.5.1	UE-requested PDU session modification	1678
10.1.6	UE-requested PDU session release	1680
10.1.6.1	UE-requested PDU session release / Abnormal / Collision with network-requested PDU session modification procedure	1680
10.1.6.2	UE-requested PDU session release / Abnormal / Collision with network-requested PDU session release procedure.....	1683
10.2	EN-DC session management	1686
10.2.1	Network initiated procedures.....	1686
10.2.1.1	Default EPS bearer context activation.....	1686
10.2.1.2	Dedicated EPS bearer context activation	1690
10.2.2	UE initiated procedures	1694
10.2.2.1	EPS bearer resource allocation / modification	1694
10.3	5GS Non-3GPP Access Session Management	1702
10.3.1	PDU session authentication and authorization.....	1702
10.3.1.1	PDU session authentication and authorization / during the UE-requested PDU session procedure..	1702
10.3.2	Network-requested PDU session modification	1708
10.3.2.1	Network-requested PDU session modification /Accepted/Rejected	1708
10.3.3	Network-requested PDU session Release	1713
10.3.4	UE-requested PDU session establishment	1713
10.3.5	UE-requested PDU session modification.....	1713
10.3.5.1	UE-requested PDU session modification/Success	1713
10.3.6	UE-requested PDU session release	1714
10.3.6.1	UE-requested PDU session release / Abnormal / Collision with network-requested PDU session modification procedure	1714
11	Multilayer Procedures	1716
11.1	5GS\EPS Fallback	1716
11.1.1	MO MMTTEL voice call setup from NR RRC_IDLE / EPS Fallback with redirection / Single registration mode with N26 interface / Success.....	1716
11.1.2	MO MMTTEL voice call setup from NR RRC_IDLE / EPS Fallback with redirection / Single registration mode without N26 interface / Success.....	1722
11.1.3	MO MMTTEL voice call setup from NR RRC_CONNECTED / EPS Fallback with handover / Single registration mode with N26 interface / Success.....	1732
11.1.4	MO MMTTEL voice call setup from NR RRC_CONNECTED / EPS Fallback with redirection / Single registration mode with N26 interface / E-UTRAN cell reselection using cell status barred / Success.....	1742
11.1.5	MO MMTTEL voice call setup from NR RRC_CONNECTED / EPS Fallback with redirection / Single registration mode without N26 interface / E-UTRAN cell reselection using cell status reservation / Success	1752

11.1.6 MT MMTEL voice call setup from NR RRC_IDLE / EPS Fallback with redirection / Single registration mode without N26 interface / Success.....1762

11.1.7 Emergency call setup from NR RRC_IDLE / Emergency Services Fallback to EPS with redirection / Single registration mode with N26 interface / Success.....1771

Annex A (informative): Change history1780

History1794

Foreword

This Technical Specification has been produced by the 3rd Generation Partnership Project (3GPP).

The contents of the present document are subject to continuing work within the TSG and may change following formal TSG approval. Should the TSG modify the contents of the present document, it will be re-released by the TSG with an identifying change of release date and an increase in version number as follows:

Version x.y.z

where:

- x the first digit:
 - 1 presented to TSG for information;
 - 2 presented to TSG for approval;
 - 3 or greater indicates TSG approved document under change control.
- y the second digit is incremented for all changes of substance, i.e. technical enhancements, corrections, updates, etc.
- z the third digit is incremented when editorial only changes have been incorporated in the document.

The present document is part 1 of a multi-part deliverable covering the 5G System (5GS) User Equipment (UE) protocol conformance specification, as identified below:

- **3GPP TS 38.523-1: "5GS; User Equipment (UE) conformance specification; Part 1: Protocol"** (the present document).
- 3GPP TS 38.523-2 [2]: "5GS; User Equipment (UE) conformance specification; Part 2: Applicability of protocol test cases".
- 3GPP TS 38.523-3 [3]: "5GS; User Equipment (UE) conformance specification; Part 3: Protocol Test Suites".

1 Scope

The present document specifies the protocol conformance testing for the 3GPP UE connecting to the 5G System (5GS) via its radio interface(s).

The following information can be found in the present document (first part of a multi-part test specification):

- the overall test structure;
- the test configurations;
- the conformance requirement and references to the core specifications;
- the test purposes; and
- a brief description of the test procedure, the specific test requirements and short message exchange table.

The applicability of the individual test cases is specified in the ICS proforma specification (3GPP TS 38.523-2 [2]). The Test Suites are specified in part 3 (3GPP TS 38.523-3 [3]).

The present document is valid for UE implemented according to 3GPP Releases starting from Release 15 up to the Release indicated on the cover page of the present document.

2 References

The following documents contain provisions which, through reference in this text, constitute provisions of the present document.

- References are either specific (identified by date of publication, edition number, version number, etc.) or non-specific.
- For a specific reference, subsequent revisions do not apply.
- For a non-specific reference, the latest version applies. In the case of a reference to a 3GPP document (including a GSM document), a non-specific reference implicitly refers to the latest version of that document *in the same Release as the present document*.

- [1] 3GPP TR 21.905: "Vocabulary for 3GPP Specifications".
- [2] 3GPP TS 38.523-2: "5GS; UE conformance specification; Part 2: Implementation Conformance Statement (ICS) proforma specification".
- [3] 3GPP TS 38.523-3: "5GS; User Equipment (UE) conformance specification; Part 3: Protocol Test Suites".
- [4] 3GPP TS 38.508-1: "5GS; User Equipment (UE) conformance specification; Part 1: Common test environment".
- [5] 3GPP TS 38.508-2: "5GS; User Equipment (UE) conformance specification; Part 2: Common Implementation Conformance Statement (ICS) proforma".
- [6] 3GPP TS 38.509: "5GS; Special conformance testing functions for User Equipment (UE)".
- [7] 3GPP TS 36.508: "Evolved Universal Terrestrial Radio Access (E-UTRA) and Evolved Universal Terrestrial Radio Access (E-UTRAN); Common Test Environments for User Equipment (UE) Conformance Testing".
- [8] 3GPP TS 36.509: "Evolved Universal Terrestrial Radio Access (E-UTRA) and Evolved Universal Terrestrial Radio Access Network (E-UTRAN); Special conformance testing functions for User Equipment (UE)".
- [9] 3GPP TS 38.113: "New Radio (NR); Requirements for support of radio resource management".

- [10] 3GPP TS 36.133: "Evolved Universal Terrestrial Radio Access (E-UTRA); Requirements for support of radio resource management".
- [11] 3GPP TS 36.331: "Evolved Universal Terrestrial Radio Access (E-UTRA); Radio Resource Control (RRC); Protocol specification".
- [12] 3GPP TS 38.331: "NR; Radio Resource Control (RRC) protocol specification".
- [13] 3GPP TS 36.523-1: "Evolved Universal Terrestrial Radio Access (E-UTRA) and Evolved Packet Core (EPC); User Equipment (UE) conformance specification; Part 1: Protocol conformance specification".
- [14] 3GPP TS 38.212: "NR; Multiplexing and channel coding".
- [15] 3GPP TS 38.214: "NR; Physical layer procedures for data".
- [16] 3GPP TS 38.101-1: "NR; User Equipment (UE) radio transmission and reception; Part 1: Range 1 Standalone".
- [17] 3GPP TS 38.101-2: "NR; User Equipment (UE) radio transmission and reception; Part 2: Range 2 Standalone".
- [18] 3GPP TS 38.321: "NR; Medium Access Control (MAC) protocol specification".
- [19] 3GPP TS 38.323: "NR; Packet Data Convergence Protocol (PDCP) specification".
- [20] 3GPP TS 33.501: "Security Architecture and Procedures for 5G System".
- [21] 3GPP TS 24.301: "Non-Access-Stratum (NAS) protocol for Evolved Packet System (EPS); Stage 3".
- [22] 3GPP TS 24.501: "Non-Access-Stratum (NAS) protocol for 5G System (5GS); Stage 3".
- [23] 3GPP TS 38.306: "NR: User Equipment (UE) radio access capabilities"[24] 3GPP TS 38.211: "NR; Physical channels and modulation".
- [25] 3GPP TS 36.523-3: "Evolved Universal Terrestrial Radio Access (E-UTRA) and Evolved Universal Terrestrial Radio Access (E-UTRAN); User Equipment (UE) conformance specification; Part 3: Abstract Test Suites (ATS)".
- [26] 3GPP TS 38.300: "NR; NR and NG-RAN Overall Description; Stage 2".
- [27] 3GPP TS 38.322: "NR; Radio Link Control (RLC) protocol specification".
- [28] 3GPP TS 37.340: "NR; Multi-connectivity; Overall description; Stage-2".
- [29] 3GPP TS 36.523-2: "Evolved Universal Terrestrial Radio Access (E-UTRA) and Evolved Packet Core (EPC); User Equipment (UE) conformance specification; Part 2: Implementation Conformance Statement (ICS) proforma specification".
- [30] 3GPP TS 38.133: "NR; Requirements for support of radio resource management".
- [31] 3GPP TS 23.502: "Procedures for the 5G System; Stage 2".
- [32] IETF RFC 7296: "Internet Key Exchange Protocol Version 2 (IKEv2)".
- [33] 3GPP TS 24.502: "Access to the 3GPP 5G Core Network (5GCN) via Non-3GPP Access Networks (N3AN); Stage 3".
- [34] 3GPP TS 23.003: "Numbering, addressing and identification".
- [35] 3GPP TS 34.229-1: "Internet Protocol (IP) multimedia call control protocol based on Session Initiation Protocol (SIP) and Session Description Protocol (SDP); User Equipment (UE) conformance specification; Part 1: Protocol conformance specification".

3 Definitions, symbols and abbreviations

3.1 Definitions

For the purposes of the present document, the terms and definitions given in 3GPP TR 21.905 [1], specifications referred to in the tests' Conformance requirements subclauses and the following apply. A term defined in the present document takes precedence.

Floor: Floor(x) is the largest integer smaller than or equal to x.

Ceil: Ceil (x) is the smallest integer larger than or equal to x.

3.2 Symbols

For the purposes of the present document, symbols defined in specifications referred to in the tests' Conformance requirements subclauses and the following apply. A symbol defined in the present document takes precedence

None.

3.3 Abbreviations

For the purposes of the present document, the abbreviations given in 3GPP TR 21.905 [1]], specifications referred to in the tests' Conformance requirements subclauses and the following apply. An abbreviation defined in the present document takes precedence.

ICS	Implementation Conformance Statement
FFS	For Further Study

4 Overview

4.1 Test methodology

4.1.1 Testing of optional functions and procedures

Any function or procedure which is optional, as indicated in the present document may be subject to a conformance test if it is implemented in the UE.

A declaration by the apparatus supplier (ICS) is used to determine whether an optional function/procedure has been implemented.

4.1.2 Test interfaces and facilities

Detailed descriptions of the UE test interfaces and special facilities for testing are provided in 3GPP TS 38.509 [6].

4.2 Implicit testing

For some 3GPP signalling and protocol features conformance is not verified explicitly in the present document. This does not imply that correct functioning of these features is not essential, but that these are implicitly tested to a sufficient degree in other tests.

Implicit testing of 5GS requirements may be done also in tests specified in other 3GPP conformance test specifications. For clarity these are listed below:

- Indication for support of EN-DC: if the UE supports E-UTRA-NR dual connectivity, then the UE shall set the DCNR bit to "dual connectivity with NR supported" in the UE network capability IE of the ATTACH

REQUEST/TRACKING AREA UPDATE REQUEST message; verified implicitly (the setting of the DCNR bit to 1) by tests specified in TS 36.523-1 [13].

NOTE 1: It is assumed that an UE supporting EN-DC will support EPS (legacy LTE) and therefore it will be tested against all relevant legacy LTE tests.

4.3 Repetition of tests

As a general rule, the test cases specified in the present document are highly reproducible and don't need to be repeated unless otherwise stated. However, the rate of correct UE behaviour such as cell re-selection, measurement and handover is specified statistically, e.g. "at least 90%" [8], [9]. Additionally, in some of the test cases, presented in TS 38.523-3 [3], HARQ retransmissions are not tolerated, because of characteristics of the test case. In such cases a repetition of test may be required. Details are FFS.

4.4 Handling of differences between conformance requirements in different releases of core specifications

The conformance requirements which determine the scope of each test case are explicitly copy-pasted from relevant core specifications in the especially dedicated for this section of each test with the title 'Conformance requirements'.

NOTE: When in the copy/pasted text there are references to other specifications the reference numbers will not match the reference numbers used in the present document. This approach has been taken in order to allow easy copy and then search for conformance requirements in those specifications.

When differences between conformance requirements in different releases of the cores specifications have impact on the Pre-test conditions, Test procedure sequence or/and the Specific message contents, the Conformance requirements related to different releases are specified separately with clear indication of the Release of the spec from which they were copied.

When there is no Release indicated for a conformance requirement text, this should be understood either as the Conformance requirements in the latest version of the spec with release = the TC Applicability release (which can be found in the column 'Release' for the relevant for the test case entry in the tables in TS 38.523-2 [2], subclause 4.1, or, as the Conformance requirements in the latest version of the spec of the release when the feature was introduced to the core specs.

5 Reference conditions and generic setup procedures

5.1 Reference conditions

The reference environments used by all signalling and protocol tests will be specified in TS 38.508-1 [4]. If a test requires an environment that is different, this will be specified in the test itself.

5.2 Generic setup procedures

A set of basic generic procedures for radio resource signalling, and generic setup procedures for layer 3 NAS signalling will be described in TS 38.508-1 [4]. These procedures will be used in numerous test cases throughout the present document.

6 Idle mode operations

6.1 NR idle mode operations

Editor's note: Intended to capture tests of Idle Mode behaviour defined in TS 38.304

FFS

6.1.1 NG-RAN Only PLMN Selection

6.1.1.1 PLMN selection of RPLMN, HPLMN/EHPLMN, UPLMN and OPLMN / Automatic mode

6.1.1.1.1 Test Purpose (TP)

(1)

```
with { UE in Automatic network selection mode and RPLMN, HPLMN, UPLMN and OPLMN NR cells available
and UE is fitted with a USIM indicating RPLMN should be selected }
ensure that {
  when { UE is switched on or return to coverage }
  then { UE selects a cell of the RPLMN and UE attempts Registration on the selected cell }
}
```

(2)

```
with { UE camped on an NG-RAN VPLMN cell and cells of a higher priority NG-RAN PLMN available }
ensure that {
  when { higher priority PLMN search timer T expires }
  then { UE selects and camps on a cell of the highest priority PLMN and UE attempts Registration
with mobility on the selected cell }
}
```

(3)

```
with { UE in Automatic network selection mode and HPLMN, UPLMN and OPLMN NG-RAN cells available and
UE is fitted with a USIM with Access Technology data files for each PLMN and there are no equivalent
HPLMNs defined}
ensure that {
  when { UE is switched on or return to coverage }
  then { UE selects a cell of the highest priority PLMN and UE attempts Registration with mobility
on the selected cell }
}
```

(4)

```
with { UE camped on an NR VPLMN cell and cells of a NG-RAN HPLMN available }
ensure that {
  when { higher priority PLMN search timer T expires }
  then { UE selects and camps on a cell of HPLMN and UE attempts Registration on the selected cell
}
}
```

6.1.1.1.2 Conformance requirements

References: The conformance requirements covered in the present TC are specified in: TS 23.122 clauses 4.4.3.1, 4.4.3.1.1 and 4.4.3.3.1. Unless otherwise stated these are Rel-15 requirements.

[TS 23.122, clause 4.4.3.1]

At switch on, or following recovery from lack of coverage, the MS selects the registered PLMN or equivalent PLMN (if it is available) using all access technologies that the MS is capable of and if necessary (in the case of recovery from lack of coverage, see subclause 4.5.2) attempts to perform a Location Registration.

NOTE 1: The MS in automatic network selection mode can end the PLMN search procedure once the registered PLMN or equivalent PLMN is found on an access technology.

NOTE 2: An MS in automatic network selection mode can use location information to determine which PLMNs can be available in its present location.

EXCEPTION: As an alternative option to this, if the MS is in automatic network selection mode and it finds coverage of an EHPLMN, the MS may register to that EHPLMN and not return to the registered PLMN or equivalent PLMN. If

the EHPLMN list is not present or is empty, and the HPLMN is available, the MS may register on the HPLMN and not return to the registered PLMN or equivalent PLMN. The operator shall be able to control by SIM configuration whether an MS that supports this option is permitted to perform this alternative behaviour.

EXCEPTION: In A/Gb mode an MS with voice capability, shall not search for CPBCCCH carriers. In A/Gb mode an MS not supporting packet services shall not search for CPBCCCH carriers.

If successful registration is achieved, the MS indicates the selected PLMN.

If there is no registered PLMN, or if registration is not possible due to the PLMN being unavailable or registration failure, the MS follows one of the following two procedures depending on its PLMN selection operating mode. At switch on, if the MS provides the optional feature of user preferred PLMN selection operating mode at switch on then this operating mode shall be used. Otherwise, the MS shall use the PLMN selection mode that was used before switching off.

EXCEPTION: At switch on, if the MS is in manual mode and neither registered PLMN nor PLMN that is equivalent to it is available but EHPLMN is available, then instead of performing the manual network selection mode procedure of subclause 4.4.3.1.2 the MS may select and attempt registration on the highest priority EHPLMN. If the EHPLMN list is not available or is empty and the HPLMN is available, then the MS may select and attempt registration on the HPLMN. The MS shall remain in manual mode.

NOTE 3: If successful registration is achieved, then the current serving PLMN becomes the registered PLMN and the MS does not store the previous registered PLMN for later use.

EXCEPTION: If registration is not possible on recovery from lack of coverage due to the registered PLMN being unavailable, an MS attached to GPRS services, attached via E-UTRAN or registered via the NG-RAN may, optionally, continue looking for the registered PLMN for an implementation dependent time.

NOTE 4: An MS attached to GPRS services, attached via E-UTRAN or registered via the NG-RAN should use the above exception only if one or more PDP contexts, PDN connections or PDU sessions are currently active.

[TS 23.122, clause 4.4.3.1.1]

The MS selects and attempts registration on other PLMN/access technology combinations, if available and allowable, in the following order:

- i) either the HPLMN (if the EHPLMN list is not present or is empty) or the highest priority EHPLMN that is available (if the EHPLMN list is present) ;
- ii) each PLMN/access technology combination in the "User Controlled PLMN Selector with Access Technology" data file in the SIM (in priority order);
- iii) each PLMN/access technology combination in the "Operator Controlled PLMN Selector with Access Technology" data file in the SIM (in priority order);
- iv) other PLMN/access technology combinations with received high quality signal in random order;
- v) other PLMN/access technology combinations in order of decreasing signal quality.

When following the above procedure the following requirements apply:

- a) An MS with voice capability shall ignore PLMNs for which the MS has identified at least one GSM COMPACT.
- b) In A/Gb mode or GSM COMPACT, an MS with voice capability, or an MS not supporting packet services shall not search for CPBCCCH carriers.
- c) In ii and iii, the MS should limit its search for the PLMN to the access technology or access technologies associated with the PLMN in the appropriate PLMN Selector with Access Technology list (User Controlled or Operator Controlled selector list).

An MS using a SIM without access technology information storage (i.e. the "User Controlled PLMN Selector with Access Technology" and the "Operator Controlled PLMN Selector with Access Technology" data files are not present) shall instead use the "PLMN Selector" data file, for each PLMN in the "PLMN Selector" data file, the MS shall search for all access technologies it is capable of. The priority ordering amongst the access technologies is implementation dependent.

- d) In iv and v, the MS shall search for all access technologies it is capable of, before deciding which PLMN to select.
- e) In ii, and iii, a packet only MS which supports GSM COMPACT, but using a SIM without access technology information storage (i.e. the "User Controlled PLMN Selector with Access Technology" and the "Operator Controlled PLMN Selector with Access Technology" data files are not present) shall instead use the "PLMN Selector" data file, for each PLMN in the "PLMN Selector" data file, the MS shall search for all access technologies it is capable of and shall assume GSM COMPACT access technology as the lowest priority radio access technology.
- f) In i, the MS shall search for all access technologies it is capable of. No priority is defined for the preferred access technology and the priority is an implementation issue, but "HPLMN Selector with Access Technology" data file on the SIM may be used to optimise the procedure.
- g) In i, an MS using a SIM without access technology information storage (i.e. the "HPLMN Selector with Access Technology" data file is not present) shall search for all access technologies it is capable of. The priority ordering amongst the access technologies is implementation dependent. A packet only MS which supports GSM COMPACT using a SIM without access technology information storage shall also assume GSM COMPACT access technology as the lowest priority radio access technology.

NOTE 1: For f) and g), the MS in automatic network selection mode can end the PLMN search procedure once the HPLMN or the highest priority EHPLMN is found on an access technology.

NOTE 2: For i, ii and iii, the MS can use location information to determine which PLMNs can be available in its present location.

- h) In v, the MS shall order the PLMN/access technology combinations in order of decreasing signal quality within each access technology. The order between PLMN/access technology combinations with different access technologies is an MS implementation issue.

NOTE 3: Requirements a) and b) apply also to requirement d), so a GSM voice capable MS should not search for GSM COMPACT PLMNs, even if capable of GSM COMPACT.

NOTE 4: Requirements a) and b) apply also to requirement f), so a GSM voice capable MS should not search for GSM COMPACT PLMNs, even if this is the only access technology on the "HPLMN Selector with Access Technology" data file on the SIM.

NOTE 5: High quality signal is defined in the appropriate AS specification.

- i) In i to v, the MS shall not consider PLMNs where voice service was not possible as PLMN selection candidate, unless such PLMN is available in GERAN or UTRAN or no other allowed PLMN is available.
- j) In i to v, if the MS only supports EMM-REGISTERED without PDN connection (see 3GPP TS 24.301 [23A]), the MS shall not consider PLMNs which do not advertise support of EMM-REGISTERED without PDN connection.
- k) In i to v, if the MS only supports control plane CIoT EPS optimization (see 3GPP TS 24.301 [23A]) and the UE camps on a E-UTRA cell which is not NB-IoT cell (see 3GPP TS 36.304 [43], 3GPP TS 36.331 [22]), the MS shall not consider PLMNs which do not advertise support of EPS services with control plane CIoT EPS optimization.
- l) In i to v, if the MS is in eCall only mode, the MS shall not consider PLMNs which do not advertise support for eCall over IMS, unless such PLMNs are available in GERAN or UTRAN.

NOTE 6: As an implementation option, an MS in eCall only mode that was not able to select any PLMN according to l) can perform a second iteration of i to v with no restriction.

If successful registration is achieved, the MS indicates the selected PLMN.

If registration cannot be achieved because no PLMNs are available and allowable, the MS indicates "no service" to the user, waits until a new PLMN is available and allowable and then repeats the procedure.

If there were one or more PLMNs which were available and allowable, but an LR failure made registration on those PLMNs unsuccessful or an entry in any of the lists "forbidden location areas for roaming", "forbidden tracking areas for roaming", "5GS forbidden tracking areas for roaming", "forbidden location areas for regional provision of service", "forbidden tracking areas for regional provision of service" or "5GS forbidden tracking areas for regional provision of service" prevented a registration attempt, the MS selects the first such PLMN again and enters a limited service state.

[TS 23.122, clause 4.4.3.3.1]

If the MS is in a VPLMN, the MS shall periodically attempt to obtain service on its HPLMN (if the EHPLMN list is not present or is empty) or one of its EHPLMNs (if the EHPLMN list is present) or a higher priority PLMN/access technology combinations listed in "user controlled PLMN selector" or "operator controlled PLMN selector" by scanning in accordance with the requirements that are applicable to i), ii) and iii) as defined in the Automatic Network Selection Mode in subclause 4.4.3.1.1. In the case that the mobile has a stored "Equivalent PLMNs" list the mobile shall only select a PLMN if it is of a higher priority than those of the same country as the current serving PLMN which are stored in the "Equivalent PLMNs" list. For this purpose, a value of timer T may be stored in the SIM. The interpretation of the stored value depends on the radio capabilities supported by the MS:

- For an MS that does not support any of the following: EC-GSM-IoT, Category M1 or Category NB1 (as defined in 3GPP TS 36.306 [54]), T is either in the range 6 minutes to 8 hours in 6 minute steps or it indicates that no periodic attempts shall be made. If no value for T is stored in the SIM, a default value of 60 minutes is used for T.
- For an MS that only supports any of the following or a combination of: EC-GSM-IoT, Category M1 or Category NB1 (as defined in 3GPP TS 36.306 [54]), T is either in the range 2 hours to 240 hours, using 2 hour steps from 2 hours to 80 hours and 4 hour steps from 84 hours to 240 hours, or it indicates that no periodic attempts shall be made. If no value for T is stored in the SIM, a default value of 72 hours is used.
- For an MS that supports both:
 - a) any of the following or a combination of: EC-GSM-IoT, Category M1 or Category NB1 (as defined in 3GPP TS 36.306 [54]); and
 - b) any access technology other than the following: EC-GSM-IoT, Category M1 or Category NB1 (as defined in 3GPP TS 36.306 [54]),

then T is interpreted depending on the access technology in use as specified below:

- 1) if the MS is using any of the following at the time of starting timer T: EC-GSM-IoT, Category M1 or Category NB1 (as defined in 3GPP TS 36.306 [54]), T is either in the range 2 hours to 240 hours, using 2 hour steps from 2 hours to 80 hours and 4 hour steps from 84 hours to 240 hours, or it indicates that no periodic attempts shall be made. If no value for T is stored in the SIM, a default value of 72 hours is used; and
- 2) if the MS is not using any of the following at the time of starting timer T: EC-GSM-IoT, Category M1 or Category NB1 (as defined in 3GPP TS 36.306 [54]), T is either in the range 6 minutes to 8 hours in 6 minute steps or it indicates that no periodic attempts shall be made. If no value for T is stored in the SIM, a default value of 60 minutes is used for T.

If the MS is configured with the MinimumPeriodicSearchTimer as specified in 3GPP TS 24.368 [50] or 3GPP TS 31.102 [40], the MS shall not use a value for T that is less than the MinimumPeriodicSearchTimer. If the value stored in the SIM, or the default value for T (when no value is stored in the SIM), is less than the MinimumPeriodicSearchTimer, then T shall be set to the MinimumPeriodicSearchTimer.

The MS does not stop timer T, as described in 3GPP TS 24.008 [23] and 3GPP TS 24.301 [23A], when it activates power saving mode (PSM) (see 3GPP TS 23.682 [27A]).

The MS can be configured for Fast First Higher Priority PLMN search as specified in 3GPP TS 31.102 [40] or 3GPP TS 24.368 [50]. Fast First Higher Priority PLMN search is enabled if the corresponding configuration parameter is present and set to enabled. Otherwise, Fast First Higher Priority PLMN search is disabled.

The attempts to access the HPLMN or an EHPLMN or higher priority PLMN shall be as specified below:

- a) The periodic attempts shall only be performed in automatic mode when the MS is roaming, and not while the MS is attached for emergency bearer services, is registered for emergency services, has a PDU session for emergency services or has a PDN connection for emergency bearer services;
- b) The MS shall make the first attempt after a period of at least 2 minutes and at most T minutes:
 - only after switch on if Fast First Higher Priority PLMN search is disabled; or
 - after switch on or upon selecting a VPLMN if Fast First Higher Priority PLMN search is enabled.
- c) The MS shall make the following attempts if the MS is on the VPLMN at time T after the last attempt;
- d) Periodic attempts shall only be performed by the MS while in idle mode;
- d1) Periodic attempts may be postponed while the MS is in power saving mode (PSM) (see 3GPP TS 23.682 [27A]).
- d2) Periodic attempts may be postponed while the MS is receiving eMBMS transport service in idle mode (see 3GPP TS 23.246 [68]).
- e) If the HPLMN (if the EHPLMN list is not present or is empty) or a EHPLMN (if the list is present) or a higher priority PLMN is not found, the MS shall remain on the VPLMN.
- f) In steps i), ii) and iii) of subclause 4.4.3.1.1 the MS shall limit its attempts to access higher priority PLMN/access technology combinations to PLMN/access technology combinations of the same country as the current serving VPLMN, as defined in Annex B.
- g) Only the priority levels of Equivalent PLMNs of the same country as the current serving VPLMN, as defined in Annex B, shall be taken into account to compare with the priority level of a selected PLMN.
- h) If the PLMN of the highest priority PLMN/access technology combination available is the current VPLMN, or one of the PLMNs in the "Equivalent PLMNs" list, the MS shall remain on the current PLMN/access technology combination.

6.1.1.1.3 Test description

6.1.1.1.3.1 Pre-test conditions

System Simulator:

- Four inter-frequency multi-PLMN NR Cells as specified in TS 38.508-1 [4] Table 4.4.2.1 are configured broadcasting PLMNs as indicated in Table 6.1.1.1.3.1-1.
- The PLMNs are identified in the test by the identifiers in Table 6.1.1.1.3.1-1.

Table 6.1.1.1.3.1–1: PLMN identifiers

NR Cell	PLMN name	MCC	MNC
1	PLMN4	001	01
12	PLMN1	001	11
13	PLMN2	001	21
14	PLMN3	001	31

All NR cells are high quality

All NR cells are suitable cells;

System information combination NR-1 as defined in TS 38.508-1 [4] clause 4.4.3.1.2 is used in NR cells

UE:

The UE is in Automatic PLMN selection mode.

The UE is registered to PLMN1 before it is switched off.

USIM configuration as defined in TS 38.508-1 [4] Table 6.4.1-1 will be loaded except for PLMN identifiers in Table 6.1.1.1.3.1-1.

Preamble:

- The UE is made to camp on NR Cell 12 and then Switched OFF (State ON-B) as defined in TS 38.508-1 [4] Table 4.4A.2-0

6.1.1.1.3.2 Test procedure sequence

Table 6.1.1.1.3.2-1 for FR1 and Table 6.1.1.1.3.2-2 for FR2 illustrates the downlink power levels and other changing parameters to be applied for the cells at various time instants of the test execution. Row marked "T0" denotes the initial conditions after preamble, while columns marked "T1", "T2" and "T3" are to be applied subsequently in the Main behaviour. The exact instants on which these values shall be applied are described in the texts in this clause.

Table 6.1.1.1.3.2-1: Cell configuration changes over time for FR1

	Parameter	Unit	NR Cell 1	NR Cell 12	NR Cell 13	NR Cell 14	Remarks
T0	SS/PBCH SSS EPRE	dBm/SCS	"Off"	-88	"Off"	"Off"	Power level "Off" is defined in TS 38.508-1 Table 6.2.2.1-3
T1	SS/PBCH SSS EPRE	dBm/SCS	-88	-88	-88	"Off"	Power level "Off" is defined in TS 38.508-1 Table 6.2.2.1-3
T2	SS/PBCH SSS EPRE	dBm/SCS	"Off"	-88	-88	"Off"	Power level "Off" is defined in TS 38.508-1 Table 6.2.2.1-3
T3	SS/PBCH SSS EPRE	dBm/SCS	"Off"	-88	-88	-88	Power level "Off" is defined in TS 38.508-1 Table 6.2.2.1-3

Table 6.1.1.1.3.2-2: Cell configuration changes over time for FR2

	Parameter	Unit	NR Cell 1	NR Cell 12	NR Cell 13	NR Cell 14	Remarks
T0	SS/PBCH SSS EPRE	dBm/SCS	"Off"	[-85]	"Off"	"Off"	Power level "Off" is defined in TS 38.508-1 Table 6.2.2.1-3
T1	SS/PBCH SSS EPRE	dBm/SCS	[-85]	[-85]	[-85]	"Off"	Power level "Off" is defined in TS 38.508-1 Table 6.2.2.1-3
T2	SS/PBCH SSS EPRE	dBm/SCS	"Off"	[-85]	[-85]	"Off"	Power level "Off" is defined in TS 38.508-1 Table 6.2.2.1-3
T3	SS/PBCH SSS EPRE	dBm/SCS	"Off"	[-85]	[-85]	[-85]	Power level "Off" is defined in TS 38.508-1 Table 6.2.2.1-3

Table 6.1.1.1.3.2-2: Main behaviour

St	Procedure	Message Sequence		TP	Verdict
		U - S	Message		
1	SS adjusts cell levels according to row T1 of table 6.1.1.1.3.2-1 for FR1 and table 6.1.1.1.3.2-2 for FR2	-	-	-	-
2	Power on the UE.	-	-	-	-
3	Check: Does the UE send a <i>RRCSetupRequest</i> on NR Cell 12?	-->	<i>RRCSetupRequest</i>	1	P
4-21	Steps 3 to 20 of the registration procedure described in TS 38.508-1 subclause 4.5.2.2-2 are performed on NR Cell 12. NOTE: The UE performs registration and the RRC connection is released.	-	-	-	-
22	Check: Does the UE send a <i>RRCSetupRequest</i> on NR Cell 1 after 120 seconds, but before 660seconds (Note 1 and 2) from power on?	-->	<i>RRCSetupRequest</i>	4	P
23-27	Steps 2 to 6 of the generic test procedure in TS 38.508-1 Table 4.9.5.2.2-1 with condition MOBILITY are performed on NR Cell 1. NOTE: The UE performs a "REGISTRATION REQUEST" procedure with type "mobility registration updating" and the RRC connection is released	-	-	-	-
28	SS adjusts cell levels according to row T2 of table 6.1.1.1.3.2-1 for FR1 and table 6.1.1.1.3.2-2 for FR2	-	-	-	-
29	Check: Does the test result of generic test procedure in TS 38.508-1 Table 4.9.5.2.2-1 indicate that the UE is camped on NR Cell 13? NOTE: The UE performs a "REGISTRATION REQUEST" procedure with type "mobility registration updating" and the RRC connection is released	-	-	3	-
30	SS adjusts cell levels according to row T3 of table 6.1.1.1.3.2-1 for FR1 and table 6.1.1.1.3.2-2 for FR2	-	-	-	-
31	Check: Does the UE send a <i>RRCSetupRequest</i> on NR Cell 14 after 120 seconds, but before 660 seconds after step 30? (Note 1 and 2)	-->	<i>RRCSetupRequest</i>	2	P
32-36	Steps 2 to 6 of the generic test procedure in TS 38.508-1 Table 4.9.5.2.2-1 with condition MOBILITY are performed. NOTE: The UE performs a "REGISTRATION REQUEST" procedure with type "mobility registration updating" and the RRC connection is released	-	-	-	-
<p>Note 1: Following attempts to access the HPLMN/EHPLMN/higher priority PLMN in VPLMN is operator specific setting (Refer to TS 23.122 Rel-15).Hence, window between 120s to T+Tolerance is being used, where the high priority PLMN search timer T defined by EF_{HPPLMN}.</p> <p>Note 2: Tolerance of 5min is added to allow time for the UE to find the proper PLMN</p>					

6.1.1.1.3.3 Specific message contents

None

6.1.1.2 PLMN selection of "Other PLMN/access technology combinations" / Automatic mode

6.1.1.2.1 Test Purpose (TP)

(1)

```
with { UE in Automatic network selection mode and EHPLMN, UPLMN and OPLMN/access technology
combinations cells available and UE is fitted with a USIM with Access Technology data files for each
PLMN }
ensure that {
  when { UE is switched on or return to coverage }
  then { UE selects a cell of the EHPLMN and UE attempts a Registration on the selected cell }
}
```

(2)

```
with { UE in Automatic network selection mode and UPLMN, OPLMN and other PLMN/access technology
combinations cells available and UE is fitted with a USIM with Access Technology data files for each
PLMN }
ensure that {
  when { UE is switched on or return to coverage }
  then { UE selects a cell of the UPLMN and UE attempts a Registration on the selected cell }
}
```

(3)

```
with { UE in Automatic network selection mode and OPLMN and other PLMN/access technology
combinations cells available and UE is fitted with a USIM with Access Technology data files for each
PLMN }
ensure that {
  when { UE is switched on or return to coverage }
  then { UE selects a cell of the OPLMN and UE attempts a Registration on the selected cell }
}
```

(4)

```
with { UE in Automatic network selection mode and other PLMN/access technology combinations cells
not belonging to any of EHPLMN, UPLMN or OPLMN available }
ensure that {
  when { UE is switched on or return to coverage }
  then { UE selects a cell of other PLMN/access technology combinations and UE attempts a
Registration on the selected cell }
}
```

6.1.1.2.2 Conformance requirements

References: The conformance requirements covered in the current TC are specified in: TS 23.122 clauses 4.4.3.1.1. Unless otherwise stated these are Rel-15 requirements.

[TS 23.122, clause 4.4.3.1.1]

The MS selects and attempts registration on other PLMN/access technology combinations, if available and allowable, in the following order:

- i) either the HPLMN (if the EHPLMN list is not present or is empty) or the highest priority EHPLMN that is available (if the EHPLMN list is present) ;
- ii) each PLMN/access technology combination in the "User Controlled PLMN Selector with Access Technology" data file in the SIM (in priority order);
- iii) each PLMN/access technology combination in the "Operator Controlled PLMN Selector with Access Technology" data file in the SIM (in priority order);
- iv) other PLMN/access technology combinations with received high quality signal in random order;
- v) other PLMN/access technology combinations in order of decreasing signal quality.

When following the above procedure the following requirements apply:

- a) An MS with voice capability shall ignore PLMNs for which the MS has identified at least one GSM COMPACT.
- b) In A/Gb mode or GSM COMPACT, an MS with voice capability, or an MS not supporting packet services shall not search for CPBCCCH carriers.
- c) In ii and iii, the MS should limit its search for the PLMN to the access technology or access technologies associated with the PLMN in the appropriate PLMN Selector with Access Technology list (User Controlled or Operator Controlled selector list).

An MS using a SIM without access technology information storage (i.e. the "User Controlled PLMN Selector with Access Technology" and the "Operator Controlled PLMN Selector with Access Technology" data files are not present) shall instead use the "PLMN Selector" data file, for each PLMN in the "PLMN Selector" data file, the MS shall search for all access technologies it is capable of. The priority ordering amongst the access technologies is implementation dependent.

- d) In iv and v, the MS shall search for all access technologies it is capable of, before deciding which PLMN to select.
- e) In ii, and iii, a packet only MS which supports GSM COMPACT, but using a SIM without access technology information storage (i.e. the "User Controlled PLMN Selector with Access Technology" and the "Operator Controlled PLMN Selector with Access Technology" data files are not present) shall instead use the "PLMN Selector" data file, for each PLMN in the "PLMN Selector" data file, the MS shall search for all access technologies it is capable of and shall assume GSM COMPACT access technology as the lowest priority radio access technology.
- f) In i, the MS shall search for all access technologies it is capable of. No priority is defined for the preferred access technology and the priority is an implementation issue, but "HPLMN Selector with Access Technology" data file on the SIM may be used to optimise the procedure.
- g) In i, an MS using a SIM without access technology information storage (i.e. the "HPLMN Selector with Access Technology" data file is not present) shall search for all access technologies it is capable of. The priority ordering amongst the access technologies is implementation dependent. A packet only MS which supports GSM COMPACT using a SIM without access technology information storage shall also assume GSM COMPACT access technology as the lowest priority radio access technology.

NOTE 1: For f) and g), the MS in automatic network selection mode can end the PLMN search procedure once the HPLMN or the highest priority EHPLMN is found on an access technology.

NOTE 2: For i, ii and iii, the MS can use location information to determine which PLMNs can be available in its present location.

- h) In v, the MS shall order the PLMN/access technology combinations in order of decreasing signal quality within each access technology. The order between PLMN/access technology combinations with different access technologies is an MS implementation issue.

NOTE 3: Requirements a) and b) apply also to requirement d), so a GSM voice capable MS should not search for GSM COMPACT PLMNs, even if capable of GSM COMPACT.

NOTE 4: Requirements a) and b) apply also to requirement f), so a GSM voice capable MS should not search for GSM COMPACT PLMNs, even if this is the only access technology on the "HPLMN Selector with Access Technology" data file on the SIM.

NOTE 5: High quality signal is defined in the appropriate AS specification.

- i) In i to v, the MS shall not consider PLMNs where voice service was not possible as PLMN selection candidate, unless such PLMN is available in GERAN or UTRAN or no other allowed PLMN is available.
- j) In i to v, if the MS only supports EMM-REGISTERED without PDN connection (see 3GPP TS 24.301 [23A]), the MS shall not consider PLMNs which do not advertise support of EMM-REGISTERED without PDN connection.

- k) In i to v, if the MS only supports control plane CIoT EPS optimization (see 3GPP TS 24.301 [23A]) and the UE camps on a E-UTRA cell which is not NB-IoT cell (see 3GPP TS 36.304 [43], 3GPP TS 36.331 [22]), the MS shall not consider PLMNs which do not advertise support of EPS services with control plane CIoT EPS optimization.
- l) In i to v, if the MS is in eCall only mode, the MS shall not consider PLMNs which do not advertise support for eCall over IMS, unless such PLMNs are available in GERAN or UTRAN.

NOTE 6: As an implementation option, an MS in eCall only mode that was not able to select any PLMN according to l) can perform a second iteration of i to v with no restriction.

If successful registration is achieved, the MS indicates the selected PLMN.

If registration cannot be achieved because no PLMNs are available and allowable, the MS indicates "no service" to the user, waits until a new PLMN is available and allowable and then repeats the procedure.

If there were one or more PLMNs which were available and allowable, but an LR failure made registration on those PLMNs unsuccessful or an entry in any of the lists "forbidden location areas for roaming", "forbidden tracking areas for roaming", "5GS forbidden tracking areas for roaming", "forbidden location areas for regional provision of service", "forbidden tracking areas for regional provision of service" or "5GS forbidden tracking areas for regional provision of service" prevented a registration attempt, the MS selects the first such PLMN again and enters a limited service state.

6.1.1.2.3 Test description

6.1.1.2.3.1 Pre-test conditions

System Simulator:

- Four inter-frequency multi-PLMN cells as specified in TS 38.508-1 [4] clause 4.4.1.1.3 are configured broadcasting default PLMNs as indicated in TS 38.508-1 [4] Table 4.4.2-3.
- The PLMNs are identified in the test by the identifiers in Table 6.1.1.2.3.1-1.

Table 6.1.1.2.3.1-1: PLMN identifiers

NR Cell	PLMN name
1	PLMN1
12	PLMN2
13	PLMN3
14	PLMN4

UE:

- The UE is in Automatic PLMN selection mode.
- The UE is equipped with a USIM configuration as defined in TS 38.508-1 [4] Table 6.4.1-4.

Preamble:

- Ensure that the UE has cleared the RPLMN. And the UE is in state Switched OFF (state 0-A).

6.1.1.2.3.2 Test procedure sequence

Table 6.1.1.2.3.2-1/2 shows the cell configurations used during the test. Subsequent configurations marked "T1", "T2" "T3" "T4" etc are applied at the points indicated in the Main behaviour description in Table 6.1.1.2.3.2-3. Cell powers are chosen for a serving cell and a non-suitable "Off" cell as defined in TS 38.508-1 [4] Table 6.2.2.1-3 for FR1 and Table 6.2.2.2-2 for FR2.

Table 6.1.1.2.3.2-1: Time instances of cell power level and parameter changes for FR1

	Parameter	Unit	NR Cell 1	NR Cell 12	NR Cell 13	NR Cell 14	Remarks
T1	SS/PBCH SSS EPRE	dBm/SCS	-88	-88	-88	"Off"	Power level "Off" is defined in TS 38.508-1 [4] Table 6.2.2.1-3.
T2	SS/PBCH SSS EPRE	dBm/SCS	"Off"	-88	-88	-88	Power level "Off" is defined in TS 38.508-1 [4] Table 6.2.2.1-3.
T3	SS/PBCH SSS EPRE	dBm/SCS	"Off"	"Off"	-88	-88	Power level "Off" is defined in TS 38.508-1 [4] Table 6.2.2.1-3.
T4	SS/PBCH SSS EPRE	dBm/SCS	"Off"	"Off"	"Off"	-88	Power level "Off" is defined in TS 38.508-1 [4] Table 6.2.2.1-3.

Table 6.1.1.2.3.2-2: Time instances of cell power level and parameter changes for FR2

	Parameter	Unit	NR Cell 1	NR Cell 12	NR Cell 13	NR Cell 14	Remarks
T1	SS/PBCH SSS EPRE	dBm/SCS	FFS	FFS	FFS	"Off"	Power level "Off" is defined in TS 38.508-1 [4] Table 6.2.2.2-2.
T2	SS/PBCH SSS EPRE	dBm/SCS	"Off"	FFS	FFS	FFS	Power level "Off" is defined in TS 38.508-1 [4] Table 6.2.2.2-2.
T3	SS/PBCH SSS EPRE	dBm/SCS	"Off"	"Off"	FFS	FFS	Power level "Off" is defined in TS 38.508-1 [4] Table 6.2.2.2-2.
T4	SS/PBCH SSS EPRE	dBm/SCS	"Off"	"Off"	"Off"	FFS	Power level "Off" is defined in TS 38.508-1 [4] Table 6.2.2.2-2.

Table 6.1.1.2.3.2-3: Main behaviour

St	Procedure	Message Sequence		TP	Verdict
		U - S	Message		
1	SS adjusts cell levels according to row T1 of table 6.1.1.2.3.2-1/2.	-	-	-	-
2	Power on the UE.	-	-	-	-
3	Check: Does the UE send an <i>RRCSetupRequest</i> on NR Cell 1?	-->	NR RRC: <i>RRCSetupRequest</i>	1	P
4-21	Steps 3 to 20 of the registration procedure described in TS 38.508-1 [4] subclause 4.5.2.2 are performed on NR Cell 1. NOTE: The UE performs registration and the RRC connection is released.	-	-	-	-
22	SS adjusts cell levels according to row T2 of table 6.1.1.2.3.2-1/2.	-	-	-	-
23	Check: Does the UE send an <i>RRCSetupRequest</i> on NR Cell 12?	-->	NR RRC: <i>RRCSetupRequest</i>	2	P
24-28b 1	Steps 2 to 6b1 of the generic test procedure in TS 38.508-1 [4] subclause 4.9.5.2.2-1 are performed on NR Cell 12. NOTE: The UE performs a registration for mobility procedure and the RRC connection is released.	-	-	-	-
29	SS adjusts cell levels according to row T3 of table 6.1.1.2.3.2-1/2.	-	-	-	-
30	Check: Does the UE send an <i>RRCSetupRequest</i> on NR Cell 13?	-->	NR RRC: <i>RRCSetupRequest</i>	3	P
31-35b 1	Steps 2 to 6b1 of the generic test procedure in TS 38.508-1 [4] subclause 4.9.5.2.2-1 are performed on NR Cell 13. NOTE: The UE performs a registration for mobility procedure and the RRC connection is released.	-	-	-	-
36	SS adjusts cell levels according to row T4 of table 6.1.1.2.3.2-1/2.	-	-	-	-
37	Check: Does the UE send an <i>RRCSetupRequest</i> on NR Cell 14?	-->	NR RRC: <i>RRCSetupRequest</i>	4	P
38-42b 1	Steps 2 to 6b1 of the generic test procedure in TS 38.508-1 [4] subclause 4.9.5.2.2-1 are performed on NR Cell 14. NOTE: The UE performs a registration for mobility procedure and the RRC connection is released.	-	-	-	-

6.1.1.2.3.3 Specific message contents

None

6.1.1.3 Cell reselection of ePLMN in manual mode

6.1.1.3.1 Test Purpose (TP)

(1)

```

with { UE camped normally on a cell and network has downloaded a list of equivalent PLMNs during the
Registration procedure }
ensure that {
  when { Higher ranked cell is a cell of a PLMN in the downloaded equivalent PLMN list }
  then { UE reselects to the equivalent PLMN cell }
}

```

(2)

```

with { UE camped normally on a cell and network has downloaded a list of equivalent PLMNs during
Registration procedure for mobility }
ensure that {
  when { Highest ranked cell is a cell of a PLMN not in the downloaded equivalent PLMN list }
  then { UE does not reselect to the cell }
}

```

6.1.1.3.2 Conformance requirements

References: The conformance requirements covered in the current TC are specified in: TS 23.122, clauses 4.4.3.1.2. Unless otherwise stated these are Rel-15 requirements.

[TS 23.122, clause 4.4.3.1.2]

The MS selects and attempts registration on other PLMN/access technology combinations, if available and allowable, in the following order:

- i) either the HPLMN (if the EHPLMN list is not present or is empty) or the highest priority EHPLMN that is available (if the EHPLMN list is present) ;
- ii) each PLMN/access technology combination in the "User Controlled PLMN Selector with Access Technology" data file in the SIM (in priority order);
- iii) each PLMN/access technology combination in the "Operator Controlled PLMN Selector with Access Technology" data file in the SIM (in priority order);
- iv) other PLMN/access technology combinations with received high quality signal in random order;
- v) other PLMN/access technology combinations in order of decreasing signal quality.

When following the above procedure the following requirements apply:

- a) An MS with voice capability shall ignore PLMNs for which the MS has identified at least one GSM COMPACT.
- b) In A/Gb mode or GSM COMPACT, an MS with voice capability, or an MS not supporting packet services shall not search for CPBCCCH carriers.
- c) In ii and iii, the MS should limit its search for the PLMN to the access technology or access technologies associated with the PLMN in the appropriate PLMN Selector with Access Technology list (User Controlled or Operator Controlled selector list).

An MS using a SIM without access technology information storage (i.e. the "User Controlled PLMN Selector with Access Technology" and the "Operator Controlled PLMN Selector with Access Technology" data files are not present) shall instead use the "PLMN Selector" data file, for each PLMN in the "PLMN Selector" data file, the MS shall search for all access technologies it is capable of. The priority ordering amongst the access technologies is implementation dependent.

- d) In iv and v, the MS shall search for all access technologies it is capable of, before deciding which PLMN to select.
- e) In ii, and iii, a packet only MS which supports GSM COMPACT, but using a SIM without access technology information storage (i.e. the "User Controlled PLMN Selector with Access Technology" and the "Operator Controlled PLMN Selector with Access Technology" data files are not present) shall instead use the "PLMN Selector" data file, for each PLMN in the "PLMN Selector" data file, the MS shall search for all access technologies it is capable of and shall assume GSM COMPACT access technology as the lowest priority radio access technology.
- f) In i, the MS shall search for all access technologies it is capable of. No priority is defined for the preferred access technology and the priority is an implementation issue, but "HPLMN Selector with Access Technology" data file on the SIM may be used to optimise the procedure.
- g) In i, an MS using a SIM without access technology information storage (i.e. the "HPLMN Selector with Access Technology" data file is not present) shall search for all access technologies it is capable of. The priority ordering amongst the access technologies is implementation dependent. A packet only MS which supports GSM

COMPACT using a SIM without access technology information storage shall also assume GSM COMPACT access technology as the lowest priority radio access technology.

NOTE 1: For f) and g), the MS in automatic network selection mode can end the PLMN search procedure once the HPLMN or the highest priority EHPLMN is found on an access technology.

NOTE 2: For i, ii and iii, the MS can use location information to determine which PLMNs can be available in its present location.

h) In v, the MS shall order the PLMN/access technology combinations in order of decreasing signal quality within each access technology. The order between PLMN/access technology combinations with different access technologies is an MS implementation issue.

NOTE 3: Requirements a) and b) apply also to requirement d), so a GSM voice capable MS should not search for GSM COMPACT PLMNs, even if capable of GSM COMPACT.

NOTE 4: Requirements a) and b) apply also to requirement f), so a GSM voice capable MS should not search for GSM COMPACT PLMNs, even if this is the only access technology on the "HPLMN Selector with Access Technology" data file on the SIM.

NOTE 5: High quality signal is defined in the appropriate AS specification.

i) In i to v, the MS shall not consider PLMNs where voice service was not possible as PLMN selection candidate, unless such PLMN is available in GERAN or UTRAN or no other allowed PLMN is available.

j) In i to v, if the MS only supports EMM-REGISTERED without PDN connection (see 3GPP TS 24.301 [23A]), the MS shall not consider PLMNs which do not advertise support of EMM-REGISTERED without PDN connection.

k) In i to v, if the MS only supports control plane CIoT EPS optimization (see 3GPP TS 24.301 [23A]) and the UE camps on a E-UTRA cell which is not NB-IoT cell (see 3GPP TS 36.304 [43], 3GPP TS 36.331 [22]), the MS shall not consider PLMNs which do not advertise support of EPS services with control plane CIoT EPS optimization.

l) In i to v, if the MS is in eCall only mode, the MS shall not consider PLMNs which do not advertise support for eCall over IMS, unless such PLMNs are available in GERAN or UTRAN.

NOTE 6: As an implementation option, an MS in eCall only mode that was not able to select any PLMN according to l) can perform a second iteration of i to v with no restriction.

If successful registration is achieved, the MS indicates the selected PLMN.

If registration cannot be achieved because no PLMNs are available and allowable, the MS indicates "no service" to the user, waits until a new PLMN is available and allowable and then repeats the procedure.

If there were one or more PLMNs which were available and allowable, but an LR failure made registration on those PLMNs unsuccessful or an entry in any of the lists "forbidden location areas for roaming", "forbidden tracking areas for roaming", "5GS forbidden tracking areas for roaming", "forbidden location areas for regional provision of service", "forbidden tracking areas for regional provision of service" or "5GS forbidden tracking areas for regional provision of service" prevented a registration attempt, the MS selects the first such PLMN again and enters a limited service state.

6.1.1.3.3 Test description

6.1.1.3.3.1 Pre-test conditions

System Simulator

- Three inter-frequency multi-PLMN NR cells.
- Each NR cell has only a single PLMN identity. The PLMNs are identified in the test by the identifiers in Table 6.1.1.3.3.1-1.

Table 6.1.1.3.3.1-1: PLMN identifiers

NR Cell	PLMN name
1	PLMN1
12	PLMN2
13	PLMN3

- System information combination NR-4 as defined in TS 38.508-1 [4] clause 4.4.3.1.2-1 is used in NR cells.

UE

- The UE is in Manual PLMN selection mode.

Preamble

- The UE is registered on PLMN1 (NR Cell 1) using the procedure described in TS 38.508-1 [4] clause 4.5.2.2-2 except that the REGISTRATION ACCEPT message indicates PLMN2 in the Equivalent PLMN list as described in Table 6.1.1.3.3.3-3.
- The UE is in state Registered, Idle Mode (state 1N-A) on NR Cell 1 according to TS 38.508-1 [4];

6.1.1.3.3.2 Test procedure sequence**Table 6.1.1.3.3.2-1: Time instances of cell power level and parameter changes for FR1**

	Parameter	Unit	NR Cell 1	NR Cell 12	NR Cell 13	Remarks
T1	SS/PBCH SSS EPRE	dBm/SCS	-99	-88	-67	
T2	SS/PBCH SSS EPRE	dBm/SCS	"off"	"off"	"off"	Power level "Off" is defined in TS 38.508-1 [4] Table 6.2.2.1-3

Table 6.1.1.3.3.2-2: Time instances of cell power level and parameter changes for FR2

	Parameter	Unit	NR Cell 1	NR Cell 12	NR Cell 13	Remarks
T1	SS/PBCH SSS EPRE	dBm/SCS	FFS	FFS	FFS	
T2	SS/PBCH SSS EPRE	dBm/SCS	"off"	"off"	"off"	Power level "Off" is defined in TS 38.508-1 [4] Table 6.2.2.2-2

Table 6.1.1.3.3.2-3: Main behaviour

St	Procedure	Message Sequence		TP	Verdict
		U - S	Message		
1	SS adjusts cell levels according to row T1 of table 6.1.1.3.3.2-1/2.	-	-	-	-
2	Check: Does the test result of generic test procedure in TS 38.508-1 [4] subclause 4.9.5.2.2-1 indicate that the UE is camped on NR Cell 12? NOTE: The REGISTRATION REQUEST is accepted with PLMN1 listed as an Equivalent PLMN.	-->	NR RRC: <i>RRCSetupRequest</i>	1	P
3	Check: Does the UE send an <i>RRCSetupRequest</i> on NR Cell 1 and 13 within 60s?	-->	NR RRC: <i>RRCSetupRequest</i>	2	F
4	SS adjusts cell levels according to row T2 of table 6.1.1.3.3.2-1/2.	-	-	-	-
5	Set UE to Automatic PLMN selection mode. (Note 1)	-	-	-	-
Note 1: Steps 5 is to ensure UE is set back to automatic PLMN selection mode for the next test case.					

6.1.1.3.3.3 Specific message contents

Table 6.1.1.3.3.3-1: SIB4 for NR Cell 1 (preamble and all steps, Table 6.1.1.3.3.2-2)

Derivation path: 38.508-1 [4] Table 4.6.2-3			
Information Element	Value/Remark	Comment	Condition
SIB4 ::= SEQUENCE {			
interFreqCarrierFreqList SEQUENCE (SIZE (1..maxFreq)) OF SEQUENCE {			
dl-CarrierFreq[1]	Same downlink NR ARFCN as used for NR Cell 12		
cellReselectionPriority[1]	4		
dl-CarrierFreq[2]	Same downlink NR ARFCN as used for NR Cell 13		
cellReselectionPriority[2]	4		
}			
}			

Table 6.1.1.3.3.3-2: SIB4 for NR Cell 12 (preamble and all steps, Table 6.1.1.3.3.2-2)

Derivation path: 38.508-1 [4] Table 4.6.2-3			
Information Element	Value/Remark	Comment	Condition
SIB4 ::= SEQUENCE {			
interFreqCarrierFreqList SEQUENCE (SIZE (1..maxFreq)) OF SEQUENCE {			
dl-CarrierFreq[1]	Same downlink NR ARFCN as used for NR Cell 1		
cellReselectionPriority[1]	4		
dl-CarrierFreq[2]	Same downlink NR ARFCN as used for NR Cell 13		
cellReselectionPriority[2]	4		
}			
}			

Table 6.1.1.3.3.3-3: REGISTRATION ACCEPT for NR Cell 1 (preamble)

Derivation path: 38.508-1 [4] Table 4.7.1-7			
Information Element	Value/Remark	Comment	Condition
Equivalent PLMNs	PLMN2		NR Cell 1

Table 6.1.1.3.3.3-4: REGISTRATION ACCEPT for NR Cell 12 (step 2, Table 6.1.1.3.3.2-2)

Derivation path: 38.508-1 [4] Table 4.7.1-7			
Information Element	Value/Remark	Comment	Condition
Equivalent PLMNs	PLMN1		NR Cell 12

6.1.1.4 PLMN selection in shared network environment / Automatic mode

6.1.1.4.1 Test Purpose (TP)

(1)

```
with { The UE is in automatic network selection mode and there is a suitable cell with multiple PLMN
identities among which the HPLMN but not the registered PLMN }
ensure that {
  when { the UE is switched on }
  then { the UE attaches to the HPLMN on the shared cell }
}
```

(2)

```
with { the UE in automatic network selection mode and there is a suitable cell with multiple PLMN
identities among which the registered PLMN }
ensure that {
  when { the UE returns to coverage }
  then { the UE performs a registration procedure due to mobility to the registered PLMN on the
shared cell }
}
```

6.1.1.4.2 Conformance requirements

References: The conformance requirements covered in the current TC are specified in: TS 38.304 clause 5.1.1.2, TS 23.122 clauses 4.4.3 and 4.4.3.1.1, TS 38.331 clauses 5.3.3.4, and TS 24.501 clause 5.3.1.1. Unless otherwise stated these are Rel-15 requirements.

[TS 38.304 clause 5.1.1.2]

The UE shall scan all RF channels in the NR bands according to its capabilities to find available PLMNs. On each carrier, the UE shall search for the strongest cell and read its system information, in order to find out which PLMN(s) the cell belongs to. If the UE can read one or several PLMN identities in the strongest cell, each found PLMN (see the PLMN reading in TS 38.331 [3]) shall be reported to the NAS as a high quality PLMN,

...

Once the UE has selected a PLMN, the cell selection procedure shall be performed in order to select a suitable cell of that PLMN to camp on.

[TS 23.122 clauses 4.4.3]

When the MS reselects to a cell in a shared network, and the cell is a suitable cell for multiple PLMN identities received on the BCCH or on the EC-BCCH the AS indicates these multiple PLMN identities to the NAS according to 3GPP TS 44.018 [34], 3GPP TS 44.060 [39], 3GPP TS 25.304 [32] and 3GPP TS 36.304 [43]. The MS shall choose one of these PLMNs. If the registered PLMN is available among these PLMNs, the MS shall not choose a different PLMN.

The MS shall not use the PLMN codes contained in the "HPLMN Selector with Access Technology" data file.

It is possible for the home network operator to identify alternative Network IDs as the HPLMN. If the EHPLMN list is present, and not empty, the entries in the EHPLMN list are used in the network selection procedures. When attempting to select a network the highest priority EHPLMN that is available shall be selected. If the EHPLMN list is present and is empty or if the EHPLMN list is not present, the HPLMN derived from the IMSI is used for network selection procedures.

NOTE 1: The "HPLMN Selector with Access Technology" data file is only used by the MS to get the HPLMN access technologies related to the HPLMN code which corresponds to the PLMN code included in the IMSI if the EHPLMN list is not present or is empty. If the EHPLMN list is present then this data field is applicable to all the entries within the EHPLMN list.

NOTE 2: Different GSM frequency bands (e.g. 900, 1800, 1900, 400) are all considered GSM access technology. An MS supporting more than one band should scan all the bands it's supports when scanning for GSM frequencies. However GSM COMPACT systems which use GSM frequency bands but with the CBPCCH broadcast channel are considered as a separate access technology from GSM.

NOTE 3: The inclusion of the HPLMN derived from the IMSI in the EHPLMN list is allowed. The priority of the HPLMN derived from the IMSI is given by its position in the EHPLMN list, see 3GPP TS 31.102 [40]

[TS 23.122 clause 4.4.3.1.1]

The MS selects and attempts registration on other PLMN/access technology combinations, if available and allowable, in the following order:

- i) either the HPLMN (if the EHPLMN list is not present or is empty) or the highest priority EHPLMN that is available (if the EHPLMN list is present) ;
- ii) each PLMN/access technology combination in the "User Controlled PLMN Selector with Access Technology" data file in the SIM (in priority order);
- iii) each PLMN/access technology combination in the "Operator Controlled PLMN Selector with Access Technology" data file in the SIM (in priority order);
- iv) other PLMN/access technology combinations with received high quality signal in random order;
- v) other PLMN/access technology combinations in order of decreasing signal quality.

When following the above procedure the following requirements apply:

- a) An MS with voice capability shall ignore PLMNs for which the MS has identified at least one GSM COMPACT.
- b) In A/Gb mode or GSM COMPACT, an MS with voice capability, or an MS not supporting packet services shall not search for CPBCCH carriers.
- c) In ii and iii, the MS should limit its search for the PLMN to the access technology or access technologies associated with the PLMN in the appropriate PLMN Selector with Access Technology list (User Controlled or Operator Controlled selector list).

An MS using a SIM without access technology information storage (i.e. the "User Controlled PLMN Selector with Access Technology" and the "Operator Controlled PLMN Selector with Access Technology" data files are not present) shall instead use the "PLMN Selector" data file, for each PLMN in the "PLMN Selector" data file, the MS shall search for all access technologies it is capable of. The priority ordering amongst the access technologies is implementation dependent.

- d) In iv and v, the MS shall search for all access technologies it is capable of, before deciding which PLMN to select.
- e) In ii, and iii, a packet only MS which supports GSM COMPACT, but using a SIM without access technology information storage (i.e. the "User Controlled PLMN Selector with Access Technology" and the "Operator Controlled PLMN Selector with Access Technology" data files are not present) shall instead use the "PLMN Selector" data file, for each PLMN in the "PLMN Selector" data file, the MS shall search for all access technologies it is capable of and shall assume GSM COMPACT access technology as the lowest priority radio access technology.

- f) In i, the MS shall search for all access technologies it is capable of. No priority is defined for the preferred access technology and the priority is an implementation issue, but "HPLMN Selector with Access Technology" data file on the SIM may be used to optimise the procedure.
- g) In i, an MS using a SIM without access technology information storage (i.e. the "HPLMN Selector with Access Technology" data file is not present) shall search for all access technologies it is capable of. The priority ordering amongst the access technologies is implementation dependent. A packet only MS which supports GSM COMPACT using a SIM without access technology information storage shall also assume GSM COMPACT access technology as the lowest priority radio access technology.

NOTE 1: For f) and g), the MS in automatic network selection mode can end the PLMN search procedure once the HPLMN or the highest priority EHPLMN is found on an access technology.

NOTE 2: For i, ii and iii, the MS can use location information to determine which PLMNs can be available in its present location.

- h) In v, the MS shall order the PLMN/access technology combinations in order of decreasing signal quality within each access technology. The order between PLMN/access technology combinations with different access technologies is an MS implementation issue.

NOTE 3: Requirements a) and b) apply also to requirement d), so a GSM voice capable MS should not search for GSM COMPACT PLMNs, even if capable of GSM COMPACT.

NOTE 4: Requirements a) and b) apply also to requirement f), so a GSM voice capable MS should not search for GSM COMPACT PLMNs, even if this is the only access technology on the "HPLMN Selector with Access Technology" data file on the SIM.

NOTE 5: High quality signal is defined in the appropriate AS specification.

- i) In i to v, the MS shall not consider PLMNs where voice service was not possible as PLMN selection candidate, unless such PLMN is available in GERAN or UTRAN or no other allowed PLMN is available.
- j) In i to v, if the MS only supports EMM-REGISTERED without PDN connection (see 3GPP TS 24.301 [23A]), the MS shall not consider PLMNs which do not advertise support of EMM-REGISTERED without PDN connection.
- k) In i to v, if the MS only supports control plane CIoT EPS optimization (see 3GPP TS 24.301 [23A]) and the UE camps on a E-UTRA cell which is not NB-IoT cell (see 3GPP TS 36.304 [43], 3GPP TS 36.331 [22]), the MS shall not consider PLMNs which do not advertise support of EPS services with control plane CIoT EPS optimization.
- l) In i to v, if the MS is in eCall only mode, the MS shall not consider PLMNs which do not advertise support for eCall over IMS, unless such PLMNs are available in GERAN or UTRAN.

NOTE 6: As an implementation option, an MS in eCall only mode that was not able to select any PLMN according to l) can perform a second iteration of i to v with no restriction.

If successful registration is achieved, the MS indicates the selected PLMN.

If registration cannot be achieved because no PLMNs are available and allowable, the MS indicates "no service" to the user, waits until a new PLMN is available and allowable and then repeats the procedure.

If there were one or more PLMNs which were available and allowable, but an LR failure made registration on those PLMNs unsuccessful or an entry in any of the lists "forbidden location areas for roaming", "forbidden tracking areas for roaming", "5GS forbidden tracking areas for roaming", "forbidden location areas for regional provision of service", "forbidden tracking areas for regional provision of service" or "5GS forbidden tracking areas for regional provision of service" prevented a registration attempt, the MS selects the first such PLMN again and enters a limited service state.

[TS 38.331 clause 5.3.3.4]

The UE shall perform the following actions upon reception of the *RRCSetup*:

...

- 1> set the content of *RRCSetupComplete* message as follows:

- 2> if upper layers provide an *5G-S-TMSI*:
 - 3> if the *RRCSetup* is received in response to an *RRCSetupRequest*:
 - 4> set the *ng-5G-S-TMSI-Value* to *ng-5G-S-TMSI-Part2*;
 - 3> else:
 - 4> set the *ng-5G-S-TMSI-Value* to *ng-5G-S-TMSI*;
- 2> set the *selectedPLMN-Identity* to the PLMN selected by upper layers (TS 24.501 [23]) from the PLMN(s) included in the *plmn-IdentityList* in *SIB1*;

...

- 1> submit the *RRCSetupComplete* message to lower layers for transmission, upon which the procedure ends

[TS 24.501 clause 5.3.1.1]

The UE NAS also provides the lower layers with the identity of the selected PLMN (see 3GPP TS 38.331 [30]). In a shared network, the UE shall choose one of the PLMN identities as specified in 3GPP TS 23.122 [5].

6.1.1.4.3 Test description

6.1.1.4.3.1 Pre-test conditions

System Simulator:

- NR Cells 1 and 2, as specified in TS 38.508-1 [4] clause 4.4.1.1.3 are configured according to Table 4.4.2-3 in TS 38.508-1 [4] except for multiple broadcasted PLMN identities as shown in Table 6.1.1.4.3.1-1: PLMN identifiers broadcasted by cells in shared network.

Table 6.1.1.4.3.1-1: PLMN identifiers

NR Cell	PLMN names
1	PLMN4 (for preamble)
	PLMN15, PLMN1 (for test body)
2	PLMN15, PLMN1, PLMN16

UE:

- The UE is in Automatic PLMN selection mode.
- The UE is equipped with a USIM configuration as defined in TS 38.508-1 [4] Table 6.4.1-5.
- The UE is registered to PLMN4 before it is switched off.

Preamble:

- The UE is in state Switched OFF (state ON-B) according to TS 38.508-1 [4].

6.1.1.4.3.2 Test procedure sequence

Table 6.1.1.4.3.2-1/2 shows the cell configurations used during the test. The configuration T0 indicates the initial conditions. Subsequent configuration marked "T1" is applied at the points indicated in the Main behaviour description in Table 6.1.1.4.3.2-2. Cell powers are chosen for a serving cell and a non-suitable cell as defined in TS 38.508-1 [4] Table 6.2.2.1-3 for FR1 and Table 6.2.2.2-2 for FR2.

Table 6.1.1.4.3.2-1: Time instances of cell power level and parameter changes for FR1

	Parameter	Unit	NR Cell 1	NR Cell 2	Remarks
T0	SS/PBCH SSS EPRE	dBm/SCS	-88	"Off"	Power level "Off" is defined in TS 38.508-1 [4] Table 6.2.2.1-3,
T1	SS/PBCH SSS EPRE	dBm/SCS	"Off"	"Off"	Close the NR Cell 1 to make sure the UE lose coverage. Power level "Off" is defined in TS 38.508-1 [4] Table 6.2.2.1-3,
T2	SS/PBCH SSS EPRE	dBm/SCS	"Off"	-88	Power level "Off" is defined in TS 38.508-1 [4] Table 6.2.2.1-3,

Table 6.1.1.4.3.2-2: Time instances of cell power level and parameter changes for FR2

	Parameter	Unit	NR Cell 1	NR Cell 2	Remarks
T0	SS/PBCH SSS EPRE	dBm/SCS	-95	"Off"	Power level "Off" is defined in TS 38.508-1 [4] Table 6.2.2.2-2.
T1	SS/PBCH SSS EPRE	dBm/SCS	"Off"	"Off"	Close the NR Cell 1 to make sure the UE lose coverage. Power level "Off" is defined in TS 38.508-1 [4] Table 6.2.2.2-2.
T2	SS/PBCH SSS EPRE	dBm/SCS	"Off"	-95	Power level "Off" is defined in TS 38.508-1 [4] Table 6.2.2.2-2.

Table 6.1.1.4.3.2-3: Main behaviour

St	Procedure	Message Sequence		TP	Verdict
		U - S	Message		
1	The SS adjusts cell levels according to row T0 of table 6.1.1.4.3.2-1/2.	-	-	-	-
2	Power on the UE.	-	-	-	-
3	Check: Does the UE transmit an <i>RRCSetupRequest</i> on NR Cell 1?	-->	NR RRC: <i>RRCSetupRequest</i>	1	P
4	The SS transmits an <i>RRCSetup</i> message.	<--	NR RRC: <i>RRCSetup</i>	-	-
5	Check: Does the UE transmit an <i>RRCSetupComplete</i> message indicating the HPLMN (second PLMN in the list)? Note: This message contains an REGISTRATION REQUEST message according to default message contents.	-->	NR RRC: <i>RRCSetupComplete</i>	1	P
6-21	Steps 5 to 20 of the registration procedure described in TS 38.508-1 [4] subclause 4.5.2.2-2 are performed on NR Cell 1. NOTE: The UE performs registration and the RRC connection is released.	-	-	-	-
22	The SS adjusts cell levels according to row T1 of table 6.1.1.4.3.2-1/2 to ensure UE to lose coverage.	-	-	-	-
23	Wait for 15s to allow UE to go out of service	-	-	-	-
24	The SS adjusts cell levels according to row T2 of table 6.1.1.4.3.2-1/2.	-	-	-	-
25	Check: Does the UE transmit an <i>RRCSetupRequest</i> on NR Cell 2?	-->	NR RRC: <i>RRCSetupRequest</i>	2	P
26	SS transmits an <i>RRCSetup</i> message.	<--	NR RRC: <i>RRCSetup</i>	-	-
27-31b1	Steps 2 to 6b1 of the generic test procedure in TS 38.508-1 [4] subclause 4.9.5.2.2-1 are performed on NR Cell 2. NOTE: The UE performs a registration for mobility procedure and the RRC connection is released.	-	-	-	-

6.1.1.4.3.3 Specific message contents

Table 6.1.1.4.3.3-1: SIB1 for NR Cell 1 (all steps, Table 6.1.1.4.3.2-1)

Derivation Path: 38.508-1 [4] Table 4.6.1-28			
Information Element	Value/remark	Comment	Condition
SIB1 ::= SEQUENCE {			
CellAccessRelatedInfo SEQUENCE {			
PLMN-IdentityInfoList ::= SEQUENCE (SIZE (1..maxPLMN)) OF SEQUENCE {			
plmn-IdentityList SEQUENCE (SIZE (1..maxPLMN)) OF PLMN-Identity {	2 entries		
plmn-Identity[1]	PLMN15		
plmn-Identity[2]	PLMN1		
}			
}			
}			
}			

Table 6.1.1.4.3.3-2: SIB1 for NR Cell 2 (all steps, Table 6.1.1.4.3.2-1)

Derivation Path: 38.508-1 [4] Table 4.6.1-28			
Information Element	Value/remark	Comment	Condition
SIB1 ::= SEQUENCE {			
CellAccessRelatedInfo SEQUENCE {			
PLMN-IdentityInfoList ::= SEQUENCE (SIZE (1..maxPLMN)) OF SEQUENCE {			
plmn-IdentityList SEQUENCE (SIZE (1..maxPLMN)) OF PLMN-Identity {	2 entries		
plmn-Identity[1]	PLMN15		
plmn-Identity[2]	PLMN1		
plmn-Identity[3]	PLMN16		
}			
}			
}			
}			

Table 6.1.1.4.3.3-3: RRCSetupComplete (step 5 and 27, Table 6.1.1.4.3.2-2)

Derivation Path: 38.508-1 [4], Table 4.6.1-22			
Information Element	Value/remark	Comment	Condition
RRCSetupComplete ::= SEQUENCE {			
criticalExtensions CHOICE {			
rrcSetupComplete SEQUENCE {			
selectedPLMN-Identity	2	PLMN1	
}			
}			
}			

6.1.1.5 PLMN selection of RPLMN, HPLMN/EHPLMN, UPLMN and OPLMN / Automatic mode / User reselection

6.1.1.5.1 Test Purpose (TP)

(1)

```

with { UE in Automatic network selection mode registered to UPLMN and RPLMN, UPLMN and OPLMN NG-RAN cells available }
ensure that {
  when { UE is requested to initiate reselection and registration onto an available PLMN }
  then { UE reselects to the cell which belongs to higher priority OPLMN }
}
    
```

(2)

```

with { UE in Automatic network selection mode registered to OPLMN and only RPLMN NG-RAN cells
available }
ensure that {
  when { UE is requested to initiate reselection and registration onto an available PLMN }
  then { UE remains on the current cell which belongs to RPLMN }
}

```

(3)

```

with { UE in Automatic network selection mode registered to OPLMN and RPLMN, UPLMN and OPLMN NG-RAN
cells available }
ensure that {
  when { UE is requested to initiate reselection and registration onto an available PLMN }
  then { UE reselects to the cell which belongs to UPLMN }
}

```

(4)

```

with { UE in Automatic network selection mode registered to UPLMN and RPLMN, UPLMN, OPLMN and HPLMN
NG-RAN cells available }
ensure that {
  when { UE is requested to initiate reselection and registration onto an available PLMN }
  then { UE reselects to the cell which belongs to HPLMN }
}

```

6.1.1.5.2 Conformance requirements

References: The conformance requirements covered in the current TC are specified in: TS 23.122 clauses 4.4.3.2 and 4.4.3.2.1. Unless otherwise stated these are Rel-15 requirements.

[TS 23.122, clause 4.4.3.2]

At any time the user may request the MS to initiate reselection and registration onto an available PLMN, according to the following procedures, dependent upon the operating mode.

[TS 23.122, clause 4.4.3.2.1]

The MS selects and attempts registration on PLMN/access technology combinations, if available and allowable, in all of its bands of operation in accordance with the following order:

- i) the HPLMN (if the EHPLMN list is not present or is empty) or the highest priority EHPLMN that is available (if the EHPLMN list is present);
- ii) PLMN/access technology combinations contained in the "User Controlled PLMN Selector with Access Technology" data file in the SIM (in priority order) excluding the previously selected PLMN/access technology combination;
- iii) PLMN/access technology combinations contained in the "Operator Controlled PLMN Selector with Access Technology" data file in the SIM (in priority order) excluding the previously selected PLMN/access technology combination;
- iv) other PLMN/access technology combinations with the received high quality signal in random order excluding the previously selected PLMN/access technology combination;
- v) other PLMN/access technology combinations, excluding the previously selected PLMN/access technology combination in order of decreasing signal quality or, alternatively, the previously selected PLMN/access technology combination may be chosen ignoring its signal quality;
- vi) The previously selected PLMN/access technology combination.

The previously selected PLMN/access technology combination is the PLMN/access technology combination which the MS has selected prior to the start of the user reselection procedure.

NOTE 1: If the previously selected PLMN is chosen, and registration has not been attempted on any other PLMNs, then the MS is already registered on the PLMN, and so registration is not necessary.

The equivalent PLMNs list shall not be applied to the user reselection in Automatic Network Selection Mode.

When following the above procedure the requirements a), b), c), e), f), g), h), j), k) and l) in subclause 4.4.3.1.1 apply: Requirement d) shall apply as shown below:

- d) In iv, v, and vi, the MS shall search for all access technologies it is capable of before deciding which PLMN/access technology combination to select.

NOTE 2: High quality signal is defined in the appropriate AS specification.

- 6.1.1.5.3 Test description
 6.1.1.5.3.1 Pre-test conditions
 6.1.1.5.3.1 Pre-test conditions

System Simulator:

- Four inter-frequency multi-PLMN cells as specified in TS 38.508-1 [4] clause 4.4.1.2 are configured broadcasting default NAS parameters as indicated in TS 38.508-1 [4] Table 4.4.2-3.
- The PLMNs are identified in the test by the identifiers in Table 6.1.1.5.3.1-1.

Table 6.1.1.5.3.1-1: PLMN identifiers

NR Cell	PLMN name
1	PLMN1
12	PLMN2
13	PLMN3
14	PLMN4

UE:

- The UE is in Automatic PLMN selection mode.
- The UE is equipped with a USIM configuration as defined in TS 38.508-1 [4] Table 6.4.1-6.

Preamble:

- The UE is in state Registered, Idle Mode (state 1N-A) on NR Cell 1 according to TS 38.508-1 [4].

- 6.1.1.5.3.2 Test procedure sequence

Table 6.1.1.5.3.2-1: Time instances of cell power level and parameter changes for FR1

	Parameter	Unit	NR Cell 1	NR Cell 12	NR Cell 13	NR Cell 14	Remark
T1	SS/PBCH SSS EPRE	dBm/ SCS	-88	-88	"Off"	-88	The power level values are assigned to satisfy $R_{NRCell\ 1} = R_{NRCell\ 12} = R_{NRCell\ 14}$. (NOTE 1).
T2	SS/PBCH SSS EPRE	dBm/ SCS	"Off"	-88	"Off"	"Off"	
T3	SS/PBCH SSS EPRE	dBm/ SCS	-88	"Off"	-88	-88	The power level values are assigned to satisfy $R_{NRCell\ 1} = R_{NRCell\ 13} = R_{NRCell\ 14}$. (NOTE 1).
NOTE 1: Power level "Off" is defined in TS 38.508-1 [4] Table 6.2.2.1-3.							

Table 6.1.1.5.3.2-2: Time instances of cell power level and parameter changes for FR2

	Parameter	Unit	NR Cell 1	NR Cell 12	NR Cell 13	NR Cell 14	Remark
T1	SS/PBCH SSS EPRE	dBm/ SCS	FFS	FFS	"Off"	FFS	The power level values are assigned to satisfy $R_{NRCell\ 1} = R_{NRCell\ 12} = R_{NRCell\ 14}$. (NOTE 1).
T2	SS/PBCH SSS EPRE	dBm/ SCS	"Off"	FFS	"Off"	"Off"	
T3	SS/PBCH SSS EPRE	dBm/ SCS	FFS	"Off"	FFS	FFS	The power level values are assigned to satisfy $R_{NRCell\ 1} = R_{NRCell\ 13} = R_{NRCell\ 14}$. (NOTE 1).
NOTE 1: Power level "Off" is defined in TS 38.508-1 [4] Table 6.2.2.2-2.							

Table 6.1.1.5.3.2-2: Main behaviour

St	Procedure	Message Sequence		TP	Verdict
		U - S	Message		
1	The SS changes the power level setting according to the row "T1" in table 6.1.1.5.3.2-1/2.	-	-	-	-
2	Cause the UE in Automatic network selection mode to initiate user reselection and registration onto an available PLMN. (see Note)	-	-	-	-
3	Check: Does the UE send an <i>RRCSetupRequest</i> on NR Cell 12?	-->	NR RRC: <i>RRCSetupRequest</i>	1	P
4-8b1	Steps 2 to 6b1 of the generic test procedure in TS 38.508-1 [4] subclause 4.9.5.2.2-1 are performed on NR Cell 12. NOTE: The UE performs a registration for mobility procedure and the RRC connection is released.	-	-	-	-
9	The SS changes the power level setting according to the row "T2" in table 6.1.1.5.3.2-1/2.	-	-	-	-
10	Cause the UE in Automatic network selection mode to initiate user reselection and registration onto an available PLMN. (see Note)	-	-	-	-
11	Check: Does the UE send an <i>RRCSetupRequest</i> on NR Cell 12 within 90 s?	-->	NR RRC: <i>RRCSetupRequest</i>	2	F
12	The SS changes the power level setting according to the row "T1" in table 6.1.1.5.3.2-1/2.	-	-	-	-
13	Cause the UE in Automatic network selection mode to initiate user reselection and registration onto an available PLMN. (see Note)	-	-	-	-
14	Check: Does the UE send an <i>RRCSetupRequest</i> on NR Cell 1?	-->	NR RRC: <i>RRCSetupRequest</i>	3	P
15-19b1	Steps 2 to 6b1 of the generic test procedure in TS 38.508-1 [4] subclause 4.9.5.2.2-1 are performed on NR Cell 1. NOTE: The UE performs a registration for mobility procedure and the RRC connection is released.	-	-	-	-
20	The SS changes the power level setting according to the row "T3" in table 6.1.1.5.3.2-1/2.	-	-	-	-
21	Cause the UE in Automatic network selection mode to initiate user reselection and registration onto an available PLMN. (see Note)	-	-	-	-
22	Check: Does the UE send an <i>RRCSetupRequest</i> on NR Cell 13?	-->	NR RRC: <i>RRCSetupRequest</i>	4	P
23-27b1	Steps 2 to 6b1 of the generic test procedure in TS 38.508-1 [4] subclause 4.9.5.2.2-1 are performed on NR Cell 13. NOTE: The UE performs a registration for mobility procedure and the RRC connection is released.	-	-	-	-
Note:	MMI command "TRIGGER_USER_RESELECTION" to be used. AT command AT+COPS is not suitable to achieve the test purpose.				

6.1.1.5.3.3 Specific message contents

None

6.1.1.6 PLMN selection / Periodic reselection / MinimumPeriodicSearchTimer

6.1.1.6.1 Test Purpose (TP)

(1)

```
with { UE configured with "MinimumPeriodicSearchTimer" }
ensure that {
  when { UE camps on an NG-RAN VPLMN cell upon switch on and cells of a higher priority NG-RAN PLMN
available }
  then { the MS shall make the first attempt to access the HPLMN or an EHPLMN or higher priority
PLMN after a period of at least 2 minutes }
}
```

(2)

```
with { UE configured with "MinimumPeriodicSearchTimer", having made first attempt to higher priority
PLMN and camped on an NG-RAN VPLMN cell and cells of a higher priority NG-RAN PLMN available }
ensure that {
  when { the higher priority PLMN search timer T stored in the USIM or the default value for T is
less than the "MinimumPeriodicSearchTimer" }
  then { UE shall not use a value for T that is less than the "MinimumPeriodicSearchTimer" and
selects and camps on a cell of the highest priority PLMN and attempts a location registration on the
selected cell upon expiry of "MinimumPeriodicSearchTimer" }
}
```

6.1.1.6.2 Conformance requirements

References: The conformance requirements covered in the present test case are specified in: TS 23.122, clause 4.4.3.3.1 Unless otherwise stated these are Rel-15 requirements.

[TS 23.122, clause 4.4.3.3.1]

If the MS is in a VPLMN, the MS shall periodically attempt to obtain service on its HPLMN (if the EHPLMN list is not present or is empty) or one of its EHPLMNs (if the EHPLMN list is present) or a higher priority PLMN/access technology combinations listed in "user controlled PLMN selector" or "operator controlled PLMN selector" by scanning in accordance with the requirements that are applicable to i), ii) and iii) as defined in the Automatic Network Selection Mode in subclause 4.4.3.1.1. In the case that the mobile has a stored "Equivalent PLMNs" list the mobile shall only select a PLMN if it is of a higher priority than those of the same country as the current serving PLMN which are stored in the "Equivalent PLMNs" list. For this purpose, a value T minutes may be stored in the SIM, T is either in the range 6 minutes to 8 hours in 6 minute steps or it indicates that no periodic attempts shall be made. If no value is stored in the SIM, a default value of 60 minutes is used for T.

If the MS is configured with the MinimumPeriodicSearchTimer as specified in 3GPP TS 24.368 [50] or 3GPP TS 31.102 [40], the MS shall not use a value for T that is less than the MinimumPeriodicSearchTimer. If the value stored in the SIM, or the default value for T (when no value is stored in the SIM), is less than the MinimumPeriodicSearchTimer, then T shall be set to the MinimumPeriodicSearchTimer.

The attempts to access the HPLMN or an EHPLMN or higher priority PLMN shall be as specified below:

- a) The periodic attempts shall only be performed in automatic mode when the MS is roaming, and not while the MS is attached for emergency bearer services or has a PDN connection for emergency bearer services;
- b) After switch on a period of at least 2 minutes and at most T minutes shall elapse before the first attempt is made;

6.1.1.6.3 Test Description

6.1.1.6.3.1 Pre-test conditions

System Simulator:

- 3 NR cells: NR Cell 11, 12 and 13 as specified in TS 38.508-1[4] table 4.4.2-3 are configured as shown in Table 6.1.1.6.3.1-1.

Table 6.1.1.6.3.1-1: PLMN identifiers

NR Cell	PLMN names
NR Cell 11	PLMN4
NR Cell 12	PLMN1
NR Cell 13	PLMN2

UE:

- The UE is in Automatic PLMN selection mode.
- The UE is configured with a value of MinimumPeriodicSearchTimer set to 7 minutes.
- The UE is equipped with a USIM configuration 11 as per TS 38.508-1 [4] Table 6.4.11.

Preamble:

- The UE performs a successful registration on PLMN1 after which it is switched OFF (State ON-B State) as per TS 38.508-1 [4] table 4.4A.2-0.

6.1.1.6.3.2 Test procedure sequence

Table 6.1.1.6.3.2-1 and Table 6.1.1.6.3.2-2 shows the cell configurations used during the test. The configuration T0 indicates the initial conditions. Subsequent configurations marked "T1" & "T2" are applied at the point indicated in the Main behaviour description in Table 6.1.1.6.3.2-3. Cell powers are chosen for a serving cell and a non-suitable [Off] cell as defined in TS 38.508-1[4] table 6.2.2.1-3.

Table 6.1.1.6.3.2-1: Time instances of cell power level and parameter changes for FR1

	Parameter	Unit	NR Cell 11	NR Cell 12	NR Cell 13	Remark
T0	SS/PBCH SSS EPRE	dBm/SC S	Off	-88	Off	
T1	SS/PBCH SSS EPRE	dBm/SC S	Off	-88	-88	
T2	SS/PBCH SSS EPRE	dBm/SC S	-88	-88	-88	

Table 6.1.1.6.3.2-2: Time instances of cell power level and parameter changes for FR2

	Parameter	Unit	NR Cell 11	NR Cell 12	NR Cell 13	Remark
T0	SS/PBCH SSS EPRE	dBm/SC S	Off	FFS	Off	
T1	SS/PBCH SSS EPRE	dBm/SC S	Off	FFS	FFS	
T2	SS/PBCH SSS EPRE	dBm/SC S	FFS	FFS	FFS	

Table 6.1.1.6.3.2-3: Main behaviour

St	Procedure	Message Sequence		TP	Verdict
		U - S	Message		
1	SS adjusts cell levels according to row T1.	-	-	-	-
2	Power on the UE.	-	-	-	-
3-22	Steps 1 to 20 of the registration procedure described in TS 38.508-1[4] table 4.5.2.2-2 are performed on NR Cell 12	-	-	-	-
23	Check: Does the UE send an <i>RRCSetupRequest</i> on NR Cell 13 after 120 seconds, but before 420 seconds ("MinimumPeriodicSearchTimer") from power on?	-->	<i>NR RRC: RRCSetupRequest</i>	1	P
24-28	Steps 2 to 6 of the mobility registration updating procedure described in TS 38.508-1[4] Table 4.9.5.2.2-1 are performed on NR Cell 13.	-	-	-	-
29	SS adjusts cell levels according to row T2.	-	-	-	-
30	Check: Does the UE send an <i>RRCSetupRequest</i> on NR Cell 11 after 420 seconds ("MinimumPeriodicSearchTimer") from step 24?	-->	<i>NR RRC: RRCSetupRequest</i>	2	P
31-35	Steps 2 to 6 of the mobility registration updating procedure described in TS 38.508-1[4] Table 4.9.5.2.2-1 are performed on NR Cell 11.	-	-	-	-
Note: Timers in Steps 23 and 30 are derived from the value defined by the "MinimumPeriodicSearchTimer".					

6.1.1.6.3.3 Specific message contents

None

6.1.1.7 PLMN selection of RPLMN or (E)HPLMN; Automatic mode

6.1.1.7.1 Test Purpose (TP)

(1)

```

with { UE in Automatic network selection mode and RPLMN, EHPLMN and HPLMN cells available and UE is
fitted with a USIM containing the EHPLMN list and the USIM indicates RPLMN or (E)HPLMN should be
selected }
ensure that {
  when { UE is switched on }
  then { UE selects a cell of the RPLMN or EHPLMN. }
}

```

(2)

```

with { UE in Automatic network selection mode and RPLMN, HPLMN and VPLMN cells available and UE is
fitted with a USIM not containing or containing empty EHPLMN list and the USIM indicates RPLMN or
(E)HPLMN should be selected }
ensure that {
  when { UE is switched on }
  then { UE selects a cell of the RPLMN or HPLMN. }
}

```

6.1.1.7.2 Conformance requirements

References: The conformance requirements covered in the present TC are specified in: TS 38.304 clause 5.1.2.2, TS 23.122 clauses 1.2, 4.4.3.1 and 4.4.3.1.1. Unless otherwise stated these are Rel-15 requirements.

[TS 38.304 clause 5.1.2.2]

The UE shall scan all RF channels in the NR bands according to its capabilities to find available PLMNs. On each carrier, the UE shall search for the strongest cell and read its system information, in order to find out which PLMN(s) the cell belongs to. If the UE can read one or several PLMN identities in the strongest cell, each found PLMN (see the PLMN reading in TS 38.331 [3]) shall be reported to the NAS as a high quality PLMN (but without the RSRP value), provided that the following high-quality criterion is fulfilled:

1. For an NR Cell, the measured RSRP value shall be greater than or equal to -110 dBm.

...

Once the UE has selected a PLMN, the cell selection procedure shall be performed in order to select a suitable cell of that PLMN to camp on.

[TS 23.122, clause 1.2]

Equivalent HPLMN list: To allow provision for multiple HPLMN codes, PLMN codes that are present within this list shall replace the HPLMN code derived from the IMSI for PLMN selection purposes. This list is stored on the USIM and is known as the EHPLMN list. The EHPLMN list may also contain the HPLMN code derived from the IMSI. If the HPLMN code derived from the IMSI is not present in the EHPLMN list then it shall be treated as a Visited PLMN for PLMN selection purposes.

[TS 23.122 clause 4.4.3.1]

At switch on, or following recovery from lack of coverage, the MS selects the registered PLMN or equivalent PLMN (if it is available) using all access technologies that the MS is capable of and if necessary (in the case of recovery from lack of coverage, see subclause 4.5.2) attempts to perform a Location Registration.

NOTE 1: The MS in automatic network selection mode can end the PLMN search procedure once the registered PLMN or equivalent PLMN is found on an access technology.

NOTE 2: An MS in automatic network selection mode can use location information to determine which PLMNs can be available in its present location.

EXCEPTION: As an alternative option to this, if the MS is in automatic network selection mode and it finds coverage of an EHPLMN, the MS may register to that EHPLMN and not return to the registered PLMN or equivalent PLMN. If the EHPLMN list is not present or is empty, and the HPLMN is available, the MS may register on the HPLMN and not return to the registered PLMN or equivalent PLMN. The operator shall be able to control by SIM configuration whether an MS that supports this option is permitted to perform this alternative behaviour.

[TS 23.122 clause 4.4.3.1.1]

The MS selects and attempts registration on other PLMN/access technology combinations, if available and allowable, in the following order:

- i) either the HPLMN (if the EHPLMN list is not present or is empty) or the highest priority EHPLMN that is available (if the EHPLMN list is present);
- ii) each PLMN/access technology combination in the "User Controlled PLMN Selector with Access Technology" data file in the SIM (in priority order);
- iii) each PLMN/access technology combination in the "Operator Controlled PLMN Selector with Access Technology" data file in the SIM (in priority order);
- iv) other PLMN/access technology combinations with received high quality signal in random order;
- v) other PLMN/access technology combinations in order of decreasing signal quality.

6.1.1.7.3 Test description

6.1.1.7.3.1 Pre-test conditions

System Simulator:

- 4 NR Cells as specified in TS 38.508-1[4] table 4.4.2-3 are configured as shown in Table 6.1.1.7.3.1–1. PLMN settings are defined in TS 36.523-1 [13] table 6.0.1-1.

Table 6.1.1.7.3.1-1: PLMN identifiers

NR Cell	PLMN names
NR Cell 12	PLMN4
NR Cell 1	PLMN1
NR Cell 13	PLMN15
NR Cell 14	PLMN3

UE:

- The UE is in Automatic PLMN selection mode.
- USIM configurations 2 and 3 will be used as specified in tables 6.4.1-2 and 6.4.1-3 in TS 38.508-1 [4]. The points at which each USIM configuration is used is specified in 6.1.1.7.3.2-2.

Preamble:

- The UE performs a successful registration on PLMN4 after which the UE is brought into the state Switched OFF (state ON-B) according to Table 4.4A.2-0 TS 38.508-1[4].

6.1.1.7.3.2 Test procedure sequence

Table 6.1.1.7.3.2-1 for both FR1 and FR2 illustrates the downlink power levels to be applied for the cells at various time instants of the test execution. Row marked "T0" denotes the initial conditions after preamble, while columns marked "T1" is to be applied subsequently in the Main behaviour. The exact instants on which these values shall be applied are described in the texts in this clause. Cell power levels referenced in table 6.1.1.7.3.2-1 are defined in 38.508-1 [4] table 6.2.2.1-3 for FR1 and table FFS for FR2.

Table 6.1.1.7.3.2-1: Cell configuration changes over time

	Parameter	Unit	NR Cell 1	NR Cell 12	NR Cell 13	NR Cell 14
T0	SS/PBCH SSS EPRE	dBm/SCS	Non-suitable "Off"	Serving Cell	Serving Cell	Non-suitable "Off"
T1	SS/PBCH SSS EPRE	dBm/SCS	Serving Cell	Serving Cell	Non-suitable "Off"	Serving Cell

Table 6.1.1.7.3.2-2 Main behaviour

St	Procedure	Message Sequence		TP	Verdict
		U - S	Message		
1	Power on the UE with the USIM configuration 2 specified in table 6.4.1-2 TS 38.508-1 [4].	-	-	-	-
2	Check: Does the UE transmit an <i>RRCSetupRequest</i> on NR Cell 12 or NR Cell 13?	-->	NR RRC: <i>RRCSetupRequest</i>	1	P
3-20	Steps 3-20 of the registration procedure described in TS 38.508-1 [4] table 4.5.2.2-2 are performed on NR Cell 12 or NR Cell 13. NOTE: The UE performs registration with valid stored security context (see preamble) and the RRC connection is released.	-	-	-	-
21	Void	-	-	-	-
22	If possible switch off is performed or USIM is removed, otherwise the power is removed.	-	-	-	-
-	EXCEPTION: Step 23a1 to 23a4 describes behaviour that depends on the UE capability.	-	-	-	-
23a1 - 23a4	If pc_SwitchOnOff or pc_USIM_Removal then switch off procedure defined in TS 38.523-3 [3] Table 10.3.2-1 Steps 2a1 to 2a4 are performed.	-	-	-	-
24	The SS adjusts cell levels according to row T1 of table 6.1.1.7.3.2-1.	-	-	-	-
25	The UE is brought back to operation with the USIM configuration 3 specified in table 6.4.1-3 TS 38.508-1 [4].	-	-	-	-
26	Check: Does the UE transmit an <i>RRCSetupRequest</i> on NR Cell 12 or NR Cell 1?	-->	NR RRC: <i>RRCSetupRequest</i>	2	P
27- 44	Steps 3 to 20 of the registration procedure described in TS 38.508-1 [4] table 4.5.2.2-2 are performed on NR Cell 12 or NR Cell 1.	-	-	-	-

6.1.1.7.3.3 Specific message contents

None

6.1.1.8 PLMN selection of RPLMN or (E)HPLMN; Manual mode

6.1.1.8.1 Test Purpose (TP)

(1)

```
with { UE in Manual network selection mode and EHPLMN and HPLMN cells available and (E)RPLMN cell is
not available and UE is fitted with a USIM containing the EHPLMN list and the UE supports the
exception to manual mode selection mode }
ensure that {
  then { UE is switched on }
  then { UE selects a cell of the highest priority EHPLMN. }
}
```

(2)

```
with { UE in Manual network selection mode and HPLMN and VPLMN cells available and (E)RPLMN cell is
not available and UE is fitted with a USIM not containing or containing empty EHPLMN list and the
UE supports the exception to manual mode selection mode }
ensure that {
  when { UE is switched on }
  then { UE selects a cell of the HPLMN. }
}
```

6.1.1.8.2 Conformance requirements

References: The conformance requirements covered in the present TC are specified in: TS 38.304 clause 5.1.2.2, TS 23.122 clauses 1.2, 4.4.3.1 and 4.4.3.1.2. Unless otherwise stated these are Rel-15 requirements.

[TS 38.304 clause 5.1.2.2]

The UE shall scan all RF channels in the NR bands according to its capabilities to find available PLMNs. On each carrier, the UE shall search for the strongest cell and read its system information, in order to find out which PLMN(s) the cell belongs to. If the UE can read one or several PLMN identities in the strongest cell, each found PLMN (see the PLMN reading in TS 38.331 [3]) shall be reported to the NAS as a high quality PLMN (but without the RSRP value), provided that the following high-quality criterion is fulfilled:

1. For an NR cell, the measured RSRP value shall be greater than or equal to -110 dBm.

...

Once the UE has selected a PLMN, the cell selection procedure shall be performed in order to select a suitable cell of that PLMN to camp on.

[TS 23.122, clause 1.2]

Equivalent HPLMN list: To allow provision for multiple HPLMN codes, PLMN codes that are present within this list shall replace the HPLMN code derived from the IMSI for PLMN selection purposes. This list is stored on the USIM and is known as the EHPLMN list. The EHPLMN list may also contain the HPLMN code derived from the IMSI. If the HPLMN code derived from the IMSI is not present in the EHPLMN list then it shall be treated as a Visited PLMN for PLMN selection purposes.

[TS 23.122 clause 4.4.3.1]

At switch on, or following recovery from lack of coverage, the MS selects the registered PLMN or equivalent PLMN (if it is available) using all access technologies that the MS is capable of and if necessary (in the case of recovery from lack of coverage, see subclause 4.5.2) attempts to perform a Location Registration.

NOTE 1: The MS in automatic network selection mode can end the PLMN search procedure once the registered PLMN or equivalent PLMN is found on an access technology.

NOTE 2: An MS in automatic network selection mode can use location information to determine which PLMNs can be available in its present location.

EXCEPTION: As an alternative option to this, if the MS is in automatic network selection mode and it finds coverage of an EHPLMN, the MS may register to that EHPLMN and not return to the registered PLMN or equivalent PLMN. If

the EHPLMN list is not present or is empty, and the HPLMN is available, the MS may register on the HPLMN and not return to the registered PLMN or equivalent PLMN. The operator shall be able to control by SIM configuration whether an MS that supports this option is permitted to perform this alternative behaviour.

[TS 23.122 clause 4.4.3.1.2]

The MS indicates whether there are any PLMNs, which are available using all supported access technologies. This includes PLMNs in the "forbidden PLMNs" list, "forbidden PLMNs for GPRS service" list and PLMNs which only offer services not supported by the MS. An MS which supports GSM COMPACT shall also indicate GSM COMPACT PLMNs (which use PBCCH).

If displayed, PLMNs meeting the criteria above are presented in the following order:

- i)- either the HPLMN (if the EHPLMN list is not present or is empty) or, if one or more of the EHPLMNs are available then based on an optional data field on the SIM either only the highest priority available EHPLMN is to be presented to the user, or all available EHPLMNs are presented to the user in priority order. If the data field is not present on the SIM, then only the highest priority available EHPLMN is presented;
- ii)- PLMN/access technology combinations contained in the " User Controlled PLMN Selector with Access Technology " data file in the SIM (in priority order);
- iii)- PLMN/access technology combinations contained in the "Operator Controlled PLMN Selector with Access Technology" data file in the SIM (in priority order);
- iv)- other PLMN/access technology combinations with received high quality signal in random order;
- v)- other PLMN/access technology combinations in order of decreasing signal quality.

6.1.1.8.3 Test description

6.1.1.8.3.1 Pre-test conditions

System Simulator:

- 3 NR cells: NR Cells 1, 13 and 14 as specified in TS 38.508-1[4] table 6.3.2.2-1 are configured as shown in Table 6.1.1.8.3.1-1. PLMN settings are defined in TS 36.523-1 [13] table 6.0.1-1.

Table 6.1.1.8.3.1-1: PLMN identifiers

NR Cell	PLMN names
NR Cell 1 (configured during preamble)	PLMN4
NR Cell 1 (configured in test body all steps)	PLMN1
NR Cell 13	PLMN15
NR Cell 14	PLMN3

UE:

- The UE is in Manual PLMN selection mode.
- USIM configurations 2 and 3 will be used as specified in tables 6.4.1-2 and 6.4.1-3 in TS 38.508-1 [4]. The points at which each USIM configuration is used is specified in 6.1.1.8.3.2-2.

Preamble:

- The UE performs a successful registration on PLMN4 after which the UE is brought into the state Switched OFF (state 0N-B) according to Table 4.4A.2-0 TS 38.508-1[4].

6.1.1.8.3.2 Test procedure sequence

Table 6.1.1.8.3.2-1 for both FR1 and FR2 illustrates the downlink power levels to be applied for the cells at various time instants of the test execution. Row marked "T0" denotes the initial conditions after preamble, while columns marked "T1" is to be applied subsequently in the Main behaviour. The exact instants on which these values shall be applied are described in the texts in this clause. Cell power levels referenced in table 6.1.1.8.3.2-1 are defined in 38.508-1 [4] table 6.2.2.1-3 for FR1 and table FFS for FR2.

Table 6.1.1.8.3.2-1: Cell configuration changes over time

	Parameter	Unit	NR Cell 1	NR Cell 13	NR Cell 14
T0	SS/PBCH SSS EPRE	dBm/SCS	Serving Cell	Serving Cell	Non-suitable "Off"
T1	SS/PBCH SSS EPRE	dBm/SCS	Serving Cell	Non-suitable "Off"	Serving Cell

Table 6.1.1.8.3.2-2: Main behaviour

St	Procedure	Message Sequence		TP	Verdict
		U - S	Message		
1	Power on the UE with the USIM configuration 2 specified in table 6.4.1-2 TS 38.508-1 [4]..	-	-	-	-
2	Check: Does the UE transmit an <i>RRCSetupRequest</i> on NR Cell 13?	-->	<i>NR RRC:RRCSetupRequest</i>	1	P
3 - 20	Steps 3 to 20 of the registration procedure described in TS 38.508-1[4] table 4.5.2.2-2 are performed on NR Cell 13. NOTE: The UE performs registration with valid stored security context (see preamble) and the RRC connection is released.	-	-	-	-
21	Void	-	-	-	-
22	If possible switch off is performed or the USIM is removed, otherwise the power is removed.	-	-	-	-
-	EXCEPTION: Steps 23a1 to 23a4 describe behaviour that depends on the UE capability.	-	-	-	-
23a1-23a4	If <i>pc_SwitchOnOff</i> or <i>pc_USIM_Removal</i> then switch off procedure defined in TS 38.523-3[3] Table 10.3.2-1 Steps 2a1 to 2a4 is performed.	-	-	-	-
24	The SS adjusts cell according to row T1 of table 6.1.1.8.3.2-1.	-	-	-	-
25	The UE is brought back to operation with the configuration 3 specified in table 6.4.1-3 TS 38.508-1 [4].USIM .	-	-	-	-
26	Check: Does the UE transmit an <i>RRCSetupRequest</i> on NR Cell 1?	-->	<i>RRCSetupRequest</i>	2	P
27-44	Steps 3 to 20 of the registration procedure described in TS 38.508-1[4] table 4.5.2.2-2 are performed on NR Cell 1.	-	-	-	-

6.1.1.8.3.3 Specific message contents

None

6.1.2 NG-RAN Only Cell Selection

6.1.2.1 Cell Selection/Qrxlevmin & Cell Reselection (Intra NR)

6.1.2.1.1 Test Purpose (TP)

(1)

```
with { UE in NR RRC_IDLE state }
ensure that {
  when { a cell fulfils all requirements for a suitable cell except the cell selection criteria
which are not fulfilled (Srxlev<0) }
    then { the UE does not consider the cell suitable and no camping on this cell can take place }
}
```

(2)

```
with { UE in NR RRC_IDLE state }
ensure that {
  when { a cell fulfils all requirements for a suitable cell including the cell selection criteria
for a cell which are also fulfilled (Srxlev>0) }
    then { the UE considers the cell suitable and camps on it }
}
```

(3)

```
with { UE in NR RRC_IDLE state }
ensure that {
  when { UE detects the cell ranked as the best cell }
    then { UE reselects the new cell }
}
```

(4)

```
with { UE in NR RRC_IDLE state }
ensure that {
  when { a cell fulfils cell selection criteria but trackingAreaCode is not provided for that PLMN }
    then { the UE does not consider the cell suitable and no camping on this cell can take place }
}
```

6.1.2.1.2 Conformance requirements

References: The conformance requirements covered in the present TC are specified in: 3GPP TS 38.300 clauses 9.2.1.1, 3GPP TS 38.304 clause 4.1, 4.5, 5.2.1, 5.2.3.1, 5.2.3.2 and 5.2.4.6. Unless otherwise stated these are Rel-15 requirements.

[TS 38.300, clause 9.2.1.1]

The principles of PLMN selection in NR are based on the 3GPP PLMN selection principles. Cell selection is required on transition from RM-DEREGISTERED to RM-REGISTERED, from CM-IDLE to CM-CONNECTED and from CM-CONNECTED to CM-IDLE and is based on the following principles:

- The UE NAS layer identifies a selected PLMN and equivalent PLMNs;
- Cell selection is always based on CD-SSBs located on the synchronization raster (see subclause 5.2.4):
 - The UE searches the NR frequency bands and for each carrier frequency identifies the strongest cell as per the CD-SSB. It then reads cell system information broadcast to identify its PLMN(s):
 - The UE may search each carrier in turn ("initial cell selection") or make use of stored information to shorten the search ("stored information cell selection").
- The UE seeks to identify a suitable cell; if it is not able to identify a suitable cell it seeks to identify an acceptable cell. When a suitable cell is found or if only an acceptable cell is found it camps on that cell and commence the cell reselection procedure:

- A suitable cell is one for which the measured cell attributes satisfy the cell selection criteria; the cell PLMN is the selected PLMN, registered or an equivalent PLMN; the cell is not barred or reserved and the cell is not part of a tracking area which is in the list of "forbidden tracking areas for roaming";
- An acceptable cell is one for which the measured cell attributes satisfy the cell selection criteria and the cell is not barred.

Transition to RRC_IDLE:

On transition from RRC_CONNECTED to RRC_IDLE, a UE should camp on the last cell for which it was in RRC_CONNECTED or a cell/any cell of set of cells or frequency be assigned by RRC in the state transition message.

Recovery from out of coverage:

The UE should attempt to find a suitable cell in the manner described for stored information or initial cell selection above. If no suitable cell is found on any frequency or RAT, the UE should attempt to find an acceptable cell.

In multi-beam operations, the cell quality is derived amongst the beams corresponding to the same cell (see subclause 9.2.4).

[TS 38.304, clause 4.1]

The RRC_IDLE state and RRC_INACTIVE state tasks can be subdivided into three processes:

- PLMN selection;
- Cell selection and reselection;
- Location registration and RNA update.

PLMN selection, cell reselection procedures, and location registration are common for both RRC_IDLE state and RRC_INACTIVE state. RNA update is only applicable for RRC_INACTIVE state. When UE selects a new PLMN, UE transitions from RRC_INACTIVE to RRC_IDLE.

When a UE is switched on, a public land mobile network (PLMN) is selected by NAS. For the selected PLMN, associated RAT(s) may be set 3GPP TS 23.122 [9]. The NAS shall provide a list of equivalent PLMNs, if available, that the AS shall use for cell selection and cell reselection.

With cell selection, the UE searches for a suitable cell of the selected PLMN, chooses that cell to provide available services, and monitors its control channel. This procedure is defined as "camping on the cell".

The UE shall, if necessary, then register its presence, by means of a NAS registration procedure, in the tracking area of the chosen cell. As an outcome of a successful Location Registration, the selected PLMN then becomes the registered PLMN 3GPP TS 23.122 [9].

If the UE finds a more suitable cell, according to the cell reselection criteria, it reselects onto that cell and camps on it. If the new cell does not belong to at least one tracking area to which the UE is registered, location registration is performed. In RRC_INACTIVE state, if the new cell does not belong to the configured RNA, an RNA update procedure is performed.

If necessary, the UE shall search for higher priority PLMNs at regular time intervals as described in 3GPP TS 23.122 [9] and search for a suitable cell if another PLMN has been selected by NAS.

If the UE loses coverage of the registered PLMN, either a new PLMN is selected automatically (automatic mode), or an indication of available PLMNs is given to the user so that a manual selection can be performed (manual mode).

Registration is not performed by UEs only capable of services that need no registration.

The purpose of camping on a cell in RRC_IDLE state and RRC_INACTIVE state is fourfold:

- a) It enables the UE to receive system information from the PLMN.
- b) When registered and if the UE wishes to establish an RRC connection or resume a suspended RRC connection, it can do this by initially accessing the network on the control channel of the cell on which it is camped.

- c) If the network needs to send a message or deliver data to the registered UE, it knows (in most cases) the set of tracking areas (in RRC_IDLE state) or RNA (in RRC_INACTIVE state) in which the UE is camped. It can then send a "paging" message for the UE on the control channels of all the cells in the corresponding set of areas. The UE will then receive the paging message and can respond.
- d) It enables the UE to receive ETWS and CMAS notifications.

[TS 38.304, clause 4.5]

The cells are categorised according to which services they offer:

acceptable cell:

An "acceptable cell" is a cell on which the UE may camp to obtain limited service (originate emergency calls and receive ETWS and CMAS notifications). Such a cell shall fulfil the following requirements, which is the minimum set of requirements to initiate an emergency call and to receive ETWS and CMAS notification in an NR network:

- The cell is not barred, see subclause 5.3.1;
- The cell selection criteria are fulfilled, see subclause 5.2.3.2.

suitable cell:

A cell is considered as suitable if the following conditions are fulfilled:

- The cell is part of either the selected PLMN or the registered PLMN or PLMN of the Equivalent PLMN list and *trackingAreaCode* is provided for that PLMN;
- The cell selection criteria are fulfilled, see subclause 5.2.3.2.

According to the latest information provided by NAS:

- The cell is not barred, see subclause 5.3.1;
- The cell is part of at least one TA that is not part of the list of "Forbidden Tracking Areas" (TS 22.261 [12]), which belongs to a PLMN that fulfils the first bullet above.

barred cell:

A cell is barred if it is so indicated in the system information, as specified in TS 38.331 [3].

reserved cell:

A cell is reserved if it is so indicated in system information, as specified in TS 38.331 [3].

Following exception to these definitions are applicable for UEs:

- if a UE has an ongoing emergency call, all acceptable cells of that PLMN are treated as suitable for the duration of the emergency call.

[TS 38.304, clause 5.2.1]

UE shall perform measurements for cell selection and reselection purposes as specified in TS 38.133 [8].

The NAS can control the RAT(s) in which the cell selection should be performed, for instance by indicating RAT(s) associated with the selected PLMN, and by maintaining a list of forbidden registration area(s) and a list of equivalent PLMNs. The UE shall select a suitable cell based on RRC_IDLE or RRC_INACTIVE state measurements and cell selection criteria.

In order to expedite the cell selection process, stored information for several RATs, if available, may be used by the UE.

When camped on a cell, the UE shall regularly search for a better cell according to the cell reselection criteria. If a better cell is found, that cell is selected. The change of cell may imply a change of RAT. Details on performance requirements for cell reselection can be found in TS 38.133 [8].

The NAS is informed if the cell selection and reselection result in changes in the received system information relevant for NAS.

For normal service, the UE shall camp on a suitable cell, monitor control channel(s) of that cell so that the UE can:

- receive system information from the PLMN; and
- receive registration area information from the PLMN, e.g., tracking area information; and
- receive other AS and NAS Information; and
- if registered:
 - receive paging and notification messages from the PLMN; and
 - initiate transfer to Connected mode.

For cell selection in multi-beam operations, measurement quantity of a cell is up to UE implementation.

For cell reselection in multi-beam operations, using a maximum number (*nrofSS-BlocksToAverage*) of beams to be considered and a threshold (*absThreshSS-BlocksConsolidation*) which are configured for a cell, the measurement quantity of this cell is derived amongst the beams corresponding to the same cell based on SS/PBCH block as follows:

- if the highest beam measurement quantity value is below the threshold:
 - derive a cell measurement quantity as the highest beam measurement quantity value, where each beam measurement quantity is described in TS 38.215 [11].
- else:
 - derive a cell measurement quantity as the linear average of the power values of up to the maximum number of highest beam measurement quantity values above the threshold.

[TS 38.304, clause 5.2.3.1]

Cell selection is performed by one of the following two procedures:

- a) Initial cell selection (no prior knowledge of which RF channels are NR frequencies):
 1. The UE shall scan all RF channels in the NR bands according to its capabilities to find a suitable cell.
 2. On each frequency, the UE need only search for the strongest cell.
 3. Once a suitable cell is found, this cell shall be selected.
- b) Cell selection by leveraging stored information:
 1. This procedure requires stored information of frequencies and optionally also information on cell parameters from previously received measurement control information elements or from previously detected cells.
 2. Once the UE has found a suitable cell, the UE shall select it.
 3. If no suitable cell is found, the initial cell selection procedure in a) shall be started.

NOTE: Priorities between different frequencies or RATs provided to the UE by system information or dedicated signalling are not used in the cell selection process.

[TS 38.304, clause 5.2.3.2]

The cell selection criterion S is fulfilled when:

$$S_{rxlev} > 0 \text{ AND } S_{qual} > 0$$

where:

$$S_{rxlev} = Q_{rxlevmeas} - (Q_{rxlevmin} + Q_{rxlevminoffset}) - P_{compensation} - Q_{offset_{temp}}$$

$$S_{qual} = Q_{qualmeas} - (Q_{qualmin} + Q_{qualminoffset}) - Q_{offset_{temp}}$$

where:

Srxlev	Cell selection RX level value (dB)
Squal	Cell selection quality value (dB)
Qoffset _{temp}	Offset temporarily applied to a cell as specified in TS 38.331 [3] (dB)
Q _{rxlevmeas}	Measured cell RX level value (RSRP)
Q _{qualmeas}	Measured cell quality value (RSRQ)
Q _{rxlevmin}	Minimum required RX level in the cell (dBm). If the UE supports SUL frequency for this cell, Q _{rxlevmin} is obtained from <i>RxLevMinSUL</i> , if present, in <i>SIB1</i> , <i>SIB2</i> and <i>SIB4</i> , additionally, if Q _{rxlevminoffsetcellSUL} is present in <i>SIB3</i> and <i>SIB4</i> for the concerned cell, this cell specific offset is added to the corresponding Q _{rxlevmin} to achieve the required minimum RX level in the concerned cell; else Q _{rxlevmin} is obtained from <i>q-RxLevMin</i> in <i>SIB1</i> , <i>SIB2</i> and <i>SIB4</i> , additionally, if Q _{rxlevminoffsetcell} is present in <i>SIB3</i> and <i>SIB4</i> for the concerned cell, this cell specific offset is added to the corresponding Q _{rxlevmin} to achieve the required minimum RX level in the concerned cell.
Q _{qualmin}	Minimum required quality level in the cell (dB). Additionally, if Q _{qualminoffsetcell} is signalled for the concerned cell, this cell specific offset is added to achieve the required minimum quality level in the concerned cell.
Q _{rxlevminoffset}	Offset to the signalled Q _{rxlevmin} taken into account in the Srxlev evaluation as a result of a periodic search for a higher priority PLMN while camped normally in a VPLMN 3GPP TS 23.122 [9]
Q _{qualminoffset}	Offset to the signalled Q _{qualmin} taken into account in the Squal evaluation as a result of a periodic search for a higher priority PLMN while camped normally in a VPLMN 3GPP TS 23.122 [9]
P _{compensation}	If the UE supports the additionalPmax in the NS-PmaxList, if present, in <i>SIB1</i> , <i>SIB2</i> and <i>SIB4</i> : $\max(P_{EMAX1} - P_{PowerClass}, 0) - (\min(P_{EMAX2}, P_{PowerClass}) - \min(P_{EMAX1}, P_{PowerClass}))$ (dB); else: $\max(P_{EMAX1} - P_{PowerClass}, 0)$ (dB)
P _{EMAX1} , P _{EMAX2}	Maximum TX power level of a UE may use when transmitting on the uplink in the cell (dBm) defined as P _{EMAX} in TS 38.101 [15]. P _{EMAX1} and P _{EMAX2} are obtained from the <i>p-Max</i> and <i>NS-PmaxList</i> respectively in <i>SIB1</i> , <i>SIB2</i> and <i>SIB4</i> as specified in TS 38.331 [3].
P _{PowerClass}	Maximum RF output power of the UE (dBm) according to the UE power class as defined in TS 38.101 [15]

The signalled values Q_{rxlevminoffset} and Q_{qualminoffset} are only applied when a cell is evaluated for cell selection as a result of a periodic search for a higher priority PLMN while camped normally in a VPLMN (3GPP TS 23.122 [9]). During this periodic search for higher priority PLMN, the UE may check the S criteria of a cell using parameter values stored from a different cell of this higher priority PLMN.

[TS 38.304, clause 5.2.4.6]

The cell-ranking criterion R_s for serving cell and R_n for neighbouring cells is defined by:

$$R_s = Q_{meas,s} + Q_{hyst} - Q_{offset,temp}$$

$$R_n = Q_{meas,n} - Q_{offset} - Q_{offset,temp}$$

where:

Q _{meas}	RSRP measurement quantity used in cell reselections.
Q _{offset}	For intra-frequency: Equals to Q _{offset_{s,n}} , if Q _{offset_{s,n}} is valid, otherwise this equals to zero. For inter-frequency: Equals to Q _{offset_{s,n}} plus Q _{offset_{frequency}} , if Q _{offset_{s,n}} is valid, otherwise this equals to Q _{offset_{frequency}} .
Q _{offset_{temp}}	Offset temporarily applied to a cell as specified in TS 38.331 [3].

The UE shall perform ranking of all cells that fulfil the cell selection criterion S, which is defined in 5.2.3.2.

The cells shall be ranked according to the R criteria specified above by deriving Q_{meas,n} and Q_{meas,s} and calculating the R values using averaged RSRP results.

If *rangeToBestCell* is not configured, the UE shall perform cell reselection to the highest ranked cell. If this cell is found to be not-suitable, the UE shall behave according to subclause 5.2.4.4.

If *rangeToBestCell* is configured, then the UE shall perform cell reselection to the cell with the highest number of beams above the threshold (i.e. *absThreshSS-BlocksConsolidation*) among the cells whose R value is within *rangeToBestCell* of the R value of the highest ranked cell. If there are multiple such cells, the UE shall perform cell reselection to the highest ranked cell among them. If this cell is found to be not-suitable, the UE shall behave according to subclause 5.2.4.4.

In all cases, the UE shall reselect the new cell, only if the following conditions are met:

- the new cell is better ranked than the serving cell during a time interval $T_{\text{reselectionRAT}}$;
- more than 1 second has elapsed since the UE camped on the current serving cell.

6.1.2.1.3 Test description

6.1.2.1.3.1 Pre-test conditions

System Simulator:

- NR Cell 1 and NR Cell 11.
- System information combination NR-2 as defined in TS 38.508-1[4] clause 4.4.3.1.2 is used in NR cells.

UE:

- None.

Preamble:

- The UE is in state Switched OFF (state 0-A) according to TS 38.508-1 [4].

6.1.2.1.3.2 Test procedure sequence

Table 6.1.2.1.3.2-1/2 illustrate the downlink power levels and other changing parameters to be applied for the cell at various time instants of the test execution. The exact instants on which these values shall be applied are described in the texts in this clause. Configurations marked "T1", "T2", "T3" and "T4" are applied at the points indicated in the Main behaviour description in Table 6.1.2.1.3.2-3.

Table 6.1.2.1.3.2-1: Time instances of cell power level and parameter changes for FR1

	Parameter	Unit	NR Cell 1	NR Cell 11	Remark
T1	SS/PBCH	dBm/	-88	Off	The power level value is such to satisfy $S_{rxlev}^{VNR_{Cell1}} < 0$ but the UE is able to read the PLMN identity
	SSS EPRE	SCS			
	Qrxlevmin	dBm	-80	-	
	Qrxlevminoffset	dB	0	-	
	Pcompensation	dB	0	-	

T2	SS/PBCH SSS EPRE	dBm/ SCS	-70	Off	The power level is such that $S_{rxlevNRCell1} > 0$
	Qrxlevmin	dBm	-80	-	
	Qrxlevminoffset	dB	0	-	
	Pcompensation	dB	0	-	
T3	SS/PBCH SSS EPRE	dBm/ SCS	-70	-65	The power level values are assigned to satisfy $R_{NRCell1} < R_{NRCell11}$.
	Qrxlevmin	dBm	-80	-80	
	Qrxlevminoffset	dB	0	0	
	Pcompensation	dB	0	0	
T4	SS/PBCH SSS EPRE	dBm/ SCS	-65	-70	The power level values are assigned to satisfy $R_{NRCell1} > R_{NRCell11}$.
	Qrxlevmin	dBm	-80	-80	
	Qrxlevminoffset	dB	0	0	
	Pcompensation	dB	0	0	
Note: The downlink signal level uncertainty is specified in TS 38.508-1 [4] section 6.2.2.1.					

Table 6.1.2.1.3.2-2: Time instances of cell power level and parameter changes for FR2

	Parameter	Unit	NR Cell 1	NR Cell 11	Remark
T1	SS/PBCH SSS EPRE	dBm/ SCS	FFS	Off	The power level value is such to satisfy $S_{rxlevNRCell1} < 0$ but the UE is able to read the PLMN identity
	Qrxlevmin	dBm	FFS	-	
	Qrxlevminoffset	dB	0	-	
	Pcompensation	dB	0	-	
T2	SS/PBCH SSS EPRE	dBm/ SCS	FFS	Off	The power level is such that $S_{rxlevNRCell1} > 0$
	Qrxlevmin	dBm	FFS	-	
	Qrxlevminoffset	dB	0	-	
	Pcompensation	dB	0	-	
T3	SS/PBCH SSS EPRE	dBm/ SCS	FFS	FFS	The power level values are assigned to satisfy $R_{NRCell1} < R_{NRCell11}$.
	Qrxlevmin	dBm	FFS	FFS	
	Qrxlevminoffset	dB	0	0	
	Pcompensation	dB	0	0	
T4	SS/PBCH SSS EPRE	dBm/ SCS	FFS	FFS	The power level values are assigned to satisfy $R_{NRCell1} > R_{NRCell11}$.
	Qrxlevmin	dBm	FFS	FFS	
	Qrxlevminoffset	dB	0	0	
	Pcompensation	dB	0	0	
Note: The downlink signal level uncertainty is specified in TS 38.508-1 [4] section FFS.					

Table 6.1.2.1.3.2-3: Main behaviour

St	Procedure	Message Sequence		TP	Verdict
		U - S	Message		
1	SS adjusts the SS/PBCH EPRE level of NR Cell 1 according to row "T1" in table 6.1.2.1.3.2-1/2.	-	-	-	-
2	The UE is switched on.	-	-	-	-
3	Check: Does the UE send an <i>RRCSetupRequest</i> on NR Cell 1 within the next 60 s?	-->	NR RRC: <i>RRCSetupRequest</i>	1	F
4	SS re-adjusts the SS/PBCH EPRE level of NR Cell 1 level according to row "T2" in table 6.1.2.1.3.2-1/2.	-	-	-	-
5	Check: Does the UE send an <i>RRCSetupRequest</i> on NR Cell 1?	-->	NR RRC: <i>RRCSetupRequest</i>	2	P
6-23	Steps 3 to 20 of the registration procedure described in TS 38.508-1 [4] Table 4.5.2.2-2 are performed on NR Cell 1. NOTE: The UE performs registration and the RRC connection is released.	-	-	-	-
24	The SS changes SS/PBCH EPRE level of NR Cell 11 according to the row "T3" in table 6.1.2.1.3.2-1/2.	-	-	-	-
25-31	Check: Does the test result of generic test procedure in TS 38.508-1 [4] clause 4.9.5 indicate that the UE is camped on NR Cell 11? NOTE 1: The UE performs registration and the RRC connection is released.	-	-	3	P
32	SS change NR Cell 1 SIB1	-	-	-	-
33	The SS changes SS/PBCH EPRE level of NR Cell 1 and 11 according to the row "T4" in table 6.1.2.1.3.2-1/2.	-	-	-	-
34	Check: Does the test result of generic test procedure in TS 38.508-1 [4] clause 4.9.5 indicate that the UE is camped on NR Cell 1?	-	-	4	F

6.1.2.1.3.3 Specific message contents

Table 6.1.2.1.3.3-1: SIB1 for NR Cell 1 (preamble) and NR Cell 11 (preamble)

Derivation Path: TS 38.508-1 [4], Table 4.6.1-28			
Information Element	Value/remark	Comment	Condition
SIB1 ::= SEQUENCE {			
cellSelectionInfo SEQUENCE {			
q-RxLevMin	-40	-80 dBm	FR1
q-RxLevMin	FFS		FR2
q-RxLevMinSUL	-40	-80 dBm	SUL
}			
}			

Table 6.1.2.1.3.3-2: SIB1 for NR Cell 1 (Step32, Table 6.1.2.1.3.2-3)

Derivation Path: TS 38.508-1 [4], Table 4.6.3-16			
Information Element	Value/remark	Comment	Condition
SIB1 ::= SEQUENCE {			
cellSelectionInfo SEQUENCE {			
q-RxLevMin	-40	-80 dBm	FR1
q-RxLevMin	FFS		FR2
q-RxLevMinSUL	-40	-80 dBm	SUL
}			
cellAccessRelatedInfo	CellAccessRelatedInfo		
}			

Table 6.1.2.1.3.3-3: CellAccessRelatedInfo (Table 6.1.2.1.3.3-2)

Derivation Path: TS 38.508-1 [4], Table 4.6.3-16			
Information Element	Value/remark	Comment	Condition
CellAccessRelatedInfo ::= SEQUENCE {			
plmn-IdentityList	PLMN-IdentityInfoList		
cellReservedForOtherUse	Not present		
}			

Table 6.1.2.1.3.3-4: PLMN-IdentityInfoList (Table 6.1.2.1.3.3-3)

Derivation Path: TS 38.508-1 [4], Table 4.6.3-108			
Information Element	Value/remark	Comment	Condition
PLMN-IdentityInfoList ::= SEQUENCE (SIZE (1..maxPLMN)) OF SEQUENCE {	1 entry		
trackingAreaCode	Not present		
}			

6.1.2.2 Cell Selection / Qualmin/Intra NR / Serving cell becomes non-suitable (Srxlev > 0, Squal < 0)

6.1.2.2.1 Test Purpose (TP)

(1)

```
with { UE in NR RRC_IDLE state }
ensure that {
  when { a cell fulfils all requirements for a suitable cell except the cell selection criteria
which are not fulfilled (Srxlev>0 AND Squal<0) }
  then { the UE does not consider the cell suitable and no camping on this cell can take place }
}
```

(2)

```
with { UE in NR RRC_IDLE state }
ensure that {
  when { a cell fulfils all requirements for a suitable cell including the cell selection criteria
for a cell which are also fulfilled (Srxlev>0 AND Squal>0) }
  then { the UE considers the cell suitable and camps on it }
}
```

(3)

```
with { UE in NR RRC_IDLE state }
ensure that {
  when { the serving cell becomes non-suitable (Srxlev > 0 and Squal < 0)and there is a suitable
neighbour cell (Srxlev > 0 and Squal > 0) }
  then { UE selects the suitable neighbour cell }
}
```

6.1.2.2.2 Conformance requirements

References: The conformance requirements covered in the present TC are specified in: 3GPP TS 38.300 clauses 9.2.1.1, 3GPP TS 38.304 clause 4.1, 4.5, 5.2.1, 5.2.3.1, 5.2.3.2, 5.2.4.6 and 5.3.1. Unless otherwise stated these are Rel-15 requirements.

[TS 38.300, clause 9.2.1.1]

The principles of PLMN selection in NR are based on the 3GPP PLMN selection principles. Cell selection is required on transition from RM-DEREGISTERED to RM-REGISTERED, from CM-IDLE to CM-CONNECTED and from CM-CONNECTED to CM-IDLE and is based on the following principles:

- The UE NAS layer identifies a selected PLMN and equivalent PLMNs;

- Cell selection is always based on CD-SSBs located on the synchronization raster (see subclause 5.2.4):
 - The UE searches the NR frequency bands and for each carrier frequency identifies the strongest cell as per the CD-SSB. It then reads cell system information broadcast to identify its PLMN(s):
 - The UE may search each carrier in turn ("initial cell selection") or make use of stored information to shorten the search ("stored information cell selection").
 - The UE seeks to identify a suitable cell; if it is not able to identify a suitable cell it seeks to identify an acceptable cell. When a suitable cell is found or if only an acceptable cell is found it camps on that cell and commence the cell reselection procedure:
 - A suitable cell is one for which the measured cell attributes satisfy the cell selection criteria; the cell PLMN is the selected PLMN, registered or an equivalent PLMN; the cell is not barred or reserved and the cell is not part of a tracking area which is in the list of "forbidden tracking areas for roaming";
 - An acceptable cell is one for which the measured cell attributes satisfy the cell selection criteria and the cell is not barred.

Transition to RRC_IDLE:

On transition from RRC_CONNECTED to RRC_IDLE, a UE should camp on the last cell for which it was in RRC_CONNECTED or a cell/any cell of set of cells or frequency be assigned by RRC in the state transition message.

Recovery from out of coverage:

The UE should attempt to find a suitable cell in the manner described for stored information or initial cell selection above. If no suitable cell is found on any frequency or RAT, the UE should attempt to find an acceptable cell.

In multi-beam operations, the cell quality is derived amongst the beams corresponding to the same cell (see subclause 9.2.4).

[TS 38.304, clause 4.1]

The RRC_IDLE state and RRC_INACTIVE state tasks can be subdivided into three processes:

- PLMN selection;
- Cell selection and reselection;
- Location registration and RNA update.

PLMN selection, cell reselection procedures, and location registration are common for both RRC_IDLE state and RRC_INACTIVE state. RNA update is only applicable for RRC_INACTIVE state. When UE selects a new PLMN, UE transitions from RRC_INACTIVE to RRC_IDLE.

When a UE is switched on, a public land mobile network (PLMN) is selected by NAS. For the selected PLMN, associated RAT(s) may be set 3GPP TS 23.122 [9]. The NAS shall provide a list of equivalent PLMNs, if available, that the AS shall use for cell selection and cell reselection.

With cell selection, the UE searches for a suitable cell of the selected PLMN, chooses that cell to provide available services, and monitors its control channel. This procedure is defined as "camping on the cell".

The UE shall, if necessary, then register its presence, by means of a NAS registration procedure, in the tracking area of the chosen cell. As an outcome of a successful Location Registration, the selected PLMN then becomes the registered PLMN 3GPP TS 23.122 [9].

If the UE finds a more suitable cell, according to the cell reselection criteria, it reselects onto that cell and camps on it. If the new cell does not belong to at least one tracking area to which the UE is registered, location registration is performed. In RRC_INACTIVE state, if the new cell does not belong to the configured RNA, an RNA update procedure is performed.

If necessary, the UE shall search for higher priority PLMNs at regular time intervals as described in 3GPP TS 23.122 [9] and search for a suitable cell if another PLMN has been selected by NAS.

If the UE loses coverage of the registered PLMN, either a new PLMN is selected automatically (automatic mode), or an indication of available PLMNs is given to the user so that a manual selection can be performed (manual mode).

Registration is not performed by UEs only capable of services that need no registration.

The purpose of camping on a cell in RRC_IDLE state and RRC_INACTIVE state is fourfold:

- a) It enables the UE to receive system information from the PLMN.
- b) When registered and if the UE wishes to establish an RRC connection or resume a suspended RRC connection, it can do this by initially accessing the network on the control channel of the cell on which it is camped.
- c) If the network needs to send a message or deliver data to the registered UE, it knows (in most cases) the set of tracking areas (in RRC_IDLE state) or RNA (in RRC_INACTIVE state) in which the UE is camped. It can then send a "paging" message for the UE on the control channels of all the cells in the corresponding set of areas. The UE will then receive the paging message and can respond.
- d) It enables the UE to receive ETWS and CMAS notifications.

[TS 38.304, clause 4.5]

The cells are categorised according to which services they offer:

acceptable cell:

An "acceptable cell" is a cell on which the UE may camp to obtain limited service (originate emergency calls and receive ETWS and CMAS notifications). Such a cell shall fulfil the following requirements, which is the minimum set of requirements to initiate an emergency call and to receive ETWS and CMAS notification in an NR network:

- The cell is not barred, see subclause 5.3.1;
- The cell selection criteria are fulfilled, see subclause 5.2.3.2.

suitable cell:

A cell is considered as suitable if the following conditions are fulfilled:

- The cell is part of either:
 - the selected PLMN, or
 - the registered PLMN, or
 - a PLMN of the Equivalent PLMN list.
- The cell selection criteria are fulfilled, see subclause 5.2.3.2;

According to the latest information provided by NAS:

- The cell is not barred, see subclause 5.3.1;
- The cell is part of at least one TA that is not part of the list of "Forbidden Tracking Areas" TS 22.261 [12], which belongs to a PLMN that fulfils the first bullet above.

barred cell:

A cell is barred if it is so indicated in the system information TS 38.331 [3].

reserved cell:

A cell is reserved if it is so indicated in system information TS 38.331 [3].

Following exception to these definitions are applicable for UEs:

- if a UE has an ongoing emergency call, all acceptable cells of that PLMN are treated as suitable for the duration of the emergency call.

[TS 38.304, clause 5.2.1]

UE shall perform measurements for cell selection and reselection purposes as specified in TS 38.133 [8].

The NAS can control the RAT(s) in which the cell selection should be performed, for instance by indicating RAT(s) associated with the selected PLMN, and by maintaining a list of forbidden registration area(s) and a list of equivalent PLMNs. The UE shall select a suitable cell based on RRC_IDLE or RRC_INACTIVE state measurements and cell selection criteria.

In order to expedite the cell selection process, stored information for several RATs, if available, may be used by the UE.

When camped on a cell, the UE shall regularly search for a better cell according to the cell reselection criteria. If a better cell is found, that cell is selected. The change of cell may imply a change of RAT. Details on performance requirements for cell reselection can be found in TS 38.133 [8].

The NAS is informed if the cell selection and reselection result in changes in the received system information relevant for NAS.

For normal service, the UE shall camp on a suitable cell, monitor control channel(s) of that cell so that the UE can:

- receive system information from the PLMN; and
- receive registration area information from the PLMN, e.g., tracking area information; and
- receive other AS and NAS Information; and
- if registered:
 - receive paging and notification messages from the PLMN; and
 - initiate transfer to Connected mode.

For cell selection in multi-beam operations, measurement quantity of a cell is up to UE implementation.

For cell reselection in multi-beam operations, using a maximum number (*nrofSS-BlocksToAverage*) of beams to be considered and a threshold (*absThreshSS-BlocksConsolidation*) which are configured for a cell, the measurement quantity of this cell is derived amongst the beams corresponding to the same cell based on SS/PBCH block as follows:

- if the highest beam measurement quantity value is below the threshold:
 - derive a cell measurement quantity as the highest beam measurement quantity value, where each beam measurement quantity is described in TS 38.215 [11].
- else:
 - derive a cell measurement quantity as the linear average of the power values of up to the maximum number of highest beam measurement quantity values above the threshold.

[TS 38.304, clause 5.2.3.1]

Cell selection is performed by one of the following two procedures:

- a) Initial cell selection (no prior knowledge of which RF channels are NR frequencies):
 1. The UE shall scan all RF channels in the NR bands according to its capabilities to find a suitable cell.
 2. On each frequency, the UE need only search for the strongest cell.
 3. Once a suitable cell is found, this cell shall be selected.
- b) Cell selection by leveraging stored information:
 1. This procedure requires stored information of frequencies and optionally also information on cell parameters from previously received measurement control information elements or from previously detected cells.
 2. Once the UE has found a suitable cell, the UE shall select it.
 3. If no suitable cell is found, the initial cell selection procedure in a) shall be started.

NOTE: Priorities between different frequencies or RATs provided to the UE by system information or dedicated signalling are not used in the cell selection process.

[TS 38.304, clause 5.2.3.2]

The cell selection criterion S is fulfilled when:

$$S_{rxlev} > 0 \text{ AND } S_{qual} > 0$$

where:

$$S_{rxlev} = Q_{rxlevmeas} - (Q_{rxlevmin} + Q_{rxlevminoffset}) - P_{compensation} - Q_{offsettemp}$$

$$S_{qual} = Q_{qualmeas} - (Q_{qualmin} + Q_{qualminoffset}) - Q_{offsettemp}$$

where:

S_{rxlev}	Cell selection RX level value (dB)
S_{qual}	Cell selection quality value (dB)
$Q_{offsettemp}$	Offset temporarily applied to a cell as specified in TS 38.331 [3] (dB)
$Q_{rxlevmeas}$	Measured cell RX level value (RSRP)
$Q_{qualmeas}$	Measured cell quality value (RSRQ)
$Q_{rxlevmin}$	Minimum required RX level in the cell (dBm). If the UE supports SUL frequency for this cell, $Q_{rxlevmin}$ is obtained from <i>RxLevMinSUL</i> , if present, in <i>SIB1</i> , <i>SIB2</i> and <i>SIB4</i> , additionally, if $Q_{rxlevminoffsetcellSUL}$ is present in <i>SIB3</i> and <i>SIB4</i> for the concerned cell, this cell specific offset is added to the corresponding $Q_{rxlevmin}$ to achieve the required minimum RX level in the concerned cell; else $Q_{rxlevmin}$ is obtained from <i>q-RxLevMin</i> in <i>SIB1</i> , <i>SIB2</i> and <i>SIB4</i> , additionally, if $Q_{rxlevminoffsetcell}$ is present in <i>SIB3</i> and <i>SIB4</i> for the concerned cell, this cell specific offset is added to the corresponding $Q_{rxlevmin}$ to achieve the required minimum RX level in the concerned cell.
$Q_{qualmin}$	Minimum required quality level in the cell (dB). Additionally, if $Q_{qualminoffsetcell}$ is signalled for the concerned cell, this cell specific offset is added to achieve the required minimum quality level in the concerned cell.
$Q_{rxlevminoffset}$	Offset to the signalled $Q_{rxlevmin}$ taken into account in the S_{rxlev} evaluation as a result of a periodic search for a higher priority PLMN while camped normally in a VPLMN 3GPP TS 23.122 [9]
$Q_{qualminoffset}$	Offset to the signalled $Q_{qualmin}$ taken into account in the S_{qual} evaluation as a result of a periodic search for a higher priority PLMN while camped normally in a VPLMN 3GPP TS 23.122 [9]
$P_{compensation}$	If the UE supports the additionalPmax in the NS-PmaxList, if present, in <i>SIB1</i> , <i>SIB2</i> and <i>SIB4</i> : $\max(P_{EMAX1} - P_{PowerClass}, 0) - (\min(P_{EMAX2}, P_{PowerClass}) - \min(P_{EMAX1}, P_{PowerClass}))$ (dB); else: $\max(P_{EMAX1} - P_{PowerClass}, 0)$ (dB)
P_{EMAX1} , P_{EMAX2}	Maximum TX power level of a UE may use when transmitting on the uplink in the cell (dBm) defined as P_{EMAX} in TS 38.101 [15]. P_{EMAX1} and P_{EMAX2} are obtained from the <i>p-Max</i> and <i>NS-PmaxList</i> respectively in <i>SIB1</i> , <i>SIB2</i> and <i>SIB4</i> as specified in TS 38.331 [3].
$P_{PowerClass}$	Maximum RF output power of the UE (dBm) according to the UE power class as defined in TS 38.101 [15]

The signalled values $Q_{rxlevminoffset}$ and $Q_{qualminoffset}$ are only applied when a cell is evaluated for cell selection as a result of a periodic search for a higher priority PLMN while camped normally in a VPLMN (3GPP TS 23.122 [9]). During this periodic search for higher priority PLMN, the UE may check the S criteria of a cell using parameter values stored from a different cell of this higher priority PLMN.

[TS 38.304, clause 5.2.4.6]

The cell-ranking criterion R_s for serving cell and R_n for neighbouring cells is defined by:

$$R_s = Q_{\text{meas},s} + Q_{\text{hyst}} - Q_{\text{offset,temp}}$$

$$R_n = Q_{\text{meas},n} - Q_{\text{offset}} - Q_{\text{offset,temp}}$$

where:

Q_{meas}	RSRP measurement quantity used in cell reselections.
Q_{offset}	For intra-frequency: Equals to $Q_{\text{offset},s,n}$, if $Q_{\text{offset},s,n}$ is valid, otherwise this equals to zero. For inter-frequency: Equals to $Q_{\text{offset},s,n}$ plus $Q_{\text{offset,frequency}}$, if $Q_{\text{offset},s,n}$ is valid, otherwise this equals to $Q_{\text{offset,frequency}}$.
$Q_{\text{offset,temp}}$	Offset temporarily applied to a cell as specified in TS 38.331 [3].

The UE shall perform ranking of all cells that fulfil the cell selection criterion S, which is defined in 5.2.3.2.

The cells shall be ranked according to the R criteria specified above by deriving $Q_{\text{meas},n}$ and $Q_{\text{meas},s}$ and calculating the R values using averaged RSRP results.

If *rangeToBestCell* is not configured, the UE shall perform cell reselection to the highest ranked cell. If this cell is found to be not-suitable, the UE shall behave according to subclause 5.2.4.4.

If *rangeToBestCell* is configured, then the UE shall perform cell reselection to the cell with the highest number of beams above the threshold (i.e. *absThreshSS-BlocksConsolidation*) among the cells whose R value is within *rangeToBestCell* of the R value of the highest ranked cell. If there are multiple such cells, the UE shall perform cell reselection to the highest ranked cell among them. If this cell is found to be not-suitable, the UE shall behave according to subclause 5.2.4.4.

In all cases, the UE shall reselect the new cell, only if the following conditions are met:

- the new cell is better ranked than the serving cell during a time interval $T_{\text{reselection,RAT}}$;
- more than 1 second has elapsed since the UE camped on the current serving cell.

[TS 38.304, clause 5.3.1]

Cell status and cell reservations are indicated in the *MIB* or *SIB1* message TS 38.331 [3] by means of three fields:

- *cellBarred* (IE type: "barred" or "not barred")
Indicated in *MIB* message. In case of multiple PLMNs indicated in *SIB1*, this field is common for all PLMNs
- *cellReservedForOperatorUse* (IE type: "reserved" or "not reserved")
Indicated in *SIB1* message. In case of multiple PLMNs indicated in *SIB1*, this field is specified per PLMN.
- *cellReservedForOtherUse* (IE type: "true")
Indicated in *SIB1* message. In case of multiple PLMNs indicated in *SIB1*, this field is common for all PLMNs.

When cell status is indicated as "not barred" and "not reserved" for operator use and not "true" for other use,

- All UEs shall treat this cell as candidate during the cell selection and cell reselection procedures.

When cell status is indicated as "true" for other use,

- The UE shall treat this cell as if cell status is "barred".

When cell status is indicated as "not barred" and "reserved" for operator use for any PLMN and not "true" for other use,

- UEs assigned to Access Identity 11 or 15 operating in their HPLMN/EHPLMN shall treat this cell as candidate during the cell selection and reselection procedures if the field *cellReservedForOperatorUse* for that PLMN set to "reserved".
- UEs assigned to an Access Identity in the range of 0 to 10 and 12 to 14 shall behave as if the cell status is "barred" in case the cell is "reserved for operator use" for the registered PLMN or the selected PLMN.

NOTE 1: Access Identities 11, 15 are only valid for use in the HPLMN/ EHPLMN; Access Identities 12, 13, 14 are only valid for use in the home country as specified in 3GPP TS 22.261 [12].

When cell status "barred" is indicated or to be treated as if the cell status is "barred",

- The UE is not permitted to select/reselect this cell, not even for emergency calls.
- The UE shall select another cell according to the following rule:
 - If the cell is to be treated as if the cell status is "barred" due to being unable to acquire the *MIB* or the *SIB1*:
 - the UE may exclude the barred cell as a candidate for cell selection/reselection for up to 300 seconds.
 - the UE may select another cell on the same frequency if the selection criteria are fulfilled.
 - else
 - If the field *intraFreqReselection* in *MIB* message is set to "allowed", the UE may select another cell on the same frequency if re-selection criteria are fulfilled;
 - The UE shall exclude the barred cell as a candidate for cell selection/reselection for 300 seconds.
 - If the field *intraFreqReselection* in *MIB* message is set to "not allowed" the UE shall not re-select a cell on the same frequency as the barred cell;
 - The UE shall exclude the barred cell and the cells on the same frequency as a candidate for cell selection/reselection for 300 seconds.

The cell selection of another cell may also include a change of RAT.

6.1.2.2.3 Test description

6.1.2.2.3.1 Pre-test conditions

System Simulator:

- NR Cell 1 and NR Cell 11 have different tracking areas according to TS 38.508-1 [4] Table 4.4.2-3.
- System information combination NR-2 as defined in TS 38.508-1[4] clause 4.4.3.1.2 is used in NR cells.

UE:

- None.

Preamble:

- The UE is in state Switched OFF (state 0-A) according to TS 38.508-1[4].

6.1.2.2.3.2 Test procedure sequence

Table 6.1.2.2.3.2-1/2 illustrate the downlink power levels and other changing parameters to be applied for the cell at various time instants of the test execution. The exact instants on which these values shall be applied are described in the texts in this clause. Configurations marked "T1" "T2" and "T3" are applied at the points indicated in the Main behaviour description in Table 6.1.2.2.3.2-3.

Table 6.1.2.2.3.2-1: Time instances of cell power level and parameter changes for FR1

	Parameter	Unit	NR Cell 1	NR Cell 11	Remark
T1	SS/PBCH SSS EPRE	dBm/ SCS	-88	Off	The power level value is such to satisfy $S_{rxlev}^{NR_{Cell1}} > 0$ and $S_{qual}^{NR_{Cell1}} < 0$ but the UE is able to read the PLMN identity
	RSRQ	dB	-19.43	-	
	Noc	dBm/ SCS	-80	-	
	Qrxlevmin	dBm	-106	-	(default value in TS 38.508-1 Table 4.6.1-28)
	Qrxlevminoffset	dB	0	-	
	Qqualmin	dB	-15	-	

	Qqualminoffset	dB	0	-	
	Pcompensation	dB	0	-	
T2	SS/PBCH SSS EPRE	dBm/SCS	-70	Off	The power level is such that $Srxlev_{NRCell1} > 0$ and $Squal_{NRCell1} > 0$
	RSRQ	dB	-11.17	-	
	Noc	dBm/SCS	-80	-	
	Qrxlevmin	dBm	-106	-	(default value in TS 38.508-1 Table 4.6.1-28)
	Qrxlevminoffset	dB	0	-	
	Qqualmin	dB	-15	-	
	Qqualminoffset	dB	0	-	
	Pcompensation	dB	0	-	
T3	SS/PBCH SSS EPRE	dBm/SCS	-88	-70	$Srxlev_{NRCell1} > 0$ and $Squal_{NRCell1} < 0$
	RSRQ	dB	-29.23	-11.23	
	Noc	dBm/SCS	-80	-80	
	Qrxlevmin	dBm	-106	-88	
	Qrxlevminoffset	dB	0	0	
	Qqualmin	dB	-15	-15	
	Qqualminoffset	dB	0	0	
	Pcompensation	dB	0	0	
	Srxlev*	dB	18	18	NR Cell 11 is suitable cell
	Squal*	dB	-14.23	3.77	
Note: The downlink signal level uncertainty is specified in TS 38.508-1 [4] section 6.2.2.1					

Table 6.1.2.3.2-2: Time instances of cell power level and parameter changes for FR2

	Parameter	Unit	NR Cell 1	NR Cell 11	Remark
T1	SS/PBCH SSS EPRE	dBm/SCS	FFS	Off	The power level value is such to satisfy $Srxlev_{NRCell1} > 0$ and $Squal_{NRCell1} < 0$ but the UE is able to read the PLMN identity
	RSRQ	dB	-FFS	-	
	Noc	dBm/SCS	FFS	-	
	Qrxlevmin	dBm	FFS	-	(default value in TS 38.508-1 Table 4.6.1-28)
	Qrxlevminoffset	dB	0	-	
	Qqualmin	dB	FFS	-	
	Qqualminoffset	dB	0	-	
	Pcompensation	dB	0	-	
T2	SS/PBCH SSS EPRE	dBm/SCS	FFS	Off	The power level is such that $Srxlev_{NRCell1} > 0$ and $Squal_{NRCell1} > 0$
	RSRQ	dB	FFS	-	
	Noc	dBm/SCS	FFS	-	
	Qrxlevmin	dBm	FFS	-	(default value in TS 38.508-1 Table 4.6.1-28)
	Qrxlevminoffset	dB	0	-	
	Qqualmin	dB	FFS	-	
	Qqualminoffset	dB	0	-	
	Pcompensation	dB	0	-	
T3	SS/PBCH SSS EPRE	dBm/SCS	FFS	FFS	$Srxlev_{NRCell1} > 0$ and $Squal_{NRCell1} < 0$
	RSRQ	dB	FFS	FFS	
	Noc	dBm/SCS	FFS	FFS	
	Qrxlevmin	dBm	FFS	FFS	
	Qrxlevminoffset	dB	0	0	
	Qqualmin	dB	FFS	FFS	
	Qqualminoffset	dB	0	0	
	Pcompensation	dB	0	0	
	Srxlev*	dB	FFS	FFS	NR Cell 11 is suitable cell
Squal*	dB	FFS	FFS		
Note: The downlink signal level uncertainty is specified in TS 38.508-1 [4] section FFS.					

Table 6.1.2.2.3.2-3: Main behaviour

St	Procedure	Message Sequence		TP	Verdict
		U - S	Message		
1	SS adjusts the SS/PBCH EPRE level of NR Cell 1 according to row "T1" in table 6.1.2.2.3.2-1/2.	-	-	-	-
2	The UE is switched on.	-	-	-	-
3	Check: Does the UE send an <i>RRCSetupRequest</i> on NR Cell 1 within the next 60 s?	-->	NR RRC: <i>RRCSetupRequest</i>	1	F
4	SS re-adjusts the SS/PBCH EPRE level of NR Cell 1 level according to row "T2" in table 6.1.2.2.3.2-1/2.	-	-	-	-
5	Check: Does the UE send an <i>RRCSetupRequest</i> on NR Cell 1?	-->	NR RRC: <i>RRCSetupRequest</i>	2	P
6-23	Steps 3 to 20 of the registration procedure described in TS 38.508-1 [4] Table 4.5.2.2-2 are performed on NR Cell 1. NOTE: The UE performs registration and the RRC connection is released.	-	-	-	-
24	SS adjusts the SS/PBCH EPRE level of NR Cell 1 and NR Cell 11 according to row "T3" in table 6.1.2.2.3.2-1/2.	-	-	-	-
25	Check: Does the test result of generic test procedure in TS 38.508-1 [4] Table 4.9.5.2.2-1 indicate that the UE is camped on NR Cell 11? NOTE: The UE performs a registration for mobility procedure and the RRC connection is released.	-	-	3	P

6.1.2.2.3.3 Specific message contents

Table 6.1.2.2.3.3-1: *SIB1* for NR Cell 1 and NR Cell 11(all steps)

Derivation Path: TS 38.508-1 [4], Table 4.6.1-28			
Information Element	Value/remark	Comment	Condition
SIB1 ::= SEQUENCE {			
cellSelectionInfo SEQUENCE {			
q-RxLevMin	-44	Only for NR Cell 11	FR1
q-RxLevMin	FFS	Only for NR Cell 11	FR2
q-QualMin	-15		FR1
q-QualMin	FFS		FR2
q-QualMinOffset	Not present		
}			
}			

6.1.2.3 Cell selection / Intra NR/ Serving cell becomes non-suitable (S<0, MIB Indicated barred)

6.1.2.3.1 Test Purpose (TP)

(1)

```

with { UE in NR RRC_IDLE state }
ensure that {
  when { the serving cell becomes non-suitable (S<0)and there is a suitable neighbour cell (S>0) }
  then { UE selects the suitable neighbour cell }
}

```

(2)

```

with { UE in NR RRC_IDLE state }
ensure that {
  when { the serving cell becomes barred and there is a suitable neighbour cell }
  then { UE selects the suitable neighbour cell }
}

```

6.1.2.3.2 Conformance requirements

References: The conformance requirements covered in the present TC are specified in: 3GPP TS 38.304 clause 4.1, 5.2.3.2 and 5.3.1. Unless otherwise stated these are Rel-15 requirements.

[TS 38.304, clause 4.1]

The RRC_IDLE state and RRC_INACTIVE state tasks can be subdivided into three processes:

- PLMN selection;
- Cell selection and reselection;
- Location registration and RNA update.

PLMN selection, cell reselection procedures, and location registration are common for both RRC_IDLE state and RRC_INACTIVE state. RNA update is only applicable for RRC_INACTIVE state. When UE selects a new PLMN, UE transitions from RRC_INACTIVE to RRC_IDLE.

When a UE is switched on, a public land mobile network (PLMN) is selected by NAS. For the selected PLMN, associated RAT(s) may be set 3GPP TS 23.122 [9]. The NAS shall provide a list of equivalent PLMNs, if available, that the AS shall use for cell selection and cell reselection.

With cell selection, the UE searches for a suitable cell of the selected PLMN, chooses that cell to provide available services, and monitors its control channel. This procedure is defined as "camping on the cell".

The UE shall, if necessary, then register its presence, by means of a NAS registration procedure, in the tracking area of the chosen cell. As an outcome of a successful Location Registration, the selected PLMN then becomes the registered PLMN 3GPP TS 23.122 [9].

If the UE finds a more suitable cell, according to the cell reselection criteria, it reselects onto that cell and camps on it. If the new cell does not belong to at least one tracking area to which the UE is registered, location registration is performed. In RRC_INACTIVE state, if the new cell does not belong to the configured RNA, an RNA update procedure is performed.

If necessary, the UE shall search for higher priority PLMNs at regular time intervals as described in 3GPP TS 23.122 [9] and search for a suitable cell if another PLMN has been selected by NAS.

If the UE loses coverage of the registered PLMN, either a new PLMN is selected automatically (automatic mode), or an indication of available PLMNs is given to the user so that a manual selection can be performed (manual mode).

Registration is not performed by UEs only capable of services that need no registration.

The purpose of camping on a cell in RRC_IDLE state and RRC_INACTIVE state is fourfold:

- a) It enables the UE to receive system information from the PLMN.
- b) When registered and if the UE wishes to establish an RRC connection or resume a suspended RRC connection, it can do this by initially accessing the network on the control channel of the cell on which it is camped.
- c) If the network needs to send a message or deliver data to the registered UE, it knows (in most cases) the set of tracking areas (in RRC_IDLE state) or RNA (in RRC_INACTIVE state) in which the UE is camped. It can then send a "paging" message for the UE on the control channels of all the cells in the corresponding set of areas. The UE will then receive the paging message and can respond.
- d) It enables the UE to receive ETWS and CMAS notifications.

[TS 38.304, clause 5.2.3.2]

The cell selection criterion S is fulfilled when:

$$S_{rxlev} > 0 \text{ AND } S_{qual} > 0$$

where:

$$S_{rxlev} = Q_{rxlevmeas} - (Q_{rxlevmin} + Q_{rxlevminoffset}) - P_{compensation} - Q_{offsettemp}$$

$$S_{qual} = Q_{qualmeas} - (Q_{qualmin} + Q_{qualminoffset}) - Q_{offsettemp}$$

where:

S_{rxlev}	Cell selection RX level value (dB)
S_{qual}	Cell selection quality value (dB)
$Q_{offsettemp}$	Offset temporarily applied to a cell as specified in TS 38.331 [3] (dB)
$Q_{rxlevmeas}$	Measured cell RX level value (RSRP)
$Q_{qualmeas}$	Measured cell quality value (RSRQ)
$Q_{rxlevmin}$	Minimum required RX level in the cell (dBm). If the UE supports SUL frequency for this cell, $Q_{rxlevmin}$ is obtained from $RxLevMinSUL$, if present, in $SIB1$, $SIB2$ and $SIB4$, additionally, if $Q_{rxlevminoffsetcellSUL}$ is present in $SIB3$ and $SIB4$ for the concerned cell, this cell specific offset is added to the corresponding $Q_{rxlevmin}$ to achieve the required minimum RX level in the concerned cell; else $Q_{rxlevmin}$ is obtained from $q-RxLevMin$ in $SIB1$, $SIB2$ and $SIB4$, additionally, if $Q_{rxlevminoffsetcell}$ is present in $SIB3$ and $SIB4$ for the concerned cell, this cell specific offset is added to the corresponding $Q_{rxlevmin}$ to achieve the required minimum RX level in the concerned cell.
$Q_{qualmin}$	Minimum required quality level in the cell (dB). Additionally, if $Q_{qualminoffsetcell}$ is signalled for the concerned cell, this cell specific offset is added to achieve the required minimum quality level in the concerned cell.
$Q_{rxlevminoffset}$	Offset to the signalled $Q_{rxlevmin}$ taken into account in the S_{rxlev} evaluation as a result of a periodic search for a higher priority PLMN while camped normally in a VPLMN 3GPP TS 23.122 [9]
$Q_{qualminoffset}$	Offset to the signalled $Q_{qualmin}$ taken into account in the S_{qual} evaluation as a result of a periodic search for a higher priority PLMN while camped normally in a VPLMN 3GPP TS 23.122 [9]
$P_{compensation}$	If the UE supports the additional P_{max} in the $NS-PmaxList$, if present, in $SIB1$, $SIB2$ and $SIB4$: $max(P_{EMAX1} - P_{PowerClass}, 0) - (min(P_{EMAX2}, P_{PowerClass}) - min(P_{EMAX1}, P_{PowerClass}))$ (dB); else: $max(P_{EMAX1} - P_{PowerClass}, 0)$ (dB)
P_{EMAX1} , P_{EMAX2}	Maximum TX power level of a UE may use when transmitting on the uplink in the cell (dBm) defined as P_{EMAX} in TS 38.101 [15]. P_{EMAX1} and P_{EMAX2} are obtained from the $p-Max$ and $NS-PmaxList$ respectively in $SIB1$, $SIB2$ and $SIB4$ as specified in TS 38.331 [3].
$P_{PowerClass}$	Maximum RF output power of the UE (dBm) according to the UE power class as defined in TS 38.101 [15]

The signalled values $Q_{rxlevminoffset}$ and $Q_{qualminoffset}$ are only applied when a cell is evaluated for cell selection as a result of a periodic search for a higher priority PLMN while camped normally in a VPLMN (3GPP TS 23.122 [9]). During this periodic search for higher priority PLMN, the UE may check the S criteria of a cell using parameter values stored from a different cell of this higher priority PLMN.

[TS 38.304, clause 5.3.1]

Cell status and cell reservations are indicated in the MIB or $SIB1$ message TS 38.331 [3] by means of three fields:

- *cellBarred* (IE type: "barred" or "not barred")
Indicated in MIB message. In case of multiple PLMNs indicated in $SIB1$, this field is common for all PLMNs
- *cellReservedForOperatorUse* (IE type: "reserved" or "not reserved")
Indicated in $SIB1$ message. In case of multiple PLMNs indicated in $SIB1$, this field is specified per PLMN.

- *cellReservedForOtherUse* (IE type: "true")
Indicated in *SIB1* message. In case of multiple PLMNs indicated in *SIB1*, this field is common for all PLMNs.

When cell status is indicated as "not barred" and "not reserved" for operator use and not "true" for other use,

- All UEs shall treat this cell as candidate during the cell selection and cell reselection procedures.

When cell status is indicated as "true" for other use,

- The UE shall treat this cell as if cell status is "barred".

When cell status is indicated as "not barred" and "reserved" for operator use for any PLMN and not "true" for other use,

- UEs assigned to Access Identity 11 or 15 operating in their HPLMN/EHPLMN shall treat this cell as candidate during the cell selection and reselection procedures if the field *cellReservedForOperatorUse* for that PLMN set to "reserved".
- UEs assigned to an Access Identity in the range of 0 to 10 and 12 to 14 shall behave as if the cell status is "barred" in case the cell is "reserved for operator use" for the registered PLMN or the selected PLMN.

NOTE 1: Access Identities 11, 15 are only valid for use in the HPLMN/ EHPLMN; Access Identities 12, 13, 14 are only valid for use in the home country as specified in 3GPP TS 22.261 [12].

When cell status "barred" is indicated or to be treated as if the cell status is "barred",

- The UE is not permitted to select/reselect this cell, not even for emergency calls.
- The UE shall select another cell according to the following rule:
 - If the cell is to be treated as if the cell status is "barred" due to being unable to acquire the *MIB* or the *SIB1*:
 - the UE may exclude the barred cell as a candidate for cell selection/reselection for up to 300 seconds.
 - the UE may select another cell on the same frequency if the selection criteria are fulfilled.
 - else
 - If the field *intraFreqReselection* in *MIB* message is set to "allowed", the UE may select another cell on the same frequency if re-selection criteria are fulfilled;
 - The UE shall exclude the barred cell as a candidate for cell selection/reselection for 300 seconds.
 - If the field *intraFreqReselection* in *MIB* message is set to "not allowed" the UE shall not re-select a cell on the same frequency as the barred cell;
 - The UE shall exclude the barred cell and the cells on the same frequency as a candidate for cell selection/reselection for 300 seconds.

The cell selection of another cell may also include a change of RAT.

6.1.2.3.3 Test description

6.1.2.3.3.1 Pre-test conditions

System Simulator:

- NR Cell 1 and NR Cell 11 have different tracking areas according to TS 38.508-1 [4] Table 4.4.2-3.
- System information combination NR-2 as defined in TS 38.508-1[4] clause 4.4.3.1.2 is used in NR cells.

UE:

None.

Preamble:

- UE is in state 1N-A on NR Cell 1(serving cell) according to 38.508-1 [4].

6.1.2.3.3.2 Test procedure sequence

Table 6.1.2.3.3.2-1/2 illustrate the downlink power levels and other changing parameters to be applied for the cells at various time instants of the test execution. The exact instants on which these values shall be applied are described in the texts in this clause. The configuration T0 indicates the initial conditions for preamble. Configurations marked "T1" and "T2" are applied at the points indicated in the Main behaviour description in Table 6.1.2.3.3.2-3.

Table 6.1.2.3.3.2-1: Time instances of cell power level and parameter changes for FR1

	Parameter	Unit	NR Cell 1	NR Cell 11	Remark
T0	SS/PBCH SSS EPRE	dBm/ SCS	-88	"Off"	The power level values are assigned to ensure the UE registered on NR Cell 1.
	Qrxlevmin	dBm	-110	-	
T1	SS/PBCH SSS EPRE	dBm/ SCS	"Off"	-88	Srxlev _{NRCell 1} < 0 (NOTE 1)
	Qrxlevmin	dBm	-	-110	
T2	SS/PBCH SSS EPRE	dBm/ SCS	-94	-88	Srxlev _{NRCell 11} > 0, Srxlev _{NRCell 1} > 0
	Qrxlevmin	dBm	-110	-110	
	cellBarred	-	notBarred	barred	

NOTE 1: Power level "Off" is defined in TS 38.508-1 [4] Table 6.2.2.1-3.

Table 6.1.2.3.3.2-2: Time instances of cell power level and parameter changes for FR2

	Parameter	Unit	NR Cell 1	NR Cell 11	Remark
T0	SS/PBCH SSS EPRE	dBm/ SCS	FFS	"Off"	The power level values are assigned to ensure the UE registered on NR Cell 1.
	Qrxlevmin	dBm	FFS	-	
T1	SS/PBCH SSS EPRE	dBm/ SCS	"Off"	FFS	Srxlev _{NRCell 1} < 0 (NOTE 1)
	Qrxlevmin	dBm	-	FFS	
T2	SS/PBCH SSS EPRE	dBm/ SCS	FFS	FFS	Srxlev _{NRCell 11} > 0, Srxlev _{NRCell 1} > 0
	Qrxlevmin	dBm	FFS	FFS	
	cellBarred	-	notBarred	barred	

NOTE 1: Power level "Off" is defined in TS 38.508-1 [4] Table 6.2.2.1-3.

NOTE: If the UE fails the test because of a failure to detect and reselect to a right cell, then the operator may re-run the test.

Table 6.1.2.3.3.2-3: Main behaviour

St	Procedure	Message Sequence		TP	Verdict
		U - S	Message		
1	SS re-adjusts the SS/PBCH EPRE level of NR Cell 1 and NR Cell 11 according to row "T1" in table 6.1.2.3.3.2-1/2.	-	-	-	-
2	Check: Does the test result of generic test procedure in TS 38.508-1 [4] clause 4.9.5 indicate that the UE is camped on NR Cell 11? NOTE: The UE performs a registration for mobility procedure and the RRC connection is released.	-	-	1	-
3	SS changes NR Cell 11 SS/PBCH EPRE level and MIB IE <i>cellBarred</i> according to row "T2" in table 6.1.2.3.3.2-1/2. And SS transmits Short Message on PDCCH addressed to P-RNTI using Short Message field in DCI format 1_0. Bit 1 of Short Message field is set to 1 to indicate the SysInfo Modification.	-	-	-	-
4	Check: Does the test result of generic test procedure in TS 38.508-1 [4] clause 4.9.5 indicate that the UE is camped on NR Cell 1? NOTE: The RRC connection is released and UE is in RRC_IDLE mode.	-	-	2	-

6.1.2.3.3.3 Specific message contents

Table 6.1.2.3.3.3-1: SIB1 for NR Cells 1 and 11 (Preamble and all steps, table 6.1.2.3.3.2-2)

Derivation Path: TS 38.508-1 [4], Table 4.6.1-28			
Information Element	Value/remark	Comment	Condition
SIB1 ::= SEQUENCE {			
cellSelectionInfo SEQUENCE {			
q-RxLevMin	-55	-110 dBm	FR1
	FFS		FR2
}			
}			

Table 6.1.2.3.3.3-2: SIB2 for NR Cells 1 and 11 (Preamble and all steps, table 6.1.2.3.3.2-2)

Derivation Path: TS 38.508-1 [4], Table 4.6.2-1			
Information Element	Value/remark	Comment	Condition
SIB2 ::= SEQUENCE {			
cellReselectionInfoCommon SEQUENCE {			
rangeToBestCell	Not present		
}			
intraFreqCellReselectionInfo SEQUENCE {			
q-RxLevMin	-55	-110 dBm	FR1
	FFS		FR2
t-ReselectionNR	7		
}			
}			

Table 6.1.2.3.3.3-3: MIB for NR Cell 11 (step 3, Table 6.1.2.3.3.2-2)

Derivation Path: TS 38.508-1 [4], Table 4.6.1-6			
Information Element	Value/remark	Comment	Condition
MIB ::= SEQUENCE {			
cellBarred	barred	Step 3	
}			

6.1.2.4 Cell Reselection for interband operation

6.1.2.4.1 Test Purpose (TP)

(1)

```
with { UE in NR RRC_IDLE state }
ensure that {
  when { UE detects the cell re-selection criteria are met for the cell on the different frequency
band }
  then { UE reselects the new cell }
}
```

6.1.2.4.2 Conformance requirements

References: The conformance requirements covered in the present TC are specified in TS 38.304: clause 5.2.3.2 and 5.2.4.5. Unless otherwise stated these are Rel-15 requirements.

[TS 38.304, clause 5.2.3.2]

The cell selection criterion S is fulfilled when:

$$S_{rxlev} > 0 \text{ AND } S_{qual} > 0$$

where:

$$S_{rxlev} = Q_{rxlevmeas} - (Q_{rxlevmin} + Q_{rxlevminoffset}) - P_{compensation} - Q_{offset_{temp}}$$

$$S_{qual} = Q_{qualmeas} - (Q_{qualmin} + Q_{qualminoffset}) - Q_{offset_{temp}}$$

where:

Srxlev	Cell selection RX level value (dB)
Squal	Cell selection quality value (dB)
Qoffset _{temp}	Offset temporarily applied to a cell as specified in TS 38.331 [3] (dB)
Qrxlevmeas	Measured cell RX level value (RSRP)
Qqualmeas	Measured cell quality value (RSRQ)
Qrxlevmin	Minimum required RX level in the cell (dBm). If the UE supports SUL frequency for this cell, Qrxlevmin is obtained from <i>RxLevMinSUL</i> , if present, in <i>SIB1</i> , <i>SIB2</i> and <i>SIB4</i> , additionally, if Qrxlevminoffset _{cellSUL} is present in <i>SIB3</i> and <i>SIB4</i> for the concerned cell, this cell specific offset is added to the corresponding Qrxlevmin to achieve the required minimum RX level in the concerned cell; else Qrxlevmin is obtained from <i>q-RxLevMin</i> in <i>SIB1</i> , <i>SIB2</i> and <i>SIB4</i> , additionally, if Qrxlevminoffset _{cell} is present in <i>SIB3</i> and <i>SIB4</i> for the concerned cell, this cell specific offset is added to the corresponding Qrxlevmin to achieve the required minimum RX level in the concerned cell.
Qqualmin	Minimum required quality level in the cell (dB). Additionally, if Qqualminoffset _{cell} is signalled for the concerned cell, this cell specific offset is added to achieve the required minimum quality level in the concerned cell.
Qrxlevminoffset	Offset to the signalled Qrxlevmin taken into account in the Srxlev evaluation as a result of a periodic search for a higher priority PLMN while camped normally in a VPLMN, as specified in TS 23.122 [9]
Qqualminoffset	Offset to the signalled Qqualmin taken into account in the Squal evaluation as a result of a periodic search for a higher priority PLMN while camped normally in a VPLMN, as specified in TS 23.122 [9]
P _{compensation}	If the UE supports the additional P _{max} in the NR-NS-P _{maxList} , if present, in <i>SIB1</i> , <i>SIB2</i> and <i>SIB4</i> : $\max(P_{EMAX1} - P_{PowerClass}, 0) - (\min(P_{EMAX2}, P_{PowerClass}) - \min(P_{EMAX1}, P_{PowerClass}))$ (dB); else: $\max(P_{EMAX1} - P_{PowerClass}, 0)$ (dB)
P _{EMAX1} , P _{EMAX2}	Maximum TX power level of a UE may use when transmitting on the uplink in the cell (dBm) defined as P _{EMAX} in TS 38.101 [15]. If UE supports SUL frequency for this cell, P _{EMAX1} and P _{EMAX2} are obtained from the <i>p-Max</i> for SUL in <i>SIB1</i> and <i>NR-NS-PmaxList</i> for SUL respectively in <i>SIB1</i> , <i>SIB2</i> and <i>SIB4</i> as specified in TS 38.331 [3], else P _{EMAX1} and P _{EMAX2} are obtained from the <i>p-Max</i> and <i>NR-NS-PmaxList</i> respectively in <i>SIB1</i> , <i>SIB2</i> and <i>SIB4</i> for regular UL as specified in TS 38.331 [3].
P _{PowerClass}	Maximum RF output power of the UE (dBm) according to the UE power class as defined in TS 38.101 [15]

The signalled values Q_{rxlevminoffset} and Q_{qualminoffset} are only applied when a cell is evaluated for cell selection as a result of a periodic search for a higher priority PLMN while camped normally in a VPLMN (TS 23.122 [9]). During this periodic search for higher priority PLMN, the UE may check the S criteria of a cell using parameter values stored from a different cell of this higher priority PLMN. [TS 38.304, clause 5.2.4.5]

If *threshServingLowQ* is broadcast in system information and more than 1 second has elapsed since the UE camped on the current serving cell, cell reselection to a cell on a higher priority NR frequency or inter-RAT frequency than the serving frequency shall be performed if:

- A cell of a higher priority NR or EUTRAN RAT/frequency fulfils $Squal > Thresh_{X, HighQ}$ during a time interval $T_{reselection_{RAT}}$

Otherwise, cell reselection to a cell on a higher priority NR frequency or inter-RAT frequency than the serving frequency shall be performed if:

- A cell of a higher priority RAT/ frequency fulfils $Srxlev > Thresh_{X, HighP}$ during a time interval $T_{reselection_{RAT}}$; and
- More than 1 second has elapsed since the UE camped on the current serving cell.

Cell reselection to a cell on an equal priority NR frequency shall be based on ranking for intra-frequency cell reselection as defined in sub-clause 5.2.4.6.

If *threshServingLowQ* is broadcast in system information and more than 1 second has elapsed since the UE camped on the current serving cell, cell reselection to a cell on a lower priority NR frequency or inter-RAT frequency than the serving frequency shall be performed if:

- The serving cell fulfils $S_{qual} < \text{Thresh}_{\text{Serving, LowQ}}$ and a cell of a lower priority NR or E-UTRAN RAT/ frequency fulfils $S_{qual} > \text{Thresh}_{X, \text{LowQ}}$ during a time interval $T_{\text{reselction}_{\text{RAT}}}$.

Otherwise, cell reselection to a cell on a lower priority NR frequency or inter-RAT frequency than the serving frequency shall be performed if:

- The serving cell fulfils $S_{rxlev} < \text{Thresh}_{\text{Serving, LowP}}$ and a cell of a lower priority RAT/ frequency fulfils $S_{rxlev} > \text{Thresh}_{X, \text{LowP}}$ during a time interval $T_{\text{reselction}_{\text{RAT}}}$; and
- More than 1 second has elapsed since the UE camped on the current serving cell.

Cell reselection to a higher priority RAT/frequency shall take precedence over a lower priority RAT/frequency if multiple cells of different priorities fulfil the cell reselection criteria.

If more than one cell meets the above criteria, the UE shall reselect a cell as follows:

- If the highest-priority frequency is an NR frequency, the highest ranked cell among the cells on the highest priority frequency(ies) meeting the criteria according to clause 5.2.4.6;
- If the highest-priority frequency is from another RAT, the highest ranked cell among the cells on the highest priority frequency(ies) meeting the criteria of that RAT.

6.1.2.4.3 Test description

6.1.2.4.3.1 Pre-test conditions

System Simulator:

- NR Cell 1 and NR Cell 10.
- System information combination NR-4 as defined in TS 38.508-1 [4] Table 4.4.3.1.2-1 is used in NR cells.

UE:

None.

Preamble:

- The UE is in state 1N-A on NR Cell 1(serving cell) according to TS 38.508-1 [4] Table 4.4A.2-1.

6.1.2.4.3.2 Test procedure sequence

Table 6.1.2.6.3.2-1/2 illustrates the downlink power levels and other changing parameters to be applied for the NR cells at various time instants of the test execution. The exact instants on which these values shall be applied are described in the texts in this clause. The configuration "T0" indicates the initial conditions. Subsequent configurations marked "T1" is applied at the points indicated in the Main behaviour description in Table 6.1.2.4.3.2-3.

Table 6.1.2.4.3.2-1: Time instances of cell power level and parameter changes for FR1

	Parameter	Unit	NR Cell 1	NR Cell 10	Remark
T0	SS/PBCH SSS EPRE	dBm/SCS	-88	Off	The power level values are assigned to ensure the UE registered on NR Cell 1.
T1	SS/PBCH SSS EPRE	dBm/SCS	-88	-76	NR Cell 10 become stronger than $\text{Thresh}_{\text{NR Cell 10, high}}$.
Note:	Power level "Off" is defined in TS38.508-1 [4] Table 6.2.2.1-3.				

Table 6.1.2.4.3.2-2: Time instances of cell power level and parameter changes for FR2

	Parameter	Unit	NR Cell 1	NR Cell 10	Remark
T0	SS/PBCH SSS EPRE	dBm/SCS	FFS	Off	The power level values are assigned to ensure the UE registered on NR Cell 1.
T1	SS/PBCH SSS EPRE	dBm/SCS	FFS	FFS	NR Cell 10 become stronger than Thresh _{NR Cell 10, high} .
Note: The uncertain downlink signal level is specified in TS 38.508-1[4] section FFS.					

Table 6.1.2.4.3.2-3: Main behaviour

St	Procedure	Message Sequence		TP	Verdict
		U - S	Message		
1	The SS changes NR Cell 10 SS/PBCH EPRE level according to the row "T1" in table 6.1.2.4.3.2-1/2.	-	-	-	-
2	Wait for 10 second to allow UE to recognise the change.	-	-	-	-
3	Check: Does the test result of generic test procedure in TS 38.508-1 [4] Table 4.9.4-1 indicate that the UE is camped on NR Cell 10?	-	-	1	-

6.1.2.4.3.3 Specific message contents

Table 6.1.2.4.3.3-1: Conditions for specific message contents in Tables below

Condition	Explanation
NR Cell 1	This condition applies to system information transmitted on NR Cell 1.
NR Cell 10	This condition applies to system information transmitted on NR Cell 10.

Table 6.1.2.4.3.3-2: SIB2 of NR Cell 1 and NR Cell10 (preamble and all steps, Table 6.1.2.4.3.2-3)

Derivation Path: TS 38.508-1 [4], Table 4.6.2-1			
Information Element	Value/remark	Comment	Condition
SIB2::= SEQUENCE {			
cellReselectionServingFreqInfo			
SEQUENCE{			
cellReselectionPriority	1		NR Cell 1
	5		NR Cell 10
}			
}			

Table 6.1.2.4.3.3-3: SIB4 of NR Cell 1 and NR Cell 10 (preamble and all steps, Table 6.1.2.4.3.2-3)

Derivation Path: TS 38.508-1 [4], Table 4.6.2-3			
Information Element	Value/remark	Comment	Condition
SIB4::= SEQUENCE {			
InterFreqCarrierFreqList SEQUENCE (SIZE (1..maxFreq)) OF SEQUENCE {	1 entry		
InterFreqCarrierFreqInfo[1] SEQUENCE {			
dl-CarrierFreq	Same downlink ARFCN as used for NR Cell 10		NR Cell 1
	Same downlink ARFCN as used for NR Cell 1		NR Cell 10
t-ReselectionNR	7	seconds	
threshX-HighP	10	20 dB	
cellReselectionPriority	5		NR Cell 1
	1		NR Cell 10
}			
}			
}			

6.1.2.5 Cell reselection for interband operation using Pcompensation / Between FDD and TDD

6.1.2.5.1 Test Purpose (TP)

(1)

```
with { UE in NR RRC_IDLE state on a FDD band }
ensure that {
  when { UE detects the cell selection using Pcompensation & reselection criteria is met for the
  cell on a TDD band }
  then { UE reselects the new cell }
}
```

6.1.2.5.2 Conformance requirements

References: The conformance requirements covered in the present TC are specified in TS 38.304: clause 5.2.3.2 and 5.2.4.5. Unless otherwise stated these are Rel-15 requirements.

[TS 38.304, clause 5.2.3.2]

The cell selection criterion S is fulfilled when:

$$S_{rxlev} > 0 \text{ AND } S_{qual} > 0$$

where:

$$S_{rxlev} = Q_{rxlevmeas} - (Q_{rxlevmin} + Q_{rxlevminoffset}) - P_{compensation} - Q_{offset_{temp}}$$

$$S_{qual} = Q_{qualmeas} - (Q_{qualmin} + Q_{qualminoffset}) - Q_{offset_{temp}}$$

where:

Srxlev	Cell selection RX level value (dB)
Squal	Cell selection quality value (dB)
Qoffset _{temp}	Offset temporarily applied to a cell as specified in TS 38.331 [3] (dB)
Qrxlevmeas	Measured cell RX level value (RSRP)
Qqualmeas	Measured cell quality value (RSRQ)
Qrxlevmin	Minimum required RX level in the cell (dBm). If the UE supports SUL frequency for this cell, Qrxlevmin is obtained from <i>RxLevMinSUL</i> , if present, in <i>SIB1</i> , <i>SIB2</i> and <i>SIB4</i> , additionally, if Q _{rxlevminoffsetcellSUL} is present in <i>SIB3</i> and <i>SIB4</i> for the concerned cell, this cell specific offset is added to the corresponding Qrxlevmin to achieve the required minimum RX level in the concerned cell; else Qrxlevmin is obtained from <i>q-RxLevMin</i> in <i>SIB1</i> , <i>SIB2</i> and <i>SIB4</i> , additionally, if Q _{rxlevminoffsetcell} is present in <i>SIB3</i> and <i>SIB4</i> for the concerned cell, this cell specific offset is added to the corresponding Qrxlevmin to achieve the required minimum RX level in the concerned cell.
Qqualmin	Minimum required quality level in the cell (dB). Additionally, if Q _{qualminoffsetcell} is signalled for the concerned cell, this cell specific offset is added to achieve the required minimum quality level in the concerned cell.
Qrxlevminoffset	Offset to the signalled Q _{rxlevmin} taken into account in the Srxlev evaluation as a result of a periodic search for a higher priority PLMN while camped normally in a VPLMN, as specified in TS 23.122 [9]
Qqualminoffset	Offset to the signalled Q _{qualmin} taken into account in the Squal evaluation as a result of a periodic search for a higher priority PLMN while camped normally in a VPLMN, as specified in TS 23.122 [9]
P _{compensation}	If the UE supports the additional P _{max} in the NR-NS-P _{maxList} , if present, in <i>SIB1</i> , <i>SIB2</i> and <i>SIB4</i> : $\max(P_{EMAX1} - P_{PowerClass}, 0) - (\min(P_{EMAX2}, P_{PowerClass}) - \min(P_{EMAX1}, P_{PowerClass}))$ (dB); else: $\max(P_{EMAX1} - P_{PowerClass}, 0)$ (dB)
P _{EMAX1} , P _{EMAX2}	Maximum TX power level of a UE may use when transmitting on the uplink in the cell (dBm) defined as P _{EMAX} in TS 38.101 [15]. If UE supports SUL frequency for this cell, P _{EMAX1} and P _{EMAX2} are obtained from the <i>p-Max</i> for SUL in <i>SIB1</i> and <i>NR-NS-PmaxList</i> for SUL respectively in <i>SIB1</i> , <i>SIB2</i> and <i>SIB4</i> as specified in TS 38.331 [3], else P _{EMAX1} and P _{EMAX2} are obtained from the <i>p-Max</i> and <i>NR-NS-PmaxList</i> respectively in <i>SIB1</i> , <i>SIB2</i> and <i>SIB4</i> for regular UL as specified in TS 38.331 [3].
P _{PowerClass}	Maximum RF output power of the UE (dBm) according to the UE power class as defined in TS 38.101 [15]

The signalled values Q_{rxlevminoffset} and Q_{qualminoffset} are only applied when a cell is evaluated for cell selection as a result of a periodic search for a higher priority PLMN while camped normally in a VPLMN (TS 23.122 [9]). During this periodic search for higher priority PLMN, the UE may check the S criteria of a cell using parameter values stored from a different cell of this higher priority PLMN. [TS 38.304, clause 5.2.4.5]

If *threshServingLowQ* is broadcast in system information and more than 1 second has elapsed since the UE camped on the current serving cell, cell reselection to a cell on a higher priority NR frequency or inter-RAT frequency than the serving frequency shall be performed if:

- A cell of a higher priority NR or EUTRAN RAT/frequency fulfils $Squal > Thresh_{X, HighQ}$ during a time interval $T_{reselection_{RAT}}$

Otherwise, cell reselection to a cell on a higher priority NR frequency or inter-RAT frequency than the serving frequency shall be performed if:

- A cell of a higher priority RAT/ frequency fulfils $Srxlev > Thresh_{X, HighP}$ during a time interval $T_{reselection_{RAT}}$; and
- More than 1 second has elapsed since the UE camped on the current serving cell.

Cell reselection to a cell on an equal priority NR frequency shall be based on ranking for intra-frequency cell reselection as defined in sub-clause 5.2.4.6.

If *threshServingLowQ* is broadcast in system information and more than 1 second has elapsed since the UE camped on the current serving cell, cell reselection to a cell on a lower priority NR frequency or inter-RAT frequency than the serving frequency shall be performed if:

- The serving cell fulfils $S_{qual} < \text{Thresh}_{\text{Serving, LowQ}}$ and a cell of a lower priority NR or E-UTRAN RAT/ frequency fulfils $S_{qual} > \text{Thresh}_{X, \text{LowQ}}$ during a time interval $T_{\text{reselectionRAT}}$.

Otherwise, cell reselection to a cell on a lower priority NR frequency or inter-RAT frequency than the serving frequency shall be performed if:

- The serving cell fulfils $S_{rxlev} < \text{Thresh}_{\text{Serving, LowP}}$ and a cell of a lower priority RAT/ frequency fulfils $S_{rxlev} > \text{Thresh}_{X, \text{LowP}}$ during a time interval $T_{\text{reselectionRAT}}$; and
- More than 1 second has elapsed since the UE camped on the current serving cell.

Cell reselection to a higher priority RAT/frequency shall take precedence over a lower priority RAT/frequency if multiple cells of different priorities fulfil the cell reselection criteria.

If more than one cell meets the above criteria, the UE shall reselect a cell as follows:

- If the highest-priority frequency is an NR frequency, the highest ranked cell among the cells on the highest priority frequency(ies) meeting the criteria according to clause 5.2.4.6;
- If the highest-priority frequency is from another RAT, the highest ranked cell among the cells on the highest priority frequency(ies) meeting the criteria of that RAT.

6.1.2.5.3 Test description

6.1.2.5.3.1 Pre-test conditions

System Simulator:

- NR Cell 1 is set to NR FDD mode and NR Cell 10 is set to NR TDD mode.
- System information combination NR-4 as defined in TS 38.508-1 [4] Table 4.4.3.1.2-1 is used in NR cells.

UE:

None.

Preamble:

- The UE is in state 1N-A on NR Cell 1(serving cell) according to TS 38.508-1 [4] Table 4.4A.2-1.

6.1.2.5.3.2 Test procedure sequence

Table 6.1.2.5.3.2-1/2 illustrates the downlink power levels and other changing parameters to be applied for the NR cells at various time instants of the test execution. The exact instants on which these values shall be applied are described in the texts in this clause. The configuration "T0" indicates the initial conditions. Subsequent configuration marked "T1" is applied at the points indicated in the Main behaviour description in Table 6.1.2.5.3.2-3.

Table 6.1.2.5.3.2-1: Time instances of cell power level and parameter changes for FR1

	Parameter	Unit	NR Cell 1	NR Cell 10	Remark
T0	SS/PBCH SSS EPRE	dBm/SCS	-88	Off	The power level values are assigned to ensure the UE registered on NR Cell 1.
T1	SS/PBCH SSS EPRE	dBm/SCS	-88	-80	NR Cell 1 become lower than $Thresh_{serving, low}$ and NR Cell 10 become stronger than $Thresh_{NR Cell 10, low}$.
Note: Power level "Off" is defined in TS38.508-1 [4] Table 6.2.2.1-3.					

Table 6.1.2.5.3.2-2: Time instances of cell power level and parameter changes for FR2

	Parameter	Unit	NR Cell 1	NR Cell 10	Remark
T0	SS/PBCH SSS EPRE	dBm/SCS	FFS	Off	The power level values are assigned to ensure the UE registered on NR Cell 1.
T1	SS/PBCH SSS EPRE	dBm/SCS	FFS	FFS	NR Cell 1 become lower than $Thresh_{serving, low}$ and NR Cell 10 become stronger than $Thresh_{NR Cell 10, low}$.
Note: The uncertain downlink signal level is specified in TS 38.508-1[4] section FFS.					

Table 6.1.2.5.3.2-3: Main behaviour

St	Procedure	Message Sequence		TP	Verdict
		U - S	Message		
1	The SS changes NR Cell 10 SS/PBCH EPRE level according to the row "T1" in table 6.1.2.5.3.2-1/2.	-	-	-	-
2	Wait for 10 second to allow UE to recognise the change.	-	-	-	-
3	Check: Does the test result of generic test procedure in TS 38.508-1 [4] Table 4.9.4-1 indicate that the UE is camped on NR Cell 10?	-	-	1	-

6.1.2.5.3.3 Specific message contents

Table 6.1.2.5.3.3-1: Conditions for specific message contents in Tables below

Condition	Explanation
NR Cell 1	This condition applies to system information transmitted on NR Cell 1.
NR Cell 10	This condition applies to system information transmitted on NR Cell 10.

Table 6.1.2.5.3.3-2: SIB1 of NR Cell 1 (preamble and all steps, Table 6.1.2.5.3.2-3)

Derivation Path: TS 38.508-1 [4], Table 4.6.1-28			
Information Element	Value/remark	Comment	Condition
SIB1::= SEQUENCE {			
servingCellConfigCommon SEQUENCE{			
uplinkConfigCommon SEQUENCE{			
FrequencyInfoUL SEQUENCE {			
p-Max	33dBm		
}			
}			
}			
}			

Table 6.1.2.5.3.3-3: SIB2 of NR Cell 1 and NR Cell10 (preamble and all steps, Table 6.1.2.5.3.2-3)

Derivation Path: TS 38.508-1 [4], Table 4.6.2-1			
Information Element	Value/remark	Comment	Condition
SIB2::= SEQUENCE {			
cellReselectionServingFreqInfo SEQUENCE{			
threshServingLowP	6	12 dB	NR Cell 1
cellReselectionPriority	5		NR Cell 1
	1		NR Cell 10
}			
}			

Table 6.1.2.5.3.3-4: SIB4 of NR Cell 1 and NR Cell 10 (preamble and all steps, Table 6.1.2.5.3.2-3)

Derivation Path: TS 38.508-1 [4], Table 4.6.2-3			
Information Element	Value/remark	Comment	Condition
SIB4::= SEQUENCE {			
InterFreqCarrierFreqList SEQUENCE (SIZE (1..maxFreq)) OF SEQUENCE {	1 entry		
InterFreqCarrierFreqInfo[1] SEQUENCE {			
dl-CarrierFreq	Same downlink ARFCN as used for NR Cell 10		NR Cell 1
	Same downlink ARFCN as used for NR Cell 1		NR Cell 10
p-Max	33dBm		NR Cell 1
t-ReselectionNR	7	seconds	
threshX-HighP	10	20 dB	
threshX-LowP	6	12 dB	
cellReselectionPriority	1		NR Cell 1
	5		NR Cell 10
}			
}			

6.1.2.6

6.1.2.7 Cell reselection / Equivalent PLMN

6.1.2.7.1 Test Purpose (TP)

(1)

with { UE camped normally on a cell and network has downloaded a list of equivalent PLMNs during the Registration procedure}
ensure that {

```

when { a suitable neighbour cell on an equivalent PLMN becomes better ranked than the suitable
Serving cell}
  then { UE reselects to this equivalent PLMN cell}
  }

```

(2)

```

with { UE camped normally on a cell and network has downloaded a list of equivalent PLMNs during the
Registration procedure}
ensure that {
  when { the Serving cell becomes unsuitable due to S<0 and a suitable cell exists on an equivalent
PLMN}
    then {UE reselects to this equivalent PLMN cell}
  }

```

(3)

```

with { UE camped normally on a cell and network has downloaded a list of equivalent PLMNs during the
Registration procedure}
ensure that {
  when { the UE evaluates cells for reselection}
    then { UE ignores suitable cells for which the UE has no reselection priority provided}
  }

```

6.1.2.7.2 Conformance requirements

References: The conformance requirements covered in the present test case are specified in: TS 23.122, clause 4.4.3, TS 38.304, clause 5.2.4.1. Unless otherwise stated these are Rel-15 requirements.

[TS 38.304, clause 5.2.4.1]

The UE shall only perform cell reselection evaluation for NR frequencies and inter-RAT frequencies that are given in system information and for which the UE has a priority provided.

[TS 23.122, clause 4.4.3]

The Mobile Equipment stores a list of "equivalent PLMNs". This list is replaced or deleted at the end of each location update procedure, routing area update procedure, GPRS attach procedure, tracking area update procedure, EPS attach procedure, and registration procedure. The list is deleted by an MS attached for emergency bearer services after detach or registered for emergency services after deregistration. The stored list consists of a list of equivalent PLMNs as downloaded by the network plus the PLMN code of the registered PLMN that downloaded the list. All PLMNs in the stored list, in all access technologies supported by the PLMN, are regarded as equivalent to each other for PLMN selection, cell selection/re-selection and handover.

6.1.2.7.3 Test Description

6.1.2.7.3.1 Pre-test conditions

System Simulator:

Three inter-frequency multi-PLMN NR Cells as specified in TS 38.508-1 Table 4.4.2.1 are configured broadcasting PLMNs as indicated in Table 6.1.2.7.3.1-1.

The PLMNs are identified in the test by the identifiers in Table 6.1.2.7.3.1-1.

Table 6.1.2.7.3.1-1: PLMN identifiers

NR Cell	PLMN name	MCC	MNC
11	PLMN1	001	11
12	PLMN2	002	21
13	PLMN3	003	31

All NR cells are high quality.

All cells are suitable cells.

System information combination NR-4 as defined in TS 38.508-1 [4] clause 4.4.3.1.3 is used in NR cells

UE:-

The UE is in Automatic PLMN selection mode.

The UE is equipped with a USIM containing default values (as per TS 38.508-1[4], clause 4.8.3) except for those listed in TS 38.508-1[4], Table 6.4.1-14.

Preamble:

The UE is registered on PLMN1 (NR Cell 11) using the procedure described in TS 38.508-1[4] clause 4.5.2.2 except that the REGISTRATION ACCEPT message indicates PLMN3 in the Equivalent PLMN list as described in Table 6.1.2.7.3.3-1.

The UE is in state Registered, Idle Mode (State 1N-A) on NR Cell 11 according to 38.508-1[4];

6.1.2.7.3.2 Test procedure sequence

Table 6.1.2.7.3.2-1 for FR1 and Table 6.1.2.7.3.2-2 for FR2 illustrates the downlink power levels and other changing parameters to be applied for the cells at various time instants of the test execution. Row marked "T0" denotes the initial conditions after preamble, while columns marked "T1" and "T2" are to be applied subsequently in the Main behaviour. The exact instants on which these values shall be applied are described in the texts in this clause.

Table 6.1.2.7.3.2-1: Cell configuration changes over time for FR1

	Parameter	Unit	NR Cell 11	NR Cell 12	NR Cell 13	Remarks
T0	SS/PBCH SSS EPRE	dBm/SCS	-67	-82	-97	All NR cells S>0
T1	SS/PBCH SSS EPRE	dBm/SCS	-115	-82	-97	NR Cell 11 S < 0 as described in TS 38.508-1 clause FFS
T2	SS/PBCH SSS EPRE	dBm/SCS	-67	-97	-82	All NR cells S>0
Note 1: The default values (including "not present") for all other parameters influencing cell reselection are suitable for this test. The values are defined in TS 38.508-1 clauses FFS.						

Table 6.1.2.7.3.2-2: Cell configuration changes over time for FR2

	Parameter	Unit	NR Cell 11	NR Cell 12	NR Cell 13	Remarks
T0	SS/PBCH SSS EPRE	FFS	FFS	FFS	FFS	All NR cells S>0
T1	SS/PBCH SSS EPRE	FFS	FFS	FFS	FFS	NR Cell 1 S < 0 as described in TS 38.508-1 clause FFS
T2	SS/PBCH SSS EPRE	FFS	FFS	FFS	FFS	All NR cells S>0
Note 1: The default values (including "not present") for all other parameters influencing cell reselection are suitable for this test. The values are defined in TS 38.508-1 clauses FFS.						

Table 6.1.2.7.3.2-3: Main behaviour

St	Procedure	Message Sequence		TP	Verdict
		U - S	Message		
1	Check: Does the UE transmit an <i>RRCSetupRequest</i> message within T seconds? (Note 1)	-->	NR RRC: <i>RRCSetupRequest</i>	1	F
2	SS adjusts cell levels according to row T1 of table 6.1.2.7.3.2-1 for FR1 (or table 6.1.2.7.3.2-2 for FR2)	-	-	-	-
3	Check: Does the test result of generic test procedure in TS 38.508-1 Table 4.9.5.2.2-1 indicate that the UE is camped on NR Cell 13? NOTE: The UE performs a "REGISTRATION REQUEST" procedure with type "mobility registration updating" with PLMN1 and PLMN2 listed as an Equivalent PLMN in the REGISTRATION ACCEPT message; the RRC connection is released.	-		2	-
4	Check: Does the test result of generic test procedure in TS 38.508-1 Table 4.9.5.2.2-1 indicate that the UE is camped on NR Cell 12? NOTE: The UE performs a "REGISTRATION REQUEST" procedure with type "mobility registration updating" with PLMN1 and PLMN3 listed as an Equivalent PLMN in the REGISTRATION ACCEPT message; the RRC connection is released.	-		1	-
5	SS adjusts cell levels according to row T0 of table 6.1.2.7.3.2-1 for FR1 (or table 6.1.2.7.3.2-2 for FR2)	-		-	-
6	Check: Does the UE transmit an <i>RRCSetupRequest</i> message within T seconds? (Note 1)	-->	NR RRC <i>RRCSetupRequest</i>	1,3	F
7	SS adjusts cell levels according to row T2 of table 6.1.2.7.3.2-1 for FR1 (or table 6.1.2.7.3.2-2 for FR2)	-	-	-	-
8	Check: Does the test result of generic test procedure in TS 38.508-1 Table 4.9.5.2.2-1 indicate that the UE is camped on NR Cell 13? NOTE: The UE performs a "REGISTRATION REQUEST" procedure with type "mobility registration updating" with PLMN1 and PLMN2 listed as an Equivalent PLMN in the REGISTRATION ACCEPT message; the RRC connection is released. (Note 2)	-		3	P
<p>Note 1: In Steps 1 and 6, wait T seconds to ensure that the UE has detected, measured and evaluated the neighbour inter-frequency NR cells is provided, see TS 38.133 clause 4.2.2.4, where in T = 100sec for FR1 and 300sec for FR2</p> <p>Note 2: In Step 8, the UE moves to Cell 13 because no reselection priority is defined for Cell 1, see Table 6.1.2.7.3.3-4.</p>					

6.1.2.7.3.3 Specific message contents

Table 6.1.2.7.3.3-1: REGISTRATION ACCEPT for NR Cell 11 (preamble)

Derivation path: TS 38.508-1 Table 4.7.1-7			
Information Element	Value/remark	Comment	Condition
Equivalent PLMNs	PLMN3		

Table 6.1.2.7.3.3-2: REGISTRATION ACCEPT for NR Cell 13 (step 3 and 18, Table 6.1.2.7.3.2-3)

Derivation path: TS 38.508-1 Table 4.7.1-7			
Information Element	Value/remark	Comment	Condition
Equivalent PLMNs	PLMN1, 2		

Table 6.1.2.7.3.3-3: REGISTRATION ACCEPT for NR Cell 12 (step 4, Table 6.1.2.7.3.2-3)

Derivation path: TS 38.508-1 Table 4.7.1-7			
Information Element	Value/remark	Comment	Condition
Equivalent PLMNs	PLMN1, 3		

Table 6.1.2.7.3.3-4: SystemInformationBlockType4 for Cell 12 (preamble and all steps, Table 6.1.2.7.3.2-3)

Derivation Path: TS 38.508-1 Table 4.6.2-3			
Information Element	Value/remark	Comment	Condition
SIB4 ::= SEQUENCE {			
interFreqCarrierFreqList SEQUENCE (SIZE (1..maxFreq)) OF SEQUENCE {	2 entries	<i>n</i> denotes the index of the entry	
dl-CarrierFreq[1]	Same downlink EARFCN as used for Cell 11		
cellReselectionPriority[1]	Not present	UE does not have a priority for frequency of Cell 11	
dl-CarrierFreq[2]	Same downlink EARFCN as used for Cell 13		
lateNonCriticalExtension	Not present		
}			

Table 6.1.2.7.3.3-5: SystemInformationBlockType4 for Cell 13 (preamble and all steps, Table 6.1.2.7.3.2-3)

Derivation Path: TS 38.508-1 Table 4.6.2-3			
Information Element	Value/remark	Comment	Condition
SIB4 ::= SEQUENCE {			
interFreqCarrierFreqList SEQUENCE (SIZE (1..maxFreq)) OF SEQUENCE {	2 entries	<i>n</i> denotes the index of the entry	
dl-CarrierFreq[1]	Same downlink EARFCN as used for Cell 11		
cellReselectionPriority[1]	Not present	UE does not have a priority for frequency of Cell 11	
dl-CarrierFreq[2]	Same downlink EARFCN as used for Cell 12		
lateNonCriticalExtension	Not present		
}			

6.1.2.8 Cell reselection / Equivalent PLMN / Single Frequency operation

6.1.2.8.1 Test Purpose (TP)

(1)

```
with { UE camped normally on a cell and network has downloaded a list of equivalent PLMNs during the
Registration procedure }
ensure that {
  when { a suitable neighbour cell on an equivalent PLMN becomes better ranked than the suitable
Serving cell }
```

```

    then { UE reselects to this equivalent PLMN cell. }
  }

```

(2)

```

with { UE camped normally on a cell and network has downloaded a list of equivalent PLMNs during the
Registration procedure }
ensure that {
  when { the Serving cell becomes unsuitable due to S<0 and a suitable cell exists on an equivalent
PLMN }
    then { UE reselects to this equivalent PLMN cell. }
}

```

6.1.2.8.2 Conformance requirements

References: The conformance requirements covered in the present TC are specified in TS 38.304: clause 5.2.4.1. Unless otherwise stated these are Rel-15 requirements.

[TS 38.304, clause 5.2.4.1]

The UE shall only perform cell reselection evaluation for NR frequencies and inter-RAT frequencies that are given in system information and for which the UE has a priority provided.

6.1.2.8.3 Test description

6.1.2.8.3.1 Pre-test conditions

System Simulator:

- Three intra-frequency multi-PLMN cells.
- The PLMNs are identified in the test by the identifiers in Table 6.1.2.8.3.1-1.
- System information combination NR-3 as defined in TS 38.508-1 [4] clause 4.4.3.1.3 is used in NR cells

Table 6.1.2.8.3.1-1: PLMN identifiers

Cell	PLMN name
1	PLMN1
2	PLMN2
4	PLMN3

- All cells are high quality.
- All cells are suitable cells.

UE:

- The UE is in Automatic PLMN selection mode.
- The UE is equipped with a USIM containing default values (as per TS 38.508-1[4], clause 4.8.3) except for those listed in TS 38.508-1[4], Table 6.4.1-14.

Preamble:

- The UE is registered on PLMN1 (NR Cell 1) using the procedure described in TS 38.508-1[4] clause 4.5.2.2 except that the REGISTRATION ACCEPT message indicates PLMN3 in the Equivalent PLMN list as described in Table 6.1.2.8.3.3-1.
- The UE is in state Registered, Idle Mode (State 1N-A) on NR Cell 1 according to [18].

6.1.2.8.3.2 Test procedure sequence

Table 6.1.2.8.3.2-1 for FR1 and Table 6.1.2.8.3.2-2 for FR2 illustrates the downlink power levels and other changing parameters to be applied for the cells at various time instants of the test execution. Row marked "T0" denotes the initial conditions after preamble, while columns marked "T1" and "T2" are to be applied subsequently in the Main behaviour. The exact instants on which these values shall be applied are described in the texts in this clause.

Table 6.1.2.8.3.2-1: Cell configuration changes over time for FR1

	Parameter	Unit	NR Cell 1	NR Cell 2	NR Cell 4	Remarks
T0	SS/PBCH SSS EPRE	dBm/SC S	-67	-73	-79	All NR cells S>0
T1	SS/PBCH SSS EPRE	dBm/SC S	-115	-88	-82	NR Cell 1 S < 0 as described in TS 38.508-1[4] clause 6.2.2.1
T2	SS/PBCH SSS EPRE	dBm/SC S	-115	-82	-88	

Table 6.1.2.8.3.2-2: Cell configuration changes over time for FR2

	Parameter	Unit	NR Cell 1	NR Cell 2	NR Cell 4	Remarks
T0	SS/PBCH SSS EPRE	FFS	FFS	FFS	FFS	All NR cells S>0
T1	SS/PBCH SSS EPRE	FFS	FFS	FFS	FFS	NR Cell 1 S < 0 as described in TS 38.508-1[4] clause FFS
T2	SS/PBCH SSS EPRE	FFS	FFS	FFS	FFS	

Table 6.1.2.8.3.2-2: Main behaviour

St	Procedure	Message Sequence		TP	Verdict
		U - S	Message		
1	Check: Does the UE send an <i>RRCSetupRequest</i> within the next T seconds? (Note) Note: The wait period of T seconds is to ensure that the UE has detected, measured and evaluated the neighbour inter-frequency NR cells is provided, see TS 38.133[30] clause 4.2.2.4, where in T = 100sec for FR1 and 300sec for FR2.	-->	NR RRC: <i>RRCSetupRequest</i>	1	F
2	SS adjusts cell levels according to row T1 of table 6.1.2.8.3.2-1 for FR1 (or table 6.1.2.8.3.2-2 for FR2).	-	-	-	-
3	Check: Does the test result of generic test procedure in TS 38.508-1 subclause 4.9.5 indicate that the UE is camped on NR Cell 4? NOTE: The UE performs a Registration procedure for mobility registration update with PLMN1 and PLMN2 listed as an Equivalent PLMN in the REGISTRATION ACCEPT message.	-	-	2	-
4	SS adjusts cell levels according to row T2 of table 6.1.2.8.3.2-1.	-	-	-	-
5	Check: Does the test result of generic test procedure in TS 38.508-1 subclause 6.4.2.7 indicate that the UE is camped on NR Cell 2? NOTE: The UE performs a Registration procedure for mobility registration update with PLMN1 and PLMN3 listed as an Equivalent PLMN in the REGISTRATION ACCEPT message.	-	-	1	-
6	SS adjusts cell levels according to row T1 of table 6.1.2.8.3.2-1.	-	-	-	-
7	Check: Does the test result of generic test procedure in TS 38.508-1 subclause 4.9.5 indicate that the UE is camped on NR Cell 4, ' <i>connected without release</i> '? NOTE: The UE performs a Registration procedure for mobility registration update with PLMN1 and PLMN2 listed as an Equivalent PLMN in the REGISTRATION ACCEPT message.	-	-	1	-

6.1.2.8.3.3 Specific message contents

Table 6.1.2.8.3.3-1: REGISTRATION ACCEPT for NR Cell 1 (preamble)

Derivation path: TS 38.508-1[4] Table 4.7.1-7			
Information Element	Value/Remark	Comment	Condition
Equivalent PLMNs	PLMN3		

Table 6.1.2.8.3.3-2: REGISTRATION ACCEPT for NR Cell 4 (steps 3 & 7 , Table 6.1.2.8.3.2-2)

Derivation path: TS 38.508-1[4] Table 4.7.1-7			
Information Element	Value/Remark	Comment	Condition
Equivalent PLMNs	PLMN1, 2		

Table 6.1.2.8.3.3-3: REGISTRATION ACCEPT for NR Cell 2 (step 5, Table 6.1.2.8.3.2-2)

Derivation path: TS 38.508-1[4] Table 4.7.1-7			
Information Element	Value/Remark	Comment	Condition
Equivalent PLMNs	PLMN1, 3		

6.1.2.9 Cell reselection using Qhyst, Qoffset and Treselection

6.1.2.9.1 Test Purpose (TP)

(1)

```
with { UE in NR RRC_IDLE state, and the UE is not in high mobility state }
ensure that {
  when { Qhyst is non-zero or its value changes in system information }
  then { UE reselects the highest ranked cell taking the actual Qhyst value into account }
}
```

(2)

```
with { UE in NR RRC_IDLE state, and the UE is not in high mobility }
ensure that {
  when { cell reselection criteria are fulfilled during a time interval Treselection }
  then { UE reselects the highest ranked cell after the Treselection interval expires }
}
```

(3)

```
with { UE in NR RRC_IDLE state, and the UE is not in high mobility }
ensure that {
  when { Qoffset is non-zero or its value changes in system information }
  then { UE reselects the highest ranked cell taking the actual Qoffset value into account }
}
```

6.1.2.9.2 Conformance requirements

References: The conformance requirements covered in the present TC are specified in TS 38.304: clause 5.2.4.6. Unless otherwise stated these are Rel-15 requirements.

[TS 38.304, clause 5.2.4.6]

The cell-ranking criterion R_s for serving cell and R_n for neighbouring cells is defined by:

$$R_s = Q_{\text{meas},s} + Q_{\text{hyst}} - Q_{\text{offset,temp}}$$

$$R_n = Q_{\text{meas},n} - Q_{\text{offset}} - Q_{\text{offset,temp}}$$

where:

Q_{meas}	RSRP measurement quantity used in cell reselections.
Q_{offset}	For intra-frequency: Equals to $Q_{\text{offset},s,n}$, if $Q_{\text{offset},s,n}$ is valid, otherwise this equals to zero. For inter-frequency: Equals to $Q_{\text{offset},s,n}$ plus $Q_{\text{offset,frequency}}$, if $Q_{\text{offset},s,n}$ is valid, otherwise this equals to $Q_{\text{offset,frequency}}$.
$Q_{\text{offset,temp}}$	Offset temporarily applied to a cell as specified in TS 38.331 [3].

The UE shall perform ranking of all cells that fulfil the cell selection criterion S , which is defined in 5.2.3.2.

The cells shall be ranked according to the R criteria specified above by deriving $Q_{\text{meas},n}$ and $Q_{\text{meas},s}$ and calculating the R values using averaged RSRP results.

If *rangeToBestCell* is not configured, the UE shall perform cell reselection to the highest ranked cell. If this cell is found to be not-suitable, the UE shall behave according to subclause 5.2.4.4.

If *rangeToBestCell* is configured, then the UE shall perform cell reselection to the cell with the highest number of beams above the threshold (i.e. *absThreshSS-BlocksConsolidation*) among the cells whose R value is within *rangeToBestCell* of the R value of the highest ranked cell. If there are multiple such cells, the UE shall perform cell reselection to the highest ranked cell among them. If this cell is found to be not-suitable, the UE shall behave according to subclause 5.2.4.4.

In all cases, the UE shall reselect the new cell, only if the following conditions are met:

- the new cell is better than the serving cell according to the cell reselection criteria specified above during a time interval $T_{reselection_{RAT}}$;
- more than 1 second has elapsed since the UE camped on the current serving cell.

6.1.2.9.3 Test description

6.1.2.9.3.1 Pre-test conditions

System Simulator:

- NR Cell 1 and NR Cell 2.
- System information combination NR-3 as defined in TS 38.508-1 [4] Table 4.4.3.1.2-1 is used in NR cells.

UE:

None.

Preamble:

- The UE is in state 1N-A on NR Cell 1(serving cell) according to TS 38.508-1 [4] Table 4.4A.2-1.

6.1.2.9.3.2 Test procedure sequence

Table 6.1.2.9.3.2-1/2 illustrates the downlink power levels and other changing parameters to be applied for the NR cells at various time instants of the test execution. The exact instants on which these values shall be applied are described in the texts in this clause. The configuration "T0" indicates the initial conditions. Subsequent configurations marked "T1", "T2" and so on are applied at the points indicated in the Main behaviour description in Table 6.1.2.9.3.2-3.

Table 6.1.2.9.3.2-1: Time instances of cell power level and parameter changes For FR1

	Parameter	Unit	NR Cell 1	NR Cell 2	Remark
T0	SS/PBCH SSS EPRE	dBm/SCS	-88	Off	The power level values are assigned to ensure the UE registered on NR Cell 1.
	Qhyst _s	dB	24	0	
	Qoffset _{s,n}	dB	0	0	
	Treselectio nNR	S	0	0	
T1	SS/PBCH SSS EPRE	dBm/SCS	-94	-88	NR Cell 2 becomes stronger than NR Cell 1 but NR Cell 1 remains the highest ranked one due to Qhyst _s NR Cell 1
	Qhyst _s	dB	24	0	
	Qoffset _{s,n}	dB	0	0	
	Treselectio nNR	S	0	0	
T2	SS/PBCH SSS EPRE	dBm/SCS	-94	-88	Qhyst _s NR Cell 1 change causes NR Cell 2 to become highest ranked cell
	Qhyst _s	dB	0	0	
	Qoffset _{s,n}	dB	0	0	
	Treselectio nNR	S	0	0	
T3	SS/PBCH SSS EPRE	dBm/SCS	-88	-94	NR Cell 1 becomes the strongest and highest ranked one due to power adjustment
	Qhyst _s	dB	0	0	
	Qoffset _{s,n}	dB	0	0	
	Treselectio nNR	S	0	0	
T4	SS/PBCH SSS EPRE	dBm/SCS	-88	-94	Qoffset _{s,n} NR Cell1 change to 24dB, Qoffset _{s,n} NR Cell 2 remains zero
	Qhyst _s	dB	0	0	
	Qoffset _{s,n}	dB	24	0	
	Treselectio nNR	S	0	0	
T5	SS/PBCH SSS EPRE	dBm/SCS	-94	-88	NR Cell 1 becomes weaker but it remains the highest ranked one due to Qoffset _{s,n} NR Cell 1
	Qhyst _s	dB	0	0	
	Qoffset _{s,n}	dB	24	0	
	Treselectio nNR	S	0	0	
T6	SS/PBCH SSS EPRE	dBm/SCS	-94	-88	NR Cell 2 becomes the highest ranked one due to Qoffset _{s,n} NR Cell 1 change
	Qhyst _s	dB	0	0	
	Qoffset _{s,n}	dB	0	0	
	Treselectio nNR	S	0	0	
T7	SS/PBCH SSS EPRE	dBm/SCS	-88	-94	NR Cell 1 becomes the highest ranked one
	Qhyst _s	dB	0	0	
	Qoffset _{s,n}	dB	0	0	
	Treselectio nNR	S	0	0	
T8	SS/PBCH SSS EPRE	dBm/SCS	-88	-94	TreselectionNR of NR Cell 1 change to 7S
	Qhyst _s	dB	0	0	
	Qoffset _{s,n}	dB	0	0	
	Treselectio nNR	S	7	0	
T9	SS/PBCH SSS EPRE	dBm/SCS	-94	-88	NR Cell 2 becomes the highest ranked one
	Qhyst _s	dB	0	0	
	Qoffset _{s,n}	dB	0	0	
	Treselectio nNR	S	7	0	

Note: Power level "Off" is defined in TS38.508-1 [4] Table 6.2.2.1-3.

Table 6.1.2.9.3.2-2: Time instances of cell power level and parameter changes For FR2

	Parameter	Unit	NR Cell 1	NR Cell 2	Remark
T0	SS/PBCH SSS EPRE	dBm/SCS	FFS	Off	The power level values are assigned to ensure the UE registered on NR Cell 1.
	Qhyst _s	dB	24	0	
	Qoffset _{s,n}	dB	0	0	
	Treselectio nNR	S	0	0	
T1	SS/PBCH SSS EPRE	dBm/SCS	FFS	FFS	NR Cell 2 becomes stronger than NR Cell 1 but NR Cell 1 remains the highest ranked one due to Qhyst _s NR Cell 1
	Qhyst _s	dB	24	0	
	Qoffset _{s,n}	dB	0	0	
	Treselectio nNR	S	0	0	
T2	SS/PBCH SSS EPRE	dBm/SCS	FFS	FFS	Qhyst _s NR Cell 1 change causes NR Cell 2 to become highest ranked cell
	Qhyst _s	dB	0	0	
	Qoffset _{s,n}	dB	0	0	
	Treselectio nNR	S	0	0	
T3	SS/PBCH SSS EPRE	dBm/SCS	FFS	FFS	NR Cell 1 becomes the strongest and highest ranked one due to power adjustment
	Qhyst _s	dB	0	0	
	Qoffset _{s,n}	dB	0	0	
	Treselectio nNR	S	0	0	
T4	SS/PBCH SSS EPRE	dBm/SCS	FFS	FFS	Qoffset _{s,n} NR Cell1 change to 24dB, Qoffset _{s,n} NR Cell 2 remains zero
	Qhyst _s	dB	0	0	
	Qoffset _{s,n}	dB	24	0	
	Treselectio nNR	S	0	0	
T5	SS/PBCH SSS EPRE	dBm/SCS	FFS	FFS	NR Cell 1 becomes weaker but it remains the highest ranked one due to Qoffset _{s,n} NR Cell 1
	Qhyst _s	dB	0	0	
	Qoffset _{s,n}	dB	24	0	
	Treselectio nNR	S	0	0	
T6	SS/PBCH SSS EPRE	dBm/SCS	FFS	FFS	NR Cell 2 becomes the highest ranked one due to Qoffset _{s,n} NR Cell 1 change
	Qhyst _s	dB	0	0	
	Qoffset _{s,n}	dB	0	0	
	Treselectio nNR	S	0	0	
T7	SS/PBCH SSS EPRE	dBm/SCS	FFS	FFS	NR Cell 1 becomes the highest ranked one
	Qhyst _s	dB	0	0	
	Qoffset _{s,n}	dB	0	0	
	Treselectio nNR	S	0	0	
T8	SS/PBCH SSS EPRE	dBm/SCS	FFS	FFS	TreselectionNR of NR Cell 1 change to 7S
	Qhyst _s	dB	0	0	
	Qoffset _{s,n}	dB	0	0	
	Treselectio nNR	S	7	0	
T9	SS/PBCH SSS EPRE	dBm/SCS	FFS	FFS	NR Cell 2 becomes the highest ranked one
	Qhyst _s	dB	0	0	
	Qoffset _{s,n}	dB	0	0	
	Treselectio nNR	S	7	0	

Note: The uncertain downlink signal level is specified in TS 38.508-1[4] section FFS.

Table 6.1.2.9.3.2-3: Main behaviour

St	Procedure	Message Sequence		TP	Verdict
		U - S	Message		
1	SS re-adjusts the SSS levels according to row "T1" in table 6.1.2.9.3.2-1/2.	-	-	-	-
2	Check: Does the UE send an NR: <i>RRCSetupRequest</i> on NR Cell 2 within the next 10s ?	-->	NR RRC: <i>RRCSetupRequest</i>	1	F
3	SS notifies UE of the system information change on NR Cell 1 by send Short Message on PDCCH using P-RNTI.	<--	NR RRC: <i>Paging</i>	-	-
4	SS resets $Q_{\text{hyst}}^{\text{NR Cell 1}}$ according to row "T2" in table 6.1.2.9.3.2-1/2, The <i>ValueTag</i> of <i>SIB2</i> in the SI-SchedulingInfo of <i>SIB1</i> is increased on NR Cell 1.	-	-	-	-
5	Wait for 2.1* modification period to allow the new system information to take effect.	-	-	-	-
6	Check: Does the test result of generic test procedure in TS 38.508-1 [4] Table 4.9.4-1 indicate that the UE is camped on NR Cell 2?	-	-	1	-
7	SS re-adjusts SSS levels according to rows "T3" in table 6.1.2.9.3.2-1/2.	-	-	-	-
8	Wait for 1 second to allow UE to recognise the change.	-	-	-	-
9	The test result of generic test procedure in TS 38.508-1 [4] Table 4.9.4-1 indicate that the UE is camped on NR Cell 1.	-	-	-	-
10	SS notifies UE of the system information change on NR Cell 1 by send Short Message on PDCCH using P-RNTI.	<--	NR RRC: <i>Paging</i>	-	-
11	SS changes $Q_{\text{offset}}^{\text{s,n NR Cell 1}}$ according to rows "T4" in table 6.1.2.9.3.2-1/2. The <i>ValueTag</i> of <i>SIB3</i> in the SI-SchedulingInfo of <i>SIB1</i> is increased on NR Cell 1.	-	-	-	-
12	Wait for 2.1* modification period to allow the new system information to take effect.	-	-	-	-
13	SS re-adjusts SSS levels according to row "T5" in table 6.1.2.9.3.2-1/2.	-	-	-	-
14	Wait for 1 second to allow UE to recognise the change.	-	-	-	-
15	Check: Does the test result of generic test procedure in TS 38.508-1 [4] Table 4.9.4-1 indicate that the UE is still camped on NR Cell 1?	-	-	3	-
16	SS notifies UE of the system information change on NR Cell 1 by send Short Message on PDCCH using P-RNTI.	<--	NR RRC: <i>Paging</i>	-	-
17	SS resets $Q_{\text{offset}}^{\text{s,n NR Cell1}}$ according to row "T6" in table 6.1.2.9.3.2-1/2, The <i>ValueTag</i> of <i>SIB3</i> in the SI-SchedulingInfo of <i>SIB1</i> is increased on NR Cell 1.	-	-	-	-
18	Wait for 2.1* modification period to allow the new system information to take effect.	-	-	-	-
19	Check: Does the test result of generic test procedure in TS 38.508-1 [4] Table 4.9.4-1 indicate that the UE is camped on NR Cell 2?	-	-	3	-
20	SS re-adjusts SSS levels according to rows "T7" in table 6.1.2.9.3.2-1/2.	-	-	-	-
21	Wait for 1 second to allow UE to recognise the change.	-	-	-	-
22	Check: Does the test result of generic test procedure in TS 38.508-1 [4] Table 4.9.4-1 indicate that the UE is camped on NR Cell 1?	-	-	3	-
23	SS sends notification of the system information change on NR Cell 1 by send Short Message on PDCCH using P-RNTI.	<--	NR RRC: <i>Paging</i>	-	-

24	SS changes $Treselection_{NR\ Cell\ 1}$ according to rows "T8" in table 6.1.2.9.3.2-1/2, The <i>ValueTag</i> of <i>SIB2</i> in the <i>SI-SchedulingInfo</i> of <i>SIB1</i> is increased on NR Cell 1.	-	-	-	-
25	Wait for 2.1* modification period to allow the new system information to take effect.	-	-	-	-
26	Start $Timer=Treselection_{NR\ Cell\ 1}$ sent in <i>SIB2</i> in step 24				
27	SS re-adjusts SSS levels according to rows "T9" in table 6.1.2.9.3.2-1/2.	-	-	-	-
28	Check: Does the UE send an NR: <i>RRCSetupRequest</i> on NR Cell 2 within $Timer=Treselection_{NR\ Cell\ 1}$?	-->	NR RRC: <i>RRCSetupRequest</i>	2	F
29	SS waits for $Timer=Treselection_{NR\ Cell\ 1}$ expires				
30	Check: Does the UE send an NR: <i>RRCSetupRequest</i> on NR Cell 2?	-->	NR RRC: <i>RRCSetupRequest</i>	2	P
31-36	Steps 3 to 8 of the generic test procedure in TS 38.508-1 [4] Table 4.9.4-1 are performed on NR Cell 2.	-	-	-	-

6.1.2.9.3.3 Specific message contents

Table 6.1.2.9.3.3-1: SIB1 of NR Cell 1 (preamble and all steps, Table 6.1.2.9.3.2-3)

Derivation Path: TS 38.508-1 [4], Table 4.6.1-28			
Information Element	Value/remark	Comment	Condition
SIB1 ::= SEQUENCE {			
si-SchedulingInfo	SI-SchedulingInfo		
}			

Table 6.1.2.21.3.3-2: SI-SchedulingInfo (si-SchedulingInfo in Table 6.1.2.9.3.3-1)

Derivation Path: TS 38.508-1 [4], Table 4.6.3-173			
Information Element	Value/remark	Comment	Condition
SI-SchedulingInfo ::= SEQUENCE {			
schedulingInfoList SEQUENCE (SIZE(1..maxSI-Message)) OF SEQUENCE{			
sib-MappingInfo SEQUENCE (SIZE (1..maxSIB)) OF SEQUENCE {	2 entry		
Type[1]	sibType2		
valueTag[1]	0	The value is increased by 1 in step 4 and step 24	
Type[2]	sibType3		
valueTag[2]	0	The value is increased by 1 in step 11 and step 17	
}			
}			
}			

Table 6.1.2.9.3.3-3: SIB2 of NR Cell 1 (preamble, Table 6.1.2.9.3.2-3)

Derivation Path: TS 38.508-1 [4], Table 4.6.2-1			
Information Element	Value/remark	Comment	Condition
SIB2 ::= SEQUENCE {			
cellReselectionInfoCommon SEQUENCE			
{			
q-Hyst	dB24		
}			
}			

Table 6.1.2.9.3.3-4: SIB2 of NR Cell 1 (step 4, Table 6.1.2.9.3.2-3)

Derivation Path: TS 38.508-1 [4], Table 4.6.2-1			
Information Element	Value/remark	Comment	Condition
SIB2 ::= SEQUENCE {			
cellReselectionInfoCommon SEQUENCE			
{			
q-Hyst	dB0		
}			
}			

Table 6.1.2.9.3.3-5: SIB3 of NR Cell 1 (step 11, Table 6.1.2.9.3.2-3)

Derivation Path: TS 38.508-1 [4], Table 4.6.2-2			
Information Element	Value/remark	Comment	Condition
SIB3 ::= SEQUENCE {			
intraFreqNeighCellList SEQUENCE (SIZE (1.. maxCellIntra)) OF SEQUENCE {	1 entry		
IntraFreqNeighCellInfo [1] SEQUENCE {			
q-OffsetCell	dB24		
}			
}			
}			

Table 6.1.2.9.3.3-6: SIB3 of NR Cell 1 (step 17, Table 6.1.2.9.3.2-3)

Derivation Path: TS 38.508-1 [4], Table 4.6.2-2			
Information Element	Value/remark	Comment	Condition
SIB3 ::= SEQUENCE {			
intraFreqNeighCellList SEQUENCE (SIZE (1.. maxCellIntra)) OF SEQUENCE {	1 entry		
IntraFreqNeighCellInfo [1] SEQUENCE {			
q-OffsetCell	dB0		
}			
}			
}			

Table 6.1.2.9.3.3-7: SIB2 of NR Cell 1 (step 24, Table 6.1.2.9.3.2-3)

Derivation Path: TS 38.508-1 [4], Table 4.6.2-1			
Information Element	Value/remark	Comment	Condition
SIB2 ::= SEQUENCE {			
intraFreqCellReselectionInfo SEQUENCE			
{			
t-ReselectionNR	7	seconds	
}			
}			

6.1.2.10

6.1.2.11

6.1.2.12 Cell reselection using cell status and cell reservations /
cellReservedForOtherUse

6.1.2.12.1 Test Purpose (TP)

(1)

```

with { UE camped normally in state NR RRC_IDLE }
ensure that {
  when { A higher ranked cell is found with cell status "true" for other use }
  then { UE does not attempt to reselect to the higher ranked cell }
}

```

6.1.2.12.2 Conformance requirements

References: The conformance requirements covered in the present TC are specified in: 3GPP TS 38.304, clause 5.2.4.4, 5.2.4.6 and 5.3.1. Unless otherwise stated these are Rel-15 requirements.

[TS 38.304, clause 5.2.4.4]

For the highest ranked cell (including serving cell) according to cell reselection criteria specified in subclause 5.2.4.6, for the best cell according to absolute priority reselection criteria specified in subclause 5.2.4.5, the UE shall check if the access is restricted according to the rules in subclause 5.3.1.

If that cell and other cells have to be excluded from the candidate list, as stated in subclause 5.3.1, the UE shall not consider these as candidates for cell reselection. This limitation shall be removed when the highest ranked cell changes.

If the highest ranked cell or best cell according to absolute priority reselection rules is an intra-frequency or inter-frequency cell which is not suitable due to being part of the "list of 5GS forbidden TAs for roaming" or belonging to a PLMN which is not indicated as being equivalent to the registered PLMN, the UE shall not consider this cell and other cells on the same frequency, as candidates for reselection for a maximum of 300 seconds. If the UE enters into state *any cell selection*, any limitation shall be removed. If the UE is redirected under NR control to a frequency for which the timer is running, any limitation on that frequency shall be removed.

If the highest ranked cell or best cell according to absolute priority reselection rules is an inter-RAT cell which is not suitable due to being part of the "list of forbidden TAs for roaming" or belonging to a PLMN which is not indicated as being equivalent to the registered PLMN, the UE shall not consider this cell and other cells on the same frequency, as candidates for reselection for a maximum of 300 seconds. If the UE enters into state *any cell selection*, any limitation shall be removed. If the UE is redirected under NR control to a frequency for which the timer is running, any limitation on that frequency shall be removed.

[TS 38.304, clause 5.2.4.6]

The cell-ranking criterion R_s for serving cell and R_n for neighbouring cells is defined by:

$$R_s = Q_{\text{meas},s} + Q_{\text{hyst}} - Q_{\text{offset,temp}}$$

$$R_n = Q_{\text{meas},n} - Q_{\text{offset}} - Q_{\text{offset,temp}}$$

where:

Q_{meas}	RSRP measurement quantity used in cell reselections.
Q_{offset}	For intra-frequency: Equals to $Q_{\text{offset},s,n}$, if $Q_{\text{offset},s,n}$ is valid, otherwise this equals to zero. For inter-frequency: Equals to $Q_{\text{offset},s,n}$ plus $Q_{\text{offset,frequency}}$, if $Q_{\text{offset},s,n}$ is valid, otherwise this equals to $Q_{\text{offset,frequency}}$.
$Q_{\text{offset,temp}}$	Offset temporarily applied to a cell as specified in TS 38.331 [3].

The UE shall perform ranking of all cells that fulfil the cell selection criterion S, which is defined in 5.2.3.2.

The cells shall be ranked according to the R criteria specified above by deriving $Q_{\text{meas},n}$ and $Q_{\text{meas},s}$ and calculating the R values using averaged RSRP results.

If *rangeToBestCell* is not configured, the UE shall perform cell reselection to the highest ranked cell. If this cell is found to be not-suitable, the UE shall behave according to subclause 5.2.4.4.

If *rangeToBestCell* is configured, then the UE shall perform cell reselection to the cell with the highest number of beams above the threshold (i.e. *absThreshSS-BlocksConsolidation*) among the cells whose R value is within *rangeToBestCell* of the R value of the highest ranked cell. If there are multiple such cells, the UE shall perform cell reselection to the highest ranked cell among them. If this cell is found to be not-suitable, the UE shall behave according to subclause 5.2.4.4.

In all cases, the UE shall reselect the new cell, only if the following conditions are met:

- the new cell is better than the serving cell according to the cell reselection criteria specified above during a time interval $T_{\text{reselection,RAT}}$;
- more than 1 second has elapsed since the UE camped on the current serving cell.

[TS 38.304, clause 5.3.1]

Cell status and cell reservations are indicated in the *MIB* or *SIB1* message as specified in TS 38.331 [3] by means of three fields:

- *cellBarred* (IE type: "barred" or "not barred")
Indicated in *MIB* message. In case of multiple PLMNs indicated in *SIB1*, this field is common for all PLMNs
- *cellReservedForOperatorUse* (IE type: "reserved" or "not reserved")
Indicated in *SIB1* message. In case of multiple PLMNs indicated in *SIB1*, this field is specified per PLMN.
- *cellReservedForOtherUse* (IE type: "true")
Indicated in *SIB1* message. In case of multiple PLMNs indicated in *SIB1*, this field is common for all PLMNs.

When cell status is indicated as "not barred" and "not reserved" for operator use and not "true" for other use,

- All UEs shall treat this cell as candidate during the cell selection and cell reselection procedures.

When cell status is indicated as "true" for other use,

- The UE shall treat this cell as if cell status is "barred".

When cell status is indicated as "not barred" and "reserved" for operator use for any PLMN and not "true" for other use,

- UEs assigned to Access Identity 11 or 15 operating in their HPLMN/EHPLMN shall treat this cell as candidate during the cell selection and reselection procedures if the field *cellReservedForOperatorUse* for that PLMN set to "reserved".
- UEs assigned to an Access Identity 1, 2 and 12 to 14 shall behave as if the cell status is "barred" in case the cell is "reserved for operator use" for the registered PLMN or the selected PLMN.

NOTE 1: Access Identities 11, 15 are only valid for use in the HPLMN/ EHPLMN; Access Identities 12, 13, 14 are only valid for use in the home country as specified in TS 22.261 [12].

When cell status "barred" is indicated or to be treated as if the cell status is "barred",

- The UE is not permitted to select/reselect this cell, not even for emergency calls.
- The UE shall select another cell according to the following rule:
- If the cell is to be treated as if the cell status is "barred" due to being unable to acquire the *MIB*:
 - the UE may exclude the barred cell as a candidate for cell selection/reselection for up to 300 seconds.
 - the UE may select another cell on the same frequency if the selection criteria are fulfilled.

- else:
 - If the cell is to be treated as if the cell status is "barred" due to being unable to acquire the *SIB1*:
 - The UE may exclude the barred cell as a candidate for cell selection/reselection for up to 300 seconds.
 - If the field *intraFreqReselection* in *MIB* message is set to "allowed", the UE may select another cell on the same frequency if re-selection criteria are fulfilled;
 - The UE shall exclude the barred cell as a candidate for cell selection/reselection for 300 seconds.
 - If the field *intraFreqReselection* in *MIB* message is set to "not allowed" the UE shall not re-select a cell on the same frequency as the barred cell;
 - The UE shall exclude the barred cell and the cells on the same frequency as a candidate for cell selection/reselection for 300 seconds.

The cell selection of another cell may also include a change of RAT.

6.1.2.12.3 Test description

6.1.2.12.3.1 Pre-test conditions

System Simulator:

- NR Cell 1 and NR Cell 11 in different tracking areas.
- System information combination NR-2 as defined in TS 38.508-1 [4] clause 4.4.3.1.2 is used in NR Cells.

UE:

None.

Preamble:

- The UE is in NR RRC Idle mode (state 1N-A) on NR Cell 1 according to 38.508-1 [4] Table 4.4A.2-1.

6.1.2.12.3.2 Test procedure sequence

Table 6.1.2.12.3.2-1/2 illustrate the downlink power levels and other changing parameters to be applied for the cell at various time instants of the test execution. The exact instants on which these values shall be applied are described in the texts in this clause. The configuration T0 indicates the initial conditions for preamble. Configurations marked "T1" is applied at the points indicated in the Main behaviour description in Table 6.1.2.12.3.2-3.

Table 6.1.2.12.3.2-1: Time instances of cell power level and parameter changes for FR1

	Parameter	Unit	NR Cell 1	NR Cell 11	Remark
T0	SS/PBCH SSS EPRE	dBm/ SCS	-88	Off	
T1	SS/PBCH SSS EPRE	dBm/ SCS	-88	-80	The power level values are assigned to satisfy $R_{NRCell\ 1} < R_{NRCell\ 11}$
	cellReservedFor OtherUse	-	-	True	

Table 6.1.2.12.3.2-2: Time instances of cell power level and parameter changes for FR2

	Parameter	Unit	NR Cell 1	NR Cell 11	Remark
T0	SS/PBCH SSS EPRE	dBm/ SCS	FFS	Off	
T1	SS/PBCH SSS EPRE	dBm/ SCS	FFS	FFS	The power level values are assigned to satisfy $R_{NRCell 1} < R_{NRCell 11}$
	cellReservedFor OtherUse	-	-	True	

Table 6.1.2.12.3.2-3: Main behaviour

St	Procedure	Message Sequence		TP	Verdict
		U - S	Message		
1	The SS re-adjusts the SS/PBCH EPRE levels and according to row "T1" in table 6.1.2.12.3.2-1/2.	-	-	-	-
2	Check: Does the UE initiate a random access procedure on NR Cell 11 within the next 120s?	-	-	1	F
3	Check: Does the test result of generic test procedure in TS 38.508-1 [4] Table 4.9.4.2.2-1 indicate that check UE is in state NR RRC_IDLE on NR Cell 1?	-	-	1	-

6.1.2.12.3.3 Specific message contents

Table 6.1.2.12.3.3-1: SIB1 for NR Cell 11 (Preamble, Table 6.1.2.12.3.2-3)

Derivation Path: TS 38.508-1 [4], Table 4.6.1-5			
Information Element	Value/Remark	Comment	Condition
SIB1 ::= SEQUENCE {			
cellAccessRelatedInfo SEQUENCE {			
cellReservedForOtherUse	true		
}			
}			

6.1.2.13 Cell reselection using cell status and cell reservations / Access Identity 1, 2 or 12 to 14 – cellReservedForOperatorUse

Editor Note: Need to move USIM Profile to 38.508-1 [4] clause 6.4.

6.1.2.13.1 Test Purpose (TP)

(1)

```
with { UE camped normally in state NR RRC_IDLE and UE fitted with a USIM with Access Identity 1,2 and 12 to 14 }
ensure that {
  when { a higher ranked cell is found "reserved" for Operator use }
  then { UE does not attempt to reselect to the higher ranked cell }
}
```

6.1.2.13.2 Conformance requirements

References: The conformance requirements covered in the present TC are specified in: 3GPP TS 38.304, clause 5.3.1. Unless otherwise stated these are Rel-15 requirements.

[TS 38.304, clause 5.3.1]

Cell status and cell reservations are indicated in the *MIB or SIB1* message as specified in TS 38.331 [3] by means of three fields:

- *cellBarred* (IE type: "barred" or "not barred")
Indicated in *MIB* message. In case of multiple PLMNs indicated in *SIB1*, this field is common for all PLMNs
- *cellReservedForOperatorUse* (IE type: "reserved" or "not reserved")
Indicated in *SIB1* message. In case of multiple PLMNs indicated in *SIB1*, this field is specified per PLMN.
- *cellReservedForOtherUse* (IE type: "true")
Indicated in *SIB1* message. In case of multiple PLMNs indicated in *SIB1*, this field is common for all PLMNs.

When cell status is indicated as "not barred" and "not reserved" for operator use and not "true" for other use,

- All UEs shall treat this cell as candidate during the cell selection and cell reselection procedures.

When cell status is indicated as "true" for other use,

- The UE shall treat this cell as if cell status is "barred".

When cell status is indicated as "not barred" and "reserved" for operator use for any PLMN and not "true" for other use,

- UEs assigned to Access Identity 11 or 15 operating in their HPLMN/EHPLMN shall treat this cell as candidate during the cell selection and reselection procedures if the field *cellReservedForOperatorUse* for that PLMN set to "reserved".
- UEs assigned to an Access Identity 1, 2 and 12 to 14 shall behave as if the cell status is "barred" in case the cell is "reserved for operator use" for the registered PLMN or the selected PLMN.

NOTE 1: Access Identities 11, 15 are only valid for use in the HPLMN/ EHPLMN; Access Identities 12, 13, 14 are only valid for use in the home country as specified in TS 22.261 [12].

When cell status "barred" is indicated or to be treated as if the cell status is "barred",

- The UE is not permitted to select/reselect this cell, not even for emergency calls.
- The UE shall select another cell according to the following rule:
 - If the cell is to be treated as if the cell status is "barred" due to being unable to acquire the *MIB*:
 - the UE may exclude the barred cell as a candidate for cell selection/reselection for up to 300 seconds.
 - the UE may select another cell on the same frequency if the selection criteria are fulfilled.
 - else:
 - If the cell is to be treated as if the cell status is "barred" due to being unable to acquire the *SIB1*:
 - The UE may exclude the barred cell as a candidate for cell selection/reselection for up to 300 seconds.
 - If the field *intraFreqReselection* in *MIB* message is set to "allowed", the UE may select another cell on the same frequency if re-selection criteria are fulfilled;
 - The UE shall exclude the barred cell as a candidate for cell selection/reselection for 300 seconds.
 - If the field *intraFreqReselection* in *MIB* message is set to "not allowed" the UE shall not re-select a cell on the same frequency as the barred cell;
 - The UE shall exclude the barred cell and the cells on the same frequency as a candidate for cell selection/reselection for 300 seconds.

The cell selection of another cell may also include a change of RAT.

6.1.2.13.3 Test description

6.1.2.13.3.1 Pre-test conditions

System Simulator:

- NR Cell 1 and NR Cell 12 with different tracking areas.

- NR Cell 1 and NR Cell 12 are HPLMN.
- System information combination NR-4 as defined in TS 38.508-1 [4] clause 4.4.3.1.2 is used in NR Cells.

UE:

None.

Preamble:

- The UE is in NR RRC Idle mode (state 1N-A) on NR Cell 1 according to TS 38.508-1 [4] Table 4.4A.2-1.
- The UE switches off and then switches on.
- The UE is in NR RRC Idle mode (state 1N-A) on NR Cell 1 according to TS 38.508-1 [4] Table 4.4A.2-1.
- The MPS indicator bit of the 5GS network feature support IE is set to "Access identity 1 valid in RPLMN or equivalent PLMN" in the REGISTRATION ACCEPT message according to TS 24.501 [22].
- The MCS indicator bit of the 5GS network feature support IE is set to "Access identity 2 valid in RPLMN or equivalent PLMN" in the REGISTRATION ACCEPT message according to TS 24.501 [22].
- The UE is equipped with a USIM containing default values (as per TS 38.508-1 [4]) except for those shown in Table 6.1.2.13.3.1-2.

Table 6.1.2.13.3.1–1: USIM Configuration

USIM field	Value
EF _{UST}	Service n°126 (for UAC Access Identities Configuration) defined in TS 31.102 clause 4.2.8 is declared "available".
EF _{UAC_AIC} and EF _{ACC}	For Bits b1, b2 in byte 1 of EF _{UAC_AIC} (defined in TS 31.102 clause 4.4.11.7) and Bits b5 to b7 in byte 1 of EF _{ACC} (defined in TS 31.102 clause 4.2.15), any single bit can be set to 1. All remaining bits of the two file are set to 0.
EF _{EHPLMN}	This file is not present or empty.

6.1.2.13.3.2 Test procedure sequence

Table 6.1.2.13.3.2-1/2 illustrate the downlink power levels and other changing parameters to be applied for the cell at various time instants of the test execution. The exact instants on which these values shall be applied are described in the texts in this clause. Configurations marked "T0" is applied for Preamble. Configurations marked "T1" is applied at the points indicated in the Main behaviour description in Table 6.1.2.13.3.2-3.

Table 6.1.2.13.3.2-1: Time instances of cell power level and parameter changes for FR1

	Parameter	Unit	NR Cell 1	NR Cell 12	Remark
T0	SS/PBCH SSS EPRE	dBm/ SCS	-88	Off	
T1	SS/PBCH SSS EPRE	dBm/ SCS	-88	-80	The power level values are assigned to satisfy $R_{NRCell\ 1} < R_{NRCell\ 12}$
	cellReservedFor OperatorUse	-	-	Reserved	

Table 6.1.2.13.3.2-2: Time instances of cell power level and parameter changes for FR2

	Parameter	Unit	NR Cell 1	NR Cell 12	Remark
T0	SS/PBCH SSS EPRE	dBm/ SCS	FFS	Off	
T1	SS/PBCH SSS EPRE	dBm/ SCS	FFS	FFS	The power level values are assigned to satisfy $R_{NRCell 1} < R_{NRCell 12}$
	cellReservedFor OperatorUse	-	-	Reserved	

Table 6.1.2.13.3.2-3: Main behaviour

St	Procedure	Message Sequence		TP	Verdict
		U - S	Message		
1	The SS adjusts the SS/PBCH EPRE levels according to row "T1" in table 6.1.2.13.3.2-1/2.	-	-	-	-
2	Check: Does the UE initiate a random access procedure on NR Cell 12 within the next 120s?	-	-	1	F
3	Check: Does the test result of generic test procedure in TS 38.508-1 [4] Table 4.9.4.2.2-1 indicate that check UE is in state NR RRC_IDLE on NR Cell 1?	-	-	1	-

6.1.2.13.3.3 Specific message contents

Table 6.1.2.13.3.3-1: SIB1 for NR Cell 12 (Preamble, Table 6.1.2.13.3.2-3)

Derivation Path: TS 38.508-1 [4], Table 4.6.1-5			
Information Element	Value/Remark	Comment	Condition
SIB1 ::= SEQUENCE {			
cellAccessRelatedInfo SEQUENCE {			
plmn-IdentityList SEQUENCE (SIZE (1..maxPLMN)) OF PLMN-Identity {			
cellReservedForOperatorUse	Reserved		
}			
}			
}			

Table 6.1.2.13.3.3-2: REGISTRATION ACCEPT (Preamble, Table 6.1.2.13.3.2-3)

Derivation Path: TS 38.508-1 [4], Table 4.7.1-7			
Information Element	Value/Remark	Comment	Condition
5GS network feature support	'1000 0001 0000 0010'B		

6.1.2.14 Cell reselection using cell status and cell reservations / Access Identity 11 or 15 - cellReservedForOperatorUse

6.1.2.14.1 Test Purpose (TP)

(1)

```

with { UE camped normally in state NR RRC_IDLE operating in their HPLMN/EHPLMN and fitted with a
USIM with access class11 or 15}
ensure that {
  when { a higher ranked cell is found "reserved" for Operator use }
  then { UE re-selects to the higher ranked cell }
}

```

6.1.2.14.2 Conformance requirements

References: The conformance requirements covered in the present TC are specified in: 3GPP TS 38.304, clause 5.3.1. Unless otherwise stated these are Rel-15 requirements.

[TS 38.304, clause 5.3.1]

Cell status and cell reservations are indicated in the *MIB* or *SIB1* message as specified in TS 38.331 [3] by means of three fields:

- *cellBarred* (IE type: "barred" or "not barred")
Indicated in *MIB* message. In case of multiple PLMNs indicated in *SIB1*, this field is common for all PLMNs
- *cellReservedForOperatorUse* (IE type: "reserved" or "not reserved")
Indicated in *SIB1* message. In case of multiple PLMNs indicated in *SIB1*, this field is specified per PLMN.
- *cellReservedForOtherUse* (IE type: "true")
Indicated in *SIB1* message. In case of multiple PLMNs indicated in *SIB1*, this field is common for all PLMNs.

When cell status is indicated as "not barred" and "not reserved" for operator use and not "true" for other use,

- All UEs shall treat this cell as candidate during the cell selection and cell reselection procedures.

When cell status is indicated as "true" for other use,

- The UE shall treat this cell as if cell status is "barred".

When cell status is indicated as "not barred" and "reserved" for operator use for any PLMN and not "true" for other use,

- UEs assigned to Access Identity 11 or 15 operating in their HPLMN/EHPLMN shall treat this cell as candidate during the cell selection and reselection procedures if the field *cellReservedForOperatorUse* for that PLMN set to "reserved".
- UEs assigned to an Access Identity 1, 2 and 12 to 14 shall behave as if the cell status is "barred" in case the cell is "reserved for operator use" for the registered PLMN or the selected PLMN.

NOTE 1: Access Identities 11, 15 are only valid for use in the HPLMN/ EHPLMN; Access Identities 12, 13, 14 are only valid for use in the home country as specified in TS 22.261 [12].

When cell status "barred" is indicated or to be treated as if the cell status is "barred",

- The UE is not permitted to select/reselect this cell, not even for emergency calls.
- The UE shall select another cell according to the following rule:
 - If the cell is to be treated as if the cell status is "barred" due to being unable to acquire the *MIB*:
 - the UE may exclude the barred cell as a candidate for cell selection/reselection for up to 300 seconds.
 - the UE may select another cell on the same frequency if the selection criteria are fulfilled.
 - else:
 - If the cell is to be treated as if the cell status is "barred" due to being unable to acquire the *SIB1*:
 - The UE may exclude the barred cell as a candidate for cell selection/reselection for up to 300 seconds.
 - If the field *intraFreqReselection* in *MIB* message is set to "allowed", the UE may select another cell on the same frequency if re-selection criteria are fulfilled;
 - The UE shall exclude the barred cell as a candidate for cell selection/reselection for 300 seconds.
 - If the field *intraFreqReselection* in *MIB* message is set to "not allowed" the UE shall not re-select a cell on the same frequency as the barred cell;
 - The UE shall exclude the barred cell and the cells on the same frequency as a candidate for cell selection/reselection for 300 seconds.

The cell selection of another cell may also include a change of RAT.

6.1.2.14.3 Test description

6.1.2.14.3.1 Pre-test conditions

System Simulator:

- NR Cell 1 and NR Cell 3 in different tracking areas.
- NR Cell 1 is HPLMN.
- System information combination NR-4 as defined in TS 38.508-1 [4] clause 4.4.3.1.2 is used in NR Cells.

UE:

None.

Preamble:

- The UE is in NR RRC Idle mode (state 1N-A) on NR Cell 1 according to TS 38.508-1 [4] Table 4.4A.2-1.
- The UE is equipped with a USIM containing default values (as per TS 38.508-1 [4]) except for those shown in Table 6.1.2.14.3.1-2.

Table 6.1.2.14.3.1-1: USIM Configuration

USIM field	Value
EF _{UST}	Service n°126 (for UAC Access Identities Configuration) defined in TS 31.102 clause 4.2.8 is declared "available"
EF _{UAC_AIC}	Bits b1 and b2 in byte 1 defined in TS 31.102 clause 4.4.11.7 are set to 0
EF _{ACC}	For Bits b4 and b8, in byte 1 defined in TS 31.102 clause 4.2.15, only single bit set to 1. All remaining bits of byte 1 and byte 2 are set to 0.
EF _{EHPLMN}	This data field only contains the HPLMN.

6.1.2.14.3.2 Test procedure sequence

Table 6.1.2.14.3.2-1/2 illustrate the downlink power levels and other changing parameters to be applied for the cell at various time instants of the test execution. The exact instants on which these values shall be applied are described in the texts in this clause. Configurations marked "T0" is applied for Preamble. Configurations marked "T1" is applied at the points indicated in the Main behaviour description in Table 6.1.2.14.3.2-3.

Table 6.1.2.14.3.2-1: Time instances of cell power level and parameter changes for FR1

	Parameter	Unit	NR Cell 1	NR Cell 3	Remark
T0	SS/PBCH SSS EPRE	dBm/ SCS	-88	Off	
T1	SS/PBCH SSS EPRE	dBm/ SCS	-88	-80	The power level values are assigned to satisfy $R_{NRCell\ 1} < R_{NRCell\ 3}$
	cellReservedFor OperatorUse	-	-	Reserved	

Table 6.1.2.14.3.2-2: Time instances of cell power level and parameter changes for FR2

	Parameter	Unit	NR Cell 1	NR Cell 3	Remark
T0	SS/PBCH SSS EPRE	dBm/ SCS	FFS	Off	
T1	SS/PBCH SSS EPRE	dBm/ SCS	FFS	FFS	The power level values are assigned to satisfy $R_{NRCell\ 1} < R_{NRCell\ 3}$
	cellReservedFor OperatorUse	-	-	Reserved	

Table 6.1.2.14.3.2-3: Main behaviour

St	Procedure	Message Sequence		TP	Verdict
		U - S	Message		
1	The SS adjusts the SS/PBCH EPRE levels according to row "T1" in table 6.1.2.14.3.2-1/2.	-	-	-	-
2	Check: Does the test result of test steps 1 to 5 of generic test procedure in TS 38.508-1 [4] Table 4.9.5.2.2-1 indicate that the UE is camped on NR Cell 3?	-	-	1	P

6.1.2.14.3.3 Specific message contents

Table 6.1.2.14.3.3-1: SIB1 for NR Cell 3 (Preamble, Table 6.1.2.14.3.2-3)

Derivation Path: TS 38.508-1 [4], Table 4.6.1-5			
Information Element	Value/Remark	Comment	Condition
SIB1 ::= SEQUENCE {			
cellAccessRelatedInfo SEQUENCE {			
plmn-IdentityList SEQUENCE (SIZE (1..maxPLMN)) OF PLMN-Identity {			
cellReservedForOperatorUse	Reserved		
}			
}			
}			

6.1.2.15 Cell reselection in shared network environment

6.1.2.15.1 Test Purpose (TP)

(1)

```

with { the UE is in NR RRC_Idle and registered on the HPLMN }
ensure that {
  when { a cell of a different PLMN but shared with the HPLMN becomes highest ranked cell }
  then { the UE reselects the cell shared with the HPLMN }
}

```

6.1.2.15.2 Conformance requirements

References: The conformance requirements covered in the present TC are specified in: 3GPP TS 23.122, clause 4.4.3, and TS 38.304, clause 5.2.4.6. Unless otherwise stated these are Rel-15 requirements.

[TS 23.122, clause 4.4.3]

The registration on the selected PLMN and the location registration are only necessary if the MS is capable of services which require registration. Otherwise, the PLMN selection procedures are performed without registration.

The ME shall utilise all the information stored in the SIM related to the PLMN selection; e.g. "HPLMN Selector with Access Technology", "User Controlled PLMN Selector with Access Technology", "Forbidden PLMNs", "Equivalent HPLMN", see 3GPP TS 31.102 [40].

The ME shall either utilise the "Operator controlled PLMN Selector with Access Technology" that it has stored locally on the ME, or the Operator controlled PLMN Selector with Access Technology" stored in the SIM, for the purposes of PLMN selection.

The "HPLMN Selector with Access Technology", "User Controlled PLMN Selector with Access Technology" and "Operator Controlled PLMN Selector with Access Technology" data files in the SIM include associated access technologies for each PLMN entry, see 3GPP TS 31.102 [40]. The PLMN/access technology combinations are listed in priority order. If an entry indicates more than one access technology, then no priority is defined for the access technologies within this entry and the priority applied to each access technology within this entry is an implementation issue. If no particular access technology is indicated in an entry, it shall be assumed that all access technologies supported by the ME apply to the entry. If an entry only indicates access technologies not supported by the ME, the entry shall be ignored. If an entry indicates at least one access technology supported by the ME, the entry shall be used in the PLMN selection procedures if the other criteria defined for the specific PLMN selection procedures are fulfilled.

The Mobile Equipment stores a list of "equivalent PLMNs". This list is replaced or deleted at the end of each location update procedure, routing area update procedure, GPRS attach procedure, tracking area update procedure, EPS attach procedure, and registration procedure. The list is deleted by an MS attached for emergency bearer services after detach or registered for emergency services after deregistration. The stored list consists of a list of equivalent PLMNs as downloaded by the network plus the PLMN code of the registered PLMN that downloaded the list. All PLMNs in the stored list, in all access technologies supported by the PLMN, are regarded as equivalent to each other for PLMN selection, cell selection/re-selection and handover.

When the MS reselects to a cell in a shared network, and the cell is a suitable cell for multiple PLMN identities received on the BCCH or on the EC-BCCH the AS indicates these multiple PLMN identities to the NAS according to 3GPP TS 44.018 [34], 3GPP TS 44.060 [39], 3GPP TS 25.304 [32] and 3GPP TS 36.304 [43]. The MS shall choose one of these PLMNs. If the registered PLMN is available among these PLMNs, the MS shall not choose a different PLMN.

The MS shall not use the PLMN codes contained in the "HPLMN Selector with Access Technology" data file.

It is possible for the home network operator to identify alternative Network IDs as the HPLMN. If the EHPLMN list is present, and not empty, the entries in the EHPLMN list are used in the network selection procedures. When attempting to select a network the highest priority EHPLMN that is available shall be selected. If the EHPLMN list is present and is empty or if the EHPLMN list is not present, the HPLMN derived from the IMSI is used for network selection procedures.

NOTE 1: The "HPLMN Selector with Access Technology" data file is only used by the MS to get the HPLMN access technologies related to the HPLMN code which corresponds to the PLMN code included in the IMSI if the EHPLMN list is not present or is empty. If the EHPLMN list is present then this data field is applicable to all the entries within the EHPLMN list.

NOTE 2: Different GSM frequency bands (e.g. 900, 1800, 1900, 400) are all considered GSM access technology. An MS supporting more than one band should scan all the bands it supports when scanning for GSM frequencies. However GSM COMPACT systems which use GSM frequency bands but with the CBPCCCH broadcast channel are considered as a separate access technology from GSM.

NOTE 3: The inclusion of the HPLMN derived from the IMSI in the EHPLMN list is allowed. The priority of the HPLMN derived from the IMSI is given by its position in the EHPLMN list, see 3GPP TS 31.102 [40]

[TS 38.304, clause 5.2.4.6]

The cell-ranking criterion R_s for serving cell and R_n for neighbouring cells is defined by:

$$R_s = Q_{\text{meas},s} + Q_{\text{hyst}} - Q_{\text{offset}_{\text{temp}}}$$

$$R_n = Q_{\text{meas},n} - Q_{\text{offset}} - Q_{\text{offset}_{\text{temp}}}$$

where:

Q_{meas}	RSRP measurement quantity used in cell reselections.
Q_{offset}	For intra-frequency: Equals to $Q_{offset_{s,n}}$, if $Q_{offset_{s,n}}$ is valid, otherwise this equals to zero. For inter-frequency: Equals to $Q_{offset_{s,n}}$ plus $Q_{offset_{frequency}}$, if $Q_{offset_{s,n}}$ is valid, otherwise this equals to $Q_{offset_{frequency}}$.
$Q_{offset_{temp}}$	Offset temporarily applied to a cell as specified in TS 38.331 [3].

The UE shall perform ranking of all cells that fulfil the cell selection criterion S, which is defined in 5.2.3.2.

The cells shall be ranked according to the R criteria specified above by deriving $Q_{meas,n}$ and $Q_{meas,s}$ and calculating the R values using averaged RSRP results.

If *rangeToBestCell* is not configured, the UE shall perform cell reselection to the highest ranked cell. If this cell is found to be not-suitable, the UE shall behave according to subclause 5.2.4.4.

If *rangeToBestCell* is configured, then the UE shall perform cell reselection to the cell with the highest number of beams above the threshold (i.e. *absThreshSS-BlocksConsolidation*) among the cells whose R value is within *rangeToBestCell* of the R value of the highest ranked cell. If there are multiple such cells, the UE shall perform cell reselection to the highest ranked cell among them. If this cell is found to be not-suitable, the UE shall behave according to subclause 5.2.4.4.

In all cases, the UE shall reselect the new cell, only if the following conditions are met:

- the new cell is better ranked than the serving cell during a time interval $T_{reselection_{RAT}}$;
- more than 1 second has elapsed since the UE camped on the current serving cell.

6.1.2.15.3 Test description

6.1.2.15.3.1 Pre-test conditions

System Simulator:

- NR Cell 1 (HPLMN)
- NR Cell 11 (primary PLMN: same MCC like HPLMN but different MNC, secondary PLMN: HPLMN)
- System information combination NR-3 as defined in TS 38.508-1 [4] clause 4.4.3.1.3 is used in NR Cells.

UE:

- None.

Preamble:

- The UE is in NR RRC Idle mode (state 1N-A) on NR Cell 1 according to 38.508-1 [4] Table 4.4A.2-1

6.1.2.15.3.2 Test procedure sequence

Table 6.1.2.15.3.2-1/2 illustrate the downlink power levels and other changing parameters to be applied for the cell at various time instants of the test execution. The exact instants on which these values shall be applied are described in the texts in this clause. Row marked "T0" denotes the conditions after the preamble. Configurations marked "T1" is applied at the points indicated in the Main behaviour description in Table 6.1.2.15.3.2-3.

Table 6.1.2.15.3.2-1: Time instances of cell power level and parameter changes for FR1

	Parameter	Unit	NR Cell 1	NR Cell 11	Remark
T0	SS/PBCH SSS EPRE	dBm/ SCS	-88	Off	
T1	SS/PBCH SSS EPRE	dBm/ SCS	-88	-75	The power level values are assigned to satisfy $Srxlev_{NRCell\ 11} > Srxlev_{NRCell\ 1}$

Table 6.1.2.15.3.2-2: Time instances of cell power level and parameter changes for FR2

	Parameter	Unit	NR Cell 1	NR Cell 11	Remark
T0	SS/PBCH SSS EPRE	dBm/ SCS	FFS	Off	
T1	SS/PBCH SSS EPRE	dBm/ SCS	FFS	FFS	The power level values are assigned to satisfy SrxleVNRCell 11 > SrxleVNRCell 1

Table 6.1.2.15.3.2-3: Main behaviour

St	Procedure	Message Sequence		TP	Verdict
		U - S	Message		
1	SS adjusts the SS/PBCH EPRE level of NR Cell 1 and NR Cell 11 according to row "T1" in table 6.1.2.1.3.2-1/2.	-	-	-	-
2	Check: Does the UE transmit an <i>RRCSetupRequest</i> message on NR Cell 11?	-->	NR RRC: <i>RRCSetupRequest</i>	1	P
3	The SS transmits an <i>RRCSetup</i> message.	<--	NR RRC: <i>RRCSetup</i>	-	-
4	Check; Does the UE transmit an <i>RRCSetupComplete</i> message indicating the HPLMN (second PLMN in the list)? Note: this message contains an REGISTRATION REQUEST message indicating "mobility registration updating" to update the registration of the actual tracking area according to default message contents.	-->	NR RRC: <i>RRCSetupComplete</i>	1	P
5 - 7	Steps 4 to 6 of the registration procedure described in TS 38.508-1 [4] Table 4.9.5.2.2-1 are performed on NR Cell 11.	-	-	-	-

6.1.2.15.3.3 Specific message contents

Table 6.1.2.15.3.3-1: SIB1 for NR Cell 1 (Preamble and all steps, Table 6.1.2.15.3.2-3)

Derivation Path: TS 38.508-1 [4], Table 4.6.1-28			
Information Element	Value/remark	Comment	Condition
SIB1 ::= SEQUENCE {			
cellAccessRelatedInfo SEQUENCE {			
plmn-IdentityList SEQUENCE (SIZE (1..maxPLMN)) OF PLMN-Identity {			
plmn-Identity[1]	Set to the same Mobile Country Code and Mobile Network Code stored in EF _{IMSI} on the test USIM card		
}			
}			
}			

Table 6.1.2.15.3.3-2: SIB1 for NR Cell 11 (Preamble and all steps, Table 6.1.2.15.3.2-3)

Derivation Path: TS 38.508-1 [4], Table 4.6.1-28			
Information Element	Value/Remark	Comment	Condition
SIB1 ::= SEQUENCE {			
cellAccessRelatedInfo SEQUENCE {			
plmn-IdentityList SEQUENCE (SIZE (1..maxPLMN)) OF PLMN-Identity {			
plmn-Identity[1]	Set to the same Mobile Country Code stored in EFIMSI on the test USIM, MNC=02	Same MCC like PLMN for NR Cell 1 but different MNC	
plmn-Identity[2]	Set to the same Mobile Country Code and Mobile Network Code stored in EFIMSI on the test USIM card	This is the same PLMN as NR Cell 1	
}			
}			
}			

Table 6.1.2.15.3.3-3: RRCSetupComplete (step 4, Table 6.1.2.15.3.2-3)

Derivation Path: TS 38.508-1 [4], Table 4.6.1-22			
Information Element	Value/remark	Comment	Condition
RRCSetupComplete ::= SEQUENCE {			
criticalExtensions CHOICE {			
rrcSetupComplete SEQUENCE {			
selectedPLMN-Identity	2	HPLMN	
}			
}			
}			

6.1.2.16

6.1.2.17 Cell reselection / Cell-specific reselection parameters provided by the network in a neighbouring cell list

6.1.2.17.1 Test Purpose (TP)

(1)

```
with { the UE is in NR RRC_IDLE and SystemInformationBlockType3 contain a cell-specific Qoffset for a neighbour intra frequency cell }
ensure that {
  when { the neighbour cell has lower power than the serving cell but it is higher ranked due to the cell-specific Qoffset }
  then { the UE reselects the neighbour cell with cell-specific Qoffset }
}
```

(2)

```
with { the UE is in RRC_IDLE and SystemInformationBlockType3 contain a black listed cell }
ensure that {
  when { a black listed intra-freq cell becomes higher ranked than the serving cell }
  then { the UE remains camped on the serving cell }
}
```

6.1.2.17.2 Conformance requirements

References: The conformance requirements covered in the present TC are specified in: 3GPP TS 38.304, clause 5.2.4.6. Unless otherwise stated these are Rel-15 requirements.

[TS 38.304, clause 5.2.4.6]

The cell-ranking criterion R_s for serving cell and R_n for neighbouring cells is defined by:

$$R_s = Q_{\text{meas},s} + Q_{\text{hyst}} - Q_{\text{offset,temp}}$$

$$R_n = Q_{\text{meas},n} - Q_{\text{offset}} - Q_{\text{offset,temp}}$$

where:

Q_{meas}	RSRP measurement quantity used in cell reselections.
Q_{offset}	For intra-frequency: Equals to $Q_{\text{offset},s,n}$, if $Q_{\text{offset},s,n}$ is valid, otherwise this equals to zero. For inter-frequency: Equals to $Q_{\text{offset},s,n}$ plus $Q_{\text{offset,frequency}}$, if $Q_{\text{offset},s,n}$ is valid, otherwise this equals to $Q_{\text{offset,frequency}}$.
$Q_{\text{offset,temp}}$	Offset temporarily applied to a cell as specified in TS 38.331 [3].

The UE shall perform ranking of all cells that fulfil the cell selection criterion S , which is defined in 5.2.3.2.

The cells shall be ranked according to the R criteria specified above by deriving $Q_{\text{meas},n}$ and $Q_{\text{meas},s}$ and calculating the R values using averaged RSRP results.

If *rangeToBestCell* is not configured, the UE shall perform cell reselection to the highest ranked cell. If this cell is found to be not-suitable, the UE shall behave according to subclause 5.2.4.4.

If *rangeToBestCell* is configured, then the UE shall perform cell reselection to the cell with the highest number of beams above the threshold (i.e. *absThreshSS-BlocksConsolidation*) among the cells whose R value is within *rangeToBestCell* of the R value of the highest ranked cell. If there are multiple such cells, the UE shall perform cell reselection to the highest ranked cell among them. If this cell is found to be not-suitable, the UE shall behave according to subclause 5.2.4.4.

In all cases, the UE shall reselect the new cell, only if the following conditions are met:

- the new cell is better ranked than the serving cell during a time interval $T_{\text{reselection,RAT}}$;
- more than 1 second has elapsed since the UE camped on the current serving cell.

6.1.2.17.3 Test description

6.1.2.17.3.1 Pre-test conditions

System Simulator:

- NR Cell 1, NR Cell 2 and NR Cell 4 in different tracking areas.
- System information combination NR-3 as defined in TS 38.508-1 [4] clause 4.4.3.1.3 is used in NR Cells.
- NR Cell 1 is transmitting *SIB3* according to specific message contents ($Q_{\text{offset},1,2}$ is -24dB).
- NR Cell 2 is transmitting *SIB3* according to specific message contents (NR Cell 4 is on black list)

UE:

None.

Preamble:

- The UE is in NR RRC Idle mode (state 1N-A) on NR Cell 1 (according to 38.508-1 [4] Table 4.4A.2-1).

6.1.2.17.3.2 Test procedure sequence

Table 6.1.2.15.3.2-1/2 illustrate the downlink power levels and other changing parameters to be applied for the cell at various time instants of the test execution. The exact instants on which these values shall be applied are described in the

texts in this clause. Row marked "T0" denotes the conditions after the preamble. Configurations marked "T1", "T2" and "T3" are applied at the points indicated in the Main behaviour description in Table 6.1.2.15.3.2-3.

Table 6.1.2.17.3.2-1: Time instances of cell power level and parameter changes for FR1

	Parameter	Unit	NR Cell 1	NR Cell 2	NR Cell 4	Remark
T0	SS/PBCH SSS EPRE	dBm/ SCS	-88	Off	Off	Only NR Cell 1 is on
T1	SS/PBCH SSS EPRE	dBm/ SCS	-88	-94	Off	NR Cell 2 has lower power but is higher ranked due to cell-specific Qoffset _{1,2}
T2	SS/PBCH SSS EPRE	dBm/ SCS	Off	-94	Off	
T3	SS/PBCH SSS EPRE	dBm/ SCS	Off	-94	-88	NR Cell 4 has higher power than NRCell 2 but is black listed

Table 6.1.2.17.3.2-2: Time instances of cell power level and parameter changes for FR2

	Parameter	Unit	NR Cell 1	NR Cell 2	NR Cell 4	Remark
T0	SS/PBCH SSS EPRE	dBm/ SCS	FFS	Off	Off	Only NR Cell 1 is on
T1	SS/PBCH SSS EPRE	dBm/ SCS	FFS	FFS	Off	NR Cell 2 has lower power but is higher ranked due to cell-specific Qoffset _{1,2}
T2	SS/PBCH SSS EPRE	dBm/ SCS	Off	FFS	Off	
T3	SS/PBCH SSS EPRE	dBm/ SCS	Off	FFS	FFS	NR Cell 4 has higher power than NRCell 2 but is black listed

Table 6.1.2.17.3.2-3: Main behaviour

St	Procedure	Message Sequence		TP	Verdict
		U - S	Message		
1	The SS adjusts the SS/PBCH EPRE levels according to row "T1" in table 6.1.2.17.3.2-1/2.	-	-	-	-
2-6	Check: Does the test result of test steps 1 to 5 of generic test procedure in TS 38.508-1 [4] Table 4.9.5.2.2-1 indicate that the UE is camped on NR Cell 2?	-	-	1	P
7	The SS re-adjusts the SS/PBCH EPRE levels according to row "T2" in table 6.1.2.17.3.2-1/2.	-	-	-	-
8	Wait for 1 second to allow UE to recognise the change.	-	-	-	-
9	The SS transmits an <i>RRCRelease</i> message to release RRC connection and move to RRC_IDLE.	<--	NR RRC: <i>RRCRelease</i>	-	-
10	The SS re-adjusts the SS/PBCH EPRE levels according to row "T3" in table 6.1.2.17.3.2-1/2.	-	-	-	-
11	Check: Does the UE initiate a random access procedure on NR Cell 4 within the next 120s?	-	-	2	F

6.1.2.17.3.3 Specific message contents

Table 6.1.2.17.3.3-1: SIB3 for NR Cell 1 (all steps, Table 6.1.2.17.3.2-3)

Derivation Path: TS 38.508-1 [4], Table 4.6.2-2			
Information Element	Value/Remark	Comment	Condition
SIB3 ::= SEQUENCE {			
intraFreqNeighCellList SEQUENCE {			
physCellId	The cell identity of NR Cell 2 defined in 38.508-1 [4] clause 4.4.2		
q-OffsetCell	dB-24		
}			
}			

Table 6.1.2.17.3.3-2: SIB3 for NR Cell 2 (all steps, Table 6.1.2.17.3.2-3)

Derivation Path: TS 38.508-1 [4], Table 4.6.2-2			
Information Element	Value/Remark	Comment	Condition
SIB3 ::= SEQUENCE {			
intraFreqBlackCellList SEQUENCE {	1 entry		
start	PhysicalCellID of NR Cell 4		
range	Not present		
}			
}			

6.1.2.18

6.1.2.19

6.1.2.20 Inter-frequency cell reselection according to cell reselection priority provided by SIBs

6.1.2.20.1 Test Purpose (TP)

(1)

```
with { UE in NR RRC_IDLE state }
ensure that {
  when { UE detects the cell re-selection criteria are met for the cell which belongs to the equal
priority frequency }
  then { UE reselects the cell which belongs to the equal priority frequency }
}
```

(2)

```
with { UE in NR RRC_IDLE state }
ensure that {
  when { UE detects the cell re-selection criteria are met for the cell which belongs to the higher
priority frequency }
  then { UE reselects the cell which belongs to the higher priority frequency }
}
```

(3)

```
with { UE in NR RRC_IDLE state }
ensure that {
  when { UE detects the cell re-selection criteria are met for the cell which belongs to the lower
priority frequency }
  then { UE reselects the cell which belongs to the lower priority frequency }
}
```

6.1.2.20.2 Conformance requirements

References: The conformance requirements covered in the present TC are specified in TS 38.304: clause 5.2.4.1, 5.2.4.2, 5.2.4.5 and 5.2.4.6. Unless otherwise stated these are Rel-15 requirements.

[TS 38.304, clause 5.2.4.1]

Absolute priorities of different NR frequencies or inter-RAT frequencies may be provided to the UE in the system information, in the *RRCRelease* message, or by inheriting from another RAT at inter-RAT cell (re)selection. In the case of system information, an NR frequency or inter-RAT frequency may be listed without providing a priority (i.e. the field *cellReselectionPriority* is absent for that frequency). If priorities are provided in dedicated signalling, the UE shall ignore all the priorities provided in system information. If UE is in *camped on any cell* state, UE shall only apply the priorities provided by system information from current cell, and the UE preserves priorities provided by dedicated signalling and *deprioritisationReq* received in *RRCRelease* unless specified otherwise. When the UE in *camped normally* state, has only dedicated priorities other than for the current frequency, the UE shall consider the current frequency to be the lowest priority frequency (i.e. lower than any of the network configured values).

The UE shall only perform cell reselection evaluation for NR frequencies and inter-RAT frequencies that are given in system information and for which the UE has a priority provided.

In case UE receives *RRCRelease* with *deprioritisationReq*, UE shall consider current frequency and stored frequencies due to the previously received *RRCRelease* with *deprioritisationReq* or all the frequencies of NR to be the lowest priority frequency (i.e. lower than any of the network configured values) while T325 is running irrespective of *camped* RAT. The UE shall delete the stored deprioritisation request(s) when a PLMN selection is performed on request by NAS (TS 23.122 [9]).

NOTE: UE should search for a higher priority layer for cell reselection as soon as possible after the change of priority. The minimum related performance requirements specified in TS 38.133 [8] are still applicable.

The UE shall delete priorities provided by dedicated signalling when:

- the UE enters a different RRC state; or
- the optional validity time of dedicated priorities (T320) expires; or
- a PLMN selection is performed on request by NAS (TS 23.122 [9]).

NOTE 2: Equal priorities between RATs are not supported.

The UE shall not consider any black listed cells as candidate for cell reselection.

The UE shall inherit the priorities provided by dedicated signalling and the remaining validity time (i.e. T320 in NR and E-UTRA), if configured, at inter-RAT cell (re)selection.

NOTE 3: The network may assign dedicated cell reselection priorities for frequencies not configured by system information.

[TS 38.304, clause 5.2.4.2]

Following rules are used by the UE to limit needed measurements:

- If the serving cell fulfils $S_{rxlev} > S_{IntraSearchP}$ and $S_{qual} > S_{IntraSearchQ}$, the UE may choose not to perform intra-frequency measurements.
- Otherwise, the UE shall perform intra-frequency measurements.
- The UE shall apply the following rules for NR inter-frequencies and inter-RAT frequencies which are indicated in system information and for which the UE has priority provided as defined in 5.2.4.1:
 - For a NR inter-frequency or inter-RAT frequency with a reselection priority higher than the reselection priority of the current NR frequency, the UE shall perform measurements of higher priority NR inter-frequency or inter-RAT frequencies according to TS 38.133 [8].

- For a NR inter-frequency with an equal or lower reselection priority than the reselection priority of the current NR frequency and for inter-RAT frequency with lower reselection priority than the reselection priority of the current NR frequency:
 - If the serving cell fulfils $S_{rxlev} > S_{nonIntraSearchP}$ and $S_{qual} > S_{nonIntraSearchQ}$, the UE may choose not to perform measurements of NR inter-frequencies or inter-RAT frequency cells of equal or lower priority;
 - Otherwise, the UE shall perform measurements of NR inter-frequencies or inter-RAT frequency cells of equal or lower priority according to TS 38.133 [8].

[TS 38.304, clause 5.2.4.5]

If *threshServingLowQ* is broadcast in system information and more than 1 second has elapsed since the UE camped on the current serving cell, cell reselection to a cell on a higher priority NR frequency or inter-RAT frequency than the serving frequency shall be performed if:

- A cell of a higher priority NR or EUTRAN RAT/frequency fulfils $S_{qual} > Thresh_{X, HighQ}$ during a time interval $T_{reselection_{RAT}}$

Otherwise, cell reselection to a cell on a higher priority NR frequency or inter-RAT frequency than the serving frequency shall be performed if:

- A cell of a higher priority RAT/ frequency fulfils $S_{rxlev} > Thresh_{X, HighP}$ during a time interval $T_{reselection_{RAT}}$; and
- More than 1 second has elapsed since the UE camped on the current serving cell.

Cell reselection to a cell on an equal priority NR frequency shall be based on ranking for intra-frequency cell reselection as defined in sub-clause 5.2.4.6.

If *threshServingLowQ* is broadcast in system information and more than 1 second has elapsed since the UE camped on the current serving cell, cell reselection to a cell on a lower priority NR frequency or inter-RAT frequency than the serving frequency shall be performed if:

- The serving cell fulfils $S_{qual} < Thresh_{Serving, LowQ}$ and a cell of a lower priority NR or E-UTRAN RAT/ frequency fulfils $S_{qual} > Thresh_{X, LowQ}$ during a time interval $T_{reselection_{RAT}}$.

Otherwise, cell reselection to a cell on a lower priority NR frequency or inter-RAT frequency than the serving frequency shall be performed if:

- The serving cell fulfils $S_{rxlev} < Thresh_{Serving, LowP}$ and a cell of a lower priority RAT/ frequency fulfils $S_{rxlev} > Thresh_{X, LowP}$ during a time interval $T_{reselection_{RAT}}$; and
- More than 1 second has elapsed since the UE camped on the current serving cell.

Cell reselection to a higher priority RAT/frequency shall take precedence over a lower priority RAT/frequency if multiple cells of different priorities fulfil the cell reselection criteria.

If more than one cell meets the above criteria, the UE shall reselect a cell as follows:

- If the highest-priority frequency is an NR frequency, the highest ranked cell among the cells on the highest priority frequency(ies) meeting the criteria according to clause 5.2.4.6;
- If the highest-priority frequency is from another RAT, the highest ranked cell among the cells on the highest priority frequency(ies) meeting the criteria of that RAT.

[TS 38.304, clause 5.2.4.6]

The cell-ranking criterion R_s for serving cell and R_n for neighbouring cells is defined by:

$$R_s = Q_{meas,s} + Q_{hyst} - Q_{offset_{temp}}$$

$$R_n = Q_{meas,n} - Q_{offset} - Q_{offset_{temp}}$$

where:

Q_{meas}	RSRP measurement quantity used in cell reselections.
Q_{offset}	For intra-frequency: Equals to $Q_{offset_{s,n}}$, if $Q_{offset_{s,n}}$ is valid, otherwise this equals to zero. For inter-frequency: Equals to $Q_{offset_{s,n}}$ plus $Q_{offset_{frequency}}$, if $Q_{offset_{s,n}}$ is valid, otherwise this equals to $Q_{offset_{frequency}}$.
$Q_{offset_{temp}}$	Offset temporarily applied to a cell as specified in TS 38.331 [3].

The UE shall perform ranking of all cells that fulfil the cell selection criterion S, which is defined in 5.2.3.2.

The cells shall be ranked according to the R criteria specified above by deriving $Q_{meas,n}$ and $Q_{meas,s}$ and calculating the R values using averaged RSRP results.

If *rangeToBestCell* is not configured, the UE shall perform cell reselection to the highest ranked cell. If this cell is found to be not-suitable, the UE shall behave according to subclause 5.2.4.4.

If *rangeToBestCell* is configured, then the UE shall perform cell reselection to the cell with the highest number of beams above the threshold (i.e. *absThreshSS-BlocksConsolidation*) among the cells whose R value is within *rangeToBestCell* of the R value of the highest ranked cell. If there are multiple such cells, the UE shall perform cell reselection to the highest ranked cell among them. If this cell is found to be not-suitable, the UE shall behave according to subclause 5.2.4.4.

In all cases, the UE shall reselect the new cell, only if the following conditions are met:

- the new cell is better than the serving cell according to the cell reselection criteria specified above during a time interval $T_{reselection_{RAT}}$;
- more than 1 second has elapsed since the UE camped on the current serving cell.

6.1.2.20.3 Test description

6.1.2.20.3.1 Pre-test conditions

System Simulator:

- NR Cell 1, NR Cell 3 and NR Cell 6.
- System information combination NR-4 as defined in TS 38.508-1 [4] Table 4.4.3.1.2-1 is used in NR cells.

UE:

None.

Preamble:

- The UE is in state 1N-A on NR Cell 1(serving cell) according to TS 38.508-1 [4] Table 4.4A.2-1.

6.1.2.20.3.2 Test procedure sequence

Table 6.1.2.20.3.2-1/2 illustrates the downlink power levels and other changing parameters to be applied for the NR cells at various time instants of the test execution. The exact instants on which these values shall be applied are described in the texts in this clause. The configuration "T0" indicates the initial conditions. Subsequent configurations marked "T1", "T2" and "T3" are applied at the points indicated in the Main behaviour description in Table 6.1.2.20.3.2-3.

Table 6.1.2.20.3.2-1: Time instances of cell power level and parameter changes for FR1

	Parameter	Unit	NR Cell 1	NR Cell 3	NR Cell 6	Remark
T0	SS/PBCH SSS EPRE	dBm/SCS	-88	Off	Off	The power level values are assigned to ensure the UE registered on NR Cell 1.
T1	SS/PBCH SSS EPRE	dBm/SCS	-88	-76	Off	The power level values are assigned to satisfy $R_{NR\ Cell\ 1} < R_{NR\ Cell\ 3}$.
T2	SS/PBCH SSS EPRE	dBm/SCS	Off	-76	-76	The power level values are assigned to satisfy $Srxlev_{NR\ Cell\ 1} < 0$ and $Srxlev_{NR\ Cell\ 6} > Thresh_{NR\ Cell\ 6, high}$.
T3	SS/PBCH SSS EPRE	dBm/SCS	Off	-76	-98	The power level values are assigned to satisfy $Srxlev_{NR\ Cell\ 6} < Thresh_{serving, low}$ and $Srxlev_{NR\ Cell\ 3} > Thresh_{NR\ Cell\ 3, low}$, $Srxlev_{NR\ Cell\ 1} < 0$.
Note: Power level "Off" is defined in TS38.508-1 [4] Table 6.2.2.1-3.						

Table 6.1.2.20.3.2-2: Time instances of cell power level and parameter changes for FR2

	Parameter	Unit	NR Cell 1	NR Cell 3	NR Cell 6	Remark
T0	SS/PBCH SSS EPRE	dBm/SCS	FFS	Off	Off	The power level values are assigned to ensure the UE registered on NR Cell 1.
T1	SS/PBCH SSS EPRE	dBm/SCS	FFS	FFS	Off	The power level values are assigned to satisfy $R_{NR\ Cell\ 1} < R_{NR\ Cell\ 3}$.
T2	SS/PBCH SSS EPRE	dBm/SCS	Off	FFS	FFS	The power level values are assigned to satisfy $Srxlev_{NR\ Cell\ 1} < 0$ and $Srxlev_{NR\ Cell\ 6} > Thresh_{NR\ Cell\ 6, high}$.
T3	SS/PBCH SSS EPRE	dBm/SCS	Off	FFS	FFS	The power level values are assigned to satisfy $Srxlev_{NR\ Cell\ 6} < Thresh_{serving, low}$ and $Srxlev_{NR\ Cell\ 3} > Thresh_{NR\ Cell\ 3, low}$, $Srxlev_{NR\ Cell\ 1} < 0$.
Note: The uncertain downlink signal level is specified in TS 38.508-1[4] section FFS.						

Table 6.1.2.20.3.2-3: Main behaviour

St	Procedure	Message Sequence		TP	Verdict
		U - S	Message		
1	The SS changes NR Cell 3 SS PBCH SSS EPRE level according to the row "T1" in table 6.1.2.20.3.2-1/2.	-	-	-	-
2	Wait for 1 second to allow UE to recognise the change.	-	-	-	-
3	Check: Does the test result of generic test procedure in TS 38.508-1 [4] Table 4.9.4-1 indicate that the UE is camped on NR Cell 3?	-	-	1	-
4	The SS changes NR Cell 1 and NR Cell 6 SSS levels according to the row "T2" in table 6.1.2.20.3.2-1/2.	-	-	-	-
5	Wait for 1 second to allow UE to recognise the change.	-	-	-	-
6	Check: Does the test result of generic test procedure in TS 38.508-1 [4] Table 4.9.4-1 indicate that the UE is camped on NR Cell 6?	-	-	2	-
7	The SS changes NR Cell 6 SSS level according to the row "T3" in table 6.1.2.20.3.2-1/2.	-	-	-	-
8	Wait for 1 second to allow UE to recognise the change.	-	-	-	-
9	Check: Does the test result of generic test procedure in TS 38.508-1 [4] Table 4.9.4-1 indicate that the UE is camped on NR Cell 3?	-	-	3	-

6.1.2.20.3.3 Specific message contents

Table 6.1.2.20.3.3-1: Conditions for specific message contents in Tables below

Condition	Explanation
NR Cell 1	This condition applies to system information transmitted on NR Cell 1.
NR Cell 3	This condition applies to system information transmitted on NR Cell 3.
NR Cell 6	This condition applies to system information transmitted on NR Cell 6.

Table 6.1.2.20.3.3-2: SIB2 of NR Cell 6 (preamble and all steps, Table 6.1.2.20.3.2-3)

Derivation Path: TS 38.508-1 [4], Table 4.6.2-1			
Information Element	Value/remark	Comment	Condition
SIB2 ::= SEQUENCE {			
cellReselectionServingFreqInfo			
SEQUENCE {			
threshServingLowP	10	20 dB	
cellReselectionPriority	5		
}			
}			

Table 6.1.2.20.3.3-3: SIB4 of NR Cell 1, NR Cell 3 and NR Cell 6 (preamble and all steps, Table 6.1.2.20.3.2-3)

Derivation Path: TS 38.508-1 [4], Table 4.6.2-3			
Information Element	Value/remark	Comment	Condition
SIB4 ::= SEQUENCE {			
interFreqCarrierFreqList SEQUENCE	2 entry		
SIZE (1..maxFreq) OF SEQUENCE {			
dl-CarrierFreq[1]	Same downlink ARFCN as used for NR Cell 6		NR Cell 1
	Same downlink ARFCN as used for NR Cell 6		NR Cell 3
	Same downlink ARFCN as used for NR Cell 3		NR Cell 6
threshX-HighP[1]	10	20 dB	NR Cell 3
cellReselectionPriority[1]	5		NR Cell 1
	5		NR Cell 3
dl-CarrierFreq[2]	Same downlink ARFCN as used for NR Cell 3		NR Cell 1
cellReselectionPriority[2]	4		NR Cell 1
}			
}			

6.1.2.21 Cell reselection, S_{Intra} SearchQ and S_{nonIntra} SearchQ

6.1.2.21.1 Test Purpose (TP)

(1)

```
with { UE in NR RRC_IDLE state, and the UE is not in high mobility state }
ensure that {
  when { SIntraSearchQ is non-zero in system information }
  then { UE perform measurement and reselects the highest ranked cell upon Squal < SIntraSearchQ }
}
```

(2)

```
with { UE in NR RRC_IDLE state, and the UE is not in high mobility state }
ensure that {
  when { SnonIntraSearchQ is non-zero in system information }
```

```

    then { UE perform measurement and reselects the cell which belong to the equal priority
frequency cell upon  $S_{qual} < S_{nonIntraSearchQ}$  }
    }

```

(3)

```

with { UE in NR RRC_IDLE state, and the UE is not in high mobility state }
ensure that {
    when {  $S_{nonIntraSearchQ}$  is non-zero in system information }
    then { UE perform measurement and reselects the cell which belong to the high priority frequency
cell upon  $S_{qual} > S_{nonIntraSearchQ}$  }
}

```

6.1.2.21.2 Conformance requirements

References: The conformance requirements covered in the present TC are specified in TS 38.304: clause 5.2.4.1, 5.2.4.2, 5.2.4.5, 5.2.4.6 and 5.2.4.7. Unless otherwise stated these are Rel-15 requirements.

[TS 38.304, clause 5.2.4.1]

Absolute priorities of different NR frequencies or inter-RAT frequencies may be provided to the UE in the system information, in the *RRCRelease* message, or by inheriting from another RAT at inter-RAT cell (re)selection. In the case of system information, an NR frequency or inter-RAT frequency may be listed without providing a priority (i.e. the field *cellReselectionPriority* is absent for that frequency). If priorities are provided in dedicated signalling, the UE shall ignore all the priorities provided in system information. If UE is in *camped on any cell* state, UE shall only apply the priorities provided by system information from current cell, and the UE preserves priorities provided by dedicated signalling and *deprioritisationReq* received in *RRCRelease* unless specified otherwise. When the UE in *camped normally* state, has only dedicated priorities other than for the current frequency, the UE shall consider the current frequency to be the lowest priority frequency (i.e. lower than any of the network configured values).

The UE shall only perform cell reselection evaluation for NR frequencies and inter-RAT frequencies that are given in system information and for which the UE has a priority provided.

In case UE receives *RRCRelease* with *deprioritisationReq*, UE shall consider current frequency and stored frequencies due to the previously received *RRCRelease* with *deprioritisationReq* or all the frequencies of NR to be the lowest priority frequency (i.e. lower than any of the network configured values) while T325 is running irrespective of *camped RAT*. The UE shall delete the stored deprioritisation request(s) when a PLMN selection is performed on request by NAS (TS 23.122 [9]).

NOTE: UE should search for a higher priority layer for cell reselection as soon as possible after the change of priority. The minimum related performance requirements specified in TS 38.133 [8] are still applicable.

The UE shall delete priorities provided by dedicated signalling when:

- the UE enters a different RRC state; or
- the optional validity time of dedicated priorities (T320) expires; or
- a PLMN selection is performed on request by NAS (TS 23.122 [9]).

NOTE 2: Equal priorities between RATs are not supported.

The UE shall not consider any black listed cells as candidate for cell reselection.

The UE shall inherit the priorities provided by dedicated signalling and the remaining validity time (i.e. T320 in NR and E-UTRA), if configured, at inter-RAT cell (re)selection.

NOTE 3: The network may assign dedicated cell reselection priorities for frequencies not configured by system information.

[TS 38.304, clause 5.2.4.2]

Following rules are used by the UE to limit needed measurements:

- If the serving cell fulfils $S_{rxlev} > S_{intraSearchP}$ and $S_{qual} > S_{intraSearchQ}$, the UE may choose not to perform intra-frequency measurements.

- Otherwise, the UE shall perform intra-frequency measurements.
- The UE shall apply the following rules for NR inter-frequencies and inter-RAT frequencies which are indicated in system information and for which the UE has priority provided as defined in 5.2.4.1:
 - For a NR inter-frequency or inter-RAT frequency with a reselection priority higher than the reselection priority of the current NR frequency, the UE shall perform measurements of higher priority NR inter-frequency or inter-RAT frequencies according to TS 38.133 [8].
 - For a NR inter-frequency with an equal or lower reselection priority than the reselection priority of the current NR frequency and for inter-RAT frequency with lower reselection priority than the reselection priority of the current NR frequency:
 - If the serving cell fulfils $S_{rxlev} > S_{nonIntraSearchP}$ and $S_{qual} > S_{nonIntraSearchQ}$, the UE may choose not to perform measurements of NR inter-frequencies or inter-RAT frequency cells of equal or lower priority;
 - Otherwise, the UE shall perform measurements of NR inter-frequencies or inter-RAT frequency cells of equal or lower priority according to TS 38.133 [8].

[TS 38.304, clause 5.2.4.5]

If *threshServingLowQ* is broadcast in system information and more than 1 second has elapsed since the UE camped on the current serving cell, cell reselection to a cell on a higher priority NR frequency or inter-RAT frequency than the serving frequency shall be performed if:

- A cell of a higher priority NR or EUTRAN RAT/frequency fulfils $S_{qual} > Thresh_{X, HighQ}$ during a time interval $T_{reselection_{RAT}}$

Otherwise, cell reselection to a cell on a higher priority NR frequency or inter-RAT frequency than the serving frequency shall be performed if:

- A cell of a higher priority RAT/ frequency fulfils $S_{rxlev} > Thresh_{X, HighP}$ during a time interval $T_{reselection_{RAT}}$; and
- More than 1 second has elapsed since the UE camped on the current serving cell.

Cell reselection to a cell on an equal priority NR frequency shall be based on ranking for intra-frequency cell reselection as defined in sub-clause 5.2.4.6.

If *threshServingLowQ* is broadcast in system information and more than 1 second has elapsed since the UE camped on the current serving cell, cell reselection to a cell on a lower priority NR frequency or inter-RAT frequency than the serving frequency shall be performed if:

- The serving cell fulfils $S_{qual} < Thresh_{Serving, LowQ}$ and a cell of a lower priority NR or E-UTRAN RAT/ frequency fulfils $S_{qual} > Thresh_{X, LowQ}$ during a time interval $T_{reselection_{RAT}}$.

Otherwise, cell reselection to a cell on a lower priority NR frequency or inter-RAT frequency than the serving frequency shall be performed if:

- The serving cell fulfils $S_{rxlev} < Thresh_{Serving, LowP}$ and a cell of a lower priority RAT/ frequency fulfils $S_{rxlev} > Thresh_{X, LowP}$ during a time interval $T_{reselection_{RAT}}$; and
- More than 1 second has elapsed since the UE camped on the current serving cell.

Cell reselection to a higher priority RAT/frequency shall take precedence over a lower priority RAT/frequency if multiple cells of different priorities fulfil the cell reselection criteria.

If more than one cell meets the above criteria, the UE shall reselect a cell as follows:

- If the highest-priority frequency is an NR frequency, the highest ranked cell among the cells on the highest priority frequency(ies) meeting the criteria according to clause 5.2.4.6;
- If the highest-priority frequency is from another RAT, the highest ranked cell among the cells on the highest priority frequency(ies) meeting the criteria of that RAT.

[TS 38.304, clause 5.2.4.6]

The cell-ranking criterion R_s for serving cell and R_n for neighbouring cells is defined by:

$$R_s = Q_{\text{meas},s} + Q_{\text{hyst}} - Q_{\text{offset,temp}}$$

$$R_n = Q_{\text{meas},n} - Q_{\text{offset}} - Q_{\text{offset,temp}}$$

where:

Q_{meas}	RSRP measurement quantity used in cell reselections.
Q_{offset}	For intra-frequency: Equals to $Q_{\text{offset},s,n}$, if $Q_{\text{offset},s,n}$ is valid, otherwise this equals to zero. For inter-frequency: Equals to $Q_{\text{offset},s,n}$ plus $Q_{\text{offset,frequency}}$, if $Q_{\text{offset},s,n}$ is valid, otherwise this equals to $Q_{\text{offset,frequency}}$.
$Q_{\text{offset,temp}}$	Offset temporarily applied to a cell as specified in TS 38.331 [3].

The UE shall perform ranking of all cells that fulfil the cell selection criterion S , which is defined in 5.2.3.2.

The cells shall be ranked according to the R criteria specified above by deriving $Q_{\text{meas},n}$ and $Q_{\text{meas},s}$ and calculating the R values using averaged RSRP results.

If *rangeToBestCell* is not configured, the UE shall perform cell reselection to the highest ranked cell. If this cell is found to be not-suitable, the UE shall behave according to subclause 5.2.4.4.

If *rangeToBestCell* is configured, then the UE shall perform cell reselection to the cell with the highest number of beams above the threshold (i.e. *absThreshSS-BlocksConsolidation*) among the cells whose R value is within *rangeToBestCell* of the R value of the highest ranked cell. If there are multiple such cells, the UE shall perform cell reselection to the highest ranked cell among them. If this cell is found to be not-suitable, the UE shall behave according to subclause 5.2.4.4.

In all cases, the UE shall reselect the new cell, only if the following conditions are met:

- the new cell is better than the serving cell according to the cell reselection criteria specified above during a time interval $T_{\text{reselection,RAT}}$;
- more than 1 second has elapsed since the UE camped on the current serving cell.

[TS 38.304, clause 5.2.4.7]

5.2.4.7.0 General reselection parameters

Cell reselection parameters are broadcast in system information and are read from the serving cell as follows:

absThreshSS-BlocksConsolidation

This specifies minimum threshold of the beam which can be used for selection of the highest ranked cell, if *rangeToBestCell* is configured.

cellReselectionPriority

This specifies the absolute priority for NR frequency or E-UTRAN frequency.

cellReselectionSubPriority

This specifies the fractional priority value added to *cellReselectionPriority* for NR frequency or E-UTRAN frequency.

$Q_{\text{offset},s,n}$

This specifies the offset between the two cells.

$Q_{\text{offset,frequency}}$

Frequency specific offset for equal priority NR frequencies.

Q_{hyst}

This specifies the hysteresis value for ranking criteria.

Q_{offset,temp}

This specifies the additional offset to be used for cell selection and re-selection. It is temporarily used in case the RRC Connection Establishment fails on the cell as specified in TS 38.331 [3].

Q_{qualmin}

This specifies the minimum required quality level in the cell in dB.

Q_{rxlevmin}

This specifies the minimum required Rx level in the cell in dBm.

Q_{rxlevminoffsetcell}

This specifies the cell specific Rx level offset in dB to Q_{rxlevmin}.

Q_{qualminoffsetcell}

This specifies the cell specific quality level offset in dB to Q_{qualmin}.

rangeToBestCell

This specifies the R value range which the cells whose R value is within the range can be a candidate for the highest ranked cell.

T_{reselection,RAT}

This specifies the cell reselection timer value. For each target NR frequency and for each RAT other than NR, a specific value for the cell reselection timer is defined, which is applicable when evaluating reselection within NR or towards other RAT (i.e. T_{reselection,RAT} for NR is T_{reselection,NR}, for E-UTRAN T_{reselection,EUTRA}).

NOTE: T_{reselection,RAT} is not broadcast in system information but used in reselection rules by the UE for each RAT.

T_{reselection,NR}

This specifies the cell reselection timer value T_{reselection,RAT} for NR. The parameter can be set per NR frequency as specified in TS 38.331 [3].

T_{reselection,EUTRA}

This specifies the cell reselection timer value T_{reselection,RAT} for E-UTRAN.

Thresh_{X, HighP}

This specifies the S_{rxlev} threshold (in dB) used by the UE when reselecting towards a higher priority RAT/ frequency than the current serving frequency. Each frequency of NR and E-UTRAN might have a specific threshold.

Thresh_{X, HighQ}

This specifies the S_{qual} threshold (in dB) used by the UE when reselecting towards a higher priority RAT/ frequency than the current serving frequency. Each frequency of NR and E-UTRAN might have a specific threshold.

Thresh_{X, LowP}

This specifies the S_{rxlev} threshold (in dB) used by the UE when reselecting towards a lower priority RAT/ frequency than the current serving frequency. Each frequency of NR and E-UTRAN might have a specific threshold.

Thresh_{X, LowQ}

This specifies the S_{qual} threshold (in dB) used by the UE when reselecting towards a lower priority RAT/ frequency than the current serving frequency. Each frequency of NR and E-UTRAN might have a specific threshold.

Thresh_{Serving, LowP}

This specifies the S_{rxlev} threshold (in dB) used by the UE on the serving cell when reselecting towards a lower priority RAT/ frequency.

Thresh_{Serving, LowQ}

This specifies the Squal threshold (in dB) used by the UE on the serving cell when reselecting towards a lower priority RAT/ frequency.

S_{IntraSearchP}

This specifies the Srxlev threshold (in dB) for intra-frequency measurements.

S_{IntraSearchQ}

This specifies the Squal threshold (in dB) for intra-frequency measurements.

S_{nonIntraSearchP}

This specifies the Srxlev threshold (in dB) for NR inter-frequency and inter-RAT measurements.

S_{nonIntraSearchQ}

This specifies the Squal threshold (in dB) for NR inter-frequency and inter-RAT measurements.

5.2.4.7.1 Speed dependent reselection parameters

Speed dependent reselection parameters are broadcast in system information and are read from the serving cell as follows:

T_{CRmax}

This specifies the duration for evaluating allowed amount of cell reselection(s).

N_{CR_M}

This specifies the maximum number of cell reselections to enter Medium-mobility state.

N_{CR_H}

This specifies the maximum number of cell reselections to enter High-mobility state.

T_{CRmaxHyst}

This specifies the additional time period before the UE can enter Normal-mobility state.

Speed dependent ScalingFactor for Q_{hyst}

This specifies scaling factor for Q_{hyst} in *sf-High* for High-mobility state and *sf-Medium* for Medium-mobility state.

Speed dependent ScalingFactor for T_{reselectionNR}

This specifies scaling factor for T_{reselectionNR} in *sf-High* for High-mobility state and *sf-Medium* for Medium-mobility state.

Speed dependent ScalingFactor for T_{reselectionEUTRA}

This specifies scaling factor for T_{reselectionEUTRA} in *sf-High* for High-mobility state and *sf-Medium* for Medium-mobility state.

6.1.2.21.3 Test description

6.1.2.21.3.1 Pre-test conditions

System Simulator:

- NR Cell 1, NR Cell 2 and NR Cell 3
- System information combination NR-4 as defined in TS 38.508-1 [4] Table 4.4.3.1.2-1 is used in NR cells.

UE:

None.

Preamble:

- The UE is in state 1N-A on NR Cell 1(serving cell) according to TS 38.508-1 [4] Table 4.4A.2-1.

6.1.2.21.3.2 Test procedure sequence

Table 6.1.2.21.3.2-1/2 illustrates the downlink power levels and other changing parameters to be applied for the NR cells at various time instants of the test execution. The exact instants on which these values shall be applied are described in the texts in this clause. The configuration "T0" indicates the initial conditions. Subsequent configurations marked "T1", "T2", "T3" and "T4" are applied at the points indicated in the Main behaviour description in Table 6.1.2.21.3.2-3.

Table 6.1.2.21.3.2-1: Time instances of cell power level and parameter changes for FR1

	Parameter	Unit	NR Cell 1	NR Cell 2	NR Cell 3	Remark
T0	SS/PBCH SSS EPRE	dBm/SCS	-88	Off	Off	The power level values are assigned to ensure the UE registered on NR Cell 1.
T1	SS/PBCH SSS EPRE	dBm/SCS	-94	-88	-118	Squal of NR Cell 1 is less than $S_{\text{IntraSearchQ}}$.
	RSRQ	dB	-18.38	-12.38	-33.81	
	Q_{rxlevmin}	dBm	-106	-106	-106	
	Qqualmin	dB	-20	-20	-20	
	$S_{\text{IntraSearchQ}}$	dB	20	20	20	
	Noc	dBm/SCS	-95	-95	-95	
	Srxlev	dB	12	18	-12	
Squal	dB	1.62	7.62	-13.81		
T2	SS/PBCH SSS EPRE	dBm/SCS	-118	-94	-88	Squal of NR Cell 2 is less than $S_{\text{nonIntraSearchQ}}$.
	RSRQ	dB	-37.32	-13.32	-11.55	
	$S_{\text{nonIntraSearchQ}}$	dB	20	20	20	
	Srxlev	dB	-12	12	18	
	Squal	dB	-17.32	6.68	8.45	
T3	$S_{\text{nonIntraSearchQ}}$	dB	20	20	2	
T4	SS/PBCH SSS EPRE	dBm/SCS	-88	-118	-88	Squal of NR Cell 3 is greater than $S_{\text{nonIntraSearchQ}}$ but NR Cell 1 is high priority cell.
	RSRQ	dB	-11.55	-41.55	-11.55	
	Srxlev	dB	18	-12	18	
	Squal	dB	8.45	-21.55	8.45	

Note: Power level "Off" is defined in TS38.508-1 [4] Table 6.2.2.1-3.

Table 6.1.2.21.3.2-2: Time instances of cell power level and parameter changes for FR2

	Parameter	Unit	NR Cell 1	NR Cell 2	NR Cell 3	Remark
T0	SS/PBCH SSS EPRE	dBm/SCS	FFS	Off	Off	The power level values are assigned to ensure the UE registered on NR Cell 1.
T1	SS/PBCH SSS EPRE	dBm/SCS	FFS	FFS	FFS	Squal of NR Cell 1 is less than $S_{\text{IntraSearchQ}}$.
	RSRQ	dB	FFS	FFS	FFS	
	Q_{rxlevmin}	dBm	-106	-106	-106	
	Q_{qualmin}	dB	-20	-20	-20	
	$S_{\text{IntraSearchQ}}$	dB	20	20	20	
	Noc	dBm/SCS	FFS	FFS	FFS	
	S_{rxlev}	dB	FFS	FFS	FFS	
Squal	dB	FFS	FFS	FFS		
T2	SS/PBCH SSS EPRE	dBm/SCS	FFS	FFS	FFS	Squal of NR Cell 2 is less than $S_{\text{nonIntraSearchQ}}$.
	RSRQ	dB	FFS	FFS	FFS	
	$S_{\text{nonIntraSearchQ}}$	dB	20	20	20	
	S_{rxlev}	dB	FFS	FFS	FFS	
Squal	dB	FFS	FFS	FFS		
T3	$S_{\text{nonIntraSearchQ}}$	dB	20	20	2	
T4	SS/PBCH SSS EPRE	dBm/SCS	FFS	FFS	FFS	Squal of NR Cell 3 is greater than $S_{\text{nonIntraSearchQ}}$ but NR Cell 1 is high priority cell.
	RSRQ	dB	FFS	FFS	FFS	
	S_{rxlev}	dB	FFS	FFS	FFS	
	Squal	dB	FFS	FFS	FFS	

Note: The uncertain downlink signal level is specified in TS 38.508-1[4] section FFS

Table 6.1.2.21.3.2-3: Main behaviour

St	Procedure	Message Sequence		TP	Verdict
		U - S	Message		
1	The SS re-adjusts the SS/PBCH EPRE levels according to row "T1" in table 6.1.2.21.3.2-1/2.	-	-	-	-
2	Wait for 1 second to allow UE to recognise the change.	-	-	-	-
3	Check: Does the test result of generic test procedure in TS 38.508-1 [4] Table 4.9.4-1 indicate that the UE is camped on NR Cell 2?	-	-	1	-
4	The SS re-adjusts the SSS levels according to row "T2" in table 6.1.2.21.3.2-1/2.	-	-	-	-
5	Wait for 1 second to allow UE to recognise the change.	-	-	-	-
6	Check: Does the test result of generic test procedure in TS 38.508-1 [4] Table 4.9.4-1 indicate that the UE is camped on NR Cell 3?	-	-	2	-
7	The SS notifies the UE of change of System Information on NR Cell 3 by send Short Message on PDCCH using P-RNTI.	<--	NR RRC: <i>Paging</i>	-	-
8	The SS changes the $S_{nonIntraSearchQ}$ for NR Cell 3 according to row "T3" in table 6.1.2.21.3.2-1/2, The <i>ValueTag</i> of <i>SIB2</i> in the SI-SchedulingInfo of <i>SIB1</i> is increased on NR Cell 3.	-	-	-	-
9	Wait for 2.1* modification period to allow the new system information to take effect.	-	-	-	-
10	The SS re-adjusts the SSS levels according to row "T4" in table 6.1.2.21.3.2-1/2.	-	-	-	-
11	Wait for 1 second to allow UE to recognise the change.	-	-	-	-
12	Check: Does the test result of generic test procedure in TS 38.508-1 [4] Table 4.9.4-1 indicate that the UE is camped on NR Cell 1?	-	-	3	-

6.1.2.21.3.3 Specific message contents

Table 6.1.2.21.3.3-1: Conditions for specific message contents in Tables below

Condition	Explanation
NR Cell 1	This condition applies to system information transmitted on NR Cell 1.
NR Cell 2	This condition applies to system information transmitted on NR Cell 2.
NR Cell 3	This condition applies to system information transmitted on NR Cell 3.

Table 6.1.2.21.3.3-2: SIB2 of NR Cell 1, NR Cell 2 and NR Cell 3 (preabmle and all steps, Table 6.1.2.21.3.2-3)

Derivation Path: TS 38.508-1 [4], Table 4.6.2-1			
Information Element	Value/remark	Comment	Condition
SIB2 ::= SEQUENCE {			
cellReselectionServingFreqInfo			
SEQUENCE {			
s-NonIntraSearchP	0	0 dB	
s-NonIntraSearchQ	20 dB		
cellReselectionPriority	5		NR Cell 1
	1		NR Cell 2 and Cell 3
}			
intraFreqCellReselectionInfo SEQUENCE			
{			
s-IntraSearchP	0	0 dB	
s-IntraSearchQ	20 dB		
}			
}			

Table 6.1.2.21.3.3-3: SIB4 of NR Cell 2 and NR Cell 3 (preabmle and all steps, Table 6.1.2.21.3.2-3)

Derivation Path: TS 38.508-1 [4], Table 4.6.2-3			
Information Element	Value/remark	Comment	Condition
SIB4 ::= SEQUENCE {			
interFreqCarrierFreqList SEQUENCE	1 entry		
(SIZE (1..maxFreq)) OF SEQUENCE {			
dl-CarrierFreq[1]	Same downlink ARFCN as used for NR Cell 3		NR Cell 2
	Same downlink ARFCN as used for NR Cell 1		NR Cell 3
t-ReselectionNR[1]	1		
threshX-HighP[1]	7	14 dBm	NR Cell 3
cellReselectionPriority[1]	5		NR Cell 3
	1		NR Cell 2
}			
}			

Table 6.1.2.21.3.3-4: SIB1 of NR Cell 3 (step 8, Table 6.1.2.21.3.2-3)

Derivation Path: TS 38.508-1 [4], Table 4.6.1-28			
Information Element	Value/remark	Comment	Condition
SIB1 ::= SEQUENCE {			
si-SchedulingInfo	SI-SchedulingInfo		
}			

Table 6.1.2.21.3.3-5: SI-SchedulingInfo (si-SchedulingInfo in Table 6.1.2.21.3.3-4)

Derivation Path: TS 38.508-1 [4], Table 4.6.3-173			
Information Element	Value/remark	Comment	Condition
SI-SchedulingInfo ::= SEQUENCE {			
schedulingInfoList SEQUENCE			
(SIZE(1..maxSI-Message)) OF			
SEQUENCE{			
sib-MappingInfo SEQUENCE (SIZE	1 entry		
(1..maxSIB)) OF SEQUENCE {			
type	sibType2		
valueTag	1		
}			
}			
}			

Table 6.1.2.21.3.3-6: SIB2 of NR Cell 3 (step 8, Table 6.1.2.21.3.2-3)

Derivation Path: TS 38.508-1 [4], Table 4.6.2-1			
Information Element	Value/remark	Comment	Condition
SIB2 ::= SEQUENCE {			
cellReselectionServingFreqInfo			
SEQUENCE {			
s-NonIntraSearchQ	2 dB		
}			
}			

6.1.2.22 Inter-frequency cell reselection based on common priority information with parameters $Thresh_{X,HighQ}$, $Thresh_{X,LowQ}$ and $Thresh_{Serving,LowQ}$

6.1.2.22.1 Test Purpose (TP)

(1)

```
with { UE in NR RRC_IDLE state }
ensure that {
  when { UE detects the cell re-selection criteria are met for the cell which belongs to the higher
priority frequency }
  then { UE reselects the cell which belongs to the higher priority frequency }
}
```

(2)

```
with { UE in NR RRC_IDLE state }
ensure that {
  when { UE detects the cell re-selection criteria are met for the cell which belongs to the lower
priority frequency }
  then { UE reselects the cell which belongs to the lower priority frequency }
}
```

6.1.2.22.2 Conformance requirements

References: The conformance requirements covered in the present TC are specified in TS 38.304: clause 5.2.4.5, and 5.2.4.7. Unless otherwise stated these are Rel-15 requirements.

[TS 38.304, clause 5.2.4.5]

If $thresh_{ServingLowQ}$ is broadcast in system information and more than 1 second has elapsed since the UE camped on the current serving cell, cell reselection to a cell on a higher priority NR frequency or inter-RAT frequency than the serving frequency shall be performed if:

- A cell of a higher priority NR or EUTRAN RAT/frequency fulfils $S_{qual} > Thresh_{X, HighQ}$ during a time interval $T_{reselectionRAT}$

Otherwise, cell reselection to a cell on a higher priority NR frequency or inter-RAT frequency than the serving frequency shall be performed if:

- A cell of a higher priority RAT/ frequency fulfils $Srxlev > Thresh_{X, HighP}$ during a time interval $Treselection_{RAT}$; and
- More than 1 second has elapsed since the UE camped on the current serving cell.

Cell reselection to a cell on an equal priority NR frequency shall be based on ranking for intra-frequency cell reselection as defined in sub-clause 5.2.4.6.

If *threshServingLowQ* is broadcast in system information and more than 1 second has elapsed since the UE camped on the current serving cell, cell reselection to a cell on a lower priority NR frequency or inter-RAT frequency than the serving frequency shall be performed if:

- The serving cell fulfils $Squal < Thresh_{Serving, LowQ}$ and a cell of a lower priority NR or E-UTRAN RAT/ frequency fulfils $Squal > Thresh_{X, LowQ}$ during a time interval $Treselection_{RAT}$.

Otherwise, cell reselection to a cell on a lower priority NR frequency or inter-RAT frequency than the serving frequency shall be performed if:

- The serving cell fulfils $Srxlev < Thresh_{Serving, LowP}$ and a cell of a lower priority RAT/ frequency fulfils $Srxlev > Thresh_{X, LowP}$ during a time interval $Treselection_{RAT}$; and
- More than 1 second has elapsed since the UE camped on the current serving cell.

Cell reselection to a higher priority RAT/frequency shall take precedence over a lower priority RAT/frequency if multiple cells of different priorities fulfil the cell reselection criteria.

If more than one cell meets the above criteria, the UE shall reselect a cell as follows:

- If the highest-priority frequency is an NR frequency, the highest ranked cell among the cells on the highest priority frequency(ies) meeting the criteria according to clause 5.2.4.6;
- If the highest-priority frequency is from another RAT, the highest ranked cell among the cells on the highest priority frequency(ies) meeting the criteria of that RAT.

[TS 38.304, clause 5.2.4.7]

5.2.4.7.0 General reselection parameters

Cell reselection parameters are broadcast in system information and are read from the serving cell as follows:

absThreshSS-BlocksConsolidation

This specifies minimum threshold of the beam which can be used for selection of the highest ranked cell, if *rangeToBestCell* is configured.

cellReselectionPriority

This specifies the absolute priority for NR frequency or E-UTRAN frequency.

cellReselectionSubPriority

This specifies the fractional priority value added to *cellReselectionPriority* for NR frequency or E-UTRAN frequency.

Qoffset_{s,n}

This specifies the offset between the two cells.

Qoffset_{frequency}

Frequency specific offset for equal priority NR frequencies.

Qhyst

This specifies the hysteresis value for ranking criteria.

Q_{offset,temp}

This specifies the additional offset to be used for cell selection and re-selection. It is temporarily used in case the RRC Connection Establishment fails on the cell as specified in TS 38.331 [3].

Q_{qualmin}

This specifies the minimum required quality level in the cell in dB.

Q_{rxlevmin}

This specifies the minimum required Rx level in the cell in dBm.

Q_{rxlevminoffsetcell}

This specifies the cell specific Rx level offset in dB to Q_{rxlevmin}.

Q_{qualminoffsetcell}

This specifies the cell specific quality level offset in dB to Q_{qualmin}.

rangeToBestCell

This specifies the R value range which the cells whose R value is within the range can be a candidate for the highest ranked cell.

T_{reselection,RAT}

This specifies the cell reselection timer value. For each target NR frequency and for each RAT other than NR, a specific value for the cell reselection timer is defined, which is applicable when evaluating reselection within NR or towards other RAT (i.e. T_{reselection,RAT} for NR is T_{reselection,NR}, for E-UTRAN T_{reselection,EUTRA}).

NOTE: T_{reselection,RAT} is not broadcast in system information but used in reselection rules by the UE for each RAT.

T_{reselection,NR}

This specifies the cell reselection timer value T_{reselection,RAT} for NR. The parameter can be set per NR frequency as specified in TS 38.331 [3].

T_{reselection,EUTRA}

This specifies the cell reselection timer value T_{reselection,RAT} for E-UTRAN.

Thresh_{X, HighP}

This specifies the S_{rxlev} threshold (in dB) used by the UE when reselecting towards a higher priority RAT/ frequency than the current serving frequency. Each frequency of NR and E-UTRAN might have a specific threshold.

Thresh_{X, HighQ}

This specifies the S_{qual} threshold (in dB) used by the UE when reselecting towards a higher priority RAT/ frequency than the current serving frequency. Each frequency of NR and E-UTRAN might have a specific threshold.

Thresh_{X, LowP}

This specifies the S_{rxlev} threshold (in dB) used by the UE when reselecting towards a lower priority RAT/ frequency than the current serving frequency. Each frequency of NR and E-UTRAN might have a specific threshold.

Thresh_{X, LowQ}

This specifies the S_{qual} threshold (in dB) used by the UE when reselecting towards a lower priority RAT/ frequency than the current serving frequency. Each frequency of NR and E-UTRAN might have a specific threshold.

Thresh_{Serving, LowP}

This specifies the S_{rxlev} threshold (in dB) used by the UE on the serving cell when reselecting towards a lower priority RAT/ frequency.

Thresh_{Serving, LowQ}

This specifies the Squal threshold (in dB) used by the UE on the serving cell when reselecting towards a lower priority RAT/ frequency.

S_{IntraSearchP}

This specifies the Srxlev threshold (in dB) for intra-frequency measurements.

S_{IntraSearchQ}

This specifies the Squal threshold (in dB) for intra-frequency measurements.

S_{nonIntraSearchP}

This specifies the Srxlev threshold (in dB) for NR inter-frequency and inter-RAT measurements.

S_{nonIntraSearchQ}

This specifies the Squal threshold (in dB) for NR inter-frequency and inter-RAT measurements.

5.2.4.7.1 Speed dependent reselection parameters

Speed dependent reselection parameters are broadcast in system information and are read from the serving cell as follows:

T_{CRmax}

This specifies the duration for evaluating allowed amount of cell reselection(s).

N_{CR_M}

This specifies the maximum number of cell reselections to enter Medium-mobility state.

N_{CR_H}

This specifies the maximum number of cell reselections to enter High-mobility state.

T_{CRmaxHyst}

This specifies the additional time period before the UE can enter Normal-mobility state.

Speed dependent ScalingFactor for Q_{hyst}

This specifies scaling factor for Q_{hyst} in *sf-High* for High-mobility state and *sf-Medium* for Medium-mobility state.

Speed dependent ScalingFactor for T_{reselectionNR}

This specifies scaling factor for T_{reselectionNR} in *sf-High* for High-mobility state and *sf-Medium* for Medium-mobility state.

Speed dependent ScalingFactor for T_{reselectionEUTRA}

This specifies scaling factor for T_{reselectionEUTRA} in *sf-High* for High-mobility state and *sf-Medium* for Medium-mobility state.

6.1.2.22.3 Test description

6.1.2.22.3.1 Pre-test conditions

System Simulator:

- NR Cell 1 and NR Cell 3.
- System information combination NR-4 as defined in TS 38.508-1 [4] Table 4.4.3.1.2-1 is used in NR cells.

UE:

None.

Preamble:

- The UE is in state 1N-A on NR Cell 1(serving cell) according to TS 38.508-1 [4] Table 4.4A.2-1.

6.1.2.22.3.2 Test procedure sequence

Table 6.1.2.22.3.2-1/2 illustrates the downlink power levels and other changing parameters to be applied for the NR cells at various time instants of the test execution. The exact instants on which these values shall be applied are described in the texts in this clause. The configuration "T0" indicates the initial conditions. Subsequent configurations marked "T1" and "T2" are applied at the points indicated in the Main behaviour description in Table 6.1.2.22.3.2-3.

Table 6.1.2.22.3.2-1: Time instances of cell power level and parameter changes for FR1

	Parameter	Unit	NR Cell 1	NR Cell 3	Remark
T0	SS/PBCH SSS EPRE	dBm/SCS	-88	Off	The power level values are assigned to ensure the UE registered on NR Cell 1.
T1	SS/PBCH SSS EPRE	dBm/SCS	-88	-88	The power level values are assigned to satisfy $Srxlev_{NR\ Cell\ 1} > 0$, $Srxlev_{NR\ Cell\ 3} < Thresh_{NR\ Cell\ 3, highP}$, $Squal_{NR\ Cell\ 1} > 0$ and $Squal_{NR\ Cell\ 3} > Thresh_{NR\ Cell\ 3, highQ}$.
	RSRQ	dB	-10.76	-10.76	
	Qqualmin	dB	-20	-20	
	Qrxlevmin	dBm	-106	-106	
	Noc	dBm/SCS	Off	Off	
T2	SS/PBCH SSS EPRE	dBm/SCS	-88	-94	The power level values are assigned to satisfy $Srxlev_{NR\ Cell\ 3} > Thresh_{serving, lowP}$ and $Squal_{NR\ Cell\ 1} > Thresh_{NR\ Cell\ 1, lowQ}$. But $Squal_{NR\ Cell\ 3}$ is larger than $Thresh_{serving, lowQ}$.
	RSRQ	dB	-10.76	-10.76	
T3	threshServingLowQ	dB	4	26	The values are assigned to satisfy $Squal_{NR\ Cell\ 3} < Thresh_{serving, lowQ}$.
Note: Power level "Off" is defined in TS38.508-1 [4] Table 6.2.2.1-3.					

Table 6.1.2.22.3.2-2: Time instances of cell power level and parameter changes for FR2

	Parameter	Unit	NR Cell 1	NR Cell 3	Remark
T0	SS/PBCH SSS EPRE	dBm/SCS	FFS	Off	The power level values are assigned to ensure the UE registered on NR Cell 1.
T1	SS/PBCH SSS EPRE	dBm/SCS	FFS	FFS	The power level values are assigned to satisfy $Srxlev_{NR\ Cell\ 1} > 0$, $Srxlev_{NR\ Cell\ 3} < Thresh_{NR\ Cell\ 3, highP}$, $Squal_{NR\ Cell\ 1} > 0$ and $Squal_{NR\ Cell\ 3} > Thresh_{NR\ Cell\ 3, highQ}$.
	RSRQ	dB	FFS	FFS	
	Qqualmin	dB	-20	-20	
	Qrxlevmin	dBm	-106	-106	
	Noc	dBm/SCS	Off	Off	
T2	SS/PBCH SSS EPRE	dBm/SCS	FFS	FFS	The power level values are assigned to satisfy $Srxlev_{NR\ Cell\ 3} > Thresh_{serving, lowP}$ and $Squal_{NR\ Cell\ 1} > Thresh_{NR\ Cell\ 1, lowQ}$. But $Squal_{NR\ Cell\ 3}$ is larger than $Thresh_{serving, lowQ}$.
	RSRQ	dB	FFS	FFS	
T3	threshServingLowQ	dB	4	26	The values are assigned to satisfy $Squal_{NR\ Cell\ 3} < Thresh_{serving, lowQ}$.
Note: The uncertain downlink signal level is specified in TS 38.508-1[4] section FFS.					

Table 6.1.2.22.3.2-3: Main behaviour

St	Procedure	Message Sequence		TP	Verdict
		U – S	Message		
1	The SS changes NR Cell 3 SS/PBCH EPRE level according to the row "T1" in table 6.1.2.22.3.2-1/2.	-	-	-	-
2	Wait for 1 second to allow UE to recognise the change.	-	-	-	-
3	Check: Does the test result of generic test procedure in TS 38.508-1 [4] Table 4.9.4-1 indicate that the UE is camped on NR Cell 3?	-	-	1	-
4	The SS changes the SSS level according to the row "T2" in table 6.1.2.22.3.2-1/2.	-	-	-	-
5	Wait for 1 second to allow UE to recognise the change.	-	-	-	-
6	The SS notifies the UE of change of System Information on NR Cell 3 by send SM on PDCCH using P-RNTI.	<--	NR RRC: <i>Paging</i>	-	-
7	The SS changes threshServingLowQ of NR Cell 3 according to the row "T3" in table 6.1.2.22.3.2-1/2. The <i>ValueTag</i> of <i>SIB2</i> in the SI-SchedulingInfo of <i>SIB1</i> is increased on NR Cell 3.	-	-	-	-
8	Wait for 2.1* modification period to allow the new system information to take effect.	-	-	-	-
9	Check: Does the test result of generic test procedure in TS 38.508-1 [4] Table 4.9.4-1 indicate that the UE is camped on NR Cell 1?	-	-	2	-

6.1.2.22.3.3 Specific message contents

Table 6.1.2.22.3.3-1: Conditions for specific message contents in Tables below

Condition	Explanation
NR Cell 1	This condition applies to system information transmitted on NR Cell 1.
NR Cell 3	This condition applies to system information transmitted on NR Cell 3.

Table 6.1.2.22.3.3-2: SIB2 of NR Cell 1 and NR Cell 3 (preamble and all steps, Table 6.1.2.22.3.2-3)

Derivation Path: TS 38.508-1 [4], Table 4.6.2-1			
Information Element	Value/remark	Comment	Condition
SIB2 ::= SEQUENCE {			
cellReselectionServingFreqInfo	1 entry		
SEQUENCE {			
threshServingLowP	1	2 dB	NR Cell3
threshServingLowQ	4	4 dB	
cellReselectionPriority	5		NR Cell3
}			
}			

Table 6.1.2.22.3.3-3: SIB4 of NR Cell 1 and NR Cell 3 (preamble and all steps, Table 6.1.2.22.3.2-3)

Derivation Path: TS 38.508-1 [4], Table 4.6.2-3			
Information Element	Value/remark	Comment	Condition
SIB4 ::= SEQUENCE {			
interFreqCarrierFreqList SEQUENCE (SIZE (1..maxFreq)) OF SEQUENCE {	1 entry		
dl-CarrierFreq[1]	Same downlink ARFCN as used for NR Cell 3		NR Cell1
	Same downlink ARFCN as used for NR Cell 1		NR Cell3
q-RxLevMin	-50	-100 dBm	
q-QualMin	-20dB		
t-ReselectionNR	1		
threshX-HighP	10	20 dBm	NR Cell1
threshX-Q SEQUENCE {			
threshX-HighQ	4	4 dB	NR Cell1
threshX-LowQ	2	2 dB	NR Cell3
}			
cellReselectionPriority	5		NR Cell1
	4		NR Cell3
}			
}			

Table 6.1.2.22.3.3-4: SIB1 of NR Cell 3 (step 7, Table 6.1.2.22.3.2-3)

Derivation Path: TS 38.508-1 [4], Table 4.6.1-28			
Information Element	Value/remark	Comment	Condition
SIB1 ::= SEQUENCE {			
si-SchedulingInfo	SI-SchedulingInfo		
}			

Table 6.1.2.22.3.3-5: SI-SchedulingInfo (si-SchedulingInfo in Table 6.1.2.22.3.3-4)

Derivation Path: TS 38.508-1 [4], Table 4.6.3-173			
Information Element	Value/remark	Comment	Condition
SI-SchedulingInfo ::= SEQUENCE {			
schedulingInfoList SEQUENCE (SIZE(1..maxSI-Message)) OF SEQUENCE{			
sib-MappingInfo SEQUENCE (SIZE (1..maxSIB)) OF SEQUENCE {	1 entry		
type	sibType2		
valueTag	1		
}			
}			

Table 6.1.2.22.3.3-6: SIB2 of NR Cell 3 (step 7, Table 6.1.2.22.3.2-3)

Derivation Path: TS 38.508-1 [4], Table 4.6.2-1			
Information Element	Value/remark	Comment	Condition
SIB2 ::= SEQUENCE {			
cellReselectionServingFreqInfo SEQUENCE {	1 entry		
threshServingLowQ	26 dB		
}			
}			

6.2 Multi-mode environment

6.2.1 Inter-RAT PLMN selection

6.2.1.1 Inter-RAT PLMN Selection / Selection of correct RAT for OPLMN / Automatic mode

6.2.1.1.1 Test Purpose (TP)

(1)

```
with { UE pre-set in Automatic network selection mode }
ensure that {
  when { UE is switched on and there are suitable NR and E-UTRAN cells some on the OPLMN list and
some not on the OPLMN list, none of them being part of the RPLMN }
  then { UE selects the highest priority OPLMN and RAT combination, attaches on the selected
cell.}
}
```

(2)

```
with { UE in Automatic network selection mode }
ensure that {
  when { UE returns to coverage and there are suitable NR and E-UTRAN cells some on the OPLMN list
and some not on the OPLMN list , none of them being part of the RPLMN }
  then { UE selects the highest priority OPLMN and RAT combination, attaches on the selected cell.
}
}
```

6.2.1.1.2 Conformance requirements

References: The conformance requirements covered in the present TC are specified in: TS 23.122 clauses 4.4.3.1 and 4.4.3.1.1. Unless otherwise stated these are Rel-15 requirements.

[TS 23.122, clause 4.4.3.1]

If successful registration is achieved, the MS indicates the selected PLMN.

...

NOTE 3: If successful registration is achieved, then the current serving PLMN becomes the registered PLMN and the MS does not store the previous registered PLMN for later use.

[TS 23.122, clause 4.4.3.1.1]

The MS selects and attempts registration on other PLMN/access technology combinations, if available and allowable, in the following order:

- i) either the HPLMN (if the EHPLMN list is not present or is empty) or the highest priority EHPLMN that is available (if the EHPLMN list is present) ;
- ii) each PLMN/access technology combination in the "User Controlled PLMN Selector with Access Technology" data file in the SIM (in priority order);
- iii) each PLMN/access technology combination in the "Operator Controlled PLMN Selector with Access Technology" data file in the SIM (in priority order);
- iv) other PLMN/access technology combinations with received high quality signal in random order;
- v) other PLMN/access technology combinations in order of decreasing signal quality.

6.2.1.1.3 Test description

6.2.1.1.3.1 Pre-test conditions

System Simulator

- 3 NR cells as specified in TS 38.508-1[4] table 4.4.2-3. System information combination NR-4 as defined in Ts 38.508-1 [4] sub-clause 4.4.3.1.2 is applied to all the NR cells.
- 1 cell belongs to E-UTRA. System information combination 1 as defined in TS 36.508 [7] clause 4.4.3.1 is used.
- PLMN settings are defined in TS 36.523-1 [13] table 6.0.1-1.

Table 6.2.1.1.3.1-1: Cell PLMN identities

Cell	PLMN name
NR Cell 1	PLMN2
NR Cell 12	PLMN13
NR Cell 13	PLMN14
E-UTRA Cell 1	PLMN13

UE

- The UE is in Automatic PLMN selection mode.
- The HPLMN is PLMN1
- There is no RPLMN.
- USIM configuration 12 as specified in tables 6.4.1-12 in TS 38.508-1 [4] will be used.

Preamble

- The UE is in state Switched OFF (state 0N-B) according to TS 38.508-1[4].

6.2.1.1.3.2 Test procedure sequence

Table 6.2.1.1.3.2-1 for both FR1 and FR2 illustrates the downlink power levels to be applied for the cells at various time instants of the test execution. Row marked "T0" denotes the initial conditions after preamble, while columns marked "T1" is to be applied subsequently in the Main behaviour. The exact instants on which these values shall be applied are described in the texts in this clause. Cell powers in table 6.2.1.1.3.2-2 for the E-UTRAN cell are defined in TS 36.508[7] Table 6.2.2.1-1 and cell powers for NR cells are defined in TS 38.508-1[4] table 6.2.2.1-3 for FR1 and table FFS for FR2.

Table 6.2.1.1.3.2-1: Cell configuration changes over time

	Parameter	Unit	NR Cell 1	NR Cell 12	NR Cell 13	E-UTRA Cell 1
T0	SS/PBCH SSS EPRE	dBm/SCS	Serving Cell	Non-suitable "Off"	Serving Cell	
	RS EPRE	dBm/15kHz				Serving Cell
T1	SS/PBCH SSS EPRE	dBm/SCS	Non-suitable "Off"	Serving Cell	Non-suitable "Off"	
	RS EPRE	dBm/15kHz				Serving Cell

Table 6.2.1.1.3.2-2: Main behaviour

St	Procedure	Message Sequence		TP	Verdict
		U – S	Message		
1	The UE is switched on.	-	-	-	-
2	Check: Does the UE send <i>RRCSetupRequest</i> on NR Cell 1?	-->	NR RRC: <i>RRCSetupRequest</i>	1	P
3-20	Steps 3-20 of the registration procedure described in TS 38.508-1[4] table 4.5.2.2-2 are performed on NR Cell 1.	-	-	-	-
21	The SS adjusts cell levels according to row T1 of table 6.2.1.1.3.2-1.	-	-	-	-
22-29	Check: Does the test result of generic test procedure in TS 36.508 Table 6.4.2.7A-1 is performed and the UE is camped on E-UTRAN Cell 1?	-	-	2	P

6.2.1.1.3.3 Specific message contents

None.

6.2.1.2 Inter-RAT PLMN Selection / Selection of correct RAT for UPLMN / Automatic mode

6.2.1.2.1 Test Purpose (TP)

(1)

```
with { UE in Automatic network selection mode and UPLMN and OPLMN cells available on NR and E-UTRAN}
ensure that {
  when { UE is switched on}
  then { UE selects a the highest priority UPLMN and RAT combination and UE attempts to register
on the selected cell. }
}
```

(2)

```
with { UE in Automatic network selection mode and UPLMN and OPLMN cells available on NR and E-UTRAN}
ensure that {
  when { UE returns to coverage}
  then { UE selects a the highest priority VPLMN and RAT combination and UE attempts to attach on
the selected cell. }
}
```

6.2.1.2.2 Conformance requirements

References: The conformance requirements covered in the present TC are specified in: TS 23.122 clauses 4.4.3.1 and 4.4.3.1.1. Unless otherwise stated these are Rel-15 requirements.

[TS 23.122, clause 4.4.3.1]

If successful registration is achieved, the MS indicates the selected PLMN.

...

NOTE 3: If successful registration is achieved, then the current serving PLMN becomes the registered PLMN and the MS does not store the previous registered PLMN for later use.

[TS 23.122, clause 4.4.3.1.1]

The MS selects and attempts registration on other PLMN/access technology combinations, if available and allowable, in the following order:

- i) either the HPLMN (if the EHPLMN list is not present or is empty) or the highest priority EHPLMN that is available (if the EHPLMN list is present) ;

- ii) each PLMN/access technology combination in the "User Controlled PLMN Selector with Access Technology" data file in the SIM (in priority order);
- iii) each PLMN/access technology combination in the "Operator Controlled PLMN Selector with Access Technology" data file in the SIM (in priority order);
- iv) other PLMN/access technology combinations with received high quality signal in random order;
- v) other PLMN/access technology combinations in order of decreasing signal quality.

6.2.1.2.3 Test description

6.2.1.2.3.1 Pre-test conditions

System Simulator

- NR Cell 1 and NR Cell 2 as specified in TS 38.508-1[4] table 4.4.2-3 are configured as shown in Table 6.2.1.2.3.2-1. System information combination NR-4 as defined in Ts 38.508-1 [4] sub-clause 4.4.3.1.2 is applied to all the NR cells.
- E-UTRA Cell 1 belongs to E-UTRA (defined in TS 36.508[7]). System information combination 1 as defined in TS 36.508 [7] clause 4.4.3.1 is used.
- PLMN settings are defined in TS 36.523-1 [13] table 6.0.1-1.

Table 6.2.1.2.3.1-1: Cell PLMN identities

Cell	PLMN name
NR Cell 1	PLMN2
NR Cell 2	PLMN13
E-UTRA Cell 1	PLMN13

UE

- The UE is in Automatic PLMN selection mode.
- The HPLMN is PLMN1.
- There is no RPLMN.
- USIM configuration 7 as specified in tables 6.4.1-7 in TS 38.508-1 [4] will be used.

Preamble

- The UE is in state Switched OFF (state 0N-B) according to TS 38.508-1[4].

6.2.1.2.3.2 Test procedure sequence

Table 6.2.1.2.3.2-1 for both FR1 and FR2 illustrates the downlink power levels to be applied for the cells at various time instants of the test execution. Row marked "T0" denotes the initial conditions after preamble, while columns marked "T1" is to be applied subsequently in the Main behaviour. The exact instants on which these values shall be applied are described in the texts in this clause. Cell powers in table 6.2.1.2.3.2-2 for the E-UTRAN cell are defined in TS 36.508[7] Table 6.2.2.1-1 and cell powers for NR cells are defined in TS 38.508-1[4] table 6.2.2.1-3 for FR1 and table FFS for FR2.

Table 6.1.1.7.3.2-1: Cell configuration changes over time

	Parameter	Unit	NR Cell 1	NR Cell 2	E-UTRA Cell 1
T0	SS/PBCH SSS EPRE	dBm/SCS	Serving Cell	Serving Cell	
	RS EPRE	dBm/15kHz			Serving Cell
T1	SS/PBCH SSS EPRE	dBm/SCS	Serving Cell	Non-suitable "Off"	
	RS EPRE	dBm/15kHz			Serving Cell

Table 6.2.1.2.3.2-2: Main behaviour

St	Procedure	Message Sequence		TP	Verdict
		U – S	Message		
1	The UE is switched on.	-	-	-	-
2	Check: Does the UE send <i>RRCSetupRequest</i> on NR Cell 2?	-->	<i>RRCSetupRequest</i>	1	P
3-20	Steps 3-20 of the registration procedure described in TS 38.508-1[4] table 4.5.2.2-2 are performed on NR Cell 1.	-	-	-	-
21	The SS adjusts cell levels according to row T1 of table 6.2.1.2.3.2-1.	-	-	-	-
22	Check: Does the UE send a <i>RRCConectionRequest</i> on E-UTRA Cell 1?	-->	<i>RRCConectionRequest</i>	2	P
23-37	Steps 3-17 of the registration procedure described in TS 36.508[7] table 4.5.2.3-1 take place on E-UTRAN Cell 1.	-	-	-	-

6.2.1.2.3.3 Specific message contents

None.

6.2.1.3 Inter-RAT PLMN Selection / Selection of correct PLMN and RAT in shared network environment / Automatic mode

6.2.1.3.1 Test Purpose (TP)

(1)

```
with { UE in Automatic network selection mode and shared OPLMN cells available on NR and E-UTRAN }
ensure that {
  when { UE is switched on }
  then { UE selects a the highest priority OPLMN and RAT combination and UE attempts to register
on the selected cell and PLMN. }
}
```

(2)

```
with { UE in Automatic network selection mode and shared OPLMN cells available on NR and E-UTRAN }
ensure that {
  then { UE selects a the highest priority OPLMN and RAT combination and UE attempts to attach on
the selected cell and PLMN. }
}
```

6.2.1.3.2 Conformance requirements

References: The conformance requirements covered in the present TC are specified in: TS 23.122 clauses 4.4.3, 4.4.3.1 and 4.4.3.1.1. Unless otherwise stated these are Rel-15 requirements.

[TS 23.122, clause 4.4.3]

When the MS reselects to a cell in a shared network, and the cell is a suitable cell for multiple PLMN identities received on the BCCH or on the EC-BCCH the AS indicates these multiple PLMN identities to the NAS according to 3GPP TS 44.018 [34], 3GPP TS 44.060 [39], 3GPP TS 25.304 [32] and 3GPP TS 36.304 [43]. The MS shall choose one of these PLMNs. If the registered PLMN is available among these PLMNs, the MS shall not choose a different PLMN.

[TS 23.122, clause 4.4.3.1]

If successful registration is achieved, the MS indicates the selected PLMN.

...

NOTE 3: If successful registration is achieved, then the current serving PLMN becomes the registered PLMN and the MS does not store the previous registered PLMN for later use.

[TS 23.122, clause 4.4.3.1.1]

The MS selects and attempts registration on other PLMN/access technology combinations, if available and allowable, in the following order:

- i) either the HPLMN (if the EHPLMN list is not present or is empty) or the highest priority EHPLMN that is available (if the EHPLMN list is present) ;
- ii) each PLMN/access technology combination in the "User Controlled PLMN Selector with Access Technology" data file in the SIM (in priority order);
- iii) each PLMN/access technology combination in the "Operator Controlled PLMN Selector with Access Technology" data file in the SIM (in priority order);
- iv) other PLMN/access technology combinations with received high quality signal in random order;
- v) other PLMN/access technology combinations in order of decreasing signal quality.

6.2.1.3.3 Test description

6.2.1.3.3.1 Pre-test conditions

System Simulator

- 2 NR cells as specified in TS 38.508-1[4] table 4.4.2-3 are configured as shown in Table 6.2.1.3.3.2-1. System information combination NR-4 as defined in Ts 38.508-1 [4] sub-clause 4.4.3.1.2 is applied to all the NR cells.
- 1 cell belongs to E-UTRA. System information combination 1 as defined in TS 36.508 [7] clause 4.4.3.1 is used.
- PLMN settings are defined in TS 36.523-1 [13] table 6.0.1-1.

Table 6.2.1.3.3.1-1: Cell PLMN identities

Cell	PLMN name
NR Cell 1	PLMN16
	PLMN15
NR Cell 2	PLMN16
	PLMN17
E-UTRA Cell 1	PLMN17
	PLMN16

UE

- The UE is in Automatic PLMN selection mode.
- The HPLMN is PLMN1.

- There is no RPLMN.
- USIM configuration 8 as specified in tables 6.4.1-8 in TS 38.508-1 [4] will be used.

Preamble

- The UE is in state Switched OFF (state 0N-B) according to TS 38.508-1[4].

6.2.1.3.3.2 Test procedure sequence

Table 6.2.1.3.3.2-1 for both FR1 and FR2 illustrates the downlink power levels to be applied for the cells at various time instants of the test execution. Row marked "T0" denotes the initial conditions after preamble, while columns marked "T1" is to be applied subsequently in the Main behaviour. The exact instants on which these values shall be applied are described in the texts in this clause. Cell powers in table 6.2.1.3.2-2 for the E-UTRAN cell are defined in TS 36.508[7] Table 6.2.2.1-1 and cell powers for NR cells are defined in TS 38.508-1[4] table 6.2.2.1-3 for FR1 and table FFS for FR2.

Table 6.2.1.3.3.2-1: Cell configuration changes over time

	Parameter	Unit	NR Cell 1	NR Cell 2	E-UTRA Cell 1
T0	SS/PBCH SSS EPRE	dBm/SCS	Serving Cell	Serving Cell	
	RS EPRE	dBm/15kHz			Serving Cell
T1	SS/PBCH SSS EPRE	dBm/SCS	Non-suitable "Off"	Serving Cell	
	RS EPRE	dBm/15kHz			Serving Cell

Table 6.2.1.3.3.2-2: Main behaviour

St	Procedure	Message Sequence		TP	Verdict
		U – S	Message		
1	The UE is switched on.	-	-	-	-
2	Check: Does the UE send <i>RRCSetupRequest</i> on NR Cell 1?	-->	NR RRC: <i>RRCSetupRequest</i>	1	P
3-20	Steps 3-20 of the registration procedure described in TS 38.508-1[4] subclause 4.5.2 are performed on NR Cell 1.	-	-	-	-
21	The SS adjusts cell levels according to row T1 of table 6.2.1.3.3.2-1.	-	-	-	-
22	Check: Does the UE send a <i>RRCConnectionRequest</i> on E-UTRAN Cell 1	-->	<i>RRCConnectionRequest</i>	2	P
23-29	Steps 2-8 of the tracking are updating procedure described in TS 36.508[7] table 6.4.2.7A-1 take place on E-UTRAN Cell 1.	-	-	-	-

6.2.1.3.3.3 Specific message contents

Table 6.2.1.3.3.3-1: SIB1 for NR Cell 1(all steps, Table 6.2.1.3.3.2-2)

Derivation path: 38.508-1[4] Table 4.6.1-28			
Information Element	Value/Remark	Comment	Condition
SIB1 ::= SEQUENCE {			
CellAccessRelatedInfo ::= SEQUENCE {			
PLMN-IdentityInfoList ::= SEQUENCE (SIZE (1..maxPLMN)) OF SEQUENCE {	1 entry		
plmn-IdentityList SEQUENCE (SIZE (1..maxPLMN)) OF PLMN-Identity {	2 entries		
PLMN-Identity[1] ::= SEQUENCE {			
mcc	PLMN16 MCC		
mnc	PLMN16 MNC		
}			
PLMN-Identity[2] ::= SEQUENCE {			
mcc	PLMN15 MCC		
mnc	PLMN15 MNC		
}			
}			
}			
}			
}			

Table 6.2.1.3.3.3-2: SIB1 for NR Cell 2(all steps, Table 6.2.1.3.3.2-2)

Derivation path: 38.508-1[4] Table 4.6.1-28			
Information Element	Value/Remark	Comment	Condition
SIB1 ::= SEQUENCE {			
CellAccessRelatedInfo ::= SEQUENCE {			
PLMN-IdentityInfoList ::= SEQUENCE (SIZE (1..maxPLMN)) OF SEQUENCE {	1 entry		
plmn-IdentityList SEQUENCE (SIZE (1..maxPLMN)) OF PLMN-Identity {	2 entries		
PLMN-Identity[1] ::= SEQUENCE {			
mcc	PLMN16 MCC		
mnc	PLMN17 MNC		
}			
PLMN-Identity[2] ::= SEQUENCE {			
mcc	PLMN17 MCC		
mnc	PLMN17 MNC		
}			
}			
}			
}			
}			

Table 6.2.1.3.3.3-3: SystemInformationBlockType1 for E-UTRAN Cell 1 (all steps, Table 6.2.1.3.3.2-2)

Derivation path: 36.508[7] Table 4.4.3.2-3			
Information Element	Value/Remark	Comment	Condition
SystemInformationBlockType1 ::= SEQUENCE {			
cellAccessRelatedInfo SEQUENCE {			
plmn-IdentityList SEQUENCE (SIZE (1..6)) OF SEQUENCE {			
plmn-Identity[1]	PLMN17		
plmn-Identity[2]	PLMN16		
}			
}			
}			

Table 6.2.1.3.3-4: *RRCSetupComplete* (Step 6, Table 6.2.1.3.3.2-2)

Derivation Path: 36.331 clause 6.2.2			
Information Element	Value/remark	Comment	Condition
RRCSetupComplete ::= SEQUENCE {			
rrc-TransactionIdentifier			
criticalExtensions CHOICE {			
rrcSetupComplete SEQUENCE {			
selectedPLMN-Identity	2	PLMN15	
}			
}			
}			

Table 6.2.1.3.3-5: *RRCConnectionSetupComplete* (Step 24, Table 6.2.1.3.3.2-2)

Derivation Path: 36.331 [11] clause 6.2.2			
Information Element	Value/remark	Comment	Condition
RRCConnectionSetupComplete ::= SEQUENCE {			
criticalExtensions CHOICE {			
c1 CHOICE {			
rrcConnectionSetupComplete-r8 SEQUENCE {			
selectedPLMN-Identity	1	PLMN17	
}			
}			
}			
}			

6.2.1.4 Inter-RAT PLMN Selection / Selection of correct RAT from the OPLMN list / Manual mode

6.2.1.4.1 Test Purpose (TP)

(1)

```
with { UE in Manual network selection mode and OPLMN cells available on NR and E-UTRA}
ensure that {
  when { the USER selects an OPLMN}
  then { UE selects a the highest priority RAT for the OPLMN and UE attempts to attach on the
selected cell and when successfully registered indicates the PLMN to the user. }
}
```

(2)

```
with { UE in Manual network selection mode and OPLMN cells available on NR and E-UTRA}
ensure that {
  when { the USER selects an OPLMN and RAT combination}
  then {UE attempts to attach on the selected OPLMN and RAT combination and when successfully
registered indicates the PLMN to the user. }
}
```

6.2.1.4.2 Conformance requirements

References: The conformance requirements covered in the present TC are specified in: TS 23.122 clauses 4.4.3.1.2. Unless otherwise stated these are Rel-15 requirements.

[TS 23.122, clause 4.4.3.1.2]

The MS indicates whether there are any PLMNs, which are available using all supported access technologies. This includes PLMNs in the "forbidden PLMNs" list, "forbidden PLMNs for GPRS service" list and PLMNs which only offer services not supported by the MS. An MS which supports GSM COMPACT shall also indicate GSM COMPACT PLMNs (which use PBCCH).

If displayed, PLMNs meeting the criteria above are presented in the following order:

- i)- either the HPLMN (if the EHPLMN list is not present or is empty) or, if one or more of the EHPLMNs are available then based on an optional data field on the SIM either only the highest priority available EHPLMN is to be presented to the user_or all available EHPLMNs are presented to the user in priority order. If the data field is not present on the SIM, then only the highest priority available EHPLMN is presented;
- ii)- PLMN/access technology combinations contained in the " User Controlled PLMN Selector with Access Technology " data file in the SIM (in priority order);
- iii)- PLMN/access technology combinations contained in the "Operator Controlled PLMN Selector with Access Technology" data file in the SIM (in priority order);
- iv)- other PLMN/access technology combinations with received high quality signal in random order;
- v)- other PLMN/access technology combinations in order of decreasing signal quality.

...

The user may select his desired PLMN and the MS then initiates registration on this PLMN using the access technology chosen by the user for that PLMN or using the highest priority available access technology for that PLMN, if the associated access technologies have a priority order. (This may take place at any time during the presentation of PLMNs). For such a registration, the MS shall ignore the contents of the "forbidden location areas for roaming", "forbidden tracking areas for roaming", "5GS forbidden tracking areas for roaming", "forbidden location areas for regional provision of service", "forbidden tracking areas for regional provision of service", "5GS forbidden tracking areas for regional provision of service", "forbidden PLMNs for GPRS service" and "forbidden PLMNs" lists.

NOTE 1: It is an MS implementation option whether to indicate access technologies to the user. If the MS does display access technologies, then the access technology selected by the user is only used for initial registration on the selected PLMN. If the MS does not display access technologies, then the access technology chosen for a particular PLMN should be the highest priority available access technology for that PLMN, if the associated access technologies have a priority order, and is only used for initial registration.

6.2.1.4.3 Test description

6.2.1.4.3.1 Pre-test conditions

System Simulator

- 3 cells are used:
- NR Cell 1 and NR Cell 2 as specified in TS 38.508-1[4] table 4.4.2-3 are configured as shown in Table 6.2.1.2.3.2-1. System information combination NR-4 as defined in Ts 38.508-1 [4] sub-clause 4.4.3.1.2 is applied to all the NR cells.
- E-UTRA Cell 1 belongs to E-UTRA (defined in TS 36.508[7]). System information combination 1 as defined in TS 36.508 [7] clause 4.4.3.1 is used.
- PLMN settings are defined in TS 36.523-1 [13] table 6.0.1-1.

Table 6.2.1.4.3.1-1: Cell PLMN identities

Cell	PLMN name
NR Cell 1	PLMN2
NR Cell 2	PLMN13
E-UTRA Cell 1	PLMN2

UE

- The HPLMN is PLMN1.
- USIM configuration 13 as specified in table 6.4.1-13 in TS 38.508-1 [4] will be used.

Preamble

- The UE is in state Switched OFF (state 0N-B) according to TS 38.508-1[4].

6.2.1.4.3.2 Test procedure sequence

Table 6.2.1.4.3.2-1 for both FR1 and FR2 illustrates the downlink power levels to be applied for the cells at various time instants of the test execution. Row marked "T0" denotes the initial conditions after preamble. The exact instants on which these values shall be applied are described in the texts in this clause. Cell powers in table 6.2.1.1.3.2-2 for the E-UTRAN cell are defined in TS 36.508[7] Table 6.2.2.1-1 and cell powers for NR cells are defined in TS 38.508-1[4] table 6.2.2.1-3 for FR1 and table FFS for FR2.

Table 6.2.1.4.3.2-1: Cell configuration changes over time

	Parameter	Unit	NR Cell 1	NR Cell 2	E-UTRA Cell 1
T0	SS/PBCH SSS EPRE	dBm/SCS	Serving Cell	Serving Cell	
	RS EPRE	dBm/15kHz			Serving Cell

Table 6.2.1.4.3.2-2: Main behaviour

St	Procedure	Message Sequence		TP	Verdict
		U – S	Message		
1	The UE is switched on.	-	-	-	-
2	Make the UE display the list of available PLMNs.	-	-	-	-
-	EXCEPTION: Steps 2a1 to 2b18 describe behaviour that depends on UE capabilities; the "lower case letter" identifies a step sequence that takes place if the condition is met.	-	-	-	-
2a1	IF pc_Available_PLMNs_Act[29]_Ind (Support of Access Technology Indication in available PLMNs list) THEN PLMN2 (E-UTRAN) is selected	-	-	-	-
2a2	Check: Does the UE send a <i>RRCConnectionRequest</i> on E-UTRA Cell 1?	-->	<i>RRCConnectionRequest</i>	2	P
2a2-2a16	Steps 3-17 of the registration procedure described in TS 36.508[7] table 4.5.2.3-1 take place on E-UTRAN Cell 1.	-	-	-	-
2a3	Check: Is PLMN2 indicated as registered PLMN by the UE?	-	-	2	P
2b1	ELSE (No Access Technology shown to the User) PLMN2 is selected				
2b2	Check: Does the UE send <i>RRCSetupRequest</i> on NR Cell 1?	-->	NR RRC: <i>RRCSetupRequest</i>	1	P
2b3-2b17	Steps 3-20 of the registration procedure described in TS 38.508-1[4] subclause 4.5.2 are performed on NR Cell 1.	-	-	-	-
2b18	Check: Is PLMN2 indicated as registered PLMN by the UE?	-	-	1	P

6.2.1.4.3.3 Specific message contents

None.

6.2.1.5 Inter-RAT Background HPLMN Search / Search for correct RAT for HPLMN / Automatic Mode

6.2.1.5.1 Test Purpose (TP)

```

with { UE in Automatic network selection mode is camped on a E-UTRAN VPLMN cell and HPLMN cell
available on NR }
ensure that {
  when { higher priority PLMN search timer T expires }
  then { UE detects NR cell and camps on the NR cell }
}

```

6.2.1.5.2 Conformance requirements

References: The conformance requirements covered in the present TC are specified in: TS 23.122 clauses 4.4.3.3.1. Unless otherwise stated these are Rel-15 requirements.

[TS 23.122, clause 4.4.3.3.1]

If the MS is in a VPLMN, the MS shall periodically attempt to obtain service on its HPLMN (if the EHPLMN list is not present or is empty) or one of its EHPLMNs (if the EHPLMN list is present) or a higher priority PLMN/access technology combinations listed in "user controlled PLMN selector" or "operator controlled PLMN selector" by scanning in accordance with the requirements that are applicable to i), ii) and iii) as defined in the Automatic Network Selection Mode in subclause 4.4.3.1.1. In the case that the mobile has a stored "Equivalent PLMNs" list the mobile shall only select a PLMN if it is of a higher priority than those of the same country as the current serving PLMN which are stored in the "Equivalent PLMNs" list. For this purpose, a value of timer T may be stored in the SIM. The interpretation of the stored value depends on the radio capabilities supported by the MS:

- For an MS that does not support any of the following: EC-GSM-IoT, Category M1 or Category NB1 (as defined in 3GPP TS 36.306 [54]), T is either in the range 6 minutes to 8 hours in 6 minute steps or it indicates that no periodic attempts shall be made. If no value for T is stored in the SIM, a default value of 60 minutes is used for T.
- For an MS that only supports any of the following or a combination of: EC-GSM-IoT, Category M1 or Category NB1 (as defined in 3GPP TS 36.306 [54]), T is either in the range 2 hours to 240 hours, using 2 hour steps from 2 hours to 80 hours and 4 hour steps from 84 hours to 240 hours, or it indicates that no periodic attempts shall be made. If no value for T is stored in the SIM, a default value of 72 hours is used.
- For an MS that supports both:
 - a) any of the following or a combination of: EC-GSM-IoT, Category M1 or Category NB1 (as defined in 3GPP TS 36.306 [54]); and
 - b) any access technology other than the following: EC-GSM-IoT, Category M1 or Category NB1 (as defined in 3GPP TS 36.306 [54]),

then T is interpreted depending on the access technology in use as specified below:

- 1) if the MS is using any of the following at the time of starting timer T: EC-GSM-IoT, Category M1 or Category NB1 (as defined in 3GPP TS 36.306 [54]), T is either in the range 2 hours to 240 hours, using 2 hour steps from 2 hours to 80 hours and 4 hour steps from 84 hours to 240 hours, or it indicates that no periodic attempts shall be made. If no value for T is stored in the SIM, a default value of 72 hours is used; and
- 2) if the MS is not using any of the following at the time of starting timer T: EC-GSM-IoT, Category M1 or Category NB1 (as defined in 3GPP TS 36.306 [54]), T is either in the range 6 minutes to 8 hours in 6 minute steps or it indicates that no periodic attempts shall be made. If no value for T is stored in the SIM, a default value of 60 minutes is used for T.

If the MS is configured with the MinimumPeriodicSearchTimer as specified in 3GPP TS 24.368 [50] or 3GPP TS 31.102 [40], the MS shall not use a value for T that is less than the MinimumPeriodicSearchTimer. If the value stored in the SIM, or the default value for T (when no value is stored in the SIM), is less than the MinimumPeriodicSearchTimer, then T shall be set to the MinimumPeriodicSearchTimer.

The MS does not stop timer T, as described in 3GPP TS 24.008 [23] and 3GPP TS 24.301 [23A], when it activates power saving mode (PSM) (see 3GPP TS 23.682 [27A]).

The MS can be configured for Fast First Higher Priority PLMN search as specified in 3GPP TS 31.102 [40] or 3GPP TS 24.368 [50]. Fast First Higher Priority PLMN search is enabled if the corresponding configuration parameter is present and set to enabled. Otherwise, Fast First Higher Priority PLMN search is disabled.

The attempts to access the HPLMN or an EHPLMN or higher priority PLMN shall be as specified below:

- a) The periodic attempts shall only be performed in automatic mode when the MS is roaming, and not while the MS is attached for emergency bearer services, is registered for emergency services, has a PDU session for emergency services or has a PDN connection for emergency bearer services;
- b) The MS shall make the first attempt after a period of at least 2 minutes and at most T minutes:
 - only after switch on if Fast First Higher Priority PLMN search is disabled; or
 - after switch on or upon selecting a VPLMN if Fast First Higher Priority PLMN search is enabled.
- c) The MS shall make the following attempts if the MS is on the VPLMN at time T after the last attempt;
- d) Periodic attempts shall only be performed by the MS while in idle mode;
- d1) periodic attempts may be postponed while the MS is in power saving mode (PSM) (see 3GPP TS 23.682 [27A]).
- e) If the HPLMN (if the EHPLMN list is not present or is empty) or a EHPLMN (if the list is present) or a higher priority PLMN is not found, the MS shall remain on the VPLMN.
- f) In steps i), ii) and iii) of subclause 4.4.3.1.1 the MS shall limit its attempts to access higher priority PLMN/access technology combinations to PLMN/access technology combinations of the same country as the current serving VPLMN, as defined in Annex B.
- g) Only the priority levels of Equivalent PLMNs of the same country as the current serving VPLMN, as defined in Annex B, shall be taken into account to compare with the priority level of a selected PLMN.
- h) If the PLMN of the highest priority PLMN/access technology combination available is the current VPLMN, or one of the PLMNs in the "Equivalent PLMNs" list, the MS shall remain on the current PLMN/access technology combination.

6.2.1.5.3 Test description

6.2.1.5.3.1 Pre-test conditions

System Simulator

- E-UTRA Cell 1 as specified in TS 36.508 [7]. System information combination 1 as defined in TS 36.508 [7] clause 4.4.3.1 is used.
- NR Cell 1 as specified in TS 38.508-1[4] table 4.4.2-3. System information combination NR-4 as defined in Ts 38.508-1 [4] sub-clause 4.4.3.1.2 is applied to the NR cell.
- PLMN settings are defined in TS 36.523-1 [13] table 6.0.1-1.

Table 6.2.1.5.3.1-1: Cell PLMN identities

Cell	PLMN name
NR Cell 1	PLMN1
E-UTRA Cell 1	PLMN15

UE

- USIM configuration 9 as specified in table 6.4.1-9 in TS 38.508-1 [4] will be used.

Preamble

- The UE is in state Switched OFF (state 0N-B) according to TS 38.508-1[4].

6.2.1.5.3.2 Test procedure sequence

Table 6.2.1.3.3.2-1 for both FR1 and FR2 illustrates the downlink power levels to be applied for the cells at various time instants of the test execution. Row marked "T0" denotes the initial conditions after preamble, while columns marked "T1" is to be applied subsequently in the Main behaviour. The exact instants on which these values shall be applied are described in the texts in this clause. Cell powers in table 6.2.1.1.3.2-2 for the E-UTRAN cell are defined in TS 36.508[7] Table 6.2.2.1-1 and cell powers for NR cells are defined in TS 38.508-1[4] table 6.2.2.1-3 for FR1 and table FFS for FR2.

Table 6.2.1.5.3.2-1: Cell configuration changes over time

	Parameter	Unit	NR Cell 1	E-UTRA Cell 1
T0	SS/PBCH SSS EPRE	dBm/SCS	Non-suitable "Off"	
	RS EPRE			Serving Cell
T1	SS/PBCH SSS EPRE	dBm/SCS	Suitable neighbour inter- frequency cell	
	RS EPRE			Serving Cell

Table 6.2.1.5.3.2-1: Main behaviour

St	Procedure	Message Sequence		TP	Verdict
		U – S	Message		
1	Power on the UE.	-	-	-	-
2	SS starts timer of tmin = 2 minutes and tmax = (6 minutes + cell selection time) (Note 1)	-	-	-	-
3-18	Steps 2-17 of the registration procedure described in TS 36.508[7] table 4.5.2.3-1 take place on E-UTRAN Cell 1.	-	-	-	-
19	The SS adjusts cell levels according to row T1 of table 6.2.1.5.3.2-1.	-	-	-	-
20	Check: Does the UE send an <i>RRCSetupRequest</i> on NR Cell 1 after tmin but before tmax expires? (Note 1)	-->	NR RRC: <i>RRCSetupRequest</i>	1	P
21-38	Steps 3-20 of the registration procedure described in TS 38.508-1[4] table 4.5.2.3-1 are performed on NR Cell 1.	-	-	-	-
Note 1: Timers tmin and tmax in step 1 and 3 are derived from the high priority PLMN search timer T defined by EF _{HPPLMN}					

6.2.2

6.2.3

6.2.3.1

6.2.3.2

6.2.3.3 Inter-RAT cell reselection / From NR RRC_IDLE to E-UTRA_IDLE (lower priority & higher priority, Srxlev based)

6.2.3.3.1 Test Purpose (TP)

(1)

```
with { UE in NR RRC_Idle state }
ensure that {
  when { UE detects the cell re-selection criteria are met for the cell which belongs to the higher
priority E-UTRA frequency }
  then { UE reselects to the E-UTRA cell }
}
```

(2)

```
with { UE in NR RRC_Idle state }
ensure that {
  when { UE detects the cell re-selection criteria are met for the neighbour cell which belongs to
the lower priority E-UTRA frequency }
  then { UE reselects to the E-UTRA cell }
}
```

6.2.3.3.2 Conformance requirements

References: The conformance requirements covered in the present TC are specified in: 3GPP TS 38.304, clause 5.2.4.1, 5.2.4.2 and 5.2.4.5. Unless otherwise stated these are Rel-15 requirements.

[TS 38.304, clause 5.2.4.1]

Absolute priorities of different NR frequencies or inter-RAT frequencies may be provided to the UE in the system information, in the *RRCRelease* message, or by inheriting from another RAT at inter-RAT cell (re)selection. In the case of system information, an NR frequency or inter-RAT frequency may be listed without providing a priority (i.e. the field *cellReselectionPriority* is absent for that frequency). If priorities are provided in dedicated signalling, the UE shall ignore all the priorities provided in system information. If UE is in *camped on any cell* state, UE shall only apply the priorities provided by system information from current cell, and the UE preserves priorities provided by dedicated signalling and *deprioritisationReq* received in *RRCRelease* unless specified otherwise. When the UE in camped normally state, has only dedicated priorities other than for the current frequency, the UE shall consider the current frequency to be the lowest priority frequency (i.e. lower than any of the network configured values).

The UE shall only perform cell reselection evaluation for NR frequencies and inter-RAT frequencies that are given in system information and for which the UE has a priority provided.

In case UE receives *RRCRelease* with *deprioritisationReq*, UE shall consider current frequency and stored frequencies due to the previously received *RRCRelease* with *deprioritisationReq* or all the frequencies of NR to be the lowest priority frequency (i.e. lower than any of the network configured values) while T325 is running irrespective of camped RAT. The UE shall delete the stored deprioritisation request(s) when a PLMN selection is performed on request by NAS (TS 23.122 [9]).

NOTE: UE should search for a higher priority layer for cell reselection as soon as possible after the change of priority. The minimum related performance requirements specified in TS 38.133 [8] are still applicable.

The UE shall delete priorities provided by dedicated signalling when:

- the UE enters a different RRC state; or
- the optional validity time of dedicated priorities (T320) expires; or
- a PLMN selection is performed on request by NAS (TS 23.122 [9]).

NOTE 2: Equal priorities between RATs are not supported.

The UE shall not consider any black listed cells as candidate for cell reselection.

The UE shall inherit the priorities provided by dedicated signalling and the remaining validity time (i.e. T320 in NR and E-UTRA), if configured, at inter-RAT cell (re)selection.

NOTE 3: The network may assign dedicated cell reselection priorities for frequencies not configured by system information.

[TS 38.304, clause 5.2.4.1]

Following rules are used by the UE to limit needed measurements:

- If the serving cell fulfils $S_{rxlev} > S_{IntraSearchP}$ and $S_{qual} > S_{IntraSearchQ}$, the UE may choose not to perform intra-frequency measurements.
- Otherwise, the UE shall perform intra-frequency measurements.
- The UE shall apply the following rules for NR inter-frequencies and inter-RAT frequencies which are indicated in system information and for which the UE has priority provided as defined in 5.2.4.1:
 - For a NR inter-frequency or inter-RAT frequency with a reselection priority higher than the reselection priority of the current NR frequency, the UE shall perform measurements of higher priority NR inter-frequency or inter-RAT frequencies according to TS 38.133 [8].
 - For a NR inter-frequency with an equal or lower reselection priority than the reselection priority of the current NR frequency and for inter-RAT frequency with lower reselection priority than the reselection priority of the current NR frequency:
 - If the serving cell fulfils $S_{rxlev} > S_{nonIntraSearchP}$ and $S_{qual} > S_{nonIntraSearchQ}$, the UE may choose not to perform measurements of NR inter-frequencies or inter-RAT frequency cells of equal or lower priority;
 - Otherwise, the UE shall perform measurements of NR inter-frequencies or inter-RAT frequency cells of equal or lower priority according to TS 38.133 [8].

[TS 38.304, clause 5.2.4.5]

If *threshServingLowQ* is broadcast in system information and more than 1 second has elapsed since the UE camped on the current serving cell, cell reselection to a cell on a higher priority NR frequency or inter-RAT frequency than the serving frequency shall be performed if:

- A cell of a higher priority NR or EUTRAN RAT/frequency fulfils $S_{qual} > Thresh_{X, HighQ}$ during a time interval $T_{reselection_{RAT}}$

Otherwise, cell reselection to a cell on a higher priority NR frequency or inter-RAT frequency than the serving frequency shall be performed if:

- A cell of a higher priority RAT/ frequency fulfils $S_{rxlev} > Thresh_{X, HighP}$ during a time interval $T_{reselection_{RAT}}$; and
- More than 1 second has elapsed since the UE camped on the current serving cell.

Cell reselection to a cell on an equal priority NR frequency shall be based on ranking for intra-frequency cell reselection as defined in sub-clause 5.2.4.6.

If *threshServingLowQ* is broadcast in system information and more than 1 second has elapsed since the UE camped on the current serving cell, cell reselection to a cell on a lower priority NR frequency or inter-RAT frequency than the serving frequency shall be performed if:

- The serving cell fulfils $Squal < Thresh_{Serving, LowQ}$ and a cell of a lower priority NR or E-UTRAN RAT/ frequency fulfils $Squal > Thresh_{X, LowQ}$ during a time interval $Treselection_{RAT}$.

Otherwise, cell reselection to a cell on a lower priority NR frequency or inter-RAT frequency than the serving frequency shall be performed if:

- The serving cell fulfils $Srxlev < Thresh_{Serving, LowP}$ and a cell of a lower priority RAT/ frequency fulfils $Srxlev > Thresh_{X, LowP}$ during a time interval $Treselection_{RAT}$; and
- More than 1 second has elapsed since the UE camped on the current serving cell.

Cell reselection to a higher priority RAT/frequency shall take precedence over a lower priority RAT/frequency if multiple cells of different priorities fulfil the cell reselection criteria.

If more than one cell meets the above criteria, the UE shall reselect a cell as follows:

- If the highest-priority frequency is an NR frequency, the highest ranked cell among the cells on the highest priority frequency(ies) meeting the criteria according to clause 5.2.4.6;
- If the highest-priority frequency is from another RAT, the highest ranked cell among the cells on the highest priority frequency(ies) meeting the criteria of that RAT.

6.2.3.3.3 Test description

6.2.3.3.3.1 Pre-test conditions

System Simulator:

- NR Cell 1, E-UTRA Cell 1 is different priority inter-RAT Cell.
- System information combination NR-6 as defined in TS 38.508-1 [4] clause 4.4.3.1.3 is used in NR Cell.
- System information combination 31 as defined in TS 36.508-1 [18] clause 4.4.3.1 is used in E-UTRA Cell.

UE:

None.

Preamble:

- With E-UTRA Cell 1 "Serving cell" and NR Cell 1 "Non-suitable "Off" cell" in accordance with TS 38.508-1 [4], Table 6.2.2.1-3, the UE is brought to state RRC_IDLE Connectivity (*E-UTRA/EPC*) in accordance with the procedure described in TS 38.508-1 [4], Table 4.5.2.2-1. 4G GUTI and eKSI are assigned and security context established.
- the UE is switched-off.
- With E-UTRA Cell 1 "Non-suitable "Off" cell" and NR Cell 1 "Serving cell" in accordance with TS 38.508-1 [4], Table 6.2.2.1-3, the UE is brought to state 1N-A, RRC_IDLE Connectivity (NR), in accordance with the procedure described in TS 38.508-1 [4], Table 4.5.2.2-2. 5G-GUTI and ngKSI are assigned and security context established.

6.2.3.3.3.2 Test procedure sequence

Table 6.2.3.3.3.2-1/2 illustrate the downlink power levels and other changing parameters to be applied for the cell at various time instants of the test execution. The exact instants on which these values shall be applied are described in the texts in this clause. Row marked "T0" denotes the conditions in the preamble. Configurations marked "T1", "T2" and "T3" are applied at the points indicated in the Main behaviour description in Table 6.2.3.3.3.2-3.

Table 6.2.3.3.2-1: Time instances of cell power level and parameter changes for E-UTRA Cell 1 and NR Cell 1 in FR1

	Parameter	Unit	NR Cell 1	E-UTRA Cell 1	Remark
T0	Cell-specific RS EPRE	dBm/15kHz	-	-Off	The power level values are assigned to ensure UE registered on NR Cell 1
	SS/PBCH SSS EPRE	dBm/SCS	-88	-	
T1	Cell-specific RS EPRE	dBm/15kHz	-	-75	The power level values are assigned to satisfy $Srxle^{VE-UTRA}_{Cell\ 1} > Thresh_{x, high}$
	SS/PBCH SSS EPRE	dBm/SCS	-95	-	
T2	Cell-specific RS EPRE	dBm/15kHz	-	-95	The power level values are assigned to ensure UE reselected back to NR Cell 1: both $Srxle^{VE-UTRA}_{Cell\ 1} < Thresh_{serving, low}$ and $Srxle^{VNR}_{Cell\ 1} > Thresh_{x, low}$.
	SS/PBCH SSS EPRE	dBm/SCS	-75	-	
T3	Cell-specific RS EPRE	dBm/15kHz	-	-75	The power level values are assigned to satisfy both $Srxle^{VNR}_{Cell\ 1} < Thresh_{serving, low}$ and $Srxle^{VE-UTRA}_{Cell\ 1} > Thresh_{x, low}$.
	SS/PBCH SSS EPRE	dBm/SCS	-95	-	

Table 6.2.3.3.2-2: Time instances of cell power level and parameter changes for E-UTRA Cell 1 and NR Cell 1 in FR2

	Parameter	Unit	NR Cell 1	E-UTRA Cell 1	Remark
T0	Cell-specific RS EPRE	dBm/15kHz	-	-Off	The power level values are assigned to ensure UE registered on NR Cell 1
	SS/PBCH SSS EPRE	dBm/SCS	FFS	-	
T1	Cell-specific RS EPRE	dBm/15kHz	-	-75	The power level values are assigned to satisfy $Srxle^{VE-UTRA}_{Cell\ 1} > Thresh_{x, high}$
	SS/PBCH SSS EPRE	dBm/SCS	FFS	-	
T2	Cell-specific RS EPRE	dBm/15kHz	-	-95	The power level values are assigned to ensure UE reselected back to NR Cell 1: both $Srxle^{VE-UTRA}_{Cell\ 1} < Thresh_{serving, low}$ and $Srxle^{VNR}_{Cell\ 1} > Thresh_{x, low}$.
	SS/PBCH SSS EPRE	dBm/SCS	FFS	-	
T3	Cell-specific RS EPRE	dBm/15kHz	-	-75	The power level values are assigned to satisfy both $Srxle^{VNR}_{Cell\ 1} < Thresh_{serving, low}$ and $Srxle^{VE-UTRA}_{Cell\ 1} > Thresh_{x, low}$.
	SS/PBCH SSS EPRE	dBm/SCS	FFS	-	

Table 6.2.3.3.2-3: Main behaviour

St	Procedure	Message Sequence		TP	Verdict
		U - S	Message		
1	The SS adjusts the NR and E-UTRAN Cell power levels according to row "T1" in table 6.2.3.3.2-1/2.	-	-	-	-
2	Void	-	-	-	-
3	Check: Does the test result of generic test procedure in TS 38.508-1 [4] Table 4.9.7.2.2-1 is performed and the UE is camped on E-UTRAN Cell 1?	-	-	1	-
4	The SS adjusts the NR and E-UTRAN Cell power levels according to row "T2" in table 6.2.3.3.2-1/2.	-	-	-	-
5	Void	-	-	-	-
6	Generic test procedure in TS 38.508-1 [4] Table 4.9.2.2-1 take place and UE is camped on NR Cell 1	-	-	-	-
7	The SS transmits RRCRelease message on NR Cell 1.	<--	NR: <i>RRCRelease</i>		
8	The SS notifies the UE of change of System Information on NR Cell 1 by send Short Message on PDCCH using P-RNTI.	<--	NR: <i>ShortMessage</i>	-	-
9	The SS changes <i>Priority</i> of E-UTRA cell 1 in the <i>SIB5</i> of NR Cell 1, The <i>ValueTag</i> of <i>SIB5</i> in the <i>SIB1</i> is increased on NR Cell 1.	-	-	-	-
10	Wait for 2.1* modification period to allow the new system information to take effect.	-	-	-	-
11	The SS adjusts the NR and E-UTRAN Cell power levels according to row "T3" in table 6.2.3.3.2-1/2.	-	-	-	-
12	Void	-	-	-	-
13	Check: Does the test result of generic test procedure in TS 38.508-1 [4] Table 4.9.7.2.2-1 is performed and the UE is camped on E-UTRAN Cell 1?	-	-	2	-

6.2.3.3.3 Specific message contents

Table 6.2.3.3.3-1: SIB2 of NR Cell 1(preamble and all steps, Table 6.2.3.3.2-3)

Derivation Path: TS 38.508-1 [4], Table 4.6.2-1			
Information Element	Value/remark	Comment	Condition
SIB2 ::= SEQUENCE {			
cellReselectionServingFreqInfo SEQUENCE {			
threshServingLowP	10	20 dB	
}			
}			

Table 6.2.3.3.3.2: SIB5 of NR Cell 1(preamble and all steps, Table 6.2.3.3.2-3)

Derivation Path: TS 38.508-1 [4], Table 4.6.2-4			
Information Element	Value/remark	Comment	Condition
SIB5 ::= SEQUENCE {			
carrierFreqListEUTRA SEQUENCE (SIZE (1..maxEUTRA-Carrier)) OF SEQUENCE {			
carrierFreq[1]	Downlink EUTRA ARFCN as E-UTRA Cell 1 used		
cellReselectionPriority[1]	5		
threshX-High	10	20 dB	
threshX-Low	20	40 dB	
}			
t-ReselectionEUTRA	7	7 Seconds	
}			

Table 6.2.3.3.3.3: SystemInformationBlockType3 of EUTRA Cell 1 (preamble and all steps, Table 6.2.3.3.2-3)

Derivation Path: TS 36.508 [7], Table 4.4.3.3-2			
Information Element	Value/remark	Comment	Condition
SystemInformationBlockType3 ::= SEQUENCE {			
cellReselectionServingFreqInfo SEQUENCE {			
threshServingLow	10	20 dB	
}			

Table 6.2.3.3.3.4: SystemInformationBlockType24 of EUTRA Cell 1 (preamble and all steps, Table 6.2.3.3.2-3)

Derivation path: TS 36.508 [7], Table 4.4.3.3-20			
Information Element	Value/Remark	Comment	Condition
SystemInformationBlockType24-r15 ::= SEQUENCE {			
carrierFreqListNR-r15 SEQUENCE (SIZE (1..maxFreq)) OF CarrierFreqNR-r15 SEQUENCE {			
carrierFreq-r15 [1]	Same downlink SSB ARFCN as used for NR Cell 1		
cellReselectionPriority-r15[1]	3		
threshX-High-r15[1]	20	40 dB	
threshX-Low-r15[1]	10	20 dB	
}			
t-ReselectionNR-r15	7	7 Seconds	
}			

Table 6.2.3.3.3.5: SIB5 of NR Cell 1(Step 9, Table 6.2.3.3.2-3)

Derivation Path: TS 38.508-1 [4], Table 4.6.2-4			
Information Element	Value/remark	Comment	Condition
SIB5 ::= SEQUENCE {			
carrierFreqListEUTRA SEQUENCE (SIZE (1..maxEUTRA-Carrier)) OF SEQUENCE {			
carrierFreq[1]	Downlink EUTRA ARFCN as E-UTRA Cell 1 used		
cellReselectionPriority[1]	3		
threshX-High	20	40 dB	
threshX-Low	10	20 dB	
}			
t-ReselectionEUTRA	7	7 Seconds	
}			

Table 6.2.3.3.3-6: SIB1 of NR Cell 1 (step 9, Table 6.2.3.3.3-2-3)

Derivation Path: TS 38.508-1 [4], Table 4.6.1-5			
Information Element	Value/remark	Comment	Condition
SIB1 ::= SEQUENCE {			
si-SchedulingInfo	SI-SchedulingInfo		
}			

Table 6.2.3.3.3-7: SI-SchedulingInfo (si-SchedulingInfo in Table 6.2.3.3.3-6)

Derivation Path: TS 38.508-1 [4], Table 4.6.3-130A			
Information Element	Value/remark	Comment	Condition
SI-SchedulingInfo ::= SEQUENCE {			
schedulingInfoList SEQUENCE			
(SIZE(1..maxSI-Message)) OF			
SEQUENCE{			
sib-MappingInfo SEQUENCE (SIZE	1 entry		
(1..maxSIB)) OF SEQUENCE {			
type	sibType5		
valueTag	1		
}			
}			
}			

6.2.3.4

6.2.3.5 Inter-RAT cell reselection/From NR RRC_IDLE to E-UTRA_Idle according to RAT priority provided by dedicated signalling (RRCRelease)

6.2.3.5.1 Test Purpose (TP)

(1)

```
with { UE in NR RRC_IDLE state having received an RRCRelease message including
cellReselectionPriorities }
ensure that {
  when { UE detects the cell re-selection criteria are met for the cell which belongs to the higher
priority RAT }
    then { UE reselects the cell which belongs to the higher priority RAT }
}
```

(2)

```
with { UE in NR RRC_IDLE state having received an RRCRelease message including a
cellReselectionPriorities }
ensure that {
  when { UE detects the cell re-selection criteria are met for the cell which belongs to the lower
priority RAT }
    then { UE reselects the cell which belongs to the lower priority RAT }
}
```

(3)

```
with { UE in NR RRC_IDLE state having received an RRCRelease message including a
cellReselectionPriorities }
ensure that {
  when { T320 expires }
    then { UE reselects a cell by applying the cellReselectionPriority broadcast in the system
information }
}
```

(4)

```

with { UE in NR RRC_IDLE state and reselection priorities have been provided in dedicated
signalling }
ensure that {
  when { T320 has not expired }
  then { The UE shall ignore all the priorities provided in system information, and not perform
cell reselection evaluation for NR frequencies and E-UTRA frequencies for which the UE doesn't have
a priority provided }
}

```

6.2.3.5.2 Conformance requirements

References: The conformance requirements covered in the present TC are specified in: 3GPP TS 38.304: clause 5.2.4.1 and 5.2.4.5, 3GPP TS 38.331: clause 5.3.8.3 and 5.3.8.4. Unless otherwise stated these are Rel-15 requirements.

[TS 38.304, clause 5.2.4.1]

Absolute priorities of different NR frequencies or inter-RAT frequencies may be provided to the UE in the system information, in the *RRCRelease* message, or by inheriting from another RAT at inter-RAT cell (re)selection. In the case of system information, an NR frequency or inter-RAT frequency may be listed without providing a priority (i.e. the field *cellReselectionPriority* is absent for that frequency). If priorities are provided in dedicated signalling, the UE shall ignore all the priorities provided in system information. If UE is in *camped on any cell* state, UE shall only apply the priorities provided by system information from current cell, and the UE preserves priorities provided by dedicated signalling and *deprioritisationReq* received in *RRCRelease* unless specified otherwise. When the UE in camped normally state, has only dedicated priorities other than for the current frequency, the UE shall consider the current frequency to be the lowest priority frequency (i.e. lower than any of the network configured values).

The UE shall only perform cell reselection evaluation for NR frequencies and inter-RAT frequencies that are given in system information and for which the UE has a priority provided.

In case UE receives *RRCRelease* with *deprioritisationReq*, UE shall consider current frequency and stored frequencies due to the previously received *RRCRelease* with *deprioritisationReq* or all the frequencies of NR to be the lowest priority frequency (i.e. lower than any of the network configured values) while T325 is running irrespective of camped RAT. The UE shall delete the stored deprioritisation request(s) when a PLMN selection is performed on request by NAS (TS 23.122 [9]).

NOTE: UE should search for a higher priority layer for cell reselection as soon as possible after the change of priority. The minimum related performance requirements specified in TS 38.133 [8] are still applicable.

The UE shall delete priorities provided by dedicated signalling when:

- the UE enters a different RRC state; or
- the optional validity time of dedicated priorities (T320) expires; or
- a PLMN selection is performed on request by NAS (TS 23.122 [9]).

NOTE 2: Equal priorities between RATs are not supported.

The UE shall not consider any black listed cells as candidate for cell reselection.

The UE shall inherit the priorities provided by dedicated signalling and the remaining validity time (i.e. T320 in NR and E-UTRA), if configured, at inter-RAT cell (re)selection.

NOTE 3: The network may assign dedicated cell reselection priorities for frequencies not configured by system information.

[TS 38.304, clause 5.2.4.2]

Following rules are used by the UE to limit needed measurements:

- If the serving cell fulfils $S_{rxlev} > S_{IntraSearchP}$ and $S_{qual} > S_{IntraSearchQ}$, the UE may choose not to perform intra-frequency measurements.
- Otherwise, the UE shall perform intra-frequency measurements.

- The UE shall apply the following rules for NR inter-frequencies and inter-RAT frequencies which are indicated in system information and for which the UE has priority provided as defined in 5.2.4.1:
 - For a NR inter-frequency or inter-RAT frequency with a reselection priority higher than the reselection priority of the current NR frequency, the UE shall perform measurements of higher priority NR inter-frequency or inter-RAT frequencies according to TS 38.133 [8].
 - For a NR inter-frequency with an equal or lower reselection priority than the reselection priority of the current NR frequency and for inter-RAT frequency with lower reselection priority than the reselection priority of the current NR frequency:
 - If the serving cell fulfils $S_{rxlev} > S_{nonIntraSearchP}$ and $S_{qual} > S_{nonIntraSearchQ}$, the UE may choose not to perform measurements of NR inter-frequencies or inter-RAT frequency cells of equal or lower priority;
 - Otherwise, the UE shall perform measurements of NR inter-frequencies or inter-RAT frequency cells of equal or lower priority according to TS 38.133 [8].

[TS 38.331, clause 5.3.8.3]

The UE shall:

- 1> delay the following actions defined in this sub-clause 60 ms from the moment the *RRCRelease* message was received or optionally when lower layers indicate that the receipt of the *RRCRelease* message has been successfully acknowledged, whichever is earlier;
 - 1> stop timer T380, if running;
 - 1> stop timer T320, if running;
 - 1> if T390 is running:
 - 2> stop timer T390 for all access categories;
 - 2> perform the actions as specified in 5.3.14.4;
 - 1> if the AS security is not activated, perform the actions upon going to RRC_IDLE as specified in 5.3.11 with the release cause 'other' upon which the procedure ends;
 - 1> if the *RRCRelease* message includes *redirectedCarrierInfo* indicating redirection to *eutra*:
 - 2> if *cnType* is included:
 - 3> after the cell selection, indicate the available CN Type(s) and the received *cnType* to upper layers;
- NOTE: Handling the case if the E-UTRA cell selected after the redirection does not support the core network type specified by the *cnType*, is up to UE implementation.
- 1> if the *RRCRelease* message includes the *cellReselectionPriorities*:
 - 2> store the cell reselection priority information provided by the *cellReselectionPriorities*;
 - 2> if the *t320* is included:
 - 3> start timer T320, with the timer value set according to the value of *t320*;
 - 1> else:
 - 2> apply the cell reselection priority information broadcast in the system information;
 - 1> if *deprioritisationReq* is included:
 - 2> start or restart timer T325 with the timer value set to the *deprioritisationTimer* signalled;
 - 2> store the *deprioritisationReq* until T325 expiry;
 - 1> if the *RRCRelease* includes *suspendConfig*:
 - 2> apply the received *suspendConfig*;

- 2> reset MAC and release the default MAC Cell Group configuration, if any;
- 2> re-establish RLC entities for SRB1;
- 2> if the *RRCRelease* message with *suspendConfig* was received in response to an *RRCResumeRequest* or an *RRCResumeRequest1*:
 - 3> stop the timer T319 if running;
 - 3> in the stored UE Inactive AS context:
 - 4> replace the K_{gNB} and K_{RRCint} keys with the current K_{gNB} and K_{RRCint} keys;
 - 4> replace the C-RNTI with the temporary C-RNTI in the cell the UE has received the *RRCRelease* message;
 - 4> replace the *cellIdentity* with the *cellIdentity* of the cell the UE has received the *RRCRelease* message;
 - 4> replace the physical cell identity with the physical cell identity of the cell the UE has received the *RRCRelease* message;
 - 4> replace the *suspendConfig* with the current *suspendConfig*;
- 2> else:
 - 3> store in the UE Inactive AS Context the configured *suspendConfig*, the current K_{gNB} and K_{RRCint} keys, the ROHC state, the C-RNTI used in the source PCell, the *cellIdentity* and the physical cell identity of the source PCell, and all other parameters configured except with *ReconfigurationWithSync*;
- 2> suspend all SRB(s) and DRB(s), except SRB0;
- 2> indicate PDCP suspend to lower layers of all DRBs;
- 2> if the *t380* is included:
 - 3> start timer T380, with the timer value set to *t380*;
- 2> if the *RRCRelease* message is including the *waitTime*:
 - 3> start timer T302 with the value set to the *waitTime*;
 - 3> inform the upper layer that access barring is applicable for all access categories except categories '0' and '2';
- 2> indicate the suspension of the RRC connection to upper layers;
- 2> enter RRC_INACTIVE and perform cell selection as specified in TS 38.304 [20];
- 1> else
 - 2> perform the actions upon going to RRC_IDLE as specified in 5.3.11, with the release cause 'other'.

[TS 38.331, clause 5.3.8.4]

The UE shall:

- 1> if T320 expires:
 - 2> if stored, discard the cell reselection priority information provided by the *cellReselectionPriorities* or inherited from another RAT;
 - 2> apply the cell reselection priority information broadcast in the system information.

6.2.3.5.3 Test description

6.2.3.5.3.1 Pre-test conditions

System Simulator:

- NR Cell 1, E-UTRA Cell 1 is inter-RAT cell.
- System information combination NR-6 as defined in TS 38.508-1 [4] clause 4.4.3.1.3 is used in NR Cell.
- System information combination 31 as defined in TS 36.508-1 [18] clause 4.4.3.1 is used in E-UTRA Cell.

UE:

None.

Preamble:

- With E-UTRA Cell 1 "Serving cell" and NR Cell 1 "Non-suitable "Off" cell" in accordance with TS 38.508-1 [4], Table 6.2.2.1-3, the UE is brought to state RRC_IDLE Connectivity (E-UTRA/EPC) in accordance with the procedure described in TS 38.508-1 [4], Table 4.5.2.2-1. 4G GUTI and eKSI are assigned and security context established.
- the UE is switched-off.
- With E-UTRA Cell 1 "Non-suitable "Off" cell" and NR Cell 1 "Serving cell" in accordance with TS 38.508-1 [4], Table 6.2.2.1-3, the UE is brought to state 3N-A, RRC_CONNECTED Connectivity (NR), in accordance with the procedure described in TS 38.508-1 [4], Table 4.5.4.2-3. 5G-GUTI and ngKSI are assigned and security context established.

6.2.3.5.3.2 Test procedure sequence

Table 6.2.3.5.3.2-1/2 illustrate the downlink power levels and other changing parameters to be applied for the cell at various time instants of the test execution. The exact instants on which these values shall be applied are described in the texts in this clause. Row marked "T0" denotes the conditions in the preamble. Configurations marked "T1", "T2" and so on are applied at the points indicated in the Main behaviour description in Table 6.1.3.5.3.2-3.

Table 6.2.3.5.3.2-1: Time instances of cell power level and parameter changes for E-UTRA cell 1 and NR cell 1 in FR1

	Parameter	Unit	NR Cell 1	E-UTRA Cell 1	Remark
T0	Cell-specific RS EPRE	dBm/15kHz	-	OFF	The power level values are assigned to satisfy $Srxlev_{NR\ Cell\ 1} > 0$ and $Srxlev_{E-UTRA\ Cell\ 1} < 0$. And UE camping on NR Cell 1 is guaranteed.
	SS/PBCH SSS EPRE	dBm/SCS	-88	-	
T1	Cell-specific RS EPRE	dBm/15kHz	-	-70	The power level values are assigned to satisfy $Srxlev_{E-UTRA\ cell\ 1} > Thresh_{x,high}$.
	SS/PBCH SSS EPRE	dBm/SCS	-90	-	
T2	Cell-specific RS EPRE	dBm/15kHz	-	-100	The power level values are such that camping on NR Cell 1 is guaranteed.
	SS/PBCH SSS EPRE	dBm/SCS	-75	-	
T3	Cell-specific RS EPRE	dBm/15kHz	-	-88	The power level values are assigned to satisfy both $Srxlev_{NR\ Cell\ 1} < Thresh_{serving, low}$ and $Srxlev_{E-UTRA\ Cell\ 1} > Thresh_{x, low}$.
	SS/PBCH SSS EPRE	dBm/SCS	-100	-	
T4	Cell-specific RS EPRE	dBm/15kHz	-	-100	The power level values are such that camping on NR Cell 1 is guaranteed.
	SS/PBCH SSS EPRE	dBm/SCS	-75	-	

T5	Cell-specific RS EPRE	dBm/15kHz	-	-70	The power level values are assigned to satisfy $S_{rxlev}^{NR \text{ Cell } 1} > \text{Thresh}_{\text{serv}, \text{low}}$ and $S_{rxlev}^{E-UTRA \text{ Cell } 1} > \text{Thresh}_{\text{x}, \text{high}}$.
	SS/PBCH SSS EPRE	dBm/SCS	-90	-	

Table 6.2.3.5.3.2-2: Time instances of cell power level and parameter changes for E-UTRA Cell 1 and NR Cell 1 in FR2

	Parameter	Unit	NR Cell 1	E-UTRA Cell 1	Remark
T0	Cell-specific RS EPRE	dBm/15kHz	-	OFF	The power level values are assigned to satisfy $S_{rxlev}^{NR \text{ Cell } 1} > 0$ and $S_{rxlev}^{E-UTRA \text{ Cell } 1} < 0$. And UE camping on NR Cell 1 is guaranteed.
	SS/PBCH SSS EPRE	dBm/SCS	FFS	-	
T1	Cell-specific RS EPRE	dBm/15kHz	-	-70	The power level values are assigned to satisfy $S_{rxlev}^{E-UTRA \text{ Cell } 1} > \text{Thresh}_{\text{x}, \text{high}}$.
	SS/PBCH SSS EPRE	dBm/SCS	FFS	-	
T2	Cell-specific RS EPRE	dBm/15kHz	-	-100	The power level values are such that camping on NR Cell 1 is guaranteed.
	SS/PBCH SSS EPRE	dBm/SCS	FFS	-	
T3	Cell-specific RS EPRE	dBm/15kHz	-	-88	The power level values are assigned to satisfy both $S_{rxlev}^{NR \text{ Cell } 1} < \text{Thresh}_{\text{serv}, \text{low}}$ and $S_{rxlev}^{E-UTRA \text{ Cell } 1} > \text{Thresh}_{\text{x}, \text{low}}$.
	SS/PBCH SSS EPRE	dBm/SCS	FFS	-	
T4	Cell-specific RS EPRE	dBm/15kHz	-	-100	The power level values are such that camping on NR Cell 1 is guaranteed.
	SS/PBCH SSS EPRE	dBm/SCS	FFS	-	
T5	Cell-specific RS EPRE	dBm/15kHz	-	-70	The power level values are assigned to satisfy $S_{rxlev}^{NR \text{ Cell } 1} > \text{Thresh}_{\text{serv}, \text{low}}$ and $S_{rxlev}^{E-UTRA \text{ Cell } 1} > \text{Thresh}_{\text{x}, \text{high}}$.
	SS/PBCH SSS EPRE	dBm/SCS	FFS	-	

Table 6.2.3.5.3.2-3: Main behaviour

St	Procedure	Message Sequence		TP	Verdict
		U - S	Message		
1	The SS transmits RRCRelease message including cellReselectionPriorities on NR Cell 1.	-	NR:RRCRelease	-	-
2	The SS adjusts the NR and E-UTRAN Cell power levels according to row "T1" in table 6.2.3.5.3.2-1/2.	-	-	-	-
3	Check: Does the UE transmit an RRC CONNECTION REQUEST on E-UTRA Cell 1 within the next 30 Seconds?	-	-	4	F
4	The test steps 1 to 8 of generic test procedure in TS 38.508-1 [4] Table 4.5.4.2-3 are performed on NR Cell 1.	-	-	-	-
5	The SS transmits RRCRelease message including cellReselectionPriorities on NR Cell 1.	<--	NR:RRCRelease	-	-
6	Check: Does the test result of generic test procedure in TS 38.508-1 [4] Table 4.9.7.2.2-1 is performed and the UE is camped on E-UTRAN Cell 1?	-	-	1	-
7	The SS adjusts the NR and E-UTRAN Cell power levels according to row "T2" in table 6.2.3.5.3.2-1/2.	-	-	-	-
8	Generic test procedure in TS 38.508-1 [4] Table 4.9.9.2.2-1 take place and the UE is camped on NR Cell 1.	-	-	-	-
9	The SS adjusts the NR and E-UTRAN Cell power levels according to row "T3" in table 6.2.3.5.3.2-1/2.	-	-	-	-
10	The SS transmits RRCRelease message including cellReselectionPriorities on NR Cell 1.	<--	NR:RRCRelease	-	-
11	Check: Does the test result of generic test procedure in TS 38.508-1 [4] Table 4.9.7.2.2-1 is performed and the UE is camped on E-UTRAN Cell 1?	-	-	2	-
12	The SS adjusts the NR and E-UTRAN Cell power levels according to row "T4" in table 6.2.3.5.3.2-1/2.	-	-	-	-
13	Generic test procedure in TS 38.508-1 [4] Table 4.9.9.2.2-1 take place and the UE is camped on NR Cell 1.	-	-	-	-
14	The SS transmits RRCRelease message including cellReselectionPriorities on NR Cell 1.	<--	NR:RRCRelease	-	-
15	The SS adjusts the NR and E-UTRAN Cell power levels according to row "T5" in table 6.2.3.5.3.2-1/2.	-	-	-	-
16	Wait for 5 minutes from step 17 to ensure that T320 expires.	-	-	-	-
17	Check: Does the test result of generic test procedure in TS 38.508-1 [4] Table 4.9.7.2.2-1 is performed and the UE is camped on E-UTRAN Cell 1?	-	-	3	-

6.2.3.5.3.3 Specific message contents

Table Table 6.2.3.5.3.3-1: SIB2 of NR Cell 1(preamble and all steps, Table 6.2.3.5.3.2-3)

Derivation Path: TS 38.508-1 [4], Table 4.6.2-1			
Information Element	Value/remark	Comment	Condition
SIB2 ::= SEQUENCE {			
cellReselectionServingFreqInfo SEQUENCE {			
threshServingLowP	5	10dB	
}			
}			

Table Table 6.2.3.5.3.3-2: SIB5 of NR Cell 1(preamble and all steps, Table 6.2.3.5.3.2-3)

Derivation Path: TS 38.508-1 [4], Table 4.6.2-4			
Information Element	Value/remark	Comment	Condition
SIB5 ::= SEQUENCE {			
carrierFreqListEUTRA SEQUENCE (SIZE (1..maxEUTRA-Carrier)) OF SEQUENCE {			
carrierFreq[1]	Downlink EARFCN as E-UTRA Cell 1 used		
cellReselectionPriority[1]	5		
threshX-High	13	26 dB	
threshX-Low	5	10 dB	
}			
t-ReselectionEUTRA	7	7 Seconds	
}			

Table 6.2.3.5.3.3-3: SystemInformationBlockType3 for EUTRA Cell 1 (preamble and all steps, Table 6.2.3.5.3.2-3)

Derivation Path: TS 36.508 [7], Table 4.4.3.2			
Information Element	Value/remark	Comment	Condition
SystemInformationBlockType3 ::= SEQUENCE {			
cellReselectionServingFreqInfo SEQUENCE {			
threshServingLow	5	10dB	
}			
}			

Table 6.2.3.5.3.3-4: SystemInformationBlockType24 for EUTRA Cell 1 (preamble and all steps, Table 6.2.3.5.3.2-3)

Derivation path: TS 36.508 [7], Table 4.4.3.3-20			
Information Element	Value/Remark	Comment	Condition
SystemInformationBlockType24-r15 ::= SEQUENCE {			
carrierFreqListNR-r15 SEQUENCE (SIZE (1..maxFreq)) OF CarrierFreqNR-r15 SEQUENCE {			
carrierFreq-r15	Same downlink SSB ARFCN as used for NR Cell 1		
cellReselectionPriority-r15	3		
threshX-High-r15	20	40dB	
threshX-Low-r15	10	20dB	
}			
t-ReselectionNR-r15	7	7 Seconds	
}			

Table 6.2.3.5.3.3-5 RRCRelease (step1, Table 6.2.3.5.3.2-3)

Derivation Path: TS 38.508-1 [4], Table 4.6.1-4B			
Information Element	Value/remark	Comment	Condition
RRCRelease ::= SEQUENCE {			
criticalExtensions CHOICE {			
rrcRelease SEQUENCE {			
cellReselection Priorities			
freqPriorityListEUTRA SEQUENCE (SIZE (1..maxFreq)) OF{			
carrierFreq	Downlink ARFCN of E-UTRA Cell 1		
cellReselectionPriority	Not present		Step1
	5		Step5
	3		Step10
	3		Step14
}			
freqPriorityListNR SEQUENCE (SIZE (1..maxFreq)) OF{			
carrierFreq	Downlink SSB ARFCN of NR Cell 1		
cellReselectionPriority	4		Step1
	4		Step5
	4		Step10
	4		Step14
}			
t320	Not present		Step1
	Not present		Step5
	Not present		Step10
	min5	5 minites	Step14
}			
}			
}			

6.2.3.6

6.2.3.7 Inter-RAT cell reselection/From NR RRC_IDLE to E-UTRA RRC_IDLE, Snonintrasearch

6.2.3.7.1 Test Purpose (TP)

(1)

```
with { UE in NR RRC_IDLE state, and the UE is not in high mobility state }
ensure that {
  when { Snonintrasearch is non-zero in system information }
  then { UE perform measurement and reselects to cell which belongs to the high priority E-UTRA cell even if Srxlev>Snonintrasearch }
}
```

6.2.3.7.2 Conformance requirements

References: The conformance requirements covered in the present TC are specified in: 3GPP TS 38.304, clause 5.2.4.1, 5.2.4.2 and 5.2.4.5. Unless otherwise stated these are Rel-15 requirements.

[TS 38.304, clause 5.2.4.1]

Absolute priorities of different NR frequencies or inter-RAT frequencies may be provided to the UE in the system information, in the RRCRelease message, or by inheriting from another RAT at inter-RAT cell (re)selection. In the case of system information, an NR frequency or inter-RAT frequency may be listed without providing a priority (i.e. the field cellReselectionPriority is absent for that frequency). If priorities are provided in dedicated signalling, the UE shall ignore all the priorities provided in system information. If UE is in camped on any cell state, UE shall only apply the priorities provided by system information from current cell, and the UE preserves priorities provided by dedicated signalling and deprioritisationReq received in RRCRelease unless specified otherwise. When the UE in camped

normally state, has only dedicated priorities other than for the current frequency, the UE shall consider the current frequency to be the lowest priority frequency (i.e. lower than any of the network configured values).

The UE shall only perform cell reselection evaluation for NR frequencies and inter-RAT frequencies that are given in system information and for which the UE has a priority provided.

In case UE receives *RRCRelease* with *deprioritisationReq*, UE shall consider current frequency and stored frequencies due to the previously received *RRCRelease* with *deprioritisationReq* or all the frequencies of NR to be the lowest priority frequency (i.e. lower than any of the network configured values) while T325 is running irrespective of camped RAT. The UE shall delete the stored deprioritisation request(s) when a PLMN selection is performed on request by NAS (TS 23.122 [9]).

NOTE: UE should search for a higher priority layer for cell reselection as soon as possible after the change of priority. The minimum related performance requirements specified in TS 38.133 [8] are still applicable.

The UE shall delete priorities provided by dedicated signalling when:

- the UE enters a different RRC state; or
- the optional validity time of dedicated priorities (T320) expires; or
- a PLMN selection is performed on request by NAS (TS 23.122 [9]).

NOTE 2: Equal priorities between RATs are not supported.

The UE shall not consider any black listed cells as candidate for cell reselection.

The UE shall inherit the priorities provided by dedicated signalling and the remaining validity time (i.e. T320 in NR and E-UTRA), if configured, at inter-RAT cell (re)selection.

NOTE 3: The network may assign dedicated cell

[TS 38.304, clause 5.2.4.2]

Following rules are used by the UE to limit needed measurements:

- If the serving cell fulfils $S_{rxlev} > S_{IntraSearchP}$ and $S_{qual} > S_{IntraSearchQ}$, the UE may choose not to perform intra-frequency measurements.
- Otherwise, the UE shall perform intra-frequency measurements.
- The UE shall apply the following rules for NR inter-frequencies and inter-RAT frequencies which are indicated in system information and for which the UE has priority provided as defined in 5.2.4.1:
 - For a NR inter-frequency or inter-RAT frequency with a reselection priority higher than the reselection priority of the current NR frequency, the UE shall perform measurements of higher priority NR inter-frequency or inter-RAT frequencies according to TS 38.133 [8].
 - For a NR inter-frequency with an equal or lower reselection priority than the reselection priority of the current NR frequency and for inter-RAT frequency with lower reselection priority than the reselection priority of the current NR frequency:
 - If the serving cell fulfils $S_{rxlev} > S_{nonIntraSearchP}$ and $S_{qual} > S_{nonIntraSearchQ}$, the UE may choose not to perform measurements of NR inter-frequencies or inter-RAT frequency cells of equal or lower priority;
- Otherwise, the UE shall perform measurements of NR inter-frequencies or inter-RAT frequency cells of equal or lower priority according to TS 38.133 [8].

[TS 38.304, clause 5.2.4.5]

If *threshServingLowQ* is broadcast in system information and more than 1 second has elapsed since the UE camped on the current serving cell, cell reselection to a cell on a higher priority NR frequency or inter-RAT frequency than the serving frequency shall be performed if:

- A cell of a higher priority NR or EUTRAN RAT/frequency fulfils $S_{qual} > Thresh_{X, HighQ}$ during a time interval $T_{reselectionRAT}$

Otherwise, cell reselection to a cell on a higher priority NR frequency or inter-RAT frequency than the serving frequency shall be performed if:

- A cell of a higher priority RAT/ frequency fulfils $Srxlev > Thresh_{X, HighP}$ during a time interval $Treselection_{RAT}$; and
- More than 1 second has elapsed since the UE camped on the current serving cell.

Cell reselection to a cell on an equal priority NR frequency shall be based on ranking for intra-frequency cell reselection as defined in sub-clause 5.2.4.6.

If *threshServingLowQ* is broadcast in system information and more than 1 second has elapsed since the UE camped on the current serving cell, cell reselection to a cell on a lower priority NR frequency or inter-RAT frequency than the serving frequency shall be performed if:

- The serving cell fulfils $Squal < Thresh_{Serving, LowQ}$ and a cell of a lower priority NR or E-UTRAN RAT/ frequency fulfils $Squal > Thresh_{X, LowQ}$ during a time interval $Treselection_{RAT}$.

Otherwise, cell reselection to a cell on a lower priority NR frequency or inter-RAT frequency than the serving frequency shall be performed if:

- The serving cell fulfils $Srxlev < Thresh_{Serving, LowP}$ and a cell of a lower priority RAT/ frequency fulfils $Srxlev > Thresh_{X, LowP}$ during a time interval $Treselection_{RAT}$; and
- More than 1 second has elapsed since the UE camped on the current serving cell.

Cell reselection to a higher priority RAT/frequency shall take precedence over a lower priority RAT/frequency if multiple cells of different priorities fulfil the cell reselection criteria.

If more than one cell meets the above criteria, the UE shall reselect a cell as follows:

- If the highest-priority frequency is an NR frequency, the highest ranked cell among the cells on the highest priority frequency(ies) meeting the criteria according to clause 5.2.4.6;
- If the highest-priority frequency is from another RAT, the highest ranked cell among the cells on the highest priority frequency(ies) meeting the criteria of that RAT.

6.2.3.7.3 Test description

6.2.3.7.3.1 Pre-test conditions

System Simulator:

- NR Cell 1, E-UTRA Cell 1 is higher priority inter-RAT cell.
- System information combination NR-6 as defined in TS 38.508-1 [4] clause 4.4.3.1.3 is used in NR Cell.
- System information combination 31 as defined in TS 36.508-1 [7] clause 4.4.3.1 is used in E-UTRA Cell.

UE:

None.

Preamble:

- With E-UTRA Cell 1 "Serving cell" and NR Cell 1 "Non-suitable "Off" cell" in accordance with TS 38.508-1 [4], Table 6.2.2.1-3, the UE is brought to state RRC_IDLE Connectivity (E-UTRA/EPC) in accordance with the procedure described in TS 38.508-1 [4], Table 4.5.2.2-1. 4G GUTI and eKSI are assigned and security context established.
- the UE is switched-off.

- With E-UTRA Cell 1 "Non-suitable "Off" cell" and NR Cell 1 "Serving cell" in accordance with TS 38.508-1 [4], Table 6.2.2.1-3, the UE is brought to state IN-A, RRC_IDLE Connectivity (NR), in accordance with the procedure described in TS 38.508-1 [4], Table 4.5.2.2-2. 5G-GUTI and ngKSI are assigned and security context established.

6.2.3.7.3.2 Test procedure sequence

Table 6.2.3.7.3.2-1/2 illustrate the downlink power levels and other changing parameters to be applied for the cell at various time instants of the test execution. The exact instants on which these values shall be applied are described in the texts in this clause. Row marked "T0" denotes the conditions in the preamble. Configurations marked "T1" is applied at the points indicated in the Main behaviour description in Table 6.2.3.7.3.2-3.

Table 6.2.3.7.3.2-1: Time instances of cell power level and parameter changes for E-UTRA Cell 1 and NR Cell 1 in FR1

	Parameter	Unit	NR Cell 1	E-UTRA Cell 1	Remark
T0	Cell-specific RS EPRE	dBm/15kHz	-	Off	The power level values are assigned to ensure UE registered on NR Cell 1
	SS/PBCH SSS EPRE	dBm/SCS	-88	-	
T1	Cell-specific RS EPRE	dBm/15kHz	-	-75	The power level values are assigned to satisfy $Srxlev_{NR\ Cell\ 1} > S_{nonintrasearch}$ and $Srxlev_{E-UTRA\ Cell\ 1} > Thresh_{x, high}$.
	SS/PBCH SSS EPRE	dBm/SCS	-90	-	

Table 6.2.3.7.3.2-2: Time instances of cell power level and parameter changes for E-UTRA Cell 1 and NR Cell 1 in FR2

	Parameter	Unit	NR Cell 1	E-UTRA Cell 1	Remark
T0	Cell-specific RS EPRE	dBm/15kHz	-	Off	The power level values are assigned to ensure UE registered on NR Cell 1
	SS/PBCH SSS EPRE	dBm/SCS	FFS	-	
T1	Cell-specific RS EPRE	dBm/15kHz	-	-75	The power level values are assigned to satisfy $Srxlev_{NR\ Cell\ 1} > S_{nonintrasearch}$ and $Srxlev_{E-UTRA\ Cell\ 1} > Thresh_{x, high}$.
	SS/PBCH SSS EPRE	dBm/SCS	FFS	-	

Table 6.2.3.7.3.2-3: Main behaviour

St	Procedure	Message Sequence		TP	Verdict
		U - S	Message		
1	The SS adjusts the NR and E-UTRAN Cell power levels according to row "T1" in table 6.2.3.7.3.2-1/2.	-	-	-	-
2	Check: Does the test result of generic test procedure in TS 38.508-1 [4] Table 4.9.7.2.2-1 is performed and the UE is camped on E-UTRAN Cell 1?	-	-	1	-

6.2.3.7.3.3 Specific message contents

Table 6.2.3.7.3.3-1: SIB2 of NR Cell 1 (preabmle and all steps, Table 6.2.3.7.3.2-3)

Derivation Path: TS 38.508-1 [4], Table 4.6.2-1			
Information Element	Value/remark	Comment	Condition
SIB2 ::= SEQUENCE {			
cellReselectionServingFreqInfo			
SEQUENCE {			
s-NonIntraSearchP	3	6 dB	
threshServingLowP	3	6 dB	
}			
}			

Table Table 6.2.3.7.3.3-2: SIB5 of NR Cell 1(preamble and all steps, Table 6.2.3.7.3.2-3)

Derivation Path: TS 38.508-1 [4], Table 4.6.2-4			
Information Element	Value/remark	Comment	Condition
SIB5 ::= SEQUENCE {			
carrierFreqListEUTRA SEQUENCE (SIZE (1..maxEUTRA-Carrier)) OF SEQUENCE {			
carrierFreq[1]	Downlink EUTRA ARFCN as E-UTRA Cell 1 used		
cellReselectionPriority[n]	5		
threshX-High	10	20 dB	
threshX-Low	20	40 dB	
}			
t-ReselectionEUTRA	7	7 Seconds	
}			

Table 6.2.3.7.3.3-3: SystemInformationBlockType3 of EUTRA Cell 1 (preamble and all steps, Table 6.2.3.7.3.2-3)

Derivation Path: TS 36.508 [7], Table 4.4.3.3-2			
Information Element	Value/remark	Comment	Condition
SystemInformationBlockType3 ::= SEQUENCE {			
cellReselectionServingFreqInfo SEQUENCE {			
threshServingLow	3	6 dB	
}			
}			

Table 6.2.3.7.3.3-4: SystemInformationBlockType24 for EUTRA Cell 1 (preamble and all steps, Table 6.2.3.7.3.2-3)

Derivation path: TS 36.508 [7], Table 4.4.3.3-20			
Information Element	Value/Remark	Comment	Condition
SystemInformationBlockType24-r15 ::= SEQUENCE {			
carrierFreqListNR-r15 SEQUENCE (SIZE (1..maxFreq)) OF CarrierFreqNR-r15 SEQUENCE {			
carrierFreq-r15[1]	Same downlink SSB ARFCN as used for NR Cell 1		
cellReselectionPriority-r15[1]	3		
threshX-High-r15[1]	15	30 dB	
threshX-Low-r15[1]	15	30 dB	
}			
t-ReselectionNR-r15	7	7 Seconds	
}			

6.3 5GS Steering of Roaming

6.3.1 Steering of Roaming

6.3.1.1 Steering of UE in roaming during registration/security check successful using List Type 1

6.3.1.1.1 Test Purpose (TP)

(1)

with {UE being in automatic PLMN selection mode, current VPLMN not part of "PLMNs where registration was aborted due to SOR" List and not part of "User Controlled PLMN Selector with Access Technology" list and UE's USIM configured with indication that the UE is to receive Steering of Roaming information due to initial registration in a VPLMN}

ensure that {

when {SOR Transparent container indicates ACK has been requested & List Type indicates PLMN ID and Access technology list in REGISTRATION ACCEPT and security check is successful}

then {UE sends ACK in REGISTRATION COMPLETE, waits for network release of the NAS signalling connection and selects higher priority PLMN}

6.3.1.1.2 Conformance requirements

References: The conformance requirements covered in the present TC are specified in: TS 23.122, clause C.2. Unless otherwise stated these are Rel-15 requirements

[TS 23.122, clause C.2]

- 6) The VPLMN AMF to the UE: The VPLMN AMF shall transparently send the received steering of roaming information to the UE in the REGISTRATION ACCEPT message;
- 7) If the steering of roaming information is received and the security check is successful, then:
 - a) if the steering of roaming information contains a secured packet (see 3GPP TS 31.115 [67]):
 - if the UDM has not requested an acknowledgement from the UE the UE shall send the REGISTRATION COMPLETE message;
 - the ME shall upload the secured packet to the USIM using procedures in 3GPP TS 31.111 [41].

NOTE 1: How the ME handles UICC responses and failures in communication between the ME and UICC is implementation specific and out of scope of this release of the specification.

- if the UDM has not requested an acknowledgement from the UE and the ME receives a USAT REFRESH command qualifier (3GPP TS 31.111 [41]) of type "Steering of Roaming" it shall perform items a), b) and c) of the procedure for steering of roaming in subclause 4.4.6 and if the UE has a list of available and allowable PLMNs in the area and based on this list the UE determines that there is a higher priority PLMN than the currently camped chosen VPLMN and the UE is in automatic network selection mode, then the UE shall either:
 - i) release the current N1 NAS signalling connection locally and then attempt to obtain service on a higher priority PLMN as specified in subclause 4.4.3.3 by acting as if timer T that controls periodic attempts has expired. In this case, steps 8 to 11 are skipped; or
 - ii) not release the current N1 NAS signalling connection locally and skip steps 8 to 10;
- b) if the steering of roaming information contains the list of preferred PLMN/access technology combinations, the ME shall replace the highest priority entries in the "Operator Controlled PLMN Selector with Access Technology" list stored in the ME with the received list of preferred PLMN/access technology combinations. Additionally, if the UDM has not requested an acknowledgement from the UE and if the UE has a list of available and allowable PLMNs in the area and based on this list the UE determines that there is a higher

priority PLMN than the currently camped chosen VPLMN and the UE is in automatic network selection mode, then the UE shall send the REGISTRATION COMPLETE message to the serving AMF without including an SOR transparent container and then either:

- i) release the current N1 NAS signalling connection locally and then attempt to obtain service on a higher priority PLMN as specified in subclause 4.4.3.3 by acting as if timer T that controls periodic attempts has expired. In this case, steps 8 to 11 are skipped; or
- ii) not release the current N1 NAS signalling connection locally and skip steps 8 and 10;

8) If:

- a) the UE's USIM is configured with indication that the UE is to receive the steering of roaming information due to initial registration in a VPLMN, but neither the list of preferred PLMN/access technology combinations nor the secured packet nor the HPLMN indication that 'no change of the "Operator Controlled PLMN Selector with Access Technology" list stored in the UE is needed and thus no list of preferred PLMN/access technology combinations is provided' is received in the REGISTRATION ACCEPT message, when the UE performs initial registration in a VPLMN or if the steering of roaming information is received but the security check is not successful; and
- b) the current chosen VPLMN is not contained in the list of "PLMNs where registration was aborted due to SOR", not part of "User Controlled PLMN Selector with Access Technology" list, the UE is not in manual mode of operation and the PDU session for emergency services is not pending to be activated;

then the UE shall send the REGISTRATION COMPLETE message to the serving AMF without including an SOR transparent container, release the current N1 NAS signalling connection locally, store the PLMN identity in the list of "PLMNs where registration was aborted due to SOR" and attempt to obtain service on a higher priority PLMN as specified in subclause 4.4.3.3 by acting as if timer T that controls periodic attempts has expired, with an exception that the current PLMN is considered as lowest priority, and skip steps 9 to 12;

NOTE 2: When the UE is in the manual mode of operation or the current chosen VPLMN is part of the "User Controlled PLMN Selector with Access Technology" list, the UE stays on the VPLMN.

9) The UE to the VPLMN AMF: If the UDM has requested an acknowledgement from the UE:

the UE verified that the steering of roaming information has been provided by the HPLMN in step 7, the UE sends the REGISTRATION COMPLETE message to the serving AMF with an SOR transparent container including the UE acknowledgement; and

if the steering of roaming information contained a secured packet and the security check was successful, then when the UE receives the USAT REFRESH command qualifier of type "Steering of Roaming", it performs items a), b) and c) of the procedure for steering of roaming in subclause 4.4.6.

10) The AMF to the UDM: If an SOR transparent container is received in the REGISTRATION COMPLETE message, the AMF uses the Nudm_SDM_Info service operation to provide the received SOR transparent container to the UDM. If the HPLMN decided that the UE is to acknowledge the successful security check of the received steering of roaming information in step 4, the UDM verifies that the acknowledgement is provided by the UE as specified in 3GPP TS 33.501 [66];

11) If the UE has a list of available PLMNs in the area and based on this list the UE determines that there is a higher priority PLMN than the currently camped chosen VPLMN and the UE is in automatic network selection mode, then the UE shall attempt to obtain service on a higher priority PLMN as specified in subclause 4.4.3.3 by acting as if timer T that controls periodic attempts has expired after the release of the N1 NAS signalling connection. If the N1 NAS signaling connection is not released after implementation dependent time, the UE may locally release the N1 signaling connection except when the UE is registered for emergency services or the UE has an established emergency PDU session (see 3GPP TS 24.501 [64]); and

12) The UE deletes the list of "PLMNs where registration was aborted due to SOR".

The list of "PLMNs where registration was aborted due to SOR" is deleted when the UE is switched off or the USIM is removed.

6.3.1.1.3 Test Description

6.3.1.1.3.1 Pre-test conditions

System Simulator:

Three inter-frequency multi-PLMN NR Cells as specified in TS 38.508-1 Table 4.4.2-1 are configured broadcasting PLMNs as indicated in Table 6.3.1.1.3.1-1.

The PLMNs are identified in the test by the identifiers in Table 6.3.1.1.3.1-1.

Table 6.3.1.1.3.1–1: PLMN identifiers

NR Cell	PLMN names	TA	PLMN		TAC	5G-GUTI
			MCC	MNC		
NR Cell 11	PLMN2	TAI-3	002	11	1	Arbitrarily selected according to TS 23.003 subclause 2.10 [X].
NR Cell 12	PLMN3	TAI-8	002	21	1	
NR Cell 13	PLMN4	TAI-9	002	31	1	

NR Cell 11 is set to "Serving Cell";

NR Cell 12 is set to "Serving Cell";

NR Cell 13 is set to "Serving Cell";

-System Information Combination NR-4 as defined in TS38.508 clause 4.4.3.1.3 is used in NR cells

UE:

The UE is in Automatic PLMN selection mode.

USIM configuration as defined in Table 6.4.10 in TS 38.508-1 will be used.

Preamble:

The UE is in Switched OFF (State 0-A) as defined in TS 38.508-1 Table 4.4A.2-0

UE's Last Registered PLMN (RPLMN) needs to be cleared

Table 6.3.1.1.3.1–2: USIM configuration

USIM field	Priority	Value	Access Technology Identifier
EF _{OPLMNwACT}	1 2 3	PLMN4 PLMN3 PLMN2 Remaining defined entries use default values	NG-RAN NG-RAN NG-RAN
EF _{UST}		Service n°127 is "available"	
EF _{HPLMN}		1(=6 min)	The HPLMN Search Period on the USIM shall be set to 6 minutes.

6.3.1.1.4 Test procedure sequence

Table 6.3.1.1.4-1: Main behaviour

St	Procedure	Message Sequence		TP	Verdict
		U - S	Message		
1	Power on the UE	-		-	-
2-14	Steps 1 to 13 of the registration procedure described in TS 38.508 subclause 4.5.2.2-2 are performed on NR Cell 13	-	-	-	-
15	The SS transmits an <i>DLInformationTransfer</i> message and an REGISTRATION ACCEPT message containing steering of roaming information indicating list of preferred PLMN/access technology combination provided with acknowledgment requested from the UE for successful reception	<--	NR RRC: <i>DLInformationTransfer</i> 5G MM: REGISTRATION ACCEPT	-	-
16	SS starts timer of $t_{max} = (6 \text{ minutes} + \text{cell selection time})$ (Note 1, 2 and 3)				
17	The UE transmits an <i>ULInformationTransfer</i> message and REGISTRATION COMPLETE message carrying acknowledgement of successful reception of the steering of roaming information	-->	NR RRC: <i>ULInformationTransfer</i> 5G MM: REGISTRATION COMPLETE	1	P
18	The SS transmits an <i>RRCRelease</i> message.	<--	NR RRC: <i>RRCRelease</i>	-	-
19	Check: Does the UE transmits an <i>RRCSetupRequest</i> on NR Cell 11 before t_{max} expires? (Note 1, 2 and 3)	-->	NR RRC: <i>RRCSetupRequest</i>	1	P
20	Steps 2 – 6 of the generic test procedure in TS 38.508 Table 4.9.5.2.2-1 with condition MOBILITY are performed on NR Cell 11. NOTE: The UE performs a " REGISTRATION REQUEST procedure with type "mobility registration updating" and the RRC connection is released	-	-	-	-
Note 1: Timer t_{max} in step 16 and 19 are derived from the high priority PLMN search timer T defined by EFHPPLMN Note 2: Following attempts to access the HPLMN/EHPLMN/higher priority PLMN in VPLMN is operator specific setting (Refer to TS 23.122 Rel-12).Hence, window between 120s to T+Tolerance is being used , where the high priority PLMN search timer T defined by EF _{HPPLMN} Note 3: Tolerance of 5min is added to allow time for the UE to find the proper PLMN					

6.3.1.1.5 Specific message contents

Table 6.3.1.1.5-1: REGISTRATION ACCEPT for NR Cell 13 (step 15, Table 6.3.1.1.4-1)

Derivation Path: 38.508-1 Table 4.7.1-7			
Information Element	Value/remark	Comment	Condition
SOR Transparent Container	Present	The SOR transparent container carries steering of roaming information.	

Table 6.3.1.1.5-2: SOR Transparent Container in REGISTRATION ACCEPT for NR Cell 13 (step 15, Table 6.3.1.1.4-1)

Derivation Path: 38.508-1 Table 4.7.1-7			
Information Element	Value/remark	Comment	Condition
SOR data type	0	The SOR transparent container carries steering of roaming information.	
List indication value	1	List of preferred PLMN/access technology combinations is provided	
List type	0	The list type is a PLMN ID and access technology list	
Acknowledgement (ACK) value	1	Acknowledgement requested	
PLMN ID 1	2		
Access Technology Identifier 1	NG-RAN		

Table 6.3.1.1.5-3: REGISTRATION COMPLETE for NR Cell 13 (step 17, Table 6.3.1.1.4-1)

Derivation Path: 38.508-1 Table 4.7.1-8			
Information Element	Value/remark	Comment	Condition
SOR Transparent Container	Present	The SOR transparent container carries acknowledgement of successful reception of the steering of roaming information.	

Table 6.3.1.1.5-4: SOR Transparent Container in REGISTRATION COMPLETE for NR Cell 13 (step 17, Table 6.3.1.1.4-1)

Derivation Path: 38.508-1 Table 4.7.1-8			
Information Element	Value/remark	Comment	Condition
SOR data type	1	The SOR transparent container carries acknowledgement of successful reception of the steering of roaming information.	

6.3.1.2 Steering of UE in roaming during registration/security check successful but SOR Transparent container indicates ACK has been NOT been requested

6.3.1.2.1 Test Purpose (TP)

(1)

with {UE being in automatic PLMN selection mode, current VPLMN not part of "PLMNs where registration was aborted due to SOR" List and not part of "User Controlled PLMN Selector with Access Technology" list and UE's USIM configured with indication that the UE is to receive Steering of Roaming information due to initial registration in a VPLMN}

ensure that {

when {SOR Transparent container indicates ACK has NOT been requested & List Type indicates PLMN ID and Access technology list in REGISTRATION ACCEPT and security check is successful and if the UE has a list of available and allowable PLMNs in the area and based on this list the UE determines that there is a higher priority PLMN than the currently camped chosen VPLMN}

then {the UE shall send the REGISTRATION COMPLETE message to the serving AMF without including an SOR transparent container and then either releases N1 NAS Signaling connection locally and then attempt to obtain service on a higher priority PLMN or optionally wait for network release of the NAS signalling connection and then selects higher priority PLMN}

6.3.1.2.2 Conformance requirements

References: The conformance requirements covered in the present TC are specified in: TS 23.122, clause C.2, TS 24.501 clause 4.4.4.2 and 5.5.1.2.4.

[TS 23.122, clause C.2]

- 6) The VPLMN AMF to the UE: The VPLMN AMF shall transparently send the received steering of roaming information to the UE in the REGISTRATION ACCEPT message;
- 7) If the steering of roaming information is received and the security check is successful, then:
 - a) if the steering of roaming information contains a secured packet (see 3GPP TS 31.115 [67]):
 - if the UDM has not requested an acknowledgement from the UE the UE shall send the REGISTRATION COMPLETE message;
 - the ME shall upload the secured packet to the USIM using procedures in 3GPP TS 31.111 [41].

NOTE 1: How the ME handles UICC responses and failures in communication between the ME and UICC is implementation specific and out of scope of this release of the specification.

- if the UDM has not requested an acknowledgement from the UE and the ME receives a USAT REFRESH command qualifier (3GPP TS 31.111 [41]) of type "Steering of Roaming" it shall perform items a), b) and c) of the procedure for steering of roaming in subclause 4.4.6 and if the UE has a list of available and allowable PLMNs in the area and based on this list the UE determines that there is a higher priority PLMN than the currently camped chosen VPLMN and the UE is in automatic network selection mode, then the UE shall either:
 - i) release the current N1 NAS signalling connection locally and then attempt to obtain service on a higher priority PLMN as specified in subclause 4.4.3.3 by acting as if timer T that controls periodic attempts has expired. In this case, steps 8 to 11 are skipped; or
 - ii) not release the current N1 NAS signalling connection locally and skip steps 8 to 10;
- b) if the steering of roaming information contains the list of preferred PLMN/access technology combinations, the ME shall replace the highest priority entries in the "Operator Controlled PLMN Selector with Access Technology" list stored in the ME with the received list of preferred PLMN/access technology combinations. Additionally, if the UDM has not requested an acknowledgement from the UE and if the UE has a list of available and allowable PLMNs in the area and based on this list the UE determines that there is a higher priority PLMN than the currently camped chosen VPLMN and the UE is in automatic network selection mode, then the UE shall send the REGISTRATION COMPLETE message to the serving AMF without including an SOR transparent container and then either:

- i) release the current N1 NAS signalling connection locally and then attempt to obtain service on a higher priority PLMN as specified in subclause 4.4.3.3 by acting as if timer T that controls periodic attempts has expired. In this case, steps 8 to 11 are skipped; or
- ii) not release the current N1 NAS signalling connection locally and skip steps 8 and 10;

8) If:

- a) the UE's USIM is configured with indication that the UE is to receive the steering of roaming information due to initial registration in a VPLMN, but neither the list of preferred PLMN/access technology combinations nor the secured packet nor the HPLMN indication that 'no change of the "Operator Controlled PLMN Selector with Access Technology" list stored in the UE is needed and thus no list of preferred PLMN/access technology combinations is provided' is received in the REGISTRATION ACCEPT message, when the UE performs initial registration in a VPLMN or if the steering of roaming information is received but the security check is not successful; and
- b) the current chosen VPLMN is not contained in the list of "PLMNs where registration was aborted due to SOR", not part of "User Controlled PLMN Selector with Access Technology" list, the UE is not in manual mode of operation and the PDU session for emergency services is not pending to be activated;

then the UE shall send the REGISTRATION COMPLETE message to the serving AMF without including an SOR transparent container, release the current N1 NAS signalling connection locally, store the PLMN identity in the list of "PLMNs where registration was aborted due to SOR" and attempt to obtain service on a higher priority PLMN as specified in subclause 4.4.3.3 by acting as if timer T that controls periodic attempts has expired, with an exception that the current PLMN is considered as lowest priority, and skip steps 9 to 12;

NOTE 2: When the UE is in the manual mode of operation or the current chosen VPLMN is part of the "User Controlled PLMN Selector with Access Technology" list, the UE stays on the VPLMN.

9) The UE to the VPLMN AMF: If the UDM has requested an acknowledgement from the UE:

the UE verified that the steering of roaming information has been provided by the HPLMN in step 7, the UE sends the REGISTRATION COMPLETE message to the serving AMF with an SOR transparent container including the UE acknowledgement; and

if the steering of roaming information contained a secured packet and the security check was successful, then when the UE receives the USAT REFRESH command qualifier of type "Steering of Roaming", it performs items a), b) and c) of the procedure for steering of roaming in subclause 4.4.6.

10) The AMF to the UDM: If an SOR transparent container is received in the REGISTRATION COMPLETE message, the AMF uses the Nudm_SDM_Info service operation to provide the received SOR transparent container to the UDM. If the HPLMN decided that the UE is to acknowledge the successful security check of the received steering of roaming information in step 4, the UDM verifies that the acknowledgement is provided by the UE as specified in 3GPP TS 33.501 [66];

11) If the UE has a list of available PLMNs in the area and based on this list the UE determines that there is a higher priority PLMN than the currently camped chosen VPLMN and the UE is in automatic network selection mode, then the UE shall attempt to obtain service on a higher priority PLMN as specified in subclause 4.4.3.3 by acting as if timer T that controls periodic attempts has expired after the release of the N1 NAS signalling connection. If the N1 NAS signaling connection is not released after implementation dependent time, the UE may locally release the N1 signaling connection except when the UE is registered for emergency services or the UE has an established emergency PDU session (see 3GPP TS 24.501 [64]); and

12) The UE deletes the list of "PLMNs where registration was aborted due to SOR".

The list of "PLMNs where registration was aborted due to SOR" is deleted when the UE is switched off or the USIM is removed.

[TS 24.501 clause 4.4.4.2]

...

The network can provide the SOR transparent container IE during the registration procedure to the UE in the REGISTRATION ACCEPT message. The SOR transparent container IE is integrity protected by the HPLMN as specified in 3GPP TS 33.501 [24].

...

[TS 24.501 clause 5.5.1.2.4]

...

If the REGISTRATION ACCEPT message includes the SOR transparent container IE and the SOR transparent container IE successfully passes the integrity check (see 3GPP TS 33.501 [24]):

- a) the UE shall proceed with the behaviour as specified in 3GPP TS 23.122 [5] annex C; and
- b) if the registration procedure is performed over 3GPP access and the UE attempts obtaining service on another PLMNs as specified in 3GPP TS 23.122 [5] annex C, then the UE may locally release the established N1 NAS signalling connection after sending a REGISTRATION COMPLETE message. Otherwise the UE shall send a REGISTRATION COMPLETE message and not release the current N1 NAS signalling connection locally. If an acknowledgement is requested in the SOR transparent container IE of the REGISTRATION ACCEPT message, the UE acknowledgement is included in the SOR transparent container IE of the REGISTRATION COMPLETE message.

If the SOR transparent container IE successfully passes the integrity check (see 3GPP TS 33.501 [24]), indicates list of preferred PLMN/access technology combinations is provided and the list type indicates:

- a) "PLMN ID and access technology list", then the ME shall replace the highest priority entries in the "Operator Controlled PLMN Selector with Access Technology" list stored in the ME and shall proceed with the behaviour as specified in 3GPP TS 23.122 [5] annex C; or
- b) "secured packet", then the ME shall behave as if a SMS is received with protocol identifier set to SIM data download, data coding scheme set to class 2 message and SMS payload as secured packet contents of SOR transparent container IE. The SMS payload is forwarded to UICC as specified in 3GPP TS 23.040 [4A] and the ME shall proceed with the behaviour as specified in 3GPP TS 23.122 [5] annex C.

...

6.3.1.2.3 Test Description

6.3.1.2.3.1 Pre-test conditions

System Simulator:

Three inter-frequency multi-PLMN NR Cells as specified in TS 38.508-1 Table 4.4.2-1 are configured broadcasting PLMNs as indicated in Table 6.3.1.2.3.1-1.

The PLMNs are identified in the test by the identifiers in Table 6.3.1.2.3.1-1.

Table 6.3.1.2.3.1–1: PLMN identifiers

NR Cell	PLMN names	TA	PLMN		TAC	5G-GUTI
			MCC	MNC		
NR Cell 11	PLMN2	TAI-3	002	11	1	Arbitrarily selected according to TS 23.003 subclause 2.10 [X].
NR Cell 12	PLMN3	TAI-8	002	21	1	
NR Cell 13	PLMN4	TAI-9	002	31	1	

NR Cell 11 is set to "Serving Cell";

NR Cell 12 is set to "Serving Cell";

NR Cell 13 is set to "Serving Cell";

-System Information Combination NR-4 as defined in TS38.508 clause 4.4.3.1.3 is used in NR cells

UE:

The UE is in Automatic PLMN selection mode.

USIM configuration as defined in Table 6.4.10 in TS 38.508-1 will be used.

Preamble:

The UE is in Switched OFF (State 0-A) as defined in TS 38.508-1 Table 4.4A.2-0

UE's Last Registered PLMN (RPLMN) needs to be cleared

Table 6.3.1.2.3.1–2: USIM configuration

USIM field	Priority	Value	Access Technology Identifier
EF _{OPLMNWACT}	1 2 3	PLMN4 PLMN3 PLMN2 Remaining defined entries use default values	NG-RAN NG-RAN NG-RAN
EF _{UST}		Service n°127 is "available"	
EF _{HPLMN}		1(=6 min)	The HPLMN Search Period on the USIM shall be set to 6 minutes.

6.3.1.2.4 Test procedure sequence

Table 6.3.1.2.4-1: Main behaviour

St	Procedure	Message Sequence		TP	Verdict
		U - S	Message		
1	Power on the UE	-		-	-
2-14	Steps 1 to 13 of the registration procedure described in TS 38.508 subclause 4.5.2.2-2 are performed on NR Cell 13	-	-	-	-
15	The SS transmits an <i>DLInformationTransfer</i> message and a REGISTRATION ACCEPT message containing steering of roaming information indicating that acknowledgment is not requested from the UE for successful reception	<--	NR RRC: <i>DLInformationTransfer</i> 5G MM: REGISTRATION ACCEPT	-	-
16	The SS also starts timer of $t_{max} = (6 \text{ minutes} + \text{cell selection time})$ (Note 1, 2 and 3)	-	-	-	-
17	The UE transmits an <i>ULInformationTransfer</i> message and REGISTRATION COMPLETE message without Steering of Roaming Transparent container.	-->	NR RRC: <i>ULInformationTransfer</i> 5G MM: REGISTRATION COMPLETE	-1	-
	EXCEPTION: Based on UE implementation the UE behaviour can either follow Steps 18a1 to 18a2 OR Steps 18b1 to 18b7; the "lower case letter" identifies a step sequence that take place depending on the UE implementation.				
18a1	Check: Does the UE send a <i>RRCSetupRequest</i> on NR Cell 11 before t_{max} expires? (Note 1, 2 and 3)	-->	<i>RRCSetupRequest</i>	1	P
18a2	Check: Does the test result of generic test procedure in TS 38.508-1 Table 4.9.5.2.2-1 indicate that the UE is camped on NR Cell 13? NOTE: The UE performs a "REGISTRATION REQUEST procedure with type "mobility registration updating" and the RRC connection is released	-	-	-	-
18b1	The SS transmits an <i>RRCRelease</i> message.	<--	NR RRC: <i>RRCRelease</i>	-	-
18b2	Check: Does the UE transmits an <i>RRCSetupRequest</i> on NR Cell 11 before t_{max} expires? (Note 1, 2 and 3)	-->	NR RRC: <i>RRCSetupRequest</i>	1	P
18b3-18b7	Steps 2 – 6 of the generic test procedure in TS 38.508 Table 4.9.5.2.2-1 with condition MOBILITY are performed on NR Cell 11. NOTE: The UE performs a "REGISTRATION REQUEST procedure with type "mobility registration updating" and the RRC connection is released	-	-	-	-
Note 1:	Timer t_{max} in step 16 and 18b2 are derived from the high priority PLMN search timer T defined by EF _{HPPLMN}				
Note 2:	Following attempts to access the HPLMN/EHPLMN/higher priority PLMN in VPLMN is operator specific setting (Refer to TS 23.122 Rel-12). Hence, window between 120s to T+Tolerance is being used, where the high priority PLMN search timer T defined by EF _{HPPLMN}				
Note 3:	Tolerance of 5min is added to allow time for the UE to find the proper PLMN				

6.3.1.2.5 Specific message contents

Table 6.3.1.2.5-1: REGISTRATION ACCEPT for NR Cell 12 (step 15, Table 6.3.1.2.4-1)

Derivation Path: 38.508-1 Table 4.7.1-7			
Information Element	Value/remark	Comment	Condition
SOR Transparent Container	Present	The SOR transparent container carries steering of roaming information.	

Table 6.3.1.2.5-2: SOR Transparent Container in REGISTRATION ACCEPT for NR Cell 12 (step 15, Table 6.3.1.2.4-1)

Derivation Path: 38.508-1 Table 4.7.1-7			
Information Element	Value/remark	Comment	Condition
SOR data type	0	The SOR transparent container carries steering of roaming information.	
List indication value	1	List of preferred PLMN/access technology combinations is provided	
List type	1	The list type is a PLMN ID and access technology list	
Acknowledgement (ACK) value	0	Acknowledgement is NOT requested	
PLMN ID 1	2		
Access Technology Identifier 1	NG-RAN		
PLMN ID 2	3		
Access Technology Identifier 2	NG-RAN		
PLMN ID 3	4		
Access Technology Identifier 3	NG-RAN		

Table 6.3.1.2.5-3: REGISTRATION COMPLETE for NR Cell 13 (step 17, Table 6.3.1.2.4-1)

Derivation Path: 38.508-1 Table 4.7.1-8			
Information Element	Value/remark	Comment	Condition
SOR Transparent Container	Not Present	The SOR transparent container should not be present when ACK is not requested by UDM.	

6.4

6.4.1

6.4.1.1

6.4.1.2 Cell reselection of ePLMN in manual mode

6.4.1.2.1 Test Purpose (TP)

(1)

```
with { UE in NR RRC_INACTIVE state on a NR cell in manual PLMN Selection mode and network has
downloaded a list of equivalent PLMNs during the Registration procedure }
ensure that {
  when { Higher ranked cell is a cell of a PLMN in the downloaded equivalent PLMN list }
  then { UE reselects to the equivalent PLMN cell , and attempts Registration with mobility on the
selected cell. }
}
```

(2)

```
with { UE in NR RRC_INACTIVE state on a cell and network has downloaded a list of equivalent PLMNs
during Registration procedure for mobility }
ensure that {
  when { Highest ranked cell is a cell of a PLMN not in the downloaded equivalent PLMN list }
  then { UE does not reselect to the cell. }
}
```

6.4.1.2.2 Conformance requirements

References: The conformance requirements covered in the current TC are specified in: TS 23.122 clauses 4.4.3.1.2 and TS 38.304, clauses 4.1 and clauses 4.2. Unless otherwise stated these are Rel-15 requirements.

[TS 23.122, clause 4.4.3.1.2]

The MS indicates whether there are any PLMNs, which are available using all supported access technologies. This includes PLMNs in the "forbidden PLMNs" list, "forbidden PLMNs for GPRS service" list and PLMNs which only offer services not supported by the MS. An MS which supports GSM COMPACT shall also indicate GSM COMPACT PLMNs (which use PBCCH).

If displayed, PLMNs meeting the criteria above are presented in the following order:

- i)- either the HPLMN (if the EHPLMN list is not present or is empty) or, if one or more of the EHPLMNs are available then based on an optional data field on the SIM either only the highest priority available EHPLMN is to be presented to the user or all available EHPLMNs are presented to the user in priority order. If the data field is not present on the SIM, then only the highest priority available EHPLMN is presented;
- ii)- PLMN/access technology combinations contained in the " User Controlled PLMN Selector with Access Technology " data file in the SIM (in priority order);
- iii)- PLMN/access technology combinations contained in the "Operator Controlled PLMN Selector with Access Technology" data file in the SIM (in priority order);
- iv)- other PLMN/access technology combinations with received high quality signal in random order;
- v)- other PLMN/access technology combinations in order of decreasing signal quality.

In ii and iii, an MS using a SIM without access technology information storage (i.e. the "User Controlled PLMN Selector with Access Technology" and the "Operator Controlled PLMN Selector with Access Technology" data files are not present) shall instead present the PLMNs contained in the "PLMN Selector" data file in the SIM (in priority order).

In v, requirement h) in subclause 4.4.3.1.1 applies.

In i to v, requirements j), k) and l) in subclause 4.4.3.1.1 apply.

In GSM COMPACT, the non support of voice services shall be indicated to the user.

The HPLMN may provide on the SIM additional information on the available PLMNs. If this information is provided then the MS shall indicate it to the user. This information, provided as free text may include:

- preferred partner,
- roaming agreement status,
- supported services

Furthermore, the MS may indicate whether the available PLMNs are present on the EHPLMN list, the Forbidden list, the User Controlled PLMN List or the Operator Controlled PLMN List. The MS may also indicate that the PLMN is not present on any of these lists.

The user may select his desired PLMN and the MS then initiates registration on this PLMN using the access technology chosen by the user for that PLMN or using the highest priority available access technology for that PLMN, if the associated access technologies have a priority order. (This may take place at any time during the presentation of PLMNs). For such a registration, the MS shall ignore the contents of the "forbidden location areas for roaming", "forbidden tracking areas for roaming", "5GS forbidden tracking areas for roaming", "forbidden location areas for regional provision of service", "forbidden tracking areas for regional provision of service", "5GS forbidden tracking areas for regional provision of service", "forbidden PLMNs for GPRS service" and "forbidden PLMNs" lists.

NOTE 1: It is an MS implementation option whether to indicate access technologies to the user. If the MS does display access technologies, then the access technology selected by the user is only used for initial registration on the selected PLMN. If the MS does not display access technologies, then the access technology chosen for a particular PLMN should be the highest priority available access technology for that PLMN, if the associated access technologies have a priority order, and is only used for initial registration.

Once the MS has registered on a PLMN selected by the user, the MS shall not automatically register on a different PLMN unless:

- i) the new PLMN is declared as an equivalent PLMN by the registered PLMN;
- ii) the user selects automatic mode;
- iii) the user initiates an emergency call while the MS is in limited service state and either the network does not broadcast the indication of support of emergency calls in limited service state, the registration request for emergency services is rejected by the network or the attach request for emergency bearer services is rejected by the network; or
- iv) the user initiates access to RLOS, while the MS is in limited service state and either the network does not broadcast the indication of support of RLOS in limited service state, or the EPS attach request for access to RLOS is rejected by the network.

NOTE 2: If case iii) or iv) occurs, the MS can provide an indication to the upper layers that the MS has exited manual network selection mode.

If the user does not select a PLMN, the selected PLMN shall be the one that was selected before the PLMN selection procedure started. If no such PLMN was selected or that PLMN is no longer available, then the MS shall attempt to camp on any acceptable cell and enter the limited service state.

NOTE 3: High quality signal is defined in the appropriate AS specification.

[TS 38.304, clause 4.1]

The RRC_IDLE state and RRC_INACTIVE state tasks can be subdivided into three processes:

- PLMN selection;
- Cell selection and reselection;
- Location registration and RNA update.

PLMN selection, cell reselection procedures, and location registration are common for both RRC_IDLE state and RRC_INACTIVE state. RNA update is only applicable for RRC_INACTIVE state. When UE selects a new PLMN, UE transitions from RRC_INACTIVE to RRC_IDLE, as specified in TS 24.501 [14].

When a UE is switched on, a public land mobile network (PLMN) is selected by NAS. For the selected PLMN, associated RAT(s) may be set, as specified in TS 23.122 [9]. The NAS shall provide a list of equivalent PLMNs, if available, that the AS shall use for cell selection and cell reselection.

With cell selection, the UE searches for a suitable cell of the selected PLMN, chooses that cell to provide available services, and monitors its control channel. This procedure is defined as "camping on the cell".

The UE shall, if necessary, then register its presence, by means of a NAS registration procedure, in the tracking area of the chosen cell. As an outcome of a successful Location Registration, the selected PLMN then becomes the registered PLMN, as specified in TS 23.122 [9].

If the UE finds a more suitable cell, according to the cell reselection criteria, it reselects onto that cell and camps on it. If the new cell does not belong to at least one tracking area to which the UE is registered, location registration is performed. In RRC_INACTIVE state, if the new cell does not belong to the configured RNA, an RNA update procedure is performed.

If necessary, the UE shall search for higher priority PLMNs at regular time intervals as described in TS 23.122 [9] and search for a suitable cell if another PLMN has been selected by NAS.

If the UE loses coverage of the registered PLMN, either a new PLMN is selected automatically (automatic mode), or an indication of available PLMNs is given to the user so that a manual selection can be performed (manual mode).

Registration is not performed by UEs only capable of services that need no registration.

The purpose of camping on a cell in RRC_IDLE state and RRC_INACTIVE state is fourfold:

- a) It enables the UE to receive system information from the PLMN.
- b) When registered and if the UE wishes to establish an RRC connection or resume a suspended RRC connection, it can do this by initially accessing the network on the control channel of the cell on which it is camped.
- c) If the network needs to send a message or deliver data to the registered UE, it knows (in most cases) the set of tracking areas (in RRC_IDLE state) or RNA (in RRC_INACTIVE state) in which the UE is camped. It can then send a "paging" message for the UE on the control channels of all the cells in the corresponding set of areas. The UE will then receive the paging message and can respond.
- d) It enables the UE to receive ETWS and CMAS notifications.

When the UE is in RRC_IDLE state, upper layers may deactivate AS layer when MICO mode is activated as specified in TS 24.501 [14]. When MICO mode is activated, the AS configuration (e.g. priorities provided by dedicated signalling) is kept and all running timers continue to run but the UE need not perform any idle mode tasks. If a timer expires while MICO mode is activated it is up to the UE implementation whether it performs the corresponding action immediately or the latest when MICO mode is deactivated. When MICO mode is deactivated, the UE shall perform all idle mode tasks.

[TS 38.304, clause 4.2]

Table 4.2-1 presents the functional division between UE non-access stratum (NAS) and UE access stratum (AS) in RRC_IDLE state and RRC_INACTIVE states. The NAS part is specified in TS 23.122 [9] and the AS part in the present document.

Table 4.2-1: Functional division between AS and NAS in RRC_IDLE state and RRC_INACTIVE state

RRC_IDLE and RRC_INACTIVE state Process	UE Non-Access Stratum	UE Access Stratum
PLMN Selection	<p>Maintain a list of PLMNs in priority order according to TS 23.122 [9]. Select a PLMN using automatic or manual mode as specified in TS 23.122 [9] and request AS to select a cell belonging to this PLMN. For each PLMN, associated RAT(s) may be set.</p> <p>Evaluate reports of available PLMNs from AS for PLMN selection.</p> <p>Maintain a list of equivalent PLMN identities.</p>	<p>Search for available PLMNs.</p> <p>If associated RAT(s) is (are) set for the PLMN, search in this (these) RAT(s) and other RAT(s) for that PLMN as specified in TS 23.122 [9].</p> <p>Perform measurements to support PLMN selection.</p> <p>Synchronise to a broadcast channel to identify found PLMNs.</p> <p>Report available PLMNs with associated RAT(s) to NAS on request from NAS or autonomously.</p>
Cell Selection	<p>Control cell selection for example by indicating RAT(s) associated with the selected PLMN to be used initially in the search of a cell in the cell selection.</p> <p>Maintain a list of "Forbidden Tracking Areas" and provide the list to AS.</p>	<p>Perform measurements needed to support cell selection.</p> <p>Detect and synchronise to a broadcast channel. Receive and handle broadcast information. Forward NAS system information to NAS.</p> <p>Search for a suitable cell. The cells broadcast one or more 'PLMN identity' in the system information. Respond to NAS whether such cell is found or not.</p> <p>If associated RATs is (are) set for the PLMN, perform the search in this (these) RAT(s) and other RATs for that PLMN as specified in TS 23.122 [9].</p> <p>If a cell is found which satisfies cell selection criteria, camp on that cell.</p>
Cell Reselection	<p>Maintain a list of equivalent PLMN identities and provide the list to AS.</p> <p>Maintain a list of "Forbidden Tracking Areas" and provide the list to AS.</p>	<p>Perform measurements needed to support cell reselection.</p> <p>Detect and synchronise to a broadcast channel. Receive and handle broadcast information. Forward NAS system information to NAS.</p> <p>Change cell if a more suitable cell is found.</p>
Location registration	<p>Register the UE as active after power on.</p> <p>Register the UE's presence in a registration area, for instance regularly or when entering a new tracking area.</p> <p>Deregister UE when shutting down.</p> <p>Maintain a list of "Forbidden Tracking Areas".</p>	<p>Report registration area information to NAS.</p>
RAN Notification Area Update	<p>Not applicable.</p>	<p>Register the UE's presence in a RAN-based notification area (RNA), periodically or when entering a new RNA.</p>

6.4.1.2.3 Test description

6.4.1.2.3.1 Pre-test conditions

System Simulator:

- NR Cell 1, NR Cell 12 and NR Cell 13 are configured according to TS 38.508-1, Table 4.4.2-3.
- System information combination NR-4 as defined in TS 38.508-1 [4] clause 4.4.3.1.2-1 is used in NR cells.

UE:

- The UE is in Manual PLMN selection mode.

Preamble:

- The UE is registered on NR Cell 1 except that the REGISTRATION ACCEPT message indicates the PLMN of NR Cell 12 in the Equivalent PLMN list as described in Table 6.4.1.2.3.3-4.
- The UE is in state 2N-A as defined in TS 38.508-1 [4], Table 4.4A.2-2 on NR Cell 1.

6.4.1.2.3.2 Test procedure sequence

Table 6.4.1.2.3.2-1 for FR1 and Table 6.4.1.2.3.2-2 for FR2 illustrates the downlink power levels and other changing parameters to be applied for the cells at various time instants of the test execution. Row marked "T0" denotes the initial conditions after preamble, while columns marked "T1", "T2" and "T3" are to be applied subsequently in the Main behaviour. The exact instants on which these values shall be applied are described in the texts in this clause.

Table 6.4.1.2.3.2-1: Cell configuration changes over time for FR1

	Parameter	Unit	NR Cell 1	NR Cell 12	NR Cell 13	Remarks
T0	SS/PBCH SSS EPRE	dBm/SCS	-99	-88	-67	
T1	SS/PBCH SSS EPRE	dBm/SCS	"Off"	"Off"	"Off"	Power level "Off" is defined in TS 38.508-1 [4] Table 6.2.2.1-3

Table 6.4.1.2.3.2-2: Cell configuration changes over time for FR2

	Parameter	Unit	NR Cell 1	NR Cell 12	NR Cell 13	Remarks
T0	SS/PBCH SSS EPRE	dBm/SCS	FFS	FFS	FFS	
T1	SS/PBCH SSS EPRE	dBm/SCS	"Off"	"Off"	"Off"	Power level "Off" is defined in TS 38.508-1 [4] Table 6.2.2.2-2

Table 6.4.1.2.3.2-3: Main behaviour

St	Procedure	Message Sequence		TP	Verdict
		U - S	Message		
1	SS adjusts cell levels according to row T0 of table 6.4.1.2.3.2-1/2.	-	-	-	-
2	Check: Does the UE transmit an <i>RRCResumeRequest</i> message on NR Cell 12?	-->	NR RRC: <i>RRCResumeRequest</i>	1	P
3-6	Steps 2 to 5 of the generic test procedure in TS 38.508-1 Table 4.9.5.2.2-1 with condition MOBILITY are performed. (Note 1)	-	-	-	-
7	The SS transmits an <i>RRCRelease</i> message with suspend.	-->	NR RRC: <i>RRCRelease</i>	-	-
8	Check: Does the UE send an <i>RRCResumeRequest</i> on NR Cell 13 and NR Cell 1 within 60s?	-->	NR RRC: <i>RRCResumeRequest</i>	2	F
9	SS adjusts cell levels according to row T1 of table 6.4.1.2.3.2-1/2.	-	-	-	-
10	Set UE to Automatic PLMN selection mode. (Note 2)	-	-	-	-

Note 1: The REGISTRATION REQUEST is accepted with the PLMN of NR Cell 1 listed as an Equivalent PLMN.
 Note 2: Steps 10 is to ensure UE is set back to automatic PLMN selection mode for the next test case.

6.4.1.2.3.3 Specific message contents

Table 6.4.1.2.3.3-1: SIB4 for NR Cell 1 (preamble and all steps, Table 6.4.1.2.3.2-2)

Derivation path: 38.508-1 [4] Table 4.6.2-3			
Information Element	Value/Remark	Comment	Condition
SIB4 ::= SEQUENCE {			
interFreqCarrierFreqList SEQUENCE (SIZE (1..maxFreq)) OF SEQUENCE {			
dl-CarrierFreq[1]	Same downlink NR ARFCN as used for NR Cell 12		
cellReselectionPriority[1]	4		
dl-CarrierFreq[2]	Same downlink NR ARFCN as used for NR Cell 13		
cellReselectionPriority[2]	4		
}			
}			

Table 6.4.1.2.3.3-2: SIB4 for NR Cell 12 (preamble and all steps, Table 6.4.1.2.3.2-2)

Derivation path: 38.508-1 [4] Table 4.6.2-3			
Information Element	Value/Remark	Comment	Condition
SIB4 ::= SEQUENCE {			
interFreqCarrierFreqList SEQUENCE (SIZE (1..maxFreq)) OF SEQUENCE {			
dl-CarrierFreq[1]	Same downlink NR ARFCN as used for NR Cell 1		
cellReselectionPriority[1]	4		
dl-CarrierFreq[2]	Same downlink NR ARFCN as used for NR Cell 13		
cellReselectionPriority[2]	4		
}			
}			

Table 6.4.1.2.3.3-3: REGISTRATION ACCEPT for NR Cell 1 (preamble)

Derivation path: 38.508-1 [4] Table 4.7.1-7			
Information Element	Value/Remark	Comment	Condition
Equivalent PLMNs	The PLMN of NR Cell 12		

Table 6.4.1.2.3.3-4: REGISTRATION ACCEPT for NR Cell 12 (step 5, Table 6.4.1.2.3.2-2)

Derivation path: 38.508-1 [4] Table 4.7.1-7			
Information Element	Value/Remark	Comment	Condition
Equivalent PLMNs	The PLMN of NR Cell 1		

Table 6.4.1.2.3.3-5: RRCRelease (step 7, Table 6.4.1.2.3.2-2)

Derivation Path: 38.508-1 [4], Table 4.6.1-4B			
Information Element	Value/remark	Comment	Condition
RRCRelease ::= SEQUENCE {			
criticalExtensions CHOICE {			
rrcRelease SEQUENCE {			
suspendConfig SEQUENCE {			NR_RRC_I NACTIVE
ran-NotificationAreaInfo CHOICE {			
cellList SEQUENCE {			
plmn-Identity		PLMN ID of NR Cell 12	
ran-AreaCells SEQUENCE {			
cellIdentity	See Table 4.4.2-2 and 4.4.2-3 in TS 38.508-1 [4]	Cell Identity of NR Cell 12	
}			
}			
}			
}			
}			

6.4.2 Cell Selection/Qrxlevmin & Cell Reselection (Intra NR in RRC_INACTIVE state)

6.4.2.1 Cell Selection/Qrxlevmin & Cell Reselection (Intra NR in RRC_INACTIVE state)

6.4.2.1.1 Test Purpose (TP)

(1)

```
with { UE in NR RRC_INACTIVE state }
ensure that {
  when { serving cell fulfils all requirements for a suitable cell except the cell selection
criteria which are not fulfilled (Srxlev<0) }
    then { UE does not consider the cell as suitable , leaves RRC_INACTIVE state and does not remain
camped on that cell }
}
```

(2)

```
with { UE in NR RRC_INACTIVE state }
ensure that {
  when { UE detects a cell ranked as the best cell }
    then { UE reselects to the new cell and continues to remain in RRC_INACTIVE state }
}
```

6.4.2.1.2 Conformance requirements

References: The conformance requirements covered in the present TC are specified in: TS 38.300, clause 9.2.1.1, and TS 38.304, clause 4.1, 4.5, 5.2.1, 5.2.3.1 and 5.2.3.2. Unless otherwise stated these are Rel-15 requirements.

[TS 38.300, clause 9.2.1.1]

The principles of PLMN selection in NR are based on the 3GPP PLMN selection principles. Cell selection is required on transition from RM-DEREGISTERED to RM-REGISTERED, from CM-IDLE to CM-CONNECTED and from CM-CONNECTED to CM-IDLE and is based on the following principles:

- The UE NAS layer identifies a selected PLMN and equivalent PLMNs;
- Cell selection is always based on CD-SSBs located on the synchronization raster (see subclause 5.2.4):
 - The UE searches the NR frequency bands and for each carrier frequency identifies the strongest cell as per the CD-SSB. It then reads cell system information broadcast to identify its PLMN(s):
 - The UE may search each carrier in turn ("initial cell selection") or make use of stored information to shorten the search ("stored information cell selection").
- The UE seeks to identify a suitable cell; if it is not able to identify a suitable cell it seeks to identify an acceptable cell. When a suitable cell is found or if only an acceptable cell is found it camps on that cell and commence the cell reselection procedure:
 - A suitable cell is one for which the measured cell attributes satisfy the cell selection criteria; the cell PLMN is the selected PLMN, registered or an equivalent PLMN; the cell is not barred or reserved and the cell is not part of a tracking area which is in the list of "forbidden tracking areas for roaming";
 - An acceptable cell is one for which the measured cell attributes satisfy the cell selection criteria and the cell is not barred.

Transition to RRC_IDLE:

On transition from RRC_CONNECTED or RRC_INACTIVE to RRC_IDLE, a UE should camp on a cell as result of cell selection according to the frequency be assigned by RRC in the state transition message if any.

Recovery from out of coverage:

The UE should attempt to find a suitable cell in the manner described for stored information or initial cell selection above. If no suitable cell is found on any frequency or RAT, the UE should attempt to find an acceptable cell.

In multi-beam operations, the cell quality is derived amongst the beams corresponding to the same cell (see subclause 9.2.4).

[TS 38.304, clause 4.1]

The RRC_IDLE state and RRC_INACTIVE state tasks can be subdivided into three processes:

- PLMN selection;
- Cell selection and reselection;
- Location registration and RNA update.

PLMN selection, cell reselection procedures, and location registration are common for both RRC_IDLE state and RRC_INACTIVE state. RNA update is only applicable for RRC_INACTIVE state. When UE selects a new PLMN, UE transitions from RRC_INACTIVE to RRC_IDLE, as specified in TS 24.501 [14].

When a UE is switched on, a public land mobile network (PLMN) is selected by NAS. For the selected PLMN, associated RAT(s) may be set, as specified in TS 23.122 [9]. The NAS shall provide a list of equivalent PLMNs, if available, that the AS shall use for cell selection and cell reselection.

With cell selection, the UE searches for a suitable cell of the selected PLMN, chooses that cell to provide available services, and monitors its control channel. This procedure is defined as "camping on the cell".

The UE shall, if necessary, then register its presence, by means of a NAS registration procedure, in the tracking area of the chosen cell. As an outcome of a successful Location Registration, the selected PLMN then becomes the registered PLMN, as specified in TS 23.122 [9].

If the UE finds a more suitable cell, according to the cell reselection criteria, it reselects onto that cell and camps on it. If the new cell does not belong to at least one tracking area to which the UE is registered, location registration is performed. In RRC_INACTIVE state, if the new cell does not belong to the configured RNA, an RNA update procedure is performed.

...

The purpose of camping on a cell in RRC_IDLE state and RRC_INACTIVE state is fourfold:

- a) It enables the UE to receive system information from the PLMN.
- b) When registered and if the UE wishes to establish an RRC connection or resume a suspended RRC connection, it can do this by initially accessing the network on the control channel of the cell on which it is camped.
- c) If the network needs to send a message or deliver data to the registered UE, it knows (in most cases) the set of tracking areas (in RRC_IDLE state) or RNA (in RRC_INACTIVE state) in which the UE is camped. It can then send a "paging" message for the UE on the control channels of all the cells in the corresponding set of areas. The UE will then receive the paging message and can respond.
- d) It enables the UE to receive ETWS and CMAS notifications.

When the UE is in RRC_IDLE state, upper layers may deactivate AS layer when MICO mode is activated as specified in TS 24.501 [14]. When MICO mode is activated, the AS configuration (e.g. priorities provided by dedicated signalling) is kept and all running timers continue to run but the UE need not perform any idle mode tasks. If a timer expires while MICO mode is activated it is up to the UE implementation whether it performs the corresponding action immediately or the latest when MICO mode is deactivated. When MICO mode is deactivated, the UE shall perform all idle mode tasks.

[TS 38.304, clause 4.5]

The cells are categorised according to which services they offer:

acceptable cell:

An "acceptable cell" is a cell on which the UE may camp to obtain limited service (originate emergency calls and receive ETWS and CMAS notifications). Such a cell shall fulfil the following requirements, which is the minimum set of requirements to initiate an emergency call and to receive ETWS and CMAS notification in an NR network:

- The cell is not barred, see subclause 5.3.1;
- The cell selection criteria are fulfilled, see subclause 5.2.3.2.

suitable cell:

A cell is considered as suitable if the following conditions are fulfilled:

- The cell is part of either the selected PLMN or the registered PLMN or PLMN of the Equivalent PLMN list and *trackingAreaCode* is provided for that PLMN;
- The cell selection criteria are fulfilled, see subclause 5.2.3.2.

According to the latest information provided by NAS:

- The cell is not barred, see subclause 5.3.1;
- The cell is part of at least one TA that is not part of the list of "Forbidden Tracking Areas" (TS 22.261 [12]), which belongs to a PLMN that fulfils the first bullet above.

barred cell:

A cell is barred if it is so indicated in the system information, as specified in TS 38.331 [3].

reserved cell:

A cell is reserved if it is so indicated in system information, as specified in TS 38.331 [3].

Following exception to these definitions are applicable for UEs:

- if a UE has an ongoing emergency call, all acceptable cells of that PLMN are treated as suitable for the duration of the emergency call.
- camped on a cell that belongs to a registration area that is forbidden for regional provision of service; a cell that belongs to a registration area that is forbidden for regional provision service (TS 23.122 [9], TS 24.501 [14]) is suitable but provides only limited service.

[TS 38.304, clause 5.2.1]

UE shall perform measurements for cell selection and reselection purposes as specified in TS 38.133 [8].

When evaluating S_{rxlev} and S_{qual} of non-serving cells for reselection evaluation purposes, the UE shall use parameters provided by the serving cell and for the final check on cell selection criterion, the UE shall use parameters provided by the target cell for cell reselection.

The NAS can control the RAT(s) in which the cell selection should be performed, for instance by indicating RAT(s) associated with the selected PLMN, and by maintaining a list of forbidden registration area(s) and a list of equivalent PLMNs. The UE shall select a suitable cell based on RRC_IDLE or RRC_INACTIVE state measurements and cell selection criteria.

In order to expedite the cell selection process, stored information for several RATs, if available, may be used by the UE.

When camped on a cell, the UE shall regularly search for a better cell according to the cell reselection criteria. If a better cell is found, that cell is selected. The change of cell may imply a change of RAT. Details on performance requirements for cell reselection can be found in TS 38.133 [8].

The NAS is informed if the cell selection and reselection result in changes in the received system information relevant for NAS.

For normal service, the UE shall camp on a suitable cell, monitor control channel(s) of that cell so that the UE can:

- receive system information from the PLMN; and
 - receive registration area information from the PLMN, e.g., tracking area information; and
 - receive other AS and NAS Information; and
- if registered:
 - receive paging and notification messages from the PLMN; and
 - initiate transfer to Connected mode.

For cell selection in multi-beam operations, measurement quantity of a cell is up to UE implementation.

For cell reselection in multi-beam operations, the measurement quantity of this cell is derived amongst the beams corresponding to the same cell based on SS/PBCH block as follows:

- if *nrofSS-BlocksToAverage* is not configured in *SIB2/SIB4*; or
- if *absThreshSS-BlocksConsolidation* is not configured in *SIB2/SIB4*; or
- if the highest beam measurement quantity value is below or equal to *absThreshSS-BlocksConsolidation*:
 - derive a cell measurement quantity as the highest beam measurement quantity value, where each beam measurement quantity is described in TS 38.215 [11].
- else:

- derive a cell measurement quantity as the linear average of the power values of up to *nrofSS-BlocksToAverage* of highest beam measurement quantity values above *absThreshSS-BlocksConsolidation*.

[TS 38.304, clause 5.2.3.1]

Cell selection is performed by one of the following two procedures:

- a) Initial cell selection (no prior knowledge of which RF channels are NR frequencies):
 1. The UE shall scan all RF channels in the NR bands according to its capabilities to find a suitable cell.
 2. On each frequency, the UE need only search for the strongest cell.
 3. Once a suitable cell is found, this cell shall be selected.
- b) Cell selection by leveraging stored information:
 1. This procedure requires stored information of frequencies and optionally also information on cell parameters from previously received measurement control information elements or from previously detected cells.
 2. Once the UE has found a suitable cell, the UE shall select it.
 3. If no suitable cell is found, the initial cell selection procedure in a) shall be started.

NOTE: Priorities between different frequencies or RATs provided to the UE by system information or dedicated signalling are not used in the cell selection process.

[TS 38.304, clause 5.2.3.2]

The cell selection criterion *S* is fulfilled when:

$$S_{rxlev} > 0 \text{ AND } S_{qual} > 0$$

where:

$$S_{rxlev} = Q_{rxlevmeas} - (Q_{rxlevmin} + Q_{rxlevminoffset}) - P_{compensation} - Q_{offset_{temp}}$$

$$S_{qual} = Q_{qualmeas} - (Q_{qualmin} + Q_{qualminoffset}) - Q_{offset_{temp}}$$

where:

Srxlev	Cell selection RX level value (dB)
Squal	Cell selection quality value (dB)
Qoffset _{temp}	Offset temporarily applied to a cell as specified in TS 38.331 [3] (dB)
Qrxlevmeas	Measured cell RX level value (RSRP)
Qqualmeas	Measured cell quality value (RSRQ)
Qrxlevmin	Minimum required RX level in the cell (dBm). If the UE supports SUL frequency for this cell, Qrxlevmin is obtained from <i>q-RxLevMinSUL</i> , if present, in <i>SIB1</i> , <i>SIB2</i> and <i>SIB4</i> , additionally, if Q _{rxlevminoffsetcellSUL} is present in <i>SIB3</i> and <i>SIB4</i> for the concerned cell, this cell specific offset is added to the corresponding Qrxlevmin to achieve the required minimum RX level in the concerned cell; else Qrxlevmin is obtained from <i>q-RxLevMin</i> in <i>SIB1</i> , <i>SIB2</i> and <i>SIB4</i> , additionally, if Q _{rxlevminoffsetcell} is present in <i>SIB3</i> and <i>SIB4</i> for the concerned cell, this cell specific offset is added to the corresponding Qrxlevmin to achieve the required minimum RX level in the concerned cell.
Qqualmin	Minimum required quality level in the cell (dB). Additionally, if Q _{qualminoffsetcell} is signalled for the concerned cell, this cell specific offset is added to achieve the required minimum quality level in the concerned cell.
Qrxlevminoffset	Offset to the signalled Q _{rxlevmin} taken into account in the Srxlev evaluation as a result of a periodic search for a higher priority PLMN while camped normally in a VPLMN, as specified in TS 23.122 [9].
Qqualminoffset	Offset to the signalled Q _{qualmin} taken into account in the Squal evaluation as a result of a periodic search for a higher priority PLMN while camped normally in a VPLMN, as specified in TS 23.122 [9].
P _{compensation}	If the UE supports the additional P _{max} in the NR-NS-P _{maxList} , if present, in <i>SIB1</i> , <i>SIB2</i> and <i>SIB4</i> : $\max(P_{EMAX1} - P_{PowerClass}, 0) - (\min(P_{EMAX2}, P_{PowerClass}) - \min(P_{EMAX1}, P_{PowerClass}))$ (dB); else: $\max(P_{EMAX1} - P_{PowerClass}, 0)$ (dB)
P _{EMAX1} , P _{EMAX2}	Maximum TX power level of a UE may use when transmitting on the uplink in the cell (dBm) defined as P _{EMAX} in TS 38.101 [15]. If UE supports SUL frequency for this cell, P _{EMAX1} and P _{EMAX2} are obtained from the <i>p-Max</i> for SUL in <i>SIB1</i> and <i>NR-NS-PmaxList</i> for SUL respectively in <i>SIB1</i> , <i>SIB2</i> and <i>SIB4</i> as specified in TS 38.331 [3], else P _{EMAX1} and P _{EMAX2} are obtained from the <i>p-Max</i> and <i>NR-NS-PmaxList</i> respectively in <i>SIB1</i> , <i>SIB2</i> and <i>SIB4</i> for normal UL as specified in TS 38.331 [3].
P _{PowerClass}	Maximum RF output power of the UE (dBm) according to the UE power class as defined in TS 38.101-1 [15].

The signalled values Q_{rxlevminoffset} and Q_{qualminoffset} are only applied when a cell is evaluated for cell selection as a result of a periodic search for a higher priority PLMN while camped normally in a VPLMN (TS 23.122 [9]). During this periodic search for higher priority PLMN, the UE may check the S criteria of a cell using parameter values stored from a different cell of this higher priority PLMN.

6.4.2.1.3 Test description

6.4.2.1.3.1 Pre-test conditions

System Simulator:

- NR Cell 1, NR Cell 2.
- System information combination NR-3 as defined in TS 38.508-1 [4] Table 4.4.3.1.2-1 is used in NR cells.

UE:

None.

Preamble:

- The UE is in state 2N-A on NR Cell 1(serving cell) according to TS 38.508-1 [4] Table 4.4A.2-2.

6.4.2.1.3.2 Test procedure sequence

Table 6.4.2.1.3.2-1/2 illustrates the downlink power levels and other changing parameters to be applied for the NR cells at various time instants of the test execution. The exact instants on which these values shall be applied are described in the texts in this clause. The configuration "T0" indicates the initial conditions. Subsequent configurations marked "T1" and "T2" are applied at the points indicated in the Main behaviour description in Table 6.4.2.1.3.2-3.

Table 6.4.2.1.3.2-1: Time instances of cell power level and parameter changes for FR1

	Parameter	Unit	NR Cell 1	NR Cell 2	Remark
T0	SS/PBCH SSS EPRE	dBm/SCS	-88	Off	The power level values are assigned to ensure the UE registered on NR Cell 1.
T1	SS/PBCH SSS EPRE	dBm/SCS	-110	Off	The power level values are assigned to satisfy $S_{rxlev, NR, Cell 1} < 0$.
T2	SS/PBCH SSS EPRE	dBm/SCS	-88	-76	The power level values are assigned to satisfy $R_{NR, Cell 2} > R_{NR, Cell 1}$.
Note 1: Power level "Off" is defined in TS 38.508-1 [4] Table 6.2.2.1-3.					

Table 6.4.2.1.3.2-2: Time instances of cell power level and parameter changes for FR2

	Parameter	Unit	NR Cell 1	NR Cell 2	Remark
T0	SS/PBCH SSS EPRE	dBm/SCS	FFS	Off	The power level values are assigned to ensure the UE registered on NR Cell 1.
T1	SS/PBCH SSS EPRE	dBm/SCS	FFS	Off	The power level values are assigned to satisfy $S_{rxlev, NR, Cell 1} < 0$.
T2	SS/PBCH SSS EPRE	dBm/SCS	FFS	FFS	The power level values are assigned to satisfy $R_{NR, Cell 2} > R_{NR, Cell 1}$.
Note 1: The uncertain downlink signal level is specified in TS 38.508-1 [4] section FFS.					

Table 6.4.2.1.3.2-3: Main behaviour

St	Procedure	Message Sequence		TP	Verdict
		U - S	Message		
1	The SS changes NR Cell 1 SSS level according to the row "T1" in table 6.4.2.1.3.2-1/2.	-	-	-	-
2	Void	-	-	-	-
3	The SS transmits a <i>Paging</i> message.	<--	NR RRC: <i>Paging</i>	-	-
4	Check: Does the UE attempt to transmit an uplink message within the next 10s?	-	-	1	F
5	The SS changes NR Cell 1 SSS levels according to the row "T0" in table 6.4.2.1.3.2-1/2.	-	-	-	-
6	Void	-	-	-	-
7-14	Steps 1-8 of Generic procedure for bringing the UE in RRC_CONNECTED state with connectivity NR as specified in TS 38.508-1 Table 4.5.4.2-3 are performed.	-	-	-	-
15	The SS transmits an <i>RRCRelease</i> message including <i>suspendConfig</i> with NR_RRC_INACTIVE condition.	<--	NR RRC: <i>RRCRelease</i>	-	-
16	The SS changes NR Cell 2 SSS level according to the row "T2" in table 6.4.2.1.3.2-1/2.	-	-	-	-
17	Void	-	-	-	-
18	Check: Does the UE transmit an <i>RRCResumeRequest</i> message on the Cell 2?	-->	NR RRC: <i>RRCResumeRequest</i>	2	P
19	The SS transmits an <i>RRCRelease</i> message including <i>suspendConfig</i> with NR_RRC_INACTIVE condition.	<--	NR RRC: <i>RRCRelease</i>	-	-

6.4.2.1.3.3 Specific message contents

Table 6.4.2.1.3.3-1: SIB3 of NR Cell 1 (preamble and all steps, Table 6.4.2.1.3.2-3)

Derivation Path: TS 38.508-1 [4], Table 4.6.2-2			
Information Element	Value/remark	Comment	Condition
SIB3 ::= SEQUENCE {			
intraFreqNeighCellList SEQUENCE (SIZE (1.. maxCellIntra)) OF SEQUENCE {	1 entry		
IntraFreqNeighCellInfo [1] SEQUENCE{			
physCellId	Physical cell identity of NR Cell 2		
}			
}			
}			

7.1.1.3.5.3 Test description

7.1.1.3.5.3.1 Pre-test conditions

Same Pre-test conditions as in clause 7.1.1.0 with the exception of 2 AM SN terminated SCG bearers configured according to Table 7.1.1.3.5.3.1-1.

Table 7.1.1.3.5.3.1-1: Logical Channel Configuration Settings

Parameter	DRB1	DRB2
LogicalChannel-Identity	4	5
Priority	7	6
prioritizedBitRate	0kbs	0kbs
logicalChannelGroup	2 (LCG ID#2)	1 (LCG ID#1)

7 Layer 2

7.1 NR Layer 2

7.1.0 Common test case specific values for Layer 2

For all layer 2 test cases, default values for periodicBSR-Timer, retxBSR-Timer and phr-Config shall be taken according to the table 7.1.0-1 unless test case specific values are given in the test case.

Table 7.1.0-1: MAC-CellGroupConfig

Derivation Path: TS 38.308 [6], clause Table 4.6.3-49			
Information Element	Value/remark	Comment	Condition
MAC-CellGroupConfig ::= SEQUENCE {			
bsr-Config SEQUENCE {			
periodicBSR-Timer	infinity		
retxBSR-Timer	sf10240		
}			
phr-Config CHOICE {			
release	NULL		
}			
}			

7.1.1 MAC

7.1.1.0 Default Pre-Test Conditions for all MAC test cases

The following pre-test conditions shall be applied in all MAC test cases until the test case explicitly over writes these conditions

System Simulator:

- The SS configures the test environment in accordance to the execution conditions in Table 7.1.1.0-1.

UE:

- None

Preamble:

- The SS performs the generic procedure in [4] to get UE in state RRC_CONNECTED in accordance to the execution conditions in Table 7.1.1.0-2 and using the message condition UE TEST LOOP MODE A to return one PDCP SDU per DL PDCP SDU.

Table 7.1.1.0-1: Test environment

Execution Condition	Cell configuration	System Information Combination
IF pc_NG_RAN_NR	NR Cell 1	NR: System information Combination NR-1
ELSE IF pc_EN_DC	E-UTRA Cell 1 is PCell, NR Cell 1 is PSCell	EUTRA: System information Combination 1 NR: N/A
ELSE IF pc_NGEN_DC	NG-RAN E-UTRA Cell 1 is PCell, NR Cell 1 is PSCell	EUTRA: System information Combination 1 NR: N/A

Table 7.1.1.0-2: Preamble parameters

Execution Condition	Multi-PDN / Multi-PDU Sessions Condition	Generic Procedure Parameters	Primary DRB used for Data testing
IF pc_NG_RAN_NR	FALSE	Connectivity(NR), Test loop function(On) One DRB	Default DRB of the first PDU session on NR Cell
	TRUE	Connectivity(NR), Test loop function(On) N DRBs ($N \geq 2$)	
ELSE IF pc_EN_DC	FALSE	Connectivity(EN-DC), DC bearer(One MN Terminated MCG bearer and One SN terminated SCG bearer), Test loop function(On)	SN Terminated SCG bearer unless explicitly specified in test case
	TRUE	Connectivity(EN-DC), DC bearer(Two MN Terminated MCG bearer and One SN terminated SCG bearer), Test loop function(On)	
ELSE IF pc_NGEN_DC	FALSE	Connectivity(NGEN-DC), DC bearer(One MN Terminated MCG bearer and One SN terminated SCG bearer), Test loop function(On)	SN Terminated SCG bearer unless explicitly specified in test case
	TRUE	Connectivity(EN-DC), DC bearer(Two MN Terminated MCG bearer and One SN terminated SCG bearer), Test loop function(On)	

Table 7.1.1.0-3: Message conditions

Execution Condition	Message condition exceptions
IF pc_NG_RAN_NR	Message with condition AM is used for step 7 in 4.5.4.2 according to [4]
ELSE IF pc_EN_DC	Message condition MCG_and_SCG with condition AM is used for step 7 in 4.5.4.2 according to [4]
ELSE IF pc_NGEN_DC	Message condition MCG_and_SCG with condition AM is used for step 7 in 4.5.4.2 according to [4]

7.1.1.1 Random Access Procedures

7.1.1.1.1 Correct selection of RACH parameters / Random access preamble and PRACH resource explicitly signalled to the UE by RRC / contention free random access procedure

7.1.1.1.1.1 Test Purpose (TP)

(1)

```
with { UE in RRC_Connected }
ensure that {
  when { SS sends an RRCReconfiguration message including RACH-ConfigDedicated information element }
  then { UE sends a prach preamble given in the RACH-ConfigDedicated on the target cell }
}
```

(2)

```
with { UE in RRC_Connected state after transmission of a PRACH preamble on NR SpCell received in RACH-ConfigDedicated on the target cell }
```

```

ensure that {
  when { UE does not receive a matching Random Access response in ra-ResponseWindowSize (hence
  considers RACH attempt as failed) and PREAMBLE_TRANSMISSION_COUNTER is less than PREAMBLE_TRANS_MAX
  }
  then { UE retransmits a PRACH preamble received in RACH-ConfigDedicated on the target cell }
}

```

7.1.1.1.1.2 Conformance requirements

References: The conformance requirements covered in the present test case are specified in: TS 38.321, clauses 5.1.2, 5.1.4. Unless otherwise stated these are Rel-15 requirements.

[TS 38.321, clause 5.1.2]

The MAC entity shall:

...

1> else if the *ra-PreambleIndex* has been explicitly provided by either PDCCH or RRC; and

1> if the *ra-PreambleIndex* is not 0b000000; and

1> if contention-free Random Access Resource associated with SSBs or CSI-RS have not been explicitly provided by RRC:

2> set the *PREAMBLE_INDEX* to the signalled *ra-PreambleIndex*.

...

1> if an SSB is selected above and an association between PRACH occasions and SSBs is configured:

2> determine the next available PRACH occasion from the PRACH occasions corresponding to the selected SSB permitted by the restrictions given by the *ra-ssb-OccasionMaskIndex* if configured (the MAC entity may take into account the possible occurrence of measurement gaps when determining the next available PRACH occasion corresponding to the selected SSB).

1> else if a CSI-RS is selected above and an association between PRACH occasions and CSI-RSs is configured:

2> determine the next available PRACH occasion from the PRACH occasions in *ra-OccasionList* corresponding to the selected CSI-RS (the MAC entity may take into account the possible occurrence of measurement gaps when determining the next available PRACH occasion corresponding to the selected CSI-RS).

1> else:

2> determine the next available PRACH occasion (the MAC entity may take into account the possible occurrence of measurement gaps when determining the next available PRACH occasion).

1> perform the Random Access Preamble transmission procedure (see subclause 5.1.3).

[TS 38.321, clause 5.1.4]

Once the Random Access Preamble is transmitted and regardless of the possible occurrence of a measurement gap, the MAC entity shall:

...

1> else:

2> start the *ra-ResponseWindow* configured in *RACH-ConfigCommon* at the first PDCCH occasion as specified in TS 38.213 [6] from the end of the Random Access Preamble transmission;

2> monitor the PDCCH of the SpCell for Random Access Response(s) identified by the RA-RNTI while the *ra-ResponseWindow* is running.

1> if notification of a reception of a PDCCH transmission is received from lower layers; and

1> if PDCCH transmission is addressed to the C-RNTI; and

- ...
- 1> else if a downlink assignment has been received on the PDCCH for the RA-RNTI and the received TB is successfully decoded:
 - 2> if the Random Access Response contains a Backoff Indicator subheader:
 - 3> set the *PREAMBLE_BACKOFF* to value of the BI field of the Backoff Indicator subheader using Table 7.2-1.
 - 2> else:
 - 3> set the *PREAMBLE_BACKOFF* to 0 ms.
 - 2> if the Random Access Response contains a Random Access Preamble identifier corresponding to the transmitted *PREAMBLE_INDEX* (see subclause 5.1.3):
 - 3> consider this Random Access Response reception successful.
 - 2> if the Random Access Response reception is considered successful:
 - 3> if the Random Access Response includes RAPID only:
 - 4> consider this Random Access procedure successfully completed;
 - 4> indicate the reception of an acknowledgement for the SI request to upper layers.
 - 3> else:
 - 4> apply the following actions for the Serving Cell where the Random Access Preamble was transmitted:
 - 5> process the received Timing Advance Command (see subclause 5.2);
 - 5> indicate the *preambleReceivedTargetPower* and the amount of power ramping applied to the latest Random Access Preamble transmission to lower layers (i.e. $(PREAMBLE_POWER_RAMPING_COUNTER - 1) \times preamblePowerRampingStep$);
 - 5> if the Serving Cell for the Random Access procedure is SRS-only SCell:
 - 6> ignore the received UL grant.
 - 5> else:
 - 6> process the received UL grant value and indicate it to the lower layers.
 - 4> if the Random Access Preamble was not selected by the MAC entity among the contention-based Random Access Preamble(s):
 - 5> consider the Random Access procedure successfully completed.
- ...
- 1> if *ra-ResponseWindow* configured in *RACH-ConfigCommon* expires, and if the Random Access Response containing Random Access Preamble identifiers that matches the transmitted *PREAMBLE_INDEX* has not been received; or:
 - 1> if *ra-ResponseWindow* configured in *BeamFailureRecoveryConfig* expires and if the PDCCH addressed to the C-RNTI has not been received:
 - 2> consider the Random Access Response reception not successful;
 - 2> increment *PREAMBLE_TRANSMISSION_COUNTER* by 1;
 - 2> if *PREAMBLE_TRANSMISSION_COUNTER* = *preambleTxMax* + 1:
 - 3> if the Random Access Preamble is transmitted on the SpCell:
 - 4> indicate a Random Access problem to upper layers.

- 3> else if the Random Access Preamble is transmitted on a SCell:
 - 4> consider the Random Access procedure unsuccessfully completed.
- 2> if in this Random Access procedure, the Random Access Preamble was selected by MAC among the contention-based Random Access Preambles:
 - 3> select a random backoff time according to a uniform distribution between 0 and the *PREAMBLE_BACKOFF*;
 - 3> delay the subsequent Random Access Preamble transmission by the backoff time.
- 2> perform the Random Access Resource selection procedure (see subclause 5.1.2).

The MAC entity may stop *ra-ResponseWindow* (and hence monitoring for Random Access Response(s)) after successful reception of a Random Access Response containing Random Access Preamble identifiers that matches the transmitted *PREAMBLE_INDEX*.

HARQ operation is not applicable to the Random Access Response transmission.

7.1.1.1.1.3 Test description

7.1.1.1.1.3.1 Pre-test conditions

Same Pre-test conditions as in clause 7.1.1.0 except the following:

- 2 NR cells (NR Cell 1 and NR Cell 2) are configured.

7.1.1.1.1.3.2 Test procedure sequence

Table 7.1.1.1.1.3.2-1: Main behaviour

St	Procedure	Message Sequence		TP	Verdict
		U - S	Message		
1	The SS transmits an <i>RRCReconfiguration</i> message to handover NR Cell 1 to target NR Cell 2, including RACH-ConfigDedicated information element (Note 1)	<--	<i>RRCReconfiguration</i>	-	-
2	Void				
3	Check: Does the UE transmit Preamble on PRACH corresponding to <i>ra-PreambleIndex</i> in step 1 on NR Cell2?	-->	(PRACH Preamble)	1	P
4	Check: Does the UE re-transmits Preamble on PRACH corresponding to <i>ra-PreambleIndex</i> in step 1 on NR Cell2?	-->	(PRACH Preamble)	2	P
5	The SS transmits Random Access Response on NR cell 2, with RAPID corresponding to <i>ra-PreambleIndex</i> in step 1	<--	Random Access Response	-	-
6	Check: Does the UE transmit an <i>RRCReconfigurationComplete</i> message? (Note 2)	-->	<i>RRCReconfigurationComplete</i>	-	-
Note 1: For EN-DC the NR <i>RRCReconfiguration</i> message is contained in <i>RRCConnectionReconfiguration</i> 36.508 [7], Table 4.6.1-8 using condition EN-DC_PSCell_HO AND RBConfig_NoKeyChange Note 2: For EN-DC the NR <i>RRCReconfigurationComplete</i> message is contained in <i>RRCConnectionReconfigurationComplete</i>					

7.1.1.1.1.3.3 Specific message contents

Table 7.1.1.1.1.3.3-1: Void

Table 7.1.1.1.1.3.3-2: RRCReconfiguration (step 1, Table 7.1.1.1.1.3.2-1)

Derivation Path: 38.508-1 [4], Table [4.6.1-13]			
Information Element	Value/remark	Comment	Condition
RRCReconfiguration ::= SEQUENCE {			
criticalExtensions CHOICE {			
radioBearerConfig	RadioBearerConfig as per TS 38.508-1[4] Table 4.6.3-132 with conditions DRBn and Recover_PDCP	n set to the default DRB of the first PDU session	NR
rrcReconfiguration ::= SEQUENCE {			
secondaryCellGroup	CellGroupConfig	DRBn set to DRB2	EN-DC
nonCriticalExtension SEQUENCE {			NR
masterCellGroup	CellGroupConfig	DRBn set to the default DRB of the first PDU session	
}			
}			
}			

Table 7.1.1.1.1.3.3-3 CellGroupConfig (Table 7.1.1.1.1.3.3-2)

Derivation Path: 38.508-1 [4], Table [4.6.3-19] with condition DRBn and HO			
Information Element	Value/remark	Comment	Condition
CellGroupConfig ::= SEQUENCE {			
spCellConfig SEQUENCE {			
reconfigurationWithSync SEQUENCE {			
rach-ConfigDedicated CHOICE {			
uplink	RACH-ConfigDedicated		
}			
}			
}			
}			

Table 7.1.1.1.1.3.3-4: RACH-ConfigDedicated (Table 7.1.1.1.1.3.3-3)

Derivation Path: TS 38.508-1 [4], Table 4.6.3-129			
Information Element	Value/remark	Comment	Condition
RACH-ConfigDedicated ::= SEQUENCE {			
cfra SEQUENCE {			
resources CHOICE {			
ssb SEQUENCE {			
ssb-ResourceList SEQUENCE (SIZE(1..maxRA-SSB-Resources)) OF SEQUENCE {	1 entry		
ssb[1]	0		
ra-PreambleIndex[1]	52	Randomly selected	
}			
}			
}			
}			

7.1.1.1.1a Correct selection of RACH parameters / Random access preamble and PRACH resource explicitly signalled to the UE by PDCCH Order / contention free random access procedure

7.1.1.1.1a.1 Test Purpose (TP)

(1)

```
with { UE in RRC_Connected }
ensure that {
  when { PDCCH control command is received in NR PsCell providing Random Access Preamble }
  then { UE sends a PRACH preamble given in the PDCCH Order in NR PsCell }
}
```

(2)

```
with { UE in RRC_Connected state after transmission of a PRACH preamble on NR SpCell received in
PDCCH control command on NR PsCell }
ensure that {
  when { UE does not receive a matching Random Access response in ra-ResponseWindowSize (hence
considers RACH attempt as failed) and PREAMBLE_TRANSMISSION_COUNTER is less than PREAMBLE_TRANS_MAX
}
  then { UE retransmits a PRACH preamble received in PDCCH control command on NR PsCell }
}
```

7.1.1.1.1a.2 Conformance requirements

References: The conformance requirements covered in the present test case are specified in: TS 38.321, clauses 5.1.2, 5.1.4 and TS 38.212 clause 7.3.1.2.1. Unless otherwise stated these are Rel-15 requirements.

[TS 38.321, clause 5.1.2]

The MAC entity shall:

...

1> else if the *ra-PreambleIndex* has been explicitly provided by either PDCCH or RRC; and

1> if the *ra-PreambleIndex* is not 0b000000; and

1> if contention-free Random Access Resource associated with SSBs or CSI-RS have not been explicitly provided by RRC:

2> set the *PREAMBLE_INDEX* to the signalled *ra-PreambleIndex*.

...

1> if an SSB is selected above and an association between PRACH occasions and SSBs is configured:

2> determine the next available PRACH occasion from the PRACH occasions corresponding to the selected SSB permitted by the restrictions given by the *ra-ssb-OccasionMaskIndex* if configured (the MAC entity may take into account the possible occurrence of measurement gaps when determining the next available PRACH occasion corresponding to the selected SSB).

1> else if a CSI-RS is selected above and an association between PRACH occasions and CSI-RSs is configured:

2> determine the next available PRACH occasion from the PRACH occasions in *ra-OccasionList* corresponding to the selected CSI-RS (the MAC entity may take into account the possible occurrence of measurement gaps when determining the next available PRACH occasion corresponding to the selected CSI-RS).

1> else:

2> determine the next available PRACH occasion (the MAC entity may take into account the possible occurrence of measurement gaps when determining the next available PRACH occasion).

1> perform the Random Access Preamble transmission procedure (see subclause 5.1.3).

[TS 38.321, clause 5.1.4]

Once the Random Access Preamble is transmitted and regardless of the possible occurrence of a measurement gap, the MAC entity shall:

...

1> else:

- 2> start the *ra-ResponseWindow* configured in *RACH-ConfigCommon* at the first PDCCH occasion as specified in TS 38.213 [6] from the end of the Random Access Preamble transmission;
- 2> monitor the PDCCH of the SpCell for Random Access Response(s) identified by the RA-RNTI while the *ra-ResponseWindow* is running.

1> if notification of a reception of a PDCCH transmission is received from lower layers; and

1> if PDCCH transmission is addressed to the C-RNTI; and

...

1> else if a downlink assignment has been received on the PDCCH for the RA-RNTI and the received TB is successfully decoded:

2> if the Random Access Response contains a Backoff Indicator subheader:

- 3> set the *PREAMBLE_BACKOFF* to value of the BI field of the Backoff Indicator subheader using Table 7.2-1.

2> else:

- 3> set the *PREAMBLE_BACKOFF* to 0 ms.

2> if the Random Access Response contains a Random Access Preamble identifier corresponding to the transmitted *PREAMBLE_INDEX* (see subclause 5.1.3):

- 3> consider this Random Access Response reception successful.

2> if the Random Access Response reception is considered successful:

3> if the Random Access Response includes RAPID only:

- 4> consider this Random Access procedure successfully completed;
- 4> indicate the reception of an acknowledgement for the SI request to upper layers.

3> else:

4> apply the following actions for the Serving Cell where the Random Access Preamble was transmitted:

- 5> process the received Timing Advance Command (see subclause 5.2);
- 5> indicate the *preambleReceivedTargetPower* and the amount of power ramping applied to the latest Random Access Preamble transmission to lower layers (i.e. $(PREAMBLE_POWER_RAMPING_COUNTER - 1) \times preamblePowerRampingStep$);
- 5> if the Serving Cell for the Random Access procedure is SRS-only SCell:
 - 6> ignore the received UL grant.

5> else:

- 6> process the received UL grant value and indicate it to the lower layers.

4> if the Random Access Preamble was not selected by the MAC entity among the contention-based Random Access Preamble(s):

- 5> consider the Random Access procedure successfully completed.

...

- 1> if *ra-ResponseWindow* configured in *RACH-ConfigCommon* expires, and if the Random Access Response containing Random Access Preamble identifiers that matches the transmitted *PREAMBLE_INDEX* has not been received; or:
- 1> if *ra-ResponseWindow* configured in *BeamFailureRecoveryConfig* expires and if the PDCCH addressed to the C-RNTI has not been received:
 - 2> consider the Random Access Response reception not successful;
 - 2> increment *PREAMBLE_TRANSMISSION_COUNTER* by 1;
 - 2> if *PREAMBLE_TRANSMISSION_COUNTER* = *preambleTxMax* + 1:
 - 3> if the Random Access Preamble is transmitted on the SpCell:
 - 4> indicate a Random Access problem to upper layers.
 - 3> else if the Random Access Preamble is transmitted on a SCell:
 - 4> consider the Random Access procedure unsuccessfully completed.
 - 2> if in this Random Access procedure, the Random Access Preamble was selected by MAC among the contention-based Random Access Preambles:
 - 3> select a random backoff time according to a uniform distribution between 0 and the *PREAMBLE_BACKOFF*;
 - 3> delay the subsequent Random Access Preamble transmission by the backoff time.
 - 2> perform the Random Access Resource selection procedure (see subclause 5.1.2).

The MAC entity may stop *ra-ResponseWindow* (and hence monitoring for Random Access Response(s)) after successful reception of a Random Access Response containing Random Access Preamble identifiers that matches the transmitted *PREAMBLE_INDEX*.

HARQ operation is not applicable to the Random Access Response transmission.

[TS 38.212, 7.3.1.2.1]

If the CRC of the DCI format 1_0 is scrambled by C-RNTI and the "Frequency domain resource assignment" field are of all ones, the DCI format 1_0 is for random access procedure initiated by a PDCCH order, with all remaining fields set as follows:

- Random Access Preamble index – 6 bits according to *ra-PreambleIndex* in Subclause 5.1.2 of [8, TS38.321]
- UL/SUL indicator – 1 bit. If the value of the "Random Access Preamble index" is not all zeros and if the UE is configured with SUL in the cell, this field indicates which UL carrier in the cell to transmit the PRACH according to Table 7.3.1.1.1-1; otherwise, this field is reserved
- SS/PBCH index – 6 bits. If the value of the "Random Access Preamble index" is not all zeros, this field indicates the SS/PBCH that shall be used to determine the RACH occasion for the PRACH transmission; otherwise, this field is reserved.
- PRACH Mask index – 4 bits. If the value of the "Random Access Preamble index" is not all zeros, this field indicates the RACH occasion associated with the SS/PBCH indicated by "SS/PBCH index" for the PRACH transmission, according to Subclause 5.1.1 of [8, TS38.321]; otherwise, this field is reserved
- Reserved bits – 10 bits

7.1.1.1.1a.3 Test description

7.1.1.1.1a.3.1 Pre-test conditions

Same Pre-test conditions as in clause 7.1.3.0.

7.1.1.1.1a.3.2 Test procedure sequence

Table 7.1.1.1.1a.3.2-1: Main behaviour

St	Procedure	Message Sequence		TP	Verdict
		U - S	Message		
0A	SS transmits an RRCReconfiguration message to configure specific parameters. Note 1	<--	RRCReconfiguration	-	-
0B	The UE transmits RRCReconfigurationComplete message. Note 2	-->	RRCReconfigurationComplete	-	-
1	The SS transmits a PDCCH order providing Random Access Preamble on NR SpCell.	<--	(PDCCH Order)	-	-
2	Check: Does the UE transmit Preamble on PRACH corresponding to <i>ra-PreambleIndex</i> in step 1?	-->	(PRACH Preamble)	1	P
3	Check: Does the UE re-transmits Preamble on PRACH corresponding to <i>ra-PreambleIndex</i> in step 1?	-->	(PRACH Preamble)	2	P
4	Check: Does the UE transmit Preamble on PRACH corresponding to <i>ra-PreambleIndex</i> in step 1?	-->	(PRACH Preamble)	2	P
5	Check: Does the UE re-transmits Preamble on PRACH corresponding to <i>ra-PreambleIndex</i> in step 1?	-->	(PRACH Preamble)	2	P
6	The SS transmits Random Access Response on NR SpCell, with RAPID corresponding to <i>ra-PreambleIndex</i> in step 1	<--	Random Access Response	-	-
Note 1: for EN-DC the NR <i>RRCReconfiguration</i> message is contained in <i>RRCConnectionReconfiguration</i> . Note 2: for EN-DC the NR <i>RRCReconfigurationComplete</i> message is contained in <i>RRCConnectionReconfigurationComplete</i> .					

7.1.1.1.1a.3.3 Specific message contents

Table 7.1.1.1.1a.3.3-1: RRCReconfiguration (step 0A, Table7.1.1.1.1a.3.2-1)

Derivation Path: TS 38.508-1 [4], Table 4.6.1-13			
Information Element	Value/remark	Comment	Condition
RRCReconfiguration ::= SEQUENCE {			
		TS 38.508-1 [4], 2	
criticalExtensions CHOICE {			
rrcReconfiguration ::= SEQUENCE {			
secondaryCellGroup	CellGroupConfig	OCTET STRING (CONTAINING CellGroupConfig)	EN-DC
nonCriticalExtension SEQUENCE {			NR
masterCellGroup	CellGroupConfig	OCTET STRING (CONTAINING CellGroupConfig)	
}			
}			
}			
}			

Table 7.1.1.1.1a.3.3-2: CellGroupConfig (Table 7.1.1.1.1a.3.3-1)

Derivation Path: TS 38.508-1 [4], Table 4.6.3-19			
Information Element	Value/remark	Comment	Condition
CellGroupConfig ::= SEQUENCE {			
spCellConfig SEQUENCE {			
reconfigurationWithSync SEQUENCE {			
spCellConfigCommon	ServingCellConfigCommon		
newUE-Identity	RNTI-Value		
t304	ms2000		
rach-ConfigDedicated	Not Present		
}			

Table 7.1.1.1.1a.3.3-3: ServingCellConfigCommon (Table 7.1.1.1.1a.3.3-2)

Derivation Path: TS 38.508-1 [4], Table 4.6.3-168			
Information Element	Value/remark	Comment	Condition
ServingCellConfigCommon ::= SEQUENCE {			
uplinkConfigCommon SEQUENCE {			
initialUplinkBWP	BWP-UplinkCommon		
}			

Table 7.1.1.1.1a.3.3-4: BWP-UplinkCommon (Table 7.1.1.1.1a.3.3-3)

Derivation Path: TS 38.508-1 [4], Table 4.6.3-10			
Information Element	Value/remark	Comment	Condition
BWP-UplinkCommon ::= SEQUENCE {			
rach-ConfigCommon CHOICE {			
setup	RACH-ConfigCommon		
}			

Table 7.1.1.1.1a.3.3-5: RACH-ConfigCommon (Table 7.1.1.1.1a.3.3-4)

Derivation Path: TS 38.508-1 [4], Table 4.6.3-128			
Information Element	Value/remark	Comment	Condition
RACH-ConfigCommon ::= SEQUENCE {			
rach-ConfigGeneric	RACH-ConfigGeneric		

Table 7.1.1.1.1a.3.3-6: RACH-ConfigGeneric (Table 7.1.1.1.1a.3.3-5)

Derivation Path: TS 38.508-1 [4], Table 4.6.3-130			
Information Element	Value/remark	Comment	Condition
RACH-ConfigGeneric ::= SEQUENCE {			
preambleTransMax	n4		

7.1.1.1.2 Random access procedure / Successful / C-RNTI Based / Preamble selected by MAC itself

7.1.1.1.2.1 Test Purpose (TP)

(1)

with { UE in RRC_Connected NR SpCell TimeAlignmentTimer expired, and has UL Data to send }
ensure that {

```

when { the UL MAC PDU Size is less than messageSizeGroupA }
then { UE transmits a random access preamble using a preamble in group A of random access
preambles }
}

```

(2)

```

with { UE in RRC_Connected state after transmission of a PRACH preamble on NR SpCell }
ensure that {
when { SS does not answer with a matching Random Access Response within ra-ResponseWindowSize }
then { UE retransmits a PRACH preamble from same group }
}

```

(3)

```

with { UE in RRC_Connected state after transmission of a PRACH preamble on NR SpCell }
ensure that {
when { UE receives while ra-ResponseWindowSizeTimer is running MAC PDU containing multiple RARs
but none of the subheaders contains a RAPID corresponding to the UE }
then { UE retransmits a PRACH preamble from same group }
}

```

(4)

```

with { UE in RRC_Connected state after transmission of a PRACH preamble on NR SpCell }
ensure that {
when { SS sends a Random Access Response including a Backoff Indicator and the Random Access
Preamble identifier is different from the value received from the UE }
then { UE triggers RA preamble after a random time between 0 and the indicated Backoff parameter
from same group }
}

```

(5)

```

with { UE in RRC_Connected state after transmission of a PRACH preamble on NR SpCell }
ensure that {
when { UE receives while ra-ResponseWindowSizeTimer is running MAC PDU containing multiple RARs
and one of the subheaders contains a RAPID corresponding to the UE and containing Backoff Indicator }
then { UE stores Backoff Indicator UE transmits RACH procedure MSG3 }
}

```

(6)

```

with { UE in RRC_Connected state after transmission of Msg3 on NR SpCell without dedicated preamble }
ensure that {
when { The SS does not schedule any PDCCH transmission addressed to UE C-RNTI before Contention
resolution timer expiry }
then { UE transmits a random access preamble using a preamble in the same group of random access
preambles as used for the first transmission of Msg3 }
}

```

(7)

```

with { UE in RRC_Connected state after transmission of Msg3 on NR SpCell without dedicated preamble }
ensure that {
when { UE receive PDCCH transmission addressed to its C-RNTI before Contention resolution timer
expiry }
then { UE considers RACH procedure as complete }
}

```

(8)

```

with { UE in RRC_CONNECTED state and Random Access Preambles group B is configured }
ensure that {
when { UE has data available for transmission and the MAC PDU Size carrying this data is greater
than ra-Msg3SizeGroupA }
then {UE transmits a random access preamble using a preamble in group B of random access
preambles}
}

```

```

with { UE in RRC_Connected NR SpCell TimeAlignmentTimer expired, and has UL Data to send }
ensure that {
  when { the UL MAC PDU Size is greater than messageSizeGroupA }
  then { UE transmits a random access preamble using a preamble in group B of random access
preambles }
}

```

(9)

```

with { UE in RRC_Connected state and having initiated a random access procedure in NR SpCell }
ensure that {
  when { The SS transmits a Timing Advance Command in a Random Access Response message }
  then {the UE applies the received Timing Advance value in the next transmitted MAC PDU }
}

```

7.1.1.1.2.2 Conformance requirements

References: The conformance requirements covered in the present test case are specified in: TS 38.321, clauses 5.1.2, 5.1.3, 5.1.4, 5.1.5, 5.2, 6.1.3.2, 6.1.5 and 6.2.3. Unless otherwise stated these are Rel-15 requirements.

[TS 38.321, clause 5.1.2]

The MAC entity shall:

...

- 1> else (i.e. for the contention-based Random Access preamble selection):
 - 2> if at least one of the SSBs with SS-RSRP above *rsrp-ThresholdSSB* is available:
 - 3> select an SSB with SS-RSRP above *rsrp-ThresholdSSB*.
 - 2> else:
 - 3> select any SSB.
 - 2> if Msg3 has not yet been transmitted:
 - 3> if Random Access Preambles group B is configured:
 - 4> if the potential Msg3 size (UL data available for transmission plus MAC header and, where required, MAC CEs) is greater than *ra-Msg3SizeGroupA* and the pathloss is less than *PCMAX* (of the Serving Cell performing the Random Access Procedure) $-preambleReceivedTargetPower - msg3-DeltaPreamble - messagePowerOffsetGroupB$; or
 - 4> if the Random Access procedure was initiated for the CCCH logical channel and the CCCH SDU size plus MAC subheader is greater than *ra-Msg3SizeGroupA*:5> select the Random Access Preambles group B.
 - 4> else:
 - 5> select the Random Access Preambles group A.
 - 3> else:
 - 4> select the Random Access Preambles group A.
 - 2> else (i.e. Msg3 is being retransmitted):
 - 3> select the same group of Random Access Preambles as was used for the Random Access Preamble transmission attempt corresponding to the first transmission of Msg3.
 - 2> if the association between Random Access Preambles and SSBs is configured:
 - 3> select a Random Access Preamble randomly with equal probability from the Random Access Preambles associated with the selected SSB and the selected Random Access Preambles group.
 - 2> else:

- 3> select a Random Access Preamble randomly with equal probability from the Random Access Preambles within the selected Random Access Preambles group.
- 2> set the *PREAMBLE_INDEX* to the selected *ra-PreambleIndex*.
- ...
- 1> if the Random Access procedure was initiated for SI request (as specified in TS 38.331 [5]); and
- 1> if *ra-AssociationPeriodIndex* and *si-RequestPeriod* are configured:
 - 2> determine the next available PRACH occasion from the PRACH occasions corresponding to the selected SSB in the association period given by *ra-AssociationPeriodIndex* in the *si-RequestPeriod* permitted by the restrictions given by the *ra-ssb-OccasionMaskIndex* (the MAC entity shall select a PRACH occasion randomly with equal probability amongst the consecutive PRACH occasions according to subclause 8.1 of TS 38.213 [6] corresponding to the selected SSB).
- 1> else if an SSB is selected above:
 - 2> determine the next available PRACH occasion from the PRACH occasions corresponding to the selected SSB permitted by the restrictions given by the *ra-ssb-OccasionMaskIndex* if configured (the MAC entity shall select a PRACH occasion randomly with equal probability amongst the consecutive PRACH occasions according to subclause 8.1 of TS 38.213 [6], corresponding to the selected SSB; the MAC entity may take into account the possible occurrence of measurement gaps when determining the next available PRACH occasion corresponding to the selected SSB).
- 1> else if a CSI-RS is selected above:
 - 2> if there is no contention-free Random Access Resource associated with the selected CSI-RS:
 - 3> determine the next available PRACH occasion from the PRACH occasions, permitted by the restrictions given by the *ra-ssb-OccasionMaskIndex* if configured, corresponding to the SSB in *candidateBeamRSList* which is quasi-collocated with the selected CSI-RS as specified in TS 38.214 [7] (the MAC entity may take into account the possible occurrence of measurement gaps when determining the next available PRACH occasion corresponding to the SSB which is quasi-collocated with the selected CSI-RS).
 - 2> else:
 - 3> determine the next available PRACH occasion from the PRACH occasions in *ra-OccasionList* corresponding to the selected CSI-RS (the MAC entity shall select a PRACH occasion randomly with equal probability amongst the PRACH occasions occurring simultaneously but on different subcarriers, corresponding to the selected CSI-RS; the MAC entity may take into account the possible occurrence of measurement gaps when determining the next available PRACH occasion corresponding to the selected CSI-RS).
- 1> perform the Random Access Preamble transmission procedure (see subclause 5.1.3).

[TS 38.321, clause 5.1.3]

The MAC entity shall, for each Random Access Preamble:

- 1> if *PREAMBLE_TRANSMISSION_COUNTER* is greater than one; and
- 1> if the notification of suspending power ramping counter has not been received from lower layers; and
- 1> if SSB selected is not changed (i.e. same as the previous Random Access Preamble transmission):
 - 2> increment *PREAMBLE_POWER_RAMPING_COUNTER* by 1.
- 1> select the value of *DELTA_PREAMBLE* according to subclause 7.3;
- 1> set *PREAMBLE_RECEIVED_TARGET_POWER* to $\text{preambleReceivedTargetPower} + \text{DELTA_PREAMBLE} + (\text{PREAMBLE_POWER_RAMPING_COUNTER} - 1) \times \text{PREAMBLE_POWER_RAMPING_STEP}$;
- 1> except for contention-free Random Access Preamble for beam failure recovery request, compute the RA-RNTI associated with the PRACH occasion in which the Random Access Preamble is transmitted;

- 1> instruct the physical layer to transmit the Random Access Preamble using the selected PRACH, corresponding RA-RNTI (if available), *PREAMBLE_INDEX* and *PREAMBLE_RECEIVED_TARGET_POWER*.

The RA-RNTI associated with the PRACH in which the Random Access Preamble is transmitted, is computed as:

$$\text{RA-RNTI} = 1 + s_id + 14 \times t_id + 14 \times 80 \times f_id + 14 \times 80 \times 8 \times ul_carrier_id$$

where *s_id* is the index of the first OFDM symbol of the specified PRACH ($0 \leq s_id < 14$), *t_id* is the index of the first slot of the specified PRACH in a system frame ($0 \leq t_id < 80$), *f_id* is the index of the specified PRACH in the frequency domain ($0 \leq f_id < 8$), and *ul_carrier_id* is the UL carrier used for Msg1 transmission (0 for NUL carrier, and 1 for SUL carrier).

[TS 38.321, clause 5.1.4]

Once the Random Access Preamble is transmitted and regardless of the possible occurrence of a measurement gap, the MAC entity shall:

...

1> else:

- 2> start the *ra-ResponseWindow* configured in *RACH-ConfigCommon* at the first PDCCH occasion as specified in TS 38.213 [6] from the end of the Random Access Preamble transmission;

- 2> monitor the PDCCH of the SpCell for Random Access Response(s) identified by the RA-RNTI while the *ra-ResponseWindow* is running.

1> if notification of a reception of a PDCCH transmission is received from lower layers on the Serving Cell where the preamble was transmitted; and

1> if PDCCH transmission is addressed to the C-RNTI; and

1> if the contention-free Random Access Preamble for beam failure recovery request was transmitted by the MAC entity:

- 2> consider the Random Access procedure successfully completed.

1> else if a downlink assignment has been received on the PDCCH for the RA-RNTI and the received TB is successfully decoded:

- 2> if the Random Access Response contains a MAC subPDU with Backoff Indicator:

- 3> set the *PREAMBLE_BACKOFF* to value of the BI field of the MAC subPDU using Table 7.2-1, multiplied with *SCALING_FACTOR_BI*.

2> else:

- 3> set the *PREAMBLE_BACKOFF* to 0 ms.

2> if the Random Access Response contains a MAC subPDU with Random Access Preamble identifier corresponding to the transmitted *PREAMBLE_INDEX* (see subclause 5.1.3):

- 3> consider this Random Access Response reception successful.

2> if the Random Access Response reception is considered successful:

3> if the Random Access Response includes RAPID only:

- 4> consider this Random Access procedure successfully completed;

- 4> indicate the reception of an acknowledgement for the SI request to upper layers.

3> else:

4> apply the following actions for the Serving Cell where the Random Access Preamble was transmitted:

- 5> process the received Timing Advance Command (see subclause 5.2);

- 5> indicate the *preambleReceivedTargetPower* and the amount of power ramping applied to the latest Random Access Preamble transmission to lower layers (i.e. $(PREAMBLE_POWER_RAMPING_COUNTER - 1) \times preamblePowerRampingStep$).
- 5> if the Serving Cell for the Random Access procedure is SRS-only SCell:
 - 6> ignore the received UL grant.
- 5> else:
 - 6> process the received UL grant value and indicate it to the lower layers.
- 4> if the Random Access Preamble was not selected by the MAC entity among the contention-based Random Access Preamble(s):
 - 5> consider the Random Access procedure successfully completed.
- 4> else:
 - 5> set the *TEMPORARY_C-RNTI* to the value received in the Random Access Response;
- ...
- 1> if *ra-ResponseWindow* configured in *RACH-ConfigCommon* expires, and if the Random Access Response containing Random Access Preamble identifiers that matches the transmitted *PREAMBLE_INDEX* has not been received; or
- 1> if *ra-ResponseWindow* configured in *BeamFailureRecoveryConfig* expires and if the PDCCH addressed to the C-RNTI has not been received on the Serving Cell where the preamble was transmitted:
 - 2> consider the Random Access Response reception not successful;
 - 2> increment *PREAMBLE_TRANSMISSION_COUNTER* by 1;
 - 2> if *PREAMBLE_TRANSMISSION_COUNTER* = *preambleTxMax* + 1:
 - 3> if the Random Access Preamble is transmitted on the SpCell:
 - 4> indicate a Random Access problem to upper layers.
 - 4> if this Random Access procedure was triggered for SI request:
 - 5> consider the Random Access procedure unsuccessfully completed.
 - > else if the Random Access Preamble is transmitted on a SCell:
 - 4> consider the Random Access procedure unsuccessfully completed.
 - 2> if the Random Access procedure is not completed:
 - 3> select a random backoff time according to a uniform distribution between 0 and the *PREAMBLE_BACKOFF*;
 - 3> if the criteria (as defined in subclause 5.1.2) to select contention-free Random Access Resources is met during the backoff time:
 - 4> perform the Random Access Resource selection procedure (see subclause 5.1.2);
 - 3> else:
 - 4> perform the Random Access Resource selection procedure (see subclause 5.1.2) after the backoff time.

The MAC entity may stop *ra-ResponseWindow* (and hence monitoring for Random Access Response(s)) after successful reception of a Random Access Response containing Random Access Preamble identifiers that matches the transmitted *PREAMBLE_INDEX*.

HARQ operation is not applicable to the Random Access Response transmission.

[TS 38.321, clause 5.1.5]

Once Msg3 is transmitted, the MAC entity shall:

- 1> start the *ra-ContentionResolutionTimer* and restart the *ra-ContentionResolutionTimer* at each HARQ retransmission in the first symbol after the end of the Msg3 transmission;
- 1> monitor the PDCCH while the *ra-ContentionResolutionTimer* is running regardless of the possible occurrence of a measurement gap;
- 1> if notification of a reception of a PDCCH transmission of the SpCell is received from lower layers:
 - 2> if the C-RNTI MAC CE was included in Msg3:
 - 3> if the Random Access procedure was initiated by the MAC sublayer itself or by the RRC sublayer and the PDCCH transmission is addressed to the C-RNTI and contains a UL grant for a new transmission; or
 - 3> if the Random Access procedure was initiated by a PDCCH order and the PDCCH transmission is addressed to the C-RNTI; or
 - 3> if the Random Access procedure was initiated by a beam failure indication from lower layer and the PDCCH transmission is addressed to the C-RNTI:
 - 4> consider this Contention Resolution successful;
 - 4> stop *ra-ContentionResolutionTimer*;
 - 4> discard the *TEMPORARY_C-RNTI*;
 - 4> consider this Random Access procedure successfully completed.

...

- 1> if *ra-ContentionResolutionTimer* expires:
 - 2> discard the *TEMPORARY_C-RNTI*;
 - 2> consider the Contention Resolution not successful.
- 1> if the Contention Resolution is considered not successful:
 - 2> flush the HARQ buffer used for transmission of the MAC PDU in the Msg3 buffer;
 - 2> increment *PREAMBLE_TRANSMISSION_COUNTER* by 1;
 - 2> if *PREAMBLE_TRANSMISSION_COUNTER* = *preambleTxMax* + 1:
 - 3> indicate a Random Access problem to upper layers.
 - 3> if this Random Access procedure was triggered for SI request:
 - 4> consider the Random Access procedure unsuccessfully completed.
 - 2> if the Random Access procedure is not completed:
 - 3> select a random backoff time according to a uniform distribution between 0 and the *PREAMBLE_BACKOFF*;
 - 3> if the criteria (as defined in subclause 5.1.2) to select contention-free Random Access Resources is met during the backoff time:
 - 4> perform the Random Access Resource selection procedure (see subclause 5.1.2);
 - 3> else:
 - 4> perform the Random Access Resource selection procedure (see subclause 5.1.2) after the backoff time.

[TS 38.321, clause 5.2]

RRC configures the following parameters for the maintenance of UL time alignment:

- *timeAlignmentTimer* (per TAG) which controls how long the MAC entity considers the Serving Cells belonging to the associated TAG to be uplink time aligned.

The MAC entity shall:

- 1> when a Timing Advance Command MAC CE is received, and if a N_{TA} (as defined in TS 38.211 [8]) has been maintained with the indicated TAG:
 - 2> apply the Timing Advance Command for the indicated TAG;
 - 2> start or restart the *timeAlignmentTimer* associated with the indicated TAG.

...

- 1> when a *timeAlignmentTimer* expires:
 - 2> if the *timeAlignmentTimer* is associated with the PTAG:
 - 3> flush all HARQ buffers for all Serving Cells;
 - 3> notify RRC to release PUCCH for all Serving Cells, if configured;
 - 3> notify RRC to release SRS for all Serving Cells, if configured;
 - 3> clear any configured downlink assignments and configured uplink grants;
 - 3> clear any PUSCH resource for semi-persistent CSI reporting;
 - 3> consider all running *timeAlignmentTimers* as expired;
 - 3> maintain N_{TA} (defined in TS 38.211 [8]) of all TAGs.
 - 2> else if the *timeAlignmentTimer* is associated with an STAG, then for all Serving Cells belonging to this TAG:
 - 3> flush all HARQ buffers;
 - 3> notify RRC to release PUCCH, if configured;
 - 3> notify RRC to release SRS, if configured;
 - 3> clear any configured downlink assignments and configured uplink grants;
 - 3> clear any PUSCH resource for semi-persistent CSI reporting;
 - 3> maintain N_{TA} (defined in TS 38.211 [8]) of this TAG.

When the MAC entity stops uplink transmissions for an SCell due to the fact that the maximum uplink transmission timing difference between TAGs of the MAC entity or the maximum uplink transmission timing difference between TAGs of any MAC entity of the UE is exceeded, the MAC entity considers the *timeAlignmentTimer* associated with the SCell as expired.

The MAC entity shall not perform any uplink transmission on a Serving Cell except the Random Access Preamble transmission when the *timeAlignmentTimer* associated with the TAG to which this Serving Cell belongs is not running. Furthermore, when the *timeAlignmentTimer* associated with the pTAG is not running, the MAC entity shall not perform any uplink transmission on any Serving Cell except the Random Access Preamble transmission on the SpCell.

[TS 38.321, clause 6.1.3.2]

The C-RNTI MAC CE is identified by MAC PDU subheader with LCID as specified in Table 6.2.1-2.

It has a fixed size and consists of a single field defined as follows (Figure 6.1.3.2-1):

- C-RNTI: This field contains the C-RNTI of the MAC entity. The length of the field is 16 bits.

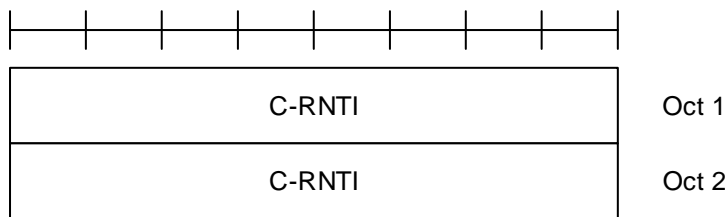

Figure 6.1.3.2-1: C-RNTI MAC CE

[TS 38.321, clause 6.1.5]

A MAC PDU consists of one or more MAC subPDUs and optionally padding. Each MAC subPDU consists one of the following:

- a MAC subheader with Backoff Indicator only;
- a MAC subheader with RAPID only (i.e. acknowledgment for SI request);
- a MAC subheader with RAPID and MAC RAR.

A MAC subheader with Backoff Indicator consists of five header fields E/T/R/R/BI as described in Figure 6.1.5-1. A MAC subPDU with Backoff Indicator only is placed at the beginning of the MAC PDU, if included. 'MAC subPDU(s) with RAPID only' and 'MAC subPDU(s) with RAPID and MAC RAR' can be placed anywhere between MAC subPDU with Backoff Indicator only (if any) and padding (if any).

A MAC subheader with RAPID consists of three header fields E/T/RAPID as described in Figure 6.1.5-2.

Padding is placed at the end of the MAC PDU if present. Presence and length of padding is implicit based on TB size, size of MAC subPDU(s).

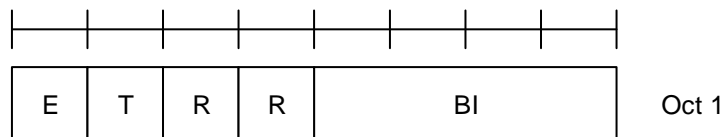

Figure 6.1.5-1: E/T/R/R/BI MAC subheader

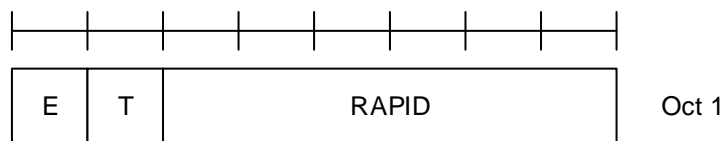

Figure 6.1.5-2: E/T/RAPID MAC subheader

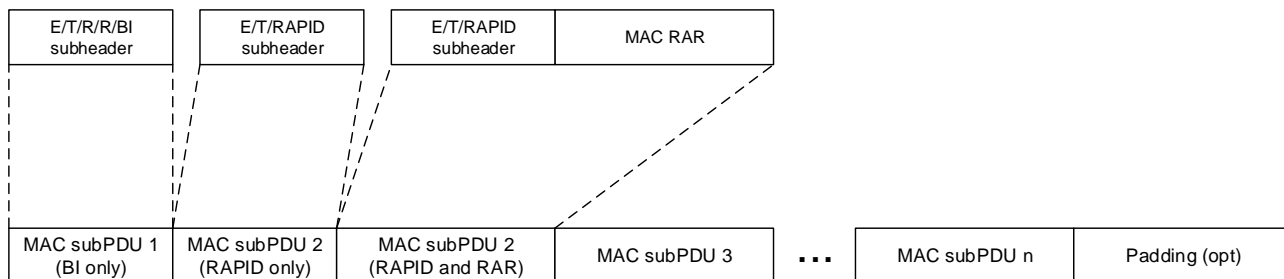

Figure 6.1.5-3: Example of MAC PDU consisting of MAC RARs

[TS 38.321, clause 6.2.3]

The MAC RAR is of fixed size as depicted in Figure 6.2.3-1, and consists of the following fields:

- R: Reserved bit, set to "0";
- Timing Advance Command: The Timing Advance Command field indicates the index value T_A used to control the amount of timing adjustment that the MAC entity has to apply in TS 38.213 [6]. The size of the Timing Advance Command field is 12 bits;
- UL Grant: The Uplink Grant field indicates the resources to be used on the uplink in TS 38.213 [6]. The size of the UL Grant field is 27 bits;
- Temporary C-RNTI: The Temporary C-RNTI field indicates the temporary identity that is used by the MAC entity during Random Access. The size of the Temporary C-RNTI field is 16 bits.

The MAC RAR is octet aligned.

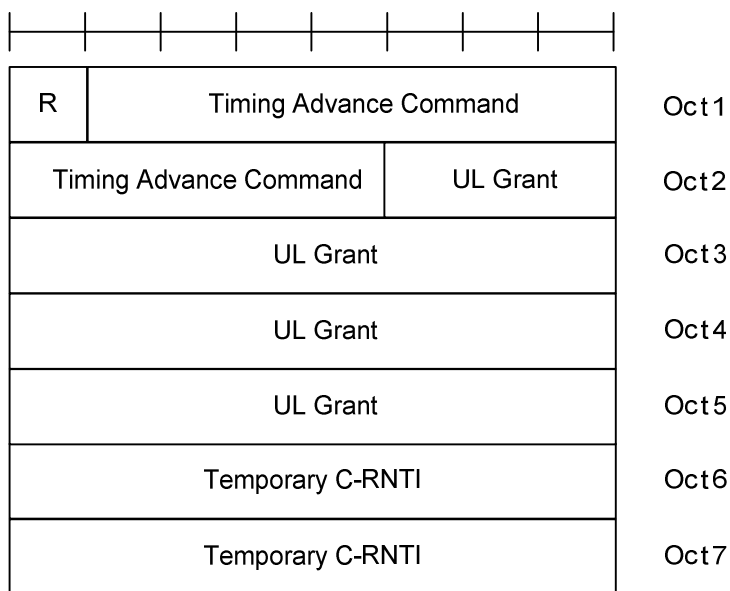

Figure 6.2.3-1: MAC RAR

7.1.1.1.2.3 Test description

7.1.1.1.2.3.1 Pre-test conditions

Same Pre-test conditions as in clause 7.1.1.0.

7.1.1.1.2.3.2 Test procedure sequence

Table 7.1.1.1.2.3.2-1: Main behaviour

St	Procedure	Message Sequence		TP	Verdict
		U - S	Message		
1	SS transmits Timing Advance command to SpCell. SS does not send any subsequent timing alignments. Start Timer_T1 = Time Alignment timer value on SS.	<--	MAC PDU (Timing Advance Command MAC Control Element)	-	-
2	40 to 50 TTI before Timer_T1 expires the SS transmits a MAC PDU containing a PDCP SDU of size 56 bits, less than ra-Msg3SizeGroupA(208 bits) on SpCell. (Note 1)	<--	MAC PDU	-	-
3	The SS ignores scheduling requests and does not allocate any uplink grant.	-	-	-	-
4	Check: Does the UE transmit preamble on PRACH using a preamble in group A defined in CellGroupConfig in RRCReconfiguration (totalNumberOfRA-Preambles, ssb-perRACH-OccasionAndCB-PreamblesPerSSB and numberOfRA-PreamblesGroupA) on SpCell in frame number X meeting condition $n_{SFN} \bmod 8 = 1$, subframe number 2,6,9 (FDD FR1) 4,9 (FR1 TDD) and frame number X and Slot number 0,1,2...39 (FR2)?	-->	PRACH Preamble	1	P
5	Check: does the UE transmit a preamble on PRACH, in frame number X+1 or X+2 subframe number 2,5,8 (FDD FR1)/ 7,8,9 (FR1 TDD) and frame number X and slot number 0,1,2...39 (FR2) using the same group A?	-->	PRACH Preamble	2	P
6	The SS transmits a MAC PDU addressed to UE RA-RNTI, containing multiple RARs but none of the MAC sub headers contains a matching RAPID on SpCell	<--	Random Access Response	-	-
-	EXCEPTION: In parallel with step 7, parallel behaviour defined in table 7.1.1.1.2.3.2-2 is executed	-	-	-	-
7	Check: Does the UE re-transmit a preamble on PRACH on SpCell using the same group A?	-->	PRACH Preamble	3	P
8	The SS transmits a Random Access Response with the back off parameter set to value Index field 'x' and with the Random Access Preamble identifier different from the value received from the UE in the Random Access Preamble. The SS sets Timer_T2 to the Back off value 'y' associated with the Index value 'x' and starts Timer_T2.	<--	Random Access Response(BI, RAPID)	-	-
9	Check: Does UE send a Random Access Preamble on SpCell while Timer_T2 is running ?	-->	Random Access Preamble	4	P
10	SS sends Random Access Response with an UL Grant of 56-bits, a back off parameter set to value Index field 'x' and the Random Access Preamble identifier value set to the same value as received from the UE in the Random Access Preamble. (Note 2)	<--	Random Access Response(BI, RAPID)	-	-
11	Check: Does UE sends a msg3 in the grant associated to the Random Access Response received in step 10 on SpCell?	-->	msg3 (C-RNTI MAC CONTROL ELEMENT)	5	P
12	SS does not schedule any PDCCH transmission for UE C-RNTI. The SS sets Timer_T3 to the Back off value 'y' associated with the Index value 'x' plus Contention Resolution Timer and starts Timer_T3.	-	-	-	-
13	Check: Does the UE transmit preamble on PRACH using a preamble belonging to group A for time equal to Timer_T3 on SpCell?	-->	PRACH Preamble	6	P

14	The SS transmits Random Access Response with an UL Grant of 56-bits and RAPID corresponding to the transmitted Preamble in step 13, including T-CRNTI.	<--	Random Access Response	-	-
15	UE sends a msg3 using the grant associated to the Random Access Response received in step 14 on SpCell?	-->	msg3 (C-RNTI MAC CONTROL ELEMENT)	-	-
16	SS schedules PDCCH transmission for UE C_RNTI and allocate uplink grant.	<--	Contention Resolution	-	-
-	EXCEPTION: In parallel with step 17, parallel behaviour defined in table 7.1.1.1.2.3.2-3 is executed	-	-	-	-
17	The UE transmits a MAC PDU with C-RNTI containing looped back PDCP SDU	-->	MAC PDU	7	P
18	SS transmits Timing Advance command to SpCell. SS does not send any subsequent timing alignments. Start Timer_T4 = Time Alignment timer value on SS	<--	MAC PDU (Timing Advance Command MAC Control Element)	-	-
19	40 to 50 TTI before Timer_T4 expires the SS transmits a MAC PDU containing a PDCP SDU of size > ra-Msg3SizeGroupA(208 bits)	<--	MAC PDU	-	-
20	The SS ignores scheduling requests and does not allocate any uplink grant.	-	-	-	-
21	Check: Does the UE transmit preamble on PRACH using a preamble in group B defined in CellGroupConfig in RRCReconfiguration (ssb-perRACH-OccasionAndCB-PreamblesPerSSB, numberOfRA-PreamblesGroupA and numberOfRA-Preambles) on SpCell?	-->	PRACH Preamble	8	P
22	The SS transmits Random Access Response with an UL Grant of 56-bits and RAPID corresponding to the transmitted Preamble in step 21, including T-CRNTI.	<--	Random Access Response	-	-
23	UE sends a msg3 using the grant associated to the Random Access Response received in step 22 on SpCell?	-->	msg3 (C-RNTI MAC CONTROL ELEMENT)	-	-
23	SS schedules PDCCH transmission for UE C_RNTI and allocate uplink grant.	<--	Contention Resolution	-	-
24	The UE transmits a MAC PDU with C-RNTI containing looped back PDCP SDU	-->	MAC PDU	9	P
Note 1: MAC PDU size of 56bits is selected to allow UE send status PDU and still stays below the limit of ra-Msg3SizeGroupA.					
Note 2: UL grant of 56bits is to make UE not send any loopback data in uplink with msg3.					

Table 7.1.1.1.2.3.2-2: Parallel behaviour

St	Procedure	Message Sequence		TP	Verdict
		U - S	Message		
1	Check: Does the UE transmit msg3 message on SpCell?	-->	msg3 (C-RNTI MAC CONTROL ELEMENT)	-	F

Table 7.1.1.1.2.3.2-3: Parallel behaviour

St	Procedure	Message Sequence		TP	Verdict
		U - S	Message		
1	Check: Does the UE transmit an PRACH preamble or msg3 on SpCell?	-->	PRACH Preamble OR msg3 (C-RNTI MAC CONTROL ELEMENT)	-	F

7.1.1.1.2.3.3 Specific message contents

Table 7.1.1.1.2.3.3-1: RRCReconfiguration (Preamble)

Derivation Path: TS 38.508-1 [4], Table 4.6.1-13			
Information Element	Value/remark	Comment	Condition
RRCReconfiguration ::= SEQUENCE {			
criticalExtensions CHOICE {		TS 38.508-1 [4], 2.	
rrcReconfiguration ::= SEQUENCE {			
secondaryCellGroup	CellGroupConfig	OCTET STRING (CONTAINING CellGroupConfig)	EN-DC
nonCriticalExtension SEQUENCE {			NR
masterCellGroup	CellGroupConfig	OCTET STRING (CONTAINING CellGroupConfig)	
}			
}			
}			
}			

Table 7.1.1.1.2.3.3-2: CellGroupConfig (Table 7.1.1.1.2.3.3-1)

Derivation Path: TS 38.508-1 [4], Table 4.6.3-19			
Information Element	Value/remark	Comment	Condition
CellGroupConfig ::= SEQUENCE {			
spCellConfig SEQUENCE {			
reconfigurationWithSync SEQUENCE {			
spCellConfigCommon	ServingCellConfigCommon		
newUE-Identity	RNTI-Value		
t304	ms2000		
rach-ConfigDedicated CHOICE {			
uplink	Not Present	CFRA resources not available	
supplementaryUplink	Not Present		
}			
}			

Table 7.1.1.1.2.3.3-3: ServingCellConfigCommon (Table 7.1.1.1.2.3.3-1)

Derivation Path: TS 38.508-1 [4], Table 4.6.3-168			
Information Element	Value/remark	Comment	Condition
ServingCellConfigCommon ::= SEQUENCE {			
uplinkConfigCommon SEQUENCE {			
initialUplinkBWP	BWP-UplinkCommon		
}			
}			

Table 7.1.1.1.2.3.3-4: BWP-UplinkCommon (Table 7.1.1.1.2.3.3-1)

Derivation Path: TS 38.508-1 [4], Table 4.6.3-10			
Information Element	Value/remark	Comment	Condition
BWP-UplinkCommon ::= SEQUENCE {			
rach-ConfigCommon CHOICE {			
setup	RACH-ConfigCommon		
}			
}			

Table 7.1.1.1.2.3.3-5: RACH-ConfigCommon (Table 7.1.1.1.2.3.3-1)

Derivation Path: TS 38.508-1 [4], Table 4.6.3-128			
Information Element	Value/remark	Comment	Condition
RACH-ConfigCommon ::= SEQUENCE {			
rach-ConfigGeneric	RACH-ConfigGeneric		
totalNumberOfRA-Preambles	42		
ssb-perRACH-OccasionAndCB-PreamblesPerSSB			
CHOICE {			
One	n32		
}			
groupBconfigured SEQUENCE {			
ra-Msg3SizeGroupA	b208		
messagePowerOffsetGroupB	minusinfinity		
numberOfRA-PreamblesGroupA	28		
}			
ra-ContentionResolutionTimer	sf48		
}			

Table 7.1.1.1.2.3.3-5a: MAC-CellGroupConfig (preamble)

Derivation Path: TS 38.508-1 [4], Table 4.6.3-68			
Information Element	Value/remark	Comment	Condition
MAC-CellGroupConfig ::= SEQUENCE {			
tag-Config SEQUENCE {			
tag-ToAddModList SEQUENCE (SIZE (1..maxNrofTAGs)) OF SEQUENCE {	1 entry		
timeAlignmentTimer	ms750		
}			
}			
}			

Table 7.1.1.1.2.3.3-6: RACH-ConfigGeneric (Table 7.1.1.1.2.3.3-1)

Derivation Path: TS 38.508-1 [4], Table 4.6.3-130			
Information Element	Value/remark	Comment	Condition
RACH-ConfigGeneric ::= SEQUENCE { prach-ConfigurationIndex	119	As per Table 6.3.3.2-2: of TS 38.211 [24], this results in PRACH preamble transmission in a radio frame meeting $n_{SFN} \bmod 8 = 1$, subframe number 2, 6, 9 and starting symbol 0 using preamble Format A2.	FR1 FDD
prach-ConfigurationIndex	94	As per Table 6.3.3.2-3: of TS 38.211 [24], this results in PRACH preamble transmission in a radio frame meeting $n_{SFN} \bmod 8 = 1$, subframe number 4, 9 and starting symbol 0 using preamble Format A2.	FR1 TDD
prach-ConfigurationIndex	6	As per Table 6.3.3.2-4: of TS 38.211 [24], this results in PRACH preamble transmission start in any radio frame number, slot number 0,1,2,...,39 and starting symbol 0.	FR2
preambleReceivedTargetPower	dBm-104		
preambleTransMax	n10		
powerRampingStep	dB2		
ra-ResponseWindow	sl8		
}			

7.1.1.1.3 Random access procedure / Successful / SI request

7.1.1.1.3.1 Test Purpose (TP)

(1)

```

with { UE in RRC Idle State and need for Updated System information }
ensure that {
  when { UE transmitted PRACH preamble and ra-ResponseWindow has expired }
  then { UE retransmits the PRACH Preamble }
}

```

(2)

```

with { UE in RRC Idle State and transmitted PRACH preamble for System information request }
ensure that {
  when { UE received a RAR message addressed to RA-RNTI and including matching RAPID only }
}

```

```

    then { UE considers the RACH procedure to be successfully completed and informs the upper
layer }
}

```

7.1.1.1.3.2 Conformance requirements

References: The conformance requirements covered in the present TC are specified in: 3GPP TS 38.321, clause 5.1.2, 5.1.3, 5.1.4, and 6.1.5. Unless otherwise stated these are Rel-15 requirements.

[TS 38.321, clause 5.1.2]

The MAC entity shall:

- 1> if the Random Access procedure was initiated for beam failure recovery (as specified in subclause 5.17); and
- 1> if the *beamFailureRecoveryTimer* (in subclause 5.17) is either running or not configured; and
- 1> if the contention-free Random Access Resources for beam failure recovery request associated with any of the SSBs and/or CSI-RSs have been explicitly provided by RRC; and
- 1> if at least one of the SSBs with SS-RSRP above *rsrp-ThresholdSSB* amongst the SSBs in *candidateBeamRSList* or the CSI-RSs with CSI-RSRP above *rsrp-ThresholdCSI-RS* amongst the CSI-RSs in *candidateBeamRSList* is available:
 - 2> select an SSB with SS-RSRP above *rsrp-ThresholdSSB* amongst the SSBs in *candidateBeamRSList* or a CSI-RS with CSI-RSRP above *rsrp-ThresholdCSI-RS* amongst the CSI-RSs in *candidateBeamRSList*;
 - 2> if CSI-RS is selected, and there is no *ra-PreambleIndex* associated with the selected CSI-RS:
 - 3> set the *PREAMBLE_INDEX* to a *ra-PreambleIndex* corresponding to the SSB in *candidateBeamRSList* which is quasi-collocated with the selected CSI-RS as specified in TS 38.214 [7].
 - 2> else:
 - 3> set the *PREAMBLE_INDEX* to a *ra-PreambleIndex* corresponding to the selected SSB or CSI-RS from the set of Random Access Preambles for beam failure recovery request.
- 1> else if the *ra-PreambleIndex* has been explicitly provided by either PDCCH or RRC; and
- 1> if the *ra-PreambleIndex* is not 0b000000; and
- 1> if contention-free Random Access Resource associated with SSBs or CSI-RSs have not been explicitly provided by RRC:
 - 2> set the *PREAMBLE_INDEX* to the signalled *ra-PreambleIndex*.
- 1> else if the contention-free Random Access Resources associated with SSBs have been explicitly provided by RRC and at least one SSB with SS-RSRP above *rsrp-ThresholdSSB* amongst the associated SSBs is available:
 - 2> select an SSB with SS-RSRP above *rsrp-ThresholdSSB* amongst the associated SSBs;
 - 2> set the *PREAMBLE_INDEX* to a *ra-PreambleIndex* corresponding to the selected SSB.
- 1> else if the contention-free Random Access Resources associated with CSI-RSs have been explicitly provided by RRC and at least one CSI-RS with CSI-RSRP above *rsrp-ThresholdCSI-RS* amongst the associated CSI-RSs is available:
 - 2> select a CSI-RS with CSI-RSRP above *rsrp-ThresholdCSI-RS* amongst the associated CSI-RSs;
 - 2> set the *PREAMBLE_INDEX* to a *ra-PreambleIndex* corresponding to the selected CSI-RS.
- 1> else:
 - 2> if at least one of the SSBs with SS-RSRP above *rsrp-ThresholdSSB* is available:
 - 3> select an SSB with SS-RSRP above *rsrp-ThresholdSSB*.
 - 2> else:

- 3> select any SSB.
 - 2> if Msg3 has not yet been transmitted:
 - 3> if Random Access Preambles group B is configured:
 - 4> if the potential Msg3 size (UL data available for transmission plus MAC header and, where required, MAC CEs) is greater than $ra-Msg3SizeGroupA$ and the pathloss is less than $PCMAX$ (of the Serving Cell performing the Random Access Procedure) – $preambleReceivedTargetPower - msg3-DeltaPreamble - messagePowerOffsetGroupB$; or
 - 4> if the Random Access procedure was initiated for the CCCH logical channel and the CCCH SDU size plus MAC subheader is greater than $ra-Msg3SizeGroupA$:
 - 5> select the Random Access Preambles group B.
 - 4> else:
 - 5> select the Random Access Preambles group A.
 - 3> else:
 - 4> select the Random Access Preambles group A.
 - 2> else (i.e. Msg3 is being retransmitted):
 - 3> select the same group of Random Access Preambles as was used for the Random Access Preamble transmission attempt corresponding to the first transmission of Msg3.
 - 2> if the association between Random Access Preambles and SSBs is configured:
 - 3> select a $ra-PreambleIndex$ randomly with equal probability from the Random Access Preambles associated with the selected SSB and the selected Random Access Preambles group.
 - 2> else:
 - 3> select a $ra-PreambleIndex$ randomly with equal probability from the Random Access Preambles within the selected Random Access Preambles group.
 - 2> set the $PREAMBLE_INDEX$ to the selected $ra-PreambleIndex$.
- 1> if an SSB is selected above and an association between PRACH occasions and SSBs is configured:
 - 2> determine the next available PRACH occasion from the PRACH occasions corresponding to the selected SSB permitted by the restrictions given by the $ra-ssb-OccasionMaskIndex$ if configured (the MAC entity shall select a PRACH occasion randomly with equal probability amongst the PRACH occasions occurring simultaneously but on different subcarriers, corresponding to the selected SSB; the MAC entity may take into account the possible occurrence of measurement gaps when determining the next available PRACH occasion corresponding to the selected SSB).
- 1> else if a CSI-RS is selected above and an association between PRACH occasions and CSI-RSs is configured:
 - 2> determine the next available PRACH occasion from the PRACH occasions in $ra-OccasionList$ corresponding to the selected CSI-RS (the MAC entity shall select a PRACH occasion randomly with equal probability amongst the PRACH occasions occurring simultaneously but on different subcarriers, corresponding to the selected CSI-RS; the MAC entity may take into account the possible occurrence of measurement gaps when determining the next available PRACH occasion corresponding to the selected CSI-RS).
- 1> else if Random Access procedure was initiated for beam failure recovery; and
- 1> if a CSI-RS is selected above and there is no contention-free Random Access Resource associated with the selected CSI-RS:
 - 2> determine the next available PRACH occasion from the PRACH occasions, permitted by the restrictions given by the $ra-ssb-OccasionMaskIndex$ if configured, corresponding to the SSB in $candidateBeamRSList$ which is quasi-collocated with the selected CSI-RS as specified in TS 38.214 [7] (the MAC entity may take

into account the possible occurrence of measurement gaps when determining the next available PRACH occasion corresponding to the SSB which is quasi-collected with the selected CSI-RS).

1> else:

- 2> determine the next available PRACH occasion (the MAC entity shall select a PRACH occasion randomly with equal probability amongst the PRACH occasions occurring simultaneously but on different subcarriers; the MAC entity may take into account the possible occurrence of measurement gaps when determining the next available PRACH occasion).

1> perform the Random Access Preamble transmission procedure (see subclause 5.1.3).

[TS 38.321, clause 5.1.3]

The MAC entity shall, for each Random Access Preamble:

- 1> if *PREAMBLE_TRANSMISSION_COUNTER* is greater than one; and
- 1> if the notification of suspending power ramping counter has not been received from lower layers; and
- 1> if SSB selected is not changed (i.e. same as the previous Random Access Preamble transmission):
 - 2> increment *PREAMBLE_POWER_RAMPING_COUNTER* by 1.
- 1> select the value of *DELTA_PREAMBLE* according to subclause 7.3;
- 1> set *PREAMBLE_RECEIVED_TARGET_POWER* to $\text{preambleReceivedTargetPower} + \text{DELTA_PREAMBLE} + (\text{PREAMBLE_POWER_RAMPING_COUNTER} - 1) \times \text{PREAMBLE_POWER_RAMPING_STEP}$;
- 1> except for contention-free Random Access Preamble for beam failure recovery request, compute the RA-RNTI associated with the PRACH occasion in which the Random Access Preamble is transmitted;
- 1> instruct the physical layer to transmit the Random Access Preamble using the selected PRACH, corresponding RA-RNTI (if available), *PREAMBLE_INDEX* and *PREAMBLE_RECEIVED_TARGET_POWER*.

The RA-RNTI associated with the PRACH in which the Random Access Preamble is transmitted, is computed as:

$$\text{RA-RNTI} = 1 + s_id + 14 \times t_id + 14 \times 80 \times f_id + 14 \times 80 \times 8 \times ul_carrier_id$$

where *s_id* is the index of the first OFDM symbol of the specified PRACH ($0 \leq s_id < 14$), *t_id* is the index of the first slot of the specified PRACH in a system frame ($0 \leq t_id < 80$), *f_id* is the index of the specified PRACH in the frequency domain ($0 \leq f_id < 8$), and *ul_carrier_id* is the UL carrier used for Msg1 transmission (0 for NUL carrier, and 1 for SUL carrier).

[TS 38.321, clause 5.1.4]

Once the Random Access Preamble is transmitted and regardless of the possible occurrence of a measurement gap, the MAC entity shall:

- 1> if the contention-free Random Access Preamble for beam failure recovery request was transmitted by the MAC entity:
 - 2> start the *ra-ResponseWindow* configured in *BeamFailureRecoveryConfig* at the first PDCCH occasion as specified in TS 38.213 [6] from the end of the Random Access Preamble transmission;
 - 2> monitor the PDCCH of the SpCell for response to beam failure recovery request identified by the C-RNTI while *ra-ResponseWindow* is running.
- 1> else:
 - 2> start the *ra-ResponseWindow* configured in *RACH-ConfigCommon* at the first PDCCH occasion as specified in TS 38.213 [6] from the end of the Random Access Preamble transmission;
 - 2> monitor the PDCCH of the SpCell for Random Access Response(s) identified by the RA-RNTI while the *ra-ResponseWindow* is running.
- 1> if notification of a reception of a PDCCH transmission is received from lower layers; and

- 1> if PDCCH transmission is addressed to the C-RNTI; and
- 1> if the contention-free Random Access Preamble for beam failure recovery request was transmitted by the MAC entity:
 - 2> consider the Random Access procedure successfully completed.
- 1> else if a downlink assignment has been received on the PDCCH for the RA-RNTI and the received TB is successfully decoded:
 - 2> if the Random Access Response contains a MAC subPDU with Backoff Indicator:
 - 3> set the *PREAMBLE_BACKOFF* to value of the BI field of the MAC subPDU using Table 7.2-1, multiplied with *SCALING_FACTOR_BI*.
 - 2> else:
 - 3> set the *PREAMBLE_BACKOFF* to 0 ms.
 - 2> if the Random Access Response contains a MAC subPDU with Random Access Preamble identifier corresponding to the transmitted *PREAMBLE_INDEX* (see subclause 5.1.3):
 - 3> consider this Random Access Response reception successful.
 - 2> if the Random Access Response reception is considered successful:
 - 3> if the Random Access Response includes a MAC subPDU with RAPID only:
 - 4> consider this Random Access procedure successfully completed;
 - 4> indicate the reception of an acknowledgement for SI request to upper layers.
 - 3> else:
 - 4> apply the following actions for the Serving Cell where the Random Access Preamble was transmitted:
 - 5> process the received Timing Advance Command (see subclause 5.2);
 - 5> indicate the *preambleReceivedTargetPower* and the amount of power ramping applied to the latest Random Access Preamble transmission to lower layers (i.e. $(PREAMBLE_POWER_RAMPING_COUNTER - 1) \times PREAMBLE_POWER_RAMPING_STEP$);
 - 5> if the Serving Cell for the Random Access procedure is SRS-only SCell:
 - 6> ignore the received UL grant.
 - 5> else:
 - 6> process the received UL grant value and indicate it to the lower layers.
 - 4> if the Random Access Preamble was not selected by the MAC entity among the contention-based Random Access Preamble(s):
 - 5> consider the Random Access procedure successfully completed.
 - 4> else:
 - 5> set the *TEMPORARY_C-RNTI* to the value received in the Random Access Response;
 - 5> if this is the first successfully received Random Access Response within this Random Access procedure:
 - 6> if the transmission is not being made for the CCCH logical channel:
 - 7> indicate to the Multiplexing and assembly entity to include a C-RNTI MAC CE in the subsequent uplink transmission.

- 6> obtain the MAC PDU to transmit from the Multiplexing and assembly entity and store it in the Msg3 buffer.
- 1> if *ra-ResponseWindow* configured in *RACH-ConfigCommon* expires, and if the Random Access Response containing Random Access Preamble identifiers that matches the transmitted *PREAMBLE_INDEX* has not been received; or
- 1> if *ra-ResponseWindow* configured in *BeamFailureRecoveryConfig* expires and if the PDCCH addressed to the C-RNTI has not been received:
 - 2> consider the Random Access Response reception not successful;
 - 2> increment *PREAMBLE_TRANSMISSION_COUNTER* by 1;
 - 2> if *PREAMBLE_TRANSMISSION_COUNTER* = *preambleTransMax* + 1:
 - 3> if the Random Access Preamble is transmitted on the SpCell:
 - 4> indicate a Random Access problem to upper layers;
 - 4> if this Random Access procedure was triggered for SI request:
 - 5> consider the Random Access procedure unsuccessfully completed.
 - 3> else if the Random Access Preamble is transmitted on a SCell:
 - 4> consider the Random Access procedure unsuccessfully completed.
 - 2> if the Random Access procedure is not completed:
 - 3> if in this Random Access procedure, the Random Access Preamble was selected by MAC among the contention-based Random Access Preambles:
 - 4> select a random backoff time according to a uniform distribution between 0 and the *PREAMBLE_BACKOFF*;
 - 4> delay the subsequent Random Access Preamble transmission by the backoff time.
 - 3> perform the Random Access Resource selection procedure (see subclause 5.1.2).

The MAC entity may stop *ra-ResponseWindow* (and hence monitoring for Random Access Response(s)) after successful reception of a Random Access Response containing Random Access Preamble identifiers that matches the transmitted *PREAMBLE_INDEX*.

HARQ operation is not applicable to the Random Access Response transmission.

[TS 38.321, clause 6.1.5]

A MAC PDU consists of one or more MAC subPDUs and optionally padding. Each MAC subPDU consists one of the following:

- a MAC subheader with Backoff Indicator only;
- a MAC subheader with RAPID only (i.e. acknowledgment for SI request);
- a MAC subheader with RAPID and MAC RAR.

A MAC subheader with Backoff Indicator consists of five header fields E/T/R/R/BI as described in Figure 6.1.5-1. A MAC subPDU with Backoff Indicator only is placed at the beginning of the MAC PDU, if included. 'MAC subPDU(s) with RAPID only' and 'MAC subPDU(s) with RAPID and MAC RAR' can be placed anywhere between MAC subPDU with Backoff Indicator only (if any) and padding (if any).

A MAC subheader with RAPID consists of three header fields E/T/RAPID as described in Figure 6.1.5-2.

Padding is placed at the end of the MAC PDU if present. Presence and length of padding is implicit based on TB size, size of MAC subPDU(s).

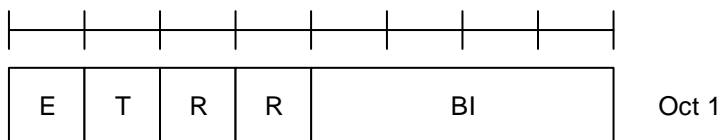

Figure 6.1.5-1: E/T/R/R/BI MAC subheader

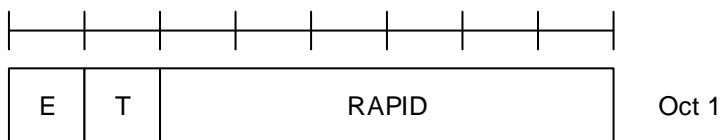

Figure 6.1.5-2: E/T/RAPID MAC subheader

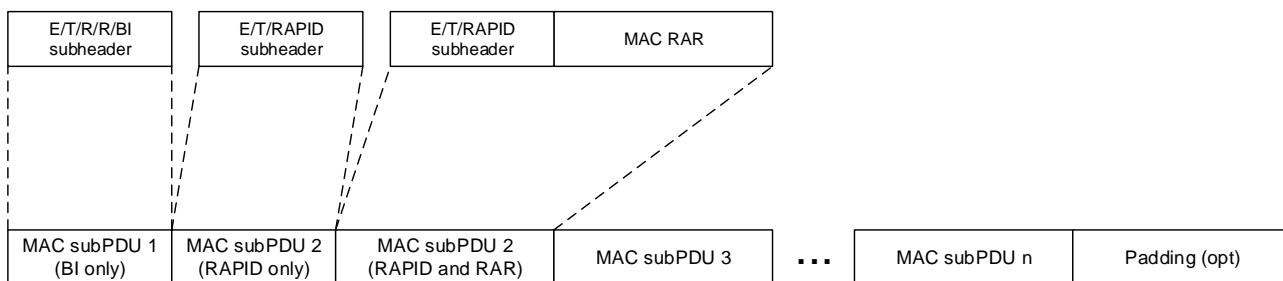

Figure 6.1.5-3: Example of MAC PDU consisting of MAC RARs

7.1.1.1.3.3 Test description

7.1.1.1.3.3.1 Pre-test conditions

System Simulator:

- NR Cell 1 and NR Cell 11.
- System information combination NR-3 as defined in TS 38.508-1 [4] clause 4.4.3.1.3 is used in NR Cell 1.

UE:

- None.

Preamble:

- The UE is in NR RRC Idle mode (state 1N-A) according to 38.508-1 [4] Table 4.4A.2-1.

7.1.1.1.3.3.2 Test procedure sequence

Table 7.1.1.1.3.3.2-1/2 illustrate the downlink power levels and other changing parameters to be applied for the cell at various time instants of the test execution. The exact instants on which these values shall be applied are described in the texts in this clause. Configurations marked "T0" is applied for Preamble. Configurations marked "T1" and "T2" are applied at the points indicated in the Main behaviour description in Table 7.1.1.1.3.3.2-3.

Table 7.1.1.1.3.3.2-1: Time instances of cell power level and parameter changes for FR1

	Parameter	Unit	NR Cell 1	NR Cell 11	Remark
T0	SS/PBCH SSS EPRE	dBm/SC S	-90	Off	The power level is such that $S_{rxlevNRCell1} > 0$
	Qrxlevmin	dBm	-106	-	
	Qrxlevminoffset	dB	0	-	
	Pcompensation	dB	0	-	
	Qoffset	dB	16	-	
T1	SS/PBCH SSS EPRE	dBm/SC S	-90	-84	The power level values are assigned to satisfy $R_{NRCell 1} > R_{NRCell 11}$
	Qrxlevmin	dBm	-106	-106	
	Qrxlevminoffset	dB	0	0	
	Pcompensation	dB	0	0	
	Qoffset	dB	16	-	
T2	SS/PBCH SSS EPRE	dBm/SC S	-90	-84	The power level values are assigned to satisfy $R_{NRCell 1} < R_{NRCell 11}$
	Qrxlevmin	dBm	-106	-106	
	Qrxlevminoffset	dB	0	0	
	Pcompensation	dB	0	0	
	Qoffset	dB	-10	-	
Note: The downlink signal level uncertainty is specified in TS 38.508-1 [4] section 6.2.2.1.					

Table 7.1.1.1.3.3.2-2: Time instances of cell power level and parameter changes for FR2

	Parameter	Unit	NR Cell 1	NR Cell 11	Remark
T0	SS/PBCH SSS EPRE	dBm/SC S	FFS	Off	The power level is such that $S_{rxlevNRCell1} > 0$
	Qrxlevmin	dBm	FFS	-	
	Qrxlevminoffset	dB	0	-	
	Pcompensation	dB	0	-	
	Qoffset	dB	FFS	-	
T1	SS/PBCH SSS EPRE	dBm/SC S	FFS	FFS	The power level values are assigned to satisfy $R_{NRCell 1} > R_{NRCell 11}$
	Qrxlevmin	dBm	FFS	FFS	
	Qrxlevminoffset	dB	0	0	
	Pcompensation	dB	0	0	
	Qoffset	dB	FFS	-	
T2	SS/PBCH SSS EPRE	dBm/SC S	FFS	FFS	The power level values are assigned to satisfy $R_{NRCell 1} < R_{NRCell 11}$
	Qrxlevmin	dBm	FFS	FFS	
	Qrxlevminoffset	dB	0	0	
	Pcompensation	dB	0	0	
	Qoffset	dB	FFS	-	
Note: The downlink signal level uncertainty is specified in TS 38.508-1 [4] section FFS.					

Table 7.1.1.1.3.3.2-3: Main behaviour

St	Procedure	Message Sequence		TP	Verdict
		U - S	Message		
1	The SS changes SS/PBCH EPRE level of NR Cell 11 according to the row "T1" in Table 7.1.1.1.3.3.2-1.	-	-	-	-
2	Check: Does the test result of generic test procedure in TS 38.508-1 [4] Table 4.9.5.2.2-1 indicate that the UE is camped on NR Cell 11 belonging to a new TA? Wait 60s to ensure UE detects NR Cell 11.			-	-
3	SS transmits Short Message on PDCCH addressed to P-RNTI using Short Message field in DCI format 1_0. Bit 1 of Short Message field is set to 1 to indicate the SI modification.	-	(Short Message)	-	-
4	The SS changes the parameter 'Qoffset' in SIB3 of NR Cell 1 according to the row "T2" in Table 7.1.1.1.3.3.2-1. The valueTag for SIB3 in the SIB1 message is increased and si-BroadcastStatus for SIB3 is set to 'notBroadcasted'.	<--		-	-
5	Check: Does the UE transmit a preamble on PRACH using the preamble indicated by ra-PreambleStartIndex defined in SI-RequestConfig in SIB1 in Table 7.1.1.1.3.3.3-2.	-->	PRACH Preamble	1	P
6	Check: Does the UE re-transmit a preamble on PRACH after ra-ResponseWindow using the preamble indicated by ra-PreambleStartIndex defined in SI-RequestConfig in SIB1 in Table 7.1.1.1.3.3.3-2?	-->	PRACH Preamble	1	P
7	Check: Does the UE re-transmit a preamble on PRACH after ra-ResponseWindow using the preamble indicated by ra-PreambleStartIndex defined in SI-RequestConfig in SIB1 in Table 7.1.1.1.3.3.3-2?	-->	PRACH Preamble	1	P
8	Check: Does the UE re-transmit a preamble on PRACH after ra-ResponseWindow using the preamble indicated by ra-PreambleStartIndex defined in SI-RequestConfig in SIB1 in Table 7.1.1.1.3.3.3-2?	-->	PRACH Preamble	1	P
9	The SS transmits a RAR message addressed to UE RA-RNTI including a MAC subPDU with a matching RAPID only. (Note 1)	<--	Random Access Response	-	-
10	Check: Does UE send Msg3 containing an RRCSetupRequest message in the grant associated to the Random Access Response received in step 9?	-->	RRCSetupRequest	2	F
11	Check: Does the test result of generic test procedure in TS 38.508-1 [4] Table 4.9.5.2.2-1 indicate that the UE is camped on NR Cell 11 belonging to a new TA?	-	-	2	P
Note 1: The UE will indicate the reception of an acknowledgement for SI request to upper layers after UE receives the RAR message including a MAC subPDU with a matching RAPID only, according to TS 38.321 [18] clause 5.1.4.					

7.1.1.1.3.3.3 Specific message contents

Table 7.1.1.1.3.3.3-1: SIB1 on NR Cell 1(Step 4, Table 7.1.1.1.3.3.2-2)

Derivation Path: TS 38.508-1 [4], Table 4.6.1-28			
Information Element	Value/remark	Comment	Condition
SIB1 ::= SEQUENCE {			
si-SchedulingInfo SEQUENCE {			
schedulingInfoList SEQUENCE {	2 entries		
si-BroadcastStatus[1]	Broadcasting		
si-Periodicity[1]	rf32		
sib-MappingInfo[1] SEQUENCE {			
type	SibType2		
valueTag	0		
areaScope	Not present		
}			
si-BroadcastStatus[2]	notBroadcasting		
si-Periodicity[2]	rf64		
sib-MappingInfo[2] SEQUENCE {			
type	SibType3		
valueTag	1		
areaScope	Not present		
}			
}			
si-Request-Config SEQUENCE {			
rach-OccasionsSI SEQUENCE {			
rach-ConfigSI	RACH-ConfigGeneric	TS 38.508-1 [4], Table 4.6.3-130	
ssb-perRACH-Occasion	one		
}			
si-RequestPeriod	two		
si-RequestResources SEQUENCE {			
ra-PreambleStartIndex	52		
ra-AssociationPeriodIndex	0		
ra-ssb-OccasionMaskIndex	0		
}			
si-Request-ConfigSUL	Not present		
}			
}			

Table 7.1.1.1.3.3.3-2: SIB3 on NR Cell 1(Preamble and Step 4, Table 7.1.1.1.3.3.2-2)

Derivation Path: TS 38.508-1 [4], Table 4.6.2-2			
Information Element	Value/remark	Comment	Condition
SIB3 ::= SEQUENCE {			
intraFreqNeighCellList SEQUENCE {			
physCellId	The cell identity of NR Cell 11 defined in 38.508-1 [4] clause 4.4.2		
q-OffsetCell	16	Preamble	
q-OffsetCell	-10	Step 4	
}			
}			

7.1.1.1.4 Random access procedure / Successful / Beam Failure / Preamble selected by MAC itself / Non Contention Free RACH procedure

7.1.1.1.4.1 Test Purpose (TP)

(1)

```
with { UE in RRC_CONNECTED state and RACH procedure due to beam failure is triggered }
ensure that {
  when { contention free random access resources for beam failure recovery request associated with
  SS blocks are not provided by RRC }
  then { UE selects initiates the non-contention free Random Access Procedure }
}
```

(2)

```
with { UE in RRC_CONNECTED state and RACH procedure due to beam failure is triggered }
ensure that {
  when { contention free random access resources for beam failure recovery request associated with
  SS blocks are explicitly provided by RRC }
  then { UE selects the PREAMBLE_INDEX to a ra-PreambleIndex corresponding to the selected SS
  block and initiates the contention free Random Access Procedure }
}
```

(3)

```
with { UE in RRC_CONNECTED state and RACH procedure due to beam failure is triggered }
ensure that {
  when { contention free random access resources for beam failure recovery request associated with
  CSI-RS are explicitly provided by RRC }
  then { UE selects the PREAMBLE_INDEX to a ra-PreambleIndex corresponding to the selected CSI-RS
  and initiates the contention free Random Access Procedure }
}
```

(4)

```
with { UE in RRC_CONNECTED state with Preamble transmitted for contention free RACH procedure for
beam failure }
ensure that {
  when { ra-ResponseWindowBFR expires and the PDCCH addressed to the C-RNTI has not been received }
  then { UE retransmits the PRACH Preamble }
}
```

(5)

```
with { UE in RRC_CONNECTED state with Preamble transmitted for contention free RACH procedure for
beam failure }
ensure that {
  when { before expiry of ra-ResponseWindowBFR the PDCCH addressed to the C-RNTI is received }
  then { UE considers the RACH procedure to be successfully completed and stops retransmitting
  PRACH preambles }
}
```

7.1.1.1.4.2 Conformance requirements

References: The conformance requirements covered in the present test case are specified in: TS 38.321, clause 5.1.2, 5.1.3, 5.1.4 and 5.17. Unless otherwise stated these are Rel-15 requirements.

[TS 38.321, clause 5.1.2]

The MAC entity shall:

- 1> if the Random Access procedure was initiated for beam failure recovery (as specified in subclause 5.17); and
- 1> if the *beamFailureRecoveryTimer* (in subclause 5.17) is either running or not configured; and
- 1> if the contention-free Random Access Resources for beam failure recovery request associated with any of the SSBs and/or CSI-RSs have been explicitly provided by RRC; and

- 1> if at least one of the SSBs with SS-RSRP above *rsrp-ThresholdSSB* amongst the SSBs in *candidateBeamRSList* or the CSI-RSs with CSI-RSRP above *rsrp-ThresholdCSI-RS* amongst the CSI-RSs in *candidateBeamRSList* is available:
 - 2> select an SSB with SS-RSRP above *rsrp-ThresholdSSB* amongst the SSBs in *candidateBeamRSList* or a CSI-RS with CSI-RSRP above *rsrp-ThresholdCSI-RS* amongst the CSI-RSs in *candidateBeamRSList*;
 - 2> if CSI-RS is selected, and there is no *ra-PreambleIndex* associated with the selected CSI-RS:
 - 3> set the *PREAMBLE_INDEX* to a *ra-PreambleIndex* corresponding to the SSB in *candidateBeamRSList* which is quasi-collocated with the selected CSI-RS as specified in TS 38.214 [7].
 - 2> else:
 - 3> set the *PREAMBLE_INDEX* to a *ra-PreambleIndex* corresponding to the selected SSB or CSI-RS from the set of Random Access Preambles for beam failure recovery request.
- 1> else if the *ra-PreambleIndex* has been explicitly provided by PDCCH; and
- 1> if the *ra-PreambleIndex* is not 0b000000:
 - 2> set the *PREAMBLE_INDEX* to the signalled *ra-PreambleIndex*;
 - 2> select the SSB signalled by PDCCH.
- 1> else if the contention-free Random Access Resources associated with SSBs have been explicitly provided by RRC and at least one SSB with SS-RSRP above *rsrp-ThresholdSSB* amongst the associated SSBs is available:
 - 2> select an SSB with SS-RSRP above *rsrp-ThresholdSSB* amongst the associated SSBs;
 - 2> set the *PREAMBLE_INDEX* to a *ra-PreambleIndex* corresponding to the selected SSB.
- 1> else if the contention-free Random Access Resources associated with CSI-RSs have been explicitly provided by RRC and at least one CSI-RS with CSI-RSRP above *rsrp-ThresholdCSI-RS* amongst the associated CSI-RSs is available:
 - 2> select a CSI-RS with CSI-RSRP above *rsrp-ThresholdCSI-RS* amongst the associated CSI-RSs;
 - 2> set the *PREAMBLE_INDEX* to a *ra-PreambleIndex* corresponding to the selected CSI-RS.
- 1> else if the Random Access procedure was initiated for SI request (as specified in TS 38.331 [5]); and
- 1> if the Random Access Resources for SI request have been explicitly provided by RRC:
 - 2> if at least one of the SSBs with SS-RSRP above *rsrp-ThresholdSSB* is available:
 - 3> select an SSB with SS-RSRP above *rsrp-ThresholdSSB*.
 - 2> else:
 - 3> select any SSB.
 - 2> select a Random Access Preamble corresponding to the selected SSB, from the Random Access Preamble(s) determined according to *ra-PreambleStartIndex* as specified in TS 38.331 [5];
 - 2> set the *PREAMBLE_INDEX* to selected Random Access Preamble.
- 1> else (i.e. for the contention-based Random Access preamble selection):
 - 2> if at least one of the SSBs with SS-RSRP above *rsrp-ThresholdSSB* is available:
 - 3> select an SSB with SS-RSRP above *rsrp-ThresholdSSB*.
 - 2> else:
 - 3> select any SSB.
 - 2> if Msg3 has not yet been transmitted:

- 3> if Random Access Preambles group B is configured:
 - 4> if the potential Msg3 size (UL data available for transmission plus MAC header and, where required, MAC CEs) is greater than *ra-Msg3SizeGroupA* and the pathloss is less than *PCMAX* (of the Serving Cell performing the Random Access Procedure) – *preambleReceivedTargetPower* – *msg3-DeltaPreamble* – *messagePowerOffsetGroupB*; or
 - 4> if the Random Access procedure was initiated for the CCCH logical channel and the CCCH SDU size plus MAC subheader is greater than *ra-Msg3SizeGroupA*:
 - 5> select the Random Access Preambles group B.
 - 4> else:
 - 5> select the Random Access Preambles group A.
- 3> else:
 - 4> select the Random Access Preambles group A.
- 2> else (i.e. Msg3 is being retransmitted):
 - 3> select the same group of Random Access Preambles as was used for the Random Access Preamble transmission attempt corresponding to the first transmission of Msg3.
- 2> if the association between Random Access Preambles and SSBs is configured:
 - 3> select a Random Access Preamble randomly with equal probability from the Random Access Preambles associated with the selected SSB and the selected Random Access Preambles group.
- 2> else:
 - 3> select a Random Access Preamble randomly with equal probability from the Random Access Preambles within the selected Random Access Preambles group.
- 2> set the *PREAMBLE_INDEX* to the selected Random Access Preamble.
- 1> if the Random Access procedure was initiated for SI request (as specified in TS 38.331 [5]); and
- 1> if *ra-AssociationPeriodIndex* and *si-RequestPeriod* are configured:
 - 2> determine the next available PRACH occasion from the PRACH occasions corresponding to the selected SSB in the association period given by *ra-AssociationPeriodIndex* in the *si-RequestPeriod* permitted by the restrictions given by the *ra-ssb-OccasionMaskIndex* (the MAC entity shall select a PRACH occasion randomly with equal probability amongst the consecutive PRACH occasions according to subclause 8.1 of TS 38.213 [6] corresponding to the selected SSB).
- 1> else if an SSB is selected above:
 - 2> determine the next available PRACH occasion from the PRACH occasions corresponding to the selected SSB permitted by the restrictions given by the *ra-ssb-OccasionMaskIndex* if configured (the MAC entity shall select a PRACH occasion randomly with equal probability amongst the consecutive PRACH occasions according to subclause 8.1 of TS 38.213 [6], corresponding to the selected SSB; the MAC entity may take into account the possible occurrence of measurement gaps when determining the next available PRACH occasion corresponding to the selected SSB).
- 1> else if a CSI-RS is selected above:
 - 2> if there is no contention-free Random Access Resource associated with the selected CSI-RS:
 - 3> determine the next available PRACH occasion from the PRACH occasions, permitted by the restrictions given by the *ra-ssb-OccasionMaskIndex* if configured, corresponding to the SSB in *candidateBeamRSList* which is quasi-collocated with the selected CSI-RS as specified in TS 38.214 [7] (the MAC entity may take into account the possible occurrence of measurement gaps when determining the next available PRACH occasion corresponding to the SSB which is quasi-collocated with the selected CSI-RS).
 - 2> else:

- 3> determine the next available PRACH occasion from the PRACH occasions in *ra-OccasionList* corresponding to the selected CSI-RS (the MAC entity shall select a PRACH occasion randomly with equal probability amongst the PRACH occasions occurring simultaneously but on different subcarriers, corresponding to the selected CSI-RS; the MAC entity may take into account the possible occurrence of measurement gaps when determining the next available PRACH occasion corresponding to the selected CSI-RS).

- 1> perform the Random Access Preamble transmission procedure (see subclause 5.1.3).

NOTE: When the UE determines if there is an SSB with SS-RSRP above *rsrp-ThresholdSSB* or a CSI-RS with CSI-RSRP above *rsrp-ThresholdCSI-RS*, the UE uses the latest unfiltered L1-RSRP measurement.

[TS 38.321, clause 5.1.4]

Once the Random Access Preamble is transmitted and regardless of the possible occurrence of a measurement gap, the MAC entity shall:

- 1> if the contention-free Random Access Preamble for beam failure recovery request was transmitted by the MAC entity:
 - 2> start the *ra-ResponseWindow* configured in *BeamFailureRecoveryConfig* at the first PDCCH occasion as specified in TS 38.213 [6] from the end of the Random Access Preamble transmission;
 - 2> monitor the PDCCH of the SpCell for response to beam failure recovery request identified by the C-RNTI while *ra-ResponseWindow* is running.
- 1> else:
 - 2> start the *ra-ResponseWindow* configured in *RACH-ConfigCommon* at the first PDCCH occasion as specified in TS 38.213 [6] from the end of the Random Access Preamble transmission;
 - 2> monitor the PDCCH of the SpCell for Random Access Response(s) identified by the RA-RNTI while the *ra-ResponseWindow* is running.
- 1> if notification of a reception of a PDCCH transmission is received from lower layers on the Serving Cell where the preamble was transmitted; and
- 1> if PDCCH transmission is addressed to the C-RNTI; and
- 1> if the contention-free Random Access Preamble for beam failure recovery request was transmitted by the MAC entity:
 - 2> consider the Random Access procedure successfully completed.
- 1> else if a downlink assignment has been received on the PDCCH for the RA-RNTI and the received TB is successfully decoded:
 - 2> if the Random Access Response contains a MAC subPDU with Backoff Indicator:
 - 3> set the *PREAMBLE_BACKOFF* to value of the BI field of the MAC subPDU using Table 7.2-1, multiplied with *SCALING_FACTOR_BI*.
 - 2> else:
 - 3> set the *PREAMBLE_BACKOFF* to 0 ms.
 - 2> if the Random Access Response contains a MAC subPDU with Random Access Preamble identifier corresponding to the transmitted *PREAMBLE_INDEX* (see subclause 5.1.3):
 - 3> consider this Random Access Response reception successful.
 - 2> if the Random Access Response reception is considered successful:
 - 3> if the Random Access Response includes a MAC subPDU with RAPID only:
 - 4> consider this Random Access procedure successfully completed;

- 4> indicate the reception of an acknowledgement for SI request to upper layers.
- 3> else:
 - 4> apply the following actions for the Serving Cell where the Random Access Preamble was transmitted:
 - 5> process the received Timing Advance Command (see subclause 5.2);
 - 5> indicate the *preambleReceivedTargetPower* and the amount of power ramping applied to the latest Random Access Preamble transmission to lower layers (i.e. $(PREAMBLE_POWER_RAMPING_COUNTER - 1) \times PREAMBLE_POWER_RAMPING_STEP$);
 - 5> if the Serving Cell for the Random Access procedure is SRS-only SCell:
 - 6> ignore the received UL grant.
 - 5> else:
 - 6> process the received UL grant value and indicate it to the lower layers.
 - 4> if the Random Access Preamble was not selected by the MAC entity among the contention-based Random Access Preamble(s):
 - 5> consider the Random Access procedure successfully completed.
 - 4> else:
 - 5> set the *TEMPORARY_C-RNTI* to the value received in the Random Access Response;
 - 5> if this is the first successfully received Random Access Response within this Random Access procedure:
 - 6> if the transmission is not being made for the CCCH logical channel:
 - 7> indicate to the Multiplexing and assembly entity to include a C-RNTI MAC CE in the subsequent uplink transmission.
 - 6> obtain the MAC PDU to transmit from the Multiplexing and assembly entity and store it in the Msg3 buffer.
- 1> if *ra-ResponseWindow* configured in *RACH-ConfigCommon* expires, and if the Random Access Response containing Random Access Preamble identifiers that matches the transmitted *PREAMBLE_INDEX* has not been received; or
- 1> if *ra-ResponseWindow* configured in *BeamFailureRecoveryConfig* expires and if the PDCCH addressed to the C-RNTI has not been received on the Serving Cell where the preamble was transmitted:
 - 2> consider the Random Access Response reception not successful;
 - 2> increment *PREAMBLE_TRANSMISSION_COUNTER* by 1;
 - 2> if *PREAMBLE_TRANSMISSION_COUNTER* = *preambleTransMax* + 1:
 - 3> if the Random Access Preamble is transmitted on the SpCell:
 - 4> indicate a Random Access problem to upper layers;
 - 4> if this Random Access procedure was triggered for SI request:
 - 5> consider the Random Access procedure unsuccessfully completed.
 - 3> else if the Random Access Preamble is transmitted on a SCell:
 - 4> consider the Random Access procedure unsuccessfully completed.
 - 2> if the Random Access procedure is not completed:

- 3> select a random backoff time according to a uniform distribution between 0 and the *PREAMBLE_BACKOFF*;
- 3> if the criteria (as defined in subclause 5.1.2) to select contention-free Random Access Resources is met during the backoff time:
 - 4> perform the Random Access Resource selection procedure (see subclause 5.1.2);
- 3> else:
 - 4> perform the Random Access Resource selection procedure (see subclause 5.1.2) after the backoff time.

The MAC entity may stop *ra-ResponseWindow* (and hence monitoring for Random Access Response(s)) after successful reception of a Random Access Response containing Random Access Preamble identifiers that matches the transmitted *PREAMBLE_INDEX*.

HARQ operation is not applicable to the Random Access Response transmission.

7.1.1.1.4.3 Test description

7.1.1.1.4.3.1 Pre-test conditions

Same Pre-test conditions as in clause 7.1.1.0 except that set to return no data in uplink.

7.1.1.1.4.3.2 Test procedure sequence

Table 7.1.1.1.4.3.2-1 illustrates the downlink power levels and other changing parameters to be applied for the cells at various time instants of the test execution. Row marked "T0" denotes the initial conditions after preamble, while columns marked "T1" and "T2" are to be applied subsequently. The exact instants on which these values shall be applied are described in the texts in this clause.

Table 7.1.1.1.4.3.2-1: Time instances of cell power level and parameter changes

	Parameter	Unit	E-UTRA Cell 1	NR Cell 1 Beam index #1	NR Cell 1 Beam index #2	Remark
T0	Cell-specific RS EPRE	dBm/1 5kHz	-85	-	-	Conducted testing
	Cell-specific RS EPRE	dBm/1 5kHz	[-96]	-	-	OTA testing
	SS/PBCH SSS EPRE	dBm/S CS	-	[-88]	OFF	Conducted testing, NR Cell 1 in FR1
	SS/PBCH SSS EPRE	dBm/S CS	-	[-95]	OFF	OTA testing, NR Cell 1 in FR2
T1	Cell-specific RS EPRE	dBm/1 5kHz	-85	-	-	Conducted testing
	Cell-specific RS EPRE	dBm/1 5kHz	[-96]	-	-	OTA testing
	SS/PBCH SSS EPRE	dBm/S CS	-	OFF	[-88]	Conducted testing, NR Cell 1 in FR1
	SS/PBCH SSS EPRE	dBm/S CS	-	OFF	[-95]	OTA testing, NR Cell 1 in FR2
T2	Cell-specific RS EPRE	dBm/1 5kHz	-85	-	-	Conducted testing
	Cell-specific RS EPRE	dBm/1 5kHz	[-96]	-	-	OTA testing
	SS/PBCH SSS EPRE	dBm/S CS	-	[-88]	OFF	Conducted testing, NR Cell 1 in FR1
	SS/PBCH SSS EPRE	dBm/S CS	-	[-95]	OFF	OTA testing, NR Cell 1 in FR2

Table 7.1.1.1.4.3.2-2: Main behaviour

St	Procedure	Message Sequence		TP	Verdict
		U - S	Message		
1	The SS transmits an NR <i>RRCReconfiguration</i> message to configure parameters for BFR. Note 1.	<--	(<i>RRCReconfiguration</i>)	-	-
2	UE responses NR <i>RRCReconfigurationComplete</i> message. Note 2.	-->	(<i>RRCReconfigurationComplete</i>)	-	-
3	The SS changes NR Cell 1 power level according to the row "T1" in table 7.1.1.1.4.3.2-1.	-	-	-	-
4	Check: Does the UE transmit a preamble on PRACH for the non-contention free Random Access Procedure on NR Cell 1 Beam index #2?	-->	PRACH Preamble	1	P
5	The SS transmits a MAC PDU addressed to UE RA-RNTI, containing multiple RAR's and one of the MAC sub headers contains a matching RAPID on NR Cell 1.	<--	Random Access Response	-	-
6	UE sends a msg3 using the grant associated to the Random Access Response received in Step 5 on NR Cell 1.	-->	msg3 (C-RNTI MAC CONTROL ELEMENT)	-	-
7	SS schedules PDCCH transmission for UE C-RNTI.	<--	Contention Resolution	-	-
8	The SS transmits an NR <i>RRCReconfiguration</i> to establish random access resources for BFR associated with SS blocks explicitly. Note 1.	<--	(<i>RRCReconfiguration</i>)	-	-
9	UE responses NR <i>RRCReconfigurationComplete</i> message. Note 2.	-->	(<i>RRCReconfigurationComplete</i>)	-	-
10	The SS changes NR Cell 1 power level according to the row "T2" in table 7.1.1.1.4.3.2-1.	-	-	-	-
11	Check: Does the UE transmit preamble on PRACH using a preamble with PREAMBLE_INDEX to a ra-PreambleIndex corresponding to the selected SS block provided by RRC on NR Cell 1 Beam index #1?	-->	PRACH Preamble	2	P
12	The SS waits for ra-ResponseWindowBFR expire. NOTE: The SS does not transmit Random Access Response to the UE.	-	-	-	-
13	Check: Does the UE retransmit a preamble on PRACH with ra-PreambleIndex same as the Step 11?	-->	PRACH Preamble	4	P
14	The SS transmits a MAC PDU addressed to UE C-RNTI, containing multiple RAR's and one of the MAC sub headers contains a matching RAPID on NR Cell 1.	<--	Random Access Response	-	-
15	The SS waits for ra-ResponseWindowBFR expire.	-	-	-	-
16	Check: Does the UE retransmit a preamble on PRACH?	-	-	5	F
-	EXCEPTION: Steps 17 to 25 describe behaviour that depends on the UE capability.	-	-	-	-
17	IF pc_csi_RS_CFRA_ForHO THEN the SS transmits an NR <i>RRCReconfiguration</i> message to establish random access resources for BFR associated with CSI-RS explicitly. Note 1.	<--	(<i>RRCReconfiguration</i>)	-	-
18	UE responses NR <i>RRCReconfigurationComplete</i> message. Note 2.	-->	(<i>RRCReconfigurationComplete</i>)	-	-
19	The SS changes NR Cell 1 power level according to the row "T1" in table 7.1.1.1.4.3.2-1.	-	-	-	-

20	Check: Does the UE transmit preamble on PRACH using a preamble with PREAMBLE_INDEX to a ra-PreambleIndex corresponding to the selected CSI-RS provided by RRC on NR Cell 1 Beam index #2?	-->	PRACH Preamble	3	P
21	The SS waits for ra-ResponseWindowBFR expire. NOTE: The SS does not transmit Random Access Response to the UE.	-	-	-	-
22	Check: Does the UE retransmit a preamble on PRACH with ra-PreambleIndex same as the Step 20?	-->	PRACH Preamble	4	P
23	The SS transmits a MAC PDU addressed to UE C-RNTI, containing multiple RAR's and one of the MAC sub headers contains a matching RAPID on NR Cell 1.	<--	Random Access Response	-	-
24	The SS waits for ra-ResponseWindowBFR expire.	-	-	-	-
25	Check: Does the UE retransmit a preamble on PRACH?	-	-	5	F
Note 1: for EN-DC the NR <i>RRCReconfiguration</i> message is contained in <i>RRCConnectionReconfiguration</i> 36.508 [7], Table 4.6.1-8 using condition EN-DC_EmbedNR_RRCRecon. Note 2: for EN-DC the NR <i>RRCReconfigurationComplete</i> message is contained in <i>RRCConnectionReconfigurationComplete</i> .					

7.1.1.1.4.3.3 Specific message contents

Table 7.1.1.1.4.3.3-1: RRCReconfiguration (Step 1, Table 7.1.1.1.4.3.2-2)

Derivation path: 38.508-1 [4], Table 4.6.1-13			
Information Element	Value/remark	Comment	Condition
RRCReconfiguration ::= SEQUENCE {			
criticalExtensions CHOICE {			
rrcReconfiguration SEQUENCE {			
secondaryCellGroup	CellGroupConfig	OCTET STRING	EN-DC
nonCriticalExtension SEQUENCE {			NR
masterCellGroup	CellGroupConfig	OCTET STRING (CONTAINING CellGroupConfig)	
}			
}			
}			

Table 7.1.1.1.4.3.3-2: CellGroupConfig (Table 7.1.1.1.4.3.3-1: RRCReconfiguration)

Derivation Path: TS 38.508-1 [4], Table 4.6.3-19			
Information Element	Value/remark	Comment	Condition
CellGroupConfig ::= SEQUENCE {			
spCellConfig SEQUENCE {			
spCellConfigDedicated	ServingCellConfig		
}			
}			

Table 7.1.1.1.4.3.3-3: ServingCellConfig (Table 7.1.1.1.4.3.3-2: CellGroupConfig)

Derivation Path: TS 38.508-1 [4], Table 4.6.3-168			
Information Element	Value/remark	Comment	Condition
ServingCellConfig ::= SEQUENCE {			
initialDownlinkBWP	BWP-DownlinkDedicated		
}			

Table 7.1.1.1.4.3.3-4: BWP-DownlinkDedicated (Table 7.1.1.1.4.3.3-3: ServingCellConfig)

Derivation Path: TS 38.508-1 [4], Table 4.6.3-11			
Information Element	Value/remark	Comment	Condition
BWP-DownlinkDedicated ::= SEQUENCE {			
radioLinkMonitoringConfig	RadioLinkMonitoringConfig		
}			

Table 7.1.1.1.4.3.3-5: RadioLinkMonitoringConfig (Table 7.1.1.1.4.3.3-4: BWP-DownlinkDedicated)

Derivation Path: TS 38.508-1 [4], Table 4.6.3-133			
Information Element	Value/remark	Comment	Condition
RadioLinkMonitoringConfig ::= SEQUENCE {			
failureDetectionResourcesToAddModList	1 entry		
SEQUENCE (SIZE(1..maxNrofFailureDetectionResources)) OF			
SEQUENCE {			
radioLinkMonitoringRS-Id[1]	RadioLinkMonitoringRS-Id	38.508-1[4] Table 4.6.3-134	
purpose[1]	beamFailure		
detectionResource[1] CHOICE {			
ssb-Index	0	NR Cell 1 Beam index #1	
}			
}			
failureDetectionResourcesToReleaseList	Not present		
beamFailureInstanceMaxCount	n1		
beamFailureDetectionTimer	pbfd1		
}			

Table 7.1.1.1.4.3.3-6: RRCReconfiguration (Step 8, Table 7.1.1.1.4.3.2-2)

Derivation path: 38.508-1 [4], Table 4.6.1-13			
Information Element	Value/remark	Comment	Condition
RRCReconfiguration ::= SEQUENCE {			
criticalExtensions CHOICE {			
rrcReconfiguration SEQUENCE {			
secondaryCellGroup	CellGroupConfig	OCTET STRING	EN-DC
nonCriticalExtension SEQUENCE {			NR
masterCellGroup	CellGroupConfig	OCTET STRING (CONTAINING CellGroupConfig)	
}			
}			
}			

Table 7.1.1.1.4.3.3-7: CellGroupConfig (Table 7.1.1.1.4.3.3-6: RRCReconfiguration)

Derivation Path: TS 38.508-1 [4], Table 4.6.3-19			
Information Element	Value/remark	Comment	Condition
CellGroupConfig ::= SEQUENCE {			
spCellConfig SEQUENCE {			
spCellConfigDedicated	ServingCellConfig		
}			
}			

Table 7.1.1.1.4.3.3-8: ServingCellConfig (Table 7.1.1.1.4.3.3-7: CellGroupConfig)

Derivation Path: TS 38.508-1 [4], Table 4.6.3-168			
Information Element	Value/remark	Comment	Condition
ServingCellConfig ::= SEQUENCE {			
initialDownlinkBWP	BWP-DownlinkDedicated		
uplinkConfig SEQUENCE {			
initialUplinkBWP	BWP-UplinkDedicated		
}			
}			

Table 7.1.1.1.4.3.3-9: BWP-DownlinkDedicated (Table 7.1.1.1.4.3.3-8: ServingCellConfig)

Derivation Path: TS 38.508-1 [4], Table 4.6.3-11			
Information Element	Value/remark	Comment	Condition
BWP-DownlinkDedicated ::= SEQUENCE {			
radioLinkMonitoringConfig	RadioLinkMonitoringConfig		
}			

Table 7.1.1.1.4.3.3-10: RadioLinkMonitoringConfig (Table 7.1.1.1.4.3.3-9: BWP-DownlinkDedicated)

Derivation Path: TS 38.508-1 [4], Table 4.6.3-133			
Information Element	Value/remark	Comment	Condition
RadioLinkMonitoringConfig ::= SEQUENCE {			
failureDetectionResourcesToAddModList SEQUENCE (SIZE(1..maxNrofFailureDetectionResources)) OF SEQUENCE {	1 entry		
radioLinkMonitoringRS-Id[1]	RadioLinkMonitoringRS-Id	38.508-1[4] Table 4.6.3-134	
Purpose[1]	beamFailure		
detectionResource[1] CHOICE {			
ssb-Index	1	NR Cell 1 Beam index #2	
}			
}			
failureDetectionResourcesToReleaseList	Not present		
beamFailureInstanceMaxCount	n1		
beamFailureDetectionTimer	pbfd1		
}			

Table 7.1.1.1.4.3.3-11: BWP-UplinkDedicated (Table 7.1.1.1.4.3.3-10: ServingCellConfig)

Derivation Path: TS 38.508-1 [4], Table 4.6.3-15			
Information Element	Value/remark	Comment	Condition
BWP-UplinkDedicated ::= SEQUENCE {			
beamFailureRecoveryConfig	BeamFailureRecoveryConfig		
}			

Table 7.1.1.1.4.3.3-12: BeamFailureRecoveryConfig (Table 7.1.1.1.4.3.3-11: BWP-UplinkDedicated)

Derivation Path: TS 38.508-1 [4], Table 4.6.3-12			
Information Element	Value/remark	Comment	Condition
BeamFailureRecoveryConfig ::= SEQUENCE {			
rootSequenceIndex-BFR	0	See TS 38.508-1[4] clause 4.4.2, Table 4.4.2-2	
rach-ConfigBFR	RACH-ConfigGeneric	38.508-1[4] Table 4.6.3-130	
rsrp-ThresholdSSB	57(-100dBm)		
candidateBeamRSList SEQUENCE (SIZE(1..maxNrofCandidateBeams)) OF PRACH-ResourceDedicatedBFR CHOICE{			
ssb SEQUENCE {			
ssb	0	NR Cell 1 Beam index #1	
ra-PreambleIndex	56	(0..63)	
}			
}			
ssb-perRACH-Occasion	one		
ra-ssb-OccasionMaskIndex	0		
recoverySearchSpaceID	SearchSpaceId with condition USS	38.508-1[4] Table 4.6.3-163	
ra-Prioritization	Not Present		
beamFailureRecoveryTimer	ms200		
}			

Table 7.1.1.1.4.3.3-13: RRCReconfiguration (Step 17, Table 7.1.1.1.4.3.2-2)

Derivation path: 38.508-1 [4], Table 4.6.1-13			
Information Element	Value/remark	Comment	Condition
RRCReconfiguration ::= SEQUENCE{			
criticalExtensions CHOICE{			
rrcReconfiguration SEQUENCE{			
secondaryCellGroup	CellGroupConfig	OCTET STRING	EN-DC
nonCriticalExtension SEQUENCE {			NR
masterCellGroup	CellGroupConfig	OCTET STRING (CONTAINING CellGroupConfig)	
}			
}			
}			
}			

Table 7.1.1.1.4.3.3-14: CellGroupConfig (Table 7.1.1.1.4.3.3-13: RRCReconfiguration)

Derivation Path: TS 38.508-1 [4], Table 4.6.3-19			
Information Element	Value/remark	Comment	Condition
CellGroupConfig ::= SEQUENCE {			
spCellConfig SEQUENCE {			
spCellConfigDedicated	ServingCellConfig		
}			
}			

Table 7.1.1.1.4.3.3-15: ServingCellConfig (Table 7.1.1.1.4.3.3-14: CellGroupConfig)

Derivation Path: TS 38.508-1 [4], Table 4.6.3-168			
Information Element	Value/remark	Comment	Condition
ServingCellConfig ::= SEQUENCE {			
initialDownlinkBWP	BWP-DownlinkDedicated		
uplinkConfig SEQUENCE {			
initialUplinkBWP	BWP-UplinkDedicated		
}			
}			

Table 7.1.1.1.4.3.3-16: BWP-DownlinkDedicated (Table 7.1.1.1.4.3.3-15: ServingCellConfig)

Derivation Path: TS 38.508-1 [4], Table 4.6.3-11			
Information Element	Value/remark	Comment	Condition
BWP-DownlinkDedicated ::= SEQUENCE {			
radioLinkMonitoringConfig	RadioLinkMonitoringConfig		
}			

Table 7.1.1.1.4.3.3-17: RadioLinkMonitoringConfig (Table 7.1.1.1.4.3.3-16: BWP-DownlinkDedicated)

Derivation Path: TS 38.508-1 [4], Table 4.6.3-133			
Information Element	Value/remark	Comment	Condition
RadioLinkMonitoringConfig ::= SEQUENCE {			
failureDetectionResourcesToAddModList SEQUENCE (SIZE(1..maxNrofFailureDetectionResources)) OF SEQUENCE {	1 entry		
radioLinkMonitoringRS-Id[1]	RadioLinkMonitoringRS-Id	38.508-1[4] Table 4.6.3-134	
Purpose[1]	beamFailure		
detectionResource[1] CHOICE {			
csi-RS-Index	0	NR Cell 1 Beam index #1	
}			
}			
failureDetectionResourcesToReleaseList	Not present		
beamFailureInstanceMaxCount	n1		
beamFailureDetectionTimer	pbfd1		
}			

Table 7.1.1.1.4.3.3-18: BWP-UplinkDedicated (Table 7.1.1.1.4.3.3-17: ServingCellConfig)

Derivation Path: TS 38.508-1 [4], Table 4.6.3-15			
Information Element	Value/remark	Comment	Condition
BWP-UplinkDedicated ::= SEQUENCE {			
beamFailureRecoveryConfig	BeamFailureRecoveryConfig		
}			

Table 7.1.1.1.4.3.3-19: BeamFailureRecoveryConfig (Table 7.1.1.1.4.3.3-18: BWP-UplinkDedicated)

Derivation Path: TS 38.508-1 [4], Table 4.6.3-12			
Information Element	Value/remark	Comment	Condition
BeamFailureRecoveryConfig ::= SEQUENCE {			
rootSequenceIndex-BFR	0	See TS 38.508-1[4] clause 4.4.2, Table 4.4.2-2	
rach-ConfigBFR	RACH-ConfigGeneric	38.508-1[4] Table 4.6.3-130	
rsrp-ThresholdSSB	57(-100dBm)		
candidateBeamRSList SEQUENCE (SIZE(1..maxNrofCandidateBeams)) OF PRACH-ResourceDedicatedBFR CHOICE{			
csi-RS SEQUENCE {			
csi-RS	1	NR Cell 1 Beam index #2	
ra-OccasionList SEQUENCE (SIZE(1..maxRA-OccasionsPerCSIRS)) OF {	1 entry		
INTEGER[1]	0		
}			
ra-PreambleIndex	59		
}			
ssb-perRACH-Occasion	Not Present		
ra-ssb-OccasionMaskIndex	Not Present		
recoverySearchSpaceID	SearchSpaceId with condition USS	38.508-1[4] Table 4.6.3-163	
ra-Prioritization	Not Present		
beamFailureRecoveryTimer	ms200		
}			

7.1.1.1.5 Random access procedure / Successful / Supplementary Uplink

7.1.1.1.5.1 Test Purpose (TP)

(1)

```

with { UE in RRC_CONNECTED state with supplemental uplink configured and RACH procedure is triggered }
ensure that {
  when { RSRP of the downlink pathloss reference is less than rsrp-ThresholdSSB-SUL }
  then { UE initiates the Random Access Procedure in Supplementary Uplink carrier }
}

```

7.1.1.1.5.2 Conformance requirements

References: The conformance requirements covered in the present TC are specified in TS 38.321: clause 5.1.1 and clause 5.16. Unless otherwise stated these are Rel-15 requirements.

[TS 38.321, clause 5.1.1]

The Random Access procedure described in this subclause is initiated by a PDCCH order, by the MAC entity itself, or by RRC for the events in accordance with TS 38.300 [2]. There is only one Random Access procedure ongoing at any point in time in a MAC entity. The Random Access procedure on an SCell shall only be initiated by a PDCCH order with *ra-PreambleIndex* different from 0b000000.

NOTE 1: If the MAC entity receives a request for a new Random Access procedure while another is already ongoing in the MAC entity, it is up to UE implementation whether to continue with the ongoing procedure or start with the new procedure (e.g. for SI request).

RRC configures the following parameters for the Random Access procedure:

- *prach-ConfigIndex*: the available set of PRACH occasions for the transmission of the Random Access Preamble;

- *preambleReceivedTargetPower*: initial Random Access Preamble power;
- *rsrp-ThresholdSSB*: an RSRP threshold for the selection of the SSB and corresponding Random Access Preamble and/or PRACH occasion. If the Random Access procedure is initiated for beam failure recovery, *rsrp-ThresholdSSB* refers to *rsrp-ThresholdSSB* in *BeamFailureRecoveryConfig* IE;
- *rsrp-ThresholdCSI-RS*: an RSRP threshold for the selection of CSI-RS and corresponding Random Access Preamble and/or PRACH occasion. If the Random Access procedure is initiated for beam failure recovery, *rsrp-ThresholdCSI-RS* shall be set to a value calculated by multiplying *rsrp-ThresholdSSB* in *BeamFailureRecoveryConfig* IE by *powerControlOffset* as specified in TS 38.214 [6];
- *rsrp-ThresholdSSB-SUL*: an RSRP threshold for the selection between the NUL carrier and the SUL carrier;
- *powerControlOffset*: a power offset between *rsrp-ThresholdSSB* and *rsrp-ThresholdCSI-RS* to be used when the Random Access procedure is initiated for beam failure recovery;
- *powerRampingStep*: the power-ramping factor;
- *powerRampingStepHighPriority*: the power-ramping factor in case of differentiated Random Access procedure;
- *scalingFactorBI*: a scaling factor for differentiated Random Access procedure;
- *ra-PreambleIndex*: Random Access Preamble;
- *ra-ssb-OccasionMaskIndex*: defines PRACH occasion(s) associated with an SSB in which the MAC entity may transmit a Random Access Preamble (see subclause 7.4);
- *ra-OccasionList*: defines PRACH occasion(s) associated with a CSI-RS in which the MAC entity may transmit a Random Access Preamble;
- *preambleTransMax*: the maximum number of Random Access Preamble transmission;
- *ssb-perRACH-OccasionAndCB-PreamblesPerSSB* (SpCell only): defines the number of SSBs mapped to each PRACH occasion and the number of Random Access Preambles mapped to each SSB;
- if *groupBconfigured* is configured, then Random Access Preambles group B is configured.
 - The Random Access Preambles in Random Access Preamble group A are the Random Access Preambles 0 to *numberOfRA-PreamblesGroupA* – 1, if Random Access Preambles group B is configured; Otherwise, the Random Access Preambles in Random Access Preamble group A are the Random Access Preambles 0 to the number of Random Access Preambles per SSB configured by *ssb-perRACH-OccasionAndCB-PreamblesPerSSB*;
 - The Random Access Preambles in Random Access Preamble group B, if configured, are the Random Access Preambles *numberOfRA-PreamblesGroupA* to the number of Random Access Preambles per SSB configured by *ssb-perRACH-OccasionAndCB-PreamblesPerSSB*.

NOTE 2: If Random Access Preambles group B is supported by the cell and SSBs are mapped to Random Access Preambles, Random Access Preambles group B is included in each SSB.

- if Random Access Preambles group B is configured:
 - *ra-Msg3SizeGroupA* (per cell): the threshold to determine the groups of Random Access Preambles;
 - *msg3-DeltaPreamble*: $\Delta_{\text{PREAMBLE_Msg3}}$ in TS 38.213 [6];
 - *messagePowerOffsetGroupB*: the power offset for preamble selection;
 - *numberOfRA-PreamblesGroupA* (SpCell only): defines the number of Random Access Preambles in Random Access Preamble group A for each SSB.
- the set of Random Access Preambles and/or PRACH occasions for SI request, if any;
- the set of Random Access Preambles and/or PRACH occasions for beam failure recovery request, if any;
- *ra-ResponseWindow*: the time window to monitor RA response(s) (SpCell only);

- *ra-ContentionResolutionTimer*: the Contention Resolution Timer (SpCell only).

In addition, the following information for related Serving Cell is assumed to be available for UEs:

- if Random Access Preambles group B is configured:
 - if the Serving Cell for the Random Access procedure is configured with *supplementaryUplink*, and SUL carrier is selected for performing Random Access Procedure:
 - $P_{\text{CMAX},f,c}$ of the SUL carrier as specified in TS 38.101 [10].
 - else:
 - $P_{\text{CMAX},f,c}$ of the NUL carrier as specified in TS 38.101 [10].

The following UE variables are used for the Random Access procedure:

- *PREAMBLE_INDEX*;
- *PREAMBLE_TRANSMISSION_COUNTER*;
- *PREAMBLE_POWER_RAMPING_COUNTER*;
- *PREAMBLE_POWER_RAMPING_STEP*;
- *PREAMBLE_RECEIVED_TARGET_POWER*;
- *PREAMBLE_BACKOFF*;
- *PCMAX*;
- *SCALING_FACTOR_BI*;
- *TEMPORARY_C-RNTI*.

When the Random Access procedure is initiated on a Serving Cell, the MAC entity shall:

- 1> flush the Msg3 buffer;
- 1> set the *PREAMBLE_TRANSMISSION_COUNTER* to 1;
- 1> set the *PREAMBLE_POWER_RAMPING_COUNTER* to 1;
- 1> set the *PREAMBLE_BACKOFF* to 0 ms;
- 1> if the carrier to use for the Random Access procedure is explicitly signalled:
 - 2> select the signalled carrier for performing Random Access procedure;
 - 2> set the *PCMAX* to $P_{\text{CMAX},f,c}$ of the signalled carrier.
- 1> else if the carrier to use for the Random Access procedure is not explicitly signalled; and
- 1> if the Serving Cell for the Random Access procedure is configured with *supplementaryUplink*; and
- 1> if the RSRP of the downlink pathloss reference is less than *rsrp-ThresholdSSB-SUL*:
 - 2> select the SUL carrier for performing Random Access procedure;
 - 2> set the *PCMAX* to $P_{\text{CMAX},f,c}$ of the SUL carrier.
- 1> else:
 - 2> select the NUL carrier for performing Random Access procedure;
 - 2> set the *PCMAX* to $P_{\text{CMAX},f,c}$ of the NUL carrier.
- 1> set *PREAMBLE_POWER_RAMPING_STEP* to *preamblePowerRampingStep*;

- 1> if *powerRampingStepHighPriority* is configured:
 - 2> if the Random Access procedure was initiated for beam failure recovery (as specified in subclause 5.1.7); or
 - 2> if the Random Access procedure was initiated for handover:
 - 3> set the *PREAMBLE_POWER_RAMPING_STEP* to *powerRampingStepHighPriority*;
- 1> set *SCALING_FACTOR_BI* to 1;
- 1> if *scalingFactorBI* is configured:
 - 2> if the Random Access procedure was initiated for beam failure recovery (as specified in subclause 5.1.7); or
 - 2> if the Random Access procedure was initiated for handover:
 - 3> set the *SCALING_FACTOR_BI* to *scalingFactorBI*;
- 1> perform the Random Access Resource selection procedure (see subclause 5.1.2).

[TS 38.321, clause 5.16]

The Supplementary UL (SUL) carrier can be configured as a complement to the normal UL (NUL) carrier. Switching between the NUL carrier and the SUL carrier means that the UL transmissions move from the PUSCH on one carrier to the other carrier. This is done via an indication in DCI. If the MAC entity receives a UL grant indicating a SUL switch while a Random Access procedure is ongoing, the MAC entity shall ignore the UL grant.

The Serving Cell configured with *supplementaryUplink* belongs to a single TAG.

7.1.1.1.5.3 Test description

7.1.1.1.5.3.1 Pre-test conditions

Same Pre-test conditions as in clause 7.1.1.0 except that supplemental uplink carrier should be configured on NR Cell 33 and Normal UL carrier of NR Cell 1 should be configured as n78 or n79.

7.1.1.1.5.3.2 Test procedure sequence

Table 7.1.1.1.5.3.2-1 illustrates the downlink power levels to be applied for the NR cells at various time instants of the test execution. Row marked "T0" denotes the initial conditions, while row marked "T1" are to be applied subsequently. The exact instants on which these values shall be applied are described in the texts in this clause.

Table 7.1.1.1.5.3.2-1: Time instances of cell power level changes

	Parameter	Unit	NR Cell 1	NR Cell 33 (SUL)	Remark
T0	SS/PBCH SSS EPRE	dBm/SCS	-75	N/A	NR Cell1 Power level is such that higher than <i>rsrp-ThresholdSSB-SUL</i> .
T1	SS/PBCH SSS EPRE	dBm/SCS	-85	N/A	NR Cell1 Power level is such that lower than <i>rsrp-ThresholdSSB-SUL</i> .

Table 7.1.1.1.5.3.2-2: Main behaviour

St	Procedure	Message Sequence		TP	Verdict
		U - S	Message		
1	The SS transmits Timing Advance command to UE on NR Cell 1 and does not send any subsequent timing alignments. Start Timer_T1 = Time Alignment timer value on SS.	<--	MAC PDU (Timing Advance Command MAC Control Element)	-	-
2	Before Timer_T1 expires the SS transmits a MAC PDU containing a PDCP SDU on NR Cell 1.	<--	MAC PDU	-	-
3	The SS changes NR Cell 1's power level according to the row "T1" in table 7.1.1.1.5.3.2-1. (Note 1)	-	-	-	-
4	The SS ignores scheduling requests and does not allocate any uplink grant, just wait until Timer_T1 expired	-	-	-	-
5	Check: Does the UE initiates the random access procedure in supplementary uplink carrier on NR Cell 33?	-->	PRACH Preamble	1	P
6	The SS transmits Random Access Response with an UL Grant of 56-bits on NR Cell 1 and RAPID corresponding to the transmitted preamble in step 5. (Note 2)	<--	Random Access Response	-	-
7	UE sends a msg3 using the grant associated to the Random Access Response received in Step 6 on NR Cell 33.	-->	Msg3 (C-RNTI MAC CONTROL ELEMENT)	-	-
8	The SS schedules PDCCH transmission on NR Cell 1 for UE C-RNTI with uplink grant's UL/SUL indicator set to 1.	<--	Contention Resolution	-	-
9	The UE transmits a MAC PDU with C-RNTI containing looped back PDCP SDU on NR Cell 33.	-->	MAC PDU	-	-
Note 1: Reduce the NR Cell 1 SS/PBCH EPRE level to ensure that RSRP of the downlink pathloss reference is lower than $rsrp-ThresholdSSB-SUL$, while UE is still able to receive msg2 and msg4 correctly. Note 2: UL grant of 56 bits is to make UE not send any loopback data in uplink with msg3, according to TS 38.321 [18] clause 5.4.3.1.					

7.1.1.1.5.3.3 Specific message contents

Table 7.1.1.1.5.3.3-1: SIB1 of NR Cell 1(preamble and all steps, Table 7.1.1.1.5.3.2-2)

Derivation Path: TS 38.508-1 [4], Table 4.6.1-28			
Information Element	Value/remark	Comment	Condition
SIB1 ::= SEQUENCE {			
servingCellConfigCommon	ServingCellConfigCommonSIB		
}			

Table 7.1.1.1.5.3.3-2: ServingCellConfigCommonSIB (Table 7.1.1.1.5.3.3-1)

Derivation Path: TS 38.508-1 [4], Table 4.6.3-169			
Information Element	Value/remark	Comment	Condition
ServingCellConfigCommonSIB ::= SEQUENCE {			
supplementaryUplink SEQUENCE {			
initialUplinkBWP	BWP-UplinkCommon		
}			
}			

Table 7.1.1.1.5.3.3-3: BWP-UplinkCommon (Table 7.1.1.1.5.3.2-2)

Derivation Path: TS 38.508-1 [4], Table 4.6.3-14			
Information Element	Value/remark	Comment	Condition
BWP-UplinkCommon ::= SEQUENCE {			
rach-ConfigCommon CHOICE {			
setup	RACH-ConfigCommon		
}			
}			

Table 7.1.1.1.5.3.3-4: RACH-ConfigCommon (Table 7.1.1.1.5.3.3-3)

Derivation Path: TS 38.508-1 [4], Table 4.6.3-128			
Information Element	Value/remark	Comment	Condition
RACH-ConfigCommon ::= SEQUENCE {			
rsrp-ThresholdSSB-SUL	76	Integer value for RSRP according to mapping table 10.1.6.1-1 in TS 38.133 [30], where 76 means -81dBm ≤ RSRP < -80dBm	SUL
}			

Table 7.1.1.1.5.3.3-5: DCI Format 0-1 (Step 8 of Table 7.1.1.1.5.3.2-2)

Derivation Path: TS 38.508-1 [4], Table 4.3.6.1.1.2-1			
Information Element	Value/remark	Comment	Condition
UL/SUL indicator	1		UE configured with SUL in the cell

7.1.1.1.6 Random access procedure / Successful/ Temporary C-RNTI Based / Preamble selected by MAC itself

7.1.1.1.6.1 Test Purpose (TP)

(1)

```
with { UE in RRC Idle state has UL CCCH PDU to send and Random Access Preambles group B is
configured }
ensure that {
  when { the UL CCCH MAC PDU Size is less than messageSizeGroupA }
    then { UE transmits a random access preamble using a preamble in group A of random access
preambles }
}
```

(2)

```
with { UE in RRC Idle state initiated Random Access procedure to transmit UL CCCH PDU and
transmitted MSG3 }
ensure that {
  when { The SS schedules any PDCCH transmission addressed to UE Temporary C-RNTI before Contention
resolution timer expiry with MAC PDU does not contain a matching UE Contention Resolution Identity
MAC CE }
    then { UE re transmits a random access preamble using a preamble in the same group of random
access preambles as used for the first transmission of Msg3 }
}
```

(3)

```
with { UE in RRC Idle state initiated Random Access procedure to transmit UL CCCH PDU and
transmitted MSG3 }
ensure that {
  when { The SS does not schedule any PDCCH transmission addressed to UE Temporary C-RNTI before
Contention resolution timer expiry }
}
```

```

    then {UE re transmits a random access preamble using a preamble in the same group of random
    access preambles as used for the first transmission of Msg3 }
    }

```

(4)

```

with { UE in RRC Idle state initiated Random Access procedure to transmit UL CCCH PDU and
transmitted MSG3 }
ensure that {
    when { The SS schedules a PDCCH transmission addressed to UE Temporary C-RNTI before Contention
resolution timer expiry }
    then {UE assumes RACH procedure as complete }
}

```

7.1.1.1.6.2 Conformance requirements

References: The conformance requirements covered in the present TC are specified in: 3GPP TS 38,321, clause 5.1.2, 5.1.3, 5.1.4, 5.1.5, 5.2, 6.1.3.2, 6.1.5 and 6.2.3. Unless otherwise stated these are Rel-15 requirements.

[TS 38.321, clause 5.1.2]

The MAC entity shall:

- 1> if the Random Access procedure was initiated for beam failure recovery (as specified in subclause 5.17); and
- 1> if the *beamFailureRecoveryTimer* (in subclause 5.17) is either running or not configured; and
- 1> if the contention-free Random Access Resources for beam failure recovery request associated with any of the SSBs and/or CSI-RSs have been explicitly provided by RRC; and
- 1> if at least one of the SSBs with SS-RSRP above *rsrp-ThresholdSSB* amongst the SSBs in *candidateBeamRSList* or the CSI-RSs with CSI-RSRP above *rsrp-ThresholdCSI-RS* amongst the CSI-RSs in *candidateBeamRSList* is available:
 - 2> select an SSB with SS-RSRP above *rsrp-ThresholdSSB* amongst the SSBs in *candidateBeamRSList* or a CSI-RS with CSI-RSRP above *rsrp-ThresholdCSI-RS* amongst the CSI-RSs in *candidateBeamRSList*;
 - 2> if CSI-RS is selected, and there is no *ra-PreambleIndex* associated with the selected CSI-RS:
 - 3> set the *PREAMBLE_INDEX* to a *ra-PreambleIndex* corresponding to the SSB in *candidateBeamRSList* which is quasi-colocated with the selected CSI-RS as specified in TS 38.214 [7].
 - 2> else:
 - 3> set the *PREAMBLE_INDEX* to a *ra-PreambleIndex* corresponding to the selected SSB or CSI-RS from the set of Random Access Preambles for beam failure recovery request.
- 1> else if the *ra-PreambleIndex* has been explicitly provided by PDCCH; and
- 1> if the *ra-PreambleIndex* is not 0b000000:
 - 2> set the *PREAMBLE_INDEX* to the signalled *ra-PreambleIndex*;
 - 2> select the SSB signalled by PDCCH.
- 1> else if the contention-free Random Access Resources associated with SSBs have been explicitly provided in *rach-ConfigDedicated* and at least one SSB with SS-RSRP above *rsrp-ThresholdSSB* amongst the associated SSBs is available:
 - 2> select an SSB with SS-RSRP above *rsrp-ThresholdSSB* amongst the associated SSBs;
 - 2> set the *PREAMBLE_INDEX* to a *ra-PreambleIndex* corresponding to the selected SSB.
- 1> else if the contention-free Random Access Resources associated with CSI-RSs have been explicitly provided in *rach-ConfigDedicated* and at least one CSI-RS with CSI-RSRP above *rsrp-ThresholdCSI-RS* amongst the associated CSI-RSs is available:

- 2> select a CSI-RS with CSI-RSRP above $rsrp\text{-}Threshold_{CSI\text{-}RS}$ amongst the associated CSI-RSs;
- 2> set the *PREAMBLE_INDEX* to a *ra-PreambleIndex* corresponding to the selected CSI-RS.
- 1> else if the Random Access procedure was initiated for SI request (as specified in TS 38.331 [5]); and
- 1> if the Random Access Resources for SI request have been explicitly provided by RRC:
 - 2> if at least one of the SSBs with SS-RSRP above $rsrp\text{-}Threshold_{SSB}$ is available:
 - 3> select an SSB with SS-RSRP above $rsrp\text{-}Threshold_{SSB}$.
 - 2> else:
 - 3> select any SSB.
 - 2> select a Random Access Preamble corresponding to the selected SSB, from the Random Access Preamble(s) determined according to *ra-PreambleStartIndex* as specified in TS 38.331 [5];
 - 2> set the *PREAMBLE_INDEX* to selected Random Access Preamble.
- 1> else (i.e. for the contention-based Random Access preamble selection):
 - 2> if at least one of the SSBs with SS-RSRP above $rsrp\text{-}Threshold_{SSB}$ is available:
 - 3> select an SSB with SS-RSRP above $rsrp\text{-}Threshold_{SSB}$.
 - 2> else:
 - 3> select any SSB.
 - 2> if Msg3 has not yet been transmitted:
 - 3> if Random Access Preambles group B is configured:
 - 4> if the potential Msg3 size (UL data available for transmission plus MAC header and, where required, MAC CEs) is greater than *ra-Msg3SizeGroupA* and the pathloss is less than $PCMAX$ (of the Serving Cell performing the Random Access Procedure) – $preambleReceivedTargetPower - msg3\text{-}DeltaPreamble - messagePowerOffsetGroupB$; or
 - 4> if the Random Access procedure was initiated for the CCCH logical channel and the CCCH SDU size plus MAC subheader is greater than *ra-Msg3SizeGroupA*:
 - 5> select the Random Access Preambles group B.
 - 4> else:
 - 5> select the Random Access Preambles group A.
 - 3> else:
 - 4> select the Random Access Preambles group A.
 - 2> else (i.e. Msg3 is being retransmitted):
 - 3> select the same group of Random Access Preambles as was used for the Random Access Preamble transmission attempt corresponding to the first transmission of Msg3.
 - > select a Random Access Preamble3 randomly with equal probability from the Random Access Preambles associated with the selected SSB and the selected Random Access Preambles group.
 - > else:
 - 2> set the *PREAMBLE_INDEX* to the selected Random Access Preamble.
- 11> if the Random Access procedure was initiated for SI request (as specified in TS 38.331 [5]); and
- 1> if *ra-AssociationPeriodIndex* and *si-RequestPeriod* are configured:

- 2> determine the next available PRACH occasion from the PRACH occasions corresponding to the selected SSB in the association period given by *ra-AssociationPeriodIndex* in the *si-RequestPeriod* permitted by the restrictions given by the *ra-ssb-OccasionMaskIndex* if configured (the MAC entity shall select a PRACH occasion randomly with equal probability amongst the consecutive PRACH occasions according to subclause 8.1 of TS 38.213 [6] corresponding to the selected SSB).
- > else if an SSB is selected above:
 - 2> determine the next available PRACH occasion from the PRACH occasions corresponding to the selected SSB permitted by the restrictions given by the *ra-ssb-OccasionMaskIndex* if configured or indicated by PDCCH (the MAC entity shall select a PRACH occasion randomly with equal probability amongst the consecutive PRACH occasions according to subclause 8.1 of TS 38.213 [6], corresponding to the selected SSB; the MAC entity may take into account the possible occurrence of measurement gaps when determining the next available PRACH occasion corresponding to the selected SSB).
- 1> else if a CSI-RS is selected above:
 - 2> if there is no contention-free Random Access Resource associated with the selected CSI-RS:
 - 3> determine the next available PRACH occasion from the PRACH occasions, permitted by the restrictions given by the *ra-ssb-OccasionMaskIndex* if configured, corresponding to the SSB in *candidateBeamRSList* which is quasi-colocated with the selected CSI-RS as specified in TS 38.214 [7] (the MAC entity shall select a PRACH occasion randomly with equal probability amongst the consecutive PRACH occasions according to subclause 8.1 of TS 38.213 [6], corresponding to the SSB which is quasi-colocated with the selected CSI-RS; the MAC entity may take into account the possible occurrence of measurement gaps when determining the next available PRACH occasion corresponding to the SSB which is quasi-colocated with the selected CSI-RS).
 - 2> else:
 - 3> determine the next available PRACH occasion from the PRACH occasions in *ra-OccasionList* corresponding to the selected CSI-RS (the MAC entity shall select a PRACH occasion randomly with equal probability amongst the PRACH occasions occurring simultaneously but on different subcarriers, corresponding to the selected CSI-RS; the MAC entity may take into account the possible occurrence of measurement gaps when determining the next available PRACH occasion corresponding to the selected CSI-RS).
- 1> else if Random Access procedure was initiated for beam failure recovery; and
- 1> if a CSI-RS is selected above and there is no contention-free Random Access Resource associated with the selected CSI-RS:
 - 2> determine the next available PRACH occasion from the PRACH occasions, permitted by the restrictions given by the *ra-ssb-OccasionMaskIndex* if configured, corresponding to the SSB in *candidateBeamRSList* which is quasi-colocated with the selected CSI-RS as specified in TS 38.214 [7] (the MAC entity may take into account the possible occurrence of measurement gaps when determining the next available PRACH occasion corresponding to the SSB which is quasi-collected with the selected CSI-RS).
- 1> else:
 - 2> determine the next available PRACH occasion (the MAC entity shall select a PRACH occasion randomly with equal probability amongst the PRACH occasions occurring simultaneously but on different subcarriers; the MAC entity may take into account the possible occurrence of measurement gaps when determining the next available PRACH occasion).
- 1> perform the Random Access Preamble transmission procedure (see subclause 5.1.3).

NOTE: When the UE determines if there is an SSB with SS-RSRP above *rsrp-ThresholdSSB* or a CSI-RS with CSI-RSRP above *rsrp-ThresholdCSI-RS*, the UE uses the latest unfiltered L1-RSRP measurement.

[TS 38.321, clause 5.1.3]

The MAC entity shall, for each Random Access Preamble:

- 1> if *PREAMBLE_TRANSMISSION_COUNTER* is greater than one; and

- 1> if the notification of suspending power ramping counter has not been received from lower layers; and
- 1> if SSB or CSI-RS selected is not changed from the selection in the last Random Access Preamble transmission:
 - 2> increment *PREAMBLE_POWER_RAMPING_COUNTER* by 1.
- 1> select the value of *DELTA_PREAMBLE* according to subclause 7.3;
- 1> set *PREAMBLE_RECEIVED_TARGET_POWER* to $\text{preambleReceivedTargetPower} + \text{DELTA_PREAMBLE} + (\text{PREAMBLE_POWER_RAMPING_COUNTER} - 1) \times \text{PREAMBLE_POWER_RAMPING_STEP}$;
- 1> except for contention-free Random Access Preamble for beam failure recovery request, compute the RA-RNTI associated with the PRACH occasion in which the Random Access Preamble is transmitted;
- 1> instruct the physical layer to transmit the Random Access Preamble using the selected PRACH occasion, corresponding RA-RNTI (if available), *PREAMBLE_INDEX* and *PREAMBLE_RECEIVED_TARGET_POWER*.

The RA-RNTI associated with the PRACH occasion in which the Random Access Preamble is transmitted, is computed as:

$$\text{RA-RNTI} = 1 + s_id + 14 \times t_id + 14 \times 80 \times f_id + 14 \times 80 \times 8 \times ul_carrier_id$$

where *s_id* is the index of the first OFDM symbol of the PRACH occasion ($0 \leq s_id < 14$), *t_id* is the index of the first slot of the PRACH occasion in a system frame ($0 \leq t_id < 80$), *f_id* is the index of the PRACH occasion in the frequency domain ($0 \leq f_id < 8$), and *ul_carrier_id* is the UL carrier used for Random Access Preamble transmission (0 for NUL carrier, and 1 for SUL carrier).

[TS 38.321, clause 5.1.4]

Once the Random Access Preamble is transmitted and regardless of the possible occurrence of a measurement gap, the MAC entity shall:

- 1> if the contention-free Random Access Preamble for beam failure recovery request was transmitted by the MAC entity:
 - 2> start the *ra-ResponseWindow* configured in *BeamFailureRecoveryConfig* at the first PDCCH occasion as specified in TS 38.213 [6] from the end of the Random Access Preamble transmission;
 - 2> monitor for a PDCCH transmission on the search space indicated by *recoverySearchSpaceId* of the SpCell identified by the C-RNTI while *ra-ResponseWindow* is running.
- 1> else:
 - 2> start the *ra-ResponseWindow* configured in *RACH-ConfigCommon* at the first PDCCH occasion as specified in TS 38.213 [6] from the end of the Random Access Preamble transmission;
 - 2> monitor the PDCCH of the SpCell for Random Access Response(s) identified by the RA-RNTI while the *ra-ResponseWindow* is running.
- 1> if notification of a reception of a PDCCH transmission on the search space indicated by *recoverySearchSpaceId* is received from lower layers on the Serving Cell where the preamble was transmitted; and
- 1> if PDCCH transmission is addressed to the C-RNTI; and
- 1> if the contention-free Random Access Preamble for beam failure recovery request was transmitted by the MAC entity:
 - 2> consider the Random Access procedure successfully completed.
- 1> else if a downlink assignment has been received on the PDCCH for the RA-RNTI and the received TB is successfully decoded:
 - 2> if the Random Access Response contains a MAC subPDU with Backoff Indicator:
 - 3> set the *PREAMBLE_BACKOFF* to value of the BI field of the MAC subPDU using Table 7.2-1, multiplied with *SCALING_FACTOR_BI*.

- 2> else:
 - 3> set the *PREAMBLE_BACKOFF* to 0 ms.
- 2> if the Random Access Response contains a MAC subPDU with Random Access Preamble identifier corresponding to the transmitted *PREAMBLE_INDEX* (see subclause 5.1.3):
 - 3> consider this Random Access Response reception successful.
- 2> if the Random Access Response reception is considered successful:
 - 3> if the Random Access Response includes a MAC subPDU with RAPID only:
 - 4> consider this Random Access procedure successfully completed;
 - 4> indicate the reception of an acknowledgement for SI request to upper layers.
 - 3> else:
 - 4> apply the following actions for the Serving Cell where the Random Access Preamble was transmitted:
 - 5> process the received Timing Advance Command (see subclause 5.2);
 - 5> indicate the *preambleReceivedTargetPower* and the amount of power ramping applied to the latest Random Access Preamble transmission to lower layers (i.e. $(PREAMBLE_POWER_RAMPING_COUNTER - 1) \times PREAMBLE_POWER_RAMPING_STEP$);
 - 5> if the Serving Cell for the Random Access procedure is SRS-only SCell:
 - 6> ignore the received UL grant.
 - 5> else:
 - 6> process the received UL grant value and indicate it to the lower layers.
 - 4> if the Random Access Preamble was not selected by the MAC entity among the contention-based Random Access Preamble(s):
 - 5> consider the Random Access procedure successfully completed.
- 4> else:
 - 5> set the *TEMPORARY_C-RNTI* to the value received in the Random Access Response;
 - 5> if this is the first successfully received Random Access Response within this Random Access procedure:
 - 6> if the transmission is not being made for the CCCH logical channel:
 - 7> indicate to the Multiplexing and assembly entity to include a C-RNTI MAC CE in the subsequent uplink transmission.
 - 6> obtain the MAC PDU to transmit from the Multiplexing and assembly entity and store it in the Msg3 buffer.

NOTE: If within a Random Access procedure, an uplink grant provided in the Random Access Response for the same group of contention-based Random Access Preambles has a different size than the first uplink grant allocated during that Random Access procedure, the UE behavior is not defined.

- 1> if *ra-ResponseWindow* configured in *BeamFailureRecoveryConfig* expires and if a PDCCH transmission on the search space indicated by *recoverySearchSpaceId* addressed to the C-RNTI has not been received on the Serving Cell where the preamble was transmitted; or
- > if *ra-ResponseWindow* configured in *RACH-ConfigCommon* expires, and if the Random Access Response containing Random Access Preamble identifiers that matches the transmitted *PREAMBLE_INDEX* has not been received¹:

- 2> consider the Random Access Response reception not successful;
- 2> increment *PREAMBLE_TRANSMISSION_COUNTER* by 1;
- 2> if *PREAMBLE_TRANSMISSION_COUNTER* = *preambleTransMax* + 1:
 - 3> if the Random Access Preamble is transmitted on the SpCell:
 - 4> indicate a Random Access problem to upper layers;
 - 4> if this Random Access procedure was triggered for SI request:
 - 5> consider the Random Access procedure unsuccessfully completed.
 - 3> else if the Random Access Preamble is transmitted on a SCell:
 - 4> consider the Random Access procedure unsuccessfully completed.
- 2> if the Random Access procedure is not completed:
 - 3> select a random backoff time according to a uniform distribution between 0 and the *PREAMBLE_BACKOFF*;
 - 3> if the criteria (as defined in subclause 5.1.2) to select contention-free Random Access Resources is met during the backoff time:
 - 4> perform the Random Access Resource selection procedure (see subclause 5.1.2);
 - 3> else:
 - 4> perform the Random Access Resource selection procedure (see subclause 5.1.2) after the backoff time.

The MAC entity may stop *ra-ResponseWindow* (and hence monitoring for Random Access Response(s)) after successful reception of a Random Access Response containing Random Access Preamble identifiers that matches the transmitted *PREAMBLE_INDEX*.

HARQ operation is not applicable to the Random Access Response reception.

[TS 38.321, clause 5.1.5]

Once Msg3 is transmitted, the MAC entity shall:

- 1> start the *ra-ContentionResolutionTimer* and restart the *ra-ContentionResolutionTimer* at each HARQ retransmission in the first symbol after the end of the Msg3 transmission;
- 1> monitor the PDCCH while the *ra-ContentionResolutionTimer* is running regardless of the possible occurrence of a measurement gap;
- 1> if notification of a reception of a PDCCH transmission of the SpCell is received from lower layers:
 - 2> if the C-RNTI MAC CE was included in Msg3:
 - 3> if the Random Access procedure was initiated for beam failure recovery (as specified in subclause 5.17) and the PDCCH transmission is addressed to the C-RNTI; or
 - 3> if the Random Access procedure was initiated by the MAC sublayer itself or by the RRC sublayer and the PDCCH transmission is addressed to the C-RNTI and contains a UL grant for a new transmission; or
 - 3> if the Random Access procedure was initiated by a PDCCH order and the PDCCH transmission is addressed to the C-RNTI;
 - > if the Random Access procedure was initiated for beam failure recovery (as specified in subclause 5.17) and the PDCCH transmission is addressed to the C-RNTI:
 - 4> consider this Contention Resolution successful;
 - 4> stop *ra-ContentionResolutionTimer*;

- 4> discard the *TEMPORARY_C-RNTI*;
 - 4> consider this Random Access procedure successfully completed.
- 2> else if the CCCH SDU was included in Msg3 and the PDCCH transmission is addressed to its *TEMPORARY_C-RNTI*:
- 3> if the MAC PDU is successfully decoded:
- 4> stop *ra-ContentionResolutionTimer*;
 - 4> if the MAC PDU contains a UE Contention Resolution Identity MAC CE; and
 - 4> if the UE Contention Resolution Identity in the MAC CE matches the CCCH SDU transmitted in Msg3:
 - 5> consider this Contention Resolution successful and finish the disassembly and demultiplexing of the MAC PDU;
 - 5> if this Random Access procedure was initiated for SI request:
 - 6> indicate the reception of an acknowledgement for SI request to upper layers.
 - 5> else:
 - 6> set the C-RNTI to the value of the *TEMPORARY_C-RNTI*;
 - 5> discard the *TEMPORARY_C-RNTI*;
 - 5> consider this Random Access procedure successfully completed.
 - 4> else:
 - 5> discard the *TEMPORARY_C-RNTI*;
 - 5> consider this Contention Resolution not successful and discard the successfully decoded MAC PDU.
- 1> if *ra-ContentionResolutionTimer* expires:
- 2> discard the *TEMPORARY_C-RNTI*;
 - 2> consider the Contention Resolution not successful.
- 1> if the Contention Resolution is considered not successful:
- 2> flush the HARQ buffer used for transmission of the MAC PDU in the Msg3 buffer;
 - 2> increment *PREAMBLE_TRANSMISSION_COUNTER* by 1;
 - 2> if *PREAMBLE_TRANSMISSION_COUNTER* = *preambleTransMax* + 1:
 - 3> indicate a Random Access problem to upper layers.
 - 3> if this Random Access procedure was triggered for SI request:
 - 4> consider the Random Access procedure unsuccessfully completed.
 - 2> if the Random Access procedure is not completed:
 - 3> select a random backoff time according to a uniform distribution between 0 and the *PREAMBLE_BACKOFF*;
 - 3> if the criteria (as defined in subclause 5.1.2) to select contention-free Random Access Resources is met during the backoff time:
 - 3> perform the Random Access Resource selection procedure (see subclause 5.1.2).

3> else:

- 4> perform the Random Access Resource selection procedure (see subclause 5.1.2) after the backoff time.

[TS 38.321, clause 5.2]

RRC configures the following parameters for the maintenance of UL time alignment:

- *timeAlignmentTimer* (per TAG) which controls how long the MAC entity considers the Serving Cells belonging to the associated TAG to be uplink time aligned.

The MAC entity shall:

- 1> when a Timing Advance Command MAC CE is received, and if an N_{TA} (as defined in TS 38.211 [8]) has been maintained with the indicated TAG:
 - 2> apply the Timing Advance Command for the indicated TAG;
 - 2> start or restart the *timeAlignmentTimer* associated with the indicated TAG.
- 1> when a Timing Advance Command is received in a Random Access Response message for a Serving Cell belonging to a TAG:
 - 2> if the Random Access Preamble was not selected by the MAC entity among the contention-based Random Access Preamble:
 - 3> apply the Timing Advance Command for this TAG;
 - 3> start or restart the *timeAlignmentTimer* associated with this TAG.
 - 2> else if the *timeAlignmentTimer* associated with this TAG is not running:
 - 3> apply the Timing Advance Command for this TAG;
 - 3> start the *timeAlignmentTimer* associated with this TAG;
 - 3> when the Contention Resolution is considered not successful as described in subclause 5.1.5; or
 - 3> when the Contention Resolution is considered successful for SI request as described in subclause 5.1.5, after transmitting HARQ feedback for MAC PDU including UE Contention Resolution Identity MAC CE:
 - 4> stop *timeAlignmentTimer* associated with this TAG.
 - 2> else:
 - 3> ignore the received Timing Advance Command.
- 1> when a *timeAlignmentTimer* expires:
 - 2> if the *timeAlignmentTimer* is associated with the PTAG:
 - 3> flush all HARQ buffers for all Serving Cells;
 - 3> notify RRC to release PUCCH for all Serving Cells, if configured;
 - 3> notify RRC to release SRS for all Serving Cells, if configured;
 - 3> clear any configured downlink assignments and configured uplink grants;
 - 3> clear any PUSCH resource for semi-persistent CSI reporting;
 - 3> consider all running *timeAlignmentTimers* as expired;
 - 3> maintain N_{TA} (defined in TS 38.211 [8]) of all TAGs.
 - 2> else if the *timeAlignmentTimer* is associated with an STAG, then for all Serving Cells belonging to this TAG:

- 3> flush all HARQ buffers;
- 3> notify RRC to release PUCCH, if configured;
- 3> notify RRC to release SRS, if configured;
- 3> clear any configured downlink assignments and configured uplink grants;
- 3> clear any PUSCH resource for semi-persistent CSI reporting;
- 3> maintain N_{TA} (defined in TS 38.211 [8]) of this TAG.

When the MAC entity stops uplink transmissions for an SCell due to the fact that the maximum uplink transmission timing difference between TAGs of the MAC entity or the maximum uplink transmission timing difference between TAGs of any MAC entity of the UE is exceeded, the MAC entity considers the *timeAlignmentTimer* associated with the SCell as expired.

The MAC entity shall not perform any uplink transmission on a Serving Cell except the Random Access Preamble transmission when the *timeAlignmentTimer* associated with the TAG to which this Serving Cell belongs is not running. Furthermore, when the *timeAlignmentTimer* associated with the PTAG is not running, the MAC entity shall not perform any uplink transmission on any Serving Cell except the Random Access Preamble transmission on the SpCell.

[TS 38.321, clause 6.1.3.2]

The C-RNTI MAC CE is identified by MAC PDU subheader with LCID as specified in Table 6.2.1-2.

It has a fixed size and consists of a single field defined as follows (Figure 6.1.3.2-1):

- C-RNTI: This field contains the C-RNTI of the MAC entity. The length of the field is 16 bits.

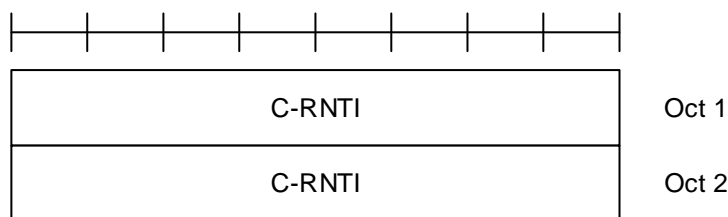

Figure 6.1.3.2-1: C-RNTI MAC CE

[TS 38.321, clause 6.1.5]

A MAC PDU consists of one or more MAC subPDUs and optionally padding. Each MAC subPDU consists one of the following:

- a MAC subheader with Backoff Indicator only;
- a MAC subheader with RAPID only (i.e. acknowledgment for SI request);
- a MAC subheader with RAPID and MAC RAR.

A MAC subheader with Backoff Indicator consists of five header fields E/T/R/R/BI as described in Figure 6.1.5-1. A MAC subPDU with Backoff Indicator only is placed at the beginning of the MAC PDU, if included. 'MAC subPDU(s) with RAPID only' and 'MAC subPDU(s) with RAPID and MAC RAR' can be placed anywhere between MAC subPDU with Backoff Indicator only (if any) and padding (if any).

A MAC subheader with RAPID consists of three header fields E/T/RAPID as described in Figure 6.1.5-2.

Padding is placed at the end of the MAC PDU if present. Presence and length of padding is implicit based on TB size, size of MAC subPDU(s).

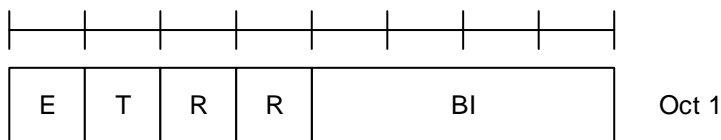

Figure 6.1.5-1: E/T/R/R/BI MAC subheader

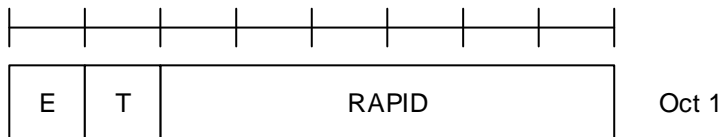

Figure 6.1.5-2: E/T/RAPID MAC subheader

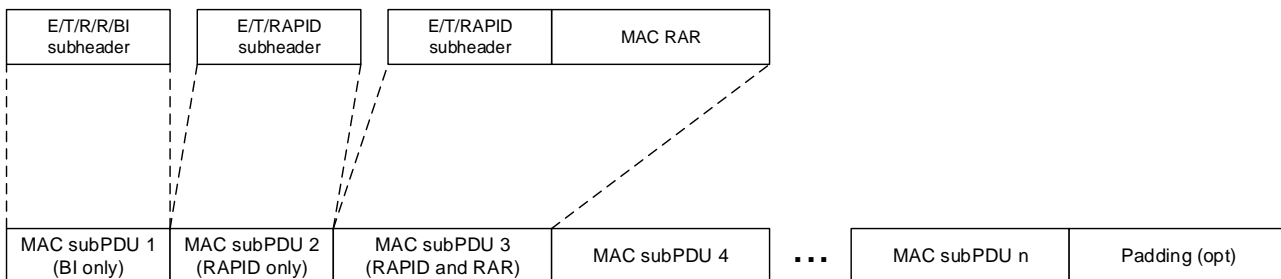

Figure 6.1.5-3: Example of MAC PDU consisting of MAC RARs

[TS 38.321, clause 6.2.3]

The MAC RAR is of fixed size as depicted in Figure 6.2.3-1, and consists of the following fields:

- R: Reserved bit, set to "0";
- Timing Advance Command: The Timing Advance Command field indicates the index value T_A used to control the amount of timing adjustment that the MAC entity has to apply in TS 38.213 [6]. The size of the Timing Advance Command field is 12 bits;
- UL Grant: The Uplink Grant field indicates the resources to be used on the uplink in TS 38.213 [6]. The size of the UL Grant field is 27 bits;
- Temporary C-RNTI: The Temporary C-RNTI field indicates the temporary identity that is used by the MAC entity during Random Access. The size of the Temporary C-RNTI field is 16 bits.

The MAC RAR is octet aligned.

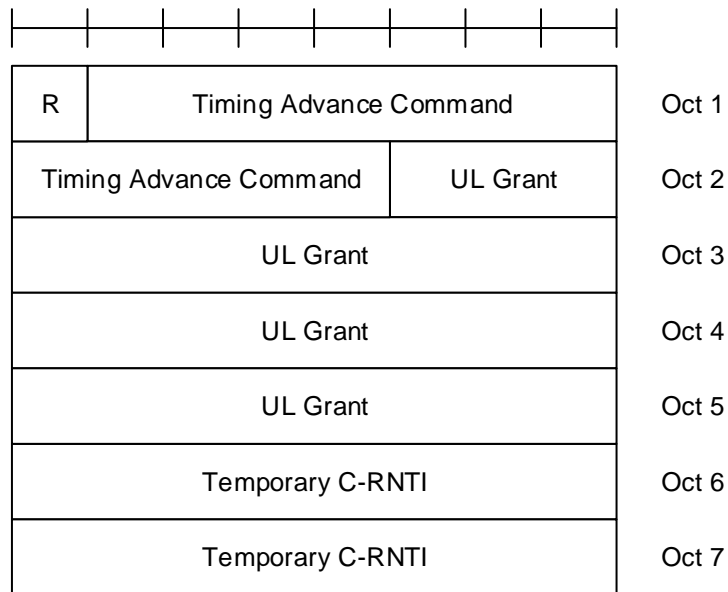

Figure 6.2.3-1: MAC RAR

7.1.1.1.6.3 Test description

7.1.1.1.6.3.1 Pre-test conditions

System Simulator:

- NR Cell 1.

UE:

- None.

Preamble:

- The UE is in NR RRC Idle mode (state 1N-A) and Test Mode Activated according to 38.508-1 [4] Table 4.4A.2-1.

7.1.1.1.6.3.2 Test procedure sequence

Table 7.1.1.1.6.3.2-1: Main behaviour

St	Procedure	Message Sequence		TP	Verdict
		U - S	Message		
1	The SS transmits a Paging message including a matched UE identity.	<--	Paging	-	-
2	Check: Does the UE transmit preamble on PRACH using a preamble in group A defined in <i>servicingCellConfigCommon</i> in <i>SIB1</i> (totalNumberOfRA-Preambles, ssb-perRACH-OccasionAndCB-PreamblesPerSSB and numberOfRA-PreamblesGroupA)?	-->	PRACH Preamble	1	P
3	The SS transmits Random Access Response with RAPID corresponding to the transmitted Preamble in step 2, including TC-RNTI and not including Back off Indicator subheader.	<--	Random Access Response	-	-
4	The UE transmits a MAC PDU containing an <i>RRCSetupRequest</i> message. (Note 1)	-->	MAC PDU (<i>RRCSetupRequest</i>)	-	-
5	Before the contention resolution timer expires, the SS does not schedule any PDCCH.				
6	Check: Does the UE re-transmit a preamble on PRACH using a preamble in the same group A?	-->	PRACH Preamble	3	P
7	The SS transmits Random Access Response with RAPID corresponding to the transmitted Preamble in step 6, including TC-RNTI and not including Back off Indicator subheader.	<--	Random Access Response	-	-
8	The UE transmits a MAC PDU containing an <i>RRCSetupRequest</i> message. (Note 1)	-->	MAC PDU (<i>RRCSetupRequest</i>)	-	-
9	The SS schedules PDCCH transmission addressed to TC-RNTI to transmit a valid MAC PDU containing an <i>RRCSetup</i> message, but not including a matching 'UE Contention Resolution Identity' MAC control element.	<--	MAC PDU (<i>RRCSetup</i>)	-	-
-	EXCEPTION: In parallel with step 10, the parallel behaviour in table 7.1.1.1.6.3.2-2 is running.	-	-	-	-
10	Check: Does the UE re-transmit a preamble on PRACH using a preamble in the same group A?	-->	PRACH Preamble	2	P
11	The SS transmits Random Access Response with RAPID corresponding to the transmitted Preamble in step 10, including TC-RNTI and not including Back off Indicator subheader.	<--	Random Access Response	-	-
12	The UE transmits a MAC PDU containing an <i>RRCSetupRequest</i> message. (Note 1)	-->	MAC PDU (<i>RRCSetupRequest</i>)	-	-
13	The SS schedules PDCCH transmission addressed to TC-RNTI to transmit a valid MAC PDU containing an <i>RRCSetup</i> message and 'UE Contention Resolution Identity' MAC control element with matched 'Contention Resolution Identity'.	<--	MAC PDU (<i>RRCSetup</i> and UE Contention Resolution Identity MAC CE)	-	-
14	Check: Does UE transmit a MAC PDU containing an <i>RRCSetupComplete</i> message indicating acceptance of <i>RRCSetup</i> message?	-->	MAC PDU (<i>RRCSetupComplete</i>)	4	P
Note 1: Size of <i>RRCSetupRequest</i> message is 45 bits, octet aligned = 48 bits. With 16 bits of MAC Header the minimum size of MAC PDU carrying <i>RRCSetupRequest</i> is 64 bits.					

Table 7.1.1.1.6.3.2-2: Parallel behaviour

St	Procedure	Message Sequence		TP	Verdict
		U - S	Message		
1	Check: UE transmits a MAC PDU containing an <i>RRCSetupComplete</i> message indicating acceptance of <i>RRCSetup</i> message?	-->	MAC PDU (<i>RRCSetupComplete</i>)	2	F

7.1.1.1.6.3.3 Specific message contents

Table 7.1.1.1.6.3.3-1: *SIB1* (Preamble, Table 7.1.1.1.6.3.2-1)

Derivation Path: TS 38.508-1 [4], Table 4.6.1-28			
Information Element	Value/remark	Comment	Condition
SIB1 ::= SEQUENCE {			
servingCellConfigCommon SEQUENCE {			
uplinkConfigCommon SEQUENCE {			
initialUplinkBWP	BWP-UplinkCommon		
}			
}			
}			

Table 7.1.1.1.6.3.3-2: *BWP-UplinkCommon* (Table 7.1.1.1.6.3.3-1)

Derivation Path: TS 38.508-1 [4], Table 4.6.3-10			
Information Element	Value/remark	Comment	Condition
BWP-UplinkCommon ::= SEQUENCE {			
rach-ConfigCommon CHOICE {			
setup	RACH-ConfigCommon		
}			
}			

Table 7.1.1.1.6.3.3-3: *RACH-ConfigCommon* (Table 7.1.1.1.6.3.3-2)

Derivation Path: TS 38.508-1 [4], Table 4.6.3-128			
Information Element	Value/remark	Comment	Condition
RACH-ConfigCommon ::= SEQUENCE {			
rach-ConfigGeneric	RACH-ConfigGeneric		
totalNumberOfRA-Preambles	42		
ssb-perRACH-OccasionAndCB-PreamblesPerSSB CHOICE {			
One	n32		
}			
groupBconfigured SEQUENCE {			
ra-Msg3SizeGroupA	b208		
messagePowerOffsetGroupB	minusinfinity		
numberOfRA-PreamblesGroupA	28		
}			
ra-ContentionResolutionTimer	sf48		
}			

7.1.1.2 Downlink Data Transfer

7.1.1.2.1 Correct Handling of DL MAC PDU / Assignment / HARQ process

7.1.1.2.1.1 Test Purpose (TP)

(1)

```
with { UE in RRC_CONNECTED state }
ensure that {
  when { UE receives downlink assignment on the PDCCH for the UE's C-RNTI and receives data in the
associated Slot and UE performs HARQ operation }
  then { UE sends a HARQ feedback on the HARQ process }
}
```

(2)

```
with { UE in RRC_CONNECTED state }
ensure that {
  when { SS transmits downlink assignment on the PDCCH with a C-RNTI unknown by the UE and data is
available in the associated Slot }
  then { UE does not send any HARQ feedback on the HARQ process }
}
```

(3)

```
with { UE in RRC_CONNECTED state }
ensure that {
  when { the UE receives a MAC PDU addressed to its C-RNTI and decode fails in the associated Slot }
  then { the UE transmits a NACK for the corresponding HARQ process }
}
```

(4)

```
with { UE in RRC_CONNECTED state }
ensure that {
  when { the UE receives a MAC PDU retransmission addressed to its C-RNTI, and results in successful
decode in the associated Slot }
  then { the UE transmits an ACK for the corresponding HARQ process and forward to higher layer }
}
```

(5)

```
with { UE in RRC_CONNECTED state }
ensure that {
  when { UE receives a MAC PDU containing multiple MAC sub PDUs each containing a MAC SDU that is
larger than 256 bytes (16 bits L field used) with padding MAC sub PDU at the end }
  then { UE successfully decodes the MAC PDU and forward to higher layer }
}
```

(6)

```
with { UE in RRC_CONNECTED state }
ensure that {
  when { UE receives a MAC PDU containing multiple MAC sub PDUs each containing a MAC SDU that is
smaller than 256 bytes (8 bits L field used) with padding MAC sub PDU at the end }
  then { UE successfully decodes the MAC PDU and forward to higher layer }
}
```

(7)

```
with { UE in RRC_CONNECTED state }
ensure that {
  when { UE receives a MAC PDU containing MAC sub PDU containing a MAC SDU and no padding MAC sub
PDU }
  then { UE successfully decodes the MAC PDU and forward to higher layer }
}
```

(8)

```

with { UE in RRC_CONNECTED state }
ensure that {
  when { UE receives a MAC PDU containing MAC sub PDU containing a MAC SDU that is smaller than 256
bytes (8 bits L field used) plus MAC sub PDU containing a MAC SDU that is greater than 256 bytes (16
bits L field used) and no padding }
  then { UE successfully decodes the MAC PDU and forwards the AMD PDUs to higher layer }
}

```

(9)

```

with { UE in RRC_CONNECTED state and configured with a specific TDD-UL-DL-ConfigCommon including
configuration of pattern2 }
ensure that {
  when { UE receives downlink assignment on the PDCCH associated with pattern2 for the UE's C-RNTI
and receives data in the associated Slot and UE performs HARQ operation }
  then { UE sends a HARQ feedback on the HARQ process }
}

```

7.1.1.2.1.2 Conformance requirements

References: The conformance requirements covered in the present TC are specified in: TS 38.321, clauses 5.3.1, 5.3.2.1, 5.3.2.2 and 6.1.2. Unless otherwise stated these are Rel-15 requirements.

[TS 38.321, clause 5.3.1]

Downlink assignments received on the PDCCH both indicate that there is a transmission on a DL-SCH for a particular MAC entity and provide the relevant HARQ information.

When the MAC entity has a C-RNTI, Temporary C-RNTI, or CS-RNTI, the MAC entity shall for each PDCCH occasion during which it monitors PDCCH and for each Serving Cell:

- 1> if a downlink assignment for this PDCCH occasion and this Serving Cell has been received on the PDCCH for the MAC entity's C-RNTI, or Temporary C-RNTI:
 - 2> if this is the first downlink assignment for this Temporary C-RNTI:
 - 3> consider the NDI to have been toggled.
 - 2> if the downlink assignment is for the MAC entity's C-RNTI, and if the previous downlink assignment indicated to the HARQ entity of the same HARQ process was either a downlink assignment received for the MAC entity's CS-RNTI or a configured downlink assignment:
 - 3> consider the NDI to have been toggled regardless of the value of the NDI.
 - 2> indicate the presence of a downlink assignment and deliver the associated HARQ information to the HARQ entity.
- 1> else if a downlink assignment for this PDCCH occasion has been received for this Serving Cell on the PDCCH for the MAC entity's CS-RNTI:
 - 2> if the NDI in the received HARQ information is 1:
 - 3> consider the NDI for the corresponding HARQ process not to have been toggled;
 - 3> indicate the presence of a downlink assignment for this Serving Cell and deliver the associated HARQ information to the HARQ entity.
 - 2> if the NDI in the received HARQ information is 0:
 - 3> if PDCCH contents indicate SPS deactivation:
 - 4> clear the configured downlink assignment for this Serving Cell (if any);
 - 4> if the timeAlignmentTimer associated with the PTAG is running:
 - 5> indicate a positive acknowledgement for the SPS deactivation to the physical layer.

3> else if PDCCH content indicates SPS activation:

- 4> store the downlink assignment for this Serving Cell and the associated HARQ information as configured downlink assignment;
- 4> initialise or re-initialise the configured downlink assignment for this Serving Cell to start in the associated PDSCH duration and to recur according to rules in subclause 5.8.1;
- 4> set the HARQ Process ID to the HARQ Process ID associated with this PDSCH duration;
- 4> consider the NDI bit for the corresponding HARQ process to have been toggled;
- 4> indicate the presence of a configured downlink assignment for this Serving Cell and deliver the stored HARQ information to the HARQ entity.

For each Serving Cell and each configured downlink assignment, if configured and activated, the MAC entity shall:

- 1> if the PDSCH duration of the configured downlink assignment does not overlap with the PDSCH duration of a downlink assignment received on the PDCCH for this Serving Cell:
 - 2> instruct the physical layer to receive, in this PDSCH duration, transport block on the DL-SCH according to the configured downlink assignment and to deliver it to the HARQ entity;
 - 2> set the HARQ Process ID to the HARQ Process ID associated with this PDSCH duration;
 - 2> consider the NDI bit to have been toggled;
 - 2> indicate the presence of a configured downlink assignment and deliver the stored HARQ information to the HARQ entity.

For configured downlink assignments, the HARQ Process ID associated with the slot where the DL transmission starts is derived from the following equation:

$$\text{HARQ Process ID} = [\text{floor}(\text{CURRENT_slot} \times 10 / (\text{numberOfSlotsPerFrame} \times \text{semiPersistSchedIntervalDL}))] \text{ modulo } \text{nrofHARQ-Processes}$$

where $\text{CURRENT_slot} = [(\text{SFN} \times \text{numberOfSlotsPerFrame}) + \text{slot number in the frame}]$ and *numberOfSlotsPerFrame* refers to the number of consecutive slots per frame as specified in TS 38.211 [8].

When the MAC entity needs to read BCCH, the MAC entity may, based on the scheduling information from RRC:

- 1> if a downlink assignment for this PDCCH occasion has been received on the PDCCH for the SI-RNTI;
- 2> indicate a downlink assignment and redundancy version for the dedicated broadcast HARQ process to the HARQ entity.

[TS 38.321, clause 5.3.2.2]

When a transmission takes place for the HARQ process, one or more (in case of downlink spatial multiplexing) TBs and the associated HARQ information are received from the HARQ entity.

For each received TB and associated HARQ information, the HARQ process shall:

- 1> if the NDI, when provided, has been toggled compared to the value of the previous received transmission corresponding to this TB; or
- 1> if the HARQ process is equal to the broadcast process, and this is the first received transmission for the TB according to the system information schedule indicated by RRC; or
- 1> if this is the very first received transmission for this TB (i.e. there is no previous NDI for this TB):
 - 2> consider this transmission to be a new transmission.
- 1> else:
 - 2> consider this transmission to be a retransmission.

The MAC entity then shall:

- 1> if this is a new transmission:
 - 2> attempt to decode the received data.
- 1> else if this is a retransmission:
 - 2> if the data for this TB has not yet been successfully decoded:
 - 3> instruct the physical layer to combine the received data with the data currently in the soft buffer for this TB and attempt to decode the combined data.
- 1> if the data which the MAC entity attempted to decode was successfully decoded for this TB; or
- 1> if the data for this TB was successfully decoded before:
 - 2> if the HARQ process is equal to the broadcast process:
 - 3> deliver the decoded MAC PDU to upper layers.
 - 2> else if this is the first successful decoding of the data for this TB:
 - 3> deliver the decoded MAC PDU to the disassembly and demultiplexing entity.
- 1> else:
 - 2> instruct the physical layer to replace the data in the soft buffer for this TB with the data which the MAC entity attempted to decode;
- 1> if the HARQ process is associated with a transmission indicated with a Temporary C-RNTI and the Contention Resolution is not yet successful (see subclause 5.1.5); or
- 1> if the HARQ process is equal to the broadcast process; or
- 1> if the *timeAlignmentTimer*, associated with the TAG containing the Serving Cell on which the HARQ feedback is to be transmitted, is stopped or expired:
 - 2> not instruct the physical layer to generate acknowledgement(s) of the data in this TB.
- 1> else:
 - 2> instruct the physical layer to generate acknowledgement(s) of the data in this TB.

The MAC entity shall ignore NDI received in all downlink assignments on PDCCH for its Temporary C-RNTI when determining if NDI on PDCCH for its C-RNTI has been toggled compared to the value in the previous transmission.

[TS 38.321, clause 6.1.2]

A MAC PDU consists of one or more MAC subPDUs. Each MAC subPDU consists of one of the following:

- A MAC subheader only (including padding);
- A MAC subheader and a MAC SDU;
- A MAC subheader and a MAC CE;
- A MAC subheader and padding.

The MAC SDUs are of variable sizes.

Each MAC subheader corresponds to either a MAC SDU, a MAC CE, or padding.

A MAC subheader except for fixed sized MAC CE and padding consists of the four header fields R/F/LCID/L. A MAC subheader for fixed sized MAC CE and padding consists of the two header fields R/LCID.

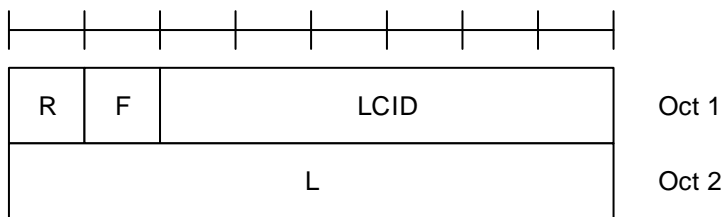

Figure 6.1.2-1: R/F/LCID/L MAC subheader with 8-bit L field

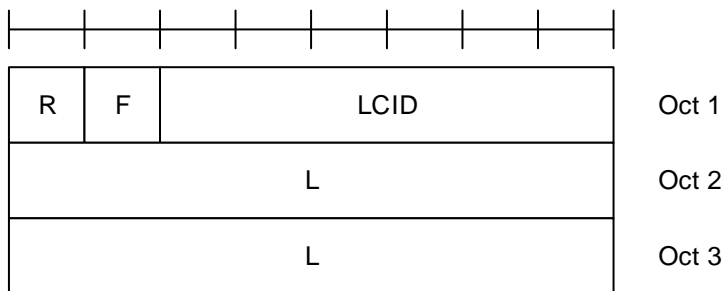

Figure 6.1.2-2: R/F/LCID/L MAC subheader with 16-bit L field

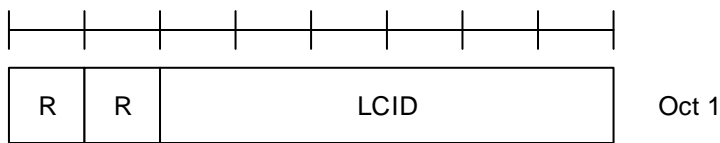

Figure 6.1.2-3: R/LCID MAC subheader

MAC CEs are placed together. DL MAC subPDU(s) with MAC CE(s) is placed before any MAC subPDU with MAC SDU and MAC subPDU with padding as depicted in Figure 6.1.2-4. UL MAC subPDU(s) with MAC CE(s) is placed after all the MAC subPDU(s) with MAC SDU and before the MAC subPDU with padding in the MAC PDU as depicted in Figure 6.1.2-5. The size of padding can be zero.

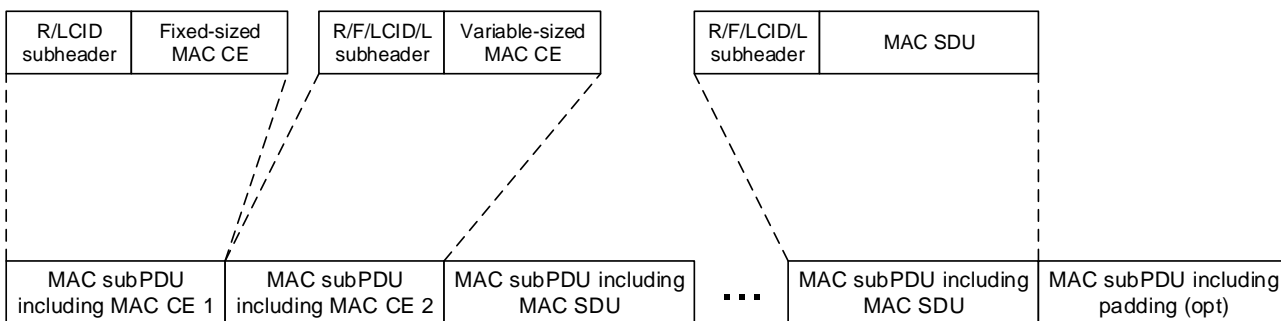

Figure 6.1.2-4: Example of a DL MAC PDU

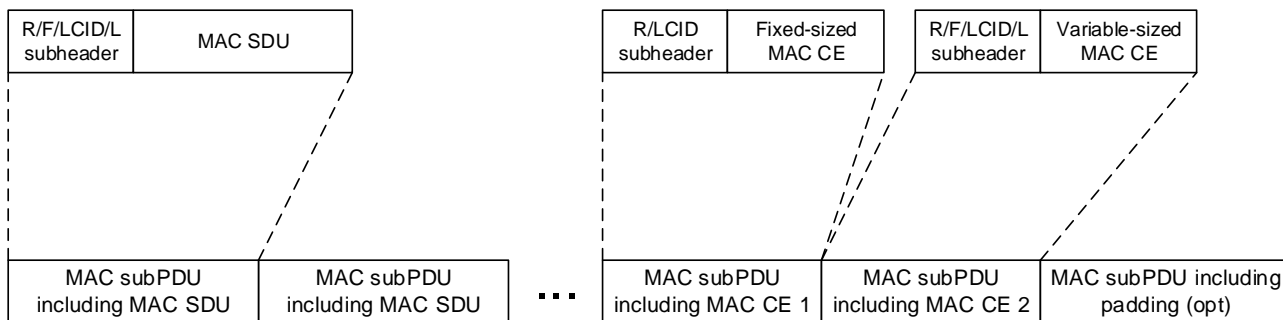

Figure 6.1.2-5: Example of a UL MAC PDU

A maximum of one MAC PDU can be transmitted per TB per MAC entity.

7.1.1.2.1.3 Test description

7.1.1.2.1.3.1 Pre-test conditions

Same Pre-test conditions as in clause 7.1.1.0 except that set to return no data in uplink and parameters as in Table 7.1.1.2.1.3.1-1.

Table 7.1.1.2.1.3.1-1: MAC Parameters

nrofHARQ-ProcessesForPDSCH	n16
----------------------------	-----

7.1.1.2.1.3.2 Test procedure sequence

Table 7.1.1.2.1.3.2-1: Main behaviour

St	Procedure	Message Sequence		TP	Verdict
		U - S	Message		
1	SS transmits a downlink assignment addressed to the C-RNTI assigned to the UE	<--	(PDCCH (C-RNTI))	-	-
2	SS transmits in the indicated downlink assignment a MAC PDU including a RLC PDU with poll bit not set.	<--	MAC PDU	-	-
3	Check: Does the UE transmit an HARQ ACK on PUCCH?	-->	HARQ ACK	1	P
4	SS transmits a downlink assignment to including a C-RNTI different from the assigned to the UE	<--	(PDCCH (unknown C-RNTI))	-	-
5	SS transmits in the indicated downlink assignment a RLC PDU in a MAC PDU including a RLC PDU with poll bit not set.	<--	MAC PDU	-	-
6	Check: Does the UE send any HARQ ACK/NACK on PUCCH?	-->	HARQ ACK/NACK	2	F
-	EXCEPTION: Steps 7 to 10 are run repeated using test parameter values as given for each iteration in table 7.1.1.2.1.3.2.-2.	-	-	-	-
7	The SS indicates a new transmission on PDCCH and transmits a MAC PDU including a RLC PDU with poll bit not set, with content set so that UE could not successfully decode the data from its soft buffer. (Note 1)	<--	MAC PDU	-	-
8	Check: Does the UE transmit a HARQ NACK?	-->	HARQ NACK	3	P
-	EXCEPTION: Step 9 shall be repeated till HARQ ACK is received at step 10 or until HARQ retransmission count = 4 is reached for MAC PDU at step 9 (Note 2).	-	-	-	-
9	The SS indicates a retransmission on PDCCH and transmits the same MAC PDU like step 7 (Note 1).	<--	MAC PDU	-	-
-	EXCEPTION: Up to [3] HARQ NACK from the UE should be allowed at step 10 (Note 2).	-	-	-	-
10	Check: Does the UE send a HARQ ACK?	-->	HARQ ACK	4	P
11	The SS transmits a MAC PDU containing three MAC sub PDUs each containing a MAC SDU(RLC PDU) that is of 260 bytes (16 bits L field used) and a padding MAC sub PDU at the end. The third RLC PDU contained will have poll bit set.	<--	MAC PDU	-	-
12	Check: Does the UE transmit a MAC PDU containing an RLC STATUS PDU acknowledging the reception of all the AMD PDUs in step 11?	-->	MAC PDU (RLC STATUS PDU)	5	P
13	The SS transmits a MAC PDU containing three MAC sub PDUs each containing a MAC SDU(RLC PDU) that is of 128 bytes (8 bits L field used) and a padding MAC sub PDU at the end. The third RLC PDU contained will have poll bit set.	<--	MAC PDU	-	-
14	Check: Does the UE transmit a MAC PDU containing an RLC STATUS PDU acknowledging the reception of all the AMD PDUs in step 13?	-->	MAC PDU (RLC STATUS PDU)	6	P
15	The SS transmits a MAC PDU containing one MAC sub PDU containing a MAC SDU(RLC PDU) that is of [128] bytes (8 bits L field used) and no padding MAC sub PDU at the end. The RLC PDU contained will have poll bit set.	<--	MAC PDU	-	-
16	Check: Does the UE transmit a MAC PDU containing an RLC STATUS PDU acknowledging the reception of the AMD PDU in step 15?	-->	MAC PDU (RLC STATUS PDU)	7	P

17	The SS transmits a MAC PDU containing one MAC sub PDU containing a MAC SDU(RLC PDU) that is of [128] bytes (8 bits L field used), one MAC sub PDU containing a MAC SDU(RLC PDU) that is of [260] bytes (16 bits L field used) and no padding MAC sub PDU at the end. The second RLC PDU contained will have poll bit set.	<--	MAC PDU	-	-
18	Check: Does the UE transmit a MAC PDU containing an RLC STATUS PDU acknowledging the reception of all the AMD PDUs in step 17?	-->	MAC PDU (RLC STATUS PDU)	8	P
19	The SS transmits an <i>RRCCoReconfiguration</i> message containing NR RRCReconfiguration message including <i>TDD-UL-DL-ConfigCommon</i> with <i>pattern2</i> specified in Table 7.1.1.2.1.3.3-1	<--	<i>RRCCoReconfiguration</i> (<i>RRCReconfiguration</i>)	-	-
20	Check: Does the UE transmit an <i>RRCCoReconfigurationComplete</i> message containing NR <i>RRCReconfigurationComplete</i> message?	-->	<i>RRCCoReconfigurationComplete</i> (<i>RRCReconfigurationComplete</i>)	9	P
21	SS transmits a downlink assignment addressed to the C-RNTI assigned to the UE indicating downlink reception in a symbol in a slot part of <i>pattern2</i> .	<--	(PDCCH (C-RNTI))	-	-
22	SS transmits in the indicated downlink assignment a MAC PDU including a RLC PDU with poll bit not set.	<--	MAC PDU	-	-
23	Check: Does the UE transmit an HARQ ACK on PUCCH?	-->	HARQ ACK	9	P
<p>Note 1: SS should transmit this PDU so as to ensure at least one NACK.</p> <p>Note 2: The value 4 for the maximum number of HARQ retransmissions has been chosen based on an assumption that, given the radio conditions used in this test case, a UE soft combiner implementation should have sufficient retransmissions to be able to successfully decode the data in its soft buffer.</p>					

Table 7.1.1.2.1.3.2-2: Test Parameters

Iteration	DL HARQ process (X)
K=1 to 16	X=K-1

7.1.1.2.1.3.3 Specific message contents

Table 7.1.1.2.1.3.3-1: RRCConnectionReconfiguration (step 19, Table 7.1.1.2.1.3.2-1)

Derivation Path: 36.508 [7], Table 4.6.1-8			
Information Element	Value/remark	Comment	Condition
RRCConnectionReconfiguration ::= SEQUENCE {			
criticalExtensions CHOICE {			
c1 CHOICE {			
rrcConnectionReconfiguration-r8 ::= SEQUENCE {			
nonCriticalExtension SEQUENCE {			
nonCriticalExtension SEQUENCE {			
nonCriticalExtension SEQUENCE {			
nonCriticalExtension SEQUENCE {			
nonCriticalExtension SEQUENCE {			
nonCriticalExtension SEQUENCE {			
nr-Config-r15 CHOICE {			
setup SEQUENCE {			
nr-SecondaryCellGroupConfig-r15	OCTET STRING including the RRCReconfiguration message containing the IE secondaryCellGroup		
}			
nonCriticalExtension ::= SEQUENCE {}			
}			
}			
}			
}			
}			
}			
}			
}			

Table 7.1.1.2.1.3.3-2: RRCReconfiguration (Table 7.1.1.2.1.3.3-1)

Derivation Path: 38.508-1 [4], Table [4.6.1-13]			
Information Element	Value/remark	Comment	Condition
RRCReconfiguration ::= SEQUENCE {			
criticalExtensions CHOICE {			
rrcReconfiguration ::= SEQUENCE {			
secondaryCellGroup	CellGroupConfig		
}			
}			
}			

Table 7.1.1.2.1.3.3-3: CellGroupConfig (Table 7.1.1.2.1.3.3-2)

Derivation Path: TS 38.508-1 [4], Table 4.6.3-19			
Information Element	Value/remark	Comment	Condition
CellGroupConfig ::= SEQUENCE {			
spCellConfig SEQUENCE {			
reconfigurationWithSync SEQUENCE {			
spCellConfigCommon	ServingCellConfigCommon		
}			
}			
}			

Table 7.1.1.2.1.3.3-4: ServingCellConfigCommon (Table 7.1.1.2.1.3.3-3)

Derivation Path: TS 38.508-1 [4], Table 4.6.3-168			
Information Element	Value/remark	Comment	Condition
ServingCellConfigCommon ::= SEQUENCE {			
uplinkConfigCommon SEQUENCE {			
initialUplinkBWP	BWP-UplinkCommon		
}			
tdd-UL-DL-ConfigurationCommon	TDD-UL-DL-ConfigCommon		
}			

Table 7.1.1.2.1.3.3-5: TDD-UL-DL-ConfigCommon (Table 7.1.1.2.1.3.3-4)

Derivation Path: TS 38.508-1 [4], Table 4.6.3-192			
Information Element	Value/remark	Comment	Condition
TDD-UL-DL-ConfigCommon ::= SEQUENCE {			
referenceSubcarrierSpacing	SubcarrierSpacing		
pattern1 SEQUENCE {			
dl-UL-TransmissionPeriodicity	ms3		FR1
nrofDownlinkSlots	3		
nrofDownlinkSymbols	6		FR1
nrofUplinkSlots	10		FR2
nrofUplinkSymbols	2		FR1
nrofUplinkSymbols	1		FR2
nrofUplinkSymbols	4		FR1
nrofUplinkSymbols	2		FR2
}			
pattern2 SEQUENCE {			
dl-UL-TransmissionPeriodicity	ms2		FR1
nrofDownlinkSlots	ms0p5		FR2
nrofDownlinkSlots	4		FR1
nrofDownlinkSlots	2		FR2
nrofDownlinkSymbols	0		FR1
nrofDownlinkSymbols	10		FR2
nrofUplinkSlots	0		FR1
nrofUplinkSlots	1		FR2
nrofUplinkSymbols	0		FR1
nrofUplinkSymbols	2		FR2
}			
}			

Table 7.1.1.2.1.3.3-6: BWP-UplinkCommon (Table 7.1.1.2.1.3.3-4)

Derivation Path: TS 38.508-1 [4], Table 4.6.3-10			
Information Element	Value/remark	Comment	Condition
BWP-UplinkCommon ::= SEQUENCE {			
rach-ConfigCommon CHOICE {			
setup	RACH-ConfigCommon		
}			
}			

Table 7.1.1.2.1.3.3-7: RACH-ConfigCommon (Table 7.1.1.2.1.3.3-6)

Derivation Path: TS 38.508-1 [4], Table 4.6.3-128			
Information Element	Value/remark	Comment	Condition
RACH-ConfigCommon ::= SEQUENCE {			
rach-ConfigGeneric	RACH-ConfigGeneric		
}			

Table 7.1.1.2.1.3.3-8: RACH-ConfigGeneric (Table 7.1.1.2.1.3.3-7)

Derivation Path: TS 38.508-1 [4], Table 4.6.3-130			
Information Element	Value/remark	Comment	Condition
RACH-ConfigGeneric ::= SEQUENCE {			
prach-configurationIndex	156		
}			

7.1.1.2.2 Correct Handling of DL HARQ process PDSCH Aggregation

7.1.1.2.2.1 Test Purpose (TP)

(1)

```
with { UE in RRC_CONNECTED state and pdsch-AggregationFactor > 1 }
ensure that {
  when { UE receives downlink assignment on the PDCCH for the UE's C-RNTI and receives data in the
associated slot and successive pdsch-AggregationFactor - 1 HARQ retransmissions within a bundle and
UE performs HARQ operation }
  then { UE sends a HARQ feedback on the HARQ process }
}
```

7.1.1.2.2.2 Conformance requirements

References: The conformance requirements covered in the current TC are specified in: TS 38.321, clauses 5.3.1, 5.3.2.1 and 5.3.2.2, TS 38.214, clause 5.1.2.1.

[TS 38.321, clause 5.3.1]

Downlink assignments received on the PDCCH both indicate that there is a transmission on a DL-SCH for a particular MAC entity and provide the relevant HARQ information.

When the MAC entity has a C-RNTI, Temporary C-RNTI, or CS-RNTI, the MAC entity shall for each PDCCH occasion during which it monitors PDCCH and for each Serving Cell:

- 1> if a downlink assignment for this PDCCH occasion and this Serving Cell has been received on the PDCCH for the MAC entity's C-RNTI, or Temporary C-RNTI:
- 2> if this is the first downlink assignment for this Temporary C-RNTI:
 - 3> consider the NDI to have been toggled.

- 2> if the downlink assignment is for the MAC entity's C-RNTI, and if the previous downlink assignment indicated to the HARQ entity of the same HARQ process was either a downlink assignment received for the MAC entity's CS-RNTI or a configured downlink assignment:
 - 3> consider the NDI to have been toggled regardless of the value of the NDI.
- 2> indicate the presence of a downlink assignment and deliver the associated HARQ information to the HARQ entity.
- 1> else if a downlink assignment for this PDCCH occasion has been received for this Serving Cell on the PDCCH for the MAC entity's CS-RNTI:
 - 2> if the NDI in the received HARQ information is 1:
 - 3> consider the NDI for the corresponding HARQ process not to have been toggled;
 - 3> indicate the presence of a downlink assignment for this Serving Cell and deliver the associated HARQ information to the HARQ entity.
 - 2> if the NDI in the received HARQ information is 0:
 - 3> if PDCCH contents indicate SPS deactivation:
 - 4> clear the configured downlink assignment for this Serving Cell (if any);
 - 4> if the timeAlignmentTimer associated with the PTAG is running:
 - 5> indicate a positive acknowledgement for the SPS deactivation to the physical layer.
 - 3> else if PDCCH content indicates SPS activation:
 - 4> store the downlink assignment for this Serving Cell and the associated HARQ information as configured downlink assignment;
 - 4> initialise or re-initialise the configured downlink assignment for this Serving Cell to start in the associated PDSCH duration and to recur according to rules in subclause 5.8.1;
 - 4> set the HARQ Process ID to the HARQ Process ID associated with this PDSCH duration;
 - 4> consider the NDI bit for the corresponding HARQ process to have been toggled;
 - 4> indicate the presence of a configured downlink assignment for this Serving Cell and deliver the stored HARQ information to the HARQ entity.

For each Serving Cell and each configured downlink assignment, if configured and activated, the MAC entity shall:

- 1> if the PDSCH duration of the configured downlink assignment does not overlap with the PDSCH duration of a downlink assignment received on the PDCCH for this Serving Cell:
 - 2> instruct the physical layer to receive, in this PDSCH duration, transport block on the DL-SCH according to the configured downlink assignment and to deliver it to the HARQ entity;
 - 2> set the HARQ Process ID to the HARQ Process ID associated with this PDSCH duration;
 - 2> consider the NDI bit to have been toggled;
 - 2> indicate the presence of a configured downlink assignment and deliver the stored HARQ information to the HARQ entity.

For configured downlink assignments, the HARQ Process ID associated with the slot where the DL transmission starts is derived from the following equation:

$$\text{HARQ Process ID} = [\text{floor}(\text{CURRENT_slot} \times 10 / (\text{numberOfSlotsPerFrame} \times \text{periodicity}))] \text{ modulo } n_{\text{rofHARQ-Processes}}$$

where $\text{CURRENT_slot} = [(\text{SFN} \times \text{numberOfSlotsPerFrame}) + \text{slot number in the frame}]$ and $\text{numberOfSlotsPerFrame}$ refers to the number of consecutive slots per frame as specified in TS 38.211 [8].

When the MAC entity needs to read BCCH, the MAC entity may, based on the scheduling information from RRC:

- 1> if a downlink assignment for this PDCCH occasion has been received on the PDCCH for the SI-RNTI;
- 2> indicate a downlink assignment and redundancy version for the dedicated broadcast HARQ process to the HARQ entity.

[TS 38.321, clause 5.3.2.1]

The MAC entity includes a HARQ entity for each Serving Cell, which maintains a number of parallel HARQ processes. Each HARQ process is associated with a HARQ process identifier. The HARQ entity directs HARQ information and associated TBs received on the DL-SCH to the corresponding HARQ processes (see subclause 5.3.2.2).

The number of parallel DL HARQ processes per HARQ entity is specified in TS 38.214 [7]. The dedicated broadcast HARQ process is used for BCCH.

The HARQ process supports one TB when the physical layer is not configured for downlink spatial multiplexing. The HARQ process supports one or two TBs when the physical layer is configured for downlink spatial multiplexing.

When the MAC entity is configured with *pdsch-AggregationFactor* > 1, the parameter *pdsch-AggregationFactor* provides the number of transmissions of a TB within a bundle of the dynamic downlink assignment. Bundling operation relies on the HARQ entity for invoking the same HARQ process for each transmission that is part of the same bundle. After the initial transmission, *pdsch-AggregationFactor* – 1 HARQ retransmissions follow within a bundle.

The MAC entity shall:

- 1> if a downlink assignment has been indicated:
 - 2> allocate the TB(s) received from the physical layer and the associated HARQ information to the HARQ process indicated by the associated HARQ information.
- 1> if a downlink assignment has been indicated for the broadcast HARQ process:
 - 2> allocate the received TB to the broadcast HARQ process.

[TS 38.321, clause 5.3.2.2]

When a transmission takes place for the HARQ process, one or two (in case of downlink spatial multiplexing) TBs and the associated HARQ information are received from the HARQ entity.

For each received TB and associated HARQ information, the HARQ process shall:

- 1> if the NDI, when provided, has been toggled compared to the value of the previous received transmission corresponding to this TB; or
- 1> if the HARQ process is equal to the broadcast process, and this is the first received transmission for the TB according to the system information schedule indicated by RRC; or
- 1> if this is the very first received transmission for this TB (i.e. there is no previous NDI for this TB):
 - 2> consider this transmission to be a new transmission.
- 1> else:
 - 2> consider this transmission to be a retransmission.

The MAC entity then shall:

- 1> if this is a new transmission:
 - 2> attempt to decode the received data.
- 1> else if this is a retransmission:
 - 2> if the data for this TB has not yet been successfully decoded:

- 3> instruct the physical layer to combine the received data with the data currently in the soft buffer for this TB and attempt to decode the combined data.
- 1> if the data which the MAC entity attempted to decode was successfully decoded for this TB; or
- 1> if the data for this TB was successfully decoded before:
 - 2> if the HARQ process is equal to the broadcast process:
 - 3> deliver the decoded MAC PDU to upper layers.
 - 2> else if this is the first successful decoding of the data for this TB:
 - 3> deliver the decoded MAC PDU to the disassembly and demultiplexing entity.
- 1> else:
 - 2> instruct the physical layer to replace the data in the soft buffer for this TB with the data which the MAC entity attempted to decode.
- 1> if the HARQ process is associated with a transmission indicated with a Temporary C-RNTI and the Contention Resolution is not yet successful (see subclause 5.1.5); or
- 1> if the HARQ process is equal to the broadcast process; or
- 1> if the *timeAlignmentTimer*, associated with the TAG containing the Serving Cell on which the HARQ feedback is to be transmitted, is stopped or expired:
 - 2> not instruct the physical layer to generate acknowledgement(s) of the data in this TB.
- 1> else:
 - 2> instruct the physical layer to generate acknowledgement(s) of the data in this TB.

The MAC entity shall ignore NDI received in all downlink assignments on PDCCH for its Temporary C-RNTI when determining if NDI on PDCCH for its C-RNTI has been toggled compared to the value in the previous transmission.

[TS 38.214, clause 5.1.2.1]

When the UE is scheduled to receive PDSCH by a DCI, the *Time domain resource assignment* field value m of the DCI provides a row index $m + 1$ to an allocation table. The determination of the used resource allocation table is defined in sub-clause 5.1.2.1.1. The indexed row defines the slot offset K_0 , the start and length indicator $SLIV$, or directly the start symbol S and the allocation length L , and the PDSCH mapping type to be assumed in the PDSCH reception.

Given the parameter values of the indexed row:

- The slot allocated for the PDSCH is $\left\lfloor n \cdot \frac{2^{\mu_{\text{PDSCH}}}}{2^{\mu_{\text{PDCCH}}}} \right\rfloor + K_0$, where n is the slot with the scheduling DCI, and K_0 is based on the numerology of PDSCH, and μ_{PDSCH} and μ_{PDCCH} are the subcarrier spacing configurations for PDSCH and PDCCH, respectively, and
- The starting symbol S relative to the start of the slot, and the number of consecutive symbols L counting from the symbol S allocated for the PDSCH are determined from the start and length indicator $SLIV$:

if $(L-1) \leq 7$ then

$$SLIV = 14 \cdot (L-1) + S$$

else

$$SLIV = 14 \cdot (14 - L + 1) + (14 - 1 - S)$$

where $0 < L \leq 14 - S$, and

- The PDSCH mapping type is set to Type A or Type B as defined in sub-clause 7.4.1.1.2 of [4, TS 38.211].

The UE shall consider the S and L combinations defined in table 5.1.2.1-1 as valid PDSCH allocations:

Table 5.1.2.1-1: Valid S and L combinations

PDSCH mapping type	Normal cyclic prefix			Extended cyclic prefix		
	S	L	$S+L$	S	L	$S+L$
Type A	{0,1,2,3} (Note 1)	{3,...,14}	{3,...,14}	{0,1,2,3} (Note 1)	{3,...,12}	{3,...,12}
Type B	{0,...,12}	{2,4,7}	{2,...,14}	{0,...,10}	{2,4,6}	{2,...,12}

Note 1: $S = 3$ is applicable only if $dmrs\text{-}TypeA\text{-}Position = 3$

When the UE is configured with $aggregationFactorDL > 1$, the same symbol allocation is applied across the $aggregationFactorDL$ consecutive slots. The UE may expect that the TB is repeated within each symbol allocation among each of the $aggregationFactorDL$ consecutive slots and the PDSCH is limited to a single transmission layer. The redundancy version to be applied on the n^{th} transmission occasion of the TB is determined according to table 5.1.2.1-2.

Table 5.1.2.1-2: Applied redundancy version when $aggregationFactorDL > 1$

rv_{id} indicated by the DCI scheduling the PDSCH	rv_{id} to be applied to n^{th} transmission occasion			
	$n \bmod 4 = 0$	$n \bmod 4 = 1$	$n \bmod 4 = 2$	$n \bmod 4 = 3$
0	0	2	3	1
2	2	3	1	0
3	3	1	0	2
1	1	0	2	3

If the UE procedure for determining slot configuration as defined in Subclause 11.1 of [6, TS 38.213] determines symbol of a slot allocated for PDSCH as uplink symbols, the transmission on that slot is omitted for multi-slot PDSCH transmission.

The UE is not expected to receive a PDSCH with mapping type A in a slot, if the PDCCH scheduling the PDSCH was received in the same slot and was not contained within the first three symbols of the slot.

The UE is not expected to receive a PDSCH with mapping type B in a slot, if the first symbol of the PDCCH scheduling the PDSCH was received in a later symbol than the first symbol indicated in the PDSCH time domain resource allocation.

7.1.1.2.2.3 Test description

7.1.1.2.2.3.1 Pre-test conditions

Same Pre-test conditions as in clause 7.1.1.0 except that set to return no data in uplink and parameters as in Table 7.1.1.2.2.3.1-1.

Table 7.1.1.2.2.3.1-1: MAC Parameters

nrofHARQ-ProcessesForPDSCH	n16
----------------------------	-----

7.1.1.2.2.3.2 Test procedure sequence

Table 7.1.1.2.2.3.2-1: Main behaviour

St	Procedure	Message Sequence		TP	Verdict
		U - S	Message		
1	SS transmits in the indicated downlink assignment an RRCReconfiguration.	<--	-	-	-
2	UE transmits RRCReconfigurationComplete message to the SS.	-->	-	-	-
3	The SS transmits a downlink assignment addressed to the C-RNTI assigned to the UE, the rv_idx is 0.	<--	-	-	-
4	The SS transmits in the indicated downlink assignment a MAC PDU including a RLC PDU, The CRC is calculated in such a way, it will result in CRC error on UE side.	<--	MAC PDU	-	-
5	In the following 3 consecutive slots, the SS transmits on the same downlink assignment a MAC PDU including a RLC PDU, The CRC is calculated in such a way, it will result in CRC error on UE side. (Note 1)	<--	MAC PDU	-	-
6	Check: Does the UE transmit a HARQ NACK?	-->	HARQ NACK	1	P
7	The SS transmits a downlink assignment addressed to the C-RNTI assigned to the UE, the rv_idx is 0.	<--	-	-	-
8	The SS transmits in the indicated downlink assignment a MAC PDU including a RLC PDU, The CRC is calculated in such a way, it will result in CRC pass on UE side.	<--	MAC PDU	-	-
9	In the following 3 consecutive slots, the SS transmits on the same downlink assignment a MAC PDU including a RLC PDU, The CRC is calculated in such a way, it will result in CRC pass on UE side. (Note 1)	<--	MAC PDU	-	-
10	Check: Does the UE transmit a HARQ ACK?	-->	HARQ ACK	1	P
Note 1: For aggregationFactorDL=4, the PDSCH will repeat in following 4-1=3 slots with same resource allocation but different redundancy version.					

7.1.1.2.2.3.3 Specific message contents

Table 7.1.1.2.2.3.3-1: RRCReconfiguration (step 1, Table 7.1.1.2.2.3.2-1)

Derivation Path: 38.508-1 [4], Table [4.6.1-13]			
Information Element	Value/remark	Comment	Condition
RRCReconfiguration ::= SEQUENCE {			
criticalExtensions CHOICE {			
rrcReconfiguration SEQUENCE {			
secondaryCellGroup	CellGroupConfig	OCTET STRING (CONTAINING CellGroupConfig)	SA
}			
}			
}			

Table 7.1.1.2.2.3.3-2: cellGroupConfig (Table 7.1.1.2.2.3.3-1: RRCReconfiguration)

Derivation Path: 38.508-1 [4], Table [4.6.3-19]			
Information Element	Value/remark	Comment	Condition
cellGroupConfig ::= SEQUENCE {			
cellGroupId	1		
spCellConfig SEQUENCE {			
spCellConfigDedicated SEQUENCE {			
servingCellConfig SEQUENCE {			
initialDownlinkBWP SEQUENCE {			
pdsch-Config SEQUENCE {			
pdsch-AggregationFactor	n4		
}			
}			
}			
}			
}			

7.1.1.2.3 Correct HARQ process handling / CCCH

7.1.1.2.3.1 Test Purpose (TP)

(1)

```
with { UE in RRC_IDLE state with RRC connection establishment procedure initiated }
ensure that {
  when { UE receives a MAC PDU addressed to RA-RNTI }
  then { UE does not transmit the HARQ feedback for the corresponding HARQ process }
}
```

(2)

```
with { UE in RRC_IDLE state with RRC connection establishment procedure initiated }
ensure that {
  when { UE receives a MAC PDU addressed to T-CRNTI without UE Contention Resolution Identity
  corresponding the transmitted RRCSetupRequest message }
  then { UE does not transmit the HARQ feedback for the corresponding HARQ process }
}
```

(3)

```
with { UE in RRC_IDLE state with RRC connection establishment procedure initiated }
ensure that {
  when { UE receives a MAC PDU addressed to T-CRNTI and cannot decode properly }
  then { UE does not transmit the HARQ feedback for the corresponding HARQ process }
}
```

(4)

```
with { UE in RRC_IDLE state with RRC connection establishment procedure initiated }
ensure that {
  when { UE receives a MAC PDU addressed to T-CRNTI with UE Contention Resolution Identity
  corresponding the transmitted RRCSetupRequest message }
  then { UE transmits the HARQ ACK for the corresponding HARQ process }
}
```

7.1.1.2.3.2 Conformance requirements

References: The conformance requirements covered in the current TC are specified in: TS 38.321, clauses 5.3.2.1 and 5.3.2.2.

[TS 38.321, clause 5.3.2.1]

The MAC entity includes a HARQ entity for each Serving Cell, which maintains a number of parallel HARQ processes. Each HARQ process is associated with a HARQ process identifier. The HARQ entity directs HARQ information and associated TBs received on the DL-SCH to the corresponding HARQ processes (see subclause 5.3.2.2).

The number of parallel DL HARQ processes per HARQ entity is specified in TS 38.214 [7]. The dedicated broadcast HARQ process is used for BCCH.

The HARQ process supports one TB when the physical layer is not configured for downlink spatial multiplexing. The HARQ process supports one or two TBs when the physical layer is configured for downlink spatial multiplexing.

When the MAC entity is configured with *pdsch-AggregationFactor* > 1, the parameter *pdsch-AggregationFactor* provides the number of transmissions of a TB within a bundle of the dynamic downlink assignment. Bundling operation relies on the HARQ entity for invoking the same HARQ process for each transmission that is part of the same bundle. After the initial transmission, *pdsch-AggregationFactor* – 1 HARQ retransmissions follow within a bundle.

The MAC entity shall:

- 1> if a downlink assignment has been indicated:
 - 2> allocate the TB(s) received from the physical layer and the associated HARQ information to the HARQ process indicated by the associated HARQ information.
- 1> if a downlink assignment has been indicated for the broadcast HARQ process:
 - 2> allocate the received TB to the broadcast HARQ process.

[TS 38.321, clause 5.3.2.2]

When a transmission takes place for the HARQ process, one or two (in case of downlink spatial multiplexing) TBs and the associated HARQ information are received from the HARQ entity.

For each received TB and associated HARQ information, the HARQ process shall:

- 1> if the NDI, when provided, has been toggled compared to the value of the previous received transmission corresponding to this TB; or
- 1> if the HARQ process is equal to the broadcast process, and this is the first received transmission for the TB according to the system information schedule indicated by RRC; or
- 1> if this is the very first received transmission for this TB (i.e. there is no previous NDI for this TB):
 - 2> consider this transmission to be a new transmission.
- 1> else:
 - 2> consider this transmission to be a retransmission.

The MAC entity then shall:

- 1> if this is a new transmission:
 - 2> attempt to decode the received data.
- 1> else if this is a retransmission:
 - 2> if the data for this TB has not yet been successfully decoded:
 - 3> instruct the physical layer to combine the received data with the data currently in the soft buffer for this TB and attempt to decode the combined data.
- 1> if the data which the MAC entity attempted to decode was successfully decoded for this TB; or
- 1> if the data for this TB was successfully decoded before:
 - 2> if the HARQ process is equal to the broadcast process:
 - 3> deliver the decoded MAC PDU to upper layers.

- 2> else if this is the first successful decoding of the data for this TB:
 - 3> deliver the decoded MAC PDU to the disassembly and demultiplexing entity.
- 1> else:
 - 2> instruct the physical layer to replace the data in the soft buffer for this TB with the data which the MAC entity attempted to decode.
- 1> if the HARQ process is associated with a transmission indicated with a Temporary C-RNTI and the Contention Resolution is not yet successful (see subclause 5.1.5); or
- 1> if the HARQ process is equal to the broadcast process; or
- 1> if the *timeAlignmentTimer*, associated with the TAG containing the Serving Cell on which the HARQ feedback is to be transmitted, is stopped or expired:
 - 2> not instruct the physical layer to generate acknowledgement(s) of the data in this TB.
- 1> else:
 - 2> instruct the physical layer to generate acknowledgement(s) of the data in this TB.

The MAC entity shall ignore NDI received in all downlink assignments on PDCCH for its Temporary C-RNTI when determining if NDI on PDCCH for its C-RNTI has been toggled compared to the value in the previous transmission.

NOTE: If the MAC entity receives a retransmission with a TB size different from the last TB size signalled for this TB, the UE behavior is left up to UE implementation.

7.1.1.2.3.3 Test description

7.1.1.2.3.3.1 Pre-test conditions

System Simulator:

- NR Cell 1.

UE:

- None

Preamble:

- The UE is in 1N-A state on NR Cell 1 using generic procedure parameter Connectivity (*NR*) according to TS 38.508-1 [4].

7.1.1.2.3.3.2 Test procedure sequence

Table 7.1.1.2.3.3.2-1: Main behaviour

St	Procedure	Message Sequence		TP	Verdict
		U - S	Message		
1	The SS transmits a Paging message including a matched identity.	<--	-	-	-
2	The UE transmits Preamble on PRACH.	-->	PRACH Preamble	-	-
3	The SS transmits Random Access Response with matching RA-RNTI and including Temporary C-RNTI. The CRC is calculated in such a way, it will result in CRC error on UE side.	<--	Random Access Response	-	-
4	Check: does the UE transmit a HARQ ACK/NACK?	-->	HARQ ACK/NACK	1	F
5	The UE transmits Preamble on PRACH.	-->	PRACH Preamble	-	-
6	The SS transmits Random Access Response with matching RA-RNTI and including Temporary C-RNTI. The CRC is calculated in such a way, it will result in CRC pass on UE side.	<--	Random Access Response	-	-
7	Check: does the UE transmit a HARQ ACK/NACK?	-->	HARQ ACK/NACK	1	F
8	The UE transmits a MAC PDU containing an <i>RRCSetupRequest</i> message.	-->	MAC PDU	-	-
9	The SS transmits a valid MAC PDU containing <i>RRCSetup</i> , and including 'UE Contention Resolution Identity' MAC control element with not matching 'Contention Resolution Identity'.	<--	MAC PDU	-	-
10	Check: does the UE transmit a HARQ ACK/NACK?	-->	HARQ ACK/NACK	2	F
11	The UE transmits Preamble on PRACH.	-->	PRACH Preamble	-	-
12	The SS transmits Random Access Response with matching RA-RNTI and including Temporary C-RNTI.	<--	Random Access Response	-	-
13	The UE transmits a MAC PDU containing an <i>RRCSetupRequest</i> message.	-->	MAC PDU	-	-
14	The SS transmits a valid MAC PDU containing <i>RRCSetup</i> , and including 'UE Contention Resolution Identity' MAC control element with matching 'Contention Resolution Identity'. The CRC is calculated in such a way that it will result in CRC error on UE side.	<--	MAC PDU	-	-
15	Check: Does UE transmit a HARQ ACK/NACK?	-->	HARQ ACK/NACK	3	F
16	The UE transmits Preamble on PRACH.	-->	PRACH Preamble	-	-
17	The SS transmits Random Access Response with matching RA-RNTI and including Temporary C-RNTI.	<--	Random Access Response	-	-
18	The UE transmits a MAC PDU containing an <i>RRCSetupRequest</i> message.	-->	MAC PDU	-	-
19	The SS transmits a valid MAC PDU containing <i>RRCSetup</i> , and including 'UE Contention Resolution Identity' MAC control element with matching 'Contention Resolution Identity'. The CRC is calculated in such a way that it will result in CRC pass on UE side.	<--	MAC PDU	-	-
20	Check: does the UE transmit a HARQ ACK?	-->	HARQ ACK	4	P
21	The UE transmits a MAC PDU containing an <i>RRCSetupComplete</i> message including SERVICE REQUEST message indicating acceptance of <i>RRCSetup</i> message	-->	MAC PDU	-	-
22	Steps x to y of the generic radio bearer establishment procedure (TS 38.508 table x.x.x.x-x) are executed to successfully complete the service request procedure.	-	-	-	-

7.1.1.2.3.3.3 Specific message contents

None.

7.1.1.2.4 Correct HARQ process handling / BCCH

7.1.1.2.4.1 Test Purpose (TP)

(1)

```
with { UE in RRC_CONNECTED state }
ensure that {
  when { UE receives a MAC PDU addressed to SI-RNTI on the broadcast HARQ process }
  then { UE does not transmit the HARQ feedback for the broadcast HARQ process }
}
```

7.1.1.2.4.2 Conformance requirements

References: The conformance requirements covered in the current TC are specified in: TS 38.321, clauses 5.3.2.1 and 5.3.2.2.

[TS 38.321, clause 5.3.2.1]

The MAC entity includes a HARQ entity for each Serving Cell, which maintains a number of parallel HARQ processes. Each HARQ process is associated with a HARQ process identifier. The HARQ entity directs HARQ information and associated TBs received on the DL-SCH to the corresponding HARQ processes (see subclause 5.3.2.2).

The number of parallel DL HARQ processes per HARQ entity is specified in TS 38.214 [7]. The dedicated broadcast HARQ process is used for BCCH.

The HARQ process supports one TB when the physical layer is not configured for downlink spatial multiplexing. The HARQ process supports one or two TBs when the physical layer is configured for downlink spatial multiplexing.

When the MAC entity is configured with *pdsch-AggregationFactor* > 1, the parameter *pdsch-AggregationFactor* provides the number of transmissions of a TB within a bundle of the dynamic downlink assignment. Bundling operation relies on the HARQ entity for invoking the same HARQ process for each transmission that is part of the same bundle. After the initial transmission, *pdsch-AggregationFactor* – 1 HARQ retransmissions follow within a bundle.

The MAC entity shall:

- 1> if a downlink assignment has been indicated:
 - 2> allocate the TB(s) received from the physical layer and the associated HARQ information to the HARQ process indicated by the associated HARQ information.
- 1> if a downlink assignment has been indicated for the broadcast HARQ process:
 - 2> allocate the received TB to the broadcast HARQ process.

[TS 38.321, clause 5.3.2.2]

When a transmission takes place for the HARQ process, one or two (in case of downlink spatial multiplexing) TBs and the associated HARQ information are received from the HARQ entity.

For each received TB and associated HARQ information, the HARQ process shall:

- 1> if the NDI, when provided, has been toggled compared to the value of the previous received transmission corresponding to this TB; or
- 1> if the HARQ process is equal to the broadcast process, and this is the first received transmission for the TB according to the system information schedule indicated by RRC; or
- 1> if this is the very first received transmission for this TB (i.e. there is no previous NDI for this TB):

2> consider this transmission to be a new transmission.

1> else:

2> consider this transmission to be a retransmission.

The MAC entity then shall:

1> if this is a new transmission:

2> attempt to decode the received data.

1> else if this is a retransmission:

2> if the data for this TB has not yet been successfully decoded:

3> instruct the physical layer to combine the received data with the data currently in the soft buffer for this TB and attempt to decode the combined data.

1> if the data which the MAC entity attempted to decode was successfully decoded for this TB; or

1> if the data for this TB was successfully decoded before:

2> if the HARQ process is equal to the broadcast process:

3> deliver the decoded MAC PDU to upper layers.

2> else if this is the first successful decoding of the data for this TB:

3> deliver the decoded MAC PDU to the disassembly and demultiplexing entity.

1> else:

2> instruct the physical layer to replace the data in the soft buffer for this TB with the data which the MAC entity attempted to decode.

1> if the HARQ process is associated with a transmission indicated with a Temporary C-RNTI and the Contention Resolution is not yet successful (see subclause 5.1.5); or

1> if the HARQ process is equal to the broadcast process; or

1> if the *timeAlignmentTimer*, associated with the TAG containing the Serving Cell on which the HARQ feedback is to be transmitted, is stopped or expired:

2> not instruct the physical layer to generate acknowledgement(s) of the data in this TB.

1> else:

2> instruct the physical layer to generate acknowledgement(s) of the data in this TB.

The MAC entity shall ignore NDI received in all downlink assignments on PDCCH for its Temporary C-RNTI when determining if NDI on PDCCH for its C-RNTI has been toggled compared to the value in the previous transmission.

NOTE: If the MAC entity receives a retransmission with a TB size different from the last TB size signalled for this TB, the UE behaviour is left up to UE implementation.

7.1.1.2.4.3 Test description

7.1.1.2.4.3.1 Pre-test conditions

System Simulator:

- NR Cell 1

UE:

- None.

Preamble:

- The UE is in state 3N-A with UE test loop mode A activated as defined in 38.508-1 [4].

7.1.1.2.4.3.2 Test procedure sequence

Table 7.1.1.2.4.3.2-1: Main behaviour

St	Procedure	Message Sequence		TP	Verdict
		U - S	Message		
1	The SS transmits a Short message on PDCCH using P-RNTI indicating a systemInfoModification. (Note 1)	<--	PDCCH (DCI 1_0): Short Message	-	-
2	The SS transmits an updated system information with SI-RNTI addressed in L1/L2 header at the start of the modification period. CRC is calculated in such a way, it will result in CRC fail on UE side. Dedicated HARQ process for broadcast is used.	<--	-	-	-
3	Check: Does the UE transmit a HARQ ACK/NACK? (Note 2 and 3)	-->	HARQ ACK/NACK	1	F
4	After 2560ms of step 3, the SS transmits an updated system information [contents same as in step 2] with SI-RNTI addressed in L1/L2 header. CRC is calculated in such a way, it will result in CRC pass on UE side. Dedicated HARQ process for broadcast is used.	<--	-	-	-
5	Check: Does the UE transmit a HARQ ACK/NACK? (Note 2 and 4)	->	HARQ ACK/NACK	1	F
6	SS is configured to not allocate UL Grants on Scheduling Request.	-	-	-	-
7	The SS transmits MAC PDU containing a RLC PDU.	<--	MAC PDU	-	-
8	The UE transmits a HARQ ACK.	-->	HARQ ACK	-	-
9	Check: Does the UE transmit PRACH Preamble, using PRACH resources as in new SI?	-->	PRACH Preamble	1	P
10	The SS transmits Random Access Response	<--	Random Access Response	-	-
11	The UE transmits a MAC PDU with C-RNTI containing loop backed RLC PDU.	-->	MAC PDU	-	-
12	SS sends PDCCH transmission for UE C-RNTI to complete contention resolution.	<--	-	-	-
<p>Note 1: The Short Message was transmitted in controlResourceSetZero as Configured in SIB1, need to guarantee that the UE will receive at least one Paging in the Modification Period preceding the SysInfo change, SS should send the Paging message in every eligible PO in this Modification Period.</p> <p>Note 2: When requested to check HARQ feedback for the dedicated broadcast HARQ process, the SS shall assume the same PUCCH reception requirement as specified in TS 38.213 section 9 for a normal HARQ process.</p> <p>Note 3: For duration of 2560ms, the SS should check HARQ NACK for all broadcast SIBs. This duration is sufficient to ensure that SS transmits few times SIBs with CRC corruption.</p> <p>Note 4: For duration of 2560=5120-2560 ms, the SS should check HARQ ACK for all broadcast SIBs. 5120 ms is the system information modification period calculated based on the default values of parameters specified in TS 38.508-1 [4]. i.e. modification period 5120 = (modificationPeriodCoeff=4) * (defaultPagingCycle P=128) * 10ms.</p>					

7.1.1.2.4.3.3 Specific message contents

Table 7.1.1.2.4.3.3-1: SystemInformationBlockType1 (steps 2 and 4 of table 7.1.1.2.4.3.2-1)

Derivation path: 38.508-1 [4] table 4.6.1-28			
Information Element	Value/Remark	Comment	Condition
SIB1 ::= SEQUENCE {			
servingCellConfigCommon SEQUENCE {			
uplinkConfigCommon SEQUENCE {			
initialUplinkBWP SEQUENCE {			
rach-ConfigCommon SEQUENCE {			
prach-RootSequenceIndex CHOICE {			
l139	20		FDD
l139	2		TDD
}			
}			
}			
}			
}			
}			

7.1.1.3 Uplink Data Transfer

7.1.1.3.1 Correct Handling of UL MAC PDU / Assignment / HARQ process

7.1.1.3.1.1 Test Purpose (TP)

(1)

```
with { UE in RRC_CONNECTED state }
ensure that {
  when { UE receives for a Slot an uplink grant with valid C-RNTI }
  then { UE transmits data and associated HARQ information to the HARQ entity for this Slot }
}
```

(2)

```
with { UE in RRC_CONNECTED state }
ensure that {
  when { SS transmits for a Slot an uplink grant with not allocated C-RNTI }
  then { UE does not transmits data and associated HARQ information to the HARQ entity for this Slot }
}
```

(3)

```
with { UE in RRC_CONNECTED state }
ensure that {
  when { UE receives an UL Grant with toggled NDI and has data available for transmission }
  then { UE transmits a new MAC PDU }
}
```

(4)

```
with { UE in RRC_CONNECTED state and having transmitted a MAC PDU on a HARQ process }
ensure that {
  when { UE receives an uplink grant on PDCCH for the next Slot corresponding to the HARQ process with old NDI not toggled }
  then { UE performs an adaptive retransmission of the MAC PDU with redundancy version as received on PDCCH }
}
```

(5)

```
with { UE in E-UTRA RRC_CONNECTED state }
```

```

ensure that {
  when { UE receives an uplink grant on PDCCH for the next Slot corresponding to the HARQ process
with toggled NDI, and data is not available for transmission }
    then { UE transmits any MAC Padding PDU }
}

```

(6)

```

with { UE in RRC_CONNECTED state }
ensure that {
  when { UE has a MAC SDU to be transmitted that is smaller or equal to 256 bytes }
    then { UE sets F field to 0 and includes 8 bit L field in the MAC sub PDU }
}

```

(7)

```

with { UE in RRC_CONNECTED state }
ensure that {
  when { UE has a MAC SDU to be transmitted that is larger than 256 bytes }
    then { UE sets F field to 1 and includes 16 bit L field in the MAC sub PDU }
}

```

(8)

```

with { UE in E-UTRA RRC_CONNECTED state }
ensure that {
  when { UE has to insert padding in a MAC PDU }
    then { UE inserts the last MAC sub PDU as a padding sub PDU }
}

```

(9)

```

with { UE in RRC_CONNECTED state and configured with a specific TDD-UL-DL-ConfigCommon including
configuration of pattern2 }
ensure that {
  when { UE receives for a Slot an uplink grant associated with pattern2 with valid C-RNTI }
    then { UE transmits data and associated HARQ information to the HARQ entity for this Slot }
}

```

7.1.1.3.1.2 Conformance requirements

References: The conformance requirements covered in the present TC are specified in: TS 38.321, clauses 5.4.1, 5.4.2.1, 5.4.2.2 and 6.1.2. Unless otherwise stated these are Rel-15 requirements.

[TS 38.322, clause 5.4.1]

Uplink grant is either received dynamically on the PDCCH, in a Random Access Response, or configured semi-persistently by RRC. The MAC entity shall have an uplink grant to transmit on the UL-SCH. To perform the requested transmissions, the MAC layer receives HARQ information from lower layers.

If the MAC entity has a C-RNTI, a Temporary C-RNTI or CS-RNTI, the MAC entity shall for each PDCCH occasion and for each Serving Cell belonging to a TAG that has a running *timeAlignmentTimer* and for each grant received for this PDCCH occasion:

- 1> if an uplink grant for this Serving Cell has been received on the PDCCH for the MAC entity's C-RNTI or Temporary C-RNTI; or
- 1> if an uplink grant has been received in a Random Access Response:
 - 2> if the uplink grant is for MAC entity's C-RNTI and if the previous uplink grant delivered to the HARQ entity for the same HARQ process was either an uplink grant received for the MAC entity's CS-RNTI or a configured uplink grant:
 - 3> consider the NDI to have been toggled for the corresponding HARQ process regardless of the value of the NDI.
 - 2> deliver the uplink grant and the associated HARQ information to the HARQ entity.

- 1> else if an uplink grant for this PDCCH occasion has been received for this serving cell on the PDCCH for the MAC entity's CS-RNTI:
 - 2> if the NDI in the received HARQ information is 1:
 - 3> consider the NDI for the corresponding HARQ process not to have been toggled;
 - 3> stop the *ConfiguredGrantTimer* for the corresponding HARQ process, if running;
 - 3> deliver the uplink grant and the associated HARQ information to the HARQ entity.
 - 2> else if the NDI in the received HARQ information is 0:
 - 3> if PDCCH contents indicate configured grant Type 2 deactivation:
 - 4> trigger configured grant confirmation.
 - 3> else if PDCCH contents indicate configured grant Type 2 activation:
 - 4> trigger configured grant confirmation;
 - 4> store the uplink grant for this serving cell and the associated HARQ information as configured uplink grant;
 - 4> initialise or re-initialise the configured uplink grant for this serving cell to start in the associated PUSCH duration and to recur according to rules in subclause 5.8.2;
 - 4> set the HARQ Process ID to the HARQ Process ID associated with this PUSCH duration;
 - 4> consider the NDI bit for the corresponding HARQ process to have been toggled;
 - 4> stop the *ConfiguredGrantTimer* for the corresponding HARQ process, if running;
 - 4> deliver the configured uplink grant and the associated HARQ information to the HARQ entity.

For each Serving Cell and each configured uplink grant, if configured and activated, the MAC entity shall:

- 1> set the HARQ Process ID to the HARQ Process ID associated with this PUSCH duration;
- 1> if the *ConfiguredGrantTimer* for the corresponding HARQ process is not running:
 - 2> consider the NDI bit for the corresponding HARQ process to have been toggled;
 - 2> deliver the configured uplink grant and the associated HARQ information to the HARQ entity.

NOTE 1: For the same serving cell, an uplink grant addressed to C-RNTI shall override a configured uplink grant in case of overlap in time domain.

For configured uplink grants, the HARQ Process ID associated with this symbol is derived from the following equation:

$$\text{HARQ Process ID} = [\text{floor}(\text{CURRENT_symbol}/\text{periodicity})] \text{ modulo } \text{numberOfConfGrant-Processes}$$

where $\text{CURRENT_symbol} = (\text{SFN} * \text{numberOfSlotsPerFrame} * \text{numberOfSymbolsPerSlot} + \text{slot number in the frame} * \text{numberOfSymbolsPerSlot} + \text{symbol number in the slot})$, and *numberOfSlotsPerFrame* and *numberOfSymbolsPerSlot* refer to the number of consecutive slots per frame and the number of consecutive symbols per slot, respectively as specified in TS 38.211 [8].

NOTE 2: *CURRENT_symbol* refers to the symbol index of the first transmission of a repetition bundle that takes place. [TS 36.322, clause 5.4.2.1]

The MAC entity includes a HARQ entity for each Serving Cell with configured uplink (including the case when it is configured with *supplementaryUplink*), which maintains a number of parallel HARQ processes.

The number of parallel UL HARQ processes per HARQ entity is specified in TS 38.214 [7].

Each HARQ process supports one TB.

Each HARQ process is associated with a HARQ process identifier. For UL transmission with UL grant in RA Response, HARQ process identifier 0 is used.

When repetition is configured with $repK > 1$, the parameter $repK$ provides the number of repetitions of a TB within a bundle. Repetition operation relies on the HARQ entity for invoking the same HARQ process for each transmission that is part of the same bundle. Within a bundle HARQ retransmissions are non-adaptive and triggered without waiting for feedback from previous transmissions according to $repK$.

For each uplink grant, the HARQ entity shall:

- 1> identify the HARQ process(es) associated with this grant, and for each identified HARQ process:
 - 2> if the received grant was not addressed to a Temporary C-RNTI on PDCCH, and the NDI provided in the associated HARQ information has been toggled compared to the value in the previous transmission of this TB of this HARQ process; or
 - 2> if the uplink grant was received on PDCCH for the C-RNTI and the HARQ buffer of the identified process is empty; or
 - 2> if the uplink grant was received in a Random Access Response:
 - 3> if there is a MAC PDU in the Msg3 buffer and the uplink grant was received in a Random Access Response:
 - 4> obtain the MAC PDU to transmit from the Msg3 buffer.
 - 3> else:
 - 4> obtain the MAC PDU to transmit from the "Multiplexing and assembly" entity, if any;
 - 3> if a MAC PDU to transmit has been obtained:
 - 4> deliver the MAC PDU and the uplink grant and the HARQ information of the TB to the identified HARQ process;
 - 4> instruct the identified HARQ process to trigger a new transmission.
 - 4> if the uplink grant is addressed to CS-RNTI or the uplink grant is a configured uplink grant:
 - 5> start or restart the *ConfiguredGrantTimer*, if configured, for the corresponding HARQ process when the transmission is performed.
 - 2> else:
 - 3> if the uplink grant received on PDCCH was addressed to CS-RNTI and if the HARQ buffer of the identified process is empty:
 - 4> ignore the uplink grant.
 - 3> else:
 - 4> deliver the uplink grant and the HARQ information (redundancy version) of the TB to the identified HARQ process;
 - 4> instruct the identified HARQ process to trigger a retransmission;
 - 4> if the uplink grant is addressed to CS-RNTI or the uplink grant is a configured uplink grant:
 - 5> start or restart the *ConfiguredGrantTimer*, if configured, for the corresponding HARQ process when the transmission is performed.

When determining if NDI has been toggled compared to the value in the previous transmission the MAC entity shall ignore NDI received in all uplink grants on PDCCH for its Temporary C-RNTI.

[TS 38.322, clause 5.4.2.2]

Each HARQ process is associated with a HARQ buffer.

New transmissions are performed on the resource and with the MCS indicated on either PDCCH, Random Access Response, or RRC. Retransmissions are performed on the resource and, if provided, with the MCS indicated on PDCCH.

If the HARQ entity requests a new transmission for a TB, the HARQ process shall:

- 1> store the MAC PDU in the associated HARQ buffer;
- 1> store the uplink grant received from the HARQ entity;
- 1> generate a transmission as described below.

If the HARQ entity requests a retransmission for a TB, the HARQ process shall:

- 1> store the uplink grant received from the HARQ entity;
- 1> generate a transmission as described below.

To generate a transmission for a TB, the HARQ process shall:

- 1> if the MAC PDU was obtained from the Msg3 buffer; or
- 1> if there is no measurement gap at the time of the transmission and, in case of retransmission, the retransmission does not collide with a transmission for a MAC PDU obtained from the Msg3 buffer:
 - 2> instruct the physical layer to generate a transmission according to the stored uplink grant.

[TS 38.322, clause 6.1.2]

A MAC PDU consists of one or more MAC subPDUs. Each MAC subPDU consists of one of the following:

- A MAC subheader only (including padding);
- A MAC subheader and a MAC SDU;
- A MAC subheader and a MAC CE;
- A MAC subheader and padding.

The MAC SDUs are of variable sizes.

Each MAC subheader corresponds to either a MAC SDU, a MAC CE, or padding.

A MAC subheader except for fixed sized MAC CE and padding consists of the four header fields R/F/LCID/L. A MAC subheader for fixed sized MAC CE and padding consists of the two header fields R/LCID.

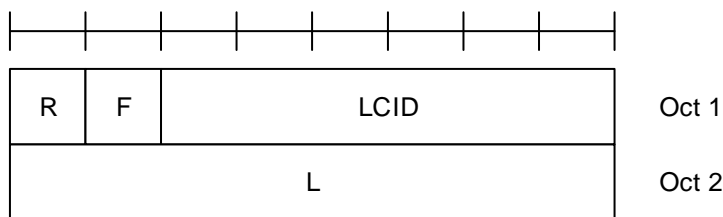

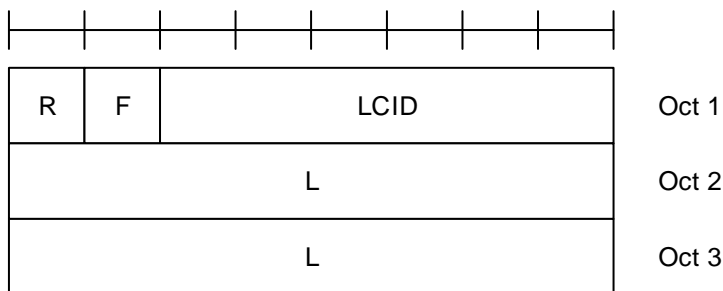

Figure 6.1.2-2: R/F/LCID/L MAC subheader with 16-bit L field

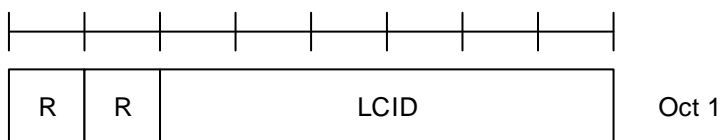

Figure 6.1.2-3: R/LCID MAC subheader

MAC CEs are placed together. DL MAC subPDU(s) with MAC CE(s) is placed before any MAC subPDU with MAC SDU and MAC subPDU with padding as depicted in Figure 6.1.2-4. UL MAC subPDU(s) with MAC CE(s) is placed after all the MAC subPDU(s) with MAC SDU and before the MAC subPDU with padding in the MAC PDU as depicted in Figure 6.1.2-5. The size of padding can be zero.

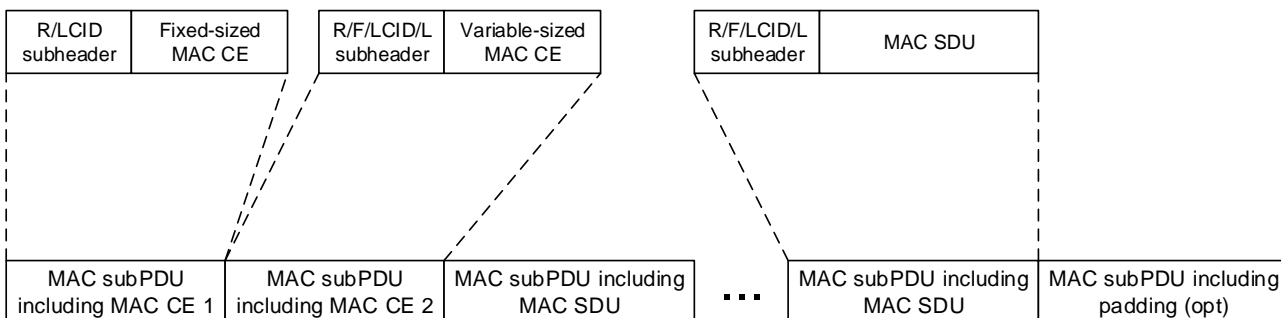

Figure 6.1.2-4: Example of a DL MAC PDU

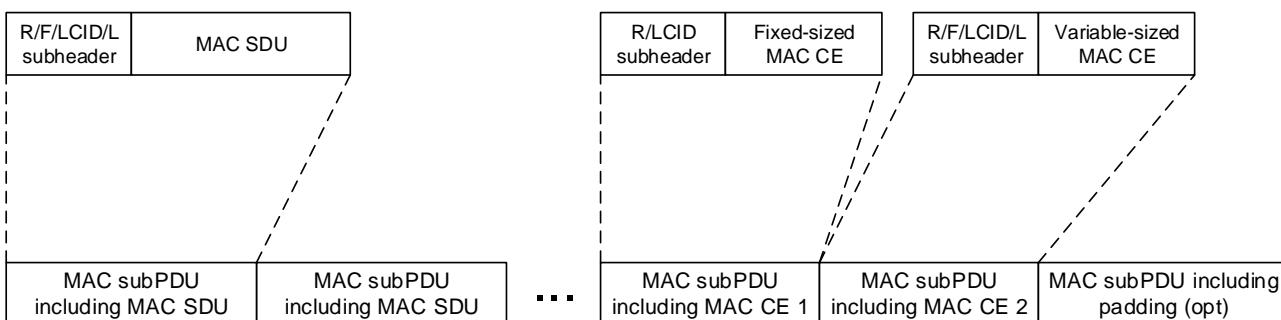

Figure 6.1.2-5: Example of a UL MAC PDU

A maximum of one MAC PDU can be transmitted per TB per MAC entity.

7.1.1.3.1.3 Test description

7.1.1.3.1.3.1 Pre-test conditions

Same Pre-test conditions as in clause 7.1.1.0.

7.1.1.3.1.3.2 Test procedure sequence

Table 7.1.1.3.1.3.2-1: Main behaviour

St	Procedure	Message Sequence		TP	Verdict
		U - S	Message		
1	The SS ignores scheduling requests and does not allocate any uplink grant.	-	-	-	-
2	SS transmits a MAC PDU including a RLC SDU	<--	MAC PDU	-	-
-	EXCEPTION: Step 3 runs in parallel with behaviour in table 7.1.1.3.1.3.2-2	-	-	-	-
3	For 400 ms SS transmits an UL Grant every 10 ms , allowing the UE to return the RLC SDU as received in step 2, on PDCCH, but with the C-RNTI different from the C-RNTI assigned to the UE.	<--	(UL Grant (unknown C-RNTI))	-	-
4	Check: Does the UE transmit a MAC PDU corresponding to grant in step 3?	-->	MAC PDU	2	F
5	SS transmits an UL Grant, allowing the UE to return the RLC SDU as received in step 2, on PDCCH with the C-RNTI assigned to the UE.	<--	(UL Grant (C-RNTI))	-	-
6	Check: Does the UE transmit a MAC PDU corresponding to grant in step 6?	-->	MAC PDU	1	P
7	The SS Transmits a valid MAC PDU containing RLC PDU	<--	MAC PDU	-	-
8	The SS allocates an UL Grant for one HARQ process X, sufficient for one RLC SDU to be looped back in a Slot, and NDI indicates new transmission redundancy version to be used as 0	<--	Uplink Grant	-	-
9	Check: Does the UE transmit a MAC PDU including one RLC SDU, in HARQ process X?	-->	MAC PDU	3	P
10	The SS transmits an UL grant corresponding to slot for HARQ process X, with NDI not toggled and redundancy version to be used as 1	<--	Uplink Grant	-	-
11	Check: Does the UE retransmit the MAC PDU in for HARQ process X, using redundancy version1?	-->	MAC PDU	4	P
12	The SS transmits an UL grant corresponding to SLOT for HARQ process X, with NDI toggled and redundancy version to be used as 2	<--	Uplink Grant	-	-
13	Check: Does the UE retransmit the MAC PDU containing padding for HARQ process X, using redundancy version 2?	-->	MAC PDU	5	P
14	SS transmits a MAC PDU including a RLC PDU of size 128 bytes	<--	MAC PDU	-	-
15	The SS transmits an UL Grant, allowing the UE to return the RLC SDU as received in step 14 and padding.	<--	(UL Grant (C-RNTI))	-	-
16	Check: Does the UE transmit a MAC PDU corresponding to grant in step 14 with F field set to 0 and includes 8 bit L field in the MAC sub PDU and includes a padding sub PDU at end?	-->	MAC PDU	6,8	P
17	SS transmits a MAC PDU including a RLC PDU of size 512 bytes	<--	MAC PDU	-	-
18	The SS transmits an UL Grant, allowing the UE to return the RLC SDU as received in step 17 and padding.	<--	(UL Grant (C-RNTI))	-	-
19	Check: Does the UE transmit a MAC PDU corresponding to grant in step 17 with F field set to 1 and includes 8 bit L field in the MAC sub PDU and includes a padding sub PDU at end?	-->	MAC PDU	7,8	P

20	The SS transmits an <i>RRCConnectionReconfiguration</i> message containing NR <i>RRCReconfiguration</i> message including <i>TDD-UL-DL-ConfigCommon</i> with <i>pattern2</i> specified in Table 7.1.1.3.1.3.3-2	<--	<i>RRCConnectionReconfiguration</i> (<i>RRCReconfiguration</i>)	-	-
21	Check: Does the UE transmit an <i>RRCConnectionReconfigurationComplete</i> message containing NR <i>RRCReconfigurationComplete</i> message?	-->	<i>RRCConnectionReconfigurationComplete</i> (<i>RRCReconfigurationComplete</i>)	9	P
22	SS transmits a MAC PDU including a RLC SDU	<--	MAC PDU	-	-
23	SS transmits an UL Grant, allowing the UE to return the RLC SDU as received in step 22, on PDCCH with the C-RNTI assigned to the UE.	<--	(UL Grant (C-RNTI))	-	-
24	Check: Does the UE transmit a MAC PDU corresponding to grant in step 23?	-->	MAC PDU	9	P

Table 7.1.1.3.1.3.2-2: Parallel behaviour

St	Procedure	Message Sequence		TP	Verdict
		U - S	Message		
1	UE transmits a Scheduling Request.	-->	(SR)	-	-

7.1.1.3.1.3.3 Specific message contents

Table 7.1.1.3.1.3.3-1: MAC-CellGroupConfig (preamble)

Derivation Path: TS 38.508-1 [4], Table 4.6.3-68			
Information Element	Value/remark	Comment	Condition
MAC-CellGroupConfig ::= SEQUENCE {			
tag-ToAddModList SEQUENCE (SIZE (1..maxNrofTAGs)) OF SEQUENCE {	1 entry		
timeAlignmentTimer	infinity		
}			
}			

Table 7.1.1.3.1.3.3-2: RRCConnectionReconfiguration (step 20, Table 7.1.1.3.1.3.2-1)

Derivation Path: 36.508 [7], Table 4.6.1-8			
Information Element	Value/remark	Comment	Condition
RRCConnectionReconfiguration ::= SEQUENCE {			
criticalExtensions CHOICE {			
c1 CHOICE {			
rrcConnectionReconfiguration-r8 ::= SEQUENCE {			
nonCriticalExtension SEQUENCE {			
nonCriticalExtension SEQUENCE {			
nonCriticalExtension SEQUENCE {			
nonCriticalExtension SEQUENCE {			
nonCriticalExtension SEQUENCE {			
nonCriticalExtension SEQUENCE {			
nr-Config-r15 CHOICE {			
setup SEQUENCE {			
nr-SecondaryCellGroupConfig-r15	OCTET STRING including the RRCReconfiguration message containing the IE secondaryCellGroup		
}			
nonCriticalExtension ::= SEQUENCE {}			
}			
}			
}			
}			
}			
}			
}			
}			

Table 7.1.1.3.1.3.3-3: RRCReconfiguration (Table 7.1.1.3.1.3.3-2)

Derivation Path: 38.508-1 [4], Table [4.6.1-13]			
Information Element	Value/remark	Comment	Condition
RRCReconfiguration ::= SEQUENCE {			
criticalExtensions CHOICE {			
rrcReconfiguration ::= SEQUENCE {			
secondaryCellGroup	CellGroupConfig		
}			
}			
}			

Table 7.1.1.3.1.3.3-4: CellGroupConfig (Table 7.1.1.3.1.3.3-3)

Derivation Path: TS 38.508-1 [4], Table 4.6.3-19			
Information Element	Value/remark	Comment	Condition
CellGroupConfig ::= SEQUENCE {			
spCellConfig SEQUENCE {			
reconfigurationWithSync SEQUENCE {			
spCellConfigCommon	ServingCellConfigCommon		
}			
}			
}			

Table 7.1.1.3.1.3.3-5: ServingCellConfigCommon (Table 7.1.1.3.1.3.3-4)

Derivation Path: TS 38.508-1 [4], Table 4.6.3-168			
Information Element	Value/remark	Comment	Condition
ServingCellConfigCommon ::= SEQUENCE {			
uplinkConfigCommon SEQUENCE {			
initialUplinkBWP	BWP-UplinkCommon		
}			
tdd-UL-DL-ConfigurationCommon	TDD-UL-DL-ConfigCommon		
}			

Table 7.1.1.3.1.3.3-5: TDD-UL-DL-ConfigCommon (Table 7.1.1.2.1.3.3-5)

Derivation Path: TS 38.508-1 [4], Table 4.6.3-192			
Information Element	Value/remark	Comment	Condition
TDD-UL-DL-ConfigCommon ::= SEQUENCE {			
referenceSubcarrierSpacing	SubcarrierSpacing		
pattern1 SEQUENCE {			
dl-UL-TransmissionPeriodicity	ms3		FR1
nrofDownlinkSlots	3		
nrofDownlinkSymbols	6		FR1
nrofUplinkSlots	10		FR2
nrofUplinkSymbols	2		FR1
nrofUplinkSymbols	1		FR2
nrofUplinkSymbols	4		FR1
nrofUplinkSymbols	2		FR2
}			
pattern2 SEQUENCE {			
dl-UL-TransmissionPeriodicity	ms2		FR1
nrofDownlinkSlots	ms0p5		FR2
nrofDownlinkSlots	4		FR1
nrofDownlinkSlots	2		FR2
nrofDownlinkSymbols	0		FR1
nrofDownlinkSymbols	10		FR2
nrofUplinkSlots	0		FR1
nrofUplinkSlots	1		FR2
nrofUplinkSymbols	0		FR1
nrofUplinkSymbols	2		FR2
}			
}			

Table 7.1.1.3.1.3.3-6: BWP-UplinkCommon (Table 7.1.1.2.1.3.3-5)

Derivation Path: TS 38.508-1 [4], Table 4.6.3-10			
Information Element	Value/remark	Comment	Condition
BWP-UplinkCommon ::= SEQUENCE {			
rach-ConfigCommon CHOICE {			
setup	RACH-ConfigCommon		
}			
}			

Table 7.1.1.3.1.3.3-7: RACH-ConfigCommon (Table 7.1.1.2.1.3.3-7)

Derivation Path: TS 38.508-1 [4], Table 4.6.3-128			
Information Element	Value/remark	Comment	Condition
RACH-ConfigCommon ::= SEQUENCE {			
rach-ConfigGeneric	RACH-ConfigGeneric		
}			

Table 7.1.1.3.1.3.3-8: RACH-ConfigGeneric (Table 7.1.1.2.1.3.3-8)

Derivation Path: TS 38.508-1 [4], Table 4.6.3-130			
Information Element	Value/remark	Comment	Condition
RACH-ConfigGeneric ::= SEQUENCE {			
prach-configurationIndex	156		
}			

7.1.1.3.2 Logical channel prioritization handling

7.1.1.3.2.1 Test Purpose (TP)

(1)

```
with {UE in RRC_CONNECTED state}
ensure that {
  when { UE is sending data on the uplink }
    then { UE serves the logical channels according to their priority and configured PBR }
}
```

7.1.1.3.1.2 Conformance requirements

References: The conformance requirements covered in the present TC are specified in: TS 38.321, clause 5.4.3.1.1, 5.4.3.1.2, 5.4.3.1.3. Unless otherwise stated these are Rel-15 requirements.

[TS 38.321, clause 5.4.3.1.1]

The Logical Channel Prioritization procedure is applied whenever a new transmission is performed.

RRC controls the scheduling of uplink data by signalling for each logical channel per MAC entity:

- *priority* where an increasing priority value indicates a lower priority level;
- *prioritisedBitRate* which sets the Prioritized Bit Rate (PBR);
- *bucketSizeDuration* which sets the Bucket Size Duration (BSD).

RRC additionally controls the LCP procedure by configuring mapping restrictions for each logical channel:

- *allowedSCS-List* which sets the allowed Subcarrier Spacing(s) for transmission;
- *maxPUSCH-Duration* which sets the maximum PUSCH duration allowed for transmission;
- *configuredGrantType1Allowed* which sets whether a Configured Grant Type 1 can be used for transmission;

- *allowedServingCells* which sets the allowed cell(s) for transmission.

The following UE variable is used for the Logical channel prioritization procedure:

- *B_j* which is maintained for each logical channel *j*.

The MAC entity shall initialize *B_j* of the logical channel to zero when the logical channel is established.

For each logical channel *j*, the MAC entity shall:

- 1> increment *B_j* by the product $PBR \times T$ before every instance of the LCP procedure, where *T* is the time elapsed since *B_j* was last updated;
- 1> if the value of *B_j* is greater than the bucket size (i.e. $PBR \times BSD$):
 - 2> set *B_j* to the bucket size.

NOTE: The exact moment(s) when the UE updates *B_j* between LCP procedures is up to UE implementation, as long as *B_j* is up to date at the time when a grant is processed by LCP.

[TS 38.321, clause 5.4.3.1.2]

The MAC entity shall, when a new transmission is performed:

- 1> select the logical channels for each UL grant that satisfy all the following conditions:
 - 2> the set of allowed Subcarrier Spacing index values in *allowedSCS-List*, if configured, includes the Subcarrier Spacing index associated to the UL grant; and
 - 2> *maxPUSCH-Duration*, if configured, is larger than or equal to the PUSCH transmission duration associated to the UL grant; and
 - 2> *configuredGrantType1Allowed*, if configured, is set to TRUE in case the UL grant is a Configured Grant Type 1; and
 - 2> *allowedServingCells*, if configured, includes the Cell information associated to the UL grant.

NOTE: The Subcarrier Spacing index, PUSCH transmission duration and Cell information are included in Uplink transmission information received from lower layers for the corresponding scheduled uplink transmission.

[TS 38.321, clause 5.4.3.1.3]

The MAC entity shall, when a new transmission is performed:

- 1> allocate resources to the logical channels as follows:
 - 2> logical channels selected in subclause 5.4.3.1.2 for the UL grant with $B_j > 0$ are allocated resources in a decreasing priority order. If the PBR of a logical channel is set to "infinity", the MAC entity shall allocate resources for all the data that is available for transmission on the logical channel before meeting the PBR of the lower priority logical channel(s);
 - 2> decrement *B_j* by the total size of MAC SDUs served to logical channel *j* above;

NOTE: The value of *B_j* can be negative.

- 2> if any resources remain, all the logical channels selected in subclause 5.4.3.1.2 are served in a strict decreasing priority order (regardless of the value of *B_j*) until either the data for that logical channel or the UL grant is exhausted, whichever comes first. Logical channels configured with equal priority should be served equally.

The UE shall also follow the rules below during the scheduling procedures above:

- the UE should not segment an RLC SDU (or partially transmitted SDU or retransmitted RLC PDU) if the whole SDU (or partially transmitted SDU or retransmitted RLC PDU) fits into the remaining resources of the associated MAC entity;

- if the UE segments an RLC SDU from the logical channel, it shall maximize the size of the segment to fill the grant of the associated MAC entity as much as possible;
- the UE should maximise the transmission of data;
- if the MAC entity is given an UL grant size that is equal to or larger than 8 bytes while having data available for transmission, the MAC entity shall not transmit only padding BSR and/or padding.

The MAC entity shall not generate a MAC PDU for the HARQ entity if the following conditions are satisfied:

- the MAC entity is configured with *skipUplinkTxDynamic* and the grant indicated to the HARQ entity was addressed to a C-RNTI, or the grant indicated to the HARQ entity is a configured uplink grant; and
- the MAC PDU includes zero MAC SDUs; and
- the MAC PDU includes only the periodic BSR and there is no data available for any LCG, or the MAC PDU includes only the padding BSR.

Logical channels shall be prioritised in accordance with the following order (highest priority listed first):

- MAC CE for C-RNTI or data from UL-CCCH;
- MAC CE for SPS confirmation;
- MAC CE for BSR, with exception of BSR included for padding;
- MAC CE for single entry PHR or multiple entry PHR;
- data from any Logical Channel, except data from UL-CCCH;
- MAC CE for BSR included for padding.

7.1.1.3.2.3 Test description

7.1.1.3.2.3.1 Pre-test conditions

Same Pre-test conditions as in clause 7.1.1.0 except the conditions mentioned in this section.

System Simulator

- The Table 7.1.2.1.2-1, mentioned in default pre-test conditions for UM RLC test cases section, needs to be replaced with the Table 7.1.1.3.2.3.1-1.

Table 7.1.1.3.2.3.1-1: Message conditions

Execution Condition	Message condition exceptions
IF pc_NG_RAN_NR	FFS
ELSE IF pc_EN_DC	message condition SCG-DRB(0,3) is used for step 7 in 4.5.4.2 according to [4]
ELSE IF [pc_NGEN_DC]	message condition SCG-DRB(0,3) is used for step 7 in 4.5.4.2 according to [4]

- The 3 UM DRBs are configured according to Table 7.1.1.3.2.3.1-2.

Table 7.1.1.3.2.3.1-2: Priority, PBR and Bucket Delay settings

DRB	priority	prioritizedBitRate (kbytes/s)	bucketSizeDuration (ms)
DRB1	6	8	100
DRB2	7	16	100
DRB3	8	32	100

Table 7.1.1.3.2.3.1-3: PDCP Settings

Parameter	Value
Discard_Timer	ms1500

7.1.1.3.2.3.2 Test procedure sequence

Table 7.1.1.3.2.3.2-1: Main behaviour

St	Procedure	Message Sequence		TP	Verdict
		U - S	Message		
-	EXCEPTION: Steps 1 to 3 are run 4 times using the parameters specified for each run in table 7.1.1.3.2.3.2-3.	-	-	-	-
1	The SS transmits N1 320-octet RLC SDUs on DRB1, N2 320-octet RLC SDUs on DRB2, and N3 320-octet RLC SDUs on DRB3.	<--	(RLC SDUs)	-	-
-	EXCEPTION: In parallel to the event described in step 2 the events specified in Table 7.1.1.3.2.3.2-2 shall take place.	-	-	-	-
2	The SS is configured for Uplink Grant Allocation Type 2 as defined in TS 38.523-3 [3]. 150 ms after Step 1 (Note1), for a duration of T2, the SS transmits an UL grant of D octets every T1.	<--	(UL grants)	-	-
3	Check: Are the total number of octets of the UL RLC SDUs received at the SS for each DRB as follows: - total number of octets received for DRB1 is D1 octets +/- 10% - total number of octets received for DRB2 is D2 octets +/- 10% - total number of octets received for DRB3 is D3 octets +/- 10% ?	-	-	1	P
Note 1: This wait time will ensure that a) all octets have been completely received by the UE on all 3 DRBs before the first UL grant is received and b) the Bjs for each logical channel have reached their maximum value i.e. the bucket size of the corresponding logical channel before the first UL grant is received.					

Table 7.1.1.3.2.3.2-2: Parallel behaviour

St	Procedure	Message Sequence		TP	Verdict
		U - S	Message		
1	Check: Does the UE transmit the RLC SDUs back to the SS?	-->	-	1	P

Table 7.1.1.3.2.3.2-3: Test parameter values

Parameter	First run	Second run	Third run	Fourth run
N1 (SDUs)	13	13	7	104
N2 (SDUs)	25	25	50	25
N3 (SDUs)	50	50	50	50
D (octets)	1153	576	1153	1153
T1 (ms)	20	20	20	10
T2 (ms)	500	700	500	500
D1 (octets)	4160	4160	2240	33350 (Note 1)
D2 (octets)	8000	8000	10435 (Note 1)	8000
D3 (octets)	16000	7790 (Note 1)	16000	16000
Note 1: Calculated using the following equation for the case of the least header size: $(D1 + D2 + D3) = (D - 6) * T2 / T1$				

NOTE: The Test parameter values above and the test procedure assume that the UE has a loopback buffer of at least 57280 octets.

Editor's Note: The UL grants, in Table 7.1.1.3.2.3.2-3, are defined in accordance with the L_{RBs} & I_{MCS} as per 38.523-3[3] annex B but it may not cover FR2 and a different table may need to be defined.

7.1.1.3.2.3.3 Specific message contents

Table 7.1.1.3.2.3.3-1: SchedulingRequest-Config (Preamble)

Derivation Path: 36.508 [7], Table 4.6.3-20			
Information Element	Value/remark	Comment	Condition
sr-TransMax	n16		

7.1.1.3.3 Correct handling of MAC control information / Scheduling requests

7.1.1.3.3.1 Test Purpose (TP)

(1)

```
with { UE in RRC_CONNECTED state with SR resource on PUCCH is configured }
ensure that {
  when { UE has UL data available for transmission and UE has no UL-SCH resources available and
SR_COUNTER is less than sr-TransMax }
    then { the UE transmits a SR on every available PUCCH until resources are granted }
}
```

(2)

```
with { UE in RRC_CONNECTED state with SR resource on PUCCH is configured }
ensure that {
  when { UE receives an UL grant for a new transmission }
    then { UE cancels all pending SR(s) }
}
```

(3)

```
with { UE in RRC_CONNECTED state with SR resource on PUCCH is configured }
ensure that {
  when { UE has UL data available for transmission and UE has no UL-SCH resources available or
SR_COUNTER becomes equal to sr-TransMax }
    then { the UE transmits a PRACH Preamble to initiate a Random Access procedure }
}
```

(4)

```
with { UE in RRC_CONNECTED state with SR resource on PUCCH is configured and logicaChannelSR-
DelayTimer is configured }
ensure that {
  when { UE has UL data available for transmission on LCH for which logicaChannelSR-DelayTimer is
configured and UE has no UL-SCH resources available and SR_COUNTER is less than sr-TransMax }
    then { the UE delays transmission of SR until logicaChannelSR-DelayTimer expires }
}
```

(5)

```
with { UE in RRC_CONNECTED state with SR resource on PUCCH is configured and logicaChannelSR-
DelayTimer is running }
ensure that {
  when { UE has UL data available for transmission for transmission on LCH for which
logicaChannelSR-DelayTimer is not configured and UE has no UL-SCH resources available and SR_COUNTER
is less than sr-TransMax }
    then { the UE transmits a SR on every available PUCCH until resources are granted }
}
```

7.1.1.3.3.2 Conformance requirements

References: The conformance requirements covered in the present TC are specified in: TS 38.321, clauses 5.4.4 and 5.4.5. Unless otherwise stated these are Rel-15 requirements.

[TS 38.321, clause 5.4.4]

The Scheduling Request (SR) is used for requesting UL-SCH resources for new transmission.

The MAC entity may be configured with zero, one, or more SR configurations. An SR configuration consists of a set of PUCCH resources for SR across different BWPs and cells. For a logical channel, at most one PUCCH resource for SR is configured per BWP.

Each SR configuration corresponds to one or more logical channels. Each logical channel may be mapped to zero or one SR configuration, which is configured by RRC. The SR configuration of the LCH that triggered the BSR (subclause 5.4.5) (if such a configuration exists) is considered as corresponding SR configuration for the triggered SR. For BSR triggered by *retxBSR-Timer* expiry, the corresponding SR configuration for the triggered SR is that of the highest priority LCH (if such a configuration exists) that has data available for transmission at the time the BSR is triggered.

RRC configures the following parameters for the scheduling request procedure:

- *sr-ProhibitTimer* (per SR configuration);
- *sr-TransMax* (per SR configuration);
- *sr-ConfigIndex*.

The following UE variables are used for the scheduling request procedure:

- *SR_COUNTER* (per SR configuration).

If an SR is triggered and there are no other SRs pending corresponding to the same SR configuration, the MAC entity shall set the *SR_COUNTER* of the corresponding SR configuration to 0.

When an SR is triggered, it shall be considered as pending until it is cancelled. All pending SR(s) shall be cancelled and each respective *sr-ProhibitTimer* shall be stopped when a MAC PDU is assembled and this PDU includes a BSR which contains buffer status up to (and including) the last event that triggered a BSR (see subclause 5.4.5), or when the UL grant(s) can accommodate all pending data available for transmission.

Only PUCCH resources on a BWP which is active at the time of SR transmission occasion are considered valid.

As long as at least one SR is pending, the MAC entity shall for each pending SR:

- 1> if the MAC entity has no valid PUCCH resource configured for the pending SR:
 - 2> initiate a Random Access procedure (see subclause 5.1) on the SpCell and cancel the pending SR.
- 1> else, for the SR configuration corresponding to the pending SR:
 - 2> when the MAC entity has an SR transmission occasion on the valid PUCCH resource for SR configured; and
 - 2> if *sr-ProhibitTimer* is not running at the time of the SR transmission occasion; and
 - 2> if the PUCCH resource for the SR transmission occasion does not overlap with a measurement gap; and
 - 2> if the PUCCH resource for the SR transmission occasion does not overlap with a UL-SCH resource:
 - 3> if *SR_COUNTER* < *sr-TransMax*:
 - 4> increment *SR_COUNTER* by 1;
 - 4> instruct the physical layer to signal the SR on one valid PUCCH resource for SR;
 - 4> start the *sr-ProhibitTimer*.
 - 3> else:
 - 4> notify RRC to release PUCCH for all serving cells;

- 4> notify RRC to release SRS for all serving cells;
- 4> clear any configured downlink assignments and uplink grants;
- 4> initiate a Random Access procedure (see subclause 5.1) on the SpCell and cancel all pending SRs.

NOTE: The selection of which valid PUCCH resource for SR to signal SR on when the MAC entity has more than one overlapping valid PUCCH resource for the SR transmission occasion is left to UE implementation.

[TS 38.321, clause 5.4.5]

For Regular BSR, the MAC entity shall:

- 1> if the BSR is triggered for a logical channel for which *logicalChannelSR-Delay* is configured by upper layers:
 - 2> start or restart the *logicalChannelSR-DelayTimer*.
- 1> else:
 - 2> if running, stop the *logicalChannelSR-DelayTimer*.

...

The MAC entity shall:

- 1> if the Buffer Status reporting procedure determines that at least one BSR has been triggered and not cancelled:
 - 2> if UL-SCH resources are available for a new immediate transmission:
 - 3> instruct the Multiplexing and Assembly procedure to generate the BSR MAC CE(s);
 - 3> start or restart *periodicBSR-Timer* except when all the generated BSRs are long or short Truncated BSRs;
 - 3> start or restart *retxBSR-Timer*.
 - 2> else if a Regular BSR has been triggered and *logicalChannelSR-DelayTimer* is not running:
 - 3> if an uplink grant is not a configured grant; or
 - 3> if the Regular BSR was not triggered for a logical channel for which logical channel SR masking (*logicalChannelSR-Mask*) is setup by upper layers:
 - 4> trigger a Scheduling Request.

7.1.1.3.3.3 Test description

7.1.1.3.3.3.1 Pre-test conditions

Same Pre-test conditions as in clause 7.1.1.0 with the exception of 2 AM DRBs configured according to Table 7.1.1.3.3.3.1-1.

Table 7.1.1.3.3.3.1-1: Logical Channel Configuration Settings

Parameter	DRB1	DRB2
LogicalChannel-Identity	4	5
Priority	7	6
prioritizedBitRate	0kbs	0kbs
logicalChannelGroup	2 (LCG ID#2)	1 (LCG ID#1)
logicalChannelSR-DelayTimerApplied	False	True
logicaChannelSR-DelayTimer	Not Present	sf512

7.1.1.3.3.3.2 Test procedure sequence

Table 7.1.1.3.3.2-1: Main behaviour

St	Procedure	Message Sequence		TP	Verdict
		U - S	Message		
1	The SS transmits a MAC PDU containing A MAC Sub PDU containing a RLC SDU on LCH 5	<--	MAC PDU (containing 1 MAC sub PDU)	-	-
2	Check: Does the UE transmit Scheduling Requests for logicalChannelSR-DelayTimer (sf512) from step 1?	-->	(SR)	4	F
3	Check: Does the UE transmit [x] Scheduling Requests separately on [x] consecutively available PUCCHs after logicalChannelSR-DelayTimer expiry? (Note 1)	-->	(SR)	1,4	P
4	The SS transmits an UL grant to allocate UL-SCH resources that are enough to transmit looped back PDU	<--	(UL Grant)	-	-
5	Check: Does the UE transmit a MAC PDU containing MAC Sub PDU containing a RLC SDU on LCH5?	-->	MAC PDU (containing 1 MAC sub PDU containing RLC SDU)	1	P
6	The SS transmits a MAC PDU containing A MAC Sub PDU containing a RLC SDU on LCH 4	<--	MAC PDU (containing 1 MAC sub PDU)	-	-
7	Check: Does the UE transmit Scheduling Requests separately on [x] consecutively available PUCCHs? (Note 1)	-->	(SR)	1,5	P
8	The SS transmits an UL grant to allocate UL-SCH resources that are enough to transmit looped back PDU	<--	(UL Grant)	-	-
9	Check: Does the UE transmit a MAC PDU containing MAC Sub PDU containing a RLC SDU on LCH4?	-->	MAC PDU (containing 1 MAC sub PDU containing RLC SDU)	1	P
10	Check: For 1 second, does the UE transmit a Scheduling Request?	-->	(SR)	1,2	F
11	The SS transmits a MAC PDU containing a Timing Advance Command MAC Control Element, but does not send any subsequent alignments.	<--	MAC PDU (Timing Advance Command)	-	-
12	The SS transmits a MAC PDU containing a MAC SDU on LCH 4	<--	MAC PDU (MAC SDU)	-	-
-	EXCEPTION: Step 13 is repeated less than sr-TransMax times	-	-	-	-
13	The UE may transmit Scheduling Requests before time alignment timer expires. The SS shall not respond to the Scheduling Requests in this step. (Note 2)	-->	(SR)	-	-
14	Check: does the UE transmit a preamble on PRACH?	-->	(PRACH Preamble)	3	P
15	The SS transmits a Random Access Response including an UL grant to enable UE to transmit C-RNTI MAC Control Element and the MAC SDU as received in step 14.	<--	Random Access Response	-	-
16	The UE transmit a MAC PDU including a C-RNTI MAC Control Element and a MAC SDU. (Note 3)	-->	MAC PDU (MAC Sub PDU containing C-RNTI control element, MAC sub PDU containing MAC SDU)	-	-
17	The SS sends PDCCH transmission for UE C-RNTI	<--	-	-	-
<p>Note 1: The UE repeats the scheduling requests on every available PUCCH as long as SR_COUNTER < dsr-TransMax and there is UL data available for transmission and there are no resources available to transmit it. At the reception of first Scheduling Request from the UE, SS will be scheduled to transmit a grant after 100ms. Hence SS will receive 10 Scheduling Requests.</p> <p>Note 2: In step 8, SR repetition of [63] times (sr-TransMax (64)) will take at least [63*10 = 630] ms which is smaller than TA timer [infinity].</p> <p>Note 3: The UE transmission of the MAC PDU ensures that the random access procedure was successful.</p>					

7.1.1.3.3.3 Specific message contents

Table 7.1.1.3.3.3-1: SchedulingRequestConfig (Preamble)

Derivation Path: TS 38.508-1 [4], Table 4.6.3-155			
Information Element	Value/remark	Comment	Condition
SchedulingRequestConfig ::= SEQUENCE { schedulingRequestToAddModList (SIZE(1..maxNrofSR-ConfigPerCellGroup)) OF SEQUENCE {	1 entry		
sr-TransMax	n64	MAX Value	
}			
}			

7.1.1.3.4 Correct handling of MAC control information / Buffer status / UL data arrive in the UE Tx buffer / Regular BSR

7.1.1.3.4.1 Test Purpose (TP)

(1)

```
with { UE in RRC_CONNECTED state }
ensure that {
  when { UL data arrives in the UE transmission buffer and the data belongs to a logical channel
with higher priority than those for which data is already available for transmission and the new
logical channel and the existing logical channels belongs to the different LCG }
    then { UE Reports a Long Buffer Status Reporting (BSR) }
}
```

(2)

```
with { UE in RRC_CONNECTED state }
ensure that {
  when { UL data arrives in the UE transmission buffer and there is no data available for
transmission for any of the logical channels which belong to a LCG }
    then { UE Reports a Short Buffer Status Reporting (BSR) }
}
```

(3)

```
with { UE in RRC_CONNECTED state }
ensure that {
  when { UL data arrives in the UE transmission buffer and the data belongs to a logical channel
with higher priority than those for which data is already available for transmission and the new
logical channel and existing logical channels belong to the same LCG }
    then { UE Reports a Short Buffer Status Reporting (BSR) }
}
```

(4)

```
with { UE in RRC_CONNECTED state }
ensure that {
  when { retxBSR-Timer expires and only one LCG has data available for transmission }
    then { UE triggers a regular BSR and Reports a Short Buffer Status Reporting (BSR) }
}
```

(5)

```
with { UE in RRC_CONNECTED state }
ensure that {
  when { a Regular BSR has been triggered and UE has pending data for transmission and UE has only
resources to send either BSR report or data }
    then { UE transmits the BSR report }
}
```

(6)

```

with { UE in E-UTRA RRC_CONNECTED state }
ensure that {
  when { UE determines that a BSR has been triggered since the last transmission of a BSR and UE has
no UL resources allocated for new transmission for this TTI }
  then { UE transmits a scheduling request }
}

```

(7)

```

with { UE in RRC_CONNECTED state }
ensure that {
  when { a Regular BSR has been triggered and UE has pending data on several logical channels for
transmission and UE has only UL resources to send all pending data available for transmission, but
UL grant is not sufficient to additionally accommodate the BSR MAC control element }
  then { UE cancels the triggered BSR report and transmits the UL data }
}

```

(8)

```

with { UE in RRC_CONNECTED state }
ensure that {
  when { a Regular BSR has been triggered and UE has pending data on several logical channels for
transmission and UE has UL resources to send all pending data including BSR }
  then { UE transmits the UL data and reports buffer status reporting (BSR) that indicates there
is no more data in the buffer }
}

```

7.1.1.3.4.2 Conformance requirements

References: The conformance requirements covered in the present TC are specified in: TS 38.321, clauses 5.4.5, 6.1.3.1, 6.2.1 and TS 38.323 clause 5.6. Unless otherwise stated these are Rel-15 requirements.

[TS 38.321, clause 5.4.5]

The Buffer Status reporting (BSR) procedure is used to provide the serving gNB with information about UL data volume in the MAC entity.

RRC configures the following parameters to control the BSR:

- *periodicBSR-Timer*;
- *retxBSR-Timer*;
- *logicalChannelsSR-Delay*;
- *logicalChannelsSR-DelayTimer*;
- *logicalChannelGroup*.

Each logical channel may be allocated to an LCG using the *logicalChannelGroup*. The maximum number of LCGs is eight.

The MAC entity determines the amount of UL data available for a logical channel according to the data volume calculation procedure in TSs 38.322 and 38.323 [3] [4].

A BSR shall be triggered if any of the following events occur:

- the MAC entity has new UL data available for a logical channel which belongs to an LCG; and either
 - the new UL data belongs to a logical channel with higher priority than the priority of any logical channel containing available UL data which belong to any LCG; or
 - none of the logical channels which belong to an LCG contains any available UL data.

in which case the BSR is referred below to as 'Regular BSR';

- UL resources are allocated and number of padding bits is equal to or larger than the size of the Buffer Status Report MAC CE plus its subheader, in which case the BSR is referred below to as 'Padding BSR';
- *retxBSR-Timer* expires, and at least one of the logical channels which belong to an LCG contains UL data, in which case the BSR is referred below to as 'Regular BSR';
- *periodicBSR-Timer* expires, in which case the BSR is referred below to as 'Periodic BSR'.

For Regular BSR, the MAC entity shall:

- 1> if the BSR is triggered for a logical channel for which *logicalChannelSR-Delay* is configured by upper layers:
 - 2> start or restart the *logicalChannelSR-DelayTimer*.
- 1> else:
 - 2> if running, stop the *logicalChannelSR-DelayTimer*.

For Regular and Periodic BSR, the MAC entity shall:

- 1> if more than one LCG has data available for transmission when the BSR is to be transmitted:
 - 2> report Long BSR for all LCGs which have data available for transmission.
- 1> else:
 - 2> report Short BSR.

For Padding BSR:

- 1> if the number of padding bits is equal to or larger than the size of the Short BSR plus its subheader but smaller than the size of the Long BSR plus its subheader:
 - 2> if more than one LCG has data available for transmission when the BSR is to be transmitted:
 - 3> if the number of padding bits is equal to the size of the Short BSR plus its subheader:
 - 4> report Short Truncated BSR of the LCG with the highest priority logical channel with data available for transmission.
 - 3> else:
 - 4> report Long Truncated BSR of the LCG(s) with the logical channels having data available for transmission following a decreasing order of priority, and in case of equal priority, in increasing order of LCGID.
 - 2> else:
 - 3> report Short BSR;
- 1> else if the number of padding bits is equal to or larger than the size of the Long BSR plus its subheader:
 - 2> report Long BSR for all LCGs which have data available for transmission.

The MAC entity shall:

- 1> if the Buffer Status reporting procedure determines that at least one BSR has been triggered and not cancelled:
 - 2> if UL-SCH resources are available for a new immediate transmission:
 - 3> instruct the Multiplexing and Assembly procedure to generate the BSR MAC CE(s);
 - 3> start or restart *periodicBSR-Timer* except when all the generated BSRs are long or short Truncated BSRs;
 - 3> start or restart *retxBSR-Timer*.
 - 2> else if a Regular BSR has been triggered and *logicalChannelSR-DelayTimer* is not running:

- 3> if an uplink grant is not a configured grant; or
- 3> if the Regular BSR was not triggered for a logical channel for which logical channel SR masking (*logicalChannelSR-Mask*) is setup by upper layers:
 - 4> trigger a Scheduling Request.

A MAC PDU shall contain at most one BSR MAC CE, even when multiple events have triggered a BSR by the time. The Regular BSR and the Periodic BSR shall have precedence over the padding BSR.

The MAC entity shall restart *retxBSR-Timer* upon reception of a grant for transmission of new data on any UL-SCH.

All triggered BSRs may be cancelled when the UL grant(s) can accommodate all pending data available for transmission but is not sufficient to additionally accommodate the BSR MAC control element plus its subheader. All triggered BSRs shall be cancelled when a BSR is included in a MAC PDU for transmission.

The MAC entity shall transmit at most one BSR in one MAC PDU. Padding BSR shall not be included when the MAC PDU contains a Regular or Periodic BSR.

[TS 38.322, clause 6.1.3.1]

Buffer Status Report (BSR) MAC CEs consist of either:

- Short BSR format (fixed size); or
- Long BSR format (variable size); or
- Short Truncated BSR format (fixed size); or
- Long Truncated BSR format (variable size).

The BSR formats are identified by MAC PDU subheaders with LCIDs as specified in Table 6.2.1-2.

The fields in the BSR MAC CE are defined as follows:

- LCG ID: The Logical Channel Group ID field identifies the group of logical channel(s) whose buffer status is being reported. The length of the field is 3 bits;
- LCG_i: For the Long BSR format, this field indicates the presence of the Buffer Size field for the logical channel group *i*. The LCG_i field set to "1" indicates that the Buffer Size field for the logical channel group *i* is reported. The LCG_i field set to "0" indicates that the Buffer Size field for the logical channel group *i* is not reported. For the Long Truncated BSR format, this field indicates whether logical channel group *i* has data available. The LCG_i field set to "1" indicates that logical channel group *i* has data available. The LCG_i field set to "0" indicates that logical channel group *i* does not have data available;
- Buffer Size: The Buffer Size field identifies the total amount of data available according to the data volume calculation procedure in TSs 38.322 and 38.323 [3] [4] across all logical channels of a logical channel group after the MAC PDU has been built (i.e. after the logical channel prioritization procedure, which may result the value of the Buffer Size field to zero). The amount of data is indicated in number of bytes. The size of the RLC and MAC headers are not considered in the buffer size computation. The length of this field for the Short BSR format and the Short Truncated BSR format is 5 bits. The length of this field for the Long BSR format and the Long Truncated BSR format is 8 bits. The values for the 5-bit and 8-bit Buffer Size fields are shown in Tables 6.1.3.1-1 and 6.1.3.1-2, respectively. For the Long BSR format and the Long Truncated BSR format, the Buffer Size fields are included in ascending order based on the LCG_i. For the Long Truncated BSR format the number of Buffer Size fields included is maximised, while not exceeding the number of padding bits.

NOTE: The number of the Buffer Size fields in the Long Truncated BSR format can be zero.

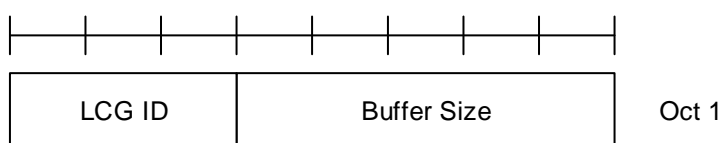

Figure 6.1.3.1-1: Short BSR and Short Truncated BSR MAC CE

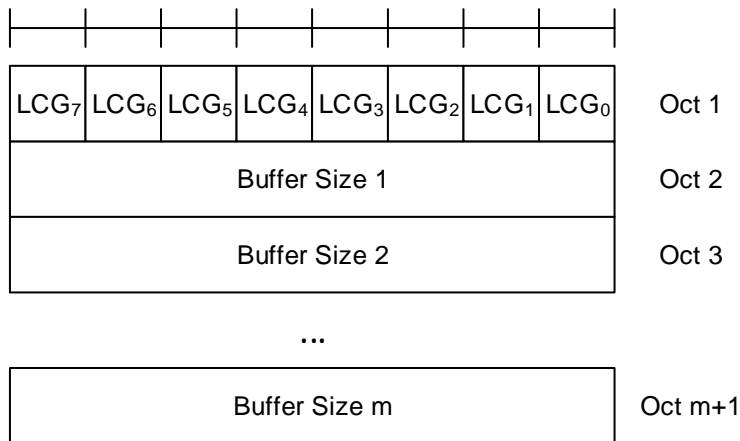

Figure 6.1.3.1-2: Long BSR and Long Truncated BSR MAC CE

Table 6.1.3.1-1: Buffer size levels (in bytes) for 5-bit Buffer Size field

Index	BS value	Index	BS value	Index	BS value	Index	BS value
0	0	8	≤ 102	16	≤ 1446	24	≤ 20516
1	≤ 10	9	≤ 142	17	≤ 2014	25	≤ 28581
2	≤ 14	10	≤ 198	18	≤ 2806	26	≤ 39818
3	≤ 20	11	≤ 276	19	≤ 3909	27	≤ 55474
4	≤ 28	12	≤ 384	20	≤ 5446	28	≤ 77284
5	≤ 38	13	≤ 535	21	≤ 7587	29	≤ 107669
6	≤ 53	14	≤ 745	22	≤ 10570	30	≤ 150000
7	≤ 74	15	≤ 1038	23	≤ 14726	31	> 150000

Table 6.1.3.1-2: Buffer size levels (in bytes) for 8-bit Buffer Size field

Index	BS value	Index	BS value	Index	BS value	Index	BS value
0	0	64	≤ 526	128	≤ 29431	192	≤ 1647644
1	≤ 10	65	≤ 560	129	≤ 31342	193	≤ 1754595
2	≤ 11	66	≤ 597	130	≤ 33376	194	≤ 1868488
3	≤ 12	67	≤ 635	131	≤ 35543	195	≤ 1989774
4	≤ 13	68	≤ 677	132	≤ 37850	196	≤ 2118933
5	≤ 13	69	≤ 720	133	≤ 40307	197	≤ 2256475
6	≤ 14	70	≤ 767	134	≤ 42923	198	≤ 2402946
7	≤ 15	71	≤ 817	135	≤ 45709	199	≤ 2558924
8	≤ 16	72	≤ 870	136	≤ 48676	200	≤ 2725027
9	≤ 17	73	≤ 926	137	≤ 51836	201	≤ 2901912
10	≤ 18	74	≤ 987	138	≤ 55200	202	≤ 3090279
11	≤ 19	75	≤ 1051	139	≤ 58784	203	≤ 3290873
12	≤ 20	76	≤ 1119	140	≤ 62599	204	≤ 3504487
13	≤ 22	77	≤ 1191	141	≤ 66663	205	≤ 3731968
14	≤ 23	78	≤ 1269	142	≤ 70990	206	≤ 3974215
15	≤ 25	79	≤ 1351	143	≤ 75598	207	≤ 4232186
16	≤ 26	80	≤ 1439	144	≤ 80505	208	≤ 4506902
17	≤ 28	81	≤ 1532	145	≤ 85730	209	≤ 4799451
18	≤ 30	82	≤ 1631	146	≤ 91295	210	≤ 5110989
19	≤ 32	83	≤ 1737	147	≤ 97221	211	≤ 5442750
20	≤ 34	84	≤ 1850	148	≤ 103532	212	≤ 5796046
21	≤ 36	85	≤ 1970	149	≤ 110252	213	≤ 6172275
22	≤ 38	86	≤ 2098	150	≤ 117409	214	≤ 6572925
23	≤ 40	87	≤ 2234	151	≤ 125030	215	≤ 6999582
24	≤ 43	88	≤ 2379	152	≤ 133146	216	≤ 7453933
25	≤ 46	89	≤ 2533	153	≤ 141789	217	≤ 7937777
26	≤ 49	90	≤ 2698	154	≤ 150992	218	≤ 8453028
27	≤ 52	91	≤ 2873	155	≤ 160793	219	≤ 9001725
28	≤ 55	92	≤ 3059	156	≤ 171231	220	≤ 9586039
29	≤ 59	93	≤ 3258	157	≤ 182345	221	≤ 10208280
30	≤ 62	94	≤ 3469	158	≤ 194182	222	≤ 10870913
31	≤ 66	95	≤ 3694	159	≤ 206786	223	≤ 11576557
32	≤ 71	96	≤ 3934	160	≤ 220209	224	≤ 12328006
33	≤ 75	97	≤ 4189	161	≤ 234503	225	≤ 13128233
34	≤ 80	98	≤ 4461	162	≤ 249725	226	≤ 13980403
35	≤ 85	99	≤ 4751	163	≤ 265935	227	≤ 14887889
36	≤ 91	100	≤ 5059	164	≤ 283197	228	≤ 15854280
37	≤ 97	101	≤ 5387	165	≤ 301579	229	≤ 16883401
38	≤ 103	102	≤ 5737	166	≤ 321155	230	≤ 17979324
39	≤ 110	103	≤ 6109	167	≤ 342002	231	≤ 19146385
40	≤ 117	104	≤ 6506	168	≤ 364202	232	≤ 20389201
41	≤ 124	105	≤ 6928	169	≤ 387842	233	≤ 21712690
42	≤ 132	106	≤ 7378	170	≤ 413018	234	≤ 23122088
43	≤ 141	107	≤ 7857	171	≤ 439827	235	≤ 24622972
44	≤ 150	108	≤ 8367	172	≤ 468377	236	≤ 26221280
45	≤ 160	109	≤ 8910	173	≤ 498780	237	≤ 27923336
46	≤ 170	110	≤ 9488	174	≤ 531156	238	≤ 29735875
47	≤ 181	111	≤ 10104	175	≤ 565634	239	≤ 31666069
48	≤ 193	112	≤ 10760	176	≤ 602350	240	≤ 33721553
49	≤ 205	113	≤ 11458	177	≤ 641449	241	≤ 35910462
50	≤ 218	114	≤ 12202	178	≤ 683087	242	≤ 38241455
51	≤ 233	115	≤ 12994	179	≤ 727427	243	≤ 40723756
52	≤ 248	116	≤ 13838	180	≤ 774645	244	≤ 43367187
53	≤ 264	117	≤ 14736	181	≤ 824928	245	≤ 46182206
54	≤ 281	118	≤ 15692	182	≤ 878475	246	≤ 49179951
55	≤ 299	119	≤ 16711	183	≤ 935498	247	≤ 52372284
56	≤ 318	120	≤ 17795	184	≤ 996222	248	≤ 55771835
57	≤ 339	121	≤ 18951	185	≤ 1060888	249	≤ 59392055
58	≤ 361	122	≤ 20181	186	≤ 1129752	250	≤ 63247269
59	≤ 384	123	≤ 21491	187	≤ 1203085	251	≤ 67352729
60	≤ 409	124	≤ 22885	188	≤ 1281179	252	≤ 71724679
61	≤ 436	125	≤ 24371	189	≤ 1364342	253	≤ 76380419
62	≤ 464	126	≤ 25953	190	≤ 1452903	254	≤ 81338368
63	≤ 494	127	≤ 27638	191	≤ 1547213	255	> 81338368

[TS 38.321, clause 6.2.1]

Table 6.2.1-2 Values of LCID for UL-SCH

Index	LCID values
000000	CCCH
000001–100000	Identity of the logical channel
100001–110110	Reserved
110111	Configured Grant Confirmation
111000	Multiple Entry PHR
111001	Single Entry PHR
111010	C-RNTI
111011	Short Truncated BSR
111100	Long Truncated BSR
111101	Short BSR
111110	Long BSR
111111	Padding

[TS 38.323, clause 5.6]

For the purpose of MAC buffer status reporting, the transmitting PDCP entity shall consider the following as PDCP data volume:

- the PDCP SDUs for which no PDCP Data PDUs have been constructed;
- the PDCP Data PDUs that have not been submitted to lower layers;
- the PDCP Control PDUs;
- for AM DRBs, the PDCP SDUs to be retransmitted according to subclause 5.1.2;
- for AM DRBs, the PDCP Data PDUs to be retransmitted according to subclause 5.5.

7.1.1.3.4.3 Test description

7.1.1.3.4.3.1 Pre-test conditions

Same Pre-test conditions as in clause 7.1.1.0 with the exception of 3 AM SN terminated SCG bearers configured according to Table 7.1.1.3.4.3.1-1.

Table 7.1.1.3.4.3.1-1: Logical Channel Configuration Settings

Parameter	Value DRB1	Value DRB2	Value DRB3
LogicalChannel-Identity	4	5	6
Priority	8	7	6
prioritizedBitRate	0 kB/s	0 kB/s	0 kB/s
logicalChannelGroup	2 (LCG ID#2)	2 (LCG ID#2)	1 (LCG ID#1)

7.1.1.3.4.3.2 Test procedure sequence

Table 7.1.1.3.4.3.2-1: Main behaviour

St	Procedure	Message Sequence		TP	Verdict
		U - S	Message		
1	The SS ignores scheduling requests and does not allocate any uplink grant.	-	-	-	-
2	The SS transmits a MAC PDU containing two RLC SDUs of size 12 bytes on LC 4	<--	MAC PDU (2 RLC SDUs on LC 4)	-	-
3	SS allocates an UL Grant of 32 bits. (Note 1)	<--	(UL Grant, 32 bits)	-	-
4	Check: Does the UE transmit a Short BSR with 'LCG ID' field set to '2' and 'Buffer size' field set to value '4' or bigger? (Note 2)	-->	MAC PDU (MAC Short BSR (LCG ID='2', Buffer Size='4' or bigger))	2,5	P
5	Wait for retxBSR-Timer expiry on UE side.	-	-	-	-
6	Check: Does the UE transmit a scheduling request?	-->	(SR)	6	P
7	The SS respond to the scheduling request in step 6 by an UL Grant of 32 bits. (Note 1)	<--	(UL Grant, 32 bits)	-	-
8	Check: Does the UE transmit a Short BSR with 'LCG ID' field set to '2' and 'Buffer size' field set to value '4' or bigger? (Note 2)	-->	MAC PDU (MAC Short BSR (LCG ID='2', Buffer Size='4' or bigger))	4,5	P
9	The SS transmits a MAC PDU containing one RLC SDUs of size 12 bytes on LC 5	<--	MAC PDU (1 RLC SDUs on LC 5)	-	-
10	Check: Does the UE transmit a scheduling request?	-->	(SR)	6	P
11	The SS respond to the scheduling request in step 10 by an UL Grant of 32 bits. (Note 1)	<--	(UL Grant, 32 bits)	-	-
12	Check: Does the UE transmit a Short BSR with 'LCG ID' field set to '2' and 'Buffer size#1' field set to value '5' or bigger? (Note 2)	-->	MAC PDU (MAC Short BSR (LCG ID='2', Buffer Size='5' or bigger))	3,5	P
13	The SS transmits a MAC PDU containing two RLC SDUs of size 5 bytes on LC 6	<--	MAC PDU (2 RLC SDUs on LC 6)	-	-
14	Check: Does the UE transmit a scheduling request?	-->	(SR)	6	P
15	The SS respond to the scheduling request in step 14 by one UL Grant of 40 bits. (Note 1)	<--	(UL Grant, 40 bits)	-	-
16	Check: Does the UE transmit a Long BSR with 'Buffer size#1' field set to value '3', 'Buffer size#2' field set to value '21' or bigger? (Note 3)	-->	MAC PDU (MAC Long BSR (Buffer size#1='1' or bigger, Buffer size#2='21' or bigger))	1,5	P
17	Wait for retxBSR-Timer expiry on the UE side.	-	-	-	-
18	Check: Does the UE transmit a scheduling request?	-->	(SR)	6	P
19	SS allocates an UL Grant of 576 bits. (Note 4)	<--	(UL Grant, 576 bits)	-	-
20	Check: Does the UE transmit a MAC PDU including five RLC SDUs and not including any BSR? (Note 5)	-->	MAC PDU (17 Byte 2 MAC sub PDU from LC 4, 17 Byte 1 MAC sub PDU from LC 5 and 10 Byte 2 MAC Sub PDU from LC 6)	7	P
21	SS transmits an RLC STATUS PDU to acknowledge correctly received data(LCID='000100')	<--	RLC STATUS PDU (ACK_SN=2)	-	-
22	SS transmits an RLC STATUS PDU to acknowledge correctly received data(LCID='000101')	<--	RLC STATUS PDU (ACK_SN=1)	-	-
23	SS transmits an RLC STATUS PDU to acknowledge correctly received data(LCID='000110')	<--	RLC STATUS PDU (ACK_SN=2)	-	-
24	The SS transmits a MAC PDU containing two MAC SDUs, the first containing a 8 byte RLC SDU with LCID set to 4 and the second containing a 7 byte RLC SDU with LCID set to 6.	<--	MAC PDU	-	-
25	The UE sends Scheduling Request	-->	(SR)	-	-
26	The SS transmits an uplink grant of size 256 bits. (Note 6)	<--	(UL grant)	-	-

27	Check: Does the UE return a MAC PDU of length 256 bits including 2 RLC SDUs, Padding and Short BSR or LongBSR with Buffer size(s) set to '0'? (Note 5)	-->	MAC PDU (13 Byte MAC Sub PDU from LC 4 and 12 Byte MAC Sub PDU from LC 6 and 5 Byte MAC Sub PDU containing Long BSR and 2 Byte MAC Sub PDU containing Padding) Or MAC PDU (13 Byte MAC Sub PDU from LC 4 and 12 Byte MAC Sub PDU from LC 6 and 2 Byte MAC Sub PDU containing short BSR and 5 Byte MAC Sub PDU containing Padding)	8	P
28	SS transmits an RLC STATUS PDU to acknowledge correctly received data(LCID='000100')	<--	RLC STATUS PDU (ACK_SN=3)	-	-
29	SS transmits an RLC STATUS PDU to acknowledge correctly received data(LCID='000110')	<--	RLC STATUS PDU (ACK_SN=3)	-	-
<p>Note 1: 40 bits enables UE to transmit a MAC PDU with a 1 byte MAC BSR header and a Short BSR (1 bytes) or a 2 byte MAC BSR header and a Long BSR (3 byte with 2 LCG configured).</p> <p>Note 2: UE triggers a Short BSR of type "Regular BSR" to report buffer status for one LCG for that TTI. The UE should not send any of the received RLC SDUs (segmented) due to Regular BSR has higher priority than U-plane logical channels.</p> <p>Note 3: UE triggers and transmit a Long BSR of type "Regular BSR". The UL grant would be enough for UE to transmit one RLC SDU as received in step 8, but Regular BSR has higher priority than U-plane logical channels.</p> <p>Note 4: The UE has 46 bytes of RLC SDU data (received in steps 2, 9 and 13) in the transmission buffer. 576 bits enables UE to transmit user data in MAC PDU 2 RLC SDU of 12 byte on LC 4, each 3 Byte RLC Header and 2 Byte MAC Header resulting in 2 MAC Sub PDU of 17 Bytes Each. Similarly one 17 Byte MAC Sub PDU for 12 Byte RLC SDU on LC 5. Two 5 Byte RLC SDUs on LC 6 with 3 Byte RLC header each and 2 Byte MAC header each, will result in 2 MAC sub PDUs of 10 bytes each. Total comes to 17+17+17+10+10 +1 B padding =72 Bytes.</p> <p>Note 5: The MAC SDUs for the different logical channels may be in any order in the MAC PDU.</p> <p>Note 6: UL grant of 256 bits (L_{RBS} & I_{MCS} as per 38.523-3[3] annex B) is chosen to enable UE to transmit two MAC SDUs of size 11 and 10 bytes in a MAC PDU (8 bytes RLC SDU + 3 bytes AMD PDU header +2 Byte MAC sub Header + 7 bytes RLC SDU+ 3 bytes AMD PDU header+2 Byte MAC sub Header + 2 Byte Long BSR MAC Sub Header + 3 Byte Long BSR + 2 Byte MAC Padding Sub PDU) or (8 bytes RLC SDU + 3 bytes AMD PDU header +2 Byte MAC sub Header + 7 bytes RLC SDU+ 3 bytes AMD PDU header+2 Byte MAC sub Header + 51 Byte Short BSR MAC Sub Header + 1 Byte Short BSR + 7 Byte MAC Padding Sub PDU) = 32 Bytes</p>					

7.1.1.3.4.3.3 Specific message contents

Table 7.1.1.3.4.3.3: MAC-CellGroupConfig (preamble)

Derivation Path: TS 38.508-1 [4], clause Table 4.6.3-68			
Information Element	Value/remark	Comment	Condition
MAC-CellGroupConfig ::= SEQUENCE {			
bsr-Config SEQUENCE {			
periodicBSR-Timer	infinity		
retxBSR-Timer	sf320		
}			
phr-Config CHOICE {			
release	NULL		
}			
}			

7.1.1.3.5 Correct handling of MAC control information / Buffer Status / UL resources are allocated / Padding BSR

7.1.1.3.5.1 Test Purpose (TP)

(1)

```
with { UE in RRC_CONNECTED state }
ensure that {
  when { UE transmits a MAC PDU and the number of padding bits is equal to the size of a Short BSR
plus its subheader and the UE has available data for transmission from more than one LCG in the TTI
where the BSR is transmitted }
  then { UE reports a Truncated short BSR of the LCG with the highest priority logical channel
with data available for transmission }
}
```

(2)

```
with { UE in E-UTRA RRC_CONNECTED state }
ensure that {
  when { UE transmits a MAC PDU and the number of padding bits is larger than the size of a Short
BSR plus its subheader but smaller than the size of a Long BSR plus its subheader and the UE has
available data for transmission from more than one LCG in the TTI where the BSR is transmitted }
  then { UE reports a Truncated long BSR }
}
```

(3)

```
with { UE in RRC_CONNECTED state }
ensure that {
  when { UE transmits a MAC PDU and the number of padding bits is equal to or larger than the size
of a Short BSR plus its subheader but smaller than the size of a Long BSR plus its subheader and the
UE has available data for transmission from only one LCG in the TTI where the BSR is transmitted }
  then { UE reports a Short BSR }
}
```

(4)

```
with { UE in RRC_CONNECTED state }
ensure that {
  when { UE transmits a MAC PDU and the number of padding bits is equal to or larger than the size
of a Long BSR plus its subheader }
  then { UE reports a long BSR }
}
```

7.1.1.3.5.2 Conformance requirements

References: The conformance requirements covered in the present TC are specified in: TS 38.321, clauses 5.4.5, 6.1.3.1 and 6.2.1. Unless otherwise stated these are Rel-15 requirements.

[TS 38.321, clause 5.4.5]

The Buffer Status reporting (BSR) procedure is used to provide the serving gNB with information about UL data volume in the MAC entity.

RRC configures the following parameters to control the BSR:

- *periodicBSR-Timer*;
- *retxBSR-Timer*;
- *logicalChannelSR-Delay*;
- *logicalChannelSR-DelayTimer*;
- *logicalChannelGroup*.

Each logical channel may be allocated to an LCG using the *logicalChannelGroup*. The maximum number of LCGs is eight.

The MAC entity determines the amount of UL data available for a logical channel according to the data volume calculation procedure in TSs 38.322 and 38.323 [3] [4].

A BSR shall be triggered if any of the following events occur:

- the MAC entity has new UL data available for a logical channel which belongs to an LCG; and either
 - the new UL data belongs to a logical channel with higher priority than the priority of any logical channel containing available UL data which belong to any LCG; or
 - none of the logical channels which belong to an LCG contains any available UL data.

in which case the BSR is referred below to as 'Regular BSR';

- UL resources are allocated and number of padding bits is equal to or larger than the size of the Buffer Status Report MAC CE plus its subheader, in which case the BSR is referred below to as 'Padding BSR';
- *retxBSR-Timer* expires, and at least one of the logical channels which belong to an LCG contains UL data, in which case the BSR is referred below to as 'Regular BSR';
- *periodicBSR-Timer* expires, in which case the BSR is referred below to as 'Periodic BSR'.

For Regular BSR, the MAC entity shall:

- 1> if the BSR is triggered for a logical channel for which *logicalChannelSR-Delay* is configured by upper layers:
 - 2> start or restart the *logicalChannelSR-DelayTimer*.
- 1> else:
 - 2> if running, stop the *logicalChannelSR-DelayTimer*.

For Regular and Periodic BSR, the MAC entity shall:

- 1> if more than one LCG has data available for transmission when the BSR is to be transmitted:
 - 2> report Long BSR for all LCGs which have data available for transmission.
- 1> else:
 - 2> report Short BSR.

For Padding BSR:

- 1> if the number of padding bits is equal to or larger than the size of the Short BSR plus its subheader but smaller than the size of the Long BSR plus its subheader:
 - 2> if more than one LCG has data available for transmission when the BSR is to be transmitted:
 - 3> if the number of padding bits is equal to the size of the Short BSR plus its subheader:
 - 4> report Short Truncated BSR of the LCG with the highest priority logical channel with data available for transmission.
 - 3> else:
 - 4> report Long Truncated BSR of the LCG(s) with the logical channels having data available for transmission following a decreasing order of priority, and in case of equal priority, in increasing order of LCGID.
 - 2> else:
 - 3> report Short BSR;
- 1> else if the number of padding bits is equal to or larger than the size of the Long BSR plus its subheader:
 - 2> report Long BSR for all LCGs which have data available for transmission.

The MAC entity shall:

- 1> if the Buffer Status reporting procedure determines that at least one BSR has been triggered and not cancelled:
 - 2> if UL-SCH resources are available for a new immediate transmission:
 - 3> instruct the Multiplexing and Assembly procedure to generate the BSR MAC CE(s);
 - 3> start or restart *periodicBSR-Timer* except when all the generated BSRs are long or short Truncated BSRs;
 - 3> start or restart *retxBSR-Timer*.
 - 2> else if a Regular BSR has been triggered and *logicalChannelSR-DelayTimer* is not running:
 - 3> if an uplink grant is not a configured grant; or
 - 3> if the Regular BSR was not triggered for a logical channel for which logical channel SR masking (*logicalChannelSR-Mask*) is setup by upper layers:
 - 4> trigger a Scheduling Request.

A MAC PDU shall contain at most one BSR MAC CE, even when multiple events have triggered a BSR by the time. The Regular BSR and the Periodic BSR shall have precedence over the padding BSR.

The MAC entity shall restart *retxBSR-Timer* upon reception of a grant for transmission of new data on any UL-SCH.

All triggered BSRs may be cancelled when the UL grant(s) can accommodate all pending data available for transmission but is not sufficient to additionally accommodate the BSR MAC control element plus its subheader. All triggered BSRs shall be cancelled when a BSR is included in a MAC PDU for transmission.

The MAC entity shall transmit at most one BSR in one MAC PDU. Padding BSR shall not be included when the MAC PDU contains a Regular or Periodic BSR.

[TS 38.322, clause 6.1.3.1]

Buffer Status Report (BSR) MAC CEs consist of either:

- Short BSR format (fixed size); or
- Long BSR format (variable size); or
- Short Truncated BSR format (fixed size); or
- Long Truncated BSR format (variable size).

The BSR formats are identified by MAC PDU subheaders with LCIDs as specified in Table 6.2.1-2.

The fields in the BSR MAC CE are defined as follows:

- LCG ID: The Logical Channel Group ID field identifies the group of logical channel(s) whose buffer status is being reported. The length of the field is 3 bits;
- LCG_i: For the Long BSR format, this field indicates the presence of the Buffer Size field for the logical channel group *i*. The LCG_i field set to "1" indicates that the Buffer Size field for the logical channel group *i* is reported. The LCG_i field set to "0" indicates that the Buffer Size field for the logical channel group *i* is not reported. For the Long Truncated BSR format, this field indicates whether logical channel group *i* has data available. The LCG_i field set to "1" indicates that logical channel group *i* has data available. The LCG_i field set to "0" indicates that logical channel group *i* does not have data available;
- Buffer Size: The Buffer Size field identifies the total amount of data available according to the data volume calculation procedure in TSs 38.322 and 38.323 [3] [4] across all logical channels of a logical channel group after the MAC PDU has been built (i.e. after the logical channel prioritization procedure, which may result the value of the Buffer Size field to zero). The amount of data is indicated in number of bytes. The size of the RLC and MAC headers are not considered in the buffer size computation. The length of this field for the Short BSR format and the Short Truncated BSR format is 5 bits. The length of this field for the Long BSR format and the Long Truncated BSR format is 8 bits. The values for the 5-bit and 8-bit Buffer Size fields are shown in Tables 6.1.3.1-1 and 6.1.3.1-2, respectively. For the Long BSR format and the Long Truncated BSR format, the Buffer

Size fields are included in ascending order based on the LCG_i. For the Long Truncated BSR format the number of Buffer Size fields included is maximised, while not exceeding the number of padding bits.

NOTE: The number of the Buffer Size fields in the Long Truncated BSR format can be zero.

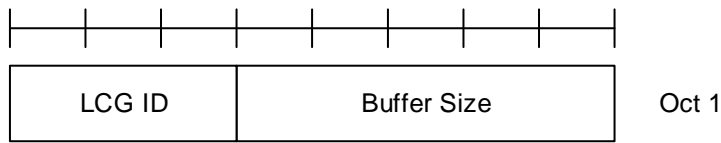

Figure 6.1.3.1-1: Short BSR and Short Truncated BSR MAC CE

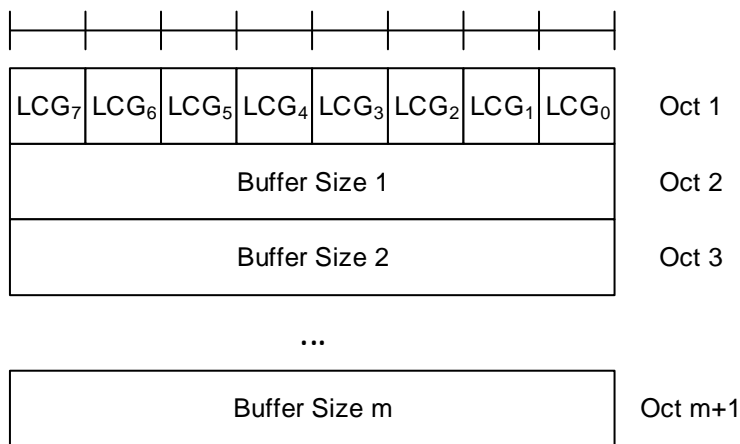

Figure 6.1.3.1-2: Long BSR and Long Truncated BSR MAC CE

Table 6.1.3.1-1: Buffer size levels (in bytes) for 5-bit Buffer Size field

Index	BS value	Index	BS value	Index	BS value	Index	BS value
0	0	8	≤ 102	16	≤ 1446	24	≤ 20516
1	≤ 10	9	≤ 142	17	≤ 2014	25	≤ 28581
2	≤ 14	10	≤ 198	18	≤ 2806	26	≤ 39818
3	≤ 20	11	≤ 276	19	≤ 3909	27	≤ 55474
4	≤ 28	12	≤ 384	20	≤ 5446	28	≤ 77284
5	≤ 38	13	≤ 535	21	≤ 7587	29	≤ 107669
6	≤ 53	14	≤ 745	22	≤ 10570	30	≤ 150000
7	≤ 74	15	≤ 1038	23	≤ 14726	31	> 150000

Table 6.1.3.1-2: Buffer size levels (in bytes) for 8-bit Buffer Size field

Index	BS value	Index	BS value	Index	BS value	Index	BS value
0	0	64	≤ 526	128	≤ 29431	192	≤ 1647644
1	≤ 10	65	≤ 560	129	≤ 31342	193	≤ 1754595
2	≤ 11	66	≤ 597	130	≤ 33376	194	≤ 1868488
3	≤ 12	67	≤ 635	131	≤ 35543	195	≤ 1989774
4	≤ 13	68	≤ 677	132	≤ 37850	196	≤ 2118933
5	≤ 13	69	≤ 720	133	≤ 40307	197	≤ 2256475
6	≤ 14	70	≤ 767	134	≤ 42923	198	≤ 2402946
7	≤ 15	71	≤ 817	135	≤ 45709	199	≤ 2558924
8	≤ 16	72	≤ 870	136	≤ 48676	200	≤ 2725027
9	≤ 17	73	≤ 926	137	≤ 51836	201	≤ 2901912
10	≤ 18	74	≤ 987	138	≤ 55200	202	≤ 3090279
11	≤ 19	75	≤ 1051	139	≤ 58784	203	≤ 3290873
12	≤ 20	76	≤ 1119	140	≤ 62599	204	≤ 3504487
13	≤ 22	77	≤ 1191	141	≤ 66663	205	≤ 3731968
14	≤ 23	78	≤ 1269	142	≤ 70990	206	≤ 3974215
15	≤ 25	79	≤ 1351	143	≤ 75598	207	≤ 4232186
16	≤ 26	80	≤ 1439	144	≤ 80505	208	≤ 4506902
17	≤ 28	81	≤ 1532	145	≤ 85730	209	≤ 4799451
18	≤ 30	82	≤ 1631	146	≤ 91295	210	≤ 5110989
19	≤ 32	83	≤ 1737	147	≤ 97221	211	≤ 5442750
20	≤ 34	84	≤ 1850	148	≤ 103532	212	≤ 5796046
21	≤ 36	85	≤ 1970	149	≤ 110252	213	≤ 6172275
22	≤ 38	86	≤ 2098	150	≤ 117409	214	≤ 6572925
23	≤ 40	87	≤ 2234	151	≤ 125030	215	≤ 6999582
24	≤ 43	88	≤ 2379	152	≤ 133146	216	≤ 7453933
25	≤ 46	89	≤ 2533	153	≤ 141789	217	≤ 7937777
26	≤ 49	90	≤ 2698	154	≤ 150992	218	≤ 8453028
27	≤ 52	91	≤ 2873	155	≤ 160793	219	≤ 9001725
28	≤ 55	92	≤ 3059	156	≤ 171231	220	≤ 9586039
29	≤ 59	93	≤ 3258	157	≤ 182345	221	≤ 10208280
30	≤ 62	94	≤ 3469	158	≤ 194182	222	≤ 10870913
31	≤ 66	95	≤ 3694	159	≤ 206786	223	≤ 11576557
32	≤ 71	96	≤ 3934	160	≤ 220209	224	≤ 12328006
33	≤ 75	97	≤ 4189	161	≤ 234503	225	≤ 13128233
34	≤ 80	98	≤ 4461	162	≤ 249725	226	≤ 13980403
35	≤ 85	99	≤ 4751	163	≤ 265935	227	≤ 14887889
36	≤ 91	100	≤ 5059	164	≤ 283197	228	≤ 15854280
37	≤ 97	101	≤ 5387	165	≤ 301579	229	≤ 16883401
38	≤ 103	102	≤ 5737	166	≤ 321155	230	≤ 17979324
39	≤ 110	103	≤ 6109	167	≤ 342002	231	≤ 19146385
40	≤ 117	104	≤ 6506	168	≤ 364202	232	≤ 20389201
41	≤ 124	105	≤ 6928	169	≤ 387842	233	≤ 21712690
42	≤ 132	106	≤ 7378	170	≤ 413018	234	≤ 23122088
43	≤ 141	107	≤ 7857	171	≤ 439827	235	≤ 24622972
44	≤ 150	108	≤ 8367	172	≤ 468377	236	≤ 26221280
45	≤ 160	109	≤ 8910	173	≤ 498780	237	≤ 27923336
46	≤ 170	110	≤ 9488	174	≤ 531156	238	≤ 29735875
47	≤ 181	111	≤ 10104	175	≤ 565634	239	≤ 31666069
48	≤ 193	112	≤ 10760	176	≤ 602350	240	≤ 33721553
49	≤ 205	113	≤ 11458	177	≤ 641449	241	≤ 35910462
50	≤ 218	114	≤ 12202	178	≤ 683087	242	≤ 38241455
51	≤ 233	115	≤ 12994	179	≤ 727427	243	≤ 40723756
52	≤ 248	116	≤ 13838	180	≤ 774645	244	≤ 43367187
53	≤ 264	117	≤ 14736	181	≤ 824928	245	≤ 46182206
54	≤ 281	118	≤ 15692	182	≤ 878475	246	≤ 49179951
55	≤ 299	119	≤ 16711	183	≤ 935498	247	≤ 52372284
56	≤ 318	120	≤ 17795	184	≤ 996222	248	≤ 55771835
57	≤ 339	121	≤ 18951	185	≤ 1060888	249	≤ 59392055
58	≤ 361	122	≤ 20181	186	≤ 1129752	250	≤ 63247269
59	≤ 384	123	≤ 21491	187	≤ 1203085	251	≤ 67352729
60	≤ 409	124	≤ 22885	188	≤ 1281179	252	≤ 71724679
61	≤ 436	125	≤ 24371	189	≤ 1364342	253	≤ 76380419
62	≤ 464	126	≤ 25953	190	≤ 1452903	254	≤ 81338368
63	≤ 494	127	≤ 27638	191	≤ 1547213	255	> 81338368

[TS 38.321, clause 6.2.1]

Table 6.2.1-2 Values of LCID for UL-SCH

Index	LCID values
000000	CCCH
000001–100000	Identity of the logical channel
100001–110110	Reserved
110111	Configured Grant Confirmation
111000	Multiple Entry PHR
111001	Single Entry PHR
111010	C-RNTI
111011	Short Truncated BSR
111100	Long Truncated BSR
111101	Short BSR
111110	Long BSR
111111	Padding

7.1.1.3.5.3.2 Test procedure sequence

Table 7.1.1.3.5.3.2-1: Main behaviour

St	Procedure	Message Sequence		TP	Verdict
		U - S	Message		
1	The SS ignores scheduling requests and does not allocate any uplink grant.	-	-	-	-
-	EXCEPTION: Step 2 shall be repeated for 3 times	-	-	-	-
2	The SS transmits a MAC PDU including an RLC PDU of size 12 bytes on logical channel 5.	<--	MAC PDU (RLC SDU on LC 5)	-	-
3	The SS transmits a MAC PDU including an RLC PDU of size 12 bytes on logical channel 4.	<--	MAC PDU (RLC SDU on LC 4)	-	-
4	UE transmits a Scheduling Request on PUCCH.	-->	(SR)	-	-
5	The SS sends an uplink grant of size 40 bits. (Note 1)	<--	(UL grant)	-	-
6	The UE transmit a Long BSR report.	-->	MAC PDU (Long BSR header (LCID='111110'), Long BSR)	-	-
7	The SS sends an uplink grant of size 128 bits. (Note 2)	<--	(UL grant)	-	-
8	Check: Does UE transmit a MAC PDU containing an RLC SDU and a short truncated BSR indicating pending data ('Buffer size' field > '0') for logicalChannelGroup 1 ('LCG ID' field set to '01')?	-->	MAC PDU (MAC sub PDU for RLC PDU, short truncated BSR header (LCID='111011'), short truncatedBSR(LCG ID ='01', Buffer size>'0'),)	1	P
9	The SS sends an uplink grant of size 144 bits. (Note 3)	<--	(UL grant)	-	-
10	Check: Does UE transmit a MAC PDU containing an RLC SDU and a long truncated BSR indicating pending data ('Buffer size' field > '0') for logicalChannelGroup 1 ('LCG ID' field set to '01')?	-->	MAC PDU (MAC sub PDU for RLC PDU, long truncated BSR header (LCID='111100'), long truncatedBSR(LCG ID ='01', Buffer size>'0'),)	2	P
11	The SS sends an uplink grant of size 128 bits. (Note 4)	<--	(UL grant)	-	-
12	Check: Does UE transmit a MAC PDU containing an RLC SDU and with a Short BSR indicating pending data ('Buffer size' field > '0') for logicalChannelGroup 2 ('LCG ID' field ='10')?	-->	MAC PDU (Short BSR header(LCID='11101'), Short BSR(LCG ID ='10',Buffer size>'0'), RLC SDU)	3	P
13	The SS sends an uplink grant of size 160 bits. (Note 5)	<--	(UL grant)	-	-
14	Check: Does UE transmit a MAC PDU containing a RLC SDU and a Long BSR?	-->	MAC PDU (Long BSR header (LCID='111110'), Long BSR), RLC SDU)	4	P
Note 1:	40 bits (LRBs & IMCS as per 38.523-3[3] annex B) enables UE to transmit a MAC PDU with a MAC BSR header (1 byte) and a Short BSR (1 bytes) or a MAC BSR header (2 byte) a Long BSR (3 byte when 2 LCG configured).				
Note 2:	UE triggers a truncated Short BSR of type "Padding BSR" to report buffer status for one LCG for that TTI. (2 Byte MAC Data sub PDU header + 12 Byte MAC SDU + 1 Byte Short truncated BSR sub header + 2 Byte Long truncated BSR)				
Note 3:	UE triggers a truncated Long BSR of type "Padding BSR" to report buffer status for one LCG for that TTI. (2 Byte MAC Data sub PDU header + 12 Byte MAC SDU + 1 Byte Short truncated BSR sub header + 2 Byte long truncated BSR)				
Note 4:	UE triggers a Short BSR of type "Padding BSR" to report buffer status for one LCG for that TTI. (2 Byte MAC Data sub PDU header + 12 Byte MAC SDU + 1 Byte Short BSR sub header + 1 Byte short BSR)				
Note 5:	UE + 1byte padding triggers a long BSR of type "Padding BSR" to report buffer status for one LCG for that TTI. (2 Byte MAC Data sub PDU header + 12 Byte MAC SDU + 2 Byte long BSR sub header + 3 Byte long BSR)				

7.1.1.3.5.3.3 Specific message contents

None

7.1.1.3.6 Correct handling of MAC control information / Buffer status / Periodic BSR timer expires

7.1.1.3.6.1 Test Purpose (TP)

(1)

```
with { UE in RRC_CONNECTED state }
ensure that {
  when { periodicBSR-Timer expires and more than one LCG has buffered data }
  then { UE triggers a Periodic BSR and reports Long BSR and restarts the periodicBSR-Timer }
}
```

(2)

```
with { UE in E-UTRA RRC_CONNECTED state }
ensure that {
  when { periodicBSR-Timer expires and one LCG has buffered data }
  then { UE triggers a Periodic BSR and reports Short BSR and restarts the periodicBSR-Timer }
}
```

7.1.1.3.6.2 Conformance requirements

References: The conformance requirements covered in the present TC are specified in: TS 38.321, clauses 5.4.5, 6.1.3.1 and 6.2.1. Unless otherwise stated these are Rel-15 requirements.

[TS 38.321, clause 5.4.5]

The Buffer Status reporting (BSR) procedure is used to provide the serving gNB with information about UL data volume in the MAC entity.

RRC configures the following parameters to control the BSR:

- *periodicBSR-Timer*;
- *retxBSR-Timer*;
- *logicalChannelSR-Delay*;
- *logicalChannelSR-DelayTimer*;
- *logicalChannelGroup*.

Each logical channel may be allocated to an LCG using the *logicalChannelGroup*. The maximum number of LCGs is eight.

The MAC entity determines the amount of UL data available for a logical channel according to the data volume calculation procedure in TSs 38.322 and 38.323 [3] [4].

A BSR shall be triggered if any of the following events occur:

- the MAC entity has new UL data available for a logical channel which belongs to an LCG; and either
 - the new UL data belongs to a logical channel with higher priority than the priority of any logical channel containing available UL data which belong to any LCG; or
 - none of the logical channels which belong to an LCG contains any available UL data.

in which case the BSR is referred below to as 'Regular BSR';

- UL resources are allocated and number of padding bits is equal to or larger than the size of the Buffer Status Report MAC CE plus its subheader, in which case the BSR is referred below to as 'Padding BSR';
- *retxBSR-Timer* expires, and at least one of the logical channels which belong to an LCG contains UL data, in which case the BSR is referred below to as 'Regular BSR';
- *periodicBSR-Timer* expires, in which case the BSR is referred below to as 'Periodic BSR'.

For Regular BSR, the MAC entity shall:

- 1> if the BSR is triggered for a logical channel for which *logicalChannelSR-Delay* is configured by upper layers:
 - 2> start or restart the *logicalChannelSR-DelayTimer*.
- 1> else:
 - 2> if running, stop the *logicalChannelSR-DelayTimer*.

For Regular and Periodic BSR, the MAC entity shall:

- 1> if more than one LCG has data available for transmission when the BSR is to be transmitted:
 - 2> report Long BSR for all LCGs which have data available for transmission.
- 1> else:
 - 2> report Short BSR.

For Padding BSR:

- 1> if the number of padding bits is equal to or larger than the size of the Short BSR plus its subheader but smaller than the size of the Long BSR plus its subheader:
 - 2> if more than one LCG has data available for transmission when the BSR is to be transmitted:
 - 3> if the number of padding bits is equal to the size of the Short BSR plus its subheader:
 - 4> report Short Truncated BSR of the LCG with the highest priority logical channel with data available for transmission.
 - 3> else:
 - 4> report Long Truncated BSR of the LCG(s) with the logical channels having data available for transmission following a decreasing order of priority, and in case of equal priority, in increasing order of LCGID.
 - 2> else:
 - 3> report Short BSR;
- 1> else if the number of padding bits is equal to or larger than the size of the Long BSR plus its subheader:
 - 2> report Long BSR for all LCGs which have data available for transmission.

The MAC entity shall:

- 1> if the Buffer Status reporting procedure determines that at least one BSR has been triggered and not cancelled:
 - 2> if UL-SCH resources are available for a new immediate transmission:
 - 3> instruct the Multiplexing and Assembly procedure to generate the BSR MAC CE(s);
 - 3> start or restart *periodicBSR-Timer* except when all the generated BSRs are long or short Truncated BSRs;
 - 3> start or restart *retxBSR-Timer*.
 - 2> else if a Regular BSR has been triggered and *logicalChannelSR-DelayTimer* is not running:
 - 3> if an uplink grant is not a configured grant; or
 - 3> if the Regular BSR was not triggered for a logical channel for which logical channel SR masking (*logicalChannelSR-Mask*) is setup by upper layers:
 - 4> trigger a Scheduling Request.

A MAC PDU shall contain at most one BSR MAC CE, even when multiple events have triggered a BSR by the time. The Regular BSR and the Periodic BSR shall have precedence over the padding BSR.

The MAC entity shall restart *retxBSR-Timer* upon reception of a grant for transmission of new data on any UL-SCH.

All triggered BSRs may be cancelled when the UL grant(s) can accommodate all pending data available for transmission but is not sufficient to additionally accommodate the BSR MAC control element plus its subheader. All triggered BSRs shall be cancelled when a BSR is included in a MAC PDU for transmission.

The MAC entity shall transmit at most one BSR in one MAC PDU. Padding BSR shall not be included when the MAC PDU contains a Regular or Periodic BSR.

[TS 38.322, clause 6.1.3.1]

Buffer Status Report (BSR) MAC CEs consist of either:

- Short BSR format (fixed size); or
- Long BSR format (variable size); or
- Short Truncated BSR format (fixed size); or
- Long Truncated BSR format (variable size).

The BSR formats are identified by MAC PDU subheaders with LCIDs as specified in Table 6.2.1-2.

The fields in the BSR MAC CE are defined as follows:

- LCG ID: The Logical Channel Group ID field identifies the group of logical channel(s) whose buffer status is being reported. The length of the field is 3 bits;
- LCG_i: For the Long BSR format, this field indicates the presence of the Buffer Size field for the logical channel group *i*. The LCG_i field set to "1" indicates that the Buffer Size field for the logical channel group *i* is reported. The LCG_i field set to "0" indicates that the Buffer Size field for the logical channel group *i* is not reported. For the Long Truncated BSR format, this field indicates whether logical channel group *i* has data available. The LCG_i field set to "1" indicates that logical channel group *i* has data available. The LCG_i field set to "0" indicates that logical channel group *i* does not have data available;
- Buffer Size: The Buffer Size field identifies the total amount of data available according to the data volume calculation procedure in TSs 38.322 and 38.323 [3] [4] across all logical channels of a logical channel group after the MAC PDU has been built (i.e. after the logical channel prioritization procedure, which may result the value of the Buffer Size field to zero). The amount of data is indicated in number of bytes. The size of the RLC and MAC headers are not considered in the buffer size computation. The length of this field for the Short BSR format and the Short Truncated BSR format is 5 bits. The length of this field for the Long BSR format and the Long Truncated BSR format is 8 bits. The values for the 5-bit and 8-bit Buffer Size fields are shown in Tables 6.1.3.1-1 and 6.1.3.1-2, respectively. For the Long BSR format and the Long Truncated BSR format, the Buffer Size fields are included in ascending order based on the LCG_i. For the Long Truncated BSR format the number of Buffer Size fields included is maximised, while not exceeding the number of padding bits.

NOTE: The number of the Buffer Size fields in the Long Truncated BSR format can be zero.

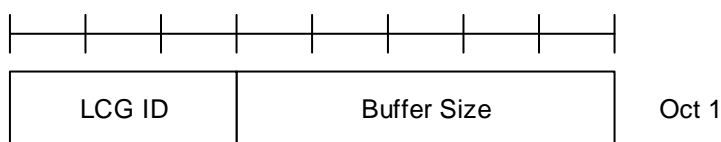

Figure 6.1.3.1-1: Short BSR and Short Truncated BSR MAC CE

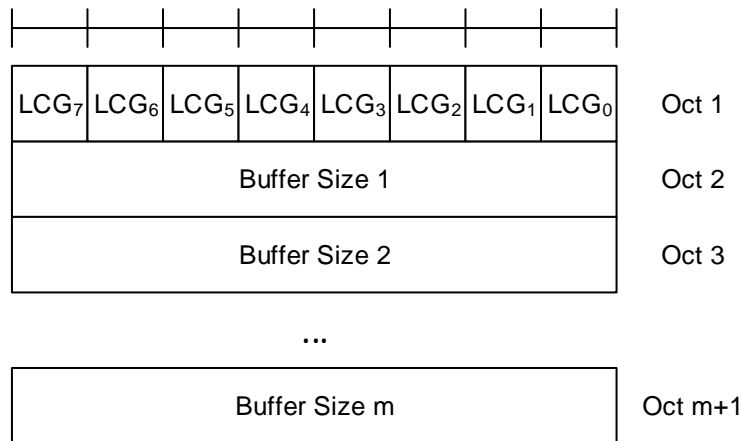

Figure 6.1.3.1-2: Long BSR and Long Truncated BSR MAC CE

Table 6.1.3.1-1: Buffer size levels (in bytes) for 5-bit Buffer Size field

Index	BS value	Index	BS value	Index	BS value	Index	BS value
0	0	8	≤ 102	16	≤ 1446	24	≤ 20516
1	≤ 10	9	≤ 142	17	≤ 2014	25	≤ 28581
2	≤ 14	10	≤ 198	18	≤ 2806	26	≤ 39818
3	≤ 20	11	≤ 276	19	≤ 3909	27	≤ 55474
4	≤ 28	12	≤ 384	20	≤ 5446	28	≤ 77284
5	≤ 38	13	≤ 535	21	≤ 7587	29	≤ 107669
6	≤ 53	14	≤ 745	22	≤ 10570	30	≤ 150000
7	≤ 74	15	≤ 1038	23	≤ 14726	31	> 150000

Table 6.1.3.1-2: Buffer size levels (in bytes) for 8-bit Buffer Size field

Index	BS value	Index	BS value	Index	BS value	Index	BS value
0	0	64	≤ 526	128	≤ 29431	192	≤ 1647644
1	≤ 10	65	≤ 560	129	≤ 31342	193	≤ 1754595
2	≤ 11	66	≤ 597	130	≤ 33376	194	≤ 1868488
3	≤ 12	67	≤ 635	131	≤ 35543	195	≤ 1989774
4	≤ 13	68	≤ 677	132	≤ 37850	196	≤ 2118933
5	≤ 13	69	≤ 720	133	≤ 40307	197	≤ 2256475
6	≤ 14	70	≤ 767	134	≤ 42923	198	≤ 2402946
7	≤ 15	71	≤ 817	135	≤ 45709	199	≤ 2558924
8	≤ 16	72	≤ 870	136	≤ 48676	200	≤ 2725027
9	≤ 17	73	≤ 926	137	≤ 51836	201	≤ 2901912
10	≤ 18	74	≤ 987	138	≤ 55200	202	≤ 3090279
11	≤ 19	75	≤ 1051	139	≤ 58784	203	≤ 3290873
12	≤ 20	76	≤ 1119	140	≤ 62599	204	≤ 3504487
13	≤ 22	77	≤ 1191	141	≤ 66663	205	≤ 3731968
14	≤ 23	78	≤ 1269	142	≤ 70990	206	≤ 3974215
15	≤ 25	79	≤ 1351	143	≤ 75598	207	≤ 4232186
16	≤ 26	80	≤ 1439	144	≤ 80505	208	≤ 4506902
17	≤ 28	81	≤ 1532	145	≤ 85730	209	≤ 4799451
18	≤ 30	82	≤ 1631	146	≤ 91295	210	≤ 5110989
19	≤ 32	83	≤ 1737	147	≤ 97221	211	≤ 5442750
20	≤ 34	84	≤ 1850	148	≤ 103532	212	≤ 5796046
21	≤ 36	85	≤ 1970	149	≤ 110252	213	≤ 6172275
22	≤ 38	86	≤ 2098	150	≤ 117409	214	≤ 6572925
23	≤ 40	87	≤ 2234	151	≤ 125030	215	≤ 6999582
24	≤ 43	88	≤ 2379	152	≤ 133146	216	≤ 7453933
25	≤ 46	89	≤ 2533	153	≤ 141789	217	≤ 7937777
26	≤ 49	90	≤ 2698	154	≤ 150992	218	≤ 8453028
27	≤ 52	91	≤ 2873	155	≤ 160793	219	≤ 9001725
28	≤ 55	92	≤ 3059	156	≤ 171231	220	≤ 9586039
29	≤ 59	93	≤ 3258	157	≤ 182345	221	≤ 10208280
30	≤ 62	94	≤ 3469	158	≤ 194182	222	≤ 10870913
31	≤ 66	95	≤ 3694	159	≤ 206786	223	≤ 11576557
32	≤ 71	96	≤ 3934	160	≤ 220209	224	≤ 12328006
33	≤ 75	97	≤ 4189	161	≤ 234503	225	≤ 13128233
34	≤ 80	98	≤ 4461	162	≤ 249725	226	≤ 13980403
35	≤ 85	99	≤ 4751	163	≤ 265935	227	≤ 14887889
36	≤ 91	100	≤ 5059	164	≤ 283197	228	≤ 15854280
37	≤ 97	101	≤ 5387	165	≤ 301579	229	≤ 16883401
38	≤ 103	102	≤ 5737	166	≤ 321155	230	≤ 17979324
39	≤ 110	103	≤ 6109	167	≤ 342002	231	≤ 19146385
40	≤ 117	104	≤ 6506	168	≤ 364202	232	≤ 20389201
41	≤ 124	105	≤ 6928	169	≤ 387842	233	≤ 21712690
42	≤ 132	106	≤ 7378	170	≤ 413018	234	≤ 23122088
43	≤ 141	107	≤ 7857	171	≤ 439827	235	≤ 24622972
44	≤ 150	108	≤ 8367	172	≤ 468377	236	≤ 26221280
45	≤ 160	109	≤ 8910	173	≤ 498780	237	≤ 27923336
46	≤ 170	110	≤ 9488	174	≤ 531156	238	≤ 29735875
47	≤ 181	111	≤ 10104	175	≤ 565634	239	≤ 31666069
48	≤ 193	112	≤ 10760	176	≤ 602350	240	≤ 33721553
49	≤ 205	113	≤ 11458	177	≤ 641449	241	≤ 35910462
50	≤ 218	114	≤ 12202	178	≤ 683087	242	≤ 38241455
51	≤ 233	115	≤ 12994	179	≤ 727427	243	≤ 40723756
52	≤ 248	116	≤ 13838	180	≤ 774645	244	≤ 43367187
53	≤ 264	117	≤ 14736	181	≤ 824928	245	≤ 46182206
54	≤ 281	118	≤ 15692	182	≤ 878475	246	≤ 49179951
55	≤ 299	119	≤ 16711	183	≤ 935498	247	≤ 52372284
56	≤ 318	120	≤ 17795	184	≤ 996222	248	≤ 55771835
57	≤ 339	121	≤ 18951	185	≤ 1060888	249	≤ 59392055
58	≤ 361	122	≤ 20181	186	≤ 1129752	250	≤ 63247269
59	≤ 384	123	≤ 21491	187	≤ 1203085	251	≤ 67352729
60	≤ 409	124	≤ 22885	188	≤ 1281179	252	≤ 71724679
61	≤ 436	125	≤ 24371	189	≤ 1364342	253	≤ 76380419
62	≤ 464	126	≤ 25953	190	≤ 1452903	254	≤ 81338368
63	≤ 494	127	≤ 27638	191	≤ 1547213	255	> 81338368

[TS 38.321, clause 6.2.1]

Table 6.2.1-2: Values of LCID for UL-SCH

Index	LCID values
000000	CCCH
000001–100000	Identity of the logical channel
100001–110110	Reserved
110111	Configured Grant Confirmation
111000	Multiple Entry PHR
111001	Single Entry PHR
111010	C-RNTI
111011	Short Truncated BSR
111100	Long Truncated BSR
111101	Short BSR
111110	Long BSR
111111	Padding

7.1.1.3.6.3 Test description

7.1.1.3.6.3.1 Pre-test conditions

Same Pre-test conditions as in clause 7.1.1.0 with the exception of 2 SN terminated SCG bearers configured according to Table 7.1.1.3.6.3.1-1.

Table 7.1.1.3.6.3.1-1: Logical Channel Configuration Settings

Parameter	DRB1	DRB2
LogicalChannel-Identity	4	5
Priority	7	6
prioritizedBitRate	0kbs	0kbs
logicalChannelGroup	2 (LCG ID#2)	1 (LCG ID#1)

7.1.1.3.6.3.2 Test procedure sequence

Table 7.1.1.3.6.3.2-1: Main behaviour

St	Procedure	Message Sequence		TP	Verdict
		U - S	Message		
1	The SS ignores scheduling requests and does not allocate any uplink grant.	-	-	-	-
2	The SS transmits a MAC PDU containing an RLC PDU on logical channel 4 (LCG ID 2), which contains 1 RLC SDU of size 14 bytes.	<--	MAC PDU (RLC PDU)		
3	The SS sends an uplink grant of size 32 bits. (Note 1)	<--	(UL grant)	-	-
4	The UE transmits a short BSR report and restarts <i>periodicBSR-Timer</i>	-->	MAC PDU ((LCID='111101', LCG ID='10', Buffer size index > 0)	-	-
-	EXCEPTION: Steps 5 to 7 shall be repeated two times (Note 2)	-	-	-	-
5	Wait for <i>periodicBSR-Timer</i> expiry.	-	-	-	-
6	The SS sends an uplink grant of size 32 bits	-	-	-	-
7	Check: Does UE transmit a MAC PDU containing a Short BSR with 'LCG ID' field set to '10' (logicalChannelGroup 2) and Buffer Size Index > 0?	-->	MAC PDU (LCID='111101', LCG ID='10', Buffer Size index > 0)	2	P
8	The SS transmits a MAC PDU containing an RLC PDU on logical channel 5 (LCG ID 1), which contains 1 RLC SDU of size 14 bytes.	<--	MAC PDU (RLC PDU)	-	-
9	The SS sends an uplink grant of size 40 bits (Note 3)	<--	(UL grant)	-	-
10	The UE transmits a long BSR report with 'Buffer size#1' (LCG ID=1) and 'Buffer size#2' (LCG ID=2) fields set to value > '0'	-->	MAC PDU (('Buffer size#1 index' > 0, 'Buffer size#2 index=' >0')	-	-
-	EXCEPTION: Step 11 to 13 shall be repeated twice. (Note 4)	-	-	-	-
11	Wait for <i>periodicBSR-Timer</i> expiry.	-	-	-	-
12	The SS sends an uplink grant of size 40 bits	-	-	-	-
13	Check: Does UE transmit a MAC PDU containing a Long BSR with 'Buffer size#1' (LCG ID=1) and 'Buffer size#2' (LCG ID=2) fields set to value > '0'?	-->	MAC PDU	1	P
14	The SS transmits 1 UL grant of size 320 bits to enable the UE to loopback RLC SDU on LCG 4 and LCG 5.			-	-
15	The UE transmits MAC PDU containing the remaining RLC SDUs as sent by the SS in steps 2 and 8.	-->	MAC PDU	-	-
Note 1:	SS transmits an UL grant of 32 bits(L _{RBS} & I _{MCS} as per 38.523-3[3] annex B) to allow UE to transmit a Regular BSR triggered by the new data received logicalChannelGroup 1 in step 2.				
Note 2:	One short BSR due to first expiry of <i>periodicBSR-Timer</i> and one short BSR due to second expiry of <i>periodicBSR-Timer</i> .				
Note 3:	SS transmits an UL grant of 40 bits(L _{RBS} & I _{MCS} as per 38.523-3[3] annex B) to allow UE to transmit a Regular BSR triggered by the new data received on higher priority logicalChannelGroup 1 in step 8.				
Note 4:	One long BSR due to expiry of <i>periodicBSR-Timer</i> and one long BSR due to second expiry of <i>periodicBSR-Timer</i> .				

7.1.1.3.6.3.3 Specific message contents

Table 7.1.1.3.6.3.3: MAC-CellGroupConfig (preamble)

Derivation Path: TS 38.308 [6], clause Table 4.6.3-49			
Information Element	Value/remark	Comment	Condition
MAC-CellGroupConfig ::= SEQUENCE {			
bsr-Config SEQUENCE {			
periodicBSR-Timer	sf160		
retxBSR-Timer	sf10240		
}			
phr-Config CHOICE {			
release	NULL		
}			
}			

7.1.1.3.7 UE power headroom reporting / Periodic reporting / DL pathloss change reporting

7.1.1.3.7.1 Test Purpose (TP)

(1)

```
with { UE in RRC_CONNECTED state }
ensure that {
  when { phr-PeriodicTimer is configured in UE }
  then { UE transmits a MAC PDU containing Power Headroom MAC Control Element }
}
```

(2)

```
with { UE in RRC_CONNECTED state with periodic power headroom reporting configured }
ensure that {
  when { phr-PeriodicTimer expires and UL resources allocated for new transmission }
  then { UE transmits a MAC PDU containing Power Headroom MAC Control Element }
}
```

(3)

```
with { UE in RRC_CONNECTED state with periodic power headroom reporting configured }
ensure that {
  when { power headroom reporting is disabled }
  then { UE stops transmitting Power Headroom MAC Control Element }
}
```

(4)

```
with { UE in RRC_Connected state with Power headroom reporting for phr-Tx-PowerFactorChange
configured }
ensure that {
  when { the DL Pathloss has changed more than phr-Tx-PowerFactorChange dB and phr-ProhibitTimer is
running }
  then { UE does not transmit a MAC PDU containing Power Headroom MAC Control Element }
}
```

(5)

```
with { UE in RRC_Connected state with Power headroom reporting for phr-Tx-PowerFactorChange
configured }
ensure that {
  when { phr-ProhibitTimer expires and power headroom report is triggered due to DL Pathloss change
}
  then { UE transmits a MAC PDU containing Power Headroom MAC Control Element }
}
```

7.1.1.3.7.2 Conformance requirements

References: The conformance requirements covered in the current TC are specified in: TS 38.321 clause 5.4.6 and 6.1.3.8. Unless otherwise stated these are Rel-15 requirements.

[TS 38.321, clause 5.4.6]

The Power Headroom reporting procedure is used to provide the serving gNB with the following information:

- Type 1 power headroom: the difference between the nominal UE maximum transmit power and the estimated power for UL-SCH transmission per activated Serving Cell;
- Type 2 power headroom: the difference between the nominal UE maximum transmit power and the estimated power for UL-SCH and PUCCH transmission on SpCell of the other MAC entity (i.e. E-UTRA MAC entity in EN-DC case only);
- Type 3 power headroom: the difference between the nominal UE maximum transmit power and the estimated power for SRS transmission per activated Serving Cell.

RRC controls Power Headroom reporting by configuring the following parameters:

- *phr-PeriodicTimer*;
- *phr-ProhibitTimer*;
- *phr-Tx-PowerFactorChange*;
- *phr-Type2PCell*;
- *phr-Type2OtherCell*;
- *phr-ModeOtherCG*;
- *multiplePHR*.

A Power Headroom Report (PHR) shall be triggered if any of the following events occur:

- *phr-ProhibitTimer* expires or has expired and the path loss has changed more than *phr-Tx-PowerFactorChange* dB for at least one activated Serving Cell of any MAC entity which is used as a pathloss reference since the last transmission of a PHR in this MAC entity when the MAC entity has UL resources for new transmission;

NOTE 1: The path loss variation for one cell assessed above is between the pathloss measured at present time on the current pathloss reference and the pathloss measured at the transmission time of the last transmission of PHR on the pathloss reference in use at that time, irrespective of whether the pathloss reference has changed in between.

- *phr-PeriodicTimer* expires;
- upon configuration or reconfiguration of the power headroom reporting functionality by upper layers, which is not used to disable the function;
- activation of an SCell of any MAC entity with configured uplink;
- addition of the PSCell (i.e. PSCell is newly added or changed);
- *phr-ProhibitTimer* expires or has expired, when the MAC entity has UL resources for new transmission, and the following is true for any of the activated Serving Cells of any MAC entity with configured uplink:
 - there are UL resources allocated for transmission or there is a PUCCH transmission on this cell, and the required power backoff due to power management (as allowed by P-MPR_c as specified in TS 38.101-1 [14], TS 38.101-2 [15], and TS 38.101-3 [16]) for this cell has changed more than *phr-Tx-PowerFactorChange* dB since the last transmission of a PHR when the MAC entity had UL resources allocated for transmission or PUCCH transmission on this cell.

NOTE 2: The MAC entity should avoid triggering a PHR when the required power backoff due to power management decreases only temporarily (e.g. for up to a few tens of milliseconds) and it should avoid reflecting such temporary decrease in the values of $P_{\text{CMAX},f,c}/\text{PH}$ when a PHR is triggered by other triggering conditions.

If the MAC entity has UL resources allocated for a new transmission the MAC entity shall:

- 1> if it is the first UL resource allocated for a new transmission since the last MAC reset:
 - 2> start *phr-PeriodicTimer*;
- 1> if the Power Headroom reporting procedure determines that at least one PHR has been triggered and not cancelled; and
- 1> if the allocated UL resources can accommodate the MAC CE for PHR which the MAC entity is configured to transmit, plus its subheader, as a result of LCP as defined in subclause 5.4.3.1:
 - 2> if *multiplePHR* is configured:
 - 3> for each activated Serving Cell with configured uplink associated with any MAC entity:
 - 4> obtain the value of the Type 1 or Type 3 power headroom for the corresponding uplink carrier as specified in subclause 7.7 of TS 38.213 [6];
 - 4> if this MAC entity has UL resources allocated for transmission on this Serving Cell; or
 - 4> if the other MAC entity, if configured, has UL resources allocated for transmission on this Serving Cell and *phr-ModeOtherCG* is set to real by upper layers:
 - 5> obtain the value for the corresponding $P_{\text{CMAX},f,c}$ field from the physical layer.
 - 3> if *phr-Type2OtherCell* is configured:
 - 4> if the other MAC entity is E-UTRA MAC entity:
 - 5> obtain the value of the Type 2 power headroom for the SpCell of the other MAC entity (i.e. E-UTRA MAC entity);
 - 5> if *phr-ModeOtherCG* is set to real by upper layers:
 - 6> obtain the value for the corresponding $P_{\text{CMAX},f,c}$ field for the SpCell of the other MAC entity (i.e. E-UTRA MAC entity) from the physical layer.
 - 3> instruct the Multiplexing and Assembly procedure to generate and transmit the Multiple Entry PHR MAC CE as defined in subclause 6.1.3.9 based on the values reported by the physical layer.
 - 2> else (i.e. Single Entry PHR format is used):
 - 3> obtain the value of the Type 1 power headroom from the physical layer for the corresponding uplink carrier of the PCell;
 - 3> obtain the value for the corresponding $P_{\text{CMAX},f,c}$ field from the physical layer;
 - 3> instruct the Multiplexing and Assembly procedure to generate and transmit the Single Entry PHR MAC CE as defined in subclause 6.1.3.8 based on the values reported by the physical layer.
 - 2> start or restart *phr-PeriodicTimer*;
 - 2> start or restart *phr-ProhibitTimer*;
 - 2> cancel all triggered PHR(s).

[TS 38.321, clause 6.1.3.8]

The Single Entry PHR MAC CE is identified by a MAC PDU subheader with LCID as specified in Table 6.2.1-2.

It has a fixed size and consists of two octet defined as follows (figure 6.1.3.8-1):

- R: Reserved bit, set to "0";
- Power Headroom (PH): This field indicates the power headroom level. The length of the field is 6 bits. The reported PH and the corresponding power headroom levels are shown in Table 6.1.3.8-1 below (the corresponding measured values in dB are specified in TS 38.133 [11]);
- $P_{CMAX,f,c}$: This field indicates the $P_{CMAX,f,c}$ (as specified in TS 38.213 [6]) used for calculation of the preceding PH field. The reported $P_{CMAX,f,c}$ and the corresponding nominal UE transmit power levels are shown in Table 6.1.3.8-2 (the corresponding measured values in dBm are specified in TS 38.133 [11]).

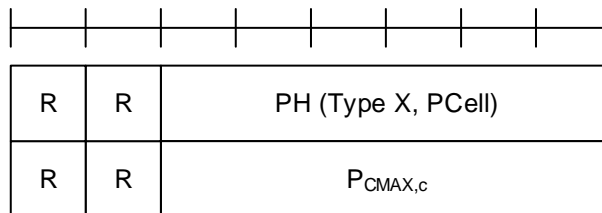

Figure 6.1.3.8-1: Single Entry PHR MAC CE

Table 6.1.3.8-1: Power Headroom levels for PHR

PH	Power Headroom Level
0	POWER_HEADROOM_0
1	POWER_HEADROOM_1
2	POWER_HEADROOM_2
3	POWER_HEADROOM_3
...	...
60	POWER_HEADROOM_60
61	POWER_HEADROOM_61
62	POWER_HEADROOM_62
63	POWER_HEADROOM_63

Table 6.1.3.8-2: Nominal UE transmit power level for PHR

$P_{CMAX,f,c}$	Nominal UE transmit power level
0	PCMAX_C_00
1	PCMAX_C_01
2	PCMAX_C_02
...	...
61	PCMAX_C_61
62	PCMAX_C_62
63	PCMAX_C_63

7.1.1.3.7.3 Test description

7.1.1.3.7.3.1 Pre-test conditions

Same Pre-test conditions as in clause 7.1.1.0 except that set to return no data in uplink.

7.1.1.3.7.3.2 Test procedure sequence

Table 7.1.1.3.7.3.2-1: Main behaviour

St	Procedure	Message Sequence		TP	Verdict
		U - S	Message		
1	The SS transmits UL grant to the UE at every 10ms in PDCCH occasion.	<--	-	-	-
2	SS transmits NR <i>RRCReconfiguration</i> message to configure specific Power Headroom parameters for NR Cell.(Note 1).	<--	(<i>RRCReconfiguration</i>)	-	-
3	Check: does the UE transmit a MAC PDU containing Power Headroom MAC Control Element? (Note 2)	-->	MAC PDU	1	P
4	The UE transmits an NR <i>RRCReconfigurationComplete</i> message to confirm the setup of Power Headroom parameters. (Note 2,3)	-->	(<i>RRCReconfigurationComplete</i>)	-	-
5	Check: does the UE transmit a MAC PDU containing Power Headroom MAC Control Element 200ms after step 3?	-->	MAC PDU	2	P
6	The SS transmits an NR <i>RRCReconfiguration</i> message to disable Power Headroom reporting.(Note 1)	<--	(<i>RRCReconfiguration</i>)	-	-
7	The UE transmits an NR <i>RRCReconfigurationComplete</i> message to confirm the disabling of Power Headroom parameters.(Note 3)	-->	(<i>RRCReconfigurationComplete</i>)	-	-
8	Check: for 2 seconds, does the UE transmit a MAC PDU containing Power Headroom MAC Control Element?	-->	MAC PDU	3	F
9	SS transmits NR <i>RRCReconfiguration</i> message to configure specific Power Headroom parameters for NR Cell.(Note 1)	<--	(<i>RRCReconfiguration</i>)	-	-
10	Check: does the UE transmit a MAC PDU containing Power Headroom MAC Control Element? (Note 4)	-->	MAC PDU	1	P
11	The UE transmits an NR <i>RRCReconfigurationComplete</i> message to confirm the setup of Power Headroom parameters. (Note 3,4)	-->	(<i>RRCReconfigurationComplete</i>)	-	-
12	Wait for T1= 10% of <i>prohibitPHR-Timer</i> .	-	-	-	-
13	Reduce SS power level for NR Cell so as to cause a DL_Pathloss change at UE by 5dB.	-	-	-	-
14	Check: for 80% of <i>prohibitPHR-Timer</i> since step 10, does the UE transmit a MAC PDU containing Power Headroom MAC Control Element?	-->	MAC PDU	4	F
15	Check: after <i>prohibitPHR-Timer</i> after step 10, does the UE transmit a MAC PDU containing Power Headroom MAC Control Element?	-->	MAC PDU	5	P
16	Increase SS power level for NR Cell so as to cause a DL_Pathloss change at UE by 5dB.	-	-	-	-
17	Check: for 80% of <i>prohibitPHR-Timer</i> since step 15, does the UE transmit a MAC PDU containing Power Headroom MAC Control Element?	-->	MAC PDU	4	F
18	Check: after <i>prohibitPHR-Timer</i> after step 15, does the UE transmit a MAC PDU containing Power Headroom MAC Control Element?	-->	MAC PDU	5	P

Note 1: for EN-DC the NR *RRCReconfiguration* message is contained in *RRCConnectionReconfiguration* 36.508 [7], Table 4.6.1-8 using condition EN-DC_EmbedNR_RRCRecon.
 Note 2: Steps 3 and 4 can happen in any order.
 Note 3: for EN-DC the NR *RRCReconfigurationComplete* message is contained in *RRCConnectionReconfigurationComplete*.
 Note 4: Steps 10 and 11 can happen in any order.

7.1.1.3.7.3.3 Specific message contents

Table 7.1.1.3.7.3.3-1: RRCReconfiguration (step 2 Table 7.1.1.3.7.3.2-1)

Derivation Path: 38.508-1 [4], Table 4.6.1-13			
Information Element	Value/remark	Comment	Condition
RRCReconfiguration ::= SEQUENCE {			
criticalExtensions CHOICE {			
rrcReconfiguration SEQUENCE {			
secondaryCellGroup	CellGroupConfig	OCTET STRING (CONTAINING CellGroupConfig)	EN-DC
nonCriticalExtension SEQUENCE {			NR
masterCellGroup	CellGroupConfig	OCTET STRING (CONTAINING CellGroupConfig)	
}			
}			
}			
}			

Table 7.1.1.3.7.3.3-2: CellGroupConfig (Table 7.1.1.3.7.3.3-1)

Derivation Path: 38.508-1 [4], Table 4.6.3-19			
Information Element	Value/remark	Comment	Condition
cellGroupConfig ::= SEQUENCE {			
cellGroupId	1		
mac-CellGroupConfig SEQUENCE {			
phr-Config CHOICE {			
setup SEQUENCE {			
phr-PeriodicTimer	sf200		
phr-ProhibitTimer	sf1000		
phr-Tx-PowerFactorChange	infinity		
multiplePHR	false		
phr-Type2PCell	false		
phr-Type2OtherCell	false		
phr-ModeOtherCG	real		
}			
}			
}			
}			

Table 7.1.1.3.7.3.3-3: RRCReconfiguration (step 6 Table 7.1.1.3.7.3.2-1)

Derivation Path: 38.508-1 [4], Table 4.6.1-13			
Information Element	Value/remark	Comment	Condition
RRCReconfiguration ::= SEQUENCE {			
criticalExtensions CHOICE {			
rrcReconfiguration SEQUENCE {			
secondaryCellGroup	CellGroupConfig	OCTET STRING (CONTAINING CellGroupConfig)	EN-DC
nonCriticalExtension SEQUENCE {			NR
masterCellGroup	CellGroupConfig	OCTET STRING (CONTAINING CellGroupConfig)	
}			
}			
}			

Table 7.1.1.3.7.3.3-4: CellGroupConfig (Table 7.1.1.3.7.3.3-3)

Derivation Path: 38.508-1 [4], Table 4.6.3-19			
Information Element	Value/remark	Comment	Condition
cellGroupConfig ::= SEQUENCE {			
cellGroupld	1		
mac-CellGroupConfig SEQUENCE {			
phr-Config CHOICE {			
release	NULL		
}			
}			
}			

Table 7.1.1.3.7.3.3-5: RRCReconfiguration (step 9 Table 7.1.1.3.7.3.2-1)

Derivation Path: 38.508-1 [4], Table 4.6.1-13			
Information Element	Value/remark	Comment	Condition
RRCReconfiguration ::= SEQUENCE {			
criticalExtensions CHOICE {			
rrcReconfiguration SEQUENCE {			
secondaryCellGroup	CellGroupConfig	OCTET STRING (CONTAINING CellGroupConfig)	EN-DC
nonCriticalExtension SEQUENCE {			NR
masterCellGroup	CellGroupConfig	OCTET STRING (CONTAINING CellGroupConfig)	
}			
}			
}			

Table 7.1.1.3.7.3.3-6: CellGroupConfig (Table 7.1.1.3.7.3.3-5)

Derivation Path: 38.508-1 [4], Table 4.6.3-19			
Information Element	Value/remark	Comment	Condition
cellGroupConfig ::= SEQUENCE {			
cellGroupId	1		
mac-CellGroupConfig SEQUENCE {			
phr-Config CHOICE {			
setup SEQUENCE {			
phr-PeriodicTimer	infinity		
phr-ProhibitTimer	sf1000		
phr-Tx-PowerFactorChange	3dB		
multiplePHR	false		
phr-Type2PCell	false		
phr-Type2OtherCell	false		
phr-ModeOtherCG	real		
}			
}			
}			
}			

7.1.1.3.8 UE power headroom reporting / SCell activation / DL pathloss change reporting

7.1.1.3.8.1 Test Purpose (TP)

(1)

```
with { UE in RRC_Connected state with Power headroom reporting with phr-Type2SpCell and phr-Type2OtherCell and an SCell with uplink is configured }
ensure that {
  when { UE receives an Activation MAC Control Element activating the SCell }
  then { UE transmits a MAC PDU containing Power Headroom Report MAC Control Element including PH type2 for SpCell and SCell }
}
```

(2)

```
with { UE in RRC_Connected state with Power headroom reporting for phr-dl-PathlossChange, phr-Type2SpCell and phr-Type2OtherCell configured }
ensure that {
  when { the DL Pathloss changes and phr-ProhibitTimer is running }
  then { UE does not transmit a MAC PDU containing Power Headroom Report MAC Control Element including PH type2 for SpCell and SCell }
}
```

(3)

```
with { UE in RRC_Connected state with Power headroom reporting for phr-dl-PathlossChange, phr-Type2SpCell and phr-Type2OtherCell configured }
ensure that {
  when { phr-ProhibitTimer expires and extended power headroom report is triggered due to DL Pathloss change }
  then { UE transmits a MAC PDU containing Power Headroom Report MAC Control Element including PH type2 for SpCell and SCell }
}
```

7.1.1.3.8.2 Conformance requirements

References: The conformance requirements covered in the current TC are specified in: TS 38.321 clause 5.4.6 and 6.1.3.8. Unless otherwise stated these are Rel-15 requirements.

[TS 38.321, clause 5.4.6]

The Power Headroom reporting procedure is used to provide the serving gNB with information about the difference between the nominal UE maximum transmit power and the estimated power for UL-SCH transmission or SRS

transmission per activated Serving Cell and also with information about the difference between the nominal UE maximum power and the estimated power for UL-SCH and PUCCH transmission on SpCell and PUCCH SCell.

RRC controls Power Headroom reporting by configuring the following parameters:

- *phr-PeriodicTimer*;
- *phr-ProhibitTimer*;
- *phr-Tx-PowerFactorChange*;
- *phr-Type2SpCell*;
- *phr-Type2OtherCell*;
- *phr-ModeOtherCG*;
- *multiplePHR*.

A Power Headroom Report (PHR) shall be triggered if any of the following events occur:

- *phr-ProhibitTimer* expires or has expired and the path loss has changed more than *phr-Tx-PowerFactorChange* dB for at least one activated Serving Cell of any MAC entity which is used as a pathloss reference since the last transmission of a PHR in this MAC entity when the MAC entity has UL resources for new transmission;

NOTE 1: The path loss variation for one cell assessed above is between the pathloss measured at present time on the current pathloss reference and the pathloss measured at the transmission time of the last transmission of PHR on the pathloss reference in use at that time, irrespective of whether the pathloss reference has changed in between.

- *phr-PeriodicTimer* expires;
- upon configuration or reconfiguration of the power headroom reporting functionality by upper layers, which is not used to disable the function;
- activation of an SCell of any MAC entity with configured uplink;
- addition of the PSCell (i.e. PSCell is newly added or changed);
- *phr-ProhibitTimer* expires or has expired, when the MAC entity has UL resources for new transmission, and the following is true for any of the activated Serving Cells of any MAC entity with configured uplink:
 - there are UL resources allocated for transmission or there is a PUCCH transmission on this cell, and the required power backoff due to power management (as allowed by $P\text{-MPR}_c$ as specified in TS 38.101 [10]) for this cell has changed more than *phr-Tx-PowerFactorChange* dB since the last transmission of a PHR when the MAC entity had UL resources allocated for transmission or PUCCH transmission on this cell.

NOTE 2: The MAC entity should avoid triggering a PHR when the required power backoff due to power management decreases only temporarily (e.g. for up to a few tens of milliseconds) and it should avoid reflecting such temporary decrease in the values of $P_{\text{CMAX},f,c}/\text{PH}$ when a PHR is triggered by other triggering conditions.

If the MAC entity has UL resources allocated for a new transmission the MAC entity shall:

- 1> if it is the first UL resource allocated for a new transmission since the last MAC reset:
 - 2> start *phr-PeriodicTimer*;
- 1> if the Power Headroom reporting procedure determines that at least one PHR has been triggered and not cancelled, and;
 - 1> if the allocated UL resources can accommodate the MAC CE for PHR which the MAC entity is configured to transmit, plus its subheader, as a result of logical channel prioritization:
 - 2> if *multiplePHR* is configured:
 - 3> for each activated Serving Cell with configured uplink associated with any MAC entity:

- 4> obtain the value of the Type 1 or Type 3 power headroom for the corresponding uplink carrier;
- 4> if this MAC entity has UL resources allocated for transmission on this Serving Cell; or
- 4> if the other MAC entity, if configured, has UL resources allocated for transmission on this Serving Cell and *phr-ModeOtherCG* is set to real by upper layers:
 - 5> obtain the value for the corresponding $P_{\text{CMAX},f,c}$ field from the physical layer.
- 3> if *phr-Type2SpCell* is configured:
 - 4> obtain the value of the Type 2 power headroom for the SpCell of this MAC entity;
 - 4> obtain the value for the corresponding $P_{\text{CMAX},f,c}$ field from the physical layer.
- 3> if *phr-Type2OtherCell* is configured:
 - 4> if other CG is configured:
 - 5> obtain the value of the Type 2 power headroom for the SpCell of the other MAC entity;
 - 5> if *phr-ModeOtherCG* is set to real by upper layers:
 - 6> obtain the value for the corresponding $P_{\text{CMAX},f,c}$ field for the SpCell of the other MAC entity from the physical layer.
 - 4> else if PUCCH SCell is configured and activated:
 - 5> obtain the value of the Type 2 power headroom for the PUCCH SCell;
 - 5> obtain the value for the corresponding $P_{\text{CMAX},f,c}$ field from the physical layer.
- 3> instruct the Multiplexing and Assembly procedure to generate and transmit a PHR MAC CE according to configured *ServCellIndex* and the PUCCH(s) for the MAC entity as defined in subclause 6.1.3.9 based on the values reported by the physical layer.
- 2> else (i.e. Single Entry PHR format is used):
 - 3> obtain the value of the Type 1 power headroom from the physical layer for the corresponding uplink carrier of the PCell;
 - 3> obtain the value for the corresponding $P_{\text{CMAX},f,c}$ field from the physical layer;
 - 3> instruct the Multiplexing and Assembly procedure to generate and transmit a PHR MAC CE as defined in subclause 6.1.3.8 based on the value reported by the physical layer.
- 2> start or restart *phr-PeriodicTimer*;
- 2> start or restart *phr-ProhibitTimer*;
- 2> cancel all triggered PHR(s).

[TS 38.321, clause 6.1.3.9]

The Multiple Entry PHR MAC CE is identified by a MAC PDU subheader with LCID as specified in Table 6.2.1-2.

It has a variable size, and includes the bitmap, a Type 2 PH field and an octet containing the associated $P_{\text{CMAX},f,c}$ field (if reported) for the SpCell of this MAC entity, a Type 2 PH field and an octet containing the associated $P_{\text{CMAX},f,c}$ field (if reported) for either SpCell of the other MAC entity or PUCCH SCell, a Type 1 PH field and an octet containing the associated $P_{\text{CMAX},f,c}$ field (if reported) for the PCell. It further includes, in ascending order based on the *ServCellIndex*, one or multiple of Type X PH fields and octets containing the associated $P_{\text{CMAX},f,c}$ fields (if reported) for Serving Cells other than PCell indicated in the bitmap. X is either 1 or 3 according to TS 38.213 [6].

The presence of Type 2 PH field for SpCell of this MAC entity is configured by *phr-Type2SpCell*, and the presence of Type 2 PH field for either SpCell of the other MAC entity or for PUCCH SCell of this MAC entity is configured by *phr-Type2OtherCell*.

A single octet bitmap is used for indicating the presence of PH per Serving Cell when the highest *ServCellIndex* of Serving Cell with configured uplink is less than 8, otherwise four octets are used.

UE determines whether PH value for an activated Serving Cell is based on real transmission or a reference format by considering the downlink control information which has been received until and including the PDCCH occasion in which the first UL grant for a new transmission is received since a PHR has been triggered.

The PHR MAC CEs are defined as follows:

- C_i : This field indicates the presence of a PH field for the Serving Cell with *ServCellIndex* i as specified in TS 38.331 [5]. The C_i field set to "1" indicates that a PH field for the Serving Cell with *ServCellIndex* i is reported. The C_i field set to "0" indicates that a PH field for the Serving Cell with *ServCellIndex* i is not reported;
- R: Reserved bit, set to "0";
- V: This field indicates if the PH value is based on a real transmission or a reference format. For Type 1 PH, V=0 indicates real transmission on PUSCH and V=1 indicates that a PUSCH reference format is used. For Type 2 PH, V=0 indicates real transmission on PUCCH and V=1 indicates that a PUCCH reference format is used. For Type 3 PH, V=0 indicates real transmission on SRS and V=1 indicates that an SRS reference format is used. Furthermore, for Type 1, Type 2, and Type 3 PH, V=0 indicates the presence of the octet containing the associated $P_{\text{CMAX},f,c}$ field, and V=1 indicates that the octet containing the associated $P_{\text{CMAX},f,c}$ field is omitted;
- Power Headroom (PH): This field indicates the power headroom level. The length of the field is 6 bits. The reported PH and the corresponding power headroom levels are shown in Table 6.1.3.8-1 (the corresponding measured values in dB for the NR Serving Cell are specified in TS 38.133 [11] while the corresponding measured values in dB for the E-UTRA Serving Cell are specified in TS 36.133 [12]);
- P: This field indicates whether the MAC entity applies power backoff due to power management. The MAC entity shall set P=1 if the corresponding $P_{\text{CMAX},f,c}$ field would have had a different value if no power backoff due to power management had been applied;
- $P_{\text{CMAX},f,c}$: If present, this field indicates the $P_{\text{CMAX},f,c}$ or $\tilde{P}_{\text{CMAX},f,c}$ (as specified in TS 38.213 [6]) used for calculation of the preceding PH field. The reported $P_{\text{CMAX},f,c}$ and the corresponding nominal UE transmit power levels are shown in Table 6.1.3.8-2 (the corresponding measured values in dBm for the NR Serving Cell are specified in TS 38.133 [11] while the corresponding measured values in dBm for the E-UTRA Serving Cell are specified in TS 36.133 [12]).

C ₇	C ₆	C ₅	C ₄	C ₃	C ₂	C ₁	R
P	V	PH (Type 2, SpCell of this MAC entity)					
R	R	$P_{\text{CMAX},f,c} 1$					
P	V	PH (Type 2, SpCell of the other MAC entity or PUCCH SCell)					
R	R	$P_{\text{CMAX},f,c} 2$					
P	V	PH (Type 1, PCell)					
R	R	$P_{\text{CMAX},f,c} 3$					
P	V	PH (Type X, Serving Cell 1)					
R	R	$P_{\text{CMAX},f,c} 4$					
...							
P	V	PH (Type X, Serving Cell n)					
R	R	$P_{\text{CMAX},f,c} m$					

Figure 6.1.3.9-1: Multiple Entry PHR MAC CE with the highest *ServCellIndex* of Serving Cell with configured uplink is less than 8

C ₇	C ₆	C ₅	C ₄	C ₃	C ₂	C ₁	R
C ₁₅	C ₁₄	C ₁₃	C ₁₂	C ₁₁	C ₁₀	C ₉	C ₈
C ₂₃	C ₂₂	C ₂₁	C ₂₀	C ₁₉	C ₁₈	C ₁₇	C ₁₆
C ₃₁	C ₃₀	C ₂₉	C ₂₈	C ₂₇	C ₂₆	C ₂₅	C ₂₄
P	V	PH (Type 2, SpCell of this MAC entity)					
R	R	P _{CMAX,f,c 1}					
P	V	PH (Type 2, SpCell of the other MAC entity or PUCCH SCell)					
R	R	P _{CMAX,f,c 2}					
P	V	PH (Type 1, PCell)					
R	R	P _{CMAX,f,c 3}					
P	V	PH (Type X, Serving Cell 1)					
R	R	P _{CMAX,f,c 4}					
...							
P	V	PH (Type X, Serving Cell n)					
R	R	P _{CMAX,f,c m}					

Figure 6.1.3.9-2: Multiple Entry PHR MAC CE with the highest ServCellIndex of Serving Cell with configured uplink is equal to or higher than 8

7.1.1.3.8.3 Test description

7.1.1.3.8.3.1 Pre-test conditions

Same Pre-test conditions as in clause 7.1.1.0 and in addition NR Cell 3 (intra band CA) or Cell 10(inter band CA) is configured as NR Active Scell.

7.1.1.3.8.3.2 Test procedure sequence

Table 7.1.1.3.8.3.2-0: Cell configuration power level changes over time

	Parameter	Unit	NR Cell 1	NR Cell 3/10	Remarks
T0	Cell-specific RS EPRE	dBm/SC S	[-82]	[-82]	
T1	Cell-specific RS EPRE	dBm/SC S	[-89]	[-82]	
T2	Cell-specific RS EPRE	dBm/SC S	[-82]	[-82]	
T3	Cell-specific RS EPRE	dBm/SC S	[-82]	[-89]	
T4	Cell-specific RS EPRE	dBm/SC S	[-82]	[-82]	

Table 7.1.1.3.8.3.2-1: Main behaviour

St	Procedure	Message Sequence		TP	Verdict
		U - S	Message		
1	SS transmits an RRCReconfiguration message to configure SCell (NR Cell 3 or Cell 10). Note 1	<--	(RRCReconfiguration)	-	-
2	The UE transmits RRCReconfigurationComplete message. Note 2	-->	(RRCReconfigurationComplete)	-	-
3	The SS is configured for Uplink Grant Allocation Type 2. SS is configured to transmit UL grant for UE at every 10 ms.	-	-	-	-
4	SS transmits an RRCReconfiguration message to provide Power Headroom parameters. Note 1	<--	(RRCReconfiguration)	-	-
	EXCEPTION: In parallel with step 5, UE executes parallel behaviour defined in Table 7.1.1.3.8.3.2-2	-	-	-	-
5	The UE transmits RRCReconfigurationComplete message to confirm the setup of Power Headroom parameters	-->	(RRCReconfigurationComplete)	-	-
6	The SS transmits an Activation MAC control element to activate SCell.	<--	MAC PDU (SCell Activation/Deactivation MAC CE of one octet (C ₁ =1))	-	-
7	Check: Does the UE transmit a MAC PDU containing Multiple Entry PHR MAC CE containing Type 2 PH of NR SpCell and Scell?	-->	MAC PDU	1	P
8	Wait for T1= 10% of <i>prohibitPHR-Timer</i> .	-	-	-	-
9	SS adjusts cell levels according to row T1 of Table 7.1.1.3.8.3.2-0.	-	-	-	-
10	Check: For 80% of <i>prohibitPHR-Timer</i> since step 7, does the UE transmit a MAC PDU containing Multiple Entry PHR MAC CE?	-->	MAC PDU	2	F
11	Check: After <i>prohibitPHR-Timer</i> after step 7, does the UE transmit a MAC PDU containing Multiple Entry PHR MAC CE containing Type 2 PH of NR SpCell and Scell?	-->	MAC PDU	3	P
12	SS adjusts cell levels according to row T2 of Table 7.1.1.3.8.3.2-0..	-	-	-	-
13	Check: For 80% of <i>prohibitPHR-Timer</i> since step 11, does the UE transmit a MAC PDU containing Multiple Entry PHR MAC CE ?	-->	MAC PDU	2	F
14	Check: After <i>prohibitPHR-Timer</i> after step 11, does the UE transmit a MAC PDU containing Multiple Entry PHR MAC CE containing Type 2 PH of NR SpCell and Scell?	-->	MAC PDU	3	P
15	SS adjusts cell levels according to row T3 of Table 7.1.1.3.8.3.2-0.	-	-	-	-
16	Check: For 80% of <i>prohibitPHR-Timer</i> since step 14, does the UE transmit a MAC PDU containing Multiple Entry PHR MAC CE containing?	-->	MAC PDU	2	F
17	Check: After <i>prohibitPHR-Timer</i> after step 14, does the UE transmit a MAC PDU containing Multiple Entry PHR MAC CE containing Type 2 PH of NR SpCell and Scell?	-->	MAC PDU	3	P
18	SS adjusts cell levels according to row T4 of Table 7.1.1.3.8.3.2-0.	-	-	-	-
19	Check: For 80% of <i>prohibitPHR-Timer</i> since step 17, does the UE transmit a MAC PDU containing Multiple Entry PHR MAC CE?	-->	MAC PDU	2	F
20	Check: After <i>prohibitPHR-Timer</i> after step 17, does the UE transmit a MAC PDU containing Multiple Entry PHR MAC CE containing Type 2 PH of NR SpCell and Scell?	-->	MAC PDU	3	P

Note 1: for EN-DC the NR *RRCReconfiguration* message is contained in *RRCConnectionReconfiguration*.
 Note 2: for EN-DC the NR *RRCReconfigurationComplete* message is contained in *RRCConnectionReconfigurationComplete*.

Table 7.1.1.3.8.3.2-2: Parallel behaviour

St	Procedure	Message Sequence		TP	Verdict
		U - S	Message		
1	The UE transmits a MAC PDU containing Multiple Entry PHR MAC CE containing Type 2 PH of NR SpCell.	-->	MAC PDU	-	-

7.1.1.3.8.3.3 Specific message contents

Table 7.1.1.3.8.3.3-1: RRCReconfiguration (step 1, Table 7.1.1.3.8.3.2-1)

Derivation Path: TS 38.508-1 [4], Table 4.6.1-13.			
Information Element	Value/remark	Comment	Condition
RRCReconfiguration ::= SEQUENCE {			
criticalExtensions CHOICE {			
c1 CHOICE {			
rrcReconfiguration ::= SEQUENCE {			
radioBearerConfig	RadioBearerConfig	TS 38.508-1 [4] table 4.6.3-132 condition SRB3	
secondaryCellGroup	CellGroupConfig		
}			
}			
}			
}			

Table 7.1.1.3.8.3.3-2: CellGroupConfig (Table 7.1.1.3.8.3.3-1)

Derivation Path: TS 38.508-1 [4], Table 4.6.3-19.			
Information Element	Value/remark	Comment	Condition
CellGroupConfig ::= SEQUENCE {			
sCellToAddModList SEQUENCE (SIZE (1..maxMeasId)) OF SEQUENCE {			
sCellIndex[1]	1		
sCellConfigCommon[1]	ServingCellConfigCommon		
sCellConfigDedicated[1]	ServingCellConfig		
}			
}			

Table 7.1.1.3.8.3.3-3: ServingCellConfigCommon (Table 7.1.1.3.8.3.3-2)

Derivation Path: TS 38.508-1 [4], Table 4.6.3-168.			
Information Element	Value/remark	Comment	Condition
ServingCellConfigCommon ::= SEQUENCE {			
physCellId	Physical Cell Identity of NR Cell 3/Cell 10		
}			

Table 7.1.1.3.8.3.3-3A: ServingCellConfig (Table 7.1.1.3.8.3.3-2)

Derivation Path: TS 38.508-1 [4], Table 4.6.3-167.			
Information Element	Value/remark	Comment	Condition
ServingCellConfig ::= SEQUENCE {			
sCellDeactivationTimer	ms320		
}			

Table 7.1.1.3.8.3.3-4: RRCReconfiguration (Step 4, Table 7.1.1.3.8.3.2-1)

Derivation Path: 38.508-1 [4], Table [4.6.1-13]			
Information Element	Value/remark	Comment	Condition
RRCReconfiguration ::= SEQUENCE {			
criticalExtensions CHOICE {			
rrcReconfiguration SEQUENCE {			
secondaryCellGroup	CellGroupConfig	OCTET STRING (CONTAINING CellGroupConfig)	EN-DC
}			
}			
}			

Table 7.1.1.3.8.3.3-5: CellGroupConfig (Table 7.1.1.3.8.3.3-4)

Derivation Path: 38.508-1 [4], Table [4.6.3-19]			
Information Element	Value/remark	Comment	Condition
CellGroupConfig ::= SEQUENCE {			
cellGroupId	1		
mac-CellGroupConfig SEQUENCE {			
phr-Config CHOICE {			
setup SEQUENCE {			
phr-PeriodicTimer	sf200		
phr-ProhibitTimer	sf500		
phr-Tx-PowerFactorChange	infinity		
multiplePHR	true		
phr-Type2SpCell	true		
phr-Type2OtherCell	true		
phr-ModeOtherCG	real		
}			
}			
}			
}			

7.1.1.3.9 Correct Handling of UL HARQ process / PUSCH Aggregation

7.1.1.3.9.1 Test Purpose (TP)

(1)

```
with { UE in RRC_CONNECTED state and PUSCH Aggregation > 1 }
ensure that {
  when { UE receives an UL Grant with toggled NDI and has data available for transmission }
  then { UE transmits a new MAC PDU and repeats the MAC PDU in pusch-AggregationFactor-1 times
after first transmission and selects the redundancy version correctly }
}
```

7.1.1.3.9.2 Conformance requirements

References: The conformance requirements covered in the present TC are specified in: TS 38.214 clauses 6.1.2.1 and 6.1.4, TS 38.321 clauses 5.4.1, 5.4.2.1 and 5.4.2.2. Unless otherwise stated these are Rel-15 requirements.

[TS 38.214, clause 6.1.2.1]

When the UE is scheduled to transmit a transport block and no CSI report, or the UE is scheduled to transmit a transport block and a CSI report on PUSCH by a DCI, the *Time domain resource assignment* field value m of the DCI provides a row index $m + 1$ to an allocated table. The determination of the used resource allocation table is defined in sub-clause 6.1.2.1.1. The indexed row defines the slot offset K_2 , the start and length indicator $SLIV$, or directly the start symbol S and the allocation length L , and the PUSCH mapping type to be applied in the PUSCH transmission.

When the UE is scheduled to transmit a PUSCH with no transport block and with a CSI report by a *CSI request* field on a DCI, the *Time-domain resource assignment* field value m of the DCI provides a row index $m + 1$ to an allocated table. The determination of the applied resource allocation table is defined in sub-clause 6.1.2.1.1. The indexed row defines the start and length indicator $SLIV$, or directly the start symbol S and the allocation length L , and the PUSCH mapping type to be applied in the PUSCH transmission and K_2 is determined based on the corresponding list entries $Y_j, j = 0, \dots, N_{Rep} - 1$ of the higher layer parameter *reportSlotConfig* in *CSI-ReportConfig* for the N_{Rep} triggered CSI Reporting Settings. The i th codepoint of K_2 is determined as $K_2 = \max_j Y_j(i)$ where $Y_j(i)$ is the i th codepoint of Y_j .

- The slot where the UE shall transmit the PUSCH is determined by K_2 as $\left\lfloor n \cdot \frac{2^{\mu_{PUSCH}}}{2^{\mu_{PDCCH}}} \right\rfloor + K_2$ where n is the slot with the scheduling DCI, K_2 is based on the numerology of PUSCH, and μ_{PUSCH} and μ_{PDCCH} are the subcarrier spacing configurations for PUSCH and PDCCH, respectively, and
- The starting symbol S relative to the start of the slot, and the number of consecutive symbols L counting from the symbol S allocated for the PUSCH are determined from the start and length indicator $SLIV$ of the indexed row:
 - if $(L-1) \leq 7$ then

$$SLIV = 14 \cdot (L-1) + S$$
 - else

$$SLIV = 14 \cdot (14-L+1) + (14-1-S)$$

where $0 < L \leq 14 - S$, and
- The PUSCH mapping type is set to Type A or Type B as defined in Subclause 6.4.1.1.3 of [4, TS 38.211] as given by the indexed row.

The UE shall consider the S and L combinations defined in table 6.1.2.1-1 as valid PUSCH allocations

Table 6.1.2.1-1: Valid S and L combinations

PUSCH mapping type	Normal cyclic prefix			Extended cyclic prefix		
	S	L	S+L	S	L	S+L
Type A	0	{4,...,14}	{4,...,14}	0	{4,...,12}	{4,...,12}
Type B	{0,...,13}	{1,...,14}	{1,...,14}	{0,...,12}	{1,...,12}	{1,...,12}

When the UE is configured with $aggregationFactorUL > 1$, the same symbol allocation is applied across the $aggregationFactorUL$ consecutive slots and the PUSCH is limited to a single transmission layer. The UE shall repeat the TB across the $aggregationFactorUL$ consecutive slots applying the same symbol allocation in each slot. The redundancy version to be applied on the n^{th} transmission occasion of the TB is determined according to table 6.1.2.1-2.

Table 6.1.2.1-2: Redundancy version when $aggregationFactorUL > 1$

$rvid$ indicated by the DCI scheduling the PUSCH	$rvid$ to be applied to n^{th} transmission occasion			
	$n \bmod 4 = 0$	$n \bmod 4 = 1$	$n \bmod 4 = 2$	$n \bmod 4 = 3$
0	0	2	3	1
2	2	3	1	0
3	3	1	0	2
1	1	0	2	3

If the UE procedure for determining slot configuration, as defined in subclause 11.1 of [6, TS 38.213], determines symbols of a slot allocated for PUSCH as downlink symbols, the transmission on that slot is omitted for multi-slot PUSCH transmission.

[TS 38.214, clause 6.1.4]

To determine the modulation order, target code rate, redundancy version and transport block size for the physical uplink shared channel, the UE shall first

- read the 5-bit modulation and coding scheme field (I_{MCS}) in the DCI to determine the modulation order (O_m) and target code rate (R) based on the procedure defined in Subclause 6.1.4.1
- read redundancy version field (rv) in the DCI to determine the redundancy version, and
- [check the "CSI request" bit field]

and second

- the UE shall use the number of layers (ν), the total number of allocated PRBs (n_{PRB}) to determine the transport block size based on the procedure defined in Subclause 6.1.4.2.

[TS 38.321, clause 5.4.1]

Uplink grant is either received dynamically on the PDCCH, in a Random Access Response, or configured semi-persistently by RRC. The MAC entity shall have an uplink grant to transmit on the UL-SCH. To perform the requested transmissions, the MAC layer receives HARQ information from lower layers.

If the MAC entity has a C-RNTI, a Temporary C-RNTI, or CS-RNTI, the MAC entity shall for each PDCCH occasion and for each Serving Cell belonging to a TAG that has a running *timeAlignmentTimer* and for each grant received for this PDCCH occasion:

- 1> if an uplink grant for this Serving Cell has been received on the PDCCH for the MAC entity's C-RNTI or Temporary C-RNTI; or
- 1> if an uplink grant has been received in a Random Access Response:
 - 2> if the uplink grant is for MAC entity's C-RNTI and if the previous uplink grant delivered to the HARQ entity for the same HARQ process was either an uplink grant received for the MAC entity's CS-RNTI or a configured uplink grant:
 - 3> consider the NDI to have been toggled for the corresponding HARQ process regardless of the value of the NDI.
 - 2> if the uplink grant is for MAC entity's C-RNTI, and the identified HARQ process is configured for a configured uplink grant:
 - 3> start or restart the *configuredGrantTimer* for the corresponding HARQ process, if configured.
 - 2> deliver the uplink grant and the associated HARQ information to the HARQ entity.
- 1> else if an uplink grant for this PDCCH occasion has been received for this Serving Cell on the PDCCH for the MAC entity's CS-RNTI:
 - 2> if the NDI in the received HARQ information is 1:
 - 3> consider the NDI for the corresponding HARQ process not to have been toggled;
 - 3> start or restart the *configuredGrantTimer* for the corresponding HARQ process, if configured;
 - 3> deliver the uplink grant and the associated HARQ information to the HARQ entity.
 - 2> else if the NDI in the received HARQ information is 0:
 - 3> if PDCCH contents indicate configured grant Type 2 deactivation:
 - 4> trigger configured uplink grant confirmation.

- 3> else if PDCCH contents indicate configured grant Type 2 activation:
 - 4> trigger configured uplink grant confirmation;
 - 4> store the uplink grant for this Serving Cell and the associated HARQ information as configured uplink grant;
 - 4> initialise or re-initialise the configured uplink grant for this Serving Cell to start in the associated PUSCH duration and to recur according to rules in subclause 5.8.2;
 - 4> set the HARQ Process ID to the HARQ Process ID associated with this PUSCH duration;
 - 4> consider the NDI bit for the corresponding HARQ process to have been toggled;
 - 4> stop the *configuredGrantTimer* for the corresponding HARQ process, if running;
 - 4> deliver the configured uplink grant and the associated HARQ information to the HARQ entity.

For each Serving Cell and each configured uplink grant, if configured and activated, the MAC entity shall:

- 1> if the PUSCH duration of the configured uplink grant does not overlap with the PUSCH duration of an uplink grant received on the PDCCH for this Serving Cell:
 - 2> set the HARQ Process ID to the HARQ Process ID associated with this PUSCH duration;
- 2> if the *configuredGrantTimer* for the corresponding HARQ process is not running:
 - 3> consider the NDI bit for the corresponding HARQ process to have been toggled;
 - 3> deliver the configured uplink grant and the associated HARQ information to the HARQ entity.

For configured uplink grants, the HARQ Process ID associated with the first symbol of a UL transmission is derived from the following equation:

$$\text{HARQ Process ID} = [\text{floor}(\text{CURRENT_symbol}/\text{periodicity})] \text{ modulo } n\text{rofHARQ-Processes}$$

where $\text{CURRENT_symbol} = (\text{SFN} \times \text{numberOfSlotsPerFrame} \times \text{numberOfSymbolsPerSlot} + \text{slot number in the frame} \times \text{numberOfSymbolsPerSlot} + \text{symbol number in the slot})$, and *numberOfSlotsPerFrame* and *numberOfSymbolsPerSlot* refer to the number of consecutive slots per frame and the number of consecutive symbols per slot, respectively as specified in TS 38.211 [8].

NOTE 1: *CURRENT_symbol* refers to the symbol index of the first transmission occasion of a repetition bundle that takes place.

NOTE 2: A HARQ process is configured for a configured uplink grant if the configured uplink grant is activated and the associated HARQ process ID is less than *nrofHARQ-Processes*.

[TS 38.321, clause 5.4.2.1]

The MAC entity includes a HARQ entity for each Serving Cell with configured uplink (including the case when it is configured with *supplementaryUplink*), which maintains a number of parallel HARQ processes.

The number of parallel UL HARQ processes per HARQ entity is specified in TS 38.214 [7].

Each HARQ process supports one TB.

Each HARQ process is associated with a HARQ process identifier. For UL transmission with UL grant in RA Response, HARQ process identifier 0 is used.

When the MAC entity is configured with *pusch-AggregationFactor* > 1, the parameter *pusch-AggregationFactor* provides the number of transmissions of a TB within a bundle of the dynamic grant. After the initial transmission, *pusch-AggregationFactor* – 1 HARQ retransmissions follow within a bundle. When the MAC entity is configured with *repK* > 1, the parameter *repK* provides the number of transmissions of a TB within a bundle of the configured uplink grant. After the initial transmission, HARQ retransmissions follow within a bundle. For both dynamic grant and configured uplink grant, bundling operation relies on the HARQ entity for invoking the same HARQ process for each transmission that is part of the same bundle. Within a bundle, HARQ retransmissions are triggered without waiting for feedback from previous transmission according to *pusch-AggregationFactor* for a dynamic grant and *repK* for a

configured uplink grant, respectively. Each transmission within a bundle is a separate uplink grant after the initial uplink grant within a bundle is delivered to the HARQ entity.

For each transmission within a bundle of the dynamic grant, the sequence of redundancy versions is determined according to subclause 6.1.4 of TS 38.214 [7]. For each transmission within a bundle of the configured uplink grant, the sequence of redundancy versions is determined according to subclause 6.1.2.3 of TS 38.214 [7].

For each uplink grant, the HARQ entity shall:

- 1> identify the HARQ process associated with this grant, and for each identified HARQ process:
 - 2> if the received grant was not addressed to a Temporary C-RNTI on PDCCH, and the NDI provided in the associated HARQ information has been toggled compared to the value in the previous transmission of this TB of this HARQ process; or
 - 2> if the uplink grant was received on PDCCH for the C-RNTI and the HARQ buffer of the identified process is empty; or
 - 2> if the uplink grant was received in a Random Access Response; or
 - 2> if the uplink grant is part of a bundle of the configured uplink grant, and may be used for initial transmission according to subclause 6.1.2.3 of TS 38.214 [7], and if no MAC PDU has been obtained for this bundle:
 - 3> if there is a MAC PDU in the Msg3 buffer and the uplink grant was received in a Random Access Response:
 - 4> obtain the MAC PDU to transmit from the Msg3 buffer.
 - 3> else:
 - 4> obtain the MAC PDU to transmit from the Multiplexing and assembly entity, if any;
 - 3> if a MAC PDU to transmit has been obtained:
 - 4> deliver the MAC PDU and the uplink grant and the HARQ information of the TB to the identified HARQ process;
 - 4> instruct the identified HARQ process to trigger a new transmission;
 - 4> if the uplink grant is addressed to CS-RNTI; or
 - 4> if the uplink grant is a configured uplink grant; or
 - 4> if the uplink grant is addressed to C-RNTI, and the identified HARQ process is configured for a configured uplink grant:
 - 5> start or restart the *configuredGrantTimer*, if configured, for the corresponding HARQ process when the transmission is performed.
 - 3> else:
 - 4> flush the HARQ buffer of the identified HARQ process.
 - 2> else (i.e. retransmission):
 - 3> if the uplink grant received on PDCCH was addressed to CS-RNTI and if the HARQ buffer of the identified process is empty; or
 - 3> if the uplink grant is part of a bundle and if no MAC PDU has been obtained for this bundle; or
 - 3> if the uplink grant is part of a bundle of the configured uplink grant, and the PUSCH of the uplink grant overlaps with a PUSCH of another uplink grant received on the PDCCH for this Serving Cell:
 - 4> ignore the uplink grant.
 - 3> else:

- 4> deliver the uplink grant and the HARQ information (redundancy version) of the TB to the identified HARQ process;
- 4> instruct the identified HARQ process to trigger a retransmission;
- 4> if the uplink grant is addressed to CS-RNTI; or
- 4> if the uplink grant is addressed to C-RNTI, and the identified HARQ process is configured for a configured uplink grant:
 - 5> start or restart the *configuredGrantTimer*, if configured, for the corresponding HARQ process when the transmission is performed.

When determining if NDI has been toggled compared to the value in the previous transmission the MAC entity shall ignore NDI received in all uplink grants on PDCCH for its Temporary C-RNTI.

[TS 38.321, clause 5.4.2.2]

Each HARQ process is associated with a HARQ buffer.

New transmissions are performed on the resource and with the MCS indicated on either PDCCH, Random Access Response, or RRC. Retransmissions are performed on the resource and, if provided, with the MCS indicated on PDCCH, or on the same resource and with the same MCS as was used for last made transmission attempt within a bundle.

If the HARQ entity requests a new transmission for a TB, the HARQ process shall:

- 1> store the MAC PDU in the associated HARQ buffer;
- 1> store the uplink grant received from the HARQ entity;
- 1> generate a transmission as described below.

If the HARQ entity requests a retransmission for a TB, the HARQ process shall:

- 1> store the uplink grant received from the HARQ entity;
- 1> generate a transmission as described below.

To generate a transmission for a TB, the HARQ process shall:

- 1> if the MAC PDU was obtained from the Msg3 buffer; or
- 1> if there is no measurement gap at the time of the transmission and, in case of retransmission, the retransmission does not collide with a transmission for a MAC PDU obtained from the Msg3 buffer:
 - 2> instruct the physical layer to generate a transmission according to the stored uplink grant.

7.1.1.3.9.3 Test description

7.1.1.3.9.3.1 Pre-test conditions

Same Pre-test conditions as in clause 7.1.1.0.

7.1.1.3.9.3.2 Test procedure sequence

Table 7.1.1.3.9.3.2-1: Main behaviour

St	Procedure	Message Sequence		TP	Verdict
		U - S	Message		
1	The SS transmits a valid MAC PDU containing RLC PDU.	<---	MAC PDU	-	-
2	The UE transmits a Scheduling Request.	-->	(SR)	-	-
3	The SS allocates an UL Grant for one HARQ process X, sufficient for one RLC SDU to be looped back in a Slot, and NDI indicates new transmission and DCI scheduling the PUSCH indicates $rv^{ID} = 0$.	<--	UL Grant	-	-
4	Check: Does the UE transmit a MAC PDU including one RLC SDU, in HARQ process X and repeats the MAC PDU in consecutive slots pusch-AggregationFactor-1 times with $rv^{ID} = 2$ for the first retransmission, $rv^{ID} = 3$ for the second retransmission and $rv^{ID} = 1$ for the third retransmission.	-->	MAC PDU	1	P

7.1.1.3.9.3.3 Specific message contents

Table 7.1.1.3.9.3.3-1: *ServingCellConfig* (preamble)

Derivation Path: TS 38.508-1 [4], Table 4.6.3-167			
Information Element	Value/remark	Comment	Condition
ServingCellConfig ::= SEQUENCE {			
uplinkConfig SEQUENCE {			
initialUplinkBWP	BWP-UplinkDedicated		
}			
}			

Table 7.1.1.3.9.3.3-2: *BWP-UplinkDedicated* (Table 7.1.1.3.9.3.3-1)

Derivation Path: TS 38.508-1 [4], Table 4.6.3-11			
Information Element	Value/remark	Comment	Condition
BWP-UplinkDedicated ::= SEQUENCE {			
pusch-Config CHOICE {			
Setup	PUSCH-Config		
}			
}			

Table 7.1.1.3.9.3.3-3: *PUSCH-Config* (Table 7.1.1.3.9.3.3-2)

Derivation Path: TS 38.508-1 [4], Table 4.6.3-118			
Information Element	Value/remark	Comment	Condition
PUSCH-Config ::= SEQUENCE {			
pusch-AggregationFactor	n4		
}			

7.1.1.4 Transport Size Selection

7.1.1.4.1 DL-SCH Transport Block Size Selection

7.1.1.4.1.0 Common parameters for DL-SCH Transport Block Size Selection

Table 7.1.1.4.1.0-1: PDSCH-TimeDomainResourceAllocationList

Derivation Path: TS 38.508-1 [4], Table 4.6.3-103			
Information Element	Value/remark	Comment	Condition
PDSCH-TimeDomainResourceAllocationList ::= SEQUENCE(SIZE(1..maxNrofDL-Allocations)) OF {	2 entries		
PDSCH-TimeDomainResourceAllocation[1]			
SEQUENCE {			
k0	Not present		
mappingType	typeA		
startSymbolAndLength	86	S=2, L=7	
}			
PDSCH-TimeDomainResourceAllocation2			
SEQUENCE {			
k0	Not present		
mappingType	typeA		
startSymbolAndLength	53	S=2, L=12	
}			
}			

7.1.1.4.1.1 DL-SCH Transport Block Size selection / DCI format 1_0

7.1.1.4.1.1.1 Test Purpose (TP)

(1)

```

with { UE in RRC_CONNECTED state }
ensure that {
  when { UE on PDCCH receives DCI format 1_0 indicating a resource block assignment correspondent to
physical resource blocks , Time domain resource assignment and a modulation and coding }
  then { UE decodes the received transport block of size correspondent as per Modulation Coding
scheme, time domain resource allocation and PRB's and forwards it to higher layers }
}

```

7.1.1.4.1.1.2 Conformance requirements

References: The conformance requirements covered in the present TC are specified in: TS 38.212 clause 7.3.1.2.1, TS 38.214 clause 5.1.2.1, 5.1.2.2, 5.1.2.2.2, 5.1.3, 5.1.3.1 and 5.1.3.2. Unless otherwise stated these are Rel-15 requirements.

[TS 38.212, clause 7.3.1.2.1]

DCI format 1_0 is used for the scheduling of PDSCH in one DL cell.

The following information is transmitted by means of the DCI format 1_0 with CRC scrambled by C-RNTI or CS-RNTI or new-RNTI:

- Identifier for DCI formats – 1 bits
- The value of this bit field is always set to 1, indicating a DL DCI format
- Frequency domain resource assignment – $\lceil \log_2 (N_{RB}^{DL,BWP} (N_{RB}^{DL,BWP} + 1) / 2) \rceil$ bits
- $N_{RB}^{DL,BWP}$ is the size of the active DL bandwidth part in case DCI format 1_0 is monitored in the UE specific search space and satisfying

- the total number of different DCI sizes monitored per slot is no more than 4 for the cell, and
- the total number of different DCI sizes with C-RNTI monitored per slot is no more than 3 for the cell

otherwise, $N_{RB}^{DL,BWP}$ is the size of the initial DL bandwidth part.

If the CRC of the DCI format 1_0 is scrambled by C-RNTI and the “Frequency domain resource assignment” field are of all ones, the DCI format 1_0 is for random access procedure initiated by a PDCCH order, with all remaining fields set as follows:

- Random Access Preamble index – 6 bits according to *ra-PreambleIndex* in Subclause 5.1.2 of [8, TS38.321]
- UL/SUL indicator – 1 bit. If the value of the “Random Access Preamble index” is not all zeros and if the UE is configured with SUL in the cell, this field indicates which UL carrier in the cell to transmit the PRACH according to Table 7.3.1.1.1-1; otherwise, this field is reserved
- SS/PBCH index – 6 bits. If the value of the “Random Access Preamble index” is not all zeros, this field indicates the SS/PBCH that shall be used to determine the RACH occasion for the PRACH transmission; otherwise, this field is reserved.
- PRACH Mask index – 4 bits. If the value of the “Random Access Preamble index” is not all zeros, this field indicates the RACH occasion associated with the SS/PBCH indicated by “SS/PBCH index” for the PRACH transmission, according to Subclause 5.1.1 of [8, TS38.321]; otherwise, this field is reserved
- Reserved bits – 10 bits

Otherwise, all remaining fields are set as follows:

- Time domain resource assignment – 4 bits as defined in Subclause 5.1.2.1 of [6, TS38.214]
- VRB-to-PRB mapping – 1 bit according to Table 7.3.1.1.2-33
- Modulation and coding scheme – 5 bits as defined in Subclause 5.1.3 of [6, TS38.214]
- New data indicator – 1 bit
- Redundancy version – 2 bits as defined in Table 7.3.1.1.1-2
- HARQ process number – 4 bits
- Downlink assignment index – 2 bits as defined in Subclause 9.1.3 of [5, TS38.213], as counter DAI
- TPC command for scheduled PUCCH – 2 bits as defined in Subclause 7.2.1 of [5, TS38.213]
- PUCCH resource indicator – 3 bits as defined in Subclause 9.2.3 of [5, TS38.213]
- PDSCH-to-HARQ_feedback timing indicator – 3 bits as defined in Subclause 9.2.3 of [5, TS38.213]

[TS 38.214, clause 5.1.2.1]

When the UE is scheduled to receive PDSCH by a DCI, the *Time domain resource assignment* field value m of the DCI provides a row index $m + 1$ to an allocation table. The determination of the used resource allocation table is defined in sub-clause 5.1.2.1.1. The indexed row defines the slot offset K_0 , the start and length indicator *SLIV*, or directly the start symbol S and the allocation length L , and the PDSCH mapping type to be assumed in the PDSCH reception.

Given the parameter values of the indexed row:

- The slot allocated for the PDSCH is $\left\lfloor n \cdot \frac{2^{\mu_{PDSCH}}}{2^{\mu_{PDCCH}}} \right\rfloor + K_0$, where n is the slot with the scheduling DCI, and K_0 is

based on the numerology of PDSCH, and μ_{PDSCH} and μ_{PDCCH} are the subcarrier spacing configurations for PDSCH and PDCCH, respectively, and

- The starting symbol S relative to the start of the slot, and the number of consecutive symbols L counting from the symbol S allocated for the PDSCH are determined from the start and length indicator *SLIV*:

if $(L-1) \leq 7$ then

$$SLIV = 14 \cdot (L-1) + S$$

else

$$SLIV = 14 \cdot (14 - L + 1) + (14 - 1 - S)$$

where $0 < L \leq 14 - S$, and

- The PDSCH mapping type is set to Type A or Type B as defined in sub-clause 7.4.1.1.2 of [4, TS 38.211].

The UE shall consider the S and L combinations defined in table 5.1.2.1-1 as valid PDSCH allocations:

Table 5.1.2.1-1: Valid S and L combinations

PDSCH mapping type	Normal cyclic prefix			Extended cyclic prefix		
	S	L	$S+L$	S	L	$S+L$
Type A	{0,1,2,3} (Note 1)	{3,...,14}	{3,...,14}	{0,1,2,3} (Note 1)	{3,...,12}	{3,...,12}
Type B	{0,...,12}	{2,4,7}	{2,...,14}	{0,...,10}	{2,4,6}	{2,...,12}

[38.214 clause 5.1.2.2]

Two downlink resource allocation schemes, type 0 and type 1, are supported. The UE shall assume that when the scheduling grant is received with DCI format 1_0, then downlink resource allocation type 1 is used.

[38.214 clause 5.1.2.2.2]

In downlink resource allocation of type 1, the resource block assignment information indicates to a scheduled UE a set of contiguously allocated non-interleaved or interleaved virtual resource blocks within the active bandwidth part of size N_{BWP}^{size} PRBs except for the case when DCI format 1_0 is decoded in any common search space in CORESET 0 in which case the initial bandwidth part of size $N_{BWP,0}^{size}$ shall be used.

A downlink type 1 resource allocation field consists of a resource indication value (RIV) corresponding to a starting virtual resource block (RB_{start}) and a length in terms of contiguously allocated resource blocks L_{RBs} . The resource indication value is defined by

if $(L_{RBs} - 1) \leq \lfloor N_{BWP}^{size} / 2 \rfloor$ then

$$RIV = N_{BWP}^{size} (L_{RBs} - 1) + RB_{start}$$

else

$$RIV = N_{BWP}^{size} (N_{BWP}^{size} - L_{RBs} + 1) + (N_{BWP}^{size} - 1 - RB_{start})$$

where $L_{RBs} \geq 1$ and shall not exceed $N_{BWP}^{size} - RB_{start}$.

[TS 38.214, clause 5.1.3]

To determine the modulation order, target code rate, and transport block size(s) in the physical downlink shared channel, the UE shall first

- read the 5-bit *modulation and coding scheme* field (I_{MCS}) in the DCI to determine the modulation order (Q_m) and target code rate (R) based on the procedure defined in Subclause 5.1.3.1, and
- read *redundancy version* field (rv) in the DCI to determine the redundancy version..

and second

- the UE shall use the number of layers (v), the total number of allocated PRBs before rate matching (n_{PRB}) to determine to the transport block size based on the procedure defined in Subclause 5.1.3.2.

The UE may skip decoding a transport block in an initial transmission if the effective channel code rate is higher than 0.95, where the effective channel code rate is defined as the number of downlink information bits (including CRC bits) divided by the number of physical channel bits on PDSCH. If the UE skips decoding, the physical layer indicates to higher layer that the transport block is not successfully decoded.

[TS 38.214, clause 5.1.3.1]

For the PDSCH scheduled by a PDCCH with DCI format 1_0 or format 1_1 with CRC scrambled by C-RNTI, new-RNTI, TC-RNTI, CS-RNTI, SI-RNTI, RA-RNTI, or P-RNTI,

if the higher layer parameter *mcs-Table* given by *PDSCH-Config* is set to 'qam256', and the PDSCH is scheduled by a PDCCH with a DCI format 1_1 and the CRC is scrambled by C-RNTI or CS-RNTI

- the UE shall use I_{MCS} and Table 5.1.3.1-2 to determine the modulation order (Q_m) and Target code rate (R) used in the physical downlink shared channel.

elseif the UE is not configured with new-RNTI, the higher layer parameter *mcs-Table* given by *PDSCH-Config* is set to 'qam64LowSE', and the PDSCH is scheduled with C-RNTI, and the PDSCH is assigned by a PDCCH in a UE-specific search space

- the UE shall use I_{MCS} and Table 5.1.3.1-3 to determine the modulation order (Q_m) and Target code rate (R) used in the physical downlink shared channel.

elseif the UE is configured with new-RNTI, and the PDSCH is scheduled with new-RNTI

- the UE shall use I_{MCS} and Table 5.1.3.1-3 to determine the modulation order (Q_m) and Target code rate (R) used in the physical downlink shared channel.

elseif the UE is not configured with the higher layer parameter *mcs-Table* given by *SPS-config*, the higher layer parameter *mcs-Table* given by *PDSCH-Config* is set to 'qam256', the PDSCH is scheduled with CS-RNTI, and the PDSCH is assigned by a PDCCH with DCI format 1_1

- the UE shall use I_{MCS} and Table 5.1.3.1-2 to determine the modulation order (Q_m) and Target code rate (R) used in the physical downlink shared channel.

elseif the UE is configured with the higher layer parameter *mcs-Table* given by *SPS-config* set to 'qam64LowSE', and the PDSCH is scheduled with CS-RNTI

- the UE shall use I_{MCS} and Table 5.1.3.1-3 to determine the modulation order (Q_m) and Target code rate (R) used in the physical downlink shared channel.

else

- the UE shall use I_{MCS} and Table 5.1.3.1-1 to determine the modulation order (Q_m) and Target code rate (R) used in the physical downlink shared channel.

End

The UE is not expected to decode a PDSCH scheduled with P-RNTI, RA-RNTI, SI-RNTI and $Q_m > 2$

Table 5.1.3.1-1: MCS index table 1 for PDSCH

MCS Index I_{MCS}	Modulation Order Q_m	Target code Rate $R \times [1024]$	Spectral efficiency
0	2	120	0.2344
1	2	157	0.3066
2	2	193	0.3770
3	2	251	0.4902
4	2	308	0.6016
5	2	379	0.7402
6	2	449	0.8770
7	2	526	1.0273
8	2	602	1.1758
9	2	679	1.3262
10	4	340	1.3281
11	4	378	1.4766
12	4	434	1.6953
13	4	490	1.9141
14	4	553	2.1602
15	4	616	2.4063
16	4	658	2.5703
17	6	438	2.5664
18	6	466	2.7305
19	6	517	3.0293
20	6	567	3.3223
21	6	616	3.6094
22	6	666	3.9023
23	6	719	4.2129
24	6	772	4.5234
25	6	822	4.8164
26	6	873	5.1152
27	6	910	5.3320
28	6	948	5.5547
29	2	reserved	
30	4	reserved	
31	6	reserved	

[TS 38.214, clause 5.1.3.2]

In case the higher layer parameter *maxNrofCodeWordsScheduledByDCI* indicates that two codeword transmission is enabled, then a transport block is disabled by DCI format 1_1 if $I_{MCS} = 26$ and if $r_{vid} = 1$ for the corresponding transport block, otherwise the transport block is enabled. If both transport blocks are enabled, transport block 1 and 2 are mapped to codeword 0 and 1 respectively. If only one transport block is enabled, then the enabled transport block is always mapped to the first codeword.

For the PDSCH assigned by a PDCCH with DCI format 1_0 or format 1_1 with CRC scrambled by C-RNTI, new-RNTI, TC-RNTI, CS-RNTI, or SI-RNTI, if Table 5.1.3.1-2 is used and $0 \leq I_{MCS} \leq 27$, or a table other than Table 5.1.3.1-2 is used and $0 \leq I_{MCS} \leq 28$, the UE shall, except if the transport block is disabled in DCI format 1_1, first determine the TBS as specified below:

1) The UE shall first determine the number of REs (N_{RE}) within the slot.

- A UE first determines the number of REs allocated for PDSCH within a PRB (N'_{RE}) by

$$N'_{RE} = N_{sc}^{RB} \cdot N_{symb}^{sh} - N_{DMRS}^{PRB} - N_{oh}^{PRB}, \text{ where } N_{sc}^{RB} = 12 \text{ is the number of subcarriers in a physical resource}$$

block, N_{symb}^{sh} is the number of symbols of the PDSCH allocation within the slot, N_{DMRS}^{PRB} is the number of REs for DM-RS per PRB in the scheduled duration including the overhead of the DM-RS CDM groups without data, as indicated by DCI format 1_1 or as described for format 1_0 in Subclause 5.1.6.2, and N_{oh}^{PRB} is the overhead configured by higher layer parameter *xOverhead* in *PDSCH-ServingCellConfig*. If the *xOverhead* in *PDSCH-ServingCellconfig* is not configured (a value from 0, 6, 12, or 18), the N_{oh}^{PRB} is set to

0. If the PDSCH is scheduled by PDCCH with a CRC scrambled by SI-RNTI, RA-RNTI or P-RNTI, N_{oh}^{PRB} is assumed to be 0.

- A UE determines the total number of REs allocated for PDSCH (N_{RE}) by $N_{RE} = \min(156, N_{RE}^i) \cdot n_{PRB}$, where n_{PRB} is the total number of allocated PRBs for the UE.

2) Intermediate number of information bits (N_{info}) is obtained by $N_{info} = N_{RE} \cdot R \cdot Q_m \cdot v$.

If $N_{info} \leq 3824$

Use step 3 as the next step of the TBS determination

else

Use step 4 as the next step of the TBS determination

end if

3) When $N_{info} \leq 3824$, TBS is determined as follows

- quantized intermediate number of information bits $N'_{info} = \max\left(24, 2^n \cdot \left\lfloor \frac{N_{info}}{2^n} \right\rfloor\right)$, where $n = \max(3, \lfloor \log_2(N_{info}) \rfloor - 6)$.
- use Table 5.1.3.2-2 find the closest TBS that is not less than N'_{info} .

Table 5.1.3.2-2: TBS for $N_{info} \leq 3824$

Index	TBS	Index	TBS	Index	TBS	Index	TBS
1	24	31	336	61	1288	91	3624
2	32	32	352	62	1320	92	3752
3	40	33	368	63	1352	93	3824
4	48	34	384	64	1416		
5	56	35	408	65	1480		
6	64	36	432	66	1544		
7	72	37	456	67	1608		
8	80	38	480	68	1672		
9	88	39	504	69	1736		
10	96	40	528	70	1800		
11	104	41	552	71	1864		
12	112	42	576	72	1928		
13	120	43	608	73	2024		
14	128	44	640	74	2088		
15	136	45	672	75	2152		
16	144	46	704	76	2216		
17	152	47	736	77	2280		
18	160	48	768	78	2408		
19	168	49	808	79	2472		
20	176	50	848	80	2536		
21	184	51	888	81	2600		
22	192	52	928	82	2664		
23	208	53	984	83	2728		
24	224	54	1032	84	2792		
25	240	55	1064	85	2856		
26	256	56	1128	86	2976		
27	272	57	1160	87	3104		
28	288	58	1192	88	3240		
29	304	59	1224	89	3368		
30	320	60	1256	90	3496		

4) When $N_{info} > 3824$, TBS is determined as follows.

- quantized intermediate number of information bits $N'_{info} = \max\left(3840, 2^n \times \text{round}\left(\frac{N_{info} - 24}{2^n}\right)\right)$, where $n = \lfloor \log_2(N_{info} - 24) \rfloor - 5$ and ties in the round function are broken towards the next largest integer.

- if $R \leq 1/4$

$$TBS = 8 \cdot C \cdot \left\lceil \frac{N'_{info} + 24}{8 \cdot C} \right\rceil - 24, \text{ where } C = \left\lceil \frac{N'_{info} + 24}{3816} \right\rceil$$

else

if $N'_{info} > 8424$

$$TBS = 8 \cdot C \cdot \left\lceil \frac{N'_{info} + 24}{8 \cdot C} \right\rceil - 24, \text{ where } C = \left\lceil \frac{N'_{info} + 24}{8424} \right\rceil$$

else

$$TBS = 8 \cdot \left\lceil \frac{N'_{info} + 24}{8} \right\rceil - 24$$

end if

end if

7.1.1.4.1.1.3 Test description

7.1.1.4.1.1.3.1 Pre-test conditions

Same Pre-test conditions as in clause 7.1.1.0 except set the NR Cell bandwidth and applicable BWP to maximum for the NR Band under test as specified in Table 5.3.5-1 in TS 38.101-1 [16] / TS 38.101-2 [17] (to enable testing of n_{PRB} up to maximum value).

Test frequency NRf1 is as specified in TS 38.508-1 [4] clause 4.3.1 using the common highest UL and DL channel bandwidth and using the default subcarrier spacing specified in TS 38.508-1 [4] clause 6.2.3.1.

7.1.1.4.1.1.3.2 Test procedure sequence

Table 7.1.1.4.1.1.3.2-1: Maximum TBS for different UE categories

UE Category	Maximum number of bits of a UL-SCH transport block received within a TTI
TS 38.306 [23] clause 4.1.2 require UE without <i>ue-CategoryDL</i> and <i>ue-CategoryUL</i> , to support Max TBS achievable based on max bandwidth of the Band under test.	

Table 7.1.1.4.1.1.3.2-2: Number of downlink PDCP SDUs and PDCP SDU size used as test data

TBS [bits]	Number of PDCP SDUs	PDCP SDU size [bits] (Note 1)
$136 \leq \text{TBS} \leq 12128$ note 2	1	$8 * \text{FLOOR}((\text{TBS} - 128)/8)$
$12129 \leq \text{TBS} \leq 24200$	2	$8 * \text{FLOOR}((\text{TBS} - 200)/16)$
$24201 \leq \text{TBS} \leq 36272$	3	$8 * \text{FLOOR}((\text{TBS} - 272)/24)$
$36273 \leq \text{TBS} \leq 48344$	4	$8 * \text{FLOOR}((\text{TBS} - 344)/32)$
$48345 \leq \text{TBS} \leq 60416$	5	$8 * \text{FLOOR}((\text{TBS} - 416)/40)$
$60417 \leq \text{TBS} \leq 72488$	6	$8 * \text{FLOOR}((\text{TBS} - 488)/48)$
$72489 \leq \text{TBS} \leq 84560$	7	$8 * \text{FLOOR}((\text{TBS} - 560)/56)$
$84561 \leq \text{TBS} \leq 96632$	8	$8 * \text{FLOOR}((\text{TBS} - 632)/64)$
$96633 < \text{TBS} \leq 108704$	9	$8 * \text{FLOOR}((\text{TBS} - 704)/72)$
$10705 \leq \text{TBS} \leq 120776$	10	$8 * \text{FLOOR}((\text{TBS} - 776)/80)$
$120777 \leq \text{TBS} \leq 132848$	11	$8 * \text{FLOOR}((\text{TBS} - 848)/88)$
$132849 \leq \text{TBS} \leq 144920$	12	$8 * \text{FLOOR}((\text{TBS} - 920)/96)$
$\text{TBS} > 144920$	13	$8 * \text{FLOOR}((\text{TBS} - 992)/104)$

Note 1: Each PDCP SDU is limited to 1500 octets (to keep below maximum SDU size of ESM as specified in TS 24.301 [21] clause 9.9.4.12).

The PDCP SDU size of each PDCP SDU is

PDCP SDU size = (TBS – N*PDCP header size – N*AMD PDU header size – N*MAC header size – Size of Timing Advance – RLC Status PDU size- MAC header for RLC Status PDU) / N, where

PDCP header size is 24 bits for the RLC AM and 18-bit SN case;
AMD PDU header size is 24 bits with 18 bit SN;

MAC header size for AMD PDU = 16 or 24 bits depending on L=8 or 16 bits. Worst case 24 is taken.

Size of Timing Advance MAC CE with header is 16 bits (if no Timing Advance and/or RLC status needs to be sent, padding will occur instead).

RLC Status PDU size = 24 bits with 1 ACK_SN, With a MAC header of 16 bits.

This gives:

PDCP SDU size = $8 * \text{FLOOR}((\text{TBS} - N * 24 - N * 24 - N * 24 - 56) / (8 * N))$ bits.

Note 2: According to the final PDCP SDU size formula in Note 1, the smallest TBS that can be tested is 136 bits.

Table 7.1.1.4.1.1.3.2-3: Specific Parameters

Parameter	Value	Comment
number of layers (v)	1	
mcs-Table	qam64	
xoh-PDSCH	Not Present	Results in value 0(xoh0)

Table 7.1.1.4.1.1.3.2-4: Main behaviour

St	Procedure	Message Sequence		TP	Verdict
		U - S	Message		
-	EXCEPTION: Steps 1 to 5 are repeated for allowed values of N_{PRB} 1 to $N_{RB}^{DL,BWP}$ in BWP, time domain resource as per table 7.1.1.4.1.0-1 and I_{MCS} from 0 to 28.	-	-	-	-
1	The SS calculates or looks up TBS in TS 38.214 [15] based on the value of S, L, I_{MCS} and n_{PRB} .	-	-	-	-
-	EXCEPTION: Steps 2 to 5 are performed if TBS is less than or equal to UE capability "Maximum number of DL-SCH transport block bits received within a TTI" as specified in Table 7.1.1.4.1.1.3.2-1 and larger than or equal to 132 bits as specified in Table 7.1.1.4.1.1.3.2-2	-	-	-	-
2	The SS creates one or more PDCP SDUs, depending on TBS, in accordance with Table 7.1.1.4.1.1.3.2-2.	-	-	-	-
3	The SS transmits the PDCP SDUs concatenated into a MAC PDU and indicates on PDCCH DCI Format 1_0 and values of S, L, I_{MCS} and n_{PRB} .	<--	MAC PDU (NxPDCP SDUs) DCI: (DCI Format 1_0, S, L, I_{MCS} and n_{PRB})	-	-
4	At the reception of scheduling request the SS transmits UL Grant for transmitting loop back PDCP SDUs.	<--	(UL Grant)	-	-
5	CHECK: Does UE return the same number of PDCP SDUs with same content as transmitted by the SS in step 3?	-->	(NxPDCP SDUs)	1	P

7.1.1.4.1.1.3.3 Specific message contents

[None].

7.1.1.4.1.2 Void

7.1.1.4.1.3 DL-SCH transport block size selection / DCI format 1_1 / RA type 0/RA Type 1 / 2 Codewords enabled

7.1.1.4.1.3.1 Test Purpose (TP)

(1)

```

with { UE in RRC_CONNECTED state and maxNrofCodeWordsScheduledByDCI set to 'n2' }
ensure that {
  when { UE on PDCCH receives DCI format 1_1 indicating resource allocation type 0 a resource block
assignment correspondent to physical resource blocks , Time domain resource assignment and a
modulation and coding }
  then { UE decodes the received transport block of size correspondent as per Modulation Coding
scheme, time domain resource allocation and PRB's and forwards it to higher layers }
}

```

(2)

```

with { UE in RRC_CONNECTED state and maxNrofCodeWordsScheduledByDCI set to 'n2' }
ensure that {
  when { UE on PDCCH receives DCI format 1_1 indicating resource allocation type 1 a resource block
assignment correspondent to physical resource blocks , Time domain resource assignment and a
modulation and coding }
  then { UE decodes the received transport block of size correspondent as per Modulation Coding
scheme, time domain resource allocation and PRB's and forwards it to higher layers }
}

```

7.1.1.4.1.3.2 Conformance requirements

References: The conformance requirements covered in the present TC are specified in: TS 38.212 clause 7.3.1.2.2, TS 38.214 clause 5.1.2.1, 5.1.2.2.1, 5.1.2.2.2, 5.1.3, 5.1.3.1 and 5.1.3.2. Unless otherwise stated these are Rel-15 requirements.

[TS 38.212, clause 7.3.1.2.2]

DCI format 1_1 is used for the scheduling of PDSCH in one cell.

The following information is transmitted by means of the DCI format 1_1 with CRC scrambled by C-RNTI or CS-RNTI or new-RNTI:

- Identifier for DCI formats – 1 bits
- The value of this bit field is always set to 1, indicating a DL DCI format
 - Carrier indicator – 0 or 3 bits as defined in Subclause 10.1 of [5, TS38.213].
 - Bandwidth part indicator – 0, 1 or 2 bits as determined by the number of DL BWPs $n_{\text{BWP,RRC}}$ configured by higher layers, excluding the initial DL bandwidth part. The bit width for this field is determined as $\lceil \log_2(n_{\text{BWP}}) \rceil$ bits, where
 - $n_{\text{BWP}} = n_{\text{BWP,RRC}} + 1$ if $n_{\text{BWP,RRC}} \leq 3$, in which case the bandwidth part indicator is equivalent to the higher layer parameter *BWP-Id*;
 - otherwise $n_{\text{BWP}} = n_{\text{BWP,RRC}}$, in which case the bandwidth part indicator is defined in Table 7.3.1.1.2-1;

If a UE does not support active BWP change via DCI, the UE ignores this bit field.

- Frequency domain resource assignment – number of bits determined by the following, where $N_{\text{RB}}^{\text{DL,BWP}}$ is the size of the active DL bandwidth part:
 - N_{RBG} bits if only resource allocation type 0 is configured, where N_{RBG} is defined in Subclause 5.1.2.2.1 of [6, TS38.214],
 - $\lceil \log_2(N_{\text{RB}}^{\text{DL,BWP}}(N_{\text{RB}}^{\text{DL,BWP}} + 1)/2) \rceil$ bits if only resource allocation type 1 is configured, or
 - $\max(\lceil \log_2(N_{\text{RB}}^{\text{DL,BWP}}(N_{\text{RB}}^{\text{DL,BWP}} + 1)/2) \rceil, N_{\text{RBG}}) + 1$ bits if both resource allocation type 0 and 1 are configured.
 - If both resource allocation type 0 and 1 are configured, the MSB bit is used to indicate resource allocation type 0 or resource allocation type 1, where the bit value of 0 indicates resource allocation type 0 and the bit value of 1 indicates resource allocation type 1.
 - For resource allocation type 0, the N_{RBG} LSBs provide the resource allocation as defined in Subclause 5.1.2.2.1 of [6, TS38.214].
 - For resource allocation type 1, the $\lceil \log_2(N_{\text{RB}}^{\text{DL,BWP}}(N_{\text{RB}}^{\text{DL,BWP}} + 1)/2) \rceil$ LSBs provide the resource allocation as defined in Subclause 5.1.2.2.2 of [6, TS38.214]

If “Bandwidth part indicator” field indicates a bandwidth part other than the active bandwidth part and if both resource allocation type 0 and 1 are configured for the indicated bandwidth part, the UE assumes resource allocation type 0 for the indicated bandwidth part if the bit width of the “Frequency domain resource assignment” field of the active bandwidth part is smaller than the bit width of the “Frequency domain resource assignment” field of the indicated bandwidth part.

- Time domain resource assignment – 0, 1, 2, 3, or 4 bits as defined in Subclause 5.1.2.1 of [6, TS38.214]. The bit width for this field is determined as $\lceil \log_2(I) \rceil$ bits, where I is the number of entries in the higher layer parameter *pusch-AllocationList*.
- VRB-to-PRB mapping – 0 or 1 bit
 - 0 bit if only resource allocation type 0 is configured;
 - 1 bit according to Table 7.3.1.1.2-33 otherwise, only applicable to resource allocation type 1, as defined in Subclause 7.3.1.6 of [4, TS38.211].
- PRB bundling size indicator – 0 bit if the higher layer parameter *prb-BundlingType* is not configured or is set to ‘static’, or 1 bit if the higher layer parameter *prb-BundlingType* is set to ‘dynamic’, according to Subclause 5.1.2.3 of [6, TS38.214].
- Rate matching indicator – 0, 1, or 2 bits according to higher layer parameter *rateMatchPattern*.
- ZP CSI-RS trigger – 0, 1, or 2 bits as defined in Subclause 5.1.4.2 of [6, TS38.214]. The bit width for this field is determined as $\lceil \log_2(n_{zP} + 1) \rceil$ bits, where n_{zP} is the number of ZP CSI-RS resource sets in the higher layer parameter *zP-CSI-RS-Resource*.

For transport block 1:

- Modulation and coding scheme – 5 bits as defined in Subclause 5.1.3.1 of [6, TS38.214]
- New data indicator – 1 bit
- Redundancy version – 2 bits as defined in Table 7.3.1.1.1-2

For transport block 2 (only present if *maxNrofCodeWordsScheduledByDCI* equals 2

- Modulation and coding scheme – 5 bits as defined in Subclause 5.1.3.1 of [6, TS38.214]
- New data indicator – 1 bit
- Redundancy version – 2 bits as defined in Table 7.3.1.1.1-2

If “Bandwidth part indicator” field indicates a bandwidth part other than the active bandwidth part and the value of *maxNrofCodeWordsScheduledByDCI* for the indicated bandwidth part equals 2 and the value of *maxNrofCodeWordsScheduledByDCI* for the active bandwidth part equals 1, the UE assumes zeros are padded when interpreting the “Modulation and coding scheme”, “New data indicator”, and “Redundancy version” fields of transport block 2 according to Subclause 12 of [5, TS38.213], and the UE ignores the “Modulation and coding scheme”, “New data indicator”, and “Redundancy version” fields of transport block 2 for the indicated bandwidth part.

- HARQ process number – 4 bits
- Downlink assignment index – number of bits as defined in the following
 - 4 bits if more than one serving cell are configured in the DL and the higher layer parameter *pdsch-HARQ-ACK-Codebook=dynamic*, where the 2 MSB bits are the counter DAI and the 2 LSB bits are the total DAI;
 - 2 bits if only one serving cell is configured in the DL and the higher layer parameter *pdsch-HARQ-ACK-Codebook=dynamic*, where the 2 bits are the counter DAI;
 - 0 bits otherwise.
- TPC command for scheduled PUCCH – 2 bits as defined in Subclause 7.2.1 of [5, TS38.213]
- PUCCH resource indicator – 3 bits as defined in Subclause 9.2.3 of [5, TS38.213]

- PDSCH-to-HARQ_feedback timing indicator – 3 0, 1, 2, or bits as defined in Subclause 9.2.3 of [5, TS38.213]. The bit width for this field is determined as $\lceil \log_2(I) \rceil$ bits, where I is the number of entries in the higher layer parameter *dl-DataToUL-ACK*.
- Antenna port(s) – 4, 5, or 6 bits as defined by Tables 7.3.1.2.2-1/2/3/4, where the number of CDM groups without data of values 1, 2, and 3 refers to CDM groups {0}, {0,1}, and {0, 1,2} respectively. The antenna ports $\{p_0, \dots, p_{v-1}\}$ shall be determined according to the ordering of DMRS port(s) given by Tables 7.3.1.2.2-1/2/3/4.

If a UE is configured with both *dmrs-DownlinkForPDSCH-MappingTypeA* and *dmrs-DownlinkForPDSCH-MappingTypeB*, the bit width of this field equals $\max\{x_A, x_B\}$, where x_A is the “Antenna ports” bit width derived according to *dmrs-DownlinkForPDSCH-MappingTypeA* and x_B is the “Antenna ports” bit width derived according to *dmrs-DownlinkForPDSCH-MappingTypeB*. A number of $|x_A - x_B|$ zeros are padded in the MSB of this field, if the mapping type of the PDSCH corresponds to the smaller value of x_A and x_B .

- Transmission configuration indication – 0 bit if higher layer parameter *tci-PresentInDCI* is not enabled; otherwise 3 bits as defined in Subclause 5.1.5 of [6, TS38.214].

If “Bandwidth part indicator” field indicates a bandwidth part other than the active bandwidth part and the “Transmission configuration indication” field is not present in the DCI format 1_1, the UE assumes *tci-PresentInDCI* is not enabled for the indicated bandwidth part.

- SRS request – 2 bits as defined by Table 7.3.1.1.2-24 for UEs not configured with SUL in the cell; 3 bits for UEs configured SUL in the cell where the first bit is the non-SUL/SUL indicator as defined in Table 7.3.1.1.1-1 and the second and third bits are defined by Table 7.3.1.1.2-24. This bit field may also indicate the associated CSI-RS according to Subclause 6.1.1.2 of [6, TS 38.214].
- CBG transmission information (CBGTI) – 0, 2, 4, 6, or 8 bits as defined in Subclause 5.1.7 of [6, TS38.214], determined by the higher layer parameters *maxCodeBlockGroupsPerTransportBlock* and *Number-MCS-HARQ-DL-DCI* for the PDSCH.
- CBG flushing out information (CBGFI) – 0 or 1 bit as defined in Subclause 5.1.7 of [6, TS38.214], determined by higher layer parameter *codeBlockGroupFlushIndicator*.
- DMRS sequence initialization – 1 bit if both *scramblingID0* and *scramblingID1* are configured in *DMRS-DownlinkConfig* for n_{SCID} selection defined in Subclause 7.4.1.1.1 of [4, TS38.211]; 0 bit otherwise.

[TS 38.214, clause 5.1.2.1]

When the UE is scheduled to receive PDSCH by a DCI, the *Time domain resource assignment* field value m of the DCI provides a row index $m + 1$ to an allocation table. The determination of the used resource allocation table is defined in sub-clause 5.1.2.1.1. The indexed row defines the slot offset K_0 , the start and length indicator *SLIV*, or directly the start symbol S and the allocation length L , and the PDSCH mapping type to be assumed in the PDSCH reception.

Given the parameter values of the indexed row:

- The slot allocated for the PDSCH is $\left\lfloor n \cdot \frac{2^{\mu_{\text{PDSCH}}}}{2^{\mu_{\text{PDCCH}}}} \right\rfloor + K_0$, where n is the slot with the scheduling DCI, and K_0 is based on the numerology of PDSCH, and μ_{PDSCH} and μ_{PDCCH} are the subcarrier spacing configurations for PDSCH and PDCCH, respectively, and
- The starting symbol S relative to the start of the slot, and the number of consecutive symbols L counting from the symbol S allocated for the PDSCH are determined from the start and length indicator *SLIV*:

if $(L-1) \leq 7$ then

$$SLIV = 14 \cdot (L-1) + S$$

else

$$SLIV = 14 \cdot (14 - L + 1) + (14 - 1 - S)$$

where $0 < L \leq 14 - S$, and

- The PDSCH mapping type is set to Type A or Type B as defined in sub-clause 7.4.1.1.2 of [4, TS 38.211].

The UE shall consider the S and L combinations defined in table 5.1.2.1-1 as valid PDSCH allocations:

Table 5.1.2.1-1: Valid S and L combinations

PDSCH mapping type	Normal cyclic prefix			Extended cyclic prefix		
	S	L	$S+L$	S	L	$S+L$
Type A	{0,1,2,3} (Note 1)	{3,...,14}	{3,...,14}	{0,1,2,3} (Note 1)	{3,...,12}	{3,...,12}
Type B	{0,...,12}	{2,4,7}	{2,...,14}	{0,...,10}	{2,4,6}	{2,...,12}
Note 1: $S = 3$ is applicable only if $dmrs\text{-}TypeA\text{-}Position = 3$						

[TS 38.214, clause 5.1.2.2.1]

In downlink resource allocation of type 0, the resource block assignment information includes a bitmap indicating the Resource Block Groups (RBGs) that are allocated to the scheduled UE where a RBG is a set of consecutive virtual resource blocks defined by higher layer parameter $rbg\text{-}Size$ configured for PDSCH and the size of the carrier bandwidth part as defined in Table 5.1.2.2.1-1.

Table 5.1.2.2.1-1: Nominal RBG size P

Bandwidth Part Size	Configuration 1	Configuration 2
1 – 36	2	4
37 – 72	4	8
73 – 144	8	16
145 – 275	16	16

The total number of RBGs (N_{RBG}) for a downlink carrier bandwidth part i of size $N_{BWP,i}^{size}$ PRBs is given by

$$N_{RBG} = \left\lfloor \left(N_{BWP,i}^{size} + \left(N_{BWP,i}^{start} \bmod P \right) \right) / P \right\rfloor, \text{ where}$$

- the size of the first RBG is $RBG_0^{size} = P - N_{BWP,i}^{start} \bmod P$,
- the size of last RBG is $RBG_{last}^{size} = \left(N_{BWP,i}^{start} + N_{BWP,i}^{size} \right) \bmod P$ if $\left(N_{BWP,i}^{start} + N_{BWP,i}^{size} \right) \bmod P > 0$ and P otherwise,
- the size of all other RBGs is P .

The bitmap is of size N_{RBG} bits with one bitmap bit per RBG such that each RBG is addressable. The RBGs shall be indexed in the order of increasing frequency and starting at the lowest frequency of the carrier bandwidth part. The order of RBG bitmap is such that RBG 0 to RBG $N_{RBG} - 1$ are mapped from MSB to LSB. The RBG is allocated to the UE if the corresponding bit value in the bitmap is 1, the RBG is not allocated to the UE otherwise.

[TS 38.214, clause 5.1.2.2.2]

In downlink resource allocation of type 1, the resource block assignment information indicates to a scheduled UE a set of contiguously allocated localized or distributed virtual resource blocks within the active carrier bandwidth part of size N_{BWP}^{size} PRBs except for the case when DCI format 1_0 is decoded in the common search space in CORESET 0 in which case the initial bandwidth part of size N_{BWP}^{size} shall be used.

A downlink type 1 resource allocation field consists of a resource indication value (RIV) corresponding to a starting virtual resource block (RB_{start}) and a length in terms of contiguously allocated resource blocks L_{RBs} . The resource indication value is defined by

$$\text{if } (L_{RBs} - 1) \leq \left\lfloor N_{BWP}^{size} / 2 \right\rfloor \text{ then}$$

$$RIV = N_{BWP}^{size} (L_{RBs} - 1) + RB_{start}$$

else

$$RIV = N_{BWP}^{size} (N_{BWP}^{size} - L_{RBs} + 1) + (N_{BWP}^{size} - 1 - RB_{start})$$

where $L_{RBs} \geq 1$ and shall not exceed $N_{BWP}^{size} - RB_{start}$.

[TS 38.214, clause 5.1.3]

To determine the modulation order, target code rate, and transport block size(s) in the physical downlink shared channel, the UE shall first

- read the 5-bit *modulation and coding scheme* field (I_{MCS}) in the DCI to determine the modulation order (Q_m) and target code rate (R) based on the procedure defined in Subclause 5.1.3.1, and
- read *redundancy version* field (rv) in the DCI to determine the redundancy version.

and second

- the UE shall use the number of layers (v), the total number of allocated PRBs before rate matching (n_{PRB}) to determine the transport block size based on the procedure defined in Subclause 5.1.3.2.

The UE may skip decoding a transport block in an initial transmission if the effective channel code rate is higher than 0.95, where the effective channel code rate is defined as the number of downlink information bits (including CRC bits) divided by the number of physical channel bits on PDSCH. If the UE skips decoding, the physical layer indicates to higher layer that the transport block is not successfully decoded.

[TS 38.214, clause 5.1.3.1]

For the PDSCH scheduled by a PDCCH with DCI format 1_0 or format 1_1 with CRC scrambled by C-RNTI, new-RNTI, TC-RNTI, CS-RNTI, SI-RNTI, RA-RNTI, or P-RNTI,

if the higher layer parameter *mcs-Table* given by *PDSCH-Config* is set to 'qam256', and the PDSCH is scheduled by a PDCCH with a DCI format 1_1 and the CRC is scrambled by C-RNTI or CS-RNTI

- the UE shall use I_{MCS} and Table 5.1.3.1-2 to determine the modulation order (Q_m) and Target code rate (R) used in the physical downlink shared channel.

elseif the UE is not configured with new-RNTI, the higher layer parameter *mcs-Table* given by *PDSCH-Config* is set to 'qam64LowSE', and the PDSCH is scheduled with C-RNTI, and the PDSCH is assigned by a PDCCH in a UE-specific search space

- the UE shall use I_{MCS} and Table 5.1.3.1-3 to determine the modulation order (Q_m) and Target code rate (R) used in the physical downlink shared channel.

elseif the UE is configured with new-RNTI, and the PDSCH is scheduled with new-RNTI

- the UE shall use I_{MCS} and Table 5.1.3.1-3 to determine the modulation order (Q_m) and Target code rate (R) used in the physical downlink shared channel.

elseif the UE is not configured with the higher layer parameter *mcs-Table* given by *SPS-config*, the higher layer parameter *mcs-Table* given by *PDSCH-Config* is set to 'qam256', the PDSCH is scheduled with CS-RNTI, and the PDSCH is assigned by a PDCCH with DCI format 1_1

- the UE shall use I_{MCS} and Table 5.1.3.1-2 to determine the modulation order (Q_m) and Target code rate (R) used in the physical downlink shared channel.

elseif the UE is configured with the higher layer parameter *mcs-Table* given by *SPS-config* set to 'qam64LowSE', and the PDSCH is scheduled with CS-RNTI

- the UE shall use I_{MCS} and Table 5.1.3.1-3 to determine the modulation order (Q_m) and Target code rate (R) used in the physical downlink shared channel.

else

- the UE shall use I_{MCS} and Table 5.1.3.1-1 to determine the modulation order (Q_m) and Target code rate (R) used in the physical downlink shared channel.

End

The UE is not expected to decode a PDSCH scheduled with P-RNTI, RA-RNTI, SI-RNTI and $Q_m > 2$

Table 5.1.3.1-1: MCS index table 1 for PDSCH

MCS Index I_{MCS}	Modulation Order Q_m	Target code Rate $R \times [1024]$	Spectral efficiency
0	2	120	0.2344
1	2	157	0.3066
2	2	193	0.3770
3	2	251	0.4902
4	2	308	0.6016
5	2	379	0.7402
6	2	449	0.8770
7	2	526	1.0273
8	2	602	1.1758
9	2	679	1.3262
10	4	340	1.3281
11	4	378	1.4766
12	4	434	1.6953
13	4	490	1.9141
14	4	553	2.1602
15	4	616	2.4063
16	4	658	2.5703
17	6	438	2.5664
18	6	466	2.7305
19	6	517	3.0293
20	6	567	3.3223
21	6	616	3.6094
22	6	666	3.9023
23	6	719	4.2129
24	6	772	4.5234
25	6	822	4.8164
26	6	873	5.1152
27	6	910	5.3320
28	6	948	5.5547
29	2	reserved	
30	4	reserved	
31	6	reserved	

[TS 38.214, clause 5.1.3.2]

In case the higher layer parameter *maxNrofCodeWordsScheduledByDCI* indicates that two codeword transmission is enabled, then a transport block is disabled by DCI format 1_1 if $I_{MCS} = 26$ and if $rv_{id} = 1$ for the corresponding transport block, otherwise the transport block is enabled. If both transport blocks are enabled, transport block 1 and 2 are mapped to codeword 0 and 1 respectively. If only one transport block is enabled, then the enabled transport block is always mapped to the first codeword.

For the PDSCH assigned by a PDCCH with DCI format 1_0 or format 1_1 with CRC scrambled by C-RNTI, new-RNTI, TC-RNTI, CS-RNTI, or SI-RNTI, if Table 5.1.3.1-2 is used and $0 \leq I_{MCS} \leq 27$, or a table other than Table 5.1.3.1-2 is used and $0 \leq I_{MCS} \leq 28$, the UE shall, except if the transport block is disabled in DCI format 1_1, first determine the TBS as specified below:

- 1) The UE shall first determine the number of REs (N_{RE}) within the slot.

- A UE first determines the number of REs allocated for PDSCH within a PRB (N'_{RE}) by

$$N'_{RE} = N_{sc}^{RB} \cdot N_{symb}^{sh} - N_{DMRS}^{PRB} - N_{oh}^{PRB}, \text{ where } N_{sc}^{RB} = 12 \text{ is the number of subcarriers in a physical resource}$$

block, $N_{\text{symp}}^{\text{sh}}$ is the number of symbols of the PDSCH allocation within the slot, $N_{\text{DMRS}}^{\text{PRB}}$ is the number of REs for DM-RS per PRB in the scheduled duration including the overhead of the DM-RS CDM groups without data, as indicated by DCI format 1_1 or as described for format 1_0 in Subclause 5.1.6.2, and $N_{\text{oh}}^{\text{PRB}}$ is the overhead configured by higher layer parameter $x\text{Overhead}$ in *PDSCH-ServingCellConfig*. If the $x\text{Overhead}$ in *PDSCH-ServingCellconfig* is not configured (a value from 0, 6, 12, or 18), the $N_{\text{oh}}^{\text{PRB}}$ is set to 0. If the PDSCH is scheduled by PDCCH with a CRC scrambled by SI-RNTI, RA-RNTI or P-RNTI, $N_{\text{oh}}^{\text{PRB}}$ is assumed to be 0.

- A UE determines the total number of REs allocated for PDSCH (N_{RE}) by $N_{\text{RE}} = \min(156, N_{\text{RE}}^{\prime}) \cdot n_{\text{PRB}}$, where n_{PRB} is the total number of allocated PRBs for the UE.

2) Intermediate number of information bits (N_{info}) is obtained by $N_{\text{info}} = N_{\text{RE}} \cdot R \cdot Q_m \cdot \nu$.

If $N_{\text{info}} \leq 3824$

Use step 3 as the next step of the TBS determination

else

Use step 4 as the next step of the TBS determination

end if

3) When $N_{\text{info}} \leq 3824$, TBS is determined as follows

- quantized intermediate number of information bits $N_{\text{info}}^{\prime} = \max\left(24, 2^n \cdot \left\lfloor \frac{N_{\text{info}}}{2^n} \right\rfloor\right)$, where $n = \max(3, \lfloor \log_2(N_{\text{info}}) \rfloor - 6)$.
- use Table 5.1.3.2-2 find the closest TBS that is not less than N_{info}^{\prime} .

Table 5.1.3.2-2: TBS for $N_{info} \leq 3824$

Index	TBS	Index	TBS	Index	TBS	Index	TBS
1	24	31	336	61	1288	91	3624
2	32	32	352	62	1320	92	3752
3	40	33	368	63	1352	93	3824
4	48	34	384	64	1416		
5	56	35	408	65	1480		
6	64	36	432	66	1544		
7	72	37	456	67	1608		
8	80	38	480	68	1672		
9	88	39	504	69	1736		
10	96	40	528	70	1800		
11	104	41	552	71	1864		
12	112	42	576	72	1928		
13	120	43	608	73	2024		
14	128	44	640	74	2088		
15	136	45	672	75	2152		
16	144	46	704	76	2216		
17	152	47	736	77	2280		
18	160	48	768	78	2408		
19	168	49	808	79	2472		
20	176	50	848	80	2536		
21	184	51	888	81	2600		
22	192	52	928	82	2664		
23	208	53	984	83	2728		
24	224	54	1032	84	2792		
25	240	55	1064	85	2856		
26	256	56	1128	86	2976		
27	272	57	1160	87	3104		
28	288	58	1192	88	3240		
29	304	59	1224	89	3368		
30	320	60	1256	90	3496		

4) When $N_{info} > 3824$, TBS is determined as follows.

- quantized intermediate number of information bits $N'_{info} = \max\left(3840, 2^n \times \text{round}\left(\frac{N_{info} - 24}{2^n}\right)\right)$, where $n = \lfloor \log_2(N_{info} - 24) \rfloor - 5$ and ties in the round function are broken towards the next largest integer.
- if $R \leq 1/4$

$$TBS = 8 \cdot C \cdot \left\lceil \frac{N'_{info} + 24}{8 \cdot C} \right\rceil - 24, \text{ where } C = \left\lceil \frac{N'_{info} + 24}{3816} \right\rceil$$

else

if $N'_{info} > 8424$

$$TBS = 8 \cdot C \cdot \left\lceil \frac{N'_{info} + 24}{8 \cdot C} \right\rceil - 24, \text{ where } C = \left\lceil \frac{N'_{info} + 24}{8424} \right\rceil$$

else

$$TBS = 8 \cdot \left\lceil \frac{N'_{info} + 24}{8} \right\rceil - 24$$

end if

end if

7.1.1.4.1.3.3 Test description

7.1.1.4.1.3.3.1 Pre-test conditions

Same Pre-test conditions as in clause 7.1.1.0 except set the NR Cell bandwidth and applicable BWP to maximum for the NR Band under test as specified in Table 5.3.5-1 in TS 38.101-1 [16] / TS 38.101-2 [17] (to enable testing of n_{PRB} up to maximum value).

Test frequency NRf1 is as specified in TS 38.508-1 [4] clause 4.3.1 using the common highest UL and DL channel bandwidth and using the default subcarrier spacing specified in TS 38.508-1 [4] clause 6.2.3.1.

7.1.1.4.1.3.3.2 Test procedure sequence

Table 7.1.1.4.1.3.3.2-1: Maximum TBS for different UE categories

UE Category	Maximum number of bits of a UL-SCH transport block received within a TTI
TS 38.306 [23] clause 4.1.2 require UE without <i>ue-CategoryDL</i> and <i>ue-CategoryUL</i> , to support Max TBS achievable based on max bandwidth of the Band under test.	

Table 7.1.1.4.1.3.3.2-2: Number of downlink PDCP SDUs and PDCP SDU size used as test data

TBS [bits]	Number of PDCP SDUs	PDCP SDU size [bits] (Note 1)
$192 \leq \text{TBS} \leq 12184$ note 2	1	$8 * \text{FLOOR}((\text{TBS} - 184)/8)$
$12185 \leq \text{TBS} \leq 24256$	2	$8 * \text{FLOOR}((\text{TBS} - 256)/16)$
$24257 \leq \text{TBS} \leq 36328$	3	$8 * \text{FLOOR}((\text{TBS} - 328)/24)$
$36329 \leq \text{TBS} \leq 48400$	4	$8 * \text{FLOOR}((\text{TBS} - 400)/32)$
$48401 \leq \text{TBS} \leq 60472$	5	$8 * \text{FLOOR}((\text{TBS} - 472)/40)$
$60473 \leq \text{TBS} \leq 72544$	6	$8 * \text{FLOOR}((\text{TBS} - 544)/48)$
$72545 \leq \text{TBS} \leq 84616$	7	$8 * \text{FLOOR}((\text{TBS} - 616)/56)$
$84617 \leq \text{TBS} \leq 96688$	8	$8 * \text{FLOOR}((\text{TBS} - 688)/64)$
$96689 < \text{TBS} \leq 108760$	9	$8 * \text{FLOOR}((\text{TBS} - 760)/72)$
$108761 \leq \text{TBS} \leq 120832$	10	$8 * \text{FLOOR}((\text{TBS} - 832)/80)$
$120833 \leq \text{TBS} \leq 132904$	11	$8 * \text{FLOOR}((\text{TBS} - 904)/88)$
$132905 \leq \text{TBS} \leq 144976$	12	$8 * \text{FLOOR}((\text{TBS} - 976)/96)$
$\text{TBS} > 144976$	13	$8 * \text{FLOOR}((\text{TBS} - 1048)/104)$
<p>Note 1: Each PDCP SDU is limited to 1500 octets (to keep below maximum SDU size of ESM as specified in TS 24.301 [21] clause 9.9.4.12).</p> <p>The PDCP SDU size of each PDCP SDU is</p> <p>PDCP SDU size = (TBS – N*PDCP header size – N*AMD PDU header size – N*MAC header size – Size of Timing Advance – RLC Status PDU size- MAC header for RLC Status PDU – 32 bit Additional RLC header with SO if one RLC SDU gets split in 2 TBS and 24 bit MAC header for this additional PDU) / N, where</p> <p>PDCP header size is 24 bits for the RLC AM and 18-bit SN case; AMD PDU header size is 24 bits with 18 bit SN;</p> <p>MAC header size for AMD PDU = 16 or 24 bits depending on L=8 or 16 bits. Worst case 24 is taken.</p> <p>Size of Timing Advance MAC CE with header is 16 bits (if no Timing Advance and/or RLC status needs to be sent, padding will occur instead). IF RLC SDU does not get split the 32 bits additional padding gets added instead</p> <p>RLC Status PDU size = 24 bits with 1 ACK_SN, With a MAC header of 16 bits.</p> <p>This gives:</p> <p>PDCP SDU size = $8 * \text{FLOOR}((\text{TBS} - N * 24 - N * 24 - N * 24 - 112) / (8 * N))$ bits.</p>		
<p>Note 2: According to the final PDCP SDU size formula in Note 1, the smallest TBS that can be tested is 192 bits.</p>		

Table 7.1.1.4.1.3.3.2-2A: Bandwidth part Dependent Parameters for Resource allocation 0 with start of BWP assumed as 0

$N_{RB}^{DL,BWP} = N_{BWP,i}^{size}$	Nominal RBG size P (Configuration1)	Size of last RBG	Allowed N_{PRB} Values
11	2	1	All 1...11
18	2	2	2,4,6,8,10,12,16,18
24	2	2	2,4,6,8,10,12,16,18,20,22,24
25	2	1	All 1...25
31	2	1	All 1...31
32	2	2	2,4,6,8,10,12,16,18,20,22,24,26,28,30,32
38	4	2	2,4,6,8,10,12,16,18,20,22,24,26,28,30,32,34,36,38
51	4	3	3,4,7,8,11,12,15,16,19,20,23,24,27,28,31,32,35,36,39,40,43,44,47,48,51
52	4	4	4,8,12,16,20,24,28,32,36,40,44,48,52
65	4	1	1,4,5,8,9,12,13,16,17,20,21,24,25,28,29,32,33,36,37,40,41,44,45,48,49,52,53,56,57,60,61,64,65
66	4	2	2,4,6,8,10,12,16,18,20,22,24,26,28,30,32,34,36,38,40,42,44,46,48,50,52,54,56,58,60,62,64,66
79	8	7	7,8,15,16,23,24,31,32,39,40,47,48,55,56,63,64,71,72,79
106	8	2	2,8,10,16,18,24,26,32,34,40,42,48,50,56,58,64,66,72,74,80,82,88,90,96,92,104,106
107	8	3	3,8,11,16,19,24,27,32,35,40,43,48,51,56,59,64,67,72,75,80,83,88,91,96,99,104,107
132	8	4	4,8,12,16,20,24,28,32,36,40,44,48,52,56,60,64,68,72,76,80,84,88,92,96,100,104,108,112,116,120,124,128,132
133	8	5	5,8,13,16,21,24,29,32,37,40,45,48,53,56,61,64,69,72,77,80,85,88,93,96,101,104,109,112,117,120,125,128,133
135	8	7	7,8,15,16,23,24,31,32,39,40,47,48,55,56,63,64,71,72,79,80,87,88,95,96,103,104,111,112,119,120,127,128,135
216	16	8	8,16,24,32,40,48,56,64,72,80,88,96,104,112,120,128,136,144,152,160,168,176,184,192,200,208,216
217	16	9	9,16,25,32,41,48,57,64,73,80,89,96,105,112,121,128,137,144,153,160,169,176,185,192,201,208,217
264	16	8	8,16,24,32,40,48,56,64,72,80,88,96,104,112,120,128,136,144,160,168,176,184,192,200,208,216,224,232,240,248,256,264
270	16	14	14,16,30,32,46,44,62,64,78,80,94,96,110,112,126,128,142,144,158,160,174,176,190,192,206,208,222,224,238,240,254,256,270
273	16	1	1,16,17,32,33,48,49,64,65,80,81,96,97,112,113,128,129,144,145,160,161,176,171,192,193,208,209,224,225,240,241,256,257,272,273

Table 7.1.1.4.1.3.3.2-3: Specific Parameter

Parameter	Value	Comments
number of layers (v)	1	
mcs-Table	qam64	
resourceAllocation	dynamicSwitch	
maxNrofCodeWordsScheduledByDCI	n2	both codewords enabled
N_{BWP}^{start}	0	

Table 7.1.1.4.1.3.3.2-4: Main behaviour

St	Procedure	Message Sequence		TP	Verdict
		U - S	Message		
-	EXCEPTION: Steps 1 to 5 are repeated for allowed values of N_{PRB} as per table 7.1.1.4.1.3.3.2-2A in BWP, time domain resource as per table 7.1.1.4.1.0-1 and I_{MCS} from 0 to 28.	-	-	-	-
1	SS calculates or looks up TBS in TS 38.214 [15] based on the value of S, L, I_{MCS} and n_{PRB} . The SS uses the same I_{MCS} and TBS for both transport blocks: $I_{MCS\#1} = I_{MCS\#2} = I_{MCS}$ TBS 1= TBS 2= TBS	-	-	-	-
-	EXCEPTION: Steps 2 to 5 are performed if TBS1 + TBS2 is less than or equal to UE capability "Maximum number of DL-SCH transport block bits received within a TTI" as specified in Table 7.1.1.4.1.3.3.2-1 and larger than or equal to 192 bits as specified in Table 7.1.1.4.1.3.3.2-2.	-	-	-	-
2	SS creates one or more PDCP SDUs for transport block 1 and 2 depending on TBS1, and TBS2 in accordance with Table 7.1.1.4.1.3.3.2-2.	-	-	-	-
3	SS transmits the PDCP SDUs concatenated into a MAC PDU and indicates on PDCCH DCI Format 1_1 resource allocation 0 and values of S, L, $I_{MCS\#1}$, $I_{MCS\#2}$ and n_{PRB} .	<--	Transport block 1: MAC PDU Transport block 2: MAC PDU DCI: (DCI Format 1_1, S, L, $I_{MCS\#1}$, $I_{MCS\#2}$ and n_{PRB} .)	-	-
4	At the reception of scheduling request the SS transmits UL Grant for transmitting loop back PDCP SDUs.	<--	(UL Grant)	-	-
5	CHECK: Does UE return the same number of PDCP SDUs with same content as transmitted by the SS in step 3?	-->	(NxPDCP SDUs)	1	P
-	EXCEPTION: Steps 6 to 10 are repeated for allowed values of N_{PRB} 1 to $N_{RB}^{DL,BWP}$ in BWP, time domain resource as per table 7.1.1.4.1.0-1 and I_{MCS} from 0 to 28.	-	-	-	-
6	SS calculates or looks up TBS in TS 38.214 [15] based on the value of S, L, I_{MCS} and n_{PRB} . The SS uses the same I_{MCS} and TBS for both transport blocks: $I_{MCS\#1} = I_{MCS\#2} = I_{MCS}$ TBS 1= TBS 2= TBS	-	-	-	-
-	EXCEPTION: Steps 7 to 10 are performed if TBS1 + TBS2 is less than or equal to UE capability "Maximum number of DL-SCH transport block bits received within a TTI" as specified in Table 7.1.1.4.1.3.3.2-1 and larger than or equal to 192 bits as specified in Table 7.1.1.4.1.3.3.2-2.	-	-	-	-

7	SS creates one or more PDCP SDUs for transport block 1 and 2 depending on TBS1, and TBS2 in accordance with Table 7.1.1.4.1.3.3.2-2.	-	-	-	-
8	SS transmits the PDCP SDUs concatenated into a MAC PDU and indicates on PDCCH DCI Format 1_1 resource allocation 1 and values of S, L, $I_{MCS\#1}$, $I_{MCS\#2}$ and n_{PRB} .	<--	Transport block 1: MAC PDU Transport block 2: MAC PDU DCI: (DCI Format 1_1, S, L, $I_{MCS\#1}$, $I_{MCS\#2}$ and n_{PRB})	-	-
9	At the reception of scheduling request the SS transmits UL Grant for transmitting loop back PDCP SDUs.	<--	(UL Grant)	-	-
10	CHECK: Does UE return the same number of PDCP SDUs with same content as transmitted by the SS in step 3?	-->	(NxPDCP SDUs)	2	P

7.1.1.4.1.3.3.3 Specific message contents

Table 7.1.1.4.1.3.3.3-1: SearchSpace

Derivation Path: TS 38.508-1 [4], Table 4.6.3-162 with Condition USS			
Information Element	Value/remark	Comment	Condition
SearchSpace ::= SEQUENCE {			
searchSpaceType CHOICE {			
ue-Specific SEQUENCE {			
dci-Formats	formats0-1-And-1-1		
}			
}			
}			

7.1.1.4.1.4 DL-SCH transport block size selection / DCI format 1_1 / RA type 0/RA Type 1 / 2 Codewords enabled / 256QAM

7.1.1.4.1.4.1 Test Purpose (TP)

(1)

```
with { UE in RRC_CONNECTED state, maxNrofCodeWordsScheduledByDCI set to 'n2' and mcs-Table is set as 'qam256' }
ensure that {
  when { UE on PDCCH receives DCI format 1_1 indicating resource allocation type 0 a resource block assignment correspondent to physical resource blocks, Time domain resource assignment and a modulation and coding }
  then { UE decodes the received transport block of size correspondent as per Modulation Coding scheme, time domain resource allocation and PRB's and forwards it to higher layers }
}
```

(2)

```
with { UE in RRC_CONNECTED state, maxNrofCodeWordsScheduledByDCI set to 'n2' and mcs-Table is set as 'qam256' }
ensure that {
  when { UE on PDCCH receives DCI format 1_1 indicating resource allocation type 1 a resource block assignment correspondent to physical resource blocks, Time domain resource assignment and a modulation and coding }
  then { UE decodes the received transport block of size correspondent as per Modulation Coding scheme, time domain resource allocation and PRB's and forwards it to higher layers }
}
```

7.1.1.4.1.4.2 Conformance requirements

References: The conformance requirements covered in the present TC are specified in: TS 38.212 clause 7.3.1.2.2, TS 38.214 clauses 5.1.2.1, 5.1.2.2.1, 5.1.2.2.2, 5.1.3, 5.1.3.1 and 5.1.3.2. Unless otherwise stated these are Rel-15 requirements.

[TS 38.212, clause 7.3.1.2.2]

DCI format 1_1 is used for the scheduling of PDSCH in one cell.

The following information is transmitted by means of the DCI format 1_1 with CRC scrambled by C-RNTI or CS-RNTI or new-RNTI:

- Identifier for DCI formats – 1 bits
- The value of this bit field is always set to 1, indicating a DL DCI format
- Carrier indicator – 0 or 3 bits as defined in Subclause 10.1 of [5, TS38.213].
- Bandwidth part indicator – 0, 1 or 2 bits as determined by the number of DL BWPs $n_{\text{BWP,RRC}}$ configured by higher layers, excluding the initial DL bandwidth part. The bit width for this field is determined as $\lceil \log_2(n_{\text{BWP}}) \rceil$ bits, where
 - $n_{\text{BWP}} = n_{\text{BWP,RRC}} + 1$ if $n_{\text{BWP,RRC}} \leq 3$, in which case the bandwidth part indicator is equivalent to the higher layer parameter *BWP-Id*;
 - otherwise $n_{\text{BWP}} = n_{\text{BWP,RRC}}$, in which case the bandwidth part indicator is defined in Table 7.3.1.1.2-1;

If a UE does not support active BWP change via DCI, the UE ignores this bit field.

- Frequency domain resource assignment – number of bits determined by the following, where $N_{\text{RB}}^{\text{DL,BWP}}$ is the size of the active DL bandwidth part:
 - N_{RBG} bits if only resource allocation type 0 is configured, where N_{RBG} is defined in Subclause 5.1.2.2.1 of [6, TS38.214],
 - $\lceil \log_2(N_{\text{RB}}^{\text{DL,BWP}}(N_{\text{RB}}^{\text{DL,BWP}} + 1)/2) \rceil$ bits if only resource allocation type 1 is configured, or
 - $\max(\lceil \log_2(N_{\text{RB}}^{\text{DL,BWP}}(N_{\text{RB}}^{\text{DL,BWP}} + 1)/2) \rceil, N_{\text{RBG}}) + 1$ bits if both resource allocation type 0 and 1 are configured.
 - If both resource allocation type 0 and 1 are configured, the MSB bit is used to indicate resource allocation type 0 or resource allocation type 1, where the bit value of 0 indicates resource allocation type 0 and the bit value of 1 indicates resource allocation type 1.
 - For resource allocation type 0, the N_{RBG} LSBs provide the resource allocation as defined in Subclause 5.1.2.2.1 of [6, TS38.214].
 - For resource allocation type 1, the $\lceil \log_2(N_{\text{RB}}^{\text{DL,BWP}}(N_{\text{RB}}^{\text{DL,BWP}} + 1)/2) \rceil$ LSBs provide the resource allocation as defined in Subclause 5.1.2.2.2 of [6, TS38.214]

If “Bandwidth part indicator” field indicates a bandwidth part other than the active bandwidth part and if both resource allocation type 0 and 1 are configured for the indicated bandwidth part, the UE assumes resource allocation type 0 for the indicated bandwidth part if the bit width of the “Frequency domain resource assignment” field of the active bandwidth part is smaller than the bit width of the “Frequency domain resource assignment” field of the indicated bandwidth part.

- Time domain resource assignment – 0, 1, 2, 3, or 4 bits as defined in Subclause 5.1.2.1 of [6, TS38.214]. The bit width for this field is determined as $\lceil \log_2(I) \rceil$ bits, where I is the number of entries in the higher layer parameter *pusch-AllocationList*.

- VRB-to-PRB mapping – 0 or 1 bit
 - 0 bit if only resource allocation type 0 is configured;
 - 1 bit according to Table 7.3.1.1.2-33 otherwise, only applicable to resource allocation type 1, as defined in Subclause 7.3.1.6 of [4, TS38.211].
- PRB bundling size indicator – 0 bit if the higher layer parameter *prb-BundlingType* is not configured or is set to ‘static’, or 1 bit if the higher layer parameter *prb-BundlingType* is set to ‘dynamic’, according to Subclause 5.1.2.3 of [6, TS38.214].
- Rate matching indicator – 0, 1, or 2 bits according to higher layer parameter *rateMatchPattern*.
- ZP CSI-RS trigger – 0, 1, or 2 bits as defined in Subclause 5.1.4.2 of [6, TS38.214]. The bit width for this field is determined as $\lceil \log_2(n_{zp} + 1) \rceil$ bits, where n_{zp} is the number of ZP CSI-RS resource sets in the higher layer parameter *zp-CSI-RS-Resource*.

For transport block 1:

- Modulation and coding scheme – 5 bits as defined in Subclause 5.1.3.1 of [6, TS38.214]
- New data indicator – 1 bit
- Redundancy version – 2 bits as defined in Table 7.3.1.1.1-2

For transport block 2 (only present if *maxNrofCodeWordsScheduledByDCI* equals 2

- Modulation and coding scheme – 5 bits as defined in Subclause 5.1.3.1 of [6, TS38.214]
- New data indicator – 1 bit
- Redundancy version – 2 bits as defined in Table 7.3.1.1.1-2

If “Bandwidth part indicator” field indicates a bandwidth part other than the active bandwidth part and the value of *maxNrofCodeWordsScheduledByDCI* for the indicated bandwidth part equals 2 and the value of *maxNrofCodeWordsScheduledByDCI* for the active bandwidth part equals 1, the UE assumes zeros are padded when interpreting the “Modulation and coding scheme”, “New data indicator”, and “Redundancy version” fields of transport block 2 according to Subclause 12 of [5, TS38.213], and the UE ignores the “Modulation and coding scheme”, “New data indicator”, and “Redundancy version” fields of transport block 2 for the indicated bandwidth part.

- HARQ process number – 4 bits
- Downlink assignment index – number of bits as defined in the following
 - 4 bits if more than one serving cell are configured in the DL and the higher layer parameter *pdsch-HARQ-ACK-Codebook=dynamic*, where the 2 MSB bits are the counter DAI and the 2 LSB bits are the total DAI;
 - 2 bits if only one serving cell is configured in the DL and the higher layer parameter *pdsch-HARQ-ACK-Codebook=dynamic*, where the 2 bits are the counter DAI;
 - 0 bits otherwise.
- TPC command for scheduled PUCCH – 2 bits as defined in Subclause 7.2.1 of [5, TS38.213]
- PUCCH resource indicator – 3 bits as defined in Subclause 9.2.3 of [5, TS38.213]
- PDSCH-to-HARQ_feedback timing indicator – 0, 1, 2, or 3 bits as defined in Subclause 9.2.3 of [5, TS38.213]. The bit width for this field is determined as $\lceil \log_2(I) \rceil$ bits, where I is the number of entries in the higher layer parameter *dl-DataToUL-ACK*.
- Antenna port(s) – 4, 5, or 6 bits as defined by Tables 7.3.1.2.2-1/2/3/4, where the number of CDM groups without data of values 1, 2, and 3 refers to CDM groups {0}, {0,1}, and {0, 1,2} respectively. The antenna ports $\{p_0, \dots, p_{v-1}\}$ shall be determined according to the ordering of DMRS port(s) given by Tables 7.3.1.2.2-1/2/3/4.

If a UE is configured with both *dmrs-DownlinkForPDSCH-MappingTypeA* and *dmrs-DownlinkForPDSCH-MappingTypeB*, the bit width of this field equals $\max\{x_A, x_B\}$, where x_A is the “Antenna ports” bit width derived according to *dmrs-DownlinkForPDSCH-MappingTypeA* and x_B is the “Antenna ports” bit width derived according to *dmrs-DownlinkForPDSCH-MappingTypeB*. A number of $|x_A - x_B|$ zeros are padded in the MSB of this field, if the mapping type of the PDSCH corresponds to the smaller value of x_A and x_B .

- Transmission configuration indication – 0 bit if higher layer parameter *tci-PresentInDCI* is not enabled; otherwise 3 bits as defined in Subclause 5.1.5 of [6, TS38.214].

If “Bandwidth part indicator” field indicates a bandwidth part other than the active bandwidth part and the “Transmission configuration indication” field is not present in the DCI format 1_1, the UE assumes *tci-PresentInDCI* is not enabled for the indicated bandwidth part.

- SRS request – 2 bits as defined by Table 7.3.1.1.2-24 for UEs not configured with SUL in the cell; 3 bits for UEs configured SUL in the cell where the first bit is the non-SUL/SUL indicator as defined in Table 7.3.1.1.1-1 and the second and third bits are defined by Table 7.3.1.1.2-24. This bit field may also indicate the associated CSI-RS according to Subclause 6.1.1.2 of [6, TS 38.214].
- CBG transmission information (CBGTI) – 0, 2, 4, 6, or 8 bits as defined in Subclause 5.1.7 of [6, TS38.214], determined by the higher layer parameters *maxCodeBlockGroupsPerTransportBlock* and *Number-MCS-HARQ-DL-DCI* for the PDSCH.
- CBG flushing out information (CBGFI) – 0 or 1 bit as defined in Subclause 5.1.7 of [6, TS38.214], determined by higher layer parameter *codeBlockGroupFlushIndicator*.
- DMRS sequence initialization – 1 bit if both *scramblingID0* and *scramblingID1* are configured in *DMRS-DownlinkConfig* for n_{SCID} selection defined in Subclause 7.4.1.1.1 of [4, TS38.211]; 0 bit otherwise.

[TS 38.214, clause 5.1.2.1]

When the UE is scheduled to receive PDSCH by a DCI, the *Time domain resource assignment* field value m of the DCI provides a row index $m + 1$ to an allocation table. The determination of the used resource allocation table is defined in sub-clause 5.1.2.1.1. The indexed row defines the slot offset K_0 , the start and length indicator *SLIV*, or directly the start symbol S and the allocation length L , and the PDSCH mapping type to be assumed in the PDSCH reception.

Given the parameter values of the indexed row:

- The slot allocated for the PDSCH is $\left\lfloor n \cdot \frac{2^{\mu_{\text{PDSCH}}}}{2^{\mu_{\text{PDCCH}}}} \right\rfloor + K_0$, where n is the slot with the scheduling DCI, and K_0 is based on the numerology of PDSCH, and μ_{PDSCH} and μ_{PDCCH} are the subcarrier spacing configurations for PDSCH and PDCCH, respectively, and
- The starting symbol S relative to the start of the slot, and the number of consecutive symbols L counting from the symbol S allocated for the PDSCH are determined from the start and length indicator *SLIV*:

if $(L-1) \leq 7$ then

$$SLIV = 14 \cdot (L-1) + S$$

else

$$SLIV = 14 \cdot (14 - L + 1) + (14 - 1 - S)$$

where $0 < L \leq 14 - S$, and

- The PDSCH mapping type is set to Type A or Type B as defined in sub-clause 7.4.1.1.2 of [4, TS 38.211].

The UE shall consider the S and L combinations defined in table 5.1.2.1-1 as valid PDSCH allocations:

Table 5.1.2.1-1: Valid S and L combinations

PDSCH mapping type	Normal cyclic prefix			Extended cyclic prefix		
	S	L	$S+L$	S	L	$S+L$
Type A	{0,1,2,3 (Note 1)}	{3,...,14}	{3,...,14}	{0,1,2,3 (Note 1)}	{3,...,12}	{3,...,12}
Type B	{0,...,12}	{2,4,7}	{2,...,14}	{0,...,10}	{2,4,6}	{2,...,12}

Note 1: $S = 3$ is applicable only if $dmrs\text{-}TypeA\text{-}Position = 3$

[TS 38.214, clause 5.1.2.2.1]

In downlink resource allocation of type 0, the resource block assignment information includes a bitmap indicating the Resource Block Groups (RBGs) that are allocated to the scheduled UE where a RBG is a set of consecutive virtual resource blocks defined by higher layer parameter $rbg\text{-}Size$ configured for PDSCH and the size of the carrier bandwidth part as defined in Table 5.1.2.2.1-1.

Table 5.1.2.2.1-1: Nominal RBG size P

Bandwidth Part Size	Configuration 1	Configuration 2
1 – 36	2	4
37 – 72	4	8
73 – 144	8	16
145 – 275	16	16

The total number of RBGs (N_{RBG}) for a downlink carrier bandwidth part i of size $N_{BWP,i}^{size}$ PRBs is given by

$$N_{RBG} = \left\lfloor \left(N_{BWP,i}^{size} + \left(N_{BWP,i}^{start} \bmod P \right) \right) / P \right\rfloor, \text{ where}$$

- the size of the first RBG is $RBG_0^{size} = P - N_{BWP,i}^{start} \bmod P$,
- the size of last RBG is $RBG_{last}^{size} = \left(N_{BWP,i}^{start} + N_{BWP,i}^{size} \right) \bmod P$ if $\left(N_{BWP,i}^{start} + N_{BWP,i}^{size} \right) \bmod P > 0$ and P otherwise,
- the size of all other RBGs is P .

The bitmap is of size N_{RBG} bits with one bitmap bit per RBG such that each RBG is addressable. The RBGs shall be indexed in the order of increasing frequency and starting at the lowest frequency of the carrier bandwidth part. The order of RBG bitmap is such that RBG 0 to RBG $N_{RBG} - 1$ are mapped from MSB to LSB. The RBG is allocated to the UE if the corresponding bit value in the bitmap is 1, the RBG is not allocated to the UE otherwise.

[TS 38.214, clause 5.1.2.2.2]

In downlink resource allocation of type 1, the resource block assignment information indicates to a scheduled UE a set of contiguously allocated localized or distributed virtual resource blocks within the active carrier bandwidth part of size N_{BWP}^{size} PRBs except for the case when DCI format 1_0 is decoded in the common search space in CORESET 0 in which case the initial bandwidth part of size N_{BWP}^{size} shall be used.

A downlink type 1 resource allocation field consists of a resource indication value (RIV) corresponding to a starting virtual resource block (RB_{start}) and a length in terms of contiguously allocated resource blocks L_{RBs} . The resource indication value is defined by

$$\text{if } (L_{RBs} - 1) \leq \left\lfloor N_{BWP}^{size} / 2 \right\rfloor \text{ then}$$

$$RIV = N_{BWP}^{size} (L_{RBs} - 1) + RB_{start}$$

else

$$RIV = N_{BWP}^{size} (N_{BWP}^{size} - L_{RBs} + 1) + (N_{BWP}^{size} - 1 - RB_{start})$$

where $L_{RBs} \geq 1$ and shall not exceed $N_{BWP}^{size} - RB_{start}$.

[TS 38.214, clause 5.1.3]

To determine the modulation order, target code rate, and transport block size(s) in the physical downlink shared channel, the UE shall first

- read the 5-bit *modulation and coding scheme* field (I_{MCS}) in the DCI to determine the modulation order (Q_m) and target code rate (R) based on the procedure defined in Subclause 5.1.3.1, and
- read *redundancy version* field (rv) in the DCI to determine the redundancy version..

and second

- the UE shall use the number of layers (v), the total number of allocated PRBs before rate matching (n_{PRB}) to determine to the transport block size based on the procedure defined in Subclause 5.1.3.2.

The UE may skip decoding a transport block in an initial transmission if the effective channel code rate is higher than 0.95, where the effective channel code rate is defined as the number of downlink information bits (including CRC bits) divided by the number of physical channel bits on PDSCH. If the UE skips decoding, the physical layer indicates to higher layer that the transport block is not successfully decoded.

[TS 38.214, clause 5.1.3.1]

For the PDSCH scheduled by a PDCCH with DCI format 1_0 or format 1_1 with CRC scrambled by C-RNTI, new-RNTI, TC-RNTI, CS-RNTI, SI-RNTI, RA-RNTI, or P-RNTI,

if the higher layer parameter *mcs-Table* given by *PDSCH-Config* is set to 'qam256', and the PDSCH is scheduled by a PDCCH with a DCI format 1_1 and the CRC is scrambled by C-RNTI or CS-RNTI

- the UE shall use I_{MCS} and Table 5.1.3.1-2 to determine the modulation order (Q_m) and Target code rate (R) used in the physical downlink shared channel.

elseif the UE is not configured with new-RNTI, the higher layer parameter *mcs-Table* given by *PDSCH-Config* is set to 'qam64LowSE', and the PDSCH is scheduled with C-RNTI, and the PDSCH is assigned by a PDCCH in a UE-specific search space

- the UE shall use I_{MCS} and Table 5.1.3.1-3 to determine the modulation order (Q_m) and Target code rate (R) used in the physical downlink shared channel.

elseif the UE is configured with new-RNTI, and the PDSCH is scheduled with new-RNTI

- the UE shall use I_{MCS} and Table 5.1.3.1-3 to determine the modulation order (Q_m) and Target code rate (R) used in the physical downlink shared channel.

elseif the UE is not configured with the higher layer parameter *mcs-Table* given by *SPS-config*, the higher layer parameter *mcs-Table* given by *PDSCH-Config* is set to 'qam256', the PDSCH is scheduled with CS-RNTI, and the PDSCH is assigned by a PDCCH with DCI format 1_1

- the UE shall use I_{MCS} and Table 5.1.3.1-2 to determine the modulation order (Q_m) and Target code rate (R) used in the physical downlink shared channel.

elseif the UE is configured with the higher layer parameter *mcs-Table* given by *SPS-config* set to 'qam64LowSE', and the PDSCH is scheduled with CS-RNTI

- the UE shall use I_{MCS} and Table 5.1.3.1-3 to determine the modulation order (Q_m) and Target code rate (R) used in the physical downlink shared channel.

else

- the UE shall use I_{MCS} and Table 5.1.3.1-1 to determine the modulation order (Q_m) and Target code rate (R) used in the physical downlink shared channel.

End

The UE is not expected to decode a PDSCH scheduled with P-RNTI, RA-RNTI, SI-RNTI and $Q_m > 2$

Table 5.1.3.1-2: MCS index table 2 for PDSCH

MCS Index I_{MCS}	Modulation Order Q_m	Target code Rate $R \times [1024]$	Spectral efficiency
0	2	120	0.2344
1	2	193	0.3770
2	2	308	0.6016
3	2	449	0.8770
4	2	602	1.1758
5	4	378	1.4766
6	4	434	1.6953
7	4	490	1.9141
8	4	553	2.1602
9	4	616	2.4063
10	4	658	2.5703
11	6	466	2.7305
12	6	517	3.0293
13	6	567	3.3223
14	6	616	3.6094
15	6	666	3.9023
16	6	719	4.2129
17	6	772	4.5234
18	6	822	4.8164
19	6	873	5.1152
20	8	682.5	5.3320
21	8	711	5.5547
22	8	754	5.8906
23	8	797	6.2266
24	8	841	6.5703
25	8	885	6.9141
26	8	916.5	7.1602
27	8	948	7.4063
28	2	reserved	
29	4	reserved	
30	6	reserved	
31	8	reserved	

[TS 38.214, clause 5.1.3.2]

In case the higher layer parameter *maxNrofCodeWordsScheduledByDCI* indicates that two codeword transmission is enabled, then a transport block is disabled by DCI format 1_1 if $I_{MCS} = 26$ and if $r_{vid} = 1$ for the corresponding transport block, otherwise the transport block is enabled. If both transport blocks are enabled, transport block 1 and 2 are mapped to codeword 0 and 1 respectively. If only one transport block is enabled, then the enabled transport block is always mapped to the first codeword.

For the PDSCH assigned by a PDCCH with DCI format 1_0 or format 1_1 with CRC scrambled by C-RNTI, new-RNTI, TC-RNTI, CS-RNTI, or SI-RNTI, if Table 5.1.3.1-2 is used and $0 \leq I_{MCS} \leq 27$, or a table other than Table 5.1.3.1-2 is used and $0 \leq I_{MCS} \leq 28$, the UE shall, except if the transport block is disabled in DCI format 1_1, first determine the TBS as specified below:

1) The UE shall first determine the number of REs (N_{RE}) within the slot.

- A UE first determines the number of REs allocated for PDSCH within a PRB (N'_{RE}) by

$$N'_{RE} = N_{sc}^{RB} \cdot N_{symb}^{sh} - N_{DMRS}^{PRB} - N_{oh}^{PRB}, \text{ where } N_{sc}^{RB} = 12 \text{ is the number of subcarriers in a physical resource}$$

block, N_{symb}^{sh} is the number of symbols of the PDSCH allocation within the slot, N_{DMRS}^{PRB} is the number of REs for DM-RS per PRB in the scheduled duration including the overhead of the DM-RS CDM groups without data, as indicated by DCI format 1_1 or as described for format 1_0 in Subclause 5.1.6.2, and N_{oh}^{PRB} is the overhead configured by higher layer parameter *xOverhead* in *PDSCH-ServingCellConfig*. If the

$xOverhead$ in *PDSCH-ServingCellconfig* is not configured (a value from 0, 6, 12, or 18), the N_{oh}^{PRB} is set to

0. If the PDSCH is scheduled by PDCCH with a CRC scrambled by SI-RNTI, RA-RNTI or P-RNTI, N_{oh}^{PRB} is assumed to be 0.

- A UE determines the total number of REs allocated for PDSCH (N_{RE}) by $N_{RE} = \min(156, N_{RE}')$ $\cdot n_{PRB}$, where n_{PRB} is the total number of allocated PRBs for the UE.

2) Intermediate number of information bits (N_{info}) is obtained by $N_{info} = N_{RE} \cdot R \cdot Q_m \cdot \nu$.

If $N_{info} \leq 3824$

Use step 3 as the next step of the TBS determination

else

Use step 4 as the next step of the TBS determination

end if

3) When $N_{info} \leq 3824$, TBS is determined as follows

- quantized intermediate number of information bits $N_{info}' = \max\left(24, 2^n \cdot \left\lfloor \frac{N_{info}}{2^n} \right\rfloor\right)$, where

$$n = \max(3, \lfloor \log_2(N_{info}) \rfloor - 6).$$

- use Table 5.1.3.2-2 find the closest TBS that is not less than N_{info}' .

Table 5.1.3.2-2: TBS for $N_{info} \leq 3824$

Index	TBS	Index	TBS	Index	TBS	Index	TBS
1	24	31	336	61	1288	91	3624
2	32	32	352	62	1320	92	3752
3	40	33	368	63	1352	93	3824
4	48	34	384	64	1416		
5	56	35	408	65	1480		
6	64	36	432	66	1544		
7	72	37	456	67	1608		
8	80	38	480	68	1672		
9	88	39	504	69	1736		
10	96	40	528	70	1800		
11	104	41	552	71	1864		
12	112	42	576	72	1928		
13	120	43	608	73	2024		
14	128	44	640	74	2088		
15	136	45	672	75	2152		
16	144	46	704	76	2216		
17	152	47	736	77	2280		
18	160	48	768	78	2408		
19	168	49	808	79	2472		
20	176	50	848	80	2536		
21	184	51	888	81	2600		
22	192	52	928	82	2664		
23	208	53	984	83	2728		
24	224	54	1032	84	2792		
25	240	55	1064	85	2856		
26	256	56	1128	86	2976		
27	272	57	1160	87	3104		
28	288	58	1192	88	3240		
29	304	59	1224	89	3368		
30	320	60	1256	90	3496		

4) When $N_{info} > 3824$, TBS is determined as follows.

- quantized intermediate number of information bits $N'_{info} = \max\left(3840, 2^n \times \text{round}\left(\frac{N_{info} - 24}{2^n}\right)\right)$, where $n = \lfloor \log_2(N_{info} - 24) \rfloor - 5$ and ties in the round function are broken towards the next largest integer.
- if $R \leq 1/4$

$$TBS = 8 \cdot C \cdot \left\lceil \frac{N'_{info} + 24}{8 \cdot C} \right\rceil - 24, \text{ where } C = \left\lceil \frac{N'_{info} + 24}{3816} \right\rceil$$

else

if $N'_{info} > 8424$

$$TBS = 8 \cdot C \cdot \left\lceil \frac{N'_{info} + 24}{8 \cdot C} \right\rceil - 24, \text{ where } C = \left\lceil \frac{N'_{info} + 24}{8424} \right\rceil$$

else

$$TBS = 8 \cdot \left\lceil \frac{N'_{info} + 24}{8} \right\rceil - 24$$

end if

end if

7.1.1.4.1.4.3 Test description

7.1.1.4.1.4.3.1 Pre-test conditions

Same Pre-test conditions as in clause 7.1.1.0 except set the NR Cell bandwidth and applicable BWP to maximum for the NR Band under test as specified in Table 5.3.5-1 in TS 38.101-1 [16] / TS 38.101-2 [17] (to enable testing of n_{PRB} up to maximum value).

Test frequency NRf1 is as specified in TS 38.508-1[4] clause 4.3.1 using the common highest UL and DL channel bandwidth and using the default subcarrier spacing specified in TS 38.508-1[4] clause 6.2.3.1.

7.1.1.4.1.4.3.2 Test procedure sequence

Table 7.1.1.4.1.4.3.2-1: Maximum TBS for different UE categories

UE Category	Maximum number of bits of a UL-SCH transport block received within a TTI
TS 38.306 [23] clause 4.1.2 require UE without <i>ue-CategoryDL</i> and <i>ue-CategoryUL</i> , to support Max TBS achievable based on max bandwidth of the Band under test.	

Table 7.1.1.4.1.4.3.2-2: Number of downlink PDCP SDUs and PDCP SDU size used as test data

TBS [bits]	Number of PDCP SDUs	PDCP SDU size [bits] (Note 1)
$192 \leq TBS \leq 12184$ note 2	1	$8 * \text{FLOOR}((TBS - 184)/8)$
$12185 \leq TBS \leq 24256$	2	$8 * \text{FLOOR}((TBS - 256)/16)$
$24257 \leq TBS \leq 36328$	3	$8 * \text{FLOOR}((TBS - 328)/24)$
$36329 \leq TBS \leq 48400$	4	$8 * \text{FLOOR}((TBS - 400)/32)$
$48401 \leq TBS \leq 60472$	5	$8 * \text{FLOOR}((TBS - 472)/40)$
$60473 \leq TBS \leq 72544$	6	$8 * \text{FLOOR}((TBS - 544)/48)$
$72545 \leq TBS \leq 84616$	7	$8 * \text{FLOOR}((TBS - 616)/56)$
$84617 \leq TBS \leq 96688$	8	$8 * \text{FLOOR}((TBS - 688)/64)$
$96689 < TBS \leq 108760$	9	$8 * \text{FLOOR}((TBS - 760)/72)$
$108761 \leq TBS \leq 120832$	10	$8 * \text{FLOOR}((TBS - 832)/80)$
$120833 \leq TBS \leq 132904$	11	$8 * \text{FLOOR}((TBS - 904)/88)$
$132905 \leq TBS \leq 144976$	12	$8 * \text{FLOOR}((TBS - 976)/96)$
$144785 \leq TBS \leq 157048$	13	$8 * \text{FLOOR}((TBS - 1048)/104)$
$157049 \leq TBS \leq 169120$	14	$8 * \text{FLOOR}((TBS - 1120)/112)$
$169121 < TBS \leq 181192$	15	$8 * \text{FLOOR}((TBS - 1192)/120)$
$181193 \leq TBS \leq 193264$	16	$8 * \text{FLOOR}((TBS - 1264)/128)$
$193337 \leq TBS \leq 205336$	17	$8 * \text{FLOOR}((TBS - 1336)/136)$
$205409 \leq TBS \leq 217408$	18	$8 * \text{FLOOR}((TBS - 1408)/144)$
$TBS > 217408$	19	$8 * \text{FLOOR}((TBS - 1480)/152)$

Note 1: Each PDCP SDU is limited to 1500 octets (to keep below maximum SDU size of ESM as specified in TS 24.301 [21] clause 9.9.4.12).

The PDCP SDU size of each PDCP SDU is

PDCP SDU size = (TBS – N*PDCP header size – N*AMD PDU header size – N*MAC header size – Size of Timing Advance – RLC Status PDU size- MAC header for RLC Status PDU – 32 bit Additional RLC header with SO if one RLC SDU gets split in 2 TBS and 24 bit MAC header for this additional PDU) / N, where

PDCP header size is 24 bits for the RLC AM and 18-bit SN case;
AMD PDU header size is 24 bits with 18 bit SN;

MAC header size for AMD PDU = 16 or 24 bits depending on L=8 or 16 bits. Worst case 24 is taken.

Size of Timing Advance MAC CE with header is 16 bits (if no Timing Advance and/or RLC status needs to be sent, padding will occur instead).
IF RLC SDU does not get split the 32 bits additional padding gets added instead

RLC Status PDU size = 24 bits with 1 ACK_SN, With a MAC header of 16 bits.

This gives:

PDCP SDU size = $8 * \text{FLOOR}((TBS - N * 24 - N * 24 - N * 24 - 112) / (8 * N))$ bits.

Note 2: According to the final PDCP SDU size formula in Note 1, the smallest TBS that can be tested is 192 bits.

Table 7.1.1.4.1.4.3.2-2A: Bandwidth part Dependent Parameters for Resource allocation 0 with start of BWP assumed as 0

$N_{RB}^{DL,BWP} = N_{BWP,i}^{size}$	Nominal RBG size P (Configuration1)	Size of last RBG	Allowed N_{PRB} Values
11	2	1	All 1...11
18	2	2	2,4,6,8,10,12,16,18
24	2	2	2,4,6,8,10,12,16,18,20,22,24
25	2	1	All 1...25
31	2	1	All 1...31
32	2	2	2,4,6,8,10,12,16,18,20,22,24,26,28,30,32
38	4	2	2,4,6,8,10,12,16,18,20,22,24,26,28,30,32,34,36,38
51	4	3	3,4,7,8,11,12,15,16,19,20,23,24,27,28,31,32,35,36,39,40,43,44,47,48,51
52	4	4	4,8,12,16,20,24,28,32,36,40,44,48,52
65	4	1	1,4,5,8,9,12,13,16,17,20,21,24,25,28,29,32,33,36,37,40,41,44,45,48,49,52,53,56,57,60,61,64,65
66	4	2	2,4,6,8,10,12,16,18,20,22,24,26,28,30,32,34,36,38,40,42,44,46,48,50,52,54,56,58,60,62,64,66
79	8	7	7,8,15,16,23,24,31,32,39,40,47,48,55,56,63,64,71,72,79
106	8	2	2,8,10,16,18,24,26,32,34,40,42,48,50,56,58,64,66,72,74,80,82,88,90,96,92,104,106
107	8	3	3,8,11,16,19,24,27,32,35,40,43,48,51,56,59,64,67,72,75,80,83,88,91,96,99,104,107
132	8	4	4,8,12,16,20,24,28,32,36,40,44,48,52,56,60,64,68,72,76,80,84,88,92,96,100,104,108,112,116,120,124,128,132
133	8	5	5,8,13,16,21,24,29,32,37,40,45,48,53,56,61,64,69,72,77,80,85,88,93,96,101,104,109,112,117,120,125,128,133
135	8	7	7,8,15,16,23,24,31,32,39,40,47,48,55,56,63,64,71,72,79,80,87,88,95,96,103,104,111,112,119,120,127,128,135
216	16	8	8,16,24,32,40,48,56,64,72,80,88,96,104,112,120,128,136,144,152,160,168,176,184,192,200,208,216
217	16	9	9,16,25,32,41,48,57,64,73,80,89,96,105,112,121,128,137,144,153,160,169,176,185,192,201,208,217
264	16	8	8,16,24,32,40,48,56,64,72,80,88,96,104,112,120,128,136,144,160,168,176,184,192,200,208,216,224,232,240,248,256,264
270	16	14	14,16,30,32,46,44,62,64,78,80,94,96,110,112,126,128,142,144,158,160,174,176,190,192,206,208,222,224,238,240,254,256,270
273	16	1	1,16,17,32,33,48,49,64,65,80,81,96,97,112,113,128,129,144,145,160,161,176,171,192,193,208,209,224,225,240,241,256,257,272,273

Table 7.1.1.4.1.4.3.2-3: Specific Parameter

Parameter	Value	Comments
PDSCH mappingType	typeA	
starting symbol S	0 Or 3 to avoid clash with PDCCH symbols	
number of consecutive symbols L	3..14- S	
k_0	0 or 1 (if $S=0$)	
number of layers (v)	1	
mcs-Table	qam256	
<i>xoh-PDSCH</i>	Not present	Results in value 0(<i>xoh</i> 0)
dmrs-AdditionalPosition	pos0	Results in 1 DMRS symbol per two carrier (N_{DMRS}^{PRB}) for Duration in symbols ≥ 3 (TS 38.211 [24], table 7.4.1.1.2-3)
resourceAllocation	dynamicSwitch	
maxNrofCodeWordsScheduledByDCI	n2	both codewords enabled
<i>rbg-Size</i>	Not present	configuration 1 applicable
N_{BWP}^{start}	0	

Table 7.1.1.4.1.4.3.2-4: Main behaviour

St	Procedure	Message Sequence		TP	Verdict
		U - S	Message		
-	EXCEPTION: Steps 1 to 5 are repeated for allowed values of N_{PRB} as per Table 7.1.1.4.1.4.3.2-2A in BWP, time domain resource as per table 7.1.1.4.1.0-1 and I_{MCS} from 0 to 27.	-	-	-	-
1	SS calculates or looks up TBS in TS 38.214 [15] based on the value of S, L, I_{MCS} and n_{PRB} . The SS uses the same I_{MCS} and TBS for both transport blocks: $I_{MCS\#1} = I_{MCS\#2} = I_{MCS}$ TBS 1= TBS 2= TBS	-	-	-	-
-	EXCEPTION: Steps 2 to 5 are performed if TBS1 + TBS2 is less than or equal to UE capability "Maximum number of DL-SCH transport block bits received within a TTI" as specified in Table 7.1.1.4.1.4.3.2-1 and larger than or equal to 192 bits as specified in Table 7.1.1.4.1.4.3.2-2.	-	-	-	-
2	SS creates one or more PDCP SDUs for transport block 1 and 2 depending on TBS1, and TBS2 in accordance with Table 7.1.1.4.1.4.3.2-2.	-	-	-	-
3	SS transmits the PDCP SDUs concatenated into a MAC PDU and indicates on PDCCH DCI Format 1_1 resource allocation 0 and values of S, L, $I_{MCS\#1}$, $I_{MCS\#2}$ and n_{PRB} .	<--	Transport block 1: MAC PDU Transport block 2: MAC PDU DCI: (DCI Format 1_1, S, L, $I_{MCS\#1}$, $I_{MCS\#2}$ and n_{PRB} .)	-	-
4	At the reception of scheduling request the SS transmits UL Grant for transmitting loop back PDCP SDUs.	<--	(UL Grant)	-	-
5	CHECK: Does UE return the same number of PDCP SDUs with same content as transmitted by the SS in step 3?	-->	(NxPDCP SDUs)	1	P
-	EXCEPTION: Steps 6 to 10 are repeated for allowed values of N_{PRB} 1 to $N_{RB}^{DL,BWP}$ in BWP, time domain resource length L 3 to 14-S and I_{MCS} from 0 to 27.	-	-	-	-
6	SS calculates or looks up TBS in TS 38.214 [15] based on the value of S, L, I_{MCS} and n_{PRB} . The SS uses the same I_{MCS} and TBS for both transport blocks: $I_{MCS\#1} = I_{MCS\#2} = I_{MCS}$ TBS 1= TBS 2= TBS	-	-	-	-
-	EXCEPTION: Steps 7 to 10 are performed if TBS1 + TBS2 is less than or equal to UE capability "Maximum number of DL-SCH transport block bits received within a TTI" as specified in Table 7.1.1.4.1.4.3.2-1 and larger than or equal to 192 bits as specified in Table 7.1.1.4.1.4.3.2-2	-	-	-	-
7	SS creates one or more PDCP SDUs for transport block 1 and 2 depending on TBS1, and TBS2 in accordance with Table 7.1.1.4.1.4.3.2-2.	-	-	-	-

8	SS transmits the PDCP SDUs concatenated into a MAC PDU and indicates on PDCCH DCI Format 1_1 resource allocation 1 and values of S, L, $I_{MCS\#1}$, $I_{MCS\#2}$ and $nPRB$.	<--	Transport block 1: MAC PDU Transport block 2: MAC PDU DCI: (DCI Format 1_1, S, L, $I_{MCS\#1}$, $I_{MCS\#2}$ and $nPRB$.)	-	-
9	At the reception of scheduling request the SS transmits UL Grant for transmitting loop back PDCP SDUs.	<--	(UL Grant)	-	-
10	CHECK: Does UE return the same number of PDCP SDUs with same content as transmitted by the SS in step 3?	-->	(NxPDCP SDUs)	2	P

7.1.1.4.1.4.3.3 Specific message contents

Table 7.1.1.4.1.4.3.3-1: SearchSpace

Derivation Path: TS 38.508-1 [4], Table 4.6.3-162 with Condition USS			
Information Element	Value/remark	Comment	Condition
SearchSpace ::= SEQUENCE {			
searchSpaceType CHOICE {			
ue-Specific SEQUENCE {			
dci-Formats	formats0-1-And-1-1		
}			
}			
}			

7.1.1.4.2 UL-SCH Transport Block Size Selection

7.1.1.4.2.0 Common parameters for UL-SCH Transport Block Size Selection

Table 7.1.1.4.2.0-1: PUSCH-TimeDomainResourceAllocationList

Derivation Path: TS 38.508-1 [4], table 4.6.3-122			
Information Element	Value/remark	Comment	Condition
PUSCH-TimeDomainResourceAllocationList ::= SEQUENCE (SIZE(1..maxNrofUL-Allocations)) OF SEQUENCE {{	2 entry		
k2	2		FR1
	4		FR2
mappingType	typeB		
startSymbolAndLength	52	Start symbol(S)=10, Length(L)=4	FR1
startSymbolAndLength	42	Start symbol(S)=0, Length(L)=4	FR2
}			
{			
k2	2		FR1
	4		FR2
mappingType	typeB		
startSymbolAndLength	27	Start symbol(S)=0, Length(L)=14	
}			

7.1.1.4.2.1 UL-SCH Transport Block Size selection / DCI format 0_0 / Transform precoding disabled

7.1.1.4.2.1.1 Test Purpose (TP)

(1)

```
with { UE in RRC_CONNECTED state }
ensure that {
  when { UE has pending data for transmission and receives on PDCCH DCI format 0_0 indicating a
resource block assignment correspondent to physical resource blocks , Time domain resource
assignment and modulation and coding }
  then { UE transmits MAC PDU on PUSCH as per Modulation Coding scheme, time domain resource
allocation and PRB's }
}
```

7.1.1.4.2.1.2 Conformance requirements

References: The conformance requirements covered in the present TC are specified in: TS 38.212 clause 7.3.1.1.1, TS 38.214 clause 6.1.2.1, 6.1.2.2, 6.1.2.2.2, 6.1.4.1, 5.1.3.1, 6.1.4.2 and 5.1.3.2. Unless otherwise stated these are Rel-15 requirements.

[TS 38.212, clause 7.3.1.1.1]

DCI format 0_0 is used for the scheduling of PUSCH in one cell.

The following information is transmitted by means of the DCI format 0_0 with CRC scrambled by C-RNTI or CS-RNTI or new-RNTI:

- Identifier for DCI formats – 1 bit
 - The value of this bit field is always set to 0, indicating an UL DCI format
- Frequency domain resource assignment – $\lceil \log_2(N_{RB}^{UL,BWP}(N_{RB}^{UL,BWP} + 1)/2) \rceil$ bits where
 - $N_{RB}^{UL,BWP}$ is the size of the active UL bandwidth part in case DCI format 0_0 is monitored in the UE specific search space and satisfying
 - the total number of different DCI sizes monitored per slot is no more than 4 for the cell, and
 - the total number of different DCI sizes with C-RNTI monitored per slot is no more than 3 for the cell
 - otherwise, $N_{RB}^{UL,BWP}$ is the size of the initial UL bandwidth part.
 - For PUSCH hopping with resource allocation type 1:
 - N_{UL_hop} MSB bits are used to indicate the frequency offset according to Subclause 6.3 of [6, TS 38.214], where $N_{UL_hop} = 1$ if the higher layer parameter *frequencyHoppingOffsetLists* contains two offset values and $N_{UL_hop} = 2$ if the higher layer parameter *frequencyHoppingOffsetLists* contains four offset values
 - $\lceil \log_2(N_{RB}^{UL,BWP}(N_{RB}^{UL,BWP} + 1)/2) \rceil - N_{UL_hop}$ bits provides the frequency domain resource allocation according to Subclause 6.1.2.2.2 of [6, TS 38.214]
 - For non-PUSCH hopping with resource allocation type 1:
 - $\lceil \log_2(N_{RB}^{UL,BWP}(N_{RB}^{UL,BWP} + 1)/2) \rceil$ bits provides the frequency domain resource allocation according to Subclause 6.1.2.2.2 of [6, TS 38.214]
- Time domain resource assignment – 4 bits as defined in Subclause 6.1.2.1 of [6, TS 38.214]
- Frequency hopping flag – 1 bit.
- Modulation and coding scheme – 5 bits as defined in Subclause 6.1.3 of [6, TS 38.214]

- New data indicator – 1 bit
- Redundancy version – 2 bits as defined in Table 7.3.1.1.1-2
- HARQ process number – 4 bits
- TPC command for scheduled PUSCH – 2 bits as defined in Subclause 7.1.1 of [5, TS 38.213]
- Padding bits, if required.
- UL/SUL indicator – 1 bit for UEs configured with SUL in the cell as defined in Table 7.3.1.1.1-1 and the number of bits for DCI format 1_0 before padding is larger than the number of bits for DCI format 0_0 before padding; 0 bit otherwise. The UL/SUL indicator, if present, locates in the last bit position of DCI format 0_0, after the padding bit(s).
 - If the UL/SUL indicator is present in DCI format 0_0 and the higher layer parameter *pusch-Config* is not configured on both UL and SUL the UE ignores the UL/SUL indicator field in DCI format 0_0, and the corresponding PUSCH scheduled by the DCI format 0_0 is for the UL or SUL for which high layer parameter *pucch-Config* is configured;
 - If the UL/SUL indicator is not present in DCI format 0_0, the corresponding PUSCH scheduled by the DCI format 0_0 is for the UL or SUL for which high layer parameter *pucch-Config* is configured.

The following information is transmitted by means of the DCI format 0_0 with CRC scrambled by TC-RNTI:

- Identifier for DCI formats – 1 bit
 - The value of this bit field is always set to 0, indicating an UL DCI format
- Frequency domain resource assignment – $\lceil \log_2(N_{RB}^{UL,BWP}(N_{RB}^{UL,BWP} + 1)/2) \rceil$ bits where
 - $N_{RB}^{UL,BWP}$ is the size of the initial UL bandwidth part.
 - For PUSCH hopping with resource allocation type 1:
 - N_{UL_hop} MSB bits are used to indicate the frequency offset according to Subclause 6.3 of [6, TS 38.214], where $N_{UL_hop} = 1$ if $N_{RB}^{UL,BWP} < 50$ and $N_{UL_hop} = 2$ otherwise
 - $\lceil \log_2(N_{RB}^{UL,BWP}(N_{RB}^{UL,BWP} + 1)/2) \rceil - N_{UL_hop}$ bits provides the frequency domain resource allocation according to Subclause 6.1.2.2.2 of [6, TS 38.214]
 - For non-PUSCH hopping with resource allocation type 1:
 - $\lceil \log_2(N_{RB}^{UL,BWP}(N_{RB}^{UL,BWP} + 1)/2) \rceil$ bits provides the frequency domain resource allocation according to Subclause 6.1.2.2.2 of [6, TS 38.214]
- Time domain resource assignment – 4 bits as defined in Subclause 6.1.2.1 of [6, TS 38.214]
- Frequency hopping flag – 1 bit.
- Modulation and coding scheme – 5 bits as defined in Subclause 6.1.3 of [6, TS 38.214], using Table 5.1.3.1-1
- New data indicator – 1 bit, reserved
- Redundancy version – 2 bits as defined in Table 7.3.1.1.1-2
- HARQ process number – 4 bits, reserved
- TPC command for scheduled PUSCH – 2 bits as defined in Subclause 7.1.1 of [5, TS 38.213]
- Padding bits, if required.

- UL/SUL indicator – 1 bit if the cell has two ULs and the number of bits for DCI format 1_0 before padding is larger than the number of bits for DCI format 0_0 before padding; 0 bit otherwise. The UL/SUL indicator, if present, locates in the last bit position of DCI format 0_0, after the padding bit(s).
- If 1 bit, reserved, and the corresponding PUSCH is always on the same UL carrier as the previous transmission of the same TB

If DCI format 0_0 is monitored in common search space and if the number of information bits in the DCI format 0_0 prior to padding is less than the payload size of the DCI format 1_0 monitored in common search space for scheduling the same serving cell, zeros shall be appended to the DCI format 0_0 until the payload size equals that of the DCI format 1_0.

If DCI format 0_0 is monitored in common search space and if the number of information bits in the DCI format 0_0 prior to padding is larger than the payload size of the DCI format 1_0 monitored in common search space for scheduling the same serving cell, the bit width of the frequency domain resource allocation field in the DCI format 0_0 is reduced by truncating the first few most significant bits such that the size of DCI format 0_0 equals to the size of the DCI format 1_0.

If DCI format 0_0 is monitored in UE specific search space but does not satisfy at least one of the following

- the total number of different DCI sizes monitored per slot is no more than 4 for the cell, and
- the total number of different DCI sizes with C-RNTI monitored per slot is no more than 3 for the cell

and if the number of information bits in the DCI format 0_0 prior to padding is less than the payload size of the DCI format 1_0 monitored in common search space for scheduling the same serving cell, zeros shall be appended to the DCI format 0_0 until the payload size equals that of the DCI format 1_0.

If DCI format 0_0 is monitored in UE specific search space but does not satisfy at least one of the following

- the total number of different DCI sizes monitored per slot is no more than 4 for the cell, and
- the total number of different DCI sizes with C-RNTI monitored per slot is no more than 3 for the cell

and if the number of information bits in the DCI format 0_0 prior to padding is larger than the payload size of the DCI format 1_0 monitored in common search space for scheduling the same serving cell, the bit width of the frequency domain resource allocation field in the DCI format 0_0 is reduced by truncating the first few most significant bits such that the size of DCI format 0_0 equals to the size of the DCI format 1_0.

If DCI format 0_0 is monitored in UE specific search space and satisfies both of the following

- the total number of different DCI sizes monitored per slot is no more than 4 for the cell, and
- the total number of different DCI sizes with C-RNTI monitored per slot is no more than 3 for the cell

and if the number of information bits in the DCI format 0_0 prior to padding is less than the payload size of the DCI format 1_0 monitored in UE specific search space for scheduling the same serving cell, zeros shall be appended to the DCI format 0_0 until the payload size equals that of the DCI format 1_0.

[TS 38.214, clause 6.1.2.1]

When the UE is scheduled to transmit a transport block and no CSI report, or the UE is scheduled to transmit a transport block and a CSI report on PUSCH by a DCI, the *Time domain resource assignment* field value m of the DCI provides a row index $m + 1$ to an allocated table. The determination of the used resource allocation table is defined in sub-clause 6.1.2.1.1. The indexed row defines the slot offset K_2 , the start and length indicator *SLIV*, or directly the start symbol S and the allocation length L , and the PUSCH mapping type to be applied in the PUSCH transmission.

When the UE is scheduled to transmit a PUSCH with no transport block and with a CSI report by a *CSI request* field on a DCI, the *Time-domain resource assignment* field value m of the DCI provides a row index $m + 1$ to an allocated table. The determination of the applied resource allocation table is defined in sub-clause 6.1.2.1.1. The indexed row defines the start and length indicator *SLIV*, or directly the start symbol S and the allocation length L , and the PUSCH mapping type to be applied in the PUSCH transmission and K_2 is determined based on the corresponding list entries $Y_j, j = 0, \dots, N_{\text{Rep}} - 1$ of the higher layer parameter *reportSlotConfig* in *CSI-ReportConfig* for the N_{Rep} triggered CSI Reporting Settings. The i th codepoint of K_2 is determined as $K_2 = \max_j Y_j(i)$ where $Y_j(i)$ is the i th codepoint of Y_j .

- The slot where the UE shall transmit the PUSCH is determined by K_2 as $\left\lfloor n \cdot \frac{2^{\mu_{\text{PUSCH}}}}{2^{\mu_{\text{PDCCH}}}} \right\rfloor + K_2$ where n is the slot with the scheduling DCI, K_2 is based on the numerology of PUSCH, and μ_{PUSCH} and μ_{PDCCH} are the subcarrier spacing configurations for PUSCH and PDCCH, respectively, and
- The starting symbol S relative to the start of the slot, and the number of consecutive symbols L counting from the symbol S allocated for the PUSCH are determined from the start and length indicator $SLIV$ of the indexed row:

if $(L-1) \leq 7$ then

$$SLIV = 14 \cdot (L-1) + S$$

else

$$SLIV = 14 \cdot (14 - L + 1) + (14 - 1 - S)$$

where $0 < L \leq 14 - S$, and

- The PUSCH mapping type is set to Type A or Type B as defined in Subclause 6.4.1.1.3 of [4, TS 38.211] as given by the indexed row.

The UE shall consider the S and L combinations defined in table 6.1.2.1-1 as valid PUSCH allocations

Table 6.1.2.1-1: Valid S and L combinations

PUSCH mapping type	Normal cyclic prefix			Extended cyclic prefix		
	S	L	$S+L$	S	L	$S+L$
Type A	0	{4,...,14}	{4,...,14}	0	{4,...,12}	{4,...,12}
Type B	{0,...,13}	{1,...,14}	{1,...,14}	{0,...,12}	{1,...,12}	{1,...,12}

When the UE is configured with $aggregationFactorUL > 1$, the same symbol allocation is applied across the $aggregationFactorUL$ consecutive slots and the PUSCH is limited to a single transmission layer. The UE shall repeat the TB across the $aggregationFactorUL$ consecutive slots applying the same symbol allocation in each slot. The redundancy version to be applied on the n^{th} transmission occasion of the TB is determined according to table 6.1.2.1-2.

Table 6.1.2.1-2: Redundancy version when $aggregationFactorUL > 1$

$rvid$ indicated by the DCI scheduling the PUSCH	$rvid$ to be applied to n^{th} transmission occasion			
	$n \bmod 4 = 0$	$n \bmod 4 = 1$	$n \bmod 4 = 2$	$n \bmod 4 = 3$
0	0	2	3	1
2	2	3	1	0
3	3	1	0	2
1	1	0	2	3

If the UE procedure for determining slot configuration, as defined in subclause 11.1 of [6, TS 38.213], determines symbols of a slot allocated for PUSCH as downlink symbols, the transmission on that slot is omitted for multi-slot PUSCH transmission.

[38.214 clause 6.1.2.2]

The UE shall determine the resource block assignment in frequency domain using the resource allocation field in the detected PDCCH DCI. Two uplink resource allocation schemes type 0 and type 1 are supported. Uplink resource allocation scheme type 0 is supported for PUSCH only when transform precoding is disabled. Uplink resource allocation scheme type 1 is supported for PUSCH for both cases when transform precoding is enabled or disabled.

If the scheduling DCI is configured to indicate the uplink resource allocation type as part of the *Frequency domain resource* assignment field by setting a higher layer parameter *resourceAllocation* in *pusch-Config* to 'dynamicswitch', the UE shall use uplink resource allocation type 0 or type 1 as defined by this DCI field. Otherwise the UE shall use the uplink frequency resource allocation type as defined by the higher layer parameter *resourceAllocation*.

The UE shall assume that when the scheduling PDCCH is received with DCI format 0_0, then uplink resource allocation type 1 is used.

If a bandwidth part indicator field is not configured in the scheduling DCI, the RB indexing for uplink type 0 and type 1 resource allocation is determined within the UE's active bandwidth part. If a bandwidth part indicator field is configured in the scheduling DCI, the RB indexing for uplink type 0 and type 1 resource allocation is determined within the UE's bandwidth part indicated by bandwidth part indicator field value in the DCI, except for the case when DCI format 0_0 is decoded in any PDCCH common search space in CORESET 0 in which case the initial bandwidth part shall be used. The UE shall upon detection of PDCCH intended for the UE determine first the uplink bandwidth part and then the resource allocation within the bandwidth part.

[38.214 clause 6.1.2.2.2]

In uplink resource allocation of type 1, the resource block assignment information indicates to a scheduled UE a set of contiguously allocated non-interleaved virtual resource blocks within the active carrier bandwidth part of size N_{BWP}^{size} PRBs except for the case when DCI format 0_0 is decoded in the Type0-PDCCH common search space in CORESET 0 in which case the initial bandwidth part of size N_{BWP}^{size} shall be used.

An uplink type 1 resource allocation field consists of a resource indication value (RIV) corresponding to a starting virtual resource block (RB_{start}) and a length in terms of contiguously allocated resource blocks L_{RBs} . The resource indication value is defined by

if $(L_{RBs} - 1) \leq \lfloor N_{BWP}^{size} / 2 \rfloor$ then

$$RIV = N_{BWP}^{size} (L_{RBs} - 1) + RB_{start}$$

else

$$RIV = N_{BWP}^{size} (N_{BWP}^{size} - L_{RBs} + 1) + (N_{BWP}^{size} - 1 - RB_{start})$$

where $L_{RBs} \geq 1$ and shall not exceed $N_{BWP}^{size} - RB_{start}$.

[TS 38.214, clause 6.1.4.1]

For the PUSCH assigned by a DCI format 0_0/0_1 with CRC scrambled by C-RNTI, new-RNTI, TC-RNTI, or SP-CSI-RNTI, the transform precoding is enabled if *transformPrecoder* in *PUSCH-Config* is set to 'enabled', or if *transformPrecoder* in *PUSCH-Config* is not configured and *msg3-transformPrecoding* in *rach-ConfigCommon* is set to 'enabled'; otherwise the transform precoding is disabled.

For the PUSCH assigned by a DCI format 0_0/0_1 with CRC scrambled by CS-RNTI, or the PUSCH with configured grant using CS-RNTI, the transform precoding is enabled if *transformPrecoder* in *ConfiguredGrantConfig* is set to 'enabled'; otherwise the transform precoding is disabled.

For a PUSCH scheduled by RAR UL grant or for a PUSCH scheduled by a DCI format 0_0/0_1 with CRC scrambled by C-RNTI, TC-RNTI, or CS-RNTI, or SP-CSI-RNTI, or for a PUSCH with configured grant using CS-RNTI,

if *transformPrecoder* is disabled for this PUSCH transmission

- if *mcs-Table* in *PUSCH-Config* is set to 'qam256', and PUSCH is scheduled with C-RNTI or SP-CSI-RNTI, and PUSCH is assigned by DCI format 0_1,
 - the UE shall use I_{MCS} and Table 5.1.3.1-2 to determine the modulation order (Q_m) and Target code rate (R) used in the physical uplink shared channel.
- elseif the UE is not configured with new-RNTI, *mcs-Table* in *PUSCH-Config* is set to 'qam64LowSE', the PUSCH is scheduled with C-RNTI, or SP-CSI-RNTI, and the PUSCH is assigned by a PDCCH in a UE-specific search space,
 - the UE shall use I_{MCS} and Table 5.1.3.1-3 to determine the modulation order (Q_m) and Target code rate (R) used in the physical uplink shared channel.

- elseif the UE is configured with new-RNTI, and the PUSCH is scheduled with new-RNTI,
 - the UE shall use I_{MCS} and Table 5.1.3.1-3 to determine the modulation order (Q_m) and Target code rate (R) used in the physical uplink shared channel.
- elseif *mcs-Table* in *ConfiguredGrantConfig* is set to 'qam256', and PUSCH is scheduled with CS-RNTI,
 - the UE shall use I_{MCS} and Table 5.1.3.1-2 to determine the modulation order (Q_m) and Target code rate (R) used in the physical uplink shared channel.
- elseif *mcs-Table* in *ConfiguredGrantConfig* is set to 'qam64LowSE', and PUSCH is scheduled with CS-RNTI,
 - the UE shall use I_{MCS} and Table 5.1.3.1-3 to determine the modulation order (Q_m) and Target code rate (R) used in the physical uplink shared channel.
- else
 - the UE shall use I_{MCS} and Table 5.1.3.1-1 to determine the modulation order (Q_m) and Target code rate (R) used in the physical uplink shared channel.

[TS 38.214, clause 5.1.3.1]

Table 5.1.3.1-1: MCS index table 1 for PDSCH

MCS Index I_{MCS}	Modulation Order Q_m	Target code Rate $R \times [1024]$	Spectral efficiency
0	2	120	0.2344
1	2	157	0.3066
2	2	193	0.3770
3	2	251	0.4902
4	2	308	0.6016
5	2	379	0.7402
6	2	449	0.8770
7	2	526	1.0273
8	2	602	1.1758
9	2	679	1.3262
10	4	340	1.3281
11	4	378	1.4766
12	4	434	1.6953
13	4	490	1.9141
14	4	553	2.1602
15	4	616	2.4063
16	4	658	2.5703
17	6	438	2.5664
18	6	466	2.7305
19	6	517	3.0293
20	6	567	3.3223
21	6	616	3.6094
22	6	666	3.9023
23	6	719	4.2129
24	6	772	4.5234
25	6	822	4.8164
26	6	873	5.1152
27	6	910	5.3320
28	6	948	5.5547
29	2	reserved	
30	4	reserved	
31	6	reserved	

[TS 38.214, clause 6.1.4.2]

For a PUSCH scheduled by RAR UL grant or for a PUSCH scheduled by a DCI format 0_0/0_1 with CRC scrambled by C-RNTI, new-RNTI, TC-RNTI, CS-RNTI, or SP-CSI-RNTI.

if

- $0 \leq I_{MCS} \leq 27$ and transform precoding is disabled and Table 5.1.3.1-2 is used, or
- $0 \leq I_{MCS} \leq 28$ and transform precoding is disabled and a table other than Table 5.1.3.1-2 is used, or
- $0 \leq I_{MCS} \leq 27$ and transform precoding is enabled and , the UE shall first determine the TBS as specified below:

The UE shall first determine the number of REs (N_{RE}) within the slot:

- A UE first determines the number of REs allocated for PUSCH within a PRB (N'_{RE}) by
- $N'_{RE} = N_{sc}^{RB} * N_{symp}^{sh} - N_{DMRS}^{PRB} - N_{oh}^{PRB}$, where $N_{sc}^{RB} = 12$ is the number of subcarriers in the frequency domain in a physical resource block, N_{symp}^{sh} is the number of symbols of the PUSCH allocation within the slot, N_{DMRS}^{PRB} is the number of REs for DM-RS per PRB in the scheduled duration including the overhead of the DM-RS CDM groups without data, as indicated by DCI format 0_1 or as described for DCI format 0_0 in Subclause 6.2.2, and N_{oh}^{PRB} is the overhead configured by higher layer parameter $xOverhead$ in *PUSCH-ServingCellConfig*. If the N_{oh}^{PRB} is not configured (a value from 0, 6, 12, or 18), the N_{oh}^{PRB} is assumed to be 0. For MSG3 transmission the N_{oh}^{PRB} is always set to 0..
- A UE determines the total number of REs allocated for PUSCH (N_{RE}) by $N_{RE} = \min(156, N'_{RE}) \cdot n_{PRB}$ where n_{PRB} is the total number of allocated PRBs for the UE.
- Next, proceed with steps 2-5 as defined in Subclause 5.1.3.2

else if

- $28 \leq I_{MCS} \leq 31$ and transform precoding is disabled and Table 5.1.3.1-2 is used, or
- $28 \leq I_{MCS} \leq 31$ and transform precoding is enabled,
- the TBS is assumed to be as determined from the DCI transported in the latest PDCCH for the same transport block using $0 \leq I_{MCS} \leq 27$. If there is no PDCCH for the same transport block using $0 \leq I_{MCS} \leq 27$, and if the initial PUSCH for the same transport block is transmitted with configured grant, the TBS shall be determined from the most recent configured scheduling PDCCH.

else

- the TBS is assumed to be as determined from the DCI transported in the latest PDCCH for the same transport block using $0 \leq I_{MCS} \leq 28$. If there is no PDCCH for the same transport block using $0 \leq I_{MCS} \leq 28$, and if the initial PUSCH for the same transport block is transmitted with configured grant, the TBS shall be determined from the most recent configured scheduling PDCCH.

[TS 38.214, clause 5.1.3.2]

- 2 Intermediate number of information bits (N_{info}) is obtained by $N_{info} = N_{RE} \cdot R \cdot Q_m \cdot v$.

If $N_{info} \leq 3824$

Use step 3 as the next step of the TBS determination

else

Use step 4 as the next step of the TBS determination

end if

- 3) When $N_{info} \leq 3824$, TBS is determined as follows

- quantized intermediate number of information bits $N'_{info} = \max\left(24, 2^n \cdot \left\lfloor \frac{N_{info}}{2^n} \right\rfloor\right)$, where
 $n = \max(3, \lfloor \log_2(N_{info}) \rfloor - 6)$.
- use Table 5.1.3.2-2 find the closest TBS that is not less than N'_{info} .

Table 5.1.3.2-2: TBS for $N_{info} \leq 3824$

Index	TBS	Index	TBS	Index	TBS	Index	TBS
1	24	31	336	61	1288	91	3624
2	32	32	352	62	1320	92	3752
3	40	33	368	63	1352	93	3824
4	48	34	384	64	1416		
5	56	35	408	65	1480		
6	64	36	432	66	1544		
7	72	37	456	67	1608		
8	80	38	480	68	1672		
9	88	39	504	69	1736		
10	96	40	528	70	1800		
11	104	41	552	71	1864		
12	112	42	576	72	1928		
13	120	43	608	73	2024		
14	128	44	640	74	2088		
15	136	45	672	75	2152		
16	144	46	704	76	2216		
17	152	47	736	77	2280		
18	160	48	768	78	2408		
19	168	49	808	79	2472		
20	176	50	848	80	2536		
21	184	51	888	81	2600		
22	192	52	928	82	2664		
23	208	53	984	83	2728		
24	224	54	1032	84	2792		
25	240	55	1064	85	2856		
26	256	56	1128	86	2976		
27	272	57	1160	87	3104		
28	288	58	1192	88	3240		
29	304	59	1224	89	3368		
30	320	60	1256	90	3496		

4) When $N_{info} > 3824$, TBS is determined as follows.

- quantized intermediate number of information bits $N'_{info} = \max\left(3840, 2^n \times \text{round}\left(\frac{N_{info} - 24}{2^n}\right)\right)$, where
 $n = \lfloor \log_2(N_{info} - 24) \rfloor - 5$ and ties in the round function are broken towards the next largest integer.

- if $R \leq 1/4$

$$TBS = 8 \cdot C \cdot \left\lceil \frac{N'_{info} + 24}{8 \cdot C} \right\rceil - 24, \text{ where } C = \left\lceil \frac{N'_{info} + 24}{3816} \right\rceil$$

else

if $N'_{info} > 8424$

$$TBS = 8 \cdot C \cdot \left\lceil \frac{N'_{info} + 24}{8 \cdot C} \right\rceil - 24, \text{ where } C = \left\lceil \frac{N'_{info} + 24}{8424} \right\rceil$$

else

$$TBS = 8 \left\lceil \frac{N_{info} + 24}{8} \right\rceil - 24$$

end if

end if

7.1.1.4.2.1.3 Test description

7.1.1.4.2.1.3.1 Pre-test conditions

Same Pre-test conditions as in clause 7.1.1.0 except set the NR Cell bandwidth and applicable BWP to maximum for the NR Band under test as specified in Table 5.3.5-1 in TS 38.101-1 [16] / TS 38.101-2 [17] (to enable testing of n_{PRB} up to maximum value).

Test frequency NRf1 is as specified in TS 38.508-1 [4] clause 4.3.1 using the common highest UL and DL channel bandwidth and using the default subcarrier spacing specified in TS 38.508-1 [4] clause 6.2.3.1.

7.1.1.4.2.1.3.2 Test procedure sequence

Table 7.1.1.4.2.1.3.2-1: Maximum TBS for different UE categories

UE Category	Maximum number of bits of a UL-SCH transport block received within a TTI
TS 38.306 [23] clause 4.1.2 <i>require UE without ue-CategoryDL and ue-CategoryUL, to support Max TBS achievable based on max bandwidth of the Band under test.</i>	

Table 7.1.1.4.2.1.3.2-2: Number of uplink PDCP SDUs and PDCP SDU size used as test data

TBS [bits]	Number of PDCP SDUs	PDCP SDU size [bits] (Note 1)
$136 \leq TBS \leq 12128$ note 2	1	$8 * \text{FLOOR}((TBS - 128) / 8)$
$12129 \leq TBS \leq 24200$	2	$8 * \text{FLOOR}((TBS - 200) / 16)$
$24201 \leq TBS \leq 36272$	3	$8 * \text{FLOOR}((TBS - 272) / 24)$
$36273 \leq TBS \leq 48344$	4	$8 * \text{FLOOR}((TBS - 344) / 32)$
$48345 \leq TBS \leq 60416$	5	$8 * \text{FLOOR}((TBS - 416) / 40)$
$60417 \leq TBS \leq 72488$	6	$8 * \text{FLOOR}((TBS - 488) / 48)$
$72489 \leq TBS \leq 84560$	7	$8 * \text{FLOOR}((TBS - 560) / 56)$
$84561 \leq TBS \leq 96632$	8	$8 * \text{FLOOR}((TBS - 632) / 64)$
$96633 < TBS \leq 108704$	9	$8 * \text{FLOOR}((TBS - 704) / 72)$
$10705 \leq TBS \leq 120776$	10	$8 * \text{FLOOR}((TBS - 776) / 80)$
$120777 \leq TBS \leq 132848$	11	$8 * \text{FLOOR}((TBS - 848) / 88)$
$132849 \leq TBS \leq 144920$	12	$8 * \text{FLOOR}((TBS - 920) / 96)$
$TBS > 144920$	13	$8 * \text{FLOOR}((TBS - 992) / 104)$

Note 1: Each PDCP SDU is limited to 1500 octets (to keep below maximum SDU size of ESM as specified in TS 24.301 [21] clause 9.9.4.12).

The PDCP SDU size of each PDCP SDU is

PDCP SDU size = (TBS – N*PDCP header size – N*AMD PDU header size – N*MAC header size – Size of Timing Advance – RLC Status PDU size- MAC header for RLC Status PDU) / N, where

PDCP header size is 24 bits for the RLC AM and 18-bit SN case;
AMD PDU header size is 24 bits with 18 bit SN;

MAC header size for AMD PDU = 16 or 24 bits depending on L=8 or 16 bits. Worst case 24 is taken.

Size of Timing Advance MAC CE with header is 16 bits (if no Timing Advance and/or RLC status needs to be sent, padding will occur instead).

RLC Status PDU size = 24 bits with 1 ACK_SN, With a MAC header of 16 bits.

This gives:

PDCP SDU size = $8 * \text{FLOOR}((TBS - N * 24 - N * 24 - N * 24 - 56) / (8 * N))$ bits.

Note 2: According to the final PDCP SDU size formula in Note 1, the smallest TBS that can be tested is 136 bits.

Table 7.1.1.4.2.1.3.2-3: Specific Parameters

Parameter	Value	Comment
number of layers (v)	1	
mcs-Table	qam64	

Table 7.1.1.4.2.1.3.2-4: Main behaviour

St	Procedure	Message Sequence		TP	Verdict
		U - S	Message		
-	EXCEPTION: Steps 1 to 5 are repeated for allowed values of N_{PRB} 1 to $N_{RB}^{UL,BWP}$ in BWP, time domain resource as per Table 7.1.1.4.2.0-1 and I_{MCS} from 0 to 28.	-	-	-	-
1	The SS calculates or looks up TBS in TS 38.214 [15] based on the value of S, L, I_{MCS} and n_{PRB} .	-	-	-	-
-	EXCEPTION: Steps 2 to 5 are performed if TBS is less than or	-	-	-	-

	equal to UE capability "Maximum number of UL-SCH transport block bits received within a TTI" as specified in Table 7.1.1.4.2.1.3.2-1 and larger than or equal to 136 bits as specified in Table 7.1.1.4.2.1.3.2-2				
2	The SS creates one or more PDCP SDUs, depending on TBS, in accordance with Table 7.1.1.4.2.1.3.2-2.	-	-	-	-
3	After 300ms, the SS transmits all PDCP SDUs (N_{SDUs}) as created in step 2 in a MAC PDU.	<--	MAC PDU (N_{xPDCP} SDUs)	-	-
4	After 60ms of step 3, SS transmits UL Grant DCI 0_0, and values of S , L , I_{MCS} and n_{PRB} .	<--	(UL Grant) (DCI Format 0_0, S , L , I_{MCS} and n_{PRB})	-	-
5	CHECK: Does UE return the same number of PDCP SDUs with same content as transmitted by the SS in step 3 using Time, frequency Resources and modulation and coding scheme as configured by the SS in step 4?	-->	MAC PDU ($N \times PDCP$ SDU)	1	P

7.1.1.4.2.1.3.3 Specific message contents

[None].

7.1.1.4.2.2 Void

7.1.1.4.2.3 UL-SCH transport block size selection / DCI format 0_1 / RA type 0/RA Type 1 / Transform precoding disabled

7.1.1.4.2.3.1 Test Purpose (TP)

(1)

```
with { UE in RRC_CONNECTED state }
ensure that {
  when { UE has pending data for transmission and receives DCI format 0_1 indicating resource allocation type 0 a resource block assignment correspondent to physical resource blocks , Time domain resource assignment and a modulation and coding }
  then { UE transmits MAC PDU's on PUSCH as per Modulation Coding scheme, time domain resource allocation and PRB's }
}
```

(2)

```
with { UE in RRC_CONNECTED state }
ensure that {
  when { UE has pending data for transmission and receives DCI format 0_1 indicating resource allocation type 1 a resource block assignment correspondent to physical resource blocks , Time domain resource assignment and a modulation and coding }
  then { UE transmits MAC PDU's on PUSCH as per Modulation Coding scheme, time domain resource allocation and PRB's }
}
```

7.1.1.4.2.3.2 Conformance requirements

References: The conformance requirements covered in the present TC are specified in: TS 38.212 clause 7.3.1.1.1, TS 38.214 clause 6.1.2.1, 6.1.2.2, 6.1.2.2.1, 6.1.2.2.2, 6.1.4.1, 5.1.3.1, 6.1.4.2 and 5.1.3.2. Unless otherwise stated these are Rel-15 requirements.

[TS 38.212, clause 7.3.1.1.2]

DCI format 0_1 is used for the scheduling of PUSCH in one cell.

The following information is transmitted by means of the DCI format 0_1 with CRC scrambled by C-RNTI or CS-RNTI or SP-CSI-RNTI or new-RNTI:

- Identifier for DCI formats – 1 bit
- The value of this bit field is always set to 0, indicating an UL DCI format
- Carrier indicator – 0 or 3 bits, as defined in Subclause 10.1 of [5, TS38.213].
- UL/SUL indicator – 0 bit for UEs not configured with SUL in the cell or UEs configured with SUL in the cell but only PUCCH carrier in the cell is configured for PUSCH transmission; 1 bit for UEs configured with SUL in the cell as defined in Table 7.3.1.1.1-1.
- Bandwidth part indicator – 0, 1 or 2 bits as determined by the number of UL BWPs $n_{\text{BWP,RRC}}$ configured by higher layers, excluding the initial UL bandwidth part. The bit width for this field is determined as $\lceil \log_2(n_{\text{BWP}}) \rceil$ bits, where
 - $n_{\text{BWP}} = n_{\text{BWP,RRC}} + 1$ if , in which case the bandwidth part indicator is equivalent to the higher layer parameter *BWP-Id*;
 - otherwise $n_{\text{BWP}} = n_{\text{BWP,RRC}}$, in which case the bandwidth part indicator is defined in Table 7.3.1.1.2-1;

If a UE does not support active BWP change via DCI, the UE ignores this bit field.

- Frequency domain resource assignment – number of bits determined by the following, where $N_{\text{RB}}^{\text{UL,BWP}}$ is the size of the active UL bandwidth part:
 - N_{RB} bits if only resource allocation type 0 is configured, where N_{RB} is defined in Subclause 6.1.2.2.1 of [6, TS 38.214],
 - $\lceil \log_2(N_{\text{RB}}^{\text{UL,BWP}}(N_{\text{RB}}^{\text{UL,BWP}} + 1)/2) \rceil$ bits if only resource allocation type 1 is configured, or $\max(\lceil \log_2(N_{\text{RB}}^{\text{UL,BWP}}(N_{\text{RB}}^{\text{UL,BWP}} + 1)/2) \rceil, N_{\text{RB}}) + 1$ bits if both resource allocation type 0 and 1 are configured.
 - If both resource allocation type 0 and 1 are configured, the MSB bit is used to indicate resource allocation type 0 or resource allocation type 1, where the bit value of 0 indicates resource allocation type 0 and the bit value of 1 indicates resource allocation type 1.
 - For resource allocation type 0, the N_{RB} LSBs provide the resource allocation as defined in Subclause 6.1.2.2.1 of [6, TS 38.214].
 - For resource allocation type 1, the $\lceil \log_2(N_{\text{RB}}^{\text{UL,BWP}}(N_{\text{RB}}^{\text{UL,BWP}} + 1)/2) \rceil$ LSBs provide the resource allocation as follows:
 - For PUSCH hopping with resource allocation type 1:
 - $N_{\text{UL-hop}}$ MSB bits are used to indicate the frequency offset according to Subclause 6.3 of [6, TS 38.214], where $N_{\text{UL-hop}} = 1$ if the higher layer parameter *frequencyHoppingOffsetLists* contains two offset values and $N_{\text{UL-hop}} = 2$ if the higher layer parameter *frequencyHoppingOffsetLists* contains four offset values
 - $\lceil \log_2(N_{\text{RB}}^{\text{UL,BWP}}(N_{\text{RB}}^{\text{UL,BWP}} + 1)/2) \rceil - N_{\text{UL-hop}}$ bits provides the frequency domain resource allocation according to Subclause 6.1.2.2.2 of [6, TS 38.214]

If "Bandwidth part indicator" field indicates a bandwidth part other than the active bandwidth part and if both resource allocation type 0 and 1 are configured for the indicated bandwidth part, the UE assumes resource allocation type 0 for the indicated bandwidth part if the bit width of the "Frequency domain resource

assignment" field of the active bandwidth part is smaller than the bit width of the "Frequency domain resource assignment" field of the indicated bandwidth part.

- For non-PUSCH hopping with resource allocation type 1:
 - $\lceil \log_2(N_{RB}^{UL,BWP}(N_{RB}^{UL,BWP} + 1)/2) \rceil$ bits provides the frequency domain resource allocation according to Subclause 6.1.2.2.2 of [6, TS 38.214]
- Time domain resource assignment – 0, 1, 2, 3, or 4 bits as defined in Subclause 6.1.2.1 of [6, TS38.214]. The bit width for this field is determined as $\lceil \log_2(I) \rceil$ bits, where I the number of entries in the higher layer parameter *pusch-AllocationList*.
- Frequency hopping flag – 0 or 1 bit:
 - 0 bit if only resource allocation type 0 is configured or if the higher layer parameter *frequencyHopping* is not configured;
 - 1 bit according to Table 7.3.1.1.2-34 otherwise, only applicable to resource allocation type 1, as defined in Subclause 6.3 of [6, TS 38.214].
- Modulation and coding scheme – 5 bits as defined in Subclause 6.1.4.1 of [6, TS 38.214]
- New data indicator – 1 bit
- Redundancy version – 2 bits as defined in Table 7.3.1.1.1-2
- HARQ process number – 4 bits
- 1st downlink assignment index – 1 or 2 bits:
 - 1 bit for semi-static HARQ-ACK codebook;
 - 2 bits for dynamic HARQ-ACK codebook.
- 2nd downlink assignment index – 0 or 2 bits:
 - 2 bits for dynamic HARQ-ACK codebook with two HARQ-ACK sub-codebooks;
 - 0 bit otherwise.
- TPC command for scheduled PUSCH – 2 bits as defined in Subclause 7.1.1 of [5, TS38.213]
- SRS resource indicator – $\left\lceil \log_2 \left(\sum_{k=1}^{\min\{L_{max}^{PUSCH}, N_{SRS}\}} \binom{N_{SRS}}{k} \right) \right\rceil$ or $\lceil \log_2(N_{SRS}) \rceil$ bits, where N_{SRS} is the number of configured SRS resources in the SRS resource set associated with the higher layer parameter *usage* of value 'codeBook' or 'nonCodeBook', and L_{max}^{PUSCH} is the maximum number of supported layers for the PUSCH.
 - $\left\lceil \log_2 \left(\sum_{k=1}^{\min\{L_{max}^{PUSCH}, N_{SRS}\}} \binom{N_{SRS}}{k} \right) \right\rceil$ bits according to Tables 7.3.1.1.2-28/29/30/31 if the higher layer parameter *txConfig* = *nonCodebook*, where N_{SRS} is the number of configured SRS resources in the SRS resource set associated with the higher layer parameter *usage* of value 'nonCodeBook';
 - $\lceil \log_2(N_{SRS}) \rceil$ bits according to Tables 7.3.1.1.2-32 if the higher layer parameter *txConfig* = *codebook*, where N_{SRS} is the number of configured SRS resources in the SRS resource set associated with the higher layer parameter *usage* of value 'codeBook'.
- Precoding information and number of layers – number of bits determined by the following:
 - 0 bits if the higher layer parameter *txConfig* = *nonCodeBook*;
 - 0 bits for 1 antenna port and if the higher layer parameter *txConfig* = *codebook*;

- 4, 5, or 6 bits according to Table 7.3.1.1.2-2 for 4 antenna ports, if $txConfig = codebook$, and according to the values of higher layer parameters $transformPrecoder$, $maxRank$, and $codebookSubset$;
- 2, 4, or 5 bits according to Table 7.3.1.1.2-3 for 4 antenna ports, if $txConfig = codebook$, and according to the values of higher layer parameters $transformPrecoder$, $maxRank$, and $codebookSubset$;
- 2 or 4 bits according to Table 7.3.1.1.2-4 for 2 antenna ports, if $txConfig = codebook$, and according to the values of higher layer parameters $maxRank$ and $codebookSubset$;
- 1 or 3 bits according to Table 7.3.1.1.2-5 for 2 antenna ports, if $txConfig = codebookmaxRank$ and $codebookSubset$, and according to the values of higher layer parameters .
- Antenna ports – number of bits determined by the following
 - 2 bits as defined by Tables 7.3.1.1.2-6, if $transformPrecoder=enabled$, $dmrs-Type=1$, and $maxLength=1$;
 - 4 bits as defined by Tables 7.3.1.1.2-7, if $transformPrecoder=enabled$, $dmrs-Type=1$, and $maxLength=2$;
 - 3 bits as defined by Tables 7.3.1.1.2-8/9/10/11, if $transformPrecoder=disabled$, $dmrs-Type=1$, and $maxLength=1$, and the value of rank is determined according to the SRS resource indicator field if the higher layer parameter $txConfig = nonCodebook$ and according to the Precoding information and number of layers field if the higher layer parameter $txConfig = codebook$;
 - 4 bits as defined by Tables 7.3.1.1.2-12/13/14/15, if $transformPrecoder=disabled$, $dmrs-Type=1$, and $maxLength=2$, and the value of rank is determined according to the SRS resource indicator field if the higher layer parameter $txConfig = nonCodebook$ and according to the Precoding information and number of layers field if the higher layer parameter $txConfig = codebook$;
 - 4 bits as defined by Tables 7.3.1.1.2-16/17/18/19, if $transformPrecoder=disabled$, $dmrs-Type=2$, and $maxLength=1$, and the value of rank is determined according to the SRS resource indicator field if the higher layer parameter $txConfig = nonCodebook$ and according to the Precoding information and number of layers field if the higher layer parameter $txConfig = codebook$;
 - 5 bits as defined by Tables 7.3.1.1.2-20/21/22/23, if $transformPrecoder=disabled$, $dmrs-Type=2$, and $maxLength=2$, and the value of rank is determined according to the SRS resource indicator field if the higher layer parameter $txConfig = nonCodebook$ and according to the Precoding information and number of layers field if the higher layer parameter $txConfig = codebook$.

where the number of CDM groups without data of values 1, 2, and 3 in Tables 7.3.1.1.2-6 to 7.3.1.1.2-23 refers to CDM groups {0}, {0,1}, and {0, 1,2} respectively.

If a UE is configured with both $dmrs-UplinkForPUSCH-MappingTypeA$ and $dmrs-UplinkForPUSCH-MappingTypeB$, the bit width of this field equals $\max\{x_A, x_B\}$, where x_A is the “Antenna ports” bit width derived according to $dmrs-UplinkForPUSCH-MappingTypeA$ and x_B is the “Antenna ports” bit width derived according to $dmrs-UplinkForPUSCH-MappingTypeB$. A number of $|x_A - x_B|$ zeros are padded in the MSB of this field, if the mapping type of the PUSCH corresponds to the smaller value of x_A and x_B .

- SRS request – 2 bits as defined by Table 7.3.1.1.2-24 for UEs not configured with SUL in the cell; 3 bits for UEs configured SUL in the cell where the first bit is the non-SUL/SUL indicator as defined in Table 7.3.1.1.1-1 and the second and third bits are defined by Table 7.3.1.1.2-24. This bit field may also indicate the associated CSI-RS according to Subclause 6.1.1.2 of [6, TS 38.214].
- CSI request – 0, 1, 2, 3, 4, 5, or 6 bits determined by higher layer parameter $reportTriggerSize$.
- CBG transmission information (CBGTI) – 0, 2, 4, 6, or 8 bits determined by higher layer parameter $maxCodeBlockGroupsPerTransportBlock$ for PUSCH.
- PTRS-DMRS association – number of bits determined as follows
 - 0 bit if $PTRS-UplinkConfig$ is not configured and $transformPrecoder=disabled$, or if $transformPrecoder=enabled$, or if $maxRank=1$;

- 2 bits otherwise, where Table 7.3.1.1.2-25 and 7.3.1.1.2-26 are used to indicate the association between PTRS port(s) and DMRS port(s) for transmission of one PT-RS port and two PT-RS ports respectively, and the DMRS ports are indicated by the Antenna ports field.

If “Bandwidth part indicator” field indicates a bandwidth part other than the active bandwidth part and the “PTRS-DMRS association” field is present for the indicated bandwidth part but not present for the active bandwidth part, the UE assumes the “PTRS-DMRS association” field is not present for the indicated bandwidth part. $\beta_{offsets} = semiStatic$

- beta_offset indicator – 0 if the higher layer parameter ; otherwise 2 bits as defined by Table 9.3-3 in [5, TS 38.213].
- DMRS sequence initialization – 0 if the higher layer parameter $transformPrecoder=enabled$; 1 bit if the higher layer parameter $transformPrecoder=disabled$ and both $scramblingID0$ and $scramblingID1$ are configured in $DMRS-UplinkConfig$, for n_{SCID} selection defined in Subclause 6.4.1.1.1.1 of [4, TS 38.211].
- UL-SCH indicator – 1 bit. A value of “1” indicates UL-SCH shall be transmitted on the PUSCH and a value of “0” indicates UL-SCH shall not be transmitted on the PUSCH.

For a UE configured with SUL in a cell, if PUSCH is configured to be transmitted on both the SUL and the non-SUL of the cell and if the number of information bits in format 0_1 for the SUL is not equal to the number of information bits in format 0_1 for the non-SUL, zeros shall be appended to smaller format 0_1 until the payload size equals that of the larger format 0_1.

Table 7.3.1.1.2-1: Bandwidth part indicator

Value of BWP indicator field 2 bits	Bandwidth part
00	First bandwidth part configured by higher layers
01	Second bandwidth part configured by higher layers
10	Third bandwidth part configured by higher layers
11	Fourth bandwidth part configured by higher layers

Table 7.3.1.1.2-2: Precoding information and number of layers, for 4 antenna ports, if *transformPrecoder=disabled* and *maxRank = 2 or 3 or 4*

Bit field mapped to index	<i>codebookSubset = fullyAndPartialAndNonCoherent</i>	Bit field mapped to index	<i>codebookSubset = partialAndNonCoherent</i>	Bit field mapped to index	<i>codebookSubset=nonCoherent</i>
0	1 layer: TPMI=0	0	1 layer: TPMI=0	0	1 layer: TPMI=0
1	1 layer: TPMI=1	1	1 layer: TPMI=1	1	1 layer: TPMI=1
...
3	1 layer: TPMI=3	3	1 layer: TPMI=3	3	1 layer: TPMI=3
4	2 layers: TPMI=0	4	2 layers: TPMI=0	4	2 layers: TPMI=0
...
9	2 layers: TPMI=5	9	2 layers: TPMI=5	9	2 layers: TPMI=5
10	3 layers: TPMI=0	10	3 layers: TPMI=0	10	3 layers: TPMI=0
11	4 layers: TPMI=0	11	4 layers: TPMI=0	11	4 layers: TPMI=0
12	1 layer: TPMI=4	12	1 layer: TPMI=4	12-15	reserved
...
19	1 layer: TPMI=11	19	1 layer: TPMI=11		
20	2 layers: TPMI=6	20	2 layers: TPMI=6		
...		
27	2 layers: TPMI=13	27	2 layers: TPMI=13		
28	3 layers: TPMI=1	28	3 layers: TPMI=1		
29	3 layers: TPMI=2	29	3 layers: TPMI=2		
30	4 layers: TPMI=1	30	4 layers: TPMI=1		
31	4 layers: TPMI=2	31	4 layers: TPMI=2		
32	1 layers: TPMI=12				
...	...				
47	1 layers: TPMI=27				
48	2 layers: TPMI=14				
...	...				
55	2 layers: TPMI=21				
56	3 layers: TPMI=3				
...	...				
59	3 layers: TPMI=6				
60	4 layers: TPMI=3				
61	4 layers: TPMI=4				
62-63	reserved				

Table 7.3.1.1.2-3: Precoding information and number of layers for 4 antenna ports, if *transformPrecoder= enabled*, or if *transformPrecoder=disabled* and *maxRank = 1*

Bit field mapped to index	<i>codebookSubset = fullyAndPartialAndNonCoherent</i>	Bit field mapped to index	<i>codebookSubset=partialAndNonCoherent</i>	Bit field mapped to index	<i>codebookSubset = nonCoherent</i>
0	1 layer: TPMI=0	0	1 layer: TPMI=0	0	1 layer: TPMI=0
1	1 layer: TPMI=1	1	1 layer: TPMI=1	1	1 layer: TPMI=1
...
3	1 layer: TPMI=3	3	1 layer: TPMI=3	3	1 layer: TPMI=3
4	1 layer: TPMI=4	4	1 layer: TPMI=4		
...		
11	1 layer: TPMI=11	11	1 layer: TPMI=11		
12	1 layers: TPMI=12	12-15	reserved		
...	...				
27	1 layers: TPMI=27				
28-31	reserved				

Table 7.3.1.1.2-4: Precoding information and number of layers, for 2 antenna ports, if *transformPrecoder=disabled* and *maxRank = 2*

Bit field mapped to index	<i>codebookSubset = fullyAndPartialAndNonCoherent</i>	Bit field mapped to index	<i>codebookSubset = nonCoherent</i>
0	1 layer: TPMI=0	0	1 layer: TPMI=0
1	1 layer: TPMI=1	1	1 layer: TPMI=1
2	2 layers: TPMI=0	2	2 layers: TPMI=0
3	1 layer: TPMI=2	3	reserved
4	1 layer: TPMI=3		
5	1 layer: TPMI=4		
6	1 layer: TPMI=5		
7	2 layers: TPMI=1		
8	2 layers: TPMI=2		
9-15	reserved		

Table 7.3.1.1.2-5: Precoding information and number of layers, for 2 antenna ports, if *transformPrecoder= enabled*, or if *transformPrecoder= disabled* and *maxRank = 1*

Bit field mapped to index	<i>codebookSubset = fullyAndPartialAndNonCoherent</i>	Bit field mapped to index	<i>codebookSubset = nonCoherent</i>
0	1 layer: TPMI=0	0	1 layer: TPMI=0
1	1 layer: TPMI=1	1	1 layer: TPMI=1
2	1 layer: TPMI=2		
3	1 layer: TPMI=3		
4	1 layer: TPMI=4		
5	1 layer: TPMI=5		
6-7	reserved		

...

Table 7.3.1.1.2-33: VRB-to-PRB mapping

Bit field mapped to index	VRB-to-PRB mapping
0	Non-interleaved
1	Interleaved

[TS 38.214, clause 6.1.2.1]

When the UE is scheduled to transmit a transport block and no CSI report, or the UE is scheduled to transmit a transport block and a CSI report on PUSCH by a DCI, the *Time domain resource assignment* field value m of the DCI provides a row index $m + 1$ to an allocated table. The determination of the used resource allocation table is defined in sub-clause 6.1.2.1.1. The indexed row defines the slot offset K_2 , the start and length indicator *SLIV*, or directly the start symbol S and the allocation length L , and the PUSCH mapping type to be applied in the PUSCH transmission.

When the UE is scheduled to transmit a PUSCH with no transport block and with a CSI report by a *CSI request* field on a DCI, the *Time-domain resource assignment* field value m of the DCI provides a row index $m + 1$ to an allocated table. The determination of the applied resource allocation table is defined in sub-clause 6.1.2.1.1. The indexed row defines the start and length indicator *SLIV*, or directly the start symbol S and the allocation length L , and the PUSCH mapping type to be applied in the PUSCH transmission and K_2 is determined based on the corresponding list entries $Y_j, j = 0, \dots, N_{\text{Rep}} - 1$ of the higher layer parameter *reportSlotConfig* in *CSI-ReportConfig* for the N_{Rep} triggered CSI Reporting Settings. The i th codepoint of K_2 is determined as $K_2 = \max_j Y_j(i)$ where $Y_j(i)$ is the i th codepoint of Y_j .

- The slot where the UE shall transmit the PUSCH is determined by K_2 as $\left\lfloor n \cdot \frac{2^{\mu_{\text{PUSCH}}}}{2^{\mu_{\text{PDCCH}}}} \right\rfloor + K_2$ where n is the slot with the scheduling DCI, K_2 is based on the numerology of PUSCH, and μ_{PUSCH} and μ_{PDCCH} are the subcarrier spacing configurations for PUSCH and PDCCH, respectively, and
- The starting symbol S relative to the start of the slot, and the number of consecutive symbols L counting from the symbol S allocated for the PUSCH are determined from the start and length indicator $SLIV$ of the indexed row:

if $(L-1) \leq 7$ then

$$SLIV = 14 \cdot (L-1) + S$$

else

$$SLIV = 14 \cdot (14-L+1) + (14-1-S)$$

where $0 < L \leq 14 - S$, and

- The PUSCH mapping type is set to Type A or Type B as defined in Subclause 6.4.1.1.3 of [4, TS 38.211] as given by the indexed row.

The UE shall consider the S and L combinations defined in table 6.1.2.1-1 as valid PUSCH allocations

Table 6.1.2.1-1: Valid S and L combinations

PUSCH mapping type	Normal cyclic prefix			Extended cyclic prefix		
	S	L	$S+L$	S	L	$S+L$
Type A	0	{4,...,14}	{4,...,14}	0	{4,...,12}	{4,...,12}
Type B	{0,...,13}	{1,...,14}	{1,...,14}	{0,...,12}	{1,...,12}	{1,...,12}

When the UE is configured with $aggregationFactorUL > 1$, the same symbol allocation is applied across the $aggregationFactorUL$ consecutive slots and the PUSCH is limited to a single transmission layer. The UE shall repeat the TB across the $aggregationFactorUL$ consecutive slots applying the same symbol allocation in each slot. The redundancy version to be applied on the n^{th} transmission occasion of the TB is determined according to table 6.1.2.1-2.

Table 6.1.2.1-2: Redundancy version when $aggregationFactorUL > 1$

r_{Vid} indicated by the DCI scheduling the PUSCH	r_{Vid} to be applied to n^{th} transmission occasion			
	$n \bmod 4 = 0$	$n \bmod 4 = 1$	$n \bmod 4 = 2$	$n \bmod 4 = 3$
0	0	2	3	1
2	2	3	1	0
3	3	1	0	2
1	1	0	2	3

If the UE procedure for determining slot configuration, as defined in subclause 11.1 of [6, TS 38.213], determines symbols of a slot allocated for PUSCH as downlink symbols, the transmission on that slot is omitted for multi-slot PUSCH transmission.

[38.214 clause 6.1.2.2]

The UE shall determine the resource block assignment in frequency domain using the resource allocation field in the detected PDCCH DCI. Two uplink resource allocation schemes type 0 and type 1 are supported. Uplink resource allocation scheme type 0 is supported for PUSCH only when transform precoding is disabled. Uplink resource allocation scheme type 1 is supported for PUSCH for both cases when transform precoding is enabled or disabled.

If the scheduling DCI is configured to indicate the uplink resource allocation type as part of the *Frequency domain resource* assignment field by setting a higher layer parameter *resourceAllocation* in *pusch-Config* to 'dynamicswitch', the UE shall use uplink resource allocation type 0 or type 1 as defined by this DCI field. Otherwise the UE shall use the uplink frequency resource allocation type as defined by the higher layer parameter *resourceAllocation*.

The UE shall assume that when the scheduling PDCCH is received with DCI format 0_0, then uplink resource allocation type 1 is used.

If a bandwidth part indicator field is not configured in the scheduling DCI, the RB indexing for uplink type 0 and type 1 resource allocation is determined within the UE's active bandwidth part. If a bandwidth part indicator field is configured in the scheduling DCI, the RB indexing for uplink type 0 and type 1 resource allocation is determined within the UE's bandwidth part indicated by bandwidth part indicator field value in the DCI, except for the case when DCI format 0_0 is decoded in any PDCCH common search space in CORESET 0 in which case the initial bandwidth part shall be used. The UE shall upon detection of PDCCH intended for the UE determine first the uplink bandwidth part and then the resource allocation within the bandwidth part.

[38.214 clause 6.1.2.2.1]

In uplink resource allocation of type 0, the resource block assignment information includes a bitmap indicating the Resource Block Groups (RBGs) that are allocated to the scheduled UE where a RBG is a set of consecutive virtual resource blocks defined by higher layer parameter *rbg-Size* configured for PUSCH and the size of the carrier bandwidth part as defined in Table 6.1.2.2.1-1.

Table 6.1.2.2.1-1: Nominal RBG size P

Carrier Bandwidth Part Size	Configuration 1	Configuration 2
1 – 36	2	4
37 – 72	4	8
73 – 144	8	16
145 – 275	16	16

The total number of RBGs (N_{RBG}) for a uplink carrier bandwidth part i of size $N_{\text{BWP},i}^{\text{size}}$ PRBs is given by

$N_{\text{RBG}} = \left\lfloor \left(N_{\text{BWP},i}^{\text{size}} + \left(N_{\text{BWP},i}^{\text{start}} \bmod P \right) \right) / P \right\rfloor$ where

- the size of the first RBG is $\text{RBG}_0^{\text{size}} = P - N_{\text{BWP},i}^{\text{start}} \bmod P$,
- the size of the last RBG is $\text{RBG}_{\text{last}}^{\text{size}} = \left(N_{\text{BWP},i}^{\text{start}} + N_{\text{BWP},i}^{\text{size}} \right) \bmod P$ if $\left(N_{\text{BWP},i}^{\text{start}} + N_{\text{BWP},i}^{\text{size}} \right) \bmod P > 0$ and P otherwise.
- the size of all other RBG is P .

The bitmap is of size N_{RBG} bits with one bitmap bit per RBG such that each RBG is addressable. The RBGs shall be indexed in the order of increasing frequency of the carrier bandwidth part and starting at the lowest frequency. The order of RBG bitmap is such that RBG 0 to RBG $N_{\text{RBG}} - 1$ are mapped from MSB to LSB of the bitmap. The RBG is allocated to the UE if the corresponding bit value in the bitmap is 1, the RBG is not allocated to the UE otherwise.

[38.214 clause 6.1.2.2.2]

In uplink resource allocation of type 1, the resource block assignment information indicates to a scheduled UE a set of contiguously allocated non-interleaved virtual resource blocks within the active carrier bandwidth part of size $N_{\text{BWP}}^{\text{size}}$ PRBs except for the case when DCI format 0_0 is decoded in the Type0-PDCCH common search space in CORESET 0 in which case the initial bandwidth part of size $N_{\text{BWP}}^{\text{size}}$ shall be used.

An uplink type 1 resource allocation field consists of a resource indication value (RIV) corresponding to a starting virtual resource block (RB_{start}) and a length in terms of contiguously allocated resource blocks L_{RBs} . The resource indication value is defined by

if $(L_{\text{RBs}} - 1) \leq \left\lfloor N_{\text{BWP}}^{\text{size}} / 2 \right\rfloor$ then

$$RIV = N_{\text{BWP}}^{\text{size}} (L_{\text{RBs}} - 1) + RB_{\text{start}}$$

else

$$RIV = N_{BWP}^{size} (N_{BWP}^{size} - L_{RB_s} + 1) + (N_{BWP}^{size} - 1 - RB_{start})$$

where $L_{RB_s} \geq 1$ and shall not exceed $N_{BWP}^{size} - RB_{start}$.

[TS 38.214, clause 6.1.4.1]

For the PUSCH assigned by a DCI format 0_0/0_1 with CRC scrambled by C-RNTI, new-RNTI, TC-RNTI, or SP-CSI-RNTI, the transform precoding is enabled if *transformPrecoder* in *PUSCH-Config* is set to 'enabled', or if *transformPrecoder* in *PUSCH-Config* is not configured and *msg3-transformPrecoding* in *rach-ConfigCommon* is set to 'enabled'; otherwise the transform precoding is disabled.

For the PUSCH assigned by a DCI format 0_0/0_1 with CRC scrambled by CS-RNTI, or the PUSCH with configured grant using CS-RNTI, the transform precoding is enabled if *transformPrecoder* in *ConfiguredGrantConfig* is set to 'enabled'; otherwise the transform precoding is disabled.

For a PUSCH scheduled by RAR UL grant or for a PUSCH scheduled by a DCI format 0_0/0_1 with CRC scrambled by C-RNTI, TC-RNTI, or CS-RNTI, or SP-CSI-RNTI, or for a PUSCH with configured grant using CS-RNTI,

if *transformPrecoder* is disabled for this PUSCH transmission

- if *mcs-Table* in *PUSCH-Config* is set to 'qam256', and PUSCH is scheduled with C-RNTI or SP-CSI-RNTI, and PUSCH is assigned by DCI format 0_1,
 - the UE shall use I_{MCS} and Table 5.1.3.1-2 to determine the modulation order (Q_m) and Target code rate (R) used in the physical uplink shared channel.
- elseif the UE is not configured with new-RNTI, *mcs-Table* in *PUSCH-Config* is set to 'qam64LowSE', the PUSCH is scheduled with C-RNTI, or SP-CSI-RNTI, and the PUSCH is assigned by a PDCCH in a UE-specific search space,
 - the UE shall use I_{MCS} and Table 5.1.3.1-3 to determine the modulation order (Q_m) and Target code rate (R) used in the physical uplink shared channel.
- elseif the UE is configured with new-RNTI, and the PUSCH is scheduled with new-RNTI,
 - the UE shall use I_{MCS} and Table 5.1.3.1-3 to determine the modulation order (Q_m) and Target code rate (R) used in the physical uplink shared channel.
- elseif *mcs-Table* in *ConfiguredGrantConfig* is set to 'qam256', and PUSCH is scheduled with CS-RNTI,
 - the UE shall use I_{MCS} and Table 5.1.3.1-2 to determine the modulation order (Q_m) and Target code rate (R) used in the physical uplink shared channel.
- elseif *mcs-Table* in *ConfiguredGrantConfig* is set to 'qam64LowSE', and PUSCH is scheduled with CS-RNTI,
 - the UE shall use I_{MCS} and Table 5.1.3.1-3 to determine the modulation order (Q_m) and Target code rate (R) used in the physical uplink shared channel.
- else
 - the UE shall use I_{MCS} and Table 5.1.3.1-1 to determine the modulation order (Q_m) and Target code rate (R) used in the physical uplink shared channel.

[TS 38.214, clause 5.1.3.1]

Table 5.1.3.1-1: MCS index table 1 for PDSCH

MCS Index I_{MCS}	Modulation Order Q_m	Target code Rate $R \times [1024]$	Spectral efficiency
0	2	120	0.2344
1	2	157	0.3066
2	2	193	0.3770
3	2	251	0.4902
4	2	308	0.6016
5	2	379	0.7402
6	2	449	0.8770
7	2	526	1.0273
8	2	602	1.1758
9	2	679	1.3262
10	4	340	1.3281
11	4	378	1.4766
12	4	434	1.6953
13	4	490	1.9141
14	4	553	2.1602
15	4	616	2.4063
16	4	658	2.5703
17	6	438	2.5664
18	6	466	2.7305
19	6	517	3.0293
20	6	567	3.3223
21	6	616	3.6094
22	6	666	3.9023
23	6	719	4.2129
24	6	772	4.5234
25	6	822	4.8164
26	6	873	5.1152
27	6	910	5.3320
28	6	948	5.5547
29	2	reserved	
30	4	reserved	
31	6	reserved	

[TS 38.214, clause 6.1.4.2]

For a PUSCH scheduled by RAR UL grant or for a PUSCH scheduled by a DCI format 0_0/0_1 with CRC scrambled by C-RNTI, new-RNTI, TC-RNTI, CS-RNTI, or SP-CSI-RNTI.

if

- $0 \leq I_{MCS} \leq 27$ and transform precoding is disabled and Table 5.1.3.1-2 is used, or
- $0 \leq I_{MCS} \leq 28$ and transform precoding is disabled and a table other than Table 5.1.3.1-2 is used, or
- $0 \leq I_{MCS} \leq 27$ and transform precoding is enabled, the UE shall first determine the TBS as specified below:

The UE shall first determine the number of REs (N_{RE}) within the slot:

- A UE first determines the number of REs allocated for PUSCH within a PRB (N'_{RE}) by
- $N'_{RE} = N_{sc}^{RB} * N_{ymb}^{sh} - N_{DMRS}^{PRB} - N_{oh}^{PRB}$, where $N_{sc}^{RB} = 12$ is the number of subcarriers in the frequency domain in a physical resource block, N_{ymb}^{sh} is the number of symbols of the PUSCH allocation within the slot, N_{DMRS}^{PRB} is the number of REs for DM-RS per PRB in the scheduled duration including the overhead of the DM-RS CDM groups without data, as indicated by DCI format 0_1 or as described for DCI format 0_0 in Subclause 6.2.2, and N_{oh}^{PRB} is the overhead configured by higher layer parameter $xOverhead$ in PUSCH-

ServingCellConfig. If the N_{oh}^{PRB} is not configured (a value from 0, 6, 12, or 18), the N_{oh}^{PRB} is assumed to be 0. For MSG3 transmission the N_{oh}^{PRB} is always set to 0..

- A UE determines the total number of REs allocated for PUSCH (N_{RE}) by $N_{RE} = \min(156, N_{RE}') \cdot n_{PRB}$ where n_{PRB} is the total number of allocated PRBs for the UE.
- Next, proceed with steps 2-4 as defined in Subclause 5.1.3.2

else if

- $28 \leq I_{MCS} \leq 31$ and transform precoding is disabled and Table 5.1.3.1-2 is used, or
- $28 \leq I_{MCS} \leq 31$ and transform precoding is enabled,
- the TBS is assumed to be as determined from the DCI transported in the latest PDCCH for the same transport block using $0 \leq I_{MCS} \leq 27$. If there is no PDCCH for the same transport block using $0 \leq I_{MCS} \leq 27$, and if the initial PUSCH for the same transport block is transmitted with configured grant, the TBS shall be determined from the most recent configured scheduling PDCCH.

else

- the TBS is assumed to be as determined from the DCI transported in the latest PDCCH for the same transport block using $0 \leq I_{MCS} \leq 28$. If there is no PDCCH for the same transport block using $0 \leq I_{MCS} \leq 28$, and if the initial PUSCH for the same transport block is transmitted with configured grant, the TBS shall be determined from the most recent configured scheduling PDCCH.

[TS 38.214, clause 5.1.3.2]

2) Intermediate number of information bits (N_{info}) is obtained by $N_{info} = N_{RE} \cdot R \cdot Q_m \cdot v$.

If $N_{info} \leq 3824$

Use step 3 as the next step of the TBS determination

else

Use step 4 as the next step of the TBS determination

end if

3) When $N_{info} \leq 3824$, TBS is determined as follows

- quantized intermediate number of information bits $N_{info}' = \max\left(24, 2^n \cdot \left\lfloor \frac{N_{info}}{2^n} \right\rfloor\right)$, where $n = \max(3, \lfloor \log_2(N_{info}) \rfloor - 6)$.
- use Table 5.1.3.2-2 find the closest TBS that is not less than N_{info}' .

Table 5.1.3.2-2: TBS for $N_{info} \leq 3824$

Index	TBS	Index	TBS	Index	TBS	Index	TBS
1	24	31	336	61	1288	91	3624
2	32	32	352	62	1320	92	3752
3	40	33	368	63	1352	93	3824
4	48	34	384	64	1416		
5	56	35	408	65	1480		
6	64	36	432	66	1544		
7	72	37	456	67	1608		
8	80	38	480	68	1672		
9	88	39	504	69	1736		
10	96	40	528	70	1800		
11	104	41	552	71	1864		
12	112	42	576	72	1928		
13	120	43	608	73	2024		
14	128	44	640	74	2088		
15	136	45	672	75	2152		
16	144	46	704	76	2216		
17	152	47	736	77	2280		
18	160	48	768	78	2408		
19	168	49	808	79	2472		
20	176	50	848	80	2536		
21	184	51	888	81	2600		
22	192	52	928	82	2664		
23	208	53	984	83	2728		
24	224	54	1032	84	2792		
25	240	55	1064	85	2856		
26	256	56	1128	86	2976		
27	272	57	1160	87	3104		
28	288	58	1192	88	3240		
29	304	59	1224	89	3368		
30	320	60	1256	90	3496		

4) When $N_{info} > 3824$, TBS is determined as follows.

- quantized intermediate number of information bits $N'_{info} = \max\left(3840, 2^n \times \text{round}\left(\frac{N_{info} - 24}{2^n}\right)\right)$, where $n = \lfloor \log_2(N_{info} - 24) \rfloor - 5$ and ties in the round function are broken towards the next largest integer.
- if $R \leq 1/4$

$$TBS = 8 \cdot C \cdot \left\lceil \frac{N'_{info} + 24}{8 \cdot C} \right\rceil - 24, \text{ where } C = \left\lceil \frac{N'_{info} + 24}{3816} \right\rceil$$

else

if $N'_{info} > 8424$

$$TBS = 8 \cdot C \cdot \left\lceil \frac{N'_{info} + 24}{8 \cdot C} \right\rceil - 24, \text{ where } C = \left\lceil \frac{N'_{info} + 24}{8424} \right\rceil$$

else

$$TBS = 8 \cdot \left\lceil \frac{N'_{info} + 24}{8} \right\rceil - 24$$

end if

end if

7.1.1.4.2.3.3 Test description

7.1.1.4.2.3.3.1 Pre-test conditions

Same Pre-test conditions as in clause 7.1.1.0 except set the NR Cell bandwidth and applicable BWP to maximum for the NR Band under test as specified in Table 5.3.5-1 in TS 38.101-1 [16] / TS 38.101-2 [17] (to enable testing of n_{PRB} up to maximum value).

Test frequency NRf1 is as specified in TS 38.508-1 [4] clause 4.3.1 using the common highest UL and DL channel bandwidth and using the default subcarrier spacing specified in TS 38.508-1 [4] clause 6.2.3.1.

7.1.1.4.2.3.3.2 Test procedure sequence

Table 7.1.1.4.2.3.3.2-1: Maximum TBS for different UE categories

UE Category	Maximum number of bits of a UL-SCH transport block received within a TTI
TS 38.306 [23] clause 4.1.2 require UE without ue-CategoryDL and ue-CategoryUL, to support Max TBS achievable based on max bandwidth of the Band under test.	

Table 7.1.1.4.2.3.3.2-2: Number of downlink PDCP SDUs and PDCP SDU size used as test data

TBS [bits]	Number of PDCP SDUs	PDCP SDU size [bits] (Note 1)
$136 \leq TBS \leq 12128$ note 2	1	$8 * \text{FLOOR}((TBS - 128) / 8)$
$12129 \leq TBS \leq 24200$	2	$8 * \text{FLOOR}((TBS - 200) / 16)$
$24201 \leq TBS \leq 36272$	3	$8 * \text{FLOOR}((TBS - 272) / 24)$
$36273 \leq TBS \leq 48344$	4	$8 * \text{FLOOR}((TBS - 344) / 32)$
$48345 \leq TBS \leq 60416$	5	$8 * \text{FLOOR}((TBS - 416) / 40)$
$60417 \leq TBS \leq 72488$	6	$8 * \text{FLOOR}((TBS - 488) / 48)$
$72489 \leq TBS \leq 84560$	7	$8 * \text{FLOOR}((TBS - 560) / 56)$
$84561 \leq TBS \leq 96632$	8	$8 * \text{FLOOR}((TBS - 632) / 64)$
$96633 < TBS \leq 108704$	9	$8 * \text{FLOOR}((TBS - 704) / 72)$
$10705 \leq TBS \leq 120776$	10	$8 * \text{FLOOR}((TBS - 776) / 80)$
$120777 \leq TBS \leq 132848$	11	$8 * \text{FLOOR}((TBS - 848) / 88)$
$132849 \leq TBS \leq 144920$	12	$8 * \text{FLOOR}((TBS - 920) / 96)$
$TBS > 144920$	13	$8 * \text{FLOOR}((TBS - 992) / 104)$

Note 1: Each PDCP SDU is limited to 1500 octets (to keep below maximum SDU size of ESM as specified in TS 24.301 [21] clause 9.9.4.12).

The PDCP SDU size of each PDCP SDU is

$\text{PDCP SDU size} = (TBS - N * \text{PDCP header size} - N * \text{AMD PDU header size} - N * \text{MAC header size} - \text{Size of Timing Advance} - \text{RLC Status PDU size} - \text{MAC header for RLC Status PDU}) / N$, where

PDCP header size is 24 bits for the RLC AM and 18-bit SN case;
 AMD PDU header size is 24 bits with 18 bit SN;

MAC header size for AMD PDU = 16 or 24 bits depending on L=8 or 16 bits. Worst case 24 is taken.

Size of Timing Advance MAC CE with header is 16 bits (if no Timing Advance and/or RLC status needs to be sent, padding will occur instead).

RLC Status PDU size = 24 bits with 1 ACK_SN, With a MAC header of 16 bits.

This gives:

$\text{PDCP SDU size} = 8 * \text{FLOOR}((TBS - N * 24 - N * 24 - N * 24 - 56) / (8 * N))$ bits.

Note 2: According to the final PDCP SDU size formula in Note 1, the smallest TBS that can be tested is 136 bits.

Table 7.1.1.4.2.3.3.2-2A: Bandwidth part Dependent Parameters for Resource allocation 0 with start of BWP assumed as 0

$N_{RB}^{DL,BWP} = N_{BWP,i}^{size}$	Nominal RBG size P (Configuration1)	Size of last RBG	Allowed N_{PRB} Values
11	2	1	All 1...11
18	2	2	2,4,6,8,10,12,16,18
24	2	2	2,4,6,8,10,12,16,18,20,22,24
25	2	1	All 1...25
31	2	1	All 1...31
32	2	2	2,4,6,8,10,12,16,18,20,22,24,26,28,30,32
38	4	2	2,4,6,8,10,12,16,18,20,22,24,26,28,30,32,34,36,38
51	4	3	3,4,7,8,11,12,15,16,19,20,23,24,27,28,31,32,35,36,39,40,43,44,47,48,51
52	4	4	4,8,12,16,20,24,28,32,36,40,44,48,52
65	4	1	1,4,5,8,9,12,13,16,17,20,21,24,25,28,29,32,33,36,37,40,41,44,45,48,49,52,53,56,57,60,61,64,65
66	4	2	2,4,6,8,10,12,16,18,20,22,24,26,28,30,32,34,36,38,40,42,44,46,48,50,52,54,56,58,60,62,64,66
79	8	7	7,8,15,16,23,24,31,32,39,40,47,48,55,56,63,64,71,72,79
106	8	2	2,8,10,16,18,24,26,32,34,40,42,48,50,56,58,64,66,72,74,80,82,88,90,96,92,104,106
107	8	3	3,8,11,16,19,24,27,32,35,40,43,48,51,56,59,64,67,72,75,80,83,88,91,96,99,104,107
132	8	4	4,8,12,16,20,24,28,32,36,40,44,48,52,56,60,64,68,72,76,80,84,88,92,96,100,104,108,112,116,120,124,128,132
133	8	5	5,8,13,16,21,24,29,32,37,40,45,48,53,56,61,64,69,72,77,80,85,88,93,96,101,104,109,112,117,120,125,128,133
135	8	7	7,8,15,16,23,24,31,32,39,40,47,48,55,56,63,64,71,72,79,80,87,88,95,96,103,104,111,112,119,120,127,128,135
216	16	8	8,16,24,32,40,48,56,64,72,80,88,96,104,112,120,128,136,144,152,160,168,176,184,192,200,208,216
217	16	9	9,16,25,32,41,48,57,64,73,80,89,96,105,112,121,128,137,144,153,160,169,176,185,192,201,208,217
264	16	8	8,16,24,32,40,48,56,64,72,80,88,96,104,112,120,128,136,144,160,168,176,184,192,200,208,216,224,232,240,248,256,264
270	16	14	14,16,30,32,46,44,62,64,78,80,94,96,110,112,126,128,142,144,158,160,174,176,190,192,206,208,222,224,238,240,254,256,270
273	16	1	1,16,17,32,33,48,49,64,65,80,81,96,97,112,113,128,129,144,145,160,161,176,171,192,193,208,209,224,225,240,241,256,257,272,273

Table 7.1.1.4.2.3.3.2-3: Specific Parameter

Parameter	Value	Comment
mcs-Table	qam64	
resourceAllocation	dynamicSwitch	
rbg-Size	Not present	configuration 1 applicable
N_{BWP}^{start}	0	

Table 7.1.1.4.2.3.3.2-4: Main behaviour

St	Procedure	Message Sequence		TP	Verdict
		U - S	Message		
-	EXCEPTION: Steps 1 to 5 are repeated for allowed values of N_{PRB} as per table 7.1.1.4.2.3.3.2-2A in BWP, time domain resource as per Table 7.1.1.4.2.0-1 and I_{MCS} from 0 to 28.	-	-	-	-
1	SS calculates or looks up TBS in TS 38.214 [15] based on the value of S, L, I_{MCS} and n_{PRB} .	-	-	-	-

-	EXCEPTION: Steps 2 to 5 are performed if TBS is less than or equal to UE capability "Maximum number of UL-SCH transport block bits received within a TTI" as specified in Table 7.1.1.4.2.3.3.2-1 and larger than or equal to 136 bits as specified in Table 7.1.1.4.2.3.3.2-2	-	-	-	-
2	SS creates one or more PDCP SDUs depending on TBS in accordance with Table 7.1.1.4.2.3.3.2-2.	-	-	-	-
3	After 300ms, the SS transmits all PDCP SDUs (N_{SDUs}) as created in step 2 in a MAC PDU.	<--	MAC PDU (N_{xPDCP} SDUs)	-	-
4	After 60ms of step 3 SS transmits UL Grant DCI 0_1, and values of S, L, I_{MCS} and n_{PRB} .	<--	(UL Grant) (DCI: (DCI Format 0_1, S, L, I_{MCS} and n_{PRB}))	-	-
5	CHECK: Does UE return the same number of PDCP SDUs with same content as transmitted by the SS in step 3 using Time, frequency Resources and modulation and coding scheme as configured by the SS in step 4?	-->	(N_{xPDCP} SDUs)	1	P
-	EXCEPTION: Steps 6 to 10 are repeated for allowed values of N_{PRB} 1 to $N_{RB}^{UL,BWP}$ in BWP, time domain resource length L 3 to 14-S and I_{MCS} from 0 to 28.	-	-	-	-
6	SS calculates or looks up TBS in TS 38.214 [15] based on the value of S, L, I_{MCS} and n_{PRB} .	-	-	-	-
-	EXCEPTION: Steps 7 to 10 are performed if TBS1 + TBS2 is less than or equal to UE capability "Maximum number of UL-SCH transport block bits received within a TTI" as specified in Table 7.1.1.4.2.3.3.2-1 and larger than or equal to 136 bits as specified in Table 7.1.1.4.2.3.3.2-2.	-	-	-	-
7	SS creates one or more PDCP SDUs depending on TBS in accordance with Table 7.1.1.4.2.3.3.2-2.	-	-	-	-
8	After 300ms, the SS transmits all PDCP SDUs (N_{SDUs}) as created in step 7 in a MAC PDU.	<--	MAC PDU (N_{xPDCP} SDUs)	-	-
9	After 60ms of step 8 SS transmits UL Grant DCI 0_1, and values of S, L, I_{MCS} and n_{PRB} .	<--	(UL Grant) (DCI: (DCI Format 0_1, S, L, I_{MCS} and n_{PRB}))	-	-
10	CHECK: Does UE return the same number of PDCP SDUs with same content as transmitted by the SS in step 8 using Time, frequency Resources and modulation and coding scheme as configured by the SS in step 9?	-->	(N_{xPDCP} SDUs)	2	P

7.1.1.4.2.3.3.3 Specific message contents

[None].

7.1.1.4.2.4 UL-SCH transport block size selection / DCI format 0_1 / RA type 0/RA Type 1 / 256QAM / Transform precoding disabled

7.1.1.4.2.4.1 Test Purpose (TP)

(1)

```
with { UE in RRC_CONNECTED state and mcs-Table is set as 'qam256' }
ensure that {
  when { UE has pending data for transmission and receives DCI format 1_1 indicating resource
allocation type 0 a resource block assignment correspondent to physical resource blocks , Time
domain resource assignment and a modulation and coding }
  then { UE transmits MAC PDU's on PUSCH as per Modulation Coding scheme, time domain resource
allocation and PRB's }
}
```

(2)

```
with { UE in RRC_CONNECTED state and mcs-Table is set as 'qam256' }
ensure that {
  when { UE has pending data for transmission and receives DCI format 1_1 indicating resource
allocation type 1 a resource block assignment correspondent to physical resource blocks , Time
domain resource assignment and a modulation and coding }
  then { UE transmits MAC PDU's on PUSCH as per Modulation Coding scheme, time domain resource
allocation and PRB's }
}
```

7.1.1.4.2.4.2 Conformance requirements

References: The conformance requirements covered in the present TC are specified in: TS 38.212 clause 7.3.1.1.1, TS 38.214 clause 6.1.2.1, 6.1.2.2, 6.1.2.2.1, 6.1.2.2.2, 6.1.4.1, 5.1.3.1, 6.1.4.2 and 5.1.3.2. Unless otherwise stated these are Rel-15 requirements.

[TS 38.212, clause 7.3.1.1.2]

DCI format 0_1 is used for the scheduling of PUSCH in one cell.

The following information is transmitted by means of the DCI format 0_1 with CRC scrambled by C-RNTI or CS-RNTI or SP-CSI-RNTI or new-RNTI:

- Identifier for DCI formats – 1 bit
- The value of this bit field is always set to 0, indicating an UL DCI format
 - Carrier indicator – 0 or 3 bits, as defined in Subclause 10.1 of [5, TS38.213].
 - UL/SUL indicator – 0 bit for UEs not configured with SUL in the cell or UEs configured with SUL in the cell but only PUCCH carrier in the cell is configured for PUSCH transmission; 1 bit for UEs configured with SUL in the cell as defined in Table 7.3.1.1.1-1.
 - Bandwidth part indicator – 0, 1 or 2 bits as determined by the number of UL BWPs $n_{\text{BWP,RRC}}$ configured by higher layers, excluding the initial UL bandwidth part. The bit width for this field is determined as $\lceil \log_2(n_{\text{BWP}}) \rceil$ bits, where
 - $n_{\text{BWP}} = n_{\text{BWP,RRC}} + 1$ if $n_{\text{BWP,RRC}} \leq 3$, in which case the bandwidth part indicator is equivalent to the higher layer parameter *BWP-Id*;
 - otherwise $n_{\text{BWP}} = n_{\text{BWP,RRC}}$, in which case the bandwidth part indicator is defined in Table 7.3.1.1.2-1;

If a UE does not support active BWP change via DCI, the UE ignores this bit field.

- Frequency domain resource assignment – number of bits determined by the following, where $N_{\text{RB}}^{\text{UL,BWP}}$ is the size of the active UL bandwidth part:

- N_{RBG} bits if only resource allocation type 0 is configured, where N_{RBG} is defined in Subclause 6.1.2.2.1 of [6, TS 38.214],
- $\lceil \log_2(N_{\text{RB}}^{\text{UL,BWP}}(N_{\text{RB}}^{\text{UL,BWP}} + 1)/2) \rceil$ bits if only resource allocation type 1 is configured, or $\max(\lceil \log_2(N_{\text{RB}}^{\text{UL,BWP}}(N_{\text{RB}}^{\text{UL,BWP}} + 1)/2) \rceil, N_{\text{RBG}}) + 1$ bits if both resource allocation type 0 and 1 are configured.
- If both resource allocation type 0 and 1 are configured, the MSB bit is used to indicate resource allocation type 0 or resource allocation type 1, where the bit value of 0 indicates resource allocation type 0 and the bit value of 1 indicates resource allocation type 1.
- For resource allocation type 0, the N_{RBG} LSBs provide the resource allocation as defined in Subclause 6.1.2.2.1 of [6, TS 38.214].
- For resource allocation type 1, the $\lceil \log_2(N_{\text{RB}}^{\text{UL,BWP}}(N_{\text{RB}}^{\text{UL,BWP}} + 1)/2) \rceil$ LSBs provide the resource allocation as follows:
 - For PUSCH hopping with resource allocation type 1:
 - $N_{\text{UL_hop}}$ MSB bits are used to indicate the frequency offset according to Subclause 6.3 of [6, TS 38.214], where $N_{\text{UL_hop}} = 1$ if the higher layer parameter *frequencyHoppingOffsetLists* contains two offset values and $N_{\text{UL_hop}} = 2$ if the higher layer parameter *frequencyHoppingOffsetLists* contains four offset values
 - $\lceil \log_2(N_{\text{RB}}^{\text{UL,BWP}}(N_{\text{RB}}^{\text{UL,BWP}} + 1)/2) \rceil - N_{\text{UL_hop}}$ bits provides the frequency domain resource allocation according to Subclause 6.1.2.2.2 of [6, TS 38.214]
 - For non-PUSCH hopping with resource allocation type 1:
 - $\lceil \log_2(N_{\text{RB}}^{\text{UL,BWP}}(N_{\text{RB}}^{\text{UL,BWP}} + 1)/2) \rceil$ bits provides the frequency domain resource allocation according to Subclause 6.1.2.2.2 of [6, TS 38.214]

If "Bandwidth part indicator" field indicates a bandwidth part other than the active bandwidth part and if both resource allocation type 0 and 1 are configured for the indicated bandwidth part, the UE assumes resource allocation type 0 for the indicated bandwidth part if the bit width of the "Frequency domain resource assignment" field of the active bandwidth part is smaller than the bit width of the "Frequency domain resource assignment" field of the indicated bandwidth part.

- Time domain resource assignment – 0, 1, 2, 3, or 4 bits as defined in Subclause 6.1.2.1 of [6, TS38.214]. The bit width for this field is determined as $\lceil \log_2(I) \rceil$ bits, where I the number of entries in the higher layer parameter *pusch-AllocationList*.
- Frequency hopping flag – 0 or 1 bit:
 - 0 bit if only resource allocation type 0 is configured or if the higher layer parameter *frequencyHopping* is not configured;
 - 1 bit according to Table 7.3.1.1.2-34 otherwise, only applicable to resource allocation type 1, as defined in Subclause 6.3 of [6, TS 38.214].
- Modulation and coding scheme – 5 bits as defined in Subclause 6.1.4.1 of [6, TS 38.214]
- New data indicator – 1 bit
- Redundancy version – 2 bits as defined in Table 7.3.1.1.1-2
- HARQ process number – 4 bits
- 1st downlink assignment index – 1 or 2 bits:
 - 1 bit for semi-static HARQ-ACK codebook;

- 2 bits for dynamic HARQ-ACK codebook.
- 2nd downlink assignment index – 0 or 2 bits:
 - 2 bits for dynamic HARQ-ACK codebook with two HARQ-ACK sub-codebooks;
 - 0 bit otherwise.
- TPC command for scheduled PUSCH – 2 bits as defined in Subclause 7.1.1 of [5, TS38.213]
- SRS resource indicator – $\left\lceil \log_2 \left(\sum_{k=1}^{\min\{L_{\max}^{\text{PUSCH}}, N_{\text{SRS}}\}} \binom{N_{\text{SRS}}}{k} \right) \right\rceil$ or $\lceil \log_2(N_{\text{SRS}}) \rceil$ bits, where N_{SRS} is the number of configured SRS resources in the SRS resource set associated with the higher layer parameter *usage* of value '*codeBook*' or '*nonCodeBook*', and L_{\max}^{PUSCH} is the maximum number of supported layers for the PUSCH.
 - $\left\lceil \log_2 \left(\sum_{k=1}^{\min\{L_{\max}^{\text{PUSCH}}, N_{\text{SRS}}\}} \binom{N_{\text{SRS}}}{k} \right) \right\rceil$ bits according to Tables 7.3.1.1.2-28/29/30/31 if the higher layer parameter *txConfig* = *nonCodebook*, where N_{SRS} is the number of configured SRS resources in the SRS resource set associated with the higher layer parameter *usage* of value '*nonCodeBook*';
 - $\lceil \log_2(N_{\text{SRS}}) \rceil$ bits according to Tables 7.3.1.1.2-32 if the higher layer parameter *txConfig* = *codebook*, where N_{SRS} is the number of configured SRS resources in the SRS resource set associated with the higher layer parameter *usage* of value '*codeBook*'.
- Precoding information and number of layers – number of bits determined by the following:
 - 0 bits if the higher layer parameter *txConfig* = *nonCodeBook*;
 - 0 bits for 1 antenna port and if the higher layer parameter *txConfig* = *codebook*;
 - 4, 5, or 6 bits according to Table 7.3.1.1.2-2 for 4 antenna ports, if *txConfig* = *codebook*, and according to the values of higher layer parameters *transformPrecoder*, *maxRank*, and *codebookSubset*;
 - 2, 4, or 5 bits according to Table 7.3.1.1.2-3 for 4 antenna ports, if *txConfig* = *codebook*, and according to the values of higher layer parameters *transformPrecoder*, *maxRank*, and *codebookSubset*;
 - 2 or 4 bits according to Table 7.3.1.1.2-4 for 2 antenna ports, if *txConfig* = *codebook*, and according to the values of higher layer parameters *maxRank* and *codebookSubset*;
 - 1 or 3 bits according to Table 7.3.1.1.2-5 for 2 antenna ports, if *txConfig* = *codebook*, and according to the values of higher layer parameters *maxRank* and *codebookSubset*.
- Antenna ports – number of bits determined by the following
 - 2 bits as defined by Tables 7.3.1.1.2-6, if *transformPrecoder*=*enabled*, *dmrs-Type*=1, and *maxLength*=1;
 - 4 bits as defined by Tables 7.3.1.1.2-7, if *transformPrecoder*=*enabled*, *dmrs-Type*=1, and *maxLength*=2;
 - 3 bits as defined by Tables 7.3.1.1.2-8/9/10/11, if *transformPrecoder*=*disabled*, *dmrs-Type*=1, and *maxLength*=1, and the value of rank is determined according to the SRS resource indicator field if the higher layer parameter *txConfig* = *nonCodebook* and according to the Precoding information and number of layers field if the higher layer parameter *txConfig* = *codebook*;
 - 4 bits as defined by Tables 7.3.1.1.2-12/13/14/15, if *transformPrecoder*=*disabled*, *dmrs-Type*=1, and *maxLength*=2, and the value of rank is determined according to the SRS resource indicator field if the higher layer parameter *txConfig* = *nonCodebook* and according to the Precoding information and number of layers field if the higher layer parameter *txConfig* = *codebook*;
 - 4 bits as defined by Tables 7.3.1.1.2-16/17/18/19, if *transformPrecoder*=*disabled*, *dmrs-Type*=2, and *maxLength*=1, and the value of rank is determined according to the SRS resource indicator field if the higher

layer parameter $txConfig = nonCodebook$ and according to the Precoding information and number of layers field if the higher layer parameter $txConfig = codebook$;

- 5 bits as defined by Tables 7.3.1.1.2-20/21/22/23, if $transformPrecoder=disabled$, $dmrs-Type=2$, and $maxLength=2$, and the value of rank is determined according to the SRS resource indicator field if the higher layer parameter $txConfig = nonCodebook$ and according to the Precoding information and number of layers field if the higher layer parameter $txConfig = codebook$.

where the number of CDM groups without data of values 1, 2, and 3 in Tables 7.3.1.1.2-6 to 7.3.1.1.2-23 refers to CDM groups $\{0\}$, $\{0,1\}$, and $\{0, 1,2\}$ respectively.

If a UE is configured with both $dmrs-UplinkForPUSCH-MappingTypeA$ and $dmrs-UplinkForPUSCH-MappingTypeB$, the bit width of this field equals $\max\{x_A, x_B\}$, where x_A is the “Antenna ports” bit width derived according to $dmrs-UplinkForPUSCH-MappingTypeA$ and x_B is the “Antenna ports” bit width derived according to $dmrs-UplinkForPUSCH-MappingTypeB$. A number of $|x_A - x_B|$ zeros are padded in the MSB of this field, if the mapping type of the PUSCH corresponds to the smaller value of x_A and x_B .

- SRS request – 2 bits as defined by Table 7.3.1.1.2-24 for UEs not configured with SUL in the cell; 3 bits for UEs configured SUL in the cell where the first bit is the non-SUL/SUL indicator as defined in Table 7.3.1.1.1-1 and the second and third bits are defined by Table 7.3.1.1.2-24. This bit field may also indicate the associated CSI-RS according to Subclause 6.1.1.2 of [6, TS 38.214].
 - CSI request – 0, 1, 2, 3, 4, 5, or 6 bits determined by higher layer parameter $reportTriggerSize$.
 - CBG transmission information (CBGTI) – 0, 2, 4, 6, or 8 bits determined by higher layer parameter $maxCodeBlockGroupsPerTransportBlock$ for PUSCH.
 - PTRS-DMRS association – number of bits determined as follows
 - 0 bit if $PTRS-UplinkConfig$ is not configured and $transformPrecoder=disabled$, or if $transformPrecoder=enabled$, or if $maxRank=1$;
 - 2 bits otherwise, where Table 7.3.1.1.2-25 and 7.3.1.1.2-26 are used to indicate the association between PTRS port(s) and DMRS port(s) for transmission of one PT-RS port and two PT-RS ports respectively, and the DMRS ports are indicated by the Antenna ports field.
- If “Bandwidth part indicator” field indicates a bandwidth part other than the active bandwidth part and the “PTRS-DMRS association” field is present for the indicated bandwidth part but not present for the active bandwidth part, the UE assumes the “PTRS-DMRS association” field is not present for the indicated bandwidth part.
- $beta_offset$ indicator – 0 if the higher layer parameter $betaOffsets = semiStatic$; otherwise 2 bits as defined by Table 9.3-3 in [5, TS 38.213].
 - DMRS sequence initialization – 0 if the higher layer parameter $transformPrecoder=enabled$; 1 bit if the higher layer parameter $transformPrecoder=disabled$ and both $scramblingID0$ and $scramblingID1$ are configured in $DMRS-UplinkConfig$, for n_{SCID} selection defined in Subclause 6.4.1.1.1.1 of [4, TS 38.211].
 - UL-SCH indicator – 1 bit. A value of “1” indicates UL-SCH shall be transmitted on the PUSCH and a value of “0” indicates UL-SCH shall not be transmitted on the PUSCH.

For a UE configured with SUL in a cell, if PUSCH is configured to be transmitted on both the SUL and the non-SUL of the cell and if the number of information bits in format 0_1 for the SUL is not equal to the number of information bits in format 0_1 for the non-SUL, zeros shall be appended to smaller format 0_1 until the payload size equals that of the larger format 0_1.

Table 7.3.1.1.2-1: Bandwidth part indicator

Value of BWP indicator field 2 bits	Bandwidth part
00	First bandwidth part configured by higher layers
01	Second bandwidth part configured by higher layers
10	Third bandwidth part configured by higher layers
11	Fourth bandwidth part configured by higher layers

Table 7.3.1.1.2-2: Precoding information and number of layers, for 4 antenna ports, if *transformPrecoder=disabled* and *maxRank = 2 or 3 or 4*

Bit field mapped to index	<i>codebookSubset = fullyAndPartialAndNonCoherent</i> <i>t</i>	Bit field mapped to index	<i>codebookSubset = partialAndNonCoherent</i> <i>t</i>	Bit field mapped to index	<i>codebookSubset = nonCoherent</i>
0	1 layer: TPMI=0	0	1 layer: TPMI=0	0	1 layer: TPMI=0
1	1 layer: TPMI=1	1	1 layer: TPMI=1	1	1 layer: TPMI=1
...
3	1 layer: TPMI=3	3	1 layer: TPMI=3	3	1 layer: TPMI=3
4	2 layers: TPMI=0	4	2 layers: TPMI=0	4	2 layers: TPMI=0
...
9	2 layers: TPMI=5	9	2 layers: TPMI=5	9	2 layers: TPMI=5
10	3 layers: TPMI=0	10	3 layers: TPMI=0	10	3 layers: TPMI=0
11	4 layers: TPMI=0	11	4 layers: TPMI=0	11	4 layers: TPMI=0
12	1 layer: TPMI=4	12	1 layer: TPMI=4	12-15	reserved
...		
19	1 layer: TPMI=11	19	1 layer: TPMI=11		
20	2 layers: TPMI=6	20	2 layers: TPMI=6		
...		
27	2 layers: TPMI=13	27	2 layers: TPMI=13		
28	3 layers: TPMI=1	28	3 layers: TPMI=1		
29	3 layers: TPMI=2	29	3 layers: TPMI=2		
30	4 layers: TPMI=1	30	4 layers: TPMI=1		
31	4 layers: TPMI=2	31	4 layers: TPMI=2		
32	1 layers: TPMI=12				
...	...				
47	1 layers: TPMI=27				
48	2 layers: TPMI=14				
...	...				
55	2 layers: TPMI=21				
56	3 layers: TPMI=3				
...	...				
59	3 layers: TPMI=6				
60	4 layers: TPMI=3				
61	4 layers: TPMI=4				
62-63	reserved				

Table 7.3.1.1.2-3: Precoding information and number of layers for 4 antenna ports, if *transformPrecoder= enabled*, or if *transformPrecoder=disabled* and *maxRank = 1*

Bit field mapped to index	<i>codebookSubset = fullyAndPartialAndNonCoherent</i> <i>t</i>	Bit field mapped to index	<i>codebookSubset= partialAndNonCoherent</i> <i>t</i>	Bit field mapped to index	<i>codebookSubset = nonCoherent</i>
0	1 layer: TPMI=0	0	1 layer: TPMI=0	0	1 layer: TPMI=0
1	1 layer: TPMI=1	1	1 layer: TPMI=1	1	1 layer: TPMI=1
...
3	1 layer: TPMI=3	3	1 layer: TPMI=3	3	1 layer: TPMI=3
4	1 layer: TPMI=4	4	1 layer: TPMI=4		
...		
11	1 layer: TPMI=11	11	1 layer: TPMI=11		
12	1 layers: TPMI=12	12-15	reserved		
...	...				
27	1 layers: TPMI=27				
28-31	reserved				

Table 7.3.1.1.2-4: Precoding information and number of layers, for 2 antenna ports, if *transformPrecoder=disabled* and *maxRank = 2*

Bit field mapped to index	<i>codebookSubset = fullyAndPartialAndNonCoherent</i>	Bit field mapped to index	<i>codebookSubset = nonCoherent</i>
0	1 layer: TPMI=0	0	1 layer: TPMI=0
1	1 layer: TPMI=1	1	1 layer: TPMI=1
2	2 layers: TPMI=0	2	2 layers: TPMI=0
3	1 layer: TPMI=2	3	reserved
4	1 layer: TPMI=3		
5	1 layer: TPMI=4		
6	1 layer: TPMI=5		
7	2 layers: TPMI=1		
8	2 layers: TPMI=2		
9-15	reserved		

Table 7.3.1.1.2-5: Precoding information and number of layers, for 2 antenna ports, if *transformPrecoder= enabled*, or if *transformPrecoder= disabled* and *maxRank = 1*

Bit field mapped to index	<i>codebookSubset = fullyAndPartialAndNonCoherent</i>	Bit field mapped to index	<i>codebookSubset = nonCoherent</i>
0	1 layer: TPMI=0	0	1 layer: TPMI=0
1	1 layer: TPMI=1	1	1 layer: TPMI=1
2	1 layer: TPMI=2		
3	1 layer: TPMI=3		
4	1 layer: TPMI=4		
5	1 layer: TPMI=5		
6-7	reserved		

...

Table 7.3.1.1.2-33: VRB-to-PRB mapping

Bit field mapped to index	VRB-to-PRB mapping
0	Non-interleaved
1	Interleaved

[TS 38.214, clause 6.1.2.1]

When the UE is scheduled to transmit a transport block and no CSI report, or the UE is scheduled to transmit a transport block and a CSI report on PUSCH by a DCI, the *Time domain resource assignment* field value m of the DCI provides a row index $m + 1$ to an allocated table. The determination of the used resource allocation table is defined in sub-clause 6.1.2.1.1. The indexed row defines the slot offset K_2 , the start and length indicator *SLIV*, or directly the start symbol S and the allocation length L , and the PUSCH mapping type to be applied in the PUSCH transmission.

When the UE is scheduled to transmit a PUSCH with no transport block and with a CSI report by a *CSI request* field on a DCI, the *Time-domain resource assignment* field value m of the DCI provides a row index $m + 1$ to an allocated table. The determination of the applied resource allocation table is defined in sub-clause 6.1.2.1.1. The indexed row defines the start and length indicator *SLIV*, or directly the start symbol S and the allocation length L , and the PUSCH mapping type to be applied in the PUSCH transmission and K_2 is determined based on the corresponding list entries $Y_j, j = 0, \dots, N_{\text{Rep}} - 1$ of the higher layer parameter *reportSlotConfig* in *CSI-ReportConfig* for the N_{Rep} triggered CSI Reporting Settings. The i th codepoint of K_2 is determined as $K_2 = \max_j Y_j(i)$ where $Y_j(i)$ is the i th codepoint of Y_j .

- The slot where the UE shall transmit the PUSCH is determined by K_2 as $\left\lfloor n \cdot \frac{2^{\mu_{\text{PUSCH}}}}{2^{\mu_{\text{PDCCH}}}} \right\rfloor + K_2$ where n is the slot with the scheduling DCI, K_2 is based on the numerology of PUSCH, and μ_{PUSCH} and μ_{PDCCH} are the subcarrier spacing configurations for PUSCH and PDCCH, respectively, and
- The starting symbol S relative to the start of the slot, and the number of consecutive symbols L counting from the symbol S allocated for the PUSCH are determined from the start and length indicator *SLIV* of the indexed row:
 - if $(L-1) \leq 7$ then

$$SLIV = 14 \cdot (L-1) + S$$
 - else

$$SLIV = 14 \cdot (14-L+1) + (14-1-S)$$

where $0 < L \leq 14 - S$, and
- The PUSCH mapping type is set to Type A or Type B as defined in Subclause 6.4.1.1.3 of [4, TS 38.211] as given by the indexed row.

The UE shall consider the S and L combinations defined in table 6.1.2.1-1 as valid PUSCH allocations

Table 6.1.2.1-1: Valid S and L combinations

PUSCH mapping type	Normal cyclic prefix			Extended cyclic prefix		
	S	L	S+L	S	L	S+L
Type A	0	{4,...,14}	{4,...,14}	0	{4,...,12}	{4,...,12}
Type B	{0,...,13}	{1,...,14}	{1,...,14}	{0,...,12}	{1,...,12}	{1,...,12}

When the UE is configured with $aggregationFactorUL > 1$, the same symbol allocation is applied across the $aggregationFactorUL$ consecutive slots and the PUSCH is limited to a single transmission layer. The UE shall repeat the TB across the $aggregationFactorUL$ consecutive slots applying the same symbol allocation in each slot. The redundancy version to be applied on the n^{th} transmission occasion of the TB is determined according to table 6.1.2.1-2.

Table 6.1.2.1-2: Redundancy version when $aggregationFactorUL > 1$

r_{vid} indicated by the DCI scheduling the PUSCH	r_{vid} to be applied to n^{th} transmission occasion			
	$n \bmod 4 = 0$	$n \bmod 4 = 1$	$n \bmod 4 = 2$	$n \bmod 4 = 3$
0	0	2	3	1
2	2	3	1	0
3	3	1	0	2
1	1	0	2	3

If the UE procedure for determining slot configuration, as defined in subclause 11.1 of [6, TS 38.213], determines symbols of a slot allocated for PUSCH as downlink symbols, the transmission on that slot is omitted for multi-slot PUSCH transmission.

[38.214 clause 6.1.2.2]

The UE shall determine the resource block assignment in frequency domain using the resource allocation field in the detected PDCCH DCI. Two uplink resource allocation schemes type 0 and type 1 are supported. Uplink resource allocation scheme type 0 is supported for PUSCH only when transform precoding is disabled. Uplink resource allocation scheme type 1 is supported for PUSCH for both cases when transform precoding is enabled or disabled.

If the scheduling DCI is configured to indicate the uplink resource allocation type as part of the *Frequency domain resource* assignment field by setting a higher layer parameter *resourceAllocation* in *pusch-Config* to 'dynamicswitch', the UE shall use uplink resource allocation type 0 or type 1 as defined by this DCI field. Otherwise the UE shall use the uplink frequency resource allocation type as defined by the higher layer parameter *resourceAllocation*.

The UE shall assume that when the scheduling PDCCH is received with DCI format 0_0, then uplink resource allocation type 1 is used.

If a bandwidth part indicator field is not configured in the scheduling DCI, the RB indexing for uplink type 0 and type 1 resource allocation is determined within the UE's active bandwidth part. If a bandwidth part indicator field is configured in the scheduling DCI, the RB indexing for uplink type 0 and type 1 resource allocation is determined within the UE's bandwidth part indicated by bandwidth part indicator field value in the DCI, except for the case when DCI format 0_0 is decoded in any PDCCH common search space in CORESET 0 in which case the initial bandwidth part shall be used. The UE shall upon detection of PDCCH intended for the UE determine first the uplink bandwidth part and then the resource allocation within the bandwidth part.

[38.214 clause 6.1.2.2.1]

In uplink resource allocation of type 0, the resource block assignment information includes a bitmap indicating the Resource Block Groups (RBGs) that are allocated to the scheduled UE where a RBG is a set of consecutive virtual resource blocks defined by higher layer parameter *rbg-Size* configured for PUSCH and the size of the carrier bandwidth part as defined in Table 6.1.2.2.1-1.

Table 6.1.2.2.1-1: Nominal RBG size P

Carrier Bandwidth Part Size	Configuration 1	Configuration 2
1 – 36	2	4
37 – 72	4	8
73 – 144	8	16
145 – 275	16	16

The total number of RBGs (N_{RBG}) for a uplink carrier bandwidth part i of size $N_{\text{BWP},i}^{\text{size}}$ PRBs is given by

$$N_{\text{RBG}} = \left\lfloor \left(N_{\text{BWP},i}^{\text{size}} + \left(N_{\text{BWP},i}^{\text{start}} \bmod P \right) \right) / P \right\rfloor \text{ where}$$

- the size of the first RBG is $\text{RBG}_0^{\text{size}} = P - N_{\text{BWP},i}^{\text{start}} \bmod P$,
- the size of the last RBG is $\text{RBG}_{\text{last}}^{\text{size}} = \left(N_{\text{BWP},i}^{\text{start}} + N_{\text{BWP},i}^{\text{size}} \right) \bmod P$ if $\left(N_{\text{BWP},i}^{\text{start}} + N_{\text{BWP},i}^{\text{size}} \right) \bmod P > 0$ and P otherwise.
- the size of all other RBG is P .

The bitmap is of size N_{RBG} bits with one bitmap bit per RBG such that each RBG is addressable. The RBGs shall be indexed in the order of increasing frequency of the carrier bandwidth part and starting at the lowest frequency. The order of RBG bitmap is such that RBG 0 to RBG $N_{\text{RBG}} - 1$ are mapped from MSB to LSB of the bitmap. The RBG is allocated to the UE if the corresponding bit value in the bitmap is 1, the RBG is not allocated to the UE otherwise.

[38.214 clause 6.1.2.2.2]

In uplink resource allocation of type 1, the resource block assignment information indicates to a scheduled UE a set of contiguously allocated non-interleaved virtual resource blocks within the active carrier bandwidth part of size $N_{\text{BWP}}^{\text{size}}$

PRBs except for the case when DCI format 0_0 is decoded in the Type0-PDCCH common search space in CORESET 0 in which case the initial bandwidth part of size N_{BWP}^{size} shall be used.

An uplink type 1 resource allocation field consists of a resource indication value (RIV) corresponding to a starting virtual resource block (RB_{start}) and a length in terms of contiguously allocated resource blocks L_{RBs} . The resource indication value is defined by

if $(L_{RBs} - 1) \leq \lfloor N_{BWP}^{size} / 2 \rfloor$ then

$$RIV = N_{BWP}^{size} (L_{RBs} - 1) + RB_{start}$$

else

$$RIV = N_{BWP}^{size} (N_{BWP}^{size} - L_{RBs} + 1) + (N_{BWP}^{size} - 1 - RB_{start})$$

where $L_{RBs} \geq 1$ and shall not exceed $N_{BWP}^{size} - RB_{start}$.

[TS 38.214, clause 6.1.4.1]

For the PUSCH assigned by a DCI format 0_0/0_1 with CRC scrambled by C-RNTI, new-RNTI, TC-RNTI, or SP-CSI-RNTI, the transform precoding is enabled if *transformPrecoder* in *PUSCH-Config* is set to 'enabled', or if *transformPrecoder* in *PUSCH-Config* is not configured and *msg3-transformPrecoding* in *rach-ConfigCommon* is set to 'enabled'; otherwise the transform precoding is disabled.

For the PUSCH assigned by a DCI format 0_0/0_1 with CRC scrambled by CS-RNTI, or the PUSCH with configured grant using CS-RNTI, the transform precoding is enabled if *transformPrecoder* in *ConfiguredGrantConfig* is set to 'enabled'; otherwise the transform precoding is disabled.

For a PUSCH scheduled by RAR UL grant or for a PUSCH scheduled by a DCI format 0_0/0_1 with CRC scrambled by C-RNTI, TC-RNTI, or CS-RNTI, or SP-CSI-RNTI, or for a PUSCH with configured grant using CS-RNTI,

if *transformPrecoder* is disabled for this PUSCH transmission

- if *mcs-Table* in *PUSCH-Config* is set to 'qam256', and PUSCH is scheduled with C-RNTI or SP-CSI-RNTI, and PUSCH is assigned by DCI format 0_1,
 - the UE shall use I_{MCS} and Table 5.1.3.1-2 to determine the modulation order (Q_m) and Target code rate (R) used in the physical uplink shared channel.
- elseif the UE is not configured with new-RNTI, *mcs-Table* in *PUSCH-Config* is set to 'qam64LowSE', the PUSCH is scheduled with C-RNTI, or SP-CSI-RNTI, and the PUSCH is assigned by a PDCCH in a UE-specific search space,
 - the UE shall use I_{MCS} and Table 5.1.3.1-3 to determine the modulation order (Q_m) and Target code rate (R) used in the physical uplink shared channel.
- elseif the UE is configured with new-RNTI, and the PUSCH is scheduled with new-RNTI,
 - the UE shall use I_{MCS} and Table 5.1.3.1-3 to determine the modulation order (Q_m) and Target code rate (R) used in the physical uplink shared channel.
- elseif *mcs-Table* in *ConfiguredGrantConfig* is set to 'qam256', and PUSCH is scheduled with CS-RNTI,
 - the UE shall use I_{MCS} and Table 5.1.3.1-2 to determine the modulation order (Q_m) and Target code rate (R) used in the physical uplink shared channel.
- elseif *mcs-Table* in *ConfiguredGrantConfig* is set to 'qam64LowSE', and PUSCH is scheduled with CS-RNTI,
 - the UE shall use I_{MCS} and Table 5.1.3.1-3 to determine the modulation order (Q_m) and Target code rate (R) used in the physical uplink shared channel.
- else

- the UE shall use I_{MCS} and Table 5.1.3.1-1 to determine the modulation order (Q_m) and Target code rate (R) used in the physical uplink shared channel.

[TS 38.214, clause 5.1.3.1]

Table 5.1.3.1-2: MCS index table 2 for PDSCH

MCS Index I_{MCS}	Modulation Order Q_m	Target code Rate $R \times [1024]$	Spectral efficiency
0	2	120	0.2344
1	2	193	0.3770
2	2	308	0.6016
3	2	449	0.8770
4	2	602	1.1758
5	4	378	1.4766
6	4	434	1.6953
7	4	490	1.9141
8	4	553	2.1602
9	4	616	2.4063
10	4	658	2.5703
11	6	466	2.7305
12	6	517	3.0293
13	6	567	3.3223
14	6	616	3.6094
15	6	666	3.9023
16	6	719	4.2129
17	6	772	4.5234
18	6	822	4.8164
19	6	873	5.1152
20	8	682.5	5.3320
21	8	711	5.5547
22	8	754	5.8906
23	8	797	6.2266
24	8	841	6.5703
25	8	885	6.9141
26	8	916.5	7.1602
27	8	948	7.4063
28	2	reserved	
29	4	reserved	
30	6	reserved	
31	8	reserved	

[TS 38.214, clause 6.1.4.2]

For a PUSCH scheduled by RAR UL grant or for a PUSCH scheduled by a DCI format 0_0/0_1 with CRC scrambled by C-RNTI, new-RNTI, TC-RNTI, CS-RNTI, or SP-CSI-RNTI.

if

- $0 \leq I_{MCS} \leq 27$ and transform precoding is disabled and Table 5.1.3.1-2 is used, or
- $0 \leq I_{MCS} \leq 28$ and transform precoding is disabled and a table other than Table 5.1.3.1-2 is used, or
- $0 \leq I_{MCS} \leq 27$ and transform precoding is enabled, the UE shall first determine the TBS as specified below:

The UE shall first determine the number of REs (N_{RE}) within the slot:

- A UE first determines the number of REs allocated for PUSCH within a PRB (N'_{RE}) by
- $N'_{RE} = N_{sc}^{RB} * N_{sym}^{sh} - N_{DMRS}^{PRB} - N_{oh}^{PRB}$, where $N_{sc}^{RB} = 12$ is the number of subcarriers in the frequency domain in a physical resource block, N_{sym}^{sh} is the number of symbols of the PUSCH allocation within the

slot, N_{DMRS}^{PRB} is the number of REs for DM-RS per PRB in the scheduled duration including the overhead of the DM-RS CDM groups without data, as indicated by DCI format 0_1 or as described for DCI format 0_0 in Subclause 6.2.2, and N_{oh}^{PRB} is the overhead configured by higher layer parameter $xOverhead$ in *PUSCH-ServingCellConfig*. If the N_{oh}^{PRB} is not configured (a value from 0, 6, 12, or 18), the N_{oh}^{PRB} is assumed to be

0. For MSG3 transmission the N_{oh}^{PRB} is always set to 0..

- A UE determines the total number of REs allocated for PUSCH (N_{RE}) by $N_{RE} = \min(156, N_{RE}') \cdot n_{PRB}$ where n_{PRB} is the total number of allocated PRBs for the UE.
- Next, proceed with steps 2-4 as defined in Subclause 5.1.3.2

else if

- $28 \leq I_{MCS} \leq 31$ and transform precoding is disabled and Table 5.1.3.1-2 is used, or
- $28 \leq I_{MCS} \leq 31$ and transform precoding is enabled,
- the TBS is assumed to be as determined from the DCI transported in the latest PDCCH for the same transport block using $0 \leq I_{MCS} \leq 27$. If there is no PDCCH for the same transport block using $0 \leq I_{MCS} \leq 27$, and if the initial PUSCH for the same transport block is transmitted with configured grant, the TBS shall be determined from the most recent configured scheduling PDCCH.

else

- the TBS is assumed to be as determined from the DCI transported in the latest PDCCH for the same transport block using $0 \leq I_{MCS} \leq 28$. If there is no PDCCH for the same transport block using $0 \leq I_{MCS} \leq 28$, and if the initial PUSCH for the same transport block is transmitted with configured grant, the TBS shall be determined from the most recent configured scheduling PDCCH.

[TS 38.214, clause 5.1.3.2]

- 2) Intermediate number of information bits (N_{info}) is obtained by $N_{info} = N_{RE} \cdot R \cdot Q_m \cdot v$.

If $N_{info} \leq 3824$

Use step 3 as the next step of the TBS determination

else

Use step 4 as the next step of the TBS determination

end if

- 3) When $N_{info} \leq 3824$, TBS is determined as follows

- quantized intermediate number of information bits $N_{info}' = \max\left(24, 2^n \cdot \left\lfloor \frac{N_{info}}{2^n} \right\rfloor\right)$, where

$$n = \max(3, \lfloor \log_2(N_{info}) \rfloor - 6).$$

- use Table 5.1.3.2-2 find the closest TBS that is not less than N_{info}' .

Table 5.1.3.2-2: TBS for $N_{info} \leq 3824$

Index	TBS	Index	TBS	Index	TBS	Index	TBS
1	24	31	336	61	1288	91	3624
2	32	32	352	62	1320	92	3752
3	40	33	368	63	1352	93	3824
4	48	34	384	64	1416		
5	56	35	408	65	1480		
6	64	36	432	66	1544		
7	72	37	456	67	1608		
8	80	38	480	68	1672		
9	88	39	504	69	1736		
10	96	40	528	70	1800		
11	104	41	552	71	1864		
12	112	42	576	72	1928		
13	120	43	608	73	2024		
14	128	44	640	74	2088		
15	136	45	672	75	2152		
16	144	46	704	76	2216		
17	152	47	736	77	2280		
18	160	48	768	78	2408		
19	168	49	808	79	2472		
20	176	50	848	80	2536		
21	184	51	888	81	2600		
22	192	52	928	82	2664		
23	208	53	984	83	2728		
24	224	54	1032	84	2792		
25	240	55	1064	85	2856		
26	256	56	1128	86	2976		
27	272	57	1160	87	3104		
28	288	58	1192	88	3240		
29	304	59	1224	89	3368		
30	320	60	1256	90	3496		

4) When $N_{info} > 3824$, TBS is determined as follows.

- quantized intermediate number of information bits $N'_{info} = \max\left(3840, 2^n \times \text{round}\left(\frac{N_{info} - 24}{2^n}\right)\right)$, where $n = \lfloor \log_2(N_{info} - 24) \rfloor - 5$ and ties in the round function are broken towards the next largest integer.
- if $R \leq 1/4$

$$TBS = 8 \cdot C \cdot \left\lceil \frac{N'_{info} + 24}{8 \cdot C} \right\rceil - 24, \text{ where } C = \left\lceil \frac{N'_{info} + 24}{3816} \right\rceil$$

else

if $N'_{info} > 8424$

$$TBS = 8 \cdot C \cdot \left\lceil \frac{N'_{info} + 24}{8 \cdot C} \right\rceil - 24, \text{ where } C = \left\lceil \frac{N'_{info} + 24}{8424} \right\rceil$$

else

$$TBS = 8 \cdot \left\lceil \frac{N'_{info} + 24}{8} \right\rceil - 24$$

end if

end if

7.1.1.4.2.4.3 Test description

7.1.1.4.2.4.3.1 Pre-test conditions

Same Pre-test conditions as in clause 7.1.1.0 except set the NR Cell bandwidth and applicable BWP to maximum for the NR Band under test as specified in Table 5.3.5-1 in TS 38.101-1 [16] / TS 38.101-2 [17] (to enable testing of n_{PRB} up to maximum value).

Test frequency NRf1 is as specified in TS 38.508-1 [4] clause 4.3.1 using the common highest UL and DL channel bandwidth and using the default subcarrier spacing specified in TS 38.508-1 [4] clause 6.2.3.1.

7.1.1.4.2.4.3.2 Test procedure sequence

Table 7.1.1.4.2.4.3.2-1: Maximum TBS for different UE categories

UE Category	Maximum number of bits of a UL-SCH transport block received within a TTI
TS 38.306 [23] clause 4.1.2 require UE without ue-CategoryDL and ue-CategoryUL, to support Max TBS achievable based on max bandwidth of the Band under test.	

Table 7.1.1.4.2.4.3.2-2: Number of downlink PDCP SDUs and PDCP SDU size used as test data

TBS [bits]	Number of PDCP SDUs	PDCP SDU size [bits] (Note 1)
$136 \leq TBS \leq 12128$ note 2	1	$8 * \text{FLOOR}((TBS - 128) / 8)$
$12129 \leq TBS \leq 24200$	2	$8 * \text{FLOOR}((TBS - 200) / 16)$
$24201 \leq TBS \leq 36272$	3	$8 * \text{FLOOR}((TBS - 272) / 24)$
$36273 \leq TBS \leq 48344$	4	$8 * \text{FLOOR}((TBS - 344) / 32)$
$48345 \leq TBS \leq 60416$	5	$8 * \text{FLOOR}((TBS - 416) / 40)$
$60417 \leq TBS \leq 72488$	6	$8 * \text{FLOOR}((TBS - 488) / 48)$
$72489 \leq TBS \leq 84560$	7	$8 * \text{FLOOR}((TBS - 560) / 56)$
$84561 \leq TBS \leq 96632$	8	$8 * \text{FLOOR}((TBS - 632) / 64)$
$96633 < TBS \leq 108704$	9	$8 * \text{FLOOR}((TBS - 704) / 72)$
$10705 \leq TBS \leq 120776$	10	$8 * \text{FLOOR}((TBS - 776) / 80)$
$120777 \leq TBS \leq 132848$	11	$8 * \text{FLOOR}((TBS - 848) / 88)$
$132849 \leq TBS \leq 144920$	12	$8 * \text{FLOOR}((TBS - 920) / 96)$
$TBS > 144920$	13	$8 * \text{FLOOR}((TBS - 992) / 104)$

Note 1: Each PDCP SDU is limited to 1500 octets (to keep below maximum SDU size of ESM as specified in TS 24.301 [21] clause 9.9.4.12).

The PDCP SDU size of each PDCP SDU is

$\text{PDCP SDU size} = (TBS - N * \text{PDCP header size} - N * \text{AMD PDU header size} - N * \text{MAC header size} - \text{Size of Timing Advance} - \text{RLC Status PDU size} - \text{MAC header for RLC Status PDU}) / N$, where

PDCP header size is 24 bits for the RLC AM and 18-bit SN case;
 AMD PDU header size is 24 bits with 18 bit SN;

MAC header size for AMD PDU = 16 or 24 bits depending on L=8 or 16 bits. Worst case 24 is taken.

Size of Timing Advance MAC CE with header is 16 bits (if no Timing Advance and/or RLC status needs to be sent, padding will occur instead).

RLC Status PDU size = 24 bits with 1 ACK_SN, With a MAC header of 16 bits.

This gives:

$\text{PDCP SDU size} = 8 * \text{FLOOR}((TBS - N * 24 - N * 24 - N * 24 - 56) / (8 * N))$ bits.

Note 2: According to the final PDCP SDU size formula in Note 1, the smallest TBS that can be tested is 136 bits.

Table 7.1.1.4.2.4.3.2-2A: Bandwidth part Dependent Parameters for Resource allocation 0 with start of BWP assumed as 0

$N_{RB}^{DL,BWP} = N_{BWP,i}^{size}$	Nominal RBG size P (Configuration1)	Size of last RBG	Allowed N_{PRB} Values
11	2	1	All 1...11
18	2	2	2,4,6,8,10,12,16,18
24	2	2	2,4,6,8,10,12,16,18,20,22,24
25	2	1	All 1...25
31	2	1	All 1...31
32	2	2	2,4,6,8,10,12,16,18,20,22,24,26,28,30,32
38	4	2	2,4,6,8,10,12,16,18,20,22,24,26,28,30,32,34,36,38
51	4	3	3,4,7,8,11,12,15,16,19,20,23,24,27,28,31,32,35,36,39,40,43,44,47,48,51
52	4	4	4,8,12,16,20,24,28,32,36,40,44,48,52
65	4	1	1,4,5,8,9,12,13,16,17,20,21,24,25,28,29,32,33,36,37,40,41,44,45,48,49,52,53,56,57,60,61,64,65
66	4	2	2,4,6,8,10,12,16,18,20,22,24,26,28,30,32,34,36,38,40,42,44,46,48,50,52,54,56,58,60,62,64,66
79	8	7	7,8,15,16,23,24,31,32,39,40,47,48,55,56,63,64,71,72,79
106	8	2	2,8,10,16,18,24,26,32,34,40,42,48,50,56,58,64,66,72,74,80,82,88,90,96,92,104,106
107	8	3	3,8,11,16,19,24,27,32,35,40,43,48,51,56,59,64,67,72,75,80,83,88,91,96,99,104,107
132	8	4	4,8,12,16,20,24,28,32,36,40,44,48,52,56,60,64,68,72,76,80,84,88,92,96,100,104,108,112,116,120,124,128,132
133	8	5	5,8,13,16,21,24,29,32,37,40,45,48,53,56,61,64,69,72,77,80,85,88,93,96,101,104,109,112,117,120,125,128,133
135	8	7	7,8,15,16,23,24,31,32,39,40,47,48,55,56,63,64,71,72,79,80,87,88,95,96,103,104,111,112,119,120,127,128,135
216	16	8	8,16,24,32,40,48,56,64,72,80,88,96,104,112,120,128,136,144,152,160,168,176,184,192,200,208,216
217	16	9	9,16,25,32,41,48,57,64,73,80,89,96,105,112,121,128,137,144,153,160,169,176,185,192,201,208,217
264	16	8	8,16,24,32,40,48,56,64,72,80,88,96,104,112,120,128,136,144,160,168,176,184,192,200,208,216,224,232,240,248,256,264
270	16	14	14,16,30,32,46,44,62,64,78,80,94,96,110,112,126,128,142,144,158,160,174,176,190,192,206,208,222,224,238,240,254,256,270
273	16	1	1,16,17,32,33,48,49,64,65,80,81,96,97,112,113,128,129,144,145,160,161,176,171,192,193,208,209,224,225,240,241,256,257,272,273

Table 7.1.1.4.2.4.3.2-3: Specific Parameter

Parameter	Value	Comment
number of layers (v)	1	
mcs-Table	qam256	
resourceAllocation	dynamicSwitch	
<i>rbg-Size</i>	Not present	configuration 1 applicable
N_{BWP}^{start}	0	

Table 7.1.1.4.2.4.3.2-4: Main behaviour

St	Procedure	Message Sequence		TP	Verdict
		U - S	Message		
-	EXCEPTION: Steps 1 to 5 are repeated for allowed values of N_{PRB} as per Table 7.1.1.4.2.4.3.2-2A in BWP, time domain resource as per Table 7.1.1.4.2.0-1 and I_{MCS} from 0 to 27.	-	-	-	-
1	SS calculates or looks up TBS in TS 38.214 [15] based on the value of S, L, I_{MCS} and n_{PRB} .	-	-	-	-
-	EXCEPTION: Steps 2 to 5 are performed if TBS is less than or equal to UE capability "Maximum number of UL-SCH transport block bits received within a TTI" as specified in Table 7.1.1.4.2.4.3.2-1 and larger than or equal to 136 bits as specified in Table 7.1.1.4.2.4.3.2-2.	-	-	-	-
2	SS creates one or more PDCP SDUs depending on TBS in accordance with Table 7.1.1.4.2.4.3.2-2.	-	-	-	-
3	After 300ms, the SS transmits all PDCP SDUs (N_{SDUs}) as created in step 2 in a MAC PDU.	<--	MAC PDU (NxPDCP SDUs)	-	-
4	After 60ms of step 3 SS transmits UL Grant DCI 0_1, and values of S, L, I_{MCS} and n_{PRB} .	<--	(UL Grant) (DCI: (DCI Format 0_1, S, L, I_{MCS} and n_{PRB}))	-	-
5	CHECK: Does UE return the same number of PDCP SDUs with same content as transmitted by the SS in step 3 using Time, frequency Resources and modulation and coding scheme as configured by the SS in step 4?	-->	(NxPDCP SDUs)	1	P
-	EXCEPTION: Steps 6 to 10 are repeated for allowed values of N_{PRB} 1 to $N_{RB}^{DL,BWP}$ in BWP, time domain resource length L 3 to 14- S and I_{MCS} from 0 to 27.	-	-	-	-
6	SS calculates or looks up TBS in TS 38.214 [15] based on the value of S, L, I_{MCS} and n_{PRB} .	-	-	-	-
-	EXCEPTION: Steps 7 to 10 are performed if TBS is less than or equal to UE capability "Maximum number of UL-SCH transport block bits received within a TTI" as specified in Table 7.1.1.4.2.4.3.2-1 and larger than or equal to 136 bits as specified in Table 7.1.1.4.2.4.3.2-2.	-	-	-	-
7	SS creates one or more PDCP SDUs depending on TBS in accordance with Table 7.1.1.4.2.4.3.2-2.	-	-	-	-
8	After 300ms, the SS transmits all PDCP SDUs (N_{SDUs}) as created in step 7 in a MAC PDU.	<--	MAC PDU (NxPDCP SDUs)	-	-
9	After 60ms of step 8 SS transmits UL Grant DCI 0_1, and values of S, L, I_{MCS} and n_{PRB} .	<--	(UL Grant) (DCI: (DCI Format 0_1, S, L, I_{MCS} and n_{PRB}))	-	-
10	CHECK: Does UE return the same number of PDCP SDUs with same content as transmitted by the SS in step 8 using Time, frequency Resources and modulation and coding scheme as configured by the SS in step 4?	-->	(NxPDCP SDUs)	2	P

7.1.1.4.2.4.3.3 Specific message contents

[None].

7.1.1.4.2.5 UL-SCH Transport Block Size selection / DCI format 0_0 / Transform precoding and 64QAM

7.1.1.4.2.5.1 Test Purpose (TP)

(1)

```
with { UE in RRC_CONNECTED state and transform precoding enabled}
ensure that {
  when { UE has pending data for transmission and receives on PDCCH DCI format 0_0 indicating a
resource block assignment correspondent to physical resource blocks , Time domain resource
assignment and modulation and coding }
  then { UE transmits MAC PDU on PUSCH as per Modulation Coding scheme, time domain resource
allocation and PRB's }
}
```

7.1.1.4.2.5.2 Conformance requirements

References: The conformance requirements covered in the present TC are specified in: TS 38.212 clause 7.3.1.1.1, TS 38.214 clause 6.1.2.1, 6.1.2.2, 6.1.2.2.2, 6.1.4.1, 5.1.3.1, 6.1.4.2 and 5.1.3.2. Unless otherwise stated these are Rel-15 requirements.

[TS 38.212, clause 7.3.1.1.1]

DCI format 0_0 is used for the scheduling of PUSCH in one cell.

The following information is transmitted by means of the DCI format 0_0 with CRC scrambled by C-RNTI or CS-RNTI or new-RNTI:

- Identifier for DCI formats – 1 bit
 - The value of this bit field is always set to 0, indicating an UL DCI format
- Frequency domain resource assignment – $\lceil \log_2(N_{RB}^{UL,BWP}(N_{RB}^{UL,BWP} + 1)/2) \rceil$ bits where
 - $N_{RB}^{UL,BWP}$ is the size of the active UL bandwidth part in case DCI format 0_0 is monitored in the UE specific search space and satisfying
 - the total number of different DCI sizes monitored per slot is no more than 4 for the cell, and
 - the total number of different DCI sizes with C-RNTI monitored per slot is no more than 3 for the cell
 - otherwise, $N_{RB}^{UL,BWP}$ is the size of the initial UL bandwidth part.
- For PUSCH hopping with resource allocation type 1:
 - N_{UL_hop} MSB bits are used to indicate the frequency offset according to Subclause 6.3 of [6, TS 38.214], where $N_{UL_hop} = 1$ if the higher layer parameter *frequencyHoppingOffsetLists* contains two offset values and $N_{UL_hop} = 2$ if the higher layer parameter *frequencyHoppingOffsetLists* contains four offset values
 - $\lceil \log_2(N_{RB}^{UL,BWP}(N_{RB}^{UL,BWP} + 1)/2) \rceil - N_{UL_hop}$ bits provides the frequency domain resource allocation according to Subclause 6.1.2.2.2 of [6, TS 38.214]
- For non-PUSCH hopping with resource allocation type 1:

- $\lceil \log_2(N_{RB}^{UL,BWP} (N_{RB}^{UL,BWP} + 1) / 2) \rceil$ bits provides the frequency domain resource allocation according to Subclause 6.1.2.2.2 of [6, TS 38.214]
- Time domain resource assignment – 4 bits as defined in Subclause 6.1.2.1 of [6, TS 38.214]
- Frequency hopping flag – 1 bit.
- Modulation and coding scheme – 5 bits as defined in Subclause 6.1.3 of [6, TS 38.214]
- New data indicator – 1 bit
- Redundancy version – 2 bits as defined in Table 7.3.1.1.1-2
- HARQ process number – 4 bits
- TPC command for scheduled PUSCH – 2 bits as defined in Subclause 7.1.1 of [5, TS 38.213]
- Padding bits, if required.
- UL/SUL indicator – 1 bit for UEs configured with SUL in the cell as defined in Table 7.3.1.1.1-1 and the number of bits for DCI format 1_0 before padding is larger than the number of bits for DCI format 0_0 before padding; 0 bit otherwise. The UL/SUL indicator, if present, locates in the last bit position of DCI format 0_0, after the padding bit(s).
 - If the UL/SUL indicator is present in DCI format 0_0 and the higher layer parameter *pusch-Config* is not configured on both UL and SUL the UE ignores the UL/SUL indicator field in DCI format 0_0, and the corresponding PUSCH scheduled by the DCI format 0_0 is for the UL or SUL for which high layer parameter *pucch-Config* is configured;
 - If the UL/SUL indicator is not present in DCI format 0_0, the corresponding PUSCH scheduled by the DCI format 0_0 is for the UL or SUL for which high layer parameter *pucch-Config* is configured.

The following information is transmitted by means of the DCI format 0_0 with CRC scrambled by TC-RNTI:

- Identifier for DCI formats – 1 bit
 - The value of this bit field is always set to 0, indicating an UL DCI format
- Frequency domain resource assignment – $\lceil \log_2(N_{RB}^{UL,BWP} (N_{RB}^{UL,BWP} + 1) / 2) \rceil$ bits where
 - $N_{RB}^{UL,BWP}$ is the size of the initial UL bandwidth part.
 - For PUSCH hopping with resource allocation type 1:
 - N_{UL_hop} MSB bits are used to indicate the frequency offset according to Subclause 6.3 of [6, TS 38.214], where $N_{UL_hop} = 1$ if $N_{RB}^{UL,BWP} < 50$ and $N_{UL_hop} = 2$ otherwise
 - $\lceil \log_2(N_{RB}^{UL,BWP} (N_{RB}^{UL,BWP} + 1) / 2) \rceil - N_{UL_hop}$ bits provides the frequency domain resource allocation according to Subclause 6.1.2.2.2 of [6, TS 38.214]
 - For non-PUSCH hopping with resource allocation type 1:
 - $\lceil \log_2(N_{RB}^{UL,BWP} (N_{RB}^{UL,BWP} + 1) / 2) \rceil$ bits provides the frequency domain resource allocation according to Subclause 6.1.2.2.2 of [6, TS 38.214]
- Time domain resource assignment – 4 bits as defined in Subclause 6.1.2.1 of [6, TS 38.214]
- Frequency hopping flag – 1 bit.
- Modulation and coding scheme – 5 bits as defined in Subclause 6.1.3 of [6, TS 38.214], using Table 5.1.3.1-1
- New data indicator – 1 bit, reserved
- Redundancy version – 2 bits as defined in Table 7.3.1.1.1-2

- HARQ process number – 4 bits, reserved
- TPC command for scheduled PUSCH – 2 bits as defined in Subclause 7.1.1 of [5, TS 38.213]
- Padding bits, if required.
- UL/SUL indicator – 1 bit if the cell has two ULs and the number of bits for DCI format 1_0 before padding is larger than the number of bits for DCI format 0_0 before padding; 0 bit otherwise. The UL/SUL indicator, if present, locates in the last bit position of DCI format 0_0, after the padding bit(s).
 - If 1 bit, reserved, and the corresponding PUSCH is always on the same UL carrier as the previous transmission of the same TB

If DCI format 0_0 is monitored in common search space and if the number of information bits in the DCI format 0_0 prior to padding is less than the payload size of the DCI format 1_0 monitored in common search space for scheduling the same serving cell, zeros shall be appended to the DCI format 0_0 until the payload size equals that of the DCI format 1_0.

If DCI format 0_0 is monitored in common search space and if the number of information bits in the DCI format 0_0 prior to padding is larger than the payload size of the DCI format 1_0 monitored in common search space for scheduling the same serving cell, the bit width of the frequency domain resource allocation field in the DCI format 0_0 is reduced by truncating the first few most significant bits such that the size of DCI format 0_0 equals to the size of the DCI format 1_0.

If DCI format 0_0 is monitored in UE specific search space but does not satisfy at least one of the following

- the total number of different DCI sizes monitored per slot is no more than 4 for the cell, and
- the total number of different DCI sizes with C-RNTI monitored per slot is no more than 3 for the cell

and if the number of information bits in the DCI format 0_0 prior to padding is less than the payload size of the DCI format 1_0 monitored in common search space for scheduling the same serving cell, zeros shall be appended to the DCI format 0_0 until the payload size equals that of the DCI format 1_0.

If DCI format 0_0 is monitored in UE specific search space but does not satisfy at least one of the following

- the total number of different DCI sizes monitored per slot is no more than 4 for the cell, and
- the total number of different DCI sizes with C-RNTI monitored per slot is no more than 3 for the cell

and if the number of information bits in the DCI format 0_0 prior to padding is larger than the payload size of the DCI format 1_0 monitored in common search space for scheduling the same serving cell, the bit width of the frequency domain resource allocation field in the DCI format 0_0 is reduced by truncating the first few most significant bits such that the size of DCI format 0_0 equals to the size of the DCI format 1_0.

If DCI format 0_0 is monitored in UE specific search space and satisfies both of the following

- the total number of different DCI sizes monitored per slot is no more than 4 for the cell, and
- the total number of different DCI sizes with C-RNTI monitored per slot is no more than 3 for the cell

and if the number of information bits in the DCI format 0_0 prior to padding is less than the payload size of the DCI format 1_0 monitored in UE specific search space for scheduling the same serving cell, zeros shall be appended to the DCI format 0_0 until the payload size equals that of the DCI format 1_0.

[TS 38.214, clause 6.1.2.1]

When the UE is scheduled to transmit a transport block and no CSI report, or the UE is scheduled to transmit a transport block and a CSI report on PUSCH by a DCI, the *Time domain resource assignment* field value m of the DCI provides a row index $m + 1$ to an allocated table. The determination of the used resource allocation table is defined in sub-clause 6.1.2.1.1. The indexed row defines the slot offset K_2 , the start and length indicator $SLIV$, or directly the start symbol S and the allocation length L , and the PUSCH mapping type to be applied in the PUSCH transmission.

When the UE is scheduled to transmit a PUSCH with no transport block and with a CSI report by a *CSI request* field on a DCI, the *Time-domain resource assignment* field value m of the DCI provides a row index $m + 1$ to an allocated table. The determination of the applied resource allocation table is defined in sub-clause 6.1.2.1.1. The indexed row defines the

start and length indicator $SLIV$, or directly the start symbol S and the allocation length L , and the PUSCH mapping type to be applied in the PUSCH transmission and K_2 is determined based on the corresponding list entries $Y_j, j=0, \dots, N_{Rep} - 1$ of the higher layer parameter $reportSlotConfig$ in $CSI-ReportConfig$ for the N_{Rep} triggered CSI Reporting Settings. The i th codepoint of K_2 is determined as $K_2 = \max_j Y_j(i)$ where $Y_j(i)$ is the i th codepoint of Y_j .

- The slot where the UE shall transmit the PUSCH is determined by K_2 as $\left\lceil n \cdot \frac{2^{\mu_{PUSCH}}}{2^{\mu_{PDCCH}}} \right\rceil + K_2$ where n is the slot with the scheduling DCI, K_2 is based on the numerology of PUSCH, and μ_{PUSCH} and μ_{PDCCH} are the subcarrier spacing configurations for PUSCH and PDCCH, respectively, and
- The starting symbol S relative to the start of the slot, and the number of consecutive symbols L counting from the symbol S allocated for the PUSCH are determined from the start and length indicator $SLIV$ of the indexed row:

if $(L-1) \leq 7$ then

$$SLIV = 14 \cdot (L-1) + S$$

else

$$SLIV = 14 \cdot (14-L+1) + (14-1-S)$$

where $0 < L \leq 14 - S$, and
- The PUSCH mapping type is set to Type A or Type B as defined in Subclause 6.4.1.1.3 of [4, TS 38.211] as given by the indexed row.

The UE shall consider the S and L combinations defined in table 6.1.2.1-1 as valid PUSCH allocations

Table 6.1.2.1-1: Valid S and L combinations

PUSCH mapping type	Normal cyclic prefix			Extended cyclic prefix		
	S	L	$S+L$	S	L	$S+L$
Type A	0	{4,...,14}	{4,...,14}	0	{4,...,12}	{4,...,12}
Type B	{0,...,13}	{1,...,14}	{1,...,14}	{0,...,12}	{1,...,12}	{1,...,12}

When the UE is configured with $aggregationFactorUL > 1$, the same symbol allocation is applied across the $aggregationFactorUL$ consecutive slots and the PUSCH is limited to a single transmission layer. The UE shall repeat the TB across the $aggregationFactorUL$ consecutive slots applying the same symbol allocation in each slot. The redundancy version to be applied on the n^{th} transmission occasion of the TB is determined according to table 6.1.2.1-2.

Table 6.1.2.1-2: Redundancy version when $aggregationFactorUL > 1$

rv_{id} indicated by the DCI scheduling the PUSCH	rv_{id} to be applied to n^{th} transmission occasion			
	$n \bmod 4 = 0$	$n \bmod 4 = 1$	$n \bmod 4 = 2$	$n \bmod 4 = 3$
0	0	2	3	1
2	2	3	1	0
3	3	1	0	2
1	1	0	2	3

If the UE procedure for determining slot configuration, as defined in subclause 11.1 of [6, TS 38.213], determines symbols of a slot allocated for PUSCH as downlink symbols, the transmission on that slot is omitted for multi-slot PUSCH transmission.

[38.214 clause 6.1.2.2]

The UE shall determine the resource block assignment in frequency domain using the resource allocation field in the detected PDCCH DCI. Two uplink resource allocation schemes type 0 and type 1 are supported. Uplink resource

allocation scheme type 0 is supported for PUSCH only when transform precoding is disabled. Uplink resource allocation scheme type 1 is supported for PUSCH for both cases when transform precoding is enabled or disabled.

If the scheduling DCI is configured to indicate the uplink resource allocation type as part of the *Frequency domain resource* assignment field by setting a higher layer parameter *resourceAllocation* in *pusch-Config* to 'dynamicswitch', the UE shall use uplink resource allocation type 0 or type 1 as defined by this DCI field. Otherwise the UE shall use the uplink frequency resource allocation type as defined by the higher layer parameter *resourceAllocation*.

The UE shall assume that when the scheduling PDCCH is received with DCI format 0_0, then uplink resource allocation type 1 is used.

If a bandwidth part indicator field is not configured in the scheduling DCI, the RB indexing for uplink type 0 and type 1 resource allocation is determined within the UE's active bandwidth part. If a bandwidth part indicator field is configured in the scheduling DCI, the RB indexing for uplink type 0 and type 1 resource allocation is determined within the UE's bandwidth part indicated by bandwidth part indicator field value in the DCI, except for the case when DCI format 0_0 is decoded in any PDCCH common search space in CORESET 0 in which case the initial bandwidth part shall be used. The UE shall upon detection of PDCCH intended for the UE determine first the uplink bandwidth part and then the resource allocation within the bandwidth part.

[38.214 clause 6.1.2.2.2]

n uplink resource allocation of type 1, the resource block assignment information indicates to a scheduled UE a set of contiguously allocated non-interleaved virtual resource blocks within the active carrier bandwidth part of size N_{BWP}^{size} PRBs except for the case when DCI format 0_0 is decoded in the Type0-PDCCH common search space in CORESET 0 in which case the initial bandwidth part of size N_{BWP}^{size} shall be used.

An uplink type 1 resource allocation field consists of a resource indication value (*RIV*) corresponding to a starting virtual resource block (RB_{start}) and a length in terms of contiguously allocated resource blocks L_{RBs} . The resource indication value is defined by

if $(L_{RBs} - 1) \leq \lfloor N_{BWP}^{size} / 2 \rfloor$ then

$$RIV = N_{BWP}^{size} (L_{RBs} - 1) + RB_{start}$$

else

$$RIV = N_{BWP}^{size} (N_{BWP}^{size} - L_{RBs} + 1) + (N_{BWP}^{size} - 1 - RB_{start})$$

where $L_{RBs} \geq 1$ and shall not exceed $N_{BWP}^{size} - RB_{start}$.

[TS 38.214, clause 6.1.4.1]

For the PUSCH assigned by a DCI format 0_0/0_1 with CRC scrambled by C-RNTI, new-RNTI, TC-RNTI, or SP-CSI-RNTI, the transform precoding is enabled if *transformPrecoder* in *PUSCH-Config* is set to 'enabled', or if *transformPrecoder* in *PUSCH-Config* is not configured and *msg3-transformPrecoding* in *rach-ConfigCommon* is set to 'enabled'; otherwise the transform precoding is disabled.

For the PUSCH assigned by a DCI format 0_0/0_1 with CRC scrambled by CS-RNTI, or the PUSCH with configured grant using CS-RNTI, the transform precoding is enabled if *transformPrecoder* in *ConfiguredGrantConfig* is set to 'enabled'; otherwise the transform precoding is disabled.

For a PUSCH scheduled by RAR UL grant or for a PUSCH scheduled by a DCI format 0_0/0_1 with CRC scrambled by C-RNTI, TC-RNTI, or CS-RNTI, or SP-CSI-RNTI, or for a PUSCH with configured grant using CS-RNTI,

if *transformPrecoder* is disabled for this PUSCH transmission

...

else

- if *mcs-TableTransformPrecoder* in *PUSCH-Config* is set to 'qam256', and the PUSCH is scheduled with C-RNTI or SP-CSI-RNTI, and PUSCH is assigned by DCI format 0_1,
 - the UE shall use I_{MCS} and Table 5.1.3.1-2 to determine the modulation order (Q_m) and Target code rate (R) used in the physical uplink shared channel.
- elseif the UE is not configured with new-RNTI, *mcs-TableTransformPrecoder* in *PUSCH-Config* is set to 'qam64LowSE', and the PUSCH is scheduled with C-RNTI, or SP-CSI-RNTI, and the PUSCH is assigned by a PDCCH in a UE-specific search space,
 - the UE shall use I_{MCS} and Table 6.1.4.1-2 to determine the modulation order (Q_m) and Target code rate (R) used in the physical uplink shared channel.
- elseif the UE is configured with new-RNTI, and the PUSCH is scheduled with new-RNTI,
 - the UE shall use I_{MCS} and Table 6.1.4.1-2 to determine the modulation order (Q_m) and Target code rate (R) used in the physical uplink shared channel.
- elseif *mcs-TableTransformPrecoder* in *ConfiguredGrantConfig* is set to 'qam256', and PUSCH is scheduled with CS-RNTI,
 - the UE shall use I_{MCS} and Table 5.1.3.1-2 to determine the modulation order (Q_m) and Target code rate (R) used in the physical uplink shared channel.
- elseif *mcs-TableTransformPrecoder* in *ConfiguredGrantConfig* is set to 'qam64LowSE', and PUSCH is scheduled with CS-RNTI,
 - the UE shall use I_{MCS} and Table 6.1.4.1-2 to determine the modulation order (Q_m) and Target code rate (R) used in the physical uplink shared channel.
- else
 - the UE shall use I_{MCS} and Table 6.1.4.1-1 to determine the modulation order (Q_m) and Target code rate (R) used in the physical uplink shared channel.

end

For Table 6.1.4.1-1 and Table 6.1.4.1-2, if higher layer parameter *PUSCH-tp-pi2BPSK* is configured, $q = 1$ otherwise $q=2$.

Table 6.1.4.1-1: MCS index table for PUSCH with transform precoding and 64QAM

MCS Index I_{MCS}	Modulation Order Q_m	Target code Rate R x 1024	Spectral efficiency
0	q	240/ q	0.2344
1	q	314/ q	0.3066
2	2	193	0.3770
3	2	251	0.4902
4	2	308	0.6016
5	2	379	0.7402
6	2	449	0.8770
7	2	526	1.0273
8	2	602	1.1758
9	2	679	1.3262
10	4	340	1.3281
11	4	378	1.4766
12	4	434	1.6953
13	4	490	1.9141
14	4	553	2.1602
15	4	616	2.4063
16	4	658	2.5703
17	6	466	2.7305
18	6	517	3.0293
19	6	567	3.3223
20	6	616	3.6094
21	6	666	3.9023
22	6	719	4.2129
23	6	772	4.5234
24	6	822	4.8164
25	6	873	5.1152
26	6	910	5.3320
27	6	948	5.5547
28	q	reserved	
29	2	reserved	
30	4	reserved	
31	6	reserved	

[TS 38.214, clause 6.1.4.2]

For a PUSCH scheduled by RAR UL grant or for a PUSCH scheduled by a DCI format 0_0/0_1 with CRC scrambled by C-RNTI, new-RNTI, TC-RNTI, CS-RNTI, or SP-CSI-RNTI.

if

- $0 \leq I_{MCS} \leq 27$ and transform precoding is disabled and Table 5.1.3.1-2 is used, or
- $0 \leq I_{MCS} \leq 28$ and transform precoding is disabled and a table other than Table 5.1.3.1-2 is used, or
- $0 \leq I_{MCS} \leq 27$ and transform precoding is enabled, the UE shall first determine the TBS as specified below:

The UE shall first determine the number of REs (N_{RE}) within the slot:

- A UE first determines the number of REs allocated for PUSCH within a PRB (N'_{RE}) by
- $N'_{RE} = N_{sc}^{RB} * N_{symp}^{sh} - N_{DMRS}^{PRB} - N_{oh}^{PRB}$, where $N_{sc}^{RB} = 12$ is the number of subcarriers in the frequency domain in a physical resource block, N_{symp}^{sh} is the number of symbols of the PUSCH allocation within the slot, N_{DMRS}^{PRB} is the number of REs for DM-RS per PRB in the scheduled duration including the overhead of the DM-RS CDM groups without data, as indicated by DCI format 0_1 or as described for DCI format 0_0 in Subclause 6.2.2, and N_{oh}^{PRB} is the overhead configured by higher layer parameter $xOverhead$ in PUSCH-

ServingCellConfig. If the N_{oh}^{PRB} is not configured (a value from 0, 6, 12, or 18), the N_{oh}^{PRB} is assumed to be 0. For MSG3 transmission the N_{oh}^{PRB} is always set to 0..

- A UE determines the total number of REs allocated for PUSCH (N_{RE}) by $N_{RE} = \min(156, N_{RE}') \cdot n_{PRB}$ where n_{PRB} is the total number of allocated PRBs for the UE.
- Next, proceed with steps 2-4 as defined in Subclause 5.1.3.2

else if

- $28 \leq I_{MCS} \leq 31$ and transform precoding is disabled and Table 5.1.3.1-2 is used, or
- $28 \leq I_{MCS} \leq 31$ and transform precoding is enabled,
- the TBS is assumed to be as determined from the DCI transported in the latest PDCCH for the same transport block using $0 \leq I_{MCS} \leq 27$. If there is no PDCCH for the same transport block using $0 \leq I_{MCS} \leq 27$, and if the initial PUSCH for the same transport block is transmitted with configured grant, the TBS shall be determined from the most recent configured scheduling PDCCH.

else

- the TBS is assumed to be as determined from the DCI transported in the latest PDCCH for the same transport block using $0 \leq I_{MCS} \leq 28$. If there is no PDCCH for the same transport block using $0 \leq I_{MCS} \leq 28$, and if the initial PUSCH for the same transport block is transmitted with configured grant, the TBS shall be determined from the most recent configured scheduling PDCCH.

[TS 38.214, clause 5.1.3.2]

2) Intermediate number of information bits (N_{info}) is obtained by $N_{info} = N_{RE} \cdot R \cdot Q_m \cdot v$.

If $N_{info} \leq 3824$

Use step 3 as the next step of the TBS determination

else

Use step 4 as the next step of the TBS determination

end if

3) When $N_{info} \leq 3824$, TBS is determined as follows

- quantized intermediate number of information bits $N_{info}' = \max\left(24, 2^n \cdot \left\lfloor \frac{N_{info}}{2^n} \right\rfloor\right)$, where $n = \max(3, \lfloor \log_2(N_{info}) \rfloor - 6)$.
- use Table 5.1.3.2-2 find the closest TBS that is not less than N_{info}' .

Table 5.1.3.2-2: TBS for $N_{info} \leq 3824$

Index	TBS	Index	TBS	Index	TBS	Index	TBS
1	24	31	336	61	1288	91	3624
2	32	32	352	62	1320	92	3752
3	40	33	368	63	1352	93	3824
4	48	34	384	64	1416		
5	56	35	408	65	1480		
6	64	36	432	66	1544		
7	72	37	456	67	1608		
8	80	38	480	68	1672		
9	88	39	504	69	1736		
10	96	40	528	70	1800		
11	104	41	552	71	1864		
12	112	42	576	72	1928		
13	120	43	608	73	2024		
14	128	44	640	74	2088		
15	136	45	672	75	2152		
16	144	46	704	76	2216		
17	152	47	736	77	2280		
18	160	48	768	78	2408		
19	168	49	808	79	2472		
20	176	50	848	80	2536		
21	184	51	888	81	2600		
22	192	52	928	82	2664		
23	208	53	984	83	2728		
24	224	54	1032	84	2792		
25	240	55	1064	85	2856		
26	256	56	1128	86	2976		
27	272	57	1160	87	3104		
28	288	58	1192	88	3240		
29	304	59	1224	89	3368		
30	320	60	1256	90	3496		

4) When $N_{info} > 3824$, TBS is determined as follows.

- quantized intermediate number of information bits $N'_{info} = \max\left(3840, 2^n \times \text{round}\left(\frac{N_{info} - 24}{2^n}\right)\right)$, where $n = \lfloor \log_2(N_{info} - 24) \rfloor - 5$ and ties in the round function are broken towards the next largest integer.
- if $R \leq 1/4$

$$TBS = 8 \cdot C \cdot \left\lceil \frac{N'_{info} + 24}{8 \cdot C} \right\rceil - 24, \text{ where } C = \left\lceil \frac{N'_{info} + 24}{3816} \right\rceil$$

else

if $N'_{info} > 8424$

$$TBS = 8 \cdot C \cdot \left\lceil \frac{N'_{info} + 24}{8 \cdot C} \right\rceil - 24, \text{ where } C = \left\lceil \frac{N'_{info} + 24}{8424} \right\rceil$$

else

$$TBS = 8 \cdot \left\lceil \frac{N'_{info} + 24}{8} \right\rceil - 24$$

end if

end if

7.1.1.4.2.5.3 Test description

7.1.1.4.2.5.3.1 Pre-test conditions

Same Pre-test conditions as in clause 7.1.1.0 except set the NR Cell bandwidth and applicable BWP to maximum for the NR Band under test as specified in Table 5.3.5-1 in TS 38.101-1 [16] / TS 38.101-2 [17] (to enable testing of n_{PRB} up to maximum value).

Test frequency NRf1 is as specified in TS 38.508-1 [4] clause 4.3.1 using the common highest UL and DL channel bandwidth and using the default subcarrier spacing specified in TS 38.508-1 [4] clause 6.2.3.1.

7.1.1.4.2.5.3.2 Test procedure sequence

Table 7.1.1.4.2.5.3.2-1: Maximum TBS for different UE categories

UE Category	Maximum number of bits of a UL-SCH transport block received within a TTI
TS 38.306 [23] clause 4.1.2 require UE without <i>ue-CategoryDL</i> and <i>ue-CategoryUL</i> , to support Max TBS achievable based on max bandwidth of the Band under test.	

Table 7.1.1.4.2.5.3.2-2: Number of uplink PDCP SDUs and PDCP SDU size used as test data

TBS [bits]	Number of PDCP SDUs	PDCP SDU size [bits] (Note 1)
$136 \leq TBS \leq 12128$ note 2	1	$8 * \text{FLOOR}((TBS - 128) / 8)$
$12129 \leq TBS \leq 24200$	2	$8 * \text{FLOOR}((TBS - 200) / 16)$
$24201 \leq TBS \leq 36272$	3	$8 * \text{FLOOR}((TBS - 272) / 24)$
$36273 \leq TBS \leq 48344$	4	$8 * \text{FLOOR}((TBS - 344) / 32)$
$48345 \leq TBS \leq 60416$	5	$8 * \text{FLOOR}((TBS - 416) / 40)$
$60417 \leq TBS \leq 72488$	6	$8 * \text{FLOOR}((TBS - 488) / 48)$
$72489 \leq TBS \leq 84560$	7	$8 * \text{FLOOR}((TBS - 560) / 56)$
$84561 \leq TBS \leq 96632$	8	$8 * \text{FLOOR}((TBS - 632) / 64)$
$96633 < TBS \leq 108704$	9	$8 * \text{FLOOR}((TBS - 704) / 72)$
$10705 \leq TBS \leq 120776$	10	$8 * \text{FLOOR}((TBS - 776) / 80)$
$120777 \leq TBS \leq 132848$	11	$8 * \text{FLOOR}((TBS - 848) / 88)$
$132849 \leq TBS \leq 144920$	12	$8 * \text{FLOOR}((TBS - 920) / 96)$
$TBS > 144920$	13	$8 * \text{FLOOR}((TBS - 992) / 104)$

Note 1: Each PDCP SDU is limited to 1500 octets (to keep below maximum SDU size of ESM as specified in TS 24.301 [21] clause 9.9.4.12).

The PDCP SDU size of each PDCP SDU is

PDCP SDU size = (TBS – N*PDCP header size – N*AMD PDU header size – N*MAC header size – Size of Timing Advance – RLC Status PDU size- MAC header for RLC Status PDU) / N, where

PDCP header size is 24 bits for the RLC AM and 18-bit SN case;
AMD PDU header size is 24 bits with 18 bit SN;

MAC header size for AMD PDU = 16 or 24 bits depending on L=8 or 16 bits. Worst case 24 is taken.

Size of Timing Advance MAC CE with header is 16 bits (if no Timing Advance and/or RLC status needs to be sent, padding will occur instead).

RLC Status PDU size = 24 bits with 1 ACK_SN, With a MAC header of 16 bits.

This gives:

PDCP SDU size = $8 * \text{FLOOR}((TBS - N * 24 - N * 24 - N * 24 - 56) / (8 * N))$ bits.

Note 2: According to the final PDCP SDU size formula in Note 1, the smallest TBS that can be tested is 136 bits.

Table 7.1.1.4.2.5.3.2-3: Specific Parameters

Parameter	Value	Comment
number of layers (v)	1	
<i>transformPrecoder</i>	enabled	

Table 7.1.1.4.2.5.3.2-4: Main behaviour

St	Procedure	Message Sequence		TP	Verdict
		U - S	Message		
-	EXCEPTION: Steps 1 to 5 are repeated for allowed values of N_{PRB} 1 to $N_{RB}^{UL,BWP}$ in BWP, time domain resource as per Table 7.1.1.4.2.0-1 and I_{MCS} from 0 to 28.	-	-	-	-
1	The SS calculates or looks up TBS in TS 38.214 [15] based on the value of S, L, I_{MCS} and n_{PRB} .	-	-	-	-
-	EXCEPTION: Steps 2 to 5 are performed if TBS is less than or equal to UE capability "Maximum number of UL-SCH transport block bits received within a TTI" as specified in Table 7.1.1.4.2.5.3.2-1 and larger than or equal to 136 bits as specified in Table 7.1.1.4.2.5.3.2-2	-	-	-	-
2	The SS creates one or more PDCP SDUs, depending on TBS, in accordance with Table 7.1.1.4.2.5.3.2-2.	-	-	-	-
3	After 300ms, the SS transmits all PDCP SDUs (N_{SDUs}) as created in step 2 in a MAC PDU.	<--	MAC PDU (N x PDCP SDUs)	-	-
4	After 60ms of step 3, SS transmits UL Grant DCI 0_0, and values of S, L, I_{MCS} and n_{PRB} .	<--	(UL Grant) (DCI Format 0_0, S, L, I_{MCS} and n_{PRB} .)	-	-
5	CHECK: Does UE return the same number of PDCP SDUs with same content as transmitted by the SS in step 3 using Time, frequency Resources and modulation and coding scheme as configured by the SS in step 4?	-->	MAC PDU (N x PDCP SDU)	1	P

7.1.1.4.2.5.3.3 Specific message contents

[None]

7.1.1.5 Discontinuous reception

7.1.1.5.1 DRX operation / Short cycle not configured / Parameters configured by RRC

(1)

```

with { UE in RRC_CONNECTED state }
ensure that {
  when { Long DRX cycle is configured and [(SFN * 10) + subframe number] modulo (drx-LongCycle) =
drx-StartOffset }
  then { UE starts the OnDurationTimer and monitors the PDCCH for OnDurationTimer PDCCH-Occasions}

```

```
    }
```

(2)

```
with { UE in RRC_CONNECTED state }
ensure that {
  when { Long DRX cycle is configured and a new DL transmission is indicated on the PDCCH during
Active Time }
  then { UE starts or restarts the Drx-InactivityTimer and monitors the PDCCH for Drx-
InactivityTimer PDCCH occasions starting from the next PDCCH occasion of the PDCCH occasion where
the DL new transmission was indicated }
}
```

(3)

```
with { UE in RRC_CONNECTED state }
ensure that {
  when { Long DRX cycle is configured and if a HARQ RTT Timer expires in this PDCCH Occasion and the
data in the soft buffer of the corresponding HARQ process was not successfully decoded }
  then { UE starts the drx-RetransmissionTimer-DL for the corresponding HARQ process and monitors
the PDCCH for drx-RetransmissionTimer consecutive PDCCH Occasion }
}
```

(4)

```
with { UE in RRC_CONNECTED state }
ensure that {
  when { Long DRX cycle is configured and an uplink grant for a pending HARQ retransmission can
occur in this PDCCH occasion}
  then { UE monitors the PDCCH in this PDCCH occasion }
}
```

7.1.1.5.1.2 Conformance requirements

References: The conformance requirements covered in the present TC are specified in: TS 38.321, clause 5.7. Unless otherwise stated these are Rel-15 requirements.

[TS 38.321, clause 5.7]

The MAC entity may be configured by RRC with a DRX functionality that controls the UE's PDCCH monitoring. . Activity for the MAC entity's C-RNTI, CS-RNTI, INT-RNTI, SFI-RNTI, SP-CSI-RNTI, TPC-PUCCH-RNTI, TPC-PUSCH-RNTI, and TPC-SRS-RNTI. When using DRX operation, the MAC entity shall also monitor PDCCH according to requirements found in other subclauses of this specification. When in RRC_CONNECTED, if DRX is configured, the MAC entity may monitor the PDCCH discontinuously using the DRX operation specified in this subclause; otherwise the MAC entity shall monitor the PDCCH continuously.

RRC controls DRX operation by configuring the following timers:

- *drx-onDurationTimer*: the duration at the beginning of a DRX Cycle;
- *drx-SlotOffset*: the delay before starting the *drx-onDurationTimer*;
- *drx-InactivityTimer*: the duration after the PDCCH occasion in which a PDCCH indicates an new UL or DL transmission for the MAC entity;
- *drx-RetransmissionTimerDL* (per DL HARQ process): the maximum duration until a DL retransmission is received;
- *drx-RetransmissionTimerUL* (per UL HARQ process): the maximum duration until a grant for UL retransmission is received;
- *drx-LongCycle StartOffset*: the Long DRX cycle and *drx-StartOffset* which defines the subframe where the Long and Short DRX Cycle starts;
- *drx-ShortCycle* (optional): the Short DRX cycle;
- *drx-ShortCycleTimer* (optional): the duration the UE shall follow the Short DRX cycle;

- *drx-HARQ-RTT-TimerDL* (per DL HARQ process): the minimum duration before a DL assignment for HARQ retransmission is expected by the MAC entity;
- *drx-HARQ-RTT-TimerUL* (per UL HARQ process): the minimum duration before a UL HARQ retransmission grant is expected by the MAC entity.

When a DRX cycle is configured, the Active Time includes the time while:

- *drx-onDurationTimer* or *drx-InactivityTimer* or *drx-RetransmissionTimerDL* or *drx-RetransmissionTimerUL* or *ra-ContentionResolutionTimer* (as described in subclause 5.1.5) is running; or
- a Scheduling Request is sent on PUCCH and is pending (as described in subclause 5.4.4); or
- a PDCCH indicating a new transmission addressed to the C-RNTI of the MAC entity has not been received after successful reception of a Random Access Response for the random access preamble not selected by the MAC entity among the contention-based Random Access Preamble (as described in subclause 5.1.4).

When DRX is configured, the MAC entity shall:

- 1> if a MAC PDU is received in a configured downlink assignment:
 - 2> start the *drx-HARQ-RTT-TimerDL* for the corresponding HARQ process in the first symbol after the end of the corresponding transmission carrying the DL HARQ feedback;
 - 2> stop the *drx-RetransmissionTimerDL* for the corresponding HARQ process.
- 1> if a MAC PDU is transmitted in a configured uplink grant:
 - 2> start the *drx-HARQ-RTT-TimerUL* for the corresponding HARQ process in the first symbol after the end of the first repetition of the corresponding PUSCH transmission;
 - 2> stop the *drx-RetransmissionTimerUL* for the corresponding HARQ process.
- 1> if a *drx-HARQ-RTT-TimerDL* expires:
 - 2> if the data of the corresponding HARQ process was not successfully decoded:
 - 3> start the *drx-RetransmissionTimerDL* for the corresponding HARQ process.
- 1> if an *drx-HARQ-RTT-TimerUL* expires:
 - 2> start the *drx-RetransmissionTimerUL* for the corresponding HARQ process.
- 1> if a DRX Command MAC CE or a Long DRX Command MAC CE is received:
 - 2> stop *drx-onDurationTimer*;
 - 2> stop *drx-InactivityTimer*.
- 1> if *drx-InactivityTimer* expires or a DRX Command MAC CE is received:
 - 2> if the Short DRX cycle is configured:
 - 3> start or restart *drx-ShortCycleTimer* in the first symbol after the expiry of *drx-HARQ-RTT-TimerDL*;
 - 3> use the Short DRX Cycle.
 - 2> else:
 - 3> use the Long DRX cycle.
- 1> if *drx-ShortCycleTimer* expires:
 - 2> use the Long DRX cycle.
- 1> if a Long DRX Command MAC CE is received:
 - 2> stop *drx-ShortCycleTimer*;

- 2> use the Long DRX cycle.
- 1> if the Short DRX Cycle is used, and $[(\text{SFN} \times 10) + \text{subframe number}] \bmod (\text{drx-ShortCycle}) = (\text{drx-StartOffset}) \bmod (\text{drx-ShortCycle})$; or
- 1> if the Long DRX Cycle is used, and $[(\text{SFN} \times 10) + \text{subframe number}] \bmod (\text{drx-LongCycle}) = \text{drx-StartOffset}$:
 - 2> if *drx-SlotOffset* is configured:
 - 3> start *drx-onDurationTimer* after *drx-SlotOffset* from the beginning of the subframe.
 - 2> else:
 - 3> start *drx-onDurationTimer*.
- 1> if the MAC entity is in Active Time:
 - 2> monitor the PDCCH;
 - 2> if the PDCCH indicates a DL transmission or if a DL assignment has been configured:
 - 3> start the *drx-HARQ-RTT-TimerDL* for the corresponding HARQ process immediately after the corresponding PUCCH transmission;
 - 3> stop the *drx-RetransmissionTimerDL* for the corresponding HARQ process.
 - 2> if the PDCCH indicates a UL transmission or if a UL grant has been configured:
 - 3> start the *drx-HARQ-RTT-TimerUL* for the corresponding HARQ process immediately after the first repetition of the corresponding PUSCH transmission;
 - 3> stop the *drx-RetransmissionTimerUL* for the corresponding HARQ process.
 - 2> if the PDCCH indicates a new transmission (DL or UL):
 - 3> start or restart *drx-InactivityTimer*.
- 1> else (i.e. not part of the Active Time):
 - 2> not report CQI/PMI/RI on PUCCH.

7.1.1.5.1.3 Test description

7.1.1.5.1.3.1 Pre-test conditions

Same Pre-test conditions as in clause 7.1.1.0 except that set to return no data in uplink.

7.1.1.5.1.3.2 Test procedure sequence

For FDD, *NormalSLT*(current SFN,current subframe, current slot,y)=y; For TDD, *NormalSLT*(current SFN, current slot,y) counts the minimum number of normal slots needed to cover y number of PDCCH-occasions(slots) until next PDCCH-occasion(slot) available, starting from current slot on current subframe.

Table 7.1.1.5.1.3.2-1: Main behaviour

St	Procedure	Message Sequence		TP	Verdict
		U - S	Message		
1	SS transmits RRCConnectionReconfiguration to configure specific DRX parameters.	<--	-	-	-
2	The UE transmits RRCConnectionReconfigurationComplete	-->	-	-	-
3	In the first PDCCH occasion when the <i>Drx-onDurationTimer</i> is running, the SS indicates the transmission of a DL MAC PDU on the PDCCH. i.e., on the PDCCH occasion <i>csn1</i> within the subframe number = $(\text{csfn1} + \text{floor}([\text{csn1} + \text{NormalSLT}(\text{SFN1}, \text{csfn1}, \text{csn1}, 0)] / \text{numberofslotswithin subframe})) \bmod 10$, and system frame number = $\text{SFN1} + \text{floor}([\text{csn1} + \text{NormalSLT}(\text{SFN1}, \text{csfn1}, \text{csn1}, 0)] / \text{numberofslotswithin subframe} / 10)$; where $[(\text{SFN1} * 10) + \text{csfn1}] \bmod (\text{LongDRX-Cycle}) = \text{drx-StartOffset}$; $\text{csn1} = \text{drx-slotoffset}$.	<--	MAC PDU	-	-
4	Check: Does the UE transmit a HARQ ACK for the DL MAC PDU in Step 3?	-->	HARQ ACK	1	P
5	At least <i>drx-InactivityTimer</i> PDCCH occasions after the transmission of the MAC PDU in Step 3 has been indicated (This means the next DRX cycle or later after Step 2) in the last PDCCH occasion while the <i>drx-onDurationTimer</i> is still running, the SS indicates the transmission a DL MAC PDU on the PDCCH. (Note 4). i.e., on the PDCCH occasion = $[\text{csn2} + \text{NormalSLT}(\text{SFN2}, \text{csfn2}, \text{csn2}, \text{drx-onDurationTimer-1})] \bmod \text{numberofslotswithin subframe}$ within the subframe number = $(\text{csfn2} + \text{floor}([\text{csn2} + \text{NormalSLT}(\text{SFN2}, \text{csfn2}, \text{csn2}, \text{drx-onDurationTimer-1})] / \text{numberofslotswithin subframe})) \bmod 10$, and system frame number = $\text{SFN2} + \text{floor}([\text{csn2} + \text{NormalSLT}(\text{SFN2}, \text{csfn2}, \text{drx-onDurationTimer-1})] / \text{numberofslotspersubframe} / 10)$; where $[(\text{SFN2} * 10) + \text{csfn2}] \bmod (\text{LongDRX-Cycle}) = \text{drx-StartOffset}$ and $\text{csn2} = \text{drx-slotoffset}$. (Note 5)	<--	MAC PDU	-	-
6	Check: Does the UE transmit a HARQ ACK for the DL MAC PDU in Step 5?	-->	HARQ ACK	1	P
7	<i>drx-InactivityTimer</i> PDCCH-occasions after the transmission of the MAC PDU transmitted in step 5 was indicated on the PDCCH, the SS indicates the transmission of a DL MAC PDU on the PDCCH. (Note 4) i.e. on the PDCCH occasion = $[\text{csn2} + \text{NormalSLT}(\text{SFN2}, \text{csfn2}, \text{csn2}, \text{drx-onDurationTimer} + \text{drx-InactivityTimer-1})] \bmod \text{numberofslotswithin subframe}$ within the subframe number = $(\text{csfn2} + \text{floor}([\text{csn2} + \text{NormalSLT}(\text{SFN2}, \text{csfn2}, \text{csn2}, \text{drx-onDurationTimer} + \text{drx-InactivityTimer-1})] / \text{numberofslotswithin subframe})) \bmod 10$, and system frame number = $\text{SFN2} + \text{floor}([\text{csn2} + \text{NormalSLT}(\text{SFN2}, \text{csfn2}, \text{drx-onDurationTimer} + \text{drx-InactivityTimer-1})] / \text{numberofslotspersubframe} / 10)$	<--	MAC PDU	-	-
8	Check: Does the UE transmit a HARQ ACK for the DL MAC PDU in Step 7?	-->	HARQ ACK	2	P

9	<p>At least drx-InactivityTimer PDCCH occasions after the transmission of the MAC PDU in Step 7 has been indicated (This means the next DRX cycle or later after Step 5) and 1 PDCCH occasion before the <i>Drx-onDurationTimer</i> expires, the SS indicates the transmission of a DL MAC PDU on the PDCCH. The DL MAC PDU transmitted is invalid. (Note 1, Note 4)</p> <p>i.e. on the PDCCH occasion = $[\text{csn3} + \text{NormalSLT}(\text{SFN3}, \text{csfn3}, \text{csn3}, \text{drx-onDurationTimer} - 2)]$ modulo numberofslotswithin subframe within the subframe number = $(\text{csfn3} + \text{floor}([\text{csn3} + \text{NormalSLT}(\text{SFN3}, \text{csfn3}, \text{csn3}, \text{drx-onDurationTimer} - 2)] / \text{numberofslotswithin subframe}))$ modulo 10, and system frame number = $\text{SFN3} + \text{floor}([\text{csfn3} + \text{floor}([\text{csn3} + \text{NormalSLT}(\text{SFN3}, \text{csfn3}, \text{drx-onDurationTimer} - 2)] / \text{numberofslotspersubframe})] / 10)$; where $[(\text{SFN3} * 10) + \text{csfn3}]$ modulo (LongDRX-Cycle) = drxStartOffset and csn3=drx-slotoffset.</p>	<--	Invalid MAC PDU	-	-
10	Check: Does the UE transmit a HARQ NACK for the DL MAC PDU in Step 9?	-->	HARQ NACK	1	P
11	<p>In the first PDCCH occasion when the <i>Drx-RetransmissionTimerDL</i> for the MAC PDU in Step 9 is started, the SS indicates the transmission of a DL MAC PDU on the PDCCH.</p> <p>i.e., on the PDCCH occasion with the subframe number = $(\text{csfn4} + \text{floor}([\text{csn4} + \text{NormalSLT}(\text{SFN4}, \text{csfn4}, 0)] / \text{numberofslotswithin subframe}))$ modulo 10, and system frame number = $\text{SFN4} + \text{floor}([\text{csfn4} + \text{floor}([\text{csn4} + \text{NormalSLT}(\text{SFN4}, \text{csfn4}, 0)] / \text{numberofslotswithin subframe})] / 10)$; where $\text{csn4} = [\text{csn3} + \text{NormalSLT}(\text{SFN3}, \text{csfn3}, \text{drx-onDurationTimer} - 2) + \text{drx-HARQ-RTT-TimerDL timer}]$ modulo numberofslotswithin subframe within the $\text{csfn4} = (\text{csfn3} + \text{floor}([\text{csn3} + \text{NormalSLT}(\text{SFN3}, \text{csfn3}, \text{drx-onDurationTimer} - 2) + \text{drx-HARQ-RTT-TimerDL timer}] / \text{numberofslotswithin subframe}))$ modulo 10, and $\text{SFN4} = \text{SFN3} + \text{floor}([\text{csfn3} + \text{floor}([\text{csn3} + \text{NormalSLT}(\text{SFN3}, \text{csfn3}, \text{drx-onDurationTimer} - 2) + \text{drx-HARQ-RTT-TimerDL timer}] / \text{numberofslotspersubframe})] / 10)$.</p>	<--	MAC PDU	-	-
12	Check: Does the UE transmit a HARQ ACK for the DL MAC PDU in Step 11?	-->	HARQ ACK	3	P

13	<p>At least drx-InactivityTimer PDCCH occasions after the transmission of the DL MAC PDU in Step 11 has been indicated (This means the next DRX cycle or later after Step 11) and 1 subframe before the <i>Drx-onDurationTimer</i> expires, the SS indicates the transmission of DL MAC PDU on the PDCCH. The DL MAC PDU transmitted is invalid. (Note 1, Note 4)</p> <p>i.e. on the PDCCH occasion = $[csn5 + NormalSLT(SFN5, csfn5, csn5, drx-onDurationTimer-1)]$ modulo numberofslotswithin subframe within the subframe number = $(csfn5 + floor([csn5 + NormalSLT(SFN5, csfn5, csn5, drx-onDurationTimer + drx-onDurationTimer-2)] / numberofslotswithin subframe))$ modulo 10, and system frame number = $SFN5 + floor([csfn5 + floor([csn5 + NormalSLT(SFN5, csfn5, csn5, drx-onDurationTimer-2)] / numberofslotspersubframe)] / 10)$; where $[(SFN5 * 10) + csfn5]$ modulo (LongDRX-Cycle) = drxStartOffset and $csn5 = drx-slotoffset$.</p>	<--	Invalid MAC PDU	-	-
14	<p>Check: Does the UE transmit a HARQ NACK for the DL MAC PDU in Step 13?</p>	-->	HARQ NACK	1	P
15	<p>In the last PDCCH occasion when the drx-RetransmissionTimerDL for MAC PDU in Step 13 is still running, the SS indicates the transmission of a DL MAC PDU on the PDCCH.</p> <p>i.e., on the PDCCH occasion with the subframe number = $csfn6 + floor([csn6 + NormalSLT(SFN6, csfn6, drx-RetransmissionTimerDL - 1)] / numberofslotswithin subframe)$, and system frame number = $SFN6 + floor([csfn6 + floor([csn6 + NormalSLT(SFN6, csfn6, drx-RetransmissionTimerDL - 1)] / numberofslotswithin subframe)] / 10)$; where $csn6 = [csn5 + NormalSLT(SFN5, csfn5, drx-onDurationTimer-2 + drx-HARQ-RTT-TimerDL)]$ modulo numberofslotswithin subframe within $csfn6 = (csfn5 + floor([csn5 + NormalSLT(SFN5, csfn5, drx-onDurationTimer-2 + drx-HARQ-RTT-TimerDL)] / numberofslotswithin subframe))$ modulo 10, and $SFN6 = SFN5 + floor([csfn5 + floor([csn5 + NormalSLT(SFN5, csfn5, csn5, drx-onDurationTimer-2 + drx-HARQ-RTT-TimerDL)] / numberofslotspersubframe)] / 10)$.</p>	<--	MAC PDU	-	-
16	<p>Check: Does the UE transmit a HARQ ACK for the DL MAC PDU in Step 15?</p>	-->	HARQ ACK	3	P

17	<p>The SS is configured for Uplink Grant Allocation Type [0]. At least drx-InactivityTimer PDCCH subframes after the transmission of the DL MAC PDU in Step 15 has been indicated in the last subframe when the onDurationTimer is still running (This means the next DRX cycle or later after Step 9), the SS indicates an UL grant to the UE on the PDCCH. (Note 4)</p> <p>i.e. on the PDCCH occasion = $[\text{csn7} + \text{NormalSLT}(\text{SFN7}, \text{csfn7}, \text{csn7}, \text{drx-onDurationTimer-1})]$ modulo numberofslotswithin subframe within the subframe number = $(\text{csfn7} + \text{floor}([\text{csn7} + \text{NormalSLT}(\text{SFN7}, \text{csfn7}, \text{csn7}, \text{drx-onDurationTimer} + \text{drx-onDurationTimer-1})] / \text{numberofslotswithin subframe}))$ modulo 10, and system frame number = $\text{SFN7} + \text{floor}([\text{csfn7} + \text{floor}([\text{csn7} + \text{NormalSLT}(\text{SFN7}, \text{csfn7}, \text{csn7}, \text{drx-onDurationTimer-1})] / \text{numberofslotspersubframe})] / 10)$; where $[(\text{SFN7} * 10) + \text{csfn7}]$ modulo (LongDRX-Cycle) = drxStartOffset and $\text{csn7} = \text{drx-slotoffset}$.</p>	<--	UL grant on PDCCH	-	-
18	Check: Does the UE transmit a Buffer Status Report on the UL indicating an empty buffer?	-->	Buffer Status Report MAC control element	1	P
19	<p>In the last PDCCH occasion when the drx-RetransmissionTimer-UL for MAC PDU from Step 17 is still running, the SS indicates the transmission of a DL MAC PDU on the PDCCH.</p> <p>i.e., on the PDCCH occasion with the subframe number = $\text{csfn8} + \text{floor}([\text{csn8} + \text{NormalSLT}(\text{SFN8}, \text{csfn8}, \text{drx-RetransmissionTimerUL} - 1)] / \text{numberofslotswithin subframe})$, and system frame number = $\text{SFN8} + \text{floor}([\text{csfn8} + \text{floor}([\text{csn8} + \text{NormalSLT}(\text{SFN8}, \text{csfn8}, \text{drx-RetransmissionTimerUL} - 1)] / \text{numberofslotswithin subframe})] / 10)$; where $\text{csn8} = [\text{csn7} + \text{NormalSLT}(\text{SFN7}, \text{csfn7}, \text{drx-onDurationTimer-2} + \text{drx-HARQ-RTT-TimerDL})]$ modulo numberofslotswithin subframe within $\text{csfn8} = (\text{csfn7} + \text{floor}([\text{csn7} + \text{NormalSLT}(\text{SFN7}, \text{csfn7}, \text{drx-onDurationTimer-2} + \text{drx-HARQ-RTT-TimerDL})] / \text{numberofslotswithin subframe}))$ modulo 10, and $\text{SFN8} = \text{SFN7} + \text{floor}([\text{csfn7} + \text{floor}([\text{csn7} + \text{NormalSLT}(\text{SFN7}, \text{csfn7}, \text{csn7}, \text{drx-onDurationTimer-1} + \text{drx-HARQ-RTT-TimerUL})] / \text{numberofslotspersubframe})] / 10)$.</p>	<--	MAC PDU	-	-
20	Check: Does the UE transmit a HARQ ACK for the DL MAC PDU in Step 19?	-->	HARQ ACK	4	P
<p>Note 1: Invalid MAC PDU is a MAC PDU that fails the CRC check.</p> <p>Note 2: All the DL MAC PDU are transmitted with the NDI set on the PDCCH.</p> <p>Note 3: Timer tolerances for the MAC DRX related timers measured in PDCCH occasions is 0. These timers are: drx-InactivityTimer, drx-RetransmissionTimerDL, drx-RetransmissionTimerUL, drx-HARQ-RTT-TimerDL and drx-HARQ-RTT-TimerUL.</p> <p>Note 4: The drx-InactivityTimer is started in the next PDCCH occasion of the PDCCH occasion where DL new transmission is indicated.</p> <p>Note 5: The timer values expressed in number of slots.</p>					

7.1.1.5.1.3.3 Specific message contents

Table 7.1.1.5.1.3.3-1: *RRCConnectionReconfiguration* (step 1, Table 7.1.1.5.1.3.2-1)

Derivation Path: 38.508-1 [4], Table [value]			
Information Element	Value/remark	Comment	Condition
RRCReconfiguration-IEs ::= SEQUENCE {			
secondaryCellGroupToAddModList SEQUENCE (SIZE (1..maxSCellGroups)) OF SEQUENCE {	[1 entry]		
cellGroupConfig [value] ::= SEQUENCE {			
mac-CellGroupConfig ::= SEQUENCE {			
drx-Config CHOICE {			
setup ::= SEQUENCE {			
drx-onDurationTimer	ms20		
drx-InactivityTimer	ms6		
drx-HARQ-RTT-TimerDL	56	Number of slots=4 due to number of symbol per slot=14	$\mu = 0,1,2,3,4$ (2 with normal CP)
drx-HARQ-RTT-TimerDL	48	Number of slots=4 due to number of symbol per slot=12	$\mu = 2$ with external CP
drx-HARQ-RTT-TimerUL	56	Number of slots=4 due to number of symbol per slot=14	$\mu = 0,1,2,3,4$ (2 with normal CP)
drx-HARQ-RTT-TimerUL	48	Number of slots=4 due to number of symbol per slot=12	$\mu = 2$ with external CP
drx-RetransmissionTimerDL	s12		
drx-RetransmissionTimerUL	s12		
drx-LongCycleStartOffset CHOICE {			
ms640	4		
}			
shortDRX	Not present		
drx-SlotOffset	ms0		
}			
}			
}			
}			
}			
}			

7.1.1.5.2 DRX operation / Short cycle not configured / Long DRX command MAC control element reception

7.1.1.5.2.1 Test Purpose (TP)

(1)

```

with { UE in CONNECTED mode }
ensure that {
  when { long DRX cycle is configured and a DRX Command MAC control element is received }
  then { UE successfully decodes the MAC control PDU }
}

```

(2)

```

with { UE in CONNECTED mode }
ensure that {
  when { long DRX cycle is configured and the HARQ RTT Timer is running and a DRX Command MAC control element is received }
}

```

```

then { UE continues running the HARQ RTT timer }
}

```

(3)

```

with { UE in CONNECTED mode }
ensure that {
  when { long DRX cycle is configured and the drx-RetransmissionTimer is running and a DRX Command
  MAC control element is received }
  then { UE continues running the drx-RetransmissionTimer and monitors the PDCCH }
}

```

7.1.1.5.2.2 Conformance requirements

References: The conformance requirements covered in the present TC are specified in: TS 38.321, clause 5.7. Unless otherwise stated these are Rel-15 requirements.

[TS 38.321, clause 5.7]

The MAC entity may be configured by RRC with a DRX functionality that controls the UE's PDCCH monitoring. Activity for the MAC entity's C-RNTI, CS-RNTI, INT-RNTI, SFI-RNTI, SP-CSI-RNTI, TPC-PUCCH-RNTI, TPC-PUSCH-RNTI, and TPC-SRS-RNTI. When using DRX operation, the MAC entity shall also monitor PDCCH according to requirements found in other subclauses of this specification. When in RRC_CONNECTED, if DRX is configured, the MAC entity may monitor the PDCCH discontinuously using the DRX operation specified in this subclause; otherwise the MAC entity shall monitor the PDCCH continuously.

RRC controls DRX operation by configuring the following timers:

- *drx-onDurationTimer*: the duration at the beginning of a DRX Cycle;
- *drx-SlotOffset*: the delay before starting the *drx-onDurationTimer*;
- *drx-InactivityTimer*: the duration after the PDCCH occasion in which a PDCCH indicates a new UL or DL transmission for the MAC entity;
- *drx-RetransmissionTimerDL* (per DL HARQ process): the maximum duration until a DL retransmission is received;
- *drx-RetransmissionTimerUL* (per UL HARQ process): the maximum duration until a grant for UL retransmission is received;
- *drx-LongCycle StartOffset*: the Long DRX cycle and *drx-StartOffset* which defines the subframe where the Long and Short DRX Cycle starts;
- *drx-ShortCycle* (optional): the Short DRX cycle;
- *drx-ShortCycleTimer* (optional): the duration the UE shall follow the Short DRX cycle;
- *drx-HARQ-RTT-TimerDL* (per DL HARQ process): the minimum duration before a DL assignment for HARQ retransmission is expected by the MAC entity;
- *drx-HARQ-RTT-TimerUL* (per UL HARQ process): the minimum duration before a UL HARQ retransmission grant is expected by the MAC entity.

When a DRX cycle is configured, the Active Time includes the time while:

- *drx-onDurationTimer* or *drx-InactivityTimer* or *drx-RetransmissionTimerDL* or *drx-RetransmissionTimerUL* or *ra-ContentionResolutionTimer* (as described in subclause 5.1.5) is running; or
- a Scheduling Request is sent on PUCCH and is pending (as described in subclause 5.4.4); or
- a PDCCH indicating a new transmission addressed to the C-RNTI of the MAC entity has not been received after successful reception of a Random Access Response for the random access preamble not selected by the MAC entity among the contention-based Random Access Preamble (as described in subclause 5.1.4).

When DRX is configured, the MAC entity shall:

- 1> if a MAC PDU is received in a configured downlink assignment:
 - 2> start the *drx-HARQ-RTT-TimerDL* for the corresponding HARQ process in the first symbol after the end of the corresponding transmission carrying the DL HARQ feedback;
 - 2> stop the *drx-RetransmissionTimerDL* for the corresponding HARQ process.
- 1> if a MAC PDU is transmitted in a configured uplink grant:
 - 2> start the *drx-HARQ-RTT-TimerUL* for the corresponding HARQ process in the first symbol after the end of the first repetition of the corresponding PUSCH transmission;
 - 2> stop the *drx-RetransmissionTimerUL* for the corresponding HARQ process.
- 1> if a *drx-HARQ-RTT-TimerDL* expires:
 - 2> if the data of the corresponding HARQ process was not successfully decoded:
 - 3> start the *drx-RetransmissionTimerDL* for the corresponding HARQ process.
- 1> if an *drx-HARQ-RTT-TimerUL* expires:
 - 2> start the *drx-RetransmissionTimerUL* for the corresponding HARQ process.
- 1> if a DRX Command MAC CE or a Long DRX Command MAC CE is received:
 - 2> stop *drx-onDurationTimer*;
 - 2> stop *drx-InactivityTimer*.
- 1> if *drx-InactivityTimer* expires or a DRX Command MAC CE is received:
 - 2> if the Short DRX cycle is configured:
 - 3> start or restart *drx-ShortCycleTimer* in the first symbol after the expiry of *drx-HARQ-RTT-TimerDL*;
 - 3> use the Short DRX Cycle.
 - 2> else:
 - 3> use the Long DRX cycle.
- 1> if *drx-ShortCycleTimer* expires:
 - 2> use the Long DRX cycle.
- 1> if a Long DRX Command MAC CE is received:
 - 2> stop *drx-ShortCycleTimer*;
 - 2> use the Long DRX cycle.
- 1> if the Short DRX Cycle is used, and $[(\text{SFN} \times 10) + \text{subframe number}] \bmod (\text{drx-ShortCycle}) = (\text{drx-StartOffset}) \bmod (\text{drx-ShortCycle})$; or
- 1> if the Long DRX Cycle is used, and $[(\text{SFN} \times 10) + \text{subframe number}] \bmod (\text{drx-LongCycle}) = \text{drx-StartOffset}$:
 - 2> if *drx-SlotOffset* is configured:
 - 3> start *drx-onDurationTimer* after *drx-SlotOffset* from the beginning of the subframe..
 - 2> else:
 - 3> start *drx-onDurationTimer*.
- 1> if the MAC entity is in Active Time:
 - 2> monitor the PDCCH;

- 2> if the PDCCH indicates a DL transmission or if a DL assignment has been configured:
 - 3> start the *drx-HARQ-RTT-TimerDL* for the corresponding HARQ process immediately after the corresponding PUCCH transmission;
 - 3> stop the *drx-RetransmissionTimerDL* for the corresponding HARQ process.
- 2> if the PDCCH indicates a UL transmission or if a UL grant has been configured:
 - 3> start the *drx-HARQ-RTT-TimerUL* for the corresponding HARQ process immediately after the first repetition of the corresponding PUSCH transmission;
 - 3> stop the *drx-RetransmissionTimerUL* for the corresponding HARQ process.
- 2> if the PDCCH indicates a new transmission (DL or UL):
 - 3> start or restart *drx-InactivityTimer*.
- 1> else (i.e. not part of the Active Time):
 - 2> not report CQI/PMI/RI on PUCCH.

7.1.1.5.2.3 Test description

7.1.1.5.2.3.1 Pre-test conditions

Same Pre-test conditions as in clause 7.1.1.0 except that set to return no data in uplink.

7.1.1.5.2.3.2 Test procedure sequence

For FDD, *NormalSLT*(current SFN,current sub-frame, current slot,y)=y; For TDD, *NormalSLT*(current SFN, current slot,y) counts the minimum number of normal slots needed to cover y number of PDCCH-occasions(slots) until next PDCCH-occasion(slot) available, starting from current slot on current SFN.

Table 7.1.1.5.2.3.2-1: Main behaviour

St	Procedure	Message Sequence		TP	Verdict
		U - S	Message		
1	SS transmits RRCConnectionReconfiguration to configure specific DRX parameters.	<--	-	-	-
2	The UE transmits RRCConnectionReconfigurationComplete.	-->	-	-	-
3	<p>In a PDCCH occasion which is X PDCCH sub frames before the PDCCH occasion in which the <i>onDurationTimer</i> expires, with $\text{drx-InactivityTimer} < X < \text{the number of PDCCH occasions encapsulated by Drx-HARQ-RTT-TimerDL}$, the SS indicates the transmission of a DL MAC PDU on the PDCCH. The SS transmits an invalid MAC PDU. (Note 1)</p> <p>i.e., on the PDCCH occasion $\text{csn2} = [\text{csn1} + \text{NormalSLT}(\text{SFN1}, \text{csfn1}, \text{csn1}, \text{drx-onDurationTimer} - 1 - X)] \text{ modulo } \text{numberofslotswithinsubframe}$ within the subframe number $\text{csfn2} = (\text{csfn1} + \text{floor}([\text{csn1} + \text{NormalSLT}(\text{SFN1}, \text{csfn1}, \text{csn1}, \text{drx-onDurationTimer} - 1 - X)] / \text{numberofslotswithinsubframe})) \text{ modulo } 10$, and system frame number $\text{SFN2} = \text{SFN1} + \text{floor}([\text{csfn1} + \text{floor}([\text{csn1} + \text{NormalSLT}(\text{SFN1}, \text{csfn1}, \text{csn1}, \text{drx-onDurationTimer} - 1 - X)] / \text{numberofslotswithinsubframe}) / 10])$; where $[(\text{SFN1} * 10) + \text{csfn1}] \text{ modulo } (\text{LongDRX-Cycle}) = \text{drx-StartOffset}$; $\text{csn1} = \text{drx-slotoffset}$.</p>	<--	MAC PDU	-	-
4	Check: Does the UE transmit a HARQ NACK for the DL MAC PDU in Step 1?	-->	HARQ NACK	1	P
5	<p>In a PDCCH sub frames before the <i>drx-onDurationTimer</i> expires, the SS indicates the transmission of a DL MAC PDU on the PDCCH. The SS transmits a DL MAC PDU with DRX MAC Control element. UE successfully decodes the MAC PDU.</p> <p>i.e., on the PDCCH occasion $= [\text{csn1} + \text{NormalSLT}(\text{SFN1}, \text{csfn1}, \text{csn1}, \text{drx-onDurationTimer} - 1 - X + Y)] \text{ modulo } \text{numberofslotswithinsubframe}$ within the subframe number $= (\text{csfn1} + \text{floor}([\text{csn1} + \text{NormalSLT}(\text{SFN1}, \text{csfn1}, \text{csn1}, \text{drx-onDurationTimer} - 1 - X + Y)] / \text{numberofslotswithinsubframe})) \text{ modulo } 10$, and system frame number $= \text{SFN1} + \text{floor}([\text{csfn1} + \text{floor}([\text{csn1} + \text{NormalSLT}(\text{SFN1}, \text{csfn1}, \text{csn1}, \text{drx-onDurationTimer} - 1 - X + Y)] / \text{numberofslotswithinsubframe}) / 10])$; and $0 < Y < X$.</p>	<--	MAC PDU(DRX MAC Control element)	-	-
6	Check: Does the UE transmit a HARQ ACK for the DL MAC PDU in Step 3?	-->	HARQ ACK	1	P

7	<p>In the PDCCH sub frame when the drx-RetransmissionTimer for the MAC PDU indicated in Step 1 on the PDCCH is started the SS indicates the transmission of a DL MAC PDU. The SS transmits an invalid MAC PDU. (Note 1)</p> <p>i.e., on the PDCCH occasion with $csn5 = csn4$ the subframe number = $(csfn4 + \text{floor}([\text{csn4} + \text{NormalSLT}(\text{SFN4}, \text{csfn4}, 0)] / \text{numberofslotswithin subframe})) \text{ modulo } 10$, and system frame number = $\text{SFN4} + \text{floor}([\text{csfn4} + \text{floor}([\text{csn4} + \text{NormalSLT}(\text{SFN4}, \text{csfn4}, 0)] / \text{numberofslotswithin subframe})] / 10)$; where $csn4 = [\text{csn2} + \text{NormalSLT}(\text{SFN2}, \text{csfn2}, \text{numberofslotswithin subframe} + \text{Drx-HARQ-RTT-TimerDL})] \text{ modulo } \text{numberofslotswithin subframe}$ within the $csfn4 = (\text{csfn2} + \text{floor}([\text{csn2} + \text{NormalSLT}(\text{SFN2}, \text{csfn2}, \text{Drx-HARQ-RTT-TimerDL})] / \text{numberofslotswithin subframe})) \text{ modulo } 10$, and $\text{SFN4} = \text{SFN2} + \text{floor}([\text{csfn2} + \text{floor}([\text{csn2} + \text{NormalSLT}(\text{SFN2}, \text{csfn2}, \text{numberofslotswithin subframe} + \text{Drx-HARQ-RTT-TimerDL})] / \text{numberofslotswithin subframe})] / 10)$;</p>	<--	MAC PDU	-	-
8	Check: Does the UE transmit a HARQ NACK for the DL MAC PDU in Step 5?	-->	HARQ NACK	2,3	P
9	<p>Z PDCCH sub frames, where $Z > \text{drx-InactivityTimer}$, before the PDCCH sub-frame in which the drx-RetransmissionTimer for the DL MAC PDU in Step 5 expires, the SS indicates the transmission of a DL MAC PDU. The SS transmits a DL MAC PDU with DRX MAC Control element.</p> <p>i.e., on the PDCCH occasion = $csn6$ within subframe = $(\text{csfn6} + \text{floor}([\text{csn6} + \text{NormalSLT}(\text{SFN6}, \text{csfn6}, \text{csn6}, \text{drx-RetransmissionTimer} - Z)] / \text{numberofslotswithin subframe})) \text{ modulo } 10$ and the system frame number = $\text{SFN6} + \text{floor}([\text{csfn6} + \text{NormalSLT}(\text{SFN6}, \text{csfn6}, 0)] / 10 * \text{numberofslotswithin subframe})$; where PDCCH occasion $csn6 = \text{floor}([\text{csn5} + \text{NormalSLT}(\text{SFN5}, \text{csfn5}, \text{csn5}, \text{Drx-HARQ-RTT-TimerDL})] \text{ modulo } \text{numberofslotswithin subframe}$, $csfn6 = (\text{csfn5} + \text{floor}([\text{csn5} + \text{NormalSLT}(\text{SFN5}, \text{csfn5}, \text{csn5}, \text{Drx-HARQ-RTT-TimerDL})] / \text{numberofslotswithin subframe})) \text{ modulo } 10$, and the $\text{SFN6} = \text{SFN5} + \text{floor}([\text{csfn5} + \text{floor}([\text{csn5} + \text{NormalSLT}(\text{SFN5}, \text{csfn5}, \text{csn5}, \text{Drx-HARQ-RTT-TimerDL})] / \text{numberofslotswithin subframe})] / 10)$;</p>	<--	MAC PDU(DRX MAC Control element)	-	-
10	Check: Does the UE transmit a HARQ ACK for the DL MAC PDU in Step 7?	-->	HARQ ACK	2,3,1	P

11	<p>In the last sub frame when the Drx-RetransmissionTimer for the DL MAC PDU indicated on the PDCCH in Step 5 is still running, the SS indicates the transmission of a DL MAC PDU.</p> <p>i.e., on the PDCCH occasion within subframe number = $(\text{csfn6} + \text{floor}([\text{csn6} + \text{NormalSLT}(\text{SFN6}, \text{csfn6}, \text{csn6}, \text{drx-RetransmissionTimer} - 1)] / \text{numberofslotswithinsubframe})) \bmod 10$, and the system frame number = $\text{SFN6} + \text{floor}([\text{csfn6} + \text{floor}([\text{csn6} + \text{NormalSLT}(\text{SFN6}, \text{csfn6}, \text{csn6}, \text{drx-RetransmissionTimer} - 1)] / \text{numberofslotswithinsubframe}) / 10]$;</p>	<--	MAC PDU	-	-
12	Check: Does the UE transmit a HARQ ACK for the DL MAC PDU in Step 9?	-->	HARQ ACK	2,3	P
<p>Note 1: Invalid MAC PDU is a MAC PDU that fails the CRC check.</p> <p>Note 2: All DL MAC PDUs are transmitted with the NDI set on the PDCCH.</p> <p>Note 3: Timer tolerances for the MAC DRX related timers measured in PDCCH occasions(slots). These timers are: drx-InactivityTimer, drx-RetransmissionTimer, Drx-HARQ-RTT-TimerDL.</p>					

7.1.1.5.2.3.3 Specific message contents

Table 7.1.1.5.2.3.3-1: *RRCConnectionReconfiguration* (step 1, Table 7.1.1.5.2.3.2-1)

Derivation Path: 38.508-1 [4], Table [4.6.1-13]			
Information Element	Value/remark	Comment	Condition
RRCReconfiguration-IEs ::= SEQUENCE {			
secondaryCellGroupToAddModList SEQUENCE {	[1 entry]		
(SIZE (1..maxSCellGroups)) OF SEQUENCE {			
cellGroupConfig ::= SEQUENCE {			
mac-CellGroupConfig ::= SEQUENCE {			
drx-Config CHOICE {			
setup ::= SEQUENCE {			
drx-onDurationTimer	ms20		
drx-InactivityTimer	ms6		
drx-HARQ-RTT-TimerDL	56	Number of slots=4 due to number of symbol per slot=14	μ =0,1,2,3,4 (2 with normal CP)
drx-HARQ-RTT-TimerDL	48	Number of slots=4 due to number of symbol per slot=12	$\mu = 2$ with external CP
drx-HARQ-RTT-TimerUL	56	Number of slots=4 due to number of symbol per slot=14	μ =0,1,2,3,4 (2 with normal CP)
drx-HARQ-RTT-TimerDL	48	Number of slots=4 due to number of symbol per slot=12	$\mu = 2$ with external CP
drx-RetransmissionTimerDL	s12		
drx-RetransmissionTimerUL	s12		
drx-LongCycleStartOffset CHOICE {			
ms640	4		
}			
shortDRX	Not present		
drx-SlotOffset	ms0		
}			
}			
}			
}			
}			
}			
}			

7.1.1.5.3 DRX operation / Short cycle configured / Parameters configured by RRC

7.1.1.5.3.1 Test Purpose (TP)

(1)

```

with { UE in RRC_CONNECTED state }
ensure that {
  when { Short DRX cycle and drx-SlotOffset is configured and [(SFN * 10) + subframe number] modulo
drx-ShortCycle) = (drx-StartOffset) modulo (drx-ShortCycle) }
  then { UE starts the OnDurationTimer after drx-SlotOffset and monitors the PDCCH for
OnDurationTimer PDCCH-subframes }
}

```

(2)

```

with { UE in RRC_CONNECTED state }
ensure that {

```

```

when { drxShortCycleTimer is expired and [(SFN * 10) + subframe number] modulo (drx-LongCycle) =
drx-StartOffset: }
  then { UE starts the OnDurationTimer after drx-SlotOffset and monitors the PDCCH for
OnDurationTimer PDCCH-subframes }
}

```

7.1.1.5.3.2 Conformance requirements

Editor's Note: The conformance requirements are based on running RAN2 CR

References: The conformance requirements covered in the present test case are specified in: TS 38.321, clause 5.7. Unless otherwise stated these are Rel-15 requirements.

[TS 38.321, clause 5.7]

The MAC entity may be configured by RRC with a DRX functionality that controls the UE's PDCCH monitoring activity for the MAC entity's C-RNTI, CS-RNTI, INT-RNTI, SFI-RNTI, SP-CSI-RNTI, TPC-PUCCH-RNTI, TPC-PUSCH-RNTI, and TPC-SRS-RNTI. When using DRX operation, the MAC entity shall also monitor PDCCH according to requirements found in other subclauses of this specification..When in RRC_CONNECTED, if DRX is configured, the MAC entity may monitor the PDCCH discontinuously using the DRX operation specified in this subclause; otherwise the MAC entity shall monitor the PDCCH continuously.

RRC controls DRX operation by configuring the following parameters:

- *drx-onDurationTimer*: the duration at the beginning of a DRX Cycle;
- *drx-SlotOffset*: the delay before starting the *drx-onDurationTimer*;
- *drx-InactivityTimer*: the duration after the PDCCH occasion in which a PDCCH indicates a new UL or DL transmission for the MAC entity;
- *drx-RetransmissionTimerDL* (per DL HARQ process): the maximum duration until a DL retransmission is received;
- *drx-RetransmissionTimerUL* (per UL HARQ process): the maximum duration until a grant for UL retransmission is received;
- *drx-LongCycleStartOffset*: the Long DRX cycle and *drx-StartOffset* which defines the subframe where the Long and Short DRX Cycle starts;
- *drx-ShortCycle* (optional): the Short DRX cycle;
- *drx-ShortCycleTimer* (optional): the duration the UE shall follow the Short DRX cycle;
- *drx-HARQ-RTT-TimerDL* (per DL HARQ process): the minimum duration before a DL assignment for HARQ retransmission is expected by the MAC entity;
- *drx-HARQ-RTT-TimerUL* (per UL HARQ process): the minimum duration before a UL HARQ retransmission grant is expected by the MAC entity.

When a DRX cycle is configured, the Active Time includes the time while:

- *drx-onDurationTimer* or *drx-InactivityTimer* or *drx-RetransmissionTimerDL* or *drx-RetransmissionTimerUL* or *ra-ContentionResolutionTimer* (as described in subclause 5.1.5) is running; or
- a Scheduling Request is sent on PUCCH and is pending (as described in subclause 5.4.4); or
- a PDCCH indicating a new transmission addressed to the C-RNTI of the MAC entity has not been received after successful reception of a Random Access Response for the Random Access Preamble not selected by the MAC entity among the contention-based Random Access Preamble (as described in subclause 5.1.4).

...

1> if *drx-InactivityTimer* expires or a DRX Command MAC CE is received:

2> if the Short DRX cycle is configured:

- 3> start or restart *drx-ShortCycleTimer* in the first symbol after the expiry of *drx-InactivityTimer* or in the first symbol after the end of DRX Command MAC CE reception;
- 3> use the Short DRX Cycle.
- 2> else:
 - 3> use the Long DRX cycle.
- 1> if *drx-ShortCycleTimer* expires:
 - 2> use the Long DRX cycle.
- 1> if a Long DRX Command MAC CE is received:
 - 2> stop *drx-ShortCycleTimer*;
 - 2> use the Long DRX cycle.
- 1> if the Short DRX Cycle is used, and $[(SFN \times 10) + \text{subframe number}] \bmod (drx-ShortCycle) = (drx-StartOffset) \bmod (drx-ShortCycle)$; or
- 1> if the Long DRX Cycle is used, and $[(SFN \times 10) + \text{subframe number}] \bmod (drx-LongCycle) = drx-StartOffset$:
 - 2> start *drx-onDurationTimer* after *drx-SlotOffset* from the beginning of the subframe.

7.1.1.5.3.3 Test description

7.1.1.5.3.3.1 Pre-test conditions

Same Pre-test conditions as in clause 7.1.1.0 except that set to return no data in uplink.

7.1.1.5.3.3.2 Test procedure sequence

For FDD, *NormalSLT* (current SFN, current sub-frame, current slot, y) = y ; For TDD, *NormalSLT* (current SFN, current slot, y) counts the minimum number of normal slots needed to cover y number of PDCCH-occasions(slots) until next PDCCH-occasion(slot) available, starting from current slot on current Subframe.

Table 7.1.1.5.3.3.2-1: Main behaviour

St	Procedure	Message Sequence		TP	Verdict
		U – S	Message		
1	SS transmits NR <i>RRCReconfiguration</i> message to configure specific DRX parameters for SpCell (Note1)	<--	-	-	-
2	The UE transmit NR <i>RRCReconfigurationComplete</i> messages (Note 2)	-->	-	-	-
3	In the first PDCCH occasion, after the <i>drx-SlotOffset</i> when the <i>drx-onDurationTimer</i> is running, the SS indicates the transmission of a DL MAC PDU on the PDCCH. i.e., on the PDCCH occasion <i>csn1</i> within the subframe number = (<i>csfn1</i> + floor([<i>csn1</i> + <i>NormalSLT</i> (<i>SFN1</i> , <i>csfn1</i> , <i>csn1</i> , 0)] / <i>numberofslotswithinframe</i>)) modulo 10, and system frame number = <i>SFN1</i> + floor([<i>csfn1</i> + floor([<i>csn1</i> + <i>NormalSLT</i> (<i>SFN1</i> , <i>csfn1</i> , <i>csn1</i> , 0)] / <i>numberofslotswithinframe</i>)/10); where [(<i>SFN1</i> * 10) + <i>csfn1</i>] modulo (<i>ShortDRX-Cycle</i>) = <i>drx-StartOffset</i> modulo (<i>ShortDRX-Cycle</i>); <i>csn1</i> = <i>drx-slotoffset</i>	<--	MAC PDU	-	-
4	Check: Does the UE transmit a HARQ ACK for the DL MAC PDU in Step 3?	-->	HARQ ACK	1	P
5	At least <i>drx-InactivityTimer</i> PDCCH occasions after the transmission of the MAC PDU in Step 3 has been indicated (This means the next DRX cycle or later after Step 1) in the last PDCCH occasion while the <i>drx-onDurationTimer</i> is still running, the SS indicates the transmission a DL MAC PDU on the PDCCH. (Note 3). i.e., on the PDCCH occasion = [<i>csn2</i> + <i>NormalSLT</i> (<i>SFN2</i> , <i>csfn2</i> , <i>csn2</i> , <i>drx-onDurationTimer</i> -1)] modulo <i>numberofslotswithinframe</i> within the subframe number = (<i>csfn2</i> + floor([<i>csn2</i> + <i>NormalSLT</i> (<i>SFN2</i> , <i>csfn2</i> , <i>csn2</i> , <i>drx-onDurationTimer</i> -1)] / <i>numberofslotswithinframe</i>)) modulo 10, and system frame number = <i>SFN2</i> + floor([<i>csfn2</i> + floor([<i>csn2</i> + <i>NormalSLT</i> (<i>SFN2</i> , <i>csfn2</i> , <i>drx-onDurationTimer</i> -1)] / <i>numberofslotspersubframe</i>)/10); where [(<i>SFN2</i> * 10) + <i>csfn2</i>] modulo (<i>ShortDRX-Cycle</i>) = <i>drx-StartOffset</i> modulo (<i>ShortDRX-Cycle</i>) and <i>csn2</i> = <i>drx-slotoffset</i> .	<--	MAC PDU	-	-
6	Check: Does the UE transmit a HARQ ACK for the DL MAC PDU in Step 5?	-->	HARQ ACK	1	P
7	UE waits for <i>drx-ShortCycleTimer</i> expire.	-	-	-	-
8	In the first PDCCH occasion after the <i>drx-SlotOffset</i> when the <i>drx-onDurationTimer</i> of <i>drx-LongCycle</i> is running, the SS indicates the transmission of a DL MAC PDU on the PDCCH. i.e., on the PDCCH occasion <i>csn1</i> within the subframe number = (<i>csfn1</i> + floor([<i>csn1</i> + <i>NormalSLT</i> (<i>SFN1</i> , <i>csfn1</i> , <i>csn1</i> , 0)] / <i>numberofslotswithinframe</i>)) modulo 10, and system frame number = <i>SFN1</i> + floor([<i>csfn1</i> + floor([<i>csn1</i> + <i>NormalSLT</i> (<i>SFN1</i> , <i>csfn1</i> , <i>csn1</i> , 0)] / <i>numberofslotswithinframe</i>)/10); where [(<i>SFN1</i> * 10) + <i>csfn1</i>] modulo (<i>LongDRX-Cycle</i>) = <i>drx-StartOffset</i> ; <i>csn1</i> = <i>drx-slotoffset</i>	<--	MAC PDU	-	-

9	Check: Does the UE transmit a HARQ ACK for the DL MAC PDU in Step 8?	-->	HARQ ACK	2	P
10	At least <i>drx-InactivityTimer</i> PDCCH occasions after the transmission of the MAC PDU in Step 8 has been indicated (This means the next DRX cycle or later after Step 5) in the last PDCCH occasion while the <i>drx-onDurationTimer</i> is still running, the SS indicates the transmission a DL MAC PDU on the PDDCH. (Note 3). i.e., on the PDCCH occasion = $[\text{csn2} + \text{NormalSLT}(\text{SFN2}, \text{csfn2}, \text{csn2}, \text{drx-onDurationTimer}-1)]$ modulo $\text{numberofslotswithinsubframe}$ within the subframe number = $(\text{csfn2} + \text{floor}([\text{csn2} + \text{NormalSLT}(\text{SFN2}, \text{csfn2}, \text{csn2}, \text{drx-onDurationTimer}-1)] / \text{numberofslotswithinsubframe}))$ modulo 10, and system frame number = $\text{SFN2} + \text{floor}([\text{csfn2} + \text{floor}([\text{csn2} + \text{NormalSLT}(\text{SFN2}, \text{csfn2}, \text{drx-onDurationTimer}-1)] / \text{numberofslotspersubframe})] / 10)$; where $[(\text{SFN2} * 10) + \text{csfn2}]$ modulo (LongDRX-Cycle) = <i>drx-StartOffset</i> and <i>csn2</i> = <i>drx-slotoffset</i> .	<--	MAC PDU	-	-
11	Check: Does the UE transmit a HARQ ACK for the DL MAC PDU in Step 10?	-->	HARQ ACK	2	P
<p>Note 1: For EN-DC the NR RRCReconfiguration message is contained in RRCConnectionReconfiguration 36.508 [7], Table 4.6.1-8 using condition EN-DC_EmbedNR_RRCRecon.</p> <p>Note 2: For EN-DC the NR RRCReconfigurationComplete message is contained in RRCConnectionReconfigurationComplete.</p> <p>Note 3: The <i>drx-InactivityTimer</i> is started in the next PDCCH occasion of the PDCCH occasion where DL new transmission is indicated.</p>					

7.1.1.5.3.3.3 Specific message contents

Table 7.1.1.5.3.3.3-1: RRCReconfiguration (step 1, Table 7.1.1.5.3.3.2-1)

Derivation Path: 38.508-1 [4], Table 4.6.1-13			
Information Element	Value/remark	Comment	Condition
RRCReconfiguration ::= SEQUENCE {			
criticalExtensions CHOICE {			
rrcReconfiguration ::= SEQUENCE {			
secondaryCellGroup	CellGroupConfig		EN-DC
}			
RRCReconfiguration-v1530-IEs ::= SEQUENCE {			
masterCellGroup	CellGroupConfig		FFS
}			
}			
}			

Table 7.1.1.5.3.3-2: *CellGroupConfig* (Table 7.1.1.5.3.3-1)

Derivation Path: 38.508-1 [4], Table 4.6.3-19			
Information Element	Value/remark	Comment	Condition
cellGroupConfig ::= SEQUENCE {			
cellGroupId	1		
mac-CellGroupConfig SEQUENCE {			
drx-Config CHOICE {			
setup SEQUENCE {			
drx-onDurationTimer	ms20		
drx-InactivityTimer	ms6		
drx-LongCycleStartOffset CHOICE {			
ms640	4		
}			
shortDRX SEQUENCE {			
drx-ShortCycle	ms64		
drx-ShortCycleTimer	4		
}			
drx-SlotOffset	ms0		
}			
}			
}			

7.1.1.5.4 DRX Operation / Short cycle configured / DRX command MAC control element reception

7.1.1.5.4.1 Test Purpose (TP)

(1)

```
with { UE in RRC_CONNECTED state }
ensure that {
  when { Short DRX cycle is configured and a DRX Command MAC control element is received }
  then { UE successfully decodes the MAC control PDU }
}
```

(2)

```
with { UE in RRC_CONNECTED state }
ensure that {
  when { Short DRX cycle is configured and the HARQ RTT Timer is running and a DRX Command MAC control element is received }
  then { UE continues running the HARQ RTT timer }
}
```

(3)

```
with { UE in RRC_CONNECTED state }
ensure that {
  when { Short DRX cycle is configured and the drx-RetransmissionTimer-DL is running and a DRX Command MAC control element is received }
  then { UE continues running the drx-RetransmissionTimer-DL and monitors the PDCCH }
}
```

7.1.1.5.4.2 Conformance requirements

References: The conformance requirements covered in the present TC are specified in: TS 38.321, clause 5.7. Unless otherwise stated these are Rel-15 requirements.

[TS 38.321, clause 5.7]

The MAC entity may be configured by RRC with a DRX functionality that controls the UE's PDCCH monitoring activity for the MAC entity's C-RNTI, CS-RNTI, INT-RNTI, SFI-RNTI, SP-CSI-RNTI, TPC-PUCCH-RNTI, TPC-PUSCH-RNTI, and TPC-SRS-RNTI. When using DRX operation, the MAC entity shall also monitor PDCCH

according to requirements found in other subclauses of this specification. When in RRC_CONNECTED, if DRX is configured, for all the activated Serving Cells, the MAC entity may monitor the PDCCH discontinuously using the DRX operation specified in this subclause; otherwise the MAC entity shall monitor the PDCCH continuously.

RRC controls DRX operation by configuring the following parameters:

- *drx-onDurationTimer*: the duration at the beginning of a DRX Cycle;
- *drx-SlotOffset*: the delay before starting the *drx-onDurationTimer*;
- *drx-InactivityTimer*: the duration after the PDCCH occasion in which a PDCCH indicates a new UL or DL transmission for the MAC entity;
- *drx-RetransmissionTimerDL* (per DL HARQ process except for the broadcast process): the maximum duration until a DL retransmission is received;
- *drx-RetransmissionTimerUL* (per UL HARQ process): the maximum duration until a grant for UL retransmission is received;
- *drx-LongCycleStartOffset*: the Long DRX cycle and *drx-StartOffset* which defines the subframe where the Long and Short DRX Cycle starts;
- *drx-ShortCycle* (optional): the Short DRX cycle;
- *drx-ShortCycleTimer* (optional): the duration the UE shall follow the Short DRX cycle;
- *drx-HARQ-RTT-TimerDL* (per DL HARQ process except for the broadcast process): the minimum duration before a DL assignment for HARQ retransmission is expected by the MAC entity;
- *drx-HARQ-RTT-TimerUL* (per UL HARQ process): the minimum duration before a UL HARQ retransmission grant is expected by the MAC entity.

When a DRX cycle is configured, the Active Time includes the time while:

- *drx-onDurationTimer* or *drx-InactivityTimer* or *drx-RetransmissionTimerDL* or *drx-RetransmissionTimerUL* or *ra-ContentionResolutionTimer* (as described in subclause 5.1.5) is running; or
- a Scheduling Request is sent on PUCCH and is pending (as described in subclause 5.4.4); or
- a PDCCH indicating a new transmission addressed to the C-RNTI of the MAC entity has not been received after successful reception of a Random Access Response for the Random Access Preamble not selected by the MAC entity among the contention-based Random Access Preamble (as described in subclause 5.1.4).

When DRX is configured, the MAC entity shall:

- 1> if a MAC PDU is received in a configured downlink assignment:
 - 2> start the *drx-HARQ-RTT-TimerDL* for the corresponding HARQ process in the first symbol after the end of the corresponding transmission carrying the DL HARQ feedback;
 - 2> stop the *drx-RetransmissionTimerDL* for the corresponding HARQ process.
- 1> if a MAC PDU is transmitted in a configured uplink grant:
 - 2> start the *drx-HARQ-RTT-TimerUL* for the corresponding HARQ process in the first symbol after the end of the first repetition of the corresponding PUSCH transmission;
 - 2> stop the *drx-RetransmissionTimerUL* for the corresponding HARQ process.
- 1> if a *drx-HARQ-RTT-TimerDL* expires:
 - 2> if the data of the corresponding HARQ process was not successfully decoded:
 - 3> start the *drx-RetransmissionTimerDL* for the corresponding HARQ process in the first symbol after the expiry of *drx-HARQ-RTT-TimerDL*.
- 1> if a *drx-HARQ-RTT-TimerUL* expires:

- 2> start the *drx-RetransmissionTimerUL* for the corresponding HARQ process in the first symbol after the expiry of *drx-HARQ-RTT-TimerUL*.
- 1> if a DRX Command MAC CE or a Long DRX Command MAC CE is received:
 - 2> stop *drx-onDurationTimer*;
 - 2> stop *drx-InactivityTimer*.
- 1> if *drx-InactivityTimer* expires or a DRX Command MAC CE is received:
 - 2> if the Short DRX cycle is configured:
 - 3> start or restart *drx-ShortCycleTimer* in the first symbol after the expiry of *drx-InactivityTimer* or in the first symbol after the end of DRX Command MAC CE reception;
 - 3> use the Short DRX Cycle.
 - 2> else:
 - 3> use the Long DRX cycle.
- 1> if *drx-ShortCycleTimer* expires:
 - 2> use the Long DRX cycle.
- 1> if a Long DRX Command MAC CE is received:
 - 2> stop *drx-ShortCycleTimer*;
 - 2> use the Long DRX cycle.
- 1> if the Short DRX Cycle is used, and $[(\text{SFN} \times 10) + \text{subframe number}] \bmod (\text{drx-ShortCycle}) = (\text{drx-StartOffset}) \bmod (\text{drx-ShortCycle})$; or
- 1> if the Long DRX Cycle is used, and $[(\text{SFN} \times 10) + \text{subframe number}] \bmod (\text{drx-LongCycle}) = \text{drx-StartOffset}$:
 - 2> start *drx-onDurationTimer* after *drx-SlotOffset* from the beginning of the subframe.
- 1> if the MAC entity is in Active Time:
 - 2> monitor the PDCCH;
 - 2> if the PDCCH indicates a DL transmission:
 - 3> start the *drx-HARQ-RTT-TimerDL* for the corresponding HARQ process in the first symbol after the end of the corresponding transmission carrying the DL HARQ feedback;
 - 3> stop the *drx-RetransmissionTimerDL* for the corresponding HARQ process.
 - 2> if the PDCCH indicates a UL transmission:
 - 3> start the *drx-HARQ-RTT-TimerUL* for the corresponding HARQ process in the first symbol after the end of the first repetition of the corresponding PUSCH transmission;
 - 3> stop the *drx-RetransmissionTimerUL* for the corresponding HARQ process.
 - 2> if the PDCCH indicates a new transmission (DL or UL):
 - 3> start or restart *drx-InactivityTimer* in the first symbol after the end of the PDCCH reception.
- 1> in current symbol *n*, if the MAC entity would not be in Active Time considering grants/assignments/DRX Command MAC CE/Long DRX Command MAC CE received and Scheduling Request sent 4 ms prior to symbol *n* when evaluating all DRX Active Time conditions as specified in this subclause:
 - 2> not transmit periodic SRS and semi-persistent SRS defined in TS 38.214 [7].

1> if CSI masking (*csi-Mask*) is setup by upper layers:

2> in current symbol *n*, if *onDurationTimer* would not be running considering grants/assignments/DRX Command MAC CE/Long DRX Command MAC CE received 4 ms prior to symbol *n* when evaluating all DRX Active Time conditions as specified in this subclause:

3> not report CSI on PUCCH.

1> else:

2> in current symbol *n*, if the MAC entity would not be in Active Time considering grants/assignments/DRX Command MAC CE/Long DRX Command MAC CE received and Scheduling Request sent 4 ms prior to symbol *n* when evaluating all DRX Active Time conditions as specified in this subclause:

3> not report CSI on PUCCH and semi-persistent CSI on PUSCH.

Regardless of whether the MAC entity is monitoring PDCCH or not, the MAC entity transmits HARQ feedback, aperiodic CSI on PUSCH, and aperiodic SRS defined in TS 38.214 [7] when such is expected.

The MAC entity needs not to monitor the PDCCH if it is not a complete PDCCH occasion (e.g. the Active Time starts or ends in the middle of a PDCCH occasion).

7.1.1.5.4.3 Test description

7.1.1.5.4.3.1 Pre-test conditions

Same Pre-test conditions as in clause 7.1.1.0 except that set to return no data in uplink.

7.1.1.5.4.3.2 Test procedure sequence

For FDD, *NormalSLT*(current SFN, current subframe, current slot, *y*)=*y*; For TDD, *NormalSLT*(current SFN, current subframe, current slot, *y*) counts the minimum number of normal slots needed to cover *y* number of PDCCH-occasions (slots) until next PDCCH-occasion (slot) available, starting from current slot on current SFN.

Table 7.1.1.5.4.3.2-1: Main behaviour

St	Procedure	Message Sequence		TP	Verdict
		U - S	Message		
1	SS transmits NR RRCReconfigurationmessage to configure specific DRX parameters for NR Cell. (Note 1)	<--	NR RRC: <i>RRCReconfiguration</i>	-	-
2	The UE transmits NR RRCReconfigurationComplete message. (Note 2)	-->	NR RRC: <i>RRCReconfigurationComplete</i>	-	-
3	In a PDCCH occasion which is X subframes before the PDCCH occasion in which the <i>drx-onDurationTimer</i> expires, with $drx-InactivityTimer < X < drx-onDurationTimer-1$, the SS indicates the transmission of a DL MAC PDU on the PDCCH. The SS transmits an invalid MAC PDU. (Note 3) i.e., on the PDCCH occasion $csn2 = [csn1 + NormalSLT(SFN1, csfn1, csn1, drx-onDurationTimer-1-X)] \text{ modulo } \text{numberofslotswithin subframe}$ within the subframe number $csfn2 = (csfn1 + \text{floor}([csn1 + NormalSLT(SFN1, csfn1, csn1, drx-onDurationTimer-1-X)] / \text{numberofslotswithin subframe})) \text{ modulo } 10$, and system frame number $SFN2 = SFN1 + \text{floor}([csfn1 + \text{floor}([csn1 + NormalSLT(SFN1, csfn1, csn1, drx-onDurationTimer-1-X)] / \text{numberofslotswithin subframe}) / 10])$; where $[(SFN1 * 10) + csfn1] \text{ modulo } (drx-ShortCycle) = (drx-StartOffset) \text{ modulo } (drx-ShortCycle)$, $csn1 = drx-SlotOffset$.	<--	MAC PDU	-	-
4	Check: Does the UE transmit a HARQ NACK for the DL MAC PDU in Step 3?	-->	HARQ NACK	1	P
5	In a PDCCH occasion before the <i>drx-onDurationTimer</i> expires, the SS indicates the transmission of a DL MAC PDU on the PDCCH. The SS transmits a DL MAC PDU with DRX MAC Control element. UE successfully decodes the MAC PDU. i.e., on the PDCCH occasion = $[csn1 + NormalSLT(SFN1, csfn1, csn1, drx-onDurationTimer-1-X+Y)] \text{ modulo } \text{numberofslotswithin subframe}$ within the subframe number = $(csfn1 + \text{floor}([csn1 + NormalSLT(SFN1, csfn1, csn1, drx-onDurationTimer-1-X+Y)] / \text{numberofslotswithin subframe})) \text{ modulo } 10$, and system frame number = $SFN1 + \text{floor}([csfn1 + \text{floor}([csn1 + NormalSLT(SFN1, csfn1, csn1, drx-onDurationTimer-1-X+Y)] / \text{numberofslotswithin subframe}) / 10])$; and $K < Y < \min\{K + drx-HARQ-RTT_TimerDL, drx-InactivityTimer\}$. (Note 6)	<--	MAC PDU (DRX MAC Control element)	-	-
6	Check: Does the UE transmit a HARQ ACK for the DL MAC PDU in Step 5?	-->	HARQ ACK	1	P

7	<p>In the first PDCCH slot when the <i>drx-RetransmissionTimerDL</i> for the MAC PDU indicated in Step 3 on the PDCCH is started, the SS indicates the transmission of a DL MAC PDU. The SS transmits an invalid MAC PDU. (Note 3)</p> <p>i.e., on the PDCCH occasion $csn3 = [csn2 + NormalSLT(SFN2, csn2, csn2, K + drx-HARQ-RTT_TimerDL)] \text{ modulo } \text{numberofslotswithinsubframe}$ within the subframe number $csfn3 = (csfn2 + \text{floor}([csn2 + NormalSLT(SFN2, csn2, csn2, K + drx-HARQ-RTT_TimerDL)] / \text{numberofslotswithinsubframe})) \text{ modulo } 10$, and system frame number $SFN3 = SFN2 + \text{floor}([csfn2 + \text{floor}([csn2 + NormalSLT(SFN2, csn2, csn2, K + drx-HARQ-RTT_TimerDL)] / \text{numberofslotswithinsubframe})/10)$;</p>	<--	MAC PDU	-	-
8	Check: Does the UE transmit a HARQ NACK for the DL MAC PDU in Step 7?	-->	HARQ NACK	2,3	P
9	<p>In a PDCCH occasion which is Z slots before the PDCCH slot in which the <i>drx-RetransmissionTimerDL</i> for the DL MAC PDU in Step 7 expires, with $1 < Z < drx-RetransmissionTimerDL$, the SS indicates the transmission of a DL MAC PDU. The SS transmits a DL MAC PDU with DRX MAC Control element.</p> <p>i.e., on the PDCCH occasion $csn4 = \text{floor}([csn3 + NormalSLT(SFN3, csn3, csn3, K + drx-HARQ-RTT-TimerDL + drx-RetransmissionTimerDL - Z)] \text{ modulo } \text{numberofslotswithinsubframe}$, $csfn4 = (csfn3 + \text{floor}([csn3 + NormalSLT(SFN3, csn3, csn3, K + drx-HARQ-RTT-TimerDL + drx-RetransmissionTimerDL - Z)] / \text{numberofslotswithinsubframe})) \text{ modulo } 10$, and the $SFN4 = SFN3 + \text{floor}([csfn3 + \text{floor}([csn3 + NormalSLT(SFN3, csn3, csn3, K + drx-HARQ-RTT-TimerDL + drx-RetransmissionTimerDL - Z)] / \text{numberofslotswithinsubframe})/10)$;</p>	<--	MAC PDU(DRX MAC Control element)	-	-
10	Check: Does the UE transmit a HARQ ACK for the DL MAC PDU in Step 9?	-->	HARQ ACK	2,3,1	P
11	<p>In the last PDCCH slot when the <i>drx-RetransmissionTimerDL</i> for the DL MAC PDU indicated on the PDCCH in Step 7 is still running, the SS indicates the transmission of a DL MAC PDU.</p> <p>i.e., on the PDCCH occasion $csn5 = \text{floor}([csn3 + NormalSLT(SFN3, csn3, csn3, K + drx-HARQ-RTT-TimerDL + drx-RetransmissionTimerDL - 1)] \text{ modulo } \text{numberofslotswithinsubframe}$, $csfn5 = (csfn3 + \text{floor}([csn3 + NormalSLT(SFN3, csn3, csn3, K + drx-HARQ-RTT-TimerDL + drx-RetransmissionTimerDL - 1)] / \text{numberofslotswithinsubframe})) \text{ modulo } 10$, and the $SFN5 = SFN3 + \text{floor}([csfn3 + \text{floor}([csn3 + NormalSLT(SFN3, csn3, csn3, K + drx-HARQ-RTT-TimerDL + drx-RetransmissionTimerDL - 1)] / \text{numberofslotswithinsubframe})/10)$.</p>	<--	MAC PDU	-	-
12	Check: Does the UE transmit a HARQ ACK for the DL MAC PDU in Step 11?	-->	HARQ ACK	2,3	P

Note 1:	For EN-DC the NR <i>RRCReconfiguration</i> message is contained in <i>RRCConnectionReconfiguration</i> .
Note 2:	For EN-DC the NR <i>RRCReconfigurationComplete</i> message is contained in <i>RRCConnectionReconfigurationComplete</i> .
Note 3:	Invalid MAC PDU is a MAC PDU that fails the CRC check.
Note 4:	All DL MAC PDUs are transmitted with the NDI set on the PDCCH.
Note 5:	Timer tolerances for the MAC DRX related timers measured in PDCCH occasions (slots). These timers are: <i>drx-InactivityTimer</i> , <i>drx-RetransmissionTimer</i> , <i>Drx-HARQ-RTT-TimerDL</i> .
Note 6:	K is the time for given PDSCH to HARQ feedback of PUCCH and shall be shorter than <i>drx-InactivityTimer</i> . In this TC, the DCI format should be configured to not include the PDSCH-to-HARQ-timing-indicator field. When the UE schedules a PDSCH reception over a number of symbols where the last symbol is within slot n-k, the UE shall provide corresponding HARQ-ACK information in a PUCCH transmission within slot n-k+4 according to TS 38.321 clause 9.2.3. Thus, the maximum value of K is 4 slots in this test case.

7.1.1.5.4.3.3 Specific message contents

Table 7.1.1.5.4.3.3-1: *RRCReconfiguration* (Step 1, Table 7.1.1.5.4.3.2-1)

Derivation Path: 38.508-1 [4], Table 4.6.1-13			
Information Element	Value/remark	Comment	Condition
<i>RRCReconfiguration</i> ::= SEQUENCE {			
<i>criticalExtensions</i> CHOICE {			
<i>rrcReconfiguration</i> SEQUENCE {			
<i>radioBearerConfig</i>	Not present		
<i>secondaryCellGroup</i>	CellGroupConfig	OCTET STRING (CONTAINING CellGroupConfig)	EN-DC
<i>nonCriticalExtension</i> ::= SEQUENCE {}	Not present		EN-DC
<i>nonCriticalExtension</i> ::= SEQUENCE{			NR
<i>masterCellGroup</i>	CellGroupConfig	OCTET STRING (CONTAINING CellGroupConfig)	
<i>dedicatedNAS-MessageList</i> SEQUENCE (SIZE(1..maxDRB)) OF <i>DedicatedNAS-Message</i> {}	Not present		
}			
}			
}			

Table 7.1.1.5.4.3.3-2: CellGroupConfig (Table 7.1.1.5.4.3.3-1)

Derivation Path: 38.508-1 [4], Table 4.6.3-n			
Information Element	Value/remark	Comment	Condition
cellGroupConfig ::= SEQUENCE {			
mac-CellGroupConfig SEQUENCE {			
drx-Config CHOICE {			
setup SEQUENCE {			
drx-onDurationTimer	ms20		
drx-InactivityTimer	ms6		
drx-HARQ-RTT-TimerDL	56		
drx-HARQ-RTT-TimerUL	56		
drx-RetransmissionTimerDL	sl12		
drx-RetransmissionTimerUL	sl12		
drx-LongCycleStartOffset CHOICE {			
ms640	4		
}			
shortDRX SEQUENCE {			
drx-ShortCycle	ms64		
drx-ShortCycleTimer	10		
}			
drx-SlotOffset	ms0		
}			
}			
}			

7.1.1.6 Semi-Persistent Scheduling

7.1.1.6.1 Correct handling of DL assignment / Semi-persistent case

7.1.1.6.1.1 Test Purpose (TP)

(1)

```
with { UE in RRC_Connected state with DRB established and sps-Configuration in DL is enabled }
ensure that {
  when { UE receives a DL assignment addressed to its stored CS-RNTI in slot y and with NDI set as 0 }
  then { UE starts receiving DL MAC PDU in slots y+n*[semiPersistSchedIntervalDL] where 'n' is positive integer starting at zero }
}
```

(2)

```
with { UE in RRC_Connected state with DRB established and stored DL SPS assignment to receive MAC PDU in slot y+n*[semiPersistSchedIntervalDL] }
ensure that {
  when { UE receives a DL assignment addressed to its CS-RNTI in slot p and with NDI set as 0, where p!= y+n*[semiPersistSchedIntervalDL] }
  then { UE starts receiving DL MAC PDU in slots p+n*[semiPersistSchedIntervalDL] and stops receiving DL MAC PDU at slots y+n*[semiPersistSchedIntervalDL] where 'n' is positive integer starting at zero }
}
```

(3)

```
with { UE in RRC_Connected state with DRB established and stored DL SPS assignment to receive MAC PDU at slot p+n*[semiPersistSchedIntervalDL] }
ensure that {
  when { UE receives a DL assignment [for retransmission] addressed to its CS-RNTI in Slot z and with NDI set as 1, where z!= p+n*[semiPersistSchedIntervalDL] }
  then { UE receives MAC PDU as per the retransmission grant for CS-RNTI }
}
```

(4)

```

with { UE in RRC_Connected state with DRB established and stored DL SPS assignment to receive MAC
PDU at slot  $y+n*[semiPersistSchedIntervalDL]$  }
ensure that {
  when { UE receives a DL assignment addressed to its C-RNTI in Slot  $p$ , such that  $p=$ 
 $y+n*[semiPersistSchedIntervalDL]$  }
  then { UE receives MAC PDU as per assignment addressed to its C-RNTI }
}

```

(5)

```

with { UE in RRC_Connected state with DRB established and stored DL SPS grant to receive MAC PDU at
slot  $z+n*[semiPersistSchedIntervalDL]$  }
ensure that {
  when { UE receives a RRC Message including sps-Configuration with sps-ConfigurationDL set as
'disable' and hence resulting in DL SPS grant deactivation }
  then { UE deletes the stored sps-Configuration DL parameters and stops receiving DL MAC PDU's as
per stored SPS assignment in slot  $z+n*[semiPersistSchedIntervalDL]$  }
}

```

7.1.1.6.1.2 Conformance requirements

References: The conformance requirements covered in the present TC are specified in TS 38.321, clause 5.3.1, 5.8.1 and TS 38.300, clause 10.2. Unless otherwise stated these are Rel-15 requirements.

[TS 38.321, clause 5.3.1]

Downlink assignments received on the PDCCH both indicate that there is a transmission on a DL-SCH for a particular MAC entity and provide the relevant HARQ information.

When the MAC entity has a C-RNTI, Temporary C-RNTI, or CS-RNTI, the MAC entity shall for each PDCCH occasion during which it monitors PDCCH and for each Serving Cell:

- 1> if a downlink assignment for this PDCCH occasion and this Serving Cell has been received on the PDCCH for the MAC entity's C-RNTI, or Temporary C-RNTI:
 - 2> if this is the first downlink assignment for this Temporary C-RNTI:
 - 3> consider the NDI to have been toggled.
 - 2> if the downlink assignment is for the MAC entity's C-RNTI, and if the previous downlink assignment indicated to the HARQ entity of the same HARQ process was either a downlink assignment received for the MAC entity's CS-RNTI or a configured downlink assignment:
 - 3> consider the NDI to have been toggled regardless of the value of the NDI.
 - 2> indicate the presence of a downlink assignment and deliver the associated HARQ information to the HARQ entity.
- 1> else if a downlink assignment for this PDCCH occasion has been received for this Serving Cell on the PDCCH for the MAC entity's CS-RNTI:
 - 2> if the NDI in the received HARQ information is 1:
 - 3> consider the NDI for the corresponding HARQ process not to have been toggled;
 - 3> indicate the presence of a downlink assignment for this Serving Cell and deliver the associated HARQ information to the HARQ entity.
 - 2> if the NDI in the received HARQ information is 0:
 - 3> if PDCCH contents indicate SPS deactivation:
 - 4> clear the configured downlink assignment for this Serving Cell (if any);
 - 4> if the timeAlignmentTimer, associated with the TAG containing the Serving Cell on which the HARQ feedback is to be transmitted, is running:

- 5> indicate a positive acknowledgement for the SPS deactivation to the physical layer.
- 3> else if PDCCH content indicates SPS activation:
 - 4> store the downlink assignment for this Serving Cell and the associated HARQ information as configured downlink assignment;
 - 4> initialise or re-initialise the configured downlink assignment for this Serving Cell to start in the associated PDSCH duration and to recur according to rules in subclause 5.8.1;

For each Serving Cell and each configured downlink assignment, if configured and activated, the MAC entity shall:

- 1> if the PDSCH duration of the configured downlink assignment does not overlap with the PDSCH duration of a downlink assignment received on the PDCCH for this Serving Cell:
 - 2> instruct the physical layer to receive, in this PDSCH duration, transport block on the DL-SCH according to the configured downlink assignment and to deliver it to the HARQ entity;
 - 2> set the HARQ Process ID to the HARQ Process ID associated with this PDSCH duration;
 - 2> consider the NDI bit for the corresponding HARQ process to have been toggled;
 - 2> indicate the presence of a configured downlink assignment and deliver the stored HARQ information to the HARQ entity.

For configured downlink assignments, the HARQ Process ID associated with the slot where the DL transmission starts is derived from the following equation:

$$\text{HARQ Process ID} = [\text{floor}(\text{CURRENT_slot} \times 10 / (\text{numberOfSlotsPerFrame} \times \text{periodicity}))] \text{ modulo } \text{nrofHARQ-Processes}$$

where $\text{CURRENT_slot} = [(\text{SFN} \times \text{numberOfSlotsPerFrame}) + \text{slot number in the frame}]$ and $\text{numberOfSlotsPerFrame}$ refers to the number of consecutive slots per frame as specified in TS 38.211 [8].

When the MAC entity needs to read BCCH, the MAC entity may, based on the scheduling information from RRC:

- 1> if a downlink assignment for this PDCCH occasion has been received on the PDCCH for the SI-RNTI;
- 2> indicate a downlink assignment and redundancy version for the dedicated broadcast HARQ process to the HARQ entity.

[TS 38.321, clause 5.8.1]

Semi-Persistent Scheduling (SPS) is configured by RRC per Serving Cell and per BWP. Activation and deactivation of the DL SPS are independent among the Serving Cells.

For the DL SPS, a DL assignment is provided by PDCCH, and stored or cleared based on L1 signalling indicating SPS activation or deactivation.

RRC configures the following parameters when SPS is configured:

- *cs-RNTI*: CS-RNTI for activation, deactivation, and retransmission;
- *nrofHARQ-Processes*: the number of configured HARQ processes for SPS;
- *periodicity*: periodicity of configured downlink assignment for SPS.

When SPS is released by upper layers, all the corresponding configurations shall be released.

After a downlink assignment is configured for SPS, the MAC entity shall consider sequentially that the N^{th} downlink assignment occurs in the slot for which:

$$[(\text{numberOfSlotsPerFrame} \times \text{SFN}_{\text{start time}} + \text{slot}_{\text{start time}}) + N \times \text{periodicity} \times \text{numberOfSlotsPerFrame} / 10] \text{ modulo } (1024 \times \text{numberOfSlotsPerFrame})$$

where $SFN_{start\ time}$ and $slot_{start\ time}$ are the SFN and slot, respectively, of the first transmission of PDSCH where the configured downlink assignment was (re-)initialised.

[TS 38.300, clause 10.2]

In the downlink, the gNB can dynamically allocate resources to UEs via the C-RNTI on PDCCH(s). A UE always monitors the PDCCH(s) in order to find possible assignments when its downlink reception is enabled (activity governed by DRX when configured). When CA is configured, the same C-RNTI applies to all serving cells.

The gNB may pre-empt an ongoing PDSCH transmission to one UE with a latency-critical transmission to another UE. The gNB can configure UEs to monitor interrupted transmission indications using INT-RNTI on a PDCCH. If a UE receives the interrupted transmission indication, the UE may assume that no useful information to that UE was carried by the resource elements included in the indication, even if some of those resource elements were already scheduled to this UE.

In addition, with Semi-Persistent Scheduling (SPS), the gNB can allocate downlink resources for the initial HARQ transmissions to UEs: RRC defines the periodicity of the configured downlink assignments while PDCCH addressed to CS-RNTI can either signal and activate the configured downlink assignment, or deactivate it; i.e. a PDCCH addressed to CS-RNTI indicates that the downlink assignment can be implicitly reused according to the periodicity defined by RRC, until deactivated.

NOTE: when required, retransmissions are explicitly scheduled on PDCCH(s).

The dynamically allocated downlink reception overrides the configured downlink assignment in the same serving cell, if they overlap in time. Otherwise a downlink reception according to the configured downlink assignment is assumed, if activated.

When CA is configured, at most one configured downlink assignment can be signalled per serving cell. When BA is configured, at most one configured downlink assignment can be signalled per BWP. On each serving cell, there can be only one configured downlink assignment active at a time, and multiple configured downlink assignment can be simultaneously active on different serving cells only. Activation and deactivation of configured downlink assignments are independent among the serving cells.

7.1.1.6.1.3 Test description

7.1.1.6.1.3.1 Pre-test conditions

Same Pre-test conditions as in clause 7.1.1.0 except that set to return no data in uplink.

7.1.1.6.1.3.2 Test procedure sequence

Table 7.1.1.6.1.3.2-1: Main behaviour

St	Procedure	Message Sequence		TP	Verdict
		U - S	Message		
1	The SS transmits a DL assignment using UE's CS-RNTI in Slot 'Y', NDI=0.	<--	(DL SPS Grant)	-	-
2	The SS transmits in Slot 'Y', a DL MAC PDU containing a RLC PDU (DL-SQN=0) on UM DRB.	<--	MAC PDU	-	-
3	Check: Does the UE transmit a HARQ ACK?	-->	HARQ ACK	1	P
4	The SS transmits in Slot 'Y+X', a DL MAC PDU containing a RLC PDU (DL-SQN=1) on DRB. (Note 1)	<--	MAC PDU	-	-
5	Check: Does the UE transmit a HARQ ACK?	-->	HARQ ACK	1	P
6	The SS transmits a DL assignment using UE's CS-RNTI in Slot 'P', NDI=0; (Where $Y+X < P < Y+2X$)	<--	(DL SPS Grant)	-	-
7	The SS transmits in Slot 'P', a DL MAC PDU containing a RLC PDU (DL-SQN=2) on UM DRB.	<--	MAC PDU	-	-
8	Check: Does the UE transmit a HARQ ACK?	-->	HARQ ACK	2	P
9	The SS transmits in Slot 'Y+2X', a DL MAC PDU containing a RLC PDU (DL-SQN=3) on UM DRB.	<--	MAC PDU	-	-
10	Check: Does the UE transmit a HARQ Feedback?	-->	HARQ ACK/NACK	2	F
11	The SS transmits a DL assignment using UE's C-RNTI in Slot 'P+X', NDI=0.	<--	(DL Grant)	-	-
12	The SS transmits in Slot 'P+X', a DL MAC PDU containing a RLC PDU (DL-SQN=3) on UM DRB. (Note 2)	<--	MAC PDU	-	-
13	Check: Does the UE transmit a HARQ ACK?	-->	HARQ ACK	4	P
14	The SS transmits in Slot 'P+2X', a DL MAC PDU containing a RLC PDU (DL-SQN=4) on UM DRB.	<--	MAC PDU	-	-
15	Check: Does the UE transmit a HARQ ACK?	-->	HARQ ACK	1	P
16	The SS transmits a DL assignment using UE's CS-RNTI in Slot 'P+3X', NDI=0.	<--	(DL SPS Grant)	-	-
17	The SS transmits in Slot 'P+3X', a DL MAC PDU containing 1 RLC PDU's (DL-SQN=5) on UM DRB; CRC is calculated in such a way will result in CRC error in UE.	<--	MAC PDU	-	-
18	Check: Does the UE transmit a HARQ NACK?	-->	HARQ NACK	-	-
-	EXCEPTION: Step 19 and 20 shall be repeated until HARQ retransmission count = 3 is reached for MAC PDU at step 17. (Note 3)	-	-	-	-
19	The SS transmits a DL assignment using UE's CS-RNTI in Slot 'Z', NDI=1; Where $(P+3X < Z < P+4X)$; The DL HARQ process is same as in step 18.	<--	(DL SPS Grant)	-	-
20	The SS re-transmits in Slot 'Z', a DL MAC PDU containing a RLC PDU (DL-SQN=5) on UM DRB.	<--	MAC PDU	-	-
-	EXCEPTION: Up to 3 HARQ NACK from the UE should be allowed at step 21 (Note 3).	-	-	-	-
21	Check: Does the UE transmit a HARQ ACK?	-->	HARQ ACK	3	P
22	SS transmits NR RRCReconfiguration to disable SPS-ConfigurationDL. (Note 4)	<--	RRCConnectionReconfiguration	-	-
23	The UE transmits NR RRCReconfigurationComplete. (Note 5)	-->	RRCConnectionReconfigurationComplete	-	-
24	The SS transmits in Slot 'P+5X', a DL MAC PDU containing 1 RLC PDU's (DL-SQN=7) on UM DRB;	<--	MAC PDU	-	-
25	Check: Does the UE transmit a HARQ Feedback?	-->	HARQ ACK/NACK	5	F

Note 1:	X is equal to semiPersistSchedIntervalDL in this document.
Note 2:	The DL assignment for C-RNTI and hence the size of MAC PDU is different in size than stored CS-RNTI DL assignment in step 6. This assures UE is receiving DSCH data as per DL assignment for C-RNTI and not as per stored grant for CS-RNTI.
Note 3:	The value 4 for the maximum number of HARQ retransmissions has been chosen based on an assumption that, given the radio conditions used in this test case, a UE soft combiner implementation should have sufficient retransmissions to be able to successfully decode the data in its soft buffer.
Note 4:	For EN-DC the NR RRCReconfiguration message is contained in RRCConnectionReconfiguration 36.508 [7], Table 4.6.1-8 using condition EN-DC_EmbedNR_RRCRecon.
Note 5:	For EN-DC the NR RRCReconfigurationComplete message is contained in RRCConnectionReconfigurationComplete.

7.1.1.6.1.3.3 Specific message contents

Table 7.1.1.6.1.3.3-1: RRCReconfiguration (Preamble)

Derivation path: 38.508-1 [4], Table 4.6.1-13			
Information Element	Value/remark	Comment	Condition
RRCReconfiguration ::= SEQUENCE {			
criticalExtensions CHOICE {			
rrcReconfiguration SEQUENCE {			
secondaryCellGroup	CellGroupConfig	OCTET STRING (CONTAINING CellGroupConfig)	EN-DC
nonCriticalExtension := SEQUENCE{			NR
masterCellGroup	CellGroupConfig	OCTET STRING (CONTAINING CellGroupConfig)	
}			
}			
}			
}			

Table 7.1.1.6.1.3.3-2: CellGroupConfig (Table 7.1.1.6.1.3.3-2)

Derivation path: 38.508-1 [4], Table 4.6.3-19			
Information Element	Value/remark	Comment	Condition
CellGroupConfig ::= SEQUENCE {			
spCellConfig SEQUENCE {			
servCellIndex	1		
spCellConfigDedicated SEQUENCE {			
initialDownlinkBWP SEQUENCE {			
sps-Config CHOICE {			
setup SEQUENCE {			
periodicity	ms40		
nrofHARQ-Processes	8		
n1PUCCH-AN SEQUENCE{			
pucch-ResourceId	0		
}			
}			
}			
}			
mac-CellGroupConfig SEQUENCE {			
cs-RNTI CHOICE {			
setup SEQUENCE{			
RNTI-Value	'FFE0'H		
}			
}			
}			
}			

Table 7.1.1.6.1.3.3-3: *RRCReconfiguration* (step 22 of Table 7.1.1.6.1.3.2-1)

Derivation path: 38.508-1 [4], Table 4.6.1-13			
Information Element	Value/remark	Comment	Condition
RRCReconfiguration ::= SEQUENCE {			
criticalExtensions CHOICE {			
rrcReconfiguration SEQUENCE {			
secondaryCellGroup	CellGroupConfig	OCTET STRING (CONTAINING CellGroupConfig)	EN-DC
nonCriticalExtension := SEQUENCE{			NR
masterCellGroup	CellGroupConfig	OCTET STRING (CONTAINING CellGroupConfig)	
}			
}			
}			

Table 7.1.1.6.1.3.3-4: *CellGroupConfig* (Table 7.1.1.6.1.3.3-3)

Derivation path: 38.508-1 [4], Table 4.6.3-19			
Information Element	Value/remark	Comment	Condition
CellGroupConfig ::= SEQUENCE {			
spCellConfig SEQUENCE {			
servCellIndex	1		
spCellConfigDedicated SEQUENCE {			
initialDownlinkBWP SEQUENCE {			
sps-Config CHOICE {			
release	Null		
}			
}			
}			
}			
}			

7.1.1.6.2 Correct handling of UL grant / configured grant Type 1

7.1.1.6.2.1 Test Purpose (TP)

(1)

```

with { UE in RRC_Connected state with DRB established and sps-Configuration in UL is enabled with
Configured grant type 1 }
ensure that {
  when { The symbol in which equation  $[(SFN \times \text{numberOfSlotsPerFrame} \times \text{numberOfSymbolsPerSlot}) +$ 
(slot number in the frame  $\times \text{numberOfSymbolsPerSlot}) + \text{symbol number in the slot}] =$ 
(timeDomainOffset  $\times \text{numberOfSymbolsPerSlot} + S + N \times \text{periodicity}) \bmod (1024 \times$ 
numberOfSlotsPerFrame  $\times \text{numberOfSymbolsPerSlot})$  is satisfied }
  then { UE starts transmitting UL MAC PDU periodically in the symbol associated with the new re-
configured grant }
}

```

(2)

```

with { UE in RRC_Connected state with DRB established and configured UL grant type 1 }
ensure that {
  when { UE receives a new UL grant type 1 in an RRC message }
  then { UE starts transmitting UL MAC PDU periodically in the symbol associated with the new re-
configured grant }
}

```

(3)

```

with { UE in RRC_Connected state with DRB established and configured UL grant type 1 }
ensure that {
  when { UE receives a RRC message including sps-Configuration with rrcConfiguredUplinkGrant set as
'release' }
  then { UE deletes the stored configured UL Grant type 1 parameters and stops transmitting UL MAC
PDU's as per configured UL grant type 1 }
}

```

(4)

```

with { UE in RRC_Connected state with DRB established and configured UL grant type 1 }
ensure that {
  when { UE receives a UL grant addressed to its CS-RNTI with NDI set as 1 for retransmission }
  then { UE re-transmits MAC PDU as per the new grant }
}

```

(5)

```

with { UE in RRC_Connected state with DRB established and configured UL grant type 1 }
ensure that {
  when { UE receives a UL grant addressed to its C-RNTI resulting in UL transmission overlap in time
domain as configured grante type 1 }
  then { UE transmits MAC PDU as per grant addressed to its C-RNTI }
}

```

7.1.1.6.2.2 Conformance requirements

References: The conformance requirements covered in the present TC are specified in: 3GPP TS 38.321 clauses 5.4.1 and 5.8.2, 3GPP TS 38.300 clause 10.3. Unless otherwise stated these are Rel-15 requirements.

[TS 38.321, clause 5.4.1]

Uplink grant is either received dynamically on the PDCCH, in a Random Access Response, or configured semi-persistently by RRC. The MAC entity shall have an uplink grant to transmit on the UL-SCH. To perform the requested transmissions, the MAC layer receives HARQ information from lower layers.

If the MAC entity has a C-RNTI, a Temporary C-RNTI, or CS-RNTI, the MAC entity shall for each PDCCH occasion and for each Serving Cell belonging to a TAG that has a running *timeAlignmentTimer* and for each grant received for this PDCCH occasion:

- 1> if an uplink grant for this Serving Cell has been received on the PDCCH for the MAC entity's C-RNTI or Temporary C-RNTI; or
- 1> if an uplink grant has been received in a Random Access Response:
 - 2> if the uplink grant is for MAC entity's C-RNTI and if the previous uplink grant delivered to the HARQ entity for the same HARQ process was either an uplink grant received for the MAC entity's CS-RNTI or a configured uplink grant:
 - 3> consider the NDI to have been toggled for the corresponding HARQ process regardless of the value of the NDI.
 - 2> if the uplink grant is for MAC entity's C-RNTI, and the identified HARQ process is configured for a configured uplink grant:
 - 3> start or restart the *configuredGrantTimer* for the corresponding HARQ process, if configured.
 - 2> deliver the uplink grant and the associated HARQ information to the HARQ entity.
- 1> else if an uplink grant for this PDCCH occasion has been received for this Serving Cell on the PDCCH for the MAC entity's CS-RNTI:
 - 2> if the NDI in the received HARQ information is 1:
 - 3> consider the NDI for the corresponding HARQ process not to have been toggled;
 - 3> start or restart the *configuredGrantTimer* for the corresponding HARQ process, if configured;

- 3> deliver the uplink grant and the associated HARQ information to the HARQ entity.
- 2> else if the NDI in the received HARQ information is 0:
 - 3> if PDCCH contents indicate configured grant Type 2 deactivation:
 - 4> trigger configured uplink grant confirmation.
 - 3> else if PDCCH contents indicate configured grant Type 2 activation:
 - 4> trigger configured uplink grant confirmation;
 - 4> store the uplink grant for this Serving Cell and the associated HARQ information as configured uplink grant;
 - 4> initialise or re-initialise the configured uplink grant for this Serving Cell to start in the associated PUSCH duration and to recur according to rules in subclause 5.8.2;
 - 4> stop the *configuredGrantTimer* for the corresponding HARQ process, if running;

For each Serving Cell and each configured uplink grant, if configured and activated, the MAC entity shall:

- 1> if the PUSCH duration of the configured uplink grant does not overlap with the PUSCH duration of an uplink grant received on the PDCCH or in a Random Access Response for this Serving Cell:
 - 2> set the HARQ Process ID to the HARQ Process ID associated with this PUSCH duration;
- 2> if the *configuredGrantTimer* for the corresponding HARQ process is not running:
 - 3> consider the NDI bit for the corresponding HARQ process to have been toggled;
 - 3> deliver the configured uplink grant and the associated HARQ information to the HARQ entity.

For configured uplink grants, the HARQ Process ID associated with the first symbol of a UL transmission is derived from the following equation:

$$\text{HARQ Process ID} = [\text{floor}(\text{CURRENT_symbol}/\text{periodicity})] \text{ modulo } nrof\text{HARQ-Processes}$$

where $\text{CURRENT_symbol} = (\text{SFN} \times \text{numberOfSlotsPerFrame} \times \text{numberOfSymbolsPerSlot} + \text{slot number in the frame} \times \text{numberOfSymbolsPerSlot} + \text{symbol number in the slot})$, and *numberOfSlotsPerFrame* and *numberOfSymbolsPerSlot* refer to the number of consecutive slots per frame and the number of consecutive symbols per slot, respectively as specified in TS 38.211 [8].

NOTE 1: *CURRENT_symbol* refers to the symbol index of the first transmission occasion of a repetition bundle that takes place.

NOTE 2: A HARQ process is configured for a configured uplink grant if the configured uplink grant is activated and the associated HARQ process ID is less than *nrofHARQ-Processes*.

NOTE 3: If the MAC entity receives both a grant in a Random Access Response and an overlapping grant for its C-RNTI or CS-RNTI, requiring concurrent transmissions on the SpCell, the MAC entity may choose to continue with either the grant for its RA-RNTI or the grant for its C-RNTI or CS-RNTI.

[TS 38.321, clause 5.8.2]

There are two types of transmission without dynamic grant:

- configured grant Type 1 where an uplink grant is provided by RRC, and stored as configured uplink grant;
- configured grant Type 2 where an uplink grant is provided by PDCCH, and stored or cleared as configured uplink grant based on L1 signalling indicating configured uplink grant activation or deactivation.

Type 1 and Type 2 are configured by RRC per Serving Cell and per BWP. Multiple configurations can be active simultaneously only on different Serving Cells. For Type 2, activation and deactivation are independent among the Serving Cells. For the same Serving Cell, the MAC entity is configured with either Type 1 or Type 2.

RRC configures the following parameters when the configured grant Type 1 is configured:

- *cs-RNTI*: CS-RNTI for retransmission;
- *periodicity*: periodicity of the configured grant Type 1;
- *timeDomainOffset*: Offset of a resource with respect to SFN=0 in time domain;
- *timeDomainAllocation*: Allocation of configured uplink grant in time domain which contains *startSymbolAndLength* (i.e. *SLIV* in TS 38.214 [7]);
- *nrofHARQ-Processes*: the number of HARQ processes for configured grant.

RRC configures the following parameters when the configured grant Type 2 is configured:

- *cs-RNTI*: CS-RNTI for activation, deactivation, and retransmission;
- *periodicity*: periodicity of the configured grant Type 2;
- *nrofHARQ-Processes*: the number of HARQ processes for configured grant.

Upon configuration of a configured grant Type 1 for a Serving Cell by upper layers, the MAC entity shall:

- 1> store the uplink grant provided by upper layers as a configured uplink grant for the indicated Serving Cell;
- 1> initialise or re-initialise the configured uplink grant to start in the symbol according to *timeDomainOffset* and *S* (derived from *SLIV* as specified in TS 38.214 [7]), and to reoccur with *periodicity*.

After an uplink grant is configured for a configured grant Type 1, the MAC entity shall consider that the uplink grant recurs associated with each symbol for which:

$$[(SFN \times \text{numberOfSlotsPerFrame} \times \text{numberOfSymbolsPerSlot}) + (\text{slot number in the frame} \times \text{numberOfSymbolsPerSlot}) + \text{symbol number in the slot}] = (\text{timeDomainOffset} \times \text{numberOfSymbolsPerSlot} + S + N \times \text{periodicity}) \text{ modulo } (1024 \times \text{numberOfSlotsPerFrame} \times \text{numberOfSymbolsPerSlot}), \text{ for all } N \geq 0.$$

After an uplink grant is configured for a configured grant Type 2, the MAC entity shall consider that the uplink grant recurs associated with each symbol for which:

$$[(SFN \times \text{numberOfSlotsPerFrame} \times \text{numberOfSymbolsPerSlot}) + (\text{slot number in the frame} \times \text{numberOfSymbolsPerSlot}) + \text{symbol number in the slot}] = [(SFN_{\text{start time}} \times \text{numberOfSlotsPerFrame} \times \text{numberOfSymbolsPerSlot} + \text{slot}_{\text{start time}} \times \text{numberOfSymbolsPerSlot} + \text{symbol}_{\text{start time}}) + N \times \text{periodicity}] \text{ modulo } (1024 \times \text{numberOfSlotsPerFrame} \times \text{numberOfSymbolsPerSlot}), \text{ for all } N \geq 0.$$

where $SFN_{\text{start time}}$, $\text{slot}_{\text{start time}}$, and $\text{symbol}_{\text{start time}}$ are the SFN, slot, and symbol, respectively, of the first transmission opportunity of PUSCH where the configured uplink grant was (re-)initialised.

When a configured uplink grant is released by upper layers, all the corresponding configurations shall be released and all corresponding uplink grants shall be cleared.

The MAC entity shall:

- 1> if the configured uplink grant confirmation has been triggered and not cancelled; and
- 1> if the MAC entity has UL resources allocated for new transmission:
 - 2> instruct the Multiplexing and Assembly procedure to generate an Configured Grant Confirmation MAC CE as defined in subclause 6.1.3.7;
 - 2> cancel the triggered configured uplink grant confirmation.

For a configured grant Type 2, the MAC entity shall clear the configured uplink grant immediately after first transmission of Configured Grant Confirmation MAC CE triggered by the configured uplink grant deactivation.

Retransmissions except for repetition of configured uplink grants use uplink grants addressed to CS-RNTI.

[TS 38.300, clause 10.3]

In the uplink, the gNB can dynamically allocate resources to UEs via the C-RNTI on PDCCH(s). A UE always monitors the PDCCH(s) in order to find possible grants for uplink transmission when its downlink reception is enabled (activity governed by DRX when configured). When CA is configured, the same C-RNTI applies to all serving cells.

In addition, with Configured Grants, the gNB can allocate uplink resources for the initial HARQ transmissions to UEs. Two types of configured uplink grants are defined:

- With Type 1, RRC directly provides the configured uplink grant (including the periodicity).
- With Type 2, RRC defines the periodicity of the configured uplink grant while PDCCH addressed to CS-RNTI can either signal and activate the configured uplink grant, or deactivate it; i.e. a PDCCH addressed to CS-RNTI indicates that the uplink grant can be implicitly reused according to the periodicity defined by RRC, until deactivated.

The dynamically allocated uplink transmission overrides the configured uplink grant in the same serving cell, if they overlap in time. Otherwise an uplink transmission according to the configured uplink grant is assumed, if activated.

Retransmissions other than repetitions are explicitly allocated via PDCCH(s).

When CA is configured, at most one configured uplink grant can be signalled per serving cell. When BA is configured, at most one configured uplink grant can be signalled per BWP. On each serving cell, there can be only one configured uplink grant active at a time. A configured uplink grant for one serving cell can either be of Type 1 or Type 2. For Type 2, activation and deactivation of configured uplink grants are independent among the serving cells. When SUL is configured, a configured uplink grant can only be signalled for one of the 2 ULs of the cell.

7.1.1.6.2.3 Test description

7.1.1.6.2.3.1 Pre-test conditions

Same Pre-test conditions as in clause 7.1.1.0 and UM DRB should be established on NR Cell 1.

7.1.1.6.2.3.2 Test procedure sequence

Table 7.1.1.6.2.3.2-1: Main behaviour

St	Procedure	Message Sequence		TP	Verdict
		U - S	Message		
1	SS transmits NR <i>RRCReconfiguration</i> message to configure UL configured grant type 1 in SFN 900, <i>timeDomainOffset</i> is set to 5. (Note 1)	<--	(NR RRC: <i>RRCReconfiguration</i>)	-	-
2	The UE transmits NR <i>RRCReconfigurationComplete</i> message. (Note 2)	-->	(NR RRC: <i>RRCReconfigurationComplete</i>)	-	-
3	SS transmits a DL MAC PDU containing 4 RLC SDUs of size 96 bytes in SFN 1022 on UM DRB. (Note 3)	<--	MAC PDU (eight RLC SDUs)	-	-
4	Check: Does the UE transmit a MAC PDU containing one RLC SDU in Symbol 'x0', Slot y0', SFN 'z0' after the SFN in step 3 wraps around? Where $[(z0 \times \text{numberOfSlotsPerFrame} \times \text{numberOfSymbolsPerSlot}) + (y0 \times \text{numberOfSymbolsPerSlot}) + x0] = (5 \times \text{numberOfSymbolsPerSlot} + S + 0 \times \text{periodicity}) \text{ modulo } (1024 \times \text{numberOfSlotsPerFrame} \times \text{numberOfSymbolsPerSlot}).$ (Note 4)	-->	MAC PDU (one RLC SDU)	1	P
5	Check: Does the UE transmit a MAC PDU containing one RLC SDU in Symbol 'x1', Slot y1', SFN 'z1'? Where $[(z1 \times \text{numberOfSlotsPerFrame} \times \text{numberOfSymbolsPerSlot}) + (y1 \times \text{numberOfSymbolsPerSlot}) + x1] = (5 \times \text{numberOfSymbolsPerSlot} + S + 1 \times \text{periodicity}) \text{ modulo } (1024 \times \text{numberOfSlotsPerFrame} \times \text{numberOfSymbolsPerSlot}).$	-->	MAC PDU (one RLC SDU)	1	P
6	SS transmits NR <i>RRCReconfiguration</i> message to configure UL configured grant type 1 in SFN 'z1 + 1', <i>timeDomainOffset</i> is set to 35.	<--	(NR RRC: <i>RRCReconfiguration</i>)	-	-
7	The UE transmits NR <i>RRCReconfigurationComplete</i> message.	-->	(NR RRC: <i>RRCReconfigurationComplete</i>)	-	-
8	Check: Does the UE transmit a MAC PDU containing one RLC SDU received in step 4 in Symbol 'x2', Slot y2', SFN 'z2'? Where $[(z2 \times \text{numberOfSlotsPerFrame} \times \text{numberOfSymbolsPerSlot}) + (y2 \times \text{numberOfSymbolsPerSlot}) + x2] = (5 \times \text{numberOfSymbolsPerSlot} + S + N \times \text{periodicity}) \text{ modulo } (1024 \times \text{numberOfSlotsPerFrame} \times \text{numberOfSymbolsPerSlot}), N \geq 2.$	-->	MAC PDU (one RLC SDU)	2	F
9	Check: Does the UE transmit a MAC PDU containing one RLC SDU in Symbol 'x3', Slot y3', SFN 'z3' after the SFN in step 8 wraps around? Where $[(z3 \times \text{numberOfSlotsPerFrame} \times \text{numberOfSymbolsPerSlot}) + (y3 \times \text{numberOfSymbolsPerSlot}) + x3] = (35 \times \text{numberOfSymbolsPerSlot} + S + 0 \times \text{periodicity}) \text{ modulo } (1024 \times \text{numberOfSlotsPerFrame} \times \text{numberOfSymbolsPerSlot}).$	-->	MAC PDU (one RLC SDU)	2	P

10	<p>Check: Does the UE transmit a MAC PDU containing one RLC SDU in Symbol 'x4', Slot y4', SFN 'z4'?</p> <p>Where</p> $[(z4 \times \text{numberOfSlotsPerFrame} \times \text{numberOfSymbolsPerSlot}) + (y4 \times \text{numberOfSymbolsPerSlot}) + x4] = (35 \times \text{numberOfSymbolsPerSlot} + S + 1 \times \text{periodicity}) \text{ modulo } (1024 \times \text{numberOfSlotsPerFrame} \times \text{numberOfSymbolsPerSlot}).$	-->	MAC PDU (one RLC SDU)	2	P
11	<p>SS transmits a UL grant addressed to UE's stored CS-RNTI with NDI set as 1 in Slot 'p0' of PDCCH (p0 = floor ((y4 + 2) * (PDCCH_{scs} / PUSCH_{scs}))), allowing the UE to transmit one loop back SDU.</p>	<--	(UL Grant)	-	-
12	<p>Check: Does the UE transmit a MAC PDU containing the same RLC SDU as in step 10 in Symbol 'S' of Slot 'q' of PUSCH?</p> <p>i.e., in the PUSCH slot q = floor (p0 * (PUSCH_{scs} / PDCCH_{scs})) + K₂. (Note 5)</p>	-->	MAC PDU (one RLC SDU)	4	P
13	<p>Check: Does the UE transmit a MAC PDU containing one RLC SDU in Symbol 'x5', Slot y5', SFN 'z5'?</p> <p>Where</p> $[(z5 \times \text{numberOfSlotsPerFrame} \times \text{numberOfSymbolsPerSlot}) + (y5 \times \text{numberOfSymbolsPerSlot}) + x5] = (35 \times \text{numberOfSymbolsPerSlot} + S + 2 \times \text{periodicity}) \text{ modulo } (1024 \times \text{numberOfSlotsPerFrame} \times \text{numberOfSymbolsPerSlot}).$	-->	MAC PDU (one RLC SDU)	1	P
14	<p>SS transmits a UL Grant using UE's C-RNTI in in Slot 'p1' of PDCCH allowing UE to transmit a MAC PDU containing one RLC SDU, where p1 = floor ((z6 * numberOfSlotsPerFrame - K₂) * (PDCCH_{scs} / PUSCH_{scs})). (Note 6)</p> <p>Where</p> $[(z6 \times \text{numberOfSlotsPerFrame} \times \text{numberOfSymbolsPerSlot}) + (y6 \times \text{numberOfSymbolsPerSlot}) + x6] = (35 \times \text{numberOfSymbolsPerSlot} + S + 3 \times \text{periodicity}) \text{ modulo } (1024 \times \text{numberOfSlotsPerFrame} \times \text{numberOfSymbolsPerSlot}).$	<--	(UL Grant)	-	-
15	<p>Check: Does the UE transmit a MAC PDU containing one RLC SDU in Symbol 'x6', Slot y6', SFN 'z6'?</p>	-->	MAC PDU (one RLC SDU)	5	P
16	<p>Check: Does the UE transmit a MAC PDU containing one RLC SDU in Symbol 'x7', Slot y7', SFN 'z7'?</p> <p>Where</p> $[(z7 \times \text{numberOfSlotsPerFrame} \times \text{numberOfSymbolsPerSlot}) + (y7 \times \text{numberOfSymbolsPerSlot}) + x7] = (35 \times \text{numberOfSymbolsPerSlot} + S + 4 \times \text{periodicity}) \text{ modulo } (1024 \times \text{numberOfSlotsPerFrame} \times \text{numberOfSymbolsPerSlot}).$	-->	MAC PDU (one RLC SDU)	1	P
17	<p>After step 16, SS transmits NR RRCReconfiguration message to release UL configured grant type 1 in SFN 'z4 + 1'.</p>	<--	(NR RRC: RRCReconfiguration)	-	-
18	<p>The UE transmits NR RRCReconfigurationComplete message.</p>	-->	(NR RRC: RRCReconfigurationComplete)	-	-
19	<p>SS transmits a DL MAC PDU containing one RLC SDU of size 96 bytes in SFN 'z7 + 10'.</p>	<--	MAC PDU (one RLC SDU)		

20	Check: Does the UE transmit a MAC PDU containing one RLC SDU in Symbol 'x8', Slot y8', SFN 'z8'? Where $[(z8 \times \text{numberOfSlotsPerFrame} \times \text{numberOfSymbolsPerSlot}) + (y8 \times \text{numberOfSymbolsPerSlot}) + x8] = (35 \times \text{numberOfSymbolsPerSlot} + S + 8 \times \text{periodicity}) \text{ modulo } (1024 \times \text{numberOfSlotsPerFrame} \times \text{numberOfSymbolsPerSlot})$	-->	MAC PDU (one RLC SDU)	3	F
Note 1: For EN-DC the NR <i>RRCReconfiguration</i> message is contained in <i>RRCConnectionReconfiguration</i> . Note 2: For EN-DC the NR <i>RRCReconfigurationComplete</i> message is contained in <i>RRCConnectionReconfigurationComplete</i> . Note 3: According to the setting parameters in Table 7.1.1.6.2.3.3-2, TB size for configured grant type 1 is 808 bits, which is enough to allow the UE to transmit one PDU at a time (96 bytes RLC SDU + 1 byte UM RLC Header + 2 bytes MAC Sub PDU header + 2 bytes for short BSR or padding). Note 4: S is the starting symbol relative to the slot of the first PUSCH transmission for new configured grant type 1. The value of S can be obtained from TS 38.508-1 [4], Table 4.6.3-122. Note 5: q is the slot where the UE shall transmit the PUSCH and is determined by K_2 as $\left\lceil n \cdot \frac{2^{\mu_{\text{PUSCH}}}}{2^{\mu_{\text{PBCH}}}} \right\rceil + K_2$ where n is the slot with the scheduling DCI, K_2 is based on the numerology of PUSCH. S is the starting symbol relative to the start of the slot q according to TS 38.214 clause 6.1.2.1. Note 6: The UL grant addressed to C-RNTI should result in UL transmission overlap in time domain as configured grante type 1.					

7.1.1.6.2.3.3 Specific message contents

Table 7.1.1.6.2.3.3-1: *RRCReconfiguration* (step 1 and step 6, Table 7.1.1.6.2.3.2-1)

Derivation path: 38.508-1 [4], Table 4.6.1-13			
Information Element	Value/remark	Comment	Condition
RRCReconfiguration ::= SEQUENCE {			
criticalExtensions CHOICE {			
rrcReconfiguration SEQUENCE {			
radioBearerConfig	Not present		
secondaryCellGroup	CellGroupConfig	OCTET STRING (CONTAINING CellGroupConfig)	EN-DC
nonCriticalExtension ::= SEQUENCE {}	Not present		EN-DC
nonCriticalExtension ::= SEQUENCE{			NR
masterCellGroup	CellGroupConfig	OCTET STRING (CONTAINING CellGroupConfig)	
dedicatedNAS-MessageList SEQUENCE (SIZE(1..maxDRB)) OF DedicatedNAS-Message {}	Not present		
}			
}			
}			
}			

Table 7.1.1.6.2.3.3-2: *CellGroupConfig* (Table 7.1.1.6.2.3.3-2: *RRCReconfiguration*)

Derivation path: 38.508-1 [4], Table 4.6.3-19			
Information Element	Value/remark	Comment	Condition
CellGroupConfig ::= SEQUENCE {			
rlc-BearerToAddModList SEQUENCE (SIZE(1..maxLCH)) OF SEQUENCE {	Not present		
mac-CellGroupConfig	Not present		
physicalCellGroupConfig SEQUENCE {			
cs-RNTI CHOICE {			
setup SEQUENCE{			
RNTI-Value	'FFE0'H		
}			
}			
}			
spCellConfig SEQUENCE{			
servCellIndex	Not present		NR
	1		EN-DC
reconfigurationWithSync	Not present		
spCellConfigDedicated SEQUENCE{			
uplinkConfig SEQUENCE {			
initialUplink SEQUENCE {			
pucch-Config CHOICE {			
setup SEQUENCE {			
schedulingRequestResourceToAddModList {			
schedulingRequestResourceId	1		
schedulingRequestID	0		
periodicityAndOffset CHOICE {			
sl20	10		
}			
}			
}			
}			
}			
}			
configuredGrantConfig CHOICE {			
setup SEQUENCE {			
cg-DMRS-Configuration	DMRS-UplinkConfig	Reference TS 38.508-1[4], Table 4.6.3-51	
uci-OnPUSCH CHOICE {			
setup SEQUENCE {			
semiStatic SEQUENCE {	BetaOffsets		
betaOffsetACK-Index1	9		
betaOffsetACK-Index2	9		
betaOffsetACK-Index3	9		
betaOffsetCSI-Part1-Index1	6		
betaOffsetCSI-Part1-Index2	6		
betaOffsetCSI-Part2-Index1	6		
betaOffsetCSI-Part2-Index2	6		
}			
}			
}			
}			
resourceAllocation	ResourceAllocationType 1		
powerControlLoopToUse	n0		
p0-PUSCH-Alpha	1		
nrofHARQ-Processes	16		
repK	n1		
periodicity	Sym40x14		15kHz
periodicity	Sym80x14		30kHz
periodicity	Sym160x14		60kHz
periodicity	Sym320x14		120kHz
rrc-ConfiguredUplinkGrant SEQUENCE{			
timeDomainOffset	5		For Step 1

	35		For Step 6
timeDomainAllocation	0	Reference TS 38.508-1 [4], Table 4.6.3-122	
frequencyDomainAllocation	BIT STRING (SIZE(18))	BIT STRING (SIZE(18), Equal to NBWPsize * (LRB-1) + RBstart), where LRB = 2 PRB, RBstart = 0, NBWPsize is the size [PRBs] of the active carrier bandwidth part and ontained in TS.38.508-1 [4] clause 4.3.1.1.	FR1_FDD, FR1_TDD
frequencyDomainAllocation	BIT STRING (SIZE(18))	BIT STRING (SIZE(18), Equal to NBWPsize * (LRB-1) + RBstart), where LRB=9 PRB, RBstart = 0and NBWPsize is the size [PRBs] of the active carrier bandwidth part and ontained in TS.38.508-1 [4] clause 4.3.1.2.	FR2_TDD
antennaPort	0		
precodingAndNumberOfLayers	0		
srs-ResourceIndicator	Not present		
mcsAndTBS	18		FR1_FDD, FR1_TDD
	25		FR2_TDD
pathlossReferenceIndex	0		
}			
}			
}			
pusch-Config CHOICE {			
setup SEQUENCE {			
PUSCH-TimeDomainResourceAllocationList SEQUENCE {			
k2	n8		FR1 and FR2
mappingType	typeB		
startSymbolAndLength	0011011	Start symbol(S)=0, Length(L)=14	FR1
startSymbolAndLength	0001110	S=0, L=2	FR2
}			
}			
}			
}			
}			
}			
}			
}			
}			
}			

Table 7.1.1.6.2.3.3-3: RRCReconfiguration (step 11, Table 7.1.1.6.2.3.2-1)

Derivation path: 38.508-1 [4], Table 4.6.1-13			
Information Element	Value/remark	Comment	Condition
RRCReconfiguration ::= SEQUENCE {			
criticalExtensions CHOICE {			
rrcReconfiguration SEQUENCE {			
radioBearerConfig	Not present		
secondaryCellGroup	CellGroupConfig	OCTET STRING (CONTAINING CellGroupConfig)	EN-DC
nonCriticalExtension ::= SEQUENCE {}	Not present		EN-DC
nonCriticalExtension ::= SEQUENCE{			NR
masterCellGroup	CellGroupConfig	OCTET STRING (CONTAINING CellGroupConfig)	
dedicatedNAS-MessageList SEQUENCE (SIZE(1..maxDRB)) OF DedicatedNAS-Message {}	Not present		
}			
}			
}			

Table 7.1.1.6.2.3.3-4: CellGroupConfig (Table 7.1.1.6.2.3.3-3: RRCReconfiguration)

Derivation path: 38.508-1 [4], Table 4.6.3-19			
Information Element	Value/remark	Comment	Condition
CellGroupConfig ::= SEQUENCE {			
spCellConfig SEQUENCE{			
spCellConfigDedicated SEQUENCE{			
uplinkConfig SEQUENCE {			
initialUplink SEQUENCE {			
configuredGrantConfig CHOICE {			
release	Null		
}			
}			
}			
}			
}			
}			

7.1.1.6.3 Correct handling of UL grant / configured grant Type 2

7.1.1.6.3.1 Test Purpose (TP)

(1)

```
with { UE in RRC_Connected state with DRB established and sps-Configuration in UL is enabled }
ensure that {
  when { UE receives a UL configured grant type 2 addressed to its stored CS-CRNTI with NDI set as 0 }
  then { UE starts transmitting UL MAC PDU periodically in the symbol associated with the configured grant }
}
```

(2)

```
with { UE in RRC_Connected state with DRB established and configured UL grant type 2 }
ensure that {
  when { UE receives a UL grant addressed to its CS-CRNTI with NDI set as 0 }
  then { UE starts transmitting UL MAC PDU periodically in the symbol associated with the new re-configured grant }
}
```

(3)

```

with { UE in RRC_Connected state with DRB established and configured UL grant type 2 }
ensure that {
  when { UE receives a UL grant addressed to its CS-CRNTI with NDI set as 1 for retransmission }
  then { UE re-transmits MAC PDU as per the new grant }
}

```

(4)

```

with { UE in RRC_Connected state with DRB established and configured UL grant type 2 }
ensure that {
  when { UE receives a UL grant addressed to its C-RNTI resulting in UL transmission overlap in time domain as configured grant type 2 }
  then { UE transmits MAC PDU as per grant addressed to its C-RNTI }
}

```

(5)

```

with { UE in RRC_Connected state with DRB established and configured UL grant type 2 }
ensure that {
  when { UE receives a RRC message including sps-Configuration with sps-ConfigurationUL set as 'disable' and hence resulting in UL SPS grant deactivation }
  then { UE deletes the stored sps-Configuration UL parameters and stops transmitting UL MAC PDU's as per configured UL grant type 2 }
}

```

(6)

```

with { UE in RRC_Connected state with DRB established and configured UL grant type 2 }
ensure that {
  when { If in the symbol in which UL Configured Grant type 2 is available but the HARQ buffer is empty (no data for transmission) }
  then { UE ignores the UL configured grant type 2 and does not send any MAC PDU }
}

```

7.1.1.6.3.2 Conformance requirements

References: The conformance requirements covered in the present TC are specified in: 3GPP TS 38.321 clauses 5.4.1 and 5.8.2, 3GPP TS 38.300 clauses 10.3. Unless otherwise stated these are Rel-15 requirements.

[TS 38.321, clause 5.4.1]

Uplink grant is either received dynamically on the PDCCH, in a Random Access Response, or configured semi-persistently by RRC. The MAC entity shall have an uplink grant to transmit on the UL-SCH. To perform the requested transmissions, the MAC layer receives HARQ information from lower layers.

If the MAC entity has a C-RNTI, a Temporary C-RNTI, or CS-RNTI, the MAC entity shall for each PDCCH occasion and for each Serving Cell belonging to a TAG that has a running *timeAlignmentTimer* and for each grant received for this PDCCH occasion:

- 1> if an uplink grant for this Serving Cell has been received on the PDCCH for the MAC entity's C-RNTI or Temporary C-RNTI; or
- 1> if an uplink grant has been received in a Random Access Response:
 - 2> if the uplink grant is for MAC entity's C-RNTI and if the previous uplink grant delivered to the HARQ entity for the same HARQ process was either an uplink grant received for the MAC entity's CS-RNTI or a configured uplink grant:
 - 3> consider the NDI to have been toggled for the corresponding HARQ process regardless of the value of the NDI.
 - 2> if the uplink grant is for MAC entity's C-RNTI, and the identified HARQ process is configured for a configured uplink grant:
 - 3> start or restart the *configuredGrantTimer* for the corresponding HARQ process, if configured.
- 2> deliver the uplink grant and the associated HARQ information to the HARQ entity.

- 1> else if an uplink grant for this PDCCH occasion has been received for this Serving Cell on the PDCCH for the MAC entity's CS-RNTI:
 - 2> if the NDI in the received HARQ information is 1:
 - 3> consider the NDI for the corresponding HARQ process not to have been toggled;
 - 3> start or restart the *configuredGrantTimer* for the corresponding HARQ process, if configured;
 - 3> deliver the uplink grant and the associated HARQ information to the HARQ entity.
 - 2> else if the NDI in the received HARQ information is 0:
 - 3> if PDCCH contents indicate configured grant Type 2 deactivation:
 - 4> trigger configured uplink grant confirmation.
 - 3> else if PDCCH contents indicate configured grant Type 2 activation:
 - 4> trigger configured uplink grant confirmation;
 - 4> store the uplink grant for this Serving Cell and the associated HARQ information as configured uplink grant;
 - 4> initialise or re-initialise the configured uplink grant for this Serving Cell to start in the associated PUSCH duration and to recur according to rules in subclause 5.8.2;
 - 4> stop the *configuredGrantTimer* for the corresponding HARQ process, if running;

For each Serving Cell and each configured uplink grant, if configured and activated, the MAC entity shall:

- 1> if the PUSCH duration of the configured uplink grant does not overlap with the PUSCH duration of an uplink grant received on the PDCCH or in a Random Access Response for this Serving Cell:
 - 2> set the HARQ Process ID to the HARQ Process ID associated with this PUSCH duration;
- 2> if the *configuredGrantTimer* for the corresponding HARQ process is not running:
 - 3> consider the NDI bit for the corresponding HARQ process to have been toggled;
 - 3> deliver the configured uplink grant and the associated HARQ information to the HARQ entity.

For configured uplink grants, the HARQ Process ID associated with the first symbol of a UL transmission is derived from the following equation:

$$\text{HARQ Process ID} = [\text{floor}(\text{CURRENT_symbol}/\text{periodicity})] \text{ modulo } nrof\text{HARQ-Processes}$$

where $\text{CURRENT_symbol} = (\text{SFN} \times \text{numberOfSlotsPerFrame} \times \text{numberOfSymbolsPerSlot} + \text{slot number in the frame} \times \text{numberOfSymbolsPerSlot} + \text{symbol number in the slot})$, and *numberOfSlotsPerFrame* and *numberOfSymbolsPerSlot* refer to the number of consecutive slots per frame and the number of consecutive symbols per slot, respectively as specified in TS 38.211 [8].

NOTE 1: CURRENT_symbol refers to the symbol index of the first transmission occasion of a repetition bundle that takes place.

NOTE 2: A HARQ process is configured for a configured uplink grant if the configured uplink grant is activated and the associated HARQ process ID is less than *nrofHARQ-Processes*.

NOTE 3: If the MAC entity receives both a grant in a Random Access Response and an overlapping grant for its C-RNTI or CS-RNTI, requiring concurrent transmissions on the SpCell, the MAC entity may choose to continue with either the grant for its RA-RNTI or the grant for its C-RNTI or CS-RNTI.

[TS 38.321, clause 5.8.2]

There are two types of transmission without dynamic grant:

- configured grant Type 1 where an uplink grant is provided by RRC, and stored as configured uplink grant;

- configured grant Type 2 where an uplink grant is provided by PDCCH, and stored or cleared as configured uplink grant based on L1 signalling indicating configured uplink grant activation or deactivation.

Type 1 and Type 2 are configured by RRC per Serving Cell and per BWP. Multiple configurations can be active simultaneously only on different Serving Cells. For Type 2, activation and deactivation are independent among the Serving Cells. For the same Serving Cell, the MAC entity is configured with either Type 1 or Type 2.

RRC configures the following parameters when the configured grant Type 1 is configured:

- *cs-RNTI*: CS-RNTI for retransmission;
- *periodicity*: periodicity of the configured grant Type 1;
- *timeDomainOffset*: Offset of a resource with respect to SFN=0 in time domain;
- *timeDomainAllocation*: Allocation of configured uplink grant in time domain which contains *startSymbolAndLength* (i.e. *SLIV* in TS 38.214 [7]);
- *nrofHARQ-Processes*: the number of HARQ processes for configured grant.

RRC configures the following parameters when the configured grant Type 2 is configured:

- *cs-RNTI*: CS-RNTI for activation, deactivation, and retransmission;
- *periodicity*: periodicity of the configured grant Type 2;
- *nrofHARQ-Processes*: the number of HARQ processes for configured grant.

Upon configuration of a configured grant Type 1 for a Serving Cell by upper layers, the MAC entity shall:

- 1> store the uplink grant provided by upper layers as a configured uplink grant for the indicated Serving Cell;
- 1> initialise or re-initialise the configured uplink grant to start in the symbol according to *timeDomainOffset* and *S* (derived from *SLIV* as specified in TS 38.214 [7]), and to reoccur with *periodicity*.

After an uplink grant is configured for a configured grant Type 1, the MAC entity shall consider that the uplink grant recurs associated with each symbol for which:

$$[(SFN \times \text{numberOfSlotsPerFrame} \times \text{numberOfSymbolsPerSlot}) + (\text{slot number in the frame} \times \text{numberOfSymbolsPerSlot}) + \text{symbol number in the slot}] = (\text{timeDomainOffset} \times \text{numberOfSymbolsPerSlot} + S + N \times \text{periodicity}) \text{ modulo } (1024 \times \text{numberOfSlotsPerFrame} \times \text{numberOfSymbolsPerSlot}), \text{ for all } N \geq 0.$$

After an uplink grant is configured for a configured grant Type 2, the MAC entity shall consider that the uplink grant recurs associated with each symbol for which:

$$[(SFN \times \text{numberOfSlotsPerFrame} \times \text{numberOfSymbolsPerSlot}) + (\text{slot number in the frame} \times \text{numberOfSymbolsPerSlot}) + \text{symbol number in the slot}] = [(SFN_{\text{start time}} \times \text{numberOfSlotsPerFrame} \times \text{numberOfSymbolsPerSlot} + \text{slot}_{\text{start time}} \times \text{numberOfSymbolsPerSlot} + \text{symbol}_{\text{start time}}) + N \times \text{periodicity}] \text{ modulo } (1024 \times \text{numberOfSlotsPerFrame} \times \text{numberOfSymbolsPerSlot}), \text{ for all } N \geq 0.$$

where $SFN_{\text{start time}}$, $\text{slot}_{\text{start time}}$, and $\text{symbol}_{\text{start time}}$ are the SFN, slot, and symbol, respectively, of the first transmission opportunity of PUSCH where the configured uplink grant was (re-)initialised.

When a configured uplink grant is released by upper layers, all the corresponding configurations shall be released and all corresponding uplink grants shall be cleared.

The MAC entity shall:

- 1> if the configured uplink grant confirmation has been triggered and not cancelled; and
- 1> if the MAC entity has UL resources allocated for new transmission:
 - 2> instruct the Multiplexing and Assembly procedure to generate an Configured Grant Confirmation MAC CE as defined in subclause 6.1.3.7;

2> cancel the triggered configured uplink grant confirmation.

For a configured grant Type 2, the MAC entity shall clear the configured uplink grant immediately after first transmission of Configured Grant Confirmation MAC CE triggered by the configured uplink grant deactivation.

Retransmissions except for repetition of configured uplink grants use uplink grants addressed to CS-RNTI.

[TS 38.300, clause 10.3]

In the uplink, the gNB can dynamically allocate resources to UEs via the C-RNTI on PDCCH(s). A UE always monitors the PDCCH(s) in order to find possible grants for uplink transmission when its downlink reception is enabled (activity governed by DRX when configured). When CA is configured, the same C-RNTI applies to all serving cells.

In addition, with Configured Grants, the gNB can allocate uplink resources for the initial HARQ transmissions to UEs. Two types of configured uplink grants are defined:

- With Type 1, RRC directly provides the configured uplink grant (including the periodicity).
- With Type 2, RRC defines the periodicity of the configured uplink grant while PDCCH addressed to CS-RNTI can either signal and activate the configured uplink grant, or deactivate it; i.e. a PDCCH addressed to CS-RNTI indicates that the uplink grant can be implicitly reused according to the periodicity defined by RRC, until deactivated.

The dynamically allocated uplink transmission overrides the configured uplink grant in the same serving cell, if they overlap in time. Otherwise an uplink transmission according to the configured uplink grant is assumed, if activated.

Retransmissions other than repetitions are explicitly allocated via PDCCH(s).

When CA is configured, at most one configured uplink grant can be signalled per serving cell. When BA is configured, at most one configured uplink grant can be signalled per BWP. On each serving cell, there can be only one configured uplink grant active at a time. A configured uplink grant for one serving cell can either be of Type 1 or Type 2. For Type 2, activation and deactivation of configured uplink grants are independent among the serving cells. When SUL is configured, a configured uplink grant can only be signalled for one of the 2 ULs of the cell.

7.1.1.6.3.3 Test description

7.1.1.6.3.3.1 Pre-test conditions

Same Pre-test conditions as in clause 7.1.1.0 and UM DRB should be established on NR Cell 1. The loop back size is set to accommodate one RLC SDU in UL of same size as one RLC SDU in DL and 1 byte MAC subheader for Configured Grant Confirmation MAC CE.

7.1.1.6.3.3.2 Test procedure sequence

Table 7.1.1.6.3.3.2-1: Main behaviour

St	Procedure	Message Sequence		TP	Verdict
		U - S	Message		
1	SS transmits NR <i>RRCReconfiguration</i> message to configure UL configured grant type 2. (Note 1)	<--	(NR RRC: <i>RRCReconfiguration</i>)	-	-
2	The UE transmits NR <i>RRCReconfigurationComplete</i> message. (Note 2)	-->	(NR RRC: <i>RRCReconfigurationComplete</i>)	-	-
3	SS transmits a DL MAC PDU containing 6 RLC SDUs on UM DRB.	<--	MAC PDU	-	-
4	The UE transmits a Scheduling Request, indicating that loop back SDUs are ready for transmission in UL RLC.	-->	(SR)	-	-
5	SS transmits a UL configured grant type 2 addressed to UE's stored CS-RNTI in Slot 'n' of PDCCH, NDI=0, allowing the UE to transmit one loop back SDU and 1 byte MAC subheader for Configured Grant Confirmation MAC CE.	<--	(UL SPS Grant)	-	-
6	Check: Does the UE transmit a MAC PDU containing one RLC SDU and a Configured Grant Confirmation MAC CE in Symbol 'S' of Slot 'y' of PUSCH as per grant in step 5? i.e., in the PUSCH slot $y = \text{floor}(n * (\text{PUSCH}_{\text{scs}} / \text{PDCCH}_{\text{scs}})) + K_2$. (Note 3)	-->	MAC PDU	1	P
7	Check: Does the UE transmit a MAC PDU containing one RLC SDU in Symbol 'S' of Slot 'y + x' of PUSCH as per grant in step 5? (Note 4)	-->	MAC PDU	1	P
8	SS transmits a UL configured grant type 2 addressed to UE's stored CS-RNTI in Slot 'p' of PDCCH ($p = \text{floor}(p_0 * (\text{PDCCH}_{\text{scs}} / \text{PUSCH}_{\text{scs}}))$), NDI = 0, allowing the UE to transmit one loop back SDU and 1 byte MAC subheader for Configured Grant Confirmation MAC CE, Where p_0 is the slot of PUSCH with $y + x < p_0 < y + 2x - K_2$.	<--	(UL SPS Grant)	-	-
9	Check: Does the UE transmit a MAC PDU containing one RLC SDU and 1 byte MAC subheader for Configured Grant Confirmation MAC CE in Symbol 'S' of Slot 'z' of PUSCH as per grant in step 8? i.e., in the PUSCH slot $z = \text{floor}(p * (\text{PUSCH}_{\text{scs}} / \text{PDCCH}_{\text{scs}})) + K_2$. (Note 3)	-->	MAC PDU	2	P
10	Check: Does the UE transmit a MAC PDU containing one RLC SDU in Symbol 'S' of Slot 'y + 2x' as per grant in step 5?	-->	MAC PDU	2	F
11	Check: Does the UE transmit a MAC PDU containing one RLC SDU in Symbol 'S' of Slot 'z + x' of PUSCH as per grant in step 8?	-->	MAC PDU	2	P
12	SS transmits a UL configured grant type 2 addressed to UE's stored CS-RNTI in Slot 'q' of PDCCH ($q = \text{floor}(q_0 * (\text{PDCCH}_{\text{scs}} / \text{PUSCH}_{\text{scs}}))$), NDI = 1; allowing the UE to transmit one loop back SDU. The UL HARQ process is the same as in step 11, Where q_0 is the slot of PUSCH with $z + x < q_0 < z + 2x - K_2$.	<--	(UL SPS Grant)	-	-
13	Check: Does the UE transmit a MAC PDU containing the same RLC SDU as in step 11 in Symbol 'S' of Slot 'w' of PUSCH? i.e., in the PUSCH slot $w = \text{floor}(q * (\text{PUSCH}_{\text{scs}} / \text{PDCCH}_{\text{scs}})) + K_2$. (Note 3)	-->	MAC PDU	3	P

14	Check: Does the UE transmit a MAC PDU containing one RLC SDU in Symbol 'S' of Slot 'z + 2x' of PUSCH as per grant in step 8?	-->	MAC PDU	1	P
15	SS transmits a UL Grant using UE's C-RNTI in in Slot 'r' of PDCCH allowing UE to transmit a MAC PDU containing one RLC SDU, where $r = \text{floor}((z + 3x - K_2) * (\text{PDCCH}_{\text{SCS}} / \text{PUSCH}_{\text{SCS}}))$.	<--	(UL Grant)	-	-
16	Check: Does the UE transmit a MAC PDU containing one RLC SDU in Symbol 'S' of Slot 'z + 3x' of PUSCH as per grant in step 8?	-->	MAC PDU	4	P
17	Check: Does the UE transmit a MAC PDU in Slot 'z + 4x' as per grant in containing zero MAC SDU? (Note 5)	-->	MAC PDU	6	F
18	SS transmits a DL MAC PDU containing 1 RLC SDU on UM DRB after step 17.	<--	MAC PDU		
19	Check: Does the UE transmit a MAC PDU containing one RLC SDU in Symbol 'S' of Slot 'z + 5x' of PUSCH as per grant in step 8?	-->	MAC PDU	1	P
20	SS transmits <i>RRCReconfiguration</i> to disable UL configured grant type 2.	<--	NR RRC: <i>RRCReconfiguration</i>	-	-
21	The UE transmits <i>RRCReconfigurationComplete</i> .	-->	NR RRC: <i>RRCReconfigurationComplete</i>	-	-
22	SS transmits a DL MAC PDU containing 1 RLC SDU.	<--	MAC PDU	-	-
23	Check: Does the UE transmit a MAC PDU in Symbol 'S' of Slot 'z + 6x' of PUSCH as per grant in step 8.	-->	MAC PDU	5	F
<p>Note 1: For EN-DC the NR <i>RRCReconfiguration</i> message is contained in <i>RRCConnectionReconfiguration</i>.</p> <p>Note 2: For EN-DC the NR <i>RRCReconfigurationComplete</i> message is contained in <i>RRCConnectionReconfigurationComplete</i>.</p> <p>Note 3: y is the slot where the UE shall transmit the PUSCH and is determined by K_2 as $\left\lceil n \cdot \frac{2^{\mu_{\text{PUSCH}}}}{2^{\mu_{\text{PDCCH}}}} \right\rceil + K_2$ where n is the slot with the scheduling DCI, K_2 is based on the numerology of PUSCH. S is the starting symbol relative to the start of the slot y according to TS 38.214 clause 6.1.2.1.</p> <p>Note 4: x is equal to <i>periodicity</i> / 14 in this test case.</p> <p>Note 5: If the MAC entity does not generate a MAC PDU, one of the conditions which shall be satisfied is that there is no aperiodic CSI requested for this PUSCH transmission as specified in TS 38.321 clause 5.4.3.1.3.</p>					

7.1.1.6.3.3.3 Specific message contents

Table 7.1.1.6.3.3.3-1: RRCReconfiguration (step 1, Table 7.1.1.6.3.3.2-1)

Derivation path: 38.508-1 [4], Table 4.6.1-13			
Information Element	Value/remark	Comment	Condition
RRCReconfiguration ::= SEQUENCE {			
criticalExtensions CHOICE {			
rrcReconfiguration SEQUENCE {			
radioBearerConfig	Not present		
secondaryCellGroup	CellGroupConfig	OCTET STRING (CONTAINING CellGroupConfig)	EN-DC
nonCriticalExtension := SEQUENCE {}	Not present		EN-DC
nonCriticalExtension := SEQUENCE{			NR
masterCellGroup	CellGroupConfig	OCTET STRING (CONTAINING CellGroupConfig)	
dedicatedNAS-MessageList SEQUENCE (SIZE(1..maxDRB)) OF DedicatedNAS-Message {}	Not present		
}			
}			
}			

Table 7.1.1.6.3.3.3-2: *CellGroupConfig* (Table 7.1.1.6.3.3.3-1: *RRCReconfiguration*)

Derivation path: 38.508-1 [4], Table 4.6.3-19			
Information Element	Value/remark	Comment	Condition
CellGroupConfig ::= SEQUENCE {			
rlc-BearerToAddModList SEQUENCE (SIZE(1..maxLCH)) OF SEQUENCE {	Not present		
mac-CellGroupConfig	Not present		
physicalCellGroupConfig SEQUENCE {			
cs-RNTI CHOICE {			
setup SEQUENCE{			
RNTI-Value	'FFE0'H		
}			
}			
}			
spCellConfig SEQUENCE{			
spCellConfigDedicated SEQUENCE{			
uplinkConfig SEQUENCE {			
initialUplinkBWP SEQUENCE {			
pucch-Config CHOICE {			
setup SEQUENCE {			
schedulingRequestResourceToAddModList {			
schedulingRequestResourceId	1		
schedulingRequestID	0		
periodicityAndOffset CHOICE {			
sl20	10		
}			
}			
}			
}			
}			
}			
configuredGrantConfig CHOICE {			
setup SEQUENCE {			
cg-DMRS-Configuration	DMRS-UplinkConfig	Reference TS 38.508-1 [4], Table 4.6.3-51	
uci-OnPUSCH CHOICE {			
setup SEQUENCE {			
semiStatic SEQUENCE {	BetaOffsets		
betaOffsetACK-Index1	9		
betaOffsetACK-Index2	9		
betaOffsetACK-Index3	9		
betaOffsetCSI-Part1-Index1	6		
betaOffsetCSI-Part1-Index2	6		
betaOffsetCSI-Part2-Index1	6		
betaOffsetCSI-Part2-Index2	6		
}			
}			
}			
}			
resourceAllocation	ResourceAllocationType1		
powerControlLoopToUse	n0		
p0-PUSCH-Alpha	1		
nrofHARQ-Processes	16		
repK	n1		
periodicity	Sym40x14		15kHz
periodicity	Sym80x14		30kHz
periodicity	Sym160x14		60kHz
periodicity	Sym320x14		120kHz
}			
}			
pusch-Config CHOICE {			
setup SEQUENCE {			
PUSCH-TimeDomainResourceAllocationList SEQUENCE {			

k2	n8		FR1 and FR2
mappingType	typeB		
startSymbolAndLength	0011011		FR1
startSymbolAndLength	0001110		FR2
}			
}			
}			
}			
}			
}			
}			

Table 7.1.1.6.3.3.3-3: RRCReconfiguration (step 20 of Table 7.1.1.6.3.3.2-1)

Derivation path: 38.508-1 [4], Table 4.6.1-13			
Information Element	Value/remark	Comment	Condition
RRCReconfiguration ::= SEQUENCE {			
criticalExtensions CHOICE {			
rrcReconfiguration SEQUENCE {			
radioBearerConfig	Not present		
secondaryCellGroup	CellGroupConfig	OCTET STRING (CONTAINING CellGroupConfig)	EN-DC
nonCriticalExtension ::= SEQUENCE {}	Not present		EN-DC
nonCriticalExtension ::= SEQUENCE{			NR
masterCellGroup	CellGroupConfig	OCTET STRING (CONTAINING CellGroupConfig)	
dedicatedNAS-MessageList SEQUENCE (SIZE(1..maxDRB)) OF DedicatedNAS-Message {}	Not present		
}			
}			
}			
}			

Table 7.1.1.6.3.3.3-4: CellGroupConfig (Table 7.1.1.6.3.3.3-3: RRCReconfiguration)

Derivation path: 38.508-1 [4], Table 4.6.3-19			
Information Element	Value/remark	Comment	Condition
CellGroupConfig ::= SEQUENCE {			
cellGroupld	1		
spCellConfig SEQUENCE{			
spCellConfigDedicated SEQUENCE{			
uplinkConfig SEQUENCE {			
initialUplink SEQUENCE {			
configuredGrantConfig CHOICE {			
release	Null		
}			
}			
}			
}			
}			

7.1.1.7 Activation/Deactivation of SCells

7.1.1.7.1 Activation/Deactivation of SCells / Activation/Deactivation MAC control element reception / sCellDeactivationTimer

7.1.1.7.1.1 Activation/Deactivation of SCells / Activation/Deactivation MAC control element reception / sCellDeactivationTimer / Intra-band Contiguous CA

7.1.1.7.1.1.1 Test Purpose (TP)

(1)

```
with { UE in RRC_CONNECTED state with SCell configured }
ensure that {
  when { the UE receives an SCell Activation/Deactivation MAC CE activating the SCell }
  then { the UE starts monitoring PDCCH on activated SCell }
}
```

(2)

```
with(UE in RRC_CONNECTED state with SCell activated)
ensure that {
  when{ the UE receives a DL assignment on SCell PDCCH }
  then { the UE restarts the sCellDeactivationTimer }
}
```

(3)

```
with ( UE in RRC_CONNECTED state with SCell activated)
ensure that {
  when{ the UE sCellDeactivationTimer expires }
  then { the UE deactivates the SCell and stops monitoring PDCCH on SCell }
}
```

(4)

```
with (UE in RRC_CONNECTED state with SCell activated )
ensure that {
  when{ the UE receives a SCell Activation/Deactivation MAC CE deactivating the SCell }
  then { the UE deactivates the SCell and stops monitoring PDCCH on SCell }
}
```

7.1.1.7.1.1.2 Conformance requirements

References: The conformance requirements covered in the present TC are specified in: TS 38.321, clauses 5.9 and TS 38.331 clause 5.3.5.5.2. Unless otherwise stated these are Rel-15 requirements.

[TS 38.321, clause 5.9]

If the MAC entity is configured with one or more SCells, the network may activate and deactivate the configured SCells. Upon configuration of an SCell, the SCell is deactivated.

The configured SCell(s) is activated and deactivated by:

- receiving the SCell Activation/Deactivation MAC CE described in subclause 6.1.3.10;
- configuring *sCellDeactivationTimer* timer per configured SCell (except the SCell configured with PUCCH, if any): the associated SCell is deactivated upon its expiry.

The MAC entity shall for each configured SCell:

- 1> if an SCell Activation/Deactivation MAC CE is received activating the SCell:
 - 2> activate the SCell according to the timing defined in TS 38.213 [6]; i.e. apply normal SCell operation including:

- 3> SRS transmissions on the SCell;
 - 3> CSI reporting for the SCell;
 - 3> PDCCH monitoring on the SCell;
 - 3> PDCCH monitoring for the SCell;
 - 3> PUCCH transmissions on the SCell, if configured.
- 2> start or restart the *sCellDeactivationTimer* associated with the SCell in the slot when the SCell Activation/Deactivation MAC CE was received;
 - 2> (re-)initialize any suspended configured uplink grants of configured grant Type 1 associated with this SCell according to the stored configuration, if any, and to start in the symbol according to rules in subclause 5.8.2;
 - 2> trigger PHR according to subclause 5.4.6.
- 1> else if an SCell Activation/Deactivation MAC CE is received deactivating the SCell; or
 - 1> if the *sCellDeactivationTimer* associated with the activated SCell expires:
 - 2> deactivate the SCell according to the timing defined in TS 38.213 [6];
 - 2> stop the *sCellDeactivationTimer* associated with the SCell;
 - 2> stop the *bwp-InactivityTimer* associated with the SCell;
 - 2> clear any configured downlink assignment and any configured uplink grant Type 2 associated with the SCell respectively;
 - 2> suspend any configured uplink grant Type 1 associated with the SCell;
 - 2> flush all HARQ buffers associated with the SCell.
 - 1> if PDCCH on the activated SCell indicates an uplink grant or downlink assignment; or
 - 1> if PDCCH on the Serving Cell scheduling the activated SCell indicates an uplink grant or a downlink assignment for the activated SCell; or
 - 1> if a MAC PDU is transmitted in a configured uplink grant or received in a configured downlink assignment:
 - 2> restart the *sCellDeactivationTimer* associated with the SCell.
 - 1> if the SCell is deactivated:
 - 2> not transmit SRS on the SCell;
 - 2> not report CSI for the SCell;
 - 2> not transmit on UL-SCH on the SCell;
 - 2> not transmit on RACH on the SCell;
 - 2> not monitor the PDCCH on the SCell;
 - 2> not monitor the PDCCH for the SCell;
 - 2> not transmit PUCCH on the SCell.

HARQ feedback for the MAC PDU containing SCell Activation/Deactivation MAC CE shall not be impacted by PCell, PSCell and PUCCH SCell interruptions due to SCell activation/deactivation in TS 38.133 [11].

When SCell is deactivated, the ongoing Random Access procedure on the SCell, if any, is aborted.

[TS 38.321, clause 6.1.3.10]

The SCell Activation/Deactivation MAC CE of one octet is identified by a MAC PDU subheader with LCID as specified in Table 6.2.1-1. It has a fixed size and consists of a single octet containing seven C-fields and one R-field. The SCell Activation/Deactivation MAC CE with one octet is defined as follows (Figure 6.1.3.10-1).

The SCell Activation/Deactivation MAC CE of four octets is identified by a MAC PDU subheader with LCID as specified in Table 6.2.1-1. It has a fixed size and consists of four octets containing 31 C-fields and one R-field. The SCell Activation/Deactivation MAC CE of four octets is defined as follows (Figure 6.1.3.10-2).

For the case with no Serving Cell with a *ServCellIndex* as specified in TS 38.331 [8] larger than 7, SCell Activation/Deactivation MAC CE of one octet is applied, otherwise SCell Activation/Deactivation MAC CE of four octets is applied.

- C_i : If there is an SCell configured for the MAC entity with *SCellIndex* i as specified in TS 38.331 [8], this field indicates the activation/deactivation status of the SCell with *SCellIndex* i , else the MAC entity shall ignore the C_i field. The C_i field is set to "1" to indicate that the SCell with *SCellIndex* i shall be activated. The C_i field is set to "0" to indicate that the SCell with *SCellIndex* i shall be deactivated;
- R: Reserved bit, set to "0".

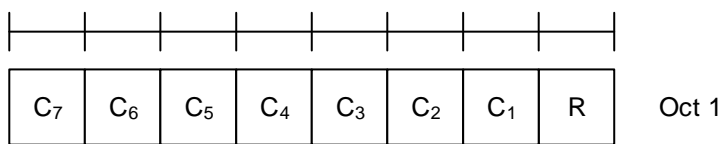

Figure 6.1.3.10-1: SCell Activation/Deactivation MAC CE of one octet

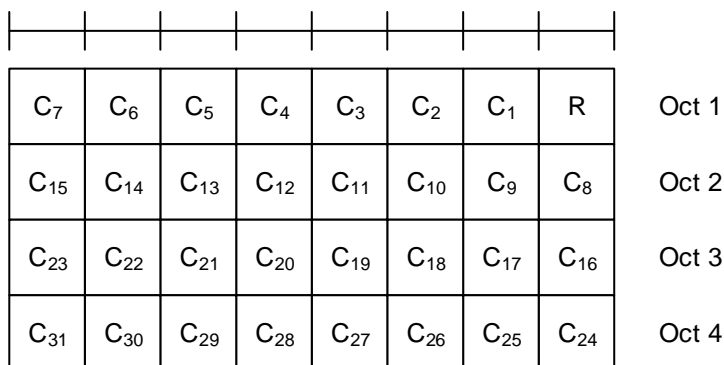

Figure 6.1.3.10-2: SCell Activation/Deactivation MAC CE of four octets

7.1.1.7.1.1.3 Test description

7.1.1.7.1.1.3.1 Pre-test conditions

Same Pre-test conditions as in clause 7.1.1.0 with the additional NR Cell 3 (intra band CA) or Cell 10(inter band CA) is configured as NR Active Scell.

7.1.1.7.1.1.3.2 Test procedure sequence

Table 7.1.1.7.1.1.3.2-1: Time instances of cell power level and parameter changes

	Parameter	Unit	NR Cell 1	NR Cell 3 or 10
T0	Cell-specific RS EPRE	dBm/15k Hz	-85	-85

Table 7.1.1.7.1.1.3.2-2: Main behaviour

St	Procedure	Message Sequence		TP	Verdict
		U - S	Message		
1	SS transmits an RRCReconfiguration message to configure SCell (NR Cell 3 or Cell 10). Note 1	<--	(RRCReconfiguration)	-	-
2	The UE transmits RRCReconfigurationComplete message. Note 2	-->	(RRCReconfigurationComplete)	-	-
3	The SS transmits Activation MAC control element to activate SCell on NR SpCell.	<--	MAC PDU (SCell Activation/Deactivation MAC CE of one octet (C ₁ =1))	-	-
4	200 ms after step 3, the SS indicates a new transmission on PDCCH of SCell and transmits a MAC PDU (containing an RLC PDU)	<--	MAC PDU	-	-
5	Check: Does the UE transmit a Scheduling Request on PUCCH?	-->	(SR)	1	P
6	The SS sends an UL grant suitable for transmitting loop back PDU on NRSpCell.	<--	(UL Grant)	-	-
7	The UE transmit a MAC PDU containing the loop back PDU corresponding to step 4.	-->	MAC PDU	-	-
8	The SS transmits a MAC PDU containing RLC status PDU acknowledging reception of RLC PDU in step 7 on NR SpCell	<--	MAC PDU	-	-
9	400 ms after step 4, the SS indicates a new transmission on PDCCH of NR Scell and transmits a MAC PDU (containing an RLC PDU)	<--	MAC PDU	-	-
10	Check: Does the UE transmit a Scheduling Request on PUCCH in next 1 second?	-->	(SR)	2	F
11	The SS transmits Activation MAC control element to activate SCell on NR SpCell.	<--	MAC PDU ((SCell Activation/Deactivation MAC CE of one octet (C ₁ =1))	-	-
12	200 ms after step 11 The SS indicates a new transmission on PDCCH of NR Scell and transmits a MAC PDU (containing just padding or RLC status PDU, but no RLC data PDU)	<--	MAC PDU	-	-
13	400 ms after step 11 the SS indicates a new transmission on PDCCH of NR Scell and transmits a MAC PDU (containing an RLC PDU)	<--	MAC PDU	-	-
14	Check: Does the UE transmit a Scheduling Request on PUCCH?	-->	(SR)	1,3	P
15	The SS sends an UL grant suitable for transmitting loop back PDU on NR SpCell.	<--	(UL Grant)	-	-
16	The UE transmits a MAC PDU containing the loop back PDU corresponding to step 12	-->	MAC PDU	-	-
17	The SS transmits a MAC PDU containing RLC status PDU acknowledging reception of RLC PDU in step 16	<--	MAC PDU	-	-
18	The SS transmits Deactivation MAC control element to de-activate SCell.	<--	MAC PDU (SCell Activation/Deactivation MAC CE of one octet (C ₁ =0))	-	-
19	The SS indicates a new transmission on PDCCH of NR Scell and transmits a MAC PDU (containing an RLC PDU)	<--	MAC PDU	-	-
20	Check: Does the UE transmit a Scheduling Request on PUCCH in next 1 second?	-->	(SR)	4	F
Note 1: for EN-DC the NR <i>RRCReconfiguration</i> message is contained in <i>RRCConnectionReconfiguration</i> . Note 2: for EN-DC the NR <i>RRCReconfigurationComplete</i> message is contained in <i>RRCConnectionReconfigurationComplete</i> .					

7.1.1.7.1.1.3.3 Specific message contents

Table 7.1.1.7.1.1.3.3-1: RRCReconfiguration (step 1, Table 7.1.1.7.1.1.3.2-2)

Derivation Path: TS 38.508-1 [4], Table 4.6.1-13.			
Information Element	Value/remark	Comment	Condition
RRCReconfiguration ::= SEQUENCE {			
criticalExtensions CHOICE {			
c1 CHOICE {			
rrcReconfiguration ::= SEQUENCE {			
radioBearerConfig	RadioBearerConfig	TS 38.508-1 [4] table 4.6.3-132 condition SRB3	
secondaryCellGroup	CellGroupConfig		
}			
}			
}			
}			

Table 7.1.1.7.1.1.3.3-2: CellGroupConfig (Table 7.1.1.7.1.1.3.3-1)

Derivation Path: TS 38.508-1 [4], Table 4.6.3-19.			
Information Element	Value/remark	Comment	Condition
CellGroupConfig ::= SEQUENCE {			
sCellToAddModList SEQUENCE (SIZE (1..maxMeasId)) OF SEQUENCE {			
sCellIndex[1]	1		
sCellConfigCommon[1]	ServingCellConfigCommon		
sCellConfigDedicated[1]	ServingCellConfig		
}			
}			

Table 7.1.1.7.1.1.3.3-3: ServingCellConfigCommon (Table 7.1.1.7.1.1.3.3-2)

Derivation Path: TS 38.508-1 [4], Table 4.6.3-168.			
Information Element	Value/remark	Comment	Condition
ServingCellConfigCommon ::= SEQUENCE {			
physCellId	Physical Cell Identity of NR Cell 3/Cell 10		
}			

Table 7.1.1.7.1.1.3.3-4: ServingCellConfig (Table 7.1.1.7.1.1.3.3-2)

Derivation Path: TS 38.508-1 [4], Table 4.6.3-167.			
Information Element	Value/remark	Comment	Condition
ServingCellConfig ::= SEQUENCE {			
sCellDeactivationTimer	ms320		
}			

7.1.1.7.1.2 Activation/Deactivation of SCells / Activation/Deactivation MAC control element reception / sCellDeactivationTimer / Inter-Band CA

The scope and description of the present TC is the same as test case 7.1.1.7.1.1 with the following differences:

- CA configuration: Inter-band CA replaces Intra-band Contiguous CA
- Cells configuration: NR Cell 10 replaces NR Cell 3

7.1.1.7.1.3 Activation/Deactivation of SCells / Activation/Deactivation MAC control element reception / sCellDeactivationTimer / Intra-band non-Contiguous CA

The scope and description of the present TC is the same as test case 7.1.1.7.1.1 with the following differences:

- CA configuration: Intra-band non-Contiguous CA replaces Intra-band Contiguous CA

7.1.1.8 Bandwidth Part (BWP) operation

7.1.1.8.1 Bandwidth Part (BWP) operation UL/DL

Editor's Note: In the definition of *ServingCellConfig* IE in TS 38.331 cl. 6.3.3, the explanation of condition "SyncAndCellAdd" used for fields "firstActiveDownlinkBWP-Id" and "firstActiveUplinkBWP-Id" suggests (= "... For SpCell, the field is optionally present, Need N, upon reconfiguration without reconfigurationWithSync. ...") that - not only for EN-DC but also for SA - the FirstActive BWP can be configured via RRC Reconfiguration message. The test design for checking of TP (1) is based on this assumption.

7.1.1.8.1.1 Test Purpose (TP)

(1)

```
with { UE in RRC_CONNECTED state }
ensure that {
  when { BandwidthPart-Config IE is included in RRC Message received on SpCell (i.e. PCell in case
of EN-DC or PCell in case of SA) }
    then { UE starts normal MAC operation in the FirstActive UL and DL Bandwidth part }
}
```

(2)

```
with { UE in RRC_CONNECTED state }
ensure that {
  when { UE receives a DL DCI format 1_1 assigning a BWP different than the previously configured
BWP }
    then { UE starts normal MAC operation in the received new BWP }
}
```

(3)

```
with { UE in RRC_CONNECTED }
ensure that {
  when { UE receives a UL DCI format 0_1 assigning a BWP different than the previously configured
BWP }
    then { UE starts normal MAC operation in the received new BWP }
}
```

(4)

```
with { UE in RRC_CONNECTED state }
ensure that {
  when { RACH Procedure is triggered in SpCell (i.e. PCell in case of EN-DC or PCell in case of SA)
and PRACH occasions are not configured}
    then { UE initiates the PRACH procedure in the initial BWP }
}
```

(5)

```
with { UE in RRC_Connected State with defaultDownlinkBWP configured }
ensure that {
  when { bwp-InactivityTimer expires }
    then { UE performs BWP switching to a BWP indicated by the defaultDownlinkBWP }
}
```

(6)

```

with { UE in RRC_Connected State with defaultDownlinkBWP configured and Active BWP is different than
defaultDownlinkBWP and bwp-InactivityTimer is running }
ensure that {
  when { UE receives UL assignment or DL grant addressed to its C-RNTI }
  then { UE restarts the bwp-InactivityTimer }
}

```

7.1.1.8.1.2 Conformance requirements

References: The conformance requirements covered in the present TC are specified in: TS 38.211 clause 4.4.5, TS 38.212 clause 7.3.1.1.2 and 7.3.1.2.2, TS 38.321 clause 5.15 and TS 38.331 clause 5.3.5.3 and 6.3.2. Unless otherwise stated these are Rel-15 requirements.

[TS 38.211, clause 4.4.5]

A bandwidth part is a subset of contiguous common resource blocks defined in subclause 4.4.4.3 for a given numerology μ_i in bandwidth part i on a given carrier. The starting position $N_{\text{BWP},i}^{\text{start},\mu}$ and the number of resource blocks $N_{\text{BWP},i}^{\text{size},\mu}$ in a bandwidth part shall fulfil $N_{\text{grid},x}^{\text{start},\mu} \leq N_{\text{BWP},i}^{\text{start},\mu} < N_{\text{grid},x}^{\text{start},\mu} + N_{\text{grid},x}^{\text{size},\mu}$ and $N_{\text{grid},x}^{\text{start},\mu} < N_{\text{BWP},i}^{\text{size},\mu} + N_{\text{BWP},i}^{\text{start},\mu} \leq N_{\text{grid},x}^{\text{start},\mu} + N_{\text{grid},x}^{\text{size},\mu}$, respectively. Configuration of a bandwidth part is described in clause 12 of [5, TS 38.213].

A UE can be configured with up to four bandwidth parts in the downlink with a single downlink bandwidth part being active at a given time. The UE is not expected to receive PDSCH, PDCCH, or CSI-RS (except for RRM) outside an active bandwidth part.

A UE can be configured with up to four bandwidth parts in the uplink with a single uplink bandwidth part being active at a given time. If a UE is configured with a supplementary uplink, the UE can in addition be configured with up to four bandwidth parts in the supplementary uplink with a single supplementary uplink bandwidth part being active at a given time. The UE shall not transmit PUSCH or PUCCH outside an active bandwidth part. For an active cell, the UE shall not transmit SRS outside an active bandwidth part.

Unless otherwise noted, the description in this specification applies to each of the bandwidth parts. When there is no risk of confusion, the index μ may be dropped from $N_{\text{BWP},i}^{\text{start},\mu}$, $N_{\text{BWP},i}^{\text{size},\mu}$, $N_{\text{grid},x}^{\text{start},\mu}$, and $N_{\text{grid},x}^{\text{size},\mu}$.

[TS 38.212, clause 7.3.1.1.2]

DCI format 0_1 is used for the scheduling of PUSCH in one cell.

The following information is transmitted by means of the DCI format 0_1 with CRC scrambled by C-RNTI or CS-RNTI or SP-CSI-RNTI or MCS-C-RNTI:

- Identifier for DCI formats – 1 bit
 - The value of this bit field is always set to 0, indicating an UL DCI format
- Carrier indicator – 0 or 3 bits, as defined in Subclause 10.1 of [5, TS 38.213].
- UL/SUL indicator – 0 bit for UEs not configured with SUL in the cell or UEs configured with SUL in the cell but only PUCCH carrier in the cell is configured for PUSCH transmission; 1 bit for UEs configured with SUL in the cell as defined in Table 7.3.1.1.1-1.
- Bandwidth part indicator – 0, 1 or 2 bits as determined by the number of UL BWPs $n_{\text{BWP,RRC}}$ configured by higher layers, excluding the initial UL bandwidth part. The bitwidth for this field is determined as $\lceil \log_2(n_{\text{BWP}}) \rceil$ bits, where
 - $n_{\text{BWP}} = n_{\text{BWP,RRC}} + 1$ if $n_{\text{BWP,RRC}} \leq 3$, in which case the bandwidth part indicator is equivalent to the ascending order of the higher layer parameter *BWP-Id*;
 - otherwise $n_{\text{BWP}} = n_{\text{BWP,RRC}}$, in which case the bandwidth part indicator is defined in Table 7.3.1.1.2-1;

If a UE does not support active BWP change via DCI, the UE ignores this bit field.

[TS 38.212, clause 7.3.1.2.2]

DCI format 1_1 is used for the scheduling of PDSCH in one cell.

The following information is transmitted by means of the DCI format 1_1 with CRC scrambled by C-RNTI or CS-RNTI or MCS-C-RNTI:

- Identifier for DCI formats – 1 bits
 - The value of this bit field is always set to 1, indicating a DL DCI format
- Carrier indicator – 0 or 3 bits as defined in Subclause 10.1 of [5, TS 38.213].
- Bandwidth part indicator – 0, 1 or 2 bits as determined by the number of DL BWPs $n_{\text{BWP,RRC}}$ configured by higher layers, excluding the initial DL bandwidth part. The bitwidth for this field is determined as $\lceil \log_2(n_{\text{BWP}}) \rceil$ bits, where
 - $n_{\text{BWP}} = n_{\text{BWP,RRC}} + 1$ if $n_{\text{BWP,RRC}} \leq 3$, in which case the bandwidth part indicator is equivalent to the higher layer parameter *BWP-Id*;
 - otherwise $n_{\text{BWP}} = n_{\text{BWP,RRC}}$, in which case the bandwidth part indicator is defined in Table 7.3.1.1.2-1;

If a UE does not support active BWP change via DCI, the UE ignores this bit field.

[TS 38.321, clause 5.15]

In addition to clause 12 of TS 38.213 [6], this subclause specifies requirements on BWP operation.

A Serving Cell may be configured with one or multiple BWPs, and the maximum number of BWP per Serving Cell is specified in TS 38.213 [6].

The BWP switching for a Serving Cell is used to activate an inactive BWP and deactivate an active BWP at a time. The BWP switching is controlled by the PDCCH indicating a downlink assignment or an uplink grant, by the *bwp-InactivityTimer*, by RRC signalling, or by the MAC entity itself upon initiation of Random Access procedure. Upon RRC (re-)configuration of *firstActiveDownlinkBWP-Id* and/or *firstActiveUplinkBWP-Id* for SpCell or activation of an SCell, the DL BWP and/or UL BWP indicated by *firstActiveDownlinkBWP-Id* and/or *firstActiveUplinkBWP-Id* respectively (as specified in TS 38.331 [5]) is active without receiving PDCCH indicating a downlink assignment or an uplink grant. The active BWP for a Serving Cell is indicated by either RRC or PDCCH (as specified in TS 38.213 [6]). For unpaired spectrum, a DL BWP is paired with a UL BWP, and BWP switching is common for both UL and DL.

For each activated Serving Cell configured with a BWP, the MAC entity shall:

- 1> if a BWP is activated:
 - 2> transmit on UL-SCH on the BWP;
 - 2> transmit on RACH on the BWP, if PRACH occasions are configured;
 - 2> monitor the PDCCH on the BWP;
 - 2> transmit PUCCH on the BWP, if configured;
 - 2> report CSI for the BWP;
 - 2> transmit SRS on the BWP, if configured;
 - 2> receive DL-SCH on the BWP;
 - 2> (re-)initialize any suspended configured uplink grants of configured grant Type 1 on the active BWP according to the stored configuration, if any, and to start in the symbol according to rules in subclause 5.8.2.
- 1> if a BWP is deactivated:
 - 2> not transmit on UL-SCH on the BWP;
 - 2> not transmit on RACH on the BWP;

- 2> not monitor the PDCCH on the BWP;
- 2> not transmit PUCCH on the BWP;
- 2> not report CSI for the BWP;
- 2> not transmit SRS on the BWP;
- 2> not receive DL-SCH on the BWP;
- 2> clear any configured downlink assignment and configured uplink grant of configured grant Type 2 on the BWP;
- 2> suspend any configured uplink grant of configured grant Type 1 on the inactive BWP.

Upon initiation of the Random Access procedure on a Serving Cell, after the selection of carrier for performing Random Access procedure as specified in subclause 5.1.1, the MAC entity shall for the selected carrier of this Serving Cell:

- 1> if PRACH occasions are not configured for the active UL BWP:
 - 2> switch the active UL BWP to BWP indicated by *initialUplinkBWP*;
 - 2> if the Serving Cell is a SpCell:
 - 3> switch the active DL BWP to BWP indicated by *initialDownlinkBWP*.
- 1> else:
 - 2> if the Serving Cell is a SpCell:
 - 3> if the active DL BWP does not have the same *bwp-Id* as the active UL BWP:
 - 4> switch the active DL BWP to the DL BWP with the same *bwp-Id* as the active UL BWP.
- 1> stop the *bwp-InactivityTimer* associated with the active DL BWP of this Serving Cell, if running.
- 1> if the Serving Cell is SCell:
 - 2> stop the *bwp-InactivityTimer* associated with the active DL BWP of SpCell, if running.
- 1> perform the Random Access procedure on the active DL BWP of SpCell and active UL BWP of this Serving Cell.

If the MAC entity receives a PDCCH for BWP switching of a Serving Cell, the MAC entity shall:

- 1> if there is no ongoing Random Access procedure associated with this Serving Cell; or
- 1> if the ongoing Random Access procedure associated with this Serving Cell is successfully completed upon reception of this PDCCH addressed to C-RNTI (as specified in subclauses 5.1.4 and 5.1.5):
 - 2> perform BWP switching to a BWP indicated by the PDCCH.

If the MAC entity receives a PDCCH for BWP switching for a Serving Cell while a Random Access procedure associated with that Serving Cell is ongoing in the MAC entity, it is up to UE implementation whether to switch BWP or ignore the PDCCH for BWP switching, except for the PDCCH reception for BWP switching addressed to the C-RNTI for successful Random Access procedure completion (as specified in subclauses 5.1.4 and 5.1.5) in which case the UE shall perform BWP switching to a BWP indicated by the PDCCH. Upon reception of the PDCCH for BWP switching other than successful contention resolution, if the MAC entity decides to perform BWP switching, the MAC entity shall stop the ongoing Random Access procedure and initiate a Random Access procedure after performing the BWP switching; if the MAC decides to ignore the PDCCH for BWP switching, the MAC entity shall continue with the ongoing Random Access procedure on the Serving Cell.

Upon reception of RRC (re-)configuration for BWP switching for a Serving Cell while a Random Access procedure associated with that Serving Cell is ongoing in the MAC entity, the MAC entity shall stop the ongoing Random Access procedure and initiate a Random Access procedure after performing the BWP switching.

The MAC entity shall for each activated Serving Cell configured with *bwp-InactivityTimer*:

- 1> if the *defaultDownlinkBWP-Id* is configured, and the active DL BWP is not the BWP indicated by the *defaultDownlinkBWP-Id*; or
- 1> if the *defaultDownlinkBWP-Id* is not configured, and the active DL BWP is not the *initialDownlinkBWP*:
 - 2> if a PDCCH addressed to C-RNTI or CS-RNTI indicating downlink assignment or uplink grant is received on the active BWP; or
 - 2> if a PDCCH addressed to C-RNTI or CS-RNTI indicating downlink assignment or uplink grant is received for the active BWP; or
 - 2> if a MAC PDU is transmitted in a configured uplink grant or received in a configured downlink assignment:
 - 3> if there is no ongoing random access procedure associated with this Serving Cell; or
 - 3> if the ongoing Random Access procedure associated with this Serving Cell is successfully completed upon reception of this PDCCH addressed to C-RNTI (as specified in subclauses 5.1.4 and 5.1.5):
 - 4> start or restart the *bwp-InactivityTimer* associated with the active DL BWP.
 - 2> if the *bwp-InactivityTimer* associated with the active DL BWP expires:
 - 3> if the *defaultDownlinkBWP-Id* is configured:
 - 4> perform BWP switching to a BWP indicated by the *defaultDownlinkBWP-Id*.
 - 3> else:
 - 4> perform BWP switching to the *initialDownlinkBWP*.

NOTE: If a Random Access procedure is initiated on an SCell, both this SCell and the SpCell are associated with this Random Access procedure.

- 1> if a PDCCH for BWP switching is received, and the MAC entity switches the active DL BWP:
 - 2> if the *defaultDownlinkBWP-Id* is configured, and the MAC entity switches to the DL BWP which is not indicated by the *defaultDownlinkBWP-Id*; or
 - 2> if the *defaultDownlinkBWP-Id* is not configured, and the MAC entity switches to the DL BWP which is not the *initialDownlinkBWP*:
 - 3> start or restart the *bwp-InactivityTimer* associated with the active DL BWP.

[TS 38.331, clause 5.2.1]

System Information (SI) is divided into the *MIB* and a number of SIBs where:

- ...
- For a UE in RRC_CONNECTED, the network can provide system information through dedicated signalling using the *RRCReconfiguration* message, e.g. if the UE has an active BWP with no common search space configured to monitor system information or paging.
- For PSCell and SCells, the network provides the required SI by dedicated signalling, i.e. within an *RRCReconfiguration* message. Nevertheless, the UE shall acquire MIB of the PSCell to get SFN timing of the SCG (which may be different from MCG). Upon change of relevant SI for SCell, RAN releases and adds the concerned SCell. For PSCell, SI can only be changed with Reconfiguration with Sync.

NOTE: The physical layer imposes a limit to the maximum size a SIB can take. The maximum *SIB1* or *SI* message size is 2976 bits.

[TS 38.331, clause 5.3.5.3]

The UE shall perform the following actions upon reception of the *RRCReconfiguration*:

...

- 1> if the UE is configured with E-UTRA *nr-SecondaryCellGroupConfig* (MCG is E-UTRA):
 - 2> if *RRCReconfiguration* was received via SRB1:
 - 3> submit the *RRCReconfigurationComplete* via the EUTRA MCG embedded in E-UTRA RRC message *RRCConnectionReconfigurationComplete* as specified in TS 36.331 [10];
 - 3> if *reconfigurationWithSync* was included in *spCellConfig* of an SCG:
 - 4> initiate the random access procedure on the SpCell, as specified in TS 38.321 [3];

...

NOTE: For EN-DC, in the case *RRCReconfiguration* is received via SRB1, the random access is triggered by RRC layer itself as there is not necessarily other UL transmission. In the case *RRCReconfiguration* is received via SRB3, the random access is triggered by the MAC layer due to arrival of *RRCReconfigurationComplete*.

[TS 38.331, clause 6.3.2]

- | | |
|---------------|---------------------|
| 7.1.1.8.1.3 | Test description |
| 7.1.1.8.1.3.1 | Pre-test conditions |
- Same Pre-test conditions as in clause 7.1.1.0.

7.1.1.8.1.3.2 Test procedure sequence

Table 7.1.1.8.1.3.2-1: Main behaviour

St	Procedure	Message Sequence		TP	Verdict
		U - S	Message		
0	The SS transmits RRCReconfiguration to configure the dedicated BWPs incl. the FirstActive BWP. (Note 1) (Note 4).	<--	(RRCReconfiguration)	-	-
-	EXCEPTION: Steps 0Aa1 to 0Ab2 describe behaviour which depends on procedure parameters; the "lower case letter" identifies a step sequence that take place if a procedure parameter has a particular value.	-	-	-	-
0A a1	IF pc_EN_DC = TRUE OR pc_NGEN_DC = TRUE, the UE sends RRCReconfigurationComplete (Note 2).	-->	(RRCReconfigurationComplete)	-	-
0A b1	IF pc_NG_RAN_NR = TRUE, the SS allocates (transmitted in FirstActiveDownlinkBWP) an UL Grant with DCI format 0_1 indicating FirstActiveUplinkBWP (BWP#1).	<--	UL Grant	-	-
0A b2	Check: Does the UE send RRCReconfigurationComplete in the FirstActive BWP configured. (Note 2) (Note 3)	-->	(RRCReconfigurationComplete)	1	P
1	The SS transmits a valid MAC PDU containing RLC PDU in the configured FirstActive Downlink BWP configured.	<--	MAC PDU	-	-
2	The SS allocates (transmitted in FirstActiveDownlinkBWP) an UL Grant.	<--	UL Grant	-	-
3	Check: Does the UE send RRCReconfigurationComplete in the FirstActive BWP configured. (Note 2) (Note 3)	-->	MAC PDU	1	P
4	VOID			-	-
5	The SS indicates on PDCCH (transmitted in Downlink BWP#1) DL DCI format 1_1 with new BWP Id (= BWP #2) and transmits a MAC PDU containing RLC PDU on the newly configured BWP (i.e. Downlink BWP#2).	<--	MAC PDU	-	-
6	The SS allocates (transmitted in Downlink BWP#2) an UL Grant (with DCI indicating BWP#2), sufficient for loopback of the RLC SDU from step 5 in a Slot. (Note 3)	<--	UL Grant	-	-
7	Check: Does the UE transmit a MAC PDU including one RLC SDU in the configured BWP (i.e. Uplink BWP#2)?	-->	MAC PDU	2	P
8	VOID	-	-	-	-
9	The SS transmits a valid MAC PDU containing RLC PDU in the configured BWP (i.e. Downlink BWP#2).	<--	MAC PDU	-	-

10	The SS indicates on PDCCH (transmitted in Downlink BWP#2) UL DCI format 0_1 with new BWP Id (= BWP #3) and allocates an UL Grant, sufficient for loopback of the RLC SDU from step 9 in a Slot.	<--	UL Grant	-	-
11	Check: Does the UE transmit a MAC PDU including one RLC SDU in the configured BWP (i.e. Uplink BWP#3 for FDD andfor TDD)?	-->	MAC PDU	3	P
12	The SS indicates PDCCH order (transmitted in Downlink BWP#2 for FDD resp. Downlink BWP#3 for TDD).	<--	-	-	-
13	Check: Does the UE sendPRACH Preamble?	-->	PRACH Preamble	-	-
13 A	The SS transmits (in Downlink BWP #0) a MAC PDU addressed to UE RA-RNTI, containing RAR with matching RAPID in MAC sub header.	<--	Random Access Response	-	-
13 B	The UE sends (in UL BWP#0) a msg3 in the grant associated to the received Random Access Response.	-->	msg3 (C-RNTI MAC CONTROL ELEMENT)	4	P
13 C	SS schedules (in Downlink BWP#0) PDCCH transmission for UE C-RNTI and allocates UL grant.	<--	Contention Resolution	-	-
14	The SS transmits RRCReconfiguration with ServingCellConfig IE containing only IE bwp-InactivityTimer and IE defaultDownlinkBWP-ID. (Note 1) (Note 4)	<--	<i>(RRCReconfiguration)</i>	-	-
15	The UE sends RRCReconfigurationComplete. (Note 2)	-->	<i>(RRCReconfigurationComplete)</i>	-	-
16	The SS transmits a valid MAC PDU containing RLC PDU in the active BWP (i.e. Downlink BWP#0).	<--	MAC PDU	-	-
17	Within 400 ms from step 16, the SS transmits another valid MAC PDU containing RLC PDU in the active BWP (i.e. Downlink BWP#0).	<--	MAC PDU	-	-
18	Within 400 ms from step 17, the SS allocates (transmitted in Downlink BWP#0) an UL Grant, sufficient for loopback of one RLC SDU containing both MAC PDUs from steps 16 and 17 in a Slot.	<--	UL Grant	-	-
19	Check: Does the UE transmit both MAC PDUs in the active BWP (i.e. Uplink BWP#0)?	-->	2x MAC PDU	6	P
20	The SS waits 1000 ms from step 18 to ensure that the bwp-InactivityTimer expired and then transmits a valid MAC PDU containing RLC PDU in the BWP with defaultDownlinkBWP-Id (= Downlink BWP#2).	<--	MAC PDU	-	-

21	The SS allocates (transmitted in the defaultDownlinkBWP, i.e. Downlink BWP#2) an UL Grant, sufficient for loopback of the RLC SDU from step 20 in a Slot.	<--	UL Grant	-	-
22	Check: Does the UE transmit a MAC PDU in Uplink BWP#2 (= BWP Id of the defaultDownlinkBWP).	-->	MAC PDU	5	P
<p>Note 1: for EN-DC the NR <i>RRCReconfiguration</i> message is contained in <i>RRCConnectionReconfiguration</i>.</p> <p>Note 2: for EN-DC the NR <i>RRCReconfigurationComplete</i> message is contained in <i>RRCConnectionReconfigurationComplete</i>.</p> <p>Note 3: In paired spectrum (= FDD), the switching of Downlink BWP and Uplink BWP can happen independently. Whereas in TDD, the switching of BWP for Downlink and Uplink is always at the same time instance. Currently, the scope of the Test Purposes (TP) is considered to <u>not</u> cover checking of a BWP deviation which results from non-synchronized Downlink and Uplink BWP switching in FDD.</p> <p>Note 4: After the preamble the UE is in RRC_CONNECTED, therefore SRBs and DRBs are already established. The RRCReconfiguration message in step 1 and step 14 shall not contain any elements like e.g. "rlc-BearerToAddModList" whose value(s) remain unchanged since the preamble. The sole purpose of the RRCReconfiguration message in step 1 and 14 is to configure BWPs and related fields for switching of BWPs.</p>					

7.1.1.8.1.3.3 Specific message contents

Table 7.1.1.8.1.3.3-1: RRCReconfiguration (step 0)

Derivation Path: TS 38.508-1 [6], Table 4.6.1-13 (see also Note 4 in Table 7.1.1.8.1.3.2-1)			
Information Element	Value/remark	Comment	Condition
RRCReconfiguration ::= SEQUENCE {			
criticalExtensions CHOICE {			
rrcReconfiguration ::= SEQUENCE {			
secondaryCellGroup	CellGroupConfig		EN-DC
nonCriticalExtension SEQUENCE {			NR
masterCellGroup	CellGroupConfig		
}			
}			
}			
}			

Table 7.1.1.8.1.3.3-1A: CellGroupConfig (Table 7.1.1.8.1.3.3-1)

Derivation Path: TS 38.331 [6], clause 6.3.2			
Information Element	Value/remark	Comment	Condition
CellGroupConfig ::= SEQUENCE {			
cellGroupId	CellGroupId	TS 38.508-1 default value	
rlc-BearerToAddModList	Not present		
rlc-BearerToReleaseList	Not present		
mac-CellGroupConfig	Not present		
physicalCellGroupConfig	Not present		
spCellConfig SEQUENCE {			
servCellIndex	Not present		
	ServCellIndex		EN-DC
reconfigurationWithSync	Not present		
rlf-TimersAndConstants	Not present		
rlmInSyncOutOfSyncThreshold	Not present		
spCellConfigDedicated	ServingCellConfig		
}			
sCellToAddModList	Not present		
sCellToReleaseList	Not present		
reportUplinkTxDirectCurrent-v1530	true		
}			

Table 7.1.1.8.1.3.3-1A: SIB1 (preamble, for SA)

Table 4.6.1-28			

Table 7.1.1.8.1.3.3-2: ServingCellConfig (Table 7.1.1.8.1.3.3-1A)

Table 4.6.3-167			

Derivation Path: TS 38.331 [6] clause 6.3.2			
Information Element	Value/remark	Comment	Condition
ServingCellConfig ::= SEQUENCE {			
tdd-UL-DL-ConfigurationDedicated	Not present		
	TDD-UL-DL-ConfigDedicated		TDD
.. initialDownlinkBWP	Not present		
downlinkBWP-ToReleaseList	Not present		
downlinkBWP-ToAddModList SEQUENCE (SIZE (1..maxNrofBWPs)) OF SEQUENCE {			
BWP-Downlink[1]	BWP-Downlink-BWP-N with condition BWP#1		
BWP-Downlink[2]	BWP-Downlink-BWP-N with condition BWP#1		
BWP-Downlink[3]	BWP-Downlink-BWP-N with condition BWP#1		
}			
firstActiveDownlinkBWP-Id	1		
bwp-InactivityTimer	Not present		
defaultDownlinkBWP-Id	Not present		
uplinkConfig SEQUENCE {			
initialUplinkBWP	Not present		
uplinkBWP-ToReleaseList	Not present		
uplinkBWP-ToAddModList SEQUENCE (SIZE (1..maxNrofBWPs)) OF SEQUENCE {			
BWP-Uplink[1]	BWP-Uplink-BWP-N with condition BWP#1		
BWP-Uplink[2]	BWP-Uplink-BWP-N with condition BWP#1		
BWP-Uplink[3]	BWP-Uplink-BWP-N with condition BWP#1		
}			
firstActiveUplinkBWP-Id	1		
pusch-ServingCellConfig	Not present		
carrierSwitching	Not present		
}			
supplementaryUplink	Not present		
pdcch-ServingCellConfig	Not present		
pdsch-ServingCellConfig	Not present		
csi-MeasConfig	Not present		
sCellDeactivationTimer	Not present		
crossCarrierSchedulingConfig	Not present		
tag-Id	TAG-Id	TS 38.508-1 default value	
dummy	Not present		
lte-CRS-ToMatchAround	Not present		
downlinkChannelBW-PerSCS-List	Not present		
}			

Condition	Explanation
BWP#1	Bandwidth part 1
BWP#2	Bandwidth part 2
BWP#3	Bandwidth part 3

Table 7.1.1.8.1.3.3-2A: BWP-Downlink-BWP-N (Table 7.1.1.8.1.3.3-2 and Table 7.1.1.8.1.3.3-4)

Derivation Path: TS 38.508-1 [4], Table 4.6.3-5			
Information Element	Value/remark	Comment	Condition
BWP-Downlink ::= SEQUENCE {			
bwp-Id	1		BWP#1
	2		BWP#2
	3		BWP#3
bwp-Common SEQUENCE {			
genericParameters SEQUENCE {			
locationAndBandwidth	1381	NOTE	BWP#1
	1387	NOTE	BWP#2
	1393	NOTE	BWP#3
}			
pdccch-ConfigCommon	Not present	no cell specific configuration for dedicated BWP	
pdsch-ConfigCommon	Not present	no cell specific configuration for dedicated BWP	
}			
bwp-Dedicated SEQUENCE {			
pdccch-Config CHOICE {			
setup	PDCCH-Config-BWP-N		
}			
pdsch-Config CHOICE {			
setup	PDSCH-Config-BWP-N		
}			
}			
}			
NOTE: According to TS 38.214 [21] clause 5.1.2.2.2 with $N_{\text{BWP}}^{\text{size}}=275$, $L_{\text{RBs}}=6$ and $\text{RB}_{\text{Start}}=6,12,18$ for BWP#1,2,3			

Table 7.1.1.8.1.3.3-2B: PDCCH-Config-BWP-N (Table 7.1.1.8.1.3.3-2A)

Derivation Path: TS 38.508-1 [4], Table 4.6.3-95			
Information Element	Value/remark	Comment	Condition
PDCCH-Config ::= SEQUENCE {			
controlResourceSetToAddModList SEQUENCE (SIZE (1..3)) OF SEQUENCE {	1 entry		
ControlResourceSet[1]	ControlResourceSet-BWP-N with condition BWP#N		
}			
searchSpacesToAddModList SEQUENCE (SIZE (1..10)) OF SEQUENCE {	1 entry		
SearchSpace[1]	SearchSpace-BWP-N with condition BWP#N		
}			
}			

Table 7.1.1.8.1.3.3-2C: PDSCH-Config (Table 7.1.1.8.1.3.3-2A)

Derivation Path: TS 38.508-1 [4], Table 4.6.3-100			
Information Element	Value/remark	Comment	Condition
PDSCH-Config ::= SEQUENCE {			
pdsch-TimeDomainAllocationList	PDSCH-TimeDomainResourceAllocationList		
}			

Table 7.1.1.8.1.3.3-2D: ControlResourceSet-BWP-N (Table 7.1.1.8.1.3.3-2B)

Derivation Path: TS 38.508-1 [4], Table 4.6.3-28			
Information Element	Value/remark	Comment	Condition
ControlResourceSet ::= SEQUENCE {			
controlResourceSetId	9		BWP#1
	10		BWP#2
	11		BWP#3
frequencyDomainResources	10000000 00000000 00000000 00000000 00000000 000000	CORESET to use the least significant 6 RBs of each BWP	
duration	2	SearchSpace duration of 2 symbols	
}			

Table 7.1.1.8.1.3.3-2E: SearchSpace-BWP-N (Table 7.1.1.8.1.3.3-2B)

Derivation Path: TS 38.508-1 [4], Table 4.6.3-162 with condition USS			
Information Element	Value/remark	Comment	Condition
SearchSpace ::= SEQUENCE {			
searchSpaceId	37		BWP#1
	38		BWP#2
	39		BWP#3
controlResourceSetId	9		BWP#1
	10		BWP#2
	11		BWP#3
nrofCandidates SEQUENCE {			
aggregationLevel1	n0		
aggregationLevel2	n0		
aggregationLevel4	n2		
aggregationLevel8	n0		
aggregationLevel16	n0		
}			
}			

Table 7.1.1.8.1.3.3-2F: BWP-Uplink-BWP-N (Table 7.1.1.8.1.3.3-2 and Table 7.1.1.8.1.3.3-4)

Derivation Path: TS 38.508-1 [4], Table 4.6.3-7A			
Information Element	Value/remark	Comment	Condition
BWP-Uplink ::= SEQUENCE {			
bwp-Id	1		BWP#1
	2		BWP#2
	3		BWP#3
bwp-Common SEQUENCE {			
genericParameters SEQUENCE {			
locationAndBandwidth	[FFS]	NOTE	BWP#1
	[FFS]	NOTE	BWP#2
	[FFS]	NOTE	BWP#3
}			
}			

rach-ConfigCommon	Not present	No cell specific configuration for dedicated BWP	
pusch-ConfigCommon	Not present	no cell specific configuration for dedicated BWP	
pucch-ConfigCommon	Not present	no cell specific configuration for dedicated BWP	
}			
bwp-Dedicated SEQUENCE {			
pucch-Config CHOICE {			
setup	PUCCH-Config-BWP-N		
}			
pusch-Config CHOICE {			
setup	PUSCH-Config-BWP-N		
}			
}			
}			

NOTE: According to TS 38.214 [21] clause 6.1.2.2.2 with $N_{BWP}^{size}=275$, $L_{RBs}=6$ and $RB_{Start}=6,12,18$ for BWP#1,2,3

Condition	Explanation
BWP#1	Bandwidth part 1
BWP#2	Bandwidth part 2
BWP#3	Bandwidth part 3

Table 7.1.1.8.1.3.3-2G: PUCCH-Config-BWP-N (Table 7.1.1.8.1.3.3-2F)

Derivation Path: TS 38.508-1 [4], Table 4.6.3-84			
Information Element	Value/remark	Comment	Condition
PUCCH-Config ::= SEQUENCE {			
[FFS]			
}			

Table 7.1.1.8.1.3.3-2H: PUSCH-Config-BWP-N (Table 7.1.1.8.1.3.3-2F)

Derivation Path: TS 38.508-1 [4], Table 4.6.3-89			
Information Element	Value/remark	Comment	Condition
PUSCH-Config ::= SEQUENCE {			
[FFS]			
}			

Table 7.1.1.8.1.3.3-3: RRCReconfiguration (step 14, Table 7.1.1.8.1.3.2-1)

Derivation Path: TS 38.508-1 [4], Table 4.6.3-15 (see also Note 4 in Table 7.1.1.8.1.3.2-1)			
Information Element	Value/remark	Comment	Condition
RRCReconfiguration ::= SEQUENCE {			
criticalExtensions CHOICE {			
rrcReconfiguration ::= SEQUENCE {			
secondaryCellGroup	CellGroupConfig		EN-DC
nonCriticalExtension SEQUENCE {			NR
masterCellGroup	CellGroupConfig with condition SRB2_DRB1		
}			
}			
}			

Table 7.1.1.8.1.3.3-3A: CellGroupConfig (Table 7.1.1.8.1.3.3-3)

Derivation Path: TS 38.331 [6], clause 6.3.2			
Information Element	Value/remark	Comment	Condition
CellGroupConfig ::= SEQUENCE {			
cellGroupId	CellGroupId		
rlc-BearerToAddModList	Not present		
rlc-BearerToReleaseList	Not present		
mac-CellGroupConfig	Not present		
mac-CellGroupConfig SEQUENCE {	Not present		EN-DC
schedulingRequestConfig SEQUENCE {			
sr-TransMax	n32		
}			
}			
physicalCellGroupConfig	Not present		
spCellConfig SEQUENCE {			
servCellIndex	Not present		
	ServCellIndex		EN-DC
reconfigurationWithSync	Not present		
rlf-TimersAndConstants	Not present		
rlmInSyncOutOfSyncThreshold	Not present		
spCellConfigDedicated	ServingCellConfig		
}			
sCellToAddModList	Not present		
sCellToReleaseList	Not present		
reportUplinkTxDirectCurrent-v1530	true		
}			

Table 7.1.1.8.1.3.3-4: ServingCellConfig (Table 7.1.1.8.1.3.3-3A)

Derivation Path: TS 38.331 [6] clause 6.3.2			
Information Element	Value/remark	Comment	Condition
ServingCellConfig ::= SEQUENCE {			
tdd-UL-DL-ConfigurationDedicated	Not present		
	TDD-UL-DL-ConfigDedicated		TDD
.. initialDownlinkBWP	Not present		
downlinkBWP-ToReleaseList	Not present		
downlinkBWP-ToAddModList SEQUENCE (SIZE (1..maxNrofBWPs)) OF SEQUENCE {			
BWP-Downlink[1]	BWP-Downlink-BWP-N with condition BWP#1		
BWP-Downlink[2]	BWP-Downlink-BWP-N with condition BWP#1		
BWP-Downlink[3]	BWP-Downlink-BWP-N with condition BWP#1		
}			
firstActiveDownlinkBWP-Id	1		
bwp-InactivityTimer	ms500		
defaultDownlinkBWP-Id	2		
uplinkConfig SEQUENCE {			
initialUplinkBWP	Not present		
uplinkBWP-ToReleaseList	Not present		
uplinkBWP-ToAddModList SEQUENCE (SIZE (1..maxNrofBWPs)) OF SEQUENCE {			
BWP-Uplink[1]	BWP-Uplink-BWP-N with condition BWP#1		
BWP-Uplink[2]	BWP-Uplink-BWP-N with condition BWP#2		
BWP-Uplink[3]	BWP-Uplink-BWP-N with condition BWP#3		
}			
firstActiveUplinkBWP-Id	1		
pusch-ServingCellConfig	Not present		
carrierSwitching	Not present		
}			
supplementaryUplink	Not present		
pdcch-ServingCellConfig	Not present		
pdsch-ServingCellConfig	Not present		
csi-MeasConfig	Not present		
sCellDeactivationTimer	Not present		
crossCarrierSchedulingConfig	Not present		
tag-Id	Tag-Id	TS 38.508-1 default value	
dummy	Not present		
lte-CRS-ToMatchAround	Not present		
downlinkChannelBW-PerSCS-List	Not present		
}			

Condition	Explanation
BWP#1	Bandwidth part 1
BWP#2	Bandwidth part 2
BWP#3	Bandwidth part 3

Table 7.1.1.8.1.3.3-5: PDCCH-Config-A (Table 7.1.1.8.1.3.3-2 and 7.1.1.8.1.3.3-4)

Table 4.6.3-95			

Table 7.1.1.8.1.3.3-6: PDSCH-Config-A (Table 7.1.1.8.1.3.3-2 and 7.1.1.8.1.3.3-4)

Table 4.6.3-100			

Table 7.1.1.8.1.3.3-7: PUCCH-Config-A (Table 7.1.1.8.1.3.3-2 and 7.1.1.8.1.3.3-4)

Table 4.6.3-112			

Table 7.1.1.8.1.3.3-8: PUSCH-Config-A (Table 7.1.1.8.1.3.3-2 and 7.1.1.8.1.3.3-4)

Table 4.6.3-118			
-----------------	--	--	--

Table 7.1.1.8.1.3.3-9: PDCCH-Config-B (Table 7.1.1.8.1.3.3-2 and 7.1.1.8.1.3.3-4)

Table 4.6.3-95			

Table 7.1.1.8.1.3.3-10: PDSCH-Config-B (Table 7.1.1.8.1.3.3-2 and 7.1.1.8.1.3.3-4)

Table 4.6.3-100			

Table 7.1.1.8.1.3.3-11: PUCCH-Config-B (Table 7.1.1.8.1.3.3-2 and 7.1.1.8.1.3.3-4)

Table 4.6.3-112			

Table 7.1.1.8.1.3.3-12: PUSCH-Config-B (Table 7.1.1.8.1.3.3-2 and 7.1.1.8.1.3.3-4)

Table 4.6.3-118			

7.1.1.9 MAC Reconfiguration and Reset

7.1.1.9.1 MAC Reset

7.1.1.9.1.1 Test Purpose (TP)

(1)

```
with { UE in RRC_CONNECTED state }
ensure that {
  when { UE MAC is reset, due to reconfiguration with sync on same cell }
  then { UE flushes DL HARQ buffer }
}
```

(2)

```
with { UE in RRC_CONNECTED state }
ensure that {
  when { UE MAC is reset, due to reconfiguration with sync on same cell }
  then { UE considers the next transmission for each DL HARQ process as very first }
```

```
    }
```

(3)

```
with(UE in RRC_CONNECTED state, with Scheduling Request procedure triggered)
ensure that {
  when{ UE MAC is reset, due to reconfiguration with sync on same cell }
  then { UE cancels Scheduling Request procedure }
}
```

(4)

```
with ( UE in RRC_CONNECTED state )
ensure that {
  when{ UE MAC is reset, due to reconfiguration with sync on same cell }
  then { UE flushes UL HARQ buffer }
}
```

(5)

```
with (UE in RRC_CONNECTED state )
ensure that {
  when{ UE MAC is reset, due to reconfiguration with sync on same cell }
  then { UE Considers the next transmission for each UL HARQ process as very first }
}
```

7.1.1.9.1.2 Conformance requirements

References: The conformance requirements covered in the present TC are specified in: TS 38.321, clauses 5.12 and TS 38.331 clause 5.3.5.5.2. Unless otherwise stated these are Rel-15 requirements.

[TS 38.321, clause 5.12]

If a reset of the MAC entity is requested by upper layers, the MAC entity shall:

- 1> initialize B_j for each logical channel to zero;
- 1> stop (if running) all timers;
- 1> consider all *timeAlignmentTimers* as expired and perform the corresponding actions in subclause 5.2;
- 1> set the NDIs for all uplink HARQ processes to the value 0;
- 1> stop, if any, ongoing RACH procedure;
- 1> discard explicitly signalled contention-free Random Access Resources, if any;
- 1> flush Msg3 buffer;
- 1> cancel, if any, triggered Scheduling Request procedure;
- 1> cancel, if any, triggered Buffer Status Reporting procedure;
- 1> cancel, if any, triggered Power Headroom Reporting procedure;
- 1> flush the soft buffers for all DL HARQ processes;
- 1> for each DL HARQ process, consider the next received transmission for a TB as the very first transmission;
- 1> release, if any, Temporary C-RNTI;
- 1> reset *BFI_COUNTER*.

[TS 38.331, clause 5.3.5.5.2]

The UE shall perform the following actions to execute a reconfiguration with sync.

- 1> stop timer T310 for the corresponding SpCell, if running;

- 1> start timer T304 for the corresponding SpCell with the timer value set to t_{304} , as included in the *reconfigurationWithSync*;
- 1> if the *frequencyInfoDL* is included:
- 2> consider the target SpCell to be one on the frequency indicated by the *frequencyInfoDL* with a physical cell identity indicated by the *physCellId*;
- 1> else:
- 2> consider the target SpCell to be one on the frequency of the source SpCell with a physical cell identity indicated by the *physCellId*;
- 1> start synchronising to the DL of the target SpCell;
- 1> apply the specified BCCH configuration defined in 9.1.1.1;
- 1> acquire the *MIB*, which is scheduled as specified in TS 38.213 [13];
- 1> perform the actions specified in clause 5.2.2.4.1

NOTE 1: The UE should perform the reconfiguration with sync as soon as possible following the reception of the RRC message triggering the reconfiguration with sync, which could be before confirming successful reception (HARQ and ARQ) of this message.

NOTE 2: The UE may omit reading the MIB if the UE already has the required timing information, or the timing information is not needed for random access.

- 1> reset the MAC entity of this cell group;
- 1> consider the SCell(s) of this cell group, if configured, to be in deactivated state;
- 1> apply the value of the *newUE-Identity* as the C-RNTI for this cell group;

Editor's Note: Verify that this does not configure some common parameters which are later discarded due to e.g. SCell release or due to LCH release.

- 1> configure lower layers in accordance with the received *spCellConfigCommon*;
- 1> configure lower layers in accordance with any additional fields, not covered in the previous, if included in the received *reconfigurationWithSync*.

7.1.1.9.1.3 Test description

7.1.1.9.1.3.1 Pre-test conditions

Same Pre-test conditions as in clause 7.1.1.0 with the exception that the AM DRB PDCP is configured according to Table 7.1.1.9.1.3.1-1

Table 7.1.1.9.1.3.1-1: PDCP parameters

discardTimer	ms60
--------------	------

7.1.1.9.1.3.2 Test procedure sequence

Table 7.1.1.9.1.3.2-1: Main behaviour

St	Procedure	Message Sequence		TP	Verdict
		U - S	Message		
1	The SS transmits a MAC PDU containing one RLC SDU on DRB, but the CRC is calculated in such a way that it will result in CRC error on UE side.	<--	MAC PDU (1 RLC SDU of 40 bytes on DRB)	-	-
2	The UE transmits a HARQ NACK	-->	HARQ NACK	-	-
3	The SS transmits NR <i>RRCReconfiguration</i> message to perform SCG change with reconfigurationWithSync with the same PSCell. Note 1	<--	(RRCReconfiguration)	-	-
4	The UE transmits an NR <i>RRCReconfigurationComplete</i> message. Note 2	-->	(RRCReconfigurationComplete)	-	-
5	Check: For 100 ms, does the UE transmit any HARQ NACK?	-->	HARQ NACK	1	F
6	The SS transmits a MAC PDU containing RLC SDU on DRB. The HARQ Process and NDI on PDCCH is same as in step 1. The SS shall ensure that the HARQ process used at step 1 will not be used in between steps 3 and 5.	<--	MAC PDU (1 RLC SDU of 40 bytes on DRB)	-	-
7	Check: Does the UE transmit a scheduling request?	-->	(SR)	2	P
8	The SS allocates UL Grant sufficient for one RLC SDU to be loop backed in a TTI, and NDI indicates new transmission	<--	Uplink Grant	-	-
9	The UE transmits a MAC PDU including one RLC SDU	-->	MAC PDU	-	-
10	The SS ignores scheduling requests and does not allocate any uplink grant.	-	-	-	-
11	The SS transmits a MAC PDU containing one RLC SDU on DRB	<--	MAC PDU (1 RLC SDU of 40 bytes on DRB)	-	-
12	The UE transmit a scheduling request	-->	(SR)	-	-
13	Wait for 60ms (Discard timer to expire at UE).	-	-	-	-
14	The SS transmits NR <i>RRCReconfiguration</i> message to perform SCG change with reconfigurationWithSync with the same PSCell. Note 1	<--	(RRCReconfiguration)	-	-
15	The UE transmits an NR <i>RRCReconfigurationComplete</i> message. Note 2	-->	(RRCReconfigurationComplete)	-	-
16	Check: For 100 ms seconds, if UE transmits a scheduling request?	-->	(SR)	3	F
17	The SS transmits a MAC PDU containing RLC SDU on DRB	<--	MAC PDU (1 RLC SDU of 40 bytes on DRB)	-	-
18	The UE transmits a scheduling request	-->	(SR)	-	-
19	The SS allocates an UL Grant for one HARQ process X, sufficient for one RLC SDU to be looped back in a TTI, and NDI indicates new transmission	<--	Uplink Grant	-	-
20	The UE transmit a MAC PDU including one RLC SDU	-->	MAC PDU	-	-
21	Void				
22	The SS transmits NR <i>RRCReconfiguration</i> message to perform SCG change with reconfigurationWithSync with the same PSCell. Note 1	<--	(RRCReconfiguration)	-	-
23	The UE transmits an NR <i>RRCReconfigurationComplete</i> message. Note 2		(RRCReconfigurationComplete)	-	-
24	Void				
25	The SS transmits a MAC PDU containing RLC SDU on DRB. The HARQ Process and NDI on PDCCH is same as in step 17. The SS shall ensure that the HARQ process used at step 17 will not be used in between steps 22 and 23.	<--	MAC PDU (1 RLC SDU of 37 bytes on DRB)	-	-
26	The UE transmits a scheduling request	-->	(SR)	-	-

27	The SS allocates an UL Grant corresponding to HARQ process X, with NDI not toggled compared to step 19 and sufficient for one RLC SDU of up to size 40 bytes to be loop backed in a TTI, and NDI indicates new transmission	<--	Uplink Grant	-	-
28	Check: Does UE transmit a MAC PDU including one RLC SDU of 37 bytes on DRB?	-->	MAC PDU	4,5	P
Note 1: for EN-DC the NR <i>RRCReconfiguration</i> message is contained in <i>RRCConnectionReconfiguration</i> . Note 2: for EN-DC the NR <i>RRCReconfigurationComplete</i> message is contained in <i>RRCConnectionReconfigurationComplete</i> .					

7.1.1.9.1.3.3 Specific message contents

Table 7.1.1.9.1.3.3-1: *RRCReconfiguration* (steps 3, 14 and 22 of Table 7.1.1.9.1.3.2-1)

Derivation Path: 38.508-1 [4], Table 4.6.1-13			
Information Element	Value/remark	Comment	Condition
<i>RRCReconfiguration</i> ::= SEQUENCE {			
<i>criticalExtensions</i> CHOICE {			
<i>rrcReconfiguration</i> ::= SEQUENCE {			
<i>radioBearerConfig</i>	Not Present		NR
<i>secondaryCellGroup</i>	CellGroupConfig with condition EN-DC		EN-DC
<i>nonCriticalExtension</i> SEQUENCE {			NR
<i>masterCellGroup</i>	CellGroupConfig with condition SRB2 and DRB1		
}			
}			
}			
}			

Condition	Explanation
EN-DC	E-UTRA-NR Dual Connectivity
NR	NG-RAN NR Radio Access

7.1.2 RLC

Editor's note: Intended to capture tests of RLC Layer behaviour defined in TS 38.322

7.1.2.1 Default Pre-Test Conditions for all RLC test cases

The following pre-test conditions shall be applied in all RLC test cases until the test case explicitly over writes these conditions.

7.1.2.1.1 Default Pre-Test Conditions for AM RLC test cases

System Simulator:

- The SS configures the test environment in accordance to the execution conditions in Table 7.1.2.1.1-1.

UE:

- None

Preamble:

- The SS performs the generic procedure in [4] to get UE in state RRC_CONNECTED in accordance to the execution conditions in Table 7.1.2.1.1-2 and the message condition UE TEST LOOP MODE A to return one UL PDCP SDU per DL PDCP SDU.

Table 7.1.2.1.1-1: Test environment

Execution Condition	Cell configuration	System Information Combination
IF pc_NG_RAN_NR	NR Cell 1	NR: System information Combination NR-1
ELSE IF pc_EN_DC	E-UTRA Cell 1 is PCell, NR Cell 1 is PSCell	EUTRA: System information Combination 1 NR: N/A
ELSE IF pc_NGEN_DC	NG-RAN E-UTRA Cell 1 is PCell, NR Cell 1 is PSCell	EUTRA: System information Combination 1 NR: N/A

Table 7.1.2.1.1-2: Preamble parameters

Execution Condition	Multi-PDN / Multi-PDU Sessions Condition	Generic Procedure Parameters	Primary DRB used for Data testing
IF pc_NG_RAN_NR	FALSE	Connectivity(NR), Test loop function(On) One DRB	Default DRB of the first PDU session on NR Cell
	TRUE	Connectivity(NR), Test loop function(On) N DRBs ($N \geq 2$)	
ELSE IF pc_EN_DC	FALSE	Connectivity(EN-DC), DC bearer(One MN Terminated MCG bearer and One SN terminated SCG bearer), Test loop function(On)	SN Terminated SCG bearer unless explicitly specified in test case
	TRUE	Connectivity(EN-DC), DC bearer(Two MN Terminated MCG bearer and One SN terminated SCG bearer), Test loop function(On)	
ELSE IF pc_NGEN_DC	FALSE	Connectivity(NGEN-DC), DC bearer(One MN Terminated MCG bearer and One SN terminated SCG bearer), Test loop function(On)	SN Terminated SCG bearer unless explicitly specified in test case
	TRUE	Connectivity(EN-DC), DC bearer(Two MN Terminated MCG bearer and One SN terminated SCG bearer), Test loop function(On)	

Table 7.1.2.1.1-3: Message conditions

Execution Condition	Message condition exceptions
IF pc_NG_RAN_NR	Message with condition AM is used for step 7 in 4.5.4.2 according to [4]
ELSE IF pc_EN_DC	Message condition MCG_and_SCG with condition SCG-DRB(1,0) is used for step 7 in 4.5.4.2 according to [4]
ELSE IF pc_NGEN_DC	Message condition MCG_and_SCG with condition SCG-DRB(1,0) is used for step 7 in 4.5.4.2 according to [4]

7.1.2.1.2 Default Pre-Test Conditions for UM RLC test cases

Same Pre-test conditions as in clause 7.1.2.1.1 with the exceptions in Table 7.1.2.1.2-1.

Table 7.1.2.1.2-1: Message conditions

Execution Condition	Message condition exceptions
IF pc_NG_RAN_NR	Message with condition UM is used for step 7 in 4.5.4.2 according to [4]
ELSE IF pc_EN_DC	Message condition MCG_and_SCG with condition SCG-DRB(0,1) is used for step 7 in 4.5.4.2 according to [4]
ELSE IF pc_NGEN_DC	Message condition MCG_and_SCG with condition SCG-DRB(0,1) is used for step 7 in 4.5.4.2 according to [4]

7.1.2.2 RLC Unacknowledged mode

7.1.2.2.1 UM RLC / Segmentation and reassembly / 6-bit SN / Segmentation Info (SI) field

7.1.2.2.1.1 Test Purpose (TP)

(1)

```
with { UE in RRC_CONNECTED state configured for 6 bit SN in RLC UM }
ensure that {
  when { UE receives UMD PDU containing a SI field set to 00 }
  then { UE correctly decodes the received UMD PDU }
}
```

(2)

```
with { UE in RRC_CONNECTED state configured for 6 bit SN in RLC UM }
ensure that {
  when { UE receives a 6 bit SN configured UMD PDU containing a SI field set to 01 }
  then { UE correctly decodes the received UMD PDU }
}
```

(3)

```
with { UE in RRC_CONNECTED state configured for 6 bit SN in RLC UM }
ensure that {
  when { UE receives a 6 bit SN configured UMD PDU containing a SI field set to 11 and SO field }
  then { UE correctly decodes the received UMD PDU }
}
```

(4)

```
with { UE in RRC_CONNECTED state configured for 6 bit SN in RLC UM }
ensure that {
  when { UE receives a 6 bit SN configured UMD PDU containing a SI field set to 10 and SO field }
  then { UE correctly decodes the received UMD PDU }
}
```

(5)

```
with { UE in RRC_CONNECTED state configured for 6 bit SN in RLC UM }
ensure that {
  when { UE has UL SDU to send and UL grant available is sufficient to send whole SDU in one PDU }
  then { UE transmits RLC SDU containing a SI field set to 00 }
}
```

(6)

```

with { UE in RRC_CONNECTED state configured for 6 bit SN in RLC UM }
ensure that {
  when { UE has UL SDU to send and UL grant available is not sufficient to send whole SDU in one PDU }
  then { UE transmits first RLC SDU segment containing a SI field set to 01 and including 6 bit SN }
}

```

(7)

```

with { UE in RRC_CONNECTED state configured for 6 bit SN in RLC UM }
ensure that {
  when { UE has UL SDU to send and UL grant available is not sufficient to send whole SDU in one PDU }
  then { UE transmits middle RLC SDU segment containing a SI field set to 11, including SO field and including 6 bit SN }
}

```

(8)

```

with { UE in RRC_CONNECTED state configured for 6 bit SN in RLC UM }
ensure that {
  when { UE has UL SDU to send and UL grant available is not sufficient to send whole SDU in one PDU }
  then { UE transmits last RLC SDU segment containing a SI field set to 10, including SO field and including 6 bit SN }
}

```

7.1.2.2.1.2 Conformance requirements

References: The conformance requirements covered in the present TC are specified in: TS 38.322, clauses 5.2.2.2.1, 5.2.2.2.2, 6.2.3.4 and 6.2.2.3. Unless otherwise stated these are Rel-15 requirements.

[TS 38.322, clause 5.2.2.2.1]

The receiving UM RLC entity shall maintain a reassembly window according to state variable *RX_Next_Highest* as follows:

- a SN falls within the reassembly window if $(RX_Next_Highest - UM_Window_Size) \leq SN < RX_Next_Highest$;
- a SN falls outside of the reassembly window otherwise.

When receiving an UMD PDU from lower layer, the receiving UM RLC entity shall:

- either deliver the UMD PDU after removing the RLC header, discard the received UMD PDU, or place it in the reception buffer (see sub clause 5.2.2.2.2);
- if the received UMD PDU was placed in the reception buffer:
 - update state variables, reassemble and deliver RLC SDUs to upper layer and start/stop *t-Reassembly* as needed (see sub clause 5.2.2.2.3).

When *t-Reassembly* expires, the receiving UM RLC entity shall:

- update state variables, discard RLC SDU segments and start *t-Reassembly* as needed (see sub clause 5.2.2.2.4).

[TS 38.322, clause 5.2.2.2.2]

When an UMD PDU is received from lower layer, the receiving UM RLC entity shall:

- if the UMD PDU header does not contain an SN:
 - remove the RLC header and deliver the RLC SDU to upper layer.
- else if $(RX_Next_Highest - UM_Window_Size) \leq SN < RX_Next_Reassembly$:

- discard the received UMD PDU.
- else:
 - place the received UMD PDU in the reception buffer.

[TS 38.322, clause 6.2.2.3]

UMD PDU consists of a Data field and an UMD PDU header. The UMD PDU header is byte aligned

When an UMD PDU contains a complete RLC SDU, the UMD PDU header only contains the SI and R fields.

An UM RLC entity is configured by RRC to use either a 6 bit SN or a 12 bit SN. An UMD PDU header contains the SN field only when the corresponding RLC SDU is segmented. An UMD PDU carrying the first segment of an RLC SDU does not carry the SO field in its header. The length of the SO field is 16 bits.

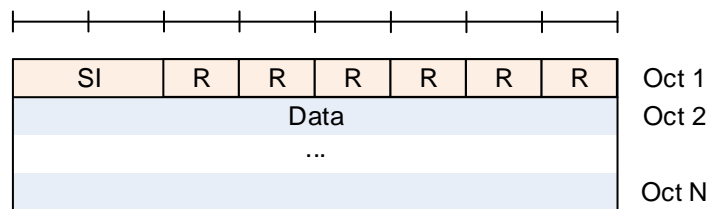

Figure 6.2.2.3-1: UMD PDU containing a complete RLC SDU

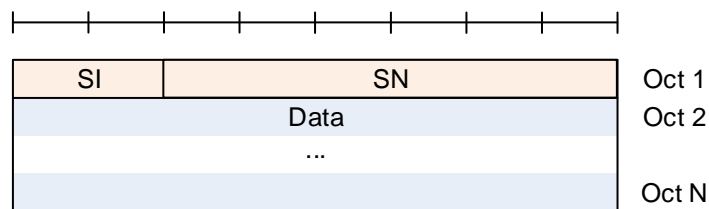

Figure 6.2.2.3-2: UMD PDU with 6 bit SN (No SO)

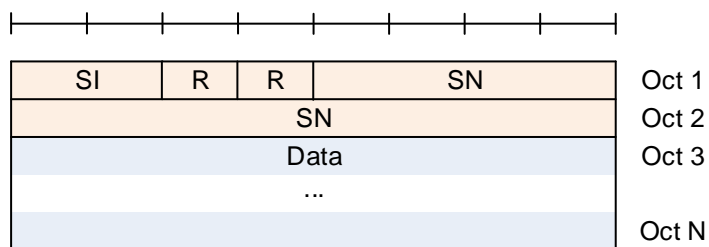

Figure 6.2.2.3-3: UMD PDU with 12 bit SN (No SO)

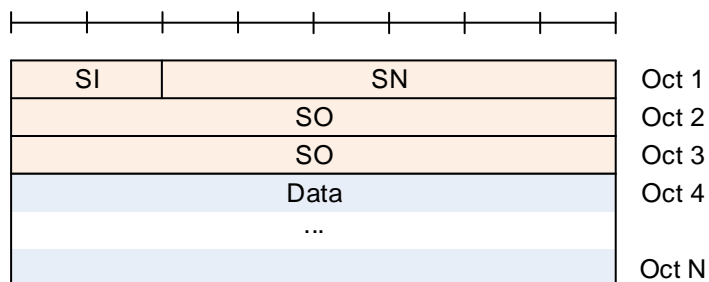

Figure 6.2.2.3-4: UMD PDU with 6 bit SN and with SO

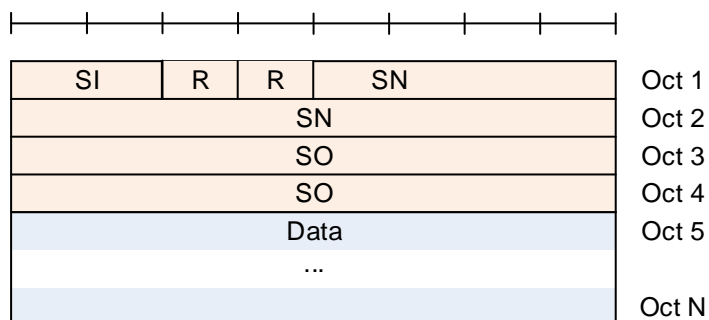

Figure 6.2.2.3-5: UMD PDU with 12 bit SN and with SO

[TS 38.322, clause 6.2.3.4]

Length: 2 bits.

The SI field indicates whether a RLC PDU contains a complete RLC SDU or the first, middle, last segment of a RLC SDU.

Table 6.2.2.6-1: SI field interpretation

Value	Description
00	Data field contains all bytes of a RLC SDU
01	Data field contains the first segment of a RLC SDU
10	Data field contains the last segment of a RLC SDU
11	Data field contains neither the first nor last segment of a RLC SDU

7.1.2.2.1.3 Test description

7.1.2.2.1.3.1 Pre-test conditions

Same Pre-test conditions as in clause 7.1.2.1.2 with the exception for the UM DRB is configured according to Table 7.1.2.2.1.3.1-1.

Table 7.1.2.2.1.3.1-1: RLC parameters

Uplink UM RLC sn-FieldLength	size6
Downlink UM RLC sn-FieldLength	size6

7.1.2.2.1.3.2 Test procedure sequence

Table 7.1.2.2.1.3.2-1: Main behaviour

St	Procedure	Message Sequence		TP	Verdict
		U - S	Message		
0	The SS stops allocating any UL grant.	-	-	-	-
1	The SS transmits UMD PDU#1 containing a complete RLC SDU#1 (SI field = 00).	<--	UMD PDU#1	-	-
2	SS allocates an UL grant sufficient to loop back RLC SDU#1 in one RLC/MAC PDU	<--	UL Grant	-	-
3	Check: Does the UE transmit RLC SDU#1?	-->	(RLC SDU#1)	1,5	P
4	The SS transmits UMD PDU#2 containing the first segment of RLC SDU#2 (SI field = 01). Note 3	<--	UMD PDU#2	-	-
5	The SS transmits UMD PDU#3 containing the second segment of RLC SDU#2 (SI field = 11) and including SO field. Note 3	<--	UMD PDU#3	-	-
6	The SS transmits UMD PDU#4 containing the last segment of RLC SDU#2 (SI field = 10) and including SO field. Note 3	<--	UMD PDU#4	-	-
7	SS allocates 3 UL grants at an interval of 20 ms so as to loop back RLC SDU#2 in 3 RLC/MAC PDUs. Note 1 & 2	<--	UL Grants	-	-
8	Check: Does the UE transmit UMD PDU#2 containing the first segment of RLC SDU#2 (SI field = 01)?	-->	(RLC SDU#2, first segment)	2,3,4,6	P
9	Check: Does the UE transmit UMD PDU#3 containing the second segment of RLC SDU#2 (SI field = 11) and including SO field?	-->	(RLC SDU#2, second segment)	2,3,4,7	P
10	Check: Does the UE transmit UMD PDU#4 containing the last segment of RLC SDU#2 (SI field = 10) and including SO field?	-->	(RLC SDU#2, last segment)	2,3,4,8	P
<p>Note 1: The UL grants for step 8,9,10 are sufficiently small (240 bits, L_{RBS} & l_{MCS} as per 38.523-3[3] annex B) that UE transmits RLC SDU#2 in 3 UL RLC PDUs by segmenting.</p> <p>Note 2: The RLC PDU containing a segment shall be of size 208 bits resp. 224 bits and a MAC sub PDU header of 16 bits and a 16-bit MAC BSR CE included in step 8 resulting in a MAC PDU of size 240 bits.</p> <p>Note 3: The data part in step 4 first segment not including SO is 200 bits (25 bytes). Step 5, second segment SO=25 and data is 200 bits (25 bytes). Step 6, third segment SO=25+25=50 and data is 200 bits (25 bytes).</p>					

7.1.2.2.1.3.3 Specific message contents

None.

7.1.2.2.2 UM RLC / Segmentation and reassembly / 12-bit SN / Segmentation Info (SI) field

7.1.2.2.2.1 Test Purpose (TP)

(1)

```
with { UE in RRC_CONNECTED state configured for 12 bit SN in RLC UM }
ensure that {
  when { UE receives UMD PDU containing a SI field set to 00 }
  then { UE correctly decodes the received UMD PDU }
}
```

(2)

```
with { UE in RRC_CONNECTED state configured for 12 bit SN in RLC UM }
ensure that {
  when { UE receives a 12 bit SN configured UMD PDU containing a SI field set to 01 }
  then { UE correctly decodes the received UMD PDU }
}
```

(3)

```

with { UE in RRC_CONNECTED state configured for 12 bit SN in RLC UM }
ensure that {
  when { UE receives a 12 bit SN configured UMD PDU containing a SI field set to 11 and SO field }
  then { UE correctly decodes the received UMD PDU }
}

```

(4)

```

with { UE in RRC_CONNECTED state configured for 12 bit SN in RLC UM }
ensure that {
  when { UE receives a 12 bit SN configured UMD PDU containing a SI field set to 10 and SO field }
  then { UE correctly decodes the received UMD PDU }
}

```

(5)

```

with { UE in RRC_CONNECTED state configured for 12 bit SN in RLC UM }
ensure that {
  when { UE has UL SDU to send and UL grant available is sufficient to send whole SDU in one PDU }
  then { UE transmits RLC SDU containing a SI field set to 00 }
}

```

(6)

```

with { UE in RRC_CONNECTED state configured for 12 bit SN in RLC UM }
ensure that {
  when { UE has UL SDU to send and UL grant available is not sufficient to send whole SDU in one PDU }
}
then { UE transmits first RLC SDU segment containing a SI field set to 01 and including 12 bit
SN}
}

```

(7)

```

with { UE in RRC_CONNECTED state configured for 12 bit SN in RLC UM }
ensure that {
  when { UE has UL SDU to send and UL grant available is not sufficient to send whole SDU in one PDU }
}
then { UE transmits middle RLC SDU segment containing a SI field set to 11, including SO field
and including 12 bit SN }
}

```

(8)

```

with { UE in RRC_CONNECTED state configured for 12 bit SN in RLC UM }
ensure that {
  when { UE has UL SDU to send and UL grant available is not sufficient to send whole SDU in one PDU }
}
then { UE transmits last RLC SDU segment containing a SI field set to 10, including SO field and
including 12 bit SN }
}

```

7.1.2.2.2.2 Conformance requirements

Same conformance requirements as clause 7.1.2.2.1.2

7.1.2.2.2.3 Test description

7.1.2.2.2.3.1 Pre-test conditions

Same Pre-test conditions as in clause 7.1.2.1.2 with the exception for the UM DRB is configured according to Table 7.1.2.2.2.3.1-1.

Table 7.1.2.2.3.1-1: RLC parameters

Uplink UM RLC sn-FieldLength	size12
Downlink UM RLC sn-FieldLength	size12

7.1.2.2.3.2 Test procedure sequence

Same test procedure sequence as 7.1.2.2.1.3.2 except that RLC UM SN is 12 bit and the data part in step 4 first segment not including SO is 192 bits (24 Bytes). Step 5, second segment SO=24 and data is 192 bits (24 bytes). Step 6, third segment SO=24+24=48 and data is 192 bits (24 bytes).

7.1.2.2.3.3 Specific message contents

None.

7.1.2.2.3 UM RLC / 6-bit SN / Correct use of sequence numbering

7.1.2.2.3.1 Test Purpose (TP)

(1)

```
with { UE in RRC_CONNECTED state with UM RLC 6 bit SN }
ensure that {
  when { UE transmits the first PDU which is segmented }
  then { UE includes the SN field equal to 0 in each RLC segment }
}
```

(2)

```
with { UE in RRC_CONNECTED state with UM RLC 6 bit SN }
ensure that {
  when { UE transmit subsequent segmented PDUs }
  then { UE includes the SN field incremented by 1 for each segmented PDU of one RLC SDU }
}
```

(3)

```
with { UE in RRC_CONNECTED state with UM RLC 6 bit SN }
ensure that {
  when { UE transmit segments belonging to more than 64 SDUs }
  then { UE wraps the SN after transmitting the segments of 64 SDUs }
}
```

(4)

```
with { UE in RRC_CONNECTED state with UM RLC 6 bit SN }
ensure that {
  when { segments of more than 64 SDUs are sent to UE }
  then { UE accepts PDUs with SNs that wrap around every 64 segmented SDUs }
}
```

7.1.2.2.3.2 Conformance requirements

References: The conformance requirements covered in the present TC are specified in: 3GPP TS 38.322, clause 5.2.2.1.1, 5.2.2.2, 6.2.2.3, 6.2.3.3 and 7.1. Unless otherwise stated these are Rel-15 requirements.

[TS 38.322, clause 5.2.2.1.1]

When submitting a UMD PDU to lower layer, the transmitting UM RLC entity shall:

- if the UMD PDU contains a segment of an RLC SDU, set the SN of the UMD PDU to TX_Next;
- if the UMD PDU contains a segment that maps to the last byte of an RLC SDU, then increment TX_Next by one.

[TS 38.322, clause 5.2.2.2]

The receiving UM RLC entity shall maintain a reassembly window according to state variable `RX_Next_Highest` as follows:

- a SN falls within the reassembly window if $(RX_Next_Highest - UM_Window_Size) \leq SN < RX_Next_Highest$;
- a SN falls outside of the reassembly window otherwise.

When receiving an UMD PDU from lower layer, the receiving UM RLC entity shall:

- either deliver the UMD PDU after removing the RLC header, discard the received UMD PDU, or place it in the reception buffer (see sub clause 5.2.2.2.2);
- if the received UMD PDU was placed in the reception buffer:
 - update state variables, reassemble and deliver RLC SDUs to upper layer and start/stop *t-Reassembly* as needed (see sub clause 5.2.2.2.3).

...

When an UMD PDU is received from lower layer, the receiving UM RLC entity shall:

- if the UMD PDU header does not contain an SN:
 - remove the RLC header and deliver the RLC SDU to upper layer.
- else if $(RX_Next_Highest - UM_Window_Size) \leq SN < RX_Next_Reassembly$:
 - discard the received UMD PDU.
- else:
 - place the received UMD PDU in the reception buffer.

...

When an UMD PDU with SN = x is placed in the reception buffer, the receiving UM RLC entity shall:

- if all byte segments with SN = x are received:
 - reassemble the RLC SDU from all byte segments with SN = x, remove RLC headers and deliver the reassembled RLC SDU to upper layer;
 - if $x = RX_Next_Reassembly$:
 - update `RX_Next_Reassembly` to the SN of the first SN > current `RX_Next_Reassembly` that has not been reassembled and delivered to upper layer.
- else if x falls outside of the reassembly window:
 - update `RX_Next_Highest` to $x + 1$;
 - discard any UMD PDUs with SN that falls outside of the reassembly window;
 - if `RX_Next_Reassembly` falls outside of the reassembly window:
 - set `RX_Next_Reassembly` to the SN of the first SN $\geq (RX_Next_Highest - UM_Window_Size)$ that has not been reassembled and delivered to upper layer.

[TS 38.322, clause 6.2.2.3]

An UM RLC entity is configured by RRC to use either a 6 bit SN or a 12 bit SN. An UMD PDU header contains the SN field only when the corresponding RLC SDU is segmented.

[TS 38.322, clause 6.2.3.3]

The SN field indicates the sequence number of the corresponding RLC SDU. For RLC UM, the sequence number is incremented by one for every segmented RLC SDU..

[TS 38.322, clause 7.1]

All state variables and all counters are non-negative integers.

...

All state variables related to UM data transfer can take values from 0 to 63 for 6 bit SN or from 0 to 4095 for 12 bit SN. All arithmetic operations contained in the present document on state variables related to UM data transfer are affected by the UM modulus (i.e. final value = [value from arithmetic operation] modulo 64 for 6 bit SN and 4096 for 12 bit SN).

...

Each transmitting UM RLC entity shall maintain the following state variables:

a) TX_Next

This state variable holds the value of the SN to be assigned for the next newly generated UMD PDU with segment. It is initially set to 0, and is updated after the UM RLC entity submits a UMD PDU including the last segment of an RLC SDU to lower layers.

Each receiving UM RLC entity shall maintain the following state variables and constant:

b) RX_Next_Reassembly – UM receive state variable

This state variable holds the value of the earliest SN that is still considered for reassembly. It is initially set to 0.

c) RX_Timer_Trigger – UM *t-Reassembly* state variable

This state variable holds the value of the SN following the SN which triggered *t-Reassembly*.

d) RX_Next_Highest– UM receive state variable

This state variable holds the value of the SN following the SN of the UMD PDU with the highest SN among received UMD PDUs. It serves as the higher edge of the reassembly window. It is initially set to 0.

7.1.2.2.3.3 Test description

7.1.2.2.3.3.1 Pre-test conditions

Same Pre-test conditions as in clause 7.1.2.1.2 with the exception for the UM DRB is configured according to Table 7.1.2.2.3.3.1-1.

Table 7.1.2.2.3.3.1-1: RLC parameters

Uplink UM RLC sn-FieldLength	size6
Downlink UM RLC sn-FieldLength	size6

7.1.2.2.3.3.2 Test procedure sequence

Table 7.1.2.2.3.3.2-1: Main behaviour

St	Procedure	Message Sequence		TP	Verdict
		U - S	Message		
0	The SS stops allocating any UL grant.	-	-	-	-
1	The SS transmits UMD PDU#1 with 6 bit SN = 0 containing the first segment of RLC SDU#1 (SI field = 01).	<--	UMD PDU#1	-	-
2	The SS transmits UMD PDU#2 with 6 bit SN=0 containing the last segment of RLC SDU#1 (SI field = 10) and including SO field.	<--	UMD PDU#2	-	-
3	SS allocates 2 UL grants at an interval of 20 ms so as to loop back RLC SDU#1 in 2 RLC/MAC PDUs. (Note 1)	<--	UL Grants	-	-
4	Check: Does the UE transmit UMD PDU#1 with 6 bit SN = 0 containing the first segment of RLC SDU#1 (SI field = 01)?	-->	(RLC SDU#1, first segment)	1	P
5	Check: Does the UE transmit UMD PDU#2 with 6 bit SN = 0 containing the last segment of RLC SDU#1 (SI field = 10)?	-->	(RLC SDU#1, last segment)	1	P
-	EXCEPTION: Steps 6 to 10 are executed 63 times, the initial value of k = 1, it is incremented by one for each iteration.	-	-	-	-
6	The SS transmits UMD PDU#(2*k+1) with 6 bit SN = k containing the first segment of RLC SDU#(k+1) (SI field = 01).	<--	UMD PDU#(2*k+1)	-	-
7	The SS transmits UMD PDU#(2*(k+1)) with 6 bit SN=k containing the last segment of RLC SDU#(k+1) (SI field = 10)	<--	UMD PDU#(2*(k+1))	-	-
8	SS allocates 2 UL grants at an interval of 20 ms so as to loop back RLC SDU#(k+1) in 2 RLC/MAC PDUs. (Note 1)	<--	UL Grants	-	-
9	Check: Does the UE transmit UMD PDU#(2*k+1) with 6 bit SN = k containing the first segment of RLC SDU#(k+1) (SI field = 01)? (Note 2)	-->	(RLC SDU#(k+1), first segment)	2	P
10	Check: Does the UE transmit UMD PDU#(2*(k+1)) with 6 bit SN = k containing the last segment of RLC SDU#(k+1) (SI field = 10) and including SO field? (Note 2)	-->	(RLC SDU#(k+1), last segment)	2	P
11	The SS transmits UMD PDU#129 with 6 bit SN = 0 containing the first segment of RLC SDU#4 (SI field = 01).	<--	UMD PDU#129	-	-
12	The SS transmits UMD PDU#130 with 6 bit SN= 0 containing the last segment of RLC SDU#65 (SI field = 10) and including SO field	<--	UMD PDU#130	-	-
13	SS allocates 2 UL grants at an interval of 20 ms so as to loop back RLC SDU#65 in 2 RLC/MAC PDUs. (Note 1)	<--	UL Grants	-	-
14	Check: Does the UE transmit UMD PDU#129 with 6 bit SN = 0 containing the first segment of RLC SDU#65 (SI field = 01)?	-->	(RLC SDU#65, first segment)	3,4	P
15	Check: Does the UE transmit UMD PDU#130 with 6 bit SN = 0 containing the last segment of RLC SDU#65 (SI field = 10) and including SO field?	-->	(RLC SDU#65, last segment)	3,4	P
Note 1:	The RLC SDU size shall be 10 octets which are segmented into 5 and 5 octets. With 2 octets of MAC header, 2 octets of Short BSR and 1 octet of RLC header (without SO) the first segment consists of 80 bits and a TBS of this size shall be allocated. With 2 octets of MAC header and 3 octets of RLC header (with SO) the second segment consists of 80 bits and a TBS of this size shall be allocated. (L _{RBs} & I _{MCS} as per 38.523-3[3] annex B)				
Note 2:	The verdict shall be provided each time (SN+1) mod 16 = 0.				

7.1.2.2.3.3.3 Specific message contents

None.

7.1.2.2.4 UM RLC / 12-bit SN / Correct use of sequence numbering

7.1.2.2.4.1 Test Purpose (TP)

(1)

```
with { UE in RRC_CONNECTED state with UM RLC 12 bit SN }
ensure that {
  when { UE transmits the first PDU which is segmented }
  then { UE includes the SN field equal to 0 in each RLC segment }
}
```

(2)

```
with { UE in RRC_CONNECTED state with UM RLC 12 bit SN }
ensure that {
  when { UE transmit subsequent segmented PDUs }
  then { UE includes the SN field incremented by 1 for each segmented PDU of one RLC SDU }
}
```

(3)

```
with { UE in RRC_CONNECTED state with UM RLC 12 bit SN }
ensure that {
  when { UE transmit segments belonging to more than 4096 SDUs }
  then { UE wraps the SN after transmitting the segments of 4096 SDUs }
}
```

(4)

```
with { UE in RRC_CONNECTED state with UM RLC 12 bit SN }
ensure that {
  when { segments of more than 4096 SDUs are sent to UE }
  then { UE accepts PDUs with SNs that wrap around every 4096 segmented SDUs }
}
```

7.1.2.2.4.2 Conformance requirements

References: The conformance requirements covered in the present TC are specified in: 3GPP TS 38.322, clause 5.2.2.1.1, 5.2.2.2, 6.2.2.3, 6.2.3.3 and 7.1. Unless otherwise stated these are Rel-15 requirements.

[TS 38.322, clause 5.2.2.1.1]

When submitting a UMD PDU to lower layer, the transmitting UM RLC entity shall:

- if the UMD PDU contains a segment of an RLC SDU, set the SN of the UMD PDU to TX_Next;
- if the UMD PDU contains a segment that maps to the last byte of an RLC SDU, then increment TX_Next by one.

[TS 38.322, clause 5.2.2.2]

The receiving UM RLC entity shall maintain a reassembly window according to state variable RX_Next_Highest as follows:

- a SN falls within the reassembly window if $(RX_Next_Highest - UM_Window_Size) \leq SN < RX_Next_Highest$;
- a SN falls outside of the reassembly window otherwise.

When receiving an UMD PDU from lower layer, the receiving UM RLC entity shall:

- either deliver the UMD PDU after removing the RLC header, discard the received UMD PDU, or place it in the reception buffer (see sub clause 5.2.2.2.2);
- if the received UMD PDU was placed in the reception buffer:
 - update state variables, reassemble and deliver RLC SDUs to upper layer and start/stop *t-Reassembly* as needed (see sub clause 5.2.2.2.3).

...

When an UMD PDU is received from lower layer, the receiving UM RLC entity shall:

- if the UMD PDU header does not contain an SN:
 - remove the RLC header and deliver the RLC SDU to upper layer.
- else if $(RX_Next_Highest - UM_Window_Size) \leq SN < RX_Next_Reassembly$:
 - discard the received UMD PDU.
- else:
- place the received UMD PDU in the reception buffer.

...

When an UMD PDU with SN = x is placed in the reception buffer, the receiving UM RLC entity shall:

- if all byte segments with SN = x are received:
 - reassemble the RLC SDU from all byte segments with SN = x, remove RLC headers and deliver the reassembled RLC SDU to upper layer;
 - if $x = RX_Next_Reassembly$:
 - update $RX_Next_Reassembly$ to the SN of the first $SN > current\ RX_Next_Reassembly$ that has not been reassembled and delivered to upper layer.
- else if x falls outside of the reassembly window:
 - update $RX_Next_Highest$ to $x + 1$;
 - discard any UMD PDUs with SN that falls outside of the reassembly window;
 - if $RX_Next_Reassembly$ falls outside of the reassembly window:
 - set $RX_Next_Reassembly$ to the SN of the first $SN \geq (RX_Next_Highest - UM_Window_Size)$ that has not been reassembled and delivered to upper layer.

[TS 38.322, clause 6.2.2.3]

An UM RLC entity is configured by RRC to use either a 6 bit SN or a 12 bit SN. An UMD PDU header contains the SN field only when the corresponding RLC SDU is segmented.

[TS 38.322, clause 6.2.3.3]

The SN field indicates the sequence number of the corresponding RLC SDU. ... For RLC UM, the sequence number is incremented by one for every segmented RLC SDU.

[TS 38.322, clause 7.1]

All state variables and all counters are non-negative integers.

...

All state variables related to UM data transfer can take values from 0 to 63 for 6 bit SN or from 0 to 4095 for 12 bit SN. All arithmetic operations contained in the present document on state variables related to UM data transfer are affected

by the UM modulus (i.e. final value = [value from arithmetic operation] modulo 64 for 6 bit SN and 4096 for 12 bit SN).

...

Each transmitting UM RLC entity shall maintain the following state variables:

a) TX_Next

This state variable holds the value of the SN to be assigned for the next newly generated UMD PDU with segment. It is initially set to 0, and is updated after the UM RLC entity submits a UMD PDU including the last segment of an RLC SDU to lower layers.

Each receiving UM RLC entity shall maintain the following state variables and constant:

b) RX_Next_Reassembly – UM receive state variable

This state variable holds the value of the earliest SN that is still considered for reassembly. It is initially set to 0.

c) RX_Timer_Trigger – UM *t-Reassembly* state variable

This state variable holds the value of the SN following the SN which triggered *t-Reassembly*.

d) RX_Next_Highest– UM receive state variable

This state variable holds the value of the SN following the SN of the UMD PDU with the highest SN among received UMD PDUs. It serves as the higher edge of the reassembly window. It is initially set to 0.

7.1.2.2.4.3 Test description

7.1.2.2.4.3.1 Pre-test conditions

Same Pre-test conditions as in clause 7.1.2.1.2 with the exception for the UM DRB is configured according to Table 7.1.2.2.4.3.1-1.

Table 7.1.2.2.4.3.1-1: RLC parameters

Uplink RLC sn-FieldLength	size12
Downlink RLC sn-FieldLength	size12

7.1.2.2.4.3.2 Test procedure sequence

Table 7.1.2.2.4.3.2-1: Main behaviour

St	Procedure	Message Sequence		TP	Verdict
		U - S	Message		
1	The SS transmits UMD PDU#1 with 12 bit SN = 0 containing the first segment of RLC SDU#1 (SI field = 01).	<--	UMD PDU#1	-	-
2	The SS transmits UMD PDU#2 with 12 bit SN=0 containing the last segment of RLC SDU#1 (SI field = 10) and including SO field	<--	UMD PDU#2	-	-
3	SS allocates 2 UL grants at an interval of 20 ms so as to loop back RLC SDU#1 in 2 RLC/MAC PDUs. (Note 1)	<--	UL Grants	-	-
4	Check: Does the UE transmit UMD PDU#1 with 12 bit SN = 0 containing the first segment of RLC SDU#1 (SI field = 01)?	-->	(RLC SDU#1, first segment)	1	P
5	Check: Does the UE transmit UMD PDU#2 with 12 bit SN = 0 containing the last segment of RLC SDU#1 (SI field = 10)?	-->	(RLC SDU#1, last segment)	1	P
-	EXCEPTION: Steps 6 to 10 are executed 4095 times, the initial value of k = 1, it is incremented by one for each iteration.	-	-	-	-
6	The SS transmits UMD PDU#(2*k+1) with 12 bit SN = k containing the first segment of RLC SDU#(k+1) (SI field = 01).	<--	UMD PDU#(2*k+1)	-	-
7	The SS transmits UMD PDU#(2*(k+1)) with 12 bit SN=k containing the last segment of RLC SDU#(k+1) (SI field = 10)	<--	UMD PDU#(2*(k+1))	-	-
8	SS allocates 2 UL grants at an interval of 20 ms so as to loop back RLC SDU#(k+1) in 2 RLC/MAC PDUs. (Note 1)	<--	UL Grants	-	-
9	Check: Does the UE transmit UMD PDU#(2*k+1) with 12 bit SN = k containing the first segment of RLC SDU#(k+1) (SI field = 01)? (Note 2)	-->	(RLC SDU#(k+1), first segment)	2	P
10	Check: Does the UE transmit UMD PDU#(2*(k+1)) with 12 bit SN = k containing the last segment of RLC SDU#(k+1) (SI field = 10) and including SO field? (Note 2)	-->	(RLC SDU#(k+1), last segment)	2	P
11	The SS transmits UMD PDU#8193 with 12 bit SN = 0 containing the first segment of RLC SDU#4097 (SI field = 01).	<--	UMD PDU#8193	-	-
12	The SS transmits UMD PDU#8194 with 12 bit SN= 0 containing the last segment of RLC SDU#4097 (SI field = 10) and including SO field	<--	UMD PDU#8194	-	-
13	SS allocates 2 UL grants at an interval of 20 ms so as to loop back RLC SDU#4097 in 2 RLC/MAC PDUs. (Note 1)	<--	UL Grants	-	-
14	Check: Does the UE transmit UMD PDU#8193 with 12 bit SN = 0 containing the first segment of RLC SDU#4097 (SI field = 01)?	-->	(RLC SDU#4097, first segment)	3,4	P
15	Check: Does the UE transmit UMD PDU#8194 with 12 bit SN = 0 containing the last segment of RLC SDU#4097 (SI field = 10) and including SO field?	-->	(RLC SDU#4097, last segment)	3,4	P
<p>Note 1: The RLC SDU size shall be 10 octets which are segmented into 5 and 5 octets. With 2 octets of MAC header, 2 octets of Short BSR and 2 octets of RLC header (without SO) the first segment consists of 88 bits and a TBS of this size shall be allocated. With 2 octets of MAC header and 4 octets of RLC header (with SO) the second segment consists of 88 bits and a TBS of this size shall be allocated. (L_{RBs} & I_{MCS} as per 38.523-3[3] annex B)</p> <p>Note 2: The verdict shall be provided each time (SN+1) mod 256 = 0.</p>					

7.1.2.2.4.3.3 Specific message contents

None.

7.1.2.2.5 UM RLC / Receive Window operation and t-Reassembly expiry

7.1.2.2.5.1 Test Purpose (TP)

(1)

```
with { UE in RRC_CONNECTED state and using UM RLC }
ensure that {
  when { UE receives a RLC PDU including SN and '(RX_Next_Highest - UM_Window_Size) <= SN <
RX_Next_Highest' }
    then { UE discards any UMD PDUs with SN that falls outside of the reassembly window }
}
```

(2)

```
with { UE in RRC_CONNECTED state and using UM RLC }
ensure that {
  when { UE receives a RLC PDU including SN and '(RX_Next_Highest - UM_Window_Size) > SN or SN >=
RX_Next_Reassembly' }
    then { UE stores the PDU in receive buffer }
}
```

(3)

```
with { UE in RRC_CONNECTED state and using UM RLC }
ensure that {
  when { UE places a RLC PDU including SN into the reception buffer and all byte segments with that
SN are received }
    then { UE delivers the reassembled SDU to upper layers }
}
```

(4)

```
with { UE in RRC_CONNECTED state and using UM RLC }
ensure that {
  when { t-Reassembly expires }
    then { UE updates RX_Next_Reassembly and discards all segments with SN < updated
RX_Next_Reassembly }
}
```

7.1.2.2.5.2 Conformance requirements

References: The conformance requirements covered in the present TC are specified in: TS 38.322, clauses 5.2.2.2.1, 5.2.2.2.2, 5.2.2.2.3, 5.2.2.2.4 and 7.1. Unless otherwise stated these are Rel-15 requirements.

[TS 38.322, clause 5.2.2.2.1]

The receiving UM RLC entity shall maintain a reassembly window according to state variable `RX_Next_Highest` as follows:

- a SN falls within the reassembly window if $(RX_Next_Highest - UM_Window_Size) \leq SN < RX_Next_Highest$;
- a SN falls outside of the reassembly window otherwise.

When receiving an UMD PDU from lower layer, the receiving UM RLC entity shall:

- either deliver the UMD PDU to upper layer after removing the RLC header, discard the received UMD PDU, or place it in the reception buffer (see sub clause 5.2.2.2.2);
- if the received UMD PDU was placed in the reception buffer:
 - update state variables, reassemble and deliver RLC SDUs to upper layer and start/stop *t-Reassembly* as needed (see sub clause 5.2.2.2.3).

When *t-Reassembly* expires, the receiving UM RLC entity shall:

- update state variables, discard RLC SDU segments and start *t-Reassembly* as needed (see sub clause 5.2.2.2.4).

[TS 38.322, clause 5.2.2.2.2]

When an UMD PDU is received from lower layer, the receiving UM RLC entity shall:

- if the UMD PDU header does not contain an SN:
 - remove the RLC header and deliver the RLC SDU to upper layer.
- else if $(RX_Next_Highest - UM_Window_Size) \leq SN < RX_Next_Reassembly$:
 - discard the received UMD PDU.
- else:
 - place the received UMD PDU in the reception buffer.

[TS 38.322, clause 5.2.2.2.3]

When an UMD PDU with SN = x is placed in the reception buffer, the receiving UM RLC entity shall:

- if all byte segments with SN = x are received:
 - reassemble the RLC SDU from all byte segments with SN = x, remove RLC headers and deliver the reassembled RLC SDU to upper layer;
 - if $x = RX_Next_Reassembly$:
 - update *RX_Next_Reassembly* to the SN of the first SN > current *RX_Next_Reassembly* that has not been reassembled and delivered to upper layer.
- else if x falls outside of the reassembly window:
 - update *RX_Next_Highest* to x + 1;
 - discard any UMD PDUs with SN that falls outside of the reassembly window;
 - if *RX_Next_Reassembly* falls outside of the reassembly window:
 - set *RX_Next_Reassembly* to the SN of the first SN $\geq (RX_Next_Highest - UM_Window_Size)$ that has not been reassembled and delivered to upper layer.
- if *t-Reassembly* is running:
 - if $RX_Timer_Trigger \leq RX_Next_Reassembly$; or
 - if *RX_Timer_Trigger* falls outside of the reassembly window and *RX_Timer_Trigger* is not equal to *RX_Next_Highest*; or
 - if $RX_Next_Highest = RX_Next_Reassembly + 1$ and there is no missing byte segment of the RLC SDU associated with SN = *RX_Next_Reassembly* before the last byte of all received segments of this RLC SDU:
 - stop and reset *t-Reassembly*.
- if *t-Reassembly* is not running (includes the case when *t-Reassembly* is stopped due to actions above):
 - if $RX_Next_Highest > RX_Next_Reassembly + 1$; or
 - if $RX_Next_Highest = RX_Next_Reassembly + 1$ and there is at least one missing byte segment of the RLC SDU associated with SN = *RX_Next_Reassembly* before the last byte of all received segments of this RLC SDU:
 - start *t-Reassembly*;
 - set *RX_Timer_Trigger* to *RX_Next_Highest*.

[TS 38.322, clause 5.2.2.2.4]

When *t-Reassembly* expires, the receiving UM RLC entity shall:

- update RX_Next_Reassembly to the SN of the first SN \geq RX_Timer_Trigger that has not been reassembled;
- discard all segments with SN $<$ updated RX_Next_Reassembly;
- if RX_Next_Highest $>$ RX_Next_Reassembly + 1; or
- if RX_Next_Highest = RX_Next_Reassembly + 1 and there is at least one missing byte segment of the RLC SDU associated with SN = RX_Next_Reassembly before the last byte of all received segments of this RLC SDU:
 - start t-Reassembly;
 - set RX_Timer_Trigger to RX_Next_Highest.

[TS 38.322, clause 5.2.2.2.4]

This sub clause describes the state variables used in AM and UM entities in order to specify the RLC protocol. The state variables defined in this subclause are normative.

All state variables and all counters are non-negative integers.

...

All state variables related to UM data transfer can take values from 0 to 63 for 6 bit SN or from 0 to 4095 for 12 bit SN. All arithmetic operations contained in the present document on state variables related to UM data transfer are affected by the UM modulus (i.e. final value = [value from arithmetic operation] modulo 64 for 6 bit SN and 4096 for 12 bit SN).

When performing arithmetic comparisons of state variables or SN values, a modulus base shall be used.

...

RX_Next_Highest– UM_Window_Size shall be assumed as the modulus base at the receiving side of an UM RLC entity. This modulus base is subtracted from all the values involved, and then an absolute comparison is performed (e.g. $(RX_Next_Highest - UM_Window_Size) \leq SN < RX_Next_Highest$ is evaluated as $[(RX_Next_Highest - UM_Window_Size) - (RX_Next_Highest - UM_Window_Size)] \bmod 2^{[sn-FieldLength]} \leq [SN - (RX_Next_Highest - UM_Window_Size)] \bmod 2^{[sn-FieldLength]} < [RX_Next_Highest - (RX_Next_Highest - UM_Window_Size)] \bmod 2^{[sn-FieldLength]}$), where *sn-FieldLength* is 6 or 12 for 6 bit SN and 12 bit SN, respectively.

...

Each transmitting UM RLC entity shall maintain the following state variables:

a) TX_Next

This state variable holds the value of the SN to be assigned for the next newly generated UMD PDU with segment. It is initially set to 0, and is updated after the UM RLC entity submits a UMD PDU including the last segment of an RLC SDU to lower layers.

Each receiving UM RLC entity shall maintain the following state variables and constant:

b) RX_Next_Reassembly – UM receive state variable

This state variable holds the value of the earliest SN that is still considered for reassembly. It is initially set to 0.

c) RX_Timer_Trigger – UM *t-Reassembly* state variable

This state variable holds the value of the SN following the SN which triggered *t-Reassembly*.

d) RX_Next_Highest– UM receive state variable

This state variable holds the value of the SN following the SN of the UMD PDU with the highest SN among received UMD PDUs. It serves as the higher edge of the reassembly window. It is initially set to 0.

7.1.2.2.5.3 Test description

7.1.2.2.5.3.1 Pre-test conditions

Same Pre-test conditions as in clause 7.1.2.1.2 with the exception that the UM DRB is configured according to Table 7.1.2.2.5.3.1-1.

Table 7.1.2.2.5.3.1-1: RLC parameters

t-Reassembly	ms200
Uplink UM RLC sn-FieldLength	IF (pc_Um_WithShortSN) size6 ELSE size12
Downlink UM RLC sn-FieldLength	F (pc_Um_WithShortSN) size6 ELSE size12

7.1.2.2.5.3.2 Test procedure sequence

Table 7.1.2.2.5.3.2-1: Main behaviour

St	Procedure	Message Sequence		TP	Verdict
		U - S	Message		
0	The SS ignores scheduling requests and does not allocate any uplink grant.	-	-	-	-
1	The SS transmits UMD PDU#1 containing first segment of RLC SDU#1, SN=0.	<--	UMD PDU#1	-	-
2	20 ms after step 1 the SS transmits UMD PDU#3 containing first segment of RLC SDU#2, SN=1.	<--	UMD PDU#3	-	-
3	40 ms after step 1 the SS transmits UMD PDU#4 containing last segment of RLC SDU#2, SN=1.	<--	UMD PDU#4	-	-
3A	60 ms after step 1 the SS transmits UMD PDU#9 containing first segment of RLC SDU#5, SN=w-1.	<--	UMD PDU#9	-	-
3B	80 ms after step 1 the SS transmits UMD PDU#10 containing last segment of RLC SDU#5, SN=w-1.	<--	UMD PDU#10	-	-
3C	100 ms after step 1 the SS assigns 2 UL grants (UL grant allocation type 2) with a time spacing of 20 ms so as to loop back RLC SDU#2.	-	-	-	-
4	Check: Does the UE transmit RLC SDU#2?	-->	(RLC SDU#2)	2,3	P
4A	Check: Does the UE transmit RLC SDU#5?	-->	(RLC SDU#5)	2,3	P
5	160 ms after step 1 the SS transmits UMD PDU#2 last segment of RLC SDU#1, SN=0.	<--	UMD PDU#2	-	-
6	Check: For 1 sec after step 5, does the UE transmit RLC SDU#1, SN=0?	-->	(RLC SDU#1)	1	F
6A	The SS starts the UL default grant transmissions.	-	-	-	-
7	The SS transmits UMD PDU#5 containing first segment of RLC SDU#3, SN=5.	<--	UMD PDU#5	-	-
8	Wait for 200 ms to ensure that <i>t</i> - Reassembly for the UMD PDU#5 expires.	-	-	-	-
9	The SS transmits UMD PDU#6 containing last segment of RLC SDU#3, SN=5.	<--	UMD PDU#6	-	-
10	Check: For 1 sec after step 9, does the UE transmit RLC SDU#3?	-->	(RLC SDU#3)	4	F
11	The SS transmits UMD PDU#7 containing first segment of RLC SDU#4, SN=8.	<--	UMD PDU#7	-	-
12	The SS transmits UMD PDU#8 containing last segment of RLC SDU#4, SN=8.	<--	UMD PDU#8	-	-
13	Check: Does the UE transmit RLC SDU#4?	-->	(RLC SDU#4)	2,3	P
Note 1:	For SN size = size6 the RLC SDU size shall be 12 octets which are segmented into 7 and 5 octets. With 2 octets of MAC header and 1 octet of RLC header (without SO) the first segment consists of 80 bits and a TBS of this size shall be allocated. With 2 octets of MAC header and 3 octets of RLC header (with SO) the second segment consists of 80 bits and a TBS of this size shall be allocated. (<i>L_{RBs}</i> & <i>I_{MCS}</i> as per 38.523-3[3] annex B)				
Note 2:	For SN size = size12 the RLC SDU size shall be 12 octets which are segmented into 7 and 5 octets. With 2 octets of MAC header and 2 octets of RLC header (without SO) the first segment consists of 88 bits and a TBS of this size shall be allocated. With 2 octets of MAC header and 4 octets of RLC header (with SO) the second segment consists of 88 bits and a TBS of this size shall be allocated. (<i>L_{RBs}</i> & <i>I_{MCS}</i> as per 38.523-3[3] annex B)				

7.1.2.2.5.3.3 Specific message contents

None

7.1.2.2.6 UM RLC / RLC re-establishment procedure

7.1.2.2.6.1 Test Purpose (TP)

(1)

```
with { UE in RRC_CONNECTED state and using UM RLC }
ensure that {
  when { RLC re-establishment is performed upon request by RRC }
  then { The UE discards all UMD PDUs where no RLC SDUs can be reassembled }
}
```

(2)

```
with { UE in RRC_CONNECTED state and using UM RLC }
ensure that {
  when { RLC re-establishment is performed upon request by RRC }
  then { The UE resets variables TX_Next, RX_Next_Reassembly, and RX_Next_Highest to their initial
value of 0 }
}
```

7.1.2.2.6.2 Conformance requirements

References: The conformance requirements covered in the present TC are specified in: TS 38.322, clauses 5.1.2 and 7.1, TS 38.331 clause 5.3.5.5.4. Unless otherwise stated these are Rel-15 requirements.

[TS 38.322, clause 5.1.2]

When upper layers request an RLC entity re-establishment, the UE shall:

- discard all RLC SDUs, RLC SDU segments, and RLC PDUs, if any;
- stop and reset all timers;
- reset all state variables to their initial values.

[TS 38.322, clause 7.1]

d) RX_Next_Highest – Highest received state variable

This state variable holds the value of the SN following the SN of the RLC SDU with the highest SN among received RLC SDUs. It is initially set to 0.

Each transmitting UM RLC entity shall maintain the following state variables:

a) TX_Next

This state variable holds the value of the SN to be assigned for the next newly generated UMD PDU with segment. It is initially set to 0, and is updated after the UM RLC entity submits a UMD PDU including the last segment of an RLC SDU to lower layers.

Each receiving UM RLC entity shall maintain the following state variables and constant:

b) RX_Next_Reassembly – UM receive state variable

This state variable holds the value of the earliest SN that is still considered for reassembly. It is initially set to 0.

c) RX_Timer_Trigger – UM *t-Reassembly* state variable

This state variable holds the value of the SN following the SN which triggered *t-Reassembly*.

d) RX_Next_Highest– UM receive state variable

This state variable holds the value of the SN following the SN of the UMD PDU with the highest SN among received UMD PDUs. It serves as the higher edge of the reassembly window. It is initially set to 0.

[TS 38.331, clause 5.3.5.5.4]

For each *RLC-Bearer-Config* received in the *rlc-BearerToAddModList* IE the UE shall:

- 1> if the UE's current configuration contains a RLC bearer with the received *logicalChannelIdentity*:
 - 2> if *reestablishRLC* is received:
 - 3> re-establish the RLC entity as specified in TS 38.322 [4];
 - 2> reconfigure the RLC entity or entities in accordance with the received *rlc-Config*;
 - 2> reconfigure the logical channel in accordance with the received *mac-LogicalChannelConfig*;

NOTE: The network does not re-associate an already configured logical channel with another radio bearer. Hence *servedRadioBearer* is not present in this case.

7.1.2.2.6.3 Test description

7.1.2.2.6.3.1 Pre-test conditions

Same Pre-test conditions as in clause 7.1.2.1.2 with the exception that the UM DRB is configured according to Table 7.1.2.2.6.3.1-1.

Table 7.1.2.2.6.3.1-1: RLC parameters

t-Reassembly	ms200
Uplink UM RLC sn-FieldLength	IF (pc_Um_WithShortSN) size6 ELSE size12
Downlink UM RLC sn-FieldLength	IF (pc_Um_WithShortSN) size6 ELSE size12

7.1.2.2.6.3.2 Test procedure sequence

Table 7.1.2.2.6.3.2-1: Main behaviour

St	Procedure	Message Sequence		TP	Verdict
		U - S	Message		
1	The SS transmits UMD PDU#1. Header of UMD PDU#1 does not contain an SN. This PDU carries RLC SDU#1.	<--	UMD PDU#1	-	-
2	The UE transmits RLC SDU#1.	-->	(RLC SDU#1)	-	-
3	The SS transmits UMD PDU#2. Header of UMD PDU#2 contains SN=0. This PDU carries the first segment of SDU#2.	<--	UMD PDU#2	-	-
4	The SS performs a RRCReconfiguration procedure including the secondaryCellGroup containing CellGroupConfig IE, including rlc-BearerToAddModList containing RLC-Bearer-Config for DRB with reestablishRLC set as true triggering RLC re-establishment.	-	-	-	-
5	The SS transmits UMD PDU#3. Header of UMD PDU#3 contains SN=0. This PDU carries the last segment of RLC SDU#2. The UE starts t-Reassembly.	<--	UMD PDU#3	-	-
6	Check: For 250 ms does the UE transmit RLC SDU#2?	-->	(RLC SDU#2)	1	F
6A	The SS stops allocating any UL grant.				
7	300 ms (1.5 * t- Reassembly) after step 5 the SS transmits UMD PDU#4. This PDU carries the first segment of RLC SDU#3.SN=1.	<--	UMD PDU#4	-	-
8	The SS transmits UMD PDU#5. This PDU carries the second and last segment of RLC SDU#3.SN=1.	<--	UMD PDU#5	-	-
8A	SS allocates 2 UL grants at an interval of 20 ms so as to loop back RLC SDU#3 in 2 RLC/MAC PDUs. Note 1 & 2	-	-	-	-
9	Check: Does the UE transmit first segment of RLC SDU#3? Header of UMD PDU contains SN=0.	-->	(RLC SDU#3 first segment)	2	P
10	Check: Does the UE transmit second and last segment of RLC SDU#3? Header of UMD PDU contains SN=0.	-->	(RLC SDU#3 last segment)	2	P
11	The SS performs a RRCReconfiguration procedure including the secondaryCellGroup containing CellGroupConfig IE, including rlc-BearerToAddModList containing RLC-Bearer-Config for DRB with reestablishRLC set as true triggering RLC re-establishment.	-	-	-	-
12	The SS transmits UMD PDU#6. Header of UMD PDU#6 contains SN=0. This PDU carries the first segment of SDU#4.	<--	UMD PDU#6	-	-
13	The SS transmits UMD PDU#7. Header of UMD PDU#6 contains SN=0. This PDU carries the second segment of SDU#4.	<--	UMD PDU#7	-	-
13A	SS allocates 2 UL grants at an interval of 20 ms so as to loop back RLC SDU#4 in 2 RLC/MAC PDUs. Note 1 & 2	-	-	-	-
14	Check: Does the UE transmit first segment of RLC SDU#4? Header of UMD PDU contains SN=0.	-->	(RLC SDU#4 first segment)	2	P
15	Check: Does the UE transmit second and last segment of RLC SDU#4? Header of UMD PDU contains SN=0.	-->	(RLC SDU#4 last segment)	2	P

Note 1:	For SN size = size6 the RLC SDU size shall be 12 octets which are segmented into 7 and 5 octets. With 2 octets of MAC header and 1 octet of RLC header (without SO) the first segment consists of 80 bits and a TBS of this size shall be allocated. With 2 octets of MAC header and 3 octets of RLC header (with SO) the second segment consists of 80 bits and a TBS of this size shall be allocated. (L _{RBs} & I _{MCS} as per 38.523-3[3] annex B)
Note 2:	For SN size = size12 the RLC SDU size shall be 12 octets which are segmented into 7 and 5 octets. With 2 octets of MAC header and 2 octets of RLC header (without SO) the first segment consists of 88 bits and a TBS of this size shall be allocated. With 2 octets of MAC header and 4 octets of RLC header (with SO) the second segment consists of 88 bits and a TBS of this size shall be allocated. (L _{RBs} & I _{MCS} as per 38.523-3[3] annex B)

7.1.2.2.6.3.3 Specific message contents

Table 7.1.2.2.6.3.3-1: RLC-Bearer-Config (steps 4, 11, Table 7.1.2.2.6.3.2-1)

Derivation Path: 38.508-1 [4], Table 4.6.3-148			
Information Element	Value/remark	Comment	Condition
RLC-Bearer-Config ::= SEQUENCE {			
logicalChannelIdentity	Set to LCID of the DRB under test		
servedRadioBearer	Not present		
reestablishRLC	true		
rlc-Config	Not present		
mac-LogicalChannelConfig	Not present		
}			

7.1.2.3 RLC Acknowledged Mode

7.1.2.3.1 AM RLC / 12-bit SN / Segmentation and reassembly / Segmentation Info (SI) field

7.1.2.3.1.1 Test Purpose (TP)

(1)

```
with { UE in RRC_CONNECTED state }
ensure that {
  when { UE receives a 12 bit SN configured AMD PDU containing a SI field set to 00 }
  then { UE correctly decodes the received AMD PDU }
}
```

(2)

```
with { UE in RRC_CONNECTED state }
ensure that {
  when { UE receives a 12 bit SN configured AMD PDU containing a SI field set to 01 }
  then { UE correctly decodes the received AMD PDU }
}
```

(3)

```
with { UE in RRC_CONNECTED state }
ensure that {
  when { UE receives a 12 bit SN configured AMD PDU containing a SI field set to 11 and SO field }
  then { UE correctly decodes the received AMD PDU }
}
```

(4)

```
with { UE in RRC_CONNECTED state }
ensure that {
  when { UE receives a 12 bit SN configured AMD PDU containing a SI field set to 10 and SO field }
  then { UE correctly decodes the received AMD PDU }
}
```

(5)

```
with { UE in RRC_CONNECTED state }
ensure that {
  when { UE has UL RLC SDU to send and the UL Grant is sufficient to send complete PDU }
  then { UE transmits AMD PDU containing a complete AMD SDU and SI field set to 00 }
}
```

(6)

```
with { UE in RRC_CONNECTED state }
ensure that {
  when { UE has UL RLC SDU to send and the UL Grant is sufficient to send first segment only }
  then { UE transmits AMD PDU containing first segment of AMD SDU and SI field set to 01 }
}
```

(7)

```
with { UE in RRC_CONNECTED state }
ensure that {
  when { UE has UL RLC SDU to send and the UL Grant is sufficient to send middle segment only }
  then { UE transmits AMD PDU containing middle segment of AMD SDU and SI field set to 11,
including SO field }
}
```

(8)

```
with { UE in RRC_CONNECTED state }
ensure that {
  when { UE has UL RLC SDU to send and the UL Grant is sufficient to send last segment only }
  then { UE transmits AMD PDU containing last segment of AMD SDU and SI field set to 10, including
SO field }
}
```

7.1.2.3.1.2 Conformance requirements

References: The conformance requirements covered in the present TC are specified in: TS 38.322, clauses 6.2.2.4 and 6.2.3.4. Unless otherwise stated these are Rel-15 requirements.

[TS 38.322, clause 6.2.2.4]

AMD PDU consists of a Data field and an AMD PDU header. The AMD PDU header is byte aligned.

An AM RLC entity is configured by RRC to use either a 12 bit SN or a 18 bit SN. The length of the AMD PDU header is two and three bytes respectively.

An AMD PDU header contains a D/C, a P, a SI, and a SN. An AMD PDU header contains the SO field only when the Data field consists of an RLC SDU segment which is not the first segment, in which case a 16 bit SO is present.

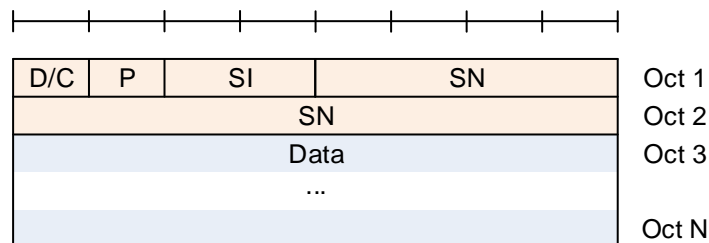

Figure 6.2.2.4-1: AMD PDU with 12 bit SN (No SO)

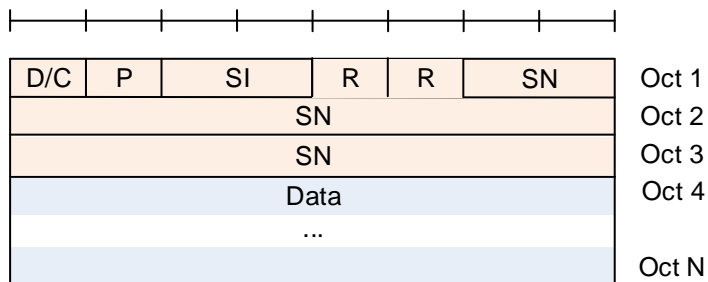

Figure 6.2.2.4-2: AMD PDU with 18 bit SN (No SO)

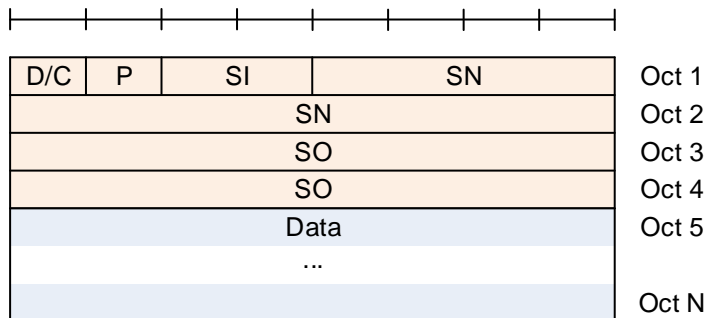

Figure 6.2.2.4-3: AMD PDU with 12 bit SN with SO

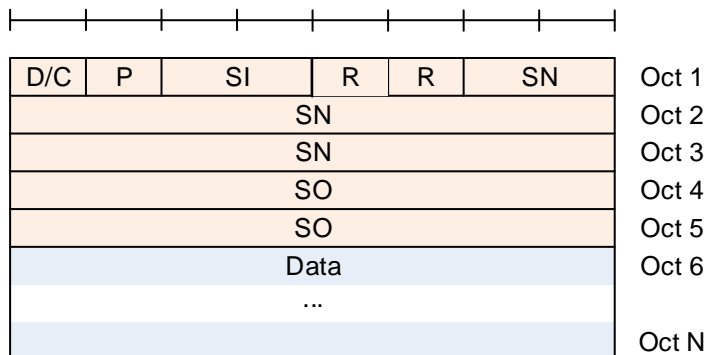

Figure 6.2.2.4-4: AMD PDU with 18 bit SN with SO

[TS 38.322, clause 6.2.3.4]

Length: 2 bits.

The SI field indicates whether an RLC PDU contains a complete RLC SDU or the first, middle, last segment of an RLC SDU.

Table 6.2.3.4-1: SI field interpretation

Value	Description
00	Data field contains all bytes of an RLC SDU
01	Data field contains the first segment of an RLC SDU
10	Data field contains the last segment of an RLC SDU
11	Data field contains neither the first nor last segment of an RLC SDU

7.1.2.3.1.3 Test description

7.1.2.3.1.3.1 Pre-test conditions

Same Pre-test conditions as in clause 7.1.2.1.1 with the exception that the AM DRB is configured according to Table 7.1.2.3.1.3.1-1.

Table 7.1.2.3.1.3.1-1: RLC parameters

Uplink SN-FieldLength-AM	size12
Downlink SN-FieldLength-AM	size12

7.1.2.3.1.3.2 Test procedure sequence

Table 7.1.2.3.1.3.2-1: Main behaviour

St	Procedure	Message Sequence		TP	Verdict
		U - S	Message		
0	The SS stops allocating any UL grant.	-	-	-	-
1	The SS transmits AMD PDU#1 containing a complete RLC SDU#1 (SI field = 00).	<--	AMD PDU#1	-	-
1A	SS allocates an UL grant sufficient to loop back RLC SDU#1 in one RLC/MAC PDU	<--	UL Grant	-	-
2	Check: Does the UE transmit AMD PDU#1 containing a complete RLC SDU#1 (SI field = 00)?	-->	(RLC SDU#1)	1,5	P
3	The SS transmits a STATUS PDU.	<--	STATUS PDU (ACK SN=1)	-	-
4	The SS transmits AMD PDU#2 containing the first segment of RLC SDU#2 (SI field = 01). Note 3	<--	AMD PDU#2	-	-
5	The SS transmits AMD PDU#3 containing the second segment of RLC SDU#2 (SI field = 11) and including SO field. Note 3	<--	AMD PDU#3	-	-
6	The SS transmits AMD PDU#4 containing the last segment of RLC SDU#2 (SI field = 10) and including SO field. Note 3	<--	AMD PDU#4	-	-
6A	SS allocates 3 UL grants at an interval of 20 ms so as to loop back RLC SDU#2 in 3 RLC/MAC PDUs. (Note 1 and Note 2)	<--	UL Grants	-	-
7	Check: Does the UE transmits AMD PDU#2 containing the first segment of RLC SDU#2 (SI field = 01)?	-->	(RLC SDU#2)	2,3, 4,6	P
8	Check: Does the UE transmits AMD PDU#3 containing the middle segment of RLC SDU#2 (SI field = 11) and including SO field?	-->	(RLC SDU#2)	2,3, 4,7	P
9	Check: Does the UE transmits AMD PDU#4 containing the last segment of RLC SDU#2 (SI field = 10) and including SO field?	-->	(RLC SDU#2)	2,3, 4,8	P
10	The SS transmits a STATUS PDU.	<--	STATUS PDU (ACK SN=2)	-	-
Note 1: The UL grants for step 7,8,9 are sufficiently small (240 bits, L _{RBS} & I _{MCS} as per 38.523-3[3] annex B) that UE transmits RLC SDU#2 in 3 UL RLC PDUs by segmenting.					
Note 2: The RLC PDU containing a segment shall be of size 208 bits resp. 224 bits and a MAC sub PDU header of 16 bits and a 16-bit MAC BSR CE included in step 8 resulting in a MAC PDU of size 240 bits.					
Note 3: The data part in step 4 first segment not including SO is 192 bits (24 bytes). Step 5, second segment SO=24 and data is 192 bits (24 bytes). Step 6, third segment SO=24+24=48 and data is 192 bits (24 bytes).					

7.1.2.3.1.3.3 Specific message contents

None

7.1.2.3.2 AM RLC / 18-bit SN / Segmentation and reassembly / Segmentation Info (SI) field

7.1.2.3.2.1 Test Purpose (TP)

(1)

```

with { UE in RRC_CONNECTED state }
ensure that {
  when { UE receives a 18 bit SN configured AMD PDU containing a SI field set to 00 }
  then { UE correctly decodes the received AMD PDU or AMD PDU segment }
}

```

(2)

```

with { UE in RRC_CONNECTED state }
ensure that {
  when { UE receives a 18 bit SN configured AMD PDU containing a SI field set to 01 }
  then { UE correctly decodes the received AMD PDU or AMD PDU segment }
}

```

(3)

```

with { UE in RRC_CONNECTED state }
ensure that {
  when { UE receives a 18 bit SN configured AMD PDU containing a SI field set to 11 and SO field }
  then { UE correctly decodes the received AMD PDU or AMD PDU segment }
}

```

(4)

```

with { UE in RRC_CONNECTED state }
ensure that {
  when { UE receives a 18 bit SN configured AMD PDU containing a SI field set to 10 and SO field }
  then { UE correctly decodes the received AMD PDU or AMD PDU segment }
}

```

(5)

```

with { UE in RRC_CONNECTED state }
ensure that {
  when { UE has UL RLC SDU to send and the UL Grant is sufficient to send complete PDU }
  then { UE transmits AMD PDU containing a complete AMD SDU and SI field set to 00 }
}

```

(6)

```

with { UE in RRC_CONNECTED state }
ensure that {
  when { UE has UL RLC SDU to send and the UL Grant is sufficient to send first segment only }
  then { UE transmits AMD PDU containing first segment of AMD SDU and SI field set to 01 }
}

```

(7)

```

with { UE in RRC_CONNECTED state }
ensure that {
  when { UE has UL RLC SDU to send and the UL Grant is sufficient to send middle segment only }
  then { UE transmits AMD PDU containing middle segment of AMD SDU and SI field set to 11,
including SO field }
}

```

(8)

```

with { UE in RRC_CONNECTED state }
ensure that {
  when { UE has UL RLC SDU to send and the UL Grant is sufficient to send last segment only }
  then { UE transmits AMD PDU containing last segment of AMD SDU and SI field set to 10, including
SO field }
}

```

7.1.2.3.2.2 Conformance requirements

Same conformance requirements as in clause 7.1.2.3.1.2

7.1.2.3.2.3 Test description

7.1.2.3.2.3.1 Pre-test conditions

Same Pre-test conditions as in clause 7.1.2.1.1 with the exception that the AM DRB is configured according to Table 7.1.2.3.2.3.1-1.

Table 7.1.2.3.2.3.1-1: RLC parameters

Uplink SN-FieldLength-AM	size18
Downlink SN-FieldLength-AM	size18

7.1.2.3.2.3.2 Test procedure sequence

Same test procedure as in clause 7.1.2.3.1.3.2 except that SN is 18 bit and the data part in step 4 first segment not including SO is 184 bits (23 Bytes). Step 5, second segment SO=23 and data is 184 bits (23 bytes). Step 6, third segment SO=23+23=46 and data is 184 bits (23 bytes).

7.1.2.3.2.3.3 Specific message contents

None

7.1.2.3.3 AM RLC / 12-bit SN / Correct use of sequence numbering

7.1.2.3.3.1 Test Purpose (TP)

(1)

```
with { UE in RRC_CONNECTED state with AM RLC 12 bit SN }
ensure that {
  when { UE transmits the PDU corresponding to first SDU }
  then { UE includes the SN field equal to 0 in PDU }
}
```

(2)

```
with { UE in RRC_CONNECTED state with AM RLC 12 bit SN }
ensure that {
  when { UE transmits subsequent SDUs }
  then { UE includes the SN field incremented by 1 per SDU of each PDU transmitted }
}
```

(3)

```
with { UE in RRC_CONNECTED state with AM RLC 12 bit SN }
ensure that {
  with { UE transmits more than 4096 SDUs }
  then { UE wraps the SN after transmitting the 4096 SDUs }
}
```

(4)

```
with { UE in RRC_CONNECTED state with AM RLC 12 bit SN }
ensure that {
  with { more than 4096 SDUs are sent to UE }
  then { UE accepts PDUs with SNs that wrap around every 4096 SDUs }
}
```

7.1.2.3.3.2 Conformance requirements

References: The conformance requirements covered in the present TC are specified in: TS 38.322, clauses 5.2.3.1.1, 5.2.3.2.1, 5.2.3.2.2, 6.2.2.4 and 7.1. Unless otherwise stated these are Rel-15 requirements.

[TS 38.322, clause 5.2.3.2.1]

The receiving side of an AM RLC entity shall maintain a receiving window according to the state variable *RX_Next* as follows:

- a SN falls within the receiving window if $RX_Next \leq SN < RX_Next + AM_Window_Size$;
- a SN falls outside of the receiving window otherwise.

When receiving an AMD PDU from lower layer, the receiving side of an AM RLC entity shall:

- either discard the received AMD PDU or place it in the reception buffer (see sub clause 5.2.3.2.2);
- if the received AMD PDU was placed in the reception buffer:
 - update state variables, reassemble and deliver RLC SDUs to upper layer and start/stop *t-Reassembly* as needed (see sub clause 5.2.3.2.3).

When *t-Reassembly* expires, the receiving side of an AM RLC entity shall:

- update state variables and start *t-Reassembly* as needed (see sub clause 5.2.3.2.4).

[TS 38.322, clause 5.2.3.2.2]

When an AMD PDU is received from lower layer, where the AMD PDU contains byte segment numbers *y* to *z* of an RLC SDU with SN = *x*, the receiving side of an AM RLC entity shall:

- if *x* falls outside of the receiving window; or
- if byte segment numbers *y* to *z* of the RLC SDU with SN = *x* have been received before:
 - discard the received AMD PDU.
- else:
 - place the received AMD PDU in the reception buffer;
 - if some byte segments of the RLC SDU contained in the AMD PDU have been received before:
 - discard the duplicate byte segments.

[TS 38.322, clause 6.2.2.4]

AMD PDU consists of a Data field and an AMD PDU header. The AMD PDU header is byte aligned.

An AM RLC entity is configured by RRC to use either a 12 bit SN or a 18 bit SN. The length of the AMD PDU header is two and three bytes respectively.

An AMD PDU header contains a D/C, a P, a SI, and a SN. An AMD PDU header contains the SO field only when the Data field consists of an RLC SDU segment which is not the first segment, in which case a 16 bit SO is present.

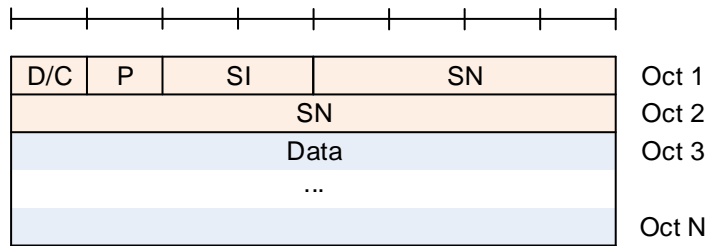

Figure 6.2.2.4-1: AMD PDU with 12 bit SN (No SO)

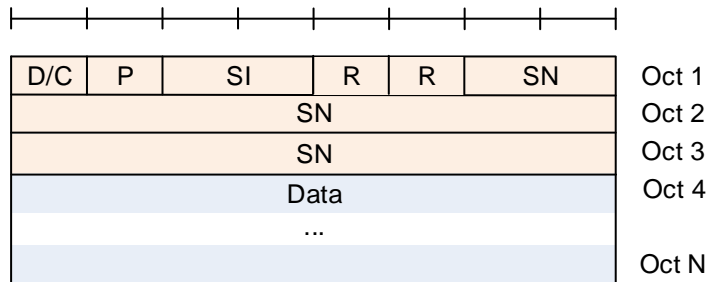

Figure 6.2.2.4-2: AMD PDU with 18 bit SN (No SO)

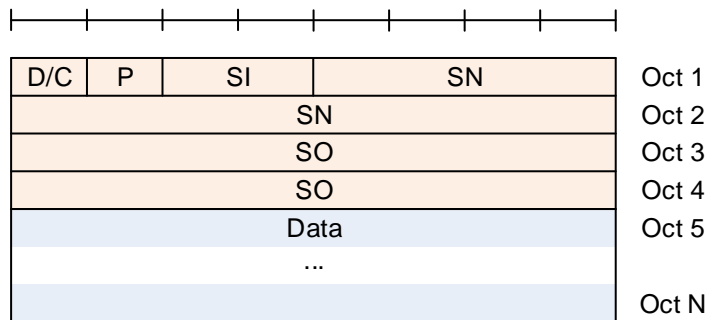

Figure 6.2.2.4-3: AMD PDU with 12 bit SN with SO

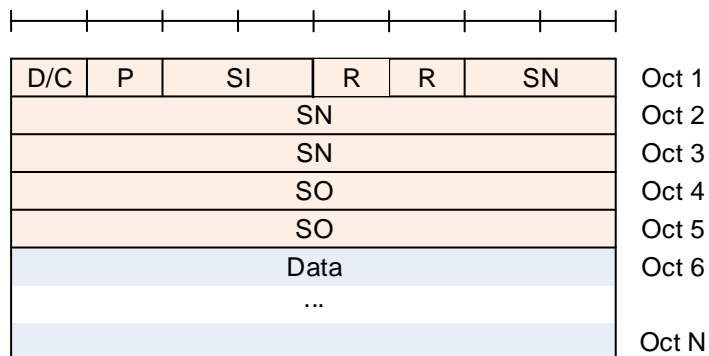

Figure 6.2.2.4-4: AMD PDU with 18 bit SN with SO

[TS 38.322, clause 7.1]

c) RETX_COUNT – Counter

This counter counts the number of retransmissions of an RLC SDU or RLC SDU segment (see subclause 5.3.2). There is one RETX_COUNT counter maintained per RLC SDU.

The receiving side of each AM RLC entity shall maintain the following state variables:

a) RX_Next – Receive state variable

This state variable holds the value of the SN following the last in-sequence completely received RLC SDU, and it serves as the lower edge of the receiving window. It is initially set to 0, and is updated whenever the AM RLC entity receives an RLC SDU with SN = RX_Next.

b) RX_Next_Status_Trigger – *t-Reassembly* state variable

This state variable holds the value of the SN following the SN of the RLC SDU which triggered *t-Reassembly*.

c) RX_Highest_Status – Maximum STATUS transmit state variable

This state variable holds the highest possible value of the SN which can be indicated by "ACK_SN" when a STATUS PDU needs to be constructed. It is initially set to 0.

d) RX_Next_Highest – Highest received state variable

This state variable holds the value of the SN following the SN of the RLC SDU with the highest SN among received RLC SDUs. It is initially set to 0.

Each transmitting UM RLC entity shall maintain the following state variables:

a) TX_Next

This state variable holds the value of the SN to be assigned for the next newly generated UMD PDU with segment. It is initially set to 0, and is updated after the UM RLC entity submits a UMD PDU including the last segment of an RLC SDU to lower layers.

Each receiving UM RLC entity shall maintain the following state variables and constant:

b) RX_Next_Reassembly – UM receive state variable

This state variable holds the value of the earliest SN that is still considered for reassembly. It is initially set to 0.

c) RX_Timer_Trigger – UM *t-Reassembly* state variable

This state variable holds the value of the SN following the SN which triggered *t-Reassembly*.

d) RX_Next_Highest – UM receive state variable

This state variable holds the value of the SN following the SN of the UMD PDU with the highest SN among received UMD PDUs. It serves as the higher edge of the reassembly window. It is initially set to 0.

7.1.2.3.3.3 Test description

7.1.2.3.3.3.1 Pre-test conditions

Same Pre-test conditions as in clause 7.1.2.3.3 with the exception that the AM DRB is configured according to Table 7.1.2.3.3.3.1-1.

Table 7.1.2.3.3.3.1-1: RLC parameters

Uplink SN-FieldLength-AM	size12
Downlink SN-FieldLength-AM	size12
pollPDU	infinity
pollByte	infinity

7.1.2.3.3.3.2 Test procedure sequence

Table 7.1.2.3.3.3.2-1: Main behaviour

St	Procedure	Message Sequence		TP	Verdict
		U - S	Message/PDU/SDU		
-	During the whole test sequence, the SS should not allocate UL grants unless when explicitly stated so in the procedure.	-	-	-	-
-	EXCEPTION: The SS is configured 500ms in advance for step 1 and 2. Step 1 is executed 2048 times such that 1 AMD PDU is transmitted every second radio frame. (Note 1). Step 2 is started 60 ms after the first DL AMD PDU has been transmitted in step 1 (Note 1,3).	-	-	-	-
-	EXCEPTION: In parallel to steps 1 and 2, the behaviour described in Table 7.1.2.3.3.3.2-2 is running.	-	-	-	-
1	The SS transmits an AMD PDU to the UE. SN equals 0 and is incremented for each PDU transmitted (Note 1,3).	<--	AMD PDU	-	-
2	The SS transmits 1 UL grant (UL grant allocation type 2) in every second radio frame to enable the UE to return each received AMD PDU in one looped back AMD PDU (Note 1,3).	<--	(UL grants)	-	-
3	The SS does not allocate any uplink grant.	-	-	-	-
-	EXCEPTION: The SS is configured 500ms in advance for step 4 and 5. Step 4 is executed 2048 times such that 1 AMD PDU is transmitted every second radio frame. (Note 1). Step 5 is started 60 ms after the first DL AMD PDU has been transmitted in step 4 (Note 1,3).	-	-	-	-
-	EXCEPTION: In parallel to steps 4 and 5, the behaviour described in Table 7.1.2.3.3.3.2-3 is running.	-	-	-	-
4	The SS transmits an AMD PDU to the UE. SN equals 2048 and is incremented for each PDU transmitted.	<--	AMD PDU	-	-
5	The SS transmits 1 UL grant (UL grant allocation type 2) in every second radio frame to enable the UE to return each received AMD PDU in one looped back AMD PDU (Note 1,3).	<--	(UL grants)	-	-
6	The SS transmits an AMD PDU to the UE. SN equals 0.	<--	AMD PDU	-	-
7	The SS starts the UL default grant transmission.	-	-	-	-
8	Check: Does the UE transmit an AMD PDU with SN=0?	-->	AMD PDU	3,4	P
9	The SS transmits a STATUS PDU with ACK_SN = 1.	<--	STATUS PDU	-	-
<p>Note 1: 20 ms gap between transmissions both in DL and UL respectively allows TTCN to tolerate one HARQ retransmission (FDD/TDD) per transport block, if such happen (TS 38.523-3 [3]).</p> <p>Note 2: Delaying first UL grant for 60 ms, ensures that UE UL buffer does not become empty every time one UL AMD PDU is sent, i.e. the UE does not enable polling for every UL AMD PDU. The SS continuously transmits the grants until it has received all PDUs in UL.</p> <p>Note 3: The RLC SDU size shall be 8 octets. With 2 octets of MAC header and 2 octets of RLC header (without SO) the RLC PDU consists of 80 bits and a TBS of 96 bits shall be allocated</p>					

Table 7.1.2.3.3.2-2: Parallel behaviour

St	Procedure	Message Sequence		TP	Verdict
		U - S	Message		
1	Check: Does the UE transmit an AMD PDU with SN = 0?	-->	AMD PDU	1	P
-	EXCEPTION: Steps 2 and 3a1 are executed 2047 times.	-	-	-	-
2	Check: Does the UE transmit an AMD PDU with SN increased by 1 compared with the previous one?(Note1)	-->	AMD PDU	2	P

Note 1: The verdict shall be provided each time $(SN+1) \bmod 256 = 0$.

Table 7.1.2.3.3.2-3: Parallel behaviour

St	Procedure	Message Sequence		TP	Verdict
		U - S	Message		
-	EXCEPTION: Steps 1 and 2a1 are executed 2048 times.	-	-	-	-
1	Check: Does the UE transmit an AMD PDU with SN increased by 1 compared with the previous one?(Note1)	-->	AMD PDU	2	P

Note 1: The verdict shall be provided each time $(SN+1) \bmod 256 = 0$.

7.1.2.3.3.3 Specific message contents

None.

7.1.2.3.4 AM RLC / 18-bit SN / Correct use of sequence numbering

7.1.2.3.4.1 Test Purpose (TP)

(1)

```
with { UE in RRC_CONNECTED state with AM RLC 18 bit SN }
ensure that {
  when { UE transmits the PDU corresponding to first SDU }
  then { UE includes the SN field equal to 0 in PDU }
}
```

(2)

```
with { UE in RRC_CONNECTED state with AM RLC 18 bit SN }
ensure that {
  when { UE transmits subsequent SDUs }
  then { UE includes the SN field incremented by 1 per SDU of each PDU transmitted }
}
```

(3)

```
with { UE in RRC_CONNECTED state with AM RLC 18 bit SN }
ensure that {
  with { UE transmits more than 262144 SDUs }
  then { UE wraps the SN after transmitting the 262144 SDUs }
}
```

(4)

```
with { UE in RRC_CONNECTED state with AM RLC 18 bit SN }
ensure that {
  with { more than 262144 SDUs are sent to UE }
  then { UE accepts PDUs with SNs that wrap around every 262144 SDUs }
}
```

7.1.2.3.4.2 Conformance requirements

References: The conformance requirements covered in the present TC are specified in: TS 38.322, clause 5.2.3.1.1, 5.2.3.2.1, 5.2.3.2.2, 6.2.2.4, 7.1. Unless otherwise stated these are Rel-15 requirements.

[TS 38.322, clause 5.2.3.2.1]

The receiving side of an AM RLC entity shall maintain a receiving window according to the state variable RX_Next as follows:

- a SN falls within the receiving window if $RX_Next \leq SN < RX_Next + AM_Window_Size$;
- a SN falls outside of the receiving window otherwise.

When receiving an AMD PDU from lower layer, the receiving side of an AM RLC entity shall:

- either discard the received AMD PDU or place it in the reception buffer (see sub clause 5.2.3.2.2);
- if the received AMD PDU was placed in the reception buffer:
 - update state variables, reassemble and deliver RLC SDUs to upper layer and start/stop *t-Reassembly* as needed (see sub clause 5.2.3.2.3).

When *t-Reassembly* expires, the receiving side of an AM RLC entity shall:

- update state variables and start *t-Reassembly* as needed (see sub clause 5.2.3.2.4).

[TS 38.322, clause 5.2.3.2.2]

When an AMD PDU is received from lower layer, where the AMD PDU contains byte segment numbers y to z of an RLC SDU with $SN = x$, the receiving side of an AM RLC entity shall:

- if x falls outside of the receiving window; or
- if byte segment numbers y to z of the RLC SDU with $SN = x$ have been received before:
 - discard the received AMD PDU.
- else:
 - place the received AMD PDU in the reception buffer;
 - if some byte segments of the RLC SDU contained in the AMD PDU have been received before:
 - discard the duplicate byte segments.

[TS 38.322, clause 6.2.2.4]

AMD PDU consists of a Data field and an AMD PDU header. The AMD PDU header is byte aligned.

An AM RLC entity is configured by RRC to use either a 12 bit SN or a 18 bit SN. The length of the AMD PDU header is two and three bytes respectively.

An AMD PDU header contains a D/C, a P, a SI, and a SN. An AMD PDU header contains the SO field only when the Data field consists of an RLC SDU segment which is not the first segment, in which case a 16 bit SO is present.

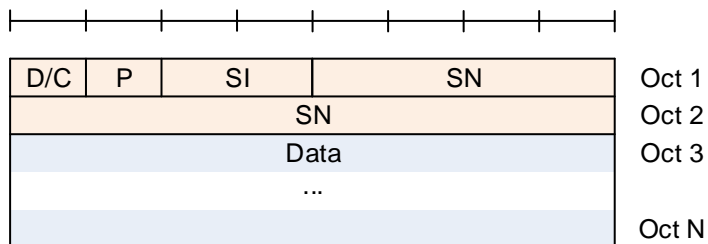

Figure 6.2.2.4-1: AMD PDU with 12 bit SN (No SO)

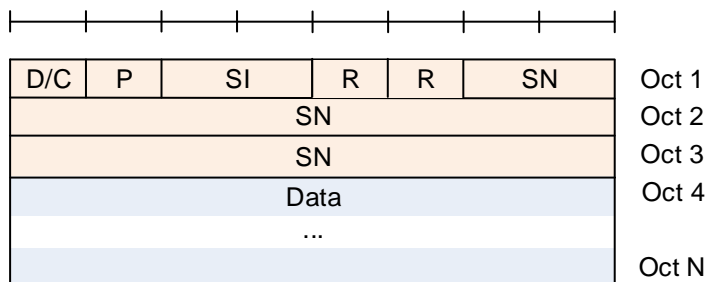

Figure 6.2.2.4-2: AMD PDU with 18 bit SN (No SO)

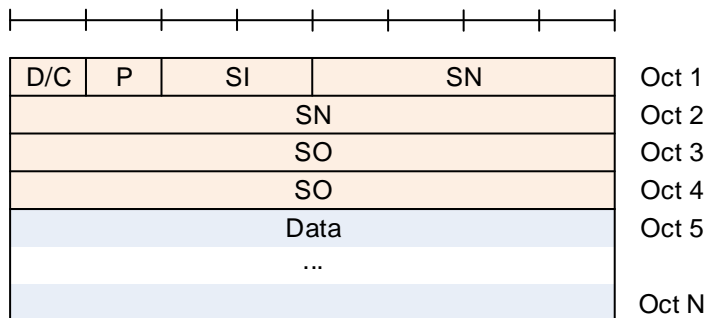

Figure 6.2.2.4-3: AMD PDU with 12 bit SN with SO

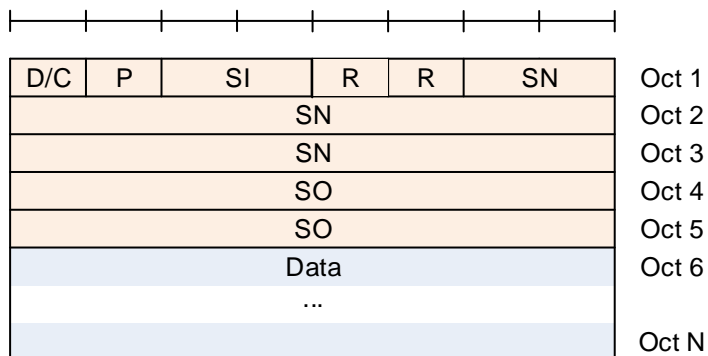

Figure 6.2.2.4-4: AMD PDU with 18 bit SN with SO

[TS 38.322, clause 7.1]

c) RETX_COUNT – Counter

This counter counts the number of retransmissions of an RLC SDU or RLC SDU segment (see subclause 5.3.2). There is one RETX_COUNT counter maintained per RLC SDU.

The receiving side of each AM RLC entity shall maintain the following state variables:

a) RX_Next – Receive state variable

This state variable holds the value of the SN following the last in-sequence completely received RLC SDU, and it serves as the lower edge of the receiving window. It is initially set to 0, and is updated whenever the AM RLC entity receives an RLC SDU with SN = RX_Next.

b) RX_Next_Status_Trigger – *t-Reassembly* state variable

This state variable holds the value of the SN following the SN of the RLC SDU which triggered *t-Reassembly*.

c) RX_Highest_Status – Maximum STATUS transmit state variable

This state variable holds the highest possible value of the SN which can be indicated by "ACK_SN" when a STATUS PDU needs to be constructed. It is initially set to 0.

d) RX_Next_Highest – Highest received state variable

This state variable holds the value of the SN following the SN of the RLC SDU with the highest SN among received RLC SDUs. It is initially set to 0.

Each transmitting UM RLC entity shall maintain the following state variables:

a) TX_Next

This state variable holds the value of the SN to be assigned for the next newly generated UMD PDU with segment. It is initially set to 0, and is updated after the UM RLC entity submits a UMD PDU including the last segment of an RLC SDU to lower layers.

Each receiving UM RLC entity shall maintain the following state variables and constant:

b) RX_Next_Reassembly – UM receive state variable

This state variable holds the value of the earliest SN that is still considered for reassembly. It is initially set to 0.

c) RX_Timer_Trigger – UM *t-Reassembly* state variable

This state variable holds the value of the SN following the SN which triggered *t-Reassembly*.

d) RX_Next_Highest – UM receive state variable

This state variable holds the value of the SN following the SN of the UMD PDU with the highest SN among received UMD PDUs. It serves as the higher edge of the reassembly window. It is initially set to 0.

7.1.2.3.4.3 Test description

7.1.2.3.4.3.1 Pre-test conditions

Same Pre-test conditions as in clause 7.1.2.3.4 with the exception that the AM DRB is configured according to Table 7.1.2.3.4.3.1-1.

Table 7.1.2.3.4.3.1-1: RLC parameters

Uplink SN-FieldLength-AM	size18
Downlink SN-FieldLength-AM	size18
pollPDU	infinity
pollByte	infinity

7.1.2.3.4.3.2 Test procedure sequence

Table 7.1.2.3.4.3.2-1: Main behaviour

St	Procedure	Message Sequence		TP	Verdict
		U - S	Message/PDU/SDU		
-	During the whole test sequence, the SS should not allocate UL grants unless when explicitly stated so in the procedure.	-	-	-	-
-	EXCEPTION: The SS is configured 500ms in advance for step 1 and 2. Step 1 is executed 131072 times such that 1 AMD PDU is transmitted every second radio frame. (Note 1). Step 2 is started 60 ms after the first DL AMD PDU has been transmitted in step 1 (Note 1,3).	-	-	-	-
-	EXCEPTION: In parallel to steps 1 and 2, the behaviour described in Table 7.1.2.3.4.3.2-2 is running.	-	-	-	-
1	The SS transmits an AMD PDU to the UE. SN equals 0 and is incremented for each PDU transmitted (Note 1,3).	<--	AMD PDU	-	-
2	The SS transmits 1 UL grant (UL grant allocation type 2) in every second radio frame to enable the UE to return each received AMD PDU in one looped back AMD PDU (Note 1,3).	<--	(UL grants)	-	-
3	The SS does not allocate any uplink grant.	-	-	-	-
-	EXCEPTION: The SS is configured 500ms in advance for step 4 and 5. Step 4 is executed 131072 times such that 1 AMD PDU is transmitted every second radio frame. (Note 1). Step 5 is started 60 ms after the first DL AMD PDU has been transmitted in step 4 (Note 1,3).	-	-	-	-
-	EXCEPTION: In parallel to steps 4 and 5, the behaviour described in Table 7.1.2.3.4.3.2-3 is running.	-	-	-	-
4	The SS transmits an AMD PDU to the UE. SN equals 131072 and is incremented for each PDU transmitted.	<--	AMD PDU	-	-
5	The SS transmits 1 UL grant (UL grant allocation type 2) in every second radio frame to enable the UE to return each received AMD PDU in one looped back AMD PDU (Note 1,3).	<--	(UL grants)	-	-
6	The SS transmits an AMD PDU to the UE. SN equals 0.	<--	AMD PDU	-	-
7	The SS starts the UL default grant transmission.	-	-	-	-
8	Check: Does the UE transmit an AMD PDU with SN=0?	-->	AMD PDU	3,4	P
9	The SS transmits a STATUS PDU with ACK_SN = 1.	<--	STATUS PDU	-	-
<p>Note 1: 20 ms gap between transmissions both in DL and UL respectively allows TTCN to tolerate one HARQ retransmission (FDD/TDD) per transport block, if such happen (TS 38.523-3 [3]).</p> <p>Note 2: Delaying first UL grant for 60 ms, ensures that UE UL buffer does not become empty every time one UL AMD PDU is sent, i.e. the UE does not enable polling for every UL AMD PDU. The SS continuously transmits the grants until it has received all PDUs in UL.</p> <p>Note 3: The RLC SDU size shall be 9 octets. With 2 octets of MAC header and 3 octets of RLC header (without SO) the RLC PDU consists of 96 bits and a TBS of 112 bits shall be allocated</p>					

Table 7.1.2.3.4.3.2-2: Parallel behaviour

St	Procedure	Message Sequence		TP	Verdict
		U - S	Message		
1	Check: Does the UE transmit an AMD PDU with SN = 0?	-->	AMD PDU	1	P
-	EXCEPTION: Steps 2 and 3a1 are executed 131071 times.	-	-	-	-
2	Check: Does the UE transmit an AMD PDU with SN increased by 1 compared with the previous one? (Note1)	-->	AMD PDU	2	P
-	EXCEPTION: Step 3a1 describes behaviour that depends on the contents of the AMD PDU transmitted at Step 2.	-	-	-	-
3a1	IF the UE has set the poll bit in the AMD PDU transmitted at Step 2 THEN the SS transmits a Status Report.	<--	STATUS PDU	-	-

Note 1: The verdict shall be provided each time $(SN+1) \bmod 4096 = 0$.

Table 7.1.2.3.4.3.2-3: Parallel behaviour

St	Procedure	Message Sequence		TP	Verdict
		U - S	Message		
-	EXCEPTION: Steps 1 and 2a1 are executed 131072 times.	-	-	-	-
1	Check: Does the UE transmit an AMD PDU with SN increased by 1 compared with the previous one? (Note1)	-->	AMD PDU	2	P
-	EXCEPTION: Step 2a1 describes behaviour that depends on the contents of the AMD PDU transmitted at Step 1.	-	-	-	-
2a1	IF the UE has set the poll bit in the AMD PDU transmitted at Step 1 THEN the SS transmits a Status Report.	<--	STATUS PDU	-	-

Note 1: The verdict shall be provided each time $(SN+1) \bmod 4096 = 0$.

7.1.2.3.4.3.3 Specific message contents

None.

7.1.2.3.5 AM RLC / Control of transmit window/Control of receive window

7.1.2.3.5.1 Test Purpose (TP)

(1)

```
with { UE in RRC_CONNECTED state and using AM RLC and pending uplink data for transmission }
ensure that {
  when { AMD PDUs in transmission buffer fall outside TX_Next_Ack <= SN < TX_Next_Ack +
AM_Window_Size }
    then { UE does not transmit these AMD PDUs }
}
```

(2)

```
with { UE in RRC_CONNECTED state and using AM RLC and pending uplink data for transmission }
ensure that {
  when { receiving a STATUS PDU where ACK_SN acknowledges at least one AMD PDU not yet acknowledged }
    then { UE transmits AMD PDUs within updated window range }
}
```

(3)

```

with { UE in RRC_CONNECTED state and using AM RLC }
ensure that {
  when { the UE receives AMD PDUs with SN outside the upper boundary of the receive window }
  then { the UE discards these AMD PDUs }
}

```

(4)

```

with { UE in RRC_CONNECTED state and using AM RLC }
ensure that {
  when { the receive window has been moved }
  then { UE continues accepting AMD PDUs within updated window range }
}

```

7.1.2.3.5.2 Conformance requirements

References: The conformance requirements covered in the present TC are specified in: TS 38.322, clauses 5.2.3.2.1, 5.2.3.2.2, 5.2.3.2.3 and 7.2. Unless otherwise stated these are Rel-15 requirements.

[TS 38.322, clause 5.2.3.2.2]

When an AMD PDU is received from lower layer, where the AMD PDU contains byte segment numbers y to z of an RLC SDU with SN = x , the receiving side of an AM RLC entity shall:

- if x falls outside of the receiving window; or
- if byte segment numbers y to z of the RLC SDU with SN = x have been received before:
 - discard the received AMD PDU.
- else:
 - place the received AMD PDU in the reception buffer;
 - if some byte segments of the RLC SDU contained in the AMD PDU have been received before:
 - discard the duplicate byte segments.

[TS 38.322, clause 5.2.3.2.3]

When an AMD PDU with SN = x is placed in the reception buffer, the receiving side of an AM RLC entity shall:

- if $x \geq \text{RX_Next_Highest}$
 - update RX_Next_Highest to $x + 1$.
- if all bytes of the RLC SDU with SN = x are received:
 - reassemble the RLC SDU from AMD PDU(s) with SN = x , remove RLC headers when doing so and deliver the reassembled RLC SDU to upper layer;
 - if $x = \text{RX_Highest_Status}$,
 - update RX_Highest_Status to the SN of the first RLC SDU with SN > current RX_Highest_Status for which not all bytes have been received.
 - if $x = \text{RX_Next}$:
 - update RX_Next to the SN of the first RLC SDU with SN > current RX_Next for which not all bytes have been received.
- if *t-Reassembly* is running:
 - if $\text{RX_Next_Status_Trigger} = \text{RX_Next}$; or
 - if $\text{RX_Next_Status_Trigger} = \text{RX_Next} + 1$ and there is no missing byte segment of the SDU associated with SN = RX_Next before the last byte of all received segments of this SDU; or

- if `RX_Next_Status_Trigger` falls outside of the receiving window and `RX_Next_Status_Trigger` is not equal to `RX_Next + AM_Window_Size`:
 - stop and reset *t-Reassembly*.
- if *t-Reassembly* is not running (includes the case *t-Reassembly* is stopped due to actions above):
 - if `RX_Next_Highest > RX_Next + 1`; or
 - if `RX_Next_Highest = RX_Next + 1` and there is at least one missing byte segment of the SDU associated with `SN = RX_Next` before the last byte of all received segments of this SDU:
 - start *t-Reassembly*;
 - set `RX_Next_Status_Trigger` to `RX_Next_Highest`.

[TS 38.322, clause 7.2]

a) `AM_Window_Size`

This constant is used by both the transmitting side and the receiving side of each AM RLC entity. `AM_Window_Size = 2048` when a 12 bit SN is used, `AM_Window_Size = 131072` when an 18 bit SN is used.

7.1.2.3.5.3 Test description

7.1.2.3.5.3.1 Pre-test conditions

Same Pre-test conditions as in clause 7.1.2.1.1 with the exception that the AM DRB is configured according to Table 7.1.2.3.5.3.1-1.

Table 7.1.2.3.5.3.1-1: RLC parameters

<code>t-PollRetransmit</code>	ms300
<code>pollPDU</code>	infinity
<code>pollByte</code>	infinity
<code>sn-FieldLength(UL-AM-RLC)</code>	IF (<code>pc_am_WithShortSN</code>) size12 ELSE size18
<code>sn-FieldLength(DL-AM-RLC)</code>	IF (<code>pc_am_WithShortSN</code>) size12 ELSE size18

7.1.2.3.5.3.2 Test procedure sequence

Table 7.1.2.3.5.3.2-1: Main behaviour

St	Procedure	Message Sequence		TP	Verdict
		U - S	Message		
-	The SS does not allocate any uplink grant.	-	-	-	-
-	EXCEPTION: The SS is configured for step 1 and 2 500ms in advance. Step 1 is repeated $W+1$ times, where $W = AM_Window_Size$. The transmission is performed every second radio frame. (Note 2). Step 2 is started 100 ms after the first DL AMD PDU has been transmitted in step 1.	-	-	-	-
-	EXCEPTION: In parallel to steps 1 and 2, the behaviour described in Table 7.1.2.3.5.3.2-2 is running.	-	-	-	-
1	The SS transmits an AMD PDU containing a SDU to the UE.	<--	AMD PDU	-	-
2	In the following steps the SS transmits 1 UL grant in every second radio frame to enable the UE to return each received AMD PDU in one looped back AMD PDU. (Note 2)	<--	(UL grants)	-	-
3	Check: Does the UE transmit an AMD PDU with the Poll bit set and with the contents of the SDU?	-->	AMD PDU(SN=W-1), Poll	1	P
4	The SS starts the UL default grant transmission.	-	-	-	-
5	Check: Does the UE transmit an AMD PDU within $t_PollRetransmit/2$?	-->	AMD PDU	1	F
6	The SS transmits a STATUS PDU to acknowledge the W uplink AMD PDUs with SN=0 to SN=W-1. ACK_SN = W.	<--	STATUS PDU	-	-
7	Check: Does the UE transmit an AMD PDU with the Poll bit set and with the contents of the SDU?	-->	AMD PDU(SN=W), Poll	2	P
8	The SS transmits a STATUS PDU with ACK_SN = W+1.	<--	STATUS PDU	-	-
9	The SS transmits the (W+1)th AMD PDU containing a SDU to the UE with the Sequence Number field set to $((2W+1 \bmod AM_Modulus) = 1)$ and the Polling bit set. (Note 3)	<--	AMD PDU	-	-
10	Check: Does the UE transmit a STATUS PDU acknowledging W+1 SDUs? (ACK_SN = W+1). (Note 1)	-->	STATUS PDU	3	P
11	The SS transmits the (W+2)nd AMD PDU to the UE with the Sequence Number field set to W+1 and the Polling bit set.	<--	AMD PDU	-	-
-	EXCEPTION: Steps 12 and 13 can happen in any order.				
12	Check: Does the UE transmit a STATUS PDU acknowledging W +1 PDUs? (ACK_SN field = W+2).	-->	STATUS PDU	4	P
13	Check: Does the UE transmit an AMD PDU with the same data as received in the corresponding DL AMD PDU in step 11?	-->	AMD PDU	4	P
<p>Note 1: SDUs are numbered 1,2, ..., W+2.</p> <p>Note 2: 20 ms gap between transmissions both in DL and UL respectively allows TTCN to tolerate one HARQ retransmission (FDD/TDD) per transport block.</p> <p>Note 3: AM_Modulus is 4096 resp 262144 for SN size is size12 or size18.</p> <p>Note 4: If SN size is size12 is used the RLC SDU size shall be 8 octets. With 2 octets of MAC header and 2 octets of RLC header (without SO) the RLC PDU consists of 80 bits and a TBS of 96 bits shall be allocated. If SN size is size18 is used the RLC SDU size shall be 9 octets. With 2 octets of MAC header and 3 octets of RLC header (without SO) the RLC PDU consists of 96 bits and a TBS of 112 bits shall be allocated</p>					

Table 7.1.2.3.5.3.2-2: Parallel behaviour

St	Procedure	Message Sequence		TP	Verdict
		U - S	Message		
-	EXCEPTION: Step 1 is executed W-1 times.	-	-	-	-
1	Check: Does the UE transmit an AMD PDU with the same data as received in the corresponding DL AMD PDU.	-->	AMD PDU	4	P
Note 1: The verdict shall be provided each time $(SN+1) \bmod 256 = 0$ resp. $(SN+1) \bmod 4096 = 0$, if SN size is size12 or size18.					

7.1.2.3.5.3.3 Specific message contents

None

7.1.2.3.6 AM RLC / Polling for status

7.1.2.3.6.1 Test Purpose (TP)

(1)

```
with { UE in RRC_CONNECTED state and using AM RLC }
ensure that {
  when { last data in the UL buffer is being transmitted }
  then { UE transmits a Poll }
}
```

(2)

```
with { UE in RRC_CONNECTED state and using AM RLC }
ensure that {
  when { the t-PollRetransmit timer expires }
  then { UE transmits a Poll }
}
```

(3)

```
with { UE in RRC_CONNECTED state and using AM RLC }
ensure that {
  when { PDU_WITHOUT_POLL >= pollPDU }
  then { UE transmits a Poll }
}
```

(4)

```
with { UE in RRC_CONNECTED state and using AM RLC }
ensure that {
  when { BYTE_WITHOUT_POLL >= pollByte }
  then { UE transmits a Poll }
}
```

7.1.2.3.6.2 Conformance requirements

References: The conformance requirements covered in the present TC are specified in: TS 38.322, clauses 5.3.3.2, 7.3 and 7.4. Unless otherwise stated these are Rel-15 requirements.

[TS 38.322, clause 5.3.3.2]

Upon notification of a transmission opportunity by lower layer, for each AMD PDU submitted for transmission such that the AMD PDU contains either a not previously transmitted RLC SDU or an RLC SDU segment containing not previously transmitted byte segment, the transmitting side of an AM RLC entity shall:

- increment PDU_WITHOUT_POLL by one;

- increment BYTE_WITHOUT_POLL by every new byte of Data field element that it maps to the Data field of the AMD PDU;
- if PDU_WITHOUT_POLL \geq pollPDU; or
- if BYTE_WITHOUT_POLL \geq pollByte:
 - include a poll in the AMD PDU as described below.

Upon notification of a transmission opportunity by lower layer, for each AMD PDU submitted for transmission, the transmitting side of an AM RLC entity shall:

- if both the transmission buffer and the retransmission buffer becomes empty (excluding transmitted RLC SDUs or RLC SDU segments awaiting acknowledgements) after the transmission of the AMD PDU; or
- if no new RLC SDU can be transmitted after the transmission of the AMD PDU (e.g. due to window stalling);
 - include a poll in the AMD PDU as described below.

NOTE: Empty RLC buffer (excluding transmitted RLC SDUs or RLC SDU segments awaiting acknowledgements) should not lead to unnecessary polling when data awaits in the upper layer. Details are left up to UE implementation.

To include a poll in an AMD PDU, the transmitting side of an AM RLC entity shall:

- set the P field of the AMD PDU to "1";
- set PDU_WITHOUT_POLL to 0;
- set BYTE_WITHOUT_POLL to 0.

After submitting an AMD PDU including a poll to lower layer and after incrementing of TX_Next if necessary, the transmitting side of an AM RLC entity shall:

- set POLL_SN to TX_Next – 1;
- if *t-PollRetransmit* is not running:
 - start *t-PollRetransmit*.
- else:
 - restart *t-PollRetransmit*.

[TS 38.322, clause 5.3.3.4]

Upon expiry of *t-PollRetransmit*, the transmitting side of an AM RLC entity shall:

- if both the transmission buffer and the retransmission buffer are empty (excluding transmitted RLC SDU or RLC SDU segment awaiting acknowledgements); or
- if no new RLC SDU or RLC SDU segment can be transmitted (e.g. due to window stalling):
 - consider the RLC SDU with SN = TX_Next – 1 for retransmission; or
 - consider any RLC SDU which has not been positively acknowledged for retransmission.
- include a poll in an AMD PDU as described in section 5.3.3.2.

[TS 38.322, clause 7.3]

a) *t-PollRetransmit*

This timer is used by the transmitting side of an AM RLC entity in order to retransmit a poll (see sub clause 5.3.3).

[TS 38.322, clause 7.4]

b) pollPDU

This parameter is used by the transmitting side of each AM RLC entity to trigger a poll for every pollPDU PDUs (see subclause 5.3.3).

c) pollByte

This parameter is used by the transmitting side of each AM RLC entity to trigger a poll for every pollByte bytes (see subclause 5.3.3).

7.1.2.3.6.3 Test description

7.1.2.3.6.3.1 Pre-test conditions

Same Pre-test conditions as in clause 7.1.2.1.1 with the exception that the AM DRB is configured according to Table 7.1.2.3.6.3.1-1.

Table 7.1.2.3.6.3.1-1: RLC parameters

t-PollRetransmit	ms400
pollPDU	p256
pollByte	kB25

7.1.2.3.6.3.2 Test procedure sequence

Table 7.1.2.3.6.3.2-1: Main behaviour

St	Procedure	Message Sequence		TP	Verdict
		U - S	Message		
1	During the whole test sequence, the SS should not allocate UL grants unless when explicitly stated so in the procedure.	-	-	-	-
2	The SS transmits 4 AMD PDUs such that 1 AMD PDU is sent every two radio frame, each containing an RLC SDU of 976 bits. (Note 2)	<--	AMD PDU (SN=0) AMD PDU (SN=1) AMD PDU (SN=2) AMD PDU (SN=3)	-	-
-	EXCEPTION: In parallel to the events described in step 3, the step specified in Table 7.1.2.3.6.3.2-2 should take place.	-	-	-	-
3	The SS waits for 100 ms after the first DL AMD PDU has been transmitted in step 2, then starts assigning UL grants in every second radio frame of size 1032 bits. (Note 1) (Note 2)	-	-	-	-
4	Check 1: Does the UE transmit an AMD PDU with a SN in range 0 to 3 and P=1? Record time T_B . Check 2: Is $(T_B - T_A) = t\text{-PollRetransmit?}$	-->	AMD PDU	2	P
5	The SS starts the UL default grant transmission on reception of SR.	-	-	-	-
6	The SS transmits an RLC Status Report ACKing reception of PDU's 0-3.	<--	STATUS PDU	-	-
7	Check: Does the UE retransmit an AMD PDU within 1 sec?	-->	AMD PDU	2	F
8	The SS performs an RRCReconfiguration procedure changing <i>pollPDU</i> to p4.	-	-	-	-
9	The SS stops allocating any UL grant.	-	-	-	-
10	The SS transmits 8 AMD PDUs such that 1 AMD PDU is sent every second radio frame, each containing an RLC SDU of 976 bits. (Note 2)	<--	AMD PDU (SN=4) AMD PDU (SN=5) ... AMD PDU (SN=11)	-	-
-	EXCEPTION: In parallel to the events described in step 11, the step specified in Table 7.1.2.3.6.3.2-3 should take place.	-	-	-	-
11	The SS waits for 100 ms after the first DL AMD PDU has been transmitted in step 10, then starts assigning UL grants (UL grant allocation type 2) in every second radio frame of size 1032 bits. (Note 1) (Note 2)	-	-	-	-
12	The SS transmits a Status Report with ACK_SN=12, NACK_SN=4, NACK_SN=5, NACK_SN=6 (constructed by NACK_SN Range), NACK_SN=8 and NACK_SN=9 (constructed by NACK_SN Range).	<--	STATUS PDU	-	-
12 A	The SS starts the UL default grant transmission on reception of SR.	-	-	-	-
13	Check: Does the UE transmit AMD PDUs with the following SN and P values? AMD PDU, SN=4, P=0 AMD PDU, SN=5, P=0 AMD PDU, SN=6, P=0 AMD PDU, SN=8, P=0 AMD PDU, SN=9, P=1	-->	AMD PDU (SN=4, P=0) AMD PDU (SN=5, P=0) AMD PDU (SN=6, P=0) AMD PDU (SN=8, P=0) AMD PDU (SN=9, P=1)	2	P
14	Void	-	-	-	-
15	The SS transmits a Status Report with ACK_SN=12 and no NACK_SN.	<--	STATUS PDU	-	-
16	The SS performs an RRCReconfiguration procedure changing <i>pollPDU</i> to p256.	-	-	-	-
17	The SS does not allocate any UL grant.	-	-	-	-
18	After 500 ms the SS transmits 412 AMD PDUs such that 1 AMD PDU is sent every second radio frame, each containing an RLC SDU of size 976 bits. (Note 2)	<--	AMD PDU (SN=12) AMD PDU (SN=13) ... AMD PDU (SN=423)	-	-

-	EXCEPTION: In parallel to the events described in step 19, the steps specified in Table 7.1.2.3.6.3.2-4 should take place.	-	-	-	-
19	The SS waits for 100 ms after the first DL AMD PDU has been transmitted in step 10, then starts assigning UL grants (UL grant allocation type 2) in every second radio frame of size 1032 bits. (Note 1) (Note 2)	-	-	-	-
20	The SS starts the UL default grant transmission	-	-	-	-
<p>Note 1: UL grant of 1032 bits (L_{RBS} & I_{MCS} as per 38.523-3[3] annex B) is chosen to allow the UE to loop back one SDU of size 976 bits and one short BSR (16 bits) into each MAC PDU sent in the uplink (1032 bits - 24 bit AMD PDU header - 16 bit MAC BSR CE - 16 bit MAC PDU subheader). The UE will include an SDU of size 976 bits and one short BSR in the looped back MAC PDU.</p> <p>Note 2: 20ms gap between transmissions both in DL and UL respectively allows TTCN to tolerate one HARQ retransmission (FDD/TDD) per transport block, if such happen (TS 38.523-3 [3]).</p>					

Table 7.1.2.3.6.3.2-2: Parallel behaviour

St	Procedure	Message Sequence		TP	Verdict
		U - S	Message		
1	Check: Does the UE transmit 4 AMD PDUs, with only the last one having the poll bit set? Record time T_A when the PDU with the poll bit set is received at the SS.	-->	AMD PDUs	1	P

Table 7.1.2.3.6.3.2-3: Parallel behaviour

St	Procedure	Message Sequence		TP	Verdict
		U - S	Message		
1	Check: Does the UE transmit 8 AMD PDUs, with the poll bit set only in the 4 th and the 8 th PDUs?	-->	AMD PDUs	3	P

Table 7.1.2.3.6.3.2-4: Parallel behaviour

St	Procedure	Message Sequence		TP	Verdict
		U - S	Message		
1	Check: Does the UE transmit 205 AMD PDUs, with the poll bit set only in the last (205 th) one? (Note 1)	-->	AMD PDUs	4	P
2	The SS transmits an RLC Status Report.	<--	STATUS PDU	-	-
3	Check: Does the UE transmit 205 AMD PDUs, with the poll bit set only in the last (410 th) one? (Note 1)	-->	AMD PDUs	4	P
4	The SS transmits an RLC Status Report.	<--	STATUS PDU	-	-
5	Check: Does the UE transmit 2 AMD PDUs, with the poll bit set only in the last (412 th) one?	-->	AMD PDUs	1	P
6	The SS transmits an RLC Status Report.	<--	STATUS PDU	-	-
Note 1: $(976 \text{ bits} \times 205 \text{ PDUs}) / 8 = 25010 > 25 \text{ KB}$, with $1 \text{ kB} = 1000 \text{ bytes}$ (TS 38.331 [12], clause 3.2)					

7.1.2.3.6.3.3 Specific message contents

None

7.1.2.3.7 AM RLC / Receiver status triggers

7.1.2.3.7.1 Test Purpose (TP)

(1)

```
with { UE in RRC_CONNECTED state and using AM RLC }
ensure that {
  when { Reception failure of an RLC data PDU is detected and t-Reassembly expires }
  then { UE initiates Status Reporting }
}
```

(2)

```
with { UE in RRC_CONNECTED state and using AM RLC }
ensure that {
  when { Status Reporting is triggered and t-StatusProhibit is running }
  then { UE wait until t-StatusProhibit has expired to send Status Report}
}
```

(3)

```
with { UE in RRC_CONNECTED state and using AM RLC }
ensure that {
  when { Polling from peer AM RLC entity is detected and the sequence number 'x' of the PDU that
  carries the Poll satisfies x < RX_Highest_Status or x >= RX_Next + AM_Window_Size }
  then { UE initiates Status Reporting }
}
```

(4)

```
with { UE in RRC_CONNECTED state and using AM RLC }
ensure that {
  when { Polling from peer AM RLC entity is detected and the sequence number 'x' of the PDU that
  carries the Poll does not satisfies x < RX_Highest_Status or x >= RX_Next + AM_Window_Size }
  then { UE waits until 'x < RX_Highest_Status or x >= RX_Next + AM_Window_Size' before initiating
  Status Reporting}
}
```

(5)

```
with { UE in RRC_CONNECTED state and using AM RLC }
ensure that {
  when { the UE needs to send a Status Report and the UL grant is not large enough to accommodate
  the whole report }
  then { UE includes as many NACK_SNs in the Status Report as allowed by the UL grant }
}
```

(6)

```
with { UE in RRC_CONNECTED state and using AM RLC }
ensure that {
  when { the UE needs to send a Status Report and continuous sequence of RLC SDUs that have not been
  received yet }
  then { UE includes NACK_SN with NACK range }
}
```

7.1.2.3.7.2 Conformance requirements

References: The conformance requirements covered in the present TC are specified in: TS 38.322, clause 5.3.4. Unless otherwise stated these are Rel-15 requirements.

[TS 38.322, clause 5.3.4]

An AM RLC entity sends STATUS PDUs to its peer AM RLC entity in order to provide positive and/or negative acknowledgements of RLC SDUs (or portions of them).

Triggers to initiate STATUS reporting include:

- Polling from its peer AM RLC entity:
 - When an AMD PDU with SN = x and the P field set to "1" is received from lower layer, the receiving side of an AM RLC entity shall:
 - if the AMD PDU is to be discarded as specified in subclause 5.2.3.2.2; or
 - if $x < \text{RX_Highest_Status}$ or $x \geq \text{RX_Next} + \text{AM_Window_Size}$:
 - trigger a STATUS report.
 - else:
 - delay triggering the STATUS report until $x < \text{RX_Highest_Status}$ or $x \geq \text{RX_Next} + \text{AM_Window_Size}$.

NOTE 1: This ensures that the RLC Status report is transmitted after HARQ reordering.

- Detection of reception failure of an AMD PDU
 - The receiving side of an AM RLC entity shall trigger a STATUS report when *t-Reassembly* expires.

NOTE 2: The expiry of *t-Reassembly* triggers both RX_Highest_Status to be updated and a STATUS report to be triggered, but the STATUS report shall be triggered after RX_Highest_Status is updated.

When STATUS reporting has been triggered, the receiving side of an AM RLC entity shall:

- if *t-StatusProhibit* is not running:
 - at the first transmission opportunity indicated by lower layer, construct a STATUS PDU and submit it to lower layer.
- else:
 - at the first transmission opportunity indicated by lower layer after *t-StatusProhibit* expires, construct a single STATUS PDU even if status reporting was triggered several times while *t-StatusProhibit* was running and submit it to lower layer.

When a STATUS PDU has been submitted to lower layer, the receiving side of an AM RLC entity shall:

- start *t-StatusProhibit*.

When constructing a STATUS PDU, the AM RLC entity shall:

- for the RLC SDUs with SN such that $\text{RX_Next} \leq \text{SN} < \text{RX_Highest_Status}$ that has not been completely received yet, in increasing SN order of RLC SDUs and increasing byte segment order within RLC SDUs, starting with SN = RX_Next up to the point where the resulting STATUS PDU still fits to the total size of RLC PDU(s) indicated by lower layer:
- for an RLC SDU for which no byte segments have been received yet:
 - include in the STATUS PDU a NACK_SN which is set to the SN of the RLC SDU.
- for a continuous sequence of byte segments of a partly received RLC SDU that have not been received yet:
 - include in the STATUS PDU a set of NACK_SN, SOstart and SOend.
- for a continuous sequence of RLC SDUs that have not been received yet:
 - include in the STATUS PDU a set of NACK_SN and NACK range;
 - include in the STATUS PDU, if required, a pair of SOstart and SOend.
- set the ACK_SN to the SN of the next not received RLC SDU which is not indicated as missing in the resulting STATUS PDU.

7.1.2.3.7.3 Test description

7.1.2.3.7.3.1 Pre-test conditions

Same Pre-test conditions as in clause 7.1.2.1.1 with the exception that the AM DRB is configured according to Table 7.1.2.3.7.3.1-1.

Table 7.1.2.3.7.3.1-1: RLC parameters

<i>t-Reassembly</i>	ms150
<i>t-StatusProhibit</i>	ms300
<i>t-PollRetransmit</i>	ms500

7.1.2.3.7.3.2 Test procedure sequence

Table 7.1.2.3.7.3.2-1: Main behaviour

St	Procedure	Message Sequence		TP	Verdict
		U - S	Message		
-	The SS ignores scheduling requests and does not allocate any uplink grant.	-	-	-	-
1	The SS transmits 4 AMD PDUs with SN=0, 1, 2, and 4. The SS sets the P field of all the AMD PDUs to 0. A time spacing of 20 ms is applied. Record time T_A when the AMD PDU with SN=4 is sent.	<--	AMD PDU (SN=0, P=0) AMD PDU (SN=1, P=0) AMD PDU (SN=2, P=0) AMD PDU (SN=4, P=0)	-	-
2	The SS waits for 70 ms after the transmission of the first AMD PDU to ensure UE RLC has all the required SDUs available and then assigns 3 UL grants (UL grant allocation type 2) with a time spacing of 20 ms of size 848 bits (UL Grant Allocation type 2). (Note 1)	<--	(UL grants, 848 bits)	-	-
3	The UE transmits RLC SDU#1.	-->	(RLC SDU#1)	-	-
4	The UE transmits RLC SDU#2.	-->	(RLC SDU#2)	-	-
5	The UE transmits RLC SDU#3.	-->	(RLC SDU#3)	-	-
6	The SS transmits a STATUS PDU	<--	STATUS PDU	-	-
7	The SS starts the UL default grant transmission.	-	-	-	-
8	Check 1: Does the UE transmit a Status Report with NACK_SN=3 and ACK_SN=5? Record time T_B Check 2: $(T_B - T_A) = t\text{-Reassembly?}$	-->	STATUS PDU	1	P
9	100 ms after the Status Report is received at Step 8, the SS transmits 4 AMD PDUs with SN=5, 6, 8 and 9. The SS sets the P field of all the AMD PDUs to 0. A time spacing of 20 ms is applied.	<--	AMD PDU (SN=5, P=0) AMD PDU (SN=6, P=0) AMD PDU (SN=8, P=0) AMD PDU (SN=9, P=0)	-	-
10	Check 1: Does the UE transmit a Status Report with NACK_SN=3, NACK_SN=7, ACK_SN=10? Record time T_C Check 2: $(T_C - T_B) = t\text{-StatusProhibit?}$	-->	STATUS PDU	2	P
11	The SS ignores scheduling requests unless otherwise specified and does not allocate any uplink grant.	-	-	-	-
12	After 300 ms the SS transmits 2 AMD PDUs with SN=3, SN=7. The SS sets the P field of all the AMD PDUs to 0 except for that of the AMD PDU with SN=7. A time spacing of 20 ms is applied.	<--	AMD PDU (SN=3, P=0) AMD PDU (SN=7, P=1)	-	-
13	The SS waits for 50 ms after the transmission of the last AMD PDU to ensure UE RLC has all the required SDUs available and then assigns 1 UL grant (UL grant allocation type 3) of size 80 bits. (Note 2)	<--	(UL grant, 80 bits)	-	-
14	Check: Does the UE transmit a Status Report with no NACK_SN and ACK_SN = 10?	-->	STATUS PDU	3	P
15	In the second frame following the one scheduled in step 13 the SS assigns 7 UL grants (UL grant allocation type 2) with a time spacing of 20 ms of size 848 bits. (Note 1)	<--	(UL grant, 848 bits)	-	-
16	The UE transmits RLC SDU#4.	-->	(RLC SDU#4)	-	-
17	The UE transmits RLC SDU#5.	-->	(RLC SDU#5)	-	-
18	The UE transmits RLC SDU#6.	-->	(RLC SDU#6)	-	-
19	The UE transmits RLC SDU#7.	-->	(RLC SDU#7)	-	-
20	The UE transmits RLC SDU#8.	-->	(RLC SDU#8)	-	-
21	The UE transmits RLC SDU#9.	-->	(RLC SDU#9)	-	-
22	The UE transmits RLC SDU#10.	-->	(RLC SDU#10)	-	-
23	The SS transmits a STATUS PDU	<--	STATUS PDU	-	-
24	After 300 ms the SS transmits an AMD PDU with SN=11 and P=0, and an AMD PDU with SN=12 and P=1. A time spacing of 20 ms is applied.	<--	AMD PDU (SN=11, P=0) AMD PDU (SN=12, P=1)	-	-

25	Check: Does the UE transmit a scheduling request within <i>t-Reassembly</i> / 2 ms after the transmission of the first AMD PDU of Step 24?	-->	(SR)	4	F
26	At <i>t-Reassembly</i> / 2 ms after the transmission of the second AMD PDU of Step 24, the SS transmits an AMD PDU with SN=10 and P=0.	<--	AMD PDU (SN=10, P=0)	-	-
27	The SS waits for 60 ms to ensure UE RLC has all the required SDUs available and then assigns 1 UL grant (UL grant allocation type 3) of size 80 bits. (Note 2)	<--	(UL grants, 80 bits)	-	-
28	Check: Does the UE transmit a Status Report with no NACK_SN and ACK_SN=13?	-->	STATUS PDU	4	P
29	The SS assigns 3 UL grants (UL grant allocation type 2) with a time spacing of 20 ms of size 848 bits. (Note 1)	<--	(UL grant, 848 bits)	-	-
30	The UE transmits RLC SDU#11.	-->	(RLC SDU#11)	-	-
31	The UE transmits RLC SDU#12.	-->	(RLC SDU#12)	-	-
32	The UE transmits RLC SDU#13.	-->	(RLC SDU#13)	-	-
33	The SS transmits a STATUS PDU.	<--	STATUS PDU	-	-
34	After 300 ms the SS transmits an AMD PDU with SN=17 and P=0, and an AMD PDU with SN=19 and P=1. A time spacing of 20 ms is applied.	<--	AMD PDU (SN=17, P=0) AMD PDU (SN=19, P=1)	-	-
35	The SS waits for <i>t-Reassembly</i> ms to ensure expiry.	-	-	-	-
36	60 ms after step 35 the SS assigns an UL grant (UL grant allocation type 3) of size 88 bits. (Note 3)	<--	(UL Grant)	-	-
37	Check: Does the UE transmit a Status Report with ACK_SN=18 and NACK_SN: 13 including NACK Range 4 (SN 13, 14, 15, 16)?	-->	STATUS PDU	5,6	P
38	After 300 ms the SS transmits an AMD PDU with SN=16 and P=1.	<--	AMD PDU (SN=16, P=1)	-	-
39	60 ms after step 38 the SS assigns an UL grant (UL grant allocation type 3) of size 112 bits. (Note 4)	<--	(UL Grant)	-	-
40	Check: Does the UE transmit a Status Report with ACK_SN=20 and NACK_SN: 13 including NACK Range 3 (SN 13, 14, 15) and NACK_SN=18 without NACK Range?	-->	STATUS PDU	5,6	P
41	60 ms after step 40 the SS transmits 4 AMD PDUs with SN=13, 14, 15 and 18. A time spacing of 20 ms is applied.	<--	AMD PDU (SN=13, P=0) AMD PDU (SN=14, P=0) AMD PDU (SN=15, P=0) AMD PDU (SN=18, P=0)	-	-
42	70 ms after the transmission of the first AMD PDU the SS assigns 7 UL grant (UL grant allocation type 3 with a time spacing of 20 ms of size 848 bits. (Note 1)	<--	(UL grant, 848 bits)	-	-
43	The UE loopbacks the complete RLC SDU.	-->	(RLC SDU#14)	-	-
44	The UE loopbacks the complete RLC SDU.	-->	(RLC SDU#15)	-	-
45	The UE loopbacks the complete RLC SDU.	-->	(RLC SDU#16)	-	-
46	The UE loopbacks the complete RLC SDU.	-->	(RLC SDU#17)	-	-
47	The UE loopbacks the complete RLC SDU.	-->	(RLC SDU#18)	-	-
48	The UE loopbacks the complete RLC SDU.	-->	(RLC SDU#19)	-	-
49	The UE loopbacks the complete RLC SDU.	-->	(RLC SDU#20)	-	-
50	The SS transmits a STATUS PDU.	<--	STATUS PDU	-	-

Note 1:	UL grant of 848 bits (L_{RBs} & I_{MCS} as per 38.523-3[3] annex B) is chosen to allow the UE to transmit one PDU at a time.
Note 2:	UL grant of 80 bits (L_{RBs} & I_{MCS} as per 38.523-3[3] annex B) is chosen to allow the UE to transmit a Status Report with ACK_SN(3 byte) + 2 byte MAC PDU subheader and (2 byte short BSR). 3 Bytes additional space provided to confirm UE does not include NACK_SN and conformant UE instead will include MAC Padding.
Note 3:	UL grant of 88 bits (L_{RBs} & I_{MCS} as per 38.523-3[3] annex B) is chosen to allow the UE to transmit (a Status Report with ACK_SN (3 Bytes)and 1 NACK_SNs with NACK Range(4 Bytes) + MAC PDU subheader (2 Bytes) + Short BSR (2 Byte).
Note 4:	UL grant of 112 bits (L_{RBs} & I_{MCS} as per 38.523-3[3] annex B) is chosen to allow the UE to transmit (a Status Report with ACK_SN (3 Bytes)and 1 NACK_SNs with NACK Range(4 Bytes) +NACK SN (3 Bytes) + MAC PDU subheader (2 Bytes) + Short BSR (2 Byte).

7.1.2.3.7.3.3 Specific message contents

None

7.1.2.3.8 AM RLC / Reconfiguration of RLC parameters by upper layers

7.1.2.3.8.1 Test Purpose (TP)

(1)

```
with { UE in RRC_CONNECTED state and using AM RLC }
ensure that {
  when { t-PollRetransmit value is changed during reconfiguration of RLC parameters by upper layers}
  then { UE starts using new t-PollRetransmit value }
}
```

(2)

```
with { UE in RRC_CONNECTED state and using AM RLC }
ensure that {
  when { t-Reassembly value is changed during reconfiguration of RLC parameters by upper layers }
  then { UE starts using new t-Reassembly value }
}
```

(3)

```
with { UE in RRC_CONNECTED state and using AM RLC }
ensure that {
  when { t-StatusProhibit value is changed during reconfiguration of RLC parameters by upper layers }
  then { UE starts using new t-StatusProhibit value }
}
```

7.1.2.3.8.2 Conformance requirements

References: The conformance requirements covered in the present TC are specified in: TS 38.322, clauses 5.3.3.1, 5.3.3.2, 5.3.3.3, 5.3.4 and 7.3. TS 38.331 clause 5.3.5.5.4. Unless otherwise stated these are Rel-15 requirements.

[TS 38.322, clause 5.3.3.1]

An AM RLC entity can poll its peer AM RLC entity in order to trigger STATUS reporting at the peer AM RLC entity.

[TS 38.322, clause 5.3.3.2]

Upon notification of a transmission opportunity by lower layer, for each AMD PDU submitted for transmission such that the AMD PDU contains either a not previously transmitted RLC SDU or an RLC SDU segment containing not previously transmitted byte segment, the transmitting side of an AM RLC entity shall:

- increment PDU_WITHOUT_POLL by one;
- increment BYTE_WITHOUT_POLL by every new byte of Data field element that it maps to the Data field of the AMD PDU;

- if PDU_WITHOUT_POLL \geq pollPDU; or
- if BYTE_WITHOUT_POLL \geq pollByte:
 - include a poll in the AMD PDU as described below.

Upon notification of a transmission opportunity by lower layer, for each AMD PDU submitted for transmission, the transmitting side of an AM RLC entity shall:

- if both the transmission buffer and the retransmission buffer becomes empty (excluding transmitted RLC SDUs or RLC SDU segments awaiting acknowledgements) after the transmission of the AMD PDU; or
- if no new RLC SDU can be transmitted after the transmission of the AMD PDU (e.g. due to window stalling);
 - include a poll in the AMD PDU as described below.

NOTE: Empty RLC buffer (excluding transmitted RLC SDUs or RLC SDU segments awaiting acknowledgements) should not lead to unnecessary polling when data awaits in the upper layer. Details are left up to UE implementation.

To include a poll in an AMD PDU, the transmitting side of an AM RLC entity shall:

- set the P field of the AMD PDU to "1";
- set PDU_WITHOUT_POLL to 0;
- set BYTE_WITHOUT_POLL to 0.

After submitting an AMD PDU including a poll to lower layer and after incrementing of TX_Next if necessary, the transmitting side of an AM RLC entity shall:

- set POLL_SN to TX_Next – 1;
- if *t-PollRetransmit* is not running:
 - start *t-PollRetransmit*.
- else:
 - restart *t-PollRetransmit*.

[TS 38.322, clause 5.3.3.3]

Upon reception of a STATUS report from the receiving RLC AM entity the transmitting side of an AM RLC entity shall:

- if the STATUS report comprises a positive or negative acknowledgement for the RLC SDU with sequence number equal to POLL_SN:
 - if *t-PollRetransmit* is running:
 - stop and reset *t-PollRetransmit*.

[TS 38.322, clause 5.3.4]

Upon expiry of *t-PollRetransmit*, the transmitting side of an AM RLC entity shall:

- if both the transmission buffer and the retransmission buffer are empty (excluding transmitted RLC SDU or RLC SDU segment awaiting acknowledgements); or
- if no new RLC SDU or RLC SDU segment can be transmitted (e.g. due to window stalling):
 - consider the RLC SDU with SN = TX_Next – 1 for retransmission; or
 - consider any RLC SDU which has not been positively acknowledged for retransmission.
- include a poll in an AMD PDU as described in section 5.3.3.2.

[TS 38.322, clause 7.3]

The following timers are configured by 3GPP TS 38.331 [5]:

a) *t-PollRetransmit*

This timer is used by the transmitting side of an AM RLC entity in order to retransmit a poll (see sub clause 5.3.3).

b) *t-Reassembly*

This timer is used by the receiving side of an AM RLC entity and receiving UM RLC entity in order to detect loss of RLC PDUs at lower layer (see sub clauses 5.2.2.2 and 5.2.3.2). If *t-Reassembly* is running, *t-Reassembly* shall not be started additionally, i.e. only one *t-Reassembly* per RLC entity is running at a given time.

c) *t-StatusProhibit*

This timer is used by the receiving side of an AM RLC entity in order to prohibit transmission of a STATUS PDU (see sub clause 5.3.4).

[TS 38.331, clause 5.3.5.5.4]

For each RLC-Bearer-Config received in the *rlc-BearerToAddModList* IE the UE shall:

- 1> if the UE's current configuration contains a RLC bearer with the received *logicalChannelIdentity*:
 - 2> if *reestablishRLC* is received:
 - 3> re-establish the RLC entity as specified in TS 38.322 [4];
 - 2> reconfigure the RLC entity or entities in accordance with the received *rlc-Config*;
 - 2> reconfigure the logical channel in accordance with the received *mac-LogicalChannelConfig*;

NOTE: The network does not re-associate an already configured logical channel with another radio bearer. Hence *servedRadioBearer* is not present in this case.

7.1.2.3.8.3 Test description

7.1.2.3.8.3.1 Pre-test conditions

Same Pre-test conditions as in clause 7.1.2.1.1 with the exception that the AM DRB is configured according to Table 7.1.2.3.8.3.1-1.

Table 7.1.2.3.8.3.1-1: RLC parameters

Parameter	Value
<i>t-Reassembly</i>	ms150
<i>t-StatusProhibit</i>	ms300
<i>t-PollRetransmit</i>	ms400
<i>pollPDU</i>	infinity
<i>pollByte</i>	infinity

7.1.2.3.8.3.2 Test procedure sequence

Table 7.1.2.3.8.3.2-1: Main behaviour

St	Procedure	Message Sequence		TP	Verdict
		U - S	Message/PDU/SDU		
1-29	Same expected sequence as in Table 7.1.2.3.8.3.2-2 with (X=0, t-Reassembly = ms150, t-StatusProhibit = ms300, t-PollRetransmit=ms400) Note 1.	-	-	1,2,3	-
30	The SS reconfigures RLC in the UE and sets: - t-Reassembly to ms200, - t-StatusProhibit to ms400, - t-PollRetransmit to ms500. (Note 1)	-	-	-	-
31-59	Same expected sequence as in Table 7.1.2.3.8.3.2-2 with (X=11, t-Reassembly = ms200, t-StatusProhibit = ms400, t-PollRetransmit=ms500).	-	-	1,2,3	-
Note 1: The RRC Reconfiguration procedure is performed.					

Table 7.1.2.3.8.3.2-2: Behaviour Sequence (X, t-Reassembly, t-StatusProhibit,t-PollRetransmit)

St	Procedure	Message Sequence		TP	Verdict
		U - S	Message/PDU/SDU		
1	The SS ignores scheduling requests and does not allocate any uplink grant.	-	-	-	-
2	The SS transmits 4 AMD PDUs with P=0 and SN=X, X+1, X+2 and X+4. The SS record time T_A when AMD PDU#5 (with SN=X+4) is sent. A time spacing of 20 ms is applied.	<--	AMD PDU#1 (SN=X, P=0) AMD PDU#2 (SN=X+1, P=0) AMD PDU#3 (SN=X+2, P=0) AMD PDU#5 (SN=X+4, P=0)	-	-
3	The SS waits for 70 ms after the transmission of the first AMD PDU to ensure UE RLC has all the required SDUs available and then assigns 3 UL grants of size 848 bits with a time spacing of 20 ms. (Note 1)	<--	(UL grants, 848 bits)	-	-
4	The UE transmits RLC SDU#1.	-->	(RLC SDU#1)	-	-
5	The UE transmits RLC SDU#2.	-->	(RLC SDU#2)	-	-
6	The UE transmits RLC SDU#3.	-->	(RLC SDU#3)	-	-
7	The SS transmits a STATUS PDU.	<--	STATUS PDU	-	-
8	The SS starts the UL default grant transmission.	-	-	-	-
9	Check 1: Does the UE transmit a STATUS PDU with NACK_SN=X+3 and ACK_SN=X+5? Record time T_B . Check 2: Is $(T_B - T_A) = t\text{-Reassembly?}$	-->	STATUS PDU	2	P
10	100 ms after the Status Report received at Step 9, the SS sends 4 AMD PDUs with P=0 and SN=X+5, X+6, X+8 and X+9. A time spacing of 20 ms is applied.	<--	AMD PDU#6 (SN=X+5, P=0) AMD PDU#7 (SN=X+6, P=0) AMD PDU#9 (SN=X+8, P=0) AMD PDU#10 (SN=X+9, P=0)	-	-
11	Check 1: Does the UE transmit a Status Report with NACK_SN=X+3, NACK_SN=X+7 and ACK_SN=X+10? Record time T_C Check 2: $(T_C - T_B) = t\text{-StatusProhibit?}$	-->	STATUS PDU	3	P
12	The SS ignores scheduling requests and does not allocate any uplink grant.	-	-	-	-
13	After 300 ms the SS transmits 3 AMD PDUs with SN=X+3, X+7 and X+9. The SS sets the P field of all the AMD PDUs to 0 except for that of the AMD PDU with SN=X+9. A time spacing of 20 ms is applied.	<--	AMD PDU#4 (SN=X+3, P=0) AMD PDU#8 (SN=X+7, P=0) AMD PDU#10 (SN=X+9, P=1)	-	-
14	The SS waits for 60 ms to ensure UE RLC has all the required SDUs available and then assigns 1 UL grant of size 80 bits (UL Grant Allocation type 3). (Note 2)	<--	(UL grant, 80 bits)	-	-
15	The UE transmits a Status Report with no NACK_SN and ACK_SN=X+10.	-->	STATUS PDU	-	-
16	In the subframe following the one scheduled in step 14 the SS assigns 7 UL grants of size 848 bits (UL Grant Allocation type 2) with a time spacing of 20 ms. (Note 1)	<--	(UL grants, 848 bits)	-	-
17	The UE transmits RLC SDU#4.	-->	(RLC SDU#4)	-	-
18	The UE transmits RLC SDU#5.	-->	(RLC SDU#5)	-	-
19	The UE transmits RLC SDU#6.	-->	(RLC SDU#6)	-	-
20	The UE transmits RLC SDU#7.	-->	(RLC SDU#7)	-	-
21	The UE transmits RLC SDU#8.	-->	(RLC SDU#8)	-	-
22	The UE transmits RLC SDU#9.	-->	(RLC SDU#9)	-	-
23	The UE transmits RLC SDU#10.	-->	(RLC SDU#10)	-	-
24	The SS transmits a STATUS PDU.	<--	STATUS PDU	-	-
25	The SS transmits an AMD PDU to the UE.	<--	AMD PDU#11 (SN=X+10, P=0)	-	-
26	The SS starts the UL default grant transmission.	-	-	-	-
27	The UE transmits an AMD PDU with the same data as received in the corresponding DL AMD PDU. Record time T_D .	-->	AMD PDU#11 (SN=X+10, P=1)	-	-

28	Check 1: Does the UE set the poll bit as both the transmission and retransmission buffers become empty? Record time T_E . Check 2: Is $(T_E - T_D) = t\text{-PollRetransmit}$?	-->	AMD PDU#11 (SN=X+10, P=1)	1	P
29	The SS transmits a STATUS PDU	<--	STATUS PDU	-	-
Note 1:	UL grant of 848 bits (L_{RBs} & I_{MCS} as per 38.523-3[3] annex B) is chosen to allow the UE to transmit one PDU at a time.				
Note 2:	UL grant of 80 bits (L_{RBs} & I_{MCS} as per 38.523-3[3] annex B) is chosen to allow the UE to transmit a Status Report with ACK_SN(3 byte) + 2 byte MAC PDU subheader and (2 byte short BSR). 3 Bytes additional space provided to confirm UE does not include NACK_SN and conformant UE instead will include MAC Padding.				
Note 3:	Every DL AMD PDU contains 1 RLC SDU size of 101 bytes.				

7.1.2.3.8.3.3 Specific message contents

None

7.1.2.3.9 AM RLC / Reassembling of AMD PDUs

7.1.2.3.9.1 Test Purpose (TP)

(1)

```
with { UE in RRC_CONNECTED state }
ensure that {
  when { UE receives AMD PDUs, and all bytes of the RLC SDU(s) with SN = x are received }
  then { UE reassembles the RLC SDU(s) from AMD PDU(s) with SN = x }
}
```

(2)

```
with { UE in RRC_CONNECTED state }
ensure that {
  when { t-Reassembly expires }
  then { update RX_Highest_Status to the SN of the first RLC SDU with SN >= RX_Next_Status_Trigger
for which not all bytes have been received }
}
```

(3)

```
with { UE in RRC_CONNECTED state }
ensure that {
  when { UE receives AM PDU segments }
  then { UE delivers reassembled RLC SDU to upper layer }
}
```

(4)

```
with { UE in RRC_CONNECTED state }
ensure that {
  when { UE receives duplicate RLC AM PDU segments }
  then { UE discards duplicate RLC AMD PDU segments }
}
```

(5)

```
with { UE in RRC_CONNECTED state }
ensure that {
  when { UE receives RLC AMD PDU segments with segments lost }
  then { UE transmits STATUS PDU to request retransmission of missing segments }
}
```

(6)

```
with { UE in RRC_CONNECTED state }
ensure that {
```



```

when { UE receives overlapping RLC AMD PDU segments }
  then { UE discards duplicate RLC AMD PDU byte segments }
    }

```

(7)

```

with { UE in RRC_CONNECTED state }
ensure that {
  when { UE receives an AMD PDU with a SN gap }
    then { UE sends STATUS PDU to request retransmissions of PDUs in the SN gap }
  }

```

7.1.2.3.9.2 Conformance requirements

References: The conformance requirements covered in the present TC are specified in: 3GPP TS 38.322 clauses 4.2.1.3.3, 5.2.3.2.1, 5.2.3.2.2, 5.2.3.2.3, 5.2.3.2.4 and 5.3.4. Unless otherwise stated these are Rel-15 requirements.

[TS 38.322, clause 4.2.1.3.3]

When the receiving side of an AM RLC entity receives AMD PDUs, it shall:

- detect whether or not the AMD PDUs have been received in duplication, and discard duplicated AMD PDUs;
- detect the loss of AMD PDUs at lower layers and request retransmissions to its peer AM RLC entity;
- reassemble RLC SDUs from the received AMD PDUs and deliver the RLC SDUs to upper layer as soon as they are available.

[TS 38.322, clause 5.2.3.2.1]

The receiving side of an AM RLC entity shall maintain a receiving window according to the state variable `RX_Next` as follows:

- a SN falls within the receiving window if $RX_Next \leq SN < RX_Next + AM_Window_Size$;
- a SN falls outside of the receiving window otherwise.

When receiving an AMD PDU from lower layer, the receiving side of an AM RLC entity shall:

- either discard the received AMD PDU or place it in the reception buffer (see sub clause 5.2.3.2.2);
- if the received AMD PDU was placed in the reception buffer:
 - update state variables, reassemble and deliver RLC SDUs to upper layer and start/stop t-Reassembly as needed (see sub clause 5.2.3.2.3).

When t-Reassembly expires, the receiving side of an AM RLC entity shall:

- update state variables and start t-Reassembly as needed (see sub clause 5.2.3.2.4).

[TS 38.322, clause 5.2.3.2.2]

When an AMD PDU is received from lower layer, where the AMD PDU contains byte segment numbers `y` to `z` of an RLC SDU with `SN = x`, the receiving side of an AM RLC entity shall:

- if `x` falls outside of the receiving window; or
- if byte segment numbers `y` to `z` of the RLC SDU with `SN = x` have been received before:
 - discard the received AMD PDU.
- else:
 - place the received AMD PDU in the reception buffer;
 - if some byte segments of the RLC SDU contained in the AMD PDU have been received before:
 - discard the duplicate byte segments.

[TS 38.322, clause 5.2.3.2.3]

When an AMD PDU with SN = x is placed in the reception buffer, the receiving side of an AM RLC entity shall:

- if $x \geq \text{RX_Next_Highest}$
 - update RX_Next_Highest to $x + 1$.
- if all bytes of the RLC SDU with SN = x are received:
 - reassemble the RLC SDU from AMD PDU(s) with SN = x, remove RLC headers when doing so and deliver the reassembled RLC SDU to upper layer;
 - if $x = \text{RX_Highest_Status}$,
 - update RX_Highest_Status to the SN of the first RLC SDU with SN > current RX_Highest_Status for which not all bytes have been received.
 - if $x = \text{RX_Next}$:
 - update RX_Next to the SN of the first RLC SDU with SN > current RX_Next for which not all bytes have been received.
- if t-Reassembly is running:
 - if $\text{RX_Next_Status_Trigger} = \text{RX_Next}$; or
 - if $\text{RX_Next_Status_Trigger} = \text{RX_Next} + 1$ and there is no missing byte segment of the SDU associated with SN = RX_Next before the last byte of all received segments of this SDU; or
 - if $\text{RX_Next_Status_Trigger}$ falls outside of the receiving window and $\text{RX_Next_Status_Trigger}$ is not equal to $\text{RX_Next} + \text{AM_Window_Size}$:
 - stop and reset t-Reassembly.
- if t-Reassembly is not running (includes the case t-Reassembly is stopped due to actions above):
 - if $\text{RX_Next_Highest} > \text{RX_Next} + 1$; or
 - if $\text{RX_Next_Highest} = \text{RX_Next} + 1$ and there is at least one missing byte segment of the SDU associated with SN = RX_Next before the last byte of all received segments of this SDU:
 - start t-Reassembly;
 - set $\text{RX_Next_Status_Trigger}$ to RX_Next_Highest .

[TS 38.322, clause 5.2.3.2.4]

When t-Reassembly expires, the receiving side of an AM RLC entity shall:

- update RX_Highest_Status to the SN of the first RLC SDU with SN $\geq \text{RX_Next_Status_Trigger}$ for which not all bytes have been received;
- if $\text{RX_Next_Highest} > \text{RX_Highest_Status} + 1$: or
- if $\text{RX_Next_Highest} = \text{RX_Highest_Status} + 1$ and there is at least one missing byte segment of the SDU associated with SN = RX_Highest_Status before the last byte of all received segments of this SDU:
 - start t-Reassembly;
 - set $\text{RX_Next_Status_Trigger}$ to RX_Next_Highest .

[TS 38.322, clause 5.3.4]

An AM RLC entity sends STATUS PDUs to its peer AM RLC entity in order to provide positive and/or negative acknowledgements of RLC SDUs (or portions of them).

Triggers to initiate STATUS reporting include:

- Polling from its peer AM RLC entity:
 - When an AMD PDU with SN = x and the P field set to "1" is received from lower layer, the receiving side of an AM RLC entity shall:
 - if the AMD PDU is to be discarded as specified in subclause 5.2.3.2.2; or
 - if $x < \text{RX_Highest_Status}$ or $x \geq \text{RX_Next} + \text{AM_Window_Size}$:
 - trigger a STATUS report.
 - else:
 - delay triggering the STATUS report until $x < \text{RX_Highest_Status}$ or $x \geq \text{RX_Next} + \text{AM_Window_Size}$.

NOTE 1: This ensures that the RLC Status report is transmitted after HARQ reordering.

- Detection of reception failure of an AMD PDU
 - The receiving side of an AM RLC entity shall trigger a STATUS report when t-Reassembly expires.

NOTE 2: The expiry of t-Reassembly triggers both RX_Highest_Status to be updated and a STATUS report to be triggered, but the STATUS report shall be triggered after RX_Highest_Status is updated.

When STATUS reporting has been triggered, the receiving side of an AM RLC entity shall:

- if *t-StatusProhibit* is not running:
 - at the first transmission opportunity indicated by lower layer, construct a STATUS PDU and submit it to lower layer.
- else:
 - at the first transmission opportunity indicated by lower layer after *t-StatusProhibit* expires, construct a single STATUS PDU even if status reporting was triggered several times while *t-StatusProhibit* was running and submit it to lower layer.

When a STATUS PDU has been submitted to lower layer, the receiving side of an AM RLC entity shall:

- start *t-StatusProhibit*.

When constructing a STATUS PDU, the AM RLC entity shall:

- for the RLC SDUs with SN such that $\text{RX_Next} \leq \text{SN} < \text{RX_Highest_Status}$ that has not been completely received yet, in increasing SN order of RLC SDUs and increasing byte segment order within RLC SDUs, starting with SN = RX_Next up to the point where the resulting STATUS PDU still fits to the total size of RLC PDU(s) indicated by lower layer:
 - for an RLC SDU for which no byte segments have been received yet:
 - include in the STATUS PDU a NACK_SN which is set to the SN of the RLC SDU.
 - for a continuous sequence of byte segments of a partly received RLC SDU that have not been received yet:
 - include in the STATUS PDU a set of NACK_SN, SOstart and SOend.
 - for a continuous sequence of RLC SDUs that have not been received yet:
 - include in the STATUS PDU a set of NACK_SN and NACK range;
 - include in the STATUS PDU, if required, a pair of SOstart and SOend.
- set the ACK_SN to the SN of the next not received RLC SDU which is not indicated as missing in the resulting STATUS PDU.

When STATUS reporting has been triggered, the receiving side of an AM RLC entity shall:

- if *t-StatusProhibit* is not running:
 - at the first transmission opportunity indicated by lower layer, construct a STATUS PDU and submit it to lower layer.
- else:
 - at the first transmission opportunity indicated by lower layer after *t-StatusProhibit* expires, construct a single STATUS PDU even if status reporting was triggered several times while *t-StatusProhibit* was running and submit it to lower layer.

When a STATUS PDU has been submitted to lower layer, the receiving side of an AM RLC entity shall:

- start *t-StatusProhibit*.

When constructing a STATUS PDU, the AM RLC entity shall:

- for the RLC SDUs with SN such that $RX_Next \leq SN < RX_Highest_Status$ that has not been completely received yet, in increasing SN order of RLC SDUs and increasing byte segment order within RLC SDUs, starting with SN = RX_Next up to the point where the resulting STATUS PDU still fits to the total size of RLC PDU(s) indicated by lower layer:
 - for an RLC SDU for which no byte segments have been received yet:
 - include in the STATUS PDU a NACK_SN which is set to the SN of the RLC SDU.
 - for a continuous sequence of byte segments of a partly received RLC SDU that have not been received yet:
 - include in the STATUS PDU a set of NACK_SN, SOstart and SOend.
 - for a continuous sequence of RLC SDUs that have not been received yet:
 - include in the STATUS PDU a set of NACK_SN and NACK range;
 - include in the STATUS PDU, if required, a pair of SOstart and SOend.
 - set the ACK_SN to the SN of the next not received RLC SDU which is not indicated as missing in the resulting STATUS PDU.

7.1.2.3.9.3 Test description

7.1.2.3.9.3.1 Pre-test conditions

Same Pre-test conditions as in clause 7.1.2.1.1 with the exception that the AM DRB is configured according to Table 7.1.2.3.9.3.1-1.

Table 7.1.2.3.9.3.1-1: RLC parameters

Parameter	Value
<i>t-Reassembly</i>	ms150
<i>t-StatusProhibit</i>	ms300
<i>t-PollRetransmit</i>	ms500

7.1.2.3.9.3.2 Test procedure sequence

Table 7.1.2.3.9.3.2-1: Main behaviour

St	Procedure	Message Sequence		TP	Verdict
		U - S	Message/PDU/SDU		
0	The SS stops the UL grant transmission.	-	-	-	-
1	The SS transmits AMD PDU#1 containing a complete RLC SDU#4 (90 bytes and SI field=00).	<--	AMD PDU#1 (SN=3)	-	-
2	The SS transmits AMD PDU#2 containing the last segment (45 bytes) of RLC SDU#1 (SI field=10, SO=45).	<--	AMD PDU#2 (SN=0) segment 2	-	-
3	The SS transmits AMD PDU#3 containing the last segment (45 bytes) of RLC SDU#2 (SI field=10, SO=45).	<--	AMD PDU#3 (SN=1) segment 2	-	-
4	The SS transmits AMD PDU#4 containing the first segment (45 bytes) of RLC SDU#2 (SI field=01).	<--	AMD PDU#4 (SN=1) segment 1	-	-
5	The SS transmits AMD PDU#5 containing the first segment (45 bytes) of RLC SDU#1 (SI field =01).	<--	AMD PDU#5 (SN=0) segment 1	-	-
6	The SS waits for 60 ms then SS transmits 2 uplink grants with a time spacing of 20ms. (Note 1)	<--	UL Grants	-	-
7	Check: Does the UE transmit an AMD PDU containing RLC SDU#1 in its data field?	-->	AMD PDU (RLC SDU#1)	1,3	P
8	Check: Does the UE transmit an AMD PDU containing RLC SDU#2 in its data field?	-->	AMD PDU (RLC SDU#2)	1,3	P
9	Void				
9A	The SS starts the UL default grant transmission.	<--	UL Grant	-	-
10	Wait for t-reassembly of UE side to expire. Check: Does the UE transmit an RLC STATUS PDU with NACK_SN=2 and ACK_SN=4 to correctly to inform SS of missing RLC SDU#3?	-->	STATUS PDU (ACK_SN=4, NACK_SN=2)	2,7	P
10A	The SS stops the UL grant transmission.	-	-	-	-
11	After 100 ms the SS transmits AMD PDU#6 containing the first 45 bytes of SDU#3 in its data field. SO=0 and LSF=0. No header extension part is provided.	<--	AMD PDU#6 (SN=2) segment 1	-	-
11A	20 ms after step 11 the SS transmits AMD PDU#6 containing the first 45 bytes of SDU#3 in its data field. SO=0 and LSF=0. No header extension part is provided.	<--	AMD PDU#6 (SN=2) segment 1	-	-
12	40 ms after step 11 the SS transmits AMD PDU#12 containing the last 45 bytes of SDU#3 in its data field, with the P-bit set. SO=45 and LSF=1. No header extension part is provided.	<--	AMD PDU#12 (SN=2, P=1) segment 2	-	-

13	The SS waits for 60 ms to ensure that the UE has all the received SDUs available in UL for loopback and then assigns 1 UL grant (UL grant allocation type 3) of size 80 bits. (Note 2)	<--	UL Grant	-	-
14	Check: Does the UE transmit a STATUS PDU with ACK_SN=4, thus acknowledging the reception of PDUs with SN=0 to SN=3, and no NACK_SN provided?	-->	STATUS PDU	1,3,4	P
14A	The SS waits for 40 ms to ensure UE has all the required SDUs available and then assigns 2 UL grants of 768 bits (Note 1).	<--	UL Grant	-	-
15	Check: Does the UE transmit RLC SDU#3?	<--	(RLC SDU#3)	1,3,4	P
15A	Check: Does the UE transmit RLC SDU#4?	<--	(RLC SDU#4)	1,3,4	P
16	The SS transmits a STATUS PDU.	-->	STATUS PDU (ACK SN=4)	-	-
17	The SS transmits AMD PDU#7 containing the last segment (45 bytes) of RLC SDU#5 (SI field=10, SO=45).	<--	AMD PDU#7 (SN=4) segment 2	-	-
17A	The SS starts the UL default grant transmission.	<--	UL Grant	-	-
18	Wait for t-reassembly of UE side to expire. Check: Does the UE transmit an RLC STATUS PDU with ACK_SN=5, NACK_SN=4 with SOStart=0 and SOEnd=44?	-->	STATUS PDU (ACK_SN=5, NACK_SN=4 with SOStart=0 /SOEnd=44)	2,5	P
18A	The SS stops the UL grant transmission.	-	-	-	-
19	The SS transmits AMD PDU#8 containing the first segment (45 bytes) of RLC SDU#5 (SI field=01).	<--	AMD PDU#8 (SN=4, P=1) segment 1	-	-
20	Void				
21	Void				
21A	The SS waits for 20 ms and then assigns 1 UL grant (UL grant allocation type 3) of size 80 bits. (Note 2)	<--	UL Grant	-	-
22	Check: Does the UE transmit an RLC STATUS PDU with ACK_SN=5?	-->	STATUS PDU (ACK_SN=5)	1,3,5	P
22A	The SS waits for 100 ms then SS transmits one uplink grant. (Note 1)	<--	UL Grant	-	-
22B	Check: Does the UE transmit an AMD PDU containing RLC SDU#5 in its data field?	-->	AMD PDU (RLC SDU#5)	1,3,5	P
23	The SS transmits AMD PDU#9 containing the last 30 bytes of RLC SDU#6 (SI field=10, SO=60).	<--	AMD PDU#9 (SN=5) segment 3	-	-
23A	The SS starts the UL default grant transmission.	<--	UL Grant	-	-
24	Wait for t-reassembly of UE side to expire. Check: Does the UE transmit an RLC STATUS PDU with ACK_SN=6, NACK_SN=5 with SOStart=0 and SOEnd=59?	-->	STATUS PDU (ACK_SN=6, NACK_SN=5 with SOStart=0 / SOEnd=59)	2,6	P

25	The SS transmits AMD PDU#10 containing the last 50 byte of RLC SDU#6 (SI field=10, SO=40).	<--	AMD PDU#10 (SN=5) segment 2	-	-
25A	Void.				
26	Wait for t-reassembly of UE side to expire. Check: Does the UE transmit an RLC STATUS PDU with ACK_SN=6, NACK_SN=5 with SOStart=0 and SOEnd=39?	-->	STATUS PDU (ACK_SN=6, NACK_SN=5 with SOStart=0 / SOEnd=39)	2,6	P
26A	The SS stops the UL grant transmission.	-	-	-	-
27	The SS transmits AMD PDU#11 containing the first 40 bytes of RLC SDU#6 (SI field =01).	<--	AMD PDU#11 (SN=5, P=1) segment 1	-	-
28	Void				
29	Void				
29A	The SS assigns 1 UL grant (UL grant allocation type 3) of size 80 bits. (Note 2)	<--	UL Grant	-	-
30	Check: Does the UE transmit an RLC STATUS PDU with ACK_SN=6, thus acknowledging the reception of RLC SDUs with SN=0 to SN=5, and no NACK_SN provided?	-->	STATUS PDU (ACK_SN=6)	1,3,6	P
30A	The SS transmits one uplink grant. (Note 1)	<--	UL Grant	-	-
30B	Check: Does the UE transmit an AMD PDU containing RLC SDU#6 in its data field?	-->	AMD PDU (RLC SDU#6)	1,3,6	P
31	The SS transmits a STATUS PDU.	<--	STATUS PDU (ACK SN=6)	-	-
<p>Note 1: UL grant of 768 bits (L_{RBs} & I_{MCS} as per 38.523-3[3] annex B) is chosen to allow the UE to transmit one PDU at a time(90 bytes RLC SDU + 2 bytes RLC Header + 2 bytes MAC Sub PDU header + 2 bytes for short BSR or padding).</p> <p>Note 2: UL grant of 80 bits (L_{RBs} & I_{MCS} as per 38.523-3 [3] annex B) is chosen to allow the UE to transmit a Status Report with ACK_SN(3 byte) + 2 Bytes MAC PDU subheader and (2 Bytes short BSR). 3 Bytes additional space provided to confirm UE does include resp. does not include NACK_SN and conformant UE instead will include MAC Padding.</p> <p>Note 3: UL grant of 112 bits (L_{RBs} & I_{MCS} as per 38.523-3[3] annex B) is chosen to allow the UE to transmit (a Status Report with ACK_SN (3 Bytes), and NACK SN (3 Bytes) + SOstart/SOend pair (4 Bytes) + MAC PDU subheader (2 Bytes) + Short BSR (2 Bytes).</p>					

7.1.2.3.9.3.3 Specific message contents

None.

7.1.2.3.10 AM RLC / Re-transmission of RLC PDU with and without re-segmentation

7.1.2.3.10.1 Test Purpose (TP)

(1)

```
with { UE in RRC_CONNECTED state }
ensure that {
  when { UE receives a STATUS PDU including a NACK_SN for missing AMD PDUs and missing AMD PDUs can
be transmitted as indicated by lower layer at the particular transmission opportunity }
  then { UE successfully retransmits missing AMD PDUs without re-segmentation }
}
```

(2)

```
with { UE in RRC_CONNECTED state }
```



```

ensure that {
  when { NACK received for missing AMD PDUs and RETX_COUNT < maxRetxThreshold }
  then { UE retransmits AMD PDUs }
}

```

(3)

```

with { UE in RRC_CONNECTED state }
ensure that {
  when { AMD PDU to be retransmitted does not fit in new allocated TBS }
  then { UE segments AMD PDU }
}

```

(4)

```

with { UE in RRC_CONNECTED state }
ensure that {
  when { AMD PDU segment to be retransmitted does not fit in new allocated TBS }
  then { UE re-segments AMD PDU segment to fit TBS }
}

```

7.1.2.3.10.2 Conformance requirements

References: The conformance requirements covered in the present test case are specified in: TS 38.322, clauses 5.3.2, 6.2.2.5, 6.2.3.3, 6.2.3.4, 6.2.3.5, 6.2.3.7, 6.2.3.10, 6.2.3.12, 6.2.3.14 and 6.2.3.15. Unless otherwise stated these are Rel-15 requirements.

[TS 38.322, clause 5.3.2]

The transmitting side of an AM RLC entity can receive a negative acknowledgement (notification of reception failure by its peer AM RLC entity) for an RLC SDU or an RLC SDU segment by the following:

- STATUS PDU from its peer AM RLC entity.

When receiving a negative acknowledgement for an RLC SDU or an RLC SDU segment by a STATUS PDU from its peer AM RLC entity, the transmitting side of the AM RLC entity shall:

- if the SN of the corresponding RLC SDU falls within the range $TX_Next_Ack \leq SN \leq$ the highest SN of the AMD PDU among the AMD PDUs submitted to lower layer:
 - consider the RLC SDU or the RLC SDU segment for which a negative acknowledgement was received for retransmission.

When an RLC SDU or an RLC SDU segment is considered for retransmission, the transmitting side of the AM RLC entity shall:

- if the RLC SDU or RLC SDU segment is considered for retransmission for the first time:
 - set the RETX_COUNT associated with the RLC SDU to zero.
- else, if it (the RLC SDU or the RLC SDU segment that is considered for retransmission) is not pending for retransmission already and the RETX_COUNT associated with the RLC SDU has not been incremented due to another negative acknowledgment in the same STATUS PDU:
 - increment the RETX_COUNT.
- if $RETX_COUNT = maxRetxThreshold$:
 - indicate to upper layers that max retransmission has been reached.

When retransmitting an RLC SDU or an RLC SDU segment, the transmitting side of an AM RLC entity shall:

- if needed, segment the RLC SDU or the RLC SDU segment;
- form a new AMD PDU which will fit within the total size of AMD PDU(s) indicated by lower layer at the particular transmission opportunity;
- submit the new AMD PDU to lower layer.

When forming a new AMD PDU, the transmitting side of an AM RLC entity shall:

- only map the original RLC SDU or RLC SDU segment to the Data field of the new AMD PDU;
- modify the header of the new AMD PDU in accordance with the description in sub clause 6.2.2.4;
- set the P field according to sub clause 5.3.3.

[TS 38.322, clause 6.2.2.4]

AMD PDU consists of a Data field and an AMD PDU header. The AMD PDU header is byte aligned.

An AM RLC entity is configured by RRC to use either a 12 bit SN or a 18 bit SN. The length of the AMD PDU header is two and three bytes respectively.

An AMD PDU header contains a D/C, a P, a SI, and a SN. An AMD PDU header contains the SO field only when the Data field consists of an RLC SDU segment which is not the first segment, in which case a 16 bit SO is present.

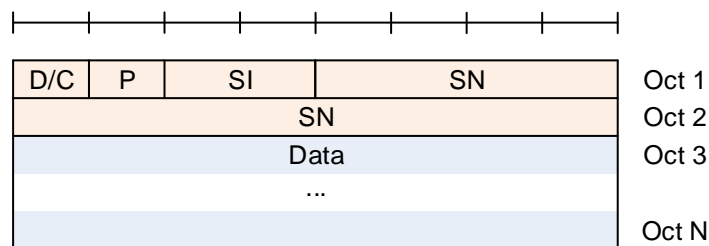

Figure 6.2.2.4-1: AMD PDU with 12 bit SN (No SO)

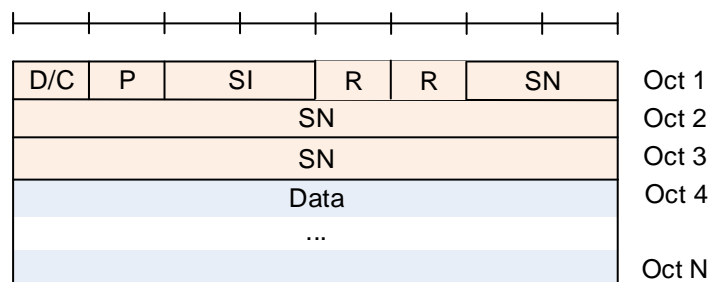

Figure 6.2.2.4-2: AMD PDU with 18 bit SN (No SO)

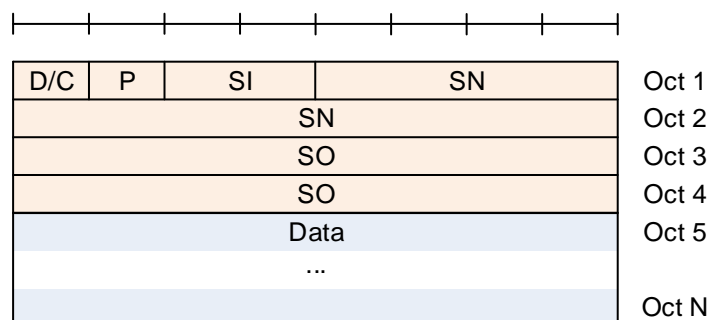

Figure 6.2.2.4-3: AMD PDU with 12 bit SN with SO

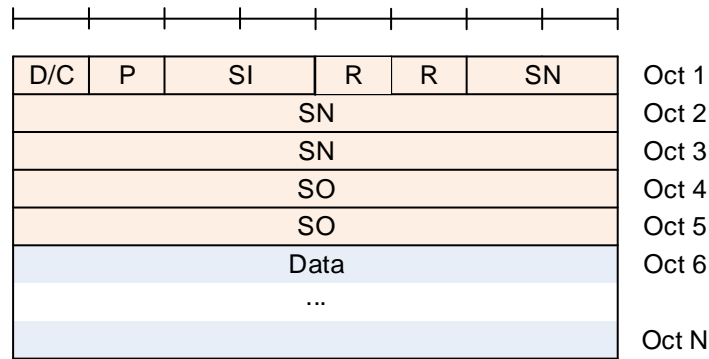

Figure 6.2.2.4-4: AMD PDU with 18 bit SN with SO

[TS 38.322, clause 6.2.2.5]

STATUS PDU consists of a STATUS PDU payload and an RLC control PDU header.

RLC control PDU header consists of a D/C and a CPT field.

The STATUS PDU payload starts from the first bit following the RLC control PDU header, and it consists of one ACK_SN and one E1, zero or more sets of a NACK_SN, an E1, an E2 and an E3, and possibly a pair of a SOstart and a SOend or a NACK range field for each NACK_SN.

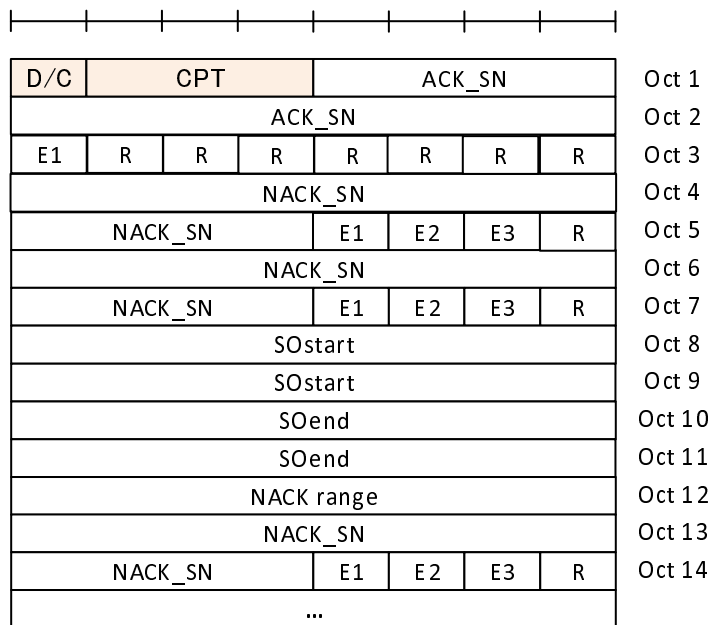

Figure 6.2.2.5-1: STATUS PDU with 12 bit SN

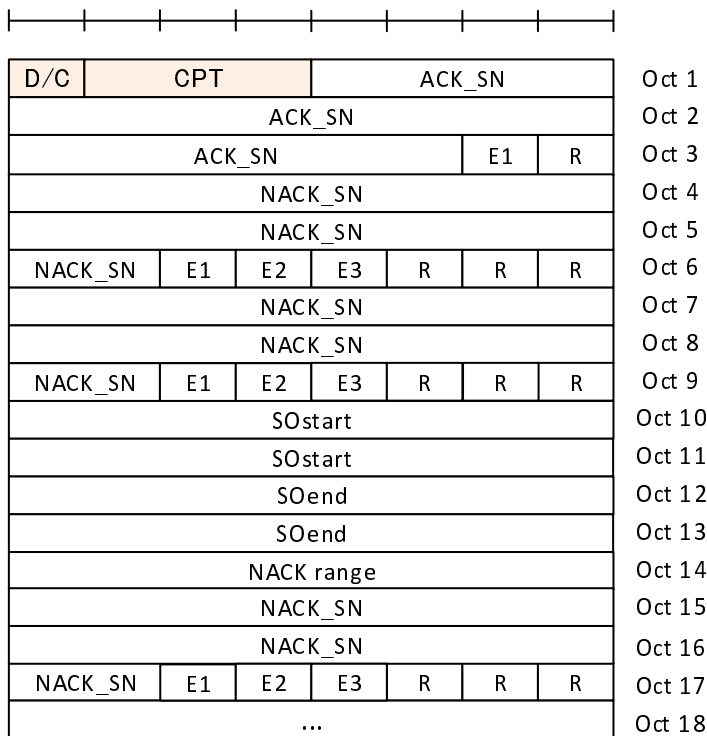

Figure 6.2.2.5-2: STATUS PDU with 18 bit SN

[TS 38.322, clause 6.2.3.3]

Length: 12 bits or 18 bits (configurable) for AMD PDU. 6 bits or 12 bits (configurable) for UMD PDU.

The SN field indicates the sequence number of the corresponding RLC SDU. For RLC AM, the sequence number is incremented by one for every RLC SDU. For RLC UM, the sequence number is incremented by one for every segmented RLC SDU.

[TS 38.322, clause 6.2.3.4]

Length: 2 bits.

The SI field indicates whether an RLC PDU contains a complete RLC SDU or the first, middle, last segment of an RLC SDU.

Table 6.2.3.4-1: SI field interpretation

Value	Description
00	Data field contains all bytes of an RLC SDU
01	Data field contains the first segment of an RLC SDU
10	Data field contains the last segment of an RLC SDU
11	Data field contains neither the first nor last segment of an RLC SDU

[TS 38.322, clause 6.2.3.5]

Length: 16 bits

The SO field indicates the position of the RLC SDU segment in bytes within the original RLC SDU. Specifically, the SO field indicates the position within the original RLC SDU to which the first byte of the RLC SDU segment in the Data field corresponds. The first byte of the original RLC SDU is referred by the SO field value "0000000000000000", i.e., numbering starts at zero.

[TS 38.322, clause 6.2.3.7]

Length: 1 bit.

The P field indicates whether or not the transmitting side of an AM RLC entity requests a STATUS report from its peer AM RLC entity. The interpretation of the P field is provided in Table 6.2.3.7-1.

Table 6.2.3.7-1: P field interpretation

Value	Description
0	Status report not requested
1	Status report is requested

[TS 38.322, clause 6.2.3.10]

Length: 12 bits or 18 bits (configurable).

The ACK_SN field indicates the SN of the next not received RLC SDU which is not reported as missing in the STATUS PDU. When the transmitting side of an AM RLC entity receives a STATUS PDU, it interprets that all RLC SDUs up to but not including the RLC SDU with SN = ACK_SN have been received by its peer AM RLC entity, excluding those RLC SDUs indicated in the STATUS PDU with NACK_SN, portions of RLC SDUs indicated in the STATUS PDU with NACK_SN, SOstart and SOend, RLC SDUs indicated in the STATUS PDU with NACK_SN and NACK_range, and portions of RLC SDUs indicated in the STATUS PDU with NACK_SN, NACK range, SOstart and SOend.

[TS 38.322, clause 6.2.3.12]

Length: 12 bits or 18 bits (configurable).

The NACK_SN field indicates the SN of the RLC SDU (or RLC SDU segment) that has been detected as lost at the receiving side of the AM RLC entity.

[TS 38.322, clause 6.2.3.14]

Length: 16 bits.

The SOstart field (together with the SOend field) indicates the portion of the RLC SDU with SN = NACK_SN (the NACK_SN for which the SOstart is related to) that has been detected as lost at the receiving side of the AM RLC entity. Specifically, the SOstart field indicates the position of the first byte of the portion of the RLC SDU in bytes within the original RLC SDU. The first byte of the original RLC SDU is referred by the SOstart field value "0000000000000000", i.e., numbering starts at zero.

[TS 38.322, clause 6.2.3.15]

Length: 16 bits.

When E3 is 0, the SOend field (together with the SOstart field) indicates the portion of the RLC SDU with SN = NACK_SN (the NACK_SN for which the SOend is related to) that has been detected as lost at the receiving side of the AM RLC entity. Specifically, the SOend field indicates the position of the last byte of the portion of the RLC SDU in bytes within the original RLC SDU. The first byte of the original RLC SDU is referred by the SOend field value "0000000000000000", i.e., numbering starts at zero. The special SOend value "1111111111111111" is used to indicate that the missing portion of the RLC SDU includes all bytes to the last byte of the RLC SDU.

When E3 is 1, the SOend field indicates the portion of the RLC SDU with SN = NACK_SN + NACK range - 1 that has been detected as lost at the receiving side of the AM RLC entity. Specifically, the SOend field indicates the position of the last byte of the portion of the RLC SDU in bytes within the original RLC SDU. The first byte of the original RLC SDU is referred by the SOend field value "0000000000000000", i.e., numbering starts at zero. The special SOend value "1111111111111111" is used to indicate that the missing portion of the RLC SDU includes all bytes to the last byte of the RLC SDU.

7.1.2.3.10.3 Test description

7.1.2.3.10.3.1 Pre-test conditions

Same Pre-test conditions as in clause 7.1.2.1.1 with the exception for the AM DRB is configured according to Tables 7.1.2.3.10.3.1-1.

Table 7.1.2.3.10.3.1-1: RLC settings

Parameter	Value
<i>t-PollRetransmit</i>	ms150

7.1.2.3.10.3.2 Test procedure sequence

Table 7.1.2.3.10.3.2-1: Main behaviour

St	Procedure	Message Sequence		TP	Verdict
		U - S	Message		
1	The SS transmits one AMD PDU containing SDU#1 (96 bytes) in its data field.	<--	AMD PDU#1	-	-
2	The UE transmits one AMD PDU containing SDU#1 in its data field.	-->	AMD PDU#1 (SN=0)	-	-
3	The SS transmits one AMD PDU containing SDU#2 (96 bytes) in its data field.	<--	AMD PDU#2	-	-
4	The UE transmits one AMD PDU containing SDU#2 in its data field.	-->	AMD PDU#2 (SN=1)	-	-
5	The SS transmits a RLC STATUS PDU. ACK_SN=2, NACK_SN=0.	<--	STATUS PDU	-	-
6	Check: Does the UE transmit the AMD PDU not yet acknowledged?	-->	AMD PDU#1 (SN=0)	1	P
7	The SS transmits a RLC STATUS PDU. ACK_SN=2.	<--	STATUS PDU	-	-
8	The SS transmits one AMD PDU containing SDU#3 (96 bytes) in its data field.	<--	AMD PDU#3	-	-
9	The UE transmits an AMD PDU containing SDU#3 in its data field.	-->	AMD PDU#3 (SN=2)	-	-
-	EXCEPTION: Steps 10 to 11 shall be repeated until RETX_COUNT= maxRetxThreshold-1.	-	-	-	-
10	The SS transmits a RLC STATUS PDU. ACK_SN=3 and NACK_SN=2.	<--	STATUS PDU	-	-
11	Check: Does the UE retransmit the AMD PDU not yet acknowledged?	-->	AMD PDU#3 (SN=2)	2	P
12	The SS transmits a RLC STATUS PDU. ACK_SN=3.	<--	STATUS PDU	-	-
13	The SS stops the UL grant transmission.	-	-	-	-
14	The SS transmits one AMD PDU containing SDU#4 (96 bytes) in its data field.	<--	AMD PDU#4 (SN=3)	-	-
15	The SS waits for 60 ms and allocates one UL grant of size 808 bits. (Note 1)	<--	(UL grant, 808 bits)	-	-
16	The UE transmits an AMD PDU with the same data contents as received in the corresponding part of SDU#4?	-->	AMD PDU#4 (SN=3)	-	-
17	The SS transmits a STATUS PDU. This PDU nacks the AMD PDU with SN=3. ACK_SN=4 and NACK_SN=3.	<--	STATUS PDU	-	-
18	The SS waits for 20 ms and then allocates 2 UL grants of size 432 bits such that there is 20 ms gap between UL grants (Note 2, Note 4)	<--	(UL grants, 432 bits)	-	-
19	Check: Does the UE transmit an SDU segment with SI=01 and SOEnd=48 and the same data contents at the received positions as in the original SDU#4?	-->	SDU#4 segment 1 (SN=3)	3	P
20	Check: Does the UE transmit an SDU segment with SI=10 and SOStart=48 and the same data contents at the received positions as in the original SDU#4?	-->	SDU#4 segment 2 (SN=3)	3	P
21	After 100 ms SS transmits a STATUS PDU. This PDU nacks the SDU with SN=3. NACK_SN=3, SOStart=0, SOEnd48 and ACK_SN=4.	<--	STATUS PDU	-	-
22	The SS waits for 20 ms and then allocates 2 UL grants (UL grant allocation type 2) of size 256 bits such that there is 20 ms gap between UL grants (Note 3) (Note 4)	<--	(UL grants, 256 bits)	-	-
23	Check: Does the UE transmit an AMD PDU segment with SI=01 and SOEnd=26 and the same data contents at the received positions as in the original SDU#4?	-->	SDU#4 segment 1, first part (SN=3)	4	P

24	Check: Does the UE transmit an AMD PDU segment with SI=10, SOStart=27 and the same data contents at the received positions as in the original SDU#4?	-->	SDU#4 segment 1, second part (SN=3)	4	P
25	The SS transmits a STATUS PDU. This PDU acks the AMD PDUs with SN=3. ACK_SN=4.	<--	STATUS PDU	-	-
<p>Note 1: UL grant of 808 bits=101 bytes (L_{RBs} & I_{MCS} as per 38.523-3[3] annex B) is chosen to allow the UE to transmit one PDU at a time.</p> <p>Note 2: UL grant of 432 bits (L_{RBs} & I_{MCS} as per 38.523-3[3] annex B) is chosen such that UE will segment into 2 AMD PDUs. MAC PDU of 432 bits=54 bytes fit an AMD PDU payload of 49 bytes + 3 bytes for the first segment of the AMD PDU header + 2 bytes for MAC header OR 5 bytes for the second segment of the AMD PDU header +2 bytes for MAC header and possible short BSR or padding.</p> <p>Note 3: UL grant of 256 bits (L_{RBs} & I_{MCS} as per 38.523-3[3] annex B) is chosen such that UE will segment into 2 AMD PDUs. MAC PDU of 256 bits=32 bytes fit an AMD PDU payload of = 27 bytes + 3 bytes for the first segment of the AMD PDU header + 2 bytes for MAC header OR 5 bytes for the second segment of the AMD PDU header +2 bytes for MAC header and possible short BSR or padding.</p> <p>Note 4: 20 ms gap between transmissions both in DL and UL respectively allows TTCN to tolerate one HARQ retransmission (FDD/TDD) per transport block, if such happen (TS 38.523-3 [3]).</p>					

7.1.2.3.10.3.3 Specific message contents

None.

7.1.2.3.11 AM RLC / RLC re-establishment procedure

7.1.2.3.11.1 Test Purpose (TP)

(1)

```
with { UE in RRC_CONNECTED state }
ensure that {
  when { RLC re-establishment is performed upon request by RRC }
  then { The UE discards all RLC SDUs, RLC SDU segments, and RLC PDUs, if any }
}
```

(2)

```
with { UE in RRC_CONNECTED state }
ensure that {
  when { RLC re-establishment is performed upon request by RRC }
  then { The UE resets all state variables to their initial values }
}
```

7.1.2.3.11.2 Conformance requirements

References:

The conformance requirements covered in the present test case are specified in: TS 38.322, clauses 5.1.2, 7.1 and TS 38.331 clause 5.3.11. Unless otherwise stated these are Rel-15 requirements.

[TS 38.322, clause 5.1.2]

When upper layers request an RLC entity re-establishment, the UE shall:

- discard all RLC SDUs, RLC SDU segments, and RLC PDUs, if any;
- stop and reset all timers;
- reset all state variables to their initial values.

[TS 38.322, clause 7.1]

This sub clause describes the state variables used in AM and UM entities in order to specify the RLC protocol. The state variables defined in this subclause are normative.

All state variables and all counters are non-negative integers.

All state variables related to AM data transfer can take values from 0 to 4095 for 12 bit SN or from 0 to 262143 for 18 bit SN. All arithmetic operations contained in the present document on state variables related to AM data transfer are affected by the AM modulus (i.e. final value = [value from arithmetic operation] modulo 4096 for 12 bit SN and 262144 for 18 bit SN).

All state variables related to UM data transfer can take values from 0 to 63 for 6 bit SN or from 0 to 4095 for 12 bit SN. All arithmetic operations contained in the present document on state variables related to UM data transfer are affected by the UM modulus (i.e. final value = [value from arithmetic operation] modulo 64 for 6 bit SN and 4096 for 12 bit SN).

When performing arithmetic comparisons of state variables or SN values, a modulus base shall be used.

TX_Next_Ack and RX_Next shall be assumed as the modulus base at the transmitting side and receiving side of an AM RLC entity, respectively. This modulus base is subtracted from all the values involved, and then an absolute comparison is performed (e.g. $RX_Next \leq SN < RX_Next + AM_Window_Size$ is evaluated as $[RX_Next - RX_Next] \bmod 2^{sn-FieldLength} \leq [SN - RX_Next] \bmod 2^{sn-FieldLength} < [RX_Next + AM_Window_Size - RX_Next] \bmod 2^{sn-FieldLength}$), where *sn-FieldLength* is 12 or 18 for 12 bit SN and 18 bit SN, respectively.

$RX_Next_Highest - UM_Window_Size$ shall be assumed as the modulus base at the receiving side of an UM RLC entity. This modulus base is subtracted from all the values involved, and then an absolute comparison is performed (e.g. $(RX_Next_Highest - UM_Window_Size) \leq SN < RX_Next_Highest$ is evaluated as $[(RX_Next_Highest - UM_Window_Size) - (RX_Next_Highest - UM_Window_Size)] \bmod 2^{sn-FieldLength} \leq [SN - (RX_Next_Highest - UM_Window_Size)] \bmod 2^{sn-FieldLength} < [RX_Next_Highest - (RX_Next_Highest - UM_Window_Size)] \bmod 2^{sn-FieldLength}$), where *sn-FieldLength* is 6 or 12 for 6 bit SN and 12 bit SN, respectively.

The transmitting side of each AM RLC entity shall maintain the following state variables:

a) TX_Next_Ack – Acknowledgement state variable

This state variable holds the value of the SN of the next RLC SDU for which a positive acknowledgment is to be received in-sequence, and it serves as the lower edge of the transmitting window. It is initially set to 0, and is updated whenever the AM RLC entity receives a positive acknowledgment for an RLC SDU with SN = TX_Next_Ack.

b) TX_Next – Send state variable

This state variable holds the value of the SN to be assigned for the next newly generated AMD PDU. It is initially set to 0, and is updated whenever the AM RLC entity constructs an AMD PDU with SN = TX_Next and contains an RLC SDU or the last segment of a RLC SDU.

c) POLL_SN – Poll send state variable

This state variable holds the value of the highest SN of the AMD PDU among the AMD PDUs submitted to lower layer when POLL_SN is set according to sub clause 5.3.3.2. It is initially set to 0.

The transmitting side of each AM RLC entity shall maintain the following counters:

a) PDU_WITHOUT_POLL – Counter

This counter is initially set to 0. It counts the number of AMD PDUs sent since the most recent poll bit was transmitted.

b) BYTE_WITHOUT_POLL – Counter

This counter is initially set to 0. It counts the number of data bytes sent since the most recent poll bit was transmitted.

c) RETX_COUNT – Counter

This counter counts the number of retransmissions of an RLC SDU or RLC SDU segment (see subclause 5.3.2). There is one RETX_COUNT counter maintained per RLC SDU.

The receiving side of each AM RLC entity shall maintain the following state variables:

a) RX_Next – Receive state variable

This state variable holds the value of the SN following the last in-sequence completely received RLC SDU, and it serves as the lower edge of the receiving window. It is initially set to 0, and is updated whenever the AM RLC entity receives an RLC SDU with SN = RX_Next.

b) RX_Next_Status_Trigger – *t-Reassembly* state variable

This state variable holds the value of the SN following the SN of the RLC SDU which triggered *t-Reassembly*.

c) RX_Highest_Status – Maximum STATUS transmit state variable

This state variable holds the highest possible value of the SN which can be indicated by "ACK_SN" when a STATUS PDU needs to be constructed. It is initially set to 0.

d) RX_Next_Highest – Highest received state variable

This state variable holds the value of the SN following the SN of the RLC SDU with the highest SN among received RLC SDUs. It is initially set to 0.

Each transmitting UM RLC entity shall maintain the following state variables:

a) TX_Next

This state variable holds the value of the SN to be assigned for the next newly generated UMD PDU with segment. It is initially set to 0, and is updated after the UM RLC entity submits a UMD PDU including the last segment of an RLC SDU to lower layers.

Each receiving UM RLC entity shall maintain the following state variables and constant:

b) RX_Next_Reassembly – UM receive state variable

This state variable holds the value of the earliest SN that is still considered for reassembly. It is initially set to 0.

c) RX_Timer_Trigger – UM *t-Reassembly* state variable

This state variable holds the value of the SN following the SN which triggered *t-Reassembly*.

d) RX_Next_Highest – UM receive state variable

This state variable holds the value of the SN following the SN of the UMD PDU with the highest SN among received UMD PDUs. It serves as the higher edge of the reassembly window. It is initially set to 0.

[TS 38.331, clause 5.3.11]

UE shall:

1> reset MAC;

1> if T302 is running:

2> stop timer T302;

2> perform the actions as specified in 5.3.14.4;

1> stop all timers that are running except T320 and T325;

1> discard the UE Inactive AS context;

1> set the variable *pendingRnaUpdate* to *false*, if that is set to *true*;

1> discard the K_{gNB} , the K_{RRcenc} key, the K_{RRcint} , the K_{UPint} key and the K_{UPenc} key, if any;

1> release all radio resources, including release of the RLC entity, the MAC configuration and the associated PDCP entity and SDAP for all established RBs;

1> indicate the release of the RRC connection to upper layers together with the release cause;

1> enter RRC_IDLE and perform cell selection as specified in TS 38.304 [20], except if going to RRC_IDLE was triggered by selecting an inter-RAT cell while T311 was running;

1> if going to RRC_IDLE was triggered by reception of the *RRCRelease* message including a *waitTime*:

2> start timer T302 with the value set to the *waitTime*;

2> inform the upper layer that access barring is applicable for all access categories except categories '0' and '2'.

7.1.2.3.11.3 Test description

7.1.2.3.11.3.1 Pre-test conditions

Same Pre-test conditions as in clause 7.1.2.1.1 with the exception for the AM DRB is configured according to Table 7.1.2.3.11.3.1-1.

Table 7.1.2.3.11.3.1-1: RLC parameters

Parameter	Value
<i>t-Reassembly</i>	ms150
<i>t-PollRetransmit</i>	ms150

Table 7.1.2.3.11.3.1-2: PDCP parameters

Parameter	Value
<i>t-Reordering</i>	ms160
<i>statusReportRequired</i>	Not present

7.1.2.3.11.3.2 Test procedure sequence

Table 7.1.2.3.11.3.2-1: Main behaviour

St	Procedure	Message Sequence		TP	Verdict
		U - S	Message		
-	The SS ignores scheduling requests and does not allocate any uplink grant.	-	-	-	-
1	The SS creates 2 RLC SDUs of size 40 bytes segmented into two AMD PDUs each. AMD PDU#1 and AMD PDU#2 belong to RLC SDU#1, AMD PDU#3 and #4 belong to RLC SDU#2. SS transmits AMD PDU#1 (SN=0), AMD PDU#2 (SN=0) and AMD PDU#4 (SN=1).	<--	AMD PDU#1 AMD PDU#2 AMD PDU#4	-	-
2	60 ms after sending PDU#1 in step 1 the SS allocates 1 UL grant of default size.	<--	(UL grant)	-	-
3	The UE returns RLC SDU#1.	-->	(RLC SDU#1)	-	-
4	The SS does not acknowledge the reception of RLC SDU#1.	-	-	-	-
5	The SS transmits NR RRCReconfiguration message to trigger RLC re-establishment on DRB using Reconfig with sync procedure. (Note 1) (Note 4) (Note 6)	<--	<i>RRCReconfiguration</i>	-	-
6	The UE transmits a NR <i>RRCReconfigurationcomplete</i> message. (Note 5)	-->	<i>RRCReconfigurationComplete</i>	-	-
7	The SS starts the UL default grant transmissions	-	-	-	-
8	The UE retransmits RLC SDU #1. (Note 2)	-->	(RLC SDU#1)	-	-
9	SS transmits a STATUS PDU (ACK_SN = 1).	<--	STATUS PDU	-	-
10	SS transmits AMD PDU#3 with SN=0 and the P field set to "1"	<--	AMD PDU#3	-	-
11	Check: Does the UE transmit a STATUS PDU?	-->	STATUS PDU (ACK_SN = 1)	2	P
12	Check: Does the UE return RLC SDU#2 (Note 3)	-->	(RLC SDU#2)	1	F
13	SS transmits AMD PDU#4 with SN=1	<--	AMD PDU#4	-	-
14	Check: Does the UE return RLC SDU#2 with its first AMD PDU set to SN=1?	-->	(RLC SDU#2)	2	P
<p>Note 1: Upon a RLC re-establishment a conformant UE discards any remaining AMD PDUs in the receiver and transmitter side, stops and resets all timers and resets all state variables to their initial values.</p> <p>Note 2: The UE will retransmit the PDCP SDU associated with RLC SDU#1 in accordance to TS 38.323 clause 5.5</p> <p>Note 3: AMD PDU#4 is discarded by a conformant UE in step 5.</p> <p>Note 4: For EN-DC the NR RRCReconfiguration message is contained in RRCConnectionReconfiguration 36.508 [7], Table 4.6.1-8 using condition EN-DC_EmbedNR_RRCRecon, EN-DC_PSCell_HO and RBCConfig_NoKeyChange.</p> <p>Note 5: For EN-DC the NR RRCReconfigurationComplete message is contained in RRCConnectionReconfigurationComplete.</p> <p>Note 6: For NR, the RRCReconfiguration message is as per RRCReconfiguration-HO with condition RBCConfig_NoKeyChange according to 38.508-1 [4], Table 4.8.1-1A.</p>					

7.1.2.3.11.3.3 Specific message contents

Table 7.1.2.3.11.3.3-1: RRCReconfiguration-HO (step 5, Table 7.1.2.3.11.3.3-1)

Derivation Path: 38.508-1 [4], Table 4.8.1-1A with condition RBCConfig_NoKeyChange
--

Table 7.1.2.3.11.3.3-2: Void

7.1.3 PDCP

Editor's note: Intended to capture tests of PDCP Layer behaviour defined in TS 38.323. E.g. testing of PDCP lossless operation for single SCG bearer is handled here.

7.1.3.0 Default Pre-Test Conditions for all PDCP test cases

The following pre-test conditions shall be applied in all PDCP test cases until the test case explicitly over writes these conditions

System Simulator:

- The SS configures the test environment in accordance to the execution conditions in Table 7.1.3.0-1.

UE:

- None

Preamble:

- The SS performs the generic procedure in [4] to get UE in state RRC_CONNECTED in accordance to the execution conditions in Table 7.1.3.0-2 and using the message condition UE TEST LOOP MODE A to return one UL PDCP SDU per DL PDCP SDU.

Table 7.1.3.0-1: Test environment

Execution Condition	Cell configuration	System Information Combination
IF pc_NG_RAN_NR	NR Cell 1	NR System information Combination NR-1
ELSE IF pc_EN_DC	E-UTRA Cell 1 is PCell, NR Cell 1 is PSCell	EUTRA: System information Combination 1 NR: N/A
ELSE IF pc_NGEN_DC	NG-RAN E-UTRA Cell 1 is PCell, NR Cell 1 is PSCell	EUTRA: System information Combination 1 NR: N/A

Table 7.1.3.0-2: Preamble parameters

Execution Condition	Multi-PDN / Multi-PDU Sessions Condition	Generic Procedure Parameters	Primary DRB used for Data testing
IF pc_NG_RAN_NR	FALSE	Connectivity(NR), Test loop function(On) One DRB	Default DRB of the first PDU session on NR Cell
	TRUE	Connectivity(NR), Test loop function(On) N DRBs ($N \geq 2$)	
ELSE IF pc_EN_DC	FALSE	Connectivity(EN-DC), DC bearer(One MN Terminated MCG bearer and One SN terminated SCG bearer), Test loop function(On)	SN Terminated SCG bearer unless explicitly specified in test case
	TRUE	Connectivity(EN-DC), DC bearer(Two MN Terminated MCG bearer and One SN terminated SCG bearer), Test loop function(On)	
ELSE IF pc_NGEN_DC	FALSE	Connectivity(NGEN-DC), DC bearer(One MN Terminated MCG bearer and One SN terminated SCG bearer), Test loop function(On)	SN Terminated SCG bearer unless explicitly specified in test case
	TRUE	Connectivity(EN-DC), DC bearer(Two MN Terminated MCG bearer and One SN terminated SCG bearer), Test loop function(On)	

Table 7.1.3.0-3: Message conditions

Execution Condition	Message condition exceptions
IF pc_NG_RAN_NR	Message with condition AM is used for step 7 in 4.5.4.2 according to [4]
ELSE IF pc_EN_DC	Message condition MCG_and_SCG with condition AM is used for step 7 in 4.5.4.2 according to [4]
ELSE IF pc_NGEN_DC	Message condition MCG_and_SCG with condition AM is used for step 7 in 4.5.4.2 according to [4]

7.1.3.1 Maintenance of PDCP sequence numbers for radio bearers

7.1.3.1.1 Maintenance of PDCP sequence numbers / User plane / 12 bit SN

7.1.3.1.1.1 Test Purpose (TP)

(1)

```
with { UE in RRC_CONNECTED state with PDCP configured for 12 bit SN }
ensure that {
  when { UE transmits a PDCP Data SDU on a DRB }
  then { UE increments SN with 1 for each transmitted PDU for SN=0 to Maximum_PDCP_SN ( $2^{[pdcp-SN-Size]} - 1$ ) }
}
```

(2)

```
with { UE in E-UTRA RRC_CONNECTED state with PDCP configured for 12 bit SN }
ensure that {
  when { UE transmits a PDCP Data SDU on a DRB and, after incrementation, TX_NEXT is larger than the Maximum_PDCP_SN ( $2^{[pdcp-SN-Size]} - 1$ ) }
}
```

```

then { UE sets SN to 0 in the next transmitted PDCP SDU}
}

```

7.1.3.1.1.2 Conformance requirements

References: The conformance requirements covered in the present TC are specified in: TS 38.323, clauses 5.2.1, 5.2.2.1 and 6.2.2.2. Unless otherwise stated these are Rel-15 requirements.

[TS 38.323, clause 5.2.1]

At reception of a PDCP SDU from upper layers, the transmitting PDCP entity shall:

- start the *discardTimer* associated with this PDCP SDU (if configured).

For a PDCP SDU received from upper layers, the transmitting PDCP entity shall:

- associate the COUNT value corresponding to TX_NEXT to this PDCP SDU;

NOTE 1: Associating more than half of the PDCP SN space of contiguous PDCP SDUs with PDCP SNs, when e.g., the PDCP SDUs are discarded or transmitted without acknowledgement, may cause HFN desynchronization problem. How to prevent HFN desynchronization problem is left up to UE implementation.

- perform header compression of the PDCP SDU as specified in the subclause 5.7.4;
- perform integrity protection, and ciphering using the TX_NEXT as specified in the subclause 5.9 and 5.8, respectively;
- set the PDCP SN of the PDCP Data PDU to TX_NEXT modulo $2^{[pdc\text{-}SN\text{-}Size]}$;
- increment TX_NEXT by one;
- submit the resulting PDCP Data PDU to lower layer as specified below.

When submitting a PDCP Data PDU to lower layer, the transmitting PDCP entity shall:

- if the transmitting PDCP entity is associated with one RLC entity:
 - submit the PDCP Data PDU to the associated RLC entity.
- else, if the transmitting PDCP entity is associated with two RLC entities:
 - if *pdcplDuplication* is configured and activated:
 - duplicate the PDCP Data PDU and submit the PDCP Data PDU to both associated RLC entities.
 - else, if *pdcplDuplication* is configured but not activated:
 - submit the PDCP Data PDU to the primary RLC entity.
 - else:
 - if the total amount of PDCP data volume and RLC data volume pending for initial transmission (as specified in TS 36.322 [5]) in the two associated RLC entities is less than *ul-DataSplitThreshold*:
 - submit the PDCP Data PDU to the primary RLC entity.
 - else:
 - submit the PDCP Data PDU to either the primary RLC entity or the secondary RLC entity.

NOTE 2: If the transmitting PDCP entity is associated with two RLC entities, the UE should minimize the amount of PDCP PDUs submitted to lower layers before receiving request from lower layers and minimize the PDCP SN gap between PDCP PDUs submitted to two associated RLC entities to minimize PDCP reordering delay in the receiving PDCP entity.

[TS 38.323, clause 5.2.2.1]

In this section, following definitions are used:

- HFN(State Variable): the HFN part (i.e. the number of most significant bits equal to HFN length) of the State Variable;
- SN(State Variable): the SN part (i.e. the number of least significant bits equal to PDCP SN length) of the State Variable;
- RCVD_SN: the PDCP SN of the received PDCP Data PDU, included in the PDU header;
- RCVD_HFN: the HFN of the received PDCP Data PDU, calculated by the receiving PDCP entity;
- RCVD_COUNT: the COUNT of the received PDCP Data PDU = [RCVD_HFN, RCVD_SN]

At reception of a PDCP Data PDU from lower layers, the receiving PDCP entity shall determine the COUNT value of the received PDCP Data PDU, i.e. RCVD_COUNT, as follows:

- if $RCVD_SN < SN(RX_DELIV) - Window_Size$:
 - $RCVD_HFN = HFN(RX_DELIV) + 1$.
- else if $RCVD_SN \geq SN(RX_DELIV) + Window_Size$:
 - $RCVD_HFN = HFN(RX_DELIV) - 1$.
- else:
 - $RCVD_HFN = HFN(RX_DELIV)$;
 - $RCVD_COUNT = [RCVD_HFN, RCVD_SN]$.

After determining the COUNT value of the received PDCP Data PDU = RCVD_COUNT, the receiving PDCP entity shall:

- if $RCVD_COUNT < RX_DELIV$; or
- if the PDCP Data PDU with COUNT = RCVD_COUNT has been received before:
 - perform deciphering and integrity verification of the PDCP Data PDU using COUNT = RCVD_COUNT;
 - if integrity verification fails:
 - indicate the integrity verification failure to upper layer;
 - discard the PDCP Data PDU.
- else:
 - perform deciphering and integrity verification of the PDCP Data PDU using COUNT = RCVD_COUNT;
 - if integrity verification fails:
 - indicate the integrity verification failure to upper layer;
 - discard the PDCP Data PDU.

If the received PDCP Data PDU with COUNT value = RCVD_COUNT is not discarded above, the receiving PDCP entity shall:

- store the resulting PDCP SDU in the reception buffer;
- if $RCVD_COUNT \geq RX_NEXT$:
 - update RX_NEXT to RCVD_COUNT + 1.
- if *outOfOrderDelivery* is configured:
 - deliver the resulting PDCP SDU to upper layers.

- if RCVD_COUNT = RX_DELIV:
 - deliver to upper layers in ascending order of the associated COUNT value after performing header decompression, if not decompressed before;
 - all stored PDCP SDU(s) with consecutively associated COUNT value(s) starting from COUNT = RX_DELIV;
 - update RX_DELIV to the COUNT value of the first PDCP SDU which has not been delivered to upper layers, with COUNT value > RX_DELIV;
- if *t-Reordering* is running, and if RX_DELIV >= RX_REORD:
 - stop and reset *t-Reordering*.
- if *t-Reordering* is not running (includes the case when *t-Reordering* is stopped due to actions above), and RX_DELIV < RX_NEXT:
 - update RX_REORD to RX_NEXT;
 - start *t-Reordering*.

[TS 38.322, clause 6.2.2.2]

Figure 6.2.2.2-1 shows the format of the PDCP Data PDU with 12 bits PDCP SN. This format is applicable for UM DRBs and AM DRBs.

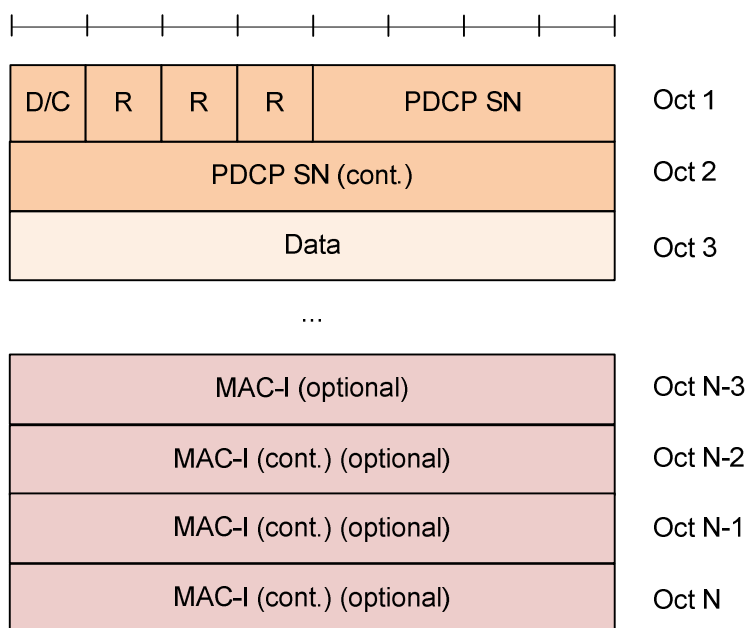

Figure 6.2.2.2-1: PDCP Data PDU format with 12 bits PDCP SN

7.1.3.1.1.3 Test description

7.1.3.1.1.3.1 Pre-test conditions

Same Pre-test conditions as in clause 7.1.3.0 exception of PDCP parameters according to Table 7.1.3.1.1.3.1-1.

Table 7.1.3.1.1.3.1-1: PDCP parameters

PDCP-Config pdcp-SN-SizeUL	len12bits
PDCP-Config pdcp-SN-SizeDL	len12bits

7.1.3.1.1.3.2 Test procedure sequence

Table 7.1.3.1.1.3.2-1: Main behaviour

St	Procedure	Message Sequence		TP	Verdict
		U - S	Message		
-	EXCEPTION: Steps 1 and 2 shall be repeated for k=0 to Maximum_PDCP_SN (increment=1).	-	-	-	-
1	SS transmits a PDCP Data PDU containing one PDCP SDU without header compression.	<--	PDCP Data PDU (SN = k)		
2	CHECK: Does UE transmit a PDCP Data PDU with SN=0 for the first iteration and then incremented by 1 at each iteration?	-->	PDCP Data PDU (SN = k)	1	P
3	SS transmits a PDCP Data PDU containing one PDCP SDU without header compression.	<--	PDCP Data PDU (SN = 0)		
4	CHECK: Does UE transmit a PDCP Data PDU with SN=0?	-->	PDCP Data PDU (SN = 0)	2	P
5	SS sends a PDCP Data PDU containing one PDCP SDU without header compression.	<--	PDCP Data PDU (SN = 1)		
6	CHECK: Does UE transmit a PDCP Data PDU with SN=1?	-->	PDCP Data PDU (SN = 1)	1	P
Note 1: Maximum_PDCP_SN = $2^{\lfloor \text{pdcp-SN-Size} \rfloor} - 1$.					

7.1.3.1.1.3.3 Specific message contents

None.

7.1.3.1.2 Maintenance of PDCP sequence numbers / User plane / 18 bit SN

7.1.3.1.2.1 Test Purpose (TP)

(1)

```

with { UE in RRC_CONNECTED state with PDCP configured for 18 bit SN }
ensure that {
  when { UE transmits a PDCP Data SDU on a DRB }
  then { UE increments SN with 1 for each transmitted PDU for SN=0 to Maximum_PDCP_SN ( $2^{\lfloor \text{pdcp-SN-Size} \rfloor} - 1$ ) }
}

```

(2)

```

with { UE in E-UTRA RRC_CONNECTED state with PDCP configured for 18 bit SN }
ensure that {
  when { UE transmits a PDCP Data SDU on a DRB and, after incrementation, TX_Next is larger than the Maximum_PDCP_SN ( $2^{\lfloor \text{pdcp-SN-Size} \rfloor} - 1$ ) }
  then { UE sets SN to 0 in the next transmitted PDCP SDU }
}

```

7.1.3.1.2.2 Conformance requirements

Same as conformance requirements in clause 7.1.3.1.1.2

7.1.3.1.2.3 Test description

7.1.3.1.2.3.1 Pre-test conditions

Same Pre-test conditions as in clause 7.1.3.0 exception of PDCP parameters according to Table 7.1.3.1.2.3.1-1.

Table 7.1.3.1.2.3.1-1: PDCP parameters

PDCP-Config pdcp-SN-SizeUL	len18bits
PDCP-Config pdcp-SN-SizeDL	len18bits

7.1.3.1.2.3.2 Test procedure sequence

Same as test procedure in clause 7.1.3.1.1.3.2

7.1.3.1.2.3.3 Specific message contents

None.

7.1.3.2 PDCP integrity protection

7.1.3.2.1 Integrity protection / Correct functionality of encryption algorithm SNOW3G / SRB / DRB

(1)

```
with { UE in RRC_CONNECTED state and SRB is configured with NR-PDCP }
ensure that {
  when { Functionality of integrity algorithms with SNOW3G is taken into use on SRB }
  then { UE performs correct integrity protection function in NR-PDCP entities associated with SRB }
}
```

(2)

```
with { UE in RRC_CONNECTED state and NOT EN-DC }
ensure that {
  when { Functionality of integrity algorithms with SNOW3G is taken into use on DRB }
  then { UE performs correct integrity protection function in PDCP entities associated with DRB }
}
```

(3)

```
with { UE in RRC_CONNECTED state and SRB3 is configured }
ensure that {
  when { message on SRB 3 is received and fails the integrity protection check }
  then { UE transmits SCGFailureInformationNR message with failure type 'srb3-IntegrityFailure' }
}
```

NOTE: TP2 (integrity on DRB) is not applicable to EN-DC as per 38.331 clause 6.3.2, the IE *PDCP-Config.drb.integrityProtection* is 'Cond ConnectedTo5GC'.

7.1.3.2.1.2 Conformance requirements

References: The conformance requirements covered in the present TC are specified in: TS 38.323, clauses 5.9, 5.2.2.1, TS 33.501 clauses 5.6.2, D.3.1 and TS 38.331 clauses 5.7.3.1, 5.7.3.2, 5.7.3.3. Unless otherwise stated these are Rel-15 requirements.

[TS 38.323, clause 5.9]

The integrity protection function includes both integrity protection and integrity verification and is performed in PDCP, if configured. The data unit that is integrity protected is the PDU header and the data part of the PDU before ciphering. The integrity protection is always applied to PDCP Data PDUs of SRBs. The integrity protection is applied to PDCP Data PDUs of DRBs for which integrity protection is configured. The integrity protection is not applicable to PDCP Control PDUs.

The integrity protection algorithm and key to be used by the PDCP entity are configured by upper layers TS 38.331 [3] and the integrity protection method shall be applied as specified in TS 33.501 [6].

The integrity protection function is activated by upper layers TS 38.331 [3]. When security is activated, the integrity protection function shall be applied to all PDUs including and subsequent to the PDU indicated by upper layers TS 38.331 [3] for the downlink and the uplink, respectively.

NOTE: As the RRC message which activates the integrity protection function is itself integrity protected with the configuration included in this RRC message, this message needs first be decoded by RRC before the integrity protection verification could be performed for the PDU in which the message was received.

For downlink and uplink integrity protection and verification, the parameters that are required by PDCP for integrity protection are defined in TS 33.501 [6] and are input to the integrity protection algorithm. The required inputs to the integrity protection function include the COUNT value, and DIRECTION (direction of the transmission: set as specified in TS 33.501 [6]). The parameters required by PDCP which are provided by upper layers TS 38.331 [3] are listed below:

- BEARER (defined as the radio bearer identifier in TS 33.501 [6]. It will use the value RB identity –1 as in TS 38.331 [3]);
- KEY (the integrity protection keys for the control plane and for the user plane are K_{RRCint} and K_{UPint} , respectively).

At transmission, the UE computes the value of the MAC-I field and at reception it verifies the integrity of the PDCP Data PDU by calculating the X-MAC based on the input parameters as specified above. If the calculated X-MAC corresponds to the received MAC-I, integrity protection is verified successfully.

[TS 38.323, clause 5.2.2.1]

At reception of a PDCP Data PDU from lower layers, the receiving PDCP entity shall determine the COUNT value of the received PDCP Data PDU, i.e. RCVD_COUNT, as follows:

- if $RCVD_SN < SN(RX_DELIV) - Window_Size$:
 - $RCVD_HFN = HFN(RX_DELIV) + 1$.
- else if $RCVD_SN \geq SN(RX_DELIV) + Window_Size$:
 - $RCVD_HFN = HFN(RX_DELIV) - 1$.
- else:
 - $RCVD_HFN = HFN(RX_DELIV)$;
 - $RCVD_COUNT = [RCVD_HFN, RCVD_SN]$.

After determining the COUNT value of the received PDCP Data PDU = RCVD_COUNT, the receiving PDCP entity shall:

- perform deciphering and integrity verification of the PDCP Data PDU using COUNT = RCVD_COUNT;
- if integrity verification fails:
 - indicate the integrity verification failure to upper layer;
 - discard the PDCP Data PDU;
- if $RCVD_COUNT < RX_DELIV$; or
- if the PDCP Data PDU with COUNT = RCVD_COUNT has been received before:
 - discard the PDCP Data PDU;

[TS 33.501, clause 5.6.2]

All Identifiers and names specified in the present subclause are for 5G.

Each Integrity Algorithm used for 5G will be assigned a 4-bit identifier. The following values for integrity algorithms are defined:

- "0000₂" NIA0 Null Integrity Protection algorithm;
- "0001₂" 128-NIA1 128-bit SNOW 3G based algorithm;
- "0010₂" 128-NIA2 128-bit AES based algorithm; and
- "0011₂" 128-NIA3 128-bit ZUC based algorithm.

128-NIA1 is based on SNOW 3G (see TS35.215 [14]).

128-NIA2 is based on 128-bit AES [15] in CMAC mode [17].

128-NIA3 is based on 128-bit ZUC (see TS35.221 [18]).

Full details of the algorithms are specified in Annex D.

[TS 33.501, clause D.3.1.1]

The input parameters to the integrity algorithm are a 128-bit integrity key named KEY, a 32-bit COUNT, a 5-bit bearer identity called BEARER, the 1-bit direction of the transmission i.e. DIRECTION, and the message itself i.e. MESSAGE. The DIRECTION bit shall be 0 for uplink and 1 for downlink. The bit length of the MESSAGE is LENGTH.

Figure D.3.1.1-1 illustrates the use of the integrity algorithm NIA to authenticate the integrity of messages.

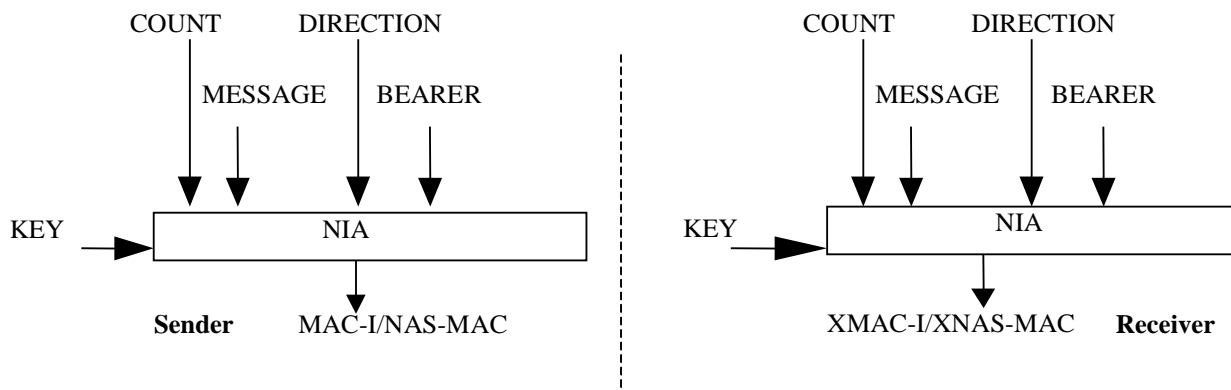

Figure D.3.1.1-1: Derivation of MAC-I/NAS-MAC (or XMAC-I/XNAS-MAC)

Based on these input parameters the sender computes a 32-bit message authentication code (MAC-I/NAS-MAC) using the integrity algorithm NIA. The message authentication code is then appended to the message when sent. For integrity protection algorithms, the receiver computes the expected message authentication code (XMAC-I/XNAS-MAC) on the message received in the same way as the sender computed its message authentication code on the message sent and verifies the data integrity of the message by comparing it to the received message authentication code, i.e. MAC-I/NAS-MAC.

[TS 38.331, clause 5.7.3.1]

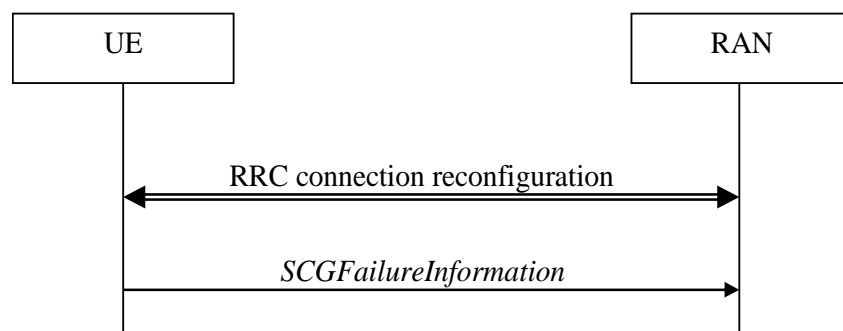

Figure 5.7.3.1-1: SCG failure information

The purpose of this procedure is to inform EUTRAN or NR MN about an SCG failure the UE has experienced i.e. SCG radio link failure, e failure of SCG reconfiguration with sync, SCG configuration failure for RRC message on SRB3, SCG integrity check failure and exceeding the maximum uplink transmission timing difference.

[TS 38.331, clause 5.7.3.2]

A UE initiates the procedure to report SCG failures when SCG transmission is not suspended and when one of the following conditions is met:

- 1> upon detecting radio link failure for the SCG, in accordance with subclause 5.3.10.3;
- 1> upon reconfiguration with sync failure of the SCG, in accordance with subclause 5.3.5.9.3;
- 1> upon SCG configuration failure, in accordance with subclause 5.3.5.9.2;
- 1> upon integrity check failure indication from SCG lower layers, in accordance with subclause 5.3.5.9.1.

Upon initiating the procedure, the UE shall:

- 1> suspend SCG transmission for all SRBs and DRBs;
- 1> reset SCG-MAC;
- 1> stop T304, if running;
- 1> if the UE is operating in EN-DC:
 - 2> initiate transmission of the *SCGFailureInformationNR* message as specified in TS 36.331 [10, 5.6.13a].

[TS 38.331, clause 5.7.3.3]

The UE shall set the SCG failure type as follows:

...

- 1> else, if the UE initiates transmission of the *SCGFailureInformationNR* message due to SRB3 IP check failure:
 - 2> set the failureType as srb3-IntegrityFailure;

7.1.3.2.1.3 Test description

7.1.3.2.1.3.1 Pre-test conditions

- Same Pre-test conditions as in clause 7.1.3.0 with the exception that integrity protection algorithm 'eia1 (SNOW3G)' is configured.
- IF *pc_EN_DC* OR *pc_NGEN_DC* is set to true, then *RRConnectionReconfiguration* message including *MobilityControlInfo* IE is transmitted on E-UTRA Cell 1 to reconfigure SRB1, SRB2 and MCG DRB from E-UTRA PDCP to NR PDCP.

7.1.3.2.1.3.2 Test procedure sequence

Table 7.1.3.2.1.3.2-1: Main behaviour

St	Procedure	Message Sequence		TP	Verdict
		U - S	Message		
-	EXCEPTION: Steps 1a1 to 1b2 describe behaviour that depends on UE configuration; the "lower case letter" identifies a step sequence that takes place depending on a particular configuration.	-	-	-	-
1a1	IF pc_EN_DC OR pc_NGEN_DC the SS sends EUTRA RRC <i>UECapabilityEnquiry</i> message including <i>RAT-Type eutra-nr</i> to the UE integrity protected.	<--	RRC: <i>UECapabilityEnquiry</i>	-	-
1a2	Check: Does the UE send a EUTRA RRC <i>UECapabilityInformation</i> message integrity protected?	-->	RRC: <i>UECapabilityInformation</i>	1	P
1b1	ELSE the SS sends NR RRC <i>UECapabilityEnquiry</i> message to the UE.	<--	NR RRC: <i>UECapabilityEnquiry</i>	-	-
1a2	Check: Does the UE send a NR RRC <i>UECapabilityInformation</i> message?	-->	NR RRC: <i>UECapabilityInformation</i>	1	P
-	EXCEPTION: Steps 2a1-2a4 describe behaviour that depends on UE configuration; the "lower case letter" identifies a step sequence that takes place if SRB3 is configured	-	-	-	-
2a1	If (pc_EN_DC OR pc_NGEN_DC) AND pc_srb3 then the SS transmits an <i>RRCReconfiguration</i> message to reconfigure NR MAC, sent on SRB3 integrity protected. Note 1	<--	<i>RRCReconfiguration</i>	-	-
2a2	Check: Does the UE transmit an <i>RRCReconfigurationComplete</i> message on SRB3 integrity protected?	-->	<i>RRCReconfigurationComplete</i>	1	P
2a3	The SS sends <i>RRCReconfiguration</i> message to the UE integrity protected on SRB3. The MAC-I is corrupted so as to result in integrity failure at UE.	<--	<i>RRCReconfiguration</i>	-	-
2a4	Check: Does the UE send <i>SCGFailureInformationNR</i> with failureType 'srb3-IntegrityFailure' on SRB1?	-->	<i>SCGFailureInformationNR</i>	3	P
-	EXCEPTION: Steps 3a1-3a2 describe behaviour that depends on whether 5GC is being emulated; the "lower case letter" identifies a step sequence that takes place if 5GC is being emulated.	-	-	-	-
3a1	If (NOT pc_EN_DC) then the SS transmits PDCP PDU on DRB integrity protected.	<--	PDCP PDU	-	-
3a2	Check: Does the UE transmit looped back PDCP PDU integrity protected on DRB?	-->	PDCP PDU	2	P
Note 1: For EN-DC the NR RRCReconfiguration is contained in <i>RRCConnectionReconfiguration</i> Table 7.1.3.2.1.3.3-1					

7.1.3.2.1.3.3 Specific message contents

Table 7.1.3.2.1.3.3-1: *RRCConnectionReconfiguration (Preamble for EN-DC or NGEN-DC)*

Condition	Explanation
SRB3	Establishment of SRB3

Table 7.1.3.2.1.3.3-1A: MobilityControlInfo-HO-SameCell (Table 7.1.3.2.1.3.3-1)

Derivation Path: 36.508 [7], Table 4.6.5-1			
Information Element	Value/remark	Comment	Condition
MobilityControlInfo-HO ::= SEQUENCE {			
targetPhysCellId	PhysicalCellIdentity of E-UTRA Cell 1		
carrierFreq	Not present		
}			

Table 7.1.3.2.1.3.3-2: MAC-CellGroupConfig (step 2a1, Table 7.1.3.2.1.3.2-1)

Derivation Path: TS 38.508-1 [4], Table 4.6.3-68			
Information Element	Value/remark	Comment	Condition
MAC-CellGroupConfig ::= SEQUENCE {			
bsr-Config SEQUENCE {			
periodicBSR-Timer	sf10	Different from default	
}			
}			

Table 7.1.3.2.1.3.3-3: SCGFailureInformationNR message (step 2a4, Table 7.1.3.2.1.3.2-1)

Derivation Path: 36.508 [7], Table 4.6.1-18AA			
Information Element	Value/remark	Comment	Condition
SCGFailureInformationNR-r15 ::= SEQUENCE {			
criticalExtensions CHOICE {			
c1 CHOICE {			
scgFailureInformationNR-r15 SEQUENCE {			
failureReportSCG-NR-r15 SEQUENCE {			
failureType-r15	srb3-IntegrityFailure		
measResultFreqListNR-r15	Not checked		
measResultSCG-r15	Not checked		
}			
nonCriticalExtension SEQUENCE {}			
}			
}			
}			

7.1.3.2.2 Integrity protection / Correct functionality of encryption algorithm AES / SRB / DRB

7.1.3.2.2.1 Test Purpose (TP)

(1)

```
with { UE in RRC_CONNECTED state and SRB is configured with NR-PDCP }
ensure that {
  when { Functionality of integrity algorithms with AES is taken into use on SRB }
  then { UE performs correct integrity protection function in NR-PDCP entity associated with SRB }
}
```

(2)

```
with { UE in RRC_CONNECTED state and NOT EN-DC }
ensure that {
  when { Functionality of integrity algorithms with AES is taken into use on DRB }
```

```

    then { UE performs correct integrity protection function in PDCP entities associated with DRB }
  }

```

(3)

```

with { UE in RRC_CONNECTED state and SRB3 is configured }
ensure that {
  when { message on SRB 3 is received and fails the integrity protection check }
  then { UE transmits SCGFailureInformationNR message with failure type as srb3-IntegrityFailure }
}

```

NOTE: TP2 (integrity on DRB) is not applicable to EN-DC as per TS 38.331 [12] clause 6.3.2, the IE *PDCP-Config.drb.integrityProtection* is 'Cond ConnectedTo5GC'.

7.1.3.2.2.2 Conformance requirements

Same conformance requirements as in clause 7.1.3.2.1.2

7.1.3.2.2.3 Test description

7.1.3.2.2.3.1 Pre-test conditions

Same Pre-test conditions as in clause 7.1.3.2.1.3.1 except that integrity protection algorithm 'eia2 (AES)' is configured.

7.1.3.2.2.3.2 Test procedure sequence

Same test procedure sequence as in clause 7.1.3.2.1.3.2.

7.1.3.2.2.3.3 Specific message contents

Same specific message contents as in clause 7.1.3.2.1.3.3 except for integrity protection algorithm 'eia2 (AES)'.

7.1.3.2.3 Integrity protection / Correct functionality of encryption algorithm ZUC / SRB / DRB

(1)

```

with { UE in RRC_CONNECTED state and SRB is configured with NR-PDCP }
ensure that {
  when { Functionality of integrity algorithms with ZUC is taken into use on SRB }
  then { UE performs correct integrity protection function in NR-PDCP entities associated with SRB }
}

```

(2)

```

with { UE in RRC_CONNECTED state and NOT EN-DC }
ensure that {
  when { Functionality of integrity algorithms with ZUC is taken into use on DRB }
  then { UE performs correct integrity protection function in PDCP entities associated with DRB }
}

```

(3)

```

with { UE in RRC_CONNECTED state and SRB3 is configured }
ensure that {
  when { message on SRB 3 is received and fails the integrity protection check }
  then { UE transmits SCGFailureInformationNR message with failure type as srb3-IntegrityFailure }
}

```

NOTE: TP2 (integrity on DRB) is not applicable to EN-DC as per TS 38.331 [12] clause 6.3.2, the IE *PDCP-Config.drb.integrityProtection* is 'Cond ConnectedTo5GC'.

7.1.3.2.3.2 Conformance requirements

Same conformance requirements as in clause 7.1.3.2.1.2.

7.1.3.2.3.3 Test description

7.1.3.2.3.3.1 Pre-test conditions

Same Pre-test conditions as in clause 7.1.3.2.1.3.1 except that integrity protection algorithm 'eia3 (ZUC)' is configured.

7.1.3.2.3.3.2 Test procedure sequence

Same test procedure sequence as in clause 7.1.3.2.1.3.2.

7.1.3.2.3.3.3 Specific message contents

Same specific message contents as in clause 7.1.3.2.1.3.3 except integrity protection algorithm 'eia3 (ZUC)'.

7.1.3.3 PDCP Ciphering and deciphering

7.1.3.3.1 Ciphering and deciphering / Correct functionality of encryption algorithm SNOW3G / SRB / DRB

7.1.3.3.1.1 Test Purpose (TP)

(1)

(1)

```
with { UE in RRC_CONNECTED state and SRB is configured with NR-PDCP }
ensure that {
  when { Functionality of encryption algorithms with SNOW3G is taken into use on SRB }
  then { UE performs correct ciphering/deciphering function in NR-PDCP entity associated with SRB }
}
```

(2)

```
with { UE in RRC_CONNECTED state }
ensure that {
  when { Functionality of encryption algorithms with SNOW3G is taken into use on DRB }
  then { UE performs correct ciphering/deciphering function in NR-PDCP entity associated with DRB }
}
```

7.1.3.3.1.2 Conformance requirements

References: The conformance requirements covered in the present TC are specified in: TS 38.323 clause 5.8, TS 33.501 clauses 5.6.1, D.2.1.1 and TS 36.331 clause 6.3.2. Unless otherwise stated these are Rel-15 requirements.

[TS 38.323, clause 5.8]

The ciphering function includes both ciphering and deciphering and is performed in PDCP, if configured. The data unit that is ciphered is the data part of the PDCP Data PDU (see subclause 6.3.3) except the SDAP header if included in the PDCP SDU, and the MAC-I (see subclause 6.3.4). The ciphering is not applicable to PDCP Control PDUs.

The ciphering algorithm and key to be used by the PDCP entity are configured by upper layers TS 38.331 [3] and the ciphering method shall be applied as specified in TS 33.501 [6].

The ciphering function is activated by upper layers TS 38.331 [3]. When security is activated, the ciphering function shall be applied to all PDCP Data PDUs indicated by upper layers TS 38.331 [3] for the downlink and the uplink, respectively.

For downlink and uplink ciphering and deciphering, the parameters that are required by PDCP for ciphering are defined in TS 33.501 [6] and are input to the ciphering algorithm. The required inputs to the ciphering function include the COUNT value, and DIRECTION (direction of the transmission: set as specified in TS 33.501 [6]). The parameters required by PDCP which are provided by upper layers TS 38.331 [3] are listed below:

- BEARER (defined as the radio bearer identifier in TS 33.501 [6]. It will use the value RB identity –1 as in TS 38.331 [3]);
- KEY (the ciphering keys for the control plane and for the user plane are $K_{RRCCenc}$ and K_{UPenc} , respectively).

[TS 33.501, clause 5.6.1]

All Identifiers and names specified in this subclause are for 5G.

Each Encryption Algorithm used for 5G will be assigned a 4-bit identifier. The following values for ciphering algorithms are defined:

"0000 ₂ "	NEA0	Null ciphering algorithm;
"0001 ₂ "	128-NEA1	128-bit SNOW 3G based algorithm;
"0010 ₂ "	128-NEA2	128-bit AES based algorithm; and
"0011 ₂ "	128-NEA3	128-bit ZUC based algorithm.

128-NEA1 is based on SNOW 3G (see TS35.215 [14]).

128-NEA2 is based on 128-bit AES [15] in CTR mode [16].

128-NEA3 is based on 128-bit ZUC (see TS35.221 [18]).

Full details of the algorithms are specified in Annex D.

[TS 33.501, clause D.2.1.1]

The input parameters to the ciphering algorithm are a 128-bit cipher key named KEY, a 32-bit COUNT, a 5-bit bearer identity BEARER, the 1-bit direction of the transmission i.e. DIRECTION, and the length of the keystream required i.e. LENGTH. The DIRECTION bit shall be 0 for uplink and 1 for downlink.

Editor's Note: For NAS layer security, the inputs may need to change depending on the solution that is selected for having simultaneous NAS connections for 3GPP and non-3GPP.

Figure D.2.1.1-1 illustrates the use of the ciphering algorithm NEA to encrypt plaintext by applying a keystream using a bit per bit binary addition of the plaintext and the keystream. The plaintext may be recovered by generating the same keystream using the same input parameters and applying a bit per bit binary addition with the ciphertext.

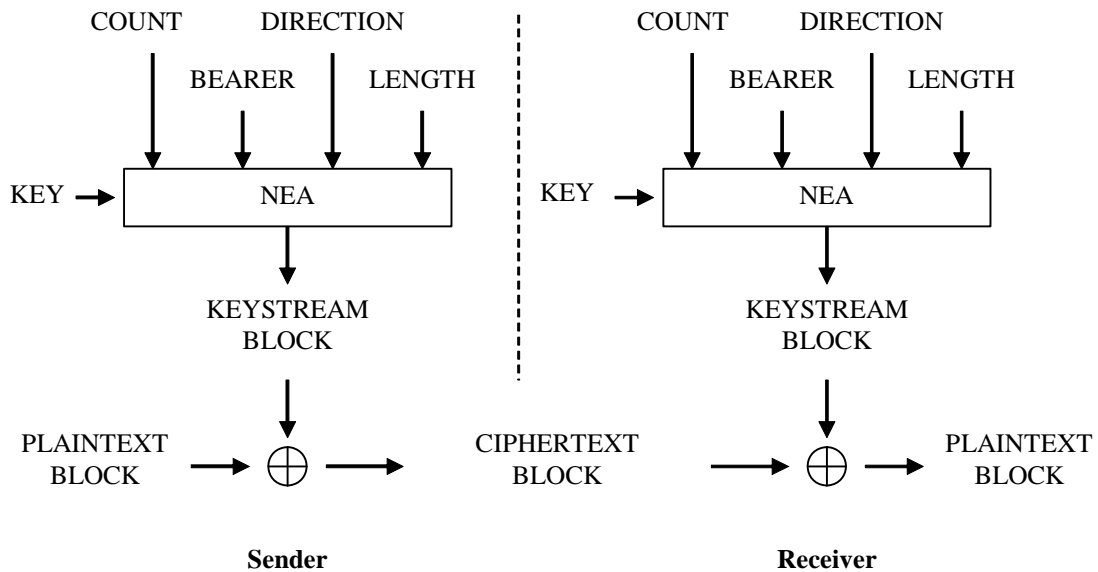

Figure D.2.1.1-1: Ciphering of data

Based on the input parameters the algorithm generates the output keystream block KEYSTREAM which is used to encrypt the input plaintext block PLAINTEXT to produce the output ciphertext block CIPHERTEXT.

The input parameter LENGTH shall affect only the length of the KEYSTREAM BLOCK, not the actual bits in it.

[TS 36.331, clause 6.3.3]

The IE *SecurityAlgorithmConfig* is used to configure AS integrity protection algorithm (SRBs) and AS ciphering algorithm (SRBs and DRBs).

...

SecurityAlgorithmConfig field descriptions	
cipheringAlgorithm	Indicates the ciphering algorithm to be used for SRBs and DRBs, as specified in TS 33.501 [11]. The algorithms nea0-nea3 are identical to the LTE algorithms eea0-3. For EN-DC, the algorithms configured for bearers using KeNB shall be the same as for all bearers using KeNB.
integrityProtAlgorithm	For EN-DC, this IE indicates the integrity protection algorithm to be used for SRBs, as specified in TS 33.501 [11]. The algorithms nia0-nia3 is identical to the LTE algorithms eia0-3. For EN-DC, the algorithms configured for SRBs using KeNB shall be the same as for all SRBs using KeNB.

7.1.3.3.1.3 Test description

7.1.3.3.1.3.1 Pre-test conditions

- Same Pre-test conditions as in clause 7.1.3.0 with the exception that ciphering algorithm ‘nea1 (SNOW3G)’ is configured.
- IF pc_EN_DC OR pc_NGEN_DC is set to true, then RRCConnectionReconfiguration message including MobilityControlInfo IE is transmitted on E-UTRA Cell 1 to reconfigure SRB1, SRB2 and MCG DRB from E-UTRA PDCP to NR PDCP.

7.1.3.3.1.3.2 Test procedure sequence

Table 7.1.3.3.1.3.2-1: Main behaviour

St	Procedure	Message Sequence		TP	Verdict
		U - S	Message		
-	Exception steps 1a1 to 1b2 depends on UE configuration.	-	-	-	-
1a1	IF pc_EN_DC OR pc_NGEN_DC, the SS sends EUTRA RRC <i>UECapabilityEnquiry</i> including <i>RAT-Type eutra</i> message to the UE.	<--	RRC: <i>UECapabilityEnquiry</i>	-	-
1a2	Check: Does the UE send a EUTRA RRC <i>UECapabilityInformation</i> message?	-->	RRC: <i>UECapabilityInformation</i>	1	P
1b1	ELSE the SS sends NR RRC <i>UECapabilityEnquiry</i> message to the UE.	<--	NR RRC: <i>UECapabilityEnquiry</i>	-	-
1b2	Check: Does the UE send a NR RRC <i>UECapabilityInformation</i> message?	-->	NR RRC: <i>UECapabilityInformation</i>	1	P
-	EXCEPTION: steps 2a1-2a2 depends on UE configuration, executed if SCG DRB is configured	-	-	-	-
2a1	If (pc_EN_DC OR pc_NGEN_DC) then SS transmits PDCP PDU on SCG DRB ciphered.	<--	PDCP PDU	-	-
2a2	Check: Does the UE transmit looped back PDCP PDU ciphered on SCG DRB?	-->	PDCP PDU	2	P
3	SS transmits PDCP PDU on MCG DRB ciphered.	<--	PDCP PDU	-	-
4	Check: Does the UE transmit looped back PDCP PDU ciphered on MCG DRB?	-->	PDCP PDU	2	P

Table 7.1.3.3.1.3.3-2: MobilityControlInfo-HO-SameCell (Table 7.1.3.3.1.3.3-1)

Derivation Path: 36.508 [7], Table 4.6.5-1			
Information Element	Value/remark	Comment	Condition
MobilityControlInfo-HO ::= SEQUENCE {			
targetPhysCellId	PhysicalCellId of E-UTRA Cell 1		
carrierFreq	Not present		
}			

Table 7.1.3.3.1.3.3-3: RadioResourceConfigDedicated-DRB-Rel-Add (Table 7.1.3.3.1.3.3-1)

Derivation Path: 36.508 [7], Table 4.6.3-19AAAAAD			
Information Element	Value/remark	Comment	Condition
RadioResourceConfigDedicated-SRB2-DRB ::= SEQUENCE {			
srb-ToAddModList	Not present		
drb-ToAddModList SEQUENCE (SIZE (1..maxDRB)) OF SEQUENCE {	1 entry		
drb-ToAddMod[1]	DRB-ToAddMod-DEFAULT (8) using condition AM except pdcp-Config not included	See TS 36.508 subclause 4.8.2	
}			
drb-ToReleaseList SEQUENCE (SIZE (1..maxDRB)) OF {	1 entry		
DRB-Identity[1]	8	Same as the DRB Identity associated with the default EPS bearer	
}			
}			

7.1.3.3.2 Ciphering and deciphering / Correct functionality of encryption algorithm AES / SRB / DRB

7.1.3.3.2.1 Test Purpose (TP)

(1)

```
with { UE in RRC_CONNECTED state and SRB is configured with NR-PDCP }
ensure that {
  when { Functionality of encryption algorithms with AES is taken into use on SRB }
  then { UE performs correct ciphering/deciphering function in NR-PDCP entity associated with SRB }
}
```

(2)

```
with { UE in RRC_CONNECTED state }
ensure that {
  when { Functionality of encryption algorithms with AES is taken into use on DRB }
  then { UE performs correct ciphering/deciphering function in NR-PDCP entity associated with DRB }
}
```

7.1.3.3.2.2 Conformance requirements

Same conformance requirement as in clause 7.1.3.3.1.2.

7.1.3.3.2.3 Test description

7.1.3.3.2.3.1 Pre-test conditions

Same Pre-test conditions as in clause 7.1.3.3.1.3.1 with the exception that ciphering algorithm 'nea2 (AES)' is configured.

7.1.3.3.2.3.2 Test procedure sequence

Same Test procedure sequence as in clause 7.1.3.3.1.3.2

7.1.3.3.2.3.3 Specific message contents

None

7.1.3.3.3 Ciphering and deciphering / Correct functionality of encryption algorithm ZUC / SRB / DRB

7.1.3.3.3.1 Test Purpose (TP)

(1)

```
with { UE in RRC_CONNECTED state and SRB is configured with NR-PDCP }
ensure that {
  when { Functionality of encryption algorithms with ZUC is taken into use on SRB }
  then { UE performs correct ciphering/deciphering function in NR-PDCP entity associated with SRB }
}
```

(2)

```
with { UE in RRC_CONNECTED state and DRB is configured with NR-PDCP }
ensure that {
  when { Functionality of encryption algorithms with ZUC is taken into use on DRB }
  then { UE performs correct ciphering/deciphering function in NR-PDCP entity associated with DRB }
}
```

7.1.3.3.3.2 Conformance requirements

Same conformance requirement as in clause 7.1.3.3.1.2.

7.1.3.3.3.3 Test description

7.1.3.3.3.3.1 Pre-test conditions

Same Pre-test conditions as in clause 7.1.3.3.1.3.1 with the exception that ciphering algorithm 'nea3 (ZUC)' is configured.

7.1.3.3.3.3.2 Test procedure sequence

Same Test procedure sequence as in clause 7.1.3.3.1.3.2.

7.1.3.3.3.3.3 Specific message contents

None

7.1.3.4 PDCP Handover

7.1.3.4.1 PDCP handover / Lossless handover / PDCP sequence number maintenance / PDCP status report to convey the information on missing or acknowledged PDCP SDUs at handover / In-order delivery and duplicate elimination in the downlink

7.1.3.4.1.1 Test Purpose (TP)

(1)

```
with { UE in RRC_CONNECTED state with default RB used RLC-AM mode }
ensure that {
  when { UE is requested to make a lossless handover by SS }
  then { UE creates a PDCP status report to SS }
}
```

(2)

```
with { UE in RRC_CONNECTED state with default RB used RLC-AM mode }
ensure that {
  when { UE is requested to make a lossless handover by SS }
  then { UE discards the corresponding PDCP PDU and PDCP SDU according to the PDCP status report
from SS }
}
```

(3)

```
with { UE in RRC_CONNECTED state with default RB using RLC-AM }
ensure that {
  when { UE is requested to make a lossless handover by SS }
  then { UE retransmits the unacknowledged data }
}
```

(4)

```
with { UE in RRC_CONNECTED state with default RB using RLC-AM }
ensure that {
  when { UE is requested to make a lossless handover by SS }
  then { UE achieves in-order delivery and discards a PDCP PDU already received in the downlink }
}
```

7.1.3.4.1.2 Conformance requirements

References: The conformance requirements covered in the present test case are specified in: TS 38.323, clauses 5.1.2, 5.2.2.1, 5.3, 5.4.1, 5.4.2 and 7.1. Unless otherwise stated these are Rel-15 requirements.

[TS 38.323, clause 5.1.2]

When upper layers request a PDCP entity re-establishment, the UE shall additionally perform once the procedures described in this section. After performing the procedures in this section, the UE shall follow the procedures in subclause 5.2.

When upper layers request a PDCP entity re-establishment, the transmitting PDCP entity shall:

- for UM DRBs and AM DRBs, reset the header compression protocol for uplink and start with an IR state in U-mode (as defined in RFC 3095 [8] and RFC 4815 [9]) if *drb-ContinueROHC* is not configured in TS 38.331 [3];
- for UM DRBs and SRBs, set TX_NEXT to the initial value;
- for SRBs, discard all stored PDCP SDUs and PDCP PDUs;
- apply the ciphering algorithm and key provided by upper layers during the PDCP entity re-establishment procedure;
- apply the integrity protection algorithm and key provided by upper layers during the PDCP entity re-establishment procedure;

- for UM DRBs, for each PDCP SDU already associated with a PDCP SN but for which a corresponding PDU has not previously been submitted to lower layers:
 - consider the PDCP SDUs as received from upper layer;
 - perform transmission of the PDCP SDUs in ascending order of the COUNT value associated to the PDCP SDU prior to the PDCP re-establishment without restarting the *discardTimer*, as specified in subclause 5.2.1;
- for AM DRBs, from the first PDCP SDU for which the successful delivery of the corresponding PDCP Data PDU has not been confirmed by lower layers, perform retransmission or transmission of all the PDCP SDUs already associated with PDCP SNs in ascending order of the COUNT values associated to the PDCP SDU prior to the PDCP entity re-establishment as specified below:
 - perform header compression of the PDCP SDU as specified in the subclause 5.7.4;
 - perform integrity protection and ciphering of the PDCP SDU using the COUNT value associated with this PDCP SDU as specified in the subclause 5.9 and 5.8;
 - submit the resulting PDCP Data PDU to lower layer, as specified in subclause 5.2.1.

When upper layers request a PDCP entity re-establishment, the receiving PDCP entity shall:

- process the PDCP Data PDUs that are received from lower layers due to the re-establishment of the lower layers, as specified in the subclause 5.2.2.1;
- for SRBs, discard all stored PDCP SDUs and PDCP PDUs;
- for SRBs and UM DRBs, if *t-Reordering* is running:
 - stop and reset *t-Reordering*;
 - for UM DRBs, deliver all stored PDCP SDUs to the upper layers in ascending order of associated COUNT values after performing header decompression;
- for AM DRBs, perform header decompression for all stored PDCP SDUs if *drb-ContinueROHC* is not configured in TS 38.331 [3];
- for UM DRBs and AM DRBs, reset the header compression protocol for downlink and start with NC state in U-mode (as defined in RFC 3095 [8] and RFC 4815 [9]) if *drb-ContinueROHC* is not configured in TS 38.331 [3];
- for UM DRBs and SRBs, set RX_NEXT and RX_DELIV to the initial value;
- apply the ciphering algorithm and key provided by upper layers during the PDCP entity re-establishment procedure;
- apply the integrity protection algorithm and key provided by upper layers during the PDCP entity re-establishment procedure.

[TS 38.323, clause 5.2.2.1]

In this section, following definitions are used:

- HFN(State Variable): the HFN part (i.e. the number of most significant bits equal to HFN length) of the State Variable;
- SN(State Variable): the SN part (i.e. the number of least significant bits equal to PDCP SN length) of the State Variable;
- RCVD_SN: the PDCP SN of the received PDCP Data PDU, included in the PDU header;
- RCVD_HFN: the HFN of the received PDCP Data PDU, calculated by the receiving PDCP entity;
- RCVD_COUNT: the COUNT of the received PDCP Data PDU = [RCVD_HFN, RCVD_SN].

At reception of a PDCP Data PDU from lower layers, the receiving PDCP entity shall determine the COUNT value of the received PDCP Data PDU, i.e. RCVD_COUNT, as follows:

- if $RCVD_SN < SN(RX_DELIV) - Window_Size$:
 - $RCVD_HFN = HFN(RX_DELIV) + 1$.
- else if $RCVD_SN \geq SN(RX_DELIV) + Window_Size$:
 - $RCVD_HFN = HFN(RX_DELIV) - 1$.
- else:
 - $RCVD_HFN = HFN(RX_DELIV)$;
 - $RCVD_COUNT = [RCVD_HFN, RCVD_SN]$.

After determining the COUNT value of the received PDCP Data PDU = RCVD_COUNT, the receiving PDCP entity shall:

- perform deciphering and integrity verification of the PDCP Data PDU using $COUNT = RCVD_COUNT$;
 - if integrity verification fails:
 - indicate the integrity verification failure to upper layer;
 - discard the PDCP Data PDU;
- if $RCVD_COUNT < RX_DELIV$; or
- if the PDCP Data PDU with $COUNT = RCVD_COUNT$ has been received before:
 - discard the PDCP Data PDU;

If the received PDCP Data PDU with COUNT value = RCVD_COUNT is not discarded above, the receiving PDCP entity shall:

- store the resulting PDCP SDU in the reception buffer;
- if $RCVD_COUNT \geq RX_NEXT$:
 - update RX_NEXT to $RCVD_COUNT + 1$.
- if *outOfOrderDelivery* is configured:
 - deliver the resulting PDCP SDU to upper layers.
- if $RCVD_COUNT = RX_DELIV$:
 - deliver to upper layers in ascending order of the associated COUNT value after performing header decompression, if not decompressed before;
 - all stored PDCP SDU(s) with consecutively associated COUNT value(s) starting from $COUNT = RX_DELIV$;
 - update RX_DELIV to the COUNT value of the first PDCP SDU which has not been delivered to upper layers, with COUNT value $> RX_DELIV$;
- if *t-Reordering* is running, and if $RX_DELIV \geq RX_REORD$:
 - stop and reset *t-Reordering*.
- if *t-Reordering* is not running (includes the case when *t-Reordering* is stopped due to actions above), and $RX_DELIV < RX_NEXT$:
 - update RX_REORD to RX_NEXT ;
- start *t-Reordering*.

[TS 38.323, clause 5.3]

When the *discardTimer* expires for a PDCP SDU, or the successful delivery of a PDCP SDU is confirmed by PDCP status report, the transmitting PDCP entity shall discard the PDCP SDU along with the corresponding PDCP Data PDU. If the corresponding PDCP Data PDU has already been submitted to lower layers, the discard is indicated to lower layers.

For SRBs, when upper layers request a PDCP SDU discard, the PDCP entity shall discard all stored PDCP SDUs and PDCP PDUs.

NOTE: Discarding a PDCP SDU already associated with a PDCP SN causes a SN gap in the transmitted PDCP Data PDUs, which increases PDCP reordering delay in the receiving PDCP entity. It is up to UE implementation how to minimize SN gap after SDU discard.

[TS 38.323, clause 5.4.1]

For AM DRBs configured by upper layers to send a PDCP status report in the uplink (*statusReportRequired* in TS 38.331 [3]), the receiving PDCP entity shall trigger a PDCP status report when:

- upper layer requests a PDCP entity re-establishment;
- upper layer requests a PDCP data recovery.

If a PDCP status report is triggered, the receiving PDCP entity shall:

- compile a PDCP status report as indicated below by:
 - setting the FMC field to RX_DELIV;
 - if RX_DELIV < RX_NEXT:
 - allocating a Bitmap field of length in bits equal to the number of COUNTs from and not including the first missing PDCP SDU up to and including the last out-of-sequence PDCP SDUs, rounded up to the next multiple of 8, or up to and including a PDCP SDU for which the resulting PDCP Control PDU size is equal to 9000 bytes, whichever comes first;
 - setting in the bitmap field as '0' for all PDCP SDUs that have not been received, and optionally PDCP SDUs for which decompression have failed;
 - setting in the bitmap field as '1' for all PDCP SDUs that have been received;
- submit the PDCP status report to lower layers as the first PDCP PDU for transmission via the transmitting PDCP entity as specified in subclause 5.2.1..

[TS 38.323, clause 5.4.2]

For AM DRBs, when a PDCP status report is received in the downlink, the transmitting PDCP entity shall:

- consider for each PDCP SDU, if any, with the bit in the bitmap set to '1', or with the associated COUNT value less than the value of FMC field as successfully delivered, and discard the PDCP SDU as specified in the subclause 5.3.

[TS 38.323, clause 7.1]

This sub clause describes the state variables used in PDCP entities in order to specify the PDCP protocol. The state variables defined in this subclause are normative.

All state variables are non-negative integers, and take values from 0 to $[2^{32} - 1]$.

PDCP Data PDUs are numbered integer sequence numbers (SN) cycling through the field: 0 to $[2^{[pdcp-SN-Size]} - 1]$.

The transmitting PDCP entity shall maintain the following state variables:

a) TX_NEXT

This state variable indicates the COUNT value of the next PDCP SDU to be transmitted. The initial value is 0.

The receiving PDCP entity shall maintain the following state variables:

a) RX_NEXT

This state variable indicates the COUNT value of the next PDCP SDU expected to be received. The initial value is 0.

b) RX_DELIV

This state variable indicates the COUNT value of the first PDCP SDU not delivered to the upper layers, but still waited for. The initial value is 0.

c) RX_REORD

This state variable indicates the COUNT value following the COUNT value associated with the PDCP Data PDU which triggered *t-Reordering*.

7.1.3.4.1.3 Test description

7.1.3.4.1.3.1 Pre-test conditions

Same Pre-test conditions as in clause 7.1.3.0 except the following:

- 2 NR cells (NR Cell 1 and NR Cell 2) are configured with SN terminated SCG bearers in RLC AM mode.
- The cell power levels are configured as per the Table 7.1.3.4.1.3.1-1.

Table 7.1.3.4.1.3.1-1: Time instances of cell power level in FR1

	Parameter	Unit	EUTRA Cell 1	NR Cell 1	NR Cell 2	Remark
T0	Cell-specific RS EPRE	dBm/SCS	-85	-	-	
	SS/PBCH SSS EPRE	dBm/SCS	-	-88	Off	
T1	Cell-specific RS EPRE	dBm/SCS	-85	-	-	
	SS/PBCH SSS EPRE	dBm/SCS	-	-88	-82	
T2	Cell-specific RS EPRE	dBm/SCS	-85	-	-	
	SS/PBCH SSS EPRE	dBm/SCS	-	-82	-88	

Table 7.1.3.4.1.3.1-2: Time instances of cell power level in FR2

	Parameter	Unit	EUTRA Cell 1	NR Cell 1	NR Cell 2	Remark
T0	Cell-specific RS EPRE	dBm/SCS	-85	-	-	
	SS/PBCH SSS EPRE	dBm/SCS	-	[-95]	Off	
T1	Cell-specific RS EPRE	dBm/SCS	-85	-	-	
	SS/PBCH SSS EPRE	dBm/SCS	-	[-95]	[-89]	
T2	Cell-specific RS EPRE	dBm/SCS	-85	-	-	
	SS/PBCH SSS EPRE	dBm/SCS	-	[-89]	[-95]	

7.1.3.4.1.3.2 Test procedure sequence

Table 7.1.3.4.1.3.2-1: Main behaviour

St	Procedure	Message Sequence		TP	Verdict
		U - S	Message		
1	The SS creates 5 PDCP Data PDUs and the TX_NEXT is set to "0".	-	-	-	-
-	EXCEPTION: Step 2 and 3 shall be repeated for k=0 to 1(increment=1).	-	-	-	-
2	The SS sends the PDCP Data PDU#k via RLC-AM RB with the following content to the UE: D/C field = 1 (PDCP Data PDU) and PDCP SN = k on NR Cell 1. After having sent a PDU, the SS set TX_NEXT = k+1.	<--	PDCP PDU DATA #k	-	-
3	The UE sends the PDCP Data PDU#k via RLC-AM RB with the following content to the UE: D/C field = 1 (PDCP Data PDU) and PDCP SN = k on NR Cell 1. Data is previously received data from PDU #k. (Note 1)	-->	PDCP PDU DATA #k	-	-
-	EXCEPTION: Step 4 to 6 shall be repeated for m=2 to 4 (increment=1).	-	-	-	-
4	The SS is configured on NR Cell 1 not to send RLC acknowledgement (RLC ACK) to the next received RLC SDU to the UE.	-	-	-	-
5	The SS sends the PDCP Data PDU #m via RLC-AM RB with the following content to the UE: D/C field = 1 (PDCP Data PDU) and PDCP SN =m. After having sent a PDU, the SS set TX_NEXT = m+1.	<--	PDCP PDU DATA #m	-	-
6	The UE sends the PDCP Data PDU#m via RLC-AM RB with the following content to the UE: D/C field = 1 (PDCP Data PDU) and PDCP SN = m. Data is previously received data from PDU #m. (Note 2)	-->	PDCP PDU DATA #m	-	-
6A	Configure SS not to allocate UL grant to the UE in NR Cell 1				
7	The SS changes NR Cell 2 parameters according to the row "T1" in table 7.1.3.4.1.3.2.0-1.	-	-	-	-
8	The SS transmits NR RRCReconfiguration message to perform PSCell change from NR Cell1 to NR Cell2 (Note 3)	<--	<i>RRCReconfiguration</i>	-	-
9	The UE transmits a NR <i>RRCReconfigurationComplete</i> message. (Note 4)	-->	<i>RRCReconfigurationComplete</i>	-	-
10	The SS assigns UL grant during the Random Access procedure on NR Cell 2 to allow the UE to send only PDCP status report.	-	-	-	-
11	Check: Does the UE send PDCP Control PDUs via RLC-AM RB with the following content to the SS: D/C field = 0 (PDCP control PDU) and PDU Type =000, FMC field = 5 on NR Cell 2?	-->	PDCP STATUS REPORT	1	P
12	The SS generates a PDCP status report message and sends it to UE: D/C field = 0 (PDCP control PDU) and PDU Type =000, FMC field = 3 on NR Cell 2.	<--	PDCP STATUS REPORT	-	-
13	Configure the SS to allocate Default UL grants to the UE in NR Cell 2.	-	-	-	-
14	Void	-	-	-	-
-	EXCEPTION: Step 15 shall be repeated for m=3 to 4 (increment=1).	-	-	-	-

15	Check: Does the UE send the PDCP Data PDU #m via RLC-AM RB with the following content to the SS: D/C field = 1 (PDCP Data PDU) and PDCP SN = m on NR Cell 2? Note: Data is previously received data from PDU #m.	-->	PDCP PDU DATA #m	3	P
16	The SS sends the PDCP Data PDU#5 via RLC-AM RB with the following content to the UE: PDCP Data PDU #5 (D/C field = 1 (PDCP Data PDU) and PDCP SN=5) on NR Cell 2.	<--	PDCP DATA PDU#5	-	-
17	The UE transmits a PDCP Data PDU via RLC-AM RB with the following content back to the SS: D/C field = 1 (PDCP Data PDU) and PDCP SN=5 on NR Cell 2. Note: Data is previously received packet in PDCP Data PDU#5. (Note 1)	-->	PDCP DATA PDU #5	-	-
18	TX_NEXT is set to "6". The SS creates a PDCP Data PDU#6 (not transmitted).	-	-	-	-
19	The TX_NEXT is set to "7". The SS creates a PDCP Data PDU #7.	-	-	-	-
20	The SS sends PDCP Data PDU#7 via RLC-AM RB with the following content to the UE: PDCP Data PDU#7; D/C field = 1 (PDCP Data PDU) and PDCP SN=7 on NR Cell 2.	<--	PDCP DATA PDU #7	-	-
21	Check: Does the UE transmit a PDCP DATA PDU#7 on NR Cell 2?	-->	PDCP DATA PDU#7	4	F
21A	Configure SS not to allocate UL grant to the UE in NR Cell 1	-	-	-	-
22	The SS changes NR Cell 1 and NR Cell 2 parameters according to row "T2" in Table 7.1.3.4.1.3.1-1.	-	-	-	-
23	The SS requests transmits NR RRCReconfiguration message to perform PSCell change from NR Cell2 to NR Cell1 with key change.. (Note 3)	<--	<i>RRCReconfiguration</i>	-	-
24	The UE transmits a NR <i>RRCReconfigurationComplete</i> message. (Note 4)	-->	<i>RRCReconfigurationComplete</i>	-	-
25	SS assigns UL grant during the Random Access procedure on NR Cell 1 to allow the UE to send only PDCP status report.	-	-	-	-
26	The UE sends PDCP Control PDUs via RLC-AM RB with the following content to the SS: D/C field = 0 (PDCP control PDU) and PDU Type =000, FMC field = 6, Bitmap = 0x80 on NR Cell 1.	-->	PDCP STATUS REPORT	-	-
27	The SS generates a PDCP status report message and sends it to UE: D/C field = 0 (PDCP control PDU) and PDU Type =000, FMC field = 6 on NR Cell 1.	<--	PDCP STATUS REPORT	-	-
28	Configure the SS to allocate Default UL grants to the UE in NR Cell 1	-	-	-	-
28A	The SS sends the PDCP Data PDU#5 via RLC-AM RB with the following content to the UE: PDCP Data PDU #5 (D/C field = 1 (PDCP Data PDU) and PDCP SN=5) on NR Cell 1.	<--	PDCP DATA PDU#5	-	-

28B	Check: Does the UE transmit a PDCP Data PDU via RLC-AM RB with the following content back to the SS: D/C field = 1 (PDCP Data PDU) and PDCP SN=5 on NR Cell 1 within the next 5 seconds?	-->	PDCP DATA PDU #5	4	F
29	The SS sends the PDCP Data PDU#6 via RLC-AM RB with the following content to the UE: PDCP Data PDU#6 (D/C field = 1 (PDCP Data PDU) and PDCP SN=6) on NR Cell 1.	<--	PDCP DATA PDU #6	-	-
30	Check: Does the UE transmit a PDCP Data PDU via RLC-AM RB with the following content back to the SS? D/C field = 1 (PDCP Data PDU) and PDCP SN=6 on NR Cell 1. Note: Data is previously received packet in PDCP Data PDU#6	-->	PDCP DATA PDU #6	4	P
31	Check: Does the UE transmit PDCP Data PDU via RLC-AM RB with the following content back to the SS? D/C field = 1 (PDCP Data PDU) and PDCP SN=7 on NR Cell 1. Note: Data is previously received packet in PDCP Data PDU#7	-->	PDCP DATA PDU #7	4	P
<p>Note 1: The SS acknowledges the received data. Note 2: SS doesn't send the RLC ACK for this data. Note 3: For EN-DC the NR RRCReconfiguration (Table 7.1.3.4.1.3.3-1 with cond EN-DC) and RadioBearerConfig message (Table 7.1.3.4.1.3.3-2) are contained in RRCConnectionReconfiguration 36.508 [7], Table 4.6.1-8 using conditions EN-DC_EmbedNR_RRCRecon, EN-DC_PSCell_HO and RBConfig_KeyChange. IE sk-Counter-r15 is included with a value incremented by 1 than previous value. Note 4: For EN-DC the NR RRCReconfigurationComplete message is contained in RRCConnectionReconfigurationComplete.</p>					

7.1.3.4.1.3.3 Specific message contents

Table 7.1.3.4.1.3.3-0: SchedulingRequest-Config (Preamble)

Derivation Path: 38.508-1 [4], Table: 4.6.3-155			
Information Element	Value/remark	Comment	Condition
sr-TransMax	n64		

Table 7.1.3.4.1.3.3-1: RRCReconfiguration (steps 8, 23,)

Derivation Path: 38.508-1 [4], Table: 4.6.1-13			
Information Element	Value/remark	Comment	Condition
RRCReconfiguration ::= SEQUENCE {			
criticalExtensions CHOICE {			
rrcReconfiguration ::= SEQUENCE {			
radioBearerConfig	RadioBearerConfig		NR
secondaryCellGroup	CellGroupConfig		EN-DC
}			
nonCriticalExtension ::= SEQUENCE {			NR
masterCellGroup	CellGroupConfig		
masterKeyUpdate ::= SEQUENCE {			
keySetChangeIndicator	True		
}			
}			
}			
}			

Table 7.1.3.4.1.3.3-4: CellGroupConfig (Table 7.1.3.4.1.3.3-1)

Derivation Path: 38.508-1 [4], Table: 4.6.3-19 with condition HO			
Information Element	Value/remark	Comment	Condition
CellGroupConfig ::= SEQUENCE {			
rlc-BearerToAddModList SEQUENCE (SIZE(1..maxLCH)) OF SEQUENCE {	1 entry		
RLC-BearerConfig[1]	RLC-BearerConfig with condition DRB2		EN-DC
}	RLC-BearerConfig with condition DRBn and Re-establish_RLC	n set to the default DRB of the first PDU session	NR
spCellConfig SEQUENCE {			
servCellIndex	ServCellIndex		EN-DC
	Not present		NR
reconfigurationWithSync SEQUENCE {			
spCellConfigCommon	ServingCellConfigCommon		
}			
}			
}			

Table 7.1.3.4.1.3.3-5: Void**Table 7.1.3.4.1.3.3-6: ServingCellConfigCommon (Table 7.1.3.4.1.3.3-4)**

Derivation Path: 38.508-1 [4], Table: 4.6.3-168			
Information Element	Value/remark	Comment	Condition
ServingCellConfigCommon ::= SEQUENCE {			
physCellId	PhysCellId	NR cell 2 at step 8 NR cell 1 at step 23	
downlinkConfigCommon ::= SEQUENCE {			
frequencyInfoDL	FrequencyInfoDL	NR cell 2 at step 8 NR cell 1 at step 23	
}			
}			

7.1.3.4.2 PDCP handover / Non-lossless handover / PDCP sequence number maintenance

Editor's Note: The test case is specified to test the Connectivity options EN-DC and NGEN-DC only. Other Connectivity options are FFS

7.1.3.4.2.1 Test Purpose (TP)

(1)

```
with { UE in RRC_CONNECTED state with default RB using RLC-UM }
ensure that {
  when { UE is requested to make a non-lossless handover by SS }
  then { UE transmits next PDCP Data PDU with SN value 0 }
}
```

(2)

```
with { UE in RRC_CONNECTED state with default RB using RLC-UM }
ensure that {
  when { UE is requested to make a non-lossless handover by SS }
  then { UE is able to receive next PDCP Data PDU with SN value 0 }
}
```

7.1.3.4.2.2 Conformance requirements

References: The conformance requirements covered in the present TC are specified in: TS 38.323, clause 5.1.2. Unless otherwise stated these are Rel-15 requirements.

[TS 38.323, clause 5.1.2]

When upper layers request a PDCP entity re-establishment, the UE shall additionally perform once the procedures described in this section. After performing the procedures in this section, the UE shall follow the procedures in subclause 5.2.

When upper layers request a PDCP entity re-establishment, the transmitting PDCP entity shall:

- for UM DRBs and AM DRBs, reset the header compression protocol for uplink and start with an IR state in U-mode (as defined in RFC 3095 [8] and RFC 4815 [9]) if *drb-ContinueROHC* is not configured in TS 38.331 [3];
- for UM DRBs and SRBs, set TX_NEXT to the initial value;
- for SRBs, discard all stored PDCP SDUs and PDCP PDUs;
- apply the ciphering algorithm and key provided by upper layers during the PDCP entity re-establishment procedure;
- apply the integrity protection algorithm and key provided by upper layers during the PDCP entity re-establishment procedure;
- for UM DRBs, for each PDCP SDU already associated with a PDCP SN but for which a corresponding PDU has not previously been submitted to lower layers:
 - consider the PDCP SDUs as received from upper layer;
 - perform transmission of the PDCP SDUs in ascending order of the COUNT value associated to the PDCP SDU prior to the PDCP re-establishment without restarting the *discardTimer*.
- for AM DRBs, from the first PDCP SDU for which the successful delivery of the corresponding PDCP Data PDU has not been confirmed by lower layers, perform retransmission or transmission of all the PDCP SDUs already associated with PDCP SNs in ascending order of the COUNT values associated to the PDCP SDU prior to the PDCP entity re-establishment as specified below:
 - perform header compression of the PDCP SDU as specified in the subclause 5.7.4;
 - perform integrity protection and ciphering of the PDCP SDU using the COUNT value associated with this PDCP SDU as specified in the subclause 5.9 and 5.8;
- submit the resulting PDCP Data PDU to lower layer.

When upper layers request a PDCP entity re-establishment, the receiving PDCP entity shall:

- process the PDCP Data PDUs that are received from lower layers due to the re-establishment of the lower layers, as specified in the subclause 5.2.2.1;
- for SRBs, discard all stored PDCP SDUs and PDCP PDUs;
- for UM DRBs, if *t-Reordering* is running:
 - stop and reset *t-Reordering*;
 - deliver all stored PDCP SDUs to the upper layers in ascending order of associated COUNT values after performing header decompression.
- for AM DRBs, perform header decompression for all stored PDCP SDUs if *drb-ContinueROHC* is not configured in TS 38.331 [3];
- for UM DRBs and AM DRBs, reset the header compression protocol for downlink and start with NC state in U-mode (as defined in RFC 3095 [8] and RFC 4815 [9]) if *drb-ContinueROHC* is not configured in TS 38.331 [3];

- for UM DRBs and SRBs, set RX_NEXT and RX_DELIV to the initial value;
- apply the ciphering algorithm and key provided by upper layers during the PDCP entity re-establishment procedure;
- apply the integrity protection algorithm and key provided by upper layers during the PDCP entity re-establishment procedure.

7.1.3.4.2.3 Test description

7.1.3.4.2.3.1 Pre-test conditions

Same Pre-test conditions as in clause 7.1.3.0 except that SCG DRB is configured in RLC UM mode. For EN-DC, ciphering algorithm is configured as null on E-UTRA.

7.1.3.4.2.3.2 Test procedure sequence

Table 7.1.3.4.2.3.2-1: Main behaviour

St	Procedure	Message Sequence		TP	Verdict
		U - S	Message		
1	The SS creates 3 PDCP Data PDUs and the TX_NEXT is set to "0".	-	-	-	-
-	EXCEPTION: Step 2 and 3 shall be repeated for k=0 to 1 (increment=1).	-	-	-	-
2	The SS sends the PDCP Data PDU #k via RLC-UM RB with the following content to the UE: D/C field = 1 (PDCP Data PDU) and PDCP SN = k. After having sent a PDU, the SS set TX_NEXT= k+1.	<--	PDCP PDU DATA #k	-	-
3	The UE sends the PDCP Data PDU #k via RLC-UM RB with the following content to the SS: D/C field = 1 (PDCP Data PDU) and PDCP SN = k.	-->	PDCP PDU DATA #k	-	-
4	The SS transmits NR <i>RRCReconfiguration</i> message to trigger handover to the same SpCell with SCG key (secondary to master) change. (Note 1)	<--	-	-	-
5	The UE transmits a NR <i>RRCReconfigurationComplete</i> message. (Note 2)	-->	-	-	-
6	The SS sends the PDCP Data PDU #2 via RLC-UM RB with the following content to the UE: D/C field = 1 (PDCP Data PDU) and PDCP SN = 0. After having sent a PDU, the SS set TX_NEXT= 1.	<--	PDCP PDU DATA #2	-	-
7	Check: Does the UE send the PDCP Data PDU #2 via RLC-UM RB with the following content back to the SS: D/C field = 1 (PDCP Data PDU) and PDCP SN = 0?	-->	PDCP PDU DATA #2	1, 2	P
Note 1: For EN-DC the NR <i>RRCReconfiguration</i> message is contained in <i>RRConnectionReconfiguration</i> 36.508 [7], Table 4.6.1-8 using condition EN-DC_PSCell_HO and <i>RBConfig_KeyChange</i> . Note 2: For EN-DC the NR <i>RRCReconfigurationComplete</i> message is contained in <i>RRConnectionReconfigurationComplete</i> .					

7.1.3.4.2.3 Specific message contents

Table 7.1.3.4.2.3-1: RRCReconfiguration for EN-DC (step 4, Table 7.1.3.4.2.3.2-1)

Derivation Path: TS 38.508-1 [4], Table 4.6.1-13 with condition EN-DC_HO.

Table 7.1.3.4.2.3-1A: RRCReconfiguration for NR/5GC (step 4, Table 7.1.3.4.2.3.2-1)

Derivation Path: TS 38.508-1 [4], Table FFS.
--

Table 7.1.3.4.2.3-2: RadioBearerConfig for EN-DC (step 4, Table 7.1.3.4.2.3.2-1)

Derivation Path: 38.508-1 [4], Table 4.6.3-132 with condition EN-DC_DRB AND Re-establish_PDCP			
Information Element	Value/remark	Comment	Condition
RadioBearerConfig ::= SEQUENCE {			
securityConfig SEQUENCE {			
securityAlgorithmConfig	SecurityAlgorithmConfig		
keyToUse	master		
}			
}			

Table 7.1.3.4.2.3-3: SecurityAlgorithmConfig (Table 7.1.3.4.2.3-2)

Derivation Path: 38.508-1 [4], Table 4.6.3-165			
Information Element	Value/remark	Comment	Condition
SecurityAlgorithmConfig ::= SEQUENCE {			
cipherringAlgorithm	nea0		
}			

7.1.3.5 PDCP other

7.1.3.5.1 PDCP Discard

7.1.3.5.1.1 Test Purpose (TP)

(1)

```

with { UE in RRC_CONNECTED state }
ensure that {
  when { the Discard Timer for a PDCP SDU expires }
  then { UE discards the corresponding PDCP SDU }
}

```

7.1.3.5.1.2 Conformance requirements

References: The conformance requirements covered in the present TC are specified in: TS 38.323, clause 5.3. Unless otherwise stated these are Rel-15 requirements.

[TS 38.323, clause 5.3]

When the *discardTimer* expires for a PDCP SDU, or the successful delivery of a PDCP SDU is confirmed by PDCP status report, the transmitting PDCP entity shall discard the PDCP SDU along with the corresponding PDCP Data PDU. If the corresponding PDCP Data PDU has already been submitted to lower layers, the discard is indicated to lower layers.

For SRBs, when upper layers request a PDCP SDU discard, the PDCP entity shall discard all stored PDCP SDUs and PDCP PDUs.

NOTE: Discarding a PDCP SDU already associated with a PDCP SN causes a SN gap in the transmitted PDCP Data PDUs, which increases PDCP reordering delay in the receiving PDCP entity. It is up to UE implementation how to minimize SN gap after SDU discard.

[TS 38.323, clause 7.1]

This sub clause describes the state variables used in PDCP entities in order to specify the PDCP protocol. The state variables defined in this subclause are normative.

All state variables are non-negative integers, and take values from 0 to $[2^{32} - 1]$.

PDCP Data PDUs are numbered integer sequence numbers (SN) cycling through the field: 0 to $[2^{[pdcp-SN-Size]} - 1]$.

The transmitting PDCP entity shall maintain the following state variables:

- a) TX_NEXT

This state variable indicates the COUNT value of the next PDCP SDU to be transmitted. The initial value is 0.

The receiving PDCP entity shall maintain the following state variables:

- a) RX_NEXT

This state variable indicates the COUNT value of the next PDCP SDU expected to be received. The initial value is 0.

- b) RX_DELIV

This state variable indicates the COUNT value of the first PDCP SDU not delivered to the upper layers, but still waited for. The initial value is 0.

- c) RX_REORD

This state variable indicates the COUNT value following the COUNT value associated with the PDCP Data PDU which triggered *t-Reordering*.

[TS 38.323, clause 6.3.5]

Length: 32 bits

The COUNT value is composed of a HFN and the PDCP SN. The size of the HFN part in bits is equal to 32 minus the length of the PDCP SN.



Figure 6.3.5-1: Format of COUNT

NOTE: COUNT does not wrap around.

7.1.3.5.1.3 Test description

7.1.3.5.1.3.1 Pre-test conditions

Same Pre-test conditions as in clause 7.1.3.0 with exceptions listed in Table 7.1.3.5.1.3.1-1 applicable for the configured UM DRB and Table 7.1.3.5.1.3.3-1 for SR configuration except that PDCP is configured for 18 bit SN.

Table 7.1.3.5.1.3.1-1: PDCP Settings

Parameter	Value
Discard_Timer	500 ms

7.1.3.5.1.3.2 Test procedure sequence

Table 7.1.3.5.1.3.2-1: Main behaviour

St	Procedure	Message Sequence		TP	Verdict
		U - S	Message		
-	EXCEPTION: The SS does not allocate UL grants unless when explicitly stated so in the procedure.	-	-	-	-
1	The SS creates 5 PDCP Data PDUs and the PDCP SN = "0" within TX_NEXT.		-	-	-
2	Void				
-	EXCEPTION: Step 3 shall be repeated for k=0 to 2 (increment=1) with the below specified PDU size sent to the UE: Data PDU#1 = 46 bytes for k=0 Data PDU#2 = 62 bytes for k=1 Data PDU#3 = 78 bytes for k=2	-	-	-	-
3	The SS sends a PDCP Data PDU via RLC-UM RB with the following content to the UE: D/C field = 1 (PDCP Data PDU) and PDCP SN = k After having sent a PDU, the SS sets PDCP SN is set to k+1 within TX_NEXT.	<--	PDCP DATA PDU (SN=k)	-	-
4	Wait for Discard_Timer to expire. Note: According to TS38.508-1, timer tolerance should be 10% of Discard_Timer.	-	-	-	-
-	EXCEPTION: Step 5 shall be repeated for k=3 to 4 (increment=1) with the below specified PDU size sent to the UE: Data PDU#4 = 94 bytes for k=3 Data PDU#5 = 110 bytes for k=4	-	-	-	-
5	The SS sends a PDCP Data PDU via RLC-UM RB with the following content to the UE: D/C field = 1 (PDCP Data PDU) and PDCP SN = k After having sent a PDU, the SS sets PDCP SN is set to k+1 within TX_NEXT.	<--	PDCP DATA PDU (SN=k)	-	-
6	The SS resumes normal UL grant allocation.	-	-	-	-
7	Check: Does UE transmit a PDCP Data PDU # 4 of size 94 bytes? (Note1)	-->	PDCP Data PDU # 4	1	P
8	Check: Does UE transmit a PDCP Data PDU # 5 of size 110 bytes? (Note1)	-->	PDCP Data PDU # 5	1	P
Note 1	PDCP Data PDU contents are checked to verify that the UL PDU is same as the DL PDU. According to the Note in TS 38.323 [19] clause 5.3 in case of PDCP SDUs being discarded it is up to the UE implementation which SN to be used and therefore the SN cannot be checked.				

7.1.3.5.1.3.3 Specific message contents

Table 7.1.3.5.1.3.3-1: SchedulingRequest-Config (Preamble)

Derivation Path: 38.508-1 [4], Table 4.6.3-155			
Information Element	Value/remark	Comment	Condition
sr-TransMax	n64		

7.1.3.5.2 PDCP Uplink Routing / Split DRB

7.1.3.5.2.1 Test Purpose

(1)

```
with { UE in RRC_CONNECTED state with SCG activated with a Split DRB established and total amount of PDCP data volume is less than ul-DataSplitThreshold and not yet transmitted RLC data volume in the two associated RLC entities }
ensure that {
  when { UE has PDCP SDUs available for transmission }
  then { the UE transmits the PDCP SDUs on the Primary RLC entity }
```

}

(2)

```
with { UE in RRC_CONNECTED state with SCG activated with a Split DRB established pdcpDuplication and
total amount of PDCP data volume is not less than ul-DataSplitThreshold and not yet transmitted RLC
data volume in the two associated RLC entities }
ensure that {
  when { UE has PDCP SDUs available for transmission }
  then { the UE transmits the PDCP SDUs on the primary or secondary RLC entity }
}
```

7.1.3.5.2.2 Conformance requirements

References: The conformance requirements covered in the present TC are specified in: TS 38.323, clause 5.2.1. Unless otherwise stated these are Rel-15 requirements.

[TS 38.323, clause 5.2.1]

At reception of a PDCP SDU from upper layers, the transmitting PDCP entity shall:

- start the *discardTimer* associated with this PDCP SDU (if configured).

For a PDCP SDU received from upper layers, the transmitting PDCP entity shall:

- associate the COUNT value corresponding to TX_NEXT to this PDCP SDU;

NOTE 1: Associating more than half of the PDCP SN space of contiguous PDCP SDUs with PDCP SNs, when e.g., the PDCP SDUs are discarded or transmitted without acknowledgement, may cause HFN desynchronization problem. How to prevent HFN desynchronization problem is left up to UE implementation.

- perform header compression of the PDCP SDU as specified in the subclause 5.7.4;
- perform integrity protection, and ciphering using the TX_NEXT as specified in the subclause 5.9 and 5.8, respectively;
- set the PDCP SN of the PDCP Data PDU to TX_NEXT modulo $2^{[pdcp-SN-Size]}$;
- increment TX_NEXT by one;
- submit the resulting PDCP Data PDU to lower layer as specified below.

When submitting a PDCP Data PDU to lower layer, the transmitting PDCP entity shall:

- if the transmitting PDCP entity is associated with one RLC entity:
 - submit the PDCP Data PDU to the associated RLC entity.
- else, if the transmitting PDCP entity is associated with two RLC entities:
 - if the PDCP duplication is activated:
 - if the PDCP PDU is a PDCP Data PDU:
 - duplicate the PDCP Data PDU and submit the PDCP Data PDU to both associated RLC entities.
 - else:
 - if the two associated RLC entities belong to the different Cell Groups; and
 - if the total amount of PDCP data volume and RLC data volume pending for initial transmission (as specified in TS 36.322 [5]) in the two associated RLC entities is equal to or larger than *ul-DataSplitThreshold*:
 - submit the PDCP Data PDU to either the primary RLC entity or the secondary RLC entity;.
- else:

- submit the PDCP Data PDU to the primary RLC entity.

NOTE 2: If the transmitting PDCP entity is associated with two RLC entities, the UE should minimize the amount of PDCP PDUs submitted to lower layers before receiving request from lower layers and minimize the PDCP SN gap between PDCP PDUs submitted to two associated RLC entities to minimize PDCP reordering delay in the receiving PDCP entity.

7.1.3.5.2.3 Test description

7.1.3.5.2.3.1 Pre-test conditions

Same Pre-test conditions as in clause 7.1.3.0 with exceptions listed in Table 7.1.3.5.2.3.1-1 and Generic procedure parameter DC bearer(MCG and *split*).

Table 7.1.3.5.2.3.1-1: PDCP Settings

Parameter	Value
Discard_Timer	500 ms
ul-DataSplitThreshold	b100

7.1.3.5.2.3.2 Test procedure sequence

Table 7.1.3.5.2.3.2-1: Main behaviour

St	Procedure	Message Sequence		TP	Verdict
		U - S	Message		
1	The SS sends a PDCP Data PDU on the split DRB on NR Cell 1 (PSCell). Data PDU = 64 bytes.	<--	PDCP DATA PDU	-	-
-	EXCEPTION: In parallel with step 2, UE may execute parallel behaviour defined in table 7.1.3.5.2.3.2-2.	-	-	-	-
2	Check: Does UE transmit a PDCP Data PDU on the AM RLC entity configured for SCG on NR Cell 1 (PSCell)?	-->	PDCP DATA PDU	1	P
3	The SS sends a PDCP Data PDU on the split DRB on NR Cell 1 (PSCell). Data PDU = 164 bytes.	<--	PDCP DATA PDU	-	-
-	EXCEPTION: Steps 4a1 to 4b2 describe optional behaviour that depends on the UE uplink path	-	-	-	-
4a1	Check: Does UE transmit a PDCP Data PDU on the AM RLC entity configured for MCG on EUTRA Cell 1 (PCell)?	-->	PDCP DATA PDU	2	P
4a2	Check: Does UE transmit a PDCP Data PDU on the AM RLC entity configured for SCG on NR Cell 1 (PSCell)?	-->	PDCP DATA PDU	2	F
4b1	Check: Does UE transmit a PDCP Data PDU on the AM RLC entity configured for SCG on NR Cell 1 (PSCell)?	-->	PDCP DATA PDU	2	P
4b2	Check: Does UE transmit a PDCP Data PDU on the AM RLC entity configured for MCG on EUTRA Cell 1 (PCell)?	-->	PDCP DATA PDU	2	F

Table 7.1.3.5.2.3.2-2: Parallel behaviour

St	Procedure	Message Sequence		TP	Verdict
		U - S	Message		
1	Check: Does UE transmit a PDCP Data PDU on the AM RLC entity configured for MCG on EUTRA Cell 1 (PCell) in next two seconds? NOTE: Two seconds sufficient time to discard PDCP PDU.	-->	PDCP DATA PDU	1	F

7.1.3.5.2.3.3 Specific message contents

None

7.1.3.5.3 PDCP Data Recovery

7.1.3.5.3.1 Test Purpose (TP)

(1)

```

with { UE in RRC_CONNECTED state with a DRB established using RLC-AM }
ensure that {
  when { network requests reconfiguration and recovery of the DRB (without handover) }
  then { UE reconfigures the DRB and performs retransmission of all the PDCP PDUs previously
submitted to re-established AM RLC entity in ascending order of the associated COUNT values from the
first PDCP PDU for which the successful delivery has not been confirmed by lower layers }
}

```

7.1.3.5.3.1.2 Conformance requirements

References: The conformance requirements covered in the present TC are specified in: TS 38.323, clauses 5.2.1, 5.4.1 and 5.5; TS 38.331, clause 5.3.5.4.3. Unless otherwise stated these are Rel-15 requirements.

[TS 38.323, clause 5.2.1]

At reception of a PDCP SDU from upper layers, the transmitting PDCP entity shall:

- start the *discardTimer* associated with this PDCP SDU (if configured).

For a PDCP SDU received from upper layers, the transmitting PDCP entity shall:

- associate the COUNT value corresponding to TX_NEXT to this PDCP SDU;

NOTE 1: Associating more than half of the PDCP SN space of contiguous PDCP SDUs with PDCP SNs, when e.g., the PDCP SDUs are discarded or transmitted without acknowledgement, may cause HFN desynchronization problem. How to prevent HFN desynchronization problem is left up to UE implementation.

- perform header compression of the PDCP SDU as specified in the subclause 5.7.4;
- perform integrity protection, and ciphering using the TX_NEXT as specified in the subclause 5.9 and 5.8, respectively;
- set the PDCP SN of the PDCP Data PDU to TX_NEXT modulo $2^{[pdep-SN-Size]}$;
- increment TX_NEXT by one;
- submit the resulting PDCP Data PDU to lower layer as specified below.

When submitting a PDCP PDU to lower layer, the transmitting PDCP entity shall:

- if the transmitting PDCP entity is associated with one RLC entity:
 - submit the PDCP PDU to the associated RLC entity;
- else, if the transmitting PDCP entity is associated with two RLC entities:
 - if *pdep-Duplication* is configured and activated:
 - duplicate the PDCP Data PDU and submit the PDCP Data PDU to both associated RLC entities;
 - else, if *pdep-Duplication* is configured but not activated:
 - submit the PDCP Data PDU to the primary RLC entity;
- else:

- if the total amount of PDCP data volume and RLC data volume pending for initial transmission (as specified in TS 38.322 [5]) in the two associated RLC entities is less than *ul-DataSplitThreshold*:
 - submit the PDCP PDU to the primary RLC entity;
- else:
 - submit the PDCP PDU to either the primary RLC entity or the secondary RLC entity.

NOTE 2: If the transmitting PDCP entity is associated with two RLC entities, the UE should minimize the amount of PDCP PDUs submitted to lower layers before receiving request from lower layers and minimize the PDCP SN gap between PDCP PDUs submitted to two associated RLC entities to minimize PDCP reordering delay in the receiving PDCP entity.

[TS 38.323, clause 5.4.1]

For AM DRBs configured by upper layers to send a PDCP status report in the uplink (*statusReportRequired* in TS 38.331 [3]), the receiving PDCP entity shall trigger a PDCP status report when:

- upper layer requests a PDCP entity re-establishment;
- upper layer requests a PDCP data recovery.

If a PDCP status report is triggered, the receiving PDCP entity shall:

- compile a PDCP status report as indicated below by:
 - setting the FMC field to RX_DELIV;
 - if RX_DELIV < RX_NEXT:
 - allocating a Bitmap field of length in bits equal to the number of COUNTs from and not including the first missing PDCP SDU up to and including the last out-of-sequence PDCP SDUs, rounded up to the next multiple of 8, or up to and including a PDCP SDU for which the resulting PDCP Control PDU size is equal to 9000 bytes, whichever comes first;
 - setting in the bitmap field as '0' for all PDCP SDUs that have not been received, and optionally PDCP SDUs for which decompression have failed;
 - setting in the bitmap field as '1' for all PDCP SDUs that have been received;
- submit the PDCP status report to lower layers as the first PDCP PDU for transmission.

[TS 38.323, clause 5.4.2]

For AM DRBs, when a PDCP status report is received in the downlink, the transmitting PDCP entity shall:

- consider for each PDCP SDU, if any, with the bit in the bitmap set to '1', or with the associated COUNT value less than the value of FMC field as successfully delivered, and discard the PDCP SDU as specified in the subclause 5.3.

[TS 38.323, clause 5.5]

For AM DRBs, when upper layers request a PDCP data recovery for a radio bearer, the transmitting PDCP entity shall:

- perform retransmission of all the PDCP Data PDUs previously submitted to re-established or released AM RLC entity in ascending order of the associated COUNT values for which the successful delivery has not been confirmed by lower layers.

After performing the above procedures, the transmitting PDCP entity shall follow the procedures in subclause 5.2.1.

7.1.3.5.3.3 Test description

7.1.3.5.3.3.1 Pre-test conditions

Same Pre-test conditions as in clause 7.1.3.0 except that DRB is configured in RLC AM mode.

7.1.3.5.3.3.2 Test procedure sequence

Table 7.1.3.5.3.3.2-1: Main behaviour

St	Procedure	Message Sequence		TP	Verdict
		U - S	Message		
1	Void	-	-	-	-
2	The SS creates 3 PDCP Data PDUs and the Next_PDCP_TX_SN is set to "0".	-	-	-	-
-	EXCEPTION: Steps 2A and 4 shall be repeated for k=0 to 2 (increment=1).	-	-	-	-
2A	The SS is configured on NR Cell 1 to not send RLC acknowledgement (RLC ACK) to the UE	-	-	-	-
3	The SS sends the PDCP Data PDU #k on SCG DRB on NR Cell 1 (PSCell): D/C field = 1 (PDCP Data PDU) and PDCP SN = k. After having sent a PDU, the SS sets Next_PDCP_TX_SN= k+1.	<--	PDCP PDU DATA #k	-	-
4	The UE sends the PDCP Data PDU #k on the AM RLC entity configured for SCG on NR Cell 1 (PSCell): D/C field = 1 (PDCP Data PDU) and PDCP SN = k. Data is previously received data from PDU #k.	-->	PDCP PDU DATA #k	-	-
4A	The SS does not allocate any UL grant.	-	-	-	-
5	The SS transmits a NR <i>RRCReconfiguration</i> . (Note 1).	<--	<i>RRCReconfiguration</i>	-	-
6	The UE transmits a NR <i>RRCReconfigurationComplete</i> . (Note 2).	-->	<i>RRCReconfigurationComplete</i>	-	-
7	The SS assigns UL grant during the Random Access procedure on NR Cell 1 to allow the UE to send only PDCP status report.	-	-	-	-
8	The UE sends PDCP Control PDUs via RLC-AM RB with the following content to the SS: D/C field = 0 (PDCP control PDU) and PDU Type =000, FMC field = 3.	-->	PDCP STATUS REPORT	-	-
8A	The SS starts the UL default grant transmission.	-	-	-	-
-	EXCEPTION: Step 9 shall be repeated for k=0 to 2 (increment=1).	-	-	-	-
9	Check: Does the UE send the PDCP Data PDU #k via the AM RLC entity configured for SCG on NR Cell 1 (PSCell): D/C field = 1 (PDCP Data PDU) and PDCP SN = k. Data is previously received data from PDU #k ?	-->	PDCP DATA PDU #k	1	P
Note 1:	For EN-DC the NR <i>RRCReconfiguration</i> message is contained in <i>RRCConnectionReconfiguration</i> 36.508 [7], Table 4.6.1-8 using condition EN-DC_EmbedNR_RBConfig.				
Note 2:	For EN-DC the NR <i>RRCReconfigurationComplete</i> message is contained in <i>RRCConnectionReconfigurationComplete</i> .				

7.1.3.5.3.3.3 Specific message contents

Table 7.1.3.5.3.3-1: RRCConnectionReconfiguration (step 5, Table 7.1.3.5.3.3-1)

Derivation Path: 36.508 [7], Table 4.6.1-8 with condition MCG_and_SCG			
Information Element	Value/remark	Comment	Condition
RRCConnectionReconfiguration ::= SEQUENCE {			
criticalExtensions CHOICE {			
c1 CHOICE{			
rrcConnectionReconfiguration-r8 ::= SEQUENCE			
{			
nonCriticalExtension SEQUENCE {			
nonCriticalExtension SEQUENCE {			
nonCriticalExtension SEQUENCE {			
nonCriticalExtension SEQUENCE {			
nonCriticalExtension SEQUENCE {			
nonCriticalExtension SEQUENCE {			
nonCriticalExtension SEQUENCE {			
nr-Config-r15 CHOICE {			
setup SEQUENCE {			
nr-SecondaryCellGroupConfig-r15	RRCReconfiguration-PDCP		
}			
}			
}			
}			
}			
}			
}			
}			
}			
}			
}			

Table 7.1.3.5.3.3-2: RRCReconfiguration-PDCP (Step 5, Table 7.1.3.5.3.3-1)

Derivation Path: 38.508-1 [4], Table 4.6.1-13			
Information Element	Value/remark	Comment	Condition
RRCReconfiguration ::= SEQUENCE {			
criticalExtensions CHOICE {			
rrcReconfiguration SEQUENCE {			
radioBearerConfig	RadioBearerConfig-PDCP		
secondaryCellGroup	CellGroupConfig		EN-DC
measConfig	Not present		
}			
}			

Table 7.1.3.5.3.3-3: RadioBearerConfig-PDCP (Table 7.1.3.5.3.3-2)

Derivation Path: TS 38.508-1 [7], Table 4.6.3-132			
Information Element	Value/remark	Comment	Condition
RadioBearerConfig ::= SEQUENCE {			
srb3-ToRelease	Not present		
drb-ToAddModList	Not present		
drb-ToAddModList SEQUENCE (SIZE (1..maxDRB)) OF SEQUENCE {	1 entry		
cnAssociation CHOICE {			
eps-BearerIdentity	6		EN-DC
sdap-Config	Not present		
}			
drb-Identity	2		EN-DC
	DRB-Identity		
reestablishPDCP	Not present		
recoverPDCP	true		
pdcp-Config	PDCP-Config-Split		EN-DC
	FFS		SA-DC
}			
drb-ToReleaseList	Not present		
}			

Table 7.1.3.5.3.3-4: PDCP-Config-Split (Table 7.1.3.5.3.3-3)

Derivation Path: 38.508-1 [4], Table 4.6.3-99 condition EN-DC			
Information Element	Value/remark	Comment	Condition
PDCP-Config ::= SEQUENCE {			
moreThanOneRLC SEQUENCE {			
primaryPath SEQUENCE {			
cellGroup	1		
}			
ul-DataSplitThreshold	infinity		
}			
}			

7.1.3.5.4 PDCP reordering / Maximum re-ordering delay below t-Reordering / t-Reordering timer operations

7.1.3.5.4.1 Test Purpose (TP)

(1)

```
with { UE in RRC_CONNECTED state using RLC-AM }
ensure that {
  when { a PDCP PDU is received from the lower layers and the COUNT value of the received PDCP Data PDU is out of the re-ordering window }
  then { UE discards the PDCP PDU }
}
```

(2)

```
with { UE in RRC_CONNECTED state using RLC-AM }
ensure that {
  when { a PDCP PDU is received from the lower layers and the COUNT value of the received PDCP Data PDU is within the re-ordering window }
  then { UE stores the resulting PDCP SDU }
}
```

(3)

```
with { UE in RRC_CONNECTED state using RLC-AM, and the RX_DELIV is not equal to the COUNT value of the RX_NEXT (there is missing PDCP PDUs) }
```

```

ensure that {
  when { a PDCP PDU is received from the lower layers and the RCVD_COUNT = RX_DELIV }
  then { UE delivers the resulting PDCP SDU and all stored PDCP SDUs with consecutive COUNT value
to upper layer, in ascending order }
}

```

(4)

```

with { UE in RRC_CONNECTED state using RLC-AM and the associated PDCP t-Reordering timer is running }
ensure that {
  when { RX_DELIV >= RX_REORD }
  then { UE stops and resets t-Reordering timer }
}

```

(5)

```

with { UE in RRC_CONNECTED state using RLC-AM and the associated PDCP t-Reordering timer is running }
ensure that {
  when { the t-Reordering timer expires }
  then { UE delivers all stored PDCP SDUs to upper layer }
}

```

(6)

```

with { UE in RRC_CONNECTED state using RLC-AM and the associated PDCP t-Reordering timer is running }
ensure that {
  when { the t-Reordering is reconfigured by upper layers }
  then { UE stops and resets t-Reordering timer }
}

```

7.1.3.5.4.2 Conformance requirements

References: The conformance requirements covered in the present test case are specified in: TS 38.323, clause 5.2.2.1, 5.2.2.2 and 5.2.2.3. Unless otherwise stated these are Rel-15 requirements.

[TS 38.323, clause 5.2.2.1]

In this section, following definitions are used:

- HFN(State Variable): the HFN part (i.e. the number of most significant bits equal to HFN length) of the State Variable;
- SN(State Variable): the SN part (i.e. the number of least significant bits equal to PDCP SN length) of the State Variable;
- RCVD_SN: the PDCP SN of the received PDCP Data PDU, included in the PDU header;
- RCVD_HFN: the HFN of the received PDCP Data PDU, calculated by the receiving PDCP entity;
- RCVD_COUNT: the COUNT of the received PDCP Data PDU = [RCVD_HFN, RCVD_SN].

At reception of a PDCP Data PDU from lower layers, the receiving PDCP entity shall determine the COUNT value of the received PDCP Data PDU, i.e. RCVD_COUNT, as follows:

- if $RCVD_SN < SN(RX_DELIV) - Window_Size$:
 - $RCVD_HFN = HFN(RX_DELIV) + 1$.
- else if $RCVD_SN \geq SN(RX_DELIV) + Window_Size$:
 - $RCVD_HFN = HFN(RX_DELIV) - 1$.
- else:
 - $RCVD_HFN = HFN(RX_DELIV)$;

- RCVD_COUNT = [RCVD_HFN, RCVD_SN].

After determining the COUNT value of the received PDCP Data PDU = RCVD_COUNT, the receiving PDCP entity shall:

- perform deciphering and integrity verification of the PDCP Data PDU using COUNT = RCVD_COUNT;
 - if integrity verification fails:
 - indicate the integrity verification failure to upper layer;
 - discard the PDCP Data PDU;
- if RCVD_COUNT < RX_DELIV; or
- if the PDCP Data PDU with COUNT = RCVD_COUNT has been received before:
 - discard the PDCP Data PDU;

If the received PDCP Data PDU with COUNT value = RCVD_COUNT is not discarded above, the receiving PDCP entity shall:

- store the resulting PDCP SDU in the reception buffer;
- if RCVD_COUNT >= RX_NEXT:
 - update RX_NEXT to RCVD_COUNT + 1.
- if *outOfOrderDelivery* is configured:
 - deliver the resulting PDCP SDU to upper layers.
- if RCVD_COUNT = RX_DELIV:
 - deliver to upper layers in ascending order of the associated COUNT value after performing header decompression, if not decompressed before;
 - all stored PDCP SDU(s) with consecutively associated COUNT value(s) starting from COUNT = RX_DELIV;
 - update RX_DELIV to the COUNT value of the first PDCP SDU which has not been delivered to upper layers, with COUNT value > RX_DELIV;
- if *t-Reordering* is running, and if RX_DELIV >= RX_REORD:
 - stop and reset *t-Reordering*.
- if *t-Reordering* is not running (includes the case when *t-Reordering* is stopped due to actions above), and RX_DELIV < RX_NEXT:
 - update RX_REORD to RX_NEXT;
 - start *t-Reordering*.

[TS 38.323, clause 5.2.2.2]

When *t-Reordering* expires, the receiving PDCP entity shall:

- deliver to upper layers in ascending order of the associated COUNT value after performing header decompression, if not decompressed before:
 - all stored PDCP SDU(s) with associated COUNT value(s) < RX_REORD;
 - all stored PDCP SDU(s) with consecutively associated COUNT value(s) starting from RX_REORD;
- update RX_DELIV to the COUNT value of the first PDCP SDU which has not been delivered to upper layers, with COUNT value >= RX_REORD;

- if RX_DELIV < RX_NEXT:
 - update RX_REORD to RX_NEXT;
 - start *t-Reordering*.

[TS 38.323, clause 5.2.2.3]

When the value of the *t-Reordering* is reconfigured by upper layers while the *t-Reordering* is running, the receiving PDCP entity shall:

- update RX_REORD to RX_NEXT;
- stop and restart *t-Reordering*.

7.1.3.5.4.3 Test description

7.1.3.5.4.3.1 Pre-test conditions

Same Pre-test conditions as in clause 7.1.3.0 exception of PDCP parameters according to Table 7.1.3.5.4.3.1-1.

Table 7.1.3.5.4.3.1-1: PDCP parameters

t-Reordering	ms300
--------------	-------

7.1.3.5.4.3.2 Test procedure sequence

Table 7.1.3.5.4.3.2-1: Main behaviour

St	Procedure	Message Sequence		TP	Verdict
		U - S	Message		
1	The SS sends the PDCP SDU #131072 D/C field = 1 (PDCP Data PDU) and PDCP SN = 131072. (Note 1)	<--	(PDCP SDU #131072)	-	-
2	Check: Does the UE transmit a PDCP SDU via the AM RLC entity in the next 1s?	-->	(PDCP SDU)	1	F
3	The SS sends the PDCP SDU #1 D/C field = 1 (PDCP Data PDU) and PDCP SN = 1. The UE starts <i>t-Reordering</i> .	<--	(PDCP SDU #1)	-	-
4	The SS sends the PDCP SDU #2 D/C field = 1 (PDCP Data PDU) and PDCP SN =2.	<--	(PDCP SDU #2)	-	-
5	Wait for 100ms (< configured <i>t-Reordering</i>).	-	-	-	-
6	The SS sends the PDCP SDU #0 D/C field = 1 (PDCP Data PDU) and PDCP SN = 0.	<--	(PDCP SDU #0)	-	-
7	Check: Does the UE transmit the PDCP SDU #0 via the AM RLC entity D/C field = 1 (PDCP Data PDU) and PDCP SN = 0?	-->	(PDCP SDU #0)	2, 3	P
8	Check: Does the UE transmit the PDCP SDU #1 via the AM RLC entity D/C field = 1 (PDCP Data PDU) and PDCP SN = 1?	-->	(PDCP SDU #1)	2, 3	P
9	Check: Does the UE transmit the PDCP SDU #2 via the AM RLC entity D/C field = 1 (PDCP Data PDU) and PDCP SN = 2?	-->	(PDCP SDU #2)	2, 3	P
10	The SS sends the PDCP SDU #4 D/C field = 1 (PDCP Data PDU) and PDCP SN = 4. The UE starts <i>t-Reordering</i> .	<--	(PDCP SDU #4)	-	-
11	Wait for 100ms (< configured <i>t-Reordering</i>)	-	-	-	-
12	The SS sends the PDCP SDU #7 D/C field = 1 (PDCP Data PDU) and PDCP SN = 7.	<--	(PDCP SDU #7)	-	-
13	The SS sends the PDCP SDU #3 D/C field = 1 (PDCP Data PDU) and PDCP SN = 3. The UE restarts <i>t-Reordering</i> timer. Note T ₁	<--	(PDCP SDU #3)	-	-
14	Check: Does the UE transmit the PDCP SDU #3 via the AM RLC entity?	-->	(PDCP SDU #3)	3	P
15	Check: Does the UE transmit the PDCP SDU #4 via the AM RLC entity?	-->	(PDCP SDU #4)	3	P
16	Check 1: Does the UE transmit the PDCP SDU #7 with PDCP SN=5 via the AM RLC entity after <i>t-Reordering</i> expiry? Note T ₂ Check 2: Is $(T_2 - T_1) > t\text{-Reordering}$?	-->	(PDCP SDU #7)	4,5	P
17	The SS sends the PDCP SDU #9 D/C field = 1 (PDCP Data PDU) and PDCP SN = 9. The UE starts <i>t-Reordering</i> .	<--	(PDCP SDU #9)	-	-
18	Wait for 100ms (< configured <i>t-Reordering</i>)	-	-	-	-
19	The SS reconfigures the <i>t-Reordering</i> by sending a NR <i>RRCReconfiguration</i> message. The UE restarts <i>t-Reordering</i> timer. (Note 2) Note T ₃	<--	<i>RRCReconfiguration</i>	-	-
20	The UE transmits a NR <i>RRCReconfigurationComplete</i> message. (Note 3)	-->	<i>RRCReconfigurationComplete</i>	-	-
21	Check 1: Does the UE transmit the PDCP SDU #9 with PDCP SN=6 via the AM RLC entity after <i>t-Reordering</i> expiry? Note T ₄ Check 2: Is $(T_4 - T_3) > t\text{-Reordering}$?	-->	(PDCP SDU #9)	6	P
Note 1:	The Reordering Window size is 131072 when 18 bit SN length is used.				
Note 2:	For EN-DC the NR <i>RRCReconfiguration</i> message is contained in <i>RRCConnectionReconfiguration</i> 36.508 [7], Table 4.6.1-8 using condition EN-DC_Embed_RBConfig.				
Note 3:	For EN-DC the NR <i>RRCReconfigurationComplete</i> message is contained in <i>RRCConnectionReconfigurationComplete</i> .				

7.1.3.5.4.3.3 Specific message contents

Table 7.1.3.5.4.3.3-1: RRCReconfiguration (step 19, Table 7.1.3.5.4.3.2-1)

Derivation Path: 38.508-1 [4], Table: 4.6.1-13			
Information Element	Value/remark	Comment	Condition
RRCReconfiguration ::= SEQUENCE {			
criticalExtensions CHOICE {			
rrcReconfiguration ::= SEQUENCE {			
radioBearerConfig	RadioBearerConfig		Not EN-DC
secondaryCellGroup	CellGroupConfig		EN-DC
}			
RRCReconfiguration-v1530-IEs ::= SEQUENCE {			
masterCellGroup	CellGroupConfig		Not-EN-DC
}			
}			

Table 7.1.3.5.4.3.3-2: RadioBearerConfig (Table 7.1.3.5.4.3.3-1)

Derivation path: 38.508-1 [4], Table 4.6.3-132			
Information Element	Value/Remark	Comment	Condition
RadioBearerConfig ::= SEQUENCE {			
drb-ToAddModList ::= SEQUENCE (SIZE 1..2)) OF SEQUENCE			
{			
pdcp-Config ::= SEQUENCE {			
drb SEQUENCE {			
outOfOrderDelivery	False		
}			
t-Reordering	ms750		
}			
}			
}			

7.1.3.5.5 PDCP Duplication

7.1.3.5.5.1 Test Purpose (TP)

(1)

```
with { UE in RRC_CONNECTED state and pdcpDuplication is configured and activated}
ensure that {
  when { UE has PDCP SDUs available for transmission}
  then { the UE transmits the PDCP SDUs on both the associated RLC entities }
}
```

(2)

```
with { UE in RRC_CONNECTED state and pdcpDuplication is configured and not activated }
ensure that {
  when { UE receives MAC Control Element to Activate PDCP Duplication on a DRB configured with PDCP
duplication }
  then { the UE activates PDCP Duplication on the PDCP associated with the DRB }
}
```

(3)

```
with { UE in RRC_CONNECTED state and pdcpDuplication is configured }
ensure that {
  when { UE has PDCP SDUs available for transmission }
  then { the UE transmits the PDCP SDUs on the primary RLC entity}
}
```

(4)

```

with { UE in RRC_CONNECTED state and pdcpDuplication is configured and activated}
ensure that {
  when { the UE had transmitted the PDCP SDUs on both the associated RLC entities and successful
delivery of a PDCP Data PDU is confirmed by one of the two associated AM RLC entities}
  then { the other AM RLC entity discards the duplicated PDCP Data PDU}
}

```

7.1.3.5.5.2 Conformance requirements

References: The conformance requirements covered in the present TC are specified in: TS 38.321:5.10, 6.1.3.10 and TS 38.323:5.2.1, 5.11.1, 5.11.2;]. Unless otherwise stated these are Rel-15 requirements.

[TS 38.323, clause 5.2.1]

When submitting a PDCP PDU to lower layer, the transmitting PDCP entity shall:

- if the transmitting PDCP entity is associated with one RLC entity:
 - submit the PDCP PDU to the associated RLC entity;
- else, if the transmitting PDCP entity is associated with two RLC entities:
 - if the PDCP duplication is activated:
 - if the PDCP PDU is a PDCP Data PDU:
 - duplicate the PDCP Data PDU and submit the PDCP Data PDU to both associated RLC entities;
 - else:
 - submit the PDCP Control PDU to the primary RLC entity;
 - else:
 - if the two associated RLC entities belong to the different Cell Groups; and
 - if the total amount of PDCP data volume and RLC data volume pending for initial transmission (as specified in TS 38.322 [5]) in the two associated RLC entities is equal to or larger than *ul-DataSplitThreshold*:
 - submit the PDCP PDU to either the primary RLC entity or the secondary RLC entity;
 - else:
 - submit the PDCP PDU to the primary RLC entity.

[TS 38.331, clause 5.3.5.6.4]

The UE shall:

- 1> for each *drb-Identity* value included in the *drb-ToReleaseList* that is part of the current UE configuration; or
- 1> for each *drb-Identity* value that is to be released as the result of full configuration according to 5.3.5.11:
 - 2> release the PDCP entity and the *drb-Identity*;
 - 2> if SDAP entity associated with this DRB is configured:
 - 3> indicate the release of the DRB to SDAP entity associated with this DRB (TS 37.324 [24], clause 5.3.3);
 - 2> if the UE is operating in EN-DC:
 - 3> if a new bearer is not added either with NR or E-UTRA with same *eps-BearerIdentity*:
 - 4> indicate the release of the DRB and the *eps-BearerIdentity* of the released DRB to upper layers.

NOTE 1: The UE does not consider the message as erroneous if the *drb-ToReleaseList* includes any *drb-Identity* value that is not part of the current UE configuration.

NOTE 2: Whether or not the RLC and MAC entities associated with this PDCP entity are reset or released is determined by the *CellGroupConfig*.

[TS 38.323, clause 5.11.1]

For the PDCP entity configured with *pdcp-Duplication*, the transmitting PDCP entity shall:

- for SRBs:
 - activate the PDCP duplication;
- for DRBs:
 - if the activation of PDCP duplication is indicated:
 - activate the PDCP duplication;
 - if the deactivation of PDCP duplication is indicated:
 - deactivate the PDCP duplication.

[TS 38.323, clause 5.11.1]

For the PDCP entity configured with *pdcp-Duplication*, the transmitting PDCP entity shall:

- if the successful delivery of a PDCP Data PDU is confirmed by one of the two associated AM RLC entities:
 - indicate to the other AM RLC entity to discard the duplicated PDCP Data PDU;
- if the deactivation of PDCP duplication is indicated:
 - indicate to the secondary RLC entity to discard all duplicated PDCP Data PDUs.

[TS 38.323, clause 5.10]

If one or more DRBs are configured with PDCP duplication, the network may activate and deactivate the PDCP duplication for the configured DRB(s).

The PDCP duplication for the configured DRB(s) is activated and deactivated by:

- receiving the Duplication Activation/Deactivation MAC CE described in subclause 6.1.3.11;
- indication by RRC.

The MAC entity shall for each DRB configured with PDCP duplication:

- 1> if a Duplication Activation/Deactivation MAC CE is received activating the PDCP duplication of the DRB:
 - 2> indicate the activation of PDCP duplication of the DRB to upper layers.
- 1> if a Duplication Activation/Deactivation MAC CE is received deactivating the PDCP duplication of the DRB:
 - 2> indicate the deactivation of PDCP duplication of the DRB to upper layers.

7.1.3.5.5.3 Test description

7.1.3.5.5.3.1 Pre-test conditions

System Simulator:

- NR Cell 1 and NR Cell 2

UE:

- None

Preamble:

- Same Pre-test conditions as in clause 7.1.3.0 and Generic procedure parameter DC bearer(MCG and split).

7.1.3.5.5.3.2 Test procedure sequence

Table 7.1.3.5.5.3.2-1: Main behaviour

St	Procedure	Message Sequence		TP	Verdict
		U - S	Message		
1	The SS transmits an NR <i>RRCReconfiguration</i> message to configure parameters for PdcplDuplication.	<--	<i>RRCReconfiguration</i>	-	-
2	UE responses NR <i>RRCReconfigurationComplete</i> message.	-->	<i>RRCReconfigurationComplete</i>		
3	The SS sends a PDCP Data PDU on the split DRB on NR Cell 1 (PCell).	<--	PDCP DATA PDU	-	-
4	Check: Does UE transmit a PDCP Data PDU on the AM RLC entity configured for MCG on NR Cell 1 (PCell)?	-->	PDCP DATA PDU	3	P
5	SS transmits to activate PDCP Duplication for split DRB on NR Cell 1(PCell).	<--	MAC PDU (Duplication Activation MAC Control Element)	-	-
6	The SS sends a PDCP Data PDU on the split DRB on NR Cell 1 (PCell).	<--	PDCP DATA PDU	-	-
-	EXCEPTION: Steps 7-8 below occurs in any sequence	-	-	-	-
7	Check: Does UE transmit a PDCP Data PDU on the AM RLC entity configured for MCG on NR Cell 1 (PCell)?	-->	PDCP DATA PDU	1,2	P
8	Check: Does UE transmit a PDCP Data PDU on the AM RLC entity configured for SCG on NR Cell 2 (PSCell)?	-->	PDCP DATA PDU	1,2	P
9	SS does not transmit STATUS PDU on NR Cell 2				
10	The SS sends a PDCP Data PDU on the split DRB on NR Cell 1 (PCell).	<--	PDCP DATA PDU	-	-
-	EXCEPTION: Steps 11-12 below occurs in any sequence	-	-	-	-
11	UE transmits a PDCP Data PDU on the AM RLC entity configured for MCG on NR Cell 1 (PCell)	-->	PDCP DATA PDU	-	-
12	UE transmits a PDCP Data PDU on the AM RLC entity configured for SCG on NR Cell 2 (PSCell)	-->	PDCP DATA PDU	-	-
13	Check: Does UE re-transmits a PDCP Data PDU on the AM RLC entity configured for SCG on NR Cell 2 (PCell) in next five seconds?	-->	PDCP DATA PDU	4	F

7.1.3.5.5.3.3 Specific message contents

FFS

7.1.4 SDAP

7.1.4.1 SDAP Data Transfer and PDU Header Handling UL/DL

7.1.4.1.1 Test Purpose (TP)

(1)

```
with { UE in RRC_CONNECTED state with multiple DRB's established, each mapping more than one QoS
flow }
ensure that {
  when { UE receives an SDAP PDU with SDAP header }
  then { UE SDAP entity retrieves the SDAP SDU from the SDAP PDU and delivers it to upper layer}
}
```

(2)

```
with { UE in RRC_CONNECTED state with multiple DRB's established configured with UL SDAP header,
each mapping more than one QoS flow configured by RRC }
ensure that {
  when { UE has to transmit a SDAP PDU with header to be included }
  then { UE builds an SDAP PDU from the SDAP SDU including the header, and maps it to the DRB as
per stored DRB mapping rule for the QoS flow }
}
```

(3)

```
with { UE in RRC_CONNECTED state with multiple DRB's and QoS flows established }
ensure that {
  when { UE receives a SDAP PDU with SDAP header and RDI fields set to 1 }
  then {the UE stores the QoS flow to DRB mapping of the DL SDAP PDU as the QoS flow to DRB
mapping rule for the UL and uses it for further UL SDAP PDU transmissions }
}
```

(4)

```
with { UE in RRC_CONNECTED state with multiple DRB's and QoS flows established }
ensure that {
  when { UE receives a SDAP PDU with SDAP header and RDI field set to 1 and the stored QoS flow to
DRB mapping rule for the QoS flow is different from the QoS flow to DRB mapping of the DL SDAP data
PDU }
  then {the UE stores the QoS flow to DRB mapping of the DL SDAP PDU as the QoS flow to DRB
mapping rule for the UL, to be used for further UL SDAP PDU transmissions and transmits an end-
marker control PDU for the QoS flow on the old DRB }
}
```

(5)

```
with { UE in RRC_CONNECTED state with multiple DRB's and QoS flows established with QoS flow to DRB
mapping }
ensure that {
  when { RRC configures a new QoS flow to DRB mapping, different from the existing mapping } then
then { the UE stores the QoS flow to DRB mapping to be used for further UL SDAP PDU transmissions
and transmits an end-marker control PDU for the QoS flow on the old DRB }
}
```

7.1.4.1.2 Conformance requirements

References: The conformance requirements covered in the present test case are specified in: TS 37.324, clauses 5.2.1, 5.2.2, 5.3.1, 5.3.2, 6.2.2.1, 6.2.2.2, 6.2.2.3, 6.2.3 and 6.3.4, TS 24.501 clause 6.2.5.1.3. Unless otherwise stated these are Rel-15 requirements.

[TS 37.324 clause 5.2.1]

At the reception of an SDAP SDU from upper layer for a QoS flow, the transmitting SDAP entity shall:

- if there is no stored QoS flow to DRB mapping rule for the QoS flow as specified in the subclause 5.3:

- map the SDAP SDU to the default DRB;
- else:
 - map the SDAP SDU to the DRB according to the stored QoS flow to DRB mapping rule;
- if the DRB to which the SDAP SDU is mapped is configured by RRC (3GPP TS 38.331 [3]) with the presence of SDAP header,
 - construct the UL SDAP data PDU as specified in the subclause 6.2.2.3;
- else:
 - construct the UL SDAP data PDU as specified in the subclause 6.2.2.1;
- submit the constructed UL SDAP data PDU to the lower layers.

NOTE 1: UE behaviour is not defined if there is neither a default DRB nor a stored QoS flow to DRB mapping rule for the QoS flow.

NOTE 2: Default DRB is always configured with UL SDAP header (3GPP TS 38.331 [3]).

[TS 37.324 clause 5.2.2]

At the reception of an SDAP data PDU from lower layers for a QoS flow, the receiving SDAP entity shall:

- if the DRB from which this SDAP data PDU is received is configured by RRC (3GPP TS 38.331 [3]) with the presence of SDAP header:
 - perform reflective QoS flow to DRB mapping as specified in the subclause 5.3.2;
 - perform RQI handling as specified in the subclause 5.4;
 - retrieve the SDAP SDU from the DL SDAP data PDU as specified in the subclause 6.2.2.2.
- else:
 - retrieve the SDAP SDU from the DL SDAP data PDU as specified in the subclause 6.2.2.1;
- deliver the retrieved SDAP SDU to the upper layer.

[TS 37.324 clause 5.3.1]

When RRC (3GPP TS 38.331 [3]) configures an UL QoS flow to DRB mapping rule for a QoS flow, the SDAP entity shall:

- if the SDAP entity has already been established and there is no stored QoS flow to DRB mapping rule for the QoS flow and a default DRB is configured:
 - construct an end-marker control PDU, as specified in the subclause 6.2.3, for the QoS flow;
 - map the end-marker control PDU to the default DRB;
 - submit the end-marker control PDU to the lower layers.
- if the stored UL QoS flow to DRB mapping rule is different from the configured QoS flow to DRB mapping rule for the QoS flow and the DRB according to the stored QoS flow to DRB mapping rule is configured by RRC (3GPP TS 38.331 [3]) with the presence of UL SDAP header:
 - construct an end-marker control PDU, as specified in the subclause 6.2.3, for the QoS flow;
 - map the end-marker control PDU to the DRB according to the stored QoS flow to DRB mapping rule;
 - submit the end-marker control PDU to the lower layers.
- store the configured UL QoS flow to DRB mapping rule for the QoS flow.

When RRC (3GPP TS 38.331 [3]) releases an UL QoS flow to DRB mapping rule for a QoS flow, the SDAP entity shall:

- remove the UL QoS flow to DRB mapping rule for the QoS flow.

[TS 37.324 clause 5.3.2]

For each received DL SDAP dataPDU with RDI set to 1, the SDAP entity shall:

- process the QFI field in the SDAP header and determine the QoS flow;
- if there is no stored QoS flow to DRB mapping rule for the QoS flow and a default DRB is configured:
 - construct an end-marker control PDU, as specified in the subclause 6.2.3, for the QoS flow;
 - map the end-marker control PDU to the default DRB;
 - submit the end-marker control PDU to the lower layers;
- if the stored QoS flow to DRB mapping rule for the QoS flow is different from the QoS flow to DRB mapping of the DL SDAP data PDU and the DRB according to the stored QoS flow to DRB mapping rule is configured by RRC (3GPP TS 38.331 [3]) with the presence of UL SDAP header:
 - construct an end-marker control PDU, as specified in the subclause 6.2.3, for the QoS flow;
 - map the end-marker control PDU to the DRB according to the stored QoS flow to DRB mapping rule;
 - submit the end-marker control PDU to the lower layers;
- store the QoS flow to DRB mapping of the DL SDAP data PDU as the QoS flow to DRB mapping rule for the UL.

[TS 37.324 clause 6.2.2.1]

An SDAP PDU consists only of a data field and does not consist of any SDAP header, as described in Figure 6.2.2.1-1.

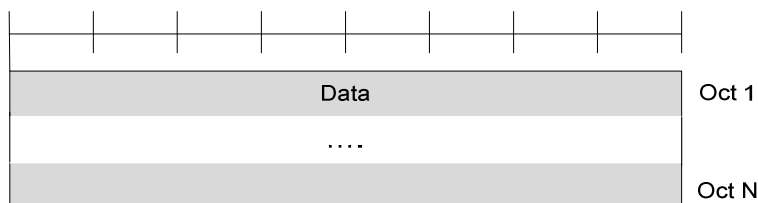

Figure 6.2.2.1-1: SDAP Data PDU format without SDAP header

[TS 37.324 clause 6.2.2.2]

Figure 6.2.2.2 – 1 shows the format of SDAP Data PDU of DL with SDAP header being configured.

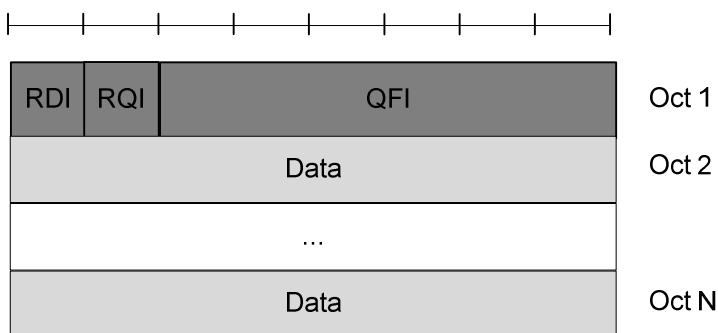

Figure 6.2.2.2-1: DL SDAP Data PDU format with SDAP header

[TS 37.324 clause 6.2.2.3]

Figure 6.2.2.3 – 1 shows the format of SDAP Data PDU of UL with SDAP header being configured.

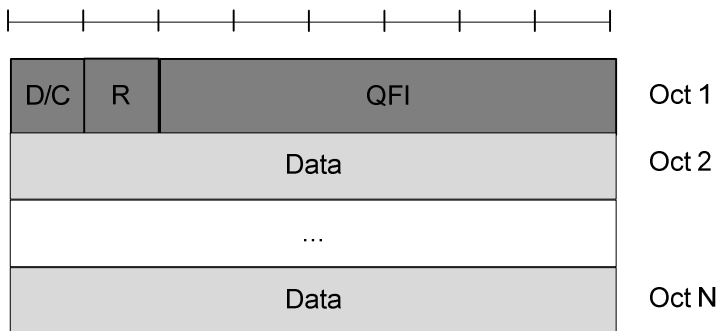

Figure 6.2.2.3-1: UL SDAP Data PDU format with SDAP header

[TS 37.324 clause 6.2.3]

Figure 6.2.3 – 1 shows the format of End-Marker Control PDU.



Figure 6.2.2.3-1: UL SDAP Data PDU format with SDAP header

[TS 37.324 clause 6.3.4]

Length: 6 bits

The QFI field indicates the ID of the QoS flow (3GPP TS 23.501 [4]) to which the SDAP PDU belongs.

[TS 24.501 clause 6.2.5.1.3]

For PDU session of IPv4, IPv6, IPv4v6 or Ethernet PDU session type, upon receiving an UL user data packet from the upper layers for transmission via a PDU session, the UE shall attempt to associate the UL user data packet with:

- a) the QFI of a signalled QoS rule associated with the PDU session which has a set of packet filters containing a packet filter for UL direction matching the UL user data packet or containing a packet filter for both UL and DL directions matching the UL user data packet; or
- b) the QFI of a derived QoS rule associated with the PDU session which has the packet filter for UL direction matching the UL user data packet;

by evaluating the QoS rules in increasing order of their precedence values until the UL user data packet is associated with a QFI or all QoS rules are evaluated.

For PDU session of unstructured PDU session type, upon receiving an UL user data packet from the upper layers for transmission via a PDU session, the UE shall associate the UL user data packet with the QFI of the default QoS rule associated with the PDU session.

If the UL user data packet is associated with a QFI, the UE shall pass the QFI along the UL user data packet to the lower layers for transmission.

NOTE: Marking of the UL user data packet with the QFI is performed by the lower layers.

If all QoS rules are evaluated and the UL user data packet is not associated with a QFI, the UE shall discard the UL user data packet.

7.1.4.1.3 Test description

7.1.4.1.3.1 Pre-test conditions

System Simulator:

- NR Cell 1

UE:

- None.

Preamble:

The UE is in 5GS state 3N-A with one PDU session active according to TS 38.508-1 [4], clause 4.4A.3 Table 4.4A.3-1 and using the message condition UE TEST LOOP MODE B active with IP PDU delay = 1 second, to return one SDAP SDU per DL SDAP SDU. 2 DRBs are configured where DRB 1 is defined as default DRB. The NAS QoS rules for the QoS flows with QFI=1, QFI=2, QFI=5 and QFI=6 are configured. QoS flows with QFI=5 and QFI=6 are mapped to DRB 1, QoS flows with QFI=1 and QFI=2 are mapped to DRB 2

7.1.4.1.3.2 Test procedure sequence

Table 7.1.4.1.3.2-1: Main behaviour

St	Procedure	Message Sequence		TP	Verdict
		U - S	Message		
1	The SS sends the SDAP Data PDU with SDAP header on DRB 2 and the following content to the UE: RDI=0, RQI=0, QFI=1.	<--	SDAP DL Data PDU	-	-
2	Check: Does the UE re-transmit SDAP Data PDU on DRB 2 with SDAP header as per the stored DRB mapping flow with QFI=1?	-->	SDAP UL Data PDU	1,2	P
3	The SS sends the SDAP Data PDU with SDAP header on DRB 2 and the following content to the UE: RDI=1, RQI=0, QFI=5.	<--	SDAP DL Data PDU	-	-
-	EXCEPTION: In parallel to the event described in step 4 the events specified in Table 7.1.4.1.3.2-2 shall take place.	-	-	-	-
4	Check: Does the UE re-transmit SDAP Data PDU on DRB 2 with SDAP header as per the stored DRB mapping Flow with QFI=5?	-->	SDAP UL Data PDU	3	P
5	The SS transmits an RRCReconfiguration message including a PDU SESSION MODIFICATION COMMAND	<--	<i>RRCReconfiguration</i> (PDU SESSION MODIFICATION COMMAND)	-	-
-	EXCEPTION: In parallel to the event described in step 6 the events specified in Tables 7.1.4.1.3.2-3 and 7.1.4.1.3.2-4 shall take place.	-	-	-	-
6	The UE transmits an RRCReconfigurationComplete message.	-->	<i>RRCReconfigurationComplete</i>	-	-
7	The SS sends the SDAP Data PDU with SDAP header on DRB 2 and the following content to the UE: RDI=0, RQI=0, QFI=4.	<--	SDAP DL Data PDU	-	-
8	Check: Does the UE re-transmit SDAP Data PDU on DRB 2 with SDAP header as per the stored DRB mapping Flow with QFI=4?	-->	SDAP UL Data PDU	5	P

Table 7.1.4.1.3.2-2: Parallel behaviour

St	Procedure	Message Sequence		TP	Verdict
		U - S	Message		
1	Check: Does the UE transmit End-Marker Control PDU on DRB 1 for QFI=5?	-->	SDAP UL Control PDU	4	P

Table 7.1.4.1.3.2-3: Parallel behaviour

St	Procedure	Message Sequence		TP	Verdict
		U - S	Message		
1	Check: Does the UE transmit End-Marker Control PDU on DRB 1 for QFI=4?	-->	SDAP UL Control PDU	5	P

Table 7.1.4.1.3.2-4: Parallel behaviour

St	Procedure	Message Sequence		TP	Verdict
		U - S	Message		
1	The UE Transmits PDU SESSION MODIFICATION COMPLETE	-	-	-	-

7.1.4.1.3.3 Specific message contents

Table 7.1.4.1.3.3-1: RadioBearerConfig-DRB (Preamble)

Derivation Path: TS 38.508-1 [4], table 4.6.3-132 and condition NR			
Information Element	Value/remark	Comment	Condition
RadioBearerConfig ::= SEQUENCE {			
drb-ToAddModList SEQUENCE (SIZE (1..maxDRB))	2 entries		
OF SEQUENCE {			
{			
cnAssociation[1] CHOICE {			
sdap-Config ::= SEQUENCE {			
pdu-Session	1		
sdap-HeaderDL	present		
sdap-HeaderUL	present		
defaultDRB	false		
mappedQoS-FlowsToAdd ::= SEQUENCE {			
QFI	1		
QFI	2		
}			
}			
}			
drb-Identity	2		
}			
{			
cnAssociation[2] CHOICE {			
sdap-Config ::= SEQUENCE {			
pdu-Session	1		
sdap-HeaderDL	present		
sdap-HeaderUL	present		
defaultDRB	true		
mappedQoS-FlowsToAdd ::= SEQUENCE {			
QFI	5		
QFI	6		
}			
}			
}			
drb-Identity	1		
}			
}			
}			

Table 7.1.4.1.3.3-2: RadioBearerConfig-DRB (step 5, Table 7.1.4.1.3.2-1)

Derivation Path: TS 38.508-1 [4], table 4.6.3-132 and condition NR			
Information Element	Value/remark	Comment	Condition
RadioBearerConfig ::= SEQUENCE {	-	-	-
drb-ToAddModList SEQUENCE (SIZE (1..maxDRB))	2	BID is the total number of established DRBs in the UE, before applying the contents of this IE	-
OF SEQUENCE {	-	-	-
cnAssociation[1] CHOICE {	-	-	-
sdap-Config ::= SEQUENCE {	-	-	-
pdu-Session -	1	-	-
sdap-HeaderDL	present	-	-
sdap-HeaderUL	present	-	-
defaultDRB	false	-	-
mappedQoS-FlowsToAdd ::= SEQUENCE {	-	-	-
QFI	4	-	-
}	-	-	-
}	-	-	-
drb-Identity	2	-	-
}	-	-	-
}	-	-	-

Table 7.1.4.1.3.3-3: PDU SESSION MODIFICATION COMMAND (step 5, Table 7.1.4.1.3.2-1)

Derivation Path: TS 38.508-1, table 4.7.2-9			
Information Element	Value/remark	Comment	Condition
PDU session ID	The same as the PDU session ID in PDU SESSION ESTABLISHMENT REQUEST		
Authorized QoS rules	One entry		
QoS rule [1]	Reference QoS rule #4a as defined in Table 4.8.2.1-4a.	QFI=4	
Authorized QoS flow descriptions	One entry		
QoS flow [1]	Reference QoS flow #2a as defined in Table 4.8.2.3-2a.	QFI=4	

s

Table 7.1.4.1.3.3-4: PDU SESSION ESTABLISHMENT ACCEPT (Preamble)

Derivation Path: TS 38.508-1, table 4.7.2-2			
Information Element	Value/remark	Comment	Condition
PDU session ID	The same as the PDU session ID in PDU SESSION ESTABLISHMENT REQUEST		
Authorized QoS rules	4 entries		
QoS rule [1]	Reference QoS rule #3 as defined in Table 4.8.2.1-3.	QFI=1	
QoS rule [2]	Reference QoS rule #4 as defined in Table 4.8.2.1-4.	QFI=2	
QoS rule [3]	Reference QoS rule #5 as defined in Table 4.8.2.1-5.	QFI=5	
QoS rule [4]	Reference QoS rule #6 as defined in Table 4.8.2.1-6.	QFI=6	
Authorized QoS flow descriptions	4 entries		
QoS flow [1]	Reference QoS flow #1 as defined in Table 4.8.2.3-1.	QFI=1	
QoS flow [2]	Reference QoS flow #2 as defined in Table 4.8.2.3-2.	QFI=2	
QoS flow [3]	Reference QoS flow #3 as defined in Table 4.8.2.3-3.	QFI=5	
QoS flow [4]	Reference QoS flow #4 as defined in Table 4.8.2.3-4.	QFI=6	

7.1.4.2 SDAP Data Transfer handling without Header UL/DL

7.1.4.2.1 Test Purpose (TP)

(1)

```
with { UE in RRC_CONNECTED state with multiple DRB's established. SDAP configured without header and no stored QoS flow mapping }
ensure that{
  when { UE receives a SDAP SDU from upper layers }
  then { UE SDAP entity transmits the SDAP PDU with header on default DRB }
```

(2)

```
with { UE in RRC_CONNECTED state with multiple DRB's established. SDAP configured without header and no stored QoS flow mapping }
ensure that {
  when { UE SDAP recieves from RRC new QoS Flow mapping }
  then { UE SDAP entity transmits an end-marker control PDU for the QoS flow on default DRB }
}
```

(3)

```
with { UE in RRC_CONNECTED state with multiple DRB's established. SDAP configured without header and stored QoS flow mapping configured by RRC }
ensure that{
  when { UE receives a SDAP SDU from upper layers }
  then { UE SDAP entity transmits the SDAP PDU without header on non default DRB as per configured QoS flow mapping}
```

7.1.4.2.2 Conformance requirements

References: The conformance requirements covered in the present test case are specified in: TS 37.324, clauses 5.2.1, 5.2.2, 5.3.1, 6.2.2.1 and 6.2.3, TS 24.501 clause 6.2.5.1.3. Unless otherwise stated these are Rel-15 requirements.

[TS 37.324 clause 5.2.1]

At the reception of an SDAP SDU from upper layer for a QoS flow, the transmitting SDAP entity shall:

- if there is no stored QoS flow to DRB mapping rule for the QoS flow as specified in the subclause 5.3:
 - map the SDAP SDU to the default DRB;
- else:
 - map the SDAP SDU to the DRB according to the stored QoS flow to DRB mapping rule;
- if the DRB to which the SDAP SDU is mapped is configured by RRC (3GPP TS 38.331 [3]) with the presence of SDAP header,
 - construct the UL SDAP data PDU as specified in the subclause 6.2.2.3;
- else:
 - construct the UL SDAP data PDU as specified in the subclause 6.2.2.1;
- submit the constructed UL SDAP data PDU to the lower layers.

NOTE 1: UE behaviour is not defined if there is neither a default DRB nor a stored QoS flow to DRB mapping rule for the QoS flow.

NOTE 2: Default DRB is always configured with UL SDAP header (3GPP TS 38.331 [3]).

[TS 37.324 clause 5.2.2]

At the reception of an SDAP data PDU from lower layers for a QoS flow, the receiving SDAP entity shall:

- if the DRB from which this SDAP data PDU is received is configured by RRC (3GPP TS 38.331 [3]) with the presence of SDAP header:
 - perform reflective QoS flow to DRB mapping as specified in the subclause 5.3.2;
 - perform RQI handling as specified in the subclause 5.4;
 - retrieve the SDAP SDU from the DL SDAP data PDU as specified in the subclause 6.2.2.2.
- else:
 - retrieve the SDAP SDU from the DL SDAP data PDU as specified in the subclause 6.2.2.1;
- deliver the retrieved SDAP SDU to the upper layer.

[TS 37.324 clause 5.3.1]

When RRC (3GPP TS 38.331 [3]) configures an UL QoS flow to DRB mapping rule for a QoS flow, the SDAP entity shall:

- if the SDAP entity has already been established and there is no stored QoS flow to DRB mapping rule for the QoS flow and a default DRB is configured:
 - construct an end-marker control PDU, as specified in the subclause 6.2.3, for the QoS flow;
 - map the end-marker control PDU to the default DRB;
 - submit the end-marker control PDU to the lower layers.

- if the stored UL QoS flow to DRB mapping rule is different from the configured QoS flow to DRB mapping rule for the QoS flow and the DRB according to the stored QoS flow to DRB mapping rule is configured by RRC (3GPP TS 38.331 [3]) with the presence of UL SDAP header:
 - construct an end-marker control PDU, as specified in the subclause 6.2.3, for the QoS flow;
 - map the end-marker control PDU to the DRB according to the stored QoS flow to DRB mapping rule;
 - submit the end-marker control PDU to the lower layers.
- store the configured UL QoS flow to DRB mapping rule for the QoS flow.

When RRC (3GPP TS 38.331 [3]) releases an UL QoS flow to DRB mapping rule for a QoS flow, the SDAP entity shall:

- remove the UL QoS flow to DRB mapping rule for the QoS flow.

[TS 37.324 clause 6.2.2.1]

An SDAP PDU consists only of a data field and does not consist of any SDAP header, as described in Figure 6.2.2.1-1.

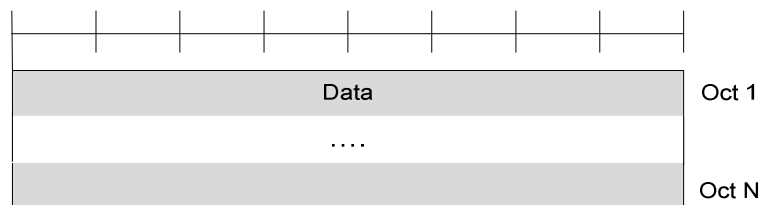

Figure 6.2.2.1-1: SDAP Data PDU format without SDAP header

[TS 37.324 clause 6.2.3]

Figure 6.2.3 – 1 shows the format of End-Marker Control PDU.

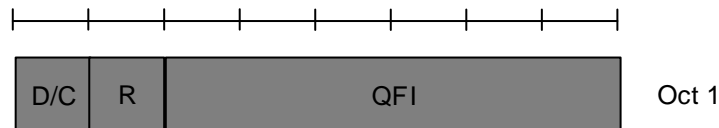

Figure 6.2.3-1: End-Marker Control PDU

[TS 24.501 clause 6.2.5.1.3]

For PDU session of IPv4, IPv6, IPv4v6 or Ethernet PDU session type, upon receiving an UL user data packet from the upper layers for transmission via a PDU session, the UE shall attempt to associate the UL user data packet with:

- a) the QFI of a signalled QoS rule associated with the PDU session which has a set of packet filters containing a packet filter for UL direction matching the UL user data packet or containing a packet filter for both UL and DL directions matching the UL user data packet; or
- b) the QFI of a derived QoS rule associated with the PDU session which has the packet filter for UL direction matching the UL user data packet;

by evaluating the QoS rules in increasing order of their precedence values until the UL user data packet is associated with a QFI or all QoS rules are evaluated.

For PDU session of unstructured PDU session type, upon receiving an UL user data packet from the upper layers for transmission via a PDU session, the UE shall associate the UL user data packet with the QFI of the default QoS rule associated with the PDU session.

If the UL user data packet is associated with a QFI, the UE shall pass the QFI along the UL user data packet to the lower layers for transmission.

NOTE: Marking of the UL user data packet with the QFI is performed by the lower layers.

If all QoS rules are evaluated and the UL user data packet is not associated with a QFI, the UE shall discard the UL user data packet.

7.1.4.2.3 Test description

7.1.4.2.3.1 Pre-test conditions

System Simulator:

- NR Cell 1

UE:

- None.

Preamble:

The UE is in 5GS state 3N-A with one PDU session active according to TS 38.508-1 [4], clause 4.4A.3 Table 4.4A.3-1 and using the message condition UE TEST LOOP MODE B active to return one UL SDAP SDU per DL SDAP SDU. 2 DRBs are configured where DRB1 is defined as default DRB. The NAS QoS rules for QoS flows QFI = 5 and QFI = 2 are configured. The 'mappedQoS-Flows' is empty for both DRB's for SDAP layer.

7.1.4.2.3.2 Test procedure sequence

Table 7.1.4.2.3.2-1: Main behaviour

St	Procedure	Message Sequence		TP	Verdict
		U - S	Message		
1	The SS sends the SDAP Data PDU without SDAP header on DRB 2 for QFI =2.	<--	SDAP DL Data PDU	-	-
2	Check: Does the UE transmits SDAP Data PDU on DRB 1, which is default DRB, with SDAP header including QFI=2?	-->	SDAP UL Data PDU	1	P
3	The SS sends the SDAP Data PDU without SDAP header on DRB 1 for QFI 5.	<--	SDAP DL Data PDU	-	-
4	Check: Does the UE transmits SDAP Data PDU on DRB 1, which is default DRB, with SDAP header including QFI=5?	-->	SDAP UL Data PDU	1	P
5	The SS transmits an NR RRCReconfiguration message to configure QoS Flow rules	<--	(<i>RRCReconfiguration</i>)	-	-
-	EXCEPTION: In parallel to the event described in step 8 the events specified in Table 7.1.4.2.3.2-2 shall take place.			-	-
6	The UE transmit an NR <i>RRCReconfigurationComplete</i> message.	-->	(<i>RRCReconfigurationComplete</i>)	-	-
7	The SS sends the SDAP Data PDU without SDAP header on DRB 2 for QFI =2.	<--	SDAP DL Data PDU	-	-
8	Check: Does the UE transmits SDAP Data PDU on DRB 2?	-->	SDAP UL Data PDU	3	P
9	The SS sends the SDAP Data PDU without SDAP header on DRB 1 for QFI 5.	<--	SDAP DL Data PDU	-	-
10	Check: Does the UE transmits SDAP Data PDU on DRB 1, with SDAP header including QFI=5?	-->	SDAP UL Data PDU	3	P

Table 7.1.4.2.3.2-2: Parallel behaviour

St	Procedure	Message Sequence		TP	Verdict
		U - S	Message		
1	Check: Does the UE transmits End-Marker Control PDU on DRB1 for QFI=2?	-->	SDAP UL Control PDU	2	P

Table 7.1.4.2.3.2-3: Void

7.1.4.2.3.3 Specific message contents

Table 7.1.4.2.3.3-1: RadioBearerConfig-DRB (Preamble)

Derivation Path: TS 38.508-1 [4], table 4.6.3-132 and condition NR			
Information Element	Value/remark	Comment	Condition
RadioBearerConfig ::= SEQUENCE {			
drb-ToAddModList SEQUENCE (SIZE (1..maxDRB))	2 entries		
OF SEQUENCE {			
{			
cnAssociation[1] CHOICE {			
sdap-Config ::= SEQUENCE {			
pdu-Session	1		
sdap-HeaderDL	absent		
sdap-HeaderUL	absent		
defaultDRB	false		
}			
}			
drb-Identity	2		
}			
{			
cnAssociation[2] CHOICE {			
sdap-Config ::= SEQUENCE {			
pdu-Session	1		
sdap-HeaderDL	absent		
sdap-HeaderUL	present		
defaultDRB	true		
}			
}			
drb-Identity	1		
}			
}			
}			

Table 7.1.4.2.3.3-2: RadioBearerConfig-DRB (step 5, Table 7.1.4.2.3.2-1)

Derivation Path: TS 38.508-1 [4], table 4.6.3-132 and condition NR			
Information Element	Value/remark	Comment	Condition
RadioBearerConfig ::= SEQUENCE {			
drb-ToAddModList SEQUENCE (SIZE (1..maxDRB))	2 entries		
OF SEQUENCE {			
{			
cnAssociation[1] CHOICE {			
sdap-Config ::= SEQUENCE {			
pdu-Session	1		
sdap-HeaderDL	absent		
sdap-HeaderUL	absent		
defaultDRB	false		
mappedQoS-FlowsToAdd ::= SEQUENCE {			
QFI	2		
}			
}			
}			
drb-Identity	2		
}			
{			
cnAssociation[2] CHOICE {			
sdap-Config ::= SEQUENCE {			
pdu-Session	1		
sdap-HeaderDL	absent		
sdap-HeaderUL	present		
defaultDRB	true		
mappedQoS-FlowsToAdd ::= SEQUENCE {			
}		The 'mappedQoS-Flows' is empty for the DRB.	
}			
}			
}			
drb-Identity	1		
}			
}			
}			

Table 7.1.4.2.3.3-3: PDU SESSION ESTABLISHMENT ACCEPT (Preamble)

Derivation Path: TS 38.508-1, table 4.7.2-2			
Information Element	Value/remark	Comment	Condition
PDU session ID	The same as the PDU session ID in PDU SESSION ESTABLISHMENT REQUEST		
Authorized QoS rules	2 entries		
QoS rule [1]	Reference QoS rule #4 as defined in Table 4.8.2.1-4.	QFI=2	
QoS rule [2]	Reference QoS rule #5 as defined in Table 4.8.2.1-5.	QFI=5	
Authorized QoS flow descriptions	2 entries		
QoS flow [1]	Reference QoS flow #2 as defined in Table 4.8.2.3-2.	QFI=2	
QoS flow [2]	Reference QoS flow #3 as defined in Table 4.8.2.3-3.	QFI=5	

8 RRC

Editor's note: Intended to capture tests of RRC Layer defined in TS 38.331 and capabilities defined in TS 38.306.

- a) SN Measurements and Reporting (various bearer options as in Impact#2)
- b) UE Capability Co-ordination (FFS in RAN2)
- c) SN Release (various bearer options as in Impact#2)
- d) SN Modifications including SCG SRBs
- e) Handover Scenarios (various bearer options as in Impact#2)
- f) Handovers with combination E-UTRA + NR (various bearer options as in Impact#2)
- g) Carrier Aggregation in NR
- h) Failure Handling with combinations of E-UTRA+NR (various bearer options as in Impact#2)
- i) SN System Information Handling

Non-Standalone resp. Standalone deployments may be handled in the following options sub-structure:

8.1 RRC 5G NR Standalone / Single Connectivity (Option 2, 5)

8.2 RRC 5G NR Non-Standalone / Dual Connectivity (Option 3, 4, 7)

8.1 NR RRC

Editor's note: Core Spec completion for Standalone NR (Option 2) to happen at RAN#80 and this section will be updated after RAN5#79 (August 2018).

8.1.1 RRC connection management procedures

8.1.1.1 Paging

8.1.1.1.1 RRC / Paging for connection / Multiple paging records

8.1.1.1.1.1 Test Purpose (TP)

(1)

```
with { UE in NR RRC_IDLE state }
ensure that {
  when { UE receives a Paging message including only unmatched identities }
  then { UE does not establish any RRC connection }
}
```

(2)

```
with { UE in NR RRC_IDLE state }
ensure that {
  when { UE receives a Paging message including a matched identity ng-5G-S-TMSI }
  then { UE successfully establishes the RRC connection }
}
```

(3)

```
with { UE in NR RRC_INACTIVE state }
ensure that {
  when { UE receives a Paging message including only unmatched identities }
  then { UE does not resume RRC connection }
}
```

(4)

```
with { UE in NR RRC_INACTIVE state }
ensure that {
  when { UE receives a Paging message including a matched identity fullI-RNTI }
  then { UE successfully resumes the RRC connection }
}
```

8.1.1.1.1.2 Conformance requirements

References: The conformance requirements covered in the current TC is specified in: TS 38.331 clause 5.3.2.3.

[TS 38.331, clause 5.3.2.3]

Upon receiving the *Paging* message, the UE shall:

- 1> if in RRC_IDLE, for each of the *PagingRecord*, if any, included in the *Paging* message:
 - 2> if the *ue-Identity* included in the *PagingRecord* matches the UE identity allocated by upper layers:
 - 3> forward the *ue-Identity* and *accessType* (if present) to the upper layers;
- 1> if in RRC_INACTIVE, for each of the *PagingRecord*, if any, included in the *Paging* message:
 - 2> if the *ue-Identity* included in the *PagingRecord* matches the UE's stored *fullI-RNTI*:
 - 3> if the UE is configured by upper layers with Access Identity 1:
 - 4> initiate the RRC connection resumption procedure according to 5.3.13 with *resumeCause* set to *mps-PriorityAccess*;
 - 3> else if the UE is configured by upper layers with Access Identity 2:
 - 4> initiate the RRC connection resumption procedure according to 5.3.13 with *resumeCause* set to *mcs-PriorityAccess*;
 - 3> else if the UE is configured by upper layers with one or more Access Identities equal to 11-15:
 - 4> initiate the RRC connection resumption procedure according to 5.3.13 with *resumeCause* set to *highPriorityAccess*;
 - 3> else:
 - 4> initiate the RRC connection resumption procedure according to 5.3.13 with *resumeCause* set to *mt-Access*;
 - 2> else if the *ue-Identity* included in the *PagingRecord* matches the UE identity allocated by upper layers:
 - 3> forward the *ue-Identity* to upper layers and *accessType* (if present) to the upper layers;
 - 3> perform the actions upon going to RRC_IDLE as specified in 5.3.11 with release cause 'other'.

8.1.1.1.1.3 Test Description

8.1.1.1.1.3.1 Pre-test conditions

System Simulator:

- NR Cell 1
- System information combination NR-1 as defined in TS 38.508-1 [4] clause 4.4.3.1.3 is used in NR cell.

UE:

- None.

Preamble:

- The UE is in 5GS state 1N-A according to TS 38.508-1 [4], clause 4.4A.2 Table 4.4A.2-1.

8.1.1.1.3.2 Test procedure sequence

Table 8.1.1.1.3.2-1: Main behaviour

St	Procedure	Message Sequence		TP	Verdict
		U - S	Message		
1	The SS transmits a <i>Paging</i> message including only unmatched identities (incorrect <i>ng-5G-S-TMSI</i>).	<--	NR RRC: <i>Paging</i>	-	-
2	Check: Does the UE transmit an <i>RRCSetupRequest</i> message within 10s?	-->	NR RRC: <i>RRCSetupRequest</i>	1	F
3	The SS transmits a <i>Paging</i> message including two unmatched identities (incorrect <i>ng-5G-S-TMSI</i>) and a matched identity (correct <i>ng-5G-S-TMSI</i>).	<--	NR RRC: <i>Paging</i>	-	-
4	Check: Does the UE transmit an <i>RRCSetupRequest</i> message?	-->	NR RRC: <i>RRCSetupRequest</i>	2	P
5	The SS transmits an <i>RRCSetup</i> message.	<--	NR RRC: <i>RRCSetup</i>	-	-
6	The UE transmit an <i>RRCSetupComplete</i> message including SERVICE REQUEST to confirm the successful completion of the connection establishment.	-->	NR RRC: <i>RRCSetupComplete</i> 5GMM: SERVICE REQUEST	-	-
7-10	Steps 5 to 8 of the NR RRC_CONNECTED procedure in TS 38.508-1 Table 4.5.4.2-3 are executed to successfully complete the service request procedure.	-	-	-	-
11	The SS transmits an <i>RRCRelease</i> message including <i>suspendConfig</i> .	<--	NR RRC: <i>RRCRelease</i>	-	-
12	The SS transmits a <i>Paging</i> message including only unmatched identities (incorrect <i>fullI-RNTI</i>).	<--	NR RRC: <i>Paging</i>	-	-
13	Check: Does the UE transmit an <i>RRCResumeRequest</i> message within 10s?	-->	NR RRC: <i>RRCResumeRequest</i>	3	F
14	The SS transmits a <i>Paging</i> message including two unmatched identities (incorrect <i>fullI-RNTI</i>) and a matched identity (correct <i>fullI-RNTI</i>).	<--	NR RRC: <i>Paging</i>	-	-
15	Check: Does the UE transmit an <i>RRCResumeRequest</i> message?	-->	NR RRC: <i>RRCResumeRequest</i>	4	P
16	The SS transmits an <i>RRCResume</i> message.	<--	NR RRC: <i>RRCResume</i>	-	-
17	The UE transmits an <i>RRCResumeComplete</i> message.	-->	NR RRC: <i>RRCResumeComplete</i>	-	-

8.1.1.1.1.3.3 Specific message contents

Table 8.1.1.1.1.3.3-1: Paging (step 1, Table 8.1.1.1.1.3.2-1)

Derivation Path: 38.508-1 Table 4.6.1-9			
Information Element	Value/remark	Comment	Condition
Paging ::= SEQUENCE {			
pagingRecordList SEQUENCE	3 entries		
(SIZE(1..maxNrofPageRec)) OF SEQUENCE {			
ue-Identity[1] CHOICE {			
ng-5G-S-TMSI	Set to the different value from the NG-5G-S-TMSI of the UE		
}			
ue-Identity[2] CHOICE {			
ng-5G-S-TMSI	Set to the different value from the NG-5G-S-TMSI of the UE		
}			
ue-Identity[3] CHOICE {			
ng-5G-S-TMSI	Set to the different value from the NG-5G-S-TMSI of the UE		
}			
}			
}			

Table 8.1.1.1.1.3.3-2: Paging (step 3, Table 8.1.1.1.1.3.2-1)

Derivation Path: 38.508-1 Table 4.6.1-9			
Information Element	Value/remark	Comment	Condition
Paging ::= SEQUENCE {			
pagingRecordList SEQUENCE	3 entries		
(SIZE(1..maxNrofPageRec)) OF SEQUENCE {			
ue-Identity[1] CHOICE {			
ng-5G-S-TMSI	Set to the different value from the NG-5G-S-TMSI of the UE		
}			
ue-Identity[2] CHOICE {			
ng-5G-S-TMSI	Set to the different value from the NG-5G-S-TMSI of the UE		
}			
ue-Identity[3] CHOICE {			
ng-5G-S-TMSI	Set to the value of the NG-5G-S-TMSI of the UE		
}			
}			
}			

Table 8.1.1.1.1.3.3-3: RRCSetupRequest (step 4, Table 8.1.1.1.1.3.2-1)

Derivation Path: 38.508-1 Table 4.6.1-23			
Information Element	Value/remark	Comment	Condition
RRCSetupRequest ::= SEQUENCE {			
rrcSetupRequest SEQUENCE {			
establishmentCause	mt-Access		
}			
}			

Table 8.1.1.1.1.3.3-4: *Paging* (step 12, Table 8.1.1.1.1.3.2-1)

Derivation Path: 38.508-1 Table 4.6.1-9			
Information Element	Value/remark	Comment	Condition
Paging ::= SEQUENCE {			
pagingRecordList SEQUENCE	3 entries		
(SIZE(1..maxNrofPageRec)) OF SEQUENCE {			
ue-Identity[1] CHOICE {			
fullI-RNTI	Set to the different value from the I-RNTI-Value of the UE		
}			
ue-Identity[2] CHOICE {			
fullI-RNTI	Set to the different value from the I-RNTI-Value of the UE		
}			
ue-Identity[3] CHOICE {			
fullI-RNTI	Set to the different value from the I-RNTI-Value of the UE		
}			
}			
}			

Table 8.1.1.1.1.3.3-5: *Paging* (step 14, Table 8.1.1.1.1.3.2-1)

Derivation Path: 38.508-1 Table 4.6.1-9			
Information Element	Value/remark	Comment	Condition
Paging ::= SEQUENCE {			
pagingRecordList SEQUENCE	3 entries		
(SIZE(1..maxNrofPageRec)) OF SEQUENCE {			
ue-Identity[1] CHOICE {			
fullI-RNTI	Set to the different value from the I-RNTI-Value of the UE		
}			
ue-Identity[2] CHOICE {			
fullI-RNTI	Set to the different value from the I-RNTI-Value of the UE		
}			
ue-Identity[3] CHOICE {			
fullI-RNTI	Set to the value of the I-RNTI-Value of the UE		
}			
}			
}			

8.1.1.1.2 RRC / Paging for connection / Shared network environment

8.1.1.1.2.1 Test Purpose (TP)

(1)

```

with { UE in NR RRC_IDLE state having been registered in the TA of the current cell which has
broadcasted a SIB1 message including multiple PLMN identities }
ensure that {
  when { UE receives a Paging message including an IE ue-Identity set to the ng-5G-S-TMSI which was
allocated to the UE during the UE registration procedure }
  then { UE initiates RRCSetupRequest with ue-Identity set to ng-5G-S-TMSI-Part1 }
}

```

(2)

```

with { UE having sent RRCSetupRequest with ue-Identity set to ng-5G-S-TMSI-Part1 }
ensure that {
  when { the UE receives RRCSetup message }
  then { UE will set the ng-5G-S-TMSI-Value to ng-5G-S-TMSI-Part2 in RRCSetupComplete message }
}

```

(3)

```

with { UE in NR RRC_INACTIVE state having been registered in the TA of the current cell which has
broadcasted a SIB1 message including multiple PLMN identities }
ensure that {
  when { UE receives a Paging message including an IE ue-Identity set to the ng-5G-S-TMSI which was
allocated to the UE during the UE registration procedure }
  then { UE releases RRC connection with release cause 'other' and goes to NR RRC_IDLE state }
}

```

8.1.1.1.2.2 Conformance requirements

Editor's note: conformance requirements will be updated according to latest core specification.

References: The conformance requirements covered in the current TC are specified in: TS 38.331, clause 5.3.2.3, 5.3.3.3, 5.3.3.4 and 5.3.11, TS 24.501, clause 5.3.1.4 and 5.6.1.1. Unless otherwise stated these are Rel-15 requirements.

[TS 38.331, clause 5.3.2.3]

Upon receiving the *Paging* message, the UE shall:

- 1> if in RRC_IDLE, for each of the *PagingRecord*, if any, included in the *Paging* message:
 - 2> if the *ue-Identity* included in the *PagingRecord* matches the UE identity allocated by upper layers:
 - 3> forward the *ue-Identity* and *accessType* (if present) to the upper layers;
- 1> if in RRC_INACTIVE, for each of the *PagingRecord*, if any, included in the *Paging* message:
 - 2> if the *ue-Identity* included in the *PagingRecord* matches the UE's stored *fullI-RNTI*:

...
 - 2> else if the *ue-Identity* included in the *PagingRecord* matches the UE identity allocated by upper layers:
 - 3> forward the *ue-Identity* to upper layers and *accessType* (if present) to the upper layers;
 - 3> perform the actions upon going to RRC_IDLE as specified in 5.3.11 with release cause 'other'.

[TS 38.331, clause 5.3.3.3]

The UE shall set the contents of *RRCSetupRequest* message as follows:

- 1> set the *ue-Identity* as follows:
 - 2> if upper layers provide an *5G-S-TMSI*:
 - 3> set the *ue-Identity* to *ng-5G-S-TMSI-Part1*;
 - 2> else:
 - 3> draw a 39-bit random value in the range $0..2^{39}-1$ and set the *ue-Identity* to this value;

NOTE 1: Upper layers provide the *5G-S-TMSI* if the UE is registered in the TA of the current cell.

- 1> set the *establishmentCause* in accordance with the information received from upper layers;

The UE shall submit the *RRCSetupRequest* message to lower layers for transmission.

The UE shall continue cell re-selection related measurements as well as cell re-selection evaluation. If the conditions for cell re-selection are fulfilled, the UE shall perform cell re-selection as specified in 5.3.3.6.

[TS 38.331, clause 5.3.3.4]

The UE shall perform the following actions upon reception of the *RRCSetup*:

...

1> set the content of *RRCSetupComplete* message as follows:

2> if upper layers provide an *5G-S-TMSI*:

3> if the *RRCSetup* is received in response to an *RRCSetupRequest*:

4> set the *ng-5G-S-TMSI-Value* to *ng-5G-S-TMSI-Part2*;

3> else:

4> set the *ng-5G-S-TMSI-Value* to *ng-5G-S-TMSI*;

...

1> submit the *RRCSetupComplete* message to lower layers for transmission, upon which the procedure ends

[TS 38.331, clause 5.3.11]

UE shall:

1> reset MAC;

1> if T302 is running:

2> stop timer T302;

2> perform the actions as specified in 5.3.14.4;

1> stop all timers that are running except T320 and T325;

1> discard the UE Inactive AS context;

1> set the variable *pendingRnaUpdate* to *false*, if that is set to *true*;

1> discard the K_{gNB} , the K_{RRCenc} key, the K_{RRCint} , the K_{UPint} key and the K_{UPenc} key, if any;

1> release all radio resources, including release of the RLC entity, the MAC configuration and the associated PDCP entity and SDAP for all established RBs;

1> indicate the release of the RRC connection to upper layers together with the release cause;

1> enter RRC_IDLE and perform cell selection as specified in TS 38.304 [20], except if going to RRC_IDLE was triggered by selecting an inter-RAT cell while T311 was running;

1> if going to RRC_IDLE was triggered by reception of the *RRCRelease* message including a *waitTime*:

2> start timer T302 with the value set to the *waitTime*;

2> inform the upper layer that access barring is applicable for all access categories except categories '0' and '2'.

[TS 24.501, clause 5.3.1.4]

...

Upon receiving AMF paging indication from the lower layers, the UE shall transition from 5GMM-CONNECTED mode with RRC inactive indication to 5GMM-IDLE mode over 3GPP access and handle the AMF paging same as the paging request received in the 5GMM-IDLE mode over 3GPP access as specified in subclause 5.6.1.

[TS 24.501, clause 5.6.1.1]

...

The UE shall invoke the service request procedure when:

- a) the UE, in 5GMM-IDLE mode over 3GPP access, receives a paging request from the network;

8.1.1.1.2.3 Test description

8.1.1.1.2.3.1 Pre-test conditions

System Simulator:

- NR Cell 1.

UE:

- None.

Preamble:

- The UE is in state 1N-A as defined in TS 38.508-1 [4], subclause 4.4A on NR Cell 1 and 5G-GUTI is allocated in REGISTRATION ACCEPT.

8.1.1.1.2.3.2 Test procedure sequence

Table 8.1.1.1.2.3.2-1: Main behaviour

St	Procedure	Message Sequence		TP	Verdict
		U - S	Message		
1	The SS transmits a <i>Paging</i> message including a matched ng-5G-S-TMSI.	<--	NR RRC: <i>Paging</i>	-	-
2	Check: Does the UE transmit an <i>RRCSetupRequest</i> message with ue-Identity set to ng-5G-S-TMSI-Part1?	-->	NR RRC: <i>RRCSetupRequest</i>	1	P
3	The SS transmits an <i>RRCSetup</i> message.	<--	NR RRC: <i>RRCSetup</i>	-	-
4	Check: Does the UE transmit an <i>RRCSetupComplete</i> message including ng-5G-S-TMSI-Part2 and a SERVICE REQUEST message and an IE <i>selectedPLMN-Identity</i> corresponding to the PLMN on which the UE has been registered to confirm the successful completion of the connection establishment?	-->	NR RRC: <i>RRCSetupComplete</i>	2	P
5-8	Steps 5 to 8 of the generic radio bearer establishment procedure (TS 38.508-1 [4] Table 4.5.4.2-3) are executed to successfully complete the service request procedure.	-	-	-	-
9	The SS transmits an <i>RRCRelease</i> message with suspendConfig to suspend RRC connection and move to RRC_INACTIVE state.	<--	NR RRC: <i>RRCRelease</i>	-	-
10	Wait 5s and the SS transmits a <i>Paging</i> message including a matched ng-5G-S-TMSI.	<--	NR RRC: <i>Paging</i>	-	-
11	Check: Does the UE transmit an <i>RRCSetupRequest</i> message on the cell specified in the test case?	-->	NR RRC: <i>RRCSetupRequest</i>	3	P
12-18	Steps 3-9 of Generic procedure for checking UE is in state 5GC RRC_IDLE on a certain cell as specified in Table 4.9.4-1 of TS 38.508-1 [4] are performed.	-	-	-	-

8.1.1.1.2.3.3 Specific message contents

Table 8.1.1.1.2.3.3-1: SIB1 (preamble and all steps, Table 8.1.1.1.2.3.2-1)

Derivation Path: 38.508-1 [4] Table 4.6.1-28			
Information Element	Value/remark	Comment	Condition
SIB1 ::= SEQUENCE {			
CellAccessRelatedInfo SEQUENCE {			
plmn-IdentityList	PLMN-IdentityInfoList		
}			
}			

Table 8.1.1.1.2.3.3-2: PLMN-IdentityInfoList (Table 8.1.1.1.2.3.3-1)

Derivation Path: 38.508-1 [4] Table 4.6.3-108			
Information Element	Value/remark	Comment	Condition
PLMN-IdentityInfoList ::= SEQUENCE (SIZE (1..maxPLMN)) OF SEQUENCE {	1 entry		
plmn-IdentityList SEQUENCE (SIZE (1..maxPLMN)) OF PLMN-Identity {	2 entries		
plmn-Identity[1] SEQUENCE {			
mcc	See Table 8.1.1.1.2.3.3-2A	PLMN1	
mnc	See Table 8.1.1.1.2.3.3-2A	PLMN1	
}			
plmn-Identity[2] SEQUENCE {			
mcc	See Table 8.1.1.1.2.3.3-2A	PLMN2	
mnc	See Table 8.1.1.1.2.3.3-2A	PLMN2	
}			
}			
}			

The PLMN Identity list broadcasted on the BCCH in NR Cell 1 shall be configured as defined in the table below.

Table 8.1.1.1.2.3.3-2A: PLMN Identity List broadcasted for NR Cell 1

Cell	PLMN Identity [1]		PLMN Identity [2]	
	MCC digits	MNC digits	MCC digits	MNC digits
1	PLMN 1	PLMN 1	PLMN 2	PLMN 2

The definition of each PLMN code is found in table below:

Table 8.1.1.1.2.3.3-2B: definition of each PLMN code

PLMN	MCC digit			MNC digit		
	1	2	3	1	2	3
1	(NOTE 2)			(NOTE 2)		
2	(NOTE 3)			0	2	-

NOTE 1: “-“ (dash) denotes “not present”

NOTE 2: Set to the same Mobile Country Code and Mobile Network Code stored in EF_{IMSI} on the test USIM card for PLMN 1.

NOTE 3: Set to the same Mobile Country Code stored in EF_{IMSI} on the test USIM card for PLMN 2.

Table 8.1.1.1.2.3.3-3: RRCSetupRequest (step 2,11, Table 8.1.1.1.2.3.2-1)

Derivation Path: 38.508-1 [4], Table 4.6.1-23			
Information Element	Value/remark	Comment	Condition
RRCSetupRequest ::= SEQUENCE {			
rrcSetupRequest SEQUENCE {			
ue-Identity CHOICE {			
ng-5G-S-TMSI-Part1	ng-5G-S-TMSI-Part1	ng-5G-S-TMSI-Part1 is rightmost 39 bits of 5G-S-TMSI. 5G-S-TMSI is derived from 5G-GUTI in REGISTRATION ACCEPT according to TS 23.003 [34]	
}			
establishmentCause	mt-Access		
}			
}			

Table 8.1.1.1.2.3.3-4: RRCSetupComplete (step 4, Table 8.1.1.1.2.3.2-1)

Derivation Path: 38.508-1 [4], Table 4.6.1-22			
Information Element	Value/remark	Comment	Condition
RRCSetupComplete ::= SEQUENCE {			
rrc-TransactionIdentifier	RRC-TransactionIdentifier		
criticalExtensions CHOICE {			
rrcSetupComplete SEQUENCE {			
ng-5G-S-TMSI-Value	ng-5G-S-TMSI-Part2	ng-5G-S-TMSI-Part2 is the leftmost 9 bits of 5G-S-TMSI. 5G-S-TMSI is derived from 5G-GUTI in REGISTRATION ACCEPT according to TS 23.003 [34]	
selectedPLMN-Identity	1 or 2	PLMN1 or PLMN2 Note1	
}			
}			
}			
Note1: If RPLMN is PLMN1, UE will select PLMN1; if RPLMN is PLMN2, UE will select PLMN2			

- 2> if the T300 has expired a consecutive *connEstFailCount* times on the same cell for which *connEstFailureControl* is included in *SIB1*:
- 3> for a period as indicated by *connEstFailOffsetValidity*:
 - 4> use *connEstFailOffset* for the parameter *Qoffsettemp* for the concerned cell when performing cell selection and reselection according to TS 38.304 [20] and TS 36.304 [27];

NOTE: When performing cell selection, if no suitable or acceptable cell can be found, it is up to UE implementation whether to stop using *connEstFailOffset* for the parameter *Qoffsettemp* during *connEstFailOffsetValidity* for the concerned cell.

- 2> inform upper layers about the failure to establish the RRC connection, upon which the procedure ends;

8.1.1.2.1.3 Test description

8.1.1.2.1.3.1 Pre-test conditions

System Simulator:

- NR Cell 1.

UE:

- None.

Preamble:

- The UE is in state 1N-A as defined in TS 38.508-1 [4], subclause 4.4A on NR Cell 1 and 5G-GUTI is allocated in REGISTRATION ACCEPT.

8.1.1.2.1.3.2 Test procedure sequence

Table 8.1.1.2.1.3.2-1: Main behaviour

St	Procedure	Message Sequence		TP	Verdict
		U - S	Message		
1	The SS transmits a <i>Paging</i> message including a matched ng-5G-S-TMSI.	<--	<i>Paging</i>	-	-
2	The UE transmits an <i>RRCSetupRequest</i> message.	-->	<i>RRCSetupRequest</i>	-	-
3	The SS waits for 2s (T300 expire).	-	-	-	-
4	Check: does UE send <i>RRCSetupRequest</i> in 5 second?	-	-	1	F
5	Check: does the test result of generic test procedure in TS 38.508-1 [4] subclause 4.9.4 indicate that the UE is in RRC_IDLE?	-	-	1	-

8.1.1.2.1.3.3 Specific message contents

Table 8.1.1.2.1.3.3-1: *RRCSetupRequest* (step 2 Table 8.1.1.2.1.3.2-1)

Derivation Path: 38.508-1 [4], Table 4.6.1-23			
Information Element	Value/remark	Comment	Condition
RRCSetupRequest ::= SEQUENCE {			
rrcSetupRequest SEQUENCE {			
establishmentCause	mt-Access		
}			
}			

8.1.1.2.3 RRC connection establishment / RRC Reject with wait time

8.1.1.2.3.1 Test Purpose (TP)

(1)

```

with { UE in NR RRC_IDLE state and has sent an RRCSetupRequest message }
ensure that {
  when { UE receives an RRCReject message including an IE waitTime }
  then { UE doesn't re-send RRCSetupRequest message before the waitTime is expired }
}

```

8.1.1.2.3.2 Conformance requirements

References: The conformance requirements covered in the current TC is specified in: TS 38.331 clause 5.3.15.2.

[TS 38.331, clause 5.3.15.2]

The UE shall:

- 1> stop timer T300, if running;
 - 1> stop timer T319, if running;
 - 1> stop timer T302, if running;
 - 1> reset MAC and release the default MAC Cell Group configuration;
 - 1> if *waitTime* is configured in the *RRCReject*:
 - 2> start timer T302, with the timer value set to the *waitTime*;
 - 1> if *RRCReject* is received in response to a request from upper layers:
 - 2> inform the upper layer that access barring is applicable for all access categories except categories '0' and '2';
 - 1> if *RRCReject* is received in response to an *RRCSetupRequest*:
 - 2> inform upper layers about the failure to setup the RRC connection, upon which the procedure ends;
 - 1> else if *RRCReject* is received in response to an *RRCResumeRequest* or an *RRCResumeRequest1*:
 - 2> if resume is triggered by upper layers:
 - 3> inform upper layers about the failure to resume the RRC connection;
- Editor's Note: FFS In which cases upper layers are informed that a resume failure occurred upon the reception of RRC Reject.**
- 2> if resume is triggered due to an RNA update:
 - 3> set the variable *pendingRnaUpdate* to *true*;
 - 2> discard the current K_{gNB} key, the $K_{RRCCenc}$ key, the K_{RRCint} key, the K_{UPint} key and the K_{UPenc} key derived in accordance with 5.3.13.3;
 - 2> suspend SRB1, upon which the procedure ends;

The RRC_INACTIVE UE shall continue to monitor paging while the timer T302 is running.

8.1.1.2.3.3 Test Description

8.1.1.2.3.3.1 Pre-test conditions

System Simulator:

- NR Cell 1
- System information combination NR-1 as defined in TS 38.508-1 [4] clause 4.4.3.1.3 is used in NR cell.

UE:

- None.

Preamble:

- The UE is in 5GS state 3N-A according to TS 38.508-1 [4], clause 4.4A.2 Table 4.4A.2-3 and Test Loop Function (On) with UE test loop mode B is established.

8.1.1.2.3.3.2 Test procedure sequence

Table 8.1.1.2.3.3.2-1: Main behaviour

St	Procedure	Message Sequence		TP	Verdict
		U - S	Message		
1	The SS transmits one IP packet to the UE on the DRB associated with the default PDU session on Cell 1.	-	-	-	-
2	Wait for 1 second after the IP packet has been transmitted in step 1. (Note 1)	-	-	-	-
3	The SS transmits an <i>RRCRelease</i> message on Cell 1.	<--	NR RRC: <i>RRCRelease</i>	-	-
4	The UE transmits an <i>RRCSetupRequest</i> message for sending the IP packet received in step 1 after IP PDU delay timer expires.	-->	NR RRC: <i>RRCSetupRequest</i>	-	-
5	The SS responds with <i>RRCReject</i> message with IE <i>waitTime</i> set to 10s.	<--	NR RRC: <i>RRCReject</i>	-	-
6	Check: Does the UE transmit an <i>RRCSetupRequest</i> message while timer T302 is running?	-->	NR RRC: <i>RRCSetupRequest</i>	1	F
7	Check: Does UE transmit <i>RRCSetupRequest</i> message for sending the IP packet received in step 1 after timer T302 expires?	-	NR RRC: <i>RRCSetupRequest</i>	1	P
8-12	Steps 3 to 7 of the NR RRC_CONNECTED procedure in TS 38.508-1 Table 4.5.4.2-3 are executed.	-	-	-	-
-	EXCEPTION: Steps 13 and 14 can occur in any order.	-	-	-	-
13	The UE transmits an <i>RRCReconfigurationComplete</i> message on Cell 1.	-->	NR RRC: <i>RRCReconfigurationComplete</i>	-	-
14	The UE loops back the IP packet received in step 1 on the DRB associated with the default PDU session on Cell 1.	-	-	-	-
Note 1: The 1 second delay is used to secure that the UE has received and forwarded the IP Packet transmitted by the SS in step 1 to the UE test loop function before the <i>RRCRelease</i> message is sent by the SS in step 3.					

8.1.1.2.3.3.3 Specific message contents

Table 8.1.1.2.3.3.3-1: RRCReject (step 5, table 8.1.1.2.3.3.2-1)

Derivation path: 38.508-1 Table 4.6.1-15			
Information Element	Value/remark	Comment	Condition
RRCReject ::= SEQUENCE {			
criticalExtensions CHOICE {			
rrcReject SEQUENCE {			
waitTime	10	10 seconds	
}			
}			
}			

Table 8.1.1.2.3.3.3-2: CLOSE UE TEST LOOP (Preamble, Table 8.1.1.2.3.3.2-1)

Derivation Path: 36.508, Table 4.7A-3, condition UE TEST LOOP MODE B			
Information Element	Value/remark	Comment	Condition
UE test loop mode B LB setup			
IP PDU delay	'0000 0101'B	5 seconds	

8.1.1.3 RRC release

8.1.1.3.1 RRC connection release / Redirection to another NR frequency

8.1.1.3.1.1 Test Purpose (TP)

(1)

```

with { UE in NR RRC_CONNECTED state }
ensure that {
  when { UE receives an RRCRelease message including an IE redirectedCarrierInfo with nr and
  carrierFreq different from the frequency UE was on in RRC_CONNECTED state }
    then { UE enters RRC_IDLE state on new frequency included in IE redirectedCarrierInfo }
}

```

8.1.1.3.1.2 Conformance requirements

References: The conformance requirements covered in the current TC are specified in: TS 38.331, clause 5.3.8.3, TS 38.304, clause 5.2.4.1. Unless otherwise stated these are Rel-15 requirements.

[TS 38.331, clause 5.3.8.3]

The UE shall:

- 1> delay the following actions defined in this sub-clause 60ms from the moment the *RRCRelease* message was received or optionally when lower layers indicate that the receipt of the *RRCRelease* message has been successfully acknowledged, whichever is earlier;
- 1> stop timer T320, if running;
- 1> if the *RRCRelease* message includes *redirectedCarrierInfo* indicating redirection to *eutra*:
 - 2> if *cnType* is included:
 - 3> the received *cnType* is provided to upper layers;

NOTE: Handling the case if the E-UTRA cell selected after the redirection does not support the core network type specified by the *cnType*, is up to UE implementation.

- 1> if the *RRCRelease* message includes the *cellReselectionPriorities*:
 - 2> store the cell reselection priority information provided by the *cellReselectionPriorities*;

2> if the $t320$ is included:

3> start timer T320, with the timer value set according to the value of $t320$;

1> else:

2> apply the cell reselection priority information broadcast in the system information;

...

[TS 38.304, clause 5.2.4.1]

...

The UE shall only perform cell reselection evaluation for NR frequencies and inter-RAT frequencies that are given in system information and for which the UE has a priority provided.

...

[TS 38.304, clause 5.2.6]

On transition from RRC_CONNECTED to RRC_IDLE state or RRC_INACTIVE state, UE shall attempt to camp on a suitable cell according to *redirectedCarrierInfo* if included in the *RRCRelease* message used for this transition. If the UE cannot find a suitable cell, the UE is allowed to camp on any suitable cell of the indicated RAT. If the *RRCRelease* message does not contain the *redirectedCarrierInfo*, UE shall attempt to select a suitable cell on an NR carrier. If no suitable cell is found according to the above, the UE shall perform cell selection using stored information in order to find a suitable cell to camp on.

When returning to RRC_IDLE state after UE moved to RRC_CONNECTED state from *camped on any cell* state, UE shall attempt to camp on an acceptable cell according to *redirectedCarrierInfo*, if included in the *RRCRelease* message. If the UE cannot find an acceptable cell, the UE is allowed to camp on any acceptable cell of the indicated RAT. If the *RRCRelease* message does not contain *redirectedCarrierInfo* UE shall attempt to select an acceptable cell on an NR frequency. If no acceptable cell is found according to the above, the UE shall continue to search for an acceptable cell of any PLMN in state *any cell selection*.

8.1.1.3.1.3 Test description

8.1.1.3.1.3.1 Pre-test conditions

System Simulator:

- 2 cells on different NR frequencies and different tracking areas:
 - NR Cell 1 (TAI-1) serving cell
 - NR Cell 23 (TAI-2) suitable neighbour inter-frequency cell
- Cell power levels are selected according to 38.508-1 [4] Table 6.2.2.1-3 and NR Cell 23 is switched on after UE has registered on NR Cell 1.
- System information combination NR-4 as defined in TS 38.508-1 [4] clause 4.4.3.1.2 is used in NR cells.

UE:

- None.

Preamble:

- The UE is in state 3N-A as defined in TS 38.508-1 [4], subclause 4.4A on NR Cell 1.

8.1.1.3.1.3.2 Test procedure sequence

Table 8.1.1.3.1.3.2-1: Main behaviour

St	Procedure	Message Sequence		TP	Verdict
		U - S	Message		
1	The SS transmits an <i>RRCRelease</i> message (IE <i>redirectedCarrierInfo</i> including NR Cell 23).	<--	RRC: <i>RRCRelease</i>	-	-
2	Check: does the test result of generic test procedure in TS 38.508-1 [4] subclause 4.9.5.2.2-1 indicate that the UE is camped on NR Cell 23?	-	-	1	P

8.1.1.3.1.3.3 Specific message contents

Table 8.1.1.3.1.3.3-1: SIB4 for NR cells 1 and 23 (preamble and all steps, Table 8.1.1.3.1.3.2-1)

Derivation Path: 38.508-1 [4] Table 4.6.2-3			
Information Element	Value/remark	Comment	Condition
SIB4 ::= SEQUENCE {			
interFreqCarrierFreqList SEQUENCE (SIZE (1..maxFreq)) OF SEQUENCE {			
dl-CarrierFreq[n]	Same downlink NR ARFCN as used for NR Cell 23		NR Cell 1
	Same downlink NR ARFCN as used for NR Cell 1		NR Cell 23
cellReselectionPriority[n]	Not present		
}			
}			

Table 8.1.1.3.1.3.3-2: *RRCRelease* message (step 1, Table 8.1.1.3.1.3.2-1)

Derivation Path: 38.508-1 [4] Table 4.6.1-16			
Information Element	Value/remark	Comment	Condition
RRCRelease ::= SEQUENCE {			
rrc-TransactionIdentifier	RRC-TransactionIdentifier		
criticalExtensions CHOICE {			
rrcRelease SEQUENCE {			
redirectedCarrierInfo CHOICE {			
nr SEQUENCE {			
carrierFreq	ARFCN-ValueNR for NR Cell 23 frequency		
ssbSubcarrierSpacing	Subcarrier spacing of SSB for NR Cell 23		
smtc	SSB-MTC	38.508-1 [4] Table 4.6.3-185	
}			
}			
}			
}			
}			

8.1.1.3.2 RRC connection release / Redirection from NR to E-UTRA

8.1.1.3.2.1 Test Purpose (TP)

(1)

```
with { UE in NR RRC_CONNECTED state }
ensure that {
  when { UE receives an RRCRelease message including an IE redirectionInformation with E-UTRA
frequency }
  then { UE enters RRC_IDLE state on E-UTRA frequency included in IE redirectionInformation }
}
```

8.1.1.3.2.2 Conformance requirements

References: The conformance requirements covered in the present TC are specified in: TS 38.331, clause 5.3.8.3, TS 38.304, clause 5.2.6.

[TS 38.331, clause 5.3.8.3]

The UE shall:

1> delay the following actions defined in this sub-clause 60ms from the moment the *RRCRelease* message was received or optionally when lower layers indicate that the receipt of the *RRCRelease* message has been successfully acknowledged, whichever is earlier;

1> stop timer T320, if running;

1> if the *RRCRelease* message includes *redirectedCarrierInfo* indicating redirection to *eutra*:

2> if *cnType* is included:

3> after the cell selection, indicate the available CN Type(s) and the received *cnType* to upper layers;

NOTE: Handling the case if the E-UTRA cell selected after the redirection does not support the core network type specified by the *cnType*, is up to UE implementation.

[TS 38.304, clause 5.2.6]

At reception of *RRCRelease* message to transition the UE to RRC_IDLE or RRC_INACTIVE, UE shall attempt to camp on a suitable cell according to *redirectedCarrierInfo* if included in the *RRCRelease* message used for this transition. If the UE cannot find a suitable cell, the UE is allowed to camp on any suitable cell of the indicated RAT. If the *RRCRelease* message does not contain the *redirectedCarrierInfo*, UE shall attempt to select a suitable cell on an NR carrier. If no suitable cell is found according to the above, the UE shall perform cell selection using stored information in order to find a suitable cell to camp on.

When returning to RRC_IDLE state after UE moved to RRC_CONNECTED state from *camped on any cell* state, UE shall attempt to camp on an acceptable cell according to *redirectedCarrierInfo*, if included in the *RRCRelease* message. If the UE cannot find an acceptable cell, the UE is allowed to camp on any acceptable cell of the indicated RAT. If the *RRCRelease* message does not contain *redirectedCarrierInfo* UE shall attempt to select an acceptable cell on an NR frequency. If no acceptable cell is found according to the above, the UE shall continue to search for an acceptable cell of any PLMN in state *any cell selection*.

8.1.1.3.2.3 Test description

8.1.1.3.2.3.1 Pre-test conditions

System Simulator:

- NR Cell 1 is the serving cell
- E-UTRA Cell 1 is a suitable neighbour cell

- The parameters settings and power levels for NR Cell 1, E-UTRA Cell 1 are selected to ensure that camping on NR Cell 1 is guaranteed and no cell re-selection to E-UTRA Cell 1 can take place (E -UTRA Cell 1 priority is lower than serving NR Cell 1).
- System information combination NR-5 as defined in TS 38.508 -1 [4] clause 4.4.3.1.2 is used

UE:

- None

Preamble:

- The UE is in state 3N-A as defined in TS 38.508-1 [4], clause 4.4A.2.

8.1.1.3.2.3.2 Test procedure sequence

Tables 8.1.1.3.2.3.2-1/ 8.1.1.3.2.3.2-1A illustrates the downlink power levels to be applied for NR Cell 1, E-UTRA Cell 1 for the test execution.

Table 8.1.1.3.2.3.2-1: Time instances of cell power level and parameter changes for FR1

	Parameter	Unit	NR Cell 1	E-UTRA Cell 1	Remark
T0	Cell-specific RS EPRE	dBm/15 kHz		-91	The power levels are such that camping on NR Cell 1 is guaranteed.
	SS/PBCH SSS EPRE	dBm/S CS	-85	-	

Table 8.1.1.3.2.3.2-1A: Time instances of cell power level and parameter changes for FR2

	Parameter	Unit	NR Cell 1	E-UTRA Cell 1	Remark
T0	Cell-specific RS EPRE	dBm/15 kHz		FFS	The power levels are such that camping on NR Cell 1 is guaranteed.
	SS/PBCH SSS EPRE	dBm/S CS	FFS	-	

Table 8.1.1.3.2.3.2-2: Main behaviour

St	Procedure	Message Sequence		TP	Verdict
		U - S	Message		
1	SS transmits an <i>RRCRelease</i> message (IE <i>redirectionInformation</i> including ARFCN-ValueEUTRA of E-UTRA Cell 1).	<--	NR RRC: <i>RRCRelease</i>	-	-
2	Check: Does the test result of generic test procedure in TS 36.508 Table 6.4.2.7A-1 is performed and the UE is camped on E-UTRAN Cell 1?	-	-	1	-

8.1.1.3.2.3.3 Specific message contents

Table 8.1.1.3.2.3.3-1 *RRCRelease* (step 1, Table 8.1.1.3.2.3.2-2)

Derivation Path: 38.508-1 table 4.6.1-16			
Information Element	Value/remark	Comment	Condition
<i>RRCRelease</i> ::= SEQUENCE {			
criticalExtensions CHOICE {			
c1 CHOICE {			
<i>rrcRelease</i> ::= SEQUENCE {			
<i>redirectedCarrierInfo</i> ::= CHOICE {			
<i>eutra</i> ::= SEQUENCE {			
<i>eutraFrequency</i>	EARFCN of E-UTRA Cell 1		
<i>cnType-r15</i>	Epc		
}			
}			
}			
}			
}			
}			

8.1.1.3.3 RRC connection release / Success / With priority information

8.1.1.3.3.1 Test Purpose (TP)

(1)

```

with { UE in NR RRC_IDLE state having received an RRCRelease message with the freqPriorityListNR
with higher priority frequency }
ensure that {
  when { UE detects the cell re-selection criteria are met for the cell which belongs to the higher
priority frequency }
    then { UE reselects the cell which belongs to the higher priority frequency }
}

```

8.1.1.3.3.2 Conformance requirements

References: The conformance requirements covered in the current TC are specified in: TS 38.331, clause 5.3.8.3 and TS38.304, clause 5.2.4.1, 5.2.4.2 and 5.2.4.5. Unless otherwise stated these are Rel-15 requirements.

[TS 38.331, clause 5.3.8.3]

The UE shall:

- 1> delay the following actions defined in this sub-clause 60 ms from the moment the *RRCRelease* message was received or optionally when lower layers indicate that the receipt of the *RRCRelease* message has been successfully acknowledged, whichever is earlier;
- 1> stop timer T380, if running;
- 1> stop timer T320, if running;
- 1> stop timer T390, if running;
- 1> if the security is not activated, perform the actions upon going to RRC_IDLE as specified in 5.3.11 with the release cause 'other' upon which the procedure ends;
- 1> if the *RRCRelease* message includes *redirectedCarrierInfo* indicating redirection to *eutra*:
 - 2> if *cnType* is included:
 - 3> after the cell selection, indicate the available CN Type(s) and the received *cnType* to upper layers;

NOTE: Handling the case if the E-UTRA cell selected after the redirection does not support the core network type specified by the *cnType*, is up to UE implementation.

1> if the *RRCRelease* message includes the *cellReselectionPriorities*:

2> store the cell reselection priority information provided by the *cellReselectionPriorities*;

2> if the *t320* is included:

3> start timer T320, with the timer value set according to the value of *t320*;

1> else:

2> apply the cell reselection priority information broadcast in the system information;

1> if *deprioritisationReq* is included:

2> start or restart timer T325 with the timer value set to the *deprioritisationTimer* signalled;

2> store the *deprioritisationReq* until T325 expiry;

1> if the *RRCRelease* includes *suspendConfig*:

2> apply the received *suspendConfig*;

2> reset MAC and release the default MAC Cell Group configuration, if any;

2> re-establish RLC entities for SRB1;

2> if the *RRCRelease* message with *suspendConfig* was received in response to an *RRCResumeRequest* or an *RRCResumeRequest1*:

3> stop the timer T319 if running;

3> in the stored UE Inactive AS context:

4> replace the K_{gNB} and K_{RRCint} keys with the current K_{gNB} and K_{RRCint} keys;

4> replace the C-RNTI with the temporary C-RNTI in the cell the UE has received the *RRCRelease* message;

4> replace the *cellIdentity* with the *cellIdentity* of the cell the UE has received the *RRCRelease* message;

4> replace the physical cell identity with the physical cell identity of the cell the UE has received the *RRCRelease* message;

4> replace the *suspendConfig* with the current *suspendConfig*;

2> else:

3> store in the UE Inactive AS Context the received *suspendConfig*, all current parameters configured with *RRCReconfiguration* or *RRCResume*, the current K_{gNB} and K_{RRCint} keys, the ROHC state, the C-RNTI used in the source PCell, the *cellIdentity* and the physical cell identity of the source PCell;

2> suspend all SRB(s) and DRB(s), except SRB0;

2> indicate PDCP suspend to lower layers of all DRBs;

2> if the *t380* is included:

3> start timer T380, with the timer value set to *t380*;

2> if the *RRCRelease* message is including the *waitTime*:

3> start timer T302 with the value set to the *waitTime*;

3> inform the upper layer that access barring is applicable for all access categories except categories '0' and '2';

- 2> indicate the suspension of the RRC connection to upper layers;
- 2> enter RRC_INACTIVE and perform cell selection as specified in TS 38.304 [20];
- 1> else
- 2> perform the actions upon going to RRC_IDLE as specified in 5.3.11, with the release cause 'other'.

[TS 38.304, clause 5.2.4.1]

Absolute priorities of different NR frequencies or inter-RAT frequencies may be provided to the UE in the system information, in the *RRCRelease* message, or by inheriting from another RAT at inter-RAT cell (re)selection. In the case of system information, an NR frequency or inter-RAT frequency may be listed without providing a priority (i.e. the field *cellReselectionPriority* is absent for that frequency). If priorities are provided in dedicated signalling, the UE shall ignore all the priorities provided in system information. If UE is in *camped on any cell* state, UE shall only apply the priorities provided by system information from current cell, and the UE preserves priorities provided by dedicated signalling and *deprioritisationReq* received in *RRCRelease* unless specified otherwise. When the UE in *camped normally* state, has only dedicated priorities other than for the current frequency, the UE shall consider the current frequency to be the lowest priority frequency (i.e. lower than any of the network configured values).

The UE shall only perform cell reselection evaluation for NR frequencies and inter-RAT frequencies that are given in system information and for which the UE has a priority provided.

In case UE receives *RRCRelease* with *deprioritisationReq*, UE shall consider current frequency and stored frequencies due to the previously received *RRCRelease* with *deprioritisationReq* or all the frequencies of NR to be the lowest priority frequency (i.e. lower than any of the network configured values) while T325 is running irrespective of *camped* RAT. The UE shall delete the stored deprioritisation request(s) when a PLMN selection is performed on request by NAS (TS 23.122 [9]).

NOTE: UE should search for a higher priority layer for cell reselection as soon as possible after the change of priority. The minimum related performance requirements specified in TS 38.133 [8] are still applicable.

The UE shall delete priorities provided by dedicated signalling when:

- the UE enters a different RRC state; or
- the optional validity time of dedicated priorities (T320) expires; or
- a PLMN selection is performed on request by NAS (TS 23.122 [9]).

NOTE 2: Equal priorities between RATs are not supported.

The UE shall not consider any black listed cells as candidate for cell reselection.

The UE shall inherit the priorities provided by dedicated signalling and the remaining validity time (i.e. T320 in NR and E-UTRA), if configured, at inter-RAT cell (re)selection.

NOTE 3: The network may assign dedicated cell reselection priorities for frequencies not configured by system information.

[TS 38.304, clause 5.2.4.2]

Following rules are used by the UE to limit needed measurements:

- If the serving cell fulfils $S_{rxlev} > S_{IntraSearchP}$ and $S_{qual} > S_{IntraSearchQ}$, the UE may choose not to perform intra-frequency measurements.
- Otherwise, the UE shall perform intra-frequency measurements.
- The UE shall apply the following rules for NR inter-frequencies and inter-RAT frequencies which are indicated in system information and for which the UE has priority provided as defined in 5.2.4.1:
 - For a NR inter-frequency or inter-RAT frequency with a reselection priority higher than the reselection priority of the current NR frequency, the UE shall perform measurements of higher priority NR inter-frequency or inter-RAT frequencies according to TS 38.133 [8].

- For a NR inter-frequency with an equal or lower reselection priority than the reselection priority of the current NR frequency and for inter-RAT frequency with lower reselection priority than the reselection priority of the current NR frequency:
 - If the serving cell fulfils $S_{rxlev} > S_{nonIntraSearchP}$ and $S_{qual} > S_{nonIntraSearchQ}$, the UE may choose not to perform measurements of NR inter-frequencies or inter-RAT frequency cells of equal or lower priority;
- Otherwise, the UE shall perform measurements of NR inter-frequencies or inter-RAT frequency cells of equal or lower priority according to TS 38.133 [8].

[TS 38.304, clause 5.2.4.5]

If *threshServingLowQ* is broadcast in system information and more than 1 second has elapsed since the UE camped on the current serving cell, cell reselection to a cell on a higher priority NR frequency or inter-RAT frequency than the serving frequency shall be performed if:

- A cell of a higher priority NR or EUTRAN RAT/frequency fulfils $S_{qual} > Thresh_{X, HighQ}$ during a time interval $T_{reselection_{RAT}}$

Otherwise, cell reselection to a cell on a higher priority NR frequency or inter-RAT frequency than the serving frequency shall be performed if:

- A cell of a higher priority RAT/ frequency fulfils $S_{rxlev} > Thresh_{X, HighP}$ during a time interval $T_{reselection_{RAT}}$; and
- More than 1 second has elapsed since the UE camped on the current serving cell.

Cell reselection to a cell on an equal priority NR frequency shall be based on ranking for intra-frequency cell reselection as defined in sub-clause 5.2.4.6.

If *threshServingLowQ* is broadcast in system information and more than 1 second has elapsed since the UE camped on the current serving cell, cell reselection to a cell on a lower priority NR frequency or inter-RAT frequency than the serving frequency shall be performed if:

- The serving cell fulfils $S_{qual} < Thresh_{Serving, LowQ}$ and a cell of a lower priority NR or E-UTRAN RAT/ frequency fulfils $S_{qual} > Thresh_{X, LowQ}$ during a time interval $T_{reselection_{RAT}}$.

Otherwise, cell reselection to a cell on a lower priority NR frequency or inter-RAT frequency than the serving frequency shall be performed if:

- The serving cell fulfils $S_{rxlev} < Thresh_{Serving, LowP}$ and a cell of a lower priority RAT/ frequency fulfils $S_{rxlev} > Thresh_{X, LowP}$ during a time interval $T_{reselection_{RAT}}$; and
- More than 1 second has elapsed since the UE camped on the current serving cell.

Cell reselection to a higher priority RAT/frequency shall take precedence over a lower priority RAT/frequency if multiple cells of different priorities fulfil the cell reselection criteria.

If more than one cell meets the above criteria, the UE shall reselect a cell as follows:

- If the highest-priority frequency is an NR frequency, the highest ranked cell among the cells on the highest priority frequency(ies) meeting the criteria according to clause 5.2.4.6;
- If the highest-priority frequency is from another RAT, the highest ranked cell among the cells on the highest priority frequency(ies) meeting the criteria of that RAT.

8.1.1.3.3.3 Test description

8.1.1.3.3.3.1 Pre-test conditions

System Simulator:

- NR Cell 1, NR Cell 3 and NR Cell6.
- NR Cell 1 (TAI-1) serving cell.

- System information combination NR-4 as defined in TS 38.508-1 [4] clause 4.4.3.1.2-1 is used in NR cells.

NOTE: For Cell 3 and 6 TAI is set to TAI-2

UE:

- None.

Preamble:

- The UE is in state 3N-A on NR Cell 1(serving cell) according to TS 38.508-1 [4] Table 4.4A.2-3.

8.1.1.3.3.3.2 Test procedure sequence

Table 8.1.1.3.3.3.2-1/2 illustrates the downlink power levels and other changing parameters to be applied for the cells at various time instants of the test execution. Row marked "T0" denotes the initial conditions after preamble, while columns marked "T1" is to be applied subsequently. The exact instants on which these values shall be applied are described in the texts in this clause.

Table 8.1.1.3.3.3.2-1: Time instances of cell power level and parameter changes for FR1

	Parameter	Unit	NR Cell 1	NR Cell 3	NR Cell 6	Remark
T0	Cell-specific RS EPRE	dBm/SCS	-88	Off	Off	The power level values are assigned to satisfy $Srxlev_{Cell\ 1} > S_{intrasearch}$. (NOTE 1)
T1	Cell-specific RS EPRE	dBm/SCS	-88	-76	-76	The power level values are assigned to satisfy both $Thresh_{x, low} < Srxlev_{Cell\ 3}$ and $Thresh_{x, high} < Srxlev_{Cell\ 6}$.

NOTE 1: Power level "Off" is defined in TS38.508 Table 6.2.2.1-3.

Table 8.1.1.3.3.3.2-2 Time instances of cell power level and parameter changes for FR2

	Parameter	Unit	NR Cell 1	NR Cell 3	NR Cell 6	Remark
T0	Cell-specific RS EPRE	dBm/SCS	FFS	FFS	FFS	The power level values are assigned to satisfy $Srxlev_{Cell\ 1} > S_{intrasearch}$. (NOTE 1)
T1	Cell-specific RS EPRE	dBm/SCS	FFS	FFS	FFS	The power level values are assigned to satisfy both $Thresh_{x, low} < Srxlev_{Cell\ 3}$ and $Thresh_{x, high} < Srxlev_{Cell\ 6}$.

NOTE 1: Power level "Off" is defined in TS38.508 Table 6.2.2.1-3.

Table 8.1.1.3.3.3.2-2: Main behaviour

St	Procedure	Message Sequence		TP	Verdict
		U - S	Message		
1	The SS changes NR Cell 1, NR Cell 3 and NR Cell 6 power level according to the row "T1" in table 8.1.1.3.3.3.2-1/2.	-	-	-	-
2	The SS transmits an <i>RRCRelease</i> message including the <i>freqPriorityListNR</i> on NR Cell 1.	<--	NR RRC: <i>RRCRelease</i>	-	-
3	Check: Does the UE perform on NR Cell 6 the Registration procedure for mobility registration update as specified in TS 38.508-1 [4] subclause 4.9.5, 'connected without release'?	-	-	1	P

8.1.1.3.3.3.3 Specific message contents

Table 8.1.1.3.3.3-1: RRCRelease (step 2, Table 8.1.1.3.3.3.2-2)

Derivation Path: 38.508 Table 4.6.1-16			
Information Element	Value/remark	Comment	Condition
RRCRelease ::= SEQUENCE {			
criticalExtensions CHOICE {			
c1 CHOICE {			
rrcRelease SEQUENCE {			
cellReselectionPriorities SEQUENCE {	3 entries		
freqPriorityListEUTRA	Not present		
freqPriorityListNR SEQUENCE (SIZE (1..maxFreq)) OF SEQUENCE {			
carrierFreq[1]	Same downlink ARFCN as used for NR Cell 1		
cellReselectionPriority[1]	4		
carrierFreq[2]	Same downlink ARFCN as used for NR Cell 3		
cellReselectionPriority[2]	1		
carrierFreq[3]	Same downlink ARFCN as used for NR Cell 6		
cellReselectionPriority[3]	5		
}			
}			
}			
}			
}			

Table 8.1.1.3.3.3-2: SystemInformationBlockType4 for Cell 1 (preamble and all steps, Table 8.1.1.3.3.3.2-2)

Derivation path: 38.508-1 [4], Table 4.6.2-3			
Information Element	Value/Remark	Comment	Condition
SystemInformationBlockType4 ::= SEQUENCE {			
interFreqCarrierFreqList SEQUENCE (SIZE (1..maxFreq)) OF SEQUENCE {	2 entries		
dl-CarrierFreq[1]	Same downlink NR ARFCN as used for NR Cell 3		
cellReselectionPriority[1]	1		
dl-CarrierFreq[2]	Same downlink NR ARFCN as used for NR Cell 6		
cellReselectionPriority[2]	5		
}			
}			

Table 8.1.1.3.3.3-3: SystemInformationBlockType4 for Cell 6 (all steps, Table 8.1.1.3.3.3.2-2)

Derivation path: 38.508-1 [4], Table 4.6.2-3			
Information Element	Value/Remark	Comment	Condition
SystemInformationBlockType4 ::= SEQUENCE {			
interFreqCarrierFreqList SEQUENCE (SIZE (1..maxFreq)) OF SEQUENCE {	2 entries		
dl-CarrierFreq[1]	Same downlink NR ARFCN as used for NR Cell 1		
cellReselectionPriority[1]	4		
dl-CarrierFreq[2]	Same downlink NR ARFCN as used for NR Cell 3		
cellReselectionPriority[2]	1		
}			
}			

8.1.1.3.4 RRC connection release / Success / With priority information / E-UTRA

8.1.1.3.4.1 Test Purpose (TP)

(1)

```
with { UE in NR RRC_IDLE state having received an RRCRelease message with the freqPriorityListEUTRA
with higher priority frequency }
ensure that {
  when { UE detects the cell re-selection criteria are met for the cell which belongs to the higher
priority EUTRA frequency }
    then { UE reselects the cell which belongs to the higher priority EUTRA frequency }
}
```

8.1.1.3.4.2 Conformance requirements

References: The conformance requirements covered in the current TC are specified in: TS 38.331, clause 5.3.8.3 and T 38.304, clause 5.2.4.1. Unless otherwise stated these are Rel-15 requirements.

[TS 38.331, clause 5.3.8.3]

The UE shall:

1> delay the following actions defined in this sub-clause 60 ms from the moment the *RRCRelease* message was received or optionally when lower layers indicate that the receipt of the *RRCRelease* message has been successfully acknowledged, whichever is earlier;

1> stop timer T380, if running;

1> stop timer T320, if running;

1> stop timer T390, if running;

1> if the security is not activated, perform the actions upon going to RRC_IDLE as specified in 5.3.11 with the release cause 'other' upon which the procedure ends;

...

1> if the *RRCRelease* message includes the *cellReselectionPriorities*:

2> store the cell reselection priority information provided by the *cellReselectionPriorities*;

2> if the *t320* is included:

3> start timer T320, with the timer value set according to the value of *t320*;

1> else:

2> apply the cell reselection priority information broadcast in the system information;

[TS 38.304, clause 5.2.4.1]

Absolute priorities of different NR frequencies or inter-RAT frequencies may be provided to the UE in the system information, in the *RRCRelease* message, or by inheriting from another RAT at inter-RAT cell (re)selection. In the case of system information, an NR frequency or inter-RAT frequency may be listed without providing a priority (i.e. the field *cellReselectionPriority* is absent for that frequency). If priorities are provided in dedicated signalling, the UE shall ignore all the priorities provided in system information. If UE is in *camped on any cell* state, UE shall only apply the priorities provided by system information from current cell, and the UE preserves priorities provided by dedicated signalling and *deprioritisationReq* received in *RRCRelease* unless specified otherwise. When the UE in *camped normally* state, has only dedicated priorities other than for the current frequency, the UE shall consider the current frequency to be the lowest priority frequency (i.e. lower than any of the network configured values).

The UE shall only perform cell reselection evaluation for NR frequencies and inter-RAT frequencies that are given in system information and for which the UE has a priority provided.

8.1.1.3.4.3 Test description

8.1.1.3.4.3.1 Pre-test conditions

System Simulator:

- NR Cell 1, E-UTRA Cell 1 and E-UTRA Cell 3.
- System information combination NR-6 as defined in TS 38.508-1 [4] clause 4.4.3.1.2 is used in NR cell.
- System information combination 3 as defined in TS 36.508 [7] clause 4.4.3.1 is used in E-UTRA cells.

UE:

None.

Preamble:

- The UE is in state 3N-A as defined in TS 38.508-1 [4], subclause 4.4A on NR Cell 1(Serving Cell).

8.1.1.3.4.3.2 Test procedure sequence

Table 8.1.1.3.4.3.2-1/2 illustrates the downlink power levels and other changing parameters to be applied for the cells at various time instants of the test execution. Row marked "T0" denotes the initial conditions after preamble, while columns marked "T1" is to be applied subsequently. The exact instants on which these values shall be applied are described in the texts in this clause.

Table 8.1.1.3.4.3.2-1: Time instances of cell power level and parameter changes in FR1

	Parameter	Unit	NR Cell 1	E-UTRA Cell 1	E-UTRA Cell 3	Remark
T0	Cell-specific RS EPRE	dBm/15kHz	-	"off"	"off"	
	SS/PBCH SSS EPRE	dBm/SCS	-88	-	-	
T1	Cell-specific RS EPRE	dBm/15kHz	-	-73	-73	The power level values are assigned to satisfy both $\text{Thresh}_{x, \text{low}} < \text{Srxlev}_{\text{E-UTRACell 1}}$ and $\text{Thresh}_{x, \text{high}} < \text{Srxlev}_{\text{E-UTRACell 3}}$ but not to satisfy $\text{Srxlev}_{\text{VNR Cell 1}} < \text{Thresh}_{\text{-serving, low}}$
	SS/PBCH SSS EPRE	dBm/SCS	-88	-	-	
NOTE 1: Power level "Off" is defined in TS36.508 [7] Table 6.2.2.1-3.						

Table 8.1.1.3.4.3.2-2: Time instances of cell power level and parameter changes in FR2

	Parameter	Unit	NR Cell 1	E-UTRA Cell 1	E-UTRA Cell 3	Remark
T0	Cell-specific RS EPRE	dBm/15kHz	-	"off"	"off"	
	SS/PBCH SSS EPRE	dBm/SCS	FFS	-	-	
T1	Cell-specific RS EPRE	dBm/15kHz	-	FFS	FFS	The power level values are assigned to satisfy both $\text{Thresh}_{x, \text{low}} < \text{Srxlev}_{\text{E-UTRA Cell 1}}$ and $\text{Thresh}_{x, \text{high}} < \text{Srxlev}_{\text{E-UTRA Cell 3}}$ but not to satisfy $\text{Srxlev}_{\text{NR Cell 1}} < \text{Thresh}_{\text{servicing, low}}$
	SS/PBCH SSS EPRE	dBm/SCS	FFS	-	-	
NOTE 1: Power level "Off" is defined in TS36.508 [7] Table 6.2.2.1-3.						

Table 8.1.1.3.4.3.2-3: Main behaviour

St	Procedure	Message Sequence		TP	Verdict
		U - S	Message		
1	The SS changes NR Cell 1, E-UTRA Cell 1 and E-UTRA Cell 3 level according to the row "T1" in Table 8.1.1.3.4.3.2-1/2	-	-	-	-
2	The SS transmits an <i>RRCRelease</i> message including the <i>freqPriorityListEUTRA</i> on NR Cell 1.	<--	NR RRC: <i>RRCRelease</i>	-	-
3	Check: Does the test result of generic test procedure in TS 36.508 [7] subclause 6.4.2.7 indicate that the UE is camped on E-UTRA Cell 3?	-	-	1	-

8.1.1.3.4.3.3 Specific message contents

Table 8.1.1.3.4.3.3-1: RRCRelease (step 1, Table 8.1.1.3.4.3.2-3)

Derivation Path: 38.508-1 [4] Table 4.6.1-16			
Information Element	Value/remark	Comment	Condition
RRCRelease ::= SEQUENCE {			
rrc-TransactionIdentifier	RRC-TransactionIdentifier		
criticalExtensions CHOICE {			
rrcRelease SEQUENCE {			
cellReselectionPriorities SEQUENCE {			
freqPriorityListEUTRA SEQUENCE (SIZE (1..maxFreq)) OF SEQUENCE {	2 entries		
carrierFreq[1]	ARFCN-ValueEUTRA for EUTRA Cell 1 frequency		
cellReselectionPriority[1]	3		
carrierFreq[2]	ARFCN-ValueEUTRA for EUTRA Cell 3 frequency		
cellReselectionPriority[2]	5		
}			
freqPriorityListNR SEQUENCE (SIZE (1..maxFreq)) OF SEQUENCE {	1 entry		
carrierFreq[1]	ARFCN-ValueNR for NR Cell 1 frequency		
cellReselectionPriority[1]	4		
}			
t320	Not Present		
}			
}			
}			
}			

Table 8.1.1.3.4.3.3-2: SIB2 for NR cell 1 (preamble and all steps, Table 8.1.1.3.4.3.2-3)

Derivation Path: TS 38.508-1 [4] Table 4.6.2-1			
Information Element	Value/remark	Comment	Condition
SIB2 ::= SEQUENCE {			
cellReselectionServingFreqInfo SEQUENCE {			
threshServingLowP	0	Actual value of threshold = field value * 2 [dB]	
threshServingLowQ	Not present		
cellReselectionPriority	4		
cellReselectionSubPriority	Not present		
}			
}			

Table 8.1.1.3.4.3.3-3: SIB5 for NR cell 1 (preamble and all steps, Table 8.1.1.3.4.3.2-3)

Derivation Path: TS 38.508-1 [4] Table 4.6.2-4			
Information Element	Value/remark	Comment	Condition
SIB5 ::= SEQUENCE {			
carrierFreqListEUTRA SEQUENCE (SIZE (1..maxEUTRA-Carrier)) OF SEQUENCE {	2 entries		
carrierFreq[1]	ARFCN-ValueEUTRA for EUTRA Cell 1 frequency		
cellReselectionPriority[1]	5		
threshX-High[1]	2 (4 dB)		
threshX-Low[1]	1 (2 dB)		
carrierFreq[2]	ARFCN-ValueEUTRA for EUTRA Cell 3 frequency		
cellReselectionPriority[2]	3		
threshX-High[2]	2 (4 dB)		
threshX-Low[2]	1 (2 dB)		
}			
}			

Table 8.1.1.3.4.3.3-4: Conditions for specific message contents in Table 8.1.1.3.4.3.3-5.

Condition	Explanation
Band > 64	If band > 64 is selected

Table 8.1.1.3.4.3.3-5: SystemInformationBlockType5 for EUTRA Cell 3 (preamble and all steps, Table 8.1.1.3.4.3.2-3)

Derivation path: 36.508 [7] table 4.4.3.3-4			
Information Element	Value/Remark	Comment	Condition
SystemInformationBlockType5 ::= SEQUENCE {			
interFreqCarrierFreqList SEQUENCE (SIZE (1..maxFreq)) OF SEQUENCE {			
dl-CarrierFreq[1]	Same downlink EARFCN as used for EUTRA Cell 1		
dl-CarrierFreq[1]	maxEARFCN		Band > 64
cellReselectionPriority [1]	3		
}			
SystemInformationBlockType5-v8h0-IEs SEQUENCE {			Band > 64
nonCriticalExtension SEQUENCE {			
interFreqCarrierFreqList-v9e0 SEQUENCE (SIZE (1..maxFreq)) OF SEQUENCE {			
dl-CarrierFreq-v9e0[1]	Same downlink EARFCN as used for EUTRA Cell 1		
}			
}			
}			
}			

8.1.1.3.5 RRC connection release / With priority information / T320 expiry

8.1.1.3.5.1 Test Purpose (TP)

(1)

```
with { UE in NR RRC_IDLE state having received an RRCRelease message with the freqPriorityListNR
with higher priority frequency and timer T320 }
ensure that {
```



```

when { T320 timer expires }
then { UE discards the cell reselection priority information provided by the
cellReselectionPriorities and apply the cell reselection priority information broadcast in the
system information to perform reselection to another NR cell }
}

```

8.1.1.3.5.2 Conformance requirements

References: The conformance requirements covered in the current TC is specified in: TS 38.331 clause 5.3.8.3, 5.3.8.4 and TS 38.304 clause 5.2.4.1, 5.2.4.2, 5.2.4.5, 5.2.4.6.

[TS 38.331, clause 5.3.8.3]

The UE shall:

...

- 1> if the *RRCRelease* message includes the *cellReselectionPriorities*:
 - 2> store the cell reselection priority information provided by the *cellReselectionPriorities*;
 - 2> if the *t320* is included:
 - 3> start timer T320, with the timer value set according to the value of *t320*;
- 1> else:
 - 2> apply the cell reselection priority information broadcast in the system information;

[TS 38.331, clause 5.3.8.4]

The UE shall:

- 1> if T320 expires:
 - 2> if stored, discard the cell reselection priority information provided by the *cellReselectionPriorities* or inherited from another RAT;
 - 2> apply the cell reselection priority information broadcast in the system information.

[TS 38.304, clause 5.2.4.1]

Absolute priorities of different NR frequencies or inter-RAT frequencies may be provided to the UE in the system information, in the *RRCRelease* message, or by inheriting from another RAT at inter-RAT cell (re)selection. In the case of system information, an NR frequency or inter-RAT frequency may be listed without providing a priority (i.e. the field *cellReselectionPriority* is absent for that frequency). If priorities are provided in dedicated signalling, the UE shall ignore all the priorities provided in system information. If UE is in *camped on any cell* state, UE shall only apply the priorities provided by system information from current cell, and the UE preserves priorities provided by dedicated signalling and *deprioritisationReq* received in *RRCRelease* unless specified otherwise. When the UE in *camped normally* state, has only dedicated priorities other than for the current frequency, the UE shall consider the current frequency to be the lowest priority frequency (i.e. lower than any of the network configured values).

The UE shall only perform cell reselection evaluation for NR frequencies and inter-RAT frequencies that are given in system information and for which the UE has a priority provided.

In case UE receives *RRCRelease* with *deprioritisationReq*, UE shall consider current frequency and stored frequencies due to the previously received *RRCRelease* with *deprioritisationReq* or all the frequencies of NR to be the lowest priority frequency (i.e. lower than any of the network configured values) while T325 is running irrespective of *camped RAT*. The UE shall delete the stored *deprioritisationReq*(s) when a PLMN selection is performed on request by NAS (TS 23.122 [9]).

NOTE: UE should search for a higher priority layer for cell reselection as soon as possible after the change of priority. The minimum related performance requirements specified in TS 38.133 [8] are still applicable.

The UE shall delete priorities provided by dedicated signalling when:

- the UE enters a different RRC state; or

- the optional validity time of dedicated priorities (T320) expires; or
- a PLMN selection is performed on request by NAS (TS 23.122 [9]).

NOTE 2: Equal priorities between RATs are not supported.

The UE shall not consider any black listed cells as candidate for cell reselection.

The UE shall inherit the priorities provided by dedicated signalling and the remaining validity time (i.e. T320 in NR and E-UTRA), if configured, at inter-RAT cell (re)selection.

NOTE 3: The network may assign dedicated cell reselection priorities for frequencies not configured by system information.

[TS 38.304, clause 5.2.4.2]

Following rules are used by the UE to limit needed measurements:

- If the serving cell fulfils $S_{rxlev} > S_{IntraSearchP}$ and $S_{qual} > S_{IntraSearchQ}$, the UE may choose not to perform intra-frequency measurements.
- Otherwise, the UE shall perform intra-frequency measurements.
- The UE shall apply the following rules for NR inter-frequencies and inter-RAT frequencies which are indicated in system information and for which the UE has priority provided as defined in 5.2.4.1:
 - For a NR inter-frequency or inter-RAT frequency with a reselection priority higher than the reselection priority of the current NR frequency, the UE shall perform measurements of higher priority NR inter-frequency or inter-RAT frequencies according to TS 38.133 [8].
 - For a NR inter-frequency with an equal or lower reselection priority than the reselection priority of the current NR frequency and for inter-RAT frequency with lower reselection priority than the reselection priority of the current NR frequency:
 - If the serving cell fulfils $S_{rxlev} > S_{nonIntraSearchP}$ and $S_{qual} > S_{nonIntraSearchQ}$, the UE may choose not to perform measurements of NR inter-frequencies or inter-RAT frequency cells of equal or lower priority;
 - Otherwise, the UE shall perform measurements of NR inter-frequencies or inter-RAT frequency cells of equal or lower priority according to TS 38.133 [8].

[TS 38.304, clause 5.2.4.5]

If *threshServingLowQ* is broadcast in system information and more than 1 second has elapsed since the UE camped on the current serving cell, cell reselection to a cell on a higher priority NR frequency or inter-RAT frequency than the serving frequency shall be performed if:

- A cell of a higher priority NR or EUTRAN RAT/frequency fulfils $S_{qual} > Thresh_{X, HighQ}$ during a time interval $T_{reselectionRAT}$

Otherwise, cell reselection to a cell on a higher priority NR frequency or inter-RAT frequency than the serving frequency shall be performed if:

- A cell of a higher priority RAT/ frequency fulfils $S_{rxlev} > Thresh_{X, HighP}$ during a time interval $T_{reselectionRAT}$; and
- More than 1 second has elapsed since the UE camped on the current serving cell.

Cell reselection to a cell on an equal priority NR frequency shall be based on ranking for intra-frequency cell reselection as defined in sub-clause 5.2.4.6.

If *threshServingLowQ* is broadcast in system information and more than 1 second has elapsed since the UE camped on the current serving cell, cell reselection to a cell on a lower priority NR frequency or inter-RAT frequency than the serving frequency shall be performed if:

- The serving cell fulfils $S_{qual} < Thresh_{Serving, LowQ}$ and a cell of a lower priority NR or E-UTRAN RAT/ frequency fulfils $S_{qual} > Thresh_{X, LowQ}$ during a time interval $T_{reselectionRAT}$.

Otherwise, cell reselection to a cell on a lower priority NR frequency or inter-RAT frequency than the serving frequency shall be performed if:

- The serving cell fulfils $Srxlev < Thresh_{Serving, LowP}$ and a cell of a lower priority RAT/ frequency fulfils $Srxlev > Thresh_{X, LowP}$ during a time interval $T_{reselection_{RAT}}$; and
- More than 1 second has elapsed since the UE camped on the current serving cell.

Cell reselection to a higher priority RAT/frequency shall take precedence over a lower priority RAT/frequency if multiple cells of different priorities fulfil the cell reselection criteria.

If more than one cell meets the above criteria, the UE shall reselect a cell as follows:

- If the highest-priority frequency is an NR frequency, the highest ranked cell among the cells on the highest priority frequency(ies) meeting the criteria according to clause 5.2.4.6;
- If the highest-priority frequency is from another RAT, the highest ranked cell among the cells on the highest priority frequency(ies) meeting the criteria of that RAT.

[TS 38.304, clause 5.2.4.6]

The cell-ranking criterion R_s for serving cell and R_n for neighbouring cells is defined by:

$$R_s = Q_{meas,s} + Q_{hyst} - Q_{offset_{temp}}$$

$$R_n = Q_{meas,n} - Q_{offset} - Q_{offset_{temp}}$$

where:

Q_{meas}	RSRP measurement quantity used in cell reselections.
Q_{offset}	For intra-frequency: Equals to $Q_{offset_{s,n}}$, if $Q_{offset_{s,n}}$ is valid, otherwise this equals to zero. For inter-frequency: Equals to $Q_{offset_{s,n}}$ plus $Q_{offset_{frequency}}$, if $Q_{offset_{s,n}}$ is valid, otherwise this equals to $Q_{offset_{frequency}}$.
$Q_{offset_{temp}}$	Offset temporarily applied to a cell as specified in TS 38.331 [3].

The UE shall perform ranking of all cells that fulfil the cell selection criterion S , which is defined in 5.2.3.2.

The cells shall be ranked according to the R criteria specified above by deriving $Q_{meas,n}$ and $Q_{meas,s}$ and calculating the R values using averaged RSRP results.

If *rangeToBestCell* is not configured, the UE shall perform cell reselection to the highest ranked cell. If this cell is found to be not-suitable, the UE shall behave according to subclause 5.2.4.4.

If *rangeToBestCell* is configured, then the UE shall perform cell reselection to the cell with the highest number of beams above the threshold (i.e. *absThreshSS-BlocksConsolidation*) among the cells whose R value is within *rangeToBestCell* of the R value of the highest ranked cell. If there are multiple such cells, the UE shall perform cell reselection to the highest ranked cell among them. If this cell is found to be not-suitable, the UE shall behave according to subclause 5.2.4.4.

In all cases, the UE shall reselect the new cell, only if the following conditions are met:

- the new cell is better than the serving cell according to the cell reselection criteria specified above during a time interval $T_{reselection_{RAT}}$;
- more than 1 second has elapsed since the UE camped on the current serving cell.

8.1.1.3.5.3 Test Description

8.1.1.3.5.3.1 Pre-test conditions

System Simulator:

- NR Cell 1 and NR Cell 13.

- System information combination NR-4 as defined in TS 38.508-1 [4] clause 4.4.3.1.3 is used in NR cell.

UE:

- None.

Preamble:

- The UE is in 5GS state 3N-A on NR Cell 1 according to 38.508-1[4], clause 4.4A.2 Table 4.4A.2-3.

8.1.1.3.5.3.2 Test procedure sequence

Table 8.1.1.3.5.3.2-1 for FR1 and 8.1.1.3.5.3.2-1A for FR2 illustrates the downlink power levels and other changing parameters to be applied for the cells at various time instants of the test execution. Row marked "T0" denotes the initial conditions after preamble, while columns marked "T1" is to be applied subsequently. The exact instants on which these values shall be applied are described in the texts in this clause.

Table 8.1.1.3.5.3.2-1: Time instances of cell power level and parameter changes for FR1

	Parameter	Unit	NR Cell 1	NR Cell 13	Remark
T0	SS/PBCH SSS EPRE	dBm/ SCS	-85	Off	The power level values are assigned to satisfy $S_{rxlevCell 1} > S_{nonintrasearch}$. (NOTE 1)
T1	SS/PBCH SSS EPRE	dBm/ SCS	-85	-73	The power level values are assigned to satisfy $Thresh_{x, high} < S_{rxlevCell 13}$.
NOTE 1: Power level "Off" is defined in TS 38.508-1 [4], Table 6.2.2.1-3.					

Table 8.1.1.3.5.3.2-1A: Time instances of cell power level and parameter changes for FR2

	Parameter	Unit	NR Cell 1	NR Cell 13	Remark
T0	SS/PBCH SSS EPRE	dBm/ SCS	FFS	Off	The power level values are assigned to satisfy $S_{rxlevCell 1} > S_{nonintrasearch}$. (NOTE 1)
T1	SS/PBCH SSS EPRE	dBm/ SCS	FFS	FFS	The power level values are assigned to satisfy $Thresh_{x, high} < S_{rxlevCell 13}$.
NOTE 1: Power level "Off" is defined in TS 38.508-1 [4], Table 6.2.2.1-3.					

Table 8.1.1.3.5.3.2-2: Main behaviour

St	Procedure	Message Sequence		TP	Verdict
		U - S	Message		
1	The SS transmits an <i>RRCRelease</i> message containing IE <i>freqPriorityListNR</i> to update the cell reselection priority of NR Cell 13 and the timer T320.	<--	NR RRC: <i>RRCRelease</i>	-	-
2	The SS changes power levels of NR Cells according to row "T1".	-	-	-	-
3	Check: Does the UE transmit an <i>RRCSetupRequest</i> message within T320 running?	-->	NR RRC: <i>RRCSetupRequest</i>	1	F
4	Check: After timer T320 expiry, does the test result of generic test procedure in TS 38.508-1 subclause 4.9.5 indicate that the UE is camped on NR Cell 13? NOTE: The UE performs a "REGISTRATION REQUEST" procedure with type "mobility registration updating".	-	-	1	P

8.1.1.3.5.3.3 Specific message contents

Table 8.1.1.3.5.3.3-1: RRCRelease (step 1, Table 8.1.1.3.5.3.2-2)

Derivation Path: TS 38.508-1 [4], Table 4.6.1-16			
Information Element	Value/remark	Comment	Condition
RRCRelease ::= SEQUENCE {			
rrc-TransactionIdentifier	RRC-TransactionIdentifier		
criticalExtensions CHOICE {			
rrcRelease SEQUENCE {			
cellReselectionPriorities SEQUENCE {			
freqPriorityListNR SEQUENCE {			
carrierFreq	ARFCN-ValueNR of NR Cell 13		
cellReselectionPriority	3		
cellReselectionSubPriority	Not present		
}			
t320	min5		
}			
}			
}			

8.1.1.3.6 RRC connection release / With priority information / T320 expiry / E-UTRA

8.1.1.3.6.1 Test Purpose (TP)

(1)

```

with { UE in NR RRC_IDLE state having received an RRCRelease message with the freqPriorityListEUTRA
with higher priority frequency and timer T320 }
ensure that {
  when { T320 timer expires }
    then { UE discards the cell reselection priority information provided by the
cellReselectionPriorities and apply the cell reselection priority information broadcast in the
system information to perform reselection to an E-UTRA cell }
}

```

8.1.1.3.6.2 Conformance requirements

References: The conformance requirements covered in the current TC is specified in: TS 38.331 clause 5.3.8.3, 5.3.8.4 and TS 38.304 clause 5.2.4.1, 5.2.4.2, 5.2.4.5, 5.2.4.6.

[TS 38.331, clause 5.3.8.3]

The UE shall:

...

- 1> if the *RRCRelease* message includes the *cellReselectionPriorities*:
 - 2> store the cell reselection priority information provided by the *cellReselectionPriorities*;
- 2> if the *t320* is included:
 - 3> start timer T320, with the timer value set according to the value of *t320*;
- 1> else:
 - 2> apply the cell reselection priority information broadcast in the system information;

[TS 38.331, clause 5.3.8.4]

The UE shall:

- 1> if T320 expires:
 - 2> if stored, discard the cell reselection priority information provided by the *cellReselectionPriorities* or inherited from another RAT;
 - 2> apply the cell reselection priority information broadcast in the system information.

[TS 38.304, clause 5.2.4.1]

Absolute priorities of different NR frequencies or inter-RAT frequencies may be provided to the UE in the system information, in the *RRCRelease* message, or by inheriting from another RAT at inter-RAT cell (re)selection. In the case of system information, an NR frequency or inter-RAT frequency may be listed without providing a priority (i.e. the field *cellReselectionPriority* is absent for that frequency). If priorities are provided in dedicated signalling, the UE shall ignore all the priorities provided in system information. If UE is in *camped on any cell* state, UE shall only apply the priorities provided by system information from current cell, and the UE preserves priorities provided by dedicated signalling and *deprioritisationReq* received in *RRCRelease* unless specified otherwise. When the UE in *camped normally* state, has only dedicated priorities other than for the current frequency, the UE shall consider the current frequency to be the lowest priority frequency (i.e. lower than any of the network configured values).

The UE shall only perform cell reselection evaluation for NR frequencies and inter-RAT frequencies that are given in system information and for which the UE has a priority provided.

In case UE receives *RRCRelease* with *deprioritisationReq*, UE shall consider current frequency and stored frequencies due to the previously received *RRCRelease* with *deprioritisationReq* or all the frequencies of NR to be the lowest priority frequency (i.e. lower than any of the network configured values) while T325 is running irrespective of *camped* RAT. The UE shall delete the stored *deprioritisationReq*(s) when a PLMN selection is performed on request by NAS (TS 23.122 [9]).

NOTE: UE should search for a higher priority layer for cell reselection as soon as possible after the change of priority. The minimum related performance requirements specified in TS 38.133 [8] are still applicable.

The UE shall delete priorities provided by dedicated signalling when:

- the UE enters a different RRC state; or
- the optional validity time of dedicated priorities (T320) expires; or
- a PLMN selection is performed on request by NAS (TS 23.122 [9]).

NOTE 2: Equal priorities between RATs are not supported.

The UE shall not consider any black listed cells as candidate for cell reselection.

The UE shall inherit the priorities provided by dedicated signalling and the remaining validity time (i.e. T320 in NR and E-UTRA), if configured, at inter-RAT cell (re)selection.

NOTE 3: The network may assign dedicated cell reselection priorities for frequencies not configured by system information.

[TS 38.304, clause 5.2.4.2]

Following rules are used by the UE to limit needed measurements:

- If the serving cell fulfils $S_{rxlev} > S_{IntraSearchP}$ and $S_{qual} > S_{IntraSearchQ}$, the UE may choose not to perform intra-frequency measurements.
- Otherwise, the UE shall perform intra-frequency measurements.
- The UE shall apply the following rules for NR inter-frequencies and inter-RAT frequencies which are indicated in system information and for which the UE has priority provided as defined in 5.2.4.1:
 - For a NR inter-frequency or inter-RAT frequency with a reselection priority higher than the reselection priority of the current NR frequency, the UE shall perform measurements of higher priority NR inter-frequency or inter-RAT frequencies according to TS 38.133 [8].

- For a NR inter-frequency with an equal or lower reselection priority than the reselection priority of the current NR frequency and for inter-RAT frequency with lower reselection priority than the reselection priority of the current NR frequency:
 - If the serving cell fulfils $S_{rxlev} > S_{nonIntraSearchP}$ and $S_{qual} > S_{nonIntraSearchQ}$, the UE may choose not to perform measurements of NR inter-frequencies or inter-RAT frequency cells of equal or lower priority;
 - Otherwise, the UE shall perform measurements of NR inter-frequencies or inter-RAT frequency cells of equal or lower priority according to TS 38.133 [8].

[TS 38.304, clause 5.2.4.5]

If *threshServingLowQ* is broadcast in system information and more than 1 second has elapsed since the UE camped on the current serving cell, cell reselection to a cell on a higher priority NR frequency or inter-RAT frequency than the serving frequency shall be performed if:

- A cell of a higher priority NR or EUTRAN RAT/frequency fulfils $S_{qual} > Thresh_{X, HighQ}$ during a time interval $T_{reselection_{RAT}}$

Otherwise, cell reselection to a cell on a higher priority NR frequency or inter-RAT frequency than the serving frequency shall be performed if:

- A cell of a higher priority RAT/ frequency fulfils $S_{rxlev} > Thresh_{X, HighP}$ during a time interval $T_{reselection_{RAT}}$; and
- More than 1 second has elapsed since the UE camped on the current serving cell.

Cell reselection to a cell on an equal priority NR frequency shall be based on ranking for intra-frequency cell reselection as defined in sub-clause 5.2.4.6.

If *threshServingLowQ* is broadcast in system information and more than 1 second has elapsed since the UE camped on the current serving cell, cell reselection to a cell on a lower priority NR frequency or inter-RAT frequency than the serving frequency shall be performed if:

- The serving cell fulfils $S_{qual} < Thresh_{Serving, LowQ}$ and a cell of a lower priority NR or E-UTRAN RAT/ frequency fulfils $S_{qual} > Thresh_{X, LowQ}$ during a time interval $T_{reselection_{RAT}}$.

Otherwise, cell reselection to a cell on a lower priority NR frequency or inter-RAT frequency than the serving frequency shall be performed if:

- The serving cell fulfils $S_{rxlev} < Thresh_{Serving, LowP}$ and a cell of a lower priority RAT/ frequency fulfils $S_{rxlev} > Thresh_{X, LowP}$ during a time interval $T_{reselection_{RAT}}$; and
- More than 1 second has elapsed since the UE camped on the current serving cell.

Cell reselection to a higher priority RAT/frequency shall take precedence over a lower priority RAT/frequency if multiple cells of different priorities fulfil the cell reselection criteria.

If more than one cell meets the above criteria, the UE shall reselect a cell as follows:

- If the highest-priority frequency is an NR frequency, the highest ranked cell among the cells on the highest priority frequency(ies) meeting the criteria according to clause 5.2.4.6;
- If the highest-priority frequency is from another RAT, the highest ranked cell among the cells on the highest priority frequency(ies) meeting the criteria of that RAT.

[TS 38.304, clause 5.2.4.6]

The cell-ranking criterion R_s for serving cell and R_n for neighbouring cells is defined by:

$$R_s = Q_{meas,s} + Q_{hyst} - Q_{offset_{temp}}$$

$$R_n = Q_{meas,n} - Q_{offset} - Q_{offset_{temp}}$$

where:

Q_{meas}	RSRP measurement quantity used in cell reselections.
Q_{offset}	For intra-frequency: Equals to $Q_{offset_{s,n}}$, if $Q_{offset_{s,n}}$ is valid, otherwise this equals to zero. For inter-frequency: Equals to $Q_{offset_{s,n}}$ plus $Q_{offset_{frequency}}$, if $Q_{offset_{s,n}}$ is valid, otherwise this equals to $Q_{offset_{frequency}}$.
$Q_{offset_{temp}}$	Offset temporarily applied to a cell as specified in TS 38.331 [3].

The UE shall perform ranking of all cells that fulfil the cell selection criterion S, which is defined in 5.2.3.2.

The cells shall be ranked according to the R criteria specified above by deriving $Q_{meas,n}$ and $Q_{meas,s}$ and calculating the R values using averaged RSRP results.

If *rangeToBestCell* is not configured, the UE shall perform cell reselection to the highest ranked cell. If this cell is found to be not-suitable, the UE shall behave according to subclause 5.2.4.4.

If *rangeToBestCell* is configured, then the UE shall perform cell reselection to the cell with the highest number of beams above the threshold (i.e. *absThreshSS-BlocksConsolidation*) among the cells whose R value is within *rangeToBestCell* of the R value of the highest ranked cell. If there are multiple such cells, the UE shall perform cell reselection to the highest ranked cell among them. If this cell is found to be not-suitable, the UE shall behave according to subclause 5.2.4.4.

In all cases, the UE shall reselect the new cell, only if the following conditions are met:

- the new cell is better than the serving cell according to the cell reselection criteria specified above during a time interval $T_{reselection_{RAT}}$;
- more than 1 second has elapsed since the UE camped on the current serving cell.

8.1.1.3.6.3 Test Description

8.1.1.3.6.3.1 Pre-test conditions

System Simulator:

- NR Cell 1, E-UTRA Cell 12 and E-UTRA Cell 13.
- System information combination NR-6 as defined in TS 38.508-1 [4] clause 4.4.3.1.3 is used in NR cell.

UE:

- None.

Preamble:

- The UE is in 5GS state 3N-A on NR Cell 1 according to 38.508-1[4], clause 4.4A.2 Table 4.4A.2-3.

8.1.1.3.6.3.2 Test procedure sequence

Table 8.1.1.3.6.3.2-1 for FR1 and 8.1.1.3.6.3.2-1A for FR2 illustrates the downlink power levels and other changing parameters to be applied for the cells at various time instants of the test execution. Row marked "T0" denotes the initial conditions after preamble, while columns marked "T1" is to be applied subsequently. The exact instants on which these values shall be applied are described in the texts in this clause.

Table 8.1.1.3.6.3.2-1: Time instances of cell power level and parameter changes for FR1

	Parameter	Unit	NR Cell 1	E-UTRA Cell 13	Remark
T0	SS/PBCH SSS EPRE	dBm/S CS	-85	-	The power level values are assigned to satisfy $S_{rxlev_{Cell 1}} > S_{noninrasearch}$. (NOTE 1)
	Cell-specific RS EPRE	dBm/1 5kHz	-	Off	

T1	SS/PBCH SSS EPRE	dBm/S CS	-85	-	The power level values are assigned to satisfy $Thresh_{x, high} < Srxlev_{Cell 13}$.
	Cell-specific RS EPRE	dBm/1 5kHz	-	-73	
NOTE 1: Power level "Off" is defined in TS 36.508 [7], Table 6.2.2.1-1.					

Table 8.1.1.3.6.3.2-1A: Time instances of cell power level and parameter changes for FR2

	Parameter	Unit	NR Cell 1	E-UTRA Cell 13	Remark
T0	SS/PBCH SSS EPRE	dBm/S CS	FFS	-	The power level values are assigned to satisfy $Srxlev_{Cell 1} > S_{nonintrasearch}$. (NOTE 1)
	Cell-specific RS EPRE	dBm/1 5kHz	-	Off	
T1	SS/PBCH SSS EPRE	dBm/S CS	FFS	-	The power level values are assigned to satisfy $Thresh_{x, high} < Srxlev_{Cell 13}$.
	Cell-specific RS EPRE	dBm/1 5kHz	-	FFS	
NOTE 1: Power level "Off" is defined in TS 36.508 [7], Table 6.2.2.1-1.					

Table 8.1.1.3.6.3.2-2: Main behaviour

St	Procedure	Message Sequence		TP	Verdict
		U - S	Message		
1	The SS transmits an <i>RRCRelease</i> message containing IE <i>freqPriorityListEUTRA</i> to update the cell reselection priority of E-UTRA Cell 13 and the timer T320.	<--	NR RRC: <i>RRCRelease</i>	-	-
2	The SS changes power levels of NR Cells according to row "T1".	-	-	-	-
3	Check: While timer T320 is running, does the test result of generic test procedure in TS 36.508 subclause 6.4.2.7A indicate that the UE is camped on E-UTRA Cell 13?	-	-	1	F
4	Check: After timer T320 expiry, does the test result of generic test procedure in TS 36.508 subclause 6.4.2.7A indicate that the UE is camped on E-UTRA Cell 13?	-	-	1	P

8.1.1.3.6.3.3 Specific message contents

Table 8.1.1.3.6.3.3-1: RRCRelease (step 1, Table 8.1.1.3.6.3.2-2)

Derivation Path: TS 38.508-1 [4], Table 4.6.1-16			
Information Element	Value/remark	Comment	Condition
RRCRelease ::= SEQUENCE {			
rrc-TransactionIdentifier	RRC-TransactionIdentifier		
criticalExtensions CHOICE {			
rrcRelease SEQUENCE {			
cellReselectionPriorities SEQUENCE {			
freqPriorityListEUTRA SEQUENCE {			
carrierFreq	ARFCN-ValueEUTRA of E-UTRA Cell 13		
cellReselectionPriority	3		
cellReselectionSubPriority	Not present		
}			
t320	min5		
}			
}			
}			

8.1.1.4 RRC resume

8.1.1.4.1 RRC resume / Suspend-Resume / Success

8.1.1.4.1.1 Test Purpose (TP)

(1)

```
with { UE in NR RRC_INACTIVE state, with stored shortI-RNTI and useFullResumeID is not signalled in SIB1 }
ensure that {
  when { UE receives a Paging message to resume RRC connection }
  then { UE sends RRCResumeRequest message by setting resumeIdentity to the stored shortI-RNTI value }
}
```

(2)

```
with { UE in NR RRC_INACTIVE state, with stored fullI-RNTI and useFullResumeID is signalled in SIB1 }
ensure that {
  when { UE receives a Paging message to resume RRC connection }
  then { UE sends RRCResumeRequest1 message by setting resumeIdentity to the stored fullI-RNTI value }
}
```

8.1.1.4.1.2 Conformance requirements

References: The conformance requirements covered in the current TC is specified in: TS 38.331 clause 5.3.8.3 and 5.3.13.3. Unless otherwise stated these are Rel-15 requirements.

[TS 38.331, clause 5.3.8.3]

The UE shall:

...

1> if the *RRCRelease* includes *suspendConfig*:

2> apply the received *suspendConfig*;

- 2> reset MAC and release the default MAC Cell Group configuration, if any;
- 2> re-establish RLC entities for SRB1;
- 2> if the *RRCRelease* message with *suspendConfig* was received in response to an *RRCResumeRequest* or an *RRCResumeRequest1*:
 - 3> stop the timer T319 if running;
 - 3> in the stored UE Inactive AS context:
 - 4> replace the K_{gNB} and K_{RRCint} keys with the current K_{gNB} and K_{RRCint} keys;
 - 4> replace the C-RNTI with the temporary C-RNTI in the cell the UE has received the *RRCRelease* message;
 - 4> replace the *cellIdentity* with the *cellIdentity* of the cell the UE has received the *RRCRelease* message;
 - 4> replace the physical cell identity with the physical cell identity of the cell the UE has received the *RRCRelease* message;
 - 4> replace the *suspendConfig* with the current *suspendConfig*;
- 2> else:
 - 3> store in the UE Inactive AS Context the configured *suspendConfig*, the current K_{gNB} and K_{RRCint} keys, the ROHC state, the C-RNTI used in the source PCell, the *cellIdentity* and the physical cell identity of the source PCell, and all other parameters configured except with *ReconfigurationWithSync*;

...

[TS 38.331, clause 5.3.13.3]

The UE shall set the contents of *RRCResumeRequest* or *RRCResumeRequest1* message as follows:

- 1> if field *useFullResumeID* is signalled in *SIB1*:
 - 2> select *RRCResumeRequest1* as the message to use;
 - 2> set the *resumeIdentity* to the stored *fullI-RNTI* value;
- 1> else:
 - 2> select *RRCResumeRequest* as the message to use;
 - 2> set the *resumeIdentity* to the stored *shortI-RNTI* value;

...

- 1> submit the selected message *RRCResumeRequest* or *RRCResumeRequest1* for transmission to lower layers.

NOTE 2: Only DRBs with previously configured UP ciphering shall resume ciphering.

...

8.1.1.4.1.3 Test Description

8.1.1.4.1.3.1 Pre-test conditions

System Simulator:

- NR Cell 1
- System information combination NR-1 as defined in TS 38.508-1 [4] clause 4.4.3.1.3 is used in NR cell.

UE:

- None.

Preamble:

- The UE is in 5GS state 3N-A according to TS 38.508-1 [4], clause 4.4A.2 Table 4.4A.2-3.

8.1.1.4.1.3.2 Test procedure sequence

Table 8.1.1.4.1.3.2-1: Main behaviour

St	Procedure	Message Sequence		TP	Verdict
		U - S	Message		
1	The SS transmits a <i>Paging</i> message including a matched identity (correct <i>fullI-RNTI</i>).	-	NR RRC: <i>Paging</i>	-	-
2	Check: Does the UE transmit an <i>RRCResumeRequest</i> message by setting <i>resumeIdentity</i> to the stored <i>shortI-RNTI</i> value?	-->	NR RRC: <i>RRCResumeRequest</i>	1	P
3	The SS transmits an <i>RRCResume</i> message.	<--	NR RRC: <i>RRCResume</i>	-	-
4	The UE transmits an <i>RRCResumeComplete</i> message.	-->	NR RRC: <i>RRCResumeComplete</i>	-	-
5	The SS transmits an <i>RRCRelease</i> message including both <i>fullI-RNTI</i> and <i>shortI-RNTI</i> in <i>suspendConfig</i> .	<--	NR RRC: <i>RRCRelease</i>	-	-
6	The SS changes the SIB1 to set the <i>useFullResumeID</i> to True.	-	-	-	-
7	The SS transmits a Short message on PDCCH using P-RNTI indicating a <i>systemInfoModification</i> .	-	PDCCH (DCI 1_0): Short Message	-	-
8	Wait for 1 second for the UE to receive system information.	-	-	-	-
9	The SS transmits a <i>Paging</i> message including a matched identity (correct <i>fullI-RNTI</i>).	-	NR RRC: <i>Paging</i>	-	-
10	Check: Does the UE transmit an <i>RRCResumeRequest1</i> message by setting <i>resumeIdentity</i> to the stored <i>fullI-RNTI</i> value?	-->	NR RRC: <i>RRCResumeRequest1</i>	2	P
11	The SS transmits an <i>RRCResume</i> message.	<--	NR RRC: <i>RRCResume</i>	-	-
12	The UE transmits an <i>RRCResumeComplete</i> message.	-->	NR RRC: <i>RRCResumeComplete</i>	-	-

8.1.1.4.1.3.3 Specific message contents

Table 8.1.1.4.1.3.3-1: Paging (step 1, Table 8.1.1.4.1.3.2-1)

Derivation Path: TS 38.508-1 [4], Table 4.6.1-9 with condition NR_RRC_RESUME

Table 8.1.1.4.1.3.3-2: RRCRelease (step 5, Table 8.1.1.4.1.3.2-1)

Derivation Path: TS 38.508-1 [4], Table 4.6.1-16 with condition NR_RRC_INACTIVE

Table 8.1.1.4.1.3.3-3: SIB1 (step 6, Table 8.1.1.4.1.3.2-1)

Derivation Path: TS 38.508-1 [4], Table 4.6.1-28

Information Element	Value/remark	Comment	Condition
SIB1 ::= SEQUENCE {			
useFullResumeID	true		
}			

Table 8.1.1.4.1.3.3-4: Paging (step 9, Table 8.1.1.4.1.3.2-1)

Derivation Path: TS 38.508-1 [4], Table 4.6.1-9 with condition NR_RRC_RESUME
--

8.1.1.4.2 RRC resume / Suspend-Resume / RRC setup / T319 expiry

8.1.1.4.2.1 Test Purpose (TP)

(1)

```
with { UE in NR RRC_INACTIVE state and sends RRCResumeRequest message to resume RRC Connection }
ensure that {
  when { UE receives a RRCSetup message }
  then { UE shall discards any stored UE Inactive AS context, suspendConfig and send
RRCSetupComplete message with ng-5G-S-TMSI-Value set to ng-5G-S-TMSI }
}
```

(2)

```
with { UE in NR RRC_INACTIVE state and sends RRCResumeRequest message to resume RRC Connection }
ensure that {
  when { T319 expires }
  then { UE shall release RRC connection with release cause RRC Resume failure and go to NR
RRC_IDLE state }
}
```

8.1.1.4.2.2 Conformance requirements

References: The conformance requirements covered in the present TC are specified in: TS 38.331, clauses 5.3.3.4, 5.3.11, 5.3.13.5 and 5.3.13.7. Unless otherwise stated these are Rel-15 requirements.

[TS 38.331, clause 5.3.3.4]

The UE shall perform the following actions upon reception of the *RRCSetup*:

...

- 1> if the *RRCSetup* is received in response to an *RRCResumeRequest* or *RRCResumeRequest1*:
 - 2> discard any stored UE Inactive AS context and *suspendConfig*;
 - 2> discard any current AS security context including the $K_{RRCCenc}$ key, the K_{RRCint} key, the K_{UPint} key and the K_{UPenc} key;
 - 2> release radio resources for all established RBs except SRB0, including release of the RLC entities, of the associated PDCP entities and of SDAP;
 - 2> release the RRC configuration except for the default MAC Cell Group configuration and CCCH configuration;
 - 2> indicate to upper layers fallback of the RRC connection;
 - 2> stop timer T380, if running;
- 1> perform the cell group configuration procedure in accordance with the received *masterCellGroup* and as specified in 5.3.5.5;
- 1> perform the radio bearer configuration procedure in accordance with the received *radioBearerConfig* and as specified in 5.3.5.6;
- 1> if stored, discard the cell reselection priority information provided by the *cellReselectionPriorities* or inherited from another RAT;
- 1> stop timer T300, T301 or T319 if running;
- 1> if T390 is running:

- 2> stop timer T390 for all access categories;
- 2> perform the actions as specified in 5.3.14.4.
- 1> stop timer T302, if running;
- 1> stop timer T320, if running;
- 1> if the *RRCSetup* is received in response to an *RRCResumeRequest*, *RRCResumeRequest1* or *RRCSetupRequest*:
 - 2> enter *RRC_CONNECTED*;
 - 2> stop the cell re-selection procedure;
- 1> consider the current cell to be the PCell;
- 1> set the content of *RRCSetupComplete* message as follows:
 - 2> if upper layers provide an *5G-S-TMSI*:
 - 3> if the *RRCSetup* is received in response to an *RRCSetupRequest*:
 - 4> set the *ng-5G-S-TMSI-Value* to *ng-5G-S-TMSI-Part2*;
 - 3> else:
 - 4> set the *ng-5G-S-TMSI-Value* to *ng-5G-S-TMSI*;
 - 2> set the *selectedPLMN-Identity* to the PLMN selected by upper layers (TS 24.501 [23]) from the PLMN(s) included in the *plmn-IdentityList* in *SIB1*;
 - 2> if upper layers provide the 'Registered AMF':
 - 3> include and set the *registeredAMF* as follows:
 - 4> if the PLMN identity of the 'Registered AMF' is different from the PLMN selected by the upper layers:
 - 5> include the *plmnIdentity* in the *registeredAMF* and set it to the value of the PLMN identity in the 'Registered AMF' received from upper layers;
 - 4> set the *amf-Identifier* to the value received from upper layers;
 - 3> include and set the *guami-Type* to the value provided by the upper layers;
 - 2> if upper layers provide one or more S-NSSAI (see TS 23.003 [21]):
 - 3> include the *s-nssai-List* and set the content to the values provided by the upper layers;
 - 2> set the *dedicatedNAS-Message* to include the information received from upper layers;
- 1> submit the *RRCSetupComplete* message to lower layers for transmission, upon which the procedure ends

[TS 38.331, clause 5.3.11]

UE shall:

- 1> reset MAC;
- 1> if T302 is running:
 - 2> stop timer T302;
 - 2> perform the actions as specified in 5.3.14.4;
- 1> stop all timers that are running except T320 and T325;
- 1> discard the UE Inactive AS context;

- 1> set the variable *pendingRnaUpdate* to *false*, if that is set to *true*;
- 1> discard the K_{gNB} , the K_{RRcenc} key, the K_{RRcint} , the K_{UPint} key and the K_{UPenc} key, if any;
- 1> release all radio resources, including release of the RLC entity, the MAC configuration and the associated PDCP entity and SDAP for all established RBs;
- 1> indicate the release of the RRC connection to upper layers together with the release cause;
- 1> enter RRC_IDLE and perform cell selection as specified in TS 38.304 [20], except if going to RRC_IDLE was triggered by selecting an inter-RAT cell while T311 was running;

[TS 38.331, clause 5.3.13.5]

The UE shall:

- 1> if timer T319 expires or upon receiving Integrity check failure indication from lower layers while T319 is running:
 - 2> perform the actions upon going to RRC_IDLE as specified in 5.3.11 with release cause 'RRC Resume failure'.

[TS 38.331, clause 5.3.13.7]

The UE shall:

- 1> perform the RRC connection setup procedure as specified in 5.3.3.4.

8.1.1.4.2.3 Test description

8.1.1.4.2.3.1 Pre-test conditions

System Simulator:

- NR Cell 1 is the serving cell.
- System information combination NR-1 as defined in TS 38.508-1 [4] clause 4.4.3.1.2 is used in NR cell.

UE:

- None.

Preamble:

- The UE is in state 2N-A as defined in TS 38.508-1 [4], Table 4.4A.2-2 on NR Cell 1.

8.1.1.4.2.3.2 Test procedure sequence

Table 8.1.1.4.2.3.2-1: Main behaviour

St	Procedure	Message Sequence		TP	Verdict
		U - S	Message		
1	The SS transmits a <i>Paging</i> message including a matched identity (correct <i>fullI-RNTI</i>).	-	NR RRC: <i>Paging</i>	-	-
2	The UE transmit an <i>RRCResumeRequest</i> message to resume RRC Connection by setting <i>resumelidentity</i> to the stored <i>shortI-RNTI</i> value?	-->	NR RRC: <i>RRCResumeRequest</i>	-	-
3	The SS transmits an <i>RRCSetup</i> message in response to <i>RRCResumeRequest</i> message.	<--	NR RRC: <i>RRCSetup</i>	-	-
4	Check: Does the UE transmits an <i>RRCSetupComplete</i> message and a REGISTRATION REQUEST message by discarding any stored UE Inactive AS context and suspendConfig, setting the <i>ng-5G-S-TMSI-Value</i> to <i>ng-5G-S-TMSI</i> ?	-->	NR RRC: <i>RRCSetupComplete</i> 5GMM: REGISTRATION REQUEST	1	P
4a1 - 4a2	Step 4-5 as defined in TS 38.508-1 [4] Table 4.9.5.2.2-1.	-	-	-	-
5	The SS transmits an <i>RRCRelease</i> message including both <i>fullI-RNTI</i> and <i>shortI-RNTI</i> in <i>suspendConfig</i> .	<--	NR RRC: <i>RRCRelease</i>	-	-
6	The SS transmits a <i>Paging</i> message including a matched identities (correct <i>fullI-RNTI</i>).	<--	NR RRC: <i>Paging</i>	-	-
7	The UE transmits an <i>RRCResumeRequest</i> message to resume RRC Connection by setting <i>resumelidentity</i> to the stored <i>shortI-RNTI</i> value?	-->	NR RRC: <i>RRCResumeRequest</i>	-	-
8	The SS waits for T319 expiry.	-	-	-	-
9	Check: Does the test result of test procedure in TS 38.508-1 [4] subclause 4.9.4 indicate that the UE is in NR RRC_IDLE?	-	-	2	-

8.1.1.4.2.3.3 Specific message contents

Table 8.1.1.4.2.3.3-1: *RRCRelease* (preamble and step 5 in Table 8.1.1.4.2.3.2-1)

Derivation Path: 38.508-1 [4], Table 4.6.1-16			
Information Element	Value/remark	Comment	Condition
<i>RRCRelease</i> ::= SEQUENCE {			
<i>criticalExtensions</i> CHOICE {			
<i>rrcRelease</i> SEQUENCE {			
<i>suspendConfig</i> SEQUENCE {			NR_RRC_I NACTIVE
<i>fullI-RNTI</i>	I-RNTI-Value		
<i>shortI-RNTI</i>	ShortI-RNTI-Value		
}			
}			
}			
}			

Table 8.1.1.4.2.3.3-2: RRCResumeRequest (step 2 and 7 Table 8.1.1.4.2.3.2-1)

Derivation Path: 38.508-1 [4], Table 4.6.1-19			
Information Element	Value/remark	Comment	Condition
RRCResumeRequest ::= SEQUENCE {			
rrcResumeRequest SEQUENCE {			
resumeCause	mt-Access		
}			
}			

Table 8.1.1.4.2.3.3-3: RRCSetupComplete (step 4 in Table 8.1.1.4.2.3.2-1)

Derivation Path: 38.508-1 [4], Table 4.6.1-22			
Information Element	Value/remark	Comment	Condition
RRCSetupComplete ::= SEQUENCE {			
criticalExtensions CHOICE {			
rrcSetupComplete SEQUENCE {			
ng-5G-S-TMSI-Value	ng-5G-S-TMSI		
}			
}			
}			

Table 8.1.1.4.2.3.3-4: REGISTRATION REQUEST (step 4 in Table 8.1.1.4.2.3.2-1)

Derivation Path: 38.508-1 [4], Table 4.7.1-6			
Information Element	Value/remark	Comment	Condition
5GS registration type			
5GS registration type value	'010'B	Mobility registration updating	
Uplink data status	Present but contents not checked		

8.1.1.4.3 RRC resume / Suspend-Resume / RNA update / Success

8.1.1.4.3.1 Test Purpose (TP)

(1)

```
with { UE in NR RRC_INACTIVE state }
ensure that {
  when { UE performs cell reselection and enters an RNA not belonging to the configured ran-
NotificationAreaInfo }
    then { UE shall initiate RRC connection resume procedure with cause value set to rna-Update }
}
```

8.1.1.4.3.2 Conformance requirements

References: The conformance requirements covered in the present TC are specified in: TS 38.331, clauses 5.2.2.4.2, 5.3.13.2 and 5.3.13.8. Unless otherwise stated these are Rel-15 requirements.

[TS 38.331, clause 5.2.2.4.2]

Upon receiving the *SIB1* the UE shall:

- 1> store the acquired *SIB1*;
- 1> if the *cellAccessRelatedInfo* contains an entry with the *PLMN-Identity* of the selected PLMN;
- 2> in the remainder of the procedures use *plmn-IdentityList*, *trackingAreaCode*, and *cellIdentity* for the cell as received in the corresponding *PLMN-IdentityInfo* containing the selected PLMN;

...

1> else:

...

2> if the UE supports the bandwidth of the initial uplink BWP and of the initial downlink BWPs indicated in the *locationAndBandwidth* fields:

3> forward the *cellIdentity* to upper layers;

3> forward the *trackingAreaCode* to upper layers;

3> if in RRC_INACTIVE and the forwarded *trackingAreaCode* does not trigger message transmission by upper layers:

4> if the serving cell does not belong to the configured *ran-NotificationAreaInfo*:

5> initiate an RNA update as specified in 5.3.13.8;

[TS 38.331, clause 5.3.13.2]

The UE initiates the procedure when upper layers or AS (when responding to RAN paging or upon triggering RNA updates while the UE is in RRC_INACTIVE) requests the resume of a suspended RRC connection.

The UE shall ensure having valid and up to date essential system information as specified in clause 5.2.2.2 before initiating this procedure.

Upon initiation of the procedure, the UE shall:

Editor's Note: FFS Whether SCG configuration should be released or whether that should be treated as any other configuration (i.e. with delta signalling).

...

1> else if the resumption of the RRC connection is triggered due to an RNA update as specified in 5.3.13.8:

...

2> perform the unified access control procedure as specified in 5.3.14 using the selected Access Category and one or more Access Identities to be applied as specified in TS 24.501 [23];

...

1> release the current dedicated Serving Cell configuration;

1> apply the default L1 parameter values as specified in corresponding physical layer specifications, except for the parameters for which values are provided in *SIB1*;

1> apply the default SRB1 configuration as specified in 9.2.1;

1> apply the default MAC Cell Group configuration as specified in 9.2.2;

1> release *delayBudgetReportingConfig*, if configured and stop timer T342, if running;

1> release *overheatingAssistanceConfig*, if configured and stop timer T345, if running;

1> apply the CCCH configuration as specified in 9.1.1.2;

1> apply the *timeAlignmentTimerCommon* included in *SIB1*;

1> start timer T319;

1> set the variable *pendingRnaUpdate* to *false*;

1> initiate transmission of the *RRCResumeRequest* message or *RRCResumeRequest1* in accordance with 5.3.13.3.

[TS 38.331, clause 5.3.13.8]

In RRC_INACTIVE state, the UE shall:

- 1> if T380 expires; or
- 1> if RNA Update is triggered at reception of SIB1, as specified in 5.2.2.4.2:
 - 2> initiate RRC connection resume procedure in 5.3.13.2 with *resumeCause* set to *rna-Update*;

8.1.1.4.3.3 Test description

8.1.1.4.3.3.1 Pre-test conditions

System Simulator:

- 2 NR cells with different tracking areas:
 - NR Cell 1 is the serving cell
 - NR Cell 2 is a suitable neighbour intra-frequency cell
 - Cell power levels are selected according to 38.508-1 [4] Table 6.2.2.1-3 and NR Cell 2 is switched on after UE has registered on NR Cell 1.
 - System information combination NR-2 as defined in TS 38.508-1 [4] clause 4.4.3.1.2 is used in NR cells.

UE:

- None.

Preamble:

- The UE is in state 2N-A as defined in TS 38.508-1 [4], Table 4.4A.2-2 on NR Cell 1.

8.1.1.4.3.3.2 Test procedure sequence

Table 8.1.1.4.3.3.2-1: Main behaviour

St	Procedure	Message Sequence		TP	Verdict
		U - S	Message		
1	The SS changes NR Cell 1 to Non-suitable "Off" cell according to 38.508-1 [4] Table 6.2.2.1-3.				
2	Check: Does the UE transmit an <i>RRCResumeRequest</i> message with <i>resumeCause</i> value set to <i>rna-Update</i> on NR Cell 2 within 60s?	-->	NR RRC: <i>RRCResumeRequest</i>	1	P
3	The SS transmits an <i>RRCResume</i> message.	<--	NR RRC: <i>RRCResume</i>	-	-
4	The UE transmit an <i>RRCResumeComplete</i> message to complete the resume procedure.	-->	NR RRC: <i>RRCResumeComplete</i>	-	-

8.1.1.4.3.3.3 Specific message contents

Table 8.1.1.4.3.3.3-1: RRCRelease (preamble)

Derivation Path: 38.508-1 [4], Table 4.6.1-16			
Information Element	Value/remark	Comment	Condition
RRCRelease ::= SEQUENCE {			
criticalExtensions CHOICE {			
rrcRelease SEQUENCE {			
suspendConfig SEQUENCE {			NR_RRC_I NACTIVE
ran-NotificationAreaInfo CHOICE {			
cellList SEQUENCE {			
plmn-Identity		PLMN ID of NR Cell 1	
ran-AreaCells SEQUENCE {			
cellIdentity	See Table 4.4.2-2 and 4.4.2-3 in TS 38.508-1 [4]	Cell Identity of NR Cell 1	
}			
}			
}			
}			
}			

Table 8.1.1.4.3.3.3-2: RRCResumeRequest (step 2 Table 8.1.1.4.3.3.2-1)

Derivation Path: 38.508-1 [4], Table 4.6.1-19			
Information Element	Value/remark	Comment	Condition
RRCResumeRequest ::= SEQUENCE {			
rrcResumeRequest SEQUENCE {			
resumeCause	rna-Update		
}			
}			

8.1.2 RRC reconfiguration

8.1.2.1 Radio bearer establishment / reconfiguration / release

8.1.2.1.1 RRC reconfiguration / DRB / SRB / Establishment / Modification / Release / Success

8.1.2.1.1.1 Test Purpose (TP)

(1)

```

with { UE having completed the RRC connection establishment procedure }
ensure that {
  when { SS sends in sequence a SecurityModeCommand and an RRCReconfiguration message to establish a
DRB }
  then { UE establishes the initial security configuration in accordance with the received
securityConfigSMC included in SecurityModeCommand and successfully completes the reconfiguration }
}

```

(2)

```

with { UE in NR RRC_CONNECTED state without SRB2 }
ensure that {
  when { SS sends an RRCReconfiguration message including SRB2 configuration }
  then { UE successfully establish the signalling radio bearer }
}

```

(3)

```

with { UE in NR RRC_CONNECTED state }
ensure that {
  when { UE receives an RRCReconfiguration message to reconfigure the current UE configuration of
SRB and DRB }
  then { UE reconfigures the data and signalling radio bearers and sends an
RRCReconfigurationComplete message }
}

```

(4)

```

with { UE in NR RRC_CONNECTED state }
ensure that {
  when { UE receives an RRCReconfiguration message including a drb-ToReleaseList }
  then { for each drb-Identity release the PDCP entity and RLC entity and logical channel and
indicate release of the DRB(s) to upper layers }
}

```

8.1.2.1.1.2 Conformance requirements

References: The conformance requirements covered in the present TC are specified in: TS 38.331, clauses 5.3.4.3, 5.3.5.6.3, 5.3.5.6.4, and 5.3.5.6.5]. Unless otherwise stated these are Rel-15 requirements.

[TS 38.331, clause 5.3.4.3]

The UE shall:

- 1> derive the K_{gNB} key, as specified in TS 33.501 [11];
- 1> derive the K_{RRcInt} key associated with the *integrityProtAlgorithm* indicated in the *SecurityModeCommand* message, as specified in TS 33.501 [11];
- 1> request lower layers to verify the integrity protection of the *SecurityModeCommand* message, using the algorithm indicated by the *integrityProtAlgorithm* as included in the *SecurityModeCommand* message and the K_{RRcInt} key;
- 1> if the *SecurityModeCommand* message passes the integrity protection check:
 - 2> derive the K_{RRcEnc} key and the K_{UPenc} key associated with the *cipheringAlgorithm* indicated in the *SecurityModeCommand* message, as specified in TS 33.501 [11];
 - 2> derive the K_{UPint} key associated with the *integrityProtAlgorithm* indicated in the *SecurityModeCommand* message, as specified in TS 33.501 [11];
 - 2> configure lower layers to apply SRB integrity protection using the indicated algorithm and the K_{RRcInt} key immediately, i.e. integrity protection shall be applied to all subsequent messages received and sent by the UE, including the *SecurityModeComplete* message;

[TS 38.331, clause 5.3.5.6.3]

The UE shall:

- 1> for each *srb-Identity* value included in the *srb-ToAddModList* that is not part of the current UE configuration (SRB establishment or reconfiguration from E-UTRA PDCP to NR PDCP):
 - 2> establish a PDCP entity;
 - 2> if AS security has been activated:
 - 3> if target RAT of handover is E-UTRA/5GC, or;
 - 3> if the UE is only connected to E-UTRA/5GC:
 - 4> configure the PDCP entity with the security algorithms and keys (K_{RRcEnc} and K_{RRcInt}) configured/derived as specified in TS 36.331 [10];

- 3> else:
 - 4> configure the PDCP entity with the security algorithms according to *securityConfig* and apply the keys (K_{RRCEnc} and K_{RRCint}) associated with the master key (K_{eNB}/K_{gNB}) or secondary key ($S-K_{gNB}$) as indicated in *keyToUse*, if applicable;
- 2> if the current UE configuration as configured by E-UTRA in TS 36.331 [10] includes an SRB identified with the same *srb-Identity* value:
 - 3> associate the E-UTRA RLC entity and DCCH of this SRB with the NR PDCP entity;
 - 3> release the E-UTRA PDCP entity of this SRB;
- 2> if the *pdcp-Config* is included:
 - 3> configure the PDCP entity in accordance with the received *pdcp-Config*;
- 2> else:
 - 3> configure the PDCP entity in accordance with the default configuration defined in 9.2.1 for the corresponding SRB;
- 1> for each *srb-Identity* value included in the *srb-ToAddModList* that is part of the current UE configuration:
 - 2> if the *reestablishPDCP* is set:
 - 3> if target RAT of handover is E-UTRA/5GC, or;
 - 3> if the UE is only connected to E-UTRA/5GC:
 - 4> configure the PDCP entity to apply the integrity protection algorithm and K_{RRCint} key configured/derived as specified in TS 36.331 [10], i.e. the integrity protection configuration shall be applied to all subsequent messages received and sent by the UE, including the message used to indicate the successful completion of the procedure;
 - 4> configure the PDCP entity to apply the ciphering algorithm and K_{RRCEnc} key configured/derived as specified in TS 36.331 [10], i.e. the ciphering configuration shall be applied to all subsequent messages received and sent by the UE, including the message used to indicate the successful completion of the procedure;
 - 3> else:
 - 4> configure the PDCP entity to apply the integrity protection algorithm and K_{RRCint} key associated with the master key (K_{eNB}/K_{gNB}) or secondary key ($S-K_{gNB}$), as indicated in *keyToUse*, i.e. the integrity protection configuration shall be applied to all subsequent messages received and sent by the UE, including the message used to indicate the successful completion of the procedure;
 - 4> configure the PDCP entity to apply the ciphering algorithm and K_{RRCEnc} key associated with the master key (K_{eNB}/K_{gNB}) or secondary key ($S-K_{gNB}$) as indicated in *keyToUse*, i.e. the ciphering configuration shall be applied to all subsequent messages received and sent by the UE, including the message used to indicate the successful completion of the procedure;
 - 4> re-establish the PDCP entity of this SRB as specified in TS 38.323 [5];
 - 2> else, if the *discardOnPDCP* is set:
 - 3> trigger the PDCP entity to perform SDU discard as specified in TS 38.323 [5];
 - 2> if the *pdcp-Config* is included:
 - 3> reconfigure the PDCP entity in accordance with the received *pdcp-Config*.

[TS 38.331, clause 5.3.5.6.4]

The UE shall:

- 1> for each *drb-Identity* value included in the *drb-ToReleaseList* that is part of the current UE configuration; or

- 1> for each *drb-Identity* value that is to be released as the result of full configuration according to 5.3.5.11:
 - 2> release the PDCP entity and the *drb-Identity*;
 - 2> if SDAP entity associated with this DRB is configured:
 - 3> indicate the release of the DRB to SDAP entity associated with this DRB (TS 37.324 [24], clause 5.3.3);
 - 2> if the UE is operating in EN-DC:
 - 3> if a new bearer is not added either with NR or E-UTRA with same *eps-BearerIdentity*:
 - 4> indicate the release of the DRB and the *eps-BearerIdentity* of the released DRB to upper layers.

NOTE 1: The UE does not consider the message as erroneous if the *drb-ToReleaseList* includes any *drb-Identity* value that is not part of the current UE configuration.

NOTE 2: Whether or not the RLC and MAC entities associated with this PDCP entity are reset or released is determined by the *CellGroupConfig*.

[TS 38.331, clause 5.3.5.6.5]

The UE shall:

- 1> for each *drb-Identity* value included in the *drb-ToAddModList* that is not part of the current UE configuration (DRB establishment including the case when full configuration option is used):
 - 2> establish a PDCP entity and configure it in accordance with the received *pdcpc-Config*;
 - 2> if the PDCP entity of this DRB is not configured with *cipheringDisabled*:
 - 3> if target RAT of handover is E-UTRA/5GC, or;
 - 3> if the UE is only connected to E-UTRA/5GC:
 - 4> configure the PDCP entity with the ciphering algorithm and K_{UPenc} key configured/derived as specified in TS 36.331 [10];
 - 3> else:
 - 4> configure the PDCP entity with the ciphering algorithms according to *securityConfig* and apply the K_{UPenc} key associated with the master key (K_{eNB}/K_{gNB}) or the secondary key ($S-K_{gNB}$) as indicated in *keyToUse*;
 - 2> if the PDCP entity of this DRB is configured with *integrityProtection*:
 - 3> configure the PDCP entity with the integrity algorithms according to *securityConfig* and apply the K_{UPint} key associated with the master (K_{eNB}/K_{gNB}) or the secondary key ($S-K_{gNB}$) as indicated in *keyToUse*;
 - 2> if an *sdap-Config* is included:
 - 3> if an SDAP entity with the received *pdu-Session* does not exist:
 - 4> establish an SDAP entity as specified in TS 37.324 [24] clause 5.1.1;
 - 4> If an SDAP entity with the received *pdu-Session* did not exist prior to receiving this reconfiguration:
 - 5> indicate the establishment of the user plane resources for the *pdu-Session* to upper layers;
 - 3> configure the SDAP entity in accordance with the received *sdap-Config* as specified in TS 37.324 [24] and associate the DRB with the SDAP entity;
 - 2> if the UE is operating in EN-DC:
 - 3> if the DRB was configured with the same *eps-BearerIdentity* either by NR or E-UTRA prior to receiving this reconfiguration:
 - 4> associate the established DRB with the corresponding *eps-BearerIdentity*;

3> else:

4> indicate the establishment of the DRB(s) and the *eps-BearerIdentity* of the established DRB(s) to upper layers;

8.1.2.1.1.3 Test description

8.1.2.1.1.3.1 Pre-test conditions

System Simulator:

- NR Cell 1

UE:

- None

Preamble:

- The UE is in 5GS state 1N-A, PDU SESSION ACTIVE according to TS 38.508-1 [4], clause 4.4A.2 Table 4.4A.2-1

8.1.2.1.1.3.2 Test procedure sequence

Table 8.1.2.1.1.3.2-1: Main behaviour

St	Procedure	Message Sequence		TP	Verdict
		U - S	Message		
1	SS transmits a <i>Paging</i> message to the UE on the appropriate paging block, and including the UE identity in one entry of the IE <i>pagingRecordList</i> .	<--	NR RRC: <i>Paging</i>	-	-
2	UE transmits an <i>RRCSetupRequest</i> message.	-->	NR RRC: <i>RRCSetupRequest</i>	-	-
3	SS transmit an <i>RRCSetup</i> message	<--	NR RRC: <i>RRCSetup</i>	-	-
4	The UE transmits an <i>RRCSetupComplete</i> to confirm the successful completion of the connection establishment.	-->	NR RRC: <i>RRCSetupComplete</i>	-	-
5	SS transmits a <i>SecurityModeCommand</i> message to activate AS security.	<--	NR RRC: <i>SecurityModeCommand</i>	-	-
6	Using the same slot as the <i>SecurityModeCommand</i> message in step 5, the SS transmits an <i>RRCReconfiguration</i> message to establish a data radio bearer, DRB1.	<--	NR RRC: <i>RRCReconfiguration</i>	-	-
7	Check: Does the UE transmit a <i>SecurityModeComplete</i> message?	-->	NR RRC: <i>SecurityModeComplete</i>	1	P
8	Check: Does the UE transmit an <i>RRCReconfigurationComplete</i> message to confirm the establishment of data radio bearer, DRB1?	-->	NR RRC: <i>RRCReconfigurationComplete</i>	1	P
9	SS transmits an <i>RRCReconfiguration</i> message to establish SRB2.	<--	NR RRC: <i>RRCReconfiguration</i>	-	-
10	Check: Does the UE transmit an <i>RRCReconfigurationComplete</i> message to confirm the establishment of signalling radio bearer, SRB2?	-->	NR RRC: <i>RRCReconfigurationComplete</i>	2	P
11	The SS transmits an <i>RRCReconfiguration</i> message to modify SRB and DRB configuration.	<--	NR RRC: <i>RRCReconfiguration</i>	-	-
12	Check: Does the UE transmit an <i>RRCReconfigurationComplete</i> message?	-->	NR RRC: <i>RRCReconfigurationComplete</i>	3	P
13	The SS transmits an <i>RRCReconfiguration</i> message with a <i>drb-ToReleaseList</i> and PDU SESSION RELEASE COMMAND	<--	NR RRC: <i>RRCReconfiguration</i> 5GMM: DL NAS TRANSPORT 5GSM: PDU SESSION RELEASE COMMAND	-	-
14	Check: Does the UE transmit an <i>RRCReconfigurationComplete</i> message?	-->	NR RRC: <i>RRCReconfigurationComplete</i>	4	P
16	The UE transmits an <i>ULInformationTransfer</i> message and a UL NAS TRASPORT containing PDU SESSION RELEASE COMPLETE.	-->	NR RRC: <i>ULInformationTransfer</i> 5GMM: UL NAS TRANSPORT 5GSM: PDU SESSION RELEASE COMPLETE	-	-

8.1.2.1.1.3.3 Specific message contents

Table 8.1.2.1.1.3.3-1: RRCReconfiguration (Step 6 Table 8.1.2.1.1.3.2-1)

Derivation Path: TS 38.508-1, table 4.6.1-13			
Information Element	Value/remark	Comment	Condition
RRCReconfiguration ::= SEQUENCE {			
criticalExtensions CHOICE {			
rrcReconfiguration ::= SEQUENCE {			
radioBearerConfig	RadioBearerConfig with condition DRB1		
nonCriticalExtension SEQUENCE {			
masterCellGroup	CellGroupConfig	OCTET STRING (CONTAINING CellGroupConfig)	
}			
}			
}			

Table 8.1.2.1.1.3.3-1A: CellGroupConfig (Table 8.1.2.1.1.3.3-1)

Derivation Path: TS 38.508-1, table 4.6.1-3			
Information Element	Value/remark	Comment	Condition
CellGroupConfig ::= SEQUENCE {			
rlc-BearerToAddModList SEQUENCE (SIZE(1..maxLCH)) OF SEQUENCE {	1 entry		
RLC-Bearer-Config[2] {			
logicalChannelIdentity[2]	LogicalChannelIdentity		
servedRadioBearer[2] CHOICE {			
drb-Identity	DRB-Identity with condition DRB1		
}			
reestablishRLC[2]	Not present		
RLC-Config[2]	Not present		
mac-LogicalChannelConfig[2]	Not present		
}			
mac-CellGroupConfig	Not present		
physicalCellGroupConfig	Not present		
spCellConfig SEQUENCE {}	Not present		
}			

Table 8.1.2.1.1.3.3-2: RRCReconfiguration (Step 9 Table 8.1.2.1.1.3.2-1)

Derivation Path: TS 38.508-1, table 4.6.1-13			
Information Element	Value/remark	Comment	Condition
RRCReconfiguration ::= SEQUENCE {			
criticalExtensions CHOICE {			
rrcReconfiguration ::= SEQUENCE {			
radioBearerConfig	RadioBearerConfig with condition SRB2		
nonCriticalExtension SEQUENCE {			
masterCellGroup	CellGroupConfig	OCTET STRING (CONTAINING CellGroupConfig)	
}			
}			
}			

Table 8.1.2.1.1.3.3-2A: CellGroupConfig (Table 8.1.2.1.1.3.3-2)

Derivation Path: TS 38.508-1, table 4.6.1-3			
Information Element	Value/remark	Comment	Condition
CellGroupConfig ::= SEQUENCE {			
rlc-BearerToAddModList SEQUENCE (SIZE(1..maxLCH)) OF SEQUENCE {	1 entry		
RLC-Bearer-Config[1] {			
logicalChannelIdentity[1]	LogicalChannelIdentity		
servedRadioBearer[1] CHOICE {			
srb-Identity	SRB-Identity with condition SRB2		
}			
reestablishRLC[1]	Not present		
RLC-Config[1]	Not present		
mac-LogicalChannelConfig[1]	Not present		
}			
mac-CellGroupConfig	Not present		
physicalCellGroupConfig	Not present		
spCellConfig SEQUENCE {}	Not present		
}			

Table 8.1.2.1.1.3.3-3: RRCReconfiguration (Step 11 Table 8.1.2.1.1.3.2-1)

Derivation Path: TS 38.508-1, table 4.6.1-13			
Information Element	Value/remark	Comment	Condition
RRCReconfiguration ::= SEQUENCE {			
criticalExtensions CHOICE {			
rrcReconfiguration ::= SEQUENCE {			
nonCriticalExtension SEQUENCE {			
masterCellGroup	CellGroupConfig	OCTET STRING (CONTAINING CellGroupConfig)	
}			
}			
}			
}			

Table 8.1.2.1.1.3.3-4: CellGroupConfig (Step 11 Table 8.1.2.1.1.3.2-1)

Derivation Path: TS 38.508-1, table 4.6.1-13			
Information Element	Value/remark	Comment	Condition
CellGroupConfig ::= SEQUENCE {			
rlc-BearerToAddModList SEQUENCE (SIZE(1..maxLCH)) OF SEQUENCE {	2 entries		
RLC-Bearer-Config[1] {			
logicalChannelIdentity[1]	LogicalChannelIdentity		
servedRadioBearer[1] CHOICE {			
srb-Identity	SRB-Identity with condition SRB2		
}			
reestablishRLC[1]	true		
RLC-Config[1]	Not present		
mac-LogicalChannelConfig[1]	Not present		
}			
RLC-Bearer-Config[2] {			
logicalChannelIdentity[2]	LogicalChannelIdentity		
servedRadioBearer[2] CHOICE {			
drb-Identity	DRB-Identity with condition DRB1		
}			
reestablishRLC[2]	true		
RLC-Config[2]	Not present		
mac-LogicalChannelConfig[2]	Not present		
}			
mac-CellGroupConfig	Not present		
physicalCellGroupConfig	Not present		
spCellConfig SEQUENCE {}	Not present		
}			

Table 8.1.2.1.1.3.3-5: RRCReconfiguration (Step 13 Table 8.1.2.1.1.3.2-1)

Derivation Path: TS 38.508-1, table 4.6.1-3			
Information Element	Value/remark	Comment	Condition
RRCReconfiguration ::= SEQUENCE {			
criticalExtensions CHOICE {			
rrcReconfiguration ::= SEQUENCE {			
radioBearerConfig	RadioBearerConfig		
nonCriticalExtension SEQUENCE {			
masterCellGroup	CellGroupConfig	OCTET STRING (CONTAINING CellGroupConfig)	
}			
}			
}			
}			

Table 8.1.2.1.1.3.3-6: RadioBearerConfig (Table 8.1.2.1.1.3.3-5)

Derivation Path: 38.508-1 [4], Table 4.6.3-132			
Information Element	Value/remark	Comment	Condition
RadioBearerConfig ::= SEQUENCE {			
drb-ToReleaseList	1	DRB1	
}			

Table 8.2.1.1.1.3.3-7: CellGroupConfig (Table 8.2.1.1.1.3.3-7)

Derivation Path: 38.508-1 [4], Table 4.6.3-19			
Information Element	Value/remark	Comment	Condition
CellGroupConfig ::= SEQUENCE {			
cellGroupId	1		
rlc-BearerToAddModList	Not Present		
rlc-BearerToReleaseList SEQUENCE (SIZE(1..maxLCH)) OF SEQUENCE {	1 entry		
logicalChannelIdentity[1]	LogicalChannelIdentit y		
}			
mac-CellGroupConfig	Not Present		
tag-Config	Not Present		
phr-Config	Not Present		
physicalCellGroupConfig	Not Present		
rlf-TimersAndConstants	Not Present		
}			

8.1.2.1.2

8.1.2.1.3 RRC reconfiguration / Radio resource reconfiguration / dedicatedSIB1-Delivery

8.1.2.1.3.1 Test Purpose (TP)

(1)

```

with { UE in NR RRC_CONNECTED state}
ensure that {
  when { UE receives an RRCReconfiguration message including dedicatedSIB1-Delivery containing SIB1
information with a change of trackingAreaCode }
  then { UE reads the updated SIB1 information and sends an RRCReconfigurationComplete message
followed by registration on the new tracking area }
}

```

8.1.2.1.3.2 Conformance requirements

References: The conformance requirements covered in the present TC are specified in: TS 38.331, clauses 5.2.2.4.2, 5.5.5.3. Unless otherwise stated these are Rel-15 requirements.

[TS 38.331, clause 5.3.5.3]

The UE shall perform the following actions upon reception of the *RRCReconfiguration*:

- 1> if the *RRCReconfiguration* includes the *fullConfig*:
 - 2> perform the full configuration procedure as specified in 5.3.5.11;
- 1> if the *RRCReconfiguration* includes the *masterCellGroup*:
 - 2> perform the cell group configuration for the received *masterCellGroup* according to 5.3.5.5;
- 1> if the *RRCReconfiguration* includes the *masterKeyUpdate*:
 - 2> perform security key update procedure as specified in 5.3.5.7;
- 1> if the *RRCReconfiguration* includes the *secondaryCellGroup*:
 - 2> perform the cell group configuration for the SCG according to 5.3.5.5;
- 1> if the *RRCReconfiguration* message contains the *radioBearerConfig*:
 - 2> perform the radio bearer configuration according to 5.3.5.6;
- 1> if the *RRCReconfiguration* message includes the *measConfig*:
 - 2> perform the measurement configuration procedure as specified in 5.5.2;
- 1> if the *RRCReconfiguration* message includes the *dedicatedNAS-MessageList*:
 - 2> forward each element of the *dedicatedNAS-MessageList* to upper layers in the same order as listed;
- 1> if the *RRCReconfiguration* message includes the *dedicatedSIB1-Delivery*:
 - 2> perform the action upon reception of *SIB1* as specified in 5.2.2.4.2;
- 1> if the *RRCReconfiguration* message includes the *dedicatedSystemInformationDelivery*:
 - 2> perform the action upon reception of System Information as specified in 5.2.2.4;
- 1> if the *RRCReconfiguration* message includes the *otherConfig*:
 - 2> perform the other configuration procedure as specified in 5.3.5.9;
- 1> set the content of *RRCReconfigurationComplete* message as follows:
 - 2> if the *RRCReconfiguration* includes the *masterCellGroup* containing the *reportUplinkTxDirectCurrent*, or;
 - 2> if the *RRCReconfiguration* includes the *secondaryCellGroup* containing the *reportUplinkTxDirectCurrent*:
 - 3> include the *uplinkTxDirectCurrentList*;
- 1> if the UE is configured with E-UTRA *nr-SecondaryCellGroupConfig* (MCG is E-UTRA):
 - 2> if *RRCReconfiguration* was received via SRB1:
 - 3> submit the *RRCReconfigurationComplete* via the E-UTRA MCG embedded in E-UTRA RRC message *RRCConnectionReconfigurationComplete* as specified in TS 36.331 [10];
 - 3> if *reconfigurationWithSync* was included in *spCellConfig* of an SCG:
 - 4> initiate the random access procedure on the SpCell, as specified in TS 38.321 [3];
 - 3> else:

4> the procedure ends;

NOTE: The order the UE sends the *RRCConnectionReconfigurationComplete* message and performs the Random Access procedure towards the SCG is left to UE implementation.

2> else (*RRCReconfiguration* was received via SRB3):

3> submit the *RRCReconfigurationComplete* message via SRB3 to lower layers for transmission using the new configuration;

NOTE: For EN-DC, in the case *RRCReconfiguration* is received via SRB1, the random access is triggered by RRC layer itself as there is not necessarily other UL transmission. In the case *RRCReconfiguration* is received via SRB3, the random access is triggered by the MAC layer due to arrival of *RRCReconfigurationComplete*.

1> else:

2> submit the *RRCReconfigurationComplete* message via SRB1 to lower layers for transmission using the new configuration;

2> if this is the first *RRCReconfiguration* message after successful completion of the RRC re-establishment procedure:

3> resume SRB2 and DRBs that are suspended;

1> if *reconfigurationWithSync* was included in *spCellConfig* of an MCG or SCG, and when MAC of an NR cell group successfully completes a random access procedure triggered above;

2> stop timer T304 for that cell group;

2> apply the parts of the CQI reporting configuration, the scheduling request configuration and the sounding RS configuration that do not require the UE to know the SFN of the respective target SpCell, if any;

2> apply the parts of the measurement and the radio resource configuration that require the UE to know the SFN of the respective target SpCell (e.g. measurement gaps, periodic CQI reporting, scheduling request configuration, sounding RS configuration), if any, upon acquiring the SFN of that target SpCell;

2> if the *reconfigurationWithSync* was included in *spCellConfig* of an MCG:

3> if T390 is running:

4> stop timer T390 for all access categories;

4> perform the actions as specified in 5.3.14.4.

3> if *RRCReconfiguration* does not include *dedicatedSIB1-Delivery* and

3> if the active downlink BWP, which is indicated by the *firstActiveDownlinkBWP-Id* for the target SpCell of the MCG, has a common search space configured by *searchSpaceSIB1*:

4> acquire the *SIB1*, which is scheduled as specified in TS 38.213 [13], of the target SpCell of the MCG;

4> upon acquiring *SIB1*, perform the actions specified in clause 5.2.2.4.2;

2> the procedure ends.

NOTE: The UE is only required to acquire broadcasted *SIB1* if the UE can acquire it without disrupting unicast data reception, i.e. the broadcast and unicast beams are quasi co-located.

[TS 38.331, clause 5.2.2.4.2]

Upon receiving the *SIB1* the UE shall:

1> store the acquired *SIB1*;

1> if the *cellAccessRelatedInfo* contains an entry with the *PLMN-Identity* of the selected PLMN:

2> in the remainder of the procedures use *plmn-IdentityList*, *trackingAreaCode*, and *cellIdentity* for the cell as received in the corresponding *PLMN-IdentityInfo* containing the selected PLMN;

1> if in RRC_CONNECTED while T311 is not running:

- 2> disregard the *frequencyBandList*, if received, while in RRC_CONNECTED;
- 2> forward the *cellIdentity* to upper layers;
- 2> forward the *trackingAreaCode* to upper layers;
- 2> apply the configuration included in the *servingCellConfigCommonSIB*;

8.1.2.1.3.3 Test description

8.1.2.1.3.3.1 Pre-test conditions

System Simulator:

- NR Cell 1, NR Cell 2

UE:

- None

Preamble:

- The UE is in 5GS state 3N-A according to TS 38.508-1 [4], clause 4.4A.2 Table 4.4A.2-1

8.1.2.1.3.3.2 Test procedure sequence

Table 8.1.2.1.3.3.2-1: Main behaviour

St	Procedure	Message Sequence		TP	Verdict
		U - S	Message		
0	The SS changes NR Cell 1 and NR Cell 2 power level according to the row "T1" in Table 8.1.2.1.3.3.2-2 and Table 8.1.2.1.3.3.2-3	-	-	-	-
1	The SS transmits an <i>RRCReconfiguration</i> including dedicatedSIB1-Delivery containing SIB1 of NR Cell 2 to order the UE to perform intra frequency handover to NR Cell 2.	<--	NR RRC: <i>RRCReconfiguration</i>	-	-
2	Check: Does the UE transmit an <i>RRCReconfigurationComplete</i> message on NR Cell 2 to confirm the successful completion of the intra frequency handover?	-->	NR RRC: <i>RRCReconfigurationComplete</i>	1	P
3	Check: Does UE transmit a REGISTRATION REQUEST message to update the registration of the actual tracking area?	-->	NR RRC: <i>ULInformationTransfer</i> 5GMM: REGISTRATION REQUEST	1	P
4	SS responds with REGISTRATION ACCEPT message.	<--	NR RRC: <i>DLInformationTransfer</i> 5GMM: REGISTRATION ACCEPT	-	-
5	The UE send a REGISTRATION COMPLETE message.	-->	NR RRC: <i>ULInformationTransfer</i> 5GMM: REGISTRATION COMPLETE	-	-

Table 8.1.2.1.3.3.2-2 and Table 8.1.2.1.3.3.2-3 illustrate the downlink power levels and other changing parameters to be applied for the cells at various time instants of the test execution. Row marked "T0" denotes the initial conditions after preamble, while columns marked "T1" is to be applied subsequently. The exact instants on which these values shall be applied are described in the texts in this clause.

Table 8.1.2.1.3.3.2-2: Time instances of cell power level and parameter changes for FR1

	Parameter	Unit	NR Cell 1	NR Cell 2	Remark
T0	Cell-specific RS EPRE	dBm/SCS	-88	Off	
T1	Cell-specific RS EPRE	dBm/SCS	-88	-76	

NOTE 1: Power level "Off" is defined in TS 38.508-1 [4] Table 6.2.2.1-1.

Table 8.1.2.1.3.3.2-3: Time instances of cell power level and parameter changes for FR2

	Parameter	Unit	NR Cell 1	NR Cell 2	Remark
T0	Cell-specific RS EPRE	dBm/SCS	FFS	FFS	
T1	Cell-specific RS EPRE	dBm/SCS	FFS	FFS	

NOTE 1: Power level "Off" is defined in TS 38.508-1 [4] Table 6.2.2.1-3.

8.1.2.1.3.3.3 Specific message contents

Table 8.1.2.1.3.3.3-1: RRCReconfiguration (Step 1 Table 8.1.2.1.3.3.2-1)

Derivation Path: RRCReconfiguration-HO 38.508-1 [4], Table 4.8.1-1A with condition DRBn AND RBConfig_NoKeyChange			
Information Element	Value/remark	Comment	Condition
RRCReconfiguration ::= SEQUENCE {			
criticalExtensions CHOICE {			
rrcReconfiguration SEQUENCE {			
nonCriticalExtension SEQUENCE {			
dedicatedSIB1-Delivery	SIB1	OCTET STRING (CONTAINING SIB1)	
}			
}			
}			
}			

Table 8.1.2.1.3.3.3-2: Void

Table 8.1.2.1.3.3.3-3: SIB1 (Step 1 Table 8.1.2.1.3.3.2-1)

Derivation Path: 38.508-1 [4], Table 4.6.1-28			
Information Element	Value/remark	Comment	Condition
SIB1 ::= SEQUENCE {			
cellAccessRelatedInfo ::= SEQUENCE {			
plmn-IdentityList ::= SEQUENCE (SIZE (1..maxPLMN)) OF SEQUENCE {	1 entry		
trackingAreaCode	2		
}			
}			
}			

8.1.3 Measurement configuration control and reporting

8.1.3.1 Intra NR measurements

8.1.3.1.1 Measurement configuration control and reporting / Intra NR measurements / Event A1 / Event A2

8.1.3.1.1.1 Test Purpose (TP)

(1)

```
with { UE in NR RRC_CONNECTED and measurement configured for event A1 and event A2 with event based
periodical reporting }
ensure that {
  when { Serving cell becomes better than absolute threshold plus hysteresis and entering condition
for event A1 is met }
  then { UE sends MeasurementReport message at regular intervals while entering condition for
event A1 is satisfied }
}
```

(2)

```
with { UE in NR RRC_CONNECTED and periodical measurement reporting triggered by event A1 ongoing }
ensure that {
  when { Serving cell becomes worse than absolute threshold minus hysteresis }
  then { UE stops sending MeasurementReport message }
}
```

(3)

```
with { UE in NR RRC_CONNECTED and measurement configured for event A1 and event A2 with event based
periodical reporting }
ensure that {
  when { Serving cell becomes worse than absolute threshold minus hysteresis and entering condition
for event A2 is met }
  then { UE sends MeasurementReport message at regular intervals while entering condition for
event A2 is satisfied }
}
```

(4)

```
with { UE in NR RRC_CONNECTED state and periodical measurement reporting triggered by event A2
ongoing }
ensure that {
  when { Serving cell becomes better than absolute threshold plus hysteresis }
  then { UE stops sending MeasurementReport message }
}
```

(5)

```
with { UE in NR RRC_CONNECTED and measurements are re-configured for event A1 with event based
periodical reporting to report on leaving condition }
ensure that {
  when { Serving cell becomes worse than absolute threshold minus hysteresis }
  then { UE sends MeasurementReport message while leaving condition for event A1 is satisfied }
}
```

8.1.3.1.1.2 Conformance requirements

References: The conformance requirements covered in the current TC are specified in: TS 38.331, clause 5.3.5.3, 5.5.2, 5.5.4.1, 5.5.4.2, 5.5.4.3 and 5.5.5. Unless otherwise stated these are Rel-15 requirements.

[TS 38.331, clause 5.3.5.3]

The UE shall perform the following actions upon reception of the *RRCReconfiguration*:

...

1> if the *RRCReconfiguration* message includes the *measConfig*:

2> perform the measurement configuration procedure as specified in 5.5.2;

...

1> if the UE is configured with E-UTRA *nr-SecondaryCellGroupConfig* (MCG is E-UTRA):

...

1> else:

2> submit the *RRCReconfigurationComplete* message via SRB1 to lower layers for transmission using the new configuration;

...

[TS 38.331, clause 5.5.2.1]

...

The UE shall:

...

1> if the received *measConfig* includes the *measObjectToAddModList*:

2> perform the measurement object addition/modification procedure as specified in 5.5.2.5;

...

1> if the received *measConfig* includes the *reportConfigToAddModList*:

2> perform the reporting configuration addition/modification procedure as specified in 5.5.2.7;

1> if the received *measConfig* includes the *quantityConfig*:

2> perform the quantity configuration procedure as specified in 5.5.2.8;

1> if the received *measConfig* includes the *measIdToRemoveList*:

2> perform the measurement identity removal procedure as specified in 5.5.2.2; 1> if the received *measConfig* includes the *measIdToAddModList*:

2> perform the measurement identity addition/modification procedure as specified in 5.5.2.3;

[TS 38.331, clause 5.5.4.1]

If security has been activated successfully, the UE shall:

1> for each *measId* included in the *measIdList* within *VarMeasConfig*:

2> if the corresponding *reportConfig* includes a *reportType* set to *eventTriggered* or *periodical*;

3> if the corresponding *measObject* concerns NR;

4> if the *eventA1* or *eventA2* is configured in the corresponding *reportConfig*:

5> consider only the serving cell to be applicable;

...

2> if the *reportType* is set to *eventTriggered* and if the entry condition applicable for this event, i.e. the event corresponding with the *eventId* of the corresponding *reportConfig* within *VarMeasConfig*, is fulfilled for one or more applicable cells for all measurements after layer 3 filtering taken during *timeToTrigger* defined for

this event within the *VarMeasConfig*, while the *VarMeasReportList* does not include a measurement reporting entry for this *measId* (a first cell triggers the event):

- 3> include a measurement reporting entry within the *VarMeasReportList* for this *measId*;
- 3> set the *numberOfReportsSent* defined within the *VarMeasReportList* for this *measId* to 0;
- 3> include the concerned cell(s) in the *cellsTriggeredList* defined within the *VarMeasReportList* for this *measId*;
- 3> initiate the measurement reporting procedure, as specified in 5.5.5;

...

- 2> else if the *reportType* is set to *eventTriggered* and if the leaving condition applicable for this event is fulfilled for one or more of the cells included in the *cellsTriggeredList* defined within the *VarMeasReportList* for this *measId* for all measurements after layer 3 filtering taken during *timeToTrigger* defined within the *VarMeasConfig* for this event:

- 3> remove the concerned cell(s) in the *cellsTriggeredList* defined within the *VarMeasReportList* for this *measId*;
- 3> if *reportOnLeave* is set to *TRUE* for the corresponding reporting configuration:
 - 4> initiate the measurement reporting procedure, as specified in 5.5.5;
- 3> if the *cellsTriggeredList* defined within the *VarMeasReportList* for this *measId* is empty:
 - 4> remove the measurement reporting entry within the *VarMeasReportList* for this *measId*;
 - 4> stop the periodical reporting timer for this *measId*, if running;

...

- 2> upon expiry of the periodical reporting timer for this *measId*:

- 3> initiate the measurement reporting procedure, as specified in 5.5.5.

...

[TS 38.331, clause 5.5.4.2]

The UE shall:

- 1> consider the entering condition for this event to be satisfied when condition A1-1, as specified below, is fulfilled;
- 1> consider the leaving condition for this event to be satisfied when condition A1-2, as specified below, is fulfilled;
- 1> for this measurement, consider the NR serving cell corresponding to the associated *measObjectNR* associated with this event.

Inequality A1-1 (Entering condition)

$$Ms - Hys > Thresh$$

Inequality A1-2 (Leaving condition)

$$Ms + Hys < Thresh$$

The variables in the formula are defined as follows:

Ms is the measurement result of the serving cell, not taking into account any offsets.

Hys is the hysteresis parameter for this event (i.e. *hysteresis* as defined within *reportConfigNR* for this event).

Thresh is the threshold parameter for this event (i.e. *a1-Threshold* as defined within *reportConfigNR* for this event).

Ms is expressed in dBm in case of RSRP, or in dB in case of RSRQ and RS-SINR.

Hys is expressed in dB.

Thresh is expressed in the same unit as **Ms**.

[TS 38.331, clause 5.5.4.3]

The UE shall:

- 1> consider the entering condition for this event to be satisfied when condition A2-1, as specified below, is fulfilled;
- 1> consider the leaving condition for this event to be satisfied when condition A2-2, as specified below, is fulfilled;
- 1> for this measurement, consider the serving cell indicated by the *measObjectNR* associated to this event.

Inequality A2-1 (Entering condition)

$$Ms + Hys < Thresh$$

Inequality A2-2 (Leaving condition)

$$Ms - Hys > Thresh$$

The variables in the formula are defined as follows:

Ms is the measurement result of the serving cell, not taking into account any offsets.

Hys is the hysteresis parameter for this event (i.e. *hysteresis* as defined within *reportConfigNR* for this event).

Thresh is the threshold parameter for this event (i.e. *a2-Threshold* as defined within *reportConfigNR* for this event).

Ms is expressed in dBm in case of RSRP, or in dB in case of RSRQ and RS-SINR.

Hys is expressed in dB.

Thresh is expressed in the same unit as **Ms**.

[TS 38.331, clause 5.5.5]



Figure 5.5.5.1-1: Measurement reporting

The purpose of this procedure is to transfer measurement results from the UE to the network. The UE shall initiate this procedure only after successful security activation.

For the *measId* for which the measurement reporting procedure was triggered, the UE shall set the *measResults* within the *MeasurementReport* message as follows:

- 1> set the *measId* to the measurement identity that triggered the measurement reporting;
- 1> set the *measResultServingCell* within *measResultServingMOList* to include , for each NR serving cell that is configured with *servingCellMO*, RSRP, RSRQ and the available SINR derived based on the *rsType* if indicated in the associated *reportConfig* , otherwise based on SSB if available, otherwise based on CSI-RS;
- 1> set the *measResultServingCell* within *measResultServingMOList* to include for each NR serving cell that is configured with *servingCellMO*, if any, the *servCellId*;

...

- 1> increment the *numberOfReportsSent* as defined within the *VarMeasReportList* for this *measId* by 1;
- 1> stop the periodical reporting timer, if running;
- 1> if the *numberOfReportsSent* as defined within the *VarMeasReportList* for this *measId* is less than the *reportAmount* as defined within the corresponding *reportConfig* for this *measId*:
 - 2> start the periodical reporting timer with the value of *reportInterval* as defined within the corresponding *reportConfig* for this *measId*;
- 1> else:
 - 2> if the *reportType* is set to *periodical*:
 - 3> remove the entry within the *VarMeasReportList* for this *measId*;
 - 3> remove this *measId* from the *measIdList* within *VarMeasConfig*;
- 1> if the UE is configured with EN-DC:
 - ...
- 1> else:
 - 2> submit the *MeasurementReport* message to lower layers for transmission, upon which the procedure ends.

8.1.3.1.1.3 Test description

8.1.3.1.1.3.1 Pre-test conditions

System Simulator:

- NR Cell 1

UE:

- None.

Preamble:

- The UE is in state 3N-A as defined in TS 38.508-1 [4], subclause 4.4A on NR Cell 1

8.1.3.1.1.3.2 Test procedure sequence

Table 8.1.3.1.1.3.2-1/2 illustrates the downlink power levels and other changing parameters to be applied for the cells at various time instants of the test execution. Row marked "T0" denotes the initial conditions after preamble, while columns marked "T1" and "T2", are to be applied subsequently. The exact instants on which these values shall be applied are described in the texts in this clause.

Table 8.1.3.1.1.3.2-1: Time instances of cell power level and parameter changes in FR1

	Parameter	Unit	NR Cell 1	Remark
T0	SS/PBCH SSS EPRE	dBm/SCS	-88	Power level is such that entry condition for event A2 is satisfied $M_s + H_{ys} < Thresh$
T1	SS/PBCH SSS EPRE	dBm/SCS	-65	Power level is such that entry condition for event A1 is satisfied $M_s - H_{ys} > Thresh$ and exit condition for event A2 is satisfied too.
T2	SS/PBCH SSS EPRE	dBm/SCS	-88	Power level is such that exit condition for event A1 is satisfied $M_s + H_{ys} < Thresh$

Table 8.1.3.1.1.3.2-2: Time instances of cell power level and parameter changes in FR2

	Parameter	Unit	NR Cell 1	Remark
T0	SS/PBCH SSS EPRE	dBm/SCS	FFS	Power level is such that entry condition for event A2 is satisfied $M_s + H_{ys} < Thresh$
T1	SS/PBCH SSS EPRE	dBm/SCS	FFS	Power level is such that entry condition for event A1 is satisfied $M_s - H_{ys} > Thresh$ and exit condition for event A2 is satisfied too.
T2	SS/PBCH SSS EPRE	dBm/SCS	FFS	Power level is such that exit condition for event A1 is satisfied $M_s + H_{ys} < Thresh$

Table 8.1.3.1.1.3.2-2: Main behaviour

St	Procedure	Message Sequence		TP	Verdict
		U - S	Message		
1	SS transmits an <i>RRCReconfiguration</i> message including <i>MeasConfig</i> to setup intra NR measurement and reporting for event A1 and event A2.	<--	NR RRC: <i>RRCReconfiguration</i>	-	-
2	The UE transmits an <i>RRCReconfigurationComplete</i> message.	-->	NR RRC: <i>RRCReconfigurationComplete</i>	-	-
3	Check: Does the UE transmit a <i>MeasurementReport</i> message to report event A2 with the measured RSRP, RSRQ and SINR value for NR Cell 1?	-->	NR RRC: <i>MeasurementReport</i>	3	P
-	EXCEPTION: Step 4 below is repeated until 3 <i>MeasurementReport</i> messages are received from the UE and Interval between two <i>MeasurementReport</i> is same as the IE <i>reportInterval</i> configured in <i>MeasConfig</i> .	-	-	-	-
4	Check: Does the UE transmit a <i>MeasurementReport</i> message at regular intervals, with the measured RSRP, RSRQ and SINR value for NR Cell 1?	-->	NR RRC: <i>MeasurementReport</i>	3	P
5	SS re-adjusts the SS/PBCH EPRE level according to row "T1" in Table 8.1.3.1.1.3.2-1/2.	-	-	-	-
6	Wait and ignore <i>MeasurementReport</i> messages for 15 s to allow change of power levels for NR Cell 1 and UE measurement.	-	-	-	-
-	EXCEPTION: In parallel with step 7, parallel behaviour defined in table 8.1.3.1.1.3.2-3 is executed	-	-	-	-
7	Check: Does the UE transmit a <i>MeasurementReport</i> message to report event A1 with the measured RSRP, RSRQ and SINR value for NR Cell 1?	-->	NR RRC: <i>MeasurementReport</i>	1	P
-	EXCEPTION: Step 8 below is repeated until 3 <i>MeasurementReport</i> messages are received from the UE and Interval between two <i>MeasurementReport</i> is same as the IE <i>reportInterval</i> configured in <i>MeasConfig</i> .	-	-	-	-
8	Check: Does the UE transmit a <i>MeasurementReport</i> message at regular intervals, with the measured RSRP, RSRQ and SINR value for NR Cell 1?	-->	NR RRC: <i>MeasurementReport</i>	1	P
9	SS re-adjusts the SS/PBCH EPRE level according to row "T2" in Table 8.1.3.1.1.3.2-1/2.	-	-	-	-
10	Wait and ignore <i>MeasurementReport</i> messages for 15 s to allow change of power levels for NR Cell 1 and UE measurement.	-	-	-	-
11	Check: Does the UE transmit a <i>MeasurementReport</i> message to report event A1 with the measured RSRP, RSRQ and SINR value for NR Cell 1 within the next 10s? NOTE: SS ignore <i>MeasurementReport</i> message for event A2.	-	-	2	F
12	SS transmits an <i>RRCReconfiguration</i> message to re-configure for event A1 with event based periodical reporting to report on leaving condition and release event A2.	<--	NR RRC: <i>RRCReconfiguration</i>	-	-
13	The UE transmits an <i>RRCReconfigurationComplete</i> message.	-->	NR RRC: <i>RRCReconfigurationComplete</i>	-	-
14	SS re-adjusts the SS/PBCH EPRE level according to row "T1" in Table 8.1.3.1.1.3.2-1/2.	-	-	-	-
15	SS receive four <i>MeasurementReport</i> messages for A1 and then wait 5s.	-	-	-	-

16	SS re-adjusts the SS/PBCH EPRE level according to row "T2" in Table 8.1.3.1.1.3.2-1/2.	-	-	-	-
17	Check: Does the UE transmit a <i>MeasurementReport</i> message to report event A1 with the measured RSRP, RSRQ and SINR value for NR Cell 1?	-->	NR RRC: <i>MeasurementReport</i>	5	P
18	Check: Does the UE attempt to transmit <i>MeasurementReport</i> message within the next 10s?	-	-	5	F

Table 8.1.3.1.1.3.2-3: Parallel behaviour

St	Procedure	Message Sequence		TP	Verdict
		U - S	Message		
1	Check: Does the UE transmit a <i>MeasurementReport</i> message to report event A2 with the measured RSRP, RSRQ and SINR value for NR Cell 1?	-	-	4	F

8.1.3.1.1.3.3 Specific message contents

Table 8.1.3.1.1.3.3-1: RRCReconfiguration (step 1 Table 8.1.3.1.1.3.2-2)

Derivation Path: TS 38.508-1 [4], Table 4.6.1-13			
Information Element	Value/remark	Comment	Condition
RRCReconfiguration ::= SEQUENCE {			
rrc-TransactionIdentifier	RRC-TransactionIdentifier		
criticalExtensions CHOICE {			
rrcReconfiguration ::= SEQUENCE {			
radioBearerConfig	Not present		
secondaryCellGroup	Not present		
measConfig	MeasConfig	Table 8.1.3.1.1.3.3-2	
lateNonCriticalExtension	Not present		
nonCriticalExtension	Not present		
}			
}			
}			

Table 8.1.3.1.1.3.3-2: MeasConfig (Table 8.1.3.1.1.3.3-1)

Derivation path: 38.508-1 [4] Table 4.6.3-69			
Information Element	Value/Remark	Comment	Condition
measConfig ::= SEQUENCE {			
measObjectToAddModList SEQUENCE (SIZE (1..maxNrofObjectld)) OF SEQUENCE {	1 entry		
measObjectld[1]	1	MeasObjectldNR-f1	
measObject CHOICE {			
measObjectNR[1]	MeasObjectNR(57)	Thres=57(-100dBm ≤ SS-RSRP < -99dBm)	
}			
}			
reportConfigToAddModList SEQUENCE (SIZE (1..maxReportConfigld)) OF SEQUENCE {	2 entries		
reportConfigld[1]	1		
reportConfig[1]	ReportConfig-EventA1		
reportConfigld[2]	2		
reportConfig[2]	ReportConfig-EventA2		
}			
measldToAddModList SEQUENCE (SIZE (1..maxNrofMeasld)) OF SEQUENCE {	2 entries		
measld[1]	1		
measObjectld[1]	1		
reportConfigld[1]	1		
measld[2]	2		
measObjectld[2]	1		
reportConfigld[2]	2		
}			
quantityConfig	QuantityConfig		
}			

Table 8.1.3.1.1.3.3-3: MeasObjectNR (Table 8.1.3.1.1.3.3-2)

Derivation Path: 38.508-1 [4], Table 4.6.3-76			
Information Element	Value/remark	Comment	Condition
MeasObjectNR ::= SEQUENCE {			
ssbFrequency	Downlink ARFCN of NR cell 1 SSB		
}			

Table 8.1.3.1.1.3.3-4: ReportConfig-EventA1 (Table 8.1.3.1.1.3.3-2)

Derivation Path: 38.508-1 [4], Table 4.6.3-142 with condition EVENT_A1			
Information Element	Value/remark	Comment	Condition
ReportConfigNR ::= SEQUENCE {			
reportType CHOICE {			
eventTriggered SEQUENCE {			
eventId CHOICE {			
eventA1 SEQUENCE {			
a1-Threshold CHOICE {			
rsrp	80	76dBm	FR1
rsrp	FFS		FR2
}			
reportOnLeave	false		
}			
}			
reportAmount	Infinity		
}			
}			

Table 8.1.3.1.1.3.3-5: ReportConfig-EventA2 (Table 8.1.3.1.1.3.3-2)

Derivation Path: 38.508-1 [4], Table 4.6.3-142 with condition EVENT_A2			
Information Element	Value/remark	Comment	Condition
ReportConfigNR ::= SEQUENCE {			
reportType CHOICE {			
eventTriggered SEQUENCE {			
eventId CHOICE {			
eventA2 SEQUENCE {			EVENT_A2
a2-Threshold CHOICE {			
rsrp	80	-77dBm ≤ SS-RSRP<- 76dBm	FR1
rsrp	73	-84dBm ≤ SS-RSRP<- 83dBm	FR2
}			
reportOnLeave	false		
}			
}			
reportAmount	Infinity		
}			
}			

Table 8.1.3.1.1.3.3-6: QuantityConfig (Table 8.1.3.1.1.3.3-2)

Derivation Path: 38.508-1 [4], Table 4.6.3-127			
Information Element	Value/remark	Comment	Condition
QuantityConfig ::= SEQUENCE {			
quantityConfigNR-List SEQUENCE (SIZE (1..maxNrofQuantityConfig)) OF SEQUENCE {	1 entry		
quantityConfigCell[1] SEQUENCE {			
ssb-FilterConfig SEQUENCE {			
filterCoefficientRSRP	fc4		
filterCoefficientRSRQ	fc4		
filterCoefficientRS-SINR	fc4		
}			
}			
}			
}			

Table 8.1.3.1.1.3.3-7: MeasurementReport (steps 3, 4, 7, 8, 17, Table 8.1.3.1.1.3.2-2)

Derivation Path: TS 38.508-1 [4], Table 4.6.1-7			
Information Element	Value/remark	Comment	Condition
MeasurementReport ::= SEQUENCE {			
criticalExtensions CHOICE {			
measurementReport ::= SEQUENCE {			
measResults SEQUENCE {			
measId	2		Step3,4
measId	1		Step 7,8,17
measResultServingMOList SEQUENCE {	1 entry		
servCellId	ServCellIndex of NR Cell 1		
measResultServingCell SEQUENCE {			
physCellId	Physical CellID of the NR Cell 1		
measResult SEQUENCE {			
cellResults SEQUENCE {			
resultsSSB-Cell SEQUENCE {			
rsrp	(0..127)		
rsrq	(0..127)		
}			
}			
}			
}			
}			
}			
}			

Table 8.1.3.1.1.3.3-8: RRCReconfiguration (step 12, Table 8.1.3.1.1.3.2-2)

Derivation Path: TS 38.508-1 [4], Table 4.6.1-13			
Information Element	Value/remark	Comment	Condition
RRCReconfiguration ::= SEQUENCE {			
rrc-TransactionIdentifier	RRC-TransactionIdentifier		
criticalExtensions CHOICE {			
rrcReconfiguration ::= SEQUENCE {			
radioBearerConfig	Not present		
secondaryCellGroup	Not present		
measConfig	MeasConfig	Table 8.1.3.1.1.3.3-9	
lateNonCriticalExtension	Not present		
nonCriticalExtension	Not present		
}			
}			
}			

Table 8.1.3.1.1.3.3-9: MeasConfig (Table 8.1.3.1.1.3.3-8)

Derivation path: 38.508-1 [4] Table 4.6.3-69			
Information Element	Value/Remark	Comment	Condition
measConfig ::= SEQUENCE {			
measObjectToAddModList	Not Present		
reportConfigToAddModList SEQUENCE (SIZE (1..maxReportConfigId)) OF SEQUENCE {	1 entry		
reportConfigId[1]	ReportConfigId		
reportConfig[1]	ReportConfig-EventA1		
}			
measIdToAddModList	Not Present		
measIdToRemoveList SEQUENCE (SIZE (1..maxNrofMeasId)) OF MeasId {			
measId[1]	2	Release event A2	
}			
quantityConfig	Not Present		
}			

Table 8.1.3.1.1.3.3-10: ReportConfig-EventA1 (Table 8.1.3.1.1.3.3-8)

Derivation Path: 38.508-1 [4], Table 4.6.3-142 with condition EVENT_A1			
Information Element	Value/remark	Comment	Condition
ReportConfigNR ::= SEQUENCE {			
reportType CHOICE {			
eventTriggered SEQUENCE {			
eventId CHOICE {			
eventA1 SEQUENCE {			
a1-Threshold CHOICE {			
rsrp	80	76dBm	FR1
rsrp	FFS		FR2
}			
reportOnLeave	true		
}			
}			
reportAmount	r4		
}			
}			

8.1.3.1.2 Measurement configuration control and reporting / Event A3 / Measurement of Neighbor NR cell / Intra-frequency measurements

8.1.3.1.2.1 Test Purpose (TP)

(1)

```
with { UE in NR RRC_CONNECTED state and intra-frequency measurements configured for event A3 }
ensure that {
  when { Entry condition for event A3 is not met for neighbor cell }
  then { UE does not send MeasurementReport }
}
```

(2)

```
with { UE in NR RRC_CONNECTED state and intra-frequency measurements configured for event A3 }
ensure that {
  when { Neighbor cell becomes offset better than serving cell }
  then { UE sends MeasurementReport with correct measId for event A3 }
}
```

8.1.3.1.2.2 Conformance requirements

References: The conformance requirements covered in the current TC are specified in: TS 38.331, clause 5.3.5.3, 5.5.2, 5.5.4.1, 5.5.4.4 and 5.5.5. Unless otherwise stated these are Rel-15 requirements.

[TS 38.331, clause 5.3.5.3]

The UE shall perform the following actions upon reception of the *RRCReconfiguration*:

...

1> if the *RRCReconfiguration* message includes the *measConfig*:

2> perform the measurement configuration procedure as specified in 5.5.2;

...

1> if the UE is configured with E-UTRA *nr-SecondaryCellGroupConfig* (MCG is E-UTRA):

...

1> else:

2> submit the *RRCReconfigurationComplete* message via SRB1 to lower layers for transmission using the new configuration;

...

[TS 38.331, clause 5.5.2.1]

...

The UE shall:

...

1> if the received *measConfig* includes the *measObjectToAddModList*:

2> perform the measurement object addition/modification procedure as specified in 5.5.2.5;

...

1> if the received *measConfig* includes the *reportConfigToAddModList*:

2> perform the reporting configuration addition/modification procedure as specified in 5.5.2.7;

1> if the received *measConfig* includes the *quantityConfig*:

2> perform the quantity configuration procedure as specified in 5.5.2.8;

[TS 38.331, clause 5.5.4.1]

If security has been activated successfully, the UE shall:

1> for each *measId* included in the *measIdList* within *VarMeasConfig*:

2> if the corresponding *reportConfig* includes a *reportType* set to *eventTriggered* or *periodical*;

3> if the corresponding *measObject* concerns NR;

4> if the *eventA3* or *eventA5* is configured in the corresponding *reportConfig*:

5> if a serving cell is associated with a *measObjectNR* and neighbors are associated with another *measObjectNR*, consider any serving cell associated with the other *measObjectNR* to be a neighboring cell as well;

...

2> if the *reportType* is set to *eventTriggered* and if the entry condition applicable for this event, i.e. the event corresponding with the *eventId* of the corresponding *reportConfig* within *VarMeasConfig*, is fulfilled for one or more applicable cells for all measurements after layer 3 filtering taken during *timeToTrigger* defined for this event within the *VarMeasConfig*, while the *VarMeasReportList* does not include a measurement reporting entry for this *measId* (a first cell triggers the event):

- 3> include a measurement reporting entry within the *VarMeasReportList* for this *measId*;
- 3> set the *numberOfReportsSent* defined within the *VarMeasReportList* for this *measId* to 0;
- 3> include the concerned cell(s) in the *cellsTriggeredList* defined within the *VarMeasReportList* for this *measId*;
- 3> initiate the measurement reporting procedure, as specified in 5.5.5;

[TS 38.331, clause 5.5.4.4]

The UE shall:

- 1> consider the entering condition for this event to be satisfied when condition A3-1, as specified below, is fulfilled;
- 1> consider the leaving condition for this event to be satisfied when condition A3-2, as specified below, is fulfilled;
- 1> use the SpCell for *Mp*, *Ofp* and *Ocp*.

NOTE The cell(s) that triggers the event has reference signals indicated in the *measObjectNR* associated to this event which may be different from the NR SpCell *measObjectNR*.

Inequality A3-1 (Entering condition)

$$Mn + Ofn + Ocn - Hys > Mp + Ofp + Ocp + Off$$

Inequality A3-2 (Leaving condition)

$$Mn + Ofn + Ocn + Hys < Mp + Ofp + Ocp + Off$$

The variables in the formula are defined as follows:

Mn is the measurement result of the neighboring cell, not taking into account any offsets.

Ofn is the measurement object specific offset of the reference signal of the neighbor cell (i.e. *offsetMO* as defined within *measObjectNR* corresponding to the neighbor cell).

Ocn is the cell specific offset of the neighbor cell (i.e. *cellIndividualOffset* as defined within *measObjectNR* corresponding to the frequency of the neighbor cell), and set to zero if not configured for the neighbor cell.

Mp is the measurement result of the SpCell, not taking into account any offsets.

Ofp is the measurement object specific offset of the SpCell (i.e. *offsetMO* as defined within *measObjectNR* corresponding to the SpCell).

Ocp is the cell specific offset of the SpCell (i.e. *cellIndividualOffset* as defined within *measObjectNR* corresponding to the SpCell), and is set to zero if not configured for the SpCell.

Hys is the hysteresis parameter for this event (i.e. *hysteresis* as defined within *reportConfigNR* for this event).

Off is the offset parameter for this event (i.e. *a3-Offset* as defined within *reportConfigNR* for this event).

Mn*, *Mp are expressed in dBm in case of RSRP, or in dB in case of RSRQ and RS-SINR.

Ofn*, *Ocn*, *Ofp*, *Ocp*, *Hys*, *Off are expressed in dB.

[TS 38.331, clause 5.5.5]



Figure 5.5.5.1-1: Measurement reporting

The purpose of this procedure is to transfer measurement results from the UE to the network. The UE shall initiate this procedure only after successful security activation.

For the *measId* for which the measurement reporting procedure was triggered, the UE shall set the *measResults* within the *MeasurementReport* message as follows:

- 1> set the *measId* to the measurement identity that triggered the measurement reporting;
- 1> set the *measResultServingCell* within *measResultServingMOList* to include, for each NR serving cell that is configured with *servingCellMO*, RSRP, RSRQ and the available SINR, derived based on the *rsType* if indicated in the associated *reportConfig*, otherwise based on SSB if available, otherwise based on CSI-RS;
- 1> set the *servCellId* within *measResultServingMOList* to include each NR serving cell that is configured with *servingCellMO*, if any;
- ...
- 1> if the *numberOfReportsSent* as defined within the *VarMeasReportList* for this *measId* is less than the *reportAmount* as defined within the corresponding *reportConfig* for this *measId*:
 - 2> start the periodical reporting timer with the value of *reportInterval* as defined within the corresponding *reportConfig* for this *measId*;
- 1> if there is at least one applicable neighboring cell to report:
 - 2> if the *reportType* is set to *eventTriggered* or *periodical*:
 - 3> set the *measResultNeighCells* to include the best neighboring cells up to *maxReportCells* in accordance with the following:
 - 4> if the *reportType* is set to *eventTriggered*:
 - 5> include the cells included in the *cellsTriggeredList* as defined within the *VarMeasReportList* for this *measId*;
 - 4> for each cell that is included in the *measResultNeighCells*, include the *physCellId*;
 - 4> if the *reportType* is set to *eventTriggered* or *periodical*:
 - 5> for each included cell, include the layer 3 filtered measured results in accordance with the *reportConfig* for this *measId*, ordered as follows:
 - 6> if the *measObject* associated with this *measId* concerns NR:
 - 7> if *rsType* in the associated *reportConfig* is set to *ssb*:
 - 8> set *resultsSSB-Cell* within the *measResult* to include the SS/PBCH block based quantity(ies) indicated in the *reportQuantityCell* within the concerned *reportConfig*, in decreasing order of the sorting quantity, determined as specified in 5.5.5.3, i.e. the best cell is included first:

8.1.3.1.2.3 Test description

8.1.3.1.2.3.1 Pre-test conditions

System Simulator:

- NR Cell 1 is the serving cell,
- NR Cell 2 is the intra-frequency neighbor cell.
- System information combination NR-2 as defined in TS 38.508-1 [4] clause 4.4.3.1.2 is used in NR cells.

UE:

- None.

Preamble:

- The UE is in state 3N-A as defined in TS 38.508-1 [4], subclause 4.4A.

8.1.3.1.2.3.2 Test procedure sequence

Table 8.1.3.1.2.3.2-1 and 8.1.3.1.2.3.2-2 illustrates the downlink power levels to be applied for NR Cell 1 and NR Cell 2 at various time instants of the test execution. Row marked "T0" denotes the conditions after the preamble, while the configuration marked "T1" and "T2", are applied at the point indicated in the Main behaviour description in Table 8.1.3.1.2.3.2-3.

Table 8.1.3.1.2.3.2-1: Time instances of cell power level and parameter changes for NR Cell 1 and NR Cell 2 in FR1

	Parameter	Unit	NR Cell 1	NR Cell 2	Remark
T0	SS/PBCH SSS EPRE	dBm/ SCS	-85	-91	Power levels are such that entry condition for event A3 is not satisfied for the neighbour NR cell: $M_n + O_{fn} + O_{cn} - H_{ys} > M_p + O_{fp} + O_{cp} + O_{of}$
T1	SS/PBCH SSS EPRE	dBm/ SCS	-85	-73	Power levels are such that entry condition for event A3 is satisfied for intra-frequency neighbour NR cell (measId 1): $M_n + O_{fn} + O_{cn} - H_{ys} > M_p + O_{fp} + O_{cp} + O_{of}$
T2	SS/PBCH SSS EPRE	dBm/ SCS	-85	-91	Power levels are such that leaving condition for event A3 is satisfied (measId 1): $M_n + O_{fn} + O_{cn} + H_{ys} < M_p + O_{fp} + O_{cp} + O_{of}$

Table 8.1.3.1.2.3.2-2: Time instances of cell power level and parameter changes for NR Cell 1 and NR Cell 2 in FR2

	Parameter	Unit	NR Cell 1	NR Cell 2	Remark
T0	SS/PBCH SSS EPRE	dBm/ SCS	FFS	FFS	Power levels are such that entry condition for event A3 is not satisfied for the neighbour NR cell: $M_n + O_{fn} + O_{cn} - H_{ys} > M_p + O_{fp} + O_{cp} + O_{of}$
T1	SS/PBCH SSS EPRE	dBm/ SCS	FFS	FFS	Power levels are such that entry condition for event A3 is satisfied for intra-frequency neighbour NR cell (measId 1): $M_n + O_{fn} + O_{cn} - H_{ys} > M_p + O_{fp} + O_{cp} + O_{of}$
T2	SS/PBCH SSS EPRE	dBm/ SCS	FFS	FFS	Power levels are such that leaving condition for event A3 is satisfied (measId 1): $M_n + O_{fn} + O_{cn} + H_{ys} < M_p + O_{fp} + O_{cp} + O_{of}$

Table 8.1.3.1.2.3.2-3: Main behaviour

St	Procedure	Message Sequence		TP	Verdict
		U - S	Message		
1	The SS transmits an <i>RRCReconfiguration</i> message including <i>MeasConfig</i> to setup NR measurement and reporting for inter-frequency event A3 (<i>measId 1</i>).	<--	NR RRC: <i>RRCReconfiguration</i>	-	-
2	The UE transmits an <i>RRCReconfigurationComplete</i> message.	-->	NR RRC: <i>RRCReconfigurationComplete</i>	-	-
3	SS re-adjusts the cell-specific reference signal level according to row "T1" in table 8.1.3.1.2.3.2-1/2.	-	-	-	-
-	EXCEPTION: Step 4 is repeated for value indicated by the reportAmount IE.	-	-	-	-
4	Check: Does the UE transmit a <i>MeasurementReport</i> message to report event A3 (<i>measId 1</i>) with the measured RSRP value for NR Cell 3?	-->	NR RRC: <i>MeasurementReport</i>	1	P
5	SS re-adjusts the cell-specific reference signal level according to row "T2" in table 8.1.3.1.2.2-1/2.	-	-	-	-
6	Check: Does the UE transmit a <i>MeasurementReport</i> message within the next 10s?	-	-	2	F

8.1.3.1.2.3.3 Specific message contents

Table 8.1.3.1.2.3.3-1: *RRCReconfiguration* (step 1, Table 8.1.3.1.2.3.2-3)

Derivation Path: 38.508-1 [4] Table 4.6.1-13			
Information Element	Value/remark	Comment	Condition
<i>RRCReconfiguration</i> ::= SEQUENCE {			
<i>rrc-TransactionIdentifier</i>	RRC- <i>TransactionIdentifier</i>		
<i>criticalExtensions</i> CHOICE {			
<i>rrcReconfiguration</i> ::= SEQUENCE {			
<i>radioBearerConfig</i>	Not present		
<i>secondaryCellGroup</i>	Not present		
<i>measConfig</i>	<i>MeasConfig</i>	Table 8.1.3.1.2.3.3-2	
<i>lateNonCriticalExtension</i>	Not present		
<i>nonCriticalExtension</i>	Not present		
}			
}			
}			

Table 8.1.3.1.2.3.3-2: *MeasConfig* (Table 8.1.3.1.2.3.3-1)

Derivation Path: 38.508-1 [4] Table 4.6.3-69			
Information Element	Value/remark	Comment	Condition
MeasConfig ::= SEQUENCE {			
measObjectToAddModList SEQUENCE (SIZE (1..maxNrofMeasId)) OF SEQUENCE {	1 entry		
measObjectId[1]	1		
measObject[1] CHOICE {			
measObjectNR	MeasObjectNR	Table 8.1.3.1.2.3.3-3	
}			
}			
reportConfigToAddModList SEQUENCE(SIZE (1..maxReportConfigId)) OF SEQUENCE {	1 entry		
reportConfigId[1]	1		
reportConfig[1] CHOICE {			
reportConfigNR	ReportConfigNR-EventA3	Table 8.1.3.1.2.3.3-4	
}			
}			
measIdToAddModList SEQUENCE (SIZE (1..maxNrofMeasId)) OF SEQUENCE {	1 entry		
measId[1]	1		
measObjectId[1]	1		
reportConfigId[1]	1		
}			
}			

Table 8.1.3.1.2.3.3-3: *MeasObjectNR* (Table 8.1.3.1.2.3.3-2)

Derivation Path: TS 38.508-1 [4], Table 4.6.3-76			
Information Element	Value/remark	Comment	Condition
MeasObjectNR ::= SEQUENCE {			
ssbFrequency	ARFCN-ValueNR for SSB of NR Cell 1		
absThreshSS-BlocksConsolidation	Not present		
nrofSS-BlocksToAverage	Not present		
}			

Table 8.1.3.1.2.3.3-4: *ReportConfigNR-EventA3* (Table 8.1.3.1.2.3.3-2)

Derivation Path: 38.508-1 [4] Table 4.6.3-142 with condition EVENT_A3			
Information Element	Value/remark	Comment	Condition
ReportConfigNR ::= SEQUENCE {			
reportType CHOICE {			
eventTriggered SEQUENCE {			
eventId CHOICE {			
eventA3 SEQUENCE {			
A3-Threshold CHOICE {			
rsrp	2	-1 dB (2*0.5 dB)	FR1
	FFS		FR2
}			
hysteresis	4	2 dB	
}			
}			
reportQuantityCell SEQUENCE {			
rsrp	true		
rsrq	false		
sinr	false		
}			
}			
}			

Table 8.1.3.1.2.3.3-5: MeasurementReport (step 4, Table 8.1.3.1.2.3.2-3)

Derivation Path: 38.508-1 [4] Table 4.6.1-7			
Information Element	Value/remark	Comment	Condition
MeasurementReport ::= SEQUENCE {			
criticalExtensions CHOICE {			
measurementReport SEQUENCE {			
measResults SEQUENCE {			
measId	1		
measResultServingMOList SEQUENCE (SIZE (1..maxNrofServingCells)) OF SEQUENCE {		Measurement report for NR Cell 1	
servCellId	ServCellIndex of NR Cell 1		
measResultServingCell SEQUENCE {			
physCellId	PCI of NR Cell 1		
measResult SEQUENCE {			
cellResults SEQUENCE {			
resultsSSB-Cell SEQUENCE {			
rsrp	(0..127)		
rsrq	(0..127)		
}			
}			
}			
}			
measResultNeighCells CHOICE {			
measResultListNR SEQUENCE (SIZE (1..maxCellReport)) OF SEQUENCE {		Measurement report for NR Cell 2	
physCellId	Physical layer cell identity of NR Cell 2		
measResult SEQUENCE {			
cellResults SEQUENCE {			
resultsSSB-Cell SEQUENCE {			
rsrp	(0..127)		
}			
}			
}			
}			
}			
}			
}			
}			
}			

8.1.3.1.3 Measurement configuration control and reporting / Event A3 / Measurement of Neighbour NR cell / Inter-frequency measurements

8.1.3.1.3.1 Test Purpose (TP)

(1)

```
with { UE in NR RRC_CONNECTED state and inter-frequency measurements configured for event A3 }
ensure that {
  when { Entry condition for event A3 is not met for neighbour cell }
  then { UE does not send MeasurementReport }
}
```

(2)

```
with { UE in NR RRC_CONNECTED state and inter-frequency measurements configured for event A3 }
ensure that {
  when { Neighbour cell becomes offset better than serving cell }
  then { UE sends MeasurementReport with correct measId for event A3 }
```

}

8.1.3.1.3.2 Conformance requirements

Same as test case 8.1.3.1.2 with the following difference:

[TS 38.331, clause 5.5.2.9]

The UE shall:

...

1> if *gapUE* is set to *setup*:

2> if a per UE measurement gap configuration is already setup, release the per UE measurement gap configuration;

2> setup the per UE measurement gap configuration indicated by the *measGapConfig* in accordance with the received *gapOffset*, i.e., the first subframe of each gap occurs at an SFN and subframe meeting the following condition:

$SFN \bmod T = \text{FLOOR}(gapOffset/10)$;

$subframe = gapOffset \bmod 10$;

with $T = MGRP/10$ as defined in TS 38.133 [14];

2> if *mgta* is configured, apply the specified timing advance to the gap occurrences calculated above (i.e. the UE starts the measurement *mgta* ms before the gap subframe occurrences);

...

8.1.3.1.3.3 Test description

8.1.3.1.3.3.1 Pre-test conditions

Same as test case 8.1.3.1.2 with the following differences:

- Cells configuration: NR Cell 3 replaces NR Cell 2.
- System information combination: NR-4 replaces NR-2.

8.1.3.1.3.3.2 Test procedure sequence

Same as test case 8.1.3.1.2 with the following differences:

- Cells configuration: NR Cell 3 replaces NR Cell 2.

8.1.3.1.3.3.3 Specific message contents

Same as test case 8.1.3.1.2 with the following difference:

- Cells configuration: NR Cell 3 replaces NR Cell 2.

Table 8.1.3.1.3.3.3-1: *MeasConfig* (Table 8.1.3.1.2.3.3-1)

Derivation Path: 38.508-1 [4] Table 4.6.3-69			
Information Element	Value/remark	Comment	Condition
MeasConfig ::= SEQUENCE {			
measObjectToAddModList SEQUENCE (SIZE (1..maxNrofMeasId)) OF SEQUENCE {	2 entries		
measObjectId[1]	1		
measObject[1] CHOICE {			
measObjectNR	MeasObjectNR-f1	Table 8.1.3.1.3.3.3-2	
}			
measObjectId[2]	2		
measObject[2] CHOICE {			
measObjectNR	MeasObjectNR-f2	Table 8.1.3.1.3.3.3-3	
}			
}			
reportConfigToAddModList SEQUENCE (SIZE (1..maxReportConfigId)) OF SEQUENCE {	1 entry		
reportConfigId[1]	1		
reportConfig[1] CHOICE {			
reportConfigNR	ReportConfigNR-EventA3	Table 8.1.3.1.2.3.3-4	
}			
}			
measIdToAddModList SEQUENCE (SIZE (1..maxNrofMeasId)) OF SEQUENCE {	1 entry		
measId[1]	1		
measObjectId[1]	2		
reportConfigId[1]	1		
}			
measGapConfig	MeasGapConfig with condition GAP_UE		
}			

Table 8.1.3.1.3.3.3-2: *MeasObjectNR-f1* (Table 8.1.3.1.3.3.3-1)

Derivation Path: TS 38.508-1 [4], Table 4.6.3-76			
Information Element	Value/remark	Comment	Condition
MeasObjectNR ::= SEQUENCE {			
ssbFrequency	ARFCN-ValueNR for SSB of NR Cell 1		
absThreshSS-BlocksConsolidation	Not present		
nrofSS-BlocksToAverage	Not present		
}			

Table 8.1.3.1.3.3.3-3: *MeasObjectNR-f2* (Table 8.1.3.1.3.3.3-1)

Derivation Path: TS 38.508-1 [4], Table 4.6.3-76			
Information Element	Value/remark	Comment	Condition
MeasObjectNR ::= SEQUENCE {			
ssbFrequency	ARFCN-ValueNR for SSB of NR Cell 3		
absThreshSS-BlocksConsolidation	Not present		
nrofSS-BlocksToAverage	Not present		
}			

8.1.3.1.4 Measurement configuration control and reporting / Event A3 / Measurement of Neighbour NR cell / Inter-band measurements

8.1.3.1.4.1 Test Purpose (TP)

(1)

```
with { UE in NR RRC_CONNECTED state and inter-band measurements configured for event A3 }
ensure that {
  when { Entry condition for event A3 is not met for neighbour cell }
  then { UE does not send MeasurementReport }
}
```

(2)

```
with { UE in NR RRC_CONNECTED state and inter-band measurements configured for event A3 }
ensure that {
  when { Neighbour cell becomes offset better than serving cell }
  then { UE sends MeasurementReport with correct measId for event A3 }
}
```

8.1.3.1.4.2 Conformance requirements

Same as test case 8.1.3.1.2 with the following difference:

[TS 38.331, clause 5.5.2.9]

The UE shall:

...

1> if *gapUE* is set to *setup*:

2> if a per UE measurement gap configuration is already setup, release the per UE measurement gap configuration;

2> setup the per UE measurement gap configuration indicated by the *measGapConfig* in accordance with the received *gapOffset*, i.e., the first subframe of each gap occurs at an SFN and subframe meeting the following condition:

$SFN \bmod T = \text{FLOOR}(gapOffset/10)$;

$subframe = gapOffset \bmod 10$;

with $T = MGRP/10$ as defined in TS 38.133 [14];

2> if *mgta* is configured, apply the specified timing advance to the gap occurrences calculated above (i.e. the UE starts the measurement *mgta* ms before the gap subframe occurrences);

...

8.1.3.1.4.3 Test description

8.1.3.1.4.3.1 Pre-test conditions

Same as test case 8.1.3.1.2 with the following differences:

- Cells configuration: NR Cell 10 replaces NR Cell 2.
- System information combination: NR-4 replaces NR-2.

8.1.3.1.4.3.2 Test procedure sequence

Same as test case 8.1.3.1.2 with the following differences:

- Cells configuration: NR Cell 10 replaces NR Cell 2.

8.1.3.1.4.3.3 Specific message contents

Same as test case 8.1.3.1.222 with the following difference:

- Cells configuration: NR Cell 10 replaces NR Cell 2.

Table 8.1.3.1.4.3.3-1: MeasConfig (Table 8.1.3.1.2.3.3-1)

Derivation Path: 38.508-1 [4] Table 4.6.3-69			
Information Element	Value/remark	Comment	Condition
MeasConfig ::= SEQUENCE {			
measObjectToAddModList SEQUENCE (SIZE (1..maxNrofMeasId)) OF SEQUENCE {	2 entries		
measObjectId[1]	1		
measObject[1] CHOICE {			
measObjectNR	MeasObjectNR-f1	Table 8.1.3.1.4.3.3-2	
}			
measObjectId[2]	2		
measObject[2] CHOICE {			
measObjectNR	MeasObjectNR-f2	Table 8.1.3.1.4.3.3-3	
}			
reportConfigToAddModList SEQUENCE (SIZE (1..maxReportConfigId)) OF SEQUENCE {	1 entry		
reportConfigId[1]	1		
reportConfig[1] CHOICE {			
reportConfigNR	ReportConfigNR-EventA3	Table 8.1.3.1.2.3.3-4	
}			
}			
measIdToAddModList SEQUENCE (SIZE (1..maxNrofMeasId)) OF SEQUENCE {	1 entry		
measId[1]	1		
measObjectId[1]	2		
reportConfigId[1]	1		
}			
measGapConfig	MeasGapConfig with condition GAP_UE		
}			

Table 8.1.3.1.4.3.3-2: MeasObjectNR-f1 (Table 8.1.3.1.4.3.3-1)

Derivation Path: TS 38.508-1 [4], Table 4.6.3-76			
Information Element	Value/remark	Comment	Condition
MeasObjectNR ::= SEQUENCE {			
ssbFrequency	ARFCN-ValueNR for SSB of NR Cell 1		
absThreshSS-BlocksConsolidation	Not present		
nrofSS-BlocksToAverage	Not present		
}			

Table 8.1.3.1.4.3.3-3: MeasObjectNR-f2 (Table 8.1.3.1.4.3.3-1)

Derivation Path: TS 38.508-1 [4], Table 4.6.3-76			
Information Element	Value/remark	Comment	Condition
MeasObjectNR ::= SEQUENCE {			
ssbFrequency	ARFCN-ValueNR for SSB of NR Cell 10		
absThreshSS-BlocksConsolidation	Not present		
nrofSS-BlocksToAverage	Not present		
}			

8.1.3.1.5 Measurement configuration control and reporting / Event A4 / Measurement of Neighbour NR cell / Intra-frequency measurements

8.1.3.1.5.1 Test Purpose (TP)

(1)

```
with { UE in NR RRC_CONNECTED state and intra-frequency measurements configured for event A4 with
event based periodical reporting }
ensure that {
  when { Neighbour cell becomes better than absolute threshold }
  then { UE sends MeasurementReport message at regular intervals while entering condition for
event A4 is satisfied }
}
```

(2)

```
with { UE in NR RRC_CONNECTED state and periodical measurement reporting triggered by event A4
ongoing }
ensure that {
  when { Neighbour cell becomes worse than absolute threshold }
  then { UE stops sending MeasurementReport message }
}
```

8.1.3.1.5.2 Conformance requirements

References: The conformance requirements covered in the current TC are specified in: TS 38.331, clauses 5.3.5.3, 5.5.2.1, 5.5.4.1, 5.5.4.5 and 5.5.5.1. Unless otherwise stated these are Rel-15 requirements.

[TS 38.331, clause 5.3.5.3]

The UE shall perform the following actions upon reception of the *RRCReconfiguration*:

...

1> if the *RRCReconfiguration* message includes the *measConfig*:

2> perform the measurement configuration procedure as specified in 5.5.2;

...

1> if the UE is configured with E-UTRA *nr-SecondaryCellGroupConfig* (MCG is E-UTRA):

...

1> else:

2> submit the *RRCReconfigurationComplete* message via SRB1 to lower layers for transmission using the new configuration;

...

[TS 38.331, clause 5.5.2.1]

...

The UE shall:

...

1> if the received *measConfig* includes the *measObjectToAddModList*:

2> perform the measurement object addition/modification procedure as specified in 5.5.2.5;

...

1> if the received *measConfig* includes the *reportConfigToAddModList*:

2> perform the reporting configuration addition/modification procedure as specified in 5.5.2.7;

...

1> if the received *measConfig* includes the *measIdToAddModList*:

2> perform the measurement identity addition/modification procedure as specified in 5.5.2.3;

...

[TS 38.331, clause 5.5.4.1]

If AS security has been activated successfully, the UE shall:

1> for each *measId* included in the *measIdList* within *VarMeasConfig*:

2> if the corresponding *reportConfig* includes a *reportType* set to *eventTriggered* or *periodical*;

3> if the corresponding *measObject* concerns NR;

...

4> for measurement events other than *eventA1* or *eventA2*:

...

5> else:

6> consider any neighbouring cell detected based on parameters in the associated *measObjectNR* to be applicable when the concerned cell is not included in the *blackCellsToAddModList* defined within the *VarMeasConfig* for this *measId*;

...

4> if the *eventA1* or *eventA2* is configured in the corresponding *reportConfig*:

...

4> else:

5> for events involving a serving cell associated with a *measObjectNR* and neighbours associated with another *measObjectNR*, consider any serving cell associated with the other *measObjectNR* to be a neighbouring cell as well;

...

2> if the *reportType* is set to *eventTriggered* and if the entry condition applicable for this event, i.e. the event corresponding with the *eventId* of the corresponding *reportConfig* within *VarMeasConfig*, is fulfilled for one or more applicable cells for all measurements after layer 3 filtering taken during *timeToTrigger* defined for this event within the *VarMeasConfig*, while the *VarMeasReportList* does not include a measurement reporting entry for this *measId* (a first cell triggers the event):

3> include a measurement reporting entry within the *VarMeasReportList* for this *measId*;

3> set the *numberOfReportsSent* defined within the *VarMeasReportList* for this *measId* to 0;

3> include the concerned cell(s) in the *cellsTriggeredList* defined within the *VarMeasReportList* for this *measId*;

3> initiate the measurement reporting procedure, as specified in 5.5.5;

2> else if the *reportType* is set to *eventTriggered* and if the entry condition applicable for this event, i.e. the event corresponding with the *eventId* of the corresponding *reportConfig* within *VarMeasConfig*, is fulfilled for one or more applicable cells not included in the *cellsTriggeredList* for all measurements after layer 3 filtering taken during *timeToTrigger* defined for this event within the *VarMeasConfig* (a subsequent cell triggers the event):

- 3> set the *numberOfReportsSent* defined within the *VarMeasReportList* for this *measId* to 0;
- 3> include the concerned cell(s) in the *cellsTriggeredList* defined within the *VarMeasReportList* for this *measId*;
- 3> initiate the measurement reporting procedure, as specified in 5.5.5;
- 2> else if the *reportType* is set to *eventTriggered* and if the leaving condition applicable for this event is fulfilled for one or more of the cells included in the *cellsTriggeredList* defined within the *VarMeasReportList* for this *measId* for all measurements after layer 3 filtering taken during *timeToTrigger* defined within the *VarMeasConfig* for this event:
 - 3> remove the concerned cell(s) in the *cellsTriggeredList* defined within the *VarMeasReportList* for this *measId*;
 - ...
 - 3> if *reportOnLeave* is set to *TRUE* for the corresponding reporting configuration:
 - 4> initiate the measurement reporting procedure, as specified in 5.5.5;
 - 3> if the *cellsTriggeredList* defined within the *VarMeasReportList* for this *measId* is empty:
 - 4> remove the measurement reporting entry within the *VarMeasReportList* for this *measId*;
 - 4> stop the periodical reporting timer for this *measId*, if running;
 - ...
- 2> upon expiry of the periodical reporting timer for this *measId*:
 - 3> initiate the measurement reporting procedure, as specified in 5.5.5.
 - ...

[TS 38.331, clause 5.5.4.5]

The UE shall:

- 1> consider the entering condition for this event to be satisfied when condition A4-1, as specified below, is fulfilled;
- 1> consider the leaving condition for this event to be satisfied when condition A4-2, as specified below, is fulfilled.

Inequality A4-1 (Entering condition)

$$Mn + Ofn + Ocn - Hys > Thresh$$

Inequality A4-2 (Leaving condition)

$$Mn + Ofn + Ocn + Hys < Thresh$$

The variables in the formula are defined as follows:

Mn is the measurement result of the neighbouring cell, not taking into account any offsets.

Ofn is the measurement object specific offset of the neighbour cell (i.e. *offsetMO* as defined within *measObjectNR* corresponding to the neighbour cell).

Ocn is the measurement object specific offset of the neighbour cell (i.e. *cellIndividualOffset* as defined within *measObjectNR* corresponding to the neighbour cell), and set to zero if not configured for the neighbour cell.

Hys is the hysteresis parameter for this event (i.e. *hysteresis* as defined within *reportConfigNR* for this event).

Thresh is the threshold parameter for this event (i.e. *a4-Threshold* as defined within *reportConfigNR* for this event).

Mn is expressed in dBm in case of RSRP, or in dB in case of RSRQ and RS-SINR.

Ofn*, *Ocn*, *Hys are expressed in dB.

Thresh is expressed in the same unit as *Mn*.

[TS 38.331, clause 5.5.5.1]



Figure 5.5.5-1: Measurement reporting

The purpose of this procedure is to transfer measurement results from the UE to the network. The UE shall initiate this procedure only after successful AS security activation.

For the *measId* for which the measurement reporting procedure was triggered, the UE shall set the *measResults* within the *MeasurementReport* message as follows:

- 1> set the *measId* to the measurement identity that triggered the measurement reporting;
- 1> set the *measResultServingCell* within *measResultServingMOList* to include RSRP, RSRQ and the available SINR for each configured serving cell derived based on the *rsType* indicated in the associated *reportConfig*;
- 1> set the *measResultServingCell* within *measResultServingMOList* to include for each NR serving cell that is configured with *servingCellMO*, if any, the *servCellId*;
- ...
- 1> if there is at least one applicable neighbouring cell to report:
 - 2> if the *reportType* is set to *eventTriggered* or *periodical*:
 - 3> set the *measResultNeighCells* to include the best neighbouring cells up to *maxReportCells* in accordance with the following:
 - 4> if the *reportType* is set to *eventTriggered*:
 - 5> include the cells included in the *cellsTriggeredList* as defined within the *VarMeasReportList* for this *measId*;
 - ...
 - 4> for each cell that is included in the *measResultNeighCells*, include the *physCellId*;
 - 4> if the *reportType* is set to *eventTriggered* or *periodical*:
 - 5> for each included cell, include the layer 3 filtered measured results in accordance with the *reportConfig* for this *measId*, ordered as follows:
 - 6> if the *measObject* associated with this *measId* concerns NR:
 - 7> if *rsType* in the associated *reportConfig* is set to *ssb*:
 - 8> set *resultsSSB-Cell* within the *measResult* to include the SS/PBCH block based quantity(ies) indicated in the *reportQuantityCell* within the concerned *reportConfig*, in decreasing order of the sorting quantity, determined as specified in 5.5.5.3, i.e. the best cell is included first;
 - ...
- 2> set the *measResultNeighCells* to include the best neighbouring cells up to *maxReportCells* in accordance with the following:

- 3> if the *reportType* is set to *eventTriggered*:
 - 4> include the cells included in the *cellsTriggeredList* as defined within the *VarMeasReportList* for this *measId*;
 - ...
 - 3> for each cell that is included in the *measResultNeighCells*, include the *physCellId*;
 - 3> if the *reportType* is set to *eventTriggered*:
 - 4> for each included cell, include the layer 3 filtered measured results in accordance with the *reportConfig* for this *measId*, ordered as follows:
 - 5> if the *measObject* associated with this *measId* concerns NR:
 - 6> if *rsType* in the associated *reportConfig* is set to *ssb*:
 - 7> set *results SSB-Cell* within the *measResult* to include the SS/PBCH block based quantity(ies) indicated in the *reportQuantityCell* within the concerned *reportConfig*, in order of decreasing trigger quantity, i.e. the best cell is included first;
 - ...
 - 1> increment the *numberOfReportsSent* as defined within the *VarMeasReportList* for this *measId* by 1;
 - 1> stop the periodical reporting timer, if running;
 - 1> if the *numberOfReportsSent* as defined within the *VarMeasReportList* for this *measId* is less than the *reportAmount* as defined within the corresponding *reportConfig* for this *measId*:
 - 2> start the periodical reporting timer with the value of *reportInterval* as defined within the corresponding *reportConfig* for this *measId*;
 - ...
 - ...
 - 1> if the UE is configured with EN-DC:
 - ...
 - 1> else:
 - 2> submit the *MeasurementReport* message to lower layers for transmission, upon which the procedure ends.

8.1.3.1.5.3 Test description

8.1.3.1.5.3.1 Pre-test conditions

System Simulator:

- NR Cell 1 is the serving cell, NR Cell 2 is the intra-frequency neighbour cell of NR Cell 1.
- System information combination NR-2 as defined in TS 38.508-1 [4] clause 4.4.3.1.2 is used in NR cells.

UE:

- None.

Preamble:

- The UE is in state 3N-A as defined in TS 38.508-1 [4], subclause 4.4A.

8.1.3.1.5.3.2 Test procedure sequence

Table 8.1.3.1.5.3.2-1 and 8.1.3.1.5.3.2-2 illustrates the downlink power levels to be applied for NR Cell 1 and NR Cell 2 at various time instants of the test execution. Row marked "T0" denotes the conditions after the preamble, while the configuration marked "T1" and "T2", are applied at the point indicated in the Main behaviour description in Table 8.1.3.1.5.3.2-3.

Table 8.1.3.1.5.3.2-1: Time instances of cell power level and parameter changes in FR1

	Parameter	Unit	NR Cell 1	NR Cell 2	Remark
T0	SS/PBCH SSS EPRE	dBm/ SCS	-85	-91	Power levels are such that entry condition for event A4 (measId 1) is not satisfied: $Mn + Ofn + Ocn - Hys \leq Thresh$
T1	SS/PBCH SSS EPRE	dBm/ SCS	-85	-73	Power levels are such that entry condition for event A4 (measId 1) is satisfied: $Mn + Ofn + Ocn - Hys > Thresh$
T2	SS/PBCH SSS EPRE	dBm/ SCS	-85	-91	Power levels are such that leaving condition for event A4 (measId 1) is satisfied: $Mn + Ofn + Ocn + Hys < Thresh$

Table 8.1.3.1.5.3.2-2: Time instances of cell power level and parameter changes in FR2

	Parameter	Unit	NR Cell 1	NR Cell 2	Remark
T0	SS/PBCH SSS EPRE	dBm/ SCS	FFS	FFS	Power levels are such that entry condition for event A4 (measId 1) is not satisfied: $Mn + Ofn + Ocn - Hys \leq Thresh$
T1	SS/PBCH SSS EPRE	dBm/ SCS	FFS	FFS	Power levels are such that entry condition for event A4 (measId 1) is satisfied: $Mn + Ofn + Ocn - Hys > Thresh$
T2	SS/PBCH SSS EPRE	dBm/ SCS	FFS	FFS	Power levels are such that leaving condition for event A4 (measId 1) is satisfied: $Mn + Ofn + Ocn + Hys < Thresh$

Table 8.1.3.1.5.3.2-3: Main behaviour

St	Procedure	Message Sequence		TP	Verdict
		U - S	Message		
1	The SS transmits an <i>RRCReconfiguration</i> message including <i>MeasConfig</i> to setup NR measurement and reporting for intra-frequency event A4 (<i>measId</i> 1).	<--	NR RRC: <i>RRCReconfiguration</i>	-	-
2	The UE transmits an <i>RRCReconfigurationComplete</i> message.	-->	NR RRC: <i>RRCReconfigurationComplete</i>	-	-
3	SS re-adjusts the cell-specific reference signal level according to row "T1" in table 8.1.3.1.5.3.2-1/2.	-	-	-	-
-	EXCEPTION: In parallel to events described in step 4 the steps specified in table 8.1.3.1.5.3.2-4 shall take place	-	-	-	-
4	Wait for 30 seconds to ensure that the UE performs a periodical intra-frequency reporting for NR Cell 2	-	-	1	-
5	SS re-adjusts the cell-specific reference signal level according to row "T2" in table 8.1.3.1.5.3.2-1/2.	-	-	-	-
6	Wait and ignore <i>MeasurementReport</i> messages for 10s to allow change of power levels for NR Cell 2 and UE measurement	-	-	-	-
7	Check: Does the UE transmit a <i>MeasurementReport</i> message within the next 10s?	-	-	2	F

Table 8.1.3.1.5.3.2-4: Parallel behaviour

St	Procedure	Message Sequence		TP	Verdict
		U - S	Message		
-	EXCEPTION: After the 1st message is received, step 1 below shall be repeated every time the duration indicated in the IE <i>reportInterval</i> has elapsed	-	-	-	-
1	Check: Does the UE transmit a <i>MeasurementReport</i> message to report event A4 (<i>measId</i> 1) with the measured RSRP value for NR Cell 2?	-->	NR RRC: <i>MeasurementReport</i>	1	P

8.1.3.1.5.3.3 Specific message contents

Table 8.1.3.1.5.3.3-1: *RRCReconfiguration* (step 1, Table 8.1.3.1.5.3.2-3)

Derivation Path: 38.508-1 [4] Table 4.6.1-13			
Information Element	Value/remark	Comment	Condition
<i>RRCReconfiguration</i> ::= SEQUENCE {			
<i>rrc-TransactionIdentifier</i>	RRC- TransactionIdentifier		
criticalExtensions CHOICE {			
<i>rrcReconfiguration</i> ::= SEQUENCE {			
<i>radioBearerConfig</i>	Not present		
<i>secondaryCellGroup</i>	Not present		
<i>measConfig</i>	MeasConfig	Table 8.1.3.1.5.3.3-2	
<i>lateNonCriticalExtension</i>	Not present		
<i>nonCriticalExtension</i>	Not present		
}			
}			
}			

Table 8.1.3.1.5.3.3-2: MeasConfig (Table 8.1.3.1.5.3.3-1)

Derivation Path: 38.508-1 [4] Table 4.6.3-69			
Information Element	Value/remark	Comment	Condition
MeasConfig ::= SEQUENCE {			
measObjectToAddModList SEQUENCE (SIZE (1..maxNrofMeasId)) OF SEQUENCE {	1 entry		
measObjectId[1]	1	MeasObjectIdNR-f1	
measObject[1] CHOICE {			
measObjectNR SEQUENCE {			
ssbFrequency	ssbFrequency IE equals the ARFCN for NR Cell 2		
absThreshSS-BlocksConsolidation	Not present		
}			
}			
reportConfigToAddModList SEQUENCE(SIZE (1..maxReportConfigId)) OF SEQUENCE {	1 entry		
reportConfigId[1]	1		
reportConfig[1] CHOICE {			
reportConfigNR	ReportConfigNR-EventA4	Table 8.1.3.1.5.3.3-3	
}			
}			
measIdToAddModList SEQUENCE (SIZE (1..maxNrofMeasId)) OF SEQUENCE {	1 entry		
measId[1]	1		
measObjectId[1]	1		
reportConfigId[1]	1		
}			
}			

Table 8.1.3.1.5.3.3-3: ReportConfigNR-EventA4 (Table 8.1.3.1.5.3.3-2)

Derivation Path: 38.508-1 [4] Table 4.6.3-142 with condition EVENT_A4			
Information Element	Value/remark	Comment	Condition
ReportConfigNR ::= SEQUENCE {			
reportType CHOICE {			
eventTriggered SEQUENCE {			
eventId CHOICE {			
eventA4 SEQUENCE {			
a4-Threshold CHOICE {			
rsrp	73	-84dBm ≤ SS-RSRP < -83dBm	FR1
}	FFS		FR2
}			
}			
}			
}			
}			
reportAmount	infinity		
reportQuantityCell SEQUENCE {			
rsrp	true		
rsrq	false		
sinr	false		
}			
}			

Table 8.1.3.1.5.3.3-4: MeasurementReport (step 1, Table 8.1.3.1.5.3.2-4)

Derivation Path: 38.508-1 [4] Table 4.6.1-7			
Information Element	Value/remark	Comment	Condition
MeasurementReport ::= SEQUENCE {			
criticalExtensions CHOICE {			
measurementReport SEQUENCE {			
measResults SEQUENCE {			
measId	1		
measResultServingMOList SEQUENCE (SIZE (1..maxNrofServingCells)) OF SEQUENCE {		Report NR Cell 1	
servCellId	ServCellIndex of NR Cell 1		
measResultServingCell SEQUENCE {			
physCellId	Physical layer cell identity of NR Cell 1		
measResult SEQUENCE {			
cellResults SEQUENCE {			
resultsSSB-Cell SEQUENCE {			
rsrp	(0..127)		
rsrq	(0..127)		
}			
}			
}			
}			
measResultNeighCells CHOICE {			
measResultListNR SEQUENCE (SIZE (1..maxCellReport)) OF SEQUENCE {		Report NR neighbour cell	
physCellId	Physical layer cell identity of NR Cell 2		
measResult SEQUENCE {			
cellResults SEQUENCE {			
resultsSSB-Cell SEQUENCE {			
rsrp	(0..127)		
}			
}			
}			
}			
}			
}			
}			
}			

8.1.3.1.6 Measurement configuration control and reporting / Event A4 / Measurement of Neighbour NR cell / Inter-frequency measurements

8.1.3.1.6.1 Test Purpose (TP)

Same as test case 8.1.3.1.5 but applied to inter-frequency case.

8.1.3.1.6.2 Conformance requirements

Same as test case 8.1.3.1.5 with the following difference:

[TS 38.331, clause 5.5.2.9]

The UE shall:

...

1> if *gapUE* is set to *setup*:

- 2> if a per UE measurement gap configuration is already setup, release the per UE measurement gap configuration;
- 2> setup the per UE measurement gap configuration indicated by the *measGapConfig* in accordance with the received *gapOffset*, i.e., the first subframe of each gap occurs at an SFN and subframe meeting the following condition:
- $$\text{SFN mod } T = \text{FLOOR}(\text{gapOffset}/10);$$
- $$\text{subframe} = \text{gapOffset mod } 10;$$
- with $T = \text{MGRP}/10$ as defined in TS 38.133 [14];
- 2> if *mgta* is configured, apply the specified timing advance to the gap occurrences calculated above (i.e. the UE starts the measurement *mgta* ms before the gap subframe occurrences);

...

8.1.3.1.6.3 Test description

8.1.3.1.6.3.1 Pre-test conditions

Same as test case 8.1.3.1.5 with the following differences:

- Cells configuration: NR Cell 3 replaces NR Cell 2.
- System information combination: NR-4 replaces NR-2.

8.1.3.1.6.3.2 Test procedure sequence

Same as test case 8.1.3.1.5 with the following differences:

- Cells configuration: NR Cell 3 replaces NR Cell 2.

8.1.3.1.6.3.3 Specific message contents

Same as test case 8.1.3.1.5 with the following difference:

- Cells configuration: NR Cell 3 replaces NR Cell 2.

Table 8.1.3.1.6.3.3-1: MeasConfig (Table 8.1.3.1.5.3.3-1)

Derivation Path: 38.508-1 [4] Table 4.6.3-69			
Information Element	Value/remark	Comment	Condition
MeasConfig ::= SEQUENCE {			
measObjectToAddModList SEQUENCE (SIZE (1..maxNrofMeasId)) OF SEQUENCE {	2 entries		
measObjectId[1]	1		
measObject[1] CHOICE {			
measObjectNR	MeasObjectNR-f1	Table 8.1.3.1.6.3.3-2	
}			
measObjectId[2]	2		
measObject[2] CHOICE {			
measObjectNR	MeasObjectNR-f2	Table 8.1.3.1.6.3.3-3	
}			
}			
reportConfigToAddModList SEQUENCE (SIZE (1..maxReportConfigId)) OF SEQUENCE {	1 entry		
reportConfigId[1]	1		
reportConfig[1] CHOICE {			
reportConfigNR	ReportConfigNR-EventA4	Table 8.1.3.1.5.3.3-3	
}			
}			
measIdToAddModList SEQUENCE (SIZE (1..maxNrofMeasId)) OF SEQUENCE {	1 entry		
measId[1]	1		
measObjectId[1]	2		
reportConfigId[1]	1		
}			
measGapConfig	MeasGapConfig with condition GAP_UE		
}			

Table 8.1.3.1.6.3.3-2: MeasObjectNR-f1 (Table 8.1.3.1.6.3.3-1)

Derivation Path: TS 38.508-1 [4], Table 4.6.3-76			
Information Element	Value/remark	Comment	Condition
MeasObjectNR ::= SEQUENCE {			
ssbFrequency	ARFCN-ValueNR for SSB of NR Cell 1		
absThreshSS-BlocksConsolidation	Not present		
nrofSS-BlocksToAverage	Not present		
}			

Table 8.1.3.1.6.3.3-3: MeasObjectNR-f2 (Table 8.1.3.1.6.3.3-1)

Derivation Path: TS 38.508-1 [4], Table 4.6.3-76			
Information Element	Value/remark	Comment	Condition
MeasObjectNR ::= SEQUENCE {			
ssbFrequency	ARFCN-ValueNR for SSB of NR Cell 3		
absThreshSS-BlocksConsolidation	Not present		
nrofSS-BlocksToAverage	Not present		
}			

8.1.3.1.7 Measurement configuration control and reporting / Event A4 / Measurement of Neighbour NR cell / Inter-band measurements

8.1.3.1.7.1 Test Purpose (TP)

Same as test case 8.1.3.1.5 but applied to inter-band case.

8.1.3.1.7.2 Conformance requirements

Same as test case 8.1.3.1.5 with the following differences:

[TS 38.331, clause 5.5.2.9]

The UE shall:

...

1> if *gapUE* is set to *setup*:

2> if a per UE measurement gap configuration is already setup, release the per UE measurement gap configuration;

2> setup the per UE measurement gap configuration indicated by the *measGapConfig* in accordance with the received *gapOffset*, i.e., the first subframe of each gap occurs at an SFN and subframe meeting the following condition:

$$\text{SFN mod } T = \text{FLOOR}(\text{gapOffset}/10);$$

$$\text{subframe} = \text{gapOffset mod } 10;$$

with $T = \text{MGRP}/10$ as defined in TS 38.133 [14];

2> if *mgta* is configured, apply the specified timing advance to the gap occurrences calculated above (i.e. the UE starts the measurement *mgta* ms before the gap subframe occurrences);

...

8.1.3.1.7.3 Test description

8.1.3.1.7.3.1 Pre-test conditions

Same as test case 8.1.3.1.5 with the following differences:

- Cells configuration: NR Cell 10 replaces NR Cell 2.
- System information combination: NR-4 replaces NR-2.

8.1.3.1.7.3.2 Test procedure sequence

Same as test case 8.1.3.1.5 with the following differences:

- Cells configuration: NR Cell 10 replaces NR Cell 2.

8.1.3.1.7.3.3 Specific message contents

Same as test case 8.1.3.1.5 with the following difference:

- Cells configuration: NR Cell 10 replaces NR Cell 2.

Table 8.1.3.1.7.3.3-1: MeasConfig (Table 8.1.3.1.5.3.3-1)

Derivation Path: 38.508-1 [4] Table 4.6.3-69			
Information Element	Value/remark	Comment	Condition
MeasConfig ::= SEQUENCE {			
measObjectToAddModList SEQUENCE (SIZE (1..maxNrofMeasId)) OF SEQUENCE {	2 entries		
measObjectId[1]	1		
measObject[1] CHOICE {			
measObjectNR	MeasObjectNR-f1	Table 8.1.3.1.7.3.3-2	
}			
measObjectId[2]	2		
measObject[2] CHOICE {			
measObjectNR	MeasObjectNR-f2	Table 8.1.3.1.7.3.3-3	
}			
}			
reportConfigToAddModList SEQUENCE (SIZE (1..maxReportConfigId)) OF SEQUENCE {	1 entry		
reportConfigId[1]	1		
reportConfig[1] CHOICE {			
reportConfigNR	ReportConfigNR-EventA4	Table 8.1.3.1.5.3.3-3	
}			
}			
measIdToAddModList SEQUENCE (SIZE (1..maxNrofMeasId)) OF SEQUENCE {	1 entry		
measId[1]	1		
measObjectId[1]	2		
reportConfigId[1]	1		
}			
measGapConfig	MeasGapConfig with condition GAP_UE		
}			

Table 8.1.3.1.7.3.3-2: MeasObjectNR-f1 (Table 8.1.3.1.7.3.3-1)

Derivation Path: TS 38.508-1 [4], Table 4.6.3-76			
Information Element	Value/remark	Comment	Condition
MeasObjectNR ::= SEQUENCE {			
ssbFrequency	ARFCN-ValueNR for SSB of NR Cell 1		
absThreshSS-BlocksConsolidation	Not present		
nrofSS-BlocksToAverage	Not present		
}			

Table 8.1.3.1.7.3.3-3: MeasObjectNR-f2 (Table 8.1.3.1.7.3.3-1)

Derivation Path: TS 38.508-1 [4], Table 4.6.3-76			
Information Element	Value/remark	Comment	Condition
MeasObjectNR ::= SEQUENCE {			
ssbFrequency	ARFCN-ValueNR for SSB of NR Cell 10		
absThreshSS-BlocksConsolidation	Not present		
nrofSS-BlocksToAverage	Not present		
}			

8.1.3.1.8 Measurement configuration control and reporting / Event A5 / Measurement of Neighbour NR cell / Intra-frequency measurements

8.1.3.1.8.1 Test Purpose (TP)

(1)

```
with { UE in NR RRC_CONNECTED state and intra-frequency measurements configured for event A5 with
event based periodical reporting }
ensure that {
  when { Serving cell becomes worse than absolute threshold1 and neighbour cell becomes better than
absolute threshold2 }
  then { UE sends MeasurementReport message at regular intervals while entering conditions for
event A5 are satisfied }
}
```

(2)

```
with { UE in NR RRC_CONNECTED state and periodical measurement reporting triggered by event A5
ongoing }
ensure that {
  when { Serving cell becomes better than absolute threshold1 or neighbour cell becomes worse than
absolute threshold2 }
  then { UE stops sending MeasurementReport message }
}
```

8.1.3.1.8.2 Conformance requirements

References: The conformance requirements covered in the current TC are specified in: TS 38.331, clauses 5.3.5.3, 5.5.2.1, 5.5.4.1, 5.5.4.6 and 5.5.5.1. Unless otherwise stated these are Rel-15 requirements.

[TS 38.331, clause 5.3.5.3]

The UE shall perform the following actions upon reception of the *RRCReconfiguration*:

...

1> if the *RRCReconfiguration* message includes the *measConfig*:

2> perform the measurement configuration procedure as specified in 5.5.2;

...

1> if the UE is configured with E-UTRA *nr-SecondaryCellGroupConfig* (MCG is E-UTRA):

...

1> else:

2> submit the *RRCReconfigurationComplete* message via SRB1 to lower layers for transmission using the new configuration;

...

[TS 38.331, clause 5.5.2.1]

...

The UE shall:

...

1> if the received *measConfig* includes the *measObjectToAddModList*:

2> perform the measurement object addition/modification procedure as specified in 5.5.2.5;

...

- 1> if the received *measConfig* includes the *reportConfigToAddModList*:
 - 2> perform the reporting configuration addition/modification procedure as specified in 5.5.2.7;

...

- 1> if the received *measConfig* includes the *measIdToAddModList*:
 - 2> perform the measurement identity addition/modification procedure as specified in 5.5.2.3;

...

[TS 38.331, clause 5.5.4.1]

If AS security has been activated successfully, the UE shall:

- 1> for each *measId* included in the *measIdList* within *VarMeasConfig*:
 - 2> if the corresponding *reportConfig* includes a *reportType* set to *eventTriggered* or *periodical*;
 - 3> if the corresponding *measObject* concerns NR;
 - ...
 - 4> if the *eventA3* or *eventA5* is configured in the corresponding *reportConfig*:
 - 5> if a serving cell is associated with a *measObjectNR* and neighbours are associated with another *measObjectNR*, consider any serving cell associated with the other *measObjectNR* to be a neighbouring cell as well;
 - ...
 - 4> if the *eventA1* or *eventA2* is configured in the corresponding *reportConfig*:
 - ...
 - 4> else:
 - 5> for events involving a serving cell associated with a *measObjectNR* and neighbours associated with another *measObjectNR*, consider any serving cell associated with the other *measObjectNR* to be a neighbouring cell as well;
 - ...
 - 2> if the *reportType* is set to *eventTriggered* and if the entry condition applicable for this event, i.e. the event corresponding with the *eventId* of the corresponding *reportConfig* within *VarMeasConfig*, is fulfilled for one or more applicable cells for all measurements after layer 3 filtering taken during *timeToTrigger* defined for this event within the *VarMeasConfig*, while the *VarMeasReportList* does not include a measurement reporting entry for this *measId* (a first cell triggers the event):
 - 3> include a measurement reporting entry within the *VarMeasReportList* for this *measId*;
 - 3> set the *numberOfReportsSent* defined within the *VarMeasReportList* for this *measId* to 0;
 - 3> include the concerned cell(s) in the *cellsTriggeredList* defined within the *VarMeasReportList* for this *measId*;
 - 3> initiate the measurement reporting procedure, as specified in 5.5.5;
 - 2> else if the *reportType* is set to *eventTriggered* and if the entry condition applicable for this event, i.e. the event corresponding with the *eventId* of the corresponding *reportConfig* within *VarMeasConfig*, is fulfilled for one or more applicable cells not included in the *cellsTriggeredList* for all measurements after layer 3 filtering taken during *timeToTrigger* defined for this event within the *VarMeasConfig* (a subsequent cell triggers the event):
 - 3> set the *numberOfReportsSent* defined within the *VarMeasReportList* for this *measId* to 0;

- 3> include the concerned cell(s) in the *cellsTriggeredList* defined within the *VarMeasReportList* for this *measId*;
- 3> initiate the measurement reporting procedure, as specified in 5.5.5;
- 2> else if the *reportType* is set to *eventTriggered* and if the leaving condition applicable for this event is fulfilled for one or more of the cells included in the *cellsTriggeredList* defined within the *VarMeasReportList* for this *measId* for all measurements after layer 3 filtering taken during *timeToTrigger* defined within the *VarMeasConfig* for this event:
 - 3> remove the concerned cell(s) in the *cellsTriggeredList* defined within the *VarMeasReportList* for this *measId*;
 - ...
 - 3> if *reportOnLeave* is set to *TRUE* for the corresponding reporting configuration:
 - 4> initiate the measurement reporting procedure, as specified in 5.5.5;
 - 3> if the *cellsTriggeredList* defined within the *VarMeasReportList* for this *measId* is empty:
 - 4> remove the measurement reporting entry within the *VarMeasReportList* for this *measId*;
 - 4> stop the periodical reporting timer for this *measId*, if running;
 - ...
- 2> upon expiry of the periodical reporting timer for this *measId*:
 - 3> initiate the measurement reporting procedure, as specified in 5.5.5.
 - ...

[TS 38.331, clause 5.5.4.6]

The UE shall:

- 1> consider the entering condition for this event to be satisfied when both condition A5-1 and condition A5-2, as specified below, are fulfilled;
- 1> consider the leaving condition for this event to be satisfied when condition A5-3 or condition A5-4, i.e. at least one of the two, as specified below, is fulfilled;
- 1> use the SpCell for *Mp*.

NOTE: The parameters of the reference signal(s) of the cell(s) that triggers the event are indicated in the *measObjectNR* associated to the event which may be different from the *measObjectNR* of the NR SpCell.

Inequality A5-1 (Entering condition 1)

$$M_p + H_{ys} < Thresh1$$

Inequality A5-2 (Entering condition 2)

$$M_n + O_{fn} + O_{cn} - H_{ys} > Thresh2$$

Inequality A5-3 (Leaving condition 1)

$$M_p - H_{ys} > Thresh1$$

Inequality A5-4 (Leaving condition 2)

$$M_n + O_{fn} + O_{cn} + H_{ys} < Thresh2$$

The variables in the formula are defined as follows:

Mp is the measurement result of the NR SpCell, not taking into account any offsets.

Mn is the measurement result of the neighbouring cell/SCell, not taking into account any offsets.

Ofn is the measurement object specific offset of the neighbour/SCell cell (i.e. *offsetMO* as defined within *measObjectNR* corresponding to the neighbour cell/SCell).

Ocn is the cell specific offset of the neighbour cell/SCell (i.e. *cellIndividualOffset* as defined within *measObjectNR* corresponding to the neighbour cell/SCell), and set to zero if not configured for the neighbour cell.

Hys is the hysteresis parameter for this event (i.e. *hysteresis* as defined within *reportConfigNR* for this event).

Thresh1 is the threshold parameter for this event (i.e. *a5-Threshold1* as defined within *reportConfigNR* for this event).

Thresh2 is the threshold parameter for this event (i.e. *a5-Threshold2* as defined within *reportConfigNR* for this event).

Mn, *Mp* are expressed in dBm in case of RSRP, or in dB in case of RSRQ and RS-SINR.

Ofn, *Ocn*, *Hys* are expressed in dB.

Thresh1 is expressed in the same unit as *Mp*.

Thresh2 is expressed in the same unit as *Mn*.

[TS 38.331, clause 5.5.5.1]



Figure 5.5.5-1: Measurement reporting

The purpose of this procedure is to transfer measurement results from the UE to the network. The UE shall initiate this procedure only after successful AS security activation.

For the *measId* for which the measurement reporting procedure was triggered, the UE shall set the *measResults* within the *MeasurementReport* message as follows:

1> set the *measId* to the measurement identity that triggered the measurement reporting;

1> set the *measResultServingCell* within *measResultServingMOList* to include, for each NR serving cell that is configured with *servingCellMO*, RSRP, RSRQ and the available SINR derived based on the *rsType* if indicated in the associated *reportConfig*, otherwise based on SSB if available, otherwise based on CSI-RS; for each configured serving cell derived based on the *rsType* indicated in the associated *reportConfig*;

set the *servCellId* within *measResultServingMOList* to include each NR serving cell that is configured with *servingCellMO*, if any;

1> set the *measResultServingCell* within *measResultServingMOList* to include for each NR serving cell that is configured with *servingCellMO*, if any, the *servCellId*;

...

1> if there is at least one applicable neighbouring cell to report:

2> if the *reportType* is set to *eventTriggered* or *periodical*:

3> set the *measResultNeighCells* to include the best neighbouring cells up to *maxReportCells* in accordance with the following:

- 4> if the *reportType* is set to *eventTriggered*:
 - 5> include the cells included in the *cellsTriggeredList* as defined within the *VarMeasReportList* for this *measId*;
 - ...
 - 4> for each cell that is included in the *measResultNeighCells*, include the *physCellId*;
 - 4> if the *reportType* is set to *eventTriggered* or *periodical*:
 - 5> for each included cell, include the layer 3 filtered measured results in accordance with the *reportConfig* for this *measId*, ordered as follows:
 - 6> if the *measObject* associated with this *measId* concerns NR:
 - 7> if *rsType* in the associated *reportConfig* is set to *ssb*:
 - 8> set *resultsSSB-Cell* within the *measResult* to include the SS/PBCH block based quantity(ies) indicated in the *reportQuantityCell* within the concerned *reportConfig*, in decreasing order of the sorting quantity, determined as specified in 5.5.5.3, i.e. the best cell is included first;
 - ...
- 2> set the *measResultNeighCells* to include the best neighbouring cells up to *maxReportCells* in accordance with the following:
 - 3> if the *reportType* is set to *eventTriggered*:
 - 4> include the cells included in the *cellsTriggeredList* as defined within the *VarMeasReportList* for this *measId*;
 - ...
 - 3> for each cell that is included in the *measResultNeighCells*, include the *physCellId*;
 - 3> if the *reportType* is set to *eventTriggered*:
 - 4> for each included cell, include the layer 3 filtered measured results in accordance with the *reportConfig* for this *measId*, ordered as follows:
 - 5> if the *measObject* associated with this *measId* concerns NR:
 - 6> if *rsType* in the associated *reportConfig* is set to *ssb*:
 - 7> set *results SSB-Cell* within the *measResult* to include the SS/PBCH block based quantity(ies) indicated in the *reportQuantityCell* within the concerned *reportConfig*, in order of decreasing trigger quantity, i.e. the best cell is included first;
 - ...
 - 1> increment the *numberOfReportsSent* as defined within the *VarMeasReportList* for this *measId* by 1;
 - 1> stop the periodical reporting timer, if running;
 - 1> if the *numberOfReportsSent* as defined within the *VarMeasReportList* for this *measId* is less than the *reportAmount* as defined within the corresponding *reportConfig* for this *measId*:
 - 2> start the periodical reporting timer with the value of *reportInterval* as defined within the corresponding *reportConfig* for this *measId*;
 - ...
 - ...
 - 1> if the UE is configured with EN-DC:

...

1> else:

2> submit the *MeasurementReport* message to lower layers for transmission, upon which the procedure ends.

8.1.3.1.8.3 Test description

8.1.3.1.8.3.1 Pre-test conditions

System Simulator:

- NR Cell 1 is the PCell, NR Cell 2 is the intra-frequency neighbour cell of NR Cell 1.
- System information combination NR-2 as defined in TS 38.508-1 [4] clause 4.4.3.1.2 is used in NR cells.

UE:

- None.

Preamble:

- The UE is in state 3N-A as defined in TS 38.508-1 [4], subclause 4.4A.

8.1.3.1.8.3.2 Test procedure sequence

Table 8.1.3.1.8.3.2-1 and 8.1.3.1.8.3.2-2 illustrates the downlink power levels to be applied for NR Cell 1 and NR Cell 2 at various time instants of the test execution. Row marked "T0" denotes the conditions after the preamble, while the configuration marked "T1" and "T2" are applied at the point indicated in the Main behaviour description in Table 8.1.3.1.8.3.2-3.

Table 8.1.3.1.8.3.2-1: Time instances of cell power level and parameter changes in FR1

	Parameter	Unit	NR Cell 1	NR Cell 2	Remark
T0	SS/PBCH SSS EPRE	dBm/ SCS	-85	-91	Power levels are such that entry condition for event A5 (measId 1) is not satisfied: $Mp + Hys \geq Thresh1$ or $Mn + Ofn + Ocn + Hys \leq Thresh2$
T1	SS/PBCH SSS EPRE	dBm/ SCS	-85	-73	Power levels are such that entry condition for event A5 (measId 1) is satisfied: $Mp + Hys < Thresh1$ and $Mn + Ofn + Ocn - Hys > Thresh2$
T2	SS/PBCH SSS EPRE	dBm/ SCS	-85	-91	Power levels are such that leaving condition for event A5 (measId 1) is satisfied: $Mp - Hys > Thresh1$ or $Mn + Ofn + Ocn + Hys < Thresh2$

Table 8.1.3.1.8.3.2-2: Time instances of cell power level and parameter changes in FR2

	Parameter	Unit	NR Cell 1	NR Cell 2	Remark
T0	SS/PBCH SSS EPRE	dBm/ SCS	FFS	FFS	Power levels are such that entry condition for event A5 (measId 1) is not satisfied: $Mp + Hys \geq Thresh1$ or $Mn + Ofn + Ocn + Hys \leq Thresh2$
T1	SS/PBCH SSS EPRE	dBm/ SCS	FFS	FFS	Power levels are such that entry condition for event A5 (measId 1) is satisfied: $Mp + Hys < Thresh1$ and $Mn + Ofn + Ocn - Hys > Thresh2$
T2	SS/PBCH SSS EPRE	dBm/ SCS	FFS	FFS	Power levels are such that leaving condition for event A5 (measId 1) is satisfied: $Mp - Hys > Thresh1$ or $Mn + Ofn + Ocn + Hys < Thresh2$

Table 8.1.3.1.8.3.2-3: Main behaviour

St	Procedure	Message Sequence		TP	Verdict
		U - S	Message		
1	The SS transmits an <i>RRCReconfiguration</i> message including <i>MeasConfig</i> to setup NR measurement and reporting for intra-frequency event A5 (<i>measId</i> 1)	<--	NR RRC: <i>RRCReconfiguration</i>	-	-
2	The UE transmits an <i>RRCReconfigurationComplete</i> message.	-->	NR RRC: <i>RRCReconfigurationComplete</i>	-	-
3	SS re-adjusts the cell-specific reference signal level according to row "T1" in table 8.1.3.1.8.3.2-1/2.	-	-	-	-
-	EXCEPTION: In parallel to events described in step 4 the steps specified in table 8.1.3.1.8.3.2-4 shall take place	-	-	-	-
4	Wait for 30 seconds to ensure that the UE performs a periodical intra-frequency reporting for NR Cell 2	-	-	1	-
5	SS re-adjusts the cell-specific reference signal level according to row "T2" in table 8.1.3.1.8.3.2-1/2.	-	-	-	-
6	Wait and ignore <i>MeasurementReport</i> messages for 10s to allow change of power levels for NR Cell 2 and UE measurement	-	-	-	-
7	Check: Does the UE transmit a <i>MeasurementReport</i> message within the next 10s?	-	-	2	F

Table 8.1.3.1.8.3.2-4: Parallel behaviour

St	Procedure		Message Sequence		TP	Verdict
	U - S	Message				
-	EXCEPTION: After the 1st message is received, step 1 below shall be repeated every time the duration indicated in the IE <i>reportInterval</i> has elapsed		-	-	-	-
1	Check: Does the UE transmit a <i>MeasurementReport</i> message to report event A5 (<i>measId</i> 1) with the measured RSRP value for NR Cell 2?		-->	<i>MeasurementReport</i>	1	P

8.1.3.1.8.3.3 Specific message contents

Table 8.1.3.1.8.3.3-1: RRCReconfiguration (step 1, Table 8.1.3.1.8.3.2-3)

Derivation Path: 38.508-1 [4] Table 4.6.1-13			
Information Element	Value/remark	Comment	Condition
RRCReconfiguration ::= SEQUENCE {			
rrc-TransactionIdentifier	RRC-TransactionIdentifier		
criticalExtensions CHOICE {			
rrcReconfiguration ::= SEQUENCE {			
radioBearerConfig	Not present		
secondaryCellGroup	Not present		
measConfig	MeasConfig	Table 8.1.3.1.8.3.3-2	
lateNonCriticalExtension	Not present		
nonCriticalExtension	Not present		
}			
}			
}			

Table 8.1.3.1.8.3.3-2: MeasConfig (Table 8.1.3.1.8.3.3-1)

Derivation Path: 38.508-1 [4] Table 4.6.3-69			
Information Element	Value/remark	Comment	Condition
MeasConfig ::= SEQUENCE {			
measObjectToAddModList SEQUENCE (SIZE (1..maxNrofMeasId)) OF SEQUENCE {	1 entry		
measObjectId[1]	1	MeasObjectIdNR-f1	
measObject[1] CHOICE {			
measObjectNR SEQUENCE {			
ssbFrequency	ssbFrequency IE equals the ARFCN for NR Cell 2		
absThreshSS-BlocksConsolidation	Not present		
}			
}			
reportConfigToAddModList SEQUENCE (SIZE (1..maxReportConfigId)) OF SEQUENCE {	1 entry		
reportConfigId[1]	1		
reportConfig[1] CHOICE {			
reportConfigNR	ReportConfigNR-EventA5	Table 8.1.3.1.8.3.3-3	
}			
}			
measIdToAddModList SEQUENCE (SIZE (1..maxNrofMeasId)) OF SEQUENCE {	1 entry		
measId[1]	1		
measObjectId[1]	1		
reportConfigId[1]	1		
}			
}			

Table 8.1.3.1.8.3.3-3: ReportConfigNR-EventA5 (Table 8.1.3.1.8.3.3-2)

Derivation Path: 38.508-1 [4] Table 4.6.3-142 with condition EVENT_A5			
Information Element	Value/remark	Comment	Condition
ReportConfigNR ::= SEQUENCE {			
reportType CHOICE {			
eventTriggered SEQUENCE {			
eventId CHOICE {			
eventA5 SEQUENCE {			
a5-Threshold1 CHOICE {			
rsrp	76	-80dBm	FR1
	FFS		FR2
}			
a5-Threshold2 CHOICE {			
rsrp	73	-83dBm	FR1
	FFS		FR2
}			
hysteresis	4	2 dB	
}			
}			
reportAmount	infinity		
reportQuantityCell SEQUENCE {			
rsrp	true		
rsrq	false		
sinr	false		
}			
}			
}			

Table 8.1.3.1.8.3.3-4: MeasurementReport (step 1, Table 8.1.3.1.8.3.2-4)

Derivation Path: 38.508-1 [4] Table 4.6.1-7			
Information Element	Value/remark	Comment	Condition
MeasurementReport ::= SEQUENCE {			
criticalExtensions CHOICE {			
measurementReport SEQUENCE {			
measResults SEQUENCE {			
measId	1		
measResultServingMOList SEQUENCE (SIZE (1..maxNrofServingCells)) OF SEQUENCE {		Report NR Cell 1	
servCellId	ServCellIndex of NR Cell 1		
measResultServingCell SEQUENCE {			
physCellId	Physical layer cell identity of NR Cell 1		
measResult SEQUENCE {			
cellResults SEQUENCE {			
resultsSSB-Cell SEQUENCE {			
rsrp	(0..127)		
rsrq	(0..127)		
}			
}			
}			
}			
measResultNeighCells CHOICE {			
measResultListNR SEQUENCE (SIZE (1..maxCellReport)) OF SEQUENCE {		Report NR neighbour cell	
physCellId	Physical layer cell identity of NR Cell 2		
measResult SEQUENCE {			
cellResults SEQUENCE {			
resultsSSB-Cell SEQUENCE {			
rsrp	(0..127)		
}			
}			
}			
}			
}			
}			
}			
}			

8.1.3.1.9 Measurement configuration control and reporting / Event A5 / Measurement of Neighbour NR cell / Inter-frequency measurements

8.1.3.1.9.1 Test Purpose (TP)

Same as test case 8.1.3.1.8 but applied to inter-frequency case.

8.1.3.1.9.2 Conformance requirements

Same as test case 8.1.3.1.8 with the following difference:

[TS 38.331, clause 5.5.2.9]

The UE shall:

...

1> if *gapUE* is set to *setup*:

- 2> if a per UE measurement gap configuration is already setup, release the per UE measurement gap configuration;
- 2> setup the per UE measurement gap configuration indicated by the *measGapConfig* in accordance with the received *gapOffset*, i.e., the first subframe of each gap occurs at an SFN and subframe meeting the following condition:
- $$\text{SFN mod } T = \text{FLOOR}(\text{gapOffset}/10);$$
- $$\text{subframe} = \text{gapOffset mod } 10;$$
- with $T = \text{MGRP}/10$ as defined in TS 38.133 [14];
- 2> if *mgta* is configured, apply the specified timing advance to the gap occurrences calculated above (i.e. the UE starts the measurement *mgta* ms before the gap subframe occurrences);

...

8.1.3.1.9.3 Test description

8.1.3.1.9.3.1 Pre-test conditions

Same as test case 8.1.3.1.8 with the following difference:

- Cells configuration: NR Cell 3 replaces NR Cell 2.
- System information combination: NR-4 replaces NR-2.

8.1.3.1.9.3.2 Test procedure sequence

Same as test case 8.1.3.1.8 with the following difference:

- Cells configuration: NR Cell 3 replaces NR Cell 2.

8.1.3.1.9.3.3 Specific message contents

Same as test case 8.1.3.1.5 with the following difference:

- Cells configuration: NR Cell 3 replaces NR Cell 2.

Table 8.1.3.1.9.3.3-1: *MeasConfig* (Table 8.1.3.1.8.3.3-1)

Derivation Path: 38.508-1 [4] Table 4.6.3-69			
Information Element	Value/remark	Comment	Condition
MeasConfig ::= SEQUENCE {			
measObjectToAddModList SEQUENCE (SIZE (1..maxNrofMeasId)) OF SEQUENCE {	2 entries		
measObjectId[1]	1		
measObject[1] CHOICE {			
measObjectNR	MeasObjectNR-f1	Table 8.1.3.1.9.3.3-2	
}			
measObjectId[2]	2		
measObject[2] CHOICE {			
measObjectNR	MeasObjectNR-f2	Table 8.1.3.1.9.3.3-3	
}			
}			
reportConfigToAddModList SEQUENCE(SIZE (1..maxReportConfigId)) OF SEQUENCE {	1 entry		
reportConfigId[1]	1		
reportConfig[1] CHOICE {			
reportConfigNR	ReportConfigNR-EventA5	Table 8.1.3.1.8.3.3-3	
}			
}			
measIdToAddModList SEQUENCE (SIZE (1..maxNrofMeasId)) OF SEQUENCE {	1 entry		
measId[1]	1		
measObjectId[1]	2		
reportConfigId[1]	1		
}			
measGapConfig	MeasGapConfig with condition GAP_UE		
}			

Table 8.1.3.1.9.3.3-2: *MeasObjectNR-f1* (Table 8.1.3.1.9.3.3-1)

Derivation Path: TS 38.508-1 [14], Table 4.6.3-76			
Information Element	Value/remark	Comment	Condition
MeasObjectNR ::= SEQUENCE {			
ssbFrequency	ARFCN-ValueNR for SSB of NR Cell 1		
absThreshSS-BlocksConsolidation	Not present		
nrofSS-BlocksToAverage	Not present		
}			

Table 8.1.3.1.9.3.3-3: *MeasObjectNR-f2* (Table 8.1.3.1.9.3.3-1)

Derivation Path: TS 38.508-1 [14], Table 4.6.3-76			
Information Element	Value/remark	Comment	Condition
MeasObjectNR ::= SEQUENCE {			
ssbFrequency	ARFCN-ValueNR for SSB of NR Cell 3		
absThreshSS-BlocksConsolidation	Not present		
nrofSS-BlocksToAverage	Not present		
}			

8.1.3.1.10 Measurement configuration control and reporting / Event A5 / Measurement of Neighbour NR cell / Inter-band measurements

8.1.3.1.10.1 Test Purpose (TP)

Same as test case 8.1.3.1.8 but applied to inter-band case.

8.1.3.1.10.2 Conformance requirements

Same as test case 8.1.3.1.8 with the following difference:

[TS 38.331, clause 5.5.2.9]

The UE shall:

...

1> if *gapUE* is set to *setup*:

2> if a per UE measurement gap configuration is already setup, release the per UE measurement gap configuration;

2> setup the per UE measurement gap configuration indicated by the *measGapConfig* in accordance with the received *gapOffset*, i.e., the first subframe of each gap occurs at an SFN and subframe meeting the following condition:

$SFN \bmod T = \text{FLOOR}(gapOffset/10)$;

$subframe = gapOffset \bmod 10$;

with $T = MGRP/10$ as defined in TS 38.133 [14];

2> if *mgta* is configured, apply the specified timing advance to the gap occurrences calculated above (i.e. the UE starts the measurement *mgta* ms before the gap subframe occurrences);

...

8.1.3.1.10.3 Test description

8.1.3.1.10.3.1 Pre-test conditions

Same as test case 8.1.3.1.8 with the following difference:

- Cells configuration: NR Cell 10 replaces NR Cell 2.
- System information combination: NR-4 replaces NR-2.

8.1.3.1.10.3.2 Test procedure sequence

Same as test case 8.1.3.1.8 with the following difference:

- Cells configuration: NR Cell 10 replaces NR Cell 2.

8.1.3.1.10.3.3 Specific message contents

Same as test case 8.1.3.1.8 with the following difference:

- Cells configuration: NR Cell 10 replaces NR Cell 2.

Table 8.1.3.1.10.3.3-1: MeasConfig (Table 8.1.3.1.8.3.3-1)

Derivation Path: 38.508-1 [4] Table 4.6.3-69			
Information Element	Value/remark	Comment	Condition
MeasConfig ::= SEQUENCE {			
measObjectToAddModList SEQUENCE (SIZE (1..maxNrofMeasId)) OF SEQUENCE {	2 entries		
measObjectId[1]	1		
measObject[1] CHOICE {			
measObjectNR	MeasObjectNR-f1	Table 8.1.3.1.10.3.3-2	
}			
measObjectId[2]	2		
measObject[2] CHOICE {			
measObjectNR	MeasObjectNR-f2	Table 8.1.3.1.10.3.3-3	
}			
}			
reportConfigToAddModList SEQUENCE(SIZE (1..maxReportConfigId)) OF SEQUENCE {	1 entry		
reportConfigId[1]	1		
reportConfig[1] CHOICE {			
reportConfigNR	ReportConfigNR-EventA5	Table 8.1.3.1.8.3.3-3	
}			
}			
measIdToAddModList SEQUENCE (SIZE (1..maxNrofMeasId)) OF SEQUENCE {	1 entry		
measId[1]	1		
measObjectId[1]	2		
reportConfigId[1]	1		
}			
measGapConfig	MeasGapConfig with condition GAP_UE		
}			

Table 8.1.3.1.10.3.3-2: MeasObjectNR-f1 (Table 8.1.3.1.10.3.3-1)

Derivation Path: TS 38.508-1 [4], Table 4.6.3-76			
Information Element	Value/remark	Comment	Condition
MeasObjectNR ::= SEQUENCE {			
ssbFrequency	ARFCN-ValueNR for SSB of NR Cell 1		
absThreshSS-BlocksConsolidation	Not present		
nrofSS-BlocksToAverage	Not present		
}			

Table 8.1.3.1.10.3.3-3: MeasObjectNR-f2 (Table 8.1.3.1.10.3.3-1)

Derivation Path: TS 38.508-1 [4], Table 4.6.3-76			
Information Element	Value/remark	Comment	Condition
MeasObjectNR ::= SEQUENCE {			
ssbFrequency	ARFCN-ValueNR for SSB of NR Cell 10		
absThreshSS-BlocksConsolidation	Not present		
nrofSS-BlocksToAverage	Not present		
}			

8.1.3.1.11 Measurement configuration control and reporting / Intra NR measurements / Two simultaneous events A3 (intra and inter-frequency measurements) / RSRQ based measurements

8.1.3.1.11.1 Test Purpose (TP)

(1)

```
with { UE in NR RRC_CONNECTED state, measurements configured for two event A3 at the same time and
triggerQuantity set to rsrq }
ensure that {
  when { Entry condition for event A3 is not met }
  then { UE does not send MeasurementReport }
}
```

(2)

```
with { UE in NR RRC_CONNECTED state, measurements configured for two event A3 at the same time and
triggerQuantity set to rsrq }
ensure that {
  when { Neighbour becomes offset better than serving }
  then { UE sends MeasurementReport with correct measId for event A3 }
}
```

8.1.3.1.11.2 Conformance requirements

References: The conformance requirements covered in the present TC are specified in: TS 38.331, clause 5.3.5.3, 5.5.2.1, 5.5.2.9, 5.5.4.1, 5.5.4.4 and 5.5.5.

[TS 38.331, clause 5.3.5.3]

The UE shall perform the following actions upon reception of the *RRCReconfiguration*:

...

- 1> if the *RRCReconfiguration* message includes the *measConfig*:
- 2> perform the measurement configuration procedure as specified in 5.5.2;

...

[TS 38.331, clause 5.5.2.1]

The UE shall:

- 1> if the received *measConfig* includes the *measObjectToRemoveList*:
 - 2> perform the measurement object removal procedure as specified in 5.5.2.4;
- 1> if the received *measConfig* includes the *measObjectToAddModList*:
 - 2> perform the measurement object addition/modification procedure as specified in 5.5.2.5;
- 1> if the received *measConfig* includes the *reportConfigToRemoveList*:
 - 2> perform the reporting configuration removal procedure as specified in 5.5.2.6;
- 1> if the received *measConfig* includes the *reportConfigToAddModList*:
 - 2> perform the reporting configuration addition/modification procedure as specified in 5.5.2.7;
- 1> if the received *measConfig* includes the *quantityConfig*:
 - 2> perform the quantity configuration procedure as specified in 5.5.2.8;
- 1> if the received *measConfig* includes the *measIdToRemoveList*:
 - 2> perform the measurement identity removal procedure as specified in 5.5.2.2;

- 1> if the received *measConfig* includes the *measIdToAddModList*:
 - 2> perform the measurement identity addition/modification procedure as specified in 5.5.2.3;
- 1> if the received *measConfig* includes the *measGapConfig*:
 - 2> perform the measurement gap configuration procedure as specified in 5.5.2.9;
- 1> if the received *measConfig* includes the *measGapSharingConfig*:
 - 2> perform the measurement gap sharing configuration procedure as specified in 5.5.2.11;
- 1> if the received *measConfig* includes the *s-MeasureConfig*:
 - 2> if *s-MeasureConfig* is set to *ssb-RSRP*, set parameter *ssb-RSRP* of *s-MeasureConfig* within *VarMeasConfig* to the lowest value of the RSRP ranges indicated by the received value of *s-MeasureConfig*;
 - 2> else, set parameter *csi-RSRP* of *s-MeasureConfig* within *VarMeasConfig* to the lowest value of the RSRP ranges indicated by the received value of *s-MeasureConfig*.

[TS 38.331, clause 5.5.2.9]

The UE shall:

...

- 1> if *gapUE* is set to setup:
 - 2> if a per UE measurement gap configuration is already setup, release the per UE measurement gap configuration;
 - 2> setup the per UE measurement gap configuration indicated by the *measGapConfig* in accordance with the received *gapOffset*, i.e., the first subframe of each gap occurs at an SFN and subframe meeting the following condition:
 - SFN mod $T = \text{FLOOR}(\text{gapOffset}/10)$;
 - subframe = $\text{gapOffset} \bmod 10$;
 - with $T = \text{MGRP}/10$ as defined in TS 38.133 [14];
 - 2> if *mgta* is configured, apply the specified timing advance to the gap occurrences calculated above (i.e. the UE starts the measurement *mgta* ms before the gap subframe occurrences);
- 1> else if *gapUE* is set to release:
 - 2> release the per UE measurement gap configuration.

NOTE 1: For *gapFR2* configuration, the SFN and subframe of a serving cell on FR2 frequency is used in the gap calculation

NOTE 2: For *gapFR1* or *gapUE* configuration, the SFN and subframe of the PCell is used in the gap calculation.

[TS 38.331, clause 5.5.4.1]

If security has been activated successfully, the UE shall:

- 1> for each *measId* included in the *measIdList* within *VarMeasConfig*:
 - 2> if the corresponding *reportConfig* includes a *reportType* set to *eventTriggered* or *periodical*;
 - 3> if the corresponding *measObject* concerns NR;
 - 4> if the *eventA1* or *eventA2* is configured in the corresponding *reportConfig*;
 - ...
 - 4> else:

- 5> for events involving a serving cell associated with a *measObjectNR* and neighbours associated with another *measObjectNR*, consider any serving cell associated with the other *measObjectNR* to be a neighbouring cell as well;
- 5> if *useWhiteCellList* is set to TRUE:
 - ...
- 5> else:
 - 6> consider any neighbouring cell detected based on parameters in the associated *measObjectNR* to be applicable when the concerned cell is not included in the *blackCellsToAddModList* defined within the *VarMeasConfig* for this *measId*;
 - ...
- 2> if the *reportType* is set to *eventTriggered* and if the entry condition applicable for this event, i.e. the event corresponding with the *eventId* of the corresponding *reportConfig* within *VarMeasConfig*, is fulfilled for one or more applicable cells for all measurements after layer 3 filtering taken during *timeToTrigger* defined for this event within the *VarMeasConfig*, while the *VarMeasReportList* does not include a measurement reporting entry for this *measId* (a first cell triggers the event):
 - 3> include a measurement reporting entry within the *VarMeasReportList* for this *measId*;
 - 3> set the *numberOfReportsSent* defined within the *VarMeasReportList* for this *measId* to 0;
 - 3> include the concerned cell(s) in the *cellsTriggeredList* defined within the *VarMeasReportList* for this *measId*;
 - 3> initiate the measurement reporting procedure, as specified in 5.5.5;
- 2> if the *reportType* is set to *eventTriggered* and if the entry condition applicable for this event, i.e. the event corresponding with the *eventId* of the corresponding *reportConfig* within *VarMeasConfig*, is fulfilled for one or more applicable cells not included in the *cellsTriggeredList* for all measurements after layer 3 filtering taken during *timeToTrigger* defined for this event within the *VarMeasConfig* (a subsequent cell triggers the event):
 - 3> set the *numberOfReportsSent* defined within the *VarMeasReportList* for this *measId* to 0;
 - 3> include the concerned cell(s) in the *cellsTriggeredList* defined within the *VarMeasReportList* for this *measId*;
 - 3> initiate the measurement reporting procedure, as specified in 5.5.5;
- 2> if the *reportType* is set to *eventTriggered* and if the leaving condition applicable for this event is fulfilled for one or more of the cells included in the *cellsTriggeredList* defined within the *VarMeasReportList* for this *measId* for all measurements after layer 3 filtering taken during *timeToTrigger* defined within the *VarMeasConfig* for this event:
 - 3> remove the concerned cell(s) in the *cellsTriggeredList* defined within the *VarMeasReportList* for this *measId*;
 - 3> if *reportOnLeave* is set to *TRUE* for the corresponding reporting configuration:
 - 4> initiate the measurement reporting procedure, as specified in 5.5.5;
 - 3> if the *cellsTriggeredList* defined within the *VarMeasReportList* for this *measId* is empty:
 - 4> remove the measurement reporting entry within the *VarMeasReportList* for this *measId*;
 - 4> stop the periodical reporting timer for this *measId*, if running;
 - ...

[TS 38.331, clause 5.5.4.4]

The UE shall:

- 1> consider the entering condition for this event to be satisfied when condition A3-1, as specified below, is fulfilled;
- 1> consider the leaving condition for this event to be satisfied when condition A3-2, as specified below, is fulfilled;
- 1> use the SpCell for *Mp*, *Ofp* and *Ocp*.

NOTE The cell(s) that triggers the event has reference signals indicated in the *measObjectNR* associated to this event which may be different from the NR SpCell *measObjectNR*.

Inequality A3-1 (Entering condition)

$$Mn + Ofn + Ocn - Hys > Mp + Ofp + Ocp + Off$$

Inequality A3-2 (Leaving condition)

$$Mn + Ofn + Ocn + Hys < Mp + Ofp + Ocp + Off$$

The variables in the formula are defined as follows:

Mn is the measurement result of the neighbouring cell, not taking into account any offsets.

Ofn is the measurement object specific offset of the reference signal of the neighbour cell (i.e. *offsetMO* as defined within *measObjectNR* corresponding to the neighbour cell).

Ocn is the cell specific offset of the neighbour cell (i.e. *cellIndividualOffset* as defined within *measObjectNR* corresponding to the frequency of the neighbour cell), and set to zero if not configured for the neighbour cell.

Mp is the measurement result of the SpCell, not taking into account any offsets.

Ofp is the measurement object specific offset of the SpCell (i.e. *offsetMO* as defined within *measObjectNR* corresponding to the SpCell).

Ocp is the cell specific offset of the SpCell (i.e. *cellIndividualOffset* as defined within *measObjectNR* corresponding to the SpCell), and is set to zero if not configured for the SpCell.

Hys is the hysteresis parameter for this event (i.e. *hysteresis* as defined within *reportConfigNR* for this event).

Off is the offset parameter for this event (i.e. *a3-Offset* as defined within *reportConfigNR* for this event).

Mn*, *Mp are expressed in dBm in case of RSRP, or in dB in case of RSRQ and RS-SINR.

Ofn*, *Ocn*, *Ofp*, *Ocp*, *Hys*, *Off are expressed in dB.

[TS 38.331, clause 5.5.5.1]



Figure 5.5.5.1-1: Measurement reporting

The purpose of this procedure is to transfer measurement results from the UE to the network. The UE shall initiate this procedure only after successful security activation.

For the *measId* for which the measurement reporting procedure was triggered, the UE shall set the *measResults* within the *MeasurementReport* message as follows:

- 1> set the *measId* to the measurement identity that triggered the measurement reporting;
- 1> set the *measResultServingCell* within *measResultServingMOList* to include RSRP, RSRQ and the available SINR for each configured serving cell derived based on the *rsType* indicated in the associated *reportConfig*;

- 1> set the *measResultServingCell* within *measResultServingMOList* to include for each NR serving cell that is configured with *servingCellMO*, if any, the *servCellId*;
- 1> if the *reportConfig* associated with the *measId* that triggered the measurement reporting includes *reportQuantityRsIndexes* and *maxNrofRSIndexesToReport*:
 - 2> for each serving cell configured with *servingCellMO*, include beam measurement information according to the associated *reportConfig* as described in 5.5.5.2;
- 1> if the *reportConfig* associated with the *measId* that triggered the measurement reporting includes *reportAddNeighMeas*:
 - 2> for each serving cell *measObjectId* referenced in the *measIdList*, other than the *measObjectId* corresponding with the *measId* that triggered the measurement reporting:
 - 3> set the *measResultBestNeighCell* within *measResultServingMOList* to include the *physCellId* and the available measurement quantities based on the *reportQuantityCell* and *rsType* indicated in *reportConfig* of the non-serving cell corresponding to the concerned *measObjectNR* with the highest measured RSRP if RSRP measurement results are available for cells corresponding to this *measObjectNR*, otherwise with the highest measured RSRQ if RSRQ measurement results are available for cells corresponding to this *measObjectNR*, otherwise with the highest measured SINR;
 - 3> if the *reportConfig* associated with the *measId* that triggered the measurement reporting includes *reportQuantityRsIndexes* and *maxNrofRSIndexesToReport*:
 - 4> for each best non-serving cell included in the measurement report:
 - 5> include beam measurement information according to the associated *reportConfig* as described in 5.5.5.2;
- 1> if there is at least one applicable neighbouring cell to report:
 - 2> set the *measResultNeighCells* to include the best neighbouring cells up to *maxReportCells* in accordance with the following:
 - 3> if the *reportType* is set to *eventTriggered*:
 - 4> include the cells included in the *cellsTriggeredList* as defined within the *VarMeasReportList* for this *measId*;
 - 3> else:
 - 4> include the applicable cells for which the new measurement results became available since the last periodical reporting or since the measurement was initiated or reset;
 - 4> if *reportQuantityRsIndexes* and *maxNrofRSIndexesToReport* are configured, include beam measurement information as described in 5.5.5.2;
 - 3> for each cell that is included in the *measResultNeighCells*, include the *physCellId*;
 - 3> if the *reportType* is set to *eventTriggered*:
 - 4> for each included cell, include the layer 3 filtered measured results in accordance with the *reportConfig* for this *measId*, ordered as follows:
 - 5> if the *measObject* associated with this *measId* concerns NR:
 - 6> if *rsType* in the associated *reportConfig* is set to *ssb*:
 - 7> set *resultsSSB-Cell* within the *measResult* to include the SS/PBCH block based quantity(ies) indicated in the *reportQuantityCell* within the concerned *reportConfig*, in order of decreasing trigger quantity, i.e. the best cell is included first;
 - 8> if *reportQuantityRsIndexes* and *maxNrofRSIndexesToReport* are configured, include beam measurement information as described in 5.5.5.2;

...

- 1> increment the *numberOfReportsSent* as defined within the *VarMeasReportList* for this *measId* by 1;
- 1> stop the periodical reporting timer, if running;
- 1> if the *numberOfReportsSent* as defined within the *VarMeasReportList* for this *measId* is less than the *reportAmount* as defined within the corresponding *reportConfig* for this *measId*:
- 2> start the periodical reporting timer with the value of *reportInterval* as defined within the corresponding *reportConfig* for this *measId*;
- ...
- 1> if the UE is configured with EN-DC:
- ...
- 1> else:
- 2> submit the *MeasurementReport* message to lower layers for transmission, upon which the procedure ends.

8.1.3.1.11.3 Test description

8.1.3.1.11.3.1 Pre-test conditions

System Simulator:

- NR Cell 1 is the serving cell, NR Cell 2 is the intra-frequency neighbour cell, and NR Cell 3 is the inter-frequency neighbour cell.
- System information combination NR-5 as defined in TS 38.508-1 [4] clause 4.4.3.1.2 is used in NR cells.

UE:

- None.

Preamble:

- The UE is in state 3N-A as defined in TS 38.508-1 [4], subclause 4.4A on NR Cell 1.

8.1.3.1.11.3.2 Test procedure sequence

Table 8.1.3.1.11.3.2-1 and 8.1.3.1.11.3.2-2 illustrate the downlink power levels to be applied for NR Cell 1, NR Cell 2 and NR Cell 3 at various time instants of the test execution for FR1 and FR2 respectively. Row marked "T0" denotes the conditions after the preamble, while rows marked "T1" and "T2" are to be applied subsequently. The exact instants on which these values shall be applied are described in the texts in this clause.

Table 8.1.3.1.11.3.2-1: Time instances of cell power level and parameter changes in FR1

	Parameter	Unit	NR Cell 1	NR Cell 2 (DL only)	NR Cell 3 (DL only)	Remark
T0	SS/PBCH SSS EPRE	dBm/S CS	-88	-100	"Off"	Power levels are such that entry condition for event A3 (<i>measId</i> 1 & 2) is not satisfied: $Mn + Ofn + Ocn - Hys < Mp + Ofp + Ocp + Off$
	SS-RSRQ	dB	-11.95	-23.95	-	
	Noc	dBm/15 kHz	-94	-94	-94	
T1	SS/PBCH SSS EPRE	dBm/S CS	-100	-88	"Off"	Power levels are such that entry condition for event A3 (<i>measId</i> 1) is satisfied: $Mn + Ofn + Ocn - Hys > Mp + Ofp + Ocp + Off$
	SS-RSRQ	dB	-23.95	-11.95	-	

T2	SS/PBCH SSS EPRE	dBm/S CS	-100	"Off"	-88	Power levels are such that entry condition for event A3 (<i>measId 2</i>) is satisfied: $Mn + Ofn + Ocn - Hys > Mp + Ofp + Ocp + Off$
	SS-RSRQ	dB	-17.76	-	-11.74	
NOTE 1: The total tolerance used is the sum of downlink signal level uncertainty (TS 38.508-1 Table 6.2.2.1-4) and absolute UE measurement accuracy (TS 38.133 clause 10).						

Table 8.1.3.1.11.3.2-2: Time instances of cell power level and parameter changes in FR2

	Parameter	Unit	NR Cell 1	NR Cell 2 (DL only)	NR Cell 10 (DL only)	Remark
T0	SS/PBCH SSS EPRE	dBm/S CS	FFS	FFS	"Off"	Power levels are such that entry condition for event A3 (<i>measId 1 & 2</i>) is not satisfied: $Mn + Ofn + Ocn - Hys < Mp + Ofp + Ocp + Off$
	RSRQ	dB	FFS	FFS	-	
	Noc	dBm/15 kHz	FFS	FFS	FFS	
T1	SS/PBCH SSS EPRE	dBm/S CS	FFS	FFS	"Off"	Power levels are such that entry condition for event A3 (<i>measId 1</i>) is satisfied: $Mn + Ofn + Ocn - Hys > Mp + Ofp + Ocp + Off$
	RSRQ	dB	FFS	FFS	-	
T2	SS/PBCH SSS EPRE	dBm/S CS	FFS	"Off"	FFS	Power levels are such that entry condition for event A3 (<i>measId 2</i>) is satisfied: $Mn + Ofn + Ocn - Hys > Mp + Ofp + Ocp + Off$
	RSRQ	dB	FFS	-	FFS	
NOTE 1: The total tolerance used is the sum of downlink signal level uncertainty (TS 38.508-1 Table 6.2.2.2-TBD) and absolute UE measurement accuracy (TS 38.133 clause 10).						

Table 8.1.3.1.11.3.2-3: Main behaviour

St	Procedure	Message Sequence		TP	Verdict
		U - S	Message		
1	The SS transmits an <i>RRCReconfiguration</i> message on NR Cell 1 including <i>MeasConfig</i> to setup NR measurement and reporting for two event A3 (<i>measId 1</i> and <i>measId 2</i>) (intra and inter frequency measurement).	<--	NR RRC: <i>RRCReconfiguration</i>	-	-
2	The UE transmits an <i>RRCReconfigurationComplete</i> message on NR Cell 1.	-->	NR RRC: <i>RRCReconfigurationComplete</i>	-	-
3	Check: Does the UE transmit a <i>MeasurementReport</i> message on NR Cell 1 within the next 10s?	-->	NR RRC: <i>MeasurementReport</i>	1	F
4	The SS re-adjusts the cell-specific reference signal level according to row "T1" in Table 8.1.3.1.11.3.2-1/2.	-	-	-	-
5	Check: Does the UE transmit a <i>MeasurementReport</i> message on NR Cell 1 to report event A3 (<i>measId 1</i>) with the measured RSRP and RSRQ values for NR Cell 2?	-->	NR RRC: <i>MeasurementReport</i>	2	P
6	The SS re-adjusts the cell-specific reference signal level according to row "T2" in Table 8.1.3.1.11.3.2-1/2.	-	-	-	-
7	Check: Does the UE transmit a <i>MeasurementReport</i> message on NR Cell 1 to report event A3 (<i>measId 2</i>) with the measured RSRP and RSRQ values for NR Cell 3?	-->	NR RRC: <i>MeasurementReport</i>	2	P

8.1.3.1.11.3.3 Specific message contents

Table 8.1.3.1.11.3.3-1: RRCReconfiguration (step 1, Table 8.1.3.1.11.3.2-3)

Derivation Path: 38.508-1 [4] table 4.6.1-13			
Information Element	Value/remark	Comment	Condition
RRCReconfiguration ::= SEQUENCE {			
rrc-TransactionIdentifier	RRC-TransactionIdentifier		
criticalExtensions CHOICE {			
rrcReconfiguration ::= SEQUENCE {			
radioBearerConfig	Not present		
secondaryCellGroup	Not present		
measConfig	MeasConfig	Table 8.1.3.1.11.3.3-2	
lateNonCriticalExtension	Not present		
nonCriticalExtension	Not present		
}			
}			
}			

Table 8.1.3.1.11.3.3-2: MeasConfig (step 1, Table 8.1.3.1.11.3.2-3)

Derivation path: 38.508-1[4] table 4.6.3-69			
Information Element	Value/Remark	Comment	Condition
measConfig ::= SEQUENCE {			
measObjectToAddModList SEQUENCE (SIZE (1..maxNrofMeasId)) OF SEQUENCE {	2 entries		
measObjectId[1]	1		
measObject[1] CHOICE {			
measObjectNR	MeasObjectNR-f1	Table 8.1.3.1.11.3.3-3	
}			
measObjectId[2]	2		
measObject[2] CHOICE {			
measObjectNR	MeasObjectNR-f2	Table 8.1.3.1.11.3.3-4	
}			
}			
reportConfigToAddModList SEQUENCE(SIZE (1..maxReportConfigId)) OF SEQUENCE {	1 entry		
reportConfigId[1]	ReportConfigId		
reportConfig[1] CHOICE {			
reportConfigNR	ReportConfigNR-A3	Table 8.1.3.1.11.3.3-5	
}			
}			
measIdToAddModList SEQUENCE (SIZE (1..maxNrofMeasId)) OF SEQUENCE {	2 entries		
measId[1]	1		
measObjectId[1]	1		
reportConfigId[1]	ReportConfigId		
measId[2]	2		
measObjectId[2]	2		
reportConfigId[1]	ReportConfigId		
}			
measGapConfig	MeasGapConfig	Table 8.1.3.1.11.3.3-6	
}			

Table 8.1.3.1.11.3.3-3: MeasObjectNR-f1 (Table 8.1.3.1.11.3.3-2)

Derivation Path: TS 38.508-1 [4], Table 4.6.3-76			
Information Element	Value/remark	Comment	Condition
MeasObjectNR ::= SEQUENCE {			
ssbFrequency	Downlink ARFCN of NR Cell 1 SSB		
absThreshSS-BlocksConsolidation	Not present		
}			

Table 8.1.3.1.11.3.3-4: MeasObjectNR-f2 (Table 8.1.3.1.11.3.3-2)

Derivation Path: TS 38.508-1 [4], Table 4.6.3-76			
Information Element	Value/remark	Comment	Condition
MeasObjectNR ::= SEQUENCE {			
ssbFrequency	Downlink ARFCN of NR Cell 3 SSB		
absThreshSS-BlocksConsolidation	Not present		
}			

Table 8.1.3.1.11.3.3-5: ReportConfigNR-A3 (Table 8.1.3.1.11.3.3-2)

Derivation Path: 38.508-1 [4] table 4.6.3-142 with condition EVENT_A3			
Information Element	Value/remark	Comment	Condition
ReportConfigNR ::= SEQUENCE {			
reportType CHOICE {			
eventTriggered SEQUENCE {			
eventId CHOICE {			
eventA3 SEQUENCE {			
a3-Offset CHOICE {			
rsrq	0	0dB	
}			
}			
}			
reportAmount	r1		
}			

Table 8.1.3.1.11.3.3-6: MeasGapConfig (Table 8.1.3.1.11.3.3-2)

Derivation Path: TS 38.508-1 [4], Table 4.6.3-70			
Information Element	Value/remark	Comment	Condition
MeasGapConfig ::= SEQUENCE {			
gapUE CHOICE {			
setup SEQUENCE {			
gapOffset	0		
mgl	ms6		
mgrp	ms160		
mgta	ms0dot25		FR2
	ms0dot5		FR1
}			
}			
}			

8.1.3.1.12 Measurement configuration control and reporting / Intra NR measurements / Two simultaneous events A5 (intra and inter-frequency measurements) / SINR based measurements

8.1.3.1.12.1 Test Purpose (TP)

(1)

```
with { UE in NR RRC_CONNECTED state, measurements configured for two event A5 at the same time and
triggerQuantity set to sinr }
ensure that {
  when { Entry condition for event A5 is not met }
  then { UE does not send MeasurementReport }
}
```

(2)

```
with { UE in NR RRC_CONNECTED state, measurements configured for two event A5 at the same time and
triggerQuantity set to sinr }
ensure that {
  when { SpCell becomes worse than threshold1 and neighbour becomes better than threshold2 }
  then { UE sends MeasurementReport with correct measId for event A5 }
}
```

8.1.3.1.12.2 Conformance requirements

References: The conformance requirements covered in the present TC are specified in: TS 38.331, clause 5.3.5.3, 5.5.2.1, 5.5.2.9, 5.5.4.1, 5.5.4.4 and 5.5.5.

[TS 38.331, clause 5.3.5.3]

The UE shall perform the following actions upon reception of the *RRCReconfiguration*:

...

- 1> if the *RRCReconfiguration* message includes the *measConfig*:
- 2> perform the measurement configuration procedure as specified in 5.5.2;

...

[TS 38.331, clause 5.5.2.1]

The UE shall:

- 1> if the received *measConfig* includes the *measObjectToRemoveList*:
 - 2> perform the measurement object removal procedure as specified in 5.5.2.4;
- 1> if the received *measConfig* includes the *measObjectToAddModList*:
 - 2> perform the measurement object addition/modification procedure as specified in 5.5.2.5;
- 1> if the received *measConfig* includes the *reportConfigToRemoveList*:
 - 2> perform the reporting configuration removal procedure as specified in 5.5.2.6;
- 1> if the received *measConfig* includes the *reportConfigToAddModList*:
 - 2> perform the reporting configuration addition/modification procedure as specified in 5.5.2.7;
- 1> if the received *measConfig* includes the *quantityConfig*:
 - 2> perform the quantity configuration procedure as specified in 5.5.2.8;
- 1> if the received *measConfig* includes the *measIdToRemoveList*:
 - 2> perform the measurement identity removal procedure as specified in 5.5.2.2;

- 1> if the received *measConfig* includes the *measIdToAddModList*:
 - 2> perform the measurement identity addition/modification procedure as specified in 5.5.2.3;
- 1> if the received *measConfig* includes the *measGapConfig*:
 - 2> perform the measurement gap configuration procedure as specified in 5.5.2.9;
- 1> if the received *measConfig* includes the *measGapSharingConfig*:
 - 2> perform the measurement gap sharing configuration procedure as specified in 5.5.2.11;
- 1> if the received *measConfig* includes the *s-MeasureConfig*:
 - 2> if *s-MeasureConfig* is set to *ssb-RSRP*, set parameter *ssb-RSRP* of *s-MeasureConfig* within *VarMeasConfig* to the lowest value of the RSRP ranges indicated by the received value of *s-MeasureConfig*;
 - 2> else, set parameter *csi-RSRP* of *s-MeasureConfig* within *VarMeasConfig* to the lowest value of the RSRP ranges indicated by the received value of *s-MeasureConfig*.

[TS 38.331, clause 5.5.2.9]

The UE shall:

...

- 1> if *gapUE* is set to setup:
 - 2> if a per UE measurement gap configuration is already setup, release the per UE measurement gap configuration;
 - 2> setup the per UE measurement gap configuration indicated by the *measGapConfig* in accordance with the received *gapOffset*, i.e., the first subframe of each gap occurs at an SFN and subframe meeting the following condition:
 - $SFN \bmod T = \text{FLOOR}(gapOffset/10)$;
 - $subframe = gapOffset \bmod 10$;
 - with $T = MGRP/10$ as defined in TS 38.133 [14];
 - 2> if *mgta* is configured, apply the specified timing advance to the gap occurrences calculated above (i.e. the UE starts the measurement *mgta* ms before the gap subframe occurrences);
- 1> else if *gapUE* is set to release:
 - 2> release the per UE measurement gap configuration.

NOTE 1: For *gapFR2* configuration, the SFN and subframe of a serving cell on FR2 frequency is used in the gap calculation

NOTE 2: For *gapFR1* or *gapUE* configuration, the SFN and subframe of the PCell is used in the gap calculation.

[TS 38.331, clause 5.5.4.1]

If security has been activated successfully, the UE shall:

- 1> for each *measId* included in the *measIdList* within *VarMeasConfig*:
 - 2> if the corresponding *reportConfig* includes a *reportType* set to *eventTriggered* or *periodical*;
 - 3> if the corresponding *measObject* concerns NR;
 - 4> if the *eventA1* or *eventA2* is configured in the corresponding *reportConfig*;
 - ...
 - 4> else:

- 5> for events involving a serving cell associated with a *measObjectNR* and neighbours associated with another *measObjectNR*, consider any serving cell associated with the other *measObjectNR* to be a neighbouring cell as well;
- 5> if *useWhiteCellList* is set to TRUE:
 - 6> consider any neighbouring cell detected based on parameters in the associated *measObjectNR* to be applicable when the concerned cell is included in the *whiteCellsToAddModList* defined within the *VarMeasConfig* for this *measId*;
- 5> else:
 - 6> consider any neighbouring cell detected based on parameters in the associated *measObjectNR* to be applicable when the concerned cell is not included in the *blackCellsToAddModList* defined within the *VarMeasConfig* for this *measId*;
- ...
- 2> if the *reportType* is set to *eventTriggered* and if the entry condition applicable for this event, i.e. the event corresponding with the *eventId* of the corresponding *reportConfig* within *VarMeasConfig*, is fulfilled for one or more applicable cells for all measurements after layer 3 filtering taken during *timeToTrigger* defined for this event within the *VarMeasConfig*, while the *VarMeasReportList* does not include a measurement reporting entry for this *measId* (a first cell triggers the event):
 - 3> include a measurement reporting entry within the *VarMeasReportList* for this *measId*;
 - 3> set the *numberOfReportsSent* defined within the *VarMeasReportList* for this *measId* to 0;
 - 3> include the concerned cell(s) in the *cellsTriggeredList* defined within the *VarMeasReportList* for this *measId*;
 - 3> initiate the measurement reporting procedure, as specified in 5.5.5;
- 2> if the *reportType* is set to *eventTriggered* and if the entry condition applicable for this event, i.e. the event corresponding with the *eventId* of the corresponding *reportConfig* within *VarMeasConfig*, is fulfilled for one or more applicable cells not included in the *cellsTriggeredList* for all measurements after layer 3 filtering taken during *timeToTrigger* defined for this event within the *VarMeasConfig* (a subsequent cell triggers the event):
 - 3> set the *numberOfReportsSent* defined within the *VarMeasReportList* for this *measId* to 0;
 - 3> include the concerned cell(s) in the *cellsTriggeredList* defined within the *VarMeasReportList* for this *measId*;
 - 3> initiate the measurement reporting procedure, as specified in 5.5.5;
- 2> if the *reportType* is set to *eventTriggered* and if the leaving condition applicable for this event is fulfilled for one or more of the cells included in the *cellsTriggeredList* defined within the *VarMeasReportList* for this *measId* for all measurements after layer 3 filtering taken during *timeToTrigger* defined within the *VarMeasConfig* for this event:
 - 3> remove the concerned cell(s) in the *cellsTriggeredList* defined within the *VarMeasReportList* for this *measId*;
 - 3> if *reportOnLeave* is set to *TRUE* for the corresponding reporting configuration:
 - 4> initiate the measurement reporting procedure, as specified in 5.5.5;
 - 3> if the *cellsTriggeredList* defined within the *VarMeasReportList* for this *measId* is empty:
 - 4> remove the measurement reporting entry within the *VarMeasReportList* for this *measId*;
 - 4> stop the periodical reporting timer for this *measId*, if running;
- ...

[TS 38.331, clause 5.5.4.4]

The UE shall:

- 1> consider the entering condition for this event to be satisfied when both condition A5-1 and condition A5-2, as specified below, are fulfilled;
- 1> consider the leaving condition for this event to be satisfied when condition A5-3 or condition A5-4, i.e. at least one of the two, as specified below, is fulfilled;
- 1> use the SpCell for *Mp*.

NOTE: The parameters of the reference signal(s) of the cell(s) that triggers the event are indicated in the *measObjectNR* associated to the event which may be different from the *measObjectNR* of the NR SpCell.

Inequality A5-1 (Entering condition 1)

$$Mp + Hys < Thresh1$$

Inequality A5-2 (Entering condition 2)

$$Mn + Ofn + Ocn - Hys > Thresh2$$

Inequality A5-3 (Leaving condition 1)

$$Mp - Hys > Thresh1$$

Inequality A5-4 (Leaving condition 2)

$$Mn + Ofn + Ocn + Hys < Thresh2$$

The variables in the formula are defined as follows:

Mp is the measurement result of the NR SpCell, not taking into account any offsets.

Mn is the measurement result of the neighbouring cell/SCell, not taking into account any offsets.

Ofn is the measurement object specific offset of the neighbour/SCell cell (i.e. *offsetMO* as defined within *measObjectNR* corresponding to the neighbour cell/SCell).

Ocn is the cell specific offset of the neighbour cell/SCell (i.e. *cellIndividualOffset* as defined within *measObjectNR* corresponding to the neighbour cell/SCell), and set to zero if not configured for the neighbour cell.

Hys is the hysteresis parameter for this event (i.e. *hysteresis* as defined within *reportConfigNR* for this event).

Thresh1 is the threshold parameter for this event (i.e. *a5-Threshold1* as defined within *reportConfigNR* for this event).

Thresh2 is the threshold parameter for this event (i.e. *a5-Threshold2* as defined within *reportConfigNR* for this event).

Mn*, *Mp are expressed in dBm in case of RSRP, or in dB in case of RSRQ and RS-SINR.

Ofn*, *Ocn*, *Hys are expressed in dB.

Thresh1 is expressed in the same unit as ***Mp***.

Thresh2 is expressed in the same unit as ***Mn***.

[TS 38.331, clause 5.5.5.1]



Figure 8.1.3.1.6.2-1: Measurement reporting

The purpose of this procedure is to transfer measurement results from the UE to the network. The UE shall initiate this procedure only after successful security activation.

For the *measId* for which the measurement reporting procedure was triggered, the UE shall set the *measResults* within the *MeasurementReport* message as follows:

- 1> set the *measId* to the measurement identity that triggered the measurement reporting;
- 1> set the *measResultServingCell* within *measResultServingMOList* to include RSRP, RSRQ and the available SINR for each configured serving cell derived based on the *rsType* indicated in the associated *reportConfig*;
- 1> set the *measResultServingCell* within *measResultServingMOList* to include for each NR serving cell that is configured with *servingCellMO*, if any, the *servCellId*;
- 1> if the *reportConfig* associated with the *measId* that triggered the measurement reporting includes *reportQuantityRsIndexes* and *maxNrofRSIndexesToReport*:
 - 2> for each serving cell configured with *servingCellMO*, include beam measurement information according to the associated *reportConfig* as described in 5.5.5.2;
- 1> if the *reportConfig* associated with the *measId* that triggered the measurement reporting includes *reportAddNeighMeas*:
 - 2> for each serving cell *measObjectId* referenced in the *measIdList*, other than the *measObjectId* corresponding with the *measId* that triggered the measurement reporting:
 - 3> set the *measResultBestNeighCell* within *measResultServingMOList* to include the *physCellId* and the available measurement quantities based on the *reportQuantityCell* and *rsType* indicated in *reportConfig* of the non-serving cell corresponding to the concerned *measObjectNR* with the highest measured RSRP if RSRP measurement results are available for cells corresponding to this *measObjectNR*, otherwise with the highest measured RSRQ if RSRQ measurement results are available for cells corresponding to this *measObjectNR*, otherwise with the highest measured SINR;
 - 3> if the *reportConfig* associated with the *measId* that triggered the measurement reporting includes *reportQuantityRsIndexes* and *maxNrofRSIndexesToReport*:
 - 4> for each best non-serving cell included in the measurement report:
 - 5> include beam measurement information according to the associated *reportConfig* as described in 5.5.5.2;
- 1> if there is at least one applicable neighbouring cell to report:
 - 2> set the *measResultNeighCells* to include the best neighbouring cells up to *maxReportCells* in accordance with the following:
 - 3> if the *reportType* is set to *eventTriggered*:
 - 4> include the cells included in the *cellsTriggeredList* as defined within the *VarMeasReportList* for this *measId*;
 - 3> else:

- 4> include the applicable cells for which the new measurement results became available since the last periodical reporting or since the measurement was initiated or reset;
- 4> if *reportQuantityRsIndexes* and *maxNrofRSIndexesToReport* are configured, include beam measurement information as described in 5.5.5.2;
- 3> for each cell that is included in the *measResultNeighCells*, include the *physCellId*;
- 3> if the *reportType* is set to *eventTriggered*:
 - 4> for each included cell, include the layer 3 filtered measured results in accordance with the *reportConfig* for this *measId*, ordered as follows:
 - 5> if the *measObject* associated with this *measId* concerns NR:
 - 6> if *rsType* in the associated *reportConfig* is set to *ssb*:
 - 7> set *resultsSSB-Cell* within the *measResult* to include the SS/PBCH block based quantity(ies) indicated in the *reportQuantityCell* within the concerned *reportConfig*, in order of decreasing trigger quantity, i.e. the best cell is included first;
 - 8> if *reportQuantityRsIndexes* and *maxNrofRSIndexesToReport* are configured, include beam measurement information as described in 5.5.5.2;
 - ...
 - 1> increment the *numberOfReportsSent* as defined within the *VarMeasReportList* for this *measId* by 1;
 - 1> stop the periodical reporting timer, if running;
 - 1> if the *numberOfReportsSent* as defined within the *VarMeasReportList* for this *measId* is less than the *reportAmount* as defined within the corresponding *reportConfig* for this *measId*:
 - 2> start the periodical reporting timer with the value of *reportInterval* as defined within the corresponding *reportConfig* for this *measId*;
 - ...
 - 2> if the UE is configured with EN-DC:
 - ...
 - 1> else:
 - 2> submit the *MeasurementReport* message to lower layers for transmission, upon which the procedure ends.

8.1.3.1.12.3 Test description

8.1.3.1.12.3.1 Pre-test conditions

System Simulator:

- NR Cell 1 is the serving cell, NR Cell 2 is the intra-frequency neighbour cell, and NR Cell 3 is the inter-frequency neighbour cell.
- System information combination NR-5 as defined in TS 38.508-1 [4] clause 4.4.3.1.2 is used in NR cells.

UE:

- None.

Preamble:

- The UE is in state 3N-A as defined in TS 38.508-1 [4], subclause 4.4A on NR Cell 1.

8.1.3.1.12.3.2 Test procedure sequence

Table 8.1.3.1.12.3.2-1 and Table 8.1.3.1.12.3.2-2 illustrates the downlink power levels to be applied for NR Cell 1, NR Cell 2 and NR Cell 3 at various time instants of the test execution for FR1 and FR2 respectively. Row marked "T0" denotes the conditions after the preamble, while rows marked "T1" and "T2" are to be applied subsequently. The exact instants on which these values shall be applied are described in the texts in this clause.

Table 8.1.3.1.12.3.2-1: Time instances of cell power level and parameter changes in FR1

	Parameter	Unit	NR Cell 1	NR Cell 2 (DL only)	NR Cell 3 (DL only)	Remark
T0	SS/PBCH SSS EPRE	dBm/S CS	-88	-94	"Off"	Power levels are such that either one entry condition for event A5 (<i>measId</i> 1 & 2) is not satisfied: $Mp + Hys > Thresh1$ or $Mn + Ofn + Ocn - Hys < Thresh2$
	SINR	dB	2.99	-6.97	-	
	Noc	dBm/15 kHz	-94	-94	-94	
T1	SS/PBCH SSS EPRE	dBm/S CS	-94	-88	"Off"	Power levels are such that both entry conditions for event A5 (<i>measId</i> 1) is satisfied: $Mp + Hys < Thresh1$ and $Mn + Ofn + Ocn - Hys > Thresh2$
	SINR	dB	-6.97	2.99	-	
T2	SS/PBCH SSS EPRE	dBm/S CS	-100	"Off"	-88	Power levels are such that both entry conditions for event A5 (<i>measId</i> 2) is satisfied: $Mp + Hys < Thresh1$ and $Mn + Ofn + Ocn - Hys > Thresh2$
	SINR	dB	-6	-	6	
NOTE 1: The total tolerance used is the sum of downlink signal level uncertainty (TS 38.508-1 Table 6.2.2.1-4) and absolute UE measurement accuracy (TS 38.133 clause 10).						

Table 8.1.3.1.12.3.2-2: Time instances of cell power level and parameter changes in FR2

	Parameter	Unit	Cell 1	Cell 2 (DL only)	Cell 10 (DL only)	Remark
T0	SS/PBCH SSS EPRE	dBm/S CS	FFS	FFS	"Off"	Power levels are such that either one entry condition for event A5 (<i>measId</i> 1 & 2) is not satisfied: $Mp + Hys > Thresh1$ or $Mn + Ofn + Ocn - Hys < Thresh2$
	SINR	dB	FFS	FFS	-	
	Noc	dBm/15 kHz	FFS	FFS	FFS	
T1	SS/PBCH SSS EPRE	dBm/S CS	FFS	FFS	"Off"	Power levels are such that both entry conditions for event A5 (<i>measId</i> 1) is satisfied: $Mp + Hys < Thresh1$ and $Mn + Ofn + Ocn - Hys > Thresh2$
	SINR	dB	FFS	FFS	-	
T2	SS/PBCH SSS EPRE	dBm/S CS	FFS	"Off"	FFS	Power levels are such that both entry conditions for event A5 (<i>measId</i> 2) is satisfied: $Mp + Hys < Thresh1$ and $Mn + Ofn + Ocn - Hys > Thresh2$
	SINR	dB	FFS	-	FFS	
NOTE 1: The total tolerance used is the sum of downlink signal level uncertainty (TS 38.508-1 Table 6.2.2.2-TBD) and absolute UE measurement accuracy (TS 38.133 clause 10).						

Table 8.1.3.1.12.3.2-3: Main behaviour

St	Procedure	Message Sequence		TP	Verdict
		U - S	Message		
1	The SS transmits an <i>RRCReconfiguration</i> message on NR Cell 1 including <i>MeasConfig</i> to setup NR measurement and reporting for two event A5 (<i>measId 1</i> and <i>measId 2</i>) (intra and inter frequency measurement).	<--	NR RRC: <i>RRCReconfiguration</i>	-	-
2	The UE transmits an <i>RRCReconfigurationComplete</i> message on NR Cell 1.	-->	NR RRC: <i>RRCReconfigurationComplete</i>	-	-
3	Check: Does the UE transmit a <i>MeasurementReport</i> message on NR Cell 1 within the next 10s?	-->	NR RRC: <i>MeasurementReport</i>	1	F
4	The SS re-adjusts the cell-specific reference signal level according to row "T1" in table 8.1.3.1.12.3.2-1/2.	-	-	-	-
5	Check: Does the UE transmit a <i>MeasurementReport</i> message on NR Cell 1 to report event A3 (<i>measId 1</i>) with the measured RSRP and SINR values for NR Cell 2?	-->	NR RRC: <i>MeasurementReport</i>	2	P
6	The SS re-adjusts the cell-specific reference signal level according to row "T2" in table 8.1.3.1.12.3.2-1/2.	-	-	-	-
7	Check: Does the UE transmit a <i>MeasurementReport</i> message on NR Cell 1 to report event A5 (<i>measId 2</i>) with the measured RSRP and SINR values for NR Cell 3?	-->	NR RRC: <i>MeasurementReport</i>	2	P

8.1.3.1.12.3.3 Specific message contents

Table 8.1.3.1.12.3.3-1: *RRCReconfiguration* (step 1, Table 8.1.3.1.12.3.2-3)

Derivation Path: 38.508-1 [4] table 4.6.1-13			
Information Element	Value/remark	Comment	Condition
<i>RRCReconfiguration</i> ::= SEQUENCE {			
<i>rrc-TransactionIdentifier</i>	RRC-TransactionIdentifier		
<i>criticalExtensions</i> CHOICE {			
<i>rrcReconfiguration</i> ::= SEQUENCE {			
<i>radioBearerConfig</i>	Not present		
<i>secondaryCellGroup</i>	Not present		
<i>measConfig</i>	MeasConfig	Table 8.1.3.1.12.3.3-2	
<i>lateNonCriticalExtension</i>	Not present		
<i>nonCriticalExtension</i>	Not present		
}			
}			
}			

Table 8.1.3.1.12.3.3-2: MeasConfig (step 1, Table 8.1.3.1.12.3.2-3)

Derivation path: 38.508-1 [4] table 4.6.3-69			
Information Element	Value/Remark	Comment	Condition
measConfig ::= SEQUENCE {			
measObjectToAddModList SEQUENCE (SIZE (1..maxNrofMeasId)) OF SEQUENCE {	2 entries		
measObjectId[1]	1		
measObject[1] CHOICE {			
measObjectNR	MeasObjectNR-f1	Table 8.1.3.1.12.3.3-3	
}			
measObjectId[2]	2		
measObject[2] CHOICE {			
measObjectNR	MeasObjectNR-f2	Table 8.1.3.1.12.3.3-4	
}			
}			
reportConfigToAddModList SEQUENCE(SIZE (1..maxReportConfigId)) OF SEQUENCE {	1 entry		
reportConfigId[1]	ReportConfigId		
reportConfig[1] CHOICE {			
reportConfigNR	ReportConfigNR-A5	Table 8.1.3.1.12.3.3-6	
}			
}			
measIdToAddModList SEQUENCE (SIZE (1..maxNrofMeasId)) OF SEQUENCE {	2 entries		
measId[1]	1		
measObjectId[1]	1		
reportConfigId[1]	ReportConfigId		
measId[2]	2		
measObjectId[2]	2		
reportConfigId[1]	ReportConfigId		
}			
measGapConfig	MeasGapConfig	Table 8.1.3.1.12.3.3-5	
}			

Table 8.1.3.1.12.3.3-3: MeasObjectNR-f1 (Table 8.1.3.1.12.3.3-2)

Derivation Path: TS 38.508-1 [4], Table 4.6.3-76			
Information Element	Value/remark	Comment	Condition
MeasObjectNR ::= SEQUENCE {			
ssbFrequency	Downlink ARFCN of NR Cell 1 SSB		
absThreshSS-BlocksConsolidation	Not present		
}			

Table 8.1.3.1.12.3.3-3A: MeasObjectNR-f2 (Table 8.1.3.1.12.3.3-2)

Derivation Path: TS 38.508-1 [4], Table 4.6.3-76			
Information Element	Value/remark	Comment	Condition
MeasObjectNR ::= SEQUENCE {			
ssbFrequency	Downlink ARFCN of NR Cell 3 SSB		
absThreshSS-BlocksConsolidation	Not present		
}			

Table 8.1.3.1.12.3.3-4: MeasGapConfig (Table 8.1.3.1.12.3.3-2)

Derivation Path: 38.508-1 [4], Table 4.6.3-70			
Information Element	Value/remark	Comment	Condition
MeasGapConfig ::= SEQUENCE {			
gapUE CHOICE {			
setup SEQUENCE {			
gapOffset	0		
mgl	ms6		
mgrp	ms160		
mgta	ms0dot25		FR2
	ms0dot5		FR1
}			
}			
}			

Table 8.1.3.1.12.3.3-5: ReportConfigNR-A5 (Table 8.1.3.1.12.3.3-2)

Derivation Path: 38.508-1 [4] table 4.6.3-142 with condition EVENT_A5			
Information Element	Value/remark	Comment	Condition
ReportConfigNR ::= SEQUENCE {			
reportType CHOICE {			
eventTriggered SEQUENCE {			
eventId CHOICE {			
eventA5 SEQUENCE {			
a5-Threshold1 CHOICE {			
sinr	47	0dB ≤ SS-SINR<0.5dB	
}			
a5-Threshold2 CHOICE {			
sinr	47	0dB ≤ SS-SINR<0.5dB	
}			
}			
}			
}			
reportQuantityCell SEQUENCE {			
sinr	true		
}			
reportAmount	r1		
}			
}			

8.1.3.1.13 Measurement configuration control and reporting / SS/PBCH block based / CSI-RS based intra-frequency measurements / Measurement of Neighbour NR cell

8.1.3.1.13.1 Test Purpose (TP)

(1)

```
with { UE in NR RRC_CONNECTED state and measurement configured for SS/PBCH measurement reporting of
intra-frequency on specified frequency}
ensure that {
  when { SS/PBCH block sorting quantity is above absThreshSS-BlocksConsolidation for each beam of
Neighbour Cell}
    then { UE sends MeasurementReport message containing rsIndexResults with resultsSSB-Indexes}
}
```

(2)

```
with { UE in NR RRC_CONNECTED state and measurement configured for SS/PBCH measurement reporting of
intra-frequency on specified frequency }
ensure that {
  when { SS/PBCH block sorting quantity is below absThreshSS-BlocksConsolidation for one beam of
Neighbour Cell and another beam(s) is above absThreshSS-BlocksConsolidation}
    then { UE sends MeasurementReport message containing rsIndexResults with resultsSSB-Indexes
includes RsIndex above absThreshSS-BlocksConsolidation and excludes RsIndex below absThreshSS-
BlocksConsolidation }
}
```

(3)

```
with { UE in NR RRC_CONNECTED state and measurement configured for CSI-RS measurement reporting of
intra frequency on specified frequency }
ensure that {
  when { CSI-RS sorting quantity is above absThreshCSI-RS-Consolidation for each beam of Neighbour
Cell}
    then { UE sends MeasurementReport message containing rsIndexResults with resultsSSB-Indexes}
}
```

(4)

```
with { UE in NR RRC_CONNECTED state and measurement configured for CSI-RS measurement reporting of
intra frequency on specified frequency }
ensure that {
  when { CSI-RS sorting quantity is below absThreshCSI-RS-Consolidation for one beam of Neighbour
Cell and another beam(s) is above absThreshCSI-RS-Consolidation }
    then { UE sends MeasurementReport message containing rsIndexResults with resultsSSB-Indexes
includes RsIndex above absThreshCSI-RS-Consolidation and excludes RsIndex below absThreshCSI-RS-
Consolidation }
}
```

8.1.3.1.13.2 Conformance requirements

References: The conformance requirements covered in the present TC are specified in: TS 38.331, clauses 5.5.5.1 and 5.5.5.2]. Unless otherwise stated these are Rel-15 requirements.

[TS 38.331, clause 5.5.5.1]

The purpose of this procedure is to transfer measurement results from the UE to the network. The UE shall initiate this procedure only after successful security activation.

For the *measId* for which the measurement reporting procedure was triggered, the UE shall set the *measResults* within the *MeasurementReport* message as follows:

- 1> set the *measId* to the measurement identity that triggered the measurement reporting;
- 1> set the *measResultServingCell* within *measResultServingFreqList* to include RSRP, RSRQ and the available SINR for each configured serving cell derived based on the *rsType* indicated in the associated *reportConfig*;
- 1> set the *measResultServingCell* within *measResultServingFreqList* to include for each NR serving cell that is configured, if any, the *servFreqId*;

- 1> if the *reportConfig* associated with the *measId* that triggered the measurement reporting includes *reportQuantityRsIndexes* and *maxNrofRSIndexesToReport*:
 - 2> for each configured serving cell, include beam measurement information according to the associated *reportConfig* as described in 5.5.5.2;
- 1> if the *reportConfig* associated with the *measId* that triggered the measurement reporting includes *reportAddNeighMeas*:
 - 2> for each serving frequency for which *measObjectId* is referenced in the *measIdList*, other than the frequency corresponding with the *measId* that triggered the measurement reporting:
 - 3> set the *measResultBestNeighCell* within *measResultServingFreqList* to include the *physCellId* and the available measurement quantities based on the *reportQuantityCell* and *rsType* indicated in *reportConfig* of the non-serving cell on the concerned serving frequency with the highest measured RSRP if RSRP measurement results are available for cells on this frequency, otherwise with the highest measured RSRQ if RSRQ measurement results are available for cells on this frequency, otherwise with the highest measured SINR;
 - 3> if the *reportConfig* associated with the *measId* that triggered the measurement reporting includes *reportQuantityRsIndexes* and *maxNrofRSIndexesToReport*:
 - 4> for each best non-serving cell included in the measurement report:
 - 5> include beam measurement information according to the associated *reportConfig* as described in 5.5.5.2;
- 1> if there is at least one applicable neighbouring cell to report:
 - 2> set the *measResultNeighCells* to include the best neighbouring cells up to *maxReportCells* in accordance with the following:
 - 3> if the *reportType* is set to *eventTriggered*:
 - 4> include the cells included in the *cellsTriggeredList* as defined within the *VarMeasReportList* for this *measId*;
 - 3> else:
 - 4> include the applicable cells for which the new measurement results became available since the last periodical reporting or since the measurement was initiated or reset;
 - 4> if *reportQuantityRsIndexes* and *maxNrofRSIndexesToReport* are configured, include beam measurement information as described in 5.5.5.2;
 - 3> for each cell that is included in the *measResultNeighCells*, include the *physCellId*;
 - 3> if the *reportType* is set to *eventTriggered*:
 - 4> for each included cell, include the layer 3 filtered measured results in accordance with the *reportConfig* for this *measId*, ordered as follows:
 - 5> if the *measObject* associated with this *measId* concerns NR:
 - 6> if *rsType* in the associated *reportConfig* is set to *ssb*:
 - 7> set *resultsSSB-Cell* within the *measResult* to include the SS/PBCH block based quantity(ies) indicated in the *reportQuantityCell* within the concerned *reportConfig*, in order of decreasing trigger quantity, i.e. the best cell is included first;
 - 8> if *reportQuantityRsIndexes* and *maxNrofRSIndexesToReport* are configured, include beam measurement information as described in 5.5.5.2;
 - 6> else if *rsType* in the associated *reportConfig* is set to *csi-rs*:

7> set *resultsCSI-RS-Cell* within the *measResult* to include the CSI-RS based quantity(ies) indicated in the *reportQuantityCell* within the concerned *reportConfig*, in order of decreasing trigger quantity, i.e. the best cell is included first:

8> if *reportQuantityRsIndexes* and *maxNrofRSIndexesToReport* are, include beam measurement information as described in 5.5.5.2;

[TS 38.331, clause 5.5.5.1]

- 1> increment the *numberOfReportsSent* as defined within the *VarMeasReportList* for this *measId* by 1;
- 1> stop the periodical reporting timer, if running;
- 1> if the *numberOfReportsSent* as defined within the *VarMeasReportList* for this *measId* is less than the *reportAmount* as defined within the corresponding *reportConfig* for this *measId*:
 - 2> start the periodical reporting timer with the value of *reportInterval* as defined within the corresponding *reportConfig* for this *measId*;
- 1> else:
 - 2> if the *reportType* is set to *periodical*:
 - 3> remove the entry within the *VarMeasReportList* for this *measId*;
 - 3> remove this *measId* from the *measIdList* within *VarMeasConfig*;
 - 1> if the UE is configured with EN-DC:
 - 2> if SRB3 is configured:
 - 3> submit the *MeasurementReport* message via SRB3 to lower layers for transmission, upon which the procedure ends;
 - 2>else:
 - 3> submit the *MeasurementReport* message via the EUTRA MCG embedded in E-UTRA RRC message *ULInformationTransferMRDC* as specified in TS 36.331 [10].
 - 1> else:
 - 2>submit the *MeasurementReport* message to lower layers for transmission, upon which the procedure ends.

[TS 38.331, clause 5.5.5.2]

For beam measurement information to be included in a measurement report the UE shall:

- 1> if *reportType* is set to *eventTriggered*:
 - 2> consider the trigger quantity as the sorting quantity;
- 1> if *reportType* is set to *periodical*:
 - 2> if a single reporting quantity is set to TRUE in *reportQuantityRsIndexes*;
 - 3> consider the configured single quantity as the sorting quantity;
 - 2> else:
 - 3> if *rsrp* is set to TRUE;
 - 4> consider RSRP as the sorting quantity;
 - 3> else:
 - 4> consider RSRQ as the sorting quantity;

1> set *rsIndexResults* to include up to *maxNrofRsIndexesToReportSS/PBCH* block indexes or CSI-RS indexes in order of decreasing sorting quantity as follows:

2> if the measurement information to be included is based on SS/PBCH block:

3> include within *resultsSSB-Indexes* the index associated to the best beam for that SS/PBCH block sorting quantity and the remaining beams whose sorting quantity is above *absThreshSS-BlocksConsolidation* defined in the *VarMeasConfig* for the corresponding *measObject*;

3> if *includeBeamMeasurements* is configured, include the SS/PBCH based measurement results for the quantities in *reportQuantityRsIndexes* set to TRUE for each SS/PBCH blockindex; 2> else if the beam measurement information to be included is based on CSI-RS:

3> include within *resultsCSI-RS-Indexes* the index associated to the best beam for that CSI-RS sorting quantity and the remaining beams whose sorting quantity is above *absThreshCSI-RS-Consolidation* defined in the *VarMeasConfig* for the corresponding *measObject*;

3> if *includeBeamMeasurements* is configured, include the CSI-RS based measurement results for the quantities in *reportQuantityRsIndexes* set to TRUE for each CSI-RS index.

8.1.3.1.13.3 Test description

8.1.3.1.13.3.1 Pre-test conditions

System Simulator:

- NR Cell 1 is the P Cell and NR Cell 2 is the intra-frequency neighbour cell of NR Cell 1. NR Cell2 has two beams with index#0 and index#1

UE:

- None

Preamble:

- The UE is in 5GS state 1N-A, PDU SESSION ACTIVE according to TS 38.508-1 [4], clause 4.4A.2 Table 4.4A.2-1

8.1.3.1.13.3.2 Test procedure sequence

Table 8.1.3.1.13.3.2-1 and Table 8.1.3.1.13.3.2-1A illustrates the downlink power levels to be applied for NR Cell 1 and NR Cell 2 at various time instants of the test execution. Row marked "T0" denotes the conditions after the preamble, while rows marked "T1" and "T2" are to be applied subsequently. The exact instants on which these values shall be applied are described in the texts in this clause.

Table 8.1.3.1.13.3.2-1: Time instances of cell power level and parameter changes for FR1

	Parameter	Unit	NR Cell 1	NR Cell 2 Beam Index# 0	NR Cell 2 Beam Index# 1	Remark
T0	SS/PBCH SSS EPRE	dBm/SC S	-94	-98	-98	
T1	SS/PBCH SSS EPRE	dBm/SC S	-106	-98	-98	$Mn+Ofn+Ocn-Hys > Mp+Ofp+Ocp+Off$ Power level is such that SS/PBCH quality of NR Cell 3, BeamIndex#0 and BeamIndex#1 is above <i>absThreshSS-BlocksConsolidation</i> .
T2	SS/PBCH SSS EPRE	dBm/SC S	-106	-98	-106	Power level is such that SS/PBCH quality of NR Cell 3 is BeamIndex#0 is above <i>absThreshSS-BlocksConsolidation</i> and BeamIndex#1 is below <i>absThreshSS-BlocksConsolidation</i> .

Table 8.1.3.1.13.3.2-1A: Time instances of cell power level and parameter changes for FR2

	Parameter	Unit	NR Cell 1	NR Cell 2 Beam Index# 0	NR Cell 2 Beam Index# 1	Remark
T0	SS/PBCH SSS EPRE	dBm/SC S	[FFS]	[FFS]	[FFS]	
T1	SS/PBCH SSS EPRE	dBm/SC S	[FFS]	[FFS]	[FFS]	$Mn+Ofn+Ocn-Hys > Mp+Ofp+Ocp+Off$ Power level is such that SS/PBCH quality of NR Cell 3, BeamIndex#0 and BeamIndex#1 is above <i>absThreshSS-BlocksConsolidation</i> .
T2	SS/PBCH SSS EPRE	dBm/SC S	[FFS]	[FFS]	[FFS]	Power level is such that SS/PBCH quality of NR Cell 3 is BeamIndex#0 is above <i>absThreshSS-BlocksConsolidation</i> and BeamIndex#1 is below <i>absThreshSS-BlocksConsolidation</i> .

Table 8.1.3.1.13.3.2-1: Main behaviour

St	Procedure	Message Sequence		TP	Verdict
		U - S	Message		
1	The SS transmits an NR <i>RRCReconfiguration</i> message including <i>measConfig</i> to setup SS/PBCH block based intra- frequency NR measurement for NR Cell 1 and reporting for event A3.	<--	NR RRC: <i>RRCReconfiguration</i>	-	-
2	The UE transmits an <i>RRCReconfigurationComplete</i> message containing NR <i>RRCReconfigurationComplete</i> .	-->	NR RRC: <i>RRCReconfigurationComplete</i>	-	-
3	SS re-adjusts the cell-specific reference signal level according to row "T1".	-	-	-	-
4	Check: Does the UE transmit a <i>MeasurementReport</i> message to report event A3 with the measured [Results] for NR Cell 2 with beam information containing RsIndex[0] and RsIndex[1]?	-->	NR RRC: <i>MeasurementReport</i>	1	P
5	SS re-adjusts the cell-specific reference signal level according to row "T2".	-	-	-	-
6	Check: Does the UE transmit a <i>MeasurementReport</i> message to report event A3 with the measured [Results] for NR Cell 2 with beam information containing RsIndex[0] and excludes RsIndex[1]?	-->	NR RRC: <i>MeasurementReport</i>	2	P
7	The SS transmits an NR <i>RRCReconfiguration</i> including <i>measConfig</i> to remove SS/PBCH block based intra- frequency NR measurement for NR Cell 1 and reporting for event A3.	<--	NR RRC: <i>RRCReconfiguration</i>	-	-
8	The UE transmits an <i>RRCReconfigurationComplete</i> message	-->	NR RRC: <i>RRCReconfigurationComplete</i>	-	-
9	The SS transmits an NR <i>RRCReconfiguration</i> including <i>measConfig</i> to setup CSI-RS based intra- frequency NR measurement for NR Cell 1 and reporting for event A3.	<--	NR RRC: <i>RRCReconfiguration</i>	-	-
10	The UE transmits an <i>RRCReconfigurationComplete</i> .	-->	NR RRC: <i>RRCReconfigurationComplete</i>	-	-
11	SS re-adjusts the cell-specific reference signal level according to row "T1".	-	-	-	-
12	Check: Does the UE transmit a <i>MeasurementReport</i> message to report event A3 with the measured [Results] for NR Cell 2 with beam information containing RsIndex[0] and RsIndex[1]?	-->	NR RRC: <i>MeasurementReport</i>	3	P
13	SS re-adjusts the cell-specific reference signal level according to row "T2".	-	-	-	-
14	Check: Does the UE transmit a <i>MeasurementReport</i> message to report event A3 with the measured [Results] for NR Cell 2 with beam information containing RsIndex[0] and excludes RsIndex[1]?	-->	NR RRC: <i>MeasurementReport</i>	4	P

8.1.3.1.13.3.3 Specific message contents

FFS

8.1.3.1.14 Void

8.1.3.1.14A Measurement configuration control and reporting / SS/PBCH block based / CSI-RS based inter-frequency measurements / Measurement of Neighbour NR cell

8.1.3.1.14A.1 Test Purpose (TP)

(1)

```
with { UE in NR RRC_CONNECTED state and measurement configured for SS/PBCH measurement reporting of
inter-frequency on specified frequency }
ensure that {
  when { SS/PBCH block sorting quantity is above absThreshSS-BlocksConsolidation for each beam of
Neighbour Cell }
  then { UE sends MeasurementReport message containing rsIndexResults with resultsSSB-Indexes }
}
```

(2)

```
with { UE in NR RRC_CONNECTED state and measurement configured for SS/PBCH measurement reporting of
inter-frequency on specified frequency }
ensure that {
  when { SS/PBCH block sorting quantity is below absThreshSS-BlocksConsolidation for one beam of
Neighbour Cell and another beam(s) is above absThreshSS-BlocksConsolidation }
  then { UE sends MeasurementReport message containing rsIndexResults with resultsSSB-Indexes
includes RsIndex above absThreshSS-BlocksConsolidation and excludes RsIndex below absThreshSS-
BlocksConsolidation }
}
```

(3)

```
with { UE in NR RRC_CONNECTED state and measurement configured for CSI-RS measurement reporting of
inter frequency on specified frequency }
ensure that {
  when { CSI-RS sorting quantity is above absThreshCSI-RS-Consolidation for each beam of Neighbour
Cell }
  then { UE sends MeasurementReport message containing rsIndexResults with resultsSSB-Indexes }
}
```

(4)

```
with { UE in NR RRC_CONNECTED state and measurement configured for CSI-RS measurement reporting of
inter frequency on specified frequency }
ensure that {
  when { CSI-RS sorting quantity is below absThreshCSI-RS-Consolidation for one beam of Neighbour
Cell and another beam(s) is above absThreshCSI-RS-Consolidation }
  then { UE sends MeasurementReport message containing rsIndexResults with resultsSSB-Indexes
includes RsIndex above absThreshCSI-RS-Consolidation and excludes RsIndex below absThreshCSI-RS-
Consolidation }
}
```

8.1.3.1.14A.2 Conformance requirements

References: The conformance requirements covered in the present TC are specified in: TS 38.331, clauses 5.5.5.1 and 5.5.5.2]. Unless otherwise stated these are Rel-15 requirements.

[TS 38.331, clause 5.5.5.1]

The purpose of this procedure is to transfer measurement results from the UE to the network. The UE shall initiate this procedure only after successful security activation.

For the *measId* for which the measurement reporting procedure was triggered, the UE shall set the *measResults* within the *MeasurementReport* message as follows:

1> set the *measId* to the measurement identity that triggered the measurement reporting;

1> set the *measResultServingCell* within *measResultServingFreqList* to include RSRP, RSRQ and the available SINR for each configured serving cell derived based on the *rsType* indicated in the associated *reportConfig*;

- 1> set the *measResultServingCell* within *measResultServingFreqList* to include for each NR serving cell that is configured, if any, the *servFreqId*;
- 1> if the *reportConfig* associated with the *measId* that triggered the measurement reporting includes *reportQuantityRsIndexes* and *maxNrofRSIndexesToReport*:
 - 2> for each configured serving cell, include beam measurement information according to the associated *reportConfig* as described in 5.5.5.2;
- 1> if the *reportConfig* associated with the *measId* that triggered the measurement reporting includes *reportAddNeighMeas*:
 - 2> for each serving frequency for which *measObjectId* is referenced in the *measIdList*, other than the frequency corresponding with the *measId* that triggered the measurement reporting:
 - 3> set the *measResultBestNeighCell* within *measResultServingFreqList* to include the *physCellId* and the available measurement quantities based on the *reportQuantityCell* and *rsType* indicated in *reportConfig* of the non-serving cell on the concerned serving frequency with the highest measured RSRP if RSRP measurement results are available for cells on this frequency, otherwise with the highest measured RSRQ if RSRQ measurement results are available for cells on this frequency, otherwise with the highest measured SINR;
 - 3> if the *reportConfig* associated with the *measId* that triggered the measurement reporting includes *reportQuantityRsIndexes* and *maxNrofRSIndexesToReport*:
 - 4> for each best non-serving cell included in the measurement report:
 - 5> include beam measurement information according to the associated *reportConfig* as described in 5.5.5.2;
- 1> if there is at least one applicable neighbouring cell to report:
 - 2> set the *measResultNeighCells* to include the best neighbouring cells up to *maxReportCells* in accordance with the following:
 - 3> if the *reportType* is set to *eventTriggered*:
 - 4> include the cells included in the *cellsTriggeredList* as defined within the *VarMeasReportList* for this *measId*;
 - 3> else:
 - 4> include the applicable cells for which the new measurement results became available since the last periodical reporting or since the measurement was initiated or reset;
 - 4> if *reportQuantityRsIndexes* and *maxNrofRSIndexesToReport* are configured, include beam measurement information as described in 5.5.5.2;
 - 3> for each cell that is included in the *measResultNeighCells*, include the *physCellId*;
 - 3> if the *reportType* is set to *eventTriggered*:
 - 4> for each included cell, include the layer 3 filtered measured results in accordance with the *reportConfig* for this *measId*, ordered as follows:
 - 5> if the *measObject* associated with this *measId* concerns NR:
 - 6> if *rsType* in the associated *reportConfig* is set to *ssb*:
 - 7> set *resultsSSB-Cell* within the *measResult* to include the SS/PBCH block based quantity(ies) indicated in the *reportQuantityCell* within the concerned *reportConfig*, in order of decreasing trigger quantity, i.e. the best cell is included first;
 - 8> if *reportQuantityRsIndexes* and *maxNrofRSIndexesToReport* are configured, include beam measurement information as described in 5.5.5.2;
 - 6> else if *rsType* in the associated *reportConfig* is set to *csi-rs*:

7> set *resultsCSI-RS-Cell* within the *measResult* to include the CSI-RS based quantity(ies) indicated in the *reportQuantityCell* within the concerned *reportConfig*, in order of decreasing trigger quantity, i.e. the best cell is included first:

8> if *reportQuantityRsIndexes* and *maxNrofRSIndexesToReport* are, include beam measurement information as described in 5.5.5.2;

[TS 38.331, clause 5.5.5.1]

- 1> increment the *numberOfReportsSent* as defined within the *VarMeasReportList* for this *measId* by 1;
- 1> stop the periodical reporting timer, if running;
- 1> if the *numberOfReportsSent* as defined within the *VarMeasReportList* for this *measId* is less than the *reportAmount* as defined within the corresponding *reportConfig* for this *measId*:
 - 2> start the periodical reporting timer with the value of *reportInterval* as defined within the corresponding *reportConfig* for this *measId*;
- 1> else:
 - 2> if the *reportType* is set to *periodical*:
 - 3> remove the entry within the *VarMeasReportList* for this *measId*;
 - 3> remove this *measId* from the *measIdList* within *VarMeasConfig*;
 - 1> if the UE is configured with EN-DC:
 - 2> if SRB3 is configured:
 - 3> submit the *MeasurementReport* message via SRB3 to lower layers for transmission, upon which the procedure ends;
 - 2>else:
 - 3> submit the *MeasurementReport* message via the EUTRA MCG embedded in E-UTRA RRC message *ULInformationTransferMRDC* as specified in TS 36.331 [10].
 - 1> else:
 - 2>submit the *MeasurementReport* message to lower layers for transmission, upon which the procedure ends.

[TS 38.331, clause 5.5.5.2]

For beam measurement information to be included in a measurement report the UE shall:

- 1> if *reportType* is set to *eventTriggered*:
 - 2> consider the trigger quantity as the sorting quantity;
- 1> if *reportType* is set to *periodical*:
 - 2> if a single reporting quantity is set to TRUE in *reportQuantityRsIndexes*;
 - 3> consider the configured single quantity as the sorting quantity;
 - 2> else:
 - 3> if *rsrp* is set to TRUE;
 - 4> consider RSRP as the sorting quantity;
 - 3> else:
 - 4> consider RSRQ as the sorting quantity;

1> set *rsIndexResults* to include up to *maxNrofRsIndexesToReportSS/PBCH* block indexes or CSI-RS indexes in order of decreasing sorting quantity as follows:

2> if the measurement information to be included is based on SS/PBCH block:

3> include within *resultsSSB-Indexes* the index associated to the best beam for that SS/PBCH block sorting quantity and the remaining beams whose sorting quantity is above *absThreshSS-BlocksConsolidation* defined in the *VarMeasConfig* for the corresponding *measObject*;

3> if *includeBeamMeasurements* is configured, include the SS/PBCH based measurement results for the quantities in *reportQuantityRsIndexes* set to TRUE for each SS/PBCH blockindex; 2> else if the beam measurement information to be included is based on CSI-RS:

3> include within *resultsCSI-RS-Indexes* the index associated to the best beam for that CSI-RS sorting quantity and the remaining beams whose sorting quantity is above *absThreshCSI-RS-Consolidation* defined in the *VarMeasConfig* for the corresponding *measObject*;

3> if *includeBeamMeasurements* is configured, include the CSI-RS based measurement results for the quantities in *reportQuantityRsIndexes* set to TRUE for each CSI-RS index.

8.1.3.1.14A.3 Test description

8.1.3.1.14A.3.1 Pre-test conditions

System Simulator:

- NR Cell 1 is the P Cell and NR Cell 3 is the inter-frequency neighbour cell of NR Cell 1. NR Cell 3 has two beams with index#0 and index#1

UE:

- None

Preamble:

- The UE is in 5GS state 1N-A, PDU SESSION ACTIVE according to TS 38.508-1 [4], clause 4.4A.2 Table 4.4A.2-1

8.1.3.1.14A.3.2 Test procedure sequence

Table 8.1.3.1.14A.3.2-1 and Table 8.1.3.1.14A.3.2-1A illustrates the downlink power levels to be applied for NR Cell 1 and NR Cell 3 at various time instants of the test execution. Row marked "T0" denotes the conditions after the preamble, while rows marked "T1" and "T2" are to be applied subsequently. The exact instants on which these values shall be applied are described in the texts in this clause.

Table 8.1.3.1.14A.3.2-1: Time instances of cell power level and parameter changes for FR1

	Parameter	Unit	NR Cell 1	NR Cell 3 Beam Index# 0	NR Cell 3 Beam Index# 1	Remark
T0	SS/PBCH SSS EPRE	dBm/SC S	-94	-98	-98	
T1	SS/PBCH SSS EPRE	dBm/SC S	-106	-98	-98	$Mn+Ofn+Ocn-Hys > Mp+Ofp+Ocp+Off$ Power level is such that SS/PBCH quality of NR Cell 3, BeamIndex#0 and BeamIndex#1 is above <i>absThreshSS-BlocksConsolidation</i> .
T2	SS/PBCH SSS EPRE	dBm/SC S	-106	-98	-106	Power level is such that SS/PBCH quality of NR Cell 3 is BeamIndex#0 is above <i>absThreshSS-BlocksConsolidation</i> and BeamIndex#1 is below <i>absThreshSS-BlocksConsolidation</i> .

Table 8.1.3.1.14A.3.2-1A: Time instances of cell power level and parameter changes for FR2

	Parameter	Unit	NR Cell 1	NR Cell 3 Beam Index# 0	NR Cell 3 Beam Index# 1	Remark
T0	SS/PBCH SSS EPRE	dBm/SC S	[FFS]	[FFS]	[FFS]	
T1	SS/PBCH SSS EPRE	dBm/SC S	[FFS]	[FFS]	[FFS]	$Mn+Ofn+Ocn-Hys > Mp+Ofp+Ocp+Off$ Power level is such that SS/PBCH quality of NR Cell 3, BeamIndex#0 and BeamIndex#1 is above <i>absThreshSS-BlocksConsolidation</i> .
T2	SS/PBCH SSS EPRE	dBm/SC S	[FFS]	[FFS]	[FFS]	Power level is such that SS/PBCH quality of NR Cell 3 is BeamIndex#0 is above <i>absThreshSS-BlocksConsolidation</i> and BeamIndex#1 is below <i>absThreshSS-BlocksConsolidation</i> .

Table 8.1.3.1.14A.3.2-1: Main behaviour

St	Procedure	Message Sequence		TP	Verdict
		U - S	Message		
1	The SS transmits an NR <i>RRCReconfiguration</i> message including <i>measConfig</i> to setup SS/PBCH block based intra- frequency NR measurement for NR Cell 1 and reporting for event A3.	<--	NR RRC: <i>RRCReconfiguration</i>	-	-
2	The UE transmits an <i>RRCReconfigurationComplete</i> message containing NR <i>RRCReconfigurationComplete</i> .	-->	NR RRC: <i>RRCReconfigurationComplete</i>	-	-
3	SS re-adjusts the cell-specific reference signal level according to row "T1".	-	-	-	-
4	Check: Does the UE transmit a <i>MeasurementReport</i> message to report event A3 with the measured [Results] for NR Cell 3 with beam information containing RsIndex[0] and RsIndex[1]?	-->	NR RRC: <i>MeasurementReport</i>	1	P
5	SS re-adjusts the cell-specific reference signal level according to row "T2".	-	-	-	-
6	Check: Does the UE transmit a <i>MeasurementReport</i> message to report event A3 with the measured [Results] for NR Cell 3 with beam information containing RsIndex[0] and excludes RsIndex[1]?	-->	NR RRC: <i>MeasurementReport</i>	2	P
7	The SS transmits an NR <i>RRCReconfiguration</i> including <i>measConfig</i> to remove SS/PBCH block based intra- frequency NR measurement for NR Cell 1 and reporting for event A3.	<--	NR RRC: <i>RRCReconfiguration</i>	-	-
8	The UE transmits an <i>RRCReconfigurationComplete</i> message	-->	NR RRC: <i>RRCReconfigurationComplete</i>	-	-
9	The SS transmits an NR <i>RRCReconfiguration</i> including <i>measConfig</i> to setup CSI-RS based inter-frequency NR measurement for NR Cell 1 and reporting for event A3.	<--	NR RRC: <i>RRCReconfiguration</i>	-	-
10	The UE transmits an <i>RRCReconfigurationComplete</i> .	-->	NR RRC: <i>RRCReconfigurationComplete</i>	-	-
11	SS re-adjusts the cell-specific reference signal level according to row "T1".	-	-	-	-
12	Check: Does the UE transmit a <i>MeasurementReport</i> message to report event A3 with the measured [Results] for NR Cell 3 with beam information containing RsIndex[0] and RsIndex[1]?	-->	NR RRC: <i>MeasurementReport</i>	3	P
13	SS re-adjusts the cell-specific reference signal level according to row "T2".	-	-	-	-
14	Check: Does the UE transmit a <i>MeasurementReport</i> message to report event A3 with the measured [Results] for NR Cell 3 with beam information containing RsIndex[0] and excludes RsIndex[1]?	-->	NR RRC: <i>MeasurementReport</i>	4	P

8.1.3.1.14A.3.3 Specific message contents

FFS

8.1.3.1.15 Void

8.1.3.1.15A Measurement configuration control and reporting / Intra NR measurements / Blacklisting

8.1.3.1.15A.1 Test Purpose (TP)

(1)

```
with { UE in NR RRC_CONNECTED state and measurement configured for event A3 reporting }
ensure that {
  when { Blacklisted neighbour cell satisfies entry condition for event A3 }
  then { It is not considered in event evaluation and UE does not send MeasurementReport message }
}
```

(2)

```
with { UE in NR RRC_CONNECTED state and measurement reporting triggered by event A3 is ongoing and
no neighbour cells are blacklisted }
ensure that {
  when { Neighbour cells satisfies entry condition for event A3 }
  then { Neighbour cells are considered in measurement reporting }
}
```

8.1.3.1.15A.2 Conformance requirements

References: The conformance requirements covered in the current TC are specified in: TS 38.331, clauses 5.5.1, 5.5.4.1, and 5.5.5. Unless otherwise stated these are Rel-15 requirements.

[TS 38.331, clause 5.5.1]

The network may configure an RRC_CONNECTED UE to perform measurements and report them in accordance with the measurement configuration. The measurement configuration is provided by means of dedicated signalling i.e. using the *RRCReconfiguration*

...

- For intra-frequency and inter-frequency measurements a measurement object indicates the frequency/time location and subcarrier spacing of reference signals to be measured. Associated with this measurement object, the network may configure a list of cell specific offsets, a list of 'blacklisted' cells and a list of 'whitelisted' cells. Blacklisted cells are not applicable in event evaluation or measurement reporting. Whitelisted cells are the only ones applicable in event evaluation or measurement reporting.

...

[TS 38.331, clause 5.5.4.1]

The UE shall:

- 1> for each measId included in the measIdList within VarMeasConfig:

...

- 2> if the corresponding reportConfig includes a reportType set to eventTriggered or periodical;
 - 3> if the corresponding measObject concerns NR;
 - 3> if the corresponding measObject concerns EUTRA:
 - 4> consider any neighbouring cell detected based on parameters in the associated measObjectNR to be applicable when the concerned cell is not included in the blackCellsToAddModList defined within the VarMeasConfig for this measId;

...

- 2> if the reportType is set to eventTriggered and if the entry condition applicable for this event, i.e. the event corresponding with the eventId of the corresponding reportConfig within VarMeasConfig, is fulfilled for one or more applicable cells for all measurements after layer 3 filtering taken during timeToTrigger defined for

this event within the VarMeasConfig, while the VarMeasReportList does not include a measurement reporting entry for this measId (a first cell triggers the event):

- 3> include a measurement reporting entry within the VarMeasReportList for this measId;
- 3> set the numberOfReportsSent defined within the VarMeasReportList for this measId to 0;
- 3> include the concerned cell(s) in the cellsTriggeredList defined within the VarMeasReportList for this measId;
- 3> initiate the measurement reporting procedure, as specified in 5.5.5;
- 2> else if the reportType is set to eventTriggered and if the entry condition applicable for this event, i.e. the event corresponding with the eventId of the corresponding reportConfig within VarMeasConfig, is fulfilled for one or more applicable cells not included in the cellsTriggeredList for all measurements after layer 3 filtering taken during timeToTrigger defined for this event within the VarMeasConfig (a subsequent cell triggers the event):
 - 3> set the numberOfReportsSent defined within the VarMeasReportList for this measId to 0;
 - 3> include the concerned cell(s) in the cellsTriggeredList defined within the VarMeasReportList for this measId;
 - 3> initiate the measurement reporting procedure, as specified in 5.5.5;
- 2> else if the reportType is set to eventTriggered and if the leaving condition applicable for this event is fulfilled for one or more of the cells included in the cellsTriggeredList defined within the VarMeasReportList for this measId for all measurements after layer 3 filtering taken during timeToTrigger defined within the VarMeasConfig for this event:
 - 3> remove the concerned cell(s) in the cellsTriggeredList defined within the VarMeasReportList for this measId;
 - 3> if reportOnLeave is set to TRUE for the corresponding reporting configuration:
 - 4> initiate the measurement reporting procedure, as specified in 5.5.5;
 - 3> if the cellsTriggeredList defined within the VarMeasReportList for this measId is empty:
 - 4> remove the measurement reporting entry within the VarMeasReportList for this measId;
 - 4> stop the periodical reporting timer for this measId, if running;

...

[TS 38.331, clause 5.5.5.1]

The purpose of this procedure is to transfer measurement results from the UE to the network. The UE shall initiate this procedure only after successful security activation.

For the *measId* for which the measurement reporting procedure was triggered, the UE shall set the *measResults* within the *MeasurementReport* message as follows:

- 1> set the *measId* to the measurement identity that triggered the measurement reporting;
- 1> set the *measResultServingCell* within *measResultServingMOList* to include RSRP, RSRQ and the available SINR for each configured serving cell derived based on the *rsType* indicated in the associated *reportConfig*;
- 1> set the *measResultServingCell* within *measResultServingMOList* to include for each NR serving cell that is configured with *servingCellMO*, if any, the *servCellId*;
- 1> if the *reportConfig* associated with the *measId* that triggered the measurement reporting includes *reportQuantityRSIndexes* and *maxNrofRSIndexesToReport*:
 - 2> for each serving cell configured with *servingCellMO*, include beam measurement information according to the associated *reportConfig* as described in 5.5.5.2;

- 1> if the *reportConfig* associated with the *measId* that triggered the measurement reporting includes *reportAddNeighMeas*:
 - 2> for each serving cell *measObjectId* referenced in the *measIdList*, other than the *measObjectId* corresponding with the *measId* that triggered the measurement reporting:
 - 3> set the *measResultBestNeighCell* within *measResultServingMOList* to include the *physCellId* and the available measurement quantities based on the *reportQuantityCell* and *rsType* indicated in *reportConfig* of the non-serving cell corresponding to the concerned *measObjectNR* with the highest measured RSRP if RSRP measurement results are available for cells corresponding to this *measObjectNR*, otherwise with the highest measured RSRQ if RSRQ measurement results are available for cells corresponding to this *measObjectNR*, otherwise with the highest measured SINR;
 - 3> if the *reportConfig* associated with the *measId* that triggered the measurement reporting includes *reportQuantityRsIndexes* and *maxNrofRSIndexesToReport*:
 - 4> for each best non-serving cell included in the measurement report:
 - 5> include beam measurement information according to the associated *reportConfig* as described in 5.5.5.2;
 - 1> if there is at least one applicable neighbouring cell to report:
 - 2> set the *measResultNeighCells* to include the best neighbouring cells up to *maxReportCells* in accordance with the following:
 - 3> if the *reportType* is set to *eventTriggered*:
 - 4> include the cells included in the *cellsTriggeredList* as defined within the *VarMeasReportList* for this *measId*;
 - 3> else:
 - 4> include the applicable cells for which the new measurement results became available since the last periodical reporting or since the measurement was initiated or reset;
 - 4> if *reportQuantityRsIndexes* and *maxNrofRSIndexesToReport* are configured, include beam measurement information as described in 5.5.5.2;
 - 3> for each cell that is included in the *measResultNeighCells*, include the *physCellId*;
 - 3> if the *reportType* is set to *eventTriggered*:
 - 4> for each included cell, include the layer 3 filtered measured results in accordance with the *reportConfig* for this *measId*, ordered as follows:
 - 5> if the *measObject* associated with this *measId* concerns NR:
 - 6> if *rsType* in the associated *reportConfig* is set to *ssb*:
 - 7> set *resultsSSB-Cell* within the *measResult* to include the SS/PBCH block based quantity(ies) indicated in the *reportQuantityCell* within the concerned *reportConfig*, in order of decreasing trigger quantity, i.e. the best cell is included first;
 - 8> if *reportQuantityRsIndexes* and *maxNrofRSIndexesToReport* are configured, include beam measurement information as described in 5.5.5.2;
 - 6> else if *rsType* in the associated *reportConfig* is set to *csi-rs*:
 - 7> set *resultsCSI-RS-Cell* within the *measResult* to include the CSI-RS based quantity(ies) indicated in the *reportQuantityCell* within the concerned *reportConfig*, in order of decreasing trigger quantity, i.e. the best cell is included first;
 - 8> if *reportQuantityRsIndexes* and *maxNrofRSIndexesToReport* are, include beam measurement information as described in 5.5.5.2;
 - 5> if the *measObject* associated with this *measId* concerns E-UTRA:

- 6> set the *measResult* to include the quantity(ies) indicated in the *reportQuantity* within the concerned *reportConfigInterRAT* in order of decreasing E-UTRA trigger quantity, i.e. the best cell is included first;
- 1> increment the *numberOfReportsSent* as defined within the *VarMeasReportList* for this *measId* by 1;
- 1> stop the periodical reporting timer, if running;
- 1> if the *numberOfReportsSent* as defined within the *VarMeasReportList* for this *measId* is less than the *reportAmount* as defined within the corresponding *reportConfig* for this *measId*:
 - 2> start the periodical reporting timer with the value of *reportInterval* as defined within the corresponding *reportConfig* for this *measId*;
- 1> else:
 - 2> if the *reportType* is set to *periodical*:
 - 3> remove the entry within the *VarMeasReportList* for this *measId*;
 - 3> remove this *measId* from the *measIdList* within *VarMeasConfig*;
- 1> if the UE is configured with EN-DC:
 - 2> if SRB3 is configured:
 - 3> submit the *MeasurementReport* message via SRB3 to lower layers for transmission, upon which the procedure ends;
 - 2>else:
 - 3> submit the *MeasurementReport* message via the EUTRA MCG embedded in E-UTRA RRC message *ULInformationTransferMRDC* as specified in TS 36.331 [10].
- 1> else:
 - 2> submit the *MeasurementReport* message to lower layers for transmission, upon which the procedure ends.

[TS 38.331, clause 5.5.2.5]

The UE shall:

- 1> for each *measObjectId* included in the received *measObjectToAddModList*:
 - 2> if an entry with the matching *measObjectId* exists in the *measObjectList* within the *VarMeasConfig*, for this entry:
 - 3> reconfigure the entry with the value received for this *measObject*, except for the fields *cellsToAddModList*, *blackCellsToAddModList*, *whiteCellsToAddModList*, *cellsToRemoveList*, *blackCellsToRemoveList* and *whiteCellsToRemoveList*;
 - 3> if the received *measObject* includes the *cellsToRemoveList*:
 - 4> for each *physCellId* included in the *cellsToRemoveList*:
 - 5> remove the entry with the matching *physCellId* from the *cellsToAddModList*;
 - 3> if the received *measObject* includes the *cellsToAddModList*:
 - 4> for each *physCellId* value included in the *cellsToAddModList*:
 - 5> if an entry with the matching *physCellId* exists in the *cellsToAddModList*:
 - 6> replace the entry with the value received for this *physCellId*;
 - 5> else:
 - 6> add a new entry for the received *physCellId* to the *cellsToAddModList*;

3> if the received *measObject* includes the *blackCellsToRemoveList*:

4> for each *pci-RangeIndex* included in the *blackCellsToRemoveList*:

5> remove the entry with the matching *pci-RangeIndex* from the *blackCellsToAddModList*;

NOTE: For each *pci-RangeIndex* included in the *blackCellsToRemoveList* that concerns overlapping ranges of cells, a cell is removed from the black list of cells only if all cell indexes containing it are removed.

3> if the received *measObject* includes the *blackCellsToAddModList*:

4> for each *pci-RangeIndex* included in the *blackCellsToAddModList*:

5> if an entry with the matching *pci-RangeIndex* is included in the *blackCellsToAddModList*:

6> replace the entry with the value received for this *pci-RangeIndex*;

5> else:

6> add a new entry for the received *pci-RangeIndex* to the *blackCellsToAddModList*;

3> for each *measId* associated with this *measObjectId* in the *measIdList* within the *VarMeasConfig*, if any:

4> remove the measurement reporting entry for this *measId* from the *VarMeasReportList*, if included;

4> stop the periodical reporting timer or timer T321, whichever one is running, and reset the associated information (e.g. *timeToTrigger*) for this *measId*;

2> else:

3> add a new entry for the received *measObject* to the *measObjectList* within *VarMeasConfig*.

[TS 38.331, clause 5.5.4.4]

The UE shall:

1> consider the entering condition for this event to be satisfied when condition A3-1, as specified below, is fulfilled;

1> consider the leaving condition for this event to be satisfied when condition A3-2, as specified below, is fulfilled;

1> use the SpCell for *Mp*, *Ofp* and *Ocp*.

NOTE The cell(s) that triggers the event has reference signals indicated in the *measObjectNR* associated to this event which may be different from the NR SpCell *measObjectNR*.

Inequality A3-1 (Entering condition)

$$Mn + Ofn + Ocn - Hys > Mp + Ofp + Ocp + Off$$

Inequality A3-2 (Leaving condition)

$$Mn + Ofn + Ocn + Hys < Mp + Ofp + Ocp + Off$$

The variables in the formula are defined as follows:

Mn is the measurement result of the neighbouring cell, not taking into account any offsets.

Ofn is the measurement object specific offset of the reference signal of the neighbour cell (i.e. *offsetMO* as defined within *measObjectNR* corresponding to the neighbour cell).

Ocn is the cell specific offset of the neighbour cell (i.e. *cellIndividualOffset* as defined within *measObjectNR* corresponding to the frequency of the neighbour cell), and set to zero if not configured for the neighbour cell.

Mp is the measurement result of the SpCell, not taking into account any offsets.

Ofp is the measurement object specific offset of the SpCell (i.e. *offsetMO* as defined within *measObjectNR* corresponding to the SpCell).

Ocp is the cell specific offset of the SpCell (i.e. *cellIndividualOffset* as defined within *measObjectNR* corresponding to the SpCell), and is set to zero if not configured for the SpCell.

Hys is the hysteresis parameter for this event (i.e. *hysteresis* as defined within *reportConfigNR* for this event).

Off is the offset parameter for this event (i.e. *a3-Offset* as defined within *reportConfigNR* for this event).

Mn, *Mp* are expressed in dBm in case of RSRP, or in dB in case of RSRQ and RS-SINR.

Ofn, *Ocn*, *Ofp*, *Ocp*, *Hys*, *Off* are expressed in dB.

8.1.3.1.15.3A Test description

8.1.3.1.15.3A.1 Pre-test conditions

System Simulator:

- NR Cell 1, Cell 2 and Cell 4:
- NR Cell 1 is the serving cell
- NR Cell 2 and Cell 4 are intra-frequency neighbour cells
- System information combination NR-2 as defined in TS 38.508-1[4] clause 4.4.3.1.2 is used in NR cells.

UE:

- None

Preamble:

- The UE is in state NR RRC_CONNECTED in Established (state 3) according to [18].

8.1.3.1.15A.3.2 Test procedure sequence

Table 8.1.3.1.15A.3.2-1 illustrates the downlink power levels to be applied for NR Cell 1, Cell 2 and Cell 4 at various time instants of the test execution. Row marked "T0" denotes the conditions after the preamble, while rows marked "T1" and "T2" are to be applied subsequently. The exact instants on which these values shall be applied are described in the texts in this clause.

Table 8.1.3.1.15A.3.2-1 : Time instances of cell power level and parameter changes for FR1

	Parameter	Unit	NR Cell 1	NR Cell 2 (DL only)	NR Cell 4 (DL only)	Remark
T0	Cell-specific RS EPRE	dBm/ 15kHz z	-85	-97	-97	Power levels are such that leaving condition for event A3 is satisfied for all neighbour NR cells: $Mn + Ofn + Ocn + Hys < Mp + Ofp + Ocp + Off$
T1	Cell-specific RS EPRE	dBm/ 15kHz z	-85	-79	-97	Power levels are such that entry condition for event A3 is satisfied for intra-frequency neighbour NR cell 2 [<i>measId 1</i>] $Mn + Ofn + Ocn - Hys > Ms + ofs + Ocs + Off$
T2	Cell-specific RS EPRE	dBm/ 15kHz z	-85	-79	-79	Power levels are such that entry condition for event A3 is satisfied for intra-frequency neighbour NR cell 4 [<i>measId 2</i>] $Mn + Ofn + Ocn - Hys > Ms + ofs + Ocs + Off$

Table 8.1.3.1.15A.3.2-1A : Time instances of cell power level and parameter changes for FR2

	Parameter	Unit	NR Cell 1	NR Cell 2 (DL only)	NR Cell 4 (DL only)	Remark
T0	Cell-specific RS EPRE	dBm/15kHz z	FSS	FSS	FSS	Power levels are such that leaving condition for event A3 is satisfied for all neighbour NR cells: $Mn + Ofn + Ocn + Hys < Mp + Ofp + Ocp + Off$
T1	Cell-specific RS EPRE	dBm/15kHz z	FSS	FSS	FSS	Power levels are such that entry condition for event A3 is satisfied for intra-frequency neighbour NR cell 2 [<i>measId 1</i>] $Mn + Ofn + Ocn - Hys > Ms + OfS + Ocs + Off$
T2	Cell-specific RS EPRE	dBm/15kHz z	FSS	FSS	FSS	Power levels are such that entry condition for event A3 is satisfied for intra-frequency neighbour NR cell 4 [<i>measId 2</i>] $Mn + Ofn + Ocn - Hys > Ms + OfS + Ocs + Off$

Table 8.1.3.1.15A.3.2-2 : Main behaviour

St	Procedure	Message Sequence		TP	Verdict
		U - S	Message		
1	SS transmits an <i>RRCReconfiguration</i> message including <i>measConfig</i> to setup intraNR measurement and reporting for event A3.	<--	NR RRC: <i>RRCReconfiguration</i>	-	-
2	The UE transmits an <i>RRCReconfigurationComplete</i> message.	-->	NR RRC: <i>RRCReconfigurationComplete</i>	-	-
3	SS re-adjusts the cell-specific reference signal levels according to row "T1" in table 8.1.3.1.15A.3.2.-1.	-	-	-	-
4	Check: does the UE transmit a <i>MeasurementReport</i> messages within the next 10s?	-	NR RRC: <i>MeasurementReport</i>	1	F
5	SS re-adjusts the cell-specific reference signal levels according to row "T2" in table 8.1.3.1.15A.3.2.-1.	-	-	-	-
6	Check: does the UE transmit a <i>MeasurementReport</i> message to report event A3 with the measured RSRP values for Cell 1 and Cell 4 without Cell 2 results?	-->	NR RRC: <i>MeasurementReport</i>	1	P
7	SS transmits an <i>RRCReconfiguration</i> message including <i>measConfig</i> to remove Cell 2 from the blacklisted cell list.	<--	NR RRC: <i>RRCReconfiguration</i>	-	-
8	The UE transmits an <i>RRCReconfigurationComplete</i> message	-->	NR RRC: <i>RRCReconfigurationComplete</i>	-	-
-	EXCEPTION: Steps 8Aa1 to 8Ab1 describe a transaction that depends on the UE behaviour; the "lower case letter" identifies a step sequence that takes place if a specific behaviour happens.	-	-	-	-
8A a1	IF the UE detects event A3 for Cell 4 before event A3 for Cell 2 THEN the UE may transmit <i>MeasurementReport</i> message to report event A3 with the measured RSRP values for Cell 1 and Cell 4.	-->	NR RRC: <i>MeasurementReport</i>	-	-
8A b1	IF the UE detects event A3 for Cell 2 before event A3 for Cell 4 THEN the UE may transmit <i>MeasurementReport</i> message to report event A3 with the measured RSRP values for Cell 1 and Cell 2.	-->	NR RRC: <i>MeasurementReport</i>	-	-
9	Check: does the UE transmit a <i>MeasurementReport</i> message to report event A3 with the measured RSRP values for Cell 1, Cell 2 and Cell 4?	-->	NR RRC: <i>MeasurementReport</i>	2	P

8.1.3.1.15A.3.3 Specific message contents

Table 8.1.3.1.15A.3.3-1: RRCReconfiguration (step 1 and Step 7 Table 8.1.3.1.15A.3.2-2)

Derivation Path: 38.508-1 [4] Table 4.6.1-13			
Information Element	Value/remark	Comment	Condition
RRCReconfiguration ::= SEQUENCE {			
rrc-TransactionIdentifier	RRC-TransactionIdentifier		
criticalExtensions CHOICE {			
rrcReconfiguration ::= SEQUENCE {			
radioBearerConfig	Not present		
secondaryCellGroup	Not present		
measConfig	MeasConfig	Table 8.1.3.1.15A.3.3-2	
lateNonCriticalExtension	Not present		
nonCriticalExtension	Not present		
}			
}			
}			

Table 8.1.3.1.15A.3.3-2: MeasConfig (Table 8.1.3.1.15A.3.3-1)

Derivation path: 38.508 clause 4.6.3 table 4.6.3-69			
Information Element	Value/remark	Comment	Condition
MeasConfig ::= SEQUENCE {			
measObjectToAddModList ::= SEQUENCE (SIZE (1..maxNrofMeasId)) OF SEQUENCE {	1 entry		
measObjectId[1]	MeasObjectId		
measObject CHOICE {			
measObjectNR	MeasObjectNR		
}			
reportConfigToAddModList SEQUENCE(SIZE (1..maxReportConfigId)) OF SEQUENCE {			
reportConfigId[1]	ReportConfigId		
reportConfig[1] CHOICE {			
reportConfigNR	ReportConfigNR(2) Same as TS 38.508-1 Table 4.6.3-142 except for reportAmount set to 'r1'	a3-Offset value set to -1 dB (2*0.5 dB)	EVENT_A3
}			
}			
measIdToAddModList ::= SEQUENCE (SIZE (1..maxNrofMeasId)) OF SEQUENCE {	[1 entries]		
measId[1]	1		
measObjectId[1]	1		
reportConfigId[1]	1		
}			
}			
}			

Table 8.1.3.1.15A.3.3-3: MeasObjectNR (66) (Table 8.1.3.1.15A.3.3-2)

Derivation path: 38.331 clause 4.3.2			
Information Element	Value/remark	Comment	Condition
MeasObjectNR ::= SEQUENCE {			
ssbFrequency	ARFCN-ValueNR for SSB of NR Cell 1		
absThreshSS-BlocksConsolidation	Not present		
nrofSS-BlocksToAverage	Not present		
blackCellsToAddModList ::= SEQUENCE (SIZE (1..maxNrofPCI-Ranges)) OF PCI-RangeElement {	1 entry	Add Cell 2	
PCI-RangeIndex [1]	1		
pci-Range [1] SEQUENCE {			
start	physicalCellIdentity-Cell2		
range	n4		
}			
}			
}			

Table 8.1.3.1.15A.3.3-4: MeasurementReport (step 6, Table 8.1.3.1.15A.3.2-2)

Derivation Path: 38.508 clause 4.6.1 table 4.6.1-7			
Information Element	Value/remark	Comment	Condition
MeasurementReport ::= SEQUENCE {			
criticalExtensions CHOICE {			
c1 CHOICE {			
measurementReport SEQUENCE {			
measResults ::= SEQUENCE {			
measId	1		
measResultServingCell ::= SEQUENCE {		Report Cell 1	
rsrp	(0..127)		
rsrq	(0..127)		
sinr	(0..127)		pc_ss_SINR_Meas
}			
measResultNeighCells CHOICE {			A3
measResultListNR ::= SEQUENCE (SIZE (1..maxCellReport)) OF SEQUENCE {		Report Cell 4	
physCellId [1]	physicalCellIdentity-Cell4		
measResult [1] SEQUENCE {			
rsrp	(0..127)		
rsrq	(0..127)		
sinr	(0..127)		pc_ss_SINR_Meas
}			
}			
}			
}			
}			
}			
}			
}			

Table 8.1.3.1.15A.3.3-5: MeasObjectNR (66) (Table 8.1.3.1.15A.3.3-2)

Derivation path: 38.331 clause 4.3.2			
Information Element	Value/remark	Comment	Condition
MeasObjectNR ::= SEQUENCE {			
ssbFrequency	ARFCN-ValueNR for SSB of NR Cell 1		
absThreshSS-BlocksConsolidation	Not present		
nrofSS-BlocksToAverage	Not present		
blackCellsToAddModList ::= SEQUENCE (SIZE (1..maxNrofPCI-Ranges)) OF PCI-RangeElement {	1 entry	Remove Cell 2	
PCI-RangeIndex [1]	1		
pci-Range [1] SEQUENCE {			
start	physicalCellIdentity-Cell2		
range	n4		
}			
}			
}			

Table 8.1.3.1.15A.3.3-6: MeasurementReport (step 8Aa1, Table 8.1.3.1.15A.3.2-2)

Derivation Path: 38.508 clause 4.6.1 table 4.6.1-7			
Information Element	Value/remark	Comment	Condition
MeasurementReport ::= SEQUENCE {			
criticalExtensions CHOICE {			
c1 CHOICE {			
measurementReport SEQUENCE {			
measResults ::= SEQUENCE {			
measId	1		
measResultServingCell ::= SEQUENCE {		Report Cell 1	
rsrp	(0..127)		
rsrq	(0..127)		
sinr	(0..127)		pc_ss_SINR_Meas
}			
measResultNeighCells CHOICE {			
measResultListEUTRA ::= SEQUENCE (SIZE (1..maxCellReport)) OF SEQUENCE {		Report Cell 4	
physCellId [2]	physicalCellIdentity-Cell4		
measResult [2] SEQUENCE {			
rsrp	(0..127)		
rsrq	(0..127)		
sinr	(0..127)		pc_ss_SINR_Meas
}			
}			
}			
}			
}			
}			

Table 8.1.3.1.15A.3.3-7: MeasurementReport (step 8Ab1, Table 8.1.3.1.15A.3.2-2)

Derivation Path: 38.508 clause 4.6.1 table 4.6.1-7			
Information Element	Value/remark	Comment	Condition
MeasurementReport ::= SEQUENCE {			
criticalExtensions CHOICE {			
c1 CHOICE {			
measurementReport SEQUENCE {			
measResults ::= SEQUENCE {			
measId	1		
measResultServingCell ::= SEQUENCE {		Report Cell 1	
rsrp	(0..127)		
rsrq	(0..127)		
sinr	(0..127)		pc_ss_SIN R_Meas
}			
measResultNeighCells CHOICE {			
measResultList ::= SEQUENCE (SIZE (1..maxCellReport)) OF SEQUENCE {		Report Cell 2	
physCellId[2]	physicalCellId-Cell2		
measResult [2] SEQUENCE {			
rsrp	(0..127)		
rsrq	(0..127)		
sinr	(0..127)		pc_ss_SIN R_Meas
}			
}			
}			
}			
}			
}			
}			

Table 8.1.3.1.15A.3.3-8: MeasurementReport (step 9, Table 8.1.3.1.15A.3.2-2)

Derivation Path: 38.508 clause 4.6.1 table 4.6.1-7			
Information Element	Value/remark	Comment	Condition
MeasurementReport ::= SEQUENCE {			
criticalExtensions CHOICE {			
c1 CHOICE {			
measurementReport SEQUENCE {			
measResults ::= SEQUENCE {			
measId	1		
measResultServingCell ::= SEQUENCE {		Report Cell 1	
rsrp	(0..127)		
rsrq	(0..127)		
sinr	(0..127)		pc_ss_SINR_Meas
}			
measResultNeighCells CHOICE {			
measResultList ::= SEQUENCE (SIZE (1..maxCellReport)) OF SEQUENCE {		Report Cell 2 and Cell 4	
physCellId [1]	physicalCellIdentity-Cell2		
measResult [1] SEQUENCE {			
rsrp	(0..127)		
rsrq	(0..127)		
sinr	(0..127)		pc_ss_SINR_Meas
}			
physCellId [2]	physicalCellIdentity-Cell4		
measResult [2] SEQUENCE {			
rsrp	(0..127)		
rsrq	(0..127)		
sinr	(0..127)		pc_ss_SINR_Meas
}			
}			
}			
}			
}			
}			
}			
}			

8.1.3.1.16

8.1.3.1.17 NR CA / Measurement configuration control and reporting / Intra NR measurements / Event A6

8.1.3.1.17.1 NR CA / Measurement configuration control and reporting / Intra NR measurements / Event A6 / Intra-band Contiguous CA

8.1.3.1.17.1.1 Test Purpose (TP)

(1)

```
with { UE in NR RRC_CONNECTED state and measurements configured for event A6 }
ensure that {
  when { Entry condition for event A6 is not met }
  then { UE does not send MeasurementReport }
}
```

(2)

```
with { UE in NR RRC_CONNECTED state and measurements configured for event A6 }
ensure that {
```

```

when { Intra-frequency neighbour becomes offset better than SCell }
  then { UE sends MeasurementReport with correct measId for event A6 }
}

```

(3)

```

with { UE in NR RRC_CONNECTED state and measurements configured for event A6 }
ensure that {
  when { UE receives a RRCReconfiguration message containing sCellToReleaseList with a sCellIndex
equal to one of the current UE SCell configuration }
  then { UE remove measId associated with event A6 and stops sending MeasurementReport message }
}

```

8.1.3.1.17.1.2 Conformance requirements

References: The conformance requirements covered in the current TC are specified in: TS 38.331, clauses 5.3.5.3, 5.3.5.5.9, 5.5.2.1, 5.5.4.1, 5.5.4.7 and 5.5.5. Unless otherwise stated these are Rel-15 requirements.

[TS 38.331, clause 5.3.5.3]

The UE shall perform the following actions upon reception of the *RRCReconfiguration*:

...

1> if the *RRCReconfiguration* includes the *masterCellGroup*:

2> perform the cell group configuration for the received *masterCellGroup* according to 5.3.5.5;

...

1> if the *RRCReconfiguration* message includes the *measConfig*:

2> perform the measurement configuration procedure as specified in 5.5.2;

...

1> if the UE is configured with E-UTRA *nr-SecondaryCellGroupConfig* (MCG is E-UTRA):

...

1> else:

2> submit the *RRCReconfigurationComplete* message via SRB1 to lower layers for transmission using the new configuration;

...

[TS 38.331, clause 5.3.5.5.9]

The UE shall:

1> for each *sCellIndex* value included in the *sCellToAddModList* that is not part of the current UE configuration (SCell addition):

2> add the SCell, corresponding to the *sCellIndex*, in accordance with the *sCellConfigCommon* and *sCellConfigDedicated*;

2> configure lower layers to consider the SCell to be in deactivated state;

Editor's Note: FFS Check automatic measurement handling for SCells.

2> for each *measId* included in the *measIdList* within *VarMeasConfig*:

3> if SCells are not applicable for the associated measurement; and

3> if the concerned SCell is included in *cellsTriggeredList* defined within the *VarMeasReportList* for this *measId*:

1. 4> remove the concerned SCell from *cellsTriggeredList* defined within the *VarMeasReportList* for this *measId*;

1> for each *sCellIndex* value included in the *sCellToAddModList* that is part of the current UE configuration (SCell modification):

- 2> modify the SCell configuration in accordance with the *sCellConfigDedicated*.

[TS 38.331, clause 5.5.2.1]

...

The UE shall:

...

1> if the received *measConfig* includes the *measObjectToAddModList*:

- 2> perform the measurement object addition/modification procedure as specified in 5.5.2.5;

...

1> if the received *measConfig* includes the *reportConfigToAddModList*:

- 2> perform the reporting configuration addition/modification procedure as specified in 5.5.2.7;

...

1> if the received *measConfig* includes the *measIdToRemoveList*:

- 2> perform the measurement identity removal procedure as specified in 5.5.2.2;

1> if the received *measConfig* includes the *measIdToAddModList*:

- 2> perform the measurement identity addition/modification procedure as specified in 5.5.2.3;

...

[TS 38.331, clause 5.5.4.1]

If security has been activated successfully, the UE shall:

1> for each *measId* included in the *measIdList* within *VarMeasConfig*:

- 2> if the corresponding *reportConfig* includes a *reportType* set to *eventTriggered* or *periodical*;

- 3> if the corresponding *measObject* concerns NR;

- 4> if the *eventA1* or *eventA2* is configured in the corresponding *reportConfig*;

...

4> else:

- 5> for events involving a serving cell associated with a *measObjectNR* and neighbours associated with another *measObjectNR*, consider any serving cell associated with the other *measObjectNR* to be a neighbouring cell as well;

...

- 2> if the *reportType* is set to *eventTriggered* and if the entry condition applicable for this event, i.e. the event corresponding with the *eventId* of the corresponding *reportConfig* within *VarMeasConfig*, is fulfilled for one or more applicable cells for all measurements after layer 3 filtering taken during *timeToTrigger* defined for this event within the *VarMeasConfig*, while the *VarMeasReportList* does not include a measurement reporting entry for this *measId* (a first cell triggers the event):

- 3> include a measurement reporting entry within the *VarMeasReportList* for this *measId*;

- 3> set the *numberOfReportsSent* defined within the *VarMeasReportList* for this *measId* to 0;
- 3> include the concerned cell(s) in the *cellsTriggeredList* defined within the *VarMeasReportList* for this *measId*;
- 3> initiate the measurement reporting procedure, as specified in 5.5.5;
- 2> if the *reportType* is set to *eventTriggered* and if the entry condition applicable for this event, i.e. the event corresponding with the *eventId* of the corresponding *reportConfig* within *VarMeasConfig*, is fulfilled for one or more applicable cells not included in the *cellsTriggeredList* for all measurements after layer 3 filtering taken during *timeToTrigger* defined for this event within the *VarMeasConfig* (a subsequent cell triggers the event):
 - 3> set the *numberOfReportsSent* defined within the *VarMeasReportList* for this *measId* to 0;
 - 3> include the concerned cell(s) in the *cellsTriggeredList* defined within the *VarMeasReportList* for this *measId*;
 - 3> initiate the measurement reporting procedure, as specified in 5.5.5;
- 2> if the *reportType* is set to *eventTriggered* and if the leaving condition applicable for this event is fulfilled for one or more of the cells included in the *cellsTriggeredList* defined within the *VarMeasReportList* for this *measId* for all measurements after layer 3 filtering taken during *timeToTrigger* defined within the *VarMeasConfig* for this event:
 - 3> remove the concerned cell(s) in the *cellsTriggeredList* defined within the *VarMeasReportList* for this *measId*;
 - 3> if *reportOnLeave* is set to *TRUE* for the corresponding reporting configuration:
 - 4> initiate the measurement reporting procedure, as specified in 5.5.5;
 - 3> if the *cellsTriggeredList* defined within the *VarMeasReportList* for this *measId* is empty:
 - 4> remove the measurement reporting entry within the *VarMeasReportList* for this *measId*;
 - 4> stop the periodical reporting timer for this *measId*, if running;
- ...
- 2> upon expiry of the periodical reporting timer for this *measId*:
 - 3> initiate the measurement reporting procedure, as specified in 5.5.5.
- ...

[TS 38.331, clause 5.5.4.7]

The UE shall:

- 1> consider the entering condition for this event to be satisfied when condition A6-1, as specified below, is fulfilled;
- 1> consider the leaving condition for this event to be satisfied when condition A6-2, as specified below, is fulfilled;
- 1> for this measurement, consider the (secondary) cell corresponding to the *measObjectNR* associated to this event to be the serving cell.

NOTE: The reference signal(s) of the neighbour(s) and the reference signal(s) of the SCell are both indicated in the associated *measObjectNR*.

Inequality A6-1 (Entering condition)

$$Mn + Ocn - Hys > Ms + Ocs + Off$$

Inequality A6-2 (Leaving condition)

$$Mn + Ocn + Hys < Ms + Ocs + Off$$

The variables in the formula are defined as follows:

Mn is the measurement result of the neighbouring cell, not taking into account any offsets.

Ocn is the cell specific offset of the neighbour cell (i.e. *cellIndividualOffset* as defined within the associated *measObjectNR*), and set to zero if not configured for the neighbour cell.

Ms is the measurement result of the serving cell, not taking into account any offsets.

Ocs is the cell specific offset of the serving cell (i.e. *cellIndividualOffset* as defined within the associated *measObjectNR*), and is set to zero if not configured for the serving cell.

Hys is the hysteresis parameter for this event (i.e. *hysteresis* as defined within *reportConfigNR* for this event).

Off is the offset parameter for this event (i.e. *a6-Offset* as defined within *reportConfigNR* for this event).

Mn, *Ms* are expressed in dBm in case of RSRP, or in dB in case of RSRQ and RS-SINR.

Ocn, *Ocs*, *Hys*, *Off* are expressed in dB.

[TS 38.331, clause 5.5.5]



Figure 5.5.5-1: Measurement reporting

The purpose of this procedure is to transfer measurement results from the UE to the network. The UE shall initiate this procedure only after successful security activation.

For the *measId* for which the measurement reporting procedure was triggered, the UE shall set the *measResults* within the *MeasurementReport* message as follows:

- 1> set the *measId* to the measurement identity that triggered the measurement reporting;
- 1> set the *measResultServingCell* within *measResultServingMOList* to include RSRP, RSRQ and the available SINR for each configured serving cell derived based on the *rsType* indicated in the associated *reportConfig*;
- 1> set the *measResultServingCell* within *measResultServingMOList* to include for each NR serving cell that is configured with *servingCellMO*, if any, the *servCellId*;
- ...
- 1> if there is at least one applicable neighbouring cell to report:
 - 2> set the *measResultNeighCells* to include the best neighbouring cells up to *maxReportCells* in accordance with the following:
 - 3> if the *reportType* is set to *eventTriggered*:
 2. 4> include the cells included in the *cellsTriggeredList* as defined within the *VarMeasReportList* for this *measId*;
 3. ...
 - 3> for each cell that is included in the *measResultNeighCells*, include the *physCellId*;
 - 3> if the *reportType* is set to *eventTriggered*:

4. 4> for each included cell, include the layer 3 filtered measured results in accordance with the *reportConfig* for this *measId*, ordered as follows:
 - 5> if the *measObject* associated with this *measId* concerns NR:
 - 6> if *rsType* in the associated *reportConfig* is set to *ssb*:
 - 7> set *resultsSSB-Cell* within the *measResult* to include the SS/PBCH block based quantity(ies) indicated in the *reportQuantityCell* within the concerned *reportConfig*, in order of decreasing trigger quantity, i.e. the best cell is included first:
 - ...
 - 1> increment the *numberOfReportsSent* as defined within the *VarMeasReportList* for this *measId* by 1;
 - 1> stop the periodical reporting timer, if running;
 - 1> if the *numberOfReportsSent* as defined within the *VarMeasReportList* for this *measId* is less than the *reportAmount* as defined within the corresponding *reportConfig* for this *measId*:
 - 2> start the periodical reporting timer with the value of *reportInterval* as defined within the corresponding *reportConfig* for this *measId*;
 - ...
 - 1> if the UE is configured with EN-DC:
 - ...
 - 1> else:
 - 2> submit the *MeasurementReport* message to lower layers for transmission, upon which the procedure ends.

8.1.3.1.17.1.3 Test description

8.1.3.1.17.1.3.1 Pre-test conditions

System Simulator:

- NR Cell 1 is the PCell, NR Cell 3 is the SCell to be added, and NR Cell 12 is the intra-frequency neighbour cell of NR Cell 3.
- NR Cell 3 is an Inactive SCell according to TS 38.508-1 [4] clause 6.3.1.
- System information combination NR-5 as defined in TS 38.508-1 [4] clause 4.4.3.1.2 is used in NR cells.

UE:

- None.

Preamble:

- The UE is in state 3N-A as defined in TS 38.508-1 [4], subclause 4.4A.

8.1.3.1.17.1.3.2 Test procedure sequence

Table 8.1.3.1.17.1.3.2-1 and 8.1.3.1.17.1.3.2-2 illustrates the downlink power levels to be applied for NR Cell 1, NR Cell 3 and NR Cell 12 at various time instants of the test execution. Row marked "T0" denotes the conditions after the preamble, while the configuration marked "T1" is applied at the point indicated in the Main behaviour description in Table 8.1.3.1.17.1.3.2-3.

Table 8.1.3.1.17.1.3.2-1: Time instances of cell power level and parameter changes in FR1

	Parameter	Unit	NR Cell 1	NR Cell 3	NR Cell 12	Remark
T0	SS/PBCH SSS EPRE	dBm/SCS	-82	-88	-94	Power levels are such that entry condition for event A6 (measId 1) is not satisfied: $Mn + Ocn + Hys < Ms + Ocs + Off$
T1	SS/PBCH SSS EPRE	dBm/SCS	-82	-88	-76	Power levels are such that entry condition for event A6 (measId 1) is satisfied: $Mn + Ocn - Hys > Ms + Ocs + Off$

Table 8.1.3.1.17.1.3.2-2: Time instances of cell power level and parameter changes in FR2

	Parameter	Unit	NR Cell 1	NR Cell 3	NR Cell 12	Remark
T0	SS/PBCH SSS EPRE	dBm/SCS	FFS	FFS	FFS	Power levels are such that entry condition for event A6 (measId 1) is not satisfied: $Mn + Ocn + Hys < Ms + Ocs + Off$
T1	SS/PBCH SSS EPRE	dBm/SCS	FFS	FFS	FFS	Power levels are such that entry condition for event A6 (measId 1) is satisfied: $Mn + Ocn - Hys > Ms + Ocs + Off$

Table 8.1.3.1.17.1.3.2-3: Main behaviour

St	Procedure	Message Sequence		TP	Verdict
		U - S	Message		
1	The SS transmits an <i>RRCReconfiguration</i> message including <i>sCellToAddModList</i> with NR Cell 3 as SCell addition.	<--	NR RRC: <i>RRCReconfiguration</i>	-	-
2	The UE transmits an <i>RRCReconfigurationComplete</i> message.	-->	NR RRC: <i>RRCReconfigurationComplete</i>	-	-
3	The SS transmits an <i>RRCReconfiguration</i> message including <i>measConfig</i> to setup intra NR measurement and reporting for event A6.	<--	NR RRC: <i>RRCReconfiguration</i>	-	-
4	The UE transmits an <i>RRCReconfigurationComplete</i> message.	-->	NR RRC: <i>RRCReconfigurationComplete</i>	-	-
5	Check: Does the UE transmit a <i>MeasurementReport</i> message within the next 10s?	-->	NR RRC: <i>MeasurementReport</i>	1	F
6	The SS re-adjusts the SS/PBCH EPRE level according to row "T1" in table 8.1.3.1.17.1.3.2-1/2.	-	-	-	-
7	Check: Does the UE transmit a <i>MeasurementReport</i> message to report event A6 with the measured RSRP value for NR Cell 12?	-->	NR RRC: <i>MeasurementReport</i>	2	P
8	The SS transmits an <i>RRCReconfiguration</i> message including <i>sCellToReleaseList</i> with NR Cell 3 as SCell release.	<--	NR RRC: <i>RRCReconfiguration</i>	-	-
9	The UE transmits an <i>RRCReconfigurationComplete</i> message.	-->	NR RRC: <i>RRCReconfigurationComplete</i>	-	-
10	Check: Does the UE attempt to transmit an uplink message for the next 15s?	-	-	3	F

8.1.3.1.17.1.3.3 Specific message contents

Table 8.1.3.1.17.1.3.3-1: RRCReconfiguration (step 1, Table 8.1.3.1.17.1.3.2-3)

Derivation Path: 38.508-1 [4] Table 4.6.1-13			
Information Element	Value/remark	Comment	Condition
RRCReconfiguration ::= SEQUENCE {			
criticalExtensions CHOICE {			
rrcReconfiguration SEQUENCE {			
nonCriticalExtension SEQUENCE{			
masterCellGroup	CellGroupConfig	Table 8.1.3.1.17.1.3.3-2	
}			
}			
}			
}			

Table 8.1.3.1.17.1.3.3-2: CellGroupConfig (Table 8.1.3.1.17.1.3.3-1)

Derivation Path: 38.508-1 [4] Table 4.6.3-19			
Information Element	Value/remark	Comment	Condition
CellGroupConfig ::= SEQUENCE {			
rlc-BearerToAddModList	Not present		
sCellToAddModList SEQUENCE (SIZE (1..maxNrofSCells)) OF SEQUENCE {	1 entry		
sCellIndex	1		
sCellConfigCommon	ServingCellConfigCommon	Table 8.1.3.1.17.1.3.3-3	
sCellConfigDedicated	ServingCellConfig		
}			
}			

Table 8.1.3.1.17.1.3.3-3: ServingCellConfigCommon (Table 8.1.3.1.17.1.3.3-2)

Derivation Path: 38.508-1 [4] Table 4.6.3-168			
Information Element	Value/remark	Comment	Condition
ServingCellConfigCommon ::= SEQUENCE {			
physCellId	Physical layer cell identity of NR Cell 3		
}			

Table 8.1.3.1.17.1.3.3-4: RRCReconfiguration (step 3, Table 8.1.3.1.17.1.3.2-3)

Derivation Path: 38.508-1 [4] Table 4.6.1-13			
Information Element	Value/remark	Comment	Condition
RRCReconfiguration ::= SEQUENCE {			
rrc-TransactionIdentifier	RRC- TransactionIdentifier		
criticalExtensions CHOICE {			
rrcReconfiguration ::= SEQUENCE {			
radioBearerConfig	Not present		
secondaryCellGroup	Not present		
measConfig	MeasConfig	Table 8.1.3.1.17.1.3.3-5	
lateNonCriticalExtension	Not present		
nonCriticalExtension	Not present		
}			
}			
}			

Table 8.1.3.1.17.1.3.3-5: MeasConfig (Table 8.1.3.1.17.1.3.3-4)

Derivation Path: 38.508-1 [4] Table 4.6.3-69			
Information Element	Value/remark	Comment	Condition
MeasConfig ::= SEQUENCE {			
measObjectToAddModList SEQUENCE (SIZE (1..maxNrofMeasId)) OF SEQUENCE {	2 entries		
measObjectId[1]	1	MeasObjectIdNR-f1	
measObject[1] CHOICE {			
measObjectNR SEQUENCE {			
ssbFrequency	ssbFrequency IE equals the ARFCN for NR Cell 1		
absThreshSS-BlocksConsolidation	Not present		
}			
measObjectId[2]	2	MeasObjectIdNR-f2	
measObject[2] CHOICE {			
measObjectNR SEQUENCE {			
ssbFrequency	ssbFrequency IE equals the ARFCN for NR Cell 3		
absThreshSS-BlocksConsolidation	Not present		
}			
}			
reportConfigToAddModList SEQUENCE (SIZE (1..maxReportConfigId)) OF SEQUENCE {	1 entry		
reportConfigId[1]	1		
reportConfig[1] CHOICE {			
reportConfigNR	ReportConfigNR-EventA6	Table 8.1.3.1.17.1.3.3-6	
}			
}			
measIdToAddModList SEQUENCE (SIZE (1..maxNrofMeasId)) OF SEQUENCE {	1 entry		
measId[1]	1		
measObjectId[1]	2		
reportConfigId[1]	1		
}			
}			

Table 8.1.3.1.17.1.3.3-6: ReportConfigNR-EventA6 (Table 8.1.3.1.17.1.3.3-5)

Derivation Path: 38.508-1 [4] Table 4.6.3-142 with condition EVENT_A6			
Information Element	Value/remark	Comment	Condition
ReportConfigNR ::= SEQUENCE {			
reportType CHOICE {			
eventTriggered SEQUENCE {			
eventId CHOICE {			
eventA6 SEQUENCE {			
a6-Offset CHOICE {			
rsrp	0		
}			
hysteresis	4	2 dB	
}			
}			
reportInterval	ms10240		
reportAmount	r2		
reportQuantityCell SEQUENCE {			
rsrp	true		
rsrq	false		
sinr	false		
}			
}			
}			

Table 8.1.3.1.17.1.3.3-7: MeasurementReport (step 7, Table 8.1.3.1.17.1.3.2-3)

Derivation Path: 38.508-1 [4] Table 4.6.1-7			
Information Element	Value/remark	Comment	Condition
MeasurementReport ::= SEQUENCE {			
criticalExtensions CHOICE {			
measurementReport SEQUENCE {			
measResults	MeasResults		
}			
}			
}			

Table 8.1.3.1.17.1.3.3-8: MeasResults (Table 8.1.3.1.17.1.3.3-7)

Derivation Path: 38.508-1 [4] Table 4.6.3-79			
Information Element	Value/remark	Comment	Condition
MeasResults ::= SEQUENCE {			
measId	1		
measResultServingMOList SEQUENCE (SIZE (1..maxNrofServingCells)) OF SEQUENCE {			
servCellId[1]	ServCellIndex of NR Cell 1		
measResultServingCell[1] SEQUENCE {			
physCellId	Physical layer cell identity of NR Cell 1		
measResult SEQUENCE {			
cellResults SEQUENCE {			
resultsSSB-Cell SEQUENCE {			
rsrp	(0..127)		
rsrq	(0..127)		
}			
}			
}			
servCellId[2]	ServCellIndex of NR Cell 3		
measResultServingCell[2] SEQUENCE {			
physCellId	Physical layer cell identity of NR Cell 3		
measResult SEQUENCE {			
cellResults SEQUENCE {			
resultsSSB-Cell SEQUENCE {			
rsrp	(0..127)		
rsrq	(0..127)		
}			
}			
}			
measResultNeighCells CHOICE {			
measResultListNR SEQUENCE (SIZE (1..maxCellReport)) OF SEQUENCE {		Report NR Cell 12	
physCellId	Physical layer cell identity of NR Cell 12		
measResult SEQUENCE {			
cellResults SEQUENCE {			
resultsSSB-Cell SEQUENCE {			
rsrp	(0..127)		
}			
}			
rsIndexResults	Not present		
}			
cgi-Info	Not present		
}			
}			
}			
}			

Table 8.1.3.1.17.1.3.3-9: RRCReconfiguration (step 8, Table 8.1.3.1.17.1.3.2-3)

Derivation Path: 38.508-1 [4] Table 4.6.1-13			
Information Element	Value/remark	Comment	Condition
RRCReconfiguration ::= SEQUENCE {			
criticalExtensions CHOICE {			
rrcReconfiguration SEQUENCE {			
nonCriticalExtension SEQUENCE{			
masterCellGroup	CellGroupConfig	Table 8.1.3.1.17.1.3.3-10	SCell release for NR Cell 3
}			
}			
}			
}			

Table 8.1.3.1.17.1.3.3-10: CellGroupConfig (Table 8.1.3.1.17.1.3.3-9)

Derivation Path: 38.508-1 [4] Table 4.6.3-19			
Information Element	Value/remark	Comment	Condition
CellGroupConfig ::= SEQUENCE {			
rlc-BearerToAddModList	Not present		
sCellToReleaseList SEQUENCE (SIZE (1..maxNrofSCells)) OF SEQUENCE {	1 entry		
sCellIndex	1	SCell release for NR Cell 3	
}			
}			

8.1.3.1.17.2 NR CA / Measurement configuration control and reporting / Intra NR measurements / Event A6 / Inter-band CA

8.1.3.1.17.2.1 Test Purpose (TP)

Same as TC 8.1.3.1.17.1 but applied to Inter-band CA case.

8.1.3.1.17.2.2 Conformance requirements

Same as TC 8.1.3.1.17.1 but applied to Inter-band CA case.

8.1.3.1.17.2.3 Test description

8.1.3.1.17.2.3.1 Pre-test conditions

Same as test case 8.1.3.1.17.1 with the following differences:

- CA configuration: Inter-band CA replaces Intra-band Contiguous CA.
- Cells configuration: NR Cell 10 replaces NR Cell 3, NR Cell 30 replaces NR Cell 12.
- NR Cell 10 is an Inactive SCell according to TS 38.508-1 [4] clause 6.3.1.

8.1.3.1.17.2.3.2 Test procedure sequence

Same as test case 8.1.3.1.17.1 with the following differences:

- CA configuration: Inter-band CA replaces Intra-band Contiguous CA.
- Cells configuration: NR Cell 10 replaces NR Cell 3, NR Cell 30 replaces NR Cell 12.

8.1.3.1.17.2.3.3 Specific message contents

Same as test case 8.1.3.1.17.1 with the following differences.

NOTE: For simplicity the steps referred below are steps in test case 8.1.3.1.17.1.

Table 8.1.3.1.17.2.3.3-1: MeasConfig (Table 8.1.3.1.17.1.3.3-5)

Derivation Path: 38.508-1 [4] Table 4.6.3-69			
Information Element	Value/remark	Comment	Condition
MeasConfig ::= SEQUENCE {			
measObjectToAddModList SEQUENCE (SIZE (1..maxNrofMeasId)) OF SEQUENCE {	2 entries		
measObjectId[1]	1	MeasObjectIdNR-f1	
measObject[1] CHOICE {			
measObjectNR SEQUENCE {			
ssbFrequency	ssbFrequency IE equals the ARFCN for NR Cell 1		
absThreshSS-BlocksConsolidation	Not present		
}			
measObjectId[2]	2	MeasObjectIdNR-f5	
measObject[2] CHOICE {			
measObjectNR SEQUENCE {			
ssbFrequency	ssbFrequency IE equals the ARFCN for NR Cell 10		
absThreshSS-BlocksConsolidation	Not present		
}			
}			
reportConfigToAddModList SEQUENCE(SIZE (1..maxReportConfigId)) OF SEQUENCE {	1 entry		
reportConfigId[1]	1		
reportConfig[1] CHOICE {			
reportConfigNR	ReportConfigNR-EventA6		
}			
}			
measIdToAddModList SEQUENCE (SIZE (1..maxNrofMeasId)) OF SEQUENCE {	1 entry		
measId[1]	1		
measObjectId[1]	2		
reportConfigId[1]	1		
}			
}			

8.1.3.1.17.3 NR CA / Measurement configuration control and reporting / Intra NR measurements / Event A6 / Intra-band non Contiguous CA

8.1.3.1.17.3.1 Test Purpose (TP)

Same as TC 8.1.3.1.17.1 but applied to Intra-band non Contiguous CA case.

8.1.3.1.17.3.2 Conformance requirements

Same as TC 8.1.3.1.17.1 but applied to Intra-band non Contiguous CA case.

8.1.3.1.17.3.3 Test description

8.1.3.1.17.3.3.1 Pre-test conditions

Same as test case 8.1.3.1.17.1 with the following differences:

- CA configuration: Intra-band non Contiguous CA replaces Intra-band Contiguous CA.
- Cells configuration: NR Cell 6 replaces NR Cell 1.

8.1.3.1.17.3.3.2 Test procedure sequence

Same as test case 8.1.3.1.17.1 with the following differences:

- CA configuration: Intra-band non Contiguous CA replaces Intra-band Contiguous CA.
- Cells configuration: NR Cell 6 replaces NR Cell 1.

8.1.3.1.17.3.3.3 Specific message contents

Same as test case 8.1.3.1.17.1 with the following differences.

NOTE: For simplicity the steps referred below are steps in test case 8.1.3.1.17.1.

Table 8.1.3.1.17.3.3.3-1: MeasConfig (Table 8.1.3.1.17.1.3.3-5)

Derivation Path: 38.508-1 [4] Table 4.6.3-69			
Information Element	Value/remark	Comment	Condition
MeasConfig ::= SEQUENCE {			
measObjectToAddModList SEQUENCE (SIZE (1..maxNrofMeasId)) OF SEQUENCE {	2 entries		
measObjectId[1]	1	MeasObjectIdNR-f3	
measObject[1] CHOICE {			
measObjectNR SEQUENCE {			
ssbFrequency	ssbFrequency IE equals the ARFCN for NR Cell 6		
absThreshSS-BlocksConsolidation	Not present		
}			
measObjectId[2]	2	MeasObjectIdNR-f2	
measObject[2] CHOICE {			
measObjectNR SEQUENCE {			
ssbFrequency	ssbFrequency IE equals the ARFCN for NR Cell 3		
absThreshSS-BlocksConsolidation	Not present		
}			
}			
reportConfigToAddModList SEQUENCE (SIZE (1..maxReportConfigId)) OF SEQUENCE {	1 entry		
reportConfigId[1]	1		
reportConfig[1] CHOICE {			
reportConfigNR	ReportConfigNR-EventA6		
}			
}			
measIdToAddModList SEQUENCE (SIZE (1..maxNrofMeasId)) OF SEQUENCE {	1 entry		
measId[1]	1		
measObjectId[1]	2		
reportConfigId[1]	1		
}			
}			

8.1.3.1.18 NR CA / Measurement configuration control and reporting / Intra NR measurements / Additional measurement reporting

8.1.3.1.18.1 NR CA / Measurement configuration control and reporting / Intra NR measurements / Additional measurement reporting / Intra-band Contiguous CA

8.1.3.1.18.1.1 Test Purpose (TP)

(1)

```
with { UE in NR RRC_CONNECTED state and measurements configured for event A2 reporting include
reportAddNeighMeas }
ensure that {
  when { Entry condition for event A2 of the concerned frequency that triggered measurement
reporting is met }
  then { UE sends MeasurementReport that does not include the best non-serving cell of the
concerned frequency in the measResultBestNeighCell }
}
```

(2)

```
with { UE in NR RRC_CONNECTED state and measurements configured for event A2 reporting include
reportAddNeighMeas }
ensure that {
  when { Entry condition for event A2 of other than the concerned frequency that triggered
measurement reporting is met }
  then { UE sends MeasurementReport that includes the best non-serving cell of the concerned
frequency in the measResultBestNeighCell }
}
```

8.1.3.1.18.1.2 Conformance requirements

References: The conformance requirements covered in the current TC are specified in: TS 38.331, clauses 5.3.5.3, 5.3.5.5.9, 5.5.2.1, 5.5.4.1, 5.5.4.7 and 5.5.5. Unless otherwise stated these are Rel-15 requirements.

[TS 38.331, clause 5.3.5.3]

The UE shall perform the following actions upon reception of the *RRCReconfiguration*:

...

1> if the *RRCReconfiguration* includes the *masterCellGroup*:

2> perform the cell group configuration for the received *masterCellGroup* according to 5.3.5.5;

...

1> if the *RRCReconfiguration* message includes the *measConfig*:

2> perform the measurement configuration procedure as specified in 5.5.2;

...

1> if the UE is configured with E-UTRA *nr-SecondaryCellGroupConfig* (MCG is E-UTRA):

...

1> else:

2> submit the *RRCReconfigurationComplete* message via SRB1 to lower layers for transmission using the new configuration;

...

[TS 38.331, clause 5.3.5.5.9]

The UE shall:

- 1> for each *sCellIndex* value included in the *sCellToAddModList* that is not part of the current UE configuration (SCell addition):
 - 2> add the SCell, corresponding to the *sCellIndex*, in accordance with the *sCellConfigCommon* and *sCellConfigDedicated*;
 - 2> configure lower layers to consider the SCell to be in deactivated state;

Editor's Note: FFS Check automatic measurement handling for SCells.

- 2> for each *measId* included in the *measIdList* within *VarMeasConfig*:
 - 3> if SCells are not applicable for the associated measurement; and
 - 3> if the concerned SCell is included in *cellsTriggeredList* defined within the *VarMeasReportList* for this *measId*:
 - 4> remove the concerned SCell from *cellsTriggeredList* defined within the *VarMeasReportList* for this *measId*;
- 1> for each *sCellIndex* value included in the *sCellToAddModList* that is part of the current UE configuration (SCell modification):
 - 2> modify the SCell configuration in accordance with the *sCellConfigDedicated*.

[TS 38.331, clause 5.5.2.1]

...

The UE shall:

...

- 1> if the received *measConfig* includes the *measObjectToAddModList*:
 - 2> perform the measurement object addition/modification procedure as specified in 5.5.2.5;
- ...
- 1> if the received *measConfig* includes the *reportConfigToAddModList*:
 - 2> perform the reporting configuration addition/modification procedure as specified in 5.5.2.7;
- ...
- 1> if the received *measConfig* includes the *measIdToAddModList*:
 - 2> perform the measurement identity addition/modification procedure as specified in 5.5.2.3;

[TS 38.331, clause 5.5.4.1]

If security has been activated successfully, the UE shall:

- 1> for each *measId* included in the *measIdList* within *VarMeasConfig*:
 - 2> if the corresponding *reportConfig* includes a *reportType* set to *eventTriggered* or *periodical*;
 - 3> if the corresponding *measObject* concerns NR;
 - 4> if the *eventA1* or *eventA2* is configured in the corresponding *reportConfig*:
 - 5> consider only the serving cell to be applicable;
 - ...
 - 2> if the *reportType* is set to *eventTriggered* and if the entry condition applicable for this event, i.e. the event corresponding with the *eventId* of the corresponding *reportConfig* within *VarMeasConfig*, is fulfilled for one or more applicable cells for all measurements after layer 3 filtering taken during *timeToTrigger* defined for

this event within the *VarMeasConfig*, while the *VarMeasReportList* does not include a measurement reporting entry for this *measId* (a first cell triggers the event):

- 3> include a measurement reporting entry within the *VarMeasReportList* for this *measId*;
 - 3> set the *numberOfReportsSent* defined within the *VarMeasReportList* for this *measId* to 0;
 - 3> include the concerned cell(s) in the *cellsTriggeredList* defined within the *VarMeasReportList* for this *measId*;
 - 3> initiate the measurement reporting procedure, as specified in 5.5.5;
- 2> if the *reportType* is set to *eventTriggered* and if the entry condition applicable for this event, i.e. the event corresponding with the *eventId* of the corresponding *reportConfig* within *VarMeasConfig*, is fulfilled for one or more applicable cells not included in the *cellsTriggeredList* for all measurements after layer 3 filtering taken during *timeToTrigger* defined for this event within the *VarMeasConfig* (a subsequent cell triggers the event):
- 3> set the *numberOfReportsSent* defined within the *VarMeasReportList* for this *measId* to 0;
 - 3> include the concerned cell(s) in the *cellsTriggeredList* defined within the *VarMeasReportList* for this *measId*;
 - 3> initiate the measurement reporting procedure, as specified in 5.5.5;
- 2> if the *reportType* is set to *eventTriggered* and if the leaving condition applicable for this event is fulfilled for one or more of the cells included in the *cellsTriggeredList* defined within the *VarMeasReportList* for this *measId* for all measurements after layer 3 filtering taken during *timeToTrigger* defined within the *VarMeasConfig* for this event:
- 3> remove the concerned cell(s) in the *cellsTriggeredList* defined within the *VarMeasReportList* for this *measId*;
 - 3> if *reportOnLeave* is set to *TRUE* for the corresponding reporting configuration:
 - 4> initiate the measurement reporting procedure, as specified in 5.5.5;
 - 3> if the *cellsTriggeredList* defined within the *VarMeasReportList* for this *measId* is empty:
 - 4> remove the measurement reporting entry within the *VarMeasReportList* for this *measId*;
 - 4> stop the periodical reporting timer for this *measId*, if running;
- ...
- 2> upon expiry of the periodical reporting timer for this *measId*:
- 3> initiate the measurement reporting procedure, as specified in 5.5.5.
- ...

[TS 38.331, clause 5.5.4.7]

The UE shall:

- 1> consider the entering condition for this event to be satisfied when condition A2-1, as specified below, is fulfilled;
- 1> consider the leaving condition for this event to be satisfied when condition A2-2, as specified below, is fulfilled;
- 1> for this measurement, consider the serving cell indicated by the *measObjectNR* associated to this event.

Inequality A2-1 (Entering condition)

$$M_s + H_{ys} < Thresh$$

Inequality A2-2 (Leaving condition)

$$M_s - H_{ys} > Thresh$$

The variables in the formula are defined as follows:

Ms is the measurement result of the serving cell, not taking into account any offsets.

Hys is the hysteresis parameter for this event (i.e. *hysteresis* as defined within *reportConfigNR* for this event).

Thresh is the threshold parameter for this event (i.e. *a2-Threshold* as defined within *reportConfigNR* for this event).

Ms is expressed in dBm in case of RSRP, or in dB in case of RSRQ and RS-SINR.

Hys is expressed in dB.

Thresh is expressed in the same unit as *Ms*.

[TS 38.331, clause 5.5.5]



Figure 5.5.5-1: Measurement reporting

The purpose of this procedure is to transfer measurement results from the UE to the network. The UE shall initiate this procedure only after successful security activation.

For the *measId* for which the measurement reporting procedure was triggered, the UE shall set the *measResults* within the *MeasurementReport* message as follows:

- 1> set the *measId* to the measurement identity that triggered the measurement reporting;
- 1> set the *measResultServingCell* within *measResultServingMOList* to include RSRP, RSRQ and the available SINR for each configured serving cell derived based on the *rsType* indicated in the associated *reportConfig*;
- 1> set the *measResultServingCell* within *measResultServingMOList* to include for each NR serving cell that is configured with *servingCellMO*, if any, the *servCellId*;
- ...
- 1> if the *reportConfig* associated with the *measId* that triggered the measurement reporting includes *reportAddNeighMeas*:
 - 2> for each serving cell *measObjectId* referenced in the *measIdList*, other than the *measObjectId* corresponding with the *measId* that triggered the measurement reporting:
 - 3> set the *measResultBestNeighCell* within *measResultServingMOList* to include the *physCellId* and the available measurement quantities based on the *reportQuantityCell* and *rsType* indicated in *reportConfig* of the non-serving cell corresponding to the concerned *measObjectNR* with the highest measured RSRP if RSRP measurement results are available for cells corresponding to this *measObjectNR*, otherwise with the highest measured RSRQ if RSRQ measurement results are available for cells corresponding to this *measObjectNR*, otherwise with the highest measured SINR;
 - ...
- 1> if there is at least one applicable neighbouring cell to report:
 - 2> set the *measResultNeighCells* to include the best neighbouring cells up to *maxReportCells* in accordance with the following:
 - 3> if the *reportType* is set to *eventTriggered*:

4> include the cells included in the *cellsTriggeredList* as defined within the *VarMeasReportList* for this *measId*;

...

3> for each cell that is included in the *measResultNeighCells*, include the *physCellId*;

3> if the *reportType* is set to *eventTriggered*:

4> for each included cell, include the layer 3 filtered measured results in accordance with the *reportConfig* for this *measId*, ordered as follows:

5> if the *measObject* associated with this *measId* concerns NR:

6> if *rsType* in the associated *reportConfig* is set to *ssb*:

7> set *resultsSSB-Cell* within the *measResult* to include the SS/PBCH block based quantity(ies) indicated in the *reportQuantityCell* within the concerned *reportConfig*, in order of decreasing trigger quantity, i.e. the best cell is included first:

...

1> increment the *numberOfReportsSent* as defined within the *VarMeasReportList* for this *measId* by 1;

1> stop the periodical reporting timer, if running;

1> if the *numberOfReportsSent* as defined within the *VarMeasReportList* for this *measId* is less than the *reportAmount* as defined within the corresponding *reportConfig* for this *measId*:

2> start the periodical reporting timer with the value of *reportInterval* as defined within the corresponding *reportConfig* for this *measId*;

...

1> if the UE is configured with EN-DC:

...

1> else:

2> submit the *MeasurementReport* message to lower layers for transmission, upon which the procedure ends.

8.1.3.1.18.1.3 Test description

8.1.3.1.18.1.3.1 Pre-test conditions

System Simulator:

- NR Cell 1 is the PCell, NR Cell 3 is the SCell to be added, NR Cell 12 (broadcast only cell) and NR Cell 23 (broadcast only cell) is the intra-frequency neighbour cell of NR Cell 3.
- NR Cell 3 is an Inactive SCell according to TS 38.508-1 [4] clause 6.3.1.
- Relative SS signal level uncertainty between Intra-freq cells is +/-1 dB for FR1 and FFS for FR2.
- System information combination NR-5 as defined in TS 38.508-1 [4] clause 4.4.3.1.2 is used in NR cells.

UE:

- None.

Preamble:

- The UE is in state 3N-A as defined in TS 38.508-1 [4], subclause 4.4A.

8.1.3.1.18.1.3.2 Test procedure sequence

Table 8.1.3.1.18.1.3.2-1 and 8.1.3.1.18.1.3.2-2 illustrates the downlink power levels to be applied for NR Cell 1, NR Cell 3, NR Cell 12 and NR Cell 23 at various time instants of the test execution. Row marked "T0" denotes the conditions after the preamble, while the configuration marked "T1" and "T2" are applied at the point indicated in the Main behaviour description in Table 8.1.3.1.18.1.3.2-3.

Table 8.1.3.1.18.1.3.2-1: Time instances of cell power level and parameter changes in FR1

	Parameter	Unit	NR Cell 1	NR Cell 3	NR Cell 12	NR Cell 23	Remark
T0	SS/PBCH SSS EPRE	dBm/ SCS	-72	-72	-91	Off	Power levels are such that entry condition for event A2 is not satisfied: $Ms + Hys > Thresh$ for NR Cell 1 and NR Cell 3
T1	SS/PBCH SSS EPRE	dBm/ SCS	-72	-90	-91	-88	Power levels are such that entry condition for event A2 in NR Cell 3 is satisfied: $Ms + Hys < Thresh$
T2	SS/PBCH SSS EPRE	dBm/ SCS	-90	-72	-69	-73	Power levels are such that entry condition for event A2 in NR Cell 1 is satisfied: $Ms + Hys < Thresh$

Table 8.1.3.1.18.1.3.2-2: Time instances of cell power level and parameter changes in FR2

	Parameter	Unit	NR Cell 1	NR Cell 3	NR Cell 12	NR Cell 23	Remark
T0	SS/PBCH SSS EPRE	dBm/ SCS	FFS	FFS	FFS	Off	Power levels are such that entry condition for event A2 is not satisfied: $Ms + Hys > Thresh$ for NR Cell 1 and NR Cell 3
T1	SS/PBCH SSS EPRE	dBm/ SCS	FFS	FFS	FFS	Off	Power levels are such that entry condition for event A2 in NR Cell 3 is satisfied: $Ms + Hys < Thresh$
T2	SS/PBCH SSS EPRE	dBm/ SCS	FFS	FFS	FFS	FFS	Power levels are such that entry condition for event A2 in NR Cell 1 is satisfied: $Ms + Hys < Thresh$

Table 8.1.3.1.18.1.3.2-3: Main behaviour

St	Procedure	Message Sequence		TP	Verdict
		U - S	Message		
1	The SS transmits an <i>RRCReconfiguration</i> message including <i>sCellToAddModList</i> with NR Cell 3 as SCell addition.	<--	NR RRC: <i>RRCReconfiguration</i>	-	-
2	The UE transmits an <i>RRCReconfigurationComplete</i> message.	-->	NR RRC: <i>RRCReconfigurationComplete</i>	-	-
3	The SS transmits an <i>RRCReconfiguration</i> message including <i>measConfig</i> to setup intra NR measurement and for event A2 reporting configuration and include <i>reportAddNeighMeas</i> .	<--	NR RRC: <i>RRCReconfiguration</i>	-	-
4	The UE transmits an <i>RRCReconfigurationComplete</i> message.	-->	NR RRC: <i>RRCReconfigurationComplete</i>	-	-
5	The SS re-adjusts the SS/PBCH EPRE level according to row "T1" in table 8.1.3.1.18.1.3.2-1/2.	-	-	-	-
6	Check: Does the UE transmit a <i>MeasurementReport</i> message that does not include the RSRP value of the best non-serving cell on the concerned serving frequency in <i>measResultBestNeighCell</i> ?	-->	NR RRC: <i>MeasurementReport</i>	1	P
7	The SS re-adjusts the cell-specific reference signal level according to row "T2" in table 8.1.3.1.18.1.3.2-1/2.	-	-	-	-
8	Check: Does the UE transmit a <i>MeasurementReport</i> message included the RSRP value of the best non-serving cell (NR Cell 12) on the concerned serving frequency in <i>measResultBestNeighCell</i> ?	-->	NR RRC: <i>MeasurementReport</i>	2	P

8.1.3.1.18.1.3.3 Specific message contents

Table 8.1.3.1.18.1.3.3-1: *RRCReconfiguration* (step 1, Table 8.1.3.1.18.1.3.2-3)

Derivation Path: 38.508-1 [4] Table 4.6.1-13			
Information Element	Value/remark	Comment	Condition
<i>RRCReconfiguration</i> ::= SEQUENCE {			
<i>criticalExtensions</i> CHOICE {			
<i>rrcReconfiguration</i> SEQUENCE {			
<i>nonCriticalExtension</i> SEQUENCE{			
<i>masterCellGroup</i>	CellGroupConfig	Table 8.1.3.1.18.1.3.3-2	
}			
}			
}			
}			

Table 8.1.3.1.18.1.3.3-2: *CellGroupConfig* (Table 8.1.3.1.18.1.3.3-1)

Derivation Path: 38.508-1 [4] Table 4.6.3-19			
Information Element	Value/remark	Comment	Condition
<i>CellGroupConfig</i> ::= SEQUENCE {			
<i>rlc-BearerToAddModList</i>	Not present		
<i>sCellToAddModList</i> SEQUENCE (SIZE (1..maxNrofSCells)) OF SEQUENCE {	1 entry		
<i>sCellIndex</i>	1		
<i>sCellConfigCommon</i>	ServingCellConfigCommon	Table 8.1.3.1.18.1.3.3-3	
<i>sCellConfigDedicated</i>	ServingCellConfig		
}			
}			

Table 8.1.3.1.18.1.3.3-3: ServingCellConfigCommon (Table 8.1.3.1.18.1.3.3-2)

Derivation Path: 38.508-1 [4] Table 4.6.3-168			
Information Element	Value/remark	Comment	Condition
ServingCellConfigCommon ::= SEQUENCE {			
physCellId	Physical layer cell identity of NR Cell 3		
}			

Table 8.1.3.1.18.1.3.3-4: RRCReconfiguration (step 3, Table 8.1.3.1.18.1.3.2-3)

Derivation Path: 38.508-1 [4] Table 4.6.1-13			
Information Element	Value/remark	Comment	Condition
RRCReconfiguration ::= SEQUENCE {			
rrc-TransactionIdentifier	RRC-TransactionIdentifier		
criticalExtensions CHOICE {			
rrcReconfiguration ::= SEQUENCE {			
radioBearerConfig	Not present		
secondaryCellGroup	Not present		
measConfig	MeasConfig	Table 8.1.3.1.18.1.3.3-5	
lateNonCriticalExtension	Not present		
nonCriticalExtension	Not present		
}			
}			
}			

Table 8.1.3.1.18.1.3.3-5: *MeasConfig* (Table 8.1.3.1.18.1.3.3-4)

Derivation Path: 38.508-1 [4] Table 4.6.3-69			
Information Element	Value/remark	Comment	Condition
MeasConfig ::= SEQUENCE {			
measObjectToAddModList SEQUENCE (SIZE (1..maxNrofMeasId)) OF SEQUENCE {	2 entries		
measObjectId[1]	1	MeasObjectIdNR-f1	
measObject[1] CHOICE {			
measObjectNR SEQUENCE {			
ssbFrequency	ssbFrequency IE equals the ARFCN for NR Cell 1		
absThreshSS-BlocksConsolidation	Not present		
}			
measObjectId[2]	2	MeasObjectIdNR-f2	
measObject[2] CHOICE {			
measObjectNR SEQUENCE {			
ssbFrequency	ssbFrequency IE equals the ARFCN for NR Cell 3		
absThreshSS-BlocksConsolidation	Not present		
}			
}			
reportConfigToAddModList SEQUENCE (SIZE (1..maxReportConfigId)) OF SEQUENCE {	1 entry		
reportConfigId[1]	1		
reportConfig[1] CHOICE {			
reportConfigNR	ReportConfigNR-EventA2	Table 8.1.3.1.18.1.3.3-6	
}			
}			
measIdToAddModList SEQUENCE (SIZE (1..maxNrofMeasId)) OF SEQUENCE {	2 entries		
measId[1]	1		
measObjectId[1]	1		
reportConfigId[1]	1		
measId[2]	2		
measObjectId[2]	2		
reportConfigId[2]	1		
}			
}			

Table 8.1.3.1.18.1.3.3-6: ReportConfigNR-EventA2 (Table 8.1.3.1.18.1.3.3-5)

Derivation Path: 38.508-1 [4] Table 4.6.3-142 with condition EVENT_A2			
Information Element	Value/remark	Comment	Condition
ReportConfigNR ::= SEQUENCE {			
reportType CHOICE {			
eventTriggered SEQUENCE {			
eventId CHOICE {			
eventA2 SEQUENCE {			
a2-Threshold SEQUENCE {			
rsrp	77	-79dBm	FR1
	FFS		FR2
}			
hysteresis	4	2 dB	
}			
}			
reportAmount	r1		
reportQuantityCell SEQUENCE {			
rsrp	true		
rsrq	false		
sinr	false		
}			
reportAddNeighMeas	setup		
}			
}			

Table 8.1.3.1.18.1.3.3-7: MeasurementReport (step 6, step 8, Table 8.1.3.1.18.1.3.2-3)

Derivation Path: 38.508-1 [4] Table 4.6.1-7			
Information Element	Value/remark	Comment	Condition
MeasurementReport ::= SEQUENCE {			
criticalExtensions CHOICE {			
measurementReport SEQUENCE {			
measResults	MeasResults1	Table 8.1.3.1.18.1.3.3-8	Step 6
	MeasResults2	Table 8.1.3.1.18.1.3.3-9	Step 8
}			
}			
}			

Table 8.1.3.1.18.1.3.3-8: MeasResults1 (Table 8.1.3.1.18.1.3.3-7)

Derivation Path: 38.508-1 [4] Table 4.6.3-79			
Information Element	Value/remark	Comment	Condition
MeasResults ::= SEQUENCE {		Step 6	
measId	2		
measResultServingMOList SEQUENCE (SIZE (1..maxNrofServingCells)) OF SEQUENCE {			
servCellId[1]	ServCellIndex of NR Cell 1		
measResultServingCell[1] SEQUENCE {			
physCellId	Physical layer cell identity of NR Cell 1		
measResult SEQUENCE {			
cellResults SEQUENCE {			
resultsSSB-Cell SEQUENCE {			
rsrp	(0..127)		
rsrq	(0..127)		
}			
}			
}			
servCellId[2]	ServCellIndex of NR Cell 3		
measResultServingCell[2] SEQUENCE {			
physCellId	Physical layer cell identity of NR Cell 3		
measResult SEQUENCE {			
cellResults SEQUENCE {			
resultsSSB-Cell SEQUENCE {			
rsrp	(0..127)		
rsrq	(0..127)		
}			
}			
}			
measResultNeighCells CHOICE {			
measResultListNR SEQUENCE (SIZE (1..maxCellReport)) OF SEQUENCE {			
physCellId[1]	Physical layer cell identity of NR Cell 12	Report NR Cell 12	
measResult[1] SEQUENCE {			
cellResults SEQUENCE {			
resultsSSB-Cell SEQUENCE {			
rsrp	(0..127)		
}			
}			
rsIndexResults	Not present		
}			
physCellId[2]	Physical layer cell identity of NR Cell 23	Report NR Cell 23	
measResult[2] SEQUENCE {			
cellResults SEQUENCE {			
resultsSSB-Cell SEQUENCE {			
rsrp	(0..127)		
}			
}			
rsIndexResults	Not present		
}			
cgi-Info	Not present		
}			
}			

Table 8.1.3.1.18.1.3.3-9: MeasResults2 (Table 8.1.3.1.18.1.3.3-7)

Derivation Path: 38.508-1 [4] Table 4.6.3-79			
Information Element	Value/remark	Comment	Condition
MeasResults ::= SEQUENCE {		Step 8	
measId	1		
measResultServingMOList SEQUENCE (SIZE (1..maxNrofServingCells)) OF SEQUENCE {			
servCellId[1]	ServCellIndex of NR Cell 1		
measResultServingCell[1] SEQUENCE {			
physCellId	Physical layer cell identity of NR Cell 1		
measResult SEQUENCE {			
cellResults SEQUENCE {			
resultsSSB-Cell SEQUENCE {			
rsrp	(0..127)		
rsrq	(0..127)		
}			
}			
}			
servCellId[2]	ServCellIndex of NR Cell 3		
measResultServingCell[2] SEQUENCE {			
physCellId	Physical layer cell identity of NR Cell 3		
measResult SEQUENCE {			
cellResults SEQUENCE {			
resultsSSB-Cell SEQUENCE {			
rsrp	(0..127)		
rsrq	(0..127)		
}			
}			
}			
measResultBestNeighCell SEQUENCE {		Report NR Cell 12	
physCellId	Physical layer cell identity of NR Cell 12		
measResult SEQUENCE {			
cellResults SEQUENCE {			
resultsSSB-Cell SEQUENCE {			
rsrp	(0..127)		
}			
}			
rsIndexResults	Not present		
}			
cgi-Info	Not present		
}			
}			
}			

8.1.3.1.18.2 NR CA / Measurement configuration control and reporting / Intra NR measurements / Additional measurement reporting / Inter-band CA

8.1.3.1.18.2.1 Test Purpose (TP)

Same as TC 8.1.3.1.18.1 but applied to Inter-band CA case.

8.1.3.1.18.2.2 Conformance requirements

Same as TC 8.1.3.1.18.1 but applied to Inter-band CA case.

8.1.3.1.18.2.3 Test description

8.1.3.1.18.2.3.1 Pre-test conditions

Same as test case 8.1.3.1.18.1 with the following differences:

- CA configuration: Inter-band CA replaces Intra-band Contiguous CA.
- Cells configuration: NR Cell 10 replaces NR Cell 3, NR Cell 30 replaces NR Cell 12 and NR Cell 31 replaces NR Cell 23.
- NR Cell 10 is an Inactive SCell according to TS 38.508-1 [4] clause 6.3.1.

8.1.3.1.18.2.3.2 Test procedure sequence

Same as test case 8.1.3.1.18.1 with the following differences:

- CA configuration: Inter-band CA replaces Inter-band Contiguous CA
- Cells configuration: NR Cell 10 replaces NR Cell 3, NR Cell 30 replaces NR Cell 12 and NR Cell 31 replaces NR Cell 23.

8.1.3.1.18.2.3.3 Specific message contents

Same as test case 8.1.3.1.18.1 with the following differences.

NOTE: For simplicity the steps referred below are steps in test case 8.1.3.1.18.1.

Table 8.1.3.1.18.2.3.3-1: MeasConfig (Table 8.1.3.1.18.1.3.3-5)

Derivation Path: 38.508-1 [4] Table 4.6.3-69			
Information Element	Value/remark	Comment	Condition
MeasConfig ::= SEQUENCE {			
measObjectToAddModList SEQUENCE (SIZE (1..maxNrofMeasId)) OF SEQUENCE {	2 entries		
measObjectId[1]	1	MeasObjectIdNR-f1	
measObject[1] CHOICE {			
measObjectNR SEQUENCE {			
ssbFrequency	ssbFrequency IE equals the ARFCN for NR Cell 1		
absThreshSS-BlocksConsolidation	Not present		
}			
measObjectId[2]	2	MeasObjectIdNR-f5	
measObject[2] CHOICE {			
measObjectNR SEQUENCE {			
ssbFrequency	ssbFrequency IE equals the ARFCN for NR Cell 10		
absThreshSS-BlocksConsolidation	Not present		
}			
}			
reportConfigToAddModList SEQUENCE(SIZE (1..maxReportConfigId)) OF SEQUENCE {	1 entry		
reportConfigId[1]	1		
reportConfig[1] CHOICE {			
reportConfigNR	ReportConfigNR-EventA2		
}			
}			
measIdToAddModList SEQUENCE (SIZE (1..maxNrofMeasId)) OF SEQUENCE {	2 entries		
measId[1]	1		
measObjectId[1]	1		
reportConfigId[1]	1		
measId[2]	2		
measObjectId[2]	2		
reportConfigId[2]	1		
}			
}			

8.1.3.1.18.3 NR CA / Measurement configuration control and reporting / Intra NR measurements / Additional measurement reporting / Intra-band non Contiguous CA

8.1.3.1.18.3.1 Test Purpose (TP)

Same as TC 8.1.3.1.18.1 but applied to Intra-band non Contiguous CA case.

8.1.3.1.18.3.2 Conformance requirements

Same as TC 8.1.3.1.18.1 but applied to Intra-band non Contiguous CA case.

8.1.3.1.18.3.3 Test description

8.1.3.1.18.3.3.1 Pre-test conditions

Same as test case 8.1.3.1.18.1 with the following differences:

- CA configuration: Intra-band non Contiguous CA replaces Intra-band Contiguous CA.

- Cells configuration: NR Cell 6 replaces NR Cell 1.

8.1.3.1.18.3.3.2 Test procedure sequence

Same as test case 8.1.3.1.18.1 with the following differences:

- CA configuration: Intra-band non Contiguous CA replaces Inter-band Contiguous CA.
- Cells configuration: NR Cell 6 replaces NR Cell 1.

8.1.3.1.18.3.3.3 Specific message contents

Same as test case 8.1.3.1.18.1 with the following differences.

NOTE: For simplicity the steps referred below are steps in test case 8.1.3.1.17.1.

Table 8.1.3.1.18.3.3-1: MeasConfig (Table 8.1.3.1.18.1.3.3-5)

Derivation Path: 38.508-1 [4] Table 4.6.3-69			
Information Element	Value/remark	Comment	Condition
MeasConfig ::= SEQUENCE {			
measObjectToAddModList SEQUENCE (SIZE (1..maxNrofMeasId)) OF SEQUENCE {	2 entries		
measObjectId[1]	1	MeasObjectIdNR-f3	
measObject[1] CHOICE {			
measObjectNR SEQUENCE {			
ssbFrequency	ssbFrequency IE equals the ARFCN for NR Cell 6		
absThreshSS-BlocksConsolidation	Not present		
}			
measObjectId[2]	2	MeasObjectIdNR-f2	
measObject[2] CHOICE {			
measObjectNR SEQUENCE {			
ssbFrequency	ssbFrequency IE equals the ARFCN for NR Cell 3		
absThreshSS-BlocksConsolidation	Not present		
}			
}			
reportConfigToAddModList SEQUENCE(SIZE (1..maxReportConfigId)) OF SEQUENCE {	1 entry		
reportConfigId[1]	1		
reportConfig[1] CHOICE {			
reportConfigNR	ReportConfigNR-EventA2		
}			
}			
measIdToAddModList SEQUENCE (SIZE (1..maxNrofMeasId)) OF SEQUENCE {	2 entries		
measId[1]	1		
measObjectId[1]	1		
reportConfigId[1]	1		
measId[2]	2		
measObjectId[2]	2		
reportConfigId[2]	1		
}			
}			

8.1.3.2

8.1.3.2.1 Measurement configuration control and reporting / Inter-RAT measurements / Event B1 / Measurement of E-UTRA cells

8.1.3.2.1.1 Test Purpose (TP)

(1)

```

with { UE is NR RRC_CONNECTED state and inter-RAT measurement event B1 to measure neighbour E-UTRA
cell is configured }
ensure that {
  when { Entering condition for the event B1 is not met }
  then { UE does not transmit any MeasurementReport }
}

```

(2)

```

with { UE is NR RRC_CONNECTED state and inter-RAT measurement event B1 to measure neighbour E-UTRA
cell is configured }
ensure that {
  when { Entering condition for the event B1 is met }
  then { UE transmits a MeasurementReport }
}

```

8.1.3.2.1.2 Conformance requirements

References: The conformance requirements covered in the current TC are specified in: TS 38.331, clauses 5.3.5.3, 5.5.2, 5.5.4.1, 5.5.4.8 and 5.5.5. Unless otherwise stated these are Rel-15 requirements.

[TS 38.331, clause 5.3.5.3]

The UE shall perform the following actions upon reception of the *RRCReconfiguration*:

...

1> if the *RRCReconfiguration* message includes the *measConfig*:

2> perform the measurement configuration procedure as specified in 5.5.2;

...

1> if the UE is configured with E-UTRA *nr-SecondaryCellGroupConfig* (MCG is E-UTRA):

2> if *RRCReconfiguration* was received via SRB1:

3> submit the *RRCReconfigurationComplete* via the EUTRA MCG embedded in E-UTRA RRC message *RRCConnectionReconfigurationComplete* as specified in TS 36.331 [10];

3> if *reconfigurationWithSync* was included in *spCellConfig* of an SCG:

5. 4> initiate the random access procedure on the SpCell, as specified in TS 38.321 [3];

3> else:

6. 4> the procedure ends;

NOTE: The order the UE sends the *RRCConnectionReconfigurationComplete* message and performs the Random Access procedure towards the SCG is left to UE implementation.

2> else (*RRCReconfiguration* was received via SRB3):

3> submit the *RRCReconfigurationComplete* message via SRB3 to lower layers for transmission using the new configuration;

NOTE: For EN-DC, in the case *RRCReconfiguration* is received via SRB1, the random access is triggered by RRC layer itself as there is not necessarily other UL transmission. In the case *RRCReconfiguration* is received via SRB3, the random access is triggered by the MAC layer due to arrival of *RRCReconfigurationComplete*.

1> else:

- 2> submit the *RRCReconfigurationComplete* message via SRB1 to lower layers for transmission using the new configuration;
- 2> if this is the first *RRCReconfiguration* message after successful completion of the RRC re-establishment procedure;
 - 3> resume SRB1 and DRBs that are suspended;

...

[TS 38.331, clause 5.5.2.1]

...

The UE shall:

...

- 1> if the received *measConfig* includes the *measObjectToAddModList*:
 - 2> perform the measurement object addition/modification procedure as specified in 5.5.2.5;
- ...
- 1> if the received *measConfig* includes the *reportConfigToAddModList*:
 - 2> perform the reporting configuration addition/modification procedure as specified in 5.5.2.7;
- ...
- 1> if the received *measConfig* includes the *measIdToAddModList*:
 - 2> perform the measurement identity addition/modification procedure as specified in 5.5.2.3;
- 1> if the received *measConfig* includes the *measGapConfig*:
 - 2> perform the measurement gap configuration procedure as specified in 5.5.2.9;

...

[TS 38.331, clause 5.5.2.9]

The UE shall:

- 1> if *gapFR1* is set to setup:
 - 2> if an FR1 measurement gap configuration is already setup, release the FR1 measurement gap configuration;
 - 2> setup the FR1 measurement gap configuration indicated by the *measGapConfig* in accordance with the received *gapOffset*, i.e., the first subframe of each gap occurs at an SFN and subframe meeting the following condition:
 - SFN mod $T = \text{FLOOR}(\text{gapOffset}/10)$;
 - subframe = $\text{gapOffset} \bmod 10$;
 - with $T = \text{MGRP}/10$ as defined in TS 38.133 [14];
 - 2> if *mgta* is configured, apply the specified timing advance to the gap occurrences calculated above (i.e. the UE starts the measurement *mgta* ms before the gap subframe occurrences);

1> else if *gapFR1* is set to release:

2> release the FR1 measurement gap configuration;

1> if *gapFR2* is set to setup:

2> if an FR2 measurement gap configuration is already setup, release the FR2 measurement gap configuration;

2> setup the FR2 measurement gap configuration indicated by the *measGapConfig* in accordance with the received *gapOffset*, i.e., the first subframe of each gap occurs at an SFN and subframe meeting the following condition:

$$\text{SFN mod } T = \text{FLOOR}(\text{gapOffset}/10);$$

$$\text{subframe} = \text{gapOffset mod } 10;$$

with $T = \text{MGRP}/10$ as defined in TS 38.133 [14];

2> if *mgta* is configured, apply the specified timing advance to the gap occurrences calculated above (i.e. the UE starts the measurement *mgta* ms before the gap subframe occurrences);

1> else if *gapFR2* is set to release:

2> release the FR2 measurement gap configuration;

1> if *gapUE* is set to setup:

2> if a per UE measurement gap configuration is already setup, release the per UE measurement gap configuration;

2> setup the per UE measurement gap configuration indicated by the *measGapConfig* in accordance with the received *gapOffset*, i.e., the first subframe of each gap occurs at an SFN and subframe meeting the following condition:

$$\text{SFN mod } T = \text{FLOOR}(\text{gapOffset}/10);$$

$$\text{subframe} = \text{gapOffset mod } 10;$$

with $T = \text{MGRP}/10$ as defined in TS 38.133 [14];

2> if *mgta* is configured, apply the specified timing advance to the gap occurrences calculated above (i.e. the UE starts the measurement *mgta* ms before the gap subframe occurrences);

1> else if *gapUE* is set to release:

2> release the per UE measurement gap configuration.

NOTE 1: For *gapFR2* configuration, the SFN and subframe of a serving cell on FR2 frequency is used in the gap calculation

NOTE 2: For *gapFR1* or *gapUE* configuration, the SFN and subframe of the PCell is used in the gap calculation.

[TS 38.331, clause 5.5.4.1]

If security has been activated successfully, the UE shall:

1> for each *measId* included in the *measIdList* within *VarMeasConfig*:

2> if the corresponding *reportConfig* includes a *reportType* set to *eventTriggered* or *periodical*;

3> if the corresponding *measObject* concerns NR;

...

4> for measurement events other than *eventA1* or *eventA2*:

5> if *useWhiteCellList* is set to TRUE;

- 6> consider any neighbouring cell detected based on parameters in the associated *measObjectNRto* to be applicable when the concerned cell is included in the *whiteCellsToAddModList* defined within the *VarMeasConfig* for this *measId*;
- 5> else:
 - 6> consider any neighbouring cell detected based on parameters in the associated *measObjectNRto* to be applicable when the concerned cell is not included in the *blackCellsToAddModList* defined within the *VarMeasConfig* for this *measId*;
- 3> else if the corresponding *measObject* concerns E-UTRA;
 - 4> consider any neighbouring cell detected on the associated frequency to be applicable when the concerned cell is not included in the *blackCellsToAddModListEUTRAN* defined within the *VarMeasConfig* for this *measId*;
- ...
- 2> if the *reportType* is set to *eventTriggered* and if the entry condition applicable for this event, i.e. the event corresponding with the *eventId* of the corresponding *reportConfig* within *VarMeasConfig*, is fulfilled for one or more applicable cells for all measurements after layer 3 filtering taken during *timeToTrigger* defined for this event within the *VarMeasConfig*, while the *VarMeasReportList* does not include a measurement reporting entry for this *measId* (a first cell triggers the event):
 - 3> include a measurement reporting entry within the *VarMeasReportList* for this *measId*;
 - 3> set the *numberOfReportsSent* defined within the *VarMeasReportList* for this *measId* to 0;
 - 3> include the concerned cell(s) in the *cellsTriggeredList* defined within the *VarMeasReportList* for this *measId*;
 - 3> initiate the measurement reporting procedure, as specified in 5.5.5;
- 2> else if the *reportType* is set to *eventTriggered* and if the entry condition applicable for this event, i.e. the event corresponding with the *eventId* of the corresponding *reportConfig* within *VarMeasConfig*, is fulfilled for one or more applicable cells not included in the *cellsTriggeredList* for all measurements after layer 3 filtering taken during *timeToTrigger* defined for this event within the *VarMeasConfig* (a subsequent cell triggers the event):
 - 3> set the *numberOfReportsSent* defined within the *VarMeasReportList* for this *measId* to 0;
 - 3> include the concerned cell(s) in the *cellsTriggeredList* defined within the *VarMeasReportList* for this *measId*;
 - 3> initiate the measurement reporting procedure, as specified in 5.5.5;
- 2> else if the *reportType* is set to *eventTriggered* and if the leaving condition applicable for this event is fulfilled for one or more of the cells included in the *cellsTriggeredList* defined within the *VarMeasReportList* for this *measId* for all measurements after layer 3 filtering taken during *timeToTrigger* defined within the *VarMeasConfig* for this event:
 - 3> remove the concerned cell(s) in the *cellsTriggeredList* defined within the *VarMeasReportList* for this *measId*;
 - 3> if *reportOnLeave* is set to *TRUE* for the corresponding reporting configuration:
 - 4> initiate the measurement reporting procedure, as specified in 5.5.5;
 - 3> if the *cellsTriggeredList* defined within the *VarMeasReportList* for this *measId* is empty:
 - 4> remove the measurement reporting entry within the *VarMeasReportList* for this *measId*;
 - 4> stop the periodical reporting timer for this *measId*, if running;
- ...
- 2> upon the expiry of T321 for this *measId*:

- 3> include a measurement reporting entry within the *VarMeasReportList* for this *measId*;
- 3> set the *numberOfReportsSent* defined within the *VarMeasReportList* for this *measId* to 0;
- 3> initiate the measurement reporting procedure, as specified in 5.5.5.

[TS 38.331, clause 5.5.4.8]

The UE shall:

- 1> consider the entering condition for this event to be satisfied when condition B1-1, as specified below, is fulfilled;
- 1> consider the leaving condition for this event to be satisfied when condition B1-2, as specified below, is fulfilled;

Inequality B1-1 (Entering condition)

$$Mn + Ofn + Ocn - Hys > Thresh$$

Inequality B1-2 (Leaving condition)

$$Mn + Ofn + Ocn + Hys < Thresh$$

The variables in the formula are defined as follows:

Mn is the measurement result of the inter-RAT neighbour cell, not taking into account any offsets.

Ofn is the measurement object specific offset of the frequency of the inter-RAT neighbour cell (i.e. *eutra-Q-OffsetRange* as defined within the *measObjectEUTRA* corresponding to the frequency of the neighbour inter-RAT cell).

Ocn is the cell specific offset of the inter-RAT neighbour cell (i.e. *cellIndividualOffset* as defined within the *measObjectEUTRA* corresponding to the neighbour inter-RAT cell), and set to zero if not configured for the neighbour cell.

Hys is the hysteresis parameter for this event (i.e. *hysteresis* as defined within *reportConfigInterRAT* for this event).

Thresh is the threshold parameter for this event (i.e. *b1-ThresholdEUTRA* as defined within *reportConfigInterRAT* for this event).

Mn is expressed in dBm or in dB, depending on the measurement quantity of the inter-RAT neighbour cell.

Ofn*, *Ocn*, *Hys are expressed in dB.

Thresh is expressed in the same unit as ***Mn***.

[TS 38.331, clause 5.5.5]



Figure 5.5.5-1: Measurement reporting

The purpose of this procedure is to transfer measurement results from the UE to the network. The UE shall initiate this procedure only after successful security activation.

For the *measId* for which the measurement reporting procedure was triggered, the UE shall set the *measResults* within the *MeasurementReport* message as follows:

- 1> set the *measId* to the measurement identity that triggered the measurement reporting;

- 1> set the *measResultServingCell* within *measResultServingMOList* to include, for each NR serving cell that is configured with *servingCellMO*, RSRP, RSRQ and the available SINR, derived based on the *rsType* if indicated in the associated *reportConfig*, otherwise based on SSB if available, otherwise based on CSI-RS;
- 1> set the *measResultServingCell* within *measResultServingMOList* to include for each NR serving cell that is configured with *servingCellMO*, if any, the *servCellId*;
- 1> if the *reportConfig* associated with the *measId* that triggered the measurement reporting includes *reportQuantityRsIndexes* and *maxNrofRSIndexesToReport*:
 - 2> for each serving cell configured with *servingCellMO*, include beam measurement information according to the associated *reportConfig* as described in 5.5.5.2;
- ...
- 1> if there is at least one applicable neighbouring cell to report:
 - 2> if the *reportType* is set to *eventTriggered* or *periodical*:
 - 3> set the *measResultNeighCells* to include the best neighbouring cells up to *maxReportCells* in accordance with the following:
 - 4> if the *reportType* is set to *eventTriggered*:
 - 5> include the cells included in the *cellsTriggeredList* as defined within the *VarMeasReportList* for this *measId*;
 - ...
 - 4> for each cell that is included in the *measResultNeighCells*, include the *physCellId*;
 - 4> if the *reportType* is set to *eventTriggered* or *periodical*:
 - 5> for each included cell, include the layer 3 filtered measured results in accordance with the *reportConfig* for this *measId*, ordered as follows:
 - 6> if the *measObject* associated with this *measId* concerns NR:
 - 7> if *rsType* in the associated *reportConfig* is set to *ssb*:
 - 8> set *resultsSSB-Cell* within the *measResult* to include the SS/PBCH block based quantity(ies) indicated in the *reportQuantityCell* within the concerned *reportConfig*, in decreasing order of the sorting quantity, determined as specified in 5.5.5.3, i.e. the best cell is included first;
 - 9> if *reportQuantityRsIndexes* and *maxNrofRSIndexesToReport* are configured, include beam measurement information as described in 5.5.5.2;
 - ...
 - 6> if the *measObject* associated with this *measId* concerns E-UTRA:
 - 7> set the *measResult* to include the quantity(ies) indicated in the *reportQuantity* within the concerned *reportConfigInterRAT* in decreasing order of the sorting quantity, determined as specified in 5.5.5.3, i.e. the best cell is included first;
 - ...
 - 1> increment the *numberOfReportsSent* as defined within the *VarMeasReportList* for this *measId* by 1;
 - 1> stop the periodical reporting timer, if running;
 - ...
 - 1> if the UE is configured with EN-DC:
 - 2> if SRB3 is configured:

3> submit the *MeasurementReport* message via SRB3 to lower layers for transmission, upon which the procedure ends;

2> else:

3> submit the *MeasurementReport* message via the EUTRA MCG embedded in E-UTRA RRC message *ULInformationTransferMRDC* as specified in TS 36.331 [10].

1> else:

2> submit the *MeasurementReport* message to lower layers for transmission, upon which the procedure ends.

8.1.3.2.1.3 Test description

8.1.3.2.1.3.1 Pre-test conditions

System Simulator:

- NR Cell 1 is the PCell, E-UTRA Cell 1 is the inter-RAT neighbour cell of NR Cell 1.
- System information combination NR-6 as defined in TS 38.508-1 [4] clause 4.4.3.1.2.

UE:

- None.

Preamble:

- The UE is in state 3N-A as defined in TS 38.508-1 [4], subclause 4.4A.

8.1.3.2.1.3.2 Test procedure sequence

Table 8.1.3.2.1.3.2-1 and 8.1.3.2.1.3.2-2 illustrates the downlink power levels to be applied for NR Cell 1, and E-UTRA Cell 1 at various time instants of the test execution. Row marked "T0" denotes the conditions after the preamble, while the configuration marked "T1" is applied at the point indicated in the Main behaviour description in Table 8.1.3.2.1.3.2-3.

Table 8.1.3.2.1.3.2-1: Time instances of cell power level and parameter changes for FR1

	Parameter	Unit	NR Cell 1	E-UTRA Cell 1	Remark
T0	SS/PBCH SSS EPRE	dBm/SCS	-85	-	Power levels are such that entry condition for event B1 is not satisfied: $Mn + Ofn + Ocn + Hys < Thresh$
	Cell-specific RS EPRE	dBm/15 kHz		-93	
T1	SS/PBCH SSS EPRE	dBm/SCS	-85	-	Power levels are such that entry condition for event B1 is satisfied: $Mn + Ofn + Ocn - Hys > Thresh$
	Cell-specific RS EPRE	dBm/15 kHz		-73	

Table 8.1.3.2.1.3.2-2: Time instances of cell power level and parameter changes for FR2

	Parameter	Unit	NR Cell 1	E-UTRA Cell 1	Remark
T0	SS/PBCH SSS EPRE	dBm/SCS	FFS	-	Power levels are such that entry condition for event B1 is not satisfied: $Mn + Ofn + Ocn + Hys < Thresh$
	Cell-specific RS EPRE	dBm/15 kHz		FFS	
T1	SS/PBCH SSS EPRE	dBm/SCS	FFS	-	Power levels are such that entry condition for event B1 is satisfied: $Mn + Ofn + Ocn - Hys > Thresh$
	Cell-specific RS EPRE	dBm/15 kHz		FFS	

Table 8.1.3.2.1.3.2-3: Main behaviour

St	Procedure	Message Sequence		TP	Verdict
		U - S	Message		
1	The SS transmits an <i>RRCReconfiguration</i> message including <i>MeasConfig</i> to setup inter-RAT measurement and reporting for event B1.	<--	NR RRC: <i>RRCReconfiguration</i>	-	-
2	The UE transmits an <i>RRCReconfigurationComplete</i> message.	-->	NR RRC: <i>RRCReconfigurationComplete</i>	-	-
3	Check: Does the UE transmit a <i>MeasurementReport</i> message within the next 10s?	-->	NR RRC: <i>MeasurementReport</i>	2	F
4	SS re-adjusts the cell-specific reference signal level according to row "T1" in table 8.1.3.2.1.3.2-1/2.	-	-	-	-
5	Check: Does the UE transmit a <i>MeasurementReport</i> message to report event B1 with the measured RSRP value for NR Cell 1?	-->	NR RRC: <i>MeasurementReport</i>	1	P

8.1.3.2.1.3.3 Specific message contents

Table 8.1.3.2.1.3.3-1: *RRCReconfiguration* (step 1, Table 8.1.3.2.1.3.2-3)

Derivation Path: 38.508-1 [4] Table 4.6.1-13			
Information Element	Value/remark	Comment	Condition
<i>RRCReconfiguration</i> ::= SEQUENCE {			
<i>rrc-TransactionIdentifier</i>	RRC-TransactionIdentifier		
<i>criticalExtensions</i> CHOICE {			
<i>rrcReconfiguration</i> ::= SEQUENCE {			
<i>radioBearerConfig</i>	Not present		
<i>secondaryCellGroup</i>	Not present		
<i>measConfig</i>	MeasConfig	Table 8.1.3.2.1.3.3-2	
<i>lateNonCriticalExtension</i>	Not present		
<i>nonCriticalExtension</i>	Not present		
}			
}			
}			

Table 8.1.3.2.1.3.3-2: *MeasConfig* (Table 8.1.3.2.1.3.3-1)

Derivation Path: 38.508-1 [4] Table 4.6.3-69			
Information Element	Value/remark	Comment	Condition
MeasConfig ::= SEQUENCE {			
measObjectToAddModList SEQUENCE (SIZE (1..maxNrofMeasId)) OF SEQUENCE {	2 entries		
measObjectId[1]	1	MeasObjectIdNR-f1	
measObject[1] CHOICE {			
measObjectNR SEQUENCE {			
ssbFrequency	ssbFrequency IE equals the ARFCN for NR Cell 1		
absThreshSS-BlocksConsolidation	Not present		
}			
}			
measObjectId[2]	2	MeasObjectIdE-UTRA-f1	
measObject[2] CHOICE {			
measObjectEUTRA SEQUENCE {			
carrierFreq	ARFCN-ValueEUTRA for E-UTRA Cell 1		
}			
}			
reportConfigToAddModList SEQUENCE(SIZE (1..maxReportConfigId)) OF SEQUENCE {	1 entry		
reportConfigId[1]	1		
reportConfig[1] CHOICE {			
reportConfigInterRAT	ReportConfigInterRAT-EventB1	Table 8.1.3.2.1.3.3-3	
}			
}			
measIdToAddModList SEQUENCE (SIZE (1..maxNrofMeasId)) OF SEQUENCE {	1 entry		
measId[1]	1		
measObjectId[1]	2		
reportConfigId[1]	1		
}			
quantityConfig	QuantityConfig with condition INTER-RAT		
measGapConfig	MeasGapConfig		
}			

Table 8.1.3.2.1.3.3-3: *ReportConfigInterRAT-EventB1* (Table 8.1.3.2.1.3.3-2)

Derivation Path: 38.508-1 [4] Table 4.6.3-142 with condition EVENT_B1			
Information Element	Value/remark	Comment	Condition
ReportConfigNR ::= SEQUENCE {			
reportType CHOICE {			
eventTriggered SEQUENCE {			
eventId CHOICE {			
eventB1 SEQUENCE {			
b1-ThresholdEUTRA SEQUENCE {			
rsrp	76	-80dBm	FR1
	FFS	FFS	FR2
}			
hysteresis	4	2 dB	
}			
}			
}			
reportAmount	r1		
}			

Table 8.1.3.2.1.3.3-4: MeasurementReport (step 5, Table 8.1.3.2.1.3.2-3)

Derivation Path: 38.508-1 [4] Table 4.6.1-7			
Information Element	Value/remark	Comment	Condition
MeasurementReport ::= SEQUENCE {			
criticalExtensions CHOICE {			
measurementReport SEQUENCE {			
measResults SEQUENCE {			
measId	1		Step 5
measResultServingMOList SEQUENCE (SIZE (1..maxNrofServingCells)) OF SEQUENCE {		Report NR Cell 1	
servCellId	ServCellIndex of NR Cell 1		
measResultServingCell SEQUENCE {			
physCellId	Physical layer cell identity of NR Cell 1		
measResult SEQUENCE {			
cellResults SEQUENCE {			
resultsSSB-Cell SEQUENCE {			
rsrp	(0..127)		
rsrq	(0..127)		
}			
}			
}			
}			
}			
}			
measResultNeighCells CHOICE {			
measResultListEUTRA SEQUENCE (SIZE (1..maxCellReport)) OF SEQUENCE {		Report E-UTRA neighbour cell	
eutra-PhysCellId	Physical layer cell identity of E-UTRA Cell 1		Step 5
measResult SEQUENCE {			
rsrp	(0..97)		
}			
}			
}			
}			

8.1.3.2.2 Measurement configuration control and reporting / Inter-RAT measurements / Event B2 / Measurement of E-UTRA cells

8.1.3.2.2.1 Test Purpose (TP)

(1)

```
with { UE is NR RRC_CONNECTED state and inter-RAT measurement event B2 to measure neighbor E-UTRA cell is configured }
ensure that {
  when { Entering condition 1 for event B2 is not met but Entering condition 2 is met }
  then { UE does not transmit any MeasurementReport }
}
```

(2)

```
with { UE is NR RRC_CONNECTED state and inter-RAT measurement event B2 to measure neighbor E-UTRA cell is configured }
ensure that {
  when { Entering condition 1 and 2 for event B2 is met }
  then { UE transmits a MeasurementReport }
}
```

8.1.3.2.2.2 Conformance requirements

References: The conformance requirements covered in the current TC are specified in: TS 38.331, clauses 5.3.5.3, 5.5.2, 5.5.4.1, 5.5.4.9 and 5.5.5. Unless otherwise stated these are Rel-15 requirements.

[TS 38.331, clause 5.3.5.3]

The UE shall perform the following actions upon reception of the *RRCReconfiguration*:

...

1> if the *RRCReconfiguration* message includes the *measConfig*:

2> perform the measurement configuration procedure as specified in 5.5.2;

...

1> if the UE is configured with E-UTRA *nr-SecondaryCellGroupConfig* (MCG is E-UTRA):

2> if *RRCReconfiguration* was received via SRB1:

3> submit the *RRCReconfigurationComplete* via the EUTRA MCG embedded in E-UTRA RRC message *RRCConnectionReconfigurationComplete* as specified in TS 36.331 [10];

3> if *reconfigurationWithSync* was included in *spCellConfig* of an SCG:

7. 4> initiate the random access procedure on the SpCell, as specified in TS 38.321 [3];

3> else:

8. 4> the procedure ends;

NOTE: The order the UE sends the *RRCConnectionReconfigurationComplete* message and performs the Random Access procedure towards the SCG is left to UE implementation.

2> else (*RRCReconfiguration* was received via SRB3):

3> submit the *RRCReconfigurationComplete* message via SRB3 to lower layers for transmission using the new configuration;

NOTE: For EN-DC, in the case *RRCReconfiguration* is received via SRB1, the random access is triggered by RRC layer itself as there is not necessarily other UL transmission. In the case *RRCReconfiguration* is received via SRB3, the random access is triggered by the MAC layer due to arrival of *RRCReconfigurationComplete*.

1> else:

2> submit the *RRCReconfigurationComplete* message via SRB1 to lower layers for transmission using the new configuration;

2> if this is the first *RRCReconfiguration* message after successful completion of the RRC re-establishment procedure;

3> resume SRB2 and DRBs that are suspended;

...

[TS 38.331, clause 5.5.2.1]

...

The UE shall:

...

1> if the received *measConfig* includes the *measObjectToAddModList*:

2> perform the measurement object addition/modification procedure as specified in 5.5.2.5;

...

- 1> if the received *measConfig* includes the *reportConfigToAddModList*:
 - 2> perform the reporting configuration addition/modification procedure as specified in 5.5.2.7;

...

- 1> if the received *measConfig* includes the *measIdToAddModList*:
 - 2> perform the measurement identity addition/modification procedure as specified in 5.5.2.3;

- 1> if the received *measConfig* includes the *measGapConfig*:
 - 2> perform the measurement gap configuration procedure as specified in 5.5.2.9;

...

[TS 38.331, clause 5.5.2.9]

The UE shall:

- 1> if *gapFR1* is set to setup:
 - 2> if an FR1 measurement gap configuration is already setup, release the FR1 measurement gap configuration;
 - 2> setup the FR1 measurement gap configuration indicated by the *measGapConfig* in accordance with the received *gapOffset*, i.e., the first subframe of each gap occurs at an SFN and subframe meeting the following condition:
 - SFN mod $T = \text{FLOOR}(\text{gapOffset}/10)$;
 - subframe = $\text{gapOffset} \bmod 10$;
 - with $T = \text{MGRP}/10$ as defined in TS 38.133 [14];
 - 2> if *mgta* is configured, apply the specified timing advance to the gap occurrences calculated above (i.e. the UE starts the measurement *mgta* ms before the gap subframe occurrences);
- 1> else if *gapFR1* is set to release:
 - 2> release the FR1 measurement gap configuration;
- 1> if *gapFR2* is set to setup:
 - 2> if an FR2 measurement gap configuration is already setup, release the FR2 measurement gap configuration;
 - 2> setup the FR2 measurement gap configuration indicated by the *measGapConfig* in accordance with the received *gapOffset*, i.e., the first subframe of each gap occurs at an SFN and subframe meeting the following condition:
 - SFN mod $T = \text{FLOOR}(\text{gapOffset}/10)$;
 - subframe = $\text{gapOffset} \bmod 10$;
 - with $T = \text{MGRP}/10$ as defined in TS 38.133 [14];
 - 2> if *mgta* is configured, apply the specified timing advance to the gap occurrences calculated above (i.e. the UE starts the measurement *mgta* ms before the gap subframe occurrences);
- 1> else if *gapFR2* is set to release:
 - 2> release the FR2 measurement gap configuration;
- 1> if *gapUE* is set to setup:
 - 2> if a per UE measurement gap configuration is already setup, release the per UE measurement gap configuration;

- 2> setup the per UE measurement gap configuration indicated by the *measGapConfig* in accordance with the received *gapOffset*, i.e., the first subframe of each gap occurs at an SFN and subframe meeting the following condition:

$$\text{SFN mod } T = \text{FLOOR}(\text{gapOffset}/10);$$

$$\text{subframe} = \text{gapOffset mod } 10;$$

with $T = \text{MGRP}/10$ as defined in TS 38.133 [14];

- 2> if *mgta* is configured, apply the specified timing advance to the gap occurrences calculated above (i.e. the UE starts the measurement *mgta* ms before the gap subframe occurrences);

- 1> else if *gapUE* is set to release:

- 2> release the per UE measurement gap configuration.

NOTE 1: For *gapFR2* configuration, the SFN and subframe of a serving cell on FR2 frequency is used in the gap calculation

NOTE 2: For *gapFR1* or *gapUE* configuration, the SFN and subframe of the PCell is used in the gap calculation.

[TS 38.331, clause 5.5.4.1]

If security has been activated successfully, the UE shall:

- 1> for each *measId* included in the *measIdList* within *VarMeasConfig*:
- 2> if the corresponding *reportConfig* includes a *reportType* set to *eventTriggered* or *periodical*;
- 3> if the corresponding *measObject* concerns NR;
- ...
9. 4> for measurement events other than *eventA1* or *eventA2*:
- 5> if *useWhiteCellList* is set to TRUE:
- 6> consider any neighbouring cell detected based on parameters in the associated *measObjectNRto* be applicable when the concerned cell is included in the *whiteCellsToAddModList* defined within the *VarMeasConfig* for this *measId*;
- 5> else:
- 6> consider any neighbouring cell detected based on parameters in the associated *measObjectNRto* be applicable when the concerned cell is not included in the *blackCellsToAddModList* defined within the *VarMeasConfig* for this *measId*;
- 3> else if the corresponding *measObject* concerns E-UTRA;
10. 4> consider any neighbouring cell detected on the associated frequency to be applicable when the concerned cell is not included in the *blackCellsToAddModListEUTRAN* defined within the *VarMeasConfig* for this *measId*;
- ...
- 2> if the *reportType* is set to *eventTriggered* and if the entry condition applicable for this event, i.e. the event corresponding with the *eventId* of the corresponding *reportConfig* within *VarMeasConfig*, is fulfilled for one or more applicable cells for all measurements after layer 3 filtering taken during *timeToTrigger* defined for this event within the *VarMeasConfig*, while the *VarMeasReportList* does not include a measurement reporting entry for this *measId* (a first cell triggers the event):
- 3> include a measurement reporting entry within the *VarMeasReportList* for this *measId*;
- 3> set the *numberOfReportsSent* defined within the *VarMeasReportList* for this *measId* to 0;

- 3> include the concerned cell(s) in the *cellsTriggeredList* defined within the *VarMeasReportList* for this *measId*;
- 3> initiate the measurement reporting procedure, as specified in 5.5.5;
- 2> else if the *reportType* is set to *eventTriggered* and if the entry condition applicable for this event, i.e. the event corresponding with the *eventId* of the corresponding *reportConfig* within *VarMeasConfig*, is fulfilled for one or more applicable cells not included in the *cellsTriggeredList* for all measurements after layer 3 filtering taken during *timeToTrigger* defined for this event within the *VarMeasConfig* (a subsequent cell triggers the event):
 - 3> set the *numberOfReportsSent* defined within the *VarMeasReportList* for this *measId* to 0;
 - 3> include the concerned cell(s) in the *cellsTriggeredList* defined within the *VarMeasReportList* for this *measId*;
 - 3> initiate the measurement reporting procedure, as specified in 5.5.5;
- 2> else if the *reportType* is set to *eventTriggered* and if the leaving condition applicable for this event is fulfilled for one or more of the cells included in the *cellsTriggeredList* defined within the *VarMeasReportList* for this *measId* for all measurements after layer 3 filtering taken during *timeToTrigger* defined within the *VarMeasConfig* for this event:
 - 3> remove the concerned cell(s) in the *cellsTriggeredList* defined within the *VarMeasReportList* for this *measId*;
 - 3> if *reportOnLeave* is set to *TRUE* for the corresponding reporting configuration:
 - 4> initiate the measurement reporting procedure, as specified in 5.5.5;
 - 3> if the *cellsTriggeredList* defined within the *VarMeasReportList* for this *measId* is empty:
 - 4> remove the measurement reporting entry within the *VarMeasReportList* for this *measId*;
 - 4> stop the periodical reporting timer for this *measId*, if running;
- ...
- 2> upon the expiry of T321 for this *measId*:
 - 3> include a measurement reporting entry within the *VarMeasReportList* for this *measId*;
 - 3> set the *numberOfReportsSent* defined within the *VarMeasReportList* for this *measId* to 0;
 - 3> initiate the measurement reporting procedure, as specified in 5.5.5.

[TS 38.331, clause 5.5.4.9]

The UE shall:

- 1> consider the entering condition for this event to be satisfied when both condition B2-1 and condition B2-2, as specified below, are fulfilled;
- 1> consider the leaving condition for this event to be satisfied when condition B2-3 or condition B2-4, i.e. at least one of the two, as specified below, is fulfilled;

Inequality B2-1 (Entering condition 1)

$$M_p + H_{ys} < Thresh1$$

Inequality B2-2 (Entering condition 2)

$$M_n + O_{fn} + O_{cn} - H_{ys} > Thresh2$$

Inequality B2-3 (Leaving condition 1)

$$M_p - H_{ys} > Thresh1$$

Inequality B2-4 (Leaving condition 2)

$$Mn + Ofn + Ocn + Hys < Thresh2$$

The variables in the formula are defined as follows:

Mp is the measurement result of the PCell, not taking into account any offsets.

Mn is the measurement result of the inter-RAT neighbour cell, not taking into account any offsets.

Ofn is the measurement object specific offset of the frequency of the inter-RAT neighbour cell (i.e. *eutra-Q-OffsetRange* as defined within the *measObjectEUTRA* corresponding to the frequency of the inter-RAT neighbour cell).

Ocn is the cell specific offset of the inter-RAT neighbour cell (i.e. *cellIndividualOffset* as defined within the *measObjectEUTRA* corresponding to the neighbour inter-RAT cell), and set to zero if not configured for the neighbour cell.

Hys is the hysteresis parameter for this event (i.e. *hysteresis* as defined within *reportConfigInterRAT* for this event).

Thresh1 is the threshold parameter for this event (i.e. *b2-Threshold1* as defined within *reportConfigInterRAT* for this event).

Thresh2 is the threshold parameter for this event (i.e. *b2-Threshold2EUTRA* as defined within *reportConfigInterRAT* for this event).

Mp is expressed in dBm in case of RSRP, or in dB in case of RSRQ and SINR.

Mn is expressed in dBm or dB, depending on the measurement quantity of the inter-RAT neighbour cell.

Ofn*, *Ocn*, *Hys are expressed in dB.

Thresh1 is expressed in the same unit as ***Mp***.

Thresh2 is expressed in the same unit as ***Mn***.

[TS 38.331, clause 5.5.5]



Figure 5.5.5-1: Measurement reporting

The purpose of this procedure is to transfer measurement results from the UE to the network. The UE shall initiate this procedure only after successful security activation.

For the *measId* for which the measurement reporting procedure was triggered, the UE shall set the *measResults* within the *MeasurementReport* message as follows:

- 1> set the *measId* to the measurement identity that triggered the measurement reporting;
- 1> set the *measResultServingCell* within *measResultServingMOList* to include, for each NR serving cell that is configured with *servingCellMO*, RSRP, RSRQ and the available SINR, derived based on the *rsType* if indicated in the associated *reportConfig*, otherwise based on SSB if available, otherwise based on CSI-RS;
- 1> set the *measResultServingCell* within *measResultServingMOList* to include for each NR serving cell that is configured with *servingCellMO*, if any, the *servCellId*;

- 1> if the *reportConfig* associated with the *measId* that triggered the measurement reporting includes *reportQuantityRsIndexes* and *maxNrofRSIndexesToReport*:
 - 2> for each serving cell configured with *servingCellMO*, include beam measurement information according to the associated *reportConfig* as described in 5.5.5.2;
- ...
- 1> if there is at least one applicable neighbouring cell to report:
 - 2> if the *reportType* is set to *eventTriggered* or *periodical*:
 - 3> set the *measResultNeighCells* to include the best neighbouring cells up to *maxReportCells* in accordance with the following:
 - 11. 4> if the *reportType* is set to *eventTriggered*:
 - 5> include the cells included in the *cellsTriggeredList* as defined within the *VarMeasReportList* for this *measId*;
 - 12. ...
 - 13. 4> for each cell that is included in the *measResultNeighCells*, include the *physCellId*;
 - 14. 4> if the *reportType* is set to *eventTriggered* or *periodical*:
 - 5> for each included cell, include the layer 3 filtered measured results in accordance with the *reportConfig* for this *measId*, ordered as follows:
 - 6> if the *measObject* associated with this *measId* concerns NR:
 - 7> if *rsType* in the associated *reportConfig* is set to *ssb*:
 - 8> set *resultsSSB-Cell* within the *measResult* to include the SS/PBCH block based quantity(ies) indicated in the *reportQuantityCell* within the concerned *reportConfig*, in decreasing order of the sorting quantity, determined as specified in 5.5.5.3, i.e. the best cell is included first;
 - 9> if *reportQuantityRsIndexes* and *maxNrofRSIndexesToReport* are configured, include beam measurement information as described in 5.5.5.2;
 - ...
 - 6> if the *measObject* associated with this *measId* concerns E-UTRA:
 - 7> set the *measResult* to include the quantity(ies) indicated in the *reportQuantity* within the concerned *reportConfigInterRAT* in decreasing order of the sorting quantity, determined as specified in 5.5.5.3, i.e. the best cell is included first;
- ...
- 1> increment the *numberOfReportsSent* as defined within the *VarMeasReportList* for this *measId* by 1;
- 1> stop the periodical reporting timer, if running;
- ...
- 1> if the UE is configured with EN-DC:
 - 2> if SRB3 is configured:
 - 3> submit the *MeasurementReport* message via SRB3 to lower layers for transmission, upon which the procedure ends;
 - 2> else:

3> submit the *MeasurementReport* message via the EUTRA MCG embedded in E-UTRA RRC message *ULInformationTransferMRDC* as specified in TS 36.331 [10].

1> else:

2> submit the *MeasurementReport* message to lower layers for transmission, upon which the procedure ends.

8.1.3.2.2.3 Test description

8.1.3.2.2.3.1 Pre-test conditions

System Simulator:

- NR Cell 1 is the PCell, E-UTRA Cell 1 is the inter-RAT neighbour cell of NR Cell 1.
- System information combination NR-6 as defined in TS 38.508-1 [4] clause 4.4.3.1.2.

UE:

- None.

Preamble:

- The UE is in state 3N-A as defined in TS 38.508-1 [4], subclause 4.4A.

8.1.3.2.2.3.2 Test procedure sequence

Table 8.1.3.2.2.3.2-1 and 8.1.3.2.2.3.2-2 illustrates the downlink power levels to be applied for NR Cell 1, and E-UTRA Cell 1 at various time instants of the test execution. Row marked "T0" denotes the conditions after the preamble, while the configuration marked "T1" is applied at the point indicated in the Main behaviour description in Table 8.1.3.2.2.3.2-3.

Table 8.1.3.2.2.3.2-1: Time instances of cell power level and parameter changes for FR1

	Parameter	Unit	NR Cell 1	E-UTRA Cell 1	Remark
T0	SS/PBCH SSS EPRE	dBm/SCS	-75	-	Power levels are such that entry condition 1 for event B2 is not satisfied and entry condition 2 is satisfied: $M_p - H_{ys} > Thresh1$ and $M_n + O_{fn} + O_{cn} - H_{ys} > Thresh2$
	Cell-specific RS EPRE	dBm/15 kHz		-73	
T1	SS/PBCH SSS EPRE	dBm/SCS	-85	-	Power levels are such that entry condition for event B2 is satisfied: $M_p + H_{ys} < Thresh1$ and $M_n + O_{fn} + O_{cn} - H_{ys} > Thresh2$
	Cell-specific RS EPRE	dBm/15 kHz		-73	

Table 8.1.3.2.2.3.2-2: Time instances of cell power level and parameter changes for FR2

	Parameter	Unit	NR Cell 1	E-UTRA Cell 1	Remark
T0	SS/PBCH SSS EPRE	dBm/SCS	FFS	-	Power levels are such that entry condition 1 for event B2 is not satisfied and entry condition 2 is satisfied: $M_p + H_{ys} > Thresh1$ and $M_n + O_{fn} + O_{cn} - H_{ys} > Thresh2$
	Cell-specific RS EPRE	dBm/15 kHz		FFS	
T1	SS/PBCH SSS EPRE	dBm/SCS	FFS	-	Power levels are such that entry condition for event B2 is satisfied: $M_p + H_{ys} < Thresh1$ and $M_n + O_{fn} + O_{cn} - H_{ys} > Thresh2$
	Cell-specific RS EPRE	dBm/15 kHz		FFS	

Table 8.1.3.2.2.3.2-3: Main behaviour

St	Procedure	Message Sequence		TP	Verdict
		U - S	Message		
1	The SS transmits an <i>RRCReconfiguration</i> message including <i>MeasConfig</i> to setup inter-RAT measurement and reporting for event B2.	<--	NR RRC: <i>RRCReconfiguration</i>	-	-
2	The UE transmits an <i>RRCReconfigurationComplete</i> message.	-->	NR RRC: <i>RRCReconfigurationComplete</i>	-	-
3	Check: Does the UE transmit a <i>MeasurementReport</i> message within the next 10s?	-->	NR RRC: <i>MeasurementReport</i>	2	F
4	SS re-adjusts the cell-specific reference signal level according to row "T1" in table 8.1.3.2.2.3.2-1/2.	-	-	-	-
5	Check: Does the UE transmit a <i>MeasurementReport</i> message to report event B2 with the measured RSRP value for NR Cell 1?	-->	NR RRC: <i>MeasurementReport</i>	1	P

8.1.3.2.2.3.3 Specific message contents

Table 8.1.3.2.2.3.3-1: *RRCReconfiguration* (step 1, Table 8.1.3.2.2.3.2-3)

Derivation Path: 38.508-1 [4] Table 4.6.1-13			
Information Element	Value/remark	Comment	Condition
<i>RRCReconfiguration</i> ::= SEQUENCE {			
<i>rrc-TransactionIdentifier</i>	RRC-TransactionIdentifier		
criticalExtensions CHOICE {			
<i>rrcReconfiguration</i> ::= SEQUENCE {			
<i>radioBearerConfig</i>	Not present		
<i>secondaryCellGroup</i>	Not present		
<i>measConfig</i>	MeasConfig	Table 8.1.3.2.2.3.3-2	
<i>lateNonCriticalExtension</i>	Not present		
<i>nonCriticalExtension</i>	Not present		
}			
}			
}			

Table 8.1.3.2.2.3.3-2: *MeasConfig* (Table 8.1.3.2.2.3.3-1)

Derivation Path: 38.508-1 [4] Table 4.6.3-69			
Information Element	Value/remark	Comment	Condition
MeasConfig ::= SEQUENCE {			
measObjectToAddModList SEQUENCE (SIZE (1..maxNrofMeasId)) OF SEQUENCE {	2 entries		
measObjectId[1]	1	MeasObjectIdNR-f1	
measObject[1] CHOICE {			
measObjectNR SEQUENCE {			
ssbFrequency	ssbFrequency IE equals the ARFCN for NR Cell 1		
absThreshSS-BlocksConsolidation	Not present		
}			
}			
measObjectId[2]	2	MeasObjectIdE-UTRA-f1	
measObject[2] CHOICE {			
measObjectEUTRA SEQUENCE {			
carrierFreq	ARFCN-ValueEUTRA for E-UTRA Cell 1		
}			
}			
reportConfigToAddModList SEQUENCE(SIZE (1..maxReportConfigId)) OF SEQUENCE {	1 entry		
reportConfigId[1]	1		
reportConfig[1] CHOICE {			
reportConfigInterRAT	ReportConfigInterRAT-EventB2	Table 8.1.3.2.2.3.3-3	
}			
}			
measIdToAddModList SEQUENCE (SIZE (1..maxNrofMeasId)) OF SEQUENCE {	1 entry		
measId[1]	1		
measObjectId[1]	2		
reportConfigId[1]	1		
}			
quantityConfig	QuantityConfig with Condition INTER-RAT		
measGapConfig	MeasGapConfig		
}			

Table 8.1.3.2.2.3.3-3: ReportConfigInterRAT-EventB2 (Table 8.1.3.2.2.3.3-2)

Derivation Path: 38.508-1 [4] Table 4.6.3-142 with condition EVENT_B2			
Information Element	Value/remark	Comment	Condition
ReportConfigNR ::= SEQUENCE {			
reportType CHOICE {			
eventTriggered SEQUENCE {			
eventId CHOICE {			
eventB2 SEQUENCE {			
b2-Threshold1 SEQUENCE {			
rsrp	76	-80dBm	FR1
	FFS	FFS	FR2
}			
b2-Threshold2EUTRA SEQUENCE {			
rsrp	73	-83dBm	FR1
	FFS	FFS	FR2
}			
hysteresis	4	2 dB	
}			
}			
reportAmount	r1		
}			
}			

Table 8.1.3.2.2.3.3-4: *MeasurementReport* (step 5, Table 8.1.3.2.2.3.2-3)

Derivation Path: 38.508-1 [4] Table 4.6.1-7			
Information Element	Value/remark	Comment	Condition
MeasurementReport ::= SEQUENCE {			
criticalExtensions CHOICE {			
measurementReport SEQUENCE {			
measResults SEQUENCE {			
measId	1		Step 5
measResultServingMOList SEQUENCE (SIZE (1..maxNrofServingCells)) OF SEQUENCE {		Report NR Cell 1	
servCellId	ServCellIndex of NR Cell 1		
measResultServingCell SEQUENCE {			
physCellId	Physical layer cell identity of NR Cell 1		
measResult SEQUENCE {			
cellResults SEQUENCE {			
resultsSSB-Cell SEQUENCE {			
rsrp	(0..127)		
rsrq	(0..127)		
}			
}			
}			
}			
measResultNeighCells CHOICE {			
measResultListEUTRA SEQUENCE (SIZE (1..maxCellReport)) OF SEQUENCE {		Report E-UTRA neighbour cell	
eutra-PhysCellId	Physical layer cell identity of E-UTRA Cell 1		Step 5
measResult SEQUENCE {			
rsrp	(0..97)		
}			
}			
}			
}			

8.1.3.2.3 Measurement configuration control and reporting / Inter-RAT measurements / Event B2 / Measurement of E-UTRA cells / RSRQ based measurements

8.1.3.2.3.1 Test Purpose (TP)

(1)

```
with { UE is NR RRC_CONNECTED state and inter-RAT measurement event B2 to measure neighbor E-UTRA cell is configured and triggerQuantity set to rsrq }
ensure that {
  when { Entering condition 1 and 2 for event B2 is not met }
  then { UE does not send MeasurementReport }
}
```

(2)

```
with { UE is NR RRC_CONNECTED state and inter-RAT measurement event B2 to measure neighbor E-UTRA cell is configured and triggerQuantity set to rsrq }
ensure that {
  when { Entering condition 1 and 2 for event B2 is met }
  then { UE transmits a MeasurementReport }
}
```

8.1.3.2.3.2 Conformance requirements

References: The conformance requirements covered in the present TC are specified in: TS 38.331, clause 5.3.5.3, 5.5.2.1, 5.5.4.1, 5.5.4.9 and 5.5.5.

[TS 38.331, clause 5.3.5.3]

The UE shall perform the following actions upon reception of the *RRCReconfiguration*:

...

- 1> if the *RRCReconfiguration* message includes the *measConfig*:
 - 2> perform the measurement configuration procedure as specified in 5.5.2;

...

[TS 38.331, clause 5.5.2.1]

The UE shall:

- 1> if the received *measConfig* includes the *measObjectToRemoveList*:
 - 2> perform the measurement object removal procedure as specified in 5.5.2.4;
- 1> if the received *measConfig* includes the *measObjectToAddModList*:
 - 2> perform the measurement object addition/modification procedure as specified in 5.5.2.5;
- 1> if the received *measConfig* includes the *reportConfigToRemoveList*:
 - 2> perform the reporting configuration removal procedure as specified in 5.5.2.6;
- 1> if the received *measConfig* includes the *reportConfigToAddModList*:
 - 2> perform the reporting configuration addition/modification procedure as specified in 5.5.2.7;
- 1> if the received *measConfig* includes the *quantityConfig*:
 - 2> perform the quantity configuration procedure as specified in 5.5.2.8;
- 1> if the received *measConfig* includes the *measIdToRemoveList*:
 - 2> perform the measurement identity removal procedure as specified in 5.5.2.2;
- 1> if the received *measConfig* includes the *measIdToAddModList*:
 - 2> perform the measurement identity addition/modification procedure as specified in 5.5.2.3;
- 1> if the received *measConfig* includes the *measGapConfig*:
 - 2> perform the measurement gap configuration procedure as specified in 5.5.2.9;
- 1> if the received *measConfig* includes the *measGapSharingConfig*:
 - 2> perform the measurement gap sharing configuration procedure as specified in 5.5.2.11;
- 1> if the received *measConfig* includes the *s-MeasureConfig*:
 - 2> if *s-MeasureConfig* is set to *ssb-RSRP*, set parameter *ssb-RSRP* of *s-MeasureConfig* within *VarMeasConfig* to the lowest value of the RSRP ranges indicated by the received value of *s-MeasureConfig*;
 - 2> else, set parameter *csi-RSRP* of *s-MeasureConfig* within *VarMeasConfig* to the lowest value of the RSRP ranges indicated by the received value of *s-MeasureConfig*.

[TS 38.331, clause 5.5.4.1]

If security has been activated successfully, the UE shall:

- 1> for each *measId* included in the *measIdList* within *VarMeasConfig*:
 - 2> if the corresponding *reportConfig* includes a *reportType* set to *eventTriggered* or *periodical*;
...
 - 3> else if the corresponding *measObject* concerns E-UTRA;
 - 4> consider any neighbouring cell detected on the associated frequency to be applicable when the concerned cell is not included in the *blackCellsToAddModListEUTRAN* defined within the *VarMeasConfig* for this *measId*;
 - ...
 - 2> if the *reportType* is set to *eventTriggered* and if the entry condition applicable for this event, i.e. the event corresponding with the *eventId* of the corresponding *reportConfig* within *VarMeasConfig*, is fulfilled for one or more applicable cells for all measurements after layer 3 filtering taken during *timeToTrigger* defined for this event within the *VarMeasConfig*, while the *VarMeasReportList* does not include a measurement reporting entry for this *measId* (a first cell triggers the event):
 - 3> include a measurement reporting entry within the *VarMeasReportList* for this *measId*;
 - 3> set the *numberOfReportsSent* defined within the *VarMeasReportList* for this *measId* to 0;
 - 3> include the concerned cell(s) in the *cellsTriggeredList* defined within the *VarMeasReportList* for this *measId*;
 - 3> initiate the measurement reporting procedure, as specified in 5.5.5;
 - 2> else if the *reportType* is set to *eventTriggered* and if the entry condition applicable for this event, i.e. the event corresponding with the *eventId* of the corresponding *reportConfig* within *VarMeasConfig*, is fulfilled for one or more applicable cells not included in the *cellsTriggeredList* for all measurements after layer 3 filtering taken during *timeToTrigger* defined for this event within the *VarMeasConfig* (a subsequent cell triggers the event):
 - 3> set the *numberOfReportsSent* defined within the *VarMeasReportList* for this *measId* to 0;
 - 3> include the concerned cell(s) in the *cellsTriggeredList* defined within the *VarMeasReportList* for this *measId*;
 - 3> initiate the measurement reporting procedure, as specified in 5.5.5;
 - 2> else if the *reportType* is set to *eventTriggered* and if the leaving condition applicable for this event is fulfilled for one or more of the cells included in the *cellsTriggeredList* defined within the *VarMeasReportList* for this *measId* for all measurements after layer 3 filtering taken during *timeToTrigger* defined within the *VarMeasConfig* for this event:
 - 3> remove the concerned cell(s) in the *cellsTriggeredList* defined within the *VarMeasReportList* for this *measId*;
 - 3> if *reportOnLeave* is set to *TRUE* for the corresponding reporting configuration:
 - 4> initiate the measurement reporting procedure, as specified in 5.5.5;
 - 3> if the *cellsTriggeredList* defined within the *VarMeasReportList* for this *measId* is empty:
 - 4> remove the measurement reporting entry within the *VarMeasReportList* for this *measId*;
 - 4> stop the periodical reporting timer for this *measId*, if running;
 - ...
 - 2> upon the expiry of T321 for this *measId*:
 - 3> include a measurement reporting entry within the *VarMeasReportList* for this *measId*;
 - 3> set the *numberOfReportsSent* defined within the *VarMeasReportList* for this *measId* to 0;

3> initiate the measurement reporting procedure, as specified in 5.5.5.

[TS 38.331, clause 5.5.4.9]

The UE shall:

- 1> consider the entering condition for this event to be satisfied when both condition B2-1 and condition B2-2, as specified below, are fulfilled;
- 1> consider the leaving condition for this event to be satisfied when condition B2-3 or condition B2-4, i.e. at least one of the two, as specified below, is fulfilled;

Inequality B2-1 (Entering condition 1)

$$M_p + H_{ys} < Thresh1$$

Inequality B2-2 (Entering condition 2)

$$M_n + Ofn + Ocn - H_{ys} > Thresh2$$

Inequality B2-3 (Leaving condition 1)

$$M_p - H_{ys} > Thresh1$$

Inequality B2-4 (Leaving condition 2)

$$M_n + Ofn + Ocn + H_{ys} < Thresh2$$

The variables in the formula are defined as follows:

M_p is the measurement result of the PCell, not taking into account any offsets.

M_n is the measurement result of the inter-RAT neighbour cell, not taking into account any offsets.

Ofn is the measurement object specific offset of the frequency of the inter-RAT neighbour cell (i.e. *eutra-Q-OffsetRange* as defined within the *measObjectEUTRA* corresponding to the frequency of the inter-RAT neighbour cell).

Ocn is the cell specific offset of the inter-RAT neighbour cell (i.e. *cellIndividualOffset* as defined within the *measObjectEUTRA* corresponding to the neighbour inter-RAT cell), and set to zero if not configured for the neighbour cell.

H_{ys} is the hysteresis parameter for this event (i.e. *hysteresis* as defined within *reportConfigInterRAT* for this event).

Thresh1 is the threshold parameter for this event (i.e. *b2-Threshold1* as defined within *reportConfigInterRAT* for this event).

Thresh2 is the threshold parameter for this event (i.e. *b2-Threshold2EUTRA* as defined within *reportConfigInterRAT* for this event).

M_p is expressed in dBm in case of RSRP, or in dB in case of RSRQ and SINR.

M_n is expressed in dBm or dB, depending on the measurement quantity of the inter-RAT neighbour cell.

Ofn, ***Ocn***, ***H_{ys}*** are expressed in dB.

Thresh1 is expressed in the same unit as ***M_p***.

Thresh2 is expressed in the same unit as ***M_n***.

[TS 38.331, clause 5.5.5.1]



Figure 5.5.5.1-1: Measurement reporting

For the *measId* for which the measurement reporting procedure was triggered, the UE shall set the *measResults* within the *MeasurementReport* message as follows:

- 1> set the *measId* to the measurement identity that triggered the measurement reporting;
- 1> set the *measResultServingCell* within *measResultServingMOList* to include, for each NR serving cell that is configured with *servingCellMO*, RSRP, RSRQ and the available SINR, derived based on the *rsType* if indicated in the associated *reportConfig*, otherwise based on SSB if available, otherwise based on CSI-RS;
- 1> set the *servCellId* within *measResultServingMOList* to include each NR serving cell that is configured with *servingCellMO*, if any;
- 1> if the *reportConfig* associated with the *measId* that triggered the measurement reporting includes *reportQuantityRS-Indexes* and *maxNrofRS-IndexesToReport*:
 - 2> for each serving cell configured with *servingCellMO*, include beam measurement information according to the associated *reportConfig* as described in 5.5.5.2;
 - ...
- 1> if there is at least one applicable neighbouring cell to report:
 - 2> if the *reportType* is set to *eventTriggered* or *periodical*:
 - 3> set the *measResultNeighCells* to include the best neighbouring cells up to *maxReportCells* in accordance with the following:
 - 4> if the *reportType* is set to *eventTriggered*:
 - 5> include the cells included in the *cellsTriggeredList* as defined within the *VarMeasReportList* for this *measId*;
 - ...
 - 4> for each cell that is included in the *measResultNeighCells*, include the *physCellId*;
 - 4> if the *reportType* is set to *eventTriggered* or *periodical*:
 - 5> for each included cell, include the layer 3 filtered measured results in accordance with the *reportConfig* for this *measId*, ordered as follows:
 - ...
 - 6> if the *measObject* associated with this *measId* concerns E-UTRA:
 - 7> set the *measResult* to include the quantity(ies) indicated in the *reportQuantity* within the concerned *reportConfigInterRAT* in decreasing order of the sorting quantity, determined as specified in 5.5.5.3, i.e. the best cell is included first;
 - 1> increment the *numberOfReportsSent* as defined within the *VarMeasReportList* for this *measId* by 1;
 - 1> stop the periodical reporting timer, if running;
 - 1> if the *numberOfReportsSent* as defined within the *VarMeasReportList* for this *measId* is less than the *reportAmount* as defined within the corresponding *reportConfig* for this *measId*:

2> start the periodical reporting timer with the value of *reportInterval* as defined within the corresponding *reportConfig* for this *measId*;

...

1> else:

2> submit the *MeasurementReport* message to lower layers for transmission, upon which the procedure ends.

8.1.3.2.3.3 Test description

8.1.3.2.3.3.1 Pre-test conditions

System Simulator:

- Cell 1 is the NR serving cell, E-UTRA Cell 1 is the inter-RAT neighbour cell.
- System information combination NR-6 as defined in TS 38.508-1 [4] clause 4.4.3.1.2 is used in NR cells.

UE:

- None.

Preamble:

- The UE is in state 3N-A as defined in TS 38.508-1 [4], subclause 4.4A on NR Cell 1.

8.1.3.2.3.3.2 Test procedure sequence

Table 8.1.3.2.3.3.2-1 and 8.1.3.2.3.3.2-2 illustrate the downlink power levels to be applied for NR Cell 1 and E-UTRA Cell 1 at various time instants of the test execution for FR1 and FR2 respectively. Row marked "T0" denotes the conditions after the preamble, while rows marked "T1" and "T2" are to be applied subsequently. The exact instants on which these values shall be applied are described in the texts in this clause.

Table 8.1.3.2.3.3.2-1: Time instances of cell power level and parameter changes for FR1

	Parameter	Unit	NR Cell 1	E-UTRA Cell	Remark
T0	SS/PBCH SSS EPRE	dBm/SCS	-88	-	Power levels are such that entry condition for event B2 is not satisfied: $Mp + Hys \geq Thresh1$ or $Mn + Ofn + Ocn - Hys \leq Thresh2$
	SS-RSRQ	dB	-11.74	-	
	Cell-specific RS EPRE	dBm/15kHz	-	-94	
	RSRQ	dB	-	-3.01	
	Noc	dBm/15kHz	-94	-94	
T1	SS/PBCH SSS EPRE	dBm/SCS	-94	-	Power levels are such that entry condition for event B2 is satisfied: $Mp + Hys < Thresh1$ and $Mn + Ofn + Ocn - Hys > Thresh2$
	SS-RSRQ	dB	-13.78	-	
	Cell-specific RS EPRE	dBm/15kHz	-	-85	
	RSRQ	dB	-	-0.52	

Table 8.1.3.2.3.3.2-2: Time instances of cell power level and parameter changes for FR2

	Parameter	Unit	NR Cell 1	E-UTRA Cell 2	Remark
T0	SS/PBCH SSS EPRE	dBm/SCS	FFS	-	Power levels are such that entry condition for event B2 is not satisfied: $Mp + Hys \geq Thresh1$ or $Mn + Ofn + Ocn - Hys \leq Thresh2$
	SS-RSRQ	dB	FFS	-	
	Cell-specific RS EPRE	dBm/15kHz	-	FFS	
	RSRQ	dB	-	FFS	
	Noc	dBm/15kHz	FFS	FFS	
T1	SS/PBCH SSS EPRE	dBm/SCS	FFS	-	Power levels are such that entry condition for event B2 is satisfied: $Mp + Hys < Thresh1$ and $Mn + Ofn + Ocn - Hys > Thresh2$
	SS-RSRQ	dB	FFS	-	
	Cell-specific RS EPRE	dBm/15kHz	-	FFS	
	RSRQ	dB	-	FFS	

Table 8.1.3.2.3.3.2-3: Main behaviour

St	Procedure	Message Sequence		TP	Verdict
		U - S	Message		
1	The SS transmits an <i>RRCReconfiguration</i> message on NR Cell 1 including <i>MeasConfig</i> to setup inter-RAT measurement and reporting for event B2	<--	NR RRC: <i>RRCReconfiguration</i>	-	-
2	The UE transmits an <i>RRCReconfigurationComplete</i> message on NR Cell 1.	-->	NR RRC: <i>RRCReconfigurationComplete</i>	-	-
3	Check: Does the UE transmit a <i>MeasurementReport</i> message on NR Cell 1 within the next 10s?	-->	NR RRC: <i>MeasurementReport</i>	1	F
4	The SS re-adjusts the cell-specific reference signal level according to row "T1" in Table 8.1.3.2.3.3.2-1/2.	-	-	-	-
5	Check: Does the UE transmit a <i>MeasurementReport</i> message on Cell 1 to report event B2 with the measured RSRP and RSRQ values for E-UTRA Cell 1?	-->	NR RRC: <i>MeasurementReport</i>	2	P

8.1.3.2.3.3.3 Specific message contents

Table 8.1.3.2.3.3.3-1: *RRCReconfiguration* (step 1, Table 8.1.3.2.3.3.2-3)

Derivation Path: 38.508-1 [4] table 4.6.1-13			
Information Element	Value/remark	Comment	Condition
<i>RRCReconfiguration</i> ::= SEQUENCE {			
rrc-TransactionIdentifier	RRC-TransactionIdentifier		
criticalExtensions CHOICE {			
rrcReconfiguration ::= SEQUENCE {			
radioBearerConfig	Not present		
secondaryCellGroup	Not present		
measConfig	MeasConfig	Table 8.1.3.2.3.3.3-2	
lateNonCriticalExtension	Not present		
nonCriticalExtension	Not present		
}			
}			
}			

Table 8.1.3.2.3.3.3-2: MeasConfig (step 1, Table 8.1.3.2.3.3.2-3)

Derivation path: 38.508-1 [4] table 4.6.3-69			
Information Element	Value/Remark	Comment	Condition
MeasConfig ::= SEQUENCE {			
measObjectToAddModList SEQUENCE (SIZE (1..maxNrofMeasId)) OF SEQUENCE {	2 entries		
measObjectId[1]	1		
measObject[1] CHOICE {			
measObjectNR	MeasObjectNR-f1	Table 8.1.3.2.3.3.3-3	
}			
measObjectId[2]	2		
measObject[2] CHOICE {			
measObjectEUTRA	MeasObjectEUTRA-f2	Table 8.1.3.2.3.3.3-4	
}			
}			
reportConfigToAddModList SEQUENCE (SIZE (1..maxReportConfigId)) OF SEQUENCE {	1 entry		
reportConfigId[1]	ReportConfigId		
reportConfig[1] CHOICE {			
reportConfigInterRAT	ReportConfigInterRAT-B2	Table 8.1.3.2.3.3.3-5	
}			
}			
measIdToAddModList SEQUENCE (SIZE (1..maxNrofMeasId)) OF SEQUENCE {	1 entry		
measId[1]	1		
measObjectId[1]	2		
reportConfigId[1]	ReportConfigId		
}			
quantityConfig	QuantityConfig with condition INTER-RAT		
measGapConfig	MeasGapConfig	Table 8.1.3.2.3.3.3-6	
}			

Table 8.1.3.2.3.3.3-3: MeasObjectNR-f1 (Table 8.1.3.2.3.3.3-2)

Derivation Path: TS 38.508-1 [4], Table 4.6.3-76			
Information Element	Value/remark	Comment	Condition
MeasObjectNR ::= SEQUENCE {			
ssbFrequency	Downlink ARFCN of NR cell 1 SSB		
absThreshSS-BlocksConsolidation	Not present		
}			

Table 8.1.3.2.3.3.3-4: MeasObjectEUTRA-f2 (Table 8.1.3.2.3.3.3-2)

Derivation Path: TS 38.508-1 [4], Table 4.6.3-74			
Information Element	Value/remark	Comment	Condition
MeasObjectEUTRA ::= SEQUENCE {			
carrierFreq	Downlink ARFCN of E-UTRA Cell 1		
}			

Table 8.1.3.2.3.3-7: MeasurementReport (steps 5, Table 8.1.3.2.3.3-2)

Derivation Path: TS 38.508-1 [4], table 4.6.1-7			
Information Element	Value/remark	Comment	Condition
MeasurementReport ::= SEQUENCE {			
criticalExtensions CHOICE {			
measurementReport SEQUENCE {			
measResults SEQUENCE {			
measId	1	Step 5	
measResultServingMOList SEQUENCE (SIZE (1..maxNrofServingCells)) OF SEQUENCE {			
servCellId	ServCellIndex of NR serving cell		
measResultServingCell SEQUENCE {			
physCellId	PhysCellId of NR serving cell		
measResult SEQUENCE {			
cellResults SEQUENCE {			
resultsSSB-Cell SEQUENCE {			
rsrp	(0..127)		
rsrq	(0..127)		
}			
resultsCSI-RS-Cell	Not present		
}			
rsIndexResults	Not present		
}			
}			
measResultBestNeighCell	Not present		
}			
measResultNeighCells CHOICE {	Not present		
MeasResultListEUTRA SEQUENCE (SIZE (1..maxCellReport)) OF SEQUENCE {			
eutra-PhysCellId	PhysCellId of E-UTRA Cell 1	Step 5	
measResult SEQUENCE {			
rsrp	(0..97)		
rsrq	(0..34)		
}			
cgi-Info	Not present		
}			
}			
}			
}			
}			

8.1.3.2.5 Measurement configuration control and reporting / Inter-RAT measurements / Simultaneous A2 and B2 / Measurements of NR and E-UTRA cells

8.1.3.2.5.1 Test Purpose (TP)

(1)

```
with { UE in NR RRC_CONNECTED state and measurements configured for event A2 to measure the NR
Serving Cell and B2 to measure the inter-RAT E-UTRAN Cell at the same time }
ensure that {
  when { UE detects entering condition for the events A2 and B2 are not met }
  then { UE does not transmit any MeasurementReport messages }
}
```

(2)

```
with { UE in NR RRC_CONNECTED state and measurements configured for event A2 to measure the NR
Serving Cell and B2 to measure the inter-RAT E-UTRAN Cell at the same time }
ensure that {
```

```

when { UE detects entering condition for the event A2 is met }
  then { UE transmits a MeasurementReport message }
    }

```

(3)

```

with { UE in NR RRC_CONNECTED state and measurements configured for event A2 to measure the NR
Serving Cell and B2 to measure the inter-RAT E-UTRAN Cell at the same time }
ensure that {
  when { UE detects entering condition for the event B2 is met }
    then { UE transmits a MeasurementReport message }
  }

```

8.1.3.2.5.2 Conformance requirements

References: The conformance requirements covered in the current TC are specified in: TS 38.331, clauses 5.3.5.3, 5.5.2.1, 5.5.2.9, 5.5.4.1, 5.5.4.9 and 5.5.5.1. Unless otherwise stated these are Rel-15 requirements.

[TS 38.331, clause 5.3.5.3]

The UE shall perform the following actions upon reception of the *RRCReconfiguration*:

...

1> if the *RRCReconfiguration* message includes the *measConfig*:

2> perform the measurement configuration procedure as specified in 5.5.2;

...

1> if the UE is configured with E-UTRA *nr-SecondaryCellGroupConfig* (MCG is E-UTRA):

...

1> else:

2> submit the *RRCReconfigurationComplete* message via SRB1 to lower layers for transmission using the new configuration;

...

[TS 38.331, clause 5.5.2.1]

...

The UE shall:

...

1> if the received *measConfig* includes the *measObjectToAddModList*:

2> perform the measurement object addition/modification procedure as specified in 5.5.2.5;

...

1> if the received *measConfig* includes the *reportConfigToAddModList*:

2> perform the reporting configuration addition/modification procedure as specified in 5.5.2.7;

...

1> if the received *measConfig* includes the *measIdToAddModList*:

2> perform the measurement identity addition/modification procedure as specified in 5.5.2.3;

...

1> if the received *measConfig* includes the *measGapConfig*:

2> perform the measurement gap configuration procedure as specified in 5.5.2.9;

...

[TS 38.331, clause 5.5.2.9]

The UE shall:

...

- 1> if *gapUE* is set to *setup*:
 - 2> if a per UE measurement gap configuration is already setup, release the per UE measurement gap configuration;
 - 2> setup the per UE measurement gap configuration indicated by the *measGapConfig* in accordance with the received *gapOffset*, i.e., the first subframe of each gap occurs at an SFN and subframe meeting the following condition:

$$\text{SFN mod } T = \text{FLOOR}(\text{gapOffset}/10);$$

$$\text{subframe} = \text{gapOffset mod } 10;$$
 with $T = \text{MGRP}/10$ as defined in TS 38.133 [14];
 - 2> if *mgta* is configured, apply the specified timing advance to the gap occurrences calculated above (i.e. the UE starts the measurement *mgta* ms before the gap subframe occurrences);

...

[TS 38.331, clause 5.5.4.1]

If AS security has been activated successfully, the UE shall:

- 1> for each *measId* included in the *measIdList* within *VarMeasConfig*:
 - 2> if the corresponding *reportConfig* includes a *reportType* set to *eventTriggered* or *periodical*:
 - 3> if the corresponding *measObject* concerns NR:
 - 4> if the *eventA1* or *eventA2* is configured in the corresponding *reportConfig*:
 - 5> consider only the serving cell to be applicable;
 - 3> else if the corresponding *measObject* concerns E-UTRA:
 - 4> consider any neighbouring cell detected on the associated frequency to be applicable when the concerned cell is not included in the *blackCellsToAddModListEUTRAN* defined within the *VarMeasConfig* for this *measId*;
- 2> if the *reportType* is set to *eventTriggered* and if the entry condition applicable for this event, i.e. the event corresponding with the *eventId* of the corresponding *reportConfig* within *VarMeasConfig*, is fulfilled for one or more applicable cells for all measurements after layer 3 filtering taken during *timeToTrigger* defined for this event within the *VarMeasConfig*, while the *VarMeasReportList* does not include a measurement reporting entry for this *measId* (a first cell triggers the event):
 - 3> include a measurement reporting entry within the *VarMeasReportList* for this *measId*;
 - 3> set the *numberOfReportsSent* defined within the *VarMeasReportList* for this *measId* to 0;
 - 3> include the concerned cell(s) in the *cellsTriggeredList* defined within the *VarMeasReportList* for this *measId*;
 - 3> initiate the measurement reporting procedure, as specified in 5.5.5;

- 2> else if the *reportType* is set to *eventTriggered* and if the entry condition applicable for this event, i.e. the event corresponding with the *eventId* of the corresponding *reportConfig* within *VarMeasConfig*, is fulfilled for one or more applicable cells not included in the *cellsTriggeredList* for all measurements after layer 3 filtering taken during *timeToTrigger* defined for this event within the *VarMeasConfig* (a subsequent cell triggers the event):
 - 3> set the *numberOfReportsSent* defined within the *VarMeasReportList* for this *measId* to 0;
 - 3> include the concerned cell(s) in the *cellsTriggeredList* defined within the *VarMeasReportList* for this *measId*;
 - 3> initiate the measurement reporting procedure, as specified in 5.5.5;
- 2> else if the *reportType* is set to *eventTriggered* and if the leaving condition applicable for this event is fulfilled for one or more of the cells included in the *cellsTriggeredList* defined within the *VarMeasReportList* for this *measId* for all measurements after layer 3 filtering taken during *timeToTrigger* defined within the *VarMeasConfig* for this event:
 - 3> remove the concerned cell(s) in the *cellsTriggeredList* defined within the *VarMeasReportList* for this *measId*;
 - 3> if *reportOnLeave* is set to *true* for the corresponding reporting configuration:
 - 4> initiate the measurement reporting procedure, as specified in 5.5.5;
 - 3> if the *cellsTriggeredList* defined within the *VarMeasReportList* for this *measId* is empty:
 - 4> remove the measurement reporting entry within the *VarMeasReportList* for this *measId*;
 - 4> stop the periodical reporting timer for this *measId*, if running;
- ...
- 2> upon expiry of the periodical reporting timer for this *measId*:
 - 3> initiate the measurement reporting procedure, as specified in 5.5.5.
- ...

[TS 38.331, clause 5.5.4.3]

The UE shall:

- 1> consider the entering condition for this event to be satisfied when condition A2-1, as specified below, is fulfilled;
- 1> consider the leaving condition for this event to be satisfied when condition A2-2, as specified below, is fulfilled;
- 1> for this measurement, consider the serving cell indicated by the *measObjectNR* associated to this event.

Inequality A2-1 (Entering condition)

$$M_s + H_{ys} < Thresh$$

Inequality A2-2 (Leaving condition)

$$M_s - H_{ys} > Thresh$$

The variables in the formula are defined as follows:

M_s is the measurement result of the serving cell, not taking into account any offsets.

H_{ys} is the hysteresis parameter for this event (i.e. *hysteresis* as defined within *reportConfigNR* for this event).

Thresh is the threshold parameter for this event (i.e. *a2-Threshold* as defined within *reportConfigNR* for this event).

M_s is expressed in dBm in case of RSRP, or in dB in case of RSRQ and RS-SINR.

H_{ys} is expressed in dB.

Thresh is expressed in the same unit as **Ms**.

[TS 38.331, clause 5.5.4.9]

The UE shall:

- 1> consider the entering condition for this event to be satisfied when both condition B2-1 and condition B2-2, as specified below, are fulfilled;
- 1> consider the leaving condition for this event to be satisfied when condition B2-3 or condition B2-4, i.e. at least one of the two, as specified below, is fulfilled;

Inequality B2-1 (Entering condition 1)

$$Mp + Hys < Thresh1$$

Inequality B2-2 (Entering condition 2)

$$Mn + Ofn + Ocn - Hys > Thresh2$$

Inequality B2-3 (Leaving condition 1)

$$Mp - Hys > Thresh1$$

Inequality B2-4 (Leaving condition 2)

$$Mn + Ofn + Ocn + Hys < Thresh2$$

The variables in the formula are defined as follows:

Mp is the measurement result of the PCell, not taking into account any offsets.

Mn is the measurement result of the inter-RAT neighbour cell, not taking into account any offsets.

Ofn is the measurement object specific offset of the frequency of the inter-RAT neighbour cell (i.e. *eutra-Q-OffsetRange* as defined within the *measObjectEUTRA* corresponding to the frequency of the inter-RAT neighbour cell).

Ocn is the cell specific offset of the inter-RAT neighbour cell (i.e. *cellIndividualOffset* as defined within the *measObjectEUTRA* corresponding to the neighbour inter-RAT cell), and set to zero if not configured for the neighbour cell.

Hys is the hysteresis parameter for this event (i.e. *hysteresis* as defined within *reportConfigInterRAT* for this event).

Thresh1 is the threshold parameter for this event (i.e. *b2-Threshold1* as defined within *reportConfigInterRAT* for this event).

Thresh2 is the threshold parameter for this event (i.e. *b2-Threshold2EUTRA* as defined within *reportConfigInterRAT* for this event).

Mp is expressed in dBm in case of RSRP, or in dB in case of RSRQ and SINR.

Mn is expressed in dBm or dB, depending on the measurement quantity of the inter-RAT neighbour cell.

Ofn, Ocn, Hys are expressed in dB.

Thresh1 is expressed in the same unit as **Mp**.

Thresh2 is expressed in the same unit as **Mn**.

[TS 38.331, clause 5.5.5.1]



Figure 5.5.5.1-1: Measurement reporting

The purpose of this procedure is to transfer measurement results from the UE to the network. The UE shall initiate this procedure only after successful AS security activation.

For the *measId* for which the measurement reporting procedure was triggered, the UE shall set the *measResults* within the *MeasurementReport* message as follows:

- 1> set the *measId* to the measurement identity that triggered the measurement reporting;
- 1> set the *measResultServingCell* within *measResultServingMOList* to include, for each NR serving cell that is configured with *servingCellMO*, RSRP, RSRQ and the available SINR, derived based on the *rsType* if indicated in the associated *reportConfig*, otherwise based on SSB if available, otherwise based on CSI-RS;
- 1> set the *servCellId* within *measResultServingMOList* to include each NR serving cell that is configured with *servingCellMO*, if any;
- ...
- 1> if there is at least one applicable neighbouring cell to report:
 - 2> if the *reportType* is set to *eventTriggered* or *periodical*:
 - 3> set the *measResultNeighCells* to include the best neighbouring cells up to *maxReportCells* in accordance with the following:
 - 4> if the *reportType* is set to *eventTriggered*:
 - 5> include the cells included in the *cellsTriggeredList* as defined within the *VarMeasReportList* for this *measId*;
 - ...
 - 4> for each cell that is included in the *measResultNeighCells*, include the *physCellId*;
 - 4> if the *reportType* is set to *eventTriggered* or *periodical*:
 - 5> for each included cell, include the layer 3 filtered measured results in accordance with the *reportConfig* for this *measId*, ordered as follows:
 - 6> if the *measObject* associated with this *measId* concerns NR:
 - 7> if *rsType* in the associated *reportConfig* is set to *ssb*:
 - 8> set *resultsSSB-Cell* within the *measResult* to include the SS/PBCH block based quantity(ies) indicated in the *reportQuantityCell* within the concerned *reportConfig*, in decreasing order of the sorting quantity, determined as specified in 5.5.5.3, i.e. the best cell is included first;
 - ...
 - 6> if the *measObject* associated with this *measId* concerns E-UTRA:
 - 7> set the *measResult* to include the quantity(ies) indicated in the *reportQuantity* within the concerned *reportConfigInterRAT* in decreasing order of the sorting quantity, determined as specified in 5.5.5.3, i.e. the best cell is included first;
 - 1> increment the *numberOfReportsSent* as defined within the *VarMeasReportList* for this *measId* by 1;

1> stop the periodical reporting timer, if running;

1> if the *numberOfReportsSent* as defined within the *VarMeasReportList* for this *measId* is less than the *reportAmount* as defined within the corresponding *reportConfig* for this *measId*:

2> start the periodical reporting timer with the value of *reportInterval* as defined within the corresponding *reportConfig* for this *measId*;

...

1> else:

2> submit the *MeasurementReport* message to lower layers for transmission, upon which the procedure ends.

8.1.3.2.5.3 Test description

8.1.3.2.5.3.1 Pre-test conditions

System Simulator:

- NR Cell 1 is the serving cell, EUTRA Cell 1 is the inter-RAT neighbour cell of NR Cell 1.
- System information combination NR-7 as defined in TS 38.508-1 [4] clause 4.4.3.1.2 is used in NR cells.

UE:

- None.

Preamble:

- The UE is in state 3N-A as defined in TS 38.508-1 [4], subclause 4.4A.

8.1.3.2.5.3.2 Test procedure sequence

Table 8.1.3.2.5.3.2-1 and 8.1.3.2.5.3.2-2 illustrates the downlink power levels to be applied for NR Cell 1 and EUTRA Cell 1 at various time instants of the test execution. Row marked "T0" denotes the conditions after the preamble, while the configuration marked "T1" and "T2", are applied at the point indicated in the Main behaviour description in Table 8.1.3.2.5.3.2-3.

Table 8.1.3.2.5.3.2-1: Time instances of cell power level and parameter changes for NR Cell 1 and E-UTRA Cell 1 in FR1

	Parameter	Unit	NR Cell 1	E-UTRA Cell 1	Remark
T0	SS/PBCH SSS EPRE	dBm/SCS	-73	-	Power levels are such that both entry conditions for event A2 and B2 are not satisfied
	Cell-specific RS EPRE	dBm/15 kHz	-	-91	
T1	SS/PBCH SSS EPRE	dBm/SCS	-91	-	Power levels are such that entry condition for event A2 is satisfied but entry condition for event B2 is not satisfied
	Cell-specific RS EPRE	dBm/15 kHz	-	-91	
T2	SS/PBCH SSS EPRE	dBm/SCS	-91	-	Power levels are such that both entry conditions for event A2 and B2 are satisfied
	Cell-specific RS EPRE	dBm/15 kHz	-	-73	

Table 8.1.3.2.5.3.2-2: Time instances of cell power level and parameter changes for NR Cell 1 and E-UTRA Cell 1 in FR2

	Parameter	Unit	NR Cell 1	EUTRA Cell 1	Remark
T0	SS/PBCH SSS EPRE	dBm/SCS	FFS	-	Power levels are such that both entry conditions for event A2 and B2 are not satisfied
	Cell-specific RS EPRE	dBm/15 kHz	-	-91	
T1	SS/PBCH SSS EPRE	dBm/SCS	FFS	-	Power levels are such that entry condition for event A2 is satisfied but entry condition for event B2 is not satisfied
	Cell-specific RS EPRE	dBm/15 kHz	-	-91	
T2	SS/PBCH SSS EPRE	dBm/SCS	FFS	-	Power levels are such that both entry conditions for event A2 and B2 are satisfied
	Cell-specific RS EPRE	dBm/15 kHz	-	-73	

Table 8.1.3.2.5.3.2-3: Main behaviour

St	Procedure	Message Sequence		TP	Verdict
		U - S	Message		
1	The SS transmits an <i>RRCReconfiguration</i> message including <i>MeasConfig</i> to setup NR intra-frequency event A2 measurement (measId #1) for NR Cell 1 and EUTRA inter-RAT event B2 measurement (measId #2) for EUTRA Cell 1.	<--	NR RRC: <i>RRCReconfiguration</i>	-	-
2	The UE transmits an <i>RRCReconfigurationComplete</i> message.	-->	NR RRC: <i>RRCReconfigurationComplete</i>	-	-
3	Check: Does the UE transmit a <i>MeasurementReport</i> message with measId #1 or measId #2 within the next 10s?	-	-	1	F
4	SS re-adjusts the cell-specific reference signal level according to row "T1" in table 8.1.3.2.5.3.2-1/2.	-	-	-	-
5	Check: Does the UE transmit a <i>MeasurementReport</i> message with measId #1 for NR Cell 1 within the next 10s?	-->	NR RRC: <i>MeasurementReport</i>	2	P
6	SS re-adjusts the cell-specific reference signal level according to row "T2" in table 8.1.3.2.5.3.2-1/2.	-	-	-	-
7	Check: Does the UE transmit a <i>MeasurementReport</i> message with measId #2 for EUTRA Cell 1 within the next 10s?	-->	NR RRC: <i>MeasurementReport</i>	3	P

8.1.3.2.5.3.3 Specific message contents

Table 8.1.3.2.5.3.3-1: RRCReconfiguration (step 1, Table 8.1.3.2.5.3.2-3)

Derivation Path: 38.508-1 [4] Table 4.6.1-13			
Information Element	Value/remark	Comment	Condition
RRCReconfiguration ::= SEQUENCE {			
rrc-TransactionIdentifier	RRC-TransactionIdentifier		
criticalExtensions CHOICE {			
rrcReconfiguration ::= SEQUENCE {			
radioBearerConfig	Not present		
secondaryCellGroup	Not present		
measConfig	MeasConfig	Table 8.1.3.2.5.3.3-2	
lateNonCriticalExtension	Not present		
nonCriticalExtension	Not present		
}			
}			
}			

Table 8.1.3.2.5.3.3-2: *MeasConfig* (Table 8.1.3.2.5.3.3-1)

Derivation Path: 38.508-1 [4] Table 4.6.3-69			
Information Element	Value/remark	Comment	Condition
MeasConfig ::= SEQUENCE {			
measObjectToAddModList SEQUENCE (SIZE (1..maxNrofMeasId)) OF SEQUENCE {	2 entries		
measObjectId[1]	1		
measObject{1} CHOICE {			
measObjectNR	MeasObjectNR-f1	Table 8.1.3.2.5.3.3-3	
}			
measObjectId[2]	2		
measObject{2} CHOICE {			
measObjectEUTRA	MeasObjectEUTRA-f2	Table 8.1.3.2.5.3.3-4	
}			
}			
reportConfigToAddModList SEQUENCE (SIZE (1..maxReportConfigId)) OF SEQUENCE {	2 entries		
reportConfigId[1]	1		
reportConfig{1} CHOICE {			
reportConfigNR	ReportConfigNR-EventA2	Table 8.1.3.2.5.3.3-5	
}			
reportConfigId[2]	2		
reportConfig{2} CHOICE {			
reportConfigInterRAT	ReportConfigInterRAT-EventB2	Table 8.1.3.2.5.3.3-5	
}			
}			
measIdToAddModList SEQUENCE (SIZE (1..maxNrofMeasId)) OF SEQUENCE {	2 entries		
measId[1]	1		
measObjectId[1]	1		
reportConfigId[1]	1		
measId[2]	2		
measObjectId[2]	2		
reportConfigId[2]	2		
}			
quantityConfig	QuantityConfig with condition INTER-RAT		
measGapConfig	MeasGapConfig with condition GAP_UE		
}			

Table 8.1.3.2.5.3.3-3: *MeasObjectNR-f1* (Table 8.1.3.2.5.3.3-2)

Derivation Path: TS 38.508-1 [4], Table 4.6.3-76			
Information Element	Value/remark	Comment	Condition
MeasObjectNR ::= SEQUENCE {			
ssbFrequency	ARFCN-ValueNR for SSB of NR Cell 1		
absThreshSS-BlocksConsolidation	Not present		
nrofSS-BlocksToAverage	Not present		
}			

Table 8.1.3.2.5.3.3-4: MeasObjectEUTRA-f2 (Table 8.1.3.2.5.3.3-2)

Derivation Path: TS 38.508-1 [4], Table 4.6.3-74			
Information Element	Value/remark	Comment	Condition
MeasObjectEUTRA ::= SEQUENCE {			
carrierFreq	ARFCN-ValueEUTRA for EUTRA Cell 1		
}			

Table 8.1.3.2.5.3.3-5: ReportConfigNR-EventA2 (Table 8.1.3.2.5.3.3-2)

Derivation Path: TS 38.508-1 [4], Table 4.6.3-142 with Condition EVENT A2			
Information Element	Value/remark	Comment	Condition
ReportConfigNR ::= SEQUENCE {			
reportType CHOICE {			
eventTriggered SEQUENCE {			
eventId CHOICE {			
eventA2 SEQUENCE {			
a2-Threshold CHOICE {			
rsrp	74	-83dBm ≤ SS-RSRP < -82dBm	FR1
	FFS		FR2
}			
}			
}			
}			
}			
}			

Table 8.1.3.2.5.3.3-5: ReportConfigInterRAT-EventB2 (Table 8.1.3.2.5.3.3-2)

Derivation Path: 38.508-1 [4] Table 4.6.3-141 with condition EVENT B2			
Information Element	Value/remark	Comment	Condition
ReportConfigInterRAT ::= SEQUENCE {			
reportType CHOICE {			
eventTriggered SEQUENCE {			
eventId CHOICE {			
eventB2 SEQUENCE {			
b2-Threshold1 CHOICE {			
rsrp	74	-83dBm ≤ SS-RSRP < -82dBm	FR1
	FFS		FR2
}			
b2-Threshold2EUTRA CHOICE {			
rsrp	58	-83dBm ≤ RSRP < -82dBm	
}			
hysteresis	4	2 dB	
}			
}			
}			
}			
}			

Table 8.1.3.2.5.3.3-6: MeasurementReport (step 5 and 7, Table 8.1.3.2.5.3.2-3)

Derivation Path: 38.508-1 [4] Table 4.6.1-7			
Information Element	Value/remark	Comment	Condition
MeasurementReport ::= SEQUENCE {			
criticalExtensions CHOICE {			
measurementReport SEQUENCE {			
measResults SEQUENCE {			
measId	1		Step 5
	2		Step 7
measResultServingMOList SEQUENCE (SIZE (1..maxNrofServingCells)) OF SEQUENCE {		Measurement report for NR Cell 1	
servCellId	ServCellIndex of NR Cell 1		
measResultServingCell SEQUENCE {			
physCellId	PCI of NR Cell 1		
measResult SEQUENCE {			
cellResults SEQUENCE {			
resultsSSB-Cell SEQUENCE {			
rsrp	(0..127)		
rsrq	(0..127)		
}			
}			
}			
}			
measResultNeighCells	Not present		Step 5
measResultNeighCells CHOICE {			Step 7
measResultListEUTRA SEQUENCE (SIZE (1..maxCellReport)) OF SEQUENCE {		Measurement report for EUTRA Cell 1	
eutra-PhysCellId	PhysCellId of EUTRA Cell 1		
measResult SEQUENCE {			
rsrp	(0..97)		
}			
cgi-Info	Not present		
}			
}			
}			
}			
}			
}			

8.1.4 Handover

8.1.4.1 Intra NR handover

8.1.4.1.1 Intra NR handover / Success / Dedicated preamble / Common preamble / Intra-frequency

8.1.4.1.1.1 Test Purpose (TP)

(1)

```

with { UE in NR RRC_CONNECTED state and having performed the intra-frequency measurements for the neighbour cell }
ensure that {
  when { UE receives an RRCReconfiguration message including a reconfigurationWithSync with rach-ConfigDedicated }
  then { UE performs handover to the target cell and transmits an RRCReconfigurationComplete message }
}

```

(2)

```

with { UE in NR RRC_CONNECTED state and having performed the intra-frequency measurements for the
neighbour cell }
ensure that {
  when { UE receives an RRCReconfiguration message including a reconfigurationWithSync without rach-
ConfigDedicated }
  then { UE performs handover to the target cell and transmits an RRCReconfigurationComplete
message }
}

```

8.1.4.1.1.2 Conformance requirements

References: The conformance requirements covered in the current TC are specified in: TS 38.331, clauses 5.3.5.3, 5.3.5.5.1, 5.5.2 and 5.3.5.5.2. Unless otherwise stated these are Rel-15 requirements.

[TS 38.331, clause 5.3.5.3]

The UE shall perform the following actions upon reception of the *RRCReconfiguration*:

...

1> if the *RRCReconfiguration* includes the *masterCellGroup*:

2> perform the cell group configuration for the received *masterCellGroup* according to 5.3.5.5;

1> if the *RRCReconfiguration* includes the *masterKeyUpdate*:

2> perform security key update procedure as specified in 5.3.5.7;

...

1> if the *RRCReconfiguration* message includes the *measConfig*:

2> perform the measurement configuration procedure as specified in 5.5.2;

...

1> if *reconfigurationWithSync* was included in *spCellConfig* of an MCG or SCG, and when MAC of an NR cell group successfully completes a random access procedure triggered above;

2> stop timer T304 for that cell group;

2> apply the parts of the CQI reporting configuration, the scheduling request configuration and the sounding RS configuration that do not require the UE to know the SFN of the respective target SpCell, if any;

2> apply the parts of the measurement and the radio resource configuration that require the UE to know the SFN of the respective target SpCell (e.g. measurement gaps, periodic CQI reporting, scheduling request configuration, sounding RS configuration), if any, upon acquiring the SFN of that target SpCell;

2> if the *reconfigurationWithSync* was included in *spCellConfig* of an MCG:

3> if T390 is running:

4> stop timer T390 for all access categories;

4> perform the actions as specified in 5.3.14.4.

3> if *RRCReconfiguration* does not include *dedicatedSIB1-Delivery* and

3> if the active downlink BWP, which is indicated by the *firstActiveDownlinkBWP-Id* for the target SpCell of the MCG, has a common search space configured by *searchSpaceSIB1*:

4> acquire the *SIB1*, which is scheduled as specified in TS 38.213 [13], of the target SpCell of the MCG;

4> upon acquiring *SIB1*, perform the actions specified in clause 5.2.2.4.2;

2> the procedure ends.

NOTE: The UE is only required to acquire broadcasted *SIB1* if the UE can acquire it without disrupting unicast data reception, i.e. the broadcast and unicast beams are quasi co-located.

[TS 38.331, clause 5.3.5.5.1]

The network configures the UE with Master Cell Group (MCG), and zero or one Secondary Cell Group (SCG). For EN-DC, the MCG is configured as specified in TS 36.331 [10]. The network provides the configuration parameters for a cell group in the *CellGroupConfig* IE.

The UE performs the following actions based on a received *CellGroupConfig* IE:

- 1> if the *CellGroupConfig* contains the *spCellConfig* with *reconfigurationWithSync*:
 - 2> perform Reconfiguration with sync according to 5.3.5.5.2;
 - 2> resume all suspended radio bearers and resume SCG transmission for all radio bearers, if suspended;

...

- 1> if the *CellGroupConfig* contains the *mac-CellGroupConfig*:
 - 2> configure the MAC entity of this cell group as specified in 5.3.5.5.5;

...

- 1> if the *CellGroupConfig* contains the *spCellConfig*:
 - 2> configure the SpCell as specified in 5.3.5.5.7;

[TS 38.331, clause 5.3.5.5.2]

The UE shall perform the following actions to execute a reconfiguration with sync.

- 1> if the security is not activated, perform the actions upon going to RRC_IDLE as specified in 5.3.11 with the release cause 'other' upon which the procedure ends;
- 1> stop timer T310 for the corresponding SpCell, if running;
- 1> start timer T304 for the corresponding SpCell with the timer value set to *t304*, as included in the *reconfigurationWithSync*;
- 1> if the *frequencyInfoDL* is included:
 - 2> consider the target SpCell to be one on the SSB frequency indicated by the *frequencyInfoDL* with a physical cell identity indicated by the *physCellId*;
- 1> else:
 - 2> consider the target SpCell to be one on the SSB frequency of the source SpCell with a physical cell identity indicated by the *physCellId*;
- 1> start synchronising to the DL of the target SpCell;
- 1> apply the specified BCCH configuration defined in 9.1.1.1;
- 1> acquire the *MIB*, which is scheduled as specified in TS 38.213 [13];
- 1> perform the actions specified in clause 5.2.2.4.1;

NOTE 1: The UE should perform the reconfiguration with sync as soon as possible following the reception of the RRC message triggering the reconfiguration with sync, which could be before confirming successful reception (HARQ and ARQ) of this message.

NOTE 2: The UE may omit reading the MIB if the UE already has the required timing information, or the timing information is not needed for random access.

- 1> reset the MAC entity of this cell group;
- 1> consider the SCell(s) of this cell group, if configured, to be in deactivated state;
- 1> apply the value of the *newUE-Identity* as the C-RNTI for this cell group;

Editor's Note: Verify that this does not configure some common parameters which are later discarded due to e.g. SCell release or due to LCH release.

- 1> configure lower layers in accordance with the received *spCellConfigCommon*;
- 1> configure lower layers in accordance with any additional fields, not covered in the previous, if included in the received *reconfigurationWithSync*.

[TS 38.331, clause 5.5.4.4]

The UE shall:

- 1> consider the entering condition for this event to be satisfied when condition A3-1, as specified below, is fulfilled;
- 1> consider the leaving condition for this event to be satisfied when condition A3-2, as specified below, is fulfilled;
- 1> use the SpCell for *Mp*, *Ofp* and *Ocp*.

NOTE The cell(s) that triggers the event has reference signals indicated in the *measObjectNR* associated to this event which may be different from the NR SpCell *measObjectNR*.

Inequality A3-1 (Entering condition)

$$Mn + Ofn + Ocn - Hys > Mp + Ofp + Ocp + Off$$

Inequality A3-2 (Leaving condition)

$$Mn + Ofn + Ocn + Hys < Mp + Ofp + Ocp + Off$$

The variables in the formula are defined as follows:

Mn is the measurement result of the neighbouring cell, not taking into account any offsets.

Ofn is the measurement object specific offset of the reference signal of the neighbour cell (i.e. *offsetMO* as defined within *measObjectNR* corresponding to the neighbour cell).

Ocn is the cell specific offset of the neighbour cell (i.e. *cellIndividualOffset* as defined within *measObjectNR* corresponding to the frequency of the neighbour cell), and set to zero if not configured for the neighbour cell.

Mp is the measurement result of the SpCell, not taking into account any offsets.

Ofp is the measurement object specific offset of the SpCell (i.e. *offsetMO* as defined within *measObjectNR* corresponding to the SpCell).

Ocp is the cell specific offset of the SpCell (i.e. *cellIndividualOffset* as defined within *measObjectNR* corresponding to the SpCell), and is set to zero if not configured for the SpCell.

Hys is the hysteresis parameter for this event (i.e. *hysteresis* as defined within *reportConfigNR* for this event).

Off is the offset parameter for this event (i.e. *a3-Offset* as defined within *reportConfigNR* for this event).

Mn*, *Mp are expressed in dBm in case of RSRP, or in dB in case of RSRQ and RS-SINR.

Ofn*, *Ocn*, *Ofp*, *Ocp*, *Hys*, *Off are expressed in dB.

8.1.4.1.1.3 Test description

8.1.4.1.1.3.1 Pre-test conditions

System Simulator:

- NR Cell 1 is the serving cell, NR Cell 2 is the intra-frequency neighbour cell of NR Cell 1.
- System information combination NR-2 as defined in TS 38.508-1 [4] clause 4.4.3.1.2 is used in NR cells.

UE:

- None.

Preamble:

- The UE is in state 3N-A in NR Cell 1 as defined in TS 38.508-1 [4], subclause 4.4A.

8.1.4.1.1.3.2 Test procedure sequence

Tables 8.1.4.1.1.3.2-1 and 8.1.4.1.1.3.2-2 illustrate the downlink power levels to be applied for NR Cell 1 and NR Cell 2 at various time instants of the test execution. Row marked "T0" denotes the conditions after the preamble, while the configuration marked "T1" and "T2", are applied at the point indicated in the Main behaviour description in Table 8.1.4.1.1.3.2-3.

Table 8.1.4.1.1.3.2-1: Power levels in FR1

	Parameter	Unit	NR Cell 1	NR Cell 2	Remark
T0	SS/PBCH SSS EPRE	dBm/ SCS	-85	-91	Power levels are such that entry condition for event A3 is not satisfied
T1	SS/PBCH SSS EPRE	dBm/ SCS	-85	-79	Power levels are such that entry condition for event A3 is satisfied for NR Cell 2
T2	SS/PBCH SSS EPRE	dBm/ SCS	-79	-85	Power levels are such that entry condition for event A3 is satisfied for NR Cell 1

Table 8.1.4.1.1.3.2-2: Power levels in FR2

	Parameter	Unit	NR Cell 1	NR Cell 2	Remark
T0	SS/PBCH SSS EPRE	dBm/ SCS	FFS	FFS	Power levels are such that entry condition for event A3 is not satisfied
T1	SS/PBCH SSS EPRE	dBm/ SCS	FFS	FFS	Power levels are such that entry condition for event A3 is satisfied for NR Cell 2
T2	SS/PBCH SSS EPRE	dBm/ SCS	FFS	FFS	Power levels are such that entry condition for event A3 is satisfied for NR Cell 1

Table 8.1.4.1.1.3.2-3: Main behaviour

St	Procedure	Message Sequence		TP	Verdict
		U - S	Message		
1	The SS transmits an <i>RRCReconfiguration</i> message including <i>MeasConfig</i> to setup intra NR measurement and reporting for intra-frequency event A3.	<--	NR RRC: <i>RRCReconfiguration</i>	-	-
2	The UE transmits an <i>RRCReconfigurationComplete</i> message.	-->	NR RRC: <i>RRCReconfigurationComplete</i>	-	-
3	SS adjusts the cell-specific reference signal level according to row "T1".	-	-	-	-
4	Check: Does the UE transmit a <i>MeasurementReport</i> message to report event A3 with the measured RSRP value for NR Cell 2?	-->	NR RRC: <i>MeasurementReport</i>	-	-
5	The SS transmits an <i>RRCReconfiguration</i> message including <i>reconfigurationWithSync</i> with <i>rach-ConfigDedicated</i> to order the UE to perform intra-frequency handover to NR Cell 2	<--	NR RRC: <i>RRCReconfiguration</i>	-	-
6	Check: Does the UE transmit <i>RRCReconfigurationComplete</i> message in NR Cell 2?	-->	NR RRC: <i>RRCReconfigurationComplete</i>	1	P
7	SS adjusts the cell-specific reference signal level according to row "T2".	-	-	-	-
8	Check: Does the UE transmit a <i>MeasurementReport</i> message to report event A3 with the measured RSRP value for NR Cell 1?	-->	NR RRC: <i>MeasurementReport</i>	-	-
9	The SS transmits an <i>RRCReconfiguration</i> message including <i>reconfigurationWithSync</i> without <i>rach-ConfigDedicated</i> to order the UE to perform intra-frequency handover to NR Cell 1	<--	NR RRC: <i>RRCReconfiguration</i>	-	-
10	Check: Does the UE transmit <i>RRCReconfigurationComplete</i> message in NR Cell 1?	-->	NR RRC: <i>RRCReconfigurationComplete</i>	2	P

8.1.4.1.1.3.3 Specific message contents

Table 8.1.4.1.1.3.3-1: *RRCReconfiguration* (step 1, Table 8.1.4.1.1.3.2-3)

Derivation Path: 38.508-1 [4] Table 4.6.1-13 with condition MEAS
--

Table 8.1.4.1.1.3.3-2: MeasConfig (Table 8.1.4.1.1.3.3-1)

Derivation Path: 38.508-1 [4] Table 4.6.3-69			
Information Element	Value/remark	Comment	Condition
MeasConfig ::= SEQUENCE {			
measObjectToAddModList SEQUENCE (SIZE (1..maxNrofMeasId)) OF SEQUENCE {	1 entry		
measObjectId[1]	1	MeasObjectIdNR-f1	
measObject[1] CHOICE {			
measObjectNR SEQUENCE {			
ssbFrequency	ssbFrequency IE equals the ARFCN for NR Cell 2		
absThreshSS-BlocksConsolidation	Not present		
}			
}			
reportConfigToAddModList SEQUENCE(SIZE (1..maxReportConfigId)) OF SEQUENCE {	1 entry		
reportConfigId[1]	1		
reportConfig[1] CHOICE {			
reportConfigNR	ReportConfigNR-EventA3		
}			
}			
measIdToAddModList SEQUENCE (SIZE (1..maxNrofMeasId)) OF SEQUENCE {	1 entry		
measId[1]	1		
measObjectId[1]	1		
reportConfigId[1]	1		
}			
}			

Table 8.1.4.1.1.3.3-3: ReportConfigNR-EventA3 (Table 8.1.4.1.1.3.3-2)

Derivation Path: 38.508-1 [4] Table 4.6.3-142 with condition EVENT_A3			
Information Element	Value/remark	Comment	Condition
ReportConfigNR ::= SEQUENCE {			
reportType CHOICE {			
eventTriggered SEQUENCE {			
eventId CHOICE {			
eventA3 SEQUENCE {			EVENT_A3
a3-Offset CHOICE {			
Rsrp	6	3dB	FR1
}	FFS		FR2
}			
Hysteresis	0	0 dB	
timeToTrigger	ms640		
}			
}			
reportAmount	r1		
reportQuantityCell SEQUENCE {			
rsrp	true		
rsrq	false		
sinr	false		
}			
}			

Table 8.1.4.1.1.3.3-4: MeasurementReport (step 4, Table 8.1.4.1.1.3.2-3)

Derivation Path: 38.508-1 [4] Table 4.6.1-7			
Information Element	Value/remark	Comment	Condition
MeasurementReport ::= SEQUENCE {			
criticalExtensions CHOICE {			
measurementReport SEQUENCE {			
measResults SEQUENCE {			
measId	1		
measResultServingMOList SEQUENCE (SIZE (1..maxNrofServingCells)) OF SEQUENCE {	1 entry		
servCellId	Cell index corresponding to NR Cell 1		
measResultServingCell SEQUENCE {			
physCellId	Physical layer cell identity of NR Cell 1		
}			
}			
measResultNeighCells CHOICE {			
measResultListNR SEQUENCE (SIZE (1..maxCellReport)) OF SEQUENCE {	1 entry		
physCellId	Physical layer cell identity of NR Cell 2		
measResult SEQUENCE {			
cellResults SEQUENCE {			
resultsSSB-Cell SEQUENCE {			
rsrp	(0..127)		
}			
resultsCSI-RS-Cell	Not present		
}			
rsIndexResults	Not present		
}			
}			
}			
}			

Table 8.1.4.1.1.3.3-5: RRCReconfiguration (step 5, Table 8.1.4.1.1.3.2-3)

Derivation Path: 38.508-1 [4] Table 4.6.1-13			
Information Element	Value/remark	Comment	Condition
RRCReconfiguration ::= SEQUENCE {			
criticalExtensions CHOICE {			
rrcReconfiguration ::= SEQUENCE {			
nonCriticalExtension SEQUENCE {			
masterCellGroup	OCTET STRING (CONTAINING CellGroupConfig)		
masterKeyUpdate SEQUENCE {			
keySetChangeIndicator	True		
nextHopChainingCount	2		
nas-Container	Not Present		
}			
}			
}			
}			
}			

Table 8.1.4.1.1.3.3-6: CellGroupConfig (Table 8.1.4.1.1.3.3-5)

Derivation Path: 38.508-1 [4], Table 4.6.3-19 with conditions HO, SRB1, SRB2, DRB1, and CFRA			
Information Element	Value/remark	Comment	Condition
CellGroupConfig ::= SEQUENCE {			
spCellConfig SEQUENCE {			
reconfigurationWithSync SEQUENCE {			
spCellConfigCommon SEQUENCE {			
physCellId	Physical cell Id of NR Cell 2		
rach-ConfigDedicated CHOICE {			
Uplink	RACH-ConfigDedicated		
}			
}			
}			
}			

Table 8.1.4.1.1.3.3-7: MeasurementReport (step 8, Table 8.1.4.1.1.3.2-3)

Derivation Path: 38.508-1 [4] Table 4.6.1-7			
Information Element	Value/remark	Comment	Condition
MeasurementReport ::= SEQUENCE {			
criticalExtensions CHOICE {			
measurementReport SEQUENCE {			
measResults SEQUENCE {			
measId	1		
measResultServingMOList SEQUENCE (SIZE (1..maxNrofServingCells)) OF SEQUENCE {	1 entry		
servCellId	Cell index corresponding to NR Cell 2		
measResultServingCell SEQUENCE {			
physCellId	Physical layer cell identity of NR Cell 2		
}			
}			
measResultNeighCells CHOICE {			
measResultListNR SEQUENCE (SIZE (1..maxCellReport)) OF SEQUENCE {	1 entry		
physCellId	Physical layer cell identity of NR Cell 1		
measResult SEQUENCE {			
cellResults SEQUENCE {			
resultsSSB-Cell SEQUENCE {			
rsrp	(0..127)		
}			
resultsCSI-RS-Cell	Not present		
}			
rsIndexResults	Not present		
}			
}			
}			
}			
}			

Table 8.1.4.1.1.3.3-8: RRCReconfiguration (step 9, Table 8.1.4.1.1.3.2-3)

Derivation Path: 38.508-1 [4] Table 4.6.1-13			
Information Element	Value/remark	Comment	Condition
RRCReconfiguration ::= SEQUENCE {			
criticalExtensions CHOICE {			
rrcReconfiguration ::= SEQUENCE {			
nonCriticalExtension SEQUENCE {			
masterCellGroup	OCTET STRING (CONTAINING CellGroupConfig)		
masterKeyUpdate SEQUENCE {			
keySetChangeIndicator	True		
nextHopChainingCount	3		
nas-Container	Not Present		
}			
}			
}			
}			

Table 8.1.4.1.1.3.3-9: CellGroupConfig (Table 8.1.4.1.1.3.3-8)

Derivation Path: 38.508-1 [4], Table 4.6.3-19 with conditions HO, SRB1, SRB2 and DRB1			
Information Element	Value/remark	Comment	Condition
CellGroupConfig ::= SEQUENCE {			
spCellConfig SEQUENCE {			
reconfigurationWithSync SEQUENCE {			
spCellConfigCommon SEQUENCE {	Same as default ServingCellConfigCommon		
physCellId	Physical cell Id of NR Cell 1		
}			
rach-ConfigDedicated	Not Present		
}			
}			

8.1.4.1.2 Intra NR handover / Success / Dedicated preamble / Common preamble / Inter-frequency

8.1.4.1.2.1 Test Purpose (TP)

(1)

```
with { UE in NR RRC_CONNECTED state and having performed the inter-frequency measurements for the neighbour cell }
ensure that {
  when { UE receives an RRCReconfiguration message including a reconfigurationWithSync with rach-ConfigDedicated }
  then { UE performs handover to the target cell and transmits an RRCReconfigurationComplete message }
}
```

(2)

```
with { UE in NR RRC_CONNECTED state and having performed the inter-frequency measurements for the neighbour cell }
ensure that {
  when { UE receives an RRCReconfiguration message including a reconfigurationWithSync without rach-ConfigDedicated }
  then { UE performs handover to the target cell and transmits an RRCReconfigurationComplete message }
}
```

}

8.1.4.1.2.2 Conformance requirements

References: The conformance requirements covered in the current TC are specified in: TS 38.331, clauses 5.3.5.3, 5.3.5.5.1, 5.5.2 and 5.3.5.5.2. Unless otherwise stated these are Rel-15 requirements.

[TS 38.331, clause 5.3.5.3]

The UE shall perform the following actions upon reception of the *RRCReconfiguration*:

...

1> if the *RRCReconfiguration* includes the *masterCellGroup*:

2> perform the cell group configuration for the received *masterCellGroup* according to 5.3.5.5;

1> if the *RRCReconfiguration* includes the *masterKeyUpdate*:

2> perform security key update procedure as specified in 5.3.5.7;

...

1> if the *RRCReconfiguration* message includes the *measConfig*:

2> perform the measurement configuration procedure as specified in 5.5.2;

...

1> if *reconfigurationWithSync* was included in *spCellConfig* of an MCG or SCG, and when MAC of an NR cell group successfully completes a random access procedure triggered above;

2> stop timer T304 for that cell group;

2> apply the parts of the CQI reporting configuration, the scheduling request configuration and the sounding RS configuration that do not require the UE to know the SFN of the respective target SpCell, if any;

2> apply the parts of the measurement and the radio resource configuration that require the UE to know the SFN of the respective target SpCell (e.g. measurement gaps, periodic CQI reporting, scheduling request configuration, sounding RS configuration), if any, upon acquiring the SFN of that target SpCell;

2> if the *reconfigurationWithSync* was included in *spCellConfig* of an MCG:

3> if T390 is running:

4> stop timer T390 for all access categories;

4> perform the actions as specified in 5.3.14.4.

3> if *RRCReconfiguration* does not include *dedicatedSIB1-Delivery* and

3> if the active downlink BWP, which is indicated by the *firstActiveDownlinkBWP-Id* for the target SpCell of the MCG, has a common search space configured by *searchSpaceSIB1*:

4> acquire the *SIB1*, which is scheduled as specified in TS 38.213 [13], of the target SpCell of the MCG;

4> upon acquiring *SIB1*, perform the actions specified in clause 5.2.2.4.2;

2> the procedure ends.

NOTE: The UE is only required to acquire broadcasted *SIB1* if the UE can acquire it without disrupting unicast data reception, i.e. the broadcast and unicast beams are quasi co-located.

[TS 38.331, clause 5.3.5.5.1]

The network configures the UE with Master Cell Group (MCG), and zero or one Secondary Cell Group (SCG). For EN-DC, the MCG is configured as specified in TS 36.331 [10]. The network provides the configuration parameters for a cell group in the *CellGroupConfig* IE.

The UE performs the following actions based on a received *CellGroupConfig* IE:

- 1> if the *CellGroupConfig* contains the *spCellConfig* with *reconfigurationWithSync*:
 - 2> perform Reconfiguration with sync according to 5.3.5.5.2;
 - 2> resume all suspended radio bearers and resume SCG transmission for all radio bearers, if suspended;
- ...
- 1> if the *CellGroupConfig* contains the *mac-CellGroupConfig*:
 - 2> configure the MAC entity of this cell group as specified in 5.3.5.5.5;
- ...
- 1> if the *CellGroupConfig* contains the *spCellConfig*:
 - 2> configure the SpCell as specified in 5.3.5.5.7;

[TS 38.331, clause 5.3.5.5.2]

The UE shall perform the following actions to execute a reconfiguration with sync.

- 1> if the security is not activated, perform the actions upon going to RRC_IDLE as specified in 5.3.11 with the release cause 'other' upon which the procedure ends;
- 1> stop timer T310 for the corresponding SpCell, if running;
- 1> start timer T304 for the corresponding SpCell with the timer value set to *t304*, as included in the *reconfigurationWithSync*;
- 1> if the *frequencyInfoDL* is included:
 - 2> consider the target SpCell to be one on the SSB frequency indicated by the *frequencyInfoDL* with a physical cell identity indicated by the *physCellId*;
- 1> else:
 - 2> consider the target SpCell to be one on the SSB frequency of the source SpCell with a physical cell identity indicated by the *physCellId*;
- 1> start synchronising to the DL of the target SpCell;
- 1> apply the specified BCCH configuration defined in 9.1.1.1;
- 1> acquire the *MIB*, which is scheduled as specified in TS 38.213 [13];
- 1> perform the actions specified in clause 5.2.2.4.1;

NOTE 1: The UE should perform the reconfiguration with sync as soon as possible following the reception of the RRC message triggering the reconfiguration with sync, which could be before confirming successful reception (HARQ and ARQ) of this message.

NOTE 2: The UE may omit reading the MIB if the UE already has the required timing information, or the timing information is not needed for random access.

- 1> reset the MAC entity of this cell group;
- 1> consider the SCell(s) of this cell group, if configured, to be in deactivated state;
- 1> apply the value of the *newUE-Identity* as the C-RNTI for this cell group;

Editor's Note: Verify that this does not configure some common parameters which are later discarded due to e.g. SCell release or due to LCH release.

1> configure lower layers in accordance with the received *spCellConfigCommon*;

1> configure lower layers in accordance with any additional fields, not covered in the previous, if included in the received *reconfigurationWithSync*.

[TS 38.331, clause 5.5.4.4]

The UE shall:

1> consider the entering condition for this event to be satisfied when condition A3-1, as specified below, is fulfilled;

1> consider the leaving condition for this event to be satisfied when condition A3-2, as specified below, is fulfilled;

1> use the SpCell for *Mp*, *Ofp* and *Ocp*.

NOTE The cell(s) that triggers the event has reference signals indicated in the *measObjectNR* associated to this event which may be different from the NR SpCell *measObjectNR*.

Inequality A3-1 (Entering condition)

$$Mn + Ofn + Ocn - Hys > Mp + Ofp + Ocp + Off$$

Inequality A3-2 (Leaving condition)

$$Mn + Ofn + Ocn + Hys < Mp + Ofp + Ocp + Off$$

The variables in the formula are defined as follows:

Mn is the measurement result of the neighbouring cell, not taking into account any offsets.

Ofn is the measurement object specific offset of the reference signal of the neighbour cell (i.e. *offsetMO* as defined within *measObjectNR* corresponding to the neighbour cell).

Ocn is the cell specific offset of the neighbour cell (i.e. *cellIndividualOffset* as defined within *measObjectNR* corresponding to the frequency of the neighbour cell), and set to zero if not configured for the neighbour cell.

Mp is the measurement result of the SpCell, not taking into account any offsets.

Ofp is the measurement object specific offset of the SpCell (i.e. *offsetMO* as defined within *measObjectNR* corresponding to the SpCell).

Ocp is the cell specific offset of the SpCell (i.e. *cellIndividualOffset* as defined within *measObjectNR* corresponding to the SpCell), and is set to zero if not configured for the SpCell.

Hys is the hysteresis parameter for this event (i.e. *hysteresis* as defined within *reportConfigNR* for this event).

Off is the offset parameter for this event (i.e. *a3-Offset* as defined within *reportConfigNR* for this event).

Mn, *Mp* are expressed in dBm in case of RSRP, or in dB in case of RSRQ and RS-SINR.

Ofn, *Ocn*, *Ofp*, *Ocp*, *Hys*, *Off* are expressed in dB.

8.1.4.1.2.3 Test description

8.1.4.1.2.3.1 Pre-test conditions

System Simulator:

- NR Cell 1 is the serving cell and NR Cell 3 is the inter-frequency neighbour cell of NR Cell 1.
- System information combination NR-4 as defined in TS 38.508-1 [4] clause 4.4.3.1.2 is used in NR cells.

UE:

- None.

Preamble:

- The UE is in state 3N-A in NR Cell 1 as defined in TS 38.508-1 [4], subclause 4.4A.

8.1.4.1.2.3.2 Test procedure sequence

Tables 8.1.4.1.2.3.2-1 and 8.1.4.1.2.3.2-2 illustrate the downlink power levels to be applied for NR Cell 1 and NR Cell 3 at various time instants of the test execution. Row marked "T0" denotes the conditions after the preamble, while the configuration marked "T1" and "T2", are applied at the point indicated in the Main behaviour description in Table 8.1.4.1.2.3.2-3.

Table 8.1.4.1.2.3.2-1: Power levels in FR1

	Parameter	Unit	NR Cell 1	NR Cell 3	Remark
T0	SS/PBCH SSS EPRE	dBm/ SCS	-85	-91	Power levels are such that entry condition for event A3 is not satisfied
T1	SS/PBCH SSS EPRE	dBm/ SCS	-85	-79	Power levels are such that entry condition for event A3 is satisfied for NR Cell 3
T2	SS/PBCH SSS EPRE	dBm/ SCS	-79	-85	Power levels are such that entry condition for event A3 is satisfied for NR Cell 1

Table 8.1.4.1.2.3.2-2: Power levels in FR2

	Parameter	Unit	NR Cell 1	NR Cell 3	Remark
T0	SS/PBCH SSS EPRE	dBm/ SCS	FFS	FFS	Power levels are such that entry condition for event A3 is not satisfied
T1	SS/PBCH SSS EPRE	dBm/ SCS	FFS	FFS	Power levels are such that entry condition for event A3 is satisfied for NR Cell 3
T2	SS/PBCH SSS EPRE	dBm/ SCS	FFS	FFS	Power levels are such that entry condition for event A3 is satisfied for NR Cell 1

Table 8.1.4.1.2.3.2-3: Main behaviour

St	Procedure	Message Sequence		TP	Verdict
		U - S	Message		
1	The SS transmits an <i>RRCReconfiguration</i> message including <i>MeasConfig</i> to setup intra NR measurement and reporting for inter-frequency event A3.	<--	NR RRC: <i>RRCReconfiguration</i>	-	-
2	The UE transmits an <i>RRCReconfigurationComplete</i> message.	-->	NR RRC: <i>RRCReconfigurationComplete</i>	-	-
3	SS adjusts the cell-specific reference signal level according to row "T1".	-	-	-	-
4	Check: Does the UE transmit a <i>MeasurementReport</i> message to report event A3 with the measured RSRP value for NR Cell 3?	-->	NR RRC: <i>MeasurementReport</i>	-	-
5	The SS transmits an <i>RRCReconfiguration</i> message including <i>reconfigurationWithSync</i> with <i>rach-ConfigDedicated</i> to order the UE to perform inter-frequency handover to NR Cell 3	<--	NR RRC: <i>RRCReconfiguration</i>	-	-
6	Check: Does the UE transmit <i>RRCReconfigurationComplete</i> message in NR Cell 3?	-->	NR RRC: <i>RRCReconfigurationComplete</i>	1	P
7	The SS transmits an <i>RRCReconfiguration</i> message including <i>MeasConfig</i> to setup intra NR measurement and reporting for inter-frequency event A3.	<--	NR RRC: <i>RRCReconfiguration</i>	-	-
8	The UE transmits an <i>RRCReconfigurationComplete</i> message.	-->	NR RRC: <i>RRCReconfigurationComplete</i>	-	-
9	SS adjusts the cell-specific reference signal level according to row "T2".	-	-	-	-
10	Check: Does the UE transmit a <i>MeasurementReport</i> message to report event A3 with the measured RSRP value for NR Cell 1?	-->	NR RRC: <i>MeasurementReport</i>	-	-
11	The SS transmits an <i>RRCReconfiguration</i> message including <i>reconfigurationWithSync</i> without <i>rach-ConfigDedicated</i> to order the UE to perform inter-frequency handover to NR Cell 1	<--	NR RRC: <i>RRCReconfiguration</i>	-	-
12	Check: Does the UE transmit <i>RRCReconfigurationComplete</i> message in NR Cell 1?	-->	NR RRC: <i>RRCReconfigurationComplete</i>	2	P

8.1.4.1.2.3.3 Specific message contents

Table 8.1.4.1.2.3.3-1: *RRCReconfiguration* (step 1, Table 8.1.4.1.2.3.2-3)

Derivation Path: 38.508-1 [4] Table 4.6.1-13 with condition MEAS
--

Table 8.1.4.1.2.3.3-2: *MeasConfig* (Table 8.1.4.1.2.3.3-1)

Derivation Path: 38.508-1 [4] Table 4.6.3-69			
Information Element	Value/remark	Comment	Condition
MeasConfig ::= SEQUENCE {			
measObjectToAddModList SEQUENCE (SIZE (1..maxNrofMeasId)) OF SEQUENCE {	2 entries		
measObjectId[1]	1		
measObject[1] CHOICE {			
measObjectNR SEQUENCE {			
ssbFrequency	ssbFrequency IE equals the ARFCN for NR Cell 3		
absThreshSS-BlocksConsolidation	Not present		
}			
measObjectId[2]	2		
measObject[2] CHOICE {			
measObjectNR SEQUENCE {			
ssbFrequency	ssbFrequency IE equals the ARFCN for NR Cell 1		
absThreshSS-BlocksConsolidation	Not present		
}			
}			
}			
reportConfigToAddModList SEQUENCE(SIZE (1..maxReportConfigId)) OF SEQUENCE {	1 entry		
reportConfigId[1]	1		
reportConfig[1] CHOICE {			
reportConfigNR	ReportConfigNR-EventA3		
}			
}			
measIdToAddModList SEQUENCE (SIZE (1..maxNrofMeasId)) OF SEQUENCE {	1 entry		
measId[1]	1		
measObjectId[1]	1		
reportConfigId[1]	1		
}			
measGapConfig	MeasGapConfig with condition GAP_UE		
}			

Table 8.1.4.1.2.3.3-4: MeasurementReport (step 4, Table 8.1.4.1.2.3.2-3)

Derivation Path: 38.508-1 [4] Table 4.6.1-7			
Information Element	Value/remark	Comment	Condition
MeasurementReport ::= SEQUENCE {			
criticalExtensions CHOICE {			
measurementReport SEQUENCE {			
measResults SEQUENCE {			
measId	1		
measResultServingMOList SEQUENCE (SIZE (1..maxNrofServingCells)) OF SEQUENCE {	1 entry		
servCellId	Cell index corresponding to NR Cell 1		
measResultServingCell SEQUENCE {			
physCellId	Physical layer cell identity of NR Cell 1		
}			
}			
measResultNeighCells CHOICE {			
measResultListNR SEQUENCE (SIZE (1..maxCellReport)) OF SEQUENCE {	1 entry		
physCellId	Physical layer cell identity of NR Cell 3		
measResult SEQUENCE {			
cellResults SEQUENCE {			
resultsSSB-Cell SEQUENCE {			
rsrp	(0..127)		
}			
resultsCSI-RS-Cell	Not present		
}			
rsIndexResults	Not present		
}			
}			
}			

Table 8.1.4.1.2.3.3-5: RRCReconfiguration (step 5, Table 8.1.4.1.2.3.2-3)

Derivation Path: 38.508-1 [4] Table 4.6.1-13			
Information Element	Value/remark	Comment	Condition
RRCReconfiguration ::= SEQUENCE {			
criticalExtensions CHOICE {			
rrcReconfiguration ::= SEQUENCE {			
nonCriticalExtension SEQUENCE {			
masterCellGroup	OCTET STRING (CONTAINING CellGroupConfig)		
masterKeyUpdate SEQUENCE {			
keySetChangeIndicator	True		
nextHopChainingCount	2		
nas-Container	Not Present		
}			
}			
}			
}			

Table 8.1.4.1.2.3.3-6: CellGroupConfig (Table 8.1.4.1.2.3.3-5)

Derivation Path: 38.508-1 [4], Table 4.6.3-19 with condition HO, SRB1, SRB2, DRB1 and CFRA			
Information Element	Value/remark	Comment	Condition
CellGroupConfig ::= SEQUENCE {			
spCellConfig SEQUENCE {			
reconfigurationWithSync SEQUENCE {			
spCellConfigCommon SEQUENCE {	Same as default		
physCellId	Physical cell Id of NR Cell 3		
}			
rach-ConfigDedicated CHOICE {			
Uplink	RACH-ConfigDedicated		
}			
}			
}			

Table 8.1.4.1.2.3.3-7: RRCReconfiguration (step 7, Table 8.1.4.1.2.3.2-3)

Derivation Path: 38.508-1 [4] Table 4.6.1-13 with condition MEAS
--

Table 8.1.4.1.2.3.3-8: *MeasConfig* (Table 8.1.4.1.2.3.3-7)

Derivation Path: 38.508-1 [4] Table 4.6.3-69			
Information Element	Value/remark	Comment	Condition
MeasConfig ::= SEQUENCE {			
measObjectToAddModList SEQUENCE (SIZE (1..maxNrofMeasId)) OF SEQUENCE {	2 entries		
measObjectId[1]	1		
measObject[1] CHOICE {			
measObjectNR SEQUENCE {			
ssbFrequency	ssbFrequency IE equals the ARFCN for NR Cell 1		
absThreshSS-BlocksConsolidation	Not present		
}			
measObjectId[2]	2		
measObject[2] CHOICE {			
measObjectNR SEQUENCE {			
ssbFrequency	ssbFrequency IE equals the ARFCN for NR Cell 3		
absThreshSS-BlocksConsolidation	Not present		
}			
}			
}			
reportConfigToAddModList SEQUENCE(SIZE (1..maxReportConfigId)) OF SEQUENCE {	1 entry		
reportConfigId[1]	1		
reportConfig[1] CHOICE {			
reportConfigNR	ReportConfigNR-EventA3		
}			
}			
measIdToAddModList SEQUENCE (SIZE (1..maxNrofMeasId)) OF SEQUENCE {	1 entry		
measId[1]	1		
measObjectId[1]	1		
reportConfigId[1]	1		
}			
measGapConfig	MeasGapConfig with condition GAP_UE		
}			

Table 8.1.4.1.2.3.3-9: MeasurementReport (step 10, Table 8.1.4.1.2.3.2-3)

Derivation Path: 38.508-1 [4] Table 4.6.1-7			
Information Element	Value/remark	Comment	Condition
MeasurementReport ::= SEQUENCE {			
criticalExtensions CHOICE {			
measurementReport SEQUENCE {			
measResults SEQUENCE {			
measId	1		
measResultServingMOList SEQUENCE (SIZE (1..maxNrofServingCells)) OF SEQUENCE {	1 entry		
servCellId	Cell index corresponding to NR Cell 3		
measResultServingCell SEQUENCE {			
physCellId	Physical layer cell identity of NR Cell 3		
}			
}			
measResultNeighCells CHOICE {			
measResultListNR SEQUENCE (SIZE (1..maxCellReport)) OF SEQUENCE {	1 entry		
physCellId	Physical layer cell identity of NR Cell 1		
measResult SEQUENCE {			
cellResults SEQUENCE {			
resultsSSB-Cell SEQUENCE {			
Rsrp	(0..127)		
}			
resultsCSI-RS-Cell	Not present		
}			
rsIndexResults	Not present		
}			
}			
}			

Table 8.1.4.1.2.3.3-10: RRCReconfiguration (step 11, Table 8.1.4.1.2.3.2-3)

Derivation Path: 38.508-1 [4] Table 4.6.1-13			
Information Element	Value/remark	Comment	Condition
RRCReconfiguration ::= SEQUENCE {			
criticalExtensions CHOICE {			
rrcReconfiguration ::= SEQUENCE {			
nonCriticalExtension SEQUENCE {			
masterCellGroup	OCTET STRING (CONTAINING CellGroupConfig)		
masterKeyUpdate SEQUENCE {			
keySetChangeIndicator	True		
nextHopChainingCount	3		
nas-Container	Not Present		
}			
}			
}			
}			

Table 8.1.4.1.2.3.3-11: *CellGroupConfig* (Table 8.1.4.1.2.3.3-10)

Derivation Path: 38.508-1 [4], Table 4.6.3-19 with condition HO, SRB1, SRB2 and DRB1			
Information Element	Value/remark	Comment	Condition
CellGroupConfig ::= SEQUENCE {			
spCellConfig SEQUENCE {			
reconfigurationWithSync SEQUENCE {			
spCellConfigCommon SEQUENCE {	Same as default ServingCellConfigCommon		
physCellId	Physical cell Id of NR Cell 1		
}			
rach-ConfigDedicated	Not Present		
}			
}			

8.1.4.1.3 Intra NR handover / Success / Security key reconfiguration

8.1.4.1.3.1 Test Purpose (TP)

(1)

```

with { UE in NR RRC_CONNECTED state }
ensure that {
  when { UE receives an RRCReconfiguration message including a reconfigurationWithSync and
keySetChangeIndicator set to 'true' in MasterKeyUpdate for handover to the target cell }
  then { UE performs handover to the target cell with security key update and transmits an
RRCReconfigurationComplete message }
}

```

8.1.4.1.3.2 Conformance requirements

References: The conformance requirements covered in the current TC is specified in: TS 38.331 clause 5.3.5.5.2 and 5.3.5.7. Unless otherwise stated these are Rel-15 requirements.

[TS 38.331, clause 5.3.5.5.2]

The UE shall perform the following actions to execute a reconfiguration with sync.

- 1> if the AS security is not activated, perform the actions upon going to RRC_IDLE as specified in 5.3.11 with the release cause 'other' upon which the procedure ends;
- 1> stop timer T310 for the corresponding SpCell, if running;
- 1> start timer T304 for the corresponding SpCell with the timer value set to *t304*, as included in the *reconfigurationWithSync*;
- 1> if the *frequencyInfoDL* is included:
 - 2> consider the target SpCell to be one on the SSB frequency indicated by the *frequencyInfoDL* with a physical cell identity indicated by the *physCellId*;
- 1> else:
 - 2> consider the target SpCell to be one on the SSB frequency of the source SpCell with a physical cell identity indicated by the *physCellId*;
- 1> start synchronising to the DL of the target SpCell;
- 1> apply the specified BCCH configuration defined in 9.1.1.1;
- 1> acquire the *MIB*, which is scheduled as specified in TS 38.213 [13];

NOTE 1: The UE should perform the reconfiguration with sync as soon as possible following the reception of the RRC message triggering the reconfiguration with sync, which could be before confirming successful reception (HARQ and ARQ) of this message.

NOTE 2: The UE may omit reading the *MIB* if the UE already has the required timing information, or the timing information is not needed for random access.

- 1> reset the MAC entity of this cell group;
- 1> consider the SCell(s) of this cell group, if configured, to be in deactivated state;
- 1> apply the value of the *newUE-Identity* as the C-RNTI for this cell group;
- 1> configure lower layers in accordance with the received *spCellConfigCommon*;
- 1> configure lower layers in accordance with any additional fields, not covered in the previous, if included in the received *reconfigurationWithSync*.

[TS 38.331, clause 5.3.5.7]

The UE shall:

- 1> if UE is connected to E-UTRA/EPC:
 - 2> upon reception of *sk-Counter* as specified in TS 36.331 [10]:
 - 3> update the $S\text{-}K_{gNB}$ key based on the K_{eNB} key and using the received *sk-Counter* value, as specified in TS 33.401 [30];
 - 3> derive the K_{RRCEnc} and K_{UPenc} keys as specified in TS 33.401 [30];
 - 3> derive the K_{RRCint} and K_{UPint} keys as specified in TS 33.401 [30].
- 1> else:
 - 2> if the *nas-Container* is included in the received *masterKeyUpdate*:
 - 3> forward the *nas-Container* to the upper layers;
 - 2> if the *keySetChangeIndicator* is set to *true*:
 - 3> derive or update the K_{gNB} key based on the K_{AMF} key, as specified in TS 33.501 [11];
 - 2> else:
 - 3> derive or update the K_{gNB} key based on the current K_{gNB} key or the NH, using the *nextHopChainingCount* value indicated in the received *masterKeyUpdate*, as specified in TS 33.501 [11];
 - 2> store the *nextHopChainingCount* value;
 - 2> derive the keys associated with the K_{gNB} key as follows:
 - 3> if the *securityAlgorithmConfig* is included in *SecurityConfig*:
 - 4> derive the K_{RRCEnc} and K_{UPenc} keys associated with the *cipheringAlgorithm* indicated in the *securityAlgorithmConfig*, as specified in TS 33.501 [11];
 - 4> derive the K_{RRCint} and K_{UPint} keys associated with the *integrityProtAlgorithm* indicated in the *securityAlgorithmConfig*, as specified in TS 33.501 [11];
 - 3> else:
 - 4> derive the K_{RRCEnc} and K_{UPenc} keys associated with the current *cipheringAlgorithm*, as specified in TS 33.501 [11];
 - 4> derive the K_{RRCint} and K_{UPint} keys associated with the current *integrityProtAlgorithm*, as specified in TS 33.501 [11].

NOTE: Cipherring and integrity protection are optional to configure for the DRBs.

8.1.4.1.3.3 Test description

8.1.4.1.3.3.1 Pre-test conditions

System Simulator:

- NR Cell 1 is the serving cell and NR Cell 2 is the suitable intra-frequency neighbour cell of NR Cell 1.
- System information combination NR-2 as defined in TS 38.508-1 [4] clause 4.4.3.1.2 is used in NR cells.

UE:

- None.

Preamble:

- The UE is in 5GS state 3N-A on NR Cell 1 according to TS 38.508-1 [4], subclause 4.4A.2.

8.1.4.1.3.3.2 Test procedure sequence

Table 8.1.4.1.3.3.2-1: Main behaviour

St	Procedure	Message Sequence		TP	Verdict
		U - S	Message		
1	The SS transmits an <i>RRCReconfiguration</i> message including <i>reconfigurationWithSync</i> with <i>keySetChangeIndicator</i> set to <i>true</i> to order the UE to perform handover to NR Cell 2 and update the K_{gNB} key.	<--	NR RRC: <i>RRCReconfiguration</i>	-	-
2	Check: Does the UE transmit <i>RRCReconfigurationComplete</i> message in NR Cell 2?	-->	NR RRC: <i>RRCReconfigurationComplete</i>	1	P

8.1.4.1.3.3.3 Specific message contents

FFS

8.1.4.1.4 Intra NR handover / Failure / Security key reconfiguration

8.1.4.1.4.1 Test Purpose (TP)

(1)

```
with { UE in NR RRC_CONNECTED state and having received an RRCReconfiguration message including a
reconfigurationWithSync and keySetChangeIndicator set to 'true' in MasterKeyUpdate for handover to
the target cell }
ensure that {
  when { UE detects handover failure and the initial cell is selectable }
  then { UE performs RRCReestablishment procedure on the source cell }
}
```

8.1.4.1.4.2 Conformance requirements

References: The conformance requirements covered in the current TC is specified in: TS 38.331 clause 5.3.5.5.2, 5.3.5.7, 5.3.5.8.3 and 5.3.7.5. Unless otherwise stated these are Rel-15 requirements.

[TS 38.331, clause 5.3.5.5.2]

The UE shall perform the following actions to execute a reconfiguration with sync.

- 1> if the AS security is not activated, perform the actions upon going to RRC_IDLE as specified in 5.3.11 with the release cause 'other' upon which the procedure ends;
- 1> stop timer T310 for the corresponding SpCell, if running;
- 1> start timer T304 for the corresponding SpCell with the timer value set to $t304$, as included in the *reconfigurationWithSync*;
- 1> if the *frequencyInfoDL* is included:
 - 2> consider the target SpCell to be one on the SSB frequency indicated by the *frequencyInfoDL* with a physical cell identity indicated by the *physCellId*;
- 1> else:
 - 2> consider the target SpCell to be one on the SSB frequency of the source SpCell with a physical cell identity indicated by the *physCellId*;
- 1> start synchronising to the DL of the target SpCell;
- 1> apply the specified BCCH configuration defined in 9.1.1.1;
- 1> acquire the *MIB*, which is scheduled as specified in TS 38.213 [13];

NOTE 1: The UE should perform the reconfiguration with sync as soon as possible following the reception of the RRC message triggering the reconfiguration with sync, which could be before confirming successful reception (HARQ and ARQ) of this message.

NOTE 2: The UE may omit reading the *MIB* if the UE already has the required timing information, or the timing information is not needed for random access.

- 1> reset the MAC entity of this cell group;
- 1> consider the SCell(s) of this cell group, if configured, to be in deactivated state;
- 1> apply the value of the *newUE-Identity* as the C-RNTI for this cell group;
- 1> configure lower layers in accordance with the received *spCellConfigCommon*;
- 1> configure lower layers in accordance with any additional fields, not covered in the previous, if included in the received *reconfigurationWithSync*.

[TS 38.331, clause 5.3.5.7]

The UE shall:

- 1> if UE is connected to E-UTRA/EPC:
 - 2> upon reception of *sk-Counter* as specified in TS 36.331 [10]:
 - 3> update the $S\text{-}K_{gNB}$ key based on the K_{eNB} key and using the received *sk-Counter* value, as specified in TS 33.401 [30];
 - 3> derive the K_{RRCEnc} and K_{UPenc} keys as specified in TS 33.401 [30];
 - 3> derive the K_{RRCint} and K_{UPint} keys as specified in TS 33.401 [30].
- 1> else:
 - 2> if the *nas-Container* is included in the received *masterKeyUpdate*:
 - 3> forward the *nas-Container* to the upper layers;
 - 2> if the *keySetChangeIndicator* is set to *true*:
 - 3> derive or update the K_{gNB} key based on the K_{AMF} key, as specified in TS 33.501 [11];

- 2> else:
 - 3> derive or update the K_{gNB} key based on the current K_{gNB} key or the NH, using the *nextHopChainingCount* value indicated in the received *masterKeyUpdate*, as specified in TS 33.501 [11];
- 2> store the *nextHopChainingCount* value;
- 2> derive the keys associated with the K_{gNB} key as follows:
 - 3> if the *securityAlgorithmConfig* is included in *SecurityConfig*:
 - 4> derive the K_{RRCEnc} and K_{UPenc} keys associated with the *cipheringAlgorithm* indicated in the *securityAlgorithmConfig*, as specified in TS 33.501 [11];
 - 4> derive the K_{RRCint} and K_{UPint} keys associated with the *integrityProtAlgorithm* indicated in the *securityAlgorithmConfig*, as specified in TS 33.501 [11];
 - 3> else:
 - 4> derive the K_{RRCEnc} and K_{UPenc} keys associated with the current *cipheringAlgorithm*, as specified in TS 33.501 [11];
 - 4> derive the K_{RRCint} and K_{UPint} keys associated with the current *integrityProtAlgorithm*, as specified in TS 33.501 [11].

NOTE: Ciphering and integrity protection are optional to configure for the DRBs.

[TS 38.331, clause 5.3.5.8.3]

The UE shall:

- 1> if T304 of the MCG expires:
 - 2> release dedicated preambles provided in *rach-ConfigDedicated* if configured;
 - 2> revert back to the UE configuration used in the source PCell;
 - 2> initiate the connection re-establishment procedure as specified in subclause 5.3.7.

NOTE 1: In the context above, "the UE configuration" includes state variables and parameters of each radio bearer.

- 1> else if T304 of a secondary cell group expires:
 - 2> release dedicated preambles provided in *rach-ConfigDedicated*, if configured;
 - 2> initiate the SCG failure information procedure as specified in subclause 5.7.3 to report SCG reconfiguration with sync failure, upon which the RRC reconfiguration procedure ends;
- 1> else if T304 expires when *RRCReconfiguration* is received via other RAT (HO to NR failure):
 - 2> reset MAC;
 - 2> perform the actions defined for this failure case as defined in the specifications applicable for the other RAT.

[TS 38.331, clause 5.3.7.5]

The UE shall:

- 1> stop timer T301;
- 1> consider the current cell to be the PCell;
- 1> store the *nextHopChainingCount* value indicated in the *RRCReestablishment* message;
- 1> update the K_{gNB} key based on the current K_{gNB} key or the NH, using the stored *nextHopChainingCount* value, as specified in TS 33.501 [11];

- 1> derive the K_{RRCEnc} and K_{UPenc} keys associated with the previously configured *cipheringAlgorithm*, as specified in TS 33.501 [11];
- 1> derive the K_{RRCint} and K_{UPint} keys associated with the previously configured *integrityProtAlgorithm*, as specified in TS 33.501 [11].
- 1> request lower layers to verify the integrity protection of the *RRCReestablishment* message, using the previously configured algorithm and the K_{RRCint} key;
- 1> if the integrity protection check of the *RRCReestablishment* message fails:
 - 2> perform the actions upon going to RRC_IDLE as specified in 5.3.11, with release cause 'RRC connection failure', upon which the procedure ends;
- 1> configure lower layers to resume integrity protection for SRB1 using the previously configured algorithm and the K_{RRCint} key immediately, i.e., integrity protection shall be applied to all subsequent messages received and sent by the UE, including the message used to indicate the successful completion of the procedure;
- 1> configure lower layers to resume ciphering for SRB1 using the previously configured algorithm and, the K_{RRCEnc} key immediately, i.e., ciphering shall be applied to all subsequent messages received and sent by the UE, including the message used to indicate the successful completion of the procedure;
- 1> release the measurement gap configuration indicated by the *measGapConfig*, if configured;
- 1> submit the *RRCReestablishmentComplete* message to lower layers for transmission;
- 1> the procedure ends.

8.1.4.1.4.3 Test description

8.1.4.1.4.3.1 Pre-test conditions

System Simulator:

- NR Cell 1 is the serving cell and NR Cell 2 is the suitable intra-frequency neighbour cell of NR Cell 1.
- System information combination NR-2 as defined in TS 38.508-1 [4] clause 4.4.3.1.2 is used in NR cells.

UE:

- None.

Preamble:

- The UE is in 5GS state 3N-A on NR Cell 1 according to TS 38.508-1 [4], subclause 4.4A.2.

8.1.4.1.4.3.2 Test procedure sequence

Table 8.1.4.1.4.3.2-1 and Table 8.1.4.1.4.3.2-2 illustrates the downlink power levels and other changing parameters to be applied for the cells at various time instants of the test execution. The exact instants on which these values shall be applied are described in the texts in this clause.

Table 8.1.4.1.4.3.2-1: Time instances of cell power level and parameter changes for FR1

	Parameter	Unit	NR Cell 1	NR Cell 2	Remark
T1	SS/PBCH SSS EPRE	dBm/SCS	-88	-94	
T2	SS/PBCH SSS EPRE	dBm/SCS	-88	"Off"	

Table 8.1.4.1.4.3.2-2: Time instances of cell power level and parameter changes for FR2

	Parameter	Unit	NR Cell 1	NR Cell 2	Remark
T1	SS/PBCH SSS EPRE	dBm/SCS	FFS	FFS	
T2	SS/PBCH SSS EPRE	dBm/SCS	FFS	"Off"	

Table 8.1.4.1.4.3.2-3: Main behaviour

St	Procedure	Message Sequence		TP	Verdict
		U - S	Message		
1	The SS changes the power level setting according to the row "T1".	-	-	-	-
2	The SS transmits an <i>RRCReconfiguration</i> message including <i>reconfigurationWithSync</i> with <i>keySetChangeIndicator</i> set to <i>true</i> to order the UE to perform handover to NR Cell 2 and update the K_{qNB} key.	<--	NR RRC: <i>RRCReconfiguration</i>	-	-
-	EXCEPTION: In parallel to the events described in step 3 the steps specified in Table 8.1.4.1.4.3.2-4 shall take place.	-	-	-	-
3	The SS changes the power level setting according to the row "T2".	-	-	-	-
4	Check: Does the UE transmit an <i>RRCReestablishmentRequest</i> message on NR Cell 1?	-->	NR RRC: <i>RRCReestablishmentRequest</i>	1	P
5	The SS transmits an <i>RRCReestablishment</i> message to reestablish RRC connection on NR Cell 1.	<--	NR RRC: <i>RRCReestablishment</i>	-	-
6	Does the UE transmit an <i>RRCReestablishmentComplete</i> on NR Cell 1?	-->	NR RRC: <i>RRCReestablishmentComplete</i>	-	-

Table 8.1.4.1.4.3.2-4: Parallel behaviour

St	Procedure	Message Sequence		TP	Verdict
		U - S	Message		
-	EXCEPTION: The steps 1 and 2 below are repeated for the duration of T304.	-	-	-	-
1	The UE attempts to perform the handover using MAC Random Access Preamble on NR Cell 2.	-	-	-	-
2	The SS does not respond.	-	-	-	-

8.1.4.1.4.3.3 Specific message contents

FFS

8.1.4.1.5 Intra NR handover / Failure / Re-establishment successful

8.1.4.1.5.1 Test Purpose (TP)

(1)

```

with { UE in NR RRC_CONNECTED state and having received an RRCReconfiguration message including a
reconfigurationWithSync for handover to the target cell }
ensure that {
  when { UE detects handover failure and the initial cell is selectable }

```

```

    then { UE performs an RRCReestablishment procedure on the source cell }
  }

```

(2)

```

with { UE detects handover failure and having transmitted an RRCReestablishmentRequest message }
ensure that {
  when { UE receives an RRCReestablishment message with a nextHopChainingCount which is different
from the NCC associated with the currently active KgNB }
    then { UE derives new KgNB from the nextHopChainingCount and completes RRCReestablishment
procedure on the source cell }
}

```

(3)

```

with { UE detects handover failure and having transmitted an RRCReestablishmentRequest message }
ensure that {
  when { UE receives an RRCReestablishment message with a nextHopChainingCount which is same as the
NCC associated with the currently active KgNB }
    then { UE derives new KgNB from the currently active KgNB and completes RRCReestablishment
procedure on the source cell }
}

```

8.1.4.1.5.2 Conformance requirements

References: The conformance requirements covered in the present test case are specified in: TS 38.331, clauses 5.3.5.5.2, 5.3.5.7, 5.3.5.8.3 and 5.3.7.5. Unless otherwise stated these are Rel-15 requirements.

[TS 38.331, clause 5.3.5.5.2]

The UE shall perform the following actions to execute a reconfiguration with sync.

- 1> if the AS security is not activated, perform the actions upon going to RRC_IDLE as specified in 5.3.11 with the release cause 'other' upon which the procedure ends;
- 1> stop timer T310 for the corresponding SpCell, if running;
- 1> start timer T304 for the corresponding SpCell with the timer value set to *t304*, as included in the *reconfigurationWithSync*;
- 1> if the *frequencyInfoDL* is included:
 - 2> consider the target SpCell to be one on the SSB frequency indicated by the *frequencyInfoDL* with a physical cell identity indicated by the *physCellId*;
- 1> else:
 - 2> consider the target SpCell to be one on the SSB frequency of the source SpCell with a physical cell identity indicated by the *physCellId*;
- 1> start synchronising to the DL of the target SpCell;
- 1> apply the specified BCCH configuration defined in 9.1.1.1;
- 1> acquire the *MIB*, which is scheduled as specified in TS 38.213 [13];

NOTE 1: The UE should perform the reconfiguration with sync as soon as possible following the reception of the RRC message triggering the reconfiguration with sync, which could be before confirming successful reception (HARQ and ARQ) of this message.

NOTE 2: The UE may omit reading the *MIB* if the UE already has the required timing information, or the timing information is not needed for random access.

- 1> reset the MAC entity of this cell group;
- 1> consider the SCell(s) of this cell group, if configured, to be in deactivated state;
- 1> apply the value of the *newUE-Identity* as the C-RNTI for this cell group;

1> configure lower layers in accordance with the received *spCellConfigCommon*;

1> configure lower layers in accordance with any additional fields, not covered in the previous, if included in the received *reconfigurationWithSync*.

[TS 38.331, clause 5.3.5.7]

The UE shall:

...

1> else:

2> if the *nas-Container* is included in the received *masterKeyUpdate*:

3> forward the *nas-Container* to the upper layers;

2> if the *keySetChangeIndicator* is set to *true*:

3> derive or update the K_{gNB} key based on the K_{AMF} key, as specified in TS 33.501 [11];

2> else:

3> derive or update the K_{gNB} key based on the current K_{gNB} key or the NH, using the *nextHopChainingCount* value indicated in the received *masterKeyUpdate*, as specified in TS 33.501 [11];

2> store the *nextHopChainingCount* value;

2> derive the keys associated with the K_{gNB} key as follows:

3> if the *securityAlgorithmConfig* is included in *SecurityConfig*:

4> derive the K_{RRCenc} and K_{UPenc} keys associated with the *cipheringAlgorithm* indicated in the *securityAlgorithmConfig*, as specified in TS 33.501 [11];

4> derive the K_{RRCint} and K_{UPint} keys associated with the *integrityProtAlgorithm* indicated in the *securityAlgorithmConfig*, as specified in TS 33.501 [11];

3> else:

4> derive the K_{RRCenc} and K_{UPenc} keys associated with the current *cipheringAlgorithm*, as specified in TS 33.501 [11];

4> derive the K_{RRCint} and K_{UPint} keys associated with the current *integrityProtAlgorithm*, as specified in TS 33.501 [11].

NOTE: Ciphering and integrity protection are optional to configure for the DRBs.

[TS 38.331, clause 5.3.5.8.3]

The UE shall:

1> if T304 of the MCG expires:

2> release dedicated preambles provided in *rach-ConfigDedicated* if configured;

2> revert back to the UE configuration used in the source PCell;

2> initiate the connection re-establishment procedure as specified in subclause 5.3.7.

NOTE 1: In the context above, "the UE configuration" includes state variables and parameters of each radio bearer.

1> else if T304 of a secondary cell group expires:

2> release dedicated preambles provided in *rach-ConfigDedicated*, if configured;

2> initiate the SCG failure information procedure as specified in subclause 5.7.3 to report SCG reconfiguration with sync failure, upon which the RRC reconfiguration procedure ends;

1> else if T304 expires when *RRCReconfiguration* is received via other RAT (HO to NR failure):

2> reset MAC;

2> perform the actions defined for this failure case as defined in the specifications applicable for the other RAT.

[TS 38.331, clause 5.3.7.5]

The UE shall:

1> stop timer T301;

1> consider the current cell to be the PCell;

1> store the *nextHopChainingCount* value indicated in the *RRCReestablishment* message;

1> update the K_{gNB} key based on the current K_{gNB} key or the NH, using the stored *nextHopChainingCount* value, as specified in TS 33.501 [11];

1> derive the K_{RRcenc} and K_{UPenc} keys associated with the previously configured *cipheringAlgorithm*, as specified in TS 33.501 [11];

1> derive the K_{RRcint} and K_{UPint} keys associated with the previously configured *integrityProtAlgorithm*, as specified in TS 33.501 [11].

1> request lower layers to verify the integrity protection of the *RRCReestablishment* message, using the previously configured algorithm and the K_{RRcint} key;

1> if the integrity protection check of the *RRCReestablishment* message fails:

2> perform the actions upon going to RRC_IDLE as specified in 5.3.11, with release cause 'RRC connection failure', upon which the procedure ends;

1> configure lower layers to resume integrity protection for SRB1 using the previously configured algorithm and the K_{RRcint} key immediately, i.e., integrity protection shall be applied to all subsequent messages received and sent by the UE, including the message used to indicate the successful completion of the procedure;

1> configure lower layers to resume ciphering for SRB1 using the previously configured algorithm and, the K_{RRcenc} key immediately, i.e., ciphering shall be applied to all subsequent messages received and sent by the UE, including the message used to indicate the successful completion of the procedure;

1> release the measurement gap configuration indicated by the *measGapConfig*, if configured;

1> submit the *RRCReestablishmentComplete* message to lower layers for transmission;

1> the procedure ends.

8.1.4.1.5.3 Test Description

8.1.4.1.5.3.1 Pre-test conditions

System Simulator:

- NR Cell 1 is the Serving cell.
- NR Cell 2 is the Suitable neighbour intra-frequency cell.
- System information combination NR-2 as defined in TS 38.508-1 [4] clause 4.4.3.1.3 is used for both NR Cells.

UE:

- None.

Preamble:

- The UE is in state 3N-A as defined in TS 38.508-1 [4], subclause 4.4A on NR Cell 1.

8.1.4.1.5.3.2 Test procedure sequence

Table 8.1.4.1.5.3.2-1 and Table 8.1.4.1.5.3.2-2 illustrates the downlink power levels and other changing parameters to be applied for the cells at various time instants of the test execution. The exact instants on which these values shall be applied are described in the texts in this clause.

Table 8.1.4.1.5.3.2-1: Time instances of cell power level and parameter changes for FR1

	Parameter	Unit	NR Cell 1	NR Cell 2	Remark
T1	SS/PBCH SSS EPRE	dBm/SC S	-88	-88	
T2	SS/PBCH SSS EPRE	dBm/SC S	-88	"Off"	
T3	SS/PBCH SSS EPRE	dBm/SC S	"Off"	-88	

Table 8.1.4.1.5.3.2-2: Time instances of cell power level and parameter changes for FR2

	Parameter	Unit	NR Cell 1	NR Cell 2	Remark
T1	SS/PBCH SSS EPRE	dBm/SC S	FFS	FFS	
T2	SS/PBCH SSS EPRE	dBm/SC S	FFS	"Off"	
T3	SS/PBCH SSS EPRE	dBm/SC S	"Off"	FFS	

Table 8.1.4.1.5.3.2-3: Main behaviour

St	Procedure	Message Sequence		TP	Verdict
		U - S	Message		
1	The SS changes the power level setting according to the row "T1".	-	-	-	-
2	The SS transmits an RRCReconfiguration message on NR Cell 1 to order the UE to perform handover to NR Cell 2.	<--	NR RRC: <i>RRCReconfiguration</i>	-	-
-	EXCEPTION: In parallel to the events described in step 3 the steps specified in Table 8.1.4.1.5.3.2-4 should take place.	-	-	-	-
3	The SS changes the power level setting according to the row "T2".	-	-	-	-
4	Check: Does the UE transmit an RRCReestablishmentRequest message on NR Cell 1?	-->	NR RRC: <i>RRCReestablishmentRequest</i>	1	P
5	The SS transmits an RRCReestablishment message to resume SRB1 operation and re-activate security on NR Cell 1.	<--	NR RRC: <i>RRCReestablishment</i>	-	-
6	Does the UE transmit an RRCReestablishmentComplete message using the security key derived from the nextHopChainingCount on NR Cell 1?	-->	NR RRC: <i>RRCReestablishmentComplete</i>	2	P
7	The SS changes the power level setting according to the row "T1".	-	-	-	-
8	The SS transmits an RRCReconfiguration message on NR Cell 1 to order the UE to perform handover to NR Cell 2.	<--	NR RRC: <i>RRCReconfiguration</i>	-	-
-	EXCEPTION: In parallel to the events described in step 9 the steps specified in Table 8.1.4.1.5.3.2-4 should take place.	-	-	-	-
9	The SS changes the power level setting according to the row "T3".	-	-	-	-
10	Check: Does the UE transmit an RRCReestablishmentRequest message on NR Cell 2?	-->	NR RRC: <i>RRCReestablishmentRequest</i>	-	-
11	The SS transmits an RRCReestablishment message to resume SRB1 operation and re-activate security on NR Cell 2.	<--	NR RRC: <i>RRCReestablishment</i>	-	-
12	Does the UE transmit an RRCReestablishmentComplete message using the security key derived from the nextHopChainingCount on NR Cell 2?	-->	NR RRC: <i>RRCReestablishmentComplete</i>	3	P
13	The SS transmits an <i>RRCRelease</i> message on NR Cell 2.	<--	NR RRC: <i>RRCRelease</i>	-	-

Table 8.1.4.1.5.3.2-4: Parallel behaviour

St	Procedure	Message Sequence		TP	Verdict
		U - S	Message		
-	EXCEPTION: The steps 1 and 2 below are repeated for the duration of T304.	-	-	-	-
1	The UE attempts to perform the handover using MAC Random Access Preamble on NR Cell 2.	-	-	-	-
2	The SS does not respond.	-	-	-	-

8.1.4.1.5.3.3 Specific message contents

Table 8.1.4.1.5.3.3-1: SIB1 for NR Cell 1 and NR Cell 2 (preamble and all steps, Table 8.1.4.1.5.3.2-3)

Derivation Path: 38.508-1, Table 4.6.3-130			
Information Element	Value/remark	Comment	Condition
RACH-ConfigGeneric ::= SEQUENCE {			
preambleTransMax	n50		
}			

Table 8.1.4.1.5.3.3-2: RRCReconfiguration-HO (steps 2, 8, Table 8.1.4.1.5.3.2-3)

Derivation Path: 38.508-1 [4] Table 4.8.1-1A with condition RBConfig_KeyChange
--

Table 8.1.4.1.5.3.3-3: RRCReestablishmentRequest (step 4, Table 8.1.4.1.5.3.2-3)

Derivation Path: 38.508-1, Table 4.6.1-12			
Information Element	Value/remark	Comment	Condition
RRCReestablishmentRequest ::= SEQUENCE {			
ue-Identity SEQUENCE {			
c-RNTI	the value of the C-RNTI of the UE		
physCellId	PhysicalCellIdentity of NR Cell 1		
shortMAC-I	The same value as the 16 least significant bits of the MAC-I value calculated by SS.		
}			
reestablishmentCause	handoverFailure		
}			

Table 8.1.4.1.5.3.3-4: RRCReestablishment (step 5, Table 8.1.4.1.5.3.2-3)

Derivation Path: 38.508-1, Table 4.6.1-10			
Information Element	Value/remark	Comment	Condition
RRCReestablishment ::= SEQUENCE {			
criticalExtensions CHOICE {			
rrcReestablishment SEQUENCE {			
nextHopChainingCount	2		
}			
}			
}			

Table 8.1.4.1.5.3.3-5: RRCReestablishmentRequest (step 10, Table 8.1.4.1.5.3.2-3)

Derivation Path: 38.508-1, Table 4.6.1-12			
Information Element	Value/remark	Comment	Condition
RRCReestablishmentRequest ::= SEQUENCE {			
ue-Identity SEQUENCE {			
c-RNTI	the value of the C-RNTI of the UE		
physCellId	PhysicalCellIdentity of NR Cell 2		
shortMAC-I	The same value as the 16 least significant bits of the MAC-I value calculated by SS.		
}			
reestablishmentCause	handoverFailure		
}			

Table 8.1.4.1.5.3.3-6: RRCReestablishment (step 11, Table 8.1.4.1.5.3.2-3)

Derivation Path: 38.508-1, Table 4.6.1-10			
Information Element	Value/remark	Comment	Condition
RRCReestablishment ::= SEQUENCE {			
criticalExtensions CHOICE {			
rrcReestablishment SEQUENCE {			
nextHopChainingCount	0		
}			
}			
}			

8.1.4.1.6 Intra NR handover / Failure / Re-establishment failure

8.1.4.1.6.1 Test Purpose (TP)

(1)

```

with { UE in NR RRC_CONNECTED state and having received an RRCReconfiguration message including a
reconfigurationWithSync for handover to the target cell }
ensure that {
  when { UE detects handover failure and fails an RRCReestablishment procedure }
  then { UE enters NR RRC_IDLE state }
}

```

8.1.4.1.6.2 Conformance requirements

References: The conformance requirements covered in the present test case are specified in: TS 38.331, clauses 5.3.5.5.2, 5.3.5.8.3 and 5.3.7.5. Unless otherwise stated these are Rel-15 requirements.

[TS 38.331, clause 5.3.5.5.2]

The UE shall perform the following actions to execute a reconfiguration with sync.

- 1> if the AS security is not activated, perform the actions upon going to RRC_IDLE as specified in 5.3.11 with the release cause 'other' upon which the procedure ends;
- 1> stop timer T310 for the corresponding SpCell, if running;
- 1> start timer T304 for the corresponding SpCell with the timer value set to *t304*, as included in the *reconfigurationWithSync*;
- 1> if the *frequencyInfoDL* is included:

2> consider the target SpCell to be one on the SSB frequency indicated by the *frequencyInfoDL* with a physical cell identity indicated by the *physCellId*;

1> else:

2> consider the target SpCell to be one on the SSB frequency of the source SpCell with a physical cell identity indicated by the *physCellId*;

1> start synchronising to the DL of the target SpCell;

1> apply the specified BCCH configuration defined in 9.1.1.1;

1> acquire the *MIB*, which is scheduled as specified in TS 38.213 [13];

NOTE 1: The UE should perform the reconfiguration with sync as soon as possible following the reception of the RRC message triggering the reconfiguration with sync, which could be before confirming successful reception (HARQ and ARQ) of this message.

NOTE 2: The UE may omit reading the *MIB* if the UE already has the required timing information, or the timing information is not needed for random access.

1> reset the MAC entity of this cell group;

1> consider the SCell(s) of this cell group, if configured, to be in deactivated state;

1> apply the value of the *newUE-Identity* as the C-RNTI for this cell group;

1> configure lower layers in accordance with the received *spCellConfigCommon*;

1> configure lower layers in accordance with any additional fields, not covered in the previous, if included in the received *reconfigurationWithSync*.

[TS 38.331, clause 5.3.5.8.3]

The UE shall:

1> if T304 of the MCG expires:

2> release dedicated preambles provided in *rach-ConfigDedicated* if configured;

2> revert back to the UE configuration used in the source PCell;

2> initiate the connection re-establishment procedure as specified in subclause 5.3.7.

NOTE 1: In the context above, "the UE configuration" includes state variables and parameters of each radio bearer.

1> else if T304 of a secondary cell group expires:

2> release dedicated preambles provided in *rach-ConfigDedicated*, if configured;

2> initiate the SCG failure information procedure as specified in subclause 5.7.3 to report SCG reconfiguration with sync failure, upon which the RRC reconfiguration procedure ends;

1> else if T304 expires when *RRCReconfiguration* is received via other RAT (HO to NR failure):

2> reset MAC;

2> perform the actions defined for this failure case as defined in the specifications applicable for the other RAT.

[TS 38.331, clause 5.3.7.5]

The UE shall:

1> stop timer T301;

1> consider the current cell to be the PCell;

1> store the *nextHopChainingCount* value indicated in the *RRCReestablishment* message;

- 1> update the K_{gNB} key based on the current K_{gNB} key or the NH, using the stored *nextHopChainingCount* value, as specified in TS 33.501 [11];
- 1> derive the K_{RRCenc} and K_{UPenc} keys associated with the previously configured *cipheringAlgorithm*, as specified in TS 33.501 [11];
- 1> derive the K_{RRCint} and K_{UPint} keys associated with the previously configured *integrityProtAlgorithm*, as specified in TS 33.501 [11].
- 1> request lower layers to verify the integrity protection of the *RRCReestablishment* message, using the previously configured algorithm and the K_{RRCint} key;
- 1> if the integrity protection check of the *RRCReestablishment* message fails:
 - 2> perform the actions upon going to RRC_IDLE as specified in 5.3.11, with release cause 'RRC connection failure', upon which the procedure ends;
- 1> configure lower layers to resume integrity protection for SRB1 using the previously configured algorithm and the K_{RRCint} key immediately, i.e., integrity protection shall be applied to all subsequent messages received and sent by the UE, including the message used to indicate the successful completion of the procedure;
- 1> configure lower layers to resume ciphering for SRB1 using the previously configured algorithm and, the K_{RRCenc} key immediately, i.e., ciphering shall be applied to all subsequent messages received and sent by the UE, including the message used to indicate the successful completion of the procedure;
- 1> release the measurement gap configuration indicated by the *measGapConfig*, if configured;
- 1> submit the *RRCReestablishmentComplete* message to lower layers for transmission;
- 1> the procedure ends.

8.1.4.1.6.3 Test Description

8.1.4.1.6.3.1 Pre-test conditions

System Simulator:

- NR Cell 1 is the Serving cell.
- NR Cell 2 is the Suitable neighbour intra-frequency cell.
- System information combination NR-2 as defined in TS 38.508-1 [4] clause 4.4.3.1.3 is used for both NR Cells.

UE:

- None.

Preamble:

- The UE is in state 3N-A as defined in TS 38.508-1 [4], subclause 4.4A on NR Cell 1.

8.1.4.1.6.3.2 Test procedure sequence

Table 8.1.4.1.6.3.2-1 and Table 8.1.4.1.6.3.2-2 illustrates the downlink power levels and other changing parameters to be applied for the cells at various time instants of the test execution. The exact instants on which these values shall be applied are described in the texts in this clause.

Table 8.1.4.1.6.3.2-1: Time instances of cell power level and parameter changes for FR1

	Parameter	Unit	NR Cell 1	NR Cell 2	Remark
T1	SS/PBCH SSS EPRE	dBm/SC S	-88	-88	
T2	SS/PBCH SSS EPRE	dBm/SC S	-88	"Off"	

Table 8.1.4.1.6.3.2-2: Time instances of cell power level and parameter changes for FR2

	Parameter	Unit	NR Cell 1	NR Cell 2	Remark
T1	SS/PBCH SSS EPRE	dBm/SC S	FFS	FFS	
T2	SS/PBCH SSS EPRE	dBm/SC S	FFS	"Off"	

Table 8.1.4.1.6.3.2-3: Main behaviour

St	Procedure	Message Sequence		TP	Verdict
		U - S	Message		
1	The SS changes the power level setting according to the row "T1".	-	-	-	-
2	The SS transmits an RRCReconfiguration message on NR Cell 1 to order the UE to perform handover to NR Cell 2.	<--	NR RRC: <i>RRCReconfiguration</i>	-	-
-	EXCEPTION: In parallel to the events described in step 3 the steps specified in Table 8.1.4.1.6.3.2-4 should take place.	-	-	-	-
3	The SS changes the power level setting according to the row "T2".	-	-	-	-
4	Check: Does the UE transmit an RRCReestablishmentRequest message on NR Cell 1?	-->	NR RRC: <i>RRCReestablishmentRequest</i>	1	P
5	The SS transmits an RRCReestablishment message to resume SRB1 operation and reactivate security on NR Cell 1.	<--	NR RRC: <i>RRCReestablishment</i>	-	-
6	The SS allows 1 second for UE to move to RRC_IDLE state upon integrity protection check failure of NR RRC: RRCReestablishment message				
7	Check: does the test result of generic test procedure in TS 38.508-1 [4] subclause 4.9.4 indicate that the UE is in RRC_IDLE?	-	-	1	-

Table 8.1.4.1.6.3.2-4: Parallel behaviour

St	Procedure	Message Sequence		TP	Verdict
		U - S	Message		
-	EXCEPTION: The steps 1 and 2 below are repeated for the duration of T304.	-	-	-	-
1	The UE attempts to perform the handover using MAC Random Access Preamble on NR Cell 2.	-	-	-	-
2	The SS does not respond.	-	-	-	-

8.1.4.1.6.3.3 Specific message contents

Table 8.1.4.1.6.3.3-1: SIB1 for NR Cell 1 and NR Cell 2 (preamble and all steps, Table 8.1.4.1.6.3.2-3)

Derivation Path: 38.508-1, Table 4.6.3-130			
Information Element	Value/remark	Comment	Condition
RACH-ConfigGeneric ::= SEQUENCE {			
preambleTransMax	n50		
}			

Table 8.1.4.1.6.3.3-2: RRCReconfiguration-HO (step 2, Table 8.1.4.1.6.3.2-3)

Derivation Path: 38.508-1 [4] Table 4.8.1-1A with condition RBConfig_KeyChange
--

Table 8.1.4.1.6.3.3-3: RRCReestablishmentRequest (step 4, Table 8.1.4.1.6.3.2-3)

Derivation Path: 38.508-1, Table 4.6.1-12			
Information Element	Value/remark	Comment	Condition
RRCReestablishmentRequest ::= SEQUENCE {			
ue-Identity SEQUENCE {			
c-RNTI	the value of the C-RNTI of the UE		
physCellId	PhysicalCellIdentity of NR Cell 1		
shortMAC-I	The same value as the 16 least significant bits of the MAC-I value calculated by SS.		
}			
reestablishmentCause	handoverFailure		
}			

Table 8.1.4.1.6.3.3-4: RRCReestablishment (step 5, Table 8.1.4.1.6.3.2-3)

Derivation Path: 38.508-1, Table 4.6.1-10			
Information Element	Value/remark	Comment	Condition
RRCReestablishment ::= SEQUENCE {			
criticalExtensions CHOICE {			
rrcReestablishment SEQUENCE {			
nextHopChainingCount	7		
}			
}			
}			

8.1.4.1.7

8.1.4.1.8

8.1.4.1.9 NR CA / Intra NR handover / Failure / Re-establishment successful

8.1.4.1.9.1 NR CA / Intra NR handover / Failure / Re-establishment successful / Intra-band Contiguous CA

8.1.4.1.9.1.1 Test Purpose (TP)

(1)

```

with { UE in NR RRC_CONNECTED state and having received an RRCReconfiguration message including a
reconfigurationWithSync for PCell change and including sCellToReleaseList with an sCellIndex set to
the configured SCell }
ensure that {
  when { UE detects handover failure and the source PCell is selectable}
  then { UE successfully performs an RRCReestablishment procedure on source Pcell}
}

```

(2)

```

with { UE in NR RRC_CONNECTED state and having received an RRCReconfiguration message including a
reconfigurationWithSync for PCell change and including sCellToReleaseList with an sCellIndex set to
the configured SCell }
ensure that {
  when { UE detects handover failure and the initial SCell is selectable}
  then { UE successfully performs an RRCReestablishment procedure on original SCell and the
original SCell becomes the PCell}
}

```

8.1.4.1.9.1.2 Conformance requirements

References: The conformance requirements covered in the present test case are specified in: TS 38.331, clause 5.3.5.5.2, 5.3.5.5.9, 5.3.5.5.8 and 5.3.7.5. Unless otherwise stated these are Rel-15 requirements.

[TS 38.331, clause 5.3.5.5.2]

The UE shall perform the following actions to execute a reconfiguration with sync.

- 1> if the AS security is not activated, perform the actions upon going to RRC_IDLE as specified in 5.3.11 with the release cause 'other' upon which the procedure ends;
- 1> stop timer T310 for the corresponding SpCell, if running;
- 1> start timer T304 for the corresponding SpCell with the timer value set to *t304*, as included in the *reconfigurationWithSync*;
- 1> if the *frequencyInfoDL* is included:
 - 2> consider the target SpCell to be one on the SSB frequency indicated by the *frequencyInfoDL* with a physical cell identity indicated by the *physCellId*;
- 1> else:
 - 2> consider the target SpCell to be one on the SSB frequency of the source SpCell with a physical cell identity indicated by the *physCellId*;
- 1> start synchronising to the DL of the target SpCell;
- 1> apply the specified BCCH configuration defined in 9.1.1.1;
- 1> acquire the *MIB*, which is scheduled as specified in TS 38.213 [13];

NOTE 1: The UE should perform the reconfiguration with sync as soon as possible following the reception of the RRC message triggering the reconfiguration with sync, which could be before confirming successful reception (HARQ and ARQ) of this message.

NOTE 2: The UE may omit reading the *MIB* if the UE already has the required timing information, or the timing information is not needed for random access.

- 1> reset the MAC entity of this cell group;
- 1> consider the SCell(s) of this cell group, if configured, to be in deactivated state;
- 1> apply the value of the *newUE-Identity* as the C-RNTI for this cell group;
- 1> configure lower layers in accordance with the received *spCellConfigCommon*;
- 1> configure lower layers in accordance with any additional fields, not covered in the previous, if included in the received *reconfigurationWithSync*.

[TS 38.331, clause 5.3.5.5.9]

The UE shall:

- 1> for each *sCellIndex* value included in the *sCellToAddModList* that is not part of the current UE configuration (SCell addition):
 - 2> add the SCell, corresponding to the *sCellIndex*, in accordance with the *sCellConfigCommon* and *sCellConfigDedicated*;
 - 2> configure lower layers to consider the SCell to be in deactivated state;
 - 2> for each *measId* included in the *measIdList* within *VarMeasConfig*:
 - 3> if SCells are not applicable for the associated measurement; and
 - 3> if the concerned SCell is included in *cellsTriggeredList* defined within the *VarMeasReportList* for this *measId*:
 - 4> remove the concerned SCell from *cellsTriggeredList* defined within the *VarMeasReportList* for this *measId*;
- 1> for each *sCellIndex* value included in the *sCellToAddModList* that is part of the current UE configuration (SCell modification):
- 2> modify the SCell configuration in accordance with the *sCellConfigDedicated*.

[TS 38.331, clause 5.3.5.5.8]

The UE shall:

- 1> if the release is triggered by reception of the *sCellToReleaseList*:
 - 2> for each *sCellIndex* value included in the *sCellToReleaseList*:
 - 3> if the current UE configuration includes an SCell with value *sCellIndex*:
 - 4> release the SCell.

[TS 38.331, clause 5.3.7.5]

The UE shall:

- 1> stop timer T301;
- 1> consider the current cell to be the PCell;
- 1> store the *nextHopChainingCount* value indicated in the *RRCReestablishment* message;
- 1> update the K_{gNB} key based on the current K_{gNB} key or the NH, using the stored *nextHopChainingCount* value, as specified in TS 33.501 [11];
- 1> derive the K_{RRcenc} and K_{UPenc} keys associated with the previously configured *cipheringAlgorithm*, as specified in TS 33.501 [11];

- 1> derive the K_{RRcInt} and K_{UPInt} keys associated with the previously configured *integrityProtAlgorithm*, as specified in TS 33.501 [11].
- 1> request lower layers to verify the integrity protection of the *RRCReestablishment* message, using the previously configured algorithm and the K_{RRcInt} key;
- 1> if the integrity protection check of the *RRCReestablishment* message fails:
 - 2> perform the actions upon going to RRC_IDLE as specified in 5.3.11, with release cause 'RRC connection failure', upon which the procedure ends;
- 1> configure lower layers to resume integrity protection for SRB1 using the previously configured algorithm and the K_{RRcInt} key immediately, i.e., integrity protection shall be applied to all subsequent messages received and sent by the UE, including the message used to indicate the successful completion of the procedure;
- 1> configure lower layers to resume ciphering for SRB1 using the previously configured algorithm and, the K_{RRcEnc} key immediately, i.e., ciphering shall be applied to all subsequent messages received and sent by the UE, including the message used to indicate the successful completion of the procedure;
- 1> release the measurement gap configuration indicated by the *measGapConfig*, if configured;
- 1> submit the *RRCReestablishmentComplete* message to lower layers for transmission;
- 1> the procedure ends.

8.1.4.1.9.1.3 Test Description

8.1.4.1.9.1.3.1 Pre-test conditions

System Simulator:

- NR Cell 1 is the PCell and NR Cell 3 is the SCell
- System information combination NR-2 as defined in TS 38.508-1 [4] clause 4.4.3.1.3 is used in all NR cells.

UE:

- None.

Preamble:

- The UE is in 5GS state 3N-A as defined in TS 38.508-1 [4], clause 4.4A.2 Table 4.4A.2-3 on NR Cell 1.

8.1.4.1.9.1.3.2 Test procedure sequence

Table 8.1.4.1.9.1.3.2-1 and Table 8.1.4.1.9.1.3.2-1A illustrates the downlink power levels to be applied for NR Cell 1 and NR Cell 3 at various time instants of the test execution. Row marked "T0" denotes the conditions after the preamble, while rows marked "T1", "T2", "T3" and "T4" are to be applied subsequently. The exact instants on which these values shall be applied are described in the texts in this clause.

Table 8.1.4.1.9.1.3.2-1: Time instances of cell power level and parameter changes for FR1

	Parameter	Unit	NR Cell 1	NR Cell 3	Remark
T0	SS/PBCH SSS EPRE	dBm/SC S	-85	-91	Power levels are such that entry condition for event A3 is not satisfied $Mn + Ofn + Ocn - Hys < Mp + Ofp + Ocp + Off$
T1	SS/PBCH SSS EPRE	dBm/SC S	-85	-79	Power levels are such that entry condition for event A3 is satisfied $Mn + Ofn + Ocn - Hys > Mp + Ofp + Ocp + Off$
T2	SS/PBCH SSS EPRE	dBm/SC S	-85	"Off"	Power levels are assigned to satisfy $SrxLevCell3 < 0$ such that selecting Cell 1 is guaranteed
T3	SS/PBCH SSS EPRE	dBm/SC S	-85	-79	Power levels are such that entry condition for event A3 is satisfied $Mn + Ofn + Ocn - Hys > Mp + Ofp + Ocp + Off$
T4	SS/PBCH SSS EPRE	dBm/SC S	"Off"	-79	Power levels are assigned to satisfy $SrxLevCell1 < 0$ such that selecting Cell 3 is guaranteed

Table 8.1.4.1.9.1.3.2-1A: Time instances of cell power level and parameter changes for FR2

	Parameter	Unit	NR Cell 1	NR Cell 3	Remark
T0	SS/PBCH SSS EPRE	dBm/SC S	[FFS]	[FFS]	Power levels are such that entry condition for event A3 is not satisfied $Mn + Ofn + Ocn - Hys < Mp + Ofp + Ocp + Off$
T1	SS/PBCH SSS EPRE	dBm/SC S	[FFS]	[FFS]	Power levels are such that entry condition for event A3 is satisfied $Mn + Ofn + Ocn - Hys > Mp + Ofp + Ocp + Off$
T2	SS/PBCH SSS EPRE	dBm/SC S	[FFS]	"Off"	Power levels are assigned to satisfy $SrxLevCell3 < 0$ such that selecting Cell 1 is guaranteed
T3	SS/PBCH SSS EPRE	dBm/SC S	[FFS]	[FFS]	Power levels are such that entry condition for event A3 is satisfied $Mn + Ofn + Ocn - Hys > Mp + Ofp + Ocp + Off$
T4	SS/PBCH SSS EPRE	dBm/SC S	"Off"	[FFS]	Power levels are assigned to satisfy $SrxLevCell1 < 0$ such that selecting Cell 3 is guaranteed

Table 8.1.4.1.9.1.3.2-2: Main behaviour

St	Procedure	Message Sequence		TP	Verdict
		U - S	Message		
1	The SS transmits an RRCReconfiguration message on NR Cell 1 to configure NR Cell 3 as an SCell	<--	NR RRC: RRCReconfiguration	-	-
2	The UE transmits an <i>RRCReconfigurationComplete</i> message on NR Cell 1.	-->	NR RRC: RRCReconfigurationComplete	-	-
3	The SS transmits an RRCReconfiguration message on NR Cell 1 to setup event A3 reporting configuration.	<--	NR RRC: RRCReconfiguration	-	-
4	The UE transmits an <i>RRCReconfigurationComplete</i> message on NR Cell 1.	-->	NR RRC: RRCReconfigurationComplete	-	-
5	The SS changes NR Cell 1 and NR Cell 3 parameters according to the row "T1" in table 8.1.4.1.9.1.3.2-1/1A	-	-	-	-
6	The UE transmits a <i>MeasurementReport</i> message on NR Cell 1 to report event A3 with the measured RSRP, RSRQ value for NR Cell 3.	-->	NR RRC: <i>MeasurementReport</i>	-	-
7	The SS transmits an RRCReconfiguration message on NR Cell 1 to order the UE to perform inter frequency handover to NR Cell 3 and to release SCell NR Cell 3.	<--	NR RRC: RRCReconfiguration	-	-
-	EXCEPTION: In parallel to the events described in step 8 the steps specified in Table 8.1.4.1.9.1.3.2-3 should take place.	-	-	-	-
8	The SS changes NR Cell 1 and NR Cell 3 parameters according to the row "T2" in table 8.1.4.1.9.1.3.2-1/1A	-	-	-	-
9	Check: Does the UE transmit an <i>RRCReestablishmentRequest</i> message on NR Cell 1?	-->	NR RRC: <i>RRCReestablishmentRequest</i>	1	P
10	The SS transmits an <i>RRCReestablishment</i> message to resume SRB1 operation and re-activate security on NR Cell 1.	<--	NR RRC: <i>RRCReestablishment</i>	-	-
11	The UE transmits an <i>RRCReestablishmentComplete</i> message	-->	NR RRC: <i>RRCReestablishmentComplete</i>	-	-
12	The SS transmits an RRCReconfiguration message to resume existing radio bearer on NR Cell 1 and configure NR Cell 3 as an SCell	<--	NR RRC: RRCReconfiguration	-	-
13	The UE transmits an <i>RRCConnectionReconfigurationComplete</i> message on NR Cell 1	-->	NR RRC: RRCReconfigurationComplete	-	-
14	The SS transmits an RRCReconfiguration message on NR Cell 1 to setup event A3 reporting configuration.	<--	NR RRC: RRCReconfiguration	-	-
15	The UE transmits an RRCReconfigurationComplete message on NR Cell 1.	-->	NR RRC: RRCReconfigurationComplete	-	-
16	The SS changes NR Cell 1 and NR Cell 3 parameters according to the row "T3" in table 8.1.4.1.9.1.3.2-1/1A	-	-	-	-
17	The UE transmits a <i>MeasurementReport</i> message on NR Cell 1 to report event A3 with the measured RSRP, RSRQ value for NR Cell 3.	-->	NR RRC: <i>MeasurementReport</i>	-	-
18	The SS transmits an <i>RRCReconfiguration</i> message on NR Cell 1 to order the UE to perform handover to NR Cell 3 and to release SCell NR Cell3.	<--	NR RRC: RRCReconfiguration	-	-
-	EXCEPTION: In parallel to the events described in step 19 the steps specified in Table 8.1.4.1.9.1.3.2-3 should take place.	-	-	-	-

19	The SS changes NR Cell 1 and NR Cell 3 parameters according to the row "T4" in table 8.1.4.1.9.1.3.2-1/1A	-	-	-	-
20	Check: Does the UE transmit an <i>RRCReestablishmentRequest</i> message on NR Cell 3?	-->	NR RRC: <i>RRCReestablishmentRequest</i>	2	P
21	The SS transmits an <i>RRCReestablishment</i> message to resume SRB1 operation and re-activate security on NR Cell 3.	<--	NR RRC: <i>RRCReestablishment</i>	-	-
22	The UE transmits an <i>RRCReestablishmentComplete</i> message	-->	NR RRC: <i>RRCReestablishmentComplete</i>	-	-
23	The SS transmits an <i>RRCReconfiguration</i> message to resume existing radio bearer on NR Cell 3.	<--	NR RRC: <i>RRCReconfiguration</i>	-	-
24	The UE transmits an <i>RRCReconfigurationComplete</i> message on NR Cell 3.	-->	NR RRC: <i>RRCReconfigurationComplete</i>	-	-

Table 8.1.4.1.9.1.3.2-3: Parallel behaviour

St	Procedure	Message Sequence		TP	Verdict
		U - S	Message		
-	EXCEPTION: The steps 1 and 2 below are repeated for the duration of T304.	-	-	-	-
1	The UE attempts to perform the inter frequency handover using MAC Random Access Preamble on NR Cell 3.	-	-	-	-
2	The SS does not respond.	-	-	-	-

8.1.4.1.9.1.3.3 Specific message contents

Table 8.1.4.1.9.1.3.3-1: SIB1 for NR Cell 1 and NR Cell 3 (Preamble and all the steps in Table 8.1.4.1.9.1.3.2-2)

Derivation path: 38.508-1 [4] table 4.6.3-130			
Information Element	Value/Remark	Comment	Condition
SIB1 ::= SEQUENCE {			
servingCellConfigCommon SEQUENCE{			
ServingCellConfigCommonSIB ::=SEQUENCE {			
UplinkConfigCommon{			
UplinkConfigCommonSIB ::= SEQUENCE {			
initialUplinkBWP{			
BWP-UplinkCommon::= SEQUENCE {			
RACH-ConfigCommon::= SEQUENCE {			
RACH-ConfigGeneric ::= SEQUENCE {			
preambleTransMax	n50		
}			
}			
}			
}			
}			
}			
}			

Table 8.1.4.1.9.1.3.3-2: RRCReconfiguration (step 1 and 12, Table 8.1.4.1.9.1.3.2-2)

Derivation Path: TS 38.508-1[4], table 4.6.1-13			
Information Element	Value/Remark	Comment	Condition
RRCReconfiguration ::= SEQUENCE {			
criticalExtensions CHOICE {			
rrcReconfiguration ::= SEQUENCE {			
masterCellGroup	CellGroupConfig		
}			
}			
}			

Table 8.1.4.1.9.1.3.3-3: CellGroupConfig (Table 8.1.4.1.9.1.3.3-2)

Derivation path: 38.508-1 [4] table 4.6.1-19			
Information Element	Value/Remark	Comment	Condition
CellGroupConfig ::= SEQUENCE {			
sCellToAddModList SEQUENCE (SIZE (1..maxNrofSCells)) OF SEQUENCE {	1 entry		
SCellConfig ::= SEQUENCE {			
sCellIndex	1		
sCellConfigCommon	ServingCellConfigCommon		
sCellConfigDedicated	ServingCellConfig		
}			
}			
sCellToReleaseList	Not present		
}			

Table 8.1.4.1.9.1.3.3-4: ServingCellConfigCommon (Table 8.1.4.1.9.1.3.3-3)

Derivation Path: 38.508-1 [4] Table 4.6.3-168			
Information Element	Value/remark	Comment	Condition
ServingCellConfigCommon ::= SEQUENCE {			
physCellId	Physical layer cell identity of NR Cell 3		
}			

Table 8.1.4.1.9.1.3.3-5: RRCReconfiguration (step 3 and 14, Table 8.1.4.1.9.1.3.2-2)

Derivation Path: TS 38.508-1[4], table 4.6.1-13 and condition MEAS			

Table 8.1.4.1.9.1.3.3-6: MeasConfig (Table 8.1.4.1.9.1.3.3-5)

Derivation path: 38.508-1[4], table 4.6.3-69			
Information Element	Value/Remark	Comment	Condition
measConfig ::= SEQUENCE {			
measObjectToAddModList SEQUENCE (SIZE (1..maxNrofMeasId)) OF SEQUENCE {	2 entries		
measObjectId[1]	1		
measObject[1] CHOICE {			
measObjectNR	MeasObjectNR-f1	NR Cell 1	
}			
measObjectId[2]	2		
measObject[2] CHOICE {			
measObjectNR	MeasObjectNR-f2	NR Cell 3	
}			
}			
reportConfigToAddModList SEQUENCE(SIZE (1..maxReportConfigId)) OF SEQUENCE {	1 entry		
reportConfigId[1]	ReportConfigId		
reportConfig[1] CHOICE {			
reportConfigNR	ReportConfigNR-A3		
}			
}			
measIdToAddModList SEQUENCE (SIZE (1..maxNrofMeasId)) OF SEQUENCE {	2 entries		
measId[1]	1		
measObjectId[1]	1		
reportConfigId[1]	ReportConfigId		
measId[2]	2		
measObjectId[2]	2		
reportConfigId[1]	ReportConfigId		
}			

Table 8.1.4.1.9.1.3.3-7: MeasObjectNR-f1 (Table 8.1.4.1.9.1.3.3-6)

Derivation Path: TS 38.331 [6], clause 6.3.2			
Information Element	Value/remark	Comment	Condition
MeasObjectNR ::= SEQUENCE {			
ssbFrequency	Downlink ARFCN of NR Cell 1 SSB		
}			

Table 8.1.4.1.9.1.3.3-8: MeasObjectNR-f1 (Table 8.1.4.1.9.1.3.3-6)

Derivation Path: TS 38.331 [6], clause 6.3.2			
Information Element	Value/remark	Comment	Condition
MeasObjectNR ::= SEQUENCE {			
ssbFrequency	Downlink ARFCN of NR Cell 3 SSB		
}			

Table 8.1.4.1.9.1.3.3-9: ReportConfigNR-A3 (Table 8.1.4.1.9.1.3.3-5)

Derivation Path: 38.508-1 [4], table 4.6.3-142 with condition EVENT_A3			
Information Element	Value/remark	Comment	Condition
ReportConfigNR ::= SEQUENCE {			
reportType CHOICE {			
eventTriggered SEQUENCE {			
eventId CHOICE {			
eventA3 SEQUENCE {			
timeToTrigger	ms2560		
}			
}			
}			
}			
}			

Table 8.1.4.1.9.1.3.3-10: MeasurementReport (step 6 and 17, Table 8.1.4.1.9.1.3.2-2)

Derivation Path: TS 38.508-1 [4], table 4.6.1-7			
Information Element	Value/remark	Comment	Condition
MeasurementReport ::= SEQUENCE {			
criticalExtensions CHOICE {			
measurementReport SEQUENCE {			
measResults SEQUENCE {			
measId	1		
measResultServingMOList SEQUENCE (SIZE (1..maxNrofServingCells)) OF SEQUENCE {			
servCellId	ServCellIndex of NR Cell 1		
measResultServingCell SEQUENCE {			
physCellId	PhysCellId of NR Cell 1		
measResult SEQUENCE {			
cellResults SEQUENCE {			
resultsSSB-Cell SEQUENCE {			
rsrp	(0..127)		
rsrq	(0..127)		
sinr	(0..127)		
}			
resultsCSI-RS-Cell	Not present		
}			
rsIndexResults	Not present		
}			
measResultBestNeighCell	Not present		
}			
measResultNeighCells CHOICE {	Not present		
measResultListNR SEQUENCE (SIZE (1..maxCellReport)) OF SEQUENCE {			
physCellId	PhysCellId of NR Cell 3		
measResult SEQUENCE {			
cellResults SEQUENCE {			
resultsSSB-Cell SEQUENCE {			
Rsrp	(0..127)		
Rsrq	(0..127)		
Sinr	(0..127)		
}			
resultsCSI-RS-Cell	Not present		
}			
rsIndexResults	Not present		
}			
}			
}			
}			
}			

Table 8.1.4.1.9.1.3.3-11: RRCReconfiguration (step 7 and 18, Table 8.1.4.1.9.1.3.2-2)

Derivation Path: TS 38.508-1[4], table 4.6.1-13 and condition NR			
Information Element	Value/Remark	Comment	Condition
RRCReconfiguration ::= SEQUENCE {			
criticalExtensions CHOICE {			
rrcReconfiguration ::= SEQUENCE {			
nonCriticalExtension ::= SEQUENCE {			
masterCellGroup	CellGroupConfig		
}			
}			
}			
}			

Table 8.1.4.1.9.1.3.3-12: CellGroupConfig (Table 8.1.4.1.9.1.3.3-11)

Derivation path: 38.508-1 [4] table 4.6.1-19			
Information Element	Value/remark	Comment	Condition
CellGroupConfig ::= SEQUENCE {			
spCellConfig ::= SEQUENCE {			
servCellIndex	ServCellIndex of NR Cell 3		
reconfigurationWithSync ::= SEQUENCE {			
spCellConfigCommon ::= SEQUENCE {			
physCellId	PhysCellId of NR Cell 3		
downlinkConfigCommon ::= SEQUENCE {			
frequencyInfoDL ::= SEQUENCE {			
absoluteFrequencySSB	Downlink ARFCN of NR Cell 3 SSB		
}			
}			
}			
t304	ms1000		
rachConfigDedicated CHOICE {			
RACH-ConfigDedicated ::= SEQUENCE {			
CFRA-SSB-Resource ::=SEQUENCE {			
ra-PreambleIndex	63		
}			
}			
}			
}			
sCellToAddModList SEQUENCE (SIZE (1..maxNrofSCells)) OF SEQUENCE {	1 entry		
SCellConfig ::= SEQUENCE {			
sCellIndex	1		
sCellConfigCommon SEQUENCE {			
physCellId	Physical Cell Identity of NR Cell 3		
}			
}			
sCellToReleaseList SEQUENCE (SIZE (1..maxNrofSCells)) OF SEQUENCE {			
SCellConfig ::= SEQUENCE {			
sCellIndex	1		
}			
}			
}			

Table 8.1.4.1.9.1.3.3-13: RRCReestablishmentRequest (step 9 and 20, Table 8.1.4.1.9.1.3.2-2)

Derivation Path: TS 38.508-1 [4], table 4.6.1-12			
Information Element	Value/remark	Comment	Condition
RRCReestablishmentRequest ::= SEQUENCE {			
ue-Identity SEQUENCE {			
physCellId	PhysCellId of NR Cell 1		
}			
reestablishmentCause	handoverFailure		
}			

Table 8.1.4.1.9.1.3.3-14: RRCReestablishment (step 10 and 21, Table 8.1.4.1.9.1.3.2-2)

Derivation Path: TS 38.508-1 [4], table 4.6.1-10			
Information Element	Value/remark	Comment	Condition
RRCReestablishment ::= SEQUENCE {			
criticalExtensions CHOICE {			
rrcReestablishment SEQUENCE {			
nextHopChainingCount	0		
}			
}			
}			
}			

Table 8.1.4.1.9.1.3.3-15: RRCReconfiguration (step 12 and 23, Table 8.1.4.1.9.1.3.2-2)

Derivation Path: TS 38.508-1[4], table 4.6.1-13 and condition NR
--

8.1.4.1.9.2 NR CA / Intra NR handover / Failure / Re-establishment successful / Inter-band CA

8.1.4.1.9.2.1 Test Purpose (TP)

Same as TC 8.1.4.1.9.1 but applied to Inter-band CA case

8.1.4.1.9.2.2 Conformance requirements

Same as TC 8.1.4.1.9.1 but applied to Inter-band CA case

8.1.4.1.9.2.3 Test Description

8.1.4.1.9.2.3.1 Pre-test conditions

Same as test case 8.1.4.1.9.1 with the following differences:

- CA configuration: Inter-band CA replaces Intra-band Contiguous CA.
- Cells configuration: NR Cell 10 replaces NR Cell 3.
- NR Cell 10 is an Inactive SCell according to TS 38.508-1 [4] clause 6.3.1.

8.1.4.1.9.2.3.2 Test procedure sequence

Same as test case 8.1.4.1.9.1 with the following differences:

- CA configuration: Inter-band CA replaces Intra-band Contiguous CA.
- Cells configuration: NR Cell 10 replaces NR Cell 3.

8.1.4.1.9.2.3.3 Specific message contents

Same as TC 8.1.4.1.9.1 but applied to Inter-band CA case

8.1.4.1.9.3 NR CA / Intra NR handover / Failure / Re-establishment successful / Intra-band non-contiguous CA

8.1.4.1.9.3.1 Test Purpose (TP)

Same as TC 8.1.4.1.9.1 but applied to Intra-band non-contiguous CA case

8.1.4.1.9.3.2 Conformance requirements

Same as TC 8.1.4.1.9.1 but applied to Intra-band non-contiguous CA case

8.1.4.1.9.3.3 Test Description

8.1.4.1.9.3.3.1 Pre-test conditions

Same as test case 8.1.4.1.9.1 with the following differences:

- CA configuration: Intra-band Contiguous CA replaces Intra-band non-contiguous CA.

8.1.4.1.9.3.3.2 Test procedure sequence

Same as test case 8.1.4.1.9.1 with the following differences:

- CA configuration: Inter-band CA replaces Intra-band Contiguous CA.

8.1.4.1.9.3.3.3 Specific message contents

Same as TC 8.1.4.1.9.1 but applied to Intra-band non-contiguous CA case

8.1.4.2 Inter-RAT handover

8.1.4.2.1 Inter-RAT handover from NR

8.1.4.2.1.1 Inter-RAT handover / From NR to E-UTRA / Success

8.1.4.2.1.1.1 Test Purpose (TP)

(1)

```
with { UE in NR RRC_CONNECTED state }
ensure that {
  when { UE receives a MobilityFromNRCommand message }
  then { UE transmits an RRCConnectionReconfigurationComplete message on the E-UTRA cell }
}
```

8.1.4.2.1.1.2 Conformance requirements

References: The conformance requirements covered in the present TC are specified in: TS 38.331, clause 5.4.3.2, clause 5.4.3.3 and clause 5.4.3.4 and TS 36.331, clause 5.4.2.2 and clause 5.4.2.3.

[TS.38.331, clause 5.4.3.2]

The network initiates the mobility from NR procedure to a UE in RRC_CONNECTED, possibly in response to a MeasurementReport message, by sending a MobilityFromNRCommand message. The network applies the procedure as follows:

- the procedure is initiated only when AS-security has been activated, and SRB2 with at least one DRB are setup and not suspended.

[TS 38.331, clause 5.4.3.3]

The UE shall:

- 1> if the targetRAT-Type is set to eutra:
 - 2> consider inter-RAT mobility as initiated towards E-UTRA;
 - 2> forward the nas-SecurityParamFromNR to the upper layers, if included;
- 1> access the target cell indicated in the inter-RAT message in accordance with the specifications of the target RAT.

[TS.38.331, clause 5.4.3.4]

Upon successfully completing the handover, at the source side the UE shall:

- 1> reset MAC;
- 1> stop all timers that are running;
- 1> release *ran-NotificationAreaInfo*, if stored;
- 1> release the AS security context including the K_{RRCEnc} key, the K_{RRCint} , the K_{UPint} key and the K_{UPenc} key, if stored;
- 1> release all radio resources, including release of the RLC entity and the MAC configuration;
- 1> if delta configuration is used:
 - 2> maintain source RAT configuration of PDCP and SDAP for applicable RBs which is used for target RAT RBs;
- 1> else:
 - 2> release the associated PDCP entity and SDAP entity for all established RBs;
- 1> indicate the release of the RRC connection to upper layers together with the release cause 'other'.

[TS 36.331, clause 5.4.2.2]

The RAN using another RAT or the E-UTRA connected to a different type of CN initiates the handover to E-UTRA procedure, in accordance with the specifications applicable for the other RAT or for the E-UTRA connected to a different type of CN, by sending the *RRCCConnectionReconfiguration* message via the radio access technology from which the inter-RAT handover is performed.

E-UTRAN applies the procedure as follows:

- to activate ciphering, possibly using NULL algorithm, if not yet activated in the other RAT or in the E-UTRA connected to a different type of CN;
- to establish SRB1, SRB2 and one or more DRBs, i.e. at least the DRB associated with the default EPS bearer is established if the target CN is EPC and at least one DRB is established if the target CN is 5GC.

[TS 36.331, clause 5.4.2.3]

If the UE is able to comply with the configuration included in the *RRCCConnectionReconfiguration* message, the UE shall:

- 1> if the *RRCCConnectionReconfiguration* message includes the fullConfig:
 - ...
- 1> else:
 - 2> apply the default physical channel configuration as specified in 9.2.4;

- 2> apply the default semi-persistent scheduling configuration as specified in 9.2.3;
- 2> apply the default MAC main configuration as specified in 9.2.2;
- 1> start timer T304 with the timer value set to t304, as included in the mobilityControlInfo;
- 1> consider the target PCell to be one on the frequency indicated by the carrierFreq with a physical cell identity indicated by the targetPhysCellId;
- 1> start synchronising to the DL of the target PCell;
- 1> set the C-RNTI to the value of the newUE-Identity;
- 1> for the target PCell, apply the downlink bandwidth indicated by the dl-Bandwidth;
- 1> for the target PCell, apply the uplink bandwidth indicated by (the absence or presence of) the ul-Bandwidth;
- 1> configure lower layers in accordance with the received radioResourceConfigCommon;
- 1> configure lower layers in accordance with any additional fields, not covered in the previous, if included in the received mobilityControlInfo;
- 1> perform the radio resource configuration procedure as specified in 5.3.10;
- 1> if the handoverType in securityConfigHO is set to fivegc-ToEPC:
 - 2> indicate to higher layer that the CN has changed from 5GC to EPC;
 - 2> derive the key KeNB based on the mapped KASME key as specified for interworking between EPS and 5GS in TS 33.501 [86];
 - 2> store the nextHopChainingCount-r15 value;
- 1> else if the handoverType in securityConfigHO is set to intra5GC:
 - ...
- 1> derive the KRRCint key associated with the integrityProtAlgorithm, as specified in TS 33.401 [32];
- 1> derive the KRRCenc key and the KUPenc key associated with the cipheringAlgorithm, as specified in TS 33.401 [32];
 - ...
- 1> if the handoverType in securityConfigHO is set to fivegc-ToEPC or if the handoverType-v1530 is not present:
 - 2> configure lower layers to apply the indicated integrity protection algorithm and the KRRCint key immediately, i.e. the indicated integrity protection configuration shall be applied to all subsequent messages received and sent by the UE, including the message used to indicate the successful completion of the procedure;
 - 2> configure lower layers to apply the indicated ciphering algorithm, the KRRCenc key and the KUPenc key immediately, i.e. the indicated ciphering configuration shall be applied to all subsequent messages received and sent by the UE, including the message used to indicate the successful completion of the procedure;
- 1> if the received RRCConnectionReconfiguration includes the sCellToAddModList:
 - ...
- 1> if the RRCConnectionReconfiguration message includes the measConfig:
 - 2> perform the measurement configuration procedure as specified in 5.5.2;
 - ...
- 1> submit the RRCConnectionReconfigurationComplete message to lower layers for transmission using the new configuration;

- 1> if the RRCConnectionReconfiguration message does not include rlf-TimersAndConstants set to setup:
 - 2> use the default values specified in 9.2.5 for timer T310, T311 and constant N310, N311;
- 1> if MAC successfully completes the random access procedure:
 - 2> stop timer T304;
 - 2> apply the parts of the CQI reporting configuration, the scheduling request configuration and the sounding RS configuration that do not require the UE to know the SFN of the target PCell, if any;
 - 2> apply the parts of the measurement and the radio resource configuration that require the UE to know the SFN of the target PCell (e.g. measurement gaps, periodic CQI reporting, scheduling request configuration, sounding RS configuration), if any, upon acquiring the SFN of the target PCell;

NOTE 1: Whenever the UE shall setup or reconfigure a configuration in accordance with a field that is received it applies the new configuration, except for the cases addressed by the above statements.

- 2> enter E-UTRA RRC_CONNECTED, upon which the procedure ends;

8.1.4.2.1.1.3 Test description

8.1.4.2.1.1.3.1 Pre-test conditions

System Simulator:

- NR Cell 1 and E-UTRA Cell 1.
- System information Combination NR-6 as defined in TS 38.508 [4] clause 4.4.3.1 is used in NR cells.

UE:

- None

Preamble:

- The UE is in state 3N-A as defined in TS 38.508-1 [4], subclause 4.4A on NR Cell.

8.1.4.2.1.1.3.2 Test procedure sequence

Table 8.1.4.2.1.1.3.2-1: Main behaviour

St	Procedure	Message Sequence		TP	Verdict
		U - S	Message		
1	The SS transmits a MobilityFromNRCommand message on NR Cell 1.	<--	MobilityFromNRCommand	-	-
2	Check: Does the UE transmit an RRCConnectionReconfigurationComplete message on E-UTRA Cell 1 using the security key derived from the new KeNB?	-->	RRCConnectionReconfigurationComplete	1	P
3	The UE transmits an ULInformationTransfer message on the cell specified in the test case. This message includes a TRACKING AREA UPDATE REQUEST message. UE integrity protects the TAU request message using the 5G security context.	-->	RRC: ULInformationTransfer NAS: TRACKING AREA UPDATE REQUEST	-	-
4	The SS transmits a DLInformationTransfer message on the cell specified in the test case. This message includes a TRACKING AREA UPDATE ACCEPT message.	<--	RRC: DLInformationTransfer NAS: TRACKING AREA UPDATE ACCEPT	-	-
5	The UE transmits an ULInformationTransfer message on the cell specified in the test case. This message includes a TRACKING AREA UPDATE COMPLETE message.	-->	RRC: ULInformationTransfer NAS: TRACKING AREA UPDATE COMPLETE	-	-

8.1.4.2.1.1.3.3 Specific message contents

Table 8.1.4.2.1.1.3.3-1: MobilityFromNRCommand (step 2, Table 8.1.4.2.1.1.3.2-1)

Derivation Path: TS 38.508-1 [4], Table 4.6.1-8			
Information Element	Value/remark	Comment	Condition
MobilityFromNRCommand ::= SEQUENCE {			
rrc-TransactionIdentifier	RRC-TransactionIdentifier		
criticalExtensions CHOICE {			
mobilityFromNRCommand ::= SEQUENCE {			
targetRAT-Type	eutra		
targetRAT-MessageContainer	RRCConnectionReconfiguration		
nas-SecurityParamFromNR	8 LSB of the downlink NAS COUNT		
}			
}			
}			

Table 8.1.4.2.1.1.3.3-2: RRCConnectionReconfiguration (Table 8.1.4.2.1.1.3.3-1)

Derivation Path: 36.508-1, Table 4.6.1-8, condition HO-TO-EUTRA(1,0)
--

Table 8.1.4.2.1.1.3.3-3: MobilityControllInfo (Table 8.1.4.2.1.1.3.3-1)

Derivation Path: 36.508 [7], Table 4.6.5-1			
Information Element	Value/remark	Comment	Condition
MobilityControllInfo ::= SEQUENCE {			
targetPhysCellId	PhysicalCellIdentity of E-UTRA Cell 1		
carrierFreq SEQUENCE {			
dl-CarrierFreq	Same downlink EARFCN as used for E-UTRA Cell 1		
}			
carrierFreq	Not present		Band > 64
carrierBandwidth SEQUENCE {			
dl-Bandwidth	Downlink system bandwidth under test.		
ul-Bandwidth	Uplink Bandwidth under test.		FDD
ul-Bandwidth	Not present		TDD
}			
additionalSpectrumEmission	1		HO-to-EUTRA
carrierFreq-v9e0 SEQUENCE {			Band > 64
dl-CarrierFreq-v9e0	Same downlink EARFCN as used for E-UTRA Cell 1		
}			
}			

Condition	Explanation
FDD	FDD cell environment
TDD	TDD cell environment
Band > 64	If band > 64 is selected

Table 8.1.4.2.1.1.3.3-4: SecurityConfigHO (Table 8.1.4.2.1.1.3.3-1)

Derivation Path: 36.508-1, Table 4.6.4-1			
Information Element	Value/remark	Comment	Condition
SecurityConfigHO-v1530 ::= SEQUENCE {			
handoverType-v1530 CHOICE {			
fivegc-ToEPC-r15 SEQUENCE {			
securityAlgorithmConfig-r15 SEQUENCE {			
cipheringAlgorithm	Set according to PIXIT parameter for default ciphering algorithm		
integrityProtAlgorithm	Set according to PIXIT parameter for default integrity protection algorithm		
}			
nextHopChainingCount-r15	0		
}			
}			

Table 8.1.4.2.1.1.3.3-5: RadioResourceConfigDedicated-HO-TO-EUTRA (Table 8.1.4.2.1.1.3.3-1)

Derivation Path: 36.508-1, Table 4.6.3-18, condition HO-TO-EUTRA(1,0)

Table 8.1.4.2.1.1.3.3-6: TRACKING AREA UPDATE REQUEST

Derivation Path: 36.508-1 clause 4.7.2-27			
Information Element	Value/remark	Comment	Condition
Old GUTI	Mapped 5G-GUTI		
GUTI type	Native		
UE status	UE is in 5GMM-REGISTERED state		

8.1.4.2.2

8.1.4.2.2.1 Inter-RAT handover / From E-UTRA to NR / Success

8.1.4.2.2.1.1 Test Purpose (TP)

(1)

```

with { UE in E-UTRA RRC_CONNECTED state }
ensure that {
  when { UE receives a MobilityFromEUTRACommand message }
  then { UE transmits a RRCReconfigurationComplete message on the NR cell }
}

```

8.1.4.2.2.1.2 Conformance requirements

References: The conformance requirements covered in the current TC are specified in: TS 38.331, clause 5.4.2.2, 5.4.2.3, TS 36.331, clause 5.4.3.2, 5.4.3.3, 5.4.3.4. Unless otherwise stated these are Rel-15 requirements.

[TS 38.331, clause 5.4.2.2]

The RAN using another RAT initiates the handover to NR procedure, in accordance with the specifications applicable for the other RAT, by sending the *RRCReconfiguration* message via the radio access technology from which the inter-RAT handover is performed.

The network applies the procedure as follows:

- to activate ciphering, possibly using NULL algorithm, if not yet activated in the other RAT;
- to re-establish SRBs and one or more DRBs;

[TS 38.331, clause 5.4.2.2]

The UE shall:

- 1> perform RRC reconfiguration procedure as specified in 5.3.5;

NOTE: If the UE is connected to 5GC of the source E-UTRA cell, the delta configuration for PDCP and SDAP can be used for intra-system inter-RAT handover.

[TS 36.331, clause 5.4.3.2]

E-UTRAN initiates the mobility from E-UTRA procedure to a UE in RRC_CONNECTED, possibly in response to a *MeasurementReport* message or in response to reception of CS fallback indication for the UE from MME, by sending a *MobilityFromEUTRACommand* message. E-UTRAN applies the procedure as follows:

- the procedure is initiated only when AS-security has been activated, and SRB2 with at least one DRB are setup and not suspended;

[TS 36.331, clause 5.4.3.3]

The UE shall be able to receive a *MobilityFromEUTRACommand* message and perform a cell change order to GERAN, even if no prior UE measurements have been performed on the target cell.

The UE shall:

- 1> stop timer T310, if running;
- 1> stop timer T312, if running;
- 1> stop timer T309, if running, for all access categories;
- 1> if the *MobilityFromEUTRACommand* message includes the *purpose* set to *handover*:
 - ...
 - 2> else if the *targetRAT-Type* is set to *nr*:
 - 3> consider inter-RAT mobility as initiated towards NR;
 - 3> access the target cell indicated in the inter-RAT message in accordance with the specifications in TS 38.331 [82];

[TS 36.331, clause 5.4.3.4]

Upon successfully completing the handover, the cell change order or enhanced 1xRTT CS fallback, the UE shall:

- ...
- 1> else if the UE is connected to 5GC and the *targetRAT-Type* in the received *MobilityFromEUTRACommand* is set to *nr*:
 - 2> reset MAC;
 - 2> stop all timers that are running;
 - 2> release *ran-NotificationAreaInfo*, if stored;
 - 2> release the AS security context including the K_{RRCEnc} key, the K_{RRCint} , the K_{UPint} key and the K_{UPenc} key, if stored;
 - 2> release all radio resources, including release of the RLC entity and the MAC configuration;
 - 2> if delta configuration is used:
 - 3> maintain source RAT configuration of PDCP and SDAP for applicable RBs which is used for target RAT RBs;
 - 2> else:
 - 3> release the associated PDCP entity and SDAP entity for all established RBs;
 - 2> indicate the release of the RRC connection to upper layers together with the release cause 'other'.

8.1.4.2.2.1.3 Test description

8.1.4.2.2.1.3.1 Pre-test conditions

System Simulator:

- E-UTRA Cell 1 and NR Cell 1.
- System information combination FFS as defined in TS 36.508 [7] clause 4.4.3.1 is used in E-UTRA cell.

UE:

- None.

Preamble:

- The UE is in state Generic RB Established (state 3) on E-UTRA Cell 1 according to [7].

8.1.4.2.2.1.3.2 Test procedure sequence

Table 8.1.4.2.2.1.3.2-1: Main behaviour

St	Procedure	Message Sequence		TP	Verdict
		U - S	Message		
1	The SS transmits a <i>MobilityFromEUTRACommand</i> message on E-UTRA Cell 1.	<--	E-UTRA RRC: <i>MobilityFromEUTRACommand</i>	-	-
2	Check: Does the UE transmit a <i>RRCReconfigurationComplete</i> message on NR Cell 1?	-->	NR RRC: <i>RRCReconfigurationComplete</i>	1	P
3	The UE transmits a <i>DLInformationTransfer</i> message and a REGISTRATION REQUEST message indicating “mobility registration updating” is sent to update the registration of the actual tracking area.	-->	NR RRC: <i>ULInformationTransfer</i> 5GMM: REGISTRATION REQUEST	-	-
4	SS sends an <i>ULInformationTransfer</i> message and a REGISTRATION ACCEPT message containing a 5G-GUTI.	<--	NR RRC: <i>DLInformationTransfer</i> 5GMM: REGISTRATION ACCEPT	-	-
5	The UE transmits an <i>ULInformationTransfer</i> message and a REGISTRATION COMPLETE message.	-->	NR RRC: <i>ULInformationTransfer</i> 5GMM: REGISTRATION COMPLETE	-	-

8.1.4.2.2.1.3.3 Specific message contents

Table 8.1.4.2.2.1.3.3-1: *MobilityFromEUTRACommand* (step 1, Table 8.1.4.2.2.1.3.2-1)

Derivation Path: 36.508 [7] table 4.6.1-6			
Information Element	Value/remark	Comment	Condition
<i>MobilityFromEUTRACommand</i> ::= SEQUENCE {			
criticalExtensions CHOICE {			
c1 CHOICE{			
<i>mobilityFromEUTRACommand-r8</i> SEQUENCE {			
purpose CHOICE {			
handover SEQUENCE {			
targetRAT-Type	nr		
targetRAT-MessageContainer	RRCReconfiguration		
nas-SecurityParamFromEUTRA	Not present		
systemInformation	Not present		
}			
}			
}			
}			
}			
}			

Table 8.1.4.2.2.1.3.3-2: *RRCReconfiguration* (Table 8.1.4.2.2.1.3.3-1)

Derivation Path: 38.508-1 [4] Table 4.6.1-13			
Information Element	Value/remark	Comment	Condition
RRCReconfiguration ::= SEQUENCE {			
rrc-TransactionIdentifier	RRC-TransactionIdentifier	TS 38.508-1 [4], Table 4.6.5-12.	
criticalExtensions CHOICE {			
rrcReconfiguration ::= SEQUENCE {			
radioBearerConfig	RadioBearerConfig with conditions SRB1,SRB2 and DRB1		
secondaryCellGroup	Not present		
measConfig	Not present		
lateNonCriticalExtension	Not present		
nonCriticalExtension SEQUENCE {			
masterCellGroup	CellGroupConfig with conditions SRB1,SRB2 and DRB1	OCTET STRING (CONTAINING CellGroupConfig)	
fullConfig	true		
dedicatedNAS-MessageList SEQUENCE (SIZE(1..maxDRB)) OF DedicatedNAS-Message {}	Not present		
masterKeyUpdate	MasterKeyUpdate		
dedicatedSIB1-Delivery	Not present		
dedicatedSystemInformationDelivery	Not present		
otherConfig	Not present		
nonCriticalExtension	Not present		
}			
}			
}			

Table 8.1.4.2.2.1.3.3-3: RadioBearerConfig (Table 8.1.4.2.2.1.3.3-2)

Derivation Path: 38.508-1 [4] Table 4.6.3-132			
Information Element	Value/remark	Comment	Condition
RadioBearerConfig ::= SEQUENCE {			
srb-ToAddModList SEQUENCE (SIZE (1..2)) OF SEQUENCE {	2 entries		
SRB-Identity[1]	SRB-Identity with condition SRB1	SRB1	
reestablishPDCP[1]	Not present		
discardOnPDCP[1]	Not present		
pdcpc-Config[1]	Not present	Default	
SRB-Identity[2]	SRB-Identity with condition SRB2	SRB2	
reestablishPDCP[2]	Not present		
discardOnPDCP[2]	Not present		
pdcpc-Config[2]	Not present	Default	
}			
srb3-ToRelease	Not present		
drb-ToAddModList SEQUENCE (SIZE (1..maxDRB)) OF SEQUENCE {	1 entry		
cnAssociation CHOICE {			
sdap-Config	SDAP-Config		
}			
drb-Identity	DRB-Identity using condition DRB1	DRB1	
reestablishPDCP	Not present		
recoverPDCP	Not present		
pdcpc-Config	PDCP-Config		
}			
drb-ToReleaseList	Not present		
securityConfig SEQUENCE {			
securityAlgorithmConfig	SecurityAlgorithmConfig		
keyToUse	Master		
}			
}			

Table 8.1.4.2.2.1.3.3-4: CellGroupConfig (Table 8.1.4.2.2.1.3.3-2)

Derivation Path: 38.508-1 [4] Table 4.6.3-19			
Information Element	Value/remark	Comment	Condition
CellGroupConfig ::= SEQUENCE {			
cellGroupId	CellGroupId		
rlc-BearerToAddModList SEQUENCE (SIZE(1..maxLCH)) OF SEQUENCE {	3 entries		
RLC-Bearer-Config[1]	RLC-Bearer-Config with condition SRB1		
RLC-Bearer-Config[2]	RLC-Bearer-Config with condition SRB2		
RLC-Bearer-Config[3]	RLC-Bearer-Config with condition DRB1		
}			
rlc-BearerToReleaseList	Not present		
mac-CellGroupConfig	MAC-CellGroupConfig		
physicalCellGroupConfig	PhysicalCellGroupConfig		
spCellConfig SEQUENCE {			
servCellIndex	Not present		
reconfigurationWithSync SEQUENCE {			
spCellConfigCommon	ServingCellConfigCommon		
newUE-Identity	RNTI-Value		
t304	ms1000		
rach-ConfigDedicated CHOICE {			
uplink	RACH-ConfigDedicated		
supplementaryUplink	Not present		
}			
}			
rlf-TimersAndConstants CHOICE {			
setup	RLF-TimersAndConstants		
}			
rlmInSyncOutOfSyncThreshold	Not present		
spCellConfigDedicated	ServingCellConfig		
}			
sCellToAddModList	Not present		
sCellToReleaseList	Not present		
}			

Table 8.1.4.2.2.1.3.3-5: ServingCellConfigCommon (Table 8.1.4.2.2.1.3.3-4)

Derivation Path: 38.508-1 [4] Table 4.6.3-168			
Information Element	Value/remark	Comment	Condition
ServingCellConfigCommon ::= SEQUENCE {			
physCellId	Physical CellID of the NR Cell 1		
}			

Table 8.1.4.2.2.1.3.3-6: MasterKeyUpdate (Table 8.1.4.2.2.1.3.3-2)

Derivation Path: 38.508-1 [4] Table FFS			
Information Element	Value/remark	Comment	Condition
MasterKeyUpdate ::= SEQUENCE {			
keySetChangeIndicator	True		
nextHopChainingCount	NextHopChainingCount	38.508-1 [4] Table 4.6.3-83	
nas-Container	<p>Octet 1 is S1 mode to N1 mode NAS transparent container IEI.</p> <p>Octet 2 is S1 mode to N1 mode NAS transparent container IE length.</p> <p>Octets 3 to 6 are Message authentication code(MAC) IE.</p> <p>Bits 1 to 4 of octet 7 are set according to PIXIT parameter for default integrity protection algorithm.</p> <p>Bits 5 to 8 of octet 7 are set according to PIXIT parameter for default ciphering algorithm.</p> <p>Bits 1 to 3 of octet 8 contains the Key set identifier in 5G.</p> <p>Bit 4 of octet 8 contains the type of security context flag(TSC).</p> <p>Bits 5 to 7 of octet 8 contains the 3bit Next hop chaining counter.</p> <p>Bit 8 of octet 8 is Spare.</p> <p>Octets 9 to 10 are 5G UE security capability .</p> <p>Octets 11 to 12 are EPS UE security capability.</p>	24.501 [22] 9.11.2.9 S1 mode to N1 mode NAS transparent container	
}			

8.1.5 RRC others

8.1.5.1 UE capability transfer

8.1.5.1.1 UE capability transfer / Success

8.1.5.1.1.1 Test Purpose (TP)

(1)

```
with { UE in NR RRC_CONNECTED state }
ensure that {
```



```

when { UE receives an UECapabilityEnquiry message }
then { UE transmits an UECapabilityInformation message including UE radio access capability
information corresponding to the ue-CapabilityRequest variable }

```

8.1.5.1.1.2 Conformance requirements

References: The conformance requirements covered in the present test case are specified in: TS 38.331, clause 5.6.1.3. Unless otherwise stated these are Rel-15 requirements.

[TS 38.331, clause 5.6.1.3]

The UE shall set the contents of *UECapabilityInformation* message as follows:

- 1> if the ue-CapabilityRAT-RequestList contains a UE-CapabilityRAT-Request with rat-Type set to nr:
 - 2> include in the ue-CapabilityRAT-ContainerList a UE-CapabilityRAT-Container of the type UE-NR-Capability and with the rat-Type set to nr;
 - 2> include the supportedBandCombinationList, featureSets and featureSetCombinations as specified in clause 5.6.1.4;
- ...
- 1> submit the *UECapabilityInformation* message to lower layers for transmission, upon which the procedure ends.

8.1.5.1.1.3 Test Description

8.1.5.1.1.3.1 Pre-test conditions

System Simulator:

- NR Cell 1
- System information combination NR-1 as defined in TS 38.508-1 [4] clause 4.4.3.1.3 is used in NR cell.

UE:

- None.

Preamble:

- The UE is in 5GS state 1N-A according to TS 38.508-1 [4], clause 4.4A.2 Table 4.4A.2-1.

8.1.5.1.1.3.2 Test procedure sequence

Table 8.1.5.1.1.3.2-1: Main behaviour

St	Procedure	Message Sequence		TP	Verdict
		U - S	Message		
1	The SS transmits a <i>UECapabilityEnquiry</i> message including <i>RAT-Type nr</i> .	<--	<i>UECapabilityEnquiry</i>	-	-
2	Check: Does the UE transmit a <i>UECapabilityInformation</i> message including UE radio access capability information as per the ue-CapabilityRequest variable?	-->	<i>UECapabilityInformation</i>	1	P

8.1.5.1.1.3.3 Specific message contents

Table 8.1.5.1.1.3.3-1: UECapabilityEnquiry (step 1, Table 8.1.5.1.1.3.2-1)

Derivation Path: 38.508-1 [4], Table 4.6.1-31			
Information Element	Value/remark	Comment	Condition
UECapabilityEnquiry ::= SEQUENCE {			
rrc-TransactionIdentifier	RRC-TransactionIdentifier		
criticalExtensions CHOICE {			
ueCapabilityEnquiry SEQUENCE {			
ue-CapabilityRAT-RequestList SEQUENCE (SIZE (1.. maxRAT-CapabilityContainers)) OF SEQUENCE {	-		
rat-Type[1]	nr		
capabilityRequestFilter	Not present		
}			
lateNonCriticalExtension	Not present		
nonCriticalExtension SEQUENCE {}	Not present		
}			
criticalExtensionsFuture SEQUENCE {}			
}			
}			
}			
}			

Table 8.1.5.1.1.3.3-2: UECapabilityInformation (step 2, Table 8.1.5.1.1.3.2-1)

Derivation Path: 38.508-1 [4], Table 4.6.1-32			
Information Element	Value/remark	Comment	Condition
UECapabilityInformation ::= SEQUENCE {			
rrc-TransactionIdentifier	RRC-TransactionIdentifier		
criticalExtensions CHOICE {			
ueCapabilityInformation SEQUENCE {			
ue-CapabilityRAT-ContainerList SEQUENCE (SIZE (0..maxRAT-CapabilityContainers)) OF SEQUENCE {			
rat-Type[1]	nr		
ueCapabilityRAT-Container [1] OCTET STRING {}	UE-NR-Capability	Encoded as per TS 38.331 [12] clause 5.6.1	
}			
lateNonCriticalExtension	Not checked		
nonCriticalExtension SEQUENCE {}	Not checked		
}			
criticalExtensionsFuture SEQUENCE {}	Not checked		
}			
}			
}			
}			

Table 8.1.5.1.1.3.3-3: *UE-NR-Capability* (Table 8.1.5.1.1.3.3-4)

Derivation Path: 38.331 [12], clause 6.3.3			
Information Element	Value/remark	Comment	Condition
UE-NR-Capability ::= SEQUENCE {			
accessStratumRelease	Checked	"rel-15" or higher	
pdcP-Parameters SEQUENCE {			
supportedROHC-Profiles SEQUENCE {			
profile0x0000	Not checked		
profile0x0001	Not checked		
profile0x0002	Not checked		
profile0x0003	Not checked		
profile0x0004	Not checked		
profile0x0006	Not checked		
profile0x0101	Not checked		
profile0x0102	Not checked		
profile0x0103	Not checked		
profile0x0104	Not checked		
}			
maxNumberROHC-ContextSessions	Not checked		
uplinkOnlyROHC-Profiles	Not checked		
continueROHC-Context	Not checked		
outOfOrderDelivery	Not checked		
shorts	Checked		pc_shortSN
pdcP-DuplicationSRB	Not checked		
pdcP-DuplicationMCG-OrSCG-DRB	Not checked		
}			
rlc-Parameters SEQUENCE {			
am-WithShortSN	Checked		pc_am_WithShortSN
um-WithShortSN	Checked		pc_um_WithShortSN
um-WithLongSN	Checked		pc_um_WithLongSN
}			
mac-Parameters SEQUENCE {			
mac-ParametersCommon SEQUENCE {			
lcp-Restriction	Not checked		
dummy	Not checked		
lch-ToSCellRestriction	Not checked		
recommendedBitRate	Not checked		
recommendedBitRateQuery	Not checked		
}			
mac-ParametersXDD-Diff SEQUENCE {			
skipUplinkTxDynamic	Checked		pc_skipUplinkTxDynamic
logicalChannelSR-DelayTimer	Not checked		
longDRX-Cycle	Checked		pc_longDRX_Cycle
shortDRX-Cycle	Checked		pc_shortDRX_Cycle
multipleSR-Configurations	Not checked		
multipleConfiguredGrants	Not checked		
}			
}			
phy-Parameters SEQUENCE {			
phy-ParametersCommon SEQUENCE {			
csi-RS-CFRA-ForHO	Checked		pc_csi_RS_CFRA_ForHO
dynamicPRB-BundlingDL	Not checked		
sp-CSI-ReportPUCCH	Not checked		
sp-CSI-ReportPUSCH	Not checked		
nzp-CSI-RS-IntefMgmt	Not checked		
type2-SP-CSI-Feedback-LongPUCCH	Not checked		
precoderGranularityCORESET	Not checked		
dynamicHARQ-ACK-Codebook	Not checked		
semiStaticHARQ-ACK-Codebook	Not checked		

spatialBundlingHARQ-ACK	Not checked		
dynamicBetaOffsetInd-HARQ-ACK-CSI	Not checked		
pucch-Repetition-F1-3-4	Not checked		
ra-Type0-PUSCH	Checked		pc_ra_Type0_PUSCH
dynamicSwitchRA-Type0-1-PDSCH	Not checked		
dynamicSwitchRA-Type0-1-PUSCH	Not checked		
pdsch-MappingTypeA	Checked		pc_pdsch_MappingTypeA
pdsch-MappingTypeB	Checked		pc_pdsch_MappingTypeB
interleavingVRB-ToPRB-PDSCH	Checked		pc_interleavingVRB_ToPRB_PDSCH
interSlotFreqHopping-PUSCH	Not checked		
type1-PUSCH-RepetitionMultiSlots	Not checked		
type2-PUSCH-RepetitionMultiSlots	Not checked		
pusch-RepetitionMultiSlots	Not checked		
pdsch-RepetitionMultiSlots	Checked		pc_pdsch_RepetitionMultiSlots
downlinkSPS	Checked		pc_downlinkSPS
configuredUL-GrantType1	Checked		pc_configuredUL_GrantType1
configuredUL-GrantType2	Checked		pc_configuredUL_GrantType2
pre-EmptIndication-DL	Not checked		
cbg-TransIndication-DL	Not checked		
cbg-TransIndication-UL	Not checked		
cbg-FlushIndication-DL	Not checked		
dynamicHARQ-ACK-CodeB-CBG-Retx-DL	Not checked		
rateMatchingResrcSetSemi-Static	Not checked		
rateMatchingResrcSetDynamic	Not checked		
bwp-SwitchingDelay	Not checked		
dummy	Not checked		
maxNumberSearchSpaces	n10		
rateMatchingCtrlResrsSetDynamic	Not checked		
maxLayersMIMO-Indication	Not checked		
}			
phy-ParametersXDD-Diff SEQUENCE {			
dynamicSFI	Not checked		
twoPUCCH-F0-2-ConsecSymbols	Not checked		
twoDifferentTPC-Loop-PUSCH	Not checked		
twoDifferentTPC-Loop-PUCCH	Not checked		
dl-SchedulingOffset-PDSCH-TypeA	Not checked		
dl-SchedulingOffset-PDSCH-TypeB	Not checked		
ul-SchedulingOffset	Not checked		
}			
phy-ParametersFRX-Diff SEQUENCE {			
dynamicSFI	Not checked		
dummy1	Not checked		
twoFL-DMRS	Not checked		
dummy2	Not checked		
dummy3	Not checked		
supportedDMRS-TypeDL	Not checked		
supportedDMRS-TypeUL	Not checked		
semiOpenLoopCSI	Not checked		
csi-ReportWithoutPMI	Not checked		
csi-ReportWithoutCQI	Not checked		
onePortsPTRS	Not checked		
twoPUCCH-F0-2-ConsecSymbols	Not checked		

pucch-F2-WithFH	Not checked		
pucch-F3-WithFH	Not checked		
pucch-F4-WithFH	Not checked		
freqHoppingPUCCH-F0-2	Not checked		
freqHoppingPUCCH-F1-3-4	Not checked		
mux-SR-HARQ-ACK-CSI-PUCCH-MultiPerSlot	Not checked		
uci-CodeBlockSegmentation	Not checked		
onePUCCH-LongAndShortFormat	Not checked		
twoPUCCH-AnyOthersInSlot	Not checked		
intraSlotFreqHopping-PUSCH	Not checked		
pusch-LBRM	Not checked		
pdccch-BlindDetectionCA	Not checked		
tpc-PUSCH-RNTI	Not checked		
tpc-PUCCH-RNTI	Not checked		
tpc-SRS-RNTI	Not checked		
absoluteTPC-Command	Not checked		
twoDifferentTPC-Loop-PUSCH	Not checked		
twoDifferentTPC-Loop-PUCCH	Not checked		
pusch-HalfPi-BPSK	Not checked		
pucch-F3-4-HalfPi-BPSK	Not checked		
almostContiguousCP-OFDM-UL	Not checked		
sp-CSI-RS	Not checked		
sp-CSI-IM	Not checked		
tdd-MultiDL-UL-SwitchPerSlot	Not checked		
multipleCORESET	Not checked		
csi-RS-IM-ReceptionForFeedback	Not checked	CSI-RS-IM-ReceptionForFeedback	
csi-RS-ProcFrameworkForSRS	Not checked	CSI-RS-ProcFrameworkForSRS	
csi-ReportFramework	Not checked	CSI-ReportFramework	
mux-SR-HARQ-ACK-CSI-PUCCH-OncePerSlot			
SEQUENCE {			
sameSymbol	Not checked		
diffSymbol	Not checked		
}			
mux-SR-HARQ-ACK-PUCCH	Not checked		
mux-MultipleGroupCtrlCH-Overlap	Not checked		
dl-SchedulingOffset-PDSCH-TypeA	Not checked		
dl-SchedulingOffset-PDSCH-TypeB	Not checked		
ul-SchedulingOffset	Not checked		
dl-64QAM-MCS-TableAlt	Not checked		
ul-64QAM-MCS-TableAlt	Not checked		
cqi-TableAlt	Not checked		
oneFL-DMRS-TwoAdditionalDMRS-UL	Not checked		
twoFL-DMRS-TwoAdditionalDMRS-UL	Not checked		
oneFL-DMRS-ThreeAdditionalDMRS-UL	Not checked		
}			
phy-ParametersFR1 SEQUENCE {			
pdccchMonitoringSingleOccasion	Not checked		
scs-60kHz	Not checked		
pdsch-256QAM-FR1	Checked		pc_pdsch_256QAM_FR1
pdsch-RE-MappingFR1-PerSymbol	Not checked		
pdsch-RE-MappingFR1-PerSlot	Not checked		
}			
phy-ParametersFR2 SEQUENCE {			
dummy	Not checked		
pdsch-RE-MappingFR2-PerSymbol	Not checked		
pCell-FR2	Not checked		
pdsch-RE-MappingFR2-PerSlot	Not checked		
}			
rf-Parameters SEQUENCE {			

supportedBandListNR SEQUENCE (SIZE (1..maxBands)) OF SEQUENCE { bandNR[i]	Checked	Checked for 'maxBands' entries of FreqBandIndicator NR[i]	pc_nrBandx ('x' being the band number/type related PICS listed in TS 38.508-2)
modifiedMPR-Behaviour[i]	Not checked		
mimo-ParametersPerBand[i]	Not checked	MIMO-ParametersPerBand[i]	
extendedCP[i]	Not checked		
multipleTCI[i]	Not checked		
bwp-WithoutRestriction[i]	Not checked		
bwp-SameNumerology[i]	Not checked		
bwp-DiffNumerology[i]	Not checked		
crossCarrierScheduling-SameSCS[i]	Not checked		
pdsch-256QAM-FR2[i]	Checked		pc_pdsch_256QAM_FR2
pusch-256QAM[i]	Checked		pc_pusch_256QAM_FR1
ue-PowerClass[i]	Not checked		
rateMatchingLTE-CRS[i]	Not checked		
channelBWs-DL-v1530[i] CHOICE { fr1 SEQUENCE { scs-15kHz scs-30kHz scs-60kHz } fr2 SEQUENCE { scs-60kHz scs-120kHz } }	Not checked Not checked Not checked Not checked Not checked Not checked Not checked		
channelBWs-UL-v1530[i] CHOICE { fr1 SEQUENCE { scs-15kHz scs-30kHz scs-60kHz } fr2 SEQUENCE { scs-60kHz scs-120kHz } }	Not checked Not checked Not checked Not checked Not checked Not checked		
maxUplinkDutyCycle-PC2-FR1[i]	Not checked		
pucch-SpatialRelInfoMAC-CE[i]	Not checked		
powerBoosting-pi2BPSK[i]	Not checked		
supportedBandCombinationList SEQUENCE (SIZE (1..maxBandComb)) OF SEQUENCE { bandList[i] SEQUENCE (SIZE (1..maxSimultaneousBands)) OF CHOICE { eutra SEQUENCE { bandEUTRA ca-BandwidthClassDL-EUTRA ca-BandwidthClassUL-EUTRA } nr SEQUENCE {	Not checked Not checked Not checked	FreqBandIndicator EUTRA CA-BandwidthClassE UTRA CA-BandwidthClassE UTRA	

bandNR	Not checked	FreqBandIndicator NR	
ca-BandwidthClassDL-NR	Not checked	CA-BandwidthClassNR	
ca-BandwidthClassUL-NR	Not checked	CA-BandwidthClassNR	
}			
}			
featureSetCombination[i]	Not checked	FeatureSetCombinationId	
ca-ParametersEUTRA[i]	Not checked	CA-ParametersEUTRA	
ca-ParametersNR[i]	Not checked	CA-ParametersNR	
mrdc-Parameters[i]	Not checked	MRDC-Parameters	
supportedBandwidthCombinationSet[i]	Not checked		
powerClass-v1530[i]	Not checked		
}			
appliedFreqBandListFilter	Not checked	FreqBandList	
supportedBandCombinationList-v1540 SEQUENCE (SIZE (1..maxBandComb)) OF SEQUENCE {			
bandList-v1540[i] SEQUENCE (SIZE (1..maxSimultaneousBands)) OF SEQUENCE {	Not checked	BandParameters-v1540	
srs-CarrierSwitch CHOICE {			
nr SEQUENCE [
srs-SwitchingTimesListNR SEQUENCE (SIZE (1..maxSimultaneousBands)) OF SRS- SwitchingTimeNR	Not checked		
eutra SEQUENCE {			
srs-SwitchingTimesListEUTRA SEQUENCE (SIZE (1..maxSimultaneousBands)) OF SRS- SwitchingTimeEUTRA	Not checked		
}			
}			
srs-TxSwitch-v1540[i] SEQUENCE {			
supportedSRS-TxPortSwitch	Not checked		
txSwitchImpactToRx	Not checked		
txSwitchWithAnotherBand	Not checked		
}			
}			
ca-ParametersNR-v1540[i]	Not checked	CA-ParametersNR-v1540	
}			
srs-SwitchingTimeRequested	Not checked		
}			
measAndMobParameters SEQUENCE {			
measAndMobParametersCommon SEQUENCE {			
supportedGapPattern	Not checked		
ssb-RLM	Not checked		
ssb-AndCSI-RS-RLM	Not checked		
eventB-MeasAndReport	Not checked		
handoverFDD-TDD	Not checked		
eutra-CGI-Reporting	Not checked		
nr-CGI-Reporting	Not checked		
independentGapConfig	Checked		pc_independentGapConfig
periodicEUTRA-MeasAndReport	Not checked		
handoverFR1-FR2	Not checked		
maxNumberCSI-RS-RRM-RS-SINR	Not checked		

}			
measAndMobParametersXDD-Diff SEQUENCE {			
intraAndInterF-MeasAndReport	Checked		pc_intraAndInterF-MeasAndReport
eventA-MeasAndReport	Checked		pc_eventA-MeasAndReport
handoverInterF	Not checked		
handoverLTE	Not checked		
handover-eLTE	Not checked		
}			
measAndMobParametersFRX-Diff SEQUENCE {			
ss-SINR-Meas	Not checked		
csi-RSRP-AndRSRQ-MeasWithSSB	Checked		pc_csi-RSRP-AndRSRQ-MeasWithSSB
csi-RSRP-AndRSRQ-MeasWithoutSSB	Not checked		
csi-SINR-Meas	Not checked		
csi-RS-RLM	Not checked		
handoverInterF	Not checked		
handoverLTE	Not checked		
handover-eLTE	Not checked		
maxNumberResource-CSI-RS-RLM	Not checked		
}			
}			
fdd-Add-UE-NR-Capabilities SEQUENCE {			
phy-ParametersXDD-Diff SEQUENCE {			
dynamicSFI	Not checked		
twoPUCCH-F0-2-ConsecSymbols	Not checked		
twoDifferentTPC-Loop-PUSCH	Not checked		
twoDifferentTPC-Loop-PUCCH	Not checked		
dl-SchedulingOffset-PDSCH-TypeA	Not checked		
dl-SchedulingOffset-PDSCH-TypeB	Not checked		
ul-SchedulingOffset	Not checked		
}			
mac-ParametersXDD-Diff SEQUENCE {			
skipUplinkTxDynamic	Not checked		
logicalChannelSR-DelayTimer	Not checked		
longDRX-Cycle	Not checked		
shortDRX-Cycle	Not checked		
multipleSR-Configurations	Not checked		
multipleConfiguredGrants	Not checked		
}			
measAndMobParametersXDD-Diff SEQUENCE {			
intraAndInterF-MeasAndReport	Checked		pc_intraAndInterF-MeasAndReport
eventA-MeasAndReport	Checked		pc_eventA-MeasAndReport
handoverInterF	Not checked		
handoverLTE	Not checked		
handover-eLTE	Not checked		
}			
}			
tdd-Add-UE-NR-Capabilities SEQUENCE {			
phy-ParametersXDD-Diff SEQUENCE {			
dynamicSFI	Not checked		
twoPUCCH-F0-2-ConsecSymbols	Not checked		
twoDifferentTPC-Loop-PUSCH	Not checked		
twoDifferentTPC-Loop-PUCCH	Not checked		

dl-SchedulingOffset-PDSCH-TypeA	Not checked		
dl-SchedulingOffset-PDSCH-TypeB	Not checked		
ul-SchedulingOffset	Not checked		
}			
mac-ParametersXDD-Diff SEQUENCE {			
skipUplinkTxDynamic	Not checked		
logicalChannelSR-DelayTimer	Not checked		
longDRX-Cycle	Not checked		
shortDRX-Cycle	Not checked		
multipleSR-Configurations	Not checked		
multipleConfiguredGrants	Not checked		
}			
measAndMobParametersXDD-Diff SEQUENCE {			
intraAndInterF-MeasAndReport	Checked		pc_intraAndInterF-MeasAndReport
eventA-MeasAndReport	Checked		pc_eventA-MeasAndReport
handoverInterF	Not checked		
handoverLTE	Not checked		
handover-eLTE	Not checked		
}			
fr1-Add-UE-NR-Capabilities SEQUENCE {			
phy-ParametersFRX-Diff SEQUENCE {			
dynamicSFI	Not checked		
dummy1	Not checked		
twoFL-DMRS	Not checked		
dummy2	Not checked		
dummy3	Not checked		
supportedDMRS-TypeDL	Not checked		
supportedDMRS-TypeUL	Not checked		
semiOpenLoopCSI	Not checked		
csi-ReportWithoutPMI	Not checked		
csi-ReportWithoutCQI	Not checked		
onePortsPTRS	Not checked		
twoPUCCH-F0-2-ConsecSymbols	Not checked		
pucch-F2-WithFH	Not checked		
pucch-F3-WithFH	Not checked		
pucch-F4-WithFH	Not checked		
freqHoppingPUCCH-F0-2	Not checked		
freqHoppingPUCCH-F1-3-4	Not checked		
mux-SR-HARQ-ACK-CSI-PUCCH-MultiPerSlot	Not checked		
uci-CodeBlockSegmentation	Not checked		
onePUCCH-LongAndShortFormat	Not checked		
twoPUCCH-AnyOthersInSlot	Not checked		
intraSlotFreqHopping-PUSCH	Not checked		
pusch-LBRM	Not checked		
pdcc-BlindDetectionCA	Not checked		
tpc-PUSCH-RNTI	Not checked		
tpc-PUCCH-RNTI	Not checked		
tpc-SRS-RNTI	Not checked		
absoluteTPC-Command	Not checked		
twoDifferentTPC-Loop-PUSCH	Not checked		
twoDifferentTPC-Loop-PUCCH	Not checked		
pusch-HalfPi-BPSK	Not checked		
pucch-F3-4-HalfPi-BPSK	Not checked		
almostContiguousCP-OFDM-UL	Not checked		
sp-CSI-RS	Not checked		
sp-CSI-IM	Not checked		
tdd-MultiDL-UL-SwitchPerSlot	Not checked		
multipleCORESET	Not checked		
csi-RS-IM-ReceptionForFeedback	Not checked		
csi-RS-ProcFrameworkForSRS	Not checked		
csi-ReportFramework	Not checked		

mux-SR-HARQ-ACK-CSI-PUCCH-OncePerSlot SEQUENCE {			
sameSymbol	Not checked		
diffSymbol	Not checked		
}			
mux-SR-HARQ-ACK-PUCCH	Not checked		
mux-MultipleGroupCtrlCH-Overlap	Not checked		
dl-SchedulingOffset-PDSCH-TypeA	Not checked		
dl-SchedulingOffset-PDSCH-TypeB	Not checked		
ul-SchedulingOffset	Not checked		
dl-64QAM-MCS-TableAlt	Not checked		
ul-64QAM-MCS-TableAlt	Not checked		
cqi-TableAlt	Not checked		
oneFL-DMRS-TwoAdditionalDMRS-UL	Not checked		
twoFL-DMRS-TwoAdditionalDMRS-UL	Not checked		
oneFL-DMRS-ThreeAdditionalDMRS-UL	Not checked		
}			
measAndMobParametersFRX-Diff SEQUENCE {			
ss-SINR-Meas	Not checked		
csi-RSRP-AndRSRQ-MeasWithSSB	Checked		pc_csi-RSRP-AndRSRQ-MeasWithSSB
csi-RSRP-AndRSRQ-MeasWithoutSSB	Not checked		
csi-SINR-Meas	Not checked		
csi-RS-RLM	Not checked		
handoverInterF	Not checked		
handoverLTE	Not checked		
handover-eLTE	Not checked		
maxNumberResource-CSI-RS-RLM	Not checked		
}			
fr2-Add-UE-NR-Capabilities SEQUENCE {			
phy-ParametersFRX-Diff SEQUENCE {	Not checked		
dynamicSFI	Not checked		
dummy1	Not checked		
twoFL-DMRS	Not checked		
dummy2	Not checked		
dummy3	Not checked		
supportedDMRS-TypeDL	Not checked		
supportedDMRS-TypeUL	Not checked		
semiOpenLoopCSI	Not checked		
csi-ReportWithoutPMI	Not checked		
csi-ReportWithoutCQI	Not checked		
onePortsPTRS	Not checked		
twoPUCCH-F0-2-ConsecSymbols	Not checked		
pucch-F2-WithFH	Not checked		
pucch-F3-WithFH	Not checked		
pucch-F4-WithFH	Not checked		
freqHoppingPUCCH-F0-2	Not checked		
freqHoppingPUCCH-F1-3-4	Not checked		
mux-SR-HARQ-ACK-CSI-PUCCH-MultiPerSlot	Not checked		
uci-CodeBlockSegmentation	Not checked		
onePUCCH-LongAndShortFormat	Not checked		
twoPUCCH-AnyOthersInSlot	Not checked		
intraSlotFreqHopping-PUSCH	Not checked		
pusch-LBRM	Not checked		
pdccch-BlindDetectionCA	Not checked		
tpc-PUSCH-RNTI	Not checked		
tpc-PUCCH-RNTI	Not checked		
tpc-SRS-RNTI	Not checked		
absoluteTPC-Command	Not checked		
twoDifferentTPC-Loop-PUSCH	Not checked		
twoDifferentTPC-Loop-PUCCH	Not checked		
pusch-HalfPi-BPSK	Not checked		

pucch-F3-4-HalfPi-BPSK	Not checked		
almostContiguousCP-OFDM-UL	Not checked		
sp-CSI-RS	Not checked		
sp-CSI-IM	Not checked		
tdd-MultiDL-UL-SwitchPerSlot	Not checked		
multipleCORESET	Not checked		
csi-RS-IM-ReceptionForFeedback	Not checked		
csi-RS-ProcFrameworkForSRS	Not checked		
csi-ReportFramework	Not checked		
mux-SR-HARQ-ACK-CSI-PUCCH-OncePerSlot			
SEQUENCE {			
sameSymbol	Not checked		
diffSymbol	Not checked		
}			
mux-SR-HARQ-ACK-PUCCH	Not checked		
mux-MultipleGroupCtrlCH-Overlap	Not checked		
dl-SchedulingOffset-PDSCH-TypeA	Not checked		
dl-SchedulingOffset-PDSCH-TypeB	Not checked		
ul-SchedulingOffset	Not checked		
dl-64QAM-MCS-TableAlt	Not checked		
ul-64QAM-MCS-TableAlt	Not checked		
cqi-TableAlt	Not checked		
oneFL-DMRS-TwoAdditionalDMRS-UL	Not checked		
twoFL-DMRS-TwoAdditionalDMRS-UL	Not checked		
oneFL-DMRS-ThreeAdditionalDMRS-UL	Not checked		
}			
measAndMobParametersFRX-Diff SEQUENCE {			
ss-SINR-Meas	Not checked		
csi-RSRP-AndRSRQ-MeasWithSSB	Checked		pc_csi- RSRP- AndRSRQ- MeasWithSS B
csi-RSRP-AndRSRQ-MeasWithoutSSB	Not checked		
csi-SINR-Meas	Not checked		
csi-RS-RLM	Not checked		
handoverInterF	Not checked		
handoverLTE	Not checked		
handover-eLTE	Not checked		
maxNumberResource-CSI-RS-RLM	Not checked		
}			
}			
featureSets SEQUENCE {			
featureSetsDownlink SEQUENCE (SIZE			
(1..maxDownlinkFeatureSets)) OF SEQUENCE {			
featureSetListPerDownlinkCC[i]	Not checked		
intraBandFreqSeparationDL[i]	Not checked		
scalingFactor[i]	Not checked		
crossCarrierScheduling-OtherSCS[i]	Not checked		
scellWithoutSSB[i]	Not checked		
csi-RS-MeasSCellWithoutSSB[i]	Not checked		
dummy1[i]	Not checked		
type1-3-CSS[i]	Not checked		
pdcch-MonitoringAnyOccasions[i]	Not checked		
dummy2[i]	Not checked		
ue-SpecificUL-DL-Assignment[i]	Not checked		
searchSpaceSharingCA-DL[i]	Not checked		
timeDurationForQCL[i] SEQUENCE {			
scs-60kHz	Not checked		
scs-120kHz	Not checked		
}			
pdsch-ProcessingType1-DifferentTB-PerSlot[i]			
SEQUENCE {			
scs-15kHz	Not checked		
scs-30kHz	Not checked		
scs-60kHz	Not checked		

scs-120kHz	Not checked		
}			
dummy3[i]	Not checked		
dummy4[i]	Not checked		
dummy5[i]	Not checked		
dummy6[i]	Not checked		
dummy7[i]	Not checked		
}			
featureSetsDownlinkPerCC SEQUENCE (SIZE (1..maxPerCC-FeatureSets)) OF SEQUENCE {			
supportedSubcarrierSpacingDL[i]	Not checked	SubcarrierSpacing	
supportedBandwidthDL[i]	Not checked	SupportedBandwidth	
channelBW-90mhz[i]	Not checked		
maxNumberMIMO-LayersPDSCH[i]	Not checked	MIMO-LayersDL	
supportedModulationOrderDL[i]	Not checked	ModulationOrder	
}			
featureSetsUplink SEQUENCE (SIZE (1..maxUplinkFeatureSets)) OF SEQUENCE {			
featureSetListPerUplinkCC[i]	Not checked		
scalingFactor[i]	Not checked		
crossCarrierScheduling-OtherSCS[i]	Not checked		
intraBandFreqSeparationUL[i]	Not checked		
searchSpaceSharingCA-UL[i]	Not checked		
dummy1[i]	Not checked		
supportedSRS-Resources[i]	Not checked	SRS-Resources	
twoPUCCH-Group[i]	Not checked		
dynamicSwitchSUL[i]	Not checked		
simultaneousTxSUL-NonSUL[i]	Not checked		
pusch-ProcessingType1-DifferentTB-PerSlot[i]			
SEQUENCE {			
scs-15kHz	Not checked		
scs-30kHz	Not checked		
scs-60kHz	Not checked		
scs-120kHz	Not checked		
}			
dummy2[i]	Not checked		
}			
featureSetsUplinkPerCC SEQUENCE (SIZE (1..maxPerCC-FeatureSets)) OF SEQUENCE {			
supportedSubcarrierSpacingUL[i]	Not checked	SubcarrierSpacing	
supportedBandwidthUL[i]	Not checked	SupportedBandwidth	
channelBW-90mHz[i]	Not checked		
mimo-CB-PUSCH[i] SEQUENCE {			
maxNumberMIMO-LayersCB-PUSCH	Checked	MIMO-LayersUL	pc_nrMIMO_CB_PUSCH
maxNumberSRS-ResourcePerSet	Not checked		
}			
maxNumberMIMO-LayersNonCB-PUSCH	Checked	MIMO-LayersUL	pc_nrMIMO_NonCB_PUSCH
supportedModulationOrderUL	Not checked	ModulationOrder	
}			
featureSetsDownlink-v1540 SEQUENCE (SIZE (1..maxDownlinkFeatureSets)) OF SEQUENCE {			
oneFL-DMRS-TwoAdditionalDMRS-DL[i]	Not checked		
additionalDMRS-DL-Alt[i]	Not checked		
twoFL-DMRS-TwoAdditionalDMRS-DL[i]	Not checked		
oneFL-DMRS-ThreeAdditionalDMRS-DL[i]	Not checked		
pdccch-MonitoringAnyOccasionsWithSpanGap[i]			
SEQUENCE {			
scs-15kHz	Not checked		
scs-30kHz	Not checked		
scs-60kHz	Not checked		
scs-120kHz	Not checked		

}			
pdsch-SeparationWithGap[i]	Not checked		
pdsch-ProcessingType2[i] SEQUENCE {			
scs-15kHz	Not checked		
scs-30kHz	Not checked		
scs-60kHz	Not checked		
}			
pdsch-ProcessingType2-Limited[i] SEQUENCE {			
differentTB-PerSlot-SCS-30kHz	Not checked		
}			
dl-MCS-TableAlt-DynamicIndication[i]	Not checked		
}			
featureSetsUplink-v1540 SEQUENCE (SIZE (1..maxUplinkFeatureSets)) OF SEQUENCE {			
zeroSlotOffsetAperiodicSRS	Not checked		
pa-PhaseDiscontinuityImpacts	Not checked		
pusch-SeparationWithGap	Not checked		
pusch-ProcessingType2 SEQUENCE {			
scs-15kHz	Not checked		
scs-30kHz	Not checked		
scs-60kHz	Not checked		
}			
ul-MCS-TableAlt-DynamicIndication	Not checked		
}			
featureSetsUplinkPerCC-v1540 SEQUENCE (SIZE (1..maxPerCC-FeatureSets)) OF SEQUENCE {			
mimo-NonCB-PUSCH SEQUENCE {			
maxNumberSRS-ResourcePerSet	Not checked		
maxNumberSimultaneousSRS-ResourceTx	Not checked		
}			
}			
}			
featureSetCombinations SEQUENCE (SIZE (1..maxFeatureSetCombinations)) OF {			
FeatureSetCombination[i] SEQUENCE (SIZE (1..maxSimultaneousBands)) OF {			
FeatureSetsPerBand[ii] SEQUENCE (SIZE (1..maxFeatureSetsPerBand)) OF {			
FeatureSet[iii] CHOICE {			
eutra SEQUENCE {			
downlinkSetEUTRA	Not checked	FeatureSetEUTRA-DownlinkId	
uplinkSetEUTRA	Not checked	FeatureSetEUTRA-UplinkId	
}			
nr SEQUENCE {			
downlinkSetNR	Not checked	FeatureSetDownlinkId	
uplinkSetNR	Not checked	FeatureSetUplinkId	
}			
}			
}			
}			
}			
lateNonCriticalExtension	Not checked		
nonCriticalExtension SEQUENCE {			
fdd-Add-UE-NR-Capabilities-v1530 SEQUENCE {			
eutra-ParametersXDD-Diff SEQUENCE {			
rsrqMeasWidebandEUTRA	Not checked		
}			
}			
tdd-Add-UE-NR-Capabilities-v1530 SEQUENCE {			
eutra-ParametersXDD-Diff SEQUENCE {			
rsrqMeasWidebandEUTRA	Not checked		
}			
}			
}			

}			
dummy	Not checked		
interRAT-Parameters SEQUENCE {			
eutra SEQUENCE {			
supportedBandListEUTRA SEQUENCE (SIZE (1..maxBandsEUTRA)) OF FreqBandIndicatorEUTRA	Not checked		
eutra-ParametersCommon SEQUENCE {			
mfbf-EUTRA	Not checked		
modifiedMRP-BehaviorEUTRA	Not checked		
multiNS-Pmax-EUTRA	Not checked		
rs-SINR-MeasEUTRA	Not checked		
}			
eutra-ParametersXDD-Diff SEQUENCE {			
rsrqMeasWidebandEUTRA	Not checked		
}			
}			
inactiveState	Not checked		
delayBudgetReporting	Not checked		
nonCriticalExtension SEQUENCE {	Not checked		
sdap-Parameters SEQUENCE {			
as-ReflectiveQoS	Checked		pc_as_ReflectiveQoS
}			
overheatingInd	Not checked		
ims-Parameters SEQUENCE {			
ims-ParametersCommon SEQUENCE {			
voiceOverEUTRA-5GC	Not checked		
}			
ims-ParametersFRX-Diff SEQUENCE {			
voiceOverNR	Not checked		
}			
fr1-Add-UE-NR-Capabilities-v1540 SEQUENCE {			
ims-ParametersFRX-Diff SEQUENCE {			
voiceOverNR	Not checked		
}			
fr2-Add-UE-NR-Capabilities-v1540 SEQUENCE {			
ims-ParametersFRX-Diff SEQUENCE {			
voiceOverNR	Not checked		
}			
fr1-fr2-Add-UE-NR-Capabilities SEQUENCE {			
phy-ParametersFRX-Diff SEQUENCE {			
dynamicSFI	Not checked		
dummy1	Not checked		
twoFL-DMRS	Not checked		
dummy2	Not checked		
dummy3	Not checked		
supportedDMRS-TypeDL	Not checked		
supportedDMRS-TypeUL	Not checked		
semiOpenLoopCSI	Not checked		
csi-ReportWithoutPMI	Not checked		
csi-ReportWithoutCQI	Not checked		
onePortsPTRS	Not checked		
twoPUCCH-F0-2-ConsecSymbols	Not checked		
pucch-F2-WithFH	Not checked		
pucch-F3-WithFH	Not checked		
pucch-F4-WithFH	Not checked		
freqHoppingPUCCH-F0-2	Not checked		
freqHoppingPUCCH-F1-3-4	Not checked		
mux-SR-HARQ-ACK-CSI-PUCCH-MultiPerSlot	Not checked		
uci-CodeBlockSegmentation	Not checked		
onePUCCH-LongAndShortFormat	Not checked		

twoPUCCH-AnyOthersInSlot	Not checked		
intraSlotFreqHopping-PUSCH	Not checked		
pusch-LBRM	Not checked		
pdccch-BlindDetectionCA	Not checked		
tpc-PUSCH-RNTI	Not checked		
tpc-PUCCH-RNTI	Not checked		
tpc-SRS-RNTI	Not checked		
absoluteTPC-Command	Not checked		
twoDifferentTPC-Loop-PUSCH	Not checked		
twoDifferentTPC-Loop-PUCCH	Not checked		
pusch-HalfPi-BPSK	Not checked		
pucch-F3-4-HalfPi-BPSK	Not checked		
almostContiguousCP-OFDM-UL	Not checked		
sp-CSI-RS	Not checked		
sp-CSI-IM	Not checked		
tdd-MultiDL-UL-SwitchPerSlot	Not checked		
multipleCORESET	Not checked		
csi-RS-IM-ReceptionForFeedback	Not checked	CSI-RS-IM-ReceptionForFeedback	
csi-RS-ProcFrameworkForSRS	Not checked	CSI-RS-ProcFrameworkForSRS	
csi-ReportFramework	Not checked	CSI-ReportFramework	
mux-SR-HARQ-ACK-CSI-PUCCH-OncePerSlot SEQUENCE {			
sameSymbol	Not checked		
diffSymbol	Not checked		
}			
mux-SR-HARQ-ACK-PUCCH	Not checked		
mux-MultipleGroupCtrlCH-Overlap	Not checked		
dl-SchedulingOffset-PDSCH-TypeA	Not checked		
dl-SchedulingOffset-PDSCH-TypeB	Not checked		
ul-SchedulingOffset	Not checked		
dl-64QAM-MCS-TableAlt	Not checked		
ul-64QAM-MCS-TableAlt	Not checked		
cqi-TableAlt	Not checked		
oneFL-DMRS-TwoAdditionalDMRS-UL	Not checked		
twoFL-DMRS-TwoAdditionalDMRS-UL	Not checked		
oneFL-DMRS-ThreeAdditionalDMRS-UL	Not checked		
}			
measAndMobParametersFRX-Diff SEQUENCE {			
ss-SINR-Meas	Not checked		
csi-RSRP-AndRSRQ-MeasWithSSB	Checked		pc_csi-RSRP-AndRSRQ-MeasWithSSB
csi-RSRP-AndRSRQ-MeasWithoutSSB	Not checked		
csi-SINR-Meas	Not checked		
csi-RS-RLM	Not checked		
handoverInterF	Not checked		
handoverLTE	Not checked		
handover-eLTE	Not checked		
maxNumberResource-CSI-RS-RLM	Not checked		
}			
}			
nonCriticalExtension SEQUENCE {}	Not checked		
}			
}			

8.1.5.2 SI change / On-demand SIB

8.1.5.2.1 SI change / Notification of BCCH modification / Short message for SI update

8.1.5.2.1.1 Test Purpose (TP)

(1)

```
with { UE in NR RRC_IDLE state }
ensure that {
  when { UE receives a short message transmitted on PDCCH using P-RNTI indicating a
systemInfoModification }
  then { UE re-acquires and applies the new system information about the correct prach-
ConfigurationIndex in random access }
}
```

(2)

```
with { UE in NR RRC_INACTIVE state }
ensure that {
  when { UE receives a short message transmitted on PDCCH using P-RNTI indicating a
systemInfoModification }
  then { UE re-acquires and applies the new system information about the correct prach-
ConfigurationIndex in random access to resume RRC connection }
}
```

8.1.5.2.1.2 Conformance requirements

References: The conformance requirements covered in the present test case are specified in: TS 38.331, clause 5.2.2.2.2, 5.2.2.3.1 and 6.5.

[TS 38.331, clause 5.2.2.2.2]

A modification period is used, i.e. updated SI (other than for ETWS and CMAS) is broadcasted in the modification period following the one where SI change indication is transmitted. The modification period boundaries are defined by SFN values for which $SFN \bmod m = 0$, where m is the number of radio frames comprising the modification period. The modification period is configured by system information. The UE receives indications about SI modifications and/or PWS notifications using Short Message transmitted with P-RNTI over DCI (see clause 6.5). Repetitions of SI change indication may occur within preceding modification period.

UEs in RRC_IDLE or in RRC_INACTIVE shall monitor for SI change indication in its own paging occasion every DRX cycle. UEs in RRC_CONNECTED shall monitor for SI change indication in any paging occasion at least once per modification period if the UE is provided with common search space on the active BWP to monitor paging, as specified in TS 38.213 [13], clause 13.

...

If the UE receives a Short Message, the UE shall:

...

- 1> if the *systemInfoModification* bit of Short Message is set:
 - 2> apply the SI acquisition procedure as defined in sub-clause 5.2.2.3 from the start of the next modification period.

[TS 38.331, clause 5.2.2.3.1]

The UE shall:

- 1> apply the specified BCCH configuration defined in 9.1.1.1;
- 1> if the UE is in RRC_IDLE or in RRC_INACTIVE:
 - 2> acquire the *MIB*, which is scheduled as specified in TS 38.213 [13];

- 2> if the UE is unable to acquire the *MIB*;
- 3> perform the actions as specified in clause 5.2.2.5;
- 2> else:
- 3> perform the actions specified in clause 5.2.2.4.1.

...

1> if UE is in RRC_IDLE or in RRC_INACTIVE:

- 2> if *ssb-SubcarrierOffset* indicates *SIB1* is transmitted in the cell (TS 38.213 [13]) and if *SIB1* acquisition is required for the UE:
- 3> acquire the *SIB1*, which is scheduled as specified in TS 38.213 [13];
- 3> if the UE is unable to acquire the *SIB1*:
- 4> perform the actions as specified in clause 5.2.2.5;
- 3> else:
- 4> upon acquiring *SIB1*, perform the actions specified in clause 5.2.2.4.2.

...

[TS 38.331, clause 6.5]

Short Messages can be transmitted on PDCCH using P-RNTI with or without associated *Paging* message using Short Message field in DCI format 1_0 (see TS 38.212 [17], clause 7.3.1.2.1).

Table 6.5-1 defines Short Messages. Bit 1 is the most significant bit.

Table 6.5-1: Short Messages

Bit	Short Message
1	<i>systemInfoModification</i> If set to 1: indication of a BCCH modification other than <i>SIB6</i> , <i>SIB7</i> and <i>SIB8</i> .
2	<i>etwsAndCmasIndication</i> If set to 1: indication of an ETWS primary notification and/or an ETWS secondary notification and/or a CMAS notification.
3 – 8	Not used in this release of the specification, and shall be ignored by UE if received.

8.1.5.2.1.3 Test Description

8.1.5.2.1.3.1 Pre-test conditions

System Simulator:

- NR Cell 1
- System information combination NR-1 as defined in TS 38.508-1 [4] clause 4.4.3.1.3 is used in NR cell.

UE:

- None.

Preamble:

- The UE is in 5GS state 1N-A according to TS 38.508-1 [4], clause 4.4A.2 Table 4.4A.2-1.

8.1.5.2.1.3.2 Test procedure sequence

Table 8.1.5.2.1.3.2-1: Main behaviour

St	Procedure	Message Sequence		TP	Verdict
		U - S	Message		
1	The SS transmits a Short message on PDCCH using P-RNTI indicating a <i>systemInfoModification</i> .	-	PDCCH (DCI 1_0): Short Message	-	-
2	The SS changes the <i>prach-ConfigurationIndex</i> in the system information.	-	-	-	-
3	Wait for 1 second after the start of the modification period in which the modified system information is broadcasted for the UE to receive the modified system information.	-	-	-	-
4	The SS transmits a <i>Paging</i> message including a matched identity (<i>correct ng-5G-S-TMSI</i>).	-	NR RRC: <i>Paging</i>	-	-
5	Check: Does the UE transmit a random access using <i>prach-ConfigurationIndex</i> given in step 2?	-	-	1	P
6	The UE transmits an <i>RRCSetupRequest</i> message.	-->	NR RRC: <i>RRCSetupRequest</i>	-	-
7	The SS transmits an <i>RRCSetup</i> message.	<--	NR RRC: <i>RRCSetup</i>	-	-
8	The UE transmit an <i>RRCSetupComplete</i> message including SERVICE REQUEST to confirm the successful completion of the connection establishment?	-->	NR RRC: <i>RRCSetupComplete</i> 5GMM: SERVICE REQUEST	-	-
9-12	Steps 5 to 8 of the NR RRC_CONNECTED procedure in TS 38.508-1 Table 4.5.4.2-3 are executed to successfully complete the service request procedure.	-	-	-	-
13	The SS transmits a <i>RRCRelease</i> message including <i>suspendConfig</i> .	<--	NR RRC: <i>RRCRelease</i>	-	-
14	The SS transmits a Short message on PDCCH using P-RNTI indicating a <i>systemInfoModification</i> .	-	PDCCH (DCI 1_0): Short Message	-	-
15	The SS changes the <i>prach-ConfigurationIndex</i> in the system information.	-	-	-	-
16	Wait for 1 second for the UE to receive system information.	-	-	-	-
17	The SS transmits a <i>Paging</i> message including a matched identity (<i>correct fullI-RNTI</i>).	-	NR RRC: <i>Paging</i>	-	-
18	Check: Does the UE transmit a random access using <i>prach-ConfigurationIndex</i> given in step 15?	-	-	2	P
19	The UE transmit an <i>RRCResumeRequest</i> message.	-->	<i>RRCResumeRequest</i>	-	-
20	The SS transmits an <i>RRCResume</i> message.	<--	<i>RRCResume</i>	-	-
21	The UE transmits an <i>RRCResumeComplete</i> message.	-->	<i>RRCResumeComplete</i>	-	-

8.1.5.2.1.3.3 Specific message contents

Table 8.1.5.2.1.3.3-1: SIB1 (step 2, step 15, Table 8.1.5.2.1.3.2-1)

Derivation Path: 38.508-1 [4] Table 4.6.1-28			
Information Element	Value/remark	Comment	Condition
SIB1 ::= SEQUENCE {			
ServingCellConfigCommon	ServingCellConfigCommonSIB		
}			

Table 8.1.5.2.1.3.3-2: ServingCellConfigCommonSIB (Table 8.1.5.2.1.3.3-1)

Derivation Path: TS 38.508-1 [4], Table 4.6.3-169			
Information Element	Value/remark	Comment	Condition
ServingCellConfigCommonSIB ::= SEQUENCE {			
UplinkConfigCommonSIB SEQUENCE {			
initialUplinkBWP	BWP-UplinkCommon		
}			
}			

Table 8.1.5.2.1.3.3-3: BWP-UplinkCommon (Table 8.1.5.2.1.3.3-2)

Derivation Path: TS 38.508-1 [4], Table 4.6.3-14			
Information Element	Value/remark	Comment	Condition
BWP-UplinkCommon ::= SEQUENCE {			
rach-ConfigCommon CHOICE {			
setup	RACH-ConfigCommon		
}			
}			

Table 8.1.5.2.1.3.3-4: RACH-ConfigCommon (Table 8.1.5.2.1.3.3-3)

Derivation Path: TS 38.508-1 [4], Table 4.6.3-128			
Information Element	Value/remark	Comment	Condition
RACH-ConfigCommon ::= SEQUENCE {			
rach-ConfigGeneric	RACH-ConfigGeneric		
}			

Table 8.1.5.2.1.3.3-5: RACH-ConfigGeneric (Table 8.1.5.2.1.3.3-4)

Derivation Path: TS 38.508-1 [4], Table 4.6.3-130			
Information Element	Value/remark	Comment	Condition
RACH-ConfigGeneric ::= SEQUENCE {			
prach-ConfigurationIndex	157	Value to be used in Step 2.	FR1
	157	Value to be used in Step 2.	FR2
	161	Value to be used in Step 15.	FR1
	156	Value to be used in Step 15.	FR2
}			

Table 8.1.5.2.1.3.3-6: Paging (step 4, Table 8.1.5.2.1.3.2-1)

Derivation Path: 38.508-1, Table 4.6.1-9			
Information Element	Value/remark	Comment	Condition
Paging ::= SEQUENCE {			
pagingRecordList SEQUENCE	1 entry		
(SIZE(1..maxNrofPageRec)) OF SEQUENCE {			
ue-Identity[1] CHOICE {			
ng-5G-S-TMSI	Set to the value of the		
}	NG-5G-S-TMSI of the UE		
}			
}			
}			

Table 8.1.5.2.1.3.3-7: Paging (step 17, Table 8.1.5.2.1.3.2-1)

Derivation Path: 38.508-1, Table 4.6.1-9			
Information Element	Value/remark	Comment	Condition
Paging ::= SEQUENCE {			
pagingRecordList SEQUENCE	1 entry		
(SIZE(1..maxNrofPageRec)) OF SEQUENCE {			
ue-Identity[1] CHOICE {			
fullI-RNTI	Set to the value of the I-		
}	RNTI-Value of the UE		
}			
}			
}			

8.1.5.2.2 SI change / Notification of BCCH modification / Short message for SI update in NR RRC_CONNECTED state

Editor's Note: FFS: How to initiate random access using updated prach-ConfigurationIndex to send uplink data when the uplink data delay timer expires.

8.1.5.2.2.1 Test Purpose (TP)

(1)

```
with { UE in NR RRC_CONNECTED state }
ensure that {
  when { UE receives a short message transmitted on PDCCH using P-RNTI indicating a
systemInfoModification }
  then { UE re-acquires the SIB1 }
}
```

8.1.5.2.2.2 Conformance requirements

References: The conformance requirements covered in the present test case are specified in: TS 38.331, clause 5.2.2.2.2, 5.2.2.3.1, 5.2.2.4.2 and 6.5. Unless otherwise stated these are Rel-15 requirements.

[TS 38.331, clause 5.2.2.2.2]

A modification period is used, i.e. updated SI (other than for ETWS and CMAS) is broadcasted in the modification period following the one where SI change indication is transmitted. The modification period boundaries are defined by SFN values for which $SFN \bmod m = 0$, where m is the number of radio frames comprising the modification period. The modification period is configured by system information. The UE receives indications about SI modifications and/or PWS notifications using Short Message transmitted with P-RNTI over DCI (see clause 6.5). Repetitions of SI change indication may occur within preceding modification period.

UEs in RRC_IDLE or in RRC_INACTIVE shall monitor for SI change indication in its own paging occasion every DRX cycle. UEs in RRC_CONNECTED shall monitor for SI change indication in any paging occasion at least once per modification period if the UE is provided with common search space on the active BWP to monitor paging, as specified in TS 38.213 [13], clause 13.

...

If the UE receives a Short Message, the UE shall:

...

1> if the *systemInfoModification* bit of Short Message is set:

2> apply the SI acquisition procedure as defined in sub-clause 5.2.2.3 from the start of the next modification.

[TS 38.331, clause 5.2.2.3.1]

The UE shall:

1> apply the specified BCCH configuration defined in 9.1.1.1;

...

1> if the UE is in RRC_CONNECTED with an active BWP with common search space configured by *searchSpaceSIB1* and *pagingSearchSpace* and has received an indication about change of system information; or

...

NOTE: The UE in RRC_CONNECTED is only required to acquire broadcasted *SIB1* if the UE can acquire it without disrupting unicast data reception, i.e. the broadcast and unicast beams are quasi co-located.

[TS 38.331, clause 5.2.2.4.2]

Upon receiving the *SIB1* the UE shall:

...

3> if the UE has a stored valid version of a SIB, in accordance with sub-clause 5.2.2.2.1, that the UE requires to operate within the cell in accordance with sub-clause 5.2.2.1:

4> use the stored version of the required SIB;

3> if the UE has not stored a valid version of a SIB, in accordance with sub-clause 5.2.2.2.1, of one or several required SIB(s), in accordance with sub-clause 5.2.2.1:

4> for the SI message(s) that, according to the *si-SchedulingInfo*, contain at least one required SIB and for which *si-BroadcastStatus* is set to broadcasting:

5> acquire the SI message(s) as defined in sub-clause 5.2.2.3.2;

Editor's Note: To be further updated when content of the *SIB1* has been completed.

[TS 38.331, clause 6.5]

Short messages can be transmitted on PDCCH using P-RNTI with or without associated *Paging* message using Short Message field in DCI format 1_0 (see TS 38.212 [17, 7.3.1.2.1]).

Table 6.5-1 defines Short Messages. Bit 1 is the most significant bit.

Table 6.5-1: Short messages

Bit	Short message
1	<i>systemInfoModification</i> If set to 1: indication of a BCCH modification other than SIB6, SIB7 and SIB8.
2	<i>etwsAndCmasIndication</i> If set to 1: indication of an ETWS primary notification and/or an ETWS secondary notification and/or a CMAS notification.
3 – [8]	Not used in this release of the specification, and shall be ignored by UE if received.

8.1.5.2.2.3 Test Description

8.1.5.2.2.3.1 Pre-test conditions

System Simulator:

- NR Cell 1
- System information combination NR-1 as defined in TS 38.508-1 [4] clause 4.4.3.1.3 is used in NR cell.

UE:

- None.

Preamble:

- The UE is in 5GS state 3N-A and Test Loop Function (ON) with UE test loop mode B established according to TS 38.508-1 [4], clause 4.4A.2 Table 4.4A.2-3.

8.1.5.2.2.3.2 Test procedure sequence

Table 8.1.5.2.2.3.2-1: Main behaviour

St	Procedure	Message Sequence		TP	Verdict
		U - S	Message		
1	The SS sends one IP Packet to the UE.	-	-	-	-
2	While Uplink data delay timer is running, the SS transmits a Short message on PDCCH using P-RNTI indicating a systemInfoModification.	-	PDCCH (DCI 1_0): Short Message	-	-
3	The SS changes the prach-ConfigurationIndex in the system information.	-	-	-	-
4	Wait for 1 second after the start of the modification period in which the modified system information is broadcasted for the UE to receive the modified system information.	-	-	-	-
5	Check: When the Uplink data delay timer expires, does the UE initiate a random access using prach-ConfigurationIndex given in step 3 to send pending Uplink data?	-	-	1	P
6	The SS transmits Random Access Response with RAPID corresponding to preamble in step 5	-	-	-	-

8.1.5.2.2.3.3 Specific message contents

Table 8.1.5.2.2.3.3-1: CLOSE UE TEST LOOP (Preamble, Table 8.1.5.2.2.3.2-1)

Derivation path: 38.508-1 [4] table FFS condition UE test loop mode B			
Information Element	Value/Remark	Comment	Condition
FFS			

Table 8.1.5.2.2.3.3-2: SIB1 (step 3, Table 8.1.5.2.2.3.2-1)

Derivation path: 38.508-1 [4] table 4.6.1-28			
Information Element	Value/Remark	Comment	Condition
SIB1 ::= SEQUENCE {			
SI-RequestConfig ::= SEQUENCE {			
rach-OccasionsSI SEQUENCE {			
rach-ConfigSI	RACH-ConfigGeneric		
RACH-ConfigGeneric ::= SEQUENCE {			
prach-ConfigurationIndex	159	Value to be used in Step 10.	FR1
	151	Value to be used in Step 10.	FR2
}			
}			
}			
}			

8.1.5.3

8.1.5.3.1 PWS notification / PWS reception in NR RRC_IDLE state

8.1.5.3.1.1 Test Purpose (TP)

(1)

```
with { UE in NR RRC_IDLE state }
ensure that {
  when { an ETWS capable UE receives a short message transmitted on PDCCH using P-RNTI indicating an
etwsAndCmasIndication and the si-SchedulingInfo includes scheduling information for SIB6 }
    then { the UE is able to retrieve the PWS message from SIB6 and alert the user }
}
```

(2)

```
with { UE in NR RRC_IDLE state }
ensure that {
  when { an ETWS capable UE receives a short message transmitted on PDCCH using P-RNTI indicating an
etwsAndCmasIndication and the si-SchedulingInfo includes scheduling information for SIB7 }
    then { the UE is able to retrieve all the PWS message segments from SIB7, reassemble the message
and alert the user }
}
```

(3)

```
with { UE in NR RRC_IDLE state }
ensure that {
  when { a CMAS capable UE receives a short message transmitted on PDCCH using P-RNTI indicating an
etwsAndCmasIndication and the si-SchedulingInfo includes scheduling information for SIB8 }
    then { the UE is able to retrieve all the PWS message segments from SIB8, reassemble the message
and alert the user }
}
```

8.1.5.3.1.2 Conformance requirements

References: The conformance requirements covered in the current TC are specified in: TS 38.331 clause 5.2.2.2.2.

[TS 38.331 clause 5.2.2.2.2]

...

ETWS or CMAS capable UEs in RRC_IDLE or in RRC_INACTIVE shall monitor for indications about PWS notification in its own paging occasion every DRX cycle. ETWS or CMAS capable UEs in RRC_CONNECTED shall monitor for indication about PWS notification in any paging occasion at least once per modification period if the UE is provided with common search spac on the active BWPe to monitor paging.

If the UE receives a Short Message, the UE shall:

- 1> if the UE is ETWS capable or CMAS capable, and the *etwsAndCmasIndication* bit of Short Message is set:
 - 2> immediately re-acquire the *SIB1*;
 - 2> if the UE is ETWS capable and *si-SchedulingInfo* includes scheduling information for *SIB6*:
 - 3> acquire *SIB6*, as specified in sub-clause 5.2.2.3.2, immediately;
 - 2> if the UE is ETWS capable and *si-SchedulingInfo* includes scheduling information for *SIB7*:
 - 3> acquire *SIB7*, as specified in sub-clause 5.2.2.3.2, immediately;
 - 2> if the UE is CMAS capable and *si-SchedulingInfo* includes scheduling information for *SIB8*:
 - 3> acquire *SIB8*, as specified in sub-clause 5.2.2.3, immediately;
- 1> if the *systemInfoModification* bit of Short Message is set:
 - 2> apply the SI acquisition procedure as defined in sub-clause 5.2.2.3 from the start of the next modification period.

8.1.5.3.1.3 Test description

8.1.5.3.1.3.1 Pre-test conditions

System Simulator:

- NR Cell 1.

UE:

None.

Preamble:

- The UE is in state Registered, Idle mode (state 1N-A) according to TS 38.508-1 [4].

8.1.5.3.1.3.2 Test procedure sequence

Table 8.1.5.3.1.3.2-1: Main behaviour

St	Procedure	Message Sequence		TP	Verdict
		U - S	Message		
-	If pc_ETWS_NR is true, step1-8 will be excuted.	-	-	-	-
1	The SS indicates an etwsAndCmasIndication by Short Message field in DCI format 1_0 and transmitted on PDCCH using P-RNTI. The SS starts transmitting SIB1 with the si-SchedulingInfo including scheduling information for SIB6 on NR Cell 1.	<--	PDCCH (DCI 1_0): Short Message	-	-
2	The SS includes an ETWS message with new <i>messageIdentifier</i> and <i>serialNumber</i> in SIB6. (Note 1)	-	-	-	-
3	Check: Does the UE indicate the contents of the "warning message" to the user, and alert or activate alerting the user (NOTE 2)?	-	-	1	P
4	The SS waits for 10s.	-	-	-	-
5	The SS indicates an etwsAndCmasIndication by Short Message field in DCI format 1_0 and transmitted on PDCCH using P-RNTI. The SS starts transmitting SIB1 with the si-SchedulingInfo including scheduling information for SIB7 on NR Cell 1.	<--	PDCCH (DCI 1_0): Short Message	-	-
6	The SS includes an ETWS message with new <i>messageIdentifier</i> and <i>serialNumber</i> in SIB7. (NOTE 3).	-	-	-	-
7	Check: Does the UE indicate the completely reassembled contents of the "warning message" to the user, and alert or activate alerting the user (NOTE 2)?	-	-	2	P
8	The SS waits for 10s.	-	-	-	-
-	If pc_CMAS_NR is true, step9-11 will be excuted.	-	-	-	-
9	The SS indicates an etwsAndCmasIndication by Short Message field in DCI format 1_0 and transmitted on PDCCH using P-RNTI. The SS starts transmitting SIB1 with the si-SchedulingInfo including scheduling information for SIB8 on NR Cell 1.	<--	PDCCH (DCI 1_0): Short Message	-	-
10	The SS includes a CMAS message with new <i>messageIdentifier</i> and <i>serialNumber</i> in SIB8. (NOTE 4).	-	-	-	-
11	Check: Does the UE indicate the completely reassembled contents of the "warning message" to the user, and alert or activate alerting the user (NOTE 2)?	-	-	3	P
NOTE 1: The NR-10 in Table 4.4.3.1.2-1 Combinations of system information blocks of TS 38.508-1 [4] is used. NOTE 2: The data indication and user alerting are the UE implementation issues. NOTE 3: The NR-11 in Table 4.4.3.1.2-1 Combinations of system information blocks of TS 38.508-1 [4] is used. NOTE 4: The NR-9 in Table 4.4.3.1.2-1 Combinations of system information blocks of TS 38.508-1 [4] is used.					

8.1.5.3.1.3.3 Specific message contents

None

8.1.5.3.2 PWS notification / PWS reception in NR RRC_INACTIVE state

8.1.5.3.2.1 Test Purpose (TP)

(1)

```
with { UE in NR RRC_INACTIVE state }
ensure that {
  when { an ETWS capable UE receives a short message transmitted on PDCCH using P-RNTI indicating an
etwsAndCmasIndication and the si-SchedulingInfo includes scheduling information for SIB6 }
  then { the UE is able to retrieve the PWS message from SIB6 and alert the user }
}
```

(2)

```
with { UE in NR RRC_INACTIVE state }
ensure that {
  when { an ETWS capable UE receives a short message transmitted on PDCCH using P-RNTI indicating an
etwsAndCmasIndication and the si-SchedulingInfo includes scheduling information for SIB7 }
  then { the UE is able to retrieve all the PWS message segments from SIB7, reassemble the message
and alert the user }
}
```

(3)

```
with { UE in NR RRC_INACTIVE state }
ensure that {
  when { a CMAS capable UE receives a short message transmitted on PDCCH using P-RNTI indicating an
etwsAndCmasIndication and the si-SchedulingInfo includes scheduling information for SIB8 }
  then { the UE is able to retrieve all the PWS message segments from SIB8, reassemble the message
and alert the user }
}
```

8.1.5.3.2.2 Conformance requirements

Same as test case 8.1.5.3.1.

8.1.5.3.2.3 Test description

8.1.5.3.2.3.1 Pre-test conditions

System Simulator:

- NR Cell 1.

UE:

None.

Preamble:

- The UE is in state Registered, Inactive mode (state 2N-A) according to TS 38.508-1 [4].

8.1.5.3.2.3.2 Test procedure sequence

Same as test case 8.1.5.3.1

8.1.5.3.2.3.3 Specific message contents

Same as test case 8.1.5.3.1.

8.1.5.3.3 PWS notification / PWS reception in NR RRC_CONNECTED state

8.1.5.3.3.1 Test Purpose (TP)

(1)

```
with { UE in NR RRC_CONNECTED state }
ensure that {
  when { an ETWS capable UE receives a short message transmitted on PDCCH using P-RNTI indicating an
etwsAndCmasIndication and the si-SchedulingInfo includes scheduling information for SIB6 }
  then { the UE is able to retrieve all the PWS message segments from SIB6, reassemble the message
and alert the user }
}
```

(2)

```
with { UE in NR RRC_CONNECTED state }
ensure that {
  when { an ETWS capable UE receives a short message transmitted on PDCCH using P-RNTI indicating an
etwsAndCmasIndication and the si-SchedulingInfo includes scheduling information for SIB7 }
  then { the UE is able to retrieve all the PWS message segments from SIB7, reassemble the message
and alert the user }
}
```

(3)

```
with { UE in NR RRC_CONNECTED state }
ensure that {
  when { a CMAS capable UE receives a short message transmitted on PDCCH using P-RNTI indicating an
etwsAndCmasIndication and the si-SchedulingInfo includes scheduling information for SIB8 }
  then { the UE is able to retrieve all the PWS message segments from SIB8, reassemble the message
and alert the user }
}
```

8.1.5.3.3.2 Conformance requirements

References: The conformance requirements covered in the current TC are specified in: TS 38.331 clause 5.2.2.2.2.

[TS 38.331 clause 5.2.2.2.2]

...

ETWS or CMAS capable UEs in RRC_IDLE or in RRC_INACTIVE shall monitor for indications about PWS notification in its own paging occasion every DRX cycle. ETWS or CMAS capable UEs in RRC_CONNECTED shall monitor for indication about PWS notification in any paging occasion at least once per modification period if the UE is provided with common search space on the active BWP to monitor paging.

If the UE receives a Short Message, the UE shall:

1> if the UE is ETWS capable or CMAS capable, and the *etwsAndCmasIndication* bit of Short Message is set:

2> immediately re-acquire the *SIB1*;

2> if the UE is ETWS capable and *si-SchedulingInfo* includes scheduling information for *SIB6*:

3> acquire *SIB6*, as specified in sub-clause 5.2.2.3.2, immediately;

2> if the UE is ETWS capable and *si-SchedulingInfo* includes scheduling information for *SIB7*:

3> acquire *SIB7*, as specified in sub-clause 5.2.2.3.2, immediately;

2> if the UE is CMAS capable and *si-SchedulingInfo* includes scheduling information for *SIB8*:

3> acquire *SIB8*, as specified in sub-clause 5.2.2.3.2, immediately;

1> if the *systemInfoModification* bit of Short Message is set:

2> apply the SI acquisition procedure as defined in sub-clause 5.2.2.3 from the start of the next modification period.

8.1.5.3.3.3 Test description

8.1.5.3.3.3.1 Pre-test conditions

System Simulator:

- NR Cell 1.

UE:

None.

Preamble:

- The UE is in state Registered, NR RRC_CONNECTED mode (state 3N-A) according to TS 38.508-1 [4].

8.1.5.3.3.3.2 Test procedure sequence

Same as test case 8.1.5.3.1 except PDCCH (DCI 1_0): Short Message is sent on active BWP.

8.1.5.3.3.3.3 Specific message contents

Same as test case 8.1.5.3.1.

8.1.5.3.4 PWS notification / PWS reception using dedicatedSystemInformationDelivery

8.1.5.3.4.1 Test Purpose (TP)

(1)

```
with { UE in NR RRC_CONNECTED state }
ensure that {
  when { UE receives an RRCReconfiguration message including dedicatedSystemInformationDelivery
containing SIB6 }
  then { UE reads the SIB6 to alert the user and sends an RRCReconfigurationComplete message }
}
```

(2)

```
with { UE in NR RRC_CONNECTED state }
ensure that {
  when { UE receives an RRCReconfiguration message including dedicatedSystemInformationDelivery
containing SIB7 }
  then { UE reads the SIB7 to alert the user and sends an RRCReconfigurationComplete message }
}
```

(3)

```
with { UE in NR RRC_CONNECTED state }
ensure that {
  when { UE receives an RRCReconfiguration message including dedicatedSystemInformationDelivery
containing SIB8 }
  then { UE reads the SIB8 to alert the user and sends an RRCReconfigurationComplete message }
}
```

8.1.5.3.4.2 Conformance requirements

References: The conformance requirements covered in the present TC are specified in: TS 38.331, clauses 5.2.2.4.7, 5.2.2.4.8, 5.2.2.4.9, 5.3.5.3. Unless otherwise stated these are Rel-15 requirements.

[TS 38.331, clause 5.3.5.3]

The UE shall perform the following actions upon reception of the *RRCReconfiguration*:

- 1> if the *RRCReconfiguration* message includes the *dedicatedSIB1-Delivery*:
 - 2> perform the action upon reception of *SIB1* as specified in 5.2.2.4.2;
- 1> if the *RRCReconfiguration* message includes the *dedicatedSystemInformationDelivery*:
 - 2> perform the action upon reception of System Information as specified in 5.2.2.4;

[TS 38.331, clause 5.2.2.4.7]

Upon receiving the *SIB6* the UE shall:

- 1> forward the received *warningType*, *messageIdentifier* and *serialNumber* to upper layers;

[TS 38.331, clause 5.2.2.4.8]

Upon receiving the *SIB7* the UE shall:

- 1> if there is no current value for *messageIdentifier* and *serialNumber* for *SIB7*; or
- 1> if either the received value of *messageIdentifier* or of *serialNumber* or of both are different from the current values of *messageIdentifier* and *serialNumber* for *SIB7*:
 - 2> use the received values of *messageIdentifier* and *serialNumber* for *SIB7* as the current values of *messageIdentifier* and *serialNumber* for *SIB7*;
 - 2> discard any previously buffered *warningMessageSegment*;
 - 2> if all segments of a warning message have been received:
 - 3> assemble the warning message from the received *warningMessageSegment*;
 - 3> forward the received warning message, *messageIdentifier*, *serialNumber* and *dataCodingScheme* to upper layers;
 - 3> stop reception of *SIB7*;
 - 3> discard the current values of *messageIdentifier* and *serialNumber* for *SIB7*;
 - 2> else:
 - 3> store the received *warningMessageSegment*;
 - 3> continue reception of *SIB7*;
- 1> else if all segments of a warning message have been received:
 - 2> assemble the warning message from the received *warningMessageSegment*;
 - 2> forward the received complete warning message, *messageIdentifier*, *serialNumber* and *dataCodingScheme* to upper layers;
 - 2> stop reception of *SIB7*;
 - 2> discard the current values of *messageIdentifier* and *serialNumber* for *SIB7*;
- 1> else:
 - 2> store the received *warningMessageSegment*;
 - 2> continue reception of *SIB7*;

The UE should discard any stored *warningMessageSegment* and the current value of *messageIdentifier* and *serialNumber* for *SIB7* if the complete warning message has not been assembled within a period of 3 hours.

[TS 38.331, clause 5.2.2.4.9]

Upon receiving the *SIB8* the UE shall:

- 1> if the *SIB8* contains a complete warning message and the complete geographical area coordinates (if any):
 - 2> forward the received warning message, *messageIdentifier*, *serialNumber*, *dataCodingScheme* and the geographical area coordinates (if any) to upper layers;
 - 2> continue reception of *SIB8*;
- 1> else:
 - 2> if the received values of *messageIdentifier* and *serialNumber* are the same (each value is the same) as a pair for which a warning message and the geographical area coordinates (if any) are currently being assembled:
 - 3> store the received *warningMessageSegment*;
 - 3> store the received *warningAreaCoordinatesSegment* (if any);
 - 3> if all segments of a warning message and geographical area coordinates (if any) have been received:
 - 4> assemble the warning message from the received *warningMessageSegment*;
 - 4> assemble the geographical area coordinates from the received *warningAreaCoordinatesSegment* (if any);
 - 4> forward the received warning message, *messageIdentifier*, *serialNumber*, *dataCodingScheme* and geographical area coordinates (if any) to upper layers;
 - 4> stop assembling a warning message and geographical area coordinates (if any) for this *messageIdentifier* and *serialNumber* and delete all stored information held for it;
 - 3> continue reception of *SIB8*;
 - 2> else if the received values of *messageIdentifier* and/or *serialNumber* are not the same as any of the pairs for which a warning message is currently being assembled:
 - 3> start assembling a warning message for this *messageIdentifier* and *serialNumber* pair;
 - 3> start assembling the geographical area coordinates (if any) for this *messageIdentifier* and *serialNumber* pair;
 - 3> store the received *warningMessageSegment*;
 - 3> store the received *warningAreaCoordinatesSegment* (if any);
 - 3> continue reception of *SIB8*;

The UE should discard *warningMessageSegment* and *warningAreaCoordinatesSegment* (if any) and the associated values of *messageIdentifier* and *serialNumber* for *SIB8* if the complete warning message and the geographical area coordinates (if any) have not been assembled within a period of 3 hours.

NOTE: The number of warning messages that a UE can re-assemble simultaneously is a function of UE implementation.

8.1.5.3.4.3 Test description

8.1.5.3.4.3.1 Pre-test conditions

System Simulator:

- NR Cell 1.

UE:

- None

Preamble:

- The UE is in 5GS state 3N-A according to TS 38.508-1 [4], clause 4.4A.2 Table 4.4A.2-1

8.1.5.3.4.3.2 Test procedure sequence

Table 8.1.5.3.4.3.2-1: Main behaviour

St	Procedure	Message Sequence		TP	Verdict
		U - S	Message		
-	If pc_ETWS_NR is true, steps 1-6 will be excuted.	-	-	-	-
1	The SS transmits an <i>RRCReconfiguration</i> message containing <i>dedicatedSystemInformationDelivery</i> containing SIB6.	<--	NR RRC: <i>RRCReconfiguration</i>	-	-
2	Check: Does the UE transmit an <i>RRCReconfigurationComplete</i> message?	-->	NR RRC: <i>RRCReconfigurationComplete</i>	-	-
3	Check: Does the UE indicate the contents of the "warning message" to the user, and alert or activate alerting the user (NOTE 1)?	-	-	1	P
4	The SS transmits an <i>RRCReconfiguration</i> message containing <i>dedicatedSystemInformationDelivery</i> containing SIB7.	<--	NR RRC: <i>RRCReconfiguration</i>	-	-
5	Check: Does the UE transmit an <i>RRCReconfigurationComplete</i> message?	-->	NR RRC: <i>RRCReconfigurationComplete</i>	-	-
6	Check: Does the UE indicate the "warning message" to the user, and alert or activate alerting the user (NOTE 1)?	-	-	2	P
-	If pc_CMAS_NR is true, steps 7-9 will be excuted.	-	-	-	-
7	The SS transmits an <i>RRCReconfiguration</i> message containing <i>dedicatedSystemInformationDelivery</i> containing SIB8.	<--	NR RRC: <i>RRCReconfiguration</i>	-	-
8	Check: Does the UE transmit an <i>RRCReconfigurationComplete</i> message?	-->	NR RRC: <i>RRCReconfigurationComplete</i>	-	-
9	Check: Does the UE indicate the "warning message" to the user, and alert or activate alerting the user (NOTE 1)?	-	-	3	P

NOTE 1: The data indication and user alerting are the UE implementation issues.

8.1.5.3.4.3.3 Specific message contents

Table 8.1.5.3.4.3.3-1: RRCReconfiguration (Steps 1, 4 and 7 Table 8.1.5.3.4.3.2-1)

Derivation Path: 38.508-1 [4], Table 4.6.1-13			
Information Element	Value/remark	Comment	Condition
RRCReconfiguration ::= SEQUENCE {			
criticalExtensions CHOICE {			
rrcReconfiguration SEQUENCE {			
nonCriticalExtension SEQUENCE {			
masterCellGroup	Not present		
dedicatedNAS-MessageList	Not present		
dedicatedSystemInformationDelivery	SystemInformation	OCTET STRING (CONTAINING SystemInformation)	
}			
}			
}			
}			

Table 8.1.5.3.4.3.3-2: SystemInformation (Steps 1, 4 and 7 Table 8.1.5.3.4.3.2-1)

Derivation Path: 38.508-1 [4], Table 4.6.1-29			
Information Element	Value/remark	Comment	Condition
SystemInformation ::= SEQUENCE {			
criticalExtensions CHOICE {			
systemInformation-r15 SEQUENCE {			
sib-TypeAndInfo SEQUENCE (SIZE (1..maxSIB))	1 entry		
OF CHOICE {			
sib6	SIB6	Acc to 38.508-1 [4] Table 4.6.2-5: SIB6	Step 1
sib7	SIB7		Step 4
sib8	SIB8		Step 7
}			
lateNonCriticalExtension	Not present		
nonCriticalExtension SEQUENCE {}	Not present		
}			
}			
}			
}			

Table 8.1.5.3.4.3.3-3: SIB7 (Step 4 in Table 8.1.5.3.4.3.2-1)

Derivation Path: TS 38.331 [6], clause 6.3.1			
Information Element	Value/remark	Comment	Condition
SIB7 ::= SEQUENCE {			
messageIdentifier	'0001 0001 0000 0010'B	ETWS message identifier for earthquake and tsunami message (see TS 23.041 [25])	
serialNumber	'0011 0000 0000 0000'B	Note 1.	
warningMessageSegmentType	lastSegment		
warningMessageSegmentNumber	0		
warningMessageSegment	Octetstring of N	Containing the complete ETWS message	
dataCodingScheme	Bitstring (8) ID of the alphabet/coding and the applied language	see TS 23.041 [25].	
lateNonCriticalExtension	Not present		
}			
Note 1: Geographical Scope (Octet 1 bit 7 ~ 6) set to 'Cell wide', Emergency User Alert (Octet 1 bit 5) set to 'Activate emergency user alert', Popup (Octet 1 bit 4) set to 'Activate popup', Update Number (Octet 2 bits 3~0) for each update, incremented by one, See TS 23.041 [25].			

Table 8.1.5.3.4.3.3-4: *SIB8* (Step 7 in Table 8.1.5.3.4.3.2-1)

Derivation Path: TS 38.331 [6], clause 6.3.1			
Information Element	Value/remark	Comment	Condition
SIB8 ::= SEQUENCE {			
messageIdentifier	'0001 0001 0001 0010'B	CMAS CBS Message Identifier for CMAS Presidential Level Alerts (see TS 23.041 [25])	
serialNumber	'0011 0000 0000 0000'B	Note 1	
warningMessageSegmentType	lastSegment		
warningMessageSegmentNumber	0		
warningMessageSegment	Octetstring of N		
dataCodingScheme	Bitstring (8) ID of the alphabet/coding and the applied language	Containing the complete CMAS message	
warningAreaCoordinatesSegment	Not present		
lateNonCriticalExtension	Not present		
}			
Note 1: Geographical Scope (Octet 1 bit 7 ~ 6) set to 'Cell wide', Emergency User Alert (Octet 1 bit 5) set to 'Activate emergency user alert', Popup (Octet 1 bit 4) set to 'Activate popup', Update Number (Octet 2 bits 3-0) for each update, incremented by one, See TS 23.041 [25].			

8.1.5.4 Counter check

8.1.5.4.1 Counter check / Reception of CounterCheck message by the UE

8.1.5.4.1.1 Test Purpose (TP)

(1)

```
with { UE in NR RRC_CONNECTED state with two DRBs established and having received 10 data packets on
each DRB }
ensure that {
  when { UE receives CounterCheck message with drb-Identity not included in the drb-CountMSB-
InfoList }
  then { UE sends CounterCheckResponse message by including the drb-Identity, the count-Uplink and
the count-Downlink set to the value of TX_NEXT - 1 and RX_NEXT - 1 in drb-CountInfoList IE for each
DRB established }
}
```

8.1.5.4.1.2 Conformance requirements

References: The conformance requirements covered in the current TC are specified in: TS 38.331, clause 5.3.6.3.
Unless otherwise stated these are Rel-15 requirements.
[TS 38.331, clause 5.3.6.3]

Upon receiving the *CounterCheck* message, the UE shall:

- 1> for each DRB that is established:
 - 2> if no COUNT exists for a given direction (uplink or downlink) because it is a uni-directional bearer configured only for the other direction:
 - 3> assume the COUNT value to be 0 for the unused direction;
 - 2> if the *drb-Identity* is not included in the *drb-CountMSB-InfoList*:

- 3> include the DRB in the *drb-CountInfoList* in the *CounterCheckResponse* message by including the *drb-Identity*, the *count-Uplink* and the *count-Downlink* set to the value of TX_NEXT – 1 and RX_NEXT – 1 (specified in TS 38.323 [5]), respectively;
- 2> else if, for at least one direction, the most significant bits of the COUNT are different from the value indicated in the *drb-CountMSB-InfoList*:
- 3> include the DRB in the *drb-CountInfoList* in the *CounterCheckResponse* message by including the *drb-Identity*, the *count-Uplink* and the *count-Downlink* set to the value of TX_NEXT – 1 and RX_NEXT – 1 (specified in TS 38.323 [5]), respectively;
- 1> for each DRB that is included in the *drb-CountMSB-InfoList* in the *CounterCheck* message that is not established:
- 2> include the DRB in the *drb-CountInfoList* in the *CounterCheckResponse* message by including the *drb-Identity*, the *count-Uplink* and the *count-Downlink* with the most significant bits set identical to the corresponding values in the *drb-CountMSB-InfoList* and the least significant bits set to zero;
- 1> submit the *CounterCheckResponse* message to lower layers for transmission upon which the procedure ends.

8.1.5.4.1.3 Test description

8.1.5.4.1.3.1 Pre-test conditions

System Simulator:

- NR Cell 1.
- System information combination NR-1 as defined in TS 38.508-1 [4] clause 4.4.3.1.3 is used in the NR cell.

UE:

- None.

Preamble:

- The UE is in 5GS state 3N-A on NR Cell 1 according to TS 38.508-1 [4], clause 4.4A.2 Table 4.4A.2-3

8.1.5.4.1.3.2 Test procedure sequence

Table 8.1.5.4.1.3.2-1: Main behaviour

St	Procedure	Message Sequence		TP	Verdict
		U - S	Message		
1	The SS transmits an <i>RRCReconfiguration</i> message to establish a DRB.	<--	NR RRC: <i>RRCReconfiguration</i>	-	-
2	The UE transmits an <i>RRCReconfigurationComplete</i> message.	-->	NR RRC: <i>RRCReconfigurationComplete</i>	-	-
3	The SS transmits 10 IP packets on each DRB	-	-	-	-
4	The SS transmits <i>CounterCheck</i> message with <i>drb-Identity</i> not included in the <i>drb-CountMSB-InfoList</i>	<--	NR RRC: <i>CounterCheck</i>	-	-
5	Check: Does the UE send <i>CounterCheckResponse</i> message by including the <i>drb-Identity</i> , the <i>count-Uplink</i> and the <i>count-Downlink</i> set to the value of TX_NEXT – 1 and RX_NEXT – 1 in <i>drb-CountInfoList</i> IE for each DRB established?	-->	NR RRC: <i>CounterCheckResponse</i>	1	P

8.1.5.4.1.3.3 Specific message contents

Table 8.1.5.4.1.3.3-1: RRCReconfiguration (step 1, Table 8.1.5.4.1.3.2-1)

FFS

Table 8.1.5.4.1.3.3-2: CounterCheck (step 4, Table 8.1.5.4.1.3.2-1)

Derivation path: 38.508-1 [4] table 4.6.1-1			
Information Element	Value/Remark	Comment	Condition
CounterCheck ::= SEQUENCE {			
criticalExtensions CHOICE {			
counterCheck SEQUENCE {			
drb-CountMSB-InfoList	Not present		
}			
}			
}			

Table 8.1.5.4.1.3.3-3: CounterCheckResponse (step 5, Table 8.1.5.4.1.3.2-1)

Derivation path: 38.508-1 [4] table 4.6.1-2			
Information Element	Value/Remark	Comment	Condition
CounterCheckResponse ::= SEQUENCE {			
criticalExtensions CHOICE {			
counterCheckResponse SEQUENCE {			
drb-CountInfoList SEQUENCE (SIZE (0..maxDRB)) OF SEQUENCE {	2 entries		
drb-Identity[0]	1		
count-Uplink[0]	0		
count-Downlink[0]	10		
drb-Identity[1]	2		
count-Uplink[1]	0		
count-Downlink[1]	10		
}			
}			
}			

8.1.5.5 Redirection to NR

8.1.5.5.1 Redirection to NR / From E-UTRA / Success

Editor's note: Test case assumes N26 interface is supported.

8.1.5.5.1.1 Test Purpose (TP)

(1)

```
with { UE in E-UTRA RRC_CONNECTED state }
ensure that {
  when { UE receives an RRCConnectionRelease message including a redirectedCarrierInfo for
redirection to an NR cell }
  then { UE enters E-UTRA RRC_IDLE state and performs redirection to NR cell }
}
```

8.1.5.5.1.2 Conformance requirements

References: The conformance requirements covered in the current TC is specified in: TS 36.331 clause 5.3.8.3. Unless otherwise stated these are Rel-15 requirements.

[TS 36.331, clause 5.3.8.3]

The UE shall:

- 1> except for NB-IoT, BL UEs or UEs in CE, delay the following actions defined in this sub-clause 60 ms from the moment the *RRCConnectionRelease* message was received or optionally when lower layers indicate that the receipt of the *RRCConnectionRelease* message has been successfully acknowledged, whichever is earlier;
- 1> for BL UEs or UEs in CE, delay the following actions defined in this sub-clause 1.25 seconds from the moment the *RRCConnectionRelease* message was received or optionally when lower layers indicate that the receipt of the *RRCConnectionRelease* message has been successfully acknowledged, whichever is earlier;
- 1> for NB-IoT, delay the following actions defined in this sub-clause 10 seconds from the moment the *RRCConnectionRelease* message was received or optionally when lower layers indicate that the receipt of the *RRCConnectionRelease* message has been successfully acknowledged, whichever is earlier.

NOTE: For BL UEs, UEs in CE and NB-IoT, when STATUS reporting, as defined in TS 36.322 [7], has not been triggered and the UE has sent positive HARQ feedback (ACK), as defined in TS 36.321 [6], the lower layers can be considered to have indicated that the receipt of the *RRCConnectionRelease* message has been successfully acknowledged.

- 1> stop T380, if running;
- 1> if T309 is running:
 - 2> stop timer T309 for all access categories;
 - 2> perform the actions as specified in 5.3.16.4.
- 1> if the *RRCConnectionRelease* message is received in response to an *RRCConnectionResumeRequest* for EDT:
 - 2> indicate to upper layers that the suspended RRC connection has been resumed;
 - 2> discard the stored UE AS context and *resumIdentity*;
 - 2> stop timer T300;
 - 2> stop timer T302, if running;
 - 2> stop timer T303, if running;
 - 2> stop timer T305, if running;
 - 2> stop timer T306, if running;
 - 2> stop timer T308, if running;
 - 2> perform the actions as specified in 5.3.3.7;
 - 2> stop timer T320, if running;
 - 2> stop timer T322, if running;
- 1> if the security is not activated and if UE is connected to 5GC:
 - 2> perform the actions upon leaving RRC_CONNECTED or RRC_INACTIVE as specified in 5.3.12 with the release cause 'other' upon which the procedure ends;
- 1> if the *RRCConnectionRelease* message includes *redirectedCarrierInfo* indicating redirection to *geran*; or
- 1> if the *RRCConnectionRelease* message includes *idleModeMobilityControlInfo* including *freqPriorityListGERAN*:
 - 2> if AS security has not been activated; and
 - 2> if upper layers indicate that redirect to GERAN without AS security is not allowed:
 - 3> ignore the content of the *RRCConnectionRelease*;
 - 3> perform the actions upon leaving RRC_CONNECTED or RRC_INACTIVE as specified in 5.3.12, with release cause 'other', upon which the procedure ends;

- 1> if AS security has not been activated:
 - 2> ignore the content of *redirectedCarrierInfo*, if included and indicating redirection to *nr*;
 - 2> ignore the content of *idleModeMobilityControlInfo*, if included and including *freqPriorityListNR*;
 - 2> if the UE ignores the content of *redirectedCarrierInfo* or of *idleModeMobilityControlInfo*:
 - 3> perform the actions upon leaving RRC_CONNECTED as specified in 5.3.12, with release cause 'other', upon which the procedure ends;
- 1> if the *RRCConnectionRelease* message includes *redirectedCarrierInfo* indicating redirection to *eutra* and if UE is connected to 5GC:
 - 2> if *cn-Type* is included:
 - 3> after the cell selection, indicate the available CN Type(s) and the received *cn-Type* to upper layers;

NOTE 1: Handling the case if the E-UTRA cell selected after the redirection does not support the core network type specified by the *cn-Type*, is up to UE implementation.

- 1> if the *RRCConnectionRelease* message includes the *idleModeMobilityControlInfo*:
 - 2> store the cell reselection priority information provided by the *idleModeMobilityControlInfo*;
 - 2> if the *t320* is included:
 - 3> start timer T320, with the timer value set according to the value of *t320*;
- 1> else:
 - 2> apply the cell reselection priority information broadcast in the system information;
- 1> if the *RRCConnectionRelease* message includes the *measIdleConfig*:
 - 2> clear *VarMeasIdleConfig* and *VarMeasIdleReport*;
 - 2> store the received *measIdleDuration* in *VarMeasIdleConfig*;
 - 2> start T331 with the value of *measIdleDuration*;
 - 2> if the *measIdleConfig* contains *measIdleCarrierListEUTRA*:
 - 3> store the received *measIdleCarrierListEUTRA* in *VarMeasIdleConfig*;
 - 3> start performing idle mode measurements as specified in 5.6.20;

NOTE 2: If the *measIdleConfig* does not contain *measIdleCarrierListEUTRA*, UE may receive *measIdleCarrierListEUTRA* as specified in 5.2.2.12.

- 1> for NB-IoT, if the *RRCConnectionRelease* message includes the *redirectedCarrierInfo*:
 - 2> if the *redirectedCarrierOffsetDedicated* is included in the *redirectedCarrierInfo*:
 - 3> store the dedicated offset for the frequency in *redirectedCarrierInfo*;
 - 3> start timer T322, with the timer value set according to the value of *T322* in *redirectedCarrierInfo*;
- 1> if the *releaseCause* received in the *RRCConnectionRelease* message indicates *loadBalancingTAURequired*:
 - 2> perform the actions upon leaving RRC_CONNECTED as specified in 5.3.12, with release cause 'load balancing TAU required';
- 1> else if the *releaseCause* received in the *RRCConnectionRelease* message indicates *cs-FallbackHighPriority*:
 - 2> perform the actions upon leaving RRC_CONNECTED as specified in 5.3.12, with release cause 'CS Fallback High Priority';

1> else:

2> if the *waitTime* is present:

3> start timer T302, with the timer value set according to the *waitTime*;

3> inform the upper layer that access barring is applicable for all access categories except categories '0' and '2';

2> if the *extendedWaitTime* is present; and

2> if the UE supports delay tolerant access or the UE is a NB-IoT UE:

3> forward the *extendedWaitTime* to upper layers;

2> if the *extendedWaitTime-CPdata* is present and the NB-IoT UE only supports the Control Plane CIoT EPS optimisation:

3> forward the *extendedWaitTime-CPdata* to upper layers;

2> if the *releaseCause* received in the *RRCConnectionRelease* message indicates *rrc-Suspend*:

3> perform the actions upon leaving RRC_CONNECTED as specified in 5.3.12, with release cause 'RRC suspension';

2> else if *rrc-InactiveConfig* is included:

3> perform the actions upon entering RRC_INACTIVE as specified in 5.3.8.7;

2> else:

3> perform the actions upon leaving RRC_CONNECTED or RRC_INACTIVE as specified in 5.3.12, with release cause 'other';

8.1.5.5.1.3 Test Description

8.1.5.5.1.3.1 Pre-test conditions

System Simulator:

- E-UTRA Cell 1 is the serving cell and NR Cell 1 is the suitable neighbour cell.

UE:

- E-UTRA RRC_CONNECTED state.

Preamble:

- The UE is in state Generic RB Established (state 3) according to TS 36.508 [7] clause 4.5.3 on E-UTRA Cell 1.

8.1.5.5.1.3.2 Test procedure sequence

Table 8.1.5.5.1.3.2-1: Main behaviour

St	Procedure	Message Sequence		TP	Verdict
		U - S	Message		
1	The SS transmits an <i>RRCConnectionRelease</i> message indicating redirection to NR Cell 1.	-	E-UTRA RRC: <i>RRCConnectionRelease</i>	-	-
2	Check: Does the test result of generic test procedure in TS 38.508-1 subclause 4.9.5 indicate that the UE has performed mobility registration updating when it camps on NR Cell 1?	-	-	1	P

8.1.5.5.1.3.3 Specific message contents

FFS

8.1.5.6 Radio link failure

8.1.5.6.1 Radio link failure / RRC connection re-establishment success

8.1.5.6.1.1 Test Purpose (TP)

(1)

```
with { UE in NR RRC_CONNECTED state }
ensure that {
  when { UE detecting physical layer problems }
  then { UE shall start timer T310 and UE does not initiate any RRC connection re-establishment
procedure before expiring of timer T310 }
}
```

(2)

```
with { UE in NR RRC_CONNECTED state }
ensure that {
  when { UE detecting radio link failure on expiring of timer T310 }
  then { UE starts timer T311 and UE initiates the RRC connection re-establishment procedure }
}
```

(3)

```
with { UE having initiated RRC connection re-establishment procedure and timer T311 running }
ensure that {
  when { UE successfully completes the RRC connection re-establishment procedure }
  then { UE is in NR RRC_CONNECTED state }
}
```

(4)

```
with { UE in NR RRC_CONNECTED state and upon detecting radio link failure UE sends
RRCReestablishmentRequest message }
ensure that {
  when { UE receives a RRCSetup message }
  then { UE completes RRC setup procedure by sending RRCSetupComplete message }
}
```

8.1.5.6.1.2 Conformance requirements

References: The conformance requirements covered in the current TC are specified in: TS 38.331 clauses 5.3.3.4, 5.3.7.2, 5.3.7.8, 5.3.10.1 and 5.3.10.3.

[TS 38.331 clause 5.3.3.4]

The UE shall perform the following actions upon reception of the *RRCSetup*:

- 1> if the *RRCSetup* is received in response to an *RRCReestablishmentRequest*; or
- 1> if the *RRCSetup* is received in response to an *RRCResumeRequest* or *RRCResumeRequest1*:
 - 2> discard any stored UE Inactive AS context and *suspendConfig*;
 - 2> discard any current AS security context including the $K_{RRCCenc}$ key, the K_{RRCint} key, the K_{UPint} key and the K_{UPenc} key;
 - 2> release radio resources for all established RBs except SRB0, including release of the RLC entities, of the associated PDCP entities and of SDAP;

- 2> release the RRC configuration except for the default L1 parameter values, default MAC Cell Group configuration and CCCH configuration;
- 2> indicate to upper layers fallback of the RRC connection;
- 2> stop timer T380, if running;
- 1> perform the cell group configuration procedure in accordance with the received *masterCellGroup* and as specified in 5.3.5.5;
- 1> perform the radio bearer configuration procedure in accordance with the received *radioBearerConfig* and as specified in 5.3.5.6;
- 1> if stored, discard the cell reselection priority information provided by the *cellReselectionPriorities* or inherited from another RAT;
- 1> stop timer T300, T301 or T319 if running;
- 1> if T390 is running:
 - 2> stop timer T390 for all access categories;
 - 2> perform the actions as specified in 5.3.14.4;
- 1> if T302 is running:
 - 2> stop timer T302;
 - 2> perform the actions as specified in 5.3.14.4;
- 1> stop timer T320, if running;
- 1> if the *RRCSetup* is received in response to an *RRCResumeRequest*, *RRCResumeRequest1* or *RRCSetupRequest*:
 - 2> enter RRC_CONNECTED;
 - 2> stop the cell re-selection procedure;
- 1> consider the current cell to be the PCell;
- 1> set the content of *RRCSetupComplete* message as follows:
 - 2> if upper layers provide a 5G-S-TMSI:
 - 3> if the *RRCSetup* is received in response to an *RRCSetupRequest*:
 - 4> set the *ng-5G-S-TMSI-Value* to *ng-5G-S-TMSI-Part2*;
 - 3> else:
 - 4> set the *ng-5G-S-TMSI-Value* to *ng-5G-S-TMSI*;
 - 2> set the *selectedPLMN-Identity* to the PLMN selected by upper layers (TS 24.501 [23]) from the PLMN(s) included in the *plmn-IdentityList* in *SIB1*;
 - 2> if upper layers provide the 'Registered AMF':
 - 3> include and set the *registeredAMF* as follows:
 - 4> if the PLMN identity of the 'Registered AMF' is different from the PLMN selected by the upper layers:
 - 5> include the *plmnIdentity* in the *registeredAMF* and set it to the value of the PLMN identity in the 'Registered AMF' received from upper layers;
 - 4> set the *amf-Identifier* to the value received from upper layers;
 - 3> include and set the *guami-Type* to the value provided by the upper layers;

- 2> if upper layers provide one or more S-NSSAI (see TS 23.003 [21]):
 - 3> include the *s-NSSAI-List* and set the content to the values provided by the upper layers;
 - 2> set the *dedicatedNAS-Message* to include the information received from upper layers;
- 1> submit the *RRCSetupComplete* message to lower layers for transmission, upon which the procedure ends

[TS 38.331 clause 5.3.7.2]

The UE initiates the procedure when one of the following conditions is met:

- 1> upon detecting radio link failure of the MCG, in accordance with 5.3.10; or
- 1> upon re-configuration with sync failure of the MCG, in accordance with sub-clause 5.3.5.8.3; or
- 1> upon mobility from NR failure, in accordance with sub-clause 5.4.3.5; or
- 1> upon integrity check failure indication from lower layers concerning SRB1 or SRB2, except if the integrity check failure is detected on the *RRCReestablishment* message; or
- 1> upon an RRC connection reconfiguration failure, in accordance with sub-clause 5.3.5.8.2.

Upon initiation of the procedure, the UE shall:

- 1> stop timer T310, if running;
- 1> stop timer T304, if running;
- 1> start timer T311;
- 1> suspend all RBs, except SRB0;
- 1> reset MAC;
- 1> release the MCG SCell(s), if configured;
- 1> release *spCellConfig*;
- 1> release *delayBudgetReportingConfig*, if configured, and stop timer T342, if running;
- 1> release *overheatingAssistanceConfig*, if configured, and stop timer T345, if running;
- 1> perform cell selection in accordance with the cell selection process as specified in TS 38.304 [20], clause 5.2.6.

[TS 38.331 clause 5.3.7.8]

The UE shall:

- 1> perform the RRC connection establishment procedure as specified in 5.3.3.4.

[TS 38.331 clause 5.3.10.1]

The UE shall:

- 1> upon receiving N310 consecutive "out-of-sync" indications for the SpCell from lower layers while neither T300, T301, T304, T311 nor T319 are running:
 - 2> start timer T310 for the corresponding SpCell.

[TS 38.331 clause 5.3.10.3]

The UE shall:

- 1> upon T310 expiry in PCell; or
- 1> upon random access problem indication from MCG MAC while neither T300, T301, T304, T311 nor T319 are running; or

- 1> upon indication from MCG RLC that the maximum number of retransmissions has been reached:
- 2> if the indication is from MCG RLC and CA duplication is configured and activated, and for the corresponding logical channel *allowedServingCells* only includes SCell(s):
- 3> initiate the failure information procedure as specified in 5.7.5 to report RLC failure.
- 2> else:
- 3> consider radio link failure to be detected for the MCG i.e. RLF;
- 3> if AS security has not been activated:
- 4> perform the actions upon going to RRC_IDLE as specified in 5.3.11, with release cause 'other';-
- 3> else if AS security has been activated but SRB2 and at least one DRB have not been setup:
- 4> perform the actions upon going to RRC_IDLE as specified in 5.3.11, with release cause 'RRC connection failure';
- 3> else:
- 4> initiate the connection re-establishment procedure as specified in 5.3.7.

8.1.5.6.1.3 Test description

8.1.5.6.1.3.1 Pre-test conditions

System Simulator:

- 3 NR Cells. NR Cell 1 is the serving cell, NR Cell 2 and NR Cell 4 are the intra-frequency neighbour cell.

None.

Preamble:

- The UE is in state 3N-A as defined in TS 38.508-1 [4], subclause 4.4A on NR Cell 1.

8.1.5.6.1.3.2 Test procedure sequence

Table 8.1.5.6.1.3.2-1: Time instances of cell power level and parameter changes for FR1

	Parameter	Unit	NR Cell 1	NR Cell 2	NR Cell 4
T1	SS/PBCH SSS EPRE	dBm/SCS	"Off"	-88	-94
T2	SS/PBCH SSS EPRE	dBm/SCS	"Off"	"Off"	-88
Power level "Off" is defined in TS 38.508-1 [4] Table 6.2.2.1-3.					

Table 8.1.5.6.1.3.2-2: Time instances of cell power level and parameter changes for FR2

	Parameter	Unit	NR Cell 1	NR Cell 2	NR Cell 4
T1	SS/PBCH SSS EPRE	dBm/SCS	"Off"	FFS	FFS
T2	SS/PBCH SSS EPRE	dBm/SCS	"Off"	"Off"	FFS
Power level "Off" is defined in TS 38.508-1 [4] Table 6.2.2.2-2.					

Table 8.1.5.6.1.3.2-3: Main behaviour

St	Procedure	Message Sequence		TP	Verdict
		U - S	Message		
1	The SS changes NR Cell 1, NR Cell 2 and NR Cell 4 parameters according to the row "T1" in table 8.1.5.6.1.3.2-1 in order that the radio link quality of NR Cell 1 is degraded, and NR Cell 2 is suitable for camping.	-	-	-	-
2	Check: Does the UE initiate an RRC connection re-establishment procedure on Cell 1 or Cell 2. This is checked during the time T=T310?	-	-	1	F
3	Check: Does the UE send <i>RRCReestablishmentRequest</i> message on NR Cell 2?	-->	NR RRC: <i>RRCReestablishmentRequest</i>	2	P
4	The SS transmits <i>RRCReestablishment</i> message.	<--	NR RRC: <i>RRCReestablishment</i>	-	-
5	The UE transmits <i>RRCReestablishmentComplete</i> message.	-->	NR RRC: <i>RRCReestablishmentComplete</i>	-	-
6	The SS transmits an <i>RRCReconfiguration</i> message to resume existing radio bearer.	<--	NR RRC: <i>RRCReconfiguration</i>	-	-
7	Check: Does the UE transmit an <i>RRCConnectionReconfigurationComplete</i> message?	-->	NR RRC: <i>RRCReconfigurationComplete</i>	3	P
8	The SS changes NR Cell 2 and NR Cell 4 parameters according to the row "T2" in table 8.1.5.6.1.3.2-1 in order that the radio link quality of NR Cell 2 is degraded and cell 4 is suitable for camping.	-	-	-	-
9	Check: Does the UE send <i>RRCReestablishmentRequest</i> message on NR Cell 4?	-->	NR RRC: <i>RRCReestablishmentRequest</i>	-	-
10	The SS transmits <i>RRCSetup</i> message.	<--	NR RRC: <i>RRCSetup</i>	-	-
11	Check: Does the UE transmit a <i>RRCSetupComplete</i> message?	-->	NR RRC: <i>RRCSetupComplete</i>	4	P
12	The SS transmits a <i>SecurityModeCommand</i> message.	<--	NR RRC: <i>SecurityModeCommand</i>	-	-
13	The UE transmits a <i>SecurityModeComplete</i> message.	-->	NR RRC: <i>SecurityModeComplete</i>	-	-
14	The SS transmits an <i>RRCReconfiguration</i> message to establish SRB2 and DRB	<--	NR RRC: <i>RRCReconfiguration</i>	-	-
15	The UE transmits an <i>RRCReconfigurationComplete</i> message.	-->	NR RRC: <i>RRCReconfigurationComplete</i>	-	-

8.1.5.6.1.3.3 Specific message contents

Table 8.1.5.6.1.3.3-1: RRCReestablishmentRequest (step 3, Table 8.1.5.6.1.3.2-3)

Derivation path: 38.508-1 [4] table 4.6.1-12			
Information Element	Value/remark	Comment	Condition
RRCReestablishmentRequest ::= SEQUENCE {			
ue-Identity SEQUENCE {			
c-RNTI	the value of the C-RNTI of the UE		
physCellId	PhysicalCellIdentity of NR Cell 1		
shortMAC-I	The same value as the 16 least significant bits of the XMAC-I value calculated by SS		
}			
reestablishmentCause	otherFailure		
}			

Table 8.1.5.6.1.3.3-2: RRCReestablishmentRequest (step 9, Table 8.1.5.6.1.3.2-3)

Derivation path: 38.508-1 [4] table 4.6.1-12			
Information Element	Value/remark	Comment	Condition
RRCReestablishmentRequest ::= SEQUENCE {			
ue-Identity SEQUENCE {			
c-RNTI	the value of the C-RNTI of the UE		
physCellId	PhysicalCellIdentity of NR Cell 2		
shortMAC-I	The same value as the 16 least significant bits of the XMAC-I value calculated by SS		
}			
reestablishmentCause	otherFailure		
}			

8.1.5.6.2 Radio link failure / T301 expiry

8.1.5.6.2.1 Test Purpose (TP)

(1)

```

with { UE in NR RRC_CONNECTED state }
ensure that {
  when { UE having sent an RRCReestablishmentRequest message on starting of timer T301 }
  then { UE goes to NR RRC_IDLE state after timer T301 is expired and trigger registration on the
new tracking area to recover RRC connection }
}

```

8.1.5.6.2.2 Conformance requirements

References: The conformance requirements covered in the current TC are specified in: TS 38.331 clauses 5.3.7.2, 5.3.7.3, 5.3.7.7, 5.3.7.8, 5.3.10.1 and 5.3.10.3.

[TS 38.331 clause 5.3.7.2]

The UE initiates the procedure when one of the following conditions is met:

- 1> upon detecting radio link failure of the MCG, in accordance with 5.3.10; or

- 1> upon re-configuration with sync failure of the MCG, in accordance with sub-clause 5.3.5.8.3; or
- 1> upon mobility from NR failure, in accordance with sub-clause 5.4.3.5; or
- 1> upon integrity check failure indication from lower layers concerning SRB1 or SRB2, except if the integrity check failure is detected on the *RRCReestablishment* message; or
- 1> upon an RRC connection reconfiguration failure, in accordance with sub-clause 5.3.5.8.2.

Upon initiation of the procedure, the UE shall:

- 1> stop timer T310, if running;
- 1> stop timer T304, if running;
- 1> start timer T311;
- 1> suspend all RBs, except SRB0;
- 1> reset MAC;
- 1> release the MCG SCell(s), if configured;
- 1> release *spCellConfig*;
- 1> release *delayBudgetReportingConfig*, if configured, and stop timer T342, if running;
- 1> release *overheatingAssistanceConfig*, if configured, and stop timer T345, if running;
- 1> perform cell selection in accordance with the cell selection process as specified in TS 38.304 [20], clause 5.2.6.

[TS 38.331 clause 5.3.7.3]

Upon selecting a suitable NR cell, the UE shall:

- 1> ensure having valid and up to date essential system information as specified in clause 5.2.2.2;
- 1> stop timer T311;
- 1> start timer T301;
- 1> if T390 is running:
 - 2> stop timer T390 for all access categories;
 - 2> perform the actions as specified in 5.3.14.4;
- 1> apply the default L1 parameter values as specified in corresponding physical layer specifications except for the parameters for which values are provided in *SIB1*;
- 1> apply the default MAC Cell Group configuration as specified in 9.2.2;
- 1> apply the CCCH configuration as specified in 9.1.1.2;
- 1> apply the *timeAlignmentTimerCommon* included in *SIB1*;
- 1> initiate transmission of the *RRCReestablishmentRequest* message in accordance with 5.3.7.4;

NOTE: This procedure applies also if the UE returns to the source PCell.

Upon selecting an inter-RAT cell, the UE shall:

- 1> perform the actions upon going to RRC_IDLE as specified in 5.3.11, with release cause 'RRC connection failure'.

[TS 38.331 clause 5.3.7.7]

The UE shall:

1> if timer T301 expires; or

1> if the selected cell becomes no longer suitable according to the cell selection criteria as specified in TS 38.304 [20]:

2> perform the actions upon going to RRC_IDLE as specified in 5.3.11, with release cause 'RRC connection failure'.

[TS 38.331 clause 5.3.7.8]

The UE shall:

1> perform the RRC connection establishment procedure as specified in 5.3.3.4.

[TS 38.331 clause 5.3.10.1]

The UE shall:

1> upon receiving N310 consecutive "out-of-sync" indications for the SpCell from lower layers while neither T300, T301, T304, T311 nor T319 are running:

2> start timer T310 for the corresponding SpCell.

[TS 38.331 clause 5.3.10.3]

The UE shall:

1> upon T310 expiry in PCell; or

1> upon random access problem indication from MCG MAC while neither T300, T301, T304, T311 nor T319 are running; or

1> upon indication from MCG RLC that the maximum number of retransmissions has been reached:

2> if the indication is from MCG RLC and CA duplication is configured and activated, and for the corresponding logical channel *allowedServingCells* only includes SCell(s):

3> initiate the failure information procedure as specified in 5.7.5 to report RLC failure.

2> else:

3> consider radio link failure to be detected for the MCG i.e. RLF;

3> if AS security has not been activated:

4> perform the actions upon going to RRC_IDLE as specified in 5.3.11, with release cause 'other';-

3> else if AS security has been activated but SRB2 and at least one DRB have not been setup:

4> perform the actions upon going to RRC_IDLE as specified in 5.3.11, with release cause 'RRC connection failure';

3> else:

4> initiate the connection re-establishment procedure as specified in 5.3.7.

8.1.5.6.2.3 Test description

8.1.5.6.2.3.1 Pre-test conditions

System Simulator:

- 2 NR Cells. NR Cell 1 is the serving cell and NR Cell 11 is the intra-frequency neighbour cell.

None.

Preamble:

- The UE is in state 3N-A as defined in TS 38.508-1 [4], subclause 4.4A on NR Cell 1.

8.1.5.6.2.3.2 Test procedure sequence

Table 8.1.5.6.2.3.2-1: Time instances of cell power level and parameter changes for FR1

	Parameter	Unit	NR Cell 1	NR Cell 11
T1	SS/PBCH SSS EPRE	dBm/SCS	"Off"	-88
Power level "Off" is defined in TS 38.508-1 [4] Table 6.2.2.1-3.				

Table 8.1.5.6.2.3.2-2: Time instances of cell power level and parameter changes for FR2

	Parameter	Unit	NR Cell 1	NR Cell 11
T1	SS/PBCH SSS EPRE	dBm/SCS	"Off"	FFS
Power level "Off" is defined in TS 38.508-1 [4] Table 6.2.2.2-2.				

Table 8.1.5.6.2.3.2-3: Main behaviour

St	Procedure	Message Sequence		TP	Verdict
		U - S	Message		
1	The SS changes NR Cell 1 and NR Cell 11 parameters according to the row "T1" in table 8.1.5.6.2.3.2-1 in order that the radio link quality of NR Cell 1 is degraded, and NR Cell 11 is suitable for camping.	-	-	-	-
2	The UE transmit a <i>RRCReestablishmentRequest</i> message on NR Cell 11	-->	NR RRC: <i>RRCReestablishmentRequest</i>	-	-
3	The SS does not respond to any <i>RRCConnectionReestablishmentRequest</i> message for 2s (T301).	-	-	-	-
4-8	Check: Does the test result of generic test procedure in TS 38.508-1 [4] subclause 4.9.5, steps 1-5, indicate that the UE performs a mobility registration updating on NR Cell 11?	-	-	1	P

8.1.5.6.2.3.3 Specific message contents

Table 8.1.5.6.2.3.3-1: *SystemInformationBlockType2* for NR Cell 11 (all steps)

Derivation path: 38.508-1 [4] table 4.6.1-28			
Information Element	Value/Remark	Comment	Condition
SIB1 ::= SEQUENCE {			
ue-TimersAndConstants SEQUENCE {			
t301	ms2000		
}			
}			

Table 8.1.5.6.2.3.3-2: RRCReestablishmentRequest (step 2, Table 8.1.5.6.2.3.2-2)

Derivation path: 38.508-1 [4] table 4.6.1-12			
Information Element	Value/remark	Comment	Condition
RRCReestablishmentRequest ::= SEQUENCE {			
ue-Identity SEQUENCE {			
c-RNTI	the value of the C-RNTI of the UE		
physCellId	PhysicalCellIdentity of NR Cell 1		
shortMAC-I	The same value as the 16 least significant bits of the XMAC-I value calculated by SS		
}			
reestablishmentCause	otherFailure		
}			

8.1.5.6.3 Radio link failure / T311 expiry

8.1.5.6.3.1 Test Purpose (TP)

(1)

```

with { UE in NR RRC_CONNECTED state and radio link failure was detected and UE attempts to select a
suitable NR cell to re-establish the RRC connection }
ensure that {
  when { UE cannot find a suitable NR cell within T311 }
    then { UE does not try to re-establish the RRC connection and goes to NR RRC_IDLE state after
T311 expired }
}

```

8.1.5.6.3.2 Conformance requirements

References: The conformance requirements covered in the current TC are specified in: TS 38.331 clauses 5.3.7.2, 5.3.7.6, 5.3.7.8, 5.3.10.1 and 5.3.10.3.

[TS 38.331 clause 5.3.7.2]

The UE initiates the procedure when one of the following conditions is met:

- 1> upon detecting radio link failure of the MCG, in accordance with 5.3.10; or
- 1> upon re-configuration with sync failure of the MCG, in accordance with sub-clause 5.3.5.8.3; or
- 1> upon mobility from NR failure, in accordance with sub-clause 5.4.3.5; or
- 1> upon integrity check failure indication from lower layers concerning SRB1 or SRB2, except if the integrity check failure is detected on the *RRCReestablishment* message; or
- 1> upon an RRC connection reconfiguration failure, in accordance with sub-clause 5.3.5.8.2.

Upon initiation of the procedure, the UE shall:

- 1> stop timer T310, if running;
- 1> stop timer T304, if running;
- 1> start timer T311;
- 1> suspend all RBs, except SRB0;
- 1> reset MAC;

1> release the MCG SCell(s), if configured;

1> release *spCellConfig*;

1> release *delayBudgetReportingConfig*, if configured, and stop timer T342, if running;

1> release *overheatingAssistanceConfig*, if configured, and stop timer T345, if running;

1> perform cell selection in accordance with the cell selection process as specified in TS 38.304 [20], clause 5.2.6.

[TS 38.331 clause 5.3.7.7]

Upon T311 expiry, the UE shall:

1> perform the actions upon going to RRC_IDLE as specified in 5.3.11, with release cause 'RRC connection failure'.

[TS 38.331 clause 5.3.7.8]

The UE shall:

1> perform the RRC connection establishment procedure as specified in 5.3.3.4.

[TS 38.331 clause 5.3.10.1]

The UE shall:

1> upon receiving N310 consecutive "out-of-sync" indications for the SpCell from lower layers while neither T300, T301, T304, T311 nor T319 are running:

2> start timer T310 for the corresponding SpCell.

[TS 38.331 clause 5.3.10.3]

The UE shall:

1> upon T310 expiry in PCell; or

1> upon random access problem indication from MCG MAC while neither T300, T301, T304, T311 nor T319 are running; or

1> upon indication from MCG RLC that the maximum number of retransmissions has been reached:

2> if the indication is from MCG RLC and CA duplication is configured and activated, and for the corresponding logical channel *allowedServingCells* only includes SCell(s):

3> initiate the failure information procedure as specified in 5.7.5 to report RLC failure.

2> else:

3> consider radio link failure to be detected for the MCG i.e. RLF;

3> if AS security has not been activated:

4> perform the actions upon going to RRC_IDLE as specified in 5.3.11, with release cause 'other';-

3> else if AS security has been activated but SRB2 and at least one DRB have not been setup:

4> perform the actions upon going to RRC_IDLE as specified in 5.3.11, with release cause 'RRC connection failure';

3> else:

4> initiate the connection re-establishment procedure as specified in 5.3.7.

8.1.5.6.3.3 Test description

8.1.5.6.3.3.1 Pre-test conditions

System Simulator:

- 2 NR Cells. NR Cell 1 is the serving cell and NR Cell 2 is the intra-frequency neighbour cell.

None.

Preamble:

- The UE is in state 3N-A as defined in TS 38.508-1 [4], subclause 4.4A on NR Cell 1.

8.1.5.6.3.3.2 Test procedure sequence

Table 8.1.5.6.3.3.2-1: Time instances of cell power level and parameter changes for FR1

	Parameter	Unit	NR Cell 1	NR Cell 2
T1	SS/PBCH SSS EPRE	dBm/SCS	"Off"	"Off"
T2	SS/PBCH SSS EPRE	dBm/SCS	"Off"	-88
Power level "Off" is defined in TS 38.508-1 [4] Table 6.2.2.1-3.				

Table 8.1.5.6.3.3.2-2: Time instances of cell power level and parameter changes for FR2

	Parameter	Unit	NR Cell 1	NR Cell 2
T1	SS/PBCH SSS EPRE	dBm/SCS	"Off"	"Off"
T2	SS/PBCH SSS EPRE	dBm/SCS	"Off"	FFS
Power level "Off" is defined in TS 38.508-1 [4] Table 6.2.2.2-2.				

Table 8.1.5.6.3.3.2-3: Main behaviour

St	Procedure	Message Sequence		TP	Verdict
		U - S	Message		
1	The SS changes NR Cell 1 and NR Cell 2 parameters according to the row "T1" in table 8.1.5.6.3.3.2-1 in order that the radio link quality of NR Cell 1 is degraded and NR Cell 2 set to Non-suitable "Off"	-	-	-	-
2	Wait for 12s (T311 (10s) is transmitted in SIB1).	-	-	-	-
3	The SS changes NR Cell 1 and NR Cell 2 parameters according to the row "T2" in table 8.1.5.6.3.3.2-1 making NR Cell 2 is suitable for camping.	-	-	-	-
4	Check: Does the test result of generic test procedure in TS 38.508-1 [4] subclause 4.9.5 indicate that the UE is camped on NR Cell 2?	-	-	1	P

8.1.5.6.3.3.3 Specific message contents

Table 8.1.5.6.3.3-1: SystemInformationBlockType2 for Cell 2 (all steps)

Derivation path: 38.508-1 [4] table 4.6.1-28			
Information Element	Value/Remark	Comment	Condition
SIB1 ::= SEQUENCE {			
ue-TimersAndConstants SEQUENCE {			
t311	ms10000		
}			
}			

8.1.5.6.4 Radio link failure / Radio link recovery while T310 is running

8.1.5.6.4.1 Test Purpose (TP)

(1)

```

with { UE in NR RRC_CONNECTED state }
ensure that {
  when { UE detecting physical layer recovery while T310 was running }
  then { UE resumes the RRC connection without explicit signalling }
}

```

8.1.5.6.4.2 Conformance requirements

References: The conformance requirements covered in the current TC are specified in: TS 38.331 clauses 5.3.10.1 and 5.3.10.2.

[TS 38.331 clause 5.3.10.1]

The UE shall:

- 1> upon receiving N310 consecutive "out-of-sync" indications for the SpCell from lower layers while neither T300, T301, T304, T311 nor T319 are running:
- 2> start timer T310 for the corresponding SpCell.

[TS 38.331 clause 5.3.10.2]

Upon receiving N311 consecutive "in-sync" indications for the SpCell from lower layers while T310 is running, the UE shall:

- 1> stop timer T310 for the corresponding SpCell.

NOTE 1: In this case, the UE maintains the RRC connection without explicit signalling, i.e. the UE maintains the entire radio resource configuration.

NOTE 2: Periods in time where neither "in-sync" nor "out-of-sync" is reported by L1 do not affect the evaluation of the number of consecutive "in-sync" or "out-of-sync" indications.

8.1.5.6.4.3 Test description

8.1.5.6.4.3.1 Pre-test conditions

System Simulator:

- 1 NR Cells, NR Cell 1 is the serving cell.

None.

Preamble:

- The UE is in state 3N-A as defined in TS 38.508-1 [4], subclause 4.4A on NR Cell 1.

8.1.5.6.4.3.2 Test procedure sequence

Table 8.1.5.6.4.3.2-1: Time instances of cell power level and parameter changes for FR1

	Parameter	Unit	NR Cell 1
T1	SS/PBCH SSS EPRE	dBm/SCS	"Off"
T2	SS/PBCH SSS EPRE	dBm/SCS	-88
Power level "Off" is defined in TS 38.508-1 [4] Table 6.2.2.1-3.			

Table 8.1.5.6.4.3.2-2: Time instances of cell power level and parameter changes for FR2

	Parameter	Unit	NR Cell 1
T1	SS/PBCH SSS EPRE	dBm/SCS	"Off"
T2	SS/PBCH SSS EPRE	dBm/SCS	FFS
Power level "Off" is defined in TS 38.508-1 [4] Table 6.2.2.2-2.			

Table 8.1.5.6.4.3.2-3: Main behaviour

St	Procedure	Message Sequence		TP	Verdict
		U - S	Message		
1	The SS changes NR Cell 1 parameters according to the row "T1" in table 8.1.5.6.4.3.2-1 to set NR Cell 1 to Non-suitable "Off"	-	-	-	-
2	The SS wait for 1,5 s (T310 (2s) is transmitted in SIB1).	-	-	-	-
3	The SS changes NR Cell 1 parameters according to the row "T2" in table 8.1.5.6.4.3.2-1 making NR Cell 1 serving cell.	-	-	-	-
4	Check: For the next 5 s does the UE transmit any signalling message?	-	-	1	F
5	Check: Does the test result of generic test procedure in TS 38.508-1 [4] subclause 4.9.10 indicate that the UE is in NR RRC_CONNECTED state on NR Cell 1?	-	-	1	P

8.1.5.6.4.3.3 Specific message contents

Table 8.1.5.6.4.3.3-1: SystemInformationBlockType2 for Cell 2 (all steps)

Derivation path: 38.508-1 [4] table 4.6.1-28			
Information Element	Value/Remark	Comment	Condition
SIB1 ::= SEQUENCE {			
ue-TimersAndConstants SEQUENCE {			
t310	ms2000		
}			
}			

8.1.5.6.5 NR CA / No Radio Link Failure on SCell / RRC Connection Continues on Pcell

8.1.5.6.5.1 NR CA / No Radio Link Failure on SCell / RRC Connection Continues on PCell / Intra-band Contiguous CA

8.1.5.6.5.1.1 Test Purpose (TP)

(1)

```

with { UE in NR RRC_CONNECTED, security activated and Scell configured }
ensure that {
  when { UE drops out out service on Scell }
  then { UE does not consider radio link failure to be detected and stay in NR RRC_CONNECTED state
}
}

```

8.1.5.6.5.1.2 Conformance requirements

References: The conformance requirements covered in the present TC are specified in: TS 38.331, clauses 5.3.5.5.6, 5.3.10.1 and 5.3.10.3.

[TS 38.331, clause 5.3.5.5.6]

The UE shall:

- 1> if the received *rlf-TimersAndConstants* is set to release:
 - 2> use values for timers T301, T310, T311 and constants N310, N311, as included in *ue-TimersAndConstants* received in *SystemInformationBlockType2*;
- 1> else:
 - 2> reconfigure the value of timers and constants in accordance with received *rlf-TimersAndConstants*;
 - 2> stop timer T310 for this cell group, if running;
 - 2> reset the counters N310 and N311.

[TS 38.331, clause 5.3.10.1]

The UE shall:

- 1> upon receiving N310 consecutive "out-of-sync" indications for the SpCell from lower layers while neither T300, T301, T304, T311 nor T319 is running:
 - 2> start timer T310 for the corresponding SpCell.

[TS 38.331, clause 5.3.10.3]

The UE shall:

- 1> upon T310 expiry in PCell; or
- 1> upon random access problem indication from MCG MAC while neither T300, T301, T304, T311 nor T319 are running; or
- 1> upon indication from MCG RLC that the maximum number of retransmissions has been reached:
 - 2> if the indication is from MCG RLC and CA duplication is configured and activated, and for the corresponding logical channel *allowedServingCells* only includes SCell(s):
 - 3> initiate the failure information procedure as specified in 5.7.5 to report RLC failure.
 - 2> else:
 - 3> consider radio link failure to be detected for the MCG i.e. RLF;

- 3> if AS security has not been activated:
 - 4> perform the actions upon going to RRC_IDLE as specified in 5.3.11, with release cause 'other';-
- 3> else if AS security has been activated but SRB2 and at least one DRB have not been setup:
 - 4> perform the actions upon going to RRC_IDLE as specified in 5.3.11, with release cause 'RRC connection failure';
- 3> else:
 - 4> initiate the connection re-establishment procedure as specified in 5.3.7.

The UE shall:

- 1> upon T310 expiry in PSCell; or
- 1> upon random access problem indication from SCG MAC; or
- 1> upon indication from SCG RLC that the maximum number of retransmissions has been reached:
 - 2> if the indication is from SCG RLC and CA duplication is configured and activated; and for the corresponding logical channel *allowedServingCells* only includes SCell(s):
 - 3> initiate the failure information procedure as specified in 5.7.5 to report RLC failure.
 - 2> else:
 - 3> consider radio link failure to be detected for the SCG, i.e. SCG RLF;
 - 3> initiate the SCG failure information procedure as specified in 5.7.3 to report SCG radio link failure.

8.1.5.6.5.1.3 Test description

8.1.5.6.5.1.3.1 Pre-test conditions

System Simulator:

- NR Cell 1, and NR Cell 3
- NR Cell 1 is PCell
- NR Cell 3 is SCell
- NR Cell 3 is an Inactive SCell according to TS 38.508-1 [4] clause 6.3.1
- System information combination NR-4 as defined in TS 38.508-1 [4] clause 4.4.3.1.2 is used in NR cells.

UE:

None.

Preamble:

- The UE is in 5GS state 3N-A according to TS 38.508-1 [4], clause 4.4A.2 Table 4.4A.2-3.

8.1.5.6.5.1.3.2 Test procedure sequence

Table 8.5.1.7.1.3.2-1 illustrates the downlink power levels and other changing parameters to be applied for the cells at various time instants of the test execution. Row marked "T0" denotes the initial conditions after preamble, while columns marked "T1" is to be applied subsequently. The exact instants on which these values shall be applied are described in the texts in this clause.

Table 8.1.5.6.5.1.3.2-1: Time instances of cell power level and parameter changes for FR1

	Parameter	Unit	NR Cell 1	NR Cell 3	Remark
T0	SS/PBCH SSS EPRE	dBm/SCS	-88	-88	NR Cell1 and NR Cell 3 are available
T1	SS/PBCH SSS EPRE	dBm/SCS	-88	"Off"	Only NR Cell 1 is available.

Table 8.1.5.6.5.1.3.2-1A: Time instances of cell power level and parameter changes for FR2

	Parameter	Unit	NR Cell 1	NR Cell 3	Remark
T0	SS/PBCH SSS EPRE	dBm/SCS	-95	-95	NR Cell1 and NR Cell 3 are available
T1	SS/PBCH SSS EPRE	dBm/SCS	-95	"Off"	Only NR Cell 1 is available.

Table 8.1.5.6.5.1.3.2-2: Main behaviour

St	Procedure	Message Sequence		TP	Verdict
		U - S	Message		
1	The SS transmits an <i>RRCReconfiguration</i> message on NR Cell 1 to configure Scell.	<--	<i>RRCReconfiguration</i>	-	-
2	The UE transmits an <i>RRCReconfigurationComplete</i> message on NR Cell 1.	-->	<i>RRCReconfigurationComplete</i>	-	-
3	Wait for 1s.	-	-	-	-
4	The SS changes power levels according to row "T1" in Table 8.1.5.6.5.1.3.2-1.	-	-	-	-
5	Wait for 1s.	-	-	-	-
6	Check: Does the UE transmit an <i>RRCReestablishmentRequest</i> message on NR Cell 1 with in next 2 seconds?	-->	<i>RRCReestablishmentRequest</i>	1	F
7	The SS sends <i>UECapabilityEnquiry</i> message to the UE.	<--	<i>UECapabilityEnquiry</i>	-	-
8	Check: Does the UE send a <i>UECapabilityInformation</i> message?	-->	<i>UECapabilityInformation</i>	1	P

8.1.5.6.5.1.3.3 Specific message contents

Table 8.1.5.6.5.1.3.3-1: RRCReconfiguration (step 1, Table 8.1.5.6.5.1.3.2-2)

Derivation Path: 38.508-1 [4] Table 4.6.1-13			
Information Element	Value/remark	Comment	Condition
RRCReconfiguration ::= SEQUENCE {			
criticalExtensions CHOICE {			
rrcReconfiguration SEQUENCE {			
nonCriticalExtension SEQUENCE{			
masterCellGroup	CellGroupConfig	SCell addition for NR Cell 3	
}			
}			
}			
}			

Table 8.1.5.6.5.1.3.3-2: CellGroupConfig (Table 8.1.5.6.5.1.3.2-1)

Derivation Path: 38.508-1 [4] Table 4.6.3-19 with condition SRB2_DRB1			
Information Element	Value/remark	Comment	Condition
CellGroupConfig ::= SEQUENCE {			
rlc-BearerToAddModList	Not present		
sCellToAddModList SEQUENCE (SIZE (1..maxNrofSCells)) OF SEQUENCE {	1 entry		
sCellIndex	1		
sCellConfigCommon	ServingCellConfigCommon		
sCellConfigDedicated	ServingCellConfig		
}			
}			

Table 8.1.5.6.5.1.3.3-3: ServingCellConfigCommon (Table 8.1.5.6.5.1.3.2-1)

Derivation Path: 38.508-1 [4] Table 4.6.3-168			
Information Element	Value/remark	Comment	Condition
ServingCellConfigCommon ::= SEQUENCE {			
physCellId	Physical layer cell identity of NR Cell 3		
}			

8.1.5.6.5.2 NR CA / No Radio Link Failure on SCell / RRC Connection Continues on PCell / Inter-band CA

8.1.5.6.5.2.1 Test Purpose (TP)

Same as TC 8.1.5.6.1 but applied to Inter-band CA Test Case

8.1.5.6.5.2.2 Conformance Requirements

Same as TC 8.1.5.6.1 but applied to Inter-band CA Test Case

8.1.5.6.5.2.3 Test Description

8.1.5.6.5.2.3.1 Pre-test conditions

Same as TC 8.1.5.6.5.1 but with the following differences:

-CA configuration: Inter-band CA replaces Intra-band Contiguous CA

-Cells configuration: Cell 10 replaces Cell 3

-Cell 10 is an Inactive SCell according to TS 38.508-1 [4] clause 6.3.1

8.1.5.6.5.2.3.2 Test procedure sequence

Same as TC 8.1.5.6.1 with the following differences:

-CA configuration: Inter-band CA replaces Intra-band Contiguous CA

-Cells configuration: Cell 10 replaces Cell 3

8.1.5.6.5.2.3.3 Specific message contents

Same as TC 8.1.5.6.1 but applied to Inter-band CA Test Case

8.2 MR-DC RRC

Editor's note: Editorial updates to test purposes and Preamble of all RRC test cases shall be updated to reflect as per generic procedure parameter for Bearers in TS 38.508-1 Table 4.5.1-1 for handling multi-PDN scenarios.

8.2.1 UE Capability

8.2.1.1 UE capability transfer / Success

8.2.1.1.1 UE capability transfer / Success / EN-DC

8.2.1.1.1.1 Test Purpose (TP)

(1)

```
with { UE in RRC_CONNECTED state with EN-DC, and, MCG(s) (E-UTRA PDCP) only }
ensure that {
  when { UE receives an UECapabilityEnquiry message that includes eutra }
  then { UE transmits an UECapabilityInformation message including UE radio access capability
information corresponding to the ue-CapabilityRequest variable }
}
```

(2)

```
with { UE in RRC_CONNECTED state with EN-DC, and, MCG(s) (E-UTRA PDCP) only }
ensure that {
  when { UE receives an UECapabilityEnquiry message that includes eutra-nr and nr }
  then { UE transmits an UECapabilityInformation message including UE radio access capability
information corresponding to the ue-CapabilityRequest variable }
}
```

8.2.1.1.1.2 Conformance requirements

References: The conformance requirements covered in the present TC are specified in: TS 36.331, clause 5.6.3.3. Unless otherwise stated these are Rel-15 requirements.

[TS 36.331, clause 5.6.3.3]

The UE shall:

- 1> for NB-IoT, set the contents of *UECapabilityInformation* message as follows:
 - 2> include the UE Radio Access Capability Parameters within the *ue-Capability-Container*;
 - 2> include *ue-RadioPagingInfo*;
 - 2> submit the *UECapabilityInformation* message to lower layers for transmission, upon which the procedure ends;
- 1> else, set the contents of *UECapabilityInformation* message as follows:

- 2> if the *ue-CapabilityRequest* includes *eutra*:
- 3> include the *UE-EUTRA-Capability* within a *ue-CapabilityRAT-Container* and with the *rat-Type* set to *eutra*;
- 3> if the UE supports FDD and TDD:
- 4> set all fields of *UECapabilityInformation*, except field *fdd-Add-UE-EUTRA-Capabilities* and *tdd-Add-UE-EUTRA-Capabilities* (including their sub-fields), to include the values applicable for both FDD and TDD (i.e. functionality supported by both modes);
- 4> if (some of) the UE capability fields have a different value for FDD and TDD:
- 5> if for FDD, the UE supports additional functionality compared to what is indicated by the previous fields of *UECapabilityInformation*:
- 6> include field *fdd-Add-UE-EUTRA-Capabilities* and set it to include fields reflecting the additional functionality applicable for FDD;
- 5> if for TDD, the UE supports additional functionality compared to what is indicated by the previous fields of *UECapabilityInformation*:
- 6> include field *tdd-Add-UE-EUTRA-Capabilities* and set it to include fields reflecting the additional functionality applicable for TDD;

NOTE 1: The UE includes fields of *XDD-Add-UE-EUTRA-Capabilities* in accordance with the following:

- The field is included only if one or more of its sub-fields (or bits in the feature group indicators string) has a value that is different compared to the value signalled elsewhere within *UE-EUTRA-Capability*;
(this value signalled elsewhere is also referred to as the *Common value* that is supported for both XDD modes)
 - For the fields that are included in *XDD-Add-UE-EUTRA-Capabilities*, the UE sets:
 - the sub-fields (or bits in the feature group indicators string) that are not allowed to be different to the same value as the *Common value*;
 - the sub-fields (or bits in the feature group indicators string) that are allowed to be different to a value indicating at least the same functionality as indicated by the *Common value*;
- 3> else (UE supports single xDD mode):
- 4> set all fields of *UECapabilityInformation*, except field *fdd-Add-UE-EUTRA-Capabilities* and *tdd-Add-UE-EUTRA-Capabilities* (including their sub-fields), to include the values applicable for the xDD mode supported by the UE;
- 3> compile a list of band combinations, candidate for inclusion in the *UECapabilityInformation* message, comprising of band combinations supported by the UE according to the following priority order (i.e. listed in order of decreasing priority):
- 4> include all non-CA bands, regardless of whether UE supports carrier aggregation, only:
- if the UE includes *ue-Category-v1020* (i.e. indicating category 6 to 8); or
 - if for at least one of the non-CA bands, the UE supports more MIMO layers with TM9 and TM10 than implied by the UE category; or
 - if the UE supports TM10 with one or more CSI processes;
 - if the UE supports 1024QAM in DL;
- 4> if the *UECapabilityEnquiry* message includes *requestedFrequencyBands* and UE supports *requestedFrequencyBands*:
- 5> include all 2DL+1UL CA band combinations, only consisting of bands included in *requestedFrequencyBands*;

- 5> include all other CA band combinations, only consisting of bands included in *requestedFrequencyBands*, and prioritized in the order of *requestedFrequencyBands*, (i.e. first include remaining band combinations containing the first-listed band, then include remaining band combinations containing the second-listed band, and so on);
- 4> else (no requested frequency bands):
 - 5> include all 2DL+1UL CA band combinations;
 - 5> include all other CA band combinations;
- 4> if UE supports *maximumCCsRetrieval* and if the *UECapabilityEnquiry* message includes the *requestedMaxCCsDL* and the *requestedMaxCCsUL* (i.e. both UL and DL maximums are given):
 - 5> remove from the list of candidates the band combinations for which the number of CCs in DL exceeds the value indicated in the *requestedMaxCCsDL* or for which the number of CCs in UL exceeds the value indicated in the *requestedMaxCCsUL*;
 - 5> indicate in *requestedCCsUL* the same value as received in *requestedMaxCCsUL*;
 - 5> indicate in *requestedCCsDL* the same value as received in *requestedMaxCCsDL*;
- 4> else if UE supports *maximumCCsRetrieval* and if the *UECapabilityEnquiry* message includes the *requestedMaxCCsDL* (i.e. only DL maximum limit is given):
 - 5> remove from the list of candidates the band combinations for which the number of CCs in DL exceeds the value indicated in the *requestedMaxCCsDL*;
 - 5> indicate value in *requestedCCsDL* the same value as received in *requestedMaxCCsDL*;
- 4> else if UE supports *maximumCCsRetrieval* and if the *UECapabilityEnquiry* message includes the *requestedMaxCCsUL* (i.e. only UL maximum limit is given):
 - 5> remove from the list of candidates the band combinations for which the number of CCs in UL exceeds the value indicated in the *requestedMaxCCsUL*;
 - 5> indicate in *requestedCCsUL* the same value as received in *requestedMaxCCsUL*;
- 4> if the UE supports *reducedIntNonContComb* and the *UECapabilityEnquiry* message includes *requestReducedIntNonContComb*:
 - 5> set *reducedIntNonContCombRequested* to true;
 - 5> remove from the list of candidates the intra-band non-contiguous CA band combinations which support is implied by another intra-band non-contiguous CA band combination included in the list of candidates as specified in TS 36.306 [5, 4.3.5.21];
- 4> if the UE supports *requestReducedFormat* and UE supports *skipFallbackCombinations* and *UECapabilityEnquiry* message includes *requestSkipFallbackComb*:
 - 5> set *skipFallbackCombRequested* to true;
 - 5> for each band combination included in the list of candidates (including 2DL+1UL CA band combinations), starting with the ones with the lowest number of DL and UL carriers, that concerns a fallback band combination of another band combination included in the list of candidates as specified in TS 36.306 [5]:
 - 6> remove the band combination from the list of candidates;
 - 6> include *differentFallbackSupported* in the band combination included in the list of candidates whose fallback concerns the removed band combination, if its capabilities differ from the removed band combination;
- 4> if the UE supports *requestReducedFormat* and *diffFallbackCombReport*, and *UECapabilityEnquiry* message includes *requestDiffFallbackCombList*:

- 5> if the UE does not support *skipFallbackCombinations* or *UECapabilityEnquiry* message does not include *requestSkipFallbackComb*:
 - 6> remove all band combination from the list of candidates;
- 5> for each CA band combination indicated in *requestDiffFallbackCombList*:
 - 6> include the CA band combination, if not already in the list of candidates;
 - 6> include the fallback combinations for which the supported UE capabilities are different from the capability of the CA band combination;
- 5> include CA band combinations indicated in *requestDiffFallbackCombList* into *requestedDiffFallbackCombList*;
- 3> if the *UECapabilityEnquiry* message includes *requestReducedFormat* and UE supports *requestReducedFormat*:
 - 4> include in *supportedBandCombinationReduced* as many as possible of the band combinations included in the list of candidates, including the non-CA combinations, determined according to the rules and priority order defined above;
- 3> else
 - 4> if the *UECapabilityEnquiry* message includes *requestedFrequencyBands* and UE supports *requestedFrequencyBands*:
 - 5> include in *supportedBandCombination* as many as possible of the band combinations included in the list of candidates, including the non-CA combinations and up to 5DL+5UL CA band combinations, determined according to the rules and priority order defined above;
 - 5> include in *supportedBandCombinationAdd* as many as possible of the remaining band combinations included in the list of candidates, (i.e. the candidates not included in *supportedBandCombination*), up to 5DL+5UL CA band combinations, determined according to the rules and priority order defined above;
 - 4> else
 - 5> include in *supportedBandCombination* as many as possible of the band combinations included in the list of candidates, including the non-CA combinations and up to 5DL+5UL CA band combinations, determined according to the rules defined above;
 - 5> if it is not possible to include in *supportedBandCombination* all the band combinations to be included according to the above, selection of the subset of band combinations to be included is left up to UE implementation;
- 3> indicate in *requestedBands* the same bands and in the same order as included in *requestedFrequencyBands*, if received;
- 3> if the UE is a category 0, M1 or M2 UE, or supports any UE capability information in *ue-RadioPagingInfo*, according to TS 36.306 [5]:
 - 4> include *ue-RadioPagingInfo* and set the fields according to TS 36.306 [5];
- 3> if the UE supports EN-DC and if *requestedFreqBandsNR-MRDC* is included in the request:
 - 4> include into *featureSetsEUTRA* the feature sets that are applicable for the received *requestedFreqBandsNR-MRDC* as specified in TS 38.331 [82], clause 5.6.1.4.

NOTE: Even if the network requests (only) capabilities for *eutra*, it may include NR band numbers in the *requestedFreqBandsNR-MRDC* in order to ensure that the UE includes all necessary feature sets (i.e. E-UTRA and NR) needed for subsequently requested *eutra-nr* capabilities.

- 3> if the *UECapabilityEnquiry* message includes *request-sTTI-sPT-Capability* and if the UE supports short TTI and/or SPT:

- 4> for each band combination the UE included in a field of the *UECapabilityInformation* message in accordance with the previous:
- 4> if the UE supports short TTI, include the short TTI capabilities for each of the band combinations using the *STTI-SPT-BandCombinationParameters*;
- 4> if the UE supports SPT, include the SPT capabilities for each of the band combinations using the *STTI-SPT-BandCombinationParameters*;

NOTE: The UE may have to add/repeat the band combinations to the list of band combinations included earlier, to include short TTI capabilities and/or SPT capabilities.

- 2> if the UE supports short TTI and/or SPT:
 - 3> include in the UE radio access capabilities the IE *sTTI-SPT-Supported* and set to *supported*;
- 2> if the *ue-CapabilityRequest* includes *geran-cs* and if the UE supports GERAN CS domain:
 - 3> include the UE radio access capabilities for GERAN CS within a *ue-CapabilityRAT-Container* and with the *rat-Type* set to *geran-cs*;
- 2> if the *ue-CapabilityRequest* includes *geran-ps* and if the UE supports GERAN PS domain:
 - 3> include the UE radio access capabilities for GERAN PS within a *ue-CapabilityRAT-Container* and with the *rat-Type* set to *geran-ps*;
- 2> if the *ue-CapabilityRequest* includes *utra* and if the UE supports UTRA:
 - 3> include the UE radio access capabilities for UTRA within a *ue-CapabilityRAT-Container* and with the *rat-Type* set to *utra*;
- 2> if the *ue-CapabilityRequest* includes *cdma2000-1XRTT* and if the UE supports CDMA2000 1xRTT:
 - 3> include the UE radio access capabilities for CDMA2000 within a *ue-CapabilityRAT-Container* and with the *rat-Type* set to *cdma2000-1XRTT*;
- 2> if the *ue-CapabilityRequest* includes *nr* and if the UE supports NR:
 - 3> include the UE radio access capabilities for NR within a *ue-CapabilityRAT-Container*, with the *rat-Type* set to *nr*;
 - 3> include band combinations and feature sets as specified in TS 38.331 [82], clause 5.6.1.4, considering the *FreqBandList* included in *requestedFreqBandsNR-MRDC* and the *utra-nr-only* flag (if present);
- 2> if the *ue-CapabilityRequest* includes *utra-nr* and if the UE supports EN-DC:
 - 3> include the UE radio access capabilities for EUTRA-NR within a *ue-CapabilityRAT-Container*, with the *rat-Type* set to *utra-nr*
 - 3> include band combinations and feature sets as specified in TS 38.331 [82], clause 5.6.1.4, considering the *FreqBandList* included in *requestedFreqBandsNR-MRDC*;
- 1> submit the *UECapabilityInformation* message to lower layers for transmission, upon which the procedure ends;

8.2.1.1.1.3 Test description

8.2.1.1.1.3.1 Pre-test conditions

System Simulator:

- EUTRA Cell 1 is the PCell and NR Cell 1 is the PS Cell.

UE:

- None

Preamble:

- The UE is in state RRC_CONNECTED in EN-DC mode according to TS 38.508-1 [4] clause 4.5.4.2 with MCG(s) and SCG.

8.2.1.1.1.3.2 Test procedure sequence

Table 8.2.1.1.1.3.2-1: Main behaviour

St	Procedure	Message Sequence		TP	Verdict
		U - S	Message		
1	The SS transmits a <i>UECapabilityEnquiry</i> message including eutra.	<--	<i>UECapabilityEnquiry</i>	-	-
2	Check: Does the UE transmit a <i>UECapabilityInformation</i> message including UE radio access capability information as per the ue-CapabilityRequest variable?	-->	<i>UECapabilityInformation</i>	1	P
3	The SS transmits a <i>UECapabilityEnquiry</i> message including eutra-nr and nr.	<--	<i>UECapabilityEnquiry</i>	-	-
4	Check: Does the UE transmit a <i>UECapabilityInformation</i> message including UE radio access capability information as per the ue-CapabilityRequest variable?	-->	<i>UECapabilityInformation</i>	2	P

8.2.1.1.1.3.3 Specific message contents

Table 8.2.1.1.1.3.3-1: UECapabilityEnquiry (step 1, Table 8.2.1.1.1.3.2-1)

Derivation Path: 36.508 [7], Table 4.6.1-22			
Information Element	Value/remark	Comment	Condition
UECapabilityEnquiry ::= SEQUENCE {			
criticalExtensions CHOICE {			
c1 CHOICE{			
ueCapabilityEnquiry-r8 SEQUENCE {			
ue-CapabilityRequest SEQUENCE (SIZE			
(1..maxRAT-Capabilities)) OF RAT TYPE {			
RAT-Type [1]	eutra		
}			
nonCriticalExtension SEQUENCE {			
lateNonCriticalExtension	Not present		
nonCriticalExtension SEQUENCE {			
requestedFrequencyBands-r11 SEQUENCE {}	Not present		
nonCriticalExtension SEQUENCE {			
requestReducedFormat-r13	Not present		
requestSkipFallbackComb-r13	Not present		
requestedMaxCCsDL-r13	Not present		
requestedMaxCCsUL-r13	Not present		
requestReducedIntNonContComb-r13	Not present		
nonCriticalExtension SEQUENCE {			
requestDiffFallbackCombList-r14	Not present		
nonCriticalExtension SEQUENCE {			
requestedFreqBandsNR-MRDC-r15	Not present		
nonCriticalExtension SEQUENCE {	Not present		
requestSTTI-SPT-Capability-r15	true		
eutra-nr-only-r15	true		
nonCriticalExtension	Not present		
}			
}			
}			
}			
criticalExtensionsFuture SEQUENCE {}			
}			
}			

Table 8.2.1.1.1.3.3-2: UECapabilityInformation (step 2, Table 8.2.1.1.1.3.2-1)

Derivation Path: 36.508 [7], Table 4.6.1-23			
Information Element	Value/remark	Comment	Condition
UECapabilityInformation ::= SEQUENCE {			
criticalExtensions CHOICE {			
c1 CHOICE{			
ueCapabilityInformation-r8 SEQUENCE {			
ue-CapabilityRAT-ContainerList SEQUENCE			
(SIZE (1..maxRAT-Capabilities)) OF SEQUENCE {			
rat-Type[1]	eutra		pc_EUTRA
ueCapabilityRAT-Container [1] OCTET	UE-EUTRA-Capability	Encoded as per	pc_EUTRA
STRING {}		TS 36.331 [11]	
}		clause 6.3.6	
}			
nonCriticalExtension SEQUENCE {}	Not present		
}			
}			
}			
}			

Table 8.2.1.1.1.3.3-3: *UE-EUTRA-Capability* (Table 8.2.1.1.1.3.3-2)

sl-Parameters-v1530	Not checked		
extendedNumberOfDRBs-r15	Not checked		
reducedCP-Latency-r15	Not checked		
laa-Parameters-v1530	Not checked		
ue-CategoryUL-v1530	Not checked		
fdd-Add-UE-EUTRA-Capabilities-v1530 SEQUENCE {		Checked if any of the sub-IEs is present	
neighCellSI-AcquisitionParameters-v1530	Not checked		
reducedCP-Latency-r15	Not checked		
}			
tdd-Add-UE-EUTRA-Capabilities-v1530 SEQUENCE {		Checked if any of the sub-IEs is present	
neighCellSI-AcquisitionParameters-v1530	Not checked		
reducedCP-Latency-r15	Not checked		
}			
nonCriticalExtension SEQUENCE {		Checked if any of the sub-IEs is present	
phyLayerParameters-v1540	Not checked		
otherParameters-v1540	Not checked		
fdd-Add-UE-EUTRA-Capabilities-v1540 SEQUENCE {		Checked if any of the sub-IEs is present	
eutra-5GC-Parameters-r15	EUTRA-5GC-Parameters-r15		
irat-ParametersNR-v1540	IRAT-ParameterNR-v1540		
}			
tdd-Add-UE-EUTRA-Capabilities-v1540 SEQUENCE {		Checked if any of the sub-IEs is present	
eutra-5GC-Parameters-r15	EUTRA-5GC-Parameters-r15		
irat-ParametersNR-v1540	IRAT-ParameterNR-v1540		
}			
sl-ParametersNR-v1540	Not checked		
irat-ParametersNR-v1540	IRAT-ParameterNR-v1540		
nonCriticalExtension SEQUENCE {	Not checked		
}			
}			
}			
}			
}			
}			
}			
}			
}			
}			
}			
}			
}			
}			
}			
}			
}			

Table 8.2.1.1.1.3.3-3A: IRAT-ParameterNR-r15 (Table 8.2.1.1.1.3.3-3)

Derivation Path: 36.331 [11], clause 6.3.6			
Information Element	Value/remark	Comment	Condition
IRAT-ParameterNR-r15 SEQUENCE {			
en-DC-r15	Not checked		
eventB2-r15	Not checked		
supportedBandListEN-DC-r15	SupportedBandListNR-r15		
}			

Table 8.2.1.1.1.3.3-3B: PDCP-ParameterNR-r15 (Table 8.2.1.1.1.3.3-3)

Derivation Path: 36.331 [11], clause 6.3.6			
Information Element	Value/remark	Comment	Condition
PDCP-ParameterNR-r15	Not checked		

Table 8.2.1.1.1.3.3-3C: EUTRA-5GC-Parameters-r15 (Table 8.2.1.1.1.3.3-3)

Derivation Path: 36.331 [11], clause 6.3.6			
Information Element	Value/remark	Comment	Condition
EUTRA-5GC-Parameters-r15 SEQUENCE {			
eutra-5GC-r15	Not checked		
eutra-EPC-HO-EUTRA-5GC-r15	Not checked		
ho-EUTRA-5GC-FDD-TDD-r15	Not checked		
ho-InterfreqEUTRA-5GC-r15	Not checked		
ims-VoiceOverMCG-BearerEUTRA-5GC-r15	Not checked		
inactiveState-r15	Not checked		
reflectiveQoS-r15	Not checked		
}			

Table 8.2.1.1.1.3.3-3D: IRAT-ParameterNR-v1540 (Table 8.2.1.1.1.3.3-3)

Derivation Path: 36.331 [11], clause 6.3.6			
Information Element	Value/remark	Comment	Condition
IRAT-ParametersNR-v1540 SEQUENCE {			
eutra-5GC-HO-ToNR-FDD-FR1-r15	Not checked		
eutra-5GC-HO-ToNR-TDD-FR1-r15	Not checked		
eutra-5GC-HO-ToNR-FDD-FR2-r15	Not checked		
eutra-5GC-HO-ToNR-TDD-FR2-r15	Not checked		
eutra-EPC-HO-ToNR-FDD-FR1-r15	Not checked		
eutra-EPC-HO-ToNR-TDD-FR1-r15	Not checked		
eutra-EPC-HO-ToNR-FDD-FR2-r15	Not checked		
eutra-EPC-HO-ToNR-TDD-FR2-r15	Not checked		
ims-VoiceOverNR-FR1-r15	Not checked		
ims-VoiceOverNR-FR2-r15	Not checked		
sa-NR-r15	Not checked		
supportedBandListNR-SA-r15	SupportedBandListNR-r15		
}			

Table 8.2.1.1.1.3.3-3E: SupportedBandListNR-r15 (Table 8.2.1.1.1.3.3-3A and Table 8.2.1.1.1.3.3-3D)

Derivation Path: 36.331 [11], clause 6.3.6			
Information Element	Value/remark	Comment	Condition
SupportedBandListNR-r15 SEQUENCE (SIZE (1..maxBandsNR-r15)) OF SEQUENCE {			
bandNR-r15[i]	Not checked		
}			

Table 8.2.1.1.1.3.3-4: UECapabilityEnquiry (step 3, Table 8.2.1.1.1.3.2-1)

Derivation Path: 36.508 [7], Table 4.6.1-22			
Information Element	Value/remark	Comment	Condition
UECapabilityEnquiry ::= SEQUENCE {			
criticalExtensions CHOICE {			
c1 CHOICE{			
ueCapabilityEnquiry-r8 SEQUENCE {			
ue-CapabilityRequest SEQUENCE (SIZE (1..maxRAT-Capabilities)) OF RAT TYPE {			
RAT-Type [1]	nr		
RAT-Type [2]	eutra-nr		
}			
nonCriticalExtension SEQUENCE {			
nonCriticalExtension SEQUENCE {			
nonCriticalExtension SEQUENCE {			
nonCriticalExtension SEQUENCE {			
nonCriticalExtension SEQUENCE {			
requestedFreqBandsNR-MRDC-r15	OCTET STRING including the FreqBandList IE according to TS 38.508-1 [4] table [4.6.4-21]		
}			
}			
}			
}			
}			

Table 8.2.1.1.1.3.3-5: UECapabilityInformation (step 4, Table 8.2.1.1.1.3.2-1)

Derivation Path: 36.508 [7], Table 4.6.1-23			
Information Element	Value/remark	Comment	Condition
UECapabilityInformation ::= SEQUENCE {			
criticalExtensions CHOICE {			
c1 CHOICE{			
ueCapabilityInformation-r8 SEQUENCE {			
ue-CapabilityRAT-ContainerList SEQUENCE (SIZE (1..maxRAT-Capabilities)) OF SEQUENCE {			
rat-Type[1]	nr		pc_NR_FDD or pc_NR_TDD
ueCapabilityRAT-Container [1] OCTET STRING {}	UE-NR-Capability	Encoded as per TS 38.331 [12] clause 5.6.1	pc_NR_FDD or pc_NR_TDD
rat-Type[2]	eutra-nr		pc_EN_DC
ueCapabilityRAT-Container [2] OCTET STRING {}	UE-MRDC-Capability	Encoded as per TS 38.331 [12] clause 5.6.1	pc_EN_DC
}			
nonCriticalExtension SEQUENCE {}	Not present		
}			
}			
}			

Table 8.2.1.1.1.3.3-6: *UE-NR-Capability* (Table 8.2.1.1.1.3.3-5)

Derivation Path: 38.331 [12], clause 6.3.3			
Information Element	Value/remark	Comment	Condition
UE-NR-Capability ::= SEQUENCE {			
accessStratumRelease	Checked	"rel-15" or higher	
pdcP-Parameters SEQUENCE {			
supportedROHC-Profiles SEQUENCE {			
profile0x0000	Not checked		
profile0x0001	Not checked		
profile0x0002	Not checked		
profile0x0003	Not checked		
profile0x0004	Not checked		
profile0x0006	Not checked		
profile0x0101	Not checked		
profile0x0102	Not checked		
profile0x0103	Not checked		
profile0x0104	Not checked		
}			
maxNumberROHC-ContextSessions	Not checked		
uplinkOnlyROHC-Profiles	Not checked		
continueROHC-Context	Not checked		
outOfOrderDelivery	Not checked		
shorts	Checked		pc_shortSN
pdcP-DuplicationSRB	Not checked		
pdcP-DuplicationMCG-OrSCG-DRB	Not checked		
}			
rlc-Parameters SEQUENCE {			
am-WithShortSN	Checked		pc_am_WithShortSN
um-WithShortSN	Checked		pc_um_WithShortSN
um-WithLongSN	Checked		pc_um_WithLongSN
}			
mac-Parameters SEQUENCE {			
mac-ParametersCommon SEQUENCE {			
lcp-Restriction	Not checked		
dummy	Not checked		
lch-ToSCellRestriction	Not checked		
recommendedBitRate	Not checked		
recommendedBitRateQuery	Not checked		
}			
mac-ParametersXDD-Diff SEQUENCE {			
skipUplinkTxDynamic	Checked		pc_skipUplinkTxDynamic
logicalChannelSR-DelayTimer	Not checked		
longDRX-Cycle	Checked		pc_longDRX_Cycle
shortDRX-Cycle	Checked		pc_shortDRX_Cycle
multipleSR-Configurations	Not checked		
multipleConfiguredGrants	Not checked		
}			
}			
phy-Parameters SEQUENCE {			
phy-ParametersCommon SEQUENCE {			
csi-RS-CFRA-ForHO	Checked		pc_csi_RS_CFRA_ForHO
dynamicPRB-BundlingDL	Not checked		
sp-CSI-ReportPUCCH	Not checked		
sp-CSI-ReportPUSCH	Not checked		
nzp-CSI-RS-IntefMgmt	Not checked		
type2-SP-CSI-Feedback-LongPUCCH	Not checked		
precoderGranularityCORESET	Not checked		
dynamicHARQ-ACK-Codebook	Not checked		
semiStaticHARQ-ACK-Codebook	Not checked		

spatialBundlingHARQ-ACK	Not checked		
dynamicBetaOffsetInd-HARQ-ACK-CSI	Not checked		
pucch-Repetition-F1-3-4	Not checked		
ra-Type0-PUSCH	Checked		pc_ra_Type0_PUSCH
dynamicSwitchRA-Type0-1-PDSCH	Not checked		
dynamicSwitchRA-Type0-1-PUSCH	Not checked		
pdsch-MappingTypeA	Checked		pc_pdsch_MappingTypeA
pdsch-MappingTypeB	Checked		pc_pdsch_MappingTypeB
interleavingVRB-ToPRB-PDSCH	Checked		pc_interleavingVRB_ToPRB_PDSCH
interSlotFreqHopping-PUSCH	Not checked		
type1-PUSCH-RepetitionMultiSlots	Not checked		
type2-PUSCH-RepetitionMultiSlots	Not checked		
pusch-RepetitionMultiSlots	Not checked		
pdsch-RepetitionMultiSlots	Checked		pc_pdsch_RepetitionMultiSlots
downlinkSPS	Checked		pc_downlinkSPS
configuredUL-GrantType1	Checked		pc_configuredUL_GrantType1
configuredUL-GrantType2	Checked		pc_configuredUL_GrantType2
pre-EmptIndication-DL	Not checked		
cbg-TransIndication-DL	Not checked		
cbg-TransIndication-UL	Not checked		
cbg-FlushIndication-DL	Not checked		
dynamicHARQ-ACK-CodeB-CBG-Retx-DL	Not checked		
rateMatchingResrcSetSemi-Static	Not checked		
rateMatchingResrcSetDynamic	Not checked		
bwp-SwitchingDelay	Not checked		
dummy	Not checked		
maxNumberSearchSpaces	Checked		pc_maxNumberSearchSpaces
rateMatchingCtrlResrsSetDynamic	Not checked		
maxLayersMIMO-Indication	Not checked		
}			
phy-ParametersXDD-Diff SEQUENCE {			
dynamicSFI	Not checked		
twoPUCCH-F0-2-ConsecSymbols	Not checked		
twoDifferentTPC-Loop-PUSCH	Not checked		
twoDifferentTPC-Loop-PUCCH	Not checked		
dl-SchedulingOffset-PDSCH-TypeA	Not checked		
dl-SchedulingOffset-PDSCH-TypeB	Not checked		
ul-SchedulingOffset	Not checked		
}			
phy-ParametersFRX-Diff SEQUENCE {			
dynamicSFI	Not checked		
dummy1	Not checked		
twoFL-DMRS	Not checked		
dummy2	Not checked		
dummy3	Not checked		
supportedDMRS-TypeDL	Not checked		
supportedDMRS-TypeUL	Not checked		
semiOpenLoopCSI	Not checked		
csi-ReportWithoutPMI	Not checked		
csi-ReportWithoutCQI	Not checked		

onePortsPTRS	Not checked		
twoPUCCH-F0-2-ConsecSymbols	Not checked		
pucch-F2-WithFH	Not checked		
pucch-F3-WithFH	Not checked		
pucch-F4-WithFH	Not checked		
freqHoppingPUCCH-F0-2	Not checked		
freqHoppingPUCCH-F1-3-4	Not checked		
mux-SR-HARQ-ACK-CSI-PUCCH-MultiPerSlot	Not checked		
uci-CodeBlockSegmentation	Not checked		
onePUCCH-LongAndShortFormat	Not checked		
twoPUCCH-AnyOthersInSlot	Not checked		
intraSlotFreqHopping-PUSCH	Not checked		
pusch-LBRM	Not checked		
pdccch-BlindDetectionCA	Not checked		
tpc-PUSCH-RNTI	Not checked		
tpc-PUCCH-RNTI	Not checked		
tpc-SRS-RNTI	Not checked		
absoluteTPC-Command	Not checked		
twoDifferentTPC-Loop-PUSCH	Not checked		
twoDifferentTPC-Loop-PUCCH	Not checked		
pusch-HalfPi-BPSK	Not checked		
pucch-F3-4-HalfPi-BPSK	Not checked		
almostContiguousCP-OFDM-UL	Not checked		
sp-CSI-RS	Not checked		
sp-CSI-IM	Not checked		
tdd-MultiDL-UL-SwitchPerSlot	Not checked		
multipleCORESET	Not checked		
csi-RS-IM-ReceptionForFeedback	Not checked	CSI-RS-IM-ReceptionForFeedback	
csi-RS-ProcFrameworkForSRS	Not checked	CSI-RS-ProcFrameworkForSRS	
csi-ReportFramework	Not checked	CSI-ReportFramework	
mux-SR-HARQ-ACK-CSI-PUCCH-OncePerSlot			
SEQUENCE {			
sameSymbol	Not checked		
diffSymbol	Not checked		
}			
mux-SR-HARQ-ACK-PUCCH	Not checked		
mux-MultipleGroupCtrlCH-Overlap	Not checked		
dl-SchedulingOffset-PDSCH-TypeA	Not checked		
dl-SchedulingOffset-PDSCH-TypeB	Not checked		
ul-SchedulingOffset	Not checked		
dl-64QAM-MCS-TableAlt	Not checked		
ul-64QAM-MCS-TableAlt	Not checked		
cqi-TableAlt	Not checked		
oneFL-DMRS-TwoAdditionalDMRS-UL	Not checked		
twoFL-DMRS-TwoAdditionalDMRS-UL	Not checked		
oneFL-DMRS-ThreeAdditionalDMRS-UL	Not checked		
}			
phy-ParametersFR1 SEQUENCE {			
pdccchMonitoringSingleOccasion	Not checked		
scs-60kHz	Not checked		
pdsch-256QAM-FR1	Checked		pc_pdsch_256QAM_FR1
pdsch-RE-MappingFR1-PerSymbol	Not checked		
pdsch-RE-MappingFR1-PerSlot	Not checked		
}			
phy-ParametersFR2 SEQUENCE {			
dummy	Not checked		
pdsch-RE-MappingFR2-PerSymbol	Not checked		
pCell-FR2	Not checked		
pdsch-RE-MappingFR2-PerSlot	Not checked		
}			

}			
rf-Parameters SEQUENCE {			
supportedBandListNR SEQUENCE (SIZE (1..maxBands)) OF SEQUENCE {			
bandNR[i]	Checked	Checked for 'maxBands' entries of FreqBandIndicator NR[i]	pc_nrBandx ('x' being the band number/type related PICS listed in TS 38.508-2)
modifiedMPR-Behaviour[i]	Not checked		
mimo-ParametersPerBand[i]	Not checked	MIMO-ParametersPerBand[i]	
extendedCP[i]	Not checked		
multipleTCI[i]	Not checked		
bwp-WithoutRestriction[i]	Not checked		
bwp-SameNumerology[i]	Not checked		
bwp-DiffNumerology[i]	Not checked		
crossCarrierScheduling-SameSCS[i]	Not checked		
pdsch-256QAM-FR2[i]	Checked		pc_pdsch_256QAM_FR2
pusch-256QAM[i]	Checked		pc_pusch_256QAM_FR1
ue-PowerClass[i]	Not checked		
rateMatchingLTE-CRS[i]	Not checked		
channelBWs-DL-v1530[i] CHOICE {			
fr1 SEQUENCE {			
scs-15kHz	Not checked		
scs-30kHz	Not checked		
scs-60kHz	Not checked		
}			
fr2 SEQUENCE {			
scs-60kHz	Not checked		
scs-120kHz	Not checked		
}			
}			
channelBWs-UL-v1530[i] CHOICE {			
fr1 SEQUENCE {			
scs-15kHz	Not checked		
scs-30kHz	Not checked		
scs-60kHz	Not checked		
}			
fr2 SEQUENCE {			
scs-60kHz	Not checked		
scs-120kHz	Not checked		
}			
maxUplinkDutyCycle-PC2-FR1[i]	Not checked		
pucch-SpatialRelInfoMAC-CE[i]	Not checked		
powerBoosting-pi2BPSK[i]	Not checked		
}			
supportedBandCombinationList SEQUENCE (SIZE (1..maxBandComb)) OF SEQUENCE {			
bandList[i] SEQUENCE (SIZE (1..maxSimultaneousBands)) OF CHOICE {			
eutra SEQUENCE {			
bandEUTRA	Not checked	FreqBandIndicator EUTRA	
ca-BandwidthClassDL-EUTRA	Not checked	CA-BandwidthClassEUTRA	
ca-BandwidthClassUL-EUTRA	Not checked	CA-BandwidthClassEUTRA	
}			

}			
nr SEQUENCE {			
bandNR	Not checked	FreqBandIndicatorNR	
ca-BandwidthClassDL-NR	Not checked	CA-BandwidthClassNR	
ca-BandwidthClassUL-NR	Not checked	CA-BandwidthClassNR	
}			
featureSetCombination[i]	Not checked	FeatureSetCombinationId	
ca-ParametersEUTRA[i]	Not checked	CA-ParametersEUTRA	
ca-ParametersNR[i]	Not checked	CA-ParametersNR	
mrdc-Parameters[i]	Not checked	MRDC-Parameters	
supportedBandwidthCombinationSet[i]	Not checked		
powerClass-v1530[i]	Not checked		
}			
appliedFreqBandListFilter	Not checked	FreqBandList	
supportedBandCombinationList-v1540 SEQUENCE (SIZE (1..maxBandComb)) OF SEQUENCE {			
bandList-v1540[i] SEQUENCE (SIZE (1..maxSimultaneousBands)) OF SEQUENCE {	Not checked	BandParameters-v1540	
srs-CarrierSwitch CHOICE {			
nr SEQUENCE [
srs-SwitchingTimesListNR SEQUENCE (SIZE (1..maxSimultaneousBands)) OF SRS-SwitchingTimeNR	Not checked		
}			
eutra SEQUENCE {			
srs-SwitchingTimesListEUTRA SEQUENCE (SIZE (1..maxSimultaneousBands)) OF SRS-SwitchingTimeEUTRA	Not checked		
}			
srs-TxSwitch-v1540 SEQUENCE {			
supportedSRS-TxPortSwitch	Not checked		
txSwitchImpactToRx	Not checked		
txSwitchWithAnotherBand	Not checked		
}			
}			
ca-ParametersNR-v1540[i]	Not checked	CA-ParametersNR-v1540	
}			
srs-SwitchingTimeRequested	Not checked		
}			
measAndMobParameters SEQUENCE {			
measAndMobParametersCommon SEQUENCE {			
supportedGapPattern	Not checked		
ssb-RLM	Not checked		
ssb-AndCSI-RS-RLM	Not checked		
eventB-MeasAndReport	Not checked		
handoverFDD-TDD	Not checked		
eutra-CGI-Reporting	Not checked		
nr-CGI-Reporting	Not checked		
independentGapConfig	Checked		pc_independentGapConfig

periodicEUTRA-MeasAndReport	Not checked		
handoverFR1-FR2	Not checked		
maxNumberCSI-RS-RRM-RS-SINR	Not checked		
}			
measAndMobParametersXDD-Diff SEQUENCE {			
intraAndInterF-MeasAndReport	Checked		pc_intraAndInterF-MeasAndReport
eventA-MeasAndReport	Checked		pc_eventA-MeasAndReport
handoverInterF	Not checked		
handoverLTE	Not checked		
handover-eLTE	Not checked		
}			
measAndMobParametersFRX-Diff SEQUENCE {			
ss-SINR-Meas	Not checked		
csi-RSRP-AndRSRQ-MeasWithSSB	Checked		pc_csi-RSRP-AndRSRQ-MeasWithSSB
csi-RSRP-AndRSRQ-MeasWithoutSSB	Not checked		
csi-SINR-Meas	Not checked		
csi-RS-RLM	Not checked		
handoverInterF	Not checked		
handoverLTE	Not checked		
handover-eLTE	Not checked		
maxNumberResource-CSI-RS-RLM	Not checked		
}			
}			
fdd-Add-UE-NR-Capabilities SEQUENCE {			
phy-ParametersXDD-Diff SEQUENCE {			
dynamicSFI	Not checked		
twoPUCCH-F0-2-ConsecSymbols	Not checked		
twoDifferentTPC-Loop-PUSCH	Not checked		
twoDifferentTPC-Loop-PUCCH	Not checked		
dl-SchedulingOffset-PDSCH-TypeA	Not checked		
dl-SchedulingOffset-PDSCH-TypeB	Not checked		
ul-SchedulingOffset	Not checked		
}			
mac-ParametersXDD-Diff SEQUENCE {			
skipUplinkTxDynamic	Not checked		
logicalChannelSR-DelayTimer	Not checked		
longDRX-Cycle	Not checked		
shortDRX-Cycle	Not checked		
multipleSR-Configurations	Not checked		
multipleConfiguredGrants	Not checked		
}			
measAndMobParametersXDD-Diff SEQUENCE {			
intraAndInterF-MeasAndReport	Checked		pc_intraAndInterF-MeasAndReport
eventA-MeasAndReport	[Checked		pc_eventA-MeasAndReport
handoverInterF	Not checked		
handoverLTE	Not checked		
handover-eLTE	Not checked		
}			
}			
tdd-Add-UE-NR-Capabilities SEQUENCE {			
phy-ParametersXDD-Diff SEQUENCE {			
dynamicSFI	Not checked		

twoPUCCH-F0-2-ConsecSymbols	Not checked		
twoDifferentTPC-Loop-PUSCH	Not checked		
twoDifferentTPC-Loop-PUCCH	Not checked		
dl-SchedulingOffset-PDSCH-TypeA	Not checked		
dl-SchedulingOffset-PDSCH-TypeB	Not checked		
ul-SchedulingOffset	Not checked		
}			
mac-ParametersXDD-Diff SEQUENCE {			
skipUplinkTxDynamic	Not checked		
logicalChannelSR-DelayTimer	Not checked		
longDRX-Cycle	Not checked		
shortDRX-Cycle	Not checked		
multipleSR-Configurations	Not checked		
multipleConfiguredGrants	Not checked		
}			
measAndMobParametersXDD-Diff SEQUENCE {			
intraAndInterF-MeasAndReport	Checked		pc_intraAndInterF-MeasAndReport
eventA-MeasAndReport	Checked		pc_eventA-MeasAndReport
handoverInterF	Not checked		
handoverLTE	Not checked		
handover-eLTE	Not checked		
}			
fr1-Add-UE-NR-Capabilities SEQUENCE {			
phy-ParametersFRX-Diff SEQUENCE {			
dynamicSFI	Not checked		
dummy1	Not checked		
twoFL-DMRS	Not checked		
dummy2	Not checked		
dummy3	Not checked		
supportedDMRS-TypeDL	Not checked		
supportedDMRS-TypeUL	Not checked		
semiOpenLoopCSI	Not checked		
csi-ReportWithoutPMI	Not checked		
csi-ReportWithoutCQI	Not checked		
onePortsPTRS	Not checked		
twoPUCCH-F0-2-ConsecSymbols	Not checked		
pucch-F2-WithFH	Not checked		
pucch-F3-WithFH	Not checked		
pucch-F4-WithFH	Not checked		
freqHoppingPUCCH-F0-2	Not checked		
freqHoppingPUCCH-F1-3-4	Not checked		
mux-SR-HARQ-ACK-CSI-PUCCH-MultiPerSlot	Not checked		
uci-CodeBlockSegmentation	Not checked		
onePUCCH-LongAndShortFormat	Not checked		
twoPUCCH-AnyOthersInSlot	Not checked		
intraSlotFreqHopping-PUSCH	Not checked		
pusch-LBRM	Not checked		
pdcch-BlindDetectionCA	Not checked		
tpc-PUSCH-RNTI	Not checked		
tpc-PUCCH-RNTI	Not checked		
tpc-SRS-RNTI	Not checked		
absoluteTPC-Command	[Not checked		
twoDifferentTPC-Loop-PUSCH	[Not checked		
twoDifferentTPC-Loop-PUCCH	[Not checked		
pusch-HalfPi-BPSK	[Not checked		
pucch-F3-4-HalfPi-BPSK	[Not checked		
almostContiguousCP-OFDM-UL	[Not checked		
sp-CSI-RS	[Not checked		
sp-CSI-IM	[Not checked		
tdd-MultiDL-UL-SwitchPerSlot	[Not checked		
multipleCORESET	[Not checked		

csi-RS-IM-ReceptionForFeedback	Not checked		
csi-RS-ProcFrameworkForSRS	Not checked		
csi-ReportFramework	Not checked		
mux-SR-HARQ-ACK-CSI-PUCCH-OncePerSlot SEQUENCE {			
sameSymbol	Not checked		
diffSymbol	Not checked		
}			
mux-SR-HARQ-ACK-PUCCH	Not checked		
mux-MultipleGroupCtrlCH-Overlap	Not checked		
dl-SchedulingOffset-PDSCH-TypeA	Not checked		
dl-SchedulingOffset-PDSCH-TypeB	Not checked		
ul-SchedulingOffset	Not checked		
dl-64QAM-MCS-TableAlt	Not checked		
ul-64QAM-MCS-TableAlt	Not checked		
cqi-TableAlt	Not checked		
oneFL-DMRS-TwoAdditionalDMRS-UL	Not checked		
twoFL-DMRS-TwoAdditionalDMRS-UL	Not checked		
oneFL-DMRS-ThreeAdditionalDMRS-UL	Not checked		
}			
measAndMobParametersFRX-Diff SEQUENCE {			
ss-SINR-Meas	Not checked		
csi-RSRP-AndRSRQ-MeasWithSSB	Checked		pc_csi-RSRP-AndRSRQ-MeasWithSSB
csi-RSRP-AndRSRQ-MeasWithoutSSB	Not checked		
csi-SINR-Meas	Not checked		
csi-RS-RLM	Not checked		
handoverInterF	Not checked		
handoverLTE	Not checked		
handover-eLTE	Not checked		
maxNumberResource-CSI-RS-RLM	Not checked		
}			
}			
fr2-Add-UE-NR-Capabilities SEQUENCE {			
phy-ParametersFRX-Diff SEQUENCE {	Not checked		
dynamicSFI	Not checked		
dummy1	Not checked		
twoFL-DMRS	Not checked		
dummy2	Not checked		
dummy3	Not checked		
supportedDMRS-TypeDL	Not checked		
supportedDMRS-TypeUL	Not checked		
semiOpenLoopCSI	Not checked		
csi-ReportWithoutPMI	Not checked		
csi-ReportWithoutCQI	Not checked		
onePortsPTRS	Not checked		
twoPUCCH-F0-2-ConsecSymbols	Not checked		
pucch-F2-WithFH	Not checked		
pucch-F3-WithFH	Not checked		
pucch-F4-WithFH	Not checked		
freqHoppingPUCCH-F0-2	Not checked		
freqHoppingPUCCH-F1-3-4	Not checked		
mux-SR-HARQ-ACK-CSI-PUCCH-MultiPerSlot	Not checked		
uci-CodeBlockSegmentation	Not checked		
onePUCCH-LongAndShortFormat	Not checked		
twoPUCCH-AnyOthersInSlot	Not checked		
intraSlotFreqHopping-PUSCH	Not checked		
pusch-LBRM	Not checked		
pdcch-BlindDetectionCA	Not checked		
tpc-PUSCH-RNTI	Not checked		
tpc-PUCCH-RNTI	Not checked		
tpc-SRS-RNTI	Not checked		
absoluteTPC-Command	Not checked		

twoDifferentTPC-Loop-PUSCH	Not checked		
twoDifferentTPC-Loop-PUCCH	Not checked		
pusch-HalfPi-BPSK	Not checked		
pucch-F3-4-HalfPi-BPSK	Not checked		
almostContiguousCP-OFDM-UL	Not checked		
sp-CSI-RS	Not checked		
sp-CSI-IM	Not checked		
tdd-MultiDL-UL-SwitchPerSlot	Not checked		
multipleCORESET	Not checked		
csi-RS-IM-ReceptionForFeedback	Not checked		
csi-RS-ProcFrameworkForSRS	Not checked		
csi-ReportFramework	Not checked		
mux-SR-HARQ-ACK-CSI-PUCCH-OncePerSlot SEQUENCE {			
sameSymbol	Not checked		
diffSymbol	Not checked		
}			
mux-SR-HARQ-ACK-PUCCH	Not checked		
mux-MultipleGroupCtrlCH-Overlap	Not checked		
dl-SchedulingOffset-PDSCH-TypeA	Not checked		
dl-SchedulingOffset-PDSCH-TypeB	Not checked		
ul-SchedulingOffset	Not checked		
dl-64QAM-MCS-TableAlt	Not checked		
ul-64QAM-MCS-TableAlt	Not checked		
cqi-TableAlt	Not checked		
oneFL-DMRS-TwoAdditionalDMRS-UL	Not checked		
twoFL-DMRS-TwoAdditionalDMRS-UL	Not checked		
oneFL-DMRS-ThreeAdditionalDMRS-UL	Not checked		
}			
measAndMobParametersFRX-Diff SEQUENCE {			
ss-SINR-Meas	Not checked		
csi-RSRP-AndRSRQ-MeasWithSSB	Checked		pc_csi-RSRP-AndRSRQ-MeasWithSSB
csi-RSRP-AndRSRQ-MeasWithoutSSB	Not checked		
csi-SINR-Meas	Not checked		
csi-RS-RLM	Not checked		
handoverInterF	Not checked		
handoverLTE	Not checked		
handover-eLTE	Not checked		
maxNumberResource-CSI-RS-RLM	Not checked		
}			
}			
featureSets SEQUENCE {			
featureSetsDownlink SEQUENCE (SIZE (1..maxDownlinkFeatureSets)) OF SEQUENCE {			
featureSetListPerDownlinkCC[i]	Not checked		
intraBandFreqSeparationDL[i]	Not checked		
scalingFactor[i]	Not checked		
crossCarrierScheduling-OtherSCS[i]	Not checked		
scellWithoutSSB[i]	Not checked		
csi-RS-MeasSCellWithoutSSB[i]	Not checked		
dummy1[i]	Not checked		
type1-3-CSS[i]	Not checked		
pdcch-MonitoringAnyOccasions[i]	Not checked		
dummy2[i]	Not checked		
ue-SpecificUL-DL-Assignment[i]	Not checked		
searchSpaceSharingCA-DL[i]	Not checked		
timeDurationForQCL[i] SEQUENCE {			
scs-60kHz	Not checked		
scs-120kHz	Not checked		
}			
}			
}			

pdsch-ProcessingType1-DifferentTB-PerSlot[i] SEQUENCE {			
scs-15kHz	Not checked		
scs-30kHz	Not checked		
scs-60kHz	Not checked		
scs-120kHz	Not checked		
}			
dummy3[i]	Not checked		
dummy4[i]	Not checked		
dummy5[i]	Not checked		
dummy6[i]	Not checked		
dummy7[i]	Not checked		
}			
featureSetsDownlinkPerCC SEQUENCE (SIZE (1..maxPerCC-FeatureSets)) OF SEQUENCE {			
supportedSubcarrierSpacingDL[i]	Not checked	SubcarrierSpacing	
supportedBandwidthDL[i]	Not checked	SupportedBandwidth	
channelBW-90mhz[i]	Not checked		
maxNumberMIMO-LayersPDSCH[i]	Not checked	MIMO-LayersDL	
supportedModulationOrderDL[i]	Not checked	ModulationOrder	
}			
featureSetsUplink SEQUENCE (SIZE (1..maxUplinkFeatureSets)) OF SEQUENCE {			
featureSetListPerUplinkCC[i]	Not checked		
scalingFactor[i]	Not checked		
crossCarrierScheduling-OtherSCS[i]	Not checked		
intraBandFreqSeparationUL[i]	Not checked		
searchSpaceSharingCA-UL[i]	Not checked		
dummy1[i]	Not checked		
supportedSRS-Resources[i]	Not checked	SRS-Resources	
twoPUCCH-Group[i]	Not checked		
dynamicSwitchSUL[i]	Not checked		
simultaneousTxSUL-NonSUL[i]	Not checked		
pusch-ProcessingType1-DifferentTB-PerSlot[i] SEQUENCE {			
scs-15kHz	Not checked		
scs-30kHz	Not checked		
scs-60kHz	Not checked		
scs-120kHz	Not checked		
}			
dummy2[i]	Not checked		
}			
featureSetsUplinkPerCC SEQUENCE (SIZE (1..maxPerCC-FeatureSets)) OF SEQUENCE {			
supportedSubcarrierSpacingUL[i]	Not checked	SubcarrierSpacing	
supportedBandwidthUL[i]	Not checked	SupportedBandwidth	
channelBW-90mhz[i]	Not checked		
mimo-CB-PUSCH[i] SEQUENCE {			
maxNumberMIMO-LayersCB-PUSCH	Checked	MIMO-LayersUL	pc_nrMIMO_CB_PUSCH
maxNumberSRS-ResourcePerSet	Not checked		
}			
maxNumberMIMO-LayersNonCB-PUSCH	Checked	MIMO-LayersUL	pc_nrMIMO_NonCB_PUSCH
supportedModulationOrderUL	Not checked	ModulationOrder	
}			
featureSetsDownlink-v1540 SEQUENCE (SIZE (1..maxDownlinkFeatureSets)) OF SEQUENCE {			
oneFL-DMRS-TwoAdditionalDMRS-DL[i]	Not checked		
additionalDMRS-DL-Alt[i]	Not checked		
twoFL-DMRS-TwoAdditionalDMRS-DL[i]	Not checked		
oneFL-DMRS-ThreeAdditionalDMRS-DL[i]	Not checked		

pdccch-MonitoringAnyOccasionsWithSpanGap[i] SEQUENCE {			
scs-15kHz	Not checked		
scs-30kHz	Not checked		
scs-60kHz	Not checked		
scs-120kHz	Not checked		
}			
pdsch-SeparationWithGap[i]	Not checked		
pdsch-ProcessingType2[i] SEQUENCE {			
scs-15kHz	Not checked		
scs-30kHz	Not checked		
scs-60kHz	Not checked		
}			
pdsch-ProcessingType2-Limited[i] SEQUENCE {			
differentTB-PerSlot-SCS-30kHz	Not checked		
}			
dl-MCS-TableAlt-DynamicIndication[i]	Not checked		
}			
featureSetsUplink-v1540 SEQUENCE (SIZE (1..maxUplinkFeatureSets)) OF SEQUENCE {			
zeroSlotOffsetAperiodicSRS	Not checked		
pa-PhaseDiscontinuityImpacts	Not checked		
pusch-SeparationWithGap	Not checked		
pusch-ProcessingType2 SEQUENCE {			
scs-15kHz	Not checked		
scs-30kHz	Not checked		
scs-60kHz	Not checked		
}			
ul-MCS-TableAlt-DynamicIndication	Not checked		
}			
featureSetsUplinkPerCC-v1540 SEQUENCE (SIZE (1..maxPerCC-FeatureSets)) OF SEQUENCE {			
mimo-NonCB-PUSCH SEQUENCE {			
maxNumberSRS-ResourcePerSet	Not checked		
maxNumberSimultaneousSRS-ResourceTx	Not checked		
}			
}			
featureSetCombinations SEQUENCE (SIZE (1..maxFeatureSetCombinations)) OF {			
FeatureSetCombination[i] SEQUENCE (SIZE (1..maxSimultaneousBands)) OF {			
FeatureSetsPerBand[jii] SEQUENCE (SIZE (1..maxFeatureSetsPerBand)) OF {			
FeatureSet[jiii] CHOICE {			
eutra SEQUENCE {			
downlinkSetEUTRA	Not checked	FeatureSetEUTRA-DownlinkId	
uplinkSetEUTRA	Not checked	FeatureSetEUTRA-UplinkId	
}			
nr SEQUENCE {			
downlinkSetNR	Not checked	FeatureSetDownlinkId	
uplinkSetNR	Not checked	FeatureSetUplinkId	
}			
}			
}			
}			
lateNonCriticalExtension	Not checked		
nonCriticalExtension SEQUENCE {			
fdd-Add-UE-NR-Capabilities-v1530 SEQUENCE {			
eutra-ParametersXDD-Diff SEQUENCE {			
rsrqMeasWidebandEUTRA	Not checked		

}			
}			
tdd-Add-UE-NR-Capabilities-v1530 SEQUENCE {			
eutra-ParametersXDD-Diff SEQUENCE {			
rsrqMeasWidebandEUTRA	Not checked		
}			
}			
dummy	Not checked		
interRAT-Parameters SEQUENCE {			
eutra SEQUENCE {			
supportedBandListEUTRA SEQUENCE (SIZE (1..maxBandsEUTRA)) OF FreqBandIndicatorEUTRA	Not checked		
eutra-ParametersCommon SEQUENCE {			
mfbf-EUTRA	Not checked		
modifiedMRP-BehaviorEUTRA	Not checked		
multiNS-Pmax-EUTRA	Not checked		
rs-SINR-MeasEUTRA	Not checked		
}			
eutra-ParametersXDD-Diff SEQUENCE {			
rsrqMeasWidebandEUTRA	Not checked		
}			
}			
inactiveState	Not checked		
delayBudgetReporting	Not checked		
nonCriticalExtension SEQUENCE {	Not checked		
sdap-Parameters SEQUENCE {			
as-ReflectiveQoS	Checked		pc_as_ReflectiveQoS
}			
overheatingInd	Not checked		
ims-Parameters SEQUENCE {			
ims-ParametersCommon SEQUENCE {			
voiceOverEUTRA-5GC	Not checked		
}			
ims-ParametersFRX-Diff SEQUENCE {			
voiceOverNR	Not checked		
}			
}			
fr1-Add-UE-NR-Capabilities-v1540 SEQUENCE {			
ims-ParametersFRX-Diff SEQUENCE {			
voiceOverNR	Not checked		
}			
}			
fr2-Add-UE-NR-Capabilities-v1540 SEQUENCE {			
ims-ParametersFRX-Diff SEQUENCE {			
voiceOverNR	Not checked		
}			
}			
fr1-fr2-Add-UE-NR-Capabilities SEQUENCE {			
phy-ParametersFRX-Diff SEQUENCE {			
dynamicSFI	Not checked		
dummy1	Not checked		
twoFL-DMRS	Not checked		
dummy2	Not checked		
dummy3	Not checked		
supportedDMRS-TypeDL	Not checked		
supportedDMRS-TypeUL	Not checked		
semiOpenLoopCSI	Not checked		
csi-ReportWithoutPMI	Not checked		
csi-ReportWithoutCQI	Not checked		
onePortsPTRS	Not checked		
twoPUCCH-F0-2-ConsecSymbols	Not checked		
pucch-F2-WithFH	Not checked		
pucch-F3-WithFH	Not checked		

pucch-F4-WithFH	Not checked		
freqHoppingPUCCH-F0-2	Not checked		
freqHoppingPUCCH-F1-3-4	Not checked		
mux-SR-HARQ-ACK-CSI-PUCCH-MultiPerSlot	Not checked		
uci-CodeBlockSegmentation	Not checked		
onePUCCH-LongAndShortFormat	Not checked		
twoPUCCH-AnyOthersInSlot	Not checked		
intraSlotFreqHopping-PUSCH	Not checked		
pusch-LBRM	Not checked		
pdccch-BlindDetectionCA	Not checked		
tpc-PUSCH-RNTI	Not checked		
tpc-PUCCH-RNTI	Not checked		
tpc-SRS-RNTI	Not checked		
absoluteTPC-Command	Not checked		
twoDifferentTPC-Loop-PUSCH	Not checked		
twoDifferentTPC-Loop-PUCCH	Not checked		
pusch-HalfPi-BPSK	Not checked		
pucch-F3-4-HalfPi-BPSK	Not checked		
almostContiguousCP-OFDM-UL	Not checked		
sp-CSI-RS	Not checked		
sp-CSI-IM	Not checked		
tdd-MultiDL-UL-SwitchPerSlot	Not checked		
multipleCORESET	Not checked		
csi-RS-IM-ReceptionForFeedback	Not checked	CSI-RS-IM- eceptionForFeedb ack	
csi-RS-ProcFrameworkForSRS	Not checked	CSI-RS- ProcFrameworkFo rSRS	
csi-ReportFramework	Not checked	CSI- ReportFramework	
mux-SR-HARQ-ACK-CSI-PUCCH-OncePerSlot SEQUENCE {			
sameSymbol	Not checked		
diffSymbol	Not checked		
}			
mux-SR-HARQ-ACK-PUCCH	Not checked		
mux-MultipleGroupCtrlCH-Overlap	Not checked		
dl-SchedulingOffset-PDSCH-TypeA	Not checked		
dl-SchedulingOffset-PDSCH-TypeB	Not checked		
ul-SchedulingOffset	Not checked		
dl-64QAM-MCS-TableAlt	Not checked		
ul-64QAM-MCS-TableAlt	Not checked		
cqi-TableAlt	Not checked		
oneFL-DMRS-TwoAdditionalDMRS-UL	Not checked		
twoFL-DMRS-TwoAdditionalDMRS-UL	Not checked		
oneFL-DMRS-ThreeAdditionalDMRS-UL	Not checked		
}			
measAndMobParametersFRX-Diff SEQUENCE {			
ss-SINR-Meas	Not checked		
csi-RSRP-AndRSRQ-MeasWithSSB	Checked		pc_csi- RSRP- AndRSRQ- MeasWithSS B
csi-RSRP-AndRSRQ-MeasWithoutSSB	Not checked		
csi-SINR-Meas	Not checked		
csi-RS-RLM	Not checked		
handoverInterF	Not checked		
handoverLTE	Not checked		
handover-eLTE	Not checked		
maxNumberResource-CSI-RS-RLM	Not checked		
}			
}			
nonCriticalExtension SEQUENCE {}	Not checked		
}			

}			
---	--	--	--

Table 8.2.1.1.1.3.3-7: *UE-MRDC-Capability* (Table 8.2.1.1.1.3.3-5)

Derivation Path: 38.331 [12], clause 6.3.3			
Information Element	Value/remark	Comment	Condition
UE-MRDC-Capability ::= SEQUENCE {			
measAndMobParametersMRDC SEQUENCE {			
measAndMobParametersMRDC-Common			
SEQUENCE {			
independentGapConfig	Checked		pc_independentGapConfig
}			
measAndMobParametersMRDC-XDD-Diff			
SEQUENCE {			
sftd-MeasPSCell	Not checked		
sftd-MeasNR-Cell	Not checked		
}			
measAndMobParametersMRDC-FRX-Diff			
SEQUENCE {			
simultaneousRxDataSSB-DiffNumerology	Not checked		
}			
}			
phy-ParametersMRDC-v1530 SEQUENCE {			
naics-Capability-List SEQUENCE (SIZE	Not checked		
(1..maxNrofNAICS-Entries)) OF SEQUENCE {			
numberOfNAICS-CapableCC[i]	Not checked		
numberOfAggregatedPRB[i]	Not checked		
}			
}			
rf-ParametersMRDC SEQUENCE {			
supportedBandCombinationList SEQUENCE {			
(SIZE (1..maxBandComb)) OF SEQUENCE {			
bandList[i] SEQUENCE (SIZE	Not checked		
(1..maxSimultaneousBands)) OF CHOICE {			
eutra SEQUENCE {			
bandEUTRA	Not checked	FreqBandIndicator EUTRA	
ca-BandwidthClassDL-EUTRA	Not checked	CA-BandwidthClassEUTRA	
ca-BandwidthClassUL-EUTRA	Not checked	CA-BandwidthClassEUTRA	
}			
nr SEQUENCE {			
bandNR	Not checked	FreqBandIndicator NR	
ca-BandwidthClassDL-NR	Not checked	CA-BandwidthClassNR	
ca-BandwidthClassUL-NR	Not checked	CA-BandwidthClassNR	
}			
}			
featureSetCombination[i]	Not checked	FeatureSetCombinationId	
ca-ParametersEUTRA[i]	Not checked	CA-ParametersEUTRA	
ca-ParametersNR[i]	Not checked	CA-ParametersNR	
mrdc-Parameters[i] SEQUENCE {			
singleUL-Transmission	Not checked		
dynamicPowerSharing	Checked		pc_dynamicPowerSharing
tdm-Pattern	Not checked		

ul-SharingEUTRA-NR	Not checked		
ul-SwitchingTimeEUTRA-NR	Not checked		
simultaneousRxTxInterBandENDC	Not checked		
asyncIntraBandENDC	Not checked		
dualPA-Architecture	Not checked		
intraBandENDC-Support-v1540	Not checked		
ul-TimingAlignmentEUTRA-NR	Not checked		
}			
supportedBandwidthCombinationSet[i]	Not checked		
powerClass-v1530	Not checked		
}			
appliedFreqBandListFilter	Not checked	FreqBandList	
srs-SwitchingTimeRequested	Not checked		
supportedBandCombinationList-v1540 SEQUENCE (SIZE (1..maxBandComb)) OF SEQUENCE {		BandCombination List-v1540	
bandList-v1540[i] SEQUENCE (SIZE (1..maxSimultaneousBands)) OF SEQUENCE {			
srs-CarrierSwitch CHOICE {			
nr SEQUENCE {			
srs-SwitchingTimesListNR SEQUENCE (SIZE (1..maxSimultaneousBands)) OF SRS-SwitchingTimeNR	Not checked		
}			
eutra SEQUENCE {			
srs-SwitchingTimesListEUTRA SEQUENCE (SIZE (1..maxSimultaneousBands)) OF SRS-SwitchingTimeEUTRA	Not checked		
}			
srs-TxSwitch-v1540 SEQUENCE {			
supportedSRS-TxPortSwitch	Not checked		
txSwitchImpactToRx	Not checked		
txSwitchWithAnotherBand	Not checked		
}			
ca-ParametersNR-v1540[i] SEQUENCE {			
simultaneousSRS-AssocCSI-RS-AIICC	Not checked		
csi-RS-IM-ReceptionForFeedbackPerBandComb SEQUENCE {			
maxNumberSimultaneousNZZP-CSI-RS-ActBWP-AIICC	Not checked		
totalNumberPortsSimultaneousNZZP-CSI-RS-ActBWP-AIICC	Not checked		
}			
simultaneousCSI-ReportsAIICC	Not checked		
dualPA-Architecture	Not checked		
}			
}			
generalParametersMRDC SEQUENCE {			
splitSRB-WithOneUL-Path	Checked		pc_splitSRB_WithOneUL_Path
splitDRB-withUL-Both-MCG-SCG	Checked		pc_splitDRB_withUL_Both_MCG_SC G
srb3	[Checked]		pc_srb3
v2x-EUTRA-v1530	[Not checked]		
}			
fdd-Add-UE-MRDC-Capabilities SEQUENCE {			
measAndMobParametersMRDC-XDD-Diff SEQUENCE {			
sftd-MeasPSCell	Not checked		
sftd-MeasNR-Cell	Not checked		

}			
generalParametersMRDC-XDD-Diff SEQUENCE {			
splitSRB-WithOneUL-Path	Checked		pc_splitSRB_WithOneUL_Path
splitDRB-withUL-Both-MCG-SCG	Checked		pc_splitDRB_withUL_Both_MCG_SC G
srb3	Checked		pc_srb3
v2x-EUTRA-v1530	Not checked		
}			
tdd-Add-UE-MRDC-Capabilities SEQUENCE {			
measAndMobParametersMRDC-XDD-Diff SEQUENCE {			
sftd-MeasPSCell	Not checked		
sftd-MeasNR-Cell	Not checked		
}			
generalParametersMRDC-XDD-Diff SEQUENCE {			
splitSRB-WithOneUL-Path	Checked		pc_splitSRB_WithOneUL_Path
splitDRB-withUL-Both-MCG-SCG	Checked		pc_splitDRB_withUL_Both_MCG_SC G
srb3	Checked		pc_srb3
v2x-EUTRA-v1530	Not checked		
}			
}			
fr1-Add-UE-MRDC-Capabilities SEQUENCE {			
measAndMobParametersMRDC-FRX-Diff SEQUENCE {			
simultaneousRxDataSSB-DiffNumerology	Not checked		
}			
}			
fr2-Add-UE-MRDC-Capabilities SEQUENCE {			
measAndMobParametersMRDC-FRX-Diff SEQUENCE {			
simultaneousRxDataSSB-DiffNumerology	Not checked		
}			
}			
featureSetCombinations SEQUENCE (SIZE (1..maxFeatureSetCombinations)) OF SEQUENCE[i] (SIZE (1..maxSimultaneousBands)) OF SEQUENCE[j] (SIZE (1..maxFeatureSetsPerBand)) OF CHOICE {{	Not checked	FeatureSetCombination	
eutra SEQUENCE {			
downlinkSetEUTRA	Not checked		
uplinkSetEUTRA	Not checked		
}			
nr SEQUENCE {			
downlinkSetNR	Not checked		
uplinkSetNR	Not checked		
}			
}			
pdcp-ParametersMRDC-v1530 SEQUENCE {			
pdcp-DuplicationSplitSRB	Not checked		
pdcp-DuplicationSplitDRB	Not checked		
}			
lateNonCriticalExtension	Not checked		
nonCriticalExtension SEQUENCE {}	Not checked		
}			

8.2.1.2 Void

8.2.2 Radio Bearer Addition, Modification and Release

8.2.2.1 Radio Bearer Addition, Modification and Release / SRB

8.2.2.1.1 SRB3 Establishment, Reconfiguration and Release / NR addition, modification and release / EN-DC

8.2.2.1.1.1 Test Purpose (TP)

(1)

```
with { UE in RRC_CONNECTED state with EN-DC, and, MCG(s) (E-UTRA PDCP) and SCG }
ensure that {
  when { UE receives an RRCConnectionReconfiguration message to add SRB3 }
  then { UE establishes SRB3 and sends an RRCConnectionReconfigurationComplete message on SRB1 }
}
```

(2)

```
with { UE in RRC_CONNECTED state with EN-DC, and, MCG(s) (E-UTRA PDCP) and SCG and SRB3 configured }
ensure that {
  when { UE receives an RRCReconfiguration message on SRB3 to reconfigure NR MAC }
  then { UE reconfigures NR MAC and sends RRCReconfigurationComplete message on SRB3 }
}
```

(3)

```
with { UE in RRC_CONNECTED state with EN-DC, and, MCG(s) (E-UTRA PDCP) and SCG and SRB3 configured }
ensure that {
  when { UE receives an RRCReconfiguration message on SRB3 to reestablish NR PDCP }
  then { UE reestablishes NR PDCP and sends RRCReconfigurationComplete message on SRB3 }
}
```

(4)

```
with { UE in RRC_CONNECTED state with EN-DC, and, MCG(s) (E-UTRA PDCP) and SCG }
ensure that {
  when { UE receives an RRCConnectionReconfiguration message to release SRB3 }
  then { UE releases SRB3 and sends an RRCConnectionReconfigurationComplete message on SRB1 }
}
```

8.2.2.1.1.2 Conformance requirements

References: The conformance requirements covered in the present test case are specified in: TS 36.331, clause 5.3.5.3, TS 38.331, clauses 5.3.5.3, 5.3.5.5.1, 5.3.5.5.3, 5.3.5.5.4, 5.3.5.5.8, 5.3.5.5.9, 5.3.5.6.1, 5.3.5.6.2 and 5.3.5.6.3. Unless otherwise stated these are Rel-15 requirements.

[TS 36.331, 5.3.5.3]

1> if the received RRCConnectionReconfiguration includes the *nr-Config* and it is set to *release*: or

1> if the received RRCConnectionReconfiguration includes *endc-ReleaseAndAdd*:

2> perform ENDC release as specified in TS38.331 [82], clause 5.3.5.10;

...

1> if the received RRCConnectionReconfiguration includes the *nr-SecondaryCellGroupConfig*:

2> perform NR RRC Reconfiguration as specified in TS 38.331 [82], clause 5.3.5.3;

- 1> if the received *RRCConnectionReconfiguration* includes the *nr-RadioBearerConfig1*:
 - 2> perform radio bearer configuration as specified in TS 38.331 [82], clause 5.3.5.6;
- 1> if the received *RRCConnectionReconfiguration* includes the *nr-RadioBearerConfig2*:
 - 2> perform radio bearer configuration as specified in TS 38.331 [82], clause 5.3.5.6;
- ...
- 1> set the content of *RRCConnectionReconfigurationComplete* message as follows:
 - 2> if the received *RRCConnectionReconfiguration* message included *nr-SecondaryCellGroupConfig*:
 - 3> include *scg-ConfigResponseNR* in accordance with TS 38.331 [82], clause 5.3.5.3;
- 1> submit the *RRCConnectionReconfigurationComplete* message to lower layers for transmission using the new configuration, upon which the procedure ends;

[TS 38.331, 5.3.5.3]

The UE shall perform the following actions upon reception of the *RRCReconfiguration*:

- 1> if the *RRCReconfiguration* includes the *secondaryCellGroup*:
 - 2> perform the cell group configuration for the SCG according to 5.3.5.5;
- ...
- 1> if the UE is configured with E-UTRA *nr-SecondaryCellGroupConfig* (MCG is E-UTRA):
 - 2> if *RRCReconfiguration* was received via SRB1:
 - 3> construct *RRCReconfigurationComplete* message and submit it via the EUTRA MCG embedded in E-UTRA RRC message *RRCConnectionReconfigurationComplete* as specified in TS 36.331 [10];
 - ...
 - 2> else (*RRCReconfiguration* was received via SRB3):
 - 3> submit the *RRCReconfigurationComplete* message via SRB3 to lower layers for transmission using the new configuration;

NOTE: In the case of SRB1, the random access is triggered by RRC layer itself as there is not necessarily other UL transmission. In the case of SRB3, the random access is triggered by the MAC layer due to arrival of *RRCReconfigurationComplete*.

[TS 38.331, 5.3.5.5.1]

The UE performs the following actions based on a received *CellGroupConfig* IE:

- ...
- 1> if the *CellGroupConfig* contains the *rlc-BearerToReleaseList*:
 - 2> perform RLC bearer release as specified in 5.3.5.5.3;
- 1> if the *CellGroupConfig* contains the *rlc-BearerToAddModList*:
 - 2> perform the RLC bearer addition/modification as specified in 5.3.5.5.4;
- 1> if the *CellGroupConfig* contains the *mac-CellGroupConfig*:
 - 2> configure the MAC entity of this cell group as specified in 5.3.5.5.5;
- 1> if the *CellGroupConfig* contains the *sCellToReleaseList*:
 - 2> perform SCell release as specified in 5.3.5.5.8;

...

- 1> if the *CellGroupConfig* contains the *sCellToAddModList*:
 - 2> perform SCell addition/modification as specified in 5.3.5.5.9.

[TS 38.331, 5.3.5.5.3]

- 1> for each *logicalChannellIdentity* value included in the *rlc-BearerToReleaseList* that is part of the current UE configuration (LCH release); or
- 1> for each *logicalChannellIdentity* value that is to be released as the result of an SCG release according to 5.3.5.4:
 - 2> release the RLC entity or entities as specified in TS 38.322 [4, section 5.1.3];
 - 2> release the corresponding logical channel.

[TS 38.331, 5.3.5.5.4]

For each *RLC-Bearer-Config* received in the *rlc-BearerToAddModList* IE the UE shall:

- 1> if the UE's current configuration contains a RLC bearer with the received *logicalChannellIdentity*:
 - ...
 - 2> reconfigure the RLC entity or entities in accordance with the received *rlc-Config*;

[TS 38.331, 5.3.5.5.8]

The UE shall:

- 1> if the release is triggered by reception of the *sCellToReleaseList*:
 - 2> for each *sCellIndex* value included in the *sCellToReleaseList*:
 - 3> if the current UE configuration includes an SCell with value *sCellIndex*:
 - 4> release the SCell.

[TS 38.331, 5.3.5.5.9]

The UE shall:

- 1> for each *sCellIndex* value included in the *sCellToAddModList* that is not part of the current UE configuration (SCell addition):
 - 2> add the SCell, corresponding to the *sCellIndex*, in accordance with the *sCellConfigCommon* and *sCellConfigDedicated*;
 - 2> configure lower layers to consider the SCell to be in deactivated state;
 - ...
- 1> for each *sCellIndex* value included in the *sCellToAddModList* that is part of the current UE configuration (SCell modification):
 - 2> modify the SCell configuration in accordance with the *sCellConfigDedicated*.

[TS 38.331, 5.3.5.6.1]

The UE shall perform the following actions based on a received *RadioBearerConfig* IE:

- 1> if the *RadioBearerConfig* includes the *srb3-ToRelease* and set to true:
 - 2> perform the SRB release as specified in 5.3.5.6.2;
- 1> if the *RadioBearerConfig* includes the *srb-ToAddModList*:
 - 2> perform the SRB addition or reconfiguration as specified in 5.3.5.6.3;

[TS 38.331, 5.3.5.6.2]

The UE shall:

- 1> release the PDCP entity of the SRB3.

[TS 38.331, 5.3.5.6.3]

The UE shall:

- 1> for each *srb-Identity* value included in the *srb-ToAddModList* that is not part of the current UE configuration (SRB establishment or reconfiguration from E-UTRA PDCP to NR PDCP):
 - 2> establish a PDCP entity and configure it with the security algorithms according to *securityConfig* and apply the keys (K_{RRCenc} and K_{RRCint}) associated with the master key (K_{eNB} / K_{gNB}) or secondary key ($S\text{-}K_{\text{gNB}}$) as indicated in *keyToUse*, if applicable;
- ...
- 2> if the *pdcp-Config* is included:
 - 3> configure the PDCP entity in accordance with the received *pdcp-Config*;

8.2.2.1.1.3 Test description

8.2.2.1.1.3.1 Pre-test conditions

System Simulator:

- E-UTRA Cell 1 is the PCell and NR Cell 1 is the PSCell
- System Information combination as defined in TS 38.508-1 [4] clause 4.4.3.1.1 is used in E-UTRA Cell 1 and NR Cell 1.

UE:

- None.

Preamble:

- The UE is in state RRC_CONNECTED using generic procedure parameter Connectivity (*EN-DC*) and DC bearers (*MCG(s)* and *SCG*) according to TS 38.508-1 [4], Table 4.5.1-1.

8.2.2.1.1.3.2 Test procedure sequence

Table 8.2.2.1.1.3.2-1: Main behaviour

St	Procedure	Message Sequence		TP	Verdict
		U - S	Message		
1	The SS transmits an <i>RRCConnectionReconfiguration</i> message containing NR <i>RRCReconfiguration</i> message to add SRB3 sent on SRB1/E-UTRA Cell 1.	<--	<i>RRCConnectionReconfiguration</i> (<i>RRCReconfiguration</i>)	-	-
2	Check: Does the UE transmit an <i>RRCConnectionReconfigurationComplete</i> message containing NR <i>RRCReconfigurationComplete</i> message on SRB1/E-UTRA Cell 1?	-->	<i>RRCConnectionReconfigurationComplete</i> (<i>RRCReconfigurationComplete</i>)	1	P
3	The SS transmits an <i>RRCReconfiguration</i> message to reconfigure NR MAC sent on SRB3/NR Cell 1.	<--	<i>RRCReconfiguration</i>	-	-
4	Check: Does the UE transmit an <i>RRCReconfigurationComplete</i> message on SRB3/NR Cell 1?	-->	<i>RRCReconfigurationComplete</i>	2	P
5	The SS transmits an <i>RRCReconfiguration</i> message to reestablish NR PDCP sent on SRB3/NR Cell 1.	<--	<i>RRCReconfiguration</i>	-	-
6	Check: Does the UE transmit an <i>RRCReconfigurationComplete</i> message on SRB3/NR Cell 1?	-->	<i>RRCReconfigurationComplete</i>	3	P
7	The SS transmits an <i>RRCConnectionReconfiguration</i> message to release SRB3 sent on SRB1/E-UTRA Cell 1.	<--	<i>RRCConnectionReconfiguration</i>	-	-
8	Check: Does the UE transmit an <i>RRCConnectionReconfigurationComplete</i> message on SRB1/E-UTRA Cell 1?	-->	<i>RRCConnectionReconfigurationComplete</i>	3	P
9	The SS releases the RRC connection.	-	-	-	-

8.2.2.1.1.3.3 Specific message contents

Table 8.2.2.1.1.3.3-1: RRCConnectionReconfiguration (step 1, Table 8.2.2.1.1.3.2-1)

Derivation Path: 36.508 [7], Table 4.6.1-8 with condition EN-DC_EmbedNR_RRCRecon and EN-DC_Embed_RBConfig			
Information Element	Value/remark	Comment	Condition
RRCConnectionReconfiguration ::= SEQUENCE {			
criticalExtensions CHOICE {			
c1 CHOICE {			
rrcConnectionReconfiguration-r8 ::= SEQUENCE {			
nonCriticalExtension SEQUENCE {			
nonCriticalExtension SEQUENCE {			
nonCriticalExtension SEQUENCE {			
nonCriticalExtension SEQUENCE {			
nonCriticalExtension SEQUENCE {			
nonCriticalExtension SEQUENCE {			
nonCriticalExtension SEQUENCE {			
nr-Config-r15 CHOICE {}	OCTET STRING including the RRCReconfiguration message according to table 8.2.2.1.1.3.3-1A.		
nr-RadioBearerConfig1-r15	RadioBearerConfig according to 38.508-1 [4] Table 4.6.3-132 with condition SRB3		
}			
}			
}			
}			
}			
}			
}			
}			
}			
}			
}			
}			
}			
}			

Table 8.2.2.1.1.3.3-1A: RRCReconfiguration (Table 8.2.2.1.1.3.3-1)

Derivation Path: 38.508-1 [4], Table 4.6.1-13			
Information Element	Value/remark	Comment	Condition
RRCReconfiguration ::= SEQUENCE {			
criticalExtensions CHOICE {			
rrcReconfiguration ::= SEQUENCE {			
secondaryCellGroup	OCTET STRING containing CellGroupConfig according to Table 8.2.2.1.1.3.3-1B.		
}			
}			
}			

Table 8.2.2.1.1.3.3-1B: CellGroupConfig (Table 8.2.2.1.1.3.3-1A)

Derivation Path: 38.508-1 [4], Table 4.6.3-19			
Information Element	Value/remark	Comment	Condition
CellGroupConfig ::= SEQUENCE {			
cellGroupId	1		
rlc-BearerToAddModList SEQUENCE (SIZE(1..maxLCH)) OF SEQUENCE {	1 entry		
RLC-Bearer-Config[1]			
logicalChannelIdentity	3		
servedRadioBearer ::= CHOICE {			
srb-Identity	3		
}			
}			
mac-CellGroupConfig	Not Present		
physicalCellGroupConfig	Not Present		
spCellConfig	Not Present		
}			

Table 8.2.2.1.1.3.3-2: RRCReconfiguration (step 3, Table 8.2.2.1.1.3.2-1)

Derivation Path: 38.508-1 [4], Table 4.6.1-13			
Information Element	Value/remark	Comment	Condition
RRCReconfiguration ::= SEQUENCE {			
criticalExtensions CHOICE {			
rrcReconfiguration ::= SEQUENCE {			
secondaryCellGroup	OCTET STRING containing CellGroupConfig according to Table 8.2.2.1.1.3.3-3.		
}			
}			
}			

Table 8.2.2.1.1.3.3-3: CellGroupConfig (Table 8.2.2.1.1.3.3-2)

Derivation Path: 38.508-1 [4], Table 4.6.3-19			
Information Element	Value/remark	Comment	Condition
CellGroupConfig ::= SEQUENCE {			
cellGroupId	1		
rlc-BearerToAddModList	Not present		
rlc-BearerToReleaseList	Not present		
mac-CellGroupConfig	MAC-CellGroupConfig according to table 8.2.2.1.1.3.3-3a		
physicalCellGroupConfig	Not present		
spCellConfig	Not present		
}			

Table 8.2.2.1.1.3.3-3a: MAC-CellGroupConfig (Table 8.2.2.1.1.3.3-3)

Derivation Path: TS 38.508-1 [4], Table 4.6.3-68			
Information Element	Value/remark	Comment	Condition
MAC-CellGroupConfig ::= SEQUENCE {			
drx-config	Not present.		
schedulingRequestConfig	Not present.		
bsr-Config SEQUENCE {			
periodicBSR-Timer	sf5		
retxBSR-Timer	sf40		
}			
tag-Config	Not present.		
phr-Config	Not present.		
skipUplinkTxDynamic	Not present.		
}			

Table 8.2.2.1.1.3.3-4: RRCReconfiguration (step 5, Table 8.2.2.1.1.3.2-1)

Derivation Path: 38.508-1 [4], Table: 4.6.1-13			
Information Element	Value/remark	Comment	Condition
RRCReconfiguration ::= SEQUENCE {			
criticalExtensions CHOICE {			
rrcReconfiguration ::= SEQUENCE {			
radioBearerConfig	RadioBearerConfig according to 38.508-1 [4] Table 4.6.3-132 with condition SRB3 and Table 8.2.2.1.1.3.3-5.		
}			
}			
}			

Table 8.2.2.1.1.3.3-5: RadioBearerConfig (Table 8.2.2.1.1.3.3-4)

Derivation Path: 38.508-1 [4], Table 4.6.3-132			
Information Element	Value/remark	Comment	Condition
RadioBearerConfig ::= SEQUENCE {			
srb-ToAddModList SEQUENCE (SIZE (1..2)) OF SEQUENCE {	1 entry		SRB3
reestablishPDCP	True		
}			
}			

Table 8.2.2.1.1.3.3-6: RRCConnectionReconfiguration (step 7, Table 8.2.2.1.1.3.2-1)

Derivation Path: 36.508 [7], Table 4.6.1-8 with condition EN-DC_EmbedNR_RRCRecon and EN-DC_Embed_RBConfig			
Information Element	Value/remark	Comment	Condition
RRCConnectionReconfiguration ::= SEQUENCE {			
criticalExtensions CHOICE {			
c1 CHOICE {			
rrcConnectionReconfiguration-r8 ::= SEQUENCE {			
nonCriticalExtension SEQUENCE {			
nonCriticalExtension SEQUENCE {			
nonCriticalExtension SEQUENCE {			
nonCriticalExtension SEQUENCE {			
nonCriticalExtension SEQUENCE {			
nonCriticalExtension SEQUENCE {			
nonCriticalExtension SEQUENCE {			
nr-Config-r15 CHOICE {}	OCTET STRING including the RRCReconfiguration message according to table 8.2.2.1.1.3.3-8.		
nr-RadioBearerConfig1-r15	RadioBearerConfig according to Table 8.2.2.1.1.3.3-7		
}			
}			
}			
}			
}			
}			
}			
}			
}			

Table 8.2.2.1.1.3.3-7: RadioBearerConfig (Table 8.2.2.1.1.3.3-6)

Derivation Path: 38.508-1 [4], Table 4.6.3-132			
Information Element	Value/remark	Comment	Condition
RadioBearerConfig ::= SEQUENCE {			
srb3-ToRelease	true		
securityConfig	Not present		
}			

Table 8.2.2.1.1.3.3-8: RRCReconfiguration (Table 8.2.2.1.1.3.3-6)

Derivation Path: 38.508-1 [4], Table 4.6.1-13			
Information Element	Value/remark	Comment	Condition
RRCReconfiguration ::= SEQUENCE {			
criticalExtensions CHOICE {			
rrcReconfiguration ::= SEQUENCE {			
secondaryCellGroup	OCTET STRING containing CellGroupConfig according to Table 8.2.2.1.1.3.3-9.		
}			
}			
}			

Table 8.2.2.1.1.3.3-9: *CellGroupConfig* (Table 8.2.2.1.1.3.3-8)

Derivation Path: 38.508-1 [4], Table 4.6.3-19			
Information Element	Value/remark	Comment	Condition
CellGroupConfig ::= SEQUENCE {			
cellGroupId	1		
rlc-BearerToAddModList	Not Present		
rlc-BearerToReleaseList SEQUENCE (SIZE(1..maxLCH)) OF SEQUENCE {	1 entry		
logicalChannelIdentity[1]	3		
}			
mac-CellGroupConfig	Not Present		
tag-Config	Not Present		
phr-Config	Not Present		
physicalCellGroupConfig	Not Present		
rlf-TimersAndConstants	Not Present		
}			

8.2.2.2 Split SRB Establishment and Release

8.2.2.2.1 Split SRB Establishment and Release / EN-DC

8.2.2.2.1.1 Test Purpose (TP)

(1)

```
with { UE in RRC_CONNECTED state with EN-DC, and, MCG(s) (E-UTRA PDCP) and SCG }
ensure that {
  when { UE receives an RRCConnectionReconfiguration message to configure Split SRB }
  then { UE configures the Split SRB establishing SRB1/SRB2 on LTE and SRB1S/ SRB2S on NR and
        sends an RRCConnectionReconfigurationComplete message }
}
```

(2)

```
with { UE in RRC_CONNECTED state with EN-DC, and, MCG(s) (E-UTRA PDCP) and SCG and Split SRB
configured }
ensure that {
  when { UE receives an RRCConnectionReconfiguration message on SRB1S on NR to release Split SRB }
  then { UE releases Split SRB and sends an RRCConnectionReconfigurationComplete message on SRB1
on LTE}
}
```

8.2.2.2.1.2 Conformance requirements

References: The conformance requirements covered in the present TC are specified in: TS 36.331, clause 5.3.5.3 and TS 38.331: clauses 5.3.5.3, 5.3.5.5, 5.3.5.5.3, 5.3.5.6, 5.3.5.6.2 and 5.3.5.6.3. Unless and otherwise stated these are Rel-15 requirements

[TS 36.331, clause 5.3.5.3]

If the *RRCConnectionReconfiguration* message does not include the *mobilityControlInfo* and the UE is able to comply with the configuration included in this message, the UE shall:

...

- 1> if the received *RRCConnectionReconfiguration* includes the *nr-SecondaryCellGroupConfig*:
 - 2> perform NR RRC Reconfiguration as specified in TS 38.331 [82], clause 5.3.5.3;
- 1> if the received *RRCConnectionReconfiguration* includes the *nr-RadioBearerConfig1*:
 - 2> perform radio bearer configuration as specified in TS 38.331 [82], clause 5.3.5.6;
- 1> if the received *RRCConnectionReconfiguration* includes the *nr-RadioBearerConfig2*:

2> perform radio bearer configuration as specified in TS 38.331 [82], clause 5.3.5.6;

...

1> set the content of *RRCConnectionReconfigurationComplete* message as follows:

...

2> if the received *RRCConnectionReconfiguration* message included *nr-SecondaryCellGroupConfig*:

3> include *scg-ConfigResponseNR* in accordance with TS 38.331 [82], clause 5.3.5.3;

1> submit the *RRCConnectionReconfigurationComplete* message to lower layers for transmission using the new configuration, upon which the procedure ends;

[TS 38.331, clause 5.3.5.3]

The UE shall perform the following actions upon reception of the *RRCReconfiguration*:

1> if the *RRCReconfiguration* includes the *secondaryCellGroup*:

2> perform the cell group configuration for the SCG according to 5.3.5.5;

1> if the *RRCReconfiguration* message contains the *radioBearerConfig*:

2> perform the radio bearer configuration according to 5.3.5.6;

...

1> if the UE is configured with E-UTRA *nr-SecondaryCellGroupConfig* (MCG is E-UTRA):

2> if *RRCReconfiguration* was received via SRB1:

3> submit the *RRCReconfigurationComplete* via the E-UTRA MCG embedded in E-UTRA RRC message *RRCConnectionReconfigurationComplete* as specified in TS 36.331 [10];

[TS 38.331, clause 5.3.5.6.1]

The UE shall perform the following actions based on a received *RadioBearerConfig* IE:

...

1> if the *RadioBearerConfig* includes the *srb-ToAddModList*:

2> perform the SRB addition or reconfiguration as specified in 5.3.5.6.3;

[TS 38.331, clause 5.3.5.6.3]

The UE shall:

1> for each *srb-Identity* value included in the *srb-ToAddModList* that is not part of the current UE configuration (SRB establishment or reconfiguration from E-UTRA PDCP to NR PDCP):

2> establish a PDCP entity;

2> if AS security has been activated:

3> if target RAT of handover is E-UTRA/5GC, or;

3> if the UE is only connected to E-UTRA/5GC:

4> configure the PDCP entity with the security algorithms and keys (K_{RRCEnc} and K_{RRCInt}) configured/derived as specified in TS 36.331 [10];

3> else:

- 4> configure the PDCP entity with the security algorithms according to *securityConfig* and apply the keys (K_{RRCenc} and K_{RRCint}) associated with the master key ($K_{\text{eNB}}/ K_{\text{gNB}}$) or secondary key ($S\text{-}K_{\text{gNB}}$) as indicated in *keyToUse*, if applicable;
- 2> if the current UE configuration as configured by E-UTRA in TS 36.331 [10] includes an SRB identified with the same *srb-Identity* value:
 - 3> associate the E-UTRA RLC entity and DCCH of this SRB with the NR PDCP entity;
 - 3> release the E-UTRA PDCP entity of this SRB;
- 2> if the *pdcp-Config* is included:
 - 3> configure the PDCP entity in accordance with the received *pdcp-Config*;
- 2> else:
 - 3> configure the PDCP entity in accordance with the default configuration defined in 9.2.1 for the corresponding SRB;

[TS 38.331, clause 5.3.5.5.3]

The UE shall:

- 1> for each *logicalChannelIdentity* value included in the *rlc-BearerToReleaseList* that is part of the current UE configuration (LCH release); or
- 1> for each *logicalChannelIdentity* value that is to be released as the result of an SCG release according to 5.3.5.4:
 - 2> release the RLC entity or entities as specified in TS 38.322 [4], clause 5.1.3;
 - 2> release the corresponding logical channel

8.2.2.2.1.3 Test description

8.2.2.2.1.3.1 Pre-test conditions

System Simulator:

- E-UTRA Cell 1 is the PCell and NR Cell 1 is the PSCell.

UE:

- None.

Preamble:

- The UE is in state RRC_CONNECTED using generic procedure parameter Connectivity (*EN-DC*), Bearers (*MCG(s)* and *SCG*) established according to TS 38.508-1 [4], clause 4.5.4.

8.2.2.2.1.3.2 Test procedure sequence

Table 8.2.2.2.1.3.2: Main behaviour

St	Procedure	Message Sequence		TP	Verdict
		U - S	Message		
1	SS transmits <i>RRCConnectionReconfiguration</i> message containing NR <i>RRCReconfiguration</i> message to configure Split SRBs.	<--	<i>RRCConnectionReconfiguration</i> (<i>RRCReconfiguration</i>)	-	-
2	Check: Does the UE send a <i>RRCConnectionReconfigurationComplete</i> message containing NR <i>RRCReconfigurationComplete</i> message?	-->	<i>RRCConnectionReconfigurationComplete</i> (<i>RRCReconfigurationComplete</i>)	1	P
2A	SS stops the UL Grant on MCG	-	-	-	-
3	SS transmits <i>UECapabilityEnquiry</i> message for NR capabilities on SRB1 on NR..	<--	<i>UECapabilityEnquiry</i>	-	-
4	Check: Does the UE send <i>UECapabilityInformation</i> message including UE radio access capability information for NR on SRB1S?	-->	<i>UECapabilityInformation</i>	1	P
4A	The SS resumes normal UL grant allocation on MCG	-	-	-	-
5	SS transmits <i>RRCConnectionReconfiguration</i> message containing NR <i>RRCReconfiguration</i> message on SRB1S to release Split SRB.	<--	<i>RRCConnectionReconfiguration</i> (<i>RRCReconfiguration</i>)	-	-
6	Check: Does the UE send <i>RRCConnectionReconfigurationComplete</i> containing NR <i>RRCReconfigurationComplete</i> message?	-->	<i>RRCConnectionReconfigurationComplete</i> (<i>RRCReconfigurationComplete</i>)	2	P

8.2.2.2.1.3.3 Specific message contents

Table 8.2.2.2.1.3.3-1: RRCConnectionReconfiguration (step 1 Table 8.2.2.2.1.3.2-2)

Derivation Path: 36.508 [7], Table 4.6.1-8 with condition MCG_and_SCG and condition HO			
Information Element	Value/remark	Comment	Condition
RRCConnectionReconfiguration ::= SEQUENCE {			
criticalExtensions CHOICE {			
c1 CHOICE{			
rrcConnectionReconfiguration-r8 ::= SEQUENCE			
{			
mobilityControllInfo	MobilityControllInfo-HO-SameCell	As per Table 8.2.2.2.1.3.3-1a	
nonCriticalExtension SEQUENCE {			
nonCriticalExtension SEQUENCE {			
nonCriticalExtension SEQUENCE {			
nonCriticalExtension SEQUENCE {			
nonCriticalExtension SEQUENCE {			
nonCriticalExtension SEQUENCE {			
nonCriticalExtension SEQUENCE {			
nr-Config-r15 CHOICE {			
setup SEQUENCE {			
nr-SecondaryCellGroupConfig-r15	OCTET STRING containing RRCReconfiguration-SplitSRB	As per Table 8.2.2.2.1.3.3-1	
}			
}			
nr-RadioBearerConfig1-r15	OCTET STRING containing RadioBearerConfig-SplitSRB	As per Table 8.2.2.2.1.3.3-4	
}			
}			
}			

Table 8.2.2.2.1.3.3-1a: MobilityControllInfo-HO-SameCell (Table 8.2.2.2.1.3.3-1)

Derivation Path: 36.508 [7], Table 4.6.5-1			
Information Element	Value/remark	Comment	Condition
MobilityControllInfo-HO ::= SEQUENCE {			
targetPhysCellId	PhysicalCellIdentity of E-UTRA Cell 1		
carrierFreq	Not present		
}			

Table 8.2.2.1.3.3-2: RRCReconfiguration-SplitSRB (Table 8.2.2.1.3.3-1)

Derivation Path: 38.508-1 [4], Table 4.6.1-13 with condition EN-DC			
Information Element	Value/remark	Comment	Condition
RRCReconfiguration ::= SEQUENCE {			
criticalExtensions CHOICE {			
rrcReconfiguration SEQUENCE {			
secondaryCellGroup	CellGroupConfig-SplitSRB		
}			
}			
}			

Table 8.2.2.1.3.3-3: CellGroupConfig-SplitSRB (Table 8.2.2.1.3.3-2)

Derivation Path: 38.508-1 [4], Table 4.6.3-8			
Information Element	Value/remark	Comment	Condition
CellGroupConfig ::= SEQUENCE {			
cellGroupId	1		
rlc-BearerToAddModList SEQUENCE (SIZE(1..maxLCH)) OF SEQUENCE {	2 entries		
logicalChannelIdentity[1]	1		
servedRadioBearer[1] CHOICE {			
srb-Identity	1		
}			
reestablishRLC[1]	Not present		
RLC-Config[1]	Not present.		
mac-LogicalChannelConfig[1]	Not present		
logicalChannelIdentity[2]	2		
servedRadioBearer[1] CHOICE {			
srb-Identity	2		
}			
reestablishRLC[2]	Not present		
RLC-Config[2]	Not present		
mac-LogicalChannelConfig [2]	Not present		
}			
}			

Table 8.2.2.1.3.3-4: RadioBearerConfig-SplitSRB (step 1, Table 8.2.2.1.3.3-1)

Derivation Path: 38.508-1 [4], Table 4.6.3-132			
Information Element	Value/remark	Comment	Condition
RadioBearerConfig ::= SEQUENCE {			
srb-ToAddModList SEQUENCE (SIZE (1..2)) OF SEQUENCE {	2 entries		
srb-Identity[1]	1		
pdcp-Config[1]	PDCP-Config-SRB1		
srb-Identity[2]	2		
pdcp-Config[2]	PDCP-Config-SRB2		
}			
}			

Table 8.2.2.2.1.3.3-5: PDCP-Config-SRB1 (Table 8.2.2.2.1.3.3-4)

Derivation Path: 38.508-1 [4], Table 4.6.3-99			
Information Element	Value/remark	Comment	Condition
PDCP-Config ::= SEQUENCE {			
drb	Not present		
moreThanOneRLC SEQUENCE {			
primaryPath SEQUENCE {			
cellGroup	1		
logicalChannel	1		
}			
ul-DataSplitThreshold	infinity		
pdcpc-Duplication	Not present		
}			
t-Reordering	Not present		
}			

Table 8.2.2.2.1.3.3-6: PDCP-Config-SRB2 (Table 8.2.2.2.1.3.3-4)

Derivation Path: 38.508-1 [4], Table 4.6.3-99			
Information Element	Value/remark	Comment	Condition
PDCP-Config ::= SEQUENCE {			
drb	Not present		
moreThanOneRLC SEQUENCE {			
primaryPath SEQUENCE {			
cellGroup	1		
logicalChannel	2		
}			
ul-DataSplitThreshold	infinity		
pdcpc-Duplication	Not present		
}			
t-Reordering	Not present		
}			

Table 8.2.2.2.1.3.3-7: RRCConnectionReconfigurationComplete (steps 2, 6, Table 8.2.2.2.1.3.2-2)

Derivation Path: 36.508 [7], Table 4.6.1-9			
Information Element	Value/remark	Comment	Condition
RRCConnectionReconfigurationComplete ::= SEQUENCE {			
criticalExtensions CHOICE {			
rrcConnectionReconfigurationComplete-r8 SEQUENCE {			
nonCriticalExtension SEQUENCE {			
nonCriticalExtension SEQUENCE {			
nonCriticalExtension SEQUENCE {			
nonCriticalExtension SEQUENCE {			
nonCriticalExtension SEQUENCE {			
scg-ConfigResponseNR-r15	Present		
}			
}			
}			
}			
}			
}			
}			
}			

Table 8.2.2.2.1.3.3-8: UECapabilityEnquiry (step 3, Table 8.2.2.2.1.3.2-2)

Derivation Path: 36.508 [7], Table 4.6.1-22			
Information Element	Value/remark	Comment	Condition
UECapabilityEnquiry ::= SEQUENCE {			
ue-CapabilityRequest SEQUENCE (SIZE (1.. maxRAT-Capabilities)) OF SEQUENCE {	1 entry		
RAT-Type[1]	nr		
}			
}			

Table 8.2.2.2.1.3.3-9: UECapabilityInformation (step 4, Table 8.2.2.2.1.3.2-2)

Derivation Path: 36.508 [7], Table 4.6.1-23			
Information Element	Value/remark	Comment	Condition
UECapabilityInformation ::= SEQUENCE {			
rrc-TransactionIdentifier	RRC-TransactionIdentifier-UL		
criticalExtensions CHOICE {			
c1 CHOICE{			
ueCapabilityInformation-r8 SEQUENCE {			
ue-CapabilityRAT-ContainerList SEQUENCE (SIZE (1..maxRAT-Capabilities)) OF SEQUENCE {	1 entry		
rat-Type	nr		
ueCapabilityRAT-Container	Not checked		
}			
}			
}			
}			
}			

Table 8.2.2.2.1.3.3-10: RRCConnectionReconfiguration (step 5, Table 8.2.2.2.1.3.2-2)

Derivation Path: 36.508 [7], Table 4.6.1-8 condition MCG_and_split			
Information Element	Value/remark	Comment	Condition
RRCConnectionReconfiguration ::= SEQUENCE {			
criticalExtensions CHOICE {			
c1 CHOICE{			
rrcConnectionReconfiguration-r8 SEQUENCE {			
nonCriticalExtension SEQUENCE {			
nonCriticalExtension SEQUENCE {			
nonCriticalExtension SEQUENCE {			
nonCriticalExtension SEQUENCE {			
nonCriticalExtension SEQUENCE {			
nonCriticalExtension SEQUENCE {			
nonCriticalExtension SEQUENCE {			
nr-Config-r15 CHOICE {			
setup SEQUENCE {			
nr-SecondaryCellGroupConfig-r15	<i>RRCReconfiguration-SplitSRBRelease</i>		
}			
}			
}			
}			
}			
}			
}			
}			
}			
}			
}			
}			

Table 8.2.2.2.1.3.3-11: RRCReconfiguration-SplitSRBRelease (Table 8.2.2.2.1.3.3-10)

Derivation Path: 38.508-1 [4], Table 4.6.1-13			
Information Element	Value/remark	Comment	Condition
RRCReconfiguration ::= SEQUENCE {			
criticalExtensions CHOICE {			
c1 CHOICE{			
rrcReconfiguration SEQUENCE {			
radioBearerConfig	Not present		
secondaryCellGroup	CellGroupConfig-SplitSRB-Release		
measConfig	Not Present		
}			
}			
}			

Table 8.2.2.2.1.3.3-12: CellGroupConfig-SplitSRB-Release (Table 8.2.2.2.1.3.3-11)

Derivation Path: 38.508-1 [4], Table 4.6.3-8			
Information Element	Value/remark	Comment	Condition
CellGroupConfig ::= SEQUENCE {			
cellGroupId	1		
rlc-BearerToReleaseList SEQUENCE	2 entries		
(SIZE(1..maxLC-ID)) OF {			
logicalChannelIdentity[1]	1		
logicalChannelIdentity[2]	2		
}			
}			

8.2.2.3 Simultaneous SRB3 and Split SRB / Sequential message flow on SRB3 and Split SRB

8.2.2.3.1 Simultaneous SRB3 and Split SRB / Sequential message flow on SRB3 and Split SRB / EN-DC

8.2.2.3.1.1 Test Purpose (TP)

(1)

```
with { UE in E-UTRA RRC_CONNECTED state in EN_DC mode and SRB1 configured }
ensure that {
  when { UE receives an RRCConnectionReconfiguration message on SRB1 to modify MCG DRB and
reconfigure SRB1 to SRB1 S with SCG UL path }
    then { UE sends RRCConnectionReconfigurationComplete message on SRB1s on the SCG path }
}
```

(2)

```
with { UE in E-UTRA RRC_CONNECTED state in EN_DC mode with SRB3 and split SRB1s configured with
uplink on SCG path }
ensure that {
  when { UE receives RRCReconfiguration message on SRB3 to modify SCG DRB }
    then { UE sends RRCReconfigurationComplete message on SRB3/SCG }
}
```

(3)

```
with { UE in RRC_CONNECTED state in EN-DC mode with SRB3 and Split SRB1s configured with uplink on
SCG path }
ensure that {
  when { UE receives an RRCConnectionReconfiguration message on SRB1s on the NR leg to release SRB3
}
    then { UE releases SRB3 and sends an RRCConnectionReconfigurationComplete message on SRB1s on
SCG }
}
```

(4)

```
with { UE in RRC_CONNECTED state in EN-DC mode with Split SRB1s configured with uplink on SCG path }
ensure that {
  when { UE receives an RRCConnectionReconfiguration message to release SRB1s on SCG path }
    then { UE releases SRB1s and sends an RRCConnectionReconfigurationComplete message on SRB1/MCG
path }
}
```

8.2.2.3.1.2 Conformance requirements

References: The conformance requirements covered in the present TC are specified in: TS 36.331, clauses 5.3.5.3 and TS 38.331:5.3.5.3, 5.3.5.5, 5.3.5.5.3, 5.3.5.6, 5.3.5.6.2 and 5.3.5.6.3. Unless and otherwise stated these are Rel-15 requirements

[TS 36.331, clause 5.3.5.3]

If the *RRCCONNECTIONRECONFIGURATION* message does not include the *mobilityControlInfo* and the UE is able to comply with the configuration included in this message, the UE shall:

...

1> if the received *RRCCONNECTIONRECONFIGURATION* includes the *nr-SecondaryCellGroupConfig*:

2> perform NR RRC Reconfiguration as specified in TS 38.331 [82], clause 5.3.5.3;

1> if the received *RRCCONNECTIONRECONFIGURATION* includes the *nr-RadioBearerConfig1*:

2> perform radio bearer configuration as specified in TS 38.331 [82], clause 5.3.5.6;

1> if the received *RRCCONNECTIONRECONFIGURATION* includes the *nr-RadioBearerConfig2*:

2> perform radio bearer configuration as specified in TS 38.331 [82], clause 5.3.5.6;

...

1> set the content of *RRCCONNECTIONRECONFIGURATIONCOMPLETE* message as follows:

...

2> if the received *RRCCONNECTIONRECONFIGURATION* message included *nr-SecondaryCellGroupConfig*:

3> include *scg-ConfigResponseNR* in accordance with TS 38.331 [82], clause 5.3.5.3;

1> submit the *RRCCONNECTIONRECONFIGURATIONCOMPLETE* message to lower layers for transmission using the new configuration, upon which the procedure ends;

[TS 38.331, clause 5.3.5.3]

The UE shall perform the following actions upon reception of the *RRCRECONFIGURATION*:

...

1> if the *RRCRECONFIGURATION* includes the *secondaryCellGroup*:

2> perform the cell group configuration for the SCG according to 5.3.5.5;

1> if the *RRCRECONFIGURATION* message contains the *radioBearerConfig*:

2> perform the radio bearer configuration according to 5.3.5.6;

...

1> if the UE is configured with E-UTRA *nr-SecondaryCellGroupConfig* (MCG is E-UTRA):

2> if *RRCRECONFIGURATION* was received via SRB1:

3> submit the *RRCRECONFIGURATIONCOMPLETE* via the EUTRA MCG embedded in E-UTRA RRC message *RRCCONNECTIONRECONFIGURATIONCOMPLETE* as specified in TS 36.331 [10].

[TS 38.331, clause 5.3.5.5.3]

The UE shall:

1> for each *logicalChannelIdentity* value included in the *rlc-BearerToReleaseList* that is part of the current UE configuration (LCH release); or

1> for each *logicalChannelIdentity* value that is to be released as the result of an SCG release according to 5.3.5.4:

2> release the RLC entity or entities as specified in TS 38.322 [4, section 5.1.3];

2> release the corresponding logical channel.

[TS 38.331, clause 5.3.5.6.1]

The UE shall perform the following actions based on a received *RadioBearerConfig* IE:

...

- 1> if the *RadioBearerConfig* includes the *srb-ToAddModList*:
 - 2> perform the SRB addition or reconfiguration as specified in 5.3.5.6.3;

[TS 38.331, clause 5.3.5.6.3]

The UE shall:

- 1> for each *srb-Identity* value included in the *srb-ToAddModList* that is not part of the current UE configuration (SRB establishment or reconfiguration from E-UTRA PDCP to NR PDCP):
 - 2> establish a PDCP entity and configure it with the security algorithms according to *securityConfig* and apply the keys (K_{RRCenc} and K_{RRCint}) associated with the master key (K_{eNB}/K_{gNB}) or secondary key ($S-K_{gNB}$) as indicated in *keyToUse*, if applicable;
 - 2> if the current UE configuration as configured by E-UTRA in TS 36.331 includes an SRB identified with the same *srb-Identity* value:
 - 3> associate the E-UTRA RLC entity and DCCH of this SRB with the NR PDCP entity;
 - 3> release the E-UTRA PDCP entity of this SRB;
 - 2> if the *pdcp-Config* is included:
 - 3> configure the PDCP entity in accordance with the received *pdcp-Config*;
 - 2> else:
 - 3> configure the PDCP entity in accordance with the default configuration defined in 9.2.1 for the corresponding SRB;

8.2.2.3.1.3 Test description

8.2.2.3.1.3.1 Pre-test conditions

System Simulator:

- E-UTRA Cell 1 is the PCell and NR Cell 1 is the PSCell.
- System Information combination as defined in TS 38.508-1 [4] clause 4.4.3.1.1 is used in E-UTRA Cell 1 and NR Cell 1.

UE:

- None.

Preamble:

- The UE is in state RRC_CONNECTED using generic procedure parameter Connectivity (*EN-DC*) and DC bearers (MCG(*s*) and SCG and SRB3) according to TS 38.508-1 [4], table 4.5.1-1.

8.2.2.3.1.3.2 Test procedure sequence

Table 8.2.2.3.1.3.2-1: Main behaviour

St	Procedure	Message Sequence		TP	Verdict
		U - S	Message		
1	The SS transmits an <i>RRConnectionReconfiguration</i> message to reconfigure MCG DRB on SRB1 over MCG path/E-UTRA Cell 1.	<--	<i>RRConnectionReconfiguration (RRCReconfiguration)</i>	-	-
2	Check: Does the UE transmits an <i>RRConnectionReconfigurationComplete</i> message on SRB1s over the SCG path/NR Cell 1?	-->	<i>RRConnectionReconfigurationComplete (RRCReconfigurationComplete)</i>	1	P
3	The SS transmits an NR <i>RRCReconfiguration</i> message to reconfigure SCG DRB on SRB3/NR Cell 1.	<--	<i>RRCReconfiguration</i>	-	-
4	Check: Does the UE transmit an NR <i>RRCReconfigurationComplete</i> message on SRB3/NR Cell 1?	-->	<i>RRCReconfigurationComplete</i>	2	P
5	The SS transmits an <i>RRConnectionReconfiguration</i> message to release SRB3 over SRB1s SCG path/NR Cell 1.	<--	<i>RRConnectionReconfiguration (RRCReconfiguration)</i>	-	-
6	Check: Does the UE transmits an <i>RRConnectionReconfigurationComplete</i> message on SRB1s over the SCG path/NR Cell 1?	-->	<i>RRConnectionReconfigurationComplete (RRCReconfigurationComplete)</i>	3	P
7	The SS transmits an <i>RRConnectionReconfiguration</i> message to release SRB1s over SRB1s/SCG path/NR Cell 1.	<--	<i>RRConnectionReconfiguration (RRCReconfiguration)</i>	-	-
8	Check: Does the UE transmits an <i>RRConnectionReconfigurationComplete</i> message on SRB1 over the MCG path/E-UTRA Cell 1?	-->	<i>RRConnectionReconfigurationComplete (RRCReconfigurationComplete)</i>	4	P

8.2.2.3.1.3.3 Specific message contents

Table 8.2.2.3.1.3.3-1: RRCConnectionReconfiguration (step 1, Table 8.2.2.3.1.3.2-1)

Derivation Path: 36.508 [7], Table 4.6.1-8			
Information Element	Value/remark	Comment	Condition
RRCConnectionReconfiguration ::= SEQUENCE {			
criticalExtensions CHOICE {			
c1 CHOICE{			
rrcConnectionReconfiguration-r8 SEQUENCE {			
radioResourceConfigDedicated	RadioResourceConfigDe dicated according to t Table 8.2.2.3.1.3.3-2		
mobilityControlInfo	MobilityControlInfo-HO- SameCell	As per Table 8.2.2.3.1.3.3-1E	
nonCriticalExtension SEQUENCE {			
nonCriticalExtension SEQUENCE {			
nonCriticalExtension SEQUENCE {			
nonCriticalExtension SEQUENCE {			
nonCriticalExtension SEQUENCE {			
nonCriticalExtension SEQUENCE {			
nonCriticalExtension SEQUENCE {			
nr-Config-r15 CHOICE {			
setup SEQUENCE {			
nr-SecondaryCellGroupConfig-r15	OCTET STRING including the RRCReconfiguration message and the IE secondaryCellGroup according table 8.2.2.3.1.3.3-1A		
}			
}			
}			
}			
}			
}			
}			
}			
}			
}			
nr-RadioBearerConfig1-r15	RadioBearerConfig according to Table 8.2.2.3.1.3.3-1C		
}			
}			
}			

Table 8.2.2.3.1.3.3-1A: RRCReconfiguration (Table 8.2.2.3.1.3.3-1)

Derivation Path: 38.508-1 [4], Table 4.6.1-13			
Information Element	Value/remark	Comment	Condition
RRCReconfiguration ::= SEQUENCE {			
criticalExtensions CHOICE {			
rrcReconfiguration ::= SEQUENCE {			
secondaryCellGroup	OCTET STRING containing CellGroupConfig according to Table 8.2.2.3.1.3.3-1B.		
}			
}			
}			

Table 8.2.2.3.1.3.3-1B: CellGroupConfig (Table 8.2.2.3.1.3.3-1A)

Derivation Path: 38.508-1 [4], Table 4.6.3-19			
Information Element	Value/remark	Comment	Condition
CellGroupConfig ::= SEQUENCE {			
cellGroupId	1		
rlc-BearerToAddModList SEQUENCE (SIZE(1..maxLCH)) OF SEQUENCE {	1 entry		
RLC-BearerConfig[1]	RLC-BearerConfig with condition SRB1		
}			
mac-LogicalChannelConfig	LogicalChannelConfig according to 38.508-1 [4], table 4.6.3-66		
}			
}			

Table 8.2.2.3.1.3.3-1C: RadioBearerConfig (Table 8.2.2.3.1.3.3-1)

Derivation Path: TS 38.331 [6], clause 6.3.2			
Information Element	Value/remark	Comment	Condition
RadioBearerConfig ::= SEQUENCE {			
srb-ToAddModList SEQUENCE {			
srb-Identity	1		
reestablishPDCP	Not present		
discardOnPDCP	Not present		
pdcp-Config	PDCP-Config according to table 8.2.2.3.1.3.3-1D		
}			
}			

Table 8.2.2.3.1.3.3-1D: PDCP-Config (Table 8.2.2.3.1.3.3-1C)

Derivation Path: 38.508-1[4] table 4.6.3-99			
Information Element	Value/remark	Comment	Condition
PDCP-Config ::= SEQUENCE {			
drb	Not present		
moreThanOneRLC SEQUENCE {			
primaryPath SEQUENCE {			
cellGroup	1	NR cell 1	
logicalChannel	1		
}			
ul-DataSplitThreshold	infinity		
pdcp-Duplication	false		
}			
t-Reordering	Not present.		
}			

Table 8.2.2.3.1.3.3-1E: MobilityControlInfo-HO-SameCell (Table 8.2.2.3.1.3.3-1)

Derivation Path: 36.508 [7], Table 4.6.5-1			
Information Element	Value/remark	Comment	Condition
MobilityControlInfo-HO ::= SEQUENCE {			
targetPhysCellId	PhysicalCellIdentity of E-UTRA Cell 1		
carrierFreq	Not present		
}			

Table 8.2.2.3.1.3.3-2: RadioResourceConfigDedicated (Table 8.2.2.3.1.3.3-1)

Derivation Path: 36.331 [11], clause 6.3.2			
Information Element	Value/remark	Comment	Condition
RadioResourceConfigDedicated ::= SEQUENCE {			
drb-ToAddModList	Not present		
drb-ToReleaseList	Not present		
mac-MainConfig CHOICE {			
explicitValue	MAC-MainConfig according to table 8.2.2.3.1.3.3-3		
}			
sps-Config	Not present		
physicalConfigDedicated	Not present		
}			

Table 8.2.2.3.1.3.3-3: MAC-MainConfig (Table 8.2.2.3.1.3.3-2)

Derivation Path: 36.508 [7], Table 4.8.2.1.5-1			
Information Element	Value/remark	Comment	Condition
MAC-MainConfig ::= SEQUENCE {			
ul-SCH-Config SEQUENCE {			
periodicBSR-Timer	sf32		
retxBSR-Timer	sf2560		
}			
phr-Config CHOICE {			
setup SEQUENCE {			
periodicPHR-Timer	sf1000		
prohibitPHR-Timer	sf500		
}			
}			
}			

Table 8.2.2.3.1.3.3-4: RRCReconfiguration (step 3, Table 8.2.2.3.1.3.2-1)

Derivation Path: 38.508-1 [4], Table 4.6.1-13			
Information Element	Value/remark	Comment	Condition
RRCReconfiguration ::= SEQUENCE {			
criticalExtensions CHOICE {			
rrcReconfiguration ::= SEQUENCE {			
secondaryCellGroup	OCTET STRING containing CellGroupConfig according to table 8.2.2.3.1.3.3-5.		
}			
}			
}			

Table 8.2.2.3.1.3.3-5: CellGroupConfig (Table 8.2.2.3.1.3.3-4)

Derivation Path: 38.508-1 [4], Table 4.6.3-19			
Information Element	Value/remark	Comment	Condition
CellGroupConfig ::= SEQUENCE {			
cellGroupId	1		
mac-CellGroupConfig	MAC-CellGroupConfig according to table 8.2.2.3.1.3.3-5a		
}			

Table 8.2.2.3.1.3.3-5A: MAC-CellGroupConfig (Table 8.2.2.3.1.3.3-5)

Derivation Path: TS 38.508-1 [4], Table 4.6.3-68			
Information Element	Value/remark	Comment	Condition
MAC-CellGroupConfig ::= SEQUENCE {			
bsr-Config SEQUENCE {			
periodicBSR-Timer	sf5		
retxBSR-Timer	sf40		
}			
}			

Table 8.2.2.3.1.3.3-6: RRCConnectionReconfiguration (step 5, Table 8.2.2.3.1.3.2-1)

Derivation Path: 36.508 [7], Table 4.6.1-8			
Information Element	Value/remark	Comment	Condition
RRCConnectionReconfiguration ::= SEQUENCE {			
criticalExtensions CHOICE {			
c1 CHOICE{			
rrcConnectionReconfiguration-r8 SEQUENCE {			
nonCriticalExtension SEQUENCE {			
nonCriticalExtension SEQUENCE {			
nonCriticalExtension SEQUENCE {			
nonCriticalExtension SEQUENCE {			
nonCriticalExtension SEQUENCE {			
nonCriticalExtension SEQUENCE {			
nr-Config-r15 CHOICE {			
setup SEQUENCE {			
nr-SecondaryCellGroupConfig-r15	OCTET STRING containing <i>RRCReconfiguration</i> according to Table 8.2.2.3.1.3.3-8.		
}			
}			
}			
}			
}			
}			
nr-RadioBearerConfig1-r15	RadioBearerConfig according to Table 8.2.2.3.1.3.3-7.		
}			
}			
}			

Table 8.2.2.3.1.3.3-7: RadioBearerConfig (Table 8.2.2.3.1.3.3-6)

Derivation Path: 38.508-1 [4], Table 4.6.3-132			
Information Element	Value/remark	Comment	Condition
RadioBearerConfig ::= SEQUENCE {			
srb-ToAddModList	Not present		
srb3-ToRelease	true		
drb-ToAddModList	Not present		
drb-ToReleaseList	Not present		
securityConfig	Not present		
}			

Table 8.2.2.3.1.3.3-8: RRCReconfiguration (Table 8.2.2.3.1.3.3-6)

Derivation Path: 38.508-1 [4], Table 4.6.1-13			
Information Element	Value/remark	Comment	Condition
RRCReconfiguration ::= SEQUENCE {			
criticalExtensions CHOICE {			
rrcReconfiguration ::= SEQUENCE {			
secondaryCellGroup	OCTET STRING containing <i>CellGroupConfig</i> according to table 8.2.2.1.1.3.3-9.		
}			
}			
}			

Table 8.2.2.3.1.3.3-9: CellGroupConfig (Table 8.2.2.3.1.3.3-8)

Derivation Path: 38.508-1 [4], Table 4.6.3-19			
Information Element	Value/remark	Comment	Condition
CellGroupConfig ::= SEQUENCE {			
cellGroupId	1		
rlc-BearerToAddModList	Not present		
rlc-BearerToReleaseList SEQUENCE (SIZE (1..maxLC-ID)) OF {	1 entry		
LogicalChannelIdentity[1]	3		
}			
mac-CellGroupConfig	Not present		
physicalCellGroupConfig	Not present		
sCellToAddModList	Not present		
sCellToReleaseList SEQUENCE (SIZE (1..maxNrofSCells)) OF SEQUENCE {			
sCellIndex[1]	SCellIndex	NR Cell 1	
}			
}			

Table 8.2.2.3.1.3.3-12: *CellGroupConfig* (Table 8.2.2.3.1.3.3-11)

Derivation Path: 38.508-1 [4], Table 4.6.3-19			
Information Element	Value/remark	Comment	Condition
CellGroupConfig ::= SEQUENCE {			
cellGroupId	1		
rlc-BearerToReleaseList SEQUENCE (SIZE (1.. maxLC-ID)) OF {	1 entry		
LogicalChannelIdentity[1]	1		
}			
mac-CellGroupConfig	MAC-CellGroupConfig according to TS 38.508-1 [4] Table 4.6.3-68		
}			

8.2.2.4 PSCell addition, modification and release / SCG DRB

8.2.2.4.1 PSCell addition, modification and release / SCG DRB / EN-DC

8.2.2.4.1.1 Test Purpose (TP)

(1)

```
with { UE in RRC_CONNECTED state with EN-DC, and, MCG(s) (E-UTRA PDCP) only }
ensure that {
  when { UE receives an RRCConnectionReconfiguration message to add PSCell with SCG DRB }
  then { UE configures the PSCell with SCG DRB and sends an RRCConnectionReconfigurationComplete message }
}
```

(2)

```
with { UE in RRC_CONNECTED state with EN-DC, and, MCG(s) (E-UTRA PDCP) and SCG }
ensure that {
  when { UE receives an RRCConnectionReconfiguration message to modify SCG DRB }
  then { UE reconfigures the SCG DRB and sends an RRCConnectionReconfigurationComplete message }
}
```

(3)

```
with { UE in RRC_CONNECTED state with EN-DC, and, MCG(s) (E-UTRA PDCP) and SCG }
ensure that {
  when { UE receives an RRCConnectionReconfiguration message to release PSCell with SCG DRB }
  then { UE releases the PSCell and SCG DRB and sends an RRCConnectionReconfigurationComplete message }
}
```

8.2.2.4.1.2 Conformance requirements

References: The conformance requirements covered in the present test case are specified in: TS 36.331, clause 5.3.5.3, TS 38.331, clauses 5.3.5.3, 5.3.5.5.7, 5.3.5.6.4 and 5.3.5.6.5. Unless otherwise stated these are Rel-15 requirements.

[TS 36.331, clause 5.3.5.3]

If the *RRCConnectionReconfiguration* message does not include the *mobilityControlInfo* and the UE is able to comply with the configuration included in this message, the UE shall:

...

- 1> if the received *RRCConnectionReconfiguration* includes the *nr-Config* and it is set to release: or
- 1> if the received *RRCConnectionReconfiguration* includes *endc-ReleaseAndAdd* and it is set to *TRUE*:
- 2> perform ENDC release as specified in TS38.331 [82], clause 5.3.5.10;

- 1> if the received *RRCCONNECTIONRECONFIGURATION* includes the *sk-Counter*:
 - 2> perform key update procedure as specified in TS 38.331 [82], clause 5.3.5.7;
- 1> if the received *RRCCONNECTIONRECONFIGURATION* includes the *nr-SecondaryCellGroupConfig*:
 - 2> perform NR RRC Reconfiguration as specified in TS 38.331 [82], clause 5.3.5.3;
- 1> if the received *RRCCONNECTIONRECONFIGURATION* includes the *nr-RadioBearerConfig1*:
 - 2> perform radio bearer configuration as specified in TS 38.331 [82], clause 5.3.5.6;
- 1> if the received *RRCCONNECTIONRECONFIGURATION* includes the *nr-RadioBearerConfig2*:
 - 2> perform radio bearer configuration as specified in TS 38.331 [82], clause 5.3.5.6;
- ...
- 1> set the content of *RRCCONNECTIONRECONFIGURATIONCOMPLETE* message as follows:
 - 2> if the *RRCCONNECTIONRECONFIGURATION* message includes *perCC-GapIndicationRequest*:
 - 3> include *perCC-GapIndicationList* and *numFreqEffective*;
 - 2> if the frequencies are configured for reduced measurement performance:
 - 3> include *numFreqEffectiveReduced*;
 - 2> if the received *RRCCONNECTIONRECONFIGURATION* message included *nr-SecondaryCellGroupConfig*:
 - 3> include *scg-ConfigResponseNR* in accordance with TS 38.331 [82], clause 5.3.5.3;
- 1> submit the *RRCCONNECTIONRECONFIGURATIONCOMPLETE* message to lower layers for transmission using the new configuration, upon which the procedure ends;

[TS 38.331, clause 5.3.5.3]

The UE shall perform the following actions upon reception of the *RRCReconfiguration*:

- ...
- 1> if the *RRCReconfiguration* includes the *secondaryCellGroup*:
 - 2> perform the cell group configuration for the SCG according to 5.3.5.5;
- 1> if the *RRCReconfiguration* message contains the *radioBearerConfig*:
 - 2> perform the radio bearer configuration according to 5.3.5.6;
- 1> if the *RRCReconfiguration* message includes the *measConfig*:
 - 2> perform the measurement configuration procedure as specified in 5.5.2;
- ...
- 1> set the content of *RRCReconfigurationComplete* message as follows:
 - 2> if the *RRCReconfiguration* includes the *masterCellGroup* containing the *reportUplinkTxDirectCurrent*, or;
 - 2> if the *RRCReconfiguration* includes the *secondaryCellGroup* containing the *reportUplinkTxDirectCurrent*:
 - 3> include the *uplinkTxDirectCurrentList*;
- 1> if the UE is configured with E-UTRA *nr-SecondaryCellGroupConfig* (MCG is E-UTRA):
 - 2> if *RRCReconfiguration* was received via SRB1:
 - 3> construct *RRCReconfigurationComplete* message and submit it via the EUTRA MCG embedded in E-UTRA RRC message *RRCCONNECTIONRECONFIGURATIONCOMPLETE* as specified in TS 36.331 [10].

3> if *reconfigurationWithSync* was included in *spCellConfig* of an SCG:

4> initiate the random access procedure on the SpCell, as specified in TS 38.321 [3];

3> else:

4> the procedure ends;

NOTE: The order the UE sends the *RRCConnectionReconfigurationComplete* message and performs the Random Access procedure towards the SCG is left to UE implementation.

2> else (*RRCReconfiguration* was received via SRB3):

3> submit the *RRCReconfigurationComplete* message via SRB3 to lower layers for transmission using the new configuration.

NOTE: For EN-DC, in the case *RRCReconfiguration* is received via SRB1, the random access is triggered by RRC layer itself as there is not necessarily other UL transmission. In the case *RRCReconfiguration* is received via SRB3, the random access is triggered by the MAC layer due to arrival of *RRCReconfigurationComplete*.

1 > else:

2> submit the *RRCReconfigurationComplete* message via SRB1 to lower layers for transmission using the new configuration;

2> if this is the first *RRCReconfiguration* message after successful completion of the RRC re-establishment procedure:

3> resume SRB2 and DRBs that are suspended;

1> if *reconfigurationWithSync* was included in *spCellConfig* of an MCG or SCG, and when MAC of an NR cell group successfully completes a random access procedure triggered above;

2> stop timer T304 for that cell group;

2> apply the parts of the CQI reporting configuration, the scheduling request configuration and the sounding RS configuration that do not require the UE to know the SFN of the respective target SpCell, if any;

2> apply the parts of the measurement and the radio resource configuration that require the UE to know the SFN of the respective target SpCell (e.g. measurement gaps, periodic CQI reporting, scheduling request configuration, sounding RS configuration), if any, upon acquiring the SFN of that target SpCell;

2> if the *reconfigurationWithSync* was included in *spCellConfig* of an MCG::

3> if T390 is running:

4> stop timer T390 for all access categories;

4> perform the actions as specified in 5.3.14.4.

3> if *RRCReconfiguration* does not include *dedicatedSIB1-Delivery* and

3> if the active downlink BWP, which is indicated by the *firstActiveDownlinkBWP-Id* for the target SpCell of the MCG, has a common search space configured by *searchSpaceSIB1*:

4> acquire the *SIB1*, which is scheduled as specified in TS 38.213 [13], of the target SpCell of the MCG;

4> upon acquiring *SIB1*, perform the actions specified in clause 5.2.2.4.2;

2> the procedure ends;

NOTE: The UE is only required to acquire broadcasted *SIB1* if the UE can acquire it without disrupting unicast data reception, i.e. the broadcast and unicast beams are quasi co-located.

[TS 38.331, clause 5.3.5.5.7]

The UE shall:

...

- 1> if the *SpCellConfig* contains *spCellConfigDedicated*:
 - 2> configure the SpCell in accordance with the *spCellConfigDedicated*;
 - 2> consider the bandwidth part indicated in *firstActiveUplinkBWP-Id* if configured to be the active uplink bandwidth part;
 - 2> consider the bandwidth part indicated in *firstActiveDownlinkBWP-Id* if configured to be the active downlink bandwidth part;
 - 2> if the any of the reference signal(s) that are used for radio link monitoring are reconfigured by the received *spCellConfigDedicated*:
 - 3> stop timer T310 for the corresponding SpCell, if running;
 - 3> reset the counters N310 and N311.

[TS 38.331, clause 5.3.5.6.4]

Editor's Note: FFS / TODO: Add handling for the new QoS concept (mapping of flows; configuration of QFI-to-DRB mapping; reflective QoS...) but keep also EPS-Bearer handling for the EN-DC case

The UE shall:

- 1> for each *drb-Identity* value included in the *drb-ToReleaseList* that is part of the current UE configuration; or;
- 1> for each *drb-Identity* value that is to be released as the result of full configuration according to 5.3.5.11:
 - 2> release the PDCP entity and the *drb-Identity*;
 - 2> if SDAP entity associated with this DRB is configured:
 - 3> indicate the release of the DRB to SDAP entity associated with this DRB (TS 37.324 24[] clause 5.3.3);
 - 2> if the UE is operating in EN-DC:
 - 3> if a new bearer is not added either with NR or E-UTRA with same *eps-BearerIdentity*;
 - 4> indicate the release of the DRB and the *eps-BearerIdentity* of the released DRB to upper layers.

NOTE: The UE does not consider the message as erroneous if the *drb-ToReleaseList* includes any *drb-Identity* value that is not part of the current UE configuration.

NOTE: Whether or not the RLC and MAC entities associated with this PDCP entity are reset or released is determined by the *CellGroupConfig*.

[TS 38.331, clause 5.3.5.6.5]

The UE shall:

- 1> for each *drb-Identity* value included in the *drb-ToAddModList* that is not part of the current UE configuration (DRB establishment including the case when full configuration option is used):
 - 2> establish a PDCP entity and configure it in accordance with the received *pdcp-Config*;
 - 2> if the PDCP entity of this DRB is not configured with *cipheringDisabled::*

- 3> if target RAT of handover is E-UTRA/5GC, or;
- 3> if the UE is only connected to E-UTRA/5GC:
 - 4> configure the PDCP entity with the ciphering algorithm and K_{UPenc} key configured/derived as specified in TS 36.331 [10];
- 3> else:
- 4> configure the PDCP entity with the ciphering algorithms according to *securityConfig* and apply the K_{UPenc} key associated with the master key (K_{eNB}/K_{gNB}) or the secondary key ($S-K_{gNB}$) as indicated in *keyToUse*;
- 2> if the PDCP entity of this DRB is configured with *integrityProtection*:
 - 3> configure the PDCP entity with the integrity algorithms according to *securityConfig* and apply the K_{UPint} key associated with the master (K_{eNB}/K_{gNB}) or the secondary key ($S-K_{gNB}$) as indicated in *keyToUse*;
- ...
- 2> if the UE is operating in EN-DC:
 - 3> if the DRB was configured with the same *eps-BearerIdentity* either by NR or E-UTRA prior to receiving this reconfiguration:
 - 4> associate the established DRB with the corresponding *eps-BearerIdentity*;
 - 3> else:
 - 4> indicate the establishment of the DRB(s) and the *eps-BearerIdentity* of the established DRB(s) to upper layers;
- 1> for each *drb-Identity* value included in the *drb-ToAddModList* that is part of the current UE configuration:
 - 2> if the *reestablishPDCP* is set:
 - 3> if target RAT is E-UTRA/5GC:, or;
 - 3> if the UE is only connected to E-UTRA/5GC:
 - 4> if the PDCP entity of this DRB is not configured with *cipheringDisabled*:
 - 5> configure the PDCP entity with the ciphering algorithm and K_{UPenc} key configured/derived as specified in TS 36.331 [10], clause 5.4.2.3, i.e. the ciphering configuration shall be applied to all subsequent PDCP PDUs received and sent by the UE;
 - 3> else:
 - 4> if the PDCP entity of this DRB is not configured with *cipheringDisabled*::
 - 5> configure the PDCP entity with the ciphering algorithm and K_{UPenc} key associated with the master key (K_{eNB}/K_{gNB}) or the secondary key ($S-K_{gNB}$), as indicated in *keyToUse*, i.e. the ciphering configuration shall be applied to all subsequent PDCP PDUs received and sent by the UE;
 - 4> if the PDCP entity of this DRB is configured with *integrityProtection*:
 - 5> configure the PDCP entity with the integrity algorithms according to *securityConfig* and apply the K_{UPint} key associated with the master (K_{eNB}/K_{gNB}) or the secondary key ($S-K_{gNB}$) as indicated in *keyToUse*;
 - 3> re-establish the PDCP entity of this DRB as specified in 38.323 [5], clause 5.1.2;
- 2> else, if the *recoverPDCP* is set:
 - 3> trigger the PDCP entity of this DRB to perform data recovery as specified in 38.323[5];
- 2> if the *pdc-Config* is included:

3> reconfigure the PDCP entity in accordance with the received *pdcp-Config*.

...

NOTE 1: Void

NOTE 2: When determining whether a drb-Identity value is part of the current UE configuration, the UE does not distinguish which *RadioBearerConfig* and *DRB-ToAddModList* that DRB was originally configured in. To re-associate a DRB with a different key (KeNB to S-KeNB or vice versa), the network provides the *drb-Identity* value in the (target) *drb-ToAddModList* and sets the *reestablishPDCP* flag. The network does not list the *drb-Identity* in the (source) *drb-ToReleaseList*.

NOTE 3: When setting the *reestablishPDCP* flag for a radio bearer, the network ensures that the RLC receiver entities do not deliver old PDCP PDUs to the re-established PDCP entity. It does that e.g. by triggering a reconfiguration with sync of the cell group hosting the old RLC entity or by releasing the old RLC entity.

NOTE 4: In this specification, UE configuration refers to the parameters configured by NR RRC unless otherwise stated.

NOTE 5: Ciphering and integrity protection can be enabled or disabled for a DRB. The enabling/disabling of ciphering or integrity protection can be changed only by releasing and adding the DRB.

8.2.2.4.1.3 Test description

8.2.2.4.1.3.1 Pre-test conditions

System Simulator:

- E-UTRA Cell 1 is the PCell and NR Cell 1 is the PSCell.

UE:

- None.

Preamble:

- If *pc_IP_Ping* is set to TRUE then, the UE is in state RRC_CONNECTED using generic procedure parameter Connectivity (*EN-DC*), Bearers (*MCG(s) only*) established according to TS 38.508-1 [4], clause 4.5.4.
- Else, the UE is in state RRC_CONNECTED using generic procedure parameter Connectivity (*EN-DC*), Bearers (*MCG(s) only*) established and Test Mode (*On*) associated with UE test loop mode B configured on E-UTRA Cell 1 according to TS 38.508-1 [4], clause 4.5.4.

8.2.2.4.1.3.2 Test procedure sequence

Table 8.2.2.4.1.3.2-1: Main behaviour

St	Procedure	Message Sequence		TP	Verdict
		U - S	Message		
1	The SS transmits an <i>RRCCoRectionReconfiguration</i> message containing NR <i>RRCReconfiguration</i> message to add NR <i>PSCell</i> with SCG DRB. <i>RRCCoRectionReconfiguration</i> message contains the ACTIVATE DEDICATED EPS BEARER CONTEXT REQUEST message.	<--	<i>RRCCoRectionReconfiguration</i> (<i>RRCReconfiguration</i>)	-	-
2	Check: Does the UE transmit an <i>RRCCoRectionReconfigurationComplete</i> message containing NR <i>RRCReconfigurationComplete</i> message?	-->	<i>RRCCoRectionReconfigurationC</i> <i>omplete</i> (<i>RRCReconfigurationComplete</i>)	1	P
3	The UE transmits an <i>ULInformationTransfer</i> message containing the ACTIVATE DEDICATED EPS BEARER CONTEXT ACCEPT message.	-->	<i>ULInformationTransfer</i>	-	-
-	EXCEPTION: Steps 4a1 to 4a2 describe behaviour that depends on the UE implementation; the "lower case letter" identifies a step sequence that take place depending on the UE implementation.	-	-	-	-
4a1	IF <i>pc_IP_Ping</i> = FALSE, then, the SS transmits a CLOSE UE TEST LOOP message.	<--	CLOSE UE TEST LOOP	-	-
4a2	The UE transmits a CLOSE UE TEST LOOP COMPLETE message.	-->	CLOSE UE TEST LOOP COMPLETE	-	-
5	Check: Does the test result of generic test procedure in TS 38.508-1 subclause 4.9.1 indicate that the UE is capable of exchanging IP data on SCG DRB#2?	-	-	1	P
6	SS transmits <i>RRCCoRectionReconfiguration</i> message containing NR <i>RadioBearerConfig</i> to modify PDCP <i>discardTimer</i> value of SCG DRB.	<--	<i>RRCCoRectionReconfiguration</i>	-	-
7	Check: Does the UE transmit an <i>RRCCoRectionReconfigurationComplete</i> message?	-->	<i>RRCCoRectionReconfigurationC</i> <i>omplete</i>	2	P
8	Check: Does the test result of generic test procedure in TS 38.508-1 subclause 4.9.1 indicate that the UE is capable of exchanging IP data on SCG DRB#2?	-	-	2	P
9	SS transmits <i>RRCCoRectionReconfiguration</i> message containing <i>nr-Config-r15</i> and NR <i>RadioBearerConfig</i> to release <i>PSCell</i> and SCG DRB. <i>RRCCoRectionReconfiguration</i> message contains the DEACTIVATE EPS BEARER CONTEXT REQUEST message.	<--	<i>RRCCoRectionReconfiguration</i>	-	-
10	Check: Does the UE transmit an <i>RRCCoRectionReconfigurationComplete</i> message containing NR <i>RRCReconfigurationComplete</i> message?	-->	<i>RRCCoRectionReconfigurationC</i> <i>omplet</i>	3	P
11	The UE transmits an <i>ULInformationTransfer</i> message containing the DEACTIVATE EPS BEARER CONTEXT ACCEPT message.	-->	<i>ULInformationTransfer</i>	-	-

Table 8.2.2.4.1.3.3-3: CellGroupConfig (Table 8.2.2.4.1.3.3-2)

Derivation Path: 38.508-1 [4], Table 4.6.3-19			
Information Element	Value/remark	Comment	Condition
CellGroupConfig ::= SEQUENCE {			
rlc-BearerToAddModList SEQUENCE (SIZE(1..maxLCH)) OF SEQUENCE {	1 entry		
servedRadioBearer CHOICE {			
drb-Identity	2	SCG DRB Id	
}			
}			
}			

Table 8.2.2.4.1.3.3-4: RadioBearerConfig (Table 8.2.2.4.1.3.3-1)

Derivation Path: 38.508-1 [4], Table 4.6.3-132			
Information Element	Value/remark	Comment	Condition
RadioBearerConfig ::= SEQUENCE {			
drb-ToAddModList SEQUENCE (SIZE (1..maxDRB)) OF SEQUENCE {	1 entry		
cnAssociation CHOICE {			
eps-BearerIdentity	6	Dedicated EPS bearer Id of SCG DRB	
}			
drb-Identity	2	SCG DRB Id	
}			
securityConfig SEQUENCE {			
keyToUse	secondary		
}			
}			

Table 8.2.2.4.1.3.3-5: RRCConnectionReconfiguration (step 6, Table 8.2.2.4.1.3.2-1)

Derivation Path: 36.508 [7], Table 4.6.1-8			
Information Element	Value/remark	Comment	Condition
RRCConnectionReconfiguration ::= SEQUENCE {			
criticalExtensions CHOICE {			
c1 CHOICE{			
rrcConnectionReconfiguration-r8 ::= SEQUENCE			
{			
nonCriticalExtension ::= SEQUENCE {			
nonCriticalExtension ::= SEQUENCE {			
nonCriticalExtension ::= SEQUENCE {			
nonCriticalExtension ::= SEQUENCE {			
nonCriticalExtension ::= SEQUENCE {			
nonCriticalExtension ::= SEQUENCE {			
nonCriticalExtension ::= SEQUENCE {			
nonCriticalExtension ::= SEQUENCE {			
nr-RadioBearerConfig1-r15	OCTET STRING		
including	RadioBearerConfig.		
}			
}			
}			
}			
}			

Table 8.2.2.4.1.3.3-6: RadioBearerConfig (Table 8.2.2.4.1.3.3-5)

Derivation Path: 38.508-1 [4], Table 4.6.3-132			
Information Element	Value/remark	Comment	Condition
RadioBearerConfig ::= SEQUENCE {			
drb-ToAddModList SEQUENCE (SIZE (1..maxDRB))	1 entry		
OF SEQUENCE {			
cnAssociation CHOICE {			
eps-BearerIdentity	6	Dedicated EPS	
}		bearer Id of SCG	
drb-Identity	2	DRB	
pdcp-Config	PDCP-Config	SCG DRB Id	
}			
}			
}			

Table 8.2.2.4.1.3.3-7: PDCP-Config (Table 8.2.2.4.1.3.3-6)

Derivation Path: 38.508-1 [4], Table 4.6.3-99			
Information Element	Value/remark	Comment	Condition
PDCP-Config ::= SEQUENCE {			
drb SEQUENCE {			
discardTimer	ms500	Other than default	
}		value.	
}			
}			

Table 8.2.2.4.1.3.3-8: RRCConnectionReconfiguration (step 9, Table 8.2.2.4.1.3.2-1)

Derivation Path: 36.508 [7], Table 4.6.1-8			
Information Element	Value/remark	Comment	Condition
RRCConnectionReconfiguration ::= SEQUENCE {			
criticalExtensions CHOICE {			
c1 CHOICE{			
rrcConnectionReconfiguration-r8 ::= SEQUENCE			
{			
nonCriticalExtension ::= SEQUENCE {			
nonCriticalExtension ::= SEQUENCE {			
nonCriticalExtension ::= SEQUENCE {			
nonCriticalExtension ::= SEQUENCE {			
nonCriticalExtension ::= SEQUENCE {			
nonCriticalExtension ::= SEQUENCE {			
nonCriticalExtension ::= SEQUENCE {			
nr-Config-r15 CHOICE {			
release			
}			
nr-RadioBearerConfig1-r15	OCTET STRING		
	including		
	RadioBearerConfig.		
}			
}			
}			
}			

Table 8.2.2.4.1.3.3-9: RadioBearerConfig (Table 8.2.2.4.1.3.3-8)

Derivation Path: 38.508-1 [4], Table 4.6.3-132			
Information Element	Value/remark	Comment	Condition
RadioBearerConfig ::= SEQUENCE {			
drb-ToReleaseList	2	SCG DRB Id	
}			

8.2.2.5 PSCell addition, modification and release / Split DRB

8.2.2.5.1 PSCell addition, modification and release / Split DRB / EN-DC

8.2.2.5.1.1 Test Purpose (TP)

(1)

```
with { UE in RRC_CONNECTED state with EN-DC, and, MCG(s) (E-UTRA PDCP) only }
ensure that {
  when { UE receives an RRCConnectionReconfiguration message to add PSCell with Split DRB }
  then { UE configures the PSCell and sends an RRCConnectionReconfigurationComplete message }
}
```

(2)

```
with { UE in RRC_CONNECTED state with EN-DC, and, MCG(s) (E-UTRA PDCP) and Split }
ensure that {
  when { UE receives an RRCConnectionReconfiguration message to modify Split DRB }
```



```

then { UE reconfigures the Split DRB and sends an RRCConnectionReconfigurationComplete message }
}

```

(3)

```

with { UE in RRC_CONNECTED state with EN-DC, and, MCG(s) (E-UTRA PDCP) and Split }
ensure that {
  when { UE receives an RRCConnectionReconfiguration message to release PSCell with Split DRB }
  then { UE releases the PSCell and Split DRB and sends an RRCConnectionReconfigurationComplete message }
}

```

8.2.2.5.1.2 Conformance requirements

References: The conformance requirements covered in the present TC are specified in: TS 36.331, clause 5.3.5.3, TS 38.331, clauses 5.3.5.3, 5.3.5.5.7, 5.3.5.6.4 and 5.3.5.6.5. Unless otherwise stated these are Rel-15 requirements.

[TS 36.331, clause 5.3.5.3]

If the *RRCConnectionReconfiguration* message does not include the *mobilityControlInfo* and the UE is able to comply with the configuration included in this message, the UE shall:

...

- 1> if the received *RRCConnectionReconfiguration* includes the *nr-Config* and it is set to *release*: or
- 1> if the received *RRCConnectionReconfiguration* includes *endc-ReleaseAndAdd* and it is set to *TRUE*:
 - 2> perform EN-DC release as specified in TS 38.331 [82], clause 5.3.5.10;
- 1> if the received *RRCConnectionReconfiguration* includes the *sk-Counter*:
 - 2> perform key update procedure as specified in TS 38.331 [82], clause 5.3.5.7;
- 1> if the received *RRCConnectionReconfiguration* includes the *nr-SecondaryCellGroupConfig*:
 - 2> perform NR RRC Reconfiguration as specified in TS 38.331 [82], clause 5.3.5.3;
- 1> if the received *RRCConnectionReconfiguration* includes the *nr-RadioBearerConfig1*:
 - 2> perform radio bearer configuration as specified in TS 38.331 [82], clause 5.3.5.6;
- 1> if the received *RRCConnectionReconfiguration* includes the *nr-RadioBearerConfig2*:
 - 2> perform radio bearer configuration as specified in TS 38.331 [82], clause 5.3.5.6;

...

- 1> set the content of *RRCConnectionReconfigurationComplete* message as follows:
 - 2> if the *RRCConnectionReconfiguration* message includes *perCC-GapIndicationRequest*:
 - 3> include *perCC-GapIndicationList* and *numFreqEffective*;
 - 2> if the frequencies are configured for reduced measurement performance:
 - 3> include *numFreqEffectiveReduced*;
 - 2> if the received *RRCConnectionReconfiguration* message included *nr-SecondaryCellGroupConfig*:
 - 3> include *scg-ConfigResponseNR* in accordance with TS 38.331 [82, 5.3.5.3];
- 1> submit the *RRCConnectionReconfigurationComplete* message to lower layers for transmission using the new configuration, upon which the procedure ends;

[TS 38.331, clause 5.3.5.3]

The UE shall perform the following actions upon reception of the *RRCReconfiguration*:

- 1> if the *RRCReconfiguration* includes the *fullConfig*:
 - 2> perform the radio configuration procedure as specified in 5.3.5.11;
 - 1> if the *RRCReconfiguration* includes the *masterCellGroup*:
 - 2> perform the cell group configuration for the received *masterCellGroup* according to 5.3.5.5;
 - 1> if the *RRCReconfiguration* includes the *masterKeyUpdate*:
 - 2> perform security key update procedure as specified in 5.3.5.7;
 - 1> if the *RRCReconfiguration* includes the *secondaryCellGroup*:
 - 2> perform the cell group configuration for the SCG according to 5.3.5.5;
 - 1> if the *RRCReconfiguration* message contains the *radioBearerConfig*:
 - 2> perform the radio bearer configuration according to 5.3.5.6;
 - 1> if the *RRCReconfiguration* message includes the *measConfig*:
 - 2> perform the measurement configuration procedure as specified in 5.5.2;
 - 1> if the *RRCReconfiguration* message includes the *dedicatedSIB1-Delivery*:
 - 2> perform the action upon reception of *SIB1* as specified in 5.2.2.4.2;
 - 1> if the *RRCReconfiguration* message includes the *dedicatedSystemInformationDelivery*:
 - 2> perform the action upon reception of System Information as specified in 5.2.2.4;
 - 1> set the content of *RRCReconfigurationComplete* message as follows:
 - 2> if the *RRCReconfiguration* includes the *masterCellGroup* containing the *reportUplinkTxDirectCurrent*, or;
 - 2> if the *RRCReconfiguration* includes the *secondaryCellGroup* containing the *reportUplinkTxDirectCurrent*:
 - 3> include the *uplinkTxDirectCurrentList*;
 - 1> if the UE is configured with E-UTRA *nr-SecondaryCellGroupConfig* (MCG is E-UTRA):
 - 2> if *RRCReconfiguration* was received via SRB1:
 - 3> submit the *RRCReconfigurationComplete* via the EUTRA MCG embedded in E-UTRA RRC message *RRCConnectionReconfigurationComplete* as specified in TS 36.331 [10];
 - 3> if *reconfigurationWithSync* was included in *spCellConfig* of an SCG:
 - 4> initiate the random access procedure on the SpCell, as specified in TS 38.321 [3];
 - 3> else:
 - 4> the procedure ends;
- NOTE: The order the UE sends the *RRCConnectionReconfigurationComplete* message and performs the Random Access procedure towards the SCG is left to UE implementation.
- 2> else (*RRCReconfiguration* was received via SRB3):
 - 3> submit the *RRCReconfigurationComplete* message via SRB3 to lower layers for transmission using the new configuration;
- NOTE: For EN-DC, in the case of SRB1, the random access is triggered by RRC layer itself as there is not necessarily other UL transmission. In the case of SRB3, the random access is triggered by the MAC layer due to arrival of *RRCReconfigurationComplete*.
- 1 > else:

- 2> submit the *RRCReconfigurationComplete* message via SRB1 to lower layers for transmission using the new configuration;
- 1> if *reconfigurationWithSync* was included in *spCellConfig* of an MCG or SCG, and when MAC of an NR cell group successfully completes a random access procedure triggered above;
 - 2> stop timer T304 for that cell group;
 - 2> apply the parts of the CQI reporting configuration, the scheduling request configuration and the sounding RS configuration that do not require the UE to know the SFN of the respective target SpCell, if any;
 - 2> apply the parts of the measurement and the radio resource configuration that require the UE to know the SFN of the respective target SpCell (e.g. measurement gaps, periodic CQI reporting, scheduling request configuration, sounding RS configuration), if any, upon acquiring the SFN of that target SpCell;
 - 2> if the *reconfigurationWithSync* was included in *spCellConfig* of an MCG:
 - 3> if the active downlink BWP, which is indicated by the *firstActiveDownlinkBWP-Id* for the target SpCell of the MCG, has a common search space configured:
 - 4> acquire the *SIB1* of the target SpCell of the MCG, as specified in 5.2.2.3.1;
 - 2> the procedure ends.

NOTE: The UE is only required to acquire broadcasted *SIB1* if the UE can acquire it without disrupting unicast data reception, i.e. the broadcast and unicast beams are quasi co-located.

[TS 38.331, clause 5.3.5.5.7]

The UE shall:

- 1> if the *SpCellConfig* contains the *rlf-TimersAndConstants*:
 - 2> configure the RLF timers and constants for this cell group as specified in 5.3.5.5.6.
- 1> else if *rlf-TimersAndConstants* is not configured for this cell group:
 - 2> use values for timers T301, T310, T311 and constants N310, N311, as included in *ue-TimersAndConstants* received in *SIB1*;
- 1> if the *SpCellConfig* contains *spCellConfigDedicated*:
 - 2> configure the SpCell in accordance with the *spCellConfigDedicated*;
 - 2> consider the bandwidth part indicated in *firstActiveUplinkBWP-Id* if configured to be the active uplink bandwidth part;
 - 2> consider the bandwidth part indicated in *firstActiveDownlinkBWP-Id* if configured to be the active downlink bandwidth part;
 - 2> if the any of the reference signal(s) that are used for radio link monitoring are reconfigured by the received *spCellConfigDedicated*:
 - 3> stop timer T310 for the corresponding SpCell, if running;
 - 3> reset the counters N310 and N311.

[TS 38.331, clause 5.3.5.6.4]

Editor's Note: FFS / TODO: Add handling for the new QoS concept (mapping of flows; configuration of QFI-to-DRB mapping; reflective QoS...) but keep also EPS-Bearer handling for the EN-DC case

The UE shall:

- 1> for each *drb-Identity* value included in the *drb-ToReleaseList* that is part of the current UE configuration (DRB release):

- 2> release the PDCP entity;
- 2> if SDAP entity associated with this DRB is configured:
 - 3> indicate the release of the DRB to SDAP entity associated with this DRB (TS 37.324 [xx] section 5.3.3);
- 2> if the UE is operating in EN-DC:
 - 3> if a new bearer is not added either with NR or E-UTRA with same *eps-BearerIdentity*:
 - 4> indicate the release of the DRB and the *eps-BearerIdentity* of the released DRB to upper layers.

NOTE: The UE does not consider the message as erroneous if the *drb-ToReleaseList* includes any *drb-Identity* value that is not part of the current UE configuration.

NOTE: Whether or not the RLC and MAC entities associated with this PDCP entity are reset or released is determined by the *CellGroupConfig*.

[TS 38.331, clause 5.3.5.6.5]

The UE shall:

- 1> for each *drb-Identity* value included in the *drb-ToAddModList* that is not part of the current UE configuration (DRB establishment including the case when full configuration option is used):
 - 2> if an *sdap-Config* is included:
 - 3> if an SDAP entity with the received *pdu-Session* does not exist:
 - 4> establish an SDAP entity as specified in TS 37.324 [xx] section 5.1.1;
 - 3> configure the SDAP entity in accordance with the received *sdap-Config* as specified in TS 37.324 [xx] and associate the DRB with the SDAP entity;
 - 2> establish a PDCP entity and configure it in accordance with the received *pdcp-Config*;
 - 2> if the PDCP entity of this DRB is not configured with *cipheringDisabled*:
 - 3> configure the PDCP entity with the ciphering algorithms according to *securityConfig* and apply the K_{UPenc} key associated with the master key (K_{eNB}/K_{gNB}) or the secondary key (S- K_{gNB}) as indicated in *keyToUse*;
 - 2> if the PDCP entity of this DRB is configured with *integrityProtection*:
 - 3> configure the PDCP entity with the integrity algorithms according to *securityConfig* and apply the K_{UPint} key associated with the master (K_{eNB}/K_{gNB}) or the secondary key (S- K_{gNB}) as indicated in *keyToUse*;
 - 2> if the UE is operating in EN-DC:
 - 3> if the DRB was configured with the same *eps-BearerIdentity* either by NR or E-UTRA prior to receiving this reconfiguration:
 - 4> associate the established DRB with the corresponding *eps-BearerIdentity*;
 - 3> else:
 - 4> indicate the establishment of the DRB(s) and the *eps-BearerIdentity* of the established DRB(s) to upper layers;
- 2> for each *drb-Identity* value included in the *drb-ToAddModList* that is part of the current UE configuration:
 - 2> if an *sdap-Config* is included, reconfigure the SDAP entity in accordance with the received *sdap-Config* as specified in TS 37.324 [xx];
 - 2> if the *reestablishPDCP* is set:
 - 3> if target RAT is E-UTRA/5GC:

4> if the PDCP entity of this DRB is not configured with *cipheringDisabled*:

5> configure the PDCP entity with the ciphering algorithm and K_{UPenc} key configured/derived as specified in TS 36.331 [10, 5.4.2.3], i.e. the ciphering configuration shall be applied to all subsequent PDCP PDUs received and sent by the UE;

3> else:

4> if the PDCP entity of this DRB is not configured with *cipheringDisabled*:

5> configure the PDCP entity with the ciphering algorithm and K_{UPenc} key associated with the master or secondary key ($K_{eNB}/S-K_{gNB}/K_{gNB}$) as indicated in *keyToUse*, i.e. the ciphering configuration shall be applied to all subsequent PDCP PDUs received and sent by the UE;

3> if the PDCP entity of this DRB is configured with *integrityProtection*:

4> configure the PDCP entity with the integrity algorithms according to *securityConfig* and apply the K_{UPint} key associated with the master (K_{eNB}/K_{gNB}) or the secondary key ($S-K_{gNB}$) as indicated in *keyToUse*;

3> re-establish the PDCP entity of this DRB as specified in 38.323 [5], section 5.1.2;

2> else, if the *recoverPDCP* is set:

3> trigger the PDCP entity of this DRB to perform data recovery as specified in 38.323;

2> if the *pdcp-Config* is included:

3> reconfigure the PDCP entity in accordance with the received *pdcp-Config*.

NOTE 1: Removal and addition of the same *drb-Identity* in a single *radioResourceConfig* is not supported. In case *drb-Identity* is removed and added due to reconfiguration with sync or re-establishment with the full configuration option, the network can use the same value of *drb-Identity*.

NOTE 2: When determining whether a *drb-Identity* value is part of the current UE configuration, the UE does not distinguish which *RadioBearerConfig* and *DRB-ToAddModList* that DRB was originally configured in. To re-associate a DRB with a different key (K_{eNB} to $S-K_{eNB}$ or vice versa), the network provides the *drb-Identity* value in the (target) *drb-ToAddModList* and sets the *reestablishPDCP* flag. The network does not list the *drb-Identity* in the (source) *drb-ToReleaseList*.

NOTE 3: When setting the *reestablishPDCP* flag for a radio bearer, the network ensures that the RLC receiver entities do not deliver old PDCP PDUs to the re-established PDCP entity. It does that e.g. by triggering a reconfiguration with sync of the cell group hosting the old RLC entity or by releasing the old RLC entity.

NOTE 4: In this specification, UE configuration refers to the parameters configured by NR RRC unless otherwise stated.

NOTE 5: Ciphering and integrity protection can be enabled or disabled for a DRB. The enabling/disabling of ciphering or integrity protection can be changed only by releasing and adding the DRB.

8.2.2.5.1.3 Test description

8.2.2.5.1.3.1 Pre-test conditions

System Simulator:

- E-UTRA Cell 1 is the PCell and NR Cell 1 is the PSCell.

UE:

- None.

Preamble:

- If `pc_IP_Ping` is set to `TRUE` then, the UE is in state `RRC_CONNECTED` using generic procedure parameter `Connectivity (EN-DC)`, Bearers (*MCG(s) only*) established according to TS 38.508-1 [4], clause 4.5.4.
- Else, the UE is in state `RRC_CONNECTED` using generic procedure parameter `Connectivity (EN-DC)`, Bearers (*MCG(s) only*) established and Test Mode (*On*) associated with UE test loop mode B configured on E-UTRA Cell 1 according to TS 38.508-1 [4], clause 4.5.4.

8.2.2.5.1.3.2 Test procedure sequence

Table 8.2.2.5.1.3.2-1: Main behaviour

St	Procedure	Message Sequence		TP	Verdict
		U - S	Message		
1	The SS transmits an <i>RRCCoRectionReconfiguration</i> message containing NR <i>RRCReconfiguration</i> message to add NR <i>PSCell</i> with Split DRB. <i>RRCCoRectionReconfiguration</i> message contains the ACTIVATE DEDICATED EPS BEARER CONTEXT REQUEST message.	<--	<i>RRCCoRectionReconfiguration</i> (<i>RRCReconfiguration</i>)	-	-
2	Check: Does the UE transmit an <i>RRCCoRectionReconfigurationComplete</i> message containing NR <i>RRCReconfigurationComplete</i> message?	-->	<i>RRCCoRectionReconfigurationC</i> <i>omplete</i> (<i>RRCReconfigurationComplete</i>)	1	P
3	The UE transmits an <i>ULInformationTransfer</i> message containing the ACTIVATE DEDICATED EPS BEARER CONTEXT ACCEPT message.	-->	<i>ULInformationTransfer</i>	-	-
-	EXCEPTION: Steps 4a1 to 4a2 describe behaviour that depends on the UE implementation; the "lower case letter" identifies a step sequence that take place depending on the UE implementation.	-	-	-	-
4a1	IF <i>pc_IP_Ping</i> = FALSE, then the SS transmits a CLOSE UE TEST LOOP message.	<--	CLOSE UE TEST LOOP	-	-
4a2	The UE transmits a CLOSE UE TEST LOOP COMPLETE message.	-->	CLOSE UE TEST LOOP COMPLETE	-	-
5	Check: Does the test result of generic test procedure in TS 38.508-1 subclause 4.9.1 indicate that the UE is capable of exchanging IP data on Split DRB#2 using NR radio path?	-	-	1	P
6	SS transmits <i>RRCCoRectionReconfiguration</i> message containing NR <i>RadioBearerConfig</i> to modify PDCP discardTimer value of Split DRB.	<--	<i>RRCCoRectionReconfiguration</i>	-	-
7	Check: Does the UE transmit an <i>RRCCoRectionReconfigurationComplete</i> message?	-->	<i>RRCCoRectionReconfigurationC</i> <i>omplete</i>	2	P
8	Check: Does the test result of generic test procedure in TS 38.508-1 subclause 4.9.1 indicate that the UE is capable of exchanging IP data on the Split DRB#2 using NR radio path?	-	-	2	P
9	SS transmits <i>RRCCoRectionReconfiguration</i> message containing <i>nr-Config-r15</i> and NR <i>RadioBearerConfig</i> to release <i>PSCell</i> and Split DRB. <i>RRCCoRectionReconfiguration</i> message contains the DEACTIVATE EPS BEARER CONTEXT REQUEST message.	<--	<i>RRCCoRectionReconfiguration</i>	-	-
10	Check: Does the UE transmit an <i>RRCCoRectionReconfigurationComplete</i> message containing NR <i>RRCReconfigurationComplete</i> message?	-->	<i>RRCCoRectionReconfigurationC</i> <i>omplete</i>	3	P
11	The UE transmits an <i>ULInformationTransfer</i> message containing the DEACTIVATE EPS BEARER CONTEXT ACCEPT message.	-->	<i>ULInformationTransfer</i>	-	-

Table 8.2.2.5.1.3.3-5: RRCConnectionReconfiguration (step 6, Table 8.2.2.5.1.3.2-1)

Derivation Path: 36.508 [7], Table 4.6.1-8			
Information Element	Value/remark	Comment	Condition
RRCConnectionReconfiguration ::= SEQUENCE {			
criticalExtensions CHOICE {			
c1 CHOICE{			
rrcConnectionReconfiguration-r8 ::= SEQUENCE			
{			
nonCriticalExtension ::= SEQUENCE {			
nonCriticalExtension ::= SEQUENCE {			
nonCriticalExtension ::= SEQUENCE {			
nonCriticalExtension ::= SEQUENCE {			
nonCriticalExtension ::= SEQUENCE {			
nonCriticalExtension ::= SEQUENCE {			
nonCriticalExtension ::= SEQUENCE {			
nonCriticalExtension ::= SEQUENCE {			
nr-RadioBearerConfig1-r15	OCTET STRING		
including	including		
RadioBearerConfig.	RadioBearerConfig.		
}			
}			
}			
}			
}			

Table 8.2.2.5.1.3.3-6: RadioBearerConfig (Table 8.2.2.5.1.3.3-5)

Derivation Path: 38.508-1 [4], Table 4.6.3-132, condition EN-DC

Table 8.2.2.5.1.3.3-7: PDCP-Config (Table 8.2.2.5.1.3.3-6)

Derivation Path: 38.508-1 [4], Table 4.6.3-99			
Information Element	Value/remark	Comment	Condition
PDCP-Config ::= SEQUENCE {			
drb SEQUENCE {			
discardTimer	ms500	Other than default value.	
}			
}			

Table 8.2.2.5.1.3.3-8: RRCConnectionReconfiguration (step 9, Table 8.2.2.5.1.3.2-1)

Derivation Path: 36.508 [7], Table 4.6.1-8			
Information Element	Value/remark	Comment	Condition
RRCConnectionReconfiguration ::= SEQUENCE {			
criticalExtensions CHOICE {			
c1 CHOICE{			
rrcConnectionReconfiguration-r8 ::= SEQUENCE			
{			
nonCriticalExtension ::= SEQUENCE {			
nonCriticalExtension ::= SEQUENCE {			
nonCriticalExtension ::= SEQUENCE {			
nonCriticalExtension ::= SEQUENCE {			
nonCriticalExtension ::= SEQUENCE {			
nonCriticalExtension ::= SEQUENCE {			
nonCriticalExtension ::= SEQUENCE {			
nr-Config-r15 CHOICE {			
release			
}			
nr-RadioBearerConfig1-r15	OCTET STRING		
}	including		
}	RadioBearerConfig.		
}			
}			
}			

Table 8.2.2.5.1.3.3-9: RadioBearerConfig (Table 8.2.2.5.1.3.3-8)

Derivation Path: 38.508-1 [4], Table 4.6.3-132			
Information Element	Value/remark	Comment	Condition
RadioBearerConfig ::= SEQUENCE {			
drb-ToReleaseList	2	Split DRB Id	
}			

8.2.2.6 Bearer Modification / MCG DRB

8.2.2.6.1 Bearer Modification / MCG DRB / SRB / PDCP version change / EN-DC

8.2.2.6.1.1 Test Purpose (TP)

(1)

```

with { UE in RRC_CONNECTED state with EN-DC, and, MCG(s) (E-UTRA PDCP) only }
ensure that {
  when { UE receives an RRCConnectionReconfiguration with mobility message to change PDCP version of
the SRB1 and SRB2 from E-UTRA PDCP to NR PDCP }
  then { UE performs PDCP version change and sends an RRCConnectionReconfigurationComplete message
}
}
    
```

(2)

```

with { UE in RRC_CONNECTED state with EN-DC, and, MCG(s) (E-UTRA PDCP) only with SRB1 and SRB2 using
NR PDCP }
ensure that {
  when { UE receives an RRCConnectionReconfiguration with mobility message to change PDCP version of
the MCG DRB from E-UTRA PDCP to NR PDCP }
  then { UE performs PDCP version change and sends an RRCConnectionReconfigurationComplete message
}
}

```

(3)

```

with { UE in RRC_CONNECTED state with EN-DC, and, MCG(s) (NR PDCP) only with SRB1 and SRB2 using NR
PDCP }
ensure that {
  when { UE receives an RRCConnectionReconfiguration with mobility message to change PDCP version of
the MCG DRB from NR PDCP to E-UTRA PDCP }
  then { UE performs PDCP version change and sends an RRCConnectionReconfigurationComplete message
}
}

```

(4)

```

with { UE in RRC_CONNECTED state with EN-DC, and, MCG(s) (E-UTRA PDCP) only with SRB1 and SRB2 using
NR PDCP }
ensure that {
  when { UE receives an RRCConnectionReconfiguration with mobility message to change PDCP version of
the SRB1 and SRB2 from NR PDCP to E-UTRA PDCP }
  then { UE performs PDCP version change and sends an RRCConnectionReconfigurationComplete message
}
}

```

8.2.2.6.1.2 Conformance requirements

References: The conformance requirements covered in the present TC are specified in: TS 36.331, clause 5.3.1.1, 5.3.5.4 and 5.3.10.3, TS 38.331, clauses 5.3.5.3, 5.3.5.5, 5.3.5.5.7, 5.3.5.6, 5.3.5.6.3 and 5.3.5.6.5. Unless otherwise stated these are Rel-15 requirements.

[TS 36.331, clause 5.3.1.1]

Change to NR PDCP or vice versa, for both SRBs and DRBs, can be performed using an *RRCConnectionReconfiguration* message including the *mobilityControlInfo* (handover) by release and addition of the concerned RB (for DRBs) or of the concerned PDCP entity (for SRBs). The same *RRCConnectionReconfiguration* message may be used to make changes regarding the CG(s) used for transmission. For SRBs, change from E-UTRA PDCP to NR PDCP type may, before initial security activation, also be performed using an *RRCConnectionReconfiguration* message not including the *mobilityControlInfo*.

[TS 36.331, clause 5.3.5.4]

If the *RRCConnectionReconfiguration* message includes the *mobilityControlInfo* and the UE is able to comply with the configuration included in this message, the UE shall:

- 1> stop timer T310, if running;
- 1> stop timer T312, if running;
- 1> start timer T304 with the timer value set to *t304*, as included in the *mobilityControlInfo*;
- 1> stop timer T370, if running;
- 1> if the *carrierFreq* is included:
 - 2> consider the target PCell to be one on the frequency indicated by the *carrierFreq* with a physical cell identity indicated by the *targetPhysCellId*;
- 1> else:

2> consider the target PCell to be one on the frequency of the source PCell with a physical cell identity indicated by the *targetPhysCellId*;

1> start synchronising to the DL of the target PCell;

NOTE 1: The UE should perform the handover as soon as possible following the reception of the RRC message triggering the handover, which could be before confirming successful reception (HARQ and ARQ) of this message.

1> reset MCG MAC and SCG MAC, if configured;

1> re-establish PDCP for all RBs configured with *pdcp-config* that are established;

NOTE 2: The handling of the radio bearers after the successful completion of the PDCP re-establishment, e.g. the re-transmission of unacknowledged PDCP SDUs (as well as the associated status reporting), the handling of the SN and the HFN, is specified in TS 36.323 [8].

1> re-establish MCG RLC and SCG RLC, if configured, for all RBs that are established;

1> apply the value of the *newUE-Identity* as the C-RNTI;

1> configure lower layers in accordance with the received *radioResourceConfigCommon*;

1> configure lower layers in accordance with any additional fields, not covered in the previous, if included in the received *mobilityControlInfo*;

1> if the *RRCConnectionReconfiguration* message includes the *radioResourceConfigDedicated*:

2> perform the radio resource configuration procedure as specified in 5.3.10;

2> store the *nextHopChainingCount* value;

2> else:

3> derive the K_{RRcInt} key associated with the current integrity algorithm, as specified in TS 33.401 [32];

3> if connected as an RN:

4> derive the K_{UPint} key associated with the current integrity algorithm, as specified in TS 33.401 [32];

3> derive the K_{RRcEnc} key and the K_{UPenc} key associated with the current ciphering algorithm, as specified in TS 33.401 [32];

1> configure lower layers to apply the integrity protection algorithm and the K_{RRcInt} key, i.e. the integrity protection configuration shall be applied to all subsequent messages received and sent by the UE, including the message used to indicate the successful completion of the procedure;

1> configure lower layers to apply the ciphering algorithm, the K_{RRcEnc} key and the K_{UPenc} key, i.e. the ciphering configuration shall be applied to all subsequent messages received and sent by the UE, including the message used to indicate the successful completion of the procedure;

1> if the received *RRCConnectionReconfiguration* includes the *nr-RadioBearerConfig1*:

2> perform radio bearer configuration as specified in TS 38.331 [82, 5.3.5.6];

1> set the content of *RRCConnectionReconfigurationComplete* message as follows:

2> else if the UE has logged measurements available for E-UTRA and if the RPLMN is included in *plmn-IdentityList* stored in *VarLogMeasReport*:

3> include the *logMeasAvailable*;

2> if the UE has connection establishment failure information available in *VarConnEstFailReport* and if the RPLMN is equal to *plmn-Identity* stored in *VarConnEstFailReport*:

3> include *connEstFailInfoAvailable*;

- 2> if the *RRCCONNECTIONReconfiguration* message includes *perCC-GapIndicationRequest*:
 - 3> include *perCC-GapIndicationList* and *numFreqEffective*;
- 2> if the frequencies are configured for reduced measurement performance:
 - 3> include *numFreqEffectiveReduced*;
- 2> if the received *RRCCONNECTIONReconfiguration* message included *nr-SecondaryCellGroupConfig*:
 - 3> include *scg-ConfigResponseNR* in accordance with TS 38.331 [82, 5.3.5.3];
- 1> submit the *RRCCONNECTIONReconfigurationComplete* message to lower layers for transmission;
- 1> if MAC successfully completes the random access procedure; or

[TS 36.331, clause 5.3.10.3]

The UE shall:

- 1> for each *drb-Identity* value included in the *drb-ToAddModList* that is part of the current UE configuration (DRB reconfiguration):
 - 2> if *drb-ToAddModListSCG* is not received or does not include the *drb-Identity* value:
 - 3> if the DRB indicated by *drb-Identity* is an MCG DRB or configured with MCG RLC bearer in EN-DC (reconfigure MCG RLC bearer for EN-DC or reconfigure MCG DRB):
 - 4> if the *pdcp-Config* is included:
 - 5> reconfigure the PDCP entity in accordance with the received *pdcp-Config*;
 - 4> if the *rlc-Config* is included:
 - 5> if *reestablishRLC* is received, re-establish the RLC entity of this DRB;
 - 5> reconfigure the RLC entity or entities in accordance with the received *rlc-Config*;
 - 4> if the *logicalChannelConfig* is included:
 - 5> reconfigure the DTCH logical channel in accordance with the received *logicalChannelConfig*;

NOTE: Removal and addition of the same *drb-Identity* in a single *radioResourceConfigDedicated* is not supported. In case *drb-Identity* is removed and added due to handover or re-establishment with the full configuration option, the eNB can use the same value of *drb-Identity*.

[TS 38.331, clause 5.3.5.3]

The UE shall perform the following actions upon reception of the *RRCReconfiguration*:

- 1> if the *RRCReconfiguration* message contains the *radioBearerConfig*:
 - 2> perform the radio bearer configuration according to 5.3.5.6;
- 1> if the *RRCReconfiguration* message includes the *measConfig*:
 - 2> perform the measurement configuration procedure as specified in 5.5.2;
- 1> if the UE is configured with E-UTRA *nr-SecondaryCellGroupConfig* (MCG is E-UTRA):
 - 2> if *RRCReconfiguration* was received via SRB1:
 - 3> construct *RRCReconfigurationComplete* message and submit it via the EUTRA MCG embedded in E-UTRA RRC message *RRCCONNECTIONReconfigurationComplete* as specified in TS 36.331 [10];
 - 3> if *reconfigurationWithSync* was included in *spCellConfig* of an SCG:
 - 4> initiate the random access procedure on the SpCell, as specified in TS 38.321 [3];

2> else (*RRCReconfiguration* was received via SRB3):

3> submit the *RRCReconfigurationComplete* message via SRB3 to lower layers for transmission using the new configuration;

NOTE: In the case of SRB1, the random access is triggered by RRC layer itself as there is not necessarily other UL transmission. In the case of SRB3, the random access is triggered by the MAC layer due to arrival of *RRCReconfigurationComplete*.

1> if MAC of an NR cell group successfully completes a random access procedure triggered above;

2> stop timer T304 for that cell group;

2> apply the parts of the CQI reporting configuration, the scheduling request configuration and the sounding RS configuration that do not require the UE to know the SFN of the respective target SpCell, if any;

2> apply the parts of the measurement and the radio resource configuration that require the UE to know the SFN of the respective target SpCell (e.g. measurement gaps, periodic CQI reporting, scheduling request configuration, sounding RS configuration), if any, upon acquiring the SFN of that target SpCell;

2> the procedure ends.

[TS 38.331, clause 5.3.5.6.3]

The UE shall:

1> for each *srb-Identity* value included in the *srb-ToAddModList* that is not part of the current UE configuration (SRB establishment or reconfiguration from E-UTRA PDCP to NR PDCP):

2> establish a PDCP entity and configure it with the security algorithms according to *securityConfig* and apply the keys (K_{RRCEnc} and K_{RRCint}) associated with the master key (K_{eNB} / K_{gNB}) or secondary key ($S\text{-}K_{\text{gNB}}$) as indicated in *keyToUse*, if applicable;

2> if the current UE configuration as configured by E-UTRA in TS 36.331 includes an SRB identified with the same *srb-Identity* value:

3> associate the E-UTRA RLC entity and DCCH of this SRB with the NR PDCP entity;

3> release the E-UTRA PDCP entity of this SRB;

2> if the *pdcp-Config* is included:

3> configure the PDCP entity in accordance with the received *pdcp-Config*;

2> else:

3> configure the PDCP entity in accordance with the default configuration defined in 9.2.1 for the corresponding SRB;

1> for each *srb-Identity* value included in the *srb-ToAddModList* that is part of the current UE configuration:

2> if the *reestablishPDCP* is set:

3> configure the PDCP entity to apply the integrity protection algorithm and K_{RRCint} key associated with the $K_{\text{eNB}}/S\text{-}K_{\text{gNB}}$ as indicated in *keyToUse*, i.e. the integrity protection configuration shall be applied to all subsequent messages received and sent by the UE, including the message used to indicate the successful completion of the procedure;

3> configure the PDCP entity to apply the ciphering algorithm and K_{RRCEnc} key associated with the $K_{\text{eNB}}/S\text{-}K_{\text{gNB}}$ as indicated in *keyToUse*, i.e. the ciphering configuration shall be applied to all subsequent messages received and sent by the UE, including the message used to indicate the successful completion of the procedure;

3> re-establish the PDCP entity of this SRB as specified in 38.323 [5];

2> else, if the *discardOnPDCP* is set:

- 3> trigger the PDCP entity to perform SDU discard as specified in TS 38.323 [5];
- 2> if the *pdcp-Config* is included:
 - 3> reconfigure the PDCP entity in accordance with the received *pdcp-Config*.

[TS 38.331, clause 5.3.5.6.5]

The UE shall:

- 1> for each *drb-Identity* value included in the *drb-ToAddModList* that is not part of the current UE configuration (DRB establishment including the case when full configuration option is used):
 - 2> establish a PDCP entity and configure it in accordance with the received *pdcp-Config*;
 - 2> configure the PDCP entity with the ciphering algorithms according to *securityConfig* and apply the K_{UPenc} key associated with the master key (KeNB/KgNB) or the secondary key (S-KgNB) as indicated in *keyToUse*;
 - 2> if the DRB was configured with the same *eps-BearerIdentity* either by NR or E-UTRA prior to receiving this reconfiguration:
 - 3> associate the established DRB with the corresponding *eps-BearerIdentity*;
 - 2> else:
 - 3> indicate the establishment of the DRB(s) and the *eps-BearerIdentity* of the established DRB(s) to upper layers;
- 1> for each *drb-Identity* value included in the *drb-ToAddModList* that is part of the current UE configuration:
 - 2> if the *reestablishPDCP* is set:
 - 3> configure the PDCP entity with the ciphering algorithm and K_{UPenc} key associated with the master or secondary key (KeNB/S-KgNB/KgNB) as indicated in *keyToUse*, i.e. the ciphering configuration shall be applied to all subsequent PDCP PDUs received and sent by the UE;
 - 3> re-establish the PDCP entity of this DRB as specified in 38.323 [5], section 5.1.2;
 - 2> else, if the *recoverPDCP* is set:
 - 3> trigger the PDCP entity of this DRB to perform data recovery as specified in 38.323;
 - 2> if the *pdcp-Config* is included:
 - 3> reconfigure the PDCP entity in accordance with the received *pdcp-Config*.

NOTE 1: Removal and addition of the same *drb-Identity* in a single *radioResourceConfig* is not supported. In case *drb-Identity* is removed and added due to reconfiguration with sync or re-establishment with the full configuration option, the network can use the same value of *drb-Identity*.

NOTE 2: When determining whether a *drb-Identity* value is part of the current UE configuration, the UE does not distinguish which *RadioBearerConfig* and *DRB-ToAddModList* that DRB was originally configured in. To re-associate a DRB with a different key (KeNB to S-KeNB or vice versa), the network provides the *drb-Identity* value in the (target) *drb-ToAddModList* and sets the *reestablishPDCP* flag. The network does not list the *drb-Identity* in the (source) *drb-ToReleaseList*.

NOTE 3: When setting the *reestablishPDCP* flag for a radio bearer, the network ensures that the RLC receiver entities do not deliver old PDCP PDUs to the re-established PDCP entity. It does that e.g. by triggering a reconfiguration with sync of the cell group hosting the old RLC entity or by releasing the old RLC entity.

NOTE 4: In this specification, UE configuration refers to the parameters configured by NR RRC unless otherwise stated.

8.2.2.6.1.3 Test description

8.2.2.6.1.3.1 Pre-test conditions

System Simulator:

- EUTRA Cell 1 is the PCell and NR Cell 1 is the PS Cell.

UE:

- None

Preamble:

- If `pc_IP_Ping` is set to TRUE then, the UE is in state `RRC_CONNECTED` using generic procedure parameter Connectivity (EN-DC), Bearers (MCG(s) only) established according to TS 38.508-1 [4], clause 4.5.4.
- Else, the UE is in state `RRC_CONNECTED` using generic procedure parameter Connectivity (*EN-DC*), Bearers (*MCG(s) only*) and Test Mode (*On*) associated with UE test loop mode B configured on E-UTRA Cell 1 according to TS 38.508-1 [4], clause 4.5.4.

8.2.2.6.1.3.2 Test procedure sequence

Table 8.2.2.6.1.3.2-1: Main behaviour

St	Procedure	Message Sequence		TP	Verdict
		U - S	Message		
1	The SS transmits an <i>RRCCONNECTIONRECONFIGURATION</i> message including <i>MOBILITYCONTROLLINFO</i> IE on E-UTRA Cell 1 to reconfigure SRB1 and SRB2 from E-UTRA PDCP to NR PDCP	<--	<i>RRCCONNECTIONRECONFIGURATION</i>	-	-
2	Check: Does the UE transmit an <i>RRCCONNECTIONRECONFIGURATIONCOMPLETE</i> message?	-->	<i>RRCCONNECTIONRECONFIGURATIONCOMPLETE</i>	1	P
-	EXCEPTION: Steps 3a1 to 3a2 describe behaviour that depends on the UE implementation; the "lower case letter" identifies a step sequence that take place depending on the UE implementation.	-	-	-	-
3a1	IF <i>pc_IP_Ping</i> = FALSE, then, the SS transmits a CLOSE UE TEST LOOP message.	<--	CLOSE UE TEST LOOP	-	-
3a2	The UE transmits a CLOSE UE TEST LOOP COMPLETE message.	-->	CLOSE UE TEST LOOP COMPLETE		
4	The SS transmits an <i>RRCCONNECTIONRECONFIGURATION</i> message including <i>MOBILITYCONTROLLINFO</i> IE on E-UTRA Cell 1 to reconfigure MCG DRB from E-UTRA PDCP to NR PDCP?	<--	<i>RRCCONNECTIONRECONFIGURATION</i>	-	-
5	Check: Does the UE transmit an <i>RRCCONNECTIONRECONFIGURATIONCOMPLETE</i> message? NOTE: <i>RRCCONNECTIONRECONFIGURATION</i> is transmitted using SRB1. This implicitly verifies SRB1 PDCP version change.	-->	<i>RRCCONNECTIONRECONFIGURATIONCOMPLETE</i>	1, 2	P
6	Check: Does the test result of generic test procedure in TS 38.508-1 subclause 4.9.1 indicate that the UE is capable of exchanging IP data on MCG DRB using NR radio path?	-	-	2	P
7	The SS transmits an <i>RRCCONNECTIONRECONFIGURATION</i> message including <i>MOBILITYCONTROLLINFO</i> IE on E-UTRA Cell 1 to reconfigure MCG DRB from NR PDCP to E-UTRA PDCP?	<--	<i>RRCCONNECTIONRECONFIGURATION</i>	-	-
8	Check: Does the UE transmit an <i>RRCCONNECTIONRECONFIGURATIONCOMPLETE</i> message?	-->	<i>RRCCONNECTIONRECONFIGURATIONCOMPLETE</i>	3	P
9	Check: Does the test result of generic test procedure in TS 38.508-1 subclause 4.9.1 indicate that the UE is capable of exchanging IP data on MCG DRB using NR radio path?	-	-	3	P
10	The SS transmits an <i>RRCCONNECTIONRECONFIGURATION</i> message including <i>MOBILITYCONTROLLINFO</i> IE on E-UTRA Cell 1 to reconfigure SRB1 and SRB2 from NR PDCP to E-UTRA PDCP.	<--	<i>RRCCONNECTIONRECONFIGURATION</i>	-	-
11	Check: Does the UE transmit an <i>RRCCONNECTIONRECONFIGURATIONCOMPLETE</i> message?	-->	<i>RRCCONNECTIONRECONFIGURATIONCOMPLETE</i>	4	P

8.2.2.6.1.3.3 Specific message contents

Table 8.2.2.6.1.3.3-1: RRCConnectionReconfiguration (step 1, Table 8.2.2.6.1.3.2-1)

Derivation Path: 36.508 [7], Table 4.6.1-8 with condition MCG_and_SCG and condition HO			
Information Element	Value/remark	Comment	Condition
RRCConnectionReconfiguration ::= SEQUENCE {			
criticalExtensions CHOICE {			
c1 CHOICE {			
rrcConnectionReconfiguration-r8 ::= SEQUENCE			
{			
mobilityControlInfo	MobilityControlInfo-HO-SameCell	As per Table 8.2.2.6.1.3.3-2	
nonCriticalExtension SEQUENCE {			
nonCriticalExtension SEQUENCE {			
nonCriticalExtension SEQUENCE {			
nonCriticalExtension SEQUENCE {			
nonCriticalExtension SEQUENCE {			
nonCriticalExtension SEQUENCE {			
nonCriticalExtension SEQUENCE {			
nr-Config-r15	Not present		
nr-RadioBearerConfig1-r15	OCTET STRING containing RadioBearerConfig-MCG-SRB	As per Table 8.2.2.6.1.3.3-3	
}			
}			
}			

Table 8.2.2.6.1.3.3-2: MobilityControlInfo-HO-SameCell (Table 8.2.2.6.1.3.3-1)

Derivation Path: 36.508 [7], Table 4.6.5-1			
Information Element	Value/remark	Comment	Condition
MobilityControlInfo-HO ::= SEQUENCE {			
targetPhysCellId	PhysicalCellIdentity of E-UTRA Cell 1		
carrierFreq	Not present		
}			

Table 8.2.2.6.1.3.3-3: RadioBearerConfig-MCG-SRB (Table 8.2.2.6.1.3.3-1)

Derivation Path: 38.508-1 [4], Table 4.6.3-132			
Information Element	Value/remark	Comment	Condition
RadioBearerConfig ::= SEQUENCE {			
srb-ToAddModList SEQUENCE (SIZE (1..2)) OF SEQUENCE {	2 entries		
srb-Identity[1]	Same as the srb-identity associated with SRB1		
pdcp-Config[1]	Same as TS 38.508-1 Table 4.6.3-99		
srb-Identity[2]	Same as the srb-identity associated with SRB2		
pdcp-Config[2]	Same as TS 38.508-1 Table 4.6.3-99		
}			
drb-ToAddModList	Not present		
securityConfig ::= SEQUENCE {			
keyToUse	master		
securityAlgorithmConfig	Same as TS 38.508-1 Table 4.6.3-165		
}			
}			

Table 8.2.2.6.1.3.3-4: RRCConnectionReconfiguration (step 4, Table 8.2.2.6.1.3.2-1)

Derivation Path: 36.508 [7], Table 4.6.1-8 with condition MCG_and_SCG and condition HO			
Information Element	Value/remark	Comment	Condition
RRCConnectionReconfiguration ::= SEQUENCE {			
criticalExtensions CHOICE {			
c1 CHOICE {			
rrcConnectionReconfiguration-r8 ::= SEQUENCE {			
mobilityControlInfo	MobilityControlInfo-HO-SameCell	As per Table 8.2.2.6.1.3.3-2	
radioResourceConfigDedicated	RadioResourceConfigDedicated-DRB-RELEASE	As per Table 8.2.2.6.1.3.3-5	
nonCriticalExtension SEQUENCE {			
nonCriticalExtension SEQUENCE {			
nonCriticalExtension SEQUENCE {			
nonCriticalExtension SEQUENCE {			
nonCriticalExtension SEQUENCE {			
nonCriticalExtension SEQUENCE {			
nonCriticalExtension SEQUENCE {			
nr-Config-r15	Not present		
nr-RadioBearerConfig1-r15	OCTET STRING containing RadioBearerConfig-MCG-DRB	As per Table 8.2.2.6.1.3.3-6	
}			
}			
}			
}			

Table 8.2.2.6.1.3.3-5: RadioResourceConfigDedicated-DRB-RELEASE (Table 8.2.2.6.1.3.3-4)

Derivation Path: 36.508 [7], Table 4.6.3-18C			
Information Element	Value/remark	Comment	Condition
RadioResourceConfigDedicated ::= SEQUENCE {			
drb-ToReleaseListSEQUENCE (SIZE (1..maxDRB))	1 entry		
OF SEQUENCE {			
drb-Identity[1]	Same as the DRB identity associated with the default EPS bearer		
}			
}			

Table 8.2.2.6.1.3.3-6: RadioBearerConfig-MCG-DRB (Table 8.2.2.6.1.3.3-4)

Derivation Path: 38.508-1 [4], Table 4.6.3-132			
Information Element	Value/remark	Comment	Condition
RadioBearerConfig ::= SEQUENCE {			
drb-ToAddModList SEQUENCE (SIZE (1.. maxDRB))	1 entry		
OF SEQUENCE {			
cnAssociation CHOICE {			
eps-BearerIdentity	Same as the default EPS bearer Identity		
}			
drb-Identity	Same as the DRB associated with the default EPS bearer		
pdcp-Config	Same as TS 38.508-1 Table 4.6.3-99		
}			
securityConfig SEQUENCE {			
keyToUse	master		
securityAlgorithmConfig	Same as TS 38.508-1 Table 4.6.3-165		
}			
}			

Table 8.2.2.6.1.3.3-7: RRCConnectionReconfiguration (step 7, Table 8.2.2.6.1.3.2-1)

Derivation Path: 36.508 [4], Table 4.6.1-8 with Condition MCG_and_SCG and condition HO			
Information Element	Value/remark	Comment	Condition
RRCConnectionReconfiguration ::= SEQUENCE {			
criticalExtensions CHOICE {			
c1 CHOICE {			
rrcConnectionReconfiguration-r8 ::= SEQUENCE {			
mobilityControllInfo	MobilityControllInfo-HO-SameCell	As per Table 8.2.2.6.1.3.3-2	
radioResourceConfigDedicated	RadioResourceConfigDedicated-DRB-AddMod	As per Table 8.2.2.6.1.3.3-8	
nonCriticalExtension ::= SEQUENCE {			
nonCriticalExtension ::= SEQUENCE {			
nonCriticalExtension ::= SEQUENCE {			
nonCriticalExtension ::= SEQUENCE {			
nonCriticalExtension ::= SEQUENCE {			
nonCriticalExtension ::= SEQUENCE {			
nonCriticalExtension ::= SEQUENCE {			
nonCriticalExtension ::= SEQUENCE {			
nr-Config-r15	Not present		
nr-RadioBearerConfig1-r15	OCTET STRING containing RadioBearerConfig-MCG-DRB-RELEASE	As per Table 8.2.2.6.1.3.3-9	
}			
}			
}			
}			
}			
}			
}			
}			
}			

Table 8.2.2.6.1.3.3-8: RadioResourceConfigDedicated-DRB-AddMod (Table 8.2.2.6.1.3.3-7)

Derivation Path: 36.508 [7], Table 4.6.3-17 using DRB configuration from Table 4.8.2.1.7-1 with condition AM			
Information Element	Value/remark	Comment	Condition
RadioResourceConfigDedicated-DRB ::= SEQUENCE {			
drb-ToAddModList SEQUENCE (SIZE (1..maxDRB)) OF SEQUENCE {			
drb-Identity[1]	Same as the DRB associated with the default EPS bearer		
rlc-Config	Not present		
logicalChannelIdentity	Not present		
logicalChannelConfig	Not present		
}			
}			

Table 8.2.2.6.1.3.3-9 RadioBearerConfig-MCG-DRB-RELEASE (Table 8.2.2.6.1.3.3-7)

Derivation Path: 38.508-1 [4], Table [4.6.3-n]			
Information Element	Value/remark	Comment	Condition
RadioBearerConfig ::= SEQUENCE {			
drb-ToAddModList	Not present		
drb-ToReleaseList SEQUENCE (SIZE (1.. maxDRB))	1 entry		
OF SEQUENCE {			
drb-Identity[1]	Same as the DRB associated with the default EPS bearer		
}			
}			

Table 8.2.2.6.1.3.3-10: RRCConnectionReconfiguration (step 10, Table 8.2.2.6.1.3.2-1)

Derivation Path: 36.508 [7], Table 4.6.1-8 with Condition HO			
Information Element	Value/remark	Comment	Condition
RRCConnectionReconfiguration ::= SEQUENCE {			
criticalExtensions CHOICE {			
c1 CHOICE {			
rrcConnectionReconfiguration-r8 ::= SEQUENCE {			
mobilityControlInfo	MobilityControlInfo-HO-SameCell	As per Table 8.2.2.6.1.3.3-2	
radioResourceConfigDedicated	RadioResourceConfigDedicated-SRB-AddMod	As per Table 8.2.2.6.1.3.3-11	
}			
}			
}			
}			

Table 8.2.2.6.1.3.3-11 RadioResourceConfigDedicated-SRB-AddMod (Table 8.2.2.6.1.3.3-10)

Derivation Path: 36.331 [11], Table 6.3.2			
Information Element	Value/remark	Comment	Condition
RadioResourceConfigDedicated			
srb-ToAddModList SEQUENCE (SIZE (1..2)) OF SEQUENCE {			
srb-Identity[1]	Same as the SRB associated with SRB1		
pdcp-verChange-r15[1]	True		
srb-Identity[2]	Same as the SRB associated with SRB2		
pdcp-verChange-r15[2]	True		
}			

8.2.2.7 Bearer Modification / Handling for bearer type change without security key change

8.2.2.7.1 Bearer Modification / Handling for bearer type change without security key change / EN-DC

8.2.2.7.1.1 Test Purpose (TP)

(1)

```
with { UE in RRC_CONNECTED state with EN-DC, and, MCG(s) (E-UTRA PDCP) and SCG }
ensure that {
  when { UE receives an RRCConnectionReconfiguration message to modify SCG DRB to Split DRB }
  then { UE reconfigures the DRB and sends an RRCConnectionReconfigurationComplete message }
}
```

(2)

```

with { UE in RRC_CONNECTED state with EN-DC, and, MCG(s) (E-UTRA PDCP) and Split }
ensure that {
  when { UE receives an RRCConnectionReconfiguration message to modify Split DRB to MCG DRB (NR PDCP) }
  then { UE reconfigures the DRB and sends an RRCConnectionReconfigurationComplete message }
}

```

(3)

```

with { UE in RRC_CONNECTED state with EN-DC, and, MCG(s) (E-UTRA PDCP) and MCG (NR PDCP) }
ensure that {
  when { UE receives an RRCConnectionReconfiguration message to modify MCG DRB (NR PDCP) to Split DRB }
  then { UE reconfigures the DRB and sends an RRCConnectionReconfigurationComplete message }
}

```

(4)

```

with { UE in RRC_CONNECTED state with EN-DC, and, MCG(s) (E-UTRA PDCP) and Split }
ensure that {
  when { UE receives an RRCConnectionReconfiguration message to modify Split DRB to SCG DRB }
  then { UE reconfigures the DRB and sends an RRCConnectionReconfigurationComplete message }
}

```

(5)

```

with { UE in RRC_CONNECTED state with EN-DC, and, MCG(s) (E-UTRA PDCP) and SCG }
ensure that {
  when { UE receives an RRCConnectionReconfiguration message to modify SCG DRB to MCG DRB (NR PDCP) }
  then { UE reconfigures the DRB and sends an RRCConnectionReconfigurationComplete message }
}

```

(6)

```

with { UE in RRC_CONNECTED state with EN-DC, and, MCG(s) (E-UTRA PDCP) and MCG (NR PDCP) }
ensure that {
  when { UE receives an RRCConnectionReconfiguration message to modify MCG DRB (NR PDCP) to SCG DRB }
  then { UE reconfigures the DRB and sends an RRCConnectionReconfigurationComplete message }
}

```

8.2.2.7.1.2 Conformance requirements

References: The conformance requirements covered in the present TC are specified in TS 36.331, clauses 5.3.5.3 and TS 38.331: 5.3.5.3, 5.3.5.5.1, 5.3.5.6.1 and 5.3.5.6.5. Unless and otherwise stated these are Rel-15 requirements

[TS 36.331, clause 5.3.5.3]

If the *RRCConnectionReconfiguration* message does not include the *mobilityControlInfo* and the UE is able to comply with the configuration included in this message, the UE shall:

- 1> if this is the first *RRCConnectionReconfiguration* message after successful completion of the RRC connection re-establishment procedure:

...

- 1> else:

- 2> if the *RRCConnectionReconfiguration* message includes the *radioResourceConfigDedicated*:
- 3> perform the radio resource configuration procedure as specified in 5.3.10;

NOTE 3: If the *RRCConnectionReconfiguration* message includes the establishment of radio bearers other than SRB1, the UE may start using these radio bearers immediately, i.e. there is no need to wait for an outstanding acknowledgment of the *SecurityModeComplete* message.

...

1> if the received *RRCConnectionReconfiguration* includes the *nr-SecondaryCellGroupConfig*:

2> perform NR RRC Reconfiguration as specified in TS 38.331 [82, 5.3.5.3];

1> if the received *RRCConnectionReconfiguration* includes the *nr-RadioBearerConfig1*:

2> perform radio bearer configuration as specified in TS 38.331 [82, 5.3.5.6];

1> if the received *RRCConnectionReconfiguration* includes the *nr-RadioBearerConfig2*:

2> perform radio bearer configuration as specified in TS 38.331 [82, 5.3.5.6];

...

1> set the content of *RRCConnectionReconfigurationComplete* message as follows:

...

2> if the received *RRCConnectionReconfiguration* message included *nr-SecondaryCellGroupConfig*:

3> include *scg-ConfigResponseNR* in accordance with TS 38.331 [82, 5.3.5.3];

1> submit the *RRCConnectionReconfigurationComplete* message to lower layers for transmission using the new configuration, upon which the procedure ends;

[TS 38.331, clause 5.3.5.3]

The UE shall perform the following actions upon reception of the *RRCReconfiguration*:

...

1> if the *RRCReconfiguration* message contains the *radioBearerConfig*:

2> perform the radio bearer configuration according to 5.3.5.6;

...

1> if the UE is configured with E-UTRA *nr-SecondaryCellGroupConfig* (MCG is E-UTRA):

2> if *RRCReconfiguration* was received via SRB1:

3> submit the *RRCReconfigurationComplete* via the EUTRA MCG embedded in E-UTRA RRC message *RRCConnectionReconfigurationComplete* as specified in TS 36.331 [10];

[TS 38.331, clause 5.3.5.5.1]

The network configures the UE with one Secondary Cell Group (SCG). For EN-DC, the MCG is configured as specified in TS 36.331 [10]. The network provides the configuration parameters for a cell group in the *CellGroupConfig* IE.

The UE performs the following actions based on a received *CellGroupConfig* IE:

1> if the *CellGroupConfig* contains the *spCellConfig* with *reconfigurationWithSync*:

2> perform Reconfiguration with sync according to 5.3.5.5.2;

2> resume all suspended radio bearers and resume SCG transmission for all radio bearers, if suspended;

1> if the *CellGroupConfig* contains the *rlc-BearerToReleaseList*:

2> perform RLC bearer release as specified in 5.3.5.5.3;

1> if the *CellGroupConfig* contains the *rlc-BearerToAddModList*:

2> perform the RLC bearer addition/modification as specified in 5.3.5.5.4;

1> if the *CellGroupConfig* contains the *mac-CellGroupConfig*:

- 2> configure the MAC entity of this cell group as specified in 5.3.5.5.5;
- 1> if the *CellGroupConfig* contains the *sCellToReleaseList*:
 - 2> perform SCell release as specified in 5.3.5.5.8;
- 1> if the *CellGroupConfig* contains the *spCellConfig*:
 - 2> configure the SpCell as specified in 5.3.5.5.7;
- 1> if the *CellGroupConfig* contains the *sCellToAddModList*:
 - 2> perform SCell addition/modification as specified in 5.3.5.5.9

[TS 38.331, clause 5.3.5.6.1]

The UE shall perform the following actions based on a received *RadioBearerConfig* IE:

...

- 1> if the *RadioBearerConfig* includes the *drb-ToReleaseList*:
 - 2> perform DRB release as specified in 5.3.5.6.4;
- 1> if the *RadioBearerConfig* includes the *drb-ToAddModList*:
 - 2> perform DRB addition or reconfiguration as specified in 5.3.5.6.5.

[TS 38.331, clause 5.3.5.6.5]

The UE shall:

- 1> for each *drb-Identity* value included in the *drb-ToAddModList* that is not part of the current UE configuration (DRB establishment including the case when full configuration option is used):
 - 2> establish a PDCP entity and configure it in accordance with the received *pdcp-Config*;
 - 2> configure the PDCP entity with the security algorithms according to *securityConfig* and apply the keys (K_{UPenc}) associated with the $K_{eNB}/S-K_{gNB}$ as indicated in *keyToUse*;
 - 2> if the DRB was configured with the same *eps-BearerIdentity* either by NR or E-UTRA prior to receiving this reconfiguration:
 - 3> associate the established DRB with the corresponding *eps-BearerIdentity*;
 - 2> else:
 - 3> indicate the establishment of the DRB(s) and the *eps-BearerIdentity* of the established DRB(s) to upper layers;
- 1> for each *drb-Identity* value included in the *drb-ToAddModList* that is part of the current UE configuration:
 - 2> if *reestablishPDCP* is set:
 - 3> configure the PDCP entity of this *RadioBearerConfig* to apply the ciphering algorithm and K_{UPenc} key associated with the $K_{eNB}/S-K_{gNB}$ as indicated in *keyToUse*, i.e. the ciphering configuration shall be applied to all subsequent PDCP PDUs received and sent by the UE;
 - 3> re-establish the PDCP entity of this DRB as specified in 38.323 [5], section 5.1.2;
 - 2> else, if *recoverPDCP* is set:
 - 3> trigger the PDCP entity of this DRB to perform data recovery as specified in 38.323;
 - 2> if the *pdcp-Config* is included:
 - 3> reconfigure the PDCP entity in accordance with the received *pdcp-Config*.

8.2.2.7.1.3 Test description

8.2.2.7.1.3.1 Pre-test conditions

System Simulator:

- E-UTRA Cell 1 is the PCell and NR Cell 1 is the PSCell.

UE:

None.

Preamble:

- If `pc_IP_Ping` is set to `TRUE` then, the UE is in state `RRC_CONNECTED` using generic procedure parameter `Connectivity (EN-DC)`, Bearers (`MCG(s)` and `SCG`) established according to TS 38.508-1 [4], clause 4.5.4.
- Else, the UE is in state `RRC_CONNECTED` using generic procedure parameter `Connectivity (EN-DC)`, Bearers (`MCG(s)` and `SCG`) established and Test Loop Function (`On`) with UE test loop mode B according to TS 38.508-1 [4], clause 4.5.4.

8.2.2.7.1.3.2 Test procedure sequence

Table 8.2.2.7.1.2-1: Main behaviour

St	Procedure	Message Sequence		TP	Verdict
		U - S	Message		
1	The SS transmits an <i>RRCCONNECTIONRECONFIGURATION</i> message containing NR RadioBearerConfig to modify SCG DRB to Split DRB.	<--	<i>RRCCONNECTIONRECONFIGURATION</i>	-	-
2	Check: Does the UE transmit an <i>RRCCONNECTIONRECONFIGURATIONCOMPLETE</i> message?	-->	<i>RRCCONNECTIONRECONFIGURATIONCOMPLETE</i>	1	P
3	Check: Does the test result of generic test procedure in TS 38.508-1 subclause 4.9.1 indicate that the UE is capable of exchanging IP data on split DRB using NR radio path?	-	-	1	P
4	The SS transmits <i>RRCCONNECTIONRECONFIGURATION</i> message containing NR <i>RRCRECONFIGURATION</i> message to modify Split DRB to MCG DRB using NR PDCP.	<--	<i>RRCCONNECTIONRECONFIGURATION (RRCRECONFIGURATION)</i>	-	-
5	Check: Does the UE transmit an <i>RRCCONNECTIONRECONFIGURATIONCOMPLETE</i> message containing NR <i>RRCRECONFIGURATIONCOMPLETE</i> message?	-->	<i>RRCCONNECTIONRECONFIGURATIONCOMPLETE (RRCRECONFIGURATIONCOMPLETE)</i>	2	P
6	Check: Does the test result of generic test procedure in TS 38.508-1 subclause 4.9.1 indicate that the UE is capable of exchanging IP data on MCG DRB?	-	-	2	P
7	The SS transmits an <i>RRCCONNECTIONRECONFIGURATION</i> message containing NR <i>RRCRECONFIGURATION</i> message to modify MCG DRB to Split DRB.	<--	<i>RRCCONNECTIONRECONFIGURATION (RRCRECONFIGURATION)</i>	-	-
8	Check: Does the UE transmit an <i>RRCCONNECTIONRECONFIGURATIONCOMPLETE</i> message containing NR <i>RRCRECONFIGURATIONCOMPLETE</i> message?	-->	<i>RRCCONNECTIONRECONFIGURATIONCOMPLETE (RRCRECONFIGURATIONCOMPLETE)</i>	3	P
9	Check: Does the test result of generic test procedure in TS 38.508-1 subclause 4.9.1 indicate that the UE is capable of exchanging IP data on split DRB using NR radio path?	-	-	3	P
10	SS transmits <i>RRCCONNECTIONRECONFIGURATION</i> message containing NR RadioBearerConfig to modify Split DRB to SCG DRB.	<--	<i>RRCCONNECTIONRECONFIGURATION (RRCRECONFIGURATION)</i>	-	-
11	Check: Does the UE transmit an <i>RRCCONNECTIONRECONFIGURATIONCOMPLETE</i> message?	-->	<i>RRCCONNECTIONRECONFIGURATIONCOMPLETE</i>	4	P
12	Check: Does the test result of generic test procedure in TS 38.508-1 subclause 4.9.1 indicate that the UE is capable of exchanging IP data on SCG DRB?	-	-	4	P
13	SS transmits <i>RRCCONNECTIONRECONFIGURATION</i> message containing NR <i>RRCRECONFIGURATION</i> message to modify SCG DRB to MCG DRB.	<--	<i>RRCCONNECTIONRECONFIGURATION (RRCRECONFIGURATION)</i>	-	-
14	Check: Does the UE transmit an <i>RRCCONNECTIONRECONFIGURATIONCOMPLETE</i> message containing NR <i>RRCRECONFIGURATIONCOMPLETE</i> message?	-->	<i>RRCCONNECTIONRECONFIGURATIONCOMPLETE (RRCRECONFIGURATIONCOMPLETE)</i>	5	P
15	Check: Does the test result of generic test procedure in TS 38.508-1 subclause 4.9.1 indicate that the UE is capable of exchanging IP data on MCG DRB?	-	-	5	P
16	SS transmits <i>RRCCONNECTIONRECONFIGURATION</i> message containing NR <i>RRCRECONFIGURATION</i> message to modify MCG DRB to SCG DRB.	<--	<i>RRCCONNECTIONRECONFIGURATION (RRCRECONFIGURATION)</i>	-	-
17	Check: Does the UE transmit an <i>RRCCONNECTIONRECONFIGURATIONCOMPLETE</i> message containing NR <i>RRCRECONFIGURATIONCOMPLETE</i> message?	-->	<i>RRCCONNECTIONRECONFIGURATIONCOMPLETE (RRCRECONFIGURATIONCOMPLETE)</i>	6	P

18	Check: Does the test result of generic test procedure in TS 38.508-1 subclause 4.9.1 indicate that the UE is capable of exchanging IP data on SCG DRB?	-	-	6	P
----	--	---	---	---	---

8.2.2.7.1.3.3 Specific message contents

Table 8.2.2.7.1.3.3-1: RRCConnectionReconfiguration (step 1, Table 8.2.2.7.1.3.2-1)

Derivation Path: 36.508 [7], Table 4.6.1-8			
Information Element	Value/remark	Comment	Condition
RRCConnectionReconfiguration ::= SEQUENCE {			
criticalExtensions CHOICE {			
c1 CHOICE{			
rrcConnectionReconfiguration-r8 ::= SEQUENCE			
{			
radioResourceConfigDedicated	RadioResourceConfigDe dicated-SCG-to-Split		
nonCriticalExtension ::= SEQUENCE {			
nonCriticalExtension ::= SEQUENCE {			
nonCriticalExtension ::= SEQUENCE {			
nonCriticalExtension ::= SEQUENCE {			
nonCriticalExtension ::= SEQUENCE {			
nonCriticalExtension ::= SEQUENCE {			
nonCriticalExtension ::= SEQUENCE {			
nr-RadioBearerConfig1-r15	OCTET STRING including RadioBearerConfig-SCG- to-Split.		
}			
}			
}			
}			
}			
}			
}			
}			
}			
}			
}			
}			
}			
}			

Table 8.2.2.7.1.3.3-2: RadioResourceConfigDedicated-SCG-to-Split (step 1, Table 8.2.2.7.1.3.2-1)

Derivation Path: 36.508 [7], Table 4.6.3-27			
Information Element	Value/remark	Comment	Condition
RadioResourceConfigDedicated-DRB ::= SEQUENCE {			
drb-ToAddModList	DRB-ToAddModList- SCG-to-Split		
}			

Table 8.2.2.7.1.3.3-3: DRB-ToAddModList-SCG-to-Split (step 1, Table 8.2.2.7.1.3.2-1)

Derivation Path: 36.508 [7], Table 4.6.3-2A			
Information Element	Value/remark	Comment	Condition
DRB-ToAddModList ::= SEQUENCE (SIZE (1..maxDRB)) OF SEQUENCE {	1 Entry		
eps-BearerIdentity[1]	6	Dedicated EPS bearer Id of SCG DRB	
drb-Identity[1]	2	SCG DRB Id	
}			

Table 8.2.2.7.1.3.3-4: RadioBearerConfig-SCG-to-Split (step 1, Table 8.2.2.7.1.3.2-1)

Derivation Path: 38.508-1 [4], Table 4.6.3-132 with condition EN-DC			
Information Element	Value/remark	Comment	Condition
RadioBearerConfig ::= SEQUENCE {			
drb-ToAddModList SEQUENCE (SIZE (1..maxDRB)) OF SEQUENCE {	1 entry		
cnAssociation CHOICE {			
eps-BearerIdentity	6	Dedicated EPS bearer Id of SCG DRB	
}			
drb-Identity	2	SCG DRB Id	
pdcp-Config	PDCP-Config		
}			
}			

Table 8.2.2.7.1.3.3-5: PDCP-Config (step 1, Table 8.2.2.7.1.3.2-1)

Derivation Path: 38.508-1 [4], Table 4.6.3-99			
Information Element	Value/remark	Comment	Condition
PDCP-Config ::= SEQUENCE {			
moreThanOneRLC SEQUENCE {			
primaryPath SEQUENCE {			
cellGroup	1		
}			
ul-DataSplitThreshold	infinity		
}			
}			

Table 8.2.2.7.1.3.3-6: RRCConnectionReconfiguration (step 5, Table 8.2.2.7.1.3.2-1)

Derivation Path: 36.508 [7], Table 4.6.1-8			
Information Element	Value/remark	Comment	Condition
RRCConnectionReconfiguration ::= SEQUENCE {			
criticalExtensions CHOICE {			
c1 CHOICE{			
rrcConnectionReconfiguration-r8 ::= SEQUENCE			
{			
radioResourceConfigDedicated	Not Present		
nonCriticalExtension ::= SEQUENCE {			
nonCriticalExtension ::= SEQUENCE {			
nonCriticalExtension ::= SEQUENCE {			
nonCriticalExtension ::= SEQUENCE {			
nonCriticalExtension ::= SEQUENCE {			
nonCriticalExtension ::= SEQUENCE {			
nonCriticalExtension ::= SEQUENCE {			
nonCriticalExtension ::= SEQUENCE {			
nr-Config-r15 CHOICE {			
setup SEQUENCE {			
nr-SecondaryCellGroupConfig-r15	OCTET STRING containing RRCReconfiguration-Split-to-MCG		
}			
}			
nr-RadioBearerConfig1-r15	OCTET STRING containing RadioBearerConfig-Split-to-MCG		
}			
}			
}			
}			
}			
}			
}			
}			
}			
}			
}			
}			
}			
}			
}			
}			
}			
}			
}			

Table 8.2.2.7.1.3.3-7: RRCReconfiguration-Split-to-MCG (step 5, Table 8.2.2.7.1.3.2-1)

Derivation Path: 38.508-1 [4], Table 4.6.1-13 with condition EN-DC			
Information Element	Value/remark	Comment	Condition
RRCReconfiguration ::= SEQUENCE {			
criticalExtensions CHOICE {			
c1 CHOICE{			
rrcReconfiguration SEQUENCE {			
radioBearerConfig	Not present		
secondaryCellGroup	OCTET STRING containing CellGroupConfig-Split-to-MCG		
}			
}			
}			

Table 8.2.2.7.1.3.3-8: CellGroupConfig-Split-to-MCG (step 5, Table 8.2.2.7.1.3.2-1)

Derivation Path: 38.508-1 [4], Table 4.6.3-19			
Information Element	Value/remark	Comment	Condition
CellGroupConfig ::= SEQUENCE {			
rlc-BearerToAddModList	Not present		
rlc-BearerToReleaseList SEQUENCE (SIZE(1..maxLCH)) OF SEQUENCE {	1 entry		
logicalChannelIdentity[1]	Logical channel identity corresponding to split bearer		
}			
mac-CellGroupConfig	Not present		
physicalCellGroupConfig	Not present		
spCellConfig	Not present		
}			

Table 8.2.2.7.1.3.3-9: RadioBearerConfig-Split-to-MCG (step 5, Table 8.2.2.7.1.3.2-1)

Derivation Path: 38.508-1 [4], Table 4.6.3-132 with condition EN-DC			
Information Element	Value/remark	Comment	Condition
RadioBearerConfig ::= SEQUENCE {			
drb-ToAddModList SEQUENCE (SIZE (1..maxDRB)) OF SEQUENCE {	1 entry		
cnAssociation CHOICE {			
eps-BearerIdentity	6		
}			
drb-Identity	2		
recoverPDCP	true		
}			
}			

Table 8.2.2.7.1.3.3-10: RRCConnectionReconfiguration (step 9, Table 8.2.2.7.1.3.2-1)

Derivation Path: 36.508 [7], Table 4.6.1-8			
Information Element	Value/remark	Comment	Condition
RRCConnectionReconfiguration ::= SEQUENCE {			
criticalExtensions CHOICE {			
c1 CHOICE{			
rrcConnectionReconfiguration-r8 ::= SEQUENCE			
{			
radioResourceConfigDedicated	Not Present		
nonCriticalExtension ::= SEQUENCE {			
nonCriticalExtension ::= SEQUENCE {			
nonCriticalExtension ::= SEQUENCE {			
nonCriticalExtension ::= SEQUENCE {			
nonCriticalExtension ::= SEQUENCE {			
nonCriticalExtension ::= SEQUENCE {			
nonCriticalExtension ::= SEQUENCE {			
nr-Config-r15 CHOICE {			
setup SEQUENCE {			
nr-SecondaryCellGroupConfig-r15	OCTET STRING containing RRCReconfiguration-MCG-to-Split		
}			
}			
}			
}			
}			
}			
}			
}			
}			
}			
}			
}			
}			

Table 8.2.2.2.4.3.3-11: RRCReconfiguration-MCG-to-Split (step 9, Table 8.2.2.7.1.3.2-1)

Derivation Path: 38.508-1 [4], Table 4.6.1-13 with condition EN-DC			
Information Element	Value/remark	Comment	Condition
RRCReconfiguration ::= SEQUENCE {			
criticalExtensions CHOICE {			
c1 CHOICE{			
rrcReconfiguration SEQUENCE {			
radioBearerConfig	Not present		
secondaryCellGroup	OCTET STRING containing CellGroupConfig-MCG-to-Split		
}			
}			
}			
}			

Table 8.2.2.7.1.3.3-12: CellGroupConfig-MCG-to-Split (step 9, Table 8.2.2.7.1.3.2-1)

Derivation Path: 38.508-1 [4], Table 4.6.3-19 with condition EN-DC			
Information Element	Value/remark	Comment	Condition
CellGroupConfig ::= SEQUENCE {			
mac-CellGroupConfig	Not present		
physicalCellGroupConfig	Not present		
spCellConfig	Not present		
}			

Table 8.2.2.7.1.3.3-13: RadioBearerConfig-MCG-to-Split (step 9, Table 8.2.2.7.1.3.2-1)

Derivation Path: 38.508-1 [4], Table 4.6.3-132 with condition EN-DC			
Information Element	Value/remark	Comment	Condition
RadioBearerConfig ::= SEQUENCE {			
drb-ToAddModList SEQUENCE (SIZE (1..maxDRB))	1 entry		
OF SEQUENCE {			
cnAssociation CHOICE {			
eps-BearerIdentity	6		
}			
drb-Identity	2		
pdcp-Config	PDCP-Config		
}			
}			
}			

Table 8.2.2.7.1.3.3-14: PDCP-Config (step 9, Table 8.2.2.7.1.3.2-1)

Derivation Path: 38.508-1 [4], Table 4.6.3-99			
Information Element	Value/remark	Comment	Condition
PDCP-Config ::= SEQUENCE {			
moreThanOneRLC SEQUENCE {			
primaryPath SEQUENCE {			
cellGroup	1		
}			
ul-DataSplitThreshold	infinity		
}			
}			

Table 8.2.2.7.1.3.3-18: RRCConnectionReconfiguration (step 17, Table 8.2.2.7.1.3.2-1)

Derivation Path: 36.508 [7], Table 4.6.1-8			
Information Element	Value/remark	Comment	Condition
RRCConnectionReconfiguration ::= SEQUENCE {			
criticalExtensions CHOICE {			
c1 CHOICE {			
rrcConnectionReconfiguration-r8 ::= SEQUENCE			
{			
radioResourceConfigDedicated	<i>RadioResourceConfigDe- dicated-SCG-to-MCG</i>		
nonCriticalExtension ::= SEQUENCE {			
nonCriticalExtension ::= SEQUENCE {			
nonCriticalExtension ::= SEQUENCE {			
nonCriticalExtension ::= SEQUENCE {			
nonCriticalExtension ::= SEQUENCE {			
nonCriticalExtension ::= SEQUENCE {			
nonCriticalExtension ::= SEQUENCE {			
nr-Config-r15 CHOICE {			
setup SEQUENCE {			
nr-SecondaryCellGroupConfig-r15	OCTET STRING containing <i>RRCReconfiguration- SCG-to-MCG</i>		
}			
}			
}			
}			
}			
}			
}			
}			
}			
nr-RadioBearerConfig1-r15	OCTET STRING including <i>RadioBearerConfig-SCG- to-MCG.</i>		
}			
}			
}			
}			

Table 8.2.2.7.1.3.3-19: RadioResourceConfigDedicated-SCG-to-MCG (step 17, Table 8.2.2.7.1.3.2-1)

Derivation Path: 36.508 [7], Table 4.6.3-27			
Information Element	Value/remark	Comment	Condition
RadioResourceConfigDedicated-DRB ::= SEQUENCE {			
drb-ToAddModList	DRB-ToAddModList- SCG-to-MCG		
}			

Table 8.2.2.7.1.3.3-20: DRB-ToAddModList-SCG-to-MCG (step 17, Table 8.2.2.7.1.3.2-1)

Derivation Path: 36.508 [7], Table 4.6.3-2A			
Information Element	Value/remark	Comment	Condition
DRB-ToAddModList ::= SEQUENCE (SIZE (1..maxDRB)) OF SEQUENCE {	1 Entry		
eps-BearerIdentity[1]	6		
drb-Identity[1]	2		
}			

Table 8.2.2.4.3.3-21: RRCReconfiguration-SCG-to-MCG (step 17, Table 8.2.2.7.1.3.2-1)

Derivation Path: 38.508-1 [4], Table 4.6.1-13 with condition EN-DC			
Information Element	Value/remark	Comment	Condition
RRCReconfiguration ::= SEQUENCE {			
criticalExtensions CHOICE {			
c1 CHOICE{			
rrcReconfiguration SEQUENCE {			
radioBearerConfig	Not present		
secondaryCellGroup	OCTET STRING containing CellGroupConfig-SCG-to- MCG		
}			
}			
}			
}			

Table 8.2.2.7.1.3.3-22: CellGroupConfig-SCG-to-MCG (step 17, Table 8.2.2.7.1.3.2-1)

Derivation Path: 38.508-1 [4] Table 4.6.3-19			
Information Element	Value/remark	Comment	Condition
CellGroupConfig ::= SEQUENCE {			
rlc-BearerToAddModList	Not present		
rlc-BearerToReleaseList SEQUENCE (SIZE(1..maxLCH)) OF SEQUENCE {	1 entry		
logicalChannelIdentity[1]	Logical channel identity corresponding to SCG Bearer		
}			
mac-CellGroupConfig	Not present		
physicalCellGroupConfig	Not present		
spCellConfig	Not present		
}			
}			

Table 8.2.2.7.1.3.3-23: RadioBearerConfig-SCG-to-MCG (step 17, Table 8.2.2.7.1.3.2-1)

Derivation Path: 38.508-1 [4], Table 4.6.3-132 with condition EN-DC			
Information Element	Value/remark	Comment	Condition
RadioBearerConfig ::= SEQUENCE {			
drb-ToAddModList SEQUENCE (SIZE (1..maxDRB)) OF SEQUENCE {	1 entry		
cnAssociation CHOICE {			
eps-BearerIdentity	6		
}			
drb-Identity	2		
recoverPDCP	true		
}			
}			
}			

Table 8.2.2.7.1.3.3-24: RRCConnectionReconfiguration (step 21, Table 8.2.2.7.1.3.2-1)

Derivation Path: 36.508 [7], Table 4.6.1-8			
Information Element	Value/remark	Comment	Condition
RRCConnectionReconfiguration ::= SEQUENCE {			
criticalExtensions CHOICE {			
c1 CHOICE{			
rrcConnectionReconfiguration-r8 ::= SEQUENCE			
{			
radioResourceConfigDedicated	<i>RadioResourceConfigDe</i> <i>dedicated-DRB-REL(2)</i>		
nonCriticalExtension ::= SEQUENCE {			
nonCriticalExtension ::= SEQUENCE {			
nonCriticalExtension ::= SEQUENCE {			
nonCriticalExtension ::= SEQUENCE {			
nonCriticalExtension ::= SEQUENCE {			
nonCriticalExtension ::= SEQUENCE {			
nonCriticalExtension ::= SEQUENCE {			
nr-Config-r15 CHOICE {			
setup SEQUENCE {			
nr-SecondaryCellGroupConfig-r15	OCTET STRING		
	containing		
	<i>RRCReconfiguration-</i>		
	<i>MCG-to-SCG</i>		
}			
}			
nr-RadioBearerConfig1-r15	OCTET STRING		
	including		
	<i>RadioBearerConfig-</i>		
	<i>MCG-to-SCG.</i>		
}			
}			
}			
}			
}			

Table 8.2.2.7.1.3.3-25: RadioResourceConfigDedicated-DRB-REL (bid) (step 13, Table 8.2.2.7.1.3.2-1)

Derivation Path: 36.508 [7], Table 4.6.3-18C			
Information Element	Value/remark	Comment	Condition
RadioResourceConfigDedicated-DRB-REL(bid) ::= SEQUENCE {		bid is the bearer identity	
drb-ToReleaseList SEQUENCE (SIZE (1..maxDRB))	one entry		
OF			
DRB-Identity[1]	2		
}			

Table 8.2.2.7.1.3.3-26: RRCReconfiguration-MCG-to-SCG (step 21, Table 8.2.2.7.1.3.2-1)

Derivation Path: 38.508-1 [4], Table 4.6.1-13 with condition EN-DC			
Information Element	Value/remark	Comment	Condition
RRCReconfiguration ::= SEQUENCE {			
criticalExtensions CHOICE {			
c1 CHOICE{			
rrcReconfiguration SEQUENCE {			
radioBearerConfig	Not present		
secondaryCellGroup	OCTET STRING containing <i>CellGroupConfig-MCG- to-SCG</i>		
}			
}			
}			
}			

Table 8.2.2.7.1.3.3-27: CellGroupConfig-MCG-to-SCG (step 21, Table 8.2.2.7.1.3.2-1)

Derivation Path: 38.508-1 [4] Table 4.6.3-19 with condition EN-DC			
Information Element	Value/remark	Comment	Condition
CellGroupConfig ::= SEQUENCE {			
mac-CellGroupConfig	Not present		
physicalCellGroupConfig	Not present		
spCellConfig	Not present		
}			

Table 8.2.2.7.1.3.3-28: RadioBearerConfig-MCG-to-SCG (step 21, Table 8.2.2.7.1.3.2-1)

Derivation Path: 38.508-1 [4], Table 4.6.3-132 with condition EN-DC			
Information Element	Value/remark	Comment	Condition
RadioBearerConfig ::= SEQUENCE {			
drb-ToAddModList SEQUENCE (SIZE (1..maxDRB)) OF SEQUENCE {	1 entry		
cnAssociation CHOICE {			
eps-BearerIdentity	6		
}			
drb-Identity	2		
recoverPDCP	true		
}			
}			

Table 8.2.2.7.1.3.3-29: RRCConnectionReconfigurationComplete (steps 6, 10, 18, 22, Table 8.2.2.7.1.3.2-1)

Derivation Path: 36.508 [7] Table 4.6.1-9			
Information Element	Value/remark	Comment	Condition
RRCConnectionReconfigurationComplete ::= SEQUENCE {			
criticalExtensions CHOICE {			
rrcConnectionReconfigurationComplete-r8 SEQUENCE {			
nonCriticalExtension SEQUENCE {			
nonCriticalExtension SEQUENCE {			
nonCriticalExtension SEQUENCE {			
nonCriticalExtension SEQUENCE {			
nonCriticalExtension SEQUENCE {			
nonCriticalExtension SEQUENCE {			
scg-ConfigResponseNR-r15	Present		
}			
}			
}			
}			
}			

8.2.2.8 Bearer Modification / Handling for bearer type change with security key change

8.2.2.8.1 Bearer Modification / Handling for bearer type change with security key change / EN-DC

8.2.2.8.1.1 Test Purpose (TP)

(1)

```
with { UE in RRC_CONNECTED state with EN-DC, and, MCG(s) (E-UTRA PDCP) and SCG }
ensure that {
  when { UE receives an RRCConnectionReconfiguration message to modify the SN terminated SCG DRB to
    MN terminated SCG DRB with security key change to keNB }
  then { UE reconfigures the DRB and sends an RRCConnectionReconfigurationComplete message }
}
```

(2)

```
with { UE in RRC_CONNECTED state with EN-DC, and, MCG(s) (E-UTRA PDCP) and MN terminated SCG DRB
  established with security key keNB }
ensure that {
  when { UE receives an RRCConnectionReconfiguration message to modify the MN terminated SCG DRB to
    SN terminated Split DRB with security key change to s-KgNB }
  then { UE reconfigures the DRB and sends an RRCConnectionReconfigurationComplete message }
}
```

(3)

```
with { UE in RRC_CONNECTED state with EN-DC, and, MCG(s) (E-UTRA PDCP) and SN terminated Split DRB
  established with security key s-KgNB }
ensure that {
  when { UE receives an RRCConnectionReconfiguration message to modify the SN terminated Split DRB
    to MN terminated Split DRB with security key change to keNB }
  then { UE reconfigures the DRB and sends an RRCConnectionReconfigurationComplete message }
}
```

(4)

```

with { UE in RRC_CONNECTED state with EN-DC, and, MCG(s) (E-UTRA PDCP) and MN terminated Split DRB
established with security key keNB }
ensure that {
  when { UE receives an RRCConnectionReconfiguration message to modify the MN terminated Split DRB
to SN terminated MCG DRB (NR PDCP) with security key change to s-KgNB }
  then { UE reconfigures the DRB and sends an RRCConnectionReconfigurationComplete message }
}

```

(5)

```

with { UE in RRC_CONNECTED state with EN-DC, and, MCG(s) (E-UTRA PDCP) and SN terminated MCG DRB (NR
PDCP) established with security key s-KgNB }
ensure that {
  when { UE receives an RRCConnectionReconfiguration message to modify the SN terminated MCG DRB (NR
PDCP) to MN terminated MCG DRB (NR PDCP) with security key change to keNB }
  then { UE reconfigures the DRB and sends an RRCConnectionReconfigurationComplete message }
}

```

(6)

```

with { UE in RRC_CONNECTED state with EN-DC, and, MCG(s) (E-UTRA PDCP) and MN terminated MCG DRB (NR
PDCP) established with security key keNB }
ensure that {
  when { UE receives an RRCConnectionReconfiguration message to modify the MN terminated MCG DRB (NR
PDCP) to SN terminated Split DRB with security key change to s-KgNB }
  then { UE reconfigures the DRB and sends an RRCConnectionReconfigurationComplete message }
}

```

(7)

```

with { UE in RRC_CONNECTED state with EN-DC, and, MCG(s) (E-UTRA PDCP) and SN terminated Split DRB
established with security key s-KgNB }
ensure that {
  when { UE receives an RRCConnectionReconfiguration message to modify the SN terminated Split DRB
to MN terminated SCG DRB with security key change to keNB }
  then { UE reconfigures the DRB and sends an RRCConnectionReconfigurationComplete message }
}

```

(8)

```

with { UE in RRC_CONNECTED state with EN-DC, and, MCG(s) (E-UTRA PDCP) and MN terminated SCG DRB
established with security key keNB }
ensure that {
  when { UE receives an RRCConnectionReconfiguration message to modify the MN terminated SCG DRB to
SN terminated MCG DRB (NR PDCP) with security key change to s-KgNB }
  then { UE reconfigures the DRB and sends an RRCConnectionReconfigurationComplete message }
}

```

(9)

```

with { UE in RRC_CONNECTED state with EN-DC, and, MCG(s) (E-UTRA PDCP) and SN terminated MCG DRB (NR
PDCP) established with security key s-KgNB }
ensure that {
  when { UE receives an RRCConnectionReconfiguration message to modify the SN terminated MCG DRB (NR
PDCP) to MN terminated SCG DRB with security key change to keNB }
  then { UE reconfigures the DRB and sends an RRCConnectionReconfigurationComplete message }
}

```

8.2.2.8.1.2 Conformance requirements

References: The conformance requirements covered in the present test case are specified in: TS 36.331, clause 5.3.5.3, TS 38.331, clauses 5.3.5.3, 5.3.5.6.1 and 5.3.5.6.5, TS 37.340, clause Annex A: Table A-1: L2 handling for bearer type change with and without security key change. Unless otherwise stated these are Rel-15 requirements.

[TS 36.331, clause 5.3.5.3]

If the *RRCConnectionReconfiguration* message does not include the *mobilityControlInfo* and the UE is able to comply with the configuration included in this message, the UE shall:

...

- 1> if the received *RRCCConnectionReconfiguration* includes the *nr-Config* and it is set to *release*: or
- 1> if the received *RRCCConnectionReconfiguration* includes *endc-ReleaseAndAdd* and it is set to *TRUE*:
 - 2> perform ENDC release as specified in TS38.331 [82], clause 5.3.5.10;
- 1> if the received *RRCCConnectionReconfiguration* includes the *sk-Counter*:
 - 2> perform key update procedure as specified in TS 38.331 [82], clause 5.3.5.7;
- 1> if the received *RRCCConnectionReconfiguration* includes the *nr-SecondaryCellGroupConfig*:
 - 2> perform NR RRC Reconfiguration as specified in TS 38.331 [82], clause 5.3.5.3;
- 1> if the received *RRCCConnectionReconfiguration* includes the *nr-RadioBearerConfig1*:
 - 2> perform radio bearer configuration as specified in TS 38.331 [82], clause 5.3.5.6;
- 1> if the received *RRCCConnectionReconfiguration* includes the *nr-RadioBearerConfig2*:
 - 2> perform radio bearer configuration as specified in TS 38.331 [82], clause 5.3.5.6;
- 1> if this is the first *RRCCConnectionReconfiguration* message after successful completion of the RRC connection re-establishment procedure:
 - 2> resume SRB2 and all DRBs that are suspended, if any, including RBs configured with NR PDCP;

NOTE 4: The handling of the radio bearers after the successful completion of the PDCP re-establishment, e.g. the re-transmission of unacknowledged PDCP SDUs (as well as the associated status reporting), the handling of the SN and the HFN, is specified in TS 36.323 [8].

NOTE 5: The UE may discard SRB2 messages and data that it receives prior to completing the reconfiguration used to resume these bearers.

...

- 1> set the content of *RRCCConnectionReconfigurationComplete* message as follows:
 - 2> if the *RRCCConnectionReconfiguration* message includes *perCC-GapIndicationRequest*:
 - 3> include *perCC-GapIndicationList* and *numFreqEffective*;
 - 2> if the frequencies are configured for reduced measurement performance:
 - 3> include *numFreqEffectiveReduced*;
 - 2> if the received *RRCCConnectionReconfiguration* message included *nr-SecondaryCellGroupConfig*:
 - 3> include *scg-ConfigResponseNR* in accordance with TS 38.331 [82], clause 5.3.5.3;
- 1> submit the *RRCCConnectionReconfigurationComplete* message to lower layers for transmission using the new configuration, upon which the procedure ends;

[TS 38.331, clause 5.3.5.3]

The UE shall perform the following actions upon reception of the *RRCReconfiguration*:

...

- 1> if the *RRCReconfiguration* includes the *secondaryCellGroup*:
 - 2> perform the cell group configuration for the SCG according to 5.3.5.5;
- 1> if the *RRCReconfiguration* message contains the *radioBearerConfig*:
 - 2> perform the radio bearer configuration according to 5.3.5.6;

- 1> if the *RRCReconfiguration* message includes the *measConfig*:
 - 2> perform the measurement configuration procedure as specified in 5.5.2;
- ...
- 1> set the content of *RRCReconfigurationComplete* message as follows:
 - 2> if the *RRCReconfiguration* includes the *masterCellGroup* containing the *reportUplinkTxDirectCurrent*, or;
 - 2> if the *RRCReconfiguration* includes the *secondaryCellGroup* containing the *reportUplinkTxDirectCurrent*:
 - 3> include the *uplinkTxDirectCurrentList*;
- 1> if the UE is configured with E-UTRA *nr-SecondaryCellGroupConfig* (MCG is E-UTRA):
 - 2> if *RRCReconfiguration* was received via SRB1:
 - 3> construct *RRCReconfigurationComplete* message and submit it via the EUTRA MCG embedded in E-UTRA RRC message *RRCConnectionReconfigurationComplete* as specified in TS 36.331 [10];
 - 3> if *reconfigurationWithSync* was included in *spCellConfig* of an SCG:
 - 4> initiate the random access procedure on the SpCell, as specified in TS 38.321 [3];
 - 3> else:
 - 4> the procedure ends;
 - NOTE: The order the UE sends the *RRCConnectionReconfigurationComplete* message and performs the Random Access procedure towards the SCG is left to UE implementation.
 - 2> else (*RRCReconfiguration* was received via SRB3):

- 3> submit the *RRCReconfigurationComplete* message via SRB3 to lower layers for transmission using the new configuration .

NOTE: For EN-DC, in the case *RRCReconfiguration* is received via SRB1, the random access is triggered by RRC layer itself as there is not necessarily other UL transmission. In the case *RRCReconfiguration* is received via SRB3, the random access is triggered by the MAC layer due to arrival of *RRCReconfigurationComplete*.

- 1> else:
 - 2> submit the *RRCReconfigurationComplete* message via SRB1 to lower layers for transmission using the new configuration;
 - 2> if this is the first *RRCReconfiguration* message after successful completion of the RRC re-establishment procedure:
 - 3> resume SRB2 and DRBs that are suspended;
- 1> if *reconfigurationWithSync* was included in *spCellConfig* of an MCG or SCG, and when MAC of an NR cell group successfully completes a random access procedure triggered above;
 - 2> stop timer T304 for that cell group;
 - 2> apply the parts of the CQI reporting configuration, the scheduling request configuration and the sounding RS configuration that do not require the UE to know the SFN of the respective target SpCell, if any;
 - 2> apply the parts of the measurement and the radio resource configuration that require the UE to know the SFN of the respective target SpCell (e.g. measurement gaps, periodic CQI reporting, scheduling request configuration, sounding RS configuration), if any, upon acquiring the SFN of that target SpCell;
 - 2> if the *reconfigurationWithSync* was included in *spCellConfig* of an MCG:

- 3> if T390 is running:
 - 4> stop timer T390 for all access categories;
 - 4> perform the actions as specified in 5.3.14.4.
- 3> if *RRCReconfiguration* does not include *dedicatedSIB1-Delivery* and
- 3> if the active downlink BWP, which is indicated by the *firstActiveDownlinkBWP-Id* for the target SpCell of the MCG, has a common search space configured by *searchSpaceSIB1*:
 - 4> acquire the *SIB1*, which is scheduled as specified in TS 38.213 [13], of the target SpCell of the MCG;
 - 4> upon acquiring *SIB1*, perform the actions specified in clause 5.2.2.4.2;
- 2> the procedure ends.

NOTE: The UE is only required to acquire broadcasted *SIB1* if the UE can acquire it without disrupting unicast data reception, i.e. the broadcast and unicast beams are quasi co-located.

[TS 38.331, clause 5.3.5.6.1]

The UE shall perform the following actions based on a received *RadioBearerConfig* IE:

...

- 1> if the *RadioBearerConfig* includes the *drb-ToAddModList*:
 - 2> perform DRB addition or reconfiguration as specified in 5.3.5.6.5.

[TS 38.331, clause 5.3.5.6.5]

The UE shall:

- 1> for each *drb-Identity* value included in the *drb-ToAddModList* that is not part of the current UE configuration (DRB establishment including the case when full configuration option is used):
 - 2> establish a PDCP entity and configure it in accordance with the received *pdcp-Config*;
 - 2> if the PDCP entity of this DRB is not configured with *cipheringDisabled*:
 - 3> if target RAT of handover is E-UTRA/5GC, or;
 - 3> if the UE is only connected to E-UTRA/5GC:
 - 4> configure the PDCP entity with the ciphering algorithm and K_{UPenc} key configured/derived as specified in TS 36.331 [10];
 - 3> else:
 - 4> configure the PDCP entity with the ciphering algorithms according to *securityConfig* and apply the K_{UPenc} key associated with the master key (K_{eNB}/K_{gNB}) or the secondary key ($S-K_{gNB}$) as indicated in *keyToUse*;
 - 2> if the PDCP entity of this DRB is configured with *integrityProtection*:
 - 3> configure the PDCP entity with the integrity algorithms according to *securityConfig* and apply the K_{UPint} key associated with the master (K_{eNB}/K_{gNB}) or the secondary key ($S-K_{gNB}$) as indicated in *keyToUse*;
- ...
- 2> if the UE is operating in EN-DC:
 - 3> if the DRB was configured with the same *eps-BearerIdentity* either by NR or E-UTRA prior to receiving this reconfiguration:
 - 4> associate the established DRB with the corresponding *eps-BearerIdentity*;

- 3> else:
 - 4> indicate the establishment of the DRB(s) and the *eps-BearerIdentity* of the established DRB(s) to upper layers;
- 3> for each *drb-Identity* value included in the *drb-ToAddModList* that is part of the current UE configuration:
 - 2> if the *reestablishPDCP* is set:
 - 3> if target RAT is E-UTRA/5GC, or:
 - 3> if the UE is only connected to E-UTRA/5GC:
 - 4> if the PDCP entity of this DRB is not configured with *cipheringDisabled*:
 - 5> configure the PDCP entity with the ciphering algorithm and K_{UPenc} key configured/derived as specified in TS 36.331 [10, 5.4.2.3], i.e. the ciphering configuration shall be applied to all subsequent PDCP PDUs received and sent by the UE;
 - 3> else:
 - 4> if the PDCP entity of this DRB is not configured with *cipheringDisabled*:
 - 5> configure the PDCP entity with the ciphering algorithm and K_{UPenc} key associated with the master key (K_{eNB}/K_{gNB}) or the secondary key ($S-K_{gNB}$), as indicated in *keyToUse*, i.e. the ciphering configuration shall be applied to all subsequent PDCP PDUs received and sent by the UE;
 - 4> if the PDCP entity of this DRB is configured with *integrityProtection*:
 - 5> configure the PDCP entity with the integrity algorithms according to *securityConfig* and apply the K_{UPint} key associated with the master (K_{eNB}/K_{gNB}) or the secondary key ($S-K_{gNB}$) as indicated in *keyToUse*;
 - 3> re-establish the PDCP entity of this DRB as specified in 38.323 [5], clause 5.1.2;
 - 2> else, if the *recoverPDCP* is set:
 - 3> trigger the PDCP entity of this DRB to perform data recovery as specified in 38.323 [5];
 - 2> if the *pdcp-Config* is included:
 - 3> reconfigure the PDCP entity in accordance with the received *pdcp-Config*.

...

NOTE 1: Void.

NOTE 2: When determining whether a *drb-Identity* value is part of the current UE configuration, the UE does not distinguish which *RadioBearerConfig* and *DRB-ToAddModList* that DRB was originally configured in. To re-associate a DRB with a different key (K_{eNB} to $S-K_{eNB}$ or vice versa), the network provides the *drb-Identity* value in the (target) *drb-ToAddModList* and sets the *reestablishPDCP* flag. The network does not list the *drb-Identity* in the (source) *drb-ToReleaseList*.

NOTE 3: When setting the *reestablishPDCP* flag for a radio bearer, the network ensures that the RLC receiver entities do not deliver old PDCP PDUs to the re-established PDCP entity. It does that e.g. by triggering a reconfiguration with sync of the cell group hosting the old RLC entity or by releasing the old RLC entity.

NOTE 4: In this specification, UE configuration refers to the parameters configured by NR RRC unless otherwise stated.

NOTE 5: Ciphering and integrity protection can be enabled or disabled for a DRB. The enabling/disabling of ciphering or integrity protection can be changed only by releasing and adding the DRB.

[TS 37.340, Annex A]

This subclause provides for information an overview on L2 handling for bearer type change in EN-DC, with and without security key change (from K_{eNB} to $S-K_{gNB}$ and from $S-K_{gNB}$ to K_{eNB}), i.e. with and without a change of the termination point.

Table A-1: L2 handling for bearer type change with and without security key change

Bearer type change from row to col	MCG		Split		SCG	
	no key change	with key change ($K_{eNB} \leftrightarrow S-K_{gNB}$)	no key change	with key change ($K_{eNB} \leftrightarrow S-K_{gNB}$)	no key change	with key change ($K_{eNB} \leftrightarrow S-K_{gNB}$)
MCG	N/A	PDCP: Re-establish MCG RLC: Re-establish MCG MAC: See Note SCG RLC: No action SCG MAC: No action	PDCP: Reconfigure MCG RLC: No action MCG MAC: No action SCG RLC: Establish SCG MAC: Reconfigure	PDCP: Re-establish MCG RLC: Re-establish MCG MAC: See Note SCG RLC: Establish SCG MAC: Reconfigure	PDCP: Recovery MCG RLC: Re-est+release MCG MAC: Reconfigure SCG RLC: Establish SCG MAC: Reconfigure	PDCP: Re-establish MCG RLC: Re-est+release MCG MAC: Reconfigure SCG RLC: Establish SCG MAC: Reconfigure
Split	PDCP: Recovery MCG RLC: No action MCG MAC: No action SCG RLC: Release SCG MAC: Reconfigure	PDCP: Re-establish MCG RLC: Re-establish MCG MAC: See Note SCG RLC: Release SCG MAC: Reconfigure	N/A	PDCP: Re-establish MCG RLC: Re-establish MCG MAC: Reset SCG RLC: Re-establish SCG MAC: Reset	PDCP: Recovery MCG RLC: Re-est+release MCG MAC: Reconfigure SCG RLC: No action SCG MAC: No action	PDCP: Re-establish MCG RLC: Re-est+release MCG MAC: Reconfigure SCG RLC: Re-establish SCG MAC: See Note
SCG	PDCP: Recovery MCG RLC: Establish MCG MAC: Reconfigure SCG RLC: Release SCG MAC: Reconfigure	PDCP: Re-establish MCG RLC: Establish MCG MAC: Reconfigure SCG RLC: Release SCG MAC: Reconfigure	PDCP: Reconfigure MCG RLC: Establish MCG MAC: Reconfigure SCG RLC: No action SCG MAC: No action	PDCP: Re-establish MCG RLC: Establish MCG MAC: Reconfigure SCG RLC: Re-establish SCG MAC: See Note	N/A	PDCP: Re-establish MCG RLC: No action MCG MAC: No action SCG RLC: Re-establish SCG MAC: See note

NOTE: MAC behaviour depends on the solution selected by the network, e.g. MAC reset, change of LCID, etc.

8.2.2.8.1.3 Test description

8.2.2.8.1.3.1 Pre-test conditions

System Simulator:

- E-UTRA Cell 1 is the PCell and NR Cell 1 is the PSCell.

UE:

- None.

Preamble:

- If `pc_IP_Ping` is set to TRUE then, the UE is in state RRC_CONNECTED using generic procedure parameter Connectivity (EN-DC), Bearers (MCG(s) and SCG) established according to TS 38.508-1 [4], clause 4.5.4.

- Else, the UE is in state RRC_CONNECTED using generic procedure parameter Connectivity (*EN-DC*), Bearers (*MCG(s) and SCG*) established and Test Loop Function (On) with UE test loop mode B according to TS 38.508-1 [4], clause 4.5.4.

8.2.2.8.1.3.2 Test procedure sequence

Table 8.2.2.8.1.3.2-1: Main behaviour

St	Procedure	Message Sequence		TP	Verdict
		U - S	Message		
1	The SS transmits an <i>RRCCONNECTIONRECONFIGURATION</i> message containing NR <i>RRCCONNECTIONRECONFIGURATION</i> message to modify SN terminated SCG DRB with security key s-KgNB to MN terminated SCG DRB with security key change to keNB.	<--	<i>RRCCONNECTIONRECONFIGURATION</i> (<i>RRCCONNECTIONRECONFIGURATION</i>)	-	-
2	Check: Does the UE transmit an <i>RRCCONNECTIONRECONFIGURATIONCOMPLETE</i> message containing NR <i>RRCCONNECTIONRECONFIGURATIONCOMPLETE</i> message?	-->	<i>RRCCONNECTIONRECONFIGURATIONCOMPLETE</i> (<i>RRCCONNECTIONRECONFIGURATIONCOMPLETE</i>)	1	P
3	Check: Does the test result of generic test procedure in TS 38.508-1 subclause 4.9.1 indicate that the UE is capable of exchanging IP data on SCG DRB#2?	-	-	1	P
4	The SS transmits an <i>RRCCONNECTIONRECONFIGURATION</i> message containing NR <i>RRCCONNECTIONRECONFIGURATION</i> message to modify MN terminated SCG DRB with security key keNB to SN terminated Split DRB with security key change to s-KgNB.	<--	<i>RRCCONNECTIONRECONFIGURATION</i> (<i>RRCCONNECTIONRECONFIGURATION</i>)	-	-
5	Check: Does the UE transmit an <i>RRCCONNECTIONRECONFIGURATIONCOMPLETE</i> message containing NR <i>RRCCONNECTIONRECONFIGURATIONCOMPLETE</i> message?	-->	<i>RRCCONNECTIONRECONFIGURATIONCOMPLETE</i> (<i>RRCCONNECTIONRECONFIGURATIONCOMPLETE</i>)	2	P
6	Check: Does the test result of generic test procedure in TS 38.508-1 subclause 4.9.1 indicate that the UE is capable of exchanging IP data on Split DRB#2 using NR radio path?	-	-	2	P
7	The SS transmits an <i>RRCCONNECTIONRECONFIGURATION</i> message containing NR <i>RRCCONNECTIONRECONFIGURATION</i> message to modify SN terminated Split DRB with security key s-KgNB to MN terminated Split DRB with security key change to keNB.	<--	<i>RRCCONNECTIONRECONFIGURATION</i> (<i>RRCCONNECTIONRECONFIGURATION</i>)	-	-
8	Check: Does the UE transmit an <i>RRCCONNECTIONRECONFIGURATIONCOMPLETE</i> message containing NR <i>RRCCONNECTIONRECONFIGURATIONCOMPLETE</i> message?	-->	<i>RRCCONNECTIONRECONFIGURATIONCOMPLETE</i> (<i>RRCCONNECTIONRECONFIGURATIONCOMPLETE</i>)	3	P
9	Check: Does the test result of generic test procedure in TS 38.508-1 subclause 4.9.1 indicate that the UE is capable of exchanging IP data on Split DRB#2 using NR radio path?	-	-	3	P
10	The SS transmits an <i>RRCCONNECTIONRECONFIGURATION</i> message containing NR <i>RRCCONNECTIONRECONFIGURATION</i> message to modify MN terminated Split DRB with security key keNB to SN terminated MCG DRB with security key change to s-KgNB.	<--	<i>RRCCONNECTIONRECONFIGURATION</i> (<i>RRCCONNECTIONRECONFIGURATION</i>)	-	-
11	Check: Does the UE transmit an <i>RRCCONNECTIONRECONFIGURATIONCOMPLETE</i> message containing NR <i>RRCCONNECTIONRECONFIGURATIONCOMPLETE</i> message?	-->	<i>RRCCONNECTIONRECONFIGURATIONCOMPLETE</i> (<i>RRCCONNECTIONRECONFIGURATIONCOMPLETE</i>)	4	P
12	Check: Does the test result of generic test procedure in TS 38.508-1 subclause 4.9.1 indicate that the UE is capable of exchanging IP data on MCG DRB#2?	-	-	4	P
13	The SS transmits an <i>RRCCONNECTIONRECONFIGURATION</i> message containing NR <i>RADIOBEARERCONFIG</i> to modify SN terminated MCG DRB with security key s-KgNB to MN terminated MCG DRB with security key change to keNB.	<--	<i>RRCCONNECTIONRECONFIGURATION</i>	-	-
14	Check: Does the UE transmit an <i>RRCCONNECTIONRECONFIGURATIONCOMPLETE</i> message?	-->	<i>RRCCONNECTIONRECONFIGURATIONCOMPLETE</i>	5	P

15	Check: Does the test result of generic test procedure in TS 38.508-1 subclause 4.9.1 indicate that the UE is capable of exchanging IP data on MCG DRB#2?	-	-	5	P
16	The SS transmits an <i>RRCConnectionReconfiguration</i> message containing NR <i>RRCReconfiguration</i> message to modify MN terminated MCG DRB with security key keNB to SN terminated Split DRB with security key change to s-KgNB.	<--	<i>RRCConnectionReconfiguration</i> (<i>RRCReconfiguration</i>)	-	-
17	Check: Does the UE transmit an <i>RRCConnectionReconfigurationComplete</i> message containing NR <i>RRCReconfigurationComplete</i> message?	-->	<i>RRCConnectionReconfigurationComplete</i> (<i>RRCReconfigurationComplete</i>)	6	P
18	Check: Does the test result of generic test procedure in TS 38.508-1 subclause 4.9.1 indicate that the UE is capable of exchanging IP data on Split DRB#2 using NR radio path?	-	-	6	P
19	The SS transmits an <i>RRCConnectionReconfiguration</i> message containing NR <i>RRCReconfiguration</i> message to modify SN terminated Split DRB with security key s-KgNB to MN terminated SCG DRB with security key change to keNB.	<--	<i>RRCConnectionReconfiguration</i> (<i>RRCReconfiguration</i>)	-	-
20	Check: Does the UE transmit an <i>RRCConnectionReconfigurationComplete</i> message containing NR <i>RRCReconfigurationComplete</i> message?	-->	<i>RRCConnectionReconfigurationComplete</i> (<i>RRCReconfigurationComplete</i>)	7	P
21	Check: Does the test result of generic test procedure in TS 38.508-1 subclause 4.9.1 indicate that the UE is capable of exchanging IP data on SCG DRB#2?	-	-	7	P
22	The SS transmits an <i>RRCConnectionReconfiguration</i> message containing NR <i>RRCReconfiguration</i> message to modify MN terminated SCG DRB with security key keNB to SN terminated MCG DRB with security key change to s-KgNB.	<--	<i>RRCConnectionReconfiguration</i> (<i>RRCReconfiguration</i>)	-	-
23	Check: Does the UE transmit an <i>RRCConnectionReconfigurationComplete</i> message containing NR <i>RRCReconfigurationComplete</i> message?	-->	<i>RRCConnectionReconfigurationComplete</i> (<i>RRCReconfigurationComplete</i>)	8	P
24	Check: Does the test result of generic test procedure in TS 38.508-1 subclause 4.9.1 indicate that the UE is capable of exchanging IP data on MCG DRB#2?	-	-	8	P
25	The SS transmits an <i>RRCConnectionReconfiguration</i> message containing NR <i>RRCReconfiguration</i> message to modify SN terminated MCG DRB with security key s-KgNB to MN terminated SCG DRB with security key change to keNB.	<--	<i>RRCConnectionReconfiguration</i> (<i>RRCReconfiguration</i>)	-	-
26	Check: Does the UE transmit an <i>RRCConnectionReconfigurationComplete</i> message containing NR <i>RRCReconfigurationComplete</i> message?	-->	<i>RRCConnectionReconfigurationComplete</i> (<i>RRCReconfigurationComplete</i>)	9	P
27	Check: Does the test result of generic test procedure in TS 38.508-1 subclause 4.9.1 indicate that the UE is capable of exchanging IP data on SCG DRB#2?	-	-	9	P

8.2.2.8.1.3.3 Specific message contents

Table 8.2.2.8.1.3.3-1: RRCConnectionReconfiguration (step 1, Table 8.2.2.8.1.3.2-1)

Derivation Path: 36.508 [7], Table 4.6.1-8			
Information Element	Value/remark	Comment	Condition
RRCConnectionReconfiguration ::= SEQUENCE {			
criticalExtensions CHOICE {			
c1 CHOICE {			
rrcConnectionReconfiguration-r8 ::= SEQUENCE			
{			
nonCriticalExtension ::= SEQUENCE {			
nonCriticalExtension ::= SEQUENCE {			
nonCriticalExtension ::= SEQUENCE {			
nonCriticalExtension ::= SEQUENCE {			
nonCriticalExtension ::= SEQUENCE {			
nonCriticalExtension ::= SEQUENCE {			
nonCriticalExtension ::= SEQUENCE {			
nonCriticalExtension ::= SEQUENCE {			
nr-Config-r15 CHOICE {			
setup SEQUENCE {			
nr-SecondaryCellGroupConfig-r15	OCTET STRING including the RRCReconfiguration message and the IE secondaryCellGroup.		
}			
}			
nr-RadioBearerConfig1-r15	OCTET STRING including RadioBearerConfig.		
}			
}			
}			
}			
}			
}			
}			
}			
}			
}			
}			
}			
}			
}			
}			
}			
}			
}			

Table 8.2.2.8.1.3.3-2: RRCReconfiguration (Table 8.2.2.8.1.3.3-1)

Derivation Path: 38.508-1 [4], Table 4.6.1-13			
Information Element	Value/remark	Comment	Condition
RRCReconfiguration ::= SEQUENCE {			
criticalExtensions CHOICE {			
rrcReconfiguration ::= SEQUENCE {			
secondaryCellGroup	CellGroupConfig		
}			
}			
}			

Table 8.2.2.8.1.3.3-3: CellGroupConfig (Table 8.2.2.8.1.3.3-2)

Derivation Path: 38.508-1 [4], Table 4.6.3-19			
Information Element	Value/remark	Comment	Condition
CellGroupConfig ::= SEQUENCE {			
rlc-BearerToAddModList SEQUENCE (SIZE(1..maxLCH)) OF SEQUENCE {	1 entry		
logicalChannelIdentity[1]	Logical channel identity corresponding to SCG DRB.		
reestablishRLC[1]	true		
}			
}			

Table 8.2.2.8.1.3.3-4: RadioBearerConfig (Table 8.2.2.8.1.3.3-1)

Derivation Path: 38.508-1 [4], Table 4.6.3-132			
Information Element	Value/remark	Comment	Condition
RadioBearerConfig ::= SEQUENCE {			
drb-ToAddModList SEQUENCE (SIZE (1..maxDRB)) OF SEQUENCE {	1 entry		
cnAssociation CHOICE {			
eps-BearerIdentity	6	Dedicated EPS bearer Id of SCG DRB	
}			
drb-Identity	2	SCG DRB Id	
reestablishPDCP	true		
}			
securityConfig SEQUENCE {			
keyToUse	master		
}			
}			

Table 8.2.2.8.1.3.3-5: RRCConnectionReconfiguration (step 4, Table 8.2.2.8.1.3.2-1)

Derivation Path: 36.508 [7], Table 4.6.1-8			
Information Element	Value/remark	Comment	Condition
RRCConnectionReconfiguration ::= SEQUENCE {			
criticalExtensions CHOICE {			
c1 CHOICE {			
rrcConnectionReconfiguration-r8 ::= SEQUENCE			
{			
radioResourceConfigDedicated	RadioResourceConfigDe- dicated-MN_SCG-to- SN_Split		
nonCriticalExtension ::= SEQUENCE {			
nonCriticalExtension ::= SEQUENCE {			
nonCriticalExtension ::= SEQUENCE {			
nonCriticalExtension ::= SEQUENCE {			
nonCriticalExtension ::= SEQUENCE {			
nonCriticalExtension ::= SEQUENCE {			
nonCriticalExtension ::= SEQUENCE {			
nonCriticalExtension ::= SEQUENCE {			
nr-Config-r15 CHOICE {			
setup SEQUENCE {			
nr-SecondaryCellGroupConfig-r15	OCTET STRING including the <i>RRCReconfiguration</i> message and the IE secondaryCellGroup.		
}			
}			
nr-RadioBearerConfig1-r15	OCTET STRING including RadioBearerConfig.		
}			
}			
}			
}			
}			
}			
}			
}			
}			
}			
}			
}			

Table 8.2.2.8.1.3.3-6: RadioResourceConfigDedicated-MN_SCG-to-SN_Split (Table 8.2.2.8.1.3.3-5)

Derivation Path: 36.508 [7], Table 4.6.3-19AAAAAB

Table 8.2.2.8.1.3.3-7: RRCReconfiguration (Table 8.2.2.8.1.3.3-5)

Derivation Path: 38.508-1 [4], Table 4.6.1-13			
Information Element	Value/remark	Comment	Condition
RRCReconfiguration ::= SEQUENCE {			
criticalExtensions CHOICE {			
rrcReconfiguration ::= SEQUENCE {			
secondaryCellGroup	CellGroupConfig		
}			
}			
}			

Table 8.2.2.8.1.3.3-8: CellGroupConfig (Table 8.2.2.8.1.3.3-7)

Derivation Path: 38.508-1 [4], Table 4.6.3-19			
Information Element	Value/remark	Comment	Condition
CellGroupConfig ::= SEQUENCE {			
rlc-BearerToAddModList SEQUENCE (SIZE(1..maxLCH)) OF SEQUENCE {	1 entry		
logicalChannelIdentity[1]	Logical channel identity corresponding to SCG DRB.		
reestablishRLC[1]	true		
}			
}			

Table 8.2.2.8.1.3.3-9: RadioBearerConfig (Table 8.2.2.8.1.3.3-5)

Derivation Path: 38.508-1 [4], Table 4.6.3-132			
Information Element	Value/remark	Comment	Condition
RadioBearerConfig ::= SEQUENCE {			
drb-ToAddModList SEQUENCE (SIZE (1..maxDRB)) OF SEQUENCE {	1 entry		
cnAssociation CHOICE {			
eps-BearerIdentity	6	Dedicated EPS bearer Id of SCG DRB	
}			
drb-Identity	2	SCG DRB Id	
reestablishPDCP	true		
pdcpc-Config	PDCP-Config		
}			
securityConfig SEQUENCE {			
keyToUse	secondary		
}			
}			

Table 8.2.2.8.1.3.3-10: PDCP-Config (Table 8.2.2.8.1.3.3-9)

Derivation Path: 38.508-1 [4], Table 4.6.3-99			
Information Element	Value/remark	Comment	Condition
PDCP-Config ::= SEQUENCE {			
moreThanOneRLC SEQUENCE {			
primaryPath SEQUENCE {			
cellGroup	1		
}			
ul-DataSplitThreshold	infinity		
}			
}			

Table 8.2.2.8.1.3.3-11: RRCConnectionReconfiguration (step 7, Table 8.2.2.8.1.3.2-1)

Derivation Path: 36.508 [7], Table 4.6.1-8			
Information Element	Value/remark	Comment	Condition
RRCConnectionReconfiguration ::= SEQUENCE {			
criticalExtensions CHOICE {			
c1 CHOICE {			
rrcConnectionReconfiguration-r8 ::= SEQUENCE			
{			
radioResourceConfigDedicated	RadioResourceConfigDe dicated-SN_Split-to- MN_Split		
nonCriticalExtension ::= SEQUENCE {			
nonCriticalExtension ::= SEQUENCE {			
nonCriticalExtension ::= SEQUENCE {			
nonCriticalExtension ::= SEQUENCE {			
nonCriticalExtension ::= SEQUENCE {			
nonCriticalExtension ::= SEQUENCE {			
nonCriticalExtension ::= SEQUENCE {			
nonCriticalExtension ::= SEQUENCE {			
nr-Config-r15 CHOICE {			
setup SEQUENCE {			
nr-SecondaryCellGroupConfig-r15	OCTET STRING including the <i>RRCReconfiguration</i> message and the IE secondaryCellGroup.		
}			
}			
nr-RadioBearerConfig1-r15	OCTET STRING including RadioBearerConfig.		
}			
}			
}			
}			

Table 8.2.2.8.1.3.3-12: RadioResourceConfigDedicated-SN_Split-to-MN_Split (Table 8.2.2.8.1.3.3-11)

Derivation Path: 36.508 [7], Table 4.6.3-27			
Information Element	Value/remark	Comment	Condition
RadioResourceConfigDedicated-DRB ::= SEQUENCE {			
drb-ToAddModList	DRB-ToAddModList- SN_Split-to-MN_Split		
}			

Table 8.2.2.8.1.3.3-13: DRB-ToAddModList-SN_Split-to-MN_Split (Table 8.2.2.8.1.3.3-12)

Derivation Path: 36.508 [7], Table 4.6.3-2A			
Information Element	Value/remark	Comment	Condition
DRB-ToAddModList ::= SEQUENCE (SIZE (1..maxDRB)) OF SEQUENCE {	1 Entry		
eps-BearerIdentity[1]	6	Dedicated EPS bearer Id of Split DRB	
drb-Identity[1]	2	Split DRB Id	
rlc-Config-v1510[1] ::= SEQUENCE {			
reestablishRLC-r15	true		
}			
}			

Table 8.2.2.8.1.3.3-14: RRCReconfiguration (Table 8.2.2.8.1.3.3-11)

Derivation Path: 38.508-1 [4], Table 4.6.1-13			
Information Element	Value/remark	Comment	Condition
RRCReconfiguration ::= SEQUENCE {			
criticalExtensions CHOICE {			
rrcReconfiguration ::= SEQUENCE {			
secondaryCellGroup	CellGroupConfig		
}			
}			
}			

Table 8.2.2.8.1.3.3-15: CellGroupConfig (Table 8.2.2.8.1.3.3-14)

Derivation Path: 38.508-1 [4], Table 4.6.3-19			
Information Element	Value/remark	Comment	Condition
CellGroupConfig ::= SEQUENCE {			
rlc-BearerToAddModList SEQUENCE (SIZE(1..maxLCH)) OF SEQUENCE {	1 entry		
logicalChannelIdentity[1]	Logical channel identity corresponding to Split DRB.		
reestablishRLC[1]	true		
}			
}			

Table 8.2.2.8.1.3.3-16: RadioBearerConfig (Table 8.2.2.8.1.3.3-11)

Derivation Path: 38.508-1 [4], Table 4.6.3-132			
Information Element	Value/remark	Comment	Condition
RadioBearerConfig ::= SEQUENCE {			
drb-ToAddModList SEQUENCE (SIZE (1..maxDRB)) OF SEQUENCE {	1 entry		
cnAssociation CHOICE {			
eps-BearerIdentity	6	Dedicated EPS bearer Id of Split DRB	
}			
drb-Identity	2	Split DRB Id	
reestablishPDCCP	true		
pdcp-Config	Not present		
}			
securityConfig SEQUENCE {			
keyToUse	master		
}			
}			

Table 8.2.2.8.1.3.3-19: DRB-ToAddModList-MN_Split-to-SN_MCG (Table 8.2.2.8.1.3.3-18)

Derivation Path: 36.508 [7], Table 4.6.3-2A			
Information Element	Value/remark	Comment	Condition
DRB-ToAddModList ::= SEQUENCE (SIZE (1..maxDRB)) OF SEQUENCE {	1 Entry		
eps-BearerIdentity[1]	6	Dedicated EPS bearer Id of Split DRB	
drb-Identity[1]	2	Split DRB Id	
rlc-Config-v1510[1] ::= SEQUENCE {			
reestablishRLC-r15	true		
}			
}			

Table 8.2.2.8.1.3.3-20: RRCReconfiguration (Table 8.2.2.8.1.3.3-17)

Derivation Path: 38.508-1 [4], Table 4.6.1-13			
Information Element	Value/remark	Comment	Condition
RRCReconfiguration ::= SEQUENCE {			
criticalExtensions CHOICE {			
rrcReconfiguration ::= SEQUENCE {			
secondaryCellGroup	CellGroupConfig		
}			
}			
}			

Table 8.2.2.8.1.3.3-21: CellGroupConfig (Table 8.2.2.8.1.3.3-20)

Derivation Path: 38.508-1 [4] Table 4.6.3-19			
Information Element	Value/remark	Comment	Condition
CellGroupConfig ::= SEQUENCE {			
rlc-BearerToAddModList	Not present		
rlc-BearerToReleaseList SEQUENCE (SIZE(1..maxLCH)) OF SEQUENCE {	1 entry		
logicalChannelIdentity[1]	Logical channel identity corresponding to Split DRB.		
}			
mac-CellGroupConfig	Not present		
physicalCellGroupConfig	Not present		
spCellConfig	Not present		
}			

Table 8.2.2.8.1.3.3-22: RadioBearerConfig (Table 8.2.2.8.1.3.3-17)

Derivation Path: 38.508-1 [4], Table 4.6.3-132 with condition EN-DC			
Information Element	Value/remark	Comment	Condition
RadioBearerConfig ::= SEQUENCE {			
drb-ToAddModList SEQUENCE (SIZE (1..maxDRB)) OF SEQUENCE {	1 entry		
drb-Identity	2	Split DRB Id	
reestablishPDCP	true		
}			
securityConfig SEQUENCE {			
keyToUse	secondary		
}			
}			

Table 8.2.2.8.1.3.3-23: RRCConnectionReconfiguration (step 13, Table 8.2.2.8.1.3.2-1)

Derivation Path: 36.508 [7], Table 4.6.1-8			
Information Element	Value/remark	Comment	Condition
RRCConnectionReconfiguration ::= SEQUENCE {			
criticalExtensions CHOICE {			
c1 CHOICE {			
rrcConnectionReconfiguration-r8 ::= SEQUENCE			
{			
radioResourceConfigDedicated	RadioResourceConfigDe- dicated-SN_MCG-to- MN_MCG		
nonCriticalExtension ::= SEQUENCE {			
nonCriticalExtension ::= SEQUENCE {			
nonCriticalExtension ::= SEQUENCE {			
nonCriticalExtension ::= SEQUENCE {			
nonCriticalExtension ::= SEQUENCE {			
nonCriticalExtension ::= SEQUENCE {			
nonCriticalExtension ::= SEQUENCE {			
nr-RadioBearerConfig1-r15	OCTET STRING including RadioBearerConfig.		
}			
}			
}			
}			
}			

Table 8.2.2.8.1.3.3-24: RadioResourceConfigDedicated-SN_MCG-to-MN_MCG (Table 8.2.2.8.1.3.3-23)

Derivation Path: 36.508 [7], Table 4.6.3-27			
Information Element	Value/remark	Comment	Condition
RadioResourceConfigDedicated-DRB ::= SEQUENCE {			
drb-ToAddModList	DRB-ToAddModList- SN_MCG-to-MN_MCG		
}			

Table 8.2.2.8.1.3.3-25: DRB-ToAddModList-SN_MCG-to-MN_MCG (Table 8.2.2.8.1.3.3-24)

Derivation Path: 36.508 [7], Table 4.6.3-2A			
Information Element	Value/remark	Comment	Condition
DRB-ToAddModList ::= SEQUENCE (SIZE (1..maxDRB)) OF SEQUENCE {	1 Entry		
eps-BearerIdentity[1]	6	Dedicated EPS bearer Id of MCG DRB	
drb-Identity[1]	2	MCG DRB Id	
rlc-Config-v1510[1] ::= SEQUENCE {			
reestablishRLC-r15	true		
}			
}			

Table 8.2.2.8.1.3.3-26: RadioBearerConfig (Table 8.2.2.8.1.3.3-23)

Derivation Path: 38.508-1 [4], Table 4.6.3-132			
Information Element	Value/remark	Comment	Condition
RadioBearerConfig ::= SEQUENCE {			
drb-ToAddModList SEQUENCE (SIZE (1..maxDRB))	1 entry		
OF SEQUENCE {			
cnAssociation CHOICE {			
eps-BearerIdentity	6	Dedicated EPS bearer Id of MCG DRB	
}			
drb-Identity	2	MCG DRB Id	
reestablishPDCP	true		
pdcpc-Config	Not present		
}			
securityConfig SEQUENCE {			
keyToUse	master		
}			
}			

Table 8.2.2.8.1.3.3-27: RRCConnectionReconfiguration (step 16, Table 8.2.2.8.1.3.2-1)

Derivation Path: 36.508 [7], Table 4.6.1-8			
Information Element	Value/remark	Comment	Condition
RRCConnectionReconfiguration ::= SEQUENCE {			
criticalExtensions CHOICE {			
c1 CHOICE{			
rrcConnectionReconfiguration-r8 ::= SEQUENCE			
{			
radioResourceConfigDedicated	RadioResourceConfigDe dicated-MN_MCG-to- SN_Split		
nonCriticalExtension ::= SEQUENCE {			
nonCriticalExtension ::= SEQUENCE {			
nonCriticalExtension ::= SEQUENCE {			
nonCriticalExtension ::= SEQUENCE {			
nonCriticalExtension ::= SEQUENCE {			
nonCriticalExtension ::= SEQUENCE {			
nonCriticalExtension ::= SEQUENCE {			
nonCriticalExtension ::= SEQUENCE {			
nr-Config-r15 CHOICE {			
setup SEQUENCE {			
nr-SecondaryCellGroupConfig-r15	OCTET STRING including the <i>RRCReconfiguration</i> message and the IE secondaryCellGroup.		
}			
}			
nr-RadioBearerConfig1-r15	OCTET STRING including RadioBearerConfig.		
}			
}			
}			
}			
}			
}			
}			
}			
}			
}			
}			
}			
}			
}			

Table 8.2.2.8.1.3.3-28: RadioResourceConfigDedicated-MN_MCG-to-SN_Split (Table 8.2.2.8.1.3.3-27)

Derivation Path: 36.508 [7], Table 4.6.3-27			
Information Element	Value/remark	Comment	Condition
RadioResourceConfigDedicated-DRB ::= SEQUENCE {			
drb-ToAddModList	DRB-ToAddModList- MN_MCG-to-SN_Split		
}			

Table 8.2.2.8.1.3.3-29: DRB-ToAddModList-MN_MCG-to-SN_Split (Table 8.2.2.8.1.3.3-30)

Derivation Path: 36.508 [7], Table 4.6.3-2A			
Information Element	Value/remark	Comment	Condition
DRB-ToAddModList ::= SEQUENCE (SIZE (1..maxDRB)) OF SEQUENCE {	1 Entry		
eps-BearerIdentity[1]	6	Dedicated EPS bearer Id of MCG DRB	
drb-Identity[1]	2	MCG DRB Id	
rlc-Config-v1510[1] ::= SEQUENCE {			
reestablishRLC-r15	true		
}			
}			

Table 8.2.2.8.1.3.3-30: RRCReconfiguration (Table 8.2.2.8.1.3.3-27)

Derivation Path: 38.508-1 [4], Table 4.6.1-13			
Information Element	Value/remark	Comment	Condition
RRCReconfiguration ::= SEQUENCE {			
criticalExtensions CHOICE {			
rrcReconfiguration ::= SEQUENCE {			
secondaryCellGroup	CellGroupConfig		
}			
}			
}			

Table 8.2.2.8.1.3.3-31: CellGroupConfig (Table 8.2.2.8.1.3.3-30)

Derivation Path: 38.508-1 [4], Table 4.6.3-19 with condition EN-DC			
Information Element	Value/remark	Comment	Condition
CellGroupConfig ::= SEQUENCE {			
rlc-BearerToAddModList SEQUENCE (SIZE(1..maxLCH)) OF SEQUENCE {	1 entry		
logicalChannelIdentity[1]	Logical channel identity corresponding to MCG DRB.		
servedRadioBearer[1] CHOICE {			
drb-Identity	2	MCG DRB Id	
}			
}			
mac-CellGroupConfig	Not present		
physicalCellGroupConfig	Not present		
spCellConfig	Not present		
}			

Table 8.2.2.8.1.3.3-32: RadioBearerConfig (Table 8.2.2.8.1.3.3-27)

Derivation Path: 38.508-1 [4], Table 4.6.3-132			
Information Element	Value/remark	Comment	Condition
RadioBearerConfig ::= SEQUENCE {			
drb-ToAddModList SEQUENCE (SIZE (1..maxDRB))	1 entry		
OF SEQUENCE {			
cnAssociation CHOICE {			
eps-BearerIdentity	6	Dedicated EPS bearer Id of MCG DRB	
}			
drb-Identity	2	MCG DRB Id	
reestablishPDCP	true		
pdcpc-Config	PDCP-Config		
}			
securityConfig SEQUENCE {			
keyToUse	secondary		
}			
}			

Table 8.2.2.8.1.3.3-33: PDCP-Config (Table 8.2.2.8.1.3.3-32)

Derivation Path: 38.508-1 [4], Table 4.6.3-99			
Information Element	Value/remark	Comment	Condition
PDCP-Config ::= SEQUENCE {			
moreThanOneRLC SEQUENCE {			
primaryPath SEQUENCE {			
cellGroup	1		
}			
ul-DataSplitThreshold	infinity		
}			
}			

Table 8.2.2.8.1.3.3-34: *RRCConnectionReconfiguration* (step 19, Table 8.2.2.8.1.3.2-1)

Derivation Path: 36.508 [7], Table 4.6.1-8			
Information Element	Value/remark	Comment	Condition
RRCConnectionReconfiguration ::= SEQUENCE {			
criticalExtensions CHOICE {			
c1 CHOICE {			
rrcConnectionReconfiguration-r8 ::= SEQUENCE			
{			
radioResourceConfigDedicated	RadioResourceConfigDe		
	dicated-DRB-REL(2)		
nonCriticalExtension ::= SEQUENCE {			
nonCriticalExtension ::= SEQUENCE {			
nonCriticalExtension ::= SEQUENCE {			
nonCriticalExtension ::= SEQUENCE {			
nonCriticalExtension ::= SEQUENCE {			
nonCriticalExtension ::= SEQUENCE {			
nonCriticalExtension ::= SEQUENCE {			
nr-Config-r15 CHOICE {			
setup SEQUENCE {			
nr-SecondaryCellGroupConfig-r15	OCTET STRING		
	including the		
	<i>RRCReconfiguration</i>		
	message and the IE		
	secondaryCellGroup.		
}			
}			
}			
}			
}			
nr-RadioBearerConfig1-r15	OCTET STRING		
	including		
	RadioBearerConfig.		
}			
}			
}			
}			

Table 8.2.2.8.1.3.3-35: *RRCReconfiguration* (Table 8.2.2.8.1.3.3-34)

Derivation Path: 38.508-1 [4], Table 4.6.1-13			
Information Element	Value/remark	Comment	Condition
RRCReconfiguration ::= SEQUENCE {			
criticalExtensions CHOICE {			
rrcReconfiguration ::= SEQUENCE {			
secondaryCellGroup	CellGroupConfig		
}			
}			
}			

Table 8.2.2.8.1.3.3-36: CellGroupConfig (Table 8.2.2.8.1.3.3-35)

Derivation Path: 38.508-1 [4], Table 4.6.3-19			
Information Element	Value/remark	Comment	Condition
CellGroupConfig ::= SEQUENCE {			
rlc-BearerToAddModList SEQUENCE (SIZE(1..maxLCH)) OF SEQUENCE {	1 entry		
logicalChannelIdentity[1]	Logical channel identity corresponding to Split DRB.		
reestablishRLC[1]	true		
}			
}			

Table 8.2.2.8.1.3.3-37: RadioBearerConfig (Table 8.2.2.8.1.3.3-34)

Derivation Path: 38.508-1 [4], Table 4.6.3-132 with condition EN-DC			
Information Element	Value/remark	Comment	Condition
RadioBearerConfig ::= SEQUENCE {			
drb-ToAddModList SEQUENCE (SIZE (1..maxDRB)) OF SEQUENCE {	1 entry		
drb-Identity	2	Split DRB Id	
reestablishPDCP	true		
}			
securityConfig SEQUENCE {			
keyToUse	master		
}			
}			

Table 8.2.2.8.1.3.3-38: RRCConnectionReconfiguration (step 22, Table 8.2.2.8.1.3.2-1)

Derivation Path: 36.508 [7], Table 4.6.1-8			
Information Element	Value/remark	Comment	Condition
RRCConnectionReconfiguration ::= SEQUENCE {			
criticalExtensions CHOICE {			
c1 CHOICE{			
rrcConnectionReconfiguration-r8 ::= SEQUENCE			
{			
radioResourceConfigDedicated	RadioResourceConfigDe dicated-MN_SCG-to- SN_MCG		
nonCriticalExtension ::= SEQUENCE {			
nonCriticalExtension ::= SEQUENCE {			
nonCriticalExtension ::= SEQUENCE {			
nonCriticalExtension ::= SEQUENCE {			
nonCriticalExtension ::= SEQUENCE {			
nonCriticalExtension ::= SEQUENCE {			
nonCriticalExtension ::= SEQUENCE {			
nonCriticalExtension ::= SEQUENCE {			
nr-Config-r15 CHOICE {			
setup SEQUENCE {			
nr-SecondaryCellGroupConfig-r15	OCTET STRING including the <i>RRCReconfiguration</i> message and the IE secondaryCellGroup.		
}			
}			
nr-RadioBearerConfig1-r15	OCTET STRING including RadioBearerConfig.		
}			
}			
}			
}			
}			
}			
}			
}			
}			
}			
}			
}			
}			
}			
}			
}			

Table 8.2.2.8.1.3.3-39: RadioResourceConfigDedicated-MN_SCG-to-SN_MCG (Table 8.2.2.8.1.3.3-38)

Derivation Path: 36.508 [7], Table 4.6.3-27			
Information Element	Value/remark	Comment	Condition
RadioResourceConfigDedicated-DRB ::= SEQUENCE {			
drb-ToAddModList	DRB-ToAddModList- MN_SCG-to-SN_MCG		
}			

Table 8.2.2.8.1.3.3-40: DRB-ToAddModList-MN_SCG-to-SN_MCG (Table 8.2.2.8.1.3.3-39)

Derivation Path: 36.508 [7], Table 4.6.3-2A			
Information Element	Value/remark	Comment	Condition
DRB-ToAddModList ::= SEQUENCE (SIZE (1..maxDRB)) OF SEQUENCE {	1 Entry		
eps-BearerIdentity[1]	6	Dedicated EPS bearer Id of SCG DRB	
drb-Identity[1]	2	SCG DRB Id	
}			

Table 8.2.2.8.1.3.3-41: RRCReconfiguration (Table 8.2.2.8.1.3.3-40)

Derivation Path: 38.508-1 [4], Table 4.6.1-13			
Information Element	Value/remark	Comment	Condition
RRCReconfiguration ::= SEQUENCE {			
criticalExtensions CHOICE {			
rrcReconfiguration ::= SEQUENCE {			
secondaryCellGroup	CellGroupConfig		
}			
}			
}			

Table 8.2.2.8.1.3.3-42: CellGroupConfig (Table 8.2.2.8.1.3.3-43)

Derivation Path: 38.508-1 [4] Table 4.6.3-19			
Information Element	Value/remark	Comment	Condition
CellGroupConfig ::= SEQUENCE {			
rlc-BearerToAddModList	Not present		
rlc-BearerToReleaseList SEQUENCE (SIZE(1..maxLCH)) OF SEQUENCE {	1 entry		
logicalChannelIdentity[1]	Logical channel identity corresponding to SCG DRB.		
}			
mac-CellGroupConfig	Not present		
physicalCellGroupConfig	Not present		
spCellConfig	Not present		
}			

Table 8.2.2.8.1.3.3-43: RadioBearerConfig (Table 8.2.2.8.1.3.3-38)

Derivation Path: 38.508-1 [4], Table 4.6.3-132			
Information Element	Value/remark	Comment	Condition
RadioBearerConfig ::= SEQUENCE {			
drb-ToAddModList SEQUENCE (SIZE (1..maxDRB)) OF SEQUENCE {	1 entry		
cnAssociation CHOICE {			
eps-BearerIdentity	6	Dedicated EPS bearer Id of SCG DRB	
}			
drb-Identity	2	SCG DRB Id	
reestablishPDCP	true		
pdcpc-Config	Not present		
}			
securityConfig SEQUENCE {			
keyToUse	secondary		
}			
}			

Table 8.2.2.8.1.3.3-46: CellGroupConfig (Table 8.2.2.8.1.3.3-45)

Derivation Path: 38.508-1 [4], Table 4.6.3-19 with condition EN-DC			
Information Element	Value/remark	Comment	Condition
CellGroupConfig ::= SEQUENCE {			
rlc-BearerToAddModList SEQUENCE (SIZE(1..maxLCH)) OF SEQUENCE {	1 entry		
logicalChannelIdentity[1]	Logical channel identity corresponding to MCG DRB.		
servedRadioBearer[1] CHOICE {			
drb-Identity	2	MCG DRB Id	
}			
}			
mac-CellGroupConfig	Not present		
physicalCellGroupConfig	Not present		
spCellConfig	Not present		
}			

Table 8.2.2.8.1.3.3-47: RadioBearerConfig (Table 8.2.2.8.1.3.3-44)

Derivation Path: 38.508-1 [4], Table 4.6.3-132			
Information Element	Value/remark	Comment	Condition
RadioBearerConfig ::= SEQUENCE {			
drb-ToAddModList SEQUENCE (SIZE (1..maxDRB)) OF SEQUENCE {	1 entry		
cnAssociation CHOICE {			
eps-BearerIdentity	6	Dedicated EPS bearer Id of MCG DRB	
}			
drb-Identity	2	MCG DRB Id	
reestablishPDCP	true		
pdcp-Config	Not present		
}			
securityConfig SEQUENCE {			
keyToUse	master		
}			
}			

Table 8.2.2.8.1.3.3-48: RRCConnectionReconfigurationComplete (steps 2, 5, 8, 11, 17, 20, 23, 26, Table 8.2.2.8.1.3.2-1)

Derivation Path: 36.508 [7] Table 4.6.1-9			
Information Element	Value/remark	Comment	Condition
RRCConnectionReconfigurationComplete ::= SEQUENCE {			
criticalExtensions CHOICE {			
rrcConnectionReconfigurationComplete-r8 SEQUENCE {			
nonCriticalExtension SEQUENCE {			
nonCriticalExtension SEQUENCE {			
nonCriticalExtension SEQUENCE {			
nonCriticalExtension SEQUENCE {			
nonCriticalExtension SEQUENCE {			
scg-ConfigResponseNR-r15	Present		
}			
}			
}			
}			
}			
}			
}			
}			

8.2.2.9 Bearer Modification / Uplink data path / Split DRB Reconfiguration

8.2.2.9.1 Bearer Modification / Uplink data path / Split DRB Reconfiguration / EN-DC

8.2.2.9.1.1 Test Purpose (TP)

(1)

```
with { UE in RRC_CONNECTED state with EN-DC, and, MCG(s) (E-UTRA PDCP) and Split }
ensure that {
  when { UE receives an RRCConnectionReconfiguration message to change the primaryPath to E-UTRA
radio path from NR }
    then { UE changes the uplink data path to E-UTRA radio path and sends an
RRCConnectionReconfigurationComplete message }
}
```

(2)

```
with { UE in RRC_CONNECTED state with EN-DC, and, MCG(s) (E-UTRA PDCP) and Split }
ensure that {
  when { UE receives an RRCConnectionReconfiguration message to change the primaryPath from E-UTRA
radio path to NR }
    then { UE changes the uplink data path to NR radio path and sends an
RRCConnectionReconfigurationComplete message }
}
```

8.2.2.9.1.2 Conformance requirements

References: The conformance requirements covered in the present test case are specified in: TS 36.331, clause 5.3.5.3, TS 38.331, clauses 5.3.5.3 and 5.3.5.6.5. Unless otherwise stated these are Rel-15 requirements.

[TS 36.331, clause 5.3.5.3]

If the *RRCConnectionReconfiguration* message does not include the *mobilityControlInfo* and the UE is able to comply with the configuration included in this message, the UE shall:

...

- 1> if the received *RRConnectionReconfiguration* includes the *nr-Config* and it is set to *release*: or
- 1> if the received *RRConnectionReconfiguration* includes *endc-ReleaseAndAdd* and it is set to *TRUE*:
 - 2> perform ENDC release as specified in TS38.331 [82], clause 5.3.5.10;
- 1> if the received *RRConnectionReconfiguration* includes the *sk-Counter*:
 - 2> perform key update procedure as specified in TS 38.331 [82], clause 5.3.5.7;
- 1> if the received *RRConnectionReconfiguration* includes the *nr-SecondaryCellGroupConfig*:
 - 2> perform NR RRC Reconfiguration as specified in TS 38.331 [82], clause 5.3.5.3;
- 1> if the received *RRConnectionReconfiguration* includes the *nr-RadioBearerConfig1*:
 - 2> perform radio bearer configuration as specified in TS 38.331 [82], clause 5.3.5.6;
- 1> if the received *RRConnectionReconfiguration* includes the *nr-RadioBearerConfig2*:
 - 2> perform radio bearer configuration as specified in TS 38.331 [82], clause 5.3.5.6;
- ...
- 1> set the content of *RRConnectionReconfigurationComplete* message as follows:
 - 2> if the *RRConnectionReconfiguration* message includes *perCC-GapIndicationRequest*:
 - 3> include *perCC-GapIndicationList* and *numFreqEffective*;
 - 2> if the frequencies are configured for reduced measurement performance:
 - 3> include *numFreqEffectiveReduced*;
 - 2> if the received *RRConnectionReconfiguration* message included *nr-SecondaryCellGroupConfig*:
 - 3> include *scg-ConfigResponseNR* in accordance with TS 38.331 [82], clause 5.3.5.3;
- 1> submit the *RRConnectionReconfigurationComplete* message to lower layers for transmission using the new configuration, upon which the procedure ends;

[TS 38.331, clause 5.3.5.3]

The UE shall perform the following actions upon reception of the *RRCReconfiguration*:

- ...
- 1> if the *RRCReconfiguration* includes the *secondaryCellGroup*:
 - 2> perform the cell group configuration for the SCG according to 5.3.5.5;
- 1> if the *RRCReconfiguration* message contains the *radioBearerConfig*:
 - 2> perform the radio bearer configuration according to 5.3.5.6;
- 1> if the *RRCReconfiguration* message includes the *measConfig*:
 - 2> perform the measurement configuration procedure as specified in 5.5.2
- ...
- 1> set the content of *RRCReconfigurationComplete* message as follows:
 - 2> if the *RRCReconfiguration* includes the *masterCellGroup* containing the *reportUplinkTxDirectCurrent*, or;
 - 2> if the *RRCReconfiguration* includes the *secondaryCellGroup* containing the *reportUplinkTxDirectCurrent*:
 - 3> include the *uplinkTxDirectCurrentList*;

- 1> if the UE is configured with E-UTRA *nr-SecondaryCellGroupConfig* (MCG is E-UTRA):
 - 2> if *RRCReconfiguration* was received via SRB1:
 - 3> construct *RRCReconfigurationComplete* message and submit it via the EUTRA MCG embedded in E-UTRA RRC message *RRCConnectionReconfigurationComplete* as specified in TS 36.331 [10];
 - 3> if *reconfigurationWithSync* was included in *spCellConfig* of an SCG:
 - 4> initiate the random access procedure on the SpCell, as specified in TS 38.321 [3];
 - 3> else:
 - 4> the procedure ends;
- NOTE: The order the UE sends the *RRCConnectionReconfigurationComplete* message and performs the Random Access procedure towards the SCG is left to UE implementation.

- 2> else (*RRCReconfiguration* was received via SRB3):
 - 3> submit the *RRCReconfigurationComplete* message via SRB3 to lower layers for transmission using the new configuration.

NOTE: For EN-DC, in the case *RRCReconfiguration* is received via SRB1, the random access is triggered by RRC layer itself as there is not necessarily other UL transmission. In the case *RRCReconfiguration* is received via SRB3, the random access is triggered by the MAC layer due to arrival of *RRCReconfigurationComplete*.

- 1 > else:
 - 2> submit the *RRCReconfigurationComplete* message via SRB1 to lower layers for transmission using the newconfiguration;
 - 2> if this is the first *RRCReconfiguration* message after successful completion of the RRC re-establishment procedure:
- 3> resume SRB2 and DRBs that are suspended;
- 1> if *reconfigurationWithSync* was included in *spCellConfig* of an MCG or SCG, and when MAC of an NR cell group successfully completes a random access procedure triggered above:
 - 2> stop timer T304 for that cell group;
 - 2> apply the parts of the CQI reporting configuration, the scheduling request configuration and the sounding RS configuration that do not require the UE to know the SFN of the respective target SpCell, if any;
 - 2> apply the parts of the measurement and the radio resource configuration that require the UE to know the SFN of the respective target SpCell (e.g. measurement gaps, periodic CQI reporting, scheduling request configuration, sounding RS configuration), if any, upon acquiring the SFN of that target SpCell;
 - 2> if the *reconfigurationWithSync* was included in *spCellConfig* of an MCG:
 - 3> if T390 is running:
 - 4> stop timer T390 for all access categories;
 - 4> perform the actions as specified in 5.3.14.4.
 - 3> if *RRCReconfiguration* does not include *dedicatedSIB1-Delivery* and
 - 3> if the active downlink BWP, which is indicated by the *firstActiveDownlinkBWP-Id* for the target SpCell of the MCG, has a common search space configured by *searchSpaceSIB1*:
 - 4> acquire the *SIB1*, which is scheduled as specified in TS 38.213 [13], of the target SpCell of the MCG;
 - 4> upon acquiring *SIB1*, perform the actions specified in clause 5.2.2.4.2;

2> the procedure ends.

NOTE: The UE is only required to acquire broadcasted *SIB1* if the UE can acquire it without disrupting unicast data reception, i.e. the broadcast and unicast beams are quasi co-located.

[TS 38.331, clause 5.3.5.6.5]

The UE shall:

- 1> for each *drb-Identity* value included in the *drb-ToAddModList* that is not part of the current UE configuration (DRB establishment including the case when full configuration option is used):
 - 2> establish a PDCP entity and configure it in accordance with the received *pdcp-Config*;
 - 2> if the PDCP entity of this DRB is not configured with *cipheringDisabled*:
 - 3> if target RAT of handover is E-UTRA/5GC, or;
 - 3> if the UE is only connected to E-UTRA/5GC:
 - 4> configure the PDCP entity with the ciphering algorithm and K_{UPenc} key configured/derived as specified in TS 36.331 [10];
 - 3> else:
 - 4> configure the PDCP entity with the ciphering algorithms according to *securityConfig* and apply the K_{UPenc} key associated with the master key (K_{eNB}/K_{gNB}) or the secondary key ($S-K_{gNB}$) as indicated in *keyToUse*;
 - 2> if the PDCP entity of this DRB is configured with *integrityProtection*:
 - 3> configure the PDCP entity with the integrity algorithms according to *securityConfig* and apply the K_{UPint} key associated with the master (K_{eNB}/K_{gNB}) or the secondary key ($S-K_{gNB}$) as indicated in *keyToUse*;
- ...
- 2> if the UE is operating in EN-DC:
 - 3> if the DRB was configured with the same *eps-BearerIdentity* either by NR or E-UTRA prior to receiving this reconfiguration:
 - 4> associate the established DRB with the corresponding *eps-BearerIdentity*;
 - 3> else:
 - 4> indicate the establishment of the DRB(s) and the *eps-BearerIdentity* of the established DRB(s) to upper layers;
- 4> for each *drb-Identity* value included in the *drb-ToAddModList* that is part of the current UE configuration:
 - 2> if the *reestablishPDCP* is set:
 - 3> if target RAT is E-UTRA/5GC, or;
 - 3> if the UE is only connected to E-UTRA/5GC:
 - 4> if the PDCP entity of this DRB is not configured with *cipheringDisabled*:
 - 5> configure the PDCP entity with the ciphering algorithm and K_{UPenc} key configured/derived as specified in TS 36.331 [10], clause 5.4.2.3, i.e. the ciphering configuration shall be applied to all subsequent PDCP PDUs received and sent by the UE;
 - 3> else:
 - 4> if the PDCP entity of this DRB is not configured with *cipheringDisabled*:

- 5> configure the PDCP entity with the ciphering algorithm and K_{UPenc} key associated with the master key (K_{eNB}/K_{gNB}) or the secondary key ($S-K_{gNB}$), as indicated in *keyToUse*, i.e. the ciphering configuration shall be applied to all subsequent PDCP PDUs received and sent by the UE;
- 4> if the PDCP entity of this DRB is configured with *integrityProtection*:
 - 5> configure the PDCP entity with the integrity algorithms according to *securityConfig* and apply the K_{UPint} key associated with the master (K_{eNB}/K_{gNB}) or the secondary key ($S-K_{gNB}$) as indicated in *keyToUse*;
- 3> re-establish the PDCP entity of this DRB as specified in 38.323 [5], clause 5.1.2;
- 2> else, if the *recoverPDCP* is set:
 - 3> trigger the PDCP entity of this DRB to perform data recovery as specified in 38.323 [5];
- 2> if the *pdcp-Config* is included:
 - 3> reconfigure the PDCP entity in accordance with the received *pdcp-Config*.

...

NOTE 1: Void.

NOTE 2: When determining whether a drb-Identity value is part of the current UE configuration, the UE does not distinguish which *RadioBearerConfig* and *DRB-ToAddModList* that DRB was originally configured in. To re-associate a DRB with a different key (K_{eNB} to $S-K_{eNB}$ or vice versa), the network provides the *drb-Identity* value in the (target) *drb-ToAddModList* and sets the *reestablishPDCP* flag. The network does not list the *drb-Identity* in the (source) *drb-ToReleaseList*.

NOTE 3: When setting the *reestablishPDCP* flag for a radio bearer, the network ensures that the RLC receiver entities do not deliver old PDCP PDUs to the re-established PDCP entity. It does that e.g. by triggering a reconfiguration with sync of the cell group hosting the old RLC entity or by releasing the old RLC entity.

NOTE 4: In this specification, UE configuration refers to the parameters configured by NR RRC unless otherwise stated.

NOTE 5: Ciphering and integrity protection can be enabled or disabled for a DRB. The enabling/disabling of ciphering or integrity protection can be changed only by releasing and adding the DRB.

8.2.2.9.1.3 Test description

8.2.2.9.1.3.1 Pre-test conditions

System Simulator:

- E-UTRA Cell 1 is the PCell and NR Cell 1 is the PSCell.

UE:

- None.

Preamble:

- If *pc_IP_Ping* is set to TRUE then, the UE is in state RRC_CONNECTED using generic procedure parameter Connectivity (*EN-DC*), Bearers (*MCG(s) and Split*) established according to TS 38.508-1 [4], clause 4.5.4.
- Else, the UE is in state RRC_CONNECTED using generic procedure parameter Connectivity (*EN-DC*), Bearers (*MCG(s) and Split*) established and Test Loop Function (*On*) with UE test loop mode B according to TS 38.508-1 [4], clause 4.5.4.

8.2.2.9.1.3.2 Test procedure sequence

Table 8.2.2.9.1.3.2-1: Main behaviour

St	Procedure	Message Sequence		TP	Verdict
		U - S	Message		
1	The SS transmits an <i>RRCCONNECTIONRECONFIGURATION</i> message containing NR RadioBearerConfig to change the primaryPath of the Split DRB to E-UTRA radio path from NR.	<--	<i>RRCCONNECTIONRECONFIGURATION</i>	-	-
2	Check: Does the UE transmit an <i>RRCCONNECTIONRECONFIGURATIONCOMPLETE</i> message?	-->	<i>RRCCONNECTIONRECONFIGURATIONCOMPLETE</i>	1	P
3	Check: Does the test result of generic test procedure in TS 38.508-1 subclause 4.9.1 indicate that the UE is capable of exchanging IP data on Split DRB#2 using E-UTRA radio path in the uplink?	-	-	1	P
4	The SS transmits an <i>RRCCONNECTIONRECONFIGURATION</i> message containing NR RadioBearerConfig to change the primaryPath of the Split DRB from E-UTRA radio path to NR.	<--	<i>RRCCONNECTIONRECONFIGURATION</i>	-	-
5	Check: Does the UE transmit an <i>RRCCONNECTIONRECONFIGURATIONCOMPLETE</i> message?	-->	<i>RRCCONNECTIONRECONFIGURATIONCOMPLETE</i>	2	P
6	Check: Does the test result of generic test procedure in TS 38.508-1 subclause 4.9.1 indicate that the UE is capable of exchanging IP data on the Split DRB#2 using NR radio path in the uplink?	-	-	2	P

8.2.2.9.1.3.3 Specific message contents

Table 8.2.2.9.1.3.3-1: RRCConnectionReconfiguration (step 1, Table 8.2.2.9.1.3.2-1)

Derivation Path: 36.508 [7], Table 4.6.1-8			
Information Element	Value/remark	Comment	Condition
RRCConnectionReconfiguration ::= SEQUENCE {			
criticalExtensions CHOICE {			
c1 CHOICE {			
rrcConnectionReconfiguration-r8 ::= SEQUENCE			
{			
nonCriticalExtension ::= SEQUENCE {			
nonCriticalExtension ::= SEQUENCE {			
nonCriticalExtension ::= SEQUENCE {			
nonCriticalExtension ::= SEQUENCE {			
nonCriticalExtension ::= SEQUENCE {			
nonCriticalExtension ::= SEQUENCE {			
nonCriticalExtension ::= SEQUENCE {			
nonCriticalExtension ::= SEQUENCE {			
nr-RadioBearerConfig1-r15	OCTET STRING including RadioBearerConfig.		
}			
}			
}			
}			
}			

Table 8.2.2.9.1.3.3-2: RadioBearerConfig (Table 8.2.2.9.1.3.3-1)

Derivation Path: 38.508-1 [4], Table 4.6.3-132			
Information Element	Value/remark	Comment	Condition
RadioBearerConfig ::= SEQUENCE {			
drb-ToAddModList SEQUENCE (SIZE (1..maxDRB))	1 entry		
OF SEQUENCE {			
pdcp-Config	PDCP-Config		
}			
}			

Table 8.2.2.9.1.3.3-3: PDCP-Config (Table 8.2.2.9.1.3.3-2)

Derivation Path: 38.508-1 [4], Table 4.6.3-99			
Information Element	Value/remark	Comment	Condition
PDCP-Config ::= SEQUENCE {			
drb SEQUENCE {			
statusReportRequired	true		
}			
moreThanOneRLC SEQUENCE {			
primaryPath SEQUENCE {			
cellGroup	0		
}			
ul-DataSplitThreshold	infinity		
}			
}			

Table 8.2.2.9.1.3.3-4: RRCConnectionReconfiguration (step 4, Table 8.2.2.9.1.3.2-1)

Derivation Path: 36.508 [7], Table 4.6.1-8			
Information Element	Value/remark	Comment	Condition
RRCConnectionReconfiguration ::= SEQUENCE {			
criticalExtensions CHOICE {			
c1 CHOICE{			
rrcConnectionReconfiguration-r8 ::= SEQUENCE			
{			
nonCriticalExtension ::= SEQUENCE {			
nonCriticalExtension ::= SEQUENCE {			
nonCriticalExtension ::= SEQUENCE {			
nonCriticalExtension ::= SEQUENCE {			
nonCriticalExtension ::= SEQUENCE {			
nonCriticalExtension ::= SEQUENCE {			
nonCriticalExtension ::= SEQUENCE {			
nr-RadioBearerConfig1-r15	OCTET STRING		
including	including		
RadioBearerConfig.	RadioBearerConfig.		
}			
}			
}			
}			
}			
}			
}			
}			
}			

Table 8.2.2.9.1.3.3-5: RadioBearerConfig (Table 8.2.2.9.1.3.3-4)

Derivation Path: 38.508-1 [4], Table 4.6.3-132			
Information Element	Value/remark	Comment	Condition
RadioBearerConfig ::= SEQUENCE {			
drb-ToAddModList SEQUENCE (SIZE (1..maxDRB))	1 entry		
OF SEQUENCE {			
pdcp-Config	PDCP-Config		
}			
}			

Table 8.2.2.9.1.3.3-6: PDCP-Config (Table 8.2.2.9.1.3.3-5)

Derivation Path: 38.508-1 [4], Table 4.6.3-99			
Information Element	Value/remark	Comment	Condition
PDCP-Config ::= SEQUENCE {			
drb SEQUENCE {			
statusReportRequired	true		
}			
moreThanOneRLC SEQUENCE {			
primaryPath SEQUENCE {			
cellGroup	1		
}			
ul-DataSplitThreshold	infinity		
}			
}			

8.2.3 Measurement Configuration Control and Reporting / Handovers

8.2.3.1 Measurement configuration control and reporting / Inter-RAT measurements / Event B1 / Measurement of NR cells

8.2.3.1.1 Measurement configuration control and reporting / Inter-RAT measurements / Event B1 / Measurement of NR cells / EN-DC

8.2.3.1.1.1 Test Purpose (TP)

(1)

```
with { UE in RRC_CONNECTED state with EN-DC, and, MCG(s) (E-UTRA PDCP) only having completed the
radio bearer establishment and performed the inter RAT measurement for NR cell and not detected
entering condition for the event B1 is met }
ensure that {
  when { UE detects entering condition for the event B1 is not met }
  then { UE does not transmit any MeasurementReport }
}
```

(2)

```
with { UE in RRC_CONNECTED state with EN-DC, and, MCG(s) (E-UTRA PDCP) only having completed the
radio bearer establishment and performed the inter RAT measurement for NR cell and not detected
entering condition for the event B1 is met }
ensure that {
  when { UE detects entering condition for the event B1 is met }
  then { UE transmits a MeasurementReport }
}
```

(3)

```
with { UE in RRC_CONNECTED state with EN-DC, and, MCG(s) (E-UTRA PDCP) only having completed the
radio bearer establishment and performed the inter RAT measurement for NR cell and detected entering
condition for the event B1 is met }
ensure that {
  when { UE detects leaving condition for the event B1 is met }
  then { UE does not transmit any MeasurementReport }
}
```

8.2.3.1.1.2 Conformance requirements

References: The conformance requirements covered in the present TC are specified in: TS 36.331, clauses 5.5.1, 5.5.4.1, 5.5.4.7, 5.5.5 and 5.5.5.3. Unless otherwise stated these are Rel-15 requirements.

[TS 36.331, clause 5.5.1]

The UE reports measurement information in accordance with the measurement configuration as provided by E-UTRAN. E-UTRAN provides the measurement configuration applicable for a UE in RRC_CONNECTED by means of dedicated signalling, i.e. using the *RRCConnectionReconfiguration* or *RRCConnectionResume* message.

The UE can be requested to perform the following types of measurements:

- Intra-frequency measurements: measurements at the downlink carrier frequency(ies) of the serving cell(s).
- Inter-frequency measurements: measurements at frequencies that differ from any of the downlink carrier frequency(ies) of the serving cell(s).
- Inter-RAT measurements of NR frequencies.
- ...

The measurement configuration includes the following parameters:

1. **Measurement objects:** The objects on which the UE shall perform the measurements.

- For intra-frequency and inter-frequency measurements a measurement object is a single E-UTRA carrier frequency. Associated with this carrier frequency, E-UTRAN can configure a list of cell specific offsets, a list of 'blacklisted' cells and a list of 'whitelisted' cells. Blacklisted cells are not considered in event evaluation or measurement reporting.
- For inter-RAT NR measurements a measurement object is a single NR carrier frequency. Associated with this carrier frequency, E-UTRAN can configure a list of 'blacklisted' cells. Blacklisted cells are not considered in event evaluation or measurement reporting.

...

NOTE 1: Some measurements using the above mentioned measurement objects, only concern a single cell, e.g. measurements used to report neighbouring cell system information, PCell UE Rx-Tx time difference, or a pair of cells, e.g. SSTD measurements between the PCell and the PSCell.

2. **Reporting configurations:** A list of reporting configurations where each reporting configuration consists of the following:
 - Reporting criterion: The criterion that triggers the UE to send a measurement report. This can either be periodical or a single event description.
 - Reporting format: The quantities that the UE includes in the measurement report and associated information (e.g. number of cells to report).
3. **Measurement identities:** A list of measurement identities where each measurement identity links one measurement object with one reporting configuration. By configuring multiple measurement identities it is possible to link more than one measurement object to the same reporting configuration, as well as to link more than one reporting configuration to the same measurement object. The measurement identity is used as a reference number in the measurement report.
4. **Quantity configurations:** One quantity configuration is configured per RAT type. The quantity configuration defines the measurement quantities and associated filtering used for all event evaluation and related reporting of that measurement type. One filter can be configured per measurement quantity, except for NR where the network may configure up to 2 sets of quantity configurations each comprising per measurement quantity separate filters for cell and RS index measurement results. The quantity configuration set that applies for a given measurement is indicated within the NR measurement object.
5. **Measurement gaps:** Periods that the UE may use to perform measurements, i.e. no (UL, DL) transmissions are scheduled.

...

For E-UTRA, the UE measures and reports on the serving cell(s), listed cells, detected cells, transmission resource pools for V2X sidelink communication, and, for RSSI and channel occupancy measurements, the UE measures and reports on any reception on the indicated frequency. For inter-RAT NR, the UE measures and reports on detected cells and, if configured with EN-DC, on NR serving cell(s). For inter-RAT UTRA, the UE measures and reports on listed cells and optionally on cells that are within a range for which reporting is allowed by E-UTRAN. For inter-RAT GERAN, the UE measures and reports on detected cells. For inter-RAT CDMA2000, the UE measures and reports on listed cells. For inter-RAT WLAN, the UE measures and reports on listed cells.

[TS 36.331, clause 5.5.4.1]

If security has been activated successfully, The UE shall:

1> for each *measId* included in the *measIdList* within *VarMeasConfig*:

...

2> else:

...

3> else if the corresponding *measObject* concerns NR:

4> if the *reportSFTD-Meas* is set to *pSCell* in the corresponding *reportConfigInterRAT*:

- 5> consider the PSCell to be applicable;
 - 4> else if the *reportSFTD-Meas* is set to *neighborCells* in the corresponding *reportConfigInterRAT*;
 - 5> if *cellsForWhichToReportSFTD* is configured in the corresponding *measObjectNR*:6> consider any neighbouring NR cell on the associated frequency that is included in *cellsForWhichToReportSFTD* to be applicable;
 - 5> else:
 - 6> consider up to 3 strongest neighbouring NR cells detected on the associated frequency to be applicable when the concerned cell is not included in the *blackCellsToAddModList* defined within the *VarMeasConfig* for this *measId*;
 - 4> else:
 - 5> if the *eventB1* or *eventB2* is configured in the corresponding *reportConfig*:
 - 6> consider a serving cell, if any, on the associated NR frequency as neighbouring cell;
- 5> consider any neighbouring cell detected on the associated frequency to be applicable when the concerned cell is not included in the *blackCellsToAddModList* defined within the *VarMeasConfig* for this *measId*;[TS 36.331, clause 5.5.4.7]

The UE shall:

- 1> for UTRA and CDMA2000, only trigger the event for cells included in the corresponding measurement object;
- 1> consider the entering condition for this event to be satisfied when condition B1-1, as specified below, is fulfilled;
- 1> consider the leaving condition for this event to be satisfied when condition B1-2, as specified below, is fulfilled;

Inequality B1-1 (Entering condition)

$$Mn + Ofn - Hys > Thresh$$

Inequality B1-2 (Leaving condition)

$$Mn + Ofn + Hys < Thresh$$

The variables in the formula are defined as follows:

Mn is the measurement result of the inter-RAT neighbour cell, not taking into account any offsets. For CDMA 2000 measurement result, *pilotStrength* is divided by -2.

Ofn is the frequency specific offset of the frequency of the inter-RAT neighbour cell (i.e. *offsetFreq* as defined within the *measObject* corresponding to the frequency of the neighbour inter-RAT cell).

Hys is the hysteresis parameter for this event (i.e. *hysteresis* as defined within *reportConfigInterRAT* for this event).

Thresh is the threshold parameter for this event (i.e. *b1-Threshold* as defined within *reportConfigInterRAT* for this event). For CDMA2000, *b1-Threshold* is divided by -2.

Mn is expressed in dBm or in dB, depending on the measurement quantity of the inter-RAT neighbour cell.

Ofn*, *Hys are expressed in dB.

Thresh is expressed in the same unit as ***Mn***.

[TS 36.331, clause 5.5.5]

The purpose of this procedure is to transfer measurement results from the UE to E-UTRAN. The UE shall initiate this procedure only after successful security activation.

For the *measId* for which the measurement reporting procedure was triggered, the UE shall set the *measResults* within the *MeasurementReport* message as follows:

- 1> set the *measId* to the measurement identity that triggered the measurement reporting;

- 1> set the *measResultPCell* to include the quantities of the PCell;
 - 1> set the *measResultServFreqList* to include for each E-UTRA SCell that is configured, if any, within *measResultSCell* the quantities of the concerned SCell, if available according to performance requirements in 36.133 [16], except if *purpose* for the *reportConfig* associated with the *measId* that triggered the measurement reporting is set to *reportLocation*;
 - 1> if the *reportConfig* associated with the *measId* that triggered the measurement reporting includes *reportAddNeighMeas*:
 - 2> for each E-UTRA serving frequency for which *measObjectId* is referenced in the *measIdList*, other than the frequency corresponding with the *measId* that triggered the measurement reporting:
 - 3> set the *measResultServFreqList* to include within *measResultBestNeighCell* the *physCellId* and the quantities of the best non-serving cell, based on RSRP, on the concerned serving frequency;
 - 1> if the *triggerType* is set to *event*; and if the corresponding *measObject* concerns NR; and if *eventId* is set to *eventB1-NR* or *eventB2-NR*; or
 - 1> if the *triggerType* is set to *event*; and if *eventId* is set to *eventA3* or *eventA4* or *eventA5*:
 - 2> if *purpose* for the *reportConfig* associated with the *measId* that triggered the measurement reporting is set to a value other than *reportLocation*:
 - 3> set the *measResultServFreqListNR* to include for each NR serving frequency that the UE is configured to measure according to TS 38.331 [82], if any, the following:
 - 4> set *measResultSCell* to include the available results of the NR serving cell, as specified in 5.5.5.2;
 - 4> if the *reportConfig* associated with the *measId* that triggered the measurement reporting includes *reportAddNeighMeas*:
 - 5> set *measResultBestNeighCell* to include the available results, as specified in 5.5.5.2, of the best non-serving cell, ordered based on the quantity determined as specified in 5.5.5.2;
 - 3> for each (serving or neighbouring) cell for which the UE reports results according to the previous, additionally include available beam results according to the following:
 - 4> if *maxReportRS-Index* is configured, set *measResultRS-IndexList* to include available results, as specified in 5.5.5.2, of up to *maxReportRS-Index* beams, ordered based on the quantity determined as specified in 5.5.5.3;
 - 1> if there is at least one applicable neighbouring cell to report:
 - 2> set the *measResultNeighCells* to include the best neighbouring cells up to *maxReportCells* in accordance with the following:
 - 3> if the *triggerType* is set to *event*:
 - 4> include the cells included in the *cellsTriggeredList* as defined within the *VarMeasReportList* for this *measId*;
 - 3> else:
 - 4> include the applicable cells for which the new measurement results became available since the last periodical reporting or since the measurement was initiated or reset;
- NOTE 1: The reliability of the report (i.e. the certainty it contains the strongest cells on the concerned frequency) depends on the measurement configuration i.e. the *reportInterval*. The related performance requirements are specified in TS 36.133 [16].
- 3> for each cell that is included in the *measResultNeighCells*, include the *physCellId*;
 - 3> if the *triggerType* is set to *event*; or the *purpose* is set to *reportStrongestCells* or to *reportStrongestCellsForSON*:

- 4> for each included cell, include the layer 3 filtered measured results in accordance with the *reportConfig* for this *measId*, ordered as follows:
 - 5> if the *measObject* associated with this *measId* concerns E-UTRA:
 - 6> set the *measResult* to include the quantity(ies) indicated in the *reportQuantity* within the concerned *reportConfig*;
 - 6> sort the included cells in order of decreasing *triggerQuantity*, i.e. the best cell is included first;
 - 5> if the *measObject* associated with this *measId* concerns NR:
 - 6> set the *measResultCell* to include the quantity(ies) indicated in the *reportQuantityCellNR* within the concerned *reportConfig*;
 - 6> if *maxReportRS-Index* and *reportQuantityRS-IndexNR* are configured, set *measResultRS-IndexList* to include results of the best beam and the beams whose quantity is above *threshRS-Index* defined in the *VarMeasConfig* for the corresponding *measObject*, up to *maxReportRS-Index* beams in total:
 - 7> order beams based on the sorting quantity determined as specified in 5.5.5.3;
 - 7> include *ssbIndex*;
 - 7> for each included beam:
 - 8> include *ssbIndex*;
 - 8> if *reportRS-IndexResultsNR* is configured, for each quantity indicated, include the corresponding measurement result in *measResultNeighCells*;
 - 6> sort the included cells in order of decreasing sorting quantity determined as specified in 5.5.5.3;
- ...

[TS 36.331, clause 5.5.5.3]

- 1> for cells on the frequency associated with the *measId* that triggered the measurement reporting, if the *reportTrigger* is set to *event*, consider the quantity used in *bN-ThresholdYNR* to be the sorting quantity;
- 1> for other cases, determine the sorting quantity as follows:
 - 2> consider the following quantities as candidate sorting quantities:
 - 3> for cells on the frequency associated with the *measId* that triggered the measurement reporting (for a *triggerType* set to *periodical*):
 - 4> the quantities defined by *reportQuantityCellNR*, when used for sorting cells;
 - 4> the quantities defined by *reportQuantityRS-IndexNR*, when used for sorting beams;
 - 3> for cells, serving or non-serving (i.e. within *reportAddNeighMeas*), on NR serving frequencies other than the one associated with the *measId* triggering reporting:
 - 4> the available quantities of available NR measurement results as specified in 5.5.5.2;
 - 2> if there is a single candidate sorting quantity;
 - 3> consider the concerned quantity to be the sorting quantity;
 - 2> else:
 - 3> if RSRP is one of the candidate sorting quantities;
 - 4> consider RSRP to be the sorting quantity;
 - 3> else:

4> consider RSRQ to be the sorting quantity;

8.2.3.1.1.3 Test description

8.2.3.1.1.3.1 Pre-test conditions

System Simulator:

- E-UTRA Cell 1 and NR Cell 1.

UE:

- None.

Preamble:

- The UE is in state RRC_CONNECTED using generic procedure parameter Connectivity (*EN-DC*) and Bearers (*MCG(s) only*) established according to TS 38.508-1 [4].

8.2.3.1.1.3.2 Test procedure sequence

Table 8.2.3.1.3.2-1 and Table 8.2.3.1.3.2-1A illustrates the downlink power levels and other changing parameters to be applied for the cells at various time instants of the test execution. Row marked "T0" denotes the initial conditions after preamble, while columns marked "T1" and "T2" are to be applied subsequently. The exact instants on which these values shall be applied are described in the texts in this clause.

Table 8.2.3.1.1.3.2-1: Time instances of cell power level and parameter changes for FR1

	Parameter	Unit	E-UTRA Cell 1	NR Cell 1	Remark
T0	Cell-specific RS EPRE	dBm/15 kHz	-85	-	The power level values are such that entering conditions for event B1 are not satisfied.
	SS/PBCH SSS EPRE	dBm/SC S	-	-91	
T1	Cell-specific RS EPRE	dBm/15 kHz	-85	-	The power level values are such that entering conditions for event B1 are satisfied.
	SS/PBCH SSS EPRE	dBm/SC S	-	-79	
T2	Cell-specific RS EPRE	dBm/15 kHz	-85	-	The power level values are such that leaving conditions for event B1 are satisfied.
	SS/PBCH SSS EPRE	dBm/SC S	-	-91	

Table 8.2.3.1.1.3.2-1A: Time instances of cell power level and parameter changes for FR2

	Parameter	Unit	E-UTRA Cell 1	NR Cell 1	Remark
T0	Cell-specific RS EPRE	dBm/15 kHz	-96	-	The power level values are such that entering conditions for event B1 are not satisfied.
	SS/PBCH SSS EPRE	dBm/SC S	-	-100	
T1	Cell-specific RS EPRE	dBm/15 kHz	-96	-	The power level values are such that entering conditions for event B1 are satisfied.
	SS/PBCH SSS EPRE	dBm/SC S	-	-82	
T2	Cell-specific RS EPRE	dBm/15 kHz	-96	-	The power level values are such that leaving conditions for event B1 are satisfied.
	SS/PBCH SSS EPRE	dBm/SC S	-	-100	

Table 8.2.3.1.1.3.2-2: Main behaviour

St	Procedure	Message Sequence		TP	Verdict
		U - S	Message		
1	The SS transmits an <i>RRCConnectionReconfiguration</i> including measConfig to setup inter RAT measurements and reporting for NR Cell 1.	<--	<i>RRCConnectionReconfiguration</i>	-	-
2	The UE transmits an <i>RRCConnectionReconfigurationComplete</i> message to confirm the setup of inter RAT measurements for NR Cell 1.	-->	<i>RRCConnectionReconfigurationComplete</i>	-	-
3	Check: Does the UE transmit a <i>MeasurementReport</i> message on E-UTRA Cell 1 to report the event B1 during the next 10s?	-->	<i>MeasurementReport</i>	1	F
4	The SS changes NR Cell 1 parameters according to the row "T1".	-	-	-	-
5	Check: Does the UE transmit a <i>MeasurementReport</i> message to report the event B1 for NR Cell 1?	-->	<i>MeasurementReport</i>	2	P
6	The SS changes NR Cell 1 parameters according to the row "T2".	-	-	-	-
7	Wait and ignore <i>MeasurementReport</i> messages for 15s to allow change of power levels and UE measurements for NR Cell 1.	-	-	-	-
8	Check: Does the UE transmit a <i>MeasurementReport</i> message on E-UTRA Cell 1 to report the event B1 during the next 10s?	-->	<i>MeasurementReport</i>	3	F

8.2.3.1.1.3.3 Specific message contents

Table 8.2.3.1.1.3.3-0: Conditions for specific message contents in Tables 8.2.3.1.1.3.3-2.

Condition	Explanation
Band > 64	If band > 64 is selected

Table 8.2.3.1.1.3.3-1: *RRCConnectionReconfiguration* (step 1, Table 8.2.3.1.1.3.2-2)

Derivation Path: 36.508 [7], Table 4.6.1-8, condition MEAS
--

Table 8.2.3.1.1.3.3-2: MeasConfig (Table 8.2.3.1.1.3.3-1)

Derivation Path: 36.508 [7], Table 4.6.6-1			
Information Element	Value/remark	Comment	Condition
MeasConfig ::= SEQUENCE {			
measObjectToAddModList SEQUENCE (SIZE (1..maxObjectld)) OF SEQUENCE {	2 entries		
measObjectld[1]	1		
measObject{1}	MeasObjectEUTRA-GENERIC(f1)		
measObject{1}	MeasObjectEUTRA-GENERIC(maxEARFCN)		Band > 64
measObjectld[2]	2		
measObject{2}	MeasObjectNR-GENERIC (NRf1)		
}			
reportConfigToAddModList SEQUENCE (SIZE (1..maxReportConfigld)) OF SEQUENCE {	1 entry		
reportConfigld[1]	1		
reportConfig{1}	ReportConfig1-B1-NR-r15(-85)		FR1
reportConfig{1}	ReportConfig2-B1-NR-r15(-91 + Δ(NRf1))		FR2
}			
measldToAddModList SEQUENCE (SIZE (1..maxMeasld)) OF SEQUENCE {	1 entry		
measld[1]	1		
measObjectld[1]	2		
reportConfigld[1]	1		
}			
quantityConfig	QuantityConfig-DEFAULT		
measGapConfig	MeasGapConfig		
measObjectToAddModList-v9e0 ::= SEQUENCE (SIZE (1..maxObjectld)) OF SEQUENCE {			Band > 64
measObjectEUTRA-v9e0[1] SEQUENCE {			
carrierFreq-v9e0	Same downlink EARFCN as used for f1		
}			
}			
}			
}			

Table 8.2.3.1.1.3.3-3: QuantityConfig-DEFAULT (Table 8.2.3.1.1.3.3-2)

Derivation Path: 36.508 [7], Table 4.6.6-3A			
Information Element	Value/remark	Comment	Condition
QuantityConfig-DEFAULT ::= SEQUENCE {			
quantityConfigNRList-r15 SEQUENCE ((SIZE (1..maxQuantSetsNR-r15)) OF SEQUENCE {			
measQuantityCellNR-r15 SEQUENCE {			
filterCoeff-RSRP-r15	fc0		
filterCoeff-RSRQ-r15	fc0		
filterCoefficient-SINR-r13	fc0		
}			
}			
}			

Table 8.2.3.1.1.3.3-4: MeasObjectNR-GENERIC (NRf1) (Table 8.2.3.1.1.3.3-2)

Derivation Path: 36.508 [7], Table 4.6.6-2B			
Information Element	Value/remark	Comment	Condition
MeasObjectNR-GENERIC(Freq) ::= SEQUENCE {			
carrierFreq-r15	Downlink carrier frequency of NR cell 1		
}			

Table 8.2.3.1.1.3.3-5: ReportConfig1-B1-NR-r15(-85) (Table 8.2.3.1.1.3.3-2)

Derivation Path: 36.508 [7], Table 4.6.6-7AA			
Information Element	Value/remark	Comment	Condition
ReportConfig-B1-NR ::= SEQUENCE {			
triggerType CHOICE {			
reportAmount	infinity		
reportQuantityCellNR-r15 ::= SEQUENCE {			
ss-rsrp	true		
ss-rsrq	true		
ss-sinr	true		
}			
}			

Table 8.2.3.1.1.3.3-6: MeasurementReport (step 5, Table 8.2.3.1.1.3.2-2)

Derivation Path: 36.508 [7], Table 4.6.1-5			
Information Element	Value/remark	Comment	Condition
MeasurementReport ::= SEQUENCE {			
criticalExtensions CHOICE {			
c1 CHOICE {			
measurementReport-r8 SEQUENCE {			
measResults SEQUENCE {			
measId	1		
measResultPCell SEQUENCE {			
rsrpResult	(0..97)		
rsrqResult	(0..34)		
}			
measResultNeighCells CHOICE {			
measResultNeighCellListNR-r15 SEQUENCE (SIZE (1..maxCellReport)) OF SEQUENCE {	1 entry		
pci-r15 [1]	PhysicalCellIdentity of NR Cell 1		
measResultCell-r15 [1] SEQUENCE {			
rsrpResult-r15	(0..127)		
rsrqResult-r15	(0..127)		
rs-sinr-Result-r15	(0..127)		
}			
measResultRS-IndexList-r15	Not present		
cgi-Info-r15	Not present		
}			
}			
}			
}			
}			
}			
}			

Table 8.2.3.1.1.3.3-7: MeasGapConfig(Table 8.2.3.1.1.3.3-2)

Derivation Path: 36.331, clause 6.3.5			
Information Element	Value/remark	Comment	Condition
MeasGapConfig-GP2 ::= CHOICE {			
setup SEQUENCE {			
gapOffset CHOICE {			
gp1	20	TGRP = 80 ms	
}			
}			
}			

Table 8.2.3.1.1.3.3-8: ReportConfig2-B1-NR-r15(-91 + $\Delta(\text{NRf1})$) (Table 8.2.3.1.1.3.3-2)

Derivation Path: 36.508 [7], Table 4.6.6-7AA			
Information Element	Value/remark	Comment	Condition
ReportConfig-B1-NR ::= SEQUENCE {			
triggerType CHOICE {			
reportAmount	Infinity		
reportQuantityCellNR-r15 ::= SEQUENCE {			
ss-rsrp	true		
ss-rsrq	true		
ss-sinr	true		
}			
}			
NOTE 1: $\Delta(\text{NRf1})$ is derived based on calibration procedure defined in the TS 38.508-1 [4], clause 6.1.3.3			

8.2.3.2 Measurement configuration control and reporting / Inter-RAT measurements / Event B1 / Measurement of NR cells / RSRQ based measurements

8.2.3.2.1 Measurement configuration control and reporting / Inter-RAT measurements / Event B1 / Measurement of NR cells / RSRQ based measurements / EN-DC

8.2.3.2.1.1 Test Purpose (TP)

(1)

```
with { UE in RRC_CONNECTED state with EN-DC, and, MCG(s) (E-UTRA PDCP) only having completed the
radio bearer establishment and performed the inter RAT measurement for NR cell, configured b1-
Threshold set to threshold-RSRQ and not detected entering condition for the event B1 is met }
ensure that {
  when { UE detects entering condition for the event B1 is not met }
  then { UE does not transmit any MeasurementReport }
}
```

(2)

```
with { UE in RRC_CONNECTED state with EN-DC, and, MCG(s) (E-UTRA PDCP) only having completed the
radio bearer establishment and performed the inter RAT measurement for NR cell, configured b1-
Threshold set to threshold-RSRQ and not detected entering condition for the event B1 is met }
ensure that {
  when { UE detects entering condition for the event B1 is met }
  then { UE transmits a MeasurementReport }
}
```

(3)

```
with { UE in RRC_CONNECTED state with EN-DC, and, MCG(s) (E-UTRA PDCP) only having completed the
radio bearer establishment and performed the inter RAT measurement for NR cell, configured b1-
Threshold set to threshold-RSRQ and detected entering condition for the event B1 is met }
ensure that {
  when { UE detects leaving condition for the event B1 is met }
  then { UE does not transmit any MeasurementReport }
}
```

8.2.3.2.1.2 Conformance requirements

References: The conformance requirements covered in the present TC are specified in: TS 36.331, clauses 5.5.1, 5.5.4.1, 5.5.4.7, 5.5.5.1 and 5.5.5.3. Unless otherwise stated these are Rel-15 requirements.

[TS 36.331, clause 5.5.1]

The UE reports measurement information in accordance with the measurement configuration as provided by E-UTRAN. E-UTRAN provides the measurement configuration applicable for a UE in RRC_CONNECTED by means of dedicated signalling, i.e. using the *RRCCONNECTIONRECONFIGURATION* or *RRCCONNECTIONRESUME* message.

The UE can be requested to perform the following types of measurements:

- Intra-frequency measurements: measurements at the downlink carrier frequency(ies) of the serving cell(s).
- Inter-frequency measurements: measurements at frequencies that differ from any of the downlink carrier frequency(ies) of the serving cell(s).
- Inter-RAT measurements of NR frequencies.
- ...

The measurement configuration includes the following parameters:

1. **Measurement objects:** The objects on which the UE shall perform the measurements.
 - For intra-frequency and inter-frequency measurements a measurement object is a single E-UTRA carrier frequency. Associated with this carrier frequency, E-UTRAN can configure a list of cell specific offsets, a list of 'blacklisted' cells and a list of 'whitelisted' cells. Blacklisted cells are not considered in event evaluation or measurement reporting.
 - For inter-RAT NR measurements a measurement object is a single NR carrier frequency. Associated with this carrier frequency, E-UTRAN can configure a list of 'blacklisted' cells. Blacklisted cells are not considered in event evaluation or measurement reporting.
 - ...

NOTE 1: Some measurements using the above mentioned measurement objects, only concern a single cell, e.g. measurements used to report neighbouring cell system information, PCell UE Rx-Tx time difference, or a pair of cells, e.g. SSTD measurements between the PCell and the PSCell.

2. **Reporting configurations:** A list of reporting configurations where each reporting configuration consists of the following:
 - Reporting criterion: The criterion that triggers the UE to send a measurement report. This can either be periodical or a single event description.
 - Reporting format: The quantities that the UE includes in the measurement report and associated information (e.g. number of cells to report).
3. **Measurement identities:** A list of measurement identities where each measurement identity links one measurement object with one reporting configuration. By configuring multiple measurement identities it is possible to link more than one measurement object to the same reporting configuration, as well as to link more than one reporting configuration to the same measurement object. The measurement identity is used as a reference number in the measurement report.
4. **Quantity configurations:** One quantity configuration is configured per RAT type. The quantity configuration defines the measurement quantities and associated filtering used for all event evaluation and related reporting of that measurement type. One filter can be configured per measurement quantity, except for NR where the network may configure up to 2 sets of quantity configurations each comprising per measurement quantity separate filters for cell and RS index measurement results. The quantity configuration set that applies for a given measurement is indicated within the NR measurement object.
5. **Measurement gaps:** Periods that the UE may use to perform measurements, i.e. no (UL, DL) transmissions are scheduled.

E-UTRAN only configures a single measurement object for a given frequency (except for WLAN and except for CBR measurements), i.e. it is not possible to configure two or more measurement objects for the same frequency with different associated parameters, e.g. different offsets and/ or blacklists. E-UTRAN may configure multiple instances of the same event e.g. by configuring two reporting configurations with different thresholds.

The UE maintains a single measurement object list, a single reporting configuration list, and a single measurement identities list. The measurement object list includes measurement objects, that are specified per RAT type, possibly including intra-frequency object(s) (i.e. the object(s) corresponding to the serving frequency(ies)), inter-frequency object(s) and inter-RAT objects. Similarly, the reporting configuration list includes E-UTRA and inter-RAT reporting configurations. Any measurement object can be linked to any reporting configuration of the same RAT type. Some reporting configurations may not be linked to a measurement object. Likewise, some measurement objects may not be linked to a reporting configuration.

[TS 36.331, clause 5.5.4.1]

If security has been activated successfully, the UE shall:

- 1> for each *measId* included in the *measIdList* within *VarMeasConfig*:
 - ...
 - 2> else:
 - ...
 - 3> else if the corresponding *measObject* concerns NR:
 - 4> if the *reportSFTD-Meas* is set to *pSCell* in the corresponding *reportConfigInterRAT*:
 - 5> consider the PSCell to be applicable;
 - 4> else if the *reportSFTD-Meas* is set to *neighborCells* in the corresponding *reportConfigInterRAT*:
 - 5> if *cellsForWhichToReportSFTD* is configured in the corresponding *measObjectNR*:
 - 6> consider any neighbouring NR cell on the associated frequency that is included in *cellsForWhichToReportSFTD* to be applicable;
 - 5> else:
 - 6> consider up to 3 strongest neighbouring NR cells detected on the associated frequency to be applicable when the concerned cells are not included in the *blackCellsToAddModList* defined within the *VarMeasConfig* for this *measId*;
 - ...
 - 2> else if the *purpose* is included and set to *reportStrongestCells*, *reportStrongestCellsForSON*, *reportLocationSidelink* or *sensingSidelink* and if a (first) measurement result is available:
 - 3> include a measurement reporting entry within the *VarMeasReportList* for this *measId*;
 - 3> set the *numberOfReportsSent* defined within the *VarMeasReportList* for this *measId* to 0;
 - 3> if the *purpose* is set to *reportStrongestCells* and *reportStrongestCSI-RSs* is not included:
 - 4> if the *triggerType* is set to *periodical* and the corresponding *reportConfig* includes the *ul-DelayConfig*:
 - 5> initiate the measurement reporting procedure, as specified in 5.5.5, immediately after a first measurement result is provided by lower layers;
 - ...
 - 4> else if the *reportAmount* exceeds 1:
 - 5> initiate the measurement reporting procedure, as specified in 5.5.5, immediately after the quantity to be reported becomes available for the PCell;

4> else (i.e. the *reportAmount* is equal to 1):

5> initiate the measurement reporting procedure, as specified in 5.5.5, immediately after the quantity to be reported becomes available for the PCell and for the strongest cell among the applicable cells, or becomes available for the pair of PCell and the PSCell in case of SSTD measurements, or becomes available for each requested pair of PCell and NR cell or the maximal measurement reporting delay as specified in TS 38.133 [84, 8.17.2.3] in case of SFTD measurements;

...

3> else:

4> initiate the measurement reporting procedure, as specified in 5.5.5, when it has determined the strongest cells on the associated frequency;

2> upon expiry of the periodical reporting timer for this *measId*:

3> initiate the measurement reporting procedure, as specified in 5.5.5;

...

NOTE 2: The UE does not stop the periodical reporting with *triggerType* set to *event* or to *periodical* while the corresponding measurement is not performed due to the PCell RSRP being equal to or better than *s-Measure* or due to the measurement gap not being setup.

NOTE 3: If the UE is configured with DRX, the UE may delay the measurement reporting for event triggered and periodical triggered measurements until the Active Time, which is defined in TS 36.321 [6].

[TS 36.331, clause 5.5.4.7]

The UE shall:

1> for UTRA and CDMA2000, only trigger the event for cells included in the corresponding measurement object;

1> consider the entering condition for this event to be satisfied when condition B1-1, as specified below, is fulfilled;

1> consider the leaving condition for this event to be satisfied when condition B1-2, as specified below, is fulfilled;

Inequality B1-1 (Entering condition)

$$Mn + Ofn - Hys > Thresh$$

Inequality B1-2 (Leaving condition)

$$Mn + Ofn + Hys < Thresh$$

The variables in the formula are defined as follows:

Mn is the measurement result of the inter-RAT neighbour cell, not taking into account any offsets. For CDMA 2000 measurement result, *pilotStrength* is divided by -2.

Ofn is the frequency specific offset of the frequency of the inter-RAT neighbour cell (i.e. *offsetFreq* as defined within the *measObject* corresponding to the frequency of the neighbour inter-RAT cell).

Hys is the hysteresis parameter for this event (i.e. *hysteresis* as defined within *reportConfigInterRAT* for this event).

Thresh is the threshold parameter for this event (i.e. *b1-Threshold* as defined within *reportConfigInterRAT* for this event). For CDMA2000, *b1-Threshold* is divided by -2.

Mn is expressed in dBm or in dB, depending on the measurement quantity of the inter-RAT neighbour cell.

Ofn, ***Hys*** are expressed in dB.

Thresh is expressed in the same unit as ***Mn***.

[TS 36.331, clause 5.5.5.1]

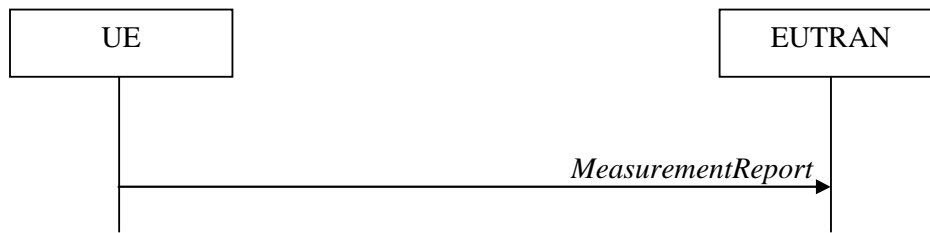

Figure 5.5.5.1-1: Measurement reporting

The purpose of this procedure is to transfer measurement results from the UE to E-UTRAN. The UE shall initiate this procedure only after successful security activation.

For the *measId* for which the measurement reporting procedure was triggered, the UE shall set the *measResults* within the *MeasurementReport* message as follows:

- 1> set the *measId* to the measurement identity that triggered the measurement reporting;
- 1> set the *measResultPCell* to include the quantities of the PCell;
- 1> set the *measResultServFreqList* to include for each E-UTRA SCell that is configured, if any, within *measResultSCell* the quantities of the concerned SCell, if available according to performance requirements in [16], except if *purpose* for the *reportConfig* associated with the *measId* that triggered the measurement reporting is set to *reportLocation*;
- 1> if the *reportConfig* associated with the *measId* that triggered the measurement reporting includes *reportAddNeighMeas*:
 - 2> for each E-UTRA serving frequency for which *measObjectId* is referenced in the *measIdList*, other than the frequency corresponding with the *measId* that triggered the measurement reporting:
 - 3> set the *measResultServFreqList* to include within *measResultBestNeighCell* the *physCellId* and the quantities of the best non-serving cell, based on RSRP, on the concerned serving frequency;
- 1> if the *triggerType* is set to *event*; and if the corresponding *measObject* concerns NR; and if *eventId* is set to *eventB1* or *eventB2*; or
- 1> if the *triggerType* is set to *event*; and if *eventId* is set to *eventA3* or *eventA4* or *eventA5*:
 - 2> if *purpose* for the *reportConfig* associated with the *measId* that triggered the measurement reporting is set to a value other than *reportLocation*:
 - 3> set the *measResultServFreqListNR* to include for each NR serving frequency, if any, the following:
 - 4> set *measResultSCell* to include the available results of the NR serving cell, as specified in 5.5.5.2;
 - 4> if the *reportConfig* associated with the *measId* that triggered the measurement reporting includes *reportAddNeighMeas*:
 - 5> set *measResultBestNeighCell* to include the available results, as specified in 5.5.5.2, of the best non-serving cell, ordered based on the quantity determined as specified in 5.5.5.3;
 - 5> for each (serving or neighbouring) cell for which the UE reports results according to the previous, additionally include available beam results according to the following:
 - 6> if *maxReportRS-Index* is configured, set *measResultCellRS-Index* to include available results, as specified in 5.5.5.2, of up to *maxReportRS-Index* beams, ordered based on the quantity determined as specified in 5.5.5.3;
 - 1> if there is at least one applicable neighbouring cell to report:
 - 2> set the *measResultNeighCells* to include the best neighbouring cells up to *maxReportCells* in accordance with the following:

- 3> if the *triggerType* is set to *event*:
 - 4> include the cells included in the *cellsTriggeredList* as defined within the *VarMeasReportList* for this *measId*;
- 3> else:
 - 4> include the applicable cells for which the new measurement results became available since the last periodical reporting or since the measurement was initiated or reset;

NOTE 1: The reliability of the report (i.e. the certainty it contains the strongest cells on the concerned frequency) depends on the measurement configuration i.e. the *reportInterval*. The related performance requirements are specified in TS 36.133 [16].

- 3> for each cell that is included in the *measResultNeighCells*, include the *physCellId*;
- 3> if the *triggerType* is set to *event*; or the *purpose* is set to *reportStrongestCells* or to *reportStrongestCellsForSON*:
 - 4> for each included cell, include the layer 3 filtered measured results in accordance with the *reportConfig* for this *measId*, ordered as follows:
 - 5> if the *measObject* associated with this *measId* concerns E-UTRA:
 - 6> set the *measResult* to include the quantity(ies) indicated in the *reportQuantity* within the concerned *reportConfig* in order of decreasing *triggerQuantity*, i.e. the best cell is included first;
 - 5> if the *measObject* associated with this *measId* concerns NR:
 - 6> set the *measResultCell* to include the quantity(ies) indicated in the *reportQuantityCellNR* within the concerned *reportConfig* in order of decreasing quantity according to *bN-ThresholdYNR*, i.e. the best cell is included first;
 - 6> if *maxReportRS-Index* and *reportQuantityRS-IndexNR* are configured, set *measResultCellRS-Index* to include results of the best beam and the beams whose quantity is above *threshRS-Index* defined in the *VarMeasConfig* for the corresponding *measObject*, up to *maxReportRS-Index* beams in total, and in order of decreasing quantity, same as used for cell reporting, and as follows:
 - 7> order beams based on the sorting quantity determined as specified in 5.5.5.2;
 - 7> include *ssbIndex*;
 - 7> if *reportRS-IndexResultsNR* is configured, for each quantity indicated, include the corresponding measurement result;

[TS 36.331, clause 5.5.5.3]

When configured to report the best cells or beams, the UE shall determine the quantity that is used to order and select as follows:

- 1> consider the quantities the UE reports as candidate sorting quantities i.e. as follows:
 - 2> for NR cells for which measurement reporting is triggered (i.e. NR cells included in *cellsTriggered*):
 - 3> the quantities defined by *reportQuantityCellNR*, when used for sorting cells;
 - 3> the quantities defined by *reportQuantityRS-IndexNR*, when used for sorting beams;
 - 2> for cells on NR serving frequencies:
 - 3> the available quantities of available NR measurement results as specified in 5.5.5.2;
- 1> if *reportType* is set to *eventTriggered*; and if *eventId* is set to *eventB1* or *eventB2*:
 - 2> consider the trigger quantity to be the sorting quantity;

- 1> if *reportType* is set to *periodical*:
 - 2> if there is a single candidate sorting quantity;
 - 3> consider the concerned quantity to be the sorting quantity;
 - 2> else:
 - 3> if RSRP is one of the candidate sorting quantities;
 - 4> consider RSRP to be the sorting quantity;
 - 3> else:
 - 4> consider RSRQ to be the sorting quantity;

8.2.3.2.1.3 Test description

8.2.3.2.1.3.1 Pre-test conditions

System Simulator:

- E-UTRA Cell 1 and NR Cell 1.

UE:

- None.

Preamble:

- The UE is in state RRC_CONNECTED using generic procedure parameter Connectivity (*EN-DC*), Bearers (*MCG(s) only*) established according to TS 38.508-1 [4], clause 4.5.4.

8.2.3.2.1.3.2 Test procedure sequence

Table 8.2.3.2.1.3.2-1 and Table 8.2.3.2.1.3.2-1A illustrates the downlink power levels and other changing parameters to be applied for the cells at various time instants of the test execution. Row marked "T0" denotes the initial conditions after preamble, while columns marked "T1" and "T2" are to be applied subsequently. The exact instants on which these values shall be applied are described in the texts in this clause.

Table 8.2.3.2.1.3.2-1: Time instances of cell power level and parameter changes for FR1

	Parameter	Unit	E-UTRA Cell 1	NR Cell 1	Remark
T0	Cell-specific RS EPRE	dBm/15 kHz	-85	-	The power level values are such that entering conditions for event B1 are not satisfied.
	SS/PBCH SSS EPRE	dBm/SC S	-	-91	
	SS-RSRQ	dB	-	-16.07	
	Noc	dBm/SC S	-	-95	
T1	Cell-specific RS EPRE	dBm/15 kHz	-85	-	The power level values are such that entering conditions for event B1 are satisfied.
	SS/PBCH SSS EPRE	dBm/SC S	-	-85	
	SS-RSRQ	dB	-	-12.80	
	Noc	dBm/SC S	-	-95	
T2	Cell-specific RS EPRE	dBm/15 kHz	-85	-	The power level values are such that leaving conditions for event B1 are satisfied.
	SS/PBCH SSS EPRE	dBm/SC S	-	-91	
	SS-RSRQ	dB	-	-16.07	
	Noc	dBm/SC S	-	-95	

Table 8.2.3.2.1.3.2-1A: Time instances of cell power level and parameter changes for FR2

	Parameter	Unit	E-UTRA Cell 1	NR Cell 1	Remark
T0	Cell-specific RS EPRE	dBm/15 kHz	FFS	-	The power level values are such that entering conditions for event B1 are not satisfied.
	SS/PBCH SSS EPRE	dBm/SC S	-	FFS	
T1	Cell-specific RS EPRE	dBm/15 kHz	FFS	-	The power level values are such that entering conditions for event B1 are satisfied.
	SS/PBCH SSS EPRE	dBm/SC S	-	FFS	
T2	Cell-specific RS EPRE	dBm/15 kHz	FFS	-	The power level values are such that leaving conditions for event B1 are satisfied.
	SS/PBCH SSS EPRE	dBm/SC S	-	FFS	

Table 8.2.3.2.1.3.2-2: Main behaviour

St	Procedure	Message Sequence		TP	Verdict
		U - S	Message		
1	The SS transmits an <i>RRCConnectionReconfiguration</i> including measConfig to setup inter RAT measurements and reporting for NR Cell 1.	<--	<i>RRCConnectionReconfiguration</i>	-	-
2	The UE transmits an <i>RRCConnectionReconfigurationComplete</i> message to confirm the setup of inter RAT measurements for NR Cell 1.	-->	<i>RRCConnectionReconfigurationComplete</i>	-	-
3	Check: Does the UE transmit a <i>MeasurementReport</i> message on E-UTRA Cell 1 to report the event B1 during the next 10s?	-->	<i>MeasurementReport</i>	1	F
4	The SS changes E-UTRA Cell 1 and NR Cell 1 parameters according to the row "T1".	-	-	-	-
5	Check: Does the UE transmit a <i>MeasurementReport</i> message to report the event B1 for NR Cell 1?	-->	<i>MeasurementReport</i>	2	P
6	The SS changes E-UTRA Cell 1 and NR Cell 1 parameters according to the row "T2".	-	-	-	-
7	Wait and ignore <i>MeasurementReport</i> messages for 15s to allow change of power levels and UE measurements for NR Cell 1.	-	-	-	-
8	Check: Does the UE transmit a <i>MeasurementReport</i> message on E-UTRA Cell 1 to report the event B1 during the next 10s?	-->	<i>MeasurementReport</i>	3	F

8.2.3.2.1.3.3 Specific message contents

Table 8.2.3.2.1.3.3-1: *RRCConnectionReconfiguration* (step 1, Table 8.2.3.2.1.3.2-2)

Derivation Path: 36.508 [7], Table 4.6.1-8, condition MEAS
--

Table 8.2.3.2.1.3.3-2: MeasConfig (Table 8.2.3.2.1.3.3-1)

Derivation Path: 36.508 [7], Table 4.6.6-1			
Information Element	Value/remark	Comment	Condition
MeasConfig ::= SEQUENCE {			
measObjectToAddModList SEQUENCE (SIZE (1..maxObjectId)) OF SEQUENCE {	2 entries		
measObjectId[1]	IdMeasObject-f1		
measObject[1]	MeasObjectEUTRA-GENERIC(f1)		
measObject[1]	MeasObjectEUTRA-GENERIC(maxEARFCN)		Band > 64
measObjectId[2]	IdMeasObject-NRf1		
measObject[2]	MeasObjectNR-GENERIC (NRf1)		
}			
reportConfigToAddModList SEQUENCE (SIZE (1..maxReportConfigId)) OF SEQUENCE {	1 entry		
reportConfigId[1]	IdReportConfig-B1-NR		
reportConfig[1]	ReportConfig-B1-NR-r15		
}			
measIdToAddModList SEQUENCE (SIZE (1..maxMeasId)) OF SEQUENCE {	1 entry		
measId[1]	1		
measObjectId[2]	IdMeasObject-NRf1		
reportConfigId[1]	IdReportConfig-B1-NR		
}			
quantityConfig	QuantityConfig-DEFAULT		
measGapConfig	MeasGapConfig		
}			

Table 8.2.3.2.1.3.3-3: QuantityConfig-DEFAULT (Table 8.2.3.2.1.3.3-2)

Derivation Path: 36.508 [7], Table 4.6.6-3A			
Information Element	Value/remark	Comment	Condition
QuantityConfig-DEFAULT SEQUENCE {			
quantityConfigNRLList-r15 SEQUENCE ((SIZE (1..maxQuantSetsNR-r15)) OF SEQUENCE {			
measQuantityCellNR-r15 SEQUENCE {			
filterCoeff-RSRP-r15	fc0		
filterCoeff-RSRQ-r15	fc0		
}			
}			
}			

Table 8.2.3.2.1.3.3-4: MeasObjectNR-GENERIC (NRf1) (Table 8.2.3.2.1.3.3-2)

Derivation Path: 36.508 [7], Table 4.6.6-2B			
Information Element	Value/remark	Comment	Condition
MeasObjectNR-GENERIC(Freq) ::= SEQUENCE {			
carrierFreq-r15	Downlink carrier frequency of NR cell 1		
}			

Table 8.2.3.2.1.3.3-5: ReportConfig-B1-NR-r15 (Table 8.2.3.2.1.3.3-2)

Derivation Path: 36.508 [7], Table 4.6.6-7AA			
Information Element	Value/remark	Comment	Condition
ReportConfig-B1-NR ::= SEQUENCE {			
triggerType CHOICE {			
event SEQUENCE {			
eventId CHOICE {			
eventB1-NR-r15 SEQUENCE{			
b1-ThresholdNR-r15 CHOICE{			
nr-RSRQ-r15	57	For FR1	
}			
}			
}			
}			
reportAmount	infinity		
}			

Table 8.2.3.2.1.3.3-6: MeasurementReport (step 5, Table 8.2.3.2.1.3.2-2)

Derivation Path: 36.508 [7], Table 4.6.1-5			
Information Element	Value/remark	Comment	Condition
MeasurementReport ::= SEQUENCE {			
criticalExtensions CHOICE {			
c1 CHOICE{			
measurementReport-r8 SEQUENCE {			
measResults SEQUENCE {			
measId	1		
measResultPCell SEQUENCE {			
rsrpResult	(0..97)		
rsrqResult	(0..34)		
}			
measResultNeighCells CHOICE {			
measResultNeighCellListNR-r15 SEQUENCE (SIZE (1..maxCellReport)) OF SEQUENCE {	1 entry		
pci-r15 [1]	PhysicalCellIdentity of NR Cell 1		
measResultCell-r15 [1] SEQUENCE {			
rsrqResult-r15	(0..127)	For FR1	
}			
}			
}			
}			
}			
}			
}			

Table 8.2.3.2.1.3.3-7: MeasGapConfig(Table 8.2.3.2.1.3.3-2)

Derivation Path: 36.331, clause 6.3.5			
Information Element	Value/remark	Comment	Condition
MeasGapConfig-GP2 ::= CHOICE {			
setup SEQUENCE {			
gapOffset CHOICE {			
gp1	20	TGRP = 80 ms	
}			
}			
}			

8.2.3.3 Measurement configuration control and reporting / Inter-RAT measurements / Periodic reporting / Measurement of NR cells

8.2.3.3.1 Measurement configuration control and reporting / Inter-RAT measurements / Periodic reporting / Measurement of NR cells / EN-DC

8.2.3.3.1.1 Test Purpose (TP)

(1)

```
with { UE in RRC_CONNECTED state with EN-DC, and, MCG(s) (E-UTRA PDCP) only having completed the
radio bearer establishment and performed the inter RAT measurement for NR cell }
ensure that {
  when { The UE receives reference signal power for cells on the NR frequencies where measurements
are configured }
  then { UE sends MeasurementReport message at regular intervals for these NR cells }
}
```

(2)

```
with { UE in RRC_CONNECTED state with EN-DC, and, MCG(s) (E-UTRA PDCP) only and a MeasurementReport
message for a configured periodic measurement reporting of NR cells on a configured frequency were
sent }
ensure that {
  when { A previously reported cell become unavailable and the UE receives reference signal power on a
reported NR frequency for a cell which was previously not reported }
  then { UE sends MeasurementReport message at regular intervals for the available NR cells }
}
```

(3)

```
with { UE in RRC_CONNECTED state with EN-DC, and, MCG(s) (E-UTRA PDCP) only and periodic measurement
reporting of NR cells ongoing }
ensure that {
  when { The UE receives a RRCConnectionReconfiguration message removing the measId of periodic
reporting of NR cells }
  then { UE stops sending MeasurementReport message for NR cells }
}
```

8.2.3.3.1.2 Conformance requirements

References: The conformance requirements covered in the present TC are specified in: TS 36.331, clauses 5.5.1, 5.5.4.1, 5.5.4.7 and 5.5.5.1. Unless otherwise stated these are Rel-15 requirements.

[TS 36.331, clause 5.5.1]

The UE reports measurement information in accordance with the measurement configuration as provided by E-UTRAN. E-UTRAN provides the measurement configuration applicable for a UE in RRC_CONNECTED by means of dedicated signalling, i.e. using the *RRCConnectionReconfiguration* or *RRCConnectionResume* message.

The UE can be requested to perform the following types of measurements:

- Intra-frequency measurements: measurements at the downlink carrier frequency(ies) of the serving cell(s).
- Inter-frequency measurements: measurements at frequencies that differ from any of the downlink carrier frequency(ies) of the serving cell(s).
- Inter-RAT measurements of NR frequencies.

...

The measurement configuration includes the following parameters:

1. **Measurement objects:** The objects on which the UE shall perform the measurements.

- For intra-frequency and inter-frequency measurements a measurement object is a single E-UTRA carrier frequency. Associated with this carrier frequency, E-UTRAN can configure a list of cell specific offsets, a

list of 'blacklisted' cells and a list of 'whitelisted' cells. Blacklisted cells are not considered in event evaluation or measurement reporting.

- For inter-RAT NR measurements a measurement object is a single NR carrier frequency. Associated with this carrier frequency, E-UTRAN can configure a list of 'blacklisted' cells. Blacklisted cells are not considered in event evaluation or measurement reporting.

...

NOTE 1: Some measurements using the above mentioned measurement objects, only concern a single cell, e.g. measurements used to report neighbouring cell system information, PCell UE Rx-Tx time difference, or a pair of cells, e.g. SSTD measurements between the PCell and the PSCell.

2. **Reporting configurations:** A list of reporting configurations where each reporting configuration consists of the following:
 - Reporting criterion: The criterion that triggers the UE to send a measurement report. This can either be periodical or a single event description.
 - Reporting format: The quantities that the UE includes in the measurement report and associated information (e.g. number of cells to report).
3. **Measurement identities:** A list of measurement identities where each measurement identity links one measurement object with one reporting configuration. By configuring multiple measurement identities it is possible to link more than one measurement object to the same reporting configuration, as well as to link more than one reporting configuration to the same measurement object. The measurement identity is used as a reference number in the measurement report.
4. **Quantity configurations:** One quantity configuration is configured per RAT type. The quantity configuration defines the measurement quantities and associated filtering used for all event evaluation and related reporting of that measurement type. One filter can be configured per measurement quantity, except for NR where the network may configure up to 2 sets of quantity configurations each comprising per measurement quantity separate filters for cell and RS index measurement results. The quantity configuration set that applies for a given measurement is indicated within the NR measurement object.
5. **Measurement gaps:** Periods that the UE may use to perform measurements, i.e. no (UL, DL) transmissions are scheduled.

E-UTRAN only configures a single measurement object for a given frequency (except for WLAN and except for CBR measurements), i.e. it is not possible to configure two or more measurement objects for the same frequency with different associated parameters, e.g. different offsets and/ or blacklists. E-UTRAN may configure multiple instances of the same event e.g. by configuring two reporting configurations with different thresholds.

The UE maintains a single measurement object list, a single reporting configuration list, and a single measurement identities list. The measurement object list includes measurement objects, that are specified per RAT type, possibly including intra-frequency object(s) (i.e. the object(s) corresponding to the serving frequency(ies)), inter-frequency object(s) and inter-RAT objects. Similarly, the reporting configuration list includes E-UTRA and inter-RAT reporting configurations. Any measurement object can be linked to any reporting configuration of the same RAT type. Some reporting configurations may not be linked to a measurement object. Likewise, some measurement objects may not be linked to a reporting configuration.

[TS 36.331, clause 5.5.4.1]

If security has been activated successfully, the UE shall:

- 1> for each *measId* included in the *measIdList* within *VarMeasConfig*:
 - ...
 - 2> else:
 - ...
 - 3> else if the corresponding *measObject* concerns NR:
 - 4> if the *reportSFTD-Meas* is set to *pSCell* in the corresponding *reportConfigInterRAT*:

- 5> consider the PSCell to be applicable;
- 4> else if the *reportSFTD-Meas* is set to *neighborCells* in the corresponding *reportConfigInterRAT*:
 - 5> if *cellsForWhichToReportSFTD* is configured in the corresponding *measObjectNR*:
 - 6> consider any neighbouring NR cell on the associated frequency that is included in *cellsForWhichToReportSFTD* to be applicable;
 - 5> else:
 - 6> consider up to 3 strongest neighbouring NR cells detected on the associated frequency to be applicable when the concerned cells are not included in the *blackCellsToAddModList* defined within the *VarMeasConfig* for this *measId*;
- 4> else:
 - 5> consider any neighbouring cell detected on the associated frequency to be applicable when the concerned cell is not included in the *blackCellsToAddModList* defined within the *VarMeasConfig* for this *measId*;
- ...
- 2> else if the *purpose* is included and set to *reportStrongestCells*, *reportStrongestCellsForSON*, *reportLocation* or *sidelink* and if a (first) measurement result is available:
 - 3> include a measurement reporting entry within the *VarMeasReportList* for this *measId*;
 - 3> set the *numberOfReportsSent* defined within the *VarMeasReportList* for this *measId* to 0;
 - 3> if the *purpose* is set to *reportStrongestCells* and *reportStrongestCSI-RSs* is not included:
 - 4> if the *triggerType* is set to *periodical* and the corresponding *reportConfig* includes the *ul-DelayConfig*:
 - 5> initiate the measurement reporting procedure, as specified in 5.5.5, immediately after a first measurement result is provided by lower layers;
 - ...
 - 4> else if the *reportAmount* exceeds 1:
 - 5> initiate the measurement reporting procedure, as specified in 5.5.5, immediately after the quantity to be reported becomes available for the PCell;
 - 4> else (i.e. the *reportAmount* is equal to 1):
 - 5> initiate the measurement reporting procedure, as specified in 5.5.5, immediately after the quantity to be reported becomes available for the PCell and for the strongest cell among the applicable cells, or becomes available for the pair of PCell and the PSCell in case of SSTD measurements, or becomes available for each requested pair of PCell and NR cell or the maximal measurement reporting delay as specified in TS 38.133 [X, 8.17.2.3] in case of SFTD measurements;
 - ...
 - 3> else:
 - 4> initiate the measurement reporting procedure, as specified in 5.5.5, when it has determined the strongest cells on the associated frequency;
 - 2> upon expiry of the periodical reporting timer for this *measId*:
 - 3> initiate the measurement reporting procedure, as specified in 5.5.5;
 - ...
 - 2> upon expiry of the T321 for this *measId*:

- 3> include a measurement reporting entry within the *VarMeasReportList* for this *measId*;
- 3> set the *numberOfReportsSent* defined within the *VarMeasReportList* for this *measId* to 0;

3> initiate the measurement reporting procedure, as specified in 5.5.5;

NOTE 2: The UE does not stop the periodical reporting with *triggerType* set to *event* or to *periodical* while the corresponding measurement is not performed due to the PCell RSRP being equal to or better than *s-Measure* or due to the measurement gap not being setup.

NOTE 3: If the UE is configured with DRX, the UE may delay the measurement reporting for event triggered and periodical triggered measurements until the Active Time, which is defined in TS 36.321 [6].

[TS 36.331, clause 5.5.5.1]

The purpose of this procedure is to transfer measurement results from the UE to E-UTRAN. The UE shall initiate this procedure only after successful security activation.

For the *measId* for which the measurement reporting procedure was triggered, the UE shall set the *measResults* within the *MeasurementReport* message as follows:

- 1> set the *measId* to the measurement identity that triggered the measurement reporting;
- 1> set the *measResultPCell* to include the quantities of the PCell;
- 1> set the *measResultServFreqList* to include for each E-UTRA SCell that is configured, if any, within *measResultSCell* the quantities of the concerned SCell, if available according to performance requirements in [16], except if *purpose* for the *reportConfig* associated with the *measId* that triggered the measurement reporting is set to *reportLocation*;
- 1> if the *reportConfig* associated with the *measId* that triggered the measurement reporting includes *reportAddNeighMeas*:
 - 2> for each E-UTRA serving frequency for which *measObjectId* is referenced in the *measIdList*, other than the frequency corresponding with the *measId* that triggered the measurement reporting:
 - 3> set the *measResultServFreqList* to include within *measResultBestNeighCell* the *physCellId* and the quantities of the best non-serving cell, based on RSRP, on the concerned serving frequency;

...

- 1> if there is at least one applicable neighbouring cell to report:
 - 2> set the *measResultNeighCells* to include the best neighbouring cells up to *maxReportCells* in accordance with the following:
 - 3> if the *triggerType* is set to *event*:
 - 4> include the cells included in the *cellsTriggeredList* as defined within the *VarMeasReportList* for this *measId*;...3> else:
 - 4> include the applicable cells for which the new measurement results became available since the last periodical reporting or since the measurement was initiated or reset;

NOTE 1: The reliability of the report (i.e. the certainty it contains the strongest cells on the concerned frequency) depends on the measurement configuration i.e. the *reportInterval*. The related performance requirements are specified in TS 36.133 [16].

- 3> for each cell that is included in the *measResultNeighCells*, include the *physCellId*;
- 3> if the *triggerType* is set to *event*; or the *purpose* is set to *reportStrongestCells* or to *reportStrongestCellsForSON*:
 - 4> for each included cell, include the layer 3 filtered measured results in accordance with the *reportConfig* for this *measId*, ordered as follows:
 - 5> if the *measObject* associated with this *measId* concerns E-UTRA:

- 6> set the *measResult* to include the quantity(ies) indicated in the *reportQuantity* within the concerned *reportConfig* in order of decreasing *triggerQuantity*, i.e. the best cell is included first;
 - 5> if the *measObject* associated with this *measId* concerns NR:
 - 6> set the *measResultCell* to include the quantity(ies) indicated in the *reportQuantityCellNR* within the concerned *reportConfig* in order of decreasing quantity according to *bN-ThresholdYNR*, i.e. the best cell is included first;
 - 6> if *maxReportRS-Index* and *reportQuantityRS-IndexNR* are configured, set *measResultCellRS-Index* to include results of the best beam and the beams whose quantity is above *threshRS-Index* defined in the *VarMeasConfig* for the corresponding *measObject*, up to *maxReportRS-Index* beams in total, and in order of decreasing quantity, same as used for cell reporting, and as follows:
 - 7> order beams based on the reporting quantity determined as specified in 5.5.5.2;
 - 7> include *ssbIndex*;
 - 7> if *reportQuantityRS-IndexNR* and *reportRS-IndexResultsNR* are configured, for each quantity indicated, include the corresponding measurement result;
 - 5> if the *measObject* associated with this *measId* concerns UTRA FDD and if *ReportConfigInterRAT* includes the *reportQuantityUTRA-FDD*:
 - 6> set the *measResult* to include the quantities indicated by the *reportQuantityUTRA-FDD* in order of decreasing *measQuantityUTRA-FDD* within the *quantityConfig*, i.e. the best cell is included first;
 - 5> if the *measObject* associated with this *measId* concerns UTRA FDD and if *ReportConfigInterRAT* does not include the *reportQuantityUTRA-FDD*; or
 - 5> if the *measObject* associated with this *measId* concerns UTRA TDD, GERAN or CDMA2000:
 - 6> set the *measResult* to the quantity as configured for the concerned RAT within the *quantityConfig* in order of either decreasing quantity for UTRA and GERAN or increasing quantity for CDMA2000 *pilotStrength*, i.e. the best cell is included first;
 - 1> for the cells included according to the previous (i.e. covering the PCell, the SCells, the best non-serving cells on serving frequencies as well as neighbouring EUTRA cells) include results according to the extended RSRQ if corresponding results are available according to the associated performance requirements defined in 36.133 [16];
 - 1> if there is at least one applicable CSI-RS resource to report:
 - 2> set the *measResultCSI-RS-List* to include the best CSI-RS resources up to *maxReportCells* in accordance with the following:
 - 3> if the *triggerType* is set to *event*:
 - 4> include the CSI-RS resources included in the *csi-RS-TriggeredList* as defined within the *VarMeasReportList* for this *measId*;
 - 3> else:
 - 4> include the applicable CSI-RS resources for which the new measurement results became available since the last periodical reporting or since the measurement was initiated or reset;
- NOTE 2: The reliability of the report (i.e. the certainty it contains the strongest CSI-RS resources on the concerned frequency) depends on the measurement configuration i.e. the *reportInterval*. The related performance requirements are specified in TS 36.133 [16].
- ...
- 1> increment the *numberOfReportsSent* as defined within the *VarMeasReportList* for this *measId* by 1;

- 1> stop the periodical reporting timer, if running;
- 1> if the *numberOfReportsSent* as defined within the *VarMeasReportList* for this *measId* is less than the *reportAmount* as defined within the corresponding *reportConfig* for this *measId*:
 - 2> start the periodical reporting timer with the value of *reportInterval* as defined within the corresponding *reportConfig* for this *measId*;
- 1> else:
 - 2> if the *triggerType* is set to *periodical*:
 - 3> remove the entry within the *VarMeasReportList* for this *measId*;
 - 3> remove this *measId* from the *measIdList* within *VarMeasConfig*;
- ...
- 1> submit the *MeasurementReport* message to lower layers for transmission, upon which the procedure ends;

8.2.3.3.1.3 Test description

8.2.3.3.1.3.1 Pre-test conditions

System Simulator:

- E-UTRA Cell 1, NR Cell 1 and NR Cell 2.

UE:

- None.

Preamble:

- The UE is in state RRC_CONNECTED using generic procedure parameter Connectivity (*EN-DC*), Bearers (*MCG(s) only*) established according to TS 38.508-1 [4], clause 4.5.4.

8.2.3.3.1.3.2 Test procedure sequence

Table 8.2.3.3.1.3.2-1 and Table 8.2.3.3.1.3.2-1A illustrates the downlink power levels and other changing parameters to be applied for the cells at various time instants of the test execution. Row marked "T0" denotes the initial conditions after preamble, while columns marked "T1", "T2" and "T3" are to be applied subsequently. The exact instants on which these values shall be applied are described in the texts in this clause.

Table 8.2.3.3.1.3.2-1: Time instances of cell power level and parameter changes for FR1

	Parameter	Unit	E-UTRA Cell 1	NR Cell 1	NR Cell 2	Remark
T0	Cell-specific RS EPRE	dBm/15 kHz	-85	-	-	The power level values are such that camping on E-UTRA Cell 1 is guarantee.
	SS/PBCH SSS EPRE	dBm/SC S	-	Off	Off	
T1	Cell-specific RS EPRE	dBm/15 kHz	-85	-	-	The power level values are such that NR Cell 1 is satisfied for periodic reporting.
	SS/PBCH SSS EPRE	dBm/SC S	-	-91	Off	
T2	Cell-specific RS EPRE	dBm/15 kHz	-85	-	-	The power level values are such that NR Cell 2 is satisfied for periodic reporting and NR Cell 1 become unavailable.
	SS/PBCH SSS EPRE	dBm/SC S	-	Off	-91	
T3	Cell-specific RS EPRE	dBm/15 kHz	-85	-	-	The power level values are such that NR Cell 1 and NR Cell 2 are satisfied for periodic reporting.
	SS/PBCH SSS EPRE	dBm/SC S	-	-91	-91	

Table 8.2.3.3.1.3.2-1A: Time instances of cell power level and parameter changes for FR2

	Parameter	Unit	E-UTRA Cell 1	NR Cell 1	NR Cell 2	Remark
T0	Cell-specific RS EPRE	dBm/15 kHz	-96	-	-	The power level values are such that camping on E-UTRA Cell 1 is guarantee.
	SS/PBCH SSS EPRE	dBm/SC S	-	Off	Off	
T1	Cell-specific RS EPRE	dBm/15 kHz	-96	-	-	The power level values are such that NR Cell 1 is satisfied for periodic reporting.
	SS/PBCH SSS EPRE	dBm/SC S	-	-82	Off	
T2	Cell-specific RS EPRE	dBm/15 kHz	-96	-	-	The power level values are such that NR Cell 2 is satisfied for periodic reporting and NR Cell 1 become unavailable.
	SS/PBCH SSS EPRE	dBm/SC S	-	Off	-82	
T3	Cell-specific RS EPRE	dBm/15 kHz	-96	-	-	The power level values are such that NR Cell 1 and NR Cell 2 are satisfied for periodic reporting.
	SS/PBCH SSS EPRE	dBm/SC S	-	-82	-82	

Table 8.2.3.3.1.3.2-2: Main behaviour

St	Procedure	Message Sequence		TP	Verdict
		U - S	Message		
1	The SS transmits an <i>RRCCONNECTIONRECONFIGURATION</i> including measConfig to setup inter RAT measurements and reporting for NR Cell.	<--	<i>RRCCONNECTIONRECONFIGURATION</i>	-	-
2	The UE transmits an <i>RRCCONNECTIONRECONFIGURATIONCOMPLETE</i> message to confirm the setup of inter RAT measurements for NR Cell.	-->	<i>RRCCONNECTIONRECONFIGURATIONCOMPLETE</i>	-	-
3	The SS changes NR Cell y parameters according to the row "T1".	-	-	-	-
4	Wait and ignore <i>MEASUREMENTREPORT</i> messages for 15s to allow change of power levels and UE measurements for NR Cell 1.	-	-	-	-
5	Check: Does the UE transmit a <i>MEASUREMENTREPORT</i> message on E-UTRA Cell 1 to perform periodical reporting for NR Cell 1?	-->	<i>MEASUREMENTREPORT</i>	1	P
6	The SS changes NR Cell y parameters according to the row "T2".	-	-	-	-
7	Wait and ignore <i>MEASUREMENTREPORT</i> messages for 15s to allow change of power levels and UE measurements for NR Cell 2.	-	-	-	-
8	Check: Does the UE transmit a <i>MEASUREMENTREPORT</i> message on E-UTRA Cell 1 to perform periodical reporting for NR Cell 2?	-->	<i>MEASUREMENTREPORT</i>	2	P
9	The SS changes NR Cell y parameters according to the row "T3".	-	-	-	-
10	Wait and ignore <i>MEASUREMENTREPORT</i> messages for 15s to allow change of power levels and UE measurements for NR Cell 1 and NR Cell 2.	-	-	-	-
11	The SS transmits an <i>RRCCONNECTIONRECONFIGURATION</i> including measConfig to remove inter RAT measurements and reporting for NR Cell.	<--	<i>RRCCONNECTIONRECONFIGURATION</i>	-	-
12	The UE transmits an <i>RRCCONNECTIONRECONFIGURATIONCOMPLETE</i> message to confirm the remove of inter RAT measurements for NR Cell.	-->	<i>RRCCONNECTIONRECONFIGURATIONCOMPLETE</i>	-	-
13	Check: Does the UE transmit a <i>MEASUREMENTREPORT</i> message on E-UTRA Cell 1 to perform periodical reporting for NR Cell 1 and NR Cell 2 during the next 10s?	-->	<i>MEASUREMENTREPORT</i>	3	F

8.2.3.3.1.3.3 Specific message contents

Table 8.2.3.3.1.3.3-1: *RRCCONNECTIONRECONFIGURATION* (step 1, Table 8.2.3.3.1.3.2-2)

Derivation Path: 36.508 [7], Table 4.6.1-8, condition MEAS
--

Table 8.2.3.3.1.3.3-2: *MeasConfig* (Table 8.2.3.3.1.3.3-1)

Derivation Path: 36.508 [7], Table 4.6.6-1			
Information Element	Value/remark	Comment	Condition
MeasConfig ::= SEQUENCE {			
measObjectToAddModList SEQUENCE (SIZE (1..maxObjectld)) OF SEQUENCE {	1 entry		
measObjectld[1]	ldMeasObject-NRf1		
measObject{1}	MeasObjectNR-GENERIC (NRf1)		
}			
reportConfigToAddModList SEQUENCE (SIZE (1..maxReportConfigld)) OF SEQUENCE {	1 entry		
reportConfigld[1]	ldReportConfig-NR		
reportConfig{1}	ReportConfigInterRAT-PERIODICAL-NR		
}			
measldToAddModList SEQUENCE (SIZE (1..maxMeasld)) OF SEQUENCE {	1 entry		
measld[1]	1		
measObjectld[1]	ldMeasObject-NRf1		
reportConfigld[1]	ldReportConfig-NR		
}			
quantityConfig	QuantityConfig-DEFAULT		
}			

Table 8.2.3.3.1.3.3-3: *QuantityConfig-DEFAULT* (Table 8.2.3.3.1.3.3-2)

Derivation Path: 36.508 [7], Table 4.6.6-3A			
Information Element	Value/remark	Comment	Condition
QuantityConfig-DEFAULT SEQUENCE {			
quantityConfigNRLList-r15 SEQUENCE ((SIZE (1..maxQuantSetsNR-r15)) OF SEQUENCE {			
measQuantityCellNR-r15 SEQUENCE {			
filterCoeff-RSRP-r15	fc0		
filterCoeff-RSRQ-r15	fc0		
filterCoefficient-SINR-r13	fc0		
}			
}			
}			

Table 8.2.3.3.1.3.3-4: *MeasObjectNR-GENERIC (NRf1)* (Table 8.2.3.3.1.3.3-2)

Derivation Path: 36.508 [7], Table 4.6.6-2B			
Information Element	Value/remark	Comment	Condition
MeasObjectNR-GENERIC(Freq) ::= SEQUENCE {			
carrierFreq-r15	Downlink carrier frequency of NR cell 1		
}			

Table 8.2.3.3.1.3.3-5: ReportConfigInterRAT-PERIODICAL-NR (Table 8.2.3.3.1.3.3-2)

Derivation path: 36.508 [7], Table 4.6.6-7			
Information Element	Value/remark	Comment	Condition
ReportConfigInterRAT ReportConfigInterRAT-PERIODICAL-NR ::= SEQUENCE {			
maxReportCells	2		
reportAmount	Infinity		
reportQuantityCellNR-r15 ::= SEQUENCE {			
ss-rsrp	true		
ss-rsrq	true		
ss-sinr	true		pc_ss_SINR_Meas
	false		
}			
}			

Table 8.2.3.3.1.3.3-6: MeasurementReport (step 5, Table 8.2.3.3.1.3.2-2)

Derivation Path: 36.508 [7], Table 4.6.1-5			
Information Element	Value/remark	Comment	Condition
MeasurementReport ::= SEQUENCE {			
criticalExtensions CHOICE {			
c1 CHOICE{			
measurementReport-r8 SEQUENCE {			
measResults SEQUENCE {			
measId	1		
measResultPCell SEQUENCE {			
rsrpResult	(0..97)		
rsrqResult	(0..34)		
}			
measResultNeighCells CHOICE {			
measResultNeighCellListNR-r15 SEQUENCE (SIZE (1..maxCellReport)) OF SEQUENCE {	1 entry		
pci-r15 [1]	PhysicalCellIdentity of NR Cell 1		
measResultCell-r15 [1] SEQUENCE {			
rsrpResult-r15	(0..127)		
rsrqResult-r15	(0..127)		
rs-sinr-Result-r15	(0..127)		pc_ss_SINR_Meas
	Not present		
}			
}			
}			
}			
}			

Table 8.2.3.3.1.3.3-7: MeasurementReport (step 8, Table 8.2.3.3.1.3.2-2)

Derivation Path: 36.508 [7], Table 4.6.1-5			
Information Element	Value/remark	Comment	Condition
MeasurementReport ::= SEQUENCE {			
criticalExtensions CHOICE {			
c1 CHOICE{			
measurementReport-r8 SEQUENCE {			
measResults SEQUENCE {			
measId	1		
measResultPCell SEQUENCE {			
rsrpResult	(0..97)		
rsrqResult	(0..34)		
}			
measResultNeighCells CHOICE {			
measResultNeighCellListNR-r15 SEQUENCE (SIZE (1..maxCellReport)) OF SEQUENCE {	1 entry		
pci-r15 [1]	PhysicalCellIdentity of NR Cell 2		
measResultCell-r15 [1] SEQUENCE {			
rsrpResult-r15	(0..127)		
rsrqResult-r15	(0..127)		
rs-sinr-Result-r15	(0..127)		pc_ss_SINR_Meas
}	Not present		
}			
}			
}			
}			
}			

Table 8.2.3.3.1.3.3-8: MeasConfig (step 11, Table 8.2.3.3.1.3.2-2)

Derivation Path: 36.508 [7], Table 4.6.6-1			
Information Element	Value/remark	Comment	Condition
MeasConfig ::= SEQUENCE {			
measIdToRemoveList SEQUENCE (SIZE (1..maxMeasId)) OF SEQUENCE {	1 entry		
measId[1]	1		
}			
}			

8.2.3.4 Measurement configuration control and reporting / Event A1 / Measurement of NR PSCell

8.2.3.4.1 Measurement configuration control and reporting / Event A1 / Measurement of NR PSCell / EN-DC

8.2.3.4.1.1 Test Purpose (TP)

(1)

```
with { UE in RRC_CONNECTED state in EN-DC, and, MCG(s) (E-UTRA PDCP) and SCG and measurement
configured for event A1 with event based periodical reporting }
ensure that {
  when { Serving NR cell becomes better than absolute threshold plus hysteresis }
  then { UE sends MeasurementReport message at regular intervals while entering condition for event
A1 is satisfied }
}
```

(2)

```
with { UE in RRC_CONNECTED state in EN-DC, and, MCG(s) (E-UTRA PDCP) and SCG and periodical
measurement reporting triggered by event A1 ongoing }
ensure that {
  when { Serving NR cell becomes worse than absolute threshold minus hysteresis }
  then { UE stops sending MeasurementReport message }
}
```

(3)

```
with { UE in RRC_CONNECTED state with EN-DC, and, MCG(s) (E-UTRA PDCP) and SCG and measurements are
re-configured for event A1 with event based reporting to report on leaving condition }
ensure that {
  when { Serving NR cell becomes worse than absolute threshold minus hysteresis }
  then { UE sends MeasurementReport message when leaving condition for event A1 is satisfied }
}
```

8.2.3.4.1.2 Conformance requirements

References: The conformance requirements covered in the present TC are specified in: TS 36.331:5.3.5.3; TS 38.331:5.3.5.3, 5.5.2, 5.5.4.1, 5.5.4.2 and 5.5.5.1. Unless otherwise stated these are Rel-15 requirements.

[TS 36.331, clause 5.3.5.3]

If the *RRCConnectionReconfiguration* message does not include the *mobilityControlInfo* and the UE is able to comply with the configuration included in this message, the UE shall:

...

- 1> if the received *RRCConnectionReconfiguration* includes the *nr-SecondaryCellGroupConfig*:
- 2> perform NR RRC Reconfiguration as specified in TS 38.331 [82, 5.3.5.3];

[TS 38.331, clause 5.3.5.3]

The UE shall perform the following actions upon reception of the *RRCReconfiguration*:

...

- 1> if the *RRCReconfiguration* message includes the *measConfig*:
 - 2> perform the measurement configuration procedure as specified in 5.5.2.
- 1> set the content of *RRCReconfigurationComplete* message as follows:
 - 2> if the *RRCReconfiguration* includes the *masterCellGroup* containing the *reportUplinkTxDirectCurrent*, or;
 - 2> if the *RRCReconfiguration* includes the *secondaryCellGroup* containing the *reportUplinkTxDirectCurrent*:
 - 3> include the *uplinkTxDirectCurrentList*;
- 1> if the UE is configured with E-UTRA *nr-SecondaryCellGroupConfig* (MCG is E-UTRA):
 - 2> if *RRCReconfiguration* was received via SRB1:
 - 3> submit the *RRCReconfigurationComplete* via the EUTRA MCG embedded in E-UTRA RRC message *RRCConnectionReconfigurationComplete* as specified in TS 36.331 [10];
 - 3> if *reconfigurationWithSync* was included in *spCellConfig* of an SCG:
 - 4> initiate the random access procedure on the SpCell, as specified in TS 38.321 [3];
 - 3> else:

4> the procedure ends;

NOTE: The order the UE sends the *RRCConnectionReconfigurationComplete* message and performs the Random Access procedure towards the SCG is left to UE implementation.

2> else (*RRCReconfiguration* was received via SRB3):

3> submit the *RRCReconfigurationComplete* message via SRB3 to lower layers for transmission using the new configuration;

NOTE: For EN-DC, in the case of SRB1, the random access is triggered by RRC layer itself as there is not necessarily other UL transmission. In the case of SRB3, the random access is triggered by the MAC layer due to arrival of *RRCReconfigurationComplete*.

1 > else:

2> submit the *RRCReconfigurationComplete* message via SRB1 to lower layers for transmission using the new configuration;

[TS 38.331, clause 5.5.2.3]

The network applies the procedure as follows:

- configure a *measId* only if the corresponding measurement object, the corresponding reporting configuration and the corresponding quantity configuration, are configured;

The UE shall:

1> for each *measId* included in the received *measIdToAddModList*:

2> if an entry with the matching *measId* exists in the *measIdList* within the *VarMeasConfig*:

3> replace the entry with the value received for this *measId*;

2> else:

3> add a new entry for this *measId* within the *VarMeasConfig*;

2> remove the measurement reporting entry for this *measId* from the *VarMeasReportList*, if included;

2> stop the periodical reporting timer and reset the associated information (e.g. *timeToTrigger*) for this *measId*;

[TS 38.331, clause 5.5.4.1]

If security has been activated successfully, the UE shall:

1> for each *measId* included in the *measIdList* within *VarMeasConfig*:

2> if the corresponding *reportConfig* includes a *reportType* set to *eventTriggered* or *periodical*;

3> if the corresponding *measObject* concerns NR;

4> if the *eventA1* or *eventA2* is configured in the corresponding *reportConfig*;

5> consider only the serving cell to be applicable;

...

2> if the *reportType* is set to *eventTriggered* and if the leaving condition applicable for this event is fulfilled for one or more of the cells included in the *cellsTriggeredList* defined within the *VarMeasReportList* for this *measId* for all measurements after layer 3 filtering taken during *timeToTrigger* defined within the *VarMeasConfig* for this event:

3> remove the concerned cell(s) in the *cellsTriggeredList* defined within the *VarMeasReportList* for this *measId*;

3> if *reportOnLeave* is set to *TRUE* for the corresponding reporting configuration:

- 4> initiate the measurement reporting procedure, as specified in 5.5.5;
- 2> upon expiry of the periodical reporting timer for this *measId*:
- ...
- 3> initiate the measurement reporting procedure, as specified in 5.5.5;

[TS 38.331, clause 5.5.4.2]

The UE shall:

- 1> consider the entering condition for this event to be satisfied when condition A1-1, as specified below, is fulfilled;
- 1> consider the leaving condition for this event to be satisfied when condition A1-2, as specified below, is fulfilled;
- 1> for this measurement, consider the NR serving cell corresponding to the associated *measObjectNR* associated with this event.

Inequality A1-1 (Entering condition)

$$Ms - Hys > Thresh$$

Inequality A1-2 (Leaving condition)

$$Ms + Hys < Thresh$$

The variables in the formula are defined as follows:

Ms is the measurement result of the serving cell, not taking into account any offsets.

Hys is the hysteresis parameter for this event (i.e. *hysteresis* as defined within *reportConfigNR* for this event).

Thresh is the threshold parameter for this event (i.e. *a1-Threshold* as defined within *reportConfigNR* for this event).

Ms is expressed in dBm in case of RSRP, or in dB in case of RSRQ and RS-SINR.

Hys is expressed in dB.

Thresh is expressed in the same unit as *Ms*.

[TS 38.331, clause 5.5.5.1]



Figure 5.5.5.1-1: Measurement reporting

The purpose of this procedure is to transfer measurement results from the UE to the network. The UE shall initiate this procedure only after successful security activation.

For the *measId* for which the measurement reporting procedure was triggered, the UE shall set the *measResults* within the *MeasurementReport* message as follows:

- 1> set the *measId* to the measurement identity that triggered the measurement reporting;
- 1> set the *measResultServingCell* within *measResultServingMOList* to include RSRP, RSRQ and the available SINR for each configured serving cell derived based on the *rsType* indicated in the associated *reportConfig*;

- 1> set the *measResultServingCell* within *measResultServingMOList* to include for each NR serving cell that is configured, if any, the *servFreqId*;
- ...
- 1> increment the *numberOfReportsSent* as defined within the *VarMeasReportList* for this *measId* by 1;
- 1> stop the periodical reporting timer, if running;
- 1> if the *numberOfReportsSent* as defined within the *VarMeasReportList* for this *measId* is less than the *reportAmount* as defined within the corresponding *reportConfig* for this *measId*:
- 2> start the periodical reporting timer with the value of *reportInterval* as defined within the corresponding *reportConfig* for this *measId*.
- 1> else:
- 2> if the *reportType* is set to *periodical*:
- 3> remove the entry within the *VarMeasReportList* for this *measId*;
- 3> remove this *measId* from the *measIdList* within *VarMeasConfig*.
- 1> if the UE is configured with EN-DC:
- 2> if SRB3 is configured:
- 3> submit the *MeasurementReport* message via SRB3 to lower layers for transmission, upon which the procedure ends;
- 2>else:
- 3> submit the *MeasurementReport* message via the EUTRA MCG embedded in E-UTRA RRC message *ULInformationTransferMRDC* as specified in TS 36.331 [10].
- 1> else:
- 2>submit the *MeasurementReport* message to lower layers for transmission, upon which the procedure ends.

8.2.3.4.1.3 Test description

System Simulator:

- EUTRA Cell 1 is the PCell and NR Cell 1 is the PSCell.

UE:

- None

Preamble:

- The UE is in state RRC_CONNECTED using generic procedure parameter Connectivity (*EN-DC*) and Bearers (*MCG(s) and SCG*) on E-UTRA Cell 1 according to TS 38.508-1 [4], clause 4.5.4.

8.2.3.4.1.3.2 Test procedure sequence

Table 8.2.3.4.1.3.2-1 and Table 8.2.3.4.1.3.2-1A illustrates the downlink power levels to be applied for NR Cell 1 at various time instants of the test execution. Row marked "T0" denotes the conditions after the preamble, while row marked "T1" are to be applied subsequently. The exact instants on which these values shall be applied are described in the texts in this clause.

Table 8.2.3.4.1.3.2-1: Time instances of cell power level and parameter changes for FR1

	Parameter	Unit	E-UTRA Cell 1	NR Cell 1	Remark
T0	Cell-specific RS EPRE	dBm/15 kHz	-85	-	Power level is such that exit condition for event A1 is satisfied $M_s < Thresh + Hys$
	SS/PBCH SSS EPRE	dBm/SC S	-	-91	
T1	Cell-specific RS EPRE	dBm/15 kHz	-85	-	Power level is such that entry condition for event A1 is satisfied $M_s - Hys > Thresh$
	SS/PBCH SSS EPRE	dBm/SC S	-	-79	

Table 8.2.3.4.1.3.2-1A: Time instances of cell power level and parameter changes for FR2

	Parameter	Unit	E-UTRA Cell 1	NR Cell 1	Remark
T0	Cell-specific RS EPRE	dBm/15 kHz	-96	-	Power level is such that $M_s < Thresh + Hys$
	SS/PBCH SSS EPRE	dBm/SC S	-	-100	
T1	Cell-specific RS EPRE	dBm/15 kHz	-96	-	Power level is such that entry condition for event A1 is satisfied $M_s - Hys > Thresh$
	SS/PBCH SSS EPRE	dBm/SC S	-	-82	
T2	Cell-specific RS EPRE	dBm/15 kHz	-96	-	Power level is such that exit condition for event A1 is satisfied $M_s < Thresh + Hys$
	SS/PBCH SSS EPRE	dBm/SC S	-	-100	

Table 8.2.3.4.1.3.2-2: Main behaviour

St	Procedure	Message Sequence		TP	Verdict
		U - S	Message		
1	The SS transmits an <i>RRCCONNECTIONRECONFIGURATION</i> message including nr Config to setup intra NR measurement for NR Cell 1 and reporting for event A1	<--	<i>RRCCONNECTIONRECONFIGURATION</i>	-	-
2	The UE transmit an <i>RRCCONNECTIONRECONFIGURATIONCOMPLETE</i> message	-->	<i>RRCCONNECTIONRECONFIGURATIONCOMPLETE</i>	-	-
3	SS re-adjusts the cell-specific reference signal level according to row "T1".	-	-	-	-
4	Check: Does the UE transmit a <i>MEASUREMENTREPORT</i> encapsulated in <i>ULINFORMATIONTRANSFERMRDC</i> message to report event A1 with the measured [Results] for NR Cell 1?	-->	<i>ULINFORMATIONTRANSFERMRDC (MeasurementReport)</i>	1	P
-	EXCEPTION: Step 5 below is repeated until 3 <i>MeasurementReport</i> messages are received from the UE	-	-	-	-
5	Check: Does the UE transmit a <i>MeasurementReport</i> encapsulated in <i>ULInformationTransferMRDC</i> message, with the measured [Results] value for NR Cell 1?	-->	<i>ULInformationTransferMRDC (MeasurementReport)</i>	1	P
6	SS re-adjusts the cell-specific reference signal level according to row "T0".	-	-	-	-
7	Wait and ignore <i>MeasurementReport</i> messages for 15 s to allow change of power levels for NR Cell 1 and UE measurement.	-	-	-	-
8	Check: Does the UE transmit a <i>MeasurementReport</i> encapsulated in <i>ULInformationTransferMRDC</i> message, with the measured [Results] value for NR Cell 1 within the next 10s?	-->	<i>ULInformationTransferMRDC (MeasurementReport)</i>	2	F
9	The SS transmits an <i>RRCCONNECTIONRECONFIGURATION</i> message including nr Config to setup intra NR measurement for NR Cell 1 and reporting for event A1 on leaving condition.	<--	<i>RRCCONNECTIONRECONFIGURATION</i>	-	-
10	The UE transmit an <i>RRCCONNECTIONRECONFIGURATIONCOMPLETE</i> message?	-->	<i>RRCCONNECTIONRECONFIGURATIONCOMPLETE</i>	-	-
11	SS re-adjusts the cell-specific reference signal level according to row "T1" in table 8.2.3.4.1.3.2-1.	-	-	-	-
12	The UE transmit a <i>MeasurementReport</i> encapsulated in <i>ULInformationTransferMRDC</i> message to report event A1 for NR Cell 1.	-->	<i>ULInformationTransferMRDC (MeasurementReport)</i>	-	-
13	SS re-adjusts the cell-specific reference signal level according to row "T0" in table 8.2.3.4.1.3.2-1.	-	-	-	-
14	Check: Does the UE transmit a <i>MeasurementReport</i> encapsulated in <i>ULInformationTransferMRDC</i> message, with the measured [Results] value for NR Cell 1?	-->	<i>ULInformationTransferMRDC (MeasurementReport)</i>	3	P

8.2.3.4.1.3.3 Specific message contents

Table 8.2.3.4.1.3.3-1: *RRCCONNECTIONRECONFIGURATION* (step 1, 9, Table 8.2.3.4.1.3.2-2)

Derivation Path: 36.508 [7], Table 4.6.1-8 with condition EN-DC_EmbedNR_RRCRecon
--

Table 8.2.3.4.1.3.3-2: RRCReconfiguration (Table 8.2.3.4.1.3.3-1)

Derivation Path: TS 38.508-1 [4], Table [4.6.1-13]			
Information Element	Value/remark	Comment	Condition
RRCReconfiguration ::= SEQUENCE {			
rrc-TransactionIdentifier	RRC-TransactionIdentifier	TS 38.508-1 [4], Table [4.6.5-12].	
criticalExtensions CHOICE {			
c1 CHOICE {			
rrcReconfiguration ::= SEQUENCE {			
radioBearerConfig	Not present		
secondaryCellGroup	Not present		
measConfig	MeasConfig		
lateNonCriticalExtension	Not present		
nonCriticalExtension	Not present		
}			
}			
}			
}			

Table 8.2.3.4.1.3.3-3: MeasConfig (Table 8.2.3.4.1.3.3-2)

Derivation path: 38.508-1[4] Table 4.6.3-69			
Information Element	Value/Remark	Comment	Condition
measConfig ::= SEQUENCE {			
measObjectToAddModList SEQUENCE (SIZE (1..maxNrofObjectld)) OF SEQUENCE {	1 entry		
measObjectld[1]	MeasObjectld		
measObject CHOICE {			
measObjectNR[1]	MeasObjectNR-GENERIC(72)		
}			
}			
reportConfigToAddModList SEQUENCE (SIZE (1..maxReportConfigld)) OF SEQUENCE {	1 entry		
reportConfigld[1]	ReportConfigld		
reportConfig[1]	ReportConfig1-A1		FR1
reportConfig[1]	ReportConfig2-A1		FR2
}			
measldToAddModList SEQUENCE (SIZE (1..maxNrofMeasld)) OF SEQUENCE {	1 entry		
measld[1]	Measld		
measObjectld[1]	MeasObjectld		
reportConfigld[1]	ReportConfigld		
}			
}			

Table 8.2.3.4.1.3.3-4: MeasObjectNR-GENERIC(72) (Table 8.2.3.4.1.3.3-3)

Derivation Path: 38.508-1 [4], Table 4.6.3-76			
Information Element	Value/remark	Comment	Condition
MeasObjectNR-GENERIC(Freq) ::= SEQUENCE {			
ssbFrequency	Downlink carrier frequency of NR cell 1		
}			

Table 8.2.3.4.1.3.3-5: ReportConfig1-A1 (Step 1, Table 8.2.3.4.1.3.3-3)

Derivation Path: 38.508-1 [4], Table 4.6.3-142 with condition EVENT_A1			
Information Element	Value/remark	Comment	Condition
ReportConfigNR ::= SEQUENCE {			
reportType CHOICE {			
eventTriggered SEQUENCE {			
eventId CHOICE {			
eventA1 SEQUENCE {			
a1-Threshold CHOICE {			
rsrp	72		
}			
Hysteresis	6	3dB	
}			
reportAmount	Infinity		
}			
}			
}			

Table 8.2.3.4.1.3.3-6: RRCConnectionReconfigurationComplete (step 2, 10 Table 8.2.3.4.1.3.2-2)

Derivation Path: 36.508 [7], Table 4.6.1-9 with condition MCG_and_SCG

Table 8.2.3.4.1.3.3-7: MeasurementReport (steps 4, 5, 12, 14, Table 8.2.3.4.1.3.2-2)

Derivation Path: 38.508-1 [4], Table 4.6.1-7			
Information Element	Value/remark	Comment	Condition
MeasurementReport ::= SEQUENCE {			
criticalExtensions CHOICE {			
measurementReport SEQUENCE {			
measResults	MeasResults		
}			
}			
}			

Table 8.2.3.4.1.3.3-8: MeasResults (Table 8.2.3.4.1.3.3-7)

Derivation Path: 38.508-1 [4], clause 4.6.3-79 with condition A1			
Information Element	Value/remark	Comment	Condition
MeasResults ::= SEQUENCE {			
measResultServingMOList ::= SEQUENCE (SIZE (1..maxNrofServingCells)) OF SEQUENCE {	1 entry		
servCellId	Cell index corresponding to NR Cell 1		
measResultServingCell SEQUENCE {			
physCellId	Physical CellID of the NR Cell 1		
measResult SEQUENCE {			
cellResults SEQUENCE {			
resultsSSB-Cell SEQUENCE {			
rsrp	(0..127)		
rsrq	(0..127)		
sinr	(0..127)		pc_ss_SINR_Meas
	Not present		
}			
}			
}			
}			

Table 8.2.3.4.1.3.3-9: ReportConfig1-A1 (Step 9, Table 8.2.3.4.1.3.3-3)

Derivation Path: 38.508-1 [4], Table 4.6.3-142 with condition EVENT_A1			
Information Element	Value/remark	Comment	Condition
ReportConfigNR ::= SEQUENCE {			
reportType CHOICE {			
eventTriggered SEQUENCE {			
eventId CHOICE {			
eventA1 SEQUENCE {			
a1-Threshold CHOICE {			
rsrp	72		
}			
reportOnLeave	True		
Hysteresis	6	3dB	
}			
reportAmount	1		
}			
}			
}			

Table 8.2.3.4.1.3.3-10: ReportConfig2-A1 (Step 1, Table 8.2.3.4.1.3.3-3)

Derivation Path: 38.508-1 [4], Table 4.6.3-142 with condition EVENT_A1			
Information Element	Value/remark	Comment	Condition
ReportConfigNR ::= SEQUENCE {			
reportType CHOICE {			
eventTriggered SEQUENCE {			
eventId CHOICE {			
eventA1 SEQUENCE {			
a1-Threshold CHOICE {			
rsrp	78+Δ(NRf1))		
}			
Hysteresis	6	3dB	
}			
reportAmount	Infinity		
}			
}			
}			

NOTE 1: Δ(NRf1) is derived based on calibration procedure defined in the TS 38.508-1 [4], clause 6.1.3.3

Table 8.2.3.4.1.3.3-11: ReportConfig2-A1 (Step 9, Table 8.2.3.4.1.3.3-3)

Derivation Path: 38.508-1 [4], Table 4.6.3-142 with condition EVENT_A1			
Information Element	Value/remark	Comment	Condition
ReportConfigNR ::= SEQUENCE {			
reportType CHOICE {			
eventTriggered SEQUENCE {			
eventId CHOICE {			
eventA1 SEQUENCE {			
a1-Threshold CHOICE {			
rsrp	78+Δ(NRf1))		
}			
reportOnLeave	True		
Hysteresis	6	3dB	
}			
reportAmount	1		
}			
}			
}			

NOTE 1: Δ(NRf1) is derived based on calibration procedure defined in the TS 38.508-1 [4], clause 6.1.3.3

8.2.3.5 Measurement configuration control and reporting / Event A2 / Measurement of NR PSCell

8.2.3.5.1 Measurement configuration control and reporting / Event A2 / Measurement of NR PSCell / EN-DC

8.2.3.5.1.1 Test Purpose (TP)

(1)

```

with { UE in RRC_CONNECTED state in EN-DC mode and measurement configured for event A2 with event
based periodical reporting }
ensure that {
  when { Serving NR cell becomes worse than absolute threshold minus hysteresis }
  then { UE sends MeasurementReport message at regular intervals while entering condition for
event A2 is satisfied }
}
    
```

(2)

```

with { UE in RRC_CONNECTED state in EN-DC mode and periodical measurement reporting triggered by
event A2 ongoing }
ensure that {
  when { Serving NR cell becomes better than absolute threshold plus hysteresis }
  then { UE stops sending MeasurementReport message }
}

```

8.2.3.5.1.2 Conformance requirements

References: The conformance requirements covered in the present TC are specified in: TS 36.331, clause 5.3.5.3, TS 38.331, clauses 5.3.5.3, 5.5.4.3. Unless otherwise stated these are Rel-15 requirements.

[TS 36.331, clause 5.3.5.3]

1> else:

2> if the *RRCCONNECTIONRECONFIGURATION* message includes the *RADIORESOURCECONFIGDEDICATED*:

3> perform the radio resource configuration procedure as specified in 5.3.10;

NOTE 3: If the *RRCCONNECTIONRECONFIGURATION* message includes the establishment of radio bearers other than SRB1, the UE may start using these radio bearers immediately, i.e. there is no need to wait for an outstanding acknowledgment of the *SECURITYMODECOMPLETE* message.

1> if the received *RRCCONNECTIONRECONFIGURATION* includes the *sCELLTORELEASELIST*:

2> perform SCell release as specified in 5.3.10.3a;

1> if the received *RRCCONNECTIONRECONFIGURATION* includes the *sCELLTOADDMODLIST*:

2> perform SCell addition or modification as specified in 5.3.10.3b;

1> if the received *RRCCONNECTIONRECONFIGURATION* includes the *scg-Configuration*; or

1> if the current UE configuration includes one or more split DRBs and the received *RRCCONNECTIONRECONFIGURATION* includes *RADIORESOURCECONFIGDEDICATED* including *drb-ToAddModList*:

2> perform SCG reconfiguration as specified in 5.3.10.10;

1> if the received *RRCCONNECTIONRECONFIGURATION* includes the *systemInformationBlockType1Dedicated*:

2> perform the actions upon reception of the *SystemInformationBlockType1* message as specified in 5.2.2.7;

1> if the *RRCCONNECTIONRECONFIGURATION* message includes the *dedicatedInfoNASList*:

2> forward each element of the *dedicatedInfoNASList* to upper layers in the same order as listed;

1> if the *RRCCONNECTIONRECONFIGURATION* message includes the *measConfig*:

2> perform the measurement configuration procedure as specified in 5.5.2;

[TS 38.331, clause 5.3.5.3]

1> if the *RRCRECONFIGURATION* includes the *fullConfig*:

2> perform the radio configuration procedure as specified in 5.3.5.11;

1> if the *RRCRECONFIGURATION* includes the *masterCellGroup*:

2> perform the cell group configuration for the received *masterCellGroup* according to 5.3.5.5;

1> if the *RRCRECONFIGURATION* includes the *masterKeyUpdate*:

2> perform security key update procedure as specified in 5.3.5.7;

1> if the *RRCRECONFIGURATION* includes the *secondaryCellGroup*:

- 2> perform the cell group configuration for the SCG according to 5.3.5.5;
- 1> if the *RRCReconfiguration* message contains the *radioBearerConfig*:
 - 2> perform the radio bearer configuration according to 5.3.5.6;
- 1> if the *RRCReconfiguration* message includes the *measConfig*:
 - 2> perform the measurement configuration procedure as specified in 5.5.2;
- 1> if the *RRCReconfiguration* message includes the *dedicatedSIB1-Delivery*:
 - 2> perform the action upon reception of *SIB1* as specified in 5.2.2.4.2;
- 1> if the *RRCReconfiguration* message includes the *dedicatedSystemInformationDelivery*:
 - 2> perform the action upon reception of System Information as specified in 5.2.2.4;
- 1> set the content of *RRCReconfigurationComplete* message as follows:
 - 2> if the *RRCReconfiguration* includes the *masterCellGroup* containing the *reportUplinkTxDirectCurrent*, or;
 - 2> if the *RRCReconfiguration* includes the *secondaryCellGroup* containing the *reportUplinkTxDirectCurrent*:
 - 3> include the *uplinkTxDirectCurrentList*;
- 1> if the UE is configured with E-UTRA *nr-SecondaryCellGroupConfig* (MCG is E-UTRA):
 - 2> if *RRCReconfiguration* was received via SRB1:
 - 3> submit the *RRCReconfigurationComplete* via the EUTRA MCG embedded in E-UTRA RRC message *RRCConnectionReconfigurationComplete* as specified in TS 36.331 [10];
 - 3> if *reconfigurationWithSync* was included in *spCellConfig* of an SCG:
 - 4> initiate the random access procedure on the SpCell, as specified in TS 38.321 [3];
 - 3> else:
 - 4> the procedure ends;

NOTE: The order the UE sends the *RRCConnectionReconfigurationComplete* message and performs the Random Access procedure towards the SCG is left to UE implementation.

- 2> else (*RRCReconfiguration* was received via SRB3):

- 3> submit the *RRCReconfigurationComplete* message via SRB3 to lower layers for transmission using the new configuration;

NOTE: For EN-DC, in the case of SRB1, the random access is triggered by RRC layer itself as there is not necessarily other UL transmission. In the case of SRB3, the random access is triggered by the MAC layer due to arrival of *RRCReconfigurationComplete*.

- 1 > else:

- 2> submit the *RRCReconfigurationComplete* message via SRB1 to lower layers for transmission using the new configuration;

- 1> if *reconfigurationWithSync* was included in *spCellConfig* of an MCG or SCG, and when MAC of an NR cell group successfully completes a random access procedure triggered above;

- 2> stop timer T304 for that cell group;

- 2> apply the parts of the CQI reporting configuration, the scheduling request configuration and the sounding RS configuration that do not require the UE to know the SFN of the respective target SpCell, if any;

- 2> apply the parts of the measurement and the radio resource configuration that require the UE to know the SFN of the respective target SpCell (e.g. measurement gaps, periodic CQI reporting, scheduling request configuration, sounding RS configuration), if any, upon acquiring the SFN of that target SpCell;
- 2> if the *reconfigurationWithSync* was included in *spCellConfig* of an MCG:
 - 3> if the active downlink BWP, which is indicated by the *firstActiveDownlinkBWP-Id* for the target SpCell of the MCG, has a common search space configured:
 - 4> acquire the *SIB1* of the target SpCell of the MCG, as specified in 5.2.2.3.1;
 - 2> the procedure ends.
- 1> if the *RRCReconfiguration* includes the *fullConfig*:
 - 2> perform the radio configuration procedure as specified in 5.3.5.11;
- 1> if the *RRCReconfiguration* includes the *masterCellGroup*:
 - 2> perform the cell group configuration for the received *masterCellGroup* according to 5.3.5.5;
- 1> if the *RRCReconfiguration* includes the *masterKeyUpdate*:
 - 2> perform security key update procedure as specified in 5.3.5.7;
- 1> if the *RRCReconfiguration* includes the *secondaryCellGroup*:
 - 2> perform the cell group configuration for the SCG according to 5.3.5.5;
- 1> if the *RRCReconfiguration* message contains the *radioBearerConfig*:
 - 2> perform the radio bearer configuration according to 5.3.5.6;
- 1> if the *RRCReconfiguration* message includes the *measConfig*:
 - 2> perform the measurement configuration procedure as specified in 5.5.2;
- 1> if the *RRCReconfiguration* message includes the *dedicatedSIB1-Delivery*:
 - 2> perform the action upon reception of *SIB1* as specified in 5.2.2.4.2;
- 1> if the *RRCReconfiguration* message includes the *dedicatedSystemInformationDelivery*:
 - 2> perform the action upon reception of System Information as specified in 5.2.2.4;
- 1> set the content of *RRCReconfigurationComplete* message as follows:
 - 2> if the *RRCReconfiguration* includes the *masterCellGroup* containing the *reportUplinkTxDirectCurrent*, or;
 - 2> if the *RRCReconfiguration* includes the *secondaryCellGroup* containing the *reportUplinkTxDirectCurrent*:
 - 3> include the *uplinkTxDirectCurrentList*;
- 1> if the UE is configured with E-UTRA *nr-SecondaryCellGroupConfig* (MCG is E-UTRA):
 - 2> if *RRCReconfiguration* was received via SRB1:
 - 3> submit the *RRCReconfigurationComplete* via the EUTRA MCG embedded in E-UTRA RRC message *RRCConnectionReconfigurationComplete* as specified in TS 36.331 [10];
 - 3> if *reconfigurationWithSync* was included in *spCellConfig* of an SCG:
 - 4> initiate the random access procedure on the SpCell, as specified in TS 38.321 [3];
 - 3> else:
 - 4> the procedure ends;

NOTE: The order the UE sends the *RRCConnectionReconfigurationComplete* message and performs the Random Access procedure towards the SCG is left to UE implementation.

2> else (*RRCReconfiguration* was received via SRB3):

3> submit the *RRCReconfigurationComplete* message via SRB3 to lower layers for transmission using the new configuration;

NOTE: For EN-DC, in the case of SRB1, the random access is triggered by RRC layer itself as there is not necessarily other UL transmission. In the case of SRB3, the random access is triggered by the MAC layer due to arrival of *RRCReconfigurationComplete*.

1 > else:

2> submit the *RRCReconfigurationComplete* message via SRB1 to lower layers for transmission using the new configuration;

1> if *reconfigurationWithSync* was included in *spCellConfig* of an MCG or SCG, and when MAC of an NR cell group successfully completes a random access procedure triggered above;

2> stop timer T304 for that cell group;

2> apply the parts of the CQI reporting configuration, the scheduling request configuration and the sounding RS configuration that do not require the UE to know the SFN of the respective target SpCell, if any;

2> apply the parts of the measurement and the radio resource configuration that require the UE to know the SFN of the respective target SpCell (e.g. measurement gaps, periodic CQI reporting, scheduling request configuration, sounding RS configuration), if any, upon acquiring the SFN of that target SpCell;

2> if the *reconfigurationWithSync* was included in *spCellConfig* of an MCG:

3> if the active downlink BWP, which is indicated by the *firstActiveDownlinkBWP-Id* for the target SpCell of the MCG, has a common search space configured:

4> acquire the *SIB1* of the target SpCell of the MCG, as specified in 5.2.2.3.1;

2> the procedure ends.

[TS 38.331, clause 5.5.4.3]

The UE shall:

1> consider the entering condition for this event to be satisfied when condition A2-1, as specified below, is fulfilled;

1> consider the leaving condition for this event to be satisfied when condition A2-2, as specified below, is fulfilled;

1> for this measurement, consider the primary or secondary cell that is configured on the frequency indicated in the associated *measObjectNR* to be the serving cell;

Inequality A2-1 (Entering condition)

$$Ms + Hys < Thresh$$

Inequality A2-2 (Leaving condition)

$$Ms - Hys > Thresh$$

The variables in the formula are defined as follows:

Ms is the measurement result of the serving cell, not taking into account any offsets.

Hys is the hysteresis parameter for this event (i.e. *hysteresis* as defined within *reportConfigEUTRA* for this event).

Thresh is the threshold parameter for this event (i.e. *a2-Threshold* as defined within *reportConfigEUTRA* for this event).

Ms is expressed in dBm in case of RSRP, or in dB in case of RSRQ and RS-SINR.

Hys is expressed in dB.

Thresh is expressed in the same unit as *Ms*.

8.2.3.5.1.3 Test description

8.2.3.5.1.3.1 Pre-test conditions

System Simulator:

- EUTRA Cell 1 is the PCell and NR Cell 1 is the PS Cell.

UE:

- None

Preamble:

- The UE is in state RRC_CONNECTED using generic procedure parameter Connectivity (EN-DC) and DC Bearers (MCG(*s*) and SCG) on E-UTRA Cell 1 according to TS 38.508-1, clause 4.5.4 [4].

8.2.3.5.1.3.2 Test procedure sequence

Table 8.2.3.5.1.3.2-1 and Table 8.2.3.5.1.3.2-1A illustrates the downlink power levels to be applied for NR Cell 1 at various time instants of the test execution. Row marked "T0" denotes the conditions after the preamble, while rows marked "T1" and "T2" are to be applied subsequently. The exact instants on which these values shall be applied are described in the texts in this clause.

Table 8.2.3.5.1.3.2-1: Time instances of cell power level and parameter changes for FR1

	Parameter	Unit	EUTRA Cell 1	NR Cell 1	Remark
T0	Cell-specific RS EPRE	dBm/15 kHz	-85	-	
	SS/PBCH SSS EPRE	dBm/S CS	-	-79	Power level is such that $Ms > Thresh + Hys$
T1	Cell-specific RS EPRE	dBm/15 kHz	-85	-	
	SS/PBCH SSS EPRE	dBm/S CS	-	-95	Power level is such that entry condition for event A2 is satisfied $Ms + Hys < Thresh$
T2	Cell-specific RS EPRE	dBm/15 kHz	-85	-	
	SS/PBCH SSS EPRE	dBm/S CS	-	-79	Power level is such that exit condition for event A2 is satisfied $Ms > Thresh + Hys$

Table 8.2.3.5.1.3.2-1A: Time instances of cell power level and parameter changes for FR2

	Parameter	Unit	EUTRA Cell 1	NR Cell 1	Remark
T0	Cell-specific RS EPRE	dBm/15 kHz	-96	-	
	SS/PBCH SSS EPRE	dBm/S CS	-	-82	Power level is such that $Ms > Thresh + Hys$
T1	Cell-specific RS EPRE	dBm/15 kHz	-96	-	
	SS/PBCH SSS EPRE	dBm/S CS	-	-100	Power level is such that entry condition for event A2 is satisfied $Ms + Hys < Thresh$
T2	Cell-specific RS EPRE	dBm/15 kHz	-96	-	
	SS/PBCH SSS EPRE	dBm/S CS	-	-82	Power level is such that exit condition for event A2 is satisfied $Ms > Thresh + Hys$

Table 8.2.3.5.1.3.2-2: Main behaviour

St	Procedure	Message Sequence		TP	Verdict
		U - S	Message		
1	The SS transmits an <i>RRCCONNECTIONRECONFIGURATION</i> message including <i>measConfig</i> to setup intra NR measurement for PSCell and reporting for event A2	<--	<i>RRCCONNECTIONRECONFIGURATION</i>	-	-
2	The UE transmits an <i>RRCCONNECTIONRECONFIGURATIONCOMPLETE</i> message	-->	<i>RRCCONNECTIONRECONFIGURATIONCOMPLETE</i>	-	-
3	SS re-adjusts the cell-specific reference signal level according to row "T1".	-	-	-	-
4	Check: Does the UE transmit <i>ULINFORMATIONTRANSFERMRDC</i> message containing NR <i>MeasurementReport</i> message to report event A2 with the measured results for NR Cell 1?	-->	<i>ULINFORMATIONTRANSFERMRDC (MeasurementReport)</i>	1	P
-	EXCEPTION: Step 5 below is repeated until 3 <i>MeasurementReport</i> messages are received from the UE	-	-	-	-
5	Check: Does the UE transmit a <i>ULINFORMATIONTRANSFERMRDC</i> message containing NR <i>MeasurementReport</i> message to report event A2 with the measured results for NR Cell 1?	-->	<i>ULINFORMATIONTRANSFERMRDC (MeasurementReport)</i>	1	P
6	SS re-adjusts the cell-specific reference signal level according to row "T2".	-	-	-	-
7	Wait and ignore <i>MeasurementReport</i> messages for 15 s to allow change of power levels for NR Cell 1 and UE measurement.	-	-	-	-
8	Check: Does the UE attempt to transmit an uplink message within the next 10s?	-	-	2	F

8.2.3.5.1.3.3 Specific message contents

Table 8.2.3.5.1.3.3-1: RRCConnectionReconfiguration (step 1, Table 8.2.3.5.1.3.2-2)

Derivation Path: 36.508 [7], Table 4.6.1-8 with condition MCG_and_SCG			
Information Element	Value/remark	Comment	Condition
RRCConnectionReconfiguration ::= SEQUENCE {			
criticalExtensions CHOICE {			
c1 CHOICE{			
rrcConnectionReconfiguration-r8 ::= SEQUENCE			
{			
nonCriticalExtension SEQUENCE {			
nonCriticalExtension SEQUENCE {			
nonCriticalExtension SEQUENCE {			
nonCriticalExtension SEQUENCE {			
nonCriticalExtension SEQUENCE {			
nonCriticalExtension SEQUENCE {			
nonCriticalExtension SEQUENCE {			
nr-Config-r15 CHOICE {			
setup SEQUENCE {			
nr-SecondaryCellGroupConfig-r15	OCTET STRING including the <i>RRCReconfiguration</i> message and the IE measConfig		
}			
}			
}			
}			
}			
}			
}			
}			
}			
}			
}			
}			

Table 8.2.3.5.1.3.3-2: RRCReconfiguration (Table 8.2.3.5.1.3.3-1)

Derivation Path: 38.508-1 [4], Table 4.6.1-13 with condition MEAS

Table 8.2.3.5.1.3.3-3: MeasConfig (Table 8.2.3.5.1.3.3-2)

Derivation path: 38.508-1[4], Table 4.6.3-69			
Information Element	Value/Remark	Comment	Condition
measConfig ::= SEQUENCE {			
measObjectToAddModList SEQUENCE (SIZE (1..maxNrofObjectld)) OF SEQUENCE {	1 entry		
measObjectld[1]	1		
measObject CHOICE {			
measObjectNR[1]	Downlink ARFCN of NR Cell2(68)	ssbFrequency IE equals to ARFCN of NR Cell1	
}			
}			
reportConfigToAddModList SEQUENCE (SIZE (1..maxReportConfigld)) OF SEQUENCE {	1 entry		
reportConfigld[1]	1		
reportConfig[1]	ReportConfigNR1-A2		FR1
reportConfig[1]	ReportConfigNR2-A2		FR2
}			
measldToAddModList SEQUENCE (SIZE (1..maxMeasld)) OF SEQUENCE {	1 entry		
measld[1]	1		
measObjectld[1]	1		
reportConfigld[1]	1		
}			
}			

Table 8.2.3.5.1.3.3-4: RRCConnectionReconfigurationComplete (step 2, Table 8.2.3.5.1.3.2-2)

Derivation Path: 36.508 [7], Table 4.6.1-9			
Information Element	Value/remark	Comment	Condition
RRCConnectionReconfigurationComplete ::= SEQUENCE {			
criticalExtensions CHOICE {			
rrcConnectionReconfigurationComplete-r8 SEQUENCE {			
nonCriticalExtension SEQUENCE {			
nonCriticalExtension SEQUENCE {			
nonCriticalExtension SEQUENCE {			
nonCriticalExtension SEQUENCE {			
nonCriticalExtension SEQUENCE {			
nonCriticalExtension SEQUENCE {			
scg-ConfigResponseNR-r15	Present		
}			
}			
}			
}			
}			

Table 8.2.3.5.1.3.3-5: MeasurementReport (steps 4, 5, Table 8.2.3.5.1.3.2-2)

Derivation Path: TS 38.331 [6], clause 6.2.2			
Information Element	Value/remark	Comment	Condition
MeasurementReport ::= SEQUENCE {			
criticalExtensions CHOICE {			
c1 CHOICE {			
measurementReport ::= SEQUENCE {			
measResults SEQUENCE {			
measId	1		
measResultServingMOList SEQUENCE {	1 entry		
servCellId	Cell index corresponding to NR Cell 1		
measResultServingCell SEQUENCE {			
physCellId	Physical CellID of the NR Cell 1		
cgi-Info	Not present		
measResult SEQUENCE {			
cellResults SEQUENCE {			
resultsSSB-Cell SEQUENCE {			
rsrp	(0..127)		
rsrq	(0..127)		
sinr	(0..127)		pc_ss_SINR_Meas
}	Not present		
}			
}			
rsIndexResults	Not checked		
}			
measResultBestNeighCell	Not checked		
}			
}			
}			
}			
}			

Table 8.2.3.5.1.3.3-6: ReportConfigNR-A2(68) (Table 8.2.3.5.1.3.3-3)

Derivation Path: 38.508-1 [4], Table 4.6.3-142 with condition EVENT_A2			
Information Element	Value/remark	Comment	Condition
ReportConfigNR ::= SEQUENCE {			
reportType CHOICE {			
eventTriggered SEQUENCE {			
eventId CHOICE {			
reportAmount	infinity		
}			
}			
}			
}			

Table 8.2.3.5.1.3.3-7: ReportConfigNR-A2(66 + Δ (NRf1)) (Table 8.2.3.5.1.3.3-3)

Derivation Path: 38.508-1 [4], Table 4.6.3-142 with condition EVENT_A2			
Information Element	Value/remark	Comment	Condition
ReportConfigNR ::= SEQUENCE {			
reportType CHOICE {			
eventTriggered SEQUENCE {			
eventId CHOICE {			
reportAmount	infinity		
}			
}			
}			
}			
NOTE 1: Δ (NRf1) is derived based on calibration procedure defined in the TS 38.508-1 [4], clause 6.1.3.3			

8.2.3.6 Measurement configuration control and reporting / Event A3 / Measurement of Neighbour NR cells

8.2.3.6.1 Measurement configuration control and reporting / Event A3 / Measurement of Neighbour NR cells / Intra-frequency measurements / EN-DC

8.2.3.6.1.1 Test Purpose (TP)

(1)

```
with { UE in RRC_CONNECTED state with EN-DC, and, MCG(s) (E-UTRA PDCP) and SCG and measurements
configured for event A3 }
ensure that {
  when { Entry condition for event A3 is not met for neighbour NR cell }
  then { UE does not send MeasurementReport }
}
```

(2)

```
with { UE in RRC_CONNECTED state with EN-DC, and, MCG(s) (E-UTRA PDCP) and SCG and measurements
configured for event A3 }
ensure that {
  when { Neighbour NR cell becomes offset better than serving NR PSCell }
  then { UE sends MeasurementReport with correct measId for event A3 }
}
```

8.2.3.6.1.2 Conformance requirements

References: The conformance requirements covered in the present TC are specified in: TS 36.331, clause 5.3.5.3, TS 38.331, clauses 5.3.5.3, 5.5.2, 5.5.4.1, 5.5.4.4 and 5.5.5. Unless otherwise stated these are Rel-15 requirements.

[TS 36.331, clause 5.3.5.3]

If the *RRCConnectionReconfiguration* message does not include the *mobilityControlInfo* and the UE is able to comply with the configuration included in this message, the UE shall:

- 1> if the *RRCConnectionReconfiguration* message includes the *measConfig*:
 - 2> perform the measurement configuration procedure as specified in 5.5.2;
- 1> set the content of *RRCConnectionReconfigurationComplete* message as follows:
 - 2> if the received *RRCConnectionReconfiguration* message included *nr-SecondaryCellGroupConfig*:
 - 3> include *scg-ConfigResponseNR* in accordance with TS 38.331 [82], clause 5.3.5.3;
- 1> set the content of *RRCConnectionReconfigurationComplete* message as follows:
 - 2> if the received *RRCConnectionReconfiguration* message included *nr-SecondaryCellGroupConfig*:

- 3> include *scg-ConfigResponseNR* in accordance with TS 38.331 [82, 5.3.5.3]; 1> submit the *RRCConnectionReconfigurationComplete* message to lower layers for transmission using the new configuration, upon which the procedure ends;

[TS 38.331, clause 5.3.5.3]

The UE shall perform the following actions upon reception of the *RRCReconfiguration*:

- 1> if the *RRCReconfiguration* includes the *secondaryCellGroup*:
 - 2> perform the cell group configuration for the SCG according to 5.3.5.5;
- 1> if the *RRCReconfiguration* message includes the *measConfig*:
 - 2> perform the measurement configuration procedure as specified in 5.5.2;
 - 1> if the UE is configured with E-UTRA *nr-SecondaryCellGroupConfig* (MCG is E-UTRA):
 - 2> if *RRCReconfiguration* was received via SRB1:
 - 3> construct *RRCReconfigurationComplete* message and submit it via the EUTRA MCG embedded in E-UTRA RRC message *RRCConnectionReconfigurationComplete* as specified in TS 36.331 [10];

[TS 38.331, clause 5.5.2]

The UE shall:

- 1> if the received *measConfig* includes the *measObjectToAddModList*:
 - 2> perform the measurement object addition/modification procedure as specified in 5.5.2.5;
- 1> if the received *measConfig* includes the *reportConfigToAddModList*:
 - 2> perform the reporting configuration addition/modification procedure as specified in 5.5.2.7;
- 1> if the received *measConfig* includes the *measIdToAddModList*:
 - 2> perform the measurement identity addition/modification procedure as specified in 5.5.2.3;

[TS 38.331, clause 5.5.4.1]

If security has been activated successfully, the UE shall:

- 1> for each *measId* included in the *measIdList* within *VarMeasConfig*:
 - 2> if the corresponding *reportConfig* includes a *reportType* set to *eventTriggered* or *periodical*;
 - 3> if the corresponding *measObject* concerns NR;
 - 4> if the *eventA1* or *eventA2* is configured in the corresponding *reportConfig*:
 - 5> consider only the serving cell to be applicable;
 - 4> else:
 - 5> for events involving a serving cell associated with a *measObjectNR* and neighbours associated with another *measObjectNR*, consider any serving cell associated with the other *measObjectNR* to be a neighbouring cell as well;
 - 2> if the *reportType* is set to *eventTriggered* and if the entry condition applicable for this event, i.e. the event corresponding with the *eventId* of the corresponding *reportConfig* within *VarMeasConfig*, is fulfilled for one or more applicable cells for all measurements after layer 3 filtering taken during *timeToTrigger* defined for this event within the *VarMeasConfig*, while the *VarMeasReportList* does not include a measurement reporting entry for this *measId* (a first cell triggers the event):
 - 3> include a measurement reporting entry within the *VarMeasReportList* for this *measId*;
 - 3> set the *numberOfReportsSent* defined within the *VarMeasReportList* for this *measId* to 0;

- 3> include the concerned cell(s) in the *cellsTriggeredList* defined within the *VarMeasReportList* for this *measId*;
- 3> initiate the measurement reporting procedure, as specified in 5.5.5;
- 2> if the *reportType* is set to *eventTriggered* and if the entry condition applicable for this event, i.e. the event corresponding with the *eventId* of the corresponding *reportConfig* within *VarMeasConfig*, is fulfilled for one or more applicable cells not included in the *cellsTriggeredList* for all measurements after layer 3 filtering taken during *timeToTrigger* defined for this event within the *VarMeasConfig* (a subsequent cell triggers the event):
 - 3> set the *numberOfReportsSent* defined within the *VarMeasReportList* for this *measId* to 0;
 - 3> include the concerned cell(s) in the *cellsTriggeredList* defined within the *VarMeasReportList* for this *measId*;
 - 3> initiate the measurement reporting procedure, as specified in 5.5.5;

[TS 38.331, clause 5.5.4.4]

The UE shall:

- 1> consider the entering condition for this event to be satisfied when condition A3-1, as specified below, is fulfilled;
- 1> consider the leaving condition for this event to be satisfied when condition A3-2, as specified below, is fulfilled;
- 1> use the SpCell for *Mp*, *Ofp* and *Ocp*.

NOTE The cell(s) that triggers the event is on the frequency indicated in the associated *measObjectNR* which may be different from the frequency used by the NR SpCell.

Inequality A3-1 (Entering condition)

$$Mn + Ofn + Ocn - Hys > Mp + Ofp + Ocp + Off$$

Inequality A3-2 (Leaving condition)

$$Mn + Ofn + Ocn + Hys < Mp + Ofp + Ocp + Off$$

The variables in the formula are defined as follows:

Mn is the measurement result of the neighbouring cell, not taking into account any offsets.

Ofn is the measurement object specific offset of the neighbour cell (i.e. *offsetMO* as defined within *measObjectNR* corresponding to the frequency of the neighbour cell).

Ocn is the cell specific offset of the neighbour cell (i.e. *cellIndividualOffset* as defined within *measObjectNR* corresponding to the frequency of the neighbour cell), and set to zero if not configured for the neighbour cell.

Mp is the measurement result of the SpCell, not taking into account any offsets.

Ofp is the measurement object specific offset of the frequency of the SpCell (i.e. *offsetMO* as defined within *measObjectNR* corresponding to the frequency of the SpCell).

Ocp is the cell specific offset of the SpCell (i.e. *cellIndividualOffset* as defined within *measObjectNR* corresponding to the frequency of the SpCell), and is set to zero if not configured for the SpCell.

Hys is the hysteresis parameter for this event (i.e. *hysteresis* as defined within *reportConfigNR* for this event).

Off is the offset parameter for this event (i.e. *a3-Offset* as defined within *reportConfigNR* for this event).

Mn, **Mp** are expressed in dBm in case of RSRP, or in dB in case of RSRQ and RS-SINR.

Ofn, **Ocn**, **Ofp**, **Ocp**, **Hys**, **Off** are expressed in dB.

[TS 38.331, clause 5.5.5]

For the *measId* for which the measurement reporting procedure was triggered, the UE shall set the *measResults* within the *MeasurementReport* message as follows:

- 1> set the *measId* to the measurement identity that triggered the measurement reporting;
- 1> set the *measResultServingCell* within *measResultServingMOList* to include RSRP, RSRQ and the available SINR for each configured serving cell derived based on the *rsType* indicated in the associated *reportConfig*;
- 1> set the *measResultServingCell* within *measResultServingMOList* to include for each NR serving cell that is configured with *servingCellMO*, if any, the *servCellId*;
- 1> if the *reportConfig* associated with the *measId* that triggered the measurement reporting includes *reportQuantityRsIndexes* and *maxNrofRSIndexesToReport*:
 - 2> for each serving cell configured with *servingCellMO*, include beam measurement information according to the associated *reportConfig* as described in 5.5.5.2;
- 1> if the *reportConfig* associated with the *measId* that triggered the measurement reporting includes *reportAddNeighMeas*:
 - 2> for each serving cell *measObjectId* referenced in the *measIdList*, other than the *measObjectId* corresponding with the *measId* that triggered the measurement reporting:
 - 3> set the *measResultBestNeighCell* within *measResultServingMOList* to include the *physCellId* and the available measurement quantities based on the *reportQuantityCell* and *rsType* indicated in *reportConfig* of the non-serving cell corresponding to the concerned *measObjectNR* with the highest measured RSRP if RSRP measurement results are available for cells on this frequency, otherwise with the highest measured RSRQ if RSRQ measurement results are available for cells on this frequency, otherwise with the highest measured SINR;
 - 3> if the *reportConfig* associated with the *measId* that triggered the measurement reporting includes *reportQuantityRsIndexes* and *maxNrofRSIndexesToReport*:
 - 4> for each best non-serving cell included in the measurement report:
 - 5> include beam measurement information according to the associated *reportConfig* as described in 5.5.5.2;
- 1> if there is at least one applicable neighbouring cell to report:
 - 2> set the *measResultNeighCells* to include the best neighbouring cells up to *maxReportCells* in accordance with the following:
 - 3> if the *reportType* is set to *eventTriggered*:
 - 4> include the cells included in the *cellsTriggeredList* as defined within the *VarMeasReportList* for this *measId*;
 - 3> else:
 - 4> include the applicable cells for which the new measurement results became available since the last periodical reporting or since the measurement was initiated or reset;
 - 4> if *reportQuantityRsIndexes* and *maxNrofRSIndexesToReport* are configured, include beam measurement information as described in 5.5.5.2;
 - 3> for each cell that is included in the *measResultNeighCells*, include the *physCellId*;
 - 3> if the *reportType* is set to *eventTriggered*:
 - 4> for each included cell, include the layer 3 filtered measured results in accordance with the *reportConfig* for this *measId*, ordered as follows:
 - 5> if the *measObject* associated with this *measId* concerns NR:
 - 6> if *rsType* in the associated *reportConfig* is set to *ssb*:

7> set resultsSSB-Cell within the measResult to include the SS/PBCH block based quantity(ies) indicated in the reportQuantityCell within the concerned reportConfig, in order of decreasing trigger quantity, i.e. the best cell is included first:

8> if reportQuantityRsIndexes and maxNrofRSIndexesToReport are configured, include beam measurement information as described in 5.5.5.2;

6> else if rsType in the associated reportConfig is set to csi-rs:

7> set resultsCSI-RS-Cell within the measResult to include the CSI-RS based quantity(ies) indicated in the reportQuantityCell within the concerned reportConfig, in order of decreasing trigger quantity, i.e. the best cell is included first:

8> if reportQuantityRsIndexes and maxNrofRSIndexesToReport are, include beam measurement information as described in 5.5.5.2;

1> if the UE is configured with EN-DC:

2> if SRB3 is configured:

3> submit the *MeasurementReport* message via SRB3 to lower layers for transmission, upon which the procedure ends;

2>else:

3> submit the *MeasurementReport* message via the EUTRA MCG embedded in E-UTRA RRC message *ULInformationTransferMRDC* as specified in TS 36.331 [10].

1> else:

2>submit the *MeasurementReport* message to lower layers for transmission, upon which the procedure ends.

8.2.3.6.1.3 Test description

8.2.3.6.1.3.1 Pre-test conditions

System Simulator:

- EUTRA Cell 1 is the PCell and NR Cell 1 is the PS Cell.
- NR Cell 2 is the intra-frequency neighbour cell.

UE:

- None

Preamble:

- The UE is in state RRC_CONNECTED in EN-DC mode and DC Bearers (MCG and SCG) on E-UTRA Cell 1 according to TS 38.508-1 [4].

8.2.3.6.1.3.2 Test procedure sequence

Table 8.2.3.6.1.3.2-1 and Table 8.2.3.6.1.3.2-1A illustrates the downlink power levels to be applied for NR Cell 1 and NR Cell 2 at various time instants of the test execution. Row marked "T0" denotes the conditions after the preamble, while rows marked "T1" is to be applied subsequently. The exact instants on which these values shall be applied are described in the texts in this clause.

Table 8.2.3.6.1.3.2-1: Time instances of cell power level and parameter changes for FR1

	Parameter	Unit	EUTRA Cell 1	NR Cell 1	NR Cell 2			Remark
T0	Cell-specific RS EPRE	dBm/15 kHz	-85	-	-			Power levels are such that entry condition for event A3 is not satisfied for any of the neighbour NR cells: $Mn + Ofn + Ocn - Hys > Mp + Ofp + Ocp + Off$
	SS/PBCH SSS EPRE	dBm/S CS	-	-85	-91			
T1	Cell-specific RS EPRE	dBm/15 kHz	-85	-	-			Power levels are such that entry condition for event A3 is satisfied for intra-frequency neighbour NR cell (<i>measId 1</i>): $Mn + Ofn + Ocn - Hys > Ms + OfS + Ocs + Off$
	SS/PBCH SSS EPRE	dBm/S CS	-	-85	-79			

Table 8.2.3.6.1.3.2-1A: Time instances of cell power level and parameter changes for FR2

	Parameter	Unit	EUTRA Cell 1	NR Cell 1	NR Cell 2			Remark
T0	Cell-specific RS EPRE	dBm/15 kHz	-96	-	-			Power levels are such that entry condition for event A3 is not satisfied for any of the neighbour NR cells: $Mn + Ofn + Ocn - Hys > Mp + Ofp + Ocp + Off$
	SS/PBCH SSS EPRE	dBm/S CS	-	-91	-100			
T1	Cell-specific RS EPRE	dBm/15 kHz	-96	-	-			Power levels are such that entry condition for event A3 is satisfied for intra-frequency neighbour NR cell (<i>measId 1</i>): $Mn + Ofn + Ocn - Hys > Ms + OfS + Ocs + Off$
	SS/PBCH SSS EPRE	dBm/S CS	-	-91	-82			

Table 8.2.3.6.1.3.2-2: Main behaviour

St	Procedure	Message Sequence		TP	Verdict
		U - S	Message		
1	The SS transmits an <i>RRCCONNECTIONRECONFIGURATION</i> message containing NR <i>RRCRECONFIGURATION</i> to setup measurements for neighbour NR Cells and reporting for event A3	<--	<i>RRCCONNECTIONRECONFIGURATION (RRCRECONFIGURATION)</i>	-	-
2	Check: Does the UE transmit an <i>RRCCONNECTIONRECONFIGURATIONCOMPLETE</i> message containing NR <i>RRCRECONFIGURATIONCOMPLETE</i> message?	-->	<i>RRCCONNECTIONRECONFIGURATIONCOMPLETE (RRCRECONFIGURATIONCOMPLETE)</i>	-	-
3	Check: Does the UE transmit an <i>ULINFORMATIONTRANSFERMRDC</i> message containing NR <i>MEASUREMENTREPORT</i> message within the next 10s to report event A3?	-->	<i>ULINFORMATIONTRANSFERMRDC (MEASUREMENTREPORT)</i>	1	F
4	The SS re-adjusts the cell-specific reference signal level according to row "T1".	-	-	-	-
5	Check: Does the UE transmit an <i>ULINFORMATIONTRANSFERMRDC</i> message containing NR <i>MEASUREMENTREPORT</i> message to report event A3 (<i>measId 1</i>) with the measured value for NR Cell 2?	-->	<i>ULINFORMATIONTRANSFERMRDC (MEASUREMENTREPORT)</i>	2	P

8.2.3.6.1.3.3 Specific message contents

Table 8.2.3.6.1.3.3-1: RRCConnectionReconfiguration (step 1, Table 8.2.3.6.1.3.2-2)

Derivation Path: 36.508 [7], Table 4.6.1-8 with condition EN-DC_EmbedNR_RRCRecon

Table 8.2.3.6.1.3.3-2: RRCReconfiguration (Table 8.2.3.6.1.3.3-1)

Derivation Path: 38.508-1 [4], Table 4.6.1-13			
Information Element	Value/remark	Comment	Condition
RRCReconfiguration ::= SEQUENCE {			
criticalExtensions CHOICE {			
rrcReconfiguration SEQUENCE {			
radioBearerConfig	Not Present		
secondaryCellGroup	Not Present		
measConfig	MeasConfig-A3		
}			
}			
}			

Table 8.2.3.6.1.3.3-3: MeasConfig-A3 (Table 8.2.3.6.1.3.3-2)

Derivation Path: 38.508-1 [4], Table 4.6.3-69			
Information Element	Value/remark	Comment	Condition
MeasConfig ::= SEQUENCE {			
measObjectToAddModList	MeasObjectNRAddMod		
ReportConfigToAddModList SEQUENCE(SIZE (1..maxReportConfigId)) OF SEQUENCE {			
reportConfigId[1]	ReportConfigId		
reportConfig[1] CHOICE {			
reportConfigNR	ReportConfigNR(2) Same as TS 38.508-1 [4], Table 4.6.3-142 except for reportAmount set to 'r1'	a3-Offset value set to -1 dB (2*0.5 dB)	EVENT_A3
}			
}			
MeasIdToAddModList ::= SEQUENCE (SIZE (1..maxNrofMeasId)) OF SEQUENCE {	1 entry		
measId[1]	1		
measObjectId[1]	1		
reportConfigId[1]	1		
}			
}			

Table 8.2.3.6.1.3.3-4: MeasObjectNRAddMod (Table 8.2.3.6.1.3.3-3)

Derivation Path: 38.508-1 [4], Table 4.6.3-76			
Information Element	Value/remark	Comment	Condition
measObjectToAddModList ::= SEQUENCE (SIZE (1.. maxNrofObjectId)) OF SEQUENCE {	1 entry		
measObjectId[1]	1		
measObject CHOICE {			
measObjectNR	MeasObjectNR(59)	ssbFrequency IE equals the ARFCN for NR Cell 2 Thresh value set to -97dBm	
}			
}			

Table 8.2.3.6.1.3.3-5: RRCConnectionReconfigurationComplete (step 2, Table 8.2.3.6.1.3.2-2)

Derivation Path: 36.508 [7], Table 4.6.1-9 with condition MCG_and_SCG

Table 8.2.3.6.1.3.3-6: ULInformationTransferMRDC (step 5, Table 8.2.3.6.1.3.2-2)

Derivation Path: 36.508 [7], Table 4.6.1-27			
Information Element	Value/remark	Comment	Condition
ULInformationTransferMRDC ::= SEQUENCE {			
ul-DCCH-MessageNR-r15	OCTET STRING including the MeasurementReport message according to Table 8.2.3.6.1.3.3-7		
}			

Table 8.2.3.6.1.3.3-7: MeasurementReport (Table 8.2.3.6.1.3.3-6)

Derivation Path: 38.508-1 [4], Table 4.6.1-7			
Information Element	Value/remark	Comment	Condition
measurementReport ::= SEQUENCE {			
measResults ::= SEQUENCE {			
measId	1		
measResultServingMOList ::= SEQUENCE (SIZE (1..maxNrofServingCells)) {		Report NR Cell 1	
servCellId	Cell index corresponding to NR Cell 1		
measResultServingCell ::= SEQUENCE {			
physCellId	Phy cell id corresponding to NR Cell 1		
measResult SEQUENCE {			
cellResults SEQUENCE {			
resultsSSB-Cell ::= SEQUENCE {			
rsrp	(0..127)		
rsrq	(0..127)		
sinr	(0..127)		pc_ss_SINR_Meas
Not present			
}			
}			
}			
}			
measResultNeighCells ::= SEQUENCE (SIZE (1..maxCellReport)) {	1 entry	Report NR Cell 2	
measResultListNR ::= SEQUENCE {			
physCellId	Phy cell id corresponding to NR Cell 2		
measResult SEQUENCE {			
cellResults SEQUENCE {			
resultsSSB-Cell ::= SEQUENCE {			
rsrp	(0..127)		
rsrq	(0..127)		
sinr	(0..127)		pc_ss_SINR_Meas
Not present			
}			
}			
}			
}			
}			

8.2.3.6.1a Measurement configuration control and reporting / Event A3 / Measurement of Neighbor NR cell / Inter-frequency measurements / EN-DC

8.2.3.6.1a.1 Test Purpose (TP)

(1)
 with { UE in RRC_CONNECTED state with EN-DC, and, MCG(s) (E-UTRA PDCP) and SCG and inter-frequency measurements configured for event A3 }
 ensure that {
 when { Entry condition for event A3 is not met for neighbour NR cell }
 then { UE does not send MeasurementReport }
 }
 }

(2)
 with { UE in RRC_CONNECTED state with EN-DC, and, MCG(s) (E-UTRA PDCP) and SCG and inter-frequency measurements configured for event A3 }
 ensure that {
 when { Neighbour NR cell becomes offset better than serving NR PSCell }
 }
 }

```

then { UE sends MeasurementReport with correct measId for event A3 }
}

```

8.2.3.6.1a.2 Conformance requirements

Same as test case 8.2.3.6.1 with the following difference:

[TS 38.331, clause 5.5.2.9]

The UE shall:

...

1> if *gapUE* is set to *setup*:

2> if a per UE measurement gap configuration is already setup, release the per UE measurement gap configuration;

2> setup the per UE measurement gap configuration indicated by the *measGapConfig* in accordance with the received *gapOffset*, i.e., the first subframe of each gap occurs at an SFN and subframe meeting the following condition:

$SFN \bmod T = \text{FLOOR}(gapOffset/10)$;

$subframe = gapOffset \bmod 10$;

with $T = MGRP/10$ as defined in TS 38.133 [14];

2> if *mgta* is configured, apply the specified timing advance to the gap occurrences calculated above (i.e. the UE starts the measurement *mgta* ms before the gap subframe occurrences);

...

Test description

8.2.3.6.1a.3.1 Pre-test conditions

Same as test case 8.2.3.6.1 with the following differences:

- Cells configuration: NR Cell 3 replaces NR Cell 2.

8.2.3.6.1a.3.2 Test procedure sequence

Same as test case 8.2.3.6.1 with the following differences:

- Cells configuration: NR Cell 3 replaces NR Cell 2.

8.2.3.6.1a.3.3 Specific message contents

Same as test case 8.2.3.6.1 with the following differences:

- Cells configuration: NR Cell 3 replaces NR Cell 2.

Table 8.2.3.6.1a.3.3-1: *MeasConfig-A3* (Table 8.2.3.6.1.3.3-2)

Derivation Path: 38.508-1 [4] Table 4.6.3-69			
Information Element	Value/remark	Comment	Condition
MeasConfig ::= SEQUENCE {			
measObjectToAddModList SEQUENCE (SIZE (1..maxNrofMeasId)) OF SEQUENCE {	2 entries		
measObjectId[1]	1		
measObject[1] CHOICE {			
measObjectNR	MeasObjectNR-f1	Table 8.2.3.6.1a.3.3-2	
}			
measObjectId[2]	2		
measObject[2] CHOICE {			
measObjectNR	MeasObjectNR-f2	Table 8.2.3.6.1a.3.3-3	
}			
}			
reportConfigToAddModList SEQUENCE (SIZE (1..maxReportConfigId)) OF SEQUENCE {	1 entry		
reportConfigId[1]	1		
reportConfig[1] CHOICE {			
reportConfigNR	ReportConfigNR(2) Same as TS 38.508-1 Table 4.6.3-107 except for reportAmount set to 'r1'	a3-Offset Thresh value set to -1 dB (2*0.5 dB)	EVENT_A3
}			
}			
measIdToAddModList SEQUENCE (SIZE (1..maxNrofMeasId)) OF SEQUENCE {	1 entry		
measId[1]	1		
measObjectId[1]	2		
reportConfigId[1]	1		
}			
measGapConfig	MeasGapConfig with condition GAP_UE		
}			

Table 8.2.3.6.1a.3.3-2: *MeasObjectNR-f1* (Table 8.2.3.6.1a.3.3-1)

Derivation Path: TS 38.508-1 [4], Table 4.6.3-76			
Information Element	Value/remark	Comment	Condition
MeasObjectNR ::= SEQUENCE {			
ssbFrequency	ARFCN-ValueNR for SSB of NR Cell 1		
absThreshSS-BlocksConsolidation	Not present		
nrofSS-BlocksToAverage	Not present		
}			

Table 8.2.3.6.1a.3.3-3: *MeasObjectNR-f2* (Table 8.2.3.6.1a.3.3-1)

Derivation Path: TS 38.508-1 [4], Table 4.6.3-76			
Information Element	Value/remark	Comment	Condition
MeasObjectNR ::= SEQUENCE {			
ssbFrequency	ARFCN-ValueNR for SSB of NR Cell 3		
absThreshSS-BlocksConsolidation	Not present		
nrofSS-BlocksToAverage	Not present		
}			

8.2.3.6.1b Measurement configuration control and reporting / Event A3 / Measurement of Neighbor NR cell / Inter-band measurements / EN-DC

8.2.3.6.1b.1 Test Purpose (TP)

(1)
 with { UE in RRC_CONNECTED state with EN-DC, and, MCG(s) (E-UTRA PDCP) and SCG and inter-band measurements configured for event A3 }
 ensure that {
 when { Entry condition for event A3 is not met for neighbour NR cell }
 then { UE does not send MeasurementReport }
 }

(2)
 with { UE in RRC_CONNECTED state with EN-DC, and, MCG(s) (E-UTRA PDCP) and SCG and inter-band measurements configured for event A3 }
 ensure that {
 when { Neighbour NR cell becomes offset better than serving NR PSCell }
 then { UE sends MeasurementReport with correct measId for event A3 }
 }

8.2.3.6.1b.2 Conformance requirements

Same as test case 8.2.3.6.1 with the following difference:

[TS 38.331, clause 5.5.2.9]

The UE shall:

...

1> if *gapUE* is set to *setup*:

- 2> if a per UE measurement gap configuration is already setup, release the per UE measurement gap configuration;
- 2> setup the per UE measurement gap configuration indicated by the *measGapConfig* in accordance with the received *gapOffset*, i.e., the first subframe of each gap occurs at an SFN and subframe meeting the following condition:

$SFN \bmod T = \text{FLOOR}(gapOffset/10)$;

$subframe = gapOffset \bmod 10$;

with $T = MGRP/10$ as defined in TS 38.133 [14];

- 2> if *mgta* is configured, apply the specified timing advance to the gap occurrences calculated above (i.e. the UE starts the measurement *mgta* ms before the gap subframe occurrences);

...

8.2.3.6.1b.3 Test description

8.2.3.6.1b.3.1 Pre-test conditions

Same as test case 8.2.3.6.1 with the following differences:

- Cells configuration: NR Cell 10 replaces NR Cell 2.

8.2.3.6.1b.3.2 Test procedure sequence

Same as test case 8.2.3.6.1 with the following differences:

- Cells configuration: NR Cell 10 replaces NR Cell 2.

8.2.3.6.1b.3.3 Specific message contents

Same as test case 8.2.3.6.1 with the following differences:

- Cells configuration: NR Cell 10 replaces NR Cell 2.

Table 8.2.3.6.1b.3.3-1: MeasConfig-A3 (Table 8.2.3.6.1.3.3-2)

Derivation Path: 38.508-1 [4] Table 4.6.3-69			
Information Element	Value/remark	Comment	Condition
MeasConfig ::= SEQUENCE {			
measObjectToAddModList SEQUENCE (SIZE (1..maxNrofMeasId)) OF SEQUENCE {	2 entries		
measObjectId[1]	1		
measObject[1] CHOICE {			
measObjectNR	MeasObjectNR-f1	Table 8.2.3.6.1b.3.3-2	
}			
measObjectId[2]	2		
measObject[2] CHOICE {			
measObjectNR	MeasObjectNR-f2	Table 8.2.3.6.1b.3.3-3	
}			
}			
reportConfigToAddModList SEQUENCE(SIZE (1..maxReportConfigId)) OF SEQUENCE {	1 entry		
reportConfigId[1]	1		
reportConfig[1] CHOICE {			
reportConfigNR	ReportConfigNR(2) Same as TS 38.508-1 Table 4.6.3-107 except for reportAmount set to 'r1'	a3-Offset Thresh value set to -1 dB (2*0.5 dB)	EVENT_A3
}			
}			
measIdToAddModList SEQUENCE (SIZE (1..maxNrofMeasId)) OF SEQUENCE {	1 entry		
measId[1]	1		
measObjectId[1]	2		
reportConfigId[1]	1		
}			
measGapConfig	MeasGapConfig with condition GAP_UE		
}			

Table 8.2.3.6.1b.3.3-2: MeasObjectNR-f1 (Table 8.2.3.6.1b.3.3-1)

Derivation Path: TS 38.508-1 [4], Table 4.6.3-76			
Information Element	Value/remark	Comment	Condition
MeasObjectNR ::= SEQUENCE {			
ssbFrequency	ARFCN-ValueNR for SSB of NR Cell 1		
absThreshSS-BlocksConsolidation	Not present		
nrofSS-BlocksToAverage	Not present		
}			

Table 8.2.3.6.1b.3.3-3: *MeasObjectNR-f2* (Table 8.2.3.6.1b.3.3-1)

Derivation Path: TS 38.508-1 [4], Table 4.6.3-76			
Information Element	Value/remark	Comment	Condition
MeasObjectNR::= SEQUENCE {			
ssbFrequency	ARFCN-ValueNR for SSB of NR Cell 10		
absThreshSS-BlocksConsolidation	Not present		
nrofSS-BlocksToAverage	Not present		
}			

8.2.3.7 Measurement configuration control and reporting / Event A4 (intra-frequency, inter-frequency and inter-band measurements) / Measurement of Neighbour NR cell

8.2.3.7.1 Measurement configuration control and reporting / Event A4 / Measurement of Neighbour NR cell / Intra-frequency measurements / EN-DC

8.2.3.7.1.1 Test Purpose (TP)

(1)

```
with { UE in RRC_CONNECTED state with EN-DC, and, MCG(s) (E-UTRA PDCP) and SCG and measurement
configured for event A4 with event based periodical reporting }
ensure that {
  when { Neighbour NR cell becomes better than absolute threshold }
  then { UE sends MeasurementReport message at regular intervals while entering condition for
event A4 is satisfied }
}
```

(2)

```
with { UE in RRC_CONNECTED state with EN-DC, and, MCG(s) (E-UTRA PDCP) and SCG and periodical
measurement reporting triggered by event A4 ongoing }
ensure that {
  when { Neighbour NR cell becomes worse than absolute threshold }
  then { UE stops sending MeasurementReport message }
}
```

8.2.3.7.1.2 Conformance requirements

References: The conformance requirements covered in the current TC are specified in: TS 36.331, clause 5.3.5.3, and TS 38.331, clause 5.3.5.3, 5.5.2.1, 5.5.4.1, 5.5.4.5 and 5.5.5.1. Unless otherwise stated these are Rel-15 requirements.

[TS 36.331, clause 5.3.5.3]

If the *RRCConnectionReconfiguration* message does not include the *mobilityControlInfo* and the UE is able to comply with the configuration included in this message, the UE shall:

...

1> if the received *RRCConnectionReconfiguration* includes the *nr-SecondaryCellGroupConfig*:

2> perform NR RRC Reconfiguration as specified in TS 38.331 [82, 5.3.5.3];

...

1> set the content of *RRCConnectionReconfigurationComplete* message as follows:

...

2> if the received *RRCConnectionReconfiguration* message included *nr-SecondaryCellGroupConfig*:

3> include *scg-ConfigResponseNR* in accordance with TS 38.331 [82, 5.3.5.3];

- 1> submit the *RRCConnectionReconfigurationComplete* message to lower layers for transmission using the new configuration, upon which the procedure ends;

[TS 38.331, clause 5.3.5.3]

The UE shall perform the following actions upon reception of the *RRCReconfiguration*:

- 1> if the *RRCReconfiguration* includes the *secondaryCellGroup*:
 - 2> perform the cell group configuration for the SCG according to 5.3.5.5;
 - ...
- 1> if the *RRCReconfiguration* message includes the *measConfig*:
 - 2> perform the measurement configuration procedure as specified in 5.5.2;
 - ...
- 1> if the UE is configured with E-UTRA *nr-SecondaryCellGroupConfig* (MCG is E-UTRA):
 - 2> if *RRCReconfiguration* was received via SRB1:
 - 3> submit the *RRCReconfigurationComplete* via the EUTRA MCG embedded in E-UTRA RRC message *RRCConnectionReconfigurationComplete* as specified in TS 36.331 [10];

[TS 38.331, clause 5.5.2.1]

The network applies the procedure as follows:

- to ensure that, whenever the UE has a *measConfig*, it includes a *measObject* for the SpCell and for each NR SCell to be measured;
- to configure at most one measurement identity using a reporting configuration with the *reportType* set to *reportCGI*;
- to ensure that, for all SSB based reporting configurations have at most one measurement object with the same *ssbFrequency* and *ssbSubcarrierSpacing*;

The UE shall:

- ...
- 1> if the received *measConfig* includes the *measObjectToAddModList*:
 - 2> perform the measurement object addition/modification procedure as specified in 5.5.2.5;
 - ...
- 1> if the received *measConfig* includes the *reportConfigToAddModList*:
 - 2> perform the reporting configuration addition/modification procedure as specified in 5.5.2.7;
 - ...
- 1> if the received *measConfig* includes the *measIdToAddModList*:
 - 2> perform the measurement identity addition/modification procedure as specified in 5.5.2.3;
- 1> if the received *measConfig* includes the *measGapConfig*:
 - 2> perform the measurement gap configuration procedure as specified in 5.5.2.9;

[TS 38.331, clause 5.5.4.1]

If security has been activated successfully, the UE shall:

- 1> for each *measId* included in the *measIdList* within *VarMeasConfig*:

- 2> if the corresponding *reportConfig* includes a *reportType* set to *eventTriggered* or *periodical*;
 - 3> if the corresponding *measObject* concerns NR;
 - 4> if the *eventA1* or *eventA2* is configured in the corresponding *reportConfig*:
 - 5> consider only the serving cell to be applicable;
 - 4> else:
 - 5> for events involving a serving cell associated with a *measObjectNR* and neighbours associated with another *measObjectNR*, consider any serving cell associated with the other *measObjectNR* to be a neighbouring cell as well;
 - 5> if *useWhiteCellList* is set to TRUE:
 - 6> consider any neighbouring cell detected based on parameters in the associated *measObjectNR* to be applicable when the concerned cell is included in the *whiteCellsToAddModList* defined within the *VarMeasConfig* for this *measId*;
 - 5> else:
 - 6> consider any neighbouring cell detected based on parameters in the associated *measObjectNR* to be applicable when the concerned cell is not included in the *blackCellsToAddModList* defined within the *VarMeasConfig* for this *measId*;
 - 3> else if the corresponding *measObject* concerns E-UTRA;
 - 4> consider any neighbouring cell detected on the associated frequency to be applicable when the concerned cell is not included in the *blackCellsToAddModListEUTRAN* defined within the *VarMeasConfig* for this *measId*;
- 2> if the corresponding *reportConfig* includes a *reportType* set to *reportCGI*:
 - 3> consider the cell detected on the associated *measObject* which has a physical cell identity matching the value of the *cellForWhichToReportCGI* included in the corresponding *reportConfig* within the *VarMeasConfig* to be applicable;
- 2> if the *reportType* is set to *eventTriggered* and if the entry condition applicable for this event, i.e. the event corresponding with the *eventId* of the corresponding *reportConfig* within *VarMeasConfig*, is fulfilled for one or more applicable cells for all measurements after layer 3 filtering taken during *timeToTrigger* defined for this event within the *VarMeasConfig*, while the *VarMeasReportList* does not include a measurement reporting entry for this *measId* (a first cell triggers the event):
 - 3> include a measurement reporting entry within the *VarMeasReportList* for this *measId*;
 - 3> set the *numberOfReportsSent* defined within the *VarMeasReportList* for this *measId* to 0;
 - 3> include the concerned cell(s) in the *cellsTriggeredList* defined within the *VarMeasReportList* for this *measId*;
 - 3> initiate the measurement reporting procedure, as specified in 5.5.5;
- 2> if the *reportType* is set to *eventTriggered* and if the entry condition applicable for this event, i.e. the event corresponding with the *eventId* of the corresponding *reportConfig* within *VarMeasConfig*, is fulfilled for one or more applicable cells not included in the *cellsTriggeredList* for all measurements after layer 3 filtering taken during *timeToTrigger* defined for this event within the *VarMeasConfig* (a subsequent cell triggers the event):
 - 3> set the *numberOfReportsSent* defined within the *VarMeasReportList* for this *measId* to 0;
 - 3> include the concerned cell(s) in the *cellsTriggeredList* defined within the *VarMeasReportList* for this *measId*;
 - 3> initiate the measurement reporting procedure, as specified in 5.5.5;

- 2> if the *reportType* is set to *eventTriggered* and if the leaving condition applicable for this event is fulfilled for one or more of the cells included in the *cellsTriggeredList* defined within the *VarMeasReportList* for this *measId* for all measurements after layer 3 filtering taken during *timeToTrigger* defined within the *VarMeasConfig* for this event:
 - 3> remove the concerned cell(s) in the *cellsTriggeredList* defined within the *VarMeasReportList* for this *measId*;
 - 3> if *reportOnLeave* is set to *TRUE* for the corresponding reporting configuration:
 - 4> initiate the measurement reporting procedure, as specified in 5.5.5;
 - 3> if the *cellsTriggeredList* defined within the *VarMeasReportList* for this *measId* is empty:
 - 4> remove the measurement reporting entry within the *VarMeasReportList* for this *measId*;
 - 4> stop the periodical reporting timer for this *measId*, if running;
- 2> if *reportType* is set to *periodical* and if a (first) measurement result is available:
 - 3> include a measurement reporting entry within the *VarMeasReportList* for this *measId*;
 - 3> set the *numberOfReportsSent* defined within the *VarMeasReportList* for this *measId* to 0;
 - 4> if the *reportAmount* exceeds 1:
 - 5> initiate the measurement reporting procedure, as specified in 5.5.5, immediately after the quantity to be reported becomes available for the NR SpCell;
 - 4> else (i.e. the *reportAmount* is equal to 1):
 - 5> initiate the measurement reporting procedure, as specified in 5.5.5, immediately after the quantity to be reported becomes available for the NR SpCell and for the strongest cell among the applicable cells;
- 2> upon expiry of the periodical reporting timer for this *measId*:
 - 3> initiate the measurement reporting procedure, as specified in 5.5.5.

[TS 38.331, clause 5.5.4.5]

The UE shall:

- 1> consider the entering condition for this event to be satisfied when condition A4-1, as specified below, is fulfilled;
- 1> consider the leaving condition for this event to be satisfied when condition A4-2, as specified below, is fulfilled.

Inequality A4-1 (Entering condition)

$$Mn + Ofn + Ocn - Hys > Thresh$$

Inequality A4-2 (Leaving condition)

$$Mn + Ofn + Ocn + Hys < Thresh$$

The variables in the formula are defined as follows:

Mn is the measurement result of the neighbouring cell, not taking into account any offsets.

Ofn is the measurement object specific offset of the neighbour cell (i.e. *offsetMO* as defined within *measObjectNR* corresponding to the neighbour cell).

Ocn is the measurement object specific offset of the neighbour cell (i.e. *cellIndividualOffset* as defined within *measObjectNR* corresponding to the neighbour cell), and set to zero if not configured for the neighbour cell.

Hys is the hysteresis parameter for this event (i.e. *hysteresis* as defined within *reportConfigNR* for this event).

Thresh is the threshold parameter for this event (i.e. *a4-Threshold* as defined within *reportConfigNR* for this event).

Mn is expressed in dBm in case of RSRP, or in dB in case of RSRQ and RS-SINR.

Ofn, *Ocn*, *Hys* are expressed in dB.

Thresh is expressed in the same unit as *Mn*.

[TS 38.331, clause 5.5.5.1]

The purpose of this procedure is to transfer measurement results from the UE to the network. The UE shall initiate this procedure only after successful security activation.

For the *measId* for which the measurement reporting procedure was triggered, the UE shall set the *measResults* within the *MeasurementReport* message as follows:

- 1> set the *measId* to the measurement identity that triggered the measurement reporting;
- 1> set the *measResultServingCell* within *measResultServingMOList* to include RSRP, RSRQ and the available SINR for each configured serving cell derived based on the *rsType* indicated in the associated *reportConfig*;
- 1> set the *measResultServingCell* within *measResultServingMOList* to include for each NR serving cell that is configured with *servingCellMO*, if any, the *servCellId*;
- 1> if the *reportConfig* associated with the *measId* that triggered the measurement reporting includes *reportQuantityRsIndexes* and *maxNrofRSIndexesToReport*:
 - 2> for each serving cell configured with *servingCellMO*, include beam measurement information according to the associated *reportConfig* as described in 5.5.5.2;
- 1> if the *reportConfig* associated with the *measId* that triggered the measurement reporting includes *reportAddNeighMeas*:
 - 2> for each serving cell *measObjectId* referenced in the *measIdList*, other than the *measObjectId* corresponding with the *measId* that triggered the measurement reporting:
 - 3> set the *measResultBestNeighCell* within *measResultServingMOList* to include the *physCellId* and the available measurement quantities based on the *reportQuantityCell* and *rsType* indicated in *reportConfig* of the non-serving cell corresponding to the concerned *measObjectNR* with the highest measured RSRP if RSRP measurement results are available for cells corresponding to this *measObjectNR*, otherwise with the highest measured RSRQ if RSRQ measurement results are available for cells corresponding to this *measObjectNR*, otherwise with the highest measured SINR;
 - 3> if the *reportConfig* associated with the *measId* that triggered the measurement reporting includes *reportQuantityRsIndexes* and *maxNrofRSIndexesToReport*:
 - 4> for each best non-serving cell included in the measurement report:
 - 5> include beam measurement information according to the associated *reportConfig* as described in 5.5.5.2;
- 1> if there is at least one applicable neighbouring cell to report:
 - 2> set the *measResultNeighCells* to include the best neighbouring cells up to *maxReportCells* in accordance with the following:
 - 3> if the *reportType* is set to *eventTriggered*:
 - 4> include the cells included in the *cellsTriggeredList* as defined within the *VarMeasReportList* for this *measId*;
 - 3> else:
 - 4> include the applicable cells for which the new measurement results became available since the last periodical reporting or since the measurement was initiated or reset;
 - 4> if *reportQuantityRsIndexes* and *maxNrofRSIndexesToReport* are configured, include beam measurement information as described in 5.5.5.2;

- 3> for each cell that is included in the *measResultNeighCells*, include the *physCellId*;
- 3> if the *reportType* is set to *eventTriggered*:
 - 4> for each included cell, include the layer 3 filtered measured results in accordance with the *reportConfig* for this *measId*, ordered as follows:
 - 5> if the *measObject* associated with this *measId* concerns NR:
 - 6> if *rsType* in the associated *reportConfig* is set to *ssb*:
 - 7> set *resultsSSB-Cell* within the *measResult* to include the SS/PBCH block based quantity(ies) indicated in the *reportQuantityCell* within the concerned *reportConfig*, in order of decreasing trigger quantity, i.e. the best cell is included first:
 - 8> if *reportQuantityRsIndexes* and *maxNrofRSIndexesToReport* are configured, include beam measurement information as described in 5.5.5.2;
 - 8> if *reportQuantityRsIndexes* and *maxNrofRSIndexesToReport* are not configured, include beam measurement information as described in 5.5.5.2;
 - 6> else if *rsType* in the associated *reportConfig* is set to *csi-rs*:
 - 7> set *resultsCSI-RS-Cell* within the *measResult* to include the CSI-RS based quantity(ies) indicated in the *reportQuantityCell* within the concerned *reportConfig*, in order of decreasing trigger quantity, i.e. the best cell is included first:
 - 8> if *reportQuantityRsIndexes* and *maxNrofRSIndexesToReport* are configured, include beam measurement information as described in 5.5.5.2;
 - 8> if *reportQuantityRsIndexes* and *maxNrofRSIndexesToReport* are not configured, include beam measurement information as described in 5.5.5.2;
 - 5> if the *measObject* associated with this *measId* concerns E-UTRA:
 - 6> set the *measResult* to include the quantity(ies) indicated in the *reportQuantity* within the concerned *reportConfigInterRAT* in order of decreasing E-UTRA trigger quantity, i.e. the best cell is included first;
 - 1> increment the *numberOfReportsSent* as defined within the *VarMeasReportList* for this *measId* by 1;
 - 1> stop the periodical reporting timer, if running;
 - 1> if the *numberOfReportsSent* as defined within the *VarMeasReportList* for this *measId* is less than the *reportAmount* as defined within the corresponding *reportConfig* for this *measId*:
 - 2> start the periodical reporting timer with the value of *reportInterval* as defined within the corresponding *reportConfig* for this *measId*;
 - 1> else:
 - 2> if the *reportType* is set to *periodical*:
 - 3> remove the entry within the *VarMeasReportList* for this *measId*;
 - 3> remove this *measId* from the *measIdList* within *VarMeasConfig*;
 - 1> if the UE is configured with EN-DC:
 - 2> if SRB3 is configured:
 - 3> submit the *MeasurementReport* message via SRB3 to lower layers for transmission, upon which the procedure ends;
 - 2> else:
 - 3> submit the *MeasurementReport* message via the EUTRA MCG embedded in E-UTRA RRC message *ULInformationTransferMRDC* as specified in TS 36.331 [10].
 - 1> else:

2> submit the *MeasurementReport* message to lower layers for transmission, upon which the procedure ends.

8.2.3.7.1.3 Test description

8.2.3.7.1.3.1 Pre-test conditions

System Simulator:

- E-UTRA Cell 1 is the PCell and NR Cell 1 is the PSCell
- NR Cell 2 is the intra-frequency neighbour cell of NR Cell 1.

UE:

- None

Preamble:

- The UE is in state RRC_CONNECTED using generic procedure parameter Connectivity (EN-DC) and DC Bearers (MCG(s) and SCG) on E-UTRA Cell 1 according to TS 38.508-1 [4], clause 4.5.4.

8.2.3.7.1.3.2 Test procedure sequence

Table 8.2.3.7.1.3.2-1 and Table 8.2.3.7.1.3.2-1A illustrates the downlink power levels to be applied for E-UTRA Cell 1, NR Cell 1 and NR Cell 2 at various time instants of the test execution. Row marked "T0" denotes the conditions after the preamble, while rows marked "T1" and "T2" are to be applied subsequently. The exact instants on which these values shall be applied are described in the texts in this clause.

Table 8.2.3.7.1.3.2-1: Time instances of cell power level and parameter changes for FR1

	Parameter	Unit	E-UTRA Cell 1	NR Cell 1	NR Cell 2	Remark
T0	Cell-specific RS EPRE	dBm/15k Hz	-85	-	-	The power level values are such that entry condition for event A4 is not satisfied
	SS/PBCH SSS EPRE	dBm/SC S	-	-88	Off	
T1	Cell-specific RS EPRE	dBm/15k Hz	-85	-	-	The power level values are such that entry condition for event A4 is satisfied for intra-frequency neighbour NR Cell 2
	SS/PBCH SSS EPRE	dBm/SC S	-	-88	-79	
T2	Cell-specific RS EPRE	dBm/15k Hz	-85	-	-	The power level values are such that entry conditions for event A4 is not satisfied for intra-frequency neighbour NR Cell 2
	SS/PBCH SSS EPRE	dBm/SC S	-	-88	-91	

Table 8.2.3.7.1.3.2-1A: Time instances of cell power level and parameter changes for FR2

	Parameter	Unit	E-UTRA Cell 1	NR Cell 1	NR Cell 2	Remark
T0	Cell-specific RS EPRE	dBm/15k Hz	-96	-	-	The power level values are such that entry condition for event A4 is not satisfied
	SS/PBCH SSS EPRE	dBm/SC S	-	-91	Off	
T1	Cell-specific RS EPRE	dBm/15k Hz	-96	-	-	The power level values are such that entry condition for event A4 is satisfied for intra-frequency neighbour NR Cell 2
	SS/PBCH SSS EPRE	dBm/SC S	-	-91	-82	
T2	Cell-specific RS EPRE	dBm/15k Hz	-96	-	-	The power level values are such that entry conditions for event A4 is not satisfied for intra-frequency neighbour NR Cell 2
	SS/PBCH SSS EPRE	dBm/SC S	-	-91	-100	

Table 8.2.3.7.1.3.2-2: Main behaviour

St	Procedure	Message Sequence		TP	Verdict
		U - S	Message		
1	The SS transmits an <i>RRCCONNECTIONRECONFIGURATION</i> message containing NR <i>RRCCONNECTIONRECONFIGURATION</i> message to setup NR measurement and reporting of event A4.	<--	<i>RRCCONNECTIONRECONFIGURATION (RRCCONNECTIONRECONFIGURATION)</i>	-	-
2	Check: Does the UE transmit an <i>RRCCONNECTIONRECONFIGURATIONCOMPLETE</i> message containing NR <i>RRCCONNECTIONRECONFIGURATIONCOMPLETE</i> message?	-->	<i>RRCCONNECTIONRECONFIGURATIONCOMPLETE (RRCCONNECTIONRECONFIGURATIONCOMPLETE)</i>	-	-
3	The SS re-adjusts the cell-specific reference signal level according to row "T1".	-	-	-	-
4	Check: Does the UE transmit <i>ULINFORMATIONTRANSFERMRDC</i> message containing NR <i>MEASUREMENTREPORT</i> message to report event A4 with the measured Results for NR Cell 2?	-->	<i>ULINFORMATIONTRANSFERMRDC (MEASUREMENTREPORT)</i>	1	P
-	EXCEPTION: Step 5 below is repeated until 3 <i>MEASUREMENTREPORT</i> messages are received from the UE	-	-	-	-
5	Check: Does the UE transmit <i>ULINFORMATIONTRANSFERMRDC</i> message containing NR <i>MEASUREMENTREPORT</i> message to report event A4 with the measured Results for NR Cell 2?	-->	<i>ULINFORMATIONTRANSFERMRDC (MEASUREMENTREPORT)</i>	1	P
6	The SS re-adjusts the cell-specific reference signal level according to row "T2".	-	-	-	-
7	Wait and ignore <i>MEASUREMENTREPORT</i> messages for 15 s to allow change of power levels for NR Cell 2 and UE measurement.	-	-	-	-
8	Check: Does the UE attempt to transmit an uplink message within the next 10s?	-	-	2	F

8.2.3.7.1.3.3 Specific message contents

Table 8.2.3.7.1.3.3-1: RRCCONNECTIONRECONFIGURATION (step 1, Table 8.2.3.7.1.3.2-2)

Derivation Path: 36.508 [7], Table 4.6.1-8 with condition EN-DC_EmbedNR_RRCCON
--

Table 8.2.3.7.1.3.3-2: RRCReconfiguration (Table 8.2.3.7.1.3.3-1)

Derivation Path: 38.508-1 [4], Table 4.6.1-13			
Information Element	Value/remark	Comment	Condition
RRCReconfiguration ::= SEQUENCE {			
criticalExtensions CHOICE {			
rrcReconfiguration SEQUENCE {			
radioBearerConfig	Not Present		
secondaryCellGroup	Not Present		
measConfig	MeasConfig-A4		
}			
}			
}			

Table 8.2.3.7.1.3.3-3: MeasConfig-A4 (Table 8.2.3.7.1.3.3-2)

Derivation Path: 38.508-1 [4], Table 4.6.3-69			
Information Element	Value/remark	Comment	Condition
MeasConfig ::= SEQUENCE {			
measObjectToAddModList	MeasObjectNR-A4		
reportConfigToAddModList	ReportConfigNR1-A4		FR1
reportConfigToAddModList	ReportConfigNR2-A4		FR2
MeasIdToAddModList ::= SEQUENCE (SIZE (1..maxNrofMeasId)) OF SEQUENCE {	1 entry		
measId[1]	1		
measObjectId[1]	1		
reportConfigId[1]	1		
}			

Table 8.2.3.7.1.3.3-4: MeasObjectNR-A4 (Table 8.2.3.7.1.3.3-3)

Derivation Path: 38.508-1 [4], Table 4.6.3-76			
Information Element	Value/remark	Comment	Condition
measObjectToAddModList ::= SEQUENCE (SIZE (1..maxNrofObjectId)) OF SEQUENCE {	1 entry		
measObjectId[1]	1		
measObject CHOICE {			
measObjectNR SEQUENCE {			
ssbFrequency	ssbFrequency IE equals the ARFCN for NR Cell 2		
absThreshSS-BlocksConsolidation	Not Present		
absThreshCSI-RS-Consolidation	Not Present		
}			
}			
}			

Table 8.2.3.7.1.3.3-5: ReportConfigNR1-A4 (Table 8.2.3.7.1.3.3-3)

Derivation Path: 38.508-1 [4], Table 4.6.3-143 with condition EVENT_A4			
Information Element	Value/remark	Comment	Condition
ReportConfigToAddModList ::= SEQUENCE (SIZE (1..maxNrofMeasId)) OF SEQUENCE {	1 entry		
reportConfigId[1]	1		
reportConfig[1] CHOICE {			
reportConfigNR SEQUENCE {			
reportType CHOICE {			
eventTriggered SEQUENCE {			
eventId CHOICE {			
eventA4 SEQUENCE {			
a4-Threshold CHOICE {			
rsrp	71	SS RSRP corresponding to -86dBm	
}			
}			
}			
}			
}			
}			
}			
reportInterval[1]	ms1024		
reportAmount[1]	Infinity		
}			

Table 8.2.3.7.1.3.3-6: RRCConnectionReconfigurationComplete (step 2, Table 8.2.3.7.1.3.2-2)

Derivation Path: 36.508 [7], Table 4.6.1-9 with condition MCG_and_SCG

Table 8.2.3.7.1.3.3-7: ULInformationTransferMRDC (steps 4, 5, Table 8.2.3.7.1.3.2-2)

Derivation Path: 36.508 [7], Table 4.6.1-27			
Information Element	Value/remark	Comment	Condition
ULInformationTransferMRDC ::= SEQUENCE {			
ul-DCCH-MessageNR-r15	OCTET STRING including the MeasurementReport message according to Table 8.2.3.7.1.3.3-8		
}			

Table 8.2.3.7.1.3.3-9: ReportConfigNR2-A4 (Table 8.2.3.7.1.3.3-3)

Derivation Path: 38.508-1 [4], Table 4.6.3-143 with condition EVENT_A4			
Information Element	Value/remark	Comment	Condition
ReportConfigToAddModList ::= SEQUENCE (SIZE (1..maxNrofMeasId)) OF SEQUENCE {	1 entry		
reportConfigId[1]	1		
reportConfig[1] CHOICE {			
reportConfigNR SEQUENCE {			
reportType CHOICE {			
eventTriggered SEQUENCE {			
eventId CHOICE {			
eventA4 SEQUENCE {			
a4-Threshold CHOICE {			
rsrp	76 + $\Delta(\text{NRf1})$	SS RSRP corresponding to -91dBm	
}			
}			
}			
}			
}			
reportInterval[1]	ms1024		
reportAmount[1]	Infinity		
}			
NOTE 1: $\Delta(\text{NRf1})$ is derived based on calibration procedure defined in the TS 38.508-1 [4], clause 6.1.3.3			

8.2.3.7.1a Measurement configuration control and reporting / Event A4 / Measurement of Neighbor NR cell / Inter-frequency measurements / EN-DC

8.2.3.7.1a.1 Test Purpose (TP)

(1)

```
with { UE in RRC_CONNECTED state with EN-DC, and, MCG(s) (E-UTRA PDCP) and SCG and inter-frequency
measurements configured for event A4 with event based periodical reporting }
ensure that {
  when { Neighbour NR cell becomes better than absolute threshold }
  then { UE sends MeasurementReport message at regular intervals while entering condition for
event A4 is satisfied }
}
```

(2)

```
with { UE in RRC_CONNECTED state with EN-DC, and, MCG(s) (E-UTRA PDCP) and SCG and periodical
measurement reporting triggered by event A4 ongoing }
ensure that {
  when { Neighbour NR cell becomes worse than absolute threshold }
  then { UE stops sending MeasurementReport message }
}
```

8.2.3.7.1a.2 Conformance requirements

References: The conformance requirements covered in the current TC are specified in: TS 36.331, clause 5.3.5.3, and TS 38.331, clause 5.3.5.3, 5.5.2.1, 5.5.4.1, 5.5.4.5 and 5.5.5.1. Unless otherwise stated these are Rel-15 requirements.

[TS 36.331, clause 5.3.5.3]

If the *RRConnectionReconfiguration* message does not include the *mobilityControlInfo* and the UE is able to comply with the configuration included in this message, the UE shall:

...

- 1> if the received *RRCConnectionReconfiguration* includes the *nr-SecondaryCellGroupConfig*:
 - 2> perform NR RRC Reconfiguration as specified in TS 38.331 [82], clause 5.3.5.3;
 - ...
- 1> set the content of *RRCConnectionReconfigurationComplete* message as follows:
 - ...
 - 2> if the received *RRCConnectionReconfiguration* message included *nr-SecondaryCellGroupConfig*:
 - 3> include *scg-ConfigResponseNR* in accordance with TS 38.331 [82], clause 5.3.5.3;
- 1> submit the *RRCConnectionReconfigurationComplete* message to lower layers for transmission using the new configuration, upon which the procedure ends;

[TS 38.331, clause 5.3.5.3]

The UE shall perform the following actions upon reception of the *RRCReconfiguration*:

- ...
- 1> if the *RRCReconfiguration* includes the *secondaryCellGroup*:
 - 2> perform the cell group configuration for the SCG according to 5.3.5.5;
 - ...
- 1> if the *RRCReconfiguration* message includes the *measConfig*:
 - 2> perform the measurement configuration procedure as specified in 5.5.2;
 - ...
- 1> if the UE is configured with E-UTRA *nr-SecondaryCellGroupConfig* (MCG is E-UTRA):
 - 2> if *RRCReconfiguration* was received via SRB1:
 - 3> submit the *RRCReconfigurationComplete* via the EUTRA MCG embedded in E-UTRA RRC message *RRCConnectionReconfigurationComplete* as specified in TS 36.331 [10];
- ...

[TS 38.331, clause 5.5.2.1]

The network applies the procedure as follows:

- to ensure that, whenever the UE has a *measConfig*, it includes a *measObject* for the SpCell and for each NR SCell to be measured;
- to configure at most one measurement identity using a reporting configuration with the *reportType* set to *reportCGI*;
- to ensure that for all SSB based measurements there is at most one measurement object with the same *ssbFrequency*;
- to ensure that all measurement objects configured in this specification and in TS 36.331 [10] with the same *ssbFrequency* have the same *ssbSubcarrierSpacing*;
- ...

The UE shall:

- ...
- 1> if the received *measConfig* includes the *measObjectToAddModList*:

2> perform the measurement object addition/modification procedure as specified in 5.5.2.5;

...

1> if the received *measConfig* includes the *reportConfigToAddModList*:

2> perform the reporting configuration addition/modification procedure as specified in 5.5.2.7;

...

1> if the received *measConfig* includes the *measIdToAddModList*:

2> perform the measurement identity addition/modification procedure as specified in 5.5.2.3;

1> if the received *measConfig* includes the *measGapConfig*:

2> perform the measurement gap configuration procedure as specified in 5.5.2.9;

...

[TS 38.331, clause 5.5.4.1]

If AS security has been activated successfully, the UE shall:

1> for each *measId* included in the *measIdList* within *VarMeasConfig*:

2> if the corresponding *reportConfig* includes a *reportType* set to *eventTriggered* or *periodical*:

3> if the corresponding *measObject* concerns NR:

4> if the *eventA1* or *eventA2* is configured in the corresponding *reportConfig*:

5> consider only the serving cell to be applicable;

4> if the *eventA3* or *eventA5* is configured in the corresponding *reportConfig*:

5> if a serving cell is associated with a *measObjectNR* and neighbours are associated with another *measObjectNR*, consider any serving cell associated with the other *measObjectNR* to be a neighbouring cell as well;

4> for measurement events other than *eventA1* or *eventA2*:

5> if *useWhiteCellList* is set to *true*:

6> consider any neighbouring cell detected based on parameters in the associated *measObjectNR* to be applicable when the concerned cell is included in the *whiteCellsToAddModList* defined within the *VarMeasConfig* for this *measId*;

5> else:

6> consider any neighbouring cell detected based on parameters in the associated *measObjectNR* to be applicable when the concerned cell is not included in the *blackCellsToAddModList* defined within the *VarMeasConfig* for this *measId*;

3> else if the corresponding *measObject* concerns E-UTRA:

4> consider any neighbouring cell detected on the associated frequency to be applicable when the concerned cell is not included in the *blackCellsToAddModListEUTRAN* defined within the *VarMeasConfig* for this *measId*;

2> else if the corresponding *reportConfig* includes a *reportType* set to *reportCGI*:

3> consider the cell detected on the associated *measObject* which has a physical cell identity matching the value of the *cellForWhichToReportCGI* included in the corresponding *reportConfig* within the *VarMeasConfig* to be applicable;

2> if the *reportType* is set to *eventTriggered* and if the entry condition applicable for this event, i.e. the event corresponding with the *eventId* of the corresponding *reportConfig* within *VarMeasConfig*, is fulfilled for one

or more applicable cells for all measurements after layer 3 filtering taken during *timeToTrigger* defined for this event within the *VarMeasConfig*, while the *VarMeasReportList* does not include a measurement reporting entry for this *measId* (a first cell triggers the event):

- 3> include a measurement reporting entry within the *VarMeasReportList* for this *measId*;
 - 3> set the *numberOfReportsSent* defined within the *VarMeasReportList* for this *measId* to 0;
 - 3> include the concerned cell(s) in the *cellsTriggeredList* defined within the *VarMeasReportList* for this *measId*;
 - 3> initiate the measurement reporting procedure, as specified in 5.5.5;
- 2> else if the *reportType* is set to *eventTriggered* and if the entry condition applicable for this event, i.e. the event corresponding with the *eventId* of the corresponding *reportConfig* within *VarMeasConfig*, is fulfilled for one or more applicable cells not included in the *cellsTriggeredList* for all measurements after layer 3 filtering taken during *timeToTrigger* defined for this event within the *VarMeasConfig* (a subsequent cell triggers the event):
- 3> set the *numberOfReportsSent* defined within the *VarMeasReportList* for this *measId* to 0;
 - 3> include the concerned cell(s) in the *cellsTriggeredList* defined within the *VarMeasReportList* for this *measId*;
 - 3> initiate the measurement reporting procedure, as specified in 5.5.5;
- 2> else if the *reportType* is set to *eventTriggered* and if the leaving condition applicable for this event is fulfilled for one or more of the cells included in the *cellsTriggeredList* defined within the *VarMeasReportList* for this *measId* for all measurements after layer 3 filtering taken during *timeToTrigger* defined within the *VarMeasConfig* for this event:
- 3> remove the concerned cell(s) in the *cellsTriggeredList* defined within the *VarMeasReportList* for this *measId*;
 - 3> if *reportOnLeave* is set to *true* for the corresponding reporting configuration:
 - 4> initiate the measurement reporting procedure, as specified in 5.5.5;
 - 3> if the *cellsTriggeredList* defined within the *VarMeasReportList* for this *measId* is empty:
 - 4> remove the measurement reporting entry within the *VarMeasReportList* for this *measId*;
 - 4> stop the periodical reporting timer for this *measId*, if running;
- 2> if *reportType* is set to *periodical* and if a (first) measurement result is available:
- 3> include a measurement reporting entry within the *VarMeasReportList* for this *measId*;
 - 3> set the *numberOfReportsSent* defined within the *VarMeasReportList* for this *measId* to 0;
 - 3> if the *reportAmount* exceeds 1:
 - 4> initiate the measurement reporting procedure, as specified in 5.5.5, immediately after the quantity to be reported becomes available for the NR SpCell;
 - 3> else (i.e. the *reportAmount* is equal to 1):
 - 4> initiate the measurement reporting procedure, as specified in 5.5.5, immediately after the quantity to be reported becomes available for the NR SpCell and for the strongest cell among the applicable cells;
- 2> upon expiry of the periodical reporting timer for this *measId*:
- 3> initiate the measurement reporting procedure, as specified in 5.5.5.

...

[TS 38.331, clause 5.5.4.5]

The UE shall:

- 1> consider the entering condition for this event to be satisfied when condition A4-1, as specified below, is fulfilled;
- 1> consider the leaving condition for this event to be satisfied when condition A4-2, as specified below, is fulfilled.

Inequality A4-1 (Entering condition)

$$Mn + Ofn + Ocn - Hys > Thresh$$

Inequality A4-2 (Leaving condition)

$$Mn + Ofn + Ocn + Hys < Thresh$$

The variables in the formula are defined as follows:

Mn is the measurement result of the neighbouring cell, not taking into account any offsets.

Ofn is the measurement object specific offset of the neighbour cell (i.e. *offsetMO* as defined within *measObjectNR* corresponding to the neighbour cell).

Ocn is the measurement object specific offset of the neighbour cell (i.e. *cellIndividualOffset* as defined within *measObjectNR* corresponding to the neighbour cell), and set to zero if not configured for the neighbour cell.

Hys is the hysteresis parameter for this event (i.e. *hysteresis* as defined within *reportConfigNR* for this event).

Thresh is the threshold parameter for this event (i.e. *a4-Threshold* as defined within *reportConfigNR* for this event).

Mn is expressed in dBm in case of RSRP, or in dB in case of RSRQ and RS-SINR.

Ofn, Ocn, Hys are expressed in dB.

Thresh is expressed in the same unit as **Mn**.

[TS 38.331, clause 5.5.5.1]

The purpose of this procedure is to transfer measurement results from the UE to the network. The UE shall initiate this procedure only after successful AS security activation.

For the *measId* for which the measurement reporting procedure was triggered, the UE shall set the *measResults* within the *MeasurementReport* message as follows:

- 1> set the *measId* to the measurement identity that triggered the measurement reporting;
- 1> set the *measResultServingCell* within *measResultServingMOList* to include, for each NR serving cell that is configured with *servingCellMO*, RSRP, RSRQ and the available SINR, derived based on the *rsType* if indicated in the associated *reportConfig*, otherwise based on SSB if available, otherwise based on CSI-RS;
- 1> set the *servCellId* within *measResultServingMOList* to include each NR serving cell that is configured with *servingCellMO*, if any;
- 1> if the *reportConfig* associated with the *measId* that triggered the measurement reporting includes *reportQuantityRS-Indexes* and *maxNrofRS-IndexesToReport*:
 - 2> for each serving cell configured with *servingCellMO*, include beam measurement information according to the associated *reportConfig* as described in 5.5.5.2;
- 1> if the *reportConfig* associated with the *measId* that triggered the measurement reporting includes *reportAddNeighMeas*:
 - 2> for each *measObjectId* referenced in the *measIdList* which is also referenced with *servingCellMO*, other than the *measObjectId* corresponding with the *measId* that triggered the measurement reporting:
 - 3> set the *measResultBestNeighCell* within *measResultServingMOList* to include the *physCellId* and the available measurement quantities based on the *reportQuantityCell* and *rsType* indicated in *reportConfig* of the non-serving cell corresponding to the concerned *measObjectNR* with the highest measured RSRP if RSRP measurement results are available for cells corresponding to this *measObjectNR*, otherwise with

the highest measured RSRQ if RSRQ measurement results are available for cells corresponding to this *measObjectNR*, otherwise with the highest measured SINR;

- 3> if the *reportConfig* associated with the *measId* that triggered the measurement reporting includes *reportQuantityRS-Indexes* and *maxNrofRS-IndexesToReport*:
 - 4> for each best non-serving cell included in the measurement report:
 - 5> include beam measurement information according to the associated *reportConfig* as described in 5.5.5.2;
- 1> if there is at least one applicable neighbouring cell to report:
 - 2> if the *reportType* is set to *eventTriggered* or *periodical*:
 - 3> set the *measResultNeighCells* to include the best neighbouring cells up to *maxReportCells* in accordance with the following:
 - 4> if the *reportType* is set to *eventTriggered*:
 - 5> include the cells included in the *cellsTriggeredList* as defined within the *VarMeasReportList* for this *measId*;
 - 4> else:
 - 5> include the applicable cells for which the new measurement results became available since the last periodical reporting or since the measurement was initiated or reset;
 - 4> for each cell that is included in the *measResultNeighCells*, include the *physCellId*;
 - 4> if the *reportType* is set to *eventTriggered* or *periodical*:
 - 5> for each included cell, include the layer 3 filtered measured results in accordance with the *reportConfig* for this *measId*, ordered as follows:
 - 6> if the *measObject* associated with this *measId* concerns NR:
 - 7> if *rsType* in the associated *reportConfig* is set to *ssb*:
 - 8> set *resultsSSB-Cell* within the *measResult* to include the SS/PBCH block based quantity(ies) indicated in the *reportQuantityCell* within the concerned *reportConfig*, in decreasing order of the sorting quantity, determined as specified in 5.5.5.3, i.e. the best cell is included first;
 - 8> if *reportQuantityRS-Indexes* and *maxNrofRS-IndexesToReport* are configured, include beam measurement information as described in 5.5.5.2;
 - 7> else if *rsType* in the associated *reportConfig* is set to *csi-rs*:
 - 8> set *resultsCSI-RS-Cell* within the *measResult* to include the CSI-RS based quantity(ies) indicated in the *reportQuantityCell* within the concerned *reportConfig*, in decreasing order of the sorting quantity, determined as specified in 5.5.5.3, i.e. the best cell is included first;
 - 8> if *reportQuantityRS-Indexes* and *maxNrofRS-IndexesToReport* are configured, include beam measurement information as described in 5.5.5.2;
 - 6> if the *measObject* associated with this *measId* concerns E-UTRA:
 - 7> set the *measResult* to include the quantity(ies) indicated in the *reportQuantity* within the concerned *reportConfigInterRAT* in decreasing order of the sorting quantity, determined as specified in 5.5.5.3, i.e. the best cell is included first;
 - 2> else:
 - 3> if the cell indicated by *cellForWhichToReportCGI* is an NR cell:

- 4> if *plmn-IdentityInfoList* of the *cgi-Info* for the concerned cell has been obtained:
 - 5> include the *plmn-IdentityInfoList* including *plmn-IdentityList*, *trackingAreaCode* (if available), *ranac* (if available) and *cellIdentity* for each entry of the *plmn-IdentityInfoList*;
 - 5> include *frequencyBandList* if available;
- 4> else if *MIB* indicates the *SIB1* is not broadcast:
 - 5> include the *noSIB1* including the *ssb-SubcarrierOffset* and *pdccch-ConfigSIB1* obtained from *MIB* of the concerned cell;
- 3> if the cell indicated by *cellForWhichToReportCGI* is an E-UTRA cell:
 - 4> if all mandatory fields of the *cgi-Info-EPC* for the concerned cell have been obtained:
 - 5> include in the *cgi-Info-EPC* the fields broadcasted in E-UTRA *SystemInformationBlockType1* associated to EPC;
 - 4> if the UE is E-UTRA/5GC capable and all mandatory fields of the *cgi-Info-5GC* for the concerned cell have been obtained:
 - 5> include in the *cgi-Info-5GC* the fields broadcasted in E-UTRA *SystemInformationBlockType1* associated to 5GC;
 - 4> include the *freqBandIndicator*;
 - 4> if the cell broadcasts the *multiBandInfoList*, include the *multiBandInfoList*;
 - 4> if the cell broadcasts the *freqBandIndicatorPriority*, include the *freqBandIndicatorPriority*;
- 1> increment the *numberOfReportsSent* as defined within the *VarMeasReportList* for this *measId* by 1;
- 1> stop the periodical reporting timer, if running;
- 1> if the *numberOfReportsSent* as defined within the *VarMeasReportList* for this *measId* is less than the *reportAmount* as defined within the corresponding *reportConfig* for this *measId*:
 - 2> start the periodical reporting timer with the value of *reportInterval* as defined within the corresponding *reportConfig* for this *measId*;
- 1> else:
 - 2> if the *reportType* is set to *periodical*:
 - 3> remove the entry within the *VarMeasReportList* for this *measId*;
 - 3> remove this *measId* from the *measIdList* within *VarMeasConfig*;
- 1> if the UE is in EN-DC:
 - 2> if SRB3 is configured:
 - 3> submit the *MeasurementReport* message via SRB3 to lower layers for transmission, upon which the procedure ends;
 - 2> else:
 - 3> submit the *MeasurementReport* message via the E-UTRA MCG embedded in E-UTRA RRC message *ULInformationTransferMRDC* as specified in TS 36.331 [10].
- 1> else:
 - 2> submit the *MeasurementReport* message to lower layers for transmission, upon which the procedure ends.

8.2.3.7.1a.3 Test description

8.2.3.7.1a.3.1 Pre-test conditions

System Simulator:

- E-UTRA Cell 1 is the PCell and NR Cell 1 is the PSCell
- NR Cell 3 is the inter-frequency neighbour cell of NR Cell 1.

UE:

- None

Preamble:

- The UE is in state RRC_CONNECTED using generic procedure parameter Connectivity (EN-DC) and Bearers (MCG(s) and SCG) established on E-UTRA Cell 1 according to TS 38.508-1 [4], clause 4.5.4.

8.2.3.7.1a.3.2 Test procedure sequence

Table 8.2.3.7.1a.3.2-1 and Table 8.2.3.7.1a.3.2-1A illustrates the downlink power levels to be applied for E-UTRA Cell 1, NR Cell 1 and NR Cell 3 at various time instants of the test execution. Row marked "T0" denotes the conditions after the preamble, while rows marked "T1", "T2" are to be applied subsequently. The exact instants on which these values shall be applied are described in the texts in this clause.

Table 8.2.3.7.1a.3.2-1: Time instances of cell power level and parameter changes for FR1

	Parameter	Unit	E-UTRA Cell 1	NR Cell 1	NR Cell 3	Remark
T0	Cell-specific RS EPRE	dBm/15kHz	-85	-	-	The power level values are such that entry condition for event A4 is not satisfied
	SS/PBCH SSS EPRE	dBm/SCS	-	-88	Off	
T1	Cell-specific RS EPRE	dBm/15kHz	-85	-	-	The power level values are such that entry condition for event A4 is satisfied for inter-frequency neighbour NR Cell 3
	SS/PBCH SSS EPRE	dBm/SCS	-	-88	-79	
T2	Cell-specific RS EPRE	dBm/15kHz	-85	-	-	The power level values are such that entry conditions for event A4 is not satisfied for inter-frequency neighbour NR Cell 3
	SS/PBCH SSS EPRE	dBm/SCS	-	-88	-91	

Table 8.2.3.7.1a.3.2-1A: Time instances of cell power level and parameter changes for FR2

	Parameter	Unit	E-UTRA Cell 1	NR Cell 1	NR Cell 3	Remark
T0	Cell-specific RS EPRE	dBm/15kHz	FFS	-	-	The power level values are such that entry condition for event A4 is not satisfied
	SS/PBCH SSS EPRE	dBm/SCS	-	FFS	FFS	
T1	Cell-specific RS EPRE	dBm/15kHz	FFS	-	-	The power level values are such that entry condition for event A4 is satisfied for inter-frequency neighbour NR Cell 3
	SS/PBCH SSS EPRE	dBm/SCS	-	FFS	FFS	
T2	Cell-specific RS EPRE	dBm/15kHz	FFS	-	-	The power level values are such that entry conditions for event A4 is not satisfied for inter-frequency neighbour NR Cell 3
	SS/PBCH SSS EPRE	dBm/SCS	-	FFS	FFS	

Table 8.2.3.7.1a.3.2-2: Main behaviour

St	Procedure	Message Sequence		TP	Verdict
		U - S	Message		
1	The SS transmits an <i>RRCCONNECTIONRECONFIGURATION</i> message containing NR <i>RRCCONNECTIONRECONFIGURATION</i> message to setup NR measurement and reporting of event A4.	<--	<i>RRCCONNECTIONRECONFIGURATION (RRCCONNECTIONRECONFIGURATION)</i>	-	-
2	Check: Does the UE transmit an <i>RRCCONNECTIONRECONFIGURATIONCOMPLETE</i> message containing NR <i>RRCCONNECTIONRECONFIGURATIONCOMPLETE</i> message?	-->	<i>RRCCONNECTIONRECONFIGURATIONCOMPLETE (RRCCONNECTIONRECONFIGURATIONCOMPLETE)</i>	-	-
3	The SS re-adjusts the cell-specific reference signal level according to row "T1".	-	-	-	-
4	Check: Does the UE transmit <i>ULINFORMATIONTRANSFERMRDC</i> message containing NR <i>MEASUREMENTREPORT</i> message to report event A4 with the measured Results for NR Cell 3?	-->	<i>ULINFORMATIONTRANSFERMRDC (MEASUREMENTREPORT)</i>	1	P
-	EXCEPTION: Step 5 below is repeated until 3 <i>MEASUREMENTREPORT</i> messages are received from the UE	-	-	-	-
5	Check: Does the UE transmit <i>ULINFORMATIONTRANSFERMRDC</i> message containing NR <i>MEASUREMENTREPORT</i> message to report event A4 with the measured Results for NR Cell 3?	-->	<i>ULINFORMATIONTRANSFERMRDC (MEASUREMENTREPORT)</i>	1	P
6	The SS re-adjusts the cell-specific reference signal level according to row "T2".	-	-	-	-
7	Wait and ignore <i>MEASUREMENTREPORT</i> messages for 15 s to allow change of power levels for NR Cell 3 and UE measurement.	-	-	-	-
8	Check: Does the UE attempt to transmit an uplink message within the next 10s?	-	-	2	F

8.2.3.7.1a.3.3 Specific message contents

Table 8.2.3.7.1a.3.3-1: RRCCONNECTIONRECONFIGURATION (step 1, Table 8.2.3.7.1a.3.2-2)

Derivation Path: 36.508 [7], Table 4.6.1-8 with condition EN-DC_EmbedNR_RRCCON

Table 8.2.3.7.1a.3.3-2: RRCReconfiguration (Table 8.2.3.7.1a.3.3-1)

Derivation Path: 38.508-1 [4], Table 4.6.1-13			
Information Element	Value/remark	Comment	Condition
RRCReconfiguration ::= SEQUENCE {			
criticalExtensions CHOICE {			
rrcReconfiguration SEQUENCE {			
radioBearerConfig	Not Present		
secondaryCellGroup	Not Present		
measConfig	MeasConfig-A4		
}			
}			
}			

Table 8.2.3.7.1a.3.3-3: MeasConfig-A4 (Table 8.2.3.7.1a.3.3-2)

Derivation Path: 38.508-1 [4], Table 4.6.3-69			
Information Element	Value/remark	Comment	Condition
MeasConfig ::= SEQUENCE {			
measObjectToAddModList	MeasObjectNR-A4		
reportConfigToAddModList	ReportConfigNR-A4		
MeasIdToAddModList ::= SEQUENCE (SIZE (1..maxNrofMeasId)) OF SEQUENCE {	1 entry		
measId[1]	1		
measObjectId[1]	1		
reportConfigId[1]	1		
}			
}			

Table 8.2.3.7.1a.3.3-4: MeasObjectNR-A4 (Table 8.2.3.7.1a.3.3-3)

Derivation Path: 38.508-1 [4], Table 4.6.3-76			
Information Element	Value/remark	Comment	Condition
measObjectToAddModList ::= SEQUENCE (SIZE (1..maxNrofObjectId)) OF SEQUENCE {	1 entry		
measObjectId[1]	1		
measObject CHOICE {			
measObjectNR SEQUENCE {			
ssbFrequency	ssbFrequency IE equals the ARFCN for NR Cell 3		
absThreshSS-BlocksConsolidation	Not Present		
absThreshCSI-RS-Consolidation	Not Present		
}			
}			
}			

Table 8.2.3.7.1a.3.3-5: ReportConfigNR-A4 (Table 8.2.3.7.1a.3.3-3)

Derivation Path: 38.508-1 [4], Table 4.6.3-143 with condition EVENT_A4			
Information Element	Value/remark	Comment	Condition
ReportConfigToAddModList ::= SEQUENCE (SIZE (1..maxNrofMeasId)) OF SEQUENCE {	1 entry		
reportConfigId[1]	1		
reportConfig[1] CHOICE {			
reportConfigNR SEQUENCE {			
reportType CHOICE {			
eventTriggered SEQUENCE {			
eventId CHOICE {			
eventA4 SEQUENCE {			
a4-Threshold CHOICE {			
rsrp	71	SS RSRP corresponding to -85dBm	
}			
}			
}			
}			
}			
}			
reportInterval[1]	ms1024		
reportAmount[1]	Infinity		
}			

Table 8.2.3.7.1a.3.3-6: RRCConnectionReconfigurationComplete (step 2, Table 8.2.3.7.1a.3.2-2)

Derivation Path: 36.508 [7], Table 4.6.1-9 with condition MCG_and_SCG

Table 8.2.3.7.1a.3.3-7: ULInformationTransferMRDC (steps 4, 5, Table 8.2.3.7.1a.3.2-2)

Derivation Path: 36.508 [7], Table 4.6.1-27			
Information Element	Value/remark	Comment	Condition
ULInformationTransferMRDC ::= SEQUENCE {			
ul-DCCH-MessageNR-r15	OCTET STRING including the MeasurementReport message according to Table 8.2.3.7.1a.3.3-8		
}			

Table 8.2.3.7.1a.3.3-8: MeasurementReport (steps 4, 5, Table 8.2.3.7.1a.3.2-2)

Derivation Path: 38.508-1 [4], Table 4.6.1-7			
Information Element	Value/remark	Comment	Condition
measurementReport ::= SEQUENCE {			
measResults ::= SEQUENCE {			
measId	1		
measResultServingMOList ::= SEQUENCE (SIZE (1..maxNrofServingCells)) {		Report NR Cell 1	
servCellId	Cell index corresponding to NR Cell 1		
measResultServingCell ::= SEQUENCE {			
physCellId	Phy cell id corresponding to NR Cell 1		
measResult SEQUENCE {			
cellResults SEQUENCE{			
resultsSSB-Cell ::= SEQUENCE {			
rsrp	(0..127)		
rsrq	(0..127)		
sinr	(0..127)		pc_ss_SINR_Meas
}			
}			
}			
}			
measResultNeighCells ::= SEQUENCE (SIZE (1..maxCellReport)) {	1 entry	Report NR Cell 3	
measResultListNR ::= SEQUENCE {			
physCellId	Phy cell id corresponding to NR Cell 3		
measResult SEQUENCE {			
cellResults SEQUENCE{			
resultsSSB-Cell ::= SEQUENCE {			
rsrp	(0..127)		
rsrq	(0..127)		
sinr	(0..127)		pc_ss_SINR_Meas
}			
}			
}			
}			
}			

8.2.3.7.1b Measurement configuration control and reporting / Event A4 / Measurement of Neighbor NR cell / Inter-band measurements / EN-DC

8.2.3.7.1b.1 Test Purpose (TP)

(1)

```

with { UE in RRC_CONNECTED state with EN-DC, and, MCG(s) (E-UTRA PDCP) and SCG and inter-band
measurements configured for event A4 with event based periodical reporting }
ensure that {
  when { Neighbour NR cell becomes better than absolute threshold }
  then { UE sends MeasurementReport message at regular intervals while entering condition for
event A4 is satisfied }
}

```

(2)

```

with { UE in RRC_CONNECTED state with EN-DC, and, MCG(s) (E-UTRA PDCP) and SCG and periodical
measurement reporting triggered by event A4 ongoing }
ensure that {
  when { Neighbour NR cell becomes worse than absolute threshold }
  then { UE stops sending MeasurementReport message }
}

```

8.2.3.7.1b.2 Conformance requirements

References: The conformance requirements covered in the current TC are specified in: TS 36.331, clause 5.3.5.3, and TS 38.331, clause 5.3.5.3, 5.5.2.1, 5.5.4.1, 5.5.4.5 and 5.5.5.1. Unless otherwise stated these are Rel-15 requirements.

[TS 36.331, clause 5.3.5.3]

If the *RRCConnectionReconfiguration* message does not include the *mobilityControlInfo* and the UE is able to comply with the configuration included in this message, the UE shall:

...

1> if the received *RRCConnectionReconfiguration* includes the *nr-SecondaryCellGroupConfig*:

2> perform NR RRC Reconfiguration as specified in TS 38.331 [82], clause 5.3.5.3;

...

1> set the content of *RRCConnectionReconfigurationComplete* message as follows:

...

2> if the received *RRCConnectionReconfiguration* message included *nr-SecondaryCellGroupConfig*:

3> include *scg-ConfigResponseNR* in accordance with TS 38.331 [82], clause 5.3.5.3;

1> submit the *RRCConnectionReconfigurationComplete* message to lower layers for transmission using the new configuration, upon which the procedure ends;

[TS 38.331, clause 5.3.5.3]

The UE shall perform the following actions upon reception of the *RRCReconfiguration*:

...

1> if the *RRCReconfiguration* includes the *secondaryCellGroup*:

2> perform the cell group configuration for the SCG according to 5.3.5.5;

...

1> if the *RRCReconfiguration* message includes the *measConfig*:

2> perform the measurement configuration procedure as specified in 5.5.2;

...

1> if the UE is configured with E-UTRA *nr-SecondaryCellGroupConfig* (MCG is E-UTRA):

2> if *RRCReconfiguration* was received via SRB1:

3> submit the *RRCReconfigurationComplete* via the EUTRA MCG embedded in E-UTRA RRC message *RRCConnectionReconfigurationComplete* as specified in TS 36.331 [10];

...

[TS 38.331, clause 5.5.2.1]

The network applies the procedure as follows:

- to ensure that, whenever the UE has a *measConfig*, it includes a *measObject* for the SpCell and for each NR SCell to be measured;
- to configure at most one measurement identity using a reporting configuration with the *reportType* set to *reportCGI*;
- to ensure that for all SSB based measurements there is at most one measurement object with the same *ssbFrequency*;
- to ensure that all measurement objects configured in this specification and in TS 36.331 [10] with the same *ssbFrequency* have the same *ssbSubcarrierSpacing*;

...

The UE shall:

...

- 1> if the received *measConfig* includes the *measObjectToAddModList*:
 - 2> perform the measurement object addition/modification procedure as specified in 5.5.2.5;
- ...
- 1> if the received *measConfig* includes the *reportConfigToAddModList*:
 - 2> perform the reporting configuration addition/modification procedure as specified in 5.5.2.7;
- ...
- 1> if the received *measConfig* includes the *measIdToAddModList*:
 - 2> perform the measurement identity addition/modification procedure as specified in 5.5.2.3;
- 1> if the received *measConfig* includes the *measGapConfig*:
 - 2> perform the measurement gap configuration procedure as specified in 5.5.2.9;
- ...

[TS 38.331, clause 5.5.4.1]

If AS security has been activated successfully, the UE shall:

- 1> for each *measId* included in the *measIdList* within *VarMeasConfig*:
 - 2> if the corresponding *reportConfig* includes a *reportType* set to *eventTriggered* or *periodical*:
 - 3> if the corresponding *measObject* concerns NR:
 - 4> if the *eventA1* or *eventA2* is configured in the corresponding *reportConfig*:
 - 5> consider only the serving cell to be applicable;
 - 4> if the *eventA3* or *eventA5* is configured in the corresponding *reportConfig*:
 - 5> if a serving cell is associated with a *measObjectNR* and neighbours are associated with another *measObjectNR*, consider any serving cell associated with the other *measObjectNR* to be a neighbouring cell as well;
 - 4> for measurement events other than *eventA1* or *eventA2*:
 - 5> if *useWhiteCellList* is set to *true*:
 - 6> consider any neighbouring cell detected based on parameters in the associated *measObjectNR* to be applicable when the concerned cell is included in the *whiteCellsToAddModList* defined within the *VarMeasConfig* for this *measId*;

- 5> else:
 - 6> consider any neighbouring cell detected based on parameters in the associated *measObjectNR* to be applicable when the concerned cell is not included in the *blackCellsToAddModList* defined within the *VarMeasConfig* for this *measId*;
- 3> else if the corresponding *measObject* concerns E-UTRA:
 - 4> consider any neighbouring cell detected on the associated frequency to be applicable when the concerned cell is not included in the *blackCellsToAddModListEUTRAN* defined within the *VarMeasConfig* for this *measId*;
- 2> else if the corresponding *reportConfig* includes a *reportType* set to *reportCGI*:
 - 3> consider the cell detected on the associated *measObject* which has a physical cell identity matching the value of the *cellForWhichToReportCGI* included in the corresponding *reportConfig* within the *VarMeasConfig* to be applicable;
 - 2> if the *reportType* is set to *eventTriggered* and if the entry condition applicable for this event, i.e. the event corresponding with the *eventId* of the corresponding *reportConfig* within *VarMeasConfig*, is fulfilled for one or more applicable cells for all measurements after layer 3 filtering taken during *timeToTrigger* defined for this event within the *VarMeasConfig*, while the *VarMeasReportList* does not include a measurement reporting entry for this *measId* (a first cell triggers the event):
 - 3> include a measurement reporting entry within the *VarMeasReportList* for this *measId*;
 - 3> set the *numberOfReportsSent* defined within the *VarMeasReportList* for this *measId* to 0;
 - 3> include the concerned cell(s) in the *cellsTriggeredList* defined within the *VarMeasReportList* for this *measId*;
 - 3> initiate the measurement reporting procedure, as specified in 5.5.5;
 - 2> else if the *reportType* is set to *eventTriggered* and if the entry condition applicable for this event, i.e. the event corresponding with the *eventId* of the corresponding *reportConfig* within *VarMeasConfig*, is fulfilled for one or more applicable cells not included in the *cellsTriggeredList* for all measurements after layer 3 filtering taken during *timeToTrigger* defined for this event within the *VarMeasConfig* (a subsequent cell triggers the event):
 - 3> set the *numberOfReportsSent* defined within the *VarMeasReportList* for this *measId* to 0;
 - 3> include the concerned cell(s) in the *cellsTriggeredList* defined within the *VarMeasReportList* for this *measId*;
 - 3> initiate the measurement reporting procedure, as specified in 5.5.5;
 - 2> else if the *reportType* is set to *eventTriggered* and if the leaving condition applicable for this event is fulfilled for one or more of the cells included in the *cellsTriggeredList* defined within the *VarMeasReportList* for this *measId* for all measurements after layer 3 filtering taken during *timeToTrigger* defined within the *VarMeasConfig* for this event:
 - 3> remove the concerned cell(s) in the *cellsTriggeredList* defined within the *VarMeasReportList* for this *measId*;
 - 3> if *reportOnLeave* is set to *true* for the corresponding reporting configuration:
 - 4> initiate the measurement reporting procedure, as specified in 5.5.5;
 - 3> if the *cellsTriggeredList* defined within the *VarMeasReportList* for this *measId* is empty:
 - 4> remove the measurement reporting entry within the *VarMeasReportList* for this *measId*;
 - 4> stop the periodical reporting timer for this *measId*, if running;
 - 2> if *reportType* is set to *periodical* and if a (first) measurement result is available:
 - 3> include a measurement reporting entry within the *VarMeasReportList* for this *measId*;

- 3> set the *numberOfReportsSent* defined within the *VarMeasReportList* for this *measId* to 0;
- 3> if the *reportAmount* exceeds 1:
 - 4> initiate the measurement reporting procedure, as specified in 5.5.5, immediately after the quantity to be reported becomes available for the NR SpCell;
- 3> else (i.e. the *reportAmount* is equal to 1):
 - 4> initiate the measurement reporting procedure, as specified in 5.5.5, immediately after the quantity to be reported becomes available for the NR SpCell and for the strongest cell among the applicable cells;
- 2> upon expiry of the periodical reporting timer for this *measId*:
 - 3> initiate the measurement reporting procedure, as specified in 5.5.5.

...

[TS 38.331, clause 5.5.4.5]

The UE shall:

- 1> consider the entering condition for this event to be satisfied when condition A4-1, as specified below, is fulfilled;
- 1> consider the leaving condition for this event to be satisfied when condition A4-2, as specified below, is fulfilled.

Inequality A4-1 (Entering condition)

$$Mn + Ofn + Ocn - Hys > Thresh$$

Inequality A4-2 (Leaving condition)

$$Mn + Ofn + Ocn + Hys < Thresh$$

The variables in the formula are defined as follows:

Mn is the measurement result of the neighbouring cell, not taking into account any offsets.

Ofn is the measurement object specific offset of the neighbour cell (i.e. *offsetMO* as defined within *measObjectNR* corresponding to the neighbour cell).

Ocn is the measurement object specific offset of the neighbour cell (i.e. *cellIndividualOffset* as defined within *measObjectNR* corresponding to the neighbour cell), and set to zero if not configured for the neighbour cell.

Hys is the hysteresis parameter for this event (i.e. *hysteresis* as defined within *reportConfigNR* for this event).

Thresh is the threshold parameter for this event (i.e. *a4-Threshold* as defined within *reportConfigNR* for this event).

Mn is expressed in dBm in case of RSRP, or in dB in case of RSRQ and RS-SINR.

Ofn*, *Ocn*, *Hys are expressed in dB.

Thresh is expressed in the same unit as ***Mn***.

[TS 38.331, clause 5.5.5.1]

The purpose of this procedure is to transfer measurement results from the UE to the network. The UE shall initiate this procedure only after successful AS security activation.

For the *measId* for which the measurement reporting procedure was triggered, the UE shall set the *measResults* within the *MeasurementReport* message as follows:

- 1> set the *measId* to the measurement identity that triggered the measurement reporting;
- 1> set the *measResultServingCell* within *measResultServingMOList* to include, for each NR serving cell that is configured with *servingCellMO*, RSRP, RSRQ and the available SINR, derived based on the *rsType* if indicated in the associated *reportConfig*, otherwise based on SSB if available, otherwise based on CSI-RS;

- 1> set the *servCellId* within *measResultServingMOList* to include each NR serving cell that is configured with *servingCellMO*, if any;
- 1> if the *reportConfig* associated with the *measId* that triggered the measurement reporting includes *reportQuantityRS-Indexes* and *maxNrofRS-IndexesToReport*:
 - 2> for each serving cell configured with *servingCellMO*, include beam measurement information according to the associated *reportConfig* as described in 5.5.5.2;
- 1> if the *reportConfig* associated with the *measId* that triggered the measurement reporting includes *reportAddNeighMeas*:
 - 2> for each *measObjectId* referenced in the *measIdList* which is also referenced with *servingCellMO*, other than the *measObjectId* corresponding with the *measId* that triggered the measurement reporting:
 - 3> set the *measResultBestNeighCell* within *measResultServingMOList* to include the *physCellId* and the available measurement quantities based on the *reportQuantityCell* and *rsType* indicated in *reportConfig* of the non-serving cell corresponding to the concerned *measObjectNR* with the highest measured RSRP if RSRP measurement results are available for cells corresponding to this *measObjectNR*, otherwise with the highest measured RSRQ if RSRQ measurement results are available for cells corresponding to this *measObjectNR*, otherwise with the highest measured SINR;
 - 3> if the *reportConfig* associated with the *measId* that triggered the measurement reporting includes *reportQuantityRS-Indexes* and *maxNrofRS-IndexesToReport*:
 - 4> for each best non-serving cell included in the measurement report:
 - 5> include beam measurement information according to the associated *reportConfig* as described in 5.5.5.2;
- 1> if there is at least one applicable neighbouring cell to report:
 - 2> if the *reportType* is set to *eventTriggered* or *periodical*:
 - 3> set the *measResultNeighCells* to include the best neighbouring cells up to *maxReportCells* in accordance with the following:
 - 4> if the *reportType* is set to *eventTriggered*:
 - 5> include the cells included in the *cellsTriggeredList* as defined within the *VarMeasReportList* for this *measId*;
 - 4> else:
 - 5> include the applicable cells for which the new measurement results became available since the last periodical reporting or since the measurement was initiated or reset;
 - 4> for each cell that is included in the *measResultNeighCells*, include the *physCellId*;
 - 4> if the *reportType* is set to *eventTriggered* or *periodical*:
 - 5> for each included cell, include the layer 3 filtered measured results in accordance with the *reportConfig* for this *measId*, ordered as follows:
 - 6> if the *measObject* associated with this *measId* concerns NR:
 - 7> if *rsType* in the associated *reportConfig* is set to *ssb*:
 - 8> set *resultsSSB-Cell* within the *measResult* to include the SS/PBCH block based quantity(ies) indicated in the *reportQuantityCell* within the concerned *reportConfig*, in decreasing order of the sorting quantity, determined as specified in 5.5.5.3, i.e. the best cell is included first;
 - 8> if *reportQuantityRS-Indexes* and *maxNrofRS-IndexesToReport* are configured, include beam measurement information as described in 5.5.5.2;
 - 7> else if *rsType* in the associated *reportConfig* is set to *csi-rs*:

- 8> set *resultsCSI-RS-Cell* within the *measResult* to include the CSI-RS based quantity(ies) indicated in the *reportQuantityCell* within the concerned *reportConfig*, in decreasing order of the sorting quantity, determined as specified in 5.5.5.3, i.e. the best cell is included first;
- 8> if *reportQuantityRS-Indexes* and *maxNrofRS-IndexesToReport* are configured, include beam measurement information as described in 5.5.5.2;
- 6> if the *measObject* associated with this *measId* concerns E-UTRA:
 - 7> set the *measResult* to include the quantity(ies) indicated in the *reportQuantity* within the concerned *reportConfigInterRAT* in decreasing order of the sorting quantity, determined as specified in 5.5.5.3, i.e. the best cell is included first;
- 2> else:
 - 3> if the cell indicated by *cellForWhichToReportCGI* is an NR cell:
 - 4> if *plmn-IdentityInfoList* of the *cgi-Info* for the concerned cell has been obtained:
 - 5> include the *plmn-IdentityInfoList* including *plmn-IdentityList*, *trackingAreaCode* (if available), *ranac* (if available) and *cellIdentity* for each entry of the *plmn-IdentityInfoList*;
 - 5> include *frequencyBandList* if available;
 - 4> else if *MIB* indicates the *SIB1* is not broadcast:
 - 5> include the *noSIB1* including the *ssb-SubcarrierOffset* and *pdccch-ConfigSIB1* obtained from *MIB* of the concerned cell;
 - 3> if the cell indicated by *cellForWhichToReportCGI* is an E-UTRA cell:
 - 4> if all mandatory fields of the *cgi-Info-EPC* for the concerned cell have been obtained:
 - 5> include in the *cgi-Info-EPC* the fields broadcasted in E-UTRA *SystemInformationBlockType1* associated to EPC;
 - 4> if the UE is E-UTRA/5GC capable and all mandatory fields of the *cgi-Info-5GC* for the concerned cell have been obtained:
 - 5> include in the *cgi-Info-5GC* the fields broadcasted in E-UTRA *SystemInformationBlockType1* associated to 5GC;
 - 4> include the *freqBandIndicator*;
 - 4> if the cell broadcasts the *multiBandInfoList*, include the *multiBandInfoList*;
 - 4> if the cell broadcasts the *freqBandIndicatorPriority*, include the *freqBandIndicatorPriority*;
 - 1> increment the *numberOfReportsSent* as defined within the *VarMeasReportList* for this *measId* by 1;
 - 1> stop the periodical reporting timer, if running;
 - 1> if the *numberOfReportsSent* as defined within the *VarMeasReportList* for this *measId* is less than the *reportAmount* as defined within the corresponding *reportConfig* for this *measId*:
 - 2> start the periodical reporting timer with the value of *reportInterval* as defined within the corresponding *reportConfig* for this *measId*;
- 1> else:
 - 2> if the *reportType* is set to *periodical*:
 - 3> remove the entry within the *VarMeasReportList* for this *measId*;
 - 3> remove this *measId* from the *measIdList* within *VarMeasConfig*;

- 1> if the UE is in EN-DC:
- 2> if SRB3 is configured:
- 3> submit the *MeasurementReport* message via SRB3 to lower layers for transmission, upon which the procedure ends;
- 2> else:
- 3> submit the *MeasurementReport* message via the E-UTRA MCG embedded in E-UTRA RRC message *ULInformationTransferMRDC* as specified in TS 36.331 [10].
- 1> else:
- 2> submit the *MeasurementReport* message to lower layers for transmission, upon which the procedure ends.

8.2.3.7.1b.3 Test description

8.2.3.7.1b.3.1 Pre-test conditions

System Simulator:

- E-UTRA Cell 1 is the PCell and NR Cell 1 is the PSCell
- NR Cell 10 is the inter-band neighbour cell of NR Cell 1.

UE:

- None

Preamble:

- The UE is in state RRC_CONNECTED using generic procedure parameter Connectivity (EN-DC) and DC Bearers (MCG(s) and SCG) on E-UTRA Cell 1 according to TS 38.508-1 [4], clause 4.5.4.

8.2.3.7.1b.3.2 Test procedure sequence

Table 8.2.3.7.1b.3.2-1 and Table 8.2.3.7.1b.3.2-1A illustrates the downlink power levels to be applied for E-UTRA Cell 1, NR Cell 1 and NR Cell 10 at various time instants of the test execution. Row marked "T0" denotes the conditions after the preamble, while rows marked "T1", "T2" are to be applied subsequently. The exact instants on which these values shall be applied are described in the texts in this clause.

Table 8.2.3.7.1b.3.2-1: Time instances of cell power level and parameter changes for FR1

	Parameter	Unit	E-UTRA Cell 1	NR Cell 1	NR Cell 10	Remark
T0	Cell-specific RS EPRE	dBm/15kHz	-85	-	-	The power level values are such that entry condition for event A4 is not satisfied
	SS/PBCH SSS EPRE	dBm/SCS	-	-88	Off	
T1	Cell-specific RS EPRE	dBm/15kHz	-85	-	-	The power level values are such that entry condition for event A4 is satisfied for inter-band neighbour NR Cell 10
	SS/PBCH SSS EPRE	dBm/SCS	-	-88	-79	
T2	Cell-specific RS EPRE	dBm/15kHz	-85	-	-	The power level values are such that entry conditions for event A4 is not satisfied for inter-band neighbour NR Cell 10
	SS/PBCH SSS EPRE	dBm/SCS	-	-88	-91	

Table 8.2.3.7.1b.3.2-1A: Time instances of cell power level and parameter changes for FR2

	Parameter	Unit	E-UTRA Cell 1	NR Cell 1	NR Cell 10	Remark
T0	Cell-specific RS EPRE	dBm/15kHz	FFS	-	-	The power level values are such that entry condition for event A4 is not satisfied
	SS/PBCH SSS EPRE	dBm/SCS	-	FFS	FFS	
T1	Cell-specific RS EPRE	dBm/15kHz	FFS	-	-	The power level values are such that entry condition for event A4 is satisfied for inter-band neighbour NR Cell 10
	SS/PBCH SSS EPRE	dBm/SCS	-	FFS	FFS	
T2	Cell-specific RS EPRE	dBm/15kHz	FFS	-	-	The power level values are such that entry conditions for event A4 is not satisfied for inter-band neighbour NR Cell 10
	SS/PBCH SSS EPRE	dBm/SCS	-	FFS	FFS	

Table 8.2.3.7.1b.3.2-2: Main behaviour

St	Procedure	Message Sequence		TP	Verdict
		U - S	Message		
1	The SS transmits an <i>RRCConnectionReconfiguration</i> message containing NR <i>RRCReconfiguration</i> message to setup NR measurement and reporting of event A4.	<--	<i>RRCConnectionReconfiguration (RRCReconfiguration)</i>	-	-
2	Check: Does the UE transmit an <i>RRCConnectionReconfigurationComplete</i> message containing NR <i>RRCReconfigurationComplete</i> message?	-->	<i>RRCConnectionReconfigurationComplete (RRCReconfigurationComplete)</i>	-	-
3	The SS re-adjusts the cell-specific reference signal level according to row "T1".	-	-	-	-
4	Check: Does the UE transmit <i>ULInformationTransferMRDC</i> message containing NR <i>MeasurementReport</i> message to report event A4 with the measured Results for NR Cell 10?	-->	<i>ULInformationTransferMRDC (MeasurementReport)</i>	1	P
-	EXCEPTION: Step 5 below is repeated until 3 <i>MeasurementReport</i> messages are received from the UE	-	-	-	-
5	Check: Does the UE transmit <i>ULInformationTransferMRDC</i> message containing NR <i>MeasurementReport</i> message to report event A4 with the measured Results for NR Cell 10?	-->	<i>ULInformationTransferMRDC (MeasurementReport)</i>	1	P
6	The SS re-adjusts the cell-specific reference signal level according to row "T2".	-	-	-	-
7	Wait and ignore <i>MeasurementReport</i> messages for 15 s to allow change of power levels for NR Cell 10 and UE measurement.	-	-	-	-
8	Check: Does the UE attempt to transmit an uplink message within the next 10s?	-	-	2	F

8.2.3.7.1b.3.3 Specific message contents

Table 8.2.3.7.1b.3.3-1: RRCConnectionReconfiguration (step 1, Table 8.2.3.7.1b.3.2-2)

Derivation Path: 36.508 [7], Table 4.6.1-8 with condition EN-DC_EmbedNR_RRCRecon
--

Table 8.2.3.7.1b.3.3-2: RRCReconfiguration (Table 8.2.3.7.1b.3.3-1)

Derivation Path: 38.508-1 [4], Table 4.6.1-13			
Information Element	Value/remark	Comment	Condition
RRCReconfiguration ::= SEQUENCE {			
criticalExtensions CHOICE {			
rrcReconfiguration SEQUENCE {			
radioBearerConfig	Not Present		
secondaryCellGroup	Not Present		
measConfig	MeasConfig-A4		
}			
}			
}			

Table 8.2.3.7.1b.3.3-3: MeasConfig-A4 (Table 8.2.3.7.1b.3.3-2)

Derivation Path: 38.508-1 [4], Table 4.6.3-69			
Information Element	Value/remark	Comment	Condition
MeasConfig ::= SEQUENCE {			
measObjectToAddModList	MeasObjectNR-A4		
reportConfigToAddModList	ReportConfigNR-A4		
MeasIdToAddModList ::= SEQUENCE (SIZE (1..maxNrofMeasId)) OF SEQUENCE {	1 entry		
measId[1]	1		
measObjectId[1]	1		
reportConfigId[1]	1		
}			
}			

Table 8.2.3.7.1b.3.3-4: MeasObjectNR-A4 (Table 8.2.3.7.1b.3.3-3)

Derivation Path: 38.508-1 [4], Table 4.6.3-76			
Information Element	Value/remark	Comment	Condition
measObjectToAddModList ::= SEQUENCE (SIZE (1..maxNrofObjectId)) OF SEQUENCE {	1 entry		
measObjectId[1]	1		
measObject CHOICE {			
measObjectNR SEQUENCE {			
ssbFrequency	ssbFrequency IE equals the ARFCN for NR Cell 10		
absThreshSS-BlocksConsolidation	Not Present		
absThreshCSI-RS-Consolidation	Not Present		
}			
}			
}			

Table 8.2.3.7.1b.3.3-5: ReportConfigNR-A4 (Table 8.2.3.7.1b.3.3-3)

Derivation Path: 38.508-1 [4], Table 4.6.3-143 with condition EVENT_A4			
Information Element	Value/remark	Comment	Condition
ReportConfigToAddModList ::= SEQUENCE (SIZE (1..maxNrofMeasId)) OF SEQUENCE {	1 entry		
reportConfigId[1]	1		
reportConfig[1] CHOICE {			
reportConfigNR SEQUENCE {			
reportType CHOICE {			
eventTriggered SEQUENCE {			
eventId CHOICE {			
eventA4 SEQUENCE {			
a4-Threshold CHOICE {			
rsrp	71	SS RSRP corresponding to -85dBm	
}			
}			
}			
}			
}			
}			
reportInterval[1]	ms1024		
reportAmount[1]	Infinity		
}			

Table 8.2.3.7.1b.3.3-6: RRCConnectionReconfigurationComplete (step 2, Table 8.2.3.7.1b.3.2-2)

Derivation Path: 36.508 [7], Table 4.6.1-9 with condition MCG_and_SCG

Table 8.2.3.7.1b.3.3-7: ULInformationTransferMRDC (steps 4, 5, Table 8.2.3.7.1b.3.2-2)

Derivation Path: 36.508 [7], Table 4.6.1-27			
Information Element	Value/remark	Comment	Condition
ULInformationTransferMRDC ::= SEQUENCE {			
ul-DCCH-MessageNR-r15	OCTET STRING including the MeasurementReport message according to Table 8.2.3.7.1b.3.3-8		
}			

Table 8.2.3.7.1b.3.3-8: MeasurementReport (steps 4, 5, Table 8.2.3.7.1b.3.2-2)

Derivation Path: 38.508-1 [4], Table 4.6.1-7			
Information Element	Value/remark	Comment	Condition
measurementReport ::= SEQUENCE {			
measResults ::= SEQUENCE {			
measId	1		
measResultServingMOList ::= SEQUENCE (SIZE (1..maxNrofServingCells)) {		Report NR Cell 1	
servCellId	Cell index corresponding to NR Cell 1		
measResultServingCell ::= SEQUENCE {			
physCellId	Phy cell id corresponding to NR Cell 1		
measResult SEQUENCE {			
cellResults SEQUENCE{			
resultsSSB-Cell ::= SEQUENCE {			
rsrp	(0..127)		
rsrq	(0..127)		
sinr	(0..127)		pc_ss_SINR_Meas
}			
}			
}			
}			
measResultNeighCells ::= SEQUENCE (SIZE (1..maxCellReport)) {	1 entry	Report NR Cell 10	
measResultListNR ::= SEQUENCE {			
physCellId	Phy cell id corresponding to NR Cell 10		
measResult SEQUENCE {			
cellResults SEQUENCE{			
resultsSSB-Cell ::= SEQUENCE {			
rsrp	(0..127)		
rsrq	(0..127)		
sinr	(0..127)		pc_ss_SINR_Meas
}			
}			
}			
}			
}			

8.2.3.8 Measurement configuration control and reporting / Event A5 / Measurement of Neighbour NR cell

8.2.3.8.1 Measurement configuration control and reporting / Event A5 / Measurement of Neighbour NR cell / Intra-frequency measurements / EN-DC

8.2.3.8.1.1 Test Purpose (TP)

(1)

```
with { UE in RRC_CONNECTED state with EN-DC, and, MCG(s) (E-UTRA PDCP) and SCG and measurement configured for event A5 with event based periodical reporting }
ensure that {
  when { Serving NR PSCell becomes worse than absolute threshold1 and neighbour NR cell becomes better than absolute threshold2 }
```

```

    then { UE sends MeasurementReport message at regular intervals while entering conditions for
event A5 are satisfied }
    }

```

(2)

```

with { UE in RRC_CONNECTED state with EN-DC, and, MCG(s) (E-UTRA PDCP) and SCG and periodical
measurement reporting triggered by event A5 ongoing }
ensure that {
    when { Serving NR PSCell becomes better than absolute threshold1 or neighbour NR cell becomes
worse than absolute threshold2 }
        then { UE stops sending MeasurementReport message }
    }

```

8.2.3.8.1.2 Conformance requirements

References: The conformance requirements covered in the present TC are specified in: TS 36.331, clause 5.3.5.3, TS 38.331, clauses 5.3.5.3, 5.5.2, 5.5.4.1 and 5.5.4.6. Unless otherwise stated these are Rel-15 requirements.

[TS 36.331, clause 5.3.5.3]

If the *RRCConnectionReconfiguration* message does not include the *mobilityControlInfo* and the UE is able to comply with the configuration included in this message, the UE shall:

- 1> if the *RRCConnectionReconfiguration* message includes the *measConfig*:
 - 2> perform the measurement configuration procedure as specified in 5.5.2;
- 1> set the content of *RRCConnectionReconfigurationComplete* message as follows:
 - 2> if the received *RRCConnectionReconfiguration* message included *nr-SecondaryCellGroupConfig*:
 - 3> include *scg-ConfigResponseNR* in accordance with TS 38.331 [82], clause 5.3.5.3;
 - 2> set the content of *RRCConnectionReconfigurationComplete* message as follows:
 - 2> if the received *RRCConnectionReconfiguration* message included *nr-SecondaryCellGroupConfig*:
 - 3> include *scg-ConfigResponseNR* in accordance with TS 38.331 [82, 5.3.5.3];
- 1> submit the *RRCConnectionReconfigurationComplete* message to lower layers for transmission using the new configuration, upon which the procedure ends;

[TS 38.331, clause 5.3.5.3]

The UE shall perform the following actions upon reception of the *RRCReconfiguration*:

- 1> if the *RRCReconfiguration* includes the *secondaryCellGroup*:
 - 2> perform the cell group configuration for the SCG according to 5.3.5.5;
- 1> if the *RRCReconfiguration* message includes the *measConfig*:
- 2> perform the measurement configuration procedure as specified in 5.5.2;
 - 1> if the UE is configured with E-UTRA *nr-SecondaryCellGroupConfig* (MCG is E-UTRA):
 - 2> if *RRCReconfiguration* was received via SRB1:
 - 3> construct *RRCReconfigurationComplete* message and submit it via the EUTRA MCG embedded in E-UTRA RRC message *RRCConnectionReconfigurationComplete* as specified in TS 36.331 [10];

[TS 38.331, clause 5.5.2]

The UE shall:

- 1> if the received *measConfig* includes the *measObjectToAddModList*:
 - 2> perform the measurement object addition/modification procedure as specified in 5.5.2.5;

- 1> if the received *measConfig* includes the *reportConfigToAddModList*:
 - 2> perform the reporting configuration addition/modification procedure as specified in 5.5.2.7;
- 1> if the received *measConfig* includes the *measIdToAddModList*:
 - 2> perform the measurement identity addition/modification procedure as specified in 5.5.2.3;

[TS 38.331, clause 5.5.4.1]

If security has been activated successfully, the UE shall:

- 1> for each *measId* included in the *measIdList* within *VarMeasConfig*:
 - 2> if the corresponding *reportConfig* includes a *reportType* set to *eventTriggered* or *periodical*;
 - 3> if the corresponding *measObject* concerns NR;
 - 4> if the *eventA1* or *eventA2* is configured in the corresponding *reportConfig*:
 - 5> consider only the serving cell to be applicable;
 - 4> else:
 - 5> for events involving a serving cell associated with a *measObjectNR* and neighbours associated with another *measObjectNR*, consider any serving cell associated with the other *measObjectNR* to be a neighbouring cell as well;
 - 2> if the *reportType* is set to *eventTriggered* and if the entry condition applicable for this event, i.e. the event corresponding with the *eventId* of the corresponding *reportConfig* within *VarMeasConfig*, is fulfilled for one or more applicable cells for all measurements after layer 3 filtering taken during *timeToTrigger* defined for this event within the *VarMeasConfig*, while the *VarMeasReportList* does not include a measurement reporting entry for this *measId* (a first cell triggers the event):
 - 3> include a measurement reporting entry within the *VarMeasReportList* for this *measId*;
 - 3> set the *numberOfReportsSent* defined within the *VarMeasReportList* for this *measId* to 0;
 - 3> include the concerned cell(s) in the *cellsTriggeredList* defined within the *VarMeasReportList* for this *measId*;
 - 3> initiate the measurement reporting procedure, as specified in 5.5.5;
 - 2> if the *reportType* is set to *eventTriggered* and if the entry condition applicable for this event, i.e. the event corresponding with the *eventId* of the corresponding *reportConfig* within *VarMeasConfig*, is fulfilled for one or more applicable cells not included in the *cellsTriggeredList* for all measurements after layer 3 filtering taken during *timeToTrigger* defined for this event within the *VarMeasConfig* (a subsequent cell triggers the event):
 - 3> set the *numberOfReportsSent* defined within the *VarMeasReportList* for this *measId* to 0;
 - 3> include the concerned cell(s) in the *cellsTriggeredList* defined within the *VarMeasReportList* for this *measId*;
 - 3> initiate the measurement reporting procedure, as specified in 5.5.5;

[TS 38.331, clause 5.5.4.6]

The UE shall:

- 1> consider the entering condition for this event to be satisfied when both condition A5-1 and condition A5-2, as specified below, are fulfilled;
- 1> consider the leaving condition for this event to be satisfied when condition A5-3 or condition A5-4, i.e. at least one of the two, as specified below, is fulfilled;
- 1> use the SpCell for *Mp*.

NOTE: The cell(s) that triggers the event is on the frequency indicated in the associated *measObjectNR* which may be different from the frequency used by the NR SpCell.

Inequality A5-1 (Entering condition 1)

$$Mp + Hys < Thresh1$$

Inequality A5-2 (Entering condition 2)

$$Mn + Ofn + Ocn - Hys > Thresh2$$

Inequality A5-3 (Leaving condition 1)

$$Mp - Hys > Thresh1$$

Inequality A5-4 (Leaving condition 2)

$$Mn + Ofn + Ocn + Hys < Thresh2$$

The variables in the formula are defined as follows:

Mp is the measurement result of the NR SpCell, not taking into account any offsets.

Mn is the measurement result of the neighbouring cell/SCell, not taking into account any offsets.

Ofn is the measurement object specific offset of the neighbour/SCell cell (i.e. *offsetMO* as defined within *measObjectNR* corresponding to the frequency of the neighbour cell/SCell).

Ocn is the cell specific offset of the neighbour cell (i.e. *cellIndividualOffset* as defined within *measObjectNR* corresponding to the neighbour cell/SCell), and set to zero if not configured for the neighbour cell.

Hys is the hysteresis parameter for this event (i.e. *hysteresis* as defined within *reportConfigNR* for this event).

Thresh1 is the threshold parameter for this event (i.e. *a5-Threshold1* as defined within *reportConfigNR* for this event).

Thresh2 is the threshold parameter for this event (i.e. *a5-Threshold2* as defined within *reportConfigNR* for this event).

Mn*, *Mp are expressed in dBm in case of RSRP, or in dB in case of RSRQ and RS-SINR.

Ofn*, *Ocn*, *Hys are expressed in dB.

Thresh1 is expressed in the same unit as ***Mp***.

Thresh2 is expressed in the same unit as ***Mn***.

[TS 38.331, clause 5.5.5]

For the *measId* for which the measurement reporting procedure was triggered, the UE shall set the *measResults* within the *MeasurementReport* message as follows:

- 1> set the *measId* to the measurement identity that triggered the measurement reporting;
- 1> set the *measResultServingCell* within *measResultServingMOList* to include RSRP, RSRQ and the available SINR for each configured serving cell derived based on the *rsType* indicated in the associated *reportConfig*;
- 1> set the *measResultServingCell* within *measResultServingMOList* to include for each NR serving cell that is configured with *servingCellMO*, if any, the *servCellId*;
- 1> if the *reportConfig* associated with the *measId* that triggered the measurement reporting includes *reportQuantityRsIndexes* and *maxNrofRSIndexesToReport*:
 - 2> for each serving cell configured with *servingCellMO*, include beam measurement information according to the associated *reportConfig* as described in 5.5.5.2;

- 1> if the *reportConfig* associated with the *measId* that triggered the measurement reporting includes *reportAddNeighMeas*:
 - 2> for each serving cell *measObjectId* referenced in the *measIdList*, other than the *measObjectId* corresponding with the *measId* that triggered the measurement reporting:
 - 3> set the *measResultBestNeighCell* within *measResultServingMOList* to include the *physCellId* and the available measurement quantities based on the *reportQuantityCell* and *rsType* indicated in *reportConfig* of the non-serving cell corresponding to the concerned *measObjectNR* with the highest measured RSRP if RSRP measurement results are available for cells on this frequency, otherwise with the highest measured RSRQ if RSRQ measurement results are available for cells on this frequency, otherwise with the highest measured SINR;
 - 3> if the *reportConfig* associated with the *measId* that triggered the measurement reporting includes *reportQuantityRsIndexes* and *maxNrofRSIndexesToReport*:
 - 4> for each best non-serving cell included in the measurement report:
 - 5> include beam measurement information according to the associated *reportConfig* as described in 5.5.5.2;
 - 1> if there is at least one applicable neighbouring cell to report:
 - 2> set the *measResultNeighCells* to include the best neighbouring cells up to *maxReportCells* in accordance with the following:
 - 3> if the *reportType* is set to *eventTriggered*:
 - 4> include the cells included in the *cellsTriggeredList* as defined within the *VarMeasReportList* for this *measId*;
 - 3> else:
 - 4> include the applicable cells for which the new measurement results became available since the last periodical reporting or since the measurement was initiated or reset;
 - 4> if *reportQuantityRsIndexes* and *maxNrofRSIndexesToReport* are configured, include beam measurement information as described in 5.5.5.2;
 - 3> for each cell that is included in the *measResultNeighCells*, include the *physCellId*;
 - 3> if the *reportType* is set to *eventTriggered*:
 - 4> for each included cell, include the layer 3 filtered measured results in accordance with the *reportConfig* for this *measId*, ordered as follows:
 - 5> if the *measObject* associated with this *measId* concerns NR:
 - 6> if *rsType* in the associated *reportConfig* is set to *ssb*:
 - 7> set *resultsSSB-Cell* within the *measResult* to include the SS/PBCH block based quantity(ies) indicated in the *reportQuantityCell* within the concerned *reportConfig*, in order of decreasing trigger quantity, i.e. the best cell is included first;
 - 8> if *reportQuantityRsIndexes* and *maxNrofRSIndexesToReport* are configured, include beam measurement information as described in 5.5.5.2;
 - 6> else if *rsType* in the associated *reportConfig* is set to *csi-rs*:
 - 7> set *resultsCSI-RS-Cell* within the *measResult* to include the CSI-RS based quantity(ies) indicated in the *reportQuantityCell* within the concerned *reportConfig*, in order of decreasing trigger quantity, i.e. the best cell is included first;
 - 8> if *reportQuantityRsIndexes* and *maxNrofRSIndexesToReport* are, include beam measurement information as described in 5.5.5.2;
- 1> if the UE is configured with EN-DC:

2> if SRB3 is configured:

3> submit the *MeasurementReport* message via SRB3 to lower layers for transmission, upon which the procedure ends;

2>else:

3> submit the *MeasurementReport* message via the EUTRA MCG embedded in E-UTRA RRC message *ULInformationTransferMRDC* as specified in TS 36.331 [10].

1> else:

2>submit the *MeasurementReport* message to lower layers for transmission, upon which the procedure ends.

8.2.3.8.1.3 Test description

8.2.3.8.1.3.1 Pre-test conditions

System Simulator:

- EUTRA Cell 1 is the PCell and NR Cell 1 is the Serving PS Cell.
- NR Cell 2 is the intra-frequency neighbour cell.

UE:

- None

Preamble:

- The UE is in state RRC_CONNECTED in EN-DC mode and DC Bearers (MCG and SCG) on E-UTRA Cell 1 according to TS 38.508-1 [4].

8.2.3.8.1.3.2 Test procedure sequence

Table 8.2.3.8.1.3.2-1 and Table 8.2.3.8.1.3.2-1A illustrates the downlink power levels to be applied for NR Cell 1 and NR Cell 2 at various time instants of the test execution. Row marked "T0" denotes the conditions after the preamble, while rows marked "T1", "T2", "T3", "T4" and "T5" and "T11" are to be applied subsequently. The exact instants on which these values shall be applied are described in the texts in this clause.

Table 8.2.3.8.1.3.2-1: Time instances of cell power level and parameter changes for FR1

	Parameter	Unit	EUTRA Cell 1	NR Cell 1	NR Cell 2	Remark
T0	Cell-specific RS EPRE	dBm/15kHz	-85	-	-	Power levels are such that entry condition for event A5 is not satisfied, i.e. condition A5-1 ($Mp+Hys<Thresh$) is fulfilled but condition A5-2 ($Mn+Ofn+Ocn-Hys>Thresh2$) is not fulfilled for intra-frequency neighbour NR Cell 2.
	SS/PBCH SSS EPRE	dBm/SCS	-	-79	-91	
T1	Cell-specific RS EPRE	dBm/15kHz	-85	-	-	Power levels are such that entry condition for event A5 is not satisfied, i.e. condition A5-1 ($Mp+Hys<Thresh$) is not fulfilled but condition A5-2 ($Mn+Ofn+Ocn-Hys>Thresh2$) is fulfilled for intra-frequency neighbour NR Cell 2.
	SS/PBCH SSS EPRE	dBm/SCS	-	-73	-85	
T2	Cell-specific RS EPRE	dBm/15kHz	-85	-	-	Power levels are such that entry condition for event A5 is satisfied, i.e. condition A5-1 ($Mp+Hys<Thresh$) and condition A5-2 ($Mn+Ofn+Ocn-Hys>Thresh2$) are fulfilled for intra-frequency neighbour NR Cell 2 (i.e. periodical reporting for event A5 starts).
	SS/PBCH SSS EPRE	dBm/SCS	-	-79	-85	
T3	Cell-specific RS EPRE	dBm/15kHz	-85	-	-	Power levels are such that leaving condition for event A5 is satisfied, i.e. condition A5-3 ($Mp-Hys>Thresh$) is satisfied but condition A5-4 ($Mn+Ofn+Ocn+Hys<Thresh2$) is not satisfied for intra-frequency neighbour NR Cell 2 (i.e. periodical reporting for event A5 stops).
	SS/PBCH SSS EPRE	dBm/SCS	-	-73	-85	
T4	Cell-specific RS EPRE	dBm/15kHz	-85	-	-	Power levels are such that entry condition for event A5 is satisfied, i.e. condition A5-1 ($Mp+Hys<Thresh$) and condition A5-2 ($Mn+Ofn+Ocn-Hys>Thresh2$) are fulfilled for intra-frequency neighbour NR Cell 2 (i.e. periodical reporting for event A5 starts).
	SS/PBCH SSS EPRE	dBm/SCS	-	-79	-85	
T5	Cell-specific RS EPRE	dBm/15kHz	-85	-	-	Power levels are such that leaving condition for event A5 is satisfied, i.e. condition A5-3 ($Mp-Hys>Thresh$) is not satisfied but condition A5-4 ($Mn+Ofn+Ocn+Hys<Thresh2$) is satisfied for intra-frequency neighbour NR Cell 2 (i.e. periodical reporting for event A5 stops).
	SS/PBCH SSS EPRE	dBm/SCS	-	-79	-91	

Table 8.2.3.8.1.3.2-1A: Time instances of cell power level and parameter changes for FR2

	Parameter	Unit	EUTRA Cell 1	NR Cell 1	NR Cell 2	Remark
T0	Cell-specific RS EPRE	dBm/15kHz	FFS	-	-	Power levels are such that entry condition for event A5 is not satisfied, i.e. condition A5-1 ($Mp+Hys<Thresh1$) is fulfilled but condition A5-2 ($Mn+Ofn+Ocn-Hys>Thresh2$) is not fulfilled for intra-frequency neighbour NR Cell 2.
	SS/PBCH SSS EPRE	dBm/SCS	-	FFS	FFS	
T1	Cell-specific RS EPRE	dBm/15kHz	FFS	-	-	Power levels are such that entry condition for event A5 is not satisfied, i.e. condition A5-1 ($Mp+Hys<Thresh1$) is not fulfilled but condition A5-2 ($Mn+Ofn+Ocn-Hys>Thresh2$) is fulfilled for intra-frequency neighbour NR Cell 2.
	SS/PBCH SSS EPRE	dBm/SCS	-	FFS	FFS	
T2	Cell-specific RS EPRE	dBm/15kHz	FFS	-	-	Power levels are such that entry condition for event A5 is satisfied, i.e. condition A5-1 ($Mp+Hys<Thresh1$) and condition A5-2 ($Mn+Ofn+Ocn-Hys>Thresh2$) are fulfilled for intra-frequency neighbour NR Cell 2 (i.e. periodical reporting for event A5 starts).
	SS/PBCH SSS EPRE	dBm/SCS	-	FFS	FFS	
T3	Cell-specific RS EPRE	dBm/15kHz	FFS	-	-	Power levels are such that leaving condition for event A5 is satisfied, i.e. condition A5-3 ($Mp-Hys>Thresh1$) is satisfied but condition A5-4 ($Mn+Ofn+Ocn+Hys<Thresh2$) is not satisfied for intra-frequency neighbour NR Cell 2 (i.e. periodical reporting for event A5 stops).
	SS/PBCH SSS EPRE	dBm/SCS	-	FFS	FFS	
T4	Cell-specific RS EPRE	dBm/15kHz	FFS	-	-	Power levels are such that entry condition for event A5 is satisfied, i.e. condition A5-1 ($Mp+Hys<Thresh1$) and condition A5-2 ($Mn+Ofn+Ocn-Hys>Thresh2$) are fulfilled for intra-frequency neighbour NR Cell 2 (i.e. periodical reporting for event A5 starts).
	SS/PBCH SSS EPRE	dBm/SCS	-	FFS	FFS	
T5	Cell-specific RS EPRE	dBm/15kHz	FFS	-	-	Power levels are such that leaving condition for event A5 is satisfied, i.e. condition A5-3 ($Mp-Hys>Thresh1$) is not satisfied but condition A5-4 ($Mn+Ofn+Ocn+Hys<Thresh2$) is satisfied for intra-frequency neighbour NR Cell 2 (i.e. periodical reporting for event A5 stops).
	SS/PBCH SSS EPRE	dBm/SCS	-	FFS	FFS	

Table 8.2.3.8.1.3.2-2: Main behaviour

St	Procedure	Message Sequence		TP	Verdict
		U - S	Message		
1	The SS transmits an <i>RRCConnectionReconfiguration</i> message containing NR <i>RRCReconfiguration</i> message to setup measurements for neighbour NR Cells and reporting for event A5.	<--	<i>RRCConnectionReconfiguration</i> (<i>RRCReconfiguration</i>)	-	-
2	Check: Does the UE transmit an <i>RRCConnectionReconfigurationComplete</i> message containing NR <i>RRCReconfigurationComplete</i> message?	-->	<i>RRCConnectionReconfigurationComplete</i> (<i>RRCReconfigurationComplete</i>)	-	-
3	Check: Does the UE transmit an <i>ULInformationTransferMRDC</i> message containing NR <i>MeasurementReport</i> message within the next 10s?	-->	<i>ULInformationTransferMRDC</i> (<i>MeasurementReport</i>)	1	F
4	The SS re-adjusts the cell-specific reference signal level according to row "T1".	-	-	-	-
5	Check: Does the UE transmit an <i>ULInformationTransferMRDC</i> message containing NR <i>MeasurementReport</i> message to report event A5 with the measured value for NR Cell 2?	-->	<i>ULInformationTransferMRDC</i> (<i>MeasurementReport</i>)	1	F
6	The SS re-adjusts the cell-specific reference signal level according to row "T2".	-	-	-	-
7	Check: Does the UE transmit an <i>ULInformationTransferMRDC</i> message containing NR <i>MeasurementReport</i> message to report event A5 with the measured value for NR Cell 2?	-->	<i>ULInformationTransferMRDC</i> (<i>MeasurementReport</i>)	1	P
-	EXCEPTION: Step 8 below is repeated until 3 <i>MeasurementReport</i> messages are received from the UE.	-	-	-	-
8	Check: Does the UE transmit an <i>ULInformationTransferMRDC</i> message containing NR <i>MeasurementReport</i> message, with the measured value for NR Cell 2?	-->	<i>ULInformationTransferMRDC</i> (<i>MeasurementReport</i>)	1	P
9	The SS re-adjusts the cell-specific reference signal level according to row "T3".	-	-	-	-
10	Wait and ignore NR <i>MeasurementReport</i> messages for 15 s to allow change of power levels for NR Cell 2 and UE measurements.	-	-	-	-
11	Check: Does the UE attempt to transmit an uplink message within the next 10s?	-->	<i>ULInformationTransferMRDC</i> (<i>MeasurementReport</i>)	2	F
12	The SS re-adjusts the cell-specific reference signal level according to row "T4".	-	-	-	-
13	Check: Does the UE transmit an <i>ULInformationTransferMRDC</i> message containing NR <i>MeasurementReport</i> message to report event A5 with the measured value for NR Cell 2?	-->	<i>ULInformationTransferMRDC</i> (<i>MeasurementReport</i>)	1	P
14	The SS re-adjusts the cell-specific reference signal level according to row "T5".	-	-	-	-
15	Wait and ignore NR <i>MeasurementReport</i> messages for 15 s to allow change of power levels for NR Cell 2 and UE measurements.	-	-	-	-
16	Check: Does the UE attempt to transmit an uplink message within the next 10s?	-->	<i>ULInformationTransferMRDC</i> (<i>MeasurementReport</i>)	2	F

8.2.3.8.1.3.3 Specific message contents

Table 8.2.3.8.1.3.3-1: *RRCConnectionReconfiguration* (step 1, Table 8.2.3.8.1.3.2-2)

Derivation Path: 36.508 [7], Table 4.6.1-8 with condition EN-DC_EmbedNR_RRCRecon
--

Table 8.2.3.8.1.3.3-2: RRCReconfiguration (Table 8.2.3.8.1.3.3-1)

Derivation Path: 38.508-1 [4], Table 4.6.1-13			
Information Element	Value/remark	Comment	Condition
RRCReconfiguration ::= SEQUENCE {			
criticalExtensions CHOICE {			
rrcReconfiguration SEQUENCE {			
radioBearerConfig	Not Present		
secondaryCellGroup	Not Present		
measConfig	MeasConfig-A5		
}			
}			
}			

Table 8.2.3.8.1.3.3-3: MeasConfig-A5 (Table 8.2.3.8.1.3.3-2)

Derivation Path: 38.508-1 [4], Table 4.6.3-69			
Information Element	Value/remark	Comment	Condition
MeasConfig ::= SEQUENCE {			
measObjectToAddModList	MeasObjectNR		
ReportConfigToAddModList SEQUENCE(SIZE (1..maxReportConfigId)) OF SEQUENCE {			
reportConfigId[1]	ReportConfigId		
reportConfig[1] CHOICE {			
reportConfigNR	ReportConfigNR(81,69). Same as TS 38.508-1 Table 4.6.3-107 except for hysteresis value in eventA5 set to '0', reportAmount set to 'infinity', and reportInterval value set to 'ms1024'.	Thresh values set to -76dBm, -88 dBm	EVENT_A5
}			
}			
MeasIdToAddModList ::= SEQUENCE (SIZE (1..maxNrofMeasId)) OF SEQUENCE {	1 entry		
measId[1]	1		
measObjectId[1]	1		
reportConfigId[1]	1		
}			
}			

Table 8.2.3.8.1.3.3-4: MeasObjectNR (Table 8.2.3.8.1.3.3-3)

Derivation Path: 38.508-1 [4], Table 4.6.3-76			
Information Element	Value/remark	Comment	Condition
measObjectToAddModList ::= SEQUENCE (SIZE (1..maxNrofObjectId)) OF SEQUENCE {	1 entry		
measObjectId[1]	1		
measObject CHOICE {			
measObjectNR	MeasObjectNR(60)	ssbFrequency IE equals the ARFCN for NR Cell 2 Thresh value set to -97dBm	
}			
}			

Table 8.2.3.8.1.3.3-5: RRCConnectionReconfigurationComplete (step 2, Table 8.2.3.8.1.3.2-2)

Derivation Path: 36.508 [7], Table 4.6.1-9 with condition MCG_and_SCG

Table 8.2.3.8.1.3.3-6: ULInformationTransferMRDC (steps 7, 8, 13 Table 8.2.3.8.1.3.2-2)

Derivation Path: 36.508 [7], Table 4.6.1-27			
Information Element	Value/remark	Comment	Condition
ULInformationTransferMRDC ::= SEQUENCE {			
ul-DCCH-MessageNR-r15	OCTET STRING including the MeasurementReport message according to Table 8.2.3.8.1.3.3-7		
}			

Table 8.2.3.8.1.3.3-7: MeasurementReport (Table 8.2.3.8.1.3.3-6)

Derivation Path: 38.508-1 [4], Table 4.6.1-7			
Information Element	Value/remark	Comment	Condition
measurementReport ::= SEQUENCE {			
measResults ::= SEQUENCE {			
measId	1		
measResultServingMOList ::= SEQUENCE (SIZE (1..maxNrofServingCells)) {		Report NR Cell 1	
servCellId	Cell index corresponding to NR Cell 1		
measResultServingCell ::= SEQUENCE {			
physCellId	Phy cell id corresponding to NR Cell 1		
measResult SEQUENCE {			
cellResults SEQUENCE{			
resultsSSB-Cell ::= SEQUENCE {			
rsrp	(0..127)		
rsrq	(0..127)		
sinr	(0..127)		pc_ss_SINR_Meas
	Not present		
}			
}			
}			
measResultNeighCells ::= SEQUENCE (SIZE (1..maxCellReport)) {	1 entry	Report NR Cell 2	
measResultListNR ::= SEQUENCE {			
physCellId	Phy cell id corresponding to NR Cell 2		
measResult SEQUENCE {			
cellResults SEQUENCE{			
resultsSSB-Cell ::= SEQUENCE {			
rsrp	(0..127)		
rsrq	(0..127)		
sinr	(0..127)		pc_ss_SINR_Meas
	Not present		
}			
}			
}			
}			

8.2.3.8.1a Measurement configuration control and reporting / Event A5 / Measurement of Neighbor NR cell / Inter-frequency measurements / EN-DC

8.2.3.8.1a.1 Test Purpose (TP)

(1)

```
with { UE in RRC_CONNECTED state with EN-DC, and, MCG(s) (E-UTRA PDCP) and SCG and inter-frequency
measurements configured for event A5 with event based periodical reporting }
ensure that {
  when { Serving NR PSCell becomes worse than absolute threshold1 and neighbour NR cell becomes
better than absolute threshold2 }
  then { UE sends MeasurementReport message at regular intervals while entering conditions for
event A5 are satisfied }
}
```

(2)

```
with { UE in RRC_CONNECTED state with EN-DC, and, MCG(s) (E-UTRA PDCP) and SCG and periodical
measurement reporting triggered by event A5 ongoing }
ensure that {
  when { Serving NR PSCell becomes better than absolute threshold1 or neighbour NR cell becomes
worse than absolute threshold2 }
  then { UE stops sending MeasurementReport message }
}
```

8.2.3.8.1a.2 Conformance requirements

Same as test case 8.2.3.8.1 with the following difference:

[TS 38.331, clause 5.5.2.9]

The UE shall:

...

1> if *gapUE* is set to *setup*:

2> if a per UE measurement gap configuration is already setup, release the per UE measurement gap configuration;

2> setup the per UE measurement gap configuration indicated by the *measGapConfig* in accordance with the received *gapOffset*, i.e., the first subframe of each gap occurs at an SFN and subframe meeting the following condition:

$SFN \bmod T = \text{FLOOR}(gapOffset/10)$;

subframe = $gapOffset \bmod 10$;

with $T = MGRP/10$ as defined in TS 38.133 [14];

2> if *mgta* is configured, apply the specified timing advance to the gap occurrences calculated above (i.e. the UE starts the measurement *mgta* ms before the gap subframe occurrences);

...

8.2.3.8.1a.3 Test description

8.2.3.8.1a.3.1 Pre-test conditions

Same as test case 8.2.3.8.1 with the following differences:

- Cells configuration: NR Cell 3 replaces NR Cell 2.

8.2.3.8.1a.3.2 Test procedure sequence

Same as test case 8.2.3.8.1 with the following differences:

- Cells configuration: NR Cell 3 replaces NR Cell 2.

8.2.3.8.1a.3.3 Specific message contents

Same as test case 8.2.3.8.1 with the following differences:

- Cells configuration: NR Cell 3 replaces NR Cell 2.

Table 8.2.3.8.1a.3.3-1: MeasConfig-A5 (Table 8.2.3.8.1.3.3-2)

Derivation Path: 38.508-1 [4] Table 4.6.3-69			
Information Element	Value/remark	Comment	Condition
MeasConfig ::= SEQUENCE {			
measObjectToAddModList SEQUENCE (SIZE (1..maxNrofMeasId)) OF SEQUENCE {	2 entries		
measObjectId[1]	1		
measObject[1] CHOICE {			
measObjectNR	MeasObjectNR-f1	Table 8.2.3.8.1a.3.3-2	
}			
measObjectId[2]	2		
measObject[2] CHOICE {			
measObjectNR	MeasObjectNR-f2	Table 8.2.3.8.1a.3.3-3	
}			
}			
reportConfigToAddModList SEQUENCE(SIZE (1..maxReportConfigId)) OF SEQUENCE {	1 entry		
reportConfigId[1]	1		
reportConfig[1] CHOICE {			
reportConfigNR	ReportConfigNR(66,60) Same as TS 38.508-1 [4], Table 4.6.3-142 except for reportAmount set to 'infinity'. ReportInterval value is set to 'ms1024'	Thresh values set to -91dBm, - 97dBm	EVENT_A5
}			
}			
measIdToAddModList SEQUENCE (SIZE (1..maxNrofMeasId)) OF SEQUENCE {	1 entry		
measId[1]	1		
measObjectId[1]	2		
reportConfigId[1]	1		
}			
measGapConfig	MeasGapConfig with condition GAP_UE		
}			

Table 8.2.3.8.1a.3.3-2: MeasObjectNR-f1 (Table 8.2.3.8.1a.3.3-1)

Derivation Path: TS 38.508-1 [4], Table 4.6.3-76			
Information Element	Value/remark	Comment	Condition
MeasObjectNR ::= SEQUENCE {			
ssbFrequency	ARFCN-ValueNR for SSB of NR Cell 1		
absThreshSS-BlocksConsolidation	Not present		
nrofSS-BlocksToAverage	Not present		
}			

Table 8.2.3.8.1a.3.3-3: *MeasObjectNR-f2* (Table 8.2.3.8.1a.3.3-1)

Derivation Path: TS 38.508-1 [4], Table 4.6.3-76			
Information Element	Value/remark	Comment	Condition
MeasObjectNR ::= SEQUENCE {			
ssbFrequency	ARFCN-ValueNR for SSB of NR Cell 3		
absThreshSS-BlocksConsolidation	Not present		
nrofSS-BlocksToAverage	Not present		
}			

8.2.3.8.1b Measurement configuration control and reporting / Event A5 / Measurement of Neighbor NR cell / Inter-band measurements / EN-DC

8.2.3.8.1b.1 Test Purpose (TP)

(1)

```
with { UE in RRC_CONNECTED state with EN-DC, and, MCG(s) (E-UTRA PDCP) and SCG and inter-band
measurements configured for event A5 with event based periodical reporting }
ensure that {
  when { Serving NR PSCell becomes worse than absolute threshold1 and neighbour NR cell becomes
better than absolute threshold2 }
  then { UE sends MeasurementReport message at regular intervals while entering conditions for
event A5 are satisfied }
}
```

(2)

```
with { UE in RRC_CONNECTED state with EN-DC, and, MCG(s) (E-UTRA PDCP) and SCG and periodical
measurement reporting triggered by event A5 ongoing }
ensure that {
  when { Serving NR PSCell becomes better than absolute threshold1 or neighbour NR cell becomes
worse than absolute threshold2 }
  then { UE stops sending MeasurementReport message }
}
```

8.2.3.8.1b.2 Conformance requirements

Same as test case 8.2.3.8.1 with the following difference:

[TS 38.331, clause 5.5.2.9]

The UE shall:

...

1> if *gapUE* is set to *setup*:

2> if a per UE measurement gap configuration is already setup, release the per UE measurement gap configuration;

2> setup the per UE measurement gap configuration indicated by the *measGapConfig* in accordance with the received *gapOffset*, i.e., the first subframe of each gap occurs at an SFN and subframe meeting the following condition:

$$\text{SFN mod } T = \text{FLOOR}(\text{gapOffset}/10);$$

$$\text{subframe} = \text{gapOffset mod } 10;$$

with $T = \text{MGRP}/10$ as defined in TS 38.133 [14];

2> if *mgta* is configured, apply the specified timing advance to the gap occurrences calculated above (i.e. the UE starts the measurement *mgta* ms before the gap subframe occurrences);

...

8.2.3.8.1b.3 Test description

8.2.3.8.1b.3.1 Pre-test conditions

Same as test case 8.2.3.8.1 with the following differences:

- Cells configuration: NR Cell 10 replaces NR Cell 2.

8.2.3.8.1b.3.2 Test procedure sequence

Same as test case 8.2.3.8.1 with the following differences:

- Cells configuration: NR Cell 10 replaces NR Cell 2.

8.2.3.8.1b.3.3 Specific message contents

Same as test case 8.2.3.8.1 with the following differences:

- Cells configuration: NR Cell 10 replaces NR Cell 2.

Table 8.2.3.8.1b.3.3-1: MeasConfig-A5 (Table 8.2.3.8.1.3.3-2)

Derivation Path: 38.508-1 [4] Table 4.6.3-69			
Information Element	Value/remark	Comment	Condition
MeasConfig ::= SEQUENCE {			
measObjectToAddModList SEQUENCE (SIZE (1..maxNrofMeasId)) OF SEQUENCE {	2 entries		
measObjectId[1]	1		
measObject[1] CHOICE {			
measObjectNR	MeasObjectNR-f1	Table 8.2.3.8.1b.3.3-2	
}			
measObjectId[2]	2		
measObject[2] CHOICE {			
measObjectNR	MeasObjectNR-f2	Table 8.2.3.8.1b.3.3-3	
}			
}			
reportConfigToAddModList SEQUENCE(SIZE (1..maxReportConfigId)) OF SEQUENCE {	1 entry		
reportConfigId[1]	1		
reportConfig[1] CHOICE {			
reportConfigNR	ReportConfigNR(66,60) Same as TS 38.508-1 [4], Table 4.6.3-142 except for reportAmount set to 'infinity'. ReportInterval value is set to 'ms1024'	Thresh values set to -91dBm, - 97dBm	EVENT_A5
}			
}			
measIdToAddModList SEQUENCE (SIZE (1..maxNrofMeasId)) OF SEQUENCE {	1 entry		
measId[1]	1		
measObjectId[1]	2		
reportConfigId[1]	1		
}			
measGapConfig	MeasGapConfig with condition GAP_UE		
}			

Table 8.2.3.8.1b.3.3-2: *MeasObjectNR-f1* (Table 8.2.3.8.1b.3.3-1)

Derivation Path: TS 38.508-1 [4], Table 4.6.3-76			
Information Element	Value/remark	Comment	Condition
MeasObjectNR ::= SEQUENCE {			
ssbFrequency	ARFCN-ValueNR for SSB of NR Cell 1		
absThreshSS-BlocksConsolidation	Not present		
nrofSS-BlocksToAverage	Not present		
}			

Table 8.2.3.8.1b.3.3-3: *MeasObjectNR-f2* (Table 8.2.3.8.1b.3.3-1)

Derivation Path: TS 38.508-1 [4], Table 4.6.3-76			
Information Element	Value/remark	Comment	Condition
MeasObjectNR ::= SEQUENCE {			
ssbFrequency	ARFCN-ValueNR for SSB of NR Cell 10		
absThreshSS-BlocksConsolidation	Not present		
nrofSS-BlocksToAverage	Not present		
}			

8.2.3.9 Measurement configuration control and reporting / SS/PBCH block based / CSI-RS based intra-frequency measurements / Measurement of Neighbour NR cell

8.2.3.9.1 Measurement configuration control and reporting / SS/PBCH block based / CSI-RS based Intra-frequency measurements / Measurement of Neighbour NR Cell / EN-DC

8.2.3.9.1.1 Test Purpose (TP)

(1)

```
with { UE in RRC_CONNECTED state in EN-DC mode and measurement configured for SS/PBCH measurement reporting of intra-frequency on specified frequency }
ensure that {
  when { SS/PBCH block sorting quantity is above absThreshSS-BlocksConsolidation for each beam of NR Neighbour Cell }
  then { UE sends MeasurementReport message containing rsIndexResults with resultsSSB-Indexes }
}
```

(2)

```
with { UE in RRC_CONNECTED state in EN-DC mode and measurement configured for SS/PBCH measurement reporting of intra-frequency on specified frequency }
ensure that {
  when { SS/PBCH block sorting quantity is below absThreshSS-BlocksConsolidation for one beam of NR Neighbour Cell and another beam(s) is above absThreshSS-BlocksConsolidation }
  then { UE sends MeasurementReport message containing rsIndexResults with resultsSSB-Indexes includes RsIndex above absThreshSS-BlocksConsolidation and excludes RsIndex below absThreshSS-BlocksConsolidation }
}
```

(3)

```
with { UE in RRC_CONNECTED state in EN-DC mode and measurement configured for CSI-RS measurement reporting of intra frequency on specified frequency }
ensure that {
  when { CSI-RS sorting quantity is above absThreshCSI-RS-Consolidation for each beam of NR Neighbour Cell }
  then { UE sends MeasurementReport message containing rsIndexResults with resultsCSI-RS-Indexes }
}
```

(4)

```

with { UE in RRC_CONNECTED state in EN-DC mode and measurement configured for CSI-RS measurement
reporting of intra frequency on specified frequency }
ensure that {
  when { CSI-RS sorting quantity is below absThreshCSI-RS-Consolidation for one beam of NR Neighbour
Cell and another beam(s) is above absThreshCSI-RS-Consolidation }
  then { UE sends MeasurementReport message containing rsIndexResults with resultsCSI-RS-Indexes
includes RsIndex above absThreshCSI-RS-Consolidation and excludes RsIndex below absThreshCSI-RS-
Consolidation }
}

```

8.2.3.9.1.2 Conformance requirements

References: The conformance requirements covered in the present TC are specified in: TS 38.331 clauses 5.5.5.1 and 5.5.5.2. Unless otherwise stated these are Rel-15 requirements.

[TS 38.331, clause 5.5.5.1]

The purpose of this procedure is to transfer measurement results from the UE to the network. The UE shall initiate this procedure only after successful security activation.

For the *measId* for which the measurement reporting procedure was triggered, the UE shall set the *measResults* within the *MeasurementReport* message as follows:

1> set the *measId* to the measurement identity that triggered the measurement reporting;

set the *measResultServingCell* within *measResultServingMOList* to include, for each cell that is configured with *servingCellMO*, RSRP, RSRQ and the available SINR for each configured serving cell derived based on the *rsType* if indicated in the associated *reportConfig*, otherwise based on SSB if available, otherwise based on CSI-RS;

1> set the *servingCellId* within *measResultServingMOList* to include for each NR serving cell that is configured, if any, the *servingCellMO*;

1> if the *reportConfig* associated with the *measId* that triggered the measurement reporting includes *reportQuantityRsIndexes* and *maxNrofRSIndexesToReport*:

2> for each serving cell configured with *servingCellMO*, include beam measurement information according to the associated *reportConfig* as described in 5.5.5.2;

1> if the *reportConfig* associated with the *measId* that triggered the measurement reporting includes *reportAddNeighMeas*:

2>for each serving cell frequency for which *measObjectId* is referenced in the *measIdList*, other than the *measObjectId* frequency corresponding with the *measId* that triggered the measurement reporting:

3> set the *measResultBestNeighCell* within *measResultServingMOList* to include the *physCellId* and the available measurement quantities based on the *reportQuantityCell* and *rsType* indicated in *reportConfig* of the non-serving cell on the concerned serving frequency with the highest measured RSRP if RSRP measurement results are available for cells on this frequency, otherwise with the highest measured RSRQ if RSRQ measurement results are available for cells on this frequency, otherwise with the highest measured SINR;

3> if the *reportConfig* associated with the *measId* that triggered the measurement reporting includes *reportQuantityRsIndexes* and *maxNrofRSIndexesToReport*:

4> for each best non-serving cell included in the measurement report:

5>include beam measurement information according to the associated *reportConfig* as described in 5.5.5.2;

1> if there is at least one applicable neighbouring cell to report:

2> if the *reportType* is set to *eventTriggered* or *periodical*:

- 3> set the *measResultNeighCells* to include the best neighbouring cells up to *maxReportCells* in accordance with the following:
 - 4> if the *reportType* is set to *eventTriggered*:
 - 5> include the cells included in the *cellsTriggeredList* as defined within the *VarMeasReportList* for this *measId*;
 - 4> else:
 - 5> include the applicable cells for which the new measurement results became available since the last periodical reporting or since the measurement was initiated or reset;
 - 5> if *reportQuantityRsIndexes* and *maxNrofRSIndexesToReport* are configured, include beam measurement information as described in 5.5.5.2;
 - 4> for each cell that is included in the *measResultNeighCells*, include the *physCellId*;
 - 4> if the *reportType* is set to *eventTriggered*:
 - 5> for each included cell, include the layer 3 filtered measured results in accordance with the *reportConfig* for this *measId*, ordered as follows:
 - 6> if the *measObject* associated with this *measId* concerns NR:
 - 7> if *rsType* in the associated *reportConfig* is set to *ssb*:
 - 8> set *resultsSSB-Cell* within the *measResult* to include the SS/PBCH block based quantity(ies) indicated in the *reportQuantityCell* within the concerned *reportConfig*, in order of decreasing trigger quantity, i.e. the best cell is included first;
 - 9> if *reportQuantityRsIndexes* and *maxNrofRSIndexesToReport* are configured, include beam measurement information as described in 5.5.5.2; 7> else if *rsType* in the associated *reportConfig* is set to *csi-rs*:
 - 8> set *resultsCSI-RS-Cell* within the *measResult* to include the CSI-RS based quantity(ies) indicated in the *reportQuantityCell* within the concerned *reportConfig*, in order of decreasing trigger quantity, i.e. the best cell is included first;
 - 9> if *reportQuantityRsIndexes* and *maxNrofRSIndexesToReport* are, include beam measurement information as described in 5.5.5.2;

[TS 38.331, clause 5.5.5.1]

- 1> increment the *numberOfReportsSent* as defined within the *VarMeasReportList* for this *measId* by 1;
- 1> stop the periodical reporting timer, if running;
- 1> if the *numberOfReportsSent* as defined within the *VarMeasReportList* for this *measId* is less than the *reportAmount* as defined within the corresponding *reportConfig* for this *measId*:
 - 2> start the periodical reporting timer with the value of *reportInterval* as defined within the corresponding *reportConfig* for this *measId*;
- 1> else:
 - 2> if the *reportType* is set to *periodical*:
 - 3> remove the entry within the *VarMeasReportList* for this *measId*;
 - 3> remove this *measId* from the *measIdList* within *VarMeasConfig*;
- 1> if the UE is configured with EN-DC:
 - 2> if SRB3 is configured:

3> submit the *MeasurementReport* message via SRB3 to lower layers for transmission, upon which the procedure ends;

2>else:

3> submit the *MeasurementReport* message via the EUTRA MCG embedded in E-UTRA RRC message *ULInformationTransferMRDC* as specified in TS 36.331 [10].

1> else:

2>submit the *MeasurementReport* message to lower layers for transmission, upon which the procedure ends.

[TS 38.331, clause 5.5.5.2]

For beam measurement information to be included in a measurement report the UE shall:

1> if *reportType* is set to *eventTriggered*:

2> consider the trigger quantity as the sorting quantity;

1> if *reportType* is set to *periodical*:

2> if a single reporting quantity is set to TRUE in *reportQuantityRsIndexes*;

3> consider the configured single quantity as the sorting quantity;

2> else:

3> if *rsrp* is set to TRUE;

4> consider RSRP as the sorting quantity;

3> else:

4> consider RSRQ as the sorting quantity;

1> set *rsIndexResults* to include up to *maxNrofRsIndexesToReportSS/PBCH* block indexes or CSI-RS indexes in order of decreasing sorting quantity as follows:

2> if the measurement information to be included is based on SS/PBCH block:

3> include within *resultsSSB-Indexes* the index associated to the best beam for that SS/PBCH block sorting quantity and the remaining beams whose sorting quantity is above *absThreshSS-BlocksConsolidation* defined in the *VarMeasConfig* for the corresponding *measObject*;

3> if *includeBeamMeasurements* is configured, include the SS/PBCH based measurement results for the quantities in *reportQuantityRsIndexes* set to TRUE for each SS/PBCH blockindex;2> else if the beam measurement information to be included is based on CSI-RS:

2> else if the beam measurement information to be included is based on CSI-RS:

3> include within *resultsCSI-RS-Indexes* the index associated to the best beam for that CSI-RS sorting quantity and the remaining beams whose sorting quantity is above *absThreshCSI-RS-Consolidation* defined in the *VarMeasConfig* for the corresponding *measObject*;

3> if *includeBeamMeasurements* is configured, include the CSI-RS based measurement results for the quantities in *reportQuantityRsIndexes* set to TRUE for each CSI-RS index.

8.2.3.9.1.3 Test description

8.2.3.9.1.3.1 Pre-test conditions

System Simulator:

- EUTRA Cell 1 is the PCell and NR Cell 1 is the PS Cell and NR Cell 2 is the intra-frequency neighbour cell of NR Cell 1. NR Cell2 has two beams with index#0 and index#1.

UE:

- None

Preamble:

- The UE is in state RRC_CONNECTED in EN-DC using generic procedure parameter Connectivity (EN-DC) and DC Bearers (MCG(s) and SCG) on E-UTRA Cell 1 according to TS 38.508-1 [4].

8.2.3.9.1.3.2 Test procedure sequence

Table 8.2.3.9.1.3.2-1 and Table 8.2.3.9.1.3.2-1A illustrates the downlink power levels to be applied for NR Cell 1 and NR Cell 2 at various time instants of the test execution. Row marked "T0" denotes the conditions after the preamble, while rows marked "T1" and "T2" are to be applied subsequently. The exact instants on which these values shall be applied are described in the texts in this clause.

Table 8.2.3.9.1.3.2-1: Time instances of cell power level and parameter changes for FR1

	Parameter	Unit	E-UTRA Cell 1	NR Cell 1	NR Cell 2	NR Cell 2 Beam Index# 0	NR Cell 2 Beam Index# 1	Remark
T0	Cell-specific RS EPRE	dBm/15k Hz	-85	-	-	-	-	
	SS/PBCH SSS EPRE	dBm/SC S	-	-94	-98	-98	-98	
T1	Cell-specific RS EPRE	dBm/15k Hz	-85	-	-	-	-	$Mn + Ofn + Ocn - Hys > Mp + Ofp + Ocp + Off$ Power level is such that SS/PBCH quality of NR Cell 2, BeamIndex#0 and BeamIndex#1 is above <i>absThreshSS-BlocksConsolidation</i> .
	SS/PBCH SSS EPRE	dBm/SC S	-	-106	-98	-98	-98	
T2	Cell-specific RS EPRE	dBm/15k Hz	-85	-	-	-	-	$Mn + Ofn + Ocn + Hys < Mp + Ofp + Ocp + Off$ Power level is such that SS/PBCH quality of NR Cell 2, BeamIndex#0 and BeamIndex#1 is below <i>absThreshSS-BlocksConsolidation</i> .
	SS/PBCH SSS EPRE	dBm/SC S	-	-94	-98	-98	-98	
T3	Cell-specific RS EPRE	dBm/15k Hz	-85	-	-	-	-	Power level is such that SS/PBCH quality of NR Cell 2 is BeamIndex#0 is above <i>absThreshSS-BlocksConsolidation</i> and BeamIndex#1 is below <i>absThreshSS-BlocksConsolidation</i> .
	SS/PBCH SSS EPRE	dBm/SC S	-	-106	-98	-98	-106	

Table 8.2.3.9.1.3.2-1A: Time instances of cell power level and parameter changes for FR2

	Parameter	Unit	E-UTRA Cell 1	NR Cell 1	NR Cell 2	NR Cell 2 Beam Index# 0	NR Cell 2 Beam Index# 1	Remark
T0	Cell-specific RS EPRE	dBm/15k Hz	-85	-	-	-	-	
	SS/PBCH SSS EPRE	dBm/SC S	-	[-94]	[FFS]	[FFS]	[FFS]	
T1	Cell-specific RS EPRE	dBm/15k Hz	-85	-	-	-	-	$Mn + Ofn + Ocn - Hys > Mp + Ofp + Ocp + Off$ Power level is such that SS/PBCH quality of NR Cell 3, BeamIndex#0 and BeamIndex#1 is above <i>absThreshSS-BlocksConsolidation</i> .
	SS/PBCH SSS EPRE	dBm/SC S	-	[-100]	[FFS]	[FFS]	[FFS]	
T3	Cell-specific RS EPRE	dBm/15k Hz	-85	-	-	-	-	$Mn + Ofn + Ocn + Hys < Mp + Ofp + Ocp + Off$ Power level is such that SS/PBCH quality of NR Cell 2, BeamIndex#0 and BeamIndex#1 is below <i>absThreshSS-BlocksConsolidation</i> .
	SS/PBCH SSS EPRE	dBm/SC S	-	[-94]	[FFS]	[FFS]	[FFS]	
T2	Cell-specific RS EPRE	dBm/15k Hz	-85	-	-	-	-	Power level is such that SS/PBCH quality of NR Cell 3 is BeamIndex#0 is above <i>absThreshSS-BlocksConsolidation</i> and BeamIndex#1 is below <i>absThreshSS-BlocksConsolidation</i> .
	SS/PBCH SSS EPRE	dBm/SC S	-	[-100]	[FFS]	[FFS]	[FFS]	

Table 8.2.3.9.1.3.2-2: Main behaviour

St	Procedure	Message Sequence		TP	Verdict
		U - S	Message		
1	The SS transmits an <i>RRCCONNECTIONRECONFIGURATION</i> message containing NR <i>RRCCONNECTIONRECONFIGURATION</i> including <i>measConfig</i> to setup SS/PBCH block based intra-frequency NR measurement for PSCell (NR Cell 1) and reporting for event A3.	<--	<i>RRCCONNECTIONRECONFIGURATION(RRCCONNECTIONRECONFIGURATION)</i>	-	-
2	The UE transmits an <i>RRCCONNECTIONRECONFIGURATIONCOMPLETE</i> message containing NR <i>RRCCONNECTIONRECONFIGURATIONCOMPLETE</i> .	-->	<i>RRCCONNECTIONRECONFIGURATIONCOMPLETE(RRCCONNECTIONRECONFIGURATIONCOMPLETE)</i>	-	-
3	SS re-adjusts the cell-specific reference signal level according to row "T1".	-	-	-	-
4	Check: Does the UE transmit a <i>MEASUREMENTREPORT</i> message to report event A3 with the measured results for NR Cell 2 with beam information containing <i>RsIndex[0]</i> and <i>RsIndex[1]</i> ?	-->	<i>ULINFORMATIONTRANSFERMRDC(MEASUREMENTREPORT)</i>	1	P
4A	The SS changes NR Cell 1 and E-UTRA Cell 1 parameters according to the row "T3".	-	-	-	-
4B	Check: Does the UE transmit a <i>MEASUREMENTREPORT</i> message on E-UTRA Cell 1 to report the event A3 during the next 10s?	-	-	1	F
5	SS re-adjusts the cell-specific reference signal level according to row "T2".	-	-	-	-
6	Check: Does the UE transmit a <i>MEASUREMENTREPORT</i> message to report event A3 with the measured results for NR Cell 2 with beam information containing <i>RsIndex[0]</i> and excludes <i>RsIndex[1]</i> ?	-->	<i>ULINFORMATIONTRANSFERMRDC(MEASUREMENTREPORT)</i>	2	P
7	The SS transmits an <i>RRCCONNECTIONRECONFIGURATION</i> message containing NR <i>RRCCONNECTIONRECONFIGURATION</i> including <i>measConfig</i> to remove SS/PBCH block based intra-frequency NR measurement for PSCell (NR Cell 1) and reporting for event A3.	<--	<i>RRCCONNECTIONRECONFIGURATION(RRCCONNECTIONRECONFIGURATION)</i>	-	-
8	The UE transmits an <i>RRCCONNECTIONRECONFIGURATIONCOMPLETE</i> message containing NR <i>RRCCONNECTIONRECONFIGURATIONCOMPLETE</i> .	-->	<i>RRCCONNECTIONRECONFIGURATIONCOMPLETE(RRCCONNECTIONRECONFIGURATIONCOMPLETE)</i>	-	-
9	The SS transmits an <i>RRCCONNECTIONRECONFIGURATION</i> message containing NR <i>RRCCONNECTIONRECONFIGURATION</i> including <i>measConfig</i> to setup CSI-RS based intra-frequency NR measurement for PSCell (NR Cell 1) and reporting for event A3.	<--	<i>RRCCONNECTIONRECONFIGURATION(RRCCONNECTIONRECONFIGURATION)</i>	-	-
10	The UE transmits an <i>RRCCONNECTIONRECONFIGURATIONCOMPLETE</i> message containing NR <i>RRCCONNECTIONRECONFIGURATIONCOMPLETE</i> .	-->	<i>RRCCONNECTIONRECONFIGURATIONCOMPLETE(RRCCONNECTIONRECONFIGURATIONCOMPLETE)</i>	-	-
11	SS re-adjusts the cell-specific reference signal level according to row "T1".	-	-	-	-
12	Check: Does the UE transmit a <i>MEASUREMENTREPORT</i> message to report event A3 with the measured results for NR Cell 2 with beam information containing <i>RsIndex[0]</i> and <i>RsIndex[1]</i> ?	-->	<i>ULINFORMATIONTRANSFERMRDC(MEASUREMENTREPORT)</i>	3	P
12A	The SS changes NR Cell 1 and E-UTRA Cell 1 parameters according to the row "T3".	-	-	-	-
12B	Check: Does the UE transmit a <i>MEASUREMENTREPORT</i> message on E-UTRA Cell 1 to report the event A3 during the next 10s?	-	-	3	F
13	SS re-adjusts the cell-specific reference signal level according to row "T2".	-	-	-	-
14	Check: Does the UE transmit a <i>MEASUREMENTREPORT</i> message to report event A3 with the measured results for NR Cell 2 with beam information containing <i>RsIndex[0]</i> and excludes <i>RsIndex[1]</i> ?	-->	<i>ULINFORMATIONTRANSFERMRDC(MEASUREMENTREPORT)</i>	4	P

8.2.3.9.1.3.3 Specific message contents

Table 8.2.3.9.1.3.3-1: RRCConnectionReconfiguration (steps 1, 7, 9 Table 8.2.3.9.1.3.2-2)

Derivation Path: 36.508 [7], Table 4.6.1-8 with condition EN-DC_EmbedNR_RRCRecon

Table 8.2.3.9.1.3.3-2: RRCReconfiguration (Table 8.2.3.9.1.3.3-1)

Derivation Path: 38.508-1 [4], Table 4.6.1-13

Table 8.2.3.9.1.3.3-3: MeasConfig (Table 8.2.3.9.1.3.3-2)

Derivation Path: 38.508-1 [4], Table 4.6.3-69			
Information Element	Value/remark	Comment	Condition
MeasConfig ::= SEQUENCE {			
measObjectToAddModList	IdMeasObjectToAdd		
reportConfigToAddModList	IdReportConfigToAdd		
measIdToAddModList	IdMeasIdToAdd		
s-MeasureConfig CHOICE {			
ssb-rsrp	[45]		
}			
}			

Table 8.2.3.9.1.3.3-4: IdMeasObjectToAdd (Table 8.2.3.9.1.3.3-3, Table 8.2.3.9.1.3.3-13)

Derivation Path: TS 38.331 [6], clause 6.3.2			
Information Element	Value/remark	Comment	Condition
MeasObjectToAddModList ::= SEQUENCE (SIZE (1..maxNrofMeasId)) OF SEQUENCE {	[1 entry]		
measObjectId[1]	1		
measObject CHOICE {			
measObjectNR	Id-MeasObjectNR		
}			
}			

Table 8.2.3.9.1.3.3-5: Id-MeasObjectNR (Table 8.2.3.9.1.3.3-4)

Derivation Path: 38.508-1 [4], Table 4.6.3-76			
Information Element	Value/remark	Comment	Condition
MeasObjectNR ::= SEQUENCE {			
ssbFrequency	Downlink ARFCN of NR Cell2		
referenceSignalConfig SEQUENCE {			
ssb-ConfigMobility SEQUENCE {			
ssb-ToMeasure CHOICE {			
setup CHOICE {			
shortBitmap	1100		(FREQ<=3G Hz AND (FR1_FDD OR NOT CASE_C)) OR (FREQ<=2.4 GHz AND FR1_TDD)
mediumBitmap	11000000		(FREQ>3G Hz AND FR1) OR (FREQ>2.4 GHz AND FR1_TDD AND CASE_C)
longBitmap	11000000 00000000 00000000 00000000 00000000 00000000 00000000 00000000		FR2
}			
}			
deriveSSB-IndexFromCell	true		
ss-RSSI-Measurement	Not present		
}			
csi-rs-ResourceConfigMobility	Not present		
}			
absThreshSS-BlocksConsolidation SEQUENCE {			
thresholdRSRP	-106		
}			
}			

Table 8.2.3.9.1.3.3-6: IdReportConfigToAdd (Table 8.2.3.9.1.3.3-3, Table 8.2.3.9.1.3.3-13, Table 8.2.3.9.1.3.3-14)

Derivation Path: TS 38.331 [6], clause 6.3.2			
Information Element	Value/remark	Comment	Condition
ReportConfigToAddModList ::= SEQUENCE(SIZE (1..maxReportConfigId)) OF SEQUENCE {	1 entry		
reportConfigId[1]	1		
reportConfig[1] CHOICE {			
reportConfigNR	IdReportConfig-A3		
}			
}			

Table 8.2.3.9.1.3.3-7: IdReportConfig-A3 (Table 8.2.3.9.1.3.3-6)

Derivation Path: 38.508-1 [4], Table 4.6.3-142 with condition EVENT_A3			
Information Element	Value/remark	Comment	Condition
ReportConfigNR ::= SEQUENCE {			
reportType CHOICE {			
eventTriggered SEQUENCE {			
eventId CHOICE {			
eventA3 SEQUENCE {			
a3-Offset CHOICE {			
rsrp	2		
}			
}			
}			
rsType	ssb		
reportQuantityRsIndexes CHOICE {			
rsrp	True		
}			
maxNrofRsIndexesToReport	2		
includeBeamMeasurements	True		
}			
reportAmount	r1		
}			

Table 8.2.3.9.1.3.3-8: IdMeasIdToAdd (Table 8.2.3.9.1.3.3-3, Table 8.2.3.9.1.3.3-13, Table 8.2.3.9.1.3.3-14)

Derivation Path: TS 38.331 [6], clause 6.3.2			
Information Element	Value/remark	Comment	Condition
MeasIdToAddModList ::= SEQUENCE (SIZE (1..maxNrofMeasId)) OF SEQUENCE {	[1 entry]		
measId[1]	1		
measObjectId[1]	1		
reportConfigId[1]	1		
}			

Table 8.2.3.9.1.3.3-9: RRCConnectionReconfigurationComplete (steps 2, 8, 10, Table 8.2.3.9.1.3.2-2)

Derivation Path: 36.508 [7], Table 4.6.1-9 with condition MCG_and_SCG			
---	--	--	--

Table 8.2.3.9.1.3.3-10: ULInformationTransferMRDC (steps 4, 6,12,14 Table 8.2.3.9.1.3.2-2)

Derivation Path: 36.508 [7], Table 4.6.1-27			
Information Element	Value/remark	Comment	Condition
ULInformationTransferMRDC-r15 ::= SEQUENCE {			
criticalExtensions CHOICE {			
c1 CHOICE {			
ulInformationTransferMRDC-r15 SEQUENCE {			
ul-DCCH-MessageNR-r15	OCTET STRING containing NR RRC MeasurementReport		
}			
}			
}			
}			

Table 8.2.3.9.1.3.3-11: MeasurementReport (step 4, Table 8.2.3.9.1.3.2-2)

Derivation Path: TS 38.331 [6], clause 6.2.2			
Information Element	Value/remark	Comment	Condition
MeasurementReport ::= SEQUENCE {			
criticalExtensions CHOICE {			
c1 CHOICE {			
measurementReport ::= SEQUENCE {			
measResults SEQUENCE {			
measId	1		
measResultServingMOList SEQUENCE {	1 entry		
servFreqId	Not checked		
measResultServingCell SEQUENCE {			
physCellId	Physical CellID of the NR Cell 1		
cgi-Info	Not present		
measResult SEQUENCE {			
cellResults SEQUENCE {			
resultsSSB-Cell SEQUENCE {			
rsrp	Not checked		
rsrq	Not checked		
sinr	Not checked		
}			
}			
rsIndexResults	Not checked		
}			
}			
}			
measResultNeighCells CHOICE {			
measResultListNR SEQUENCE {	1 entry		
physCellId	Physical CellID of the NR Cell 2		
cgi-Info	Not present		
measResult SEQUENCE {			
cellResults SEQUENCE {			
resultsSSB-Cell SEQUENCE {			
rsrp	Not checked		
rsrq	Not checked		
sinr	Not checked		
}			
}			
rsIndexResults SEQUENCE {			
resultsSSB-Indexes SEQUENCE {	2 entries		
ssb-Index	SSB index for BeamIndex0		BeamIndex0
ssb-Results SEQUENCE {			
rsrp	Not checked		
rsrq	Not checked		
sinr	Not checked		
}			
}			
ssb-Index	SSB index for BeamIndex1		BeamIndex1
ssb-Results SEQUENCE {			
rsrp	Not checked		
rsrq	Not checked		
sinr	Not checked		
}			
resultsCSI-RS-Indexes	Not present		
}			
}			
}			
}			

}			
}			

Table 8.2.3.9.1.3.3-12: MeasurementReport (step 6, Table 8.2.3.9.1.3.2-2)

Derivation Path: TS 38.331 [6], clause 6.2.2			
Information Element	Value/remark	Comment	Condition
MeasurementReport ::= SEQUENCE {			
criticalExtensions CHOICE {			
c1 CHOICE {			
measurementReport ::= SEQUENCE {			
measResults SEQUENCE {			
measId	1		
measResultServingMOList SEQUENCE {	1 entry		
servFreqId			
measResultServingCell SEQUENCE {	Not checked		
physCellId	Physical CellID of the NR Cell 1		
cgi-Info	Not present		
measResult SEQUENCE {			
cellResults SEQUENCE {			
resultsSSB-Cell SEQUENCE {			
rsrp	Not checked		
rsrq	Not checked		
sinr	Not checked		
}			
}			
rsIndexResults	Not checked		
}			
}			
}			
measResultNeighCells CHOICE {			
measResultListNR SEQUENCE {	1 entry		
physCellId	Physical CellID of the NR Cell2		
cgi-Info	Not present		
measResult SEQUENCE {			
cellResults SEQUENCE {			
resultsSSB-Cell SEQUENCE {			
rsrp	Not checked		
rsrq	Not checked		
sinr	Not checked		
}			
}			
rsIndexResults SEQUENCE {			
resultsSSB-Indexes SEQUENCE {	1 entry		
ssb-Index	SSB index for BeamIndex#0		
ssb-Results SEQUENCE {			
rsrp	Not checked		
rsrq	Not checked		
sinr	Not checked		
}			
}			
resultsCSI-RS-Indexes	Not present		
}			
}			
}			

Table 8.2.3.9.1.3.3-13: MeasConfig (step 7, Table 8.2.3.9.1.3.2-2)

Derivation Path: 38.508-1 [4], Table 4.6.3-69			
Information Element	Value/remark	Comment	Condition
MeasConfig ::= SEQUENCE {			
measObjectToAddModList	Not Present		
measIdToRemoveList SEQUENCE (SIZE (1..maxMeasId)) OF SEQUENCE {	One entry		
Meas-Id[1]	1		
}			
reportConfigToAddModList	Not Present		
measIdToAddModList	Not Present		
}			

Table 8.2.3.9.1.3.3-14: MeasConfig (step 9, Table 8.2.3.9.1.3.2-2)

Derivation Path: 38.508-1 [4], Table 4.6.3-69			
Information Element	Value/remark	Comment	Condition
MeasConfig ::= SEQUENCE {			
measObjectToAddModList	IdMeasObjectToAdd		
reportConfigToAddModList	IdReportConfigToAdd		
measIdToAddModList	IdMeasIdToAdd		
s-MeasureConfig CHOICE {			
csi-rsrp	45		
}			
}			

Table 8.2.3.9.1.3.3-14A: IdMeasObjectToAdd (Table 8.2.3.9.1.3.3-14)

Derivation Path: TS 38.331 [6], clause 6.3.2			
Information Element	Value/remark	Comment	Condition
MeasObjectToAddModList ::= SEQUENCE (SIZE (1..maxNrofMeasId)) OF SEQUENCE {	1 entry		
measObjectId[1]	1		
measObject CHOICE {			
measObjectNR	Id-MeasObjectNR		
}			
}			

Table 8.2.3.9.1.3.3-14B: Id-MeasObjectNR (Table 8.2.3.9.1.3.3-14A)

}			
---	--	--	--

Table 8.2.3.9.1.3.3-15: MeasurementReport (step 12, Table 8.2.3.9.1.3.2-2)

Derivation Path: TS 38.331 [6], clause 6.2.2			
Information Element	Value/remark	Comment	Condition
MeasurementReport ::= SEQUENCE {			
criticalExtensions CHOICE {			
c1 CHOICE {			
measurementReport ::= SEQUENCE {			
measResults SEQUENCE {			
measId			
measResultServingFreqList SEQUENCE {	1 entry		
servFreqId	Not Checked		
measResultServingCell SEQUENCE {			
physCellId	Physical CellID of the NR Cell 1		
cgi-Info	Not present		
measResult SEQUENCE {			
cellResults SEQUENCE {			
resultsSSB-Cell SEQUENCE {			
rsrp	Not checked		
rsrq	Not checked		
sinr	Not checked		
}			
}			
rsIndexResults	Not checked		
}			
}			
}			
measResultNeighCells CHOICE {			
measResultListNR SEQUENCE {	1 entry		
physCellId	Physical CellID of the NR Cell 2		
cgi-Info	Not present		
measResult SEQUENCE {			
cellResults SEQUENCE {			
resultsSSB-Cell SEQUENCE {			
Rsrp	Not checked		
Rsrq	Not checked		
Sinr	Not checked		
}			
}			
rsIndexResults SEQUENCE {			
resultsSSB-Indexes	Not Present		
resultsCSI-RS-Indexes SEQUENCE {	2 entries		
csi-RS-Index	CSI-RS-index for BeamIndex0		BeamIndex0
csi-RS--Results SEQUENCE {			
rsrp	Not checked		
rsrq	Not checked		
sinr	Not checked		
}			
}			
csi-RS-Index			BeamIndex1
csi-RS--Results SEQUENCE {	CSI-RS-index for BeamIndex0		
rsrp	Not checked		
rsrq	Not checked		
sinr	Not checked		
}			
}			
}			
}			
}			
}			

}			
}			

Table 8.2.3.9.1.3.3-16: MeasurementReport (step 14. Table 8.2.3.9.1.3.2-2)

Derivation Path: TS 38.331 [6], clause 6.2.2			
Information Element	Value/remark	Comment	Condition
MeasurementReport ::= SEQUENCE {			
criticalExtensions CHOICE {			
c1 CHOICE {			
measurementReport ::= SEQUENCE {			
measResults SEQUENCE {			
measId			
measResultServingMOList SEQUENCE {	1 entry		
servFreqId			
measResultServingCell SEQUENCE {			
physCellId	Physical CellID of the NR Cell 1		
cgi-Info	Not present		
measResult SEQUENCE {			
cellResults SEQUENCE {			
resultsSSB-Cell SEQUENCE {			
rsrp	Not checked		
rsrq	Not checked		
sinr	Not checked		
}			
}			
rsIndexResults	Not checked		
}			
}			
}			
measResultNeighCells CHOICE {			
measResultListNR SEQUENCE {	1 entry		
physCellId	Physical CellID of the NR Cell 2		
cgi-Info	Not present		
measResult SEQUENCE {			
cellResults SEQUENCE {			
resultsSSB-Cell SEQUENCE {			
rsrp	Not checked		
rsrq	Not checked		
sinr	Not checked		
}			
}			
rsIndexResults SEQUENCE {			
resultsSSB-Indexes	Not Present		
resultsCSI-RS-Indexes SEQUENCE {	1 entry		
csi-RS-Index	CSI-RS-Index for BeamIndex0		
csi-RS--Results SEQUENCE {			
rsrp	Not Checked		
rsrq	Not Checked		
sinr	Not Checked		
}			
}			
}			
}			
}			
}			
}			
}			

Table 8.2.3.9.1.3.3-17: IdReportConfig-A3 (Table 8.2.3.9.1.3.3-14)

Derivation Path: 38.508-1 [4], Table 4.6.3-142 with condition EVENT_A3			
Information Element	Value/remark	Comment	Condition
ReportConfigNR ::= SEQUENCE {			
reportType CHOICE {			
eventTriggered SEQUENCE {			
eventId CHOICE {			
eventA3 SEQUENCE {			
a3-Offset CHOICE {			
rsrp	2		
}			
}			
}			
rsType	csi-rs		
reportQuantityRsIndexes CHOICE {			
rsrp	True		
}			
maxNrofRSIndexesToReport	2		
includeBeamMeasurements	True		
}			
}			

8.2.3.10 Measurement configuration control and reporting / SS/PBCH block based / CSI-RS based inter-frequency measurements / Measurement of Neighbour NR cell

8.2.3.10.1 Measurement configuration control and reporting / SS/PBCH block based / CSI-RS based Inter-frequency measurements / Measurement of Neighbour NR Cell / EN-DC

8.2.3.10.1.1 Test Purpose (TP)

(1)

```
with { UE in RRC_CONNECTED state in EN-DC mode and measurement configured for SS/PBCH measurement reporting of inter frequency on specified frequency }
ensure that {
  when { SS/PBCH block sorting quantity is above absThreshSS-BlocksConsolidation for each beam of NR Neighbour Cell }
  then { UE sends MeasurementReport message containing rsIndexResults with resultsSSB-Indexes }
}
```

(2)

```
with { UE in RRC_CONNECTED state in EN-DC mode and measurement configured for SS/PBCH measurement reporting of inter frequency on specified frequency }
ensure that {
  when { SS/PBCH block sorting quantity is below absThreshSS-BlocksConsolidation for one beam of NR Neighbour Cell and another beam(s) is above absThreshSS-BlocksConsolidation }
  then { UE sends MeasurementReport message containing rsIndexResults with resultsSSB-Indexes includes RsIndex above absThreshSS-BlocksConsolidation and excludes RsIndex below absThreshSS-BlocksConsolidation }
}
```

(3)

```
with { UE in RRC_CONNECTED state in EN-DC mode and measurement configured for CSI-RS measurement reporting of inter frequency on specified frequency }
ensure that {
```

```

when { CSI-RS sorting quantity is above absThreshCSI-RS-Consolidation for each beam of NR
Neighbour Cell }
  then { UE sends MeasurementReport message containing rsIndexResults with resultsCSI-RS-Indexes }
}

```

(4)

```

with { UE in RRC_CONNECTED state in EN-DC mode and measurement configured for CSI-RS measurement
reporting of inter frequency on specified frequency }
ensure that {
  when { CSI-RS sorting quantity is below absThreshCSI-RS-Consolidation for one beam of NR Neighbour
Cell and another beam(s) is above absThreshCSI-RS-Consolidation }
  then { UE sends MeasurementReport message containing rsIndexResults with resultsCSI-RS-Indexes
includes RsIndex above absThreshCSI-RS-Consolidation and excludes RsIndex below absThreshCSI-RS-
Consolidation }
}

```

8.2.3.10.1.2 Conformance requirements

References: The conformance requirements covered in the present TC are specified in: TS 38.331 clauses 5.5.5.1 and 5.5.5.2. Unless otherwise stated these are Rel-15 requirements.

[TS 38.331, clause 5.5.5.1]

The purpose of this procedure is to transfer measurement results from the UE to the network. The UE shall initiate this procedure only after successful security activation.

For the *measId* for which the measurement reporting procedure was triggered, the UE shall set the *measResults* within the *MeasurementReport* message as follows:

- 1> set the *measId* to the measurement identity that triggered the measurement reporting;
- 1> set the *measResultServingCell* within *measResultServingMOList* to include, for each cell that is configured with *servingCellMO*, RSRP, RSRQ and the available SINR for each configured serving cell derived based on the *rsType* if indicated in the associated *reportConfig*, otherwise based on SSB if available, otherwise based on CSI-RS;
- 1> set the *servingCellId* within *measResultServingMOList* to include for each NR serving cell that is configured, if any, the *servingCellMO*;
- 1> if the *reportConfig* associated with the *measId* that triggered the measurement reporting includes *reportQuantityRsIndexes* and *maxNrofRSIndexesToReport*:
 - 2> for each serving cell configured with *servingCellMO*, include beam measurement information according to the associated *reportConfig* as described in 5.5.5.2;
- 1> if the *reportConfig* associated with the *measId* that triggered the measurement reporting includes *reportAddNeighMeas*:
 - 2>for each serving cell frequency for which *measObjectId* is referenced in the *measIdList*, other than the *measObjectId* frequency corresponding with the *measId* that triggered the measurement reporting:
 - 3> set the *measResultBestNeighCell* within *measResultServingMOList* to include the *physCellId* and the available measurement quantities based on the *reportQuantityCell* and *rsType* indicated in *reportConfig* of the non-serving cell on the concerned serving frequency with the highest measured RSRP if RSRP measurement results are available for cells on this frequency, otherwise with the highest measured RSRQ if RSRQ measurement results are available for cells on this frequency, otherwise with the highest measured SINR;
 - 3> if the *reportConfig* associated with the *measId* that triggered the measurement reporting includes *reportQuantityRsIndexes* and *maxNrofRSIndexesToReport*:
 - 4> for each best non-serving cell included in the measurement report:
 - 5>include beam measurement information according to the associated *reportConfig* as described in 5.5.5.2;

- 1> if there is at least one applicable neighbouring cell to report:
 - 2> if the *reportType* is set to *eventTriggered* or *periodical*:
 - 3> set the *measResultNeighCells* to include the best neighbouring cells up to *maxReportCells* in accordance with the following:
 - 4> if the *reportType* is set to *eventTriggered*:
 - 5> include the cells included in the *cellsTriggeredList* as defined within the *VarMeasReportList* for this *measId*;
 - 4> else:
 - 5> include the applicable cells for which the new measurement results became available since the last periodical reporting or since the measurement was initiated or reset;
 - 5> if *reportQuantityRsIndexes* and *maxNrofRSIndexesToReport* are configured, include beam measurement information as described in 5.5.5.2;
 - 4> for each cell that is included in the *measResultNeighCells*, include the *physCellId*;
 - 4> if the *reportType* is set to *eventTriggered* or *periodical*:
 - 5> for each included cell, include the layer 3 filtered measured results in accordance with the *reportConfig* for this *measId*, ordered as follows:
 - 6> if the *measObject* associated with this *measId* concerns NR:
 - 7> if *rsType* in the associated *reportConfig* is set to *ssb*:
 - 8> set *resultsSSB-Cell* within the *measResult* to include the SS/PBCH block based quantity(ies) indicated in the *reportQuantityCell* within the concerned *reportConfig*, in order of decreasing trigger quantity, i.e. the best cell is included first;
 - 9> if *reportQuantityRsIndexes* and *maxNrofRSIndexesToReport* are configured, include beam measurement information as described in 5.5.5.2;
 - 7> else if *rsType* in the associated *reportConfig* is set to *csi-rs*:
 - 8> set *resultsCSI-RS-Cell* within the *measResult* to include the CSI-RS based quantity(ies) indicated in the *reportQuantityCell* within the concerned *reportConfig*, in order of decreasing trigger quantity, i.e. the best cell is included first;
 - 9> if *reportQuantityRsIndexes* and *maxNrofRSIndexesToReport* are, include beam measurement information as described in 5.5.5.2;

[TS 38.331, clause 5.5.5.1]

- 1> increment the *numberOfReportsSent* as defined within the *VarMeasReportList* for this *measId* by 1;
- 1> stop the periodical reporting timer, if running;
- 1> if the *numberOfReportsSent* as defined within the *VarMeasReportList* for this *measId* is less than the *reportAmount* as defined within the corresponding *reportConfig* for this *measId*:
 - 2> start the periodical reporting timer with the value of *reportInterval* as defined within the corresponding *reportConfig* for this *measId*;
- 1> else:
 - 2> if the *reportType* is set to *periodical*:
 - 3> remove the entry within the *VarMeasReportList* for this *measId*;
 - 3> remove this *measId* from the *measIdList* within *VarMeasConfig*;

- 1> if the UE is configured with EN-DC:
 - 2> if SRB3 is configured:
 - 3> submit the *MeasurementReport* message via SRB3 to lower layers for transmission, upon which the procedure ends;
 - 2>else:
 - 3> submit the *MeasurementReport* message via the EUTRA MCG embedded in E-UTRA RRC message *ULInformationTransferMRDC* as specified in TS 36.331 [10].
- 1> else:
 - 2>submit the *MeasurementReport* message to lower layers for transmission, upon which the procedure ends.

[TS 38.331, clause 5.5.5.2]

For beam measurement information to be included in a measurement report the UE shall:

- 1> if reportType is set to eventTriggered:
 - 2> consider the trigger quantity as the sorting quantity;
- 1> if reportType is set to periodical:
 - 2> if a single reporting quantity is set to TRUE in *reportQuantityRsIndexes*;
 - 3> consider the configured single quantity as the sorting quantity;
 - 2> else:
 - 3> if *rsrp* is set to TRUE;
 - 4> consider RSRP as the sorting quantity;
 - 3> else:
 - 4> consider RSRQ as the sorting quantity;
- 1> set *rsIndexResults* to include up to *maxNrofRsIndexesToReportSS/PBCH* block indexes or CSI-RS indexes in order of decreasing sorting quantity as follows:
 - 2> if the measurement information to be included is based on SS/PBCH block:
 - 3> include within *resultsSSB-Indexes* the index associated to the best beam for that SS/PBCH block sorting quantity and the remaining beams whose sorting quantity is above *absThreshSS-BlocksConsolidation* defined in the *VarMeasConfig* for the corresponding *measObject*;
 - 3> if *includeBeamMeasurements* is configured, include the SS/PBCH based measurement results for the quantities in *reportQuantityRsIndexes* set to TRUE for each SS/PBCH blockindex;2> else if the beam measurement information to be included is based on CSI-RS:
 - 2> else if the beam measurement information to be included is based on CSI-RS:
 - 3> include within *resultsCSI-RS-Indexes* the index associated to the best beam for that CSI-RS sorting quantity and the remaining beams whose sorting quantity is above *absThreshCSI-RS-Consolidation* defined in the *VarMeasConfig* for the corresponding *measObject*;
 - 3> if *includeBeamMeasurements* is configured, include the CSI-RS based measurement results for the quantities in *reportQuantityRsIndexes* set to TRUE for each CSI-RS index.

8.2.3.10.1.3 Test description

8.2.3.10.1.3.1 Pre-test conditions

System Simulator:

- EUTRA Cell 1 is the PCell and NR Cell 1 is the PS Cell and NR Cell 3 is the inter-frequency neighbour cell of NR Cell 1. NR Cell 3 has two beams with index#0 and index#1.

UE:

- None

Preamble:

- The UE is in state RRC_CONNECTED in EN-DC using generic procedure parameter Connectivity (EN-DC) and DC Bearers (MCG(s) and SCG) on E-UTRA Cell 1 according to TS 38.508-1 [4].

8.2.3.10.1.3.2 Test procedure sequence

Table 8.2.3.10.1.3.2-1 and Table 8.2.3.10.1.3.2-1A illustrates the downlink power levels to be applied for NR Cell 1 and NR Cell 3 at various time instants of the test execution. Row marked "T0" denotes the conditions after the preamble, while rows marked "T1" and "T2" are to be applied subsequently. The exact instants on which these values shall be applied are described in the texts in this clause.

Table 8.2.3.10.1.3.2-1: Time instances of cell power level and parameter changes for FR1

	Parameter	Unit	E-UTRA Cell 1	NR Cell 1	NR Cell 3	NR Cell 3 Beam Index# 0	NR Cell 3 Beam Index# 1	Remark
T0	Cell-specific RS EPRE	dBm/15k Hz	-85	-	-	-	-	
	SS/PBCH SSS EPRE	dBm/SC S	-	-94	-98	-98	-98	
T1	Cell-specific RS EPRE	dBm/15k Hz	-85	-	-	-	-	$Mn + Ofn + Ocn - Hys > Mp + Ofp + Ocp + Off$ Power level is such that SS/PBCH quality of NR Cell 3, BeamIndex#0 and BeamIndex#1 is above <i>absThreshSS-BlocksConsolidation</i> .
	SS/PBCH SSS EPRE	dBm/SC S	-	-106	-98	-98	-98	
T3	Cell-specific RS EPRE	dBm/15k Hz	-85	-	-	-	-	$Mn + Ofn + Ocn + Hys < Mp + Ofp + Ocp + Off$ Power level is such that SS/PBCH quality of NR Cell 3, BeamIndex#0 and BeamIndex#1 is below <i>absThreshSS-BlocksConsolidation</i> .
	SS/PBCH SSS EPRE	dBm/SC S	-	-94	-98	-98	-98	
T2	Cell-specific RS EPRE	dBm/15k Hz	-85	-	-	-	-	Power level is such that SS/PBCH quality of NR Cell 3 is BeamIndex#0 is above <i>absThreshSS-BlocksConsolidation</i> and BeamIndex#1 is below <i>absThreshSS-BlocksConsolidation</i> .
	SS/PBCH SSS EPRE	dBm/SC S	-	-106	-98	-98] -98	

Table 8.2.3.10.1.3.2-1A: Time instances of cell power level and parameter changes for FR2

	Parameter	Unit	E-UTRA Cell 1	NR Cell 1	NR Cell 3	NR Cell 3 Beam Index# 0	NR Cell 3 Beam Index# 1	Remark
T0	Cell-specific RS EPRE	dBm/15k Hz	-85	-	-	-	-	
	SS/PBCH SSS EPRE	dBm/SC S	-	[-94]	[FFS]	[FFS]	[FFS]	
T1	Cell-specific RS EPRE	dBm/15k Hz	-85	-	-	-	-	$Mn + Ofn + Ocn - Hys > Mp + Ofp + Ocp + Off$ Power level is such that SS/PBCH quality of NR Cell 3, BeamIndex#0 and BeamIndex#1 is above <i>absThreshSS-BlocksConsolidation</i> .
	SS/PBCH SSS EPRE	dBm/SC S	-	[-100]	[FFS]	[FFS]	[FFS]	
T3	Cell-specific RS EPRE	dBm/15k Hz	-85	-	-	-	-	
	SS/PBCH SSS EPRE	dBm/SC S	-	[-94]	[FFS]	[FFS]	[FFS]	
T2	Cell-specific RS EPRE	dBm/15k Hz	-85	-	-	-	-	Power level is such that SS/PBCH quality of NR Cell 3 is BeamIndex#0 is above <i>absThreshSS-BlocksConsolidation</i> and BeamIndex#1 is below <i>absThreshSS-BlocksConsolidation</i> .
	SS/PBCH SSS EPRE	dBm/SC S	-	[-100]	[FFS]	[FFS]	[FFS]	

Table 8.2.3.10.1.3.2-2: Main behaviour

St	Procedure	Message Sequence		TP	Verdict
		U - S	Message		
1	The SS transmits an <i>RRCCONNECTIONRECONFIGURATION</i> message containing NR <i>RRCReconfiguration</i> including <i>measConfig</i> to setup SS/PBCH block based inter-frequency NR measurement for PSCell (NR Cell 1) and reporting for A3.	<--	<i>RRCCONNECTIONRECONFIGURATION(RRCReconfiguration)</i>	-	-
2	The UE transmits an <i>RRCCONNECTIONRECONFIGURATIONCOMPLETE</i> message containing NR <i>RRCReconfigurationComplete</i> .	-->	<i>RRCCONNECTIONRECONFIGURATIONCOMPLETE(RRCReconfigurationComplete)</i>	-	-
3	The SS re-adjusts the cell-specific reference signal level according to row "T1".	-	-	-	-
4	Check: Does the UE transmit a <i>MEASUREMENTREPORT</i> message to report event A3 with the measured results for NR Cell 3 with beam information containing <i>RsIndex[0]</i> and <i>RsIndex[1]</i> ?	-->	<i>ULINFORMATIONTRANSFERMRDC(MEASUREMENTREPORT)</i>	1	P
4A	The SS changes NR Cell 1 and E-UTRA Cell 1 parameters according to the row "T3".	-	-	-	-
4B	Check: Does the UE transmit a <i>MEASUREMENTREPORT</i> message on E-UTRA Cell 1 to report the event A3 during the next 10s?1.	-	-	1	F
5	The SS re-adjusts the cell-specific reference signal level according to row "T2".	-	-	-	-
6	Check: Does the UE transmit a <i>MEASUREMENTREPORT</i> message to report event A3 with the measured results for NR Cell 3 with beam information containing <i>RsIndex[0]</i> and excludes <i>RsIndex[1]</i> ?	-->	<i>ULINFORMATIONTRANSFERMRDC(MEASUREMENTREPORT)</i>	2	P
7	The SS transmits an <i>RRCCONNECTIONRECONFIGURATION</i> message containing NR <i>RRCReconfiguration</i> including <i>measConfig</i> to remove SS/PBCH block based inter-frequency NR measurement for PSCell (NR Cell 1) and reporting for event A3.	<--	<i>RRCCONNECTIONRECONFIGURATION(RRCReconfiguration)</i>	-	-
8	The UE transmits an <i>RRCCONNECTIONRECONFIGURATIONCOMPLETE</i> message containing NR <i>RRCReconfigurationComplete</i> .	-->	<i>RRCCONNECTIONRECONFIGURATIONCOMPLETE(RRCReconfigurationComplete)</i>	-	-
9	The SS transmits an <i>RRCCONNECTIONRECONFIGURATION</i> message containing NR <i>RRCReconfiguration</i> including <i>measConfig</i> to setup CSI-RS based inter-frequency NR measurement for PSCell (NR Cell 1) and event A3.	<--	<i>RRCCONNECTIONRECONFIGURATION(RRCReconfiguration)</i>	-	-
10	The UE transmits an <i>RRCCONNECTIONRECONFIGURATIONCOMPLETE</i> message.	-->	<i>RRCCONNECTIONRECONFIGURATIONCOMPLETE(RRCReconfigurationComplete)</i>	-	-
11	The SS re-adjusts the cell-specific reference signal level according to row "T1".	-	-	-	-
12	Check: Does the UE transmit a <i>MEASUREMENTREPORT</i> message to report event A3 with the measured results for NR Cell 3 with beam information containing <i>RsIndex[0]</i> and <i>RsIndex[1]</i> ?	-->	<i>ULINFORMATIONTRANSFERMRDC(MEASUREMENTREPORT)</i>	3	P
12A	The SS changes NR Cell 1 and E-UTRA Cell 1 parameters according to the row "T3".	-	-	-	-
12B	Check: Does the UE transmit a <i>MEASUREMENTREPORT</i> message on E-UTRA Cell 1 to report the event A3 during the next 10s?	-	-	-	-
13	The SS re-adjusts the cell-specific reference signal level according to row "T2".	-	-	-	-
14	Check: Does the UE transmit a <i>MEASUREMENTREPORT</i> message to report event A3 with the measured results for NR Cell 3 with beam information containing <i>RsIndex[0]</i> and excludes <i>RsIndex[1]</i> ?	-->	<i>ULINFORMATIONTRANSFERMRDC(MEASUREMENTREPORT)</i>	4	P

8.2.3.10.1.3.3 Specific message contents

Table 8.2.3.10.1.3.3-1: RRCConnectionReconfiguration (steps 1, 7, 9. Table 8.2.3.10.1.3.2-2)

Derivation Path: 36.508 [7], Table 4.6.1-8 with condition EN-DC_EmbedNR_RRCRecon

Table 8.2.3.10.1.3.3-2: RRCReconfiguration (Table 8.2.3.10.1.3.3-1)

Derivation Path: 38.508-1 [4], Table 4.6.1-13

Table 8.2.3.10.1.3.3-3: MeasConfig (Table 8.2.3.10.1.3.3-2,)

Derivation Path: 38.508-1 [4], Table 4.6.3-69			
Information Element	Value/remark	Comment	Condition
MeasConfig ::= SEQUENCE {			
measObjectToAddModList	IdMeasObjectToAdd		
reportConfigToAddModList	IdReportConfigToAdd		
measIdToAddModList	IdMeasIdToAdd		
s-MeasureConfig CHOICE {			
ssb-rsrp	45		
}			
}			

Table 8.2.3.10.1.3.3-4: IdMeasObjectToAdd (Table 8.2.3.10.1.3.3-3, Table 8.2.3.10.1.3.3-12, Table 8.2.3.10.1.3.3-14)

Derivation Path: TS 38.331 [6], clause 6.3.2			
Information Element	Value/remark	Comment	Condition
MeasObjectToAddModList ::= SEQUENCE (SIZE (1..maxNrofMeasId)) OF SEQUENCE {	2 entries		
measObjectId[1]	1		
measObject[1] CHOICE {			
measObjectNR	Id-MeasObjectNR-f1		
}			
measObjectId[2]	2		
measObject[2] CHOICE {			
measObjectNR	Id-MeasObjectNR-f2		
}			
}			

Table 8.2.3.10.1.3.3-5: Id-MeasObjectNR-f1 (Table 8.2.3.10.1.3.3-4)

Derivation Path: 38.508-1 [4], Table 4.6.3-76			
Information Element	Value/remark	Comment	Condition
MeasObjectNR ::= SEQUENCE {			
ssbFrequency	Downlink ARFCN of NCell 1		
absThreshSS-BlocksConsolidation SEQUENCE {			
thresholdRSRP	-106		
}			
}			

Table 8.2.3.10.1.3.3-5A: Id-MeasObjectNR-f2 (Table 8.2.3.10.1.3.3-4)

Derivation Path: 38.508-1 [4], Table 4.6.3-76			
Information Element	Value/remark	Comment	Condition
MeasObjectNR ::= SEQUENCE {			
ssbFrequency	Downlink ARFCN of NCell 3		
absThreshSS-BlocksConsolidation SEQUENCE {			
thresholdRSRP	-90		
}			
referenceSignalConfig SEQUENCE {			
ssb-ConfigMobility SEQUENCE {			
ssb-ToMeasure CHOICE {			
setup CHOICE {			
shortBitmap	1100		(FREQ<=3G Hz AND (FR1_FDD OR NOT CASE_C)) OR (FREQ<=2.4 GHz AND FR1_TDD)
mediumBitmap	11000000		(FREQ>3G Hz AND FR1) OR (FREQ>2.4 GHz AND FR1_TDD AND CASE_C)
longBitmap	11000000 00000000 00000000 00000000 00000000 00000000 00000000 00000000		FR2
}			
}			
deriveSSB-IndexFromCell	true		
ss-RSSI-Measurement	Not present		
}			
csi-rs-ResourceConfigMobility	Not present		
}			
}			

Table 8.2.3.10.1.3.3-6: IdReportConfigToAdd (Table 8.2.3.10.1.3.3-3, Table 8.2.3.10.1.3.3-12)

Derivation Path: TS 38.331 [6], clause 6.3.2			
Information Element	Value/remark	Comment	Condition
ReportConfigToAddModList ::= SEQUENCE(SIZE (1..maxReportConfigId)) OF SEQUENCE {	1 entry		
reportConfigId[1]	1		
reportConfig[1] CHOICE {			
reportConfigNR	IdReportConfig-A3		
}			
}			

Table 8.2.3.10.1.3.3-7: IdReportConfig-A3 (Table 8.2.3.10.1.3.3-3)

Derivation Path: 38.508-1 [4], Table 4.6.3-142 with condition EVENT_A3			
Information Element	Value/remark	Comment	Condition
ReportConfigNR ::= SEQUENCE {			
reportType CHOICE {			
eventTriggered SEQUENCE {			
eventId CHOICE {			
eventA3 SEQUENCE {			
a3-Offset CHOICE {			
rsrp	2		
}			
}			
}			
reportQuantityRsIndexes CHOICE {			
rsrp	True		
}			
maxNrofRSIndexesToReport	2		
includeBeamMeasurements	True		
}			
reportAmount	r1		
}			

Table 8.2.3.10.1.3.3-8: IdMeasIdToAdd (Table 8.2.3.10.1.3.3-3, Table 8.2.3.10.1.3.3-12 Table 8.2.3.10.1.3.3-14)

Derivation Path: TS 38.331 [6], clause 6.3.2			
Information Element	Value/remark	Comment	Condition
MeasIdToAddModList ::= SEQUENCE (SIZE (1..maxNrofMeasId)) OF SEQUENCE {	1 entry		
measId[1]	1		
measObjectId[1]	2		
reportConfigId[1]	1		
}			

Table 8.2.3.10.1.3.3-9: RRCConnectionReconfigurationComplete (steps 2, 8, 10, Table 8.2.3.10.1.3.2-2)

Derivation Path: 36.508 [7], Table 4.6.1-9 with condition MCG_and_SCG			
---	--	--	--

Table 8.2.3.10.1.3.3-10: ULInformationTransferMRDC (steps 4, 6,12,14 Table 8.2.3.10.1.3.2-2)

Derivation Path: 36.508 [7], Table 4.6.1-27			
Information Element	Value/remark	Comment	Condition
ULInformationTransferMRDC-r15 ::= SEQUENCE {			
criticalExtensions CHOICE {			
c1 CHOICE {			
ulInformationTransferMRDC-r15 SEQUENCE {			
ul-DCCH-MessageNR-r15	OCTET STRING containing NR RRC MeasurementReport		
}			
}			
}			
}			

Table 8.2.3.10.1.3.3-11: MeasurementReport (step 4, Table 8.2.3.10.1.3.2-2)

Derivation Path: TS 38.331 [6], clause 6.2.2			
Information Element	Value/remark	Comment	Condition
MeasurementReport ::= SEQUENCE {			
criticalExtensions CHOICE {			
c1 CHOICE {			
measurementReport ::= SEQUENCE {			
measResults SEQUENCE {			
measId	2		
measResultServingMOList SEQUENCE {	1 entry		
servFreqId	Not checked		
measResultServingCell SEQUENCE {			
physCellId	Physical CellID of the NR Cell 1		
cgi-Info	Not present		
measResult SEQUENCE {			
cellResults SEQUENCE {			
resultsSSB-Cell SEQUENCE {			
rsrp	Not checked		
rsrq	Not checked		
sinr	Not checked		
}			
}			
rsIndexResults	Not checked		
}			
}			
}			
measResultNeighCells CHOICE {			
measResultListNR SEQUENCE {	1 entry		
physCellId	Physical CellID of the NR Cell 3		
cgi-Info	Not present		
measResult SEQUENCE {			
cellResults SEQUENCE {			
resultsSSB-Cell SEQUENCE {			
rsrp	Not checked		
rsrq	Not checked		
sinr	Not checked		
}			
}			
rsIndexResults SEQUENCE {			
resultsSSB-Indexes SEQUENCE {	Contains SSB index for BeamIndex0 and BeamIndex1		
ssb-Index	SSB index for BeamIndex0		BeamIndex0
ssb-Results SEQUENCE {			
rsrp	Not checked		
rsrq	Not checked		
sinr	Not checked		
}			
ssb-Index	SSB index for BeamIndex1		BeamIndex1
ssb-Results SEQUENCE {			
rsrp	Not checked		
rsrq	Not checked		
sinr	Not checked		
}			
resultsCSI-RS-Indexes	Not present		
}			
}			
}			
}			
}			

}			
}			
}			

Table 8.2.3.10.1.3.3-12: MeasurementReport (step 6, Table 8.2.3.10.1.3.2-2)

Derivation Path: TS 38.331 [6], clause 6.2.2			
Information Element	Value/remark	Comment	Condition
MeasurementReport ::= SEQUENCE {			
criticalExtensions CHOICE {			
c1 CHOICE {			
measurementReport ::= SEQUENCE {			
measResults SEQUENCE {			
measId	2		
measResultServingList SEQUENCE {	1 entry		
servFreqId	Not checked		
measResultServingCell SEQUENCE {			
physCellId	Physical CellID of the NR Cell 1		
cgi-Info	Not present		
measResult SEQUENCE {			
cellResults SEQUENCE {			
resultsSSB-Cell SEQUENCE {			
rsrp	Not checked		
rsrq	Not checked		
sinr	Not checked		
}			
}			
rsIndexResults	Not checked		
}			
}			
}			
measResultNeighCells CHOICE {			
measResultListNR SEQUENCE {	1 entry		
physCellId	Physical CellID of the NR Cell 3		
cgi-Info	Not present		
measResult SEQUENCE {			
cellResults SEQUENCE {			
resultsSSB-Cell SEQUENCE {			
rsrp	Not checked		
rsrq	Not checked		
sinr	Not checked		
}			
}			
rsIndexResults SEQUENCE {			
resultsSSB-Indexes SEQUENCE {	1 entry		
ssb-Index	Ssb index of BeamIndex#0		
ssb-Results SEQUENCE {			
rsrp	Not checked		
rsrq	Not checked		
sinr	Not checked		
}			
}			
resultsCSI-RS-Indexes	Not present		
}			
}			
}			
}			
}			
}			

Table 8.2.3.10.1.3.3-13: MeasConfig (step 7, Table 8.2.3.10.1.3.3-2)

Derivation Path: 38.508-1 [4], Table 4.6.3-69			
Information Element	Value/remark	Comment	Condition
MeasConfig ::= SEQUENCE {			
measObjectToAddModList	Not Present		
measIdToRemoveList SEQUENCE (SIZE (1..maxMeasId)) OF SEQUENCE {	1 entry		
Meas-Id[1]	1		
}			
reportConfigToAddModList	Not Present		
measIdToAddModList	Not Present		
}			

Table 8.2.3.10.1.3.3-14: MeasConfig (step 9, Table 8.2.3.10.1.3.3-2)

Derivation Path: 38.508-1 [4], Table 4.6.3-69			
Information Element	Value/remark	Comment	Condition
MeasConfig ::= SEQUENCE {			
measObjectToAddModList	IdMeasObjectToAdd		
reportConfigToAddModList	IdReportConfigToAdd		
measIdToAddModList	IdMeasIdToAdd		
s-MeasureConfig CHOICE {			
csi-rsrp	[45]		
}			
}			

Table 8.2.3.10.1.3.3-14A: IdMeasObjectToAdd (Table 8.2.3.9.1.3.3-14)

Derivation Path: TS 38.331 [6], clause 6.3.2			
Information Element	Value/remark	Comment	Condition
MeasObjectToAddModList ::= SEQUENCE (SIZE (1..maxNrofMeasId)) OF SEQUENCE {	1 entry		
measObjectId[1]	1		
measObject CHOICE {			
measObjectNR	Id-MeasObjectNR-f1		
}			
measObjectId[2]	2		
measObject[2] CHOICE {			
measObjectNR	Id-MeasObjectNR-f2		
}			
}			

Table 8.2.3.10.1.3.3-14B: Id-MeasObjectNR-f1 (Table 8.2.3.10.1.3.3-4)

Derivation Path: 38.508-1 [4], Table 4.6.3-76			
Information Element	Value/remark	Comment	Condition
MeasObjectNR ::= SEQUENCE {			
ssbFrequency	Downlink ARFCN of NCell 1		
absThreshSS-BlocksConsolidation SEQUENCE {			
thresholdRSRP	-106		
}			
}			

Table 8.2.3.10.1.3.3-14C: Id-MeasObjectNR-f2 (Table 8.2.3.9.1.3.3-14A)

}			
---	--	--	--

Table 8.2.3.10.1.3.3-15: MeasurementReport (step 12, Table 8.2.3.10.1.3.2-2)

Derivation Path: TS 38.331 [6], clause 6.2.2			
Information Element	Value/remark	Comment	Condition
MeasurementReport ::= SEQUENCE {			
criticalExtensions CHOICE {			
c1 CHOICE {			
measurementReport ::= SEQUENCE {			
measResults SEQUENCE {			
measId	2		
measResultServingMOList SEQUENCE {	1 entry		
servFreqId	Not checked		
measResultServingCell SEQUENCE {			
physCellId	Physical CellID of the NR Cell 1		
cgi-Info	Not present		
measResult SEQUENCE {			
cellResults SEQUENCE {			
resultsSSB-Cell SEQUENCE {			
rsrp	Not checked		
rsrq	Not checked		
sinr	Not checked		
}			
}			
rsIndexResults SEQUENCE {			
resultsCSI-RS-Indexes	Not Checked		
}			
}			
}			
measResultNeighCells CHOICE {			
measResultListNR SEQUENCE {	1 entry		
physCellId	Physical CellID of the NR Cell 3		
cgi-Info	Not present		
measResult SEQUENCE {			
cellResults SEQUENCE {			
resultsSSB-Cell SEQUENCE {			
rsrp	Not checked		
rsrq	Not checked		
sinr	Not checked		
}			
}			
rsIndexResults SEQUENCE {			
resultsSSB-Indexes	Not Present		
resultsCSI-RS-Indexes SEQUENCE {	Contains CSI-RS index for BeamIndex0		
csi-RS-Index	CSI-Rs-Index of BeamIndex#0		BeamIndex# 0
csi-RS--Results SEQUENCE {			
rsrp	Not checked		
rsrq	Not checked		
sinr	Not checked		
}			
csi-RS-Index			BeamIndex1
csi-RS--Results SEQUENCE {	CSI-RS-index for BeamIndex0		
rsrp	Not checked		
rsrq	Not checked		
sinr	Not checked		
}			
}			
}			
}			
}			
}			
}			

}			
}			

Table 8.2.3.10.1.3.3-16: MeasurementReport (step 14, Table 8.2.3.10.1.3.2-2)

Derivation Path: TS 38.331 [6], clause 6.2.2			
Information Element	Value/remark	Comment	Condition
MeasurementReport ::= SEQUENCE {			
criticalExtensions CHOICE {			
c1 CHOICE {			
measurementReport ::= SEQUENCE {			
measResults SEQUENCE {			
measId	2		
measResultServingMOList SEQUENCE {	1 entry		
servFreqId	Not checked		
measResultServingCell SEQUENCE {			
physCellId	Physical CellID of the NR Cell 1		
cgi-Info	Not present		
measResult SEQUENCE {			
cellResults SEQUENCE {			
resultsSSB-Cell SEQUENCE {			
rsrp	Not checked		
rsrq	Not checked		
sinr	Not checked		
}			
}			
rsIndexResults	Not checked		
}			
}			
}			
measResultNeighCells CHOICE {			
measResultListNR SEQUENCE {	1 entry		
physCellId	Physical CellID of the NR Cell 3		
cgi-Info	Not present		
measResult SEQUENCE {			
cellResults SEQUENCE {			
resultsSSB-Cell SEQUENCE {			
rsrp	Not checked		
rsrq	Not checked		
sinr	Not checked		
}			
}			
rsIndexResults SEQUENCE {			
resultsSSB-Indexes	Not Present		
resultsCSI-RS-Indexes SEQUENCE {	1 entry		
csi-RS-Index	Contains CSI-RS index for BeamIndex0		
csi-RS--Results SEQUENCE {			
rsrp	Not checked		
rsrq	Not checked		
sinr	Not checked		
}			
}			
}			
}			
}			

Table 8.2.3.10.1.3.3-17: IdReportConfig-A3 (Table 8.2.3.10.1.3.3-14)

Derivation Path: 38.508-1 [4], Table 4.6.3-142 with condition EVENT_A3			
Information Element	Value/remark	Comment	Condition
ReportConfigNR ::= SEQUENCE {			
reportType CHOICE {			
eventTriggered SEQUENCE {			
eventId CHOICE {			
eventA3 SEQUENCE {			
a3-Offset CHOICE {			
Rsrp	2		
}			
}			
}			
rsType	csi-rs		
reportQuantityRsIndexes CHOICE {			
Rsrp	True		
}			
maxNrofRSIndexesToReport	2		
includeBeamMeasurements	True		
}			
}			

8.2.3.11 Measurement configuration control and reporting / Measurement Gaps

8.2.3.11.1 Measurement configuration control and reporting / Measurement Gaps / NR FR1 / EN-DC

8.2.3.11.1.1 Test Purpose (TP)

(1)

```
with { UE in RRC_CONNECTED state with EN-DC, and, MCG (E-UTRA PDCP) and SCG }
ensure that {
  when { UE receives RRCConnectionReconfiguration message to setup fr1-Gap to report periodical
measurements for LTE serving and NR neighbor cell on FR1 frequency }
  then { UE applies fr1-Gap and sends periodical measurement reports for LTE serving and NR
neighbor cell on FR1 frequency }
}
```

(2)

```
with { UE in RRC_CONNECTED state with EN-DC, and, MCG (E-UTRA PDCP) and SCG }
ensure that {
  when { UE receives RRCConnectionReconfiguration message to setup fr1-Gap and nr-Config IE
containing MeasConfig to report periodical measurements for NR serving and neighbor cells on FR1
frequency }
  then { UE applies fr1-Gap and sends periodical measurement reports for NR serving and neighbor
cells on FR1 frequency }
}
```

8.2.3.11.1.2 Conformance requirements

References: The conformance requirements covered in the current TC are specified in: TS 36.331, clause 5.3.5.3 and 5.5.2.9, and TS 38.331, clause 5.5.2.1 and 5.5.5.1. Unless otherwise stated these are Rel-15 requirements.

[TS 36.331, clause 5.3.5.3]

If the *RRCConnectionReconfiguration* message does not include the *mobilityControlInfo* and the UE is able to comply with the configuration included in this message, the UE shall:

...

- 1> if the received *RRCConnectionReconfiguration* includes the *nr-SecondaryCellGroupConfig*:
 - 2> perform NR RRC Reconfiguration as specified in TS 38.331 [82], clause 5.3.5.3;
- ...
- 1> if the *RRCConnectionReconfiguration* message includes the *measConfig*:
 - 2> perform the measurement configuration procedure as specified in 5.5.2;
- ...
- 1> set the content of *RRCConnectionReconfigurationComplete* message as follows:
 - ...
 - 2> if the received *RRCConnectionReconfiguration* message included *nr-SecondaryCellGroupConfig*:
 - 3> include *scg-ConfigResponseNR* in accordance with TS 38.331 [82, 5.3.5.3];
- 1> submit the *RRCConnectionReconfigurationComplete* message to lower layers for transmission using the new configuration, upon which the procedure ends;

[TS 36.331, clause 5.5.2.9]

The UE shall:

- 1> if *measGapConfig* is set to *setup*:
 - 2> if a measurement gap configuration *measGapConfig* or *measGapConfigPerCC-List* is already setup, release the measurement gap configuration;
 - 2> if the *gapOffset* in *measGapConfig* indicates a non-uniform gap pattern:
 - ...
 - 2> else:
 - 3> setup the measurement gap configuration indicated by the *measGapConfig* in accordance with the received *gapOffset*, i.e., the first subframe of each gap occurs at an SFN and subframe meeting the following condition (SFN and subframe of MCG cells):

$$\text{SFN mod } T = \text{FLOOR}(\text{gapOffset}/10);$$

$$\text{subframe} = \text{gapOffset mod } 10;$$
 with $T = \text{MGRP}/10$ as defined in TS 36.133 [16];
 - 2> if EN-DC is configured:
 - 3> if the UE is configured with *fr1-Gap* set to *TRUE*:
 - 4> apply the gap configuration for LTE serving cells and for NR serving cells on FR1;
 - 3> else:
 - 4> apply the gap configuration for all LTE and NR serving cells;
 - 2> if *mgta* is set to *TRUE*, apply a timing advance value of 0.5ms to the gap occurrences calculated above according to TS 38.133 [16];

NOTE 1: The UE applies a single gap, which timing is relative to the MCG cells, even when configured with DC. In case of EN-DC, the UE may either be configured with a single (common) gap or with two separate gaps i.e. a first one for FR1 (configured by E-UTRA RRC) and a second one for FR2 (configured by NR RRC).

- 1> else if *measGapConfig* is set to *release*:

2> release the measurement gap configuration *measGapConfig*;

...

[TS 38.331, clause 5.5.2.1]

The network applies the procedure as follows:

- to ensure that, whenever the UE has a *measConfig*, it includes a *measObject* for the SpCell and for each NR SCell to be measured;
- to configure at most one measurement identity using a reporting configuration with the *reportType* set to *reportCGI*;
- to ensure that, for all SSB based reporting configurations have at most one measurement object with the same *ssbFrequency* and *ssbSubcarrierSpacing*;

The UE shall:

- 1> if the received *measConfig* includes the *measObjectToRemoveList*:
 - 2> perform the measurement object removal procedure as specified in 5.5.2.4;
- 1> if the received *measConfig* includes the *measObjectToAddModList*:
 - 2> perform the measurement object addition/modification procedure as specified in 5.5.2.5;
- 1> if the received *measConfig* includes the *reportConfigToRemoveList*:
 - 2> perform the reporting configuration removal procedure as specified in 5.5.2.6;
- 1> if the received *measConfig* includes the *reportConfigToAddModList*:
 - 2> perform the reporting configuration addition/modification procedure as specified in 5.5.2.7;
- 1> if the received *measConfig* includes the *quantityConfig*:
 - 2> perform the quantity configuration procedure as specified in 5.5.2.8;
- 1> if the received *measConfig* includes the *measIdToRemoveList*:
 - 2> perform the measurement identity removal procedure as specified in 5.5.2.2;
- 1> if the received *measConfig* includes the *measIdToAddModList*:
 - 2> perform the measurement identity addition/modification procedure as specified in 5.5.2.3;
- 1> if the received *measConfig* includes the *measGapConfig*:
 - 2> perform the measurement gap configuration procedure as specified in 5.5.2.9;

...

[TS 38.331, clause 5.5.5.1]



Figure 5.5.5.1-1: Measurement reporting

The purpose of this procedure is to transfer measurement results from the UE to the network. The UE shall initiate this procedure only after successful security activation.

For the *measId* for which the measurement reporting procedure was triggered, the UE shall set the *measResults* within the *MeasurementReport* message as follows:

- 1> set the *measId* to the measurement identity that triggered the measurement reporting;
- 1> set the *measResultServingCell* within *measResultServingMOList* to include RSRP, RSRQ and the available SINR for each configured serving cell derived based on the *rsType* indicated in the associated *reportConfig*;
- 1> set the *measResultServingCell* within *measResultServingMOList* to include for each NR serving cell that is configured with *servingCellMO*, if any, the *servCellId*;
- 1> if the *reportConfig* associated with the *measId* that triggered the measurement reporting includes *reportQuantityRsIndexes* and *maxNrofRSIndexesToReport*:
 - 2> for each serving cell configured with *servingCellMO*, include beam measurement information according to the associated *reportConfig* as described in 5.5.5.2;
- ...
- 1> if there is at least one applicable neighbouring cell to report:
 - 2> set the *measResultNeighCells* to include the best neighbouring cells up to *maxReportCells* in accordance with the following:
 - 3> if the *reportType* is set to *eventTriggered*:
 - 4> include the cells included in the *cellsTriggeredList* as defined within the *VarMeasReportList* for this *measId*;
 - 3> else:
 - 4> include the applicable cells for which the new measurement results became available since the last periodical reporting or since the measurement was initiated or reset;
 - 4> if *reportQuantityRsIndexes* and *maxNrofRSIndexesToReport* are configured, include beam measurement information as described in 5.5.5.2;
 - 3> for each cell that is included in the *measResultNeighCells*, include the *physCellId*;
 - ...
 - 3> if the *reportType* is set to *periodical*:
 - 4> if a single reporting quantity is set to *TRUE* in *reportQuantityRsIndexes*:
 - 5> consider the configured single quantity as the sorting quantity;
 - 4> else:
 - 5> if *rsrp* is set to *TRUE*;
 - 6> consider RSRP as the sorting quantity;
 - 5> else:
 - 6> consider RSRQ as the sorting quantity;
 - ...
 - 1> increment the *numberOfReportsSent* as defined within the *VarMeasReportList* for this *measId* by 1;
 - 1> stop the periodical reporting timer, if running;
 - 1> if the *numberOfReportsSent* as defined within the *VarMeasReportList* for this *measId* is less than the *reportAmount* as defined within the corresponding *reportConfig* for this *measId*:

- 2> start the periodical reporting timer with the value of *reportInterval* as defined within the corresponding *reportConfig* for this *measId*;
- 1> else:
 - 2> if the *reportType* is set to *periodical*:
 - 3> remove the entry within the *VarMeasReportList* for this *measId*;
 - 3> remove this *measId* from the *measIdList* within *VarMeasConfig*;
- 1> if the UE is configured with EN-DC:
 - 2> if SRB3 is configured:
 - 3> submit the *MeasurementReport* message via SRB3 to lower layers for transmission, upon which the procedure ends;
 - 2> else:
 - 3> submit the *MeasurementReport* message via the EUTRA MCG embedded in E-UTRA RRC message *ULInformationTransferMRDC* as specified in TS 36.331 [10].

...

8.2.3.11.1.3 Test description

8.2.3.11.1.3.1 Pre-test conditions

System Simulator:

- E-UTRA Cell 1 is PCell , NR Cell 1 is PSCell on FR1 and NR Cell 3 is inter-frequency neighbour Cell on FR1.

UE:

- None.

Preamble:

- The UE is in state RRC_CONNECTED using generic procedure parameter Connectivity (*EN-DC*) and Bearers (*MCG and SCG*) established according to TS 38.508-1 [4].

8.2.3.11.1.3.2 Test procedure sequence

Table 8.2.3.11.3.2-1 illustrates the downlink power levels and other changing parameters to be applied for the cells at various time instants of the test execution. Row marked "T0" denotes the initial conditions after preamble. The exact instants on which these values shall be applied are described in the texts in this clause.

Table 8.2.3.11.1.3.2-1: Time instances of cell power level and parameter changes

	Parameter	Unit	E-UTRA Cell 1	NR Cell 1	NR Cell 3	Remark
T0	Cell-specific RS EPRE	dBm/15 kHz	-85	-	-	Switch on NR neighbour Cell and UE start to perform E-UTRA interRAT measurement.
	SS/PBCH SSS EPRE	dBm/SCS	-	-88	-88	

Table 8.2.3.11.1.3.2-2: Main behaviour

St	Procedure	Message Sequence		TP	Verdict
		U - S	Message		
1	The SS transmits an <i>RRCCONNECTIONRECONFIGURATION</i> message to setup fr1-Gap for report periodical measurements for E-UTRA serving Cell 1 and NR neighbor cell 3 on FR1 frequency.	<--	<i>RRCCONNECTIONRECONFIGURATION</i>	-	-
2	The UE transmits an <i>RRCCONNECTIONRECONFIGURATIONCOMPLETE</i> message to confirm the setup of fr1-Gap and report periodical measurements for E-UTRA serving cell1 and NR neighbor cell 3 on FR1 frequency.	-->	<i>RRCCONNECTIONRECONFIGURATIONCOMPLETE</i>	-	-
3	Wait and ignore <i>MEASUREMENTREPORT</i> messages for 8 s to allow UE to measure the neighbouring cells.	-	-	-	-
-	EXCEPTION: In parallel to events described in step 4 the steps specified in table 8.2.3.11.1.3.2-3 shall take place.	-	-	-	-
4	Wait for 30 s to ensure that the UE performs a periodical inter frequency reporting.	-	-	-	-
-	EXCEPTION: Steps 5 to 7 shall be repeated for k=1 to 11 (increment=1). Note: skip the gap pattern among #2 - #11 not supported by the UE (UE indicated supportedGapPattern in UEcapabilityinformation)	-	-	-	-
5	The SS transmits an <i>RRCCONNECTIONRECONFIGURATION</i> including measConfig to change fr1-Gap.	<--	<i>RRCCONNECTIONRECONFIGURATION</i>	-	-
6	The UE transmits an <i>RRCCONNECTIONRECONFIGURATIONCOMPLETE</i> message to confirm the change of fr1-Gap.	-->	<i>RRCCONNECTIONRECONFIGURATIONCOMPLETE</i>	-	-
-	EXCEPTION: In parallel to events described in step 7 the steps specified in table 8.2.3.11.1.3.2-3 shall take place.	-	-	-	-
7	Wait for 30 s to ensure that the UE performs a periodical inter frequency reporting.	-	-	-	-
8	SS transmits an <i>RRCCONNECTIONRECONFIGURATION</i> message including measConfig to release fr1-Gap and measid of periodical measurements.	<--	<i>RRCCONNECTIONRECONFIGURATION</i>	-	-
9	The UE transmits an <i>RRCCONNECTIONRECONFIGURATIONCOMPLETE</i> message.	-->	<i>RRCCONNECTIONRECONFIGURATIONCOMPLETE</i>	-	-
10	Wait 10s	-	-	-	-
11	The SS transmits an <i>RRCCONNECTIONRECONFIGURATION</i> including measConfig to setup fr1-Gap and nr-Config IE containing measConfig to report periodical measurements for NR serving Cell 1 and NR neighbor cell 3 on FR1 frequency.	<--	<i>RRCCONNECTIONRECONFIGURATION (RRCRECONFIGURATION)</i>	-	-
12	The UE transmits an <i>RRCCONNECTIONRECONFIGURATIONCOMPLETE</i> message to confirm the setup of fr1-Gap and report periodical measurements for NR serving Cell 1 and NR neighbor cell 3 on FR1 frequency.	-->	<i>RRCCONNECTIONRECONFIGURATIONCOMPLETE (RRCRECONFIGURATIONCOMPLETE)</i>	-	-
13	Wait and ignore <i>MEASUREMENTREPORT</i> messages for 8 s to allow for UE to measure the neighbouring cells.	-	-	-	-
-	EXCEPTION: In parallel to events described in step 14 the steps specified in table 8.2.3.11.1.3.2-4 shall take place.	-	-	-	-
14	Wait for 30 s to ensure that the UE performs a periodical inter frequency reporting.	-	-	-	-

-	EXCEPTION: Steps 15 to 17 shall be repeated for k=1 to 11 (increment=1). Note: skip the gap pattern among #2 - #11 not supported by the UE (UE indicated supportedGapPattern in UEcapabilityinformation)	-	-	-	-
15	The SS transmits an <i>RRCCONNECTIONRECONFIGURATION</i> including measConfig to change fr1-Gap.	<--	<i>RRCCONNECTIONRECONFIGURATION</i>	-	-
16	The UE transmits an <i>RRCCONNECTIONRECONFIGURATIONCOMPLETE</i> message to confirm the change of fr1-Gap.	-->	<i>RRCCONNECTIONRECONFIGURATIONCOMPLETE</i>	-	-
-	EXCEPTION: In parallel to events described in step 17 the steps specified in table 8.2.3.11.1.3.2-4 shall take place.	-	-	-	-
17	Wait for 30 s to ensure that the UE performs a periodical inter frequency reporting.	-	-	-	-
18	SS transmits an <i>RRCCONNECTIONRECONFIGURATION</i> message including measConfig to release fr1-Gap and measid of periodical measurements.	<--	<i>RRCCONNECTIONRECONFIGURATION</i>	-	-
19	The UE transmits an <i>RRCCONNECTIONRECONFIGURATIONCOMPLETE</i> message.	-->	<i>RRCCONNECTIONRECONFIGURATIONCOMPLETE</i>	-	-

Table 8.2.3.11.1.3.2-3: Parallel behaviour

St	Procedure	Message Sequence		TP	Verdict
		U - S	Message		
-	EXCEPTION: After the 1st message is received, step 1 below shall be repeated every time the duration indicated in the IE <i>reportInterval</i> has elapsed.	-	-	-	-
1	Check: Does the UE transmit a <i>MeasurementReport</i> message to perform periodical interRAT reporting for E-UTRA serving Cell 1 and NR Cell 3?	-->	<i>MeasurementReport</i>	1	P

Table 8.2.3.11.1.3.2-4: Parallel behaviour

St	Procedure	Message Sequence		TP	Verdict
		U - S	Message		
-	EXCEPTION: After the 1st message is received, step 1 below shall be repeated every time the duration indicated in the IE <i>reportInterval</i> has elapsed.	-	-	-	-
1	Check: Does the UE transmit a <i>MeasurementReport</i> encapsulated in <i>ULInformationTransferMRDC</i> message to perform periodical inter frequency reporting for NR serving Cell 1 and NR Cell 3?	-->	<i>ULInformationTransferMRDC (MeasurementReport)</i>	2	P

8.2.3.11.1.3.3 Specific message contents

Table 8.2.3.11.1.3.3-0: Conditions for specific message contents in Table 8.2.3.11.1.3.3-1

Condition	Explanation
Band > 64	If band > 64 is selected

Table 8.2.3.11.1.3.3-1: RRCConnectionReconfiguration (step 1, Table 8.2.3.11.1.3.2-2)

Derivation Path: 36.508 [7], Table 4.6.1-8			
Information Element	Value/remark	Comment	Condition
RRCConnectionReconfiguration ::= SEQUENCE {			
criticalExtensions CHOICE {			
c1 CHOICE{			
rrcConnectionReconfiguration-r8 SEQUENCE {			
measConfig SEQUENCE {			
measObjectToAddModList SEQUENCE (SIZE (1.. maxNrofObjectld)) OF SEQUENCE {	2 entry		
measObjectld[1]	1	MeasObjectldEutra-f1	
measObject[1] CHOICE {			
measObjectEUTRA	MeasObjectEUTRA-GENERIC(f1)		
measObjectEUTRA	MeasObjectEUTRA-GENERIC(maxEARFCN)		Band > 64
}			
measObjectld[2]	2	MeasObjectldNR-f2	
measObject[2] CHOICE {			
measObjectNR-r15	MeasObjectNR-GENERIC(NRf2)		
}			
}			
reportConfigToAddModList SEQUENCE (SIZE (1..maxReportConfigld)) OF SEQUENCE {	1 entry		
reportConfigld[1]	1		
reportConfig[1]	ReportConfigInterRAT-PERIODICAL		
}			
measldToAddModList SEQUENCE (SIZE (1.. maxNrofMeasld)) OF SEQUENCE {	1 entry		
measld[1]	1		
measObjectld[1]	2	MeasObjectldNR-f2	
reportConfigld[1]	1		
}			
quantityConfig	QuantityConfig-DEFAULT		
measGapConfig CHOICE {			
setup SEQUENCE {			
gapOffset CHOICE {			
gp0	0	MGRP = 40 ms, MGL = 6 ms	
}			
}			
}			
measObjectToAddModList-v9e0 ::= SEQUENCE (SIZE (1..maxObjectld)) OF SEQUENCE {	1 entry		Band > 64
measObjectEUTRA-v9e0[1] SEQUENCE {			
carrierFreq-v9e0	Same downlink EARFCN as used for f1		
}			
fr1-gap-r15	True		
mgta-r15	True	Mgta=0.5ms	
}			
}			
}			
}			
}			

Table 8.2.3.11.1.3.3-2: MeasObjectNR-GENERIC(NRf2) (Table 8.2.3.11.1.3.3-1)

Derivation Path: 36.508 [7], Table 4.6.6-2B			
Information Element	Value/remark	Comment	Condition
MeasObjectNR-r15 ::= SEQUENCE {			
carrierFreq-r15	Downlink carrier frequency of NR cell 3		
}			

Table 8.2.3.11.1.3.3-3: ReportConfigInterRAT-PERIODICAL (Table 8.2.3.11.1.3.3-1)

Derivation Path: 36.508 [7], Table 4.6.6-9			
Information Element	Value/remark	Comment	Condition
ReportConfigInterRAT-PERIODICAL ::= SEQUENCE {			
reportQuantityCellNR-r15 SEQUENCE {			
ss-rsrp	true		
ss-rsrq	true		
ss-sinr	true		
}			
}			

Table 8.2.3.11.1.3.3-4: QuantityConfig-DEFAULT (Table 8.2.3.11.1.3.3-1)

Derivation Path: 36.508 [7], Table 4.6.6-3A			
Information Element	Value/remark	Comment	Condition
QuantityConfig-DEFAULT ::= SEQUENCE {			
quantityConfigNRList-r15 SEQUENCE ((SIZE (1..maxQuantSetsNR-r15)) OF SEQUENCE {			
measQuantityCellNR-r15 SEQUENCE {			
filterCoeff-RSRP-r15	fc4		
filterCoeff-RSRQ-r15	fc4		
filterCoefficient-SINR-r13	fc4		
}			
}			
}			

Table 8.2.3.11.1.3.3-5: MeasurementReport (step 1, Table 8.2.3.11.1.3.2-3)

Derivation Path: 36.508 [7], Table 4.6.1-5			
Information Element	Value/remark	Comment	Condition
MeasurementReport ::= SEQUENCE {			
criticalExtensions CHOICE {			
c1 CHOICE{			
measurementReport-r8 SEQUENCE {			
measResults SEQUENCE {			
measId	1		
measResultPCell SEQUENCE {			
rsrpResult	(0..97)		
rsrqResult	(0..34)		
}			
measResultNeighCells CHOICE {			
measResultNeighCellListNR-r15 SEQUENCE (SIZE (1..maxCellReport)) OF SEQUENCE {	1 entry		
pci-r15 [1]	PhysicalCellIdentity of NR Cell 3		
measResultCell-r15 [1] SEQUENCE {			
rsrpResult-r15	(0..127)		
rsrqResult-r15	(0..127)		
rs-sinr-Result-r15	(0..127)		
}			
}			
}			
}			
}			

Table 8.2.3.11.1.3.3-6: RRCConnectionReconfiguration (steps 5, 15 Table 8.2.3.11.1.3.2-2)

Derivation Path: 36.508 [7], Table 4.6.1-8			
Information Element	Value/remark	Comment	Condition
RRCConnectionReconfiguration ::= SEQUENCE {			
criticalExtensions CHOICE {			
c1 CHOICE{			
rrcConnectionReconfiguration-r8 SEQUENCE {			
measConfig SEQUENCE {			
quantityConfig	Not present		
measGapConfig CHOICE {			
setup SEQUENCE {			
gapOffset CHOICE {			
gp1	0	Gap Pattern #1, MGRP = 80 ms, MGL = 6 ms	k=1
gp2-r14	0	Gap Pattern #2, MGRP = 40 ms, MGL = 3 ms	k=2
gp3-r14	0	Gap Pattern #3, MGRP = 80 ms, MGL = 3 ms	k=3
gp4-r15	0	Gap Pattern #4, MGRP = 20 ms, MGL = 6 ms	k=4
gp5-r15	0	Gap Pattern #5, MGRP = 160 ms, MGL = 6 ms	k=5
gp6-r15	0	Gap Pattern #6, MGRP = 20 ms, MGL = 4 ms	k=6
gp7-r15	0	Gap Pattern #7, MGRP = 40 ms, MGL = 4 ms	k=7
gp8-r15	0	Gap Pattern #8, MGRP = 80 ms, MGL = 4 ms	k=8
gp9-r15	0	Gap Pattern #9, MGRP = 160 ms, MGL = 4 ms	k=9
gp10-r15	0	Gap Pattern #10, MGRP = 20 ms, MGL = 3 ms	k=10
gp11-r15	0	Gap Pattern #11, MGRP = 160 ms, MGL = 3 ms	k=11
}			
}			
}			
fr1-gap-r15	True		
mgta-r15	False	Mgta=0ms	k=6-11
	True	Mgta=0.5ms	k=1-5
}			
}			
}			

Table 8.2.3.11.1.3.3-7: RRCConnectionReconfiguration (step 8 Table 8.2.3.11.1.3.2-2)

Derivation Path: 36.508 [7], Table 4.6.1-8			
Information Element	Value/remark	Comment	Condition
RRCConnectionReconfiguration ::= SEQUENCE {			
criticalExtensions CHOICE {			
c1 CHOICE{			
rrcConnectionReconfiguration-r8 SEQUENCE {			
measConfig SEQUENCE {			
measIdToRemoveList SEQUENCE (SIZE (1..maxMeasId)) OF SEQUENCE {	1 entry		
MeasId[1]	1		
}			
quantityConfig	Not present		
measConfig SEQUENCE {			
measGapConfig CHOICE {			
release	NULL		
}			
}			
}			
}			
}			
}			

Table 8.2.3.11.1.3.3-8: RRCConnectionReconfiguration (step 11, Table 8.2.3.11.1.3.2-2)

Derivation Path: 36.508 [7], Table 4.6.1-8			
Information Element	Value/remark	Comment	Condition
RRCConnectionReconfiguration ::= SEQUENCE {			
criticalExtensions CHOICE {			
c1 CHOICE{			
rrcConnectionReconfiguration-r8 SEQUENCE {			
measConfig SEQUENCE {			
quantityConfig	Not present		
measGapConfig CHOICE {			
setup SEQUENCE {			
gapOffset CHOICE {			
gp0	0	MGRP = 40 ms, MGL = 6 ms	
}			
}			
}			
fr1-gap-r15	True		
mgta-r15	True	Mgta=0.5ms	
}			
nonCriticalExtension SEQUENCE {			
nonCriticalExtension SEQUENCE {			
nonCriticalExtension SEQUENCE {			
nonCriticalExtension SEQUENCE {			
nonCriticalExtension SEQUENCE {			
nonCriticalExtension SEQUENCE {			
nonCriticalExtension SEQUENCE {			
nr-Config-r15 CHOICE {			
setup SEQUENCE {			
nr-SecondaryCellGroupConfig-r15	<i>RRCReconfiguration</i>	OCTET STRING including the <i>RRCReconfiguration</i>	
}			
}			
}			
}			
}			

Table 8.2.3.11.1.3.3-9: RRCReconfiguration (Table 8.2.3.11.1.3.3-8)

Derivation Path: TS 38.508-1 [4], Table 4.6.1-13			
Information Element	Value/remark	Comment	Condition
RRCReconfiguration ::= SEQUENCE {			
rrc-TransactionIdentifier	RRC-TransactionIdentifier	38.508-1 [4] Table 4.6.5-12.	
criticalExtensions CHOICE {			
c1 CHOICE {			
rrcReconfiguration ::= SEQUENCE {			
radioBearerConfig	Not present		
secondaryCellGroup	Not present		
measConfig	MeasConfig		
lateNonCriticalExtension	Not present		
nonCriticalExtension	Not present		
}			
}			
}			
}			

Table 8.2.3.11.1.3.3-10: MeasConfig (Table 8.2.3.11.1.3.3-9)

Derivation path: 38.508-1[4] Table 4.6.3-69			
Information Element	Value/Remark	Comment	Condition
measConfig ::= SEQUENCE {			
measObjectToAddModList SEQUENCE (SIZE (1..maxNrofObjectId)) OF SEQUENCE {	2 entry		
measObjectId[1]	1	MeasObjectIdNR-f1	
measObject CHOICE {			
measObjectNR[1]	MeasObjectNR-GENERIC(0)	NR Cell 1	
}			
measObjectId[2]	2	MeasObjectIdNR-f2	
measObject CHOICE {			
measObjectNR[2]	MeasObjectNR-GENERIC(0)	NR Cell 3	
}			
}			
reportConfigToAddModList SEQUENCE (SIZE (1..maxReportConfigId)) OF SEQUENCE {	1 entry		
reportConfigId[1]	1	ReportConfigId	
reportConfig[1]	ReportConfig-Periodical		
}			
measIdToAddModList SEQUENCE (SIZE (1..maxNrofMeasId)) OF SEQUENCE {	1 entry		
measId[1]	2		
measObjectId[1]	2	MeasObjectIdNR-f2	
reportConfigId[1]	1	ReportConfigId	
}			
quantityConfig	QuantityConfig		
}			

Table 8.2.3.11.1.3.3-11: MeasObjectNR-GENERIC(0) (Table 8.2.3.11.1.3.3-10)

Derivation Path: 38.508-1 [4], Table 4.6.3-76			
Information Element	Value/remark	Comment	Condition
MeasObjectNR ::= SEQUENCE {			
ssbFrequency	Downlink ARFCN of NR cell 3 SSB		
}			

Table 8.2.3.11.1.3.3-12: MeasObjectNR-GENERIC(0) (Table 8.2.3.11.1.3.3-10)

Derivation Path: 38.508-1 [4], Table 4.6.3-76			
Information Element	Value/remark	Comment	Condition
MeasObjectNR ::= SEQUENCE {			
ssbFrequency	Downlink ARFCN of NR cell 1 SSB		
}			

Table 8.2.3.11.1.3.3-13: ReportConfig-Periodical (Table 8.2.3.11.1.3.3-10)

Derivation Path: 38.508-1 [4], Table 4.6.3-142 with condition Periodical			
Information Element	Value/remark	Comment	Condition
ReportConfigNR ::= SEQUENCE {			
reportType CHOICE {			
Periodical SEQUENCE {			
rsType	ssb		
reportInterval	ReportInterval	38.508-1 [4] Table 4.6.3-144	
reportAmount	infinity		
reportQuantityCell SEQUENCE {			
rsrp	true		
rsrq	true		
sinr	true		
}			
maxReportCells	1		
reportQuantityRsIndexes	Not present		
maxNrofRSIndexesToReport	Not present		
includeBeamMeasurements	false		
useWhiteCellList	false		
}			
}			
}			

Table 8.2.3.11.1.3.3-14: QuantityConfig (Table 8.2.3.11.1.3.3-10)

Derivation Path: 38.508-1 [4], Table 4.6.3-127			
Information Element	Value/remark	Comment	Condition
QuantityConfig ::= SEQUENCE {			
quantityConfigNR-List SEQUENCE (SIZE (1..maxNrofQuantityConfig)) OF SEQUENCE {	1 entry		
quantityConfigCell[1] SEQUENCE {			
ssb-FilterConfig SEQUENCE {			
filterCoefficientRSRP	fc4		
filterCoefficientRSRQ	fc4		
filterCoefficientRS-SINR	fc4		
}			
}			
}			
}			

Table 8.2.3.11.1.3.3-15: ULInformationTransferMRDC (step1, Table 8.2.3.11.1.3.2-4)

Derivation Path: 36.508 [7], Table 4.6.1-27			
Information Element	Value/remark	Comment	Condition
ULInformationTransferMRDC ::= SEQUENCE {			
ul-DCCH-MessageNR-r15	OCTET STRING including the MeasurementReport message according to Table 8.2.3.11.1.3.3-16		
}			

Table 8.2.3.11.1.3.3-16: MeasurementReport (Table 8.2.3.11.1.3.3-15)

Derivation Path: TS 38.508-1 [4], clause 4.6.1-7			
Information Element	Value/remark	Comment	Condition
MeasurementReport ::= SEQUENCE {			
criticalExtensions CHOICE {			
c1 CHOICE {			
measurementReport ::= SEQUENCE {			
measResults SEQUENCE {			
measId	2		
measResultServingMOList SEQUENCE {	1 entry		
servCellId	ServCellIndex of NR Cell 1		
measResultServingCell SEQUENCE {			
physCellId	Physical CellID of the NR Cell 1		
measResult SEQUENCE {			
cellResults SEQUENCE {			
resultsSSB-Cell SEQUENCE {			
rsrp	(0..127)		
rsrq	(0..127)		
sinr	(0..127)		
}			
}			
}			
}			
measResultNeighCells CHOICE {			
measResultListNR SEQUENCE {	1 entry		
physCellId	Physical CellID of the NR Cell 3		
measResult SEQUENCE {			
cellResults SEQUENCE {			
resultsSSB-Cell SEQUENCE {			
rsrp	(0..127)		
rsrq	(0..127)		
sinr	(0..127)		
}			
}			
}			
}			
}			
}			
}			
}			
}			

Table 8.2.3.11.1.3.3-17: RRCConnectionReconfiguration (step 18, Table 8.2.3.11.1.3.2-2)

Derivation Path: 36.508 [7], Table 4.6.1-8			
Information Element	Value/remark	Comment	Condition
RRCConnectionReconfiguration ::= SEQUENCE {			
criticalExtensions CHOICE {			
c1 CHOICE {			
rrcConnectionReconfiguration-r8 SEQUENCE {			
measConfig SEQUENCE {			
measGapConfig CHOICE {			
release	NULL		
}			
}			
nonCriticalExtension SEQUENCE {			
nonCriticalExtension SEQUENCE {			
nonCriticalExtension SEQUENCE {			
nonCriticalExtension SEQUENCE {			
nonCriticalExtension SEQUENCE {			
nonCriticalExtension SEQUENCE {			
nonCriticalExtension SEQUENCE {			
nonCriticalExtension SEQUENCE {			
nr-Config-r15 CHOICE {			
setup SEQUENCE {			
nr-SecondaryCellGroupConfig-r15	<i>RRCReconfiguration</i>	OCTET STRING including the <i>RRCReconfiguration</i>	
}			
}			
}			
}			
}			
}			
}			
}			
}			

Table 8.2.3.11.1.3.3-18: RRCReconfiguration (Table 8.2.3.11.1.3.3-17)

Derivation Path: TS 38.508-1 [4], Table 4.6.1-13			
Information Element	Value/remark	Comment	Condition
RRCReconfiguration ::= SEQUENCE {			
rrc-TransactionIdentifier	RRC-TransactionIdentifier	38.508-1 [4] Table 4.6.5-12.	
criticalExtensions CHOICE {			
c1 CHOICE {			
rrcReconfiguration SEQUENCE {			
radioBearerConfig	Not present		
secondaryCellGroup	Not present		
measConfig SEQUENCE {			
measObjectToAddModList	Not present		
reportConfigToAddModList	Not present		
measIdToRemoveList SEQUENCE (SIZE (1..maxMeasId)) OF SEQUENCE {	1 entry		
MeasId[1]	2		
}			
measIdToAddModList	Not present		
quantityConfig	Not present		
}			
lateNonCriticalExtension	Not present		
nonCriticalExtension	Not present		
}			
}			

8.2.3.11.2 Measurement configuration control and reporting / Measurement Gaps / NR FR2 / EN-DC

8.2.3.11.2.1 Test Purpose (TP)

(1)

```
with { UE in RRC_CONNECTED state with EN-DC, and, MCG (E-UTRA PDCP) and SCG }
ensure that {
  when { UE receives RRCConnectionReconfiguration message with nr-Config IE containing MeasConfig to
  setup gapFR2 and report periodical measurements for NR neighbor cell on FR2 frequency }
  then { UE applies gapFR2 and sends periodical measurements for NR neighbor cell on FR2 frequency
}
}
```

8.2.3.11.2.2 Conformance requirements

References: The conformance requirements covered in the current TC are specified in: TS 36.331, clause 5.3.5.3, and TS 38.331, clause 5.5.2.9. Unless otherwise stated these are Rel-15 requirements.

[TS 36.331, clause 5.3.5.3]

If the *RRCConnectionReconfiguration* message does not include the *mobilityControlInfo* and the UE is able to comply with the configuration included in this message, the UE shall:

...

1> set the content of *RRCConnectionReconfigurationComplete* message as follows:

...

2> if the received *RRCConnectionReconfiguration* message included *nr-SecondaryCellGroupConfig*:

3> include *scg-ConfigResponseNR* in accordance with TS 38.331 [82, 5.3.5.3];

- 1> submit the *RRCConnectionReconfigurationComplete* message to lower layers for transmission using the new configuration, upon which the procedure ends;

[TS 38.331, clause 5.5.2.9]

The UE shall:

...

- 1> if *gapFR2* is set to setup:

- 2> if an FR2 measurement gap configuration is already setup, release the FR2 measurement gap configuration;
- 2> setup the FR2 measurement gap configuration indicated by the *measGapConfig* in accordance with the received *gapOffset*, i.e., the first subframe of each gap occurs at an SFN and subframe meeting the following condition:

$$\text{SFN mod } T = \text{FLOOR}(\text{gapOffset}/10);$$

$$\text{subframe} = \text{gapOffset mod } 10;$$

with $T = \text{MGRP}/10$ as defined in TS 38.133 [14];

- 2> if *mgta* is configured, apply the specified timing advance to the gap occurrences calculated above (i.e. the UE starts the measurement *mgta* ms before the gap subframe occurrences);

- 1> else if *gapFR2* is set to release:

- 2> release the FR2 measurement gap configuration;

- 1> if *gapUE* is set to setup:

- 2> if a per UE measurement gap configuration is already setup, release the per UE measurement gap configuration;
- 2> setup the per UE measurement gap configuration indicated by the *measGapConfig* in accordance with the received *gapOffset*, i.e., the first subframe of each gap occurs at an SFN and subframe meeting the following condition:

$$\text{SFN mod } T = \text{FLOOR}(\text{gapOffset}/10);$$

$$\text{subframe} = \text{gapOffset mod } 10;$$

with $T = \text{MGRP}/10$ as defined in TS 38.133 [14];

- 2> if *mgta* is configured, apply the specified timing advance to the gap occurrences calculated above (i.e. the UE starts the measurement *mgta* ms before the gap subframe occurrences);

- 1> else if *gapUE* is set to release:

- 2> release the per UE measurement gap configuration.

...

NOTE 1: For *gapFR2* configuration, the SFN and subframe of a serving cell on FR2 frequency is used in the gap calculation

8.2.3.11.2.3 Test description

8.2.3.11.2.3.1 Pre-test conditions

System Simulator:

- E-UTRA Cell 1 is PCell, NR Cell 1 is PSCell on FR2 and NR Cell 3 is inter-frequency neighbour Cell on FR2.

UE:

- None.

Preamble:

- The UE is in state RRC_CONNECTED using generic procedure parameter Connectivity (*EN-DC*) and Bearers (*MCG and SCG*) established according to TS 38.508-1 [4].

8.2.3.11.2.3.2 Test procedure sequence

Table 8.2.3.11.3.2-1 illustrates the downlink power levels and other changing parameters to be applied for the cells at various time instants of the test execution. Row marked "T0" denotes the initial conditions after preamble. The exact instants on which these values shall be applied are described in the texts in this clause.

Table 8.2.3.11.2.3.2-1: Time instances of cell power level and parameter changes

	Parameter	Unit	E-UTRA Cell 1	NR Cell 1	NR Cell 3	Remark
T0	Cell-specific RS EPRE	dBm/15 kHz	FFS	-	-	Switch on NR neighbour Cell and UE start to perform E-UTRA interRAT measurement.
	SS/PBCH SSS EPRE	dBm/SCS	-	FFS	FFS	

Table 8.2.3.11.2.3.2-2: Main behaviour

St	Procedure	Message Sequence		TP	Verdict
		U - S	Message		
1	The SS transmits an <i>RRConnectionReconfiguration</i> including nr-Config IE containing measConfig to setup gapFR2 and report periodical measurements for NR neighbor cell 3 on FR2 frequency.	<--	<i>RRConnectionReconfiguration</i> (<i>RRCReconfiguration</i>)	-	-
2	The UE transmits an <i>RRConnectionReconfigurationComplete</i> message to confirm the setup gapFR2 and report periodical measurements for NR neighbor cell 3 on FR2 frequency.	-->	<i>RRConnectionReconfigurationComplete</i> (<i>RRCReconfigurationComplete</i>)	-	-
3	Wait and ignore <i>MeasurementReport</i> messages for 8 s to allow for UE to measure the neighbouring cells.	-	-	-	-
-	EXCEPTION: In parallel to events described in step 4 the steps specified in table 8.2.3.11.2.3.2-3 shall take place	-	-	-	-
4	Wait for 30 s to ensure that the UE performs a periodical inter frequency reporting.	-	-	-	-
-	EXCEPTION: Steps 5 to 7 shall be repeated for k=13 to 23 (increment=1). Note: skip the gap pattern among #13 - #23 not supported by the UE (UE indicated supportedGapPattern in UEcapabilityinformation)	-	-	-	-
5	The SS transmits an <i>RRConnectionReconfiguration</i> including nr-Config IE containing measConfig to change gapFR2	<--	<i>RRConnectionReconfiguration</i> (<i>RRCReconfiguration</i>)	-	-
6	The UE transmits an <i>RRConnectionReconfigurationComplete</i> message to confirm the change of gapFR2	-->	<i>RRConnectionReconfigurationComplete</i> (<i>RRCReconfigurationComplete</i>)	-	-
-	EXCEPTION: In parallel to events described in step 7 the steps specified in table 8.2.3.11.1.3.2-3 shall take place	-	-	-	-
7	Wait for 30 s to ensure that the UE performs a periodical inter frequency reporting.	-	-	-	-
8	SS transmits an <i>RRConnectionReconfiguration</i> message including measConfig to release gapFR2 and measid of periodical measurements.	<--	<i>RRConnectionReconfiguration</i> (<i>RRCReconfiguration</i>)	-	-
9	The UE transmits an <i>RRConnectionReconfigurationComplete</i> message	-->	<i>RRConnectionReconfigurationComplete</i> (<i>RRCReconfigurationComplete</i>)	-	-

Table 8.2.3.11.2.3.2-3: Parallel behaviour

St	Procedure	Message Sequence		TP	Verdict
		U - S	Message		
-	EXCEPTION: After the 1st message is received, step 1 below shall be repeated every time the duration indicated in the IE <i>reportInterval</i> has elapsed	-	-	-	-
1	Check: Does the UE transmit a <i>MeasurementReport</i> encapsulated in <i>ULInformationTransferMRDC</i> message to perform periodical inter frequency reporting for NR serving Cell 1 and NR Cell 3?	-->	<i>ULInformationTransferMRDC</i> (<i>MeasurementReport</i>)	1	P

8.2.3.11.2.3.3 Specific message contents

Table 8.2.3.11.2.3.3-1: RRCConnectionReconfiguration (step 1, Table 8.2.3.11.2.3.2-2)

Derivation Path: 36.508 [7], Table 4.6.1-8 with condition EN-DC_EmbedNR_RRCRecon
--

Table 8.2.3.11.2.3.3-2: RRCReconfiguration (Table 8.2.3.11.2.3.3-1)

Derivation Path: TS 38.508-1 [4], Table 4.6.1-13			
Information Element	Value/remark	Comment	Condition
RRCReconfiguration ::= SEQUENCE {			
rrc-TransactionIdentifier	RRC-TransactionIdentifier	38.508-1 [4] Table 4.6.5-12.	
criticalExtensions CHOICE {			
c1 CHOICE {			
rrcReconfiguration ::= SEQUENCE {			
radioBearerConfig	Not present		
secondaryCellGroup	Not present		
measConfig	MeasConfig		
lateNonCriticalExtension	Not present		
nonCriticalExtension	Not present		
}			
}			
}			
}			

Table 8.2.3.11.2.3.3-3: MeasConfig (Table 8.2.3.11.2.3.3-2)

Derivation path: 38.508-1[4] Table 4.6.3-69			
Information Element	Value/Remark	Comment	Condition
measConfig ::= SEQUENCE {			
measObjectToAddModList SEQUENCE (SIZE (1..maxNrofObjectld)) OF SEQUENCE {	2 entry		
measObjectld[1]	1	MeasObjectldNR-f1	
measObject CHOICE {			
measObjectNR[1]	MeasObjectNR-GENERIC(0)	NR Cell 1	
}			
measObjectld[2]	2	MeasObjectldNR-f2	
measObject CHOICE {			
measObjectNR[2]	MeasObjectNR-GENERIC(0)	NR Cell 3	
}			
}			
reportConfigToAddModList SEQUENCE (SIZE (1..maxReportConfigld)) OF SEQUENCE {	1 entry		
reportConfigld[1]	1	ReportConfigld	
reportConfig[1]	ReportConfig-Periodical		
}			
measldToAddModList SEQUENCE (SIZE (1..maxNrofMeasld)) OF SEQUENCE {	1 entry		
measld[1]	1		
measObjectld[1]	2	MeasObjectldNR-f2	
reportConfigld[1]	1	ReportConfigld	
}			
quantityConfig	QuantityConfig		
measGapConfig SEQUENCE {	MeasGapConfig		
gapFR2 SteupRelease {			
gapOffset	0		
mgl	ms5dot5	5.5ms, Note 1	
mgrp	ms20	20ms, Note 1	
mgta	ms0dot25	0.25ms, Note 1	
}			
}			
}			
}			
Note 1: If UE does not support gapPattern#12, configure an UE supported gapPattern among #13-#23. (UE indicated supportedGapPattern in UeCapabilityInformation)			

Table 8.2.3.11.2.3.3-4: MeasObjectNR-GENERIC(0) (Table 8.2.3.11.2.3.3-3)

Derivation Path: 38.508-1 [4], Table 4.6.3-76			
Information Element	Value/remark	Comment	Condition
MeasObjectNR ::= SEQUENCE {			
ssbFrequency	Downlink ARFCN of NR cell 1 SSB		
}			

Table 8.2.3.11.2.3.3-5: MeasObjectNR-GENERIC(0) (Table 8.2.3.11.2.3.3-3)

Derivation Path: 38.508-1 [4], Table 4.6.3-76			
Information Element	Value/remark	Comment	Condition
MeasObjectNR ::= SEQUENCE {			
ssbFrequency	Downlink ARFCN of NR cell 3 SSB		
}			

Table 8.2.3.11.2.3.3-6: ReportConfig-Periodical (Table 8.2.3.11.2.3.3-3)

Derivation Path: 38.508-1 [4], Table 4.6.3-142 with condition Periodical			
Information Element	Value/remark	Comment	Condition
ReportConfigNR ::= SEQUENCE {			
reportType CHOICE {			
Periodical SEQUENCE {			
rsType	ssb		
reportInterval	ReportInterval	38.508-1 [4]Table 4.6.3-144	
reportAmount	infinity		
reportQuantityCell SEQUENCE {			
rsrp	true		
rsrq	true		
sinr	true		
}			
maxReportCells	1		
reportQuantityRsIndexes	Not present		
maxNrofRSIndexesToReport	Not present		
includeBeamMeasurements	false		
useWhiteCellList	false		
}			
}			
}			

Table 8.2.3.11.2.3.3-7: QuantityConfig (Table 8.2.3.11.1.3.3-3)

Derivation Path: 38.508-1 [4], Table 4.6.3-127			
Information Element	Value/remark	Comment	Condition
QuantityConfig ::= SEQUENCE {			
quantityConfigNR-List SEQUENCE (SIZE (1..maxNrofQuantityConfig)) OF SEQUENCE {	1 entry		
quantityConfigCell[1] SEQUENCE {			
ssb-FilterConfig SEQUENCE {			
filterCoefficientRSRP	fc4		
filterCoefficientRSRQ	fc4		
filterCoefficientRS-SINR	fc4		
}			
}			
}			
}			

Table 8.2.3.11.2.3.3-8: ULInformationTransferMRDC (step1, Table 8.2.3.11.2.3.2-3)

Derivation Path: 36.508 [7], Table 4.6.1-27			
Information Element	Value/remark	Comment	Condition
ULInformationTransferMRDC ::= SEQUENCE {			
ul-DCCH-MessageNR-r15	OCTET STRING including the MeasurementReport message according to Table 8.2.3.11.2.3.3-9		
}			

Table 8.2.3.11.2.3.3-9: MeasurementReport (Table 8.2.3.11.2.3.3-8)

Derivation Path: TS 38.508-1 [4], clause 4.6.1-7			
Information Element	Value/remark	Comment	Condition
MeasurementReport ::= SEQUENCE {			
criticalExtensions CHOICE {			
c1 CHOICE {			
measurementReport ::= SEQUENCE {			
measResults SEQUENCE {			
measId	1		
measResultServingMOList SEQUENCE {	1 entry		
servCellId	ServCellIndex of NR Cell 1		
measResultServingCell SEQUENCE {			
physCellId	Physical CellID of the NR Cell 1		
measResult SEQUENCE {			
cellResults SEQUENCE {			
resultsSSB-Cell SEQUENCE {			
rsrp	(0..127)		
rsrq	(0..127)		
sinr	(0..127)		
}			
}			
}			
}			
}			
measResultNeighCells CHOICE {			
measResultListNR SEQUENCE {	1 entry		
physCellId	Physical CellID of the NR Cell 3		
measResult SEQUENCE {			
cellResults SEQUENCE {			
resultsSSB-Cell SEQUENCE {			
rsrp	(0..127)		
rsrq	(0..127)		
sinr	(0..127)		
}			
}			
}			
}			
}			
}			
}			

Table 8.2.3.11.2.3.3-10: RRCConnectionReconfiguration (step 5, Table 8.2.3.11.2.3.2-2)

Derivation Path: 36.508 [7], Table 4.6.1-8 with condition EN-DC_EmbedNR_RRCRecon
--

Table 8.2.3.11.2.3.3-11: RRCReconfiguration (Table 8.2.3.11.2.3.3-10)

Derivation Path: TS 38.508-1 [4], Table 4.6.1-13			
Information Element	Value/remark	Comment	Condition
RRCReconfiguration ::= SEQUENCE {			
rrc-TransactionIdentifier	RRC-TransactionIdentifier	38.508-1 [4] Table 4.6.5-12.	
criticalExtensions CHOICE {			
c1 CHOICE {			
rrcReconfiguration ::= SEQUENCE {			
radioBearerConfig	Not present		
secondaryCellGroup	Not present		
measConfig	MeasConfig		
lateNonCriticalExtension	Not present		
nonCriticalExtension	Not present		
}			
}			
}			
}			

Table 8.2.3.11.2.3.3-12: MeasConfig (Table 8.2.3.11.2.3.3-11)

Derivation path: 38.508-1[4] Table 4.6.3-69			
Information Element	Value/Remark	Comment	Condition
measConfig ::= SEQUENCE {			
measObjectToAddModList	Not present		
reportConfigToAddModList	Not present		
measIdToAddModList	Not present		
quantityConfig	Not present		
measGapConfig SEQUENCE {	MeasGapConfig		
gapFR2 CHOICE {			
Setup SEQUENCE{			
gapOffset	0		k=13-23
mgl	ms5dot5	Gap Pattern #13, 5.5ms	k=13
mgl	ms5dot5	Gap Pattern #14, 5.5ms	k=14
mgl	ms5dot5	Gap Pattern #15, 5.5ms	k=15
mgl	ms3dot5	Gap Pattern #16, 3.5ms	k=16
mgl	ms3dot5	Gap Pattern #17, 3.5ms	k=17
mgl	ms3dot5	Gap Pattern #18, 3.5ms	k=18
mgl	ms3dot5	Gap Pattern #19, 3.5ms	k=19
mgl	ms1dot5	Gap Pattern #20, 1.5ms	k=20
mgl	ms1dot5	Gap Pattern #21, 1.5ms	k=21
mgl	ms1dot5	Gap Pattern #22, 1.5ms	k=22
mgl	ms1dot5	Gap Pattern #23, 1.5ms	k=23
mgrp	ms40	Gap Pattern #13, 40ms	k=13
mgrp	ms80	Gap Pattern #14, 80ms	k=14
mgrp	ms160	Gap Pattern #15, 160ms,	k=15
mgrp	ms20	Gap Pattern #16, 20ms	k=16
mgrp	ms40	Gap Pattern #17, 40ms	k=17
mgrp	ms80	Gap Pattern #18, 80ms	k=18
mgrp	ms160	Gap Pattern #19, 160ms	k=19
mgrp	ms20	Gap Pattern #20, 20ms	k=20
mgrp	ms40	Gap Pattern #21, 40ms	k=21
mgrp	ms80	Gap Pattern #22, 80ms	k=22
mgrp	ms160	Gap Pattern #23, 160ms	k=23
mgta	ms0dot25	0.25ms	k=18-23
mgta	ms0	0 ms	k=13-17
}			
}			
}			
}			

Table 8.2.3.11.2.3.3-13: RRCConnectionReconfiguration (step 8, Table 8.2.3.11.2.3.2-2)

Derivation Path: 36.508 [7], Table 4.6.1-8 with condition EN-DC_EmbedNR_RRCRecon
--

Table 8.2.3.11.2.3.3-14: RRCReconfiguration (Table 8.2.3.11.2.3.3-13)

Derivation Path: TS 38.508-1 [4], Table 4.6.1-13			
Information Element	Value/remark	Comment	Condition
RRCReconfiguration ::= SEQUENCE {			
rrc-TransactionIdentifier	RRC-TransactionIdentifier	TS 38.508-1 [4], Table 4.6.5-12	
criticalExtensions CHOICE {			
c1 CHOICE {			
rrcReconfiguration ::= SEQUENCE {			
radioBearerConfig	Not present		
secondaryCellGroup	Not present		
measConfig	MeasConfig		
lateNonCriticalExtension	Not present		
nonCriticalExtension	Not present		
}			
}			
}			
}			

Table 8.2.3.11.2.3.3-15: MeasConfig (Table 8.2.3.11.2.3.3-14)

Derivation path: 38.508-1[4] Table 4.6.3-69			
Information Element	Value/Remark	Comment	Condition
measConfig ::= SEQUENCE {			
measObjectToAddModList	Not present		
reportConfigToAddModList	Not present		
MeasIdToRemoveList SEQUENCE (SIZE (1..maxNrofMeasId)) OF SEQUENCE {			
measId[1]	1		
}			
measIdToAddModList	Not present		
quantityConfig	Not present		
measGapConfig SEQUENCE {	MeasGapConfig		
gapFR2 CHOICE {			
release	NULL		
}			
}			
}			

8.2.3.12 Measurement configuration control and reporting / Inter-RAT measurements / Event B2 / Measurement of NR cells

8.2.3.12.1 Measurement configuration control and reporting / Inter-RAT measurements / Event B2 / Measurement of NR cells / EN-DC

8.2.3.12.1.1 Test Purpose (TP)

(1)

```

with { UE in RRC_CONNECTED state with EN-DC, and, MCG(s) (E-UTRA PDCP) only having completed the
radio bearer establishment and performed the inter RAT measurement for NR cell and not detected
entering condition for the event B2 is met }
ensure that {
  when { UE detects entering condition for the event B2 is not met }
    then { UE does not transmit any MeasurementReport }
}

```

(2)

```

with { UE in RRC_CONNECTED state with EN-DC, and, MCG(s) (E-UTRA PDCP) only having completed the
radio bearer establishment and performed the inter RAT measurement for NR cell and not detected
entering condition for the event B2 is met }
ensure that {
  when { UE detects entering condition for the event B2 is met }
  then { UE transmits a MeasurementReport }
}

```

(3)

```

with { UE in RRC_CONNECTED state with EN-DC, and, MCG(s) (E-UTRA PDCP) only having completed the
radio bearer establishment and performed the inter RAT measurement for NR cell and detected entering
condition for the event B2 is met }
ensure that {
  when { UE detects leaving condition for the event B2 is met }
  then { UE does not transmit any MeasurementReport }
}

```

8.2.3.12.1.2 Conformance requirements

References: The conformance requirements covered in the present TC are specified in: TS 36.331, clauses 5.5.1, 5.5.4.1, 5.5.4.8, 5.5.5 and 5.5.5.3. Unless otherwise stated these are Rel-15 requirements.

[TS 36.331, clause 5.5.1]

The UE reports measurement information in accordance with the measurement configuration as provided by E-UTRAN. E-UTRAN provides the measurement configuration applicable for a UE in RRC_CONNECTED by means of dedicated signalling, i.e. using the *RRCCConnectionReconfiguration* or *RRCCConnectionResume* message.

The UE can be requested to perform the following types of measurements:

- Intra-frequency measurements: measurements at the downlink carrier frequency(ies) of the serving cell(s).
- Inter-frequency measurements: measurements at frequencies that differ from any of the downlink carrier frequency(ies) of the serving cell(s).
- Inter-RAT measurements of NR frequencies.

...

The measurement configuration includes the following parameters:

1. **Measurement objects:** The objects on which the UE shall perform the measurements.

- For intra-frequency and inter-frequency measurements a measurement object is a single E-UTRA carrier frequency. Associated with this carrier frequency, E-UTRAN can configure a list of cell specific offsets, a list of 'blacklisted' cells and a list of 'whitelisted' cells. Blacklisted cells are not considered in event evaluation or measurement reporting.
- For inter-RAT NR measurements a measurement object is a single NR carrier frequency. Associated with this carrier frequency, E-UTRAN can configure a list of 'blacklisted' cells. Blacklisted cells are not considered in event evaluation or measurement reporting.

...

NOTE 1: Some measurements using the above mentioned measurement objects, only concern a single cell, e.g. measurements used to report neighbouring cell system information, PCell UE Rx-Tx time difference, or a pair of cells, e.g. SSTD measurements between the PCell and the PSCell.

2. **Reporting configurations:** A list of reporting configurations where each reporting configuration consists of the following:

- Reporting criterion: The criterion that triggers the UE to send a measurement report. This can either be periodical or a single event description.

- Reporting format: The quantities that the UE includes in the measurement report and associated information (e.g. number of cells to report).
3. **Measurement identities:** A list of measurement identities where each measurement identity links one measurement object with one reporting configuration. By configuring multiple measurement identities it is possible to link more than one measurement object to the same reporting configuration, as well as to link more than one reporting configuration to the same measurement object. The measurement identity is used as a reference number in the measurement report.
 4. **Quantity configurations:** One quantity configuration is configured per RAT type. The quantity configuration defines the measurement quantities and associated filtering used for all event evaluation and related reporting of that measurement type. One filter can be configured per measurement quantity, except for NR where the network may configure up to 2 sets of quantity configurations each comprising per measurement quantity separate filters for cell and RS index measurement results. The quantity configuration set that applies for a given measurement is indicated within the NR measurement object.

[TS 36.331, clause 5.5.4.1]

If security has been activated successfully, the UE shall:

- 1> for each *measId* included in the *measIdList* within *VarMeasConfig*:
 - ...
 - 2> else:
 - ...
 - 3> else if the corresponding *measObject* concerns NR:
 - 4> if the *reportSFTD-Meas* is set to *pSCell* in the corresponding *reportConfigInterRAT*:
 - 5> consider the PSCell to be applicable;
 - 4> else if the *reportSFTD-Meas* is set to *neighborCells* in the corresponding *reportConfigInterRAT*:
 - 5> if *cellsForWhichToReportSFTD* is configured in the corresponding *measObjectNR*:
 - 6> consider any neighbouring NR cell on the associated frequency that is included in *cellsForWhichToReportSFTD* to be applicable;
 - 5> else:
 - 6> consider up to 3 strongest neighbouring NR cells detected on the associated frequency to be applicable when the concerned cells are not included in the *blackCellsToAddModList* defined within the *VarMeasConfig* for this *measId*;
 - 4> else:
 - 5> if the *eventB1* or *eventB2* is configured in the corresponding *reportConfig*:
 - 6> consider a serving cell, if any, on the associated NR frequency as neighbouring cell;
 - 5> consider any neighbouring cell detected on the associated frequency to be applicable when the concerned cell is not included in the *blackCellsToAddModList* defined within the *VarMeasConfig* for this *measId*;

[TS 36.331, clause 5.5.4.8]

The UE shall:

- 1> for UTRA and CDMA2000, only trigger the event for cells included in the corresponding measurement object;
- 1> consider the entering condition for this event to be satisfied when both condition B2-1 and condition B2-2, as specified below, are fulfilled;

- 1> consider the leaving condition for this event to be satisfied when condition B2-3 or condition B2-4, i.e. at least one of the two, as specified below, is fulfilled;

Inequality B2-1 (Entering condition 1)

$$Mp + Hys < Thresh1$$

Inequality B2-2 (Entering condition 2)

$$Mn + Ofn - Hys > Thresh2$$

Inequality B2-3 (Leaving condition 1)

$$Mp - Hys > Thresh1$$

Inequality B2-4 (Leaving condition 2)

$$Mn + Ofn + Hys < Thresh2$$

The variables in the formula are defined as follows:

Mp is the measurement result of the PCell, not taking into account any offsets.

Mn is the measurement result of the inter-RAT neighbour cell, not taking into account any offsets. For CDMA2000 measurement result, *pilotStrength* is divided by -2.

Ofn is the frequency specific offset of the frequency of the inter-RAT neighbour cell (i.e. *offsetFreq* as defined within the *measObject* corresponding to the frequency of the inter-RAT neighbour cell).

Hys is the hysteresis parameter for this event (i.e. *hysteresis* as defined within *reportConfigInterRAT* for this event).

Thresh1 is the threshold parameter for this event (i.e. *b2-Threshold1* as defined within *reportConfigInterRAT* for this event).

Thresh2 is the threshold parameter for this event (i.e. *b2-Threshold2* as defined within *reportConfigInterRAT* for this event). For CDMA2000, *b2-Threshold2* is divided by -2.

Mp is expressed in dBm in case of RSRP, or in dB in case of RSRQ.

Mn is expressed in dBm or dB, depending on the measurement quantity of the inter-RAT neighbour cell.

Ofn, ***Hys*** are expressed in dB.

Thresh1 is expressed in the same unit as ***Mp***.

Thresh2 is expressed in the same unit as ***Mn***.

[TS 36.331, clause 5.5.5]

The purpose of this procedure is to transfer measurement results from the UE to E-UTRAN. The UE shall initiate this procedure only after successful security activation.

For the *measId* for which the measurement reporting procedure was triggered, the UE shall set the *measResults* within the *MeasurementReport* message as follows:

- 1> set the *measId* to the measurement identity that triggered the measurement reporting;
- 1> set the *measResultPCell* to include the quantities of the PCell;
- 1> set the *measResultServFreqList* to include for each E-UTRA SCell that is configured, if any, within *measResultSCell* the quantities of the concerned SCell, if available according to performance requirements in TS 36.133 [16], except if *purpose* for the *reportConfig* associated with the *measId* that triggered the measurement reporting is set to *reportLocation*;
- 1> if the *reportConfig* associated with the *measId* that triggered the measurement reporting includes *reportAddNeighMeas*:

- 2> for each E-UTRA serving frequency for which *measObjectId* is referenced in the *measIdList*, other than the frequency corresponding with the *measId* that triggered the measurement reporting:
 - 3> set the *measResultServFreqList* to include within *measResultBestNeighCell* the *physCellId* and the quantities of the best non-serving cell, based on RSRP, on the concerned serving frequency;
 - 1> if the *triggerType* is set to *event*; and if the corresponding *measObject* concerns NR; and if *eventId* is set to *eventB1-NR* or *eventB2-NR*; or
 - ...
 - 2> if *purpose* for the *reportConfig* or *reportConfigInterRAT* associated with the *measId* that triggered the measurement reporting is set to a value other than *reportLocation*:
 - 3> set the *measResultServFreqListNR* to include for each NR serving frequency that the UE is configured to measure according to TS 38.331 [82], if any, the following:
 - 4> set *measResultSCell* to include the available results of the NR serving cell, as specified in 5.5.5.2;
 - 4> if the *reportConfig* associated with the *measId* that triggered the measurement reporting includes *reportAddNeighMeas*:
 - 5> set *measResultBestNeighCell* to include the available results, as specified in 5.5.5.2, of the non-serving cell with the highest sorting quantity determined as specified in 5.5.5.3;
 - 3> for each (serving or neighbouring) cell for which the UE reports results according to the previous, additionally include available beam results according to the following:
 - 4> if *maxReportRS-Index* is configured, set *measResultCellRS-Index* to include available results, as specified in 5.5.5.2, of up to *maxReportRS-Index* beams, ordered based on the quantity determined as specified in 5.5.5.3;
 - 1> if there is at least one applicable neighbouring cell to report:
 - 2> set the *measResultNeighCells* to include the best neighbouring cells up to *maxReportCells* in accordance with the following:
 - 3> if the *triggerType* is set to *event*:
 - 4> include the cells included in the *cellsTriggeredList* as defined within the *VarMeasReportList* for this *measId*;
 - 3> else:
 - 4> include the applicable cells for which the new measurement results became available since the last periodical reporting or since the measurement was initiated or reset;
- NOTE 1: The reliability of the report (i.e. the certainty it contains the strongest cells on the concerned frequency) depends on the measurement configuration i.e. the *reportInterval*. The related performance requirements are specified in TS 36.133 [16].
- 3> for each cell that is included in the *measResultNeighCells*, include the *physCellId*;
 - 3> if the *triggerType* is set to *event*; or the *purpose* is set to *reportStrongestCells* or to *reportStrongestCellsForSON*:
 - 4> for each included cell, include the layer 3 filtered measured results in accordance with the *reportConfig* for this *measId*, ordered as follows:
 - 5> if the *measObject* associated with this *measId* concerns E-UTRA:
 - 6> set the *measResult* to include the quantity(ies) indicated in the *reportQuantity* within the concerned *reportConfig*;
 - 6> sort the included cells in order of decreasing *triggerQuantity*, i.e. the best cell is included first;
 - 5> if the *measObject* associated with this *measId* concerns NR:

- 6> set the *measResultCell* to include the quantity(ies) indicated in the *reportQuantityCellNR* within the concerned *reportConfig*;
- 6> if *maxReportRS-Index* and *reportQuantityRS-IndexNR* are configured, set *measResultRS-IndexList* to include the result of the best beam if *threshRS-Index* is included in the *VarMeasConfig* for the corresponding *measObject*, and the remaining beams whose quantity is above *threshRS-Index*, up to *maxReportRS-Index* beams in total:
 - 7> order beams based on the sorting quantity determined as specified in 5.5.5.3;
 - 7> for each included beam:
 - 8> include *ssbIndex*;
 - 8> if *reportRS-IndexResultsNR* is set to TRUE, for each quantity indicated, include the corresponding measurement result in *measResultSSB-Index* for each *ssb-Index*;

[TS 36.331, clause 5.5.5.3]

When configured to report the best cells or beams, the UE shall determine the quantity that is used to order and select as follows:

- 1> for cells on the frequency associated with the *measId* that triggered the measurement reporting, if the *reportTrigger* is set to *event*, consider the quantity used in *bN-ThresholdYNR* to be the sorting quantity;
- 1> for other cases, determine the sorting quantity as follows:
 - 1> consider the quantities the UE reports as candidate sorting quantities i.e. as follows:
 - 2> consider the following quantities as candidate sorting quantities:
 - 3> for cells on the frequency associated with the *measId* that triggered the measurement reporting (for a *triggerType* set to *periodical*):
 - 4> the quantities defined by *reportQuantityCellNR*, when used for sorting cells;
 - 4> the quantities defined by *reportQuantityRS-IndexNR*, when used for sorting beams;
 - 3> for cells, serving or non-serving (i.e. within *reportAddNeighMeas*), on NR serving frequencies other than the one associated with the *measId* triggering reporting:
 - 4> the available quantities of available NR measurement results as specified in 5.5.5.2;
 - 2> if there is a single candidate sorting quantity;
 - 3> consider the concerned quantity to be the sorting quantity;
 - 2> else:
 - 3> if RSRP is one of the candidate sorting quantities;
 - 4> consider RSRP to be the sorting quantity;
 - 3> else:
 - 4> consider RSRQ to be the sorting quantity;

8.2.3.12.1.3 Test description

8.2.3.12.1.3.1 Pre-test conditions

System Simulator:

- E-UTRA Cell 1 and NR Cell 1.

UE:

- None.

Preamble:

- The UE is in state RRC_CONNECTED using generic procedure parameter Connectivity (*EN-DC*) with MCG(s) only established according to [4].

8.2.3.12.1.3.2 Test procedure sequence

Table 8.2.3.12.1.3.2-1 and Table 8.2.3.12.1.3.2-1A illustrates the downlink power levels and other changing parameters to be applied for the cells at various time instants of the test execution. Row marked "T0" denotes the initial conditions after preamble, while columns marked "T1", "T2", "T3", "T4" and "T5" are to be applied subsequently. The exact instants on which these values shall be applied are described in the texts in this clause.

Table 8.2.3.12.1.3.2-1: Time instances of cell power level and parameter changes for FR1

	Parameter	Unit	E-UTRA Cell 1	NR Cell 1	Remark
T0	Cell-specific RS EPRE	dBm/15 kHz	-84	-	The power level values are such that entering conditions for event B2 are not satisfied, i.e. condition B2-1($Mp + Hys < Thresh1$) is fulfilled but condition B2-2($Mn + Ofn - Hys > Thresh2$) is not fulfilled.
	SS/PBCH SSS EPRE	dBm/SC S	-	-91	
T1	Cell-specific RS EPRE	dBm/15 kHz	-60		The power level values are such that entering conditions for event B2 are not satisfied, i.e condition B2-1($Mp + Hys < Thresh1$) is not fulfilled but condition B2-2($Mn + Ofn - Hys > Thresh2$) is fulfilled.
	SS/PBCH SSS EPRE	dBm/SC S		-79	
T2	Cell-specific RS EPRE	dBm/15 kHz	-84	-	The power level values are such that entering conditions for event B2 are satisfied, i.e. condition B2-1($Mp + Hys < Thresh1$) and B2-2($Mn + Ofn - Hys > Thresh2$) are fulfilled.
	SS/PBCH SSS EPRE	dBm/SC S	-	-79	
T3	Cell-specific RS EPRE	dBm/15 kHz	-60	-	The power level values are such that leaving conditions for event B2 are satisfied, i.e. condition B2-3($Mp - Hys > Thresh1$) is fulfilled but condition B2-4($Mn + Ofn + Hys < Thresh2$) is not fulfilled.
	SS/PBCH SSS EPRE	dBm/SC S	-	-79	
T4	Cell-specific RS EPRE	dBm/15 kHz	-84	-	The power level values are such that entering conditions for event B2 are satisfied, i.e. condition B2-1($Mp + Hys < Thresh1$) and B2-2($Mn + Ofn - Hys > Thresh2$) are fulfilled.
	SS/PBCH SSS EPRE	dBm/SC S	-	-79	
T5	Cell-specific RS EPRE	dBm/15 kHz	-84	-	The power level values are such that leaving conditions for event B2 are satisfied, i.e. condition B2-3($Mp - Hys > Thresh1$) is not fulfilled but condition B2-4($Mn + Ofn + Hys < Thresh2$) is fulfilled.
	SS/PBCH SSS EPRE	dBm/SS C	-	-91	

Table 8.2.3.12.1.3.2-1A: Time instances of cell power level and parameter changes for FR2

	Parameter	Unit	E-UTRA Cell 1	NR Cell 1	Remark
T0	Cell-specific RS EPRE	dBm/15 kHz	FFS	-	The power level values are such that entering conditions for event B2 are not satisfied, i.e. condition B2-1($Mp + Hys < Thresh1$) is fulfilled but condition B2-2($Mn + Ofn - Hys > Thresh2$) is not fulfilled.
	SS/PBCH SSS EPRE	dBm/SC S	-	FFS	
T1	Cell-specific RS EPRE	dBm/15 kHz	FFS	-	The power level values are such that entering conditions for event B2 are not satisfied, i.e condition B2-1($Mp + Hys < Thresh1$) is not fulfilled but condition B2-2($Mn + Ofn - Hys > Thresh2$) is fulfilled.
	SS/PBCH SSS EPRE	dBm/SC S	-	FFS	
T2	Cell-specific RS EPRE	dBm/15 kHz	FFS	-	The power level values are such that entering conditions for event B2 are satisfied, i.e. condition B2-1($Mp + Hys < Thresh1$) and B2-2($Mn + Ofn - Hys > Thresh2$) are fulfilled.
	SS/PBCH SSS EPRE	dBm/SC S	-	FFS	
T3	Cell-specific RS EPRE	dBm/15 kHz	FFS	-	The power level values are such that leaving conditions for event B2 are satisfied, i.e. condition B2-3($Mp - Hys > Thresh1$) is fulfilled but condition B2-4($Mn + Ofn + Hys < Thresh2$) is not fulfilled.
	SS/PBCH SSS EPRE	dBm/SC S	-	FFS	
T4	Cell-specific RS EPRE	dBm/15 kHz	FFS	-	The power level values are such that entering conditions for event B2 are satisfied, i.e. condition B2-1($Mp + Hys < Thresh1$) and B2-2($Mn + Ofn - Hys > Thresh2$) are fulfilled.
	SS/PBCH SSS EPRE	dBm/SC S	-	FFS	
T5	Cell-specific RS EPRE	dBm/15 kHz	FFS	-	The power level values are such that leaving conditions for event B2 are satisfied, i.e. condition B2-3($Mp - Hys > Thresh1$) is not fulfilled but condition B2-4($Mn + Ofn + Hys < Thresh2$) is fulfilled.
	SS/PBCH SSS EPRE	dBm/SC S	-	FFS	

Table 8.2.3.12.1.3.2-2: Main behaviour

St	Procedure	Message Sequence		TP	Verdict
		U – S	Message		
1	The SS transmits an <i>RRCCONNECTIONRECONFIGURATION</i> including measConfig to setup inter RAT measurements and reporting for NR Cell 1.	<--	<i>RRCCONNECTIONRECONFIGURATION</i>	-	-
2	The UE transmits an <i>RRCCONNECTIONRECONFIGURATIONCOMPLETE</i> message to confirm the setup of inter RAT measurements for NR Cell 1.	-->	<i>RRCCONNECTIONRECONFIGURATIONCOMPLETE</i>	-	-
3	Check: Does the UE transmit a <i>MEASUREMENTREPORT</i> message on E-UTRA Cell 1 to report the event B2 during the next 10s?	-->	<i>MEASUREMENTREPORT</i>	1	F
4	The SS changes NR Cell 1 and E-UTRA Cell 1 parameters according to the row "T1".	-	-	-	-
5	Check: Does the UE transmit a <i>MEASUREMENTREPORT</i> message on E-UTRA Cell 1 to report the event B2 during the next 10s?	-->	<i>MEASUREMENTREPORT</i>	1	F
6	The SS changes NR Cell 1 and E-UTRA Cell 1 parameters according to the row "T2".	-	-	-	-
7	Check: Does the UE transmit a <i>MEASUREMENTREPORT</i> message to report the event B2 for NR Cell 1?	-->	<i>MEASUREMENTREPORT</i>	2	P
8	The SS changes NR Cell 1 and E-UTRA Cell 1 parameters according to the row "T3".	-	-	-	-
9	Wait and ignore <i>MEASUREMENTREPORT</i> messages for 15s to allow change of power levels and UE measurements for NR Cell 1 and E-UTRA Cell 1.	-	-	-	-
10	Check: Does the UE transmit a <i>MEASUREMENTREPORT</i> message on E-UTRA Cell 1 to report the event B2 during the next 10s?	-->	<i>MEASUREMENTREPORT</i>	3	F
11	The SS changes NR Cell 1 and E-UTRA Cell 1 parameters according to the row "T4" in table 8.2.3.12.1.3.2-1.	-	-	-	-
12	Void				
13	Check: Does the UE transmit a <i>MEASUREMENTREPORT</i> message to report the event B2 for NR Cell 1?	-->	<i>MEASUREMENTREPORT</i>	2	P
14	The SS changes NR Cell 1 and E-UTRA Cell 1 parameters according to the row "T5" in table 8.2.3.12.1.3.2-1.	-	-	-	-
15	Wait and ignore <i>MEASUREMENTREPORT</i> messages for 15s to allow change of power levels and UE measurements for NR Cell 1 and E-UTRA Cell 1.	-	-	-	-
16	Check: Does the UE transmit a <i>MEASUREMENTREPORT</i> message on E-UTRA Cell 1 to report the event B2 during the next 10s?	-->	<i>MEASUREMENTREPORT</i>	3	F

8.2.3.12.1.3.3 Specific message contents

Table 8.2.3.12.1.3.3-1: *RRCCONNECTIONRECONFIGURATION* (step 1, Table 8.2.3.12.1.3.2-2)

Derivation Path: 36.508 [7], Table 4.6.1-8, condition MEAS
--

Table 8.2.3.12.1.3.3-2: *MeasConfig* (Table 8.2.3.12.1.3.3-1)

Derivation Path: 36.508 [7], Table 4.6.6-1			
Information Element	Value/remark	Comment	Condition
MeasConfig ::= SEQUENCE {			
measObjectToAddModList SEQUENCE (SIZE (1..maxObjectld)) OF SEQUENCE {	1 entries		
measObjectld[1]	ldMeasObject-NRf1		
measObject[1]	MeasObjectNR-GENERIC (NRf1)		
}			
reportConfigToAddModList SEQUENCE (SIZE (1..maxReportConfigld)) OF SEQUENCE {	1 entry		
reportConfigld[1]	ldReportConfig-B2-NR		
reportConfig[1]	ReportConfigInterRAT-B2-NR-r15(-72, -85)		
}			
measldToAddModList SEQUENCE (SIZE (1..maxMeasld)) OF SEQUENCE {	1 entry		
measld[1]	1		
measObjectld[1]	ldMeasObject-NRf1		
reportConfigld[1]	ldReportConfig-B2-NR		
}			
quantityConfig	QuantityConfig-DEFAULT		
measGapConfig	MeasGapConfig		
}			

Table 8.2.3.12.1.3.3-3: *QuantityConfig-DEFAULT* (Table 8.2.3.12.1.3.3-2)

Derivation Path: 36.508 [7], Table 4.6.6-3A			
Information Element	Value/remark	Comment	Condition
QuantityConfig-DEFAULT ::= SEQUENCE {			
quantityConfigNRLList-r15 SEQUENCE ((SIZE (1..maxQuantSetsNR-r15)) OF SEQUENCE {			
measQuantityCellNR-r15 SEQUENCE {			
filterCoeff-RSRP-r15	fc0		
filterCoeff-RSRQ-r15	fc0		
filterCoefficient-SINR-r13	fc0		
}			
}			
}			

Table 8.2.3.12.1.3.3-4: *MeasObjectNR-GENERIC (NRf1)* (Table 8.2.3.12.1.3.3-2)

Derivation Path: 36.508 [7], Table 4.6.6-2B			
Information Element	Value/remark	Comment	Condition
MeasObjectNR-GENERIC(Freq) ::= SEQUENCE {			
carrierFreq-r15	Downlink carrier frequency of NR cell 1		
}			

Table 8.2.3.12.1.3.3-5: ReportConfigInterRAT-B2-NR-r15 (-72, -85) (Table 8.2.3.12.1.3.3-2)

Derivation Path: 36.508 [7], Table 4.6.6-8A			
Information Element	Value/remark	Comment	Condition
ReportConfig-B2-NR ::= SEQUENCE {			
reportQuantityCellNR-r15 ::= SEQUENCE {			
ss-rsrp	true		
ss-rsrq	true		
ss-sinr	true		
}			
}			

Table 8.2.3.12.1.3.3-6: MeasurementReport (step 3, 5, 7, 10, 13, 16, Table 8.2.3.12.1.3.2-2)

Derivation Path: 36.508 [7], Table 4.6.1-5			
Information Element	Value/remark	Comment	Condition
MeasurementReport ::= SEQUENCE {			
criticalExtensions CHOICE {			
c1 CHOICE {			
measurementReport-r8 SEQUENCE {			
measResults SEQUENCE {			
measId	1		
measResultPCell SEQUENCE {			
rsrpResult	(0..97)		
rsrqResult	(0..34)		
}			
measResultNeighCells CHOICE {			
measResultNeighCellListNR-r15 SEQUENCE (SIZE (1..maxCellReport)) OF SEQUENCE {	1 entry		
pci-r15 [1]	PhysicalCellIdentity of NR Cell 1		
measResultCell-r15 [1] SEQUENCE {			
rsrpResult-r15	(0..127)		
rsrqResult-r15	(0..127)		
rs-sinr-Result-r15	(0..127)		
}			
}			
}			
}			
}			

Table 8.2.3.12.1.3.3-7: MeasGapConfig (Table 8.2.3.12.1.3.3-2)

Derivation Path: 36.331, clause 6.3.5			
Information Element	Value/remark	Comment	Condition
MeasGapConfig-GP2 ::= CHOICE {			
setup SEQUENCE {			
gapOffset CHOICE {			
gp1	20	TGRP = 80 ms	
}			
}			
}			

8.2.3.13 PCell Handover with SCG change / Reconfiguration with sync / SCG DRB

8.2.3.13.1 PCell Handover with SCG change / Reconfiguration with sync / SCG DRB / EN-DC

8.2.3.13.1.1 Test Purpose (TP)

(1)

```
with { UE in RRC_CONNECTED state in EN-DC mode, and, MCG(s) (E-UTRA PDCP) and SCG DRB established }
ensure that {
  when { UE receives an RRCConnectionReconfiguration message containing mobilityControlInfo to
handover to target E-UTRAN PCell involving SCG change with reconfigurationWithSync on the same
PSCell }
  then { UE sends an RRCConnectionReconfigurationComplete message }
}
```

8.2.3.13.1.2 Conformance requirements

References: The conformance requirements covered in the present TC are specified in: TS 36.331, clause 5.3.5.4, TS 38.331, clauses 5.3.5.3, 5.3.5.5.1 and 5.3.5.5.2. Unless otherwise stated these are Rel-15 requirements.

[TS 36.331, clause 5.3.5.4]

If the *RRCConnectionReconfiguration* message includes the *mobilityControlInfo* and the UE is able to comply with the configuration included in this message, the UE shall:

- 1> stop timer T310, if running;
- 1> stop timer T312, if running;
- 1> start timer T304 with the timer value set to *t304*, as included in the *mobilityControlInfo*;
- 1> stop timer T370, if running;
- 1> if the *carrierFreq* is included:
 - 2> consider the target PCell to be one on the frequency indicated by the *carrierFreq* with a physical cell identity indicated by the *targetPhysCellId*;
- 1> else:
 - 2> consider the target PCell to be one on the frequency of the source PCell with a physical cell identity indicated by the *targetPhysCellId*;
- 1> stop timer T309, if running, for all access categories;
- 1> start synchronising to the DL of the target PCell;

NOTE 1: The UE should perform the handover as soon as possible following the reception of the RRC message triggering the handover, which could be before confirming successful reception (HARQ and ARQ) of this message.

...

- 1> if the received *RRCConnectionReconfiguration* includes the *nr-SecondaryCellGroupConfig*:
 - 2> perform NR RRC Reconfiguration as specified in TS 38.331 [82], clause 5.3.5.3.

...

- 1> set the content of *RRCConnectionReconfigurationComplete* message as follows:

...

- 2> if the received *RRCConnectionReconfiguration* message included *nr-SecondaryCellGroupConfig*:

3> perform NR RRC Reconfiguration as specified in TS 38.331 [82], clause 5.3.5.3.

[TS 38.331, clause 5.3.5.3]

The UE shall perform the following actions upon reception of the *RRCReconfiguration*:

...

1> if the *RRCReconfiguration* includes the *secondaryCellGroup*:

2> perform the cell group configuration for the SCG according to 5.3.5.5;

...

1> set the content of *RRCReconfigurationComplete* message as follows:

2> if the *RRCReconfiguration* includes the *masterCellGroup* containing the *reportUplinkTxDirectCurrent*, or;

2> if the *RRCReconfiguration* includes the *secondaryCellGroup* containing the *reportUplinkTxDirectCurrent*:

3> include the *uplinkTxDirectCurrentList*;

1> if the UE is configured with E-UTRA *nr-SecondaryCellGroupConfig* (MCG is E-UTRA):

2> if *RRCReconfiguration* was received via SRB1:

3> submit the *RRCReconfigurationComplete* via the EUTRA MCG embedded in E-UTRA RRC message *RRCConnectionReconfigurationComplete* as specified in TS 36.331 [10];

3> if *reconfigurationWithSync* was included in *spCellConfig* of an SCG:

4> initiate the random access procedure on the SpCell, as specified in TS 38.321 [3];

3> else:

4> the procedure ends;

NOTE: The order the UE sends the *RRCConnectionReconfigurationComplete* message and performs the Random Access procedure towards the SCG is left to UE implementation.

2> else (*RRCReconfiguration* was received via SRB3):

3> submit the *RRCReconfigurationComplete* message via SRB3 to lower layers for transmission using the new configuration;

NOTE: For EN-DC, in the case of SRB1, the random access is triggered by RRC layer itself as there is not necessarily other UL transmission. In the case of SRB3, the random access is triggered by the MAC layer due to arrival of *RRCReconfigurationComplete*.

1> else:

2> submit the *RRCReconfigurationComplete* message via SRB1 to lower layers for transmission using the new configuration;

...

1> if *reconfigurationWithSync* was included in *spCellConfig* of an MCG or SCG, and when MAC of an NR cell group successfully completes a random access procedure triggered above;

2> stop timer T304 for that cell group;

2> apply the parts of the CQI reporting configuration, the scheduling request configuration and the sounding RS configuration that do not require the UE to know the SFN of the respective target SpCell, if any;

2> apply the parts of the measurement and the radio resource configuration that require the UE to know the SFN of the respective target SpCell (e.g. measurement gaps, periodic CQI reporting, scheduling request configuration, sounding RS configuration), if any, upon acquiring the SFN of that target SpCell;

- 2> if the *reconfigurationWithSync* was included in *spCellConfig* of an MCG:
 - 3> if T390 is running:
 - 4> stop timer T390 for all access categories;
 - 4> perform the actions as specified in 5.3.14.4.
 - ...

[TS 38.331, clause 5.3.5.5.1]

The network configures the UE with Master Cell Group (MCG), and zero or one Secondary Cell Group (SCG). For EN-DC, the MCG is configured as specified in TS 36.331 [10]. The network provides the configuration parameters for a cell group in the *CellGroupConfig* IE.

The UE performs the following actions based on a received *CellGroupConfig* IE:

- 1> if the *CellGroupConfig* contains the *spCellConfig* with *reconfigurationWithSync*:
 - 2> perform Reconfiguration with sync according to 5.3.5.5.2;
 - 2> resume all suspended radio bearers and resume SCG transmission for all radio bearers, if suspended;
- 1> if the *CellGroupConfig* contains the *rlc-BearerToReleaseList*:
 - 2> perform RLC bearer release as specified in 5.3.5.5.3;
- 1> if the *CellGroupConfig* contains the *rlc-BearerToAddModList*:
 - 2> perform the RLC bearer addition/modification as specified in 5.3.5.5.4;
- 1> if the *CellGroupConfig* contains the *mac-CellGroupConfig*:
 - 2> configure the MAC entity of this cell group as specified in 5.3.5.5.5;
- 1> if the *CellGroupConfig* contains the *sCellToReleaseList*:
 - 2> perform SCell release as specified in 5.3.5.5.8;
- 1> if the *CellGroupConfig* contains the *spCellConfig*:
 - 2> configure the SpCell as specified in 5.3.5.5.7;
- 1> if the *CellGroupConfig* contains the *sCellToAddModList*:
 - 2> perform SCell addition/modification as specified in 5.3.5.5.9.

[TS 38.331, clause 5.3.5.5.2]

The UE shall perform the following actions to execute a reconfiguration with sync.

- 1> if the security is not activated, perform the actions upon going to RRC_IDLE as specified in 5.3.11 with the release cause 'other' upon which the procedure ends;
- 1> stop timer T310 for the corresponding SpCell, if running;
- 1> start timer T304 for the corresponding SpCell with the timer value set to *t304*, as included in the *reconfigurationWithSync*;
- 1> if the *frequencyInfoDL* is included:
 - 2> consider the target SpCell to be one on the frequency indicated by the *frequencyInfoDL* with a physical cell identity indicated by the *physCellId*;
- 1> else:

2> consider the target SpCell to be one on the SSB frequency of the source SpCell with a physical cell identity indicated by the *physCellId*;

1> start synchronising to the DL of the target SpCell;

1> apply the specified BCCH configuration defined in 9.1.1.1;

1> acquire the *MIB*, which is scheduled as specified in TS 38.213 [13];

1> perform the actions specified in clause 5.2.2.4.1;

NOTE 1: The UE should perform the reconfiguration with sync as soon as possible following the reception of the RRC message triggering the reconfiguration with sync, which could be before confirming successful reception (HARQ and ARQ) of this message.

NOTE 2: The UE may omit reading the MIB if the UE already has the required timing information, or the timing information is not needed for random access.

1> reset the MAC entity of this cell group;

1> consider the SCell(s) of this cell group, if configured, to be in deactivated state;

1> apply the value of the *newUE-Identity* as the C-RNTI for this cell group;

Editor's Note: Verify that this does not configure some common parameters which are later discarded due to e.g. SCell release or due to LCH release.

1> configure lower layers in accordance with the received *spCellConfigCommon*;

1> configure lower layers in accordance with any additional fields, not covered in the previous, if included in the received *reconfigurationWithSync*.

8.2.3.13.1.3 Test description

8.2.3.13.1.3.1 Pre-test conditions

System Simulator:

- E-UTRA Cell 1 is the PCell, E-UTRA Cell 2 is the target PCell and NR Cell 1 is the PSCell.

UE:

- None.

Preamble:

- If *pc_IP_Ping* is set to TRUE then, the UE is in state RRC_CONNECTED using generic procedure parameter Connectivity (EN-DC), Bearers (MCG(s) and SCG) established according to TS 38.508-1 [4], clause 4.5.4.2-1.
- Else, the UE is in state RRC_CONNECTED using generic procedure parameter Connectivity (EN-DC), Bearers (MCG(s) and SCG) and Test Loop Function (On) with UE test loop mode B activated according to TS 38.508-1 [4], table 4.5.4.2-1.

8.2.3.13.1.3.2 Test procedure sequence

Tables 8.2.3.13.1.3.2-1 and 8.2.3.13.1.3.2-2 and Table 8.2.3.13.1.3.2-1A illustrate the downlink power levels and other changing parameters to be applied for the cells, with NR cells configured with FR1 and FR2 bands respectively, at various time instants of the test execution. Row marked "T0" denotes the initial conditions after preamble, while columns marked "T1" is to be applied subsequently. The exact instants on which these values shall be applied are described in the texts in this clause.

Table 8.2.3.13.1.3.2-1: Time instances of cell power level and parameter changes for FR1

	Parameter	Unit	E-UTRA Cell 1	E-UTRA Cell 2	NR Cell 1	Remark
T0	Cell-specific RS EPRE	dBm/15kHz	-85	-91	-	
	SS/PBCH SSS EPRE	dBm/SCS	-	-	-88	
T1	Cell-specific RS EPRE	dBm/15kHz	-85	-79	-	
	SS/PBCH SSS EPRE	dBm/SCS	-	-	-88	

Table 8.2.3.13.1.3.2-2: Time instances of cell power level and parameter changes for FR2

	Parameter	Unit	E-UTRA Cell 1	E-UTRA Cell 2	NR Cell 1	Remark
T0	Cell-specific RS EPRE	dBm/15kHz	FFS	FFS	-	
	SS/PBCH SSS EPRE	[dBm/SCS]	-	-	FFS	
T1	Cell-specific RS EPRE	dBm/15kHz	FFS	FFS	-	
	SS/PBCH SSS EPRE	[dBm/SCS]	-	-	FFS	

Table 8.2.3.13.1.3.2-3: Main behaviour

St	Procedure	Message Sequence		TP	Verdict
		U - S	Message		
1	SS re-adjusts the cell-specific reference signal level according to row "T1" 8.2.3.13.1.3.2-1 or 8.2.3.13.1.3.2-1A depending upon whether NR cell is configured on FR1 or FR2 band respectively.	-	-	-	-
2	The SS transmits an <i>RRConnectionReconfiguration</i> message containing <i>mobilityControlInfo</i> to handover to E-UTRA Cell 2 and NR <i>RRReconfiguration</i> message to perform SCG change with <i>reconfigurationWithSync</i> with the same PSCell.	<--	<i>RRConnectionReconfiguration (RRReconfiguration)</i>	-	-
3	Check: Does the UE transmit an <i>RRConnectionReconfigurationComplete</i> message containing NR <i>RRReconfigurationComplete</i> message on E-UTRA Cell 2?	-->	<i>RRConnectionReconfigurationComplete (RRReconfigurationComplete)</i>	1	P
4	Void	-	-	-	-
5	Check: Does the test result of generic test procedure in TS 38.508-1 subclause 4.9.1 indicate that the UE is capable of exchanging IP data on SCG DRB using NR radio path?	-	-	1	P

8.2.3.13.1.3.3 Specific message contents

Table 8.2.3.13.1.3.3-1: RRCConnectionReconfiguration (step 2, Table 8.2.3.13.1.3.2-2)

Derivation Path: 36.508 [7], Table 4.6.1-8 with condition EN-DC_EmbedNR_RRCRecon and EN-DC_PSCell_HO AND RBConfig_NoKeyChange			
Information Element	Value/remark	Comment	Condition
RRCConnectionReconfiguration ::= SEQUENCE {			
criticalExtensions CHOICE {			
c1 CHOICE {			
rrcConnectionReconfiguration-r8 ::= SEQUENCE {			
mobilityControllInfo SEQUENCE {	MobilityControllInfo-HO		
targetPhysCellId	PhysicalCellIdentity of E-UTRA Cell 2		
carrierFreq SEQUENCE {			
dl-CarrierFreq	Same downlink EARFCN as used for E-UTRA Cell 2		
}			
carrierFreq SEQUENCE { }	Not present		Band > 64
carrierFreq-v9e0 SEQUENCE {			Band > 64
dl-CarrierFreq-v9e0	Same downlink EARFCN as used for E-UTRA Cell 2		
}			
}			
}			
}			
}			
}			

Condition	Explanation
Band > 64	If band > 64 is selected

Table 8.2.3.13.1.3.3-2: MobilityControllInfo-HO (Table 8.2.3.13.1.3.3-1)

Derivation Path: 36.508 [7], Table 4.6.5-1
--

8.2.3.14 SCG change / Reconfiguration with sync / Split DRB

8.2.3.14.1 SCG change / Reconfiguration with sync / Split DRB / EN-DC

8.2.3.14.1.1 Test Purpose (TP)

(1)

```
with { UE in RRC_CONNECTED state with EN-DC, and, MCG(s) (E-UTRA PDCP) and Split }
ensure that {
  when { UE receives an RRCConnectionReconfiguration message to handover from NR PSCell involving
SCG change with reconfigurationWithSync to the target NR cell with Split DRB }
  then { UE sends an RRCConnectionReconfigurationComplete message }
}
```

8.2.3.14.1.2 Conformance requirements

References: The conformance requirements covered in the present TC are specified in: TS 36.331, clause 5.3.5.3, TS 38.331, clauses 5.3.5.3, 5.3.5.5.1 and 5.3.5.5.2. Unless otherwise stated these are Rel-15 requirements.

[TS 36.331, clause 5.3.5.3]

If the *RRCCONNECTIONRECONFIGURATION* message does not include the *mobilityControlInfo* and the UE is able to comply with the configuration included in this message, the UE shall:

...

1> if the received *RRCCONNECTIONRECONFIGURATION* includes the *sk-Counter*:

2> perform key update procedure as specified in TS 38.331 [82], clause 5.3.5.7;

1> if the received *RRCCONNECTIONRECONFIGURATION* includes the *nr-SecondaryCellGroupConfig*:

2> perform NR RRC Reconfiguration as specified in TS 38.331 [82], clause 5.3.5.3;

...

1> set the content of *RRCCONNECTIONRECONFIGURATIONCOMPLETE* message as follows:

...

2> if the received *RRCCONNECTIONRECONFIGURATION* message included *nr-SecondaryCellGroupConfig*:

3> include *scg-ConfigResponseNR* in accordance with TS 38.331 [82], clause 5.3.5.3;

1> submit the *RRCCONNECTIONRECONFIGURATIONCOMPLETE* message to lower layers for transmission using the new configuration, upon which the procedure ends;

[TS 38.331, clause 5.3.5.3]

The UE shall perform the following actions upon reception of the *RRCRECONFIGURATION*:

...

1> if the *RRCRECONFIGURATION* includes the *secondaryCellGroup*:

2> perform the cell group configuration for the SCG according to 5.3.5.5;

...

1> set the content of *RRCRECONFIGURATIONCOMPLETE* message as follows:

2> if the *RRCRECONFIGURATION* includes the *masterCellGroup* containing the *reportUplinkTxDirectCurrent*, or;

2> if the *RRCRECONFIGURATION* includes the *secondaryCellGroup* containing the *reportUplinkTxDirectCurrent*:

3> include the *uplinkTxDirectCurrentList*;

1> if the UE is configured with E-UTRA *nr-SecondaryCellGroupConfig* (MCG is E-UTRA):

2> if *RRCRECONFIGURATION* was received via SRB1:

3> submit the *RRCRECONFIGURATIONCOMPLETE* via the EUTRA MCG embedded in E-UTRA RRC message *RRCCONNECTIONRECONFIGURATIONCOMPLETE* as specified in TS 36.331 [10];

3> if *reconfigurationWithSync* was included in *spCellConfig* of an SCG:

4> initiate the random access procedure on the SpCell, as specified in TS 38.321 [3];

3> else:

4> the procedure ends;

NOTE: The order the UE sends the *RRCCONNECTIONRECONFIGURATIONCOMPLETE* message and performs the Random Access procedure towards the SCG is left to UE implementation.

2> else (*RRCRECONFIGURATION* was received via SRB3):

3> submit the *RRCRECONFIGURATIONCOMPLETE* message via SRB3 to lower layers for transmission using the new configuration;

NOTE: For EN-DC, in the case of SRB1, the random access is triggered by RRC layer itself as there is not necessarily other UL transmission. In the case of SRB3, the random access is triggered by the MAC layer due to arrival of *RRCReconfigurationComplete*.

1> else:

...

- 1> if *reconfigurationWithSync* was included in *spCellConfig* of an MCG or SCG, and when MAC of an NR cell group successfully completes a random access procedure triggered above;
 - 2> stop timer T304 for that cell group;
 - 2> apply the parts of the CQI reporting configuration, the scheduling request configuration and the sounding RS configuration that do not require the UE to know the SFN of the respective target SpCell, if any;
 - 2> apply the parts of the measurement and the radio resource configuration that require the UE to know the SFN of the respective target SpCell (e.g. measurement gaps, periodic CQI reporting, scheduling request configuration, sounding RS configuration), if any, upon acquiring the SFN of that target SpCell;
- 2> if the *reconfigurationWithSync* was included in *spCellConfig* of an MCG:
 - 3> if T390 is running:
 - 4> stop timer T390 for all access categories;
 - 4> perform the actions as specified in 5.3.14.4.

[TS 38.331, clause 5.3.5.5.1]

The network configures the UE with Master Cell Group (MCG), and zero or one Secondary Cell Group (SCG). For EN-DC, the MCG is configured as specified in TS 36.331 [10]. The network provides the configuration parameters for a cell group in the *CellGroupConfig* IE.

The UE performs the following actions based on a received *CellGroupConfig* IE:

- 1> if the *CellGroupConfig* contains the *spCellConfig* with *reconfigurationWithSync*:
 - 2> perform Reconfiguration with sync according to 5.3.5.5.2;
 - 2> resume all suspended radio bearers and resume SCG transmission for all radio bearers, if suspended;
- 1> if the *CellGroupConfig* contains the *rlc-BearerToReleaseList*:
 - 2> perform RLC bearer release as specified in 5.3.5.5.3;
- 1> if the *CellGroupConfig* contains the *rlc-BearerToAddModList*:
 - 2> perform the RLC bearer addition/modification as specified in 5.3.5.5.4;
- 1> if the *CellGroupConfig* contains the *mac-CellGroupConfig*:
 - 2> configure the MAC entity of this cell group as specified in 5.3.5.5.5;
- 1> if the *CellGroupConfig* contains the *sCellToReleaseList*:
 - 2> perform SCell release as specified in 5.3.5.5.8;
- 1> if the *CellGroupConfig* contains the *spCellConfig*:
 - 2> configure the SpCell as specified in 5.3.5.5.7;
- 1> if the *CellGroupConfig* contains the *sCellToAddModList*:
 - 2> perform SCell addition/modification as specified in 5.3.5.5.9.

[TS 38.331, clause 5.3.5.5.2]

The UE shall perform the following actions to execute a reconfiguration with sync.

- 1> if the security is not activated, perform the actions upon going to RRC_IDLE as specified in 5.3.11 with the release cause 'other' upon which the procedure ends;
- 1> stop timer T310 for the corresponding SpCell, if running;
- 1> start timer T304 for the corresponding SpCell with the timer value set to *t304*, as included in the *reconfigurationWithSync*;
- 1> if the *frequencyInfoDL* is included:
 - 2> consider the target SpCell to be one on the frequency indicated by the *frequencyInfoDL* with a physical cell identity indicated by the *physCellId*;
- 1> else:
 - 2> consider the target SpCell to be one on the SSB frequency of the source SpCell with a physical cell identity indicated by the *physCellId*;
- 1> start synchronising to the DL of the target SpCell;
- 1> apply the specified BCCH configuration defined in 9.1.1.1;
- 1> acquire the *MIB*, which is scheduled as specified in TS 38.213 [13];
- 1> perform the actions specified in clause 5.2.2.4.1;

NOTE 1: The UE should perform the reconfiguration with sync as soon as possible following the reception of the RRC message triggering the reconfiguration with sync, which could be before confirming successful reception (HARQ and ARQ) of this message.

NOTE 2: The UE may omit reading the MIB if the UE already has the required timing information, or the timing information is not needed for random access.

- 1> reset the MAC entity of this cell group;
- 1> consider the SCell(s) of this cell group, if configured, to be in deactivated state;
- 1> apply the value of the *newUE-Identity* as the C-RNTI for this cell group;

Editor's Note: Verify that this does not configure some common parameters which are later discarded due to e.g. SCell release or due to LCH release.

- 1> configure lower layers in accordance with the received *spCellConfigCommon*;
- 1> configure lower layers in accordance with any additional fields, not covered in the previous, if included in the received *reconfigurationWithSync*.

8.2.3.14.1.3 Test description

8.2.3.14.1.3.1 Pre-test conditions

System Simulator:

- E-UTRA Cell 1 is the PCell, NR Cell 1 is the source PSCell and NR Cell 2 is the target PSCell.

UE:

- None.

Preamble:

- If `pc_IP_Ping` is set to TRUE then, the UE is in state RRC_CONNECTED using generic procedure parameter Connectivity (*EN-DC*), Bearers (*MCG(s) and Split*) established according to TS 38.508-1 [4], clause 4.5.4.2-1.
- Else, the UE is in state RRC_CONNECTED using generic procedure parameter Connectivity (*EN-DC*), Bearers (*MCG(s) and Split*) and Test Loop Function (On) with UE test loop mode B activated according to TS 38.508-1 [4], table 4.5.4.2-1.

8.2.3.14.1.3.2 Test procedure sequence

Table 8.2.3.14.1.3.2-1 and 8.2.3.14.1.3.2-2 illustrate the downlink power levels and other changing parameters to be applied for the cells, with NR cell configured with FR1 and FR2 band respectively, at various time instants of the test execution. Row marked "T0" denotes the initial conditions after preamble, while columns marked "T1" is to be applied subsequently. The exact instants on which these values shall be applied are described in the texts in this clause.

Table 8.2.3.14.1.3.2-1: Time instances of cell power level and parameter changes for FR1

	Parameter	Unit	E-UTRA Cell 1	NR Cell 1	NR Cell 2	Remark
T0	Cell-specific RS EPRE	dBm/15kHz	-85	-	-	
	SS/PBCH SSS EPRE	dBm/SCS	-	-88	"Off"	
T1	Cell-specific RS EPRE	dBm/15kHz	-85	-	-	
	SS/PBCH SSS EPRE	dBm/SCS	-	-88	-82	

Table 8.2.3.14.1.3.2-2: Time instances of cell power level and parameter changes for FR2

	Parameter	Unit	E-UTRA Cell 1	NR Cell 1	NR Cell 2	Remark
T0	Cell-specific RS EPRE	dBm/15kHz	-96	-	-	
	SS/PBCH SSS EPRE	dBm/SCS	-	-95	"Off"	
T1	Cell-specific RS EPRE	dBm/15kHz	-96	-	-	
	SS/PBCH SSS EPRE	dBm/SCS	-	FFS	FFS	

Table 8.2.3.14.1.3.2-3: Main behaviour

St	Procedure	Message Sequence		TP	Verdict
		U - S	Message		
1	SS re-adjusts the cell-specific reference signal level according to row "T1" in table 8.2.3.14.1.3.2-1 or 8.2.3.14.1.3.2-2 depending upon whether NR cells are configured on FR1 or FR2 bands respectively.	-	-	-	-
2	The SS transmits an <i>RRCConnectionReconfiguration</i> message containing NR <i>RRCReconfiguration</i> message including <i>reconfigurewithsync</i> to handover source PSCell NR Cell 1 to target NR Cell 2 with Split DRB	<--	<i>RRCConnectionReconfiguration</i> (<i>RRCReconfiguration</i>)	-	-
3	Check: Does the UE transmit an <i>RRCConnectionReconfigurationComplete</i> message containing NR <i>RRCReconfigurationComplete</i> message?	-->	<i>RRCConnectionReconfigurationC</i> <i>omplete</i> (<i>RRCReconfigurationComplete</i>)	1	P
4	Void.	-	-	-	-
5	Check: Does the test result of generic test procedure in TS 38.508-1 subclause 4.9.1 indicate that the UE is capable of exchanging IP data on Split DRB using NR radio path on NR Cell 2?	-	-	1	P

Table 8.2.3.14.1.3.3-3 *CellGroupConfig* (Table 8.2.3.14.1.3.3-2)

Derivation Path: 38.508-1 [4], Table 4.6.3-19 with condition DRB2 and HO			
Information Element	Value/remark	Comment	Condition
CellGroupConfig ::= SEQUENCE {			
spCellConfig SEQUENCE {			
reconfigurationWithSync SEQUENCE {			
spCellConfigCommon SEQUENCE {			
physCellId	Physical Cell Identity of NR Cell 2		
}			
newUE-Identity	'4148'H		
}			
}			

8.2.3.15 Measurement configuration control and reporting / Two simultaneous events A2 and A3 (intra-frequency measurements) / Measurement of Neighbour NR cells

8.2.3.15.1 Measurement configuration control and reporting / Two simultaneous events A2 and A3 (intra-frequency measurements) / Measurement of Neighbour NR cells / EN-DC

8.2.3.15.1.1 Test Purpose (TP)

(1)

```
with { UE in RRC_CONNECTED state with EN-DC, and, MCG(s) (E-UTRA PDCP) and SCG and measurements
configured for event A2 and event A3 }
ensure that {
  when { Serving NR cell becomes worse than absolute threshold minus hysteresis }
  then { UE sends MeasurementReport for event A2 }
}
```

(2)

```
with { UE in RRC_CONNECTED state with EN-DC, and, MCG(s) (E-UTRA PDCP) and SCG and measurements
configured for event A2 and event A3 }
ensure that {
  when { Neighbour NR cell becomes offset better than serving NR PSCell }
  then { UE sends MeasurementReport for event A3 }
}
```

8.2.3.15.1.2 Conformance requirements

References: The conformance requirements covered in the present TC are specified in: TS 36.331, clause 5.3.5.3, TS 38.331, clauses 5.3.5.3, 5.5.2, 5.5.4.1, 5.5.4.3, 5.5.4.4 and 5.5.5. Unless otherwise stated these are Rel-15 requirements.

[TS 36.331, clause 5.3.5.3]

If the *RRCConnectionReconfiguration* message does not include the *mobilityControlInfo* and the UE is able to comply with the configuration included in this message, the UE shall:

...

1> else:

2> if the *RRCConnectionReconfiguration* message includes the *radioResourceConfigDedicated*:

3> perform the radio resource configuration procedure as specified in 5.3.10;

NOTE 3: If the *RRCCONNECTIONRECONFIGURATION* message includes the establishment of radio bearers other than SRB1, the UE may start using these radio bearers immediately, i.e. there is no need to wait for an outstanding acknowledgment of the *SECURITYMODECOMPLETE* message.

- 1> if the received *RRCCONNECTIONRECONFIGURATION* includes the *sCellToReleaseList*:
 - 2> perform SCell release as specified in 5.3.10.3a;
- 1> if the received *RRCCONNECTIONRECONFIGURATION* includes the *sCellToAddModList*:
 - 2> perform SCell addition or modification as specified in 5.3.10.3b;
- 1> if the received *RRCCONNECTIONRECONFIGURATION* includes the *scg-Configuration*; or
- 1> if the current UE configuration includes one or more split DRBs configured with *pdcp-Config* and the received *RRCCONNECTIONRECONFIGURATION* includes *radioResourceConfigDedicated* including *drb-ToAddModList*:
 - 2> perform SCG reconfiguration as specified in 5.3.10.10;

...

- 1> if the received *RRCCONNECTIONRECONFIGURATION* includes the *systemInformationBlockType1Dedicated*:
 - 2> perform the actions upon reception of the *SystemInformationBlockType1* message as specified in 5.2.2.7;
- 1> if the *RRCCONNECTIONRECONFIGURATION* message includes the *dedicatedInfoNASList*:
 - 2> forward each element of the *dedicatedInfoNASList* to upper layers in the same order as listed;
- 1> if the *RRCCONNECTIONRECONFIGURATION* message includes the *measConfig*:
 - 2> perform the measurement configuration procedure as specified in 5.5.2;

...

- 1> set the content of *RRCCONNECTIONRECONFIGURATIONCOMPLETE* message as follows:

...

- 2> if the received *RRCCONNECTIONRECONFIGURATION* message included *nr-SecondaryCellGroupConfig*:
 - 3> include *scg-ConfigResponseNR* in accordance with TS 38.331 [82], clause 5.3.5.3;
- 1> submit the *RRCCONNECTIONRECONFIGURATIONCOMPLETE* message to lower layers for transmission using the new configuration, upon which the procedure ends;

[TS 38.331, clause 5.3.5.3]

The UE shall perform the following actions upon reception of the *RRCRECONFIGURATION*:

- 1> if the *RRCRECONFIGURATION* includes the *fullConfig*:
 - 2> perform the radio configuration procedure as specified in 5.3.5.11;
- 1> if the *RRCRECONFIGURATION* includes the *masterCellGroup*:
 - 2> perform the cell group configuration for the received *masterCellGroup* according to 5.3.5.5;
- 1> if the *RRCRECONFIGURATION* includes the *masterKeyUpdate*:
 - 2> perform security key update procedure as specified in 5.3.5.7;
- 1> if the *RRCRECONFIGURATION* includes the *secondaryCellGroup*:
 - 2> perform the cell group configuration for the SCG according to 5.3.5.5;
- 1> if the *RRCRECONFIGURATION* message contains the *radioBearerConfig*:
 - 2> perform the radio bearer configuration according to 5.3.5.6;

- 1> if the *RRCReconfiguration* message includes the *measConfig*:
 - 2> perform the measurement configuration procedure as specified in 5.5.2;
 - 1> if the *RRCReconfiguration* message includes the *dedicatedSIB1-Delivery*:
 - 2> perform the action upon reception of *SIB1* as specified in 5.2.2.4.2;
 - 1> if the *RRCReconfiguration* message includes the *dedicatedSystemInformationDelivery*:
 - 2> perform the action upon reception of System Information as specified in 5.2.2.4;
 - 1> set the content of *RRCReconfigurationComplete* message as follows:
 - 2> if the *RRCReconfiguration* includes the *masterCellGroup* containing the *reportUplinkTxDirectCurrent*, or;
 - 2> if the *RRCReconfiguration* includes the *secondaryCellGroup* containing the *reportUplinkTxDirectCurrent*:
 - 3> include the *uplinkTxDirectCurrentList*;
 - 1> if the UE is configured with E-UTRA *nr-SecondaryCellGroupConfig* (MCG is E-UTRA):
 - 2> if *RRCReconfiguration* was received via SRB1:
 - 3> submit the *RRCReconfigurationComplete* via the EUTRA MCG embedded in E-UTRA RRC message *RRCConnectionReconfigurationComplete* as specified in TS 36.331 [10];
 - 3> if *reconfigurationWithSync* was included in *spCellConfig* of an SCG:
 - 4> initiate the random access procedure on the SpCell, as specified in TS 38.321 [3];
 - 3> else:
 - 4> the procedure ends;
- NOTE: The order the UE sends the *RRCConnectionReconfigurationComplete* message and performs the Random Access procedure towards the SCG is left to UE implementation.
- 2> else (*RRCReconfiguration* was received via SRB3):
 - 3> submit the *RRCReconfigurationComplete* message via SRB3 to lower layers for transmission using the new configuration;
- NOTE: For EN-DC, in the case of SRB1, the random access is triggered by RRC layer itself as there is not necessarily other UL transmission. In the case of SRB3, the random access is triggered by the MAC layer due to arrival of *RRCReconfigurationComplete*.
- 1> else:
 - 2> submit the *RRCReconfigurationComplete* message via SRB1 to lower layers for transmission using the new configuration;
 - 1> if *reconfigurationWithSync* was included in *spCellConfig* of an MCG or SCG, and when MAC of an NR cell group successfully completes a random access procedure triggered above:
 - 2> stop timer T304 for that cell group;
 - 2> apply the parts of the CQI reporting configuration, the scheduling request configuration and the sounding RS configuration that do not require the UE to know the SFN of the respective target SpCell, if any;
 - 2> apply the parts of the measurement and the radio resource configuration that require the UE to know the SFN of the respective target SpCell (e.g. measurement gaps, periodic CQI reporting, scheduling request configuration, sounding RS configuration), if any, upon acquiring the SFN of that target SpCell;
 - 2> if the *reconfigurationWithSync* was included in *spCellConfig* of an MCG:
 - 3> if the active downlink BWP, which is indicated by the *firstActiveDownlinkBWP-Id* for the target SpCell of the MCG, has a common search space configured:

4> acquire the *SIB1* of the target SpCell of the MCG, as specified in 5.2.2.3.1;

2> the procedure ends.

NOTE: The UE is only required to acquire broadcasted *SIB1* if the UE can acquire it without disrupting unicast data reception, i.e. the broadcast and unicast beams are quasi co-located.

[TS 38.331, clause 5.5.2]

The UE shall:

...

1> if the received *measConfig* includes the *measObjectToAddModList*:

2> perform the measurement object addition/modification procedure as specified in 5.5.2.5;

...

1> if the received *measConfig* includes the *reportConfigToAddModList*:

2> perform the reporting configuration addition/modification procedure as specified in 5.5.2.7;

...

1> if the received *measConfig* includes the *measIdToAddModList*:

2> perform the measurement identity addition/modification procedure as specified in 5.5.2.3;

[TS 38.331, clause 5.5.4.1]

If security has been activated successfully, the UE shall:

1> for each *measId* included in the *measIdList* within *VarMeasConfig*:

2> if the corresponding *reportConfig* includes a *reportType* set to *eventTriggered* or *periodical*;

3> if the corresponding *measObject* concerns NR;

4> if the *eventA1* or *eventA2* is configured in the corresponding *reportConfig*:

5> consider only the serving cell to be applicable;

4> else:

5> for events involving a serving cell associated with a *measObjectNR* and neighbours associated with another *measObjectNR*, consider any serving cell associated with the other *measObjectNR* to be a neighbouring cell as well;

...

2> if the *reportType* is set to *eventTriggered* and if the entry condition applicable for this event, i.e. the event corresponding with the *eventId* of the corresponding *reportConfig* within *VarMeasConfig*, is fulfilled for one or more applicable cells for all measurements after layer 3 filtering taken during *timeToTrigger* defined for this event within the *VarMeasConfig*, while the *VarMeasReportList* does not include a measurement reporting entry for this *measId* (a first cell triggers the event):

3> include a measurement reporting entry within the *VarMeasReportList* for this *measId*;

3> set the *numberOfReportsSent* defined within the *VarMeasReportList* for this *measId* to 0;

3> include the concerned cell(s) in the *cellsTriggeredList* defined within the *VarMeasReportList* for this *measId*;

3> initiate the measurement reporting procedure, as specified in 5.5.5;

...

- 2> if the *reportType* is set to *eventTriggered* and if the entry condition applicable for this event, i.e. the event corresponding with the *eventId* of the corresponding *reportConfig* within *VarMeasConfig*, is fulfilled for one or more applicable cells not included in the *cellsTriggeredList* for all measurements after layer 3 filtering taken during *timeToTrigger* defined for this event within the *VarMeasConfig* (a subsequent cell triggers the event):
- 3> set the *numberOfReportsSent* defined within the *VarMeasReportList* for this *measId* to 0;
- 3> include the concerned cell(s) in the *cellsTriggeredList* defined within the *VarMeasReportList* for this *measId*;
- 3> initiate the measurement reporting procedure, as specified in 5.5.5;

[TS 38.331, clause 5.5.4.3]

The UE shall:

- 1> consider the entering condition for this event to be satisfied when condition A2-1, as specified below, is fulfilled;
- 1> consider the leaving condition for this event to be satisfied when condition A2-2, as specified below, is fulfilled;
- 1> for this measurement, consider the serving cell indicated by the *measObjectNR* associated to this event.

Inequality A2-1 (Entering condition)

$$Ms + Hys < Thresh$$

Inequality A2-2 (Leaving condition)

$$Ms - Hys > Thresh$$

The variables in the formula are defined as follows:

Ms is the measurement result of the serving cell, not taking into account any offsets.

Hys is the hysteresis parameter for this event (i.e. *hysteresis* as defined within *reportConfigNR* for this event).

Thresh is the threshold parameter for this event (i.e. *a2-Threshold* as defined within *reportConfigNR* for this event).

Ms is expressed in dBm in case of RSRP, or in dB in case of RSRQ and RS-SINR.

Hys is expressed in dB.

Thresh is expressed in the same unit as ***Ms***.

[TS 38.331, clause 5.5.4.4]

The UE shall:

- 1> consider the entering condition for this event to be satisfied when condition A3-1, as specified below, is fulfilled;
- 1> consider the leaving condition for this event to be satisfied when condition A3-2, as specified below, is fulfilled;
- 1> use the SpCell for *Mp*, *Ofp* and *Ocp*.

NOTE The cell(s) that triggers the event has reference signals indicated in the *measObjectNR* associated to this event which may be different from the NR SpCell*measObjectNR*.

Inequality A3-1 (Entering condition)

$$Mn + Ofn + Ocn - Hys > Mp + Ofp + Ocp + Off$$

Inequality A3-2 (Leaving condition)

$$Mn + Ofn + Ocn + Hys < Mp + Ofp + Ocp + Off$$

The variables in the formula are defined as follows:

Mn is the measurement result of the neighbouring cell, not taking into account any offsets.

Ofn is the measurement object specific offset of the reference signal of the neighbour cell (i.e. *offsetMO* as defined within *measObjectNR* corresponding to the neighbour cell).

Ocn is the cell specific offset of the neighbour cell (i.e. *cellIndividualOffset* as defined within *measObjectNR* corresponding to the frequency of the neighbour cell), and set to zero if not configured for the neighbour cell.

Mp is the measurement result of the SpCell, not taking into account any offsets.

Ofp is the measurement object specific offset of the SpCell (i.e. *offsetMO* as defined within *measObjectNR* corresponding to the SpCell).

Ocp is the cell specific offset of the SpCell (i.e. *cellIndividualOffset* as defined within *measObjectNR* corresponding to the SpCell), and is set to zero if not configured for the SpCell.

Hys is the hysteresis parameter for this event (i.e. *hysteresis* as defined within *reportConfigNR* for this event).

Off is the offset parameter for this event (i.e. *a3-Offset* as defined within *reportConfigNR* for this event).

Mn, Mp are expressed in dBm in case of RSRP, or in dB in case of RSRQ and RS-SINR.

Ofn, Ocn, Ofp, Ocp, Hys, Off are expressed in dB.

[TS 38.331, clause 5.5.5]

For the *measId* for which the measurement reporting procedure was triggered, the UE shall set the *measResults* within the *MeasurementReport* message as follows:

- 1> set the *measId* to the measurement identity that triggered the measurement reporting;
- 1> set the *measResultServingCell* within *measResultServingMOList* to include RSRP, RSRQ and the available SINR for each configured serving cell derived based on the *rsType* indicated in the associated *reportConfig*;
- 1> set the *measResultServingCell* within *measResultServingMOList* to include for each NR serving cell that is configured with *servingCellMO*, if any, the *servCellId*;
- 1> if the *reportConfig* associated with the *measId* that triggered the measurement reporting includes *reportQuantityRsIndexes* and *maxNrofRSIndexesToReport*:
 - 2> for each serving cell configured with *servingCellMO*, include beam measurement information according to the associated *reportConfig* as described in 5.5.5.2;
- 1> if the *reportConfig* associated with the *measId* that triggered the measurement reporting includes *reportAddNeighMeas*:
 - 2> for each serving cell *measObjectId* referenced in the *measIdList*, other than the *measObjectId* corresponding with the *measId* that triggered the measurement reporting:
 - 3> set the *measResultBestNeighCell* within *measResultServingMOList* to include the *physCellId* and the available measurement quantities based on the *reportQuantityCell* and *rsType* indicated in *reportConfig* of the non-serving cell corresponding to the concerned *measObjectNR* with the highest measured RSRP if RSRP measurement results are available for cells corresponding to this *measObjectNR*, otherwise with the highest measured RSRQ if RSRQ measurement results are available for cells corresponding to this *measObjectNR*, otherwise with the highest measured SINR;
 - 3> if the *reportConfig* associated with the *measId* that triggered the measurement reporting includes *reportQuantityRsIndexes* and *maxNrofRSIndexesToReport*:
 - 4> for each best non-serving cell included in the measurement report:
 - 5> include beam measurement information according to the associated *reportConfig* as described in 5.5.5.2;
 - 1> if there is at least one applicable neighbouring cell to report:

- 2> set the *measResultNeighCells* to include the best neighbouring cells up to *maxReportCells* in accordance with the following:
 - 3> if the *reportType* is set to *eventTriggered*:
 - 4> include the cells included in the *cellsTriggeredList* as defined within the *VarMeasReportList* for this *measId*;
 - 3> else:
 - 4> include the applicable cells for which the new measurement results became available since the last periodical reporting or since the measurement was initiated or reset;
 - 4> if *reportQuantityRsIndexes* and *maxNrofRSIndexesToReport* are configured, include beam measurement information as described in 5.5.5.2;
 - 3> for each cell that is included in the *measResultNeighCells*, include the *physCellId*;
 - 3> if the *reportType* is set to *eventTriggered*:
 - 4> for each included cell, include the layer 3 filtered measured results in accordance with the *reportConfig* for this *measId*, ordered as follows:
 - 5> if the *measObject* associated with this *measId* concerns NR:
 - 6> if *rsType* in the associated *reportConfig* is set to *ssb*:
 - 7> set *resultsSSB-Cell* within the *measResult* to include the SS/PBCH block based quantity(ies) indicated in the *reportQuantityCell* within the concerned *reportConfig*, in order of decreasing trigger quantity, i.e. the best cell is included first;
 - 8> if *reportQuantityRsIndexes* and *maxNrofRSIndexesToReport* are configured, include beam measurement information as described in 5.5.5.2;
 - 6> else if *rsType* in the associated *reportConfig* is set to *csi-rs*:
 - 7> set *resultsCSI-RS-Cell* within the *measResult* to include the CSI-RS based quantity(ies) indicated in the *reportQuantityCell* within the concerned *reportConfig*, in order of decreasing trigger quantity, i.e. the best cell is included first;
 - 8> if *reportQuantityRsIndexes* and *maxNrofRSIndexesToReport* are, include beam measurement information as described in 5.5.5.2;
- ...
- 1> if the UE is configured with EN-DC:
 - 2> if SRB3 is configured:
 - 3> submit the *MeasurementReport* message via SRB3 to lower layers for transmission, upon which the procedure ends;
 - 2> else:
 - 3> submit the *MeasurementReport* message via the EUTRA MCG embedded in E-UTRA RRC message *ULInformationTransferMRDC* as specified in TS 36.331 [10].
 - 1> else:
 - 2> submit the *MeasurementReport* message to lower layers for transmission, upon which the procedure ends.

8.2.3.15.1.3 Test description

8.2.3.15.1.3.1 Pre-test conditions

System Simulator:

- EUTRA Cell 1 is the PCell and NR Cell 1 is the PS Cell.
- NR Cell 2 is the intra-frequency neighbour cell.

UE:

- None

Preamble:

- The UE is in state RRC_CONNECTED using generic procedure parameter Connectivity (EN-DC) and DC Bearers (MCG(s) and SCG) on E-UTRA Cell 1 according to TS 38.508-1, clause 4.5.4 [4].

8.2.3.15.1.3.2 Test procedure sequence

Table 8.2.3.15.1.3.2-1 and Table 8.2.3.15.1.3.2-1A illustrates the downlink power levels to be applied for NR Cell 1 and NR Cell 2 at various time instants of the test execution. Row marked "T0" denotes the conditions after the preamble, while rows marked "T1" and "T2" are to be applied subsequently. The exact instants on which these values shall be applied are described in the texts in this clause.

Table 8.2.3.15.1.3.2-1: Time instances of cell power level and parameter changes for FR1

	Parameter	Unit	EUTRA Cell 1	NR Cell 1	NR Cell 2	Remark
T0	Cell-specific RS EPRE	dBm/15 kHz	-85	-	-	Power levels are such that entry condition for event A2 and event A3 is not satisfied: $M_s - H_{ys} > Thresh$ AND $M_n + O_{fn} + O_{cn} + H_{ys} < M_s + O_{fs} + O_{cs} + Off$
	SS/PBCH SSS EPRE	dBm/S CS	-	-79	-91	
T1	Cell-specific RS EPRE	dBm/15 kHz	-85	-	-	Power level of Cell 1 is such that entry condition for event A2 is satisfied for the serving cell: $M_s + H_{ys} < Thresh$ AND Power levels of Cell 1 and Cell 2 are such that entry condition for event A3 is not satisfied for any of the neighbour NR cells: $M_n + O_{fn} + O_{cn} + H_{ys} < M_s + O_{fs} + O_{cs} + Off$
	SS/PBCH SSS EPRE	dBm/S CS	-	-103	-113	
T2	Cell-specific RS EPRE	dBm/15 kHz	-85	-	-	Power levels are such that entry condition for event A2 is not satisfied: $M_s - H_{ys} > Thresh$ Power levels of Cell 1 and Cell 2 are such that entry condition for event A3 is satisfied for intra-frequency neighbour NR cell: $M_n + O_{fn} + O_{cn} - H_{ys} > M_s + O_{fs} + O_{cs} + Off$
	SS/PBCH SSS EPRE	dBm/S CS	-	-79	-69	

Table 8.2.3.15.1.3.2-1A: Time instances of cell power level and parameter changes for FR2

	Parameter	Unit	EUTRA Cell 1	NR Cell 1	NR Cell 2	Remark
T0	Cell-specific RS EPRE	dBm/15 kHz	FFS	-	-	Power levels are such that entry condition for event A2 and event A3 is not satisfied:
	SS/PBCH SSS EPRE	dBm/S CS	-	FFS	FFS	$M_s - H_{ys} > Thresh$ AND $M_n + O_{fn} + O_{cn} + H_{ys} < M_s + O_{fs} + O_{cs} + O_{ff}$
T1	Cell-specific RS EPRE	dBm/15 kHz	FFS	-	-	Power level of Cell 1 is such that entry condition for event A2 is satisfied for the serving cell:
	SS/PBCH SSS EPRE	dBm/S CS	-	FFS	FFS	$M_s + H_{ys} < Thresh$ AND Power levels of Cell 1 and Cell 2 are such that entry condition for event A3 is not satisfied for any of the neighbour NR cells: $M_n + O_{fn} + O_{cn} + H_{ys} < M_s + O_{fs} + O_{cs} + O_{ff}$
T2	Cell-specific RS EPRE	dBm/15 kHz	FFS	-	-	Power levels are such that entry condition for event A2 is not satisfied:
	SS/PBCH SSS EPRE	dBm/S CS	-	FFS	FFS	$M_s - H_{ys} > Thresh$ Power levels of Cell 1 and Cell 2 are such that entry condition for event A3 is satisfied for intra-frequency neighbour NR cell: $M_n + O_{fn} + O_{cn} - H_{ys} > M_s + O_{fs} + O_{cs} + O_{ff}$

Table 8.2.3.15.1.3.2-2: Main behaviour

St	Procedure	Message Sequence		TP	Verdict
		U - S	Message		
1	The SS transmits an <i>RRCCONNECTIONRECONFIGURATION</i> message containing NR <i>RRCCONNECTIONRECONFIGURATION</i> to setup measurement for PSCell and reporting for event A2, and measurement for neighbour NR Cell and reporting for event A3 (intra-frequency measurement)	<--	<i>RRCCONNECTIONRECONFIGURATION (RRCCONNECTIONRECONFIGURATION)</i>	-	-
2	Check: Does the UE transmit an <i>RRCCONNECTIONRECONFIGURATIONCOMPLETE</i> message containing NR <i>RRCCONNECTIONRECONFIGURATIONCOMPLETE</i> message?	-->	<i>RRCCONNECTIONRECONFIGURATIONCOMPLETE (RRCCONNECTIONRECONFIGURATIONCOMPLETE)</i>	-	-
3	Check: Does the UE transmit an <i>ULINFORMATIONTRANSFERMRDC</i> message containing NR <i>MEASUREMENTREPORT</i> message within the next 10s to report event A2 or A3?	-->	<i>ULINFORMATIONTRANSFERMRDC (MEASUREMENTREPORT)</i>	1	F
4	The SS re-adjusts the cell-specific reference signal level according to row "T1".	-	-	-	-
5	Check: Does the UE transmit an <i>ULINFORMATIONTRANSFERMRDC</i> message containing NR <i>MEASUREMENTREPORT</i> message to report event A2 (<i>measId 1</i>) with the measured value for NR Cell 1?	-->	<i>ULINFORMATIONTRANSFERMRDC (MEASUREMENTREPORT)</i>	1	P
6	The SS re-adjusts the cell-specific reference signal level according to row "T2".	-	-	-	-
7	Check: Does the UE transmit an <i>ULINFORMATIONTRANSFERMRDC</i> message containing NR <i>MEASUREMENTREPORT</i> message to report event A3 (<i>measId 2</i>) with the measured value for NR Cell 2?	-->	<i>ULINFORMATIONTRANSFERMRDC (MEASUREMENTREPORT)</i>	2	P

8.2.3.15.1.3.3 Specific message contents

Table 8.2.3.15.1.3.3-1: RRCConnectionReconfiguration (step 1, Table 8.2.3.15.1.3.2-2)

Derivation Path: 36.508 [7], Table 4.6.1-8 with condition EN-DC_EmbedNR_RRCRecon

Table 8.2.3.15.1.3.3-2: RRCReconfiguration (Table 8.2.3.15.1.3.3-1)

Derivation Path: 38.508-1 [4], Table 4.6.1-13 with condition MEAS

Table 8.2.3.15.1.3.3-3: MeasConfig (Table 8.2.3.15.1.3.3-2)

Derivation Path: 38.508-1 [4], Table 4.6.3-69			
Information Element	Value/remark	Comment	Condition
MeasConfig ::= SEQUENCE {			
measObjectToAddModList SEQUENCE (SIZE (1..maxNrofObjectId)) OF SEQUENCE {	2 entries		
measObjectId[1]	1		
measObject[1] CHOICE {			
measObjectNR	MeasObjectNR(54)	ssbFrequency IE equals the ARFCN for NR Cell 1 Thresh value set to -103dBm	
}			
measObjectId[2]	2		
measObject[2] CHOICE {			
measObjectNR	MeasObjectNR(88)	ssbFrequency IE equals the ARFCN for NR Cell 2 Thresh value set to -69dBm	
}			
}			
ReportConfigToAddModList SEQUENCE(SIZE (1..maxReportConfigId)) OF SEQUENCE {	2 entries		
reportConfigId[1]	1		
reportConfig[1] CHOICE {			
reportConfigNR	ReportConfigNR(66)	Thresh value set to -91dBm	EVENT_A2
}			
reportConfigId[2]	2		
reportConfig[2] CHOICE {			
reportConfigNR	ReportConfigNR(0)	Offset value set to 0dBm	EVENT_A3
}			
}			
MeasIdToAddModList ::= SEQUENCE (SIZE (1..maxNrofMeasId)) OF SEQUENCE {	2 entries		
measId[1]	1		
measObjectId[1]	1		
reportConfigId[1]	1		
measId[2]	2		
measObjectId[2]	2		
reportConfigId[2]	2		
}			
}			

Table 8.2.3.15.1.3.3-3a: ReportConfigNR(Thres) (Table 8.2.3.15.1.3.3-3)

Derivation Path: 38.508-1 [4], Table 4.6.3-142			
Information Element	Value/remark	Comment	Condition
ReportConfigNR ::= SEQUENCE {			
reportType CHOICE {			
eventTriggered SEQUENCE {			
reportAmount	r1		
}			
}			
}			

Table 8.2.3.15.1.3.3-4: RRCConnectionReconfigurationComplete (step 2, Table 8.2.3.15.1.3.2-2)

Derivation Path: 36.508 [7], Table 4.6.1-9 with condition MCG_and_SCG

Table 8.2.3.15.1.3.3-5: ULInformationTransferMRDC (step 5, Table 8.2.3.15.1.3.2-2)

Derivation Path: 36.508 [7], Table 4.6.1-27			
Information Element	Value/remark	Comment	Condition
ULInformationTransferMRDC ::= SEQUENCE {			
ul-DCCH-MessageNR-r15	OCTET STRING including the MeasurementReport message according to Table 8.2.3.15.1.3.3-6		
}			

Table 8.2.3.15.1.3.3-6: MeasurementReport (Table 8.2.3.15.1.3.3-5)

Derivation Path: 38.508-1 [4], Table 4.6.1-7			
Information Element	Value/remark	Comment	Condition
measurementReport ::= SEQUENCE {			
measResults ::= SEQUENCE {			
measId	1		
measResultServingMOList ::= SEQUENCE (SIZE (1..maxNrofServingCells)) {	1 entry		
servCellId	Cell index corresponding to NR Cell 1		
measResultServingCell ::= SEQUENCE {			
physCellId	Physical CellID of the NR Cell 1		
measResult SEQUENCE {			
cellResults SEQUENCE {			
resultsSSB-Cell ::= SEQUENCE {			
rsrp	(0..127)		
rsrq	(0..127)		
sinr	Not present		
}	(0..127)		pc_ss_SINR_Meas
}			
}			
}			
}			

Table 8.2.3.15.1.3.3-7: ULInformationTransferMRDC (step 7, Table 8.2.3.15.1.3.2-2)

Derivation Path: 36.508 [7], Table 4.6.1-27			
Information Element	Value/remark	Comment	Condition
ULInformationTransferMRDC ::= SEQUENCE {			
ul-DCCH-MessageNR-r15	OCTET STRING including the MeasurementReport message according to Table 8.2.3.15.1.3.3-8		
}			

Table 8.2.3.15.1.3.3-8: MeasurementReport (Table 8.2.3.15.1.3.3-7)

Derivation Path: 38.508-1 [4], Table 4.6.1-7			
Information Element	Value/remark	Comment	Condition
measurementReport ::= SEQUENCE {			
measResults ::= SEQUENCE {			
measId	2		
measResultServingMOList ::= SEQUENCE (SIZE (1..maxNrofServingCells)) {	1 entry	Report NR Cell 1	
servCellId	Cell index corresponding to NR Cell 1		
measResultServingCell ::= SEQUENCE {			
physCellId	Physical CellID of the NR Cell 1		
measResult SEQUENCE {			
cellResults SEQUENCE{			
resultsSSB-Cell ::= SEQUENCE {			
rsrp	(0..127)		
rsrq	(0..127)		
sinr	Not present		
	(0..127)		pc_ss_SINR_Meas
}			
}			
}			
}			
measResultNeighCells ::= SEQUENCE (SIZE (1..maxCellReport)) {	1 entry		
measResultListNR ::= SEQUENCE {			
physCellId	Phy cell id corresponding to NR Cell 2	Report NR Cell 2	
measResult SEQUENCE {			
cellResults SEQUENCE{			
resultsSSB-Cell ::= SEQUENCE {			
rsrp	(0..127)		
rsrq	(0..127)		
sinr	Not present		
	(0..127)		pc_ss_SINR_Meas
}			
}			
}			
}			
}			

8.2.4 Carrier Aggregation

8.2.4.1 NR CA / NR SCell addition / modification / release / Success

8.2.4.1.1 NR CA / NR SCell addition / modification / release / Success / EN-DC

8.2.4.1.1.1 NR CA / NR SCell addition / modification / release / Success / EN-DC / Intra-band Contiguous CA

8.2.4.1.1.1.1 Test Purpose (TP)

(1)

```
with { UE in RRC_CONNECTED state with EN-DC, and, MCG(s) (E-UTRA PDCP) and SCG with initial AS security activated }
ensure that {
  when { UE receives an RRCConnectionReconfiguration message with nr-Config IE including NR RRCReconfiguration message containing sCellToAddModList with an sCellIndex set to the configured SCell }
  then { UE adds the new SCell, configures lower layers to consider the SCell to be in deactivated state and sends an RRCConnectionReconfigurationComplete message }
}
```

(2)

```
with { UE in RRC_CONNECTED state with EN-DC, and, MCG(s) (E-UTRA PDCP) and SCG with SCell(s) configured }
ensure that {
  when { UE receives an RRCConnectionReconfiguration message with nr-Config IE including NR RRCReconfiguration message containing sCellToAddModList with an sCellIndex matching one of the current UE SCell configuration }
  then { UE modifies the affected SCell dedicated configurations and sends an RRCConnectionReconfigurationComplete message }
}
```

(3)

```
with { UE in RRC_CONNECTED state with EN-DC, and, MCG(s) (E-UTRA PDCP) and SCG with SCell(s) configured }
ensure that {
  when { UE receives an RRCConnectionReconfiguration message with nr-Config IE including NR RRCReconfiguration message containing sCellToReleaseList with an sCellIndex matching one of the current UE SCell configuration }
  then { UE releases the SCell and sends an RRCConnectionReconfigurationComplete message }
}
```

8.2.4.1.1.1.2 Conformance requirements

References: The conformance requirements covered in the present TC are specified in: TS 36.331: 5.3.5.3; TS 38.331: 5.3.5.3, 5.3.5.5.8, 5.3.5.5.9. Unless otherwise stated these are Rel-15 requirements.

[TS 36.331, clause 5.3.5.3]

If the *RRCConnectionReconfiguration* message does not include the *mobilityControlInfo* and the UE is able to comply with the configuration included in this message, the UE shall:

- 1> if this is the first *RRCConnectionReconfiguration* message after successful completion of the RRC connection re-establishment procedure:
 - 2> re-establish PDCP for SRB2 configured with E-UTRA PDCP entity and for all DRBs that are established and configured with E-UTRA PDCP, if any;
 - 2> re-establish RLC for SRB2 and for all DRBs that are established and configured with E-UTRA RLC, if any;
 - 2> if the *RRCConnectionReconfiguration* message includes the *fullConfig*:

3> perform the radio configuration procedure as specified in 5.3.5.8;

2> if the *RRCCConnectionReconfiguration* message includes the *radioResourceConfigDedicated*:

3> perform the radio resource configuration procedure as specified in 5.3.10;

NOTE 1: Void

NOTE 2: Void

1> else:

2> if the *RRCCConnectionReconfiguration* message includes the *radioResourceConfigDedicated*:

3> perform the radio resource configuration procedure as specified in 5.3.10;

NOTE 3: If the *RRCCConnectionReconfiguration* message includes the establishment of radio bearers other than SRB1, the UE may start using these radio bearers immediately, i.e. there is no need to wait for an outstanding acknowledgment of the *SecurityModeComplete* message.

1> if the received *RRCCConnectionReconfiguration* includes the *sCellToReleaseList*:

2> perform SCell release as specified in 5.3.10.3a;

1> if the received *RRCCConnectionReconfiguration* includes the *sCellToAddModList*:

2> perform SCell addition or modification as specified in 5.3.10.3b;

1> if the received *RRCCConnectionReconfiguration* includes the *scg-Configuration*; or

1> if the current UE configuration includes one or more split DRBs configured with *pdcp-Config* and the received *RRCCConnectionReconfiguration* includes *radioResourceConfigDedicated* including *drb-ToAddModList*:

2> perform SCG reconfiguration as specified in 5.3.10.10;

1> if the received *RRCCConnectionReconfiguration* includes the *nr-Config* and it is set to *release*: or

1> if the received *RRCCConnectionReconfiguration* includes *endc-ReleaseAndAdd* and it is set to *TRUE*:

2> perform EN-DC release as specified in TS 38.331 [82], clause 5.3.5.10;

1> if the received *RRCCConnectionReconfiguration* includes the *sk-Counter*:

2> perform key update procedure as specified in TS 38.331 [82], clause 5.3.5.7;

1> if the received *RRCCConnectionReconfiguration* includes the *nr-SecondaryCellGroupConfig*:

2> perform NR RRC Reconfiguration as specified in TS 38.331 [82], clause 5.3.5.3;

1> if the received *RRCCConnectionReconfiguration* includes the *nr-RadioBearerConfig1*:

2> perform radio bearer configuration as specified in TS 38.331 [82], clause 5.3.5.6;

1> if the received *RRCCConnectionReconfiguration* includes the *nr-RadioBearerConfig2*:

2> perform radio bearer configuration as specified in TS 38.331 [82], clause 5.3.5.6;

1> if this is the first *RRCCConnectionReconfiguration* message after successful completion of the RRC connection re-establishment procedure:

2> resume SRB2 and all DRBs that are suspended, if any, including RBs configured with NR PDCP;

NOTE 4: The handling of the radio bearers after the successful completion of the PDCP re-establishment, e.g. the re-transmission of unacknowledged PDCP SDUs (as well as the associated status reporting), the handling of the SN and the HFN, is specified in TS 36.323 [8].

NOTE 5: The UE may discard SRB2 messages and data that it receives prior to completing the reconfiguration used to resume these bearers.

- 1> if the received *RRCConnectionReconfiguration* includes the *systemInformationBlockType1Dedicated*:
 - 2> perform the actions upon reception of the *SystemInformationBlockType1* message as specified in 5.2.2.7;
- 1> if the *RRCConnectionReconfiguration* message includes the *dedicatedInfoNASList*:
 - 2> forward each element of the *dedicatedInfoNASList* to upper layers in the same order as listed;
- 1> if the *RRCConnectionReconfiguration* message includes the *measConfig*:
 - 2> perform the measurement configuration procedure as specified in 5.5.2;
- 1> perform the measurement identity autonomous removal as specified in 5.5.2.2a;
- 1> if the *RRCConnectionReconfiguration* message includes the *otherConfig*:
 - 2> perform the other configuration procedure as specified in 5.3.10.9;
- 1> upon RRC connection establishment, if UE does not need UL gaps during continuous uplink transmission:
 - 2> configure lower layers to stop using UL gaps during continuous uplink transmission in FDD for *RRCConnectionReconfigurationComplete* message and subsequent uplink transmission in RRC_CONNECTED except for UL transmissions as specified in TS36.211 [21];
- 1> set the content of *RRCConnectionReconfigurationComplete* message as follows:
 - 2> if the *RRCConnectionReconfiguration* message includes *perCC-GapIndicationRequest*:
 - 3> include *perCC-GapIndicationList* and *numFreqEffective*;
 - 2> if the frequencies are configured for reduced measurement performance:
 - 3> include *numFreqEffectiveReduced*;
 - 2> if the received *RRCConnectionReconfiguration* message included *nr-SecondaryCellGroupConfig*:
 - 3> include *scg-ConfigResponseNR* in accordance with TS 38.331 [82, 5.3.5.3];
- 1> submit the *RRCConnectionReconfigurationComplete* message to lower layers for transmission using the new configuration, upon which the procedure ends;

[TS 38.331, clause 5.3.5.3]

The UE shall perform the following actions upon reception of the *RRCReconfiguration*:

- 1> if the *RRCReconfiguration* includes the *fullConfig*:
 - 2> perform the radio configuration procedure as specified in 5.3.5.11;
- 1> if the *RRCReconfiguration* includes the *masterCellGroup*:
 - 2> perform the cell group configuration for the received *masterCellGroup* according to 5.3.5.5;
- 1> if the *RRCReconfiguration* includes the *masterKeyUpdate*:
 - 2> perform security key update procedure as specified in 5.3.5.7;
- 1> if the *RRCReconfiguration* includes the *secondaryCellGroup*:
 - 2> perform the cell group configuration for the SCG according to 5.3.5.5;
- 1> if the *RRCReconfiguration* message contains the *radioBearerConfig*:
 - 2> perform the radio bearer configuration according to 5.3.5.6;
- 1> if the *RRCReconfiguration* message includes the *measConfig*:
 - 2> perform the measurement configuration procedure as specified in 5.5.2;

- 1> if the *RRCReconfiguration* message includes the *dedicatedNAS-MessageList*:
 - 2> forward each element of the *dedicatedNAS-MessageList* to upper layers in the same order as listed;
 - 1> if the *RRCReconfiguration* message includes the *dedicatedSIB1-Delivery*:
 - 2> perform the action upon reception of *SIB1* as specified in 5.2.2.4.2;
 - 1> if the *RRCReconfiguration* message includes the *dedicatedSystemInformationDelivery*:
 - 2> perform the action upon reception of System Information as specified in 5.2.2.4;
 - 1> set the content of *RRCReconfigurationComplete* message as follows:
 - 2> if the *RRCReconfiguration* includes the *masterCellGroup* containing the *reportUplinkTxDirectCurrent*, or;
 - 2> if the *RRCReconfiguration* includes the *secondaryCellGroup* containing the *reportUplinkTxDirectCurrent*:
 - 3> include the *uplinkTxDirectCurrentList*;
 - 1> if the UE is configured with E-UTRA *nr-SecondaryCellGroupConfig* (MCG is E-UTRA):
 - 2> if *RRCReconfiguration* was received via SRB1:
 - 3> submit the *RRCReconfigurationComplete* via the EUTRA MCG embedded in E-UTRA RRC message *RRCConnectionReconfigurationComplete* as specified in TS 36.331 [10];
 - 3> if *reconfigurationWithSync* was included in *spCellConfig* of an SCG:
 - 4> initiate the random access procedure on the SpCell, as specified in TS 38.321 [3];
 - 3> else:
 - 4> the procedure ends;
- NOTE: The order the UE sends the *RRCConnectionReconfigurationComplete* message and performs the Random Access procedure towards the SCG is left to UE implementation.
- 2> else (*RRCReconfiguration* was received via SRB3):
 - 3> submit the *RRCReconfigurationComplete* message via SRB3 to lower layers for transmission using the new configuration;
- NOTE: For EN-DC, in the case *RRCReconfiguration* is received via SRB1, the random access is triggered by RRC layer itself as there is not necessarily other UL transmission. In the case *RRCReconfiguration* is received via SRB3, the random access is triggered by the MAC layer due to arrival of *RRCReconfigurationComplete*.
- 1 > else:
 - 2> submit the *RRCReconfigurationComplete* message via SRB1 to lower layers for transmission using the new configuration;
 - 2> if this is the first *RRCReconfiguration* message after successful completion of the RRC re-establishment procedure:
 - 3> resume SRB2 and DRBs that are suspended;
 - 1> if *reconfigurationWithSync* was included in *spCellConfig* of an MCG or SCG, and when MAC of an NR cell group successfully completes a random access procedure triggered above:
 - 2> stop timer T304 for that cell group;
 - 2> apply the parts of the CQI reporting configuration, the scheduling request configuration and the sounding RS configuration that do not require the UE to know the SFN of the respective target SpCell, if any;

- 2> apply the parts of the measurement and the radio resource configuration that require the UE to know the SFN of the respective target SpCell (e.g. measurement gaps, periodic CQI reporting, scheduling request configuration, sounding RS configuration), if any, upon acquiring the SFN of that target SpCell;
- 2> if the *reconfigurationWithSync* was included in *spCellConfig* of an MCG:
 - 3> if T390 is running:
 - 4> stop timer T390 for all access categories;
 - 4> perform the actions as specified in 5.3.14.4.
 - 3> if *RRCReconfiguration* does not include *dedicatedSIB1-Delivery* and
 - 3> if the active downlink BWP, which is indicated by the *firstActiveDownlinkBWP-Id* for the target SpCell of the MCG, has a common search space configured by *searchSpaceSIB1*:
 - 4> acquire the *SIB1*, which is scheduled as specified in TS 38.213 [13], of the target SpCell of the MCG;
 - 4> upon acquiring *SIB1*, perform the actions specified in clause 5.2.2.4.2;
- 2> the procedure ends.

NOTE: The UE is only required to acquire broadcasted *SIB1* if the UE can acquire it without disrupting unicast data reception, i.e. the broadcast and unicast beams are quasi co-located.

[TS 38.331, clause 5.3.5.5.8]

The UE shall:

- 1> if the release is triggered by reception of the *sCellToReleaseList*:
 - 2> for each *sCellIndex* value included in the *sCellToReleaseList*:
 - 3> if the current UE configuration includes an SCell with value *sCellIndex*:
 - 4> release the SCell.

[TS 38.331, clause 5.3.5.5.9]

The UE shall:

- 1> for each *sCellIndex* value included in the *sCellToAddModList* that is not part of the current UE configuration (SCell addition):
 - 2> add the SCell, corresponding to the *sCellIndex*, in accordance with the *sCellConfigCommon* and *sCellConfigDedicated*;
 - 2> configure lower layers to consider the SCell to be in deactivated state;

Editor's Note: FFS Check automatic measurement handling for SCells.

- 2> for each *measId* included in the *measIdList* within *VarMeasConfig*:
 - 3> if SCells are not applicable for the associated measurement; and
 - 3> if the concerned SCell is included in *cellsTriggeredList* defined within the *VarMeasReportList* for this *measId*:
 - 4> remove the concerned SCell from *cellsTriggeredList* defined within the *VarMeasReportList* for this *measId*;
- 1> for each *sCellIndex* value included in the *sCellToAddModList* that is part of the current UE configuration (SCell modification):
 - 2> modify the SCell configuration in accordance with the *sCellConfigDedicated*.

8.2.4.1.1.1.3 Test description

8.2.4.1.1.1.3.1 Pre-test conditions

System Simulator:

- E-UTRA Cell 1 is the PCell. NR Cell 1 is the PSCell and NR Cell 2 is the SCell.

UE:

- None.

Preamble:

- The UE is in state RRC_CONNECTED using generic procedure parameter Connectivity (*EN-DC*), Bearers (*MCG(s) and SCG*) established according to TS 38.508-1 [4].

8.2.4.1.1.1.3.2 Test procedure sequence

Table 8.2.4.1.1.1.3.2-1: Main behaviour

St	Procedure	Message Sequence		TP	Verdict
		U - S	Message		
1	The SS transmits a <i>RRCConnectionReconfiguration</i> message including NR <i>RRCReconfiguration</i> message to configure the NR SCell	<--	<i>RRCConnectionReconfiguration</i> (<i>RRCReconfiguration</i>)	-	-
2	Check: Does the UE transmit a <i>RRCConnectionReconfigurationComplete</i> message containing <i>RRCReconfigurationComplete</i> message?	-->	<i>RRCConnectionReconfigurationComplete</i> (<i>RRCReconfigurationComplete</i>)	1	P
3	The SS transmits a <i>RRCConnectionReconfiguration</i> message including NR <i>RRCReconfiguration</i> message to modify the <i>startingBitOfFormat2-3</i> of the NR SCell	<--	<i>RRCConnectionReconfiguration</i> (<i>RRCReconfiguration</i>)	-	-
4	Check: Does the UE transmit a <i>RRCConnectionReconfigurationComplete</i> message containing NR <i>RRCReconfigurationComplete</i> message?	-->	<i>RRCConnectionReconfigurationComplete</i> (<i>RRCReconfigurationComplete</i>)	2	P
5	The SS transmits a <i>RRCConnectionReconfiguration</i> message including NR <i>RRCReconfiguration</i> message to release the NR SCell	<--	<i>RRCConnectionReconfiguration</i> (<i>RRCReconfiguration</i>)	-	-
6	Check: Does the UE release SCell and sends a <i>RRCConnectionReconfigurationComplete</i> message containing NR <i>RRCReconfigurationComplete</i> message?	-->	<i>RRCConnectionReconfigurationComplete</i> (<i>RRCReconfigurationComplete</i>)	3	P

Table 8.2.4.1.1.3.3-3: CellGroupConfig (Table 8.2.4.1.1.3.3-2)

Derivation Path: TS 38.508-1 [4], Table 4.6.3-19.			
Information Element	Value/remark	Comment	Condition
CellGroupConfig ::= SEQUENCE {			
sCellToAddModList SEQUENCE (SIZE (1..maxMeasId)) OF SEQUENCE {			
sCellIndex[1]	1		
sCellConfigCommon[1]	ServingCellConfigCommon		
sCellConfigDedicated[1]	ServingCellConfig	TS 38.508-1 [4] table 4.6.3-167	
}			
}			

Table 8.2.4.1.1.3.3-4: ServingCellConfigCommon (Table 8.2.4.1.1.3.3-3)

Derivation Path: TS 38.508-1 [4], Table 4.6.3-168.			
Information Element	Value/remark	Comment	Condition
ServingCellConfigCommon ::= SEQUENCE {			
PhysCellId	Physical Cell Identity of NR Cell 2		
}			

Table 8.2.4.1.1.3.3-5: RRCConnectionReconfiguration (step 3, Table 8.2.4.1.1.3.2-1)

Derivation Path: 36.508 [7], Table 4.6.1-8			
Information Element	Value/remark	Comment	Condition
RRCConnectionReconfiguration ::= SEQUENCE {			
criticalExtensions CHOICE {			
c1 CHOICE {			
rrcConnectionReconfiguration-r8 ::= SEQUENCE {			
nonCriticalExtension ::= SEQUENCE {			
nonCriticalExtension ::= SEQUENCE {			
nonCriticalExtension ::= SEQUENCE {			
nonCriticalExtension ::= SEQUENCE {			
nonCriticalExtension ::= SEQUENCE {			
nonCriticalExtension ::= SEQUENCE {			
nonCriticalExtension ::= SEQUENCE {			
nr-Config-r15 CHOICE {			
setup SEQUENCE {			
nr-SecondaryCellGroupConfig-r15	OCTET STRING including the <i>RRCReconfiguration</i> message and the IE <i>secondaryCellGroup</i> .		
}			
}			
}			
}			
}			
}			
}			

Table 8.2.4.1.1.3.3-6: RRCReconfiguration (Table 8.2.4.1.1.3.3-5)

Derivation Path: 38.508-1 [4], Table 4.6.1-13			
Information Element	Value/remark	Comment	Condition
RRCReconfiguration ::= SEQUENCE {			
criticalExtensions CHOICE {			
rrcReconfiguration ::= SEQUENCE {			
secondaryCellGroup	CellGroupConfig		
}			
}			
}			

Table 8.2.4.1.1.3.3-7: CellGroupConfig (Table 8.2.4.1.1.3.3-6)

Derivation Path: 38.508-1 [4], Table 4.6.3-19			
Information Element	Value/remark	Comment	Condition
CellGroupConfig ::= SEQUENCE {			
sCellToAddModList SEQUENCE	1 entry		
(SIZE(1..maxNrofSCells)) OF SEQUENCE {			
sCellConfigDedicated	ServingCellConfig		
}			
}			

Table 8.2.4.1.1.3.3-8: ServingCellConfig (Table 8.2.4.1.1.3.3-7)

Derivation Path: TS 38.508-1 [4], Table 4.6.3-167			
Information Element	Value/remark	Comment	Condition
ServingCellConfig ::= SEQUENCE {			
initialDownlinkBWP	BWP-DownlinkDedicated		
}			

Table 8.2.4.1.1.3.3-9: BWP-DownlinkDedicated (Table 8.2.4.1.1.3.3-8)

Derivation Path: TS 38.508-1 [4], Table 4.6.3-10			
Information Element	Value/remark	Comment	Condition
BWP-DownlinkDedicated ::= SEQUENCE {			
pdcch-Config CHOICE {			
setup	PDCCH-Config		
}			
}			

Table 8.2.4.1.1.3.3-10: PDCCH-Config (Table 8.2.4.1.1.3.3-9)

Derivation Path: TS 38.508-1 [4], Table 4.6.3-100			
Information Element	Value/remark	Comment	Condition
PDCCH-Config ::= SEQUENCE {			
tpc-SRS SetupRelease {			
setup	SRS-TPC-CommandConfig		
}			
}			

Table 8.2.4.1.1.1.3.3-11: SRS-TPC-CommandConfig (Table 8.2.4.1.1.1.3.3-10)

Derivation Path: TS 38.508-1 [4], Table 4.6.3-183			
Information Element	Value/remark	Comment	Condition
SRS-TPC-CommandConfig ::= SEQUENCE {			
startingBitOfFormat2-3	1		
}			

Table 8.2.4.1.1.1.3.3-12: RRCConnectionReconfiguration (step 5, Table 8.2.4.1.1.1.3.2-1)

Derivation Path: 36.508 [7], Table 4.6.1-8			
Information Element	Value/remark	Comment	Condition
RRCConnectionReconfiguration ::= SEQUENCE {			
criticalExtensions CHOICE {			
c1 CHOICE {			
rrcConnectionReconfiguration-r8 ::= SEQUENCE {			
nonCriticalExtension ::= SEQUENCE {			
nonCriticalExtension ::= SEQUENCE {			
nonCriticalExtension ::= SEQUENCE {			
nonCriticalExtension ::= SEQUENCE {			
nonCriticalExtension ::= SEQUENCE {			
nonCriticalExtension ::= SEQUENCE {			
nonCriticalExtension ::= SEQUENCE {			
nr-Config-r15 CHOICE {			
setup SEQUENCE {			
nr-SecondaryCellGroupConfig-r15	OCTET STRING including the <i>RRCReconfiguration</i> message and the IE <i>secondaryCellGroup</i> .		
}			
}			
}			
}			
}			
}			
}			

Table 8.2.4.1.1.1.3.3-13: RRCReconfiguration (Table 8.2.4.1.1.1.3.3-12)

Derivation Path: 38.508-1 [4], Table 4.6.1-13			
Information Element	Value/remark	Comment	Condition
RRCReconfiguration ::= SEQUENCE {			
criticalExtensions CHOICE {			
rrcReconfiguration ::= SEQUENCE {			
secondaryCellGroup	CellGroupConfig		
}			
}			
}			

Table 8.2.4.1.1.3.3-14: CellGroupConfig (Table 8.2.4.1.1.3.3-13)

Derivation Path: 38.508-1 [4], Table 4.6.3-19			
Information Element	Value/remark	Comment	Condition
CellGroupConfig ::= SEQUENCE {			
sCellToReleaseList SEQUENCE	1 entry		
(SIZE(1..maxNrofSCells)) OF SEQUENCE {			
sCellIndex	1		
}			
}			

8.2.4.1.1.2 NR CA / NR SCell addition / modification / release / Success / EN-DC / Intra-band non-Contiguous CA

8.2.4.1.1.2.1 Test Purpose (TP)

Same as TC 8.2.4.1.1.1 but applied to Intra-band non-Contiguous CA.

8.2.4.1.1.2.2 Conformance requirements

Same as TC 8.2.4.1.1.1 but applied to Intra-band non-Contiguous CA.

8.2.4.1.1.2.3 Test description

8.2.4.1.1.2.3.1 Pre-test conditions

Same as TC 8.2.4.1.1.1 with the following differences:

- CA configuration: Intra-band non-Contiguous CA replaces Intra-band Contiguous CA
- Cells configuration: NR Cell 3 replaces NR Cell 2

8.2.4.1.1.2.3.2 Test procedure sequence

Same as TC 8.2.4.1.1.1 with the following differences:

- CA configuration: Intra-band non-Contiguous CA replaces Intra-band Contiguous CA
- Cells configuration: NR Cell 3 replaces NR Cell 2

8.2.4.1.1.3 NR CA / NR SCell addition / modification / release / Success / EN-DC / Inter-band CA

8.2.4.1.1.3.1 Test Purpose (TP)

Same as TC 8.2.4.1.1.1 but applied to Inter-band CA

8.2.4.1.1.3.2 Conformance requirements

Same as TC 8.2.4.1.1.1 but applied to Inter-band CA

8.2.4.1.1.3.3 Test description

8.2.4.1.1.3.3.1 Pre-test conditions

Same as TC 8.2.4.1.1.1 with the following differences:

- CA configuration: Inter-band CA replaces Intra-band Contiguous CA
- Cells configuration: NR Cell 10 replaces NR Cell 2

8.2.4.1.1.3.3.2 Test procedure sequence

Same as TC 8.2.4.1.1.1 with the following differences:

- CA configuration: Inter-band CA replaces Intra-band Contiguous CA
- Cells configuration: NR Cell 10 replaces NR Cell 2

8.2.4.2 NR CA / Simultaneous PSCell and SCell addition / PSCell and SCell change / CA Release

8.2.4.2.1 NR CA / Simultaneous PSCell and SCell addition / PSCell and SCell change / CA Release/ EN-DC

8.2.4.2.1.1 NR CA / Simultaneous PSCell and SCell addition / PSCell and SCell change / CA Release / EN-DC / Intra-band Contiguous CA

8.2.4.2.1.1.1 Test Purpose (TP)

(1)

```
with { UE in RRC_CONNECTED state with E-UTRA }
ensure that {
  when { UE receives an RRCConnectionReconfiguration message with nr-Config IE including NR
RRCReconfiguration message to configure NR PSCell and sCellToAddModList with an sCellIndex set to
the configured SCell }
  then { UE sends an RRCConnectionReconfigurationComplete message indicating the addition of
PSCell and configures lower layers to consider the SCell to be in deactivated state }
}
```

(2)

```
with { UE in RRC_CONNECTED state with EN-DC, and, MCG(s) (E-UTRA PDCP) and SCG with SCell(s)
configured }
ensure that {
  when { UE receives an RRCConnectionReconfiguration message with nr-Config IE including NR
RRCReconfiguration message to perform both PSCell and SCell change to the configured target PSCell
and SCell }
  then { UE sends an RRCConnectionReconfigurationComplete message and configures new PSCell and
configures lower layers to consider the SCell to be in deactivated state }
}
```

(3)

```
with { UE in RRC_CONNECTED state with EN-DC, and, MCG(s) (E-UTRA PDCP) and SCG with SCell(s)
configured }
ensure that {
  when { UE receives an RRCConnectionReconfiguration message with nr-Config IE including NR
RRCReconfiguration message to perform PSCell change to one of the SCell equaling to one of the
current UE SCell configuration }
  then { UE sends an RRCConnectionReconfigurationComplete message and reconfigures the current NR
Scell to PSCell }
}
```

8.2.4.2.1.1.2 Conformance requirements

References: The conformance requirements covered in the present TC are specified in: TS 36.331: 5.3.5.3; TS 38.331: 5.3.5.3, 5.3.5.5.7, 5.3.5.5.8, 5.3.5.5.9, 5.3.5.6.4 and 5.3.5.6.5. Unless otherwise stated these are Rel-15 requirements.

[TS 36.331, clause 5.3.5.3]

If the *RRCConnectionReconfiguration* message does not include the *mobilityControlInfo* and the UE is able to comply with the configuration included in this message, the UE shall:

- 1> if this is the first *RRCConnectionReconfiguration* message after successful completion of the RRC connection re-establishment procedure:

- 2> re-establish PDCP for SRB2 configured with E-UTRA PDCP entity and for all DRBs that are established and configured with E-UTRA PDCP, if any;
- 2> re-establish RLC for SRB2 and for all DRBs that are established and configured with E-UTRA RLC, if any;
- 2> if the *RRCCConnectionReconfiguration* message includes the *fullConfig*:
 - 3> perform the radio configuration procedure as specified in 5.3.5.8;
- 2> if the *RRCCConnectionReconfiguration* message includes the *radioResourceConfigDedicated*:
 - 3> perform the radio resource configuration procedure as specified in 5.3.10;

NOTE 1: Void

NOTE 2: Void

1> else:

- 2> if the *RRCCConnectionReconfiguration* message includes the *radioResourceConfigDedicated*:
 - 3> perform the radio resource configuration procedure as specified in 5.3.10;

NOTE 3: If the *RRCCConnectionReconfiguration* message includes the establishment of radio bearers other than SRB1, the UE may start using these radio bearers immediately, i.e. there is no need to wait for an outstanding acknowledgment of the *SecurityModeComplete* message.

- 1> if the received *RRCCConnectionReconfiguration* includes the *sCellToReleaseList*:
 - 2> perform SCell release as specified in 5.3.10.3a;
- 1> if the received *RRCCConnectionReconfiguration* includes the *sCellToAddModList*:
 - 2> perform SCell addition or modification as specified in 5.3.10.3b;
- 1> if the received *RRCCConnectionReconfiguration* includes the *scg-Configuration*; or
- 1> if the current UE configuration includes one or more split DRBs configured with *pdcp-Config* and the received *RRCCConnectionReconfiguration* includes *radioResourceConfigDedicated* including *drb-ToAddModList*:
 - 2> perform SCG reconfiguration as specified in 5.3.10.10;
- 1> if the received *RRCCConnectionReconfiguration* includes the *nr-Config* and it is set to *release*: or
- 1> if the received *RRCCConnectionReconfiguration* includes *endc-ReleaseAndAdd* and it is set to *TRUE*:
 - 2> perform EN-DC release as specified in TS 38.331 [82], clause 5.3.5.10;
- 1> if the received *RRCCConnectionReconfiguration* includes the *sk-Counter*:
 - 2> perform key update procedure as specified in TS 38.331 [82], clause 5.3.5.7;
- 1> if the received *RRCCConnectionReconfiguration* includes the *nr-SecondaryCellGroupConfig*:
 - 2> perform NR RRC Reconfiguration as specified in TS 38.331 [82], clause 5.3.5.3;
- 1> if the received *RRCCConnectionReconfiguration* includes the *nr-RadioBearerConfig1*:
 - 2> perform radio bearer configuration as specified in TS 38.331 [82], clause 5.3.5.6;
- 1> if the received *RRCCConnectionReconfiguration* includes the *nr-RadioBearerConfig2*:
 - 2> perform radio bearer configuration as specified in TS 38.331 [82], clause 5.3.5.6;
- 1> if this is the first *RRCCConnectionReconfiguration* message after successful completion of the RRC connection re-establishment procedure:
 - 2> resume SRB2 and all DRBs that are suspended, if any, including RBs configured with NR PDCP;

NOTE 4: The handling of the radio bearers after the successful completion of the PDCP re-establishment, e.g. the re-transmission of unacknowledged PDCP SDUs (as well as the associated status reporting), the handling of the SN and the HFN, is specified in TS 36.323 [8].

NOTE 5: The UE may discard SRB2 messages and data that it receives prior to completing the reconfiguration used to resume these bearers.

1> if the received *RRCCConnectionReconfiguration* includes the *systemInformationBlockType1Dedicated*:

2> perform the actions upon reception of the *SystemInformationBlockType1* message as specified in 5.2.2.7;

1> if the *RRCCConnectionReconfiguration* message includes the *dedicatedInfoNASList*:

2> forward each element of the *dedicatedInfoNASList* to upper layers in the same order as listed;

1> if the *RRCCConnectionReconfiguration* message includes the *measConfig*:

2> perform the measurement configuration procedure as specified in 5.5.2;

1> perform the measurement identity autonomous removal as specified in 5.5.2.2a;

1> if the *RRCCConnectionReconfiguration* message includes the *otherConfig*:

2> perform the other configuration procedure as specified in 5.3.10.9;

1> if the *RRCCConnectionReconfiguration* message includes the *sl-DiscConfig* or *sl-CommConfig*:

2> perform the sidelink dedicated configuration procedure as specified in 5.3.10.15;

1> if the *RRCCConnectionReconfiguration* message includes the *sl-V2X-ConfigDedicated*:

2> perform the V2X sidelink communication dedicated configuration procedure as specified in 5.3.10.15a;

1> if the *RRCCConnectionReconfiguration* message includes *wlan-OffloadInfo*:

2> perform the dedicated WLAN offload configuration procedure as specified in 5.6.12.2;

1> if the *RRCCConnectionReconfiguration* message includes *rclwi-Configuration*:

2> perform the WLAN traffic steering command procedure as specified in 5.6.16.2;

1> if the *RRCCConnectionReconfiguration* message includes *lwa-Configuration*:

2> perform the LWA configuration procedure as specified in 5.6.14.2;

1> if the *RRCCConnectionReconfiguration* message includes *lwip-Configuration*:

2> perform the LWIP reconfiguration procedure as specified in 5.6.17.2;

1> upon RRC connection establishment, if UE does not need UL gaps during continuous uplink transmission:

2> configure lower layers to stop using UL gaps during continuous uplink transmission in FDD for *RRCCConnectionReconfigurationComplete* message and subsequent uplink transmission in RRC_CONNECTED except for UL transmissions as specified in TS36.211 [21];

1> set the content of *RRCCConnectionReconfigurationComplete* message as follows:

2> if the *RRCCConnectionReconfiguration* message includes *perCC-GapIndicationRequest*:

3> include *perCC-GapIndicationList* and *numFreqEffective*;

2> if the frequencies are configured for reduced measurement performance:

3> include *numFreqEffectiveReduced*;

2> if the received *RRCCConnectionReconfiguration* message included *nr-SecondaryCellGroupConfig*:

3> include *scg-ConfigResponseNR* in accordance with TS 38.331 [82, 5.3.5.3];

- 1> submit the *RRCConnectionReconfigurationComplete* message to lower layers for transmission using the new configuration, upon which the procedure ends;

[TS 38.331, clause 5.3.5.3]

The UE shall perform the following actions upon reception of the *RRCReconfiguration*:

- 1> if the *RRCReconfiguration* includes the *fullConfig*:
 - 2> perform the radio configuration procedure as specified in 5.3.5.11;
- 1> if the *RRCReconfiguration* includes the *masterCellGroup*:
 - 2> perform the cell group configuration for the received *masterCellGroup* according to 5.3.5.5;
- 1> if the *RRCReconfiguration* includes the *masterKeyUpdate*:
 - 2> perform security key update procedure as specified in 5.3.5.7;
- 1> if the *RRCReconfiguration* includes the *secondaryCellGroup*:
 - 2> perform the cell group configuration for the SCG according to 5.3.5.5;
- 1> if the *RRCReconfiguration* message contains the *radioBearerConfig*:
 - 2> perform the radio bearer configuration according to 5.3.5.6;
- 1> if the *RRCReconfiguration* message includes the *measConfig*:
 - 2> perform the measurement configuration procedure as specified in 5.5.2;
- 1> if the *RRCReconfiguration* message includes the *dedicatedSIB1-Delivery*:
 - 2> perform the action upon reception of *SIB1* as specified in 5.2.2.4.2;
- 1> if the *RRCReconfiguration* message includes the *dedicatedSystemInformationDelivery*:
 - 2> perform the action upon reception of System Information as specified in 5.2.2.4;
- 1> set the content of *RRCReconfigurationComplete* message as follows:
 - 2> if the *RRCReconfiguration* includes the *masterCellGroup* containing the *reportUplinkTxDirectCurrent*, or;
 - 2> if the *RRCReconfiguration* includes the *secondaryCellGroup* containing the *reportUplinkTxDirectCurrent*:
 - 3> include the *uplinkTxDirectCurrentList*;
- 1> if the UE is configured with E-UTRA *nr-SecondaryCellGroupConfig* (MCG is E-UTRA):
 - 2> if *RRCReconfiguration* was received via SRB1:
 - 3> submit the *RRCReconfigurationComplete* via the EUTRA MCG embedded in E-UTRA RRC message *RRCConnectionReconfigurationComplete* as specified in TS 36.331 [10];
 - 3> if *reconfigurationWithSync* was included in *spCellConfig* of an SCG:
 - 4> initiate the random access procedure on the SpCell, as specified in TS 38.321 [3];
 - 3> else:
 - 4> the procedure ends;

NOTE: The order the UE sends the *RRCConnectionReconfigurationComplete* message and performs the Random Access procedure towards the SCG is left to UE implementation.

- 2> else (*RRCReconfiguration* was received via SRB3):
 - 3> submit the *RRCReconfigurationComplete* message via SRB3 to lower layers for transmission using the new configuration;

NOTE: For EN-DC, in the case of SRB1, the random access is triggered by RRC layer itself as there is not necessarily other UL transmission. In the case of SRB3, the random access is triggered by the MAC layer due to arrival of *RRCReconfigurationComplete*.

1> else:

2> submit the *RRCReconfigurationComplete* message via SRB1 to lower layers for transmission using the new configuration;

1> 1> if *reconfigurationWithSync* was included in *spCellConfig* of an MCG or SCG, and when MAC of an NR cell group successfully completes a random access procedure triggered above;

2> stop timer T304 for that cell group;

2> apply the parts of the CQI reporting configuration, the scheduling request configuration and the sounding RS configuration that do not require the UE to know the SFN of the respective target SpCell, if any;

2> apply the parts of the measurement and the radio resource configuration that require the UE to know the SFN of the respective target SpCell (e.g. measurement gaps, periodic CQI reporting, scheduling request configuration, sounding RS configuration), if any, upon acquiring the SFN of that target SpCell;

2> if the *reconfigurationWithSync* was included in *spCellConfig* of an MCG:

3> if the active downlink BWP, which is indicated by the *firstActiveDownlinkBWP-Id* for the target SpCell of the MCG, has a common search space configured:

4> acquire the *SIB1* of the target SpCell of the MCG, as specified in 5.2.2.3.1;

2> the procedure ends.

NOTE: The UE is only required to acquire broadcasted *SIB1* if the UE can acquire it without disrupting unicast data reception, i.e. the broadcast and unicast beams are quasi co-located.

[TS 38.331, clause 5.3.5.5.7]

The UE shall:

1> if the *SpCellConfig* contains the *rlf-TimersAndConstants*:

2> configure the RLF timers and constants for this cell group as specified in 5.3.5.5.6.

1> else if *rlf-TimersAndConstants* is not configured for this cell group:

2> use values for timers T301, T310, T311 and constants N310, N311, as included in *ue-TimersAndConstants* received in *SIB1*;

1> 1> if the *SpCellConfig* contains *spCellConfigDedicated*:

2> configure the SpCell in accordance with the *spCellConfigDedicated*;

2> consider the bandwidth part indicated in *firstActiveUplinkBWP-Id* if configured to be the active uplink bandwidth part;

2> consider the bandwidth part indicated in *firstActiveDownlinkBWP-Id* if configured to be the active downlink bandwidth part;

2> if the any of the reference signal(s) that are used for radio link monitoring are reconfigured by the received *spCellConfigDedicated*:

3> stop timer T310 for the corresponding SpCell, if running;

3> reset the counters N310 and N311.

[TS 38.331, clause 5.3.5.5.8]

The UE shall:

- 1> if the release is triggered by reception of the *sCellToReleaseList*:
 - 2> for each *sCellIndex* value included in the *sCellToReleaseList*:
 - 3> if the current UE configuration includes an SCell with value *sCellIndex*:
 - 4> release the SCell.

[TS 38.331, clause 5.3.5.5.9]

The UE shall:

- 1> for each *sCellIndex* value included in the *sCellToAddModList* that is not part of the current UE configuration (SCell addition):
 - 2> add the SCell, corresponding to the *sCellIndex*, in accordance with the *sCellConfigCommon* and *sCellConfigDedicated*;
 - 2> configure lower layers to consider the SCell to be in deactivated state;

Editor's Note: FFS Check automatic measurement handling for SCells.

- 2> for each *measId* included in the *measIdList* within *VarMeasConfig*:
 - 3> if SCells are not applicable for the associated measurement; and
 - 3> if the concerned SCell is included in *cellsTriggeredList* defined within the *VarMeasReportList* for this *measId*:
 - 4> remove the concerned SCell from *cellsTriggeredList* defined within the *VarMeasReportList* for this *measId*;
- 1> for each *sCellIndex* value included in the *sCellToAddModList* that is part of the current UE configuration (SCell modification):
 - 2> modify the SCell configuration in accordance with the *sCellConfigDedicated*.

[TS 38.331, clause 5.3.5.6.4]

Editor's Note: FFS / TODO: Add handling for the new QoS concept (mapping of flows; configuration of QFI-to-DRB mapping; reflective QoS...) but keep also EPS-Bearer handling for the EN-DC case

The UE shall:

- 1> for each *drb-Identity* value included in the *drb-ToReleaseList* that is part of the current UE configuration (DRB release):
 - 2> release the PDCP entity;
 - 2> if SDAP entity associated with this DRB is configured:
 - 3> indicate the release of the DRB to SDAP entity associated with this DRB (TS 37.324 [xx] section 5.3.3);
 - 2> if the UE is operating in EN-DC:
- 3> if a new bearer is not added either with NR or E-UTRA with same *eps-BearerIdentity*:
 - 4> indicate the release of the DRB and the *eps-BearerIdentity* of the released DRB to upper layers.

NOTE 1: The UE does not consider the message as erroneous if the *drb-ToReleaseList* includes any *drb-Identity* value that is not part of the current UE configuration.

NOTE 2: Whether or not the RLC and MAC entities associated with this PDCP entity are reset or released is determined by the *CellGroupConfig*.

[TS 38.331, clause 5.3.5.6.5]

The UE shall:

- 1> for each *drb-Identity* value included in the *drb-ToAddModList* that is not part of the current UE configuration (DRB establishment including the case when full configuration option is used):
 - 2> if an *sdap-Config* is included:
 - 3> if an SDAP entity with the received *pdu-Session* does not exist:
 - 4> establish an SDAP entity as specified in TS 37.324 [xx] section 5.1.1;
 - 3> configure the SDAP entity in accordance with the received *sdap-Config* as specified in TS 37.324 [xx] and associate the DRB with the SDAP entity;
 - 2> establish a PDCP entity and configure it in accordance with the received *pdcip-Config*;
 - 2> if the PDCP entity of this DRB is not configured with *cipheringDisabled*:
 - 3> configure the PDCP entity with the ciphering algorithms according to *securityConfig* and apply the K_{UPenc} key associated with the master key (K_{eNB}/K_{gNB}) or the secondary key ($S-K_{gNB}$) as indicated in *keyToUse*;
 - 2> if the PDCP entity of this DRB is configured with *integrityProtection*:
 - 3> configure the PDCP entity with the integrity algorithms according to *securityConfig* and apply the K_{UPint} key associated with the master (K_{eNB}/K_{gNB}) or the secondary key ($S-K_{gNB}$) as indicated in *keyToUse*;
 - 2> if the UE is operating in EN-DC:
 - 3> if the DRB was configured with the same *eps-BearerIdentity* either by NR or E-UTRA prior to receiving this reconfiguration:
 - 4> associate the established DRB with the corresponding *eps-BearerIdentity*;
 - 3> else:
 - 4> indicate the establishment of the DRB(s) and the *eps-BearerIdentity* of the established DRB(s) to upper layers;
- 1> for each *drb-Identity* value included in the *drb-ToAddModList* that is part of the current UE configuration:
 - 2> if an *sdap-Config* is included, reconfigure the SDAP entity in accordance with the received *sdap-Config* as specified in TS 37.324 [xx];
 - 2> if the reestablishPDCP is set:
 - 3> if target RAT is E-UTRA/5GC:
 - 4> if the PDCP entity of this DRB is not configured with *cipheringDisabled*:
 - 5> configure the PDCP entity with the ciphering algorithm and K_{UPenc} key configured/derived as specified in TS 36.331 [10, 5.4.2.3], i.e. the ciphering configuration shall be applied to all subsequent PDCP PDUs received and sent by the UE;
 - 3> else:
 - 4> if the PDCP entity of this DRB is not configured with *cipheringDisabled*:
 - 5> configure the PDCP entity with the ciphering algorithm and K_{UPenc} key associated with the master or secondary key ($K_{eNB}/S-K_{gNB}/K_{gNB}$) as indicated in *keyToUse*, i.e. the ciphering configuration shall be applied to all subsequent PDCP PDUs received and sent by the UE;
 - 4> if the PDCP entity of this DRB is configured with *integrityProtection*:
 - 5> configure the PDCP entity with the integrity algorithms according to *securityConfig* and apply the K_{UPint} key associated with the master (K_{eNB}/K_{gNB}) or the secondary key ($S-K_{gNB}$) as indicated in *keyToUse*;
 - 3> re-establish the PDCP entity of this DRB as specified in 38.323 [5], section 5.1.2;

2> else, if the *recoverPDCP* is set:

3> trigger the PDCP entity of this DRB to perform data recovery as specified in 38.323;

2> if the *pdcp-Config* is included:

3> reconfigure the PDCP entity in accordance with the received *pdcp-Config*.

NOTE 1: Removal and addition of the same *drb-Identity* in a single *radioResourceConfig* is not supported. In case *drb-Identity* is removed and added due to reconfiguration with sync or re-establishment with the full configuration option, the network can use the same value of *drb-Identity*.

NOTE 2: When determining whether a *drb-Identity* value is part of the current UE configuration, the UE does not distinguish which *RadioBearerConfig* and *DRB-ToAddModList* that DRB was originally configured in. To re-associate a DRB with a different key (KeNB to S-KeNB or vice versa), the network provides the *drb-Identity* value in the (target) *drb-ToAddModList* and sets the *reestablishPDCP* flag. The network does not list the *drb-Identity* in the (source) *drb-ToReleaseList*.

NOTE 3: When setting the *reestablishPDCP* flag for a radio bearer, the network ensures that the RLC receiver entities do not deliver old PDCP PDUs to the re-established PDCP entity. It does that e.g. by triggering a reconfiguration with sync of the cell group hosting the old RLC entity or by releasing the old RLC entity.

NOTE 4: In this specification, UE configuration refers to the parameters configured by NR RRC unless otherwise stated.

NOTE 5: Ciphering and integrity protection can be enabled or disabled for a DRB. The enabling/disabling of ciphering or integrity protection can be changed only by releasing and adding the DRB.

8.2.4.2.1.1.3 Test description

8.2.4.2.1.1.3.1 Pre-test conditions

System Simulator:

- E-UTRA Cell 1 is the PCell, NR Cell 1 is the PSCell to be added, and NR Cell 3 is Scell to be added. NR Cell 2 and NR Cell 12 are the target PSCell and SCell.
- NR Cell 1 and NR Cell 3 are Intra-band Contiguous. NR Cell 2 and NR Cell 12 are Intra-band Contiguous.

UE:

None

Preamble:

- The UE is in state `RRC_CONNECTED` using generic procedure parameter *Connectivity (EN-DC)* according to TS 38.508-1 [4].

8.2.4.2.1.1.3.2 Test procedure sequence

Table 8.2.4.2.1.1.3.2-1 illustrates the downlink power levels to be applied for EUTRA Cell 1, NR Cell 1, NR Cell 3, NR Cell 2 and NR Cell 12 at various time instants of the test execution. Row marked "T0" denotes the conditions after the preamble, while rows marked "T1" are to be applied subsequently. The exact instants on which these values shall be applied are described in the texts in this clause.

Table 8.2.4.2.1.1.3.2-1: Power levels

	Parameter	Unit	E-UTRA Cell 1	NR Cell 1	NR Cell 3	NR Cell 2	NR Cell 12	Remark
T0	Cell-specific RS EPRE	dBm/15kHz	-85	-	-	-	-	EUTRA Cell 1, NR Cell 1 and NR Cell 3 are available. NR Cell 2 and NR Cell 12 are not available.
	SS/PBCH SSS EPRE	dBm/SCS	-	-88	-88	off	off	
T1	Cell-specific RS EPRE	dBm/15kHz	-85	-	-	-	-	EUTRA Cell 1, NR Cell 1, NR Cell 3, NR Cell 2 and NR Cell 12 are available.
	SS/PBCH SSS EPRE	dBm/SCS	-	-88	-88	-88	-88	

Table 8.2.4.2.1.1.3.2-2: Main behaviour

St	Procedure	Message Sequence		TP	Verdict
		U – S	Message		
1	The SS changes Cell parameters according to the row "T0" in table 8.2.4.2.1.1.3.2-1.	-	-	-	-
2	The SS transmits an <i>RRCCONNECTIONRECONFIGURATION</i> message with nr-Config IE including NR RRCReconfiguration message to configure NR Cell 1 as the NR PSCell and sCellToAddModList with an sCellIndex set to NR Cell 3 as the configured Scell.	<--	<i>RRCCONNECTIONRECONFIGURATION</i>	-	-
3	Check: Does the UE transmit an <i>RRCCONNECTIONRECONFIGURATIONCOMPLETE</i> message?	-->	<i>RRCCONNECTIONRECONFIGURATIONCOMPLETE</i>	1	P
4	The SS changes NR Cell 2 and NR Cell 12 parameters according to the row "T1" in table 8.2.4.2.1.1.3.2-1.	-	-	-	-
5	The SS transmits an <i>RRCCONNECTIONRECONFIGURATION</i> message with nr-Config IE including NR RRCReconfiguration message to perform both NR Cell 1 and NR Cell 3 changed to the configured target NR Cell 2 and NR Cell 12.	<--	<i>RRCCONNECTIONRECONFIGURATION</i>	-	-
6	Check: Does the UE transmit an <i>RRCCONNECTIONRECONFIGURATIONCOMPLETE</i> message configuring the new PSCell and SCell and configure lower layers to consider the SCell to be in deactivated state?	-->	<i>RRCCONNECTIONRECONFIGURATIONCOMPLETE</i>	2	P
7	The SS transmits an <i>RRCCONNECTIONRECONFIGURATION</i> message with nr-Config IE including NR RRCReconfiguration message to change the current PSCell (NR Cell 2) to NR Cell 12 equaling to one of the current UE SCell configuration.	<--	<i>RRCCONNECTIONRECONFIGURATION</i>	-	-
8	Check: Does the UE send an <i>RRCCONNECTIONRECONFIGURATIONCOMPLETE</i> message and reconfigure the current NR Scell to PSCell?	-->	<i>RRCCONNECTIONRECONFIGURATIONCOMPLETE</i>	3	P

Table 8.2.4.2.1.1.3.3-3: CellGroupConfig (Table 8.2.4.2.1.1.3.3-2: RRCReconfiguration)

Derivation Path: 38.508-1 [4], Table 4.6.3-19			
Information Element	Value/remark	Comment	Condition
CellGroupConfig ::= SEQUENCE {			
spCellConfig SEQUENCE {			
servCellIndex	1		
reconfigurationWithSync SEQUENCE {			EN-DC
spCellConfigCommon ::= SEQUENCE {			
physCellId	Physical Cell Identity of NR Cell 1		
}			
}			
}			
sCellToAddModList SEQUENCE (SIZE (1..maxNrofSCells)) OF SEQUENCE {	1 entry		
sCellIndex[1]	1		
sCellConfigCommon[1] SEQUENCE {			
physCellId	Physical Cell Identity of NR Cell 3		
}			
}			
sCellToReleaseList	Not present		
}			

Table 8.2.4.2.1.1.3.3-4: RRCConnectionReconfigurationComplete (step 3, step 6 and step 8, Table 8.2.4.2.1.1.3.2-2)

Derivation Path: 36.508 [7], Table 4.6.1-9			
Information Element	Value/remark	Comment	Condition
RRCConnectionReconfigurationComplete ::= SEQUENCE {			
criticalExtensions CHOICE {			
rrcConnectionReconfigurationComplete-r8 SEQUENCE {			
nonCriticalExtension SEQUENCE {			
nonCriticalExtension SEQUENCE {			
nonCriticalExtension SEQUENCE {			
nonCriticalExtension SEQUENCE {			
nonCriticalExtension SEQUENCE {			
nonCriticalExtension SEQUENCE {			
scg-ConfigResponseNR-r15	Present		
}			
}			
}			
}			
}			

Table 8.2.4.2.1.1.3.3-7: CellGroupConfig (Table 8.2.4.2.1.1.3.3-6: RRCReconfiguration)

Derivation Path: 38.508-1 [4], Table 4.6.3-19			
Information Element	Value/remark	Comment	Condition
CellGroupConfig ::= SEQUENCE {			
spCellConfig SEQUENCE {			
servCellIndex	1		
reconfigurationWithSync SEQUENCE {			EN-DC
spCellConfigCommon ::= SEQUENCE {			
physCellId	Physical Cell Identity of NR Cell 2		
}			
}			
sCellToAddModList SEQUENCE (SIZE (1..maxNrofSCells)) OF SEQUENCE {	1 entry		
sCellIndex[1]	1		
sCellConfigCommon[1] SEQUENCE {			
physCellId	Physical Cell Identity of NR Cell 12		
}			
}			
sCellToReleaseList	Not present		
}			

Table 8.2.4.2.1.1.3.3-8: RRCConnectionReconfiguration (step 7, Table 8.2.4.2.1.1.3.2-2)

Derivation Path: 36.508 [7], Table 4.6.1-8			
Information Element	Value/remark	Comment	Condition
RRCConnectionReconfiguration ::= SEQUENCE {			
criticalExtensions CHOICE {			
c1 CHOICE {			
rrcConnectionReconfiguration-r8 SEQUENCE {			
nonCriticalExtension SEQUENCE {			
nonCriticalExtension SEQUENCE {			
nonCriticalExtension SEQUENCE {			
nonCriticalExtension SEQUENCE {			
nonCriticalExtension SEQUENCE {			
nonCriticalExtension SEQUENCE {			
nonCriticalExtension SEQUENCE {			
nr-Config-r15 CHOICE {			
setup SEQUENCE {			
endc-ReleaseAndAdd	True		
nr-SecondaryCellGroupConfig-r15	RRCReconfiguration	OCTET STRING including the RRCReconfiguration	
}			
}			
}			
}			
}			
}			
}			
}			
}			

Table 8.2.4.2.1.1.3.3-9: RRCReconfiguration (Table 8.2.4.2.1.1.3.3-8: RRCConnectionReconfiguration)

Derivation Path: 38.508-1 [4], Table 4.6.1-13			
Information Element	Value/remark	Comment	Condition
RRCReconfiguration ::= SEQUENCE {			
criticalExtensions CHOICE {			
rrcReconfiguration SEQUENCE {			
secondaryCellGroup	CellGroupConfig	OCTET STRING (CONTAINING CellGroupConfig)	EN-DC
}			
}			
}			

Table 8.2.4.2.1.1.3.3-10: CellGroupConfig (Table 8.2.4.2.1.1.3.3-10: RRCReconfiguration)

Derivation Path: 38.508-1 [4], Table 4.6.3-19			
Information Element	Value/remark	Comment	Condition
CellGroupConfig ::= SEQUENCE {			
spCellConfig SEQUENCE {			
servCellIndex	1		
reconfigurationWithSync SEQUENCE {			EN-DC
spCellConfigCommon ::= SEQUENCE {			
physCellId	Physical Cell Identity of NR Cell 12		
}			
}			
}			
sCellToAddModList	Not present		
sCellToReleaseList	Not present		
}			

8.2.4.2.1.2 NR CA / Simultaneous PSCell and SCell addition / PSCell and SCell change / CA Release / EN-DC / Intra-band non-Contiguous CA

8.2.4.2.1.2.1 Test Purpose (TP)

Same as TC 8.2.4.2.1.1 but applied to Intra-band non-Contiguous CA.

8.2.4.2.1.2.2 Conformance requirements

Same as TC 8.2.4.2.1.1 but applied to Intra-band non-Contiguous CA.

8.2.4.2.1.2.3 Test description

8.2.4.2.1.2.3.1 Pre-test conditions

Same as TC 8.2.4.2.1.1 with the following differences:

- CA configuration: Intra-band non-Contiguous CA replaces Intra-band Contiguous CA

8.2.4.2.1.2.3.2 Test procedure sequence

Same as TC 8.2.4.2.1.1 with the following differences:

- CA configuration: Intra-band non-Contiguous CA replaces Intra-band Contiguous CA

8.2.4.2.1.3 NR CA / Simultaneous PSCell and SCell addition / PSCell and SCell change / CA Release / EN-DC / Inter-band CA

8.2.4.2.1.3.1 Test Purpose (TP)

Same as TC 8.2.4.2.1.1 but applied to Inter-band CA.

8.2.4.2.1.3.2 Conformance requirements

Same as TC 8.2.4.2.1.1 but applied to Inter-band CA.

8.2.4.2.1.3.3 Test description

8.2.4.2.1.3.3.1 Pre-test conditions

Same as TC 8.2.4.2.1.1 with the following differences:

- CA configuration: Inter-band CA replaces Intra-band Contiguous CA

8.2.4.2.1.3.3.2 Test procedure sequence

Same as TC 8.2.4.2.1.1 with the following differences:

- CA configuration: Inter-band CA replaces Intra-band Contiguous CA
- Cells configuration: NR Cell 10 replaces NR Cell 3, NR Cell 30 replaces NR Cell 10

8.2.4.3 NR CA / SCell change / Intra-NR measurement event A6 / SRB3

8.2.4.3.1 NR CA / SCell change / Intra-NR measurement event A6 / SRB3 / EN-DC

8.2.4.3.1.1 NR CA / SCell change / Intra-NR measurement event A6 / SRB3 / EN-DC / Intra-band Contiguous CA

8.2.4.3.1.1.1 Test Purpose (TP)

(1)

```
with { UE in RRC_CONNECTED state with EN-DC, and MCG(s) (E-UTRA PDCP) and SCG with SCell(s)
configured and SRB3 configured and Intra-NR measurement configured for event A6 }
ensure that {
  when { Neighbour becomes offset better than NR SCell }
  then { UE sends a Measurement Report message on SRB3 While entering condition for event A6 is
satisfied }
}
```

(2)

```
with { UE in RRC_CONNECTED state with EN-DC, and MCG(s) (E-UTRA PDCP) and SCG with SCell(s)
configured and received event A6 triggered measurement report }
ensure that {
  when { UE receives an RRCReconfiguration message containing sCellToReleaseList with an sCellIndex
equalling to one of the current UE SCell configuration and sCellToAddModList with an sCellIndex set
to the configured target SCell }
  then { UE sends an RRCReconfigurationComplete message and changes the SCell }
}
```

8.2.4.3.1.1.2 Conformance requirements

References: The conformance requirements covered in the present test case are specified in: TS 36.331, clause 5.3.5.3, TS 38.331, clauses 5.3.5.3, 5.3.5.5.8, 5.3.5.5.9, 5.5.4.7 and 5.5.5. Unless otherwise stated these are Rel-15 requirements.

[TS 36.331, clause 5.3.5.3]

If the *RRCCConnectionReconfiguration* message does not include the *mobilityControlInfo* and the UE is able to comply with the configuration included in this message, the UE shall:

...

- 1> if the received *RRCCConnectionReconfiguration* includes the *nr-Config* and it is set to *release*: or
- 1> if the received *RRCCConnectionReconfiguration* includes *endc-ReleaseAndAdd* and it is set to *TRUE*:
 - 2> perform ENDC release as specified in TS38.331 [82], clause 5.3.5.10;
- 1> if the received *RRCCConnectionReconfiguration* includes the *sk-Counter*:
 - 2> perform key update procedure as specified in TS 38.331 [82], clause 5.3.5.7;
- 1> if the received *RRCCConnectionReconfiguration* includes the *nr-SecondaryCellGroupConfig*:
 - 2> perform NR RRC Reconfiguration as specified in TS 38.331 [82], clause 5.3.5.5;
- 1> if the received *RRCCConnectionReconfiguration* includes the *nr-RadioBearerConfig1*:
 - 2> perform radio bearer configuration as specified in TS 38.331 [82], clause 5.3.5.6;
- 1> if the received *RRCCConnectionReconfiguration* includes the *nr-RadioBearerConfig2*:
 - 2> perform radio bearer configuration as specified in TS 38.331 [82], clause 5.3.5.6;

...

- 1> set the content of *RRCCConnectionReconfigurationComplete* message as follows:
 - 2> if the *RRCCConnectionReconfiguration* message includes *perCC-GapIndicationRequest*:
 - 3> include *perCC-GapIndicationList* and *numFreqEffective*;
 - 2> if the frequencies are configured for reduced measurement performance:
 - 3> include *numFreqEffectiveReduced*;
 - 2> if the received *RRCCConnectionReconfiguration* message included *nr-SecondaryCellGroupConfig*:
 - 3> include *scg-ConfigResponseNR* in accordance with TS 38.331 [82, 5.3.5.3];
- 1> submit the *RRCCConnectionReconfigurationComplete* message to lower layers for transmission using the new configuration, upon which the procedure ends;

[TS 38.331, clause 5.3.5.3]

The UE shall perform the following actions upon reception of the *RRCCReconfiguration*:

- 1> if the *RRCCReconfiguration* includes the *fullConfig*:
 - 2> perform the radio configuration procedure as specified in 5.3.5.11;
- 1> if the *RRCCReconfiguration* includes the *masterCellGroup*:
 - 2> perform the cell group configuration for the received *masterCellGroup* according to 5.3.5.5;
- 1> if the *RRCCReconfiguration* includes the *masterKeyUpdate*:
 - 2> perform security key update procedure as specified in 5.3.5.7;
- 1> if the *RRCCReconfiguration* includes the *secondaryCellGroup*:
 - 2> perform the cell group configuration for the SCG according to 5.3.5.5;
- 1> if the *RRCCReconfiguration* message contains the *radioBearerConfig*:
 - 2> perform the radio bearer configuration according to 5.3.5.6;

- 1> if the *RRCReconfiguration* message includes the *measConfig*:
 - 2> perform the measurement configuration procedure as specified in 5.5.2;
- 1> if the *RRCReconfiguration* message includes the *dedicatedSIB1-Delivery*:
 - 2> perform the action upon reception of *SIB1* as specified in 5.2.2.4.2;
- 1> if the *RRCReconfiguration* message includes the *dedicatedSystemInformationDelivery*:
 - 2> perform the action upon reception of System Information as specified in 5.2.2.4;
- 1> set the content of *RRCReconfigurationComplete* message as follows:
 - 2> if the *RRCReconfiguration* includes the *masterCellGroup* containing the *reportUplinkTxDirectCurrent*, or;
 - 2> if the *RRCReconfiguration* includes the *secondaryCellGroup* containing the *reportUplinkTxDirectCurrent*:
 - 3> include the *uplinkTxDirectCurrentList*;
- 1> if the UE is configured with E-UTRA *nr-SecondaryCellGroupConfig* (MCG is E-UTRA):
 - 2> if *RRCReconfiguration* was received via SRB1:
 - 3> submit the *RRCReconfigurationComplete* message via the EUTRA MCG embedded in E-UTRA RRC message *RRCConnectionReconfigurationComplete* as specified in TS 36.331 [10].
 - 3> if *reconfigurationWithSync* was included in *spCellConfig* of an SCG:
 - 4> initiate the random access procedure on the SpCell, as specified in TS 38.321 [3];
 - 3> else:
 - 4> the procedure ends;
 - NOTE: The order the UE sends the *RRCConnectionReconfigurationComplete* message and performs the Random Access procedure towards the SCG is left to UE implementation.
 - 2> else (*RRCReconfiguration* was received via SRB3):
 - 3> submit the *RRCReconfigurationComplete* message via SRB3 to lower layers for transmission using the new configuration;
- NOTE: For EN-DC, in the case of SRB1, the random access is triggered by RRC layer itself as there is not necessarily other UL transmission. In the case of SRB3, the random access is triggered by the MAC layer due to arrival of *RRCReconfigurationComplete*.
- 1> else:
 - 2> submit the *RRCReconfigurationComplete* message via SRB1 to lower layers for transmission using the new configuration;
- 1> if *reconfigurationWithSync* was included in *spCellConfig* of an MCG or SCG, and when MAC of an NR cell group successfully completes a random access procedure triggered above:
 - 2> stop timer T304 for that cell group;
 - 2> apply the parts of the CQI reporting configuration, the scheduling request configuration and the sounding RS configuration that do not require the UE to know the SFN of the respective target SpCell, if any;
 - 2> apply the parts of the measurement and the radio resource configuration that require the UE to know the SFN of the respective target SpCell (e.g. measurement gaps, periodic CQI reporting, scheduling request configuration, sounding RS configuration), if any, upon acquiring the SFN of that target SpCell;
 - 2> if the *reconfigurationWithSync* was included in *spCellConfig* of an MCG:
 - 3> if the active downlink BWP, which is indicated by the *firstActiveDownlinkBWP-Id* for the target SpCell of the MCG, has a common search space configured:

4> acquire the *SIB1* of the target SpCell of the MCG, as specified in 5.2.2.3.1;

2> the procedure ends;

NOTE: The UE is only required to acquire broadcasted *SIB1* if the UE can acquire it without disrupting unicast data reception, i.e. the broadcast and unicast beams are quasi co-located.

[TS 38.331, clause 5.3.5.5.8]

The UE shall:

1> if the release is triggered by reception of the *sCellToReleaseList*:

2> for each *sCellIndex* value included in the *sCellToReleaseList*:

3> if the current UE configuration includes an SCell with value *sCellIndex*:

4> release the SCell;

[TS 38.331, clause 5.3.5.5.9]

The UE shall:

1> for each *sCellIndex* value included in the *sCellToAddModList* that is not part of the current UE configuration (SCell addition):

2> add the SCell, corresponding to the *sCellIndex*, in accordance with the *sCellConfigCommon* and *sCellConfigDedicated*;

2> configure lower layers to consider the SCell to be in deactivated state;

Editor's Note: FFS Check automatic measurement handling for SCells.

2> for each *measId* included in the *measIdList* within *VarMeasConfig*:

3> if SCells are not applicable for the associated measurement; and

3> if the concerned SCell is included in *cellsTriggeredList* defined within the *VarMeasReportList* for this *measId*:

4> remove the concerned SCell from *cellsTriggeredList* defined within the *VarMeasReportList* for this *measId*;

1> for each *sCellIndex* value included in the *sCellToAddModList* that is part of the current UE configuration (SCell modification):

2> modify the SCell configuration in accordance with the *sCellConfigDedicated*;

[TS 38.331, clause 5.5.4.7]

The UE shall:

1> consider the entering condition for this event to be satisfied when condition A6-1, as specified below, is fulfilled;

1> consider the leaving condition for this event to be satisfied when condition A6-2, as specified below, is fulfilled;

1> for this measurement, consider the (secondary) cell corresponding to the *measObjectNR* associated to this event to be the serving cell.

NOTE: The reference signal(s) of the neighbour(s) and the reference signal(s) of the SCell are both indicated in the associated *measObjectNR*.

Inequality A6-1 (Entering condition)

$$Mn + Ocn - Hys > Ms + Ocs + Off$$

Inequality A6-2 (Leaving condition)

$$Mn + Ocn + Hys < Ms + Ocs + Off$$

The variables in the formula are defined as follows:

Mn is the measurement result of the neighbouring cell, not taking into account any offsets.

Ocn is the cell specific offset of the neighbour cell (i.e. *cellIndividualOffset* as defined within the associated *measObjectNR*), and set to zero if not configured for the neighbour cell.

Ms is the measurement result of the serving cell, not taking into account any offsets.

Ocs is the cell specific offset of the serving cell (i.e. *cellIndividualOffset* as defined within the associated *measObjectNR*), and is set to zero if not configured for the serving cell.

Hys is the hysteresis parameter for this event (i.e. *hysteresis* as defined within *reportConfigNR* for this event).

Off is the offset parameter for this event (i.e. *a6-Offset* as defined within *reportConfigNR* for this event).

Mn*, *Ms are expressed in dBm in case of RSRP, or in dB in case of RSRQ and RS-SINR.

Ocn*, *Ocs*, *Hys*, *Off are expressed in dB.

[TS 38.331, clause 5.5.5]



Figure 5.5.5.1-1: Measurement reporting

The purpose of this procedure is to transfer measurement results from the UE to the network. The UE shall initiate this procedure only after successful security activation.

For the *measId* for which the measurement reporting procedure was triggered, the UE shall set the *measResults* within the *MeasurementReport* message as follows:

- 1> set the *measId* to the measurement identity that triggered the measurement reporting;
- 1> set the *measResultServingCell* within *measResultServingMOList* to include RSRP, RSRQ and the available SINR for each configured serving cell derived based on the *rsType* indicated in the associated *reportConfig*;
- 1> set the *measResultServingCell* within *measResultServingMOList* to include for each NR serving cell that is configured with *servingCellMO*, if any, the *servCellId*;
- 1> if the *reportConfig* associated with the *measId* that triggered the measurement reporting includes *reportQuantityRsIndexes* and *maxNrofRSIndexesToReport*:
 - 2> for each serving cell configured with *servingCellMO*, include beam measurement information according to the associated *reportConfig* as described in 5.5.5.2;
- 1> if the *reportConfig* associated with the *measId* that triggered the measurement reporting includes *reportAddNeighMeas*:
 - 2> for each serving cell *measObjectId* referenced in the *measIdList*, other than the *measObjectId* corresponding with the *measId* that triggered the measurement reporting:

- 3> set the *measResultBestNeighCell* within *measResultServingMOList* to include the *physCellId* and the available measurement quantities based on the *reportQuantityCell* and *rsType* indicated in *reportConfig* of the non-serving cell corresponding to the concerned *measObjectNR* with the highest measured RSRP if RSRP measurement results are available for cells corresponding to this *measObjectNR*, otherwise with the highest measured RSRQ if RSRQ measurement results are available for cells corresponding to this *measObjectNR*, otherwise with the highest measured SINR;
- 3> if the *reportConfig* associated with the *measId* that triggered the measurement reporting includes *reportQuantityRsIndexes* and *maxNrofRSIndexesToReport*:
 - 4> for each best non-serving cell included in the measurement report:
 - 5> include beam measurement information according to the associated *reportConfig* as described in 5.5.5.2;
- 1> if there is at least one applicable neighbouring cell to report:
 - 2> set the *measResultNeighCells* to include the best neighbouring cells up to *maxReportCells* in accordance with the following:
 - 3> if the *reportType* is set to *eventTriggered*:
 - 4> include the cells included in the *cellsTriggeredList* as defined within the *VarMeasReportList* for this *measId*;
 - 3> else:
 - 4> include the applicable cells for which the new measurement results became available since the last periodical reporting or since the measurement was initiated or reset;
 - 4> if *reportQuantityRsIndexes* and *maxNrofRSIndexesToReport* are configured, include beam measurement information as described in 5.5.5.2;
 - 3> for each cell that is included in the *measResultNeighCells*, include the *physCellId*;
 - 3> if the *reportType* is set to *eventTriggered*:
 - 4> for each included cell, include the layer 3 filtered measured results in accordance with the *reportConfig* for this *measId*, ordered as follows:
 - 5> if the *measObject* associated with this *measId* concerns NR:
 - 6> if *rsType* in the associated *reportConfig* is set to *ssb*:
 - 7> set *resultsSSB-Cell* within the *measResult* to include the SS/PBCH block based quantity(ies) indicated in the *reportQuantityCell* within the concerned *reportConfig*, in order of decreasing trigger quantity, i.e. the best cell is included first;
 - 8> if *reportQuantityRsIndexes* and *maxNrofRSIndexesToReport* are configured, include beam measurement information as described in 5.5.5.2;
 - 6> else if *rsType* in the associated *reportConfig* is set to *csi-rs*:
 - 7> set *resultsCSI-RS-Cell* within the *measResult* to include the CSI-RS based quantity(ies) indicated in the *reportQuantityCell* within the concerned *reportConfig*, in order of decreasing trigger quantity, i.e. the best cell is included first;
 - 8> if *reportQuantityRsIndexes* and *maxNrofRSIndexesToReport* are, include beam measurement information as described in 5.5.5.2;
 - 5> if the *measObject* associated with this *measId* concerns E-UTRA:
 - 6> set the *measResult* to include the quantity(ies) indicated in the *reportQuantity* within the concerned *reportConfigInterRAT* in order of decreasing E-UTRA trigger quantity, i.e. the best cell is included first;
 - 3> if the *reportType* is set to *periodical*:

- 4> if a single reporting quantity is set to *TRUE* in *reportQuantityRsIndexes*;
 - 5> consider the configured single quantity as the sorting quantity;
- 4> else:
 - 5> if *rsrp* is set to *TRUE*;
 - 6> consider RSRP as the sorting quantity;
 - 5> else:
 - 6> consider RSRQ as the sorting quantity;
- 3> if the *reportType* is set to *reportCGI*:
 - 4> if the cell indicated by *cellForWhichToReportCGI* is an NR cell:
 - 5> if all mandatory fields of the *cgi-Info* for the concerned cell have been obtained:
 - 6> include the *plmn-IdentityInfoList* including *plmn-IdentityList*, *trackingAreaCode* (if available), *ranac* (if available) and *cellIdentity* for each entry of the *plmn-IdentityInfoList*;
 - 6> include *frequencyBandList* if available;
 - 5> else if MIB indicates the SIB1 is not broadcast:
 - 6> include the *noSIB1* including the *ssb-SubcarrierOffset* and *pdccch-ConfigSIB1* obtained from MIB of the concerned cell;
 - 4> if the cell indicated by *cellForWhichToReportCGI* is an EUTRA cell:
 - 5> if all mandatory fields of the *cgi-Info-EPC* for the concerned cell have been obtained:
 - 6> include in the *cgi-Info-EPC* the fields broadcasted in EUTRA *SystemInformationBlockType1* associated to EPC;
 - 5> if UE is E-UTRA/5GC capable and all mandatory fields of the *cgi-Info-5GC* for the concerned cell have been obtained:
 - 6> include in the *cgi-Info-5GC* the fields broadcasted in EUTRA *SystemInformationBlockType1* associated to 5GC;
 - 5> include the *freqBandIndicator*;
 - 5> if the cell broadcasts the *multiBandInfoList*, include the *multiBandInfoList*;
 - 5> if the cell broadcasts the *freqBandIndicatorPriority*, include the *freqBandIndicatorPriority*;
- 1> increment the *numberOfReportsSent* as defined within the *VarMeasReportList* for this *measId* by 1;
- 1> stop the periodical reporting timer, if running;
- 1> if the *numberOfReportsSent* as defined within the *VarMeasReportList* for this *measId* is less than the *reportAmount* as defined within the corresponding *reportConfig* for this *measId*:
 - 2> start the periodical reporting timer with the value of *reportInterval* as defined within the corresponding *reportConfig* for this *measId*;
- 1> else:
 - 2> if the *reportType* is set to *periodical*:
 - 3> remove the entry within the *VarMeasReportList* for this *measId*;
 - 3> remove this *measId* from the *measIdList* within *VarMeasConfig*;
- 1> if the UE is configured with EN-DC:

2> if SRB3 is configured:

3> submit the *MeasurementReport* message via SRB3 to lower layers for transmission, upon which the procedure ends;

2> else:

3> submit the *MeasurementReport* message via the EUTRA MCG embedded in E-UTRA RRC message *ULInformationTransferMRDC* as specified in TS 36.331 [10].

1> else:

2> submit the *MeasurementReport* message to lower layers for transmission, upon which the procedure ends.

8.2.4.3.1.1.3 Test description

8.2.4.3.1.1.3.1 Pre-test conditions

System Simulator:

- E-UTRA Cell 1 is the PCell. NR Cell 1 is the PSCell and NR Cell 3 is the SCell to be added, NR Cell 12 is the intra-frequency neighbour cell of NR Cell 3.

UE:

None.

Preamble:

- The UE is in state RRC_CONNECTED using generic procedure parameter Connectivity (*EN-DC*) and DC bearers (*MCG(s)* and *SCG*) according to TS 38.508-1 [4], table 4.5.4.

8.2.4.3.1.1.3.2 Test procedure sequence

Table 8.2.4.3.1.1.3.2-1 illustrates the downlink power levels to be applied for E-UTRA Cell 1, NR Cell 1, NR Cell 3 and NR Cell 12 at various time instants of the test execution. Row marked "T0" denotes the conditions after the preamble, while the configuration marked "T1" is applied at the point indicated in the Main behaviour description in Table 8.2.4.3.1.1.3.2-2.

Table 8.2.4.3.1.1.3.2-1: Power levels

	Parameter	Unit	E-UTRA Cell 1	NR Cell 1	NR Cell 3	NR Cell 12	Remark
T0	Cell-specific RS EPRE	dBm/15 kHz	-79	-	-	-	Power levels are such that entry condition for event A6 is not satisfied: $Mn + Ocn + Hys < Ms + Ocs + Off$
	SS/PBCH SSS EPRE	dBm/15 kHz	-	[-79]	[-85]	[-97]	
T1	Cell-specific RS EPRE	dBm/15 kHz	-79	-	-	-	Power levels are such that entry condition for event A6 is satisfied: $Mn + Ocn - Hys > Ms + Ocs + Off$
	SS/PBCH SSS EPRE	dBm/15 kHz	-	[-79]	[-97]	[-85]	

Table 8.2.4.3.1.1.3.2-2: Main behaviour

St	Procedure	Message Sequence		TP	Verdict
		U – S	Message		
1	SS transmits an <i>RRCConnectionReconfiguration</i> message containing <i>RRCReconfiguration</i> message to configure SCell (NR Cell 3) and SRB3.	<--	<i>RRCConnectionReconfiguration(RRCReconfiguration)</i>	-	-
2	The UE transmits an <i>RRCConnectionReconfigurationComplete</i> message containing <i>RRCReconfigurationComplete</i> message.	-->	<i>RRCConnectionReconfigurationComplete(RRCReconfigurationComplete)</i>	-	-
3	SS transmits an <i>RRCConnectionReconfiguration</i> message containing <i>RRCReconfiguration</i> message including <i>measConfig</i> to setup intra NR measurement and reporting for event A6	<--	<i>RRCConnectionReconfiguration(RRCReconfiguration)</i>	-	-
4	The UE transmits an <i>RRCConnectionReconfigurationComplete</i> message containing <i>RRCReconfigurationComplete</i> message.	-->	<i>RRCConnectionReconfigurationComplete(RRCReconfigurationComplete)</i>	-	-
5	SS re-adjusts the cell-specific reference signal level according to row "T1" in table 8.2.4.3.1.1.3.2-1.	-	-	-	-
6	Check: Does the UE transmit a <i>MeasurementReport</i> message via SRB3 to report event A6 with the measured RSRP and RSRQ value for NR Cell 12?	-->	<i>MeasurementReport</i>	1	P
7	The SS transmits an <i>RRCReconfiguration</i> message including <i>sCellToReleaseList</i> with NR Cell 3 as SCell release and <i>sCellToAddModList</i> with NR Cell 12 as SCell addition via SRB3.	<--	<i>RRCReconfiguration</i>	-	-
8	Check: Does the UE transmit an <i>RRCConnectionReconfigurationComplete</i> message on NR Cell 1?	-->	<i>RRCReconfigurationComplete</i>	2	P

8.2.4.3.1.1.3.3 Specific message contents

Table 8.2.4.3.1.1.3.3-1: *RRCConnectionReconfiguration* (step 1, Table 8.2.4.3.1.1.3.2-2)

Derivation Path: TS 36.508 [7], Table 4.6.1-8 condition MCG_and_SCG.

Table 8.2.4.3.1.1.3.3-2: *RRCReconfiguration* (step 1, Table 8.2.4.3.1.1.3.2-2)

Derivation Path: TS 38.508-1 [4], Table 4.6.1-13.			
Information Element	Value/remark	Comment	Condition
<i>RRCReconfiguration</i> ::= SEQUENCE {			
criticalExtensions CHOICE {			
rrcReconfiguration ::= SEQUENCE {			
radioBearerConfig	RadioBearerConfig	TS 38.508-1 [4] table 4.6.3-132 condition SRB3	
secondaryCellGroup	CellGroupConfig		
}			
}			
}			

Table 8.2.4.3.1.1.3.3-3: CellGroupConfig (Table 8.2.4.3.1.1.3.3-2)

Derivation Path: TS 38.508-1 [4], Table 4.6.3-19.			
Information Element	Value/remark	Comment	Condition
CellGroupConfig ::= SEQUENCE {			
sCellToAddModList SEQUENCE (SIZE (1..maxMeasId)) OF SEQUENCE {			
sCellIndex[1]	1		
sCellConfigCommon[1]	ServingCellConfigCommon		
sCellConfigDedicated[1]	ServingCellConfig	TS 38.508-1 [4] table 4.6.3-167	
}			
}			

Table 8.2.4.3.1.1.3.3-4: ServingCellConfigCommon (Table 8.2.4.3.1.1.3.3-3)

Derivation Path: TS 38.508-1 [4], Table 4.6.3-168.			
Information Element	Value/remark	Comment	Condition
ServingCellConfigCommon ::= SEQUENCE {			
PhysCellId	Physical Cell Identity of NR Cell 3		
}			

Table 8.2.4.3.1.1.3.3-5: RRCReconfiguration (step 3, Table 8.2.4.3.1.1.3.2-2)

Derivation Path: TS 38.508-1 [4], Table 4.6.1-13.			
Information Element	Value/remark	Comment	Condition
RRCReconfiguration ::= SEQUENCE {			
criticalExtensions CHOICE {			
rrcReconfiguration ::= SEQUENCE {			
measConfig	MeasConfig		
}			
}			
}			

Table 8.2.4.3.1.1.3.3-6: *MeasConfig* (Table 8.2.4.3.1.1.3.3-5)

Derivation path: TS 38.508-1 [4], Table 4.6.3-69.			
Information Element	Value/Remark	Comment	Condition
measConfig ::= SEQUENCE {			
measObjectToAddModList SEQUENCE (SIZE (1..maxNrofObjectId)) OF SEQUENCE {	2 entry		
measObjectId[1]	IdMeasObject-NRf1	NR Cell 1	
measObject[1] CHOICE {			
measObjectNR	MeasObjectNR-GENERIC(NRf1)		
}			
measObjectId[2]	IdMeasObject-NRf2	NR Cell 3	
measObject[2] CHOICE {			
measObjectNR	MeasObjectNR-GENERIC(NRf2)		
}			
}			
reportConfigToAddModList SEQUENCE (SIZE (1..maxReportConfigId)) OF SEQUENCE {	1 entry		
reportConfigId[1]	IdReportConfig-A6		
reportConfig[1] CHOICE {			
reportConfigNR	ReportConfigNR	TS 38.508-1 [4] table 4.6.3-142 condition EVENT_A6	
}			
}			
measIdToAddModList SEQUENCE (SIZE (1..maxMeasId)) OF SEQUENCE {	1 entry		
measId[1]	1		
measObjectId[1]	IdMeasObject-NRf2		
reportConfigId[1]	IdReportConfig-A6		
}			
}			

Table 8.2.4.3.1.1.3.3-7: MeasurementReport (step 6, Table 8.2.4.3.1.1.3.2-2)

Derivation Path: TS 38.508-1 [4], Table 4.6.1-7.			
Information Element	Value/remark	Comment	Condition
MeasurementReport ::= SEQUENCE {			
criticalExtensions CHOICE {			
measurementReport SEQUENCE {			
measResults ::= SEQUENCE {			
measId	1		
measResultServingMOList ::=SEQUENCE(SIZE (1..maxNrofServingCells)) OF SEQUENCE {			
servCellId[1]	1		
measResultServingCell[1] SEQUENCE {		Report NR Cell 3	
physCellId	physCellId of NR Cell 3		
measResult SEQUENCE {			
cellResults SEQUENCE {			
resultsSSB-Cell SEQUENCE {			
rsrp	(0..127)		
rsrq	(0..127)		
sinr	(0..127)		
}			
}			
}			
measResultBestNeighCell[1] SEQUENCE {		Report NR Cell 12	
physCellId	physCellId of NR Cell 12		
measResult SEQUENCE {			
cellResults SEQUENCE {			
resultsSSB-Cell SEQUENCE {			
rsrp	(0..127)		
rsrq	(0..127)		
sinr	(0..127)		
}			
}			
}			
}			
}			
}			
}			
}			
}			

Table 8.2.4.3.1.1.3.3-8: RRCReconfiguration (step 7, Table 8.2.4.3.1.1.3.2-2)

Derivation Path: 38.508-1 [4], Table 4.6.1-13.			
Information Element	Value/remark	Comment	Condition
RRCReconfiguration ::= SEQUENCE {			
criticalExtensions CHOICE {			
rrcReconfiguration ::= SEQUENCE {			
SecondaryCellGroup	CellGroupConfig		
}			
}			
}			

Table 8.2.4.3.1.1.3.3-9: CellGroupConfig (Table 8.2.4.3.1.1.3.3-8)

Derivation Path: 38.508-1 [4], Table 4.6.3-19.			
Information Element	Value/remark	Comment	Condition
CellGroupConfig ::= SEQUENCE {			
sCellToAddModList SEQUENCE (SIZE (1.. maxNrofSCells)) OF SEQUENCE {			
sCellIndex[1]	2		
sCellConfigCommon[1]	ServingCellConfigCommon		
sCellConfigDedicated[1]	ServingCellConfig	TS 38.508-1 [4] table 4.6.3-167	
}			
sCellToReleaseList SEQUENCE (SIZE (1.. maxNrofSCells)) OF {	1 entry		
sCellIndex[1]	1		
}			
}			

Table 8.2.4.3.1.1.3.3-10: ServingCellConfigCommon (Table 8.2.4.3.1.1.3.3-9)

Derivation Path: TS 38.508-1 [4], Table 4.6.3-168.			
Information Element	Value/remark	Comment	Condition
ServingCellConfigCommon ::= SEQUENCE {			
PhysCellId	Physical Cell Identity of NR Cell 12		
}			

8.2.4.3.1.2 NR CA / SCell change / Intra-NR measurement event A6 / SRB3 / EN-DC / Intra-band non-Contiguous CA

The scope and description of the present TC is the same as test case 8.2.4.3.1.1 with the following differences:

- CA configuration: Intra-band non-contiguous CA replaces Intra-band Contiguous CA

8.2.4.3.1.3 NR CA / SCell change / Intra-NR measurement event A6 / SRB3 / EN-DC / Inter-band CA

8.2.4.3.1.3.1 Test Purpose (TP)

Same as TC 8.2.4.3.1.1 but applied to Inter-band CA case.

8.2.4.3.1.3.2 Conformance requirements

Same as TC 8.2.4.3.1.1.

8.2.4.3.1.3.3 Test description

8.2.4.3.1.3.3.1 Pre-test conditions

Same as test case 8.2.4.3.1.1 with the following differences:

- Cells configuration: NR Cell 10 replaces NR Cell 3, NR Cell 30 replaces NR Cell 12

8.2.4.3.1.3.3.2 Test procedure sequence

Same as test case 8.2.4.3.1.1 with the following differences:

- Cells configuration: NR Cell 10 replaces NR Cell 3, NR Cell 30 replaces NR Cell 12

8.2.4.3.1.3.3.3 Specific message contents

Table 8.2.4.3.1.3.3-1: *MeasConfig* (Table 8.2.4.3.1.1.3.3-6)

Derivation path: TS 38.508-1 [4], Table 4.6.3-69.			
Information Element	Value/Remark	Comment	Condition
measConfig ::= SEQUENCE {			
measObjectToAddModList SEQUENCE (SIZE (1..maxNrofObjectId)) OF SEQUENCE {	2 entry		
measObjectId[1]	IdMeasObject-NRf1	NR Cell 1	
measObject[1] CHOICE {			
measObjectNR	MeasObjectNR-GENERIC(NRf1)		
}			
measObjectId[2]	IdMeasObject-NRf5	NR Cell 10	
measObject[2] CHOICE {			
measObjectNR	MeasObjectNR-GENERIC(NRf5)		
}			
}			
reportConfigToAddModList SEQUENCE (SIZE (1..maxReportConfigId)) OF SEQUENCE {	1 entry		
reportConfigId[1]	IdReportConfig-A6		
reportConfig[1] CHOICE {			
ReportConfigNR	ReportConfigNR	TS 38.508-1 [4] table 4.6.3-142 condition EVENT_A6	
}			
}			
measIdToAddModList SEQUENCE (SIZE (1..maxMeasId)) OF SEQUENCE {	1 entry		
measId[1]	1		
measObjectId[1]	IdMeasObject-NRf5		
reportConfigId[1]	IdReportConfig-A6		
}			
}			

8.2.5 Reconfiguration Failure / Radio link failure

8.2.5.1 Radio link failure / PSCell addition failure

8.2.5.1.1 Radio link failure / Random access problem / EN-DC

8.2.5.1.1.1 Test Purpose (TP)

(1)

```

with { UE in RRC_CONNECTED state with EN-DC, and, MCG(s) (E-UTRA PDCP) and SCG }
ensure that {
  when { UE receives an IP Packet to loopback on SCG DRB and the SS does not respond to the
Scheduling Requests from UE }
  then { UE encounters random access problem and initiates the NR SCG failure information
procedure to report SCGFailureInformationNR with failure type randomAccessProblem }
}

```

8.2.5.1.1.2 Conformance requirements

References: The conformance requirements covered in the present TC are specified in: TS 36.331, clauses 5.6.13a.3, TS 38.331, clauses 5.3.10.3, 5.7.3.2, 5.7.3.3. Unless otherwise stated these are Rel-15 requirements.

[TS 36.331, clause 5.6.13a.3]

The UE shall set the contents of the *SCGFailureInformationNR* message as follows:

- 1> include *failureType* within *failureReportSCG-NR* and set it to indicate the SCG failure in accordance with TS 38.331 [82], clause 5.7.3.3;

...

The UE shall submit the *SCGFailureInformationNR* message to lower layers for transmission.

[TS 38.331, clause 5.3.10.3]

The UE shall:

...

- 1> upon random access problem indication from SCG MAC; or

...

- 3> consider radio link failure to be detected for the SCG i.e. SCG-RLF;
- 3> initiate the SCG failure information procedure as specified in 5.7.3 to report SCG radio link failure.

[TS 38.331, clause 5.7.3.2]

A UE initiates the procedure to report SCG failures when SCG transmission is not suspended and when one of the following conditions is met:

...

- 1> upon SCG configuration failure, in accordance with subclause 5.3.5.8.2;

...

Upon initiating the procedure, the UE shall:

- 1> suspend SCG transmission for all SRBs and DRBs;
- 1> reset SCG-MAC;
- 1> stop T304, if running;
- 1> if the UE is operating in EN-DC:
 - 2> initiate transmission of the *SCGFailureInformationNR* message as specified in TS 36.331 [10], clause 5.6.13a.

[TS 38.331, clause 5.7.3.3]

The UE shall set the SCG failure type as follows:

...

- 1> else if the UE initiates transmission of the *SCGFailureInformationNR* message to provide random access problem indication from SCG MAC:
 - 2> set the *failureType* as *randomAccessProblem*;

8.2.5.1.1.3 Test description

8.2.5.1.1.3.1 Pre-test conditions

System Simulator:

- E-UTRA Cell 1 is the PCell and NR Cell 1 is the PSCell.

UE:

- None.

Preamble:

- The UE is in state RRC_CONNECTED using generic procedure parameter Connectivity (*EN-DC*) and Bearers (*MCG(s) and SCG*) established and Test Loop Function (On) with UE test loop mode B according to TS 38.508-1 [4], clause 4.5.4.

8.2.5.1.1.3.2 Test procedure sequence

Table 8.2.5.1.1.3.2-1: Main behaviour

St	Procedure	Message Sequence		TP	Verdict
		U - S	Message		
1	The SS shall not respond to the Scheduling Requests for the IP Packet transmitted at next step (Note)	-	-	-	-
2	The SS transmits one IP Packet on SCG DRB	-	-	-	-
3	The SS shall not respond to the PRACH Preambles thereby simulating a random access problem.	-	-	-	-
4	Check: Does the UE transmit in the next 5 sec (arbitrary value) a <i>SCGFailureInformationNR</i> message with <i>failureType</i> set to ' <i>randomAccessProblem</i> '?	-->	<i>SCGFailureInformationNR</i>	1	P

Note: The UE initiates random access procedure once SR number of attempts reach sr-transMax.

Table 8.2.5.1.1.3.2-2: Void

Table 8.2.5.1.1.3.2-3: Void

8.2.5.1.1.3.3 Specific message contents

Table 8.2.5.1.1.3.3-1: Void

Table 8.2.5.1.1.3.3-2: Void

Table 8.2.5.1.1.3.3-3: Void

Table 8.2.5.1.1.3.3-4: Void

Table 8.2.5.1.1.3.3-5: SCGFailureInformationNR (step 4, Table 8.2.5.1.1.3.2-1)

Derivation Path: 36.508 [7], Table 4.6.1-18AA			
Information Element	Value/remark	Comment	Condition
SCGFailureInformationNR-r15 ::= SEQUENCE {			
criticalExtensions CHOICE {			
c1 CHOICE {			
scgFailureInformationNR-r15 SEQUENCE {			
failureReportSCG-NR-r15 SEQUENCE {			
failureType-r15	randomAccessProblem		
measResultFreqListNR-r15	Not checked		
measResultSCG-r15	Not checked		
}			
nonCriticalExtension SEQUENCE {}			
}			
}			
}			

8.2.5.2 Radio link failure / PSCell out of sync indication

8.2.5.2.1 Radio link failure / PSCell out of sync indication / EN-DC

8.2.5.2.1.1 Test Purpose (TP)

(1)

```
with { UE in RRC_CONNECTED state with EN-DC, and, MCG(s) (E-UTRA PDCP) and SCG DRB established }
ensure that {
  when { UE receives N310 consecutive "out-of-sync" indications for the SpCell from lower layers due
to radio link failure }
  then { UE starts timer T310 for the corresponding SpCell, and, upon timer expiry initiates the
NR SCG failure information procedure to report SCGFailureInformationNR with failure type set to
't310-Expiry' }
}
```

8.2.5.2.1.2 Conformance requirements

References: The conformance requirements covered in the present test case are specified in: TS 36.331, clause 5.6.13a.3, TS 38.331, clauses 5.3.10.1, 5.3.10.3, 5.7.3.2, 5.7.3.3. Unless otherwise stated these are Rel-15 requirements.

[TS 36.331, clause 5.6.13a.3]

The UE shall set the contents of the *SCGFailureInformationNR* message as follows:

- 1> include *failureType* within *failureReportSCG-NR* and set it to indicate the SCG failure in accordance with TS 38.331 [82, 5.7.3.3];

...

The UE shall submit the *SCGFailureInformationNR* message to lower layers for transmission.

[TS 38.331, clause 5.3.10.1]

The UE shall:

- 1> upon receiving N310 consecutive "out-of-sync" indications for the SpCell from lower layers while T311 is not running;
- 2> start timer T310 for the corresponding SpCell.

[TS 38.331, clause 5.3.10.3]

The UE shall:

1> upon T310 expiry in PSCell; or

...

2> initiate the SCG failure information procedure as specified in 5.7.3 to report SCG radio link failure.

[TS 38.331, clause 5.7.3.2]

A UE initiates the procedure to report SCG failures when SCG transmission is not suspended and when one of the following conditions is met:

1> upon detecting radio link failure for the SCG, in accordance with subclause 5.3.10.3;

...

Upon initiating the procedure, the UE shall:

1> suspend SCG transmission for all SRBs and DRBs;

1> reset SCG-MAC;

1> stop T304, if running;

1> if the UE is operating in EN-DC:

2> initiate transmission of the *SCGFailureInformationNR* message as specified in TS 36.331 [10, 5.6.13a].

[TS 38.331, clause 5.7.3.3]

The UE shall set the SCG failure type as follows:

1> if the UE initiates transmission of the *SCGFailureInformationNR* message due to T310 expiry:

2> set the failureType as t310-Expiry;

8.2.5.2.1.3 Test description

8.2.5.2.1.3.1 Pre-test conditions

System Simulator:

- E-UTRA Cell 1 is the PCell and NR Cell 1 is the PSCell.

UE:

- None.

Preamble:

- The UE is in state RRC_CONNECTED using generic procedure parameter Connectivity (EN-DC) and DC Bearers (MCG(s) and SCG) on E-UTRA Cell 1 according to TS 38.508-1 [4], clause 4.5.4.

8.2.5.2.1.3.2 Test procedure sequence

Table 8.2.5.2.1.3.3-0A: RRCReconfiguration (Preamble)

Derivation path: 38.508-1 [4], Table 4.6.1-13			
Information Element	Value/remark	Comment	Condition
RRCReconfiguration ::= SEQUENCE {			
criticalExtensions CHOICE {			
rrcReconfiguration SEQUENCE {			
secondaryCellGroup	CellGroupConfig	OCTET STRING	
}			
}			
}			

Table 8.2.5.2.1.3.3-0B: CellGroupConfig (Table 8.2.5.2.1.3.3-0A: RRCReconfiguration)

Derivation Path: TS 38.508-1 [4], Table 4.6.3-19			
Information Element	Value/remark	Comment	Condition
CellGroupConfig ::= SEQUENCE {			
spCellConfig SEQUENCE {			
spCellConfigDedicated	ServingCellConfig		
}			
}			

Table 8.2.5.2.1.3.3-0E: RadioLinkMonitoringConfig (Table 8.2.5.2.1.3.3-0D: BWP-DownlinkDedicated)

Derivation Path: TS 38.508-1 [4], Table 4.6.3-133			
Information Element	Value/remark	Comment	Condition
RadioLinkMonitoringConfig ::= SEQUENCE {			
failureDetectionResourcesToAddModList	1 entry		
SEQUENCE			
(SIZE(1..maxNrofFailureDetectionResources)) OF			
SEQUENCE {			
radioLinkMonitoringRS-Id[1]	0		
purpose[1]	rIf		
detectionResource[1] CHOICE {			
ssb-Index	1		
}			
}			
failureDetectionResourcesToReleaseList	Not present		
beamFailureInstanceMaxCount	Not present		
beamFailureDetectionTimer	Not present		
}			

Table 8.2.5.2.1.3.2-1: Main behaviour

St	Procedure	Message Sequence		TP	Verdict
		U - S	Message		
1	The SS changes NR Cell 1 parameter to non-suitable "Off" in order to simulate radio link failure.	-	-	-	-
2	Void.	-	-	-	-
3	Check: Does the UE transmit in the next 5 sec (NOTE 1) a <i>SCGFailureInformationNR</i> message with <i>failureType</i> set to 't310-Expiry'?	-->	<i>SCGFailureInformationNR</i>	1	P

NOTE 1: The time of 5 sec is chosen arbitrary. When the UE will send the Failure report depends on (1) the values pre-set for N310 and T310 (see TS 38.508-1 [4], *RLF-TimersAndConstants* - set at the moment to 'n1' and 'ms1000' respectively), and, (2) the time it will take for the SS to complete step 1 and the UE to notice the change and perform internally all relevant to it actions. Because of the uncertainties associated with (2), and, the lower values used in typical network setting for (1), testing if the UE obeys the exact values of (1) is unreliable.

Table 8.2.5.2.1.3.3-3: *ServingCellConfig* (Table 8.2.5.2.1.3.3-0B: *CellGroupConfig*)

Derivation Path: TS 38.508-1 [4], Table 4.6.3-167			
Information Element	Value/remark	Comment	Condition
ServingCellConfig ::= SEQUENCE {			
initialDownlinkBWP	BWP-DownlinkDedicated		
}			

Table 8.2.5.2.1.3.3-4: *BWP-DownlinkDedicated* (Table 8.2.5.2.1.3.3-0C: *ServingCellConfig*)

Derivation Path: TS 38.508-1 [4], Table 4.6.3-11			
Information Element	Value/remark	Comment	Condition
BWP-DownlinkDedicated ::= SEQUENCE {			
radioLinkMonitoringConfig	RadioLinkMonitoringConfig		
}			

8.2.5.2.1.3.3 Specific message contents

Table 8.2.5.2.1.3.3-1: *SCGFailureInformationNR* (step 3, Table 8.2.5.2.1.3.2-1)

Derivation Path: 36.508 [7], Table 4.6.1-18AA			
Information Element	Value/remark	Comment	Condition
SCGFailureInformationNR-r15 ::= SEQUENCE {			
criticalExtensions CHOICE {			
c1 CHOICE {			
scgFailureInformationNR-r15 SEQUENCE {			
failureReportSCG-NR-r15 SEQUENCE {			
failureType-r15	t310-Expiry		
measResultFreqListNR-r15	Not checked		
measResultSCG-r15	Not present		
}			
nonCriticalExtension SEQUENCE {}			
}			
}			
}			

8.2.5.3 Radio link failure / rlc-MaxNumRetx failure

8.2.5.3.1 Radio link failure / rlc-MaxNumRetx failure / EN-DC

8.2.5.3.1.1 Test Purpose (TP)

(1)

```
with { UE in RRC_CONNECTED state with EN-DC MCG(s) (E-UTRA PDCP) and SCG DRB established }
ensure that {
  when { the transmitting side of the UE's AM RLC entity for the SCG DRB has retransmitted an RLC
SDU until RETX_COUNT = maxRetxThreshold }
  then { the UE shall transmit a SCGFailureInformationNR message with failureType set to 'rlc-
MaxNumRetx' }
}
```

8.2.5.3.1.2 Conformance requirements

References: The conformance requirements covered in the present test case are specified in: TS 38.322, clause 5.3.2, TS 36.331, clause 5.6.13a.3, TS 38.331, clauses 5.3.10.3, 5.7.3.2, 5.7.3.3. Unless otherwise stated these are Rel-15 requirements.

[TS 38.322, clause 5.3.2]

When an RLC SDU or an RLC SDU segment is considered for retransmission, the transmitting side of the AM RLC entity shall:

- if the RLC SDU or RLC SDU segment is considered for retransmission for the first time:
 - set the RETX_COUNT associated with the RLC SDU to zero.
- else, if it (the RLC SDU or the RLC SDU segment that is considered for retransmission) is not pending for retransmission already and the RETX_COUNT associated with the RLC SDU has not been incremented due to another negative acknowledgment in the same STATUS PDU:
 - increment the RETX_COUNT.
- if RETX_COUNT = *maxRetxThreshold*:
 - indicate to upper layers that max retransmission has been reached.

...

[TS 36.331, clause 5.6.13a.3]

The UE shall set the contents of the *SCGFailureInformationNR* message as follows:

- 1> include *failureType* within *failureReportSCG-NR* and set it to indicate the SCG failure in accordance with TS 38.331 [82] clause 5.7.3.3;

...

The UE shall submit the *SCGFailureInformationNR* message to lower layers for transmission.

[TS 38.331, clause 5.3.10.3]

The UE shall:

...

- 1> upon indication from SCG RLC that the maximum number of retransmissions has been reached:
 - 2> if CA duplication is configured and activated; and for the corresponding logical channel *allowedServingCells* only includes SCell(s):
 - 3> initiate the failure information procedure as specified in 5.7.5 to report RLC failure.
 - 2> else:
 - 3> consider radio link failure to be detected for the SCG i.e. SCG-RLF;
 - 3> initiate the SCG failure information procedure as specified in 5.7.3 to report SCG radio link failure.

...

else3> consider radio link failure to be detected for the SCG i.e. SCG-RLF;

3[TS 38.331, clause 5.7.3.2]

A UE initiates the procedure to report SCG failures when SCG transmission is not suspended and when one of the following conditions is met:

- 1> upon detecting radio link failure for the SCG, in accordance with subclause 5.3.10.3;

...

Upon initiating the procedure, the UE shall:

- 1> suspend SCG transmission for all SRBs and DRBs;
- 1> reset SCG-MAC;

1> stop T304, if running;

1> if the UE is operating in EN-DC:

2> initiate transmission of the *SCGFailureInformationNR* message as specified in TS 36.331 [10], clause 5.6.13a.

Editor's Note: The section for transmission of *SCGFailureInformation* in NR RRC entity for SA is *FFS_Standalone*.

[TS 38.331, clause 5.7.3.3]

Editor's Note: *FFS / TODO:* Either use this section also for NR-DC or change section title (add "for EN-DC").

The UE shall set the SCG failure type as follows:

...

1> else if the UE initiates transmission of the *SCGFailureInformationNR* message to provide indication from SCG RLC that the maximum number of retransmissions has been reached:

2> set the *failureType* as *rlc-MaxNumRetx*;

8.2.5.3.1.3 Test description

8.2.5.3.1.3.1 Pre-test conditions

System Simulator:

- E-UTRA Cell 1 is the PCell and NR Cell 1 is the PSCell.

UE:

- None.

Preamble:

- The UE is in state *RRC_CONNECTED* using generic procedure parameter *Connectivity (EN-DC)*, Bearers (*MCG(s) and SCG*) established and Test Loop Function (*On*) with UE test loop mode A (message condition UE TEST LOOP MODE A to return one UL PDCP SDU per DL PDCP SDU) according to TS 38.508-1 [4] the exception that ciphering algorithm 'nea0 (NULL)' is configured.
- The RLC Acknowledged Mode is enabled

8.2.5.3.1.3.2 Test procedure sequence

Table 8.2.5.3.1.3.2-1: Main behaviour

St	Procedure	Message Sequence		TP	Verdict
		U - S	Message		
1	The SS transmits AMD PDU#1 containing a complete RLC SDU#1 (on the SCG bearer).	<--	AMD PDU#1	-	-
1A	SS allocates an UL grant sufficient to loop back RLC SDU#1 in one RLC/MAC PDU	<--	UL Grant	-	-
1B	The UE transmits one AMD PDU#1 containing a complete RLC SDU#1 (on the SCG bearer).	-->	AMD PDU#1 (SN=0)	-	-
-	EXCEPTION: Steps 1C-3 are repeated maxRetxThreshold times NOTE: maxRetxThreshold is configured by RLC-Config.	-	-	-	-
1C	The SS transmits an RLC STATUS PDU. ACK_SN =1 and NACK_SN =0.	<--	STATUS PDU	-	-
2	SS allocates an UL grant sufficient to loop back RLC SDU#1 in one RLC/MAC PDU	<--	UL Grant	-	-
3	The UE transmits one AMD PDU#1 containing a complete RLC SDU#1 (on the SCG bearer).	-->	AMD PDU#1 (SN=0)	-	-
3A	The SS transmits an RLC STATUS PDU. ACK_SN =1 and NACK_SN =0.	<--	STATUS PDU	-	-
4	Check: Does the UE transmit in the next 5 sec (arbitrary value) a SCGFailureInformationNR message with failureType set to 'rlc-MaxNumRetx'?	-->	SCGFailureInformationNR	1	P

8.2.5.3.1.3.3 Specific message contents

Table 8.2.5.3.1.3.3-1: SCGFailureInformationNR (step 4, Table 8.2.5.3.1.3.2-1)

Derivation Path: 36.508 [7], Table 4.6.1-18AA			
Information Element	Value/remark	Comment	Condition
SCGFailureInformationNR-r15 ::= SEQUENCE {			
criticalExtensions CHOICE {			
c1 CHOICE {			
scgFailureInformationNR-r15 SEQUENCE {			
failureReportSCG-NR-r15 SEQUENCE {			
failureType-r15	rlc-MaxNumRetx		
measResultFreqListNR-r15	Not checked		
measResultSCG-r15	Not checked		
}			
nonCriticalExtension SEQUENCE {}			
}			
}			
}			

8.2.5.4 Reconfiguration failure / SCG change failure

8.2.5.4.1 Reconfiguration failure / SCG change failure / EN-DC

8.2.5.4.1.1 Test Purpose (TP)

(1)

with { UE in RRC_CONNECTED state with EN-DC, and, MCG(s) (E-UTRA PDCP) and SCG DRB established }
ensure that {

```

when { UE receives an RRCConnectionReconfiguration message with nr-Config IE containing NR
RRCReconfiguration message with reconfigurationWithSync for configured PSCell and if T304 of a
secondary cell group expires }
  then { UE initiates the NR SCG failure information procedure to report SCGFailureInformationNR
with failure type set to 'synchReconfigFailure-SCG' }
}

```

8.2.5.4.1.2 Conformance requirements

References: The conformance requirements covered in the present test case are specified in: TS 36.331, clause 5.6.13a.3, TS 38.331, clauses 5.3.5.3, 5.3.5.5.1, 5.3.5.5.2, 5.3.5.8.3, 5.7.3.2 and 5.7.3.3. Unless otherwise stated these are Rel-15 requirements.

[TS 36.331, clause 5.6.13a.3]

The UE shall set the contents of the *SCGFailureInformationNR* message as follows:

- 1> include *failureType* within *failureReportSCG-NR* and set it to indicate the SCG failure in accordance with TS 38.331 [82, 5.7.3.3];

...

The UE shall submit the *SCGFailureInformationNR* message to lower layers for transmission.

[TS 38.331, clause 5.3.5.3]

The UE shall perform the following actions upon reception of the *RRCReconfiguration*:

- 1> if the *RRCReconfiguration* includes the *secondaryCellGroup*:
 - 2> perform the cell group configuration for the SCG according to 5.3.5.5;
- ...
- 1> if the UE is configured with E-UTRA *nr-SecondaryCellGroupConfig* (MCG is E-UTRA):
 - 2> if *RRCReconfiguration* was received via SRB1:
 - 3> construct *RRCReconfigurationComplete* message and submit it via the EUTRA MCG embedded in E-UTRA RRC message *RRCConnectionReconfigurationComplete* as specified in TS 36.331 [10];
 - 3> if *reconfigurationWithSync* was included in *spCellConfig* of an SCG:
 - 4> initiate the random access procedure on the SpCell, as specified in TS 38.321 [3];

...

[TS 38.331, clause 5.3.5.5.1]

The network configures the UE with Master Cell Group (MCG), and zero or one Secondary Cell Group (SCG). For EN-DC, the MCG is configured as specified in TS 36.331 [10]. The network provides the configuration parameters for a cell group in the *CellGroupConfig* IE.

The UE performs the following actions based on a received *CellGroupConfig* IE:

- 1> if the *CellGroupConfig* contains the *spCellConfig* with *reconfigurationWithSync*:
 - 2> perform Reconfiguration with sync according to 5.3.5.5.2;

[TS 38.331, clause 5.3.5.5.2]

The UE shall perform the following actions to execute a reconfiguration with sync.

- 1> stop timer T310 for the corresponding SpCell, if running;
- 1> start timer T304 for the corresponding SpCell with the timer value set to *t304*, as included in the *reconfigurationWithSync*;

[TS 38.331, clause 5.3.5.8.3]

The UE shall:

- 1> else if T304 of a secondary cell group expires:
 - 2> release dedicated preambles provided in *rach-ConfigDedicated*, if configured;
 - 2> initiate the SCG failure information procedure as specified in subclause 5.7.3 to report SCG reconfiguration with sync failure, upon which the RRC reconfiguration procedure ends.

[TS 38.331, clause 5.7.3.2]

A UE initiates the procedure to report SCG failures when SCG transmission is not suspended and when one of the following conditions is met:

...

- 1> upon reconfiguration with sync failure of the SCG, in accordance with subclause 5.3.5.8.3;

...

Upon initiating the procedure, the UE shall:

- 1> suspend SCG transmission for all SRBs and DRBs;
- 1> reset SCG-MAC;
- 1> stop T304, if running;
- 1> if the UE is operating in EN-DC:
 - 2> initiate transmission of the *SCGFailureInformationNR* message as specified in TS 36.331 [10], clause 5.6.13a.

[TS 38.331, clause 5.7.3.3]

The UE shall set the SCG failure type as follows:

...

- 1> else if the UE initiates transmission of the *SCGFailureInformationNR* message to provide reconfiguration with sync failure information for an SCG:
 - 2> set the failureType as *synchReconfigFailure-SCG*;

8.2.5.4.1.3 Test description

8.2.5.4.1.3.1 Pre-test conditions

System Simulator:

- E-UTRA Cell 1 is the PCell and NR Cell 1 is the PSCell.

UE:

- None.

Preamble:

- The UE is in state RRC_CONNECTED using generic procedure parameter Connectivity (EN-DC) and DC Bearers (MCG(s) and SCG) on E-UTRA Cell 1 according to TS 38.508-1 [4], clause 4.5.4.

8.2.5.4.1.3.2 Test procedure sequence

Table 8.2.5.4.1.3.2-1: Main behaviour

St	Procedure	Message Sequence		TP	Verdict
		U - S	Message		
1	The SS transmits an <i>RRConnectionReconfiguration</i> message containing NR <i>RRCReconfiguration</i> message to perform SCG change with <i>reconfigurationWithSync</i> with the same PSCell.	<--	<i>RRConnectionReconfiguration (RRCReconfiguration)</i>	-	-
-	EXCEPTION: In parallel to the event described in step 2 the event described in Table 8.2.5.4.1.3.2-2 takes place.	-	-	-	-
2	Wait for t304 ms to ensure that T304 expires (the value is defined in <i>CellGroupConfig</i>). NOTE: SS does not respond to the UE transmitted RACH preambles on NR Cell 1	-	-	-	-
3	Check: Does the UE transmit on PCell (E-UTRA Cell 1) in the next 5 sec (arbitrary value) a <i>SCGFailureInformationNR</i> message with <i>failureType</i> set to 'synchReconfigFailure-SCG'?	-->	<i>SCGFailureInformationNR</i>	1	P

Table 8.2.5.4.1.3.2-2: Parallel behaviour

St	Procedure	Message Sequence		TP	Verdict
		U - S	Message		
1	The UE transmits an <i>RRConnectionReconfigurationComplete</i> message containing NR <i>RRCReconfigurationComplete</i> message on E-UTRA Cell 1.	-->	<i>RRConnectionReconfigurationComplete (RRCReconfigurationComplete)</i>	-	-

8.2.5.4.1.3.3 Specific message contents

Table 8.2.5.4.1.3.3-1: *RRConnectionReconfiguration* (step 1, Table 8.2.5.4.1.3.2-1)

Derivation Path: 36.508 [7], Table 4.6.1-8, with condition EN-DC_EmbedNR_RRCRecon

Table 8.2.5.4.1.3.3-1A: *RRCReconfiguration* (Table 8.2.5.4.1.3.3-1)

Derivation Path: 38.508-1 [4], Table 4.6.1-13 with condition EN-DC			
Information Element	Value/remark	Comment	Condition
<i>RRCReconfiguration</i> ::= SEQUENCE {			
<i>rrc-TransactionIdentifier</i>			
criticalExtensions CHOICE {			
<i>rrcReconfiguration</i> ::= SEQUENCE {			
<i>secondaryCellGroup</i>	CellGroupConfig		EN-DC
}			
}			
}			

Table 8.2.5.4.1.3.3-1B: CellGroupConfig (Table 8.2.5.4.1.3.3-1A)

Derivation Path: TS 38.508-1 [4], Table 4.6.3-19 with condition EN-DC			
Information Element	Value/remark	Comment	Condition
CellGroupConfig ::= SEQUENCE {			
spCellConfig ::= SEQUENCE {			
reconfigurationWithSync ::= SEQUENCE {			
spCellConfigCommon	ServingCellConfigCommon		
}			
}			
}			

Table 8.2.5.4.1.3.3-1C: ServingCellConfigCommon (Table 8.2.5.4.1.3.3-1B)

Derivation Path: TS 38.508-1 [4], Table 4.6.3-168			
Information Element	Value/remark	Comment	Condition
ServingCellConfigCommon ::= SEQUENCE {			
uplinkConfigCommon SEQUENCE {			
initialUplinkBWP	BWP-UplinkCommon		
}			
}			

Table 8.2.5.4.1.3.3-1D: BWP-UplinkCommon (Table 8.2.5.4.1.3.3-1C)

Derivation Path: TS 38.508-1 [4], Table 4.6.3-14			
Information Element	Value/remark	Comment	Condition
BWP-UplinkCommon ::= SEQUENCE {			
rach-ConfigCommon CHOICE {			
setup	RACH-ConfigCommon		
}			
}			

Table 8.2.5.4.1.3.3-1E: RACH-ConfigCommon (Table 8.2.5.4.1.3.3-1D)

Derivation Path: TS 38.508-1 [4], Table 4.6.3-128			
Information Element	Value/remark	Comment	Condition
RACH-ConfigCommon ::= SEQUENCE {			
rach-ConfigGeneric	RACH-ConfigGeneric		
}			

Table 8.2.5.4.1.3.3-1F: RACH-ConfigGeneric (Table 8.2.5.4.1.3.3-1E)

Derivation Path: TS 38.508-1 [4], Table 4.6.3-130			
Information Element	Value/remark	Comment	Condition
RACH-ConfigGeneric ::= SEQUENCE {			
preambleTransMax	n200		
}			

Table 8.2.5.4.1.3.3-2: SCGFailureInformationNR (step 3, Table 8.2.5.4.1.3.2-1)

Derivation Path: 36.508 [7], Table 4.6.1-18AA			
Information Element	Value/remark	Comment	Condition
SCGFailureInformationNR-r15 ::= SEQUENCE {			
criticalExtensions CHOICE {			
c1 CHOICE {			
scgFailureInformationNR-r15 SEQUENCE {			
failureReportSCG-NR-r15 SEQUENCE {			
failureType-r15	synchReconfigFailure-SCG		
measResultFreqListNR-r15	Not checked		
measResultSCG-r15	Not checked		
}			
nonCriticalExtension SEQUENCE {}			
}			
}			
}			

8.2.5.5 Reconfiguration failure / SCG Reconfiguration failure / SRB3

Note: Core specs requirements cannot be simulated and verified as conformance test.

8.2.5.5.1 Void

8.2.5.6 Reconfiguration failure / SCG Reconfiguration failure / SRB1

Note: Core specs requirements cannot be simulated and verified as conformance test.

8.2.5.6.1 Void

9 Mobility management

Editor's note: Intended to capture tests of 5G Core Network behaviour defined in TS 24.301, TS 24.501 et.al.

Multi-RAT Dual Connectivity behaviour defined in TS 37.340.

Possible configurations may be handled in the following sub-structure:

- a) E-UTRA–NR DC via EPC with E-UTRA as master (also referred to EN-DC, option 3, 3a, 3x)*
- b) E-UTRA–NR DC via 5GC*
 - with E-UTRA as master (also referred to NGEN-DC, option 7, 7a, 7x)*
 - with NR as master (also referred to NE-DC, option 4, 4A)*

9.1 5GS Mobility Management

9.1.1 Primary authentication and key agreement

9.1.1.1 EAP based primary authentication and key agreement / EAP-AKA' related procedures

9.1.1.1.1 Test Purpose (TP)

(1)

with { the UE in 5GMM-REGISTERED-INITIATED state }

```

ensure that {
  when { the SS sends the EAP-request/AKA'-challenge message within AUTHENTICATION REQUEST with the
  SNN check fails }
  then { the UE sends an EAP-response/AKA'-authentication-reject message within AUTHENTICATION
  RESPONSE }
}

```

(2)

```

with { the UE in 5GMM-REGISTERED-INITIATED state }
ensure that {
  when { the SS sends the EAP-request/AKA'-challenge message within AUTHENTICATION REQUEST with the
  sequence number in AUTN is not correct }
  then { the UE sends an EAP-response/AKA'-synchronization-failure message within AUTHENTICATION
  RESPONSE }
}

```

(3)

```

with { the UE in 5GMM-REGISTERED-INITIATED state }
ensure that {
  when { the SS sends the EAP-request/AKA'-challenge message within AUTHENTICATION REQUEST with
  ngKSI is already in use }
  then { the UE sends an AUTHENTICATION FAILURE message with 5GMM cause #71 "ngKSI already in use"
  }
}

```

(4)

```

with { the UE in 5GMM-REGISTERED-INITIATED state }
ensure that {
  when { the SS sends an EAP-request/AKA'-challenge message within AUTHENTICATION REQUEST }
  then { the UE sends an EAP-response/AKA'-challenge message within AUTHENTICATION RESPONSE }
}

```

(5)

```

with { the UE in 5GMM-REGISTERED-INITIATED state with valid 5G-GUTI and SS initiates an EAP based
primary authentication and key agreement procedure }
ensure that {
  when { the SS sends an EAP-failure message within AUTHENTICATION RESULT }
  then { the UE considers the procedure complete and authentication procedure failed }
}

```

(6)

```

with { the UE in 5GMM-REGISTERED-INITIATED state }
ensure that {
  when { the SS sends an EAP-Request/Identity message for SUCI in the AUTHENTICATION REQUEST message
  }
  then { the UE sends an EAP-Response/AKA'-Identity for SUCI within AUTHENTICATION RESPONSE message
  }
}

```

(7)

```

with { the UE in 5GMM-REGISTERED-INITIATED state and SS initiates an EAP based primary
authentication and key agreement procedure }
ensure that {
  when { the SS sends an EAP-success message within AUTHENTICATION RESULT }
  then { the UE considers the procedure complete and authentication procedure succeed }
}

```

9.1.1.1.2 Conformance requirements

References: The conformance requirements covered in the present TC are specified in: TS 24.501 clauses 5.4.1.2.2.3, 5.4.1.2.2.4, 5.4.1.2.2.6, 5.4.1.2.2.8, 5.4.1.2.2.10, 5.4.1.2.4.5.

[TS 24.501, clause 5.4.1.2.2.4 (TP1, TP2)]

If a USIM is present, the SNN check fails or the UE does not accept AUTN during handling of the EAP-request/AKA'-challenge message as specified in IETF RFC 5448 [40], the UE shall send an EAP-response/AKA'-authentication-reject message as specified in IETF RFC 5448 [40].

If a USIM is present, the SNN check is successful but the UE detects that the sequence number in AUTN is not correct during handling of the EAP-request/AKA'-challenge message as specified in IETF RFC 5448 [40], the UE shall send an EAP-response/AKA'-synchronization-failure message as specified in IETF RFC 5448 [40].

If a USIM is present, the SNN check is successful, the sequence number in AUTN is correct and the UE detects another error during handling of the EAP-request/AKA'-challenge message as specified in IETF RFC 5448 [40], the UE shall send an EAP-response/AKA'-client-error message as specified in IETF RFC 5448 [40].

If a USIM is not present, the UE shall send an EAP-response/AKA'-client-error message as specified in IETF RFC 5448 [40].

For any of the above, the UE shall start timer T3520 when the AUTHENTICATION RESPONSE message containing the EAP-response message is sent. Furthermore, the UE shall stop any of the retransmission timers that are running (e.g. T3510, T3517 or T3521). Upon receiving an AUTHENTICATION REQUEST message with the EAP message IE containing an EAP-request/AKA'-challenge from the network, the UE shall stop timer T3520, if running, and then process the EAP-request/AKA'-challenge information as normal.

[TS 24.501, clause 5.4.1.2.4.5 (TP3)]

The following abnormal cases can be identified:

- a) Authentication failure (5GMM cause #71 "ngKSI already in use").

The UE shall send an AUTHENTICATION FAILURE message, with 5GMM cause #71 "ngKSI already in use", to the network and start the timer T3520 (see example in figure 5.4.1.3.7.1). Furthermore, the UE shall stop any of the retransmission timers that are running (e.g. T3510, T3517 or T3521). Upon the first receipt of an AUTHENTICATION FAILURE message from the UE with 5GMM cause #71 "ngKSI already in use", the network performs necessary actions to select a new ngKSI and send the same EAP-request/AKA'-challenge to the UE.

NOTE 1: Upon receipt of an AUTHENTICATION FAILURE message from the UE with 5GMM cause #71 "ngKSI already in use", the network may also re-initiate the EAP based primary authentication and key agreement procedure (see subclause 5.4.1.2.2.2).

...

[TS 24.501, clause 5.4.1.2.2.3 (TP4)]

If a USIM is present and the SNN check is successful, the UE shall handle the EAP-request/AKA'-challenge message as specified in IETF RFC 5448 [40]. The USIM shall derive CK and IK and compute the authentication response (RES) using the 5G authentication challenge data received from the ME, and pass RES to the ME. The ME shall derive CK' and IK' from CK and IK, and EMSK from CK' and IK'. Furthermore, the ME may generate KAUSF from the EMSK, the KSEAF from the KAUSF, and the KAMF from the ABBA received together with the EAP-request/AKA'-challenge message, and the KSEAF as described in 3GPP TS 33.501 [24], and create a partial native 5G NAS security context identified by the ngKSI value received together with the EAP-request/AKA'-challenge message in subclause 5.4.1.2.4.2 in the volatile memory of the ME. If the KAMF and the partial native 5G NAS security context are created, the ME shall store the KAMF in the created partial native 5G NAS security context, and shall send an EAP-response/AKA'-challenge message as specified in IETF RFC 5448 [40].

If the EAP-request/AKA'-challenge message contains AT_RESULT_IND attribute, the UE may include AT_RESULT_IND attribute in the EAP-response/AKA'-challenge message as specified in IETF RFC 5448 [40].

[TS 24.501, clause 5.4.1.2.2.10 (TP5)]

Upon reception of the EAP-response/AKA'-notification message, if earlier procedures for handling an EAP-request/AKA'-challenge message as specified in IETF RFC 5448 [40] were not successful, the AUSF shall send an EAP-failure message as specified in IETF RFC 5448 [40] and shall consider the procedure complete.

If the authentication response (RES) returned by the UE in the AT_RES attribute of the EAP-response/AKA'-challenge message is not valid, the network handling depends upon the type of identity used by the UE in the initial NAS message, that is:

- if the 5G-GUTI was used; or
- if the SUCI was used.

If the 5G-GUTI was used, the network should transport the EAP-failure message in the AUTHENTICATION RESULT message of the EAP result message transport procedure, initiate an identification procedure to retrieve SUCI from the UE and restart the EAP based primary authentication and key agreement procedure with the received SUCI.

If the SUCI was used for identification in the initial NAS message or in a restarted EAP based primary authentication and key agreement procedure, or the network decides not to initiate the identification procedure to retrieve SUCI from the UE after an unsuccessful EAP based primary authentication and key agreement procedure, the network should transport the EAP-failure message in an AUTHENTICATION REJECT message of the EAP result message transport procedure.

Depending on local requirements or operator preference for emergency services, if the UE initiates a registration procedure with 5GS registration type IE set to "emergency registration" and the AMF is configured to allow emergency registration without user identity, the AMF needs not follow the procedures specified for transporting the EAP-failure message in the AUTHENTICATION REJECT message of the EAP result message transport procedure in the present subclause. The AMF may include the EAP-failure message in a response of the current 5GMM specific procedure or in the AUTHENTICATION RESULT of the EAP result message transport procedure.

[TS 24.501, clause 5.4.1.2.2.6 (TP6)]

Upon receiving an EAP-request/AKA'-notification message, the UE shall send an EAP-response/AKA'-notification message as specified in IETF RFC 5448 [40].

5.4.1.2.2.6A EAP based Identification initiation by the network

If AUSF decides to initiate the EAP based identification procedure, the AUSF shall send an EAP-Request/Identity or EAP-Request/AKA'-Identity message as specified in IETF RFC 5448 [40].

The AMF shall encapsulate the EAP-Request/Identity or EAP-Request/AKA'-Identity message in the AUTHENTICATION REQUEST message and send it to the UE.

5.4.1.2.2.6B EAP based Identification response by the UE

Upon receipt of the AUTHENTICATION REQUEST message with EAP-Request/Identity message the UE shall send an AUTHENTICATION RESPONSE message with EAP-Response/Identity to the network. In the EAP-Response/Identity message, the UE shall provide the requested identity according to 3GPP TS 33.501 [24] annex F.2, in the UE identity in the EAP-Response/Identity message as specified in IETF RFC 5448 [40].

Upon receipt of the AUTHENTICATION REQUEST message with EAP-Request/AKA'-Identity message the UE shall send an AUTHENTICATION RESPONSE message with EAP-Response/AKA'-Identity to the network. Based on the attribute received in the EAP-Request/AKA'-Identity, the UE shall provide the requested identity according to 3GPP TS 33.501 [24] annex F.2, in the EAP-Response/AKA'-Identity message, as specified in IETF RFC 5448 [40].

If the EAP-Request/AKA'-Identity carries the AT_PERMANENT_REQ, the UE shall respond with EAP-Response/AKA'-Client-Error with the error code "unable to process packet".

[TS 24.501, clause 5.4.1.2.2.8 (TP7)]

Upon receiving an EAP-success message, if the ME has not generated a partial native 5G NAS security context as described in subclause 5.4.1.2.2.3, the ME shall:

- a) generate the KAUSF from the EMSK, the KSEAF from the KAUSF, and the KAMF from the ABBA that was received with the EAP-success message, and the KSEAF as described in 3GPP TS 33.501 [24];
- b) create a partial native 5G NAS security context identified by the ngKSI value in the volatile memory of the ME; and
- c) store the KAMF in the created partial native 5G NAS security context.

The UE shall consider the procedure complete.

9.1.1.1.3 Test description

9.1.1.1.3.1 Pre-test conditions

FFS

9.1.1.1.3.2 Test procedure sequence

FFS

9.1.1.1.3.3 Specific message contents

FFS

9.1.1.2 EAP based primary authentication and key agreement / Reject

9.1.1.2.1 Test Purpose (TP)

(1)

```
with {the UE in 5GMM-REGISTERED-INITIATED state and SS initiates an EAP based primary authentication
and key agreement procedure}
ensure that {
  when { the SS sends an an EAP-failure message within AUTHENTICATION REJECT }
  then { the UE deletes the stored 5G-GUTI, TAI list, last visited registered TAI and ngKSI and
enter state 5GMM-DEREGISTERED, the USIM is considered invalid until switching off the UE }
}
```

(2)

```
with { the UE in single-registration mode and 5GMM-REGISTERED-INITIATED state and SS initiates an
EAP based primary authentication and key agreement procedure }
ensure that {
  when { the SS sends an an EAP-failure message within AUTHENTICATION RESULT }
  then { the UE deletes the stored 4G-GUTI, last visited registered TAI, TAI list and eKSI and
enter state EMM-DEREGISTERED, the USIM shall be considered as invalid also for non-EPS services
until switching off the UE }
}
```

9.1.1.2.2 Conformance requirements

References: The conformance requirements covered in the current TC are specified in: TS 24.501, clauses 5.4.1.2.2.11.

[TS 24.501, clause 5.4.1.2.2.11]

Upon receiving an EAP-failure message, the UE shall delete the partial native 5G NAS security context if any was created as described in subclause 5.4.1.2.2.3.

The UE shall consider the procedure complete.

If the EAP-failure message is received in an AUTHENTICATION REJECT message:

- the UE shall set the update status to 5U3 ROAMING NOT ALLOWED, delete the stored 5G-GUTI, TAI list, last visited registered TAI and ngKSI. The USIM shall be considered invalid until switching off the UE or the UICC containing the USIM is removed; and
- if the UE is operating in single-registration mode, the UE shall handle 4G-GUTI, last visited registered TAI, TAI list and eKSI as specified in 3GPP TS 24.301 [15] for the case when the authentication procedure is not accepted by the network. The USIM shall be considered as invalid also for non-EPS services until switching off or the UICC containing the USIM is removed.

If the AUTHENTICATION REJECT message is received by the UE, the UE shall abort any 5GMM signalling procedure, stop any of the timers T3510, T3517 or T3521 (if they were running) and enter state 5GMM-DEREGISTERED.

9.1.1.2.3 Test description

9.1.1.2.3.1 Pre-test conditions

System Simulator:

- 2 cells, NGC Cell A and E-UTRA Cell A belonging to the same PLMN
- NGC Cell A "Serving cell" TS 38.508-1 [4] Table 6.2.2.1-3
- E-UTRA Cell A "Non-Suitable cell" TS 36.508 [7] Table 6.3.2.2-1

UE:

- None

Preamble:

- The UE is in state Switched OFF (state ON-B) according to TS 38.508-1 [4].

9.1.1.2.3.2 Test procedure sequence

Table 9.1.1.2.3.2-1: Main behaviour

St	Procedure	Message Sequence	TP	Verdict
----	-----------	------------------	----	---------

		U – S	Message		
1	The UE is switched on.	-	-	-	-
2-6	The UE executes steps 2-6 of Table 4.5.2.2-2 in TS38.508-1 [4].	-	-	-	-
7	The SS transmits an "EAP-failure" message within AUTHENTICATION REJECT	<--	5GMM: AUTHENTICATION REJECT	-	-
8	SS releases the RRC connection	-	-	-	-
9	Check: Does the UE transmit a REGISTRATION REQUEST message within the next 30 seconds?	-->	5GMM: REGISTRATION REQUEST	1	F
10	The UE is switched off by executing generic procedure in Table 4.9.6.1-1 in TS 38.508-1 [4].	-	-	-	-
11	The UE is switched on.	-	-	-	-
12	Check: Does the UE transmit a REGISTRATION REQUEST message?	-->	5GMM: REGISTRATION REQUEST	1	P
	EXCEPTION: steps 13a1 to 13a9 describe behaviour that depends on the UE capability; the "lower case letter" identifies a step sequence that take place if UE supports S1 mode.	-	-	-	-
13a1	The SS transmits an AUTHENTICATION REQUEST message.	<--	5GMM: AUTHENTICATION REQUEST	-	-
13a2	The UE transmits AUTHENTICATION RESPONSE message.	-->	5GMM: AUTHENTICATION RESPONSE	-	-
13a3	The SS transmits an "EAP-failure" message within AUTHENTICATION REJECT	<--	5GMM: AUTHENTICATION REJECT	-	-
13a4	SS releases the RRC connection	-	-	-	-
13a5	The SS configures - E-UTRA Cell A as "Serving Cell" - NGC Cell A as "Non-Suitable Cell"	-	-	-	-
13a6	Check: Does the UE transmit an ATTACH REQUEST message on E-UTRA cell A in the next 30 seconds?	-->	EMM: ATTACH REQUEST	2	F
13a7	The UE is switched off by executing generic procedure in Table 4.9.6.1-1 in TS 38.508-1 [4].	-	-	-	-
13a8	The UE is switched on.	-	-	-	-
13a9	Check: Does the UE transmit an ATTACH REQUEST message on E-UTRA cell A in the next 60 seconds?	-->	EMM: ATTACH REQUEST	2	P

9.1.1.2.3.3 Specific message contents

Table 9.1.1.2.3.3-1: Message AUTHENTICATION REJECT (step 7 and 13a3, Table 9.1.1.2.3.2-1)

Derivation path: TS 38.508-1 [4], table 4.7.1-5			
Information Element	Value/Remark	Comment	Condition
Extended protocol discriminator	5GMM		
Security header type	'0000'B	Plain 5GS NAS message, not security protected	
Spare half octet	'0000'B		
EAP message	EAP-failure	EAP-failure	

Table 9.1.1.2.3.3-2: Message REGISTRATION REQUEST (step 9 and 12, Table 9.1.1.2.3.2-1)

Derivation path: TS 38.508-1 [4], table 4.7.1-6			
Information Element	Value/Remark	Comment	Condition
5GS registration type	'0000 0010'B	Initial registration	
Last visited registered TAI	Not present		
5GS mobile identity	SUCI of the UE		

Table 9.1.1.2.3.3-3: Message ATTACH REQUEST (step 13a6 and 13a9, Table 9.1.1.2.3.2-1)

Derivation path: TS 36.508-1 [7], table 4.7.2-4			
Information Element	Value/Remark	Comment	Condition
Old GUTI or IMSI	IMSI of the UE		
Last visited registered TAI	Not present		

9.1.1.3 EAP based primary authentication and key agreement / EAP message transport / Abnormal

9.1.1.3.1 Test Purpose (TP)

(1)

with { the UE in 5GMM-REGISTERED state and 5GMM-IDLE mode over 3GPP access, starts SERVICE REQUEST procedure after received a paging request from the network }

ensure that {

when { the SS sends the EAP-request/AKA'-challenge message within AUTHENTICATION REQUEST and the UE fails on transmission of AUTHENTICATION RESPONSE message by entering a cell with TAI not in the TAI list }

then { the UE initiates a mobility registration update procedure }

(2)

with { the UE in 5GMM-REGISTERED state and initiates a mobility registration update procedure }

ensure that {

when { the SS sends the EAP-request/AKA'-challenge message within AUTHENTICATION REQUEST and the UE fails on transmission of AUTHENTICATION RESPONSE message with the indication from lower layers }

then { the UE re-initiate the mobility registration update procedure }

9.1.1.3.2 Conformance requirements

References: The conformance requirements covered in the present TC are specified in: TS 24.501 clauses 5.4.1.2.4.5.

[TS 24.501, clause 5.4.1.2.4.5 (TP1, TP2)]

The following abnormal cases can be identified:

- a) Authentication failure (5GMM cause #71 "ngKSI already in use").

The UE shall send an AUTHENTICATION FAILURE message, with 5GMM cause #71 "ngKSI already in use", to the network and start the timer T3520 (see example in figure 5.4.1.3.7.1). Furthermore, the UE shall stop any of the retransmission timers that are running (e.g. T3510, T3517 or T3521). Upon the first receipt of an AUTHENTICATION FAILURE message from the UE with 5GMM cause #71 "ngKSI already in use", the network performs necessary actions to select a new ngKSI and send the same EAP-request/AKA'-challenge to the UE.

NOTE 1: Upon receipt of an AUTHENTICATION FAILURE message from the UE with 5GMM cause #71 "ngKSI already in use", the network may also re-initiate the EAP based primary authentication and key agreement procedure (see subclause 5.4.1.2.2.2).

- b) Transmission failure of AUTHENTICATION RESPONSE message or AUTHENTICATION FAILURE message indication from lower layers (if the EAP based primary authentication and key agreement procedure is triggered by a registration procedure for mobility and periodic registration update).

The UE shall stop the timer T3520, if running, and re-initiate the registration procedure for mobility and periodic registration update.

- c) Transmission failure of AUTHENTICATION RESPONSE message or AUTHENTICATION FAILURE message indication with TAI change from lower layers (if the EAP based primary authentication and key agreement procedure is triggered by a service request procedure).

The UE shall stop the timer T3520, if running.

If the current TAI is not in the TAI list, the EAP based primary authentication and key agreement procedure shall be aborted and a registration procedure for mobility and periodic registration update shall be initiated.

If the current TAI is still part of the TAI list, it is up to the UE implementation how to re-run the ongoing procedure that triggered the EAP based primary authentication and key agreement procedure.

...

9.1.1.3.3 Test description

9.1.1.3.3.1 Pre-test conditions

FFS

9.1.1.3.3.2 Test procedure sequence

FFS

9.1.1.3.3.3 Specific message contents

FFS

9.1.1.4

9.1.1.5

9.1.1.6 5G AKA based primary authentication and key agreement / Abnormal

9.1.1.6 Test Purpose (TP)

(1)

```
with { the UE in 5GMM-REGISTERED state and 5GMM-IDLE mode over 3GPP access, starts SERVICE REQUEST
procedure after received a paging request from the network }
ensure that {
  when { the SS initiates a 5G AKA based primary authentication and key agreement procedure by
sending AUTHENTICATION REQUEST and the UE fails on transmission of AUTHENTICATION RESPONSE message
by entering a cell with TAI not in the TAI list }
  then { the UE initiates a mobility registration update procedure }
}
```

(2)

```
with { the UE in 5GMM-REGISTERED state and initiates a mobility registration update procedure }
ensure that {
  when { the SS initiates a 5G AKA based primary authentication and key agreement procedure by
sending AUTHENTICATION REQUEST and the UE fails on transmission of AUTHENTICATION RESPONSE message
with the indication from lower layers }
  then { the UE re-initiate the mobility registration update procedure }
}
```

9.1.1.6.2 Conformance requirements

References: The conformance requirements covered in the current TC are specified in: TS 24.501 clauses 5.4.1.3.7. Unless otherwise stated these are Rel-15 requirements.

[TS 24.501, clause 5.4.1.3.7]

- h) Transmission failure of AUTHENTICATION RESPONSE message or AUTHENTICATION FAILURE message indication from lower layers (if the 5G AKA based primary authentication and key agreement procedure is triggered by a registration procedure for mobility and periodic registration update).

The UE shall stop the timer T3520, if running, and re-initiate the registration procedure for mobility and periodic registration update.

...

- i) Transmission failure of AUTHENTICATION RESPONSE message or AUTHENTICATION FAILURE message indication with TAI change from lower layers (if the 5G AKA based primary authentication and key agreement procedure is triggered by a service request procedure).

The UE shall stop the timer T3520, if running.

If the current TAI is not in the TAI list, the 5G AKA based primary authentication and key agreement procedure shall be aborted and a registration procedure for mobility and periodic registration update shall be initiated.

If the current TAI is still part of the TAI list, it is up to the UE implementation how to re-run the ongoing procedure that triggered the 5G AKA based primary authentication and key agreement procedure.

9.1.1.6.3 Test description

9.1.1.6.3.1 Pre-test conditions

System Simulator:

- NGC Cell A and NGC Cell B are configured according to table 6.3.2.2-1 in TS 38.508-1 [4].

UE:

- UE has previously registered on NGC Cell B, and the tracking area of NGC Cell A is not in the list of tracking areas that the UE previously registered.

Preamble:

- The UE is in state Registered, Idle Mode (state 1N-A) on NGC Cell B according to TS 38.508-1 [4].

9.1.1.6.3.2 Test procedure sequence

Table 9.1.1.6.3.2-1: Main behaviour

St	Procedure	Message Sequence		TP	Verdict
		U - S	Message		
1	The SS transmits a <i>Paging</i> message.	<--	NR RRC: Paging	-	-
2-4	The UE establishes RRC connection by executing steps 2-4 of Table 4.5.2.2-2 in TS38.508-1 [4].	-	-	-	-
5	The UE transmits an <i>RRCSetupComplete</i> message and a SERVICE REQUEST message.	-->	5GMM: SERVICE REQUEST	-	-
6	Simulate lower layer failure. Note: How to Simulate lower layer failure is FFS	-	-	-	-
7	SS transmits an AUTHENTICATION REQUEST message to initiate the 5G-AKA procedure.	<--	5GMM: AUTHENTICATION REQUEST	-	-
8	The SS configures: - NGC Cell A as the "Serving cell". - NGC Cell B as the "Non-Suitable "off" cell".	-	-	-	-
9-11	The UE establishes RRC connection by executing steps 2-4 of Table 4.5.2.2-2 in TS 38.508-1 [4].	-	-	-	-
12	Check: Does the UE transmit an REGISTRATION REQUEST message with the 5GS registration type IE setting as Mobility registration updating?	-->	5GMM: REGISTRATION REQUEST	1	P
13	The SS cuts off the UL grant, so that the UE cannot respond to the AUTHENTICATION REQUEST.	-	-	-	-
14	SS transmits an AUTHENTICATION REQUEST message to initiate the 5G-AKA procedure.	<--	5GMM: AUTHENTICATION REQUEST	-	-
15-17	The UE establishes RRC connection by executing steps 2-4 of Table 4.5.2.2-2 in TS 38.508-1 [4].	-	-	-	-
18	Check: Does the UE transmit an REGISTRATION REQUEST message with the 5GS registration type IE setting as Mobility registration updating?	-->	5GMM: REGISTRATION REQUEST	2	P
19-34	Steps 5-20 of Table 4.5.2.2-2 of the generic procedure in TS 38.508-1 [4] are performed.	-	-	-	-

9.1.1.6.3.3 Specific message contents

Table 9.1.1.6.3.3-1: Message REGISTRATION REQUEST (step 12 and step 18, Table 9.1.1.6.3.2-1)

Derivation path: TS 38.508-1 [4], table 4.7.1-6			
Information Element	Value/Remark	Comment	Condition
5GS registration type	'0000 0010'B	mobility registration updating	

9.1.2 Security mode control

9.1.2.1 NAS security mode command

9.1.2.1.1 Test Purpose (TP)

(1)

```
with { the UE is in 5GMM-REGISTERED-INITIATED state and the SS initiates the NAS security mode
control procedure by sending a SECURITY MODE COMMAND message during initial registration procedure }
ensure that {
  when { the UE receives an integrity protected SECURITY MODE COMMAND message including not matching
replayed security capabilities }
  then { the UE send a SECURITY MODE REJECT message and does not start applying the NAS security
in both UL and DL }
}
```

(2)

```
with { the UE is in 5GMM-REGISTERED-INITIATED state and the SS initiates the NAS security mode
control procedure by sending a SECURITY MODE COMMAND message during initial registration procedure }
ensure that {
  when { the UE receives an integrity protected SECURITY MODE COMMAND message including IMEISV
request }
  then { the UE send an integrity protected and ciphered SECURITY MODE COMPLETE message including
IMEISV and starts applying the NAS Security in both UL and DL }
}
```

9.1.2.1.2 Conformance requirements

References: The conformance requirements covered in the present test case are specified in: TS 24.501, clauses 5.4.2.1, 5.4.2.3 and 5.4.2.5. Unless otherwise stated these are Rel-15 requirements.

[TS 24.501, clause 5.4.2.1]

The purpose of the NAS security mode control procedure is to take a 5G NAS security context into use, and initialise and start NAS signalling security between the UE and the AMF with the corresponding 5G NAS keys and 5G NAS security algorithms.

Furthermore, the network may also initiate the security mode control procedure in the following cases:

- a) in order to change the 5G NAS security algorithms for a current 5G NAS security context already in use; and
- b) in order to change the value of uplink NAS COUNT used in the latest SECURITY MODE COMPLETE message as described in 3GPP TS 33.501 [24], subclause 6.9.4.4.

For restrictions concerning the concurrent running of a security mode control procedure with other security related procedures in the AS or inside the core network see 3GPP TS 33.501 [24], subclause 6.9.5.

[TS 24.501, clause 5.4.2.3]

Upon receipt of the SECURITY MODE COMMAND message, the UE shall check whether the security mode command can be accepted or not. This is done by performing the integrity check of the message, by checking that the Replayed S1 UE security capabilities IE is included if the Selected EPS NAS security algorithms IE is included in the message, and by checking that the received replayed UE security capabilities have not been altered compared to the latest values that the UE sent to the network.

When the SECURITY MODE COMMAND message includes an EAP-success message the UE handles the EAP-success message and the ABBA as described in subclause 5.4.1.2.2.8.

If the UE is registered for emergency services, performing initial registration for emergency services or establishing an emergency PDU session and the SECURITY MODE COMMAND message is received with ngKSI value "000" and 5G-IA0 and 5G-EA0 as selected 5G NAS security algorithms, the UE shall locally derive and take in use 5G NAS security context. The UE shall delete existing current 5G NAS security context.

The UE shall accept a SECURITY MODE COMMAND message indicating the "null integrity protection algorithm" 5G-EA0 as the selected 5G NAS integrity algorithm only if the message is received when the UE is registered for emergency services, performing initial registration for emergency services or establishing an emergency PDU session.

If the type of security context flag included in the SECURITY MODE COMMAND message is set to "native security context" and if the ngKSI matches a valid non-current native 5G NAS security context held in the UE while the UE has a mapped 5G NAS security context as the current 5G NAS security context, the UE shall take the non-current native 5G NAS security context into use which then becomes the current native 5G NAS security context and delete the mapped 5G NAS security context.

If the SECURITY MODE COMMAND message can be accepted, the UE shall take the 5G NAS security context indicated in the message into use. The UE shall in addition reset the uplink NAS COUNT counter if:

- a) the SECURITY MODE COMMAND message is received in order to take a 5G NAS security context into use created after a successful execution of the 5G AKA based primary authentication and key agreement procedure or the EAP based primary authentication and key agreement procedure; or
- b) the SECURITY MODE COMMAND message received includes the type of security context flag set to "mapped security context" in the NAS key set identifier IE the ngKSI does not match the current 5G NAS security context, if it is a mapped 5G NAS security context.

If the SECURITY MODE COMMAND message can be accepted and a new 5G NAS security context is taken into use and SECURITY MODE COMMAND message does not indicate the "null integrity protection algorithm" 5G-IA0 as the selected NAS integrity algorithm, the UE shall:

- if the SECURITY MODE COMMAND message has been successfully integrity checked using an estimated downlink NAS COUNT equal to 0, then the UE shall set the downlink NAS COUNT of this new 5G NAS security context to 0;
- otherwise the UE shall set the downlink NAS COUNT of this new 5G NAS security context to the downlink NAS COUNT that has been used for the successful integrity checking of the SECURITY MODE COMMAND message.

If the SECURITY MODE COMMAND message includes the horizontal derivation parameter indicating "K_{AMF} derivation is required", the UE shall derive a new K'_{AMF}, as specified in 3GPP TS 33.501 [24] for K_{AMF} to K'_{AMF} derivation in mobility, and set both uplink and downlink NAS COUNTs to zero.

If the SECURITY MODE COMMAND message can be accepted, the UE shall send a SECURITY MODE COMPLETE message integrity protected with the selected 5GS integrity algorithm and the 5G NAS integrity key based on the K_{AMF} or mapped K'_{AMF} if the type of security context flag is set to "mapped security context" indicated by the ngKSI. When the SECURITY MODE COMMAND message includes the type of security context flag set to "mapped security context" in the NAS key set identifier IE, then the UE shall check whether the SECURITY MODE COMMAND message indicates the ngKSI of the current 5GS security context, if it is a mapped 5G NAS security context, in order not to re-generate the K'_{AMF}.

Furthermore, if the SECURITY MODE COMMAND message can be accepted, the UE shall cipher the SECURITY MODE COMPLETE message with the selected 5GS ciphering algorithm and the 5GS NAS ciphering key based on the K_{AMF} or mapped K'_{AMF} indicated by the ngKSI. The UE shall set the security header type of the message to "integrity protected and ciphered with new 5G NAS security context".

From this time onward the UE shall cipher and integrity protect all NAS signalling messages with the selected 5GS integrity and ciphering algorithms.

If the AMF indicated in the SECURITY MODE COMMAND message that the IMEISV is requested, the UE shall include its IMEISV in the SECURITY MODE COMPLETE message.

If, during an ongoing registration procedure or service request procedure, the SECURITY MODE COMMAND message includes the Additional 5G security information IE with the RINMR bit set to "Retransmission of the initial NAS message requested", the UE shall include the entire unciphered REGISTRATION REQUEST message or SERVICE REQUEST message, which the UE had previously included in the NAS message container IE of the initial NAS message (i.e. REGISTRATION REQUEST message or SERVICE REQUEST message, respectively), in the NAS message container IE of the SECURITY MODE COMPLETE message.

If, prior to receiving the SECURITY MODE COMMAND message, the UE without a valid 5GS NAS security context had sent a REGISTRATION REQUEST message the UE shall include the entire REGISTRATION REQUEST

message in the NAS message container IE of the SECURITY MODE COMPLETE message as described in subclause 4.4.6.

If the UE operating in the single-registration mode receives the Selected EPS NAS security algorithms IE, the UE shall use the IE according to 3GPP TS 33.501 [24].

For a UE operating in single-registration mode with N26 interface supported in the network, after an inter-system change from S1 mode to N1 mode in 5GMM-CONNECTED mode, the UE shall set the value of the Selected EPS NAS security algorithms IE in the 5G NAS security context to the NAS security algorithms that were received from the source MME when the UE was in S1 mode.

[TS 24.501, clause 5.4.2.5]

If the security mode command cannot be accepted, the UE shall send a SECURITY MODE REJECT message. The SECURITY MODE REJECT message contains a 5GMM cause that typically indicates one of the following cause values:

- #23 UE security capabilities mismatch.
- #24 security mode rejected, unspecified.

If the UE detects that the network included the Selected EPS NAS security algorithms IE in the SECURITY MODE COMMAND message without including a Replayed S1 UE security capabilities IE, or that the received replayed UE security capabilities have been altered compared to the latest values that the UE sent to the network, the UE shall set the cause value to #23 "UE security capabilities mismatch".

Upon receipt of the SECURITY MODE REJECT message, the AMF shall stop timer T3560. The AMF shall also abort the ongoing procedure that triggered the initiation of the NAS security mode control procedure.

Both the UE and the AMF shall apply the 5G NAS security context in use before the initiation of the security mode control procedure, if any, to protect the SECURITY MODE REJECT message and any other subsequent messages according to the rules in subclause 4.4.4 and 4.4.5.

9.1.2.1.3 Test description

9.1.2.1.3.1 Pre-test conditions

System Simulator:

- NGC Cell A.

UE:

- None.

Preamble:

- The procedure defined in subclause 4.9.8 in 38.501-1 [4] has been performed to ensure that the UE does not have a valid 5G NAS security context.
- The UE is in state 0N-B on NGC Cell A according to TS 38.508-1 [4].

9.1.2.1.3.2 Test procedure sequence

Table 9.1.2.1.3.2-1: Main behaviour

St	Procedure	Message Sequence		TP	Verdict
		U - S	Message		
1	The UE is switched on.	-	-	-	-
2	Steps 1-6 of the generic procedure for UE registration specified in TS 38.508-1 [4] table 4.5.2.2-2 are performed.	-	-	-	-
3	The SS transmits a SECURITY MODE COMMAND message to activate NAS security. It is integrity protected and includes unmatched replayed security capabilities.	<--	SECURITY MODE COMMAND	-	-
4	Check: Does the UE transmit a SECURITY MODE REJECT message with cause'#23: UE security capabilities mismatch'?	-->	SECURITY MODE REJECT	1	P
5	The SS transmits an IDENTITY REQUEST message (Security not applied).	<--	IDENTITY REQUEST	-	-
6	Check: Does the UE transmit a non security protected IDENTITY RESPONSE message?	-->	IDENTITY RESPONSE	1	P
7	The SS transmits a SECURITY MODE COMMAND message to activate NAS security. It is integrity protected and includes IMEISV.	<--	SECURITY MODE COMMAND	-	-
8	Check: Does the UE transmit a SECURITY MODE COMPLETE message and does it establish the initial security configuration?	-->	SECURITY MODE COMPLETE	2	P
9	Steps 9a1-19a1 of the generic procedure for UE registration specified in TS 38.508-1 [4] table 4.5.2.2-2 are performed.	-	-	-	-
10	The SS transmits an IDENTITY REQUEST message (Security protected as per the algorithms specified in step 7).	<-	IDENTITY REQUEST	-	-
11	Check: Does the UE transmit an IDENTITY RESPONSE message (Security Protected as per the algorithms specified in step 7)?	->	IDENTITY RESPONSE	2	P

9.1.2.1.3.3 Specific message contents

Table 9.1.2.1.3.3-1: SECURITY MODE COMMAND (Step 3, Table 9.1.2.1.3.2-1)

Derivation path: 38.508-1 [4],table 4.7.1-25			
Information Element	Value/Remark	Comment	Condition
Replayed UE security capabilities	Set to mismatch the security capability of UE under test		

Table 9.1.2.1.3.3-2: SECURITY MODE REJECT (Step 4, Table 9.1.2.1.3.2-1)

Derivation path: 38.508-1 [4],table 4.7.1-27			
Information Element	Value/Remark	Comment	Condition
5GMM cause	#23		

Table 9.1.2.1.3.3-3: IDENTITY REQUEST (Step 5, Table 9.1.2.1.3.2-1)

Derivation path: 38.508-1 [4],table 4.7.1-21			
Information Element	Value/Remark	Comment	Condition
Identity type	'0001'B	SUCI	

Table 9.1.2.1.3.3-4: IDENTITY RESPONSE (Step 6, Table 9.1.2.1.3.2-1)

Derivation path: 38.508-1 [4], table 4.7.1-22			
Information Element	Value/Remark	Comment	Condition
Mobile identity			
Type of identity	'001'B	SUCI	

Table 9.1.2.1.3.3-5: SECURITY MODE COMMAND (Step 7, Table 9.1.2.1.3.2-1)

Derivation path: 38.508-1 [4], table 4.7.1-25			
Information Element	Value/Remark	Comment	Condition
Selected NAS security algorithms			
Type of ciphering algorithm	Set according to PIXIT parameter for default ciphering algorithm if it is set to a value different to 5G-EA0, or, set to any value different to 5G-EA0 otherwise	Non-zero ciphering algorithm	
IMEISV request	Present		

Table 9.1.2.1.3.3-6: SECURITY MODE COMPLETE (Step 8, Table 9.1.2.1.3.2-1)

Derivation path: 38.508-1 [4], table 4.7.1-26			
Information Element	Value/Remark	Comment	Condition
IMEISV	Present		

Table 9.1.2.1.3.3-7: IDENTITY REQUEST (Step 10, Table 9.1.2.1.3.2-1)

Derivation path: 38.508-1 [4], table 4.7.1-21			
Information Element	Value/Remark	Comment	Condition
Identity type	'0011'B	IMEI	

Table 9.1.2.1.3.3-8: IDENTITY RESPONSE (Step 11, Table 9.1.2.1.3.2-1)

Derivation path: 38.508-1 [4], table 4.7.1-22			
Information Element	Value/Remark	Comment	Condition
Mobile identity			
Type of identity	'011'B	IMEI	

9.1.2.2 Protection of initial NAS signalling messages

9.1.2.2.1 Test Purpose (TP)

(1)

```
with { the UE is switched-off with no valid 5G NAS security context }
ensure that {
  when { the UE is switched on }
  then {the UE sends a REGISTRATION REQUEST message including cleartext IEs only }
}
```

(2)

```
with { the UE is in 5GMM-REGISTERED-INITIATED state }
ensure that {
  when { the UE is activating a 5G NAS security context resulting from a security mode control procedure }
  then {the UE sends SECURITY MODE COMPLETE message with the entire REGISTRATION REQUEST message }
}
```

9.1.2.2.2 Conformance requirements

References: The conformance requirements covered in the present test case are specified in: TS 24.501, clauses 4.4.6 and 5.5.1.

[TS 24.501, clause 4.4.6]

The 5GS supports protection of initial NAS messages as specified in 3GPP TS 33.501 [24]. The protection of initial NAS messages applies to the REGISTRATION REQUEST and SERVICE REQUEST message, and is achieved as follows:

- a) If the UE does not have a valid 5G NAS security context, the UE sends a REGISTRATION REQUEST message including cleartext IEs only. After activating a 5G NAS security context resulting from a security mode control procedure:
 - 1) if the UE needs to send non-cleartext IEs, the UE shall include the entire REGISTRATION REQUEST message (i.e. containing both cleartext IEs and non-cleartext IEs) in the NAS message container IE and shall include the NAS message container IE in the SECURITY MODE COMPLETE message;
 - 2) if the UE does not need to send non-cleartext IEs, the UE shall include the entire REGISTRATION REQUEST message (i.e. containing cleartext IEs only) in the NAS message container IE and shall include the NAS message container IE in the SECURITY MODE COMPLETE message.
- b) If the UE has a valid 5G NAS security context and the UE needs to send non-cleartext IEs in a REGISTRATION REQUEST or SERVICE REQUEST message, the UE includes the entire REGISTRATION REQUEST or SERVICE REQUEST message (i.e. containing both cleartext IEs and non-cleartext IEs) in the NAS message container IE and shall cipher the value part of the NAS message container IE. The UE shall then send a REGISTRATION REQUEST or SERVICE REQUEST message containing the cleartext IEs and the NAS message container IE.

When the initial NAS message is a REGISTRATION REQUEST message, the cleartext IEs are:

- Extended protocol discriminator;
- Security header type;
- Spare half octet;
- Registration request message identity;
- 5GS registration type;
- ngKSI;
- 5GS mobile identity;
- UE security capability;
- Additional GUTI;
- UE status; and
- EPS NAS message container.

...

When the UE sends a REGISTRATION REQUEST or SERVICE REQUEST message that includes a NAS message container IE, the UE shall set the security header type of the initial NAS message to "integrity protected".

If the UE does not need to send non-cleartext IEs in the initial NAS message, the UE shall send the initial NAS message i.e. REGISTRATION REQUEST or SERVICE REQUEST message with cleartext IEs only i.e. without including the NAS message container IE in the initial NAS message.

...

[TS 24.501, clause 5.5.1]

...

If the UE does not have a valid 5G NAS security context, the UE shall send the REGISTRATION REQUEST message without including the NAS message container IE. The UE shall include the entire REGISTRATION REQUEST message (i.e. containing cleartext IEs and non-cleartext IEs) in the NAS message container IE that is sent as part of the SECURITY MODE COMPLETE message as described in subclauses 4.4.6 and 5.2.4.

...

9.1.2.2.3 Test description

9.1.2.2.3.1 Pre-test conditions

System Simulator:

- NGC Cell A.

UE:

- None.

Preamble:

- The UE is in state 0-A on NGC Cell A according to TS 38.508-1 [4].
- The procedure defined in subclause 4.9.8 in 38.501-1 [4] has been performed to ensure that the UE does not have a valid 5G NAS security context.

9.1.2.2.3.2 Test procedure sequence

Table 9.1.2.2.3.2-1: Main behaviour

St	Procedure	Message Sequence		TP	Verdict
		U - S	Message		
1	The UE is switched on.	-	-	-	-
2-4	Steps 1-3 of the generic procedure for UE registration specified in TS 38.508-1 [4] table 4.5.2.2-2 are performed.	-	-	-	-
5	The UE transmits an <i>RRConnectionSetupComplete</i> message and a REGISTRATION REQUEST message.	-->	REGISTRATION REQUEST	1	P
6	The SS transmits a <i>DLInformationTransfer</i> message and a AUTHENTICATION REQUEST message.	<--	AUTHENTICATION REQUEST		
7	The UE transmits an <i>ULInformationTransfer</i> message and a AUTHENTICATION RESPONSE message.	-->	AUTHENTICATION RESPONSE		
8	The SS transmits a <i>DLInformationTransfer</i> message and a SECURITY MODE COMMAND message.	<--	SECURITY MODE COMMAND		
9	The UE transmits an <i>ULInformationTransfer</i> message and a SECURITY MODE COMPLETE message.	-->	SECURITY MODE COMPLETE	2	P
10-20	Steps 10-20 of the generic procedure for UE registration specified in TS 38.508-1 [4] table 4.5.2.2-2 are performed.	-	-	-	-

9.1.2.2.3.3 Specific message contents

Table 9.1.2.2.3.3-1: REGISTRATION REQUEST (Step 5, Table 9.1.2.2.3.2-1)

Derivation path: 38.508-1 [4],table 4.7.1-6 using condition NON_CLEARTEXT_IE

Table 9.1.2.2.3.3-2: REGISTRATION REQUEST (Step 9, Table 9.1.2.2.3.2-1)

Derivation path: 38.508-1 [4],table 4.7.1-6 using condition CIPHERED_MESSAGE

Table 9.1.2.2.3.3-3: SECURITY MODE COMPLETE (Step 9, Table 9.1.2.2.3.2-1)

Derivation path: 38.508-1 [4],table 4.7.1-26			
Information Element	Value/Remark	Comment	Condition
NAS message container	Contents of Table 9.1.2.2.3.3-2		

9.1.3 Identification

9.1.3.1 Identification procedure

9.1.3.1.1 Test Purpose (TP)

(1)

```
with { The UE is in 5GMM-REGISTERED-INITIATED state and the SS sends an IDENTITY REQUEST message }
ensure that {
  when { UE detects transmission failure of IDENTITY RESPONSE message }
  then { The UE re-initiates the Initial registration procedure }
}
```

(2)

```
with { The UE is in 5GMM-CONNECTED mode and the SS sends an IDENTITY REQUEST message }
ensure that {
  when { The UE receives the unprotected IDENTITY REQUEST message with identity type as SUCI }
  then { UE transmits the IDENTITY RESPONSE message with identity type set to SUCI }
}
```

(3)

```
with { The UE is in 5GMM-CONNECTED mode and the SS sends an IDENTITY REQUEST message }
ensure that {
  when { the UE receives an IDENTITY REQUEST with identity type set as IMEISV }
  then { UE transmits an IDENTITY RESPONSE with identity type set as IMEISV }
}
```

(4)

```
with { The UE is in 5GMM-CONNECTED mode and the SS sends an IDENTITY REQUEST message }
ensure that {
  when { the UE receives an IDENTITY REQUEST with identity type set as "IMEI" }
  then { UE transmits an IDENTITY RESPONSE with identity type set as "IMEI" }
}
```

(5)

```
with { The UE is in 5GMM-CONNECTED mode and the SS sends an IDENTITY REQUEST message }
ensure that {
  when { the UE receives an IDENTITY REQUEST with identity type set as "5G-GUTI" and has no valid
5G-GUTI available }
  then { UE transmits an IDENTITY RESPONSE with identity type set as "No identity" }
}
```

9.1.3.1.2 Conformance requirements

References: The conformance requirements covered in the present TC are specified in: TS 24.501, clauses 5.4.3.3, 4.4.4.3 and 5.4.3.5. Unless otherwise stated these are Rel-15 requirements.

[TS 24.501, clause 5.4.3.3]

A UE shall be ready to respond to an IDENTITY REQUEST message at any time whilst in 5GMM-CONNECTED mode.

Upon receipt of the IDENTITY REQUEST message:

- a) if the Identity type IE in the IDENTITY REQUEST message is not set to "SUCI", the UE shall send an IDENTITY RESPONSE message to the network. The IDENTITY RESPONSE message shall contain the identification parameters as requested by the network; and
- b) if the Identity type IE in the IDENTITY REQUEST message is set to "SUCI", the UE shall:
 - 1) if timer T3519 is not running, generate a fresh SUCI as specified in 3GPP TS 33.501 [24], send an IDENTITY RESPONSE message with the SUCI, start timer T3519 and store the value of the SUCI sent in the IDENTITY RESPONSE message; and
 - 2) if timer T3519 is running, send an IDENTITY RESPONSE message with the stored SUCI.

[TS 24.501, clause 4.4.4.3]

Except the messages listed below, no NAS signalling messages shall be processed by the receiving 5GMM entity in the AMF or forwarded to the 5GSM entity, unless the secure exchange of NAS messages has been established for the NAS signalling connection:

- a) REGISTRATION REQUEST;
- b) IDENTITY RESPONSE (if requested identification parameter is SUCI);
- c) AUTHENTICATION RESPONSE;
- d) AUTHENTICATION FAILURE;
- e) SECURITY MODE REJECT;
- f) DEREGISTRATION REQUEST; and
- g) DEREGISTRATION ACCEPT;

NOTE 1: The REGISTRATION REQUEST message is sent by the UE without integrity protection, if the registration procedure is initiated due to an inter-system change in 5GMM-IDLE mode and no current 5G NAS security context is available in the UE. The other messages are accepted by the AMF without integrity protection, as in certain situations they are sent by the UE before security can be activated.

NOTE 2: The DEREGISTRATION REQUEST message can be sent by the UE without integrity protection, e.g. if the UE is registered for emergency services and there is no shared 5G NAS security context available, or if due to user interaction a registration procedure is cancelled before the secure exchange of NAS messages has been established. For these cases the network can attempt to use additional criteria (e.g. whether the UE is subsequently still performing periodic registration update or still responding to paging) before marking the UE as 5GMM-DEREGISTERED.

Integrity protection is never applied directly to 5GSM messages, but to the 5GMM message in which the 5GSM message is included.

Once a current 5G NAS security context exists, until the secure exchange of NAS messages has been established for the NAS signalling connection, the receiving 5GMM entity in the AMF shall process the following NAS signalling messages, even if the MAC included in the message fails the integrity check or cannot be verified, as the 5G NAS security context is not available in the network:

- a) REGISTRATION REQUEST;

- b) IDENTITY RESPONSE (if requested identification parameter is SUCI);
 - c) AUTHENTICATION RESPONSE;
 - d) AUTHENTICATION FAILURE;
 - e) SECURITY MODE REJECT;
 - f) DEREGISTRATION REQUEST;
 - g) DEREGISTRATION ACCEPT; and
 - h) SERVICE REQUEST;
- ...

[TS 24.501, clause 5.4.3.5]

The following abnormal cases can be identified:

- a) Transmission failure of the IDENTITY RESPONSE message (if the identification procedure is triggered by a registration procedure).

The UE shall re-initiate the registration procedure.

- b) Requested identity is not available

If the UE cannot encode the requested identity in the IDENTITY RESPONSE message, e.g. because no valid USIM is available, then it shall encode the identity type as "No identity".

9.1.3.1.3 Test description

9.1.3.1.3.1 Pre test conditions

System Simulator:

- NGC Cell A "Serving cell" [TS 38.508 Table 6.3.2.2-1], PLMN1, TAI-1
- System information combination NR-1 as defined in TS 38.508[4] clause 4.4.3.1.2 is used.

UE:

None.

Preamble:

- The UE is in state Switched OFF [State 0N-B as per TS 38.508-1 Table 4.4A.2-0].

9.1.3.1.3.2 Test procedure sequence

Table 9.1.3.1.3.2-1: Main behaviour

St	Procedure	Message Sequence		TP	Verdict
		U - S	Message		
	The SS configures NGC Cell A as the serving cell	-	-	-	-
1	The UE is switched on	-	-	-	-
2-4	The UE establishes RRC connection by executing steps 2-4 of Table 4.5.2.2-2 in TS38.508-1 [4].	-		-	-
5	SS is configured to not allocate any UL grant			-	-
6	The SS transmits an IDENTITY REQUEST requesting SUCI in the IE identity type	<--	IDENTITY REQUEST	-	-
7-9	The UE establishes RRC connection by executing steps 2-4 of Table 4.5.2.2-2 in TS38.508-1 [4].	-->		1	P
10	The SS transmits an unprotected IDENTITY REQUEST requesting SUCI in the IE identity type	<--	IDENTITY REQUEST	-	-
11	Check : Does the UE respond with an IDENTITY RESPONSE message with IE identity type set to "SUCI" ?	-->	IDENTITY RESPONSE	2	P
11 A	The SS transmits a REGISTRATION REJECT (Cause #3, illegal UE)	<--	REGISTRATION REJECT	-	-
11 B	The SS releases the RRC	-	-	-	-
11 C	The UE is Switched OFF	-	-	-	-
11 D	The UE is Switched ON	-	-	-	-
12-29	Steps 5–19a1 of Table 4.5.2.2-2 in TS38.508-1 [4] are performed	-			
30	The SS transmits an IDENTITY REQUEST requesting IMEISV in the IE identity type	<--	IDENTITY REQUEST	-	-
31	Check : Does the UE respond with an IDENTITY RESPONSE message with IE identity type set to IMEISV ?	-->	IDENTITY RESPONSE	3	P
32	The SS transmits an IDENTITY REQUEST requesting IMEI in the IE identity type	<--	IDENTITY REQUEST	-	-
33	Check : Does the UE respond with an IDENTITY RESPONSE message with IE identity type set to IMEI ?	-->	IDENTITY RESPONSE	4	P
34	The SS transmits an IDENTITY REQUEST requesting 5G-GUTI in the IE identity type	<--	IDENTITY REQUEST	-	-
35	Check : Does the UE respond with an IDENTITY RESPONSE message with IE identity type set to "No identity" ?	-->	IDENTITY RESPONSE	5	P

9.1.3.1.3.3 Specific message contents

Table 9.1.3.1.3.3-1: IDENTITY REQUEST (step 6, 10 Table 9.1.3.1.3.2-1)

Derivation Path: TS 38.508-1 [4], Table 4.7.1-21			
Information Element	Value/remark	Comment	Condition
Identity type	'001'B	SUCI	

Table 9.1.3.1.3.3-2: IDENTITY RESPONSE (step 11 Table 9.1.3.1.3.2-1)

Derivation Path: TS 38.508-1 [4], Table 4.7.1-22			
Information Element	Value/remark	Comment	Condition
Identity type	'001'B	SUCI	

Table 9.1.3.1.3.3-3: IDENTITY REQUEST (step 30 Table 9.1.3.1.3.2-1)

Derivation Path: TS 38.508-1 [4], Table 4.7.1-21			
Information Element	Value/remark	Comment	Condition
Identity type	'01'B	IMEISV	

Table 9.1.3.1.3.3-4: IDENTITY RESPONSE (step 31 Table 9.1.3.1.3.2-1)

Derivation Path: TS 38.508-1 [4], Table 4.7.1-22			
Information Element	Value/remark	Comment	Condition
Identity type	'01'B	IMEISV	

Table 9.1.3.1.3.3-5: IDENTITY REQUEST (step 32 Table 9.1.3.1.3.2-1)

Derivation Path: TS 38.508-1 [4], Table 4.7.1-21			
Information Element	Value/remark	Comment	Condition
Identity type	'01'B	IMEI	

Table 9.1.3.1.3.3-6: IDENTITY RESPONSE (step 33 Table 9.1.3.1.3.2-1)

Derivation Path: 38.508-1 [4], Table 4.7.1-22			
Information Element	Value/remark	Comment	Condition
Identity type	'01'B	IMEI	

Table 9.1.3.1.3.3-7: IDENTITY REQUEST (step 34 Table 9.1.3.1.3.2-1)

Derivation Path: TS 38.508-1 [4], Table 4.7.1-21			
Information Element	Value/remark	Comment	Condition
Identity type	'010'B	5G-GUTI	

Table 9.1.3.1.3.3-8: IDENTITY RESPONSE (step 35 Table 9.1.3.1.3.2-1)

Derivation Path: TS 38.508-1 [4], Table 4.7.1-22			
Information Element	Value/remark	Comment	Condition
Identity type	'000'B	No Identity	

Table 9.1.3.1.3.3-9: REGISTRATION ACCEPT (step 21 Table 9.1.3.1.3.2-1)

Derivation Path: TS 38.508-1 [4], Table 4.7.1-7			
Information Element	Value/remark	Comment	Condition
5G-GUTI	Not present	No 5G-GUTI assigned	

Table 9.1.3.1.3.3-10: REGISTRATION REJECT (step 11A Table 9.1.3.1.3.2-1)

Derivation Path: TS 38.508-1 [4], Table 4.7.1-9			
Information Element	Value/remark	Comment	Condition
5GMM cause	'00000011'B	Illegal UE	

9.1.4

9.1.4.1 Generic UE configuration update / New 5G-GUTI, NITZ, registration requested, Network slicing indication, New Allowed NSSAI / acknowledgement from the UE

9.1.4.1.1 Test Purpose (TP)

(1)

```
with { UE in 5GMM-REGISTERED state }
ensure that {
  when { UE receives a new 5G-GUTI in the CONFIGURATION UPDATE COMMAND message and acknowledgement
from the UE is requested }
  then { UE sends a CONFIGURATION UPDATE COMPLETE message and UE shall consider new 5G-GUTI as
valid }
}
```

(2)

```
with { UE in 5GMM-REGISTERED state }
ensure that {
  when { UE receives a NITZ information in the CONFIGURATION UPDATE COMMAND message and
acknowledgement from the UE is not requested }
  then { UE updates NITZ information }
}
```

(3)

```
with { UE in 5GMM-REGISTERED state }
ensure that {
  when { UE receives CONFIGURATION UPDATE COMMAND message indicating "registration requested" and
contains no other parameters }
  then { UE deletes any stored allowed NSSAI for this PLMN and then release the existing N1 NAS
signalling connection, starts a mobility registration procedure }
}
```

(4)

```
with { UE in 5GMM-REGISTERED state }
ensure that {
  when { UE receives a new allowed NSSAI in the CONFIGURATION UPDATE COMMAND message and
registration is not requested }
  then { UE replaces any stored allowed NSSAI for this PLMN with new allowed NSSAI }
}
```

(5)

```
with { UE in 5GMM-REGISTERED state }
ensure that {
  when { UE receives a Network Slicing subscription change indication set to "Network slicing
subscription changed" in the CONFIGURATION UPDATE COMMAND message and registration is not requested
}
  then { UE deletes the network slicing information for each and every PLMN except for the current
PLMN and default configured NSSAI }
}
```

9.1.4.1.2 Conformance requirements

References: The conformance requirements covered in the present TC are specified in: TS 24.501, clause 4.6.2.2, 5.4.4.1, 5.4.4.2 and 5.4.4.3. Unless otherwise stated these are Rel-15 requirements.

[TS 24.501 clause 4.6.2.2]

If available, the configured NSSAI(s) shall be stored in a non-volatile memory in the ME as specified in annex C.

...

If the UE receives the CONFIGURATION UPDATE COMMAND message indicating "registration requested" and contains no other parameters (see subclauses 5.4.4.2 and 5.4.4.3), the UE shall delete any stored allowed NSSAI for this PLMN, and delete any stored mapping of each S-NSSAI of the allowed NSSAI to the S-NSSAI(s) of the HPLMN, if available;

...

- d) When the UE receives the Network slicing indication IE with the Network slicing subscription change indication set to "Network slicing subscription changed" in the REGISTRATION ACCEPT message or in the CONFIGURATION UPDATE COMMAND message, the UE shall delete the network slicing information for each of the PLMNs that the UE has slicing information stored for (excluding the current PLMN). The UE shall not delete the default configured NSSAI. Additionally, the UE shall update the network slicing information for the current PLMN (if received) as specified above in bullets a), b) and c):

[TS 24.501 clause 5.4.4.1]

The purpose of this procedure is to:

- a) allow the AMF to update the UE configuration for access and mobility management-related parameters decided and provided by the AMF by providing new parameter information within the command; or
- b) request the UE to perform a registration procedure for mobility and periodic registration update towards the network to update access and mobility management-related parameters decided and provided by the AMF (see subclause 5.5.1.3).

This procedure is initiated by the network and can only be used when the UE has an established 5GMM context, and the UE is in 5GMM-CONNECTED mode. When the UE is in 5GMM-IDLE mode, the AMF may use the paging or notification procedure to initiate the generic UE configuration update procedure. The AMF can request a confirmation response in order to ensure that the parameter has been updated by the UE.

This procedure shall be initiated by the network to assign a new 5G-GUTI to the UE after a successful service request procedure invoked as a response to a paging request from the network and before the release of the N1 NAS signalling connection. If the service request procedure was triggered due to 5GSM downlink signalling pending, the procedure for assigning a new 5G-GUTI can be initiated by the network after the transport of the 5GSM downlink signalling.

The following parameters are supported by the generic UE configuration update procedure without the need to request the UE to perform the registration procedure for mobility and periodic registration update:

- a) 5G-GUTI;
- b) TAI list;
- c) Service area list;
- d) Network identity and time zone information (Full name for network, short name for network, local time zone, universal time and local time zone, network daylight saving time);
- e) LADN information;
- f) Rejected NSSAI;
- g) Network slicing indication;
- h) Operator-defined access category definitions; and
- i) SMS indication.

The following parameters can be sent to the UE with or without a request to perform the registration procedure for mobility and periodic registration update:

- a) Allowed NSSAI; or
- b) Configured NSSAI.

The following parameter is sent to the UE with a request to perform the registration procedure for mobility and periodic registration update:

- a) MICO indication.

The following parameters are sent over 3GPP access only:

- a) LADN information;
- b) MICO indication;
- c) TAI list; and
- d) Service area list.

The following parameters are managed and sent per access type i.e., independently over 3GPP access or non 3GPP access:

- a) Allowed NSSAI; and
- b) Rejected NSSAI (when the NSSAI is rejected for the current registration area).

The following parameters are managed commonly and sent over 3GPP access or non 3GPP access:

- a) 5G-GUTI;
- b) Network identity and time zone information;
- c) Rejected NSSAI (when the NSSAI is rejected for the current PLMN);
- d) Configured NSSAI; and
- e) SMS indication.

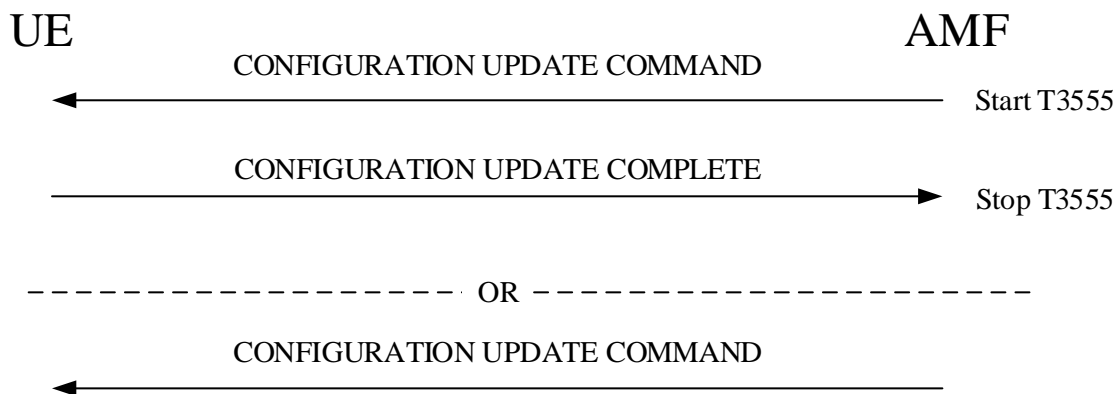

Figure 5.4.4.1.1: Generic UE configuration update procedure

[TS 24.501 clause 5.4.4.2]

The AMF shall initiate the generic UE configuration update procedure by sending the CONFIGURATION UPDATE COMMAND message to the UE.

The AMF shall in the CONFIGURATION UPDATE COMMAND message either:

- a) include one or more of the following parameters: 5G-GUTI, TAI list, allowed NSSAI that may include the mapped S-NSSAI(s), LADN information, service area list, MICO indication NITZ information, configured NSSAI that may include the mapped S-NSSAI(s), rejected NSSAI, network slicing indication, operator-defined access category definitions or SMS indication;
- b) include the Configuration update indication IE with the Registration requested bit set to "registration requested";
or
- c) include a combination of both a) and b).

If an acknowledgement from the UE is requested, the AMF shall indicate "acknowledgement requested" in the Acknowledgement bit of the Configuration update indication IE in the CONFIGURATION UPDATE COMMAND message and shall start timer T3555. Acknowledgement shall be requested for all parameters except when only NITZ is included.

To initiate parameter re-negotiation between the UE and network, the AMF shall indicate "registration requested" in the Registration requested bit of the Configuration update indication IE in the CONFIGURATION UPDATE COMMAND message.

If a new allowed NSSAI information or AMF re-configuration of supported S-NSSAIs requires an AMF relocation, the AMF shall indicate "registration requested" in the Registration requested bit of the Configuration update indication IE and include the Allowed NSSAI IE in the CONFIGURATION UPDATE COMMAND message.

If the AMF includes a new configured NSSAI in the CONFIGURATION UPDATE COMMAND message and the new configured NSSAI requires an AMF relocation as specified in 3GPP TS 23.501 [8], the AMF shall indicate "registration requested" in the Registration requested bit of the Configuration update indication IE in the message.

If the AMF indicates "registration requested" in the Registration requested bit of the Configuration update indication IE, acknowledgement shall be requested.

If changes to the allowed NSSAI require the UE to initiate a registration procedure, but the AMF is unable to determine an allowed NSSAI for the UE as specified in 3GPP TS 23.501 [8], the CONFIGURATION UPDATE COMMAND message shall indicate "registration requested" in the Registration requested bit of the Configuration update indication IE, and shall not contain any other parameters.

If the AMF needs to update the LADN information, the AMF shall include the LADN information in the LADN information IE of the CONFIGURATION UPDATE COMMAND message.

During an established 5GMM context, the network may send none, one, or more CONFIGURATION UPDATE COMMAND messages to the UE. If more than one CONFIGURATION UPDATE COMMAND message is sent, the messages need not have the same content.

[TS 24.501 clause 5.4.4.3]

Upon receiving the CONFIGURATION UPDATE COMMAND message, the UE shall stop timer T3346 if running and use the contents to update appropriate information stored within the UE.

If "acknowledgement requested" is indicated in the Acknowledgement bit of the Configuration update indication IE in the CONFIGURATION UPDATE COMMAND message, the UE shall send a CONFIGURATION UPDATE COMPLETE message.

If the UE receives a new 5G-GUTI in the CONFIGURATION UPDATE COMMAND message, the UE shall consider the new 5G-GUTI as valid, the old 5G-GUTI as invalid, stop timer T3519 if running, and delete any stored SUCI; otherwise, the UE shall consider the old 5G-GUTI as valid. The UE shall provide the 5G-GUTI to the lower layer of 3GPP access if the CONFIGURATION UPDATE COMMAND message is sent over the non-3GPP access, and the UE is in 5GMM-REGISTERED in both 3GPP access and non-3GPP access in the same PLMN.

If the UE receives a new TAI list in the CONFIGURATION UPDATE COMMAND message, the UE shall consider the new TAI list as valid and the old TAI list as invalid; otherwise, the UE shall consider the old TAI list as valid.

If the UE receives a new service area list in the CONFIGURATION UPDATE COMMAND message, the UE shall consider the new service area list as valid and the old service area list as invalid; otherwise, the UE shall consider the old service area list, if any, as valid.

If the UE receives new NITZ information in the CONFIGURATION UPDATE COMMAND message, the UE considers the new NITZ information as valid and the old NITZ information as invalid; otherwise, the UE shall consider the old NITZ information as valid.

If the UE receives a LADN information IE in the CONFIGURATION UPDATE COMMAND message, the UE shall consider the old LADN information as invalid and the new LADN information as valid, if any; otherwise, the UE shall consider the old LADN information as valid.

If the UE receives a new allowed NSSAI for the associated access type in the CONFIGURATION UPDATE COMMAND message, the UE shall consider the new allowed NSSAI as valid for the associated access type, store the allowed NSSAI for the associated access type as specified in subclause 4.6.2.2 and consider the old allowed NSSAI for

the associated access type as invalid; otherwise, the UE shall consider the old Allowed NSSAI as valid for the associated access type.

If the UE receives a new configured NSSAI in the CONFIGURATION UPDATE COMMAND message, the UE shall consider the new configured NSSAI for the registered PLMN as valid and the old configured NSSAI for the registered PLMN as invalid; otherwise, the UE shall consider the old configured NSSAI for the registered PLMN as valid. The UE shall store the new configured NSSAI as specified in subclause 4.6.2.2.

If the UE receives the Network slicing indication IE in the CONFIGURATION UPDATE COMMAND message with the Network slicing subscription change indication set to "Network slicing subscription changed", the UE shall delete the network slicing information for each and every PLMN except for the current PLMN as specified in subclause 4.6.2.2.

If the UE receives Operator-defined access category definitions IE in the CONFIGURATION UPDATE COMMAND message and the Operator-defined access category definitions IE contains one or more operator-defined access category definitions, the UE shall delete any operator-defined access category definitions stored for the RPLMN and shall store the received operator-defined access category definitions for the RPLMN. If the UE receives the Operator-defined access category definitions IE in the CONFIGURATION UPDATE COMMAND message and the Operator-defined access category definitions IE contains no operator-defined access category definitions, the UE shall delete any operator-defined access category definitions stored for the RPLMN. If the CONFIGURATION UPDATE COMMAND message does not contain the Operator-defined access category definitions IE, the UE shall not delete the operator-defined access category definitions stored for the RPLMN.

If the UE receives the SMS indication IE in the CONFIGURATION UPDATE COMMAND message with the SMS availability indication set to:

- a) "SMS over NAS not available", the UE shall consider that SMS over NAS transport is not allowed by the network; and
- b) "SMS over NAS available", the UE may request the use of SMS over NAS transport by performing a registration procedure for mobility and periodic registration update as specified in subclause 5.5.1.3, after the completion of the generic UE configuration update procedure.

If the CONFIGURATION UPDATE COMMAND message indicates "registration requested" in the Registration requested bit of the Configuration update indication IE and:

- a) contains no other parameters or contains at least one of the following parameters: a new allowed NSSAI, a new configured NSSAI or the Network slicing subscription change indication, and:
 - 1) an emergency PDU session exists, the UE shall, after the completion of the generic UE configuration update procedure and the release of the emergency PDU session, release the existing N1 NAS signalling connection, and start a registration procedure for mobility and periodic registration update as specified in subclause 5.5.1.3; or
 - 2) no emergency PDU Session exists, the UE shall, after the completion of the generic UE configuration update procedure and the release of the existing N1 NAS signalling connection, start a registration procedure for mobility and periodic registration update as specified in subclause 5.5.1.3; or
- b) an MICO indication is included without a new allowed NSSAI or a new configured NSSAI, the UE shall, after the completion of the generic UE configuration update procedure, start a registration procedure for mobility and registration update as specified in subclause 5.5.1.3 to re-negotiate MICO mode with the network.

The UE receiving the rejected NSSAI in the CONFIGURATION UPDATE COMMAND message takes the following actions based on the rejection cause in the rejected NSSAI:

"S-NSSAI not available in the current PLMN"

The UE shall add the rejected S-NSSAI(s) in the rejected NSSAI for the current PLMN as specified in subclause 4.6.2.2 and not attempt to use this S-NSSAI in the current PLMN until switching off the UE or the UICC containing the USIM is removed.

"S-NSSAI not available in the current registration area"

The UE shall add the rejected S-NSSAI(s) in the rejected NSSAI for the current registration area as specified in subclause 4.6.2.2 and not attempt to use this S-NSSAI in the current registration area until switching off the UE, the UE moving out of the current registration area or the UICC containing the USIM is removed.

9.1.4.1.3 Test description

9.1.4.1.3.1 Pre-test conditions

System Simulator:

- NGC Cell A configured according to Table 6.3.2.2-1 in 38.508-1 [4] belongs to Home PLMN and set as serving cell;
- NGC Cell G configured according to Table 6.3.2.2-1 in 38.508-1 [4] and set as Non-Suitable “Off” cell.

UE:

- UE is configured with NSSAI associated with HPLMN and with 5G-GUTI assigned.

Preamble:

- The UE is in state 3N-A on NGC cell A according to TS 38.508-1 [4].

9.1.4.1.3.2 Test procedure sequence

Table 9.1.4.1.3.2-1: Main behaviour

St	Procedure	Message Sequence		TP	Verdict
		U - S	Message		
1	The SS transmits a CONFIGURATION UPDATE COMMAND message including a new 5G-GUTI.	<--	CONFIGURATION UPDATE COMMAND	-	-
2	Check: Does UE transmit a CONFIGURATION UPDATE COMPLETE message?	-->	CONFIGURATION UPDATE COMPLETE	1	P
3	The SS transmits an <i>RRCRelease</i> message.	-	-	-	-
4	The SS transmits a <i>Paging</i> message with the new 5G-GUTI.	-	-	-	-
5-11	Steps 2 to 8 of the generic procedure for NR_RRC_CONNECTED specified in TS 38.508-1 [4] subclause 4.5.4.2-3 are performed.	-	-	1	P
12	The SS transmits a CONFIGURATION UPDATE COMMAND message including NITZ information.	<--	CONFIGURATION UPDATE COMMAND	-	-
13	Check: Does the UE transmit a CONFIGURATION UPDATE COMPLETE message within the expiry of T3555?	-->	CONFIGURATION UPDATE COMPLETE	2	F
14	Check: Using MMI/AT command verify the NITZ update on the UE.	-	-	2	P
15	Switch off procedure in RRC_Connected specified in TS 38.508-1 [4] subclause 4.9.6.3 is performed.	-	-	-	-
16	The UE is switched On.	-	-	-	-
17-30	Steps 1 to13 of the generic procedure for NR RRC_IDLE specified in TS 38.508-1 [4] subclause 4.5.2 are performed.	-	-	-	-
31	The SS transmits a REGISTRATION ACCEPT message including Configured NSSAI.	<--	REGISTRATION ACCEPT	-	-
32	The SS transmits a CONFIGURATION UPDATE COMMAND message including registration requested IE.	<--	CONFIGURATION UPDATE COMMAND	-	-
	The UE transmits a CONFIGURATION UPDATE COMPLETE message.	-->	CONFIGURATION UPDATE COMPLETE	-	-
33	Check: Does UE transmit a REGISTRATION REQUEST message with registration type value set to "Mobility" and including the Requested NSSAI?	-->	REGISTRATION REQUEST	3	P
34-42	Steps 5 to13 of the generic procedure for NR RRC_IDLE specified in TS 38.508-1 [4] subclause 4.5.2 are performed.	-	-	-	-
43	The SS transmits a REGISTRATION ACCEPT message including Allowed NSSAI.	<--	REGISTRATION ACCEPT	-	-
44	The UE transmits an <i>ULInformationTransfer</i> message and a REGISTRATION COMPLETE message.	-	REGISTRATION COMPLETE	-	-
45	Check: Using MMI/AT command (+C5GNSSAIRDP) verify the update of allowed NSSAI.	-	-	3	P
46	The SS transmits a CONFIGURATION UPDATE COMMAND message including a new allowed NSSAI list.	<--	CONFIGURATION UPDATE COMMAND	-	-
47	The UE transmits a CONFIGURATION UPDATE COMPLETE message.	-->	CONFIGURATION UPDATE COMPLETE	-	-
48	Check: Using MMI/AT command (+C5GNSSAIRDP) verify the update of allowed NSSAI.	-	-	4	P
49	The SS configures NGC Cell A as the "Non-suitable cell" and NGC Cell G as the "Serving cell".	-	-	-	-
50-63	Steps 1 to13 of the generic procedure for NR RRC_IDLE specified in TS 38.508-1 [4] subclause 4.5.2 are performed on NGC Cell G	-	-	-	-

64	The SS transmits a REGISTRATION ACCEPT message including Allowed and Configured NSSAIs.	<--	REGISTRATION ACCEPT	-	-
65	The UE transmits an <i>ULInformationTransfer</i> message and a REGISTRATION COMPLETE message.	-	REGISTRATION COMPLETE	-	-
66	The SS transmits a CONFIGURATION UPDATE COMMAND message with Network slicing subscription changed.	<--	CONFIGURATION UPDATE COMMAND	-	-
67	The UE transmits a CONFIGURATION UPDATE COMPLETE message.	-->	CONFIGURATION UPDATE COMPLETE	-	-
68	Check: Using MMI/AT command (+C5GNSSAIRDP) verify the update of allowed NSSAI.	-	-	5	P

9.1.4.1.3.3 Specific message contents

Table 9.1.4.1.3.3-1: CONFIGURATION UPDATE COMMAND (step 1, Table 9.1.4.1.3.2-1)

Derivation Path: 38.508-1 [4], Table 4.7.1-19			
Information Element	Value/remark	Comment	Condition
Configuration update indication	0001	Acknowledgement (ACK) requested	
5G-GUTI	Other than the default value		

Table 9.1.4.1.3.3-2: CONFIGURATION UPDATE COMMAND (step 12, Table 9.1.4.1.3.2-1)

Derivation Path: 38.508-1 [4], Table 4.7.1-19			
Information Element	Value/remark	Comment	Condition
Full name for network	Present		
Universal time and local time zone	Present		

Table 9.1.4.1.3.3-3: REGISTRATION ACCEPT (step 31, Table 9.1.4.1.3.2-1)

Derivation Path: 38.508-1 [4], Table 4.7.1-7			
Information Element	Value/remark	Comment	Condition
5GS registration result value	'001'B	3GPP access	
Configured NSSAI			
S-NSSAI IEI		S-NSSAI value 2	
Length of S-NSSAI contents	'00000001'B	SST	
SST	'00000001'B	2	
SD	Not Present		
Mapped configured SST	Not Present		
Mapped configured SD	Not Present		
S-NSSAI IEI		S-NSSAI value 3	
Length of S-NSSAI contents	'00000001'B	SST	
SST	'00000010'B	3	
SD	Not Present		
Mapped configured SST	Not Present		
Mapped configured SD	Not Present		

Table 9.1.4.1.3.3-4: CONFIGURATION UPDATE COMMAND (step 32, Table 9.1.4.1.3.2-1)

Derivation Path: 38.508-1 [4], Table 4.7.1-19			
Information Element	Value/remark	Comment	Condition
Configuration update indication	0010	Registration requested	

Table 9.1.4.1.3.3-5: REGISTRATION REQUEST (step 33, Table 9.1.4.1.3.2-1)

Derivation Path: 38.508-1 [4], Table 4.7.1-6			
Information Element	Value/remark	Comment	Condition
5GS registration type value	'010'B		MOBILITY
Requested NSSAI			
S-NSSAI IEI		S-NSSAI value 2	
Length of S-NSSAI contents	'00000001'B	SST	
SST	'00000010'B	2	
SD	Not Present		
Mapped configured SST	Not Present		
Mapped configured SD	Not Present		
S-NSSAI IEI		S-NSSAI value 3	
Length of S-NSSAI contents	'00000001'B	SST	
SST	'00000011'B	3	
SD	Not Present		
Mapped configured SST	Not Present		
Mapped configured SD	Not Present		

Table 9.1.4.1.3.3-6: REGISTRATION ACCEPT (step 43, Table 9.1.4.1.3.2-1)

Derivation Path: 38.508-1 [4], Table 4.7.1-7			
Information Element	Value/remark	Comment	Condition
5GS registration result value	'001'B	3GPP access	
Allowed NSSAI			
S-NSSAI IEI		S-NSSAI value 1	
Length of S-NSSAI contents	'00000001'B	SST	
SST	'00000001'B	1	
SD	Not Present		
Mapped configured SST	Not Present		
Mapped configured SD	Not Present		
S-NSSAI IEI		S-NSSAI value 2	
Length of S-NSSAI contents	'00000001'B	SST	
SST	'00000010'B	2	
SD	Not Present		
Mapped configured SST	Not Present		
Mapped configured SD	Not Present		
S-NSSAI IEI		S-NSSAI value 3	
Length of S-NSSAI contents	'00000001'B	SST	
SST	'00000011'B	3	
SD	Not Present		
Mapped configured SST	Not Present		
Mapped configured SD	Not Present		

Table 9.1.4.1.3.3-7: CONFIGURATION UPDATE COMMAND (step 46, Table 9.1.4.1.3.2-1)

Derivation Path: 38.508-1 [4], Table 4.7.1-19			
Information Element	Value/remark	Comment	Condition
Configuration update indication	0001	Acknowledgement (ACK) requested	
Allowed NSSAI			
S-NSSAI IEI		S-NSSAI value 1	
Length of S-NSSAI contents	'00000001'B	SST	
SST	'00000001'B	1	
SD	Not Present		
Mapped configured SST	Not Present		
Mapped configured SD	Not Present		
S-NSSAI IEI		S-NSSAI value 2	
Length of S-NSSAI contents	'00000001'B	SST	
SST	'00000010'B	2	
SD	Not Present		
Mapped configured SST	Not Present		
Mapped configured SD	Not Present		

Table 9.1.4.1.3.3-8: REGISTRATION ACCEPT (step 64, Table 9.1.4.1.3.2-1)

Derivation Path: 38.508-1 [4], Table 4.7.1-7			
Information Element	Value/remark	Comment	Condition
5GS registration result value	'001'B	3GPP access	
Configured NSSAI			
S-NSSAI IEI		S-NSSAI value 2	
Length of S-NSSAI contents	'00000001'B	SST	
SST	'00000001'B	2	
SD	Not Present		
Mapped configured SST	Not Present		
Mapped configured SD	Not Present		
S-NSSAI IEI		S-NSSAI value 3	
Length of S-NSSAI contents	'00000001'B	SST	
SST	'00000010'B	3	
SD	Not Present		
Mapped configured SST	Not Present		
Mapped configured SD	Not Present		

Table 9.1.4.1.3.3-9: CONFIGURATION UPDATE COMMAND (step 66, Table 9.1.4.1.3.2-1)

Derivation Path: 38.508-1 [4], Table 4.7.1-19			
Information Element	Value/remark	Comment	Condition
Network slicing indication	0001	Network slicing subscription changed	

9.1.5 Registration

9.1.5.1 Initial Registration

9.1.5.1.1 Initial registration / Success / 5G-GUTI reallocation, Last visited TAI

9.1.5.1.1.1 Test Purpose (TP)

(1)

with { the UE has no valid 5G-GUTI but available SUCI }
 ensure that {

```

when { the UE is switched off and switched on }
then { the UE sends a REGISTRATION REQUEST message including the SUCI in the 5GS mobile identity
IE }
}

```

(2)

```

with { the UE is 5GMM-REGISTERED state with a cell belong to a non-equivalent PLMN with assigned 5G-
GUTI and last visited registered TAI }
ensure that {
when { the UE is switched off and switched on with a cell belong to another PLMN }
then { the UE sends a REGISTRATION REQUEST message including the 5G-GUTI assigned by the last
PLMN in the 5GS mobile identity IE and the last visited registered TAI }
}

```

(3)

```

with { the UE is 5GMM-REGISTERED state with a cell belong to an equivalent PLMN with assigned 5G-
GUTI }
ensure that {
when { the UE is switched off and switched on with a cell belong to another PLMN }
then { the UE sends a REGISTRATION REQUEST message including the 5G-GUTI assigned by the
equivalent PLMN in the 5GS mobile identity IE }
}

```

(4)

```

with { the UE is 5GMM-REGISTERED state with an assigned 5G-GUTI }
ensure that {
when { the UE is switched off and switched on with a cell belong to the same PLMN }
then { the UE sends a REGISTRATION REQUEST message including the 5G-GUTI assigned by the last
registered PLMN in the 5GS mobile identity IE }
}

```

9.1.5.1.1.2 Conformance requirements

References: The conformance requirements covered in the current TC are specified in: TS 24.501 clauses 5.5.1.2.2 and 5.5.1.2.4. Unless otherwise stated these are Rel-15 requirements.

[TS 24.501, clause 5.5.1.2.2]

The UE initiates the registration procedure for initial registration by sending a REGISTRATION REQUEST message to the AMF, starting timer T3510. If timer T3502 is currently running, the UE shall stop timer T3502. If timer T3511 is currently running, the UE shall stop timer T3511.

During initial registration the UE handles the 5GS mobile identity IE in the following order:

...

- b) if the UE holds a valid 5G-GUTI that was previously assigned, over 3GPP access or non-3GPP access, by the same PLMN with which the UE is performing the registration, the UE shall indicate the 5G-GUTI in the 5GS mobile identity IE;
- c) if the UE holds a valid 5G-GUTI that was previously assigned, over 3GPP access or non-3GPP access, by an equivalent PLMN, the UE shall indicate the 5G-GUTI in the 5GS mobile identity IE;
- d) if the UE holds a valid 5G-GUTI that was previously assigned, over 3GPP access or non-3GPP, by any other PLMN, the UE shall indicate the 5G-GUTI in the 5GS mobile identity IE;
- e) if a SUCI is available the UE shall include the SUCI in the 5GS mobile identity IE; and

If the SUCI is included in the 5GS mobile identity IE and the timer T3519 is not running, the UE shall start timer T3519 and store the value of the SUCI sent in the REGISTRATION REQUEST message. The UE shall include the stored SUCI in the REGISTRATION REQUEST message while timer T3519 is running.

...

If the last visited registered TAI is available, the UE shall include the last visited registered TAI in the REGISTRATION REQUEST message.

9.1.5.1.1.3 Test description

9.1.5.1.1.3.1 Pre-test conditions

System Simulator:

- NGC Cell A, NGC Cell C and NGC Cell H are configured according to Table 6.3.2.2-1 in 38.508-1 [4].

UE:

- None.

Preamble:

- The UE is in state Switched OFF (state ON-B) according to TS 38.508-1 [4].

9.1.5.1.1.3.2 Test procedure sequence

Table 9.1.5.1.1.3.2-1: Main behaviour

St	Procedure	Message Sequence		TP	Verdict
		U – S	Message		
1	The SS configures: - NGC Cell A as the "Serving cell". - NGC Cell H and NGC Cell C as the "Non-Suitable "off" cell".	-	-	-	-
2	The UE is switched on.	-	-	-	-
-	The following messages are to be observed on NGC Cell A unless explicitly stated otherwise.	-	-	-	-
3-5	The UE establishes RRC connection by executing steps 2-4 of Table 4.5.2.2-2 in TS38.508-1 [4].	-	-	-	-
6	SS transmits an REGISTRATION REJECT message with the 5GMM cause IE setting as "Illegal UE". NOTE1: 5G-GUTI-1 should be deleted, then UE has no valid 5G-GUTI but available SUCI now.	<--	REGISTRATION REJECT	-	-
7	The generic test procedure in TS 38.508-1 Table 4.9.6.1-1 of Switch off procedure in RRC_IDLE are performed.				
8	The UE is brought back to operation or the USIM is inserted.				
9-11	The UE establishes RRC connection by executing steps 2-4 of Table 4.5.2.2-2 in TS38.508-1 [4].	-	-	-	-
12	Check: Does the UE transmit an REGISTRATION REQUEST message including the SUCI in the 5GS mobile identity IE?	-->	REGISTRATION REQUEST	1	P
13-21	Steps 5-13 of Table 4.5.2.2-2 of the generic procedure in TS 38.508-1 [4] are performed.	-	-	-	-
22	SS transmits an REGISTRATION ACCEPT message with a new assigned 5G-GUTI-2.	<--	REGISTRATION ACCEPT	-	-
23-27a1	Steps 15-19a1 of Table 4.5.2.2-2 of the generic procedure in TS 38.508-1 [4] are performed.	-	-	-	-
28	The generic test procedure in TS 38.508-1 Table 4.9.6.3-1 of Switch off procedure in RRC_CONNECTED are performed.	-	-	-	-
29	The SS configures: - NGC Cell H as the "Serving cell". - NGC Cell A and NGC Cell C as a "Non-Suitable "off" cell".	-	-	-	-
30	The UE is brought back to operation or the USIM is inserted.	-	-	-	-
-	The following messages are to be observed on NGC Cell H unless explicitly stated otherwise.	-	-	-	-
31-33	The UE establishes RRC connection by executing steps 2-4 of Table 4.5.2.2-2 in TS38.508-1 [4].	-	-	-	-
34	Check: Does the UE transmit an REGISTRATION REQUEST message including the 5G-GUTI-2 assigned by the last PLMN in the 5GS mobile identity IE and the last visited registered TAI?	-->	REGISTRATION REQUEST	2	P
35-43	Steps 5-13 of Table 4.5.2.2-2 of the generic procedure in TS 38.508-1 [4] are performed.	-	-	-	-
44	SS transmits an REGISTRATION ACCEPT message with a new assigned 5G-GUTI-3 and the PLMN of NGC Cell A as Equivalent PLMNs.	<--	REGISTRATION ACCEPT	-	-
45-49a1	Steps 15-19a1 of Table 4.5.2.2-2 of the generic procedure in TS 38.508-1 [4] are performed.	-	-	-	-

50	The generic test procedure in TS 38.508-1 Table 4.9.6.3-1 of Switch off procedure in RRC_CONNECTED is performed.	-	-	-	-
51	The SS configures: - NGC Cell A as the "Serving cell". - NGC Cell H and NGC Cell C as a "Non-Suitable "off" cell".	-	-	-	-
52	The UE is brought back to operation or the USIM is inserted.	-	-	-	-
-	The following messages are to be observed on NGC Cell A unless explicitly stated otherwise.	-	-	-	-
53-55	The UE establishes an RRC connection by executing steps 2-4 of Table 4.5.2.2-2 in TS38.508-1 [4].	-	-	-	-
56	Check: Does the UE transmit an REGISTRATION REQUEST message including the 5G-GUTI-3 assigned by the equivalent PLMN in the 5GS mobile identity IE?	-->	REGISTRATION REQUEST	3	P
57-65	Steps 5-13 of Table 4.5.2.2-2 of the generic procedure in TS 38.508-1 [4] are performed.	-	-	-	-
66	SS transmits an REGISTRATION ACCEPT message with a new assigned 5G-GUTI-4.	<--	REGISTRATION ACCEPT	-	-
67-71a1	Steps 15-19a1 of Table 4.5.2.2-2 of the generic procedure in TS 38.508-1 [4] are performed.	-	-	-	-
72	The generic test procedure in TS 38.508-1 Table 4.9.6.3-1 of Switch off procedure in RRC_CONNECTED is performed.	-	-	-	-
73	The SS configures: - NGC Cell C as the "Serving cell". - NGC Cell A and NGC Cell H as a "Non-Suitable off cell".	-	-	-	-
74	The UE is brought back to operation or the USIM is inserted.	-	-	-	-
-	The following messages are to be observed on NGC Cell C unless explicitly stated otherwise.	-	-	-	-
75-77	The UE establishes an RRC connection by executing steps 2-4 of Table 4.5.2.2-2 in TS38.508-1 [4].	-	-	-	-
78	Check: Does the UE transmit an REGISTRATION REQUEST message including the 5G-GUTI-4 assigned by last registered PLMN in the 5GS mobile identity IE?	-->	REGISTRATION REQUEST	4	P
79-94	Steps 5-20 of Table 4.5.2.2-2 of the generic procedure in TS 38.508-1 [4] are performed.	-	-	-	-

9.1.5.1.1.3.3 Specific message contents

Table 9.1.5.1.1.3.3-1: Message REGISTRATION REJECT (step 6, Table 9.1.5.1.1.3.2-1)

Derivation path: TS 38.508-1 [4], table 4.7.1-9			
Information Element	Value/Remark	Comment	Condition
5GMM cause	'0000 0011'B	Illegal UE	

Table 9.1.5.1.1.3.3-2: Message REGISTRATION REQUEST (step 12, Table 9.1.5.1.1.3.2-1)

Derivation path: TS 38.508-1 [4], table 4.7.1-6			
Information Element	Value/Remark	Comment	Condition
5GS registration type	'0000 0001'B	Initial registration	
5GS mobile identity	SUCI	The SUCI of UE	
Last visited registered TAI	TAI-1	TAI of NGC Cell A	

Table 9.1.5.1.1.3.3-3: Message REGISTRATION ACCEPT (step 22, Table 9.1.5.1.1.3.2-1)

Derivation path: TS 38.508-1 [4], table 4.7.1-7			
Information Element	Value/Remark	Comment	Condition
5G-GUTI	5G-GUTI-2		

Table 9.1.5.1.1.3.3-4: Message REGISTRATION REQUEST (step 34, Table 9.1.5.1.1.3.2-1)

Derivation path: TS 38.508-1 [4], table 4.7.1-6			
Information Element	Value/Remark	Comment	Condition
5GS registration type	'0000 0001'B	Initial registration	
5GS mobile identity	5G-GUTI		
Last visited registered TAI	TAI-1	TAI of NGC Cell A	

Table 9.1.5.1.1.3.3-5: Message REGISTRATION ACCEPT (step 44, Table 9.1.5.1.1.3.2-1)

Derivation path: TS 38.508-1 [4], table 4.7.1-7			
Information Element	Value/Remark	Comment	Condition
5G-GUTI	5G-GUTI-3		
Equivalent PLMNs	The PLMN ID of NGC Cell A		

Table 9.1.5.1.1.3.3-6: Message REGISTRATION REQUEST (step 56, Table 9.1.5.1.1.3.2-1)

Derivation path: TS 38.508-1 [4], table 4.7.1-6			
Information Element	Value/Remark	Comment	Condition
5GS registration type	'0000 0001'B	Initial registration	
5GS mobile identity	5G-GUTI-3		
Last visited registered TAI	TAI-8	TAI of NGC Cell H	

Table 9.1.5.1.1.3.3-7: Message REGISTRATION ACCEPT (step 66, Table 9.1.5.1.1.3.2-1)

Derivation path: TS 38.508-1 [4], table 4.7.1-7			
Information Element	Value/Remark	Comment	Condition
5G-GUTI	5G-GUTI-4		

Table 9.1.5.1.1.3.3-8: Message REGISTRATION REQUEST (step 78, Table 9.1.5.1.1.3.2-1)

Derivation path: TS 38.508-1 [4], table 4.7.1-6			
Information Element	Value/Remark	Comment	Condition
5GS registration type	'0000 0001'B	Initial registration	
5GS mobile identity	5G-GUTI-4		
Last visited registered TAI	TAI-1	TAI of NGC Cell A	

9.1.5.1.2 Initial registration / 5GS services / Equivalent PLMN list handling

9.1.5.1.2.1 Test Purpose (TP)

(1)

```

with { The UE in 5GMM-REGISTERED-INITIATED state }
ensure that {
  when { UE receives a REGISTRATION ACCEPT with a new set of Equivalent PLMNs, then after Switch OFF and Switch ON }
  then { The UE deletes the old equivalent PLMN list and uses the new equivalent PLMN list }
}

```

(2)

```

with { The UE in 5GMM-REGISTERED-INITIATED state }
ensure that {
  when { UE receives a REGISTRATION ACCEPT that does not include Equivalent PLMNs, then after Switch
OFF and Switch ON }
    then { UE deletes the old equivalent PLMN list }
}

```

(3)

```

with { The UE in 5GMM-REGISTERED-INITIATED state }
ensure that {
  when { the UE receives a REGISTRATION ACCEPT that includes equivalent PLMN list, and the UE
detects that an entry in the equivalent PLMN list is also present in forbidden PLMN list }
    then { UE deletes the entry in equivalent PLMN list that is also present in forbidden PLMN list }
}
}

```

9.1.5.1.2.2 Conformance requirements

References: The conformance requirements covered in the present TC are specified in: TS 24.501, clauses 5.5.1.2.4 and 5.5.1.3.4. Unless otherwise stated these are Rel-15 requirements.

[TS 24.501, clause 5.5.1.2.4]

....

The AMF may also include a list of equivalent PLMNs in the REGISTRATION ACCEPT message. Each entry in the list contains a PLMN code (MCC+MNC). The UE shall store the list as provided by the network, and if the initial registration procedure is not for emergency services, the UE shall remove from the list any PLMN code that is already in the list of "forbidden PLMNs". In addition, the UE shall add to the stored list the PLMN code of the registered PLMN that sent the list. The UE shall replace the stored list on each receipt of the REGISTRATION ACCEPT message. If the REGISTRATION ACCEPT message does not contain a list, then the UE shall delete the stored list.

....

[TS 24.501, clause 5.5.1.3.4]

....

The AMF may also include a list of equivalent PLMNs in the REGISTRATION ACCEPT message. Each entry in the list contains a PLMN code (MCC+MNC). The UE shall store the list as provided by the network, and if there is no emergency PDU session established, the UE shall remove from the list any PLMN code that is already in the list of "forbidden PLMNs". If the UE is not registered for emergency services and there is an emergency PDU session established, the UE shall remove from the list of equivalent PLMNs any PLMN code present in the "forbidden PLMNs list" when the emergency PDU session is released. In addition, the UE shall add to the stored list the PLMN code of the registered PLMN that sent the list. The UE shall replace the stored list on each receipt of the REGISTRATION ACCEPT message. If the REGISTRATION ACCEPT message does not contain a list, then the UE shall delete the stored list.

....

9.1.5.1.2.3 Test description

9.1.5.1.2.3.1 Pre-test conditions

System Simulator:

- NGC Cell A and NGC Cell E and NGC Cell F are configured according to Table 6.3.2.2.1-1 in TS 38.508-1[4].
- System information combination NR-4 as defined in TS 38.508[4] clause 4.4.3.1.2 is used.

UE:

None.

Preamble:

- The UE is in state Switched OFF [State 0-A as per TS 38.508-1 [4] Table 4.4A.2-0].

9.1.5.1.2.3.2 Test procedure sequence

Table 9.1.5.1.2.3.2-1: Main behaviour

St	Procedure	Message Sequence		TP	Verdict
		U - S	Message		
1	The SS configures: - NGC Cell A as the "Serving cell". - NGC Cell E as the "Non-Suitable "off" cell". - NGC Cell F as the "Non-Suitable "off" cell".	-	-	-	-
2	The UE is Switched ON	-	-	-	-
-	The following messages are to be observed on NGC Cell A unless explicitly stated otherwise	-	-	-	-
3-14	Steps 2-13 of Table 4.5.2.2-2 of the generic procedure in TS 38.508-1 [4] are performed.	-	-	-	-
15	SS transmits a REGISTRATION ACCEPT message with PLMN ID of NGC Cell F included in the Equivalent PLMNs IE	<--	REGISTRATION ACCEPT	-	-
16-20a1	Steps 15-19a1 of Table 4.5.2.2-2 of the generic procedure in TS 38.508-1 [4] are performed.	-	-	-	-
21	The UE is switched off by executing generic procedure in Table 4.9.6.3-1 in TS 38.508-1 [4]	-	-	-	-
22	The UE is Switched ON	-	-	-	-
23-34	Steps 2-13 of Table 4.5.2.2-2 of the generic procedure in TS 38.508-1 [4] are performed.	-	-	-	-
35	SS transmits a REGISTRATION ACCEPT message with PLMN ID of NGC Cell E included in the Equivalent PLMNs IE	<--	REGISTRATION ACCEPT	-	-
36-40a1	Steps 15-19a1 of Table 4.5.2.2-2 of the generic procedure in TS 38.508-1 [4] are performed.	-	-	-	-
41	The UE is switched off by executing generic procedure in Table 4.9.6.3-1 in TS 38.508-1 [4].	-	-	-	-
42	The SS configures: - NGC Cell A as the "Non-Suitable "off" cell". - NGC Cell E as the "Suitable neighbour cell". - NGC Cell F as the "Serving cell".	-	-	-	-
43	The UE is Switched ON	-	-	-	-
-	The following messages are to be observed on NGC Cell E unless explicitly stated otherwise	-	-	-	-
44-62	Steps 2-20 of Table 4.5.2.2-2 of the generic procedure in TS 38.508-1 [4] are performed.	-	-	1	P
63	The UE is switched off by executing generic procedure in Table 4.9.6.1-1 in TS 38.508-1 [4].	-	-	-	-
64	The UE is Switched ON	-	-	-	-
-	The following messages are to be observed on NGC Cell F unless explicitly stated otherwise	-	-	-	-
65-76	Steps 2-13 of Table 4.5.2.2-2 of the generic procedure in TS 38.508-1 [4] are performed.	-	-	2	P
77	SS transmits a REGISTRATION REJECT with cause #11 (PLMN not allowed)	<--	REGISTRATION REJECT	-	-
78	The SS releases the RRC connection	-	-	-	-
79	The SS configures: - NGC Cell A as the "Serving cell". - NGC Cell E as the "Suitable neighbour cell". - NGC Cell F as the "Non-Suitable "off" cell".	-	-	-	-
-	The following messages are to be observed on NGC Cell A unless explicitly stated otherwise	-	-	-	-
80-93	Steps 2-13 of Table 4.5.2.2-2 of the generic procedure in TS 38.508-1 [4] are performed.	-	-	-	-
94	SS transmits a REGISTRATION ACCEPT message with PLMN ID of NGC Cell E and NGC Cell F included in the Equivalent PLMNs IE	<--	REGISTRATION ACCEPT	-	-
95-99a1	Steps 15-19a1 of Table 4.5.2.2-2 of the generic procedure in TS 38.508-1 [4] are performed.	-	-	-	-

100	The UE is switched off by executing generic procedure in Table 4.9.6.3-1 in TS 38.508-1 [4].	-	-	-	-
101	The SS configures: - NGC Cell A as the "Non-Suitable "off" cell ". - NGC Cell E as the "Suitable neighbour cell". - NGC Cell F as the "Serving cell".	-	-	-	-
-	The following messages are to be observed on NGC Cell E unless explicitly stated otherwise	-	-	-	-
102	The UE is Switched ON	-	-	-	-
103 - 121	Steps 2-20 of Table 4.5.2.2-2 of the generic procedure in TS 38.508-1 [4] are performed.	-	-	3	P
122	The UE is switched off by executing generic procedure in Table 4.9.6.1-1 in TS 38.508-1 [4].	-	-	-	-
123	The SS configures: - NGC Cell A as the "Non-Suitable "off" cell ". - NGC Cell E as the "Non-Suitable "off" cell ". - NGC Cell F as the "Serving cell".	-	-	-	-
124	The UE is Switched ON	-	-	-	-
-	The user is prompted to manually select PLMN of NGC Cell F	-	-	-	-
-	The following messages are to be observed on NGC Cell F unless explicitly stated otherwise	-	-	-	-
125 - 143	Steps 2-20 of Table 4.5.2.2-2 of the generic procedure in TS 38.508-1 [4] are performed.	-	-	-	-

9.1.5.1.2.3.3 Specific message contents

Table 9.1.5.1.2.3.3-1: REGISTRATION ACCEPT (step 15 Table 9.1.5.1.2.3.2-1)

Derivation Path: TS 38.508-1 [4], Table 4.7.1-7			
Information Element	Value/remark	Comment	Condition
Equivalent PLMNs	MCC=003, MNC=101	PLMN ID of NGC Cell F	

Table 9.1.5.1.2.3.3-2: REGISTRATION ACCEPT (step 35 Table 9.1.5.1.2.3.2-1)

Derivation Path: TS 38.508-1 [4], Table 4.7.1-7			
Information Element	Value/remark	Comment	Condition
Equivalent PLMNs	MCC=002, MNC=101	PLMN ID of NGC Cell E	

Table 9.1.5.1.2.3.3-3: REGISTRATION ACCEPT (step 94 Table 9.1.5.1.2.3.2-1)

Derivation Path: TS 38.508-1 [4], Table 4.7.1-7			
Information Element	Value/remark	Comment	Condition
Equivalent PLMNs	MCC=003, MNC=101 and MCC=002, MNC=101	PLMN ID of NGC Cell F and PLMN ID of NGC Cell E	

Table 9.1.5.1.2.3.3-4: REGISTRATION REJECT (step 77 Table 9.1.5.1.2.3.2-1)

Derivation Path: TS 38.508-1 [4], Table 4.7.1-9			
Information Element	Value/remark	Comment	Condition
5GMM Cause	'0000 1011'B	PLMN not allowed	

9.1.5.1.3 Initial registration / 5GS services / NSSAI handling

9.1.5.1.3.1 Test Purpose (TP)

(1)

```
with { UE has sent a REGISTRATION REQUEST message including requested NSSAI}
ensure that {
  when { UE receives REGISTRATION ACCEPT message with allowed NSSAI }
  then { UE shall replace any stored allowed NSSAI for the current PLMN with new allowed NSSAI for
the current PLMN }
}
```

(2)

```
with { UE has sent a REGISTRATION REQUEST message including Requested NSSAI}
ensure that {
  when { UE receives REGISTRATION ACCEPT message with Rejected NSSAI with reject cause "S-NSSAI not
available in the current PLMN" }
  then { UE shall add the rejected S-NSSAI(s) in the rejected NSSAI for the current PLMN and not
attempt to use the Rejected NSSAI in the current PLMN until switching off the UE or the UICC
containing the USIM is removed }
}
```

(3)

```
with { UE receives REGISTRATION ACCEPT message with Rejected NSSAI with reject cause "S-NSSAI not
available in the current PLMN" }
ensure that {
  when { UE has been switched off, then switched on }
  then { UE shall delete the stored Rejected NSAAI and shall send the NSSAI in Requested NSSAI IE
of the REGISTRATION REQUEST message as per the configured and Allowed NSSAI for current PLMN }
}
```

(4)

```
with { UE has sent a REGISTRATION REQUEST message including Requested NSSAI}
ensure that {
  when { UE receives REGISTRATION ACCEPT message with Rejected NSSAI with reject cause "S-NSSAI not
available in the current registration area" }
  then { UE shall add the rejected S-NSSAI(s) in the rejected NSSAI for the current PLMN and
registration area combination and not attempt to use the Rejected NSSAI in the current registration
area until switching off the UE, the UE moving out of the current registration area or the UICC
containing the USIM is removed }
}
```

(5)

```
with { UE receives REGISTRATION ACCEPT message with Rejected NSSAI with reject cause "S-NSSAI not
available in the current registration area" }
ensure that {
  when { UE has been moved out of the current registration area }
  then { UE shall delete the stored Rejected NSAAI for the current PLMN as well as registration
area combination and shall send the NSSAI in Requested NSSAI IE of the REGISTRATION REQUEST message
as per the configured and Allowed NSSAI for current PLMN }
}
```

9.1.5.1.3.2 Conformance requirements

References: The conformance requirements covered in the present TC are specified in: TS 24.501, clause 5.5.1.2.2 and 5.5.1.2.4. Unless otherwise stated these are Rel-15 requirements.

[TS 24.501 clause 5.5.1.2.2]

5.5.1.2.1 General

This procedure can be used by a UE for initial registration for 5GS services.

...

The UE shall include the requested NSSAI containing the S-NSSAI(s) corresponding to the slice(s) to which the UE wants to register and shall include the mapping of the requested NSSAI which is the mapping of each S-NSSAI of the requested NSSAI to the S-NSSAI(s) of the HPLMN, if available, in the REGISTRATION REQUEST message. If the UE has allowed NSSAI or configured NSSAI for the current PLMN, the requested NSSAI shall be either:

- a) the configured NSSAI for the current PLMN, or a subset thereof as described below, if the UE has no allowed NSSAI for the current PLMN;
- b) the allowed NSSAI for the current PLMN, or a subset thereof as described below, if the UE has an allowed NSSAI for the current PLMN; or
- c) the allowed NSSAI for the current PLMN, or a subset thereof as described below, plus one or more S-NSSAIs from the configured NSSAI for which no corresponding S-NSSAI is present in the allowed NSSAI and those are neither in the rejected NSSAI for the current PLMN nor in the rejected NSSAI for the current PLMN and registration area combination.

If the UE has neither allowed NSSAI for the current PLMN nor configured NSSAI for the current PLMN and has a default configured NSSAI, the UE shall:

- a) include the S-NSSAI(s) in the Requested NSSAI IE of the REGISTRATION REQUEST message using the default configured NSSAI; and
- b) include the Network slicing indication IE with the Default configured NSSAI indication bit set to "Requested NSSAI created from default configured NSSAI" in the REGISTRATION REQUEST message.

If the UE has no allowed NSSAI for the current PLMN, no configured NSSAI for the current PLMN, and no default configured NSSAI, the UE shall not include a requested NSSAI in the REGISTRATION message.

The subset of configured NSSAI provided in the requested NSSAI consists of one or more S-NSSAIs in the configured NSSAI applicable to the current PLMN, if the S-NSSAI is neither in the rejected NSSAI for the current PLMN nor in the rejected NSSAI for the current PLMN and registration area combination.

The subset of allowed NSSAI provided in the requested NSSAI consists of one or more S-NSSAIs in the allowed NSSAI for the current PLMN.

NOTE 3: How the UE selects the subset of configured NSSAI or allowed NSSAI to be provided in the requested NSSAI is implementation.

NOTE 4: The number of S-NSSAI(s) included in the requested NSSAI cannot exceed eight.

[TS 24.501 clause 5.5.1.2.4]

The AMF shall include the allowed NSSAI for the current PLMN and shall include the mapping of each S-NSSAI of the allowed NSSAI to the S-NSSAI(s) of the HPLMN contained in the requested NSSAI from the UE if available, in the REGISTRATION ACCEPT message if the UE included the requested NSSAI in the REGISTRATION REQUEST message and the AMF allows one or more S-NSSAIs in the requested NSSAI. The AMF may also include rejected NSSAI in the REGISTRATION ACCEPT message. Rejected NSSAI contains S-NSSAI(s) which was included in the requested NSSAI but rejected by the network associated with rejection cause(s).

The AMF may include a new configured NSSAI for the current PLMN in the REGISTRATION ACCEPT message if:

- a) the REGISTRATION REQUEST message did not include the requested NSSAI;
- b) the REGISTRATION REQUEST message included the requested NSSAI containing an S-NSSAI that is not valid in the serving PLMN; or
- c) the REGISTRATION REQUEST message included the Network slicing indication IE with the Default configured NSSAI indication bit set to "Requested NSSAI created from default configured NSSAI".

If a new configured NSSAI for the current PLMN is included in the REGISTRATION ACCEPT message, the AMF shall also include the mapping of the configured NSSAI for the current PLMN the S-NSSAI(s) of the to HPLMN if available in the REGISTRATION ACCEPT message. In this case the AMF shall start timer T3550 and enter state 5GMM-COMMON-PROCEDURE-INITIATED as described in subclause 5.1.3.2.3.3.

The AMF shall include the Network slicing indication IE with the Network slicing subscription change indication set to "Network slicing subscription changed" in the REGISTRATION ACCEPT message if the UDM has indicated that the

subscription data for network slicing has changed. In this case the AMF shall start timer T3550 and enter state 5GMM-COMMON-PROCEDURE-INITIATED as described in subclause 5.1.3.2.3.3.

The UE receiving the rejected NSSAI in the REGISTRATION ACCEPT message takes the following actions based on the rejection cause in the rejected NSSAI:

"S-NSSAI not available in the current PLMN"

The UE shall add the rejected S-NSSAI(s) in the rejected NSSAI for the current PLMN as specified in subclause 4.6.2.2 and not attempt to use this S-NSSAI in the current PLMN until switching off the UE or the UICC containing the USIM is removed.

"S-NSSAI not available in the current registration area"

The UE shall add the rejected S-NSSAI(s) in the rejected NSSAI for the current PLMN and registration area combination as specified in subclause 4.6.2.2 and not attempt to use this S-NSSAI in the current registration area until switching off the UE, the UE moving out of the current registration area or the UICC containing the USIM is removed.

If the UE did not include the requested NSSAI in the REGISTRATION REQUEST message or none of the requested NSSAI are present in the subscribed S-NSSAIs, and one or more subscribed S-NSSAIs (containing one or more S-NSSAIs each of which may be associated with a new S-NSSAI) marked as default are available, the AMF shall put the subscribed S-NSSAIs marked as default in the allowed NSSAI of the REGISTRATION ACCEPT message. The AMF shall determine a registration area such that all S-NSSAIs of the allowed NSSAI are available in the registration area.

9.1.5.1.3.3 Test description

9.1.5.1.3.3.1 Pre-test conditions

System Simulator:

- NGC Cell A belongs to Home PLMN and TAI-1 and set as serving cell;
- NGC Cell B belongs to Home PLMN and TAI-2 and set as Non-Suitable "Off" cell.
- NGC Cell C belongs to Home PLMN and TAI-3 and set as Non-Suitable "Off" cell.

UE:

- UE is previously registered on NGC Cell A using default message contents according to TS 38.508-1 [4];
- Empty URSP Configuration.

Preamble:

- The UE is in state Switched OFF (state ON-B) according to TS 38.508-1 [4].

9.1.5.1.3.3.2 Test procedure sequence

Table 9.1.5.1.3.3.2-1: Main behaviour

St	Procedure	Message Sequence		TP	Verdict
		U - S	Message		
1	The UE is switched on.	-	-	-	-
2	Check: Does UE transmit a REGISTRATION REQUEST message?	-->	REGISTRATION REQUEST	-	-
3-11	Steps 5 to 13 of the generic procedure for NR RRC_IDLE specified in TS 38.508-1 subclause 4.5.2 are performed.	-	-	-	-
12	The SS transmits a REGISTRATION ACCEPT message including Allowed NSSAI and Configured NSSAI.	<--	REGISTRATION ACCEPT	-	-
13-18	Steps 15 to 20 of the generic procedure for NR RRC_IDLE specified in TS 38.508-1 subclause 4.5.2 are performed.	-	-	-	-
19	Switch off procedure in RRC_Idle specified in TS 38.508-1 subclause 4.9.6.1 is performed.	-	-	-	-
20	The UE is brought back to operation or the USIM is inserted.	-	-	-	-
21	Check: Does UE transmit a REGISTRATION REQUEST message including Requested NSSAI?	-->	REGISTRATION REQUEST	1	P
22-30	Steps 5 to 13 of the generic procedure for NR RRC_IDLE specified in TS 38.508-1 subclause 4.5.2 are performed.	-	-	-	-
31	The SS transmits a REGISTRATION ACCEPT message including Allowed NSSAI and Rejected NSSAI.	<--	REGISTRATION ACCEPT	-	-
32-37	Steps 15 to 20 of the generic procedure for NR RRC_IDLE specified in TS 38.508-1 subclause 4.5.2 are performed.	-	-	-	-
38	The SS configures NGC Cell A as a "Non-suitable cell" and NGC Cell C as the "Serving cell".	-	-	-	-
39	Check: Does UE transmit a REGISTRATION REQUEST message including Requested NSSAI?	-->	REGISTRATION REQUEST	2	P
40-48	Steps 5 to 13 of the generic procedure for NR RRC_IDLE specified in TS 38.508-1 subclause 4.5.2 are performed.	-	-	-	-
49	The SS transmits a REGISTRATION ACCEPT message including Allowed NSSAI.	<--	REGISTRATION ACCEPT	-	-
50	The UE transmits a REGISTRATION COMPLETE message.	-->	REGISTRATION COMPLETE	-	-
51	The SS transmits an <i>RRCRelease</i> message..	-	-	-	-
52	Check: Is S-NSSAI=2 in the Rejected NSSAI list with cause "S-NSSAI not available in the current PLMN" associated with current PLMN using AT/MMI?	-	-	2	P
53	Switch off procedure in RRC_Idle specified in TS 38.508-1 subclause 4.9.6.1 is performed.	-	-	-	-
54	The UE is brought back to operation or the USIM is inserted	-	-	-	-
55	Check: Does UE transmit a REGISTRATION REQUEST message including Requested NSSAI?	-->	REGISTRATION REQUEST	3	P
56-64	Steps 5 to 13 of the generic procedure for NR RRC_IDLE specified in TS 38.508-1 subclause 4.5.2 are performed.	-	-	-	-
65	The SS transmits a REGISTRATION ACCEPT message including Allowed NSSAI and Rejected NSSAI.	<--	REGISTRATION ACCEPT	-	-
66-71	Steps 15 to 20 of the generic procedure for NR RRC_IDLE specified in TS 38.508-1 subclause 4.5.2 are performed.	-	-	-	-
72	Check: Is S-NSSAI=2 removed from the Rejected NSSAI list associated with current PLMN?	-	-	3	P

73	The SS configures NGC Cell C as the "Non-suitable cell" and NGC Cell B as the "Serving cell".	-	-	-	-
74	Check: Does UE transmit a REGISTRATION REQUEST message including Requested NSSAI?	-->	REGISTRATION REQUEST	4	P
75-83	Steps 5 to13 of the generic procedure for NR RRC_IDLE specified in TS 38.508-1 subclause 4.5.2 are performed.	-	-	-	-
84	The SS transmits a REGISTRATION ACCEPT message including Allowed NSSAI.	<--	REGISTRATION ACCEPT	-	-
85	The UE transmits a REGISTRATION COMPLETE message.	-->	REGISTRATION COMPLETE	-	-
86	The SS transmits an <i>RRCRelease</i> message.	-	-	-	-
87	Check: Is S-NSSAI=1 in the Rejected NSSAI list with cause "S-NSSAI not available in the current registration area" associated with current PLMN and registration area combination using AT/MMI?	-	-	4	P
88	The SS configures NGC Cell B as the "Non-suitable cell" and NGC Cell A as the "Serving cell".	-	-	-	-
89	Check: Does UE transmit a REGISTRATION REQUEST message including Requested NSSAI?	-->	REGISTRATION REQUEST	5	P
90-98	Steps 5 to13 of the generic procedure for NR RRC_IDLE specified in TS 38.508-1 subclause 4.5.2 are performed.	-	-	-	-
99	The SS transmits a REGISTRATION ACCEPT message including Allowed NSSAI.	<--	REGISTRATION ACCEPT	-	-
100	The UE transmits a REGISTRATION COMPLETE message.	-->	REGISTRATION COMPLETE	-	-
101	The SS transmits an <i>RRCRelease</i> message.	-	-	-	-
102	Check: Is S-NSSAI=1 removed from the Rejected NSSAI list associated with current PLMN and registration area combination?	-	-	5	P

9.1.5.1.3.3.3 Specific message contents

Table 9.1.5.1.3.3-1: REGISTRATION REQUEST (step 2, Table 9.1.5.1.3.3-1)

Derivation Path: 38.508-1 Table 4.7.1-6			
Information Element	Value/remark	Comment	Condition
5GS registration type value	'001'B	Initial registration	
Requested NSSAI		Note	
S-NSSAI IEI		S-NSSAI value 1	Note
Length of S-NSSAI contents	'00000001'B	SST	
SST	'00000001'B	1	
SD	Not Present		
Mapped configured SST	Not Present		
Mapped configured SD	Not Present		
Note:	S-NSSAI =1 will be always included from the allowed NSSAI list associated with PLMN of NCG Cell A by the UE but may include other S-NSSAI from Configured NSSAI list associated with PLMN of NCG Cell A if configured in the UE. See TS 24.501 sub-clause 5.5.1.2.1		

Table 9.1.5.1.3.3.2: REGISTRATION ACCEPT (step 12, Table 9.1.5.1.3.3.2-1)

Derivation Path: 38.508-1 Table 4.7.1-7			
Information Element	Value/remark	Comment	Condition
5GS registration result value	'001'B	3GPP access	
Allowed NSSAI			
S-NSSAI IEI		S-NSSAI value 1	
Length of S-NSSAI contents	'00000001'B	SST	
SST	'00000010'B	2	
SD	Not Present		
Mapped configured SST	Not Present		
Mapped configured SD	Not Present		
Configured NSSAI			
S-NSSAI IEI		S-NSSAI value 1	
Length of S-NSSAI contents	'00000001'B	SST	
SST	'00000001'B	1	
SD	Not Present		
Mapped configured SST	Not Present		
Mapped configured SD	Not Present		
S-NSSAI IEI		S-NSSAI value 2	
Length of S-NSSAI contents	'00000001'B	SST	
SST	'00000010'B	2	
SD	Not Present		
Mapped configured SST	Not Present		
Mapped configured SD	Not Present		

Table 9.1.5.1.3.3.3: PDU SESSION ESTABLISHMENT ACCEPT (step 15 , Table 9.1.5.1.3.3.2-1)

Derivation Path: 38.508-1 clause 4.7.2-2			
Information Element	Value/remark	Comment	Condition
S-NSSAI			
Length of S-NSSAI contents	'0000 0001'B	SST	
SST	'0000 0010'B	SST value 2	

Table 9.1.5.1.3.3.4: REGISTRATION REQUEST (step 21, Table 9.1.5.1.3.3.2-1)

Derivation Path: 38.508-1 Table 4.7.1-6			
Information Element	Value/remark	Comment	Condition
5GS registration type value	'001'B	Initial registration	
Requested NSSAI		Note	
S-NSSAI IEI		S-NSSAI value 1	
Length of S-NSSAI contents	'00000001'B	SST	
SST	'00000010'B	2	
SD	Not Present		
Mapped configured SST	Not Present		
Mapped configured SD	Not Present		
S-NSSAI IEI		S-NSSAI value 2	Note
Length of S-NSSAI contents	'00000001'B	SST	
SST	'00000001'B	1	
SD	Not Present		
Mapped configured SST	Not Present		
Mapped configured SD	Not Present		
Note:	S-NSSAI =2 will be always included by the UE from the allowed NSSAI list associated with PLMN of NCG Cell A but may include S-NSSAI =1 from Configured NSSAI list associated with PLMN of NCG Cell A. See TS 24.501 sub-clause 5.5.1.2.1		

Table 9.1.5.1.3.3.3-5: REGISTRATION ACCEPT (step 31, Table 9.1.5.1.3.3.2-1)

Derivation Path: 38.508-1 Table 4.7.1-7			
Information Element	Value/remark	Comment	Condition
5GS registration result value	'001'B	3GPP access	
Allowed NSSAI		Note	
S-NSSAI IEI		S-NSSAI value 1	Note
Length of S-NSSAI contents	'00000001'B	SST	
SST	'00000001'B	1	
SD	Not Present		
Mapped configured SST	Not Present		
Mapped configured SD	Not Present		
Rejected NSSAI			
Rejected S-NSSAI-1		Rejected S-NSSAI value 1	
Cause value	'0000'B	S-NSSAI not available in the current PLMN	
SST	'00000010'B	2	
SD	Not Present		
Note:	If UE has requested only S-NSSAI =2 in step 22 and S-NSSAI =2 is added in the Rejected NSSAI list by the SS then AMF/SS can include default subscribed S-NSSAIs in the allowed NSSAI of REGISTRATION ACCEPT message, see TS 24.501 sub-clause 5.5.1.2.4.		

Table 9.1.5.1.3.3.3-6: REGISTRATION REQUEST (step 39, Table 9.1.5.1.3.3.2-1)

Derivation Path: 38.508-1 Table 4.7.1-6			
Information Element	Value/remark	Comment	Condition
5GS registration type value	'011'B	mobility registration updating	
Requested NSSAI			
S-NSSAI IEI		S-NSSAI value 1	
Length of S-NSSAI contents	'00000001'B	SST	
SST	'00000001'B	1	
SD	Not Present		
Mapped configured SST	Not Present		
Mapped configured SD	Not Present		
PDU session status	PDU session IDs	PDU session IDs of the ACTIVE PDU sessions to be transferred to a new cell.	

Table 9.1.5.1.3.3.3-7: REGISTRATION ACCEPT (step 49, Table 9.1.5.1.3.3.2-1)

Derivation Path: 38.508-1 Table 4.7.1-7			
Information Element	Value/remark	Comment	Condition
5GS registration result value	'001'B	3GPP access	
Allowed NSSAI			
S-NSSAI IEI		S-NSSAI value 1	
Length of S-NSSAI contents	'00000001'B	SST	
SST	'00000001'B	1	
SD	Not Present		
Mapped configured SST	Not Present		
Mapped configured SD	Not Present		
PDU session status	PDU session IDs	PDU session IDs of the ACTIVE PDU sessions to be transferred to a new cell. Same value as sent by the UE in step 40.	

Table 9.1.5.1.3.3.3-8: REGISTRATION REQUEST (step 55, Table 9.1.5.1.3.3.2-1)

Derivation Path: 38.508-1 Table 4.7.1-6			
Information Element	Value/remark	Comment	Condition
5GS registration type value	'001'B	Initial registration	
Requested NSSAI		Note	
S-NSSAI IEI		S-NSSAI value 1	Note
Length of S-NSSAI contents	'00000001'B	SST	
SST	'00000001'B	1	
SD	Not Present		
Mapped configured SST	Not Present		
Mapped configured SD	Not Present		
S-NSSAI IEI		S-NSSAI value 1	
Length of S-NSSAI contents	'00000001'B	SST	
SST	'00000010'B	2	
SD	Not Present		
Mapped configured SST	Not Present		
Mapped configured SD	Not Present		
Note:	S-NSSAI =1 will be always included by the UE from the allowed NSSAI list associated with PLMN of NCG Cell C but may include S-NSSAI =2 from Configured NSSAI list associated with PLMN of NCG Cell C. See TS 24.501 sub-clause 5.5.1.2.1		

Table 9.1.5.1.3.3.3-9: REGISTRATION ACCEPT (step 65, Table 9.1.5.1.3.3.2-1)

Derivation Path: 38.508-1 Table 4.7.1-7			
Information Element	Value/remark	Comment	Condition
5GS registration result value	'001'B	3GPP access	
TAI list			
Type of list	'01'B	list of TACs belonging to one PLMN, with consecutive TAC values	
Number of elements	'00001'B	2 Elements	
TAC	PLMN =MCC/MNC stored in EF _{IMSI} TAC 1 = 2	TAI2, TAI 3	
Allowed NSSAI			
S-NSSAI IEI		S-NSSAI value 1	
Length of S-NSSAI contents	'00000001'B	SST	
SST	'00000010'B	2	
SD	Not Present		
Mapped configured SST	Not Present		
Mapped configured SD	Not Present		
Rejected NSSAI			
Rejected S-NSSAI-1		Rejected S-NSSAI value 1	
Cause value	'0001'B	S-NSSAI not available in the current registration area	
SST	'00000001'B	1	
SD	Not Present		
Note:	If UE has requested only S-NSSAI =1 in step 57 and S-NSSAI =1 is added in the Rejected NSSAI list by the SS then AMF/SS can include default subscribed S-NSSAIs in the allowed NSSAI of REGISTRATION ACCEPT message, see TS 24.501 sub-clause 5.5.1.2.4.		

Table 9.1.5.1.3.3.3-10: PDU SESSION ESTABLISHMENT ACCEPT (step 68 , Table 9.1.5.1.3.3.2-1)

Derivation Path: 38.508-1 clause 4.7.2-2			
Information Element	Value/remark	Comment	Condition
S-NSSAI			
Length of S-NSSAI contents	'0000 0001'B	SST	
SST	'0000 0010'B	SST value 2	

Table 9.1.5.1.3.3.3-11: REGISTRATION REQUEST (step 74, Table 9.1.5.1.3.3.2-1)

Derivation Path: 38.508-1 Table 4.7.1-6			
Information Element	Value/remark	Comment	Condition
5GS registration type value	'010'B	mobility registration updating	
Requested NSSAI		Note	
S-NSSAI IEI		S-NSSAI value 1	
Length of S-NSSAI contents	'00000001'B	SST	
SST	'00000001'B	2	
SD	Not Present		
Mapped configured SST	Not Present		
Mapped configured SD	Not Present		
PDU session status	PDU session IDs	PDU session IDs of the ACTIVE PDU sessions to be transferred to a new cell.	

Table 9.1.5.1.3.3.3-12: REGISTRATION ACCEPT (step 84, Table 9.1.5.1.3.3.2-1)

Derivation Path: 38.508-1 Table 4.7.1-7			
Information Element	Value/remark	Comment	Condition
5GS registration result value	'001'B	3GPP access	
Allowed NSSAI			
S-NSSAI IEI		S-NSSAI value 1	
Length of S-NSSAI contents	'00000010'B	SST	
SST	'00000001'B	2	
SD	Not Present		
Mapped configured SST	Not Present		
Mapped configured SD	Not Present		
PDU session status	PDU session IDs	PDU session IDs of the ACTIVE PDU sessions to be transferred to a new cell. Same value as sent by the UE in step 76.	

Table 9.1.5.1.3.3-13: REGISTRATION REQUEST (step 89, Table 9.1.5.1.3.3.2-1)

Derivation Path: 38.508-1 Table 4.7.1-6			
Information Element	Value/remark	Comment	Condition
5GS registration type value	'010'B	mobility registration updating	
Requested NSSAI		Note	
S-NSSAI IEI		S-NSSAI value 1	
Length of S-NSSAI contents	'00000001'B	SST	
SST	'00000001'B	2	
SD	Not Present		
Mapped configured SST	Not Present		
Mapped configured SD	Not Present		
S-NSSAI IEI		S-NSSAI value 1	
Length of S-NSSAI contents	'00000001'B	SST	
SST	'00000010'B	1	
SD	Not Present		
Mapped configured SST	Not Present		
Mapped configured SD	Not Present		
PDU session status	PDU session IDs	PDU session IDs of the ACTIVE PDU sessions to be transferred to a new cell.	
Note:	S-NSSAI =2 will be always included by the UE from the allowed NSSAI list associated with PLMN of NCG Cell A but may include S-NSSAI =1 from Configured NSSAI list associated with PLMN of NCG Cell A. See TS 24.501 sub-clause 5.5.1.2.1		

Table 9.1.5.1.3.3-14: REGISTRATION ACCEPT (step 99, Table 9.1.5.1.3.3.2-1)

Derivation Path: 38.508-1 Table 4.7.1-7			
Information Element	Value/remark	Comment	Condition
5GS registration result value	'001'B	3GPP access	
Allowed NSSAI			
S-NSSAI IEI		S-NSSAI value 1	
Length of S-NSSAI contents	'00000010'B	SST	
SST	'00000001'B	2	
SD	Not Present		
Mapped configured SST	Not Present		
Mapped configured SD	Not Present		
S-NSSAI IEI		S-NSSAI value 2	Note
Length of S-NSSAI contents	'00000001'B	SST	
SST	'00000001'B	1	
SD	Not Present		
Mapped configured SST	Not Present		
Mapped configured SD	Not Present		
PDU session status	PDU session IDs	PDU session IDs of the ACTIVE PDU sessions to be transferred to a new cell. Same value as sent by the UE in step 77.	
Note:	SS will send allowed NSSAIs based on the Requested NSSAIs sent by UE in step 89.		

9.1.5.1.4 Initial registration / 5GS services / MICO mode / TAI list handling

9.1.5.1.4.1 Test Purpose (TP)

(1)

with { The UE is in 5GMM-DEREGISTERED state and is switched off }

```

ensure that {
  when { the UE supports MICO mode and requests the use of MICO mode}
  then { the UE includes the MICO indication IE in the REGISTRATION REQUEST message }
}

```

(2)

```

with { The UE has received REGISTRATION ACCEPT message }
ensure that {
  when { the REGISTRATION ACCEPT message included MICO indication IE indicating "all PLMN
registration area allocated" }
  then { the UE treats all TAIs in the current PLMN as a registration area and deletes its old TAI
list }
}

```

(3)

```

with { The UE detecting a better NG cell in same PLMN }
ensure that {
  when { the UE treats all TAIs in the current PLMN as a registration area and has deleted its old
TAI list as a result of REGISTRATION ACCEPT message included MICO indication IE indicating "all PLMN
registration area allocated" }
  then { the UE does not perform the REGISTRATION procedure for mobility }
}

```

(4)

```

with { The UE detecting a better NG cell in a different PLMN }
ensure that {
  when { the UE transmits the REGISTRATION REQUEST }
  then { the UE sets the IE 5GS registration type to "mobility registration updating" and performs
a REGISTRATION procedure for Mobility }
}

```

9.1.5.1.4.2 Conformance requirements

References: The conformance requirements covered in the present TC are specified in: TS 24.501, clause 5.5.1.2.2 and 5.5.1.2.4. Unless otherwise stated these are Rel-15 requirements.

[TS 24.501, clause 5.5.1.2.2]

...

If the UE supports MICO mode and requests the use of MICO mode, then the UE shall include the MICO indication IE in the REGISTRATION REQUEST message.

...

[TS 24.501, clause 5.5.1.2.4]

...

The AMF shall include the MICO indication IE in the REGISTRATION ACCEPT message only if the MICO indication IE was included in the REGISTRATION REQUEST message, the AMF supports and accepts the use of MICO mode. If the AMF supports and accepts the use of MICO mode, the AMF may indicate "all PLMN registration area allocated" in the MICO indication IE in the REGISTRATION ACCEPT message. If "all PLMN registration area allocated" is indicated in the MICO indication IE, the AMF shall not assign and include the TAI list in the REGISTRATION ACCEPT message. If the REGISTRATION ACCEPT message included an MICO indication IE indicating "all PLMN registration area allocated", the UE shall treat all TAIs in the current PLMN as a registration area and delete its old TAI list.

...

9.1.5.1.4.3 Test description

9.1.5.1.4.3.1 Pre-test conditions

System Simulator:

- NGC Cell A, NGC Cell C and NGC Cell E are configured according to Table 6.3.2.2.1-1 in TS 38.508-1[4].

UE:

None.

Preamble:

- The UE is in state Switched OFF [State 0-A as per TS 38.508-1 Table 4.4A.2-0].

9.1.5.1.4.3.2 Test procedure sequence

Table 9.1.5.1.4.3.2-1: Main behaviour

St	Procedure	Message Sequence		TP	Verdict
		U - S	Message		
0	The SS configures: - NGC Cell A as the "Non-Suitable "off" cell". - NGC Cell C as the "Non-Suitable "off" cell". - NGC Cell E as the "Non-Suitable "off" cell".				
1	The UE is switched ON				
2	The user requests enabling of MICO mode by MMI or AT command	-		-	-
3	The SS configures: - NGC Cell A as the "Serving cell". - NGC Cell C as the "Non-Suitable "off" cell". - NGC Cell E as the "Non-Suitable "off" cell".	-		-	-
4-6	The UE establishes an RRC connection by executing steps 2–4 of Table 4.5.2.2-2 in TS38.508-1 [4].	-		-	-
7	Check : Does the UE transmit a REGISTRATION REQUEST message including IE MICO indication	-->	REGISTRATION REQUEST	1	P
8-16	Steps 5-13 of Table 4.5.2.2-2 of the generic procedure in TS 38508-1 [4] are performed	-		-	-
17	SS transmits a REGISTRATION ACCEPT message that includes IE MICO indication	<--	REGISTRATION ACCEPT	-	-
18	The SS releases the RRC Connection	-		-	-
19	The SS configures: - NGC Cell A as the "Non-suitable cell". - NGC Cell C as the "Serving cell". - NGC Cell E as the "Non-suitable cell".	-			
20	Check : Does the UE transmit a RRCSetupRequest on NGC Cell C ? This is checked for 60s	-->	NR RRC: <i>RRCSetupRequest</i>	2,3	F
21	The SS configures: - NGC Cell A as the "Non-suitable cell". - NGC Cell C as the "Non-suitable cell". - NGC Cell E as the "Serving cell".	-		-	-
	The following messages are to be observed on NGC Cell E unless explicitly stated otherwise				
22-24	The UE establishes an RRC connection by executing steps 2–4 of Table 4.5.2.2-2 in TS38.508-1 [4].	-		-	-
25	Check : Does the UE transmit a REGISTRATION REQUEST message with IE 5GS registration type set to "mobility registration updating"	-->	REGISTRATION REQUEST	4	P
26-27	Steps 4–5 of Table 4.9.5.2.2-1 in TS38.508-1 [4] are performed				

9.1.5.1.4.3.3 Specific message contents

Table 9.1.5.1.4.3.3-1: REGISTRATION REQUEST (step 6 Table 9.1.5.1.4.3.2-1)

Derivation Path: TS 38.508-1 [4], Table 4.7.1-6			
Information Element	Value/remark	Comment	Condition
5GS registration type			
5GS registration type value	'001'B	Initial registration	INITIAL
MICO indication	'0000'B		

Table 9.1.5.1.4.3.2: REGISTRATION ACCEPT (step 16 Table 9.1.5.1.4.3.2-1)

Derivation Path: TS 38.508 [4], Table 4.7.1-7			
Information Element	Value/remark	Comment	Condition
MICO Indication	'0001'B	All PLMN registration area allocated	
TAI list	Not present		

Table 9.1.5.1.4.3.3: REGISTRATION REQUEST (step 23 Table 9.1.5.1.4.3.2-1)

Derivation Path: TS 38.508-1 [4], Table 4.7.1-6			
Information Element	Value/remark	Comment	Condition
5GS registration type			
5GS registration type value	'010'B	Mobility registration updating	MOBILITY

9.1.5.1.5 Initial registration / Abnormal / Failure after 5 attempts

9.1.5.1.5.1 Test Purpose (TP)

(1)

```
with { The UE in 5GMM-REGISTERED-INITIATED state and T3510 timer expired }
ensure that {
  when { T3511 timer expires and registration attempt counter is less than 5 }
  then { UE restarts the initial registration procedure }
}
```

(2)

```
with { The UE in 5GMM-REGISTERED-INITIATED state }
ensure that {
  when { UE receives lower layer failure before the REGISTRATION ACCEPT or REGISTRATION REJECT
message is received }
  then { UE restarts the initial registration procedure }
}
```

(3)

```
with { The UE has sent initial REGISTRAION REQUEST message }
ensure that {
  when { UE receives a REGISTRATION REJECT message including 5GMM cause value #95 }
  then { UE deletes 5G-GUTI, last visited TAI and ngKSI, performs a PLMN selection after timer
T3502 timeout }
}
```

9.1.5.1.5.2 Conformance requirements

References: The conformance requirements covered in the present TC are specified in: TS 24.501, clauses 5.5.1.1, 5.5.1.2.7, and 10.2. Unless otherwise stated these are Rel-15 requirements.

[TS 24.501, clause 5.5.1.1]

Additionally, the registration attempt counter shall be reset when the UE is in sub state 5GMM-DEREGISTERED.ATTEMPTING-REGISTRATION or 5GMM-REGISTERED.ATTEMPTING-REGISTRATION-UPDATE, and:

- a new tracking area is entered;
- timer T3502 expires; or
- timer T3346 is started.

[TS 24.501, clause 5.5.1.2.7]

The following abnormal cases can be identified:

...

c) T3510 timeout.

The UE shall abort the registration procedure for initial registration and the NAS signalling connection, if any, shall be released locally if the initial registration request is not for emergency services. The UE shall proceed as described below.

d) REGISTRATION REJECT message, other 5GMM cause values than those treated in subclause 5.5.1.2.5, and cases of 5GMM cause value #22, if considered as abnormal cases according to subclause 5.5.1.2.5.

If the registration request is not an initial registration request for emergency services, upon reception of the 5GMM causes #95, #96, #97, #99 and #111 the UE should set the registration attempt counter to 5.

The UE shall proceed as described below.

e) Lower layer failure or release of the NAS signalling connection received from lower layers before the REGISTRATION ACCEPT or REGISTRATION REJECT message is received.

The UE shall abort the registration procedure for initial registration and proceed as described below.

...

For the cases c, d and e, the UE shall proceed as follows:

Timer T3510 shall be stopped if still running.

If the registration procedure is neither an initial registration for emergency services nor for establishing an emergency PDU session with registration type not set to "emergency registration", the registration attempt counter shall be incremented, unless it was already set to 5.

If the registration attempt counter is less than 5:

- if the initial registration request is not for emergency services, timer T3511 is started and the state is changed to 5GMM-DEREGISTERED.ATTEMPTING-REGISTRATION. When timer T3511 expires the registration procedure for initial registration shall be restarted, if still required.

If the registration attempt counter is equal to 5

- the UE shall delete 5G-GUTI, TAI list, last visited TAI, list of equivalent PLMNs and ngKSI, start timer T3502 and shall set the 5GS update status to 5U2 NOT UPDATED. The state is changed to 5GMM-DEREGISTERED.ATTEMPTING-REGISTRATION or optionally to 5GMM-DEREGISTERED.PLMN-SEARCH in order to perform a PLMN selection according to 3GPP TS 23.122 [5].

[TS 24.501, clause 10.2]

Table 10.2.1: Timers of 5GS mobility management – UE side

TIMER NUM.	TIMER VALUE	STATE	CAUSE OF START	NORMAL STOP	ON EXPIRY
T3510	15s	5GMM-REGISTERED-INITIATED	Transmission of REGISTRATION REQUEST message	REGISTRATION ACCEPT message received or REGISTRATION REJECT message received	Start T3511 or T3502 as specified in subclause 5.5.1.2.7 if T3510 expired during registration procedure for initial registration. Start T3511 or T3502 as specified in subclause 5.5.1.3.7 if T3510 expired during the registration procedure for mobility and periodic registration update
T3502	Default 12 min. NOTE 1	5GMM-REGISTERED	At registration failure and the attempt counter is equal to 5	Transmission of REGISTRATION REQUEST message	Initiation of the registration procedure, if still required
T3511	10s	5GMM-DEREGISTERED.ATTEMPTING-REGISTRATION 5GMM-REGISTERED.ATTEMPTING-REGISTRATION-UPDATE 5GMM-REGISTERED.NORMAL-SERVICE	At registration failure due to lower layer failure, T3510 timeout or registration rejected with other 5GMM cause values than those treated in subclause 5.5.1.2.5 for initial registration or subclause 5.5.1.3.5 for mobility and periodic registration	Transmission of REGISTRATION REQUEST message 5GMM-CONNECTED mode entered (NOTE 5)	Retransmission of the REGISTRATION REQUEST, if still required

9.1.5.1.5.3 Test description

9.1.5.1.5.3.1 Pre-test conditions

System Simulator:

- NGC Cell A is configured according to Table 6.3.2.2-1 in TS 38.508-1 [4].

UE:

None.

Preamble:

- The UE is in state 0-A according to TS 38.508-1 [4] Table 4.4A.2-0.

9.1.5.1.5.3.2 Test procedure sequence

Table 9.1.5.1.5.3.2-1: Main behaviour

St	Procedure	Message Sequence		TP	Verdict
		U - S	Message		
1	The SS configures: - NGC Cell A as the "Serving cell".	-	-	-	-
-	The following messages are to be observed on NGC Cell A unless explicitly stated otherwise.	-	-	-	-
2	The UE is switched on.	-	-	-	-
3-5	Steps 2-4 of Table 4.5.2.2-2 of the generic procedure in TS 38.508-1 [4] are performed and the UE transmits a REGISTRATION REQUEST with IE 5GS registration type set to "initial registration".	-->	REGISTRATION REQUEST	-	-
6	The SS waits 25 seconds (15 seconds T3510 and 10 seconds T3511). (UE's registration attempt counter = 1)	-	-	-	-
7	Check: Does the UE transmit a REGISTRATION REQUEST message with IE 5GS registration type set to "initial registration"?	-->	REGISTRATION REQUEST	1	P
8	Simulate lower layer failure and SS does not respond to the REGISTRATION REQUEST message. Note: How to Simulate lower layer failure is FFS.	-	-	-	-
9-11	Steps 2-4 of Table 4.5.2.2-2 of the generic procedure in TS 38.508-1 [4] are performed. Check: Does the UE transmit a REGISTRATION REQUEST message with IE 5GS registration type set to "initial registration"?	-->	REGISTRATION REQUEST	2	P
12-16	Steps 5-9 of Table 4.5.2.2-2 of the generic procedure in TS 38.508-1 [4] are performed.	-	-	-	-
17	The SS transmits a REGISTRATION REJECT with cause #95 (Semantically incorrect message). (UE's registration attempt counter = 5)	<--	REGISTRATION REJECT	-	-
18	Check: Does the UE transmit a REGISTRATION REQUEST message with IE 5GS registration type set to "initial registration" after 12 minutes after step 17? (UE's registration attempt counter has been reset to 0 after expiry of T3502)	-->	REGISTRATION REQUEST	3	P
19-34	Steps 5-20a1 of Table 4.5.2.2-2 of the generic procedure in TS 38.508-1 [4] are performed.	-	-	-	-
<p>NOTE 1: Steps 8-9 simulate the RRC connection failure needed in order for the UE "NAS layer" to receive an indication of "RRC Connection failure" from the lower layers. This is based on the following assumptions as specified in TS 38.331 [12], subclauses 5.3.10.1, 5.3.10.3, 5.3.11:</p> <p>(1) With the degradation of NGC Cell A the UE will receive N310 consecutive "out-of-sync" and start timer T310.</p> <p>(2) Because there will be no improvement in the cell situation the T310 will expire and the UE will report the RRC connection failure to the upper layers.</p> <p>Note that N310, T310 values are set in TS 38.508-1 [4], <i>RLF-TimersAndConstants</i>.</p>					

9.1.5.1.5.3.3 Specific message contents

Table 9.1.5.1.5.3.3-1: REGISTRATION REJECT (step 17, Table 9.1.5.1.5.3.2-1)

Derivation Path: 38.508-1 [4], Table 4.7.1-9			
Information Element	Value/remark	Comment	Condition
5GMM cause	'01011111'B	Cause #95 (Semantically incorrect message)	

Table 9.1.5.1.5.3.3-2: REGISTRATION REQUEST (step 18, Table 9.1.5.1.5.3.2-1)

Derivation Path: 38.508-1 [4], Table 4.7.1-6			
Information Element	Value/remark	Comment	Condition
ngKSI			
NAS key set identifier	'111'B	no key is available	
TSC	Any allowed value	TSC does not apply for NAS key set identifier value "111"	
5GS mobile identity	SUCI		
Last visited registered TAI	Not present		

Table 9.1.5.1.5.3.3-3: Void

9.1.5.1.6 Initial registration / Rejected / Illegal UE

9.1.5.1.6.1 Test Purpose (TP)

(1)

```

with { the UE in 5GMM-REGISTERED-INITIATED state }
ensure that {
  when { the SS sends a REGISTRATION REJECT message to the UE including an appropriate 5GMM cause value #3 (Illegal UE) }
  then { the UE deletes the stored 5G-GUTI, last visited registered TAI and ngKSI, deletes the list of equivalent PLMNs and enter state 5GMM-DEREGISTERED, the USIM is considered invalid until switching off the UE }
}

```

9.1.5.1.6.2 Conformance requirements

References: The conformance requirements covered in the present TC are specified in: TS 24.501 clause 5.5.1.2.5.

[TS 24.501, clause 5.5.1.2.5]

If the initial registration request cannot be accepted by the network, the AMF shall send a REGISTRATION REJECT message to the UE including an appropriate 5GMM cause value.

If the initial registration request is rejected due to general NAS level mobility management congestion control, the network shall set the 5GMM cause value to #22 "congestion" and assign a back-off timer T3346.

The UE shall take the following actions depending on the 5GMM cause value received in the REGISTRATION REJECT message.

#3 (Illegal UE); or

#6 (Illegal ME).

The UE shall set the 5GS update status to 5U3 ROAMING NOT ALLOWED (and shall store it according to subclause 5.1.3.2.2) and shall delete any 5G-GUTI, last visited registered TAI, TAI list and ngKSI. The UE shall consider the USIM as invalid for 5GS services until switching off or the UICC containing the USIM is removed. The UE shall delete the list of equivalent PLMNs and enter the state 5GMM-DEREGISTERED.

If the UE is operating in single-registration mode, the UE shall handle the EMM parameters EMM state, EPS update status, 4G-GUTI, TAI list and eKSI as specified in 3GPP TS 24.301 [15] for the case when the EPS attach request procedure is rejected with the EMM cause with the same value. The USIM shall be considered as invalid also for non-EPS services until switching off or the UICC containing the USIM is removed.

If the UE also supports the registration procedure over the other access, the UE shall in addition handle 5GMM parameters and 5GMM state for this access, as described for this 5GMM cause value.

9.1.5.1.6.3 Test description

9.1.5.1.6.3.1 Pre-test conditions

System Simulator:

- NGC Cell A is configured according to table 6.3.2.2-1 in TS 38.508-1 [4].

UE:

None.

Preamble:

- The UE is in state Switched OFF (state 0N-B) according to TS 38.508-1 [4].

9.1.5.1.6.3.2 Test procedure sequence

Table 9.1.5.1.6.3.2-1: Main behaviour

St	Procedure	Message Sequence		TP	Verdict
		U - S	Message		
1	The SS configures: - NGC cell A as the "Serving cell".	-	-	-	-
-	The following messages are to be observed on NGC Cell A unless explicitly stated otherwise.	-	-	-	-
2	The UE is switched on.	-	-	-	-
3-14	Steps 2-13 of Table 4.5.2.2-2 of the generic procedure in TS 38.508-1 [4] are performed.	-	-	-	-
15	The SS transmits a REGISTRATION REJECT message with the 5GMM cause set to 'Illegal UE' as specified.	<--	5GMM: REGISTRATION REJECT	-	-
16	The SS releases the RRC connection.	-	-	-	-
17	Check: Does the UE transmit an REGISTRATION REQUEST message on NGC cell A in the next 30 seconds?	-->	5GMM: REGISTRATION REQUEST	1	F
18	The user initiates Registration Request by MMI or by AT command.	-	-	-	-
19	Check: Does the UE transmit the REGISTRATION REQUEST message in the next 30 seconds?	-->	5GMM: REGISTRATION REQUEST	1	F
20	If possible (see ICS) switch off is performed or the USIM is removed. Otherwise the power is removed.	-	-	-	-
21	The UE is brought back to operation or the USIM is inserted. The UE is powered on or switched on.	-	-	-	-
22	Check: Does the UE transmit an REGISTRATION REQUEST message on NGC Cell A?	-->	5GMM: REGISTRATION REQUEST	1	P
23-38	Steps 5-20 of Table 4.5.2.2-2 of the generic procedure in TS 38.508-1 [4] are performed on NGC Cell B.	-	-	-	-

9.1.5.1.6.3.3 Specific message contents

Table 9.1.5.1.6.3.3-1: REGISTRATION REJECT (step 15, Table 9.1.5.1.6.3.2-1)

Derivation Path: TS 38.508-1 Table 4.7.1-9			
Information Element	Value/remark	Comment	Condition
5GMM cause	'0000 0011'B	Illegal UE	

Table 9.1.5.1.6.3.3-2: REGISTRATION REQUEST (step 22, Table 9.1.5.1.6.3.2-1)

Derivation path: 38.508-1 [4], table 4.7.1-6			
Information Element	Value/Remark	Comment	Condition
ngKSI			
NAS key set identifier	'111'B	no key is available (UE to network)	
TSC	Any allowed value	TSC does not apply for NAS key set identifier value "111"	
5GS mobile identity	The valid SUCI	.	
Last visited registered TAI	Not present		

9.1.5.1.7 Void

9.1.5.1.8 Initial registration / Rejected / Serving network not authorized

9.1.5.1.8.1 Test Purpose (TP)

(1)

```
with { The UE has sent initial REGISTRAION REQUEST message }
ensure that {
  when { the UE receives a REGISTRATION REJECT with cause #73 (Serving network not authorized) }
  then { the UE stores the PLMN identity in the "forbidden PLMN list" and does not attempt to
register on a cell belong to that PLMN }
}
```

9.1.5.1.8.2 Conformance requirements

References: The conformance requirements covered in the present TC are specified in: TS 24.501, clauses 5.5.1.2.5. Unless otherwise stated these are Rel-15 requirements.

[TS 24.501, clause 5.5.1.2.5]

If the initial registration request cannot be accepted by the network, the AMF shall send a REGISTRATION REJECT message to the UE including an appropriate 5GMM cause value.

If the initial registration request is rejected due to general NAS level mobility management congestion control, the network shall set the 5GMM cause value to #22 "congestion" and assign a back-off timer T3346.

The UE shall take the following actions depending on the 5GMM cause value received in the REGISTRATION REJECT message.

#3 (Illegal UE); or

#6 (Illegal ME).

....

#73 (Serving network not authorized).

The UE shall set the 5GS update status to 5U2 NOT UPDATED, reset the registration attempt counter, store the PLMN identity in the "forbidden PLMN list" and enter state 5GMM-DEREGISTERED.PLMN-SEARCH in order to perform a PLMN selection according to 3GPP TS 23.122 [5].

9.1.5.1.8.3 Test description

9.1.5.1.8.3.1 Pre-test conditions

System Simulator:

- 3 NGC Cells NGC Cell E, NGC Cell I and NGC Cell A are configured as specified in TS 38.508-1[4] table 6.3.2.2-1

UE:

- The UE is in Automatic PLMN selection mode.

Preamble:

- NGC Cell E is set to "Serving Cell".
- NGC Cell I is set to "Suitable neighbour cell".

- NGC Cell A is set to “Non-Suitable cell”.
- The UE is in state ON-B with a successful registration on NGC Cell E according to 38.508-1[4].

9.1.5.1.8.3.2 Test procedure sequence

Table 9.1.5.1.8.3.2-1: Main behaviour

St	Procedure	Message Sequence		TP	Verdict
		U - S	Message		
1	The UE is switched on	-	-	-	-
2-9	Steps 2-9 of Table 4.5.2.2-2 in TS38.508-1 [4] are performed on NGC Cell E.	-	-	-	-
10	The SS transmits a REGISTRATION REJECT with cause #73 (Serving network not authorized).	<--	REGISTRATION REJECT	-	-
11	The SS releases the RRC connection	-	-	-	-
12	Check: Does the UE send in the next 30 sec a request for RRC connection establishment on Cell E or Cell I.	-->	NR RRC: <i>RRCSetupRequest</i>	1	F
13	The SS configures - NGC Cell A as “Serving Cell”	-	-	-	-
14	Check: Does the UE perform Registration procedure on NGC Cell A as specified in TS 38.508-1 [4] subclause 4.5.2?	-	-	1	P
15	The SS configures - NGC Cell A as “Non-Suitable cell”	-	-	-	-
16	Set the UE in manual PLMN selection mode or request a PLMN search.	-	-	-	-
17	The user selects the PLMN of NGC Cell E.	-	-	-	-
18	The UE performs Registration procedure on NGC Cell E as specified in TS 38.508-1 [4] subclause 4.5.2 with ' <i>connected without release</i> '.	-	-	-	-
19	Set the UE in Automatic PLMN selection mode.	-	-	-	-

9.1.5.1.8.3.3 Specific message contents

Table 9.1.5.1.8.3.3-1: REGISTRATION REJECT (step 10 Table 9.1.5.1.8.3.2-1)

Derivation Path: TS 38.508-1 [4], Table 4.7.1-9			
Information Element	Value/remark	Comment	Condition
5GMM cause	'01001001'B	Cause #73 (Serving network not authorized)	

9.1.5.1.9 Initial registration / Abnormal / Change of cell into a new tracking area

9.1.5.1.9.1 Test Purpose (TP)

(1)

```
with { the UE in 5GMM-REGISTERED-INITIATED state }
ensure that {
  when { the UE receives transmission failure of REGISTRATION COMPLETE message indication with TAI
change from lower layers }
then { the UE restarts the registration procedure with 5G-GUTI allocated during the last
registration procedure }
}
```

9.1.5.1.9.2 Conformance requirements

References: The conformance requirements covered in the present TC are specified in: TS 24.501, clause 5.5.1.2.7.

[TS 24.501, clause 5.5.1.2.7]

The following abnormal cases can be identified:

...

h) Change of cell into a new tracking area.

If a cell change into a new tracking area occurs before the registration procedure for initial registration is completed, the registration procedure for initial registration shall be aborted and re-initiated immediately. If a tracking area border is crossed when the REGISTRATION ACCEPT message has been received but before a REGISTRATION COMPLETE message is sent, the registration procedure for initial registration shall be re-initiated. If a 5G-GUTI was allocated during the registration procedure, this 5G-GUTI shall be used in the registration procedure.

9.1.5.1.9.3 Test description

9.1.5.1.9.3.1 Pre-test conditions

System Simulator:

- NGC Cell A and NGC Cell B are configured according to Table 6.3.2.2-1 in TS 38.508-1 [4].

UE:

- the UE is previously registered on NGC, and when on NGC, the UE is last authenticated and registered on NGC cell A using default message contents according to TS 38.508-1 [4].

Preamble:

- The UE is in state Switched OFF (state ON-B) according to TS 38.508-1 [4].

9.1.5.1.9.3.2 Test procedure sequence

Table 9.1.5.1.9.3.2-1: Main behaviour

St	Procedure	Message Sequence		TP	Verdict
		U - S	Message		
1	The SS configures: - NGC cell A as the "Serving cell". - NGC cell B as the "Non-suitable cell".	-	-	-	-
-	The following messages are to be observed on NGC Cell A unless explicitly stated otherwise.	-	-	-	-
2	The UE is switched on.	-	-	-	-
3-14	Steps 2–13 of Table 4.5.2.2-2 in TS38.508-1 [4] are performed.	-	-	-	-
15	The SS transmits an REGISTRATION ACCEPT message with 5G-GUTI-1 assigned to UE.	<--	5GMM: REGISTRATION ACCEPT	-	-
16	The SS does not allocate UL grant for the REGISTRATION COMPLETE message on NGC Cell A	-	-	-	-
17	The SS configures: - NGC cell B as the "Serving cell". - NGC cell A as the "Non-suitable cell".	-	-	-	-
-	The following messages are to be observed on NGC Cell B unless explicitly stated otherwise.	-	-	-	-
18	Check: Does the UE transmit an REGISTRATION REQUEST message including the 5G-GUTI-1 assigned by the last registration procedure in step15?	-->	5GMM: REGISTRATION REQUEST	1	P
19-34	Steps 5–20 of Table 4.5.2.2-2 in TS38.508-1 [4] are performed	-	-	-	-

9.1.5.1.10 Initial registration / Rejected / PLMN not allowed

9.1.5.1.10.1 Test Purpose (TP)

(1)

```

with { the UE in 5GMM-REGISTERED-INITIATED state }
ensure that {
  when { the SS sends a REGISTRATION REJECT message to the UE including an appropriate 5GMM cause value #11 (PLMN not allowed) }
  then { the UE deletes any 5G-GUTI, last visited registered TAI, TAI list and ngKSI, deletes the list of equivalent PLMNs, stores the PLMN identity in the "forbidden PLMN list" and performs a PLMN selection }
}

```

(2)

```

with { the UE is operating in single-registration mode }
ensure that {
  when { the SS sends a REGISTRATION REJECT message to the UE including an appropriate 5GMM cause value #11 (PLMN not allowed) }
  then { the UE deletes the stored 4G-GUTI, last visited registered TAI, TAI list and eKSI, deletes the list of equivalent PLMNs, stores the PLMN identity in the "forbidden PLMN list" and performs a PLMN selection with EPC cells." }
}

```

9.1.5.1.10.2 Conformance requirements

References: The conformance requirements covered in the current TC are specified in: TS 24.501 clauses 5.5.1.2.5. Unless otherwise stated these are Rel-15 requirements.

[TS 24.501, clause 5.5.1.2.5]

If the initial registration request cannot be accepted by the network, the AMF shall send a REGISTRATION REJECT message to the UE including an appropriate 5GMM cause value.

If the initial registration request is rejected due to general NAS level mobility management congestion control, the network shall set the 5GMM cause value to #22 "congestion" and assign a back-off timer T3346.

The UE shall take the following actions depending on the 5GMM cause value received in the REGISTRATION REJECT message.

...

#11 (PLMN not allowed).

The UE shall set the 5GS update status to 5U3 ROAMING NOT ALLOWED (and shall store it according to subclause 5.1.3.2.2) and shall delete any 5G-GUTI, last visited registered TAI, TAI list and ngKSI. The UE shall delete the list of equivalent PLMNs and reset the registration attempt counter and store the PLMN identity in the "forbidden PLMN list". The UE shall enter state 5GMM-DEREGISTERED.PLMN-SEARCH and perform a PLMN selection according to 3GPP TS 23.122 [5].

If the UE is operating in single-registration mode, the UE shall in addition handle the EMM parameters EMM state, EPS update status, 4G-GUTI, last visited registered TAI, TAI list, eKSI and attach attempt counter as specified in 3GPP TS 24.301 [15] for the case when the EPS attach request procedure is rejected with the EMM cause with the same value.

If the REGISTRATION REJECT message is integrity protected and the UE also supports the registration procedure over the other access to the same PLMN, the UE shall in addition handle 5GMM parameters and 5GMM state for this access, as described for this 5GMM cause value.

9.1.5.1.10.3 Test description

9.1.5.1.10.3.1 Pre-test conditions

System Simulator:

- Four Cells are needed: Two NGC Cells (NGC cell G and NGC cell I) and two E-UTRAN Cells (cell I and cell J).
- The NGC cells are configured according to Table 6.3.2.2-1 and Table 6.3.2.2-3 in 38.508-1 [4], except replacing f3 with f1;
- The LTE cells are configured according to Table 6.3.2.2-1 and Table 6.3.2.2-3 in 36.508 [7], except replacing f3 and f4 with f1;

UE:

- the UE is previously registered on NGC, and when on NGC, the UE is last authenticated and registered on NGC cell G using default message contents according to TS 38.508-1 [4];
- the UE is previously registered on E-UTRAN, and when on E-UTRAN, the UE is last authenticated and registered on cell I using default message contents according to TS 36.508 [7];

Preamble:

- the UE is in state ON-B according to TS 38.508-1 [4].

9.1.5.1.10.3.2 Test procedure sequence

Table 9.1.5.1.10.3.2-1: Main behaviour

St	Procedure	Message Sequence		TP	Verdict
		U – S	Message		
1	The SS configures: - NGC Cell G as the "Serving cell". - NGC Cell I as a "Non-Suitable Off cell".	-	-	-	-
2	The following messages are to be observed on Cell G unless explicitly stated otherwise.	-	-	-	-
3	The UE is switched on.	-	-	-	-
4-11	Steps 2-9 of Table 4.5.2.2-2 of the generic procedure in TS 38.508-1 [4] are performed.	-	-	-	-
12	The SS transmits an REGISTRATION REJECT message including an appropriate 5GMM cause value #11 (PLMN not allowed).	<--	5GMM: REGISTRATION REJECT	-	-
13	The SS releases the RRC connection.	-	-	-	-
14	Check: Does the UE transmit an REGISTRATION REQUEST message on NGC cell G in the next 90 seconds?	-->	5GMM: REGISTRATION REQUEST	1	F
15	If possible (see ICS) switch off is performed or the USIM is removed. Otherwise the power is removed.	-	-	-	-
16	The UE is brought back to operation or the USIM is inserted. The UE is powered on or switched on.	-	-	-	-
17	Check: Does the UE transmit an REGISTRATION REQUEST message in the next 30 seconds?	-->	5GMM: REGISTRATION REQUEST	1	F
18	The SS configures: -NGC Cell G as the "Serving cell" -NGC Cell I as a "Suitable neighbour cell". -all LTE Cells as a "Non-Suitable Off cell"	-	-	-	-
19	The following messages are to be observed on NGC Cell I unless explicitly stated otherwise.	-	-	-	-
20-22	The UE establishes RRC connection by executing steps 2-4 of Table 4.5.2.2-2 in TS 38.508-1 [4].	-	-	-	-
23	Check: Does the UE transmit an REGISTRATION REQUEST message as specified?	-->	5GMM: REGISTRATION REQUEST	1	P
24-31	Steps 2-9 of Table 4.5.2.2-2 of the generic procedure in TS 38.508-1 [4] are performed.	-	-	-	-
32	The SS transmits an REGISTRATION REJECT message including an appropriate 5GMM cause value #11 (PLMN not allowed).	<--	5GMM: REGISTRATION REJECT	-	-
33	The SS releases the RRC connection.	-	-	-	-
-	EXCEPTION: Steps 34 to 72b1 describe behaviour that depends on the UE capability which support single-registration mode (see ICS, FFS).	-	-	-	-
34	The SS configures: -Cell I as the "Serving cell" -Cell J and all NGC Cells as a "Non-Suitable Off cell"	-	-	-	-
35	Check: Does the UE transmit an ATTACH REQUEST message on Cell I?	-->	EMM: ATTACH REQUEST	2	F
36	The SS configures: -Cell I as the "Serving cell" -Cell J as a "Suitable neighbour cell" -all NGC Cells as a "Non-Suitable Off cell" Note: Cell J doesn't belong to the forbidden PLMN.	-	-	-	-
37	The following messages are to be observed on Cell J unless explicitly stated otherwise.	-	-	-	-
38-40	The UE establishes RRC connection by executing steps 2-4 of TS 36.508 [7] sub clause 4.5.2.3.	-	-	-	-
41	Check: Does the UE transmit an ATTACH REQUEST message as specified?	-	EMM: ATTACH REQUEST	2	P

42-55b 1	The attach procedure is completed and the RRC connection is released by executing steps 5 to 18b1 of the UE registration procedure in TS 36.508 [7] clause 4.5.2.3.	-	-	-	-
56	The user sets the UE in manual PLMN selection mode or requests a PLMN search.	-	-	-	-
57	The SS configures: -Cell I as the "Serving cell" -Other Cells as a "Non-Suitable Off cell"	-	-	-	-
58	The user selects PLMN of Cell I.	-	-	-	-
59-72b 1	The attach procedure is completed and the RRC connection is released by executing steps 5 to 18b1 of the UE registration procedure in TS 36.508 [7] clause 4.5.2.3.	-	-	-	-
73	The SS configures: -NGC Cell I as the "Serving cell" -Other Cells as a "Non-Suitable Off cell"	-	-	-	-
74	The user selects PLMN of NGC Cell I.	-	-	-	-
75-93	Steps 2 to 20 of the registration procedure described in TS 38.508-1 [4] subclause 4.5.2 are performed on NGC Cell I.	-	-	-	-
94	The user sets the UE in Automatic PLMN selection mode.	-	-	-	-

9.1.5.1.10.3.3 Specific message contents

Table 9.1.5.1.10.3.3-1: Message REGISTRATION REJECT (step 12, step 29, Table 9.1.5.1.10.3.2-1)

Derivation path: 38.508-1 [4], table 4.7.1-9			
Information Element	Value/Remark	Comment	Condition
5GMM cause	'00001011'B	#11 "PLMN not allowed"	

Table 9.1.5.1.10.3.3-2: Message REGISTRATION REQUEST (step 23, Table 9.1.5.1.10.3.2-1)

Derivation path: 38.508-1 [4], table 4.7.1-6			
Information Element	Value/Remark	Comment	Condition
ngKSI			
NAS key set identifier	'111'B	no key is available (UE to network)	
TSC	Any allowed value	TSC does not apply for NAS key set identifier value "111"	
5GS mobile identity	The valid SUCI	.	
Last visited registered TAI	Not present		

Table 9.1.5.1.10.3.3-3: Message ATTACH REQUEST (step 41, Table 9.1.5.1.10.3.2-1)

Derivation Path: TS 36.508 [7], Table 4.7.2-4			
Information Element	Value/remark	Comment	Condition
NAS key set identifier			
NAS key set identifier	'111'B	no key is available	
TSC	Any allowed value	TSC does not apply for NAS key set identifier value "111".	
Old GUTI or IMSI	IMSI-1		
Last visited registered TAI	Not present		

9.1.5.1.11 Initial registration / Rejected / Tracking area not allowed

9.1.5.1.11.1 Test Purpose (TP)

(1)

```
with { the UE in 5GMM-REGISTERED-INITIATED state }
ensure that {
  when { the SS sends a REGISTRATION REJECT message to the UE including an appropriate 5GMM cause
value #12 (Tracking area not allowed)}
    then { the UE deletes any 5G-GUTI, last visited registered TAI, TAI list and ngKSI, stores the
current TAI in the list of "5GS forbidden tracking areas for regional provision of service". }
}
```

(2)

```
with { the UE is in 5GMM-DEREGISTERED.LIMITED-SERVICE state and the TAI of the current cell belongs
to the list of "forbidden tracking areas for regional provision of service"}
ensure that {
  when { the UE enters a cell belonging to a tracking area not in the list of "forbidden tracking
areas for regional provision of service"}
    then { the UE attempts to registration }
}
```

(3)

```
with { the UE is in 5GMM-DEREGISTERED.LIMITED-SERVICE state and the list of "forbidden tracking
areas for regional provision of service" contains more than one TAI}
ensure that {
  when { the UE selects a cell belonging to one of the TAIs in the list of "forbidden tracking areas
for regional provision of service" }
    then { the UE does not attempt to registration }
}
```

(4)

```
with { the UE is operating in single-registration mode }
ensure that {
  when { the SS sends a REGISTRATION REJECT message to the UE including an appropriate 5GMM cause
value #12 (Tracking area not allowed) }
    then { the UE deletes the stored 4G-GUTI, last visited registered TAI, TAI list and eKSI }
}
```

(5)

```
with { the UE is switched off or the UICC containing the USIM is removed }
ensure that {
  when { UE is powered on in the cell belonging to the TAI which was in the list of "forbidden
tracking areas for regional provision of service" before the UE was switched off or the USIM is
inserted again on that cell }
    then { UE performs registration on that cell }
}
```

9.1.5.1.11.2 Conformance requirements

References: The conformance requirements covered in the current TC are specified in: TS 24.501, clauses 5.5.1.2.5, 5.1.3.2.2, TS 24.301 clauses 5.3.2 and 5.5.1.2.5.

[TS 24.501, clause 5.5.1.2.5]

If the initial registration request cannot be accepted by the network, the AMF shall send a REGISTRATION REJECT message to the UE including an appropriate 5GMM cause value.

If the initial registration request is rejected due to general NAS level mobility management congestion control, the network shall set the 5GMM cause value to #22 "congestion" and assign a back-off timer T3346.

The UE shall take the following actions depending on the 5GMM cause value received in the REGISTRATION REJECT message.

...

#12 (Tracking area not allowed).

The UE shall set the 5GS update status to 5U3 ROAMING NOT ALLOWED (and shall store it according to subclause 5.1.3.2.2) and shall delete 5G-GUTI, last visited registered TAI, TAI list and ngKSI. Additionally, the UE shall reset the registration attempt counter.

The UE shall store the current TAI in the list of "5GS forbidden tracking areas for regional provision of service" and enter the state 5GMM-DEREGISTERED.LIMITED-SERVICE.

If the UE is operating in single-registration mode, the UE shall handle the EMM parameters EMM state, EPS update status, 4G-GUTI, last visited registered TAI, TAI list, eKSI and attach attempt counter as specified in 3GPP TS 24.301 [15] for the case when the EPS attach request procedure is rejected with the EMM cause with the same value.

[TS 24.501, clause 5.1.3.2.2]

In order to describe the detailed UE behaviour, the 5GS update (5U) status pertaining to a specific subscriber is defined.

The 5GS update status is stored in a non-volatile memory in the USIM if the corresponding file is present in the USIM, else in the non-volatile memory in the ME, as described in annex C.

The 5GS update status value is changed only after the execution of a registration, network-initiated de-registration, 5GS based primary authentication and key agreement, service request or paging procedure.

5U1: UPDATED

The last registration attempt was successful.

5U2: NOT UPDATED

The last registration attempt failed procedurally, e.g. no response or reject message was received from the AMF.

5U3: ROAMING NOT ALLOWED

The last registration, service request, or registration for mobility or periodic registration update attempt was correctly performed, but the answer from the AMF was negative (because of roaming or subscription restrictions).

[TS 24.501, clause 5.3.13]

The UE shall store a list of "5GS forbidden tracking areas for roaming", as well as a list of "5GS forbidden tracking areas for regional provision of service". Within the 5GS, these lists are managed independently per access type, i.e., 3GPP access or non-3GPP access. These lists shall be erased when

- a) the UE is switched off or the UICC containing the USIM is removed; and
- b) periodically (with a period in the range 12 to 24 hours).

Over 3GPP access, when the lists are erased, the UE performs cell selection according to 3GPP TS 38.304 [28]. A tracking area shall be removed from the list of "5GS forbidden tracking areas for roaming", as well as the list of "5GS forbidden tracking areas for regional provision of service", if the UE receives the tracking area in the TAI list or the Service area list of "allowed tracking areas" in REGISTRATION ACCEPT message or a CONFIGURATION UPDATE COMMAND message. The UE shall not remove the tracking area from "5GS forbidden tracking areas for roaming" or "5GS forbidden tracking areas for regional provision of service" if the UE is registered for emergency services.

In N1 mode, the UE shall update the suitable list whenever a REGISTRATION REJECT, SERVICE REJECT or DEREGISTRATION REQUEST message is received with the 5GMM cause #12 "tracking area not allowed", #13 "roaming not allowed in this tracking area", or #15 "no suitable cells in tracking area".

Each list shall accommodate 40 or more TAIs. When the list is full and a new entry has to be inserted, the oldest entry shall be deleted.

[TS 24.301, clause 5.3.2]

The UE shall store a list of "forbidden tracking areas for roaming", as well as a list of "forbidden tracking areas for regional provision of service". These lists shall be erased when the UE is switched off or when the UICC containing the USIM is removed, and periodically (with a period in the range 12 to 24 hours).

...

In S1 mode, the UE shall update the suitable list whenever an ATTACH REJECT, TRACKING AREA UPDATE REJECT, SERVICE REJECT or DETACH REQUEST message is received with the EMM cause #12 "tracking area not allowed", #13 "roaming not allowed in this tracking area", or #15 "no suitable cells in tracking area".

Each list shall accommodate 40 or more TAIs. When the list is full and a new entry has to be inserted, the oldest entry shall be deleted.

[TS 24.301, clause 5.5.1.2.5]

If the attach request cannot be accepted by the network, the MME shall send an ATTACH REJECT message to the UE including an appropriate EMM cause value.

...

Upon receiving the ATTACH REJECT message, if the message is integrity protected or contains a reject cause other than EMM cause value #25, the UE shall stop timer T3410.

...

#12 (Tracking area not allowed);

- The UE shall set the EPS update status to EU3 ROAMING NOT ALLOWED (and shall store it according to subclause 5.1.3.3) and shall delete any GUTI, last visited registered TAI and KSI. Additionally, the UE shall reset the attach attempt counter.
- If the UE is operating in single-registration mode, the UE shall in addition handle the 5GMM parameters as specified in 3GPP TS 24.501 [54] for the case when the initial registration procedure is rejected with the 5GMM cause with the same value.

9.1.5.1.11.3 Test description

9.1.5.1.11.3.1 Pre-test conditions

System Simulator:

- NGC Cell A (home PLMN), NGC Cell B (home PLMN, another TA) and NGC Cell C (home PLMN, different TA with NGC Cell A and NGC Cell B) are configured according to Table 6.3.2.2-1 in TS 38.508-1 [4].
- EUTRAN Cell A (home PLMN). The EUTRAN cell is configured according to Table 6.3.2.2-1 in 36.508 [7].
- System information combination NR-5 as defined in TS 38.508-1 [4] clause 4.4.3.1.2.

UE:

None.

Preamble:

- The UE is in state Switched OFF (state 0N-B) according to TS 38.508-1 [4].

9.1.5.1.11.3.2 Test procedure sequence

Table 9.1.5.1.11.3.2-1: Main behaviour

St	Procedure	Message Sequence		TP	Verdict
		U - S	Message		
1	The SS configures: - NGC Cell A as the "Serving cell". - NGC Cell B as a "Suitable Neighbour cell". - NGC Cell C and EUTRAN Cell A as "Non-suitable "Off" cell".	-	-	-	-
2	The UE is switched on.	-	-	-	-
3-14	Steps 2-13 of Table 4.5.2.2-2 of the generic procedure in TS 38.508-1 [4] are performed.	-	-	-	-
15	The SS transmits a REGISTRATION REJECT message, 5GMM cause value = #12 "Tracking area not allowed".	<--	REGISTRATION REJECT	-	-
16	The SS releases the RRC connection.	-	-	-	-
17	Check: Does the UE transmit the REGISTRATION REQUEST message in the next 30 seconds?	-->	REGISTRATION REQUEST	1	F
18	The SS reconfigures: - NGC cell B as the "Serving cell". - NGC cell A as a "Suitable Neighbour cell", - NGC Cell C and EUTRAN Cell A as "Non-suitable "Off" cell".	-	-	-	-
19	Check: Does the UE transmit the REGISTRATION REQUEST message on NGC Cell B?	-->	REGISTRATION REQUEST	1,2	P
20-26	Steps 5 to 11 from procedure in TS 38.508-1 [4] Table 4.5.2.2-2 are performed.	-	-	-	-
27	The SS transmits a REGISTRATION REJECT message, 5GMM cause value = #12 "Tracking area not allowed".	<--	REGISTRATION REJECT	-	-
28	The SS releases the RRC connection.	-	-	-	-
29	Check: Does the UE transmit the REGISTRATION REQUEST message in the next 30 seconds on NGC Cell A or NGC Cell B?	-->	REGISTRATION REQUEST	1,3	F
-	EXCEPTION: Steps 30 to 44 describe behaviour that depends on the UE capability which support single-registration mode (see ICS, FFS).	-	-	-	-
30	The SS configures: - EUTRAN Cell A as the "Serving cell". - all NGC Cells as "Non-suitable "Off" cell".	-	-	-	-
31	UE performs on EUTRAN cell A the Registration procedure as specified in TS 36.508 [7] clause 4.5.2.3.	-	-	-	-
32	The SS reconfigures: - NGC Cell C as the "Serving cell". - EUTRAN cell A and other NGC cells as "Non-suitable "Off" cell".	-	-	-	-
33	Check: Does the UE transmit the REGISTRATION REQUEST message on NGC Cell C?	-->	REGISTRATION REQUEST	-	-
34-40	Steps 5-11 of Table 4.5.2.2-2 of the generic procedure in TS 38.508-1 [4] are performed on NGC Cell C.	-	-	-	-
41	The SS transmits a REGISTRATION REJECT message, 5GMM cause value = #12 "Tracking area not allowed".	<--	REGISTRATION REJECT	-	-
42	The SS releases the RRC connection.	-	-	-	-
43	The SS configures: - EUTRAN Cell A as the "Serving cell". - all NGC Cells as "Non-suitable "Off" cell".	-	-	-	-
44	Check: Does the UE performs on EUTRAN Cell A the Registration procedure as specified in TS 36.508 [7] clause 4.5.2.3?	-	-	4	P
45	Switch off UE in RRC_IDLE as described in TS38.508-1 [4] subclause 4.9.6.1	-	-	-	-

46	The SS reconfigures: - NGC cell A as the "Serving cell". - EUTRAN Cell A and other NGC cells as "Non-suitable "Off" cell".	-	-	-	-
47	Switch on UE.	-	-	-	-
48	Check: Does the UE perform on NGC Cell A the Registration procedure as specified in TS 38.508-1 [4] Table 4.5.2.2-2, 'connected without release'?	-		5	

9.1.5.1.11.3.3 Specific message contents

Table 9.1.5.1.11.3.3-1: REGISTRATION REJECT (step 15, step 27, step 41, Table 9.1.5.1.11.3.2-1)

Derivation path: 38.508-1 [4] table 4.7.1-9			
Information Element	Value/remark	Comment	Condition
5GMM cause	'00001100'B	#12 "Tracking area not allowed"	

Table 9.1.5.1.11.3.3-2: REGISTRATION REQUEST (step 19, Table 9.1.5.1.11.3.2-1)

Derivation path: 38.508-1 [4] table 4.7.1-6			
Information Element	Value/Remark	Comment	Condition
ngKSI			
NAS key set identifier	'111'B	no key is available	
TSC	Any allowed value	TSC does not apply for NAS key set identifier value "111"	
5GS mobile identity	The valid SUCI	5G-GUTI has been deleted after receiving REGISTRATION REJECT; only SUCI is available.	

Table 9.1.5.1.11.3.3-3: REGISTRATION REQUEST (step 33, Table 9.1.5.1.11.3.2-1)

Derivation path: 38.508-1 [4] table 4.7.1-6			
Information Element	Value/Remark	Comment	Condition
5GS mobile identity	5G-GUTI	5G-GUTI has been mapped from 4G-GUTI	

Table 9.1.5.1.11.3.3-4: ATTACH REQUEST (step 43, Table 9.1.5.1.11.3.2-1; step 4, TS 36.508 [7] Table 4.5.2.3-1)

Derivation path: 36.508 [7] table 4.7.2-4			
Information Element	Value/remark	Comment	Condition
NAS key set identifier			
NAS key set identifier	'111'B	no key is available	
TSC	Any allowed value	TSC does not apply for NAS key set identifier value "111".	
Old GUTI or IMSI	IMSI-1		
Last visited registered TAI	Not present		

Table 9.1.5.1.11.3.3-5: REGISTRATION REQUEST (step 48, Table 9.1.5.1.11.3.2-1; step 4, TS 38.508-1 [4] Table 4.5.2.2.2-2)

Derivation path: 38.508-1 [4] table 4.7.1-6			
Information Element	Value/Remark	Comment	Condition
5GS mobile identity	5G-GUTI	5G-GUTI has been mapped from 4G-GUTI	

9.1.5.1.12 Initial registration / Rejected / Roaming not allowed in this tracking area

9.1.5.1.12.1 Test Purpose (TP)

(1)

```
with { the UE in 5GMM-REGISTERED-INITIATED state }
ensure that {
  when { the SS sends a REGISTRATION REJECT message to the UE including an appropriate 5GMM cause value #13 (Roaming not allowed in this tracking area)
  then { the UE deletes any 5G-GUTI, last visited registered TAI, TAI list and ngKSI, deletes the list of equivalent PLMNs, stores the current TAI in the list of "5GS forbidden tracking areas for roaming" }
}
```

(2)

```
with { the initial registration request cannot be accepted by the network }
ensure that {
  when { the SS sends a REGISTRATION REJECT message to the UE including an appropriate 5GMM cause value #13 (Roaming not allowed in this tracking area)}
  then { The UE performs a PLMN selection }
}
```

(3)

```
with { the UE is in 5GMM-DEREGISTERED.LIMITED-SERVICE or 5GMM-DEREGISTERED.PLMN-SEARCH state and the TAI of the current cell belongs to the list of "forbidden tracking areas for roaming"}
ensure that {
  when { the UE enters a cell belonging to a tracking area not in the list of "forbidden tracking areas for roaming"}
  then { the UE attempts to registration }
}
```

(4)

```
with { the UE is in 5GMM-DEREGISTERED.LIMITED-SERVICE or 5GMM-DEREGISTERED.PLMN-SEARCH state and the list of "forbidden tracking areas for roaming" contains more than one TAI}
ensure that {
  when { the UE selects a cell belonging to one of the TAIs in the list of "forbidden tracking areas for roaming" }
  then { the UE does not attempt to registration }
}
```

(5)

```
with { the UE is operating in single-registration mode }
ensure that {
  when { the SS sends a REGISTRATION REJECT message to the UE including an appropriate 5GMM cause value #13 (Roaming not allowed in this tracking area) }
  then { the UE deletes the stored 4G-GUTI, last visited registered TAI, TAI list and eKSI }
}
```

(6)

```
with { the UE is switched off or the UICC containing the USIM is removed }
ensure that {
```

```

when { UE is powered on in the cell belonging to the TAI which was in the list of "forbidden
tracking areas for roaming" before the UE was switched off or the USIM is inserted again on that
cell }
  then { UE performs registration on that cell }
}

```

9.1.5.1.12.2 Conformance requirements

References: The conformance requirements covered in the current TC are specified in: TS 24.501 clauses 5.5.1.2.5, 5.1.3.2.1, 5.1.3.2.2, TS 23.122 clauses 3.1, TS 24.301 clauses 5.3.2 and 5.5.1.2.5.

[TS 24.501, clause 5.5.1.2.5]

If the initial registration request cannot be accepted by the network, the AMF shall send a REGISTRATION REJECT message to the UE including an appropriate 5GMM cause value.

If the initial registration request is rejected due to general NAS level mobility management congestion control, the network shall set the 5GMM cause value to #22 "congestion" and assign a back-off timer T3346.

The UE shall take the following actions depending on the 5GMM cause value received in the REGISTRATION REJECT message.

...

#13 (Roaming not allowed in this tracking area).

The UE shall set the 5GS update status to 5U3 ROAMING NOT ALLOWED (and shall store it according to subclause 5.1.3.2.2) and shall delete 5G-GUTI, last visited registered TAI, TAI list and ngKSI. Additionally, the UE shall delete the list of equivalent PLMNs and reset the registration attempt counter.

The UE shall store the current TAI in the list of "5GS forbidden tracking areas for roaming" and enter the state 5GMM-DEREGISTERED.LIMITED-SERVICE or optionally 5GMM-DEREGISTERED.PLMN-SEARCH. The UE shall perform a PLMN selection according to 3GPP TS 23.122 [5].

If the UE is operating in single-registration mode, the UE shall handle the EMM parameters EMM state, EPS update status, 4G-GUTI, last visited registered TAI, TAI list, eKSI and attach attempt counter as specified in 3GPP TS 24.301 [15] for the case when the EPS attach request procedure is rejected with the EMM cause with the same value.

[TS 24.501, clause 5.1.3.2.1.3.3]

The sub state 5GMM-DEREGISTERED.LIMITED-SERVICE is chosen in the UE, when it is known that a selected cell for 3GPP access or TA for non-3GPP access is unable to provide normal service (e.g. the selected cell over 3GPP access is in a forbidden PLMN or is in a forbidden tracking area or TA for non-3GPP access is forbidden).

[TS 24.501, clause 5.1.3.2.1.3.5]

The sub state 5GMM-DEREGISTERED.PLMN-SEARCH is chosen in the UE, if the UE is searching for PLMNs. This sub state is left either when a cell has been selected (the new sub state is NORMAL-SERVICE or LIMITED-SERVICE) or when it has been concluded that no cell is available at the moment (the new sub state is NO-CELL-AVAILABLE).

This sub state is not applicable to non-3GPP access.

[TS 24.501, clause 5.1.3.2.2]

In order to describe the detailed UE behaviour, the 5GS update (5U) status pertaining to a specific subscriber is defined.

The 5GS update status is stored in a non-volatile memory in the USIM if the corresponding file is present in the USIM, else in the non-volatile memory in the ME, as described in annex C.

The 5GS update status value is changed only after the execution of a registration, network-initiated de-registration, 5GS based primary authentication and key agreement, service request or paging procedure.

5U1: UPDATED

The last registration attempt was successful.

5U2: NOT UPDATED

The last registration attempt failed procedurally, e.g. no response or reject message was received from the AMF.

5U3: ROAMING NOT ALLOWED

The last registration, service request, or registration for mobility or periodic registration update attempt was correctly performed, but the answer from the AMF was negative (because of roaming or subscription restrictions).

[TS 23.122, clause 3.1]

The tracking area is added to the list of "5GS forbidden tracking areas for roaming" which is stored in the MS. The MS shall then search for a suitable cell in the same PLMN but belonging to a tracking area which is not in the "5GS forbidden tracking areas for roaming" list.

[TS 24.301, clause 5.3.2]

The UE shall store a list of "forbidden tracking areas for roaming", as well as a list of "forbidden tracking areas for regional provision of service". These lists shall be erased when the UE is switched off or when the UICC containing the USIM is removed, and periodically (with a period in the range 12 to 24 hours).

...

In S1 mode, the UE shall update the suitable list whenever an ATTACH REJECT, TRACKING AREA UPDATE REJECT, SERVICE REJECT or DETACH REQUEST message is received with the EMM cause #12 "tracking area not allowed", #13 "roaming not allowed in this tracking area", or #15 "no suitable cells in tracking area".

Each list shall accommodate 40 or more TAIs. When the list is full and a new entry has to be inserted, the oldest entry shall be deleted.

[TS 24.301, clause 5.5.1.2.5]

If the attach request cannot be accepted by the network, the MME shall send an ATTACH REJECT message to the UE including an appropriate EMM cause value.

...

Upon receiving the ATTACH REJECT message, if the message is integrity protected or contains a reject cause other than EMM cause value #25, the UE shall stop timer T3410.

...

#13 (Roaming not allowed in this tracking area);

The UE shall set the EPS update status to EU3 ROAMING NOT ALLOWED (and shall store it according to subclause 5.1.3.3) and shall delete any GUTI, last visited registered TAI and KSI. The UE shall delete the list of equivalent PLMNs and reset the attach attempt counter.

...

If the UE is operating in single-registration mode, the UE shall in addition handle the 5GMM parameters as specified in 3GPP TS 24.501 [54] for the case when the initial registration procedure is rejected with the 5GMM cause with the same value.

9.1.5.1.12.3 Test description

9.1.5.1.12.3.1 Pre-test conditions

System Simulator:

-NGC cell C (MCC/MNC=MCC/MNC in USIM), NGC cell E (visited PLMN, mcc=002, mnc=101) and NGC cell I (visited PLMN, mcc=002, mnc=101, another TA) are configured according to Table 6.3.2.2-1 in TS 38.508-1 [4].

-E-UTRAN cell E is configured according to Table 6.3.2.2-1 in 36.508 [7].

-System information combination NR-5 as defined in TS 38.508-1 [4] clause 4.4.3.1.2.

UE:

None.

Preamble:

- The UE is in state Switched OFF (state ON-B) according to TS 38.508-1 [4] Table 4.4A.2-0.

9.1.5.1.12.3.2 Test procedure sequence

Table 9.1.5.1.12.3.2-1: Main behaviour

St	Procedure	Message Sequence		TP	Verdict
		U - S	Message		
1	The SS configures: - NGC cell E as the "Serving cell". - EUTRAN cell and other NGC cells as "Non-suitable "Off" cell".	-	-	-	-
2	The UE is switched on.	-	-	-	-
3-14	Steps 2-13 of Table 4.5.2.2-2 of the generic procedure in TS 38.508-1 [4] are performed.	-	-	-	-
15	The SS transmits a REGISTRATION REJECT message, 5GMM cause value = #13 " roaming not allowed in this tracking area ".	<--	REGISTRATION REJECT	-	-
16	The SS releases the RRC connection.	-	-	-	-
17	Check: Does the UE transmit the REGISTRATION REQUEST message in the next 30 seconds?	-->	REGISTRATION REQUEST	1	F
18	The SS reconfigures: - NGC cell I as the "Serving cell". - NGC cell E as a "Suitable Neighbour cell", - NGC cell C and EUTRAN cell E as "Non-suitable "Off" cell".	-	-	-	-
19	Check: Does the UE transmit the REGISTRATION REQUEST message on NGC Cell I?	-->	REGISTRATION REQUEST	1,3	P
20-26	Steps 5 to 11 from procedure in TS 38.508-1 [4] Table 4.5.2.2-2 are performed.	-	-	-	-
27	The SS transmits a REGISTRATION REJECT message, 5GMM cause value = #13 " roaming not allowed in this tracking area ".	<--	REGISTRATION REJECT	-	-
28	The SS releases the RRC connection.	-	-	-	-
29	Check: Does the UE transmit the REGISTRATION REQUEST message in the next 30 seconds on NGC cell I or NGC cell E?	-->	REGISTRATION REQUEST	1,4	F
-	EXCEPTION: Steps 30 to 44 describe behaviour that depends on the UE capability which support single-registration mode (see ICS, FFS).	-	-	-	-
30	The SS reconfigures: - EUTRAN cell E as the "Serving cell". - all NGC Cells as a "Non-suitable "Off" cell"	-	-	-	-
31	UE performs on EUTRAN Cell E the Registration procedure as specified in TS 36.508 [7] clause 4.5.2.3.	-	-	-	-
32	The SS reconfigures: - NGC Cell C as the "Serving cell". - EUTRAN cell E and other NGC cells as "Non-suitable "Off" cell".	-	-	-	-
33	Check: Does the UE transmit the REGISTRATION REQUEST message on NGC Cell C?	-->	REGISTRATION REQUEST	-	-
34-40	Steps 5-11 of Table 4.5.2.2-2 of the generic procedure in TS 38.508-1 [4] are performed on NGC Cell C.	-	-	-	-
41	The SS transmits a REGISTRATION REJECT message, 5GMM cause value = #13 " roaming not allowed in this tracking area ".	<--	REGISTRATION REJECT	-	-
42	The SS releases the RRC connection.	-	-	-	-
43	The SS configures: - EUTRAN Cell E as the "Serving cell ". - all NGC Cells as "Non-suitable "Off" cell".	-	-	-	-
44	Check: Does the UE performs on EUTRAN Cell E the Registration procedure as specified in TS 36.508 [7] clause 4.5.2.3?	-	-	5	P
45	Switch off UE in RRC_IDLE as described in TS38.508-1 [4] subclause 4.9.6.1.	-	-	-	-

46	The SS reconfigures: - NGC cell E as the "Serving cell". - EUTRAN cell E and other NGC cells as "Non-suitable "Off" cell".	-	-	-	-
47	Switch on UE.	-	-	-	-
48	Check: Does the UE transmit the REGISTRATION REQUEST message on NGC Cell E?	-->	REGISTRATION REQUEST	6	P
49-57	Steps 5 to 13 from procedure in TS 38.508-1 [4] Table 4.5.2.2-2 are performed.	-	-	-	-
58	The SS transmits a REGISTRATION REJECT message, 5GMM cause value = #13 "roaming not allowed in this tracking area".	<--	REGISTRATION REJECT	-	-
59	The SS releases the RRC connection.	-	-	-	-
60	The SS reconfigures: - NGC Cell E as the "Serving cell", - NGC Cell C as a "Suitable neighbour cell". - NGC Cell I and EUTRAN cell E as "Non-suitable "Off" cell".	-	-	-	-
61	Check: Does the UE perform on NGC Cell C the Registration procedure as specified in TS 38.508-1 [4] Table 4.5.2.2-2, 'connected without release'?	-	-	2	-

9.1.5.1.12.3.3 Specific message contents

Table 9.1.5.1.12.3.3-1: REGISTRATION REJECT (step 15, step 27, step 41, step 58, Table 9.1.5.1.12.3.2-1)

Derivation path: 38.508-1 [4] table 4.7.1-9			
Information Element	Value/remark	Comment	Condition
5GMM cause	'00001101'B	#13 "roaming not allowed in this tracking area"	

Table 9.1.5.1.12.3.3-2: REGISTRATION REQUEST (step 19, step 61, Table 9.1.5.1.12.3.2-1; step 4, TS 38.508-1 [4] Table 4.5.2.2-2)

Derivation path: 38.508-1 [4] table 4.7.1-6			
Information Element	Value/Remark	Comment	Condition
ngKSI			
NAS key set identifier	'111'B	no key is available	
TSC	Any allowed value	TSC does not apply for NAS key set identifier value "111"	
5GS mobile identity	The valid SUCI	5G-GUTI has been deleted after receiving REGISTRATION REJECT at step 4; only SUCI is available.	

Table 9.1.5.1.12.3.3-3: REGISTRATION REQUEST (step 33, step 48, Table 9.1.5.1.12.3.2-1)

Derivation path: 38.508-1 [4] table 4.7.1-6			
Information Element	Value/Remark	Comment	Condition
5GS mobile identity	5G-GUTI	5G-GUTI has been mapped from 4G-GUTI	

Table 9.1.5.1.12.3.3-4: ATTACH REQUEST (step 44, Table 9.1.5.1.12.3.2-1; step 4, TS 36.508 [7] Table 4.5.2.3-1)

Derivation path: 36.508 [7] table 4.7.2-4			
Information Element	Value/remark	Comment	Condition
NAS key set identifier	'111'B	no key is available	
TSC	Any allowed value	TSC does not apply for NAS key set identifier value "111".	
Old GUTI or IMSI	IMSI-1		
Last visited registered TAI	Not present		

9.1.5.1.13 Initial registration / Rejected / No suitable cells in tracking area

9.1.5.1.13.1 Test Purpose (TP)

(1)

```
with { the UE has sent initial REGISTRAION REQUEST message }
ensure that {
  when { the UE receives a REGISTRATION REJECT with cause #15 (No suitable cells in tracking area)}
  then { the UE sets the 5GS update status to 5U3 ROAMING NOT ALLOWED and delete any 5G-GUTI, last
visited registered TAI, TAI list and ngKSI }
}
```

(2)

```
with { the UE is in 5GMM-DEREGISTERED.LIMITED-SERVICE state and the current TAI in the list of
"forbidden tracking areas for roaming"}
ensure that {
  when { the UE re-selects a cell that belongs to the TAI where UE was rejected }
  then { the UE does not attempt to perform registration}
}
```

(3)

```
with { the UE has sent initial REGISTRAION REQUEST message }
ensure that {
  when { the UE receives a REGISTRATION REJECT with cause #15 (No suitable cells in tracking area)}
  then { the UE searches for a suitable cell in another tracking area }
}
```

9.1.5.1.13.2 Conformance requirements

References: The conformance requirements covered in the present TC are specified in: TS 24.501, clauses 5.5.1.2.5. Unless otherwise stated these are Rel-15 requirements.

[TS 24.501, clause 5.5.1.2.5]

If the initial registration request cannot be accepted by the network, the AMF shall send a REGISTRATION REJECT message to the UE including an appropriate 5GMM cause value.

If the initial registration request is rejected due to general NAS level mobility management congestion control, the network shall set the 5GMM cause value to #22 "congestion" and assign a back-off timer T3346.

The UE shall take the following actions depending on the 5GMM cause value received in the REGISTRATION REJECT message.

#3 (Illegal UE); or

#6 (Illegal ME).

....

#15 (No suitable cells in tracking area);

The UE shall set the 5GS update status to 5U3 ROAMING NOT ALLOWED (and shall store it according to subclause 5.1.3.2.2) and shall delete any 5G-GUTI, TAI list and ngKSI. Additionally, the UE shall reset the registration attempt counter.

The UE shall store the current TAI in the list of "5GS forbidden tracking areas for roaming" and enter the state 5GMM-DEREGISTERED.LIMITED-SERVICE. The UE shall search for a suitable cell in another tracking area according to 3GPP TS 38.304 [15].

9.1.5.1.13.3 Test description

9.1.5.1.13.3.1 Pre-test conditions

System Simulator:

- 3 cells, NGC Cell A and NGC Cell B belonging to TAI-1, NGC Cell C is in TAI-2. All Cells in the same PLMN.

UE:

- None.

Preamble:

- The UE is switched OFF.
- NGC Cell A is set to "Serving Cell".
- NGC Cell B is set to "Suitable neighbour cell".
- NGC Cell C is set to "Non-Suitable cell".

9.1.5.1.13.3.2 Test procedure sequence

Table 9.1.5.1.13.3.2-1: Main behaviour

St	Procedure	Message Sequence		TP	Verdict
		U - S	Message		
1	The UE is switched on	-	-	-	-
2-9	Steps 2-9 of Table 4.5.2.2-2 in TS38.508-1 [4] are performed on NGC Cell A.	-	-	-	-
10	The SS transmits a REGISTRATION REJECT with cause #15 (No suitable cells in tracking area).	<--	REGISTRATION REJECT	-	-
11	The SS releases the RRC connection	-	-	-	-
12	Check: Does the UE transmit a REGISTRATION REQUEST message on NGC Cell A or NGC Cell B in the next 30 seconds?	-->	REGISTRATION REQUEST	1,2	F
13	The SS configures - NGC Cell C as "Serving Cell"	-	-	-	-
14	Check: Does the UE transmit a REGISTRATION REQUEST message on NGC Cell C?	-->	REGISTRATION REQUEST	3	P
15-29	Steps 5-19a1 of Table 4.5.2.2-2 in TS38.508-1 [4] are performed.	-	-	-	-

9.1.5.1.13.3.3 Specific message contents

Table 9.1.5.1.13.3.3-1: REGISTRATION REJECT (step 10 Table 9.1.5.1.13.3.2-1)

Derivation Path: TS 38.508-1 [4], Table 4.7.1-9			
Information Element	Value/remark	Comment	Condition
5GMM cause	'00001111'B	Cause #15(No suitable cells in tracking area)	

Table 9.1.5.1.13.3.3-2: REGISTRATION REQUEST (step 14 Table 9.1.5.1.13.3.2-1)

Derivation Path: TS 38.508-1 [4], Table 4.7.1-6			
Information Element	Value/remark	Comment	Condition
ngKSI			
NAS key set identifier	'111'B	"No key is available"	
5GS mobile identity			
Type of identity	'001'B	5GS mobile identity is SUCI, 5G-GUTI has been deleted after receiving REGISTRATION REJECT at step 10.	
Last visited registered TAI	Not present	TAI has been deleted after receiving REGISTRATION REJECT at step 10.	

Table 9.1.5.1.13.3.3-3: Void

9.1.5.1.14 Initial registration / Rejected / Congestion / Abnormal cases / T3346

9.1.5.1.14.1 Test Purpose (TP)

(1)

```
with { The UE has sent initial REGISTRAION REQUEST message }
ensure that {
  when { UE receives a REGISTRATION REJECT with cause #22 (Congestion) with T3346 included and the
  UE is NOT configured for High Priority Access in the selected PLMN }
  then { UE does not start the Initial registration until T3346 expires }
}
```

(2)

```
with { The UE has received initial REGISTRATION REJECT with T3346 included }
ensure that {
  when { upon expiry of T3346 }
  then { UE starts the Initial registration procedure }
}
```

(3)

```
with { The UE has received initial REGISTRATION REJECT with T3346 included }
ensure that {
  when { the timer T3346 is running and the UE needs to perform initial registration for emergency
  services }
  then { UE starts the Initial registration procedure }
}
```



```

    }

```

(4)

```

with { The UE has received initial REGISTRATION REJECT with T3346 included }
ensure that {
  when { the timer T3346 is running and the UE detects a cell better than serving cell (S criterion
for detected cell > S criterion for serving cell )
    then { UE starts the Initial registration procedure on the detected cell }
}

```

9.1.5.1.14.2 Conformance requirements

References: The conformance requirements covered in the present TC are specified in: TS 24.501, clauses 5.5.1.2.5 and 5.5.1.2.7. Unless otherwise stated these are Rel-15 requirements.

[TS 24.501, clause 5.5.1.2.5]

If the initial registration request cannot be accepted by the network, the AMF shall send a REGISTRATION REJECT message to the UE including an appropriate 5GMM cause value.

If the initial registration request is rejected due to general NAS level mobility management congestion control, the network shall set the 5GMM cause value to #22 "congestion" and assign a back-off timer T3346.

The UE shall take the following actions depending on the 5GMM cause value received in the REGISTRATION REJECT message.

#3 (Illegal UE);

#6 (Illegal ME); or

....

#22 (Congestion).

If the T3346 value IE is present in the REGISTRATION REJECT message and the value indicates that this timer is neither zero nor deactivated, the UE shall proceed as described below; otherwise it shall be considered as an abnormal case and the behaviour of the UE for this case is specified in subclause 5.5.1.2.7.

The UE shall abort the initial registration procedure, set the 5GS update status to 5U2 NOT UPDATED and enter state 5GMM-DEREGISTERED.ATTEMPTING-REGISTRATION.

The UE shall stop timer T3346 if it is running.

If the REGISTRATION REJECT message is integrity protected, the UE shall start timer T3346 with the value provided in the T3346 value IE.

If the REGISTRATION REJECT message is not integrity protected, the UE shall start timer T3346 with a random value from the default range specified in 3GPP TS 24.008 [12].

The UE stays in the current serving cell and applies the normal cell reselection process. The initial registration procedure is started if still needed when timer T3346 expires or is stopped.

#27 (N1 mode not allowed).

The UE capable of S1 mode shall disable the N1 mode capability for both 3GPP access and non-3GPP access (see subclause 4.9).

Other values are considered as abnormal cases. The behaviour of the UE in those cases is specified in subclause 5.5.1.2.7.

[TS 24.501, clause 5.5.1.2.7]

The following abnormal cases can be identified:

- a) Timer T3346 is running.

The UE shall not start the registration procedure for initial registration unless:

- 1) the UE is a UE configured for high priority access in selected PLMN; or
- 2) the UE needs to perform the registration procedure for initial registration for emergency services.

The UE stays in the current serving cell and applies the normal cell reselection process.

NOTE 1: It is considered an abnormal case if the UE needs to initiate a registration procedure for initial registration while timer T3346 is running independent on whether timer T3346 was started due to an abnormal case or a non-successful case.

9.1.5.1.14.3 Test description

9.1.5.1.14.3.1 Pre-test conditions

System Simulator:

- NGC Cell A and NGC Cell B are configured according to Table 6.3.2.2.1-1 in TS 38.508-1[4].
- System information combination NR-2 as defined in TS 38.508[4] clause 4.4.3.1.2 is used.

UE:

None.

Preamble:

- The UE is in state Switched OFF [State 0-A as per TS 38.508-1 [4] Table 4.4A.2-0].

9.1.5.1.14.3.2 Test procedure sequence

Table 9.1.5.1.14.3.2-1: Main behaviour

St	Procedure	Message Sequence		TP	Verdict
		U - S	Message		
0	The SS configures: - NGC Cell A as the "Serving cell". - NGC Cell B as the "Non-Suitable "off" cell".	-		-	
0A	The UE is Switched/Powerd ON	-	-	-	-
1-12	Steps 2-13 of Table 4.5.2.2-2 of the generic procedure in TS 38.508-1 [4] are performed.	-		-	-
13	SS transmits a REGISTRATION REJECT message with cause #22 (Congestion) and T3346 set to 3 minutes. (Note 1)	<--	REGISTRATION REJECT	-	-
14	The SS releases the RRC connection	-		-	-
15	Check : Does the UE transmit a RRCSetupRequest on NGC Cell A (Note 1)	-->	NR RRC: <i>RRCSetupRequest</i>	1	F
16	Check : Does the UE transmit a RRCSetupRequest on NGC Cell A	-->	NR RRC: <i>RRCSetupRequest</i>	2	P
17-25	Steps 3-11 of Table 4.5.2.2-2 of the generic procedure in TS 38.508-1 [4] are performed.				
26	SS transmits a REGISTRATION REJECT message with cause #22 (Congestion) and T3346 set to 3 minutes. (Note 1)	<--	REGISTRATION REJECT	-	-
27	The SS releases the RRC connection	-			
28	The SS configures: - NGC Cell A as the "Non-suitable cell". - NGC Cell B as the "Serving cell".				
29	Check : Does the UE transmit a RRCSetupRequest on NGC Cell B within 3 minutes of Step 18 (Note 1)	-->	NR RRC: <i>RRCSetupRequest</i>	4	P
30-38	Steps 3-11 of Table 4.5.2.2-2 of the generic procedure in TS 38.508-1 [4] are performed.				
39	SS transmits a REGISTRATION REJECT message with cause #22 (Congestion) and T3346 set to 3 minutes. (Note 1)	<--	REGISTRATION REJECT	-	-
40	The SS releases the RRC connection	-		-	-
	The UE is made to establish an emergence PDU session. This can be done by an AT/MMI command				
41	Check : Does the UE transmit a RRCSetupRequest on NGC Cell B within 3 minutes of Step 39 indicating "emergency registration" (Note 1)	-->	NR RRC: <i>RRCSetupRequest</i>	3	P
42-43	Steps 3–4 of Table 4.5.2.2-2 in TS38.508-1 [4] are performed				
44	Check : Does the UE transmit a REGISTRATION REQUEST message with IE 5GS registration type set to "emergency registration"	-->	REGISTRATION REQUEST	3	P
45-59b1	Steps 5–19b1 of Table 4.5.2.2-2 in TS38.508-1 [4] are performed			-	-
Note 1: This is checked for 3 minutes less tolerance.					

9.1.5.1.14.3.3 Specific message contents

Table 9.1.5.1.14.3.3-1: REGISTRATION REJECT (steps 13, 28, 42 Table 9.1.5.1.14.3.2-1)

Derivation Path: TS 38.508-1 [4], Table 4.7.1-9			
Information Element	Value/remark	Comment	Condition
5GMM cause	'00010110'B	Cause #22 (Congestion)	
T3346 Value	'00100011'B	3 minutes	

Table 9.1.5.1.14.3.3-2: REGISTRATION REQUEST (step 47 Table 9.1.5.1.14.3.2-1)

Derivation Path: TS 38.508-1 [4], Table 4.7.1-6			
Information Element	Value/remark	Comment	Condition
5GS registration type			
5GS registration type value	'100'B	Emergency registration	EMERGEN CY

9.1.5.2 Mobility and periodic registration update

9.1.5.2.1 Mobility registration update / TAI list handling

9.1.5.2.1.1 Test Purpose (TP)

(1)

```

with { UE in state 5GMM-REGISTERED, and 5GMM-IDLE mode over 3GPP access }
ensure that {
  when { UE detects entering a tracking area which is not in the list of forbidden TAs and is not in
the list of tracking areas that the UE previously registered in the AMF }
  then { UE initiates and successfully completes the registration procedure for mobility
registration update }
}

```

(2)

```

with { UE in state 5GMM-REGISTERED, and 5GMM-IDLE mode over 3GPP access }
ensure that {
  when { UE detects entering a tracking area which is not in the list of forbidden TAs and is in the
list of tracking areas that the UE previously registered in the AMF }
  then { UE does not initiate the registration procedure for mobility registration update }
}

```

(3)

```

with { UE in state 5GMM-REGISTERED, and 5GMM-IDLE mode over 3GPP access }
ensure that {
  when { UE receives a new TAI list during a mobility registration update procedure }
  then { UE shall delete its old TAI list and store the received TAI list }
}

```

9.1.5.2.1.2 Conformance requirements

References: The conformance requirements covered in the present TC are specified in: TS 24.501, clauses 5.5.1.3.2, 5.5.1.3.4. Unless otherwise stated these are Rel-15 requirements.

[TS 24.501, clause 5.5.1.3.2]

The UE in state 5GMM-REGISTERED shall initiate the registration procedure for mobility and periodic registration update by sending a REGISTRATION REQUEST message to the AMF,

- a) when the UE detects entering a tracking area that is not in the list of tracking areas that the UE previously registered in the AMF;

...

If case b) is the only reason for initiating the registration procedure for mobility and periodic registration update, the UE shall indicate "periodic registration updating" in the 5GS registration type IE; otherwise the UE shall indicate "mobility registration updating".

...

After sending the REGISTRATION REQUEST message to the AMF the UE shall start timer T3510. If timer T3502 is currently running, the UE shall stop timer T3502. If timer T3511 is currently running, the UE shall stop timer T3511.

If the last visited registered TAI is available, the UE shall include the last visited registered TAI in the REGISTRATION REQUEST message.

The UE shall handle the 5GS mobility identity IE in the REGISTRATION REQUEST message as follows:

...

- b) for all other cases, if the UE holds a valid 5G-GUTI, the UE shall indicate the 5G-GUTI in the 5GS mobile identity IE.

...

When the registration procedure for mobility and periodic registration update is initiated in 5GMM-IDLE mode, the UE may include a PDU session status IE in the REGISTRATION REQUEST message, indicating which PDU sessions associated with the access type the REGISTRATION REQUEST message is sent over are active in the UE.

...

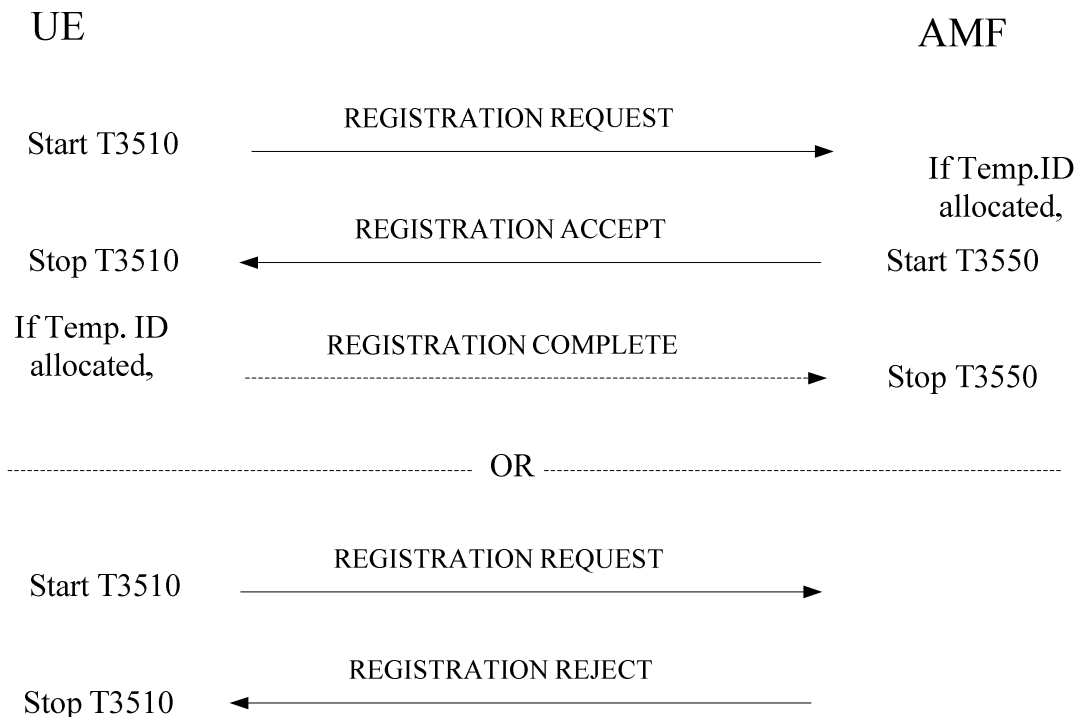

Figure 5.5.1.3.2.1: Registration procedure for mobility and periodic registration update

[TS 24.501, clause 5.5.1.3.4]

The AMF shall assign and include a TAI list as a registration area the UE is registered to in the REGISTRATION ACCEPT message. The UE, upon receiving a REGISTRATION ACCEPT message, shall delete its old TAI list and

store the received TAI list. If the REGISTRATION REQUEST message was received over non-3GPP access, the AMF shall include only the N3GPP TAI in the TAI list.

...

Upon receipt of the REGISTRATION ACCEPT message, the UE shall reset the registration attempt counter, enter state 5GMM-REGISTERED and set the 5GS update status to 5U1 UPDATED.

...

If the REGISTRATION ACCEPT message contains a 5G-GUTI, the UE shall return a REGISTRATION COMPLETE message to the AMF to acknowledge the received 5G-GUTI, stop timer T3519 if running, and delete any stored SUCI.

9.1.5.2.1.3 Test description

9.1.5.2.1.3.1 Pre-test conditions

System Simulator:

- 3 cells, NGC Cell A, and NGC Cell B and NGC Cell D belonging to the same PLMN and different TA in accordance with TS 38.508-1 [4] Table 6.3.2.2-1
- Default system information combination as defined in TS 38.508-1 [4], sub-clause 4.4.3.1.2 is used in all cells when active.

UE:

None.

Preamble:

- Cell configuration " in accordance with TS 38.508-1 [4] Table 6.3.2.2-1:
 - NGC Cell A "Serving cell"
 - NGC Cell B "Non-Suitable cell"
 - NGC Cell D "Non-Suitable cell"
- The UE is in test state [1N-A as defined in 38.508-1 \[4\], subclause 4.4A](#) on NGC Cell A.
- During the initial registration:
 - In the list of tracking areas provided by the AMF (IE 'TAI list') contains only the TAI of NGC Cell A.

9.1.5.2.1.3.2 Test procedure sequence

Table 9.1.5.2.1.3.2-1: Main behaviour

St	Procedure	Message Sequence		TP	Verdict
		U - S	Message		
1	The SS configures: - NGC Cell B as "Serving cell" - NGC Cell A as "Non-Suitable cell".	-	-	-	-
2	Check: Does the UE perform on NGC Cell B the Registration procedure for mobility registration update by executing the Test procedure to check that UE is camped on a new cell belonging to a new TA as specified in TS 38.508-1 [4] subclause 4.9.5? NOTE: During the procedure the SS assigns a TAI list containing the TAI of NGC Cell B and NGC Cell D.	-	-	1	-
3	The SS configures: - NGC Cell D as "Serving cell" - NGC Cell B as "Non-Suitable cell".	-	-	-	-
4	Check: Does the UE send in the next 30 sec a request for RRC connection establishment.	-->	NR RRC: <i>RRCSetupRequest</i>	2	F
5	Check: Does the result of generic test procedure in TS 38.508-1 [4] subclause 4.9.4 indicate that the UE is in 5GC RRC_IDLE state on the NGC Cell D?	-	-	2	-
6	The SS configures: - NGC Cell A as "Serving cell" - NGC Cell D as "Non-Suitable cell".	-	-	-	-
7	Check: Does the UE perform on NGC Cell A the Registration procedure for mobility registration update as specified in TS 38.508-1 [4] subclause 4.9.5, ' <i>connected without release</i> '?	-	-	3	-

9.1.5.2.1.3.3 Specific message contents

Table 9.1.5.2.1.3.3-1: REGISTRATION REQUEST (step 2, Table 9.1.5.2.1.3.2-1; step 3, TS 38.508-1 [4] Table 4.9.5.2.2-1)

Derivation Path: 38.508-1 [4], Table 4.7.1-6.			
Information Element	Value/remark	Comment	Condition
5GS registration type	'00xxx010'	mobility registration updating x - not checked	
5GS mobile identity	Active 5G-GUTI assigned in the preamble		
5GMM capability	Any value		
Last visited registered TAI	The TAI of the NGC Cell A, see TS 38.508-1 [4] Table 6.3.2.2-1		
S1 UE network capability	If included then Any value	Shall be included if S1 mode indicated as supported in the IE '5GMM capability'	

Table 9.1.5.2.1.3.3-2: REGISTRATION ACCEPT (step 2, Table 9.1.5.2.1.3.2-1; step 4, TS 38.508-1 [4] Table 4.9.5.2.2-1)

Derivation Path: 38.508-1 [4], Table 4.7.1-7.			
Information Element	Value/remark	Comment	Condition
5GS registration result			
5GS registration result value	'001'	3GPP access	
SMS allowed	'0'	SMS over NAS not allowed	
5G-GUTI	A 5G-GUTI different to the one provided by the UE in the REGISTRATION REQUEST		
TAI list			
Type of list	"00"	list of TACs belonging to one PLMN, with non-consecutive TAC values	
MCC	The MCC of the PLMN to which the NGC Cell A, NGC Cell B and NGC Cell D belong to, see TS 38.508-1 [4] Table 6.3.2.2-1		
MNC	The MNC of the PLMN to which the NGC Cell A, NGC Cell B and NGC Cell D belong to, see TS 38.508-1 [4] Table 6.3.2.2-1		
TAC 1	The TAI of the NGC Cell B, see TS 38.508-1 [4] Table 6.3.2.2-1		
TAC 2	The TAI of the NGC Cell D, see TS 38.508-1 [4] Table 6.3.2.2-1		
PDU session status	If PDU session status was included in the REGISTRATION REQUEST, the indicated as active PDN sessions shall be confirmed as active		

Table 9.1.5.2.1.3.3-3: REGISTRATION REQUEST (step 7, Table 9.1.5.2.1.3.2-1; step 3, TS 38.508-1 [4] Table 4.9.5.2.2-1)

Derivation Path: 38.508-1 [4], Table 4.7.1-6.			
Information Element	Value/remark	Comment	Condition
5GS registration type	'00xxx010'	mobility registration updating x - not checked	
5GS mobile identity	Active 5G-GUTI assigned in Table 9.1.5.2.1.3.3-2: REGISTRATION ACCEPT		
5GMM capability	Any value		
Last visited registered TAI	The TAI of the NGC Cell D, see TS 38.508-1 [4] Table 6.3.2.2-1		
S1 UE network capability	If included then Any value	Shall be included if S1 mode indicated as supported in the IE '5GMM capability'	

Table 9.1.5.2.1.3.3-4: REGISTRATION ACCEPT (step 7, Table 9.1.5.2.1.3.2-1; step 4, TS 38.508-1 [4] Table 4.9.5.2.2-1)

Derivation Path: 38.508-1 [4], Table 4.7.1-7.			
Information Element	Value/remark	Comment	Condition
5GS registration result			
5GS registration result value	'001'	3GPP access	
SMS allowed	'0'	SMS over NAS not allowed	
5G-GUTI	Active 5G-GUTI assigned in the preamble		
TAI list			
Type of list	"00"	list of TACs belonging to one PLMN, with non-consecutive TAC values	
MCC	The MCC of the PLMN to which the NGC Cell A, NGC Cell B and NGC Cell D belong to, see TS 38.508-1 [4] Table 6.3.2.2-1		
MNC	The MNC of the PLMN to which the NGC Cell A, NGC Cell B and NGC Cell D belong to, see TS 38.508-1 [4] Table 6.3.2.2-1		
TAC 1	The TAI of the NGC Cell A, see TS 38.508-1 [4] Table 6.3.2.2-1		
PDU session status	If PDU session status was included in the REGISTRATION REQUEST, the indicated as active PDU sessions shall be confirmed as active		

9.1.5.2.2 Periodic registration update / Accepted

9.1.5.2.2.1 Test Purpose (TP)

(1)

```
with { the UE in 5GMM-REGISTERED state and 5GMM-IDLE mode over 3GPP access }
ensure that {
  when { the periodic registration updating timer T3512 expires }
  then { the UE initiates the registration procedure for mobility and periodic registration update
and indicates "periodic registration updating" in the 5GS registration type IE }
}
```

(2)

```
with { the UE in 5GMM-REGISTERED-INITIATED state }
ensure that {
  when { the UE receives an REGISTRATION ACCEPT message included a new T3512 value IE }
  then { the UE uses the new value in T3512 value IE as periodic registration update timer (T3512)
}
}
```

9.1.5.2.2.2 Conformance requirements

References: The conformance requirements covered in the present TC are specified in: TS 24.501, clauses 5.5.1.3.1, 5.5.1.3.2 and 5.5.1.3.4. Unless otherwise stated these are Rel-15 requirements.

[TS 24.501, clause 5.5.1.3.1]

This procedure is used by a UE for both mobility and periodic registration update of 5GS services. This procedure, when used for periodic registration update of 5GS services, is performed only in 3GPP access.

This procedure used for periodic registration update of 5GS services is controlled in the UE by timer T3512. When timer T3512 expires, the registration procedure for mobility and periodic registration area updating is started. Start and reset of timer T3512 is described in subclause 10.2.

[TS 24.501, clause 5.5.1.3.2]

The UE in state 5GMM-REGISTERED shall initiate the registration procedure for mobility and periodic registration update by sending a REGISTRATION REQUEST message to the AMF,

- a) when the UE detects entering a tracking area that is not in the list of tracking areas that the UE previously registered in the AMF;
- b) when the periodic registration updating timer T3512 expires;

...

If item b) is the only reason for initiating the registration procedure for mobility and periodic registration update, the UE shall indicate "periodic registration updating" in the 5GS registration type IE; otherwise the UE shall indicate "mobility registration updating".

...

[TS 24.501, clause 5.5.1.3.4]

...

If the REGISTRATION ACCEPT message included a T3512 value IE, the UE shall use the value in T3512 value IE as periodic registration update timer (T3512). If the T3512 value IE is not included, the UE shall use the value currently stored, e.g. from a prior REGISTRATION ACCEPT message.

...

9.1.5.2.2.3 Test description

9.1.5.2.2.3.1 Pre-test conditions

System Simulator:

- NGC Cell A.

UE:

- None.

Preamble:

- The UE is in state ON-B on NGC Cell A according to TS 38.508-1[4].

9.1.5.2.2.3.2 Test procedure sequence

Table 9.1.5.2.2.3.2-1: Main behaviour

St	Procedure	Message Sequence		TP	Verdict
		U - S	Message		
1	The UE is switched on.	-	-	-	-
2-14	Steps 1-13 of the generic procedure for UE registration specified in TS 38.508-1 [4] table 4.5.2.2-2 are performed.	-	-	-	-
15	The SS transmits a REGISTRATION ACCEPT message.	<--	REGISTRATION ACCEPT	-	-
16-21	Steps 15-20 of the generic procedure for UE registration specified in TS 38.508-1 [4] table 4.5.2.2-2 are performed.	-	-	-	-
22	The SS waits 3 minutes. (Expire of T3512)	-	-	-	-
23	Check: Does the UE transmit a REGISTRATION REQUEST message with the 5GS registration type IE indicating "periodic registration updating"?	-->	REGISTRATION REQUEST	1	P
24	The SS transmits a REGISTRATION ACCEPT message.	<--	REGISTRATION ACCEPT	2	-
25	The SS releases the RRC connection.	-	-	-	-
26	The SS waits 1 minute. (Expire of T3512)	-	-	-	-
27	Check: Does the UE transmit a REGISTRATION REQUEST message?	-->	REGISTRATION REQUEST	2	P
28	The SS transmits a REGISTRATION ACCEPT message.	<--	REGISTRATION ACCEPT	-	-

9.1.5.2.2.3.3 Specific message contents

Table 9.1.5.2.2.3.3-1: REGISTRATION ACCEPT (Step 3, Table 9.1.5.2.2.3.2-1)

Derivation path: 38.508-1 [4], table 4.7.1-7			
Information Element	Value/Remark	Comment	Condition
T3512 value			
Unit	'101'B	value is incremented in multiples of 1 minute	
Timer value	'0 0011'B	3 minutes	

Table 9.1.5.2.2.3.3-2: REGISTRATION REQUEST (Step 6 & 11, Table 9.1.5.2.2.3.2-1)

Derivation path: 38.508-1 [4], table 4.7.1-6			
Information Element	Value/Remark	Comment	Condition
5GS registration type			
5GS registration type value	'011'B	periodic registration updating	

Table 9.1.5.2.2.3.3-3: REGISTRATION ACCEPT (Step 7, Table 9.1.5.2.2.3.2-1)

Derivation path: 38.508-1 [4], table 4.7.1-7			
Information Element	Value/Remark	Comment	Condition
T3512 value			
Unit	'101'B	value is incremented in multiples of 1 minute	
Timer value	'0 0001'B	1 minute	

9.1.5.2.3

9.1.5.2.4 Mobility registration update / The lower layer requests NAS signalling connection recovery

9.1.5.2.4.1 Test Purpose (TP)

(1)

```
with { UE in state 5GMM-REGISTERED, and 5GMM-CONNECTED mode over 3GPP access and does not have
signalling or user uplink data pending }
ensure that {
  when { UE receives an indication of "RRC Connection failure" from the lower layers }
  then { UE initiates and successfully completes the registration procedure for mobility
registration update }
}
```

9.1.5.2.4.2 Conformance requirements

References: The conformance requirements covered in the present TC are specified in: TS 24.501, clauses 5.5.1.3.2, 5.5.1.3.4. Unless otherwise stated these are Rel-15 requirements.

[TS 24.501, clause 5.5.1.3.2]

The UE in state 5GMM-REGISTERED shall initiate the registration procedure for mobility and periodic registration update by sending a REGISTRATION REQUEST message to the AMF,

...

- f) when the UE receives an indication of "RRC Connection failure" from the lower layers and does not have signalling or user uplink data pending (i.e. when the lower layer requests NAS signalling connection recovery);

...

If case b) is the only reason for initiating the registration procedure for mobility and periodic registration update, the UE shall indicate "periodic registration updating" in the 5GS registration type IE; otherwise the UE shall indicate "mobility registration updating".

...

After sending the REGISTRATION REQUEST message to the AMF the UE shall start timer T3510. If timer T3502 is currently running, the UE shall stop timer T3502. If timer T3511 is currently running, the UE shall stop timer T3511.

If the last visited registered TAI is available, the UE shall include the last visited registered TAI in the REGISTRATION REQUEST message.

The UE shall handle the 5GS mobility identity IE in the REGISTRATION REQUEST message as follows:

...

- b) for all other cases, if the UE holds a valid 5G-GUTI, the UE shall indicate the 5G-GUTI in the 5GS mobile identity IE.

...

When the registration procedure for mobility and periodic registration update is initiated in 5GMM-IDLE mode, the UE may include a PDU session status IE in the REGISTRATION REQUEST message, indicating which PDU sessions associated with the access type the REGISTRATION REQUEST message is sent over are active in the UE.

...

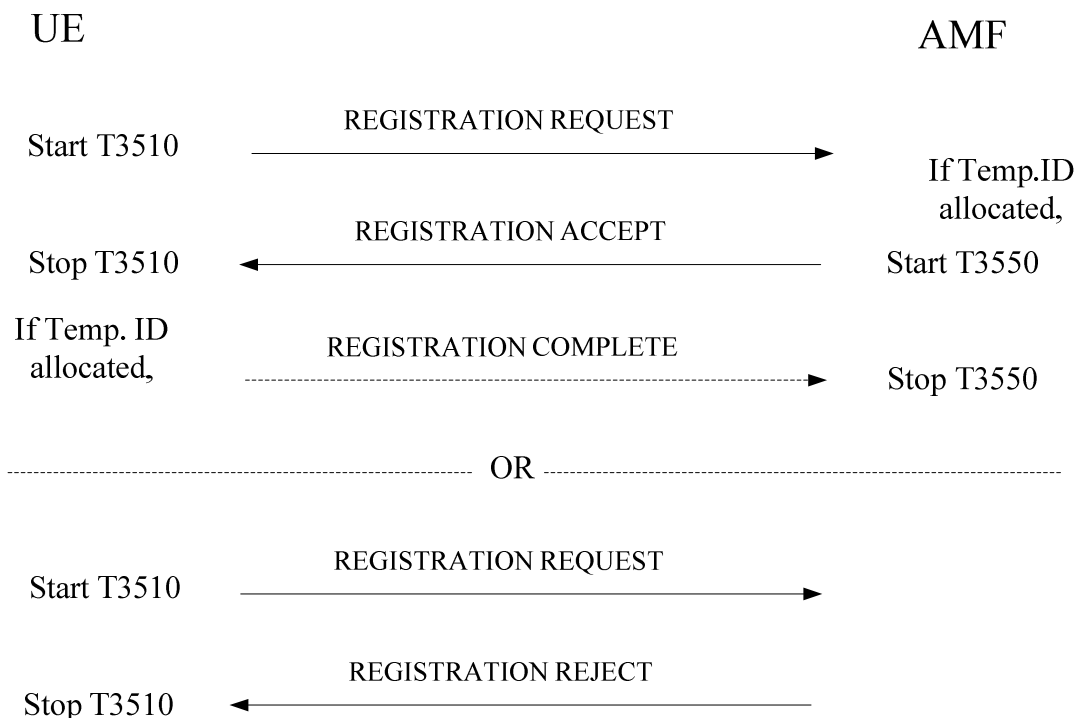

Figure 5.5.1.3.2.1: Registration procedure for mobility and periodic registration update

[TS 24.501, clause 5.5.1.3.4]

Upon receipt of the REGISTRATION ACCEPT message, the UE shall reset the registration attempt counter, enter state 5GMM-REGISTERED and set the 5GS update status to 5U1 UPDATED.

...

If the REGISTRATION ACCEPT message contains a 5G-GUTI, the UE shall return a REGISTRATION COMPLETE message to the AMF to acknowledge the received 5G-GUTI, stop timer T3519 if running, and delete any stored SUCI.

9.1.5.2.4.3 Test description

9.1.5.2.4.3.1 Pre-test conditions

System Simulator:

- NGC Cell A, default system information in accordance with TS 38.508-1 [4] sub-clause 4.4.3.1.2.

UE:

- None.

Preamble:

- Cell configuration in accordance with TS 38.508-1 [4] Table 6.3.2.2-1:
 - NGC Cell A "Serving cell"
- The UE is in test state 3N-A as defined in TS 38.508-1 [4], subclause 4.4A.2 on NGC Cell A.

9.1.5.2.4.3.2 Test procedure sequence

Table 9.1.5.2.4.3.2-1: Main behaviour

St	Procedure	Message Sequence		TP	Verdict
		U - S	Message		
1	The SS configures: - NGC Cell A as "Non-suitable "off" cell" in order to simulate radio link failure. (NOTE 1)	-	-	-	-
2	Wait for T=T310+1 sec. (NOTE 1)	-	-	-	-
3	The SS configures: - NGC Cell A as "Serving cell".	-	-	-	-
4	Check: Does the UE perform on NGC Cell A the Registration procedure for mobility registration update by executing the Test procedure to check that UE is camped on a new cell belonging to a new TA as specified in TS 38.508-1 [4] subclause 4.9.5.2.2-1, 'connected without release'?	-	-	1	-
NOTE 1: Steps 1-2 simulate the RRC connection failure needed in order for the UE "NAS layer" to receive an indication of "RRC Connection failure" from the lower layers. This is based on the following assumptions as specified in TS 38.331 [12], subclauses 5.3.10.1, 5.3.10.3, 5.3.11: (1) With the degradation of NGC Cell A the UE will receive N310 consecutive "out-of-sync" indications for NGC Cell A and start timer T310. (2) Because there will be no improvement in the cell situation the T310 will expire and the UE will report the RRC connection failure to the upper layers. Note that N310, T310 values are set in TS 38.508-1 [4], Table 4.6.3-200, <i>RLF-TimersAndConstants</i> .					

9.1.5.2.4.3.3 Specific message contents

Table 9.1.5.2.4.3.3-1: REGISTRATION REQUEST (step 4, Table 9.1.5.2.4.3.2-1; step 3, TS 38.508-1 [4] Table 4.9.5.2.2-1)

Derivation Path: TS 38.508-1 [4], Table 4.7.1-6.			
Information Element	Value/remark	Comment	Condition
5GS registration type	'00xxx010'	mobility registration updating x - not checked	
5GS mobile identity	Active 5G-GUTI assigned in the preamble		
5GMM capability	Any value		
Last visited registered TAI	The TAI of the NGC Cell A, see TS 38.508-1 [4] Table 6.3.2.2-1		
S1 UE network capability	If included then Any value	Shall be included if S1 mode indicated as supported in the IE '5GMM capability'	

Table 9.1.5.2.4.3.3-2: REGISTRATION ACCEPT (step 4, Table 9.1.5.2.4.3.2-1; step 4, TS 38.508-1 [4] Table 4.9.5.2.2-1)

Derivation Path: TS 38.508-1 [4], Table 4.7.1-7.			
Information Element	Value/remark	Comment	Condition
5GS registration result			
5GS registration result value	'001'	3GPP access	
SMS allowed	'0'	SMS over NAS not allowed	
5G-GUTI	Active 5G-GUTI assigned in the preamble		
TAI list			
Type of list	"00"	list of TACs belonging to one PLMN, with non-consecutive TAC values	
MCC	The MCC of the PLMN to which the NGC Cell A, NGC Cell B and NGC Cell D belong to, see TS 38.508-1 [4] Table 6.3.2.2-1		
MNC	The MNC of the PLMN to which the NGC Cell A, NGC Cell B and NGC Cell D belong to, see TS 38.508-1 [4] Table 6.3.2.2-1		
TAC 1	The TAI of the NGC Cell A, see TS 38.508-1 [4] Table 6.3.2.2-1		
PDU session status	If PDU session status was included in the REGISTRATION REQUEST, the indicated as active PDN sessions shall be confirmed as active		

9.1.5.2.6 Mobility registration update / Registered slice(s) change

FFS

9.1.5.2.7 Mobility and periodic registration update / Rejected / UE identity cannot be derived by the network

9.1.5.2.7.1 Test Purpose (TP)

(1)

```

with { UE in state 5GMM-REGISTERED on an NGC cell }
ensure that {
  when { UE initiates a Mobility and periodic registration procedure on an NGC cell and receives a
REGISTRATION REJECT message including 5GMM cause value #9 (UE identity cannot be derived by the
network) }
  then { UE deletes any 5G-GUTI, last visited registered TAI and ngKSI, enters the state 5GMM-
DEREGISTERED 5U2 NOT UPDATED, and, subsequently automatically initiates the initial registration
procedure }
}

```

9.1.5.2.7.2 Conformance requirements

References: The conformance requirements covered in the present TC are specified in: TS 24.501, clause 5.5.1.3.5. Unless otherwise stated these are Rel-15 requirements.

[TS 24.501, clause 5.5.1.3.5]

If the mobility and periodic registration update request cannot be accepted by the network, the AMF shall send a REGISTRATION REJECT message to the UE including an appropriate 5GMM cause value.

The UE shall take the following actions depending on the 5GMM cause value received in the REGISTRATION REJECT message.

...

#9 (UE identity cannot be derived by the network).

The UE shall set the 5GS update status to 5U2 NOT UPDATED (and shall store it according to subclause 5.1.3.2.2) and shall delete any 5G-GUTI, last visited registered TAI, TAI list and ngKSI. The UE shall enter the state 5GMM-DEREGISTERED.

If the rejected request was not for initiating an emergency PDU session, the UE shall subsequently, automatically initiate the initial registration procedure.

9.1.5.2.7.3 Test description

9.1.5.2.7.3.1 Pre test conditions

System Simulator:

- 1 cell
- NGC Cell A as defined in TS 38.508-1 [4] Table 6.3.2.2-1. Default system information combination as defined in TS 38.508-1 [4], sub-clause 4.4.3.1.2.

UE:

None.

Preamble:

- The UE is brought to state 1N-A, RRC_IDLE Connectivity (NR), in accordance with the procedure described in TS 38.508-1 [4], Table 4.5.2.2-2. 5G-GUTI and ngKSI are assigned and security context established.

9.1.5.2.7.2 Test procedure sequence

Table 9.1.5.2.7.3.2-1: Main behaviour

St	Procedure	Message Sequence		TP	Verdict
		U - S	Message		
1	Wait for 25 seconds (expiry of T3512 periodic registration update timer, the value of 30 sec is provided during the initial registration in the Preamble).	-	-	-	-
2	The UE transmit a REGISTRATION REQUEST message with the 5GS registration type IE indicating "periodic registration updating".	-->	REGISTRATION REQUEST	-	-
3	The SS transmits a REGISTRATION REJECT message including 5GMM cause value #9 (UE identity cannot be derived by the network).	<--	REGISTRATION REJECT	-	-
4	SS releases the RRC connection.	-	-	-	-
5	Check: Does the UE perform initial registration on NGC Cell A as specified in TS 38.508-1 [4], Table 4.5.2.2-2? The UE does not provide 5G-GUTI, last visited registered TAI or ngKSI.	-	-	1	P

9.1.5.2.7.3.3 Specific message contents

Table 9.1.5.2.7.3.3-1: REGISTRATION ACCEPT (Preamble; TS 38.508-1 [4] Table 4.5.2.2-2)

Derivation Path: 38.508-1 [4], Table 4.7.1-7.			
Information Element	Value/remark	Comment	Condition
T3512 value			
Unit	'100'B	value is incremented in multiples of 30 seconds	
Timer value	'0 0001'B	30 seconds	

Table 9.1.5.2.7.3.3-2: REGISTRATION REQUEST (step 2, Table 9.1.5.2.7.3.2-1)

Derivation Path: TS 38.508-1 [4], Table 4.7.1-6.			
Information Element	Value/remark	Comment	Condition
5GS registration type	'00xxx011'	periodic registration updating x - not checked	
ngKSI	Active ngKSI assigned in the Preamble		
5GS mobile identity	Active 5G-GUTI assigned in the Preamble		
Last visited registered TAI	The TAI of the NGC Cell A, see TS 38.508-1 [4] Table 6.3.2.2-1		

Table 9.1.5.2.7.3.3-3: REGISTRATION REJECT (step 3, Table 9.1.5.2.7.3.2-1)

Derivation Path: TS 38.508-1 [4], Table 4.7.1-9.			
Information Element	Value/remark	Comment	Condition
5GMM cause	'0000 1001'B	#9 - UE identity cannot be derived by the network	

Table 9.1.5.2.7.3.3-4: REGISTRATION REQUEST (step 5, Table 9.1.5.2.7.3.2-1; step 4, TS 38.508-1 [4] Table 4.5.2.2-2)

Derivation Path: TS 38.508-1 [4], Table 4.7.1-6, condition NON_CLEARTEXT_IE			
Information Element	Value/remark	Comment	Condition
5GS registration type	'00xxx001'	Initial registration x - not checked	
ngKSI	'111'	no key is available	
5GS mobile identity	SUCI		
Non-current native NAS key set identifier	Not present		
Last visited registered TAI	Not present		
Additional GUTI	Not present		
Payload container	"UE policy container"		
NAS message container	Not included		

Table 9.1.5.2.7.3.3-5: SECURITY MODE COMPLETE (step 5, Table 9.1.5.2.7.3.2-1; step 9, TS 38.508-1 [4] Table 4.5.2.2-2)

Derivation Path: TS 38.508-1 [4], Table 4.7.1-26, condition RINMR_INDICATED.
--

9.1.5.2.8 Mobility and periodic registration update / Rejected / Implicitly de-registered

9.1.5.2.8.1 Test Purpose (TP)

(1)

```
with { UE in state 5GMM-REGISTERED on an NGC cell }
ensure that {
  when { UE initiates a Mobility and periodic registration procedure on an NGC cell and receives a
REGISTRATION REJECT message including 5GMM cause value #10 (implicitly de-registered) }
  then { UE deletes any partial native 5G security context, enters the state 5GMM-
DEREGISTERED.NORMAL-SERVICE, and, initiates a new registration procedure for initial registration }
}
```

9.1.5.2.8.2 Conformance requirements

References: The conformance requirements covered in the present TC are specified in: TS 24.501, clause 5.5.1.3.5. Unless otherwise stated these are Rel-15 requirements.

[TS 24.501, clause 5.5.1.3.5]

If the mobility and periodic registration update request cannot be accepted by the network, the AMF shall send a REGISTRATION REJECT message to the UE including an appropriate 5GMM cause value.

The UE shall take the following actions depending on the 5GMM cause value received in the REGISTRATION REJECT message.

...

#10 (implicitly de-registered).

The UE shall enter the state 5GMM-DEREGISTERED.NORMAL-SERVICE. The UE shall delete any mapped 5G security context or partial native 5G security context.

If the registration rejected request was not for initiating an emergency PDU session, the UE shall perform a new registration procedure for initial registration.

9.1.5.2.8.3 Test description

9.1.5.2.8.3.1 Pre test conditions

System Simulator:

- 2 cells, NGC Cell A, and NGC Cell B belonging to the same PLMN and different TA in accordance with TS 38.508-1 [4] Table 6.3.2.2-1. Default system information combination as defined in TS 38.508-1 [4], sub-clause 4.4.3.1.2 is used in all cells when active.

UE:

None.

Preamble:

- Cell configuration in accordance with TS 38.508-1 [4] Table 6.2.2.1-3:
 - NGC Cell A "Serving cell"
 - NGC Cell B "Non-suitable "Off" cell"
- The UE is in test state 1N-A as defined in 38.508-1 [4], subclause 4.4A.2 on NGC Cell A.
 - During the initial registration:
 - In the list of tracking areas provided by the AMF (IE 'TAI list') contains only the TAI of NGC Cell A.

9.1.5.2.8.2 Test procedure sequence

Table 9.1.5.2.8.3.2-1: Main behaviour

St	Procedure	Message Sequence		TP	Verdict
		U - S	Message		
1	The SS configures: - NGC Cell B as "Serving cell" - NGC Cell A as "Non-Suitable "Off" cell".	-	-	-	-
-	EXCEPTION: Unless otherwise stated the following messages are exchange on NGC Cell B.	-	-	-	-
2	The UE transmits an REGISTRATION REQUEST message indicating "mobility registration updating".	-->	5GMM: REGISTRATION REQUEST	-	-
3	The SS transmits an AUTHENTICATION REQUEST message to establish a new security context.	<--	5GMM: AUTHENTICATION REQUEST	-	-
4	The UE transmits an AUTHENTICATION RESPONSE message.	-->	5GMM: AUTHENTICATION RESPONSE	-	-
5	The SS transmits a REGISTRATION REJECT message including 5GMM cause value #10 (implicitly de-registered) prior to imitating a SMC to take into account the created during the steps 3-4 partial native 5G security context. (NOTE 1)	<--	REGISTRATION REJECT	-	-
6	SS releases the RRC connection.	-	-	-	-
7-9	Steps 1-3 from the generic procedure for UE initial Registration as specified in TS 38.508-1 [4], subclause 4.5.2, Table 4.5.2.2-2 (connectivity NR) take place.	-	-	-	-
10	Check: Does the UE send a REGISTRATION REQUEST message, 5GS registration type IE set to Initial registration?	-->	5GMM: REGISTRATION REQUEST	1	P
11	The SS transmits a SECURITY MODE COMMAND message indicating the ngKSI of the partial native 5G security context assigned in the AUTHENTICATION REQUEST message sent in step 3.	<--	5GMM: SECURITY MODE COMMAND	-	-
12	The UE transmits a SECURITY MODE REJECT message.	-->	5GMM: SECURITY MODE REJECT	1	P
13-27a 1	Steps 5-19a1 from the generic procedure for UE initial Registration as specified in TS 38.508-1 [4], subclause 4.5.2, Table 4.5.2.2-2 (connectivity NR) take place.	-	-	-	-
NOTE 1: This 5GMM cause is sent to the UE either if the network has implicitly de-registered the UE, e.g. after the implicit de-registration timer has expired, or if the 5GMM context data related to the subscription does not exist in the AMF e.g. because of a AMF restart, or because of a registration request for mobility or registration update is routed to a new AMF (see TS 24.301 [22], subclause A.1). The latter is an example when the serving AMF will not initiate a security mode control procedure after the primary authentication and key agreement procedure.					

9.1.5.2.8.3.3 Specific message contents

Table 9.1.5.2.8.3.3-1: REGISTRATION REQUEST (step 2, Table 9.1.5.2.8.3.2-1)

Derivation Path: TS 38.508-1 [4], Table 4.7.1-6.			
Information Element	Value/remark	Comment	Condition
5GS registration type	'00xxx011'	periodic registration updating x - not checked	
ngKSI	Active ngKSI assigned in the Preamble		
5GS mobile identity	Active 5G-GUTI assigned in the Preamble		
Last visited registered TAI	The TAI of the NGC Cell A, see TS 38.508-1 [4] Table 6.3.2.2-1		

Table 9.1.5.2.8.3.3-2: REGISTRATION REJECT (step 5, Table 9.1.5.2.8.3.2-1)

Derivation Path: TS 38.508-1 [4], Table 4.7.1-9.			
Information Element	Value/remark	Comment	Condition
5GMM cause	'0000 1001'B	#9 - UE identity cannot be derived by the network	

Table 9.1.5.2.8.3.3-3: REGISTRATION REQUEST (step 10, Table 9.1.5.2.8.3.2-1)

Derivation Path: 38.508-1 [4], Table 4.7.1-6.			
Information Element	Value/remark	Comment	Condition
5GS registration type	'00xxx001'	Initial registration x - not checked	
ngKSI	ngKSI assigned in the preamble	Native current security context is still present	
5GS mobile identity	Active 5G-GUTI assigned in the preamble		
Non-current native NAS key set identifier	Not present	partial native 5G security context has been deleted	
Last visited registered TAI	The TAI of the NGC Cell A, see TS 38.508-1 [4] Table 6.3.2.2-1		

Table 9.1.5.2.8.3.3-4: SECURITY MODE COMMAND (step 11, Table 9.1.5.2.8.3.2-1)

Derivation Path: TS 38.508-1 [4], Table 4.7.1-25.			
Information Element	Value/remark	Comment	Condition
ngKSI	The ngKSI of the partial native 5G security context assigned in the AUTHENTICATION REQUEST message sent in step 4		

Table 9.1.5.2.8.3.3-5: SECURITY MODE REJECT (step 12, Table 9.1.5.2.8.3.2-1)

Derivation Path: TS 38.508-1 [4], Table 4.7.1-25.			
Information Element	Value/remark	Comment	Condition
5GMM cause	'0001 1000'	#24 - Security mode rejected, unspecified	

9.1.5.2.9 Mobility and periodic registration update / Abnormal / Change of cell into a new tracking area, collision with generic UE configuration update procedure

9.1.5.2.9.1 Test Purpose (TP)

(1)

```
with { UE initiates a Mobility and periodic registration procedure in 5GMM-REGISTERED state }
ensure that {
  when { UE changes the cell into a new tracking area before the registration procedure for mobility
and periodic registration update has been completed }
  then { UE shall abort registration procedure for mobility and periodic registration update and
re-initiate immediately }
}
```

(2)

```
with { UE initiates a Mobility and periodic registration procedure in 5GMM-REGISTERED state }
ensure that {
  when { UE receives a CONFIGURATION UPDATE COMMAND message before the registration procedure for
mobility and periodic registration update has been completed }
  then { UE shall ignore the message and proceed with the mobility and periodic registration
update procedure }
}
```

9.1.5.2.9.2 Conformance requirements

References: The conformance requirements covered in the present TC are specified in: TS 24.501, clauses 5.5.1.3.7 and 5.4.4.5. Unless otherwise stated these are Rel-15 requirements.

[TS 24.501, clause 5.5.1.3.7]

The following abnormal cases can be identified:

...

f) Change of cell into a new tracking area.

If a cell change into a new tracking area occurs before the registration procedure for mobility and periodic registration update is completed, the registration procedure for mobility and periodic registration update shall be aborted and re-initiated immediately. The UE shall set the 5GS update status to 5U2 NOT UPDATED.

...

h) Registration procedure for mobility and periodic registration update and generic UE configuration update procedure collision.

If the UE receives a CONFIGURATION UPDATE COMMAND message before the registration procedure for mobility and periodic registration update has been completed, UE shall behave as specified in subclause 5.4.4.5.

[TS 24.501, clause 5.4.4.5]

The following abnormal cases can be identified:

...

d) Generic UE configuration update and registration procedure for mobility and periodic registration update collision

If the UE receives a CONFIGURATION UPDATE COMMAND message before the ongoing registration procedure for mobility and periodic registration update has been completed, and the Configuration update indication IE in the CONFIGURATION UPDATE COMMAND message indicates that the acknowledgement is requested, then the UE shall ignore the CONFIGURATION UPDATE COMMAND message and proceed with registration procedure for mobility and periodic update procedure. Otherwise the UE shall proceed with both the procedures.

9.1.5.2.9.3 Test description

9.1.5.2.9.3.1 Pre-test conditions

System Simulator:

- 2 NGC cells with system information combination NR-2 in accordance with TS 38.508-1 [4] sub-clause 4.4.3.1.2.
- NGC cell A configured as "Serving cell" according to TS 38.508-1 [4] Table 6.2.2.1-3, HPLMN, TAI-1
- NGC cell B configured as "Non-Suitable cell" according to TS 38.508-1 [4] Table 6.2.2.1-3, HPLMN, TAI-2

UE:

None.

Preamble:

- The UE is in state 1N-A on NGC cell A according to TS 38.508-1 [4] Table 4.4A.2-1.

9.1.5.2.9.3.2 Test procedure sequence

Table 9.1.5.2.9.3.2-1: Main behaviour

St	Procedure	Message Sequence		TP	Verdict
		U - S	Message		
-	The following messages are to be observed on NGC cell B unless explicitly stated otherwise.	-	-	-	-
1	Change NGC cell A to "Non-Suitable "Off" cell". Change NGC cell B to "Serving cell".	-	-	-	-
2-9	Steps 2-9 of Table 4.5.2.2-2 of the generic procedure in TS 38.508-1 [4] are performed.				
10	The SS transmits a CONFIGURATION UPDATE COMMAND message with the Configuration update indication IE indicating that the acknowledgement is requested.	<--	CONFIGURATION UPDATE COMMAND	-	-
11	Check: Does the UE transmit a CONFIGURATION UPDATE COMPLETE message within the expiry of T3555?	-->	CONFIGURATION UPDATE COMPLETE	2	F
12-16	Steps 10-14 of Table 4.5.2.2-2 of the generic procedure in TS 38.508-1 [4] are performed with a new assigned 5G-GUTI in the REGISTRATION ACCEPT message.				
17	Check: Does the UE transmit a REGISTRATION COMPLETE message?	-->	REGISTRATION COMPLETE	2	P
18	Waits for 2 minutes until T3512 expiry.	-	-	-	-
19	The UE transmits a REGISTRATION REQUEST message with IE 5GS registration type set to "periodic registration updating".	-->	REGISTRATION REQUEST	-	-
20-24	Steps 5-9 of Table 4.5.2.2-2 of the generic procedure in TS 38.508-1 [4] are performed.				
-	The following messages are to be observed on NGC cell A unless explicitly stated otherwise.	-	-	-	-
25	Change NGC cell B to "Non-Suitable "Off" cell". Change NGC cell A to "Serving cell". Note: T3510 value is specified as 15s in TS 24.501 and it is assumed that SS can configure cells within this time.	-	-	-	-
26	Check: Does the UE transmit a REGISTRATION REQUEST message with IE 5GS registration type set to "mobility registration updating"?	-->	REGISTRATION REQUEST	1	P
27-42	Steps 5-20 of Table 4.5.2.2-2 of the generic procedure in TS 38.508-1 [4] are performed.				

9.1.5.2.9.3.3 Specific message contents

Table 9.1.5.2.9.3.3-1: REGISTRATION REQUEST (step 4 and 26 Table 9.1.5.2.9.3.2-1)

Derivation Path: 38.508-1 [4], Table 4.7.1-6			
Information Element	Value/remark	Comment	Condition
5GS registration type			
5GS registration type value	'010'B	Mobility registration updating	

Table 9.1.5.2.9.3.3-2: CONFIGURATION UPDATE COMMAND (step 10 Table 9.1.5.2.9.3.2-1)

Derivation Path: 38.508-1 [4], Table 4.7.1-19			
Information Element	Value/remark	Comment	Condition
Configuration update indication	Not Present		
ACK	'1'B	acknowledgement requested	

Table 9.1.5.2.9.3.3-3: REGISTRATION ACCEPT (step 16 Table 9.1.5.2.9.3.2-1)

Derivation Path: 38.508-1 [4], Table 4.7.1-7			
Information Element	Value/remark	Comment	Condition
T3512 value			
Timer value	'0 0010'B	2 minutes	
Unit	'101'B	value is incremented in multiples of 1 minute	

Table 9.1.5.2.9.3.3-4: REGISTRATION REQUEST (step 19 Table 9.1.5.2.9.3.2-1)

Derivation Path: 38.508-1 [4], Table 4.7.1-6			
Information Element	Value/remark	Comment	Condition
5GS registration type			
5GS registration type value	'011'B	Periodic registration updating	

9.1.6 De-registration

9.1.6.1 UE-initiated de-registration

9.1.6.1.1 UE-initiated de-registration / Switch off / Abnormal / De-registration and 5GMM common procedure collision

9.1.6.1.1.1 Test Purpose (TP)

(1)

```

with { the UE in 5GMM-REGISTERED state }
ensure that {
  when { the UE is switched off }
  then { the UE shall send DEREGISTRATION REQUEST message with De-registration type IE indicated
to "Switch off" }
}

```

(2)

```

with { the UE in 5GMM-DEREGISTERED-INITIATED state }
ensure that {
  when { the UE receives a DEREGISTRATION REQUEST message before the UE-initiated de-registration
procedure has been completed }
  then { the UE ignores the message and shall continue de-registration procedure }
}

```

(3)

```

with { the UE in 5GMM-DEREGISTERED-INITIATED state }
ensure that {
  when { the UE receives a 5GMM common procedure before the UE-initiated de-registration procedure
has been completed }
  then { the UE ignores the message and shall continue de-registration procedure }
}

```

(4)

```

with { the UE supports remove USIM without power down and in 5GMM-REGISTERED state }
ensure that {
  when { the USIM is removed from the UE }
  then { the UE shall send DEREGISTRATION REQUEST message with De-registration type IE indicated
to "Switch off" }
}

```

9.1.6.1.1.2 Conformance requirements

References: The conformance requirements covered in the present TC are specified in: TS 24.501, clauses 5.5.2.1, 5.5.2.2.1 and 5.5.2.2.6. Unless otherwise stated these are Rel-15 requirements.

[TS 24.501, clause 5.5.2.1]

The de-registration procedure is used:

- a) by the UE to de-register for 5GS services over 3GPP access when the UE is registered over 3GPP access;;
- b) by the UE to de-register for 5GS services over 3GPP access, non-3GPP access, or both when the UE is registered in the same PLMN over both accesses;
- c) by the network to inform the UE that it is deregistered for 5GS services over 3GPP access when the UE is registered over 3GPP access;
- d) by the network to inform the UE that it is deregistered for 5GS services over 3GPP access, non-3GPP access, or both when the UE is registered in the same PLMN over both accesses; and
- e) by the network to inform the UE to re-register to the network.

The de-registration procedure with appropriate de-registration type shall be invoked by the UE:

- a) if the UE is switched off; and
- b) as part of the eCall inactivity procedure defined in subclause 5.5.3.

The de-registration procedure with appropriate de-registration type shall be invoked by the network:

- a) if the network informs whether the UE should re-register to the network.

The de-registration procedure with appropriate access type shall be invoked by the UE:

- a) if the UE wants to de-register for 5GS services over 3GPP access when the UE is registered over 3GPP access;
or
- b) the UE wants to de-register for 5GS services over 3GPP access, non-3GPP access, or both when the UE is registered in the same PLMN over both accesses.

If the de-registration procedure is triggered due to USIM removal, the UE shall indicate "switch off" in the de-registration type IE.

If the de-registration procedure is requested by the UDM for a UE that has an emergency PDU session, the AMF shall not send a DEREGISTRATION REQUEST message to the UE.

If the de-registration procedure for 5GS services is performed, the PDU sessions, if any, for this particular UE are released locally without peer-to-peer signalling between the UE and the network.

The UE is allowed to initiate the de-registration procedure even if the timer T3346 is running.

NOTE: When the UE has no PDU sessions over non-3GPP access, or the UE moves all the PDU sessions over a non-3GPP access to a 3GPP access, the UE and the AMF need not initiate de-registration over the non-3GPP access.

The AMF shall provide the UE with a non-3GPP de-registration timer.

[TS 24.501, clause 5.5.2.2.1]

The de-registration procedure is initiated by the UE by sending a DEREGISTRATION REQUEST message (see example in figure 5.5.2.2.1). The De-registration type IE included in the message indicates whether the de-registration procedure is due to a "switch off" or not. The access type included in the message indicates whether the de-registration procedure is:

- a) for 5GS services over 3GPP access when the UE is registered over 3GPP access only;
- b) for 5GS services over non-3GPP access when the UE is registered over non-3GPP access only; or
- c) for 5GS services over 3GPP access, non-3GPP access or both 3GPP access and non-3GPP access when the UE is registered in the same PLMN over both accesses.

If the UE has a valid 5G-GUTI, the UE shall populate the 5GS mobile identity IE with the valid 5G-GUTI. If the UE does not have a valid 5G-GUTI, the UE shall populate the 5GS mobile identity IE with its SUCI.

If the UE does not have a valid 5G-GUTI and it does not have a valid SUCI, then the UE shall populate the 5GS mobile identity IE with its PEI.

If the de-registration request is not due to switch off and the UE is in the state 5GMM-REGISTERED or 5GMM-REGISTERED-INITIATED, timer T3521 shall be started in the UE after the DEREGISTRATION REQUEST message has been sent. The UE shall enter the state 5GMM-DEREGISTERED-INITIATED.

If the UE is to be switched off, the UE shall try for a period of 5 seconds to send the DEREGISTRATION REQUEST message. During this period, the UE may be switched off as soon as the DEREGISTRATION REQUEST message has been sent.

[TS 24.501, clause 5.5.2.2.6]

...

- d) De-registration procedure collision.

De-registration containing de-registration type "switch off":

- If the UE receives a DEREGISTRATION REQUEST message before the UE-initiated de-registration procedure has been completed, this message shall be ignored and the UE-initiated de-registration procedure shall continue.

Otherwise:

- If the UE receives a DEREGISTRATION REQUEST message before the UE-initiated de-registration procedure has been completed, it shall treat the message as specified in subclause 5.5.2.3.2 with the following modification:
 - If the DEREGISTRATION REQUEST message received by the UE contains de-registration type "re-registration required", and the UE-initiated de-registration procedure is with de-registration type "normal de-registration", the UE need not initiate the registration procedure for initial registration.

- e) De-registration and 5GMM common procedure collision.

De-registration containing de-registration type "switch off":

- If the UE receives a message used in a 5GMM common procedure before the de-registration procedure has been completed, this message shall be ignored and the de-registration procedure shall continue.

Otherwise:

- If the UE receives a message used in a 5GMM common procedure before the de-registration procedure has been completed, both the 5GMM common procedure and the de-registration procedure shall continue.

...

9.1.6.1.1.3 Test description

9.1.6.1.1.3.1 Pre-test conditions

System Simulator:

- NGC Cell A.

UE:

- None.

Preamble:

- The UE is in state 3N-A on NGC Cell A according to 38.508-1[4].

9.1.6.1.1.3.2 Test procedure sequence

Table 9.1.6.1.1.3.2-1: Main behaviour

St	Procedure	Message Sequence		TP	Verdict
		U - S	Message		
0	SS is configured not to transmit RLC ACK for Deregistration Request message to be received on SRB2	-	-	-	-
1	Cause switch off	-	-	-	-
2	Check: Does the UE transmit a Deregistration Request with the De-registration type IE indicating "switch off"?	-->	DEREGISTRATION REQUEST	1	P
3	The SS transmits a Deregistration Request message.	<--	DEREGISTRATION REQUEST	-	-
4	Check: Does the UE transmit a Deregistration Accept message within 6 seconds (T3522)?	-->	DEREGISTRATION ACCEPT	2	F
5	The SS releases the RRC connection.	-	-	-	-
6	Switch on the UE	-	-	-	-
7	The UE performs Registration procedure as specified in TS 38.508-1 [4] subclause 4.5.2 with 'connected without release'.	-	-	-	-
7A	SS is configured not to transmit RLC ACK for Deregistration Request message to be received on SRB2	-	-	-	-
8	Cause switch off.	-	-	-	-
9	The UE transmits a Deregistration Request with the De-registration type IE indicating "switch off".	-->	DEREGISTRATION REQUEST	-	-
10	The SS transmits an Identity Request message.	<--	IDENTITY REQUEST	-	-
11	Check: Does the UE transmit an Identity Response message within 6 seconds (T3570)?	-->	IDENTITY RESPONSE	3	F
12	The SS releases the RRC connection.	-	-	-	-
-	EXCEPTION: Steps 13a1 to 13a4 describe behaviour that depends on the UE capability; the "lower case letter" identifies a step sequence that take place if the UE supports remove USIM without power down: pc_USIM_Removal = TRUE [29]	-	-	-	-
13a1	Switch on the UE	-	-	-	-
13a2	The UE performs Registration procedure as specified in TS 38.508-1 [4] subclause 4.5.2 with 'connected without release'.	-	-	-	-
13a3	Cause removal of USIM from the UE without powering down.	-	-	-	-
13a4	Check: Does the UE transmit a Deregistration Request with the De-registration type IE indicating "switch off"?	-->	DEREGISTRATION REQUEST	4	P

9.1.6.1.1.3.3 Specific message contents

Table 9.1.6.1.1.3.3-1: Deregistration Request (Step 1, 9 and 13a4, Table 9.1.6.1.1.3.2-1)

Derivation path: 38.508-1 [4], table 4.7.1-12			
Information Element	Value/Remark	Comment	Condition
De-registration type			
Switch off	'1'B		

9.1.6.1.2 UE-initiated de-registration / Normal de-registration / Abnormal / Transmission failure without TAI change from lower layers, De-registration and 5GMM common procedure collision, T3521 timeout

9.1.6.1.2.1 Test Purpose (TP)

(1)

```
with { the UE in 5GMM-REGISTERED state }
ensure that {
  when { the UE initiates "normal de-registration" type deregistration from 5GS services over 3GPP access }
  then { the UE sends DEREGISTRATION REQUEST message with De-registration type IE indicated to "Normal de-registration" and starts timer T3521 }
}
```

(2)

```
with { the UE in 5GMM-DEREGISTERED-INTIATED state }
ensure that {
  when { Transmission failure of DEREGISTRATION REQUEST message indication without TAI change from lower layers }
  then { the UE restarts the de-registration procedure }
}
```

(3)

```
with { the UE in 5GMM-DEREGISTERED-INTIATED state }
ensure that {
  when { the UE receives a message used in a 5GMM common procedure before the de-registration procedure has been completed }
  then { both the 5GMM common procedure and the de-registration procedure shall continue }
}
```

(4)

```
with { the UE in 5GMM-DEREGISTERED-INTIATED state }
ensure that {
  when { the first four expiries of the timer T3521 }
  then { the UE shall retransmit the DEREGISTRATION REQUEST message and shall reset and restart timer T3521 }
}
```

(5)

```
with { the UE in 5GMM-DEREGISTERED-INTIATED state }
ensure that {
  when { On the fifth expiry of timer T3521 }
  then { the detach procedure shall be aborted and the UE performs local detach }
}
```

9.1.6.1.2.2 Conformance requirements

References: The conformance requirements covered in the current TC are specified in: TS 24.501 clause 5.5.2.2.6 and TS 38.331 clause 5.7.2.4. Unless otherwise stated these are Rel-15 requirements.

[TS 24.501, clause 5.5.2.2.6]

c) T3521 timeout.

On the first four expiries of the timer, the UE shall retransmit the DEREGISTRATION REQUEST message and shall reset and restart timer T3521. On the fifth expiry of timer T3521, the de-registration procedure shall be aborted and the UE proceeds as follows:

- 1) if the de-registration procedure was performed due to disabling of 5GS services, the UE shall enter the 5GMM-NULL state; or

- 2) if the de-registration type "normal de-registration" was requested for reasons other than disabling of 5GS services, the UE shall enter the 5GMM-DEREGISTERED state.

...

- h) Transmission failure of DEREGISTRATION REQUEST message indication without TAI change from lower layers.

The UE shall restart the de-registration procedure.

[TS 38.331, clause 5.7.2.4]

The UE shall:

- 1> if AS security is not started and radio link failure occurs before the successful delivery of ULInformationTransfer messages has been confirmed by lower layers; or
- 1> if mobility (i.e. handover, RRC connection re-establishment) occurs before the successful delivery of ULInformationTransfer messages has been confirmed by lower layers:
 - 2> inform upper layers about the possible failure to deliver the information contained in the concerned ULInformationTransfer messages.

9.1.6.1.2.3 Test description

9.1.6.1.2.3.1 Pre-test conditions

System Simulator:

- NGC Cell A and NGC Cell B
- both cells are configured as per table 6.3.2.2-1 TS 38.508-1 [4] with the below exceptions

Table 9.1.6.1.2.3.1–1: Cell configuration

NGC Cell	TAC	TAI
B	1	TAI-1

UE:

- None.

Preamble:

- the UE is in state 3N-A on NGC Cell A according to TS 38.508-1 [4].

9.1.6.1.2.3.2 Test procedure sequence

Table 9.1.6.1.2.3.2-1: Main behaviour

St	Procedure	Message Sequence		TP	Verdict
		U - S	Message		
1	AT or MMI command to cause UE to initiate de-registration. Note: The below messages will be sent/received on NGC Cell A unless otherwise stated.	-	-	-	-
1A	The SS is configured not send RLC ACK for the message sent in step 2.	-	-	-	-
2	Does the UE transmit a DEREGISTRATION REQUEST message with De-registration type IE indicating "Normal de-registration"? The UE starts timer T3521.	-->	5GMM: DEREGISTRATION REQUEST	1	P
3	The SS configures: - NGC Cell B as "Suitable neighbour cell".	-	-	-	-
3A	The SS transmits an <i>RRCReconfiguration</i> message including reconfigurationWithSync with rach-ConfigDedicated to order the UE to perform intra-frequency handover to NGC Cell B. Note: The below messages will be sent/received on NGC Cell B unless otherwise stated.	<--	NR RRC: <i>RRCReconfiguration</i>	-	-
3B	The UE transmits an <i>RRCReconfigurationComplete</i> message.	-->	NR RRC: <i>RRCReconfigurationComplete</i>	-	-
4	Check: Does the UE restart the de-registration procedure by sending DEREGISTRATION REQUEST message? Timer T3521 is started.	-->	5GMM: DEREGISTRATION REQUEST	2	P
5	With T3521 still running the SS shall send AUTHENTICATION REQUEST.	<--	5GMM: AUTHENTICATION REQUEST	-	-
6	Check: Does the UE transmit an AUTHENTICATION RESPONSE message?	-->	5GMM: AUTHENTICATION RESPONSE	3	P
7	SS responds with DEREGISTRATION ACCEPT message.	<--	5GMM: DEREGISTRATION ACCEPT	-	-
8	The SS releases the RRC connection.	-	-	-	-
9	AT or MMI command to cause UE to initiate registration.	-	-	-	-
10-24a4	Steps 2-19a1 of Table 4.5.2.2-2 of the generic procedure in TS 38.508-1 [4] are performed to complete the registration.	-	-	-	-
25	Cause UE to initiate de-registration.	-	-	-	-
26	Check: Does the UE transmit a DEREGISTRATION REQUEST message with De-registration type IE indicating "Normal de-registration"? The UE starts timer T3521.	-->	5GMM: DEREGISTRATION REQUEST	1	P
27	SS does not respond to the DEREGISTRATION REQUEST message.	-	-	-	-
28	Check: When the timer T3521 expires does the UE re-transmit DEREGISTRATION REQUEST message? Timer T3521 is re-started (1 st expiry).	-->	5GMM: DEREGISTRATION REQUEST	4	P
29	The SS does not respond to the DEREGISTRATION REQUEST message.	-	-	-	-
30	Check: When the timer T3521 expires does the UE re-transmit DEREGISTRATION REQUEST message? Timer T3521 is re-started (2 nd expiry).	-->	5GMM: DEREGISTRATION REQUEST	4	P
31	The SS does not respond to the DEREGISTRATION REQUEST message.	-	-	-	-
32	Check: When the timer T3521 expires does the UE re-transmit DEREGISTRATION REQUEST message? Timer T3521 is re-started (3 rd expiry).	-->	5GMM: DEREGISTRATION REQUEST	4	P
33	The SS does not respond to the DEREGISTRATION REQUEST message.	-	-	-	-

34	Check: When the timer T3521 expires does the UE re-transmit DEREGISTRATION REQUEST message? Timer T3521 is re-started (4 th expiry).	-->	5GMM: DEREGISTRATION REQUEST	4	P
35	The SS does not respond to the DEREGISTRATION REQUEST message.	-	-	-	-
36	Check: When the timer T3521 expires does the UE re-transmit DEREGISTRATION REQUEST message in 10s? The UE shall abort the de-registration procedure and enter the 5GMM-DEREGISTERED (5 th expiry).	-->	5GMM: DEREGISTRATION REQUEST	5	F
Note: T3521 value is specified as 15s in TS 24.501 [22].					

9.1.6.1.2.3.3 Specific message contents

Table 9.1.6.1.2.3.3-1: Message DEREGISTRATION REQUEST (steps 2, 4, 26, 28, 30, 32 and 34, Table 9.1.6.1.2.3.2-1)

Derivation Path: 38.508-1 [4], Table 4.7.1-12			
Information Element	Value/remark	Comment	Condition
De-registration type			
Switch off	'0'B	Normal de-registration	
Access type	'01'B	3GPP access	

Table 9.1.6.1.2.3.3-2: RRCReconfiguration-HO (step 3A Table 9.1.6.1.2.3.2-1)

Derivation Path: 38.508-1 [4] Table 4.8.1-1A with condition RBConfig_KeyChange
--

9.1.6.1.3 UE-initiated de-registration / Abnormal / Change of cell into a new tracking area

9.1.6.1.3.1 Test Purpose (TP)

(1)

```
with { UE in 5GMM-DEREGISTERED-INITIATED state and de-registration request is not due to switch off }
ensure that {
  when { UE changes into a new tracking area that is not in the stored TAI list }
  then { UE aborts the de-registration procedure and initiates a mobility registration procedure }
}
```

(2)

```
with { UE in 5GMM-REGISTERED-INITIATED state for a mobility registration procedure due to change of cell into a new tracking area list during UE-initiated de-registration procedure }
ensure that {
  when { UE receives REGISTRATION ACCEPT message }
  then { UE re-initiates the de-registration procedure after completing the mobility registration procedure }
}
```

(3)

```
with { UE in 5GMM-DEREGISTERED-INITIATED state and de-registration request is due to switch off }
ensure that {
  when { UE changes into a new tracking area that is not in the stored TAI list }
  then { UE aborts the de-registration procedure and enter the state 5GMM-DEREGISTERED }
}
```

9.1.6.1.3.2 Conformance requirements

References: The conformance requirements covered in the present TC are specified in: TS 24.501, clause 5.2.2.6. Unless otherwise stated these are Rel-15 requirements.

[TS 24.501 clause 5.2.2.6]

The following abnormal cases can be identified:

...

f) Change of cell into a new tracking area.

If a cell change into a new tracking area that is not in the stored TAI list occurs before the UE-initiated de-registration procedure is completed, the de-registration procedure shall be aborted and re-initiated after successfully performing a registration procedure for mobility or periodic update used for mobility (i.e. the 5GS registration type IE set to "mobility registration updating" in the REGISTRATION REQUEST message). If the de-registration procedure was initiated due to removal of the USIM or the UE is to be switched off, the UE shall abort the de-registration procedure and enter the state 5GMM-DEREGISTERED.

9.1.6.1.3.3 Test description

9.1.6.1.3.3.1 Pre-test conditions

System Simulator:

- NGC Cell A belongs to Home PLMN and TAI-1 and set as serving cell;
- NGC Cell B belongs to Home PLMN and TAI-2 and set as Non-Suitable cell.

UE:

- None;

Preamble:

- The UE is in state 3N-A on NGC cell A according to TS 38.508-1 [4].

9.1.6.1.3.3.2 Test procedure sequence

Table 9.1.6.1.3.3.2-1: Main behaviour

St	Procedure	Message Sequence		TP	Verdict
		U - S	Message		
-	The following messages are to be observed on NGC Cell A unless explicitly stated otherwise.	-	-	-	-
1	Cause UE to de-register for non Switch off reason using MMI or AT commands.	-	-	-	-
2	The UE transmits DEREGISTRATION REQUEST message. (The UE starts timer T3521)	-->	DEREGISTRATION REQUEST		
3	The SS does not respond to DEREGISTRATION REQUEST message.	-	-	-	-
4	The SS configures NGC Cell A as the "suitable cell" and NGC Cell B as the "Serving cell". Note: T3521 value is specified as 15s in TS 24.501 [22] and it is assumed that SS can configure cells within this time.	-	-	-	-
5	The SS transmits an <i>RRCReconfiguration</i> message on NGC Cell A to order the UE to perform intra-frequency handover to NGC Cell B.	-	-	-	-
6	The UE transmits a <i>RRCReconfigurationComplete</i> message on NGC Cell B to confirm the successful completion of the intra frequency handover.	-	-	-	-
-	The following messages are to be observed on NGC Cell B unless explicitly stated otherwise.	-	-	-	-
7	Check: Does the UE transmit a REGISTRATION REQUEST message with registration type value set to "mobility registration updating"	-->	REGISTRATION REQUEST	1	P
8 - 23	Steps 5 to 20 of the generic procedure for NR RRC IDLE as specified in TS 38.508-1 [4] subclause 4.5.2.2-2 with 'connected without release' are performed.	-	-	-	-
24	The UE transmits DEREGISTRATION REQUEST message.	-->	DEREGISTRATION REQUEST	2	P
25	The SS transmits DEREGISTRATION ACCEPT message.	<--	DEREGISTRATION ACCEPT	-	-
26	The SS transmits an <i>RRCRelease</i> message.	-	-	-	-
27	Check: Does the test result of the generic procedure in TS 38.508-1 [4] subclause 4.5.4.2-3 indicates that the UE responds to paging when paged with NG-5G-S-TMSI?	-	-	2	P
28	Cause UE to initiate registration using MMI or AT commands.	-	-	-	-
29	The UE performs Registration procedure as specified in TS 38.508-1 [4] subclause 4.5.2 with 'connected without release'.	-	-	-	-
30	The SS is configured on NGC Cell B not to send RLC acknowledgements (RLC ACKs) to the UE (Note1).	-	-	-	-
31	If possible (see ICS) switch off is performed or the USIM is removed. Otherwise the power is removed.	-	-	-	-
32	The UE transmits DEREGISTRATION REQUEST message.	-->	DEREGISTRATION REQUEST	-	-

33	The SS configures NGC Cell B as the "suitable cell" and NGC Cell A as the "Serving cell". Note: UE will try for 5 seconds to send deregistration request message and then switch off and it is assumed that SS can configure cells within this time.	-	-	-	-
34	The SS transmits an <i>RRCReconfiguration</i> message on NGC Cell B to order the UE to perform intra-frequency handover to NGC Cell A.	-	-	-	-
35	UE transmit a <i>RRCReconfigurationComplete</i> message on NGC Cell A to confirm the successful completion of the intra frequency handover (Note 2).	-	-	-	-
36	Check: Does the UE transmit a REGISTRATION REQUEST message with registration type value set to "mobility registration updating" within 5 seconds?	-->	REGISTRATION REQUEST	3	F
37	Check: Does the UE responds to paging with an <i>RRCSetupRequest</i> message when paged with NG-5G-S-TMSI?	-	-	3	F
<p>Note 1: $t\text{-PollRetransmit} = \text{ms}300$ and $\text{maxRetxThreshold} = \text{t}16$ so the PDU for deregistration request message will be tried for $16 \times 300\text{ms} = 4800\text{ms}$. After 4.8sec RLC will declare Tx failure to NAS and UE will be switched off. UE will remain ON for 4.8 sec and in meanwhile Handover message from the NW will be sent to UE.</p> <p>Note 2: This will be sent by the UE as RRC doesn't know that UE has triggered switch off. RRC will complete the HO and inform NAS about the cell change. Here NAS will abort the de-registration procedure and shut off the UE.</p>					

9.1.6.1.3.3.3 Specific message contents

Table 9.1.6.1.3.3.3-1: DEREGISTRATION REQUEST (steps 2 and 24, Table 9.1.6.1.3.3.2-1)

Derivation Path: 38.508-1 [4], Table 4.7.1-12			
Information Element	Value/remark	Comment	Condition
De-registration type			
Switch off	'0'B	Normal de-registration	
Re-registration required	'0'B	Spare bit	
Access type	'01'B	3GPP access	
5GS mobile identity	5G-GUTI	Same value as assigned in REGISTRATION ACCEPT	

Table 9.1.6.1.3.3.3-2: RRCReconfiguration-HO (steps 5 and 34 Table 9.1.6.1.3.3.2-1)

Derivation Path: TS 38.508-1 [4], Table 4.8.1-1A with condition RBConfig_KeyChange
--

Table 9.1.6.1.3.3.3-3: RLC-Config (Table 9.1.6.1.3.3.3-5)

Derivation Path: TS 38.508-1 [4], Table 4.6.3-111			
Information Element	Value/remark	Comment	Condition
RLC-Config ::= CHOICE {			
am SEQUENCE {			AM
ul-AM-RLC SEQUENCE {			
t-PollRetransmit	ms300		FR1,FR2
maxRetxThreshold	t16		
}			
}			
}			

Table 9.1.6.1.3.3-4: REGISTRATION REQUEST (step 7 and 36, Table 9.1.6.1.3.3.2-1)

Derivation Path: 38.508-1 [4], Table 4.7.1-6			
Information Element	Value/remark	Comment	Condition
5GS registration type value	'010'B		Mobility
PDU session status	PDU session IDs	PDU session IDs of the ACTIVE PDU sessions to be transferred to a new cell.	

Table 9.1.6.1.3.3-5: DEREGISTRATION REQUEST (step 32, Table 9.1.6.1.3.3.2-1)

Derivation Path: 38.508-1 [4], Table 4.7.1-12			
Information Element	Value/remark	Comment	Condition
De-registration type			
Switch off	'1'B	Switch off	
Re-registration required	'0'B	Spare bit	
Access type	'01'B	3GPP access	
5GS mobile identity	5G-GUTI	Same value as assigned in REGISTRATION ACCEPT	

9.1.6.1.4 UE-initiated de-registration / Abnormal / Transmission failure with TAI change from lower layers

9.1.6.1.4.1 Test Purpose (TP)

(1)

```

with { UE initiates de-registration procedure for 5GS services over 3GPP access with de-registration
type "Normal de-registration" in 5GMM-REGISTERED state }
ensure that {
  when { UE receives transmission failure of DEREGISTRATION REQUEST message indication with TAI
change from lower layers and the current TAI is not in the TAI list }
  then { UE shall abort the de-registration procedure and re-initiate after successfully
performing a registration procedure for mobility update }
}

```

(2)

```

with { UE initiates de-registration procedure for 5GS services over 3GPP access with de-registration
type "Normal de-registration" in 5GMM-REGISTERED state }
ensure that {
  when { UE receives transmission failure of DEREGISTRATION REQUEST message indication with TAI
change from lower layers and the current TAI is still part of the TAI list }
  then { UE shall restart the de-registration procedure }
}

```

9.1.6.1.4.2 Conformance requirements

References: The conformance requirements covered in the present TC are specified in: TS 24.501, clauses 5.5.2.2.6. Unless otherwise stated these are Rel-15 requirements.

[TS 24.501, clause 5.5.2.2.6]

The following abnormal cases can be identified:

...

- g) Transmission failure of DEREGISTRATION REQUEST message indication with TAI change from lower layers.

If the current TAI is not in the TAI list, the de-registration procedure shall be aborted and re-initiated after successfully performing a registration procedure for mobility or periodic update. If the de-registration procedure was initiated due to removal of the USIM or the UE is to be switched off, the UE shall abort the de-registration procedure and enter the state 5GMM-DEREGISTERED.

If the current TAI is still part of the TAI list, the UE shall restart the de-registration procedure.

9.1.6.1.4.3 Test description

9.1.6.1.4.3.1 Pre-test conditions

System Simulator:

- 2 NGC cells with system information combination NR-2 in accordance with TS 38.508-1 [4] sub-clause 4.4.3.1.2.
- NGC cell A configured as "Serving cell" according to TS 38.508-1 [4] Table 6.2.2.1-3, HPLMN, TAI-1
- NGC cell B configured as "Non-Suitable cell" according to TS 38.508-1 [4] Table 6.2.2.1-3, HPLMN, TAI-2

UE:

None.

Preamble:

- The UE is in state 1N-A on NGC cell A according to TS 38.508-1 [4] Table 4.4A.2-1.

9.1.6.1.4.3.2 Test procedure sequence

Table 9.1.6.1.4.3.2-1: Main behaviour

St	Procedure	Message Sequence		TP	Verdict
		U - S	Message		
-	The following messages are to be observed on NGC cell A unless explicitly stated otherwise.	-	-	-	-
1	The SS stops sending UL grants.	-	-	-	-
2	The UE initiates a normal de-registration for 5GS services over 3GPP access. (Note 1)	-	-	-	-
3	The UE transmits a DEREGISTRATION REQUEST message with IE de-registration type set to "Normal de-registration" for 3GPP access. Note: Message transmission failure due to no UL grant.	-	-	-	-
-	The following messages are to be observed on NGC cell B unless explicitly stated otherwise.	-	-	-	-
4	Change NGC cell A to "Non-Suitable "Off" cell". Change NGC cell B to "Serving cell". Note: T3521 value is specified as 15s in TS 24.501 and it is assumed that SS can configure cells within this time.	-	-	-	-
5	Check: Does the UE transmit a REGISTRATION REQUEST message with IE 5GS registration type set to "mobility registration updating"?	-->	REGISTRATION REQUEST	1	P
6-21	Steps 5-20 of Table 4.5.2.2-2 of the generic procedure in TS 38.508-1 [4] are performed with a new assigned 5G-GUTI and TAI list containing two consecutive TAI in the REGISTRATION ACCEPT message.				
22	The SS stops sending UL grants.	-	-	-	-
23	The UE transmit a DEREGISTRATION REQUEST message with IE de-registration type set to "Normal de-registration" for 3GPP access. Note: Message transmission failure due to no UL grant.	-	-	-	-
-	The following messages are to be observed on NGC cell A unless explicitly stated otherwise.	-	-	-	-
24	Change NGC cell B to "Non-Suitable "Off" cell". Change NGC cell A to "Serving cell". Note: T3521 value is specified as 15s in TS 24.501 and it is assumed that SS can configure cells within this time.	-	-	-	-
25	Check: Does the UE transmit a DEREGISTRATION REQUEST message with IE de-registration type set to "Normal de-registration" for 3GPP access?	-->	DEREGISTRATION REQUEST	1, 2	P
26	The SS transmits a DEREGISTRATION ACCEPT message.	<--	DEREGISTRATION ACCEPT	-	-
Note 1: The request of normal deregistration for 3GPP access may be performed by MMI or AT command.					

9.1.6.1.4.3.3 Specific message contents

Table 9.1.6.1.4.3.3-1: REGISTRATION REQUEST (step 5 Table 9.1.6.1.4.3.2-1)

Derivation Path: 38.508-1 [4], Table 4.7.1-6			
Information Element	Value/remark	Comment	Condition
5GS registration type			
5GS registration type value	'010'B	Mobility registration updating	

Table 9.1.6.1.4.3.3-2: REGISTRATION ACCEPT (step 15 Table 9.1.6.1.4.3.2-1)

Derivation Path: 38.508-1 [4], Table 4.7.1-7			
Information Element	Value/remark	Comment	Condition
TAI list		Contains 2 consecutive partial tracking area IDs	
Length of tracking area identity list contents	'0000 0111'B	7 octets	
Partial tracking area identity list 1			
Number of elements	'0 0001'B	2 elements	
Type of list	'01'B	list of TACs belonging to one PLMN, with consecutive TAC values	
MCC	See Table 4.4.2-3 in TS 38.508-1 [4]	MCC of HPLMN	
MNC	See Table 4.4.2-3 in TS 38.508-1 [4]	MNC of HPLMN	
TAC 1	See Table 4.4.2-3 in TS 38.508-1 [4]	TAC of TAI-1	

Table 9.1.6.1.4.3.3-3: DEREGISTRATION REQUEST (25 Table 9.1.6.1.4.3.2-1)

Derivation Path: 38.508-1 [4], Table 4.7.1-12			
Information Element	Value/remark	Comment	Condition
De-registration type			
Switch off	'0'B	Normal de-registration	

9.1.6.2 Network-initiated de-registration

9.1.6.2.1 Network-initiated de-registration / De-registration for 3GPP access / Re-registration required

9.1.6.2.1.1 Test Purpose (TP)

(1)

```

with { the UE in 5GMM-REGISTERED state }
ensure that {
  when { the SS sends a DEREGISTRATION REQUEST message indicates "re-registration required" and the
de-registration request is for 3GPP access }
  then { the UE sends a DEREGISTRATION ACCEPT message to the network and releases the existing NAS
signalling connection, then initiates an initial registration and also re-establishes any previously
established PDU sessions. }
}

```

9.1.6.2.1.2 Conformance requirements

References: The conformance requirement covered in the present TC is specified in: 3GPP TS 24.501 clauses 5.5.2.3.2. Unless otherwise stated these are Rel-15 requirements.

[TS 24.501 clause 5.5.2.3.2]

...

NOTE 1: When the de-registration type indicates "re-registration required", user interaction is necessary in some cases when the UE cannot re-establish the PDU session (s), if any, automatically.

...

Upon sending a DEREGISTRATION ACCEPT message, the UE shall delete the rejected NSSAI as specified in subclause 4.6.2.2.

If the de-registration type indicates "re-registration required", then the UE shall ignore the 5GMM cause IE if received.

If the de-registration type indicates "re-registration not required", the UE shall take the actions depending on the received 5GMM cause value:

#3 (Illegal UE);

...

As an implementation option, the UE may enter the state 5GMM-DEREGISTERED.PLMN-SEARCH in order to perform a PLMN selection according to 3GPP TS 23.122 [5].

9.1.6.2.1.3 Test description

9.1.6.2.1.3.1 Pre-test conditions

System Simulator:

- NGC Cell A.

UE:

- None.

Preamble:

- the UE is in state 3N-A on NGC Cell A according to TS 38.508-1 [4].

9.1.6.2.1.3.2 Test procedure sequence

Table 9.1.6.2.1.3.2-1: Main behaviour

St	Procedure	Message Sequence		TP	Verdict
		U - S	Message/PDU/SDU		
1	The SS transmits a DEREGISTRATION REQUEST with indicates "re-registration required".	<--	DEREGISTRATION REQUEST	-	-
2	Check: Does the UE transmits a DEREGISTRATION ACCEPT message?	-->	DEREGISTRATION ACCEPT	1	P
3	The SS releases RRC connection.	-	-	-	-
4	The UE transmits an <i>RRCSetupRequest</i> message.	-->	NR RRC: <i>RRCSetupRequest</i>	-	-
5	The SS transmits an <i>RRCSetup</i> message.	<--	NR RRC: <i>RRCSetup</i>	-	-
6	Check: Does the UE transmits an <i>RRCSetupComplete</i> message and REGISTRATION REQUEST message with registration type set to "initial registration".	-->	NR RRC: <i>RRCSetupComplete</i> 5GMM: REGISTRATION REQUEST	1	P
7-23	Steps 5-20 of Table 4.5.2.2-2 of the generic procedure in TS 38.508-1 [4] are performed.	-	-	-	-

9.1.6.2.1.3.3 Specific message contents

Table 9.1.6.2.1.3.3-1: DEREGISTRATION REQUEST (step 1, Table 9.1.6.2.1.3.2-1)

Derivation path: 38.508-1 [4] Table 4.7.1-14			
Information Element	Value/Remark	Comment	Condition
DEREGISTRATION type			
Switch off	'0'B	Normal de-registration	
Re-registration required	'1'B	re-registration required	
Access type	'01'B	3GPP access	

9.1.6.2.2 Network-initiated de-registration / De-registration for 3GPP access / Re-registration not required

9.1.6.2.2.1 Test Purpose (TP)

(1)

```

with { the UE in 5GMM-REGISTERED state }
ensure that {
  when { the SS sends a DEREGISTRATION REQUEST message indicates no 5GMM cause IE, "re-registration not required" and the de-registration request is for 3GPP access }
  then { the UE deletes 5G-GUTI, TAI list, last visited registered TAI, list of equivalent PLMNs, ngKSI, sends a DEREGISTRATION ACCEPT message enter the state 5GMM-DEREGISTERED for 3GPP access }
}

```

(2)

```

with { the UE is operating in single-registration mode }
ensure that {
  when { the SS sends a DEREGISTRATION REQUEST message indicates no 5GMM cause IE, "re-registration not required" and the de-registration request is for 3GPP access }
  then { the UE deletes the EMM parameters 4G-GUTI, last visited registered TAI, TAI list and eKSI and shall enter the state EMM-DEREGISTERED }
}

```

9.1.6.2.2.2 Conformance requirements

References: The conformance requirements covered in the current TC are specified in: TS 24.501 clauses 5.5.2.3.2 and 5.5.2.3.4. Unless otherwise stated these are Rel-15 requirements.

[TS 24.501, clause 5.5.2.3.2]

Upon receiving the DEREGISTRATION REQUEST message, if the DEREGISTRATION REQUEST message indicates "re-registration not required" and the de-registration request is for 3GPP access, the UE shall release locally the PDU sessions over 3GPP access, if any. The UE shall send a DEREGISTRATION ACCEPT message to the network and enter the state 5GMM-DEREGISTERED for 3GPP access.

[TS 24.501, clause 5.5.2.3.4]

- b) DEREGISTRATION REQUEST, other 5GMM cause values than those treated in subclause 5.5.2.3.2 or no 5GMM cause IE is included, and the De-registration type IE indicates "re-registration not required".

The UE shall delete 5G-GUTI, TAI list, last visited registered TAI, list of equivalent PLMNs, ngKSI, shall set the 5GS update status to 5U2 NOT UPDATED and shall start timer T3502.

A UE not supporting S1 mode may enter the state 5GMM-DEREGISTERED.PLMN-SEARCH in order to perform a PLMN selection according to 3GPP TS 23.122 [5]; otherwise the UE shall enter the state 5GMM-DEREGISTERED.ATTEMPTING-REGISTRATION.

A UE operating in single-registration mode shall:

- enter the state 5GMM-DEREGISTERED and attempt to select E-UTRAN radio access technology and proceed with the appropriate EMM specific procedures. In this case, the UE may disable N1 mode capability (see subclause 4.9); or
- enter the state 5GMM-DEREGISTERED.PLMN-SEARCH in order to perform a PLMN selection according to 3GPP TS 23.122 [5].

A UE operating in single-registration mode shall set the EPS update status to EU2 NOT UPDATED and shall delete the EMM parameters 4G-GUTI, last visited registered TAI, TAI list and eKSI and shall enter the state EMM-DEREGISTERED.

9.1.6.2.2.3 Test description

9.1.6.2.2.3.1 Pre-test conditions

System Simulator:

- NGC Cell A and E-UTRAN Cell A.

UE:

- the UE is previously registered on 5GC, and when on 5GC, the UE is last authenticated and registered on NGC cell A using default message contents according to TS 38.508-1 [4];
- the UE is previously registered on E-UTRAN, and when on E-UTRAN, the UE is last authenticated and registered on cell A using default message contents according to TS 36.508 [7];

Preamble:

- The UE is in state 3N-A on NGC Cell A according to TS 38.508-1 [4].
- The T3502 in UE set to 2 minutes.

9.1.6.2.2.3.2 Test procedure sequence

Table 9.1.6.2.2.3.2-1: Main behaviour

St	Procedure	Message Sequence		TP	Verdict
		U – S	Message		
-	The SS configures: -E-UTRAN Cell A as the "Non-Suitable "OFF" Cell".	-	-	-	-
1	SS sends a DEREGISTRATION REQUEST message indicates no 5GMM cause IE, "re-registration not required" and the de-registration request is for 3GPP access	<--	5GMM: DEREGISTRATION REQUEST	-	-
2	Check: Does the UE transmit a DEREGISTRATION ACCEPT message? Note: Now UE should start timer T3502.	-->	5GMM: DEREGISTRATION ACCEPT	1	P
3	The SS releases the RRC connection.	-	-	-	-
4	The SS waits 2 mins for T3502 to expire.	-	-	-	-
5-7	The UE establishes RRC connection by executing steps 2-4 of Table 4.5.2.2-2 in TS 38.508-1 [4].	-	-	-	-
8	Check: Does the UE transmit a REGISTRATION REQUEST message?	-->	5GMM: REGISTRATION REQUEST	1	P
9-23a	Steps 5-19a1 of Table 4.5.2.2-2 of the generic procedure in TS 38.508-1 [4] are performed. NOTE: The REGISTRATION ACCEPT with the 5GS network feature support IE setting to "interworking without N26 not supported" should be sent, then the UE shall operate in single-registration mode	-	-	-	-
-	EXCEPTION: Steps 24 to 45b1 describe behaviour that depends on the UE capability which support single-registration mode (see ICS, FFS).	-	-	-	-
24	SS sends a DEREGISTRATION REQUEST message indicates no 5GMM cause IE, "re-registration not required" and the de-registration request is for 3GPP access	<--	5GMM: DEREGISTRATION REQUEST	-	-
25	The UE transmits a DEREGISTRATION ACCEPT message.	-->	5GMM: DEREGISTRATION ACCEPT	-	-
26	The SS releases the RRC connection.	-	-	-	-
-	The SS configures: -E-UTRAN Cell A as the "Serving cell".	-	-	-	-
27-29	The UE establishes RRC connection by executing steps 2-4 of TS 36.508 [7] sub clause 4.5.2.3.	-	-	-	-
30	Check: Does the UE transmit an ATTACH REQUEST message on E-UTRAN Cell A?	-->	EMM: ATTACH REQUEST	2	P
31-44b	The attach procedure is completed by executing steps 5 to 18b1 of the UE registration procedure in TS 36.508 [7] sub clause 4.5.2.3.	-	-	-	-

9.1.6.2.2.3.3 Specific message contents

Table 9.1.6.2.2.3.3-1: Message REGISTRATION ACCEPT (preamble)

Derivation Path: 38.508-1 [4], Table 4.7.1-7			
Information Element	Value/remark	Comment	Condition
T3502 Value	2mins		
Timer value	'0 0010'B	The timer value is 2mins.	
Unit	'001'B		

Table 9.1.6.2.2.3.3-2: Message DEREGISTRATION REQUEST (step 1, Table 9.1.6.2.2.3.2-1)

Derivation Path: 38.508-1 [4], Table 4.7.1-12			
Information Element	Value/remark	Comment	Condition
De-registration type			
Switch off	'0'B	Normal de-registration	
Re-registration required	'0'B	re-registration not required	
Access type	'01'B	3GPP access	
5GMM cause	Not Present		

Table 9.1.6.2.2.3.3-3: Message REGISTRATION REQUEST (step 8, Table 9.1.6.2.2.3.2-1)

Derivation path: 38.508-1 [4], table 4.7.1-6			
Information Element	Value/Remark	Comment	Condition
ngKSI			
NAS key set identifier	'111'B	no key is available (UE to network)	
TSC	Any allowed value	TSC does not apply for NAS key set identifier value "111"	
5GS mobile identity	The valid SUCI		
Last visited registered TAI	Not present		

Table 9.1.6.2.2.3.3-4: Message ATTACH REQUEST (step 30, Table 9.1.6.2.2.3.2-1)

Derivation Path: TS 36.508 [7], Table 4.7.2-4			
Information Element	Value/remark	Comment	Condition
NAS key set identifier			
NAS key set identifier	'111'B	no key is available	
TSC	Any allowed value	TSC does not apply for NAS key set identifier value "111".	
Old GUTI or IMSI	IMSI1		
Last visited registered TAI	Not present		

9.1.7 Service request

9.1.7.1 Service request / IDLE mode uplink user data transport / Rejected / Restricted service area, Abnormal / T3517, T3525

9.1.7.1.1 Test Purpose (TP)

(1)

```
with { the UE is in 5GMM-REGISTERED state and 5GMM-IDLE state over 3GPP access }
ensure that {
when { UE has uplink user data pending }
then { the UE sends a SERVICE REQUEST message }
}
```

(2)

```
with { the UE sent a SERVICE REQUEST message }
ensure that {
when { UE receives a SERVICE REJECT message including an appropriate 5GMM cause value #28(Restricted service area) }
```

```
then { the UE performs the mobility registration update procedure }
}
```

(3)

```
with { the UE is in 5GMM-REGISTERED state and 5GMM-IDLE mode }
ensure that {
  when { T3517 expired}
  then { the UE increases the service request attempt counter, aborts the procedure and release
locally any resources allocated for the service request procedure }
}
```

(4)

```
with { the UE is in 5GMM-REGISTERED state and 5GMM-IDLE mode }
ensure that {
  when { the service request attempt counter is equal to 5}
  then { the UE starts timer T3525 and not attempts service request until expiry of T3525}
}
```

9.1.7.1.2 Conformance requirements

References: The conformance requirements covered in the current TC are specified in: TS 24.501, clause 5.6.1.1, 5.6.1.5 and 5.6.1.7. Unless otherwise stated these are Rel-15 requirements.

[TS 24.501, clause 5.6.1.1]

The purpose of the service request procedure is to change the 5GMM mode from 5GMM-IDLE to 5GMM-CONNECTED mode, and/or to request the establishment of user-plane resources for PDU sessions which are established without user-plane resources. In latter case, the 5GMM mode can be the 5GMM-IDLE mode or the 5GMM-CONNECTED mode if the UE requires to establish user-plane resources for PDU sessions.

...

The UE shall invoke the service request procedure when:

...

d) the UE, in 5GMM-IDLE mode over 3GPP access, has uplink user data pending;

If one of the above criteria to invoke the service request procedure is fulfilled, then the service request procedure shall only be initiated by the UE when the following conditions are fulfilled:

- its 5GS update status is 5U1 UPDATED, and the TAI of the current serving cell is included in the TAI list; and
- no 5GMM specific procedure is ongoing.

The UE shall not invoke the service request procedure when the UE is in the state 5GMM-SERVICE-REQUEST-INITIATED.

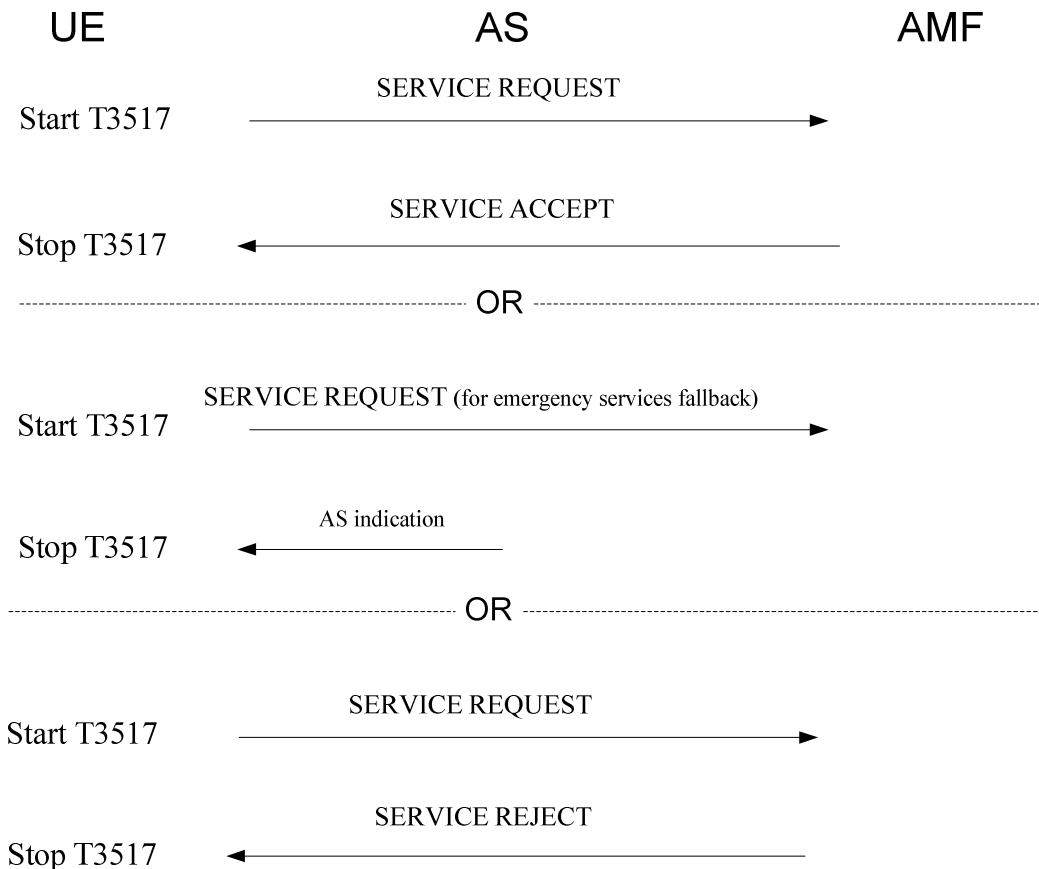

Figure 5.6.1.1.1: Service Request procedure

[TS 24.501, clause 5.6.1.5]

If the service request cannot be accepted, the network shall return a SERVICE REJECT message to the UE including an appropriate 5GMM cause value and stop timer T3517.

...

If the AMF determines that the UE is in a non-allowed area or is not in an allowed area as specified in subclause 5.3.5, then:

- a) if the service type IE in the SERVICE REQUEST message is set to "signalling" or "data", the AMF shall send a SERVICE REJECT message with the 5GMM cause value set to #28 "Restricted service area";

...

The UE shall take the following actions depending on the 5GMM cause value received in the SERVICE REJECT message.

- #28 (Restricted service area).

The UE shall enter the state 5GMM-REGISTERED.NON-ALLOWED-SERVICE, and perform the registration procedure for mobility and periodic registration update (see subclause 5.3.5 and 5.5.1.3).

[TS 24.501, clause 5.6.1.7]

The following abnormal cases can be identified:

- a) T3517 expired.

The UE shall enter the state 5GMM-REGISTERED.

If the UE triggered the service request procedure in 5GMM-IDLE mode and the service type of the SERVICE REQUEST message was not set to "emergency services fallback", then the 5GMM sublayer shall increment the service request attempt counter, abort the procedure and release locally any resources allocated for the service request procedure. The service request attempt counter shall not be incremented, if:

- 1) the service request procedure is initiated to establish an emergency PDU session;
- 2) the UE has an emergency PDU session established;
- 3) the UE is a UE configured for high priority access in selected PLMN; or
- 4) the service request is initiated in response to paging or notification from the network.

If the service request attempt counter is greater than or equal to 5, the UE shall start timer T3525. Additionally, if the service request was initiated for an MO MMTEL voice call, a notification that the service request was not accepted due to the UE having started timer T3525 shall be provided to the upper layers.

NOTE 1: This can result in the upper layers requesting implementation specific mechanisms, e.g. the MMTEL voice call being attempted to another IP-CAN, or establishment of a CS voice call (if supported and not already attempted in the CS domain).

The UE shall not attempt service request until expiry of timer T3525 unless:

- 1) the service request is initiated in response to paging or notification from the network;
- 2) the UE is a UE configured for high priority access in selected PLMN;
- 3) the service request is initiated to establish an emergency PDU session;
- 4) the UE has an emergency PDU session established; or
- 5) the UE is registered in a new PLMN.

NOTE 2: The NAS signalling connection can also be released if the UE deems that the network has failed the authentication check as specified in subclause 5.4.1.3.7.

9.1.7.1.3 Test description

9.1.7.1.3.1 Pre-test conditions

System Simulator:

- NGC Cell A and NGC Cell B belonging to the same PLMN and different TA in accordance with TS 38.508-1 [4] Table 6.3.2.2-1, default system information in accordance with TS 38.508-1 [4] clause 4.4.3.1.2.

UE:

None.

Preamble:

- The UE is in state 3N-A with UE test loop mode B active ($T_{\text{delay_modeB}} = 5$) according to TS 38.508-1 [4].

9.1.7.1.3.2 Test procedure sequence

Table 9.1.7.1.3.2-1: Main behaviour

St	Procedure	Message Sequence		TP	Verdict
		U - S	Message		
1	The SS configures: - NGC Cell A as the "Serving cell". - NGC Cell B as a "Non-Suitable cell".	-	-	-	-
2	The SS transmits one IP Packet to the UE.	<--	IP packet	-	-
3	The SS waits 1 second after the IP packet has been transmitted in step 2 and then transmits an RRCRelease message. (Note 1)	-	-	-	-
4	Check: Does UE transmit a SERVICE REQUEST message with Service type IE set to 'data'? (Note 2)	-->	SERVICE REQUEST	1	P
5	The SS transmits a SERVICE REJECT message with 5GMM cause = "Restricted service area".	<--	SERVICE REJECT	-	-
6	The SS releases the RRC connection.	-	-	-	-
7	The SS configures: - NGC Cell A as the "Serving cell". - NGC Cell B as a "Suitable neighbour cell".	-	-	-	-
8	Check: Does the UE perform mobility registration updating on NGC Cell B as specified in TS 38.508-1 [4] Table 4.9.5.2.2-1, 'connected without release'?	-	-	2	-
	EXCEPTION: Steps 9 to 10 are repeated for 5 times.	-	-	-	-
9	The UE transmits a SERVICE REQUEST message.	-->	SERVICE REQUEST	-	-
10	Check: Does the UE transmit a SERVICE REQUEST message before T3517 expires?	-	-	3	F
11	Check: Does the UE transmits a SERVICE REQUEST message within 60 seconds (minimum value of T3525)?	-->	SERVICE REQUEST	4	F
Note 1: The 1 second delay is used to secure that the UE have received and forwarded the IP Packet transmitted by the SS in step 1 to the UE test loop function before the RRCRelease message is sent by the SS in step 3.					
Note 2: Triggered when timer T_delay_modeB (IP PDU delay time) expires and pending uplink data exist in buffered PDCP SDUs according to [6] clause 5.3.4.2.3 and [8] clause 5.4.4.3.					

9.1.7.1.3.3 Specific message contents

Table 9.1.7.1.3.3-1: ACTIVATE TEST MODE (preamble)

Derivation Path: TS 38.508-1 [4]			
Information Element	Value/remark	Comment	Condition
Protocol discriminator	1 1 1 1		
Skip indicator	0 0 0 0		
Message type	1 0 0 0 0 1 0 0		
UE test loop mode	0 0 0 0 0 0 0 1	UE test loop mode B	UE TEST LOOP MODE B

Table 9.1.7.1.3.3-2: CLOSE UE TEST LOOP (preamble)

Derivation Path: TS 38.508-1 [4]			
Information Element	Value/remark	Comment	Condition
Protocol discriminator	1 1 1 1		
Skip indicator	0 0 0 0		
Message type	1 0 0 0 0 0 0		
UE test loop mode	0 0 0 0 0 0 1	UE test loop mode B	UE TEST LOOP MODE B
UE test loop mode B LB setup			
IP PDU delay	0 0 0 0 1 0 1	5 seconds	

Table 9.1.7.1.3.3-3: SERVICE REQUEST (step 4, Table 9.1.7.1.3.2-1)

Derivation Path: TS 38.508-1 [4] Table 4.7.1-16			
Information Element	Value/remark	Comment	Condition
Service type			
Service type value	'0001'B	data	

Table 9.1.7.1.3.3-4: SERVICE REJECT (step 5, Table 9.1.7.1.3.2-1)

Derivation Path: TS 38.508-1 [4] Table 4.7.1-18			
Information Element	Value/remark	Comment	Condition
5GMM cause	'0001 1100'B	Restricted service area	

Table 9.1.7.1.3.3-5: REGISTRATION REQUEST (step 8, Table 9.1.7.1.3.2-1; step 3, TS 38.508-1 [4] Table 4.9.5.2.2-1)

Derivation Path: TS 38.508-1 [4] Table 4.7.1-6			
Information Element	Value/remark	Comment	Condition
5GS registration type	'010'B	mobility registration updating	

9.1.7.2 Service request / CONNECTED mode user data transport / Abnormal / T3517, T3525

9.1.7.2.1 Test Purpose (TP)

(1)

```
with { the UE is in 5GMM-REGISTERED state and 5GMM-CONNECTED mode over 3GPP access }
ensure that {
  when { the UE has user data pending due to no user-plane resources established for PDU session(s)
    used for user data transport }
  then { the UE sends a SERVICE REQUEST message }
}
```

(2)

```
with { the UE is in 5GMM-REGISTERED state and 5GMM-IDLE mode }
ensure that {
  when { T3517 expired }
  then { the UE increases the service request attempt counter, abort the procedure and release
    locally any resources allocated for the service request procedure }
}
```

(3)

```
with { the UE is in 5GMM-REGISTERED state and 5GMM-IDLE mode }
ensure that {
```

```
when { the service request attempt counter is equal to 5 }  
  then { the UE starts timer T3525 and not attempts service request until expiry of timer T3525" }  
}
```

9.1.7.2.2 Conformance requirements

References: The conformance requirements covered in the current TC are specified in: TS 24.501 clauses 5.6.1.1, 5.6.1.2 and 5.6.1.7. Unless otherwise stated these are Rel-15 requirements.

[TS 24.501, clause 5.6.1.1]

The purpose of the service request procedure is to change the 5GMM mode from 5GMM-IDLE to 5GMM-CONNECTED mode, and/or to request the establishment of user-plane resources for PDU sessions which are established without user-plane resources. In latter case, the 5GMM mode can be the 5GMM-IDLE mode or the 5GMM-CONNECTED mode if the UE requires to establish user-plane resources for PDU sessions.

NOTE 1: The lower layer indicates when the user-plane resources for PDU sessions are successfully established or released.

This procedure is used when:

...

- the UE has user data pending over 3GPP access and the UE is in 5GMM-IDLE or 5GMM-CONNECTED mode over 3GPP access;

The UE shall invoke the service request procedure when:

...

- e) the UE, in 5GMM-CONNECTED mode or in 5GMM-CONNECTED mode with RRC inactive indication, has user data pending due to no user-plane resources established for PDU session(s) used for user data transport;

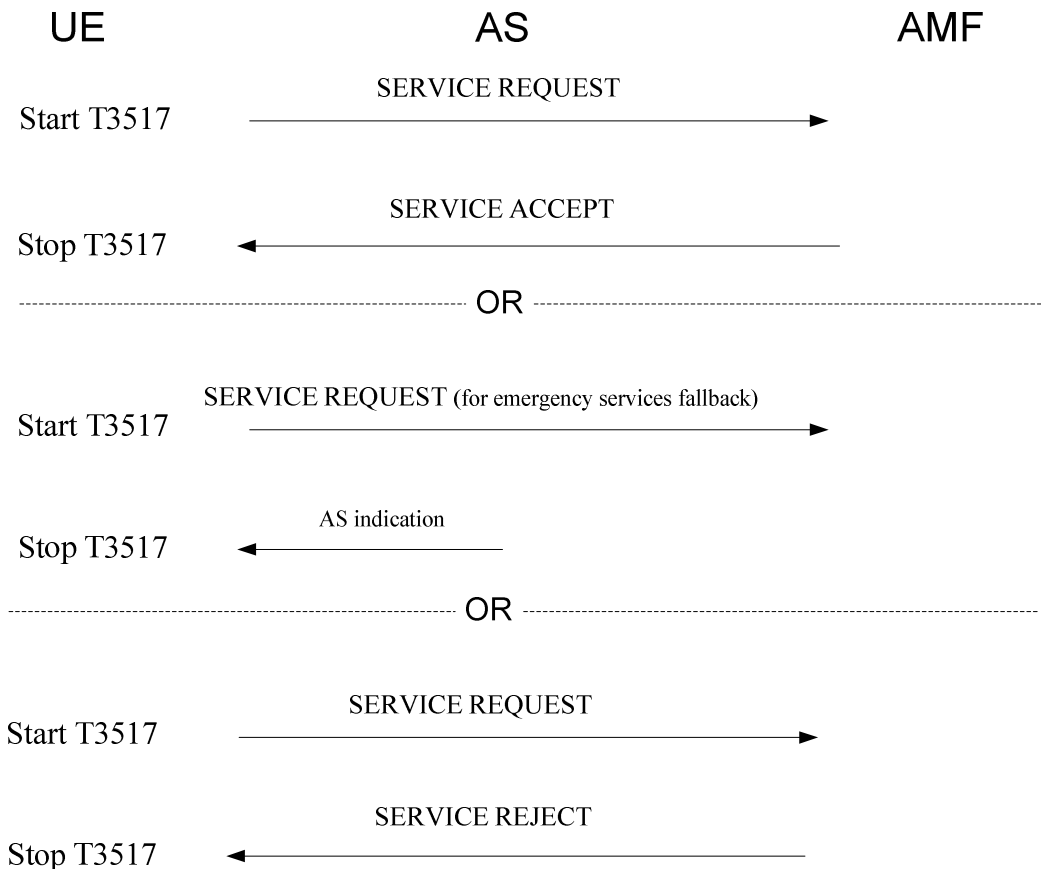

Figure 5.6.1.1.1: Service Request procedure

[TS 24.501, clause 5.6.1.2]

The UE initiates the service request procedure by sending a SERVICE REQUEST message to the AMF and starts timer T3517.

...

For cases d) and e) in subclause 5.6.1.1, the Uplink data status IE shall be included in the SERVICE REQUEST message to indicate the PDU session(s) the UE has pending user data to be sent. If the UE is not a UE configured for high priority access in selected PLMN:

- a) if there exists an emergency PDU session which is indicated in the Uplink data status IE the service type IE in the SERVICE REQUEST message shall be set to "emergency services"; or
- b) otherwise, the service type IE in the SERVICE REQUEST message shall be set to "data".

...

The Uplink data status IE may be included in the SERVICE REQUEST message to indicate which PDU session(s) associated with the access type the SERVICE REQUEST message is sent over have pending user data to be sent.

...

[TS 24.501, clause 5.6.1.7]

The following abnormal cases can be identified:

- a) T3517 expired.

The UE shall enter the state 5GMM-REGISTERED.

If the UE triggered the service request procedure in 5GMM-IDLE mode and the service type of the SERVICE REQUEST message was not set to "emergency services fallback", then the 5GMM sublayer shall increment the service request attempt counter, abort the procedure and release locally any resources allocated for the service request procedure. The service request attempt counter shall not be incremented, if:

- 1) the service request procedure is initiated to establish an emergency PDU session;
- 2) the UE has an emergency PDU session established;
- 3) the UE is a UE configured for high priority access in selected PLMN; or
- 4) the service request is initiated in response to paging or notification from the network.

If the service request attempt counter is greater than or equal to 5, the UE shall start timer T3525. Additionally, if the service request was initiated for an MO MMTEL voice call, a notification that the service request was not accepted due to the UE having started timer T3525 shall be provided to the upper layers.

NOTE 1: This can result in the upper layers requesting implementation specific mechanisms, e.g. the MMTEL voice call being attempted to another IP-CAN, or establishment of a CS voice call (if supported and not already attempted in the CS domain).

The UE shall not attempt service request until expiry of timer T3525 unless:

- 1) the service request is initiated in response to paging or notification from the network;
- 2) the UE is a UE configured for high priority access in selected PLMN;
- 3) the service request is initiated to establish an emergency PDU session;
- 4) the UE has an emergency PDU session established; or
- 5) the UE is registered in a new PLMN.

NOTE 2: The NAS signalling connection can also be released if the UE deems that the network has failed the authentication check as specified in subclause 5.4.1.3.7.

...

9.1.7.2.3 Test description

9.1.7.2.3.1 Pre-test conditions

System Simulator:

- NGC Cell A

UE:

- None.

Preamble:

- the UE is in 5GS state 3N-A and using the message condition UE TEST LOOP MODE B with IP PDU delay = 1 second according to TS 38.508-1 [4].

9.1.7.2.3.2 Test procedure sequence

Table 9.1.7.2.3.2-1: Main behaviour

St	Procedure	Message Sequence		TP	Verdict
		U – S	Message		
1	The SS transmits one IP PDU.	<--	-	-	-
2	The SS transmits an <i>RRCReconfiguration</i> message to release User-plane resources for the PDU session.	<--	NR RRC: <i>RRCReconfiguration</i>	-	-
3	The UE transmits an <i>RRCReconfigurationComplete</i> message.	-->	NR RRC: <i>RRCReconfigurationComplete</i>	-	-
4	Check: Does the UE transmit a <i>SERVICE REQUEST</i> message?	-->	NR 5GMM: <i>SERVICE REQUEST</i>	1	P
5	The SS does not respond to the <i>SERVICE REQUEST</i> message.	-	-	-	-
6	The SS transmits an <i>RRCRelease</i> message.	-	-	-	-
7	Check: Does the UE transmit a <i>SERVICE REQUEST</i> message?	-->	NR 5GMM: <i>SERVICE REQUEST</i>	2	P
8	The SS does not respond to the NAS <i>SERVICE REQUEST</i> message.	-	-	-	-
9	Wait for T3517 seconds (Note 1).	-	-	-	-
10-18	Step 7-9 are repeated for another 3 times. (Note 2)	-	-	-	-
19	Check: Does the UE transmit a <i>SERVICE REQUEST</i> message within next T3525 seconds?	-	-	3	F
20	T3525 expires, Check: Does the UE transmit a <i>SERVICE REQUEST</i> message? (Note 3)	-->	NR 5GMM: <i>SERVICE REQUEST</i>	3	P
21	The SS transmits a <i>SERVICE ACCEPT</i> message.	<--	NR 5GMM: <i>SERVICE ACCEPT</i>	-	-

Note 1: T3517 expires after 15 seconds.
 Note 2: The service request attempt counter is equal to 5 after T3517 expires for 5 times, then T3525 start.
 Note 3: T3525 expires after 60 seconds.

9.1.7.2.3.3 Specific message contents

Table 9.1.7.2.3.3-1: RRCReconfiguration (step 2, Table 9.1.7.2.3.2-1)

Derivation Path: TS 38.508-1 [4], Table 4.6.1-13			
Information Element	Value/remark	Comment	Condition
RRCReconfiguration ::= SEQUENCE {			
criticalExtensions CHOICE {			
rrcReconfiguration SEQUENCE {			
radioBearerConfig	RadioBearerConfig		
}			
}			
}			
}			

Table 9.1.7.2.3.3-2: RadioBearerConfig (Table 9.1.7.2.3.3-1)

Derivation Path: TS 38.508-1 [4], Table 4.6.3-132			
Information Element	Value/remark	Comment	Condition
RadioBearerConfig ::= SEQUENCE {			
drb-ToReleaseList SEQUENCE {			
drb-Identity[1]	DRB-Identity		
}			
}			

Table 9.1.7.2.3.3-3: SERVICE REQUEST (step 4, 7, 10, 13, 16, Table 9.1.7.2.3.2-1)

Derivation path: TS 38.508-1 [4], table 4.7.1-16			
Information Element	Value/Remark	Comment	Condition
Service type	'0001'B	data	
Uplink data status			
PSI(1)	'1'B	PSI(1) is set to 1 indicates that uplink data are pending for the corresponding PDU session identity.	

Table 9.1.7.2.3.3-4: SERVICE ACCEPT (step 21, Table 9.1.7.2.3.2-1)

Derivation path: TS 38.508-1 [4], table 4.7.1-17			
Information Element	Value/Remark	Comment	Condition
PDU session reactivation result			
PSI(1)	'0'B	PSI(1) is set to 0 indicates that establishment of user-plane resource of the PDU session is successful.	

9.1.8 SMS over NAS

9.1.8.1 SMS over NAS / MO and MT SMS over NAS - Idle mode

9.1.8.1.1 Test Purpose (TP)

(1)

```
with { the UE in switched off state with valid USIM inserted }
ensure that {
  when { the UE requests initial registration for SMS over NAS }
  then { the UE shall send REGISTRATION REQUEST message with SMS requested bit of the 5GS
registration type IE "SMS over NAS supported" }
}
```

(2)

```
with { the UE in 5GMM-REGISTERED state }
ensure that {
  when { the UE initiates a periodic registration update and the requirements to use SMS over NAS
transport have not changed in the UE }
  then { the UE sets the SMS requested bit of the 5GS registration type IE in the REGISTRATION
REQUEST message to the same value as indicated by the UE in the last REGISTRATION REQUEST message }
}
```

(3)

```
with { the UE in 5GMM_Connected state with NR RRC_IDLE mode and the UE has sent a SERVICE REQUEST
message triggered by initiating MO SMS }
ensure that {
  when { UE receives a SERVICE ACCEPT message from SS }
  then { UE sends CP-DATA containing RP-DATA RPDU (SMS SUBMIT TPDU) encapsulated in an Uplink NAS
transport message }
}
```

(4)

```

with { UE has sent CP-DATA containing an RP-DATA RPDU (SMS SUBMIT TPDU) encapsulated in an Uplink
NAS transport message }
ensure that {
  when { UE receives a CP-DATA containing an RP-ACK RPDU encapsulated in a Downlink NAS transport
message }
  then { UE sends a CP-ACK encapsulated in an Uplink NAS Transport message }

```

(5)

```

with { the UE in 5GMM-REGISTERED state with NR RRC_IDLE mode, UE has received a paging request and
UE has completed a SERVICE REQUEST procedure}
ensure that {
  when { UE receives a CP-DATA containing an RP-DATA RPDU (SMS DELIVER TPDU) encapsulated in a
Downlink NAS transport message }
  then { UE sends a CP-ACK encapsulated in an Uplink NAS transport message followed by a CP-DATA
containing an RP-ACK RPDU encapsulated in an Uplink NAS transport message}

```

9.1.8.1.2 Conformance requirements

References: The conformance requirements covered in the present TC are specified in: TS 24.501, clause 5.5.1.2.2, 5.5.1.2.4, 5.5.1.3.2, 5.5.1.3.4, 9.11.3.6 and 9.11.3.9A. Unless otherwise stated these are Rel-15 requirements.

[TS 24.501 clause 5.5.1.2.2]

The UE in state 5GMM-DEREGISTERED shall initiate the registration procedure for initial registration by sending a REGISTRATION REQUEST message to the AMF,

- a) when the UE performs initial registration for 5GS services;
- b) when the UE performs initial registration for emergency services;
- c) when the UE performs initial registration for SMS over NAS; and
- d) when the UE moves from GERAN to NG-RAN coverage or the UE moves from a UTRAN to NG-RAN coverage.

...

The UE initiates the registration procedure for initial registration by sending a REGISTRATION REQUEST message to the AMF, starting timer T3510. If timer T3502 is currently running, the UE shall stop timer T3502. If timer T3511 is currently running, the UE shall stop timer T3511.

...

If the UE requests the use of SMS over NAS, the UE shall include the 5GS update type IE in the REGISTRATION REQUEST message with the SMS requested bit set to "SMS over NAS supported". When the 5GS update type IE is included in the REGISTRATION REQUEST for reasons other than requesting the use of SMS over NAS, and the UE does not need to register for SMS over NAS, the UE shall set the SMS requested bit of the 5GS update type IE to "SMS over NAS not supported" in the REGISTRATION REQUEST message.

[TS 24.501 clause 5.5.1.2.4]

If the initial registration request is accepted by the network, the AMF shall send a REGISTRATION ACCEPT message to the UE.

...

If the 5GS update type IE was included in the REGISTRATION REQUEST message with the SMS requested bit set to "SMS over NAS supported", and SMSF selection is successful, then the AMF shall send the REGISTRATION ACCEPT message after the SMSF has confirmed that the activation of the SMS service was successful. When sending the REGISTRATION ACCEPT message, the AMF shall:

- a) set the SMS allowed bit of the 5GS registration result IE to "SMS over NAS allowed" in the REGISTRATION ACCEPT message, if the UE has set the SMS requested bit of the 5GS registration type IE to "SMS over NAS supported" in the REGISTRATION REQUEST message and the network allows the use of SMS over NAS for the UE; and

b) store the SMSF address and the value of the SMS allowed bit of the 5GS registration result IE in the UE 5GMM context and consider the UE available for SMS over NAS.

[TS 24.501 clause 5.5.1.3.2]

The UE in state 5GMM-REGISTERED shall initiate the registration procedure for mobility and periodic registration update by sending a REGISTRATION REQUEST message to the AMF,

- l) when the UE needs to register for SMS over NAS, indicate a change in the requirements to use SMS over NAS, or de-register from SMS over NAS;

...

The UE in state 5GMM-REGISTERED shall initiate the registration procedure for mobility and periodic update by sending a REGISTRATION REQUEST message to the AMF when the UE needs to request the use of SMS over NAS transport or the current requirements to use SMS over NAS transport change in the UE. The UE shall set the SMS requested bit of the 5GS update type IE in the REGISTRATION REQUEST message as specified in subclause 5.5.1.2.2.

When initiating a registration procedure for mobility and periodic registration update and the UE needs to send the 5GS update type IE for a reason different than indicating a change in requirement to use SMS over NAS, the UE shall set the SMS requested bit of the 5GS update type IE in the REGISTRATION REQUEST message to the same value as indicated by the UE in the last REGISTRATION REQUEST message.

If the UE no longer requires the use of SMS over NAS, then the UE shall include the 5GS update type IE in the REGISTRATION REQUEST message with the SMS requested bit set to "SMS over NAS not supported".

[TS 24.501 clause 5.5.1.3.4]

If the registration update request has been accepted by the network, the AMF shall send a REGISTRATION ACCEPT message to the UE.

...

If the 5GS update type IE was included in the REGISTRATION REQUEST message with the SMS requested bit set to "SMS over NAS not supported" and:

- a) the SMSF address is stored in the UE 5GMM context and:
 - 1) the UE is considered available for SMS over NAS; or
 - 2) the UE is considered not available for SMS over NAS and the SMSF has confirmed that the activation of the SMS service is successful; or
- b) the SMSF address is not stored in the UE 5GMM context, the SMSF selection is successful and the SMSF has confirmed that the activation of the SMS service is successful;

then the AMF shall set the SMS allowed bit of the 5GS registration result IE in the REGISTRATION ACCEPT message as specified in subclause 5.5.1.2.4. If the UE 5GMM context does not contain an SMSF address or the UE is not considered available for SMS over NAS, then the AMF shall:

- a) store the SMSF address in the UE 5GMM context if not stored already; and
- b) store the value of the SMS allowed bit of the 5GS registration result IE in the UE 5GMM context and consider the UE available for SMS over NAS.

If SMSF selection in the AMF or SMS activation via the SMSF is not successful, or the AMF does not allow the use of SMS over NAS, then the AMF shall set the SMS allowed bit of the 5GS registration result IE to "SMS over NAS not allowed" in the REGISTRATION ACCEPT message.

If the 5GS update type IE was included in the REGISTRATION REQUEST message with the SMS requested bit set to "SMS over NAS not supported", then the AMF shall:

- a) mark the 5GMM context to indicate that the UE is not available for SMS over NAS; and

NOTE 2: The AMF can notify the SMSF that the UE is deregistered from SMS over NAS based on local configuration.

- b) set the SMS allowed bit of the 5GS registration result IE to "SMS over NAS not supported" in the REGISTRATION ACCEPT message.

When the UE receives the REGISTRATION ACCEPT message, if the UE is also registered over another access to the same PLMN, the UE considers the value indicated by the SMS allowed bit of the 5GS registration result IE as applicable for both accesses over which the UE is registered.

[TS 24.501 clause 9.11.3.6]

The purpose of the 5GS registration result information element is to specify the result of a registration procedure.

The 5GS registration result information element is coded as shown in figure 9.11.3.6.1 and table 9.11.3.6.1.

The 5GS registration result is a type 4 information element with a length of 3 octets.

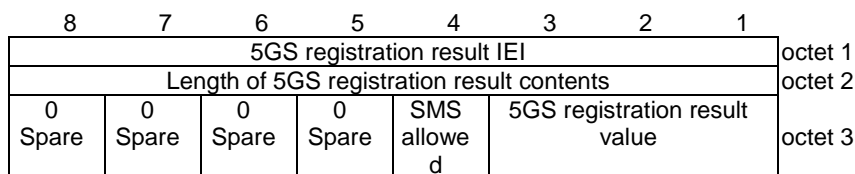

Figure 9.11.3.6.1: 5GS registration result information element

Table 9.11.3.6.1: 5GS registration result information element

5GS registration result value (octet 3, bits 1 to 3)			
Bits			
3	2	1	
0	0	1	3GPP access
0	1	0	Non-3GPP access
0	1	1	3GPP access and non-3GPP access
1	1	1	reserved
All other values are unused and shall be treated as "3GPP access", if received by the UE.			
SMS over NAS transport allowed (SMS allowed) (octet 3, bit 4)			
Bit			
4			
0	SMS over NAS not allowed		
1	SMS over NAS allowed		
Bits 5 to 8 of octet 3 are spare and shall be coded as zero.			

[TS 24.501 clause 9.11.3.9A]

The purpose of the 5GS update type IE is to allow the UE to provide additional information to the network when performing a registration procedure.

The 5GS update type information element is coded as shown in figure 9.11.3.9A.1 and table 9.11.3.9A.1.

The 5GS update type is a type 4 information element.

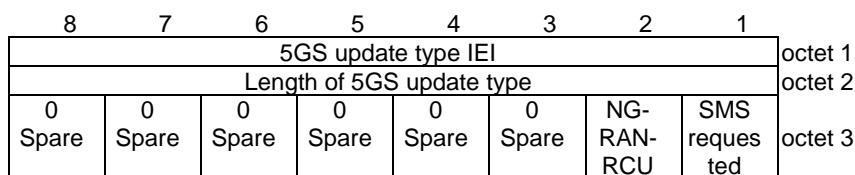

Figure 9.11.3.9A.1: 5GS update type information element

Table 9.11.3.9A.1: 5GS update type information element

SMS over NAS transport requested (SMS requested) (octet 3, bit 1)	
Bit	
1	
0	SMS over NAS not supported
1	SMS over NAS supported
NG-RAN Radio Capability Update (NG-RAN-RCU) (octet 3, bit 2)	
Bits	
2	
0	NG-RAN radio capability update not needed
1	NG-RAN radio capability update needed
Bits 3 to 8 of octet 3 are spare and shall be coded as zero.	

9.1.8.1.3 Test description

9.1.8.1.3.1 Pre-test conditions

System Simulator:

NGC Cell A belongs to Home PLMN and TAI1;

UE:

The UE does not have any stored SMS message.

Preamble:

The UE is in state Switched OFF (state-0A) according to TS 38.508-1 [4].

9.1.8.1.3.2 Test procedure sequence

Table 9.1.8.1.3.2-1: Main behaviour

St	Procedure	Message Sequence		TP	Verdict
		U - S	Message		
1	The UE is switched ON	-	-	-	-
2 - 4	UE establishes RRC connection by executing steps 2-4 of Table 4.5.2.2-2 in TS 38.508-1	-	-	-	-
5	Check: Does UE transmit a REGISTRATION REQUEST message including 5GS update type IE with SMS requested bit set to "SMS over NAS supported"?	-->	REGISTRATION REQUEST	1	P
6 - 14	Steps 5 to 13 of the generic procedure for NR RRC IDLE specified in TS 38.508-1 subclause 4.5.2, Table 4.5.2.2-2: NR RRC_IDLE are performed.	-	-	-	-
15	SS transmits REGISTRATION ACCEPT message including 5GS registration result with SMS allowed bit set to "SMS over NAS allowed" and T3512 value set to 3 minutes.	<--	REGISTRATION ACCEPT		
16 - 21	Steps 15 to 20 of the generic procedure for NR RRC IDLE specified in TS 38.508-1 subclause 4.5.2, Table 4.5.2.2-2: NR RRC_IDLE are performed.	-	-	-	-
22 - 24	UE establishes RRC connection by executing steps 2-4 of Table 4.5.2.2-2 in TS38.508-1	-	-	-	-
25	Check: Does UE perform periodic Registration (Based on T3512 value indicated in the REGISTRATION ACCEPT message with timer starting in step-15) including 5GS update type IE with SMS requested bit set to "SMS over NAS supported"?	-->	REGISTRATION REQUEST	2	P
26 - 34	Steps 5 to 13 of the generic procedure for NR RRC IDLE specified in TS 38.508-1 subclause 4.5.2, Table 4.5.2.2-2: NR RRC_IDLE are performed.	-	-	-	-
35	SS transmits REGISTRATION ACCEPT message including 5GS registration result with SMS allowed bit set to "SMS over NAS allowed" and T3512 value set to 3 minutes.	<--	REGISTRATION ACCEPT		
36	The SS transmits a <i>RRCRelease</i> message	-	-	-	-
37	Sending of a 160 character MO SMS is initiated at the UE via MMI or AT command	-	-	-	-
38	Check: Does the UE transmit a SERVICE REQUEST message?	-->	SERVICE REQUEST		
39 - 42	Steps 5 to 8 of the generic procedure for NR RRC CONNECTED specified in TS 38.508-1 subclause 4.5.4, Table 4.5.4.2-3: NR RRC_CONNECTED are performed.	-	-	-	-
43	Check: Does the UE transmit a CP-DATA containing an RP-DATA RPDU (SMS SUBMIT TPDU) encapsulated in an Uplink NAS transport message?	-->	UPLINK NAS TRANSPORT	3	P
44	The SS transmits a CP-ACK encapsulated in a Downlink NAS Transport message.	<--	DOWNLINK NAS TRANSPORT	-	-
45	The SS transmits a CP-DATA containing an RP-ACK RPDU encapsulated in a Downlink NAS transport message	<--	DOWNLINK NAS TRANSPORT	-	-

46	Check: Does the UE transmit a CP-ACK encapsulated in an Uplink NAS Transport message?	-->	UPLINK NAS TRANSPORT	4	P
47	The SS transmits a <i>RRCRelease</i> message	-	-	-	-
48	The SS pages the UE using NG-5G-S-TMSI.	-	-	-	-
49	The UE transmits a SERVICE REQUEST message.	-->	SERVICE REQUEST	-	-
50-53	Steps 5 to 8 of the generic procedure for NR RRC CONNECTED specified in TS 38.508-1 subclause 4.5.4, Table 4.5.4.2-3: NR RRC_CONNECTED are performed.	-	-	-	-
54	The SS transmits a CP-DATA containing a RP-DATA RPDU (SMS DELIVER TPDU) encapsulated in a Downlink NAS transport message to the UE.	<--	DOWNLINK NAS TRANSPORT	-	-
55	Check: Does the UE transmit a CP-ACK encapsulated in an Uplink NAS transport message?	-->	UPLINK NAS TRANSPORT	5	P
56	Check: Does the UE transmit a CP-DATA containing a RP-ACK RPDU encapsulated in an Uplink NAS transport message?	-->	UPLINK NAS TRANSPORT	5	P
57	The SS transmits a CP-ACK encapsulated in a Downlink NAS transport message to the UE.	<--	DOWNLINK NAS TRANSPORT	-	-

9.1.8.1.3.3 Specific message contents

Table 9.1.8.1.3.3-1: REGISTRATION REQUEST (step 5, Table 9.1.8.1.3.2-1)

Derivation Path: 38.508-1 [4], Table 4.7.1-6			
Information Element	Value/remark	Comment	Condition
5GS registration type			
5GS registration type value	'001'B		INITIAL
5GS update type			
SMS requested	SMS over NAS supported		

Table 9.1.8.1.3.3-2: REGISTRATION ACCEPT (steps 15 and 35, Table 9.1.8.1.3.2-1)

Derivation Path: 38.508-1 [4], Table 4.7.1-7			
Information Element	Value/remark	Comment	Condition
5GS registration result			
SMS allowed	SMS over NAS allowed		
T3512 value			
Timer value	'00011'B		
Unit	'101'B		

Table 9.1.8.1.3.3-3: REGISTRATION REQUEST (step 25, Table 9.1.8.1.3.2-1)

Derivation Path: 38.508-1 [4], Table 4.7.1-6			
Information Element	Value/remark	Comment	Condition
5GS registration type			
5GS registration type value	'011'B		PERIODIC
5GS update type			
SMS requested	SMS over NAS supported		

Table 9.1.8.1.3.3-4: UL NAS TRANSPORT (step 43, Table 9.1.8.1.3.2-1)

Derivation Path: 38.508-1 [4], Table 4.7.1-10			
Information Element	Value/remark	Comment	Condition
Payload container type	'0010'B	SMS	
Payload container	CP-DATA	RP-DATA RPDU	

Table 9.1.8.1.3.3-5: DL NAS TRANSPORT (step 44, Table 9.1.8.1.3.2-1)

Derivation Path: 38.508-1 [4], Table 4.7.1-11			
Information Element	Value/remark	Comment	Condition
Payload container type	'0010'B	SMS	
Payload container	CP-ACK		

Table 9.1.8.1.3.3-6: DL NAS TRANSPORT (step 45, Table 9.1.8.1.3.2-1)

Derivation Path: 38.508-1 [4], Table 4.7.1-11			
Information Element	Value/remark	Comment	Condition
Payload container type	'0010'B	SMS	
Payload container	CP-DATA	RP-ACK RPDU	

Table 9.1.8.1.3.3-7: UL NAS TRANSPORT (step 46, Table 9.1.8.1.3.2-1)

Derivation Path: 38.508-1 [4], Table 4.7.1-10			
Information Element	Value/remark	Comment	Condition
Payload container type	'0010'B	SMS	
Payload container	CP-ACK		

Table 9.1.8.1.3.3-8: DL NAS TRANSPORT (step 54, Table 9.1.8.1.3.2-1)

Derivation Path: 38.508-1 [4], Table 4.7.1-11			
Information Element	Value/remark	Comment	Condition
Payload container type	'0010'B	SMS	
Payload container	CP-DATA	RP-DATA	

Table 9.1.8.1.3.3-9: UL NAS TRANSPORT (step 55, Table 9.1.8.1.3.2-1)

Derivation Path: 38.508-1 [4], Table 4.7.1-10			
Information Element	Value/remark	Comment	Condition
Payload container type	'0010'B	SMS	
Payload container	CP-ACK		

Table 9.1.8.1.3.3-10: UL NAS TRANSPORT (step 56, Table 9.1.8.1.3.2-1)

Derivation Path: 38.508-1 [4], Table 4.7.1-10			
Information Element	Value/remark	Comment	Condition
Payload container type	'0010'B	SMS	
Payload container	CP-DATA	RP-ACK	

Table 9.1.8.1.3.3-11: DL NAS TRANSPORT (step 57, Table 9.1.8.1.3.2-1)

Derivation Path: 38.508-1 [4], Table 4.7.1-11			
Information Element	Value/remark	Comment	Condition
Payload container type	'0010'B	SMS	
Payload container	CP-ACK		

9.2 5GS Non-3GPP Access Mobility Management

9.2.1 Primary authentication and key agreement procedure

9.2.2 Security Mode Control

9.2.2.1 NAS security mode command

9.2.2.1.1 Test Purpose (TP)

(1)

```
with { the UE is in 5GMM-REGISTERED-INITIATED state and the SS initiates the NAS security mode
control procedure by sending a SECURITY MODE COMMAND message during initial registration procedure }
ensure that {
  when { the UE receives an integrity protected SECURITY MODE COMMAND message including not matching
replayed security capabilities }
  then { the UE send a SECURITY MODE REJECT message and does not start applying the NAS security
in both UL and DL }
}
```

(2)

```
with { the UE is in 5GMM-REGISTERED-INITIATED state and the SS initiates the NAS security mode
control procedure by sending a SECURITY MODE COMMAND message during initial registration procedure }
ensure that {
  when { the UE receives an integrity protected SECURITY MODE COMMAND message including IMEISV
request }
  then { the UE send an integrity protected and ciphered SECURITY MODE COMPLETE message including
IMEISV and starts applying the NAS Security in both UL and DL }
}
```

9.2.2.1.2 Conformance requirements

References: The conformance requirements covered in the present test case are specified in: TS 24.501, clauses 5.4.2.1, 5.4.2.3 and 5.4.2.5. Unless otherwise stated these are Rel-15 requirements.

[TS 24.501, clause 5.4.2.1]

The purpose of the NAS security mode control procedure is to take a 5G NAS security context into use, and initialise and start NAS signalling security between the UE and the AMF with the corresponding 5G NAS keys and 5G NAS security algorithms.

Furthermore, the network may also initiate the security mode control procedure in the following cases:

- a)- in order to change the 5G NAS security algorithms for a current 5G NAS security context already in use; and
- b) in order to change the value of uplink NAS COUNT used in the latest SECURITY MODE COMPLETE message as described in 3GPP TS 33.501 [24], subclause 6.9.4.4.

For restrictions concerning the concurrent running of a security mode control procedure with other security related procedures in the AS or inside the core network see 3GPP TS 33.501 [24], subclause 6.9.5.

[TS 24.501, clause 5.4.2.3]

Upon receipt of the SECURITY MODE COMMAND message, the UE shall check whether the security mode command can be accepted or not. This is done by performing the integrity check of the message, by checking that the Replayed S1 UE security capabilities IE is included if the Selected EPS NAS security algorithms IE is included in the message, and by checking that the received replayed UE security capabilities have not been altered compared to the latest values that the UE sent to the network.

When the SECURITY MODE COMMAND message includes an EAP-success message the UE handles the EAP-success message and the ABBA as described in subclause 5.4.1.2.2.8.

If the UE is registered for emergency services, performing initial registration for emergency services or establishing an emergency PDU session and the SECURITY MODE COMMAND message is received with ngKSI value "000" and 5G-IA0 and 5G-EA0 as selected 5G NAS security algorithms, the UE shall locally derive and take in use 5G NAS security context. The UE shall delete existing current 5G NAS security context.

The UE shall accept a SECURITY MODE COMMAND message indicating the "null integrity protection algorithm" 5G-EA0 as the selected 5G NAS integrity algorithm only if the message is received when the UE is registered for emergency services, performing initial registration for emergency services or establishing an emergency PDU session.

If the type of security context flag included in the SECURITY MODE COMMAND message is set to "native security context" and if the ngKSI matches a valid non-current native 5G NAS security context held in the UE while the UE has a mapped 5G NAS security context as the current 5G NAS security context, the UE shall take the non-current native 5G NAS security context into use which then becomes the current native 5G NAS security context and delete the mapped 5G NAS security context.

If the SECURITY MODE COMMAND message can be accepted, the UE shall take the 5G NAS security context indicated in the message into use. The UE shall in addition reset the uplink NAS COUNT counter if:

- a) the SECURITY MODE COMMAND message is received in order to take a 5G NAS security context into use created after a successful execution of the 5G AKA based primary authentication and key agreement procedure or the EAP based primary authentication and key agreement procedure; or
- b) the SECURITY MODE COMMAND message received includes the type of security context flag set to "mapped security context" in the NAS key set identifier IE the ngKSI does not match the current 5G NAS security context, if it is a mapped 5G NAS security context.

If the SECURITY MODE COMMAND message can be accepted and a new 5G NAS security context is taken into use and SECURITY MODE COMMAND message does not indicate the "null integrity protection algorithm" 5G-IA0 as the selected NAS integrity algorithm, the UE shall:

- if the SECURITY MODE COMMAND message has been successfully integrity checked using an estimated downlink NAS COUNT equal to 0, then the UE shall set the downlink NAS COUNT of this new 5G NAS security context to 0;
- otherwise the UE shall set the downlink NAS COUNT of this new 5G NAS security context to the downlink NAS COUNT that has been used for the successful integrity checking of the SECURITY MODE COMMAND message.

If the SECURITY MODE COMMAND message includes the horizontal derivation parameter indicating " K'_{AMF} derivation is required", the UE shall derive a new K'_{AMF} , as specified in 3GPP TS 33.501 [24] for K_{AMF} to K'_{AMF} derivation in mobility, and set both uplink and downlink NAS COUNTs to zero.

If the SECURITY MODE COMMAND message can be accepted, the UE shall send a SECURITY MODE COMPLETE message integrity protected with the selected 5GS integrity algorithm and the 5G NAS integrity key based on the K_{AMF} or mapped K'_{AMF} if the type of security context flag is set to "mapped security context" indicated by the ngKSI. When the SECURITY MODE COMMAND message includes the type of security context flag set to "mapped security context" in the NAS key set identifier IE, then the UE shall check whether the SECURITY MODE COMMAND message indicates the ngKSI of the current 5GS security context, if it is a mapped 5G NAS security context, in order not to re-generate the K'_{AMF} .

Furthermore, if the SECURITY MODE COMMAND message can be accepted, the UE shall cipher the SECURITY MODE COMPLETE message with the selected 5GS ciphering algorithm and the 5GS NAS ciphering key based on the K_{AMF} or mapped K'_{AMF} indicated by the ngKSI. The UE shall set the security header type of the message to "integrity protected and ciphered with new 5G NAS security context".

From this time onward the UE shall cipher and integrity protect all NAS signalling messages with the selected 5GS integrity and ciphering algorithms.

If the AMF indicated in the SECURITY MODE COMMAND message that the IMEISV is requested, the UE shall include its IMEISV in the SECURITY MODE COMPLETE message.

If, during an ongoing registration procedure or service request procedure, the SECURITY MODE COMMAND message includes the Additional 5G security information IE with the RINMR bit set to "Retransmission of the initial NAS message requested", the UE shall include the entire unciphered REGISTRATION REQUEST message or SERVICE REQUEST message, which the UE had previously included in the NAS message container IE of the initial

NAS message (i.e. REGISTRATION REQUEST message or SERVICE REQUEST message, respectively), in the NAS message container IE of the SECURITY MODE COMPLETE message.

If, prior to receiving the SECURITY MODE COMMAND message, the UE without a valid 5GS NAS security context had sent a REGISTRATION REQUEST message the UE shall include the entire REGISTRATION REQUEST message in the NAS message container IE of the SECURITY MODE COMPLETE message as described in subclause 4.4.6.

If the UE operating in the single-registration mode receives the Selected EPS NAS security algorithms IE, the UE shall use the IE according to 3GPP TS 33.501 [24].

For a UE operating in single-registration mode with N26 interface supported in the network, after an inter-system change from S1 mode to N1 mode in 5GMM-CONNECTED mode, the UE shall set the value of the Selected EPS NAS security algorithms IE in the 5G NAS security context to the NAS security algorithms that were received from the source MME when the UE was in S1 mode.

[TS 24.501, clause 5.4.2.5]

If the security mode command cannot be accepted, the UE shall send a SECURITY MODE REJECT message. The SECURITY MODE REJECT message contains a 5GMM cause that typically indicates one of the following cause values:

- #23 UE security capabilities mismatch.
- #24 security mode rejected, unspecified.

If the UE detects that the network included the Selected EPS NAS security algorithms IE in the SECURITY MODE COMMAND message without including a Replayed S1 UE security capabilities IE, or that the received replayed UE security capabilities have been altered compared to the latest values that the UE sent to the network, the UE shall set the cause value to #23 "UE security capabilities mismatch".

Upon receipt of the SECURITY MODE REJECT message, the AMF shall stop timer T3560. The AMF shall also abort the ongoing procedure that triggered the initiation of the NAS security mode control procedure.

Both the UE and the AMF shall apply the 5G NAS security context in use before the initiation of the security mode control procedure, if any, to protect the SECURITY MODE REJECT message and any other subsequent messages according to the rules in subclause 4.4.4 and 4.4.5.

9.2.2.1.3 Test description

9.2.2.1.3.1 Pre-test conditions

System Simulator:

- NGC Cell A.

UE:

- None.

Preamble:

- The UE is in state ON-B on NGC Cell A according to TS 38.508-1 [4].

9.2.2.1.3.2 Test procedure sequence

Table 9.2.2.1.3.2-1: Main behaviour

St	Procedure	Message Sequence		TP	Verdict
		U - S	Message		
1	The UE is switched on.	-	-	-	-
2-6	Steps 1-5 of the generic procedure for UE registration specified in TS 38.508-1 [4] table 4.5.2.2-3 are performed.	-	-	-	-
7	The SS transmits a SECURITY MODE COMMAND message to activate NAS security. It is integrity protected and includes unmatched replayed security capabilities.	<--	SECURITY MODE COMMAND	-	-
8	Check: Does the UE transmit a SECURITY MODE REJECT message with cause'#23: UE security capabilities mismatch'?	-->	SECURITY MODE REJECT	1	P
9	The SS transmits an IDENTITY REQUEST message (Security not applied).	<--	IDENTITY REQUEST	-	-
10	Check: Does the UE transmit a non-security protected IDENTITY RESPONSE message?	-->	IDENTITY RESPONSE	1	P
11	The SS transmits a SECURITY MODE COMMAND message to activate NAS security. It is integrity protected and includes IMEISV.	<--	SECURITY MODE COMMAND	-	-
12	Check: Does the UE transmit a SECURITY MODE COMPLETE message and does it establish the initial security configuration?	-->	SECURITY MODE COMPLETE	2	P
13-15	Steps 8-10 of the generic procedure for UE registration specified in TS 38.508-1 [4] table 4.5.2.2-3 are performed.	-	-	-	-
16	The SS transmits an IDENTITY REQUEST message (Security protected as per the algorithms specified in step 11).	<-	IDENTITY REQUEST	-	-
17	Check: Does the UE transmit an IDENTITY RESPONSE message (Security Protected as per the algorithms specified in step 11)?	->	IDENTITY RESPONSE	2	P
Note 1: The UE establishes an IPsec tunnel in parallel to 5GC registration steps 4 to 12 as per the IKEv2 protocol as defined in 3GPP TS 23.502 [31] clause 4.12.2.2 figure 4.12.2.2-1.					

9.2.2.1.3.3 Specific message contents

Table 9.2.2.1.3.3-1: SECURITY MODE COMMAND (Step 7, Table 9.2.2.1.3.2-1)

Derivation path: 38.508-1 [4],table 4.7.1-25			
Information Element	Value/Remark	Comment	Condition
Replayed UE security capabilities	Set to mismatch the security capability of UE under test		

Table 9.2.2.1.3.3-2: SECURITY MODE REJECT (Step 8, Table 9.2.2.1.3.2-1)

Derivation path: 38.508-1 [4],table 4.7.1-27			
Information Element	Value/Remark	Comment	Condition
5GMM cause	#23		

Table 9.2.2.1.3.3-3: IDENTITY REQUEST (Step 9, Table 9.2.2.1.3.2-1)

Derivation path: 38.508-1 [4],table 4.7.1-21			
Information Element	Value/Remark	Comment	Condition
Identity type	'0001'B	SUCI	

Table 9.2.2.1.3.3-4: IDENTITY RESPONSE (Step 10, Table 9.2.2.1.3.2-1)

Derivation path: 38.508-1 [4],table 4.7.1-22			
Information Element	Value/Remark	Comment	Condition
Mobile identity			
Type of identity	'001'B	SUCI	

Table 9.2.2.1.3.3-5: SECURITY MODE COMMAND (Step 11, Table 9.2.2.1.3.2-1)

Derivation path: 38.508-1 [4], table 4.7.1-25			
Information Element	Value/Remark	Comment	Condition
Selected NAS security algorithms			
Type of ciphering algorithm	Set according to PIXIT parameter for default ciphering algorithm if it is set to a value different to 5G-EA0, or, set to any value different to 5G-EA0 otherwise	Non-zero ciphering algorithm	
IMEISV request	Present		

Table 9.2.2.1.3.3-6: SECURITY MODE COMPLETE (Step 12, Table 9.2.2.1.3.2-1)

Derivation path: 38.508-1 [4], table 4.7.1-26			
Information Element	Value/Remark	Comment	Condition
IMEISV	Present		

Table 9.2.2.1.3.3-7: IDENTITY REQUEST (Step 16, Table 9.2.2.1.3.2-1)

Derivation path: 38.508-1 [4],table 4.7.1-21			
Information Element	Value/Remark	Comment	Condition
Identity type	'0011'B	IMEI	

Table 9.2.2.1.3.3-8: IDENTITY RESPONSE (Step 17, Table 9.2.2.1.3.2-1)

Derivation path: 38.508-1 [4],table 4.7.1-22			
Information Element	Value/Remark	Comment	Condition
Mobile identity			
Type of identity	'011'B	IMEI	

9.2.2.2 Protection of initial NAS signalling messages

9.2.2.2.1 Test Purpose (TP)

Same Test purpose as in clause 9.1.2.2.1

9.2.2.2.2 Conformance requirements

Same conformance requirements as in clause 9.1.2.2.2

9.2.2.2.3 Test description

9.2.2.2.3.1 Pre-test conditions

System Simulator:

- WLAN Cell 27.

UE:

- None.

Preamble:

- The UE is in state 0W-B on WLAN Cell 27 according to TS 38.508-1 [4].
- The UE does not have a valid 5G NAS security context.

9.2.2.2.3.2 Test procedure sequence

Table 9.2.2.2.3.2-1: Main behaviour

St	Procedure	Message Sequence		TP	Verdict
		U - S	Message		
1	The UE is switched on.	-	-	-	-
2-3	Steps 1-2 of the generic procedure for UE registration specified in TS 38.508-1 [4] table 4.5.2.2-3 are performed.	-	-	-	-
-	Exception: The UE establishes an IPsec tunnel in parallel to 5GC registration steps 4 to 8 as per the IKEv2 protocol as defined in 3GPP TS 23.502 [31] clause 4.12.2.2 figure 4.12.2.2-1.	-	-	-	-
4	The UE transmits a REGISTRATION REQUEST message.	-->	REGISTRATION REQUEST	1	P
5	The SS transmits a <i>DLInformationTransfer</i> message and a AUTHENTICATION REQUEST message.	<--	AUTHENTICATION REQUEST	-	-
6	The UE transmits an <i>ULInformationTransfer</i> message and a AUTHENTICATION RESPONSE message.	-->	AUTHENTICATION RESPONSE	-	-
7	The SS transmits a <i>DLInformationTransfer</i> message and a SECURITY MODE COMMAND message.	<--	SECURITY MODE COMMAND		
8	The UE transmits an <i>ULInformationTransfer</i> message and a SECURITY MODE COMPLETE message.	-->	SECURITY MODE COMPLETE	2	P
9-11	Steps 8-10 of the generic procedure for UE registration specified in TS 38.508-1 [4] table 4.5.2.2-3 are performed.	-	-	-	-

9.2.2.2.3.3 Specific message contents

Table 9.2.2.2.3.3-1: REGISTRATION REQUEST (Step 4, Table 9.2.2.2.3.2-1)

Derivation path: 38.508-1 [4],table 4.7.1-6 using condition NON_CLEARTEXT_IE			
Information Element	Value/Remark	Comment	Condition

Table 9.2.2.2.3.3-2: SECURITY MODE COMPLETE (Step 8, Table 9.2.2.2.3.2-1)

Derivation path: 38.508-1 [4],table 4.7.1-26			
Information Element	Value/Remark	Comment	Condition
NAS message container	Contents of Table 9.2.2.2.3.3-3		

Table 9.2.2.2.3.3-3: REGISTRATION REQUEST (Step 8, Table 9.2.2.2.3.2-1)

Derivation path: 38.508-1 [4],table 4.7.1-6 using condition CIPHERED_MESSAGE			
Information Element	Value/Remark	Comment	Condition

9.2.3 Identification

9.2.4 Generic UE configuration

9.2.5 Registration

9.2.5.1 Initial Registration

9.2.5.1.1 Initial registration / Success / 5G-GUTI reallocation, Last visited TAI

9.2.5.1.1.1 Test Purpose (TP)

(1)

```
with { the UE has no valid 5G-GUTI but available SUCI and switched off }
ensure that {
  when { the UE is switched on }
  then { the UE sends a REGISTRATION REQUEST message including the SUCI in the 5GS mobile identity
IE }
}
```

(2)

```
with { the UE is 5GMM-REGISTERED state with assigned 5G-GUTI and last visited registered TAI and
switched off }
ensure that {
  when { the UE is switched on }
  then { the UE sends a REGISTRATION REQUEST message including the 5G-GUTI assigned previously in
the 5GS mobile identity IE and the last visited registered TAI }
}
```

9.2.5.1.1.2 Conformance requirements

References: The conformance requirements covered in the current TC are specified in: TS 24.501 clauses 5.5.1.2.2 and 5.5.1.2.4. Unless otherwise stated these are Rel-15 requirements.

[TS 24.501, clause 5.5.1.2.2]

The UE initiates the registration procedure for initial registration by sending a REGISTRATION REQUEST message to the AMF, starting timer T3510. If timer T3502 is currently running, the UE shall stop timer T3502. If timer T3511 is currently running, the UE shall stop timer T3511.

During initial registration the UE handles the 5GS mobile identity IE in the following order:

...

- b) if the UE holds a valid 5G-GUTI that was previously assigned, over 3GPP access or non-3GPP access, by the same PLMN with which the UE is performing the registration, the UE shall indicate the 5G-GUTI in the 5GS mobile identity IE;
- c) if the UE holds a valid 5G-GUTI that was previously assigned, over 3GPP access or non-3GPP access, by an equivalent PLMN, the UE shall indicate the 5G-GUTI in the 5GS mobile identity IE;
- d) if the UE holds a valid 5G-GUTI that was previously assigned, over 3GPP access or non-3GPP, by any other PLMN, the UE shall indicate the 5G-GUTI in the 5GS mobile identity IE;
- e) if a SUCI is available the UE shall include the SUCI in the 5GS mobile identity IE; and

If the SUCI is included in the 5GS mobile identity IE and the timer T3519 is not running, the UE shall start timer T3519 and store the value of the SUCI sent in the REGISTRATION REQUEST message. The UE shall include the stored SUCI in the REGISTRATION REQUEST message while timer T3519 is running.

...

If the last visited registered TAI is available, the UE shall include the last visited registered TAI in the REGISTRATION REQUEST message.

[TS 24.501, clause 5.5.1.2.4]

The 5G-GUTI reallocation shall be part of the initial registration procedure. During the initial registration procedure, if the AMF has not allocated a new 5G-GUTI by the generic UE configuration update procedure, the AMF shall include in the REGISTRATION ACCEPT message the new assigned 5G-GUTI together with the assigned TAI list.

9.2.5.1.1.3 Test description

9.2.5.1.1.3.1 Pre-test conditions

System Simulator:

- WLAN Cell 27

UE:

- None.

Preamble:

- The UE is in state Switched OFF (state 0W-B) according to TS 38.508-1 [4].

9.2.5.1.1.3.2 Test procedure sequence

Table 9.2.5.1.1.3.2-1: Main behaviour

St	Procedure	Message Sequence		TP	Verdict
		U – S	Message		
1	The UE is switched on.	-	-	-	-
2-8	UE establishes an IPSEC SA and trigger 5GMM Registration procedure by executing steps 1 to 7 of Table 4.5.2.2-3 in TS38.508-1 [4].	-	-	-	-
9	SS transmits an REGISTRATION REJECT message with the 5GMM cause IE setting as "Illegal ME". NOTE1: 5G-GUTI-1 should be deleted, then UE has no valid 5G-GUTI but available SUCI now.	<--	REGISTRATION REJECT	-	-
10	The generic procedure for SS-requested IPsec Secure tunnel disconnection, specified in subclause 4.5A.3 of TS 38.508-1 [4], takes place performing disconnection of security association.	-	-	-	-
11	If possible (see ICS) switch off is performed or the USIM is removed. Otherwise the power is removed.	-	-	-	-
12	The UE is brought back to operation or the USIM is inserted.	-	-	-	-
13-23	Steps 1-11 of Table 4.5.2.2-2 of the generic procedure in TS 38.508-1 [4] are performed	-	-	1	P
24	If possible (see ICS) switch off is performed or the USIM is removed. Otherwise the power is removed.	-	-	-	-
25	The UE is brought back to operation or the USIM is inserted.	-	-	-	-
26-35	Steps 1-11 of Table 4.5.2.2-2 of the generic procedure in TS 38.508-1 [4] are performed	-	-	2,3	P

9.2.5.1.1.3.3 Specific message contents

Table 9.2.5.1.1.3.3-1: Message REGISTRATION REJECT (step 9, Table 9.2.5.1.1.3.2-1)

Derivation path: TS 38.508-1 [4], table 4.7.1-9			
Information Element	Value/Remark	Comment	Condition
5GMM cause	'0000 0011'B	Illegal UE	

Table 9.2.5.1.1.3.3-2: Message REGISTRATION REQUEST (step 15, Table 9.2.5.1.1.3.2-1)

Derivation path: TS 38.508-1 [4], table 4.7.1-6			
Information Element	Value/Remark	Comment	Condition
5GS registration type	'0000 0001'B	Initial registration	
5GS mobile identity	SUCI	The SUCI of UE	

Table 9.2.5.1.1.3.3-3: Message REGISTRATION ACCEPT (step 21, Table 9.2.5.1.1.3.2-1)

Derivation path: TS 38.508-1 [4], table 4.7.1-7			
Information Element	Value/Remark	Comment	Condition
5G-GUTI	5G-GUTI-2		

Table 9.2.5.1.1.3.3-4: Message REGISTRATION REQUEST (step 34, Table 9.2.5.1.1.3.2-1)

Derivation path: TS 38.508-1 [4], table 4.7.1-6			
Information Element	Value/Remark	Comment	Condition
5GS registration type	'0000 0001'B	Initial registration	
5GS mobile identity	5G-GUTI-2		
Last visited registered TAI	TAI-1	N3GPP TAI	

9.2.5.1.2

9.2.5.1.3

9.2.5.1.4 Initial registration / Rejected / Congestion / Abnormal cases / T3346

9.2.5.1.4.1 Test Purpose (TP)

(1)

```
with { The UE has sent initial REGISTRATION REQUEST message }
ensure that {
  when { UE receives a REGISTRATION REJECT with cause #22 (Congestion) with T3346 included and the
  UE is NOT configured for High Priority Access }
  then { UE does not start the Initial registration until T3346 expires }
}
```

(2)

```
with { The UE has received initial REGISTRATION REJECT with T3346 included }
ensure that {
  when { upon expiry of T3346 }
  then { UE starts the Initial registration procedure }
}
```

(3)

```
with { The UE has received initial REGISTRATION REJECT with T3346 included }
ensure that {
  when { the timer T3346 is running and the UE needs to perform initial registration for emergency
  services }
  then { UE starts the Initial registration procedure }
}
```

9.2.5.1.4.2 Conformance requirements

References: The conformance requirements covered in the present TC are specified in: TS 24.501, clauses 5.5.1.2.5 and 5.5.1.2.7 and TS 24.301, clause 5.5.1.2.5. Unless otherwise stated these are Rel-15 requirements.

[TS 24.501, clause 5.5.1.2.5]

If the initial registration request cannot be accepted by the network, the AMF shall send a REGISTRATION REJECT message to the UE including an appropriate 5GMM cause value.

If the initial registration request is rejected due to general NAS level mobility management congestion control, the network shall set the 5GMM cause value to #22 "congestion" and assign a back-off timer T3346.

The UE shall take the following actions depending on the 5GMM cause value received in the REGISTRATION REJECT message.

#3 (Illegal UE);

#6 (Illegal ME); or

....

#22 (Congestion).

If the T3346 value IE is present in the REGISTRATION REJECT message and the value indicates that this timer is neither zero nor deactivated, the UE shall proceed as described below; otherwise it shall be considered as an abnormal case and the behaviour of the UE for this case is specified in subclause 5.5.1.2.7.

The UE shall abort the initial registration procedure, set the 5GS update status to 5U2 NOT UPDATED and enter state 5GMM-DEREGISTERED.ATTEMPTING-REGISTRATION.

The UE shall stop timer T3346 if it is running.

If the REGISTRATION REJECT message is integrity protected, the UE shall start timer T3346 with the value provided in the T3346 value IE.

If the REGISTRATION REJECT message is not integrity protected, the UE shall start timer T3346 with a random value from the default range specified in 3GPP TS 24.008 [12].

The UE stays in the current serving cell and applies the normal cell reselection process. The initial registration procedure is started if still needed when timer T3346 expires or is stopped.

#27 (N1 mode not allowed).

The UE capable of S1 mode shall disable the N1 mode capability for both 3GPP access and non-3GPP access (see subclause 4.9).

Other values are considered as abnormal cases. The behaviour of the UE in those cases is specified in subclause 5.5.1.2.7.

[TS 24.501, clause 5.5.1.2.7]

The following abnormal cases can be identified:

a) Timer T3346 is running.

The UE shall not start the registration procedure for initial registration unless:

- 1) the UE is a UE configured for high priority access in selected PLMN; or
- 2) the UE needs to perform the registration procedure for initial registration for emergency services.

The UE stays in the current serving cell and applies the normal cell reselection process.

NOTE 1: It is considered an abnormal case if the UE needs to initiate a registration procedure for initial registration while timer T3346 is running independent on whether timer T3346 was started due to an abnormal case or a non-successful case.

[TS 24.301, clause 5.5.1.2.5]

...

#22 (Congestion);

If the T3346 value IE is present in the ATTACH REJECT message and the value indicates that this timer is neither zero nor deactivated, the UE shall proceed as described below; otherwise it shall be considered as an abnormal case and the behaviour of the UE for this case is specified in subclause 5.5.1.2.6.

The UE shall abort the attach procedure, reset the attach attempt counter, set the EPS update status to EU2 NOT UPDATED and enter state EMM-DEREGISTERED.ATTEMPTING-TO-ATTACH.

The UE shall stop timer T3346 if it is running.

If the ATTACH REJECT message is integrity protected, the UE shall start timer T3346 with the value provided in the T3346 value IE.

If the ATTACH REJECT message is not integrity protected, the UE shall start timer T3346 with a random value from the default range specified in 3GPP TS 24.008 [13].

The UE stays in the current serving cell and applies the normal cell reselection process. The attach procedure is started if still needed when timer T3346 expires or is stopped.

If A/Gb mode or Iu mode is supported by the UE, the UE shall in addition handle the GMM parameters GMM state, GPRS update status and GPRS attach attempt counter as specified in 3GPP TS 24.008 [13] for the case when the normal attach procedure is rejected with the GMM cause with the same value.

If the UE is operating in single-registration mode, the UE shall in addition handle the 5GMM parameters as specified in 3GPP TS 24.501 [54] for the case when the initial registration procedure is rejected with the 5GMM cause with the same value.

...

9.2.5.1.4.3 Test description

9.2.5.1.4.3.1 Pre-test conditions

System Simulator:

- WLAN Cell 27

UE:

None.

Preamble:

- The UE is in state Switched OFF (State 0W-A as per TS 38.508-1 [4] Table 4.4A.2-0).

9.2.5.1.4.3.2 Test procedure sequence

Table 9.2.5.1.4.3.2-1: Main behaviour

St	Procedure	Message Sequence		TP	Verdict
		U - S	Message		
1	UE is switched on.	-	-	-	-
2-8	Steps 1-7 of Table 4.5.2.2-3 of the generic procedure in TS 38.508-1 [4] are performed.	-	-	-	-
9	SS transmits a REGISTRATION REJECT message with cause #22 (Congestion) and T3346 set to 3 minutes. (Note 1)	<--	REGISTRATION REJECT	-	-
10	The generic procedure for SS-requested IPsec Secure tunnel disconnection, specified in subclause 4.5A.3 of TS 38.508-1 [4], takes place performing disconnection of security association.	-	-	-	-
11	Check : Does the UE initiate IPsec secure tunnel as per 3GPP TS 24.502 [33] clause 7.3.2 (Note 1)	-	-	1	F
12-18	Steps 1-7 of Table 4.5.2.2-3 of the generic procedure in TS 38.508-1 [4] are performed.	-	-	2	P
19	SS transmits a REGISTRATION REJECT message with cause #22 (Congestion) and T3346 set to 3 minutes. (Note 1)	<--	REGISTRATION REJECT	-	-
20	The generic procedure for SS-requested IPsec Secure tunnel disconnection, specified in subclause 4.5A.3 of TS 38.508-1 [4], takes place performing disconnection of security association.	-	-	-	-
21	The UE is made to establish an emergence PDU session. This can be done by an AT/MMI command	-	-	-	-
22-32	Steps 1-11 of Table 4.5.2.2-2 of the generic procedure in TS 38.508-1 [4] are performed, REGISTRATION REQUEST message with IE 5GS registration type set to "emergency registration"	-	-	3	P

Note 1: This is checked for 3 minutes less tolerance.

9.2.5.1.4.3.3 Specific message contents

Table 9.2.5.1.4.3.3-1: REGISTRATION REJECT (steps 9, 19 Table 9.2.5.1.4.3.2-1)

Derivation Path: TS 38.508-1 [4], Table 4.7.1-9			
Information Element	Value/remark	Comment	Condition
5GMM cause	'0001 0110'B	Cause #22 (Congestion)	
T3346 Value	'00100011'B	3 minutes	

Table 9.2.5.1.4.3.3-2: REGISTRATION REQUEST (step 24 Table 9.2.5.1.4.3.2-1)

Derivation Path: TS 38.508-1 [4], Table 4.7.1-6			
Information Element	Value/remark	Comment	Condition
5GS registration type			
5GS registration type value	'100'B	Emergency registration	EMERGENCY

9.2.6 De-registration

9.2.6.1 UE-initiated de-registration

9.2.6.1.1 UE-initiated de-registration / switch off

9.2.6.1.1.1 Test Purpose (TP)

(1)

```
with { the UE in 5GMM-REGISTERED state }
ensure that {
  when { the UE is switched off }
  then { the UE shall send DEREGISTRATION REQUEST message with De-registration type IE indicated
to "Switch off" }
}
```

(2)

```
with { the UE supports remove USIM without power down and in 5GMM-REGISTERED state }
ensure that {
  when { the USIM is removed from the UE }
  then { the UE shall send DEREGISTRATION REQUEST message with De-registration type IE indicated
to "Switch off" }
}
```

(3)

```
with { the UE in 5GMM-DEREGISTERED-INTIATED state }
ensure that {
  when { the first four expiries of the timer T3521 }
  then { the UE shall retransmit the DEREGISTRATION REQUEST message and shall reset and restart
timer T3521 }
}
```

(4)

```
with { the UE in 5GMM-DEREGISTERED-INTIATED state }
ensure that {
  when { On the fifth expiry of timer T3521 }
  then { the deregistration procedure shall be aborted and the UE perform local detach }
}
```

9.2.6.1.1.2 Conformance requirements

References: The conformance requirements covered in the present TC are specified in: TS 24.501, clauses 5.5.2.1, 5.5.2.2.1 and 5.5.2.2.6. Unless otherwise stated these are Rel-15 requirements.

[TS 24.501, clause 5.5.2.1]

The de-registration procedure is used:

- a) by the UE to de-register for 5GS services over 3GPP access when the UE is registered over 3GPP access;;
- b) by the UE to de-register for 5GS services over 3GPP access, non-3GPP access, or both when the UE is registered in the same PLMN over both accesses;
- c) by the network to inform the UE that it is deregistered for 5GS services over 3GPP access when the UE is registered over 3GPP access;
- d) by the network to inform the UE that it is deregistered for 5GS services over 3GPP access, non-3GPP access, or both when the UE is registered in the same PLMN over both accesses; and
- e) by the network to inform the UE to re-register to the network.

The de-registration procedure with appropriate de-registration type shall be invoked by the UE:

- a) if the UE is switched off; and
- b) as part of the eCall inactivity procedure defined in subclause 5.5.3.

The de-registration procedure with appropriate de-registration type shall be invoked by the network:

- a) if the network informs whether the UE should re-register to the network.

The de-registration procedure with appropriate access type shall be invoked by the UE:

- a) if the UE wants to de-register for 5GS services over 3GPP access when the UE is registered over 3GPP access;
or
- b) the UE wants to de-register for 5GS services over 3GPP access, non-3GPP access, or both when the UE is registered in the same PLMN over both accesses.

If the de-registration procedure is triggered due to USIM removal, the UE shall indicate "switch off" in the de-registration type IE.

If the de-registration procedure is requested by the UDM for a UE that has an emergency PDU session, the AMF shall not send a DEREGISTRATION REQUEST message to the UE.

If the de-registration procedure for 5GS services is performed, the PDU sessions, if any, for this particular UE are released locally without peer-to-peer signalling between the UE and the network.

The UE is allowed to initiate the de-registration procedure even if the timer T3346 is running.

- NOTE: When the UE has no PDU sessions over non-3GPP access, or the UE moves all the PDU sessions over a non-3GPP access to a 3GPP access, the UE and the AMF need not initiate de-registration over the non-3GPP access.

The AMF shall provide the UE with a non-3GPP de-registration timer.

[TS 24.501, clause 5.5.2.2.1]

The de-registration procedure is initiated by the UE by sending a DEREGISTRATION REQUEST message (see example in figure 5.5.2.2.1). The De-registration type IE included in the message indicates whether the de-registration procedure is due to a "switch off" or not. The access type included in the message indicates whether the de-registration procedure is:

- a) for 5GS services over 3GPP access when the UE is registered over 3GPP access only;
- b) for 5GS services over non-3GPP access when the UE is registered over non-3GPP access only; or
- c) for 5GS services over 3GPP access, non-3GPP access or both 3GPP access and non-3GPP access when the UE is registered in the same PLMN over both accesses.

If the UE has a valid 5G-GUTI, the UE shall populate the 5GS mobile identity IE with the valid 5G-GUTI. If the UE does not have a valid 5G-GUTI, the UE shall populate the 5GS mobile identity IE with its SUCI.

If the UE does not have a valid 5G-GUTI and it does not have a valid SUCI, then the UE shall populate the 5GS mobile identity IE with its PEI.

If the de-registration request is not due to switch off and the UE is in the state 5GMM-REGISTERED or 5GMM-REGISTERED-INITIATED, timer T3521 shall be started in the UE after the DEREGISTRATION REQUEST message has been sent. The UE shall enter the state 5GMM-DEREGISTERED-INITIATED.

If the UE is to be switched off, the UE shall try for a period of 5 seconds to send the DEREGISTRATION REQUEST message. During this period, the UE may be switched off as soon as the DEREGISTRATION REQUEST message has been sent.

[TS 24.501, clause 5.5.2.2.6]

...

c) T3521 timeout.

On the first four expiries of the timer, the UE shall retransmit the DEREGISTRATION REQUEST message and shall reset and restart timer T3521. On the fifth expiry of timer T3521, the de-registration procedure shall be aborted and the UE proceeds as follows:

9.2.6.1.1.3 Test description

9.2.6.1.1.3.1 Pre-test conditions

System Simulator:

- WLAN Cell 27.

UE:

- None.

Preamble:

- The UE is in state 3W-A on WLAN Cell 27 according to 38.508-1[4].

9.2.6.1.1.3.2 Test procedure sequence

Table 9.2.6.1.1.3.2-1: Main behaviour

St	Procedure	Message Sequence		TP	Verdict
		U - S	Message		
1	Cause switch off	-	-	-	-
2	Check: Does the UE transmit a DEREGISTRATION REQUEST with the De-registration type IE indicating "switch off"?	-->	DEREGISTRATION REQUEST	1	P
3	SS Transmits DEREGISTRATION ACCEPT	<--	DEREGISTRATION ACCEPT	-	-
4	The generic procedure for SS-requested IPsec Secure tunnel disconnection, specified in subclause 4.5A.3 of TS 38.508-1 [4], takes place performing disconnection of security association.	-	-	-	-
5	The UE is switched on.	-	-	-	-
6-15	The registration procedure is completed by executing steps 1-10 of the UE registration procedure in TS 38.508-1 [4] table 4.5.2.2-3.	-	-	-	-
16	Cause UE to initiate deregistration.	-	-	-	-
17	The UE transmits UE transmit a DEREGISTRATION REQUEST message. The UE starts timer T3521.	-->	DEREGISTRATION REQUEST	-	-
18	The SS does not respond to the DEREGISTRATION REQUEST message.	-	-	-	-
19	Check: When the timer T3521 expires does the UE re-transmit DETACH REQUEST message. Timer T3421 is re-started (1 st expiry).	-->	DEREGISTRATION REQUEST	3	P
20	The SS does not respond to the DEREGISTRATION REQUEST message.	-	-	-	-
21	Check: When the timer T3521 expires does the UE re-transmit DEREGISTRATION REQUEST message. Timer T3521 is re-started (2 nd expiry).	-->	DEREGISTRATION REQUEST	3	P
22	The SS does not respond to the DEREGISTRATION REQUEST message.	-	-	-	-
23	Check: When the timer T3521 expires does the UE re-transmit DEREGISTRATION REQUEST message. Timer T3521 is re-started (3 rd expiry).	-->	DEREGISTRATION REQUEST	3	P
24	The SS does not respond to the DEREGISTRATION REQUEST message.	-	-	-	-
25	Check: When the timer T3521 expires does the UE re-transmit DEREGISTRATION REQUEST message. Timer T3521 is re-started (4 th expiry).	-->	DEREGISTRATION REQUEST	3	P
26	The SS does not respond to the DETACH REQUEST message.	-	-	-	-
27	When the timer T3521 expires the UE aborts the detach procedure and performs a local detach (5 th expiry).	-	-	4	P
28	SS Transmits PDU SESSION MODIFICATION COMMAND	<--	PDU SESSION MODIFICATION COMMAND	-	-
29	Check: Does the UE transmit a PDU SESSION MODIFICATION COMPLETE?	-->	PDU SESSION MODIFICATION COMPLETE	4	F
30	The generic procedure for SS-requested IPsec Secure tunnel disconnection, specified in subclause 4.5A.3 of TS 38.508-1 [4], takes place performing disconnection of security association.	-	-	-	-
-	EXCEPTION: Steps 31 to 46 shall be implemented if the UE supports remove USIM without power down: pc_USIM_Removal = TRUE [29]	-	-	-	-
31	The UE is switched off.	-	-	-	-
32	The UE is switched on.	-	-	-	-
33-42	The registration procedure is completed by executing steps 1-10 of the UE registration procedure in TS 38.508-1 [4] table 4.5.2.2-3.	-	-	-	-

43	Cause removal of USIM from the UE without powering down.	-	-	-	-
44	Check: Does the UE transmit a DEREGISTRATION REQUEST with the De-registration type IE indicating "switch off"?	-->	DEREGISTRATION REQUEST	2	P
45	SS Transmits DEREGISTRATION ACCEPT	<--	DEREGISTRATION ACCEPT	-	-
46	The generic procedure for SS-requested IPsec Secure tunnel disconnection, specified in subclause 4.5A.3 of TS 38.508-1 [4], takes place performing disconnection of security association.	-	-	-	-

9.2.6.1.1.3.3 Specific message contents

Table 9.2.6.1.1.3.3-1: DEREGISTRATION REQUEST (Step 1 and step 44, Table 9.2.6.1.1.3.2-1)

Derivation path: 38.508-1 [4], table 4.7.1-12			
Information Element	Value/Remark	Comment	Condition
De-registration type			
Switch off	'1'B		

9.2.6.2 Network-initiated de-registration

9.2.6.2.1 Network-initiated de-registration / De-registration for Non-3GPP access / Re-registration required

9.2.6.2.1.1 Test Purpose (TP)

(1)

```

with { the UE in 5GMM-REGISTERED state }
ensure that {
  when { the SS sends a DEREGISTRATION REQUEST message indicates "re-registration required" and the
de-registration request is for non 3GPP access }
  then { the UE sends a DEREGISTRATION ACCEPT message to the network and releases the existing NAS
signalling connection, then initiates an initial registration and also re-establishes any previously
established PDU sessions }
}

```

9.2.6.2.1.2 Conformance requirements

References: The conformance requirement covered in the present TC is specified in: 3GPP TS 24.501 clauses 5.5.2.3.2. Unless otherwise stated these are Rel-15 requirements.

[TS 24.501 clause 5.5.2.3.2]

...

NOTE 1: When the de-registration type indicates "re-registration required", user interaction is necessary in some cases when the UE cannot re-establish the PDU session (s), if any, automatically.

...

Upon sending a DEREGISTRATION ACCEPT message, the UE shall delete the rejected NSSAI as specified in subclause 4.6.2.2.

If the de-registration type indicates "re-registration required", then the UE shall ignore the 5GMM cause IE if received.

If the de-registration type indicates "re-registration not required", the UE shall take the actions depending on the received 5GMM cause value:

#3 (Illegal UE);

#6 (Illegal ME); or

#7 (5GS services not allowed).

The UE shall set the 5GS update status to 5U3 ROAMING NOT ALLOWED (and shall store it according to subclause 5.1.3.2.2) and shall delete any 5G-GUTI, last visited registered TAI, TAI list and ngKSI. The UE shall consider the USIM as invalid for 5GS services until switching off or the UICC containing the USIM is removed. The UE shall delete the list of equivalent PLMNs and shall enter the state 5GMM-DEREGISTERED.

If the UE is operating in single-registration mode, the UE shall handle the EMM parameters EMM state, EPS update status, 4G-GUTI, last visited registered TAI, TAI list and eKSI as specified in 3GPP TS 24.301 [15] for the case when a DETACH REQUEST is received with the EMM cause with the same value and with detach type set to "re-attach not required".

NOTE 2: The possibility to configure a UE so that the radio transceiver for a specific radio access technology is not active, although it is implemented in the UE, is out of scope of the present specification.

If the UE also supports the registration procedure over the other access, the UE shall in addition handle 5GMM parameters and 5GMM state for this access, as described for this 5GMM cause value.

...

#72 (Non-3GPP access to 5GCN not allowed).

The UE shall set the 5GS update status to 5U3 ROAMING NOT ALLOWED (and shall store it according to subclause 5.1.3.2.2) and shall delete 5G-GUTI, last visited registered TAI, TAI list and ngKSI. Additionally, the UE shall reset the registration attempt counter and enter the state 5GMM-DEREGISTERED.

NOTE 3: The 5GMM sublayer states, the 5GMM parameters and the registration status are managed per access type independently, i.e. 3GPP access or non-3GPP access (see subclauses 4.7.2 and 5.1.3).

The UE shall disable the N1 mode capability for non-3GPP access (see subclause 4.9.3).

As an implementation option, the UE may enter the state 5GMM-DEREGISTERED.PLMN-SEARCH in order to perform a PLMN selection according to 3GPP TS 23.122 [5].

9.2.6.2.1.3 Test description

9.2.6.2.1.3.1 Pre-test conditions

System Simulator:

- WLAN Cell 27.

UE:

- None.

Preamble:

- the UE is in state 3W-A on WLAN Cell 27 according to TS 38.508-1 [4].

9.2.6.2.1.3.2 Test procedure sequence

Table 9.2.6.2.1.3.2-1: Main behaviour

St	Procedure	Message Sequence		TP	Verdict
		U - S	Message/PDU/SDU		
1	The SS transmits a DEREGISTRATION REQUEST with indicates "re-registration required".	<--	DEREGISTRATION REQUEST	-	-
2	Check: Does the UE transmits a DEREGISTRATION ACCEPT message?	-->	DEREGISTRATION ACCEPT	1	P
3	The generic procedure for SS-requested IPsec Secure tunnel disconnection, specified in subclause 4.5A.3 of TS 38.508-1 [4], takes place performing disconnection of security association.	-	-	-	-
-	EXCEPTION: step 4 describes a behaviour which depends on the UE capability	-	-	-	-
4	IF NOT pc_Automatic_Re_registration, the user initiates a registration by MMI.	-	-	-	-
6-15	The registration procedure is completed by executing steps 1-10 of the UE registration procedure in TS 38.508-1 [4] table 4.5.2.2-3.	-	-	1	P

9.2.6.2.1.3.3 Specific message contents

Table 9.2.6.2.1.3.3-1: DEREGISTRATION REQUEST (step 1, Table 9.2.6.2.1.3.2-1)

Derivation path: 38.508-1 [4] Table 4.7.1-14			
Information Element	Value/Remark	Comment	Condition
DEREGISTRATION type			
Switch off	'0'B	Normal de-registration	
Re-registration required	'1'B	re-registration required	
Access type	'10'B	Non 3GPP access	
5GMM cause	'0000 0011'B	Cause #3 (Illegal UE)	

Table 9.2.6.2.1.3.3-2: REGISTRATION REQUEST (step 8, Table 9.2.6.2.1.3.2-1)

Derivation Path: 38.508-1 [4] Table 4.7.1-6			
Information Element	Value/remark	Comment	Condition
5GS mobile identity	The valid 5G-GUTI that UE holds		

9.2.6.2.2 Network-initiated de-registration / De-registration for Non 3GPP access / Re-registration not required

9.2.6.2.2.1 Test Purpose (TP)

(1)

```

with { the UE in 5GMM-REGISTERED state }
ensure that {
  when { the SS sends a DEREGISTRATION REQUEST message indicates no 5GMM cause IE, "re-registration not required" and the de-registration request is for npn-3GPP access and 5GMM cause value is not included }

```

```

    then { the UE deletes 5G-GUTI, TAI list, last visited registered TAI, list of equivalent PLMNs,
ngKSI, sends a DEREGISTRATION ACCEPT message enter the state 5GMM-DEREGISTERED for non 3GPP access }
}

```

(2)

```

with { the UE in 5GMM-REGISTERED state }
ensure that {
  when { the SS sends a DEREGISTRATION REQUEST message indicates no 5GMM cause IE, "re-registration
not required" and the de-registration request is for non-3GPP access and 5GMM cause value set to #7
5GS services not allowed }
  then { the UE deletes 5G-GUTI, TAI list, last visited registered TAI, list of equivalent PLMNs,
ngKSI, consider the USIM as invalid for 5GS services until switching off or the UICC containing the
USIM is removed, sends a DEREGISTRATION ACCEPT message enter the state 5GMM-DEREGISTERED for Non
3GPP access }
}

```

(3)

```

with { the UE in 5GMM-REGISTERED state }
ensure that {
  when { the SS sends a DEREGISTRATION REQUEST message indicates no 5GMM cause IE, "re-registration
not required" and the de-registration request is for non-3GPP access and 5GMM cause value set to #72
Non-3GPP access to 5GCN not allowed }
  then { the UE deletes 5G-GUTI, TAI list, last visited registered TAI, ngKSI, disable the N1 mode
capability for non-3GPP access, sends a DEREGISTRATION ACCEPT message enter the state 5GMM-
DEREGISTERED for Non 3GPP access }
}

```

9.2.6.2.2.2 Conformance requirements

References: The conformance requirements covered in the current TC are specified in: TS 24.501 clauses 5.5.2.3.2 and 5.5.2.3.4. Unless otherwise stated these are Rel-15 requirements.

[TS 24.501, clause 5.5.2.3.2]

Upon receiving the DEREGISTRATION REQUEST message, if the DEREGISTRATION REQUEST message indicates "re-registration not required" and the de-registration request is for 3GPP access, the UE shall release locally the PDU sessions over 3GPP access, if any. The UE shall send a DEREGISTRATION ACCEPT message to the network and enter the state 5GMM-DEREGISTERED for 3GPP access.

...

If the de-registration type indicates "re-registration not required", the UE shall take the actions depending on the received 5GMM cause value:

...

#7 (5GS services not allowed).

The UE shall set the 5GS update status to 5U3 ROAMING NOT ALLOWED (and shall store it according to subclause 5.1.3.2.2) and shall delete any 5G-GUTI, last visited registered TAI, TAI list and ngKSI. The UE shall consider the USIM as invalid for 5GS services until switching off or the UICC containing the USIM is removed. The UE shall delete the list of equivalent PLMNs and shall enter the state 5GMM-DEREGISTERED.

If the UE is operating in single-registration mode, the UE shall handle the EMM parameters EMM state, EPS update status, 4G-GUTI, last visited registered TAI, TAI list and eKSI as specified in 3GPP TS 24.301 [15] for the case when a DETACH REQUEST is received with the EMM cause with the same value and with detach type set to "re-attach not required".

NOTE 2: The possibility to configure a UE so that the radio transceiver for a specific radio access technology is not active, although it is implemented in the UE, is out of scope of the present specification.

If the UE also supports the registration procedure over the other access, the UE shall in addition handle 5GMM parameters and 5GMM state for this access, as described for this 5GMM cause value.

...

#72 (Non-3GPP access to 5GCN not allowed).

The UE shall set the 5GS update status to 5U3 ROAMING NOT ALLOWED (and shall store it according to subclause 5.1.3.2.2) and shall delete 5G-GUTI, last visited registered TAI, TAI list and ngKSI. Additionally, the UE shall reset the registration attempt counter and enter the state 5GMM-DEREGISTERED.

NOTE 3: The 5GMM sublayer states, the 5GMM parameters and the registration status are managed per access type independently, i.e. 3GPP access or non-3GPP access (see subclauses 4.7.2 and 5.1.3).

The UE shall disable the N1 mode capability for non-3GPP access (see subclause 4.9.3).

As an implementation option, the UE may enter the state 5GMM-DEREGISTERED.PLMN-SEARCH in order to perform a PLMN selection according to 3GPP TS 23.122 [5].

[TS 24.501, clause 5.5.2.3.4]

- b) DEREGISTRATION REQUEST, other 5GMM cause values than those treated in subclause 5.5.2.3.2 or no 5GMM cause IE is included, and the De-registration type IE indicates "re-registration not required".

The UE shall delete 5G-GUTI, TAI list, last visited registered TAI, list of equivalent PLMNs, ngKSI, shall set the 5GS update status to 5U2 NOT UPDATED and shall start timer T3502.

A UE not supporting S1 mode may enter the state 5GMM-DEREGISTERED.PLMN-SEARCH in order to perform a PLMN selection according to 3GPP TS 23.122 [5]; otherwise the UE shall enter the state 5GMM-DEREGISTERED.ATTEMPTING-REGISTRATION.

A UE operating in single-registration mode shall:

- enter the state 5GMM-DEREGISTERED and attempt to select E-UTRAN radio access technology and proceed with the appropriate EMM specific procedures. In this case, the UE may disable N1 mode capability (see subclause 4.9); or
- enter the state 5GMM-DEREGISTERED.PLMN-SEARCH in order to perform a PLMN selection according to 3GPP TS 23.122 [5].

A UE operating in single-registration mode shall set the EPS update status to EU2 NOT UPDATED and shall delete the EMM parameters 4G-GUTI, last visited registered TAI, TAI list and eKSI and shall enter the state EMM-DEREGISTERED.

9.2.6.2.2.3 Test description

9.2.6.2.2.3.1 Pre-test conditions

System Simulator:

- WLAN Cell 27.

UE:

- None

Preamble:

- The UE is in state 3W-A on WLAN Cell 27 according to TS 38.508-1 [4].

9.2.6.2.2.3.2 Test procedure sequence

Table 9.2.6.2.2.3.2-1: Main behaviour

St	Procedure	Message Sequence		TP	Verdict
		U – S	Message		
1	SS sends a DEREGISTRATION REQUEST message indicates no 5GMM cause IE, "re-registration not required" and the de-registration request is for non 3GPP access	<--	NR 5GMM: DEREGISTRATION REQUEST	-	-
2	Check: Does the UE transmit an DEREGISTRATION ACCEPT message?	-->	NR 5GMM: DEREGISTRATION ACCEPT	1	P
3	The generic procedure for SS-requested IPsec Secure tunnel disconnection, specified in subclause 4.5A.3 of TS 38.508-1 [4], takes place performing disconnection of security association.	-	-	-	-
4	Cause UE to initiate registration.	-	-	-	-
5-15	The registration procedure is completed by executing steps 1-10 of the UE registration procedure in TS 38.508-1 [4] table 4.5.2.2-3.	-	-	1	P
16	SS sends a DEREGISTRATION REQUEST message indicates no 5GMM cause IE, "re-registration not required", 5GMM Cause set to #7 (5GS services not allowed) and the de-registration request is for non 3GPP access	<--	NR 5GMM: DEREGISTRATION REQUEST	-	-
17	Check: Does the UE transmit an DEREGISTRATION ACCEPT message?	-->	NR 5GMM: DEREGISTRATION ACCEPT	2	P
18	The generic procedure for SS-requested IPsec Secure tunnel disconnection, specified in subclause 4.5A.3 of TS 38.508-1 [4], takes place performing disconnection of security association.	-	-	-	-
19	Check for 60 seconds if UE initiates Registration procedure	-	NR 5GMM: REGISTRATION REQUEST	2	F
20	The UE is switched off.	-	-	-	-
21	The UE is switched on.	-	-	-	-
22-31	The registration procedure is completed by executing steps 1-10 of the UE registration procedure in TS 38.508-1 [4] table 4.5.2.2-3.	-	-	-	-
32	SS sends a DEREGISTRATION REQUEST message indicates no 5GMM cause IE, "re-registration not required", 5GMM Cause set to #72 (Non-3GPP access to 5GCN not allowed) and the de-registration request is for non 3GPP access	<--	NR 5GMM: DEREGISTRATION REQUEST	-	-
33	Check: Does the UE transmit an DEREGISTRATION ACCEPT message?	-->	NR 5GMM: DEREGISTRATION ACCEPT	3	P
34	The generic procedure for SS-requested IPsec Secure tunnel disconnection, specified in subclause 4.5A.3 of TS 38.508-1 [4], takes place performing disconnection of security association.	-	-	-	-
35	Check for 60 seconds if UE initiates Registration procedure	-	NR 5GMM: REGISTRATION REQUEST	3	F
36	The UE is switched off.	-	-	-	-

9.2.6.2.2.3.3 Specific message contents

Table 9.2.6.2.2.3.3-1: Message DEREGISTRATION REQUEST (step 1, Table 9.2.6.2.2.3.2-1)

Derivation Path: 38.508-1 [4], Table 4.7.1-12			
Information Element	Value/remark	Comment	Condition
De-registration type			
Switch off	'0'B	Normal de-registration	
Re-registration required	'0'B	re-registration not required	
Access type	'01'B	3GPP access	
5GMM cause	Not Present		

Table 9.2.6.2.2.3.3-2: Message REGISTRATION REQUEST (step 8, Table 9.2.6.2.2.3.2-1)

Derivation path: 38.508-1 [4], table 4.7.1-6			
Information Element	Value/Remark	Comment	Condition
ngKSI			
NAS key set identifier	'111'B	no key is available (UE to network)	
TSC	Any allowed value	TSC does not apply for NAS key set identifier value "111"	
5GS mobile identity	The valid SUCI		
Last visited registered TAI	Not present		

Table 9.2.6.2.2.3.3-2: Message ATTACH REQUEST (step 28, Table 9.2.6.2.2.3.2-1)

Derivation Path: TS 36.508 [7], Table 4.7.2-4			
Information Element	Value/remark	Comment	Condition
NAS key set identifier			
NAS key set identifier	'111'B	no key is available	
TSC	Any allowed value	TSC does not apply for NAS key set identifier value "111".	
Old GUTI or IMSI	IMSI1		
Last visited registered TAI	Not present		

9.2.7 Service request

9.2.8 SMS over NAS

9.2.8.1 SMS over NAS / MO SMS over NAS - 5GMM-Idle mode

9.2.8.1.1 Test Purpose (TP)

(1)

```

with { the UE in switched off state with valid USIM inserted }
ensure that {
  when { the UE requests initial registration for SMS over NAS }
  then { the UE shall send REGISTRATION REQUEST message with SMS requested bit of the 5GS
registration type IE "SMS over NAS supported" }
}

```

(2)

```
with { the UE in 5GMM_Connected state with 5GMM-Idle mode and the UE has sent a SERVICE REQUEST
message triggered by initiating MO SMS}
ensure that {
  when { UE receives a SERVICE ACCEPT message from SS }
  then { UE sends CP-DATA containing RP-DATA RPDU (SMS SUBMIT TPDU) encapsulated in an Uplink NAS
transport message }
}
```

(3)

```
with { UE has sent CP-DATA containing an RP-DATA RPDU (SMS SUBMIT TPDU) encapsulated in an Uplink
NAS transport message }
ensure that {
  when { UE receives a CP-DATA containing an RP-ACK RPDU encapsulated in a Downlink NAS transport
message }
  then { UE sends a CP-ACK encapsulated in an Uplink NAS Transport message }
}
```

9.2.8.1.2 Conformance requirements

Same conformance requirements as in clause 9.2.8.1.2

9.2.8.1.3 Test description

9.2.8.1.3.1 Pre-test conditions

System Simulator:

WLAN Cell 27;

UE:

The UE does not have any stored SMS message.

Preamble:

The UE is in state Switched OFF (state-0W-B) according to TS 38.508-1 [4].

9.2.8.1.3.2 Test procedure sequence

Table 9.2.8.1.3.2-1: Main behaviour

St	Procedure	Message Sequence		TP	Verdict
		U - S	Message		
1	The UE is switched ON	-	-	-	-
2-3	Steps 1-2 of the generic procedure for UE registration specified in TS 38.508-1 [4] table 4.5.2.2-3 are performed.	-	-	-	-
-	Exception: The UE establishes an IPsec tunnel in parallel to 5GC registration steps 4 to 8 as per the IKEv2 protocol as defined in 3GPP TS 23.502 [31] clause 4.12.2.2 figure 4.12.2.2-1.	-	-	-	-
4	Check: Does UE transmit a REGISTRATION REQUEST message including 5GS update type IE with SMS requested bit set to "SMS over NAS supported"?	-->	REGISTRATION REQUEST	1	P
5 - 8	Steps 4-5 of the generic procedure for UE registration specified in TS 38.508-1 [4] table 4.5.2.2-3 are performed.	-	-	-	-
9	SS transmits REGISTRATION ACCEPT message including 5GS registration result with SMS allowed bit set to "SMS over NAS allowed".	<--	REGISTRATION ACCEPT	-	-
10 - 12	Steps 9-11 of the generic procedure for UE registration specified in TS 38.508-1 [4] table 4.5.2.2-3 are performed.	-	-	-	-
13	Sending of a 160 character MO SMS is initiated at the UE via MMI or AT command	-	-	-	-
14	UE transmits establishes a IPSEC SA and NAS signalling connection as per generic procedure in table 4.5A.4.2.2-1 of 38.508-1 [4].	-	-	-	-
15	Check: Does the UE transmit a CP-DATA containing an RP-DATA RPDU (SMS SUBMIT TPDU) encapsulated in an Uplink NAS transport message?	-->	UPLINK NAS TRANSPORT	2	P
16	The SS transmits a CP-ACK encapsulated in a Downlink NAS Transport message.	<--	DOWNLINK NAS TRANSPORT	-	-
17	The SS transmits a CP-DATA containing an RP-ACK RPDU encapsulated in a Downlink NAS transport message	<--	DOWNLINK NAS TRANSPORT	-	-
18	Check: Does the UE transmit a CP-ACK encapsulated in an Uplink NAS Transport message?	-->	UPLINK NAS TRANSPORT	3	P

9.2.8.1.3.3 Specific message contents

Table 9.2.8.1.3.3-1: REGISTRATION REQUEST (step 4, Table 9.2.8.1.3.2-1)

Derivation Path: 38.508-1 [4], Table 4.7.1-6			
Information Element	Value/remark	Comment	Condition
5GS registration type			
5GS registration type value	'001'B		INITIAL
5GS update type			
SMS requested	SMS over NAS supported		

Table 9.2.8.1.3.3-2: REGISTRATION ACCEPT (step 9, Table 9.2.8.1.3.2-1)

Derivation Path: 38.508-1 [4], Table 4.7.1-7			
Information Element	Value/remark	Comment	Condition
5GS registration result			
SMS allowed	SMS over NAS allowed		
T3512 value			
Timer value	'00011'B		
Unit	'101'B		

Table 9.2.8.1.3.3-3: UL NAS TRANSPORT (step 15, Table 9.2.8.1.3.2-1)

Derivation Path: 38.508-1 [4], Table 4.7.1-10			
Information Element	Value/remark	Comment	Condition
Payload container type	'0010'B	SMS	
Payload container	CP-DATA	RP-DATA RPDU	

Editor's note: CP-DATA, RP-DATA RPDU, CP-ACK and RP-ACK RPDU needs to be defined in TS 38.508-1 and Specific message contents will be updated accordingly.

Table 9.2.8.1.3.3-4: DL NAS TRANSPORT (step 16, Table 9.2.8.1.3.2-1)

Derivation Path: 38.508-1 [4], Table 4.7.1-11			
Information Element	Value/remark	Comment	Condition
Payload container type	'0010'B	SMS	
Payload container	CP-ACK		

Table 9.2.8.1.3.3-5: DL NAS TRANSPORT (step 17, Table 9.2.8.1.3.2-1)

Derivation Path: 38.508-1 [4], Table 4.7.1-11			
Information Element	Value/remark	Comment	Condition
Payload container type	'0010'B	SMS	
Payload container	CP-DATA	RP-ACK RPDU	

Table 9.2.8.1.3.3-6: UL NAS TRANSPORT (step 18, Table 9.2.8.1.3.2-1)

Derivation Path: 38.508-1 [4], Table 4.7.1-10			
Information Element	Value/remark	Comment	Condition
Payload container type	'0010'B	SMS	
Payload container	CP-ACK		

9.3 Inter-system mobility

9.3.1 5GS-EPC Inter-system mobility

9.3.1.1 Mobility registration update / Single-registration mode with N26 / 5GMM-IDLE / 5GC to EPC

9.3.1.1.1 Test Purpose (TP)

(1)

```
with { UE in state 5GMM-REGISTERED and 5GMM-IDLE on a 5GC NR cell and has been previously registered
on EPC as well, UE supporting S1 and N1 and operating in single-registration mode, NWK supporting
Single-registration mode with N26 interface }
ensure that {
  when { UE detects a suitable EPC E-UTRA cell }
```

```

then { UE performs a Inter-system change from N1 mode to S1 mode by initiating and successfully
completing a TAU procedure, mapped EPC context used }
}

```

9.3.1.1.2 Conformance requirements

References: The conformance requirements covered in the present TC are specified in: TS 24.501, subclause 5.1.4.2; TS 24.301, subclause 4.4.2.3. Unless otherwise stated these are Rel-15 requirements.

[TS 24.501, subclause 5.1.4.2]

At Inter-system change from N1 mode to S1 mode when there is at least one active PDU session for which interworking with EPS is supported as specified in subclause 6.1.4.1, the UE shall enter substates EMM-REGISTERED.NORMAL-SERVICE and 5GMM-REGISTERED.NO-CELL-AVAILABLE and initiate a tracking area updating procedure (see 3GPP TS 24.301 [15]).

[TS 24.301, clause 4.4.2.3]

During Inter-system change from N1 mode to S1 mode in 5GMM-IDLE mode, if the UE is operating in the single-registration mode and:

- 1) if the tracking area updating procedure is initiated as specified in 3GPP TS 24.501 [54], the UE shall transmit a TRACKING AREA UPDATE REQUEST message integrity protected with the current 5G NAS security context and the UE shall derive a mapped EPS security context (see subclause 8.6.1 of 3GPP TS 33.501 [56]). The UE shall include the eKSI indicating the 5G NAS security context value in the TRACKING AREA UPDATE REQUEST message.

After receiving the TRACKING AREA UPDATE REQUEST message including the eKSI, the MME forwards the TRACKING AREA UPDATE REQUEST message to the source AMF, if possible, to obtain the mapped EPS security context from the AMF as specified in 3GPP TS 33.501 [56]. The MME re-establishes the secure exchange of NAS messages by either:

- replying with a TRACKING AREA UPDATE ACCEPT message that is integrity protected and ciphered using the mapped EPS NAS security context. From this time onward, all NAS messages exchanged between the UE and the MME are sent integrity protected and except for the messages specified in subclause 4.4.5, all NAS messages exchanged between the UE and the MME are sent ciphered; or

9.3.1.1.3 Test description

9.3.1.1.3.1 Pre test conditions

System Simulator:

- 2 cells
 - NGC Cell A as defined in TS 38.508-1 [4] Table 6.3.2.2-1. Default system information combination as defined in TS 38.508-1 [4], subclause 4.4.3.1.2.
 - E-UTRA Cell A as defined in TS 38.508 [7] Table 6.3.2.2-1. System information combination 1 as defined in TS 38.508 [7], subclause 4.4.3.1.1.

UE:

None.

Preamble:

- With E-UTRA Cell A "Serving cell" and NGC Cell A "Non-suitable "Off" cell", the UE is brought to state RRC_IDLE Connectivity (*E-UTRA/EPC*) in accordance with the procedure described in TS 38.508-1 [4], Table 4.5.2.2-1. 4G GUTI and eKSI are assigned and security context established
- the UE is switched-off

- With NGC Cell A "Serving cell" and E-UTRA Cell A "Non-suitable "Off" cell", the UE is brought to state 1N-A, RRC_IDLE Connectivity (NR), in accordance with the procedure described in TS 38.508-1 [4], Table 4.5.2.2-2. 5G-GUTI and ngKSI are assigned and security context established.

9.3.1.1.2 Test procedure sequence

Table 9.3.1.1.3.2-1: Main behaviour

St	Procedure	Message Sequence		TP	Verdict
		U - S	Message		
1	The SS configures: - E-UTRA Cell A as "Serving cell" - NGC Cell A as "Non-suitable "off" cell".	-	-	-	-
2	Check: Does the UE perform on the E-UTRA Cell A the TAU procedure for Inter-system change from N1 mode to S1 mode in 5GMM/EMM-IDLE mode as described in TS 38.508-1 [4], Table 4.9.7.2.2-1, 'connected without release'?	-	-	1	-

9.3.1.1.3.3 Specific message contents

None.

9.3.1.2 Mobility registration update / Single-registration mode with N26 / 5GMM-IDLE / EPC to 5GC

9.3.1.2.1 Test Purpose (TP)

(1)

```

with { UE in state EMM-REGISTERED and EMM-IDLE on an E-UTRA cell and has been previously registered
on 5GC, UE supporting S1 and N1 and operating in single-registration mode, NWK supporting Single-
registration mode with N26 interface }
ensure that {
  when { UE detects a suitable 5GC NR cell }
  then { UE performs a Inter-system change from S1 mode to N1 mode by initiating and successfully
completing a mobility and periodic registration update procedure, mapped 5GC context used }
}

```

9.3.1.2.2 Conformance requirements

References: The conformance requirements covered in the present TC are specified in: TS 24.501, subclauses 4.4.2.5, 5.1.4.2, 5.5.1.3.2; TS 24.301, subclause 5.5.5. Unless otherwise stated these are Rel-15 requirements.

[TS 24.501, subclause 4.4.2.5]

Secure exchange of NAS messages via a NAS signalling connection is usually established by the AMF during the registration procedure by initiating a security mode control procedure. After successful completion of the security mode control procedure, all NAS messages exchanged between the UE and the AMF are sent integrity protected using the current 5G security algorithms, and except for the messages specified in subclause 4.4.5, all NAS messages exchanged between the UE and the AMF are sent ciphered using the current 5G security algorithms.

...

During inter-system change from S1 mode to N1 mode in 5GMM-IDLE mode, if the UE is operating in single-registration mode and:

- if the UE has a valid native 5G NAS security context, the UE shall transmit a REGISTRATION REQUEST message integrity protected with the native 5G NAS security context. The UE shall include the ngKSI indicating the native 5G NAS security context value in the REGISTRATION REQUEST message.

After receiving the REGISTRATION REQUEST message including the ngKSI indicating a native 5G NAS security context value, the AMF shall check whether the ngKSI included in the REGISTRATION REQUEST message belongs to a 5G NAS security context available in the AMF, and shall verify the MAC of the REGISTRATION REQUEST message. If the verification is successful, the AMF deletes the EPS security context received from the source MME if any, and the AMF re-establishes the secure exchange of NAS messages by either:

- 1) replying with a REGISTRATION ACCEPT message that is integrity protected and ciphered using the native 5G NAS security context. From this time onward, all NAS messages exchanged between the UE and the AMF are sent integrity protected and except for the messages specified in subclause 4.4.5, all NAS messages exchanged between the UE and the AMF are sent ciphered; or
- 2) initiating a security mode control procedure. This can be used by the AMF to take a non-current 5G NAS security context into use or to modify the current 5G NAS security context by selecting new NAS security algorithms.

[TS 24.501, subclause 5.1.4.2]

At inter-system change from S1 mode to N1 mode, the UE shall enter substates 5GMM-REGISTERED.NORMAL-SERVICE and EMM-REGISTERED.NO-CELL-AVAILABLE and initiate a registration procedure for mobility and periodic registration update indicating "mobility registration updating" in the 5GS registration type IE of the REGISTRATION REQUEST message (see subclause 5.5.1.3).

[TS 24.501, subclause 5.5.1.3.2]

The UE in state 5GMM-REGISTERED shall initiate the registration procedure for mobility and periodic registration update by sending a REGISTRATION REQUEST message to the AMF,

...

- e) upon Inter-system change from S1 mode to N1 mode;

...

If case b) is the only reason for initiating the registration procedure for mobility and periodic registration update, the UE shall indicate "periodic registration updating" in the 5GS registration type IE; otherwise the UE shall indicate "mobility registration updating".

If the UE indicates "mobility registration updating" in the 5GS registration type IE and the UE supports S1 mode, the UE shall:

- set the S1 mode bit to "S1 mode supported" in the 5GMM capability IE of the REGISTRATION REQUEST message;
- include the S1 UE network capability IE in the REGISTRATION REQUEST message; and
- if the UE supports sending an ATTACH REQUEST message containing a PDN CONNECTIVITY REQUEST message with request type set to "handover" to transfer a PDU session from N1 mode to S1 mode, set the HO attach bit to "attach request message containing PDN connectivity request with request type set to handover to transfer PDU session from N1 mode to S1 mode supported" in the 5GMM capability IE of the REGISTRATION REQUEST message.

...

If the last visited registered TAI is available, the UE shall include the last visited registered TAI in the REGISTRATION REQUEST message.

The UE shall handle the 5GS mobility identity IE in the REGISTRATION REQUEST message as follows:

- a) if the UE is operating in the single-registration mode, performs Inter-system change from S1 mode to N1 mode, and the UE holds a valid 4G-GUTI, the UE shall include the 5G-GUTI mapped from the 4G-GUTI as specified in 3GPP TS 23.003 [4] in the 5GS mobility identity IE. Additionally, if the UE holds a valid 5G-GUTI, the UE shall include the 5G-GUTI in the Additional GUTI IE in the REGISTRATION REQUEST message in the following order:

- 1) a valid 5G-GUTI that was previously assigned by the same PLMN with which the UE is performing the registration, if available;
- 2) a valid 5G-GUTI that was previously assigned by an equivalent PLMN, if available; and
- 3) a valid 5G-GUTI that was previously assigned by any other PLMN, if available; and

...

If the UE operating in the single-registration mode performs Inter-system change from S1 mode to N1 mode, the UE:

- a) shall include the UE status IE with the EMM registration status set to "UE is in EMM-REGISTERED state" in the REGISTRATION REQUEST message;

NOTE 1: Inclusion of the UE status IE with this setting corresponds to the indication that the UE is "moving from EPC" as specified in 3GPP TS 23.502 [9], subclause 4.11.1.3.3 and 4.11.2.3.

- b) may include the PDU session status IE in the REGISTRATION REQUEST message indicating the status of the PDU session(s) mapped during the Inter-system change from S1 mode to N1 mode from the PDN connection(s) for which the EPS indicated that interworking to 5GS is supported, if any (see subclause 6.1.4.1); and
- c) shall include a TRACKING AREA UPDATE REQUEST message as specified in 3GPP TS 24.301 [15] in the IE in the REGISTRATION REQUEST message.

...

The UE shall send the REGISTRATION REQUEST message including the NAS message container IE as described in subclause 4.4.6:

...

- b) when the UE is sending the message after an Inter-system change from S1 mode to N1 mode in 5GMM-IDLE mode and the UE has a valid 5G NAS security context and needs to send non-cleartext IEs.

...

If the UE is sending the REGISTRATION REQUEST message after an Inter-system change from S1 mode to N1 mode in 5GMM-CONNECTED mode and the UE needs to send non-cleartext IEs, the UE shall cipher the NAS message container IE using the mapped 5G NAS security context and shall send the REGISTRATION REQUEST message including the NAS message container IE as described in subclause 4.4.6. If the UE does not need to send non-cleartext IEs, the UE shall send the REGISTRATION REQUEST message without including the NAS message container IE.

[TS 24.301, clause 5.5.5]

The tracking area updating procedure is used to construct a TRACKING AREA UPDATE REQUEST message for the inter-system change from S1 mode to N1 mode for further security verification by the MME.

The TRACKING AREA UPDATE REQUEST message is created by EMM by request of 5GMM which further includes the message in the REGISTRATION REQUEST message as described in 3GPP TS 24.501 [54].

The TRACKING AREA UPDATE REQUEST message shall contain only mandatory information elements.

The UE shall set the EPS update type IE in the TRACKING AREA UPDATE REQUEST message to "TA updating".

If the UE has a current EPS security context, the UE shall include the eKSI (either KSI_{ASME} or KSI_{SGSN}) in the NAS Key Set Identifier IE in the TRACKING AREA UPDATE REQUEST message. Otherwise, the UE shall set the NAS Key Set Identifier IE to the value "no key is available". If the UE has a current EPS security context, the UE shall integrity protect the TRACKING AREA UPDATE REQUEST message with the current EPS security context and increase the uplink NAS COUNT by one. Otherwise the UE shall not integrity protect the TRACKING AREA UPDATE REQUEST message. The UE shall set associated GUTI in the Old GUTI IE.

When the UE is in EMM-REGISTERED.NO-CELL-AVAILABLE substate and needs to construct the TRACKING AREA UPDATE REQUEST message for inter-system change from S1 mode to N1 mode, the UE shall consider that the tracking area updating procedure is not initiated and the UE shall remain in EMM-REGISTERED.NO-CELL-AVAILABLE state.

9.3.1.2.3 Test description

9.3.1.2.3.1 Pre test conditions

System Simulator:

- 2 cells
- NGC Cell A as defined in TS 38.508-1 [4] Table 6.3.2.2-1. Default system information combination as defined in TS 38.508-1 [4], subclause 4.4.3.1.2.
- E-UTRA Cell A as defined in TS 38.508 [7] Table 6.3.2.2-1. System information combination 1 as defined in TS 38.508 [7], subclause 4.4.3.1.1.

UE:

None.

Preamble:

- With NGC Cell A "Serving cell" and E-UTRA Cell A "Non-suitable "Off" cell", the UE is brought to state 1N-A, RRC_IDLE Connectivity (NR), in accordance with the procedure described in TS 38.508-1 [4], Table 4.5.2.2-2. 5G-GUTI and ngKSI are assigned and security context established.
- the UE is switched-off
- With E-UTRA Cell A "Serving cell" and NGC Cell A "Non-suitable "Off" cell", the UE is brought to state RRC_IDLE Connectivity (*E-UTRA/EPC*) in accordance with the procedure described in TS 38.508-1 [4], Table 4.5.2.2-1. 4G GUTI and eKSI are assigned and security context established

9.3.1.2.3.2 Test procedure sequence

Table 9.3.1.2.3.2-1: Main behaviour

St	Procedure	Message Sequence		TP	Verdict
		U - S	Message		
1	The SS configures: - NGC Cell A as "Serving cell" - E-UTRA Cell A as "Non-suitable "off" cell".	-	-	-	-
2	Check: Does the UE perform on the E-UTRA Cell A the TAU procedure for Inter-system change from S1 mode to N1 mode in 5GMM/EMM-IDLE mode as described in TS 38.508-1 [4], Table 4.9.9.2.2-1, ' <i>connected without release</i> '?	-	-	1	-

9.3.1.2.3.3 Specific message contents

Table 9.3.1.2.3.3-1: REGISTRATION REQUEST (Preamble; TS 38.508-1 [4], Table 4.5.2.2-2)

Derivation Path: TS 38.508-1 [4], Table 4.7.1-6			
Information Element	Value/remark	Comment	Condition
5GMM capability	'0000 0xx1'	S1 mode supported x - not checked	
S1 UE network capability			
All octets with the exception of octet 9, bit 6	Not checked		
N1 mode supported (N1 mode) (octet 9, bit 6)	'1'	N1 mode supported	

Table 9.3.1.2.3.3-2: REGISTRATION ACCEPT (Preamble; TS 38.508-1 [4], Table 4.5.2.2-2)

Derivation Path: 38.508-1 [4], Table 4.7.1-7			
Information Element	Value/remark	Comment	Condition
5GS network feature support			
Interworking without N26 interface indicator (IWK N26) (octet 3, bit 7)	'0'	Interworking without N26 interface not supported	

9.3.1.3 Mobility and periodic registration update / Rejected / Single-registration mode with N26 / Handling of EPC relevant parameters

9.3.1.3.1 Test Purpose (TP)

(1)

```

with { UE in state 5GMM-REGISTERED on an NGC cell, UE supporting S1 and N1 and operating in single-
registration mode, NWK supporting Single-registration mode with N26 interface }
ensure that {
  when { UE initiates a Mobility and periodic registration procedure on an NGC cell and receives a
REGISTRATION REJECT message including 5GMM cause value #9 (UE identity cannot be derived by the
network) }
  then { UE deletes the EPS relevant parameters 4G-GUTI, last visited registered TAI and eKSI and
enters the state EMM-DEREGISTERED, and, subsequently, automatically initiate the attach procedure }
}

```

9.3.1.3.2 Conformance requirements

References: The conformance requirements covered in the present TC are specified in: TS 24.501, clause 5.5.1.3.5, TS 24.301, clause 5.5.3.2.5. Unless otherwise stated these are Rel-15 requirements.

[TS 24.501, clause 5.5.1.3.5]

If the mobility and periodic registration update request cannot be accepted by the network, the AMF shall send a REGISTRATION REJECT message to the UE including an appropriate 5GMM cause value.

The UE shall take the following actions depending on the 5GMM cause value received in the REGISTRATION REJECT message.

...

#9 (UE identity cannot be derived by the network).

...

If the UE is operating in single-registration mode, the UE shall handle the EMM parameters EMM state, EPS update status, 4G-GUTI, last visited registered TAI, TAI list and eKSI as specified in 3GPP TS 24.301 [15] for the case when the normal tracking area updating procedure is rejected with the EMM cause with the same value.

[TS 24.301, clause 5.5.3.2.5]

If the tracking area updating cannot be accepted by the network, the MME sends a TRACKING AREA UPDATE REJECT message to the UE including an appropriate EMM cause value.

...

#9 (UE identity cannot be derived by the network);

The UE shall set the EPS update status to EU2 NOT UPDATED (and shall store it according to subclause 5.1.3.3) and shall delete any GUTI, last visited registered TAI, TAI list and eKSI. The UE shall enter the state EMM-DEREGISTERED.

If the rejected request was not for initiating a PDN connection for emergency bearer services, the UE shall subsequently, automatically initiate the attach procedure.

9.3.1.3.3 Test description

9.3.1.3.3.1 Pre test conditions

System Simulator:

- 2 cells
- NGC Cell A as defined in TS 38.508-1 [4] Table 6.3.2.2-1. Default system information combination as defined in TS 38.508-1 [4], subclause 4.4.3.1.2.
- E-UTRA Cell A as defined in TS 38.508 [7] Table 6.3.2.2-1. System information combination 1 as defined in TS 38.508 [7], subclause 4.4.3.1.1.

UE:

None.

Preamble:

- With E-UTRA Cell A "Serving cell" and NGC Cell A "Non-suitable "Off" cell", the UE is brought to state RRC_IDLE Connectivity (*E-UTRA/EPC*) in accordance with the procedure described in TS 38.508-1 [4], Table 4.5.2.2-1. 4G GUTI and eKSI are assigned and security context established
- the UE is switched-off
- With NGC Cell A "Serving cell" and E-UTRA Cell A "Non-suitable "Off" cell", the UE is brought to state 1N-A, RRC_IDLE Connectivity (NR), in accordance with the procedure described in TS 38.508-1 [4], Table 4.5.2.2-2. 5G-GUTI and ngKSI are assigned and security context established.

9.3.1.3.3.2 Test procedure sequence

Table 9.3.1.3.3.2-1: Main behaviour

St	Procedure	Message Sequence		TP	Verdict
		U - S	Message		
1	Wait for 25 seconds (expiry of T3512 periodic registration update timer, the value of 30 sec is provided during the initial registration in the Preamble).	-	-	-	-
2	The UE transmit a REGISTRATION REQUEST message with the 5GS registration type IE indicating "periodic registration updating".	-->	REGISTRATION REQUEST	-	-
3	The SS configures: - NGC Cell A as "Non-suitable "Off" cell" - E-UTRA Cell A "Serving cell".	-	-	-	-
4	The SS transmits a REGISTRATION REJECT message including 5GMM cause value #9 (UE identity cannot be derived by the network).	<--	REGISTRATION REJECT	-	-
5	Check: Does the UE perform on the E-UTRA Cell A an attach procedure as described in TS 38.508-1 [4], Table 4.5.2.2-1, ' <i>connected without release</i> '? The UE does not provide 4G-GUTI or 4G eKSI; nor last visited registered TAI.	-	-	1	-

9.3.1.3.3.3 Specific message contents

Table 9.3.1.3.3.3-1: REGISTRATION ACCEPT (Preamble; TS 38.508-1 [4] Table 4.5.2.2-2)

Derivation Path: 38.508-1 [4], Table 4.7.1-7.			
Information Element	Value/remark	Comment	Condition
T3512 value			
Unit	'100'B	value is incremented in multiples of 30 seconds	
Timer value	'0 0001'B	30 seconds	

Table 9.3.1.3.3.3-2: REGISTRATION REQUEST (step 2, Table 9.3.1.3.3.2-1)

Derivation Path: TS 38.508-1 [4], Table 4.7.1-6.			
Information Element	Value/remark	Comment	Condition
5GS registration type	'00xxx011'	periodic registration updating x - not checked	
ngKSI	Active ngKSI assigned in the Preamble		
5GS mobile identity	Active 5G-GUTI assigned in the Preamble		
Last visited registered TAI	The TAI of the NGC Cell A, see TS 38.508-1 [4] Table 6.3.2.2-1		

Table 9.3.1.3.3.3-3: REGISTRATION REJECT (step 4, Table 9.3.1.3.3.2-1)

Derivation Path: TS 38.508-1 [4], Table 4.7.1-9.			
Information Element	Value/remark	Comment	Condition
5GMM cause	'0000 1001'B	#9 - UE identity cannot be derived by the network	

Table 9.3.1.3.3.3-4: ATTACH REQUEST (step 5, Table 9.3.1.3.3.2-1; step 5, TS 38.508-1 [4] Table 4.5.2.2-1)

Derivation Path: TS 36.508 [7], Table 4.7.2-4.			
Information Element	Value/remark	Comment	Condition
NAS key set identifier	'111'	no key is available	
EPS mobile identity	IMSI		
Old P-TMSI signature	Not present		
Last visited registered TAI	Not present		
Old location area identification	Not present		
Old GUTI type	Not present		

10 Session management

10.1 5GS session management

Editor's note: Intended to capture tests of 5G Core Network behaviour defined in TS 24.301, TS 24.501 et.al. (TR 24.890).

FFS.

10.1.1 PDU session authentication and authorization

10.1.1.1 PDU session authentication and authorization / during the UE-requested PDU session procedure

10.1.1.1.1 Test Purpose (TP)

(1)

```
with { UE is establishing UE-requested PDU session by sending PDU Session establishment Request message }
ensure that {
  when { UE receives a PDU SESSION AUTHENTICATION COMMAND message }
  then { UE transmits a PDU SESSION AUTHENTICATION COMPLETE message }
}
```

(2)

```
with { PDU session authentication and authorization procedure is performed during the UE-requested PDU session establishment procedure }
ensure that {
  when { UE receives EAP-failure message in the PDU SESSION ESTABLISHMENT REJECT message }
  then { UE consider that the PDU session is not established }
}
```

(3)

```
with { PDU session authentication and authorization procedure is performed during the UE-requested PDU session establishment procedure }
ensure that {
  when { UE receives EAP-success message in the PDU SESSION ESTABLISHMENT ACCEPT message }
  then { UE consider that the PDU session is established }
}
```

10.1.1.1.2 Conformance requirements

References: The conformance requirements covered in the present TC are specified in: TS 24.501, clause 6.3.1.2.1, 6.3.1.2.2 and 6.4.1.4. Unless otherwise stated these are Rel-15 requirements.

[TS 24.501 clause 6.3.1.2.1]

In order to initiate the PDU EAP message reliable transport procedure, the SMF shall create a PDU SESSION AUTHENTICATION COMMAND message.

The SMF shall set the PTI IE of the PDU SESSION AUTHENTICATION COMMAND message to "No procedure transaction identity assigned".

The SMF shall set the EAP message IE of the PDU SESSION AUTHENTICATION COMMAND message to the EAP-request message provided by the DN or generated locally.

The SMF shall send the PDU SESSION AUTHENTICATION COMMAND message, and the SMF shall start timer T3590 (see example in figure 6.3.1.1).

Upon receipt of a PDU SESSION AUTHENTICATION COMMAND message and a PDU session ID, using the NAS transport procedure as specified in subclause 5.4.5, the UE passes to the upper layers the EAP message received in the EAP message IE of the PDU SESSION AUTHENTICATION COMMAND message. Apart from this action, the authentication and authorization procedure initiated by the DN is transparent to the 5GSM layer of the UE.

[TS 24.501 clause 6.3.1.2.2]

When the upper layers provide an EAP-response message responding to the received EAP-request message, the UE shall create a PDU SESSION AUTHENTICATION COMPLETE message.

The UE shall set the EAP message IE of the PDU SESSION AUTHENTICATION COMPLETE message to the EAP-response message.

The UE shall transport the PDU SESSION AUTHENTICATION COMPLETE message and the PDU session ID, using the NAS transport procedure as specified in subclause 5.4.5. Apart from this action, the authentication and authorization procedure initiated by the DN is transparent to the 5GSM layer of the UE.

Upon receipt of a PDU SESSION AUTHENTICATION COMPLETE message, the SMF shall stop timer T3590 and provides the EAP message received in the EAP message IE of the PDU SESSION AUTHENTICATION COMPLETE message to the DN or handles it locally.

[TS 24.501 clause 6.4.1.4]

If the connectivity with the requested DN is rejected by the network, the SMF shall create a SM PDU SESSION ESTABLISHMENT REJECT message.

The SMF shall set the 5GSM cause IE of the PDU SESSION ESTABLISHMENT REJECT message to indicate the reason for rejecting the PDU session establishment.

The 5GSM cause IE typically indicates one of the following SM cause values:

- #8 operator determined barring;
- #26 insufficient resources;
- #27 missing or unknown DNN;
- #28 unknown PDU session type;
- #29 user authentication or authorization failed;

10.1.1.1.3 Test description

10.1.1.1.3.1 Pre-test conditions

System Simulator:

NGC Cell A

UE:

None.

Preamble:

The UE is in state 1N-A with PDU session Active state using the generic procedure NR RRC_IDLE according to TS 38.508-1 [4].

10.1.1.1.3.2 Test procedure sequence

Table 10.1.1.1.3.2-1: Main behaviour

St	Procedure	Message Sequence		TP	Verdict
		U - S	Message		
1	Cause the UE to request connectivity to an additional PDU session. (see Note 1)	-	-	-	-
2	UE transmits an <i>RRCSetupRequest</i> message followed by a SERVICE REQUEST message with service type IE to "signalling".	-->	SERVICE REQUEST	-	-
3	Steps 5 and 6 of the generic procedure for NR RRC_Connected specified in TS 38.508-1 subclause 4.5.4.2 are performed.	-	-	-	-
4	The SS transmits an <i>RRCReconfiguration</i> message and a SERVICE ACCEPT message to establish SRB2.	<--	NR RRC: RRCReconfiguration 5GMM: SERVICE ACCEPT	-	-
5	The UE transmits a PDU SESSION ESTABLISHMENT REQUEST message to request an additional PDU session. Note: PDU SESSION ESTABLISHMENT REQUEST is included in UL NAS transport. UL NAS transport message is included in dedicatedNAS-Message of <i>ULInformationTransfer</i> message. DNN information is included in UL NAS transport message.	-->	5GMM: UL NAS TRANSPORT 5GSM: PDU SESSION ESTABLISHMENT REQUEST	-	-
6	The SS transmits PDU SESSION AUTHENTICATION COMMAND including an EAP-Request message.	<--	PDU SESSION AUTHENTICATION COMMAND		
7	Check: Does the UE transmit a PDU SESSION AUTHENTICATION COMPLETE containing EAP-Response message?	-->	PDU SESSION AUTHENTICATION COMPLETE	1	P
8	The SS transmits PDU SESSION ESTABLISHMENT REJECT message with 5GSM cause #29 including an EAP-Failure message.	<--	PDU SESSION ESTABLISHMENT REJECT		
9	The SS releases the RRC connection.	-	-	-	-
10	Cause the UE to request connectivity to an additional PDU session. (see Note 1)	-	-	-	-
11	UE transmits an <i>RRCSetupRequest</i> message followed by a SERVICE REQUEST message with service type IE to "signalling".	-->	SERVICE REQUEST	-	-
12	Steps 5 and 6 of the generic procedure for NR RRC_Connected specified in TS 38.508-1 subclause 4.5.4.2 are performed.	-	-	-	-
13	The SS transmits an <i>RRCReconfiguration</i> message and a SERVICE ACCEPT message to establish SRB2.	<--	NR RRC: RRCReconfiguration 5GMM: SERVICE ACCEPT	-	-
14	The UE transmits a PDU SESSION ESTABLISHMENT REQUEST message to request an additional PDU session. Note: PDU SESSION ESTABLISHMENT REQUEST is included in UL NAS transport. UL NAS transport message is included in dedicatedNAS-Message of <i>ULInformationTransfer</i> message. DNN information is included in UL NAS transport message.	-->	5GMM: UL NAS TRANSPORT 5GSM: PDU SESSION ESTABLISHMENT REQUEST	2	P
15	The SS transmits PDU SESSION AUTHENTICATION COMMAND including an EAP-Request message.	<--	PDU SESSION AUTHENTICATION COMMAND		
16	Check: Does the UE transmit a PDU SESSION AUTHENTICATION COMPLETE containing EAP-Response message?	-->	PDU SESSION AUTHENTICATION COMPLETE	-	-
17	The SS transmits <i>RRCReconfiguration</i> message containing PDU SESSION ESTABLISHMENT ACCEPT message containing an EAP-Success message.	<--	PDU SESSION ESTABLISHMENT ACCEPT		

18	The UE transmits <i>RRCReconfigurationComplete</i> message to confirm the establishment of DRB.	-	-	3	P
-	EXCEPTION: Step 19a1 describes behaviour depending UE implementation; the "lower case letter" identifies a step sequence that take place if the UE performs a specific action.	-	-	-	-
19a1	If initiated by the UE, the generic procedure for IP address allocation in the user plane, specified in subclause 4.5.6, takes place performing IP address allocation in the user plane.	-	-	-	-
Note 1: The request of connectivity to an additional PDU session may be performed by MMI or AT command.					

10.1.1.1.3.3 Specific message contents

Table 10.1.1.1.3.3-1: SERVICE REQUEST (step 2 and 11, Table 10.1.1.1.3.2-1)

Derivation Path: 38.508-1 [4], Table 4.7.1-16			
Information Element	Value/remark	Comment	Condition
Service type	'0000'B	signalling	
PDU session status	PDU session IDs	PDU session IDs of the ACTIVE PDU session established during Preamble.	

Table 10.1.1.1.3.3-2: SERVICE ACCEPT (step 4 and 13, Table 10.1.1.1.3.2-1)

Derivation Path: 38.508-1 [4], Table 4.7.1-17			
Information Element	Value/remark	Comment	Condition
PDU session status	PDU session IDs	PDU session IDs of the ACTIVE PDU session established during Preamble.	

Table 10.1.1.1.3.3-3: PDU SESSION ESTABLISHMENT REQUEST (step 5 and 14, Table 10.1.1.1.3.2-1)

Derivation Path: 38.508-1 [4], Table 4.7.2-1			
Information Element	Value/remark	Comment	Condition
PDU session ID	PSI-1	UE assigns a particular PSI not yet used between 1 and 15	
PTI	PTI-1	UE assigns a particular PTI not yet used between 1 and 254	

Table 10.1.1.1.3.3-4: UL NAS Transport (step 5 and 14, Table 10.1.1.1.3.2-1)

Derivation Path: 38.508-1 [4], Table 4.7.1-10			
Information Element	Value/remark	Comment	Condition
Payload container type	'0001'B	N1 SM information	
PDU session ID	PSI-1		
Request type	'001'B	Initial request	
S-NSSAI	Not Present		
DNN	DNN-1 (New DNN name)	The requested DNN is different from default DNN.	

Table 10.1.1.1.3.3-5: PDU SESSION ESTABLISHMENT REJECT (step 8, Table 10.1.1.1.3.2-1)

Derivation Path: 38.508-1 [4], Table 4.7.2-3			
Information Element	Value/remark	Comment	Condition
PDU session ID	PSI-1		
PTI	PTI-1		
5GSM cause	'00011 101'	User authentication or authorization failed	

Table 10.1.1.1.3.3-6: PDU SESSION ESTABLISHMENT ACCEPT (step 17, Table 10.1.1.1.3.2-1)

Derivation Path: 38.508-1 [4], Table 4.7.2-2			
Information Element	Value/remark	Comment	Condition
PDU session ID	PSI-1		
PTI	PTI-1		
Authorized QoS rules			
QoS rule			
QoS rule identifier	'0000 0001'B		
Rule operation code	'001'B	Create new QoS rule	
DQR bit	'1'B	The QoS rule is the default QoS rule.	
Number of packet filters	'0001'B	1 packet filter	
Packet filter list	See table 4.8.2.1-1	Packet filter list #1	
Packet filter direction	'11'B	bidirectional	
Packet filter identifier	'0000'B	Id 0	
Component type 1 ID	'0000 0001'B	Match-all type	
QoS rule precedence	'0000 0000'B	0	
QoS flow identifier (QFI)	'00 0011'B	QFI 3	
EAP message			
QoS flow description			
QFI	'00 0011'B	QFI 3	
Operation code	'001'B	Create new QoS flow description	
E bit	'1'B	Parameters list is included	
Number of parameters	'00 0001'B	1 parameters	
5QI	'0000 1001'B	5QI 9	
DNN	DNN-1		

10.1.1.2 PDU session authentication and authorization / after the UE-requested PDU session procedure

10.1.1.2.1 Test Purpose (TP)

(1)

```
with { the UE is in 5GMM-REGISTERED state with an established PDU session }
ensure that {
  when { UE receives a PDU SESSION AUTHENTICATION COMMAND message }
  then { UE transmits a PDU SESSION AUTHENTICATION COMPLETE message }
}
```

(2)

```
with { PDU session authentication and authorization procedure is performed after the UE-requested
PDU session establishment procedure }
ensure that {
  when { UE receives EAP-failure message in the PDU SESSION RELEASE COMMAND message }
  then { the 5GSM state of the UE is PDU SESSION INACTIVE state }
}
```

(3)

```
with { PDU session authentication and authorization procedure is performed after the UE-requested
PDU session establishment procedure }
ensure that {
  when { UE receives EAP-success message in the PDU SESSION AUTHENTICATION RESULT message }
  then { the 5GSM state of the UE is PDU SESSION ACTIVE state }
}
```

10.1.1.2.2 Conformance requirements

References: The conformance requirements covered in the present TC are specified in: TS 24.501, clause 6.3.1.1, clause 6.3.1.2.1, 6.3.1.2.2 and 6.3.1.3.1. Unless otherwise stated these are Rel-15 requirements.

[TS 24.501 clause 6.3.1.1]

The purpose of the PDU session authentication and authorization procedure is to enable the DN:

- a) to authenticate the upper layers of the UE, when establishing the PDU session;
- b) to authorize the upper layers of the UE, when establishing the PDU session;
- c) both of the above; or
- d) to re-authenticate the upper layers of the UE after establishment of the PDU session.

The PDU session authentication and authorization procedure can be performed only during or after the UE-requested PDU session procedure establishing a non-emergency PDU session. The PDU session authentication and authorization procedure shall not be performed during or after the UE-requested PDU session establishment procedure establishing an emergency PDU session.

The network authenticates the UE using the Extensible Authentication Protocol (EAP) as specified in IETF RFC 3748 [32].

EAP has defined four types of EAP messages:

- a) an EAP-request message;
- b) an EAP-response message;
- c) an EAP-success message; and
- d) an EAP-failure message.

The EAP-request message is transported from the network to the UE using the PDU SESSION AUTHENTICATION COMMAND message of the PDU EAP message reliable transport procedure.

The EAP-response message to the EAP-request message is transported from the UE to the network using the PDU SESSION AUTHENTICATION COMPLETE message of the PDU EAP message reliable transport procedure.

If the PDU session authentication and authorization procedure is performed during the UE-requested PDU session establishment procedure:

- a) and the DN authentication of the UE completes successfully, the EAP-success message is transported from the network to the UE as part of the UE-requested PDU session establishment procedure in the PDU SESSION ESTABLISHMENT ACCEPT message.
- b) and the DN authentication of the UE completes unsuccessfully, the EAP-failure message is transported from the network to the UE as part of the UE-requested PDU session establishment procedure in the PDU SESSION ESTABLISHMENT REJECT message.

If the PDU session authentication and authorization procedure is performed after the UE-requested PDU session establishment procedure:

- a) and the DN authentication of the UE completes successfully, the EAP-success message is transported from the network to the UE using the PDU SESSION AUTHENTICATION RESULT message of the PDU EAP result message transport procedure.
- b) and the DN authentication of the UE completes unsuccessfully, the EAP-failure message is transported from the network to the UE using the PDU SESSION RELEASE COMMAND message of the network-requested PDU session release procedure.

There can be several rounds of exchange of an EAP-request message and a related EAP-response message for the DN to complete the authentication and authorization of the request for a PDU session (see example in figure 6.3.1.1).

The SMF shall set the authenticator retransmission timer specified in IETF RFC 3748 [34] subclause 4.3 to infinite value.

NOTE: The PDU session authentication and authorization procedure provides a reliable transport of EAP messages and therefore retransmissions at the EAP layer of the SMF do not occur.

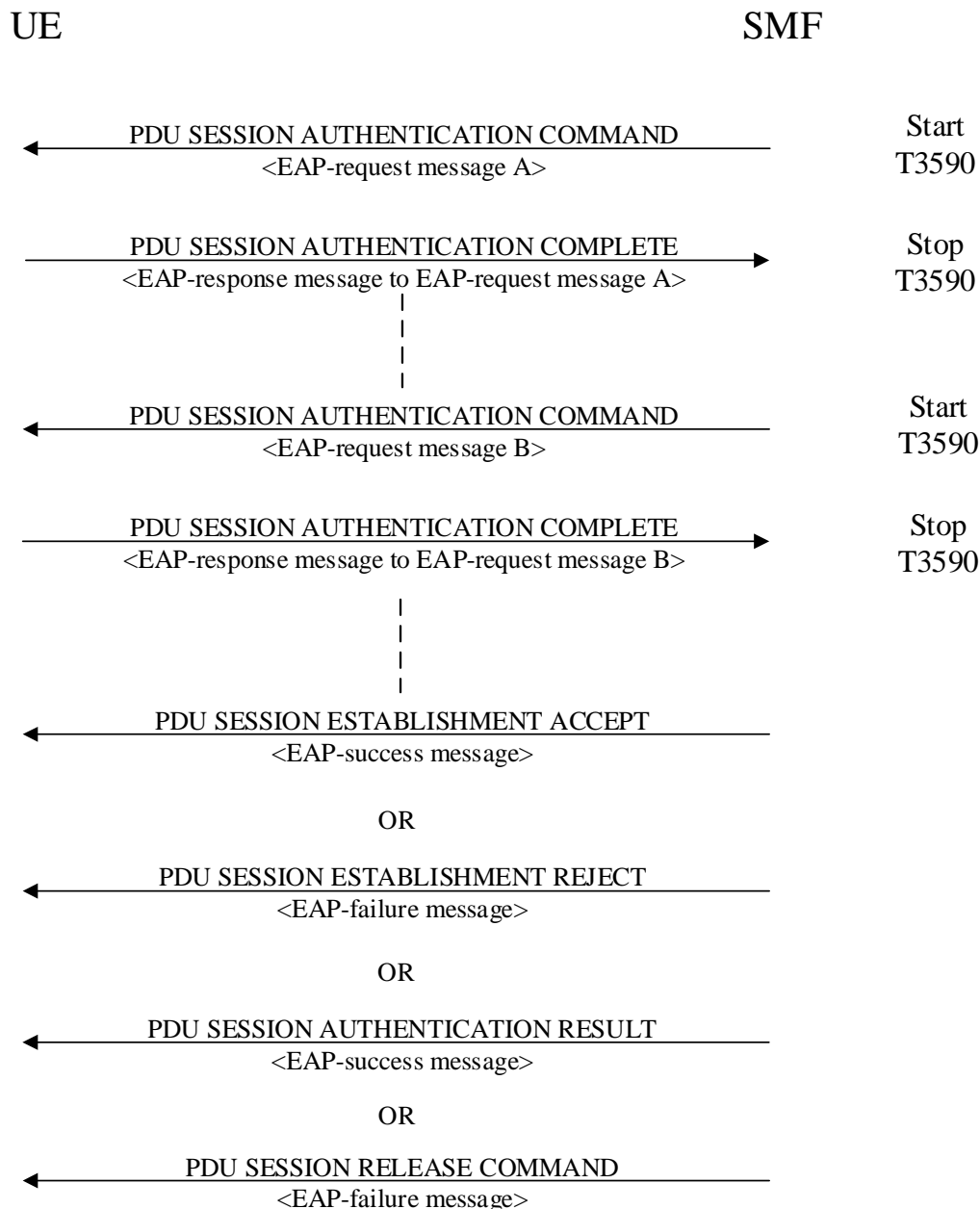

Figure 6.3.1.1: PDU session authentication and authorization procedure

[TS 24.501 clause 6.3.1.2.1]

In order to initiate the PDU EAP message reliable transport procedure, the SMF shall create a PDU SESSION AUTHENTICATION COMMAND message.

The SMF shall set the PTI IE of the PDU SESSION AUTHENTICATION COMMAND message to "No procedure transaction identity assigned".

The SMF shall set the EAP message IE of the PDU SESSION AUTHENTICATION COMMAND message to the EAP-request message provided by the DN or generated locally.

The SMF shall send the PDU SESSION AUTHENTICATION COMMAND message, and the SMF shall start timer T3590 (see example in figure 6.3.1.1).

Upon receipt of a PDU SESSION AUTHENTICATION COMMAND message and a PDU session ID, using the NAS transport procedure as specified in subclause 5.4.5, the UE passes to the upper layers the EAP message received in the

EAP message IE of the PDU SESSION AUTHENTICATION COMMAND message. Apart from this action, the authentication and authorization procedure initiated by the DN is transparent to the 5GSM layer of the UE.

[TS 24.501 clause 6.3.1.2.2]

When the upper layers provide an EAP-response message responding to the received EAP-request message, the UE shall create a PDU SESSION AUTHENTICATION COMPLETE message.

The UE shall set the EAP message IE of the PDU SESSION AUTHENTICATION COMPLETE message to the EAP-response message.

The UE shall transport the PDU SESSION AUTHENTICATION COMPLETE message and the PDU session ID, using the NAS transport procedure as specified in subclause 5.4.5. Apart from this action, the authentication and authorization procedure initiated by the DN is transparent to the 5GSM layer of the UE.

Upon receipt of a PDU SESSION AUTHENTICATION COMPLETE message, the SMF shall stop timer T3590 and provides the EAP message received in the EAP message IE of the PDU SESSION AUTHENTICATION COMPLETE message to the DN or handles it locally.

[TS 24.501 clause 6.3.1.3.1]

In order to initiate the PDU EAP result message transport procedure, the SMF shall create a PDU SESSION AUTHENTICATION RESULT message.

The SMF shall set the PTI IE of the PDU SESSION AUTHENTICATION RESULT message to "No procedure transaction identity assigned".

The SMF shall set the EAP message IE of the PDU SESSION AUTHENTICATION RESULT message to the EAP-success message provided by the DN.

The SMF shall send the PDU SESSION AUTHENTICATION RESULT message.

Upon receipt of a PDU SESSION AUTHENTICATION RESULT message and a PDU session ID, using the NAS transport procedure as specified in subclause 5.4.5, the UE passes to the upper layers the EAP message received in the EAP message IE of the PDU SESSION AUTHENTICATION RESULT message. Apart from this action, the authentication and authorization procedure initiated by the DN is transparent to the 5GSM layer of the UE.

10.1.1.2.3 Test description

10.1.1.2.3.1 Pre-test conditions

System Simulator:

 NGC Cell A

UE:

None.

Preamble:

 The UE is in state 1N-A, '*connected without Release*' with PDU session Active state using the generic procedure NR RRC_IDLE according to TS 38.508-1 [4].

10.1.1.2.3.2 Test procedure sequence

Table 10.1.1.2.3.2-1: Main behaviour

St	Procedure	Message Sequence		TP	Verdict
		U - S	Message		
1	The SS transmits PDU SESSION AUTHENTICATION COMMAND including an EAP-Request message.	<--	PDU SESSION AUTHENTICATION COMMAND	-	-
2	Check: Does the UE transmit a PDU SESSION AUTHENTICATION COMPLETE containing EAP-Response message?	-->	PDU SESSION AUTHENTICATION COMPLETE	1	P
3	The SS transmits PDU SESSION AUTHENTICATION RESULT message containing an EAP-Success message.	<--	PDU SESSION AUTHENTICATION RESULT	-	-
4	The SS transmits PDU SESSION AUTHENTICATION COMMAND including an EAP-Request message.	<--	PDU SESSION AUTHENTICATION COMMAND	-	-
5	Check: Does the UE transmit a PDU SESSION AUTHENTICATION COMPLETE containing EAP-Response message?	-->	PDU SESSION AUTHENTICATION COMPLETE	3	P
6	The SS transmits a PDU SESSION RELEASE COMMAND including 5GSM cause #26 "insufficient resources".	<--	PDU SESSION RELEASE COMMAND	-	-
7	The UE transmit a PDU SESSION RELEASE COMPLETE message.	-->	PDU SESSION RELEASE COMPLETE	-	-
8	Cause the UE to request establishment of PDU session. (see Note 1)	-	-	-	-
9	UE transmits an RRCSetupRequest message followed by a SERVICE REQUEST message with service type IE to "signalling".	-->	SERVICE REQUEST	-	-
10-11	Steps 5 and 6 of the generic procedure for NR RRC_Connected specified in TS 38.508-1 subclause 4.5.4.2 are performed.	-	-	-	-
12	The SS transmits an RRCReconfiguration message and a SERVICE ACCEPT message to establish SRB2.	<--	SERVICE ACCEPT	-	-
13	The UE transmits a PDU SESSION ESTABLISHMENT REQUEST message to request an additional PDU session. Note: PDU SESSION ESTABLISHMENT REQUEST is included in UL NAS transport. UL NAS transport message is included in dedicatedNAS-Message of <i>ULInformationTransfer</i> message DNN information is included in UL NAS transport message.	-->	PDU SESSION ESTABLISHMENT REQUEST	-	-
14	The SS transmits <i>RRCReconfiguration</i> message containing PDU SESSION ESTABLISHMENT ACCEPT message.	<--	PDU SESSION ESTABLISHMENT ACCEPT	-	-
15	The UE transmits <i>RRCReconfigurationComplete</i> message to confirm the establishment of DRB.	-	-	-	-
-	EXCEPTION: Step 15a1 describes behaviour depending UE implementation; the "lower case letter" identifies a step sequence that take place if the UE performs a specific action.	-	-	-	-
15a1	If initiated by the UE, the generic procedure for IP address allocation in the user plane, specified in subclause 4.5.6, takes place performing IP address allocation in the user plane.	-	-	-	-
16	The SS transmits PDU SESSION AUTHENTICATION COMMAND including an EAP-Request message.	<--	PDU SESSION AUTHENTICATION COMMAND	-	-
17	UE transmits a PDU SESSION AUTHENTICATION COMPLETE containing EAP-Response message?	-->	PDU SESSION AUTHENTICATION COMPLETE	-	-

18	SS transmits a PDU SESSION RELEASE COMMAND including 5GSM cause #29 "user authentication or authorization failed".	-->	PDU SESSION PDU SESSION RELEASE COMMAND	-	-
19	Check: Does UE transmit a PDU SESSION RELEASE COMPLETE message?	-->	PDU SESSION PDU SESSION RELEASE COMPLETE	2	P
Note 1: The request of connectivity to an additional PDU session may be performed by MMI or AT command.					

10.1.1.2.3.3 Specific message contents

Table 10.1.1.2.3.3-1: PDU SESSION MODIFICATION COMMAND (Step 4, Table 10.1.1.2.3.2-1)

Derivation path: 38.508-1 [4], table 4.7.2-9			
Information Element	Value/Remark	Comment	Condition
PDU session ID	The different value from the value set in PDU SESSION ESTABLISHMENT REQUEST message in preamble		

Table 10.1.1.2.3.3-2: PDU SESSION MODIFICATION REJECT (Step 5, Table 10.1.1.2.3.2-1)

Derivation path: 38.508-1 [4], table 4.7.2-8			
Information Element	Value/Remark	Comment	Condition
PDU session ID	The same value as the value set in PDU SESSION modification command message		
5GSM cause	'00101011'B	Invalid PDU session identity	

Table 10.1.1.2.3.3-3: PDU SESSION RELEASE COMMAND (step 6, Table 10.1.3.2.3.2-1)

Derivation Path: TS 38.508-1 [4] Table 4.7.2-14			
Information Element	Value/remark	Comment	Condition
PDU session ID	The same ID as the ID of PDU session which UE request in step 13 in Table 10.1.1.2.3.2-1		
5GSM cause	'0001 1010'B	insufficient resources	
Back-off timer value	'1010 0000'B	0 minutes	

Table 10.1.1.2.3.3-4: PDU SESSION ESTABLISHMENT REQUEST (step 13, Table 10.1.1.2.3.2-1)

Derivation Path: 38.508-1 [4], Table 4.7.2-1			
Information Element	Value/remark	Comment	Condition
PDU session ID	PSI-1	UE assigns a particular PSI not yet used between 1 and 15	
PTI	PTI-1	UE assigns a particular PTI not yet used between 1 and 254	

Table 10.1.1.2.3.3-5: PDU SESSION RELEASE COMMAND (step 18, Table 10.1.1.2.3.2-1)

Derivation Path: TS 38.508-1 [4] Table 4.7.2-14			
Information Element	Value/remark	Comment	Condition
PDU session ID	The same ID as the ID of PDU session which UE request in step 13 in Table 10.1.1.2.3.2-1		
5GSM cause	'0001 1101'B	user authentication or authorization failed	
Back-off timer value	'1010 0000'B	0 minutes	

10.1.2 Network-requested PDU session modification

10.1.2.1

10.1.2.2 Network-requested PDU session modification / Abnormal / PDU session in state PDU SESSION INACTIVE

10.1.2.2.1 Test Purpose (TP)

(1)

```

with { the UE in PDU SESSION ACTIVE state and 5GMM-CONNECTED mode }
ensure that {
  when { the UE receives a PDU SESSION MODIFICATION COMMAND message include the PDU session ID which
belong to any PDU session in PDU SESSION INACTIVE state in UE }
  then { UE sends a 5GSM STATUS message and set the 5GSM cause to #43: invalid PDU session
identity }
}

```

10.1.2.2.2 Conformance requirements

References: The conformance requirements covered in the present TC are specified in: TS 24.501, clauses 6.3.2.4, 6.3.2.6 and 7.3.2. Unless otherwise stated these are Rel-15 requirements.

[TS 24.501, clause 6.3.2.4]

Upon receipt of a PDU SESSION MODIFICATION COMMAND message and a PDU session ID, using the NAS transport procedure as specified in subclause 5.4.5, if the UE rejects the PDU SESSION MODIFICATION COMMAND message, the UE shall create a PDU SESSION MODIFICATION COMMAND REJECT message.

If the PDU SESSION MODIFICATION COMMAND message contains the PTI value allocated in the UE-requested PDU session modification procedure, the UE shall stop the timer T3581. The UE should ensure that the PTI value assigned to this procedure is not released immediately.

NOTE 1: The way to achieve this is implementation dependent. For example, the UE can ensure that the PTI value assigned to this procedure is not released during the time equal to or greater than the default value of timer T3591.

While the PTI value is not released, the UE regards any received PDU SESSION MODIFICATION COMMAND message with the same PTI value as a network retransmission (see subclause 7.3.1).

The UE shall set the 5GSM cause IE of the PDU SESSION MODIFICATION COMMAND REJECT message to indicate the reason for rejecting the PDU session modification.

The 5GSM cause IE typically indicates one of the following 5GSM cause values:

- #26 insufficient resources;
- #43 invalid PDU session identity;

- #44 semantic error in packet filter(s);
- #45 syntactical error in packet filter(s);
- #83 semantic error in the QoS operation; or
- #84 syntactical error in the QoS operation.

[TS 24.501, clause 6.3.2.6]

The following abnormal cases can be identified:

- a) PDU session inactive for the received PDU session ID.

If the PDU session ID in the PDU SESSION MODIFICATION COMMAND message belongs to any PDU session in state PDU SESSION INACTIVE in the UE, the UE shall set the 5GSM cause IE to #43 "Invalid PDU session identity" in the 5GSM STATUS message, and set the PDU session ID to the received PDU session ID in the UL NAS TRANSPORT message as specified in subclause 5.4.5.

[TS 24.501, clause 7.3.2]

The following UE procedures shall apply for handling an unknown, erroneous, or unforeseen PDU session identity received in the header of a 5GSM message:

- a) If the UE receives a 5GSM message which includes an unassigned or reserved PDU session identity value, the UE shall ignore the message.
- b) If the UE receives a 5GSM message which includes a PDU session identity belonging to any PDU session in state PDU SESSION INACTIVE in the UE, the UE shall respond with a 5GSM STATUS message including 5GSM cause #43 "invalid PDU session identity".

10.1.2.2.3 Test description

10.1.2.2.3.1 Pre-test conditions

System Simulator:

- NGC Cell A.

UE:

- None.

Preamble:

- The UE is in state 3N-A on NGC Cell A according to 38.508-1[4]

10.1.2.2.3.2 Test procedure sequence

Table 10.1.2.2.3.2-1: Main behaviour

St	Procedure	Message Sequence		TP	Verdict
		U - S	Message		
1	The SS transmits a PDU session release command message with PDU session ID IE is set to one of value from the value set in PDU SESSION ESTABLISHMENT REQUEST message in preamble. This message is included in a DLInformationTransfer message.	<--	PDU SESSION RELEASE COMMAND	-	-
2	UE transmits a PDU session release complete message with PDU session ID IE is set to the value indicated in PDU SESSION RELEASE COMMAND message.	-->	PDU SESSION RELEASE COMPLETE	-	-
3	The SS transmits a PDU session modification command message with PDU session ID IE is set to the same value in PDU SESSION RELEASE COMMAND message. This message is included in a DLInformationTransfer message.	<--	PDU SESSION MODIFICATION COMMAND	-	-
4	Check: Does the UE transmit a 5GSM STATUS with the 5GSM cause IE indicating #43 "invalid PDU session identity"?	-->	5GSM STATUS	1	P
1	The SS transmits a PDU session modification command message with PDU session ID IE is set to a different value from the value set in PDU SESSION ESTABLISHMENT REQUEST message. This message is included in a DLInformationTransfer message.	<--	PDU SESSION MODIFICATION COMMAND	-	-
2	Check: Does the UE transmit a PDU session modification reject with the 5GSM cause IE indicating #43 "invalid PDU session identity"?	-->	PDU SESSION MODIFICATION REJECT	1	P

10.1.2.2.3.3 Specific message contents

Table 10.1.2.2.3.3-1: PDU SESSION MODIFICATION COMMAND (Step 3, Table 10.1.2.2.3.2-1)

Derivation path: 38.508-1 [4], table 4.7.2-9			
Information Element	Value/Remark	Comment	Condition
PDU session ID	The same value in PDU SESSION RELEASE COMMAND message		

Table 10.1.2.2.3.3-2: 5GSM STATUS (Step 4, Table 10.1.2.2.3.2-1)

Derivation path: 38.508-1 [4], table 4.7.2-16			
Information Element	Value/Remark	Comment	Condition
PDU session ID	The same value as the value set in PDU SESSION modification command message		
5GSM cause	'00101011'B	Invalid PDU session identity	

Table 10.1.2.2.3.3-3: PDU SESSION RELEASE COMMAND (Step 1, Table 10.1.2.2.3.2-1)

Derivation path: 38.508-1 [4], table 4.7.2-14			
Information Element	Value/Remark	Comment	Condition
PDU session ID	One of value from the value set in PDU SESSION ESTABLISHMENT REQUEST message in preamble		

10.1.3

Editor's note: CAICT forgot 2700

10.1.3.1

10.1.3.2 Network-requested PDU session release / Accepted / Insufficient resources / T3396, Accepted / Insufficient resources for specific slice and DNN / T3584, Abnormal / No PDU session context active for the received PDU session ID

Editor's Note: The configuration of PDU session establishment by UE with NSSAI/DNN parameters is FFS.

10.1.3.2.1 Test Purpose (TP)

(1)

```
with { UE is in PDU SESSION ACTIVE state }
ensure that {
  when { UE receives a PDU SESSION RELEASE COMMAND message including 5GSM cause #26 "insufficient
resources" and the Back-off timer value that indicates neither zero nor deactivated }
  then { UE does not send a PDU SESSION ESTABLISHMENT REQUEST until timer T3396 expires or timer
T3396 is stopped }
}
```

(2)

```
with { UE is in PDU SESSION ACTIVE state }
ensure that {
  when { UE receives a PDU SESSION RELEASE COMMAND message including 5GSM cause #26 "insufficient
resources" and the Back-off timer value that indicates zero }
  then { UE sends a PDU SESSION ESTABLISHMENT REQUEST message }
}
```

(3)

```
with { UE is in PDU SESSION ACTIVE state }
ensure that {
  when { UE receives a PDU SESSION RELEASE COMMAND message including 5GSM cause #26 "insufficient
resources" and the Back-off timer value that indicates deactivated }
  then { UE does not send a PDU SESSION ESTABLISHMENT REQUEST message until the UE is switched off
or the USIM is removed }
}
```

(4)

```
with { UE is in PDU SESSION ACTIVE state }
ensure that {
  when { UE receives a PDU SESSION RELEASE COMMAND message including 5GSM cause #67 "insufficient
resources for specific slice and DNN" and the Back-off timer value that indicates neither zero nor
deactivated }
  then { UE does not send a PDU SESSION ESTABLISHMENT REQUEST message for the same [S-NSSAI, DNN]
combination until timer T3584 expires }
}
```

(5)

```

with { UE is in PDU SESSION ACTIVE state }
ensure that {
  when { UE receives a PDU SESSION RELEASE COMMAND message including 5GSM cause #67 "insufficient
resources for specific slice and DNN" and the Back-off timer value that indicates zero }
  then { UE sends a PDU SESSION ESTABLISHMENT REQUEST message for the same [S-NSSAI, DNN]
combination }
}

```

(6)

```

with { UE is in PDU SESSION ACTIVE state }
ensure that {
  when { UE receives a PDU SESSION RELEASE COMMAND message including 5GSM cause #67 "insufficient
resources for specific slice and DNN" and the Back-off timer value that indicates deactivated }
  then { UE does not send a PDU SESSION ESTABLISHMENT REQUEST message for the same [S-NSSAI, DNN]
combination until the UE is switched off or the USIM is removed }
}

```

(7)

```

with { UE is in PDU SESSION ACTIVE state }
ensure that {
  when { UE receives a PDU SESSION RELEASE COMMAND message, in which the PDU session ID belongs to
any PDU session in state PDU SESSION INACTIVE in the UE }
  then { UE sends 5GSM STATUS message including 5GSM cause #43 "Invalid PDU session identity" }
}

```

10.1.3.2.2 Conformance requirements

References: The conformance requirements covered in the current TC are specified in: TS 24.501, clause 6.3.3.2 and 6.3.3.3. Unless otherwise stated these are Rel-15 requirements.

[TS 24.501, clause 6.3.3.2]

In order to initiate the network-requested PDU session release procedure, the SMF shall create a PDU SESSION RELEASE COMMAND message.

The SMF shall set the SM cause IE of the PDU SESSION RELEASE COMMAND message to indicate the reason for releasing the PDU session.

The SM cause IE typically indicates one of the following SM cause values:

- #26 insufficient resources;
- ...
- #67 insufficient resources for specific slice and DNN;
- ...

The SMF may include a Back-off timer value IE in the PDU SESSION RELEASE COMMAND message when the 5GSM cause value #26 "insufficient resources" is included in the PDU SESSION RELEASE COMMAND message. If the 5GSM cause value is #26 "insufficient resources" and the PDU SESSION RELEASE COMMAND message is sent to a UE configured for high priority access in selected PLMN or the request type was set to "initial emergency request" or "existing emergency PDU session" for the establishment of the PDU session, the network shall not include a Back-off timer value IE.

The SMF may include a Back-off timer value IE in the PDU SESSION RELEASE COMMAND message when the 5GSM cause value #67 "insufficient resources for specific slice and DNN" is included in the PDU SESSION RELEASE COMMAND message. If the 5GSM cause value is #67 "insufficient resources for specific slice and DNN" and the PDU SESSION RELEASE COMMAND message is sent to a UE configured for high priority access in selected PLMN or the request type was set to "initial emergency request" or "existing emergency PDU session" for the establishment of the PDU session, the network shall not include a Back-off timer value IE.

[TS 24.501, clause 6.3.3.3]

Upon receipt of a PDU SESSION RELEASE COMMAND message and a PDU session ID, using the NAS transport procedure as specified in subclause 5.4.5, the UE considers the PDU session as released and the UE shall create a PDU SESSION RELEASE COMPLETE message.

...

If the PDU SESSION RELEASE COMMAND message includes 5GSM cause #26 "insufficient resources" and the Back-off timer value IE, the UE shall take different actions depending on the timer value received for timer T3396 in the Back-off timer value:

- a) If the timer value indicates neither zero nor deactivated and a DNN was provided during the PDU session establishment, the UE shall stop timer T3396 associated with the corresponding DNN, if it is running. If the timer value indicates neither zero nor deactivated and no DNN was provided during the PDU session establishment and the request type was different from "initial emergency request" and different from "existing emergency PDU session", the UE shall stop timer T3396 associated with no DNN if it is running. The UE shall then start timer T3396 with the value provided in the Back-off timer value IE and:
 - 1) shall not send a PDU SESSION ESTABLISHMENT REQUEST message or PDU SESSION MODIFICATION REQUEST message with exception of those identified in subclause 6.4.2.1, for the same DNN that was sent by the UE, until timer T3396 expires or timer T3396 is stopped; and
 - 2) shall not send a PDU SESSION ESTABLISHMENT REQUEST message without an DNN and with request type different from "initial emergency request" and different from "existing emergency PDU session", or a PDU SESSION MODIFICATION REQUEST message with exception of those identified in subclause 6.4.2.1, for a non-emergency PDU session established without an DNN provided by the UE, if no DNN was provided during the PDU session establishment and the request type was different from "initial emergency request" and different from "existing emergency PDU session", until timer T3396 expires or timer T3396 is stopped.

The UE shall not stop timer T3396 upon a PLMN change or inter-system change;

- b) if the timer value indicates that this timer is deactivated and a DNN was provided during the PDU session establishment, the UE shall stop timer T3396 associated with the corresponding DNN, if it is running. If the timer value indicates that this timer is deactivated and no DNN was provided during the PDU session establishment and the request type was different from "initial emergency request" and different from "existing emergency PDU session", the UE shall stop timer T3396 associated with no DNN if it is running. The UE:
 - 1) shall not send a PDU SESSION ESTABLISHMENT REQUEST message or PDU SESSION MODIFICATION REQUEST message with exception of those identified in subclause 6.4.2.1, for the same DNN until the UE is switched off or the USIM is removed, or the UE receives a PDU SESSION MODIFICATION COMMAND message for the same DNN from the network or a PDU SESSION RELEASE COMMAND message including 5GSM cause #39 "reactivation requested" for the same DNN from the network; and
 - 2) shall not send a PDU SESSION ESTABLISHMENT REQUEST message without an DNN and with request type different from "initial emergency request" and different from "existing emergency PDU session", or a PDU SESSION MODIFICATION REQUEST message with exception of those identified in subclause 6.4.2.1, for a non-emergency PDU session established without an DNN provided by the UE, if no DNN was provided during the PDU session establishment and the request type was different from "initial emergency request" and different from "existing emergency PDU session", until the UE is switched off or the USIM is removed, or the UE receives a PDU SESSION MODIFICATION COMMAND message for a non-emergency PDU session established without an DNN provided by the UE, or a PDU SESSION RELEASE COMMAND message including 5GSM cause IE set to 5GSM cause #39 "reactivation requested" for a non-emergency PDU session established without an DNN provided by the UE.

The timer T3396 remains deactivated upon a PLMN change or inter-system change; and

- c) if the timer value indicates zero, the UE:
 - 1) shall stop timer T3396 associated with the corresponding DNN, if running, and may send a PDU SESSION ESTABLISHMENT REQUEST message or PDU SESSION MODIFICATION REQUEST message for the same DNN; and

- 2) if no DNN was provided during the PDU session establishment and the request type was different from "initial emergency request" and different from "existing emergency PDU session", the UE shall stop timer T3396 associated with no DNN, if running, and may send a PDU SESSION ESTABLISHMENT REQUEST message without a DNN, or a PDU SESSION MODIFICATION REQUEST message without an DNN provided by the UE.

If the PDU SESSION RELEASE COMMAND message includes 5GSM cause #26 "insufficient resources" and the Back-off timer value IE is not included, then the UE may send a PDU SESSION ESTABLISHMENT REQUEST message or PDU SESSION MODIFICATION REQUEST message for the same DNN or without a DNN.

When the timer T3396 is running or the timer is deactivated, the UE is allowed to initiate a PDU session establishment procedure for emergency services.

If the timer T3396 is running when the UE enters state 5GMM-DEREGISTERED, the UE remains switched on, and the USIM in the UE remains the same, then timer T3396 is kept running until it expires or it is stopped.

If the UE is switched off when the timer T3396 is running, and if the USIM in the UE remains the same when the UE is switched on, the UE shall behave as follows:

- let t_1 be the time remaining for T3396 timeout at switch off and let t be the time elapsed between switch off and switch on. If t_1 is greater than t , then the timer shall be restarted with the value $t_1 - t$. If t_1 is equal to or less than t , then the timer need not be restarted. If the UE is not capable of determining t , then the UE shall restart the timer with the value t_1 .

If the 5GSM cause value is #67 "insufficient resources for specific slice and DNN" and the Back-off timer value IE is included, the UE shall take different actions depending on the timer value received for timer T3584 in the Back-off timer value:

- a) If the timer value indicates neither zero nor deactivated, the UE shall stop timer T3584 associated with the same [S-NSSAI, DNN] combination as that the UE provided when the PDU session is established, if it is running. The UE shall then start timer T3584 with the value provided in the Back-off timer value IE.

The UE shall not send another PDU SESSION ESTABLISHMENT REQUEST message with request type different from "initial emergency request" and different from "existing emergency PDU session", or PDU SESSION MODIFICATION REQUEST message with exception of those identified in subclause 6.4.2.1, for the same [S-NSSAI, DNN] combination that was sent by the UE, until timer T3584 expires or timer T3584 is stopped;

The UE shall not stop timer T3584 upon a PLMN change or inter-system change;

- b) if the timer value indicates that this timer is deactivated, the UE shall stop timer T3584 associated with the same [S-NSSAI, DNN] combination as that the UE provided when the PDU session is established, if it is running.

The UE shall not send another PDU SESSION ESTABLISHMENT REQUEST message with request type different from "initial emergency request" and different from "existing emergency PDU session", or PDU SESSION MODIFICATION REQUEST message with exception of those identified in subclause 6.4.2.1, for the same [S-NSSAI, DNN] combination that was sent by the UE, until the UE is switched off or the USIM is removed, or the UE receives a PDU SESSION MODIFICATION REQUEST message for the same [S-NSSAI, DNN] combination from the network or a PDU SESSION RELEASE COMMAND message including 5GSM cause #39 "reactivation requested" for the same [S-NSSAI, DNN] combination from the network; and

The timer T3584 remains deactivated upon a PLMN change or inter-system change; and

- c) if the timer value indicates zero, the UE shall stop timer T3584 associated with the same [S-NSSAI, DNN] combination that was sent by the UE, if running, and may send another PDU SESSION ESTABLISHMENT REQUEST message or PDU SESSION MODIFICATION REQUEST message for the same [S-NSSAI, DNN] combination.

If the 5GSM cause value is #67 "insufficient resources for specific slice and DNN" and the Back-off timer value IE is not included, then the UE may send another PDU SESSION ESTABLISHMENT REQUEST message or PDU SESSION MODIFICATION REQUEST message for the same [S-NSSAI, DNN] combination.

When the timer T3584 is running or the timer is deactivated, the UE is allowed to initiate a PDU session establishment procedure for emergency services.

If the timer T3584 is running when the UE enters state 5GMM-DEREGISTERED, the UE remains switched on, and the USIM in the UE remains the same, then timer T3584 is kept running until it expires or it is stopped.

If the UE is switched off when the timer T3584 is running, and if the USIM in the UE remains the same when the UE is switched on, the UE shall behave as follows:

- let t_1 be the time remaining for T3584 timeout at switch off and let t be the time elapsed between switch off and switch on. If t_1 is greater than t , then the timer shall be restarted with the value $t_1 - t$. If t_1 is equal to or less than t , then the timer need not be restarted. If the UE is not capable of determining t , then the UE shall restart the timer with the value t_1 .

[TS 24.501, clause 6.3.3.6]

The following abnormal cases can be identified:

- a) PDU session inactive for the received PDU session ID.

If the PDU session ID in the PDU SESSION RELEASE COMMAND message belongs to any PDU session in state PDU SESSION INACTIVE in the UE, the UE shall include the 5GSM cause #43 "Invalid PDU session identity" in the 5GSM STATUS message, and set the PDU session ID to the received PDU session ID in the UL NAS TRANSPORT message as specified in subclause 5.4.5.

[TS 24.501, clause B.1]

Cause #43 –Invalid PDU session identity

This 5GSM cause is used by the network or the UE to indicate that the PDU session identity value provided to it is not a valid value or the PDU session identified by the PDU session identity IE in the request or the command is not active.

[24.501, clause 7.3.2]

...

The following UE procedures shall apply for handling an unknown, erroneous, or unforeseen PDU session identity received in the header of a 5GSM message:

- a) If the UE receives a 5GSM message which includes an unassigned or reserved PDU session identity value, the UE shall ignore the message.
- b) If the UE receives a 5GSM message which includes a PDU session identity belonging to any PDU session in state PDU SESSION INACTIVE in the UE, the UE shall respond with a 5GSM STATUS message including 5GSM cause #43 "invalid PDU session identity".

10.1.3.2.3 Test description

10.1.3.2.3.1 Pre-test conditions

System Simulator:

- NGC Cell A.

UE:

None.

Preamble:

- The UE is in state 3N-A on NGC Cell A according to TS 38.508-1 [4] with 2 PDU sessions active. The first PDU session is requested to establish by UE without DNN provided. The second PDU session is requested to establish by UE with [S-NSSAI, DNN] combination provided.

10.1.3.2.3.2 Test procedure sequence

Table 10.1.3.2.3.2-1: Main behaviour

St	Procedure	Message Sequence		TP	Verdict
		U – S	Message		
1	Cause the UE to request establishment of PDU session without DNN.(Note 1)	-	-	-	-
2	The PDU session establishment procedure as specified in TS 38.508-1 [4] subclause 4.5A.2 take place.	-	-	-	-
3	The SS transmits a PDU SESSION RELEASE COMMAND including 5GSM cause #26 "insufficient resources" and T3396 value (5 minutes).	<--	5GMM: DL NAS TRANSPORT 5GSM: PDU SESSION RELEASE COMMAND	-	-
4	The UE transmits a PDU SESSION RELEASE COMPLETE message.	-->	5GMM: UL NAS TRANSPORT 5GSM: PDU SESSION RELEASE COMPLETE	-	-
5	Cause the UE to request establishment of PDU session without DNN.(Note 1)	-	-	-	-
6	Check: Does the UE transmit a PDU SESSION ESTABLISHMENT REQUEST message before timer T3396 has expired?	-->	5GMM: UL NAS TRANSPORT 5GSM: PDU SESSION ESTABLISHMENT REQUEST	1	F
7	Cause the UE to request establishment of PDU session without DNN.(Note 1)	-	-	-	-
8	Check: Does the UE transmit a PDU SESSION ESTABLISHMENT REQUEST message?	-->	5GMM: UL NAS TRANSPORT 5GSM: PDU SESSION ESTABLISHMENT REQUEST	1	P
9	The SS transmits a PDU SESSION ESTABLISHMENT ACCEPT message.	<--	5GMM: DL NAS TRANSPORT 5GSM: PDU SESSION ESTABLISHMENT ACCEPT	-	-
10	The SS transmits a PDU SESSION RELEASE COMMAND including 5GSM cause #26 "insufficient resources" and T3396 value (zero).	<--	5GMM: DL NAS TRANSPORT 5GSM: PDU SESSION RELEASE COMMAND	-	-
11	The UE transmits a PDU SESSION RELEASE COMPLETE message.	-->	5GMM: UL NAS TRANSPORT 5GSM: PDU SESSION RELEASE COMPLETE	-	-
12	Cause the UE to request establishment of PDU session without DNN.(Note 1)	-	-	-	-
13	Check: Does the UE transmit a PDU SESSION ESTABLISHMENT REQUEST message?	-->	5GMM: UL NAS TRANSPORT 5GSM: PDU SESSION ESTABLISHMENT REQUEST	2	P
14	The SS transmits a PDU SESSION ESTABLISHMENT ACCEPT message.	<--	5GMM: DL NAS TRANSPORT 5GSM: PDU SESSION ESTABLISHMENT ACCEPT	-	-
15	The SS transmits a PDU SESSION RELEASE COMMAND including 5GSM cause #26 "insufficient resources" and T3396 value (deactivated).	<--	5GMM: DL NAS TRANSPORT 5GSM: PDU SESSION RELEASE COMMAND	-	-
16	The UE transmits a PDU SESSION RELEASE COMPLETE message.	-->	5GMM: UL NAS TRANSPORT 5GSM: PDU SESSION RELEASE COMPLETE	-	-
17	Cause the UE to request establishment of PDU session without DNN.(Note 1)	-	-	-	-
18	Check: Does the UE transmit a PDU SESSION ESTABLISHMENT REQUEST message?	-->	5GMM: UL NAS TRANSPORT 5GSM: PDU SESSION ESTABLISHMENT REQUEST	3	F
19	Switch off UE in RRC CONNECTED as described in TS38.508-1 [4] subclause 4.9.6.3	-	-	-	-
20	Switch on UE.	-	-	-	-
21	The general procedure is completed by executing of the UE registration procedure in TS 38.508-1 [4] table 4.5.2.2-2 , 'connected without release'.	-	-	-	-
22	Cause the UE to request establishment of PDU session without DNN.(Note 1)	-	-	-	-
23	Check: Does the UE transmit a PDU SESSION ESTABLISHMENT REQUEST message?	-->	5GMM: UL NAS TRANSPORT 5GSM: PDU SESSION ESTABLISHMENT REQUEST	3	P

24	The SS transmits a PDU SESSION ESTABLISHMENT ACCEPT message.	<--	5GMM: DL NAS TRANSPORT 5GSM: PDU SESSION ESTABLISHMENT ACCEPT	-	-
25	Cause the UE to request establishment of PDU session with [S-NSSAI, DNN] combination.(Note 1)	-	-	-	-
26	The PDU session establishment procedure as specified in TS 38.508-1 [4] subclause 4.5A.2 take place.	-	-	-	-
27	The SS transmits a PDU SESSION RELEASE COMMAND including 5GSM cause #67 "insufficient resources for specific slice and DNN" and T3584 value (5 minutes).	<--	5GMM: DL NAS TRANSPORT 5GSM: PDU SESSION RELEASE COMMAND	-	-
28	The UE transmits a PDU SESSION RELEASE COMPLETE message.	-->	5GMM: UL NAS TRANSPORT 5GSM: PDU SESSION RELEASE COMPLETE	-	-
29	Cause the UE to request establishment of PDU session with the same [S-NSSAI, DNN] combination as the PDU session established at step 26.(Note 1)	-	-	-	-
30	Check: Does the UE transmit a PDU SESSION ESTABLISHMENT REQUEST before timer T3584 has expired?	-->	5GMM: UL NAS TRANSPORT 5GSM: PDU SESSION ESTABLISHMENT REQUEST	4	F
31	Cause the UE to request establishment of PDU session with the same [S-NSSAI, DNN] combination as the PDU session established at step 26.(Note 1)	-	-	-	-
32	Check: Does the UE transmit a PDU SESSION ESTABLISHMENT REQUEST?	-->	5GMM: UL NAS TRANSPORT 5GSM: PDU SESSION ESTABLISHMENT REQUEST	4	P
33	The SS transmits a PDU SESSION ESTABLISHMENT ACCEPT message.	<--	5GMM: DL NAS TRANSPORT 5GSM: PDU SESSION ESTABLISHMENT ACCEPT	-	-
34	The SS transmits a PDU SESSION RELEASE COMMAND including 5GSM cause #67 "insufficient resources for specific slice and DNN" and T3584 value (zero).	<--	5GMM: DL NAS TRANSPORT 5GSM: PDU SESSION RELEASE COMMAND	-	-
35	The UE transmits a PDU SESSION RELEASE COMPLETE message.	-->	5GMM: UL NAS TRANSPORT 5GSM: PDU SESSION RELEASE COMPLETE	-	-
36	Cause the UE to request establishment of PDU session with the same [S-NSSAI, DNN] combination as the PDU session established at step 26.(Note 1)	-	-	-	-
37	Check: Does the UE transmit a PDU SESSION ESTABLISHMENT REQUEST?	-->	5GMM: UL NAS TRANSPORT 5GSM: PDU SESSION ESTABLISHMENT REQUEST	5	P
38	The SS transmits a PDU SESSION ESTABLISHMENT ACCEPT message.	<--	5GMM: DL NAS TRANSPORT 5GSM: PDU SESSION ESTABLISHMENT ACCEPT	-	-
39	The SS transmits a PDU SESSION RELEASE COMMAND including 5GSM cause #67 "insufficient resources for specific slice and DNN" and T3584 value (deactivated).	<--	5GMM: DL NAS TRANSPORT 5GSM: PDU SESSION RELEASE COMMAND	-	-
40	The UE transmits a PDU SESSION RELEASE COMPLETE message.	-->	5GMM: UL NAS TRANSPORT 5GSM: PDU SESSION RELEASE COMPLETE	-	-
41	Cause the UE to request establishment of PDU session with the same [S-NSSAI, DNN] combination as the PDU session established at step 26.(Note 1)	-	-	-	-
42	Check: Does the UE transmit a PDU SESSION ESTABLISHMENT REQUEST?	-->	5GMM: UL NAS TRANSPORT 5GSM: PDU SESSION ESTABLISHMENT REQUEST	6	F
43	The SS transmits a PDU SESSION RELEASE COMMAND including the PDU session ID UE requested in step 42.	<--	5GMM: DL NAS TRANSPORT 5GSM: PDU SESSION RELEASE COMMAND	-	-

44	Check: Does the UE transmit a 5GSM STATUS message with value #43?	-->	5GSM: UL NAS TRANSPORT 5GSM: 5GSM STATUS	7	P
45	Switch off UE in RRC CONNECTED as described in TS38.508-1 [4] subclause 4.9.6.3	-	-	-	-
46	Switch on UE.	-	-	-	-
47	The general procedure is completed by executing of the UE registration procedure in TS 38.508-1 [4] table 4.5.2.2-2 , 'connected without release'.	-	-	-	-
48	Cause the UE to request establishment of PDU session with the same [S-NSSAI, DNN] combination as the PDU session established at step 26.(Note 1)	-	-	-	-
49	Check: Does the UE transmit a PDU SESSION ESTABLISHMENT REQUEST?	-->	5GMM: UL NAS TRANSPORT 5GSM: PDU SESSION ESTABLISHMENT REQUEST	6	P
50	The SS transmits a PDU SESSION ESTABLISHMENT ACCEPT message.	<--	5GMM: DL NAS TRANSPORT 5GSM: PDU SESSION ESTABLISHMENT ACCEPT	-	-
Note 1: The request to establish a PDU session may be performed by [FFS].					
Note 2: The request to modify a PDU session may be performed by [FFS].					

Table 10.1.3.2.3.2-2: Void

Table 10.1.3.2.3.2-3: Void

10.1.3.2.3.3 Specific message contents

Table 10.1.3.2.3.3-1: UL NAS TRANSPORT (step 2, 8, 13 and 23, Table 10.1.3.2.3.2-1)

Derivation Path: TS 38.508-1 [4] Table 4.7.1-10			
Information Element	Value/remark	Comment	Condition
Payload container type	'0001'B	N1 SM information	
Payload container	PDU SESSION ESTABLISHMENT REQUEST		
DNN	Not present		

Table 10.1.3.2.3.3-2: PDU SESSION RELEASE COMMAND (step 3, Table 10.1.3.2.3.2-1)

Derivation Path: TS 38.508-1 [4] Table 4.7.2-14			
Information Element	Value/remark	Comment	Condition
PDU session ID	The same ID as the ID of PDU session which UE request in step 2 in Table 10.1.3.2.3.2-1		
5GSM cause	'0001 1010'B	insufficient resources	
Back-off timer value	'1010 0101'B	5 minutes	

Table 10.1.3.2.3.3-3: Void

Table 10.1.3.2.3.3-4: PDU SESSION RELEASE COMMAND (step 10, Table 10.1.3.2.3.2-1)

Derivation Path: TS 38.508-1 [4] Table 4.7.2-14			
Information Element	Value/remark	Comment	Condition
PDU session ID	The same ID as the ID of PDU session which UE request in step 8 in Table 10.1.3.2.3.2-1		
5GSM cause	'0001 1010'B	insufficient resources	
Back-off timer value	'1010 0000'B	0 minutes	

Table 10.1.3.2.3.3-5: PDU SESSION RELEASE COMMAND (step 15, Table 10.1.3.2.3.2-1)

Derivation Path: TS 38.508-1 [4] Table 4.7.2-14			
Information Element	Value/remark	Comment	Condition
PDU session ID	The same ID as the ID of PDU session which UE request in step 13 in Table 10.1.3.2.3.2-1		
5GSM cause	'0001 1010'B	insufficient resources	
Back-off timer value	'1110 0000'B	deactivated	

Table 10.1.3.2.3.3-6: UL NAS TRANSPORT (step 26, Table 10.1.3.2.3.2-1)

Derivation Path: TS 38.508-1 [4] Table 4.7.1-10			
Information Element	Value/remark	Comment	Condition
Payload container type	'0001'B	N1 SM information	
Payload container	PDU SESSION ESTABLISHMENT REQUEST		
S-NSSAI	present		
DNN	present		

Table 10.1.3.2.3.3-7: PDU SESSION RELEASE COMMAND (step 27, Table 10.1.3.2.3.2-1)

Derivation Path: TS 38.508-1 [4] Table 4.7.2-14			
Information Element	Value/remark	Comment	Condition
PDU session ID	The same ID as the ID of PDU session which UE request in step 26 in Table 10.1.3.2.3.2-1		
5GSM cause	'0100 0011'B	insufficient resources for specific slice and DNN	
Back-off timer value	'1010 0101'B	5 minutes	

Table 10.1.3.2.3.3-8: UL NAS TRANSPORT (step 32, 37 and 49, Table 10.1.3.2.3.2-1)

Derivation Path: TS 38.508-1 [4] Table 4.7.1-10			
Information Element	Value/remark	Comment	Condition
Payload container type	'0001'B	N1 SM information	
Payload container	PDU SESSION ESTABLISHMENT REQUEST		
S-NSSAI	The same S-NSSAI as the S-NSSAI of the PDU session which UE request at step 26		
DNN	The same DNN as the DNN of the PDU session which UE request at step 26		

Table 10.1.3.2.3.3-9: PDU SESSION RELEASE COMMAND (step 34, Table 10.1.3.2.3.2-1)

Derivation Path: TS 38.508-1 [4] Table 4.7.2-14			
Information Element	Value/remark	Comment	Condition
PDU session ID	The same ID as the ID of PDU session which UE request in step 32 in Table 10.1.3.2.3.2-1		
5GSM cause	'0100 0011'B	insufficient resources for specific slice and DNN	
Back-off timer value	'1010 0000'B	0 minutes	

Table 10.1.3.2.3.3-10: PDU SESSION RELEASE COMMAND (step 39, Table 10.1.3.2.3.2-1)

Derivation Path: TS 38.508-1 [4] Table 4.7.2-14			
Information Element	Value/remark	Comment	Condition
PDU session ID	The same ID as the ID of PDU session which UE request in step 37 in Table 10.1.3.2.3.2-1		
5GSM cause	'0100 0011'B	insufficient resources for specific slice and DNN	
Back-off timer value	'1110 0000'B	deactivated	

Table 10.1.3.2.3.3-11: PDU SESSION RELEASE COMMAND (step 43, Table 10.1.3.2.3.2-1)

Derivation Path: TS 38.508-1 [4] Table 4.7.2-14			
Information Element	Value/remark	Comment	Condition
PDU session ID	The same ID as the ID of PDU session which UE request in step 37 in Table 10.1.3.2.3.2-1		
5GSM cause	'0010 0100'B	#36 regular deactivation	

Table 10.1.3.2.3.3-11A: UL NAS TRANSPORT (step 44, Table 10.1.3.2.3.2-1)

Derivation Path: TS 38.508-1 [4] Table 4.7.1-10			
Information Element	Value/remark	Comment	Condition
PDU session ID	The same ID as the ID of PDU session which UE request in step 37 in Table 10.1.3.2.3.2-1		
Payload container type	'0001'B	N1 SM information	
Payload container	5GSM STATUS		

Table 10.1.3.2.3.3-12: 5GSM STATUS (Table 10.1.3.2.3.3-11)

Derivation Path: TS 38.508-1 [4] Table 4.7.2-16			
Information Element	Value/remark	Comment	Condition
5GSM cause	'0010 1011'B	#43 Invalid PDU session identity	

10.1.4

10.1.5 UE-requested PDU session modification

10.1.5.1 UE-requested PDU session modification

10.1.5.1.1 Test Purpose (TP)

(1)

```
with { UE in PDU SESSION ACTIVE state and in 5GMM-CONNECTED mode }
ensure that {
  when { UE is requested to modify of PDU session }
  then { UE sends a PDU SESSION MODIFICATION REQUEST message }
}
```

10.1.5.1.2 Conformance requirements

References: The conformance requirements covered in the present TC are specified in: TS 24.501, clause 6.4.2.1 and 6.4.2.2. Unless otherwise stated these are Rel-15 requirements.

[TS 24.501, clause 6.4.2.1]

The purpose of the UE-requested PDU session modification procedure is:

- a) to enable the UE to request modification of a PDU session;
- b) to indicate a change of 3GPP PS data off UE status for a PDU session;
- c) to revoke the previously indicated support for reflective QoS;
- d) to request specific QoS handling and segregation of service data flows;
- e) to indicate to the network the relevant 5GSM parameters and capabilities (e.g. the UE's 5GSM capabilities, whether the UE supports more than 16 packet filters, the maximum data rate per UE for user-plane integrity protection supported by the UE for uplink and the maximum data rate per UE for user-plane integrity protection supported by the UE for downlink) for a PDN connection established when in S1 mode, after the first inter-system change from S1 mode to N1 mode, if the UE is operating in single-registration mode in the network supporting N26 interface; or
- f) to delete one or more mapped EPS bearer contexts.

NOTE: The UE does not request a PDU session modification for an LADN when the UE is located outside the LADN service area.

[TS 24.501, clause 6.4.2.2]

In order to initiate the UE-requested PDU session modification procedure, the UE shall create a PDU SESSION MODIFICATION REQUEST message.

The UE shall allocate a PTI value currently not used and shall set the PTI IE of the PDU SESSION MODIFICATION REQUEST message to the allocated PTI value.

The UE shall not perform the UE-requested PDU session modification procedure for an emergency PDU session.

The UE shall not perform the UE-requested PDU session modification procedure for a PDU session for LADN when the UE is located outside the LADN service area.

If the UE requests a specific QoS handling, the UE shall include the requested QoS rules IE indicating requested QoS rules and the requested QoS flow descriptions IE indicating requested QoS flow descriptions for the specific QoS handling. The QoS rules IE includes the packet filters which describe the service data flows requested by the UE. The specific QoS parameters requested by the UE is specified in the QoS flow descriptions IE. If the UE requests the network to bind specific service data flows to a dedicated QoS flow, the UE shall create a new QoS rule by setting the rule operation code to "Create new QoS rule" and shall set the segregation bit to "Segregation requested" for the corresponding QoS rule in the QoS rules IE. The UE shall set the QRI values to "no QoS rule identifier assigned" in the requested QoS rules IE, if the QoS rules are newly created; otherwise, the UE shall set the QRI values to those of the existing QoS rules for which the specific QoS handling applies. The UE shall set the QFI values to "no QoS flow identifier assigned" in the requested QoS flow descriptions IE, if the QoS flow descriptions are newly created; otherwise, the UE shall set the QFI values to the QFIs of the existing QoS flow descriptions for which the specific QoS handling applies.

...

If the UE is performing the PDU session modification procedure to request the deletion of a non-default QoS rule due to errors in QoS operations or packet filters, the UE shall include the 5GSM cause IE in the PDU SESSION MODIFICATION REQUEST message as described in subclause 6.4.1.3.

Even if the timer T3396, T3584, or T3585 is running or is deactivated, the UE shall indicate a change of 3GPP PS data off UE status associated to a PDU session, by including the extended protocol configuration options IE in the PDU SESSION MODIFICATION REQUEST message and setting the 3GPP PS data off UE status.

For a PDN connection established when in S1 mode, after the first inter-system change from S1 mode to N1 mode, if the UE is operating in single-registration mode in the network supporting N26 interface and the UE requests the PDU session to be an always-on PDU session in the 5GS, the UE shall include the Always-on PDU session requested IE and set the value of the IE to "Always-on PDU session requested" in the PDU SESSION MODIFICATION REQUEST message.

The UE shall transport the PDU SESSION MODIFICATION REQUEST message, the PDU session ID, and the request type set to "modification request", using the NAS transport procedure as specified in subclause 5.4.5, and the UE shall start timer T3581 (see example in figure 6.4.2.2.1).

10.1.5.1.3 Test description

10.1.5.1.3.1 Pre-test conditions

System Simulator:

- NGC Cell A.

UE:

- None.

Preamble:

- The UE is in state 3N-A on NGC Cell A with PDU SESSION ACTIVE according to TS 38.508-1[4].

10.1.5.1.3.2 Test procedure sequence

Table 10.1.5.1.3.2-1: Main behaviour

St	Procedure	Message Sequence		TP	Verdict
		U - S	Message		
1	Cause the UE to pdu session modification with the previously established PDN session at preamble. (see Note)	-	-	-	-
2	Check: Does the UE transmit a PDU SESSION MODIFICATION REQUEST message?	-->	PDU SESSION MODIFICATION REQUEST	1	P
3	The SS transmits an PDU SESSION MODIFICATION COMMAND message.	<--	PDU SESSION MODIFICATION COMMAND	-	-
4	the UE transmit an PDU SESSION MODIFICATION COMPLETE message.	-->	PDU SESSION MODIFICATION COMPLETE	-	-
Note: The request of pdu session modification may be performed by MMI or AT command.					

10.1.5.1.3.3 Specific message contents

Table 10.1.5.1.3.3-1: PDU SESSION MODIFICATION COMMAND (step 3, Table 10.1.5.1.3.2-1)

Derivation Path: 36.508, Table 4.7.2-9			
Information Element	Value/remark	Comment	Condition
PDU session ID	The value indicated in PDU SESSION MODIFICATION REQUEST		
PTI	The value indicated in PDU SESSION MODIFICATION REQUEST		
Authorized QoS rules	According to QoS rule #2 except for Rule operation code set to '100'B - see TS 38.508-1[4]		

10.1.6 UE-requested PDU session release

10.1.6.1 UE-requested PDU session release / Abnormal / Collision with network-requested PDU session modification procedure

10.1.6.1.1 Test Purpose (TP)

(1)

```

with { the UE is in PDU SESSION ACTIVE state and has sent a PDU SESSION RELEASE REQUEST message }
ensure that {
  when { UE receives a PDU SESSION MODIFICATION COMMAND message indicating a PDU session that UE
wants to release }
  then { the UE ignores the PDU SESSION MODIFICATION COMMAND message and proceed with the PDU
session release procedure }
}

```

10.1.6.1.2 Conformance requirements

References: The conformance requirements covered in the current TC are specified in: TS 24.501, clause 6.4.3.2, 6.4.3.3 and 6.4.3.5. Unless otherwise stated these are Rel-15 requirements.

[TS 24.501, clause 6.4.3.2]

In order to initiate the UE-requested PDU session release procedure, the UE shall create a PDU SESSION RELEASE REQUEST message.

The UE may set the 5GSM cause IE of the PDU SESSION RELEASE REQUEST message to indicate the reason for releasing the PDU session.

The 5GSM cause IE typically indicates one of the following 5GSM cause values:

- #36 regular deactivation;
- #41 Semantic error in the TFT operation;
- #42 Syntactical error in the TFT operation;
- #44 Semantic errors in packet filter(s);
- #45 Syntactical error in packet filter(s).

The UE shall allocate a PTI value currently not used and shall set the PTI IE of the PDU SESSION RELEASE REQUEST message to the allocated PTI value.

The UE shall transport the PDU SESSION RELEASE REQUEST message and the PDU session ID, using the NAS transport procedure as specified in subclause 5.4.5, and the UE shall start timer T3582 (see example in figure 6.4.3.2.1).

[TS 24.501, clause 6.4.3.3]

Upon receipt of a PDU SESSION RELEASE REQUEST message and a PDU session ID, if the SMF accepts the request to release the PDU session, and shall perform the network-requested PDU session release procedure as specified in subclause 6.3.3.

[TS 24.501, clause 6.4.3.5]

The following abnormal cases can be identified:

- b) Collision of UE-requested PDU session release procedure and network-requested PDU session modification procedure.

When the UE receives a PDU SESSION MODIFICATION COMMAND message during the UE-requested PDU session release procedure, and the PDU session indicated in PDU SESSION MODIFICATION COMMAND message is the PDU session that the UE wants to release, the UE shall ignore the PDU SESSION MODIFICATION COMMAND message and proceed with the PDU session release procedure.

10.1.6.1.3 Test description

10.1.6.1.3.1 Pre-test conditions

System Simulator:

- NGC Cell A.

UE:

None.

Preamble:

The UE is in state 3N-A on NGC Cell A according to TS 38.508-1 [4].

10.1.6.1.3.2 Test procedure sequence

Table 10.1.6.1.3.2-1: Main behaviour

St	Procedure	Message Sequence		TP	Verdict
		U - S	Message		
1	Cause the UE to request establishment of PDU session to the DN.(Note 1)	-	-	-	-
2	The PDU session establishment procedure as specified in TS 38.508-1 [4] subclause 4.5A.2 take place.	-	-	-	-
3	Cause the UE to request release of PDU session established during step 2.(Note 2)	-	-	-	-
4	The UE transmits a PDU SESSION RELEASE REQUEST message.	-->	PDU SESSION RELEASE REQUEST	-	-
5	The SS transmits a PDU SESSION MODIFICATION COMMAND message.	<--	PDU SESSION MODIFICATION COMMAND	-	-
6	Check: Does the UE transmit a PDU SESSION MODIFICATION COMPLETE or PDU SESSION MODIFICATION REJECT message?	-	-	1	F
7	The SS transmits a PDU SESSION RELEASE COMMAND message.	<--	PDU SESSION RELEASE COMMAND	-	-
8	Check: Does the UE transmit PDU SESSION RELEASE COMPLETE message?	-->	PDU SESSION RELEASE COMPLETE	1	P

Note 1: The request to establish a PDU session may be performed by MMI or AT command.
Note 2: The request to release a PDU session may be performed by MMI.

10.1.6.1.3.3 Specific message contents

Table 10.1.6.1.3.3-1: PDU SESSION RELEASE REQUEST (step 4, Table 10.1.6.1.3.2-1)

Derivation Path: TS 38.508-1 [4] Table 4.7.2-12			
Information Element	Value/remark	Comment	Condition
PDU session ID	Set to the ID UE requested in step 2 in Table 10.1.6.1.3.2-1		
PTI	Any value from 1 to 254		

Table 10.1.6.1.3.3-2: PDU SESSION MODIFICATION COMMAND (step 5, Table 10.1.6.1.3.2-1)

Derivation Path: TS 38.508-1 [4] Table 4.7.2-9			
Information Element	Value/remark	Comment	Condition
PDU session ID	Set to the ID UE requested in step 2 in Table 10.1.6.1.3.2-1		
PTI	'0000 0000'B	No procedure transaction identity assigned	

Table 10.1.6.1.3.3-3: PDU SESSION RELEASE COMMAND (step 7, Table 10.1.6.1.3.2-1)

Derivation Path: TS 38.508-1 [4] Table 4.7.2-14			
Information Element	Value/remark	Comment	Condition
PDU session ID	Same ID as the ID UE requested in step 2 in Table 10.1.6.1.3.2-1		
PTI	The value indicated in PDU SESSION RELEASE REQUEST		
5GSM cause	'0010 0100'B	#36 regular deactivation	

Table 10.1.6.1.3.3-4: PDU SESSION RELEASE COMPLETE (step 8, Table 10.1.6.1.3.2-1)

Derivation Path: TS 38.508-1 [4] Table 4.7.2-15			
Information Element	Value/remark	Comment	Condition
PDU session ID	Same ID as the ID UE requested in step 2 in Table 10.1.6.1.3.2-1		
PTI	The value indicated in PDU SESSION RELEASE REQUEST		

10.1.6.2 UE-requested PDU session release / Abnormal / Collision with network-requested PDU session release procedure

10.1.6.2.1 Test Purpose (TP)

(1)

```

with { the UE is in PDU SESSION ACTIVE state and transported the PDU SESSION RELEASE REQUEST message
}
ensure that {
  when { UE receives a PDU SESSION RELEASE COMMAND message with the PTI IE set to "No procedure
transaction identity assigned" indicating a PDU session that UE wants to release }
  then { the UE aborts the UE-requested PDU session release procedure and proceeds with the
network-requested PDU session release procedure }
}

```

10.1.6.2.2 Conformance requirements

References: The conformance requirements covered in the current TC are specified in: TS 24.501, clause 6.4.3.2, 6.4.3.3 and 6.4.3.5. Unless otherwise stated these are Rel-15 requirements.

[TS 24.501, clause 6.4.3.2]

In order to initiate the UE-requested PDU session release procedure, the UE shall create a PDU SESSION RELEASE REQUEST message.

The UE may set the 5GSM cause IE of the PDU SESSION RELEASE REQUEST message to indicate the reason for releasing the PDU session.

The 5GSM cause IE typically indicates one of the following 5GSM cause values:

- #36 regular deactivation;
- #41 Semantic error in the TFT operation;
- #42 Syntactical error in the TFT operation;
- #44 Semantic errors in packet filter(s);

#45 Syntactical error in packet filter(s).

The UE shall allocate a PTI value currently not used and shall set the PTI IE of the PDU SESSION RELEASE REQUEST message to the allocated PTI value.

The UE shall transport the PDU SESSION RELEASE REQUEST message and the PDU session ID, using the NAS transport procedure as specified in subclause 5.4.5, and the UE shall start timer T3582 (see example in figure 6.4.3.2.1).

[TS 24.501, clause 6.4.3.3]

Upon receipt of a PDU SESSION RELEASE REQUEST message and a PDU session ID, if the SMF accepts the request to release the PDU session, and shall perform the network-requested PDU session release procedure as specified in subclause 6.3.3.

[TS 24.501, clause 6.4.3.5]

The following abnormal cases can be identified:

...

- c) Collision of UE-requested PDU session release procedure and network-requested PDU session release procedure.

When the UE receives a PDU SESSION RELEASE COMMAND message with the PTI IE set to "No procedure transaction identity assigned" during the UE-requested PDU session release procedure, and the PDU session indicated in the PDU SESSION RELEASE COMMAND message is the same as the PDU session that the UE requests to release, the UE shall abort the UE-requested PDU session release procedure and proceed with the network-requested PDU session release procedure.

10.1.6.2.3 Test description

10.1.6.2.3.1 Pre-test conditions

System Simulator:

- NGC Cell A.

UE:

None.

Preamble:

- The UE is in state 3N-A on NGC Cell A according to TS 38.508-1 [4].

10.1.6.2.3.2 Test procedure sequence

Table 10.1.6.2.3.2-1: Main behaviour

St	Procedure	Message Sequence		TP	Verdict
		U - S	Message		
1	Cause the UE to request establishment of PDU session to the DN.(Note 1)	-	-	-	-
2	The PDU session establishment procedure as specified in TS 38.508-1 [4] subclause 4.5A.2 take place.	-	-	-	-
3	Cause the UE to request release of PDU session established during step 2.(Note 2)	-	-	-	-
4	The UE transmits a PDU SESSION RELEASE REQUEST message.	-->	PDU SESSION RELEASE REQUEST	-	-
5	The SS transmits a PDU SESSION RELEASE COMMAND message.	<--	PDU SESSION RELEASE COMMAND	-	-
6	Check: Does the UE transmit PDU SESSION RELEASE COMPLETE message?	-->	PDU SESSION RELEASE COMPLETE	1	P

Note 1: The request to establish a PDU session may be performed by MMI or AT command.
Note 2: The request to release a PDU session may be performed by MMI.

10.1.6.2.3.3 Specific message contents

Table 10.1.6.2.3.3-1: PDU SESSION RELEASE REQUEST (step 4, Table 10.1.6.2.3.2-1)

Derivation Path: TS 38.508-1 [4] Table 4.7.2-12			
Information Element	Value/remark	Comment	Condition
PDU session ID	Set to the ID UE requested in step 2 in Table 10.1.6.2.3.2-1		
PTI	Any value from 1 to 254		

Table 10.1.6.2.3.3-2: PDU SESSION RELEASE COMMAND (step 5, Table 10.1.6.2.3.2-1)

Derivation Path: TS 38.508-1 [4] Table 4.7.2-14			
Information Element	Value/remark	Comment	Condition
PDU session ID	Set to the ID UE requested in step 2 in Table 10.1.6.2.3.2-1		
PTI	'0000 0000'B	No procedure transaction identity assigned	
5GSM cause	'0010 0100'B	#36 regular deactivation	

Table 10.1.6.2.3.3-3: PDU SESSION RELEASE COMPLETE (step 6, Table 10.1.6.2.3.2-1)

Derivation Path: TS 38.508-1 [4] Table 4.7.2-15			
Information Element	Value/remark	Comment	Condition
PDU session ID	Set to the ID UE requested in step 2 in Table 10.1.6.2.3.2-1		
PTI	'0000 0000'B	unassigned	

10.2 EN-DC session management

10.2.1 Network initiated procedures

10.2.1.1 Default EPS bearer context activation

10.2.1.1.1 Test Purpose (TP)

(1)

```
with { UE has sent a PDN CONNECTIVITY REQUEST message }
ensure that {
  when { UE receives an RRCConnectionReconfiguration message including an ACTIVATE DEFAULT EPS
  BEARER CONTEXT REQUEST message with IE Procedure transaction identity matching the PDN CONNECTIVITY
  REQUEST message and including the Extended APN-AMBR IE }
  then { UE transmits an ACTIVATE DEFAULT EPS BEARER CONTEXT ACCEPT message and enters BEARER
  CONTEXT ACTIVE state }
}
```

10.2.1.1.2 Conformance requirements

References: The conformance requirements covered in the present TC are specified in: TS 24.301, clause 6.4.1.3, 8.3.6.17 and 9.9.4.29. Unless otherwise stated these are Rel-15 requirements.

[TS 24.301, clause 6.4.1.3]

Upon receipt of the ACTIVATE DEFAULT EPS BEARER CONTEXT REQUEST message, if the UE provided an APN for the establishment of the PDN connection, the UE shall stop timer T3396 if it is running for the APN provided by the UE. If the UE did not provide an APN for the establishment of the PDN connection and the request type was different from "emergency" and from "handover of emergency bearer services", the UE shall stop the timer T3396 associated with no APN if it is running. If the ACTIVATE DEFAULT EPS BEARER CONTEXT REQUEST message was received in response to a request for an emergency PDN connection, the UE shall not stop the timer T3396 associated with no APN if it is running. For any case, the UE shall then send an ACTIVATE DEFAULT EPS BEARER CONTEXT ACCEPT message and enter the state BEARER CONTEXT ACTIVE. When the default bearer is activated as part of the attach procedure, the UE shall send the ACTIVATE DEFAULT EPS BEARER CONTEXT ACCEPT message together with ATTACH COMPLETE message. When the default bearer is activated as the response to the stand-alone PDN CONNECTIVITY REQUEST message, the UE shall send the ACTIVATE DEFAULT EPS BEARER CONTEXT ACCEPT message alone.

If a WLAN offload indication information element is included in the ACTIVATE DEFAULT EPS BEARER CONTEXT REQUEST message, the UE shall store the WLAN offload acceptability values for this PDN connection and use the E-UTRAN offload acceptability value to determine whether this PDN connection is offloadable to WLAN or not.

The UE checks the PTI in the ACTIVATE DEFAULT EPS BEARER CONTEXT REQUEST message to identify the UE requested PDN connectivity procedure to which the default bearer context activation is related (see subclause 6.5.1).

If the UE receives a serving PLMN rate control IE in the ACTIVATE DEFAULT EPS BEARER CONTEXT REQUEST message, the UE shall store the serving PLMN rate control IE value and use the stored serving PLMN rate control value as the maximum allowed limit of uplink User data container IEs included in ESM DATA TRANSPORT messages for the corresponding PDN connection in accordance with 3GPP TS 23.401 [10].

If the UE receives an APN rate control parameters container in the protocol configuration options IE or extended protocol configuration options IE in the ACTIVATE DEFAULT EPS BEARER CONTEXT REQUEST message, the UE shall store the APN rate control parameters value and use the stored APN rate control parameters value as the maximum allowed limit of uplink user data related to the APN indicated in the ACTIVATE DEFAULT EPS BEARER CONTEXT REQUEST message in accordance with 3GPP TS 23.401 [10]. If the UE has a previously stored APN rate control parameters value for this APN, the UE shall replace the stored APN rate control parameters value for this APN with the received APN rate control parameters value.

If the UE receives an additional APN rate control parameters for exception data container in the protocol configuration options IE or extended protocol configuration options IE in the ACTIVATE DEFAULT EPS BEARER CONTEXT REQUEST message, the UE shall store the additional APN rate control parameters for exception data value and use the

stored additional APN rate control parameters for exception data value as the maximum allowed limit of uplink exception data related to the APN indicated in the ACTIVATE DEFAULT EPS BEARER CONTEXT REQUEST message in accordance with 3GPP TS 23.401 [10]. If the UE has a previously stored additional APN rate control parameters for exception data value for this APN, the UE shall replace the stored additional APN rate control parameters for exception data value for this APN with the received additional APN rate control parameters for exception data value.

If the UE receives non-IP Link MTU parameter or IPv4 Link MTU parameter of the protocol configuration options IE in the ACTIVATE DEFAULT EPS BEARER CONTEXT REQUEST message, the UE shall pass the received Non-IP Link MTU or IPv4 Link MTU to the upper layer.

NOTE: The Non-IP Link MTU and the IPv4 Link MTU size correspond to the maximum length of user data that can be sent either in the user data container in the ESM DATA TRANSPORT message or via S1-U interface.

If the UE receives a session-AMBR and QoS rule(s), which correspond to the default EPS bearer of the PDN connectivity being activated, in the protocol configuration options IE or the extended protocol configuration options IE in the ACTIVATE DEFAULT EPS BEARER CONTEXT REQUEST message, the UE stores the session-AMBR and QoS rule(s) for use during inter-system change from S1 mode to N1 mode.

Upon receipt of the ACTIVATE DEFAULT EPS BEARER CONTEXT ACCEPT message, the MME shall enter the state BEARER CONTEXT ACTIVE and stop the timer T3485, if the timer is running. If the PDN CONNECTIVITY REQUEST message included a low priority indicator set to "MS is configured for NAS signalling low priority", the MME shall store the NAS signalling low priority indication within the default EPS bearer context.

[TS 24.301, clause 8.3.6.17]

This IE shall be included in the message only if the network wishes to transmit the APN-AMBR values to the UE for possible uplink policy enforcement and at least one of the values to be transmitted exceeds the maximum value specified in the APN aggregate maximum bit rate information element in subclause 9.9.4.2.

[TS 24.301, clause 9.9.4.29]

The purpose of the extended APN aggregate maximum bit rate information element is to indicate the initial subscribed APN-AMBR with a value higher than 65280 Mbps when the UE establishes a PDN connection or to indicate the new APN-AMBR with a value higher than 65280 Mbps if it is changed by the network.

The receiving entity shall ignore the bit rate values which are included in the extended APN aggregate maximum bit rate information element and not higher than 65280 Mbps.

The extended APN aggregate maximum bit rate information element is coded as shown in figure 9.9.4.29.1 and table 9.9.4.29.1.

The extended APN aggregate maximum bit rate is a type 4 information element with a length of 8 octets.

8	7	6	5	4	3	2	1	
Extended APN aggregate maximum bit rate IEI								octet 1
Length of extended APN aggregate maximum bit rate contents								octet 2
Unit for extended APN-AMBR for downlink								octet 3
Extended APN-AMBR for downlink								octet 4
Extended APN-AMBR for downlink (continued)								octet 5
Unit for extended APN-AMBR for uplink								octet 6
Extended APN-AMBR for uplink								octet 7
Extended APN-AMBR for uplink (continued)								octet 8

Figure 9.9.4.29.1: Extended APN aggregate maximum bit rate information element

Table 9.9.4.29.1: Extended APN aggregate maximum bit rate information element

Unit for extended APN-AMBR for downlink (octet 3)	
0 0 0 0 0 0 0 0	value is not used
0 0 0 0 0 0 0 1	value is not used
0 0 0 0 0 0 1 0	value is not used
0 0 0 0 0 0 1 1	value is incremented in multiples of 4 Mbps
0 0 0 0 0 1 0 0	value is incremented in multiples of 16 Mbps
0 0 0 0 0 1 0 1	value is incremented in multiples of 64 Mbps
0 0 0 0 0 1 1 0	value is incremented in multiples of 256 Mbps
0 0 0 0 0 1 1 1	value is incremented in multiples of 1 Gbps
0 0 0 0 1 0 0 0	value is incremented in multiples of 4 Gbps
0 0 0 0 1 0 0 1	value is incremented in multiples of 16 Gbps
0 0 0 0 1 0 1 0	value is incremented in multiples of 64 Gbps
0 0 0 0 1 0 1 1	value is incremented in multiples of 256 Gbps
0 0 0 0 1 1 0 0	value is incremented in multiples of 1 Tbps
0 0 0 0 1 1 0 1	value is incremented in multiples of 4 Tbps
0 0 0 0 1 1 1 0	value is incremented in multiples of 16 Tbps
0 0 0 0 1 1 1 1	value is incremented in multiples of 64 Tbps
0 0 0 1 0 0 0 0	value is incremented in multiples of 256 Tbps
0 0 0 1 0 0 0 1	value is incremented in multiples of 1 Pbps
0 0 0 1 0 0 1 0	value is incremented in multiples of 4 Pbps
0 0 0 1 0 0 1 1	value is incremented in multiples of 16 Pbps
0 0 0 1 0 1 0 0	value is incremented in multiples of 64 Pbps
0 0 0 1 0 1 0 1	value is incremented in multiples of 256 Pbps
Other values shall be interpreted as multiples of 256 Pbps in this version of the protocol.	
Extended APN-AMBR for downlink (octets 4 and 5)	
Octets 4 and 5 represent the binary coded value of extended APN-AMBR for downlink in units defined by octet 3	
Unit for extended APN-AMBR for uplink (octet 6)	
The coding is identical to that of the unit for extended APN-AMBR for downlink (octet 3)	
Extended APN-AMBR for uplink (octets 7 and 8)	
Octets 7 and 8 represent the binary coded value of extended APN-AMBR for uplink in units defined by octet 6.	

10.2.1.1.3 Test description

10.2.1.1.3.1 Pre-test conditions

System Simulator:

- E-UTRA Cell 1 is the PCell and NR Cell 1 is the PSCell.

UE:

None.

Preamble:

- The UE is in RRC_IDLE state on E-UTRA Cell 1 using generic procedure parameter Connectivity (*EN-DC*) and Bearers (*MCG only*) established according to TS 38.508-1 [4].

10.2.1.1.3.2 Test procedure sequence

Table 10.2.1.1.3.2-1: Main behaviour

St	Procedure	Message Sequence		TP	Verdict
		U - S	Message		
1	Cause the UE to request connectivity to an additional PDN (see Note 1)	-	-	-	-
2	UE transmit an <i>RRCCONNECTIONREQUEST</i> message with <i>establishmentCause</i> set to 'mo-Data' followed by a SERVICE REQUEST message.	-->	SERVICE REQUEST	-	-
3	The SS establishes SRB2 and DRB associated with default EPS bearer context (a first PDN obtained during the attach procedure).	-	-	-	-
4	The UE transmit a PDN CONNECTIVITY REQUEST message as specified to request an additional PDN.	-->	PDN CONNECTIVITY REQUEST	-	-
5	The SS transmits an <i>RRCCONNECTIONRECONFIGURATION</i> message containing NR <i>RRCRECONFIGURATION</i> message to add NR <i>PSCell</i> with SCG DRB. The <i>RRCCONNECTIONRECONFIGURATION</i> message contains ACTIVATE DEFAULT EPS BEARER CONTEXT REQUEST message containing Extended APN-AMBR IE.	<--	RRC: <i>RRCCONNECTIONRECONFIGURATION</i> ((<i>RRCRECONFIGURATION</i>) NAS: ACTIVATE DEFAULT EPS BEARER CONTEXT REQUEST	-	-
6	The UE transmits an <i>RRCCONNECTIONRECONFIGURATIONCOMPLETE</i> message to confirm the establishment of default bearer.	-->	RRC: <i>RRCCONNECTIONRECONFIGURATIONCOMPLETE</i> (<i>RRCRECONFIGURATIONCOMPLETE</i>)	-	-
-	EXCEPTION: In parallel to the event described in step 7 below, if initiated by the UE the generic procedure for IP address allocation in the U-plane specified in TS 36.508 subclause 4.5A.1 takes place performing IP address allocation in the U-plane.	-	-	-	-
7	The UE transmits ACTIVATE DEFAULT EPS BEARER CONTEXT ACCEPT message.	-->	RRC: <i>ULINFORMATIONTRANSFER</i> NAS: ACTIVATE DEFAULT EPS BEARER CONTEXT ACCEPT	1	P

Note 1: The request of connectivity to an additional PDN may be performed by MMI or AT command.

10.2.1.1.3.3 Specific message contents

Table 10.2.1.1.3.3-1: PDN CONNECTIVITY REQUEST (step 4, Table 10.2.1.1.3.2-1)

Derivation Path: 36.508 [7], Table 4.7.3-20			
Information Element	Value/remark	Comment	Condition
Protocol discriminator	ESM		
EPS bearer identity	'0000'B	No EPS bearer identity assigned	
Procedure transaction identity	PTI-1	UE assigns a particular PTI not yet used between 1 and 254	
Access point name	APN-1(New PDN name)	The requested PDN is different from default PDN	

Table 10.2.1.1.3.3-2: ACTIVATE DEFAULT EPS BEARER CONTEXT REQUEST (step 5, Table 10.2.1.1.3.2-1)

Derivation Path: TS 36.508 [7], Table 4.7.3-6			
Information Element	Value/remark	Comment	Condition
Protocol discriminator	ESM		
EPS bearer identity	'0110'B		
Procedure transaction identity	PTI-1	SS re-uses the particular PTI defined by UE for this present additional PDN connectivity request procedure.	
EPS QoS			
QCI	8		
Maximum bit rate for uplink	384 kbps		
Maximum bit rate for downlink	'11111110'B (8640 kbps)		
Guaranteed bit rate for uplink	128 kbps		
Guaranteed bit rate for downlink	128 kbps		
Maximum bit rate for uplink (extended)	0		
Maximum bit rate for downlink (extended)	'11111010'B (256 Mbps)		
Guaranteed bit rate for uplink (extended)	0		
Guaranteed bit rate for downlink (extended)	0		
Maximum bit rate for uplink (extended-2)	0		
Maximum bit rate for downlink (extended-2)	'11110110'B (10 Gbps)		
Guaranteed bit rate for uplink (extended-2)	0		
Guaranteed bit rate for downlink (extended-2)	0		
APN-AMBR			
APN-AMBR for downlink	'11111110'B (8640 kbps)		
APN-AMBR for uplink	'11111110'B (8640 kbps)		
APN-AMBR for downlink (extended)	'11111010' B(256 Mbps)		
APN-AMBR for uplink (extended)	'11111010' B(256 Mbps)		
APN-AMBR for downlink (extended-2)	'11111110'B (65280 Mbps)		
APN-AMBR for uplink (extended-2)	0		
Access point name	APN-1	SS re-uses the particular APN defined by UE for this present additional PDN connectivity request procedure	
Extended APN-AMBR			
Unit for extended APN-AMBR for downlink	'00000111'B (value is incremented in multiples of 1 Gbps)		
Extended APN-AMBR for downlink	'0000000010000000' (128 Gbps)		
Unit for extended APN-AMBR for uplink	0		
Extended APN-AMBR for uplink	0		

10.2.1.2 Dedicated EPS bearer context activation

10.2.1.2.1 Test Purpose (TP)

(1)

```

with { UE in EMM-REGISTERED state }
ensure that {
  when { UE receives an ACTIVATE DEDICATED EPS BEARER CONTEXT REQUEST message, including the
Extended EPS QoS IE, linked to the existing default EPS bearer }
  then { UE transmits an ACTIVATE DEDICATED EPS BEARER CONTEXT ACCEPT }
}

```

(2)

```
with { the UE in BEARER CONTEXT ACTIVE STATE and in EMM-CONNECTED mode }
ensure that {
  when { the UE receives a MODIFY EPS BEARER CONTEXT REQUEST message including the Extended EPS QoS
and Extended APN-AMBR IEs }
  then { UE transmits a MODIFY EPS BEARER CONTEXT ACCEPT }
}
```

10.2.1.2.2 Conformance requirements

References: The conformance requirements covered in the present TC are specified in: TS 24.301, clauses 6.4.2.3, 6.4.3.1, 6.4.3.2, 6.4.3.3, 8.3.3.11, 9.9.4.29 and 9.9.4.30. Unless otherwise stated these are Rel-15 requirements.

[TS 24.301, clause 6.4.2.3]

Upon receipt of the ACTIVATE DEDICATED EPS BEARER CONTEXT REQUEST message, if the UE provided an APN for the establishment of the PDN connection, the UE shall stop timer T3396, if it is running for the APN provided by the UE. If the UE did not provide an APN for the establishment of the PDN connection and the request type was different from "emergency" and from "handover of emergency bearer services", the UE shall stop the timer T3396 associated with no APN if it is running. If the ACTIVATE DEDICATED EPS BEARER CONTEXT REQUEST message was received for an emergency PDN connection, the UE shall not stop the timer T3396 associated with no APN if it is running. For any case, the UE shall then check the received TFT before taking it into use, send an ACTIVATE DEDICATED EPS BEARER CONTEXT ACCEPT message and enter the state BEARER CONTEXT ACTIVE. The ACTIVATE DEDICATED EPS BEARER CONTEXT ACCEPT message shall include the EPS bearer identity.

The linked EPS bearer identity included in the ACTIVATE DEDICATED EPS BEARER CONTEXT REQUEST message indicates to the UE to which default bearer, IP address and PDN the dedicated bearer is linked.

If the ACTIVATE DEDICATED EPS BEARER CONTEXT REQUEST message contains a PTI value other than "no procedure transaction identity assigned" and "reserved" (see 3GPP TS 24.007 [12]), the UE uses the PTI to identify the UE requested bearer resource allocation procedure or the UE requested bearer resource modification procedure to which the dedicated bearer context activation is related.

[TS 24.301, clause 6.4.3.1]

The purpose of the EPS bearer context modification procedure is to modify an EPS bearer context with a specific QoS and TFT, or re-negotiate header compression configuration associated to an EPS bearer context. The EPS bearer context modification procedure is initiated by the network, but it may also be initiated as part of the UE requested bearer resource allocation procedure or the UE requested bearer resource modification procedure.

The network may also initiate the EPS bearer context modification procedure to update the APN-AMBR of the UE, for instance after an inter-system handover. See 3GPP TS 23.401 [10] annex E.

[TS 24.301, clause 6.4.3.2]

The MME shall initiate the EPS bearer context modification procedure by sending a MODIFY EPS BEARER CONTEXT REQUEST message to the UE, starting the timer T3486, and entering the state BEARER CONTEXT MODIFY PENDING (see example in figure 6.4.3.2.1).

The MME shall include an EPS bearer identity that identifies the EPS bearer context to be modified in the MODIFY EPS BEARER CONTEXT REQUEST message.

[TS 24.301, clause 6.4.3.3]

Upon receipt of the MODIFY EPS BEARER CONTEXT REQUEST message, if the UE provided an APN for the establishment of the PDN connection, the UE shall stop timer T3396, if it is running for the APN provided by the UE. If the UE did not provide an APN for the establishment of the PDN connection and the request type was different from "emergency" and from "handover of emergency bearer services", the UE shall stop the timer T3396 associated with no APN if it is running. If the MODIFY EPS BEARER CONTEXT REQUEST message was received for an emergency PDN connection, the UE shall not stop the timer T3396 associated with no APN if it is running. For any case, the UE shall then check the received TFT before taking it into use and send a MODIFY EPS BEARER CONTEXT ACCEPT message to the MME.

If the MODIFY EPS BEARER CONTEXT REQUEST message contains a PTI value other than "no procedure transaction identity assigned" and "reserved" (see 3GPP TS 24.007 [12]), the UE uses the PTI to identify the UE requested bearer resource allocation procedure or the UE requested bearer resource modification procedure to which the EPS bearer context modification is related (see subclause 6.5.3 and subclause 6.5.4).

If the MODIFY EPS BEARER CONTEXT REQUEST message contains a PTI value other than "no procedure transaction identity assigned" and "reserved" (see 3GPP TS 24.007 [12]) and the PTI is associated to a UE requested bearer resource allocation procedure or a UE requested bearer resource modification procedure, the UE shall release the traffic flow aggregate description associated to the PTI value provided.

...

Upon receipt of the MODIFY EPS BEARER CONTEXT ACCEPT message, the MME shall stop the timer T3486 and enter the state BEARER CONTEXT ACTIVE.

[TS 24.301, clause 8.3.3.11]

This IE shall be included in the message only if the network wishes to transmit the maximum and guaranteed bit rate values to the UE and at least one of the values to be transmitted exceeds the maximum value specified in the EPS quality of service information element in subclause 9.9.4.3

[TS 24.301, clause 9.9.4.29]

The purpose of the extended APN aggregate maximum bit rate information element is to indicate the initial subscribed APN-AMBR with a value higher than 65280 Mbps when the UE establishes a PDN connection or to indicate the new APN-AMBR with a value higher than 65280 Mbps if it is changed by the network.

The receiving entity shall ignore the bit rate values which are included in the extended APN aggregate maximum bit rate information element and not higher than 65280 Mbps.

The extended APN aggregate maximum bit rate information element is coded as shown in figure 9.9.4.29.1 and table 9.9.4.29.1.

The extended APN aggregate maximum bit rate is a type 4 information element with a length of 8 octets

[TS 24.301, clause 9.9.4.30]

The purpose of the Extended EPS quality of service information element is to indicate for an EPS bearer context the maximum bit rates for uplink and downlink and the guaranteed bit rates for uplink and downlink, if at least one of the bit rates has a value higher than 10 Gbps.

The Extended EPS quality of service information element is coded as shown in figure 9.9.4.30.1 and table 9.9.4.30.1. For uplink and downlink, if sending entity only has to indicate one bit rate (i.e., with a value higher than 10 Gbps), it shall encode the other bit rate (i.e., with a value smaller or equal to 10 Gbps) as "00000000". The receiving entity shall ignore the bit rate which is included in the extended quality of service information element and has a value smaller or equal to 10 Gbps.

10.2.1.2.3 Test description

10.2.1.2.3.1 Pre-test conditions

System Simulator:

- E-UTRA Cell 1 is the PCell and NR Cell 1 is the PSCell.

UE:

- None.

Preamble:

- The UE is in RRC_IDLE state on E-UTRA Cell 1 using generic procedure parameter Connectivity (EN-DC) according to TS 38.508-1 [4].

10.2.1.2.3.2 Test procedure sequence

Table 10.2.1.2.3.2-1: Main behaviour

St	Procedure	Message Sequence		TP	Verdict
		U - S	Message		
1-6	Steps 1 to 6 of generic procedure defined in clause 4.5.4 in TS 38.508-1 [4].	-	-	-	-
7	The SS configures a dedicated EPS bearer associated with the default EPS bearer context by sending ACTIVATE DEDICATED EPS BEARER CONTEXT REQUEST including the Extended QoS IE. (See Note 1 and Note 2).	<--	NAS: ACTIVATE DEDICATED EPS BEARER CONTEXT REQUEST	-	-
8	Check: Does the UE transmit an ACTIVATE DEDICATED EPS BEARER CONTEXT ACCEPT message as specified?	-->	ACTIVATE DEDICATED EPS BEARER CONTEXT ACCEPT	1	P
9	The SS transmits a MODIFY EPS BEARER CONTEXT REQUEST message with Extended EPS QoS and Extended APN-AMBR IEs. This message is included in a DLInformationTransfer message.	<--	MODIFY EPS BEARER CONTEXT REQUEST	-	-
10	Check: Does the UE transmit a MODIFY EPS BEARER CONTEXT ACCEPT message?	-->	MODIFY EPS BEARER CONTEXT ACCEPT	2	P
Note 1: The ACTIVATE DEDICATED EPS BEARER CONTEXT REQUEST message is included in a <i>RRCConnectionReconfiguration</i> message including a DRB setup for the same EPS bearer ID.					
Note 2: The <i>RRCConnectionReconfiguration</i> uses the condition for DC bearer MCG and SCG					

10.2.1.2.3.3 Specific message contents

Table 10.2.1.2.3.3-1: ACTIVATE DEDICATED EPS BEARER CONTEXT REQUEST (step 7, Table 10.2.1.2.3.2-1)

Derivation Path: TS 38.508-1[4], Table 4.5.4.3-1			
Information Element	Value/remark	Comment	Condition
Protocol discriminator	ESM		
EPS bearer identity	6		
Procedure transaction identity	'0000 0000'B	No procedure transaction identity assigned	
EPS QoS			
QCI	8		
Maximum bit rate for uplink	'01101000'B (384 kbps)		
Maximum bit rate for downlink	'11111110'B (8640 kbps)		
Guaranteed bit rate for uplink	'01001000'B (128 kbps)		
Guaranteed bit rate for downlink	'01001000'B (128 kbps)		
Maximum bit rate for uplink (extended)	0		
Maximum bit rate for downlink (extended)	'1111010'B (256 Mbps)		
Guaranteed bit rate for uplink (extended)	0		
Guaranteed bit rate for downlink (extended)	0		
Maximum bit rate for uplink (extended-2)	0		
Maximum bit rate for downlink (extended-2)	'11110110'B (10 Gbps)		
Guaranteed bit rate for uplink (extended-2)	0		
Guaranteed bit rate for downlink (extended-2)	0		
Extended EPS QoS			
Unit for maximum bit rate	'0000111' (value is incremented in multiples of 1 Gbps)		
Maximum bit rate for uplink	'0000000000000000'B		
Maximum bit rate for downlink	'0000000000001100'B (12 Gbps)		
Unit for guaranteed bit rate	'00000000'B		
Guaranteed bit rate for uplink	'00000000'B		
Guaranteed bit rate for downlink	'00000000'B		

Table 10.2.1.2.3.3-2: MODIFY EPS BEARER CONTEXT REQUEST (step 9, Table 10.2.1.2.3.2-1)

Derivation path: 36.508 [7], Table 4.7.3-18			
Information Element	Value/Remark	Comment	Condition
New EPS QoS			
QCI	8		
Maximum bit rate for uplink	'01101000'B (384 kbps)		
Maximum bit rate for downlink	'11111110'B (8640 kbps)		
Guaranteed bit rate for uplink	'01001000'B (128 kbps)		
Guaranteed bit rate for downlink	'01001000'B (128 kbps)		
Maximum bit rate for uplink (extended)	0		
Maximum bit rate for downlink (extended)	'1111010'B (256 Mbps)		
Guaranteed bit rate for uplink (extended)	0		
Guaranteed bit rate for downlink (extended)	0		
Maximum bit rate for uplink (extended-2)	0		
Maximum bit rate for downlink (extended-2)	'11110110'B (10 Gbps)		
Guaranteed bit rate for uplink (extended-2)	0		
Guaranteed bit rate for downlink (extended-2)	0		
APN-AMBR			
APN-AMBR for downlink	'11111110'B (8640 kbps)		
APN-AMBR for uplink	'11111110'B (8640 kbps)		
APN-AMBR for downlink (extended)	'1111010' B(256 Mbps)		
APN-AMBR for uplink (extended)	'1111010' B(256 Mbps)		
APN-AMBR for downlink (extended-2)	'11111110'B (65280 Mbps)		
APN-AMBR for uplink (extended-2)	0		
Extended APN-AMBR			
Unit for extended APN-AMBR for downlink	'00000111'B (value is incremented in multiples of 1 Gbps)		
Extended APN-AMBR for downlink	'0000000010000000' (128 Gbps)		
Unit for extended APN-AMBR for uplink	0		
Extended APN-AMBR for uplink	0		
Extended EPS QoS			
Unit for maximum bit rate	'00000111' (value is incremented in multiples of 1 Gbps)		
Maximum bit rate for uplink	'0000000000000000'B		
Maximum bit rate for downlink	'0000000000001110'B		
Unit for guaranteed bit rate	'00000000'B		
Guaranteed bit rate for uplink	'00000000'B		
Guaranteed bit rate for downlink	'00000000'B		

10.2.2 UE initiated procedures

10.2.2.1 EPS bearer resource allocation / modification

10.2.2.1.1 Test Purpose (TP)

(1)

```
with { UE in PROCEDURE TRANSACTION INACTIVE state and in EMM-IDLE mode }
ensure that {
  when { UE is requested to allocate bearer resource using Extended EPS QoS }
  then { UE sends a BEARER RESOURCE ALLOCATION REQUEST including the Extended EPS QoS IE }
}
```

(2)

```
with { UE has sent the BEARER RESOURCE ALLOCATION REQUEST message }
ensure that {
  when { UE receives an ACTIVATE DEDICATED EPS BEARER CONTEXT REQUEST message with the procedure
transaction identity (PTI) indicated in the BEARER RESOURCE ALLOCATION REQUEST message }
}
```

```

then { UE sends an ACTIVATE DEDICATED EPS BEARER CONTEXT ACCEPT message }
}

```

(3)

```

with { UE in PROCEDURE TRANSACTION INACTIVE state and in EMM-CONNECTED mode }
ensure that {
  when { UE is requested to modify of bearer resource corresponding to the dedicated bearer using
Extended EPS QoS }
  then { UE sends a BEARER RESOURCE MODIFICATION REQUEST message including the Extended EPS QoS IE
}
}

```

(4)

```

with { UE having sent the BEARER RESOURCE MODIFICATION REQUEST message }
ensure that {
  when { UE receives an MODIFY EPS BEARER CONTEXT REQUEST message with the procedure transaction
identity (PTI) indicated in the BEARER RESOURCE MODIFICATION REQUEST message }
  then { UE sends a MODIFY EPS BEARER CONTEXT ACCEPT message }
}

```

10.2.2.1.2 Conformance requirements

References: The conformance requirements covered in the present TC are specified in: TS 24.301, clauses 6.4.2.3, 6.5.3.2, 6.5.3.3, 6.5.4.2, 6.5.4.3, 8.3.8, 8.3.10 and 9.9.4.30. Unless otherwise stated these are Rel-15 requirements.

[TS 24.301, clause 6.4.2.3]

The linked EPS bearer identity included in the ACTIVATE DEDICATED EPS BEARER CONTEXT REQUEST message indicates to the UE to which default bearer, IP address and PDN the dedicated bearer is linked.

If the ACTIVATE DEDICATED EPS BEARER CONTEXT REQUEST message contains a PTI value other than "no procedure transaction identity assigned" and "reserved" (see 3GPP TS 24.007 [12]), the UE uses the PTI to identify the UE requested bearer resource allocation procedure or the UE requested bearer resource modification procedure to which the dedicated bearer context activation is related.

[TS 24.301, clause 6.5.3.2]

In order to request the allocation of bearer resources for one traffic flow aggregate, the UE shall send a BEARER RESOURCE ALLOCATION REQUEST message to the MME, start timer T3480 and enter the state PROCEDURE TRANSACTION PENDING (see example in figure 6.5.3.2.1).

The UE shall include the EPS bearer identity of the default EPS bearer associated with the requested bearer resource in the Linked EPS bearer identity IE. The UE shall set the TFT operation code in the Traffic flow aggregate IE to "Create new TFT". The packet filters in the Traffic flow aggregate IE shall include at least one packet filter applicable for the uplink direction. In the Required traffic flow QoS IE, the UE shall indicate a QCI and, if the UE also includes a GBR, the additional GBR required for the traffic flow aggregate.

[TS 24.301, clause 6.5.3.3]

If the bearer resource allocation requested is accepted by the network, the MME shall initiate either a dedicated EPS bearer context activation procedure or an EPS bearer context modification procedure. Upon receipt of an ACTIVATE DEDICATED EPS BEARER CONTEXT REQUEST or MODIFY EPS BEARER CONTEXT REQUEST message with a PTI which matches the value used for the BEARER RESOURCE ALLOCATION REQUEST message, the UE shall stop timer T3480 and enter the state PROCEDURE TRANSACTION INACTIVE. The UE should ensure that the procedure transaction identity (PTI) assigned to this procedure is not released immediately. The way to achieve this is implementation dependent. While the PTI value is not released, the UE regards any received ACTIVATE DEDICATED EPS BEARER CONTEXT REQUEST or MODIFY EPS BEARER CONTEXT REQUEST message with the same PTI value as a network retransmission (see subclause 7.3.1).

If the ACTIVATE DEDICATED EPS BEARER CONTEXT REQUEST message is received, the UE shall verify that the EPS bearer identity given in the EPS bearer identity IE is not already used by any EPS bearer context. The UE shall then proceed as described in subclause 6.4.2.3 or subclause 6.4.2.4.

[TS 24.301, clause 6.5.4.2]

In order to request the modification of bearer resources for one traffic flow aggregate, the UE shall send a BEARER RESOURCE MODIFICATION REQUEST message to the MME, start timer T3481 and enter the state PROCEDURE TRANSACTION PENDING (see example in figure 6.5.4.2.1).

[TS 24.301, clause 6.5.4.3]

Upon receipt of the BEARER RESOURCE MODIFICATION REQUEST message, the MME checks whether the resources requested by the UE can be established, modified or released by verifying the EPS bearer identity given in the EPS bearer identity for packet filter IE.

If the bearer resource modification requested is accepted by the network, the MME shall initiate either a dedicated EPS bearer context activation procedure, an EPS bearer context modification procedure or an EPS bearer context deactivation procedure.

...

Upon receipt of an ACTIVATE DEDICATED EPS BEARER CONTEXT REQUEST, MODIFY EPS BEARER CONTEXT REQUEST or DEACTIVATE EPS BEARER CONTEXT REQUEST message with a PTI which matches the value used for the BEARER RESOURCE MODIFICATION REQUEST message, the UE shall stop timer T3481 and enter the state PROCEDURE TRANSACTION INACTIVE. The UE should ensure that the procedure transaction identity (PTI) assigned to this procedure is not released immediately. The way to achieve this is implementation dependent. While the PTI value is not released, the UE regards any received ACTIVATE DEDICATED EPS BEARER CONTEXT REQUEST or MODIFY EPS BEARER CONTEXT REQUEST message with the same PTI value as a network retransmission (see subclause 7.3.1).

- i) If the ACTIVATE DEDICATED EPS BEARER CONTEXT REQUEST message is received, the UE shall verify that the EPS bearer identity given in the EPS bearer identity IE is not already used by any EPS bearer context. The UE shall then proceed as described in subclause 6.4.2.3 or subclause 6.4.2.4.

[TS 24.301, clause 8.3.8]

This IE shall be included in the message only if the UE wishes to transmit the maximum and guaranteed bit rate values to the network and at least one of the values to be transmitted exceeds the maximum value specified in the EPS quality of service information element in subclause 9.9.4.3.

[TS 24.301, clause 8.3.10]

This IE shall be included in the message only if the UE wishes to transmit the maximum and guaranteed bit rate values to the network and at least one of the values to be transmitted exceeds the maximum value specified in the EPS quality of service information element in subclause 9.9.4.3.

[TS 24.301, clause 9.9.4.30]

The purpose of the Extended quality of service information element is to indicate for an EPS bearer context the maximum bit rates for uplink and downlink and the guaranteed bit rates for uplink and downlink, if at least one of the bit rates has a value higher than 10 Gbps.

The Extended quality of service information element is coded as shown in figure 9.9.4.30.1 and table 9.9.4.30.1. For uplink and downlink, if the sending entity only has to indicate one bit rate (i.e., with a value higher than 10 Gbps), it shall encode the other bit rate (i.e., with a value smaller or equal to 10 Gbps) as "00000000". The receiving entity shall ignore a bit rate which is included in the extended quality of service information element and has a value smaller or equal to 10 Gbps.

The Extended quality of service is a type 4 information element with a length of 12 octets.

8	7	6	5	4	3	2	1	
Extended quality of service IEI								octet 1
Length of Extended quality of service contents								octet 2
Unit for maximum bit rate								octet 3
Maximum bit rate for uplink								octet 4
Maximum bit rate for uplink (continued)								octet 5
Maximum bit rate for downlink								octet 6
Maximum bit rate for downlink (continued)								octet 7
Unit for guaranteed bit rate								octet 8
Guaranteed bit rate for uplink								octet 9
Guaranteed bit rate for uplink (continued)								octet 10
Guaranteed bit rate for downlink								octet 11
Guaranteed bit rate for downlink (continued)								octet 12

Figure 9.9.4.30.1: Extended quality of service information element

Table 9.9.4.30.1: Extended quality of service information element

Unit for maximum bit rate (octet 3)	
0 0 0 0 0 0 0 0	value is not used
0 0 0 0 0 0 0 1	value is incremented in multiples of 200 kbps
0 0 0 0 0 0 1 0	value is incremented in multiples of 1 Mbps
0 0 0 0 0 0 1 1	value is incremented in multiples of 4 Mbps
0 0 0 0 0 1 0 0	value is incremented in multiples of 16 Mbps
0 0 0 0 0 1 0 1	value is incremented in multiples of 64 Mbps
0 0 0 0 0 1 1 0	value is incremented in multiples of 256 Mbps
0 0 0 0 0 1 1 1	value is incremented in multiples of 1 Gbps
0 0 0 0 1 0 0 0	value is incremented in multiples of 4 Gbps
0 0 0 0 1 0 0 1	value is incremented in multiples of 16 Gbps
0 0 0 0 1 0 1 0	value is incremented in multiples of 64 Gbps
0 0 0 0 1 0 1 1	value is incremented in multiples of 256 Gbps
0 0 0 0 1 1 0 0	value is incremented in multiples of 1 Tbps
0 0 0 0 1 1 0 1	value is incremented in multiples of 4 Tbps
0 0 0 0 1 1 1 0	value is incremented in multiples of 16 Tbps
0 0 0 0 1 1 1 1	value is incremented in multiples of 64 Tbps
0 0 0 1 0 0 0 0	value is incremented in multiples of 256 Tbps
0 0 0 1 0 0 0 1	value is incremented in multiples of 1 Pbps
0 0 0 1 0 0 1 0	value is incremented in multiples of 4 Pbps
0 0 0 1 0 0 1 1	value is incremented in multiples of 16 Pbps
0 0 0 1 0 1 0 0	value is incremented in multiples of 64 Pbps
0 0 0 1 0 1 0 1	value is incremented in multiples of 256 Pbps
Other values shall be interpreted as multiples of 256 Pbps in this version of the protocol.	
Maximum bit rate for uplink (octets 4 and 5)	
Octets 4 and 5 represent the binary coded value of maximum bit rate for uplink in units defined by octet 3.	
Maximum bit rate for downlink (octets 6 and 7)	
Octets 6 and 7 represent the binary coded value of maximum bit rate for downlink in units defined by octet 3.	
Unit for guaranteed bit rate (octet 8)	
The coding is identical to that of the unit for maximum bit rate (octet 3).	
Guaranteed bit rate for uplink (octets 9 and 10)	
Octets 9 and 10 represent the binary coded value of guaranteed bit rate for uplink in units defined by octet 8.	
Guaranteed bit rate for downlink (octets 11 and 12)	
Octets 11 and 12 represent the binary coded value of guaranteed bit rate for downlink in units defined by octet 8.	

10.2.2.1.3 Test description

10.2.2.1.3.1 Pre-test conditions

System Simulator:

- E-UTRA Cell 1 and NR Cell 1.

UE:

- None.

Preamble:

- The UE is in state RRC_IDLE using generic procedure parameter Connectivity (*EN-DC*) according to [4].

10.2.2.1.3.2 Test procedure sequence

Table 10.2.2.1.3.2-1: Main behaviour

St	Procedure	Message Sequence		TP	Verdict
		U - S	Message		
1	Cause the UE to request bearer resource allocation of dedicated EPS bearer associated with non-IMS PDN connectivity if pc_MULTI_PDN=TRUE else first PDN connectivity. (Note 1).	-	-	-	-
2	The UE transmits a SERVICE REQUEST message.	-->	SERVICE REQUEST	-	-
3	The SS establishes SRB2 and the MCG DRBs associated with the default EPS bearer context activated during the preamble.	-	-	-	-
4	Check: Does the UE transmit a BEARER RESOURCE ALLOCATION REQUEST message?	-->	BEARER RESOURCE ALLOCATION REQUEST	1	P
5	The SS transmits an ACTIVATE DEDICATED EPS BEARER CONTEXT REQUEST message and establishes a RLC-AM SCG DRB bearer using MCG_and_SCG condition.	<--	ACTIVATE DEDICATED EPS BEARER CONTEXT REQUEST	-	-
6	Check: Does the UE transmit an ACTIVATE DEDICATED EPS BEARER CONTEXT ACCEPT message?	-->	ACTIVATE DEDICATED EPS BEARER CONTEXT ACCEPT	2	P
7	Cause the UE to request bearer resource modification of dedicated EPS bearer associated with non-IMS PDN connectivity if pc_MULTI_PDN=TRUE else first PDN connectivity. (Note 2).	-	-	-	-
8	Check: Does the UE transmit a BEARER RESOURCE MODIFICATION REQUEST message?	-->	BEARER RESOURCE MODIFICATION REQUEST	3	P
9	The SS transmits an ACTIVATE DEDICATED EPS BEARER CONTEXT REQUEST message.	<--	MODIFY EPS BEARER CONTEXT REQUEST	-	-
10	Check: Does the UE transmit an ACTIVATE DEDICATED EPS BEARER CONTEXT ACCEPT message?	-->	MODIFY EPS BEARER CONTEXT ACCEPT	4	P
Note 1: The request is assumed to be triggered by AT command +CGDSCONT, and +CGACT (activated).					
Note 2: The request is assumed to be triggered by AT command +CGCMOD.					

10.2.2.1.3.3 Specific message contents

Table 10.2.2.1.3.3-1: Message BEARER RESOURCE ALLOCATION REQUEST (step 4, Table 10.2.2.1.3.2-1)

Derivation path: TS 36.508 [7], Table 4.7.3-6B			
Information Element	Value/Remark	Comment	Condition
Linked EPS bearer identity	12		
EPS QoS			
QCI	8		
Maximum bit rate for uplink	384 kbps		
Maximum bit rate for downlink	'11111110'B (8640 kbps)		
Guaranteed bit rate for uplink	128 kbps		
Guaranteed bit rate for downlink	128 kbps		
Maximum bit rate for uplink (extended)	0		
Maximum bit rate for downlink (extended)	'11111010'B (256 Mbps)		
Guaranteed bit rate for uplink (extended)	0		
Guaranteed bit rate for downlink (extended)	0		
Maximum bit rate for uplink (extended-2)	0		
Maximum bit rate for downlink (extended-2)	'11110110'B (10 Gbps)		
Guaranteed bit rate for uplink (extended-2)	0		
Guaranteed bit rate for downlink (extended-2)	0		
Extended EPS QoS			
Unit for maximum bit rate	'00000111' (value is incremented in multiples of 1 Gbps)		
Maximum bit rate for uplink	'00000000'B		
Maximum bit rate for downlink	'0000000000001100' B (12 Gbps)		
Unit for guaranteed bit rate	'00000000'B		
Guaranteed bit rate for uplink	'00000000'B		
Guaranteed bit rate for downlink	'00000000'B		

Table 10.2.2.1.3.3-2: Message ACTIVATE DEDICATED EPS BEARER CONTEXT REQUEST (step 5, Table 10.2.2.1.3.2-1)

Derivation path: TS 38.508-1 [4], Table 4.5.4.3-1 , condition UE-INITIATED			
Information Element	Value/Remark	Comment	Condition
EPS bearer identity	6		
EPS QoS			
QCI	8		
Maximum bit rate for uplink	384 kbps		
Maximum bit rate for downlink	'11111110'B (8640 kbps)		
Guaranteed bit rate for uplink	128 kbps		
Guaranteed bit rate for downlink	128 kbps		
Maximum bit rate for uplink (extended)	0		
Maximum bit rate for downlink (extended)	'11111010'B (256 Mbps)		
Guaranteed bit rate for uplink (extended)	0		
Guaranteed bit rate for downlink (extended)	0		
Maximum bit rate for uplink (extended-2)	0		
Maximum bit rate for downlink (extended-2)	'11110110'B (10 Gbps)		
Guaranteed bit rate for uplink (extended-2)	0		
Guaranteed bit rate for downlink (extended-2)	0		
Extended EPS QoS			
Unit for maximum bit rate	'00000111' (value is incremented in multiples of 1 Gbps)		
Maximum bit rate for uplink	'00000000'B		
Maximum bit rate for downlink	'0000000000001100' B (12 Gbps)		
Unit for guaranteed bit rate	'00000000'B		
Guaranteed bit rate for uplink	'00000000'B		
Guaranteed bit rate for downlink	'00000000'B		

Table 10.2.2.1.3.3-3: Message BEARER RESOURCE MODIFICATION REQUEST (step 8, Table 10.2.2.1.3.2-1)

Derivation path: TS 36.508 [7], Table 4.7.3-8			
Information Element	Value/Remark	Comment	Condition
EPS bearer identity for packet filter	6		
Required traffic flow QoS			
QCI	8		
Maximum bit rate for uplink	384 kbps		
Maximum bit rate for downlink	'11111110'B (8640 kbps)		
Guaranteed bit rate for uplink	128 kbps		
Guaranteed bit rate for downlink	128 kbps		
Maximum bit rate for uplink (extended)	0		
Maximum bit rate for downlink (extended)	'11111010'B (256 Mbps)		
Guaranteed bit rate for uplink (extended)	0		
Guaranteed bit rate for downlink (extended)	0		
Maximum bit rate for uplink (extended-2)	0		
Maximum bit rate for downlink (extended-2)	'11110110'B (10 Gbps)		
Guaranteed bit rate for uplink (extended-2)	0		
Guaranteed bit rate for downlink (extended-2)	0		
Extended EPS QoS			
Unit for maximum bit rate	'0000111' (value is incremented in multiples of 1 Gbps)		
Maximum bit rate for uplink	'00000000'B		
Maximum bit rate for downlink	'000000000010000'B (16 Gbps)		
Unit for guaranteed bit rate	'00000000'B		
Guaranteed bit rate for uplink	'00000000'B		
Guaranteed bit rate for downlink	'00000000'B		

Table 10.2.2.1.3.3-4: Message MODIFY EPS BEARER CONTEXT REQUEST (step 7, Table 10.2.2.1.3.2-1)

Derivation path: TS 36.508 [7], Table 4.7.3-18, condition UE-INITIATED			
Information Element	Value/Remark	Comment	Condition
EPS bearer identity	6		
Linked EPS bearer identity	12		
New EPS QoS			
QCI	8		
Maximum bit rate for uplink	384 kbps		
Maximum bit rate for downlink	'11111110'B (8640 kbps)		
Guaranteed bit rate for uplink	128 kbps		
Guaranteed bit rate for downlink	128 kbps		
Maximum bit rate for uplink (extended)	0		
Maximum bit rate for downlink (extended)	'11111010'B (256 Mbps)		
Guaranteed bit rate for uplink (extended)	0		
Guaranteed bit rate for downlink (extended)	0		
Maximum bit rate for uplink (extended-2)	0		
Maximum bit rate for downlink (extended-2)	'11110110'B (10 Gbps)		
Guaranteed bit rate for uplink (extended-2)	0		
Guaranteed bit rate for downlink (extended-2)	0		
APN-AMBR			
APN-AMBR for downlink	'11111110'B (8640 kbps)		
APN-AMBR for uplink	'11111110'B (8640 kbps)		
APN-AMBR for downlink (extended)	'11111010' B(256 Mbps)		
APN-AMBR for uplink (extended)	'11111010' B(256 Mbps)		
APN-AMBR for downlink (extended-2)	'11111110'B (65280 Mbps)		
APN-AMBR for uplink (extended-2)	0		
Extended APN-AMBR			
Unit for extended APN-AMBR for downlink	'00000111'B (value is incremented in multiples of 1 Gbps)		
Extended APN-AMBR for downlink	'0000000010000000' (128 Gbps)		
Unit for extended APN-AMBR for uplink	0		
Extended APN-AMBR for uplink	0		
Extended EPS QoS			
Unit for maximum bit rate	'00000111' (value is incremented in multiples of 1 Gbps)		
Maximum bit rate for uplink	'00000000'B		
Maximum bit rate for downlink	'000000000010000' B (16 Gbps)		
Unit for guaranteed bit rate	'00000000'B		
Guaranteed bit rate for uplink	'00000000'B		
Guaranteed bit rate for downlink	'00000000'B		

10.3 5GS Non-3GPP Access Session Management

10.3.1 PDU session authentication and authorization

10.3.1.1 PDU session authentication and authorization / during the UE-requested PDU session procedure

10.3.1.1.1 Test Purpose (TP)

Same Test Purpose as in clause 10.1.1.1.1

10.3.1.1.2 Conformance requirements

Same conformance requirements as in clause 10.1.1.1.2

10.3.1.1.3 Test description

10.3.1.1.3.1 Pre-test conditions

System Simulator:

WLAN Cell 27

UE:

None.

Preamble:

The UE is in state 1W-A with PDU session Active state according to TS 38.508-1 [4].

10.3.1.1.3.2 Test procedure sequence

Table 10.3.1.1.3.2-1: Main behaviour

St	Procedure	Message Sequence		TP	Verdict
		U - S	Message		
1	Cause the UE to request connectivity to an additional PDU session. (see Note 1)	-	-	-	-
2	UE transmits establishes a IPSEC SA and NAS signalling connection as per generic procedure in table 4.5A.4.2.2-1 of 38.508-1 [4].	-	-	-	-
3	The UE transmits a PDU SESSION ESTABLISHMENT REQUEST message to request an additional PDU session. Note: PDU SESSION ESTABLISHMENT REQUEST is included in UL NAS transport. UL NAS transport message is included in dedicatedNAS-Message of <i>ULInformationTransfer</i> message. DNN information is included in UL NAS transport message.	-->	5GMM: UL NAS TRANSPORT 5GSM: PDU SESSION ESTABLISHMENT REQUEST	-	-
4	The SS transmits PDU SESSION AUTHENTICATION COMMAND including an EAP-Request message.	<--	PDU SESSION AUTHENTICATION COMMAND		
5	Check: Does the UE transmit a PDU SESSION AUTHENTICATION COMPLETE containing EAP-Response message?	-->	PDU SESSION AUTHENTICATION COMPLETE	1	P
6	The SS transmits PDU SESSION ESTABLISHMENT REJECT message with 5GSM cause #29 including an EAP-Failure message.	<--	PDU SESSION ESTABLISHMENT REJECT		
7	The generic procedure for SS-requested IPsec Secure tunnel disconnection, specified in subclause 4.5A.3 of TS 38.508-1 [4], takes place performing disconnection of security association.	-		-	-
8	Cause the UE to request connectivity to an additional PDU session. (see Note 1)	-	-	-	-
9	UE transmits establishes a IPSEC SA and NAS signalling connection as per generic procedure in table 4.5A.4.2.2-1 of 38.508-1 [4].	-	-	-	-
10	The UE transmits a PDU SESSION ESTABLISHMENT REQUEST message to request an additional PDU session. Note: PDU SESSION ESTABLISHMENT REQUEST is included in UL NAS transport. UL NAS transport message is included in dedicatedNAS-Message of <i>ULInformationTransfer</i> message. DNN information is included in UL NAS transport message.	-->	5GMM: UL NAS TRANSPORT 5GSM: PDU SESSION ESTABLISHMENT REQUEST	2	P
11	The SS transmits PDU SESSION AUTHENTICATION COMMAND including an EAP-Request message.	<--	PDU SESSION AUTHENTICATION COMMAND		
12	Check: Does the UE transmit a PDU SESSION AUTHENTICATION COMPLETE containing EAP-Response message?	-->	PDU SESSION AUTHENTICATION COMPLETE	-	-
13	The SS establishes an IPSec child security association according to the IKEv2 specification in RFC 7296 [32]	-	-	-	-
14	The SS transmits PDU SESSION ESTABLISHMENT ACCEPT message containing an EAP-Success message.	<--	PDU SESSION ESTABLISHMENT ACCEPT		
15	SS Transmits PDU SESSION MODIFICATION COMMAND	<--	PDU SESSION MODIFICATION COMMAND	-	-

	Check: Does the UE transmit a PDU SESSION MODIFICATION COMPLETE?	-->	PDU SESSION MODIFICATION COMPLETE	3	P
-	EXCEPTION: Step 16a1 describes behaviour depending UE implementation; the "lower case letter" identifies a step sequence that take place if the UE performs a specific action.	-	-	-	-
16a1	If initiated by the UE, the generic procedure for IP address allocation in the user plane, specified in subclause 4.5.6, takes place performing IP address allocation in the user plane.	-	-	-	-
Note 1: The request of connectivity to an additional PDU session may be performed by MMI or AT command.					

10.3.1.1.3.3 Specific message contents

Table 10.3.1.1.3.3-1: SERVICE REQUEST (step 2 and 9, Table 10.3.1.1.3.2-1)

Derivation Path: 38.508-1 [4], Table 4.7.1-16			
Information Element	Value/remark	Comment	Condition
Service type	'0000'B	signalling	
PDU session status	PDU session IDs	PDU session IDs of the ACTIVE PDU session established during Preamble.	

Table 10.3.1.1.3.3-2: SERVICE ACCEPT (step 2 and 9, Table 10.3.1.1.3.2-1)

Derivation Path: 38.508-1 [4], Table 4.7.1-17			
Information Element	Value/remark	Comment	Condition
PDU session status	PDU session IDs	PDU session IDs of the ACTIVE PDU session established during Preamble.	

Table 10.3.1.1.3.3-3: PDU SESSION ESTABLISHMENT REQUEST (step 3 and 10, Table 10.3.1.1.3.2-1)

Derivation Path: 38.508-1 [4], Table 4.7.2-1			
Information Element	Value/remark	Comment	Condition
PDU session ID	PSI-1	UE assigns a particular PSI not yet used between 1 and 15	
PTI	PTI-1	UE assigns a particular PTI not yet used between 1 and 254	

Table 10.3.1.1.3.3-4: UL NAS Transport (step 3 and 10, Table 10.3.1.1.3.2-1)

Derivation Path: 38.508-1 [4], Table 4.7.1-10			
Information Element	Value/remark	Comment	Condition
Payload container type	'0001'B	N1 SM information	
PDU session ID	PSI-1		
Request type	'001'B	Initial request	
S-NSSAI	Not Present		
DNN	DNN-1 (New DNN name)	The requested DNN is different from default DNN.	

Table 10.3.1.1.3.3-5: PDU SESSION ESTABLISHMENT REJECT (step 6, Table 10.3.1.1.3.2-1)

Derivation Path: 38.508-1 [4], Table 4.7.2-3			
Information Element	Value/remark	Comment	Condition
PDU session ID	PSI-1		
PTI	PTI-1		
5GSM cause	'00011 101'	User authentication or authorization failed	

Table 10.3.1.1.3.3-6: PDU SESSION ESTABLISHMENT ACCEPT (step 14, Table 10.3.1.1.3.2-1)

Derivation Path: 38.508-1 [4], Table 4.7.2-2			
Information Element	Value/remark	Comment	Condition
PDU session ID	PSI-1		
PTI	PTI-1		
Authorized QoS rules			
QoS rule			
QoS rule identifier	'0000 0001'B		
Rule operation code	'001'B	Create new QoS rule	
DQR bit	'1'B	The QoS rule is the default QoS rule.	
Number of packet filters	'0001'B	1 packet filter	
Packet filter list	See table 4.8.2.1-1	Packet filter list #1	
Packet filter direction	'11'B	bidirectional	
Packet filter identifier	'0000'B	Id 0	
Component type 1 ID	'0000 0001'B	Match-all type	
QoS rule precedence	'0000 0000'B	0	
QoS flow identifier (QFI)	'00 0011'B	QFI 3	
EAP message			
QoS flow description			
QFI	'00 0011'B	QFI 3	
Operation code	'001'B	Create new QoS flow description	
E bit	'1'B	Parameters list is included	
Number of parameters	'00 0001'B	1 parameters	
5QI	'0000 1001'B	5QI 9	
DNN	DNN-1		

10.3.2 Network-requested PDU session modification

10.3.2.1 Network-requested PDU session modification /Accepted/Rejected

10.3.2.1.1 Test Purpose (TP)

(1)

```
with { the UE in PDU SESSION ACTIVE state and 5GMM-CONNECTED mode }
ensure that {
  when { the UE receives a PDU SESSION MODIFICATION COMMAND message include the PDU session ID which
does not belong to any PDU session in PDU SESSION ACTIVE state in UE }
  then { UE sends a PDU SESSION MODIFICATION COMMAND REJECT message and set the 5GSM cause to #43:
invalid PDU session identity }
}
```

(2)

```
with { the UE in PDU SESSION ACTIVE state and 5GMM-CONNECTED mode }
ensure that {
  when { the UE receives a PDU SESSION MODIFICATION COMMAND message include the PDU session ID which
belongs to a PDU session in PDU SESSION ACTIVE state in UE }
  then { UE sends a PDU SESSION MODIFICATION COMMAND REJECT message and set the 5GSM cause to #43:
invalid PDU session identity }
}
```

10.3.2.1.2 Conformance requirements

References: The conformance requirements covered in the present TC are specified in: TS 24.501, clauses 6.3.2.2, 6.3.2.4. Unless otherwise stated these are Rel-15 requirements.

[TS 24.501, clause 6.3.2.2]

In order to initiate the network-requested PDU session modification procedure, the SMF shall create a PDU SESSION MODIFICATION COMMAND message.

If the authorized QoS rules of the PDU session is modified, the SMF shall set the authorized QoS rules IE of the PDU SESSION MODIFICATION COMMAND message to the authorized QoS rules of the PDU session. The SMF shall ensure that the number of the packet filters used in the authorized QoS rules of the PDU Session does not exceed the maximum number of packet filters supported by the UE for the PDU session. The SMF may bind service data flows for which the UE has requested traffic segregation to a dedicated QoS flow for the PDU session, if possible. Otherwise the SMF may bind the service data flows to an existing QoS flow. The SMF shall use only one dedicated QoS flow for traffic segregation. If the UE has requested traffic segregation for multiple service data flows with different QoS handling, the SMF shall bind all these service data flows to a single QoS flow. If the SMF allows traffic segregation for service data flows in a QoS rule, then the SMF shall create a new authorized QoS rule for these service data flows and shall delete packet filters corresponding to these service data flows from the other authorized QoS rules.

If the authorized QoS flow descriptions of the PDU session is modified, the SMF shall set the authorized QoS flow descriptions IE of the PDU SESSION MODIFICATION COMMAND message to the authorized QoS flow descriptions of the PDU session.

If SMF creates a new authorized QoS rule for a new QoS flow, then SMF shall include the authorized QoS flow description for that QoS flow in the authorized QoS flow descriptions IE of the PDU SESSION MODIFICATION COMMAND message, if:

- a) the newly created authorized QoS rules is for a new GBR QoS flow;
- b) the QFI of the new QoS flow is not the same as the 5QI of the QoS flow identified by the QFI; or
- c) the new QoS flow can be mapped to an EPS bearer as specified in subclause 4.11.2 of 3GPP TS 23.502 [9].

If the session-AMBR of the PDU session is modified, the SMF shall set the selected Session-AMBR IE of the PDU SESSION MODIFICATION COMMAND message to the session-AMBR of the PDU session.

If interworking with EPS is supported for the PDU session and if the mapped EPS bearer contexts of the PDU session is modified, the SMF shall set the mapped EPS bearer contexts IE of the PDU SESSION MODIFICATION COMMAND message to the mapped EPS bearer contexts of the PDU session. If the association between a QoS flow and the mapped EPS bearer context is changed, the SMF shall set the EPS bearer identity parameter in authorized QoS flow descriptions IE of the PDU SESSION MODIFICATION COMMAND message to the new EPS bearer identity associated with the QoS flow.

If the network-requested PDU session modification procedure is triggered by a UE-requested PDU session modification procedure and the PDU SESSION MODIFICATION REQUEST message includes a 5GSM capability IE, the SMF shall:

- a) if the RQoS bit is set to:
 - 1) "Reflective QoS supported", consider that the UE supports reflective QoS for this PDU session; or
 - 2) "Reflective QoS not supported", consider that the UE does not support reflective QoS for this PDU session; and;
- b) if the MH6-PDU bit is set to:
 - 1) "Multi-homed IPv6 PDU session supported", consider that this PDU session is supported to use multiple IPv6 prefixes; or
 - 2) "Multi-homed IPv6 PDU session not supported", consider that this PDU session is not supported to use multiple IPv6 prefixes.

If the SMF considers that reflective QoS is supported for QoS flows belonging to this PDU session, the SMF may include the RQ timer IE set to an RQ timer value in the PDU SESSION MODIFICATION COMMAND message.

If the network-requested PDU session modification procedure is triggered by a UE-requested PDU session modification procedure, the PDU session type is "IPv4", "IPv6", "IPv4v6" or "Ethernet" and the PDU SESSION MODIFICATION REQUEST message includes a Maximum number of supported packet filters IE, the SMF shall consider this number as the maximum number of packet filters that can be supported by the UE for this PDU session. Otherwise the SMF considers that the UE supports 16 packet filters for this PDU session.

For a PDN connection established when in S1 mode, upon the first inter-system change from S1 mode to N1 mode, if the network-requested PDU session modification procedure is triggered by a UE-requested PDU session modification procedure, the SMF shall consider that the maximum data rate per UE for user-plane integrity protection supported by the UE for uplink and the maximum data rate per UE for user-plane integrity protection supported by the UE for downlink are valid for the lifetime of the PDU session.

For a PDN connection established when in S1 mode, upon the first inter-system change from S1 mode to N1 mode, if the network-requested PDU session modification procedure is triggered by a UE-requested PDU session modification procedure and the SMF determines, based on local policies or configurations in the SMF and the Always-on PDU session requested IE in the PDU SESSION MODIFICATION REQUEST message (if available), that either:

- a) the requested PDU session needs to be an always-on PDU session, the SMF shall include the Always-on PDU session indication IE in the PDU SESSION MODIFICATION COMMAND message and shall set the value to "Always-on PDU session required"; or
- b) the requested PDU session shall not be an always-on PDU session and:
 - i) if the UE included the Always-on PDU session requested IE, the SMF shall include the Always-on PDU session indication IE in the PDU SESSION MODIFICATION COMMAND message and shall set the value to "Always-on PDU session not allowed"; or
 - ii) if the UE did not include the Always-on PDU session requested IE, the SMF shall not include the Always-on PDU session indication IE in the PDU SESSION MODIFICATION COMMAND message.

If the value of the RQ timer is set to "deactivated" or has a value of zero, the UE considers that RQoS is not applied for this PDU session and remove the derived QoS rule(s) associated with the PDU session, if any.

If the network-requested PDU session modification procedure is triggered by a UE-requested PDU session modification procedure, the SMF shall set the PTI IE of the PDU SESSION MODIFICATION COMMAND message to the PTI of the PDU SESSION MODIFICATION REQUEST message received as part of the UE-requested PDU session modification procedure.

If the network-requested PDU session modification procedure is not triggered by a UE-requested PDU session modification procedure, the SMF shall set the PTI IE of the PDU SESSION MODIFICATION COMMAND message to "No procedure transaction identity assigned".

If the selected SSC mode of the PDU session is "SSC mode 3" and the SMF requests the relocation of SSC mode 3 PDU session anchor with multiple PDU sessions as specified in 3GPP TS 23.502 [9], the SMF shall include 5GSM cause #39 "reactivation requested", in the PDU SESSION MODIFICATION COMMAND message, and may include the PDU session address lifetime in a PDU session address lifetime PCO parameter in the Extended protocol configuration options IE of the PDU SESSION MODIFICATION COMMAND message.

The SMF shall send the PDU SESSION MODIFICATION COMMAND message, and the SMF shall start timer T3591 (see example in figure 6.3.2.2.1).

- NOTE: If the SMF requests the relocation of SSC mode 3 PDU session anchor with multiple PDU sessions as specified in 3GPP TS 23.502 [9], the reallocation requested indication indicating whether the SMF is to be reallocated or the SMF is to be reused is provided to the AMF.

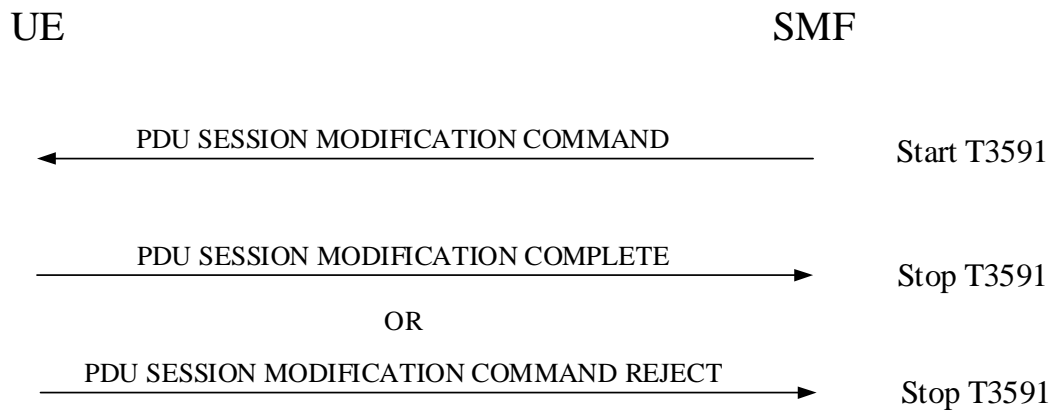

Figure 6.3.2.2.1: Network-requested PDU session modification procedure

[TS 24.501, clause 6.3.2.4]

Upon receipt of a PDU SESSION MODIFICATION COMMAND message and a PDU session ID, using the NAS transport procedure as specified in subclause 5.4.5, if the UE rejects the PDU SESSION MODIFICATION COMMAND message, the UE shall create a PDU SESSION MODIFICATION COMMAND REJECT message.

If the PDU SESSION MODIFICATION COMMAND message contains the PTI value allocated in the UE-requested PDU session modification procedure, the UE shall release the PTI indicated by the PTI IE and shall stop the timer T3581.

The UE shall set the 5GSM cause IE of the PDU SESSION MODIFICATION COMMAND REJECT message to indicate the reason for rejecting the PDU session modification.

The 5GSM cause IE typically indicates one of the following 5GSM cause values:

- #26 insufficient resources;
- #43 invalid PDU session identity;
- #44 semantic error in packet filter(s);
- #45 syntactical error in packet filter(s);
- #83 semantic error in the QoS operation; or
- #84 syntactical error in the QoS operation.

10.3.2.1.3 Test description

10.3.2.1.3.1 Pre-test conditions

System Simulator:

WLAN Cell 27

UE:

None.

Preamble:

The UE is in state 3W-A on WLAN Cell 27 with PDU session Active state according to TS 38.508-1 [4].

10.3.2.1.3.2 Test procedure sequence

Table 10.3.2.1.3.2-1: Main behaviour

St	Procedure	Message Sequence		TP	Verdict
		U - S	Message		
1	The SS transmits a PDU session modification command message with PDU session ID IE is set to a different value from the value set in PDU SESSION ESTABLISHMENT REQUEST message. This message is included in a DLInformationTransfer message.	<--	PDU SESSION MODIFICATION COMMAND	-	-
2	Check: Does the UE transmit a PDU session modification reject with the 5GSM cause IE indicating #43 "invalid PDU session identity"?	-->	PDU SESSION MODIFICATION REJECT	1	P
3	The SS transmits a PDU session modification command message with PDU session ID IE is the value set in PDU SESSION ESTABLISHMENT REQUEST message. This message is included in a DLInformationTransfer message.	<--	PDU SESSION MODIFICATION COMMAND	-	-
4	Check: Does the UE transmit a PDU session modification complete?	-->	PDU SESSION MODIFICATION COMPLETE	2	P

10.3.2.1.3.3 Specific message contents

Table 10.3.2.1.3.3-1: PDU SESSION MODIFICATION COMMAND (Step 1, Table 10.3.2.1.3.2-1)

Derivation path: 38.508-1 [4], table 4.7.2-9			
Information Element	Value/Remark	Comment	Condition
PDU session ID	The different value from the value set in PDU SESSION ESTABLISHMENT REQUEST message in preamble		

Table 10.3.2.1.3.3-2: PDU SESSION MODIFICATION REJECT (Step 2, Table 10.3.2.1.3.2-1)

Derivation path: 38.508-1 [4], table 4.7.2-8			
Information Element	Value/Remark	Comment	Condition
PDU session ID	The same value as the value set in PDU SESSION modification command message		
5GSM cause	'00101011'B	Invalid PDU session identity	

Table 10.3.2.1.3.3-1: PDU SESSION MODIFICATION COMMAND (Step 3, Table 10.3.2.1.3.2-1)

Derivation path: 38.508-1 [4], table 4.7.2-9			
Information Element	Value/Remark	Comment	Condition
PDU session ID	The value set in PDU SESSION ESTABLISHMENT REQUEST message in preamble		
Authorized QoS rules	Reference QoS rule #3 as defined in 38.508-1 [4]Table 4.8.2.1-1.		

10.3.3 Network-requested PDU session Release

10.3.4 UE-requested PDU session establishment

10.3.5 UE-requested PDU session modification

10.3.5.1 UE-requested PDU session modification/Success

10.3.5.1.1 Test Purpose (TP)

(1)

```
with { UE in PDU SESSION ACTIVE state and in 5GMM-CONNECTED mode }
ensure that {
  when { UE is requested to modify of PDU session }
  then { UE sends a PDU SESSION MODIFICATION REQUEST message }
}
```

10.3.5.1.2 Conformance requirements

Same conformance requirements as in clause 10.1.5.1.2

10.3.5.1.3 Test description

10.3.5.1.3.1 Pre-test conditions

System Simulator:

- WLAN Cell 27.

UE:

- None.

Preamble:

- The UE is in state 3W-A onWLAN Cell 27 with PDU SESSION ACTIVE according to TS 38.508-1[4].

10.3.5.1.3.2 Test procedure sequence

Same test procedure sequence as in clause 10.1.5.1.3.2

10.3.5.1.3.3 Specific message contents

Same specific message contents as in clause 10.1.5.1.3.3

10.3.6 UE-requested PDU session release

10.3.6.1 UE-requested PDU session release / Abnormal / Collision with network-requested PDU session modification procedure

10.3.6.1.1 Test Purpose (TP)

(1)

```
with { the UE is in PDU SESSION ACTIVE state and has sent a PDU SESSION RELEASE REQUEST message }
ensure that {
  when { UE receives a PDU SESSION MODIFICATION COMMAND message indicating a PDU session that UE
wants to release }
  then { the UE ignores the PDU SESSION MODIFICATION COMMAND message and proceed with the PDU
session release procedure }
}
```

10.3.6.1.2 Conformance requirements

Same conformance requirements as in clause 10.1.6.1.2

10.3.6.1.3 Test description

10.3.6.1.3.1 Pre-test conditions

System Simulator:

- WLAN Cell 27.

UE:

None.

Preamble:

- The UE is in state 3W-A on WLAN Cell 27 according to TS 38.508-1 [4].

10.3.6.1.3.2 Test procedure sequence

Table 10.3.6.1.3.2-1: Main behaviour

St	Procedure	Message Sequence		TP	Verdict
		U - S	Message		
1	Cause the UE to request establishment of PDU session to the DN.(Note 1)	-	-	-	-
2	New PDU session establishment procedure is performed as per generic procedure in clause 4.5A.2A of TS 38.508-1 [4]	-	-	-	-
3	Cause the UE to request release of PDU session established during preamble.(Note 2)	-	-	-	-
4	The UE transmits a PDU SESSION RELEASE REQUEST message.	-->	5GMM: UL NAS TRANSPORT 5GSM: PDU SESSION RELEASE REQUEST	-	-
5	The SS transmits a PDU SESSION MODIFICATION COMMAND message.	<--	5GMM: DL NAS TRANSPORT 5GSM: PDU SESSION MODIFICATION COMMAND	-	-
6	The SS transmits a PDU SESSION RELEASE COMMAND message.	<--	5GMM: DL NAS TRANSPORT 5GSM: PDU SESSION RELEASE COMMAND	-	-
7	Check: Does the UE transmit PDU SESSION RELEASE COMPLETE message?	-->	5GMM: UL NAS TRANSPORT 5GSM: PDU SESSION RELEASE COMPLETE	1	P
8	The SS deletes the payload associated with IPSec child security association according to the IKEv2 specification in RFC 7296 [32]	-	-	-	-

Note 1: The request to establish a PDU session may be performed by MMI or AT command.
Note 2: The request to release a PDU session may be performed by MMI or AT command.

10.3.6.1.3.3 Specific message contents

Table 10.3.6.1.3.3-1: PDU SESSION RELEASE REQUEST (step 4, Table 10.3.6.1.3.2-1)

Derivation Path: TS 38.508-1 [4] Table 4.7.2-12			
Information Element	Value/remark	Comment	Condition
PDU session ID	Set to the ID UE requested in step 2 in Table 10.3.6.1.3.2-1		
PTI	Any value from 1 to 254		

Table 10.3.6.1.3.3-2: PDU SESSION MODIFICATION COMMAND (step 5, Table 10.3.6.1.3.2-1)

Derivation Path: TS 38.508-1 [4] Table 4.7.2-9			
Information Element	Value/remark	Comment	Condition
PDU session ID	Set to the ID UE requested in step 2 in Table 10.3.6.1.3.2-1		
PTI	'0000 0000'B	No procedure transaction identity assigned	

Table 10.3.6.1.3.3-3: PDU SESSION RELEASE COMMAND (step 6, Table 10.3.6.1.3.2-1)

Derivation Path: TS 38.508-1 [4] Table 4.7.2-14			
Information Element	Value/remark	Comment	Condition
PDU session ID	Set to the ID UE requested in step 2 in Table 10.3.6.1.3.2-1		
PTI	The value indicated in PDU SESSION RELEASE REQUEST		
5GSM cause	'0010 0100'B	#36 regular deactivation	

Table 10.3.6.1.3.3-4: PDU SESSION RELEASE COMPLETE (step 7, Table 10.3.6.1.3.2-1)

Derivation Path: TS 38.508-1 [4] Table 4.7.2-15			
Information Element	Value/remark	Comment	Condition
PDU session ID	Set to the ID UE requested in step 2 in Table 10.3.6.1.3.2-1		
PTI	The value indicated in PDU SESSION RELEASE REQUEST		

11 Multilayer Procedures

11.1 5GS\EPS Fallback

11.1.1 MO MMTEL voice call setup from NR RRC_IDLE / EPS Fallback with redirection / Single registration mode with N26 interface / Success

11.1.1.1 Test Purpose (TP)

(1)

```

with { UE supporting both S1 mode and N1 mode and operating in single-registration mode and the
Network has indicated "interworking without N26 interface not supported" and the UE in NR RRC_IDLE
state}
ensure that {
  when { User initiates a MMTEL call and the UE completes Access control and checking in 5GMM-IDLE
mode}
  then { UE requests the establishment of a MMTEL call by transmitting an RRCSetupRequest message
with establishmentCause set to 'mo-VoiceCall', and, a SERVICE REQUEST message with Service type set
to 'data'}
}

```

(2)

```

with { : UE is NR RRC_CONNECTED state after having requested a MMTEL call establishment and the MO
IMS voice session establishment has been initiated}
ensure that {
  when { UE receives a RRCRelease message which includes redirectedCarrierInfo indicating
redirection to eutra}
  then {UE selects the E-UTRA cell, performs a TAU procedure, and, successfully completes the MO
MMTEL call setup in EPS}
}

```

11.1.1.2 Conformance requirements

References: The conformance requirements covered in the present TC are specified in: TS 24.501, clauses 4.5.4.1, 5.6.1.2 and TS 38.331: clauses 5.3.3.2, 5.3.3.3. Unless and otherwise stated these are Rel-15 requirements.

[TS 24.501, clause 4.5.4.1]

When the UE is in 5GMM-IDLE mode, upon receiving a request from the upper layers for an access attempt, the NAS shall categorize the access attempt into access identities and an access category following subclause 4.5.2, table 4.5.2.1 and table 4.5.2.2, and subclause 4.5.3, and provide the applicable access identities and the access category to the lower layers for the purpose of access control checking. In this request to the lower layer the NAS can also provide to the lower layer the RRC establishment cause determined as specified in subclause 4.5.6 of this specification.

NOTE 1: The access barring check is performed by the lower layers.

NOTE 2: As an implementation option, the NAS can provide the RRC establishment cause to the lower layers after being informed by the lower layers that the access attempt is allowed.

If the UE has uplink user data pending for one or more PDU sessions when it builds a REGISTRATION REQUEST or SERVICE REQUEST message as initial NAS message, the UE shall indicate the respective PDU sessions in the Uplink data status IE as specified in subclause 5.5.1.3.2 and 5.6.1.2, regardless of the access category for which the access barring check is performed.

NOTE 3: The UE indicates pending user data for all the respective PDU sessions, even if barring timers are running for some of the corresponding access categories.

If the lower layers indicate that the access attempt is allowed, the NAS shall initiate the procedure to send the initial NAS message for the access attempt.

[TS 24.501, clause 5.6.1.2]

For cases d) and e) in subclause 5.6.1.1, the Uplink data status IE shall be included in the SERVICE REQUEST message to indicate the PDU session(s) the UE has pending user data to be sent. If the UE is not a UE configured for high priority access in selected PLMN:

- a) if there exists an emergency PDU session which is indicated in the Uplink data status IE the service type IE in the SERVICE REQUEST message shall be set to "emergency services"; or
- b) otherwise, the service type IE in the SERVICE REQUEST message shall be set to "data".

[TS 38.331, clause 5.3.3.2]

The UE initiates the procedure when upper layers request establishment of an RRC connection while the UE is in RRC_IDLE and it has acquired essential system information as described in 5.2.2.1.

The UE shall ensure having valid and up to date essential system information as specified in clause 5.2.2.2 before initiating this procedure.

Upon initiation of the procedure, the UE shall:

- 1> if the upper layers provide an Access Category and one or more Access Identities upon requesting establishment of an RRC connection:
 - 2> perform the unified access control procedure as specified in 5.3.14 using the Access Category and Access Identities provided by upper layers;

[TS 38.331, clause 5.3.3.3]

The UE shall set the contents of *RRCSetupRequest* message as follows:

- 1> set the *ue-Identity* as follows:
 - 2> if upper layers provide a 5G-S-TMSI:
 - 3> set the *ue-Identity* to *ng-5G-S-TMSI-Part1*;

2> else:

3> draw a 39-bit random value in the range $0..2^{39}-1$ and set the *ue-Identity* to this value;

NOTE 1: Upper layers provide the *5G-S-TMSI* if the UE is registered in the TA of the current cell.

1> set the *establishmentCause* in accordance with the information received from upper layers;

The UE shall submit the *RRCSetupRequest* message to lower layers for transmission.

11.1.1.3 Test Description

11.1.1.3.1 Pre-test conditions

System Simulator:

- NGC Cell 1 is configured according to TS 38.508-1 [4] Table 4.4.2-3 and is connected to 5GC.
- E-UTRA Cell 1 is configured to TS 36.508 [7] Table 4.4.2-2 and is connected to EPC.
- Default system information in accordance with combination NR-6 in TS 38.508-1 [4] sub-clause 4.4.3.1.2.
- N26 interface is configured.
- Power levels are constant and as defined in Table 11.1.1.3.1-1

Table 11.1.1.3.1-1: Cell power levels

	Parameter name	Unit	NGC Cell 1	E-UTRA Cell 1
T0	SS PBCH EPRE	dBm/15kHz	"Serving Cell"	
	RS EPRE	dBm/15kHz		
	CPICH_Ec	dBm/3.84 MHz		"Serving Cell"
	P-CCPCH	dBm/1.28 MHz		"Serving Cell"

UE:

None.

Preamble:

With E-UTRA Cell 1 "Serving cell" and NGC Cell 1 "Non-suitable "Off" cell", the UE is brought to state RRC_IDLE Connectivity (*E-UTRA/EPC*) in accordance with the procedure described in TS 38.508-1 [4], Table 4.5.2.2-1. 4G GUTI and eKSI are assigned and security context established

The UE is switched-off

With E-UTRA Cell 1 "Non-suitable "Off" cell" and NGC Cell 1 "Serving cell", the UE is brought to state 1N-A, RRC_IDLE Connectivity (NR), in accordance with the procedure described in TS 38.508-1 [4], Table 4.5.2.2-2. 5G-GUTI and ngKSI are assigned and security context established.

11.1.1.3.2

Test procedure sequence

Table 11.1.1.3.2-1: Main behaviour

St	Procedure	Message Sequence		TP	Verdict
		U - S	Message		
0	Set the power levels according to "T0" as per Table 11.1.1.3.1-1				
1	Make the UE attempt an MTSI MO Speech Call (Note 1)				
2	Check: Does the UE send NR <i>RRCSetupRequest</i> with <i>EstablishmentCause</i> set to 'mo-VoiceCall'?	→	NR RRC: <i>RRCSetupRequest</i>	1	P
3	SS transmits an NR <i>RRCSetup</i> message	←	NR RRC: <i>RRCSetup</i>		
4	Check: Does the UE transmit an NR <i>RRCSetupComplete</i> message to confirm the successful completion of the connection establishment including initiation of 5GSM procedure by including the SERVICE REQUEST message with <i>Service Type</i> set to 'data'?	→	NR RRC: <i>RRCSetupComplete</i> 5GSM: SERVICE REQUEST	1	-
5-8	Steps 5-8 of expected sequence from Table 4.5.4.2-3 as defined in 38.508-1[] is performed				
9-13	Steps 2-6 of expected sequence from C.21e as defined in TS 34.229-1 is performed for MTSI MO Speech call for NR				
14	SS transmits <i>RRCRelease</i> message indicating redirection to E-UTRA Cell 1	←	NR RRC: <i>RRCRelease</i>	-	-
15-20	UE performs generic procedure as defined in TS 38.508-1, Table 4.9.7.2.2-1 Steps 1-6 for N1 to S1 Inter mode change with condition 'connected without release' & 'mapped 5G security context'				
21-23	Generic Test Procedure as defined in Step 5-7 of 36.508 Table 4.5A.6.3-1 is performed to establish radio bearer corresponding to IMS PDN				
	EXCEPTION: Step 24a1-24a9 describes step sequence depending on UE implementation				
24a1-24a9	The UE may perform steps 10a2a1-10a2a9 as defined in Table 4.5A.3-1 in TS 36.508 to perform IMS re-registration on EUTRAN				
25	The SS configures a new RLC-UM data radio bearer with condition DRB (0,1), associated with the dedicated EPS bearer context. <i>RRCConnectionReconfiguration</i> message contains the ACTIVATE DEDICATED EPS BEARER CONTEXT REQUEST message. EPS bearer context #4 (QCI 1) according to table 6.6.2-1: Reference dedicated EPS bearer contexts.	<--	RRC: <i>RRCConnectionReconfiguration</i> NAS: ACTIVATE DEDICATED EPS BEARER CONTEXT REQUEST		
	EXCEPTION: In parallel to the events described in steps 26-27, the steps specified in table 11.1.1.3.1-3 will take place				
26	The UE transmits an <i>RRCConnectionReconfigurationComplete</i> message to confirm the establishment of the new data radio bearer, associated with the dedicated EPS bearer.	-->	RRC: <i>RRCConnectionReconfigurationComplete</i>		
27	The UE transmits an ACTIVATE DEDICATED EPS BEARER CONTEXT ACCEPT message.	-->	RRC: ULInformationTransfer NAS:ACTIVATE DEDICATED EPS BEARER CONTEXT ACCEPT		
28	UE is triggered by MMI to release the call				
29-32	Follow the Test Steps 2-5 as defined in C.32 TS 34.229-1 for Generic test procedure for MO release of IMS call followed by EPS Bearer Deactivation				

33	SS transmits <i>RRCConnectionRelease</i> message indicating redirection to NGC Cell 1		E-UTRA RRC: <i>RRCConnectionRelease</i>		
34-39	Generic Test procedure for Mobility Update Registration as mentioned in Table 4.9.5.2.2-1 as defined in TS 38.508-1 is performed with condition ' <i>connected without release</i> '				
40	IF 'UE performed IMS registration over E-UTRAN in Steps 24a1-24a9 THEN the UE may perform IMS re-registration on NGC Cell1 as per Table 4.5A.4.2.2-1 as defined in TS 38.508-1.				
41-44	Generic Procedure as defined in Table Table 4.9.6.3-1 to switch off the UE in NR RRC_CONNECTED mode is performed				
Note 1: UE is configured such that Access Control check passes for MO MMTEL Voice call					

Table 11.1.1.3.2-2: Parallel behaviour

St	Procedure	Message Sequence		TP	Verdict
		U - S	Message		
1-5	Step 7 of 12 of the MTSI MO speech call for EPS procedure according TS 34.229-1 [XX] subclause C.21e takes place.	-	-		
6	Step 13 of the MTSI MO speech call for EPS procedure according TS 34.229-1 [XX] subclause C.21 takes place.			2	P

11.1.1.3.3 Specific message contents

Table 11.1.1.3.3-1: RRCSetupRequest (step 2, table 11.1.1.3.1-2)

Derivation Path: TS 38.508-1 Table 4.6.1-23			
Information Element	Value/remark	Comment	Condition
RRCSetupRequest ::= SEQUENCE {			
rrcSetupRequest SEQUENCE {			
establishmentCause	Mo-Voicecall		
}			
}			

Table 11.1.1.3.3-2: SERVICE REQUEST (step 4, table 11.1.1.3.1-2)

Derivation path: 38.508-1 Table 4.7.1-16			
Information Element	Value/Remark	Comment	Condition
Service type	0001	data	
Uplink data status	Present	PSI bit corresponding to IMS PDN needs to be set	

Table 11.1.1.3.3-3: RRCRelease (step 14, table 11.1.1.3.1-2)

Derivation path: 38.508-1 Table Table 4.6.1-16			
Information Element	Value/Remark	Comment	Condition
RRCRelease ::= SEQUENCE {			
criticalExtensions CHOICE {			
rrcRelease SEQUENCE {			
redirectedCarrierInfo ::= CHOICE {			
eutra SEQUENCE {			
eutraFrequency	Downlink EARFCN of EUTRA cell 1		
cnType	epc		
}			
}			
}			
}			
}			

Table 11.1.1.3.3-4: RRCConnectionRelease (step 33, table 11.1.1.3.1-2)

Derivation path: 38.508 table 4.6.1-15			
Information Element	Value/Remark	Comment	Condition
RRCConnectionRelease ::= SEQUENCE {			
criticalExtensions CHOICE {			
c1 CHOICE {			
rrcConnectionRelease-r8 SEQUENCE {			
redirectedCarrierInfo ::= SEQUENCE {			
nr-r15 ::= SEQUENCE {			
carrierFreq-r15	Downlink NR SSB ARFCN of cell NGC Cell 1		TS38.508-1[] cl.6.2.3.1
subcarrierSpacingSSB-r15			
}			
}			
}			
}			
}			
}			

11.1.2 MO MMTEL voice call setup from NR RRC_IDLE / EPS Fallback with redirection / Single registration mode without N26 interface / Success

11.1.2.1 Test Purpose (TP)

(1)

```
with {UE supporting both S1 mode and N1 mode and operating in single-registration mode, and, the Network has indicated "interworking without N26 interface supported", and, the UE is in NR RRC_IDLE state}
ensure that {
  when {User initiates a MMTEL call and the UE completes Access control and checking in 5GMM-IDLE mode}
  then {UE requests the establishment of a MMTEL call by transmitting an RRCSetupRequest message with establishmentCause set to 'mo-VoiceCall', and, a SERVICE REQUEST message with Service type set to 'data'}
}
```

(2)

```
with {the UE is NR RRC_CONNECTED state after having requested a MMTEL call establishment and the MO IMS voice session establishment has been initiated}
ensure that {
  when {the UE receives a RRCRelease message which includes redirectedCarrierInfo indicating redirection to eutra}
}
```

```

then {the UE selects the E-UTRA cell, performs a TAU procedure, and, successfully completes the
MO MMTEL call setup in EPS}
}
    
```

11.1.2.2 Conformance requirements

References: The conformance requirements covered in the current TC are specified in: TS23.502, clauses 4.11.1.3.2, 4.13.6.1; TS 24.501, clauses 4.5.4.1, 4.8.2.3; TS 38.331, clauses 5.3.3.2, 5.3.3.3, 5.3.8.3, and 5.3.11. Unless otherwise stated these are Rel-15 requirements.

[TS 23.502, clause 4.11.1.3.2]

Clause 4.11.1.3.2 covers the case of idle mode mobility from 5GC to EPC. UE performs Tracking Area Update procedure in E-UTRA/EPS when it moves from NG-RAN/5GS to E-UTRA/EPS coverage area.

The procedure involves a Tracking Area Update to EPC and setup of default EPS bearer and dedicated bearers in EPC in steps 1-11 and re-activation, if required.

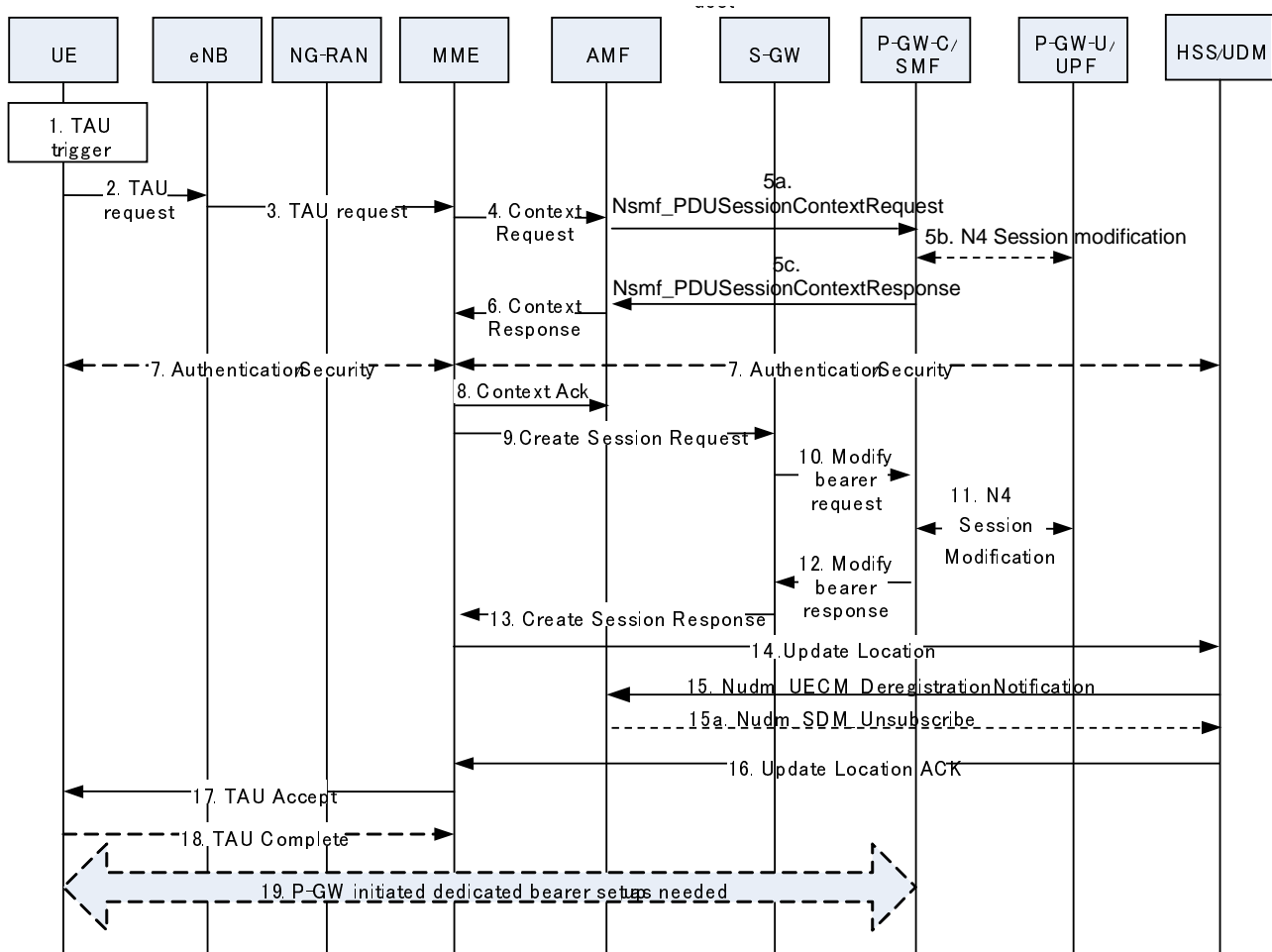

Figure 4.11.1.3.2-1: 5GS to EPS Idle mode mobility using N26 interface

The TAU procedure in TS 23.401 [13] is used with the following 5GS interaction:

1. Step 1 from clause 5.3.3.1 (Tracking Area Update procedure with Serving GW change) in TS 23.401 [13].
2. Step 2 from clause 5.3.3.1 (Tracking Area Update procedure with Serving GW change) in TS 23.401 [13] with the modification captured in clause 4.11.1.5.3.
- 3-4. Steps 3-4 from clause 5.3.3.1 (Tracking Area Update procedure with Serving GW change) in TS 23.401 [13].
- 5a. The AMF verifies the integrity of the TAU request message and requests the PGW-C+SMF to provide SM Context by using Nsmf_PDUSession_ContextRequest that also includes the mapped EPS Bearer Contexts. The

AMF provides the target MME capability to SMF in the request to allow the SMF to determine whether to include EPS Bearer context for non-IP PDN Type or not. This step is performed with all the PGW-C+SMFs corresponding to PDU Sessions of the UE which are associated with 3GPP access and have EBI(s) allocated to them. In this step, if the AMF correctly validates the UE, then the AMF starts a timer.

NOTE 1: The AMF knows the MME capability to support non-IP PDN type or not through local configuration.

5b. For Non-roaming or roaming with local breakout scenario, if CN Tunnel Info is allocated by the PGW-U+UPF, the SMF sends N4 Session Modification Request to PGW-U+UPF to establish the tunnel for each EPS bearers, and PGW-U+UPF provides the PGW-U Tunnel Info for each EPS bearers to PGW-C+SMF.

NOTE2: In home routed roaming case, the CN Tunnel Info for each EPS bearer has been prepared by the PGW-C+SMF and provided to the V-SMF as specified in clause 4.11.1.4.1.

5c. SMF returns mapped EPS bearer contexts, which includes PGW-C control plane tunnel information of the PDN connection corresponding to the PDU session, EBI for each EPS bearer, PGW-U tunnel information for each EPS bearer, and EPS QoS parameters for each EPS bearer. For PDU Sessions with PDU Session Type Ethernet or Unstructured, the SMF provides SM Context for non-IP PDN Type.

6. The AMF responds with a Context Response message carrying mapped MM context (including mapped security context), Return preferred and SM EPS UE Context (default and dedicated GBR bearers) to the MME. If the verification of the integrity protection fails, the AMF returns an appropriate error cause. Return preferred is an optional indication by the AMF of a preferred return of the UE to the 5GS PLMN at a later access change to a 5GS shared network. The AMF may start an implementation specific (guard) timer for the UE context.

7 - 14. Steps 6-12 from clause 5.3.3.1 (Tracking Area Update procedure with Serving GW change) in TS 23.401 [13] are performed with following addition and modification:

In the step 10, If the QoS Flow associated with the default QoS rule has an EPS Bearer ID assigned, the PGW-C+SMF keeps the PDU Session (PDN connection) and for the remaining QoS Flows that do not have EPS bearer ID(s) assigned, the PGW-C+SMF deletes the PCC rule(s) associated with those QoS Flows and informs the PCF about the removed PCC rule(s).

In the step 11, the PGW-C+SMF requests the PGW-U+UPF to establish the tunnel for each EPS bearer by providing SGW-U Tunnel Info, and PGW-U Tunnel Info if the PGW-U Tunnel Info is allocated by the PGW-C+SMF.

In step 10, the PGW-C+SMF may need to report some subscribed event to the PCF by performing an SMF initiated SM Policy Association Modification procedure as defined in clause 4.16.5.

Step 9a from clause 5.3.3.1 (Tracking Area Update procedure with Serving GW change) in TS 23.401 [13] with the modification captured in clause 4.11.1.5.3

15a. The HSS+UDM invokes Nudm_UECM_DeregistrationNotification to notify the AMF associated with 3GPP access with reason as 5GS to EPS Mobility. If the timer started in step 6 is not running, the old AMF removes the UE context. Otherwise, the AMF may remove UE context when the timer expires. The AMF request the release of the PDU Session which is associated with 3GPP access, not expected to be transferred to EPC, i.e. no EBI(s) allocated to them, and corresponding to the PGW-C+SMF which is not contacted by AMF for SM context at step 5a. The AMF requests the release of the SM context in the V-SMF only, for Home Routed PDU Session with EBIs allocated. The 5GC may also keep UE context to allow the use of native security parameters when UE moves back from EPS to 5GS later.

Registration associated with the non-3GPP access in the AMF is not removed (i.e. an AMF that was serving the UE over both 3GPP and non-3GPP accesses does not consider the UE as deregistered over non 3GPP access and will remain registered and subscribed to subscription data updates in UDM).

When the UE decides to deregister over non-3GPP access or the old AMF decides not to maintain a UE registration for non-3GPP access anymore, the old AMF then deregisters from UDM by sending a Nudm_UECM_Deregistration service operation, unsubscribes from Subscription Data updates by sending a Nudm_SDM_Unsubscribe service operation to UDM and releases all the AMF and AN resources related to the UE.

16 - 18. Steps 17-21 from clause 5.3.3.1 (Tracking Area Update procedure with Serving GW change) in TS 23.401 [13] with the following modification:

The MME may provide the eNodeB with a PLMN list in the Handover Restriction List taking into account the last used 5GS PLMN ID and the Return preferred indication. The Handover Restriction List contains a list of PLMN IDs as specified by TS 23.251 [35] clause 5.2a for eNodeB functions.

The MME may not release the signaling connection with the UE based on the indication received in the step 1 that the UE is moving from 5GC.

19. [conditional] Step 19 from clause 4.11.1.2.1 applies.

[TS 23.502, clause 4.13.6.1]

Figure 4.13.6.1-1 describes the EPS fallback procedure for IMS voice.

When the UE is served by the 5G System, the UE has one or more ongoing PDU Sessions each including one or more QoS Flows. The serving PLMN AMF has sent an indication towards the UE during the Registration procedure that IMS voice over PS session is supported, see clause 5.16.3.10 in TS 23.501 [2] and the UE has registered in the IMS. If N26 is not supported, the serving PLMN AMF sends an indication towards the UE during the Registration procedure that interworking without N26 is supported, see clause 5.17.2.3.1 in TS 23.501 [2].

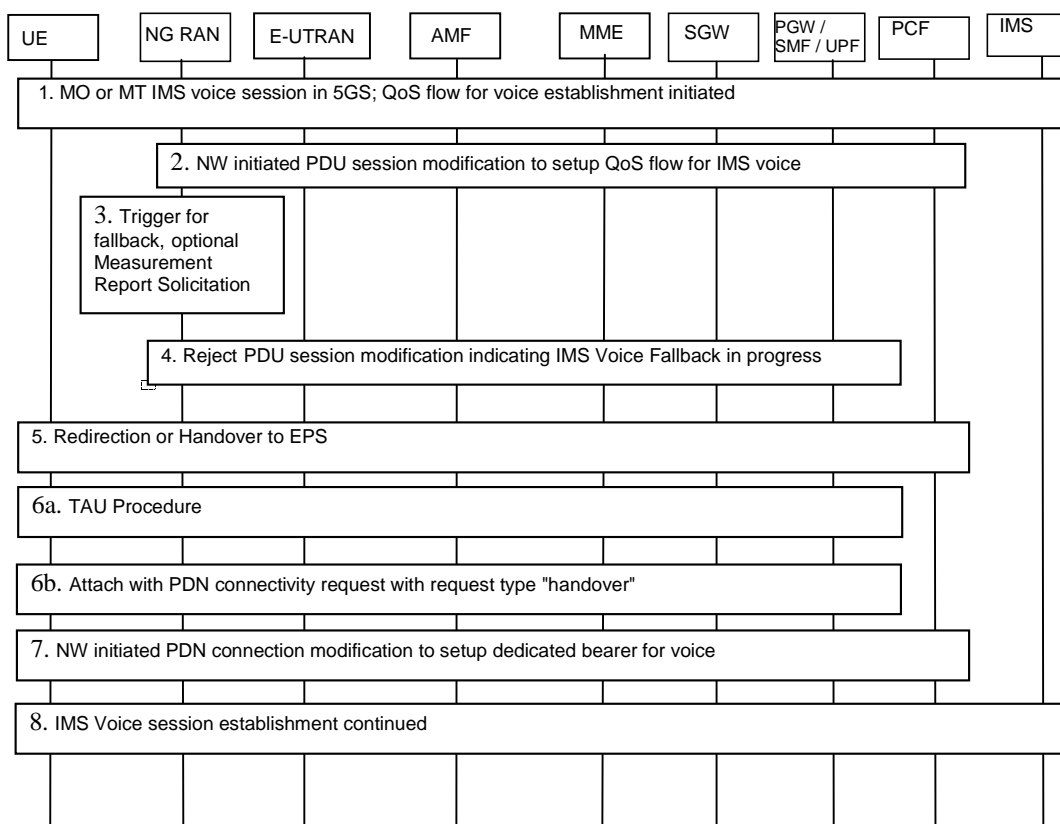

Figure 4.13.6.1-1: EPS Fallback for IMS voice

1. UE camps on NG-RAN in the 5GS and an MO or MT IMS voice session establishment has been initiated.
2. Network initiated PDU Session modification to setup QoS flow for voice reaches the NG-RAN (see N2 PDU Session Request in clause 4.3.3).
3. NG-RAN is configured to support EPS fallback for IMS voice and decides to trigger fallback to EPS, taking into account UE capabilities, indication from AMF that "Redirection for EPS fallback for voice is possible" (received as part of initial context setup as defined in TS 38.413 [10]), network configuration (e.g. N26 availability configuration) and radio conditions. If NG-RAN decides not to trigger fallback to EPS, then the procedure stops here and following steps are not executed.

NG-RAN may initiate measurement report solicitation from the UE including E-UTRAN as target.

NOTE 1: If AMF has indicated that "Redirection for EPS fallback for voice is not possible", then AN Release via inter-system redirection to EPS is not performed in step 5.

4. NG-RAN responds indicating rejection of the PDU Session modification to setup QoS flow for IMS voice received in step 2 by PDU Session Response message towards the PGW-C+SMF (or H-SMF+P-GW-C via V-SMF, in case of roaming scenario) via AMF with an indication that mobility due to fallback for IMS voice is ongoing. The PGW-C+SMF maintains the PCC rule(s) associated with the QoS Flow(s).
5. NG-RAN initiates either handover (see clause 4.11.1.2.1), or AN Release via inter-system redirection to EPS (see clause 4.2.6 and clause 4.11.1.3.2), taking into account UE capabilities. The PGW-C+SMF reports change of the RAT type if subscribed by PCF as specified in clause 4.11.1.2.1, or clause 4.11.1.3.2.6. When the UE is connected to EPS, either 6a or 6b is executed
 - 6a. In the case of 5GS to EPS handover, see clause 4.11.1.2.1, and in the case of inter-system redirection to EPS with N26 interface, see clause 4.11.1.3.2. In either case the UE initiates TAU procedure; or
 - 6b. In the case of inter-system redirection to EPS without N26 interface, see clause 4.11.2.2. If the UE supports Request Type flag "handover" for PDN connectivity request during the attach procedure as described in clause 5.3.2.1 of TS 23.401 [13] and has received the indication that interworking without N26 is supported, then the UE initiates Attach with PDN connectivity request with request type "handover".

In inter-system redirection, the UE uses the emergency indication in the RRC message as specified in clause 6.2.2 of TS 36.331 [16] and E-UTRAN provides the emergency indication to MME during Tracking Area Update or Attach procedure. For the handover procedure see clause 4.11.1.2.1, step 1.
7. After completion of the mobility procedure to EPS or as part of the 5GS to EPS handover procedure (see clause 4.11.1.2.1), the SMF/PGW re-initiates the setup of the dedicated bearer for IMS voice, mapping the 5G QoS to EPC QoS parameters. The PGW-C+SMF behaves as specified in clause 4.9.1.3.1. The PGW-C+SMF reports about Successful Resource Allocation and Access Network Information if subscribed by PCF.
8. The IMS voice session establishment is continued.

At least for the duration of the voice call in EPS the E-UTRAN is configured to not trigger any handover to 5GS.

[TS 24.501, clause 4.5.4.1]

When the UE is in 5GMM-IDLE mode, upon receiving a request from the upper layers for an access attempt, the NAS shall categorize the access attempt into access identities and an access category following subclause 4.5.2, table 4.5.2.1 and table 4.5.2.2, and subclause 4.5.3, and provide the applicable access identities and the access category to the lower layers for the purpose of access control checking. In this request to the lower layer the NAS can also provide to the lower layer the RRC establishment cause determined as specified in subclause 4.5.6 of this specification.

NOTE 1: The access barring check is performed by the lower layers.

NOTE 2: As an implementation option, the NAS can provide the RRC establishment cause to the lower layers after being informed by the lower layers that the access attempt is allowed.

If the UE has uplink user data pending for one or more PDU sessions when it builds a REGISTRATION REQUEST or SERVICE REQUEST message as initial NAS message, the UE shall indicate the respective PDU sessions in the Uplink data status IE as specified in subclause 5.5.1.3.2 and 5.6.1.2, regardless of the access category for which the access barring check is performed.

NOTE 3: The UE indicates pending user data for all the respective PDU sessions, even if barring timers are running for some of the corresponding access categories.

If the lower layers indicate that the access attempt is allowed, the NAS shall initiate the procedure to send the initial NAS message for the access attempt.

If the lower layers indicate that the access attempt is barred, the NAS shall not initiate the procedure to send the initial NAS message for the access attempt. Additionally:

- a) if the event which triggered the access attempt was an MO-MMTEL-voice-call-started indication or an MO-MMTEL-video-call-started indication:
 - 1) if the UE is operating in the single-registration mode and the UE's usage setting is "voice centric", the UE may attempt to select an E-UTRA cell connected to EPC. If the UE finds a suitable E-UTRA cell connected to EPC, it then proceeds with the appropriate EMM specific procedures and, if necessary, ESM procedures to make a PDN connection providing access to IMS available; see subclause 4.8.2 and 3GPP TS 24.301 [15];

- 2) if the UE is operating in the dual-registration mode, the UE may proceed in S1 mode with the appropriate EMM specific procedures and ESM procedures to make a PDN connection providing access to IMS available; see subclause 4.8.3 and 3GPP TS 24.301 [15];
 - 3) otherwise, the NAS shall notify the upper layers that the access attempt is barred. In this case, upon receiving an indication from the lower layers that the barring is alleviated for the access category with which the access attempt was associated, the NAS shall notify the upper layers that the barring is alleviated for the access category and may initiate the procedure to send the initial NAS message, if still needed; and
- b) if the event which triggered the access attempt was an MO-SMSoIP-attempt-started indication:
- 1) if the UE is operating in the single-registration mode, the UE may attempt to select an E-UTRA cell connected to EPC. If the UE finds a suitable E-UTRA cell connected to EPC, it then proceeds with the appropriate EMM specific procedures and, if necessary, ESM procedures to make a PDN connection providing access to IMS available; see subclause 4.8.2 and 3GPP TS 24.301 [15];
 - 2) if the UE is operating in the dual-registration mode, the UE may proceed in S1 mode with the appropriate EMM specific procedures and ESM procedures to make a PDN connection providing access to IMS available; see subclause 4.8.3 and 3GPP TS 24.301 [15];
 - 3) otherwise, the NAS layer shall notify the upper layers that the access attempt is barred. In this case, upon receiving an indication from the lower layers that the barring is alleviated for the access category with which the access attempt was associated, the NAS shall notify the upper layers that the barring is alleviated for the access category and may initiate the procedure to send the initial NAS message, if still needed.

NOTE 4: Barring timers, on a per access category basis, are run by the lower layers. At expiry of barring timers, the indication of alleviation of access barring is indicated to the NAS on a per access category basis.

[TS 24.501, clause 4.8.2.3]

At inter-system change from N1 mode to S1 mode in EMM-IDLE mode when: (PDU SEESION ACTIVE)

- a) the UE supports non-IP PDN type and at least one PDU session is active; or
- b) the UE does not support non-IP PDN type and at least one PDU session of IPv4, IPv6 or IPv4v6 PDU session type is active,

the UE shall proceed as follows:

- a) if the UE supports sending an ATTACH REQUEST message containing a PDN CONNECTIVITY REQUEST message with request type set to "handover" to transfer a PDU session from N1 mode to S1 mode and the UE has received an "interworking without N26 interface supported" indication from the network, the UE shall:
 - 1) enter substates EMM-DEREGISTERED.NORMAL-SERVICE and 5GMM-REGISTERED.NO-CELL-AVAILABLE;
 - 2) map the PDU session(s) which the UE intends to transfer to EPS to the default EPS bearer context of the corresponding PDN connection(s) as specified in subclause 6.1.4.2; and
 - 3) initiate an EPS attach procedure and include a PDN CONNECTIVITY REQUEST message with request type set to "handover" in the ATTACH REQUEST message to activate a default EPS bearer context for one of the active PDU sessions which the UE intends to transfer to EPS.

After successful completion of the EPS attach procedure, the UE shall reset the registration attempt counter and the attach attempt counter (see 3GPP TS 24.301 [15]) and attempt to activate each of the other default EPS bearer contexts, if any, by initiating a stand-alone PDN connectivity procedure with request type set to "handover" in the PDN CONNECTIVITY REQUEST message; and

- b) otherwise, enter substates EMM-REGISTERED.NORMAL-SERVICE and 5GMM-REGISTERED.NO-CELL-AVAILABLE and initiate a tracking area update procedure (see 3GPP TS 24.301 [15]).

At inter-system change from N1 mode to S1 mode in EMM-IDLE mode when: (NO PDU SESSION)

- a) the UE supports non-IP PDN type and no PDU session is active; or

- b) the UE does not support non-IP PDN type and no PDU session of IPv4, IPv6 or IPv4v6 PDU session type is active,

the UE shall enter substates EMM-DEREGISTERED.NORMAL-SERVICE and 5GMM-DEREGISTERED.NO-CELL-AVAILABLE, and initiate an attach procedure.

At inter-system change from S1 mode to N1 mode in 5GMM-IDLE mode, the UE shall:

- a) enter substate 5GMM-REGISTERED.NORMAL-SERVICE and substate EMM-REGISTERED.NO-CELL-AVAILABLE;
- b) map the default EPS bearer context(s) of the PDN connection(s) which the UE intends to transfer to 5GS, if any, to the corresponding PDU session(s) as specified in subclause 6.1.4.2; and
- c) initiate the registration procedure for mobility and periodic registration update indicating "mobility registration updating" in the 5GS registration type IE of the REGISTRATION REQUEST message (see subclause 5.5.1.3).

After having successfully registered in N1 mode the UE shall reset the registration attempt counter and the attach attempt counter (see 3GPP TS 24.301 [15]) and:

- a) if the UE supports the PDU session establishment procedure with request type set to "existing PDU session" to transfer a PDN connection from S1 mode to N1 mode and the UE has received an "interworking without N26 interface supported" indication from the network, attempt to transfer the PDN connection(s) which the UE intends to transfer to 5GS, if any, from S1 mode to N1 mode by initiating the PDU session establishment procedure with request type set to "existing PDU session"; and
- b) otherwise, establish PDU session(s) corresponding to the PDN connection(s) which the UE intends to transfer to 5GS, if any, by initiating the PDU session establishment procedure with request type set to "initial request".

See subclause 5.1.4.3 for coordination between 5GMM and EMM and subclause 6.1.4.2 for coordination between 5GSM and ESM.

[TS 38.331, clause 5.3.11]

UE shall:

- 1> reset MAC;
- 1> if T302 is running:
 - 2> stop timer T302;
 - 2> perform the actions as specified in 5.3.14.4;
- 1> stop all timers that are running except T320 and T325;
- 1> discard the UE Inactive AS context;
- 1> set the variable *pendingRnaUpdate* to *false*, if that is set to *true*;
- 1> discard the K_{gNB} , the K_{RRCenc} key, the K_{RRCint} , the K_{UPint} key and the K_{UPenc} key, if any;
- 1> release all radio resources, including release of the RLC entity, the MAC configuration and the associated PDCP entity and SDAP for all established RBs;
- 1> indicate the release of the RRC connection to upper layers together with the release cause;
- 1> enter RRC_IDLE and perform cell selection as specified in TS 38.304 [20], except if going to RRC_IDLE was triggered by selecting an inter-RAT cell while T311 was running;
- 1> if going to RRC_IDLE was triggered by reception of the *RRCRelease* message including a *waitTime*:
 - 2> start timer T302 with the value set to the *waitTime*;
 - 2> inform the upper layer that access barring is applicable for all access categories except categories '0' and '2'.

11.1.2.3 Test description

11.1.2.3.1 Pre-test conditions

System Simulator:

- 2 cells
- NGC Cell A as defined in TS 38.508-1 [4] Table 6.3.2.2-1. Default system information combination as defined in TS 38.508-1 [4], sub-clause 4.4.3.1.2.
- E-UTRA Cell 1 as defined in TS 36.508 [7] Table 4.4.2-2. System information combination 1 as defined in TS 36.508 [7], sub-clause 4.4.3.1.1.

UE:

- None

Preamble:

- With E-UTRA Cell 1 "Serving cell" and NGC Cell A "Non-suitable "Off" cell" in accordance with TS 38.508-1 [4], Table 6.2.2.1-3, the UE is brought to state RRC_IDLE Connectivity (*E-UTRA/EPC*) in accordance with the procedure described in TS 38.508-1 [4], Table 4.5.2.2-1. 4G GUTI and eKSI are assigned and security context established
- The UE is switched-off
- With E-UTRA Cell 1 "Non-suitable "Off" cell" and NGC Cell A "Serving cell" in accordance with TS 38.508-1 [4], Table 6.2.2.1-3, the UE is brought to state 1N-A, RRC_IDLE Connectivity (NR), in accordance with the procedure described in TS 38.508-1 [4], Table 4.5.2.2-2. 5G-GUTI and ngKSI are assigned and security context established.

11.1.2.3.2 Test procedure sequence

Table 11.1.2.3.2-1: Main behaviour

St	Procedure	Message Sequence		TP	Verdict
		U – S	Message		
1	The SS configures: - E-UTRA Cell 1 as "Suitable neighbour intra-frequency cell" in accordance with TS 38.508-1 [4], Table 6.2.2.1-3.	-	-	-	-
-	EXCEPTION: Unless otherwise stated the following messages are exchange on NGC Cell A.	-	-	-	-
2	User initiates a MMTEL call.	-	-	-	-
3	Check: Does the UE transmits an <i>RRCSetupRequest</i> message?	-->	NR RRC: <i>RRCSetupRequest</i>	1	P
4	The SS transmits an <i>RRCSetup</i> message.	<--	NR RRC: <i>RRCSetup</i>	-	-
5	Check: Does the UE transmits an <i>RRCSetupComplete</i> message and a SERVICE REQUEST message?	-->	NR RRC: <i>RRCSetupComplete</i> 5GMM: SERVICE REQUEST	1	P
6	The SS transmits an <i>RRCRelease</i> message.	<--	NR RRC: <i>RRCRelease</i>	-	-
-	EXCEPTION: Unless otherwise stated the following messages are exchange on E-UTRA Cell 1.	-	-	-	-
7-11	Steps 1 to 5 of the the generic test procedure for Tracking area updating / inter-system change from N1 mode to S1 mode in 5GMM/EMM-IDLE mode (TS38.508-1 Table 4.9.7.2.2-1) are performed.	-	-	-	-
12	Check: Does the UE transmit TRACKING AREA UPDATE COMPLETE?	-->	RRC: <i>ULInformationTransfer</i> NAS: TRACKING AREA UPDATE COMPLETE	2	P
-	EXCEPTION: In parallel to the events described in steps 12 to 21 the UE may perform IMS re-registration on EUTRAN as per steps 3-11 as defined in 34.229-1 subclause C.2.	-	-	-	-
13-19	Steps 7-13 from the Generic Test Procedure for MTSI MO speech call establishment (TS 36.508 table 4.5A.6.3-1) are performed.	-	-	-	-
20	Check: Does the UE transmit an ACTIVATE DEDICATED EPS BEARER CONTEXT ACCEPT message?	-->	RRC: <i>ULInformationTransfer</i> NAS:ACTIVATE DEDICATED EPS BEARER CONTEXT ACCEPT	2	P
21	The SS waits 1 second.	-	-	-	-
22	Release IMS Call as specified in the generic procedure in TS 34.229-1 [x1] subclause C.32.	-	-	-	-
23	The SS transmits a DEACTIVATE EPS BEARER CONTEXT REQUEST including the EPS bearer identity of the default EPS bearer to the emergency PDN.	<--	DEACTIVATE EPS BEARER CONTEXT REQUEST	-	-
24	The UE transmits a DEACTIVATE EPS BEARER CONTEXT ACCEPT.	-->	DEACTIVATE EPS BEARER CONTEXT ACCEPT	-	-

11.1.2.3.3 Specific message contents

Table 11.1.2.3.3-1: RRCSetupRequest (step 3, table 11.1.2.3.2-1)

Derivation Path: TS 38.508-1 Table 4.6.1-23			
Information Element	Value/remark	Comment	Condition
RRCSetupRequest ::= SEQUENCE {			
rrcSetupRequest SEQUENCE {			
establishmentCause	Mo-Voicecall		
}			
}			

Table 11.1.2.3.3-2: SERVICE REQUEST (step 5, table 11.1.2.3.2-1)

Derivation path: 38.508-1 Table 4.7.1-16			
Information Element	Value/Remark	Comment	Condition
Service type	0001	data	
Uplink data status	Present	PSI bit corresponding to IMS PDN needs to be set	

Table 11.1.2.3.3-3: RRCRelease (step 6, table 11.1.2.3.2-1)

Derivation path: 38.508-1 Table Table 4.6.1-16			
Information Element	Value/Remark	Comment	Condition
RRCRelease ::= SEQUENCE {			
criticalExtensions CHOICE {			
rrcRelease SEQUENCE {			
redirectedCarrierInfo ::= CHOICE {			
eutra.SEQUENCE{			
eutraFrequency	Downlink EARFCN of E-UTRA cell 1		
cnType	epc		
}			
}			
}			
}			

Table 11.1.2.3.3-4: TRACKING AREA UPDATE REQUEST (step 9, table 11.1.2.3.2-1)

Derivation Path: TS 36.508 [2], Table 4.7.2-27, condition NR.			
Information Element	Value/Remark	Comment	Condition
"Active" flag	0001	Bearer Establishment requested	
EPS bearer context status	Present	EBI corresponding to active PDU Sessions need to be set to 1	
NAS key set identifier	the eKSI indicating the 5G NAS security context value assigned at the initial registration when the UE entered N1		
Old GUTI	GUTI, mapped from the 5G-GUTI assigned at the initial registration when the UE entered N1		
Last visited registered TAI	The TAI to which the NGC cell belonged to (the cell in which the UE was when in N1 before moving to S1).		
Old GUTI type	"Native GUTI"		
UE status	"UE is in 5GMM-REGISTERED state"		

11.1.3 MO MMTEL voice call setup from NR RRC_CONNECTED / EPS Fallback with handover / Single registration mode with N26 interface / Success

11.1.3.1 Test Purpose (TP)

(1)

with { UE supporting both S1 mode and N1 mode and operating in single-registration mode, and, the Network has indicated "interworking without N26 interface not supported", **and**, the UE is in NR RRC_CONNECTED state after having established connection with *establishmentCause* set to 'mo-Data', and, the UE is receiving and transmitting PS data }

ensure that {

when { User initiates a MMTEL call, the MO IMS voice session establishment has been initiated and the UE receives a *MobilityFromNRCommand* message which includes *targetRAT-Type* set to *eutra* }

then { UE performs a handover to the E-UTRA including a TAU procedure, **and**, while the UE continues receiving and transmitting PS data the UE successfully completes the MO MMTEL call in EPS }

11.1.3.2 Conformance requirements

References: The conformance requirements covered in the present test case are specified in: TS 23.502, clauses 4.13.6.1, TS 24.501, clauses 4.8.2.2, 5.5.1.2.2, 5.5.1.2.4, 5.1.4.2 and 6.1.4.1, TS 38.331, clause 5.4.3.3 and 5.4.3.4. Unless otherwise stated these are Rel-15 requirements.

[TS 23.502, clause 4.13.6.1]

Figure 4.13.6.1-1 describes the EPS fallback procedure for IMS voice.

When the UE is served by the 5G System, the UE has one or more ongoing PDU Sessions each including one or more QoS Flows. The serving PLMN AMF has sent an indication towards the UE during the Registration procedure that IMS voice over PS session is supported, see clause 5.16.3.10 in TS 23.501 [2] and the UE has registered in the IMS. If N26 is not supported, the serving PLMN AMF sends an indication towards the UE during the Registration procedure that interworking without N26 is supported, see clause 5.17.2.3.1 in TS 23.501 [2].

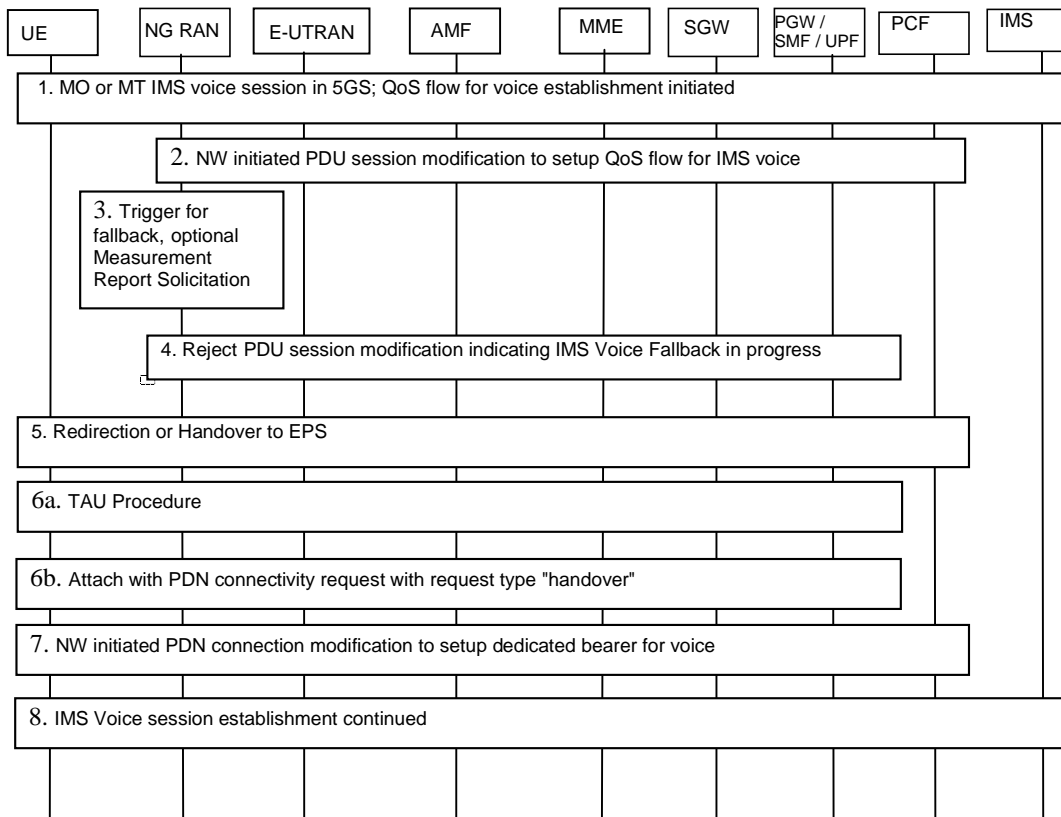

Figure 4.13.6.1-1: EPS Fallback for IMS voice

1. UE camps on NG-RAN in the 5GS and an MO or MT IMS voice session establishment has been initiated.
2. Network initiated PDU Session modification to setup QoS flow for voice reaches the NG-RAN (see N2 PDU Session Request in clause 4.3.3).
3. NG-RAN is configured to support EPS fallback for IMS voice and decides to trigger fallback to EPS, taking into account UE capabilities, indication from AMF that "Redirection for EPS fallback for voice is possible" (received as part of initial context setup as defined in TS 38.413 [10]), network configuration (e.g. N26 availability configuration) and radio conditions. If NG-RAN decides not to trigger fallback to EPS, then the procedure stops here and following steps are not executed.

NG-RAN may initiate measurement report solicitation from the UE including E-UTRAN as target.

NOTE 1: If AMF has indicated that "Redirection for EPS fallback for voice is not possible", then AN Release via inter-system redirection to EPS is not performed in step 5.

4. NG-RAN responds indicating rejection of the PDU Session modification to setup QoS flow for IMS voice received in step 2 by PDU Session Response message towards the PGW-C+SMF (or H-SMF+P-GW-C via V-SMF, in case of roaming scenario) via AMF with an indication that mobility due to fallback for IMS voice is ongoing. The PGW-C+SMF maintains the PCC rule(s) associated with the QoS Flow(s).
5. NG-RAN initiates either handover (see clause 4.11.1.2.1), or AN Release via inter-system redirection to EPS (see clause 4.2.6 and clause 4.11.1.3.2), taking into account UE capabilities. The PGW-C+SMF reports change of the RAT type if subscribed by PCF as specified in clause 4.11.1.2.1, or clause 4.11.1.3.2.6. When the UE is connected to EPS, either 6a or 6b is executed
 - 6a. In the case of 5GS to EPS handover, see clause 4.11.1.2.1, and in the case of inter-system redirection to EPS with N26 interface, see clause 4.11.1.3.2. In either case the UE initiates TAU procedure; or
 - 6b. In the case of inter-system redirection to EPS without N26 interface, see clause 4.11.2.2. If the UE supports Request Type flag "handover" for PDN connectivity request during the attach procedure as described in clause 5.3.2.1 of TS 23.401 [13] and has received the indication that interworking without N26 is supported, then the UE initiates Attach with PDN connectivity request with request type "handover".

In inter-system redirection, the UE uses the emergency indication in the RRC message as specified in clause 6.2.2 of TS 36.331 [16] and E-UTRAN provides the emergency indication to MME during Tracking Area Update or Attach procedure. For the handover procedure see clause 4.11.1.2.1, step 1.

7. After completion of the mobility procedure to EPS or as part of the 5GS to EPS handover procedure (see clause 4.11.1.2.1), the SMF/PGW re-initiates the setup of the dedicated bearer for IMS voice, mapping the 5G QoS to EPC QoS parameters. The PGW-C+SMF behaves as specified in clause 4.9.1.3.1. The PGW-C+SMF reports about Successful Resource Allocation and Access Network Information if subscribed by PCF.
8. The IMS voice session establishment is continued.

At least for the duration of the voice call in EPS the E-UTRAN is configured to not trigger any handover to 5GS.

[TS 24.501, clause 4.8.2.2]

See subclause 5.1.4.2 for coordination between 5GMM and EMM and subclause 6.1.4.1 for coordination between 5GSM and ESM.

[TS 24.501, clause 5.5.1.2.2]

If the UE supports S1 mode, the UE shall:

- set the S1 mode bit to "S1 mode supported" in the 5GMM capability IE of the REGISTRATION REQUEST message;
- include the S1 UE network capability IE in the REGISTRATION REQUEST message; and
- if the UE supports sending an ATTACH REQUEST message containing a PDN CONNECTIVITY REQUEST message with request type set to "handover" to transfer a PDU session from N1 mode to S1 mode, set the HO attach bit to "attach request message containing PDN connectivity request with request type set to handover to transfer PDU session from N1 mode to S1 mode supported" in the 5GMM capability IE of the REGISTRATION REQUEST message.

[TS 24.501, clause 5.5.1.2.4]

If the UE included S1 mode supported indication in the REGISTRATION REQUEST message, the AMF supporting interworking with EPS shall set the IWK N26 bit to either:

- a) "interworking without N26 interface not supported" if the AMF supports N26 interface ; or
- b) "interworking without N26 interface supported" if the AMF does not support N26 interface

in the 5GS network feature support IE in the REGISTRATION ACCEPT message.

The UE supporting S1 mode shall operate in the mode for interworking with EPS as follows:

- a) if the IWK N26 bit in the 5GS network feature support IE is set to "interworking without N26 interface not supported", the UE shall operate in single-registration mode;
- b) if the IWK N26 bit in the 5GS network feature support IE is set to "interworking without N26 interface supported" and the UE supports dual-registration mode, the UE may operate in dual-registration mode; or

NOTE 3: The registration mode used by the UE is implementation dependent.

- c) if the IWK N26 bit in the 5GS network feature support IE is set to "interworking without N26 interface supported" and the UE only supports single-registration mode, the UE shall operate in single-registration mode.

The UE shall treat the received interworking without N26 interface indicator for interworking with EPS as valid in the entire PLMN and its equivalent PLMN(s).

The network informs the UE about the support of specific features, such as IMS voice over PS session, emergency services or emergency services fallback, in the 5GS network feature support information element. In a UE with IMS voice over PS session capability, the IMS voice over PS session indicator, the Emergency services support indicator, and the Emergency services fallback indicator shall be provided to the upper layers. The upper layers take the IMS voice over PS session indicator into account when selecting the access domain for voice sessions or calls. When

initiating an emergency call, the upper layers also take the IMS voice over PS session indicator, the Emergency services support indicator, and the Emergency services fallback indicator into account for the access domain selection.

[TS 24.501, clause 5.1.4.2]

At inter-system change from N1 mode to S1 mode when there is at least one active PDU session for which interworking with EPS is supported as specified in subclause 6.1.4.1, the UE shall enter substates EMM-REGISTERED.NORMAL-SERVICE and 5GMM-REGISTERED.NO-CELL-AVAILABLE and initiate a tracking area updating procedure (see 3GPP TS 24.301 [15]).

[TS 24.501, clause 6.1.4.1]

Upon inter-system change from N1 mode to S1 mode, the UE shall create the default EPS bearer context and the dedicated EPS bearer context(s) based on the parameters of the mapped EPS bearer contexts or the associations between QoS flow and mapped EPS bearer in the PDU session, if available. The EPS bearer identity assigned for the QoS flow of the default QoS rule becomes the EPS bearer identity of the default bearer in the corresponding PDN connection. If there is no EPS bearer identity assigned to the QoS flow of the default QoS rule, the UE shall release locally the PDU session. If there is no EPS bearer identity assigned to the QoS flow(s) which is not associated with the default QoS rule, the UE shall locally delete the QoS rules and the QoS flow level QoS parameters associated with the QoS flow(s). The UE uses the parameters from each PDU session for which interworking with EPS is supported to create corresponding default EPS bearer context and optionally dedicated EPS bearer context(s) as follows:

- a) the PDU session type of the PDU session shall be mapped to the PDN type of the default EPS bearer context as follows:
 - 1) the PDN type shall be set to "non-IP" if the PDU session type is "Ethernet" or "Unstructured";
 - 2) the PDN type shall be set to "IPv4" if the PDU session type is "IPv4";
 - 3) the PDN type shall be set to "IPv6" if the PDU session type is "IPv6"; and
 - 4) the PDN type shall be set to "IPv4v6" if the PDU session type is "IPv4v6";
- b) the PDU address of the PDU session shall be mapped to the PDN address of the default EPS bearer context as follows:
 - 1) the PDN address of the default EPS bearer context is set to the PDU address of the PDU session, if the PDU session type is "IPv4", "IPv6" or "IPv4v6"; and
 - 2) the PDN address of the default EPS bearer context is set to zero, if the PDU session type is "Ethernet" or "Unstructured";
- c) the DNN of the PDU session shall be mapped to the APN of the default EPS bearer context;
- d) the APN-AMBR and extended APN-AMBR received in the parameters of the default EPS bearer context of the mapped EPS bearer contexts shall be mapped to the APN-AMBR and extended APN-AMBR of the default EPS bearer context;
- e) for each PDU session in state PDU SESSION ACTIVE, PDU SESSION MODIFICATION PENDING or PDU SESSION INACTIVE PENDING the UE shall set the state of the mapped EPS bearer context(s) to BEARER CONTEXT ACTIVE; and
- f) for any other PDU session the UE shall set the state of the mapped EPS bearer context(s) to BEARER CONTEXT INACTIVE.

Additionally, for each mapped EPS bearer context or the association between QoS flow and mapped EPS bearer in the PDU session:

- a) the EPS bearer identity shall be set to the EPS bearer identity received in the mapped EPS bearer context, or the EPS bearer identity associated with the QoS flow;
- b) the EPS QoS parameters shall be set to the mapped EPS QoS parameters of the EPS bearer received in the mapped EPS bearer context, or the EPS QoS parameters associated with the QoS flow;

- c) the extended EPS QoS parameters shall be set to the mapped extended EPS QoS parameters of the EPS bearer received in the mapped EPS bearer context, or the extended EPS QoS parameters associated with the QoS flow; and
- d) the traffic flow template shall be set to the mapped traffic flow template of the EPS bearer received in the mapped EPS bearer context, or the stored traffic flow template associated with the QoS flow, if available.

After inter-system change from N1 mode to S1 mode, the UE shall associate the PDU session identity, the S-NSSAI, and the session-AMBR with the default EPS bearer context, and for each EPS bearer context mapped from one or more QoS flows, associate the QoS rule(s) for the QoS flow(s) and the QoS flow description(s) for the QoS flow(s) with the EPS bearer context.

After inter-system change from N1 mode to S1 mode, the UE and the SMF shall maintain the PDU session type of the PDU session until the PDN connection corresponding to the PDU session is released if the UE supports non-IP PDN type and the PDU session type is "Ethernet" or "Unstructured".

After inter-system change from N1 mode to S1 mode, the UE and the SMF shall maintain the always-on PDU session indication.

After inter-system change from N1 mode to S1 mode, the UE and the SMF shall maintain the maximum number of supported packet filters until the PDN connection corresponding to the PDU session is released.

[TS 38.331, clause 5.4.3.3]

The UE shall:

- 1> if T390 is running:
 - 2> stop timer T390 for all access categories;
 - 2> perform the actions as specified in 5.3.14.4;
- 1> if the *targetRAT-Type* is set to *eutra*:
 - 2> consider inter-RAT mobility as initiated towards E-UTRA;
 - 2> forward the *nas-SecurityParamFromNR* to the upper layers, if included;
- 1> access the target cell indicated in the inter-RAT message in accordance with the specifications of the target RAT.

[TS 38.331, clause 5.4.3.4]

Upon successfully completing the handover, at the source side the UE shall:

- 1> reset MAC;
- 1> stop all timers that are running;
- 1> release *ran-NotificationAreaInfo*, if stored;
- 1> release the AS security context including the $K_{RRCCenc}$ key, the K_{RRCint} key, the K_{UPint} key and the K_{UPenc} key, if stored;
- 1> release all radio resources, including release of the RLC entity and the MAC configuration;
- 1> if the E-UTRA *RRCConnectionReconfiguration* message included in the received *MobilityFromNRCommand* does not include *fullConfig*:
 - 2> maintain source RAT configuration of PDCP and SDAP for applicable RBs which is used for target RAT RBs;
- 1> else:
 - 2> release the associated PDCP entity and SDAP entity for all established RBs;
- 1> indicate the release of the RRC connection to upper layers together with the release cause 'other'.

11.1.3.3 Test Description

11.1.3.3.1 Pre-test conditions

System Simulator:

- 2 cells
- NGC Cell A as defined in TS 38.508-1 [4] Table 6.3.2.2-1. Default system information combination as defined in TS 38.508-1 [4], sub-clause 4.4.3.1.2.
- E-UTRA Cell 1 as defined in TS 36.508 [7] Table 4.4.2-2. System information combination 1 as defined in TS 36.508 [7], sub-clause 4.4.3.1.1.
- Default system information in accordance with combination NR-6 in TS 38.508-1 [4] sub-clause 4.4.3.1.2.
- N26 interface is configured.

UE:

- None.

Preamble:

- With E-UTRA Cell 1 "Serving cell" and NGC Cell A "Non-suitable "Off" cell", the UE is brought to state RRC_IDLE Connectivity (*E-UTRA/EPC*) in accordance with the procedure described in TS 38.508-1 [4], Table 4.5.2.2-1. 4G GUTI and eKSI are assigned and security context established.
- The UE is switched-off.
- With E-UTRA Cell 1 "Non-suitable "Off" cell" and NGC Cell A "Serving cell", the UE is brought to state 1N-A, RRC_IDLE Connectivity (NR), in accordance with the procedure described in TS 38.508-1 [4], Table 4.5.2.2-2. 5G-GUTI and ngKSI are assigned and security context established.

11.1.3.3.2

Test procedure sequence

Table 11.1.3.3.2-1: Main behaviour

St	Procedure	Message Sequence		TP	Verdict
		U - S	Message		
-	The following messages are to be observed on NR Cell 1 unless explicitly stated otherwise.	-	-	-	-
1	The UE initiates transmission of uplink IP data, by MMI or by AT command (see Note 2).	-	-	-	-
2	The UE transmits an <i>RRCSetupRequest</i> message with <i>establishmentCause</i> set to 'mo-Data'.	-->	NR RRC: <i>RRCSetupRequest</i>	-	-
3-9a2	Steps 3 to 9a2 of the NR RRC_CONNECTED procedure in TS 38.508-1 Table 4.5.4.2-3 are executed to successfully complete the service request procedure. In step 9a2, UE test loop mode B is activated.	-	-	-	-
10	The SS transmits IP packets to the UE on the DRB associated with the PDU session for PS data.	-	-	-	-
	EXCEPTION: In parallel to the events described in steps 13 to 28 the steps specified in Table 11.1.3.3.2-2 will take place to keep PS data transmission during EPS fallback.				
11-16	Steps 1-6 of the MTSI MO speech call for 5GS procedure according TS 34.229-1 [TBD] subclause C.21e take place.	-	-	-	-
17	The SS transmits a <i>MobilityFromNRCommand</i> message which includes targetRAT-Type set to eutra according to 38.508-1 Table 4.6.1-8.	<--	NR RRC: <i>MobilityFromNRCommand</i>	-	-
-	The following messages are to be observed on E-UTRA Cell 1 unless explicitly stated otherwise.	-	-	-	-
18	Check: Does the UE transmit an <i>RRCConnectionReconfigurationComplete</i> message to confirm the successful completion of handover?	-->	RRC: <i>RRCConnectionReconfigurationComplete</i>	1	P
19	The UE transmits an <i>ULInformationTransfer</i> message on the cell specified in the test case. This message includes a TRACKING AREA UPDATE REQUEST message.	-->	RRC: <i>ULInformationTransfer</i> NAS: TRACKING AREA UPDATE REQUEST	1	P
20-23	Steps 4-7 of the generic test procedure in TS 36.508 [7] Table 6.4.2.7A-1 are performed to make sure successfully camped on E-UTRAN cell upon mobility from NR.	-	-	-	-
24	The SS configures a new RLC-UM data radio bearer with condition DRB (n,m), associated with the dedicated EPS bearer context. <i>RRCConnectionReconfiguration</i> message contains the ACTIVATE DEDICATED EPS BEARER CONTEXT REQUEST message. EPS bearer context #4 (QCI 1) according to TS 36.508 [7] Table 6.6.2-1: Reference dedicated EPS bearer contexts. Reference dedicated EPS bearer contexts is to establish the dedicated EPS bearer context on IMS PDN.	<--	RRC: <i>RRCConnectionReconfiguration</i> NAS: ACTIVATE DEDICATED EPS BEARER CONTEXT REQUEST	-	-
	EXCEPTION: In parallel to the events described in steps 25-28 below, the steps specified in table 11.1.3.3.2-3 will take place.	-	-	-	-

25	The UE transmits an <i>RRCConnectionReconfigurationComplete</i> message.	-->	RRC: <i>RRCConnectionReconfigurationComplete</i>	-	-
26	The UE transmits an <i>ULInformationTransfer</i> message including the ACTIVATE DEDICATED EPS BEARER CONTEXT ACCEPT message.	-->	RRC: <i>ULInformationTransfer</i> NAS: ACTIVATE DEDICATED EPS BEARER CONTEXT ACCEPT	-	-
27	The SS waits 1 second for call duration.	-	-	-	-
28	Release IMS Call as specified in the generic procedure in TS 34.229-1 [TBD] subclause C.32.	-	-	-	-
Note 1: The request of connectivity to the PDU session may be performed by MMI or AT command.					
Note 2: The UE initiates transmission of uplink IP data, by MMI or by AT command, and the AT command might need to be updated to support 5GC.					

Table 11.1.3.3.2-2: Parallel behaviour

St	Procedure	Message Sequence		TP	Verdict
		U - S	Message		
1	The UE loops back the IP packet received in step 11 on the DRB associated with the Internet PDU session.	-	-	1	P

Table 11.1.3.3.2-3: Parallel behaviour

St	Procedure	Message Sequence		TP	Verdict
		U - S	Message		
	EXCEPTION: Steps 1a1 to 1b7 describe behaviour that depends on the UE capability; the "lower case letter" identifies a step sequence that take place if a capability is supported	-	-	-	-
1a1-a9	The UE performs IMS re-registration on EUTRAN as per steps 3-11 as defined in TS 34.229-1 [TBD] C.2..	-	-	-	-
1a10-1a15	Step 7 of 12 of the MTSI MO speech call for EPS procedure according TS 34.229-1 [TBD] subclause C.21 takes place.	-	-	-	-
1a16	Check: Does the UE send an ACK to acknowledge receipt of the 200 OK for INVITE?	-->	SIP: ACK	1	P
1b1-1b6	Step 7 of 12 of the MTSI MO speech call for EPS procedure according TS 34.229-1 [TBD] subclause C.21 takes place.	-	-	-	-
1b7	Check: Does the UE send an ACK to acknowledge receipt of the 200 OK for INVITE?	-->	SIP: ACK	1	P

11.1.3.3.3 Specific message contents

Table 11.1.3.3.3-1: REGISTRATION REQUEST (preamble, Table 11.1.3.3.2-1)

Derivation Path: 38.508-1 Table 4.7.1-6			
Information Element	Value/remark	Comment	Condition
5GMM capability			
S1 mode	'1'B	S1 mode supported	
S1 UE network capability	Present but contents not checked		

Table 11.1.3.3.3-2: REGISTRATION ACCEPT (preamble, Table 11.1.3.3.2-1)

Derivation Path: 38.508-1 Table 4.7.1-7			
Information Element	Value/remark	Comment	Condition
5GS network feature support			
IMS- VoPS-3GPP	'1'B	IMS voice over PS session supported over 3GPP access	
IWK N26	'0'B	Interworking without N26 interface not supported	

Table 11.1.3.3.3-3: PDU SESSION ESTABLISHMENT ACCEPT (preamble for PDU Session for PS data, Table 11.1.3.3.2-1)

Derivation Path: 38.508-1 Table 4.7.2-2, condition Interworking_with_EPS
--

Table 11.1.3.3.3-4: PDU SESSION ESTABLISHMENT ACCEPT (preamble for IMS PDU Session, Table 11.1.3.3.2-1)

Derivation Path: 38.508-1 Table 4.7.2-2, condition Interworking_with_EPS, IMS_DNN_Requested

Table 11.1.3.3.3-5: RRCSetupRequest (step 2, Table 11.1.3.3.2-1)

Derivation Path: 38.508-1 Table 4.6.1-4H			
Information Element	Value/remark	Comment	Condition
RRCSetupRequest ::= SEQUENCE {			
rrcSetupRequest SEQUENCE {			
establishmentCause	mo-Data		
}			
}			

Table 11.1.3.3.3-6: TRACKING AREA UPDATE REQUEST (step 19, Table 11.1.3.3.2-1)

Derivation Path: TS 36.508 [2], Table 4.7.2-27, condition NR.			
Information Element	Value/remark	Comment	Condition
EPS update type			
EPS update type Value	'00'B	TA updating	
"Active" flag	'0'B	No bearer establishment requested	
NAS key set identifier	the eKSI indicating the 5G NAS security context value assigned at the initial registration when the UE entered N1		
Old GUTI	GUTI, mapped from the 5G-GUTI assigned at the initial registration when the UE entered N1		
Last visited registered TAI	The TAI to which the NGC cell belonged to (the cell in which the UE was when in N1 before moving to S1).		
UE radio capability information update needed	'1'B	UE radio capability information update needed	
EPS bearer context status	Present, Content not checked	EBI corresponding to active PDU Sessions need to be set to 1	
Old GUTI type	"Native GUTI"		
UE status	"UE is in 5GMM-REGISTERED state"		
NOTE: The message shall be integrity protected using the 5GS security context available in the UE.			

11.1.4 MO MMTEL voice call setup from NR RRC_CONNECTED / EPS Fallback with redirection / Single registration mode with N26 interface / E-UTRAN cell reselection using cell status barred / Success

11.1.4.1 Test Purpose (TP)

(1)

```

with { UE supporting both S1 mode and N1 mode and operating in single-registration mode, and, the Network has indicated "interworking without N26 interface not supported", and, the UE in NR RRC_CONNECTED state after having established connection with establishmentCause set to 'mo-Data', and, the UE receiving and transmitting PS data }
ensure that {
  when { User initiates a MMTEL call, the MO IMS voice session establishment has been initiated and the UE receives a RRCRelease message which includes redirectedCarrierInfo indicating redirection to eutra, and, a higher ranked E-UTRA cell is found with cell status "barred" and a lower ranked E-UTRA cell is found which is not "barred" }
  then { UE selects the not "barred" E-UTRA cell, performs a TAU procedure, and, while the UE continues receiving and transmitting PS data the UE successfully completes the MO MMTEL call in EPS }
}

```

11.1.4.2 Conformance requirements

References: The conformance requirements covered in the present test case are specified in: TS 23.502, clause 4.13.6.1, and clause 4.11.1.3.2. Unless otherwise stated these are Rel-15 requirements.

[TS 23.502, clause 4.13.6.1]

Figure 4.13.6.1-1 describes the EPS fallback procedure for IMS voice.

When the UE is served by the 5G System, the UE has one or more ongoing PDU Sessions each including one or more QoS Flows. The serving PLMN AMF has sent an indication towards the UE during the Registration procedure that IMS voice over PS session is supported, see clause 5.16.3.10 in TS 23.501 [2] and the UE has registered in the IMS. If N26 is not supported, the serving PLMN AMF sends an indication towards the UE during the Registration procedure that interworking without N26 is supported, see clause 5.17.2.3.1 in TS 23.501 [2].

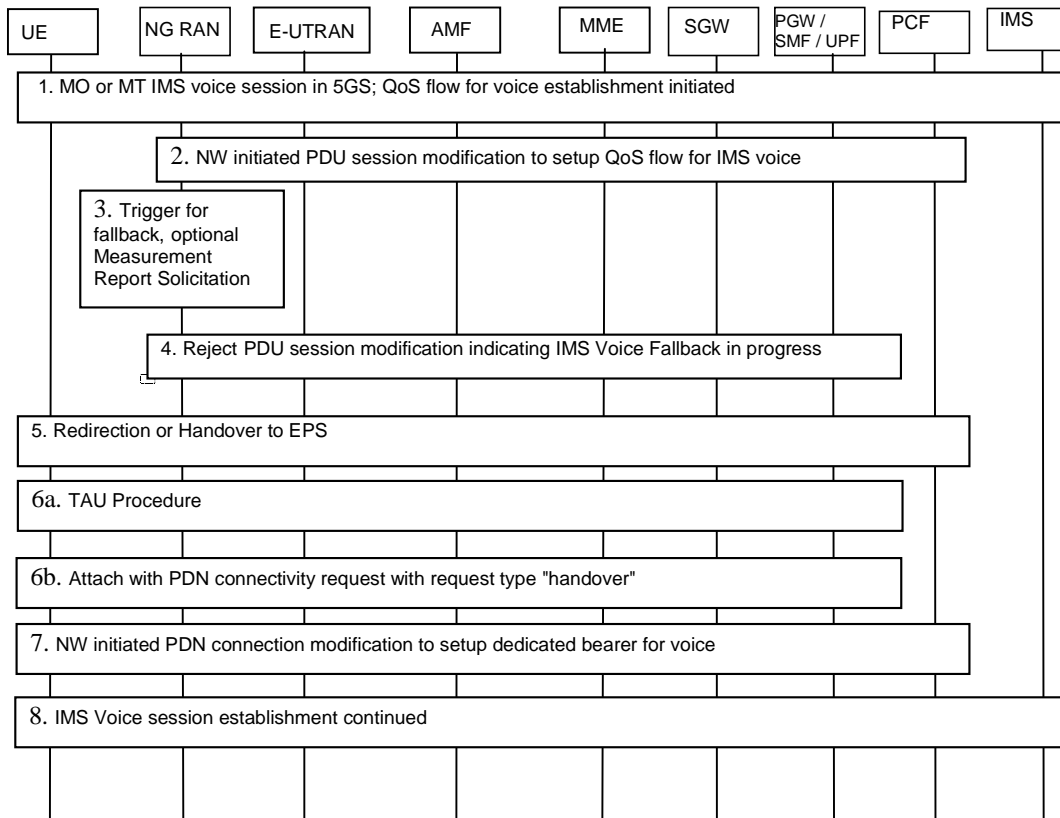

Figure 4.13.6.1-1: EPS Fallback for IMS voice

1. UE camps on NG-RAN in the 5GS and an MO or MT IMS voice session establishment has been initiated.
2. Network initiated PDU Session modification to setup QoS flow for voice reaches the NG-RAN (see N2 PDU Session Request in clause 4.3.3).
3. NG-RAN is configured to support EPS fallback for IMS voice and decides to trigger fallback to EPS, taking into account UE capabilities, indication from AMF that "Redirection for EPS fallback for voice is possible" (received as part of initial context setup as defined in TS 38.413 [10]), network configuration (e.g. N26 availability configuration) and radio conditions. If NG-RAN decides not to trigger fallback to EPS, then the procedure stops here and following steps are not executed.

NG-RAN may initiate measurement report solicitation from the UE including E-UTRAN as target.

NOTE 1: If AMF has indicated that "Redirection for EPS fallback for voice is not possible", then AN Release via inter-system redirection to EPS is not performed in step 5.

4. NG-RAN responds indicating rejection of the PDU Session modification to setup QoS flow for IMS voice received in step 2 by PDU Session Response message towards the PGW-C+SMF (or H-SMF+P-GW-C via V-SMF, in case of roaming scenario) via AMF with an indication that mobility due to fallback for IMS voice is ongoing. The PGW-C+SMF maintains the PCC rule(s) associated with the QoS Flow(s).
5. NG-RAN initiates either handover (see clause 4.11.1.2.1), or AN Release via inter-system redirection to EPS (see clause 4.2.6 and clause 4.11.1.3.2), taking into account UE capabilities. The PGW-C+SMF reports change

of the RAT type if subscribed by PCF as specified in clause 4.11.1.2.1, or clause 4.11.1.3.2.6. When the UE is connected to EPS, either 6a or 6b is executed

6a. In the case of 5GS to EPS handover, see clause 4.11.1.2.1, and in the case of inter-system redirection to EPS with N26 interface, see clause 4.11.1.3.2. In either case the UE initiates TAU procedure; or

6b. In the case of inter-system redirection to EPS without N26 interface, see clause 4.11.2.2. If the UE supports Request Type flag "handover" for PDN connectivity request during the attach procedure as described in clause 5.3.2.1 of TS 23.401 [13] and has received the indication that interworking without N26 is supported, then the UE initiates Attach with PDN connectivity request with request type "handover".

In inter-system redirection, the UE uses the emergency indication in the RRC message as specified in clause 6.2.2 of TS 36.331 [16] and E-UTRAN provides the emergency indication to MME during Tracking Area Update or Attach procedure. For the handover procedure see clause 4.11.1.2.1, step 1.

7. After completion of the mobility procedure to EPS or as part of the 5GS to EPS handover procedure (see clause 4.11.1.2.1), the SMF/PGW re-initiates the setup of the dedicated bearer for IMS voice, mapping the 5G QoS to EPC QoS parameters. The PGW-C+SMF behaves as specified in clause 4.9.1.3.1. The PGW-C+SMF reports about Successful Resource Allocation and Access Network Information if subscribed by PCF.
8. The IMS voice session establishment is continued.

At least for the duration of the voice call in EPS the E-UTRAN is configured to not trigger any handover to 5GS.

[TS 23.502, clause 4.11.1.3.2]

Clause 4.11.1.3.2 covers the case of idle mode mobility from 5GC to EPC. UE performs Tracking Area Update procedure in E-UTRA/EPS when it moves from NG-RAN/5GS to E-UTRA/EPS coverage area.

The procedure involves a Tracking Area Update to EPC and setup of default EPS bearer and dedicated bearers in EPC in steps 1-11 and re-activation, if required.

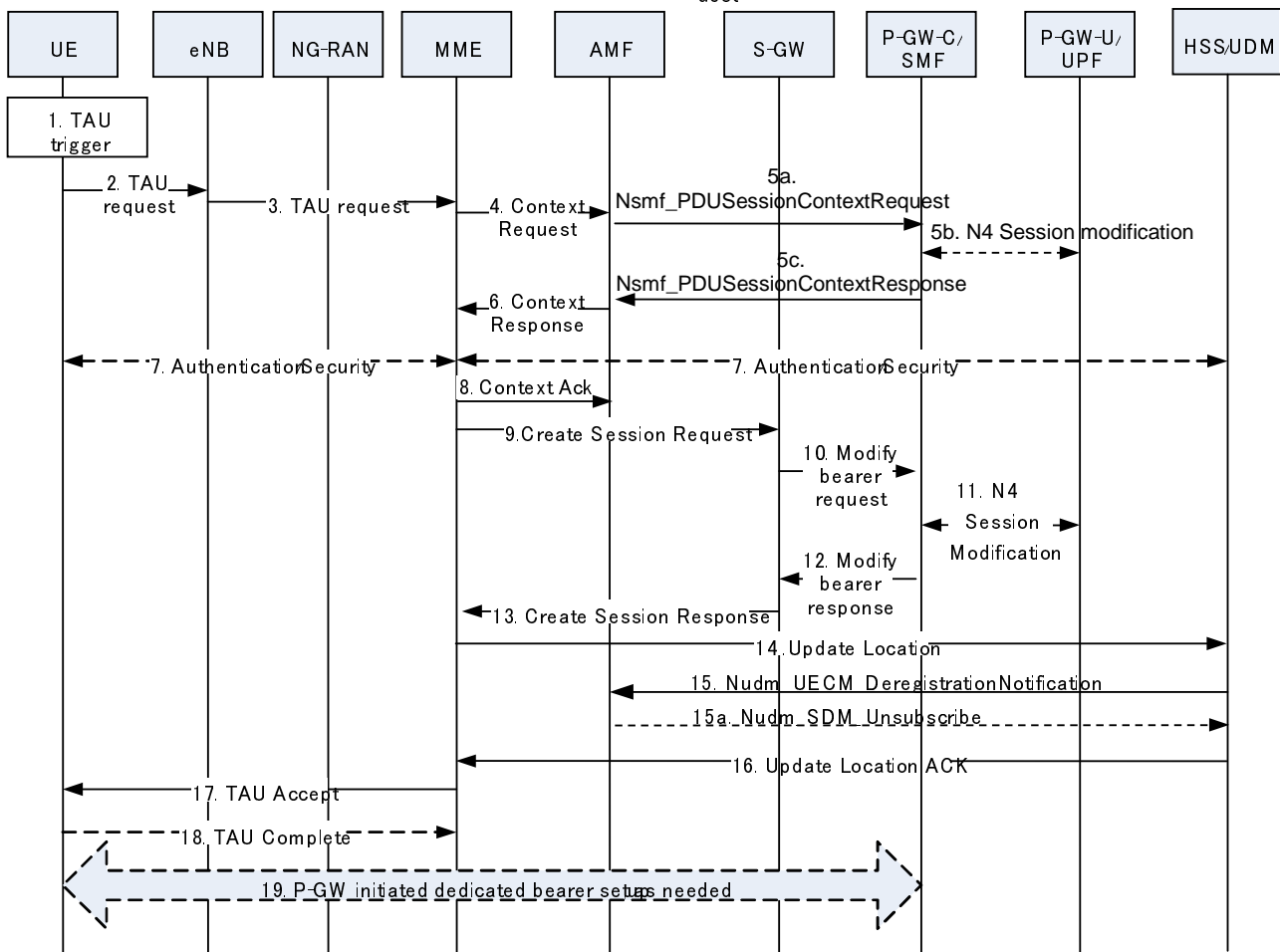

Figure 4.11.1.3.2-1: 5GS to EPS Idle mode mobility using N26 interface

The TAU procedure in TS 23.401 [13] is used with the following 5GS interaction:

1. Step 1 from clause 5.3.3.1 (Tracking Area Update procedure with Serving GW change) in TS 23.401 [13].
2. Step 2 from clause 5.3.3.1 (Tracking Area Update procedure with Serving GW change) in TS 23.401 [13] with the modification captured in clause 4.11.1.5.3.
- 3-4. Steps 3-4 from clause 5.3.3.1 (Tracking Area Update procedure with Serving GW change) in TS 23.401 [13].
- 5a. The AMF verifies the integrity of the TAU request message and requests the PGW-C+SMF to provide SM Context by using Nsmf_PDUSession_ContextRequest that also includes the mapped EPS Bearer Contexts. The AMF provides the target MME capability to SMF in the request to allow the SMF to determine whether to include EPS Bearer context for non-IP PDN Type or not. This step is performed with all the PGW-C+SMFs corresponding to PDU Sessions of the UE which are associated with 3GPP access and have EBI(s) allocated to them. In this step, if the AMF correctly validates the UE, then the AMF starts a timer.

NOTE 1: The AMF knows the MME capability to support non-IP PDN type or not through local configuration.

5b. For Non-roaming or roaming with local breakout scenario, if CN Tunnel Info is allocated by the PGW-U+UPF, the SMF sends N4 Session Modification Request to PGW-U+UPF to establish the tunnel for each EPS bearers, and PGW-U+UPF provides the PGW-U Tunnel Info for each EPS bearers to PGW-C+SMF.

NOTE2: In home routed roaming case, the CN Tunnel Info for each EPS bearer has been prepared by the PGW-C+SMF and provided to the V-SMF as specified in clause 4.11.1.4.1.

5c. SMF returns mapped EPS bearer contexts, which includes PGW-C control plane tunnel information of the PDN connection corresponding to the PDU session, EBI for each EPS bearer, PGW-U tunnel information for each

EPS bearer, and EPS QoS parameters for each EPS bearer. For PDU Sessions with PDU Session Type Ethernet or Unstructured, the SMF provides SM Context for non-IP PDN Type.

6. The AMF responds with a Context Response message carrying mapped MM context (including mapped security context), Return preferred and SM EPS UE Context (default and dedicated GBR bearers) to the MME. If the verification of the integrity protection fails, the AMF returns an appropriate error cause. Return preferred is an optional indication by the AMF of a preferred return of the UE to the 5GS PLMN at a later access change to a 5GS shared network. The AMF may start an implementation specific (guard) timer for the UE context.
- 7 - 14. Steps 6-12 from clause 5.3.3.1 (Tracking Area Update procedure with Serving GW change) in TS 23.401 [13] are performed with following addition and modification:

In the step 10, If the QoS Flow associated with the default QoS rule has an EPS Bearer ID assigned, the PGW-C+SMF keeps the PDU Session (PDN connection) and for the remaining QoS Flows that do not have EPS bearer ID(s) assigned, the PGW-C+SMF deletes the PCC rule(s) associated with those QoS Flows and informs the PCF about the removed PCC rule(s).

In the step 11, the PGW-C+SMF requests the PGW-U+UPF to establish the tunnel for each EPS bearer by providing SGW-U Tunnel Info, and PGW-U Tunnel Info if the PGW-U Tunnel Info is allocated by the PGW-C+SMF.

In step 10, the PGW-C+SMF may need to report some subscribed event to the PCF by performing an SMF initiated SM Policy Association Modification procedure as defined in clause 4.16.5.

Step 9a from clause 5.3.3.1 (Tracking Area Update procedure with Serving GW change) in TS 23.401 [13] with the modification captured in clause 4.11.1.5.3

- 15a. The HSS+UDM invokes Nudm_UECM_DeregistrationNotification to notify the AMF associated with 3GPP access with reason as 5GS to EPS Mobility. If the timer started in step 6 is not running, the old AMF removes the UE context. Otherwise, the AMF may remove UE context when the timer expires. The AMF request the release of the PDU Session which is associated with 3GPP access, not expected to be transferred to EPC, i.e. no EBI(s) allocated to them, and corresponding to the PGW-C+SMF which is not contacted by AMF for SM context at step 5a. The AMF requests the release of the SM context in the V-SMF only, for Home Routed PDU Session with EBIs allocated. The 5GC may also keep UE context to allow the use of native security parameters when UE moves back from EPS to 5GS later.

Registration associated with the non-3GPP access in the AMF is not removed (i.e. an AMF that was serving the UE over both 3GPP and non-3GPP accesses does not consider the UE as deregistered over non 3GPP access and will remain registered and subscribed to subscription data updates in UDM).

When the UE decides to deregister over non-3GPP access or the old AMF decides not to maintain a UE registration for non-3GPP access anymore, the old AMF then deregisters from UDM by sending a Nudm_UECM_Deregistration service operation, unsubscribes from Subscription Data updates by sending an Nudm_SDM_Unsubscribe service operation to UDM and releases all the AMF and AN resources related to the UE.

- 16 - 18. Steps 17-21 from clause 5.3.3.1 (Tracking Area Update procedure with Serving GW change) in TS 23.401 [13] with the following modification:

The MME may provide the eNodeB with a PLMN list in the Handover Restriction List taking into account the last used 5GS PLMN ID and the Return preferred indication. The Handover Restriction List contains a list of PLMN IDs as specified by TS 23.251 [35] clause 5.2a for eNodeB functions.

The MME may not release the signaling connection with the UE based on the indication received in the step 1 that the UE is moving from 5GC.

19. [conditional] Step 19 from clause 4.11.1.2.1 applies.

11.1.4.3 Test Description

11.1.4.3.1 Pre-test conditions

System Simulator:

- NGC Cell A is configured according to TS 38.508-1 [4] Table 6.3.2.2-1 and is connected to 5GC.
- E-UTRA Cell 1 and E-UTRA Cell 2 are configured to TS 36.508 [7] Table 4.4.2-2 and is connected to EPC.

- E-UTRA Cell 1 is barred.
- Default system information in accordance with combination NR-6 in TS 38.508-1 [4] sub-clause 4.4.3.1.2.
- N26 interface is configured.

UE:

- None.

Preamble:

- With E-UTRA Cell 1 "Serving cell" and NGC Cell A "Non-suitable "Off" cell", the UE is brought to state RRC_IDLE Connectivity (*E-UTRA*) in accordance with the procedure described in TS 38.508-1 [4], Table 4.5.2.2-1. 4G GUTI and eKSI are assigned and security context established.
- The UE is switched-off.
- With E-UTRA Cell 1 "Non-suitable "Off" cell" and NGC Cell A "Serving cell", the UE is brought to state 1N-A, RRC_IDLE Connectivity (NR), in accordance with the procedure described in TS 38.508-1 [4], Table 4.5.2.2-2. 5G-GUTI and ngKSI are assigned and security context established.

11.1.4.3.2

Test procedure sequence

Table 11.1.4.3.2-1: Main behaviour

St	Procedure	Message Sequence		TP	Verdict
		U - S	Message		
-	The following messages are to be observed on NR Cell 1 unless explicitly stated otherwise.	-	-	-	-
1	The UE initiates transmission of uplink IP data, by MMI or by AT command (see Note 2).	-	-		
2	The UE transmits an <i>RRCSetupRequest</i> message with <i>establishmentCause</i> set to 'mo-Data'.	-->	NR RRC: <i>RRCSetupRequest</i>	-	-
3-9a2	Steps 3 to 9a2 of the NR RRC_CONNECTED procedure in TS 38.508-1 Table 4.5.4.2-3 are executed to successfully complete the service request procedure. In step 9a2, UE test loop mode B is activated.	-	-	-	-
10	The SS transmits IP packets to the UE on the DRB associated with the PDU session for PS data.	-	-	-	-
	EXCEPTION: In parallel to the events described in steps 13 to 29 the steps specified in Table 11.1.3.3.2-2 will take place to keep PS data transmission during EPS fallback.				
11	Make the UE attempt an IMS speech call.	-	-	-	-
12-16	Steps 2-6 of the MTSI MO speech call for 5GS procedure according TS 34.229-1 [TBD] subclause C.21e take place.	-	-	-	-
17	The SS transmits an <i>RRCRelease</i> message	<--	NR RRC: <i>RRCRelease</i>	-	-
-	The following messages are to be observed on E-UTRA Cell 2 unless explicitly stated otherwise.	-	-	-	-
18	Generic test procedure in TS 38.508-1 [4] Table 4.9.7.2.2-1 is performed without 'connected without release' on E-UTRAN cell upon mobility from NR.	-	-	-	-
19	The SS configures a new RLC-UM data radio bearer with condition DRB (n,m), associated with the dedicated EPS bearer context. <i>RRCConnectionReconfiguration</i> message contains the ACTIVATE DEDICATED EPS BEARER CONTEXT REQUEST message. EPS bearer context #4 (QCI 1) according to TS 36.508 [7] Table 6.6.2-1: Reference dedicated EPS bearer contexts. Reference dedicated EPS bearer contexts is to establish the dedicated EPS bearer context on IMS PDN.	<--	RRC: <i>RRCConnectionReconfiguration</i> NAS: ACTIVATE DEDICATED EPS BEARER CONTEXT REQUEST	-	-
	EXCEPTION: In parallel to the events described in steps 20-23 below, the steps specified in table 11.1.4.3.2-3 will take place.	-	-	-	-
20	The UE transmits an <i>RRCConnectionReconfigurationComplete</i> message.	-->	RRC: <i>RRCConnectionReconfigurationComplete</i>	-	-
21	The UE transmits an <i>ULInformationTransfer</i> message including the ACTIVATE DEDICATED EPS BEARER CONTEXT ACCEPT message.	-->	RRC: <i>ULInformationTransfer</i> NAS: ACTIVATE DEDICATED EPS BEARER CONTEXT ACCEPT	-	-
22	The SS waits 1 second for call duration.	-	-	-	-
23	Release IMS Call as specified in the generic procedure in TS 34.229-1 [TBD] subclause C.32.	-	-	-	-
<p>Note 1: The request of connectivity to the PDU session may be performed by MMI or AT command.</p> <p>Note 2: The UE initiates transmission of uplink IP data, by MMI or by AT command, and the AT command might need to be updated to support 5GC.</p>					

Table 11.1.4.3.2-2: Parallel behaviour

St	Procedure	Message Sequence		TP	Verdict
		U - S	Message		
1	The UE loops back the IP packet received in step 11 on the DRB associated with the Internet PDU session.	-	-	1	P

Table 11.1.4.3.2-3: Parallel behaviour

St	Procedure	Message Sequence		TP	Verdict
		U - S	Message		
	EXCEPTION: Steps 1a1 to 1b7 describe behaviour that depends on the UE capability; the "lower case letter" identifies a step sequence that take place if a capability is supported	-	-	-	-
1a1-a9	The UE performs IMS re-registration on EUTRAN as per steps 3-11 as defined in TS 34.229-1 [TBD] C.2..	-	-	-	-
1a10 - 1a15	Step 7 of 12 of the MTSI MO speech call for EPS procedure according TS 34.229-1 [TBD] subclause C.21 takes place.	-	-	-	-
1a16	Check: Does the UE send an ACK to acknowledge receipt of the 200 OK for INVITE?	-->	SIP: ACK	1	P
1b1-1b6	Step 7 of 12 of the MTSI MO speech call for EPS procedure according TS 34.229-1 [TBD] subclause C.21 takes place.	-	-	-	-
1b7	Check: Does the UE send an ACK to acknowledge receipt of the 200 OK for INVITE?	-->	SIP: ACK	1	P

11.1.4.3.3 Specific message contents

Table 11.1.4.3.3-1: REGISTRATION REQUEST (preamble, Table 11.1.4.3.2-1)

Derivation Path: 38.508-1 Table 4.7.1-6			
Information Element	Value/remark	Comment	Condition
5GMM capability			
S1 mode	'1'B	S1 mode supported	
S1 UE network capability	Present but contents not checked		

Table 11.1.4.3.3-2: REGISTRATION ACCEPT (preamble, Table 11.1.4.3.2-1)

Derivation Path: 38.508-1 Table 4.7.1-7			
Information Element	Value/remark	Comment	Condition
5GS network feature support			
IMS- VoPS-3GPP	'1'B	IMS voice over PS session supported over 3GPP access	
IWK N26	'0'B	Interworking without N26 interface not supported	

Table 11.1.4.3.3-3: PDU SESSION ESTABLISHMENT ACCEPT (preamble for PDU Session for PS data, Table 11.1.4.3.2-1)

Derivation Path: 38.508-1 Table 4.7.2-2, condition <u>Interworking_with_EPS</u>

Table 11.1.4.3.3-4: PDU SESSION ESTABLISHMENT ACCEPT (preamble for IMS PDU Session, Table 11.1.4.3.2-1)

Derivation Path: 38.508-1 Table 4.7.2-2, condition <u>Interworking_with_EPS</u> , <u>IMS_DNN_Requested</u>
--

Table 11.1.4.3.3-5: RRCSetupRequest (step 1a1 and 3, Table 11.1.4.3.2-1)

Derivation Path: 38.508-1 Table 4.6.1-4H			
Information Element	Value/remark	Comment	Condition
RRCSetupRequest ::= SEQUENCE {			
rrcSetupRequest SEQUENCE {			
establishmentCause	mo-Data		
}			
}			

Table 14.1.4.3.3-6: RRCRelease message (step 17, table 11.1.4.3.2-1)

Derivation Path: 38.508-1 [4] Table 4.6.1-16			
Information Element	Value/remark	Comment	Condition
RRCRelease ::= SEQUENCE {			
criticalExtensions CHOICE {			
rrcRelease SEQUENCE {			
redirectedCarrierInfo CHOICE {			
eutra SEQUENCE {			
eutraFrequency	Cell 1's EARFCN		
}			
}			
redirectedCarrierInfo CHOICE {			
eutra SEQUENCE {			
eutraFrequency	Cell 2's EARFCN		
}			
}			
cellReselectionPriorities SEQUENCE {			
freqPriorityListEUTRA SEQUENCE (SIZE (1..maxFreq)) OF SEQUENCE{			
freqPriorityListEUTRA SEQUENCE {			
carrierFreq	Cell 1's EARFCN		
cellReselectionPriority	1		
}			
freqPriorityListEUTRA SEQUENCE {			
carrierFreq	Cell 2's EARFCN		
cellReselectionPriority	0		
}			
}			
}			
}			

11.1.5 MO MMTEL voice call setup from NR RRC_CONNECTED / EPS Fallback with redirection / Single registration mode without N26 interface / E-UTRAN cell reselection using cell status reservation / Success

11.1.5.1 Test Purpose (TP)

(1)

```

with {UE supporting both S1 mode and N1 mode and operating in single-registration mode, and, the
Network has indicated "interworking without N26 interface supported", and, the UE is in in NR
RRC_CONNECTED state after having established connection with establishmentCause set to 'mo-Data',
and, the UE receiving and transmitting PS data}
ensure that {
  when {User initiates a MMTEL call, the MO IMS voice session establishment has been initiated and
the UE receives a RRCRelease message which includes redirectedCarrierInfo indicating redirection to
eutra, and, a higher ranked E-UTRA cell is found with cell status "reserved for operator use" and a
lower ranked E-UTRA cell is found which is not "reserved for operator use" both cells belonging to
the UE's HPLMN}
  then { UE selects the E-UTRA cell respecting the UE Access Class, performs an ATTACH procedure,
and, while the UE continues receiving and transmitting PS data the UE successfully completes the MO
MMTEL call in EPS}
}

```

11.1.5.2 Conformance requirements

References: The conformance requirements covered in the current TC are specified in: TS23.502, clauses 4.11.1.3.2, 4.13.6.1; TS 24.501, clause 6.1.4.2; TS 38.331, clause 5.3.11. Unless otherwise stated these are Rel-15 requirements.

[TS 23.502, clause 4.11.1.3.2]

Clause 4.11.1.3.2 covers the case of idle mode mobility from 5GC to EPC. UE performs Tracking Area Update procedure in E-UTRA/EPS when it moves from NG-RAN/5GS to E-UTRA/EPS coverage area.

The procedure involves a Tracking Area Update to EPC and setup of default EPS bearer and dedicated bearers in EPC in steps 1-11 and re-activation, if required.

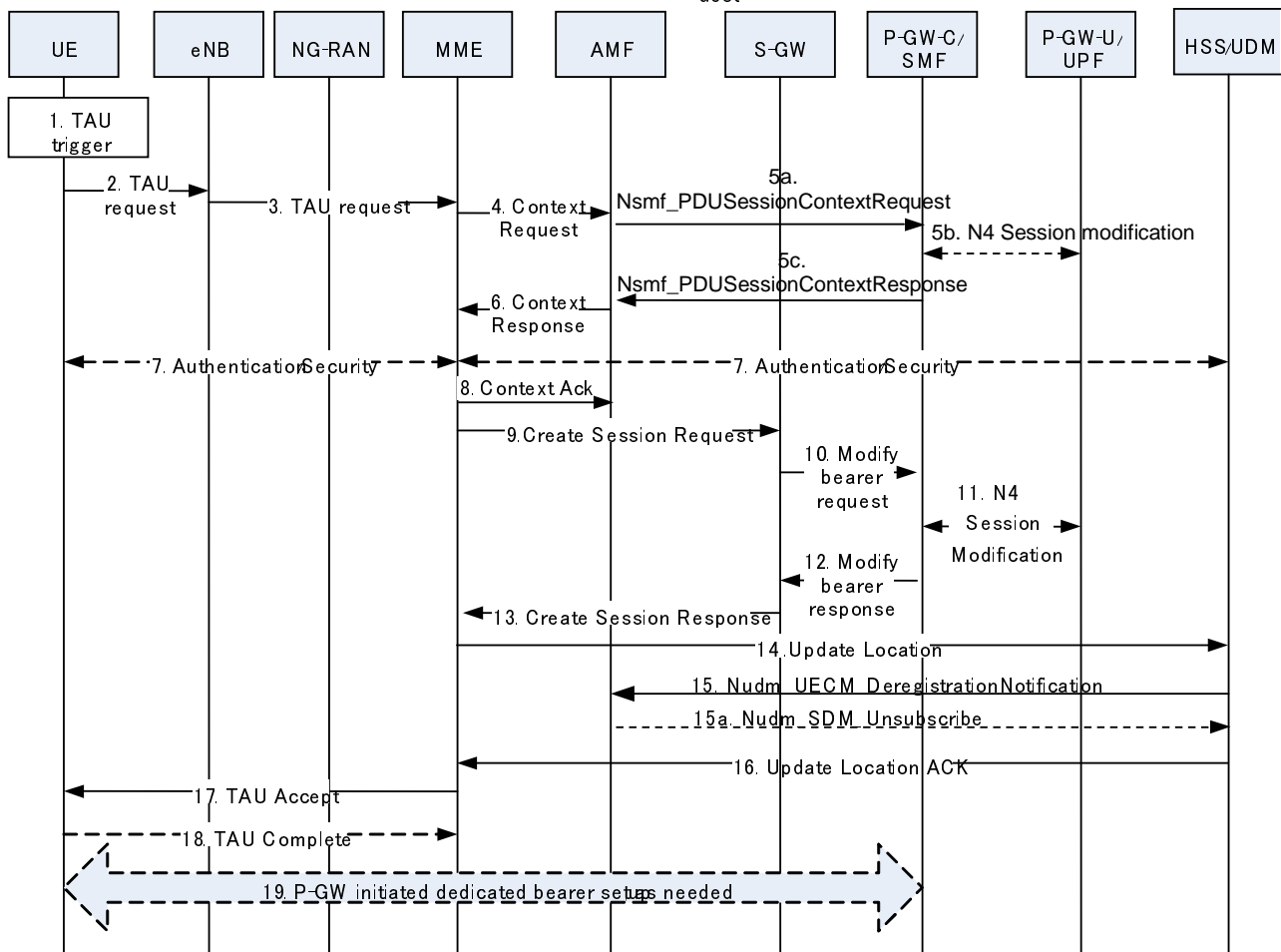

Figure 4.11.1.3.2-1: 5GS to EPS Idle mode mobility using N26 interface

The TAU procedure in TS 23.401 [13] is used with the following 5GS interaction:

1. Step 1 from clause 5.3.3.1 (Tracking Area Update procedure with Serving GW change) in TS 23.401 [13].
2. Step 2 from clause 5.3.3.1 (Tracking Area Update procedure with Serving GW change) in TS 23.401 [13] with the modification captured in clause 4.11.1.5.3.
- 3-4. Steps 3-4 from clause 5.3.3.1 (Tracking Area Update procedure with Serving GW change) in TS 23.401 [13].
- 5a. The AMF verifies the integrity of the TAU request message and requests the PGW-C+SMF to provide SM Context by using Nsmf_PDUSession_ContextRequest that also includes the mapped EPS Bearer Contexts. The AMF provides the target MME capability to SMF in the request to allow the SMF to determine whether to include EPS Bearer context for non-IP PDN Type or not. This step is performed with all the PGW-C+SMFs corresponding to PDU Sessions of the UE which are associated with 3GPP access and have EBI(s) allocated to them. In this step, if the AMF correctly validates the UE, then the AMF starts a timer.

NOTE 1: The AMF knows the MME capability to support non-IP PDN type or not through local configuration.

- 5b. For Non-roaming or roaming with local breakout scenario, if CN Tunnel Info is allocated by the PGW-U+UPF, the SMF sends N4 Session Modification Request to PGW-U+UPF to establish the tunnel for each EPS bearers, and PGW-U+UPF provides the PGW-U Tunnel Info for each EPS bearers to PGW-C+SMF.

NOTE2: In home routed roaming case, the CN Tunnel Info for each EPS bearer has been prepared by the PGW-C+SMF and provided to the V-SMF as specified in clause 4.11.1.5.1.

- 5c. SMF returns mapped EPS bearer contexts, which includes PGW-C control plane tunnel information of the PDN connection corresponding to the PDU session, EBI for each EPS bearer, PGW-U tunnel information for each EPS bearer, and EPS QoS parameters for each EPS bearer. For PDU Sessions with PDU Session Type Ethernet or Unstructured, the SMF provides SM Context for non-IP PDN Type.
6. The AMF responds with a Context Response message carrying mapped MM context (including mapped security context), Return preferred and SM EPS UE Context (default and dedicated GBR bearers) to the MME. If the verification of the integrity protection fails, the AMF returns an appropriate error cause. Return preferred is an optional indication by the AMF of a preferred return of the UE to the 5GS PLMN at a later access change to a 5GS shared network. The AMF may start an implementation specific (guard) timer for the UE context.
- 7 - 14. Steps 6-12 from clause 5.3.3.1 (Tracking Area Update procedure with Serving GW change) in TS 23.401 [13] are performed with following addition and modification:

In the step 10, If the QoS Flow associated with the default QoS rule has an EPS Bearer ID assigned, the PGW-C+SMF keeps the PDU Session (PDN connection) and for the remaining QoS Flows that do not have EPS bearer ID(s) assigned, the PGW-C+SMF deletes the PCC rule(s) associated with those QoS Flows and informs the PCF about the removed PCC rule(s).

In the step 11, the PGW-C+SMF requests the PGW-U+UPF to establish the tunnel for each EPS bearer by providing SGW-U Tunnel Info, and PGW-U Tunnel Info if the PGW-U Tunnel Info is allocated by the PGW-C+SMF.

In step 10, the PGW-C+SMF may need to report some subscribed event to the PCF by performing an SMF initiated SM Policy Association Modification procedure as defined in clause 4.16.5.

Step 9a from clause 5.3.3.1 (Tracking Area Update procedure with Serving GW change) in TS 23.401 [13] with the modification captured in clause 4.11.1.5.3

- 15a. The HSS+UDM invokes Nudm_UECM_DeregistrationNotification to notify the AMF associated with 3GPP access with reason as 5GS to EPS Mobility. If the timer started in step 6 is not running, the old AMF removes the UE context. Otherwise, the AMF may remove UE context when the timer expires. The AMF request the release of the PDU Session which is associated with 3GPP access, not expected to be transferred to EPC, i.e. no EBI(s) allocated to them, and corresponding to the PGW-C+SMF which is not contacted by AMF for SM context at step 5a. The AMF requests the release of the SM context in the V-SMF only, for Home Routed PDU Session with EBIs allocated. The 5GC may also keep UE context to allow the use of native security parameters when UE moves back from EPS to 5GS later.

Registration associated with the non-3GPP access in the AMF is not removed (i.e. an AMF that was serving the UE over both 3GPP and non-3GPP accesses does not consider the UE as deregistered over non 3GPP access and will remain registered and subscribed to subscription data updates in UDM).

When the UE decides to deregister over non-3GPP access or the old AMF decides not to maintain a UE registration for non-3GPP access anymore, the old AMF then deregisters from UDM by sending a Nudm_UECM_Deregistration service operation, unsubscribes from Subscription Data updates by sending an Nudm_SDM_Unsubscribe service operation to UDM and releases all the AMF and AN resources related to the UE.

- 16 - 18. Steps 17-21 from clause 5.3.3.1 (Tracking Area Update procedure with Serving GW change) in TS 23.401 [13] with the following modification:

The MME may provide the eNodeB with a PLMN list in the Handover Restriction List taking into account the last used 5GS PLMN ID and the Return preferred indication. The Handover Restriction List contains a list of PLMN IDs as specified by TS 23.251 [35] clause 5.2a for eNodeB functions.

The MME may not release the signaling connection with the UE based on the indication received in the step 1 that the UE is moving from 5GC.

19. [conditional] Step 19 from clause 4.11.1.2.1 applies.

[TS 23.502, clause 4.13.6.1]

Figure 4.13.6.1-1 describes the EPS fallback procedure for IMS voice.

When the UE is served by the 5G System, the UE has one or more ongoing PDU Sessions each including one or more QoS Flows. The serving PLMN AMF has sent an indication towards the UE during the Registration procedure that IMS voice over PS session is supported, see clause 5.16.3.10 in TS 23.501 [2] and the UE has registered in the IMS. If N26 is not supported, the serving PLMN AMF sends an indication towards the UE during the Registration procedure that interworking without N26 is supported, see clause 5.17.2.3.1 in TS 23.501 [2].

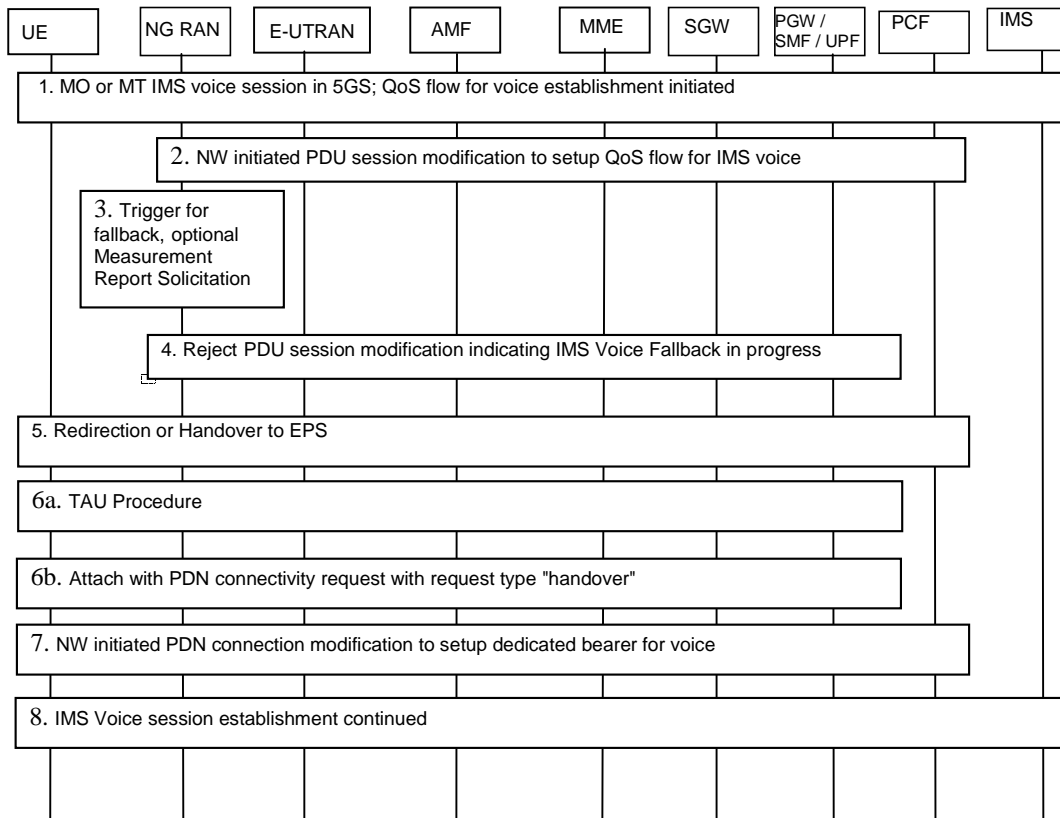

Figure 4.13.6.1-1: EPS Fallback for IMS voice

1. UE camps on NG-RAN in the 5GS and an MO or MT IMS voice session establishment has been initiated.
2. Network initiated PDU Session modification to setup QoS flow for voice reaches the NG-RAN (see N2 PDU Session Request in clause 4.3.3).
3. NG-RAN is configured to support EPS fallback for IMS voice and decides to trigger fallback to EPS, taking into account UE capabilities, indication from AMF that "Redirection for EPS fallback for voice is possible" (received as part of initial context setup as defined in TS 38.413 [10]), network configuration (e.g. N26 availability configuration) and radio conditions. If NG-RAN decides not to trigger fallback to EPS, then the procedure stops here and following steps are not executed.

NG-RAN may initiate measurement report solicitation from the UE including E-UTRAN as target.

NOTE 1: If AMF has indicated that "Redirection for EPS fallback for voice is not possible", then AN Release via inter-system redirection to EPS is not performed in step 5.

4. NG-RAN responds indicating rejection of the PDU Session modification to setup QoS flow for IMS voice received in step 2 by PDU Session Response message towards the PGW-C+SMF (or H-SMF+P-GW-C via V-SMF, in case of roaming scenario) via AMF with an indication that mobility due to fallback for IMS voice is ongoing. The PGW-C+SMF maintains the PCC rule(s) associated with the QoS Flow(s).
5. NG-RAN initiates either handover (see clause 4.11.1.2.1), or AN Release via inter-system redirection to EPS (see clause 4.2.6 and clause 4.11.1.3.2), taking into account UE capabilities. The PGW-C+SMF reports change

of the RAT type if subscribed by PCF as specified in clause 4.11.1.2.1, or clause 4.11.1.3.2.6. When the UE is connected to EPS, either 6a or 6b is executed

6a. In the case of 5GS to EPS handover, see clause 4.11.1.2.1, and in the case of inter-system redirection to EPS with N26 interface, see clause 4.11.1.3.2. In either case the UE initiates TAU procedure; or

6b. In the case of inter-system redirection to EPS without N26 interface, see clause 4.11.2.2. If the UE supports Request Type flag "handover" for PDN connectivity request during the attach procedure as described in clause 5.3.2.1 of TS 23.401 [13] and has received the indication that interworking without N26 is supported, then the UE initiates Attach with PDN connectivity request with request type "handover".

In inter-system redirection, the UE uses the emergency indication in the RRC message as specified in clause 6.2.2 of TS 36.331 [16] and E-UTRAN provides the emergency indication to MME during Tracking Area Update or Attach procedure. For the handover procedure see clause 4.11.1.2.1, step 1.

7. After completion of the mobility procedure to EPS or as part of the 5GS to EPS handover procedure (see clause 4.11.1.2.1), the SMF/PGW re-initiates the setup of the dedicated bearer for IMS voice, mapping the 5G QoS to EPC QoS parameters. The PGW-C+SMF behaves as specified in clause 4.9.1.3.1. The PGW-C+SMF reports about Successful Resource Allocation and Access Network Information if subscribed by PCF.

8. The IMS voice session establishment is continued.

At least for the duration of the voice call in EPS the E-UTRAN is configured to not trigger any handover to 5GS.

[TS 24.501, clause 6.1.4.2]

When the network does not support N26 interface, the SMF does not provide the UE with the mapped EPS bearer context for a PDU session.

NOTE 1: Since the SMF does not provide the UE with the mapped EPS bearer context for a PDU session, the UE does not know whether interworking with EPS is supported for a PDU session before attempting to transfer the PDU session from N1 mode to S1 mode.

NOTE 2: It is up to UE implementation to decide which PDU session(s) to be attempted to transfer from N1 mode to S1 mode, e.g. based on UE policy or user preference.

Upon inter-system change from N1 mode to S1 mode in EMM-IDLE mode, the UE shall use the parameters from each PDU session which the UE intends to transfer to EPS to create the contents of a PDN CONNECTIVITY REQUEST message as follows:

- a) if the PDU session is an emergency PDU session, the request type shall be set to "handover of emergency bearer services". Otherwise the request type shall be set to "handover";
- b) the PDU session type of the PDU session shall be mapped to the PDN type of the default EPS bearer context as follows:
 - 1) the PDN type shall be set to "non-IP" if the PDU session type is "Ethernet" or "Unstructured";
 - 2) the PDN type shall be set to "IPv4" if the PDU session type is "IPv4";
 - 3) the PDN type shall be set to "IPv6" if the PDU session type is "IPv6"; and
 - 4) the PDN type shall be set to "IPv4v6" if the PDU session type is "IPv4v6";
- c) the DNN of the PDU session shall be mapped to the APN of the default EPS bearer context; and
- d) the PDU session ID parameter in the PCO IE shall be set to the PDU session identity of the PDU session.

After inter-system change from N1 mode to S1 mode, the UE shall associate the PDU session identity with the default EPS bearer context.

Upon successful completion of an EPS attach procedure after inter-system change from N1 mode to S1 mode (see 3GPP TS 24.301 [15]), the UE shall delete any UE derived QoS rules.

The UE shall locally release the PDU session(s) and QoS flow(s) associated with the 3GPP access which have not been transferred to EPS.

...

[TS 38.331, clause 5.3.11]

UE shall:

- 1> reset MAC;
- 1> if T302 is running:
 - 2> stop timer T302;
 - 2> perform the actions as specified in 5.3.14.4;
- 1> stop all timers that are running except T320 and T325;
- 1> discard the UE Inactive AS context;
- 1> set the variable *pendingRnaUpdate* to *false*, if that is set to *true*;
- 1> discard the K_{gNB} , the K_{RRCenc} key, the K_{RRCint} , the K_{UPint} key and the K_{UPenc} key, if any;
- 1> release all radio resources, including release of the RLC entity, the MAC configuration and the associated PDCP entity and SDAP for all established RBs;
- 1> indicate the release of the RRC connection to upper layers together with the release cause;
- 1> enter RRC_IDLE and perform cell selection as specified in TS 38.304 [20], except if going to RRC_IDLE was triggered by selecting an inter-RAT cell while T311 was running;
- 1> if going to RRC_IDLE was triggered by reception of the *RRCRelease* message including a *waitTime*:
 - 2> start timer T302 with the value set to the *waitTime*;
 - 2> inform the upper layer that access barring is applicable for all access categories except categories '0' and '2'.

11.1.5.3 Test description

11.1.5.3.1 Pre-test conditions

System Simulator:

- 3 cells
 - NGC Cell A as defined in TS 38.508-1 [4] Table 6.3.2.2-1. Default system information combination as defined in TS 38.508-1 [4], sub-clause 4.4.3.1.2.
 - E-UTRA Cell 1 as defined in TS 36.508 [7] Table 4.4.2-2. System information combination 1 as defined in TS 36.508 [7], sub-clause 4.4.3.1.1.
 - E-UTRA Cell 2 as defined in TS 36.508 [7] Table 4.4.2-2. System information combination 1 as defined in TS 36.508 [7], sub-clause 4.4.3.1.1. Cell 2 is set as "reserved for operator use" in SIB1.

UE:

- The UE fitted with a USIM with access class 0..9

Preamble:

- With E-UTRA Cell 1 "Serving cell", E-UTRA Cell 2 "Non-suitable "Off" cell" and NGC Cell A "Non-suitable "Off" cell" in accordance with TS 38.508-1 [4], Table 6.2.2.1-3, the UE is brought to state RRC_IDLE Connectivity (*E-UTRA/EPC*) in accordance with the procedure described in TS 38.508-1 [4], Table 4.5.2.2-1. 4G GUTI and eKSI are assigned and security context established
- The UE is switched-off

- With E-UTRA Cell 1 "Non-suitable "Off" cell", E-UTRA Cell 2 "Non-suitable "Off" cell" and NGC Cell A "Serving cell" in accordance with TS 38.508-1 [4], Table 6.2.2.1-3, the UE is brought to state 1N-A, RRC_IDLE Connectivity (NR), in accordance with the procedure described in TS 38.508-1 [4], Table 4.5.2.2-2. 5G-GUTI and ngKSI are assigned and security context established.

11.1.5.3.2

Test procedure sequence

Table 11.1.5.3.2-1: Main behaviour

St	Procedure	Message Sequence		TP	Verdict
		U – S	Message		
-	The following messages are to be observed on NGC Cell A unless explicitly stated otherwise.	-	-	-	-
1	The SS configures: - E-UTRA Cell 1 as "Suitable neighbour intra-frequency cell" in accordance with TS 38.508-1 [4], Table 6.2.2.1-3. - E-UTRA Cell 2 as "Serving cell" in accordance with TS 38.508-1 [4], Table 6.2.2.1-3.	-	-	-	-
2-10	Call steps 1 to 9 of the the generic test procedure in Table 4.5.4.2-3 of TS38.508-1 on NGC Cell A. Instep 9a2, UE test loop mode B is activated.	-	-	-	-
11	Make the UE attempt an MTSI MO Speech Call.				
12	The UE transmits an INVITE message.	-	-	-	-
13	The SS transmits IP packets to the UE on the DRB associated with the PDU session for PS data.	-	-	-	-
14	The SS transmits an <i>RRCRelease</i> message.	<--	NR RRC: <i>RRCRelease</i>	-	-
-	The following messages are to be observed on E-UTRA Cell 1 unless explicitly stated otherwise.	-	-	-	-
15	UE transmits an <i>RRCConnectionRequest</i> message.	-->	RRC: <i>RRCConnectionRequest</i>		
16	SS transmits an <i>RRCConnectionSetup</i> message.	<--	RRC: <i>RRCConnectionSetup</i>		
17	Check: Does the UE transmit an <i>RRCConnectionSetupComplete</i> message to confirm the successful completion of the connection establishment and to initiate the Attach procedure by including the ATTACH REQUEST message? The PDN CONNECTIVITY REQUEST message is piggybacked in ATTACH REQUEST?	-->	RRC: <i>RRCConnectionSetupComplete</i> NAS: ATTACH REQUEST NAS: PDN CONNECTIVITY REQUEST	1	P
18 - 29	Call steps 5 to 16 of the the generic test procedure in Table Table 4.5.2.3-1 of TS36.508-1.	-	-	-	-
-	In parallel to the events described in steps 30 to 41 the steps specified in Table 11.1.3.3.2-2 will take place to keep PS data transmission during EPS fallback.	-	-	-	-
-	EXCEPTION: In parallel to the events described in steps 30 to 41 the UE may perform IMS re-registration on EUTRAN as per steps 3-11 as defined in 34.229-1 subclause C.2.	-	-	-	-
30-36	Steps 7-13 from the Generic Test Procedure for MTSI MO speech call establishment (TS 36.508 table 4.5A.6.3-1) are performed.	-	-	-	-
37	Check: Does the UE transmit an ACTIVATE DEDICATED EPS BEARER CONTEXT ACCEPT message.	-->	RRC: <i>ULInformationTransfer</i> NAS:ACTIVATE DEDICATED EPS BEARER CONTEXT ACCEPT	1	P
38	The SS waits 1 second.	-	-	-	-
39	Release IMS Call as specified in the generic procedure in TS 34.229-1 [x1] subclause C.32.	-	-	-	-
40	The SS transmits a DEACTIVATE EPS BEARER CONTEXT REQUEST including the EPS bearer identity of the default EPS bearer to the emergency PDN.	<--	DEACTIVATE EPS BEARER CONTEXT REQUEST	-	-
41	The UE transmits a DEACTIVATE EPS BEARER CONTEXT ACCEPT.	-->	DEACTIVATE EPS BEARER CONTEXT ACCEPT	-	-

Table 11.1.5.3.2-2: Parallel behaviour

St	Procedure	Message Sequence		TP	Verdict
		U - S	Message		
1	Check: Does the UE loop back the IP packet received in step 12 on the DRB associated with the Internet PDU session.	-	-	1	P

11.1.5.3.3 Specific message contents

Table 11.1.5.3.3-1: RRCRelease (step 5, table 11.1.5.3.2-1)

Derivation path: 38.508-1 Table Table 4.6.1-16			
Information Element	Value/Remark	Comment	Condition
RRCRelease ::= SEQUENCE {			
criticalExtensions CHOICE {			
rrcRelease SEQUENCE {			
redirectedCarrierInfo ::= CHOICE {			
eutra.SEQUENCE{			
eutraFrequency	Downlink EARFCN of cell 1		
cnType	epc		
}			
}			
}			
}			
}			

Table 11.1.5.3.3-2: ATTACH REQUEST (step 14, table 11.1.5.3.2-1)

Derivation Path: TS 36.508 [2], Table 4.7.2-4.			
Information Element	Value/Remark	Comment	Condition
NAS key set identifier	the eKSI indicating the 5G NAS security context value assigned at the initial registration when the UE entered N1		
Old GUTI	GUTI, mapped from the 5G-GUTI assigned at the initial registration when the UE entered N1		
Last visited registered TAI	The TAI to which the NGC cell belonged to (the cell in which the UE was when in N1 before moving to S1).		
Old GUTI type	"Native GUTI"		
ESM message container	PDN CONNECTIVITY REQUEST message to active PDU sessions which the UE intends to transfer to EPS.		

Table 11.1.5.3.3-3: PDN CONNECTIVITY REQUEST (step 14, table 11.1.5.3.2-1)

Derivation Path: TS 36.508 [2], Table 4.7.3-20.			
Information Element	Value/remark	Comment	Condition
EPS bearer identity	'0000'B	No EPS bearer identity assigned	
Procedure transaction identity	Any value from 1 to 254		
PDN connectivity request message identity	'1101 0000'B	PDN connectivity request	
Request type	'010'B	Handover	
PDN type	Any value between '001'B, '010'B, '011'B and '100'B	The allowed values are respectively IPv4, IPv6, IPv4v6 and "unused but interpreted as IPv6 by the network"	

11.1.6 MT MMTEL voice call setup from NR RRC_IDLE / EPS Fallback with redirection / Single registration mode without N26 interface / Success

11.1.6.1 Test Purpose (TP)

(1)

```

with {UE supporting both S1 mode and N1 mode and operating in single-registration mode, and, the
Network has indicated "interworking without N26 interface supported", and, the UE is in NR RRC_IDLE
state}
ensure that {
  when { UE receives a Paging message with MT MMTEL voice call, the MT IMS voice session
establishment has been initiated and the UE receives a RRCRelease message which includes
redirectedCarrierInfo indicating redirection to eutra }
  then {{the UE selects the E-UTRA cell, performs an ATTACH or a TAU procedure, and, successfully
completes the MT MMTEL call setup in EPS }
}

```

11.1.6.2 Conformance requirements

References: The conformance requirements covered in the current TC are specified in: TS23.502, clauses 4.11.1.3.2, 4.13.6.1; TS 24.501, clauses 4.5.4.1, 4.8.2.3; TS 38.331, clause 5.3.11. Unless otherwise stated these are Rel-15 requirements.

[TS 23.502, clause 4.11.1.3.2]

Clause 4.11.1.3.2 covers the case of idle mode mobility from 5GC to EPC. UE performs Tracking Area Update procedure in E-UTRA/EPS when it moves from NG-RAN/5GS to E-UTRA/EPS coverage area.

The procedure involves a Tracking Area Update to EPC and setup of default EPS bearer and dedicated bearers in EPC in steps 1-11 and re-activation, if required.

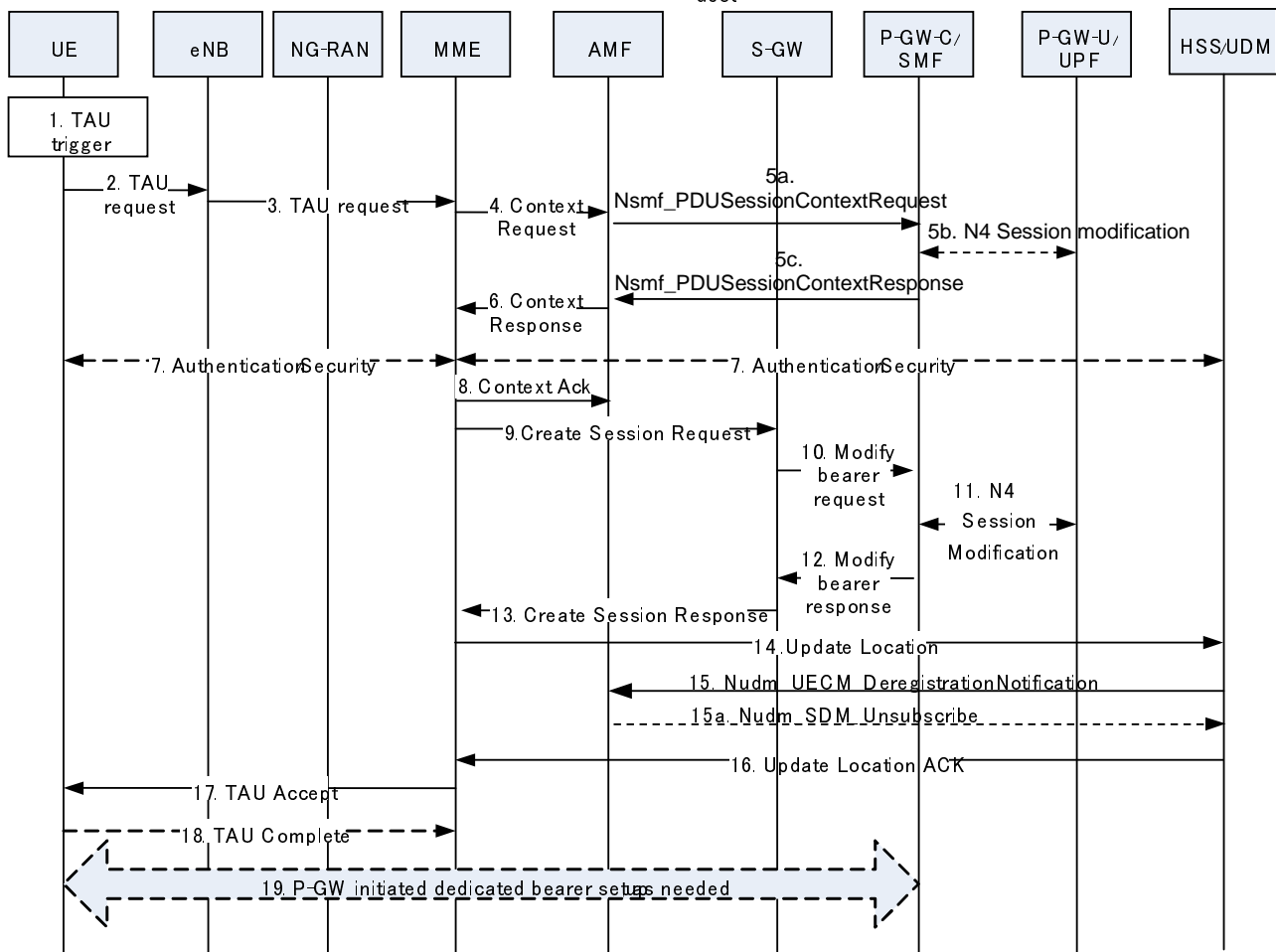

Figure 4.11.1.3.2-1: 5GS to EPS Idle mode mobility using N26 interface

The TAU procedure in TS 23.401 [13] is used with the following 5GS interaction:

1. Step 1 from clause 5.3.3.1 (Tracking Area Update procedure with Serving GW change) in TS 23.401 [13].
2. Step 2 from clause 5.3.3.1 (Tracking Area Update procedure with Serving GW change) in TS 23.401 [13] with the modification captured in clause 4.11.1.5.3.
- 3-4. Steps 3-4 from clause 5.3.3.1 (Tracking Area Update procedure with Serving GW change) in TS 23.401 [13].

5a. The AMF verifies the integrity of the TAU request message and requests the PGW-C+SMF to provide SM Context by using Nsmf_PDUSession_ContextRequest that also includes the mapped EPS Bearer Contexts. The AMF provides the target MME capability to SMF in the request to allow the SMF to determine whether to include EPS Bearer context for non-IP PDN Type or not. This step is performed with all the PGW-C+SMFs corresponding to PDU Sessions of the UE which are associated with 3GPP access and have EBI(s) allocated to them. In this step, if the AMF correctly validates the UE, then the AMF starts a timer.

NOTE 1: The AMF knows the MME capability to support non-IP PDN type or not through local configuration.

5b. For Non-roaming or roaming with local breakout scenario, if CN Tunnel Info is allocated by the PGW-U+UPF, the SMF sends N4 Session Modification Request to PGW-U+UPF to establish the tunnel for each EPS bearers, and PGW-U+UPF provides the PGW-U Tunnel Info for each EPS bearers to PGW-C+SMF.

NOTE2: In home routed roaming case, the CN Tunnel Info for each EPS bearer has been prepared by the PGW-C+SMF and provided to the V-SMF as specified in clause 4.11.1.4.1.

5c. SMF returns mapped EPS bearer contexts, which includes PGW-C control plane tunnel information of the PDN connection corresponding to the PDU session, EBI for each EPS bearer, PGW-U tunnel information for each

EPS bearer, and EPS QoS parameters for each EPS bearer. For PDU Sessions with PDU Session Type Ethernet or Unstructured, the SMF provides SM Context for non-IP PDN Type.

6. The AMF responds with a Context Response message carrying mapped MM context (including mapped security context), Return preferred and SM EPS UE Context (default and dedicated GBR bearers) to the MME. If the verification of the integrity protection fails, the AMF returns an appropriate error cause. Return preferred is an optional indication by the AMF of a preferred return of the UE to the 5GS PLMN at a later access change to a 5GS shared network. The AMF may start an implementation specific (guard) timer for the UE context.
- 7 - 14. Steps 6-12 from clause 5.3.3.1 (Tracking Area Update procedure with Serving GW change) in TS 23.401 [13] are performed with following addition and modification:

In the step 10, If the QoS Flow associated with the default QoS rule has an EPS Bearer ID assigned, the PGW-C+SMF keeps the PDU Session (PDN connection) and for the remaining QoS Flows that do not have EPS bearer ID(s) assigned, the PGW-C+SMF deletes the PCC rule(s) associated with those QoS Flows and informs the PCF about the removed PCC rule(s).

In the step 11, the PGW-C+SMF requests the PGW-U+UPF to establish the tunnel for each EPS bearer by providing SGW-U Tunnel Info, and PGW-U Tunnel Info if the PGW-U Tunnel Info is allocated by the PGW-C+SMF.

In step 10, the PGW-C+SMF may need to report some subscribed event to the PCF by performing an SMF initiated SM Policy Association Modification procedure as defined in clause 4.16.5.

Step 9a from clause 5.3.3.1 (Tracking Area Update procedure with Serving GW change) in TS 23.401 [13] with the modification captured in clause 4.11.1.5.3

- 15a. The HSS+UDM invokes Nudm_UECM_DeregistrationNotification to notify the AMF associated with 3GPP access with reason as 5GS to EPS Mobility. If the timer started in step 6 is not running, the old AMF removes the UE context. Otherwise, the AMF may remove UE context when the timer expires. The AMF request the release of the PDU Session which is associated with 3GPP access, not expected to be transferred to EPC, i.e. no EBI(s) allocated to them, and corresponding to the PGW-C+SMF which is not contacted by AMF for SM context at step 5a. The AMF requests the release of the SM context in the V-SMF only, for Home Routed PDU Session with EBIs allocated. The 5GC may also keep UE context to allow the use of native security parameters when UE moves back from EPS to 5GS later.

Registration associated with the non-3GPP access in the AMF is not removed (i.e. an AMF that was serving the UE over both 3GPP and non-3GPP accesses does not consider the UE as deregistered over non 3GPP access and will remain registered and subscribed to subscription data updates in UDM).

When the UE decides to deregister over non-3GPP access or the old AMF decides not to maintain a UE registration for non-3GPP access anymore, the old AMF then deregisters from UDM by sending a Nudm_UECM_Deregistration service operation, unsubscribes from Subscription Data updates by sending an Nudm_SDM_Unsubscribe service operation to UDM and releases all the AMF and AN resources related to the UE.

- 16 - 18. Steps 17-21 from clause 5.3.3.1 (Tracking Area Update procedure with Serving GW change) in TS 23.401 [13] with the following modification:

The MME may provide the eNodeB with a PLMN list in the Handover Restriction List taking into account the last used 5GS PLMN ID and the Return preferred indication. The Handover Restriction List contains a list of PLMN IDs as specified by TS 23.251 [35] clause 5.2a for eNodeB functions.

The MME may not release the signaling connection with the UE based on the indication received in the step 1 that the UE is moving from 5GC.

19. [conditional] Step 19 from clause 4.11.1.6.1 applies.

[TS 23.502, clause 4.13.6.1]

Figure 4.13.6.1-1 describes the EPS fallback procedure for IMS voice.

When the UE is served by the 5G System, the UE has one or more ongoing PDU Sessions each including one or more QoS Flows. The serving PLMN AMF has sent an indication towards the UE during the Registration procedure that IMS voice over PS session is supported, see clause 5.16.3.10 in TS 23.501 [2] and the UE has registered in the IMS. If N26

is not supported, the serving PLMN AMF sends an indication towards the UE during the Registration procedure that interworking without N26 is supported, see clause 5.17.2.3.1 in TS 23.501 [2].

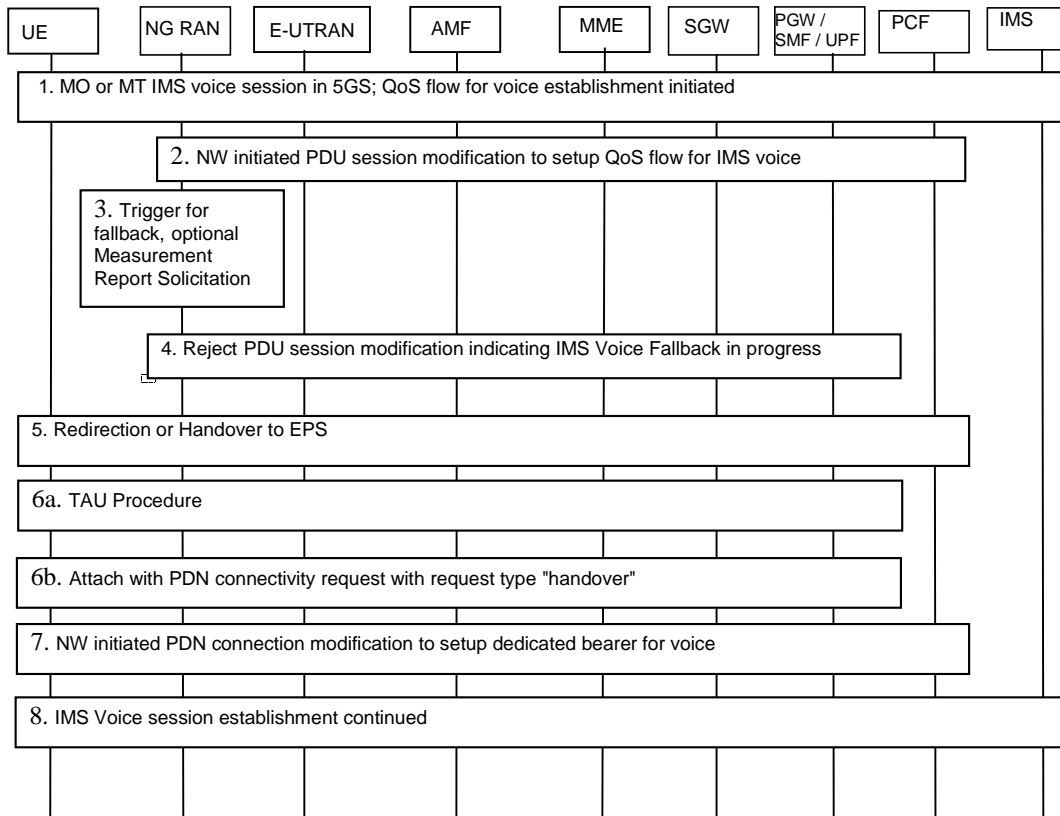

Figure 4.13.6.1-1: EPS Fallback for IMS voice

1. UE camps on NG-RAN in the 5GS and an MO or MT IMS voice session establishment has been initiated.
2. Network initiated PDU Session modification to setup QoS flow for voice reaches the NG-RAN (see N2 PDU Session Request in clause 4.3.3).
3. NG-RAN is configured to support EPS fallback for IMS voice and decides to trigger fallback to EPS, taking into account UE capabilities, indication from AMF that "Redirection for EPS fallback for voice is possible" (received as part of initial context setup as defined in TS 38.413 [10]), network configuration (e.g. N26 availability configuration) and radio conditions. If NG-RAN decides not to trigger fallback to EPS, then the procedure stops here and following steps are not executed.

NG-RAN may initiate measurement report solicitation from the UE including E-UTRAN as target.

NOTE 1: If AMF has indicated that "Redirection for EPS fallback for voice is not possible", then AN Release via inter-system redirection to EPS is not performed in step 5.

4. NG-RAN responds indicating rejection of the PDU Session modification to setup QoS flow for IMS voice received in step 2 by PDU Session Response message towards the PGW-C+SMF (or H-SMF+P-GW-C via V-SMF, in case of roaming scenario) via AMF with an indication that mobility due to fallback for IMS voice is ongoing. The PGW-C+SMF maintains the PCC rule(s) associated with the QoS Flow(s).
5. NG-RAN initiates either handover (see clause 4.11.1.6.1), or AN Release via inter-system redirection to EPS (see clause 4.2.6 and clause 4.11.1.3.2), taking into account UE capabilities. The PGW-C+SMF reports change of the RAT type if subscribed by PCF as specified in clause 4.11.1.6.1, or clause 4.11.1.3.2.6. When the UE is connected to EPS, either 6a or 6b is executed
- 6a. In the case of 5GS to EPS handover, see clause 4.11.1.6.1, and in the case of inter-system redirection to EPS with N26 interface, see clause 4.11.1.3.2. In either case the UE initiates TAU procedure; or

6b. In the case of inter-system redirection to EPS without N26 interface, see clause 4.11.2.2. If the UE supports Request Type flag "handover" for PDN connectivity request during the attach procedure as described in clause 5.3.2.1 of TS 23.401 [13] and has received the indication that interworking without N26 is supported, then the UE initiates Attach with PDN connectivity request with request type "handover".

In inter-system redirection, the UE uses the emergency indication in the RRC message as specified in clause 6.2.2 of TS 36.331 [16] and E-UTRAN provides the emergency indication to MME during Tracking Area Update or Attach procedure. For the handover procedure see clause 4.11.1.6.1, step 1.

7. After completion of the mobility procedure to EPS or as part of the 5GS to EPS handover procedure (see clause 4.11.1.6.1), the SMF/PGW re-initiates the setup of the dedicated bearer for IMS voice, mapping the 5G QoS to EPC QoS parameters. The PGW-C+SMF behaves as specified in clause 4.9.1.3.1. The PGW-C+SMF reports about Successful Resource Allocation and Access Network Information if subscribed by PCF.
8. The IMS voice session establishment is continued.

At least for the duration of the voice call in EPS the E-UTRAN is configured to not trigger any handover to 5GS.

[TS 24.501, clause 4.5.4.1]

When the UE is in 5GMM-IDLE mode, upon receiving a request from the upper layers for an access attempt, the NAS shall categorize the access attempt into access identities and an access category following subclause 4.5.2, table 4.5.2.1 and table 4.5.2.2, and subclause 4.5.3, and provide the applicable access identities and the access category to the lower layers for the purpose of access control checking. In this request to the lower layer the NAS can also provide to the lower layer the RRC establishment cause determined as specified in subclause 4.5.6 of this specification.

NOTE 1: The access barring check is performed by the lower layers.

NOTE 2: As an implementation option, the NAS can provide the RRC establishment cause to the lower layers after being informed by the lower layers that the access attempt is allowed.

If the UE has uplink user data pending for one or more PDU sessions when it builds a REGISTRATION REQUEST or SERVICE REQUEST message as initial NAS message, the UE shall indicate the respective PDU sessions in the Uplink data status IE as specified in subclause 5.5.1.3.2 and 5.6.1.2, regardless of the access category for which the access barring check is performed.

NOTE 3: The UE indicates pending user data for all the respective PDU sessions, even if barring timers are running for some of the corresponding access categories.

If the lower layers indicate that the access attempt is allowed, the NAS shall initiate the procedure to send the initial NAS message for the access attempt.

If the lower layers indicate that the access attempt is barred, the NAS shall not initiate the procedure to send the initial NAS message for the access attempt. Additionally:

- a) if the event which triggered the access attempt was an MO-MMTEL-voice-call-started indication or an MO-MMTEL-video-call-started indication:
 - 1) if the UE is operating in the single-registration mode and the UE's usage setting is "voice centric", the UE may attempt to select an E-UTRA cell connected to EPC. If the UE finds a suitable E-UTRA cell connected to EPC, it then proceeds with the appropriate EMM specific procedures and, if necessary, ESM procedures to make a PDN connection providing access to IMS available; see subclause 4.8.2 and 3GPP TS 24.301 [15];
 - 2) if the UE is operating in the dual-registration mode, the UE may proceed in S1 mode with the appropriate EMM specific procedures and ESM procedures to make a PDN connection providing access to IMS available; see subclause 4.8.3 and 3GPP TS 24.301 [15];
 - 3) otherwise, the NAS shall notify the upper layers that the access attempt is barred. In this case, upon receiving an indication from the lower layers that the barring is alleviated for the access category with which the access attempt was associated, the NAS shall notify the upper layers that the barring is alleviated for the access category and may initiate the procedure to send the initial NAS message, if still needed; and
- b) if the event which triggered the access attempt was an MO-SMSoIP-attempt-started indication:
 - 1) if the UE is operating in the single-registration mode, the UE may attempt to select an E-UTRA cell connected to EPC. If the UE finds a suitable E-UTRA cell connected to EPC, it then proceeds with the

appropriate EMM specific procedures and, if necessary, ESM procedures to make a PDN connection providing access to IMS available; see subclause 4.8.2 and 3GPP TS 24.301 [15];

- 2) if the UE is operating in the dual-registration mode, the UE may proceed in S1 mode with the appropriate EMM specific procedures and ESM procedures to make a PDN connection providing access to IMS available; see subclause 4.8.3 and 3GPP TS 24.301 [15];
- 3) otherwise, the NAS layer shall notify the upper layers that the access attempt is barred. In this case, upon receiving an indication from the lower layers that the barring is alleviated for the access category with which the access attempt was associated, the NAS shall notify the upper layers that the barring is alleviated for the access category and may initiate the procedure to send the initial NAS message, if still needed.

NOTE 4: Barring timers, on a per access category basis, are run by the lower layers. At expiry of barring timers, the indication of alleviation of access barring is indicated to the NAS on a per access category basis.

[TS 24.501, clause 4.8.2.3]

At inter-system change from N1 mode to S1 mode in EMM-IDLE mode when: (PDU SEESION ACTIVE)

- a) the UE supports non-IP PDN type and at least one PDU session is active; or
- b) the UE does not support non-IP PDN type and at least one PDU session of IPv4, IPv6 or IPv4v6 PDU session type is active,

the UE shall proceed as follows:

- a) if the UE supports sending an ATTACH REQUEST message containing a PDN CONNECTIVITY REQUEST message with request type set to "handover" to transfer a PDU session from N1 mode to S1 mode and the UE has received an "interworking without N26 interface supported" indication from the network, the UE shall:
 - 1) enter substates EMM-DEREGISTERED.NORMAL-SERVICE and 5GMM-REGISTERED.NO-CELL-AVAILABLE;
 - 2) map the PDU session(s) which the UE intends to transfer to EPS to the default EPS bearer context of the corresponding PDN connection(s) as specified in subclause 6.1.4.2; and
 - 3) initiate an EPS attach procedure and include a PDN CONNECTIVITY REQUEST message with request type set to "handover" in the ATTACH REQUEST message to activate a default EPS bearer context for one of the active PDU sessions which the UE intends to transfer to EPS.

After successful completion of the EPS attach procedure, the UE shall reset the registration attempt counter and the attach attempt counter (see 3GPP TS 24.301 [15]) and attempt to activate each of the other default EPS bearer contexts, if any, by initiating a stand-alone PDN connectivity procedure with request type set to "handover" in the PDN CONNECTIVITY REQUEST message; and

- b) otherwise, enter substates EMM-REGISTERED.NORMAL-SERVICE and 5GMM-REGISTERED.NO-CELL-AVAILABLE and initiate a tracking area update procedure (see 3GPP TS 24.301 [15]).

At inter-system change from N1 mode to S1 mode in EMM-IDLE mode when: (NO PDU SESSION)

- a) the UE supports non-IP PDN type and no PDU session is active; or
- b) the UE does not support non-IP PDN type and no PDU session of IPv4, IPv6 or IPv4v6 PDU session type is active,

the UE shall enter substates EMM-DEREGISTERED.NORMAL-SERVICE and 5GMM-DEREGISTERED.NO-CELL-AVAILABLE, and initiate an attach procedure.

At inter-system change from S1 mode to N1 mode in 5GMM-IDLE mode, the UE shall:

- a) enter substate 5GMM-REGISTERED.NORMAL-SERVICE and substate EMM-REGISTERED.NO-CELL-AVAILABLE;
- b) map the default EPS bearer context(s) of the PDN connection(s) which the UE intends to transfer to 5GS, if any, to the corresponding PDU session(s) as specified in subclause 6.1.4.2; and

- c) initiate the registration procedure for mobility and periodic registration update indicating "mobility registration updating" in the 5GS registration type IE of the REGISTRATION REQUEST message (see subclause 5.5.1.3).

After having successfully registered in N1 mode the UE shall reset the registration attempt counter and the attach attempt counter (see 3GPP TS 24.301 [15]) and:

- a) if the UE supports the PDU session establishment procedure with request type set to "existing PDU session" to transfer a PDN connection from S1 mode to N1 mode and the UE has received an "interworking without N26 interface supported" indication from the network, attempt to transfer the PDN connection(s) which the UE intends to transfer to 5GS, if any, from S1 mode to N1 mode by initiating the PDU session establishment procedure with request type set to "existing PDU session"; and
- b) otherwise, establish PDU session(s) corresponding to the PDN connection(s) which the UE intends to transfer to 5GS, if any, by initiating the PDU session establishment procedure with request type set to "initial request".

See subclause 5.1.4.3 for coordination between 5GMM and EMM and subclause 6.1.4.2 for coordination between 5GSM and ESM.

[TS 38.331, clause 5.3.11]

UE shall:

- 1> reset MAC;
- 1> if T302 is running:
 - 2> stop timer T302;
 - 2> perform the actions as specified in 5.3.14.4;
- 1> stop all timers that are running except T320 and T325;
- 1> discard the UE Inactive AS context;
- 1> set the variable *pendingRnaUpdate* to *false*, if that is set to *true*;
- 1> discard the K_{gNB} , the K_{RRcenc} key, the K_{RRcint} , the K_{UPint} key and the K_{UPenc} key, if any;
- 1> release all radio resources, including release of the RLC entity, the MAC configuration and the associated PDCP entity and SDAP for all established RBs;
- 1> indicate the release of the RRC connection to upper layers together with the release cause;
- 1> enter RRC_IDLE and perform cell selection as specified in TS 38.304 [20], except if going to RRC_IDLE was triggered by selecting an inter-RAT cell while T311 was running;
- 1> if going to RRC_IDLE was triggered by reception of the *RRCRelease* message including a *waitTime*:
 - 2> start timer T302 with the value set to the *waitTime*;
 - 2> inform the upper layer that access barring is applicable for all access categories except categories '0' and '2'.

11.1.6.3 Test description

11.1.6.3.1 Pre-test conditions

System Simulator:

- 2 cells
 - NGC Cell A as defined in TS 38.508-1 [4] Table 6.3.2.2-1. Default system information combination as defined in TS 38.508-1 [4], sub-clause 4.4.3.1.2.
 - E-UTRA Cell 1 as defined in TS 36.508 [7] Table 4.4.2-2. System information combination 1 as defined in TS 36.508 [7], sub-clause 4.4.3.1.1.

UE:

- The UE supports S1 mode

Preamble:

- With E-UTRA Cell 1 "Serving cell" and NGC Cell A "Non-suitable "Off" cell" in accordance with TS 38.508-1 [4], Table 6.2.2.1-3, the UE is brought to state RRC_IDLE Connectivity (*E-UTRA/EPC*) in accordance with the procedure described in TS 38.508-1 [4], Table 4.5.2.2-1. 4G GUTI and eKSI are assigned and security context established
- The UE is switched-off
- With E-UTRA Cell 1 "Non-suitable "Off" cell" and NGC Cell A "Serving cell" in accordance with TS 38.508-1 [4], Table 6.2.2.1-3, the UE is brought to state 1N-A, RRC_IDLE Connectivity (NR), in accordance with the procedure described in TS 38.508-1 [4], Table 4.5.2.2-2. 5G-GUTI and ngKSI are assigned and security context established.

11.1.6.3.2 Test procedure sequence

Table 11.1.6.3.2-1: Main behaviour

St	Procedure	Message Sequence		TP	Verdict
		U – S	Message		
1	The SS configures: - E-UTRA Cell 1 as "Suitable neighbour intra-frequency cell" in accordance with TS 38.508-1 [4], Table 6.2.2.1-3.	-	-	-	-
-	EXCEPTION: Unless otherwise stated the following messages are exchange on NGC Cell A.	-	-	-	-
2	The SS transmits a <i>Paging</i> message.	<--	NR RRC: Paging	-	-
3	The UE transmits an <i>RRCSetupRequest</i> message.	-->	NR RRC: RRCSetupRequest	-	-
4	The SS transmits an <i>RRCSetup</i> message.	<--	NR RRC: RRCSetup	-	-
5	The UE transmits an <i>RRCSetupComplete</i> message and a SERVICE REQUEST message.	-->	NR RRC: RRCSetupComplete 5GMM: SERVICE REQUEST	-	-
6	The SS transmits an <i>RRCRelease</i> message.	<--	NR RRC: RRCRelease	-	-
-	The following message was sent on on E-UTRA Cell 1.	-	-	-	-
7-11	Steps 1 to 5 of the the generic test procedure for Tracking area updating / inter-system change from N1 mode to S1 mode in 5GMM/EMM-IDLE mode (TS38.508-1 Table 4.9.7.2.2-1).	-	-	-	-
12	Check: Does the UE transmit TRACKING AREA UPDATE COMPLETE?	-->	RRC: ULInformationTransfer NAS: TRACKING AREA UPDATE COMPLETE	1	P
-	EXCEPTION: In parallel to the events described in steps 12 to 21 the UE may perform IMS re-registration on EUTRAN as per steps 3-11 as defined in 34.229-1 subclause C.2.	-	-	-	-
13-20	Steps 7-14 from the Generic Test Procedure for MTSI MT speech call establishment (TS 36.508 table 4.5A.7.3-1) are performed.	-	-	-	-
21	Check: Does the UE transmit an ACTIVATE DEDICATED EPS BEARER CONTEXT ACCEPT message?	-->	RRC: ULInformationTransfer NAS:ACTIVATE DEDICATED EPS BEARER CONTEXT ACCEPT	1	P
22	The SS waits 1 second.	-	-	-	-
23	Release IMS Call as specified in the generic procedure in TS 34.229-1 [x1] subclause C.33.	-	-	-	-
24	The SS transmits a DEACTIVATE EPS BEARER CONTEXT REQUEST including the EPS bearer identity of the default EPS bearer to the emergency PDN.	<--	DEACTIVATE EPS BEARER CONTEXT REQUEST	-	-
25	The UE transmits a DEACTIVATE EPS BEARER CONTEXT ACCEPT.	-->	DEACTIVATE EPS BEARER CONTEXT ACCEPT	-	-

11.1.6.3.3 Specific message contents

Table 11.1.6.3.3-1: RRCRelease (step 6, table 11.1.6.3.2-1)

Derivation path: 38.508-1 Table Table 4.6.1-16			
Information Element	Value/Remark	Comment	Condition
RRCRelease ::= SEQUENCE {			
criticalExtensions CHOICE {			
rrcRelease SEQUENCE {			
redirectedCarrierInfo ::= CHOICE {			
eutra.SEQUENCE{			
eutraFrequency	Downlink EARFCN of cell 1		
cnType	epc		
}			
}			
}			
}			
}			

Table 11.1.6.3.3-2: TRACKING AREA UPDATE REQUEST (step 9, table 11.1.6.3.2-1)

Derivation Path: TS 36.508 [2], Table 4.7.2-27, condition NR.			
Information Element	Value/Remark	Comment	Condition
"Active" flag	0001	Bearer Establishment requested	
EPS bearer context status	Present	EBI corresponding to active PDU Sessions need to be set to 1	
NAS key set identifier	the eKSI indicating the 5G NAS security context value assigned at the initial registration when the UE entered N1		
Old GUTI	GUTI, mapped from the 5G-GUTI assigned at the initial registration when the UE entered N1		
Last visited registered TAI	The TAI to which the NGC cell belonged to (the cell in which the UE was when in N1 before moving to S1).		
Old GUTI type	"Native GUTI"		
UE status	"UE is in 5GMM-REGISTERED state"		

11.1.7 Emergency call setup from NR RRC_IDLE / Emergency Services Fallback to EPS with redirection / Single registration mode with N26 interface / Success

11.1.7.1 Test Purpose (TP)

(1)

with { UE supporting both S1 mode and N1 mode and operating in single-registration mode, and, the Network has indicated "interworking without N26 interface not supported", and, the UE in NR RRC_IDLE state }
ensure that {

```

when { User initiates an Emergency call and the UE completes Access control and checking in 5GMM-IDLE mode }
  then { UE requests the establishment of an Emergency call by transmitting an RRCSetupRequest message with establishmentCause set to 'emergency', and, a SERVICE REQUEST message with Service type set to 'emergency services fallback' }
}

```

(2)

```

with { UE is NR RRC_CONNECTED state after having requested a MMTEL call establishment and the MO IMS voice session establishment has been initiated }
ensure that {
  when { UE receives a RRCRelease message which includes redirectedCarrierInfo indicating redirection to epc }
  then { UE selects the E-UTRA cell, performs a TAU procedure, and, successfully completes the Emergency call setup in EPS }
}

```

11.1.7.2 Conformance requirements

References: The conformance requirements covered in the present TC are specified in: TS 24.501, subclauses 5.6.1.1, 5.6.1.2, 5.6.1.4; TS 23.502, subclause 4.13.4.2; TS 24.301, subclauses 4.4.2.3, 5.5.3.2.2. Unless otherwise stated these are Rel-15 requirements.

NOTE: Conformance requirements in regard to establishing an emergency call in EPS are not provided. This can be found in IMS Emergency tests specified in TS 36.523-1 [13].

[TS 24.501, subclause 5.6.1.1]

The UE shall invoke the service request procedure when:

...

- h) the UE, in 5GMM-IDLE, 5GMM-CONNECTED mode over 3GPP access, or 5GMM-CONNECTED mode with RRC inactive indication, receives a request for emergency services fallback from the upper layer and performs emergency services fallback as specified in subclause 4.13.4.2 of 3GPP TS 23.502 [9]; or

[TS 24.501, subclause 5.6.1.2]

For case h) in subclause 5.6.1.1, the UE shall send a SERVICE REQUEST message with service type set to "emergency services fallback".

[TS 24.501, subclause 5.6.1.4]

For case h) in subclause 5.6.1.1, the UE shall treat the indication from the lower layers when the UE has changed to S1 mode or E-UTRA connected to 5GCN (see 3GPP TS 23.502 [9]) as successful completion of the procedure and stop timer T3517.

[TS 23.502, subclause 4.13.4.2]

The call flow in Figure 4.13.4.2-1 describes the procedure for emergency services fallback.

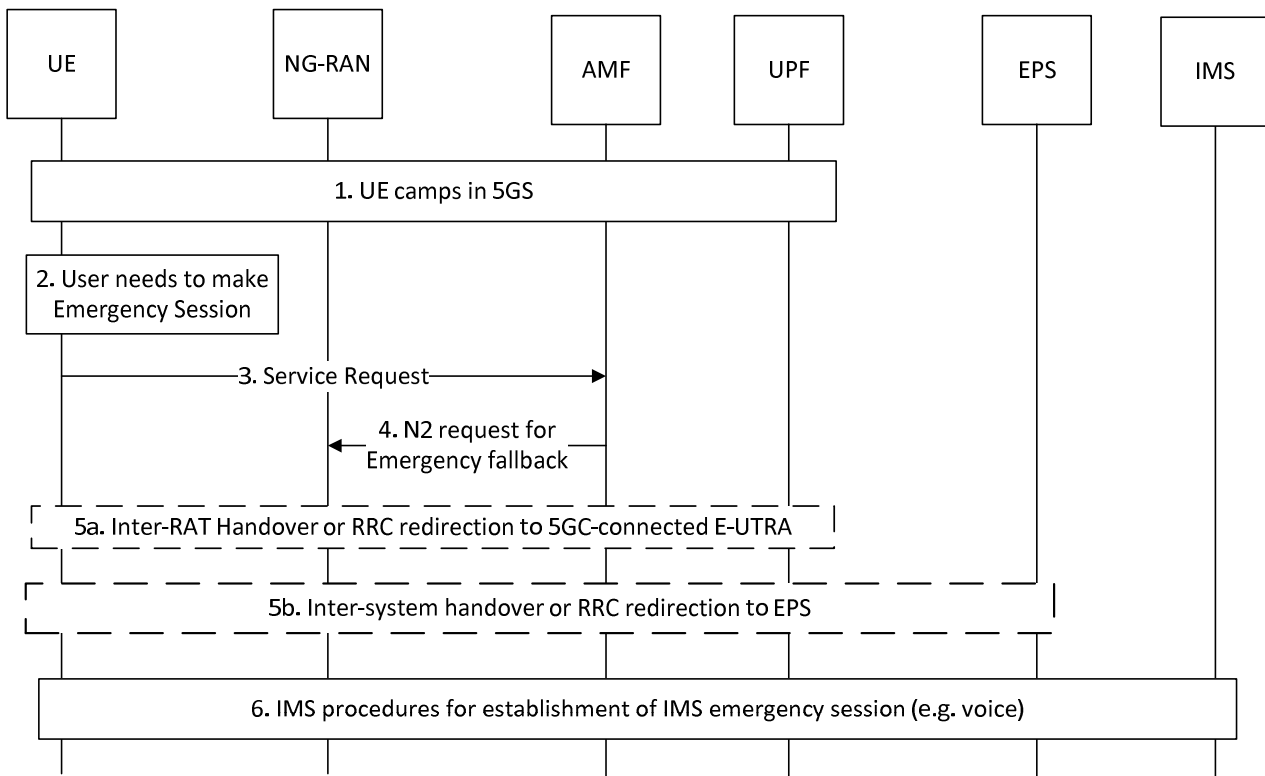

Figure 4.13.4.2-1: Emergency Services Fallback

1. UE camps on E-UTRA or NR cell in the 5GS (in either CM_IDLE or CM_CONNECTED state).
2. UE has a pending IMS emergency session request (e.g. voice) from the upper layers.
3. If the AMF has indicated support for emergency services using fallback via the Registration Accept message for the current RAT, the UE sends a Service Request message indicating that it requires emergency services fallback.
- ...
5. Based on the target CN indicated in message 4, one of the following procedures is executed by NG-RAN:
 - 5a. Inter-RAT Handover or RRC redirection to 5GC-connected E-UTRA
 - 5b. Inter-system handover or RRC redirection to EPS
- ...
- 5b. NG-RAN initiates handover (see clause 4.11.1.2.1) or redirection to E-UTRAN connected to EPS. NG-RAN uses the security context provided by the AMF to secure the redirection procedure.

If the redirection procedure is used either in 5a or 5b the target CN is also conveyed to the UE in order to be able to perform the appropriate NAS procedures (S1 or N1 Mode).

[TS 24.301, subclause 4.4.2.3]

Secure exchange of NAS messages via a NAS signalling connection is usually established by the MME during the attach procedure by initiating a security mode control procedure. After successful completion of the security mode control procedure, all NAS messages exchanged between the UE and the MME are sent integrity protected using the current EPS security algorithms, and except for the messages specified in subclause 4.4.5, all NAS messages exchanged between the UE and the MME are sent ciphered using the current EPS security algorithms.

...

During inter-system change from N1 mode to S1 mode in 5GMM-IDLE mode, if the UE is operating in the single-registration mode and:

- 1) if the tracking area updating procedure is initiated as specified in 3GPP TS 24.501 [54], the UE shall transmit a TRACKING AREA UPDATE REQUEST message integrity protected with the current 5G NAS security context and the UE shall derive a mapped EPS security context (see subclause 8.6.1 of 3GPP TS 33.501 [56]). The UE shall include the eKSI indicating the 5G NAS security context value in the TRACKING AREA UPDATE REQUEST message.

After receiving the TRACKING AREA UPDATE REQUEST message including the eKSI, the MME forwards the TRACKING AREA UPDATE REQUEST message to the source AMF, if possible, to obtain the mapped EPS security context from the AMF as specified in 3GPP TS 33.501 [56]. The MME re-establishes the secure exchange of NAS messages by either:

- replying with a TRACKING AREA UPDATE ACCEPT message that is integrity protected and ciphered using the mapped EPS NAS security context. From this time onward, all NAS messages exchanged between the UE and the MME are sent integrity protected and except for the messages specified in subclause 4.4.5, all NAS messages exchanged between the UE and the MME are sent ciphered; or

[TS 24.301, subclause 5.5.3.2.2]

The UE in state EMM-REGISTERED shall initiate the tracking area updating procedure by sending a TRACKING AREA UPDATE REQUEST message to the MME,

...

- z) when the UE performs inter-system change from N1 mode to S1 mode in EMM-IDLE mode, the UE operates in single-registration mode, and conditions specified in 3GPP TS 24.501 [54] apply;

...

- zd) when the UE performs inter-system change from N1 mode to S1 mode in EMM-CONNECTED mode.

For all cases except case b, the UE shall set the EPS update type IE in the TRACKING AREA UPDATE REQUEST message to "TA updating". For case b, the UE shall set the EPS update type IE to "periodic updating".

...

When initiating a tracking area updating procedure while in S1 mode, the UE shall use the current EPS NAS integrity key to integrity protect the TRACKING AREA UPDATE REQUEST message, unless the UE is performing inter-system change from N1 mode to S1 mode.

...

If a UE has established PDN connection(s) and uplink user data pending to be sent via user plane when it initiates the tracking area updating procedure, or uplink signalling not related to the tracking area updating procedure when the UE does not support control plane CIoT EPS optimization, it may also set an "active" flag in the TRACKING AREA UPDATE REQUEST message to indicate the request to establish the user plane to the network and to keep the NAS signalling connection after the completion of the tracking area updating procedure.

...

If the UE has a current EPS security context, the UE shall include the eKSI (either KSI_{ASME} or KSI_{SGSN}) in the NAS Key Set Identifier IE in the TRACKING AREA UPDATE REQUEST message. Otherwise, the UE shall set the NAS Key Set Identifier IE to the value "no key is available". If the UE has a current EPS security context, the UE shall integrity protect the TRACKING AREA UPDATE REQUEST message with the current EPS security context. Otherwise the UE shall not integrity protect the TRACKING AREA UPDATE REQUEST message.

...

For the case z and zd, the TRACKING AREA UPDATE REQUEST message shall be integrity protected using the 5GS security context available in the UE. The UE shall include a GUTI, mapped from 5G-GUTI (see 3GPP TS 23.501 [54] and 3GPP TS 23.003 [2]), in the Old GUTI IE in the TRACKING AREA UPDATE REQUEST message. In addition, the UE shall include Old GUTI type IE with GUTI set to "Native GUTI", and the UE shall include a UE status IE with a 5GMM registration status set to "UE is in 5GMM-REGISTERED state".

When the tracking area updating procedure is initiated in EMM-IDLE mode, the UE may also include an EPS bearer context status IE in the TRACKING AREA UPDATE REQUEST message, indicating which EPS bearer contexts are

active in the UE. The UE shall include the EPS bearer context status IE in TRACKING AREA UPDATE REQUEST message:

- ...
- for the case z; and
- ...

If the UE initiates the first tracking area updating procedure following an initial registration in N1 mode and the UE is operating in the single-registration mode, the UE shall include a UE radio capability information update needed IE in the TRACKING AREA UPDATE REQUEST message.

...

If the UE supports NB-S1 mode, Non-IP PDN type, or N1 mode, then the UE shall support the extended protocol configuration options IE.

For all cases except case b, if the UE supports the extended protocol configuration options IE, then the UE shall set the ePCO bit to "extended protocol configuration options supported" in the UE network capability IE of the TRACKING AREA UPDATE REQUEST message.

...

For all cases except case b, if the UE supports dual connectivity with NR, then the UE shall set the DCNR bit to "dual connectivity with NR supported" in the UE network capability IE of the TRACKING AREA UPDATE REQUEST message and shall include the UE additional security capability IE in the TRACKING AREA UPDATE REQUEST message.

...

For all cases except case b, if the UE supports N1 mode, the UE shall set the N1mode bit to "N1 mode supported" in the UE network capability IE of the TRACKING AREA UPDATE REQUEST message and shall include the UE additional security capability IE in the TRACKING AREA UPDATE REQUEST message.

11.1.7.3 Test description

11.1.7.3.1 Pre test conditions

System Simulator:

- 2 cells
 - NGC Cell A as defined in TS 38.508-1 [4] Table 6.3.2.2-1. Default system information combination as defined in TS 38.508-1 [4], subclause 4.4.3.1.2.
 - E-UTRA Cell 1 as defined in TS 36.508 [7] Table 4.4.2-2. System information combination 1 as defined in TS 36.508 [7], subclause 4.4.3.1.1.

UE:

None.

Preamble:

- With E-UTRA Cell 1 "Serving cell" and NGC Cell A "Non-suitable "Off" cell" in accordance with TS 38.508-1 [4], Table 6.2.2.1-3, the UE is brought to state RRC_IDLE Connectivity (*E-UTRA/EPC*) in accordance with the procedure described in TS 38.508-1 [4], Table 4.5.2.2-1. 4G GUTI and eKSI are assigned and security context established
 - the UE is switched-off
- With E-UTRA Cell 1 "Non-suitable "Off" cell" and NGC Cell A "Serving cell" in accordance with TS 38.508-1 [4], Table 6.2.2.1-3, the UE is brought to state 1N-A, RRC_IDLE Connectivity (NR), in accordance with the

procedure described in TS 38.508-1 [4], Table 4.5.2.2-2. 5G-GUTI and ngKSI are assigned and security context established.

11.1.7.2 Test procedure sequence

Table 11.1.7.3.2-1: Main behaviour

St	Procedure	Message Sequence		TP	Verdict
		U - S	Message		
1	The SS configures: - E-UTRA Cell 1 as "Suitable neighbour intra-frequency cell" in accordance with TS 38.508-1 [4], Table 6.2.2.1-3.	-	-	-	-
-	EXCEPTION: Unless otherwise stated the following messages are exchange on NGC Cell A.	-	-	-	-
2	Make the UE initiate an Emergency call.	-	-	-	-
3	Check: Does the UE transmit an <i>RRCSetupRequest</i> message with <i>establishmentCause</i> set to 'emergency'?	-->	NR RRC: <i>RRCSetupRequest</i>	1	P
4	The SS transmits an <i>RRCSetup</i> message.	<--	NR RRC: <i>RRCSetup</i>	-	-
5	Check: Does the UE transmit a SERVICE REQUEST message with Service type set to 'emergency services fallback'? NOTE: The UE shall request 'emergency services fallback' when the AMF has indicated support for emergency services using fallback via the Registration Accept message for the current RAT as per TS 23.502 [31], subclause 4.13.4.2.	-->	NR RRC: <i>RRCSetupComplete</i> 5GMM: SERVICE REQUEST	1	P
6	SS transmits <i>RRCRelease</i> message indicating redirection to E-UTRA Cell 1.	<--	NR RRC: <i>RRCRelease</i>		
-	EXCEPTION: Unless otherwise stated the following messages are exchange on E-UTRA Cell 1.	-	-	-	-
7	The UE transmits an <i>RRCConnectionRequest</i> message with 'establishmentCause' set to 'emergency'.	-->	RRC: <i>RRCConnectionRequest</i>	2	P
8-10	Steps 3-5 from the Tracking area updating procedure as specified in TS 36.508 [7], Table 4.5A.2.1-1 are performed (UE performs inter-system change from N1 to S1, mapped EPS NAS security context from the 5GC).	-	-	-	-
11	Check: Does the UE transmit a TRACKING AREA UPDATE COMPLETE message?	-->	RRC: <i>ULInformationTransfer</i> NAS: TRACKING AREA UPDATE COMPLETE	2	P
12-19	Steps 7-14 from the Generic Test Procedure for IMS Emergency call establishment in EUTRA: Normal Service as specified in TS 36.508 [7], Table 4.5A.4.3-1 are performed.	-	-	-	-
20	Check: Does the UE transmit an ACTIVATE DEDICATED EPS BEARER CONTEXT ACCEPT message?	-->	RRC: <i>ULInformationTransfer</i> NAS: ACTIVATE DEDICATED EPS BEARER CONTEXT ACCEPT	2	P
21	The SS waits 1 second.	-	-	-	-
22	Release IMS Call as specified in the generic procedure in TS 34.229-1 [x1] subclause C.32.	-	-	-	-

11.1.7.3.3 Specific message contents

Table 11.1.7.3.1-1: REGISTRATION REQUEST (Preamble; TS 38.508-1 [4], Table 4.5.2.2-2)

Derivation Path: TS 38.508-1 [4], Table 4.7.1-6			
Information Element	Value/remark	Comment	Condition
5GMM capability	'0000 0xx1'	S1 mode supported x - not checked	

Table 11.1.7.3.1-2: REGISTRATION ACCEPT (Preamble; TS 38.508-1 [4], Table 4.5.2.2-2)

Derivation Path: 38.508-1 [4], Table 4.7.1-7			
Information Element	Value/remark	Comment	Condition
5GS network feature support			
Emergency service fallback indicator for 3GPP access (EMF) (octet 3, bit 5 and bit 6)	'01'	Emergency services fallback supported in NR connected to 5GCN only	

Table 11.1.7.3.1-3: RRCSetupRequest (step 3, table 11.1.7.3.1-2)

Derivation Path: TS 38.508-1 [4], Table 4.6.1-23			
Information Element	Value/remark	Comment	Condition
RRCSetupRequest ::= SEQUENCE {			
rrcSetupRequest SEQUENCE {			
establishmentCause	emergency		
}			
}			

Table 11.1.7.3.1-4: SERVICE REQUEST (step 5, table 11.1.7.3.1-2)

Derivation path: TS 38.508-1 [4], Table 4.7.1-16			
Information Element	Value/Remark	Comment	Condition
Service type	'0100'	emergency services fallback	

Table 11.1.7.3.1-5: RRCRelease (step 6, table 11.1.7.3.1-2)

Derivation path: TS 38.508-1 [4], Table 4.6.1-16			
Information Element	Value/Remark	Comment	Condition
RRCRelease ::= SEQUENCE {			
criticalExtensions CHOICE {			
rrcRelease SEQUENCE {			
redirectedCarrierInfo ::= CHOICE {			
eutra SEQUENCE {			
eutraFrequency	Downlink EARFCN of E-UTRA Cell 1		
cnType	epc		
}			
}			
}			
}			

Table 11.1.7.3.1-6: RRCConnectionRequest (step 7, Table 11.2.1.3.2-1)

Derivation Path: TS 36.508 [7], Table 4.6.1-16			
Information Element	Value/remark	Comment	Condition
RRCConnectionRequest ::= SEQUENCE {			
criticalExtensions CHOICE {			
rrcConnectionRequest-r8 SEQUENCE {			
establishmentCause	emergency		
}			
}			
}			

Table 11.1.7.3.1-7: TRACKING AREA UPDATE REQUEST (step 9, table 11.1.7.3.1-2)

Derivation Path: TS 36.508 [7], Table 4.7.2-27.			
Information Element	Value/Remark	Comment	Condition
EPS update type			
EPS update type Value	'000'B	TA updating	
"Active" flag	'0'B	No Bearer Establishment requested	
NAS key set identifier	the eKSI indicating the 5G NAS security context value assigned at the initial registration when the UE entered N1		
Old GUTI	GUTI, mapped from the 5G-GUTI assigned at the initial registration when the UE entered N1		
Last visited registered TAI	The TAI to which the NGC cell belonged to (the cell in which the UE was when in N1 before moving to S1).		
UE radio capability information update needed	'1'B	UE radio capability information update needed	
EPS bearer context status	Present, Content Not checked	EBI corresponding to active PDU Sessions need to be set to 1	
Old GUTI type	"Native GUTI"		
UE status	"UE is in 5GMM-REGISTERED state"		
NOTE: The message shall be integrity protected using the 5GS security context available in the UE.			

Table 11.1.7.3.1-8: TRACKING AREA UPDATE ACCEPT (step 10, table 11.1.7.3.1-2)

Derivation Path: TS 36.508 [7], Table 4.7.2-24.			
Information Element	Value/Remark	Comment	Condition
NOTE: The message is integrity protected and ciphered using the mapped EPS NAS security context			

Table 11.1.7.3.1-9: Message PDN CONNECTIVITY REQUEST (step 14, Table 11.2.1.3.2-1)

Derivation Path: TS 36.508 [7], Table 4.7.2-1.			
Information Element	Value/Remark	Comment	Condition
Request type	'0100'B	emergency	
Access point name	Not present		

Table 11.1.7.3.1-10: Message ACTIVATE DEFAULT EPS BEARER CONTEXT REQUEST (step 15, Table 11.2.1.3.2-1)

Derivation path: TS 36.508 [7], Table 4.7.3-6 and table 4.6.1-8 with condition UM-DRB-ADD(2).			
Information Element	Value/Remark	Comment	Condition
EPS bearer identity	an additional EPS Bearer Id different from default EPS Bearer Id or/and any mapped EPS bearer		
Access point name	APN-1		

Annex A (informative): Change history

Change history							
Date	Meeting	TDoc	CR	R ev	Cat	Subject/Comment	New version
2017-08	RAN5#76	R5-174427	-	-	-	Introduction of TS 38.523-1.	0.0.1
2017-12	RAN5#77	R5-176926	-	-	-	Addition of new NR PDCP test case 7.3.1.2	0.1.0
2017-12	RAN5#77	R5-176928	-	-	-	Addition of new NR MAC test case 7.1.3.1	0.1.0
2017-12	RAN5#77	R5-177072	-	-	-	Addition of new NR RLC UM test case 7.2.2.1	0.1.0
2017-12	RAN5#77	R5-177073	-	-	-	Addition of new NR RLC UM test case 7.2.2.2	0.1.0
2017-12	RAN5#77	R5-177074	-	-	-	Addition of new NR PDCP test case 7.3.1.1	0.1.0
2017-12	RAN5#77	R5-177075	-	-	-	Addition of new NR MAC test case 7.1.2.1	0.1.0
2018-03	RAN5#77	R5-181171	-	-	-	5GS RRC TC 8.2.2.2.1	0.2.0
2018-03	RAN5#77	R5-181172	-	-	-	5GS RRC TC 8.2.2.2.6	0.2.0
2018-03	RAN5#77	R5-181173	-	-	-	5GS RRC TC 8.2.3.1	0.2.0
2018-03	RAN5#77	R5-181174	-	-	-	5GS RRC TC 8.2.3.16	0.2.0
2018-03	RAN5#77	R5-181175	-	-	-	5GS RRC TC 8.2.5.1	0.2.0
2018-03	RAN5#77	R5-181176	-	-	-	5GS MAC Test case 7.1.1.2	0.2.0
2018-03	RAN5#77	R5-181177	-	-	-	Addition of new NR MAC test case 7.1.3.2	0.2.0
2018-03	RAN5#77	R5-181178	-	-	-	Addition of new NR MAC test case 7.1.3.3	0.2.0
2018-03	RAN5#77	R5-181179	-	-	-	Addition of new NR MAC test case 7.1.3.4	0.2.0
2018-03	RAN5#77	R5-181180	-	-	-	Addition of new NR MAC test case 7.1.3.5	0.2.0
2018-03	RAN5#77	R5-181181	-	-	-	Addition of new NR MAC test case 7.1.3.6	0.2.0
2018-03	RAN5#77	R5-181182	-	-	-	Addition of new NR RLC test case 7.2.3.1	0.2.0
2018-03	RAN5#77	R5-181183	-	-	-	Addition of new NR RLC test case 7.2.3.2	0.2.0
2018-03	RAN5#77	R5-181184	-	-	-	Addition of new NR PDCP test case 7.3.2.1	0.2.0
2018-03	RAN5#77	R5-181185	-	-	-	Addition of new NR PDCP test case 7.3.2.2	0.2.0
2018-03	RAN5#77	R5-181186	-	-	-	Addition of new NR PDCP test case 7.3.2.3	0.2.0
2018-03	RAN5#77	R5-181187	-	-	-	Addition of new NR PDCP test case 7.3.3.1	0.2.0
2018-03	RAN5#77	R5-181188	-	-	-	Addition of new NR PDCP test case 7.3.3.2	0.2.0
2018-03	RAN5#77	R5-181189	-	-	-	Addition of new NR PDCP test case 7.3.3.3	0.2.0
2018-03	RAN5#77	R5-181201	-	-	-	Addition of new NR MAC test case 7.1.5.1	0.2.0
2018-03	RAN5#77	R5-181202	-	-	-	Addition of new NR MAC test case 7.1.5.2	0.2.0
2018-03	RAN5#77	R5-181203	-	-	-	Addition of new NR PDCP test case 7.3.5.1	0.2.0
2018-03	RAN5#77	R5-181204	-	-	-	Addition of new NR RRC test case 8.2.2.2.5	0.2.0
2018-03	RAN5#77	R5-181205	-	-	-	Addition of new NR RRC test case 8.2.3.5	0.2.0
2018-03	RAN5#77	R5-181206	-	-	-	Update of NR MAC test cases	0.2.0
2018-03	RAN5#77	R5-181207	-	-	-	Update of NR RLC test cases	0.2.0
2018-03	RAN5#77	R5-181208	-	-	-	Update of NR PDCP test cases	0.2.0
2018-03	RAN5#77	R5-181209	-	-	-	5GS MAC Test case 7.1.5.3	0.2.0
2018-03	RAN5#77	R5-181312	-	-	-	Addition of new NR PDCP test case 7.3.5.2	0.2.0
2018-03	RAN5#77	R5-181334	-	-	-	Addition of new NR PDCP test case 7.3.4.2	0.2.0
2018-04	RAN5#2- 5G-NR Adhoc	R5-181805	-	-	-	Corrections to RRC TC 8.2.3.1 Measurement configuration control and reporting / Inter-RAT measurements / Event B1 / Measurement of NR cells	0.3.0
2018-04	RAN5#2- 5G-NR Adhoc	R5-181806	-	-	-	5GS RRC TC 8.2.1.2	0.3.0
2018-04	RAN5#2- 5G-NR Adhoc	R5-181914	-	-	-	Addition of 5GS NR RRC test case 8.2.3.6	0.3.0
2018-04	RAN5#2- 5G-NR Adhoc	R5-181951	-	-	-	Correction to RLC UM Test cases	0.3.0
2018-04	RAN5#2- 5G-NR Adhoc	R5-181952	-	-	-	Correction to RLC AM Test cases	0.3.0
2018-04	RAN5#2- 5G-NR Adhoc	R5-181967	-	-	-	Correction to PDCP ciphering test cases	0.3.0
2018-04	RAN5#2- 5G-NR Adhoc	R5-181980	-	-	-	5GS RRC TC 8.2.2.2.9	0.3.0
2018-04	RAN5#2- 5G-NR Adhoc	R5-181981	-	-	-	Corrections to RRC TC 8.2.3.16 Handover with PSCell release / SCG DRB	0.3.0
2018-04	RAN5#2- 5G-NR Adhoc	R5-181982	-	-	-	5GS RRC TC 8.2.3.2	0.3.0
2018-04	RAN5#2- 5G-NR Adhoc	R5-181983	-	-	-	5GS RRC TC 8.2.3.3	0.3.0
2018-04	RAN5#2- 5G-NR Adhoc	R5-181984	-	-	-	5GS RRC TC 8.2.3.4	0.3.0

2018-04	RAN5#2-5G-NR Adhoc	R5-181986	-	-	-	Addition of new NR RRC test case 8.2.2.2.4	0.3.0
2018-04	RAN5#2-5G-NR Adhoc	R5-181988	-	-	-	Addition of new NR NAS test case for dedicated EPS bearer context activation	0.3.0
2018-04	RAN5#2-5G-NR Adhoc	R5-181991	-	-	-	Addition of text to clarify that 5GS requirements may be implicitly tested in other specs	0.3.0
2018-04	RAN5#2-5G-NR Adhoc	R5-181992	-	-	-	New NAS test case EPS bearer resource allocation / New EPS bearer context	0.3.0
2018-04	RAN5#2-5G-NR Adhoc	R5-181994	-	-	-	Addition of new NR MAC test case 7.1.4.1.1	0.3.0
2018-04	RAN5#2-5G-NR Adhoc	R5-181995	-	-	-	Addition of new NR MAC test case 7.1.4.1.2	0.3.0
2018-04	RAN5#2-5G-NR Adhoc	R5-181996	-	-	-	Addition of new NR MAC test case 7.1.4.1.3	0.3.0
2018-04	RAN5#2-5G-NR Adhoc	R5-181997	-	-	-	Addition of new NR MAC test case 7.1.4.1.4	0.3.0
2018-04	RAN5#2-5G-NR Adhoc	R5-181998	-	-	-	Addition of new NR RLC test case 7.2.2.6	0.3.0
2018-04	RAN5#2-5G-NR Adhoc	R5-181999	-	-	-	Addition of new NR RLC test case 7.2.3.5	0.3.0
2018-04	RAN5#2-5G-NR Adhoc	R5-182050	-	-	-	Addition of new NR RLC test case 7.2.2.5	0.3.0
2018-04	RAN5#2-5G-NR Adhoc	R5-182051	-	-	-	Addition of new NR RLC test case 7.2.3.6	0.3.0
2018-04	RAN5#2-5G-NR Adhoc	R5-182052	-	-	-	Addition of new NR RLC test case 7.2.3.7	0.3.0
2018-04	RAN5#2-5G-NR Adhoc	R5-182053	-	-	-	Addition of new NR RLC test case 7.2.3.8	0.3.0
2018-04	RAN5#2-5G-NR Adhoc	R5-182054	-	-	-	Addition of new NR RLC test case 7.2.3.3	0.3.0
2018-04	RAN5#2-5G-NR Adhoc	R5-182055	-	-	-	Addition of new NR RLC test case 7.2.3.4	0.3.0
2018-04	RAN5#2-5G-NR Adhoc	R5-182056	-	-	-	Addition of new NR RRC test case 8.2.3.9	0.3.0
2018-04	RAN5#2-5G-NR Adhoc	R5-182057	-	-	-	Addition of new NR RRC test case 8.2.3.10	0.3.0
2018-04	RAN5#2-5G-NR Adhoc	R5-182058	-	-	-	Addition of new NR RRC test case 8.2.3.11	0.3.0
2018-04	RAN5#2-5G-NR Adhoc	R5-182059	-	-	-	Addition of new NR RRC test case 8.2.3.12	0.3.0
2018-04	RAN5#2-5G-NR Adhoc	R5-182060	-	-	-	Correction to MAC test case 7.1.2.1	0.3.0
2018-04	RAN5#2-5G-NR Adhoc	R5-182061	-	-	-	Addition of new NR RRC test case 8.2.3.19	0.3.0
2018-04	RAN5#2-5G-NR Adhoc	R5-182076	-	-	-	5GS PDCP Test case 7.3.4.1	0.3.0
2018-04	RAN5#2-5G-NR Adhoc	R5-182077	-	-	-	5GS PDCP Test case 7.3.5.4	0.3.0
2018-04	RAN5#2-5G-NR Adhoc	R5-182078	-	-	-	5GS RLC test case 7.2.3.11	0.3.0

2018-04	RAN5#2-5G-NR Adhoc	R5-182079	-	-	-	5GS RLC test case 7.2.3.12	0.3.0
2018-04	RAN5#2-5G-NR Adhoc	R5-182080	-	-	-	Addition of new NR RRC test case 8.2.3.7	0.3.0
2018-04	RAN5#2-5G-NR Adhoc	R5-182081	-	-	-	Addition of new NR RLC test case 7.2.2.3	0.3.0
2018-04	RAN5#2-5G-NR Adhoc	R5-182082	-	-	-	Addition of new NR RLC test case 7.2.2.4	0.3.0
2018-04	RAN5#2-5G-NR Adhoc	R5-182083	-	-	-	Addition of new NR RRC test case 8.2.3.17	0.3.0
2018-04	RAN5#2-5G-NR Adhoc	R5-182085	-	-	-	Correction to PDCP integrity protection test cases	0.3.0
2018-04	RAN5#2-5G-NR Adhoc	R5-182089	-	-	-	5GS RRC TC 8.2.5.5	0.3.0
2018-04	RAN5#2-5G-NR Adhoc	R5-182100	-	-	-	5GS RRC TC 8.2.5.6	0.3.0
2018-04	RAN5#2-5G-NR Adhoc	R5-182101	-	-	-	5GS RRC TC 8.2.5.7	0.3.0
2018-04	RAN5#2-5G-NR Adhoc	R5-182102	-	-	-	5GS RRC TC 8.2.2.2.7	0.3.0
2018-04	RAN5#2-5G-NR Adhoc	R5-182103	-	-	-	Corrections to RRC TC 8.2.5.1 RRC connection reconfiguration / PSCell addition failure	0.3.0
2018-04	RAN5#2-5G-NR Adhoc	R5-182104	-	-	-	Corrections to RRC TC 8.2.2.2.1 PSCell addition, modification and release / SCG DRB	0.3.0
2018-04	RAN5#2-5G-NR Adhoc	R5-182105	-	-	-	Corrections to RRC TC 8.2.2.2.6 Bearer Modification / SCG DRB / Split DRB Reconfiguration	0.3.0
2018-04	RAN5#2-5G-NR Adhoc	R5-182106	-	-	-	Addition of new NR RRC test case 8.2.2.1.2	0.3.0
2018-04	RAN5#2-5G-NR Adhoc	R5-182115	-	-	-	Introduction of 5GS RRC TC 8.2.4.3.1	0.3.0
2018-04	RAN5#2-5G-NR Adhoc	R5-182116	-	-	-	Adding NR test case 8.2.2.1.1	0.3.0
2018-04	RAN5#2-5G-NR Adhoc	R5-182117	-	-	-	Adding NR test case 8.2.2.1.3	0.3.0
2018-04	post RAN5#2-5G-NR Adhoc	-	-	-	-	Editorial update to apply with the 3GPP drafting rules (styles)	0.3.1
2018-05	RAN5#79	R5-183094	-	-	-	Addition of UE power headroom reporting test case 7.1.1.3.7	1.0.0
2018-05	RAN5#79	R5-183101	-	-	-	Addition of DRX Operation test case 7.1.1.5.4	1.0.0
2018-05	RAN5#79	R5-183102	-	-	-	Addition of Correct handling of DL assignment/Semi-persistent test case 7.1.1.6.1	1.0.0
2018-05	RAN5#79	R5-183103	-	-	-	Addition of AM RLC test case 7.1.2.3.10	1.0.0
2018-05	RAN5#79	R5-183227	-	-	-	Editorial updates to 38.523-1	1.0.0
2018-05	RAN5#79	R5-183229	-	-	-	Correction to PDCP Test case - PDCP reordering/Maximum re-ordering delay below t-Reordering/ t-Reordering timer operations	1.0.0
2018-05	RAN5#79	R5-183109	-	-	-	Update to MAC Test case - Random access procedure / Successful/ C-RNTI Based/Preamble selected by MAC itself	1.0.0
2018-05	RAN5#79	R5-183111	-	-	-	Update RLC test case - AM RLC / Re-transmission of RLC PDU with and without re-segmentation	1.0.0
2018-05	RAN5#79	R5-183112	-	-	-	Correction to MAC Test case - DRX operation / Short cycle configured / Parameters configured by RRC	1.0.0
2018-05	RAN5#79	R5-183113	-	-	-	Correction to PDCP Test case - PDCP handover / Lossless handover / PDCP sequence number maintenance/PDCP status report to convey the information on missing or acknowledged PDCP SDUs at handover/ In-order delivery and duplicate elimination in the downlink	1.0.0
2018-05	RAN5#79	R5-182497	-	-	-	Corrections to RRC TC - BandwidthPart Configuration / SCG	1.0.0

2018-05	RAN5#79	R5-183230	-	-	-	Corrections to RRC TC - PSCell addition, modification and release / SCG DRB	1.0.0
2018-05	RAN5#79	R5-183114	-	-	-	Corrections to RRC TC - Bearer Modification / Handling for bearer type change with security key change	1.0.0
2018-05	RAN5#79	R5-183115	-	-	-	Corrections to RRC TC - Bearer Modification / Uplink data path / Split DRB Reconfiguration	1.0.0
2018-05	RAN5#79	R5-183117	-	-	-	Corrections to RRC TC - Measurement configuration control and reporting / Inter-RAT measurements / Event B1 / Measurement of NR cells	1.0.0
2018-05	RAN5#79	R5-183116	-	-	-	Corrections to RRC TC - RRC connection reconfiguration / PSCell addition failure	1.0.0
2018-05	RAN5#79	R5-183231	-	-	-	Corrections to RRC TC - NR SCG Failure Information / RLC-MaxNumRetx	1.0.0
2018-05	RAN5#79	R5-183118	-	-	-	Corrections to RRC TC - SCG Reconfiguration Failure / SRB3	1.0.0
2018-05	RAN5#79	R5-183119	-	-	-	Corrections to RRC TC - SCG Reconfiguration Failure / SRB1	1.0.0
2018-05	RAN5#79	R5-182508	-	-	-	Void RRC TC - Handover with PSCell release / SCG DRB	1.0.0
2018-05	RAN5#79	R5-182509	-	-	-	Void RRC TC - Bearer Modification / SCG DRB / Split DRB Reconfiguration	1.0.0
2018-05	RAN5#79	R5-183120	-	-	-	Correction to NR RRC test case 8.2.3.17	1.0.0
2018-05	RAN5#79	R5-183121	-	-	-	Correction to NR RRC test case 8.2.3.19	1.0.0
2018-05	RAN5#79	R5-183228	-	-	-	Correction to NR MAC test case 7.1.1.3.2	1.0.0
2018-05	RAN5#79	R5-183122	-	-	-	Correction to NR PDCP test case 7.1.3.4.2	1.0.0
2018-05	RAN5#79	R5-183123	-	-	-	Addition of new NR RRC test case 8.2.5.2.1	1.0.0
2018-05	RAN5#79	R5-183124	-	-	-	Addition of new NR RRC test case 8.2.5.4.1	1.0.0
2018-05	RAN5#79	R5-182601	-	-	-	Removal of NR RRC test case 8.2.2.5	1.0.0
2018-05	RAN5#79	R5-183126	-	-	-	Addition of new 5GS RRC TC 8.2.4.3.1.1	1.0.0
2018-05	RAN5#79	R5-183127	-	-	-	Addition of new NR RRC test case - Bearer Modification / Handling for bearer type change without security key change / EN-DC	1.0.0
2018-05	RAN5#79	R5-182652	-	-	-	Void RRC TC - Bearer Modification / MCG DRB / SCG DRB Reconfiguration	1.0.0
2018-05	RAN5#79	R5-182774	-	-	-	Addition of 5GS NR RRC test case 8.2.3.8.1	1.0.0
2018-05	RAN5#79	R5-183130	-	-	-	Removal of RRC TC 8.2.4.3.1	1.0.0
2018-05	RAN5#79	R5-182798	-	-	-	Update of 5GS NR RRC test case 8.2.3.6	1.0.0
2018-05	RAN5#79	R5-183232	-	-	-	Addition of 5GS NR RRC test case 8.2.2.6.1	1.0.0
2018-05	RAN5#79	R5-183233	-	-	-	Addition of 5GS NR PDCP test case 7.1.3.5.3	1.0.0
2018-05	RAN5#79	R5-183132	-	-	-	Update of NR RRC TC - Measurement configuration control and reporting / Inter-RAT measurements / Event B1 / Measurement of NR cells / RSRQ based measurements	1.0.0
2018-05	RAN5#79	R5-183133	-	-	-	Update of NR RRC TC - Measurement configuration control and reporting / Inter-RAT measurements / Periodic reporting / Measurement of NR cells	1.0.0
2018-05	RAN5#79	R5-183134	-	-	-	Update of NR RRC TC - Measurement configuration control and reporting / Event A1 / Measurement of NR PSCell	1.0.0
2018-05	RAN5#79	R5-183135	-	-	-	Addition of NR RRC TC - PSCell addition, modification and release / Split DRB / EN-DC	1.0.0
2018-05	RAN5#79	R5-183137	-	-	-	Addition of 5GS NR RRC test case 8.2.1.1.1	1.0.0
2018-05	RAN5#79	R5-183138	-	-	-	Addition of new NR MAC UL TBS test case 7.1.1.4.2.1	1.0.0
2018-05	RAN5#79	R5-183139	-	-	-	Addition of new NR MAC UL TBS test case 7.1.1.4.2.2	1.0.0
2018-05	RAN5#79	R5-183140	-	-	-	Addition of new NR MAC UL TBS test case 7.1.1.4.2.3	1.0.0
2018-05	RAN5#79	R5-183141	-	-	-	Addition of new NR MAC UL TBS test case 7.1.1.4.2.4	1.0.0
2018-05	RAN5#79	R5-183142	-	-	-	Addition of Layer 2 test case specific parameters	1.0.0
2018-05	RAN5#79	R5-183143	-	-	-	Correction to MAC Pre-test conditions	1.0.0
2018-05	RAN5#79	R5-183144	-	-	-	Correction to RLC Pre-test conditions	1.0.0
2018-05	RAN5#79	R5-183145	-	-	-	Correction to PDCP Pre-test conditions	1.0.0
2018-05	RAN5#79	R5-183146	-	-	-	Correction to MAC RACH Test Cases	1.0.0
2018-05	RAN5#79	R5-182940	-	-	-	Correction to MAC DL Data Transfer test cases	1.0.0
2018-05	RAN5#79	R5-183147	-	-	-	Correction to MAC UL Data Transfer test cases	1.0.0
2018-05	RAN5#79	R5-183148	-	-	-	Correction to MAC DL-SCH TBS test cases	1.0.0
2018-05	RAN5#79	R5-183149	-	-	-	Correction to RLC UM Test cases	1.0.0
2018-05	RAN5#79	R5-183150	-	-	-	Correction to RLC AM Test cases	1.0.0
2018-05	RAN5#79	R5-182945	-	-	-	Corrections to PDCP sequence number test cases	1.0.0
2018-05	RAN5#79	R5-183151	-	-	-	Correction to PDCP integrity protection test cases	1.0.0
2018-05	RAN5#79	R5-182947	-	-	-	Correction to PDCP Ciphering test cases	1.0.0
2018-05	RAN5#79	R5-183152	-	-	-	Corrections to PDCP other test cases	1.0.0
2018-05	RAN5#79	R5-183153	-	-	-	Addition of new NR RACH test case 7.1.1.1.1	1.0.0
2018-05	RAN5#79	R5-182966	-	-	-	Correction to NR RLC test case 7.1.2.3.4	1.0.0
2018-05	RAN5#79	R5-183154	-	-	-	Correction to PDCP test case 7.1.3.5.2	1.0.0
2018-05	RAN5#79	R5-183155	-	-	-	Correction to NR MAC DRX Test cases	1.0.0
2018-05	RAN5#79	R5-183156	-	-	-	Correction to NR RRC intra frequency measurement Test case 8.2.3.9	1.0.0
2018-05	RAN5#79	R5-183157	-	-	-	Correction to NR RRC inter frequency measurement Test case 8.2.3.10	1.0.0
2018-05	RAN5#79	R5-183016	-	-	-	Removal of NR RRC test case 8.2.3.11	1.0.0

2018-05	RAN#79	R5-183017	-	-	-	Removal of NR RRC test case 8.2.3.12	1.0.0
2018-05	RAN#79	R5-183129	-	-	-	Addition of new 5GS RRC TC 8.2.3.13.1	1.0.0
2018-05	RAN#79	R5-183136	-	-	-	Correction to NR RRC test case 8.2.3.5	1.0.0
2018-05	RAN#79	R5-183263	-	-	-	Addition of new NR NAS test case Default EPS bearer context activation	1.0.0
2018-05	RAN#79	R5-183265	-	-	-	Updates to session management TC 10.2.2.1	1.0.0
2018-06	RAN#80	RP-181210	-	-	-	put under revision control as v15.0.0 with small editorial changes	15.0.0
2018-09	RAN#81	R5-184226	0010	-	F	Addition of Correct handling of Configured UL grant Type 1 test case 7.1.1.6.2	15.1.0
2018-09	RAN#81	R5-184227	0011	-	F	Addition of Correct handling of Configured UL grant Type 2 test case 7.1.1.6.3	15.1.0
2018-09	RAN#81	R5-184228	0012	-	F	CR of Correct handling of DL assignment Semi persistent test case 7.1.1.6.1	15.1.0
2018-09	RAN#81	R5-184229	0013	-	F	CR of UE power headroom reporting test case 7.1.1.3.7	15.1.0
2018-09	RAN#81	R5-184343	0020	-	F	Correction to 5GS PDCP Test case 7.1.3.4.1 PDCP handover / Lossless handover / PDCP sequence number maintenance / PDCP status report to convey the information on missing or acknowledged PDCP SDUs at handover / In-order delivery and duplicate elimination in the downlink	15.1.0
2018-09	RAN#81	R5-184344	0021	-	F	Correction to 5GS PDCP Test case 7.1.3.5.4 PDCP reordering / Maximum re-ordering delay below t-Reordering / t-Reordering timer operations	15.1.0
2018-09	RAN#81	R5-184353	0023	-	F	Corrections to RRC TC - BandwidthPart Configuration / SCG / EN-DC	15.1.0
2018-09	RAN#81	R5-184500	0031	-	F	Addition of new 5GS RRC TC 8.2.4.3.1.3	15.1.0
2018-09	RAN#81	R5-184517	0032	-	F	Correction to NR PDCP test case 7.1.3.4.2	15.1.0
2018-09	RAN#81	R5-184523	0036	-	F	Corrections to MAC TBS test cases	15.1.0
2018-09	RAN#81	R5-184527	0040	-	F	Addition of new MAC test case for Reset	15.1.0
2018-09	RAN#81	R5-184680	0055	-	F	Update of RRC SCG failure TC 8.2.5.5.1	15.1.0
2018-09	RAN#81	R5-184681	0056	-	F	Update of RRC SCG failure TC 8.2.5.6.1	15.1.0
2018-09	RAN#81	R5-184760	0059	-	F	Correction to RRC TC - PSCell addition, modification and release / Split DRB / EN-DC	15.1.0
2018-09	RAN#81	R5-184761	0060	-	F	Correction to RRC TC - Measurement configuration control and reporting / Inter-RAT measurements / Periodic reporting / Measurement of NR cells / EN-DC	15.1.0
2018-09	RAN#81	R5-184763	0061	-	F	Correction to RRC TC - Measurement configuration control and reporting / Inter-RAT measurements / Event B1 / Measurement of NR cells / RSRQ based measurements / EN-DC	15.1.0
2018-09	RAN#81	R5-184769	0063	-	F	Update of 5GS NR RRC test case 8.2.2.6.1	15.1.0
2018-09	RAN#81	R5-185059	0001	1	F	Correction to NR MAC test case 7.1.1.3.2	15.1.0
2018-09	RAN#81	R5-185060	0004	1	F	Addition of Correct Handling of DL HARQ process PDSCH Aggregation test case 7.1.1.2.2	15.1.0
2018-09	RAN#81	R5-185061	0005	1	F	Addition of NR CA reconfiguration test case 8.2.4.2.1.1	15.1.0
2018-09	RAN#81	R5-185062	0006	1	F	Addition of NR CA reconfiguration test case 8.2.4.2.1.2	15.1.0
2018-09	RAN#81	R5-185064	0015	1	F	Addition of 5GS NR SDAP test case 7.1.4.1	15.1.0
2018-09	RAN#81	R5-185065	0016	1	F	Correction to 5GS MAC Test case 7.1.1.1.2 Random access procedure / Successful / C-RNTI Based / Preamble selected by MAC itself	15.1.0
2018-09	RAN#81	R5-185066	0017	1	F	Correction to 5GS MAC Test case 7.1.1.5.3 DRX operation / Short cycle configured / Parameters configured by RRC	15.1.0
2018-09	RAN#81	R5-185067	0018	1	F	Correction to 5GS RLC Test case 7.1.2.3.10 AM RLC / Re-transmission of RLC PDU with and without re-segmentation	15.1.0
2018-09	RAN#81	R5-185068	0019	1	F	Correction to 5GS RLC Test case 7.1.2.3.11 AM RLC / RLC re-establishment procedure	15.1.0
2018-09	RAN#81	R5-185069	0022	1	F	Addition of NR CA / NR SCell addition / modification / release / Success test cases 8.2.4.1.1.1, 8.2.4.1.1.2 and 8.2.4.1.1.3	15.1.0
2018-09	RAN#81	R5-185070	0027	1	F	Corrections to RRC TC - Measurement configuration control and reporting / Inter-RAT measurements / Event B1 / Measurement of NR cells / EN-DC	15.1.0
2018-09	RAN#81	R5-185071	0029	1	F	Correction to 5GS RRC TC 8.2.4.3.1.1	15.1.0
2018-09	RAN#81	R5-185072	0030	1	F	Addition of 5GS RRC TC 8.2.4.3.1.2	15.1.0
2018-09	RAN#81	R5-185073	0033	1	F	Corrections to Layer 2 test cases	15.1.0
2018-09	RAN#81	R5-185074	0034	1	F	Corrections to MAC test case 7.1.2.2.1	15.1.0
2018-09	RAN#81	R5-185075	0035	1	F	Corrections to MAC test case 7.1.2.3.1	15.1.0
2018-09	RAN#81	R5-185076	0037	1	F	Addition of new MAC RACH test case for PDCCH order	15.1.0
2018-09	RAN#81	R5-185077	0039	1	F	Addition of new MAC test case for SCell Activation Deactivation	15.1.0
2018-09	RAN#81	R5-185078	0041	1	F	Addition of new MAC UL TBS test case with transform precoding configured	15.1.0
2018-09	RAN#81	R5-185079	0042	1	F	Correction to default pre-test conditions for UM RLC test cases	15.1.0
2018-09	RAN#81	R5-185080	0043	1	F	New NAS test case 9.1.5.1.12	15.1.0
2018-09	RAN#81	R5-185082	0045	1	F	Correction to NR PDCP test case 7.1.3.5.1	15.1.0
2018-09	RAN#81	R5-185083	0046	1	F	Correction to NR RLC test case 7.1.2.3.3 and 7.1.2.3.4	15.1.0

2018-09	RAN#81	R5-185089	0049	1	F	Corrections to RRC TC - Measurement configuration control and reporting / Inter-RAT measurements / Event B2 / Measurement of NR cells / EN-DC	15.1.0
2018-09	RAN#81	R5-185090	0050	1	F	CR of AM RLC test case 7.1.2.3.10	15.1.0
2018-09	RAN#81	R5-185091	0051	1	F	Update of RRC SCG failure TC 8.2.5.1.1	15.1.0
2018-09	RAN#81	R5-185092	0052	1	F	Update of RRC SCG failure TC 8.2.5.2.1	15.1.0
2018-09	RAN#81	R5-185093	0053	1	F	Update of RRC SCG failure TC 8.2.5.3.1	15.1.0
2018-09	RAN#81	R5-185094	0054	1	F	Update of RRC SCG failure TC 8.2.5.4.1	15.1.0
2018-09	RAN#81	R5-185095	0057	1	F	Addition of 5GS NR SDAP test case 7.1.4.2	15.1.0
2018-09	RAN#81	R5-185096	0064	1	F	Update of 5GS NR RRC test case 8.2.3.6.1	15.1.0
2018-09	RAN#81	R5-185097	0066	1	F	Update of 5GS NR RRC test case 8.2.3.8.1	15.1.0
2018-09	RAN#81	R5-185098	0067	1	F	Update of 5GS NR RRC test case 8.2.1.1.1	15.1.0
2018-09	RAN#81	R5-185099	0068	1	F	L2 Preamble Parameter Update for Multi-PDN configuration	15.1.0
2018-09	RAN#81	R5-185100	0069	1	F	Correction to NR RLC test cases 7.1.2.2.3 and 7.1.2.2.4	15.1.0
2018-09	RAN#81	R5-185101	0070	1	F	Correction to NR RRC test case 8.2.3.14.1	15.1.0
2018-09	RAN#81	R5-185148	0007	1	F	Addition of NR CA reconfiguration test case 8.2.4.2.1.3	15.1.0
2018-09	RAN#81	R5-185149	0024	1	F	Corrections to RRC TC - PSCell addition, modification and release / SCG DRB / EN-DC	15.1.0
2018-09	RAN#81	R5-185150	0025	1	F	Corrections to RRC TC - Bearer Modification / Handling for bearer type change with security key change / EN-DC	15.1.0
2018-09	RAN#81	R5-185151	0026	1	F	Corrections to RRC TC - Bearer Modification / Uplink data path / Split DRB Reconfiguration / EN-DC	15.1.0
2018-09	RAN#81	R5-185152	0038	1	F	Addition of new MAC test case for Power Headroom report	15.1.0
2018-09	RAN#81	R5-185153	0047	1	F	Addition of RRC Default Pre-test conditions for NSA	15.1.0
2018-09	RAN#81	R5-185154	0058	1	F	Correction to RRC TC - Measurement configuration control and reporting / Event A1 / Measurement of NR PSCell / EN-DC	15.1.0
2018-09	RAN#81	R5-185155	0062	1	F	Updates to NAS test case 10.2.1.2	15.1.0
2018-09	RAN#81	R5-185167	0071	1	F	Update to EPS SM Test case for Multi-PDN	15.1.0
2018-12	RAN#82	R5-186649	0157	-	F	Correction to NR PDCP test case 7.1.3.5.1	15.2.0
2018-12	RAN#82	R5-186650	0158	-	F	Correction to NR PDCP test case 7.1.3.5.2	15.2.0
2018-12	RAN#82	R5-186679	0163	-	F	Corrections to PDCP test case 7.1.3.5.3	15.2.0
2018-12	RAN#82	R5-186725	0167	-	F	Correction to 5GS test case 7.1.2.2.5	15.2.0
2018-12	RAN#82	R5-186801	0178	-	F	Update RRC TC 8.2.2.2.1 - Split SRB Establishment and Release / EN-DC	15.2.0
2018-12	RAN#82	R5-186802	0179	-	F	Update RRC TC 8.2.2.7.1 - Bearer Modification / Handling for bearer type change without security key change / EN-DC	15.2.0
2018-12	RAN#82	R5-186803	0180	-	F	Update RRC TC 8.2.3.7.1 - Measurement configuration control and reporting / Event A4 (intra-frequency, inter-frequency and inter-band measurements) / Measurement of Neighbour NR cell / EN-DC	15.2.0
2018-12	RAN#82	R5-186872	0181	-	F	Removal of RRC SCG failure TC 8.2.5.5.1	15.2.0
2018-12	RAN#82	R5-186873	0182	-	F	Removal of RRC SCG failure TC 8.2.5.6.1	15.2.0
2018-12	RAN#82	R5-186890	0185	-	F	Correction to NR RRC test case 8.2.3.14.1	15.2.0
2018-12	RAN#82	R5-186891	0186	-	F	Correction to NR RRC test case 8.2.3.13.1	15.2.0
2018-12	RAN#82	R5-186892	0187	-	F	Correction to NR PDCP test case 7.1.3.4.2	15.2.0
2018-12	RAN#82	R5-186995	0228	-	F	CR of test case 8.2.4.2_Nr CA release_Resubmission of 186101	15.2.0
2018-12	RAN#82	R5-187104	0229	-	F	Correction to MAC test cases	15.2.0
2018-12	RAN#82	R5-187105	0230	-	F	Correction to RLC UM test cases	15.2.0
2018-12	RAN#82	R5-187106	0231	-	F	Correction to RLC AM test cases	15.2.0
2018-12	RAN#82	R5-187236	0235	-	F	Update RRC TC 8.2.1.2.1 - BandwidthPart Configuration / SCG / EN-DC	15.2.0
2018-12	RAN#82	R5-187237	0236	-	F	Update RRC TC 8.2.2.4.1 - PSCell addition, modification and release / SCG DRB / EN-DC	15.2.0
2018-12	RAN#82	R5-187238	0237	-	F	Update RRC TC 8.2.2.8.1 - Bearer Modification / Handling for bearer type change with security key change / EN-DC	15.2.0
2018-12	RAN#82	R5-187239	0238	-	F	Update RRC TC 8.2.2.9.1 - Bearer Modification / Uplink data path / Split DRB Reconfiguration / EN-DC	15.2.0
2018-12	RAN#82	R5-187248	0247	-	F	Correction to MAC Test case 7.1.1.1.2 Random access procedure / Successful / C-RNTI Based / Preamble selected by MAC itself	15.2.0
2018-12	RAN#82	R5-187249	0248	-	F	Correction to MAC Test case 7.1.1.5.3 DRX operation / Short cycle configured / Parameters configured by RRC	15.2.0
2018-12	RAN#82	R5-187250	0249	-	F	Correction to RLC Test case 7.1.2.3.10 AM RLC / Re-transmission of RLC PDU with and without re-segmentation	15.2.0
2018-12	RAN#82	R5-187251	0250	-	F	Correction to RLC Test case 7.1.2.3.11 AM RLC / RLC re-establishment procedure	15.2.0
2018-12	RAN#82	R5-187252	0251	-	F	Correction to PDCP Test case 7.1.3.4.1 PDCP handover / Lossless handover / PDCP sequence number maintenance / PDCP status report to convey the information on missing or acknowledged PDCP SDUs at handover / In-order delivery and duplicate elimination	15.2.0
2018-12	RAN#82	R5-187254	0253	-	F	Update RRC TCs 8.2.4.1.1.1, 8.2.4.1.1.2 and 8.2.4.1.1.3 NR CA / NR SCell addition / modification / release / Success	15.2.0
2018-12	RAN#82	R5-187255	0254	-	F	Correction to EN-DC NAS test case 10.2.1.1 - Default EPS bearer context activation	15.2.0
2018-12	RAN#82	R5-187302	0260	-	F	Correction to test case 8.2.4.3.1.1	15.2.0

2018-12	RAN#82	R5-187410	0273	-	F	Update of 5GS NR RRC test case 8.2.2.6.1	15.2.0
2018-12	RAN#82	R5-187411	0274	-	F	Addition of 5GS NR MAC test case 7.1.1.3.9	15.2.0
2018-12	RAN#82	R5-187492	0278	-	F	Correction to test case 8.2.2.1.1	15.2.0
2018-12	RAN#82	R5-187497	0279	-	F	Correction to test case 8.2.2.3.1	15.2.0
2018-12	RAN#82	R5-187528	0285	-	F	Update to RRC TC - PSCell addition, modification and release / Split DRB / EN-DC	15.2.0
2018-12	RAN#82	R5-187530	0286	-	F	Update to RRC TC - Measurement configuration control and reporting / Inter-RAT measurements / Event B1 / Measurement of NR cells / RSRQ based measurements / EN-DC	15.2.0
2018-12	RAN#82	R5-187534	0287	-	F	Update to RRC TC - Measurement configuration control and reporting / Inter-RAT measurements / Periodic reporting / Measurement of NR cells / EN-DC	15.2.0
2018-12	RAN#82	R5-187540	0290	-	F	Update to 5G-NR RRC TCs for Multi-PDN support and specific message content IEs	15.2.0
2018-12	RAN#82	R5-187611	0294	-	F	Correction to MAC TBS test cases	15.2.0
2018-12	RAN#82	R5-187686	0283	1	F	Adding test case 6.1.1.7	15.2.0
2018-12	RAN#82	R5-187688	0202	1	F	Addition of NR test case 7.1.1.1.3_SI Request	15.2.0
2018-12	RAN#82	R5-187689	0203	1	F	Addition of NR test case 7.1.1.1.6_Random access	15.2.0
2018-12	RAN#82	R5-187690	0204	1	F	Addition of NR test case 7.1.1.2.3_CCCH HARQ	15.2.0
2018-12	RAN#82	R5-187691	0213	1	F	CR of NR test case 7.1.2.3.9_RLC Reassembling	15.2.0
2018-12	RAN#82	R5-187692	0252	1	F	Correction to PDCP Test case 7.1.3.5.4 PDCP reordering / Maximum re-ordering delay below t-Reordering / t-Reordering timer operations	15.2.0
2018-12	RAN#82	R5-187693	0234	1	F	Correction to SDAP test cases	15.2.0
2018-12	RAN#82	R5-187695	0243	1	F	Addition of 5GS SA RRC TC 8.1.1.1.1	15.2.0
2018-12	RAN#82	R5-187696	0246	1	F	Addition of 5GS SA RRC TC 8.1.5.2.1	15.2.0
2018-12	RAN#82	R5-187698	0159	1	F	Correction to NR RRC test case 8.2.3.5.1	15.2.0
2018-12	RAN#82	R5-187699	0160	1	F	Correction to NR RRC test case 8.2.3.9.1 and 8.2.3.10.1	15.2.0
2018-12	RAN#82	R5-187700	0239	1	F	Update RRC TC 8.2.3.1.1 - Measurement configuration control and reporting / Inter-RAT measurements / Event B1 / Measurement of NR cells / EN-DC	15.2.0
2018-12	RAN#82	R5-187701	0272	1	F	Update RRC TC 8.2.3.12.1	15.2.0
2018-12	RAN#82	R5-187702	0276	1	F	Update of 5GS NR RRC test case 8.2.3.6.1	15.2.0
2018-12	RAN#82	R5-187703	0277	1	F	Update of 5GS NR RRC test case 8.2.3.8.1	15.2.0
2018-12	RAN#82	R5-187704	0288	1	F	Update to RRC TC - Measurement configuration control and reporting / Event A1 / Measurement of NR PSCell / EN-DC	15.2.0
2018-12	RAN#82	R5-187705	0289	1	F	Update to 5G-NR RRC measurement report TCs for FR1/FR2 cell power level	15.2.0
2018-12	RAN#82	R5-187706	0168	1	F	Updates to EN-DC TC 8.2.5.3.1	15.2.0
2018-12	RAN#82	R5-187707	0140	1	F	Corrections to NAS test case 9.1.5.1.14	15.2.0
2018-12	RAN#82	R5-187778	0284	1	F	Adding test case 6.1.1.8	15.2.0
2018-12	RAN#82	R5-187779	0226	1	F	Addition of NR test case 7.1.1.1.4_Beam Failure	15.2.0
2018-12	RAN#82	R5-187780	0227	1	F	Addition of NR test case 7.1.1.1.5 SUL	15.2.0
2018-12	RAN#82	R5-187781	0281	1	F	Correction to NR MAC test case 7.1.1.3.2	15.2.0
2018-12	RAN#82	R5-187782	0291	1	F	Addition of 5GS NR MAC test case 7.1.1.8.1	15.2.0
2018-12	RAN#82	R5-187784	0184	1	F	Correction to the default Pre-Test Conditions for AM and UM RLC test cases	15.2.0
2018-12	RAN#82	R5-187785	0232	1	F	Correction to PDCP Ciphering test cases	15.2.0
2018-12	RAN#82	R5-187786	0233	1	F	Correction to PDCP Integrity test cases	15.2.0
2018-12	RAN#82	R5-187787	0216	1	F	Addition of NR test case 8.1.1.2.3_T300 expiry	15.2.0
2018-12	RAN#82	R5-187789	0245	1	F	Addition of 5GS SA RRC TC 8.1.1.2.5	15.2.0
2018-12	RAN#82	R5-187790	0275	1	F	Addition of 5GS NR RRC test case 8.1.1.3.2	15.2.0
2018-12	RAN#82	R5-187792	0224	1	F	Addition of NR test case 8.2.3.11.1_gapFR1	15.2.0
2018-12	RAN#82	R5-187794	0221	1	F	Addition of NR test case 8.1.5.3.1_PWS notification	15.2.0
2018-12	RAN#82	R5-187795	0240	1	F	Update RRC SCG failure TC 8.2.5.1.1	15.2.0
2018-12	RAN#82	R5-187797	0263	1	F	Addition of new 5GC TC 9.1.6.1.1	15.2.0
2018-12	RAN#82	R5-188159	0222	2	F	Addition of NR test case 9.1.5.1.1_Registration Request	15.2.0
2018-12	RAN#82	R5-188187	0296	-	F	Correction to NR MAC DRX test cases 7.1.1.5.1 and 7.1.1.5.2	15.2.0
2018-12	RAN#82	R5-188188	0217	2	F	Addition of NR test case 8.1.1.3.1_Redirection to NR	15.2.0
2018-12	RAN#82	R5-188190	0225	2	F	Addition of NR test case 8.2.3.11.2_gapFR2	15.2.0
2019-01	RAN#82	R5-188192	0205	2	F	Addition of NR test case 7.1.1.2.4_BCCH HARQ	15.2.1
2019-01	RAN#82	R5-188193	0295	2	F	Correction to Layer 2 Pre Test conditions	15.2.1
2019-01	RAN#82	R5-188194	0218	2	F	Addition of NR test case 8.1.3.1.1_Event A1	15.2.1
2019-01	RAN#82	R5-188195	0183	2	F	Update to 5G TC TA registration update	15.2.1
2019-01	RAN#82	R5-188202	0280	2	F	Update of 5GS NR RRC test case 8.2.1.1.1	15.2.1
2019-03	RAN#83	R5-191197	0421	-	F	Correction to 5GS RLC Test case 7.1.2.2.5	15.3.0
2019-03	RAN#83	R5-191198	0422	-	F	Correction to 5GS RLC Test case 7.1.2.3.8	15.3.0
2019-03	RAN#83	R5-191199	0423	-	F	Correction to 5GS RLC Test case 7.1.2.3.9	15.3.0
2019-03	RAN#83	R5-191200	0424	-	F	Correction to EN-DC RRC test case 8.2.5.3.1	15.3.0
2019-03	RAN#83	R5-191202	0426	-	F	Correction to 5GS RLC Test case 7.1.2.3.10	15.3.0
2019-03	RAN#83	R5-191203	0427	-	F	Correction to EN-DC RRC test case 8.2.2.2.1	15.3.0
2019-03	RAN#83	R5-191353	0431	-	F	Correcting test case 7.1.1.3.1	15.3.0

2019-03	RAN#83	R5-191393	0445	-	F	Correction to NR test case 7.1.1.1.6-Random access procedure	15.3.0
2019-03	RAN#83	R5-191397	0449	-	F	Correction to NR test case 7.1.2.3.9-RLC Reassembling	15.3.0
2019-03	RAN#83	R5-191403	0455	-	F	Correction to NR test case 8.1.3.1.1-Event A1 and A2	15.3.0
2019-03	RAN#83	R5-191405	0457	-	F	Correction to NR test case 8.2.3.11.2-ENDC measurement gap FR2	15.3.0
2019-03	RAN#83	R5-191415	0466	-	F	Addition of TC 8.1.3.2.3-inter-RAT measurement B2 RSRQ	15.3.0
2019-03	RAN#83	R5-191426	0475	-	F	Addition of NR test case 6.1.2.4-Cell Reselection for interband operation	15.3.0
2019-03	RAN#83	R5-191427	0476	-	F	Addition of NR test case 6.1.2.5-Cell Reselection for interband operation using Pcompensation Between FDD and TDD	15.3.0
2019-03	RAN#83	R5-191430	0479	-	F	Addition of NR test case 6.1.2.21-Cell reselection, SIntra SearchQ and SnonIntraSeqrchQ	15.3.0
2019-03	RAN#83	R5-191431	0480	-	F	Addition of NR test case 6.1.2.22-Inter-frequency cell reselection with parameters ThreshX, HighQ, ThreshX, LowQ and ThreshServing, LowQ	15.3.0
2019-03	RAN#83	R5-191432	0481	-	F	Correction to NR test case 7.1.1.3.7-Power Headroom Reporting	15.3.0
2019-03	RAN#83	R5-191433	0482	-	F	Correction to NR test case 7.1.1.6.1-Correct handling of DL assignment Semi persistent	15.3.0
2019-03	RAN#83	R5-191434	0483	-	F	Addition of NR test case 8.1.1.1.2-Paging	15.3.0
2019-03	RAN#83	R5-191435	0484	-	F	Correction to NR test case 8.1.1.2.1-T300 expiry	15.3.0
2019-03	RAN#83	R5-191436	0485	-	F	Addition of NR test case 8.1.5.3.3-PWS notification	15.3.0
2019-03	RAN#83	R5-191445	0494	-	F	Correction to NR test case 9.1.5.1.1-Initial Registration	15.3.0
2019-03	RAN#83	R5-191447	0495	-	F	Addition of NR test case 8.1.3.1.5-Two event A3 RSRQ	15.3.0
2019-03	RAN#83	R5-191448	0496	-	F	Addition of NR test case 8.1.3.1.6 Two event A5 SINR	15.3.0
2019-03	RAN#83	R5-191449	0497	-	F	Correction to NR test case 8.1.5.3.1-ETWS	15.3.0
2019-03	RAN#83	R5-191509	0504	-	F	Addition of new RRC TC 8.1.5.3.2	15.3.0
2019-03	RAN#83	R5-191621	0514	-	F	Update of 5GS NR RRC test case 8.1.1.3.2	15.3.0
2019-03	RAN#83	R5-191641	0523	-	F	Updates to 5GS SA RRC TC - RRC / Paging for connection / Multiple paging records	15.3.0
2019-03	RAN#83	R5-191642	0524	-	F	Updates to 5GS SA RRC TC - RRC connection establishment / RRC Reject with wait time	15.3.0
2019-03	RAN#83	R5-191643	0525	-	F	Updates to 5GS SA RRC TC - SI change / Notification of BCCH modification / Short message for SI update	15.3.0
2019-03	RAN#83	R5-191651	0530	-	F	Update EN-DC RRC TC 8.2.2.4.1	15.3.0
2019-03	RAN#83	R5-191652	0531	-	F	Update EN-DC RRC TC 8.2.2.8.1	15.3.0
2019-03	RAN#83	R5-191653	0532	-	F	Update EN-DC RRC TC 8.2.2.9.1	15.3.0
2019-03	RAN#83	R5-191654	0533	-	F	Update EN-DC RRC TC 8.2.4.1.1.1	15.3.0
2019-03	RAN#83	R5-191656	0535	-	F	Update EN-DC RRC TC 8.2.5.3.1	15.3.0
2019-03	RAN#83	R5-191660	0539	-	F	Addition of 5GC TC- PDU session authentication and authorization / during the UE-requested PDU session procedure	15.3.0
2019-03	RAN#83	R5-191661	0540	-	F	Addition of Idle Mode TC - Steering of UE in roaming during registration/security check successful using List Type 1	15.3.0
2019-03	RAN#83	R5-191663	0542	-	F	Addition of Idle mode Test Case - PLMN selection of RPLMN, HPLMN/EHPLMN, UPLMN and OPLMN / Automatic mode	15.3.0
2019-03	RAN#83	R5-191733	0546	-	F	Update RRC TC 8.2.2.1.1 - SRB3 Establishment, Reconfiguration and Release / NR addition, modification and release / EN-DC	15.3.0
2019-03	RAN#83	R5-191764	0550	-	F	Addition of new TC 8.2.3.15	15.3.0
2019-03	RAN#83	R5-191804	0552	-	F	Title correction to MAC TC 7.1.1.7.1.1	15.3.0
2019-03	RAN#83	R5-191806	0553	-	F	Addition of new RRC TC 8.1.1.4.3	15.3.0
2019-03	RAN#83	R5-191810	0554	-	F	Addition of new 5GC TC 9.1.5.2.9	15.3.0
2019-03	RAN#83	R5-191823	0555	-	F	Addition of new 5GC TC 9.1.6.1.4	15.3.0
2019-03	RAN#83	R5-191827	0556	-	F	Addition of new RRC TC 8.1.1.4.2	15.3.0
2019-03	RAN#83	R5-191859	0559	-	F	Addition of new 5G-NR Idle Mode TC 6.1.1.6 - PLMN selection / Periodic reselection / MinimumPeriodicSearchTimer	15.3.0
2019-03	RAN#83	R5-191869	0561	-	F	Update to 5G-NR RRC Measurement configuration and reporting TC 8.2.3.3.1	15.3.0
2019-03	RAN#83	R5-191877	0562	-	F	Update to 5G-NR RRC Measurement configuration and reporting TC 8.2.3.4.1	15.3.0
2019-03	RAN#83	R5-191897	0570	-	F	Update to TC 8.2.5.4.1 SCG change failure / EN-DC	15.3.0
2019-03	RAN#83	R5-191898	0571	-	F	Editorial update to TC 7.1.3.2.1	15.3.0
2019-03	RAN#83	R5-191911	0574	-	F	Correction to MAC TBS test cases	15.3.0
2019-03	RAN#83	R5-191916	0577	-	F	Introduction of Non 3GPP Access over WLAN test cases	15.3.0
2019-03	RAN#83	R5-192203	0587	-	F	Update to 5G-NR RRC Measurement configuration and reporting TCs 8.2.3.x.x	15.3.0
2019-03	RAN#83	R5-192222	0589	-	F	Correction to NR RRC test case 8.2.3.5.1	15.3.0
2019-03	RAN#83	R5-192282	0429	1	F	Addition of new 5G-NR Idle Mode TC 6.1.2.19 - Speed-dependent cell reselection	15.3.0
2019-03	RAN#83	R5-192283	0440	1	F	Addition of NR test case 6.1.2.15-Cell reselection in shared network environment	15.3.0
2019-03	RAN#83	R5-192284	0441	1	F	Addition of NR test case 6.1.2.17-Cell reselection	15.3.0
2019-03	RAN#83	R5-192285	0541	1	F	Addition of Idle mode Test Case 6.1.2.7: Cell reselection / Equivalent PLMN	15.3.0
2019-03	RAN#83	R5-192286	0446	1	F	Correction to NR test case 7.1.1.5.4-CDRX	15.3.0
2019-03	RAN#83	R5-192287	0447	1	F	Correction to NR test case 7.1.1.6.2-Configured grant Type 1	15.3.0

2019-03	RAN#83	R5-192288	0448	1	F	Correction to NR test case 7.1.1.6.3-Configured grant Type 2	15.3.0
2019-03	RAN#83	R5-192289	0548	1	F	Addition of a new test purpose to TC 7.1.1.2.1 and TC 7.1.1.3.1 for a TDD-UL-DL-ConfigCommon including pattern2	15.3.0
2019-03	RAN#83	R5-192291	0575	1	F	Reduction of loops in MAC TBS test cases	15.3.0
2019-03	RAN#83	R5-192293	0565	1	F	Correction to 5GS RLC Test case 7.1.2.3.11	15.3.0
2019-03	RAN#83	R5-192296	0536	1	F	Correction to PDCP Test case 7.1.3.4.1 PDCP handover / Lossless handover / PDCP sequence number maintenance / PDCP status report to convey the information on missing or acknowledged PDCP SDUs at handover / In-order delivery and duplicate elimination in th	15.3.0
2019-03	RAN#83	R5-192297	0544	1	F	Correction to SDAP Test Cases	15.3.0
2019-03	RAN#83	R5-192298	0451	1	F	Addition of NR test case 8.1.1.3.4-RRCRelease with priority information of E-UTRA	15.3.0
2019-03	RAN#83	R5-192299	0526	1	F	Addition of 5GS SA RRC TC - RRC connection release / With priority information / T320 expiry	15.3.0
2019-03	RAN#83	R5-192300	0527	1	F	Addition of 5GS SA RRC TC - RRC connection release / With priority information / T320 expiry / E-UTRA	15.3.0
2019-03	RAN#83	R5-192301	0528	1	F	Addition of 5GS SA RRC TC - RRC resume / Suspend-Resume / Success	15.3.0
2019-03	RAN#83	R5-192302	0588	1	F	Addition of 5GS SA RRC TC - 8.1.2.1.1	15.3.0
2019-03	RAN#83	R5-192303	0590	1	F	Addition of 5GS SA RRC TC - 8.1.2.1.3	15.3.0
2019-03	RAN#83	R5-192304	0591	1	F	Addition of 5GS SA RRC TC - 8.1.5.3.4	15.3.0
2019-03	RAN#83	R5-192307	0557	1	F	Update ENDC TC 8.2.2.3.1	15.3.0
2019-03	RAN#83	R5-192308	0420	1	F	Update to 5G-NR RRC Measurement configuration and reporting TC 8.2.3.2.1	15.3.0
2019-03	RAN#83	R5-192329	0456	1	F	Correction to NR test case 8.2.3.11.1-ENDC measurement gap FR1	15.3.0
2019-03	RAN#83	R5-192330	0428	1	F	Correction to NR RRC test case 8.2.3.13.1	15.3.0
2019-03	RAN#83	R5-192331	0579	1	F	Correction to NR RRC test case 8.2.3.12.1	15.3.0
2019-03	RAN#83	R5-192332	0581	1	F	Correction to NR RRC test case 8.2.3.14.1	15.3.0
2019-03	RAN#83	R5-192333	0582	1	F	Correction to NR RRC test case 8.2.3.1.1	15.3.0
2019-03	RAN#83	R5-192334	0596	1	F	Correction to NR RRC test case 8.2.3.9.1 and 8.2.3.10.1	15.3.0
2019-03	RAN#83	R5-192339	0534	1	F	Update EN-DC RRC TC 8.2.5.1.1	15.3.0
2019-03	RAN#83	R5-192340	0506	1	F	Update to 5G testcase 9.1.5.1.14	15.3.0
2019-03	RAN#83	R5-192341	0572	1	F	Update to 5G TC 9.1.5.2.1 TA registration update	15.3.0
2019-03	RAN#83	R5-192342	0543	1	F	Correction to EN-DC NAS test case 10.2.1.1 - Default EPS bearer context activation	15.3.0
2019-03	RAN#83	R5-192343	0537	1	F	Addition of 5GC TC SMS over NAS service	15.3.0
2019-03	RAN#83	R5-192383	0459	1	F	Addition of NR test case 9.1.5.1.10-PLMN not allowed	15.3.0
2019-03	RAN#83	R5-192385	0498	1	F	Addition of new 5GC TC 9.1.7.1	15.3.0
2019-03	RAN#83	R5-192386	0502	1	F	Addition of new 5GC TC 9.1.5.1.11	15.3.0
2019-03	RAN#83	R5-192387	0503	1	F	Addition of new 5GC TC 9.1.5.1.12	15.3.0
2019-03	RAN#83	R5-192388	0507	1	F	Addition of 5G testcase 9.1.5.1.4	15.3.0
2019-03	RAN#83	R5-192389	0508	1	F	Addition of 5G testcase 9.1.3.1	15.3.0
2019-03	RAN#83	R5-192390	0538	1	F	Addition of 5GC TC - Initial registration / 5GS services / NSSAI handling	15.3.0
2019-03	RAN#83	R5-192391	0545	1	F	Addition of new 5GC TC 9.1.5.1.5	15.3.0
2019-03	RAN#83	R5-192392	0547	1	F	Introduction of TC 9.1.1.1 EAP based primary authentication and key agreement	15.3.0
2019-03	RAN#83	R5-192393	0549	1	F	Introduction of TC 9.1.1.3 EAP based primary authentication and key agreement	15.3.0
2019-03	RAN#83	R5-192394	0558	1	F	Addition of new 5GC TC 9.1.5.1.7	15.3.0
2019-03	RAN#83	R5-192396	0564	1	F	Addition of new 5GC TC 9.1.5.1.8	15.3.0
2019-03	RAN#83	R5-192397	0566	1	F	Update TC 9.1.6.1.1	15.3.0
2019-03	RAN#83	R5-192398	0573	1	F	Introduction of TC 9.1.5.2.4 Mobility registration update / The lower layer requests NAS signalling connection recovery	15.3.0
2019-03	RAN#83	R5-192399	0580	1	F	New 5GC test case 9.1.2.2	15.3.0
2019-03	RAN#83	R5-192700	0499	1	F	Addition of new 5GC TC 10.1.3.2	15.3.0
2019-03	RAN#83	R5-192701	0500	1	F	Addition of new 5GC TC 10.1.6.1	15.3.0
2019-03	RAN#83	R5-192702	0501	1	F	Addition of new 5GC TC 10.1.6.2	15.3.0
2019-03	RAN#83	R5-192703	0563	1	F	Addition of new 5GC TC 10.1.2.2	15.3.0
2019-03	RAN#83	R5-192749	0474	1	F	Addition of NR test case 6.1.2.2-Cell selection based on Qqualmin	15.3.0
2019-03	RAN#83	R5-192750	0432	1	F	Correcting test case 6.1.1.7	15.3.0
2019-03	RAN#83	R5-192751	0433	1	F	Updating test case 6.1.1.8	15.3.0
2019-03	RAN#83	R5-192754	0599	-	F	Addition of NR test case 6.1.2.1-Cell selection based on Qrxlevmin and Cell Reselection for Intra Frequency	15.3.0
2019-03	RAN#83	R5-192756	0600	-	F	Addition of NR test case 6.1.2.3-Cell selection-Serving cell bar	15.3.0
2019-03	RAN#83	R5-192757	0470	1	F	Addition of NR test case 6.1.1.2- PLMN selection of Other PLMN	15.3.0
2019-03	RAN#83	R5-192758	0471	1	F	Addition of NR test case 6.1.1.3-Cell reselection of ePLMN	15.3.0
2019-03	RAN#83	R5-192759	0473	1	F	Addition of NR test case 6.1.1.5-PLMN selection	15.3.0
2019-03	RAN#83	R5-192760	0477	1	F	Addition of NR test case 6.1.2.9-Cell Reselection using Qhyst, Qoffset and Treselection	15.3.0
2019-03	RAN#83	R5-192761	0478	1	F	Addition of NR test case 6.1.2.20-Inter-frequency cell reselection according to priority	15.3.0
2019-03	RAN#83	R5-192762	0509	1	F	Adding test case 6.2.1.2	15.3.0

2019-03	RAN#83	R5-192763	0510	1	F	Adding test case 6.2.1.1	15.3.0
2019-03	RAN#83	R5-192764	0511	1	F	Adding test case 6.2.1.3	15.3.0
2019-03	RAN#83	R5-192765	0512	1	F	Adding test case 6.2.1.4	15.3.0
2019-03	RAN#83	R5-192766	0513	1	F	Adding test case 6.2.1.5	15.3.0
2019-03	RAN#83	R5-192767	0592	1	F	Addition of Idle Mode test case 6.1.2.8	15.3.0
2019-03	RAN#83	R5-192768	0472	1	F	Addition of NR test case 6.1.1.4-PLMN selection in shared network environment	15.3.0
2019-03	RAN#83	R5-192769	0444	1	F	Correction to NR test case 7.1.1.1.3-SI request	15.3.0
2019-03	RAN#83	R5-192770	0585	1	F	Update to NR MAC Bandwidth Part operation TC 7.1.1.8.1	15.3.0
2019-03	RAN#83	R5-192771	0521	1	F	Correction to 5GS PDCP Test case 7.1.3.5.3 PDCP Data Recovery	15.3.0
2019-03	RAN#83	R5-192772	0450	1	F	Addition of NR test case 8.1.1.3.3-RRC connection release-Success-With priority information	15.3.0
2019-03	RAN#83	R5-192774	0453	1	F	Addition of NR test case 8.1.4.2.2.1-L2NR handover success	15.3.0
2019-03	RAN#83	R5-192776	0464	1	F	Addition of TC 8.1.3.2.1-Event B1 E-UTRA	15.3.0
2019-03	RAN#83	R5-192777	0465	1	F	Addition of TC 8.1.3.2.2-Event B2 E-UTRA	15.3.0
2019-03	RAN#83	R5-192782	0488	1	F	Addition of NR test case 8.1.3.1.11.1_intra-band Contiguous CA Event A6	15.3.0
2019-03	RAN#83	R5-192783	0489	1	F	Addition of NR test case 8.1.3.1.11.2_inter-band CA Event A6	15.3.0
2019-03	RAN#83	R5-192784	0490	1	F	Addition of NR test case 8.1.3.1.11.3_intra-band non Contiguous CA Event A6	15.3.0
2019-03	RAN#83	R5-192785	0491	1	F	Addition of NR test case 8.1.3.1.12.1_ Additional intra-band Contiguous CA	15.3.0
2019-03	RAN#83	R5-192786	0492	1	F	Addition of NR test case 8.1.3.1.12.2_ Additional inter-band CA	15.3.0
2019-03	RAN#83	R5-192787	0493	1	F	Addition of NR test case 8.1.3.1.12.3_ Additional intra-band non Contiguous CA	15.3.0
2019-03	RAN#83	R5-192794	0516	1	F	Addition of 5GS NR RRC test case 8.1.5.1.1	15.3.0
2019-03	RAN#83	R5-192795	0586	1	F	Addition of TC 8.1.4.2.1.1 Inter-RAT handover / From NR to E-UTRA	15.3.0
2019-03	RAN#83	R5-192796	0598	1	F	New RRC test case 8.1.5.2.2 SI change / Notification of BCCH modification / Short message for SI update in NR RRC_CONNECTED state	15.3.0
2019-03	RAN#83	R5-192798	0425	1	F	Update to EN-DC test case 8.2.3.7.1	15.3.0
2019-03	RAN#83	R5-192800	0435	1	F	Addition of 5GC test case 9.1.1.2	15.3.0
2019-03	RAN#83	R5-192801	0458	1	F	Addition of NR test case 9.1.1.6-Authentication abnormal	15.3.0
2019-03	RAN#83	R5-192802	0460	1	F	Addition of NR test case 9.1.6.1.2-T3521 timeout	15.3.0
2019-03	RAN#83	R5-192803	0461	1	F	Addition of NR test case 9.1.6.2.1-Network-initiated deregistration-deregistration for 3GPP access-reregistration required	15.3.0
2019-03	RAN#83	R5-192805	0463	1	F	Addition of NR test case 9.1.7.2-Service request for user data pending	15.3.0
2019-03	RAN#83	R5-192806	0568	1	F	Addition of new 5GC TC 9.1.5.2.2	15.3.0
2019-03	RAN#83	R5-192815	0567	1	F	Addition of new 5GC TC 9.1.2.1	15.3.0
2019-03	RAN#83	R5-192816	0569	1	F	Addition of 5GC Test case 10.1.5.1	15.3.0
2019-03	RAN#83	R5-192819	0576	2	F	Update of 5GS NR MAC test case 7.1.1.9.1	15.3.0
2019-03	RAN#83	R5-192824	0560	2	F	Addition of new 5GC TC 9.1.5.1.13	15.3.0
2019-03	RAN#83	R5-192829	0517	2	F	Update of 5GS NR RRC test case 8.2.1.1.1	15.3.0
2019-03	RAN#83	R5-192830	0595	2	F	Addition of 5GS PDCP TC 7.1.3.5.5	15.3.0
2019-03	RAN#83	R5-192838	0603	-	F	Addition of 5GS SA RRC TC - 8.1.3.1.13	15.3.0
2019-03	RAN#83	R5-192839	0604	-	F	Addition of 5GS SA RRC TC - 8.1.3.1.14	15.3.0
2019-03	RAN#83	R5-192852	0601	1	F	Addition of NR test case Event A4	15.3.0
2019-03	RAN#83	R5-192853	0602	1	F	Addition of NR test case Event A5	15.3.0
2019-03	RAN#83	R5-192854	0518	2	F	Update of 5GS NR RRC test case 8.2.3.6.1 and 8.2.3.8.1	15.3.0
2019-03	RAN#83	R5-192855	0462	2	F	Addition of NR test case 9.1.6.2.2-Reregistration not required	15.3.0
2019-03	RAN#83	-	-	-	-	Editorial update to align referenced to TS 38.508-1 table numbers	15.3.0
2019-06	RAN#84	R5-193861	0676	-	F	Correction to NR RLC test cases 7.1.2.2.3 and 7.1.2.2.4	15.4.0
2019-06	RAN#84	R5-193869	0677	-	F	Correction to 5GMM test case 9.1.5.2.4	15.4.0
2019-06	RAN#84	R5-193884	0681	-	F	Update of TC 9.1.5.1.13	15.4.0
2019-06	RAN#84	R5-193898	0687	-	F	Removal of TC 9.1.5.1.7	15.4.0
2019-06	RAN#84	R5-193984	0689	-	F	Clarification on DRB to use in MAC test cases	15.4.0
2019-06	RAN#84	R5-193986	0691	-	F	Clarification on DRB to use in RLC test cases	15.4.0
2019-06	RAN#84	R5-193987	0692	-	F	Correction to NR RLC test case 7.1.2.3.9	15.4.0
2019-06	RAN#84	R5-193988	0693	-	F	Clarification on DRB to use in PDCP test cases	15.4.0
2019-06	RAN#84	R5-194008	0698	-	F	Correction to EN-DC RRC test case 8.2.5.2.1	15.4.0
2019-06	RAN#84	R5-194031	0703	-	F	Correction to PDCP test case 7.1.3.5.1	15.4.0
2019-06	RAN#84	R5-194033	0705	-	F	Correction to 5GC NAS test case 9.1.8.1 - SMS over NAS / MO and MT SMS over NAS - Idle mode	15.4.0
2019-06	RAN#84	R5-194045	0713	-	F	Updates to 5GS SA RRC TC 8.1.1.4.1	15.4.0
2019-06	RAN#84	R5-194046	0714	-	F	Updates to 5GS SA RRC TC 8.1.5.2.1	15.4.0
2019-06	RAN#84	R5-194050	0718	-	F	Addition of 5GS SA RRC TC - Intra NR handover / Success / Security key reconfiguration	15.4.0
2019-06	RAN#84	R5-194051	0719	-	F	Addition of 5GS SA RRC TC - Intra NR handover / Failure / Security key reconfiguration	15.4.0
2019-06	RAN#84	R5-194119	0730	-	F	Correction to EN-DC RRC measurement test cases	15.4.0
2019-06	RAN#84	R5-194266	0735	-	F	Correction to EN-DC RRC test case 8.2.5.1.1	15.4.0

2019-06	RAN#84	R5-194288	0742	-	F	Correction to EN-DC RRC test case 8.2.5.3.1	15.4.0
2019-06	RAN#84	R5-194296	0745	-	F	Correction to RLC test case - AM RLC / RLC re-establishment procedure	15.4.0
2019-06	RAN#84	R5-194395	0751	-	F	Update of NR RRC TC 8.2.3.12.1	15.4.0
2019-06	RAN#84	R5-194396	0752	-	F	Addition of new RRC TC 8.1.5.6.5.1	15.4.0
2019-06	RAN#84	R5-194448	0759	-	F	Addition of new TC 9.1.5.1.6	15.4.0
2019-06	RAN#84	R5-194481	0764	-	F	Updates to 5GC NAS test case 9.1.2.2	15.4.0
2019-06	RAN#84	R5-194514	0776	-	F	Update of TC 9.1.5.2.4 Mobility registration update / The lower layer requests NAS signalling connection recovery	15.4.0
2019-06	RAN#84	R5-194637	0786	-	F	Update to TC 8.1.4.2.1.1	15.4.0
2019-06	RAN#84	R5-194696	0791	-	F	Correction to NR RLC test case 7.1.2.3.1	15.4.0
2019-06	RAN#84	R5-194699	0793	-	F	Correction to NR PDCP test case 7.1.3.5.2	15.4.0
2019-06	RAN#84	R5-194787	0795	-	F	Correction to NR test case 6.1.2.3-Cell selection-Serving cell bar	15.4.0
2019-06	RAN#84	R5-194788	0796	-	F	Correction to NR test case 6.1.2.9-Cell reselection using Qhyst, Qoffset and Treselection	15.4.0
2019-06	RAN#84	R5-194792	0797	-	F	Update to IDLE mode test case 6.1.1.1	15.4.0
2019-06	RAN#84	R5-194819	0727	1	F	Correcton to MAC test cases	15.4.0
2019-06	RAN#84	R5-194822	0629	1	F	Correction to NR test case 7.1.1.1.3-SI request	15.4.0
2019-06	RAN#84	R5-194823	0611	1	F	Addition of NR test case 6.1.2.12-Cell reselection CellReservedForOtherUse	15.4.0
2019-06	RAN#84	R5-194833	0628	1	F	Correction to NR test case 6.1.2.1-Cell selection Qrxlevmin	15.4.0
2019-06	RAN#84	R5-194834	0746	1	F	Editorial Corrections to Test Cases 6.3.1.1, 6.1.1.1, 6.1.2.7, 7.1.1.1.3, 8.1.1.3.1, 8.1.1.3.5, 9.1.5.2.4	15.4.0
2019-06	RAN#84	R5-194835	0747	1	F	Corrections to Test Case 6.3.1.1	15.4.0
2019-06	RAN#84	R5-194836	0726	1	F	Correction to EN-DC RLC test cases 7.1.2.2.1, 7.1.2.2.2, 7.1.2.3.1 and 7.1.2.3.2	15.4.0
2019-06	RAN#84	R5-194837	0704	1	F	Correction to PDCP test case 7.1.3.5.4 - PDCP reordering / Maximum re-ordering delay below t-Reordering / t-Reordering timer operations	15.4.0
2019-06	RAN#84	R5-194838	0711	1	F	Updates to 5GS SA RRC TC 8.1.1.1.1	15.4.0
2019-06	RAN#84	R5-194839	0712	1	F	Updates to 5GS SA RRC TC 8.1.1.2.3	15.4.0
2019-06	RAN#84	R5-194840	0734	1	F	Correction of 5GC Test case 8.1.1.3.5	15.4.0
2019-06	RAN#84	R5-194841	0641	1	F	Correction of NR test case 8.1.3.1.5-Intra Freq Event A4	15.4.0
2019-06	RAN#84	R5-194842	0642	1	F	Correction of NR test case 8.1.3.1.8-Intra Freq Event A5	15.4.0
2019-06	RAN#84	R5-194843	0717	1	F	Removal of EN-DC RRC TC - BandwidthPart Configuration / SCG	15.4.0
2019-06	RAN#84	R5-194844	0770	1	F	Update of 5GS NR RRC test case 8.2.1.1.1	15.4.0
2019-06	RAN#84	R5-194845	0657	1	F	Correction to NR test case 8.2.3.11.1-ENDC measurement gap FR1	15.4.0
2019-06	RAN#84	R5-194846	0658	1	F	Correction to NR test case 8.2.3.11.2-ENDC measurement gap FR2	15.4.0
2019-06	RAN#84	R5-194847	0661	1	F	Corrections to 5G-NR RRC Measurement configuration and reporting test cases	15.4.0
2019-06	RAN#84	R5-194848	0673	1	F	Correction to EN-DC RRC test case 8.2.3.6.1	15.4.0
2019-06	RAN#84	R5-194849	0674	1	F	Correction to EN-DC RRC test case 8.2.3.7.1	15.4.0
2019-06	RAN#84	R5-194850	0675	1	F	Correction to EN-DC RRC test case 8.2.3.3.1	15.4.0
2019-06	RAN#84	R5-194851	0740	1	F	Correction to EN-DC RRC test case 8.2.3.8.1	15.4.0
2019-06	RAN#84	R5-194853	0741	1	F	Correction to EN-DC RRC test case 8.2.3.4.1 and 8.2.3.5.1	15.4.0
2019-06	RAN#84	R5-194854	0749	1	F	Update TC 8.2.3.15.1	15.4.0
2019-06	RAN#84	R5-194855	0755	1	F	Correction to EN-DC RRC measurement test cases 8.2.3.9.1 and 8.2.3.10.1 Editor's note: could not be implemented	15.4.0
2019-06	RAN#84	R5-194856	0665	1	F	Update of RRC TC 8.2.5.4.1	15.4.0
2019-06	RAN#84	R5-194857	0679	1	F	Correction to 5GMM test case 9.1.2.1	15.4.0
2019-06	RAN#84	R5-194858	0756	1	F	Correction to NR5GC testcase 9.1.3.1	15.4.0
2019-06	RAN#84	R5-194859	0659	1	F	Correction to NR test case 9.1.5.1.1-Registration Request	15.4.0
2019-06	RAN#84	R5-194867	0668	1	F	Update of TC 9.1.6.1.1	15.4.0
2019-06	RAN#84	R5-194868	0758	1	F	Correction to NR5GC testcase 9.1.5.1.14	15.4.0
2019-06	RAN#84	R5-194869	0609	1	F	Correction to 5GC TC 9.1.7.1	15.4.0
2019-06	RAN#84	R5-194871	0610	1	F	Correction to 5GC TC 10.1.3.2	15.4.0
2019-06	RAN#84	R5-194872	0680	1	F	Correction on 5GC TC 10.1.2.2	15.4.0
2019-06	RAN#84	R5-194873	0607	1	F	Correction to 5GC TC 10.1.6.1	15.4.0
2019-06	RAN#84	R5-194874	0608	1	F	Correction to 5GC TC 10.1.6.2	15.4.0
2019-06	RAN#84	R5-194890	0728	1	F	Introduction of Non 3GPP Access over WLAN test cases	15.4.0
2019-06	RAN#84	R5-195208	0765	1	F	Addition of new TC 9.1.5.1.9	15.4.0
2019-06	RAN#84	R5-195209	0707	1	F	Addition of 5GC NAS Test Case - Generic UE configuration update / New 5G-GUTI / NITZ / registration requested / Network slicing indication / New Allowed NSSAI / acknowledgement from the UE	15.4.0
2019-06	RAN#84	R5-195210	0708	1	F	Addition of 5GC NAS Test Case - UE-initiated de-registration / Abnormal / Change of cell into a new tracking area	15.4.0
2019-06	RAN#84	R5-195211	0757	1	F	Addition of NR5GC testcase 9.1.5.1.2	15.4.0
2019-06	RAN#84	R5-195212	0774	1	F	Introduction of TC 9.1.5.2.7 Mobility and periodic registration update / Rejected / UE identity cannot be derived by the network	15.4.0
2019-06	RAN#84	R5-195213	0775	1	F	Introduction of TC 9.1.5.2.8 Mobility and periodic registration update / Rejected / Implicitly de-registered	15.4.0

2019-06	RAN#84	R5-195226	0794	1	F	Addition of 5GSM test case 10.1.1.2	15.4.0
2019-06	RAN#84	R5-195228	0777	1	F	Introduction of TC 9.3.1.1 Mobility registration update / Single-registration mode with N26 / 5GMM-IDLE / 5GC to EPC	15.4.0
2019-06	RAN#84	R5-195229	0778	1	F	Introduction of TC 9.3.1.2 Mobility registration update / Single-registration mode with N26 / 5GMM-IDLE / EPC to 5GC	15.4.0
2019-06	RAN#84	R5-195230	0779	1	F	Introduction of TC 9.3.1.3 Mobility and periodic registration update / Rejected / Single-registration mode with N26 / Handling of EPS relevant parameters	15.4.0
2019-06	RAN#84	R5-195231	0682	1	F	New multilayer test case 11.1.3	15.4.0
2019-06	RAN#84	R5-195238	0780	1	F	Introduction of new TC 11.1.7 Emergency call setup from NR RRC_IDLE / Emergency Services Fallback to EPS with redirection / Single registration mode with N26 interface / Success	15.4.0
2019-06	RAN#84	R5-195243	0616	1	F	Addition of NR test case 6.2.3.3-Inter-RAT Cell reselection NR2L by priority Srxlev based	15.4.0
2019-06	RAN#84	R5-195244	0612	1	F	Addition of NR test case 6.1.2.13-Cell reselection CellReservedForOperatorUse with Access Identity 1-2-12-13-14	15.4.0
2019-06	RAN#84	R5-195245	0613	1	F	Addition of NR test case 6.1.2.14-Cell reselection CellReservedForOperatorUse with Access Identity 11-15	15.4.0
2019-06	RAN#84	R5-195247	0618	1	F	Addition of NR test case 6.2.3.5-Inter-RAT Cell reselection NR2L by priority from dedicated signalling	15.4.0
2019-06	RAN#84	R5-195249	0620	1	F	Addition of NR test case 6.2.3.7-Inter-RAT Cell reselection NR2L Snonintrasearch	15.4.0
2019-06	RAN#84	R5-195252	0623	1	F	Addition of NR test case 6.4.2.1-Cell selection Qrxlevmin and Cell reselection	15.4.0
2019-06	RAN#84	R5-195256	0627	1	F	Addition of NR test case 6.4.1.2-Cell reselection of ePLMN in manual mode	15.4.0
2019-06	RAN#84	R5-195257	0709	1	F	Addition of Idle Mode Test Case - Steering of UE in roaming during registration/security check successful but SOR Transparent container indicates ACK has been NOT been requested	15.4.0
2019-06	RAN#84	R5-195259	0631	1	F	Addition of NR test case 8.1.3.1.6-Inter Freq Event A4	15.4.0
2019-06	RAN#84	R5-195260	0632	1	F	Addition of NR test case 8.1.3.1.7-Inter Band Event A4	15.4.0
2019-06	RAN#84	R5-195261	0633	1	F	Addition of NR test case 8.1.3.1.9-Inter Freq Event A5	15.4.0
2019-06	RAN#84	R5-195262	0634	1	F	Addition of NR test case 8.1.3.1.10-Inter Band Event A5	15.4.0
2019-06	RAN#84	R5-195268	0640	1	F	Addition of NR test case 8.1.3.2.5-Event A2 and B2	15.4.0
2019-06	RAN#84	R5-195269	0643	1	F	Correction of NR test case 8.1.3.1.11-Two Event A3 RSRQ	15.4.0
2019-06	RAN#84	R5-195270	0644	1	F	Correction of NR test case 8.1.3.1.12-Two Event A5 SINR	15.4.0
2019-06	RAN#84	R5-195271	0645	1	F	Correction of NR test case 8.1.3.1.17.1-Intra Band Event A6	15.4.0
2019-06	RAN#84	R5-195272	0646	1	F	Correction of NR test case 8.1.3.1.17.2-Inter Band Event A6	15.4.0
2019-06	RAN#84	R5-195273	0647	1	F	Correction of NR test case 8.1.3.1.17.3-Intra Band non Contiguous Event A6	15.4.0
2019-06	RAN#84	R5-195274	0648	1	F	Correction of NR test case 8.1.3.1.18.1-Additional Reporting Intra Band	15.4.0
2019-06	RAN#84	R5-195275	0649	1	F	Correction of NR test case 8.1.3.1.18.2-Additional Reporting Inter Band	15.4.0
2019-06	RAN#84	R5-195276	0650	1	F	Correction of NR test case 8.1.3.1.18.3-Additional Reporting Intra Band non Contiguous	15.4.0
2019-06	RAN#84	R5-195277	0782	1	F	Addition of 5GS NR RRC test case 8.1.3.1.2	15.4.0
2019-06	RAN#84	R5-195278	0783	1	F	Addition of 5GS NR RRC test case 8.1.3.1.3	15.4.0
2019-06	RAN#84	R5-195279	0784	1	F	Addition of 5GS NR RRC test case 8.1.3.1.4	15.4.0
2019-06	RAN#84	R5-195280	0790	1	F	Addition of 5GS NR RRC test case for Intra NR measurements / Blacklisting	15.4.0
2019-06	RAN#84	R5-195285	0699	1	F	New 5GS SA RRC TC 8.1.4.1.9.1	15.4.0
2019-06	RAN#84	R5-195286	0700	1	F	New 5GS SA RRC TC 8.1.4.1.9.2	15.4.0
2019-06	RAN#84	R5-195287	0701	1	F	New 5GS SA RRC TC 8.1.4.1.9.3	15.4.0
2019-06	RAN#84	R5-195288	0724	1	F	Addition of 5GS SA RRC TC - Intra NR handover / Failure / Re-establishment successful	15.4.0
2019-06	RAN#84	R5-195289	0725	1	F	Addition of 5GS SA RRC TC - Intra NR handover / Failure / Re-establishment failure	15.4.0
2019-06	RAN#84	R5-195290	0731	1	F	Addition of Intra-NR intra-frequency handover test case 8.1.4.1.1	15.4.0
2019-06	RAN#84	R5-195291	0732	1	F	Addition of Intra-NR inter-frequency handover test case 8.1.4.1.2	15.4.0
2019-06	RAN#84	R5-195292	0720	1	F	Addition of 5GS SA RRC TC - Redirection to NR / From E-UTRA / Success	15.4.0
2019-06	RAN#84	R5-195293	0736	1	F	New 5G Radio link failure test case 8.1.5.6.1	15.4.0
2019-06	RAN#84	R5-195294	0753	1	F	Addition of new RRC TC 8.1.5.6.5.2	15.4.0
2019-06	RAN#84	R5-195295	0754	1	F	Addition of new RRC TC 8.1.5.6.5.3 Editor's note: could not be implemented	15.4.0
2019-06	RAN#84	R5-195296	0768	1	F	Addition of 5GS NR RRC test case 8.1.5.4.1	15.4.0
2019-06	RAN#84	R5-195297	0771	1	F	New 5G Radio link failure test case 8.1.5.6.2	15.4.0
2019-06	RAN#84	R5-195298	0772	1	F	New 5G Radio link failure test case 8.1.5.6.3	15.4.0
2019-06	RAN#84	R5-195299	0773	1	F	New 5G Radio link failure test case 8.1.5.6.4	15.4.0
2019-06	RAN#84	R5-195300	0696	1	F	Correction to RRC test case 8.2.3.13.1	15.4.0
2019-06	RAN#84	R5-195301	0697	1	F	Correction to RRC test case 8.2.3.14.1	15.4.0

2019-06	RAN#84	R5-195302	0722	1	F	Addition of new EN-DC RRC TC - Measurement configuration control and reporting / Event A4 / Measurement of Neighbor NR cell / Inter-frequency measurements / EN-DC	15.4.0
2019-06	RAN#84	R5-195303	0723	1	F	Addition of new EN-DC RRC TC - Measurement configuration control and reporting / Event A4 / Measurement of Neighbor NR cell / Inter-band measurements / EN-DC	15.4.0
2019-06	RAN#84	R5-195336	0690	1	F	Correction to NR MAC test case 7.1.1.1.1	15.4.0
2019-06	RAN#84	R5-195338	0694	1	F	Correction to NR PDCP test case 7.1.3.4.1	15.4.0
2019-06	RAN#84	R5-195339	0715	1	F	Updates to PDCP Integrity Protection TCs 7.1.3.2.x	15.4.0
2019-06	RAN#84	R5-195340	0716	1	F	Updates to PDCP Ciphering and Deciphering TCs 7.1.3.3.x	15.4.0
2019-06	RAN#84	R5-195341	0662	1	F	Update of RRC TC 8.1.1.4.2	15.4.0
2019-06	RAN#84	R5-195342	0743	1	F	Correction to RRC test case 8.1.2.1.3	15.4.0
2019-06	RAN#84	R5-195343	0744	1	F	Correction to 5GS SA RRC TC - 8.1.2.1.1	15.4.0
2019-06	RAN#84	R5-195344	0669	1	F	Correction of NR test case 8.1.3.1.1-Intra Freq Event A1 A2	15.4.0
2019-06	RAN#84	R5-195345	0670	1	F	Correction of NR test case 8.1.3.2.1-Event B1	15.4.0
2019-06	RAN#84	R5-195346	0671	1	F	Correction of NR test case 8.1.3.2.2-Event B2	15.4.0
2019-06	RAN#84	R5-195347	0672	1	F	Correction of NR test case 8.1.3.2.3-Event B2 RSRQ	15.4.0
2019-06	RAN#84	R5-195350	0667	1	F	Update of 5GC TC 9.1.5.1.5	15.4.0
2019-06	RAN#84	R5-195351	0688	1	F	New multilayer test case 11.1.4	15.4.0
2019-06	RAN#84	R5-195352	0683	1	F	Addition of Multilayer test case 11.1.2	15.4.0
2019-06	RAN#84	R5-195353	0684	1	F	Addition of Multilayer test case 11.1.5	15.4.0
2019-06	RAN#84	R5-195354	0685	1	F	Addition of Multilayer test case 11.1.6	15.4.0
2019-06	RAN#84	R5-195355	0710	1	F	Addition of 5GS Multilayer Test Case 11.1.1 MO MMTEL voice call setup from NR RRC_IDLE / EPS Fallback with redirection / Single registration mode with N26 interface / Success	15.4.0
2019-06	RAN#84	R5-195358	0798	1	F	Update of EN-DC RRC TC 8.2.3.2.1	15.4.0
2019-06	RAN#84	R5-195363	0781	2	F	Update to NR MAC Bandwidth Part operation TC 7.1.1.8.1	15.4.0
2019-06	RAN#84	R5-195364	0695	2	F	Correction to NR PDCP test case 7.1.3.4.2	15.4.0
2019-06	RAN#84	R5-195365	0785	2	F	Addition of 5GS NR RRC test case 8.2.3.6.1a	15.4.0
2019-06	RAN#84	R5-195366	0787	2	F	Addition of 5GS NR RRC test case 8.2.3.6.1b	15.4.0
2019-06	RAN#84	R5-195367	0788	2	F	Addition of 5GS NR RRC test case 8.2.3.8.1a	15.4.0
2019-06	RAN#84	R5-195368	0789	2	F	Addition of 5GS NR RRC test case 8.2.3.8.1b	15.4.0
2019-06	RAN#84	R5-195369	0799	2	F	Correction to EN-DC RRC Measurement test cases for FR2 Power table	15.4.0
2019-06	RAN#84	R5-195370	0666	2	F	Update of 5GC TC 9.1.6.1.2	15.4.0

History

Document history		
V15.0.0	July 2018	Publication
V15.1.0	October 2018	Publication
V15.2.0	April 2019	Publication
V15.3.0	May 2019	Publication
V15.4.0	July 2019	Publication