

# ETSI TS 138 523-3 V16.3.0 (2021-10)



TECHNICAL SPECIFICATION

**5G;  
LTE;  
5GS;  
User Equipment (UE) conformance specification;  
Part 3: Protocol Test Suites  
(3GPP TS 38.523-3 version 16.3.0 Release 16)**



---

Reference

RTS/TSGR-0538523-3vg30

---

Keywords

5G,LTE

**ETSI**

650 Route des Lucioles  
F-06921 Sophia Antipolis Cedex - FRANCE

Tel.: +33 4 92 94 42 00 Fax: +33 4 93 65 47 16

Siret N° 348 623 562 00017 - NAF 742 C  
Association à but non lucratif enregistrée à la  
Sous-Préfecture de Grasse (06) N° 7803/88

---

**Important notice**

The present document can be downloaded from:

<http://www.etsi.org/standards-search>

The present document may be made available in electronic versions and/or in print. The content of any electronic and/or print versions of the present document shall not be modified without the prior written authorization of ETSI. In case of any existing or perceived difference in contents between such versions and/or in print, the prevailing version of an ETSI deliverable is the one made publicly available in PDF format at [www.etsi.org/deliver](http://www.etsi.org/deliver).

Users of the present document should be aware that the document may be subject to revision or change of status.

Information on the current status of this and other ETSI documents is available at

<https://portal.etsi.org/TB/ETSIDeliverableStatus.aspx>

If you find errors in the present document, please send your comment to one of the following services:

<https://portal.etsi.org/People/CommitteeSupportStaff.aspx>

---

**Copyright Notification**

No part may be reproduced or utilized in any form or by any means, electronic or mechanical, including photocopying and microfilm except as authorized by written permission of ETSI.

The content of the PDF version shall not be modified without the written authorization of ETSI.

The copyright and the foregoing restriction extend to reproduction in all media.

© ETSI 2021.

All rights reserved.

**DECT™**, **PLUGTESTS™**, **UMTS™** and the ETSI logo are trademarks of ETSI registered for the benefit of its Members.

**3GPP™** and **LTE™** are trademarks of ETSI registered for the benefit of its Members and of the 3GPP Organizational Partners.

**oneM2M™** logo is a trademark of ETSI registered for the benefit of its Members and of the oneM2M Partners.

**GSM®** and the GSM logo are trademarks registered and owned by the GSM Association.

---

## Intellectual Property Rights

### Essential patents

IPRs essential or potentially essential to normative deliverables may have been declared to ETSI. The information pertaining to these essential IPRs, if any, is publicly available for **ETSI members and non-members**, and can be found in ETSI SR 000 314: *"Intellectual Property Rights (IPRs); Essential, or potentially Essential, IPRs notified to ETSI in respect of ETSI standards"*, which is available from the ETSI Secretariat. Latest updates are available on the ETSI Web server (<https://ipr.etsi.org/>).

Pursuant to the ETSI IPR Policy, no investigation, including IPR searches, has been carried out by ETSI. No guarantee can be given as to the existence of other IPRs not referenced in ETSI SR 000 314 (or the updates on the ETSI Web server) which are, or may be, or may become, essential to the present document.

### Trademarks

The present document may include trademarks and/or tradenames which are asserted and/or registered by their owners. ETSI claims no ownership of these except for any which are indicated as being the property of ETSI, and conveys no right to use or reproduce any trademark and/or tradename. Mention of those trademarks in the present document does not constitute an endorsement by ETSI of products, services or organizations associated with those trademarks.

---

## Legal Notice

This Technical Specification (TS) has been produced by ETSI 3rd Generation Partnership Project (3GPP).

The present document may refer to technical specifications or reports using their 3GPP identities. These shall be interpreted as being references to the corresponding ETSI deliverables.

The cross reference between 3GPP and ETSI identities can be found under <http://webapp.etsi.org/key/queryform.asp>.

---

## Modal verbs terminology

In the present document "**shall**", "**shall not**", "**should**", "**should not**", "**may**", "**need not**", "**will**", "**will not**", "**can**" and "**cannot**" are to be interpreted as described in clause 3.2 of the [ETSI Drafting Rules](#) (Verbal forms for the expression of provisions).

"**must**" and "**must not**" are **NOT** allowed in ETSI deliverables except when used in direct citation.

# Contents

Intellectual Property Rights .....	2
Legal Notice .....	2
Modal verbs terminology.....	2
Foreword.....	9
1 Scope .....	10
2 References .....	10
3 Definitions, symbols and abbreviations .....	11
3.1 Definitions .....	11
3.2 Symbols.....	12
3.3 Abbreviations .....	12
4 Test system architecture .....	13
4.1 General system architecture .....	13
4.2 Component architecture .....	13
5 Test models .....	14
5.1 EN-DC.....	14
5.1.1 Layer 3.....	14
5.1.1.1 Single NR carrier .....	14
5.1.1.2 NR carrier aggregation.....	17
5.1.2 Layer 2.....	18
5.1.2.1 PDCP.....	18
5.1.2.2 RLC.....	19
5.1.2.3 MAC .....	20
5.1.2.3.1 Single NR carrier .....	20
5.1.2.3.2 NR carrier aggregation .....	22
5.2 NR/5GC.....	23
5.2.1 Layer 3.....	23
5.2.1.1 Single NR carrier .....	23
5.2.1.2 NR carrier aggregation.....	24
5.2.1.3 NR/5GC Inter-RAT.....	25
5.2.1.3.1 NR/E-UTRA Inter-RAT .....	25
5.2.1.3.2 NR/UTRAN Inter-RAT.....	26
5.2.1.4 NR supplementary uplink .....	27
5.2.1.5 NR dual connectivity.....	28
5.2.2 Layer 2.....	30
5.2.2.1 SDAP .....	30
5.2.2.2 PDCP.....	31
5.2.2.2.1 Single NR carrier.....	31
5.2.2.2.2 NR dual connectivity .....	32
5.2.2.3 RLC.....	33
5.2.2.4 MAC .....	34
5.2.2.4.1 Single NR carrier .....	34
5.2.2.4.2 NR carrier aggregation .....	35
6 System interface .....	36
6.1 Upper tester interface .....	36
6.2 Abstract system primitives .....	36
6.2.1 Introduction.....	36
6.2.2 General requirements and assumptions.....	36
6.2.3 E-UTRAN ASP definitions .....	36
6.2.4 NR ASP definitions .....	36
6.2.5 UTRAN ASP definitions .....	37
7 Test methods and design considerations .....	37
7.1 Common aspects .....	37

7.1.1	Introduction.....	37
7.1.2	Physical layer aspects .....	37
7.1.2.1	Search spaces and DCI.....	37
7.1.2.1.1	Parameters .....	37
7.1.2.2.1.1	Search space configuration .....	37
7.1.2.1.2	PDCCH search spaces .....	37
7.1.2.1.3	DCI formats .....	38
7.1.2.1.3.1	Introduction.....	38
7.1.2.1.3.2	Timing.....	38
7.1.2.1.3.3	DAI .....	38
7.1.2.1.4	PDCCH candidate selection .....	39
7.1.2.2	Downlink resource allocation.....	39
7.1.2.2.1	Parameters .....	39
7.1.2.2.1.1	Time domain resource allocation.....	40
7.1.2.2.1.2	Frequency domain resource allocation configured at the UE via RRC signalling .....	40
7.1.2.2.1.3	DCI parameters .....	40
7.1.2.2.2	Timing .....	41
7.1.2.2.3	DL scheduling scheme .....	43
7.1.2.2.3.1	DL scheduling scheme: Frequency domain multiplexing, RA type1, non-interleaved.....	44
7.1.2.2.4	Transport block size determination .....	44
7.1.2.2.4.1	Parameters affecting TBS determination .....	44
7.1.2.2.4.2	Automatic mode - Determination of <b>IMCS</b> and <b>LRBs</b> .....	48
7.1.2.2.4.3	Explicit mode - Determination of <b>IMCS</b> and <b>LRBs</b> for given TBS .....	49
7.1.2.3	Uplink grant .....	49
7.1.2.3.1	General principles and grant allocation types.....	49
7.1.2.3.1.1	PUCCH synchronisation in connected mode .....	49
7.1.2.3.1.2	Grant allocation types .....	49
7.1.2.3.1.2.1	Grant allocation by RACH procedure .....	49
7.1.2.3.1.2.2	Grant allocation type 1: Uplink grant triggered by SR.....	50
7.1.2.3.1.2.3	Grant allocation type 2: Periodic uplink grant.....	50
7.1.2.3.1.2.4	Grant allocation type 3: Single uplink grant.....	50
7.1.2.3.1.2.5	Grant allocation type 4: Periodic uplink grant triggered by SR .....	50
7.1.2.3.2	Determination of explicit uplink grants .....	50
7.1.2.3.2.1	Parameters.....	50
7.1.2.3.2.2	Determination of <b>IMCS</b> and <b>LRBs</b> for given TBS .....	52
7.1.2.3.3	Default grants .....	53
7.1.2.5	Noise generator .....	57
7.1.3	System information.....	57
7.1.4	Cell(s) handling .....	57
7.1.4.1	Multi-cells environment .....	57
7.1.4.2	Cell power change.....	57
7.1.5	Timing aspects .....	57
7.1.5.1	SS time .....	57
7.1.5.2	Cell(s) timing .....	57
7.2	EN-DC.....	58
7.2.1	Introduction.....	58
7.2.2	Physical layer aspects .....	58
7.2.2.1	Search spaces and DCI.....	58
7.2.3	System information.....	58
7.2.4	Bearers .....	59
7.2.5	Random Access procedure.....	59
7.2.5.1	NR.....	59
7.2.5.2	E-UTRA.....	59
7.2.6	PSCell change.....	59
7.2.6.1	Sequence of EN-DC NR inter-cell PSCell change.....	59
7.2.6.2	Sequence of EN-DC NR intra-cell PSCell change.....	60
7.2.6.3	UL grants used in RA procedure during EN-DC NR PSCell change.....	60
7.2.6.4	Sequence of EN-DC NR CA inter-cell PSCell change .....	60
7.3	NR/5GC.....	61
7.3.1	Introduction.....	61
7.3.2	Physical layer aspects .....	61
7.3.3	System information.....	61

7.3.3.1	General SS requirements.....	61
7.3.3.2	Scheduling information.....	62
7.3.3.3	System information modification.....	64
7.3.3.4	Request for on demand system information.....	65
7.3.4	Paging and Short Message.....	65
7.3.5	RRC connection control.....	66
7.3.5.1	Early contention resolution.....	66
7.3.5.2	RRC connection release sequence.....	66
7.3.5.3	Handover.....	66
7.3.5.3.1	Sequence of intra-NR inter-cell handover.....	66
7.3.5.3.2	Sequence of intra-NR intra-cell handover.....	67
7.3.5.3.3	UL grants used in RA procedure during handover.....	68
7.3.5.3.4	Sequence of intra-NR inter-cell CA handover.....	68
7.3.5.4	RRC connection re-establishment.....	69
7.3.5.5	NR-DC PSCell change.....	70
7.3.5.5.1	Sequence of NR-DC inter-cell PSCell change.....	70
7.3.5.5.2	Sequence of NR-DC intra-cell PSCell change.....	70
7.3.5.5.3	Sequence of NR-DC intra-PCell handover and intra-cell PSCell change.....	71
7.3.6	Bearers.....	71
7.3.6.1	DRB Identity Management.....	71
7.3.7	Processing delay testing for RRC procedures.....	72
7.3.7.1	Introduction.....	72
7.3.7.2	Procedure delays in PUCCH synchronized state.....	72
8	Other SS requirements with TTCN-3 impact.....	74
8.1	Codec requirements.....	74
8.2	External function definitions.....	74
9	IXIT proforma.....	76
9.1	Introduction.....	76
9.2	E-UTRA and NR PIXIT.....	76
9.3	5GC PIXIT.....	77
10	Postambles.....	77
10.1	Introduction.....	77
10.2	On E-UTRA/EPC.....	77
10.2.1	UE postamble states and procedures.....	77
10.2.2	Switch/Power off procedure in State E1.....	78
10.2.3	Switch/Power off procedure in States E2 and E3.....	78
10.2.3.1	Procedure for E2 and E3.....	78
10.2.3.2	Procedure for E2_T3440.....	79
10.2.4	Switch/Power off procedure in State E4.....	79
10.2.5	Automatic selection mode procedure in State E5 (current cell, neighbour cell).....	79
10.3	On NR/5GC.....	79
10.3.1	UE postamble states and procedures.....	79
10.3.2	Switch/Power off procedure in State 1N-A.....	80
10.3.3	Switch/Power off procedure in State 2N-A.....	80
10.3.4	Switch/Power off procedure in State 3N-A.....	80
10.3.4A	Switch/Power off procedure in State 3N-A with T3540 started.....	80
10.3.5	Switch/Power off procedure in NR DEREGISTERED.....	81
10.3.6	Switch/Power off procedure after EMERGENCY CALL RELEASED in RRC_IDLE.....	81
10.3.7	Switch/Power off procedure after EMERGENCY CALL RELEASED in RRC_CONNECTED.....	81
10.4	On UTRAN.....	82
11	Guidelines on test execution.....	82
11.1	Introduction.....	82
11.2	EN-DC.....	82
11.2.1	Single NR carrier.....	82
11.3	NR/5GC.....	83
11.3.1	NR/5GC single RAT.....	83
11.3.1.1	Single NR carrier.....	83
11.3.1.2	NR carrier aggregation.....	83
11.3.2	NR/5GC Inter-RAT.....	84

11.3.2.1	NR/E-UTRA Inter-RAT.....	84
11.3.2.2	NR/EN-DC Inter-RAT.....	84
11.3.3	NR MFBI.....	85
<b>Annex A (normative): Test Suites.....</b>		<b>86</b>
A.1	Baseline of specifications.....	86
A.2	5GS Test Suites.....	86
A.2.1	EN-DC Test Suites.....	86
A.2.2	NR/5GC Test Suites.....	89
<b>Annex B: NR TBS tables.....</b>		<b>96</b>
B.1	Downlink TBS (normative).....	96
B.1.1	Downlink TBS using MCS index table 5.1.3.1-1.....	96
B.1.1.1	Downlink TBS using MCS index table 5.1.3.1-1, dmrs-AdditionalPosition = 0, number of CDM groups = 1.....	96
B.1.1.2	Downlink TBS using MCS index table 5.1.3.1-1, dmrs-AdditionalPosition = 1, number of CDM groups = 1.....	97
B.1.1.3	Downlink TBS using MCS index table 5.1.3.1-1, dmrs-AdditionalPosition = 2, number of CDM groups = 2, modulation order <= 2.....	97
B.1.1.4	Downlink TBS using MCS index table 5.1.3.1-1, dmrs-AdditionalPosition = 2, number of CDM groups = 2.....	99
B.1.2	Void.....	99
B.2	Uplink TBS (informative).....	99
B.2.1	Uplink TBS using MCS index table 5.1.3.1-1.....	100
B.2.1.1	Uplink TBS using MCS index table 5.1.3.1-1, dmrs-AdditionalPosition = 0, number of CDM groups = 1.....	100
B.2.1.2	Uplink TBS using MCS index table 5.1.3.1-1, dmrs-AdditionalPosition = 1, number of CDM groups = 1.....	101
B.2.1.3	Void.....	102
B.2.1.4	Void.....	102
B.2.1.5	Uplink TBS using MCS index table 5.1.3.1-1, dmrs-AdditionalPosition = 2, number of CDM groups = 2.....	102
B.2.2	Void.....	103
B.2.3	Void.....	103
<b>Annex C (informative): Style guide and design principles.....</b>		<b>104</b>
C.1	Style guide.....	104
C.2	Design principles.....	104
<b>Annex D (normative): TTCN-3 definitions.....</b>		<b>105</b>
D.0	Introduction.....	105
D.1	NR_ASP_TypeDefs.....	105
D.1.1	ASN1_Container.....	105
D.1.2	System_Configuration.....	109
D.1.3	Cell_Configuration.....	110
D.1.3.1	Cell_Configuration_Common.....	111
D.1.3.2	PhysicalLayer.....	113
D.1.3.2.1	PhysicalLayer_Common.....	114
D.1.3.2.2	PhysicalLayer_Downlink.....	115
D.1.3.2.2.1	SS_PBCH_Block.....	115
D.1.3.2.2.2	CSI_Configuration.....	119
D.1.3.2.2.3	Cell_Level_Configuration_PDSCH.....	121
D.1.3.2.2.4	Downlink_BWP.....	122
D.1.3.2.2.4.1	PDSCH_Configuration.....	123
D.1.3.2.2.4.2	PDCCH_Configuration.....	123
D.1.3.2.2.4.2.1	Search_Space_Configuration.....	125
D.1.3.2.2.4.2.2	Search_Space_DCI_Assignment.....	127

D.1.3.2.3	PhysicalLayer_Uplink.....	128
D.1.3.2.3.1	Uplink_BWP .....	129
D.1.3.2.4	DCI_Configuration .....	130
D.1.3.2.4.1	Common_Fields .....	130
D.1.3.2.4.2	Resource_Allocation .....	133
D.1.3.2.4.3	PDSCH_Scheduling .....	137
D.1.3.2.4.4	PUSCH_Scheduling .....	144
D.1.3.3	MAC_Layer.....	149
D.1.3.3.1	MAC_Layer_Common .....	149
D.1.3.3.2	Random_Access_Procedure.....	150
D.1.3.3.2.1	Random_Access_Response .....	150
D.1.3.3.2.2	Contention_Resolution .....	153
D.1.3.4	System_Information_Control .....	154
D.1.3.5	Paging_Control .....	157
D.1.3.6	CCCH_DCCH_DTCH_Configuration .....	158
D.1.3.7	Cell_Group_Configuration .....	159
D.1.4	Cell_Power_Attenuation .....	160
D.1.5	Radio_Bearer_Configuration .....	160
D.1.5.1	RLC_Configuration .....	162
D.1.5.2	MAC_Configuration.....	164
D.1.6	AS_Security .....	165
D.1.7	Paging_Trigger.....	167
D.1.8	Delta_Value_Trigger.....	168
D.1.9	System_Indication_Control.....	168
D.1.10	PDCP_Count .....	169
D.1.11	PDCP_Handover .....	170
D.1.12	L1_Test_Mode .....	171
D.1.13	DCI_Trigger.....	171
D.1.14	Configured_Scheduling.....	176
D.1.15	System_Indications .....	177
D.1.16	System_Interface.....	178
D.2	NR_ASP_DrbDefs .....	179
D.2.1	PDU_TypeDefs .....	180
D.2.1.1	MAC_PDU .....	180
D.2.1.1.1	MAC_PDU_SubPDU .....	180
D.2.1.1.2	MAC_ControlElements.....	182
D.2.1.1.2.1	MAC_ControlElement_Common.....	183
D.2.1.1.2.2	MAC_ControlElement_BSR.....	183
D.2.1.1.2.3	MAC_ControlElement_ContentionResolutionId .....	184
D.2.1.1.2.4	MAC_ControlElement_TimingAdvance.....	184
D.2.1.1.2.5	MAC_ControlElement_PHR.....	184
D.2.1.1.2.6	MAC_ControlElement_SCellActivationDeactivation.....	185
D.2.1.1.2.7	MAC_ControlElement_DuplicationActivationDeactivation.....	185
D.2.1.1.2.8	MAC_ControlElement_SP_ResourceSetActivationDeactivation .....	185
D.2.1.1.2.9	MAC_ControlElement_CSI_TriggerStateSubselection .....	186
D.2.1.1.2.10	MAC_ControlElement_TCI_StatesActivationDeactivation.....	187
D.2.1.1.2.11	MAC_ControlElement_TCI_StateIndication .....	187
D.2.1.1.2.12	MAC_ControlElement_SP_CSI_ReportingActivationDeactivation .....	187
D.2.1.1.2.13	MAC_ControlElement_SP_SRS_ActivationDeactivation .....	188
D.2.1.1.2.14	MAC_ControlElement_PUCCH_SpatialRelationActivationDeactivation.....	189
D.2.1.1.2.15	MAC_ControlElement_ZP_ResourceSetActivationDeactivation .....	189
D.2.1.1.2.16	MAC_ControlElement_RecommendedBitrate .....	190
D.2.1.2	RLC_PDU.....	190
D.2.1.2.1	Common.....	191
D.2.1.2.2	TM_Data .....	191
D.2.1.2.3	UM_Data.....	191
D.2.1.2.4	AM_Data.....	192
D.2.1.2.5	AM_Status .....	194
D.2.2	DRB_Primitive_Definitions .....	196
D.2.2.1	DRB_Common .....	197
D.2.2.2	Downlink .....	198



D.2.2.3	Uplink .....	199
D.2.3	System_Interface .....	200
D.3	NR_ASP_SrbDefs .....	201
D.3.1	SRB_DATA_ASPs .....	201
D.3.2	Port_Definitions .....	204
D.4	NR_CommonDefs .....	204
D.4.1	Common_Types .....	204
D.4.2	RRC_Nested_Types .....	205
D.4.3	ASP_CommonPart .....	205
D.4.3.1	ASP_CommonPart_Definitions .....	205
D.4.3.1.1	Routing_Info .....	205
D.4.3.2	REQ_ASP_CommonPart .....	206
D.4.3.3	CNF_ASP_CommonPart .....	206
D.4.3.4	IND_ASP_CommonPart .....	206
D.5	IP_ASP_TypeDefs .....	206
D.5.1	IP_Common .....	207
D.5.2	IP_Config .....	208
D.5.3	IPsec_Config .....	210
D.5.4	IP_SocketHandling .....	212
D.5.4.1	Socket_Common .....	212
D.5.4.2	Socket_Datagram .....	213
D.5.4.3	TCP_Socket .....	214
D.5.4.4	UDP_Socket .....	220
D.5.4.5	ICMP_Socket .....	222
D.5.4.6	Socket_Primitives .....	224
D.5.5	System_Interface .....	225
D.6	NR_PDCP_TypeDefs .....	227
D.6.1	NR_PDCP_Config_Parameters .....	227
D.6.2	NR_PDCP_Configuration .....	228
D.6.3	NR_PDCP_DrbDefs .....	230
D.7	SDAP_TypeDefs .....	231
D.7.1	SDAP_Configuration .....	231
D.7.2	SDAP_DrbDefs .....	232
D.8	NR_ASP_VirtualNoiseDefs .....	234
D.9	CommonDefs .....	235
D.10	CommonAspDefs .....	241
D.10.1	Cell_Configuration_Common .....	241
D.10.2	MAC_Layer .....	241
D.10.3	System_Indications .....	243
D.10.4	ASP_CommonPart .....	243
D.10.4.1	ASP_CommonPart_Definitions .....	243
D.10.4.1.1	Routing_Info .....	243
D.10.4.1.2	Timing_Info .....	243
D.10.4.2	REQ_ASP_CommonPart .....	245
D.10.4.3	CNF_ASP_CommonPart .....	245
D.10.4.4	IND_ASP_CommonPart .....	245
D.11	References to TTCN-3 .....	246
<b>Annex E (informative): Change history .....</b>		<b>247</b>
History .....		281

---

# Foreword

This Technical Specification has been produced by the 3rd Generation Partnership Project (3GPP).

The contents of the present document are subject to continuing work within the TSG and may change following formal TSG approval. Should the TSG modify the contents of the present document, it will be re-released by the TSG with an identifying change of release date and an increase in version number as follows:

Version x.y.z

where:

- x the first digit:
  - 1 presented to TSG for information;
  - 2 presented to TSG for approval;
  - 3 or greater indicates TSG approved document under change control.
- y the second digit is incremented for all changes of substance, i.e. technical enhancements, corrections, updates, etc.
- z the third digit is incremented when editorial only changes have been incorporated in the document.

The present document is part 3 of a multi-part deliverable covering the 5G System (5GS) User Equipment (UE) protocol conformance specification, as identified below:

- 3GPP TS 38.523-1 [8]: "5GS; User Equipment (UE) conformance specification; Part 1: Protocol".
- 3GPP TS 38.523-2 [9]: "5GS; User Equipment (UE) conformance specification; Part 2: Applicability of protocol test cases".
- **3GPP TS 38.523-3: "5GS; User Equipment (UE) conformance specification; Part 3: Protocol Test Suites"** (the present document).

---

# 1 Scope

The present document specifies the protocol and signalling conformance testing in TTCN-3 for the 3GPP UE connecting to the 5G System (5GS) via its radio interface(s).

The following TTCN test specification and design considerations can be found in the present document:

- the test system architecture;
- the overall test suite structure;
- the test models and ASP definitions;
- the test methods and usage of communication ports definitions;
- the test configurations;
- the design principles and assumptions;
- TTCN styles and conventions;
- the partial PIXIT proforma;
- the test suites.

The Test Suites designed in the document are based on the test cases specified in prose in 3GPP TS 38.523-1 [8]. The applicability of the individual test cases is specified in 3GPP TS 38.523-2 [9].

The present document is valid for TTCN development for 5GS UE conformance test according to 3GPP Releases starting from Release 15 up to the Release indicated on the cover page of the present document.

---

# 2 References

The following documents contain provisions which, through reference in this text, constitute provisions of the present document.

- References are either specific (identified by date of publication, edition number, version number, etc.) or non-specific.
- For a specific reference, subsequent revisions do not apply.
- For a non-specific reference, the latest version applies. In the case of a reference to a 3GPP document (including a GSM document), a non-specific reference implicitly refers to the latest version of that document *in the same Release as the present document*.

- [1] 3GPP TR 21.905: "Vocabulary for 3GPP Specifications".
- [2] ISO/IEC 9646-1: "Information technology - Open Systems Interconnection - Conformance testing methodology and framework - Part 1: General concepts".
- [3] ISO/IEC 9646-7: "Information technology - Open systems interconnection - Conformance testing methodology and framework - Part 7: Implementation Conformance Statements".
- [4] ETSI ES 201 873: "Methods for Testing and Specification (MTS); The Testing and Test Control Notation version 3".
- [5] 3GPP TS 38.508-1: "5GS; User Equipment (UE) conformance specification; Part 1: Common test environment".
- [6] 3GPP TS 38.508-2: "5GS; User Equipment (UE) conformance specification; Part 2: Common Implementation Conformance Statement (ICS) proforma".
- [7] 3GPP TS 38.509: "5GS; Special conformance testing functions for User Equipment (UE)".

- [8] 3GPP TS 38.523-1: "5GS; User Equipment (UE) conformance specification; Part 1: Protocol".
- [9] 3GPP TS 38.523-2: "5GS; User Equipment (UE) conformance specification; Part 2: Applicability of protocol test cases".
- [10] 3GPP TS 36.508: "Common test environments for User Equipment (UE) conformance testing".
- [11] 3GPP TS 36.509: "Terminal logical test interface; Special conformance testing functions".
- [12] 3GPP TS 36.523-3: "Evolved Universal Terrestrial Radio Access (E-UTRA) and Evolved Packet Core (EPC); User Equipment (UE) conformance specification; Part 3: Test suites".
- [13] 3GPP TS 38.321: "NR; Medium Access Control (MAC) protocol specification".
- [14] 3GPP TS 38.322: "NR; Radio Link Control (RLC) protocol specification".
- [15] 3GPP TS 38.323: "NR; Packet Data Convergence Protocol (PDCP) specification".
- [16] 3GPP TS 38.331: "NR; Radio Resource Control (RRC); Protocol specification".
- [17] 3GPP TS 36.331: "Evolved Universal Terrestrial Radio Access (E-UTRA) Radio Resource Control (RRC); Protocol Specification".
- [18] 3GPP TS 24.301: "Non-Access-Stratum (NAS) Protocol for Evolved Packet System (EPS); Stage 3".
- [19] 3GPP TS 38.211: "NR; Physical channels and modulation".
- [20] 3GPP TS 38.212: "NR; Multiplexing and channel coding".
- [21] 3GPP TS 38.213: "NR; Physical layer procedures for control".
- [22] 3GPP TS 38.214: "NR; Physical layer procedures for data".
- [23] 3GPP TS 36.211: "Evolved Universal Terrestrial Radio Access (E-UTRA); Physical channels and modulation".
- [24] 3GPP TS 38.304: "NR; User Equipment (UE) procedures in Idle mode and RRC Inactive state".
- [25] 3GPP TS 33.501: "Security architecture and procedures for 5G system".
- [26] 3GPP TS 24.501: "Non-Access-Stratum (NAS) Protocol for 5G System (5GS); Stage 3".
- [27] RFC 5448: "Improved Extensible Authentication Protocol Method for 3rd Generation Authentication and Key Agreement (EAP-AKA'")"

---

## 3 Definitions, symbols and abbreviations

### 3.1 Definitions

For the purposes of the present document, the terms and definitions given in 3GPP TR 21.905 [1] and the following apply. A term defined in the present document takes precedence over the definition of the same term, if any, in 3GPP TR 21.905 [1].

In addition for the purposes of the present document, the following terms, definitions, symbols and abbreviations apply:

- such given in ISO/IEC 9646-1 [2] and ISO/IEC 9646-7 [3]

NOTE: Some terms and abbreviations defined in [2] and [3] are explicitly included below with small modification to reflect the terminology used in 3GPP.

**Implementation eXtra Information for Testing (IXIT):** A statement made by a supplier or implementer of an UEUT which contains or references all of the information (in addition to that given in the ICS) related to the UEUT and its testing environment, which will enable the test laboratory to run an appropriate test suite against the UEUT.

**IXIT proforma:** A document, in the form of a questionnaire, which when completed for an UEUT becomes an IXIT.

**Protocol Implementation Conformance Statement (PICS):** An ICS for an implementation or system claimed to conform to a given protocol specification.

**Protocol Implementation eXtra Information for Testing (PIXIT):** An IXIT related to testing for conformance to a given protocol specification.

## 3.2 Symbols

No specific symbols have been identified so far.

## 3.3 Abbreviations

For the purposes of the present document, the abbreviations given in 3GPP TR 21.905 [1] and the following apply. An abbreviation defined in the present document takes precedence over the definition of the same abbreviation, if any, in 3GPP TR 21.905 [1].

5GC	5G Core Network
ASP	Abstract Service Primitive
ATS	Abstract Test Suite
AWGN	Additive White Gaussian Noise
CA	Carrier Aggregation
CBRA	Contention Based Random Access
CCE	Control Channel Element
CFRA	Contention Free Random Access
CORESET	Control Resource Set
DAI	Downlink Assignment Index
DCI	Downlink Control Information
DL	Downlink
DL-SCH	Downlink Shared Channel
DMRS	Demodulation Reference Signal
EN-DC	E-UTRA-NR Dual Connectivity
EPC	Evolved Packet Core
FR1	Frequency Range 1
FR2	Frequency Range 2
HO	Handover
H-SFN	Hyper SFN
ICS	Implementation Conformance Statement
IUT	Implementation Under Test
IXIT	Implementation eXtra Information for Testing
LSB	Least Significant Bit
MCG	Master Cell Group
MN	Master Node
MSB	Most Significant Bit
NR	NR Radio Access
PDCCH	Physical Downlink Control Channel
PDSCH	Physical Downlink Shared Channel
PRACH	Physical Random Access Channel
PRB	Physical Resource Block
PSCell	Primary SCG Cell
PSS	Primary Synchronisation Signal
PUCCH	Physical Uplink Control Channel
PUSCH	Physical Uplink Shared Channel
RA	Random Access
RACH	Random Access Channel
RAR	Random Access Response
RAT	Radio Access Technology
RMSI	Remaining Minimum SI
SCG	Secondary Cell Group

SFN	System Frame Number
SN	Secondary Node
SRS	Sounding Reference Signal
SS	System Simulator
SSB	Synchronization Signal and PBCH block
SSS	Secondary Synchronisation Signal
TC	Test Case
UL	Uplink
UL-SCH	Uplink Shared Channel
UT	Upper Tester
VNG	Virtual Noise Generator

---

## 4 Test system architecture

### 4.1 General system architecture

The architecture specified in TS 36.523-3 [12] subclause 4.1.1 applies to the present document.

### 4.2 Component architecture

The architecture specified in TS 36.523-3 [12] subclause 4.1.2 applies to the present document, with NR RAT as another separate TTCN-3 parallel component.

# 5 Test models

## 5.1 EN-DC

### 5.1.1 Layer 3

#### 5.1.1.1 Single NR carrier

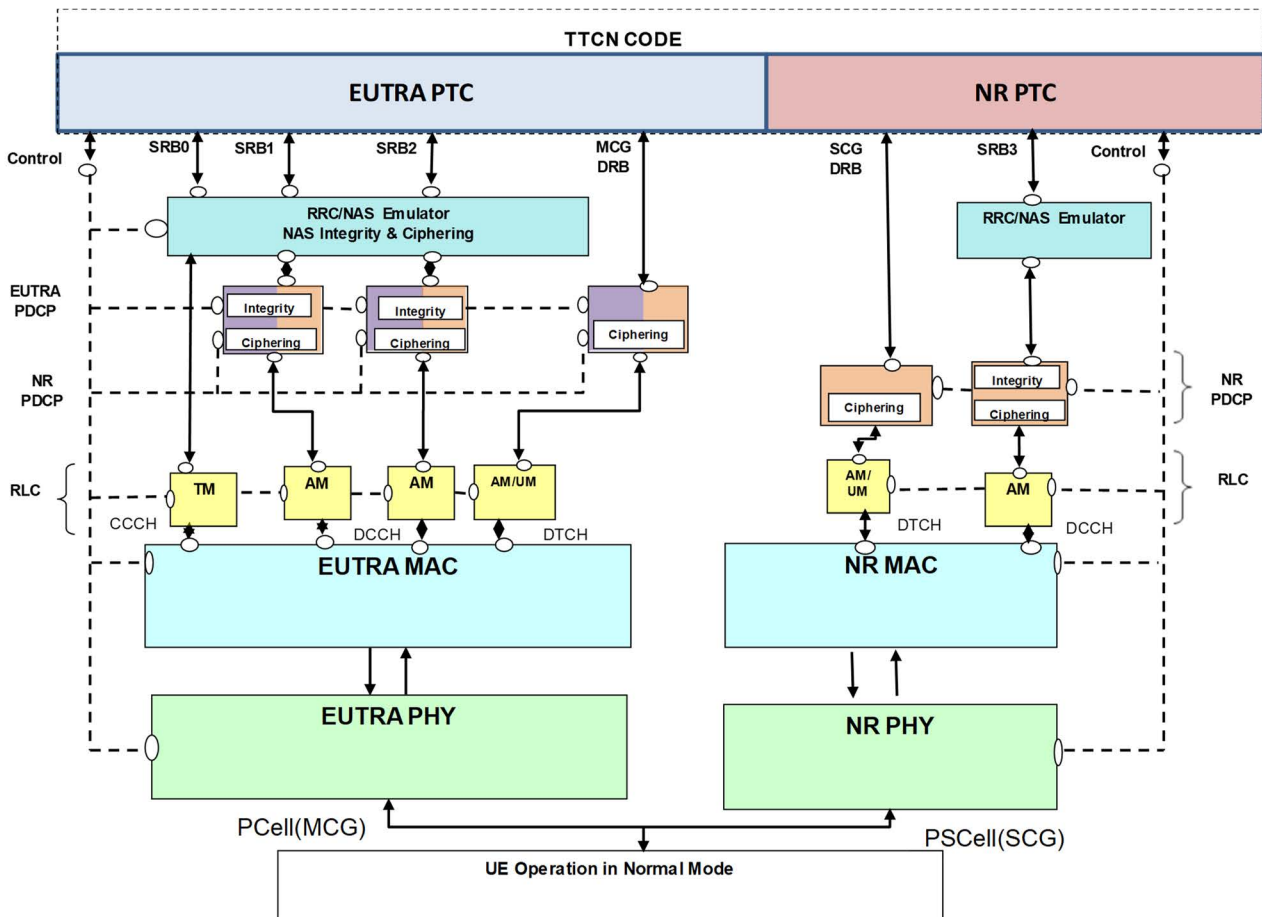

Figure 5.1.1.1-1: Test model for EN-DC Layer3 testing (MCG and SCG)

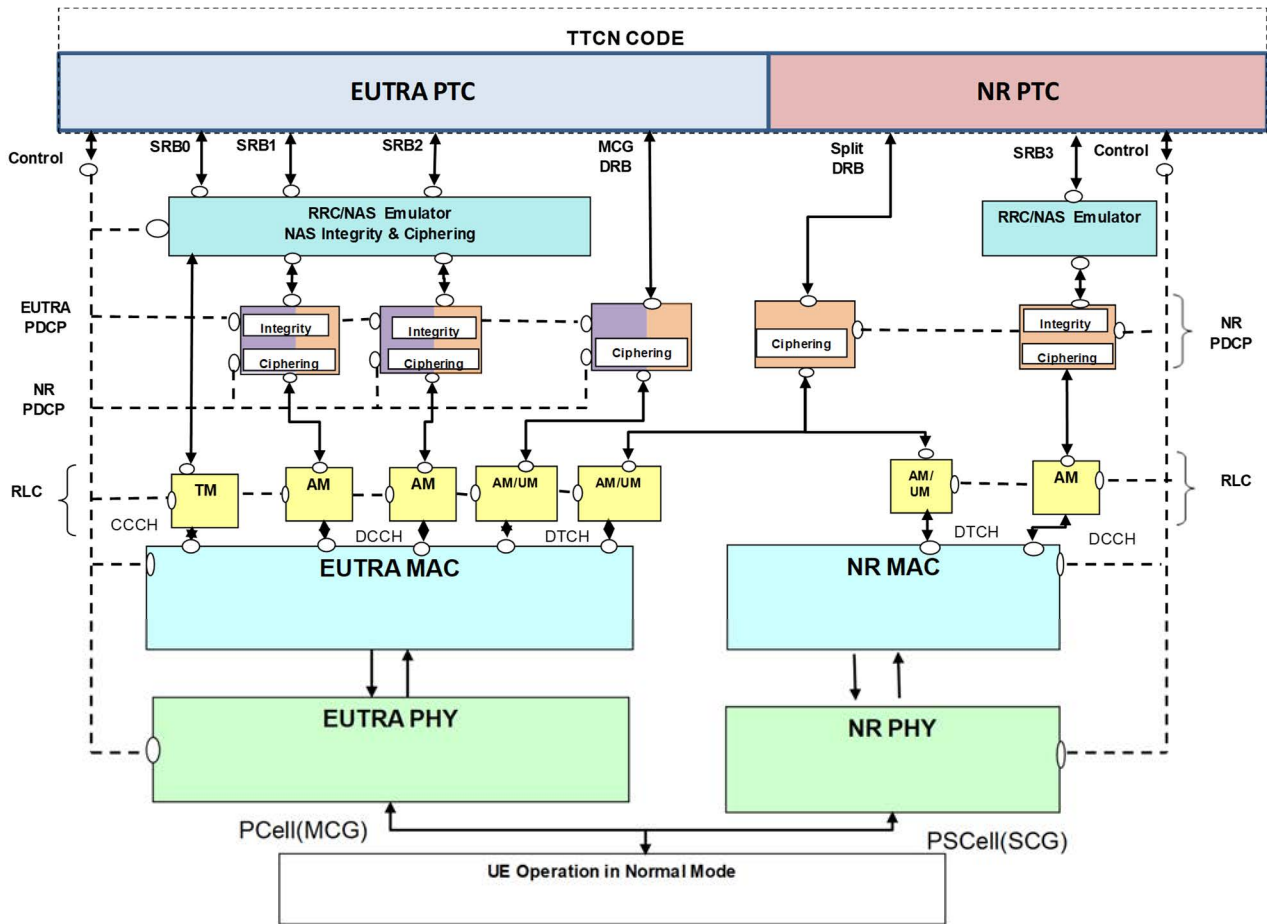
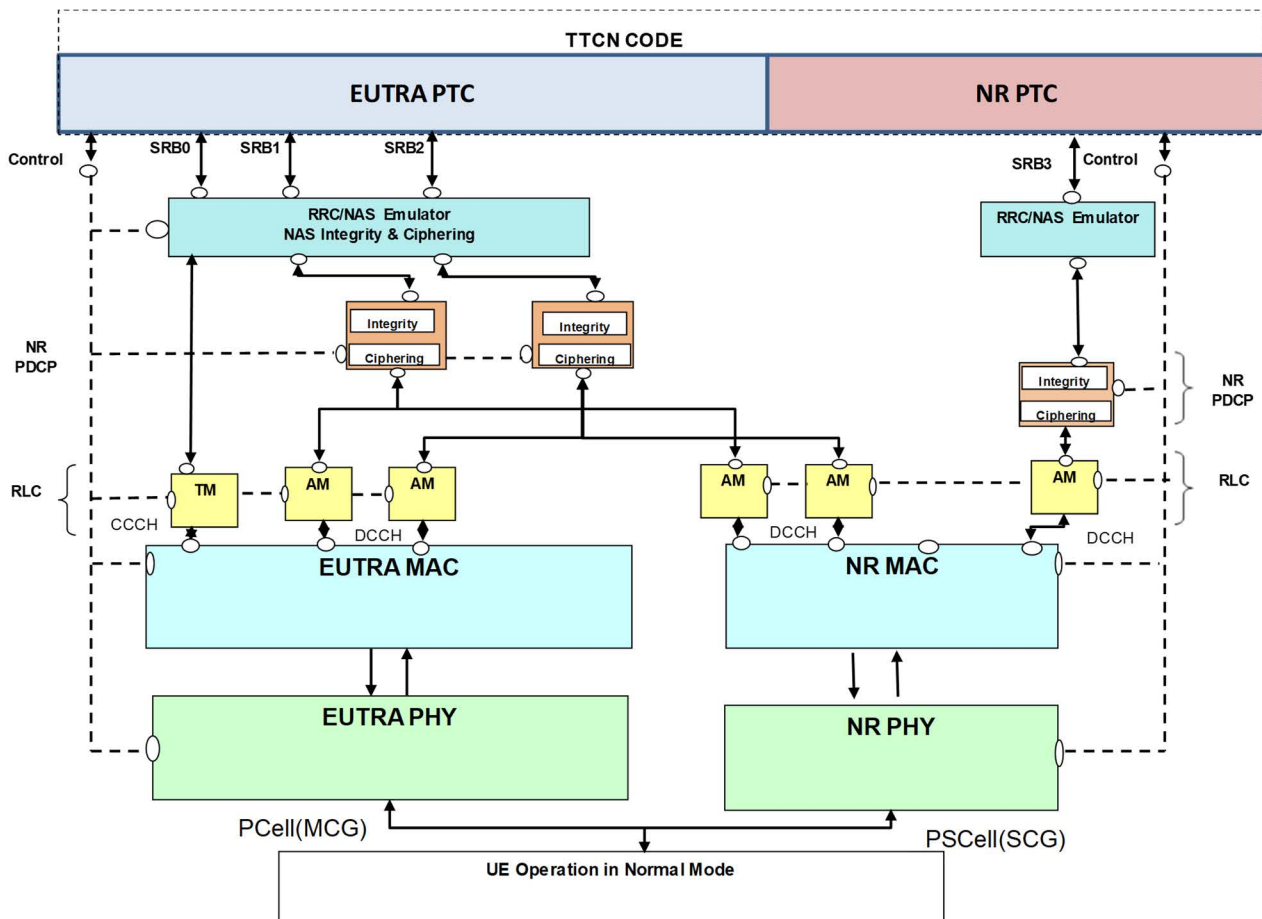

Figure 5.1.1.1-2: Test model for EN-DC Layer3 testing (MCG and split DRB)





**Figure 5.1.1.1-3: Test model for EN-DC Layer3 testing (Split SRB(s), DRBs removed for clarity)**

The UE is configured in normal mode. On the UE side Ciphering and Integrity (PDCP and NAS) are enabled and ROHC is not configured.

On the SS Side L1, MAC and RLC (EUTRA/NR) and PDCP (EUTRA/NR) are configured in normal way and shall perform all their functions. SRB0, 1 & 2 are configured only in EUTRA. For SRB0 the DL and UL port is above RLC. For SRB1 and SRB2 the port is above/below the EUTRA RRC and NAS emulator, which is implemented as a parallel test component. For DRB, the port is above PDCP. PDCP Ciphering/Integrity is enabled. NAS integrity/Ciphering is enabled.

**NOTE:** PDCP (EUTRA/NR) is always configured in the EUTRA PTC for SRB1 & 2.

The EUTRA RRC/NAS emulator for SRB1 and SRB2 shall provide the Ciphering and Integrity functionality for the EPS NAS messages. In UL direction, SS shall report RRC messages, still containing (where appropriate) the secure and encoded NAS message, to the RRC port. In DL, RRC and NAS messages with same timing information shall be embedded in one PDU after integrity and ciphering for NAS messages.

SRB3 is connected directly to the SRB port in the NR PTC/dummy NR RRC/NAS emulator.

The NR PDCP can be configured in either the EUTRA or NR PTC for one or more SRBs or DRBs. If NR PDCP is configured, the bearer can be split. In this case the PDCP will be fully configured on the cell upon which the bearer is terminated and the other PTC will be configured with a proxy PDCP. Data shall be sent/received only on the PTC upon which the bearer is terminated. The SS shall route data to/from either cell, via the routing information provided.

5.1.1.2 NR carrier aggregation

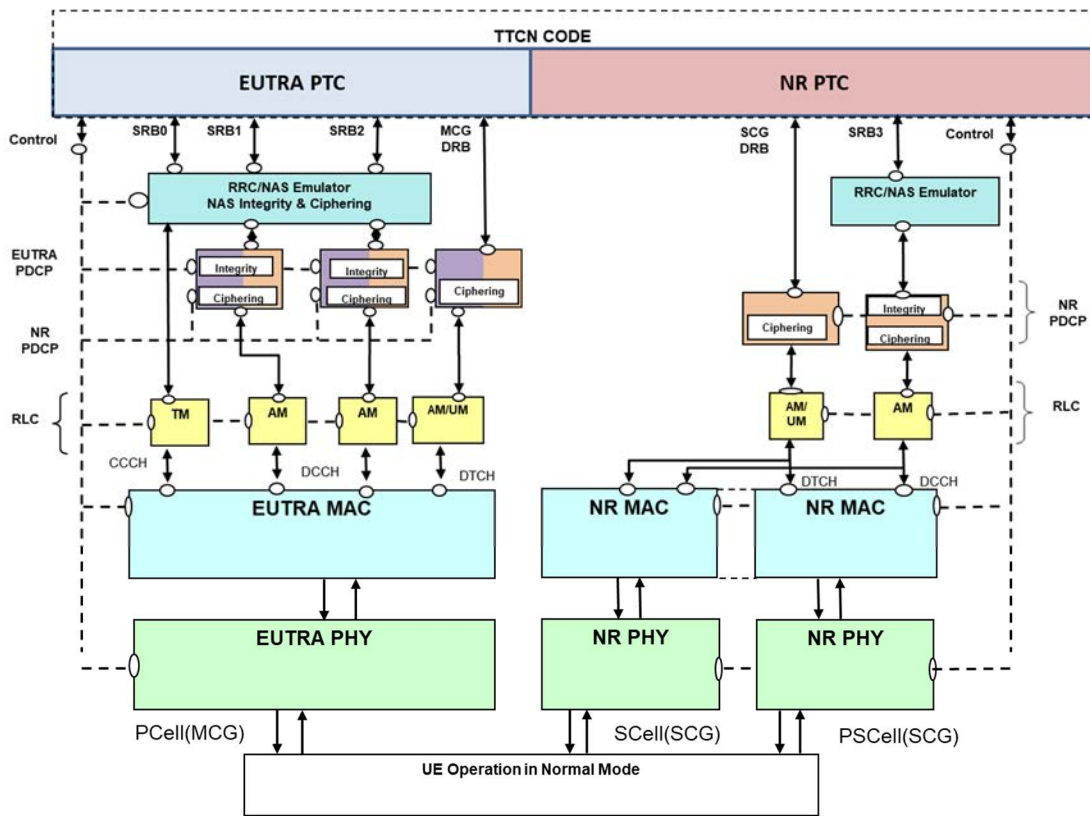

Figure 5.1.1.2-1: Test model for EN-DC Layer3 CA testing

The EN-DC Layer3 CA test model builds on top of the EN-DC Layer3 test model, with the differences specified hereafter.

On the SS NR side, in the SCG there is one PSCell and one SCell configured:

- PSCell: The associated SCell is linked to this PSCell, to enable the connection of the SCell MAC layer to the PSCell RLC/PDCP layers for DCCH/DTCH.
- SCell: Only PHY and MAC layers are configured, and MIB is broadcast.

The UL Scheduling Grant and DL Scheduling assignments are configured from TTCN over system control port. SS reports PUCCH scheduling information reception in PSCell over system indication port, if configured.

The NR data routing between the RLC layer of PSCell and the lower layers of either PSCell or SCell shall be provided to/by SS in the common part of the data ASP using the MacBearerRouting field.

In a similar way the reception of PRACH preambles in PSCell / SCell is reported by SS over the same port, if configured.

### 5.1.2 Layer 2

#### 5.1.2.1 PDCP

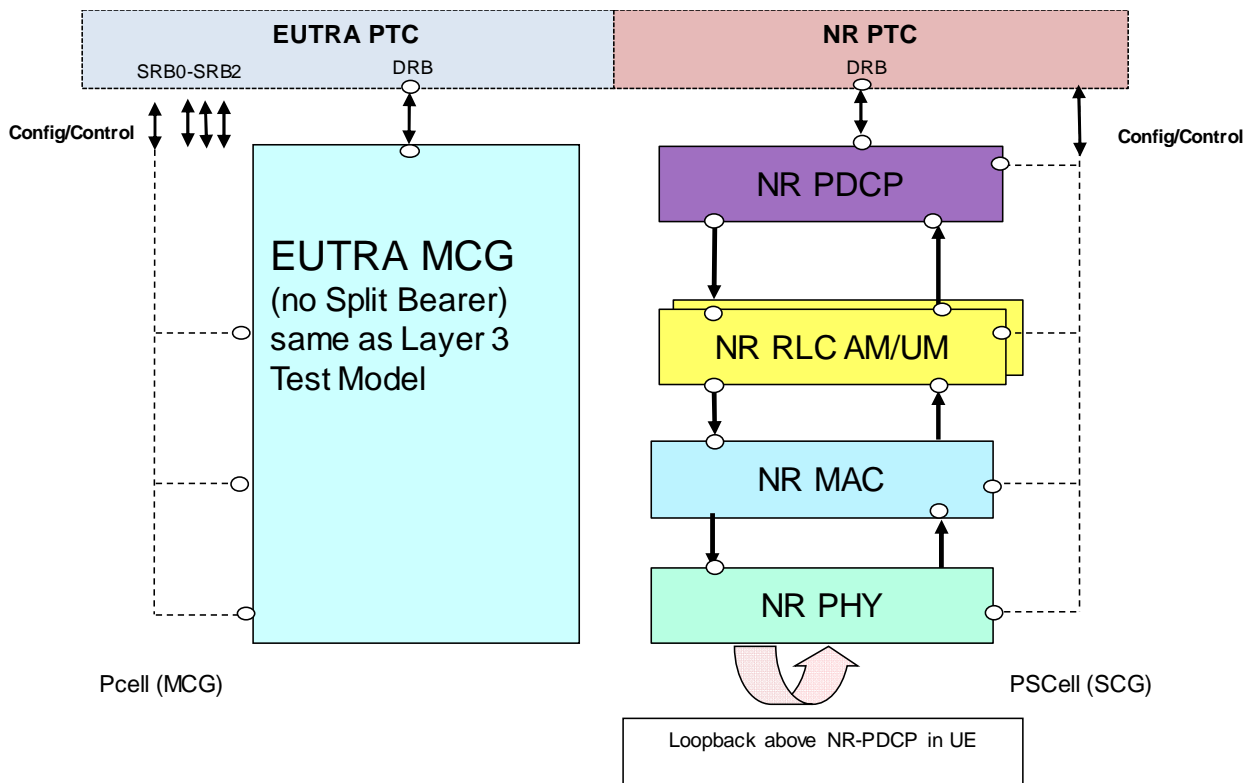

Figure 5.1.2.1-1: Test model for EN-DC PDCP testing (MCG and SCG)

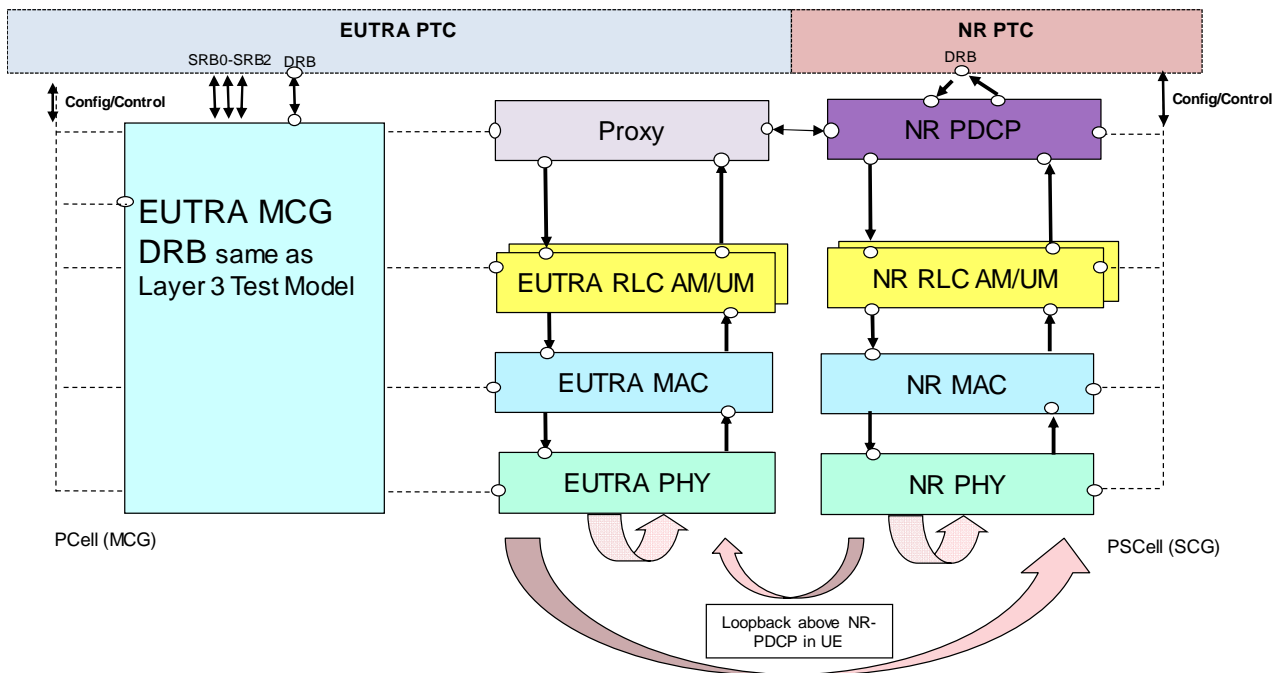

Figure 5.1.2.1-2: Test model for EN-DC PDCP testing (MCG and split DRB)

The UE is configured in Test Loop Mode, to loop back the user domain data above PDCP layer. On UE side Ciphering is enabled as null algorithm and ROHC is not configured.

Test Loop Mode can be active on SCG DRB as shown in Figure 5.1.2.1-1 or active split DRB as shown in Figure 5.1.2.1-2.

NOTE: Test loop Mode activation on MCG DRB with NR-PDCP is not considered in Figure 5.1.2.1-2.

On the SS NR, Layer 1, MAC and RLC are configured in the normal operation. The PDCP is configured in a special mode, where SS does not add any PDCP headers in DL and/or not remove any PDCP headers in UL directions respectively at DRB port on the NR PTC. The TTCN maintains sequence numbers and state variables for the PDCP layer.

On the SS Side the EUTRA MCG layer 1, MAC, RLC is configured in normal operation. They shall perform their functions. In case of split DRB, PDCP layer is configured as Proxy mode, TTCN shall configure EUTRA for EN-DC PDCP testing only when a Test Loop Mode is active on a split DRB.

The SS shall route DL PDCP PDUs from TTCN to PCell and/or PSCell and SS shall indicate that the UL PDCP PDU is received from PCell or PSCell.

Duplication function:

- DL is FFS.
- UL SS shall include routing information for each UL PDCP PDU.

The UL Scheduling Grant and DL Scheduling assignments are configured from TTCN over system control port. SS reports PUCCH scheduling information reception over system indication port, if configured.

### 5.1.2.2 RLC

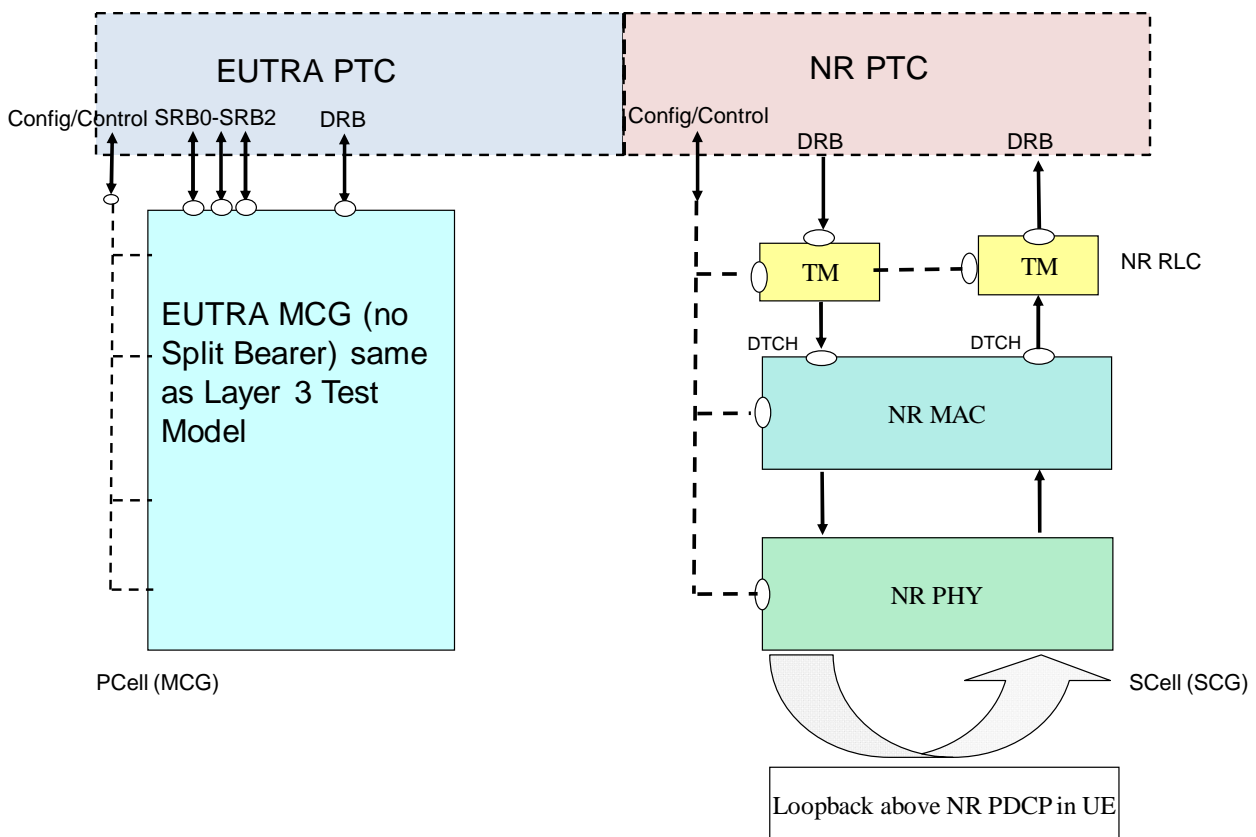

Figure 5.1.2.2-1: Test model for EN-DC RLC AM/UM testing

The PCell is an EUTRA Cell and PSCell is an NR cell on which testing happens. The UE is registered in EUTRA, using SRBs 0-2, and configured for EN-DC operation.

This model is suitable for testing both UM/AM mode of operation of DRBs on UE side.

The UE is configured in Test Loop Mode, to loop back the user domain data above PDCP layer. On UE side Ciphering is enabled (since mandatory) but with dummy ciphering algorithm, which is equivalent to not using ciphering. ROHC is not configured on UE Side.

On the SS Side, L1 and MAC are configured in the normal way. The RLC of the SCG DRBs is configured in transparent mode. Hence with this configuration PDUs out of SS RLC are same as the SDUs in it. There is no PDCP configured on SS NR PTC side. The ports are directly above RLC.

The PDUs, exchanged between TTCN and SS, shall be the final RLC PDUs consisting of RLC and PDCP headers. TTCN code shall take care in DL of building RLC headers and PDCP headers and in UL handle RLC and PDCP headers. TTCN code shall take care of maintaining sequence numbers and state variables for RLC and PDCP layers. If RLC on UE side is in AM mode, TTCN shall take care of generating polls in DL and responding with RLC control PDUs on reception of UL Poll.

### 5.1.2.3 MAC

#### 5.1.2.3.1 Single NR carrier

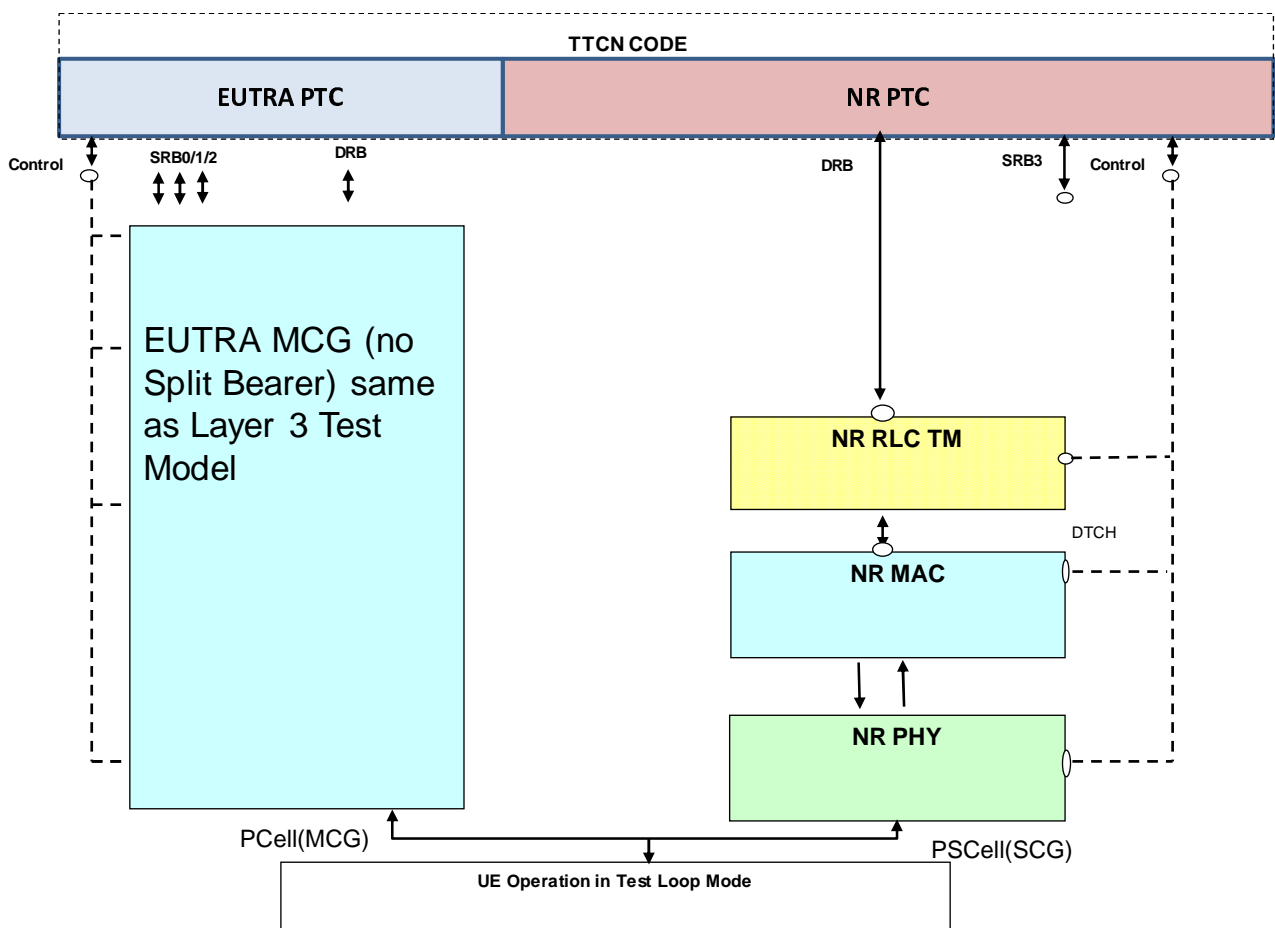

Figure 5.1.2.3.1-1: Test model for EN-DC MAC testing

The UE is configured in Test Loop Mode, to loop back the User Plane data above PDCP layer. On UE side Ciphering is enabled (since Mandatory) but with dummy ciphering algorithm, which is equivalent to not using ciphering. ROHC is not configured on UE Side.

On the SS Side the EUTRA MCG is configured as per the EN-DC Layer 3 test model in normal operation. The EN-DC MAC test model expects no split bearers to be configured.

On the SS NR, Layer 1 is configured in the normal way. NR MAC is configured in a special mode, where it does not add any MAC headers in DL and /or not remove any MAC headers in UL directions respectively at DRB port. In this case, the TTCN shall provide the final MAC PDU, including padding. Except for this, the NR MAC layer shall perform all its other functions. SRB3 if present is configured as in Layer 3 test model in normal operation.

On DRBs the NR RLC is configured in transparent mode. Hence with this configuration PDUs out of SS RLC are same as the SDUs in it. There is no NR PDCP configured on SS Side. The ports are directly above NR RLC.

There are two different test modes in which NR MAC header addition/removal can be configured:

1. DL/UL header-transparent mode: no header addition in DL and no header removal in UL.
2. DL only header-transparent mode: no header addition in DL; UL NR MAC is configured in normal mode to remove MAC header and de-multiplex the MAC SDUs according to the logical channel IDs.

If SS NR MAC is configured in DL/UL header-transparent mode, the PDUs, exchanged at the DRB port between TTCN and SS, shall be the final MAC PDUs consisting of MAC, RLC and PDCP headers. TTCN code shall take care in DL of building MAC header, RLC headers and PDCP headers and in UL handle MAC, RLC and PDCP headers. TTCN code shall take care of maintaining sequence numbers and state variables for RLC and PDCP layers. During testing of multiple DRBs at the UE side, it shall still be possible to configure only one DRB on SS side with configuration in the figure 5.1.2.3-1. Other DRBs will not be configured, to facilitate routing of UL MAC PDUs. Multiplexing/de-multiplexing of PDUs meant/from different DRBs shall be performed in TTCN. Since the MAC layer does not evaluate the MAC headers in UL it cannot distinguish between SRB and DRB data in UL. There shall be no SRB3 traffic while MAC is configured in this test mode. The SS MAC shall take care of automatic repetitions/retransmission in UL and DL, based on normal MAC HARQ behaviour.

If SS NR MAC is configured in DL only header-transparent mode, the UL PDUs exchanged at the DRB port between TTCN and SS shall be final RLC PDUs consisting of RLC and PDCP headers. SS shall route these PDUs based on logical channel IDs. In DL, TTCN sends fully encoded MAC PDUs at the DRB port (consisting of MAC, RLC and PDCP headers). In this case TTCN needs to take care of maintaining sequence numbers and state variables for RLC and PDCP layers. Furthermore, in UL and DL the SS MAC layer shall be capable of dealing with SRB3 data (i.e. it shall handle DL RLC PDUs coming from SRB3 RLC layer or de-multiplex UL RLC PDUs to SRB3) as in normal mode. The SS MAC shall take care of automatic repetitions/retransmissions in UL and DL, based on normal MAC HARQ behaviour. TTCN shall ensure that no DL MAC SDUs in normal mode and DL MAC PDUs in test mode are mixed for the same TTI.

The UL Scheduling Grant and DL Scheduling assignments are configured from TTCN over system control port. SS reports PUCCH scheduling information reception over system indication port, if configured. In a similar way the reception of PRACH preambles is reported by SS over the same port.

When SS is configured with *pusch-AggregationFactor* > 1 and SS NR MAC is configured in DL/UL header-transparent mode, SS shall handle UE automatic subsequent repetitions/retransmissions in UL on the same HARQ process according to TS 38.214[22] clause 6.1.2.1, and in addition SS shall transmit to TTCN every received UL HARQ transmission/retransmission within a bundle as separate MAC PDUs.

5.1.2.3.2 NR carrier aggregation

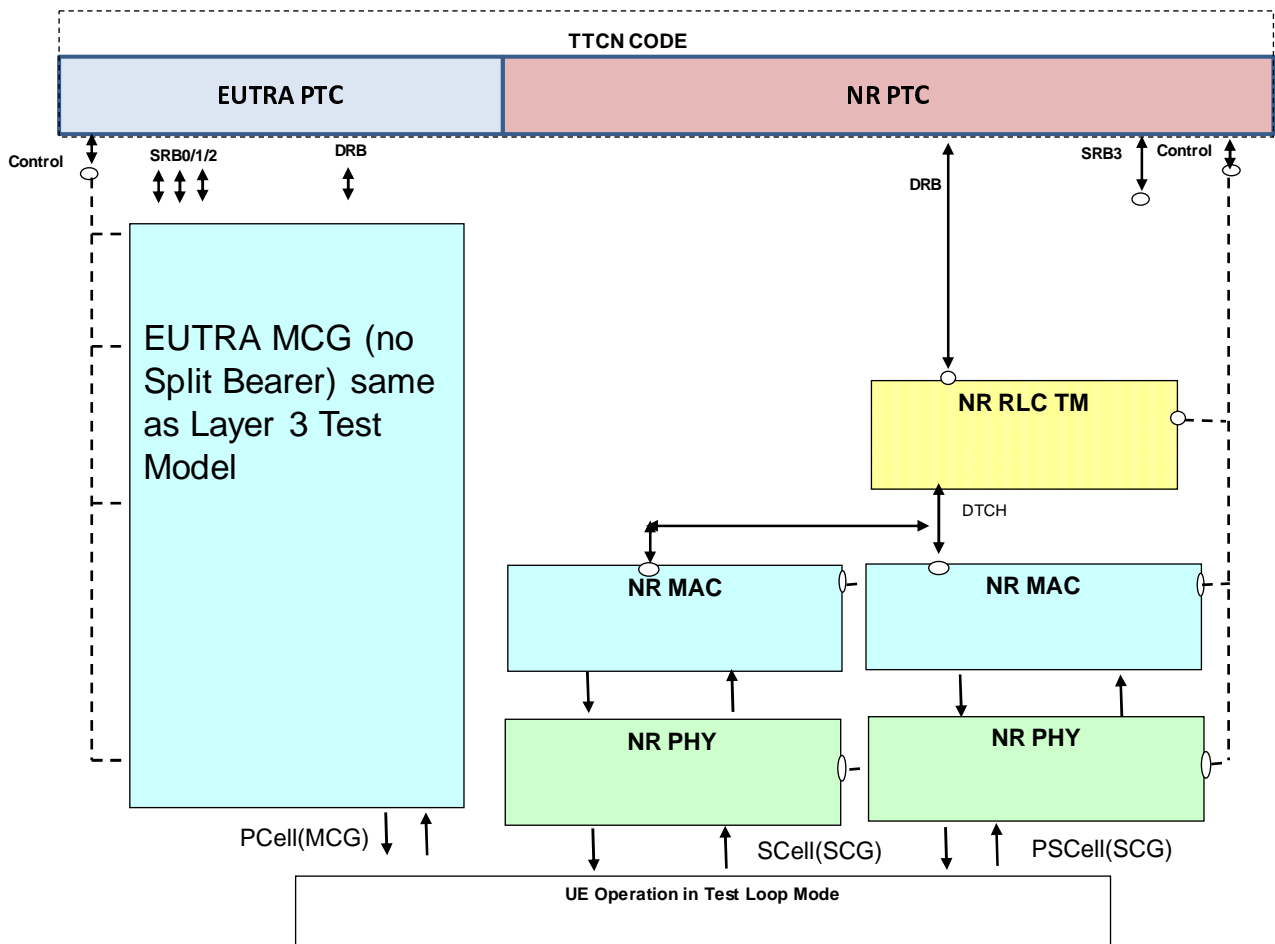

Figure 5.1.2.3.2-1: Test model for EN-DC MAC CA testing

The EN-DC MAC CA test model builds on top of the EN-DC MAC test model, with the differences specified hereafter.

On the SS NR side, in the SCG there is one PSCell and one SCell configured:

- PSCell only: On DRBs the NR RLC is configured in transparent mode. Hence with this configuration PDUs out of SS RLC are same as the SDUs in it. There is no NR PDCP configured in the SS. The ports are directly above NR RLC.
- PSCell / SCell: Layer 1 is configured in the normal way. NR MAC is configured in a special mode, where it does not add any MAC headers in DL and /or not remove any MAC headers in UL directions respectively at DRB port. In this case, the TTCN shall provide the final MAC PDU, including padding. Except for this, the MAC layer shall perform all of its other functions.

The UL Scheduling Grant and DL Scheduling assignments are configured from TTCN over system control port. SS reports PUCCH scheduling information reception in PSCell over system indication port, if configured. In a similar way the reception of PRACH preambles in PSCell / SCell is reported by SS over the same port, if configured.

## 5.2 NR/5GC

### 5.2.1 Layer 3

#### 5.2.1.1 Single NR carrier

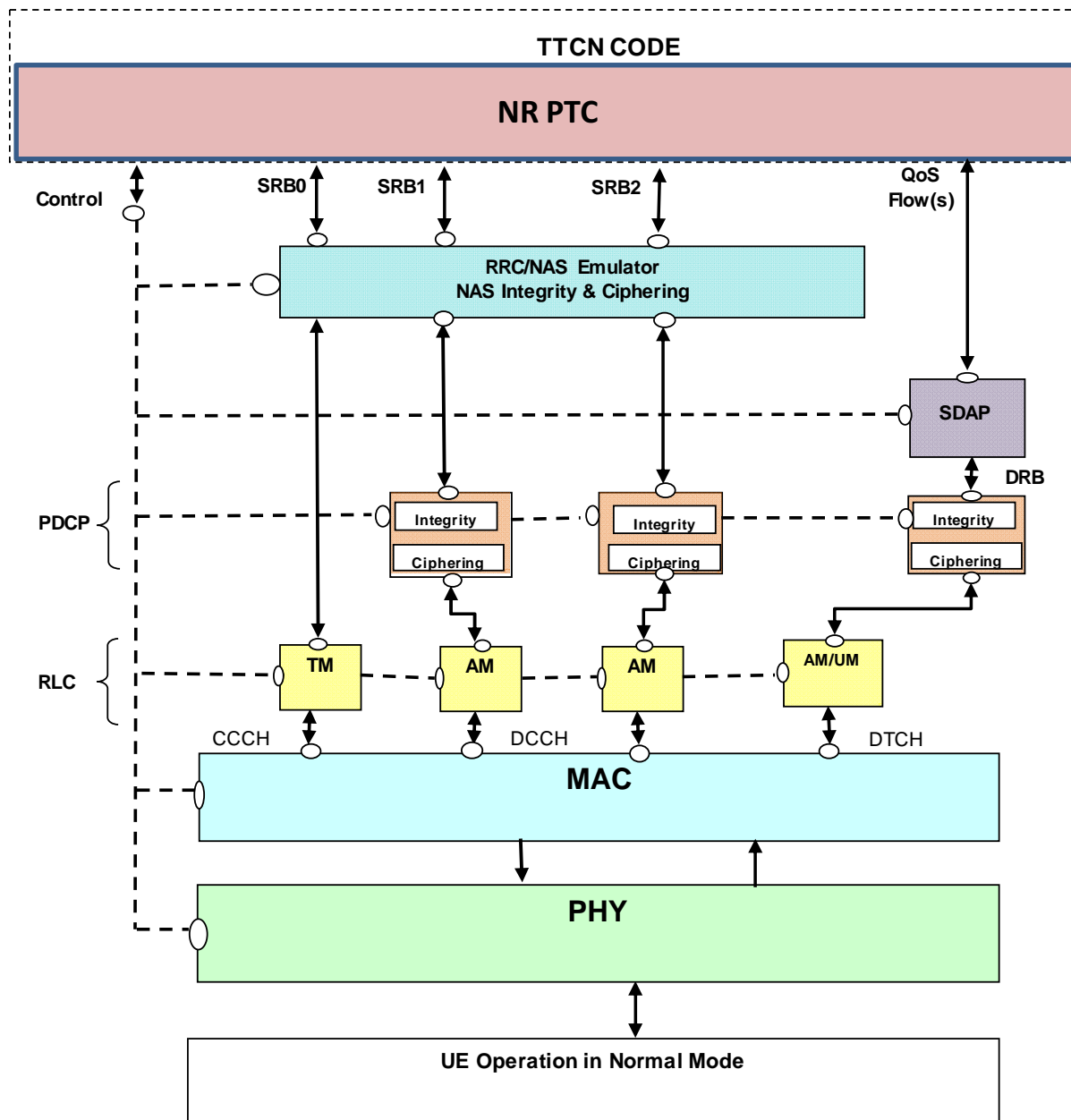

Figure 5.2.1.1-1: Test model for NR/5GC Layer3 testing

The UE is configured in normal mode. On the UE side Ciphering and Integrity (PDCP and NAS) are enabled and ROHC is not configured.

On the SS Side L1, MAC, RLC, PDCP and SDAP are configured in the normal way and shall perform all their functions. For SRB0 the DL and UL port is above RLC. For SRB1 and SRB2 the port is above/below the NR RRC and NAS emulator, which is implemented as a parallel test component. For DRB, the port is above SDAP. PDCP Ciphering/Integrity is enabled. NAS integrity/Ciphering is enabled.



The RRC/NAS emulator for SRB1 and SRB2 shall provide the Ciphering and Integrity functionality for the 5GC NAS messages. In UL, the SS shall report RRC messages, still containing (where appropriate) the secure and encoded NAS message, to the RRC port. In DL, RRC and NAS messages with same timing information shall be embedded in one PDU after integrity and ciphering of the NAS messages.

5.2.1.2 NR carrier aggregation

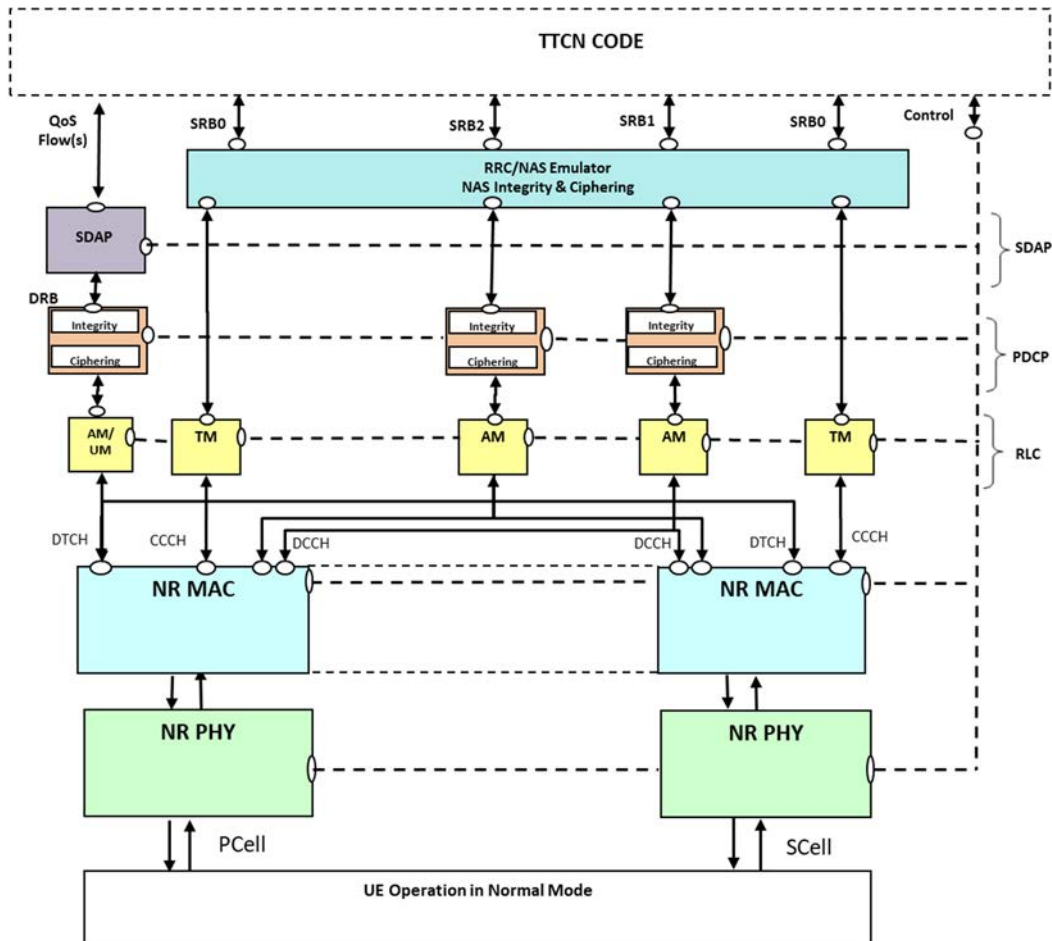

Figure 5.2.1.2-1: Test model for NR/5GC Layer3 CA testing

The NR/5GC Layer3 CA test model builds on top of the NR/5GC Layer3 test model, with the differences specified hereafter.

In the SS side, there is one PCell and one SCell configured:

- PCell: The associated SCell is linked to this PCell to enable the connection of the SCell MAC layer to the PCell RLC/PDCP layers for DCCH/DTCH.
- SCell: PHY and MAC layers are configured in normal way. RLC layer is configured only for BCCH/PCCH/CCCH.

The UL Scheduling Grant and DL Scheduling assignments are configured from TTCN over system control port. The SS reports PUCCH scheduling information reception in PCell over system indication port, if configured.

The NR data routing between the RLC layer of PCell and the lower layers of either PCell or SCell shall be provided to/by SS in the common part of the data ASP using the MacBearerRouting field.

In a similar way the reception of PRACH preambles in PCell / SCell is reported by SS over the same port, if configured.

5.2.1.3 NR/5GC Inter-RAT

5.2.1.3.1 NR/E-UTRA Inter-RAT

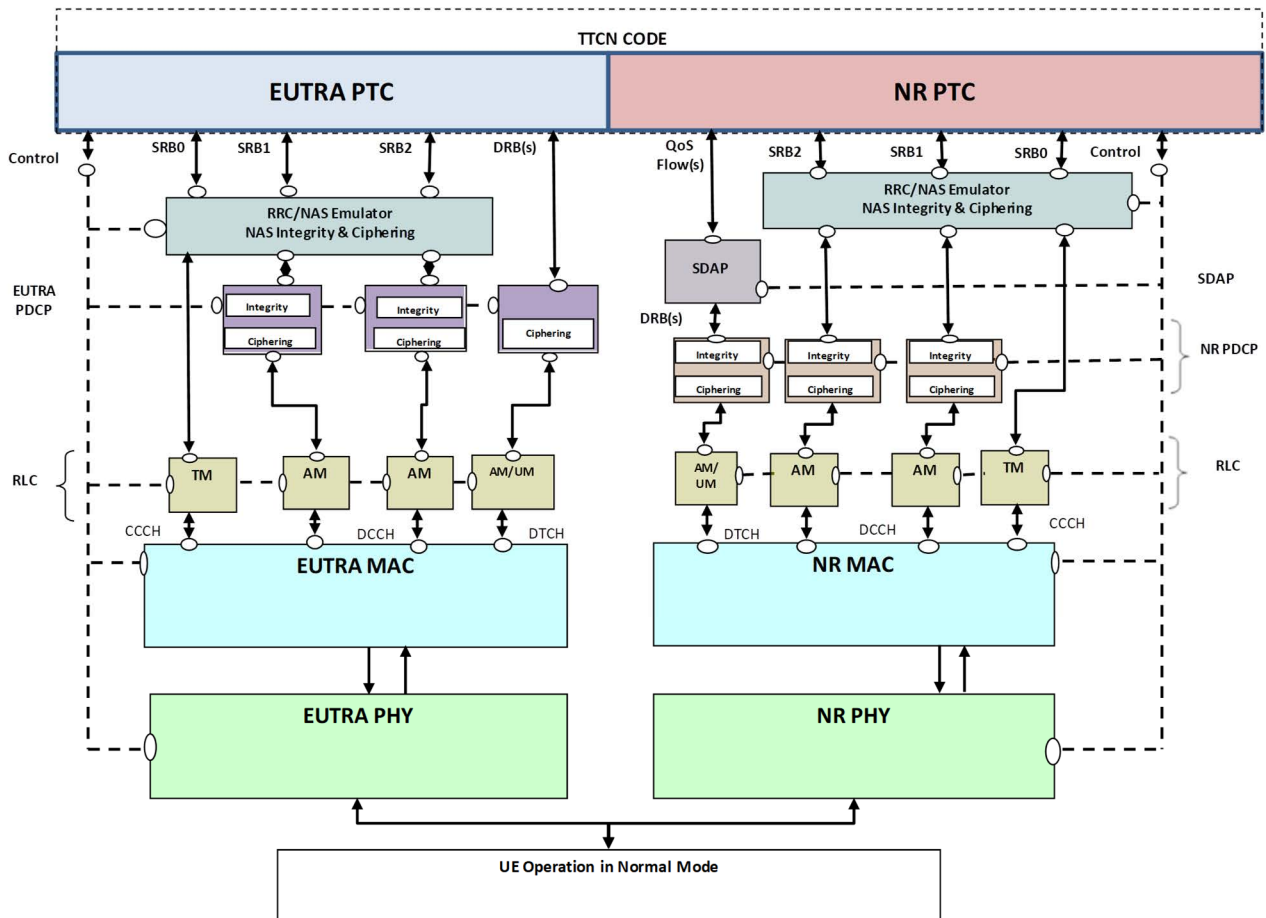

Figure 5.2.1.3.1-1: Test model for NR/E-UTRA Inter-RAT testing

This test model is only relevant for NR/5GC to/from E-UTRA/EPC inter-RAT and is not applicable to E-UTRA/5GC. The model consists of a dual protocol stack: one for NR and one for E-UTRA. The TTCN implementation for NR and E-UTRA functionalities will be in separate Parallel Test Components.

The SS NR part is the same as the model defined in subclause 5.2.1.1 for NR/5GC L3 testing.

The SS E-UTRA part is the same as the model defined in 36.523-3 [12] clause 4.2.2 for RRC testing.

The UE is configured in normal mode. Ciphering/Integrity (PDCP and NAS) are enabled and ROHC is not configured.

5.2.1.3.2 NR/UTRAN Inter-RAT

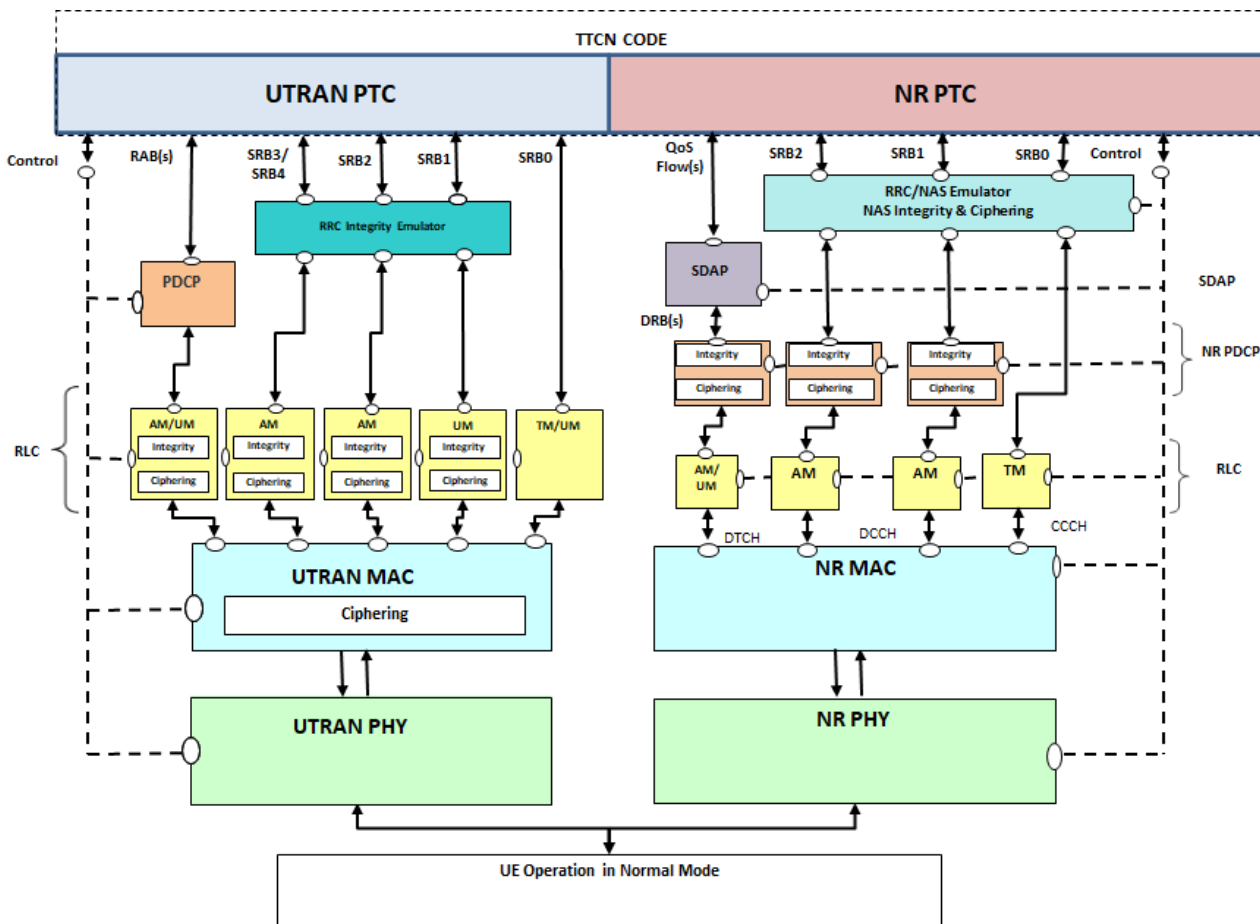

Figure 5.2.1.3.2-1: Test model for NR/UTRAN Inter-RAT testing

The model consists of a dual protocol stack: one for NR and one for UTRAN. The TTCN implementation for NR and UTRAN functionalities will be in separate Parallel Test Components.

The SS NR part is the same as the model defined in subclause 5.2.1.1 for NR/5GC L3 testing.

The SS UTRAN part consisting of PHY, MAC, RLC and PDCP (optionally, if PS user RB established only), are configured in normal mode. They shall perform all of their functions normally. Ciphering is enabled and shall be performed in RLC (AM/UM) and MAC (TM RLC). Integrity is enabled, and SS shall provide RRC emulator for integrity protection calculation and checking and 'Direct transfer' adaptation. Ports are above RLC (CS RAB and SRB0), PDCP (PS RAB) and RRC Emulator (SRB1 to SRB4).

The UE is configured in normal mode. Ciphering/Integrity (PDCP and NAS) are enabled. Ciphering is enabled in UTRAN and ROHC is not configured.

## 5.2.1.4 NR supplementary uplink

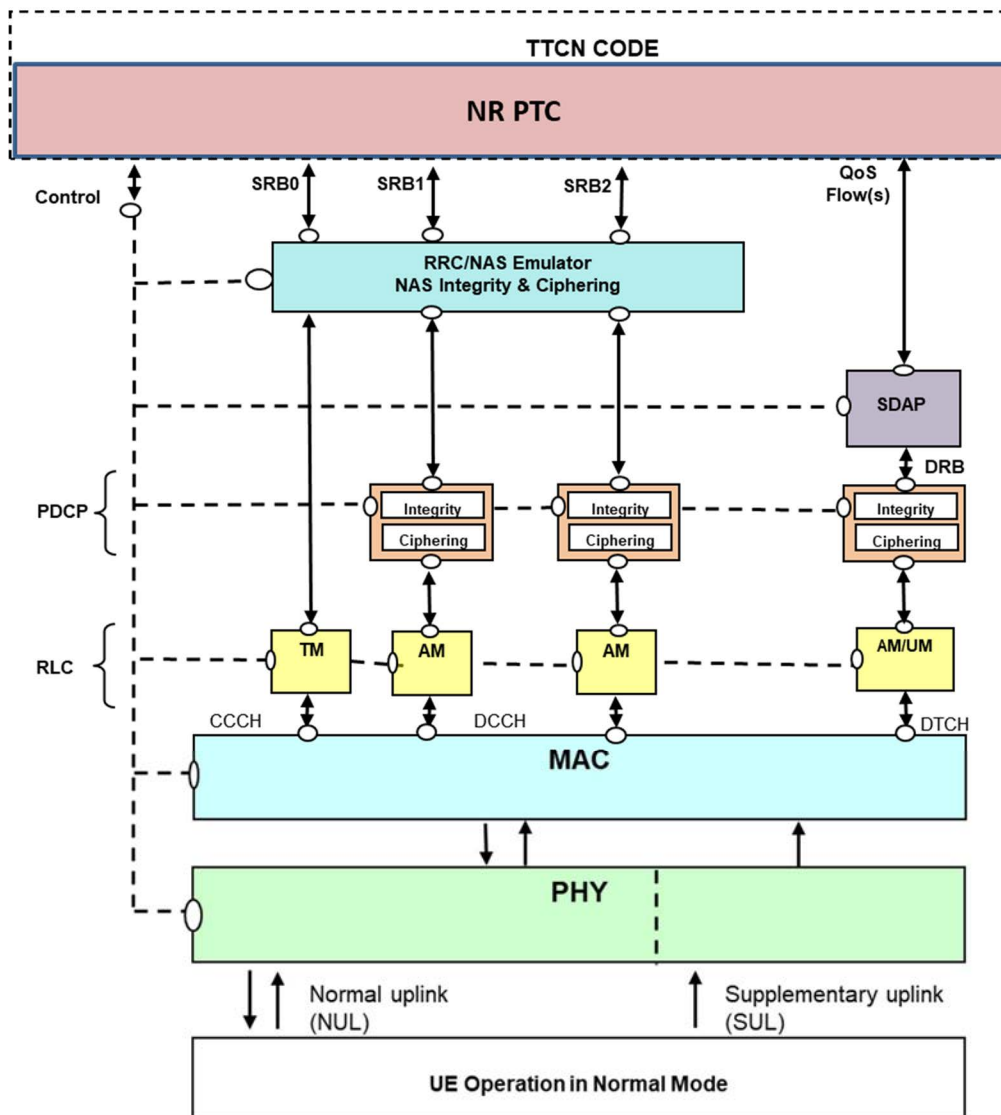

Figure 5.2.1.4-1: Test model for NR/5GC Layer3 supplementary uplink testing

The NR/5GC Layer3 supplementary uplink test model builds on top of the NR/5GC Layer3 test model, with the differences specified hereafter.

In the SS side:

- The NR cell is configured with one uplink (NUL) carrier and one supplementary uplink (SUL) carrier. See NOTE 1.
- The SUL routing information shall be provided by SS in the common part of the indication ASP when the data is received from the SUL carrier.
- The SS shall monitor both NUL carrier and SUL carrier for PRACH reception. TTCN checks whether RA Msg1 and RA Msg3 are received from NUL or SUL carrier using the SUL routing information in the indication ASP.
- The UL scheduling Grants are configured from TTCN over the system control port for PUSCH transmission on the NUL carrier or the SUL carrier.

NOTE 1: While TS 38.508-1 [5] defines an SUL carrier as a pseudo-standalone NR Cell 33, in the present test model, the SUL carrier is an additional carrier to the NR Cell operating on the NUL carrier. So NR Cell of identity 33 is not used in TTCN.

5.2.1.5 NR dual connectivity

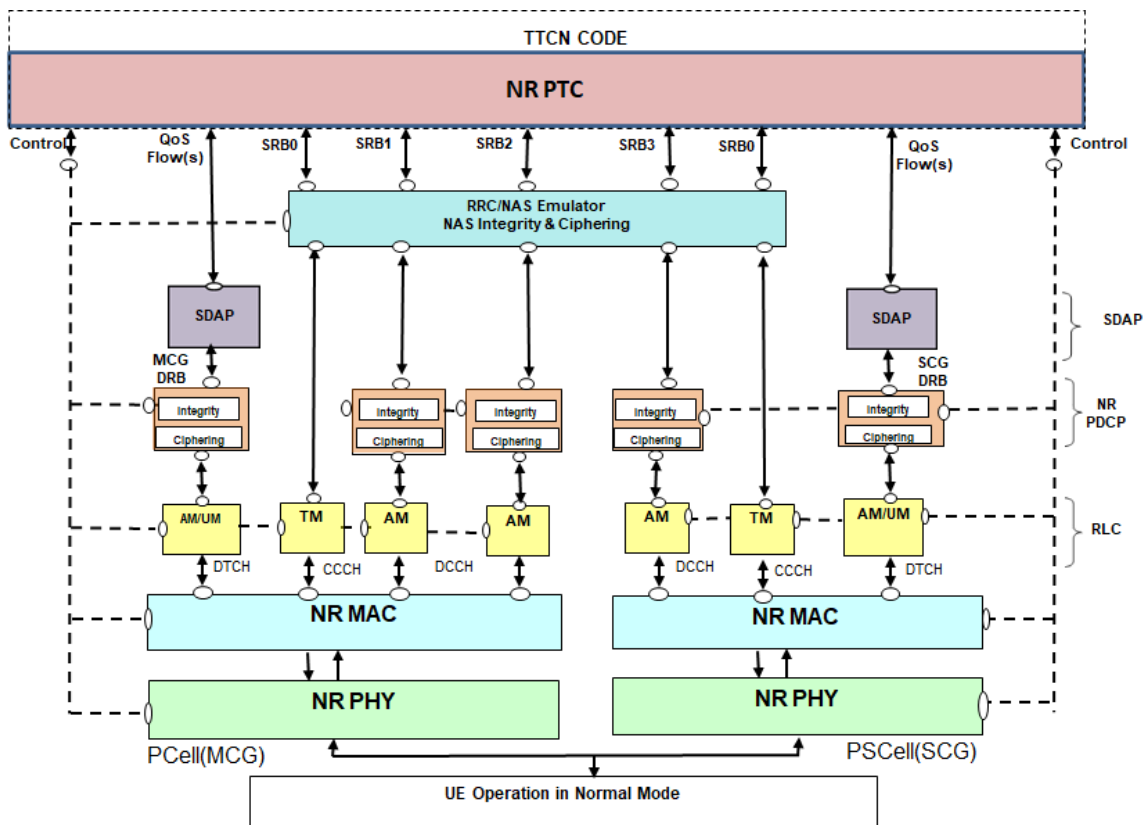

Figure 5.2.1.5-1: Test model for NR/5GC NR-DC Layer3: MCG and SCG

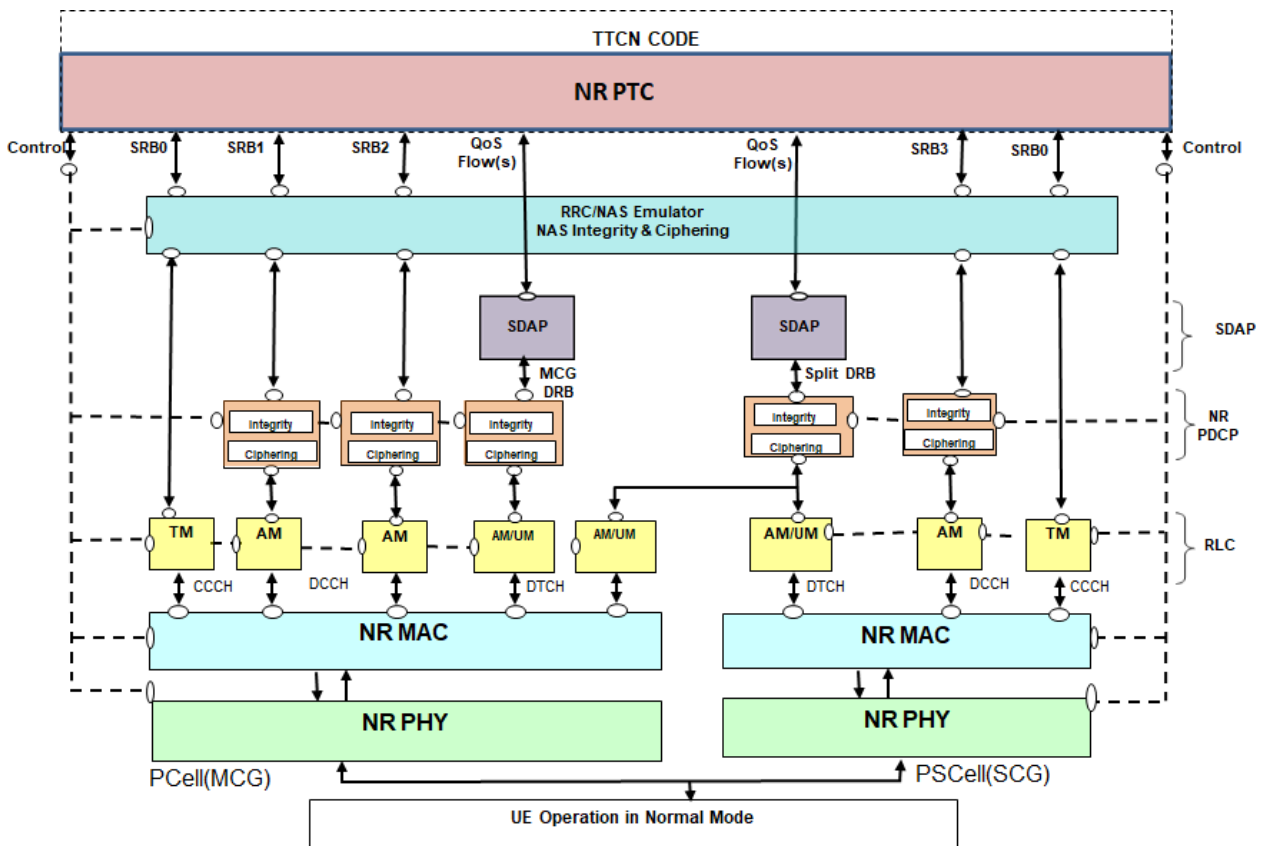

Figure 5.2.1.5-2: Test model for NR/5GC NR-DC Layer3 testing: MCG and split DRB

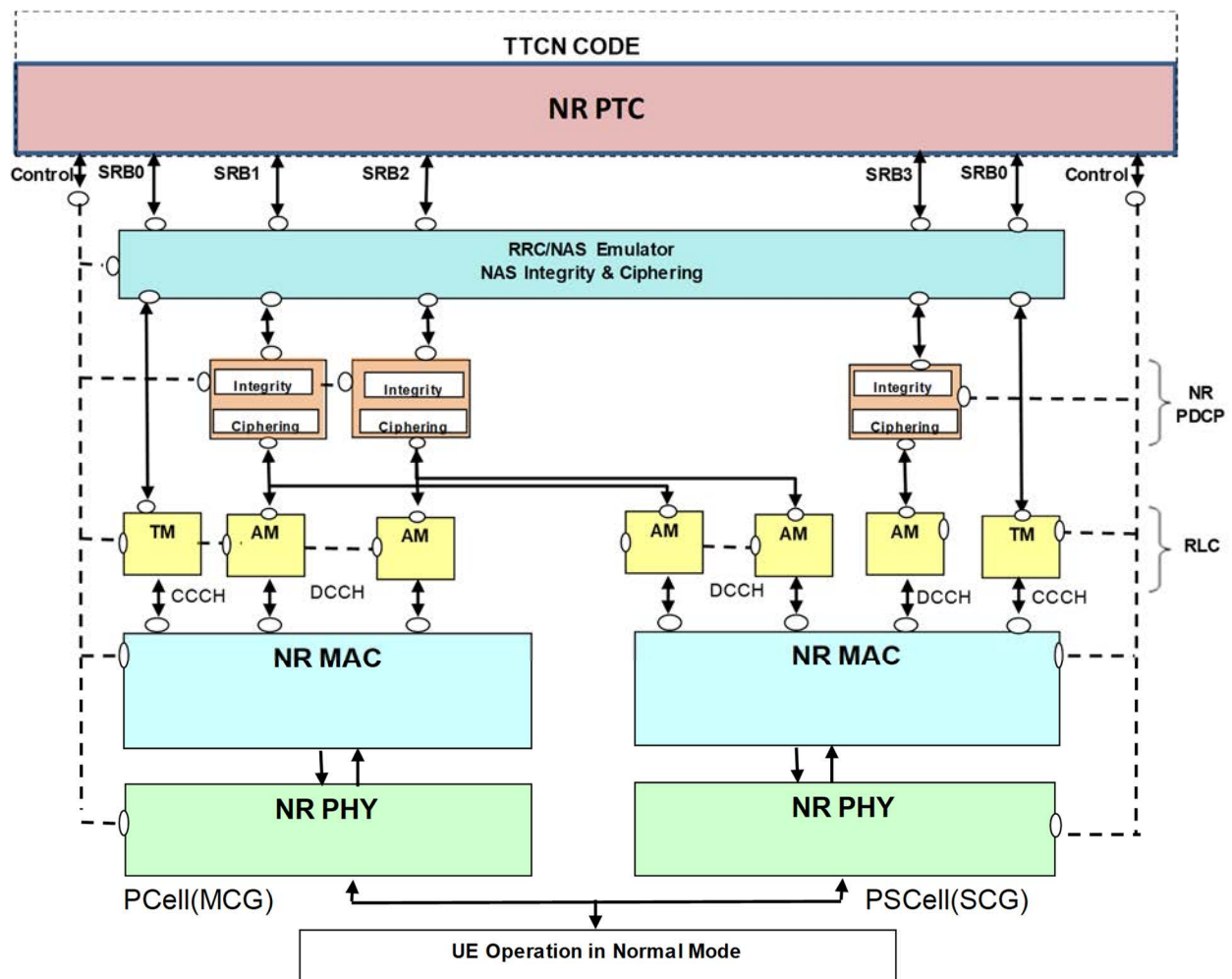

Figure 5.2.1.5-3: Test model for NR/5GC NR-DC Layer3 testing: Split SRB(s), DRBs removed for clarity

The NR/5GC Layer3 NR-DC test model builds on top of the NR/5GC Layer3 test model, with the differences specified hereafter:

- SRB1 and SRB2 are configured only in the PCell,
- SRB3 can be configured in the PSCell,
- The NR PDCP can be configured in split for one or more SRBs or DRBs. In this case NR PDCP is configured in one cell and a proxy PDCP will be configured in the other cell. The SS shall route data to/from either cell, via the routing information provided.

## 5.2.2 Layer 2

### 5.2.2.1 SDAP

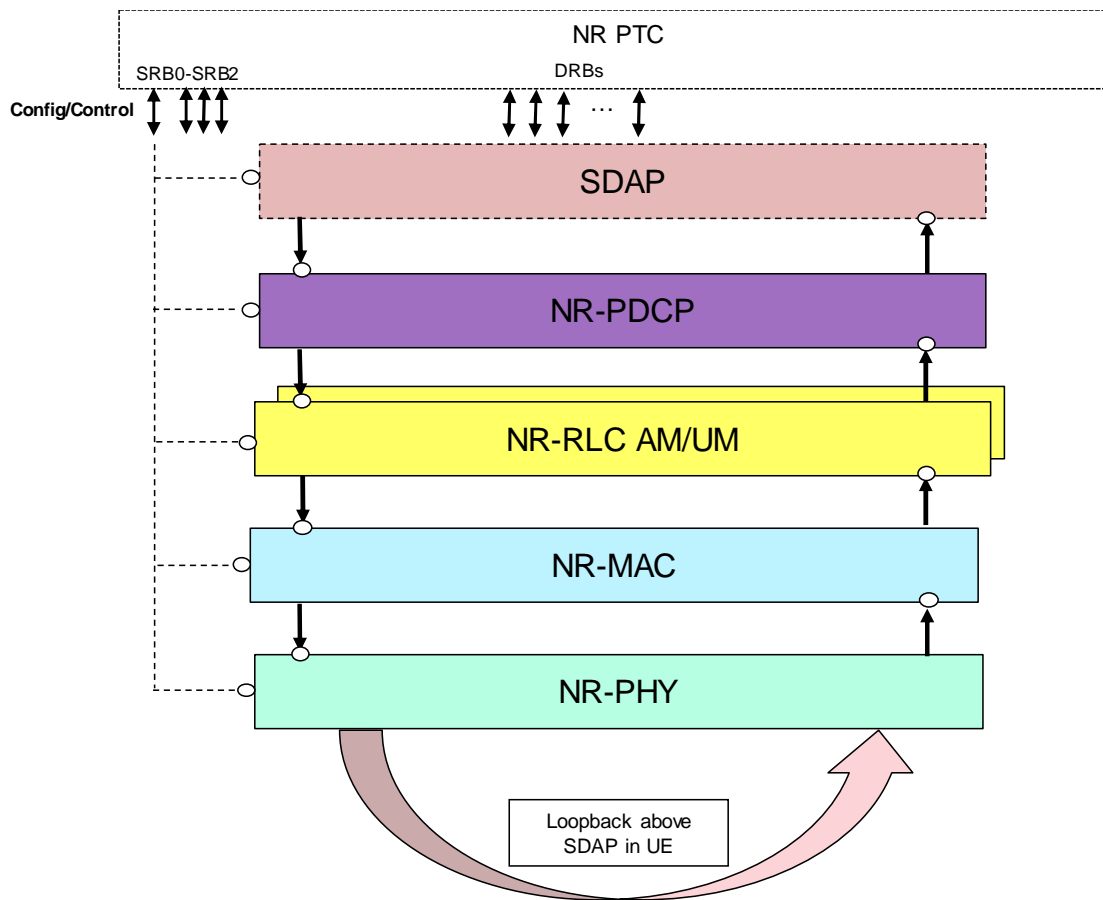

**Figure 5.2.2.1-1: Test model for NR/5GC SDAP testing**

The UE is configured in Test Loop Mode, to loop back the user domain data above SDAP layer. On UE side Ciphering is enabled with null algorithm and ROHC is not configured.

On the SS, Layer 1, MAC, RLC and PDCP are configured in the normal operation. The SDAP is configured in a special mode, where SS does not add any SDAP header in DL and does not remove any SDAP header in UL at the DRB port on the NR PTC. The TTCN code will take care of the SDAP header handling and of the QoS flow to DRB mapping, i.e. the SS will route DL SDAP PDUs from TTCN to the corresponding DRB.

The UL Scheduling Grant and DL Scheduling assignments are configured from TTCN over system control port.

## 5.2.2.2 PDCP

## 5.2.2.2.1 Single NR carrier

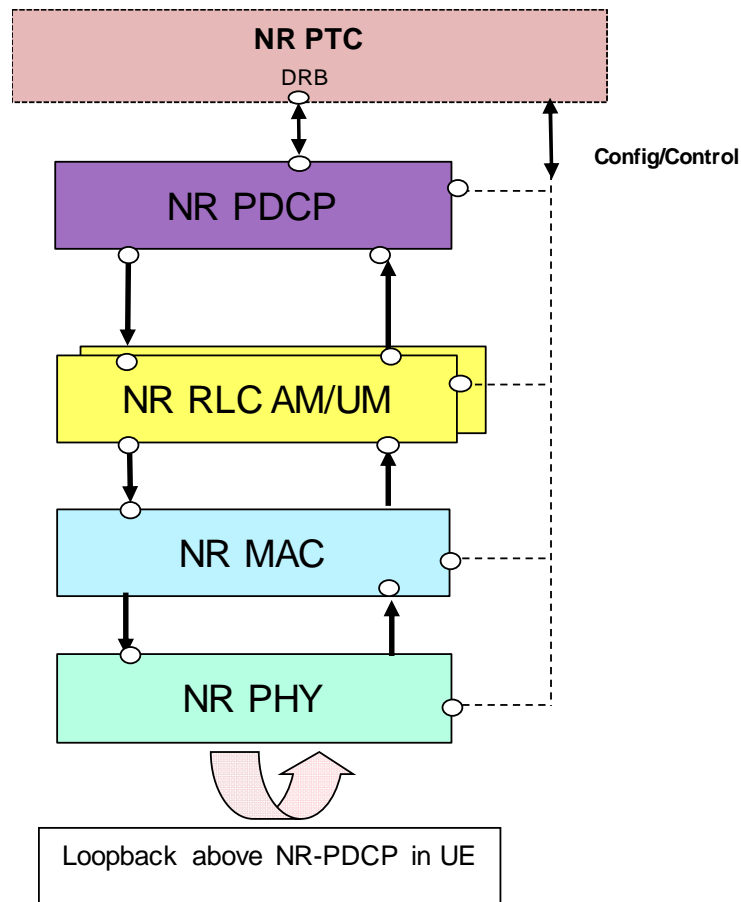

**Figure 5.2.2.2.1-1: Test model for NR/5GC PDCP testing**

The UE is configured in Test Loop Mode, to loop back the user domain data above PDCP layer. On UE side Ciphering is enabled as null algorithm and ROHC is not configured.

On the SS NR, Layer 1, MAC and RLC is configured in the normal operation.

The PDCP is configured in a special mode, where SS does not add any PDCP headers in DL and/or not remove any PDCP headers in UL directions respectively at DRB port on the NR PTC. The TTCN maintains sequence numbers and state variables for the PDCP layer.

The UL Scheduling Grant and DL Scheduling assignments are configured from TTCN over system control port. SS reports PUCCH scheduling information reception over system indication port, if configured.



5.2.2.2.2 NR dual connectivity

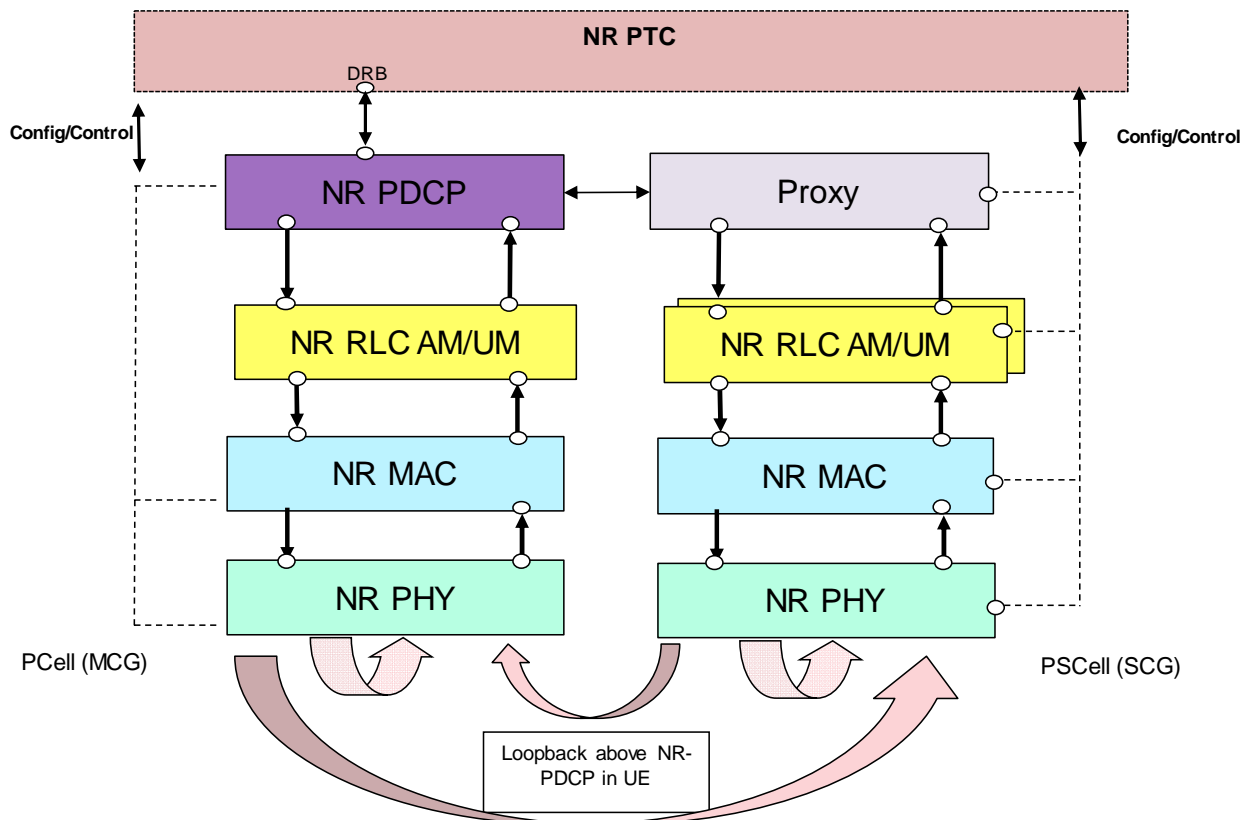

Figure 5.2.2.2-1: Test model for NR/5GC NR-DC PDCP testing (*split DRB*)

The UE is configured in Test Loop Mode, to loop back the user domain data above PDCP layer.

On UE side Ciphering is enabled as null algorithm and ROHC is not configured.

The SS configures in the First Cell, Layer 1, MAC and RLC in the normal operation. The NR PDCP is configured in a special mode, where SS does not add any PDCP headers in DL and/or not remove any PDCP headers in UL directions respectively at DRB port on the NR PTC. The TTCN maintains sequence numbers and state variables for the PDCP layer.

The SS configures in the Second Cell, Layer 1, MAC and RLC in the normal operation. The NR PDCP is configured as Proxy. DRB data will be sent between the NR PDCP Proxy and the NR PDCP.

Note that the First Cell refers to MCG PCell and the Second Cell to SCG PSCell, or viceversa.

The UL Scheduling Grant and DL Scheduling assignments are configured from TTCN over system control port. SS reports PUCCH scheduling information reception over system indication port, if configured.

5.2.2.3 RLC

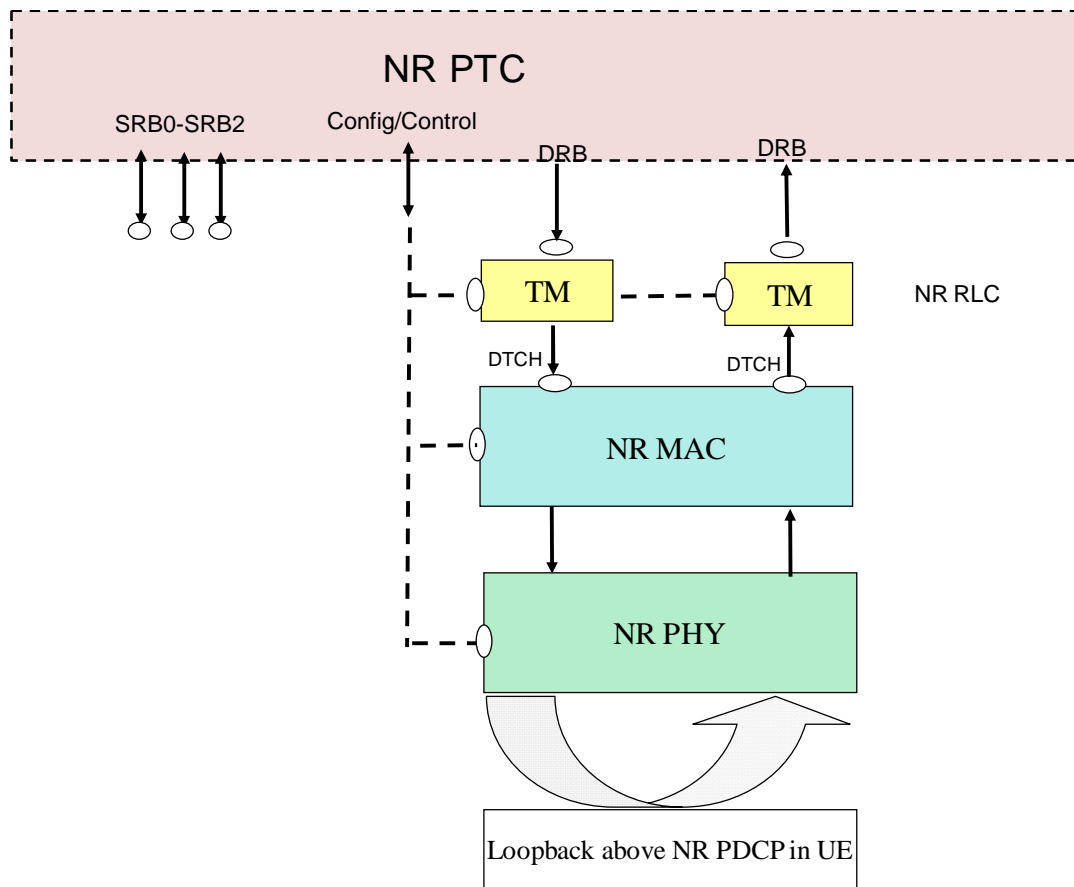

Figure 5.2.2.3-1: Test model for NR/5GC RLC testing

The UE is registered in NR, using SRBs 0-2, and configured for NR/5GC operation.

This model is suitable for testing both UM/AM mode of operation of DRBs on UE side.

The UE is configured in Test Loop Mode, to loop back the user domain data above PDCP layer. On UE side Ciphering is enabled (since mandatory) but with dummy ciphering algorithm, which is equivalent to not using ciphering. ROHC is not configured on UE Side.

On the SS Side, L1 and MAC are configured in the normal way. The RLC of the DRBs is configured in transparent mode. Hence with this configuration PDUs out of SS RLC are same as the SDUs in it. There is no PDCP configured on SS side. The ports are directly above RLC.

The PDUs, exchanged between TTCN and SS, shall be the final RLC PDUs consisting of RLC and PDCP headers. TTCN code shall take care in DL of building RLC headers and PDCP headers and in UL handle RLC and PDCP headers. TTCN code shall take care of maintaining sequence numbers and state variables for RLC and PDCP layers. If RLC on UE side is in AM mode, TTCN shall take care of generating polls in DL and responding with RLC control PDUs on reception of UL Poll.

## 5.2.2.4 MAC

## 5.2.2.4.1 Single NR carrier

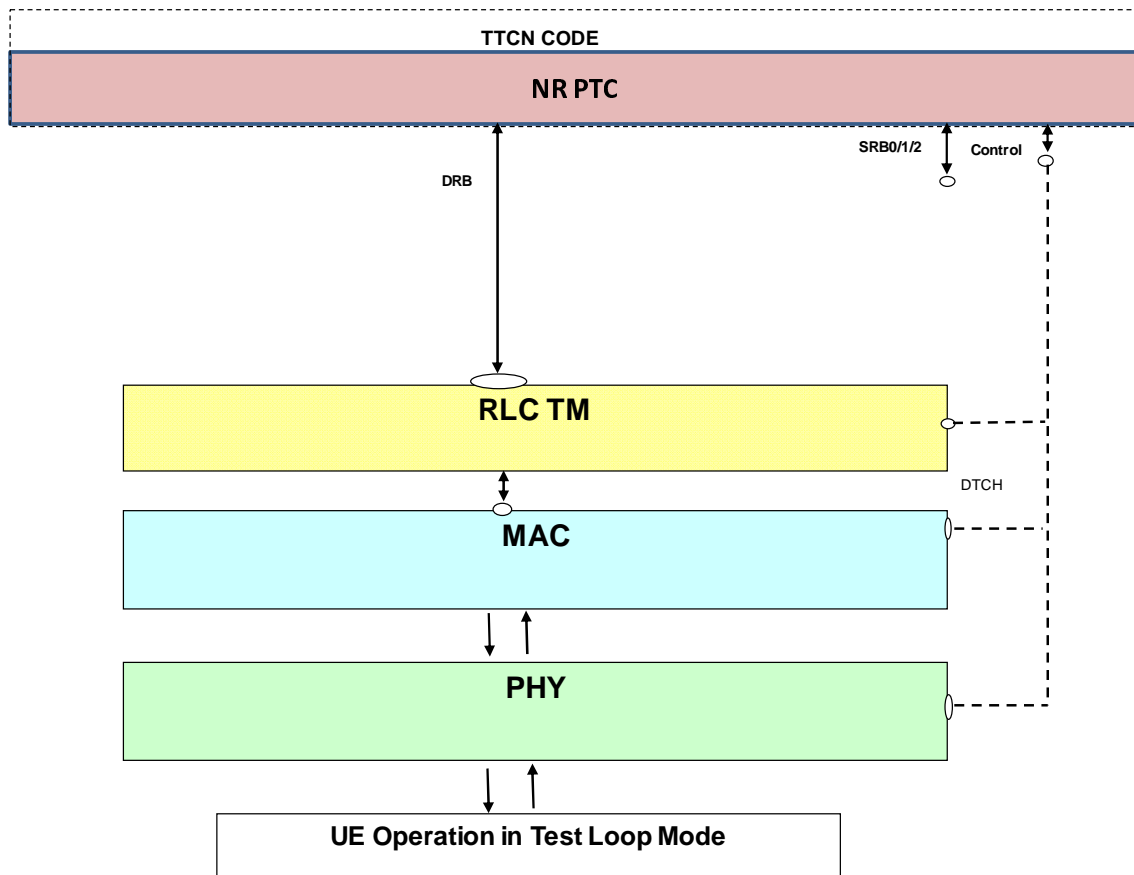

Figure 5.2.2.4.1-1: Test model for NR/5GC MAC testing

The UE is configured in Test Loop Mode A, to loop back the User Plane data above PDCP layer. On UE side Ciphering is enabled (since Mandatory) but with dummy ciphering algorithm, which is equivalent to not using ciphering. ROHC is not configured on UE Side.

On the SS Side the NR MAC test model expects no split bearers to be configured.

On the SS NR, Layer 1 is configured in the normal way. NR MAC is configured in a special mode, where it does not add any MAC headers in DL and /or not remove any MAC headers in UL directions respectively at DRB port. In this case, the TTCN shall provide the final MAC PDU, including padding. Except for this, the NR MAC layer shall perform all its other functions. SRBs are configured as in Layer 3 test model in normal operation.

On DRBs the NR RLC is configured in transparent mode. Hence with this configuration PDUs out of SS RLC are same as the SDUs in it. There is no NR PDCP and SDAP configured on SS Side. The ports are directly above NR RLC.

There are two different test modes in which NR MAC header addition/removal can be configured:

1. DL/UL header-transparent mode: no header addition in DL and no header removal in UL.
2. DL only header-transparent mode: no header addition in DL; UL NR MAC is configured in normal mode to remove MAC header and de-multiplex the MAC SDUs according to the logical channel Ids.

If SS NR MAC is configured in DL/UL header-transparent mode, the PDUs, exchanged at the DRB port between TTCN and SS, shall be the final MAC PDUs consisting of MAC, RLC and PDCP headers. TTCN code shall take care in DL of building MAC header, RLC headers and PDCP headers and in UL handle MAC, RLC and PDCP headers. TTCN code shall take care of maintaining sequence numbers and state variables for RLC and PDCP layers. During testing of multiple DRBs at the UE side, it shall still be possible to configure only one DRB on SS side with

configuration in the figure 5.2.2.4.1-1. Other DRBs will not be configured, to facilitate routing of UL MAC PDUs. Multiplexing/de-multiplexing of PDUs meant/from different DRBs shall be performed in TTCN. Since the MAC layer does not evaluate the MAC headers in UL it cannot distinguish between SRB and DRB data in UL. There shall be no SRB traffic while MAC is configured in this test mode. The SS MAC shall take care of automatic repetitions/retransmission in UL and DL, based on normal MAC HARQ behaviour.

NOTE: There is no need to handle SDAP headers in TTCN for UL/DL as UE Test loop Mode A is above PDCP.

If SS NR MAC is configured in DL only header-transparent mode, the UL PDUs exchanged at the DRB port between TTCN and SS shall be final RLC PDUs consisting of RLC and PDCP headers. SS shall route these PDUs based on logical channel IDs. In DL, TTCN sends fully encoded MAC PDUs at the DRB port (consisting of MAC, RLC and PDCP headers). In this case TTCN needs to take care of maintaining sequence numbers and state variables for RLC and PDCP layers. Furthermore, in UL and DL the SS MAC layer shall be capable of dealing with SRB data (i.e. it shall handle DL RLC PDUs coming from SRB RLC layers or de-multiplex UL RLC PDUs to SRB's) as in normal mode. The SS MAC shall take care of automatic repetitions/retransmissions in UL and DL, based on normal MAC HARQ behaviour. TTCN shall ensure that no DL MAC SDUs in normal mode and DL MAC PDUs in test mode are mixed for the same TTI.

The UL Scheduling Grant and DL Scheduling assignments are configured from TTCN over system control port. SS reports PUCCH scheduling information reception over system indication port, if configured. In a similar way the reception of PRACH preambles is reported by SS over the same port.

When SS is configured with *pusch-AggregationFactor* > 1 and SS NR MAC is configured in DL/UL header-transparent mode, SS shall handle UE automatic subsequent repetitions/retransmissions in UL on the same HARQ process according to TS 38.214[22] clause 6.1.2.1, and in addition SS shall transmit to TTCN every received UL HARQ transmission/retransmission within a bundle as separate MAC PDUs.

### 5.2.2.4.2 NR carrier aggregation

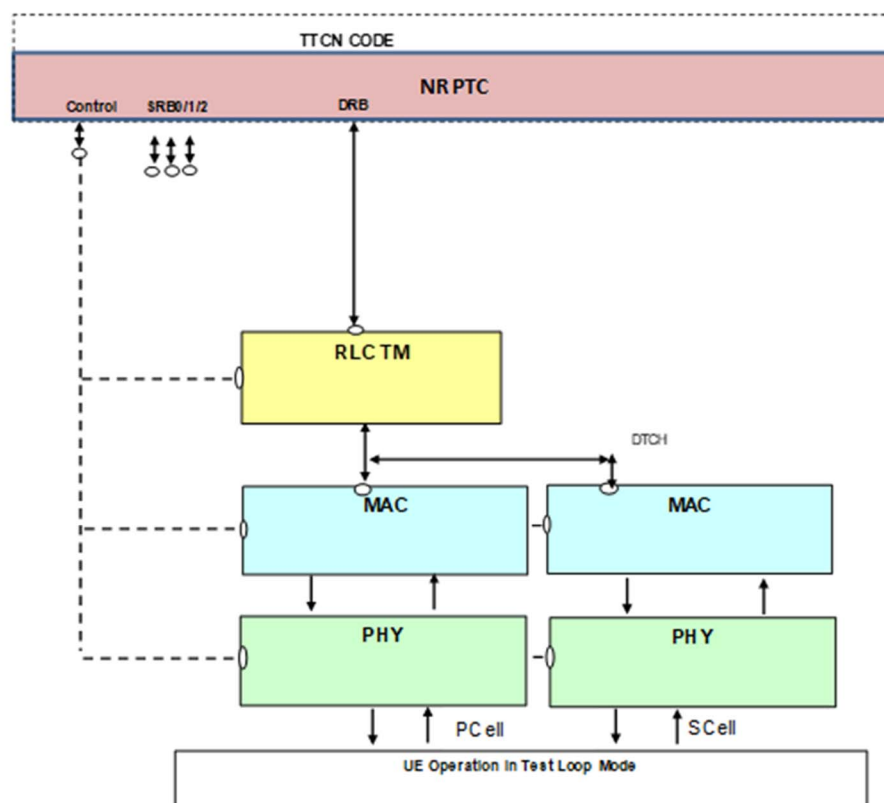

Figure 5.2.2.4.2-1: Test model for NR/5GC MAC CA testing

The NR/5GC MAC CA test model builds on top of the NR/5GC MAC test model, with the differences specified hereafter.

On the SS NR side, there is one PCell and one SCell configured:

- PCell only: On DRBs the NR RLC is configured in transparent mode. Hence with this configuration PDUs out of SS RLC are same as the SDUs in it. There is no NR PDCP and SDAP configured in the SS. The ports are directly above NR RLC.
- PCell / SCell: Layer 1 is configured in the normal way. NR MAC is configured in a special mode, where it does not add any MAC headers in DL and /or not remove any MAC headers in UL directions respectively at DRB port. In this case, the TTCN shall provide the final MAC PDU, including padding. Except for this, the MAC layer shall perform all of its other functions.

The UL Scheduling Grant and DL Scheduling assignments are configured from TTCN over system control port. SS reports PUCCH scheduling information reception in PCell over system indication port, if configured. In a similar way the reception of PRACH preambles in PCell / SCell is reported by SS over the same port, if configured.

---

## 6 System interface

### 6.1 Upper tester interface

The Upper Tester (UT) interface is the same as specified in TS 36.523-3 [12] clause 5.

In addition, the following AT commands are also applied in the TTCN.

**Table 6.1-1: AT Commands**

Command
AT+C5GNSSAI
AT+C5GNSSAIRDP
AT+C5GQOS
AT+CMICO

AT commands are referred to TS 27.007 [49].

### 6.2 Abstract system primitives

#### 6.2.1 Introduction

The present subclause 6.2 specifies the abstract system primitives (ASPs) used on the system interface to configure and control the SS.

#### 6.2.2 General requirements and assumptions

The requirements and assumptions specified in TS 36.523-3 [12] subclause 6.1 apply to the present document.

#### 6.2.3 E-UTRAN ASP definitions

Please refer to TS 36.523-3 [12] subclause 6.2.

#### 6.2.4 NR ASP definitions

See Annex D.

## 6.2.5 UTRAN ASP definitions

Please refer to TS 36.523-3 [12] subclause 6.3.

---

# 7 Test methods and design considerations

## 7.1 Common aspects

### 7.1.1 Introduction

Subclause 7.1 specifies test methods and design considerations that are common to all 5GS deployment options.

### 7.1.2 Physical layer aspects

#### 7.1.2.1 Search spaces and DCI

##### 7.1.2.1.1 Parameters

For each search space there are several parameters specifying the location of this search space in the time and frequency domain.

##### 7.1.2.2.1.1 Search space configuration

<b>PDCCH monitoring periodicity</b>	
<b>Comment/description</b>	slot periodicity in time domain
<b>ASN.1 parameter</b>	SearchSpace.monitoringSlotPeriodicityAndOffset
<b>Core spec reference</b>	TS 38.213 [21] clause 10.1
<b>PDCCH monitoring offset</b>	
<b>Comment/description</b>	slot offset
<b>ASN.1 parameter</b>	SearchSpace.monitoringSlotPeriodicityAndOffset
<b>Core spec reference</b>	TS 38.213 [21] clause 10.1
<b>PDCCH monitoring pattern</b>	
<b>Comment/description</b>	first symbol(s) of the control resource set within a slot for PDCCH monitoring; in general a search space starts with first symbol of a slot; the duration is given by the L1 parameter 'CORESET-time-duration'
<b>ASN.1 parameter</b>	SearchSpace.monitoringSymbolsWithinSlot
<b>Core spec reference</b>	TS 38.213 [21] clause 10.1
<b>CORESET time duration</b>	
<b>Comment/description</b>	Duration of a search space in time domain: 1, 2 or 3 symbols
<b>ASN.1 parameter</b>	ControlResourceSet.duration
<b>Core spec reference</b>	TS 38.213 [21] clause 10.1
<b>CORESET frequency domain allocation</b>	
<b>Comment/description</b>	Bitmap specifying the frequency domain allocation of a search space NOTE: The allocations needs to fit into the BWP to which the CORESET belongs
<b>ASN.1 parameter</b>	ControlResourceSet.frequencyDomainResources
<b>Core spec reference</b>	TS 38.213 [21] clause 10.1, TS 38.211 [19] clause 7.3.2.2

##### 7.1.2.1.2 PDCCH search spaces

For each configured DL BWP, the TTCN may configure one or several search spaces.

For each search space, TTCN configures the SS with:

- The configuration of this search space as given to the UE, enabling the SS to determine the PDCCH transmission occasions (same as the UE PDCCH monitoring occasions) and associated CORESET.  
For SearchSpaceZero the configuration according to TS 38.213 [21] clauses 10.1 and 13 is mapped to ASN.1 type SearchSpace to configure the SS; for CORESET#0 the configuration according to TS 38.211 [19] clause 7.3.2.2 is mapped to ASN.1 type ControlResourceSet to configure the SS.
- The CCE aggregation level  $L$  that the SS shall use for PDCCH transmission on this search space.  
In general an aggregation level of 4 is used for SearchSpaceZero, common and UE-specific search space.
- The priority  $P$  of this search space that the SS shall consider in its PDCCH candidate selection algorithm.
  - a value of 0 represents the highest priority, a value of 1 the second highest priority and so on.

NOTE: "Search space" is used in terms of TS 38.213 [21] clause 10.1 and a single search space configuration (ASN.1 type 'SearchSpace') may contain several search spaces (see NR\_BWP\_SearchSpaceConfig\_Type in Annex D).

### 7.1.2.1.3 DCI formats

#### 7.1.2.1.3.1 Introduction

The SS shall support several DCI formats. For each 5GS option, the set of DCI formats to support may be different (see relevant option-specific subclauses).

#### 7.1.2.1.3.2 Timing

The transmission of DCI formats may be explicitly requested from TTCN or semi-autonomously handled by the SS. In case of explicit request:

- If the associated timing information is explicit, the TTCN shall ensure that this timing information matches one of the configured PDCCH transmission occasions.
- If the associated timing information is now, the SS shall determine and use the next valid PDCCH transmission occasion.

#### 7.1.2.1.3.3 DAI

In the DCI formats to be used by the SS, TTCN may set the DAI fields explicitly or may configure the SS to set the DAI fields automatically. TTCN configures the DAI parameters in the SS according to one of the columns of Table 7.1.2.1.3.3-1.

**Table 7.1.2.1.3.3-1: DAI parameter settings**

DAI field \ HARQ-ACK Codebook type	Semi-static		Dynamic with 1 sub-codebook		Dynamic with 2 sub-codebooks	
	Explicit mode	Auto mode	Explicit mode	Auto mode	Explicit mode	Auto mode
DCI0_1 FirstDAI	Index	Automatic	Index	Automatic	Index	Automatic
DCI0_1 SecondDAI	None	None	None	None	Index	Automatic
DCI1_0 DAI	Index	Automatic	Index	Automatic	Index	Automatic
DCI1_1 DAI	None	None	Index	Automatic	Index	Automatic

When TTCN configures the SS to use the automatic mode, the SS shall:

- Create DL association/transmission set, according to the setting by TTCN of TimeDomain, PdschHarqTimingIndicator and PucchResourceIndicator for DCI formats 1\_x, their associated transmission timing information, and the set of serving cells configured, then
- Identify the need to multiplex a HARQ-ACK codebook into a PUSCH transmission according to above DL association/transmission set and the transmission timing information of received UL Grant(s), then

- Set the DAI fields in the DCI formats 1\_x and 0\_1 according to the above and the requirements on DAI values specified in TS 38.213 [21] subclause 9.1.2 for semi-static HARQ-ACK Codebook or subclause 9.1.3 for dynamic HARQ-ACK Codebook.

#### 7.1.2.1.4 PDCCH candidate selection

The SS shall consider search space priorities as configured by TTCN to find appropriate PDCCH candidates for scheduling of DCI formats in case of:

- a) Overlapping search spaces:
  - Depending on system configuration and slot number candidates of the different search spaces may be located in same (or overlapping) CCEs.
  - Example: system information is automatically scheduled by the SS and UE-specific data transmission requires scheduling of PDCCH for the same slot and symbols

=> Candidates of the UE-specific search space may collide with actual PDCCH of a common search space (e.g. system information).
- b) Within a search space if different search space types are mapped to the same search space configuration.

For every PDCCH assignment (in terms of TS 38.213 [21] clause 10.1) the SS shall apply the PDCCH candidate selection algorithm specified hereafter:

- 1) For each search space the SS selects the PDCCH candidate with index  $m(\text{search space}, L) = 0$

With (see TS 38.213 [21] subclause 10.1):

- candidate index  $m(\text{search space}, L) := 0 .. M(\text{search space}, L) - 1$ ;
  - $M(\text{search space}, L)$ : number of PDCCH candidates per CCE aggregation level for the given search space;
  - $L$ : CCE aggregation level
- 2) If there is an overlapping of the selected candidates, the SS shall:
    - keep the PDCCH candidate of the search space with higher priority  $P$ ,
    - increment  $m$  for the search space with lower priority;
  - 3) The SS shall repeat 2) until there is no overlapping anymore.

In the following cases the SS shall raise an error:

- i) Collision of PDCCH candidates of search spaces with the same priority,
- ii) When a DL transmission or a single UL grant is scheduled with specific TimingInfo and after applying the above rules there is no PDCCH candidate left anymore.  
NOTE: For TimingInfo 'Now' there is no error as the SS can shift the transmission to the next PDCCH occasion

In case of continuous UL grant configuration, the SS shall not raise an error when a grant cannot be scheduled at a specific point in time but skip it, if the grant is configured to be at every occasion, or shift it to the next occasion otherwise.

#### 7.1.2.2 Downlink resource allocation

##### 7.1.2.2.1 Parameters

There are several parameters specifying the resource allocation on PDCCH (see subclause 7.1.2.2.1.1) and PDSCH for a DL transmission. The following sub-clauses summarise the parameters being most relevant for downlink resource allocation from the test model's point of view.



## 7.1.2.2.1.1 Time domain resource allocation

For time domain resource allocation, either a default PDSCH time domain allocation according to TS 38.214 [22] clause 5.1.2.1.1 is applied or a table (pdsch-AllocationList) is configured via RRC signalling (pdsch-ConfigCommon.pdsch-TimeDomainAllocationList or pdsch-Config.pdsch-TimeDomainAllocationList, see TS 38.331 [16]). This table corresponds to L1 parameter “pdsch-AllocationList” and the entries are referred to by DCI.

pdsch-AllocationList has the following fields:

<b>PDSCH slot offset (<math>K_0</math>)</b>	
<b>Comment/description</b>	Slot offset of PDSCH transmission based on the corresponding PDCCH transmission (DCI) Assuming the same numerology for PDSCH and PDCCH: $K_0 = 0$ PDCCH and corresponding PDSCH transmission are in the same slot $K_0 > 0$ PDCCH and corresponding PDSCH transmission are in different slots
<b>ASN.1 parameter</b>	PDSCH-TimeDomainResourceAllocation.k0
<b>Core spec reference</b>	TS 38.214 [22] clause 5.1.2.1
<b>PDSCH mapping type</b>	
<b>Comment/description</b>	PDSCH mapping type A or B NOTE: In general - at least for early releases - type A is expected to be used by conformance testing (Type B seems to be intended for mini-slots)
<b>ASN.1 parameter</b>	PDSCH-TimeDomainResourceAllocation.mappingType
<b>Core spec reference</b>	TS 38.214 [22] clause 5.1.2.1
<b>Start and length indicator (SLIV)</b>	
<b>Comment/description</b>	The SLIV specifies the starting symbol (S) and the number of symbols (L) of the PDSCH resource assignment according to TS 38.214 [22] clause 5.1.2.1; valid start/length combinations depend on the PDSCH mapping type
<b>ASN.1 parameter</b>	PDSCH-TimeDomainResourceAllocation.startSymbolAndLength
<b>Core spec reference</b>	TS 38.214 [22] clause 5.1.2.1

## 7.1.2.2.1.2 Frequency domain resource allocation configured at the UE via RRC signalling

<b>Resource allocation type</b>	
<b>Comment/description</b>	Specifies the format of the frequency domain resource assignment field of DCI format 1_1 (resource allocation type 0, resource allocation type 1 or both) NOTE: for DCI format 1_0 this parameter seems to be not relevant.
<b>ASN.1 parameter</b>	PDSCH-Config.resourceAllocation
<b>Core spec reference</b>	TS 38.212 [20] clause 7.3.1.2.2

## 7.1.2.2.1.3 DCI parameters

<b>Frequency domain resource assignment</b>	
<b>Comment/description</b>	Resource allocation type 0: bitmap indicating resource block groups (RBGs) being allocated to the UE Resource allocation type 1: resource indication value (RIV) indicating start and length of a set of contiguously allocated resource blocks NOTE: for DCI format 1_0 only resource allocation type 1 is applicable (according to TS 38.214 [22] clause 5.1.2.2)
<b>Core spec reference</b>	TS 38.212 [20] clauses 7.3.1.2.1 and 7.3.1.2.2, TS 38.214 [22] clause 5.1.2.2
<b>Time domain resource assignment</b>	
<b>Comment/description</b>	Index addressing pre-configured time domain resource allocation (see clause 7.1.2.2.1.1)
<b>Core spec reference</b>	TS 38.212 [20] clauses 7.3.1.2.1 and 7.3.1.2.2
<b>VRB-to-PRB mapping</b>	
<b>Comment/description</b>	To distinguish non-interleaved and interleaved allocation of virtual resource blocks in case of resource allocation type 1
<b>Core spec reference</b>	TS 38.212 [20] clauses 7.3.1.2.1 and 7.3.1.2.2, TS 38.214 [22] clause 5.1.2.2
<b>Modulation and coding scheme (MCS)</b>	
<b>Comment/description</b>	Modulation and coding scheme according to TS 38.214 [22] clause 5.1.3: The DCI provides the MCS index ( $I_{MCS}$ ) which refers to the respective tables in clause 5.1.3.1 of TS 38.214 [22]
<b>Core spec reference</b>	TS 38.212 [20] clauses 7.3.1.2.1 and 7.3.1.2.2, TS 38.214 [22] clause 5.1.3
<b>Antenna port configuration</b>	

<b>Comment/description</b>	Configuration of antenna port(s) according to tables 7.3.1.2.2-1/2/3/4 of TS 38.212 [20] for DCI format 1_1: Specifies the number of CDM groups without data and the antenna ports being used for a transmission. The number of CDM groups affects the number of REs which cannot be used for PDSCH transmission according to step 1 of clause 5.1.3.2 in TS 38.214 [22]. The number of antenna ports being used for the DL transmission corresponds to the number of layers $\nu$ being used for the respective transport block transmission (1, 2, 3 or 4 layers per transport block). DCI format 1_0 does not have any field for antenna port configuration: TS 38.214 [22] clause 5.1.6.2 specifies that in general the UE shall assume 2 CDM groups i.e. there are no REs available for PDSCH transmission in any symbol where DMRS is sent. Regarding the number of layers $\nu=1$ is assumed for PDSCH transmissions scheduled with DCI format 1_0
<b>Core spec reference</b>	TS 38.212 [20] clauses 7.3.1.2.2, TS 38.214 [22] clause 5.1.3, TS 38.211 [19] clause 7.3.1.3/4

### 7.1.2.2.2 Timing

The timing information provided by the request ASP for a DL transmission specifies the slot in which the DCI on PDCCH is transmitted scheduling the corresponding PDSCH transmission. The exact timing of the PDSCH transmission is depending on the parameters for time domain resource allocation as described in the previous clause. If the timing information specifies a specific slot it is up to TTCN that an appropriate search space is configured for this slot. The SS shall not schedule the DL transmission otherwise and may raise an error.

In case of TimingInfo indicating “Now” or “Any slot” it is up to the SS to find the appropriate slot for scheduling of the DCI. The SS shall not use slots in which SS/PBCH blocks are scheduled.

NOTE: The restriction for slots containing SS/PBCH can be removed when there is clarification in core specs (e.g. TS 38.214 [22]) how “rate matching around” SS/PBCH blocks is reflected in the calculation of the transport block size (see clause 7.1.2.2.4).

In case of TimingInfo not being “Now” TTCN shall ensure that the data is scheduled at least 100ms in advance. Furthermore, it is up to the test case prose to avoid any overlapping of PDSCH and PDCCH transmissions in time domain and it is up to TTCN implementation to address an appropriate slot for which the TBS size determination is well-defined according to clause 7.1.2.2.4; the SS shall raise an error otherwise.

When SS is configured with *pdsch-AggregationFactor*, SS shall repeat PDSCH data on the same HARQ process automatically in *pdsch-AggregationFactor* consecutive slots. As according to TS 38.214[22] clause 5.1.2.1, for any of the consecutive slots, if at least one symbol from a set of symbols where SS schedules PDSCH transmission in the slot is an uplink symbol, then SS shall skip transmission in that slot.

Figures 7.1.2.2.2-1 and 7.1.2.2.2-2 illustrate the timing for  $K_0 = 0$  and  $K_0 > 0$ .

pdsch-symbolAllocation pre-configured at the UE:

Index	$K_0$	Mapping type	SLIV
...	...	...	...
i	0	A	58
...	...	...	...

DCI:  
Time domain resource assignment = i

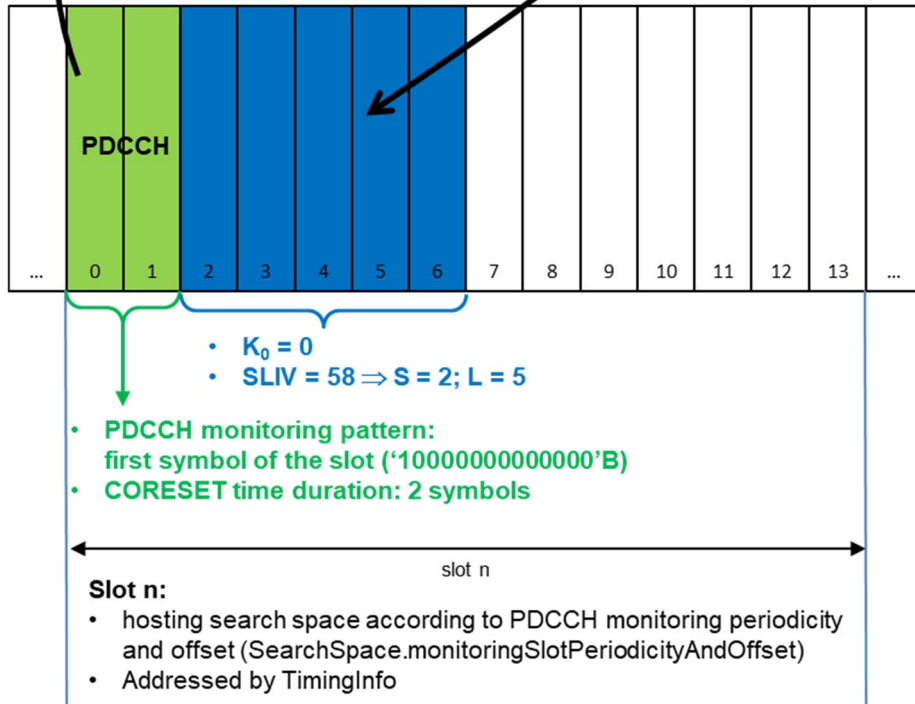
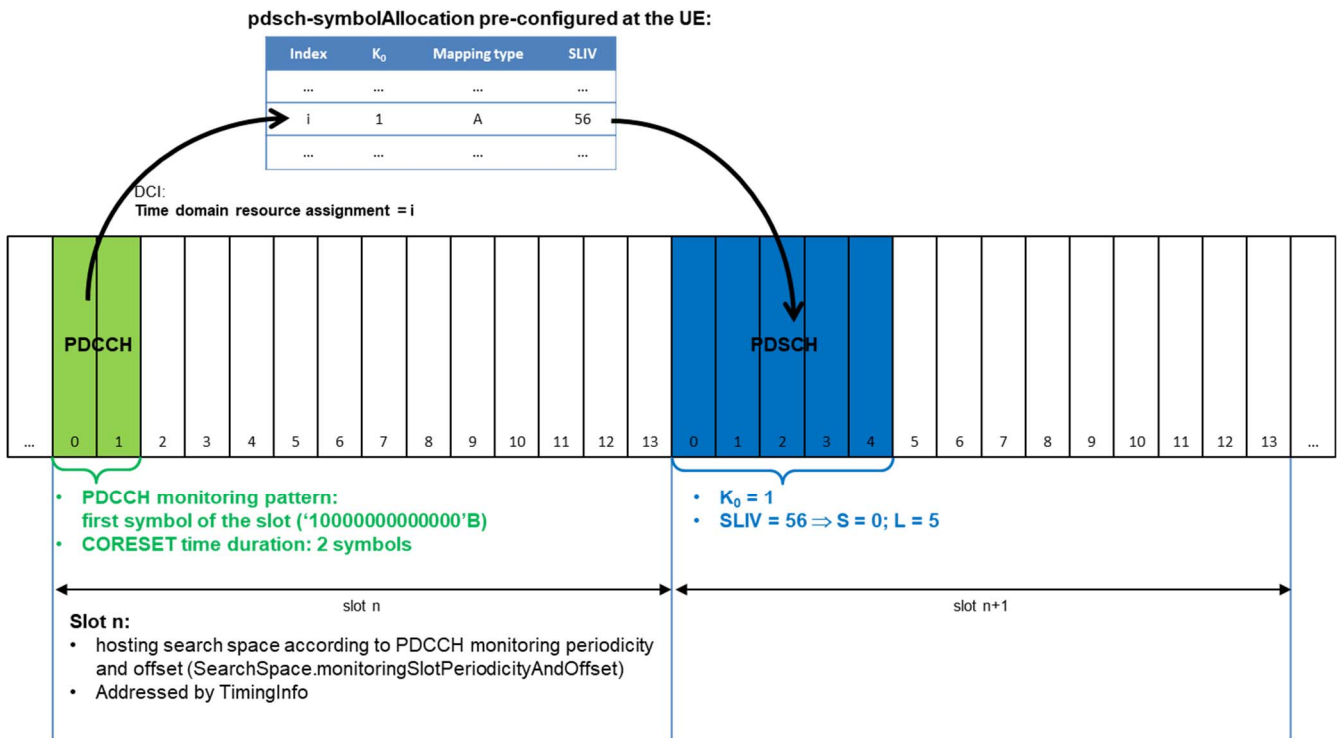

Figure 7.1.2.2.2-1: Example for time domain resource allocation for  $K_0 = 0$



**Figure 7.1.2.2-2: Example for time domain resource allocation for  $K_0 > 0$**

### 7.1.2.2.3 DL scheduling scheme

Different kinds of PDSCH transmissions need to be scheduled:

- System information (SI: SIB1 and other system information)
- Paging
- Random access response (RAR)
- DCCH/DTCH transmissions

The scheduling needs to be done so that there is no overlapping in frequency or time domain.

In general there are different ways to do the scheduling:

- a) Multiplexing in frequency domain of a single BWP
- b) Multiplexing in time domain of a single BWP (at slot or at symbol level)
- c) Use of different BWPs: e.g. initial BWP for SI, RAR, Paging + dedicated BWP for DCCH/DTCH
- d) Combinations of the above

In frequency domain the different kinds of PDSCH transmissions may use different resource allocation types (TS 38.214 [22] clause 5.1.2.2):

- Resource allocation (RA) type 0: Bitmap-based allocation of Resource Block Groups (RBGs): Applicable only for DCI format 1\_1  $\Rightarrow$  not applicable for scheduling of SI, Paging and RAR
- Resource allocation (RA) type 1, non-interleaved: continuous allocation of RBs with one-by-one mapping of virtual resource blocks (VRBs) to physical resource blocks (PRBs).
- Resource allocation (RA) type 1, interleaved: continuous allocation of RBs with interleaved VRB-to-PRB mapping according to TS 38.211 [19] clause 6.3.1.7.

### 7.1.2.2.3.1 DL scheduling scheme: Frequency domain multiplexing, RA type1, non-interleaved

This scheduling scheme multiplexes the different kinds of PDSCH transmissions in the frequency domain of a single BWP by exclusively using resource allocation type 1 with non-interleaved VRB-to-PRB mapping. Assuming the resource blocks being numbered from 0 to  $N_{\text{BWP}}-1$  (with  $N_{\text{BWP}}$  being the size of the BWP) the following allocation is done:

**Table 7.1.2.2.3.1-1: Resource allocation for frequency domain multiplexing, RA type1, non-interleaved**

Kind of PDSCH transmission (Note 1)	CORESET#	SSB index of the cell (Note 4)	Resource block allocation (Note 2)	
			RB <sub>start</sub> (Note 2)	L <sub>RBs,max</sub> (Note 2)
System information	0	SSB#1	0	7
		SSB#0	$N_{\text{BWP}}-7$	7
Paging (Note 3)	0	SSB#1	7	$N_{\text{BWP}}-7$
		SSB#0	0	$N_{\text{BWP}}-7$
Random access response (Note 3)	0	SSB#1	7	$N_{\text{BWP}}-7$
		SSB#0	0	$N_{\text{BWP}}-7$
CCCH and DCCH transmission on CSS (Note 3)	0	SSB#1	7	$N_{\text{BWP}}-7$
		SSB#0	0	$N_{\text{BWP}}-7$
DCCH/DTCH transmissions (Note 3)	1	SSB#1	7+ Offset Carrier CORESET#0 [RBs] (Note 5)	$N_{\text{BWP}}-7$
		SSB#0	0	$N_{\text{BWP}}-7$

NOTE 1: In context of a generic 5G test model it is not relevant whether or not there is SI and Paging for a given deployment option (e.g. EN-DC).

NOTE 2:  $L_{\text{RBs}} \leq L_{\text{RBs,max}}$  with  $L_{\text{RBs}}$ : number of resource blocks being eventually used for a particular transmission.  $L_{\text{RBs}}$  and  $\text{RB}_{\text{start}}$  are as specified in TS 38.214 [22] subclause 5.1.2.2.2.

NOTE 3: In general Paging, Random access response and CCCH/DCCH/DTCH transmissions are mutual exclusive and therefore share the same allocation.

NOTE 4: The SSB index used by an NR Cell is specified in TS 38.508-1 [5] Table 4.4.2-2.

NOTE 5: Offset Carrier CORESET#0 [RBs] values are specified in the frequency tables in TS 38.508-1 [5].

In order to achieve a test case behaviour being independent from the frequency channel bandwidth  $N_{\text{BWP}}$  is limited to the minimum value of 24 RBs in accordance to Table 5.3.2-1 of TS 38.101-1/2 [5, 6]. This implies that  $L_{\text{RBs,max}} < 24$  RBs for all configurations.

In general PDCCH and corresponding PDSCH transmissions are in the same slot ( $K_0 = 0$ ).

### 7.1.2.2.4 Transport block size determination

TS 38.214 [22] clause 5.1.3.2 describes the transport block size (TBS) determination from the UE's point of view: the UE calculates the TBS depending on several parameters. From a test model's point of view appropriate values need to be found for the parameters to achieve a given TBS.

There are two modes specified for DL scheduling:

- automatic mode
- explicit mode

In explicit mode all parameters for the TBS determination are provided by TTCN, i.e. it is up to the TTCN implementation to find proper values. In automatic mode TTCN only provides  $\text{RB}_{\text{start}}$  and  $L_{\text{RBs,max}}$  and it is up to the SS to determine the values of  $L_{\text{RBs}}$  and  $I_{\text{MCS}}$  to achieve the TBS which is needed for a particular DL transmission.

The SS shall apply the rules as described in clause 7.1.2.2.4.2.

#### 7.1.2.2.4.1 Parameters affecting TBS determination

The following parameters need to be considered for TBS determination:

Table 7.1.2.2.4.1-1: Parameters affecting TBS determination

Parameter	Comment/Description	Reference
Number of RBs in frequency domain	Indicated by DCI	Clause 7.1.2.2.1.3
Number of symbols in time domain	Pre-configured at UE, selected by DCI; corresponds to "PDSCH duration" TS 38.211 [19] clause 7.4.1.1.2	Clause 7.1.2.2.1.1
MCS index $I_{MCS}$	Indicated by DCI: Modulation Order $Q_m$ , Target code Rate $R$	Clause 7.1.2.2.1.3; TS 38.214 [22] Table 5.1.3.1-1 and 5.1.3.1-2
Number of layers $\nu$	The number of layers being used for transmission of a transport block can be derived from the antenna port configuration provided by DCI format 1_1 taking into account the layer mapping according to TS 38.211 clause 7.3.1.3. For DCI format 1_1 in general $\nu = 1$ according to TS 38.508-1 [5] Table 4.3.6.1.2.2-1. For DCI format 1_0 $\nu = 1$ is assumed (in accordance to TS 38.214 [22] clause 5.1.6.2 specifying antenna port 1000 to be used for DMRS).	TS 38.214 [22] clause 5.1.1.1 and 5.1.6.2, TS 38.211 [19] clause 7.3.1.4, TS 38.212 [20] clause 7.3.1.2.2 and tables 7.3.1.2.2-1/2/3/4
PDSCH mcs-Table	Pre-configured at the UE via RRC signalling: PDSCH-Config.mcs-Table := {qam64, qam256}; indicates which MCS table to be applied when DL transmission is scheduled with C-RNTI NOTE: qam256 is applicable only when DCI format 1_1 is used.	TS 38.214 [22] clause 5.1.3.1
Number of REs per PRB	Number of REs per PRB which are applicable for the PDSCH transmission	Table 7.1.2.2.4.1-2
Rate matching	TS 38.214 [22] clause 5.1.3.2 does not specify how rate matching needs to be considered for TBS determination ⇒ at least for early implementations slots containing SS/PBCH block transmission shall not be used for PDSCH transmissions and further rate matching is assumed not to be configured via RRC signalling	TS 38.214 [22] clause 5.1.4

**Table 7.1.2.2.4.1-2: Parameters affecting number of REs allocated for PDSCH per PRB**

Parameter	Comment/Description	Reference
PDSCH mapping type	Type A or B	Clause 7.1.2.2.1.1; TS 38.211 [19] clause 7.4.1.1.2
dmrs-Type	DMRS Configuration type 1 or 2 as indicated to the UE by DMRS-DownlinkConfig.dmrs-Type	TS 38.211 [19] clause 7.4.1.1.2
dmrs-AdditionalPosition	Number of additional DMRS positions: For DCI format 1_1 as indicated to the UE by DMRS-DownlinkConfig.dmrs-AdditionalPosition 0, 1, 2 or 3 additional positions. For DCI format 1_0 according to TS 38.214 [22] clause 5.1.6.2 the UE shall assume dmrs-AdditionalPosition='pos2'	TS 38.211 [19] clause 7.4.1.1.2 and tables 7.4.1.1.2-3/4
maxLength	Number of OFDM symbols used for DMRS: For DCI format 1_1 as indicated to the UE by DMRS-DownlinkConfig.maxLength: Single or double symbol DM-RS. For DCI format 1_0 according to TS 38.214 [22] clause 5.1.6.2 single symbol DM-RS is applied.	TS 38.211 [19] clause 7.4.1.1.2 and table 7.4.1.1.2-5
number of CDM groups without data	The maximum number of CDM groups without data depends on the DMRS Configuration type (dmrs-Type): type 1: up to 2 CDM groups (TS 38.211 [19] Table 7.4.1.1.2-1) type 2: up to 3 CDM groups (TS 38.211 [19] Table 7.4.1.1.2-2)  For DCI format 1_1 the number of CDM groups without data for a single transmission is determined by the antenna port configuration provided in the DCI (TS 38.212 [20] tables 7.3.1.2.2-1/2/3/4)  For DCI format 1_0 according to TS 38.214 [22] clause 5.1.6.2 for mapping type A and PDSCH duration > 2 the UE shall assume that the number of DM-RS CDM groups without data is 2 (what results in PDSCH not being present in any symbol carrying DM-RS)	TS 38.211 [19] clause 7.4.1.1.2, TS 38.212 [20] clause 7.3.1.2.2 and tables 7.3.1.2.2-1/2/3/4, TS 38.214 [22] clause 5.1.3.2 and 5.1.6.2
xOverhead	Number of REs used for additional overhead as indicated to the UE by PDSCH-ServingCellConfig.xOverhead: 0, 6, 12, 18 REs	TS 38.214 [22] clause 5.1.3.2
PDSCH duration	Number of symbols allocated for the PDSCH transmission	Clause 7.1.2.2.1.1

Table 7.1.2.2.4.1-3 gives examples for the position of DMRS within a resource block depending on different parameters, with DMRS CDM group 0 shown in blue and DMRS CDM group 1 (if any) shown in green. For DCI format 1\_0 and PDSCH mapping type A the UE assumes both CDM groups to be used; for DCI format 1\_1 the number of DMRS CDM groups without data depends on the antenna port configuration of the DCI: In case of dmrs-Type=1, maxLength=1 and only one code word TS 38.212 [20] table 7.3.1.2.2-1 is applied and '0000'B (as specified in TS 38.508-1 [5] table 4.3.6.1.2.2-1) corresponds one DRMS CDM group at port 1000 which results in the REs shown in blue.

**Table 7.1.2.2.4.1-3: Examples for the position of DMRS in an RB with PDSCH mapping type A, DMRS configuration type 1, maxLength=1, dmrs-AdditionalPosition=2**

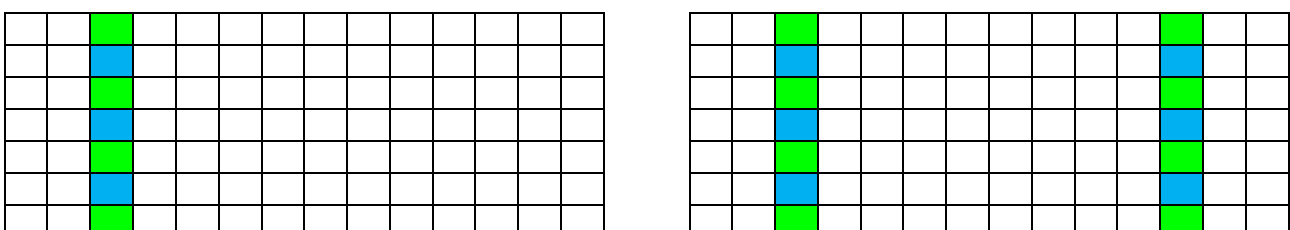

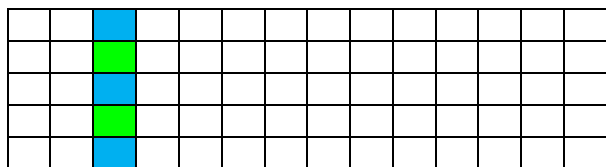

**DL-DMRS-add-pos = 0:**  
 $k = 4n + 2k' + \Delta; k' = 0, 1; \Delta = 0, 1$   
 $l_0 = 2$

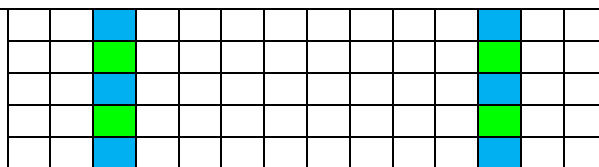

**DL-DMRS-add-pos = 1, PDSCH duration = 13, 14:**  
 $k = 4n + 2k' + \Delta; k' = 0, 1; \Delta = 0, 1$   
 $l_0 = 2, l_1 = 11$

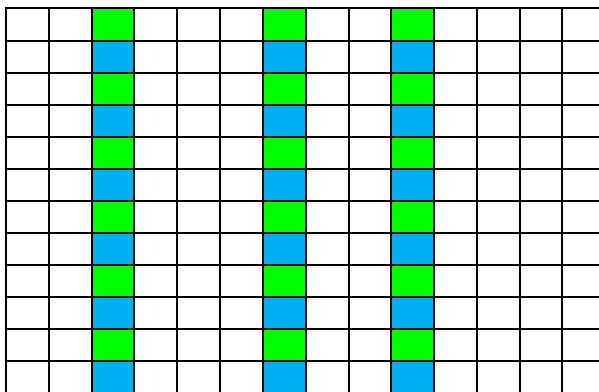

**DL-DMRS-add-pos = 2, PDSCH duration = 10, 11, 12:**  
 $k = 4n + 2k' + \Delta; k' = 0, 1; \Delta = 0, 1$   
 $l_0 = 2, l_1 = 6, l_2 = 9$

For PDSCH mapping type A and single-symbol DMRS according to TS 38.211 [19] Table 7.4.1.1.2-3 the number  $N_{\text{Symbols with DMRS}}$  of symbols with DMRS per resource block is as shown in table 7.1.2.2.4.1-4.

**Table 7.1.2.2.4.1-4: Number of symbols with DMRS per resource block**

PDSCH duration	dmrs-AdditionalPosition			
	0	1	2	3
2	1	1	1	1
3				
4				
5				
6		2	2	2
7				
8			3	3
9				
10				
11			4	
12				
13				
14				

Assuming DMRS configuration type 1, maxLength=1, Xoh-PDSCH=0 and no rate matching, depending on the number of CDM groups without data, this results in the number of REs for DMRS per PRB including the overhead of the DMRS CDM groups without data as shown in Table 7.1.2.2.4.1-5.



**Table 7.1.2.2.4.1-5: Number of REs for DMRS per PRB including the overhead of the DMRS CDM groups without data for DMRS configuration type 1, maxLength=1, Xoh-PDSCH=0, no rate matching**

	dmrs-AdditionalPosition	PDSCH duration	Number of REs for DMRS	
DCI format 1_1 indicating one DMRS CDM group without data according to TS 38.212 [20] Table 7.3.1.2.2-1	0 (NOTE 1)	any	6	$6 * N_{\text{Symbols with DMRS}}$
	1 (NOTE 1)	< 8	6	
		$\geq 8$	12	
DCI format 1_0	2 (NOTE 2)	< 8	12	$12 * N_{\text{Symbols with DMRS}}$
		8, 9	24	
		> 9	36	
NOTE 1: TS 38.508-1 [5] table 4.6.3-36 specifies pos0 or pos1				
NOTE 2: pos2 for DCI format 1_0 according to TS 38.214 clause 5.1.6.2				

#### 7.1.2.2.4.2 Automatic mode - Determination of TBS and corresponding $L_{\text{RBs}}$ and $I_{\text{MCS}}$

In automatic mode, for each PDSCH transmission, the SS shall autonomously select a TBS and a  $L_{\text{RBs}} / I_{\text{MCS}}$  pair for this TBS.

Common requirements for TBS determination:

The SS shall follow the below rules to determine the TBS for a PDSCH transmission:

- The SS shall maximise the data being sent in a single transmission (i.e. the SS shall not do RLC segmentation without need);
- The SS shall minimise padding (i.e. the SS shall not use a TBS greater than needed);
- If the maximum TBS for a given configuration is not sufficient to carry all data then:
  - if the RLC layer configuration at the SS allows segmentation for the given bearer then:
    - the SS shall apply RLC segmentation with minimised number of segments;
  - else:
    - the SS shall raise an error.

$L_{\text{RBs}} / I_{\text{MCS}}$  pair determination:

Using the selected TBS, the SS shall apply the following rules:

- When the TBS can be achieved with more than one  $L_{\text{RBs}} / I_{\text{MCS}}$  pairs the SS shall choose the  $L_{\text{RBs}} / I_{\text{MCS}}$  pairs with maximum  $L_{\text{RBs}}$ ;
- When there is more than one  $L_{\text{RBs}} / I_{\text{MCS}}$  pair with maximum  $L_{\text{RBs}}$  the pair with minimum  $I_{\text{MCS}}$  shall be chosen.

The SS implementation shall comply to the above requirements and be based on the following assumptions (unless stated otherwise for a specific table):

- Number of layers  $v = 1$
- PDSCH mapping type A
- dmrs-Type: type1
- maxLength: single symbol DM-RS
- xOverhead = 0

Further details are left up to SS implementation.

#### 7.1.2.2.4.3 Explicit mode - Determination of $I_{MCS}$ and $L_{RBs}$ for given TBS

In explicit mode, for a PDSCH scheduled by a PDCCH with CRC scrambled by C-RNTI, it is up to the TTCN to determine the values of  $I_{MCS}$  and  $L_{RBs}$  to achieve the TBS specified in a test case prose.

Annex B.1 may be used to select a valid pair of  $\{L_{RBs}, I_{MCS}\}$ . The NR TBS table to be used is based on the TS 38.508-1 [5] default configurations outlined in Tables 7.1.2.2.4.3-1 and 7.1.2.2.4.3-2 below.

**Table 7.1.2.2.4.3-1: TS 38.508-1 [5] default configurations for DCI format 1\_0 affecting DL scheduling**

Parameter	Value	Reference(s)
MCS index table	table 5.1.3.1-1 (MCS index table 1)	TS 38.214 [22] clause 5.1.3.1 with DCI format 1_0
dmrs-AdditionalPosition	2	Table 7.1.2.2.4.1-2 with DCI format 1_0
number of CDM groups	2	Table 7.1.2.2.4.1-2 with DCI format 1_0, mapping type A and PDSCH duration > 2
PDSCH duration	12 (mapping type A)	TS 38.508-1 [5] Tables 4.6.3-76 ( <i>PDSCH-ConfigCommon</i> ) and 4.6.3-78 ( <i>PDSCH-TimeDomainResourceAllocationList</i> ) and DCI format with "Time domain resource assignment"=0

**Table 7.1.2.2.4.3-2: TS 38.508-1 [5] default configurations for DCI format 1\_1 affecting DL scheduling**

Parameter	Value	Reference(s)
MCS index table	table 5.1.3.1-1 (MCS index table 1)	TS 38.214 [22] clause 5.1.3.1 with DCI format 1_1 and mcs-Table=qam64 as according to TS 38.508-1 [5] Tables 4.6.3-75
dmrs-AdditionalPosition	1 (FR1) 0 (FR2)	TS 38.508-1 [5] Table 4.6.3-36 (DMRS-DownlinkConfig)
number of CDM groups	1	according to antenna port configuration (TS 38.508-1 [5] Table 4.3.6.1.2.2-1)
PDSCH duration	12 (mapping type A)	TS 38.508-1 [5] Tables 4.6.3-76 ( <i>PDSCH-ConfigCommon</i> ) and 4.6.3-78 ( <i>PDSCH-TimeDomainResourceAllocationList</i> ) and DCI format with "Time domain resource assignment"=0

### 7.1.2.3 Uplink grant

#### 7.1.2.3.1 General principles and grant allocation types

Uplink grants assignments for NR follow similar principles as for LTE (TS 36.523-3 [12] clause 7.2).

##### 7.1.2.3.1.1 PUCCH synchronisation in connected mode

To prevent the UE from doing RACH procedure for purpose of PUCCH synchronisation the SS gets configured to maintain PUCCH synchronisation at UE by periodically sending a MAC PDU containing the MAC control element 'Timing Advance Command'. The period as configured by TTCN is set to 80 % of the '*timeAlignmentTimer*' value configured at UE.

As in general the PUCCH synchronisation is not time critical, the SS shall choose the next possible occasion for sending of the Timing Advance Command from expiry of the period onward (i.e. the SS shall not raise an error when sending of the Timing Advance Command is not possible at the calculated end of the period).

##### 7.1.2.3.1.2 Grant allocation types

In general PUCCH synchronisation is configured at the SS for the different grant allocation types when the UE is in connected mode.

##### 7.1.2.3.1.2.1 Grant allocation by RACH procedure

The UE gets assigned an uplink grant by the Random Access Response message being configured at the SS: Per default an UL grant as according to Table 7.1.2.3.3-1 is configured by TTCN.

#### 7.1.2.3.1.2.2 Grant allocation type 1: Uplink grant triggered by SR

The SS gets configured to automatically assign an uplink grant when requested by the UE with a Scheduling Request (SR). The size of this UL grant is configured by TTCN, i.e. there is no requirement for SS implementation to determine the grant size but the configured value shall be used regardless of how much data the UE wants to send. The SS shall assign the UL grant within less than 10ms after it has received the scheduling requests.

#### 7.1.2.3.1.2.3 Grant allocation type 2: Periodic uplink grant

The SS gets configured to assign uplink grants periodically irrespective of any Scheduling Request sent by the UE. The configuration specifies:

- the uplink grant size
- the periodicity: once, several times, continuous
- the period in number of slots (e.g. every slot, every second slot, etc.)

The first uplink grant transmitted is as specified in the explicit timing information. If timing information is "now" the SS selects the first suitable subframe for UL transmission.

The SS shall not assign any additional uplink grant due to a Scheduling Request sent by the UE.

#### 7.1.2.3.1.2.4 Grant allocation type 3: Single uplink grant

Special case of Grant allocation type 2: Uplink grant is assigned only once.

#### 7.1.2.3.1.2.5 Grant allocation type 4: Periodic uplink grant triggered by SR

Combination of Grant allocation type 1 and 2: Periodic uplink grant according to clause 7.1.2.3.1.2.3 is triggered by a Scheduling Request sent by the UE.

### 7.1.2.3.2 Determination of explicit uplink grants

#### 7.1.2.3.2.1 Parameters

Similar as for the downlink the UE gets preconfigured with parameters for time and frequency domain and a particular UL transmission is addressed by DCI:

1. Time domain resource allocation:  
Similar parameters are defined for UL as for DL (see clause 7.1.2.2.1.1, TS 38.214 [22] clause 6.1.2.1).
2. Frequency domain resource allocation:  
Similar as for the DL there is resource allocation type 0 and 1 for the UL (see clause 7.1.2.2.1.2, TS 38.214 [22] clause 6.1.2.2).  
Uplink resource allocation type 1 is assumed to be used for signalling conformance testing.
3. DCI parameters:  
Similar parameters are defined for UL as for DL (see clause 7.1.2.2.1.3, TS 38.212 [20] clauses 7.3.1.1.1 and 7.3.1.1.2, TS 38.214 [22] clause 6.1).

In detail for a particular uplink grant the parameters listed in tables 7.1.2.3.2.1-1 and 7.1.2.3.2.1-2 need to be considered.

Table 7.1.2.3.2.1-1: Parameters affecting TBS determination

Parameter	Comment/Description	Reference
Number of RBs in frequency domain	Indicated by DCI	
Number of symbols in time domain	Pre-configured at UE, selected by DCI; corresponds to "Duration in symbols" TS 38.211 [19] clause 6.4.1.1.3	
MCS index $I_{MCS}$	Indicated by DCI: Modulation Order $Q_m$ , Target code Rate $R$	TS 38.214 [22] clause 6.1.4.1; TS 38.214 [22] Table 5.1.3.1-1, 5.1.3.1-2, 6.1.4.1-1
Number of layers $u$	The number of layers being used for transmission of a transport block can be derived from the precoding information and the antenna port configuration provided by DCI format 0_1. For DCI format 0_1 in general $u = 1$ according to TS 38.508-1 [5] Table 4.3.6.1.1.2-1. For DCI format 0_0 $u = 1$ is assumed.	TS 38.214 [22] clause 6.1.1.1, TS 38.211 [19] clause 6.3.1.5, TS 38.212 [20] clause 7.3.1.1.2 and tables Table 7.3.1.1.2-2..5
PUSCH Parameters $mcs$ -Table, $mcs$ -TableTransformPrecoder, transformPrecoder, msg3-transformPrecoder	Pre-configured at the UE via RRC signalling: PUSCH-Config.mcs-Table := {qam64, qam256}; (NOTE 1) PUSCH-Config.mcs-TableTransformPrecoder := {qam64, qam256}; (NOTE 1) PUSCH-Config.transformPrecoder := {enabled, disabled}; or RACH-ConfigCommon.msg3-transformPrecoder := {enabled, disabled} (NOTE 2) indicates which MCS table to be applied NOTE 1: qam256 is applicable only when DCI format 0_1 is used. NOTE 2: msg3-transformPrecoder applies when DCI format 0_0 is used or when transformPrecoder is not configured; transformPrecoder applies only when DCI format 0_1 is used.	TS 38.214 [22] clause 6.1.4.1 and clause 6.1.3
Support of pi/2 BPSK modulation	In case of transformPrecoder==enabled and mcs-TableTransformPrecoder,==qam64 the first two entries of TS 38.214 [22] Table 6.1.4.1-1 depend on whether or not the UE supports pi/2 BPSK modulation.	TS 38.214 [22] clause 6.1.4.1
Number of REs per PRB	Number of REs per PRB which are applicable for the PUSCH transmission	Table 7.1.2.3.2.1-2

**Table 7.1.2.3.2.1-2: Parameters affecting number of REs allocated for PUSCH per PRB**

Parameter	Comment/Description	Reference
PUSCH mapping type	Type A or B	TS 38.211 [19] clause 6.4.1.1.3
dmrs-Type	DMRS Configuration type 1 or 2 as indicated to the UE by DMRS-UplinkConfig.dmr-Type	TS 38.211 [19] clause 6.4.1.1.3
dmrs-AdditionalPosition	Number of additional DMRS positions: For DCI format 0_1 as indicated to the UE by DMRS-UplinkConfig.dmr-AdditionalPosition: 0, 1, 2 or 3 additional positions. For DCI format 0_0 according to TS 38.214 [22] clause 6.2.2 the UE shall assume dmrs-AdditionalPosition='pos2' when frequency hopping is disabled and dmrs-AdditionalPosition='pos1' when frequency hopping is enabled.	TS 38.211 [19] clause 6.4.1.1.3 and tables 6.4.1.1.3-3/4, TS 38.214 [22] clause 6.2.2
maxLength	Number of OFDM symbols used for DMRS: For DCI format 0_1 as indicated to the UE by DMRS-UplinkConfig.maxLength: Single or double symbol DM-RS. For DCI format 0_0 according to TS 38.214 [22] clause 6.2.2 single symbol DM-RS is applied.	TS 38.211 [19] clause 6.4.1.1.3 and table 6.4.1.1.3-5, TS 38.214 [22] clause 6.2.2
number of CDM groups without data	The maximum number of CDM groups without data depends on the DMRS Configuration type (dmrs-Type): type 1: up to 2 CDM groups (TS 38.211 [19] Table 6.4.1.1.3-1) type 2: up to 3 CDM groups (TS 38.211 [19] Table 6.4.1.1.3-2) For DCI format 0_1 the number of CDM groups without data for a single transmission is determined by the antenna port configuration provided in the DCI (TS 38.212 [20] tables 7.3.1.1.2-6..23)  For DCI format 0_0 according to TS 38.214 [22] clause 6.2.2 for PUSCH duration > 2 the UE shall assume that the number of DM-RS CDM groups without data is 2 (what results in PUSCH not being present in any symbol carrying DM-RS); for PUSCH duration = 2 the number of DM-RS CDM groups without data is 1.	TS 38.211 [19] clause 6.4.1.1.3, TS 38.212 [20] clause 7.3.1.1.2 and tables 7.3.1.1.2-6..23, TS 38.214 [22] clause 6.1.4.2 and 6.2.2
xOverhead	Number of REs used for additional overhead as indicated to the UE by PUSCH-ServingCellConfig.xOverhead: 0, 6, 12, 18 REs	TS 38.214 [22] clause 6.1.4.2
PUSCH duration	Number of symbols allocated for the PUSCH transmission by DCI	

The number of REs for DMRS and PDSCH per PRB is determined in the same way for UL as for DL (TS 38.211 [19] clause 7.4.1.1.2) ⇒ The same values are applicable for UL and DL (see Table 7.1.2.2.4.1-4).

#### 7.1.2.3.2.2 Determination of $I_{MCS}$ and $L_{RBs}$ for given TBS

Uplink grant assignments are fully controlled by TTCN, i.e. it is up to the TTCN to determine the values of  $I_{MCS}$  and  $L_{RBs}$  to achieve the TBS specified in a test case prose.

Annex B.2 may be used to select a valid pair of  $\{L_{RBs}, I_{MCS}\}$ , based on the following assumptions (unless stated otherwise for a specific table):

- Number of layers  $v = 1$
- PUSCH mapping type A (as according to PUSCH-TimeDomainResourceAllocationList and PUSCH-Config in TS 38.508-1 [5])
- dmrs-Type: type1

- maxLength: single symbol DM-RS
- xOverhead = 0

The NR TBS tables for uplink grants in annex B.2 are based on the TS 38.508-1 [5] default configurations outlined in Tables 7.1.2.3.2.2-1 and 7.1.2.3.2.2-2 below.

**Table 7.1.2.3.2.2-1: TS 38.508-1 [5] default configurations for DCI format 0\_0 affecting UL scheduling**

Parameter	Value	Reference(s)
MCS index table	table 5.1.3.1-1 (MCS index table 1)	TS 38.214 [22] clause 6.1.4.1 with DCI format 0_0, transform precoding disabled as per TS 38.508-1 [5] Table 4.6.3-97 ( <i>RACH-ConfigCommon.msg3-transformPrecoder</i> )
dmrs-AdditionalPosition	2	Table 7.1.2.3.2.1-2 with DCI format 0_0, no frequency hopping as per TS 38.508-1 [5] Table 4.3.6.1.1.1-1
number of CDM groups	2	Table 7.1.2.3.2.1-2 with DCI format 0_0, transform precoding disabled as per TS 38.508-1 [5] Table 4.6.3-97 ( <i>RACH-ConfigCommon.msg3-transformPrecoder</i> )
PUSCH duration in symbols	14	TS 38.508-1 [5] Tables 4.6.3-90 (PUSCH-ConfigCommon) and 4.6.3-93 (PUSCH-TimeDomainResourceAllocationList) and DCI format with "Time domain resource assignment"=0

**Table 7.1.2.3.2.2-2: TS 38.508-1 [5] default configurations for DCI format 0\_1 affecting UL scheduling**

Parameter	Value	Reference(s)
MCS index table	table 5.1.3.1-1 (MCS index table 1)	TS 38.214 [22] clause 6.1.4.1 with DCI format 0_1, transform precoding disabled as per TS 38.508-1 [5] Table 4.6.3-89 ( <i>PUSCH-Config.transformPrecoder</i> )
dmrs-AdditionalPosition	1 (FR1) 0 (FR2)	TS 38.508-1 [5] Table 4.6.3-37 (DMRS-UplinkConfig)
number of CDM groups	1	according to antenna port configuration (TS 38.508-1 [5] Table 4.3.6.1.1.2-1)
PUSCH duration in symbols	14	TS 38.508-1 [5] Tables 4.6.3-90 ( <i>PUSCH-ConfigCommon</i> ) and 4.6.3-93 ( <i>PUSCH-TimeDomainResourceAllocationList</i> ) and DCI format with "Time domain resource assignment"=0

NOTE: Configuration according to Table 7.1.2.3.2.2-2 with PUSCH duration of 14 symbols and one CDM group results in the same TBS sizes for dmrs-AdditionalPosition=0 and dmrs-AdditionalPosition=1 as according to step 1 of TS 38.214 [22] clause 5.1.3.2 the number of resource elements allocated for PDSCH per resource block is limited by 156.  
 ⇒ The transport block sizes corresponding to Table 7.1.2.3.2.2-2 are the same for FR1 and FR2.

### 7.1.2.3.3 Default grants

In general test cases for layer 3 and above do not need test case specific grants but use default grants as listed in table 7.1.2.3.3-1.

Table 7.1.2.3.3-1: Default grants

Purpose	Grant size (NOTE 1) or {L <sub>RBs</sub> l <sub>MCS</sub> } pair	Comment
Scheduling of Random Access Msg3, initial access	256 bits (NOTE 2)	grant provided by Random Access Response (Msg2)
Scheduling of Random Access Msg3, handover or EN-DC	48 bits (NOTE 2, 3)	grant provided by Random Access Response (Msg2)
Random Access Msg4 for C-RNTI based CBRA for synchronisation (e.g. EN-DC)	L <sub>RBs</sub> = 1, l <sub>MCS</sub> = 0	minimum grant (24 or 32 bits)
Random Access Msg4 for C-RNTI based CBRA for handover	144 bits (NOTE 4)	initial UL grant after handover
Default USS grant	L <sub>RBs</sub> = 24, l <sub>MCS</sub> = 9 (NOTE 5)	default grant: e.g. for test cases with main focus on control plane signalling
<p>NOTE 1: In general for a given grant size TTCN uses the {L<sub>RBs</sub> l<sub>MCS</sub>} pair according to annex B.2.</p> <p>NOTE 2: According to TS 38.213 [21] subclause 8.3, the RAR UL grant is always interpreted according to DCI format 0_0, so contents of Table 7.1.2.3.2.2-1 apply.</p> <p>NOTE 3: Minimum grant which can be assigned by the Random Access Response: The grant is sufficient to convey C-RNTI (3 bytes) and short BSR (2 bytes) or long BSR (minimum of 3 bytes). Even with short BSR there is not enough space to convey any segment of the <i>RRCReconfigurationComplete</i> (at least 6 bytes: 2 bytes MAC header + 3 bytes RLC header + 1 byte payload).</p> <p>NOTE 4: Initial grant of RA procedure big enough to completely convey the <i>RRCReconfigurationComplete</i> (10 bits). This requires a minimum of 13 bytes (2 bytes MAC header + 3 bytes RLC header + 6 bytes PDCP header + 2 bytes payload). Additionally an optional PHR MAC element (3 bytes) needs to be considered since the PHR has higher priority than the MAC SDU. Any further user data would require a minimum of 6 additional bytes (2 bytes MAC header + 3 bytes RLC header + 1 byte payload, it is assumed that if UE has any data to transmit that will be on AM DRB).</p> <p>NOTE 5: Applicable only when MCS index table 5.1.3.1-1 or 6.1.4.1-1 is configured to be used for UL grants (e.g. in case of mcs-Table = qam256, a different l<sub>MCS</sub> value needs to be defined)</p>		

#### 7.1.2.4 Data scheduling

As according to TS 38.508-1[5] the SSB periodicity is set to 20ms, TTCN configures the SS to broadcast the SSB burst in half-frame 0 of frames with even SFN.

For scheduling of DL data or UL Grant, when timing information is explicit, the timing provided by TTCN corresponds to the time at which the SS shall transmit to the UE the PDCCH carrying the DCI message. The data scheduling applied by TTCN is specified in Tables 7.1.2.4-1 to 7.1.2.4-4.

Table 7.1.2.4-1: Data scheduling for FR1: FDD, SCS=15kHz

Frame									
Subframe 0	Subframe 1	Subframe 2	Subframe 3	Subframe 4	Subframe 5	Subframe 6	Subframe 7	Subframe 8	Subframe 9
Slot 0	Slot 0	Slot 0	Slot 0	Slot 0	Slot 0	Slot 0	Slot 0	Slot 0	Slot 0
0 PDCCH (UL)	0	0 PDCCH (DL)	0	0	0 PDCCH (UL)	0	0 PDCCH (DL)	0	0
1 SSB #0	1	1	1	1	1	1	1	1	1
2	2	2	2	2	2	2	2	2	2
3	3	3	3	3	3	3	3	3	3
4	4	4	4	4	4	4	4	4	4
5	5	5	5	5	5	5	5	5	5
6	6	6 PDSCH	6	6 PUSCH	6	6	6 PDSCH	6	6
7	7	7	7	7	7	7	7	7	7
8	8	8	8	8	8	8	8	8	8
9	9	9	9	9	9	9	9	9	9
10	10	10	10	10	10	10	10	10	10
11	11	11	11	11	11	11	11	11	11
12	12	12	12	12	12	12	12	12	12
13	13	13	13	13	13	13	13	13	13

NOTE 1: The PDCCH assignment in subframe 2 and 7 address DL transmissions in the same ( $K_0 = 0$ ).

NOTE 2: The UL grants in subframe 0 and 5 address UL transmissions in subframe 4 and 9 respectively ( $K_2 = 4$ ).

Table 7.1.2.4-2: Data scheduling for FR1: TDD, SCS=15kHz

Frame									
Subframe 0	Subframe 1	Subframe 2	Subframe 3	Subframe 4	Subframe 5	Subframe 6	Subframe 7	Subframe 8	Subframe 9
Slot 0	Slot 0	Slot 0	Slot 0	Slot 0	Slot 0	Slot 0	Slot 0	Slot 0	Slot 0
0 PDCCH (UL)	0 D	0 PDCCH (DL)	0 D	0 UL	0 PDCCH (UL)	0 D	0 PDCCH (DL)	0 D	0 UL
1 SSB #0	1 D	1	1	1	1	1	1	1	1
2	2 D	2	2	2	2	2	2	2	2
3	3 D	3	3	3	3	3	3	3	3
4	4 D	4	4	4	4	4	4	4	4
5	5 D	5	5	5	5	5	5	5	5
6	6 D	6 PDSCH	6	6 UL	6	6	6 PDSCH	6	6 UL
7	7 D	7	7	7	7	7	7	7	7
8	8 D	8	8	8	8	8	8	8	8
9	9 D	9	9	9	9	9	9	9	9
10	10 D	10	10	10	10	10	10	10	10
11	11 D	11	11	11	11	11	11	11	11
12	12 D	12	12	12	12	12	12	12	12
13	13 D	13	13	13	13	13	13	13	13

NOTE 1: The PDCCH assignment in subframe 2 and 7 address DL transmissions in the same ( $K_0 = 0$ ).

NOTE 2: The UL grants in subframe 0 and 5 address UL transmissions in subframe 4 and 9 respectively ( $K_2 = 4$ ).

Table 7.1.2.4-3: Data scheduling for FR1: TDD, SCS=30kHz

Frame									
Subframe 0	Subframe 1	Subframe 2	Subframe 3	Subframe 4	Subframe 5	Subframe 6	Subframe 7	Subframe 8	Subframe 9
Slot 0	Slot 0	Slot 0	Slot 0	Slot 0	Slot 0	Slot 0	Slot 0	Slot 0	Slot 0
0 DL	0 DL	0 DL PDCCH (DL)	0 DL	0 UL	0 DL	0 DL	0 DL PDCCH (DL)	0 DL	0 UL
1 SSB #0	1 DL	1	1	1	1	1	1	1	1
2	2 DL	2	2	2	2	2	2	2	2
3	3 DL	3	3	3	3	3	3	3	3
4	4 DL	4	4	4	4	4	4	4	4
5	5 DL	5	5	5	5	5	5	5	5
6	6 DL	6 PDSCH	6	6 UL	6	6	6 PDSCH	6	6 UL
7	7 DL	7	7	7	7	7	7	7	7
8	8 DL	8	8	8	8	8	8	8	8
9	9 DL	9	9	9	9	9	9	9	9
10	10 DL	10	10	10	10	10	10	10	10
11	11 DL	11	11	11	11	11	11	11	11
12	12 DL	12	12	12	12	12	12	12	12
13	13 DL	13	13	13	13	13	13	13	13
Slot 1	Slot 1	Slot 1	Slot 1	Slot 1	Slot 1	Slot 1	Slot 1	Slot 1	Slot 1
0 DL	0 DL	0 DL PDCCH (UL)	0 DL	0 UL	0 DL	0 DL	0 DL PDCCH (UL)	0 DL	0 UL
1	1 DL	1	1	1	1	1	1	1	1
2	2 DL	2	2	2	2	2	2	2	2
3	3 DL	3	3	3	3	3	3	3	3
4	4 DL	4	4	4	4	4	4	4	4
5	5 DL	5	5	5	5	5	5	5	5
6	6 DL	6 PUSCH	6	6 UL	6	6	6	6	6 UL
7	7 DL	7	7	7	7	7	7	7	7
8	8 DL	8	8	8	8	8	8	8	8
9	9 DL	9	9	9	9	9	9	9	9
10	10 DL	10	10	10	10	10	10	10	10
11	11 DL	11	11	11	11	11	11	11	11
12	12 DL	12	12	12	12	12	12	12	12
13	13 DL	13	13	13	13	13	13	13	13

NOTE 1: The DL assignments in slots 0 of subframe 2 and 7 address DL transmissions in the same slots ( $K_0 = 0$ ).

NOTE 2: The UL grants in slots 1 of subframe 2 and 7 address UL transmissions in slot 1 of subframe 4 and 9 respectively ( $K_2 = 4$ ).





NOTE 1: The DL assignments in slots 0 of subframe 2 and 7 address DL transmissions in the same slots ( $K_0 = 0$ ).

NOTE 2: The UL grants in slots 3 of subframe 4 and 9 address UL transmissions in slot 7 of the same subframe ( $K_2 = 4$ ).

### 7.1.2.5 Noise generator

Several test cases require one or several NR cells to be subject to noise interference at a well-defined level. To achieve this, a Virtual Noise Generator (VNG) is modelled, located in the SS and controlled by TTCN.

A VNG instance has a one-to-one relation with an NR cell instance and therefore operates on the same frequency as the operating frequency of the associated NR cell. Default configuration of VNG models AWGN transmission across the whole carrier bandwidth and in every time slot. The test model allows varying the power level of the AWGN referred to as a *CellNocLevel* and measured in dBm/SCS.

The NR cell shall be configured before the associated VNG instance is configured. A VNG instance is first configured with noise source being “off”, and subsequently activated to a specified *CellNocLevel*. VNG instance deactivation stops the noise generation.

### 7.1.3 System information

TTCN provides the MIB message to the SS as a structured ASN.1 type using a control ASP (NR\_SYSTEM\_CTRL\_REQ). The SS shall:

- set the *systemFrameNumber* in the MIB to the 6 MSBs of the current SFN. A dummy value is provided by TTCN. The SS shall convey the 4 LSBs of the current SFN in the PBCH transport block. The SS shall fulfil  $\text{current SFN mod } 80 = 0$ .
- encode the MIB ASN.1 message as specified in Table 8.1-1.
- transmit the encoded MIB message periodically as specified in TS 38.331 [16]. For each transmission, the SS shall update *systemFrameNumber* value as specified above.

### 7.1.4 Cell(s) handling

#### 7.1.4.1 Multi-cells environment

The same principles and rules are applied as according to clause 7.4.5 of TS 36.523-3 [12] to both E-UTRA and NR cells.

#### 7.1.4.2 Cell power change

The same principles and rules are applied as according to clause 7.4.2 of TS 36.523-3 [12].

### 7.1.5 Timing aspects

#### 7.1.5.1 SS time

The SS shall provide one system time common across all RATs and cells being configured in a test case. The timing of each configured cell is specified as an offset to this common system time.

#### 7.1.5.2 Cell(s) timing

The timing of E-UTRA cells is specified in TS 36.523-3 [12] subclause 7.4.3.1.

The timing information used in an NR cell is specified in terms of H-SFN / SFN / subframe / slot. In the context of NR cells, the Hyper SFN (H-SFN) is used as an SFN wraparound counter (0..1023).

The DL timing offset of each NR cell is specified in Table 7.1.5.2-1.

Table 7.1.5.2-1: DL timing parameters of simulated NR cells

NR cell Id	H-SFN-offset (note1)	SFN-offset for FDD (note2)	SFN-offset for TDD (note2)	Tcell (note3)	Tc-offset (note4)
NR Cell 1	0	0	0	0	0
NR Cell 2	0	124	0	0	0
NR Cell 3	0	257	257	0	0
NR Cell 4	0	1000	0	0	0
NR Cell 6	0	656	656	0	0
NR Cell 10	0	129	129	0	0
NR Cell 11	0	956	0	0	0
NR Cell 12	0	1015	257	0	0
NR Cell 13	0	890	656	0	0
NR Cell 14	0	680	680	0	0
NR Cell 23	0	383	257	0	0
NR Cell 28	0	890	890	0	0
NR Cell 29	0	680	890	0	0
NR Cell 30	0	1015	129	0	0
NR Cell 31	0	53	129	0	0

NOTE1: H-SFN-offset corresponds to the offset applied on H-SFN as defined for E-UTRA. It shall be set to 0 for an NR cell.  
NOTE2: SFN-offset corresponds to the offset applied on system frame number (0..1023).  
NOTE3: Tcell corresponds to the timing offset in  $T_s$ .  $T_s = 1/(15000 * 2048)$  as for E-UTRA.  
NOTE4: Tc-offset corresponds to the timing offset in  $T_c$ .  $\kappa = T_s/T_c = 64$  with  $T_c = 1/(480000 * 4096)$ . See TS 38.211 [19] subclause 4.1 and TS 36.211 [23] subclause 4).

The UL timing offset of each NR cell is configured as an offset (timing advance) to its DL timing specified in Table 7.1.5.2-1. By default, the timing advance is initialised to 0 (unless specifically specified otherwise in the test case prose).

In test cases involving configuration of SCell(s), the H-SFN-offset / SFN-offset / Tcell / Tc-offset of SCell(s) are set to the same values as that of associated PCell(s).

In test cases involving NR-DC configuration, the H-SFN-offset / SFN-offset / Tcell / Tc-offset of PSCell(s) are set to the same values as that of associated PCell(s).

## 7.2 EN-DC

### 7.2.1 Introduction

Subclause 7.2 specifies test methods and design considerations that are specific to EN-DC.

### 7.2.2 Physical layer aspects

#### 7.2.2.1 Search spaces and DCI

For EN-DC test cases, TTCN provides the DCI configuration only for the following PDCCH search spaces on the active DL BWP:

- Type1-PDCCH common search space: used for the Random Access procedure on the NR cell, and
- UE specific search space (UL and DL): used for data exchange in RRC\_CONNECTED state on the NR cell.
  - For the default NR cell operation, TTCN configures DCI formats 0\_1 and 1\_1 in the SS.

### 7.2.3 System information

For EN-DC only MIB is configured and broadcast. SIB1 (RMSI) and Other SI are not configured.

## 7.2.4 Bearers

From a 3GPP network perspective, each bearer (MCG, SCG and split bearer) can be terminated either in MN or in SN.

From a EN-DC Test Model and PTC architecture perspective however, there is no dependency between the PTC on which the NR PDCP of a bearer is configured and the type of bearer (MN terminated or SN terminated), e.g. an SCG bearer may have its NR PDCP configured on the NR PTC and act as a MN terminated bearer.

## 7.2.5 Random Access procedure

### 7.2.5.1 NR

In EN-DC on NR side, when *reconfigurationWithSync* is indicated by RRC signalling, the UE performs a Random Access procedure, which is either contention free (CFRA) or contention based (CBRA) with C-RNTI based contention resolution. This is distinguished by whether or not *RACH-ConfigDedicated* is provided in the *reconfigurationWithSync* field of *CellGroupConfig*.

TTCN configures the SS accordingly, and in case of CBRA with C-RNTI based contention resolution, the UE gets a temporary C-RNTI being different than the C-RNTI the UE has got already and the UE gets an UL grant as according to Table 7.1.2.3.3-1.

### 7.2.5.2 E-UTRA

In EN-DC on E-UTRA side, in case of E-UTRA handover (when *mobilityControlInfo* is indicated in the *RRCConnectionReconfiguration* message), a Random Access procedure will take place. In that case TS 36.523-3 [12] subclause 7.16.3 applies, with the following amendment:

Initial grant: 208 bits.

NOTE: The *RRCConnectionReconfigurationComplete* including NR *RRCReconfigurationComplete* (5 bytes) shall completely be conveyed in the initial grant of RA procedure. This requires a minimum of 13 or 14 bytes (1 byte MAC header + 2 bytes RLC header + 6 bytes PDCP header (in case of NR PDCP) or 5 bytes PDCP header (in case of E-UTRA PDCP) + 5 bytes payload). Additionally an optional DC-PHR MAC element (9 bytes) needs to be considered since the DC-PHR has higher priority than the MAC SDU. Any further user data would require a minimum of 5 additional bytes (2 bytes MAC header + 2 bytes RLC header + 1 byte payload).

## 7.2.6 PSCell change

### 7.2.6.1 Sequence of EN-DC NR inter-cell PSCell change

In general, the NR inter-cell PSCell change is done without activation time, i.e. the timing information for configuration of the SS and sending of the *RRCConnectionReconfiguration* is 'Now'.

1. NR Target Cell: Configuration of SRB3 (if necessary) and DRBs
2. Transfer of the PDCP Count for DRBs and SRB3 (if necessary) from NR source to NR target cell:
  - a) NR Source Cell: Get PDCP COUNT.
  - b) NR Target Cell: Set PDCP COUNT.

NOTE 1: No further sending/receiving of DRB data before the PSCell change is done.

NOTE 2: For AM DRBs the PDCP count is maintained. For SRB3 (if applied) and UM DRBs, the PDCP count is maintained or reset depending on the *RRCConnectionReconfiguration* message content.

3. NR Target Cell: Inform the SS about the PSCell change and about the source cell id.
4. NR Target Cell: Configure RACH procedure either dedicated or C-RNTI based.

NOTE 3: The FollowOnFlag is set to true in the ASP reconfiguring C-RNTI.

5. NR Target Cell: Activate security.
  6. NR Target Cell: Configure UL grant configuration ("OnSR", default grant).
- NOTE 4: Unless explicitly specified UL grant configuration keeps configured as per default at the NR source cell.
7. E-UTRA Cell: Send *RRCCConnectionReconfiguration*.
  8. E-UTRA Cell: Receive *RRCCConnectionReconfigurationComplete*.
  9. NR Target Cell: Inform the SS about completion of the PSCell change (e.g. to trigger PDCP STATUS REPORT PDU).
  10. NR Source Cell: Release SRB3 (if necessary) and DRBs.

### 7.2.6.2 Sequence of EN-DC NR intra-cell PSCell change

For EN-DC NR intra-cell PSCell change dedicated timing information is used: the sequence starts at time T with sending of the *RRCCConnectionReconfiguration*. T is set to 300 ms in advance of the PSCell change.

1. NR Cell before T: Get PDCP count for DRBs and SRB3 (if applied).
2. E-UTRA Cell at T: Send *RRCCConnectionReconfiguration*.
3. NR Cell at T: Release SRB3 (if necessary) and DRBs.
4. NR Cell at T: Configure RACH procedure either dedicated or C-RNTI based.

NOTE 1: The FollowOnFlag is set to true in the ASPs reconfiguring the RadioBearerList (step 3) and C-RNTI (step 4).

5. NR Cell at T + 5ms: (Re-)configure SRB3 (if necessary) and DRBs.
6. NR Cell at T + 5ms: Restore the PDCP counts

NOTE 2: For AM DRBs the PDCP count is maintained. For SRB3 (if applied) and UM DRBs, the PDCP count is maintained or reset depending on the *RRCCConnectionReconfiguration* message content.

7. NR Cell at T + 5ms: Re-establish security.
8. E-UTRA Cell (after step 2): Receive *RRCCConnectionReconfigurationComplete*.
9. Void

### 7.2.6.3 UL grants used in RA procedure during EN-DC NR PSCell change

An UL grant is assigned to the UE by the RAR and in case of CBRA with C-RNTI based contention resolution, another UL grant, as initial grant, is assigned for contention resolution. The default Random Access procedure specified in clause 7.2.5.1 is applied.

### 7.2.6.4 Sequence of EN-DC NR CA inter-cell PSCell change

This procedure is applicable when there are more than one CC in NR before and after the PSCell change.

In general, the NR CA inter-cell PSCell change is done without activation time, i.e. the timing information for configuration of the SS and sending of the *RRCCConnectionReconfiguration* is 'Now'.

1. NR Target PSCell: Configuration of SRB3 (if necessary) and DRBs
2. Transfer of the PDCP Count for DRBs and SRB3 (if necessary) from NR source PSCell to NR target PSCell:
  - a) NR Source PSCell: Get PDCP COUNT.
  - b) NR Target PSCell: Set PDCP COUNT.

NOTE 1: No further sending/receiving of DRB data before the PSCell change is done.

NOTE 2: For AM DRBs the PDCP count is maintained. For SRB3 (if applied) and UM DRBs, the PDCP count is maintained or reset depending on the *RRCCConnectionReconfiguration* message content.

3. NR Target PSCell: Inform the SS about the PSCell change and about the source cell id.

4. NR Target PSCell: Configure RACH procedure either dedicated or C-RNTI based.

NOTE 3: The FollowOnFlag is set to true in the ASP reconfiguring C-RNTI.

5. NR Target PSCell: Activate security.

6. NR Target PSCell: Configure UL grant configuration ("OnSR", default grant).

NOTE 4: Unless explicitly specified UL grant configuration keeps configured as per default at the NR source PSCell.

7. NR Target PSCell: Configure Target PSCell as PSCell.

NOTE 5: The FollowOnFlag is set to true in the ASP reconfiguring PSCell.

8. NR Target SCell: Configure Target SCell as SCell with new PSCell association.

9. E-UTRA Cell: Send *RRCCConnectionReconfiguration*.

10. E-UTRA Cell: Receive *RRCCConnectionReconfigurationComplete*.

11. NR Target PSCell: Inform the SS about completion of the PSCell change (e.g. to trigger PDCP STATUS REPORT PDU).

12. NR Source PSCell: If source PSCell is not the same as target SCell, Release SRB3 (if necessary) and DRBs, reconfigure the cell as a normal cell.

13. NR Source SCell: If source SCell is not the same as target SCell or target PSCell, reconfigure the cell as a normal cell.

NOTE 6: The FollowOnFlag is set to true in the ASP reconfiguring PSCell.

## 7.3 NR/5GC

### 7.3.1 Introduction

Subclause 7.3 specifies test methods and design considerations that are specific to NR/5GC.

### 7.3.2 Physical layer aspects

### 7.3.3 System information

#### 7.3.3.1 General SS requirements

TTCN provides the complete system information and scheduling information to the SS as a structured ASN.1 type using a single control ASP (*NR\_SYSTEM\_CTRL\_REQ*). The following rules apply:

- The system information is sent to SS using the *asn.1* types. The SS shall encode each SI message as specified in Table 8.1-1 and add the necessary padding bits as specified in TS 38.331 [16], clause 8.5.
- The SS shall start scheduling all system information from the same SFN.
- The scheduling information sent to SS is the same as the scheduling information sent to the UE. For each SI message, the *slotOffset* list in *NR\_SYSTEM\_CTRL\_REQ* indicates the exact point in time in the SI-window at which SS shall transmit of the related SI to the UE.

### 7.3.3.2 Scheduling information

The maximum number of resource blocks as defined in table 7.3.3.2-1 are used to broadcast the system information.

**Table 7.3.3.2-1: Maximum number of resource blocks**

	Maximum number of resource blocks assigned	Number of symbols assigned
SIB1	7	12
for all SIs	7	12

The slot offset values defined in Table 7.3.3.2-1A are used for all SI messages with their respective SI-window.

**Table 7.3.3.2-1A: SubframeOffset values**

Configuration	subframeOffset list
FR1 FDD & TDD SCS=15kHz	{5, 6, 15, 16}
FR1 TDD SCS=30kHz	{5, 6}
FR2 TDD SCS=120kHz	{5}

All System Information messages are sent only once within the SI-window and redundancy version 0 is selected.

SIB1 is broadcasted in slot#1 in frames with even SFN.

Tables 7.3.3.2-2 to 7.3.3.2-4 give the SFN's and subframe numbers in which the MIB, SIB1 and other SIs are actually scheduled as per default parameters for si-WindowLength s80 for FR1 and s160 for FR2, periodicity for SI are defined in TS 38.508-1 [5].

**Table 7.3.3.2-2: MIB, SIB1 and SI scheduling for FR1: FDD and TDD, SCS=15kHz**

SFN	Frame									
	Subframe 0	Subframe 1	Subframe 2	Subframe 3	Subframe 4	Subframe 5	Subframe 6	Subframe 7	Subframe 8	Subframe 9
0	MIB	SIB1				SI1	SI1			
1						SI1	SI1			
2	MIB	SIB1								
3										
4	MIB	SIB1								
5										
6	MIB	SIB1								
7										
8	MIB	SIB1				SI2	SI2			
9						SI2	SI2			
10	MIB	SIB1								
11										
12	MIB	SIB1								
13										
14	MIB	SIB1								
15										
16	MIB	SIB1				SI3	SI3			
17						SI3	SI3			
18	MIB	SIB1								
19										
20	MIB	SIB1								
21										

22	S10	MIB	S10	SIB1	S10	S10	S10	S10	S10	S10	S10	S10	S10	S10
23	S10		S10		S10	S10	S10	S10	S10	S10	S10	S10	S10	S10
24	S10	MIB	S10	SIB1	S10	S10	S10	S10	S14	S10	S14	S10	S10	S10
25	S10		S10		S10	S10	S10	S10	S14	S10	S14	S10	S10	S10

Table 7.3.3.2-3: MIB, SIB1 and SI scheduling for FR1 TDD, SCS=30kHz

SFN	Frame										
	Subframe 0	Subframe 1	Subframe 2	Subframe 3	Subframe 4	Subframe 5	Subframe 6	Subframe 7	Subframe 8	Subframe 9	
0	MIB			SI1							
	SIB1		SI1								
1											
2	MIB										
	SIB1										
3											
4	MIB			SI2							
	SIB1		SI2								
5											
6	MIB										
	SIB1										
7											
8	MIB			SI3							
	SIB1		SI3								
9											
10	MIB										
	SIB1										
11											
12	MIB			SI4							
	SIB1		SI4								
13											
14	MIB										
	SIB1										
15											

Table 7.3.3.2-4: MIB, SIB1 and SI scheduling for FR2: TDD, SCS=120kHz

SFN	Frame									
	Subframe 0	Subframe 1	Subframe 2	Subframe 3	Subframe 4	Subframe 5	Subframe 6	Subframe 7	Subframe 8	Subframe 9
0	MIB									
	SIB1									
	SI1									
1										



2	MIB	S17 S16 S15 S14 S13 S12 S11 S10
	SIB1	S17 S16 S15 S14 S13 S12 S11 S10
	S12	S17 S16 S15 S14 S13 S12 S11 S10
		S17 S16 S15 S14 S13 S12 S11 S10
		S17 S16 S15 S14 S13 S12 S11 S10
		S17 S16 S15 S14 S13 S12 S11 S10
		S17 S16 S15 S14 S13 S12 S11 S10
		S17 S16 S15 S14 S13 S12 S11 S10
		S17 S16 S15 S14 S13 S12 S11 S10
		S17 S16 S15 S14 S13 S12 S11 S10
		S17 S16 S15 S14 S13 S12 S11 S10
3		S17 S16 S15 S14 S13 S12 S11 S10
		S17 S16 S15 S14 S13 S12 S11 S10
		S17 S16 S15 S14 S13 S12 S11 S10
		S17 S16 S15 S14 S13 S12 S11 S10
		S17 S16 S15 S14 S13 S12 S11 S10
		S17 S16 S15 S14 S13 S12 S11 S10
		S17 S16 S15 S14 S13 S12 S11 S10
		S17 S16 S15 S14 S13 S12 S11 S10
		S17 S16 S15 S14 S13 S12 S11 S10
		S17 S16 S15 S14 S13 S12 S11 S10
		S17 S16 S15 S14 S13 S12 S11 S10
4	MIB	S17 S16 S15 S14 S13 S12 S11 S10
	SIB1	S17 S16 S15 S14 S13 S12 S11 S10
	S13	S17 S16 S15 S14 S13 S12 S11 S10
		S17 S16 S15 S14 S13 S12 S11 S10
		S17 S16 S15 S14 S13 S12 S11 S10
		S17 S16 S15 S14 S13 S12 S11 S10
		S17 S16 S15 S14 S13 S12 S11 S10
		S17 S16 S15 S14 S13 S12 S11 S10
		S17 S16 S15 S14 S13 S12 S11 S10
		S17 S16 S15 S14 S13 S12 S11 S10
		S17 S16 S15 S14 S13 S12 S11 S10
5		S17 S16 S15 S14 S13 S12 S11 S10
		S17 S16 S15 S14 S13 S12 S11 S10
		S17 S16 S15 S14 S13 S12 S11 S10
		S17 S16 S15 S14 S13 S12 S11 S10
		S17 S16 S15 S14 S13 S12 S11 S10
		S17 S16 S15 S14 S13 S12 S11 S10
		S17 S16 S15 S14 S13 S12 S11 S10
		S17 S16 S15 S14 S13 S12 S11 S10
		S17 S16 S15 S14 S13 S12 S11 S10
		S17 S16 S15 S14 S13 S12 S11 S10
		S17 S16 S15 S14 S13 S12 S11 S10
6	MIB	S17 S16 S15 S14 S13 S12 S11 S10
	SIB1	S17 S16 S15 S14 S13 S12 S11 S10
	S14	S17 S16 S15 S14 S13 S12 S11 S10
		S17 S16 S15 S14 S13 S12 S11 S10
		S17 S16 S15 S14 S13 S12 S11 S10
		S17 S16 S15 S14 S13 S12 S11 S10
		S17 S16 S15 S14 S13 S12 S11 S10
		S17 S16 S15 S14 S13 S12 S11 S10
		S17 S16 S15 S14 S13 S12 S11 S10
		S17 S16 S15 S14 S13 S12 S11 S10
		S17 S16 S15 S14 S13 S12 S11 S10

### 7.3.3.3 System information modification

For system information modification, the same rules as defined in clause 7.3.3.1 and 7.3.3.2 are applied.

The SFN for the start of modification period is calculated by TTCN. The modified system information and the calculated SFN are provided in the ASP NR\_SYSTEM\_CTRL\_REQ. When the cell is switched off, ‘activateNow’ is used.

The updated SI other than ETWS and CMAS, is broadcasted in the modification period following the one where SI change indication is transmitted. The updated SI for ETWS and CMAS is broadcasted in the same modification period as the one where SI change indication is transmitted. Short message indications are transmitted as follows:

- When UE is in RRC\_IDLE or in RRC\_INACTIVE, a single Short Message indication is transmitted in UE paging occasions of the modification period. With the default values provided in TS 38.508-1[5], this results in 4 Short Messages transmitted by SS during the modification period.
- When UE is in RRC\_CONNECTED, Short Message indications are transmitted in every paging occasions of each frame throughout the modification period. With the default values provided in TS 38.508-1[5], this results in  $64 \times 4 \times 2$  Short Messages transmitted by SS during the modification period.

### 7.3.3.4 Request for on demand system information

In case PRACH preamble (Msg1) is used for indication of requested other SI:

- TTCN configures SS with the SI-RequestConfig as provided to UE in SIB1 and SS shall monitor these PRACH resources.
- TTCN configures SS to report PRACH preambles and to transmit Random Access Response (Msg2) as response to Msg1 but not to handle contention resolution.
- TTCN reconfigures SS to stop broadcasting a specific SI from the start of a modification period and reconfigures SS to restart broadcasting the SI with activation time 'Now' (after the reception of PRACH preamble in TTCN). When activation time 'Now' is applied, SS shall start broadcasting from the next SI-window.

In case Msg3 is used for indication of requested other SI:

- TTCN configures the SS to transmit a Msg4 with Contention Resolution Identity upon receipt of *RRCSystemInfoRequest* (Msg3).
- TTCN reconfigures SS to stop broadcasting a specific SI from the start of a modification period and reconfigures SS to restart broadcasting the SI with activation time 'Now' (after the reception of *RRCSystemInfoRequest* in TTCN). When activation time 'Now' is applied, SS shall start broadcasting from the next SI-window.

## 7.3.4 Paging and Short Message

SS can be configured with a DCI including Short Messages. In that case, when SS is triggered to transmit a *Paging* message, the Short Message indication shall be included in the DCI.

SS can be triggered to transmit Short Messages alone, this is achieved in TTCN with the *DciTrigger* type. SS is triggered to send the *Paging* message or a Short Message indication at a calculated Paging Occasion provided in the activation time and optionally a list slot offsets when multiple paging occasions are applied. Discontinuous Reception (DRX) is applied for the transmission of a *Paging* message or a Short Message indication to the UE in the RRC\_IDLE or RRC\_INACTIVE states. The paging frame calculation is according to TS 38.304 [24] clause 7. The following default values are provided in TS 38.508-1[5]:

- $\text{defaultPagingCycle} = 128$
- $N_s = \text{one}$
- $N = 64$
- $\text{PF\_Offset} = 0$

When these default values are applied, the Paging Frame calculation is:

- Paging Frame:  $\text{SFN mod } 128 = 2 * (\text{UE\_ID mod } 64)$  so depending on UE\_ID, the Paging Frame is set to 0,2,4,6,... 126 of the paging cycle.

When UE is in RRC\_IDLE or RRC\_INACTIVE and when PDCCH monitoring occasions with default association is applied, the Paging Occasion is set to:

- slot#2 of the Paging Frame when the cell is configured with SSB#1 or
- slot#1 of the Paging Frame when the cell is configured with SSB#0.

To notify system information modification when UE is in RRC\_CONNECTED and when PDCCH monitoring occasions with default association is applied, the Paging Occasion is set to:

- slot#1 and slot#2 of the Paging Frame when the cell is configured with SSB#1 or
- slot#0 and slot#1 of the Paging Frame when the cell is configured with SSB#0.

## 7.3.5 RRC connection control

### 7.3.5.1 Early contention resolution

When the contention based RACH procedure is being executed (RRC connection establishment, RRC reconfiguration, RRC connection resume or RRC re-establishment), in general the UE Contention Resolution Identity MAC CE and the DL RRC PDU on DL CCCH (*RRCSetup/RRCReject*) or DL DCCH (*RRCResume/RRCReestablishment/RRCRelease*) are sent in one MAC PDU (RA Msg4). This is achieved by pre-configuring the SS (before the start of the RRC procedure) to send the encoded DL message and UE Contention Resolution Identity MAC CE in one MAC PDU.

There are cases however where it is necessary to send the DL CCCH or DL DCCH message separately from RA Msg4, this is implemented in TTCN using the test case attribute *EarlyContentionResolution*:

- RRC connection establishment: when *RRCSetup* message is part of the test purpose,
- RRC connection reject: when *RRCReject* message is part of the test purpose,
- RRC connection resume: when *RRCResume* or *RRCRelease* message is part of the test purpose,
- RRC connection re-establishment: when *RRCReestablishment* message is part of the test purpose
- Special cases: e.g. when no contention resolution shall be sent according to the test purpose.

### 7.3.5.2 RRC connection release sequence

According to TS 38.331 [19], clause 5.3.8.3, after reception of the *RRCRelease* message the UE may either wait 60 ms or for indication of acknowledgement from lower layer. After the *RRCRelease* message there are cases where the UE may immediately come up with an *RRCSetupRequest* message. This requires scheduled release of resources at the SS:

1. At T: Send *RRCRelease*, stop UL grants.
2. At T + 5ms: Release security.
3. At T + 10ms: Release DRX configuration at the SS.
4. At T + 15ms: Release measurement gap configuration at the SS.
5. At T + 55ms: Release SRBs and DRBs.
6. At T + 60ms: (Re-)configure SRBs.
7. Delay of 840ms (NOTE)

T is set to 300ms in advance of *RRCRelease*.

NOTE: The delay ensures that the UE is camping on the serving cell again to avoid side effects e.g. due to subsequent power level changes. It does not affect any sending of messages by the UE. The delay 840 ms is chosen to ensure the UE is re-camping on the cell and has read relevant system information (MIB, SIB1 and all other SIs).

### 7.3.5.3 Handover

#### 7.3.5.3.1 Sequence of intra-NR inter-cell handover

In general, the intra-NR inter-cell handover is done without activation time, i.e. the timing information for configuration of the SS and sending of the *RRCReconfiguration* is 'Now'.

The sequence may be interrupted if other events need to be handled. E.g. when a Mobility procedure is performed in the target cell and there are procedures left to be executed on the source cell.

1. Target Cell: Configuration of DRBs
2. Transfer of the PDCP Count for AM DRBs and SRBs (if applied) from source to target cell:
  - a) Source Cell: Get PDCP COUNT.
  - b) Target Cell: Set PDCP COUNT.

NOTE 1: No further sending/receiving of DRB data before the HO is done.

NOTE 2: For AM DRBs the PDCP count is maintained, for UM DRBs the PDCP count is reset. For SRBs, the PDCP count is maintained or reset depending on the *RRCReconfiguration* message content.

3. Target Cell: Inform the SS about the HO and about the source cell id.
4. Target Cell: Configure RACH procedure either dedicated or C-RNTI based.

NOTE 3: The FollowOnFlag is set to true in the ASP reconfiguring C-RNTI.

5. Target Cell: Activate security.
6. Void
7. Source Cell: Stop periodic TA.

NOTE 4: Unless explicitly specified UL grant configuration keeps configured as per default at the source cell.

8. Target Cell: Configure UL grant configuration ("OnSR", periodic TA is not started).
9. Source Cell: Send *RRCReconfiguration*.
10. Target Cell: Receive *RRCReconfigurationComplete*.
11. Target Cell: Start periodic TA.
12. Target Cell: Inform the SS about completion of the HO (e.g. to trigger PDCP STATUS REPORT PDU).
13. Target Cell: Re-configure RACH procedure as for initial access.
14. Target Cell: Configure measurement gap (if configured in the source cell or as provided in the *RRCReconfiguration* message).
15. Source Cell: Reset SRBs and release DRBs.
16. Source Cell: Release MeasGapConfig configuration.

### 7.3.5.3.2 Sequence of intra-NR intra-cell handover

For intra-NR intra-cell handover dedicated timing information is used: the sequence starts at time T with sending of the *RRCReconfiguration*. T is set to 300 ms in advance of the handover.

1. Before T: Get PDCP count for AM DRBs and SRBs (if applied).
2. At T: Send *RRCReconfiguration*.
3. At T + 5ms: Release SRBs and DRBs.
4. At T + 5ms: Configure RACH procedure either dedicated or C-RNTI based.

NOTE 1: Since the RACH procedure may require a new C-RNTI to be used it cannot be configured before sending out the *RRCReconfiguration*.

NOTE 2: The FollowOnFlag is set to true in the ASPs reconfiguring the RadioBearerList (step 3) and C-RNTI (step 4).

5. At T + 5ms: (Re-)configure measurement gap if provided in the *RRCReconfiguration* message.
6. At T + 10ms: (Re-) configure SRBs and DRBs.

7. At T + 10ms: Set PDCP COUNT for AM DRBs and SRBs (if applied).

NOTE 3: For AM DRBs the PDCP count is maintained while for UM DRBs the PDCP count is reset. For SRBs, the PDCP count is maintained or reset depending on the *RRCReconfiguration* message content.

8. At T + 10ms: Re-establish security, disable TA transmission.

9. (after step 7) Receive *RRCReconfigurationComplete*.

10. (after step 8) Re-configure RACH procedure as for initial access, enable TA transmissions.

NOTE 4: The FollowOnFlag is set to true in the ASP reconfiguring RACH.

### 7.3.5.3.3 UL grants used in RA procedure during handover

An UL grant is assigned to the UE by the RAR and in case of CBRA with C-RNTI based contention resolution another UL grant, as initial grant, is assigned for contention resolution.

When UL data is pending, the UE will try to put as much data into given grants as possible, i.e. it will segment the user data and send it e.g. with the initial grant if possible. To avoid this segmentation of user data, the grant assigned by RAR and the initial grant during handover are set according to Table 7.1.2.3.3-1.

### 7.3.5.3.4 Sequence of intra-NR inter-cell CA handover

This procedure is applicable when there are more than one CC before and after the handover.

The intra-NR inter-cell CA handover is done with activation time, i.e. the timing information for configuration of the SS and sending of the *RRCReconfiguration* is explicit. Time 'T' is set to 700 ms in advance of the handover, time T1 = T + 10 ms and time T2 = T + 20 ms.

At Time T, steps 1-3:

1. Source PCell: Stop periodic TA.

NOTE 1: Unless explicitly specified UL grant configuration keeps configured as per default at the source cell.

2. Target PCell: Configure target PCell for no RACH response transmission.

3. Source PCell: Schedule the transmission of *RRCReconfiguration* message to UE requesting Handover to target PCell and SCell.

At time T1 if target PCell is the same as source SCell, else at time "Now", steps 4-6:

4. Target PCell: If target PCell is same as source SCell, configure SS for target PCell to be converted from a SCell to PCell.

5. Target PCell: Configuration of DRBs

6. Transfer of the PDCP Count for AM DRBs and SRBs (if applied) from source to target PCell:

a) Source PCell: Get PDCP COUNT.

b) Target PCell: Set PDCP COUNT.

NOTE 2: No further sending/receiving of DRB data before the HO is done.

NOTE 3: For AM DRBs the PDCP count is maintained, for UM DRBs the PDCP count is reset. For SRBs, the PDCP count is maintained or reset depending on the *RRCReconfiguration* message content.

At time T2, steps 7-12:

7. Target PCell: Inform the SS about the HO and about the source PCell id.

8. Target PCell: Configure RACH procedure either dedicated or C-RNTI based.

NOTE 4: The FollowOnFlag is set to true in the ASP reconfiguring C-RNTI.

- 9. Target PCell: Activate security.
- 10. Target PCell: Configure UL grant configuration ("OnSR", periodic TA is not started).
- 11. Target PCell: Configure Target PCell as PCell.

NOTE 5: The FollowOnFlag is set to true in the ASP reconfiguring PCell.

- 12. Target SCell: Configure Target SCell as SCell with new PCell association.

After time T2 (without activation time):

- 13. Target PCell: Receive *RRCReconfigurationComplete*.
- 14. Target PCell: Start periodic TA.
- 15. Target PCell: Inform the SS about completion of the HO (e.g. to trigger PDCP STATUS REPORT PDU).
- 16. Target PCell: Re-configure RACH procedure as for initial access.
- 17. Source PCell: If source PCell is not target SCell:
  - 17.1 Reset SRBs and release DRBs.
  - 17.2 Configure from PCell to normal cell.
- 18. Source SCell: If source SCell is neither target PCell nor target SCell:
  - 18.1 Re-configure source SCell to normal cell and remove source SCell from the SCell list in the source PCell.

#### 7.3.5.4 RRC connection re-establishment

In general, the re-establishment is done without activation time, i.e. the timing information for configuration of the SS and sending of the *RRCReestablishment* is 'Now'.

The Source Cell and Target cell can be the same cell.

- 1. Target Cell: Reconfigure DCCH/DTCH DCI on CSS and reconfigure RACH procedure contention-based with UE Contention Resolution Identity MAC CE and with a new C-RNTI.

NOTE 1: The FollowOnFlag is set to true in the ASP reconfiguring C-RNTI.

- 2. Target Cell: Receive *RRCReestablishmentRequest*.
- 3. Source Cell: If the Source Cell is the same as the Target Cell:
  - Reset SRBs and release DRBs.
  - Stop periodic TA.

NOTE 2: The FollowOnFlag is set to true in the ASP configuring the SRBs.

- 4. Target Cell: If the Source Cell is different from the Target Cell:
  - Configure UL grant configuration ("OnSR").
- 5. Target Cell: Activate Security.
- 6. Target Cell: Send *RRCReestablishment*.
- 7. Target Cell: Receive *RRCReestablishmentComplete*.
- 8. Target Cell: Reconfigure DRBs and reconfigure UL DCCH/DTCH DCI on USS.
- 9. Target Cell: Send *RRCReconfiguration*.
- 10. Target Cell: Receive *RRCReconfigurationComplete*.

11. Target Cell: Reconfigure DL DCCH/DTCH DCI on USS.

NOTE 3: The FollowOnFlag is set to true in the ASP reconfiguring the target PCell.

12. Target Cell: Re-configure RACH procedure as for initial access, enable TA transmissions.

NOTE 4: The FollowOnFlag is set to true in the ASP reconfiguring the target PCell.

13. Source Cell: If the Source Cell is different from the Target Cell:

Reset SRBs and release DRBs.

Stop periodic UL grant and periodic TA.

NOTE 5: The FollowOnFlag is set to true in the ASP configuring the SRBs

### 7.3.5.5 NR-DC PSCell change

#### 7.3.5.5.1 Sequence of NR-DC inter-cell PSCell change

In general, the NR inter-cell PSCell change is done without activation time, i.e. the timing information for configuration of the SS and sending of the *RRCReconfiguration* is 'Now'.

1. NR Target PSCell: Configuration of SRB3 (if necessary) and DRBs.
2. Transfer of the PDCP Count for DRBs and SRB3 (if necessary) from NR source to NR target PSCell:
  - a) NR Source PSCell: Get PDCP COUNT.
  - b) NR Target PSCell: Set PDCP COUNT.

NOTE 1: No further sending/receiving of DRB data before the PSCell change is done.

NOTE 2: For AM DRBs the PDCP count is maintained. For SRB3 (if applied) and UM DRBs, the PDCP count is maintained or reset depending on the *RRCReconfiguration* message content.

3. NR Target PSCell: Inform the SS about the PSCell change and about the source cell id.
4. NR Target PSCell: Configure RACH procedure either dedicated or C-RNTI based.

NOTE 3: The FollowOnFlag is set to true in the ASP reconfiguring C-RNTI.

5. NR Target PSCell: Activate security.
6. NR Target PSCell: Configure UL grant configuration ("OnSR", default grant).

NOTE 4: Unless explicitly specified UL grant configuration keeps configured as per default at the NR source PSCell.

7. NR PCell: Send *RRCReconfiguration*.
8. NR PCell: Receive *RRCReconfigurationComplete*.
9. NR Target PSCell: Inform the SS about completion of the PSCell change (e.g. to trigger PDCP STATUS REPORT PDU).
10. NR Source PSCell: Release SRB3 (if necessary) and DRBs.

#### 7.3.5.5.2 Sequence of NR-DC intra-cell PSCell change

For NR-DC NR intra-cell PSCell change dedicated timing information is used: the sequence starts at time T with sending of the *RRCReconfiguration*. T is set to 300 ms in advance of the PSCell change.

1. NR PCell before T: Get PDCP count for DRBs and SRB3 (if applied).
2. NR PCell at T: Send *RRCReconfiguration*.

3. NR PSCell at T: Release SRB3 (if necessary) and DRBs.
4. NR PSCell at T: Configure RACH procedure either dedicated or C-RNTI based.

NOTE 1: The FollowOnFlag is set to true in the ASP reconfiguring C-RNTI.

5. NR PSCell at T + 5ms: (Re-)configure SRB3 (if necessary) and DRBs.
6. NR PSCell at T + 5ms: Restore the PDCP counts

NOTE 2: For AM DRBs the PDCP count is maintained. For SRB3 (if applied) and UM DRBs, the PDCP count is maintained or reset depending on the *RRCReconfiguration* message content.

7. NR PSCell at T + 5ms: Re-establish security.
8. NR PCell: Receive *RRCReconfigurationComplete*.

### 7.3.5.5.3 Sequence of NR-DC intra-PCell handover and intra-cell PSCell change

For NR-DC intra-NR intra PCell handover dedicated timing information is used: the sequence starts at time T with sending of the *RRCReconfiguration*. T is set to 300 ms in advance of the handover.

1. PCell and PSCell before T: Get PDCP count for AM DRBs and SRBs (if applied).
2. PCell At T : Send *RRCReconfiguration*.
3. PCell and PSCell at T + 5ms: Release SRBs and DRBs.
4. PCell and PSCell at T + 5ms: Configure RACH procedure either dedicated or C-RNTI based.

NOTE 1: Since the RACH procedure may require a new C-RNTI to be used it cannot be configured before sending out the *RRCReconfiguration*.

NOTE 2: The FollowOnFlag is set to true in the ASPs reconfiguring the RadioBearerList (step 3) and C-RNTI (step 4).

5. PCell and PSCell at T + 10ms: (Re-) configure SRBs and DRBs.
7. PCell and PSCell at T + 10ms: Set PDCP COUNT for AM DRBs and SRBs (if applied).

NOTE 3: For AM DRBs the PDCP count is maintained while for UM DRBs the PDCP count is reset. For SRBs, the PDCP count is maintained or reset depending on the *RRCReconfiguration* message content.

8. PCell and PSCell at T + 10ms: Re-establish security, disable TA transmission.
9. PCell (after step 8) Receive *RRCReconfigurationComplete*.
10. PCell (after step 9) Re-configure RACH procedure as for initial access, enable TA transmissions.

NOTE 4: The FollowOnFlag is set to true in the ASP reconfiguring RACH.

## 7.3.6 Bearers

### 7.3.6.1 DRB Identity Management

If a UE is configured to establish more than one PDU session at switch on, the order in which they are requested by the UE cannot be guaranteed; and in fact may be different between successive instances of switching on in the same test case. In order to align NR/5GC with EN-DC and E-UTRA/EPC, TTCN allocates:

- *drb-Identity 1* for the default DRB of the PDU session for IMS.
- *drb-Identity 2* onwards for other DRB(s).



## 7.3.7 Processing delay testing for RRC procedures

### 7.3.7.1 Introduction

Test cases testing RRC procedure delay (according to TS 38.331 [16] clause 12), when UE is PUCCH synchronized and can respond to UL grant, require special test method.

### 7.3.7.2 Procedure delays in PUCCH synchronized state

The following SS and UE configurations apply:

By default in TS 38.508-1[5] DRX is not configured.

By default SS is configured to retransmit any DL MAC PDU max 4 times.

HARQ retransmissions in UL cannot be compensated, any HARQ error in UL shall result in an inconclusive verdict for the test case (otherwise a UE may get fail due to a HARQ error).

SS is configured to report UL HARQ ACK/NACK received from UE to TTCN.

NOTE: Due to L2 signalling (e.g. RLC STATUS PDUs) it is necessary to limit the reporting of UL HARQ ACK/NACK to the time between sending of the DL RRC message and receiving the HARQ ACK.

To avoid unexpected side effects the *timeAlignmentTimer* is set to infinity and TTCN configures the SS to not send any Timing Advance Command MAC CE during the test case body (since this may result in additional UL HARQ ACK/NACK).

SS is configured to report HARQ errors and in the case of an UL HARQ error, an inconclusive verdict is assigned.

The following timing applies:

Let  $N_{sf}$  be the maximum allowed RRC procedure delay value (in ms) as specified in the test case prose.  $N_{sf}$  is the maximum time allowed for UE from the end of reception of the DL message on the UE physical layer up to when the UE shall be ready for the reception of UL grant for the transmission of the response message.

NOTE: A tolerance may have been added to the  $N_{sf}$  value in the test case prose on top of the RRC procedure delay specified in TS 38.331 [16] clause 12.

$$\text{Let } N_{\text{slot}} = (N_{\text{sf}} * N_{\text{slot}}^{\text{subframe}, \mu}) + 1$$

TTCN schedules at time  $T_1$  the transmission of the DL message to the UE.

$T_2$  is the time HARQ ACK is received.

TTCN schedules UL grants from  $T_3$ :  $T_3 = T_1 + N_{\text{slot}} + \Delta_1$

$\Delta_1$  is expressed in slots.  $T_1$  and  $T_3$  timing are expressed in SFN/subframe/slots.

For FDD

$$\Delta_1 = 0$$

The UL grant is repeated continuously in every slot

For FR1 TDD SCS=15kHz

$\Delta_1 = 5 - (T_1 + N_{\text{slot}}) \bmod 5$ . This is the possible slot delay since not all slots can be used for UL grant.

The UL grant periodicity is set to 5 slots. It is repeated in subframe#0 and subframe#5, to cope with  $K_2=4$  and the UL subframe#4 and subframe#9.

For FR1 TDD SCS=30kHz

$\Delta_1 = (4 - (T_1 + N_{\text{slot}}) \bmod 10) \bmod 10$ . This is the possible slot delay since not all slots can be used for UL grant.

The UL grant periodicity is set to 10 slots. It is repeated in slot#0 in subframe#2 and subframe#7, to cope with K2=4 and the UL slots: slot#0 in subframe#4 and subframe#9.

For FR2 TDD SCS=120kHz

$\Delta_1 = (5 - (T1 + Nslot) \bmod 5) \bmod 5$ . This is the possible slot delay since not all slots can be used for UL grant.

The UL grant periodicity is set to 5 slots. It is repeated for possible transmission in every UL slots.

The UL data is received by SS at T4.

The RRC procedure delay requirements are fulfilled when:  $(T4 - K2) - (T2 - K1) \leq Nslot + \Delta_2$

$\Delta_2$  is expressed in slots. T4 and T2 timing are expressed in SFN/subframe/slots.

For FDD

$\Delta_2 = 0$

For FR1 TDD SCS=15kHz

$\Delta_2 = 5 - (T2 - K1 + Nslot) \bmod 5$

For FR1 TDD SCS=30kHz

$\Delta_2 = (4 - (T2 - K1 + Nslot) \bmod 10) \bmod 10$

For FR2 TDD SCS=120kHz

$\Delta_2 = (5 - (T2 - K1 + Nslot) \bmod 5) \bmod 5$

Figure 7.3.7.2-1 shows the RRC procedure delay check sequence that will be applied when the DL Message is retransmitted once when UE is in PUCCH synchronized state and can respond to UL grants.

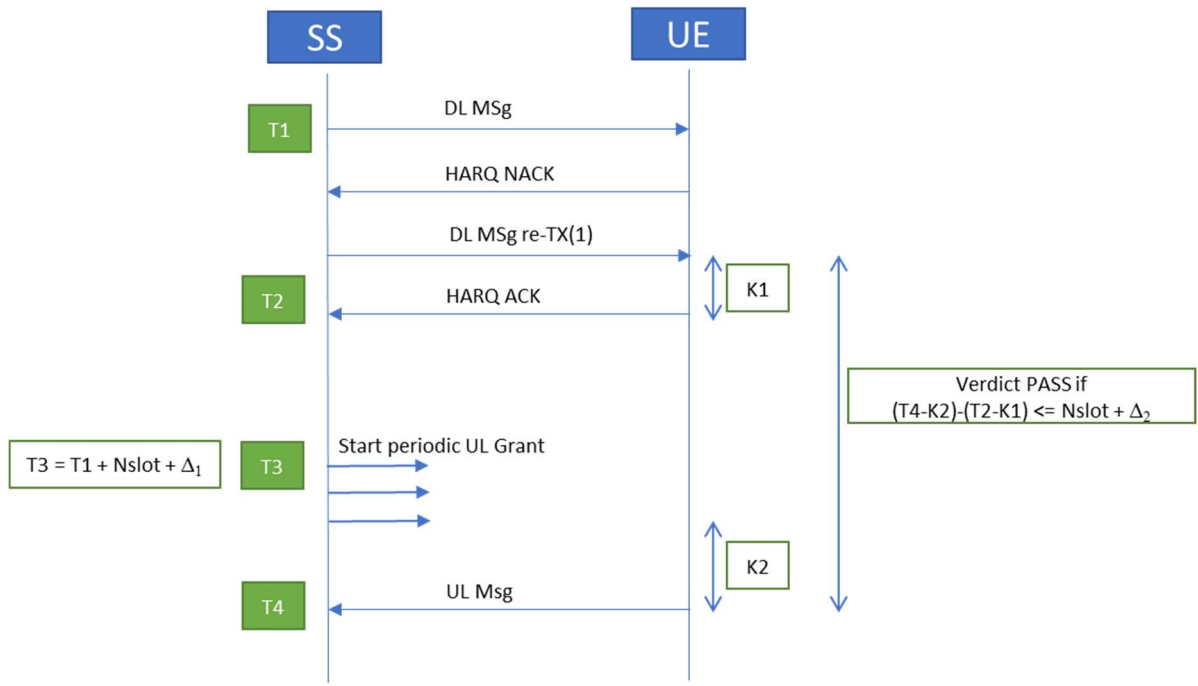

Figure 7.3.7.2-1: Delays in PUCCH synchronized state

## 8 Other SS requirements with TTCN-3 impact

### 8.1 Codec requirements

The SS shall comply with the requirements specified in TS 36.523-3 [12] subclause 8.1. In addition, the SS shall also comply with the codec requirements specified in Table 8.1-1.

**Table 8.1-1: Codec requirements**

Type definitions	Codec requirements	Encoding rule in TTCN-3
NR ASN.1 types used for RRC signalling	shall comply to TS 38.331 [16] subclause 8.3	UNALIGNED_PER_OctetAligned
EAP types	shall comply to Tabular Notated (see note)	EAP Types
NOTE: Tabular Notated is performed by concatenation of all the present fields in the TTCN-3 template.		

### 8.2 External function definitions

The SS shall implement the external functions specified in TS 36.523-3 [12] subclause 8.2.

The following external functions shall also be implemented by the SS.

TTCN-3 External Function		
<b>Name</b>	<b>fx_NG_NasIntegrityAlgorithm</b>	
<b>Description</b>	Apply integrity protection algorithm on a given octetstring	
<b>Parameters</b>	NAS PDU	octetstring according to TS 24.501 [26], clause 4.4.3.3 this shall include octet 7 to n of the security protected NAS message, i.e. the sequence number IE and the NAS message IE
	Integrity Algorithm	4 bits as defined in TS 24.501 [26], clause 9.11.3.34
	KNAS <sub>int</sub>	Integrity key
	NAS COUNT	as documented in TS 24.501 [26]
	BEARER Id	fix value of '00000'B for 3GPP access and '00001'B for non-3GPP access
	Direction	UL: 0 DL: 1 (acc. to TS 33.501 [25], clause D.3.1)
<b>Return Value</b>	Message Authentication Code (4 octets)	

TTCN-3 External Function		
<b>Name</b>	<b>fx_NG_NasCiphering</b>	
<b>Description</b>	Apply ciphering on a given octetstring	
<b>Parameters</b>	NAS PDU	octetstring
	Ciphering Algorithm	4 bits as defined in TS 24.501 [26], clause 9.11.3.34
	KNAS <sub>enc</sub>	Ciphering Key
	NAS COUNT	as documented in TS 24.501 [26]
	BEARER Id	fix value of '00000'B for 3GPP access and '00001'B for non-3GPP access
<b>Return Value</b>	ciphered octet string	

TTCN-3 External Function		
<b>Name</b>	<b>fx_NG_NasDeciphering</b>	
<b>Description</b>	Apply deciphering on a given octetstring	
<b>Parameters</b>	ciphred NAS PDU	octetstring
	Ciphering Algorithm	4 bits as defined in TS 24.501 [26], clause 9.11.3.34
	KNAS <sub>enc</sub>	Ciphering Key
	NAS COUNT	as documented in TS 24.501 [26]
	BEARER Id	fix value of '00000'B for 3GPP access and '00001'B for non-3GPP access
<b>Return Value</b>	deciphered octet string	

TTCN-3 External Function		
<b>Name</b>	<b>fx_NR_AsIntegrityAlgorithm</b>	
<b>Description</b>	Apply integrity protection algorithm on a given octetstring	
<b>Parameters</b>	PDCP PDU	octetstring
	Integrity Algorithm	3 bits as defined in TS 33.501 [25]
	KRRC <sub>int</sub>	Integrity key
	PDCP COUNT	octetstring, length 4
	BEARER Id	the value of the DRB identity minus one
	Direction	UL: 0 DL: 1 (acc. to TS 33.501 [25], clause D.3)
<b>Return Value</b>	Message Authentication Code (4 octets)	

## 9 IXIT proforma

### 9.1 Introduction

The partial IXIT proforma contained in the present document is provided for completion, when the related Abstract Test Suite(s) is(are) to be used against the Implementation Under Test (IUT).

The completed partial IXIT will normally be used in conjunction with the completed ICS, as it adds precision to the information provided by the ICS.

The PIXITs specified in TS 36.523-3 [12] clause 9 apply. Additional 5GS PIXITs are specified in the following subclauses.

### 9.2 E-UTRA and NR PIXIT

**Table 9.2-1: EUTRA and NR PIXIT**

Parameter Name	Parameter Type	Default Value	Supported Values	Description
px_ENDC_BandCombination	ENDC_BandCombination_Type	DC_1A_n28A		Band combination for EN-DC test case
px_ENDC_CA_BandCombination	ENDC_CA_BandCombination_Type	DC_1A_n28A_n78A		EN-DC CA Band Combination
px_ENDC_SecondaryBandCombination	ENDC_BandCombination_Type	DC_1A_n77A		Secondary band combination for EN-DC test case
px_NR_CA_BandCombination	NR_CA_BandCombination_Type	CA_n3A_n77A		NR CA Band Combination
px_NR_DC_BandCombination	NR_DC_BandCombination_Type	DC_n78A_n257A		NR DC Band Combination
px_NR_DC_CA_BandCombination	NR_DC_CA_BandCombination_Type	DC_n78A_n257G		NR DC CA Band Combination
px_NR_CipheringAlgorithm	CipheringAlgorithm	nea2		Ciphering Algorithm (see Note 1)
px_NR_IntegrityProtAlgorithm	IntegrityProtAlgorithm	nia2		Integrity Algorithm (see Note 1)
px_NR_OverlappingNotSupportedBand_MFBI	integer	1		A not supported NR band that is overlapping with a supported band (px_NR_PrimaryBand). Applied to MFBI test case scenario.
px_NR_PrimaryBand	integer	1		NR primary band
px_NR_SecondaryBand	integer	2		NR secondary band. Applied to inter-band and SUL test cases.
NOTE 1: Unless specified otherwise in the test case prose, the null algorithm shall not be used for verification.				
NOTE 2: Void.				
NOTE 3: Void.				

### 9.3 5GC PIXIT

Table 9.3-1: Void

Table 9.3-2: 5GC PIXIT

Parameter Name	Parameter Type	Default Value	Supported Values	Description
px_NAS_5GC_AuthenticationType	NAS_5GC_AKA_Type	AKA_5G	AKA_5G, AKAP_EAP	NAS 5GC Authentication type
px_NAS_5GC_CipheringAlgorithm	B4_Type	'0010'B		NAS 5GC Ciphering Algorithm (see Note 1)
px_NAS_5GC_IntegrityProtAlgorithm	B4_Type	'0010'B		NAS 5GC Integrity Algorithm (see Note 1)
px_NAS_5GC_XRES_Length	integer	16		NAS 5GC XRES length, in octets, used in Authentication

NOTE 1: Unless specified otherwise in the test case prose, the null algorithm shall not be used for verification.

## 10 Postambles

### 10.1 Introduction

The purpose of the present clause 10 is to specify the postambles used to bring the UE to a well-defined state regardless of the UE state at the termination of main test body or of the SS conditions and values of the system information inherited from the test.

### 10.2 On E-UTRA/EPC

#### 10.2.1 UE postamble states and procedures

In order to bring the UE to switched/power off state there are some procedures that need to be executed. The identified procedures are shown in figure 10.2.1-1.

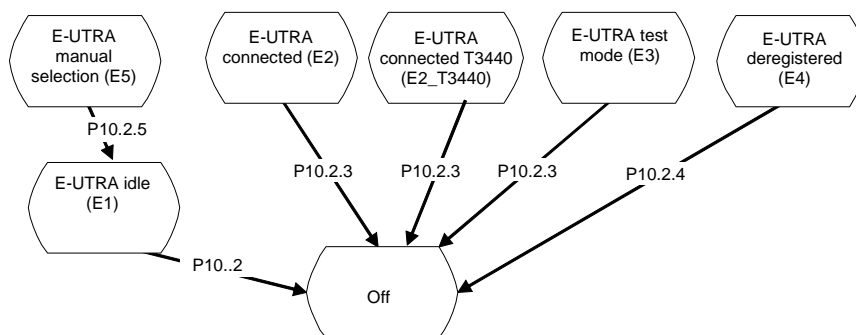

Figure 10.2.1-1: UE postamble states and procedures for E-UTRA/EPC

## 10.2.2 Switch/Power off procedure in State E1

**Table 10.2.2-1: Switch/Power off procedure**

Step	Procedure	Message Sequence	
		U - S	Message
1-2a3Aa5	Same as TS 36.523-3 [12] table 10.3.2.1-1, steps 1-2a3Aa5.	-	-
-	EXCEPTION: Step 2a3Aa5Aa1 describes behaviour depending UE implementation; the "lower case letter" identifies a step sequence that take place if the UE performs a specific action.	-	-
2a3Aa5Aa1	IF the UE is connected to one or more additional PDNs, then the procedure specified in table 10.2.2-2 may take place.	-	-
2a3Aa6 - 2a4	Same as TS 36.523-3 [12] table 10.3.2.1-1, steps 2a3Aa6 - 2a4.	-	-

**Table 10.2.2-2: PDN disconnect procedure**

Step	Procedure	Message Sequence	
		U - S	Message
1	The UE transmits a PDN DISCONNECT REQUEST	-->	RRC: <i>ULInformationTransfer</i> PDN DISCONNECT REQUEST
2	The SS transmits an <i>RRCConnectionReconfiguration</i> message to deactivate an EPS bearer.	<--	RRC: <i>RRCConnectionReconfiguration</i> NAS: DEACTIVATE EPS BEARER CONTEXT REQUEST
-	EXCEPTION: The events in steps 3 and 4 may occur in any order	-	-
3	The UE transmits an <i>RRCConnectionReconfigurationComplete</i> message to confirm the deactivation of EPS bearer.	-->	RRC: <i>RRCConnectionReconfigurationComplete</i>
4	The UE transmits an <i>ULInformationTransfer</i> message to accept deactivation of the EPS bearer.	-->	RRC: <i>ULInformationTransfer</i> NAS: DEACTIVATE EPS BEARER CONTEXT ACCEPT

## 10.2.3 Switch/Power off procedure in States E2 and E3

### 10.2.3.1 Procedure for E2 and E3

**Table 10.2.3.1-1: Switch/Power off procedure**

Step	Procedure	Message Sequence	
		U - S	Message
1-2a1Aa2	Same as TS 36.523-3 [12] table 10.3.3.1-1, steps 1-2a1Aa2.	-	-
-	EXCEPTION: Step 2a1Aa3a1 describes behaviour depending UE implementation; the "lower case letter" identifies a step sequence that take place if the UE performs a specific action.	-	-
2a1Aa3a1	IF the UE is connected to one or more additional PDNs, then the procedure specified in table 10.2.2-2 may take place.	-	-
2a1-2a2	Same as TS 36.523-3 [12] table 10.3.3.1-1, steps 2a1-2a2.	-	-

10.2.3.2 Procedure for E2\_T3440

**Table 10.2.3.2-1: RRC release and switch/power off procedure**

Step	Procedure	Message Sequence	
		U - S	Message
1-4a3Aa5	Same as TS 36.523-3 [12] table 10.3.3.2-1, steps 1-4a3Aa5.	-	-
-	EXCEPTION: Step 4a3Aa5Aa1 describes behaviour depending UE implementation; the "lower case letter" identifies a step sequence that take place if the UE performs a specific action.	-	-
4a3Aa5Aa1	IF the UE is connected to one or more additional PDNs, then the procedure specified in table 10.2.2-2 may take place.	-	-
4a3Aa6 - 4a4	Same as TS 36.523-3 [12] table 10.3.3.2-1, steps 4a3Aa6 – 4a4.	-	-

10.2.4 Switch/Power off procedure in State E4

The procedure specified in TS 36.523-3 [12] subclause 10.3.4 applies.

10.2.5 Automatic selection mode procedure in State E5 (current cell, neighbour cell)

The procedure specified in TS 36.523-3 [12] subclause 10.3.5 applies.

10.3 On NR/5GC

10.3.1 UE postamble states and procedures

In order to bring the UE to the switched/powered off state, a procedure needs to be executed, which depends on the UE state at the end of test case body. The UE postamble start states and associated procedures are shown in figure 10.3.1-1.

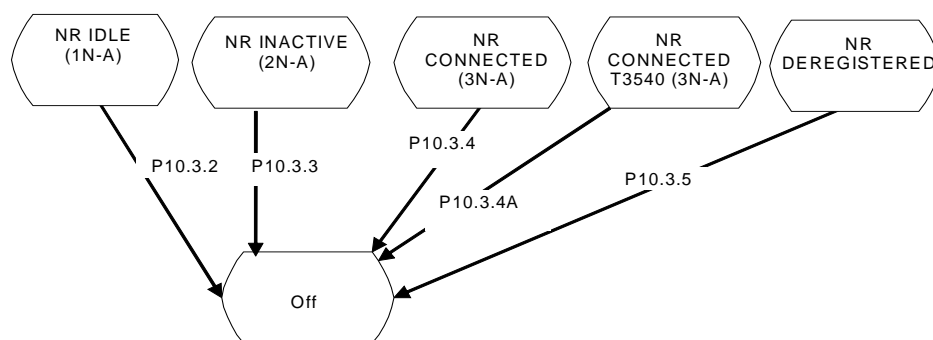

**Figure 10.3.1-1: UE postamble states and procedures for NR/5GC**

If the test body ends by releasing an emergency call whilst in limited service, the UE may be in either NR REGISTERED or in NR DEREGISTERED state as the UE behaviour is not specified. The postamble procedures shall allow for both possible start states.



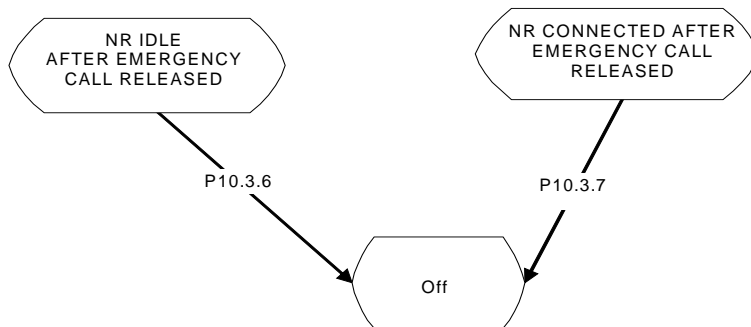

Figure 10.3.1-2: UE postamble states and procedures after emergency call release in limited service

### 10.3.2 Switch/Power off procedure in State 1N-A

Table 10.3.2-1: Switch/Power off procedure

Step	Procedure	Message Sequence	
		U - S	Message
1	Test procedure for Switch off / Power off in RRC_IDLE as specified in 38.508-1 [5] subclause 4.9.6.1	-	-

### 10.3.3 Switch/Power off procedure in State 2N-A

Table 10.3.3-1: Switch/Power off procedure

Step	Procedure	Message Sequence	
		U - S	Message
1	Test procedure for Switch off / Power off in RRC_INACTIVE as specified in 38.508-1 [5] subclause 4.9.6.2		

### 10.3.4 Switch/Power off procedure in State 3N-A

Table 10.3.4-1: Switch/Power off procedure

Step	Procedure	Message Sequence	
		U - S	Message
1	Test procedure for Switch off / Power off in RRC_CONNECTED as specified in 38.508-1 [5] subclause 4.9.6.3	-	-

### 10.3.4A Switch/Power off procedure in State 3N-A with T3540 started

Table 10.3.4A-1: Switch/Power off procedure

Step	Procedure	Message Sequence	
		U - S	Message
1	Test procedure for Switch off / Power off in RRC_CONNECTED with T3540 started as specified in 38.508-1 [5] subclause 4.9.6.3A	-	-

### 10.3.5 Switch/Power off procedure in NR DEREGISTERED

**Table 10.3.5-1: Switch/Power off procedure**

Step	Procedure	Message Sequence	
		U - S	Message
1	Test procedure for Switch off / Power off in State DEREGISTERED as specified in 38.508-1 [5] subclause 4.9.6.4	-	-

### 10.3.6 Switch/Power off procedure after EMERGENCY CALL RELEASED in RRC\_IDLE

**Table 10.3.6-1: Switch/Power off procedure**

Step	Procedure	Message Sequence	
		U - S	Message
-	EXCEPTION: Steps 1a1 to 1b1 describe behaviour that depends on the UE capability; the "lower case letter" identifies a step sequence that take place if [36] pc_SwitchOnOff or [37] pc_USIM_Removal is supported.	-	-
1a1	IF pc_SwitchOnOff THEN switch off UE, IF pc_USIM_Removal THEN remove the USIM (NOTE 1)	-	-
1a2	Start T_Delay=5 sec		
-	EXCEPTION: Steps 1a3a1 to 1a3b1 describe behaviour depending UE implementation; the "lower case letter" identifies a step sequence that take place if the UE performs a specific action.	-	-
1a3a1	The UE transmits an <i>RRCSetupRequest</i> message	-->	NR RRC: <i>RRCSetupRequest</i>
1a3a2	Stop T_Delay		
1a3a3	SS transmits an <i>RRCSetup</i> message	<--	NR RRC: <i>RRCSetup</i>
1a3a4	The UE transmits an <i>RRCSetupComplete</i> message including the DEREGISTRATION REQUEST message	-->	NR RRC: <i>RRCSetupComplete</i> 5GMM: DEREGISTRATION REQUEST
1a3a5	The SS transmits an <i>RRCRelease</i> message	<--	RRC: <i>RRCRelease</i>
1a3b1	T_Delay expires (NOTE 2)	-	-
1b1	ELSE power off UE (NOTE 3)	-	-
NOTE 1: USIM removal is a feasible alternative to switch off UE.			
NOTE 2: The UE has performed local deregistration			
NOTE 3: Power off is used when UE does not support switch off or USIM removal, in which case no UE originated deregistration procedure is expected.			

### 10.3.7 Switch/Power off procedure after EMERGENCY CALL RELEASED in RRC\_CONNECTED

**Table 10.3.7-1: Switch/Power off procedure**

Step	Procedure	Message Sequence	
		U - S	Message

1	The SS transmits a DEREGISTRATION REQUEST message with Deregistration type IE set to "re-registration not required".	<--	NR RRC: <i>DLInformationTransfer</i> 5GMM: DEREGISTRATION REQUEST
2	Start T_Delay=5 sec.		
-	EXCEPTION: Steps 3a1 – 3b2 describes optional behaviour that depends on the UE implementation.	-	-
3a1	The UE transmits a DEREGISTRATION ACCEPT message.	-->	NR RRC: <i>ULInformationTransfer</i> 5GMM: DEREGISTRATION ACCEPT
3a2	Stop T_Delay.		
3a3	The SS transmits an <i>RRCRelease</i> message	<--	RRC: <i>RRCRelease</i>
3b1	T_Delay expires. (NOTE 1)	-	-
3b2	The SS locally releases the RRC connection.		
4	Test procedure for Switch off / Power off in State DEREGISTERED as specified in TS 38.508-1 [5] subclause 4.9.6.4.	-	-
NOTE 1: The UE has performed local deregistration, so the SS shall also perform the deregistration procedure.			

Table 10.3.7-2: DEREGISTRATION REQUEST (Step 1, Table 10.3.7-1)

Derivation Path: TS 38.508-1 [5], Table 4.7.1-14.			
Information Element	Value/remark	Comment	Condition
De-registration type	'0001'B	Re-registration not required	

## 10.4 On UTRAN

Please refer to TS 36.523-3 [12] subclause 10.1.

# 11 Guidelines on test execution

## 11.1 Introduction

Clause 11 provides the guidelines on test executions.

The restriction on test case execution is due to the number of frequencies available for the specific band under test specified in TS 38.508-1[5] and the number of frequencies used by the test cases specified in TS 38.523-1[8].

## 11.2 EN-DC

### 11.2.1 Single NR carrier

This clause provides the guidelines for the EN-DC test cases.

A test case using more than one radio frequency on NR, i.e. using the radio frequencies NRf2 or NRf3 or NRf4 specified in TS 38.508-1 [5], shall not be executed on:

- Band combination DC\_1A\_n51A
- Band combination DC\_20A\_n51A
- Band combination DC\_28A\_n51A
- Band combination DC\_3A\_n51A
- Band combination DC\_41A\_n41A

Band combination DC\_42A\_n51A

Band combination DC\_7A\_n51A

The list of test cases is given below:

8.2.3.6.1a, 8.2.3.7.1a, 8.2.3.8.1a, 8.2.3.10.1, 8.2.3.11.1, 8.2.3.11.2

## 11.3 NR/5GC

### 11.3.1 NR/5GC single RAT

#### 11.3.1.1 Single NR carrier

This clause provides the guidelines for the NR/5GC test cases.

A test case using more than one radio frequency, i.e. using the radio frequencies NRf2 or NRf3 or NRf4 specified in TS 38.508-1 [5], shall not be executed on:

Band n51.

The list of test cases is given below:

6.1.1.1, 6.1.1.2, 6.1.1.3, 6.1.1.5, 6.1.1.6, 6.1.1.7, 6.1.1.8, 6.1.2.7, 6.1.2.11, 6.1.2.13, 6.1.2.14, 6.1.2.16, 6.1.2.18, 6.1.2.20, 6.1.2.21, 6.1.2.22, 6.3.1.1, 6.3.1.2, 6.3.1.3, 6.3.1.4, 6.3.1.5, 6.3.1.8, 6.3.1.9, 6.4.1.1, 6.4.1.2, 6.4.2.2,

8.1.1.2.1, 8.1.1.3.1, 8.1.1.3.3, 8.1.1.3.7, 8.1.3.1.3, 8.1.3.1.6, 8.1.3.1.9, 8.1.3.1.11, 8.1.3.1.12, 8.1.3.1.14A, 8.1.3.1.15A, 8.1.3.1.20, 8.1.3.21, 8.1.4.1.2, 8.1.6.1.2.2, 8.1.6.1.2.10, 8.1.6.1.3.2, 8.1.6.1.3.3, 8.1.6.1.3.7, 8.1.6.1.4.7,

9.1.4.1, 9.1.5.1.1, 9.1.5.1.2, 9.1.5.1.4, 9.1.5.1.8, 9.1.5.1.10, 9.1.5.1.12, 9.1.5.1.14,

11.3.6, 11.3.8, 11.3.9,

11.4.7, 11.4.8.

A test case using more than two radio frequencies, i.e. using the radio frequencies NRf3 or NRf4 specified in TS 38.508-1 [5], shall not be executed on:

Band n14,

Band n30,

Band n53.

The list of test cases is given below:

6.1.1.1, 6.1.1.2, 6.1.1.3, 6.1.1.5, 6.1.1.6, 6.1.1.7, 6.1.1.8, 6.1.2.7, 6.1.2.11, 6.1.2.20, 6.3.1.1, 6.3.1.2, 6.3.1.3, 6.3.1.5, 6.3.1.8, 6.4.1.1, 6.4.1.2, 6.4.2.2,

8.1.1.3.3, 8.1.6.3.3,

9.1.5.1.2, 9.1.5.1.8.

#### 11.3.1.2 NR carrier aggregation

The restriction on NR CA test case execution as listed in this clause is due to the restriction of bandwidth of an NR CA configuration accommodating the necessary number of NR radio frequencies.

These test cases with switched allocation of PCell and SCell on SCell shall avoid to be executed on an NR CA configuration with a secondary band having no UL frequency:

CA\_n28A\_n75A,

CA\_n29A\_n66A,  
CA\_n75A\_n78A,  
CA\_n76A\_n78A,  
CA\_n8A\_n75A

The list of test cases is given below:

8.1.4.1.7.2

## 11.3.2 NR/5GC Inter-RAT

### 11.3.2.1 NR/E-UTRA Inter-RAT

This clause contains the guidelines for the NR/5GC and E-UTRA inter-RAT test cases executed on the different bands. According to TS 38.508-1 [5] clause 6.2.3.3, it is assumed that the NR and E-UTRA bands under test are not overlapping.

A test case using more than one radio frequency on E-UTRA, i.e. using the radio frequencies f2, f3 or f4 specified in TS 36.508 [10], shall not be executed on:

Band 13,  
Band 18,  
Band 31,  
Band 72,  
Band 73

The list of test cases is given below:

6.4.3.1,  
8.1.1.3.4,  
11.1.4, 11.1.5.

A test case using more than one radio frequency on NR, i.e. using the radio frequencies NRf2 or NRf3 or NRf4 specified in TS 38.508-1 [5], shall not be executed on:

Band n51.

The list of test cases is given below:

6.2.1.1, 6.2.1.3.

A test case using more than two radio frequencies on NR, i.e. using the radio frequencies NRf3 or NRf4 specified in TS 38.508-1 [5], shall not be executed on:

Band n14,  
Band n30,  
Band n53

The list of test cases is given below:

6.2.1.1.

### 11.3.2.2 NR/EN-DC Inter-RAT

This clause contains the guidelines for the NR/5GC and EN-DC inter-RAT test cases.

A test case using more than one radio frequency on NR, i.e. using the radio frequencies NRf2 or NRf3 or NRf4 specified in TS 38.508-1 [5], shall not be executed on:

Band combination DC\_1A\_n51A

Band combination DC\_20A\_n51A

Band combination DC\_28A\_n51A

Band combination DC\_3A\_n51A

Band combination DC\_41A\_n41A

Band combination DC\_42A\_n51A

Band combination DC\_7A\_n51A

The list of test cases is given below:

8.1.4.2.1.2

### 11.3.3 NR MFBI

The following NR MFBI test case shall be executed using the combinations specified in Table 11.3.3-1 for px\_NR\_OverlappingNotSupportedBand\_MFBI and px\_NR\_PrimaryBand:

6.1.2.23.

**Table 11.3.3-1: NR MFBI bands combinations**

px_NR_OverlappingNotSupportedBand_MFBI	px_NR_PrimaryBand (Note)
n2	n25
n25	n2
n38	n41
n41	n38
n77	n78
n78	n77
n257	n258, n261
n258	n257
n261	n257
Note:	The UE supports one or more of the listed MFBI bands and does not support at least one overlapping band. If the UE supports all overlapping bands, these test cases are not applicable.

## Annex A (normative): Test Suites

This annex references the approved Test Suites, which accompany the present document. The Test Suites have been produced using the Testing and Test Control Notation version 3 (TTCN-3) according to ES 201 873 [4].

### A.1 Baseline of specifications

Table A.1-1 lists the core specifications and test specifications, which the delivered Test Suites are based upon.

**Table A.1-1: References of the test and core specifications**

Type	Specification	Release	Version
<b>Core specifications</b>	TS 38.321 [13]	Note 1	Note 2
	TS 38.322 [14]	Note 1	Note 2
	TS 38.323 [15]	Note 1	Note 2
	TS 36.331 [17]	Note 1	Note 2
	TS 38.331 [16]	Note 1	Note 2
	TS 24.301 [18]	Note 1	Note 2
<b>Test specifications</b>	TS 36.508 [10]	Note 2	Note 2
	TS 36.509 [11]	Note 1	Note 2
	TS 38.508-1 [5]	Note 2	Note 2
	TS 38.508-2 [6]	Note 2	Note 2
	TS 38.509 [7]	Note 1	Note 2
	TS 38.523-1 [8]	Note 2	Note 2
	TS 38.523-2 [9]	Note 2	Note 2
NOTE 1: Latest release available, up to the release number of the present document.			
NOTE 2: Latest available.			

### A.2 5GS Test Suites

#### A.2.1 EN-DC Test Suites

Table A.2.1-1 lists all approved test cases.

For a given test case, the following variants are distinguished (if applicable):

- FR1: FR1 NR frequency band(s) in the NR cell(s).
- FR2: FR2 NR frequency band(s) in the NR cell(s).
- FRx: Mix of FR1 NR frequency band(s) and FR2 NR frequency band(s) in the NR cell(s).

An "X" in columns FR1, FR2 or FRx indicates the test case is approved for the respective variant.

An "-" in columns FR1, FR2 or FRx indicates the test case is not applicable to the respective variant.

**Table A.2.1-1: EN-DC TTCN test cases**

Test case	Description	FR1	FR2	FRx
7.1.1.1.1.ENDC	Correct selection of RACH parameters / Random access preamble and PRACH resource explicitly signalled to the UE by RRC / contention free random access procedure	X	X	-
7.1.1.1.1a.ENDC	Correct selection of RACH parameters / Random access preamble and PRACH resource explicitly signalled to the UE by PDCCH Order / contention free random access procedure	X	X	-

7.1.1.1.2.ENDC	Random access procedure / Successful/ C-RNTI Based/Preamble selected by MAC itself	X	X	-
7.1.1.2.1.ENDC	Correct Handling of DL MAC PDU / Assignment / HARQ process	X	X	-
7.1.1.3.1.ENDC	Correct Handling of UL MAC PDU / Assignment / HARQ process	X	X	-
7.1.1.3.2.ENDC	Logical channel prioritization handling	X	X	-
7.1.1.3.3.ENDC	Correct handling of MAC control information / Scheduling requests	X	X	-
7.1.1.3.4.ENDC	Correct handling of MAC control information / Buffer status / UL data arrive in the UE Tx buffer / Regular BSR	X	X	-
7.1.1.3.5.ENDC	Correct handling of MAC control information / Buffer Status / UL resources are allocated / Padding BSR	X	X	-
7.1.1.3.6.ENDC	Correct handling of MAC control information / Buffer status / Periodic BSR timer expires	X	X	-
7.1.1.3.7.ENDC	UE power headroom reporting / Periodic reporting / DL pathloss change reporting	X	X	-
7.1.1.3.8.1.ENDC	UE power headroom reporting / SCell activation / DL pathloss change reporting / Intra-band Contiguous CA	X		-
7.1.1.4.1.1.ENDC	DL-SCH Transport Block Size selection / DCI format 1_0	X		-
7.1.1.4.2.1.ENDC	UL-SCH transport block size selection / DCI format 0_0 / Transform precoding disabled	X		-
7.1.1.4.2.3.ENDC	UL-SCH transport block size selection / DCI format 0_1 / RA type 0/RA Type 1 / Transform precoding disabled	X		-
7.1.1.4.2.5.ENDC	UL-SCH Transport Block Size selection / DCI format 0_0 / Transform precoding and 64QAM	X		-
7.1.1.5.1.ENDC	DRX operation / Short cycle not configured / Parameters configured by RRC	X	X	-
7.1.1.5.2.ENDC	DRX operation / Short cycle not configured /Long DRX command MAC control element reception	X	X	-
7.1.1.5.3.ENDC	DRX operation / Short cycle configured / Parameters configured by RRC	X	X	-
7.1.1.5.4.ENDC	DRX Operation / Short cycle configured / DRX command MAC control element reception	X	X	-
7.1.1.5.5.ENDC	DRX Operation / Short cycle configured / Long DRX command MAC control element reception	X	X	-
7.1.1.7.1.1.ENDC	Activation/Deactivation of SCells / Activation/Deactivation MAC control element reception / sCellDeactivationTimer / Intra-band Contiguous CA	X	X	-
7.1.1.7.1.2.ENDC	Activation/Deactivation of SCells / Activation/Deactivation MAC control element reception / sCellDeactivationTimer / Inter-band CA	X		
7.1.2.2.1.ENDC	UM RLC / Segmentation and reassembly / 6-bit SN / Segmentation Info (SI) field	X	X	-
7.1.2.2.2.ENDC	UM RLC / Segmentation and reassembly / 12-bit SN / Segmentation Info (SI) field	X	X	-
7.1.2.2.3.ENDC	UM RLC / 6-bit SN / Correct use of sequence numbering	X	X	-
7.1.2.2.4.ENDC	UM RLC / 12-bit SN / Correct use of sequence numbering	X	X	-
7.1.2.2.5.ENDC	UM RLC / Receive Window operation and t-Reassembly expiry	X	X	-
7.1.2.2.6.ENDC	UM RLC / RLC re-establishment procedure	X	X	-
7.1.2.3.1.ENDC	AM RLC / 12-bit SN/Segmentation and reassembly / Segmentation Info (SI) field	X	X	-
7.1.2.3.2.ENDC	AM RLC / 18-bit SN/Segmentation and reassembly / Segmentation Info (SI) field	X	X	-
7.1.2.3.3.ENDC	AM RLC / 12-bit SN / Correct use of sequence numbering	X	X	-
7.1.2.3.4.ENDC	AM RLC / 18-bit SN / Correct use of sequence numbering	X	X	-
7.1.2.3.5.ENDC	AM RLC / Control of transmit window / Control of receive window	X	X	-
7.1.2.3.6.ENDC	AM RLC / Polling for status	X	X	-
7.1.2.3.7.ENDC	AM RLC / Receiver status triggers	X	X	-
7.1.2.3.8.ENDC	AM RLC / Reconfiguration of RLC parameters by upper layers	X	X	-
7.1.2.3.9.ENDC	AM RLC / Reassembling of AMD PDUs	X	X	-
7.1.2.3.10.ENDC	AM RLC / Re-transmission of RLC PDU with and without re-segmentation	X	X	-
7.1.2.3.11.ENDC	AM RLC / RLC re-establishment procedure	X	X	-
7.1.3.1.1.ENDC	Maintenance of PDCP sequence numbers / User plane / 12-bit SN	X	X	-
7.1.3.1.2.ENDC	Maintenance of PDCP sequence numbers / User plane / 18-bit SN	X	X	-
7.1.3.2.1.ENDC	Integrity protection / Correct functionality of encryption algorithm SNOW3G / SRB / DRB	X	X	-
7.1.3.2.2.ENDC	Integrity protection / Correct functionality of encryption algorithm AES / SRB / DRB	X	X	-
7.1.3.2.3.ENDC	Integrity protection / Correct functionality of encryption algorithm ZUC / SRB / DRB	X	X	-
7.1.3.3.1.ENDC	Ciphering and deciphering / Correct functionality of encryption algorithm SNOW3G / SRB / DRB	X	X	-
7.1.3.3.2.ENDC	Ciphering and deciphering / Correct functionality of encryption algorithm AES / SRB / DRB	X	X	-
7.1.3.3.3.ENDC	Ciphering and deciphering / Correct functionality of encryption algorithm ZUC / SRB / DRB	X	X	-
7.1.3.4.1.ENDC	PDCP handover / Lossless handover / PDCP sequence number maintenance/PDCP status report to convey the information on missing or acknowledged PDCP SDUs at handover/ In-order delivery and duplicate elimination in the downlink	X	X	-



7.1.3.4.2.ENDC	PDCP handover / Non-lossless handover / PDCP sequence number maintenance	X	X	-
7.1.3.5.1.ENDC	PDCP Discard	X	X	-
7.1.3.5.2.ENDC	PDCP Uplink Routing / Split DRB	X	X	-
7.1.3.5.3.ENDC	PDCP Data Recovery	X	X	-
7.1.3.5.4.ENDC	PDCP reordering / Maximum re-ordering delay below t-Reordering / t-Reordering timer operations	X	X	-
8.2.1.1.1.ENDC	UE capability transfer / Success / EN-DC	X	X	-
8.2.2.1.1.ENDC	SRB3 Establishment, Reconfiguration and Release / NR addition, modification and release / EN-DC	X	X	-
8.2.2.2.1.ENDC	Split SRB Establishment and Release / EN-DC	X		-
8.2.2.3.1.ENDC	Simultaneous SRB3 and Split SRB / Sequential message flow on SRB3 and Split SRB with one UL path / EN-DC	X		-
8.2.2.4.1.ENDC	PSCell addition, modification and release / SCG DRB / EN-DC	X	X	-
8.2.2.5.1.ENDC	PSCell addition, modification and release / Split DRB / EN-DC	X	X	-
8.2.2.6.1.ENDC	Bearer Modification / MCG DRB / SRB / PDCP version change / EN-DC	X	X	-
8.2.2.7.1.ENDC	Bearer Modification / Handling for bearer type change without security key change / EN-DC	X	X	-
8.2.2.8.1.ENDC	Bearer Modification / Handling for bearer type change with security key change / EN-DC	X	X	-
8.2.2.9.1.ENDC	Bearer Modification / Uplink data path / Split DRB Reconfiguration / EN-DC	X	X	-
8.2.3.1.1.ENDC	Measurement configuration control and reporting / Inter-RAT measurements / Event B1 / Measurement of NR cells / EN-DC	X	X	-
8.2.3.2.1.ENDC	Measurement configuration control and reporting / Inter-RAT measurements / Event B1 / Measurement of NR cells / RSRQ based measurements / EN-DC	X		-
8.2.3.3.1.ENDC	Measurement configuration control and reporting / Inter-RAT measurements / Periodic reporting / Measurement of NR cells / EN-DC	X	X	-
8.2.3.4.1.ENDC	Measurement configuration control and reporting / Event A1 / Measurement of NR PSCell / EN-DC	X	X	-
8.2.3.5.1.ENDC	Measurement configuration control and reporting / Event A2 / Measurement of NR PSCell / EN-DC	X	X	-
8.2.3.6.1.ENDC	Measurement configuration control and reporting / Event A3 / Measurement of Neighbor NR cell / Intra-frequency measurements / EN-DC	X	X	-
8.2.3.6.1a.ENDC	Measurement configuration control and reporting / Event A3 / Measurement of Neighbour NR cell / Inter-frequency measurements / EN-DC	X	X	-
8.2.3.6.1b.ENDC	Measurement configuration control and reporting / Event A3 / Measurement of Neighbour NR cell / Inter-band measurements / EN-DC			-
8.2.3.7.1.ENDC	Measurement configuration control and reporting / Event A4 / Measurement of Neighbor NR cell / Intra-frequency measurements / EN-DC	X	X	-
8.2.3.7.1a.ENDC	Measurement configuration control and reporting / Event A4 / Measurement of Neighbour NR cell / Inter-frequency measurements / EN-DC	X	X	-
8.2.3.7.1b.ENDC	Measurement configuration control and reporting / Event A4 / Measurement of Neighbour NR cell / Inter-band measurements / EN-DC	X		-
8.2.3.8.1.ENDC	Measurement configuration control and reporting / Event A5 / Measurement of Neighbor NR cell / Intra-frequency measurements / EN-DC	X	X	-
8.2.3.8.1a.ENDC	Measurement configuration control and reporting / Event A5 / Measurement of Neighbour NR cell / Inter-frequency measurements / EN-DC	X	X	-
8.2.3.8.1b.ENDC	Measurement configuration control and reporting / Event A5 / Measurement of Neighbour NR cell / Inter-band measurements / EN-DC	X		-
8.2.3.12.1.ENDC	Measurement configuration control and reporting / Inter-RAT measurements / Event B2 / Measurement of NR cells / EN-DC	X		-
8.2.3.13.1.ENDC	PCell Handover with SCG change / Reconfiguration with sync / SCG DRB / EN-DC	X		-
8.2.3.14.1.ENDC	SCG change / Reconfiguration with sync / Split DRB / EN-DC	X	X	-
8.2.3.15.1.ENDC	Measurement configuration control and reporting / Two simultaneous events A2 and A3 (intra-frequency measurements) / Measurement of Neighbour NR cells / EN-DC	X		-
8.2.3.16.1.ENDC	Measurement configuration control and reporting / SRB3 / Intra NR measurements / EN-DC	X	X	-
8.2.4.1.1.1.ENDC	NR CA / NR SCell addition / modification / release / Success / EN-DC / Intra-band Contiguous CA	X	X	-
8.2.4.1.1.3.ENDC	NR CA / NR SCell addition / modification / release / Success / EN-DC / Inter-band CA	X		-
8.2.4.3.1.1.ENDC	NR CA / SCell change / Intra-NR measurement event A6 / SRB3 / EN-DC / Intra-band Contiguous CA	X		-
8.2.4.3.1.3.ENDC	NR CA / SCell change / Intra-NR measurement event A6 / SRB3 / EN-DC / Inter-band CA	X		-
8.2.5.1.1.ENDC	Radio link failure / PSCell addition failure - random access problem / EN-DC	X	X	-
8.2.5.2.1.ENDC	Radio link failure / PSCell out of sync indication / Radio link failure / EN-DC	X	X	-

8.2.5.3.1.ENDC	Radio link failure / rlc-MaxNumRetx failure / EN-DC	X	X	-
8.2.5.4.1.ENDC	Reconfiguration failure / SCG change failure / EN-DC	X	X	-
8.2.6.2.1.ENDC	Processing delay / PSCell addition / SCG DRB / Success / Latency check / EN-DC	X	X	-
10.2.1.1.ENDC	Default EPS bearer context activation	X	X	-
10.2.1.2.ENDC	Dedicated EPS bearer context activation	X	X	-
10.2.2.1.ENDC	EPS bearer resource allocation / modification	X	X	-

## A.2.2 NR/5GC Test Suites

Table A.2.2-1 lists all approved test cases.

For a given test case, the following variants are distinguished (if applicable):

- FR1: FR1 NR frequency band(s) in the NR cell(s).
- FR2: FR2 NR frequency band(s) in the NR cell(s).
- FRx: Mix of FR1 NR frequency band(s) and FR2 NR frequency band(s) in the NR cell(s).

An "X" in columns FR1 or FR2 indicates the test case is approved for the respective variant.

An "-" in columns FR1, FR2 or FRx indicates the test case is not applicable to the respective variant.

**Table A.2.2-1: NR/5GC TTCN test cases**

Test case	Description	FR1	FR2	FRx
6.1.1.1.NR5GC	PLMN selection of RPLMN, HPLMN/EHPLMN, UPLMN and OPLMN / Automatic mode	X		-
6.1.1.2.NR5GC	PLMN selection of "Other PLMN/access technology combinations" / Automatic mode	X		-
6.1.1.3.NR5GC	Cell reselection of ePLMN in manual mode	X		-
6.1.1.4.NR5GC	PLMN selection in shared network environment / Automatic mode	X		-
6.1.1.5.NR5GC	PLMN selection of RPLMN, HPLMN/EHPLMN, UPLMN and OPLMN / Automatic mode / User reselection	X		-
6.1.1.6.NR5GC	PLMN selection / Periodic reselection / MinimumPeriodicSearchTimer	X		-
6.1.1.7.NR5GC	PLMN selection of RPLMN or (E)HPLMN; Automatic mode	X		-
6.1.1.8.NR5GC	PLMN selection of RPLMN or (E)HPLMN; Manual mode	X		-
6.1.2.1.NR5GC	Cell Selection/Qrxlevmin & Cell Reselection (Intra NR)	X		-
6.1.2.2.NR5GC	Cell Selection/Qqualmin/Intra NR / Serving cell becomes non-suitable (Srxlev > 0, Squal < 0)			-
6.1.2.3.NR5GC	Cell selection / Intra NR/ Serving cell becomes non-suitable (S<0 , MIB Indicated barred)	X		-
6.1.2.4.NR5GC	Cell reselection for interband operation	X		-
6.1.2.5.NR5GC	Cell reselection for interband operation using Pcompensation / Between FDD and TDD	X		-
6.1.2.7.NR5GC	Cell reselection / Equivalent PLMN	X		-
6.1.2.8.NR5GC	Cell reselection / Equivalent PLMN / Single Frequency operation	X		-
6.1.2.9.NR5GC	Cell reselection using Qhyst, Qoffset and Treselection	X		-
6.1.2.11.NR5GC	Area Specific SIBs using systemInformationAreaID	X		-
6.1.2.12.NR5GC	Cell reselection using cell status and cell reservations / cellReservedForOtherUse	X		-
6.1.2.13.NR5GC	Cell reselection using cell status and cell reservations / Access Identity 1 , 2 and 12 to 14 - cellReservedForOperatorUse	X		-
6.1.2.14.NR5GC	Cell reselection using cell status and cell reservations / Access Identity 11 or 15 - cellReservedForOperatorUse	X		-
6.1.2.15.NR5GC	Cell reselection in shared network environment	X	X	-
6.1.2.16.NR5GC	Inter-frequency cell reselection (equal priority)	X		-
6.1.2.17.NR5GC	Cell reselection / Cell-specific reselection parameters provided by the network in a neighbouring cell list	X		-
6.1.2.18.NR5GC	Cell reselection, Sintrasearch, Snonintrasearch	X		-
6.1.2.19.NR5GC	Speed Dependent Cell Reselection	X		-
6.1.2.20.NR5GC	Inter-frequency cell reselection according to cell reselection priority provided by SIBs	X		-
6.1.2.21.NR5GC	Cell reselection , SintraSearchQ and SnonIntraSearchQ	X		-
6.1.2.22.NR5GC	Inter-frequency cell reselection based on common priority information with parameters ThreshX, HighQ, ThreshX, LowQ and ThreshServing, LowQ	X		-

6.1.2.23.NR5GC	Cell Reselection / MFBI	X		-
6.2.1.1.NR5GC	Inter-RAT PLMN Selection / Selection of correct RAT for OPLMN / Automatic mode	X		-
6.2.1.2.NR5GC	Inter-RAT PLMN Selection / Selection of correct RAT for UPLMN / Automatic mode	X		-
6.2.1.3.NR5GC	Inter-RAT PLMN Selection / Selection of correct PLMN and RAT in shared network environment / Automatic mode	X		-
6.2.1.4.NR5GC	Inter-RAT PLMN Selection / Selection of correct RAT from the OPLMN list / Manual mode	X		-
6.2.1.5.NR5GC	Inter-RAT Background HPLMN Search / Search for correct RAT for HPLMN / Automatic Mode	X		-
6.2.2.1.NR5GC	Inter-RAT cell selection / From NR RRC_IDLE to E-UTRA_Idle / Serving cell becomes non-suitable	X		-
6.2.2.2.NR5GC	Inter-RAT cell selection / From E-UTRA_Idle to NR RRC_IDLE / Serving cell becomes non-suitable	X		-
6.2.3.1.NR5GC	Inter-RAT cell reselection / From E-UTRA_Idle to NR RRC_IDLE (lower priority & higher priority , Srxlev based)	X		-
6.2.3.2.NR5GC	Inter-RAT cell reselection / From E-UTRA_Idle to NR RRC_IDLE (lower priority & higher priority , Squal based)	X		-
6.2.3.3.NR5GC	Inter-RAT cell reselection / From NR RRC_Idle to E-UTRA_IDLE (lower priority & higher priority , Srxlev based)	X		-
6.2.3.4.NR5GC	Inter-RAT cell reselection / From NR RRC_Idle to E-UTRA_IDLE (lower priority & higher priority , Squal based)	X		-
6.2.3.5.NR5GC	Inter-RAT cell reselection / From NR RRC_IDLE to E-UTRA_Idle according to RAT priority provided by dedicated signalling (RRCRelease)	X		-
6.2.3.6.NR5GC	Inter-RAT cell reselection / From E-UTRA_Idle to NR RRC_IDLE according to RAT priority provided by dedicated signalling (RRCConnRelease)	X		-
6.2.3.7.NR5GC	Inter-RAT cell reselection / From NR RRC_IDLE to E-UTRA RRC_Idle, Snonintrasearch	X		-
6.2.3.8.NR5GC	Inter-RAT cell reselection / From E-UTRA RRC_IDLE to NR RRC_Idle, Snonintrasearch	X		-
6.2.3.9.NR5GC	Speed Dependent Cell Reselection (NR RRC_IDLE to E-UTRA RRC_IDLE)	X		-
6.2.3.10.NR5GC	Inter-RAT cell reselection / From E-UTRA_Idle to NR RRC_IDLE / schedulingInfoList-v12j0	X		-
6.2.3.11.NR5GC	Inter-RAT cell reselection / From E-UTRA_Idle to NR RRC_IDLE / schedulingInfoListExt-r12	X		-
6.3.1.1.NR5GC	Steering of UE in roaming during registration/security check successful using List Type 1	X		-
6.3.1.2.NR5GC	Steering of UE in roaming during registration/security check successful but SOR Transparent container indicates ACK has been NOT been requested	X		-
6.3.1.3.NR5GC	Steering of UE in roaming during registration/security check unsuccessful/Automatic mode	X		-
6.3.1.4.NR5GC	Steering of UE in roaming during registration/security check unsuccessful/Manual mode	X		-
6.3.1.5.NR5GC	Steering of UE in roaming during registration/UE configured to receive Steering of Roaming information but does not receive Steering of Roaming from Network	X		-
6.3.1.7.NR5GC	Steering of UE in roaming during registration/security check unsuccessful but emergency service pending to be activated	X		-
6.3.1.8.NR5GC	Steering of UE in roaming after registration/automatic plmn selection mode	X		-
6.3.1.9.NR5GC	Steering of UE in roaming after registration/manual plmn selection mode	X		-
6.4.1.1.NR5GC	PLMN Selection/Higher priority/HPLMN in Automatic PLMN Selection Mode	X		-
6.4.1.2.NR5GC	Cell reselection of ePLMN in manual mode	X		-
6.4.2.1.NR5GC	Cell Selection/Qrxlevmin & Cell Reselection (Intra NR in RRC_INACTIVE state)	X		-
6.4.2.2.NR5GC	Inter-frequency cell reselection according to cell reselection priority provided by SIBs in RRC_INACTIVE state	X		-
6.4.3.1.NR5GC	Inter-RAT cell reselection / From NR RRC_INACTIVE to E-UTRA RRC_IDLE (lower priority & higher priority , Srxlev based)	X		-
7.1.1.1.1.NR5GC	Correct selection of RACH parameters / Random access preamble and PRACH resource explicitly signalled to the UE by RRC / contention free random access procedure	X		-
7.1.1.1.1a.NR5GC	Correct selection of RACH parameters / Random access preamble and PRACH resource explicitly signalled to the UE by PDCCH Order / contention free random access procedure	X		-
7.1.1.1.2.NR5GC	Random access procedure / Successful/ C-RNTI Based/Preamble selected by MAC itself	X		-
7.1.1.1.3.NR5GC	Random access procedure / Successful/SI request	X		-
7.1.1.1.6.NR5GC	Random access procedure / Successful/ Temporary C-RNTI Based/Preamble selected by MAC itself	X		-

7.1.1.2.1.NR5GC	Correct Handling of DL MAC PDU / Assignment / HARQ process	X		-
7.1.1.2.3.NR5GC	Correct HARQ process handling / CCCH	X		-
7.1.1.2.4.NR5GC	Correct HARQ process handling / BCCH	x		-
7.1.1.3.1.NR5GC	Correct Handling of UL MAC PDU / Assignment / HARQ process	X		-
7.1.1.3.2.NR5GC	Logical channel prioritization handling	X		-
7.1.1.3.3.NR5GC	Correct handling of MAC control information / Scheduling requests	X		-
7.1.1.3.4.NR5GC	Correct handling of MAC control information / Buffer status / UL data arrive in the UE Tx buffer / Regular BSR	X		-
7.1.1.3.5.NR5GC	Correct handling of MAC control information / Buffer Status / UL resources are allocated / Padding BSR	X		-
7.1.1.3.6.NR5GC	Correct handling of MAC control information / Buffer status / Periodic BSR timer expires	X		-
7.1.1.3.7.NR5GC	UE power headroom reporting / Periodic reporting / DL pathloss change reporting	X		-
7.1.1.3.8.1.NR5GC	UE power headroom reporting / SCell activation / DL pathloss change reporting / Intra-band Contiguous CA	X		-
7.1.1.3.8.2.NR5GC	UE power headroom reporting / SCell activation / DL pathloss change reporting/ Inter-band CA	X		-
7.1.1.4.1.1.NR5GC	DL-SCH Transport Block Size selection / DCI format 1_0	X		-
7.1.1.4.2.1.NR5GC	UL-SCH transport block size selection / DCI format 0_0 / Transform precoding disabled	X		-
7.1.1.4.2.3.NR5GC	UL-SCH transport block size selection / DCI format 1_1 / RA type 0 / RA Type 1 / Transform precoding disabled	X		-
7.1.1.4.2.5.NR5GC	UL-SCH Transport Block Size selection / DCI format 0_0 / Transform precoding and 64QAM	X		-
7.1.1.5.1.NR5GC	DRX operation / Short cycle not configured / Parameters configured by RRC	X		-
7.1.1.5.2.NR5GC	DRX operation / Short cycle not configured /Long DRX command MAC control element reception	X		-
7.1.1.5.3.NR5GC	DRX operation / Short cycle configured / Parameters configured by RRC	X		-
7.1.1.5.4.NR5GC	DRX Operation / Short cycle configured / DRX command MAC control element reception	X		-
7.1.1.5.5.NR5GC	DRX Operation / Short cycle configured / Long DRX command MAC control element reception	X		-
7.1.1.7.1.1.NR5GC	Activation/Deactivation of SCells / Activation/Deactivation MAC control element reception / sCellDeactivationTimer / Intra-band Contiguous CA	X		-
7.1.1.7.1.2.NR5GC	Activation/Deactivation of SCells / Activation/Deactivation MAC control element reception / sCellDeactivationTimer / Inter-band CA	X		-
7.1.1.9.1.NR5GC	MAC Reset	X		-
7.1.1.10.1.NR5GC	DataInactivityTimer expiry	X		-
7.1.2.2.1.NR5GC	UM RLC / Segmentation and reassembly / 6-bit SN / Segmentation Info (SI) field	X		-
7.1.2.2.2.NR5GC	UM RLC / Segmentation and reassembly / 12-bit SN / Segmentation Info (SI) field	X		-
7.1.2.2.3.NR5GC	UM RLC / 6-bit SN / Correct use of sequence numbering	X		-
7.1.2.2.4.NR5GC	UM RLC / 12-bit SN / Correct use of sequence numbering	X		-
7.1.2.2.5.NR5GC	UM RLC / Receive Window operation and t-Reassembly expiry	X		-
7.1.2.2.6.NR5GC	UM RLC / RLC re-establishment procedure	X		-
7.1.2.3.1.NR5GC	AM RLC / 12-bit SN/Segmentation and reassembly / Segmentation Info (SI) field	X		-
7.1.2.3.2.NR5GC	AM RLC / 18-bit SN/Segmentation and reassembly / Segmentation Info (SI) field	X		-
7.1.2.3.3.NR5GC	AM RLC / 12-bit SN / Correct use of sequence numbering	X		-
7.1.2.3.4.NR5GC	AM RLC / 18-bit SN / Correct use of sequence numbering	X		-
7.1.2.3.5.NR5GC	AM RLC / Control of transmit window / Control of receive window	X		-
7.1.2.3.6.NR5GC	AM RLC / Polling for status	X		-
7.1.2.3.7.NR5GC	AM RLC / Receiver status triggers	X		-
7.1.2.3.9.NR5GC	AM RLC / Reassembling of AMD PDUs	X		-
7.1.2.3.8.NR5GC	AM RLC / Reconfiguration of RLC parameters by upper layers	X		-
7.1.2.3.10.NR5GC	AM RLC / Re-transmission of RLC PDU with and without re-segmentation	X		-
7.1.2.3.11.NR5GC	AM RLC / RLC re-establishment procedure	X		-
7.1.3.1.1.NR5GC	Maintenance of PDCP sequence numbers / User plane / 12-bit SN	X		-
7.1.3.1.2.NR5GC	Maintenance of PDCP sequence numbers / User plane / 18-bit SN	X		-
7.1.3.2.1.NR5GC	Integrity protection / Correct functionality of encryption algorithm SNOW3G / SRB / DRB	X		-
7.1.3.2.2.NR5GC	Integrity protection / Correct functionality of encryption algorithm AES / SRB / DRB	X		-
7.1.3.2.3.NR5GC	Integrity protection / Correct functionality of encryption algorithm ZUC / SRB / DRB	X		-
7.1.3.3.1.NR5GC	Ciphering and deciphering / Correct functionality of encryption algorithm SNOW3G / SRB / DRB	X		-

7.1.3.3.2.NR5GC	Ciphering and deciphering / Correct functionality of encryption algorithm AES / SRB / DRB	X		-
7.1.3.3.3.NR5GC	Ciphering and deciphering / Correct functionality of encryption algorithm ZUC / SRB / DRB	X		-
7.1.3.4.1.NR5GC	PDCP handover / Lossless handover / PDCP sequence number maintenance/PDCP status report to convey the information on missing or acknowledged PDCP SDUs at handover/ In-order delivery and duplicate elimination in the downlink	X		-
7.1.3.4.2.NR5GC	PDCP handover / Non-lossless handover / PDCP sequence number maintenance	X		-
7.1.3.5.1.NR5GC	PDCP Discard	X		-
7.1.3.5.4.NR5GC	PDCP reordering / Maximum re-ordering delay below t-Reordering / t-Reordering timer operations	X		-
7.1.4.1.NR5GC	SDAP Data Transfer and PDU Header Handling UL/DL	X		-
7.1.4.2.NR5GC	SDAP Data Transfer handling without Header UL/DL	X		-
8.1.1.1.1.NR5GC	RRC / Paging for connection / Multiple paging records	X		-
8.1.1.1.2.NR5GC	RRC / Paging for connection / Shared network environment	X		-
8.1.1.2.1.NR5GC	RRC connection establishment / Return to idle state after T300 expiry	X		-
8.1.1.2.3.NR5GC	RRC connection establishment / RRC Reject with wait time	X		-
8.1.1.2.4.NR5GC	RRC connection establishment / Extended and spare fields in SI	X		-
8.1.1.3.1.NR5GC	RRC connection release / Redirection to another NR frequency	X		-
8.1.1.3.2.NR5GC	RRC connection release / Redirection from NR to E-UTRAN	X		-
8.1.1.3.3.NR5GC	RRC connection release / Success / With priority information	X		-
8.1.1.3.4.NR5GC	RRC connection release / Success / With priority information / E-UTRA	X		-
8.1.1.4.1.NR5GC	RRC resume / Suspend-Resume / RNA update / Success	X		-
8.1.1.4.2.NR5GC	RRC resume / Suspend-Resume / RRC setup / T319 expiry	X		-
8.1.2.1.1.NR5GC	RRC reconfiguration / DRB / SRB / Establishment / Modification / Release / Success	X		-
8.1.2.1.2.NR5GC	RRC reconfiguration / RRC bearer establishment / uplinkTxDirectCurrentList	X		-
8.1.2.1.4.NR5GC	RRC reconfiguration / Dedicated RLF timer	X		-
8.1.2.1.5.1.NR5GC	NR CA / RRC reconfiguration / SCell addition / modification / release / Success / Intra-band Contiguous CA	X		-
8.1.2.1.5.2.NR5GC	NR CA / RRC reconfiguration / SCell addition / modification / release / Success / Inter-band CA	X		-
8.1.2.1.5.3.NR5GC	NR CA / RRC reconfiguration / SCell addition / modification / release / Success / Intra-band non-contiguous CA	X		-
8.1.3.1.1.NR5GC	Measurement configuration control and reporting / Intra NR measurements / Event A1 / Event A2	X		-
8.1.3.1.2.NR5GC	Measurement configuration control and reporting / Event A3 / Measurement of Neighbor NR cell / Intra-frequency measurements	X		
8.1.3.1.3.NR5GC	Measurement configuration control and reporting / Event A3 / Measurement of Neighbor NR cell / Inter-frequency measurements	X		-
8.1.3.1.4.NR5GC	Measurement configuration control and reporting / Event A3 / Measurement of Neighbor NR cell / Inter-band measurements	X		-
8.1.3.1.5.NR5GC	Measurement configuration control and reporting / Event A4 / Measurement of Neighbor NR cell / Intra-frequency measurements	X		-
8.1.3.1.6.NR5GC	Measurement configuration control and reporting / Event A4 / Measurement of Neighbor NR cell / Inter-frequency measurements	X		-
8.1.3.1.7.NR5GC	Measurement configuration control and reporting / Event A4 / Measurement of Neighbor NR cell / Inter-band measurements	X		-
8.1.3.1.8.NR5GC	Measurement configuration control and reporting / Event A5 / Measurement of Neighbor NR cell / Intra-frequency measurements	X		-
8.1.3.1.9.NR5GC	Measurement configuration control and reporting / Event A5 / Measurement of Neighbor NR cell / Inter-frequency measurements	X		-
8.1.3.1.10.NR5GC	Measurement configuration control and reporting / Event A5 / Measurement of Neighbor NR cell / Inter-band measurements	X		-
8.1.3.1.11.NR5GC	Measurement configuration control and reporting / Intra NR measurements / Two simultaneous events A3 (intra and inter-frequency measurements) / RSRQ based measurements	X		-
8.1.3.1.12.NR5GC	Measurement configuration control and reporting / Intra NR measurements / Two simultaneous events A5 (intra and inter-frequency measurements) / SINR based measurements	X		-
8.1.3.1.15A.NR5GC	Measurement configuration control and reporting / Intra NR measurements / Blacklisting	X		-
8.1.3.1.16.NR5GC	Measurement configuration control and reporting / Intra NR measurements / Whitelisting	X		-
8.1.3.1.17.1.NR5GC	NR CA / Measurement configuration control and reporting / Intra NR measurements / Event A6 / Intra-band Contiguous CA	X		-

8.1.3.1.17.2.NR5GC	NR CA / Measurement configuration control and reporting / Intra NR measurements / Event A6 / Inter-band CA	X		-
8.1.3.1.17.3.NR5GC	NR CA / Measurement configuration control and reporting / Intra NR measurements / Event A6 / Intra-band non-Contiguous CA	X		-
8.1.3.1.18.1.NR5GC	NR CA / Measurement configuration control and reporting / Intra NR measurements / Additional measurement reporting / Intra-band Contiguous CA	X		
8.1.3.1.18.2.NR5GC	NR CA / Measurement configuration control and reporting / Intra NR measurements / Additional measurement reporting / Inter-band CA	X		-
8.1.3.1.18.3.NR5GC	NR CA / Measurement configuration control and reporting / Intra NR measurements / Additional measurement reporting / Intra-band non-Contiguous CA	X		-
8.1.3.1.20.NR5GC	Measurement configuration control and reporting / Measurement Gaps / gapFR1	X		-
8.1.3.1.23.NR5GC	Measurement configuration control and reporting / Intra NR measurements / Continuation of the measurements after RRC Resume	X		-
8.1.3.2.1.NR5GC	Measurement configuration control and reporting / Inter-RAT measurements / Event B1 / Measurement of E-UTRA cells	X		
8.1.3.2.2.NR5GC	Measurement configuration control and reporting / Inter-RAT measurements / Event B2 / Measurement of E-UTRA cells	X		-
8.1.3.2.3.NR5GC	Measurement configuration control and reporting / Inter-RAT measurements / Event B2 / Measurement of E-UTRA cells / RSRQ based measurements	X		-
8.1.3.2.4.NR5GC	Measurement configuration control and reporting / Inter-RAT measurements / Event B2 / Measurement of E-UTRA cells / SINR based measurements	X		-
8.1.3.3.1.NR5GC	Measurement configuration control and reporting / CGI reporting of NR cell	X		-
8.1.3.3.2.NR5GC	Measurement configuration control and reporting / CGI reporting of E-UTRA cell	X		-
8.1.4.1.2.NR5GC	Intra NR handover / Success / Inter-frequency	X		-
8.1.4.1.5.NR5GC	Intra NR handover / Failure / Re-establishment successful	X		-
8.1.4.1.6.NR5GC	Intra NR handover / Failure / Re-establishment failure	X		-
8.1.4.1.7.1.NR5GC	NR CA / Intra NR handover / Success / PCell Change and SCell addition / SCell release / Intra-band Contiguous CA	X		-
8.1.4.1.7.2.NR5GC	NR CA / Intra NR handover / Success / PCell Change and SCell addition / SCell release / Inter-band CA	X		
8.1.4.1.8.1.NR5GC	NR CA / Intra NR handover / Success / PCell Change / SCell no Change / Intra-band Contiguous CA	X		-
8.1.4.1.8.2.NR5GC	NR CA / Intra NR handover / Success / PCell Change / SCell no Change / Inter-band CA	X		
8.1.4.2.1.1.NR5GC	Inter-RAT handover / From NR to E-UTRA / Success	X		-
8.1.4.2.2.1.NR5GC	Inter-RAT handover / From E-UTRA to NR / Success	X		-
8.1.5.1.1.NR5GC	UE capability transfer / Success	X		-
8.1.5.2.1.NR5GC	SI change / Notification of BCCH modification / Short message for SI update	X		-
8.1.5.2.2.NR5GC	SI change / Notification of BCCH modification / Short message for SI update in NR RRC_CONNECTED state	X		-
8.1.5.3.1.NR5GC	PWS notification / PWS reception in NR RRC_IDLE state	X		
8.1.5.3.2.NR5GC	PWS notification / PWS reception in NR RRC_INACTIVE state	X		-
8.1.5.3.3.NR5GC	PWS notification / PWS reception in NR RRC_CONNECTED state	X		-
8.1.5.3.4.NR5GC	PWS notification / PWS reception using dedicatedSystemInformationDelivery	X		-
8.1.5.4.1.NR5GC	Counter check / Reception of CounterCheck message by the UE	X		-
8.1.5.5.1.NR5GC	Redirection to NR / From E-UTRA / Success	X		-
8.1.5.6.1.NR5GC	Radio link failure / RRC connection re-establishment success	X		-
8.1.5.6.3.NR5GC	Radio link failure / T311 expiry	X		-
8.1.5.6.5.1.NR5GC	NR CA / No Radio Link Failure on SCell / RRC Connection Continues on PCell / Intra-band Contiguous CA	X		-
8.1.5.6.5.2.NR5GC	NR CA / No Radio Link Failure on SCell / RRC Connection Continues on PCell / Inter-band CA	X		-
8.1.5.6.5.3.NR5GC	NR CA / No Radio Link Failure on SCell / RRC Connection Continues on PCell / Intra-band non-Contiguous CA	X		-
8.1.5.8.2.1.NR5GC	Processing delay / RRC_Inactive to RRC_Connected / Success / Latency check / SCell addition / Intra-band Contiguous CA	X		-
8.1.5.8.2.2.NR5GC	Processing delay / RRC_Inactive to RRC_Connected / Success / Latency check / SCell addition / Inter-band CA	X		-
8.1.6.1.4.1.NR5GC	Connection Establishment Failure / Logging and reporting / T300 expiry	X		-
8.1.6.1.4.4.NR5GC	Connection Establishment Failure / Logging and reporting / Reporting at RRC connection re-establishment	X		-
8.2.2.4.2.NR5GC	PSCell addition, modification and release / SCG DRB / NR-DC	-	-	X

8.2.5.1.2.NR5GC	Radio link failure / Random access problem / NR-DC	-	-	X
8.2.5.2.2.NR5GC	Radio link failure / PSCell out of sync indication / NR-DC	-	-	X
9.1.1.1.NR5GC	EAP based primary authentication and key agreement / EAP-AKA' related procedures	X	X	-
9.1.1.2.NR5GC	EAP based primary authentication and key agreement / Reject	X	X	-
9.1.1.3.NR5GC	EAP based primary authentication and key agreement / EAP message transport / Abnormal	X		-
9.1.1.4.NR5GC	5G AKA based primary authentication and key agreement / 5G-AKA related procedures	X	X	-
9.1.1.5.NR5GC	5G AKA based primary authentication and key agreement / Reject	X		
9.1.1.6.NR5GC	5G AKA based primary authentication and key agreement / Abnormal	X		-
9.1.2.1.NR5GC	NAS security mode command	X	X	-
9.1.2.2.NR5GC	Protection of initial NAS signalling messages	X	X	-
9.1.2.3.NR5GC	Integrity protection / Correct functionality of 5G NAS integrity algorithm / SNOW3G	X	X	-
9.1.2.4.NR5GC	Integrity protection / Correct functionality of 5G NAS integrity algorithm / AES	X	X	-
9.1.2.5.NR5GC	Integrity protection / Correct functionality of 5G NAS integrity algorithm / ZUC	X	X	-
9.1.2.6.NR5GC	Ciphering and deciphering / Correct functionality of 5G NAS encryption algorithm / SNOW3G	X	X	-
9.1.2.7.NR5GC	Ciphering and deciphering / Correct functionality of 5G NAS encryption algorithm / AES	X	X	-
9.1.2.8.NR5GC	Ciphering and deciphering / Correct functionality of 5G NAS encryption algorithm / ZUC	X	X	-
9.1.3.1.NR5GC	Identification procedure	X	X	-
9.1.4.1.NR5GC	Generic UE configuration update / New 5G-GUTI, NITZ, registration requested, Network slicing indication, New Allowed NSSAI / acknowledgement from the UE	X		-
9.1.5.1.1.NR5GC	Initial registration / Success / 5G-GUTI reallocation, Last visited TAI	X		-
9.1.5.1.2.NR5GC	Initial registration / 5GS services / Equivalent PLMN list handling	X		-
9.1.5.1.3.NR5GC	Initial registration / 5GS services / NSSAI handling	X		-
9.1.5.1.3a.NR5GC	Initial registration / 5GS services / NSSAI handling / NSSAI Storage	X		-
9.1.5.1.5.NR5GC	Initial registration / Abnormal / Failure after 5 attempts	X	X	-
9.1.5.1.6.NR5GC	Initial registration / Rejected / Illegal UE	X	X	-
9.1.5.1.8.NR5GC	Initial registration / Rejected / Serving network not authorized	X		-
9.1.5.1.9.NR5GC	Initial registration / Abnormal / Change of cell into a new tracking area	X		-
9.1.5.1.10.NR5GC	Initial registration / Rejected / PLMN not allowed	X		-
9.1.5.1.11.NR5GC	Initial registration / Rejected / Tracking area not allowed	X		-
9.1.5.1.12.NR5GC	Initial registration / Rejected / Roaming not allowed in this tracking area	X		-
9.1.5.1.13.NR5GC	Initial registration / Rejected / No suitable cells in tracking area	X		-
9.1.5.1.14.NR5GC	Initial registration / Rejected / Congestion / Abnormal cases / T3346	X		-
9.1.5.1.15.NR5GC	Initial registration / Success / Extended and spare fields in UE network capability	X	X	-
9.1.5.2.1.NR5GC	Mobility registration update / TAI list handling	X		-
9.1.5.2.2.NR5GC	Periodic registration update / Accepted	X	X	-
9.1.5.2.4.NR5GC	Mobility registration update / The lower layer requests NAS signalling connection recovery	X		-
9.1.5.2.6.NR5GC	Mobility registration update / Registered slice(s) change	X		-
9.1.5.2.7.NR5GC	Mobility and periodic registration update / Rejected / UE identity cannot be derived by the network	X	X	-
9.1.5.2.8.NR5GC	Mobility and periodic registration update / Rejected / implicitly de-registered	X	X	-
9.1.5.2.9.NR5GC	Mobility and periodic registration update / Abnormal / Change of cell into a new tracking area, collision with generic UE configuration update procedure	X		-
9.1.6.1.1.NR5GC	UE-initiated de-registration / switch off / Abnormal / De-registration and 5GMM common procedure collision	X		-
9.1.6.1.2.NR5GC	UE-initiated de-registration / normal de-registration / Abnormal / Transmission failure without TAI change from lower layers, De-registration and 5GMM common procedure collision, T3521 timeout	X		-
9.1.6.1.3.NR5GC	UE-initiated de-registration / Abnormal / Change of cell into a new tracking area	X		-
9.1.6.1.4.NR5GC	UE-initiated de-registration / Abnormal / Transmission failure with TAI change from lower layers	X		-
9.1.6.2.1.NR5GC	Network-initiated de-registration / de-registration for 3GPP access / re-registration required	X		-
9.1.6.2.2.NR5GC	Network-initiated de-registration / de-registration for 3GPP access / re-registration not required	X		-
9.1.7.1.NR5GC	Service request / IDLE mode uplink user data transport / Rejected / Restricted service area, Abnormal / T3517 / T3525	X		-
9.1.7.2.NR5GC	Service request / CONNECTED mode user data transport / Abnormal / T3517	X		-
9.1.8.1.NR5GC	SMS over NAS / MO and MT SMS over NAS - Idle mode	X		-
9.1.8.2.NR5GC	SMS over NAS / Multiple MO and MT SMS over NAS - CONNECTED mode	X		-

9.3.1.1.NR5GC	Inter-system mobility registration update / Single-registration mode with N26 / 5GMM-IDLE / 5GC to EPC	X		-
9.3.1.2.NR5GC	Inter-system mobility registration update / Single-registration mode with N26 / 5GMM-IDLE / EPC to 5GC	X		-
9.3.1.3.NR5GC	Inter-system mobility and periodic registration update / Rejected / Single-registration mode with N26 / Handling of EPC relevant parameters	X		-
10.1.1.1.NR5GC	PDU session authentication and authorization / During the UE-requested PDU session procedure	X	X	-
10.1.1.2.NR5GC	PDU session authentication and authorization / After the UE-requested PDU session procedure	X		-
10.1.2.1.NR5GC	Network-requested PDU session modification / Accepted	X		-
10.1.3.2.NR5GC	Network-requested PDU session release / Accepted / Insufficient resources / T3396, Accepted / Insufficient resources for specific slice and DNN / T3584, Abnormal / No PDU session context active for the received PDU session ID	X		-
10.1.4.1.NR5GC	UE-requested PDU session establishment / Abnormal / T3580	X		-
10.1.5.1.NR5GC	UE-requested PDU session modification	X		-
10.1.2.2.NR5GC	Network-requested PDU session modification / Abnormal / PDU session in state PDU SESSION INACTIVE	X		-
10.1.6.1.NR5GC	UE-requested PDU session release / Abnormal / collision with network-requested PDU session modification procedure	X		-
10.1.6.2.NR5GC	UE-requested PDU session release / Abnormal / collision with network-requested PDU session release procedure	X		-
11.1.1.NR5GC	MO MMTEL voice call setup from NR RRC_IDLE / EPS Fallback with redirection / Single registration mode with N26 interface / Success	X		-
11.1.3.NR5GC	MO MMTEL voice call setup from NR RRC_CONNECTED / EPS Fallback with handover / Single registration mode with N26 interface / Success	X		-
11.1.4.NR5GC	MO MMTEL voice call setup from NR RRC_CONNECTED / EPS Fallback with redirection / Single registration mode with N26 interface / E-UTRAN cell selection using cell status barred / Success	X		-
11.1.7.NR5GC	Emergency call setup from NR RRC_IDLE / Emergency Services Fallback to EPS with redirection / Single registration mode with N26 interface / Success	X		-
11.3.2.NR5GC	UAC / Access Identity 0 / 0% access probability / Paging for MT Access/Emergency Call	X		-
11.3.3.NR5GC	UAC / Access Identity 0 / AC8 / RRC_INACTIVE / RNAUpdate/RRC Resume	X		-
11.3.4.NR5GC	UAC / Access Identity 0 / Registration procedure for mobility and periodic registration update / BarringPerPLMN/Implicit AC Barring List	X		-
11.3.6.NR5GC	UAC / Access Identity 2 / New cell not in the country of its HPLMN/EHPLMN 0% access probability/MCS indicator / HPLMN/0%/100% accessibility AC7/RRC_INACTIVE	X		-
11.3.7.NR5GC	UAC / Access Identity 11..15 / High Priority Access / HPLMN/0% accessibility AC2/Emergency call	X		-
11.3.8.NR5GC	UAC / Access Identity 0 / NR RRC_IDLE / Cell re-selection while T390 is running	X		-
11.3.9.NR5GC	UAC / Access Identity 0 / ODAC / PLMN / RPLMN / not EPLMN	X		-
11.4.3.NR5GC	5GMM-DEREGISTERED.NO-SUPI / Emergency call / Utilisation of emergency numbers stored on the ME / Initial registration for emergency services	X		-
11.4.4.NR5GC	5GMM-REGISTERED.ATTEMPTING-REGISTRATION-UPDATE T3346 running / Emergency call establishment / 5GMM-REGISTERED.NORMAL-SERVICE / Emergency call establishment before T3396 expiry	X		-
11.4.6.NR5GC	5GMM-REGISTERED.NON-ALLOWED-SERVICE / Emergency call establishment and release / Handling of non-allowed tracking areas	X		-
11.4.7.NR5GC	Handling of Local and Extended emergency numbers / Mobility	X		-
11.4.8.NR5GC	Handling of Local and extended emergency numbers / Switch-off and maximum local numbers storage	X		-



## Annex B: NR TBS tables

### B.1 Downlink TBS (normative)

The tables in this clause are depending on parameters provided by RRC signalling as described in subclause 7.1.2.2.4.1.  $L_{RBs}$  is limited according to the DL scheduling scheme in subclause 7.1.2.2.3.

#### B.1.1 Downlink TBS using MCS index table 5.1.3.1-1

##### B.1.1.1 Downlink TBS using MCS index table 5.1.3.1-1, dmrs-AdditionalPosition = 0, number of CDM groups = 1

Table B.1.1.1-1: Void

Table B.1.1.1-2: Void

Table B.1.1.1-3: TBS for PDSCH using MCS index table 5.1.3.1-1 with dmrs-AdditionalPosition = 0,  
number of CDM groups = 1, PDSCH-duration = 12

TBS	$L_{RBs}$	$\mu_{MCS}$	TBS	$L_{RBs}$	$\mu_{MCS}$	TBS	$L_{RBs}$	$\mu_{MCS}$	TBS	$L_{RBs}$	$\mu_{MCS}$
32	1	0	576	11	2	2216	12	9	5760	10	23
40	1	1	608	14	1	2280	16	7	5888	14	19
48	1	2	640	15	1	2408	17	7	6016	17	16
64	2	0	672	16	1	2472	15	8	6144	8	28
80	2	1	704	5	7	2536	6	19	6272	15	19
96	3	0	736	17	1	2600	16	8	6400	17	18
104	2	2	768	11	3	2664	13	11	6656	16	19
120	3	1	808	15	2	2728	15	9	6784	11	24
128	4	0	848	16	2	2792	17	8	6912	15	20
136	1	7	888	17	2	2856	14	11	7040	17	19
152	3	2	928	11	4	2976	16	9	7296	16	20
160	5	0	984	14	3	3104	17	9	7424	15	21
168	4	1	1032	15	3	3240	16	11	7552	14	22
176	1	9	1064	4	13	3368	14	12	7680	11	26
192	6	0	1128	16	3	3496	17	11	7808	17	20
208	5	1	1160	17	3	3624	12	14	7936	16	21
224	7	0	1192	5	12	3752	16	12	8064	15	22
240	2	6	1224	12	5	3840	13	14	8456	17	21
256	8	0	1256	15	4	3904	11	16	8712	16	22
272	4	3	1288	9	7	3968	17	12	9224	17	22
288	9	0	1320	13	5	4032	7	23	9480	13	27
304	7	1	1352	16	4	4096	14	14	9992	17	23
320	10	0	1416	17	4	4224	16	13	10248	14	27
336	8	1	1480	14	5	4352	13	15	10504	17	24
352	11	0	1544	15	5	4480	17	13	10760	14	28
368	7	2	1608	13	6	4608	14	15	11016	15	27
384	12	0	1672	16	5	4736	16	14	11272	17	25
408	6	3	1736	17	5	4864	13	18	11528	15	28
432	13	0	1800	11	8	4992	17	14	11784	16	27
456	14	0	1864	15	6	5120	7	27	12040	17	26
480	15	0	1928	5	18	5248	16	15	12296	16	28
504	12	1	2024	16	6	5376	13	19	12552	17	27
528	16	0	2088	17	6	5504	12	20	13064	17	28
552	17	0	2152	15	7	5632	17	15			

### B.1.1.2 Downlink TBS using MCS index table 5.1.3.1-1, dmrs-AdditionalPosition = 1, number of CDM groups = 1

Table B.1.1.2-1: Void

Table B.1.1.2-2: Void

**Table B.1.1.2-3: TBS for PDSCH using MCS index table 5.1.3.1-1 with dmrs-AdditionalPosition = 1,  
number of CDM groups = 1, PDSCH-duration = 12**

TBS	LRBs	IMCS	TBS	LRBs	IMCS	TBS	LRBs	IMCS	TBS	LRBs	IMCS
24	1	0	552	11	2	2280	13	9	6016	15	19
40	1	1	576	14	1	2408	17	7	6144	17	18
48	1	2	608	15	1	2472	16	8	6272	10	25
56	2	0	640	16	1	2536	13	11	6400	16	19
64	1	3	672	5	7	2600	9	14	6528	15	20
72	1	4	704	17	1	2664	17	8	6656	14	21
80	2	1	736	9	4	2728	14	11	6784	17	19
88	3	0	768	15	2	2792	16	9	6912	11	25
96	2	2	808	16	2	2856	10	14	7040	16	20
112	1	6	848	17	2	2976	17	9	7168	15	21
120	4	0	888	11	4	3104	16	11	7296	10	28
128	2	3	928	14	3	3240	11	14	7424	17	20
144	3	2	984	15	3	3368	17	11	7552	16	21
152	5	0	1032	16	3	3496	12	14	7680	15	22
160	4	1	1064	9	6	3624	16	12	7808	14	23
168	1	9	1128	17	3	3752	13	14	8064	17	21
184	6	0	1160	10	6	3824	17	12	8192	16	22
192	4	2	1192	15	4	3840	7	23	8456	14	24
208	5	1	1224	9	7	3904	9	20	8712	17	22
224	7	0	1256	8	8	3968	14	14	8968	16	23
240	8	0	1288	16	4	4032	16	13	9224	13	27
256	5	2	1320	3	20	4096	13	15	9480	17	23
272	9	0	1352	17	4	4224	17	13	9736	14	27
288	7	1	1416	14	5	4352	13	16	9992	15	26
304	10	0	1480	15	5	4480	16	14	10248	17	24
320	8	1	1544	13	6	4608	13	18	10504	15	27
336	11	0	1608	16	5	4736	15	15	10760	17	25
352	7	2	1672	17	5	4864	17	14	11016	15	28
368	12	0	1736	15	6	4992	14	18	11272	16	27
384	6	3	1800	13	7	5120	16	15	11528	17	26
408	13	0	1864	16	6	5248	12	20	11784	16	28
432	14	0	1928	14	7	5376	17	15	12040	17	27
456	11	1	2024	17	6	5504	10	23	12552	17	28
480	15	0	2088	15	7	5632	14	19			
504	16	0	2152	16	7	5760	17	16			
528	17	0	2216	10	12	5888	10	24			

### B.1.1.3 Downlink TBS using MCS index table 5.1.3.1-1, dmrs-AdditionalPosition = 2, number of CDM groups = 2, modulation order <= 2

NOTE: The major purpose of the tables in this clause is to cope with PDSCH transmissions being restricted to  $Q_m \leq 2$  (QPSK) like PDSCH transmissions being scheduled with P-RNTI, RA-RNTI, SI-RNTI (see TS 38.214 clause 5.1.3.1 [22]).

Table B.1.1.3-1: Void

Table B.1.1.3-2: Void

Table B.1.1.3-3: TBS for PDSCH using MCS index table 5.1.3.1-1 with dmrs-AdditionalPosition = 2, number of CDM groups = 2, modulation order  $\leq 2$ , PDSCH-duration = 12

TBS	LRBs	IMCS	TBS	LRBs	IMCS	TBS	LRBs	IMCS	TBS	LRBs	IMCS
24	1	0	128	4	1	256	4	4	504	4	8
32	1	1	136	1	9	272	5	3	552	7	5
40	1	2	144	6	0	288	7	2	576	6	6
48	2	0	152	3	3	320	6	3	640	5	8
64	2	1	160	5	1	336	3	7	672	7	6
72	3	0	176	7	0	368	7	3	736	5	9
80	2	2	184	2	6	384	6	4	768	6	8
88	1	6	192	6	1	408	5	5	808	7	7
96	4	0	208	5	2	432	3	9	888	7	8
104	2	3	224	7	1	456	7	4	1032	7	9
120	5	0	240	6	2	480	6	5			

### B.1.1.4 Downlink TBS using MCS index table 5.1.3.1-1, dmrs-AdditionalPosition = 2, number of CDM groups = 2

Table B.1.1.4-1: Void

Table B.1.1.4-2: Void

**Table B.1.1.4-3: TBS for PDSCH using MCS index table 5.1.3.1-1 with dmrs-AdditionalPosition = 2,  
number of CDM groups = 2, PDSCH-duration = 12**

TBS	L <sub>RBs</sub>	I <sub>MCS</sub>	TBS	L <sub>RBs</sub>	I <sub>MCS</sub>	TBS	L <sub>RBs</sub>	I <sub>MCS</sub>	TBS	L <sub>RBs</sub>	I <sub>MCS</sub>
24	1	0	456	14	1	1800	16	7	4736	17	16
32	1	1	480	9	3	1864	13	9	4864	15	19
40	1	2	504	15	1	1928	17	7	4992	17	18
48	2	0	528	16	1	2024	16	8	5120	10	25
64	2	1	552	7	5	2088	13	11	5248	16	19
72	3	0	576	17	1	2152	17	8	5376	15	20
80	2	2	608	15	2	2216	14	11	5504	17	19
88	1	6	640	12	3	2280	16	9	5760	16	20
96	4	0	672	16	2	2408	15	11	5888	14	22
104	2	3	704	17	2	2472	17	9	6016	17	20
120	5	0	736	14	3	2536	16	11	6272	16	21
128	4	1	768	8	6	2600	14	12	6400	14	23
136	1	9	808	15	3	2664	13	13	6528	11	28
144	6	0	848	16	3	2728	17	11	6656	17	21
152	3	3	888	11	5	2792	12	14	6784	15	23
160	5	1	928	17	3	2856	11	15	6912	12	27
176	7	0	984	15	4	2976	16	12	7168	17	22
184	2	6	1032	16	4	3104	17	12	7296	16	23
192	6	1	1064	11	6	3240	11	18	7424	13	27
208	8	0	1128	17	4	3368	16	13	7680	17	23
224	9	0	1160	12	6	3496	17	13	7808	16	24
240	6	2	1192	15	5	3624	14	15	8064	14	27
256	10	0	1224	13	6	3752	16	14	8192	17	24
272	11	0	1256	6	13	3824	9	22	8456	14	28
288	7	2	1288	16	5	3840	14	16	8712	17	25
304	12	0	1320	14	6	3904	15	15	8968	15	28
320	8	2	1352	17	5	3968	17	14	9224	16	27
336	13	0	1416	15	6	4032	7	27	9480	17	26
352	14	0	1480	13	7	4096	16	15	9736	17	27
368	11	1	1544	16	6	4224	13	19	10248	17	28
384	15	0	1608	17	6	4352	17	15			
408	16	0	1672	15	7	4480	16	16			
432	17	0	1736	12	9	4608	14	19			

## B.1.2 Void

---

## B.2 Uplink TBS (informative)

The tables in this clause are depending on parameters provided by RRC signalling as described in subclause 7.1.2.3.2. L<sub>RBs</sub> is limited to the minimum value of N<sub>BWP</sub>=24 in accordance to Table 5.3.2-1 of TS 38.101-1/2 [5, 6].

For selection of the L<sub>RBs</sub> / I<sub>MCS</sub> pair for a particular TBS, the same criteria are applied, as specified for the DL in subclause 7.1.2.2.4.2 paragraph 'L<sub>RBs</sub> / I<sub>MCS</sub> pair determination'.

## B.2.1 Uplink TBS using MCS index table 5.1.3.1-1

### B.2.1.1 Uplink TBS using MCS index table 5.1.3.1-1, dmrs-AdditionalPosition = 0, number of CDM groups = 1

**Table B.2.1.1-1: TBS for PUSCH using MCS index table 5.1.3.1-1 with dmrs-AdditionalPosition = 0, number of CDM groups = 1, PUSCH-duration = 14**

TBS	LRBs	IMCS	TBS	LRBs	IMCS	TBS	LRBs	IMCS	TBS	LRBs	IMCS
32	1	0	848	23	0	3496	19	8	8192	22	15
40	1	1	888	24	0	3624	22	7	8456	21	16
56	1	2	928	19	1	3752	23	7	8712	23	15
72	2	0	984	20	1	3824	8	19	8968	24	15
88	2	1	1032	21	1	3840	24	7	9224	23	16
104	3	0	1064	22	1	3904	19	9	9480	24	16
112	2	2	1128	23	1	3968	15	12	9736	23	18
136	3	1	1160	24	1	4032	22	8	9992	21	19
144	4	0	1192	20	2	4096	20	9	10248	24	18
152	2	3	1224	16	3	4224	23	8	10504	22	19
160	1	7	1256	21	2	4352	24	8	10760	23	19
176	5	0	1288	22	2	4480	22	9	11016	18	22
184	4	1	1320	17	3	4608	20	11	11272	24	19
208	1	9	1352	23	2	4736	23	9	11528	19	22
224	6	0	1416	24	2	4864	21	11	11784	23	20
240	5	1	1480	19	3	4992	24	9	12040	20	22
256	7	0	1544	20	3	5120	13	17	12296	24	20
272	2	6	1608	21	3	5248	23	11	12552	19	23
288	8	0	1672	14	5	5376	18	13	12808	23	21
304	4	3	1736	22	3	5504	24	11	13064	20	23
320	2	7	1800	23	3	5632	19	13	13320	22	22
336	9	0	1864	24	3	5760	22	12	13576	24	21
352	6	2	1928	20	4	5888	20	13	13832	21	23
368	10	0	2024	21	4	6016	23	12	14088	23	22
384	8	1	2088	22	4	6144	13	19	14344	22	23
408	11	0	2152	23	4	6272	24	12	14600	24	22
432	12	0	2216	19	5	6400	19	14	14856	21	24
456	6	3	2280	24	4	6528	22	13	15112	23	23
480	13	0	2408	21	5	6656	20	14	15624	22	24
504	14	0	2472	18	6	6784	23	13	15880	24	23
528	11	1	2536	22	5	6912	8	28	16136	23	24
552	15	0	2600	19	6	7040	21	14	16392	22	25
576	12	1	2664	23	5	7168	24	13	16896	24	24
608	16	0	2728	20	6	7296	13	21	17424	23	25
640	17	0	2792	24	5	7424	22	14	17928	24	25
672	18	0	2856	21	6	7552	19	16	18432	23	26
704	19	0	2976	18	7	7680	23	14	18960	24	26
736	20	0	3104	22	6	7808	21	15	19968	24	27
768	21	0	3240	23	6	7936	20	16	21000	24	28
808	22	0	3368	24	6	8064	24	14			

Table B.2.1.1-2: Void

B.2.1.2 Uplink TBS using MCS index table 5.1.3.1-1,  
dmrs-AdditionalPosition = 1, number of CDM groups = 1

Table B.2.1.2-1: TBS for PUSCH using MCS index table 5.1.3.1-1 with dmrs-AdditionalPosition = 1,  
number of CDM groups = 1, PUSCH-duration = 14

TBS	LRBs	IMCS	TBS	LRBs	IMCS	TBS	LRBs	IMCS	TBS	LRBs	IMCS
32	1	0	848	23	0	3496	19	8	8192	22	15
40	1	1	888	24	0	3624	22	7	8456	21	16
56	1	2	928	19	1	3752	23	7	8712	23	15
72	2	0	984	20	1	3824	8	19	8968	24	15
88	2	1	1032	21	1	3840	24	7	9224	23	16
104	3	0	1064	22	1	3904	19	9	9480	24	16
112	2	2	1128	23	1	3968	15	12	9736	23	18
136	3	1	1160	24	1	4032	22	8	9992	21	19
144	4	0	1192	20	2	4096	20	9	10248	24	18
152	2	3	1224	16	3	4224	23	8	10504	22	19
160	1	7	1256	21	2	4352	24	8	10760	23	19
176	5	0	1288	22	2	4480	22	9	11016	18	22
184	4	1	1320	17	3	4608	20	11	11272	24	19
208	1	9	1352	23	2	4736	23	9	11528	19	22
224	6	0	1416	24	2	4864	21	11	11784	23	20
240	5	1	1480	19	3	4992	24	9	12040	20	22
256	7	0	1544	20	3	5120	13	17	12296	24	20
272	2	6	1608	21	3	5248	23	11	12552	19	23
288	8	0	1672	14	5	5376	18	13	12808	23	21
304	4	3	1736	22	3	5504	24	11	13064	20	23
320	2	7	1800	23	3	5632	19	13	13320	22	22
336	9	0	1864	24	3	5760	22	12	13576	24	21
352	6	2	1928	20	4	5888	20	13	13832	21	23
368	10	0	2024	21	4	6016	23	12	14088	23	22
384	8	1	2088	22	4	6144	13	19	14344	22	23
408	11	0	2152	23	4	6272	24	12	14600	24	22
432	12	0	2216	19	5	6400	19	14	14856	21	24
456	6	3	2280	24	4	6528	22	13	15112	23	23
480	13	0	2408	21	5	6656	20	14	15624	22	24
504	14	0	2472	18	6	6784	23	13	15880	24	23
528	11	1	2536	22	5	6912	8	28	16136	23	24
552	15	0	2600	19	6	7040	21	14	16392	22	25
576	12	1	2664	23	5	7168	24	13	16896	24	24
608	16	0	2728	20	6	7296	13	21	17424	23	25
640	17	0	2792	24	5	7424	22	14	17928	24	25
672	18	0	2856	21	6	7552	19	16	18432	23	26
704	19	0	2976	18	7	7680	23	14	18960	24	26
736	20	0	3104	22	6	7808	21	15	19968	24	27
768	21	0	3240	23	6	7936	20	16	21000	24	28
808	22	0	3368	24	6	8064	24	14			

Table B.2.1.2-2: Void

## B.2.1.3 Void

## B.2.1.4 Void

B.2.1.5 Uplink TBS using MCS index table 5.1.3.1-1,  
dmrs-AdditionalPosition = 2, number of CDM groups = 2Table B.2.1.5-1: TBS for PUSCH using MCS index table 5.1.3.1-1 with dmrs-AdditionalPosition = 2,  
number of CDM groups = 2, PUSCH-duration = 14

TBS	LRBs	IMCS	TBS	LRBs	IMCS	TBS	LRBs	IMCS	TBS	LRBs	IMCS
24	1	0	672	21	0	2856	21	7	7552	24	15
40	1	1	704	23	0	2976	22	7	7680	15	22
48	1	2	736	24	0	3104	23	7	7808	23	16
56	2	0	768	19	1	3240	24	7	7936	22	18
64	1	3	808	20	1	3368	19	9	8064	24	16
72	1	4	848	21	1	3496	22	8	8192	23	18
80	2	1	888	22	1	3624	23	8	8456	21	19
88	3	0	928	23	1	3752	24	8	8712	24	18
96	2	2	984	24	1	3824	17	12	8968	19	21
112	1	6	1032	20	2	3840	22	9	9224	23	19
120	4	0	1064	21	2	3904	20	11	9480	24	19
128	2	3	1128	22	2	3968	14	14	9736	22	20
144	3	2	1160	23	2	4032	23	9	9992	23	20
152	5	0	1192	24	2	4096	21	11	10248	20	22
160	4	1	1224	19	3	4224	24	9	10504	24	20
168	1	9	1256	8	8	4352	13	16	10760	21	22
184	6	0	1288	20	3	4480	23	11	11016	23	21
192	4	2	1320	3	20	4608	24	11	11272	22	22
208	5	1	1352	21	3	4736	21	12	11528	24	21
224	7	0	1416	22	3	4864	22	12	11784	23	22
240	8	0	1480	18	4	4992	20	13	12040	20	24
256	5	2	1544	23	3	5120	23	12	12296	24	22
272	9	0	1608	24	3	5248	21	13	12552	21	24
288	7	1	1672	21	4	5376	24	12	12808	23	23
304	10	0	1736	15	6	5504	22	13	13064	22	24
320	8	1	1800	22	4	5632	20	14	13320	24	23
336	11	0	1864	23	4	5760	23	13	13576	20	26
352	7	2	1928	24	4	5888	10	24	13832	23	24
368	12	0	2024	20	5	6016	24	13	14088	22	25
384	6	3	2088	21	5	6144	18	16	14344	24	24
408	13	0	2152	22	5	6272	22	14	14600	23	25
432	14	0	2216	19	6	6400	19	16	14856	22	26
456	11	1	2280	23	5	6528	23	14	15368	24	25
480	15	0	2408	24	5	6656	21	15	15624	23	26
504	16	0	2472	18	7	6784	24	14	16136	24	26
528	17	0	2536	22	6	6912	22	15	16896	24	27
552	18	0	2600	19	7	7040	21	16	17424	24	28
576	14	1	2664	23	6	7168	20	18			
608	19	0	2728	20	7	7296	23	15			
640	20	0	2792	24	6	7424	22	16			

**Table B.2.1.5-2: Void**

B.2.2 Void

B.2.3 Void



---

## Annex C (informative): Style guide and design principles

### C.1 Style guide

The style guide specified in TS 36.523-3 [12] Annex B applies to the present document.

---

### C.2 Design principles

The design principles specified in TS 36.523-3 [12] Annex B apply to the present document.

## Annex D (normative): TTCN-3 definitions

### D.0 Introduction

The present Annex D specifies the TTCN-3 type definitions used at the system interface to configure and control the SS.

In case of discrepancy between the content of the present Annex D and the equivalent TTCN-3 definitions / semantic requirements found in the TTCN modules provided as attachments to the present specification, the latter shall take precedence.

**NOTE:** This annex is automatically generated from the TTCN-3 modules provided as attachment to the present specification and containing the listed TTCN-3 type definitions.

### D.1 NR\_ASP\_TypeDefs

Type definitions for configuration of the system simulator;

Common design principles:

Semantics of OMIT: unless specified otherwise, for all TTCN-3 type definitions used in ASPs omit means "keep as it is" =>

- on initial configuration in general all fields shall be provided
- no default values for fields are foreseen
- if necessary non-existence of information shall be explicitly configured (e.g. with a union of "no configuration" and "configuration parameters")
- fields within structures imported from the core spec are excepted from this rule
- if a sub-structure is explicitly excluded from this rule all fields and sub-fields shall be fully specified for each (re-)configuration

#### D.1.1 ASN1\_Container

Definitions containing ASN.1 types for backward compatibility

##### NR\_ASN1\_ARFCN\_ValueNR\_Type

TTCN-3 Union Type	
<b>Name</b>	NR_ASN1_ARFCN_ValueNR_Type
<b>Comment</b>	
R15	ARFCN_ValueNR

##### NR\_ASN1\_UL\_AM\_RLC\_Type

TTCN-3 Union Type	
<b>Name</b>	NR_ASN1_UL_AM_RLC_Type
<b>Comment</b>	
R15	UL_AM_RLC

##### NR\_ASN1\_DL\_AM\_RLC\_Type

TTCN-3 Union Type	
<b>Name</b>	NR_ASN1_DL_AM_RLC_Type
<b>Comment</b>	
R15	DL_AM_RLC

## NR\_ASN1\_UL\_UM\_RLC\_Type

TTCN-3 Union Type		
Name	NR_ASN1_UL_UM_RLC_Type	
Comment		
R15	UL_UM_RLC	

## NR\_ASN1\_DL\_UM\_RLC\_Type

TTCN-3 Union Type		
Name	NR_ASN1_DL_UM_RLC_Type	
Comment		
R15	DL_UM_RLC	

## NR\_ASN1\_PDSCH\_Config\_Type

TTCN-3 Union Type		
Name	NR_ASN1_PDSCH_Config_Type	
Comment		
R15	PDSCH_Config	

## NR\_ASN1\_PDSCH\_ConfigCommon\_Type

TTCN-3 Union Type		
Name	NR_ASN1_PDSCH_ConfigCommon_Type	
Comment		
R15	PDSCH_ConfigCommon	

## NR\_ASN1\_SPS\_Config\_Type

TTCN-3 Union Type		
Name	NR_ASN1_SPS_Config_Type	
Comment		
R15	SPS_Config	

## NR\_ASN1\_TDD\_UL\_DL\_ConfigCommon\_Type

TTCN-3 Union Type		
Name	NR_ASN1_TDD_UL_DL_ConfigCommon_Type	
Comment		
R15	TDD_UL_DL_ConfigCommon	

## NR\_ASN1\_TDD\_UL\_DL\_SlotConfig\_Type

TTCN-3 Union Type		
Name	NR_ASN1_TDD_UL_DL_SlotConfig_Type	
Comment		
R15	TDD_UL_DL_SlotConfig	

## NR\_ASN1\_FrequencyInfoDL\_Type

TTCN-3 Union Type		
Name	NR_ASN1_FrequencyInfoDL_Type	
Comment		
R15	FrequencyInfoDL	

**NR\_ASN1\_FrequencyInfoUL\_Type**

TTCN-3 Union Type	
Name	NR_ASN1_FrequencyInfoUL_Type
Comment	
R15	FrequencyInfoUL

**NR\_ASN1\_BWP\_UplinkCommon\_Type**

TTCN-3 Union Type	
Name	NR_ASN1_BWP_UplinkCommon_Type
Comment	
R15	BWP_UplinkCommon

**NR\_ASN1\_BWP\_UplinkDedicated\_Type**

TTCN-3 Union Type	
Name	NR_ASN1_BWP_UplinkDedicated_Type
Comment	
R15	BWP_UplinkDedicated

**NR\_ASN1\_RACH\_ConfigDedicated\_Type**

TTCN-3 Union Type	
Name	NR_ASN1_RACH_ConfigDedicated_Type
Comment	
R15	RACH_ConfigDedicated

**NR\_ASN1\_SI\_RequestConfig\_Type**

TTCN-3 Union Type	
Name	NR_ASN1_SI_RequestConfig_Type
Comment	
R15	SI_RequestConfig

**NR\_ASN1\_PDSCH\_ServingCellConfig\_Type**

TTCN-3 Union Type	
Name	NR_ASN1_PDSCH_ServingCellConfig_Type
Comment	
R15	PDSCH_ServingCellConfig

**NR\_ASN1\_PUSCH\_ServingCellConfig\_Type**

TTCN-3 Union Type	
Name	NR_ASN1_PUSCH_ServingCellConfig_Type
Comment	
R15	PUSCH_ServingCellConfig

**NR\_ASN1\_SearchSpace\_Type**

TTCN-3 Union Type	
Name	NR_ASN1_SearchSpace_Type
Comment	
R15	SearchSpace

**NR\_ASN1\_ControlResourceSet\_Type**

TTCN-3 Union Type		
Name	NR_ASN1_ControlResourceSet_Type	
Comment		
R15	ControlResourceSet	

**NR\_ASN1\_BWP\_Type**

TTCN-3 Union Type		
Name	NR_ASN1_BWP_Type	
Comment		
R15	BWP	

**NR\_ASN1\_DRX\_Config\_Type**

TTCN-3 Union Type		
Name	NR_ASN1_DRX_Config_Type	
Comment		
R15	DRX_Config	

**NR\_ASN1\_MeasGapConfig\_Type**

TTCN-3 Union Type		
Name	NR_ASN1_MeasGapConfig_Type	
Comment		
R15	MeasGapConfig	

**NR\_ASN1\_MAC\_CellGroupConfig\_Type**

TTCN-3 Union Type		
Name	NR_ASN1_MAC_CellGroupConfig_Type	
Comment		
R15	MAC_CellGroupConfig	

**NR\_ASN1\_PhysicalCellGroupConfig\_Type**

TTCN-3 Union Type		
Name	NR_ASN1_PhysicalCellGroupConfig_Type	
Comment		
R15	PhysicalCellGroupConfig	

**NR\_ASN1\_RateMatchPattern\_Type**

TTCN-3 Union Type		
Name	NR_ASN1_RateMatchPattern_Type	
Comment		
R15	RateMatchPattern	

**NR\_ASN1\_RateMatchPatternLTE\_CRS\_Type**

TTCN-3 Union Type		
Name	NR_ASN1_RateMatchPatternLTE_CRS_Type	
Comment		
R15	RateMatchPatternLTE_CRS	

## D.1.2 System\_Configuration

Formal ASP Definitions for system configuration

### NR\_SystemRequest\_Type

TTCN-3 Union Type		
Name	NR_SystemRequest_Type	
Comment		
Cell	<a href="#">NR_CellConfigRequest_Type</a>	configure/release a cell
CellAttenuationList	<a href="#">NR_CellAttenuationList_Type</a>	power attenuation for one or several cells; all cells included in the list shall be changed at the same time; all cells in the list shall reach the new cell power within a maximum of 100ms (10 frames) as according to TS 38.523-3 clause 7.1.4.2 CellId: In the common ASP part the CellId shall be set - to the cell the timing information refers to if activation time shall be applied - to nr_Cell_NonSpecific when there is no activation time TimingInfo: 'Now' (in general, but activation time may be used also)
RadioBearerList	<a href="#">NR_RadioBearerList_Type</a>	configure/release one or several SRBs and/or DRBs at an SpCell NOTE: RBs are not configured in an SCell
EnquireTiming	<a href="#">Null_Type</a>	get current timing information for the given cell TimingInfo : 'Now'
AS_Security	<a href="#">NR_AS_Security_Type</a>	StartRestart/Release of AS security
SystemIndCtrl	<a href="#">NR_System_IndicationControl_Type</a>	to configure SS to generate system indications
PdcpCount	<a href="#">NR_PDCP_CountReq_Type</a>	to set or enquire PDCP COUNT for one or more RBs
DciTrigger	<a href="#">NR_DCI_Trigger_Type</a>	to trigger a specific DCI to be transmitted on PDCCH (e.g. PDCCH order)
Paging	<a href="#">NR_PagingTrigger_Type</a>	to trigger SS to send paging at the given paging occasion (as calculated in TTCN) NOTE: The SS shall use the DCI configuration as provided by NR_PcchConfig_Type; the DCI may or may not carry a short message but it in any case it shall indicate presence
MacCommandTrigger	<a href="#">NR_MAC_ControlElementDL_Type</a>	to trigger a specific MAC control element to be transmitted to the UE
L1_TestMode	<a href="#">NR_L1_TestMode_Type</a>	to Set L1/MAC in special Test modes e.g. DL CRC etc. per default (at initial configuration) no test mode is activated
PdcpHandoverControl	<a href="#">NR_PDCP_HandoverControlReq_Type</a>	to inform the target cell about the handover (or PSCell change) procedure.
DeltaValues	<a href="#">NR_Band_SsbForDelta_Type</a>	to provide the primary and secondary frequency info for deriving the delta values
SpsCg	<a href="#">NR_SPS_CG_ActDeact_Type</a>	to configure/activate or release/deactivate DL SPS assignment or UL configured grant type 2 scheduling

## NR\_SystemConfirm\_Type

TTCN-3 Union Type		
Name	<b>NR_SystemConfirm_Type</b>	
Comment	confirmations for system configuration; in general to be sent after the configuration has been done	
Cell	<a href="#">Null_Type</a>	(no further parameters from SS)
CellAttenuationList	<a href="#">Null_Type</a>	(no further parameters from SS) NOTE 1: the confirmation shall be sent when all cells have changed power levels NOTE 2: for the CellId in the common ASP part the same rules are applied as for the SYSTEM REQ
RadioBearerList	<a href="#">Null_Type</a>	(no further parameters from SS)
EnquireTiming	<a href="#">Null_Type</a>	the cell's timing information is contained in the TimingInfo of the ASP's common part
AS_Security	<a href="#">Null_Type</a>	(no further parameters from SS)
SystemIndCtrl	<a href="#">Null_Type</a>	(no further parameters from SS)
PdcpCount	<a href="#">NR_PDCP_CountCnf_Type</a>	as response to 'Get' a list is returned containing COUNT information for the requested RBs
DciTrigger	<a href="#">Null_Type</a>	(no further parameters from SS)
MacCommandTrigger	<a href="#">Null_Type</a>	(no further parameters from SS)
L1_TestMode	<a href="#">Null_Type</a>	confirmation for L1 test mode
PdcpHandoverControl	<a href="#">Null_Type</a>	confirmation for PDCP handover control
DeltaValues	<a href="#">UE_NR_DeltaValues_Type</a>	Delta values to be used for primary and secondary band
SpsCg	<a href="#">Null_Type</a>	confirmation for DL SPS or UL configured grant type 2 Activation/Deactivation

## NR\_SystemIndication\_Type

TTCN-3 Union Type		
Name	<b>NR_SystemIndication_Type</b>	
Comment		
Error	charstring	indicates an error situation in SS; is not explicitly handled in TTCN but causes an INCONC due to default behaviour; an additional error code can be signalled in the common part of the ASP; SS shall raise an error when in TS 38.523-3 or in any other ASP definitions
RlcDiscardInd	<a href="#">NR_RlcDiscardInd_Type</a>	indicates discarded PDUs
MAC	<a href="#">NR_MAC_ControlElementUL_Type</a>	indicates MAC control element being receive from the UE
RachPreamble	<a href="#">NR_RachPreamble_Type</a>	RACH preamble being sent by the UE
SchedReq	<a href="#">Null_Type</a>	indication for scheduling request sent by the UE
UL_HARQ	<a href="#">HARQ_Type</a>	to report the UL HARQ as received on PUCCH or PUSCH for corresponding DL transmission
HarqError	<a href="#">NR_HarqError_Type</a>	indicates detection of HARQ error: 1. HARQ CRC error for UL data 2. HARQ NACK from the UE unless SS is configured to report HARQ ACK/NACK

## D.1.3 Cell\_Configuration

Specific Info for Cell Configuration Primitive

### D.1.3.1 Cell\_Configuration\_Common

#### NR\_ASP\_TypeDefs: Constant Definitions

TTCN-3 Basic Types			
tsc_NR_CellAttenuation_Off	<a href="#">NR_Attenuation_Type</a>	{Off:=true}	

#### Cell\_Configuration\_Common: Basic Type Definitions

TTCN-3 Basic Types		
NR_InitialAttenuation_Type	<a href="#">NR_Attenuation_Type</a> ( <a href="#">tsc_NR_CellAttenuation_Off</a> )	Attenuation restricted to 'Off'

#### NR\_CellConfigRequest\_Type

TTCN-3 Union Type		
Name	<b>NR_CellConfigRequest_Type</b>	
Comment		
AddOrReconfigure	<a href="#">NR_CellConfigInfo_Type</a>	for cell configuration: TimingInfo : 'Now' for initial configuration; specific TimingInfo may be used for reconfiguration ControlInfo : FollowOnFlag:=false (unless explicitly specified otherwise in TS 38.523-3 clause 7)
Release	<a href="#">Null_Type</a>	to remove a cell completely - CellId : identifier of the cell to be released; nr_Cell_NonSpecific, in case all cells shall be released TimingInfo : 'Now' ControlInfo : FollowOnFlag:=false



## NR\_CellConfigInfo\_Type

TTCN-3 Record Type			
Name	<b>NR_CellConfigInfo_Type</b>		
Comment	common information for initial cell configuration or reconfiguration; in case of reconfiguration omit means 'keep configuration as it is'		
StaticResourceConfig	<a href="#">NR_SS_StaticCellResourceConfig_Type</a>	opt	mandatory for the initial configuration; to be omitted afterwards
CellConfigCommon	<a href="#">NR_CellConfigCommon_Type</a>	opt	common configuration parameters which are not specific to physical layer (or any other layer)
PhysicalLayer	<a href="#">NR_CellConfigPhysicalLayer_Type</a>	opt	Physical layer configuration: physical channels, signals and BWPs for UL and DL; DCI
BcchConfig	<a href="#">NR_BcchConfig_Type</a>	opt	configuration of BCCH/BCH; SS is triggered to configure RLC/MAC accordingly; BCCH data on the PDSCH is distinguished by the SI-RNTI PBCH: MIB; PDSCH: scheduling and resource allocation; SIBs
PcchConfig	<a href="#">NR_PcchConfig_Type</a>	opt	configuration of PCCH/PCH; SS is triggered to configure RLC/MAC accordingly; PCCH data on the PDSCH is distinguished by the P-RNTI (needed even to modify SI => shall be configured for CELL_BROADCASTING)
RachProcedureConfig	<a href="#">NR_RachProcedureConfig_Type</a>	opt	to configure the SS's behaviour for the RACH procedure; may be omitted at initial configuration e.g. in case that the cell shall not have an uplink; NOTE: there is no way to explicitly remove the RACH procedure configuration after it has been configured for a cell
DcchDtchConfig	<a href="#">NR_DcchDtchConfig_Type</a>	opt	Parameters related to DCCH/DTCH in UL and DL
ServingCellConfig	<a href="#">NR_ServingCellConfig_Type</a>	opt	To be configured at initial configuration of a cell: for non-CA scenarios it shall be either 'SpCell' or 'None' ('None' applies for pure neighbouring cells)

## NR\_SS\_StaticCellResourceConfig\_Type

TTCN-3 Record Type			
Name	<b>NR_SS_StaticCellResourceConfig_Type</b>		
Comment	capabilities of a cell according to the initial condition of a test case, to allow resource management at SS implementation (see TS 38.508-1 clause 6.3.3)		
CA_Capability	<a href="#">NR_CellCA_Capability_Type</a>		capability of a cell in context of carrier aggregation

## NR\_CellCA\_Capability\_Type

TTCN-3 Enumerated Type	
Name	<b>NR_CellCA_Capability_Type</b>
Comment	static information about the cell's capability for carrier aggregation, not being changed during a test case; may be used for resource management at the SS; according to TS 38.508-1 clause 6.3.3.2
SpCell	Cell can be used as SpCell during a test case (primary cell of a master or secondary cell group; TS 37.340 clause 3.1); normal case i.e. applicable even when SpCell is the only cell of the cell group
Scell_Active	Active SCell: An NR cell that may become an SCell at any point of time during the test case and which, while being an SCell, may be activated
Scell_Inactive	Inactive SCell: An NR cell that may become an SCell at any point of time during the test case but is never activated while being an SCell
None	e.g. when a cell is not used for connected mode during a test case (pure neighbouring cell)

## NR\_CellConfigCommon\_Type

TTCN-3 Record Type			
Name	NR_CellConfigCommon_Type		
Comment	common configuration parameters which are not specific to physical layer (or any other layer)		
C_RNTI	<a href="#">RNTI_Value_Type</a>	opt	(pre-)configured C-RNTI used by physical layer and by MAC layer; affects scrambling of PDSCH/PUSCH and CRC of PDCCH(s); shall be used implicitly in RACH procedure (i.e. as CE in RAR)
CellTimingInfo	<a href="#">CellTimingInfo_Type</a>	opt	
InitialCellPower	<a href="#">NR_InitialCellPower_Type</a>	opt	reference cell power of each antenna in DL NOTE 1: the power of an antenna may be reduced by antenna specific configuration NOTE 2: in general the power may be adjusted on a per resource element basis => all physical channel/signal power settings shall be adjusted relatively to the reference cell power; if there are more than one TX antennas each one may have its own attenuation; independently from those relative power settings the cell power can easily be adjusted by just changing the reference power

## NR\_Attenuation\_Type

TTCN-3 Union Type			
Name	NR_Attenuation_Type		
Comment	attenuation of the reference power		
Value	integer (0..149)		cell power reference power reduced by the given attenuation (value is in dB); corresponds to AbsoluteCellPower_Type
Off	<a href="#">Null_Type</a>		=< -145dBm according to TS 38.508-1 Table 6.2.2.1-3

## NR\_InitialCellPower\_Type

TTCN-3 Record Type			
Name	NR_InitialCellPower_Type		
Comment			
MaxReferencePower	<a href="#">NR_AbsoluteCellPower_Type</a>		maximum value of cell reference power (in dBm/SCS as per TS 38.508-1, clause 6.2.2); a cell is initialised with this reference power; its value is the upper bound of the cell power during the test case
Attenuation	<a href="#">NR_InitialAttenuation_Type</a>		initial attenuation

## D.1.3.2 PhysicalLayer

## NR\_CellConfigPhysicalLayer\_Type

TTCN-3 Record Type			
Name	NR_CellConfigPhysicalLayer_Type		
Comment	Common configuration of physical channels, signals and BWPs		
Common	<a href="#">NR_CellConfigPhysicalLayerCommon_Type</a>	opt	Configuration common for UL and DL
Downlink	<a href="#">NR_CellConfigPhysicalLayerDownlink_Type</a>	opt	DL configuration
Uplink	<a href="#">NR_CellConfigPhysicalLayerUplink_Type</a>	opt	UL configuration; may be omitted at initial configuration e.g. in case that the cell shall not have an uplink; NOTE: there is no way to explicitly remove the uplink configuration after it has been configured for a cell

## D.1.3.2.1 PhysicalLayer\_Common

## NR\_CellConfigPhysicalLayerCommon\_Type

TTCN-3 Record Type			
<b>Name</b>	<b>NR_CellConfigPhysicalLayerCommon_Type</b>		
<b>Comment</b>	Configuration common for UL and DL		
PhysicalCellId	PhysCellId	opt	Physical-layer cell identity according to 38.211 clause 7.4.2.1; EN-DC: corresponds to ServingCellConfigCommon.physCellId
DuplexMode	<a href="#">NR_DuplexMode_Type</a>	opt	FDD or TDD; FDD/TDD specific parameters

## NR\_DuplexMode\_Type

TTCN-3 Union Type			
<b>Name</b>	<b>NR_DuplexMode_Type</b>		
<b>Comment</b>	FDD/TDD and maybe other types of duplex mode; in general FDD/TDD mode is determined from the frequency band		
FDD	<a href="#">NR_FDD_Info_Type</a>		
TDD	<a href="#">NR_TDD_Info_Type</a>		

## NR\_FDD\_Info\_Type

TTCN-3 Record Type			
<b>Name</b>	<b>NR_FDD_Info_Type</b>		
<b>Comment</b>	FDD (paired spectrum) specific parameters: no further parameters defined for FDD		

## NR\_TDD\_UL\_DL\_SlotConfigList\_Type

TTCN-3 Record of Type			
<b>Name</b>	<b>NR_TDD_UL_DL_SlotConfigList_Type</b>		
<b>Comment</b>	corresponds to ServingCellConfig.tdd-UL-DL-ConfigurationDedicated		
record of <a href="#">NR_ASN1_TDD_UL_DL_SlotConfig_Type</a>			

## NR\_TDD\_Config\_Type

TTCN-3 Record Type			
<b>Name</b>	<b>NR_TDD_Config_Type</b>		
<b>Comment</b>	Common and dedicated TDD configuration		
Common	<a href="#">NR_ASN1_TDD_UL_DL_ConfigCommon_Type</a>	opt	Common TDD configuration as used in TS 38.213 clause 11 corresponding to ServingCellConfigCommon.tdd-UL-DL-ConfigurationCommon; shall be present for TDD at initial configuration
Dedicated	<a href="#">NR_TDD_UL_DL_SlotConfigList_Type</a>	opt	Dedicated TDD configuration for single slots over-ruling the flexible slots of the common configuration; corresponds to ServingCellConfig.tdd-UL-DL-ConfigurationDedicated; shall be present for TDD at initial configuration: the list is empty when there is no dedicated slot configuration; (omit means "keep as it is"); NOTE: The dedicated configuration can only exist together with common configuration as a single slot configuration is related to the periodicity given by the common configuration (see TDD-UL-DL-SlotConfig field description for slotIndex in TS 38.331)

## NR\_TDD\_Info\_Type

TTCN-3 Union Type		
Name	NR_TDD_Info_Type	
Comment	cell specific parameters for TDD (unpaired spectrum)	
Config	<a href="#">NR_TDD_Config_Type</a>	specific TDD configuration with sets of symbols for UL and DL and possibly flexible symbols which are not specified as UL or DL (corresponding to TDD-UL-DL-ConfigurationCommon and TDD-UL-DL-ConfigDedicated according to TS 38.213 clause 11.1)
FullFlexible	<a href="#">Null_Type</a>	No TDD configuration is provided to the UE: all slots and symbols are considered as flexible according to TS 38.213 clause 11.1

## D.1.3.2.2 PhysicalLayer\_Downlink

## PhysicalLayer\_Downlink: Basic Type Definitions

TTCN-3 Basic Types		
NR_EPRES_Ratio_Type	integer	Energy per resource element relative to given reference signal or abstract reference cell power (dB)

## NR\_CellConfigPhysicalLayerDownlink\_Type

TTCN-3 Record Type			
Name	NR_CellConfigPhysicalLayerDownlink_Type		
Comment	physical layer configuration at the SS for the downlink of a cell		
FrequencyInfoDL	<a href="#">NR_ASN1_FrequencyInfoDL_Type</a>	opt	carries information about location of SSB and reference resource block (point A) in frequency domain and about associated frequency bands (list of FreqBandIndicatorNR)
SSPBCHBlock	<a href="#">NR_SSB_Config_Type</a>	opt	Configuration of SS/PBCH-block transmission
PdschCellLevelConfig	<a href="#">NR_PDSCH_CellLevelConfig_Type</a>	opt	Cell-level configuration of PDSCH being applicable independent from the BWP a PDSCH is associated to
BWPs	<a href="#">NR_DownlinkBWPs_Type</a>	opt	Configuration of DL BWPs and their associated physical channels and signals
CsiConfig	<a href="#">NR_CSI_Config_Type</a>	opt	Configuration of CSI Reference Signals

## D.1.3.2.2.1 SS\_PBCH\_Block

SS/PBCH block configuration according to TS 38.213 clause 4.1:

SS/PBCH block consists of synchronisation Signals (PSS and SSS) and PBCH (see e.g. TS 38.300 figure 5.2.4-1); a demodulation reference signal (DM-RS) is frequency multiplexed on the PBCH symbols (TS 38.300 clause 5.2.4, TS 38.211 clause 7.4.1.4) and

the DM-RS sequence corresponds to the three LSBs of the SS/PBCH index (TS 38.213 clause 4.1 and TS 38.211 clause 7.4.1.4.1);

the SS/PBCH index needs to be maintained by the SS (as the system frame number);

the physical layer cell id is carried by PSS and SSS according to TS 38.211 clause 7.4.2

## SS\_PBCH\_Block: Basic Type Definitions

TTCN-3 Basic Types		
NR_SSB_Periodicity_Type	ServingCellConfigCommon.ssb_periodicityServingCell	
NR_SSB_PositionsInBurst_Type	ServingCellConfigCommon.ssb_PositionsInBurst	

### NR\_SS\_BlockPattern\_Type

TTCN-3 Enumerated Type	
Name	<b>NR_SS_BlockPattern_Type</b>
Comment	TS 38.101-1 Table 5.4.3.3-1 specifies for a given operating band and SS Block subcarrier spacing which case of TS 38.213 clause 4.1 to be applied => first symbol indexes for candidate SS/PBCH blocks and the size of the bitmap are determined accordingly
caseA	15 kHz subcarrier spacing: 4 bits (<= 3GHz) or 8 bits (> 3GHz); first symbol indexes: {2,8} + 14*n
caseB	30 kHz subcarrier spacing: 4 bits (<= 3GHz) or 8 bits (> 3GHz); first symbol indexes: {4,8,16,20} + 28*n
caseC	30 kHz subcarrier spacing: 4 bits (<= 3GHz) or 8 bits (> 3GHz); first symbol indexes: {2,8} + 14*n
caseD	120 kHz subcarrier spacing: 64 bits (> 6GHz); first symbol indexes: {4,8,16,20} + 28*n
caseE	240 kHz subcarrier spacing: 64 bits (> 6GHz); first symbol indexes: {8,12,16,20,32,36,40,44} + 56*n

### NR\_SSB\_Beam\_Type

TTCN-3 Record Type			
Name	<b>NR_SSB_Beam_Type</b>		
Comment			
SsbIndex	integer	opt	SSB index starting at 0 according to TS 38.213 clause 4.1
Attenuation	integer	opt	Beam power: reference power for SSB transmissions relative to the actual reference cell power (MaxReferencePower - Attenuation of cell power); the beam power is reduced by 'Attenuation' relative to the actual reference cell power; the attenuation may be negative in which case the power level of the SSB transmission is higher than the actual cell power

### NR\_SSB\_BeamArray\_Type

TTCN-3 Record of Type	
Name	<b>NR_SSB_BeamArray_Type</b>
Comment	
record of <a href="#">NR_SSB_Beam_Type</a>	

### NR\_SSB\_BurstConfig\_Type

TTCN-3 Record Type			
Name	<b>NR_SSB_BurstConfig_Type</b>		
Comment	To describe the SSB burst		
BlockPattern	<a href="#">NR_SS_BlockPattern_Type</a>	opt	case A..E according to 38.213 clause 4.1; mandatory for initial configuration, "keep as it is" in case of omit otherwise
PositionsInBurst	<a href="#">NR_SSB_PositionsInBurst_Type</a>	opt	"SSB-transmitted" parameter as used by the UE to rate-match around SSBs acc. 38.214 cl. 5.1; 4, 8 or 64 bits; mandatory for initial configuration, "keep as it is" in case of omit otherwise
BeamArray	<a href="#">NR_SSB_BeamArray_Type</a>	opt	beam specific configuration: if omit, all SSBs as configured in 'Bitmap' shall be transmitted with no attenuation (i.e. using the actual reference cell power); if present only the SSBs contained in the array shall be transmitted (with beam power as according to their entry in the array); when the array contains beams with an SSB index not included in 'Bitmap', the SS may raise an error

## NR\_SSB\_EPRES\_Type

TTCN-3 Record Type			
Name	NR_SSB_EPRES_Type		
Comment	EPRE for PBCH and related signals relative to the reference power (EPRE_SSB#N) of an SSB (beam) given by SSB index N		
PbchToDmrs	<a href="#">NR_EPRE_Ratio_Type</a>	opt	transmit power for resource elements (REs) being occupied by PBCH; EPRE ratio of PBCH to PBCH DMRS
PssToSss	<a href="#">NR_EPRE_Ratio_Type</a>	opt	Primary synchronization signal; 38.211 clause 7.4.2.2; EPRE ratio of PSS to SSS
SssToSsbBeam	<a href="#">NR_EPRE_Ratio_Type</a>	opt	Secondary synchronization signal; 38.211 clause 7.4.2.3; EPRE ratio of SSS to EPRE_SSB#N; in general the SSS power is the same as the reference beam power, i.e. SssToSsbBeam = 0dB
DmrsToSss	<a href="#">NR_EPRE_Ratio_Type</a>	opt	DM-RS associated to PBCH (Demodulation reference signals for PBCH; 38.211 clause 7.4.1.4); EPRE ratio of PBCH DMRS to SSS

## NR\_SSB\_Config\_Type

TTCN-3 Record Type			
Name	NR_SSB_Config_Type		
Comment	Synchronization signals and PBCH; TS 38.211 clause 7.4.3, TS 38.300 clause 5.2.4; NOTE: SSB location in frequency domain is specified by NR_CellConfigPhysicalLayerDownlink_Type.FrequencyInfoDL.absoluteFrequencySSB		
SubCarrierSpacing	SubcarrierSpacing	opt	sub-carrier spacing for SS/PBCH block (as specified by ServingCellConfigCommon.subcarrierSpacing in case of non-initial access): According to comments for ServingCellConfigCommon.subcarrierSpacing "Only the values 15 or 30 kHz (<6GHz), 120 or 240 kHz (>6GHz) are applicable"; this corresponds to tables 13-1 .. 13.10 in TS 38.213 where only 15 or 30 kHz and 120 or 240 kHz are considered for SS/PBCH block sub-carrier spacing; and it corresponds to 38.211 clause 7.4.3.1 defining SS/PBCH block type A as numerology=0,1 and type B as numerology=3,4 (i.e. there is no numerology=2 for SS/PBCH block) NOTE 1: in contrast to SS/PBCH block sub-carrier spacing the sub-carrier spacing for SIB1, Msg.2/4 for initial access and broadcast SI-messages is restricted to 15kHz or 30kHz for carrier frequency <= 6 GHz and 60kHz or 120kHz for carrier frequency > 6 GHz (see comments for MIB.subCarrierSpacingCommon and TS 38.213 tables 13-1 .. 13.10) NOTE 2: As long as there is no sub-carrier spacing of 60kHz (numerology=2) for the SS/PBCH block acc. to TS 38.211 Table 4.2-1 there is no extended cyclic prefix either (even though Table 4.2-1 is mainly for BWP there is no indication for any extended cyclic prefix for SS/PBCH block) => there is no need to specify the cyclic prefix for SS/PBCH block configuration (normal cyclic prefix is assumed for all cases)
SubcarrierOffset	integer	opt	k_SSB as defined in TS 38.211 clause 7.4.3.1; needs to be consistent with absoluteFrequencySSB and absoluteFrequencyPointA as provided by FrequencyInfoDL to the UE and the SS
Periodicity	<a href="#">NR_SSB_Periodicity_Type</a>	opt	in multiples of half frames (5ms)
HalfFrameOffset	integer	opt	to specify together the Periodicity the half-frames in which the SSB burst shall be transmitted: - for Periodicity = 5ms SSB burst in every half-frame - for a Periodicity >= 5ms SSB burst in frames with (SFN mod (Periodicity / 10)) = (HalfFrameOffset / 2) and in the - lower half-frame for (HalfFrameOffset mod 2) = 0 - higher half-frame for (HalfFrameOffset mod 2) = 1 Depending on the Periodicity the HalfFrameOffset has a range of 0 .. ((Periodicity / 5) - 1) Unless explicitly required by a test case the HalfFrameOffset is always 0
BurstConfig	<a href="#">NR_SSB_BurstConfig_Type</a>	opt	to specify the burst configuration and a bitmap for the SS/PBCH block candidates which are eventually used for transmission of SS/PBCH blocks in a half frame
RelativeTxPower	<a href="#">NR_SSB_EPRES_Type</a>	opt	transmit power for PBCH and SS/PBCH signals NOTE: Parameter SS-PBCHBlockPower is provided to the UE in SIB1.ss-PBCH-BlockPower, ServingCellConfigCommon.ss-PBCH-BlockPower) as referenceSignalPower; The UE uses referenceSignalPower to determine the transmission power of the PRACH (TS 38.213 clause 7.4) => For signalling tests there seems to be no need to provide this parameter to the SS (nevertheless the value provided to the UE shall not conflict with the power settings for the SSB at the SS)

## D.1.3.2.2.2 CSI\_Configuration

## NR\_CSI\_RS\_Periodicity\_Type

TTCN-3 Union Type		
Name	<b>NR_CSI_RS_Periodicity_Type</b>	
Comment	NOTE: may be extended with 'Aperiodic' branch if needed	
PeriodicityAndOffset	CSI_ResourcePeriodicityAndOffset	periodicity and slot offset as used by NZP-CSI-RS-Resource for periodic and semi-persistent configuration; the periodicity is given in the number of slots whereas CSI-RS-Resource-Mobility.slotConfig specifies the periodicity in milliseconds => to configure the CSI-RS configuration corresponding to CSI-RS-Resource-Mobility the periodicity needs to be converted in TTCN depending on the numerology



## NR\_NZP\_CSI\_RS\_Config\_Type

TTCN-3 Record Type			
Name	NR_NZP_CSI_RS_Config_Type		
Comment	Channel-state information reference signal (CSI) according to TS 38.211 clause 7.4.1.5, TS 38.214 clause 5.1.6.1 and clause 5.2.2.3; the UE may be configured with non-zero-power (NZP) CSI-RS by a) NZP-CSI-RS-Resource (contained in CSI-MeasConfig) or b) CSI-RS-Resource-Mobility (contained in MeasConfig) (according to TS 38.211 clause 7.4.1.5.1)		
ScramblingId	ScramblingId	opt	INTEGER(0..1023); Scrambling ID for CSI-RS as provided to the UE in NZP-CSI-RS-Resource.scramblingID or CSI-RS-Resource-Mobility.sequenceGenerationConfig
ResourceMapping	CSI_RS_ResourceMapping	opt	resource mapping as used in NZP-CSI-RS-Resource; there is the following mapping with CSI-RS-CellMobility - frequencyDomainAllocation: For CSI-RS-Resource-Mobility there are row1 or row2 only - nrofPorts: One port for CSI-RS-Resource-Mobility (according to TS 38.211 Table 7.4.1.5.3-1 for Row=1 and Row=2) - firstOFDMSymbolInTimeDomain (I0): same for CSI-RS-ResourceMapping and CSI-RS-Resource-Mobility - firstOFDMSymbolInTimeDomain2 (I1): Not present for CSI-RS-Resource-Mobility (there is no I1 for Row=1 and Row=2 in Table 7.4.1.5.3-1 of TS 38.211) - cdm-Type: No CDM for CSI-RS-Resource-Mobility (according to Row=1 and Row=2 in Table 7.4.1.5.3-1 of TS 38.211) - density: ENUMERATED {d1,d3} for CSI-RS-CellMobility to be mapped to CHOICE (one, three) of CSI-RS-ResourceMapping - freqBand: According to TS 38.331 a) CSI-FrequencyOccupation specifies the frequency range for CSI-RS relative to a given BWP (CSI-ResourceConfig.bwp-id) whereas b) CSI-RS-CellMobility specifies the position relative to point A (given by MeasObjectNR.refFreqCSI-RS) => As there is no equivalent to CSI-ResourceConfig.bwp-id for variant b), 'OffsetToFreqBand' is used to fully specify the frequency range (see below)
OffsetToFreqBand	integer	opt	The frequency band for CSI-RS starts at OffsetToFreqBand + ResourceMapping.freqBand.startingRB from point A. a) When the UE is configured with NZP-CSI-RS-Resource: ResourceMapping.freqBand shall be set to the same value as signalled to the UE and OffsetToFreqBand shall be set offsetToCarrier + BWP.RB_Start. (NOTE: in general RB_Start is 0 in BWP.locationAndBandwidth: i.e. BWP.RB_Start=0 => OffsetToFreqBand = offsetToCarrier) b) When the UE is configured with CSI-RS-CellMobility: OffsetToFreqBand and ResourceMapping.freqBand.startingRB shall be set so that OffsetToFreqBand + ResourceMapping.freqBand.startingRB = CSI-RS-CellMobility.csi-rs-MeasurementBW.startPRB. (NOTE: In general it shall be OffsetToFreqBand = offsetToCarrier and ResourceMapping.freqBand.startingRB = CSI-RS-CellMobility.csi-rs-MeasurementBW.startPRB - offsetToCarrier)
Periodicity	<a href="#">NR_CSI_RS_Periodicity_Type</a>	opt	
Attenuation	integer	opt	Beam power: reference power for CSI-RS transmissions relative to the actual reference cell power (MaxReferencePower - Attenuation of cell power); see NR_SSB_Beam_Type

## NR\_NZP\_CSI\_RS\_ConfigList\_Type

TTCN-3 Record of Type	
Name	NR_NZP_CSI_RS_ConfigList_Type
Comment	Array with set of CSI reference signals; each CSI-RS may belong to a different beam
record of <a href="#">NR_NZP_CSI_RS_Config_Type</a>	

## NR\_CSI\_Config\_Type

TTCN-3 Union Type		
Name	NR_CSI_Config_Type	
Comment	Primitive for configuration CSI at the SS NOTE: further branches may be added e.g. to support CSI-IM	
CSI_RS	<a href="#">NR_NZP_CSI_RS_ConfigList_Type</a>	Configuration of CSI reference signals: Configuration of CSI reference signals does not necessarily mean that there is CSI reporting but CSI-RS is also needed for - link monitoring (beam failure scenarios) and - neighbouring cell measurement. For these cases periodic CSI-RS is used and may be started immediately (TimingInfo=Now) or at a specific point in time with periodicity as specified by Periodicity.PeriodicityAndOffset. Semi-persistent CSI-RS could be realised in the same way as periodic CSI-RS (but with specific TimingInfo). Aperiodic CSI-RS is not considered so far (NOTE: For simple cases of aperiodic CSI-RS NR_CSI_RS_Periodicity_Type may be extended with an 'Aperiodic' branch but e.g. combination of periodic and aperiodic CSI-RS would require a more complex approach, e.g. with explicit trigger for the transmission of the CSI-RS)
None	<a href="#">Null_Type</a>	

## D.1.3.2.2.3 Cell\_Level\_Configuration\_PDSCH

## Cell\_Level\_Configuration\_PDSCH: Basic Type Definitions

TTCN-3 Basic Types		
NR_PDSCH_DMRS_TypeA_Position_Type	MIB.drms_TypeA_Position	same as ServingCellConfigCommon.drms-TypeA-Position

## NR\_PDSCH\_CellLevelConfig\_Type

TTCN-3 Record Type			
Name	NR_PDSCH_CellLevelConfig_Type		
Comment	cell-level parameters for PDSCH: in contrast to BWP specific parameters the cell-level parameters apply to any PDSCH independent from the BWP a PDSCH is associated to		
DMRS_TypeA_Position	<a href="#">NR_PDSCH_DMRS_TypeA_Position_Type</a>	opt	Provided to the UE by MIB.drms-TypeA-Position or ServingCellConfigCommon.drms-TypeA-Position; dmrs-TypeA-Position defines position of the first DM-RS symbol in the sequence of DM-RS symbols according to TS 38.211 clause 7.4.1.1.
RateMatchPattern	<a href="#">NR_CellLevelRateMatchPattern_Type</a>	opt	rate match pattern according to TS 38.214 clause 5.1.4
ServingCellConfig	<a href="#">NR_ASN1_PDSCH_ServingCellConfig_Type</a>	opt	PDSCH related parameters not being BWP-specific; corresponds to ServingCellConfig.pdsch-ServingCellConfig

## NR\_RateMatchPatternList\_Type

TTCN-3 Record of Type	
Name	NR_RateMatchPatternList_Type
Comment	
record of <a href="#">NR ASN1 RateMatchPattern_Type</a>	

## NR\_RateMatchPatternLteCrslList\_Type

TTCN-3 Record of Type	
Name	NR_RateMatchPatternLteCrslList_Type
Comment	
record of <a href="#">NR ASN1 RateMatchPatternLTE CRS_Type</a>	

## NR\_CellLevelRateMatchPattern\_Type

TTCN-3 Record Type			
Name	NR_CellLevelRateMatchPattern_Type		
Comment	configuration of rate match pattern on cell level (see TS 38.214 clause 5.1.4)		
PatternList	<a href="#">NR_RateMatchPatternList_Type</a>	opt	up to 4 cell-level RateMatchPattern according to TS 38.214 clause 5.1.4 (L1 RateMatchPattern); corresponds to ServingCellConfigCommon.rateMatchPatternToAddModList/rateMatchPatternToReleaseList; empty list per default (i.e. at initial configuration)
PatternListLteCrsls	<a href="#">NR_RateMatchPatternLteCrslList_Type</a>	opt	0 or 1 LTE CRS pattern to rate match around (see TS 38.214 clause 5.1.4.2) corresponds to ServingCellConfigCommon.lte-CRS-ToMatchAround; empty list per default (i.e. at initial configuration)

## D.1.3.2.2.4 Downlink\_BWP

## NR\_DownlinkBWP\_Type

TTCN-3 Record Type			
Name	NR_DownlinkBWP_Type		
Comment	Configuration of single BWP at the SS		
Id	BWP_Id	opt	Initial BWP: 0 Dedicated BWP: 1..4
BWP	<a href="#">NR ASN1 BWP_Type</a>	opt	Frequency domain location and bandwidth, subcarrier spacing, cyclic prefix
Pdccb	<a href="#">NR BWP PDCCH Configuration_Type</a>	opt	
Pdsch	<a href="#">NR BWP PDSCH Configuration_Type</a>	opt	
Sps	<a href="#">NR ASN1 SPS Config_Type</a>	opt	BWP-DownlinkDedicated.SPS-Config

## NR\_DownlinkBWP\_List\_Type

TTCN-3 Record of Type	
Name	NR_DownlinkBWP_List_Type
Comment	configuration of BWPs: each entry shall have a distinct Id with ID=0 for the initial BWP; NOTE 1: Even though in general the BWP-Id corresponds to the index of the element within the array of BWPs, the SS shall not take this as assumption
record of <a href="#">NR_DownlinkBWP_Type</a>	

### NR\_DownlinkBWPs\_Type

TTCN-3 Record Type			
Name	NR_DownlinkBWPs_Type		
Comment	configuration of downlink BWPs		
ActiveBWP	BWP_Id	opt	Id of the currently active BWP (this does not need to be the same as the index) According to TS 38.211 clause 4.4.5: "A UE can be configured with up to four carrier bandwidth parts in the downlink with a single downlink carrier bandwidth part being active at a given time. The UE is not expected to receive PDSCH, PDCCH, CSI-RS, or TRS outside an active bandwidth part."
BwpArray	<a href="#">NR_DownlinkBWP_List_Type</a>	opt	array of band width parts: initial BWP + up to 4 dedicated BWPs

#### D.1.3.2.2.4.1 PDSCH\_Configuration

Configuration of PDSCH and its related reference signals:

- DM-RS (Demodulation reference signal); TS 38.211 clause 7.4.1.1
- PT-RS (Phase-tracking reference signals for PDSCH); TS 38.211 clause 7.4.1.2

### NR\_BWP\_PDSCH\_Configuration\_Type

TTCN-3 Record Type			
Name	NR_BWP_PDSCH_Configuration_Type		
Comment	PDSCH configuration at the SS for specific BWP		
ConfigCommon	<a href="#">NR_ASN1_PDSCH_Config_Common_Type</a>	opt	
ConfigDedicated	<a href="#">NR_ASN1_PDSCH_Config_Type</a>	opt	
RelativeTxPower	<a href="#">NR_PDSCH_EPRES_Type</a>	opt	

### NR\_PDSCH\_EPRES\_Type

TTCN-3 Record Type			
Name	NR_PDSCH_EPRES_Type		
Comment	EPRE for PDSCH and related signals		
PdschToCell	<a href="#">NR_EPRES_Ratio_Type</a>	opt	transmit power relative to given reference cell power for resource elements (REs) being occupied by PDSCH
PdschToDmrs	<a href="#">NR_EPRES_Ratio_Type</a>	opt	EPRE power ratio of PDSCH to DM-RS being associated to the PDSCH according to TS 38.214 clause 4.1
PdschToPtrs	<a href="#">NR_EPRES_Ratio_Type</a>	opt	EPRE power ratio of PDSCH to PT-RS being associated to the PDSCH according to TS 38.214 clause 4.1 NOTE: PT-RS need only to be considered when being present (TS 38.211 clause 7.4.1.2.2 according to TS 38.214 clause 4.1), i.e. the SS shall ignore the PT-RS's EPRE if no PT-RS is present

#### D.1.3.2.2.4.2 PDCCH\_Configuration

Configuration of PDSCH and its related reference signals:

- DM-RS (Demodulation reference signal); TS 38.211 clause 7.4.1.3

### NR\_BWP\_PDCCH\_Configuration\_Type

TTCN-3 Record Type			
<b>Name</b>	<b>NR_BWP_PDCCH_Configuration_Type</b>		
<b>Comment</b>	PDCCH configuration at the SS for specific BWP; NOTE: There are no fields for PDCCH-Config's "downlinkPreemption", "slotFormatIndicator", "tpc-PUSCH" and "tpc-PUCCH": This information is related to triggering DCI formats 2_X an shall be configured there (NR_DCI_Trigger_Type) according to test case requirements		
SearchSpaceArray	<a href="#">NR_BWP_SearchSpaceList_Type</a>	opt	
CoresetArray	<a href="#">NR_BWP_CoresetList_Type</a>	opt	
RelativeTxPower	<a href="#">NR_PDCCH_EPRES_Type</a>	opt	
Coreset0_OffsetRBs	integer	opt	Number of Offset RBs as specified in 38.213 clause 13. Applied to CORESET#0 only

### NR\_BWP\_CoresetList\_Type

TTCN-3 Record of Type	
<b>Name</b>	<b>NR_BWP_CoresetList_Type</b>
<b>Comment</b>	list of CORESETs defined for a single BWP; according to TS 38.213 clause 10.1 "The control resource set configured for Type0-PDCCH common search space has control resource set index 0" NOTE: even though in general (array) index and controlResourceSetId are the same it is not clear what is meant by TS 38.213
record of <a href="#">NR_ASN1_ControlResourceSet_Type</a>	

### NR\_BWP\_SearchSpaceList\_Type

TTCN-3 Record of Type	
<b>Name</b>	<b>NR_BWP_SearchSpaceList_Type</b>
<b>Comment</b>	list of search spaces defined for a single BWP; according to TS 38.213 clause 10.1 "The Type0-PDCCH common search space has search space index 0" NOTE: even though in general (array) index and searchSpaceId are the same it is not clear what is meant by TS 38.213
record of <a href="#">NR_BWP_SearchSpaceConfig_Type</a>	

### NR\_PDCCH\_EPRES\_Type

TTCN-3 Record Type			
<b>Name</b>	<b>NR_PDCCH_EPRES_Type</b>		
<b>Comment</b>	EPRE for PDCCH and related signals		
PdcchToCell	<a href="#">NR_EPRES_Ratio_Type</a>	opt	transmit power relative to given reference cell power for resource elements (REs) being occupied by PDCCH
PdcchToDmrs	<a href="#">NR_EPRES_Ratio_Type</a>	opt	EPRE power ratio of PDCCH to DM-RS being associated to the PDCCH; further DMRS parameters are given by ASN.1 PDCCH-Config as signalled to the UE or by additional parameters of the initial BWP configuration

## D.1.3.2.2.4.2.1 Search\_Space\_Configuration

**Search\_Space\_Configuration: Basic Type Definitions**

TTCN-3 Basic Types		
NR_SearchSpaceCandidatePriority_Type	<a href="#">UInt_Type</a>	Priorities to be considered by the SS in order to choose the candidate of a search space not colliding with the candidate of some other search space; a value of 0 represents the highest priority, a value of 1 the second highest priority and so on. (see TS 38.523-3 clause 7.1.2.1.4 for further details)

**NR\_SearchSpaceType\_Type**

TTCN-3 Enumerated Type	
Name	NR_SearchSpaceType_Type
Comment	types of search spaces according to TS 38.213 clause 10.1; NOTE 1: In principle there could be more than one instance for the same kind of search space; if this is ever needed, this enumerated shall be enhanced by introduction of a second entry for a particular type. NOTE 2: For the USS UL and DL are distinguished as they may need different priority in terms of scheduling of DCIs
cssType0	Type0-PDCCH common search space for scheduling of SIB1 (SI-RNTI); the SS shall scramble the DCI format's CRC with SI-RNTI; aggregation level and number of candidates correspond to TS 38.213 Table 10.1-1; For stand-alone options parameters of search space and associated CORESET are according MIB.pdcch-ConfigSIB1 (TS 38.213 clause 13)
cssType0A	Type0A-PDCCH common search space for scheduling of other system information (SI-RNTI); the SS shall scramble the DCI format's CRC with SI-RNTI
cssType1	Type1-PDCCH common search space for scheduling of Msg2 or Msg4 of RACH procedure; the SS shall scramble the DCI format's CRC with RA-RNTI for Msg2 or with TC-RNTI for Msg4 (temporary C-RNTI) as configured for Msg4 (NR_TempC_RNTI_Type in NR_RAR_Payload_Type)
cssType2	Type2-PDCCH common search space for scheduling of Paging messages or short messages (P-RNTI); the SS shall scramble the DCI format's CRC with P-RNTI
cssType3	Type3-PDCCH common search space for other purpose DCIs (INT-RNTI, SFI-RNTI, TPC-PUSCH-RNTI, TPC-PUCCH-RNTI, TPC-SRS-RNTI, C-RNTI, CS-RNTI(s)); the SS shall scramble the DCI format's CRC with the RNTI-value as according to the ASP triggering the DCI to be sent
ussDL	UE-specific search space (C-RNTI, CS-RNTI(s)); the SS shall scramble the DCI format's CRC with the C-RNTI value as stored for the cell (NR_CellConfigCommon_Type)
ussUL	UE-specific search space: as USS_DL but in general with lower priority to give DL assignments precedence over periodic UL grants

**NR\_SearchSpaceTypeAndPriority\_Type**

TTCN-3 Record Type		
Name	NR_SearchSpaceTypeAndPriority_Type	
Comment		
Type	<a href="#">NR_SearchSpaceType_Type</a>	
CandidatePriority	<a href="#">NR_SearchSpaceCandidatePriority_Type</a>	priority to be considered when candidates of a different or the same search space overlap the same CCEs

## NR\_SearchSpaceTypeAndPriorityList\_Type

TTCN-3 Record of Type	
Name	NR_SearchSpaceTypeAndPriorityList_Type
Comment	
record of <a href="#">NR_SearchSpaceTypeAndPriority_Type</a>	

## NR\_PDCCH\_CCE\_AggregationLevel\_Type

TTCN-3 Enumerated Type	
Name	NR_PDCCH_CCE_AggregationLevel_Type
Comment	Aggregation level for a search space
AggregationLevel1	
AggregationLevel2	
AggregationLevel4	
AggregationLevel8	
AggregationLevel16	

## NR\_BWP\_SearchSpaceConfig\_Type

TTCN-3 Record Type			
Name	NR_BWP_SearchSpaceConfig_Type		
Comment	<p>configuration of a single search space at the SS:  The position of a particular search space candidate in frequency and time domain depends on configuration of the search space and its associated CORESET (see TS 38.213 clause 10.1):</p> <ul style="list-style-type: none"> <li>- Common or UE-specific search space</li> <li>- aggregation level L</li> <li>- number of candidates per aggregation level</li> <li>- PDCCH monitoring periodicity and offset</li> <li>- frequency domain resources</li> <li>- number of symbols (time domain)</li> </ul> <p>in addition in case of UE-specific search space:</p> <ul style="list-style-type: none"> <li>- C-RNTI (as configured for the active cell)</li> <li>- carrier indicator field value (in case of cross carrier scheduling)</li> </ul> <p>all fields are mandatory as modification of a single field may cause inconsistencies</p>		
TypeAndPriorityList	<a href="#">NR_SearchSpaceTypeAndPriorityList_Type</a>		<p>list of search space types (according to TS 38.213 clause 10.1) to be mapped to the given search space configuration.</p> <p>NOTE 1: In general the lists of search space types for different search spaces shall be mutual exclusive;</p> <p>NOTE 2: TS 38.213 clause 10.1 could be read as if the different types of search spaces use distinct instances of search spaces; nevertheless RRC type definitions allow use of different types in one and the same search space</p>
AggregationLevel	<a href="#">NR_PDCCH_CCE_AggregationLevel_Type</a>		aggregation level to be applied for an actual PDCCH of the given search space
SearchSpaceConfigAtUE	<a href="#">NR_ASN1_SearchSpace_Type</a>		<p>search space configuration as sent to the UE; contains searchSpaceId and controlResourceSetId referring to the associated CORESET;</p> <p>furthermore the SS may need e.g. the number of candidates to detect error situations in context of candidate selection</p>

## D.1.3.2.2.4.2.2 Search\_Space\_DCI\_Assignment

**NR\_BWP\_Id\_List\_Type**

TTCN-3 Record of Type	
Name	<b>NR_BWP_Id_List_Type</b>
Comment	
record of BWP_Id	

**NR\_AssignedBWPs\_Type**

TTCN-3 Record Type			
Name	<b>NR_AssignedBWPs_Type</b>		
Comment	definition of a set of BWPs being assigned e.g. to system information scheduling or RACH procedures NOTE 1: there is no error when e.g. "ActiveBWP" is set and the currently active BWP is contained in DedicatedBWPs too NOTE 2: it is up to use of this type in TTCN to ensure that a specific BWP assignment makes sense, in most cases multiple BWPs may not be applicable		
ActiveBWP	<a href="#">Null_Type</a>	opt	SS shall assign the currently active BWP
InitialBWP	<a href="#">Null_Type</a>	opt	SS shall assign the initial BWP
DedicatedBWPs	<a href="#">NR_BWP_Id_List_Type</a>		SS shall assign all BWPs as listed (on top of active or initial BWP if set); an empty list indicates that no (additional) BWPs are assigned

**NR\_SearchSpaceDIDciAssignment\_Type**

TTCN-3 Record Type			
Name	<b>NR_SearchSpaceDIDciAssignment_Type</b>		
Comment	configuration of DCI for a specific search space; in general the configuration belongs to a transport channel configuration (e.g. BCH, PCH, DL-SCH): the DCI is applied for DL transmission on the respective channel and can be explicitly initiated by TTCN (e.g. PCH, DL-SCH) or automatically by the SS (e.g. BCH or Msg2/Msg4 scheduling of RACH procedure); all fields are mandatory for the first configuration of an instance for modifications "omit" means "keep as it is"		
AssignedBWPs	<a href="#">NR_AssignedBWPs_Type</a>	opt	BWP where given DCI shall be scheduled in given search space; NOTE 1: When there is no BWP according to configuration of AssignedBWPs, there is no DL assignment; this can be used e.g. to prevent automatic scheduling of system information; NOTE 2: In principle a DL assignment can happen simultaneously in more than one BWP e.g. if system information shall be scheduled in active and initial BWP; but as long as there is no use case for simultaneous DL assignments, configuration of AssignedBWPs shall be restricted to a maximum of one BWP
SearchSpaceType	<a href="#">NR_SearchSpaceType_Type</a>	opt	search space to be used for sending of given DCI; when at the scheduled point in time of a DL transmission there is no such search space configured at the given BWP, the SS may raise an error
DciInfo	<a href="#">NR_DciDInfo_Type</a>	opt	DCI to be used



**NR\_SearchSpaceUIDciAssignment\_Type**

TTCN-3 Record Type			
Name	<b>NR_SearchSpaceUIDciAssignment_Type</b>		
Comment	configuration of DCI for UL grants in the UL USS; in general the configuration belongs to a transport channel configuration (e.g. UL-SCH); all fields are mandatory for the first configuration of an instance for modifications "omit" means "keep as it is"		
AssignedBWPs	<a href="#">NR_AssignedBWPs_Type</a>	opt	BWP where given DCI shall be scheduled in given search space; AssignedBWPs shall specify exactly one BWP (ActiveBWP in general); the SS may raise an error otherwise
SearchSpaceType	<a href="#">NR_SearchSpaceType_Type</a>	opt	search space to be used for sending of given DCI; when at the scheduled point in time of a UL grant transmission there is no such search space configured at the given BWP, the SS may raise an error
DciInfo	<a href="#">NR_DciUInfo_Type</a>	opt	DCI to be used

**D.1.3.2.3 PhysicalLayer\_Uplink**

Uplink physical layer configuration: UL channels and BWPs

**NR\_CellConfigPhysicalLayerUplink\_Type**

TTCN-3 Record Type			
Name	<b>NR_CellConfigPhysicalLayerUplink_Type</b>		
Comment	physical layer configuration at the SS for the uplink of a cell		
Uplink	<a href="#">NR_Uplink_Type</a>	opt	
Supplementary Uplink	<a href="#">NR_Uplink_Type</a>	opt	
TimingAdvance	<a href="#">NR_SS_TimingAdvanceConfig_Type</a>	opt	
PUSCH_ServingCellConfig	<a href="#">NR_ASN1_PUSCH_ServingCellConfig_Type</a>	opt	
PUSCH_ServingCellConfigSUL	<a href="#">NR_ASN1_PUSCH_ServingCellConfig_Type</a>	opt	

**NR\_Uplink\_Type**

TTCN-3 Union Type			
Name	<b>NR_Uplink_Type</b>		
Comment			
Config	<a href="#">NR_UplinkConfig_Type</a>		
None	<a href="#">Null_Type</a>		in case the uplink or supplementary uplink is not used/needed

**NR\_SS\_TimingAdvanceConfig\_Type**

TTCN-3 Union Type			
Name	<b>NR_SS_TimingAdvanceConfig_Type</b>		
Comment			
InitialValue	<a href="#">NR_RACH_TimingAdvance_Type</a>		initial 12 bit value corresponding to Timing Advance Command field of the Random Access Response (TS 38.321 clause 6.2.3); value of 0..3846 according to TS 38.213 clause 4.2; 0 in normal cases)
Relative	<a href="#">NR_TimingAdvanceIndex_Type</a>		timing advance command to adjust changes of timing advance acc. to TS 38.213 clause 4.2; (range acc. 6 bit value: -31..32)

D.1.3.2.3.1 Uplink\_BWP

**NR\_UplinkBWP\_Type**

TTCN-3 Record Type			
Name	NR_UplinkBWP_Type		
Comment	Configuration of single BWP at the SS; NOTE: for rel-15 this is the same as the ASN.1 type "BWP-Uplink" but nevertheless the TTCN type may be useful for future extensions		
Id	BWP_Id	opt	Initial BWP: 0 Dedicated BWP: 1..4
Common	<a href="#">NR ASN1 BWP UplinkCommon_Type</a>	opt	contains common configuration for RACH, PUSCH, PUCCH configuration at the UE: - Initial BWP: -> ServingCellConfigCommon.uplinkConfigCommon.initialUplinkBWP  ServingCellConfigCommon.supplementaryUplinkConfig.initialUplinkBWP -> SIB1.uplinkConfigCommon.initialUplinkBWP  SIB1.supplementaryUplink.uplinkConfigCommon.initialUplinkBWP - Dedicated BWP: -> ServingCellConfig.uplinkConfig.uplinkBWP-ToAddModList[-].bwp-Common ServingCellConfig.supplementaryUplink.uplinkBWP-ToAddModList[-].bwp-Common
Dedicated	<a href="#">NR ASN1 BWP UplinkDedicated_Type</a>	opt	contains dedicated configuration for PUCCH, PUSCH, ConfiguredGrant, SRS, BeamFailureRecovery configuration at the UE: - Initial BWP: -> ServingCellConfig.uplinkConfig.initialUplinkBWP ServingCellConfig.supplementaryUplink.initialUplinkBWP - Dedicated BWP: -> ServingCellConfig.uplinkConfig.uplinkBWP-ToAddModList[-].bwp-Dedicated ServingCellConfig.supplementaryUplink.uplinkBWP-ToAddModList[-].bwp-Dedicated

**NR\_UplinkBWP\_List\_Type**

TTCN-3 Record of Type	
Name	NR_UplinkBWP_List_Type
Comment	configuration of BWPs: each entry shall have a distinct Id with ID=0 for the initial BWP NOTE: Even though in general the BWP-Id corresponds to the index of the element within the array of BWPs, the SS shall not take this as assumption
record of <a href="#">NR_UplinkBWP_Type</a>	

**NR\_ActiveUplinkBWP\_Id\_Type**

TTCN-3 Union Type		
Name	NR_ActiveUplinkBWP_Id_Type	
Comment		
Explicit	BWP_Id	in case that BWP-Id of active UL-BWP (and/or active UL-BWP of supplementary UL) is different than BWP-Id of active DL-BWP
SameIdAsDL	<a href="#">Null_Type</a>	same BWP-Id as of the active DL-BWP

## NR\_UplinkBWPs\_Type

TTCN-3 Record Type			
Name	NR_UplinkBWPs_Type		
Comment	configuration of uplink BWPs		
ActiveBWP	<a href="#">NR_ActiveUplinkBWP_Id_Type</a>	opt	Id of the currently active BWP (this does not need to be the same as the index)
BwpArray	<a href="#">NR_UplinkBWP_List_Type</a>	opt	array of band width parts: initial BWP + up to 4 dedicated BWPs

## NR\_UplinkConfig\_Type

TTCN-3 Record Type			
Name	NR_UplinkConfig_Type		
Comment	configuration of a single uplink (uplink or supplementary uplink)		
FrequencyInfoUL	<a href="#">NR_ASN1_FrequencyInfoUL_Type</a>	opt	carries information about location of reference resource block (point A) in frequency domain and about associated frequency bands (list of FreqBandIndicatorNR)
BWPs	<a href="#">NR_UplinkBWPs_Type</a>	opt	
RACH_ConfigDedicated	<a href="#">NR_ASN1_RACH_ConfigDedicated_Type</a>	opt	configuration at the UE: -> SpCellConfig.reconfigurationWithSync.rach-ConfigDedicated.uplink/supplementaryUplink
SI_RequestConfig	<a href="#">NR_ASN1_SI_RequestConfig_Type</a>	opt	configuration of PRACH preamble(s) and PRACH resource(s) for si-RequestConfig configuration at the UE: -> in SIB1.si-SchedulingInfo.si-RequestConfig

## D.1.3.2.4 DCI\_Configuration

Definitions for resource assignment and DCI according to TS 38.212 clause 7.3 and TS 38.214 clause 5.1.2 and 6.1.2

## D.1.3.2.4.1 Common\_Fields

Common type definitions for DCI fields being used for UL and DL assignments (format 0\_X and 1\_X);  
NOTE: in general fields of DCIs are defined as union in the first place to allow backward compatible enhancements, e.g. when a dynamic SS behaviour needs to replace the static value assignment

## NR\_DciCommon\_CarrierIndicator\_Type

TTCN-3 Union Type		
Name	NR_DciCommon_CarrierIndicator_Type	
Comment	Carrier indicator field (CIF) of DCI formats 0_1 and 1_1 according to TS 38.212 and TS 38.213 clause 10.1	
None	<a href="#">Null_Type</a>	no cell index to be indicated in Carrier indicator field
CellIndex	<a href="#">B3_Type</a>	3 bits cell index to be indicated in Carrier indicator field; applicable when the UE is configured with higher layer parameter CrossCarrierSchedulingConfig

## NR\_DciCommon\_BWPIndicator\_Type

TTCN-3 Union Type		
<b>Name</b>	<b>NR_DciCommon_BWPIndicator_Type</b>	
<b>Comment</b>	Bandwidth part indicator according to TS 38.212 Table 7.3.1.1.2-1; used to address RRC-configured BandwidthPart-Config; NOTE: in general the BWP configuration at the SS is static i.e. dedicated BWPs may be preconfigured in a test case preamble => a) BWP configuration at the SS is not always the same as at the UE and SS cannot determine the number of BWPs being configured at the UE from its BWP configuration. b) The number and order of BWPs may differ at SS and UE. c) The index used in the DCI's BWP indicator is not identical with the BWP-Id as the BWP indicator is the index in the UE's BWP array => in general the SS cannot determine the size and value of the DCI's BWP indicator but this need to be done in TTCN	
Index	bitstring	0, 1 or 2 bits

## NR\_DciCommon\_TpcCommand\_Type

TTCN-3 Union Type		
<b>Name</b>	<b>NR_DciCommon_TpcCommand_Type</b>	
<b>Comment</b>	TPC Command Field according to TS 38.213 Table 7.1.1-1 and Table 7.2.1-1	
Value	<a href="#">B2_Type</a>	2 bits; default value: '01'B (0 dB; accumulated TPC)

## NR\_DciCommon\_UL\_SUL\_Indicator\_Type

TTCN-3 Union Type		
<b>Name</b>	<b>NR_DciCommon_UL_SUL_Indicator_Type</b>	
<b>Comment</b>	TS 38.212 clause 7.3.1.1.1/2: UL/SUL indicator	
None	<a href="#">Null_Type</a>	to be used when no SUL is configured
Value	<a href="#">B1_Type</a>	UL/SUL indicator according to TS 38.212 Table 7.3.1.1.1-1

## NR\_DciCommon\_VrbPrbMapping\_Type

TTCN-3 Union Type		
<b>Name</b>	<b>NR_DciCommon_VrbPrbMapping_Type</b>	
<b>Comment</b>	to specify how VRB-to-PRB mapping shall be controlled by DCI if applicable (see TS 38.212 Table 7.3.1.2.2-5 and where it is referred)	
None	<a href="#">Null_Type</a>	0 bit, applicable for format 1_0 when only resource allocation type 0 is configured
Index	<a href="#">B1_Type</a>	1 bit, index in TS 38.212 Table 7.3.1.2.2-5 indicating non-interleaved or interleaved VRB-to-PRB mapping according to TS 38.211 clause 6.3.1.7

## NR\_DciCommon\_TimeDomainResourceAssignment\_Type

TTCN-3 Union Type		
<b>Name</b>	<b>NR_DciCommon_TimeDomainResourceAssignment_Type</b>	
<b>Comment</b>	Common type definition for UL/DL Resource allocation in time domain according to TS 38.214 clause 5.1.2.1 and 6.1.2.1	
Index	bitstring	index of entry in SEQUENCE OF PUSCH/PDSCH-TimeDomainResourceAllocation provided e.g. by PUSCH/PDSCH-Config; number of bits in a particular DCI depends on the size of the SEQUENCE OF PUSCH/PDSCH-TimeDomainResourceAllocation (e.g. Time domain resource assignment is an empty bitstring ("B) when only one time-domain configuration is provided to the UE) NOTE: PDSCH/PUSCH-Config overrules list in PDSCH/PUSCH-ConfigCommon

## NR\_DciFormat\_X\_1\_SrsRequest\_Type

TTCN-3 Union Type		
Name	NR_DciFormat_X_1_SrsRequest_Type	
Comment	TS 38.212 clause 7.3.1.2: SRS request	
SingleUL	<a href="#">B2_Type</a>	2 bits: Index of the SRS resource set to be used according to TS 38.212 Table 7.3.1.1.2-24
UL_SUL	<a href="#">B3_Type</a>	3 bits: Index of the SRS resource set to be used according to TS 38.212 Table 7.3.1.1.2-24 plus first bit to distinguish UL/SUL

## NR\_DciFormat\_X\_1\_DmrsSequenceInit\_Type

TTCN-3 Union Type		
Name	NR_DciFormat_X_1_DmrsSequenceInit_Type	
Comment	TS 38.212 clause 7.3.1.1.2 (format 0_1) and clause 7.3.1.2.2 (format 1_1): DMRS sequence initialization	
None	<a href="#">Null_Type</a>	0 bit for format 0_1 and if transform precoder is enabled
Value	<a href="#">B1_Type</a>	1 bit else

## NR\_DciFormat\_X\_1\_PriorityIndicator\_Type

TTCN-3 Union Type		
Name	NR_DciFormat_X_1_PriorityIndicator_Type	
Comment	TS 38.212 clause 7.3.1.1.2 (format 0_1) and clause 7.3.1.2.2 (format 1_1): Priority indicator	
None	<a href="#">Null_Type</a>	0 bit no Priority indicator, if higher layer parameter priorityIndicatorDCI-0-1/priorityIndicatorDCI-1-1 is not configured
Value	<a href="#">B1_Type</a>	1 bit as defined in Clause 9 in TS 38.213.

## NR\_DciFormat\_X\_1\_MinimumApplicableSchedulingOffset\_Type

TTCN-3 Union Type		
Name	NR_DciFormat_X_1_MinimumApplicableSchedulingOffset_Type	
Comment	TS 38.212 clause 7.3.1.1.2 (format 0_1) and clause 7.3.1.2.2 (format 1_1): Minimum applicable scheduling offset indicator	
None	<a href="#">Null_Type</a>	0 bit no Minimum applicable scheduling offset indicator
Value	<a href="#">B1_Type</a>	1 bit if minimumSchedulingOffsetK0((format 0_1)/minimumSchedulingOffsetK0((format 1_1)) is configured. Set according to TS 38.212 according to TS 38.212 Table 7.3.1.1.2-33.

## NR\_DciFormat\_X\_1\_SCellDormancyIndication\_Type

TTCN-3 Union Type		
Name	NR_DciFormat_X_1_SCellDormancyIndication_Type	
Comment	TS 38.212 clause 7.3.1.1.2 (format 0_1) and clause 7.3.1.2.2 (format 1_1): SCell dormancy indication	
None	<a href="#">Null_Type</a>	0 bit no SCell dormancy indication
Value	bitstring	1, 2, 3, 4 or 5 bits: determined according to dormancyGroupWithinActiveTime parameter

## NR\_DciFormat\_X\_0\_ChannelAccessCPext\_Type

TTCN-3 Union Type		
Name	NR_DciFormat_X_0_ChannelAccessCPext_Type	
Comment	TS 38.212 clause 7.3.1.1.1 and 7.3.1.2.1: ChannelAccess-CPext	
None	<a href="#">Null_Type</a>	0 bit no ChannelAccess-CPext
Value	<a href="#">B2_Type</a>	2 bits indicating combinations of channel access type and CP extension as defined in TS 38.212 Table 7.3.1.1.1-4 for operation in a cell with shared spectrum channel access.

## D.1.3.2.4.2 Resource\_Allocation

Type definitions for resource allocation which do not correspond directly to DCI fields but are used to configure how the SS maintains resource allocation for a given DCI

**Resource\_Allocation: Basic Type Definitions**

TTCN-3 Basic Types		
<b>NR_ImcsValue_Type</b>	integer (0..31)	Modulation and coding scheme index coding
<b>NR_RedundancyVersion_Type</b>	integer (0..255)	Redundancy Version (RV): - 2 bits if the number of scheduled PUSCH indicated by the Time domain resource assignment field is 1 - 2, 3, 4, 5, 6, 7 or 8 bits determined by the maximum number of schedulable PUSCHs among all entries in pusch-TimeDomainAllocationListForMultiPUSCH (TS 38.212 clause 7.3.1.1.2).

**NR\_ResourceAllocationType\_Type**

TTCN-3 Enumerated Type	
Name	NR_ResourceAllocationType_Type
<b>Comment</b>	to specify the format of the resource allocation type being used for frequency domain resource assignment in DCI; NOTE 1: For DCI Format 0_0 and 1_0 only resourceAllocationType1 is applicable (TS 38.214 clause 5.1.2.2 and 6.1.2.2) NOTE 2: The SS needs to determine based on RRC configuration whether MSB of the frequency domain resource assignment needs to be used as discriminator for type 0/1 (see TS 38.212 clause 7.3.1.1.2 and clause 7.3.1.2.2 and PUSCH/PDSCH-Config.resourceAllocation) NOTE 3: The SS shall raise an error if the DCI configuration conflicts with the configuration given by PUSCH/PDSCH-Config.resourceAllocation
resourceAllocationType0	resource allocation type 0 according to TS 38.214 clause 5.1.2.2.1 and 6.1.2.2.1: bitmap indicating the Resource Block Groups (RBGs) that are allocated; not applicable for DCI Format 0_0 and 1_0
resourceAllocationType1	resource allocation type 1 according to TS 38.214 clause 5.1.2.2.2 and 6.1.2.2.2: resource indication value (RIV) corresponding to a starting virtual resource block and a length in terms of contiguously allocated resource blocks

**NR\_ModulationSchemePDSCH\_Type**

TTCN-3 Enumerated Type	
Name	NR_ModulationSchemePDSCH_Type
<b>Comment</b>	Supported modulation schemes for PDSCH according to 38.211 Table 7.3.1.2-1
qpsk	
qam16	
qam64	
qam256	

**NR\_FreqDomainSchedulExplicit\_Type**

TTCN-3 Record Type		
Name	NR_FreqDomainSchedulExplicit_Type	
<b>Comment</b>	type used for explicit DL scheduling; Nprb is the exact number of RBs whereas in NR_FreqDomainSchedulCommon_Type MaxRbCnt is the upper bound	
FirstRbIndex	integer	index of the first resource block in frequency domain
Nprb	integer	number of resource blocks to be assigned

## NR\_FreqDomainSchedulCommonDL\_Type

TTCN-3 Record Type		
Name	NR_FreqDomainSchedulCommonDL_Type	
Comment	common type to specify restrictions for frequency domain scheduling by a start index and a maximum range of RBs (similar to EUTRA, but for NR in general the frequency domain scheduling is not related to the whole frequency band but to a given band width part (BWP))	
FirstRbIndex	integer	index of the first (virtual) resource block in frequency domain
MaxRbCnt	integer	maximum number of resource-blocks to be used for a transport block; SS shall not assigned more than the given resource blocks; FirstRbIndex + MaxRbCnt shall not exceed the total number of available resource blocks in frequency domain; the SS shall raise an error otherwise

## NR\_FreqDomainResourceAssignmentDL\_Type

TTCN-3 Union Type		
Name	NR_FreqDomainResourceAssignmentDL_Type	
Comment		
Automatic	<a href="#">NR_FreqDomainSchedulCommonDL_Type</a>	The SS shall automatically do the resource assignment needed for a DL transmission based on TBS evaluation guideline given in Annex B.1 of 38.523-3
Explicit	<a href="#">NR_FreqDomainSchedulExplicit_Type</a>	Frequency domain resource assignment is given explicitly by TTCN; the SS needs to calculate the RIV (resource allocation type 1) or generate the bitmap (resource allocation type 0). In case of resource allocation type 0 the allocation shall also be in consecutive RBGs. NOTE: So far there is no requirement for signalling tests to use non-consecutive RBGs ((neither for LTE nor for NR)

## NR\_RedundancyVersionList\_Type

TTCN-3 Record of Type	
Name	NR_RedundancyVersionList_Type
Comment	There shall be as many entries in the list as re-transmissions are allowed; if there are not enough elements specified SS shall raise an error; In 4G at least in UL the array length corresponds to maxHARQ-Tx (i.e. up to 28 re-transmissions according to RRC ASN.1)
record of <a href="#">NR_RedundancyVersion_Type</a>	

## NR\_TransportBlockSchedulingDL\_Automatic\_Type

TTCN-3 Record Type		
Name	NR_TransportBlockSchedulingDL_Automatic_Type	
Comment	transport block information for a DL transmission and potential retransmission in automatic mode	
TransportBlock 1	<a href="#">NR_ModulationSchemePD SCH_Type</a>	
TransportBlock 2	<a href="#">NR_ModulationSchemePD SCH_Type</a>	opt MCS for 2nd transport block (if any); 'omit' means that there is no 2nd transport block; presence corresponds to PDSCH-Config.maxNrofCodeWordsScheduledByDCI
RedundancyVersionList	<a href="#">NR_RedundancyVersionList_Type</a>	opt list of Redundancy versions to be used for DL transmission and possible retransmissions; not present, if the DL transmission does not make use of harq processing (e.g. paging); in automatic mode the same list of redundancy versions is used for both transport blocks; if there are not enough elements to achieve successful DL transmission, SS shall raise an error

## RetransmissionTiming\_Type

TTCN-3 Union Type		
Name	RetransmissionTiming_Type	
Comment	to specify the timing of potential retransmissions related to the initial transmission. Rules in case of necessary UL or DL retransmissions: - When a transmission is scheduled with TimingInfo=Now, then any retransmission of a previous transmission takes precedence over the new transmission - Re-transmissions take precedence over periodic UL grants - The SS shall raise an error indication when - a retransmission collides with another UL or DL transmission which is scheduled by TTCN with specific TimingInfo for the same slot as the retransmission - a new DL transmission would take over an ongoing DL transmission - the retransmission is not possible at the given time for any other reason (e.g. due to slot format)	
SlotOffset	integer	the kth retransmission shall be $k * \text{SlotOffset}$ slots after the initial transmission: e.g. slots per subframe = N and initial transmission at subframeX and slotX => 1. retransmission at subframeX + (slotX + SlotOffset) / N and (slotX + SlotOffset) mod N 2. retransmission at subframeX + (slotX + 2*SlotOffset) / N and (slotX + 2*SlotOffset) mod N and so on
SubframeOffset	integer	the kth retransmission shall be $k * \text{SubframeOffset}$ subframes after the initial transmission in the same slot of subframe as for the initial transmission: e.g. initial transmission at subframeX and slotX 1. retransmission at subframeX + SubframeOffset and slotX 2. retransmission at subframeX + 2*SubframeOffset and slotX and so on
AnyTime	<a href="#">Null_Type</a>	the SS shall autonomously determine the next possible Occasion for the retransmission

## TransmissionTimingOffset\_Type

TTCN-3 Union Type		
Name	TransmissionTimingOffset_Type	
Comment	Timing information for retransmissions	
None	<a href="#">Null_Type</a>	initial transmission: no timing offset but timing info as according to common part of the ASP
Retransmission	<a href="#">RetransmissionTiming_Type</a>	retransmission with timing offset relative to initial transmission

## NR\_TransportBlockSingleTransmission\_Type

TTCN-3 Record Type		
Name	NR_TransportBlockSingleTransmission_Type	
Comment	TS 38.212 clause 7.3.1.2.1 and 7.3.1.2.2: parameters for transmission (or re-transmission) of a single transport block; used for explicit mode of DL transmission and for UL grants	
TimingOffset	<a href="#">TransmissionTimingOffset_Type</a>	in general "None" in case of a new transmission (i.e. no timing offset) and "Retransmission" for any retransmission
ImcsValue	<a href="#">NR_ImcsValue_Type</a>	Imcs value to be mapped to the Modulation and coding scheme field of DCI format 1_0 or 1_1
RedundancyVersion	<a href="#">NR_RedundancyVersion_Type</a>	Redundancy version for a single transmission or re-transmission
ToggleNDI	boolean	"true" for transmission of a new transport block, "false" for a re-transmission; the NDI (New data indicator) itself is maintained by the SS and therefore not provided as configuration parameter



### NR\_TransportBlockRetransmissionList\_Type

TTCN-3 Record of Type	
<b>Name</b>	<b>NR_TransportBlockRetransmissionList_Type</b>
<b>Comment</b>	list of (initial) transmission and potential retransmissions; used for explicit mode of DL transmission and for UL grants; in general the Imcs is the same for all (re-)transmissions and the NDI is not toggled for the retransmissions
record of <a href="#">NR_TransportBlockSingleTransmission_Type</a>	

### NR\_TransportBlockSchedulingDL\_Explicit\_Type

TTCN-3 Record Type			
<b>Name</b>	<b>NR_TransportBlockSchedulingDL_Explicit_Type</b>		
<b>Comment</b>			
TransportBlock 1	<a href="#">NR_TransportBlockRetransmissionList_Type</a>		list of transmission and retransmissions for transport block 1
TransportBlock 2	<a href="#">NR_TransportBlockRetransmissionList_Type</a>	opt	'omit' means that there is no 2nd transport block; Presence corresponds to PDSCH-Config.maxNrofCodeWordsScheduledByDCI

### NR\_TransportBlockSchedulingDL\_Type

TTCN-3 Union Type		
<b>Name</b>	<b>NR_TransportBlockSchedulingDL_Type</b>	
<b>Comment</b>		
Automatic	<a href="#">NR_TransportBlockSchedulingDL_Automatic_Type</a>	
Explicit	<a href="#">NR_TransportBlockSchedulingDL_Explicit_Type</a>	

### NR\_HarqProcessConfig\_Type

TTCN-3 Union Type		
<b>Name</b>	<b>NR_HarqProcessConfig_Type</b>	
<b>Comment</b>	HARQ processes to be used automatically for UL grants or DL assignments	
None	<a href="#">Null_Type</a>	when there is no HARQ for the given DCI (paging)
Broadcast	<a href="#">Null_Type</a>	when the broadcast process shall be used
AnyProcess	<a href="#">Null_Type</a>	The SS may choose any process for scheduling of the UL/DL data transfer
SpecificSubset	<a href="#">NR_HarqProcessList_Type</a>	only the HARQ processes of this list shall be used automatically, other processes are excluded from automatic assignments; nevertheless for DL any HARQ processes may be addressed explicitly by NR_DRB_DataPerSlot_DL_Type.HarqProcess

## D.1.3.2.4.3 PDSCH\_Scheduling

## NR\_DciDlInfo\_Type

TTCN-3 Record Type			
Name	NR_DciDlInfo_Type		
Comment	scheduling for CCCH/DCCH/DTCH mapped to DL-SCH mapped to PDSCH; for all parameters: mandatory for initial configuration of an instance, omit means "keep as it is" afterwards; definition is applicable for DCI format 1_0 (C-RNTI, RA-RNTI, TC-RNTI) and DCI format 1_1		
ResourceAssignment	<a href="#">NR_DciFormat_1_X_ResourceAssignment_Type</a>	opt	resource assignment; to control setting of the following fields in DCI formats 1_0 and 1_1 (TS 38.212 clause 7.3.1.2.1 and 7.3.1.2.2): Frequency domain resource assignment Time domain resource assignment Modulation and coding scheme New data indicator Redundancy version HARQ process number
VrbPrbMapping	<a href="#">NR_DciCommon_VrbPrbMapping_Type</a>	opt	VRB-to-PRB mapping
Format	<a href="#">NR_DciFormat_1_X_SpecificInfo_Type</a>	opt	DCI format and DCI format specific parameters

## NR\_DciFormat\_1\_X\_ResourceAssignment\_Type

TTCN-3 Record Type			
Name	NR_DciFormat_1_X_ResourceAssignment_Type		
Comment	Common definition to be used for resource scheduling in DL		
ResourceAllocationType	<a href="#">NR_ResourceAllocationType_Type</a>	opt	resource allocation type to be used for the frequency domain resource assignment
FreqDomain	<a href="#">NR_FreqDomainResourceAssignmentDL_Type</a>	opt	
TimeDomain	<a href="#">NR_DciCommon_TimeDomainResourceAssignment_Type</a>	opt	
TransportBlockScheduling	<a href="#">NR_TransportBlockSchedulingDL_Type</a>	opt	information about MCS and RV for one or two transport blocks
HarqProcessConfig	<a href="#">NR_HarqProcessConfig_Type</a>	opt	configures which HARQ processes the SS may use; corresponds to "HARQ process number" in TS 38.212 clause 7.3.1.2.1 and 7.3.1.2.2

## NR\_DciFormat\_1\_X\_SpecificInfo\_Type

TTCN-3 Union Type		
Name	NR_DciFormat_1_X_SpecificInfo_Type	
Comment		
Format_1_0	<a href="#">NR_DciFormat_1_0_SpecificInfo_Type</a>	
Format_1_0_P_RNTI	<a href="#">NR_DciFormat_1_0_P_RNTI_SpecificInfo_Type</a>	
Format_1_0_SI_RNTI	<a href="#">NR_DciFormat_1_0_SI_RNTI_SpecificInfo_Type</a>	
Format_1_0_RA_RNTI	<a href="#">NR_DciFormat_1_0_RA_RNTI_SpecificInfo_Type</a>	
Format_1_1	<a href="#">NR_DciFormat_1_1_SpecificInfo_Type</a>	

## NR\_DciFormat\_1\_0\_SpecificInfo\_Type

TTCN-3 Record Type			
Name	NR_DciFormat_1_0_SpecificInfo_Type		
Comment	TS 38.212 clause 7.3.1.2.1: scheduling of PDSCH in one DL cell; default parameters according to TS 38.508-1 clause 4.3.6.1.2.1		
DAI	<a href="#">NR_DciFormat_1_0_DAI_Type</a>	opt	downlink assignment index
TpcCommandPucch	<a href="#">NR_DciCommon_TpcCommand_Type</a>	opt	TPC command for scheduled PUCCH; to be set to 1 per default (0 dB; accumulated TPC)
PucchResourceIndicator	<a href="#">NR_DciFormat_1_X_PucchResourceIndicator_Type</a>	opt	PUCCH resource indicator
PdschHarqTimingIndicator	<a href="#">NR_DciFormat_1_X_PdschHarqTimingIndicator_Type</a>	opt	PDSCH-to-HARQ_feedback timing indicator
ChannelAccessCPext	<a href="#">NR_DciFormat_X_0_ChannelAccessCPext_Type</a>	opt	ChannelAccess-CPext

## NR\_DciFormat\_1\_0\_P\_RNTI\_SpecificInfo\_Type

TTCN-3 Record Type			
Name	NR_DciFormat_1_0_P_RNTI_SpecificInfo_Type		
Comment	TS 38.212 clause 7.3.1.2.1: scheduling of PDSCH with DCI scrambled by P-RNTI; default parameters according to TS 38.508-1 clause 4.3.6.1.2.1		
ShortMessageIndicator	<a href="#">B2_Type</a>	opt	Short Message Indicator according to TS 38.212 Table 7.3.1.2.1-1
ShortMessages	<a href="#">B8_Type</a>	opt	Short Messages according to TS 38.331 Table 6.5-1
TbScaling	<a href="#">B2_Type</a>	opt	Scaling factor according to TS 38.214 Table 5.1.3.2-2

## NR\_DciFormat\_1\_0\_SI\_RNTI\_SpecificInfo\_Type

TTCN-3 Record Type			
Name	NR_DciFormat_1_0_SI_RNTI_SpecificInfo_Type		
Comment	TS 38.212 clause 7.3.1.2.1: scheduling of PDSCH with DCI scrambled by SI-RNTI; default parameters according to TS 38.508-1 clause 4.3.6.1.2.1		
SystemInfoIndicator	<a href="#">B1_Type</a>	opt	System information indicator according to TS 38.212 Table 7.3.1.2.1-2

## NR\_DciFormat\_1\_0\_RA\_RNTI\_SpecificInfo\_Type

TTCN-3 Record Type			
Name	NR_DciFormat_1_0_RA_RNTI_SpecificInfo_Type		
Comment	TS 38.212 clause 7.3.1.2.1: scheduling of PDSCH with DCI scrambled by RA-RNTI; default parameters according to TS 38.508-1 clause 4.3.6.1.2.1. FFS whether this is applicable to MsgB-RNTI		
TbScaling	<a href="#">B2_Type</a>	opt	Scaling factor according to TS 38.214 Table 5.1.3.2-2
LSBsOfSFN	<a href="#">NR_DciFormat_1_0_LSBsOfSFN_Type</a>	opt	LSBs of SFN

## NR\_DciFormat\_1\_1\_SpecificInfo\_Type

TTCN-3 Record Type			
Name	NR_DciFormat_1_1_SpecificInfo_Type		
Comment	TS 38.212 clause 7.3.1.2.2: scheduling of PDSCH in one cell; default parameters according to TS 38.508-1 clause 4.3.6.1.2.2 For all fields: 'omit' means that the information shall not be contained in the DCI on PDCCH		
CarrierIndicator	<a href="#">NR_DciCommon_CarrierIndicator_Type</a>	opt	Carrier indicator - CIF value for Cross Carrier Scheduling; 'None' otherwise
BWPIndicator	<a href="#">NR_DciCommon_BWPIndicator_Type</a>	opt	Bandwidth part indicator
PrbBundlingSizeIndicator	<a href="#">NR_DciFormat_1_1_PrbbundlingSizeIndicator_Type</a>	opt	PRB bundling size indicator
RateMatchingIndicator	<a href="#">NR_DciFormat_1_1_RateMatchingIndicator_Type</a>	opt	Rate matching indicator
ZP_CSI_RS_Trigger	<a href="#">NR_DciFormat_1_1_ZP_CSI_RS_Trigger_Type</a>	opt	ZP CSI-RS trigger
DAI	<a href="#">NR_DciFormat_1_1_DAI_Type</a>	opt	downlink assignment index
TpcCommandPucch	<a href="#">NR_DciCommon_TpcCommand_Type</a>	opt	TPC command for scheduled PUCCH; to be set to 1 per default (0 dB; accumulated TPC)
PucchResourceIndicator	<a href="#">NR_DciFormat_1_X_PucchResourceIndicator_Type</a>	opt	PUCCH resource indicator
PdschHarqTimingIndicator	<a href="#">NR_DciFormat_1_X_PdschHarqTimingIndicator_Type</a>	opt	PDSCH-to-HARQ_feedback timing indicator
OneShotHarqAckRequest	<a href="#">NR_DciFormat_1_1_OneShotHarqAckRequest_Type</a>	opt	One-shot HARQ-ACK request
PdschGroupIndex	<a href="#">NR_DciFormat_1_1_PdschGroupIndex_Type</a>	opt	PDSCH group index
NewFeedbackIndicator	<a href="#">NR_DciFormat_1_1_NewFeedbackIndicator_Type</a>	opt	New feedback indicator
NumberRequestedPdschGroup	<a href="#">NR_DciFormat_1_1_NumberRequestedPdschGroup_Type</a>	opt	Number of requested PDSCH group
AntennaPorts	<a href="#">NR_DciFormat_1_1_AntennaPorts_Type</a>	opt	Antenna port(s)
TCI	<a href="#">NR_DciFormat_1_1_TCI_Type</a>	opt	Transmission configuration indication
SrsRequest	<a href="#">NR_DciFormat_X_1_SrsRequest_Type</a>	opt	SRS request
CBGTI	<a href="#">NR_DciFormat_1_1_CBGTI_Type</a>	opt	CBG transmission information (CBGTI)
CBGFI	<a href="#">NR_DciFormat_1_1_CBGFI_Type</a>	opt	CBG flushing out information (CBGFI)
DmrsSequenceInit	<a href="#">NR_DciFormat_X_1_DmrsSequenceInit_Type</a>	opt	DMRS sequence initialization
PriorityIndicator	<a href="#">NR_DciFormat_X_1_PriorityIndicator_Type</a>	opt	Priority indicator
ChannelAccessCPext	<a href="#">NR_DciFormat_1_1_ChannelAccessCPext_Type</a>	opt	ChannelAccess-CPext
MinimumApplicableSchedulingOffset	<a href="#">NR_DciFormat_X_1_MinimumApplicableSchedulingOffset_Type</a>	opt	Minimum applicable scheduling offset indicator
SCellDormancyIndication	<a href="#">NR_DciFormat_X_1_SCellDormancyIndication_Type</a>	opt	SCell dormancy indication

## NR\_DciFormat\_1\_X\_PucchResourceIndicator\_Type

TTCN-3 Union Type		
Name	NR_DciFormat_1_X_PucchResourceIndicator_Type	
Comment	TS 38.212 clause 7.3.1.2.1/2: PUCCH resource indicator	
Value	<a href="#">B3_Type</a>	3 bits as defined in TS 38.213 clause 9.2.3 or reserved bits; index to "PUCCH-ResourceSet" according to 38.213 clause 9.2.3 as provided by PUCCH-Config

### NR\_DciFormat\_1\_X\_PdschHarqTimingIndicator\_Type

TTCN-3 Union Type		
<b>Name</b>	<b>NR_DciFormat_1_X_PdschHarqTimingIndicator_Type</b>	
<b>Comment</b>	TS 38.212 clause 7.3.1.2.1/2: PDSCH-to-HARQ feedback timing indicator (TS 38.213 clause 9.2.3)	
Value	bitstring	Format 1_0: 3 bits, addresses one of {1, 2, 3, 4, 5, 6, 7, 8} according to TS 38.213 clause 9.2.3; Format 1_1: 0..3 bits, addresses entry in table provided by PUCCH-Config.dl-DataToUL-ACK

### NR\_DciFormat\_1\_0\_DAI\_Type

TTCN-3 Union Type		
<b>Name</b>	<b>NR_DciFormat_1_0_DAI_Type</b>	
<b>Comment</b>	TS 38.212 clause 7.3.1.2.1: DAI (downlink assignment indicator)	
Index	<a href="#">DAI_B2_Type</a>	2 bits according to TS 38.213 clause 9.1.3 or reserved bits

### NR\_DciFormat\_1\_0\_LSBsOfSFN\_Type

TTCN-3 Union Type		
<b>Name</b>	<b>NR_DciFormat_1_0_LSBsOfSFN_Type</b>	
<b>Comment</b>	TS 38.212 clause 7.3.1.2.1: LSBs of SFN	
None	<a href="#">Null_Type</a>	no LSBs of SFN
Automatic	<a href="#">Null_Type</a>	LSBs of SFN automatically assigned by SS; 2 bits

### NR\_DciFormat\_1\_1\_PrbBundlingSizeIndicator\_Type

TTCN-3 Union Type		
<b>Name</b>	<b>NR_DciFormat_1_1_PrbBundlingSizeIndicator_Type</b>	
<b>Comment</b>	TS 38.212 clause 7.3.1.2.2: PRB bundling size indicator	
None	<a href="#">Null_Type</a>	no PRB bundling
Dynamic	<a href="#">B1_Type</a>	when PDSCH-Config.prb-BundlingType is set to 'dynamicBundling'; indicates which set of PRG values to be used (see 38.214 clause 5.1.2.3)

### NR\_DciFormat\_1\_1\_RateMatchingIndicator\_Type

TTCN-3 Union Type		
<b>Name</b>	<b>NR_DciFormat_1_1_RateMatchingIndicator_Type</b>	
<b>Comment</b>	TS 38.212 clause 7.3.1.2.2: Rate matching indicator; rateMatchPatternGroup1 and rateMatchPatternGroup2 configured by PDSCH-Config	
Bitmap	bitstring	0, 1, or 2 bits: bitmap indicating rateMatchPatternGroup1 and/or rateMatchPatternGroup2 to be applied; size depending on whether rateMatchPatternGroup1, rateMatchPatternGroup2 or both are configured by PDSCH-Config at the UE

### NR\_DciFormat\_1\_1\_ZP\_CSI\_RS\_Trigger\_Type

TTCN-3 Union Type		
<b>Name</b>	<b>NR_DciFormat_1_1_ZP_CSI_RS_Trigger_Type</b>	
<b>Comment</b>	TS 38.212 clause 7.3.1.2.2: ZP CSI-RS trigger	
Index	bitstring	0, 1, or 2 bits: Index in list of ZP-CSI-RS-Resource as configured by PDSCH-Config at the UE

## NR\_DciFormat\_1\_1\_DAI\_Type

TTCN-3 Union Type		
Name	<b>NR_DciFormat_1_1_DAI_Type</b>	
Comment	TS 38.212 clause 7.3.1.2.2: DAI (downlink assignment indicator) - 6 bits if more than one serving cell are configured in the DL and the higher layer parameter NFI-TotalDAI-Included-r16 = enable - 4 bits if only one serving cell are configured in the DL and the higher layer parameter NFI-TotalDAI-Included-r16 = enable - 4 bits if more than one serving cell are configured in the DL, the higher layer parameter pdsch-HARQ-ACK-Codebook=dynamic or pdsch-HARQ-ACK-Codebook=enhancedDynamic-r16, and NFI-TotalDAI-Included-r16 is not configured - 4 bits if only one serving cell is configured in the DL, and the higher layer parameter pdsch-HARQ-ACK-Codebook=dynamic, and the UE is not provided CORESETPoolIndex or is provided CORESETPoolIndex with value 0 for one or more first CORESETs and is provided CORESETPoolIndex with value 1 for one or more second CORESETs, and is provided ACKNACKFeedbackMode = JointFeedback - 2 bits if only one serving cell is configured in the DL, the higher layer parameter pdsch-HARQ-ACK-Codebook=dynamic or pdsch-HARQ-ACK-Codebook=enhancedDynamic-r16, and NFI-TotalDAI-Included-r16 is not configured, when the UE is not configured with CORESETPoolIndex or the value of CORESETPoolIndex is the same for all CORESETs if CORESETPoolIndex is provided or the UE is not configured with ACKNACKFeedbackMode = JointFeedback	
None	<a href="#">Null_Type</a>	no DAI
TwoBits	<a href="#">DAI_B2_Type</a>	
FourBits	<a href="#">DAI_B4_Type</a>	
SixBits	<a href="#">DAI_B6_Type</a>	

## NR\_DciFormat\_1\_1\_AntennaPorts\_Type

TTCN-3 Union Type		
Name	<b>NR_DciFormat_1_1_AntennaPorts_Type</b>	
Comment	TS 38.212 clause 7.3.1.2.2: Antenna ports as defined by TS 38.212 Tables 7.3.1.2.2-1..4 and Tables 7.3.1.2.2-1A/2A/3A/4A	
Index	bitstring	bitstring presentation of index to TS 38.212 Tables 7.3.1.2.2-1..4 and Tables 7.3.1.2.2-1A/2A/3A/4A

## NR\_DciFormat\_1\_1\_TCI\_Type

TTCN-3 Union Type		
Name	<b>NR_DciFormat_1_1_TCI_Type</b>	
Comment	TS 38.212 clause 7.3.1.2.2: Transmission configuration indication (TCI)	
None	<a href="#">Null_Type</a>	if ControlResourceSet.tci-PresentInDCI does not indicate 'enabled'
Value	<a href="#">B3_Type</a>	if ControlResourceSet.tci-PresentInDCI=='enabled': TCI according to TS 38.213 clause 5.1.5/6

## NR\_DciFormat\_1\_1\_CBGTI\_Type

TTCN-3 Union Type		
Name	<b>NR_DciFormat_1_1_CBGTI_Type</b>	
Comment	TS 38.212 clause 7.3.1.2.2: CBG transmission information (CBGTI)	
Bitmap	bitstring	0, 2, 4, 6, or 8 bits according to PDSCH-CodeBlockGroupTransmission.maxCodeBlockGroupsPerTransportBlock and PDSCH-Config.maxNrofCodeWordsScheduledByDCI and TS 38.214 clause 5.1.7.2

## NR\_DciFormat\_1\_1\_CBGFI\_Type

TTCN-3 Union Type		
<b>Name</b>	<b>NR_DciFormat_1_1_CBGFI_Type</b>	
<b>Comment</b>	TS 38.212 clause 7.3.1.2.2: CBG flushing out information (CBGFI)	
None	<a href="#">Null_Type</a>	no CBGFI
Flag	<a href="#">B1_Type</a>	CBGFI flag, if codeBlockGroupTransmission is configured in PDSCH-ServingCellConfig with codeBlockGroupFlushIndicator set to true

## NR\_DciFormat\_1\_1\_ChannelAccessCPext\_Type

TTCN-3 Union Type		
<b>Name</b>	<b>NR_DciFormat_1_1_ChannelAccessCPext_Type</b>	
<b>Comment</b>	TS 38.212 clause 7.3.1.2.2: ChannelAccess-CPext	
None	<a href="#">Null_Type</a>	no ChannelAccess-CPext
Value	bitstring	1, 2, 3 or 4 bits. Determined with dl-DCI-triggered-UL-ChannelAccess-CPext-r16 and from Table 7.3.1.2.2-6.

## DAI\_B1\_Type

TTCN-3 Union Type		
<b>Name</b>	<b>DAI_B1_Type</b>	
<b>Comment</b>		
Index	<a href="#">B1_Type</a>	1 bit DAI value
Automatic	<a href="#">Null_Type</a>	DAI automatically assigned by SS according to clause 7.1.2.1.3.3

## DAI\_B2\_Type

TTCN-3 Union Type		
<b>Name</b>	<b>DAI_B2_Type</b>	
<b>Comment</b>		
Index	<a href="#">B2_Type</a>	2 bits DAI value
Automatic	<a href="#">Null_Type</a>	DAI automatically assigned by SS according to clause 7.1.2.1.3.3

## DAI\_B4\_Type

TTCN-3 Union Type		
<b>Name</b>	<b>DAI_B4_Type</b>	
<b>Comment</b>		
Index	<a href="#">B4_Type</a>	4 bits DAI value
Automatic	<a href="#">Null_Type</a>	DAI automatically assigned by SS according to clause 7.1.2.1.3.3

## DAI\_B6\_Type

TTCN-3 Union Type		
<b>Name</b>	<b>DAI_B6_Type</b>	
<b>Comment</b>		
Index	<a href="#">B6_Type</a>	6 bits DAI value
Automatic	<a href="#">Null_Type</a>	DAI automatically assigned by SS according to clause 7.1.2.1.3.3

## NR\_DciFormat\_1\_1\_OneShotHarqAckRequest\_Type

TTCN-3 Union Type		
<b>Name</b>	<b>NR_DciFormat_1_1_OneShotHarqAckRequest_Type</b>	
<b>Comment</b>	TS 38.212 clause 7.3.1.2.2: One-shot HARQ-ACK request	
None	<a href="#">Null_Type</a>	no One-shot HARQ-ACK request
Value	<a href="#">B1_Type</a>	1 bit if higher layer parameter pdsch-HARQ-ACK-OneShotFeedback-r16 is configured

## NR\_DciFormat\_1\_1\_PdschGroupIndex\_Type

TTCN-3 Union Type		
<b>Name</b>	<b>NR_DciFormat_1_1_PdschGroupIndex_Type</b>	
<b>Comment</b>	TS 38.212 clause 7.3.1.2.2: PDSCH group index	
None	<a href="#">Null_Type</a>	no PDSCH group index
Value	<a href="#">B1_Type</a>	1 bit if the higher layer parameter pdsch-HARQ-ACK-Codebook = enhancedDynamic-r16

## NR\_DciFormat\_1\_1\_NewFeedbackIndicator\_Type

TTCN-3 Union Type		
<b>Name</b>	<b>NR_DciFormat_1_1_NewFeedbackIndicator_Type</b>	
<b>Comment</b>	TS 38.212 clause 7.3.1.2.2: New feedback indicator	
None	<a href="#">Null_Type</a>	no New feedback indicator
Value	bitstring	1 or 2 bits if pdsch-HARQ-ACK-Codebook = enhancedDynamic-r16

## NR\_DciFormat\_1\_1\_NumberRequestedPdschGroup\_Type

TTCN-3 Union Type		
<b>Name</b>	<b>NR_DciFormat_1_1_NumberRequestedPdschGroup_Type</b>	
<b>Comment</b>	TS 38.212 clause 7.3.1.2.2: Number of requested PDSCH group(s)	
None	<a href="#">Null_Type</a>	no Number of requested PDSCH group(s)
Value	<a href="#">B1_Type</a>	if the higher layer parameter pdsch-HARQ-ACK-Codebook = enhancedDynamic-r16



## D.1.3.2.4.4 PUSCH\_Scheduling

## NR\_DciUIInfo\_Type

TTCN-3 Record Type			
Name	NR_DciUIInfo_Type		
Comment	scheduling for CCCH/DCCH/DTCH mapped to UL-SCH mapped to PUSCH; for all parameters: mandatory for initial configuration of an instance, omit means "keep as it is" afterwards		
ResourceAssignment	<a href="#">NR_DciFormat_0_X_ResourceAssignment_Type</a>	opt	resource assignment; to control setting of the following fields in DCI formats 0_0 and 0_1 (TS 38.212 clause 7.3.1.1.1 and 7.3.1.1.2): Frequency domain resource assignment Time domain resource assignment Modulation and coding scheme New data indicator Redundancy version HARQ process number
PuschHoppingCtrl	<a href="#">NR_DciFormat_0_X_PuschHoppingCtrl_Type</a>	opt	control of frequency hopping in DCI formats 0_0 and 0_1 (TS 38.212 Table 7.3.1.1.1-3)
TpcCommandPusch	<a href="#">NR_DciCommon_TpcCommand_Type</a>	opt	TPC command for scheduled PUSCH; to be set to 1 per default (0 dB; accumulated TPC)
UL_SUL_Indicator	<a href="#">NR_DciCommon_UL_SUL_Indicator_Type</a>	opt	to control use of supplementary UL by DCI
Format	<a href="#">NR_DciFormat_0_X_SpecificInfo_Type</a>	opt	DCI format and DCI format specific parameters

## NR\_DciFormat\_0\_X\_ResourceAssignment\_Type

TTCN-3 Record Type			
Name	NR_DciFormat_0_X_ResourceAssignment_Type		
Comment	Common definition to be used for resource scheduling in UL		
ResourceAllocationType	<a href="#">NR_ResourceAllocationType_Type</a>	opt	resource allocation type to be used for the frequency domain resource assignment
FreqDomain	<a href="#">NR_FreqDomainSchedulingExplicit_Type</a>	opt	explicit resource assignment: first RB, number of RBs; corresponds to "Frequency domain resource assignment" in TS 38.212 clause 7.3.1.1.1 and 7.3.1.1.2
TimeDomain	<a href="#">NR_DciCommon_TimeDomainResourceAssignment_Type</a>	opt	corresponds to "Time domain resource assignment" in TS 38.212 clause 7.3.1.1.1 and 7.3.1.1.2
TransportBlockScheduling	<a href="#">NR_TransportBlockRetransmissionList_Type</a>	opt	information about MCS and RV for transport block transmission and possible re-transmissions; corresponds to "Modulation and coding scheme", "New data indicator" and "Redundancy version" in TS 38.212 clause 7.3.1.1.1 and 7.3.1.1.2
HarqProcessConfig	<a href="#">NR_HarqProcessConfig_Type</a>	opt	HARQ process to be used for the scheduled UL data transfer corresponds to "HARQ process number" in TS 38.212 clause 7.3.1.1.1 and 7.3.1.1.2; NOTE: for 5G there is no synchronous HARQ anymore but HARQ is asynchronous even for UL (TS 38.300 clause 5.3.5.4; TS 38.212 clause 7.3.1: 4-bit HARQ process number included in all DCI Formats for UL)

## NR\_DciFormat\_0\_X\_SpecificInfo\_Type

TTCN-3 Union Type	
Name	NR_DciFormat_0_X_SpecificInfo_Type
Comment	
Format_0_0	<a href="#">NR_DciFormat_0_0_SpecificInfo_Type</a>
Format_0_1	<a href="#">NR_DciFormat_0_1_SpecificInfo_Type</a>

## NR\_DciFormat\_0\_0\_SpecificInfo\_Type

TTCN-3 Record Type			
Name	NR_DciFormat_0_0_SpecificInfo_Type		
Comment	TS 38.212 clause 7.3.1.1: scheduling of PUSCH in one cell; default parameters according to TS 38.508-1 clause 4.3.6.1.1.1		
ChannelAccessCPext	<a href="#">NR_DciFormat_X_0_ChannelAccessCPext_Type</a>	opt	ChannelAccess-CPext

## NR\_DciFormat\_0\_1\_SpecificInfo\_Type

TTCN-3 Record Type			
Name	NR_DciFormat_0_1_SpecificInfo_Type		
Comment	TS 38.212 clause 7.3.1.2: scheduling of PUSCH in one cell; default parameters according to TS 38.508-1 clause 4.3.6.1.1.2; for all parameters: mandatory for initial configuration of an instance, omit means "keep as it is" afterwards		
CarrierIndicator	<a href="#">NR_DciCommon_CarrierIndicator_Type</a>	opt	Carrier indicator - CIF value for Cross Carrier Scheduling; 'None' otherwise
DfiFlag	<a href="#">NR_DciFormat_0_1_DfiFlag_Type</a>	opt	DFI flag
BWPIndicator	<a href="#">NR_DciCommon_BWPIndicator_Type</a>	opt	Bandwidth part indicator
FirstDAI	<a href="#">NR_DciFormat_0_1_FirstDAI_Type</a>	opt	1st downlink assignment index
SecondDAI	<a href="#">NR_DciFormat_0_1_SecondDAI_Type</a>	opt	2nd downlink assignment index
SrsResourceIndicator	<a href="#">NR_DciFormat_0_1_SrsResourceIndicator_Type</a>	opt	SRS resource indicator
PrecodingInfo	<a href="#">NR_DciFormat_0_1_PrecodingInfo_Type</a>	opt	Precoding information and number of layers
AntennaPorts	<a href="#">NR_DciFormat_0_1_AntennaPorts_Type</a>	opt	Antenna ports
SrsRequest	<a href="#">NR_DciFormat_X_1_SrsRequest_Type</a>	opt	SRS request
CsiRequest	<a href="#">NR_DciFormat_0_1_CsiRequest_Type</a>	opt	CSI request
CBGTI	<a href="#">NR_DciFormat_0_1_CBGTI_Type</a>	opt	CBG transmission information (CBGTI)
PtrsDmrsAssociation	<a href="#">NR_DciFormat_0_1_PtrsDmrsAssociation_Type</a>	opt	PTRS-DMRS association
BetaOffsetIndicator	<a href="#">NR_DciFormat_0_1_BetaOffsetIndicator_Type</a>	opt	beta_offset indicator
DmrsSequenceInit	<a href="#">NR_DciFormat_X_1_DmrsSequenceInit_Type</a>	opt	DMRS sequence initialization
UlschIndicator	<a href="#">NR_DciFormat_0_1_UlschIndicator_Type</a>	opt	UL-SCH indicator
ChannelAccessCPextCAPC	<a href="#">NR_DciFormat_0_1_ChannelAccessCPextCAPC_Type</a>	opt	ChannelAccess-CPext-CAPC
OpenLoopPowerControl	<a href="#">NR_DciFormat_0_1_OpenLoopPowerControl_Type</a>	opt	Open-loop power control parameter set indication
PriorityIndicator	<a href="#">NR_DciFormat_X_1_PriorityIndicator_Type</a>	opt	Priority indicator
InvalidSymbolPatternIndicator	<a href="#">NR_DciFormat_0_1_InvalidSymbolPatternIndicator_Type</a>	opt	Invalid symbol pattern indicator
MinimumApplicableSchedulingOffset	<a href="#">NR_DciFormat_X_1_MinimumApplicableSchedulingOffset_Type</a>	opt	Minimum applicable scheduling offset indicator
SCellDormancyIndication	<a href="#">NR_DciFormat_X_1_SCellDormancyIndication_Type</a>	opt	SCell dormancy indication
SidelinkAssignmentIndex	<a href="#">NR_DciFormat_0_1_SidelinkAssignmentIndex_Type</a>	opt	Sidelink assignment index

## NR\_DciFormat\_0\_X\_PuschHoppingCtrl\_Type

TTCN-3 Union Type		
Name	<b>NR_DciFormat_0_X_PuschHoppingCtrl_Type</b>	
Comment	TS 38.212 7.3.1.1.1 (format 0_0) and 7.3.1.1.2 (format 0_1)	
None	<a href="#">Null_Type</a>	DCI format 0_1 only: 0 bit if only resource allocation type 0 is configured or PUSCH-Config.frequencyHopping is not configured
Flag	<a href="#">B1_Type</a>	1 bit if resource allocation type 1 is configured (or type 0 and type 1) '1'B to indicate frequency hopping according to TS 38.214 clause 6.3

## NR\_DciFormat\_0\_1\_FirstDAI\_Type

TTCN-3 Union Type		
Name	<b>NR_DciFormat_0_1_FirstDAI_Type</b>	
Comment	TS 38.212 clause 7.3.1.1.2: First DAI (downlink assignment indicator) depending on PhysicalCellGroupConfig.pdsch-HARQ-ACK-Codebook	
SemiStaticCodebook	<a href="#">DAI_B1_Type</a>	1 bit according to TS 38.213 clause 9.1.2.2 for Type-1 HARQ-ACK (pdsch-HARQ-ACK-codebook=semi-static)
DynamicCodebook	<a href="#">DAI_B2_Type</a>	2 bits according to TS 38.213 Table 9.1.3-2 for Type-2 HARQ-ACK (pdsch-HARQ-ACK-codebook=dynamic or for enhanced dynamic HARQ-ACK codebook without UL-TotalDAI-Included-r16 configured)
EnhancedDynamicCodebook	<a href="#">DAI_B4_Type</a>	4 bits for enhanced dynamic HARQ-ACK codebook and with UL-TotalDAI-Included-r16 = "enable".

## NR\_DciFormat\_0\_1\_SecondDAI\_Type

TTCN-3 Union Type		
Name	<b>NR_DciFormat_0_1_SecondDAI_Type</b>	
Comment	TS 38.212 clause 7.3.1.1.2: Second DAI (downlink assignment indicator) depending on PhysicalCellGroupConfig.pdsch-HARQ-ACK-Codebook	
None	<a href="#">Null_Type</a>	no 2nd DAI
DynamicCodebook	<a href="#">DAI_B2_Type</a>	2 bits according to TS 38.213 Table 9.1.3-2 for Type-2 HARQ-ACK (pdsch-HARQ-ACK-codebook=dynamic or for enhanced dynamic HARQ-ACK codebook with two HARQ-ACK sub-codebooks and without UL-TotalDAI-Included-r16 configured)
EnhancedDynamicCodebook	<a href="#">DAI_B4_Type</a>	4 bits for enhanced dynamic HARQ-ACK codebook with two HARQ-ACK sub-codebooks and with UL-TotalDAI-Included-r16 = "enable"

## NR\_DciFormat\_0\_1\_SrsResourceIndicator\_Type

TTCN-3 Union Type		
Name	<b>NR_DciFormat_0_1_SrsResourceIndicator_Type</b>	
Comment	TS 38.212 clause 7.3.1.1.2: SRS resource indicator depending on PUSCH-Config.txConfig	
NonCodeBook	bitstring	txConfig==NonCodeBook: bitstring of 0..3 bits according to TS 38.212 Tables 7.3.1.1.2-28/29/30/31 (according to TS 38.331 clause 6.3.2 "SRS-Config" there are at most 4 entries with usage==nonCodebook)
CodeBook	bitstring	txConfig==CodeBook: - bitstring of 0 or 1 bits according to TS 38.212 Table 7.3.1.1.2-32 - bitstring of 4 bits according to TS 38.212 Table 7.3.1.1.2-32A/32B if ul-FullPowerTransmission-r16 is configured (according to TS 38.331 clause 6.3.2 "SRS-Config" there are at most 2 entries with usage==codebook)

### NR\_DciFormat\_0\_1\_PrecodingInfo\_Type

TTCN-3 Union Type		
<b>Name</b>	<b>NR_DciFormat_0_1_PrecodingInfo_Type</b>	
<b>Comment</b>	TS 38.212 clause 7.3.1.1.2: Precoding information and number of layers depending on PUSCH-Config.txConfig	
NonCodeBook	<a href="#">Null_Type</a>	txConfig==NonCodeBook: 0 bits
CodeBook	bitstring	txConfig==CodeBook: bitstring according to TS 38.212 Tables 7.3.1.1.2-2..5; empty string for one antenna port only

### NR\_DciFormat\_0\_1\_AntennaPorts\_Type

TTCN-3 Union Type		
<b>Name</b>	<b>NR_DciFormat_0_1_AntennaPorts_Type</b>	
<b>Comment</b>	TS 38.212 clause 7.3.1.1.2: Antenna ports depending (mainly) on - PUSCH-Config.transformPrecoder, - DMRS-UplinkConfig.dmr-Type, - DMRS-UplinkConfig.maxLength, - dmrs-UplinkTransformPrecoding-r16, - tp-pi2BPSK	
Index	bitstring	bitstring presentation of index to Tables 7.3.1.1.2-6..23

### NR\_DciFormat\_0\_1\_CsiRequest\_Type

TTCN-3 Union Type		
<b>Name</b>	<b>NR_DciFormat_0_1_CsiRequest_Type</b>	
<b>Comment</b>	TS 38.212 clause 7.3.1.1.2: CSI request	
Index	bitstring	0, 1, 2, 3, 4, 5, or 6 bits determined by CSI-MeasConfig.reportTriggerSize; TS 38.214 clause 5.2.1.5.1)

### NR\_DciFormat\_0\_1\_CBGTI\_Type

TTCN-3 Union Type		
<b>Name</b>	<b>NR_DciFormat_0_1_CBGTI_Type</b>	
<b>Comment</b>	TS 38.212 clause 7.3.1.1.2: CBG transmission information (CBGTI)	
Index	bitstring	0, 2, 4, 6, or 8 bits determined by PUSCH-CodeBlockGroupTransmission.maxCodeBlockGroupsPerTransportBlock configured by PUSCH-ServingCellConfig

### NR\_DciFormat\_0\_1\_PtrsDmrsAssociation\_Type

TTCN-3 Union Type		
<b>Name</b>	<b>NR_DciFormat_0_1_PtrsDmrsAssociation_Type</b>	
<b>Comment</b>	TS 38.212 clause 7.3.1.1.2: PTRS-DMRS association	
None	<a href="#">Null_Type</a>	0 bit PTRS-UplinkConfig is not configured in either dmrs-UplinkForPUSCH-MappingTypeA or dmrs-UplinkForPUSCH-MappingTypeB and transform precoder is disabled, or if transform precoder is enabled, or if maxRank=1
Value	<a href="#">B2_Type</a>	2 bits according to TS 38.212 Table 7.3.1.1.2-25 and 7.3.1.1.2-26

### NR\_DciFormat\_0\_1\_BetaOffsetIndicator\_Type

TTCN-3 Union Type		
<b>Name</b>	<b>NR_DciFormat_0_1_BetaOffsetIndicator_Type</b>	
<b>Comment</b>	TS 38.212 clause 7.3.1.1.2: beta_offset indicator	
None	<a href="#">Null_Type</a>	0 bit if uci-on-PUSCH != dynamic (ConfiguredGrantConfig.uci-OnPUSCH
Value	<a href="#">B2_Type</a>	2 bits according to TS 38.213 Table 9.3-3 and Table 9.3-3A

## NR\_DciFormat\_0\_1\_UlschIndicator\_Type

TTCN-3 Union Type		
Name	<b>NR_DciFormat_0_1_UlschIndicator_Type</b>	
Comment	TS 38.212 clause 7.3.1.1.2: UL-SCH indicator	
None	<a href="#">Null_Type</a>	0 bit if the number of scheduled PUSCH indicated by the Time domain resource assignment field is larger than 1
Value	<a href="#">B1_Type</a>	1 bit: "1" indicates UL-SCH shall be transmitted on the PUSCH, "0" indicates UL-SCH shall not be transmitted on the PUSCH. Except for DCI format 0_1 with CRC scrambled by SP-CSI-RNTI, a UE is not expected to receive a DCI format 0_1 with UL-SCH indicator of "0" and CSI request of all zero(s).

## NR\_DciFormat\_0\_1\_DfiFlag\_Type

TTCN-3 Union Type		
Name	<b>NR_DciFormat_0_1_DfiFlag_Type</b>	
Comment	TS 38.212 clause 7.3.1.1.2: DFI flag indicator	
None	<a href="#">Null_Type</a>	0 bit no DFI flag indicator
Flag	<a href="#">B1_Type</a>	1 bit: if the UE is configured to monitor DCI format 0_1 with CRC scrambled by CS-RNTI and for operation in a cell with shared spectrum channel access.

## NR\_DciFormat\_0\_1\_ChannelAccessCPextCAPC\_Type

TTCN-3 Union Type		
Name	<b>NR_DciFormat_0_1_ChannelAccessCPextCAPC_Type</b>	
Comment	TS 38.212 clause 7.3.1.1.2: ChannelAccess-CPext-CAPC	
None	<a href="#">Null_Type</a>	0 bit: no ChannelAccess-CPext-CAPC
Value	bitstring	1, 2, 3, 4, 5 or 6 bits. One or more entries from Table 7.3.1.1.2-35 are configured by the higher layer parameter ul-dci-triggered-UL-ChannelAccess-CPext-CAPC-r16

## NR\_DciFormat\_0\_1\_OpenLoopPowerControl\_Type

TTCN-3 Union Type		
Name	<b>NR_DciFormat_0_1_OpenLoopPowerControl_Type</b>	
Comment	TS 38.212 clause 7.3.1.1.2: Open-loop power control parameter set indication	
None	<a href="#">Null_Type</a>	0 bit no Open-loop power control parameter set indication
Value	bitstring	1 or 2 bits - 1 bit if SRS resource indicator is present in the DCI format 0_1; - 1 or 2 bits as determined by higher layer parameter olpc-ParameterSetForDCI-Format0-1 if SRS resource indicator is not present in the DCI format 0_1.

## NR\_DciFormat\_0\_1\_InvalidSymbolPatternIndicator\_Type

TTCN-3 Union Type		
Name	<b>NR_DciFormat_0_1_InvalidSymbolPatternIndicator_Type</b>	
Comment	TS 38.212 clause 7.3.1.1.2: Invalid symbol pattern indicator	
None	<a href="#">Null_Type</a>	0 bit no Invalid symbol pattern indicator
Value	<a href="#">B1_Type</a>	1 bit as defined in Clause 6.1.2.1 in TS 38.214

### NR\_DciFormat\_0\_1\_SidelinkAssignmentIndex\_Type

TTCN-3 Union Type		
Name	<b>NR_DciFormat_0_1_SidelinkAssignmentIndex_Type</b>	
Comment	TS 38.212 clause 7.3.1.1.2: Sidelink assignment index	
None	<a href="#">Null_Type</a>	0 bit no Sidelink assignment index
Value	bitstring	1 or 2 bits: 1 bit if the UE is configured with pdsch-HARQ-ACK-Codebook = semi-static ; 2 bits if the UE is configured with pdsch-HARQ-ACK-Codebook = dynamic

### D.1.3.3 MAC\_Layer

Configuration for MAC procedures according to TS 38.321 clause 5 and related physical layer configuration

#### D.1.3.3.1 MAC\_Layer\_Common

##### MAC\_Layer\_Common: Basic Type Definitions

TTCN-3 Basic Types		
<b>NR_TimingAdvanceIndex_Type</b>	integer (0..63)	acc. to TS 38.321, clause 6.1.3.4 "Timing Advance Command MAC CE" and TS 38.213 clause 4.2 "Transmission timing adjustments"
<b>NR_TimingAdvance_Period_Type</b>	integer (400, 600, 1020, 1530, 2040, 4090, 8190)	the values correspond to 80 % of TimeAlignmentTimer (acc. to TS 38.523-3, clause 6.3.2): - TAG-Id=0 for the SpCell - TAG-Id as configured for an SCell the transmission shall be continuously until being stopped

##### NR\_UplinkTimeAlignment\_AutoSynch\_Type

TTCN-3 Record Type		
Name	<b>NR_UplinkTimeAlignment_AutoSynch_Type</b>	
Comment	Parameters for automatic synchronisation of UL time alignment; The SS shall periodically transmit TA MAC control elements according to 38.321 clause 6.1.3.4 with - TAG-Id=0 for the SpCell - TAG-Id as configured for an SCell the transmission shall be continuously until being stopped	
TimingAdvance	<a href="#">NR_TimingAdvanceIndex_Type</a>	amount of timing adjustment that MAC entity has to apply
TA_Period	<a href="#">NR_TimingAdvance_Period_Type</a>	time period after which TA MAC control elements need to be automatically transmitted

##### NR\_UplinkTimeAlignment\_Synch\_Type

TTCN-3 Union Type		
Name	<b>NR_UplinkTimeAlignment_Synch_Type</b>	
Comment	Configuration of Time Alignment of the UL	
None	<a href="#">Null_Type</a>	no PUCCH Synchronisation applied
Auto	<a href="#">NR_UplinkTimeAlignment_AutoSynch_Type</a>	SS automatically maintains PUCCH synchronization at UE

## D.1.3.3.2 Random\_Access\_Procedure

## NR\_RachProcedureConfig\_Type

TTCN-3 Record Type			
<b>Name</b>	<b>NR_RachProcedureConfig_Type</b>		
<b>Comment</b>	parameters to control the random access procedure; TS 38.321, clause 5.1. When SUL is configured, SS shall monitor UE RACH transmissions on both uplink and supplementary uplink carriers. NOTE: RACH-ConfigCommon and RACH-ConfigDedicated are contained in NR_UplinkBWP_Type already (RACH-ConfigCommon as part of BWP-UplinkCommon). When supplementary uplink is configured, RACH-ConfigCommon and RACH-ConfigDedicated are contained in the fields Uplink and SupplementaryUplink.		
RachProcedureList	<a href="#">NR_RachProcedureList_Type</a>	opt	in normal cases there is one element which is used for any RA procedure

## NR\_RachProcedureList\_Type

TTCN-3 Record of Type	
<b>Name</b>	<b>NR_RachProcedureList_Type</b>
<b>Comment</b>	to simulate RACH procedure with one or more than one attempt by the UE: There is one element in the list per PRACH Preamble attempt
record of <a href="#">NR_RachProcedure_Type</a>	

## NR\_RachProcedure\_Type

TTCN-3 Record Type			
<b>Name</b>	<b>NR_RachProcedure_Type</b>		
<b>Comment</b>			
RandomAccessResponse	<a href="#">NR_RandomAccessResponseConfig_Type</a>	opt	configures how the SS shall react on a PRACH Preamble attempt, in general: - RAR with RAPID matching the RAPID of the UE's PRACH Preamble - RAR with RAPID not matching the RAPID of the UE's PRACH Preamble - BackoffIndicator - no response at all
ContentionResolution	<a href="#">NR_ContentionResolutionControl_Type</a>	opt	Random Access Procedure may be 1. Contention free (Non-contention based) => no contention resolution 2. Contention based (see TS 38.321 clause 5.1.5): 2a) C-RNTI based: Msg3 contains MAC C-RNTI control element and in general contention resolution is done by assignment of an UL grant for this C-RNTI 2b) UE Contention Resolution Identity based: Msg3 contains RRC message to setup or restore RRC connection => contention resolution is done by sending of Msg4 with UE Contention Resolution Identity MAC CE

## D.1.3.3.2.1 Random\_Access\_Response

## Random\_Access\_Response: Basic Type Definitions

TTCN-3 Basic Types		
<b>NR_RACH_TimingAdvance_Type</b>	integer (0..3846)	12 bit value corresponding to Timing Advance Command field of the Random Access Response (TS 38.321 clause 6.2.3): 0..3846 according to TS 38.213 clause 4.2)
<b>NR_RAR_BackoffIndicator_Type</b>	integer (0..15)	MAC subPDU for Backoff Indicator only according to TS 38.321 clause 6.1.5

## NR\_RAR\_UplinkGrant\_Type

TTCN-3 Record Type		
Name	NR_RAR_UplinkGrant_Type	
Comment	27 bits according to TS 38.213 Table 8.2-1 and TS 38.321 Figure 6.2.3-1	
HoppingFlag	<a href="#">B1_Type</a>	Hopping flag
Msg3FrequencyResourceAllocation	<a href="#">B14_Type</a>	Msg3 PUSCH frequency resource allocation: RIV value as defined in TS 38.213 clause 8.2 and TS 38.214 clause 6.1.2.2.2
Msg3TimeResourceAllocation	<a href="#">B4_Type</a>	Msg3 PUSCH time resource allocation similar to the Time-domain resource assignment field of DCI format 0_0: index addressing an entry of the applicable PUSCH time domain resource allocation table as specified in TS 38.214 clause 6.1.2.1.1; the timing between the RAR and Msg3 is given by K2 (as in the time domain resource allocation table) and a delta value as according to Table 6.1.2.1.1-5 in TS 38.214. It is the responsibility of SS implementation to send the RAR in an appropriate DL slot so that the corresponding Msg3 transmission is scheduled for a valid UL slot; it is responsibility of test specification to provide a correct K2 value for the given numerology.
MCS	<a href="#">B4_Type</a>	Modulation and Coding Scheme: first sixteen indices of the applicable MCS index table for PUSCH (TS 38.214 Table 6.1.4.1-1)
TPC_Command	<a href="#">B3_Type</a>	TPC command for Msg3 PUSCH
CQI_Req	<a href="#">B1_Type</a>	CQI request

## NR\_TempC\_RNTI\_Type

TTCN-3 Union Type		
Name	NR_TempC_RNTI_Type	
Comment		
SameAsC_RNTI	<a href="#">Null_Type</a>	in the RA response SS shall use the same C-RNTI as configured in NR_CellConfigCommon_Type; this is useful for initial random access
Explicit	<a href="#">RNTI_Value_Type</a>	in the RA response SS shall use different value as configured in NR_CellConfigCommon_Type; this can be used when the UE already is in RRC_CONNECTED to have a temporary C-RNTI different from the one used by the UE; NOTE: when the UE is not in RRC_CONNECTED there shall be no explicit temp. C-RNTI since then the UE would assume this value as C-RNTI



## NR\_RAR\_Payload\_Type

TTCN-3 Record Type			
<b>Name</b>	<b>NR_RAR_Payload_Type</b>		
<b>Comment</b>	MAC payload for Random Access Response according to TS 38.321 clause 6.2.3		
TimingAdvance	<a href="#">NR_RACH_TimingAdvance_Type</a>		timing advance: TS 38.321 clause 6.2.3 and TS 38.213 clause 4.2 NOTE: timing advance has impact not only on the RA procedure; SS in general needs to adjust its timing accordingly
UplinkGrant	<a href="#">NR_RAR_UplinkGrant_Type</a>		initial UL grant
TempC_RNTI	<a href="#">NR_TempC_RNTI_Type</a>		NOTE: In general for initial Random Access Procedure TempC_RNTI shall be 'SameAsC_RNTI' For Random Access Procedure in RRC_CONNECTED state the NW assigns a temporary C-RNTI which is replaced by the one stored at the UE; => TempC_RNTI may be 'SameAsC_RNTI' (in this case temp. C-RNTI and C-RNTI are equal what is not likely in a real network), or there is an explicit temp. C-RNTI what is used during RA procedure only (as in a real network)

## NR\_RAR\_RapIdOnly\_Type

TTCN-3 Record Type			
<b>Name</b>	<b>NR_RAR_RapIdOnly_Type</b>		
<b>Comment</b>	MAC subPDU for RAPID only (acknowledgment for SI request) according to TS 38.321 clause 6.1.5		
RapId	<a href="#">RAR_RapIdCtrl_Type</a>		

## NR\_RAR\_RapIdAndPayload\_Type

TTCN-3 Record Type			
<b>Name</b>	<b>NR_RAR_RapIdAndPayload_Type</b>		
<b>Comment</b>	MAC subPDU for RAPID and RAR payload according to TS 38.321 clause 6.1.5		
RapId	<a href="#">RAR_RapIdCtrl_Type</a>		
Payload	<a href="#">NR_RAR_Payload_Type</a>		

## NR\_RAR\_SubPdu\_Type

TTCN-3 Union Type			
<b>Name</b>	<b>NR_RAR_SubPdu_Type</b>		
<b>Comment</b>	Random Access Response sub-PDU according to TS 38.321 clause 6.1.5		
BackoffIndicator	<a href="#">NR_RAR_BackoffIndicator_Type</a>		
RapIdOnly	<a href="#">NR_RAR_RapIdOnly_Type</a>		
RapIdAndPayload	<a href="#">NR_RAR_RapIdAndPayload_Type</a>		

## NR\_RAR\_SubPduList\_Type

TTCN-3 Record of Type	
<b>Name</b>	<b>NR_RAR_SubPduList_Type</b>
<b>Comment</b>	list of MAC subPDUs; if a Backoff Indicator is included it has to be the first element (TS 38.321 clause 6.1.5)
	record of <a href="#">NR_RAR_SubPdu_Type</a>

## NR\_RAR\_MacPdu\_Type

TTCN-3 Record Type			
Name	NR_RAR_MacPdu_Type		
Comment			
SubPduList	<a href="#">NR_RAR_SubPduList_Type</a>	opt	list of Backoff Indicator (optional) and random access responses; empty list if no RAR shall be sent at all (omit means "keep as it is" as usual)
CrcError	boolean	opt	if set, MAC PDU shall transmitted with CRC bits (0-3) being toggled

## NR\_RandomAccessResponseConfig\_Type

TTCN-3 Record Type			
Name	NR_RandomAccessResponseConfig_Type		
Comment	configuration for Random Access Response mapped to DL-SCH mapped to PDSCH		
SearchSpaceAndDci	<a href="#">NR_SearchSpaceDIDciAssignment_Type</a>	opt	in general a RACH procedure is expected at the BWP currently being configured as active BWP at the SS; Type1-PDCCH common search space is used for scheduling of the Random Access Response (Msg2)
MacPdu	<a href="#">NR_RAR_MacPdu_Type</a>	opt	MAC PDU to be sent automatically by the SS when there has been a RACH preamble

## D.1.3.3.2.2 Contention\_Resolution

## NR\_ContentionResolutionCtrl\_Type

TTCN-3 Union Type			
Name	NR_ContentionResolutionCtrl_Type		
Comment			
None	<a href="#">Null_Type</a>		no contention resolution: e.g. in case of contention free random access procedure or for special cases of contention based random access procedure
CRNTI_Based	<a href="#">NR_SearchSpaceUIDciAssignment_Type</a>		contention resolution based on C-RNTI on PDCCH: The SS assigns UL grant on PDCCH; the UL grant is scrambled by C-RNTI and associated with the UE-specific search space
Msg4_Based	<a href="#">NR_RachProcedureMsg4_Type</a>		contention resolution based on UE Contention Resolution Identity on DL-SCH

## NR\_RachProcedureMsg4\_Type

TTCN-3 Record Type			
Name	NR_RachProcedureMsg4_Type		
Comment	Msg4 of the RACH procedure in case of contention resolution based on UE Contention Resolution Identity		
SearchSpaceAndDci	<a href="#">NR_SearchSpaceDIDciAssignment_Type</a>	opt	DCI to be used for Msg4; the DCI is scrambled by the temporary C-RNTI and associated with the Type1-PDCCH common search space
ContentionResolutionId	<a href="#">NR_ContentionResolutionId_Type</a>	opt	Contention Resolution Id contained in MAC PDU of Msg4
RrcPdu	<a href="#">NR_RachProcedureMsg4RrcMsg_Type</a>	opt	RRC message to be contained in Msg4 of the RACH procedure
CrcError	boolean	opt	if set, MAC PDU shall transmitted with CRC bits (0-3) being toggled

## NR\_ContentionResolutionId\_Type

TTCN-3 Union Type		
Name	NR_ContentionResolutionId_Type	
Comment		
XorMask	<a href="#">B48_Type</a>	When SS receives Contention Resolution ID from the UE, SS shall XOR it with the given mask and use this as Contention Resolution ID; this allows to get an unmatching Contention Resolution ID; in normal cases mask shall be set to tsc_ContentionResolutionId_Unchanged (i.e. the Contention Resolution ID remains unchanged) NOTE: In case of UL_CCCH1_Message the contention resolution id shall be cut down to the first 48 bits according to TS 38.321 clause 6.1.3.3
None	<a href="#">Null_Type</a>	MAC Contention Resolution Control Element is not contained in the MAC PDU sent out as response for Msg3

## NR\_RachProcedureMsg4RrcMsg\_Type

TTCN-3 Union Type		
Name	NR_RachProcedureMsg4RrcMsg_Type	
Comment		
RrcCchMsg	octetstring	encoded RRC message for CCCH; LCID=000000 for CCCH
RrcDchMsg	octetstring	encoded RRC message for DCCH; the SS shall <ul style="list-style-type: none"> <li>- apply integrity protection,</li> <li>- add a PDCP header accordingly,</li> <li>- add an AM RLC header,</li> <li>- use LCID=000001 corresponding to SRB1 as logical channel id</li> </ul>
None	<a href="#">Null_Type</a>	Msg4 does not contain any RRC message, e.g. when RRC message is sent stand-alone in separate DL transmission

## D.1.3.4 System\_Information\_Control

Primitive to configuration scheduling of system information on BCCH/BCH

## System\_Information\_Control: Basic Type Definitions

TTCN-3 Basic Types		
NR_BcchToPbchConfig_Type	<a href="#">Null_Type</a>	place holder for BCCH mapped to BCH mapped to PBCH: MIB using fixed periodicity (80ms) and repetitions (80ms) according to TS 38.331 clause 5.2.1; the position of SS/PBCH blocks in frequency and time domain is specified in TS 38.211 clause 7.4.3 and TS 38.213 clause 4.1 the SS configuration for SS/PBCH blocks is defined by NR_SSB_Config_Type as part of physical layer configuration of a cell

## NR\_Sib1Schedul\_Type

TTCN-3 Record Type			
Name	NR_Sib1Schedul_Type		
Comment	Scheduling of SIB1 (RMSI - Remaining Minimum SI, according to TS 38.300 clause 7.3): fixed scheduling in time domain according to TS 38.331 clause 5.2.1 (periodicity: 160ms according to TS 38.331 clause 5.2.1)		
SearchSpaceAndDci	<a href="#">NR_SearchSpaceDIDciAssignment_Type</a>	opt	in general SIB scheduling is assigned to the initial BWP's Type0-PDCCH common search space (searchSpaceZero); in principle SIB scheduling can be configured to happen simultaneously in more than one BWP (e.g. initial BWP and active BWP); SIB1 scheduling may be stopped by not assigning any BWP (AssignedBWPs being empty)
Periodicity	integer	opt	SIB1 repetition transmission period in milliseconds. According to TS 38.331 clause 5.2.1 the SIB1 repetition transmission period is 20 ms in case of SSB and CORESET multiplexing pattern 1; for SSB and CORESET multiplexing pattern 2/3 it is the same as the SSB period
SlotOffsetList	<a href="#">IntegerList_Type</a>	opt	List of slot offsets for SIB1: For single beam configuration there is exactly one offset corresponding to the SSB index of the beam. For multiple beam configuration with N beams, SIB1 may be scheduled per beam so that there can be up-to N SIB1-transmission per repetition period. The offsets correspond to the SSB index of the respective beam as according to TS 38.213 clause 13: For a repetition period of 20ms the offset is relative to start of frames with even SFN (i.e. SFN mod 2 = 0) => in terms of TS 38.213 clause 13 for a given SSB index the slot offset is $n_0$ when nO refers to a frame with even SFN $n_0 + (\text{number of slots per frame})$ when nO refers to a frame with odd SFN A repetition period other than 20ms is not considered as long as there is no test requirement. NOTE: the SIB1 scheduling for a given offset shall match the Type0-PDCCH common search space configuration as configured in the SearchSpaceArray of the BWP

## NR\_SingleSiSchedul\_Type

TTCN-3 Record Type			
Name	NR_SingleSiSchedul_Type		
Comment	Scheduling for a single SI in its SI-window within a BWP (or even within several BWPs)		
SearchSpaceAndDci	<a href="#">NR_SearchSpaceDIDciAssignment_Type</a>	opt	in general SIB scheduling is assigned to the initial BWP's Type0A-PDCCH common search space; nevertheless in principle scheduling can be configured to happen simultaneously in more than one BWP (e.g. initial BWP and active BWP)
SlotOffset	integer	opt	slot-offset within the SI-window

## NR\_OtherSiSchedul\_Type

TTCN-3 Record Type			
Name	NR_OtherSiSchedul_Type		
Comment	Scheduling of other SI ("other SI" according to TS 38.300 clause 7.3): specifies for a specific SI the scheduling and repetitions within its SI window		
Periodicity	<a href="#">NR_SiPeriodicity_Type</a>	opt	
Window	record of <a href="#">NR_SingleSiSchedul_Type</a>	opt	one or more repetitions within the si-window

## NR\_OtherSiSchedulList\_Type

TTCN-3 Record of Type	
Name	NR_OtherSiSchedulList_Type
Comment	
record of <a href="#">NR_OtherSiSchedul_Type</a>	

## NR\_AllOtherSiSchedul\_Type

TTCN-3 Record Type			
Name	NR_AllOtherSiSchedul_Type		
Comment	Scheduling of (all) other SI (i.e. SIB2 and above according to TS 38.300 clause 7.3)		
WindowLength	<a href="#">NR_SiWindowLength_Type</a>	opt	to calculate start of each SI window according to TS 38.331 clause 5.2.2.3.2
SiList	<a href="#">NR_OtherSiSchedulList_Type</a>	opt	list of scheduling info for the SIs containing one or more SIBs
SegmentedSiList	<a href="#">NR_OtherSiSchedulList_Type</a>	opt	list of scheduling info for segmented SIs (e.g. SI containing SIB7 or SIB8); corresponds to SegmentedSIs in NR_BcchInfo_Type: SS shall subsequently schedule the elements of the corresponding SegmentedSIs (NR_BcchInfo_Type); SegmentedSiList[i] provides scheduling info for BcchInfo_Type's SegmentedSIs[i] The kth element of SegmentedSIs[i] is sent at the following slot number from T0: SlotOffset + ((N+i)* WindowLength) + k*Periodicity with k : kth element in SegmentedSIs[i], i.e. SegmentedSIs[i][k] N : number of SI provided in SIs in NR_BcchInfo_Type T0: start of the modification period SlotOffset, Periodicity: scheduling info as given by SegmentedSiList[i] - in slots WindowLength: provided in NR_AllOtherSiSchedul_Type - in slots

## NR\_BcchToPdschConfig\_Type

TTCN-3 Record Type			
Name	NR_BcchToPdschConfig_Type		
Comment	configuration for BCCH mapped to DL-SCH mapped to PDSCH		
Sib1Schedul	<a href="#">NR_Sib1Schedul_Type</a>	opt	SIB1 scheduling
SiSchedul	<a href="#">NR_AllOtherSiSchedul_Type</a>	opt	scheduling of other SI

## NR\_SI\_List\_Type

TTCN-3 Record of Type	
Name	NR_SI_List_Type
Comment	list of system information messages
record of BCCH_DL_SCH_Message	

## NR\_SegmentedSI\_List\_Type

TTCN-3 Record of Type	
Name	NR_SegmentedSI_List_Type
Comment	Each element is a list of segments; used for segmented SIBs Used for SIB7/SIB8 segmentation
record of <a href="#">NR_SI_List_Type</a>	

**NR\_BcchInfo\_Type**

TTCN-3 Record Type			
Name	<b>NR_BcchInfo_Type</b>		
Comment	Configuration of system information message contents to be scheduled at the SS		
MIB	BCCH_BCH_Message	opt	TS 38.331, clause 6.2.1 BCCH-BCH-Message and clause 6.2.2 MIB; NOTE: the system frame number included in MIB needs to be handled and maintained by the system simulator; that means that the system frame number being setup by TTCN shall be ignored and overwritten by the SS
SIB1	BCCH_DL_SCH_Message	opt	TS 38.331, clause 6.2.1 BCCH-DL-SCH-Message and clause 6.2.2 SIB1
SIs	<a href="#">NR_Si_List_Type</a>	opt	list of SIs corresponding to SiList of NR_AllOtherSiSchedul_Type (i.e. element i of NR_AllOtherSiSchedul_Type's SiList specifies the scheduling for SIs[i])
SegmentedSIs	<a href="#">NR_SegmentedSi_List_Type</a>	opt	list of SIs containing segmented SIBs; corresponds to SegmentedSiList in NR_AllOtherSiSchedul_Type

**NR\_BcchConfig\_Type**

TTCN-3 Record Type			
Name	<b>NR_BcchConfig_Type</b>		
Comment	Configuration of system information scheduling and content at the SS		
Pbch	<a href="#">NR_BcchToPbchConfig_Type</a>	opt	
Pdsch	<a href="#">NR_BcchToPdschConfig_Type</a>	opt	
BcchInfo	<a href="#">NR_BcchInfo_Type</a>	opt	

**D.1.3.5 Paging\_Control**

Primitive to configuration PCCH/PCH

**NR\_PcchConfig\_Type**

TTCN-3 Record Type			
Name	<b>NR_PcchConfig_Type</b>		
Comment	configuration for PCCH mapped to PCH mapped to PDSCCH		
SearchSpaceAndDci	<a href="#">NR_SearchSpaceDciAssignment_Type</a>	opt	in general Paging happens at the BWP currently being configured as active BWP at the SS and Type2-PDCCH common search space is used for scheduling; NOTE 1: there is no use case to schedule Paging simultaneously in multiple BWPs NOTE 2: the DCI may or may not carry a short message but in any case it shall indicate presence of the paging (to send only a short message the "DciTrigger" primitive shall be used)

## D.1.3.6 CCCH\_DCCH\_DTCH\_Configuration

## NR\_DcchDtchConfigDL\_Type

TTCN-3 Record Type			
<b>Name</b>	<b>NR_DcchDtchConfigDL_Type</b>		
<b>Comment</b>	configuration for DCCH/DTCH mapped to DL-SCH mapped to DL-SCH mapped to PDSCH; NOTE: in contrast to EUTRA the configuration of HARQ processes to be used is done as part of DCI configuration		
SearchSpaceAndDci	<a href="#">NR_SearchSpaceDIDciAssignment_Type</a>	opt	in general DCCH/DTCH transmissions happen at the BWP currently being the active BWP at the SS and the UE specific search space is used for scheduling; DCI configuration for Msg2 of the RACH procedure is done as part of the RACH procedure configuration (NR_RandomAccessResponseConfig_Type)

## NR\_DcchDtchConfigUL\_Type

TTCN-3 Record Type			
<b>Name</b>	<b>NR_DcchDtchConfigUL_Type</b>		
<b>Comment</b>	scheduling for DCCH/DTCH mapped to UL-SCH mapped to PUSCH		
SearchSpaceAndDci	<a href="#">NR_SearchSpaceUIDciAssignment_Type</a>	opt	in general DCCH/DTCH transmissions happen at the BWP currently being the active BWP at the SS and the UE specific search space is used for scheduling
PUCCH_Synch	<a href="#">NR_UplinkTimeAlignment_Synch_Type</a>	opt	parameters for automatic control of timing advance
GrantConfig	<a href="#">UL_GrantConfig_Type</a>	opt	configuration how UL grant allocation is done (as response to scheduling request, periodically, etc.

## NR\_DrxCtrl\_Type

TTCN-3 Union Type		
<b>Name</b>	<b>NR_DrxCtrl_Type</b>	
<b>Comment</b>	DRX configuration for connected mode (TS 38.321, clause 5.7)	
None	<a href="#">Null_Type</a>	DRX not configured
Config	<a href="#">NR_ASN1_DRX_Config_Type</a>	DRX is configured as signalled to the UE

## NR\_MeasGapCtrl\_Type

TTCN-3 Union Type		
<b>Name</b>	<b>NR_MeasGapCtrl_Type</b>	
<b>Comment</b>	support of measurement gap configuration	
None	<a href="#">Null_Type</a>	no measurement gap configuration
Config	<a href="#">NR_ASN1_MeasGapConfig_Type</a>	measurement gap configuration acc. to TS 38.331, clause 5.5.2.9; NOTE: the release branch of MeasGapConfig in general is not used for configuration of the SS

### NR\_DcchDtchConfig\_Type

TTCN-3 Record Type			
Name	NR_DcchDtchConfig_Type		
Comment			
DL	<a href="#">NR_DcchDtchConfigDL_Type</a>	opt	Scheduling, parameters related to DCCH and DTCH in DL
UL	<a href="#">NR_DcchDtchConfigUL_Type</a>	opt	Scheduling, parameters related to DCCH and DTCH in UL
DrxCtrl	<a href="#">NR_DrxCtrl_Type</a>	opt	DRX configuration as sent to the UE (or 'None' when the UE does not support connected mode DRX)
MeasGapCtrl	<a href="#">NR_MeasGapCtrl_Type</a>	opt	to tell the SS when no assignments/grants shall be assigned to the UE

### D.1.3.7 Cell\_Group\_Configuration

Configuration of cell group(s) in terms of dual connectivity and carrier aggregation

#### Cell\_Group\_Configuration: Basic Type Definitions

TTCN-3 Basic Types		
NR_ServingCellIndex_Type	integer	corresponds to ASN.1 (v15.1.0) definitions SCellIndex (1..31) and ServCellIndex (0..maxNrofServingCells-1): According to ASN.1 "The value range is shared across the Cell Groups" and "the PCell of the Master Cell Group uses ID = 0"

### NR\_ServingCellConfig\_Type

TTCN-3 Union Type		
Name	NR_ServingCellConfig_Type	
Comment	serving cell capabilities of a cell	
SpCell	<a href="#">NR_SpCellConfig_Type</a>	parameters specific for an SpCell and cell group configuration
SCell	<a href="#">NR_SCellConfig_Type</a>	parameters specific for an SCell
None	<a href="#">Null_Type</a>	there is no serving cell at all (e.g. neighbouring cell only)

### NR\_SCellConfig\_Type

TTCN-3 Record Type			
Name	NR_SCellConfig_Type		
Comment	cell parameters specific for an SCell; NOTE: the corresponding SpCell can be derived from the SpCell's SCellList; further parameters may be added according to test requirements for CA test cases		
ServingCellIndex	<a href="#">NR_ServingCellIndex_Type</a>	opt	
TAG_Id	TAG_Id	opt	Id of the Timing Advance Group the SCell belongs to (according to TS 38.321 clause 6.1.3.4 the SpCell has the TAG Identity 0); the SS shall use the given TAG_Id e.g. for automatic time alignment in UL (see NR_UplinkTimeAlignment_AutoSynch_Type)



### NR\_SpCellConfig\_Type

TTCN-3 Record Type			
<b>Name</b>	<b>NR_SpCellConfig_Type</b>		
<b>Comment</b>	cell parameters specific for an SpCell (PCell of the MCG or the PSCell of the SCG) and additional parameters of the cell group; further parameters may be added according to test requirements for CA test cases		
ServingCellIndex	<a href="#">NR_ServingCellIndex_Type</a>	opt	
CellGroupConfig	<a href="#">NR_SpCell_CellGroupConfig_Type</a>	opt	parameters of the cell group of which the cell is SpCell (PCell or PSCell): assigned to SpCell as in many test cases the cell group consists of the SpCell only and on the other hand every cell group has to have at least an SpCell

### NR\_SpCell\_CellGroupConfig\_Type

TTCN-3 Record Type			
<b>Name</b>	<b>NR_SpCell_CellGroupConfig_Type</b>		
<b>Comment</b>	Configuration of an NR cell group; NOTE 1: The type of cell group (MCG, SCG) may be derived from the CellGroupId (CellGroupId==0 => MCG, CellGroupId>0 => SCG) NOTE 2: Further cell group specific MAC and PHY parameters may be added corresponding to ASN.1 MAC-CellGroupConfig or may need to be added (but e.g. the DRX configuration is assigned to NR_CcchDcchDtchConfig_Type already i.e. there is no need to configure it here)		
CellGroupId	CellGroupId	opt	0 for MCG (i.e. EUTRA in EN-DC), 1 for SCG (NR in EN-DC); see comments to ASN.1 definition of CellGroupId (v15.1.0)
SCellList	<a href="#">NR_CellIdList_Type</a>	opt	list of SCells belonging to the SpCell's cell group; shall be initialised as empty list
MAC_CellGroupConfig	<a href="#">NR_ASN1_MAC_CellGroupConfig_Type</a>	opt	Cell group specific MAC parameters as sent to the UE in CellGroupConfig.MAC-CellGroupConfig
PhysicalCellGroupConfig	<a href="#">NR_ASN1_PhysicalCellGroupConfig_Type</a>	opt	Cell group specific physical layer parameters as sent to the UE in CellGroupConfig.PhysicalCellGroupConfig

## D.1.4 Cell\_Power\_Attenuation

### NR\_CellAttenuationConfig\_Type

TTCN-3 Record Type			
<b>Name</b>	<b>NR_CellAttenuationConfig_Type</b>		
<b>Comment</b>			
CellId	<a href="#">NR_CellId_Type</a>		
Attenuation	<a href="#">NR_Attenuation_Type</a>		
TimingInfo	<a href="#">TimingInfo_Type</a>	opt	

### NR\_CellAttenuationList\_Type

TTCN-3 Record of Type			
<b>Name</b>	<b>NR_CellAttenuationList_Type</b>		
<b>Comment</b>			
record of <a href="#">NR_CellAttenuationConfig_Type</a>			

## D.1.5 Radio\_Bearer\_Configuration

Radio Bearer Configuration: SRBs/DRBs

NOTE: Type definitions for PDCP configuration are in NR\_PDCP\_TypeDefs

## NR\_RlcBearerConfigInfo\_Type

TTCN-3 Record Type			
Name	NR_RlcBearerConfigInfo_Type		
Comment	RLC bearer as defined in TS 37.340: RLC and MAC logical channel configuration of a radio bearer in one cell group		
Rlc	<a href="#">NR_RLC_Configuration_Type</a>	opt	mandatory for initial configuration; omit means "keep as it is"
LogicalChannelId	<a href="#">NR_LogicalChannelId_Type</a>	opt	DRBs: DTCH-LogicalChannelIdentity as for rb-MappingInfo in DRB-ToAddModifyList; SRBs: for SRBs specified configurations acc. to 38.331 clause 9.2.1 shall be applied: SRB1: ul-LogicalChannel-Identity = dl-LogicalChannel-Identity = 1 SRB2: ul-LogicalChannel-Identity = dl-LogicalChannel-Identity = 2 SRB3: ul-LogicalChannel-Identity = dl-LogicalChannel-Identity = 3 for SRB0 being mapped to CCCH the SS shall apply - LCID=0 for DL according to TS 38.321 Table 6.2.1-1 - LCID=0 or LCID=52 for UL according to TS 38.321 Table 6.2.1-2 depending on whether it is a CCCH1 or a CCCH message; For DRBs and SRBs - except SRB0: mandatory for initial configuration; omit means "keep as it is" For SRB0 LogicalChannelId is always omit and the SS shall apply the LCIDs according to TS 38.321
Mac	<a href="#">NR_MAC_Configuration_Type</a>	opt	
DiscardULData	boolean	opt	if omitted: initial configuration: data is handed over to TTCN as usual re-configuration: "keep as it is" if set: true - SS shall discard any data in UL for this radio bearer false - (re)configuration back to normal mode NOTE: typically applicable for UM DRBs only

## NR\_RlcBearerConfig\_Type

TTCN-3 Union Type		
Name	NR_RlcBearerConfig_Type	
Comment	configuration of RLC bearer below NR-PDCP	
Config	<a href="#">NR_RlcBearerConfigInfo_Type</a>	"normal" configuration: there is an RLC bearer configured for the cell which is linked to the PDCP being configured at the cell (the PDCP can be either 'RBTerminating' or 'Proxy')
None	<a href="#">Null_Type</a>	No RLC bearer is configured at NR below the NR-PDCP: NR_PDCP_Configuration_Type shall be 'RBTerminating' with LinkToOtherCellGroup indicating cell with RLC bearer to be used

## NR\_RadioBearerConfigInfo\_Type

TTCN-3 Record Type			
Name	NR_RadioBearerConfigInfo_Type		
Comment			
Sdap	<a href="#">SDAP_Configuration_Type</a>	opt	omitted for EN-DC, otherwise mandatory for initial configuration; omit means "keep as it is" for SRBs: Sdap.None:=true
Pdcp	<a href="#">NR_PDCP_Configuration_Type</a>	opt	for SRB0: "Pdcp.None:=true" mandatory for initial configuration; omit means "keep as it is"
RlcBearer	<a href="#">NR_RlcBearerConfig_Type</a>	opt	mandatory for initial configuration; omit means "keep as it is"

**NR\_RadioBearerConfig\_Type**

TTCN-3 Union Type		
Name	<b>NR_RadioBearerConfig_Type</b>	
Comment		
AddOrReconfigure	<a href="#">NR_RadioBearerConfigInfo_Type</a>	add / re-configure RB
Release	<a href="#">Null_Type</a>	release RB

**NR\_RadioBearer\_Type**

TTCN-3 Record Type		
Name	<b>NR_RadioBearer_Type</b>	
Comment		
Id	<a href="#">NR_RadioBearerId_Type</a>	either for SRB or DRB
Config	<a href="#">NR_RadioBearerConfig_Type</a>	

**NR\_RadioBearerList\_Type**

TTCN-3 Record of Type	
Name	<b>NR_RadioBearerList_Type</b>
Comment	array of SRBs and/or DRBs. TimingInfo: 'Now' in general; activation time may be used in special case for release and/or reconfiguration of one or several RBs; the following rules shall be considered: - release/Reconfiguration of an RB shall not be scheduled earlier than 5ms after a previous data transmission on this RB - subsequent release and reconfiguration(s) shall be scheduled with an interval of at least 5ms - a subsequent data transmission on an RB shall not be scheduled earlier than 5ms after the last reconfiguration of the RB the configuration shall be performed exactly at the given time ControllInfo : FollowOnFlag:=false (unless explicitly specified otherwise in TS 38.523-3 clause 7)
record of <a href="#">NR_RadioBearer_Type</a>	

**D.1.5.1 RLC\_Configuration**

RLC configuration: radio bearer specific

**RLC\_Configuration: Basic Type Definitions**

TTCN-3 Basic Types		
<b>NR_SS_RLC_TM_Type</b>	<a href="#">Null_Type</a>	TM to configure SRB0; no parameters to be defined

**NR\_RLC\_ACK\_Prohibit\_Type**

TTCN-3 Enumerated Type	
Name	<b>NR_RLC_ACK_Prohibit_Type</b>
Comment	
Prohibit	cause SS RLC layer to stop any ACK transmission for UL PDUs received from UE
Continue	bring back the SS RLC in normal mode, where ACK/NACK are transmitted at polling

## NR\_RLC\_NotACK\_NextRLC\_PDU\_Type

TTCN-3 Enumerated Type	
Name	NR_RLC_NotACK_NextRLC_PDU_Type
Comment	
Start	cause SS RLC layer not to ACK the next received RLC PDU; this is done regardless of whether the poll bit is set or not; Example [from UMTS]: when the UE gets new security information in a SECURITY MODE COMMAND the response (SECURITY MODE COMPLETE) sent by the UE is not acknowledged at the RLC level; this causes the UE to continue using the "old" security information

## NR\_RLC\_TransparentMode

TTCN-3 Union Type		
Name	NR_RLC_TransparentMode	
Comment		
Umd	SN_FieldLengthUM	SN-FieldLengthUM ::= ENUMERATED {size6, size12} TS 38.331
Amd	SN_FieldLengthAM	SN-FieldLengthAM ::= ENUMERATED {size12, size18} TS 38.331

## NR\_RLC\_TestModelInfo\_Type

TTCN-3 Union Type		
Name	NR_RLC_TestModelInfo_Type	
Comment		
AckProhibit	<a href="#">NR_RLC_ACK_Prohibit_Type</a>	valid only when the RLC is configured in AM
NotACK_NextRLC_PDU	<a href="#">NR_RLC_NotACK_NextRLC_PDU_Type</a>	valid only when the RLC is configured in AM
TransparentMode	<a href="#">NR_RLC_TransparentMode</a>	

## NR\_RLC\_TestModeConfig\_Type

TTCN-3 Union Type		
Name	NR_RLC_TestModeConfig_Type	
Comment		
None	<a href="#">Null_Type</a>	
Info	<a href="#">NR_RLC_TestModelInfo_Type</a>	

## NR\_SS\_RLC\_AM\_Type

TTCN-3 Record Type			
Name	NR_SS_RLC_AM_Type		
Comment			
Tx	<a href="#">NR_ASN1_UL_AM_RLC_Type</a>	opt	the UE's UL setting to be used in SS's tx direction
Rx	<a href="#">NR_ASN1_DL_AM_RLC_Type</a>	opt	the UE's DL setting to be used in SS's rx direction

**NR\_SS\_RLC\_UM\_Type**

TTCN-3 Record Type			
Name	NR_SS_RLC_UM_Type		
Comment			
Tx	<a href="#">NR_ASN1_UL_UM_RLC_Type</a>	opt	the UE's UL setting to be used in SS's tx direction
Rx	<a href="#">NR_ASN1_DL_UM_RLC_Type</a>	opt	the UE's DL setting to be used in SS's rx direction

**NR\_RLC\_RbConfig\_Type**

TTCN-3 Union Type			
Name	NR_RLC_RbConfig_Type		
Comment			
AM	<a href="#">NR_SS_RLC_AM_Type</a>		
UM	<a href="#">NR_SS_RLC_UM_Type</a>		
TM	<a href="#">NR_SS_RLC_TM_Type</a>		normally SRB0 only; may be used for test purposes also

**NR\_RLC\_Configuration\_Type**

TTCN-3 Record Type			
Name	NR_RLC_Configuration_Type		
Comment			
Rb	<a href="#">NR_RLC_RbConfig_Type</a>	opt	mandatory for initial configuration; omit means "keep as it is"
TestMode	<a href="#">NR_RLC_TestModeConfig_Type</a>	opt	mandatory for initial configuration; omit means "keep as it is"

**D.1.5.2 MAC\_Configuration**

MAC configuration: radio bearer specific configuration

**MAC\_Configuration: Basic Type Definitions**

TTCN-3 Basic Types		
NR_LogicalChannelId_Type	<a href="#">UInt_Type</a>	

**NR\_MAC\_Test\_DLLogChID\_Type**

TTCN-3 Union Type		
Name	NR_MAC_Test_DLLogChID_Type	
Comment		
LogChId	<a href="#">NR_LogicalChannelId_Type</a>	Specifies to over write the logical channel ID in MAC header in all the DL messages sent on the configured logical channel
ConfigLchId	<a href="#">Null_Type</a>	Specifies that the normal mode of correct logical channel ID to be used in DL MAC header. This will be the default mode, when SS is initially configured.

**NR\_MAC\_Test\_SCH\_NoHeaderManipulation\_Type**

TTCN-3 Enumerated Type	
Name	<b>NR_MAC_Test_SCH_NoHeaderManipulation_Type</b>
Comment	
NormalMode	MAC header is fully controlled by the SS
DL_SCH_Only	TTCN can submit a final MAC PDU including header and payloads; SS does not do anything with this MAC PDU i.e. no header is added for the DL SCH transport channel. It is possible that data belonging to multiple DRBs is sent in one MAC PDU and from one special RB configured. NOTE: SRBs shall work as in normal mode and data can be sent/received on SRBs but sending on SRBs shall be in different TTIs than sending data PDUs.
DL_UL_SCH	In UL and DL the SS' MAC layer is transparent i.e. SS does not add or remove any MAC header

**NR\_MAC\_TestModelInfo\_Type**

TTCN-3 Record Type		
Name	<b>NR_MAC_TestModelInfo_Type</b>	
Comment	Parameters/Configuration for MAC tests	
DiffLogChld	<a href="#">NR_MAC_Test_DLLogChlD_Type</a>	to be used in test cases 7.1.1.1 and 7.1.1.2 for using a different logical channel ID in MAC-header on DL-SCH channel
No_HeaderManipulation	<a href="#">NR_MAC_Test_SCH_NoHeaderManipulation_Type</a>	to configure mode for no header manipulation in SS MAC layer for DL/UL SCH

**NR\_MAC\_TestModeConfig\_Type**

TTCN-3 Union Type		
Name	<b>NR_MAC_TestModeConfig_Type</b>	
Comment		
None	<a href="#">Null_Type</a>	
Info	<a href="#">NR_MAC_TestModelInfo_Type</a>	

**NR\_MAC\_LogicalChannelConfig\_Type**

TTCN-3 Record Type		
Name	<b>NR_MAC_LogicalChannelConfig_Type</b>	
Comment		
Priority	integer	logical channel priority for the DL as described in TS 38.321, clause 5.4.3.1 for the UL
PrioritizedBitRate	<a href="#">NR_PrioritizedBitRate_Type</a>	PBR as described for the UL; probably not needed at SS

**NR\_MAC\_Configuration\_Type**

TTCN-3 Record Type			
Name	<b>NR_MAC_Configuration_Type</b>		
Comment			
LogicalChannel	<a href="#">NR_MAC_LogicalChannelConfig_Type</a>	opt	mandatory for initial configuration; omit means "keep as it is"
TestMode	<a href="#">NR_MAC_TestModeConfig_Type</a>	opt	mandatory for initial configuration; omit means "keep as it is"; for none MAC tests "TestMode.None:=true"

**D.1.6 AS\_Security**

Primitive for control of AS security

## NR\_PdcpSQN\_Type

TTCN-3 Record Type			
Name	NR_PdcpSQN_Type		
Comment			
Format	<a href="#">NR_PdcpCountFormat_Type</a>		12 bit or 18 bit SQN
Value	integer		SQN value (12 bit or 18 bit SQN) NOTE: in TTCN the test case writer is responsible to deal with potential overflows (e.g. there shall be a "mod 32", "mod 128" or "mod 4096" according to the format)

## NR\_PDCP\_ActTime\_Type

TTCN-3 Union Type			
Name	NR_PDCP_ActTime_Type		
Comment	The sequence number in UL and DL for SRB1 should be one more than the present SQN, as Ciphering starts in UL and DL soon after SMC and SMComp; For other SRB/DRB it should be the present SQN.		
None	<a href="#">Null_Type</a>		No Activation time; to be used if Ciphering is not applied
SQN	<a href="#">NR_PdcpSQN_Type</a>		PDCP sequence number

## NR\_SecurityActTime\_Type

TTCN-3 Record Type			
Name	NR_SecurityActTime_Type		
Comment			
RadioBearerId	<a href="#">NR_RadioBearerId_Type</a>		
UL	<a href="#">NR_PDCP_ActTime_Type</a>		
DL	<a href="#">NR_PDCP_ActTime_Type</a>		

## NR\_SecurityActTimeList\_Type

TTCN-3 Record of Type			
Name	NR_SecurityActTimeList_Type		
Comment			
	record of <a href="#">NR_SecurityActTime_Type</a>		

## NR\_AS\_IntegrityInfo\_Type

TTCN-3 Record Type			
Name	NR_AS_IntegrityInfo_Type		
Comment	for initial configuration activation time is not needed for integrity protection as all messages in DL after security activation are integrity protected; this means this ASP is invoked before transmission of Security mode command; if there is a integrity violation in UL SS shall set the IndicationStatus in the common ASP part to flag the integrity error (IndicationStatus.Error.Integrity.Pdcp := true); integrity to be provided for each SRB as per core spec		
Algorithm	IntegrityProtAlgorithm		IntegrityProtAlgorithm being defined in RRC ASN.1
KRRCint	<a href="#">B128_Key_Type</a>		
KUPint	<a href="#">B128_Key_Type</a>	opt	Not used when UE connected to EPS (i.e. set to omit for EPS)
ActTimeList	<a href="#">NR_SecurityActTimeList_Type</a>	opt	omit for initial configuration (i.e. all SRBs to be integrity protected immediately); in HO scenarios activation time may be needed e.g. for SRB1

## NR\_AS\_CipheringInfo\_Type

TTCN-3 Record Type			
Name	NR_AS_CipheringInfo_Type		
Comment			
Algorithm	CipheringAlgorithm		CipheringAlgorithm_Type being defined in RRC ASN.1
KRRCenc	<a href="#">B128_Key_Type</a>		
KUPenc	<a href="#">B128_Key_Type</a>		KUPenc is mandatory; and SS uses it when DRB are configured
ActTimeList	<a href="#">NR_SecurityActTimeList_Type</a>		

## NR\_AS\_SecStartRestart\_Type

TTCN-3 Record Type			
Name	NR_AS_SecStartRestart_Type		
Comment			
Integrity	<a href="#">NR_AS_IntegrityInfo_Type</a>	opt	optional to allow separated activation of integrity and ciphering; omit: keep as it is
Ciphering	<a href="#">NR_AS_CipheringInfo_Type</a>	opt	optional to allow separated activation of integrity and ciphering; omit: keep as it is

## NR\_AS\_Security\_Type

TTCN-3 Union Type			
Name	NR_AS_Security_Type		
Comment	Security mode command procedure (TS 38.331, clause 5.3.4)		
StartRestart	<a href="#">NR_AS_SecStartRestart_Type</a>		information to start/restart AS security protection in the PDCP TimingInfo : 'Now' (in general) NOTE: "activation time" may be specified in the primitive based on PDCP SQN
Release	<a href="#">Null_Type</a>		to release AS security protection in the PDCP (if any; if there is no AS security the SS does not need to do anything) TimingInfo : 'Now' (in general) NOTE: "activation time" may be specified in the primitive based on PDCP SQN

## D.1.7 Paging\_Trigger

## NR\_SlotOffsetList\_Type

TTCN-3 Record of Type	
Name	NR_SlotOffsetList_Type
Comment	
record length (1..infinity) of integer	



### NR\_PagingTrigger\_Type

TTCN-3 Record Type			
<b>Name</b>	<b>NR_PagingTrigger_Type</b>		
<b>Comment</b>	to trigger transmission of a paging message on the PCCH at a calculated paging occasion (TS 38.304, clause 7); the paging occasion is calculated by TTCN and activation time is applied TimingInfo : Calculated paging occasion		
Paging	PCCH_Message		paging to be send out at paging occasion and being announced on PDCCH using P-RNTI SS shall add the necessary padding bits as specified in TS 38.331, clause 8.5
SlotOffsetList	<a href="#">NR_SlotOffsetList_Type</a>	opt	list of slot offsets relative to the absolute timing information given in the common part of the ASP; if present, multiple pagings are sent out at all occasions given by the list; if omitted only a single paging is sent at the occasion given by the timing information in the common part of the ASP

## D.1.8 Delta\_Value\_Trigger

### NR\_Band\_SsbForDelta\_Type

TTCN-3 Record Type			
<b>Name</b>	<b>NR_Band_SsbForDelta_Type</b>		
<b>Comment</b>	Primary and secondary bands for requesting Delta values CellId: nr_Cell_NonSpecific TimingInfo : 'Now'		
DeltaPrimary	<a href="#">Band_SsbInfo_Type</a>		
DeltaSecondary	<a href="#">Band_SsbInfo_Type</a>		

### Band\_SsbInfo\_Type

TTCN-3 Record Type			
<b>Name</b>	<b>Band_SsbInfo_Type</b>		
<b>Comment</b>	Band and SSB Frequency value for which Delta values are requested		
DeltaBand	FreqBandIndicatorNR		
Ssb_NRf1	<a href="#">NR_ASN1_ARFCN_ValueNR_Type</a>	opt	
Ssb_NRf2	<a href="#">NR_ASN1_ARFCN_ValueNR_Type</a>	opt	
Ssb_NRf3	<a href="#">NR_ASN1_ARFCN_ValueNR_Type</a>	opt	
Ssb_NRf4	<a href="#">NR_ASN1_ARFCN_ValueNR_Type</a>	opt	

## D.1.9 System\_Indication\_Control

Primitive for control of system indications for special purposes

### NR\_System\_IndicationControl\_Type

TTCN-3 Record Type			
Name	NR_System_IndicationControl_Type		
Comment	Initially all indications apart from "Error" are disabled in SS (i.e. it shall not be necessary in 'normal' test cases to use this primitive but only if a specific indication is needed); omit means indication mode is not changed. TimingInfo : 'Now' (in general)		
RLC_Discard	<a href="#">IndicationAndControlMode_Type</a>	opt	To enable/disable reporting of discarded RLC PDUs
MAC_BSR	<a href="#">IndicationAndControlMode_Type</a>	opt	To enable/disable reporting of short/long BSR
MAC_PHR	<a href="#">IndicationAndControlMode_Type</a>	opt	To enable/disable reporting of short/long PHR
RachPreamble	<a href="#">IndicationAndControlMode_Type</a>	opt	To enable/disable reporting of PRACH preamble
SchedReq	<a href="#">IndicationAndControlMode_Type</a>	opt	To enable/disable reporting of Scheduling Request
UL_HARQ	<a href="#">IndicationAndControlMode_Type</a>	opt	To enable/disable reporting of reception of HARQ ACK/NACK
HarqError	<a href="#">IndicationAndControlMode_Type</a>	opt	To enable/disable reporting of HARQ errors

## D.1.10 PDCP\_Count

Primitives to enquire PDCP COUNT

### NR\_PdcpCountFormat\_Type

TTCN-3 Enumerated Type	
Name	NR_PdcpCountFormat_Type
Comment	
PdcpCount_Srb	20 bit HFN; 12 bit SQN
PdcpCount_DrbSQN 12	20 bit HFN; 12 bit SQN
PdcpCount_DrbSQN 18	14 bit HFN; 18 bit SQN

### NR\_PdcpCount\_Type

TTCN-3 Record Type			
Name	NR_PdcpCount_Type		
Comment			
Format	<a href="#">NR_PdcpCountFormat_Type</a>		
Value	<a href="#">PdcpCountValue_Type</a>		

### NR\_PdcpCountInfo\_Type

TTCN-3 Record Type			
Name	NR_PdcpCountInfo_Type		
Comment			
RadioBearerId	<a href="#">NR_RadioBearerId_Type</a>		
UL	<a href="#">NR_PdcpCount_Type</a>	opt	omit: keep as it is
DL	<a href="#">NR_PdcpCount_Type</a>	opt	omit: keep as it is

## NR\_PdcpCountInfoList\_Type

TTCN-3 Record of Type	
Name	NR_PdcpCountInfoList_Type
Comment	
record of <a href="#">NR_PdcpCountInfo_Type</a>	

## NR\_PdcpCountGetReq\_Type

TTCN-3 Union Type		
Name	NR_PdcpCountGetReq_Type	
Comment		
AllRBs	<a href="#">Null_Type</a>	return COUNT values for all RBs being configured on this PTC NOTE: in case of multi-RAT dual connectivity RBs may be configured by different PTCs
SingleRB	<a href="#">NR_RadioBearerId_Type</a>	

## NR\_PDCP\_CountReq\_Type

TTCN-3 Union Type		
Name	NR_PDCP_CountReq_Type	
Comment		
Get	<a href="#">NR_PdcpCountGetReq_Type</a>	Request PDCP count for one or all RBs being configured at the PDCP TimingInfo: 'Now'
Set	<a href="#">NR_PdcpCountInfoList_Type</a>	Set PDCP count for one or all RBs being configured at the PDCP; list for RBs which's COUNT shall be manipulated TimingInfo: 'Now' (in general) activation time may be used in case of CA inter cell handover to set the PdcpCount

## NR\_PDCP\_CountCnf\_Type

TTCN-3 Union Type		
Name	NR_PDCP_CountCnf_Type	
Comment		
Get	<a href="#">NR_PdcpCountInfoList_Type</a>	RBs in ascending order; SRBs first
Set	<a href="#">Null_Type</a>	

## D.1.11 PDCP\_Handover

Primitives to control PDCP regarding handover

## NR\_PDCP\_HandoverInit\_Type

TTCN-3 Record Type		
Name	NR_PDCP_HandoverInit_Type	
Comment		
SourceCellId	<a href="#">NR_CellId_Type</a>	

## NR\_PDCP\_HandoverControlReq\_Type

TTCN-3 Union Type		
Name	NR_PDCP_HandoverControlReq_Type	
Comment		
HandoverInit	<a href="#">NR_PDCP_HandoverInit_Type</a>	to inform SS that a handover (or PSCell change) will follow, for SS handling of PDCP context from the source cell to the target cell. CellId : In the common ASP part the CellId shall be set to the id of the target cell TimingInfo : 'Now'
HandoverComplete	<a href="#">Null_Type</a>	to inform SS that the handover (or PSCell change) has successfully been performed by the UE; this shall trigger the SS to send a PDCP Status Report on AM DRB(s) to the UE; CellId : the CellId shall be set to the id of the target cell TimingInfo : 'Now'

## D.1.12 L1\_Test\_Mode

Primitive for control of L1 Test Modes

## NR\_L1\_TestMode\_Type

TTCN-3 Record Type		
Name	NR_L1_TestMode_Type	
Comment	TimingInfo : depends on the test mode; activation time is used e.g. for manipulation of the CRC	
DL_SCH_CRC	<a href="#">NR_DL_SCH_CRC_Type</a>	Manipulation of CRC bit generation for DL-SCH

## NR\_MAC\_Test\_DL\_SCH\_CRC\_Mode\_Type

TTCN-3 Enumerated Type	
Name	NR_MAC_Test_DL_SCH_CRC_Mode_Type
Comment	
Normal	default mode, the CRC generation is correct
Erroneous	SS shall generate CRC error by toggling CRC bits; the CRC error shall be applied for all PDUs of the given RNTI and their retransmission until SS is configured back to 'normal' operation
Error1AndNormal	the SS generates wrong CRC for first transmission and correct CRC on first retransmission. Later SS operates in normal mode. The retransmission is automatically triggered by reception of HARQ NACK

## NR\_DL\_SCH\_CRC\_Type

TTCN-3 Union Type		
Name	NR_DL_SCH_CRC_Type	
Comment	NOTE: CRC error mode for RA_RNTI is not addressed as it will be configured in RACHProcedureConfig	
C_RNTI	<a href="#">NR_MAC_Test_DL_SCH_CRC_Mode_Type</a>	to configure mode for CRC bit for all MAC PDUs for which C-RNTI is used in PDCCH transmission
SI_RNTI	<a href="#">NR_MAC_Test_DL_SCH_CRC_Mode_Type</a>	to configure mode for CRC bit for all MAC PDUs for which SI-RNTI is used in PDCCH transmission
CS_RNTI	<a href="#">NR_MAC_Test_DL_SCH_CRC_Mode_Type</a>	to configure mode for CRC bit for all MAC PDUs for which CS-RNTI is used in PDCCH transmission

## D.1.13 DCI\_Trigger

Primitive to trigger SS to send specific DCI (e.g. PDCCH order) which is not associated with any PDSCH or PUSCH transmission

## NR\_DCI\_Trigger\_Type

TTCN-3 Record Type		
<b>Name</b>	<b>NR_DCI_Trigger_Type</b>	
<b>Comment</b>	TimingInfo : 'Now' or specific activation time	
AssignedBWPs	<a href="#">NR_AssignedBWPs_Type</a>	BWP which shall be used to schedule the DCI
SearchSpaceType	<a href="#">NR_SearchSpaceType_Type</a>	search space to be used for sending of given DCI; the SS may raise an error when there is no such search space at the scheduled point in time
DciFormat	<a href="#">NR_DCI_TriggerFormat_Type</a>	

## NR\_DCI\_TriggerFormat\_Type

TTCN-3 Union Type		
<b>Name</b>	<b>NR_DCI_TriggerFormat_Type</b>	
<b>Comment</b>		
PdcchOrder	<a href="#">NR_PDCCH_Order_Type</a>	
ShortMessage	<a href="#">NR_DciWithShortMessageOnly_Type</a>	
DciFormat_2_0	<a href="#">NR_DciFormat_2_0_Type</a>	
DciFormat_2_1	<a href="#">NR_DciFormat_2_1_Type</a>	
DciFormat_2_2	<a href="#">NR_DciFormat_2_2_Type</a>	
DciFormat_2_3	<a href="#">NR_DciFormat_2_3_Type</a>	

## NR\_DciWithShortMessageOnly\_Type

TTCN-3 Record Type		
<b>Name</b>	<b>NR_DciWithShortMessageOnly_Type</b>	
<b>Comment</b>	"stand-alone" DCI with CRC scrambled by P-RNTI with no PCCH-Message being associated; => all fields apart from the ones listed in this record are reserved (see TS 38.212 clause 7.3.1.2.1)	
ShortMessageIndicator	<a href="#">B2_Type</a>	Short Message Indicator according to TS 38.212 Table 7.3.1.2.1-1; to be set to '10'B indicating that only short message is present in the DCI
ShortMessages	<a href="#">B8_Type</a>	Short Messages according to TS 38.331 Table 6.5-1
SlotOffsetList	<a href="#">NR_SlotOffsetList_Type</a>	opt list of slot offsets relative to the absolute timing information given in the common part of the ASP; if present, multiple short messages are sent out at all occasions given by the list; if omitted only a single short message is sent at the occasion given by the timing information in the common part of the ASP

## NR\_PDCCH\_Order\_Type

TTCN-3 Record Type			
Name	NR_PDCCH_Order_Type		
Comment	PDCCH order according to TS 38.212 clause 7.3.1.2.1 to initiate RA procedure (TS 38.321, clause 5.1.1): DCI format 1_0 with CRC scrambled by C-RNTI and the "Frequency domain resource assignment" field are of all ones		
RA_PreambleIndex	<a href="#">B6_Type</a>		ra-PreambleIndex according to TS 38.321 clause 5.1.2
UL_SUL_Indicator	<a href="#">NR_DciCommon_UL_SUL_Indicator_Type</a>		indicates which UL carrier in the cell to transmit the PRACH if the UE is configured with SUL in the cell and RA_PreambleIndex != '000000'B; "None" otherwise
SSB_Index	<a href="#">B6_Type</a>		indicates the SS/PBCH that shall be used to determine the RACH occasion for the PRACH transmission if RA_PreambleIndex != '000000'B; '000000'B (reserved) otherwise
PrachMaskIndex	<a href="#">B4_Type</a>		indicates the RACH occasion associated with the SS/PBCH indicated by "SS/PBCH index" for the PRACH transmission, according to TS 38.321 clause 5.1.1; '0000'B (reserved) otherwise

## NR\_DciFormat\_2\_0\_SfiList\_Type

TTCN-3 Record of Type	
Name	NR_DciFormat_2_0_SfiList_Type
Comment	list of SFI-indexes as used as slotFormatCombinationId in SlotFormatCombination (see TS 38.331): Each index addresses the SlotFormatCombination for a serving cell in SlotFormatCombinationsPerCell (the position is given by 'positionInDCI'); the size of each SFI-index depends on the maximum value of slotFormatCombinationIds (maxSFIindex) in the sequence of SlotFormatCombinations: SFI-index-length = MAX(CEIL(log2(maxSFIindex+1)), 1); see TS 38.213 clause 11.1.1; !!!! NR OPEN ISSUE: it is not fully clear whether the maximum slotFormatCombinationId is determined per Cell or over all cells !!!! !!!! ASSUMPTION: it is per cell and therefore different SFI-indexes may use bitstrings of different length !!!!
record of bitstring	

## NR\_DciFormat\_2\_0\_Type

TTCN-3 Record Type	
Name	NR_DciFormat_2_0_Type
Comment	TS 38.212 clause 7.3.1.3.1: for notifying the slot format; default parameters according to TS 38.508-1 clause 4.3.6.1.3.1
SfiList	<a href="#">NR_DciFormat_2_0_SfiList_Type</a>

## NR\_DciFormat\_2\_1\_IntValueList\_Type

TTCN-3 Record of Type	
Name	NR_DciFormat_2_1_IntValueList_Type
Comment	list of 14 bit INT values per serving cell (see DownlinkPreemption, INT-ConfigurationPerServingCell in TS 38.331 and TS 38.213 clause 11.2)
record length (1..9) of <a href="#">B14_Type</a>	

## NR\_DciFormat\_2\_1\_Type

TTCN-3 Record Type	
<b>Name</b>	<b>NR_DciFormat_2_1_Type</b>
<b>Comment</b>	TS 38.212 clause 7.3.1.3.2: notifying the PRB(s) and OFDM symbol(s) where UE may assume no transmission is intended for the UE; default parameters according to TS 38.508-1 clause 4.3.6.1.3.2
IntValueList	<a href="#">NR_DciFormat_2_1_IntValueList_Type</a>

## NR\_DciFormat\_2\_2\_ClosedLoopIndicator\_Type

TTCN-3 Record Type	
<b>Name</b>	<b>NR_DciFormat_2_2_ClosedLoopIndicator_Type</b>
<b>Comment</b>	TS 38.212 clause 7.3.1.3.3: Closed loop indicator
None	<a href="#">Null_Type</a> 0 bit if the UE is not configured with higher layer parameter twoPUSCH-PC-AdjustmentStates
Index	<a href="#">B1_Type</a> 1 bit otherwise

## NR\_DciFormat\_2\_2\_TpcBlock\_Type

TTCN-3 Union Type	
<b>Name</b>	<b>NR_DciFormat_2_2_TpcBlock_Type</b>
<b>Comment</b>	TS 38.212 clause 7.3.1.3.3: single TPC block
ClosedLoopIndicator	<a href="#">NR_DciFormat_2_2_ClosedLoopIndicator_Type</a>
TpcCommand	<a href="#">NR_DciCommon_TpcCommand_Type</a>

## NR\_DciFormat\_2\_2\_TpcBlockList\_Type

TTCN-3 Record of Type	
<b>Name</b>	<b>NR_DciFormat_2_2_TpcBlockList_Type</b>
<b>Comment</b>	list of TPC blocks according to TS 38.212 clause 7.3.1.3.3; beginning of each block is configured at the UE by tpc-IndexPCell or tpc-IndexPUCCH-SCell for PUCCH and by tpc-Index or tpc-IndexSUL for PUCCH (see PUCCH-TPC-CommandConfig and PUSCH-TPC-CommandConfig in TS 38.331 and TS 38.213 clause 11.3)
	record of <a href="#">NR_DciFormat_2_2_TpcBlock_Type</a>

## NR\_DciFormat\_2\_2\_Type

TTCN-3 Record Type	
<b>Name</b>	<b>NR_DciFormat_2_2_Type</b>
<b>Comment</b>	TS 38.212 clause 7.3.1.3.3: for the transmission of TPC commands for PUCCH and PUSCH; default parameters according to TS 38.508-1 clause 4.3.6.1.3.3
TpcBlockList	<a href="#">NR_DciFormat_2_2_TpcBlockList_Type</a>

## NR\_DciFormat\_2\_3\_SrsRequest\_Type

TTCN-3 Record Type	
<b>Name</b>	<b>NR_DciFormat_2_3_SrsRequest_Type</b>
<b>Comment</b>	TS 38.212 clause 7.3.1.3.4: according to TS 38.213 clause 11.4 the presence of SRS request(s) depends on fieldTypeFormat2-3 (see SRS-TPC-CommandConfig in TS 38.331)
None	<a href="#">Null_Type</a> 0 bit: no SRS request
SrsRequestValue	<a href="#">B2_Type</a> 2 bits: Index of the SRS resource set to be used according to TS 38.212 Table 7.3.1.1.2-24

**NR\_DciCommon\_TpcCommandList\_Type**

TTCN-3 Record of Type	
<b>Name</b>	<b>NR_DciCommon_TpcCommandList_Type</b>
<b>Comment</b>	
record of <a href="#">NR_DciCommon_TpcCommand_Type</a>	

**NR\_DciFormat\_2\_3\_TypeA\_Type**

TTCN-3 Record Type	
<b>Name</b>	<b>NR_DciFormat_2_3_TypeA_Type</b>
<b>Comment</b>	TS 38.212 clause 7.3.1.3.4: srs-TPC-PDCCH-Group = typeA (see SRS-CarrierSwitching in TS 38.331)
SrsRequest	<a href="#">NR_DciFormat_2_3_SrsRequest_Type</a>
TpcCommandList	<a href="#">NR_DciCommon_TpcCommandList_Type</a>

**NR\_DciFormat\_2\_3\_SingleBlockTypeB\_Type**

TTCN-3 Record Type	
<b>Name</b>	<b>NR_DciFormat_2_3_SingleBlockTypeB_Type</b>
<b>Comment</b>	TS 38.212 clause 7.3.1.3.4: srs-TPC-PDCCH-Group = typeB (see SRS-CarrierSwitching in TS 38.331)
SrsRequest	<a href="#">NR_DciFormat_2_3_SrsRequest_Type</a>
TpcCommand	<a href="#">NR_DciCommon_TpcCommand_Type</a>

**NR\_DciFormat\_2\_3\_TypeB\_Type**

TTCN-3 Record of Type	
<b>Name</b>	<b>NR_DciFormat_2_3_TypeB_Type</b>
<b>Comment</b>	
record of <a href="#">NR_DciFormat_2_3_SingleBlockTypeB_Type</a>	

**NR\_DciFormat\_2\_3\_TypeA\_B\_Type**

TTCN-3 Union Type	
<b>Name</b>	<b>NR_DciFormat_2_3_TypeA_B_Type</b>
<b>Comment</b>	
TypeA	<a href="#">NR_DciFormat_2_3_TypeA_Type</a> Type-A as indicated in srs-TPC-PDCCH-Group (see SRS-CarrierSwitching in TS 38.331)
TypeB	<a href="#">NR_DciFormat_2_3_TypeB_Type</a> Type-B as indicated in srs-TPC-PDCCH-Group (see SRS-CarrierSwitching in TS 38.331)

**NR\_DciFormat\_2\_3\_Type**

TTCN-3 Record Type	
<b>Name</b>	<b>NR_DciFormat_2_3_Type</b>
<b>Comment</b>	TS 38.212 clause 7.3.1.3.4: for the transmission of a group of TPC commands for SRS transmissions by one or more UEs; default parameters according to TS 38.508-1 clause 4.3.6.1.3.4
TypeA_B	<a href="#">NR_DciFormat_2_3_TypeA_B_Type</a>



## D.1.14 Configured\_Scheduling

Primitive for control of DL SPS assignment and UL Configured Grant Type 2 configuration

### NR\_SPS\_CG\_ActDeact\_Type

TTCN-3 Union Type		
Name	<b>NR_SPS_CG_ActDeact_Type</b>	
Comment		
Activate	<a href="#">NR_SpsCgActivateInfo_Type</a>	CellId : identifier of the cell where the UE is active RoutingInfo : None RlcBearerRouting : 'None' TimingInfo : activation time for DL SPS assignment or UL configured grant type 2 transmission; ControllInfo : CnfFlag:=false; FollowOnFlag:=false
Deactivate	<a href="#">NR_SpsCgDeactivateInfo_Type</a>	CellId : identifier of the cell where the UE is active RoutingInfo : None RlcBearerRouting : 'None' TimingInfo : activation time for DL SPS assignment or UL configured grant type 2 release indicated by PDCCH transmission or SS local deactivation ControllInfo : CnfFlag:=false; FollowOnFlag:=false

### NR\_SpsCgActivateInfo\_Type

TTCN-3 Record Type			
Name	<b>NR_SpsCgActivateInfo_Type</b>		
Comment	Even though DL SPS assignment or UL configured grant type 2 is pre-configured at the UE, it needs to be activated by L1 signalling => SS shall 'activate' DL SPS assignment or UL configured grant type 2 by sending appropriate assignments/grants to the UE; this shall be done with an activation time. If DL SPS assignment or UL configured grant type 2 is already configured and new Activate command is received, at the activation time SS locally deactivates old configuration, sends UE a PDCCH assignment for new DL SPS assignment or UL configured grant type 2 and locally activates new SPS configuration. In DL, in addition to SS SPS assignment configuration with activation time 'T', TTCN writer shall also schedule a DL MAC PDU with same activation time 'T' and at every DL assignment periodicity (NOTE: in general it is an error when TTCN does not provide data for a periodicity; SS shall send no data in this case). The SS sends the MAC PDU in 'T+ PDSCH slot offset (K0)'		
UplinkConfiguredGrant	<a href="#">NR_UL_ConfiguredGrant_Type</a>	opt	
DownlinkSpsAssignment	<a href="#">NR_DL_SpsAssignment_Type</a>	opt	

### NR\_UL\_ConfiguredGrant\_Type

TTCN-3 Record Type			
Name	<b>NR_UL_ConfiguredGrant_Type</b>		
Comment	information to assign UL configured grant type schedules in UL		
DciInfo	<a href="#">NR_DciUlInfo_Type</a>	opt	to apply an UL grant
SetNDI_1	<a href="#">Null_Type</a>	opt	if present then NDI is set as 1 indicating a retransmission; If absent then NDI is set as 0 indicating a new transmission

### NR\_DL\_SpsAssignment\_Type

TTCN-3 Record Type			
Name	<b>NR_DL_SpsAssignment_Type</b>		
Comment	information to assign semi-persistent scheduling in DL		
DciInfo	<a href="#">NR_DciDlInfo_Type</a>	opt	to apply a DL assignment
SetNDI_1	<a href="#">Null_Type</a>	opt	if present then NDI is set as 1 indicating a retransmission; If absent then NDI is set as 0 indicating a new transmission

## NR\_SPS\_CG\_ReleasePdcchDciFormat\_Type

TTCN-3 Enumerated Type	
Name	NR_SPS_CG_ReleasePdcchDciFormat_Type
Comment	DCI format to be used for DL SPS assignment and UL configured grant type 2 acc. to TS 38.213, Table 10.2-2
dci_0_0	
dci_1_0	

## NR\_SpsCgDeactivateInfo\_Type

TTCN-3 Union Type		
Name	NR_SpsCgDeactivateInfo_Type	
Comment		
LocalRelease	<a href="#">Null_Type</a>	DL SPS assignment and UL configured grant type 2 configuration shall be released at the SS, that means as well that the SS shall not address CS-RNTI anymore from the given TimingInfo onward; NOTE: there is no DL SPS or UL configured grant type 2 release to be signalled on PDCCH (this is done with PdcchExplicitRelease - see below)
PdcchExplicitRelease	<a href="#">NR_SPS_CG_ReleasePdcchDciFormat_Type</a>	SS transmits PDCCH content indicating DL SPS assignment or UL configured grant type 2 release but holds the local configuration until it is locally released

## D.1.15 System\_Indications

Primitives for System indications

## NR\_HarqProcessInfo\_Type

TTCN-3 Record Type			
Name	NR_HarqProcessInfo_Type		
Comment			
Id	<a href="#">NR_HarqProcessId_Type</a>		

## NR\_HarqError\_Type

TTCN-3 Union Type		
Name	NR_HarqError_Type	
Comment		
UL	<a href="#">NR_HarqProcessInfo_Type</a>	indicates HARQ error detected at the SS side (error at UL transmission)
DL	<a href="#">NR_HarqProcessInfo_Type</a>	indicates HARQ NACK sent by the UE (error at DL transmission)

## NR\_RachPreamble\_Type

TTCN-3 Record Type			
Name	NR_RachPreamble_Type		
Comment			
RAPID	integer		indicates the RAPID of the preamble (integer (0..63))

**NR\_RlcDiscardInd\_Type**

TTCN-3 Record Type		
<b>Name</b>	<b>NR_RlcDiscardInd_Type</b>	
<b>Comment</b>	SS shall send this indication if it discards a received RLC AMD PDU as specified in TS 38.322 cl. 5.2.3.2.2	
SequenceNumber	integer	sequence number of the PDU being discarded

**D.1.16 System\_Interface****NR\_SYSTEM\_CTRL\_REQ**

TTCN-3 Record Type		
<b>Name</b>	<b>NR_SYSTEM_CTRL_REQ</b>	
<b>Comment</b>		
Common	<a href="#">NR_RegAspCommonPart_Type</a>	Unless specified otherwise for a particular primitive, the following applies: CellId: identifier of the cell RoutingInfo : 'None' RlcBearerRouting : 'None' MacBearerRouting : 'omit' TimingInfo : 'Now' or specific activation time, depends on respective primitive ControllInfo : CnfFlag: depends on TimingInfo; in general 'false' when specific activation time is used, 'true' for 'Now' FollowOnFlag 'false'
Request	<a href="#">NR_SystemRequest_Type</a>	

**NR\_SYSTEM\_CTRL\_CNF**

TTCN-3 Record Type		
<b>Name</b>	<b>NR_SYSTEM_CTRL_CNF</b>	
<b>Comment</b>		
Common	<a href="#">NR_CnfAspCommonPart_Type</a>	TimingInfo is ignored by TTCN (apart from EnquireTiming) => SS may set TimingInfo to "None"
Confirm	<a href="#">NR_SystemConfirm_Type</a>	

## NR\_SYSTEM\_IND

TTCN-3 Record Type	
Name	NR_SYSTEM_IND
Comment	
Common	<a href="#">NR_IndAspCommonPart_Type</a> CellId : identifier of the cell RoutingInfo : 'none' RoutingInfoSUL: 'omit' RlcBearerRouting : 'none' MacBearerRouting : 'omit' TimingInfo : The SS shall provide TimingInfo depending on the respective indication (see below)
Indication	<a href="#">NR_SystemIndication_Type</a> - Error TimingInfo: related to the error (if available) - RlcDiscardInd TimingInfo: slot in which the RLC PDU has been received - MAC TimingInfo: slot in which the MAC PDU has been received containing the MAC CE being indicated - RachPreamble TimingInfo: start of the RACH preamble - SchedReq TimingInfo: slot containing the SR - UL_HARQ TimingInfo: slot containing the UL HARQ - HarqError TimingInfo: slot containing the UL HARQ

## NR\_SYSTEM\_PORT

TTCN-3 Port Type	
Name	NR_SYSTEM_PORT
Comment	NR PTC: Port for system configuration
out	<a href="#">NR_SYSTEM_CTRL_REQ</a>
in	<a href="#">NR_SYSTEM_CTRL_CNF</a>

## NR\_SYSIND\_PORT

TTCN-3 Port Type	
Name	NR_SYSIND_PORT
Comment	NR PTC: Port for system indications
in	<a href="#">NR_SYSTEM_IND</a>

---

## D.2 NR\_ASP\_DrbDefs

ASP interface for DRBs

## D.2.1 PDU\_TypeDefs

### D.2.1.1 MAC\_PDU

#### NR\_MAC\_PDU\_DL\_Type

TTCN-3 Record Type			
Name	NR_MAC_PDU_DL_Type		
Comment			
CE_SubPDUList	<a href="#">NR_MAC_CE_SubPDU_DL_List_Type</a>	opt	list of subPDUs with MAC CE
SDU_SubPDUList	<a href="#">NR_MAC_SDU_SubPDU_List_Type</a>	opt	list of subPDUs with MAC SDU
Padding_SubPDU	<a href="#">NR_MAC_Padding_SubPDU_Type</a>	opt	subPDU with padding

#### NR\_MAC\_PDU\_UL\_Type

TTCN-3 Record Type			
Name	NR_MAC_PDU_UL_Type		
Comment			
SDU_SubPDUList	<a href="#">NR_MAC_SDU_SubPDU_List_Type</a>	opt	list of subPDUs with MAC SDU
CE_SubPDUList	<a href="#">NR_MAC_CE_SubPDU_UL_List_Type</a>	opt	list of subPDUs with MAC CE
Padding_SubPDU	<a href="#">NR_MAC_Padding_SubPDU_Type</a>	opt	subPDU with padding

#### NR\_MAC\_PDU\_Type

TTCN-3 Union Type		
Name	NR_MAC_PDU_Type	
Comment		
DL	<a href="#">NR_MAC_PDU_DL_Type</a>	
UL	<a href="#">NR_MAC_PDU_UL_Type</a>	

#### NR\_MAC\_PDUList\_Type

TTCN-3 Record of Type	
Name	NR_MAC_PDUList_Type
Comment	
record of <a href="#">NR_MAC_PDU_Type</a>	

### D.2.1.1.1 MAC\_PDU\_SubPDU

MAC subPDU (TS 38.321 clause 6.1.2)

#### MAC\_PDU\_SubPDU: Basic Type Definitions

TTCN-3 Basic Types		
B8_16_Type	bitstring length(8..16)	NOTE: length restriction can only be a range but not two distinct lengths
NR_MAC_SDU_Type	octetstring	

## NR\_MAC\_PDU\_SubHeader\_Type

TTCN-3 Record Type			
Name	NR_MAC_PDU_SubHeader_Type		
Comment	MAC PDU SubHeader (TS 38.321 clause 6.1.2)		
Reserved	<a href="#">B1_Type</a>		Reserved bit
Format	<a href="#">B1_Type</a>		F: The Format field indicates the size of the Length field according to TS 38.321 clause 6.2.1: value 0 => 8 bits, value 1 => 16 bits. In case of MAC subheader for fixed sized MAC CE or padding (R/LCID MAC subheader) this field is reserved (i.e. treated as another R field)
LCID	<a href="#">B6_Type</a>		LCID: Logical Channel ID field according to TS 38.321 Tables 6.2.1-1 and 6.2.1-2
ELCID	<a href="#">B8_16_Type</a>	opt	eLCID: The extended Logical Channel ID field according to TS 38.321 Tables 6.2.1-1a, 6.2.1-1b, 6.2.1-2a and 6.2.1-2b for the DL-SCH and UL-SCH respectively. The size of the eLCID field is either 8 bits or 16 bits.
Length	<a href="#">B8_16_Type</a>	opt	Either omit (fixed-sized MAC CE) or 8 bits (F=0) or 16 bits (F=1)

## NR\_MAC\_CE\_SubPDU\_DL\_Type

TTCN-3 Record Type			
Name	NR_MAC_CE_SubPDU_DL_Type		
Comment	MAC DL subPPU with MAC subheader only (in case of MAC CE with fixed size of zero bits) or MAC subheader + MAC CE		
SubHeader	<a href="#">NR_MAC_PDU_SubHeader_Type</a>		
ControlElement	<a href="#">NR_MAC_ControlElementDL_Type</a>	opt	omit if MAC CE has fixed size of zero bits

## NR\_MAC\_CE\_SubPDU\_DL\_List\_Type

TTCN-3 Set of Type	
Name	NR_MAC_CE_SubPDU_DL_List_Type
Comment	
set of <a href="#">NR_MAC_CE_SubPDU_DL_Type</a>	

## NR\_MAC\_CE\_SubPDU\_UL\_Type

TTCN-3 Record Type			
Name	NR_MAC_CE_SubPDU_UL_Type		
Comment	MAC UL subPPU with MAC subheader only (in case of MAC CE with fixed size of zero bits) or MAC subheader + MAC CE		
SubHeader	<a href="#">NR_MAC_PDU_SubHeader_Type</a>		
ControlElement	<a href="#">NR_MAC_ControlElementUL_Type</a>	opt	omit if MAC CE has fixed size of zero bits

## NR\_MAC\_CE\_SubPDU\_UL\_List\_Type

TTCN-3 Set of Type	
Name	NR_MAC_CE_SubPDU_UL_List_Type
Comment	
set of <a href="#">NR_MAC_CE_SubPDU_UL_Type</a>	

## NR\_MAC\_SDU\_SubPDU\_Type

TTCN-3 Record Type	
<b>Name</b>	<b>NR_MAC_SDU_SubPDU_Type</b>
<b>Comment</b>	MAC subPPU with MAC subheader + MAC SDU
SubHeader	<a href="#">NR_MAC_PDU_SubHeader_Type</a>
SDU	<a href="#">NR_MAC_SDU_Type</a>

## NR\_MAC\_SDU\_SubPDU\_List\_Type

TTCN-3 Set of Type	
<b>Name</b>	<b>NR_MAC_SDU_SubPDU_List_Type</b>
<b>Comment</b>	set of <a href="#">NR_MAC_SDU_SubPDU_Type</a>

## NR\_MAC\_Padding\_SubPDU\_Type

TTCN-3 Record Type	
<b>Name</b>	<b>NR_MAC_Padding_SubPDU_Type</b>
<b>Comment</b>	MAC subPPU with MAC subheader + Padding
SubHeader	<a href="#">NR_MAC_PDU_SubHeader_Type</a>
Padding	octetstring 0 or more octets padding

## D.2.1.1.2 MAC\_ControlElements

MAC Control Elements (CEs) (TS 38.321 clause 6.1.3)

## NR\_MAC\_ControlElementDL\_Type

TTCN-3 Union Type	
<b>Name</b>	<b>NR_MAC_ControlElementDL_Type</b>
<b>Comment</b>	TimingInfo : 'Now' or specific activation time
ContentionResolutionID	<a href="#">NR_MAC_CE_ContentionResolutionID_Type</a> TS 38.321 clause 6.1.3.3
TimingAdvance	<a href="#">NR_MAC_CE_TimingAdvance_Type</a> TS 38.321 clause 6.1.3.4
SCellActDeact	<a href="#">NR_MAC_CE_SCellActDeact_Type</a> TS 38.321 clause 6.1.3.10
DuplicationActDeact	<a href="#">NR_MAC_CE_DuplicationActDeact_Type</a> TS 38.321 clause 6.1.3.11
SP_ResourceSetActDeact	<a href="#">NR_MAC_CE_SP_ResourceSetActDeact_Type</a> TS 38.321 clause 6.1.3.12
CSI_TriggerStateSubselection	<a href="#">NR_MAC_CE_CSI_TriggerStateSubselection_Type</a> TS 38.321 clause 6.1.3.13
TCI_StatesActDeact	<a href="#">NR_MAC_CE_TCI_StatesActDeact_Type</a> TS 38.321 clause 6.1.3.14
TCI_StateIndication	<a href="#">NR_MAC_CE_TCI_StateIndication_Type</a> TS 38.321 clause 6.1.3.15
SP_CSI_ReportingActDeact	<a href="#">NR_MAC_CE_SP_CSI_ReportingActDeact_Type</a> TS 38.321 clause 6.1.3.16
SP_SRS_ActDeact	<a href="#">NR_MAC_CE_SP_SRS_ActDeact_Type</a> TS 38.321 clause 6.1.3.17
PUCCH_SpatialRelationActDeact	<a href="#">NR_MAC_CE_PUCCH_SpatialRelationActDeact_Type</a> TS 38.321 clause 6.1.3.18
SP_ZP_ResourceSetActDeact	<a href="#">NR_MAC_CE_SP_ZP_ResourceSetActDeact_Type</a> TS 38.321 clause 6.1.3.19
RecommendedBitrate	<a href="#">NR_MAC_CE_RecommendedBitrate_Type</a> TS 38.321 clause 6.1.3.20

**NR\_MAC\_ControlElementUL\_Type**

TTCN-3 Union Type		
Name	<b>NR_MAC_ControlElementUL_Type</b>	
Comment		
ShortBSR	<a href="#">NR_MAC_CE_ShortBSR_Type</a>	TS 38.321 clause 6.1.3.1
LongBSR	<a href="#">NR_MAC_CE_LongBSR_Type</a>	TS 38.321 clause 6.1.3.1
C_RNTI	<a href="#">RNTI_B16_Type</a>	TS 38.321 clause 6.1.3.2
SingleEntryPHR	<a href="#">NR_MAC_CE_SingleEntryPHR_Type</a>	TS 38.321 clause 6.1.3.8
MultiEntryPHR	<a href="#">NR_MAC_CE_MultiEntryPHR_Type</a>	TS 38.321 clause 6.1.3.9
Recommended Bitrate	<a href="#">NR_MAC_CE_RecommendedBitrate_Type</a>	TS 38.321 clause 6.1.3.20

## D.2.1.1.2.1 MAC\_ControlElement\_Common

**NR\_MAC\_CE\_SCellFlags\_Type**

TTCN-3 Record Type			
Name	<b>NR_MAC_CE_SCellFlags_Type</b>		
Comment	bitmap to indicate presence of SCell with SCellIndex according to TS 38.331 either SCellIndex7_1 is present only or all octets are present		
SCellIndex7_1	<a href="#">B8_Type</a>		leftmost bit corresponds to SCellIndex7, 2nd bit from the right corresponds to SCellIndex1, rightmost bit is reserved
SCellIndex15_8	<a href="#">B8_Type</a>	opt	leftmost bit corresponds to SCellIndex15, rightmost bit corresponds to SCellIndex8
SCellIndex23_16	<a href="#">B8_Type</a>	opt	leftmost bit corresponds to SCellIndex23, rightmost bit corresponds to SCellIndex16
SCellIndex31_24	<a href="#">B8_Type</a>	opt	leftmost bit corresponds to SCellIndex31, rightmost bit corresponds to SCellIndex24

**NR\_MAC\_CE\_ServCellId\_Bwpld\_Type**

TTCN-3 Record Type			
Name	<b>NR_MAC_CE_ServCellId_Bwpld_Type</b>		
Comment	Common definition for first octet of CEs defined in TS 38.321 clause 6.1.3.12 .. TS 38.321 clause 6.1.3.19		
Field1	<a href="#">B1_Type</a>		A/D field for NR_MAC_CE_SP_ResourceSetActDeact_Type and NR_MAC_CE_SP_SRS_ActDeact_Type or CORESET Pool ID for NR_MAC_CE_TCI_StatesActDeact_Type reserved (set to 0) otherwise
ServCellId	<a href="#">B5_Type</a>		identity of the Serving Cell for which the MAC CE applies
Bwpld	<a href="#">B2_Type</a>		BWP-Id (as specified in TS 38.331) of the uplink/downlink bandwidth part for which the MAC CE applies

## D.2.1.1.2.2 MAC\_ControlElement\_BSR

TS 38.321 clause 6.1.3.1 (Buffer Status Report MAC CEs)

**MAC\_ControlElement\_BSR: Basic Type Definitions**

TTCN-3 Basic Types		
NR_MAC_LongBSR_BufferSize_Type	<a href="#">O1_Type</a>	



## NR\_MAC\_CE\_ShortBSR\_Type

TTCN-3 Record Type	
Name	NR_MAC_CE_ShortBSR_Type
Comment	Short BSR and Short Truncated BSR MAC CE according to TS 38.321 Figure 6.1.3.1-1
LCG	B3_Type
BufferSize	B5_Type

## NR\_MAC\_LongBSR\_BufferSizeList\_Type

TTCN-3 Record of Type	
Name	NR_MAC_LongBSR_BufferSizeList_Type
Comment	
record length (0..8) of NR_MAC_LongBSR_BufferSize_Type	

## NR\_MAC\_CE\_LongBSR\_Type

TTCN-3 Record Type	
Name	NR_MAC_CE_LongBSR_Type
Comment	Long BSR, Long Truncated BSR and Pre-emptive BSR MAC CE according to TS 38.321 Figure 6.1.3.1-2
LCG_Presence	B8_Type
BufferSizeList	NR_MAC_LongBSR_BufferSizeList_Type
	'1' indicates that the Buffer Size field for a logical channel group i is reported, with i = 7 for the leftmost bit and i = 0 for the rightmost
	According to TS 38.321 clause 6.1.3.1 the Buffer Size fields are included in ascending order based on the LCGi

## D.2.1.1.2.3 MAC\_ControlElement\_ContentionResolutionId

TS 38.321 clause 6.1.3.3 (UE Contention Resolution Identity MAC CE)

## MAC\_ControlElement\_ContentionResolutionId: Basic Type Definitions

TTCN-3 Basic Types	
NR_MAC_CE_ContentionResolutionId_Type	B48_Type
	TS 38.321 Figure 6.1.3.3-1; fix size of 48 bits

## D.2.1.1.2.4 MAC\_ControlElement\_TimingAdvance

TS 38.321 clause 6.1.3.4 (Timing Advance Command MAC CE)

## NR\_MAC\_CE\_TimingAdvance\_Type

TTCN-3 Record Type	
Name	NR_MAC_CE_TimingAdvance_Type
Comment	TS 38.321 Figure 6.1.3.4-1
TAG_ID	B2_Type
TimingAdvanceCommand	B6_Type
	TAG Identity of the addressed TAG
	index value TA (0..63) used to control the amount of timing adjustment that MAC entity has to apply (as specified in TS 38.213)

## D.2.1.1.2.5 MAC\_ControlElement\_PHR

TS 38.321 clause 6.1.3.8 (Single Entry PHR) and 6.1.3.9 (Multiple Entry PHR)

**MAC\_ControlElement\_PHR: Basic Type Definitions**

TTCN-3 Basic Types		
<b>NR_MAC_CE_SingleEntry_PHR_Type</b>	<a href="#">NR_MAC_CE_PH_Record_Type</a>	TS 38.321 Figure 6.1.3.8-1

**NR\_MAC\_CE\_PH\_Record\_Type**

TTCN-3 Record Type			
Name	<b>NR_MAC_CE_PH_Record_Type</b>		
Comment			
P_Bit	<a href="#">B1_Type</a>		P bit: 1 indicates the UE applies power backoff due to power management; For Single Entry PHR MAC CE: If mpe-Reporting is configured indicates the applied power backoff to meet MPE requirements.
V_Bit	<a href="#">B1_Type</a>		V bit: Indicates when the PH value is based on a real transmission or a reference format; reserved (R = '0'B) for Single Entry PHR MAC CE
Value	<a href="#">B6_Type</a>		The power headroom level. Ph Type 2 (if configured) for PCell and Type 1 for PCell and SCell
MPE_or_R	<a href="#">B2_Type</a>	opt	2 reserved bits or MPE (Maximum Permissible Exposure); present if V=0
PCMaxc	<a href="#">B6_Type</a>	opt	present if V=0

**NR\_MAC\_CE\_MultiEntryPHR\_Type**

TTCN-3 Record Type			
Name	<b>NR_MAC_CE_MultiEntryPHR_Type</b>		
Comment	TS 38.321 Figure 6.1.3.9-1 and Figure 6.1.3.9-2		
PHFieldPresentForSCell	<a href="#">NR_MAC_CE_SCellFlags_Type</a>		to indicate presence of PH field for particular SCell
PH_Record	record of <a href="#">NR_MAC_CE_PH_Record_Type</a>		list of PH_Records for PCell and SCells as described in TS 38.321 clause 6.1.3.9

**D.2.1.1.2.6 MAC\_ControlElement\_SCellActivationDeactivation**

TS 38.321 clause 6.1.3.10 (SCell Activation/Deactivation MAC CEs)

**MAC\_ControlElement\_SCellActivationDeactivation: Basic Type Definitions**

TTCN-3 Basic Types		
<b>NR_MAC_CE_SCellActDeact_Type</b>	<a href="#">NR_MAC_CE_SCellFlags_Type</a>	TS 38.321 Figure 6.1.3.10-1 and Figure 6.1.3.10-2

**D.2.1.1.2.7 MAC\_ControlElement\_DuplicationActivationDeactivation**

TS 38.321 clause 6.1.3.11 (Duplication Activation/Deactivation MAC CE)

**MAC\_ControlElement\_DuplicationActivationDeactivation: Basic Type Definitions**

TTCN-3 Basic Types		
<b>NR_MAC_CE_DuplicationActDeact_Type</b>	<a href="#">B8_Type</a>	TS 38.321 Figure 6.1.3.11-1

**D.2.1.1.2.8 MAC\_ControlElement\_SP\_ResourceSetActivationDeactivation**

TS 38.321 clause 6.1.3.12 (SP CSI-RS / CSI-IM Resource Set Activation/Deactivation MAC CE)

## NR\_MAC\_CE\_SP\_ResourceSetActDeact\_Octet2\_Type

TTCN-3 Record Type			
Name	NR_MAC_CE_SP_ResourceSetActDeact_Octet2_Type		
Comment			
Reserved	<a href="#">B1_Type</a>		
IM	<a href="#">B1_Type</a>		indicates whether or not octet 3 is present
CSI_RS_ResourceSetId	<a href="#">B6_Type</a>		

## NR\_MAC\_CE\_SP\_ResourceSetActDeact\_Octet3\_Type

TTCN-3 Record Type			
Name	NR_MAC_CE_SP_ResourceSetActDeact_Octet3_Type		
Comment			
Reserved	<a href="#">B2_Type</a>		
CSI_IM_ResourceSetId	<a href="#">B6_Type</a>		

## NR\_MAC\_CE\_SP\_ResourceSetActDeact\_TciStateId\_Type

TTCN-3 Record Type			
Name	NR_MAC_CE_SP_ResourceSetActDeact_TciStateId_Type		
Comment			
Reserved	<a href="#">B1_Type</a>		
Id	<a href="#">B7_Type</a>		

## NR\_MAC\_CE\_SP\_ResourceSetActDeact\_TciStateIdList\_Type

TTCN-3 Record of Type	
Name	NR_MAC_CE_SP_ResourceSetActDeact_TciStateIdList_Type
Comment	record of <a href="#">NR_MAC_CE_SP_ResourceSetActDeact_TciStateId_Type</a> Id_Type

## NR\_MAC\_CE\_SP\_ResourceSetActDeact\_Type

TTCN-3 Record Type			
Name	NR_MAC_CE_SP_ResourceSetActDeact_Type		
Comment	TS 38.321 Figure 6.1.3.12-1		
Octet1	<a href="#">NR_MAC_CE_ServCellId</a> <a href="#">BwpId_Type</a>		Field1: A/D field
Octet2	<a href="#">NR_MAC_CE_SP_ResourceSetActDeact_Octet2_Type</a>		
Octet3	<a href="#">NR_MAC_CE_SP_ResourceSetActDeact_Octet3_Type</a>	opt	present if IM=1 in octet 2
IdList	<a href="#">NR_MAC_CE_SP_ResourceSetActDeact_TciStateIdList_Type</a>		

## D.2.1.1.2.9 MAC\_ControlElement\_CSI\_TriggerStateSubselection

TS 38.321 clause 6.1.3.13 (Aperiodic CSI Trigger State Subselection MAC CE)

**NR\_MAC\_CE\_CSI\_TriggerStateSubselection\_Type**

TTCN-3 Record Type			
<b>Name</b>	<b>NR_MAC_CE_CSI_TriggerStateSubselection_Type</b>		
<b>Comment</b>	TS 38.321 Figure 6.1.3.13-1		
Octet1	<a href="#">NR_MAC_CE_ServCellId</a> <a href="#">Bwpld_Type</a>		Field1: reserved
Selection	<a href="#">B8_List_Type</a>		

## D.2.1.1.2.10 MAC\_ControlElement\_TCI\_StatesActivationDeactivation

TS 38.321 clause 6.1.3.14 (TCI States Activation/Deactivation for UE-specific PDSCH MAC CE)

**NR\_MAC\_CE\_TCI\_StatesActDeact\_Type**

TTCN-3 Record Type			
<b>Name</b>	<b>NR_MAC_CE_TCI_StatesActDeact_Type</b>		
<b>Comment</b>	TS 38.321 Figure 6.1.3.14-1		
Octet1	<a href="#">NR_MAC_CE_ServCellId</a> <a href="#">Bwpld_Type</a>		Field1: CORESET Pool ID field
Status	<a href="#">B8_List_Type</a>		

## D.2.1.1.2.11 MAC\_ControlElement\_TCI\_StateIndication

TS 38.321 clause 6.1.3.15 (TCI State Indication for UE-specific PDCCH MAC CE)

**NR\_MAC\_CE\_TCI\_StateIndication\_Type**

TTCN-3 Record Type			
<b>Name</b>	<b>NR_MAC_CE_TCI_StateIndication_Type</b>		
<b>Comment</b>	TS 38.321 Figure 6.1.3.15-1		
ServCellId	<a href="#">B5_Type</a>		identity of the Serving Cell for which the MAC CE applies
CoresetId	<a href="#">B4_Type</a>		ControlResourceSetId for which the TCI State is being indicated
TciStateId	<a href="#">B7_Type</a>		TCI-StateId applicable to the Control Resource Set identified by CORESET ID field

## D.2.1.1.2.12 MAC\_ControlElement\_SP\_CSI\_ReportingActivationDeactivation

TS 38.321 clause 6.1.3.16 (SP CSI reporting on PUCCH Activation/Deactivation MAC CE)

**NR\_MAC\_CE\_SP\_CSI\_ReportingActDeact\_Type**

TTCN-3 Record Type			
<b>Name</b>	<b>NR_MAC_CE_SP_CSI_ReportingActDeact_Type</b>		
<b>Comment</b>	TS 38.321 Figure 6.1.3.16-1		
Octet1	<a href="#">NR_MAC_CE_ServCellId</a> <a href="#">Bwpld_Type</a>		Field1: reserved
Reserved	<a href="#">B4_Type</a>		
ConfigState	<a href="#">B4_Type</a>		

D.2.1.1.2.13 MAC\_ControlElement\_SP\_SRS\_ActivationDeactivation

**NR\_MAC\_CE\_SP\_SRS\_ActDeact\_Octet2\_Type**

TTCN-3 Record Type			
<b>Name</b>	NR_MAC_CE_SP_SRS_ActDeact_Octet2_Type		
<b>Comment</b>	TS 38.321 clause 6.1.3.17 (SP SRS Activation/Deactivation MAC CE)		
Reserved	<a href="#">B2_Type</a>		
C	<a href="#">B1_Type</a>		
SUL	<a href="#">B1_Type</a>		
SRS_Resource setId	<a href="#">B4_Type</a>		

**NR\_MAC\_CE\_SP\_SRS\_ActDeact\_ResourceId\_Type**

TTCN-3 Record Type			
<b>Name</b>	NR_MAC_CE_SP_SRS_ActDeact_ResourceId_Type		
<b>Comment</b>			
F	<a href="#">B1_Type</a>		
Id	<a href="#">B7_Type</a>		

**NR\_MAC\_CE\_SP\_SRS\_ActDeact\_ResourceIdList\_Type**

TTCN-3 Record of Type			
<b>Name</b>	NR_MAC_CE_SP_SRS_ActDeact_ResourceIdList_Type		
<b>Comment</b>	record of <a href="#">NR_MAC_CE_SP_SRS_ActDeact_ResourceId_Type</a>		

**NR\_MAC\_CE\_SP\_SRS\_ActDeact\_ResourceInfo\_Type**

TTCN-3 Record Type			
<b>Name</b>	NR_MAC_CE_SP_SRS_ActDeact_ResourceInfo_Type		
<b>Comment</b>			
Reserved	<a href="#">B1_Type</a>		
ServingCellId	<a href="#">B5_Type</a>		
BwpId	<a href="#">B2_Type</a>		

**NR\_MAC\_CE\_SP\_SRS\_ActDeact\_ResourceInfoList\_Type**

TTCN-3 Record of Type			
<b>Name</b>	NR_MAC_CE_SP_SRS_ActDeact_ResourceInfoList_Type		
<b>Comment</b>	record of <a href="#">NR_MAC_CE_SP_SRS_ActDeact_ResourceInfo_Type</a>		

**NR\_MAC\_CE\_SP\_SRS\_ActDeact\_Type**

TTCN-3 Record Type			
<b>Name</b>	<b>NR_MAC_CE_SP_SRS_ActDeact_Type</b>		
<b>Comment</b>	TS 38.321 Figure 6.1.3.17-1		
Octet1	<a href="#">NR_MAC_CE_ServCellId_Bwpld_Type</a>		Field1: A/D field
Octet2	<a href="#">NR_MAC_CE_SP_SRS_ActDeact_Octet2_Type</a>		
ResourceIdList	<a href="#">NR_MAC_CE_SP_SRS_ActDeact_ResourceIdList_Type</a>		
ResourceInfoList	<a href="#">NR_MAC_CE_SP_SRS_ActDeact_ResourceInfoList_Type</a>		empty list when C=0

D.2.1.1.2.14 **MAC\_ControlElement\_PUCCH\_SpatialRelationActivationDeactivation**

TS 38.321 clause 6.1.3.18 (PUCCH spatial relation Activation/Deactivation MAC CE)

**NR\_MAC\_CE\_PUCCH\_SpatialRelationActDeact\_Octet2\_Type**

TTCN-3 Record Type			
<b>Name</b>	<b>NR_MAC_CE_PUCCH_SpatialRelationActDeact_Octet2_Type</b>		
<b>Comment</b>			
Reserved	<a href="#">B1_Type</a>		
ResourceId	<a href="#">B7_Type</a>		

**NR\_MAC\_CE\_PUCCH\_SpatialRelationActDeact\_Type**

TTCN-3 Record Type			
<b>Name</b>	<b>NR_MAC_CE_PUCCH_SpatialRelationActDeact_Type</b>		
<b>Comment</b>	TS 38.321 Figure 6.1.3.18-1		
Octet1	<a href="#">NR_MAC_CE_ServCellId_Bwpld_Type</a>		Field1: reserved
Octet2	<a href="#">NR_MAC_CE_PUCCH_SpatialRelationActDeact_Octet2_Type</a>		
ActivationStatus	<a href="#">B8_Type</a>		

D.2.1.1.2.15 **MAC\_ControlElement\_ZP\_ResourceSetActivationDeactivation**

TS 38.321 clause 6.1.3.19 (SP ZP CSI-RS Resource Set Activation/Deactivation MAC CE)

**NR\_MAC\_CE\_SP\_ZP\_ResourceSetActDeact\_Octet2\_Type**

TTCN-3 Record Type			
<b>Name</b>	<b>NR_MAC_CE_SP_ZP_ResourceSetActDeact_Octet2_Type</b>		
<b>Comment</b>			
Reserved	<a href="#">B4_Type</a>		
Id	<a href="#">B4_Type</a>		

## NR\_MAC\_CE\_SP\_ZP\_ResourceSetActDeact\_Type

TTCN-3 Record Type			
<b>Name</b>	NR_MAC_CE_SP_ZP_ResourceSetActDeact_Type		
<b>Comment</b>	TS 38.321 Figure 6.1.3.19-1		
Octet1	<a href="#">NR_MAC_CE_ServCellId</a> <a href="#">BwpId_Type</a>		Field1: A/D field
Octet2	<a href="#">NR_MAC_CE_SP_ZP_ResourceSetActDeact_Octet2</a> <a href="#">Type</a>		

## D.2.1.1.2.16 MAC\_ControlElement\_RecommendedBitrate

TS 38.321 clause 6.1.3.20 (Recommended bit rate MAC CE)

## NR\_MAC\_CE\_RecommendedBitrate\_Type

TTCN-3 Record Type			
<b>Name</b>	NR_MAC_CE_RecommendedBitrate_Type		
<b>Comment</b>	TS 38.321 Figure 6.1.3.20-1		
LCID	<a href="#">B6_Type</a>		
UL_DL	<a href="#">B1_Type</a>		
Bitrate	<a href="#">B6_Type</a>		
X	<a href="#">B1_Type</a>		Bit rate multiplier
Reserved	<a href="#">B2_Type</a>		

## D.2.1.2 RLC\_PDU

## RLC\_PDU: Basic Type Definitions

TTCN-3 Basic Types		
NR_RLC_SDU_Type	octetstring	

## NR\_RLC\_PDU\_Type

TTCN-3 Union Type		
<b>Name</b>	NR_RLC_PDU_Type	
<b>Comment</b>		
TMD	<a href="#">NR_RLC_TMD_PDU_Type</a>	
UMD	<a href="#">NR_RLC_UMD_PDU_Type</a>	
AMD	<a href="#">NR_RLC_AMD_PDU_Type</a>	
Status	<a href="#">NR_RLC_AM_StatusPDU_Type</a>	

## NR\_RLC\_PDUList\_Type

TTCN-3 Record of Type	
<b>Name</b>	NR_RLC_PDUList_Type
<b>Comment</b>	record of <a href="#">NR_RLC_PDU_Type</a>

## NR\_RLC\_SDUList\_Type

TTCN-3 Record of Type	
<b>Name</b>	NR_RLC_SDUList_Type
<b>Comment</b>	record of <a href="#">NR_RLC_SDU_Type</a>

D.2.1.2.1 Common

RLC PDU definition: common AM/UM field definitions

**Common: Basic Type Definitions**

TTCN-3 Basic Types		
NR_RLC_SegmentationInfo_Type	<a href="#">B2_Type</a>	Segmentation Info (SI) field (TS 38.322, clause 6.2.3.4) 00 - Data field contains all bytes of an RLC SDU 01 - Data field contains the first segment of an RLC SDU 10 - Data field contains the last segment of an RLC SDU 11 - Data field contains neither the first nor last segment of an RLC SDU
NR_RLC_SegmentOffset_Type	<a href="#">B16_Type</a>	Segment Offset (SO) field (TS 38.322, 6.2.3.5)

D.2.1.2.2 TM\_Data

RLC PDU definition: UM (TS 38.322, clause 6.2.2.2)

**TM\_Data: Basic Type Definitions**

TTCN-3 Basic Types		
NR_RLC_TMD_PDU_Type	octetstring	TS 38.322, clause 6.2.2.2

D.2.1.2.3 UM\_Data

RLC PDU definition: UM (TS 38.322, clause 6.2.2.3)

**UM\_Data: Basic Type Definitions**

TTCN-3 Basic Types		
NR_RLC_UMD_Data_Type	octetstring	TS 38.322, clause 6.2.2.3

**NR\_RLC\_UMD\_HeaderNoSN\_Type**

TTCN-3 Record Type			
Name	NR_RLC_UMD_HeaderNoSN_Type		
Comment	TS 38.322, clause 6.2.2.3 (Figure 6.2.2.3-1); one octet		
SegmentationInfo	<a href="#">NR_RLC_SegmentationInfo_Type</a>		
Reserved	<a href="#">B6_Type</a>		

**NR\_RLC\_UMD\_PduNoSN\_Type**

TTCN-3 Record Type			
Name	NR_RLC_UMD_PduNoSN_Type		
Comment	TS 38.322, clause 6.2.2.3 (Figure 6.2.2.3-1); one octet		
Header	<a href="#">NR_RLC_UMD_HeaderNoSN_Type</a>		
Data	<a href="#">NR_RLC_UMD_Data_Type</a>		



## NR\_RLC\_UMD\_HeaderSN6Bit\_Type

TTCN-3 Record Type			
<b>Name</b>	<b>NR_RLC_UMD_HeaderSN6Bit_Type</b>		
<b>Comment</b>	TS 38.322, clause 6.2.2.3 (6.2.2.3-2, 6.2.2.3-4); one octet		
SegmentationInfo	<a href="#">NR_RLC_SegmentationInfo_Type</a>		2 bits SI
SequenceNumber	<a href="#">B6_Type</a>		6 bits SN
SegmentOffset	<a href="#">NR_RLC_SegmentOffset_Type</a>	opt	16 bits SO; included in case of segmentation but not for the first segment (TS 38.322 clause 6.2.2.3)

## NR\_RLC\_UMD\_PduSN6Bit\_Type

TTCN-3 Record Type			
<b>Name</b>	<b>NR_RLC_UMD_PduSN6Bit_Type</b>		
<b>Comment</b>	TS 38.322, clause 6.2.2.3 (6.2.2.3-2, 6.2.2.3-4); one octet		
Header	<a href="#">NR_RLC_UMD_HeaderSN6Bit_Type</a>		
Data	<a href="#">NR_RLC_UMD_Data_Type</a>		

## NR\_RLC\_UMD\_HeaderSN12Bit\_Type

TTCN-3 Record Type			
<b>Name</b>	<b>NR_RLC_UMD_HeaderSN12Bit_Type</b>		
<b>Comment</b>	TS 38.322, clause 6.2.2.3 (Figure 6.2.2.3-3, 6.2.2.3-5); two octets		
SegmentationInfo	<a href="#">NR_RLC_SegmentationInfo_Type</a>		2 bits SI
Reserved	<a href="#">B2_Type</a>		2 bits reserved
SequenceNumber	<a href="#">B12_Type</a>		12 bits SN
SegmentOffset	<a href="#">NR_RLC_SegmentOffset_Type</a>	opt	16 bits SO; included in case of segmentation but not for the first segment (TS 38.322 clause 6.2.2.3)

## NR\_RLC\_UMD\_PduSN12Bit\_Type

TTCN-3 Record Type			
<b>Name</b>	<b>NR_RLC_UMD_PduSN12Bit_Type</b>		
<b>Comment</b>	TS 38.322, clause 6.2.2.3 (Figure 6.2.2.3-3, 6.2.2.3-5); two octets		
Header	<a href="#">NR_RLC_UMD_HeaderSN12Bit_Type</a>		
Data	<a href="#">NR_RLC_UMD_Data_Type</a>		

## NR\_RLC\_UMD\_PDU\_Type

TTCN-3 Union Type			
<b>Name</b>	<b>NR_RLC_UMD_PDU_Type</b>		
<b>Comment</b>			
NoSN	<a href="#">NR_RLC_UMD_PduNoSN_Type</a>		
SN6Bit	<a href="#">NR_RLC_UMD_PduSN6Bit_Type</a>		
SN12Bit	<a href="#">NR_RLC_UMD_PduSN12Bit_Type</a>		

## D.2.1.2.4 AM\_Data

RLC PDU definition: AM (TS 38.322, clause 6.2.2.4)

## AM\_Data: Basic Type Definitions

TTCN-3 Basic Types		
NR_RLC_AMD_Data_Type	octetstring	TS 38.322, clause 6.2.2.4

## NR\_RLC\_AMD\_HeaderSN12Bit\_Type

TTCN-3 Record Type			
Name	NR_RLC_AMD_HeaderSN12Bit_Type		
Comment	TS 38.322, clause 6.2.2.4 (Figure 6.2.2.4-1, 6.2.2.4-3)		
D_C	B1_Type		1 bit, '1'B for Data PDU
Poll	B1_Type		1 bit, '0'B - Status report not requested '1'B - Status report is requested
SegmentationInfo	NR_RLC_SegmentationInfo_Type		2 bits SI
SequenceNumber	B12_Type		12 bits SN
SegmentOffset	NR_RLC_SegmentOffset_Type	opt	16 bits SO; included in case of segmentation but not for the first segment (TS 38.322 clause 6.2.2.4)

## NR\_RLC\_AMD\_PduSN12Bit\_Type

TTCN-3 Record Type			
Name	NR_RLC_AMD_PduSN12Bit_Type		
Comment	TS 38.322, clause 6.2.2.4 (Figure 6.2.2.4-1, 6.2.2.4-3)		
Header	NR_RLC_AMD_HeaderSN12Bit_Type		
Data	NR_RLC_AMD_Data_Type		

## NR\_RLC\_AMD\_HeaderSN18Bit\_Type

TTCN-3 Record Type			
Name	NR_RLC_AMD_HeaderSN18Bit_Type		
Comment	TS 38.322, clause 6.2.2.4 (Figure 6.2.2.4-2, 6.2.2.4-4)		
D_C	B1_Type		1 bit, '1'B for Data PDU
Poll	B1_Type		1 bit, 0 - Status report not requested 1 - Status report is requested
SegmentationInfo	NR_RLC_SegmentationInfo_Type		2 bits SI
Reserved	B2_Type		2 bits reserved
SequenceNumber	B18_Type		18 bits SN
SegmentOffset	NR_RLC_SegmentOffset_Type	opt	16 bits SO; included in case of segmentation but not for the first segment (TS 38.322 clause 6.2.2.4)

## NR\_RLC\_AMD\_PduSN18Bit\_Type

TTCN-3 Record Type			
Name	NR_RLC_AMD_PduSN18Bit_Type		
Comment	TS 38.322, clause 6.2.2.4 Figure 6.2.2.4-2, 6.2.2.4-4)		
Header	NR_RLC_AMD_HeaderSN18Bit_Type		
Data	NR_RLC_AMD_Data_Type		

## NR\_RLC\_AMD\_PDU\_Type

TTCN-3 Union Type	
<b>Name</b>	<b>NR_RLC_AMD_PDU_Type</b>
<b>Comment</b>	TS 38.322, clause 6.2.2.4
SN12Bit	<a href="#">NR_RLC_AMD_PduSN12Bit_Type</a>
SN18Bit	<a href="#">NR_RLC_AMD_PduSN18Bit_Type</a>

## D.2.1.2.5 AM\_Status

AM Status PDU (TS 36.322, clause 6.2.1.6)

## AM\_Status: Basic Type Definitions

TTCN-3 Basic Types		
<b>NR_RLC_Status_ExtensionBit1_Type</b>	<a href="#">B1_Type</a>	TS 38.322, clause 6.2.3.11 Extension bit 1 (E1) field: '0'B A set of NACK_SN, E1, E2 and E3 does not follow. '1'B A set of NACK_SN, E1, E2 and E3 follows.
<b>NR_RLC_Status_ExtensionBit2_Type</b>	<a href="#">B1_Type</a>	TS 38.322, clause 6.2.3.13 Extension bit 2 (E2) field: '0'B A set of SOstart and SOend does not follow for this NACK_SN. '1'B A set of SOstart and SOend follows for this NACK_SN.
<b>NR_RLC_Status_ExtensionBit3_Type</b>	<a href="#">B1_Type</a>	TS 38.322, clause 6.2.3.16 Extension bit 3 (E3) field: '0'B A set of NACK_SN, E1, E2 and E3 follows. '1'B NACK range field follows for this NACK_SN.

## NR\_RLC\_Status\_NackSN12Bit\_Type

TTCN-3 Record Type			
<b>Name</b>	<b>NR_RLC_Status_NackSN12Bit_Type</b>		
<b>Comment</b>	TS 38.322, clause 6.2.2.5 (Figure 6.2.2.5-1)		
SequenceNumberNACK	<a href="#">B12_Type</a>		12 bits SN
E1	<a href="#">NR_RLC_Status_ExtensionBit1_Type</a>		1 bit E1 field; set if further NACK set follows
E2	<a href="#">NR_RLC_Status_ExtensionBit2_Type</a>		1 bit E2 field
E3	<a href="#">NR_RLC_Status_ExtensionBit3_Type</a>		1 bit E3 field
Reserved	<a href="#">B1_Type</a>		1 bit reserved
SOstart	<a href="#">NR_RLC_SegmentOffset_Type</a>	opt	segment offset (start), present only if E2 is set to '1'B
SOstop	<a href="#">NR_RLC_SegmentOffset_Type</a>	opt	segment offset (stop), present only if E2 is set to '1'B
NACKrange	<a href="#">B8_Type</a>	opt	NACK range, present only if E3 is set to '1'B

## NR\_RLC\_Status\_NackListSN12Bit\_Type

TTCN-3 Record of Type	
Name	NR_RLC_Status_NackListSN12Bit_Type
Comment	
record of <a href="#">NR_RLC_Status_NackSN12Bit_Type</a>	

## NR\_RLC\_StatusPduSN12Bit\_Type

TTCN-3 Record Type		
Name	NR_RLC_StatusPduSN12Bit_Type	
Comment	TS 38.322, clause 6.2.2.5 (Figure 6.2.2.5-1)	
D_C	<a href="#">B1_Type</a>	1 bit, '0'B for Control PDU
CPT	<a href="#">B3_Type</a>	3 bits, TS 38.322, clause 6.2.3.9 Control PDU Type (CPT) field: '000'B STATUS PDU ELSE reserved
SequenceNumberACK	<a href="#">B12_Type</a>	12 bits SN
E1	<a href="#">NR_RLC_Status_Extension Bit1_Type</a>	1 bit E1 field
Reserved	<a href="#">B7_Type</a>	7 bits reserved
NackList	<a href="#">NR_RLC_Status_NackListS N12Bit_Type</a>	opt zero or more sets of a NACK_SN, E1, E2 and E3 and possibly a pair of SOstart/SOend or NACK range field for each NACK_SN

## NR\_RLC\_Status\_NackSN18Bit\_Type

TTCN-3 Record Type		
Name	NR_RLC_Status_NackSN18Bit_Type	
Comment	TS 38.322, clause 6.2.2.5 (Figure 6.2.2.5-1)	
SequenceNumberNACK	<a href="#">B18_Type</a>	18 bits SN
E1	<a href="#">NR_RLC_Status_Extension Bit1_Type</a>	1 bit E1 field; set if further NACK set follows
E2	<a href="#">NR_RLC_Status_Extension Bit2_Type</a>	1 bit E2 field
E3	<a href="#">NR_RLC_Status_Extension Bit3_Type</a>	1 bit E3 field
Reserved	<a href="#">B3_Type</a>	3 bits reserved
SOstart	<a href="#">NR_RLC_SegmentOffset_T ype</a>	opt segment offset (start), present only if E2 is set to '1'B
SOstop	<a href="#">NR_RLC_SegmentOffset_T ype</a>	opt segment offset (stop), present only if E2 is set to '1'B
NACKrange	<a href="#">B8_Type</a>	opt NACK range, present only if E3 is set to '1'B

## NR\_RLC\_Status\_NackListSN18Bit\_Type

TTCN-3 Record of Type	
Name	NR_RLC_Status_NackListSN18Bit_Type
Comment	
record of <a href="#">NR_RLC_Status_NackSN18Bit_Type</a>	

## NR\_RLC\_StatusPduSN18Bit\_Type

TTCN-3 Record Type			
Name	NR_RLC_StatusPduSN18Bit_Type		
Comment	TS 38.322, clause 6.2.2.5 (Figure 6.2.2.5-1)		
D_C	<a href="#">B1_Type</a>		1 bit, '0'B for Control PDU
CPT	<a href="#">B3_Type</a>		3 bits, TS 38.322, clause 6.2.3.9 Control PDU Type (CPT) field: '000'B STATUS PDU ELSE reserved
SequenceNum berACK	<a href="#">B18_Type</a>		18 bits SN
E1	<a href="#">NR_RLC_Status_Extension Bit1_Type</a>		1 bit E1 field
Reserved	<a href="#">B1_Type</a>		1 bit reserved
NackList	<a href="#">NR_RLC_Status_NackListS N18Bit_Type</a>	opt	zero or more sets of a NACK_SN, E1, E2 and E3 and possibly a pair of SOstart/SOend or NACK range field for each NACK_SN

## NR\_RLC\_AM\_StatusPDU\_Type

TTCN-3 Union Type			
Name	NR_RLC_AM_StatusPDU_Type		
Comment	TS 38.322, clause 6.2.254		
SN12Bit	<a href="#">NR_RLC_StatusPduSN12Bit_Type</a>		
SN18Bit	<a href="#">NR_RLC_StatusPduSN18Bit_Type</a>		

## D.2.2 DRB\_Primitive\_Definitions

Primitive definitions to send/receive data PDUs over DRB's

## D.2.2.1 DRB\_Common

## NR\_L2DataList\_Type

TTCN-3 Union Type		
Name	<b>NR_L2DataList_Type</b>	
Comment	MAC: acc. to rel-15 protocols there is exactly one MAC PDU per TB but in case of spatial multiplexing there can be one or more TB per HARQ process; any MAC PDU is completely included in one slot (TTI) RLC: one or more RLC PDUs per slot (TTI) (e.g. RLC Data + Status PDU on a logical channel; more than one RLC Data PDU in one MAC PDU is valid too) any RLC PDU is completely included in one slot (TTI) PDCP: one or more PDUs per slot (TTI); one PDCP PDU may be included in more than one slot (TTI)	
MacPdu	<a href="#">NR_MAC_PDUList_Type</a>	SS configuration: RLC TM mode, MAC no header removal (PDCP is not configured)
RlcPdu	<a href="#">NR_RLC_PDUList_Type</a>	SS configuration: RLC TM mode, MAC header removal (PDCP is not configured)
RlcSdu	<a href="#">NR_RLC_SDUList_Type</a>	SS configuration: RLC UM mode with no PDCP
PdcpPdu	<a href="#">NR_PDCP_PDUList_Type</a>	SS configuration: RLC AM/UM mode, no handling of PDCP header
PdcpSdu	<a href="#">NR_PDCP_SDUList_Type</a>	SS configuration: RLC AM/UM mode, PDCP normal mode (automatic handling of PDCP header)
SdapPdu	<a href="#">SDAP_PDUList_Type</a>	SS configuration: RLC AM/UM mode, PDCP normal mode (automatic handling of PDCP header), no handling of SDAP header
SdapSdu	<a href="#">SDAP_SDUList_Type</a>	SS configuration: RLC AM/UM mode, PDCP normal mode (automatic handling of PDCP header), automatic handling of SDAP header

## NR\_HarqProcessAssignment\_Type

TTCN-3 Union Type		
Name	<b>NR_HarqProcessAssignment_Type</b>	
Comment	in DL the HARQ process id may be specified by the test case or automatically assigned by SS	
Id	<a href="#">NR_HarqProcessId_Type</a>	HARQ process as specified by the test case NOTE1: the scope of this type is only for data being sent in one slot (TTI); if data needs more than one slot (TTI) the HarqProcessId is undefined for the 2nd TTI onward what shall be handled as an error at the SS; SS may send a SYSTEM_IND indicating an error in this case; NOTE2: The initial value of the NDI shall be the same for all HARQ processes and cells
Automatic	<a href="#">Null_Type</a>	HARQ process id automatically assigned by SS

## D.2.2.2 Downlink

## NR\_DRB\_DataPerSlot\_DL\_Type

TTCN-3 Record Type			
<b>Name</b>	<b>NR_DRB_DataPerSlot_DL_Type</b>		
<b>Comment</b>	<p>common definition for one or several PDUs/SDUs;  in NR the DL data is sent in the slot given by the slot offset  NOTE 1:  For MAC and RLC PDUs a single PDU is always sent in one slot;  SS shall raise an error indication (using SYSTEM_IND) when that is not possible  NOTE 2:  For PDCP the data may be spread over more than one slot (segmented by the RLC);  the TTCN implementation is responsible to calculate appropriate offsets accordingly;  the exact timing depends on (and is exactly specified by) configuration of the DL scheduling;  SS shall raise an error when there is any conflict</p>		
SlotOffset	integer		<p>NR:  Slot offset relative to the absolute timing information given in the common part of the ASP;  NOTE:  if a PDCP PDU or SDU takes more than one slot, SlotOffset specifies the first slot (TTI)</p>
HarqProcess	<a href="#">NR_HarqProcessAssignment_Type</a>	opt	<p>HARQ process to be used: specific value or automatically assigned by SS;  in automatic mode SS chooses HARQ process out of the set configured by CcchDcchDtchConfigDL_Type.HarqProcessConfig  NOTE:  for PDCP SDUs or PDUs automatic mode shall be used;  otherwise SS shall raise an error</p>
PduSduList	<a href="#">NR_L2DataList_Type</a>		list of PDUs/SDUs to be sent in one slot (TTI)

## NR\_DRB\_DataPerSlotList\_DL\_Type

TTCN-3 Record of Type			
<b>Name</b>	<b>NR_DRB_DataPerSlotList_DL_Type</b>		
<b>Comment</b>	<p>list of user plane data to be sent in slots given by list the SlotOffset in the single elements of the list;  Timing:  the start time for the whole sequence is given by the timing info of the ASP (common information);  the timing for the respective data pdus is given by the SlotOffset relative to the common timing info;  design consideration:  repetitions of this sequence are not foreseen  (in which case the slot offset could not be related to the timing info of the ASP)</p>		
record of <a href="#">NR_DRB_DataPerSlot_DL_Type</a>			

## NR\_L2Data\_Request\_Type

TTCN-3 Record Type			
<b>Name</b>	<b>NR_L2Data_Request_Type</b>		
<b>Comment</b>	NOTE: formal type definition to allow later enhancements		
SlotDataList	<a href="#">NR_DRB_DataPerSlotList_DL_Type</a>		

### D.2.2.3 Uplink

#### NR\_DRB\_DataPerSlot\_UL\_Type

TTCN-3 Record Type			
<b>Name</b>	<b>NR_DRB_DataPerSlot_UL_Type</b>		
<b>Comment</b>	common definition for one or several PDUs/SDUs being received in one slot or to receive one PDCP PDU or SDU being spread over more than one slot (TTI); NOTE: There is a fix relation between HARQ process id and slot in UL => it is not necessary to include HARQ process id for UL data		
PduSduList	<a href="#">NR_L2DataList_Type</a>		list of PDUs/SDUs being received in one TTI; elements of the list appear in the same order as the PDUs/SDUs in the MAC PDU; for PDCP when a PDU or SDU takes more than one TTI the list only contains this PDU or SDU
NoOfTTIs	integer		in case of PDCP: number of TTIs the SDU or PDU has taken NOTE 1: for the time being the NoOfTTIs is not checked by TTCN-3 and may be set to 1 by SS; NOTE 2: the timing info in common part of the ASP refers to the last TTI NOTE 3: when NoOfTTIs > 1 => PduSduList shall only contain one PDCP PDU or SDU in case of MAC or RLC PDUs: NoOfTTIs shall always be 1

#### NR\_L2Data\_Indication\_Type

TTCN-3 Record Type			
<b>Name</b>	<b>NR_L2Data_Indication_Type</b>		
<b>Comment</b>	NOTE: formal type definition to allow later enhancements; L2Data_Indication_Type defines data being received in a single slot i.e. PDUs of subsequent TTIs are indicated in separated ASPs		
SlotData	<a href="#">NR_DRB_DataPerSlot_UL_Type</a>		



## D.2.3 System\_Interface

## NR\_DRB\_COMMON\_REQ

TTCN-3 Record Type			
Name	NR_DRB_COMMON_REQ		
Comment	common ASP to send PDUs to DRBs		
Common	<a href="#">NR_ReqAspCommonPart_Type</a>		<p>CellId : identifier of the cell</p> <p>RoutingInfo : QosFlow when SDAP is configured in non-transparent mode at the SS, else DRB id</p> <p>RlcBearerRouting : TTCN provides the id of the cell hosting the RLC bearer, which the SS shall use to send the data out to the UE (for non-split bearers in general same as CellId)</p> <p>MacBearerRouting : If MAC is configured in non-transparent mode and NR CA is configured, TTCN provides the id of the cell hosting the physical layer, which the SS shall use to send the data out to the UE. Else 'omit'</p> <p>TimingInfo : starting point when to start sending sequence of data PDUs</p> <p>e.g.</p> <p>SFN = X, subframe number = x; slot number = slot_i depending on numerology</p> <p>U_Plane.SubframeDataList[i].SlotOffset := offset_i; =&gt; U_Plane.SubframeDataList[0].PduSduList shall be sent out at (X, x, i)</p> <p>U_Plane.SubframeDataList[i].PduSduList shall be sent out offset_i slots after U_Plane.SubframeDataList[0].PduSduList (depending on the numerology)</p> <p>NOTE: In case of K0&gt;0 (K0 according to 38.214 clause 5.1.2.1) the timing specifies the PDCCH assignment (rather than the PDSCH transmission)</p> <p>ControllInfo : CnfFlag:=false; FollowOnFlag:=false</p>
U_Plane	<a href="#">NR_L2Data_Request_Type</a>		
SuppressPdcch ForC_RNTI	<a href="#">Null_Type</a>	opt	<p>By default all DRB_COMMON_REQ scheduled DL PDU's are associated with an appropriate explicit configured or SS selected DL assignment allocation on PDCCH.</p> <p>For SuppressPdcch:=true in the sub frame in which DL PDU's are transmitted, there is no associated DL assignment allocation for configured C-RNTI. This will be used for SPS assignment based transmission or in any error scenarios;</p> <p>NOTE: this flag has no impact on PDCCH messages required for SPS activation</p>

## NR\_DRB\_COMMON\_IND

TTCN-3 Record Type	
Name	NR_DRB_COMMON_IND
Comment	common ASP to receive PDUs from DRBs
Common	<p><a href="#">NR_IndAspCommonPart_Type</a></p> <p>CellId : identifier of the cell  RoutingInfo : QosFlow when SDAP is configured in non-transparent mode at the SS, else DRB id  RoutingInfoSUL : The SS shall include this field when data is received from SUL carrier. Else 'omit'.  RlcBearerRouting : The SS shall provide the id of the cell hosting the RLC bearer in which the data has been received from the UE  MacBearerRouting : If MAC is configured in non-transparent mode and NR CA is configured, the SS shall provide the id of the cell hosting the physical layer in which the data has been received from the UE. Else 'omit'  TimingInfo : time when message has been received  NOTE 1:  For MAC and RLC PDUs per definition L2Data_Indication_Type corresponds to exactly one slot  =&gt; TimingInfo refers to this slot  NOTE 2:  For PDCP a single PDU or SDU may take more than one TTI  =&gt; TimingInfo refers to the end of the PDU/SDU and the length is given by NoOfTTIs in L2Data_Indication_Type (the end of the PDU/SDU is the last RLC PDU being received; in case of retransmissions this is not necessarily the RLC PDU with the last SN)</p>
U_Plane	<a href="#">NR_L2Data_Indication_Type</a>

## NR\_DRB\_PORT

TTCN-3 Port Type	
Name	NR_DRB_PORT
Comment	
out	<a href="#">NR_DRB_COMMON_REQ</a>
in	<a href="#">NR_DRB_COMMON_IND</a>

---

## D.3 NR\_ASP\_SrbDefs

### D.3.1 SRB\_DATA\_ASPs

ASP Definitions to send/receive peer-to-peer messages on SRBs

## NR\_C\_Plane\_Request\_Type

TTCN-3 Record Type			
<b>Name</b>	<b>NR_C_Plane_Request_Type</b>		
<b>Comment</b>	RRC and/or NAS PDU to be send to the UE; Note: it may be necessary to allow more than one NAS PDU (-> "record of")		
Rrc	<a href="#">NR_RRC_MSG_Request_Type</a>	opt	omit: NAS message shall be present; NAS message shall be sent in DLInformationTransfer present: if NAS message is present also, (piggybacked) NAS PDU shall be security protected (if necessary) and inserted in RRC PDU's DedicatedInfoNAS
Nas	NG_NAS_MSG_RequestList_Type	opt	omit: RRC message shall be present; RRC message does not contain (piggybacked) NAS PDU present: if RRC message is omitted => NAS message shall be sent embedded in DLInformationTransfer if RRC message is present => NAS message is piggybacked in RRC message in case of RRC message is sent on CCCH, NAS message shall be omitted

## NR\_C\_Plane\_Indication\_Type

TTCN-3 Record Type			
<b>Name</b>	<b>NR_C_Plane_Indication_Type</b>		
<b>Comment</b>	RRC and/or NAS PDU to be received from the UE; Note: it may be necessary to allow more than one NAS PDU (-> "record of")		
Rrc	<a href="#">NR_RRC_MSG_Indication_Type</a>	opt	omit: NAS message shall be present; NAS message is received in ULInformationTransfer present: if NAS message is present also, DedicatedInfoNAS contains unstructured and ciphered NAS message and the NAS message is the deciphered message in structured format
Nas	NG_NAS_MSG_IndicationList_Type	opt	omit: RRC message shall be present; RRC message does not contain (piggybacked) NAS PDU present: if RRC message is omitted => NAS message has been received in ULInformationTransfer if RRC message is present => NAS message has been piggybacked in RRC message NOTE: even though currently (DEC 08 ASN.1) there is no RRC PDU in UL containing more than one DedicatedInfoNAS we provide a list to allow extendability

## NR\_SRB\_COMMON\_REQ

TTCN-3 Record Type		
Name	NR_SRB_COMMON_REQ	
Comment	common ASP to send PDUs to SRB0, SRB1 or SRB2	
Common	<a href="#">NR_ReqAspCommonPart_Type</a>	<p>CellId : identifier of the cell  RoutingInfo : SRB0, SRB1, SRB2, SRB3  RlcBearerRouting : TTCN provides the id of the cell hosting the RLC bearer which the SS shall use to send the data out to the UE (for non-split bearers in general same as CellId)  MacBearerRouting : If MAC is configured in non-transparent mode and NR CA is configured, TTCN provides the id of the cell hosting the physical layer, which the SS shall use to send the data out to the UE. Else 'omit'  TimingInfo : Now in normal cases;  For latency tests TimingInfo can be set to the SFN/subframe in which the RRC messages shall be sent out (in this case and if the RRC PDU is too long to be sent in one TTI the TimingInfo corresponds to the first TTI)  ControllInfo  CnfFlag:=false;  FollowOnFlag  true: Indicates that the message(s) to be sent on the same TTI will follow  NOTE 1: When FollowOnFlag is true, TimingInfo shall always be "Now". Otherwise SS shall produce an error  NOTE 2: the FollowOnFlag applies only for messages of the same SRB  false: Indicates that no more message(s) will follow</p>
Signalling	<a href="#">NR_C Plane Request Type</a>	

## NR\_SRB\_COMMON\_IND

TTCN-3 Record Type		
Name	NR_SRB_COMMON_IND	
Comment	common ASP to receive PDUs from SRB0, SRB1 or SRB2	
Common	<a href="#">NR_IndAspCommonPart_Type</a>	<p>CellId : identifier of the cell  RoutingInfo : SRB0, SRB1, SRB2, SRB3  RoutingInfoSUL : The SS shall include this field when data is received from SUL carrier. Else 'omit'.  RlcBearerRouting : The SS shall provide the id of the cell hosting the RLC bearer in which the data has been received from the UE  MacBearerRouting : If MAC is configured in non-transparent mode and NR CA is configured, the SS shall provide the id of the cell hosting the physical layer in which the data has been received from the UE. Else 'omit'  TimingInfo : time when message has been received (as received from the SS by the NAS emulator)</p>
Signalling	<a href="#">NR_C Plane Indication Type</a>	

## D.3.2 Port\_Definitions

### NR\_SRB\_PORT

TTCN-3 Port Type	
<b>Name</b>	<b>NR_SRB_PORT</b>
<b>Comment</b>	NR PTC: Port for Sending/Receiving data on SRBs
out	<a href="#">NR_SRB_COMMON_REQ</a>
in	<a href="#">NR_SRB_COMMON_IND</a>

### NASEMU\_NR\_SRB\_PORT

TTCN-3 Port Type	
<b>Name</b>	<b>NASEMU_NR_SRB_PORT</b>
<b>Comment</b>	NASEMU PTC: Port for Sending/Receiving data on SRBs (interface to NR PTC)
out	<a href="#">NR_SRB_COMMON_IND</a>
in	<a href="#">NR_SRB_COMMON_REQ</a>

## D.4 NR\_CommonDefs

### D.4.1 Common\_Types

#### Common\_Types: Basic Type Definitions

TTCN-3 Basic Types		
<b>NR_HarqProcessId_Type</b>	integer	HARQ process id; NOTE: there seems to be no need for any value restriction
<b>NR_AbsoluteCellPower_Type</b>	integer (-150..0)	absolute cell power (dBm)

#### NR\_RRC\_MSG\_Request\_Type

TTCN-3 Union Type	
<b>Name</b>	<b>NR_RRC_MSG_Request_Type</b>
<b>Comment</b>	DL RRC PDU on CCCH or DCCH
Cch	DL_CCCH_Message
Dch	DL_DCCH_Message

#### NR\_RRC\_MSG\_Indication\_Type

TTCN-3 Union Type	
<b>Name</b>	<b>NR_RRC_MSG_Indication_Type</b>
<b>Comment</b>	UL RRC PDU on CCCH or DCCH
Cch	UL_CCCH_Message
Cch1	UL_CCCH1_Message
Dch	UL_DCCH_Message

#### NR\_HarqProcessList\_Type

TTCN-3 Record of Type	
<b>Name</b>	<b>NR_HarqProcessList_Type</b>
<b>Comment</b>	list of HARQ processes: each element shall be unique; NOTE: there seems to be no need for any length restriction
record of <a href="#">NR_HarqProcessId_Type</a>	

## D.4.2 RRC\_Nested\_Types

### RRC\_Nested\_Types: Basic Type Definitions

TTCN-3 Basic Types		
NR_PrioritizedBitRate_Type	LogicalChannelConfig.ul_SpecificParameters.prioritisedBitRate	
NR_SiPeriodicity_Type	SchedulingInfo.si_Periodicity	
NR_SiWindowLength_Type	SI_SchedulingInfo.si_WindowLength	

## D.4.3 ASP\_CommonPart

Definition of ASP common parts for REQ-, CNF- and IND-ASPs

### D.4.3.1 ASP\_CommonPart\_Definitions

#### D.4.3.1.1 Routing\_Info

#### Routing\_Info: Basic Type Definitions

TTCN-3 Basic Types		
NR_RoutingInfoSUL_Type	<a href="#">Null_Type</a>	

#### NR\_RadioBearerId\_Type

TTCN-3 Union Type		
Name	NR_RadioBearerId_Type	
Comment		
Srb	<a href="#">SRB_Identity_Type</a>	
Drb	DRB_Identity	

#### NR\_RoutingInfo\_Type

TTCN-3 Union Type		
Name	NR_RoutingInfo_Type	
Comment		
None	<a href="#">Null_Type</a>	
RadioBearerId	<a href="#">NR_RadioBearerId_Type</a>	routing of signalling and user plane data when SDAP is not configured at the SS for the DRB or it is configured in transparent mode
QosFlow	<a href="#">QosFlow_Identification_Type</a>	routing of user plane data with SDAP being configured in non-transparent mode at the SS

#### MacBearerRouting\_Type

TTCN-3 Record Type		
Name	MacBearerRouting_Type	
Comment	Physical layer cell data routing. Applicable for NR CA, multi-RAT Dual Connectivity (MR-DC) with NR CA as well as single-RAT Dual Connectivity with NR CA	
NR	<a href="#">NR_CellId_Type</a>	

### D.4.3.2 REQ\_ASP\_CommonPart

#### NR\_ReqAspCommonPart\_Type

TTCN-3 Record Type			
Name	NR_ReqAspCommonPart_Type		
Comment			
CellId	<a href="#">NR_CellId_Type</a>		
RoutingInfo	<a href="#">NR_RoutingInfo_Type</a>		
RlcBearerRouting	<a href="#">RlcBearerRouting_Type</a>		
MacBearerRouting	<a href="#">MacBearerRouting_Type</a>	opt	
TimingInfo	<a href="#">TimingInfo_Type</a>		
ControllInfo	<a href="#">ReqAspControllInfo_Type</a>		

### D.4.3.3 CNF\_ASP\_CommonPart

#### NR\_CnfAspCommonPart\_Type

TTCN-3 Record Type			
Name	NR_CnfAspCommonPart_Type		
Comment			
CellId	<a href="#">NR_CellId_Type</a>		
RoutingInfo	<a href="#">NR_RoutingInfo_Type</a>		
TimingInfo	<a href="#">TimingInfo_Type</a>		
Result	<a href="#">ConfirmationResult_Type</a>		

### D.4.3.4 IND\_ASP\_CommonPart

#### NR\_IndAspCommonPart\_Type

TTCN-3 Record Type			
Name	NR_IndAspCommonPart_Type		
Comment			
CellId	<a href="#">NR_CellId_Type</a>		
RoutingInfo	<a href="#">NR_RoutingInfo_Type</a>		
RoutingInfoSUL	<a href="#">NR_RoutingInfoSUL_Type</a>	opt	
RlcBearerRouting	<a href="#">RlcBearerRouting_Type</a>		
MacBearerRouting	<a href="#">MacBearerRouting_Type</a>	opt	
TimingInfo	<a href="#">TimingInfo_Type</a>		
Status	<a href="#">IndicationStatus_Type</a>		

## D.5 IP\_ASP\_TypeDefs

General Notes:

NOTE 1:

In general the handling of IP data shall be independent from the RAT being used on lower layers.

NOTE 2:

It shall be possible for SS implementation to reuse existing IP stack implementations in the system adaptor; therefore the well-known concept of socket programming shall be supported (regardless of whether those are used in the system adaptor implementation or not)

NOTE 3:

Since in general at the network side there are several different IP addresses the SS needs to simulate more than one IP

address;  
that can be based on a concept of multiple virtual network adaptors

NOTE 4:

There is no easy way to control the routing of IP data for an IP connection from above the IP stack  
i.e. there are no parameters at the socket interface to determine e.g. cell id and DRB id  
=> another independent logical entity (DRB-MUX) is needed below the IP stack which is responsible to control the routing of IP packets from/to DRBs in different cells of different RATs

Reference:

An introduction to socket programming can be found in  
UNIX Network Programming Volume 1, Third Edition: The Sockets Networking API  
by W. Richard Stevens, Bill Fenner, Andrew M. Rudoff

## D.5.1 IP\_Common

### IP\_Common: Basic Type Definitions

TTCN-3 Basic Types	
PortNumber_Type	<a href="#">UInt16_Type</a>

#### IPv4\_AddrInfo\_Type

TTCN-3 Record Type	
Name	<b>IPv4_AddrInfo_Type</b>
Comment	IPv4 specific info of the socket addr (AF_INET)
Addr	charstring
	IP Address as string (IP v4 dot notation) to be converted to 32-bit unsigned integer

#### IPv6\_AddrInfo\_Type

TTCN-3 Record Type	
Name	<b>IPv6_AddrInfo_Type</b>
Comment	IPv6 specific info of the socket addr (AF_INET6); NOTE: sin6_flowinfo can be ignored and set to 0
Addr	charstring
Scopeld	<a href="#">UInt32_Type</a> opt
	to be converted to sin6_addr sin6_scope_id in general an IPv6 address is like "fe80::1%eth0" with eth0 being the network adaptor mapped to a scope id (Unix) assumption: for UE conformance testing it is not necessary to distinguish different scopes and the scope id in general can be determined by the system adaptor => omit

#### IP\_AddrInfo\_Type

TTCN-3 Union Type	
Name	<b>IP_AddrInfo_Type</b>
Comment	
V4	<a href="#">IPv4_AddrInfo_Type</a>
V6	<a href="#">IPv6_AddrInfo_Type</a>

#### IP\_Socket\_Type

TTCN-3 Record Type	
Name	<b>IP_Socket_Type</b>
Comment	Socket
IpAddr	<a href="#">IP_AddrInfo_Type</a> opt
Port	<a href="#">PortNumber_Type</a> opt
	IP address
	port number



### InternetProtocol\_Type

TTCN-3 Enumerated Type	
Name	InternetProtocol_Type
Comment	
udp	
tcp	
icmp	
icmpv6	

### IP\_Connection\_Type

TTCN-3 Record Type			
Name	IP_Connection_Type		
Comment	A connection between peer-to-peer entities is unambiguously defined by the protocol (udp/tcp/icmp/icmpv4), the local socket and the remote socket		
Protocol	<a href="#">InternetProtocol_Type</a>		
Local	<a href="#">IP_Socket_Type</a>	opt	
Remote	<a href="#">IP_Socket_Type</a>	opt	

## D.5.2 IP\_Config

Configuration of the routing table managed by the system adaptor's DRB-MUX:

foreach IP connection it is specified which

- RAT
- Cell
- DRB

to be used.

The IP connection does not need to be fully specified depending on the role SS plays (e.g. in case of a server role the port number of the remote side is not known in advance).

The configurations of DRBs within the same cell shall be mutual exclusive.

With the configuration of the IP routing the DRB is configured either in IP or in raw mode:

either there are entries for the DRB in the routing table (IP mode) or not (raw mode)

=> It is not necessary to reconfigure this for the respective RAT.

Behaviour of the DRB-MUX in UL:

- SS gets data packet from the lower layers (e.g. PDCP SDU)
- SS checks whether there is any IP connection configured for this DRB (identified by {RAT, CellId, DrbId})
  - if YES => packet is routed to the IP stack (IP mode)
  - if NO => packet is handed over to the DRB port (raw mode)

NOTE 1:

If there is any entry for a DRB in the routing table this DRB is considered as being in IP mode and all UL IP packets are sent to the IP stack regardless of whether their addresses match the DRB's routing entries or not (in general 'unknown' packets are discarded by the IP stack)

=> a DRB can be either in IP or in raw mode

NOTE 2:

=> The SS does not need to evaluate any IP headers to decide whether data shall be routed to the DRB port or to the IP stack (i.e. there is no conflict with unstructured loopback data)

Behaviour of the DRB-MUX in DL:

- SS gets IP packets from the IP stack for an IP connection
- SS compares the IP connection (protocol, local/remote IP Addr) against the IP routing table and checks whether the corresponding protocol stack is configured at the lower layers =>

1. no match:

no entry in the routing table fits to the address in the IP packet  
or the corresponding RB is not configured

=> SS shall raise an error (DRBMUX\_COMMON\_IND\_CNF.Error)

2. one match:

There is exactly one possibility to route the IP packet

=> SS shall send the packet to this RB

3. several matches:

There are more than one DRBs, cells or RATs to which the packet may be routed

=> SS shall raise an error if there is more than one DRB in one cell matching;  
if the DRBs belong to different cells or RATs SS shall send the data to all of them  
(whether this may occur in test cases is FFS)

General notes:

NOTE 1:

SS may use the information of the routing table to determine which network adaptors it needs to simulate (implementation dependent);

in general there will be more than one IP address at the network side.

NOTE 2:

In general the routing table is a simplified DL TFT implementation

NOTE 3:

When the routing table is empty all DRBs are in raw mode; this shall be the initial condition at the DRB-MUX;

=> for L2 testing in general (and apart from the preamble) there is no need to use/configure the IP\_PTC; the configuration of the RAT specific U-plane stacks is not affected

### IP\_DataMode\_Type

TTCN-3 Enumerated Type	
Name	IP_DataMode_Type
Comment	
discard	
loopbackRTP	
loopbackRTCP	
IPsecTunnel	

**IP\_RoutingInfo\_Type**

TTCN-3 Record Type			
Name	IP_RoutingInfo_Type		
Comment			
IpInfo	<a href="#">IP_Connection_Type</a>		<p>IP connection tuple: protocol, local socket, remote socket depending on the role the SS plays the following information may be provided (informative; even less information can be sufficient):</p> <ol style="list-style-type: none"> <li>1. TCP/UDP server                     <ul style="list-style-type: none"> <li>- local IP addr -- provided</li> <li>- local port -- provided</li> <li>- remote IP addr -- omit</li> <li>- remote port -- omit</li> </ul> </li> <li>2. TCP/UDP client                     <ul style="list-style-type: none"> <li>- local IP addr -- provided (to inform SS about the local IP addr for this service)</li> <li>- local port -- omit; for UDP a well-defined port may be defined (protocol dependent, e.g. DHCP)</li> <li>- remote IP addr -- provided</li> <li>- remote port -- provided</li> </ul> </li> <li>3. ICMP (in general ICMP may be mapped only to a single DRB)                     <ul style="list-style-type: none"> <li>- local IP addr -- provided (to inform SS about the local IP addr for this service)</li> <li>- local port -- n/a (shall be set to omit)</li> <li>- remote IP addr -- omit</li> <li>- remote port -- n/a (shall be set to omit)</li> </ul> </li> </ol> <p>NOTE: In case of broadcasts in UL the broadcast address shall match any local IP address; in DL for broadcast services typically no remote IP address is specified in the routing table</p>
DRB	<a href="#">IP_DrbInfo_Type</a>		
DataMode	<a href="#">IP_DataMode_Type</a>	opt	present when IP packets matching this entry shall be discarded or be looped back to the UE as defined for RTP or RTCP

**IP\_RoutingTable\_Type**

TTCN-3 Record of Type	
Name	IP_RoutingTable_Type
Comment	NOTE: configurations of DRBs within the same cell shall be mutual exclusive
record of <a href="#">IP_RoutingInfo_Type</a>	

**D.5.3 IPsec\_Config**

**IP\_ASP\_TypeDefs: Constant Definitions**

TTCN-3 Basic Types			
tsc_IPsec_SPI_Max	integer	4294967295	

**IPsec\_Config: Basic Type Definitions**

TTCN-3 Basic Types		
IPsec_SPI_Type	integer (0.. <a href="#">tsc_IPsec_SPI_Max</a> )	security parameter index for IPsec; According to RFC 2406, SPI values from 0 to 255 are reserved

**IPsec\_IntegrityAlgorithm\_Type**

TTCN-3 Enumerated Type	
Name	<b>IPsec_IntegrityAlgorithm_Type</b>
Comment	
hmac_md5_96	
hmac_sha_1_96	

**IPsec\_CipheringAlgorithm\_Type**

TTCN-3 Enumerated Type	
Name	<b>IPsec_CipheringAlgorithm_Type</b>
Comment	
des_ed3_cbc	
aes_cbc	
nociph	no ciphering

**IPsec\_SecurityKeys\_Type**

TTCN-3 Record Type			
Name	<b>IPsec_SecurityKeys_Type</b>		
Comment	to install the security keys		
MD5_96Key	bitstring length (128)		
SHA_1_96Key	bitstring length (160)		
DES_EDE3_C BCKey	bitstring length (192)		
AES_CBCKey	bitstring length (128)		

**IPsec\_SecurityAssociation\_Type**

TTCN-3 Record Type			
Name	<b>IPsec_SecurityAssociation_Type</b>		
Comment	single security association (SA); for configuration of an SA at the SS all fields are mandatory; to release an SA the optional information is omitted		
SPI	<a href="#">IPsec_SPI_Type</a>		
SrcAddress	charstring		
DestAddress	charstring		
SrcPort	<a href="#">UInt16_Type</a>		
DestPort	<a href="#">UInt16_Type</a>		
IntegrityAlgorith m	<a href="#">IPsec_IntegrityAlgorithm_T ype</a>	opt	mandatory to set-up an SA
CipheringAlgori thm	<a href="#">IPsec_CipheringAlgorithm_ Type</a>	opt	mandatory to set-up an SA

**IPsec\_SecurityAssociationList\_Type**

TTCN-3 Record of Type	
Name	<b>IPsec_SecurityAssociationList_Type</b>
Comment	
	record of <a href="#">IPsec_SecurityAssociation_Type</a>

**IPsec\_Configure\_Type**

TTCN-3 Record Type	
<b>Name</b>	<b>IPsec_Configure_Type</b>
<b>Comment</b>	add new security associations; existing SAs are not affected
SA_List	<a href="#">IPsec_SecurityAssociationList_Type</a>
SecurityKeys	<a href="#">IPsec_SecurityKeys_Type</a>

**IPsec\_Release\_Type**

TTCN-3 Record Type	
<b>Name</b>	<b>IPsec_Release_Type</b>
<b>Comment</b>	release security associations; NOTE: in context with multiple PDNs it cannot be ensured that all SPIs are unique; e.g. the UE may use the same SPI values in different PDNs in which case uniqueness cannot be achieved furthermore it depends on the system implementation how entries in the IPsec SAD and SPD are administrated => to release SAs the SS gets the same information as for configuration but without the security algorithms
SA_List	<a href="#">IPsec_SecurityAssociationList_Type</a>

## D.5.4 IP\_SocketHandling

Handling of IP data and IP connections

NOTE 1:

In general IP connections are distinguished by the tuple {protocol, local socket, remote socket}; this information is used at the interface between TTCN and the system adaptor.

It is up to the system adaptor implementation to associate the IP connection with the internal socket (file descriptor; implementation dependent)

NOTE 2:

In general the association of the IP connections to (internal) sockets and the routing table for the DRB mapping (as configured with IP\_RoutingTable\_Type) are independent from each other

### D.5.4.1 Socket\_Common

**IP\_SockOpt\_Type**

TTCN-3 Union Type	
<b>Name</b>	<b>IP_SockOpt_Type</b>
<b>Comment</b>	socket options acc. to the setsockopt system call (i.e. for level=SOL_SOCKET in case of Berkeley socket API); NOTE: only options being relevant for a specific applications (upon a socket) are configured by TTCN other options (e.g. SO_REUSEADDR) are out of TTCN and therefore a matter of system adaptor implementation
SO_BROADCAST	boolean set to true when IP broadcast messages shall be allowed for a port; this is required e.g. in case of DHCP
IP_MTU_SIZE	integer MTU size to be used for IP data; NOTES: - Even though the MTU size is defined as socket option it shall be the same for all sockets of a given interface (i.e. at least within one PDN the MTU size shall be the same) - in general a PIXIT is used as constant value for all sockets

**IP\_SockOptList\_Type**

TTCN-3 Record of Type	
<b>Name</b>	<b>IP_SockOptList_Type</b>
<b>Comment</b>	
record of <a href="#">IP_SockOpt_Type</a>	

**IP\_SocketError\_Type**

TTCN-3 Union Type		
<b>Name</b>	<b>IP_SocketError_Type</b>	
<b>Comment</b>	used to indicate errors related to sockets; the IP_Connection shall contain as much address information as available at the system adaptor	
InvalidAddress	<a href="#">Null_Type</a>	TTCN error: e.g. invalid or incomplete address information
System	integer	system error caused by system call; the integer value may be used for validation but shall not be evaluated by TTCN

**D.5.4.2 Socket\_Datagram**

**Socket\_Datagram: Basic Type Definitions**

TTCN-3 Basic Types		
<b>Datagram_Content_Type</b>	octetstring	data as sent/received with sendto()/recvfrom() on UDP or ICMP socket; NOTE: For ICMP the data may depend on the socket options; in general it does not include the IP header and the checksum of the ICMP packet needs to be calculated/checked in TTCN

**Datagram\_DL\_Type**

TTCN-3 Record Type		
<b>Name</b>	<b>Datagram_DL_Type</b>	
<b>Comment</b>	datagram to be sent at a UDP or ICMP socket	
Buffer	<a href="#">Datagram_Content_Type</a>	content of the IP packet

**Datagram\_UL\_Type**

TTCN-3 Record Type		
<b>Name</b>	<b>Datagram_UL_Type</b>	
<b>Comment</b>	datagram as received on a UDP or ICMP socket	
Buffer	<a href="#">Datagram_Content_Type</a>	content of the IP packet
DrbInfo	<a href="#">IP_DrbInfo_Type</a>	opt "interface id" where the data comes from in case of broadcast or multicast packets: for the LTE test model this is the DRB on which the IP packet has been received; the information is necessary when the SS cannot resolve an IP address being assigned to that DRB. => when the SS provides a broadcast or multicast address as local address in the ConnectionId of the ASP, the SS shall provide the DRB information in this field When the ConnectionId of the ASP is fully specified and unique (unicast address at least for local address) the DrbId is ignored by TTCN

### D.5.4.3 TCP\_Socket

TCP primitives used on the IP port

#### TCP\_Socket: Basic Type Definitions

TTCN-3 Basic Types		
TCP_Data_Type	octetstring	data as sent/received with send()/recv() on a TCP socket

#### InternetApplication\_Type

TTCN-3 Enumerated Type	
Name	InternetApplication_Type
Comment	as TCP is stream oriented SS may need information about which criteria to be applied to get start/end of an application message
ims	
http	

#### TLS\_CIPHER\_Type

TTCN-3 Enumerated Type	
Name	TLS_CIPHER_Type
Comment	Cipher suite to be used for TLS
TLS_PSK_WITH_RC4_128_SHA	RFC 4279
TLS_PSK_WITH_3DES_EDE_CBC_SHA	RFC 4279
TLS_PSK_WITH_AES_128_CBC_SHA	RFC 4279
TLS_PSK_WITH_AES_256_CBC_SHA	RFC 4279
TLS_PSK_WITH_AES_128_CBC_SHA256	RFC 5487
TLS_RSA_WITH_NULL_MD5	RFC 5246
TLS_RSA_WITH_NULL_SHA	RFC 5246
TLS_RSA_WITH_NULL_SHA256	RFC 5246
TLS_RSA_WITH_RC4_128_MD5	RFC 5246
TLS_RSA_WITH_RC4_128_SHA	RFC 5246
TLS_RSA_WITH_3DES_EDE_CBC_SHA	RFC 5246
TLS_RSA_WITH_AES_128_CBC_SHA	RFC 5246
TLS_RSA_WITH_AES_256_CBC_SHA	RFC 5246
TLS_RSA_WITH_AES_128_CBC_SHA256	RFC 5246
TLS_RSA_WITH_AES_256_CBC_SHA256	RFC 5246

## PSK\_BootstrappingInfo\_Type

TTCN-3 Record Type			
<b>Name</b>	<b>PSK_BootstrappingInfo_Type</b>		
<b>Comment</b>	bootstrapping information as defined in 24.109		
BTid	charstring		
Ks_NAF	bitstring		

## TLS\_PSK\_Info\_Type

TTCN-3 Record Type			
<b>Name</b>	<b>TLS_PSK_Info_Type</b>		
<b>Comment</b>	configuration information for PSK TLS		
IdentityHint	charstring		
BootstrappingInfo	<a href="#">PSK_BootstrappingInfo_Type</a>		

## TLS\_CipherSuiteInfo\_Type

TTCN-3 Union Type			
<b>Name</b>	<b>TLS_CipherSuiteInfo_Type</b>		
<b>Comment</b>			
psk	<a href="#">TLS_PSK_Info_Type</a>		

## TLSPSKInfo\_Type

TTCN-3 Record Type			
<b>Name</b>	<b>TLSPSKInfo_Type</b>		
<b>Comment</b>			
cipherSuite	<a href="#">TLS_CIPHER_Type</a>		Cipher suite to be used
cipherSuiteInfo	<a href="#">TLS_CipherSuiteInfo_Type</a>		parameters for the respective cipher suite

## TLSCertificateInfo\_Type

TTCN-3 Record Type			
<b>Name</b>	<b>TLSCertificateInfo_Type</b>		
<b>Comment</b>			
certificate	charstring		name or file location of the certificate to be used by the SS; in general provided by a PIXIT: the PIXIT contains the SS implementation specific information for the SS to identify the certificate to be used for a particular TLS connection; in case of only one certificate being used by TTCN, the string may be empty
cipherSuite	<a href="#">TLS_CIPHER_Type</a>		(non-PSK) cipher suite to be used for the TLS tunnel; the SS shall raise an error when it detects that the UE does not support the configured cipher suite

## TLSConfig\_Type

TTCN-3 Union Type			
<b>Name</b>	<b>TLSConfig_Type</b>		
<b>Comment</b>			
pskinfo	<a href="#">TLSPSKInfo_Type</a>		Used in the case of PSK
certificateInfo	<a href="#">TLSCertificateInfo_Type</a>		Used in the case of certificate based TLS



## TCP\_ConnectRequest\_Type

TTCN-3 Record Type			
<b>Name</b>	<b>TCP_ConnectRequest_Type</b>		
<b>Comment</b>	TCP client: -> 'connect' system call		
SockOptList	<a href="#">IP_SockOptList_Type</a>		when there are no options to configure the list is empty
Application	<a href="#">InternetApplication_Type</a>		to specify start/end criteria for application messages

## TCP\_Listen\_Type

TTCN-3 Record Type			
<b>Name</b>	<b>TCP_Listen_Type</b>		
<b>Comment</b>	TCP server: -> 'listen' system call		
SockOptList	<a href="#">IP_SockOptList_Type</a>		when there are no options to configure the list is empty
Application	<a href="#">InternetApplication_Type</a>		to specify start/end criteria for application messages
TLSConfig	<a href="#">TLSConfig_Type</a>	opt	to support TLS for HTTP server implementation

## TCP\_CtrlRequest\_Type

TTCN-3 Union Type		
Name	TCP_CtrlRequest_Type	
Comment		
ConnectReq	<a href="#">TCP_ConnectRequest_Type</a>	<p>request a 'connect' to a remote server</p> <p>system calls (informative)  socket -- get file descriptor  (setsockopt) -- normally not needed  bind -- assign local IP addr (to cope with multiple IP addresses) and dedicated port number (if local port is given)  connect -- connect to the client</p> <p>IP_Connection:  protocol -- tcp  local IP addr -- mandatory to distinguish different network adaptors  local port -- omit (ephemeral port will be assigned by the system) or specific port to be used for this connection (e.g. to bind a given port number to the IMS client)  remote IP addr -- mandatory  remote port -- mandatory</p>
Listen	<a href="#">TCP_Listen_Type</a>	<p>establish a server at the local (SS) side</p> <p>system calls (informative)  socket -- get file descriptor  (setsockopt) -- if needed  bind -- assign local IP addr and port  listen -- await incoming connection</p> <p>IP_Connection:  protocol -- tcp  local IP addr -- mandatory to distinguish different network adaptors  local port -- mandatory  remote IP addr -- omit  remote port -- omit</p>
Close	<a href="#">Null_Type</a>	<p>close a connection</p> <p>system calls (informative):  close</p> <p>IP_Connection:  protocol -- tcp  local IP addr -- mandatory  local port -- mandatory  remote IP addr -- mandatory for TCP connections, omit for TCP server  remote port -- mandatory for TCP connections, omit for TCP server</p>

## TCP\_DataRequest\_Type

TTCN-3 Union Type		
Name	TCP_DataRequest_Type	
Comment		
Send	<a href="#">TCP_Data_Type</a>	send data  system calls (informative): send or write  IP_Connection: protocol -- tcp local IP addr -- mandatory local port -- mandatory remote IP addr -- mandatory remote port -- mandatory

## TCP\_CtrlIndication\_Type

TTCN-3 Union Type		
Name	TCP_CtrlIndication_Type	
Comment		
ConnectCnf	<a href="#">Null_Type</a>	<p>confirm a 'connect' to a remote server</p> <p>system calls (informative): getsockname -- get local port (ephemeral port assigned by the system)</p> <p>IP_Connection: protocol -- tcp local IP addr -- mandatory (as in corresponding TCP_ConnectRequest) local port -- mandatory (if there is more than one connection to the same server the local port is necessary to distinguish the connections) remote IP addr -- mandatory (as in corresponding TCP_ConnectRequest) remote port -- mandatory (as in corresponding TCP_ConnectRequest)</p>
Accept	<a href="#">Null_Type</a>	<p>sent by the SS when it 'accepts' an incoming connection</p> <p>system calls (informative): accept</p> <p>IP_Connection: protocol -- tcp local IP addr -- mandatory (as in corresponding TCP_ListenRequest) local port -- mandatory (as in corresponding TCP_ListenRequest) remote IP addr -- mandatory (as gotten from 'accept') remote port -- mandatory (as gotten from 'accept')</p>
Close	<a href="#">Null_Type</a>	<p>indicate 'close' by the remote side</p> <p>system calls (informative): indicated by recv or read</p> <p>IP_Connection: protocol -- tcp local IP addr -- mandatory local port -- mandatory remote IP addr -- mandatory remote port -- mandatory</p>
CloseCnf	<a href="#">Null_Type</a>	<p>Confirmation for 'close' request; necessary since for TCP there are IP packets to release the connection</p> <p>system calls (informative): close</p> <p>IP_Connection: protocol -- tcp local IP addr -- mandatory local port -- mandatory remote IP addr -- mandatory for TCP connections, omit for TCP server remote port -- mandatory for TCP connections, omit for TCP server</p>

**TCP\_DataIndication\_Type**

TTCN-3 Union Type		
Name	<b>TCP_DataIndication_Type</b>	
Comment		
Recv	<a href="#">TCP_Data_Type</a>	receive data  system calls (informative): recv or read  IP_Connection: protocol -- tcp local IP addr -- mandatory local port -- mandatory remote IP addr -- mandatory remote port -- mandatory

**D.5.4.4 UDP\_Socket**

UDP primitives used on the IP port

NOTE:

In principle a UDP socket may communicate with different remote entities;  
 therefore the system adaptor may associate the socket handle with the local socket only  
 (local IP address and local port)

**UDP\_SocketReq\_Type**

TTCN-3 Record Type		
Name	<b>UDP_SocketReq_Type</b>	
Comment	to establish a UDP server or to bind local port number	
SockOptList	<a href="#">IP_SockOptList_Type</a>	e.g. to allow broadcast messages; when there are no options to configure the list is empty

## UDP\_CtrlRequest\_Type

TTCN-3 Union Type		
Name	UDP_CtrlRequest_Type	
Comment		
SocketReq	<a href="#">UDP_SocketReq_Type</a>	<p>request the system adaptor to bind a socket to a local address; this is needed in general when the system adaptor acts as</p> <ol style="list-style-type: none"> <li>1. UDP server</li> <li>2. UDP client when it uses a well-known port rather than an ephemeral port (this is e.g. for DHCP)</li> <li>3. UDP client when a local address needs to be bond (e.g. when there are several local addresses)</li> </ol> <p>system calls (informative):  socket -- get file descriptor  (setsockopt) -- needed e.g. to allow broad cast message  bind -- assign local IP address (to cope with multiple IP addresses) and local port (in case of well-known local port)</p> <p>IP_Connection:  protocol -- udp  local IP addr -- mandatory (to distinguish multiple IP addresses)  local port -- optional (mandatory in case of a UDP server)  remote IP addr -- omit  remote port -- omit</p>
Close	<a href="#">Null_Type</a>	<p>release local socket</p> <p>system calls (informative):  close</p> <p>IP_Connection:  protocol -- udp  local IP addr -- mandatory (to identify local socket)  local port -- mandatory (to identify local socket)  remote IP addr -- omit  remote port -- omit</p>

## UDP\_DataRequest\_Type

TTCN-3 Union Type		
Name	UDP_DataRequest_Type	
Comment		
SendTo	<a href="#">Datagram_DL_Type</a>	<p>send data to (any) remote socket;</p> <p>NOTE:  To simplify implementation of the system adaptor the local socket shall be bond in any case (using 'SocketReq') to specify the local IP address before sending data;  (in general the sendto system call can be used without explicitly binding the socket before;  in this case the port gets implicitly bond to an ephemeral port and the default IP address is used)</p> <p>system calls (informative):  sendto</p> <p>IP_Connection:  protocol -- udp  local IP addr -- mandatory (to identify local socket)  local port -- mandatory (to identify local socket)  remote IP addr -- mandatory (to address remote socket)  remote port -- mandatory (to address remote socket)</p>

## UDP\_CtrlIndication\_Type

TTCN-3 Union Type		
Name	UDP_CtrlIndication_Type	
Comment		
SocketCnf	<a href="#">Null_Type</a>	<p>confirm 'SocketReq' and tell TTCN about assignment of ephemeral port;</p> <p>system calls (informative):  getsockname -- get local port (ephemeral port assigned by the system; not needed if local port is well-known)</p> <p>IP_Connection:  protocol -- udp  local IP addr -- mandatory  local port -- mandatory (well-known or ephemeral port assigned by the system)  remote IP addr -- omit  remote port -- omit</p>

## UDP\_DataIndication\_Type

TTCN-3 Union Type		
Name	UDP_DataIndication_Type	
Comment		
RecvFrom	<a href="#">Datagram_UL_Type</a>	<p>receive data;</p> <p>system calls (informative):  recvfrom -- get data and src addr</p> <p>IP_Connection:  protocol -- udp  local IP addr -- mandatory (see note)  local port -- mandatory  remote IP addr -- mandatory (as gotten from recvfrom)  remote port -- mandatory (as gotten from recvfrom)</p> <p>NOTE:  The UE may send a UDP packet as broadcast (IP Addr 255.255.255.255 - e.g. in case of DHCP) or multicast (e.g. ICMPv6)  SS shall consider a broadcast address as matching every IP for UL and DL;  the SS shall not replace the broadcast/multicast address by the local unicast address, but shall provide DRB information in RecvFrom;  example:  - SS gets DHCPDISCOVER with  DEST_Addr=255.255.255.255 DEST_Port=67,  SRC_Addr=0.0.0.0 SRC_Port=68  - TTCN gets DHCPDISCOVER with local  Addr=(255.255.255.255 Port=67), remote Addr=(0.0.0.0 Port=68), Drbld=(LTE, cell1, DRB1)  - TTCN sends DHCPOFFER with local Addr=(local IP Addr Port=67), remote Addr=(255.255.255.255 Port=68)</p>

## D.5.4.5 ICMP\_Socket

ICMP primitives used on the IP port

NOTE:

the local side is identified by the protocol and in general by the local IP address

**ICMP\_SocketReq\_Type**

TTCN-3 Record Type		
<b>Name</b>	<b>ICMP_SocketReq_Type</b>	
<b>Comment</b>	to establish a raw socket to send/receive ICMP packets	
SockOptList	<a href="#">IP_SockOptList_Type</a>	e.g. to set the IP_HDRINCL socket option (to include the IP header in the data buffer) when there are no options to configure the list is empty

**ICMP\_CtrlRequest\_Type**

TTCN-3 Union Type		
<b>Name</b>	<b>ICMP_CtrlRequest_Type</b>	
<b>Comment</b>		
SocketReq	<a href="#">ICMP_SocketReq_Type</a>	request the system adaptor to open a raw socket (IPv4 or IPv6)  system calls (informative): socket -- get file descriptor (IPPROTO_ICMP or IPPROTO_IPV6); (setsockopt) -- optional; to set socket options bind -- assign local IP address (to cope with multiple IP addresses)  IP_Connection: protocol -- icmp or icmpv6 local IP addr -- mandatory (to distinguish multiple IP addresses) local port -- omit (not applicable for ICMP) remote IP addr -- omit remote port -- omit (not applicable for ICMP)
Close	<a href="#">Null_Type</a>	release local socket  system calls (informative): close  IP_Connection: protocol -- icmp or icmpv6 local IP addr -- mandatory (to identify local socket) local port -- omit remote IP addr -- omit remote port -- omit

**ICMP\_DataRequest\_Type**

TTCN-3 Union Type		
<b>Name</b>	<b>ICMP_DataRequest_Type</b>	
<b>Comment</b>		
SendTo	<a href="#">Datagram_DL_Type</a>	send datagram  system calls (informative): sendto  IP_Connection: protocol -- icmp or icmpv6 local IP addr -- mandatory (to identify local socket) local port -- omit remote IP addr -- mandatory remote port -- omit



**ICMP\_CtrlIndication\_Type**

TTCN-3 Union Type		
Name	<b>ICMP_CtrlIndication_Type</b>	
Comment		
SocketCnf	<a href="#">Null_Type</a>	confirm 'SocketReq'  system calls (informative): (SocketCnf is sent when all system calls for SocketReq have been successful)  IP_Connection: protocol -- icmp or icmpv6 local IP addr -- mandatory local port -- omit remote IP addr -- omit remote port -- omit

**ICMP\_DataIndication\_Type**

TTCN-3 Union Type		
Name	<b>ICMP_DataIndication_Type</b>	
Comment		
RecvFrom	<a href="#">Datagram_UL_Type</a>	receive datagram  system calls (informative): recvfrom -- get data and src addr  IP_Connection: protocol -- icmp or icmpv6 local IP addr -- mandatory (see note) local port -- omit remote IP addr -- mandatory (as gotten from recvfrom) remote port -- omit  NOTE: As for UDP there may be multicast/broadcast packets. In this case - as for UDP - the SS shall provide the DRB information in RecvFrom.

**D.5.4.6 Socket\_Primitives****IP\_CtrlRequest\_Type**

TTCN-3 Union Type		
Name	<b>IP_CtrlRequest_Type</b>	
Comment		
TCP	<a href="#">TCP_CtrlRequest_Type</a>	
UDP	<a href="#">UDP_CtrlRequest_Type</a>	
ICMP	<a href="#">ICMP_CtrlRequest_Type</a>	

**IP\_DataRequest\_Type**

TTCN-3 Union Type		
Name	<b>IP_DataRequest_Type</b>	
Comment		
TCP	<a href="#">TCP_DataRequest_Type</a>	
UDP	<a href="#">UDP_DataRequest_Type</a>	
ICMP	<a href="#">ICMP_DataRequest_Type</a>	

**IP\_CtrlIndication\_Type**

TTCN-3 Union Type	
Name	<b>IP_CtrlIndication_Type</b>
Comment	
TCP	<a href="#">TCP_CtrlIndication_Type</a>
UDP	<a href="#">UDP_CtrlIndication_Type</a>
ICMP	<a href="#">ICMP_CtrlIndication_Type</a>
Error	<a href="#">IP_SocketError_Type</a>

**IP\_DataIndication\_Type**

TTCN-3 Union Type	
Name	<b>IP_DataIndication_Type</b>
Comment	
TCP	<a href="#">TCP_DataIndication_Type</a>
UDP	<a href="#">UDP_DataIndication_Type</a>
ICMP	<a href="#">ICMP_DataIndication_Type</a>

**D.5.5 System\_Interface**

**DRBMUX\_CONFIG\_REQ**

TTCN-3 Union Type	
Name	<b>DRBMUX_CONFIG_REQ</b>
Comment	NOTE 1: There is just one primitive to configure the whole routing table. It is not foreseen to add, remove or manipulate single entries but the table is managed in TTCN and completely configured on any change; (otherwise it might get complicated to identify single entries) NOTE 2: the SS's routing table shall be empty at the beginning and can be cleared by an empty record (DRBMUX_CONFIG_REQ.RoutingInfo = {}) NOTE 3: In general a reconfiguration of the routing table during a test case would be necessary only if an ephemeral port is needed to distinguish different routing (e.g. when there are several TCP connections of the same service routed to different DRBs)
RoutingInfo	<a href="#">IP_RoutingTable_Type</a>

**DRBMUX\_COMMON\_IND\_CNF**

TTCN-3 Union Type	
Name	<b>DRBMUX_COMMON_IND_CNF</b>
Comment	
Confirm	<a href="#">Null_Type</a> confirm DRBMUX_CONFIG_REQ
Error	<a href="#">Null_Type</a> indication of errors at the DRB-MUX: An Error shall be raised by the DRB-MUX e.g. in the following cases: - in DL when there are IP packets which cannot be routed to any DRB i.e. the IP packet does not match to any entry in the routing table or the corresponding RB is not configured - in DL when there are several DRBs possible for routing in the same cell

## IPSEC\_CONFIG\_REQ

TTCN-3 Union Type	
Name	IPSEC_CONFIG_REQ
Comment	
Configure	<a href="#">IPsec_Configure_Type</a>
Release	<a href="#">IPsec_Release_Type</a>

## IPSEC\_CONFIG\_CNF

TTCN-3 Union Type	
Name	IPSEC_CONFIG_CNF
Comment	
Confirm	<a href="#">Null_Type</a> confirm IPSEC_CONFIG_REQ
Error	<a href="#">Null_Type</a> to indicate invalid configuration of IPsec

## IP\_SOCKET\_CTRL\_REQ

TTCN-3 Record Type	
Name	IP_SOCKET_CTRL_REQ
Comment	
ConnectionId	<a href="#">IP_Connection_Type</a>
Req	<a href="#">IP_CtrlRequest_Type</a>

## IP\_SOCKET\_DATA\_REQ

TTCN-3 Record Type	
Name	IP_SOCKET_DATA_REQ
Comment	
ConnectionId	<a href="#">IP_Connection_Type</a>
Req	<a href="#">IP_DataRequest_Type</a>

## IP\_SOCKET\_CTRL\_IND

TTCN-3 Record Type	
Name	IP_SOCKET_CTRL_IND
Comment	
ConnectionId	<a href="#">IP_Connection_Type</a>
Ind	<a href="#">IP_CtrlIndication_Type</a>

## IP\_SOCKET\_DATA\_IND

TTCN-3 Record Type	
Name	IP_SOCKET_DATA_IND
Comment	
ConnectionId	<a href="#">IP_Connection_Type</a>
Ind	<a href="#">IP_DataIndication_Type</a>

## IP\_SOCKET\_REQ

TTCN-3 Union Type	
Name	IP_SOCKET_REQ
Comment	
CTRL	<a href="#">IP_SOCKET_CTRL_REQ</a>
DATA	<a href="#">IP_SOCKET_DATA_REQ</a>

## IP\_SOCKET\_IND

TTCN-3 Union Type	
Name	IP_SOCKET_IND
Comment	
CTRL	<a href="#">IP_SOCKET_CTRL_IND</a>
DATA	<a href="#">IP_SOCKET_DATA_IND</a>

## IP\_CONTROL\_PORT

TTCN-3 Port Type	
Name	IP_CONTROL_PORT
Comment	
out	<a href="#">DRBMUX_CONFIG_REQ</a>
in	<a href="#">DRBMUX_COMMON_IND_CNF</a>

## IPSEC\_CONTROL\_PORT

TTCN-3 Port Type	
Name	IPSEC_CONTROL_PORT
Comment	
out	<a href="#">IPSEC_CONFIG_REQ</a>
in	<a href="#">IPSEC_CONFIG_CNF</a>

## IP\_SOCKET\_PORT

TTCN-3 Port Type	
Name	IP_SOCKET_PORT
Comment	
out	<a href="#">IP_SOCKET_REQ</a>
in	<a href="#">IP_SOCKET_IND</a>

---

## D.6 NR\_PDCP\_TypeDefs

### D.6.1 NR\_PDCP\_Config\_Parameters

Parameters defined in or related to NR ASN.1 type PDCP-Config

#### NR\_PDCP\_SN\_Size\_Type

TTCN-3 Enumerated Type	
Name	NR_PDCP_SN_Size_Type
Comment	PDCP Sequence Number
PDCP_SNLength12	TS 38.323 clause 6.2.2.1 and clause 6.2.2.2
PDCP_SNLength18	TS 38.323 clause 6.2.2.3

#### NR\_PDCP\_DRB\_HeaderCompression\_Type

TTCN-3 Union Type	
Name	NR_PDCP_DRB_HeaderCompression_Type
Comment	place holder for header compression
None	<a href="#">Null_Type</a>

## NR\_PDCP\_DRB\_Config\_Parameters\_Type

TTCN-3 Record Type			
Name	NR_PDCP_DRB_Config_Parameters_Type		
Comment	parameters corresponding to NR ASN.1 PDCP-Config.drb; the following parameter are not included and may be added if needed: - integer DiscardTimer (timer value in milliseconds) - boolean StatusReportRequired - boolean OutOfOrderDelivery		
SN_SizeUL	<a href="#">NR_PDCP_SN_Size_Type</a>		PDCP-Config.drb.pdcp-SN-SizeUL
SN_SizeDL	<a href="#">NR_PDCP_SN_Size_Type</a>		PDCP-Config.drb.pdcp-SN-SizeDL
HeaderCompression	<a href="#">NR_PDCP_DRB_HeaderCompression_Type</a>		PDCP-Config.drb.headerCompression
IntegrityProtectionEnabled	boolean		PDCP-Config.drb.integrityProtection

## NR\_PDCP\_RB\_Config\_Parameters\_Type

TTCN-3 Union Type			
Name	NR_PDCP_RB_Config_Parameters_Type		
Comment			
Srb	<a href="#">Null_Type</a>		no SRB specific parameters in NR ASN.1 PDCP-Config
Drb	<a href="#">NR_PDCP_DRB_Config_Parameters_Type</a>		DRB specific parameters corresponding to NR ASN.1 PDCP-Config.drb

## NR\_PDCP\_Config\_Parameters\_Type

TTCN-3 Record Type			
Name	NR_PDCP_Config_Parameters_Type		
Comment	parameters corresponding to NR ASN.1 PDCP-Config: the following parameter are not included and may be added if needed: - integer TReorderingTimer (timer value in milliseconds)		
Rb	<a href="#">NR_PDCP_RB_Config_Parameters_Type</a>		

## D.6.2 NR\_PDCP\_Configuration

## NR\_PDCP\_TransparentMode

TTCN-3 Record Type			
Name	NR_PDCP_TransparentMode		
Comment			
SN_Size	<a href="#">NR_PDCP_SN_Size_Type</a>		

## NR\_PDCP\_RbConfig\_Type

TTCN-3 Union Type		
Name	NR_PDCP_RbConfig_Type	
Comment		
Params	<a href="#">NR_PDCP_Config_Parameters_Type</a>	PDCP configuration parameters corresponding to UE configuration
TransparentMode	<a href="#">NR_PDCP_TransparentMode</a>	PDCP configuration for transparent (test) mode: used for PDCP tests (TS 38.523-3, cl. 5.1.2.1): the SS does not apply ciphering, not apply integrity protection and does not maintain PDCP sequence numbers and state variables; ROHC is not applied by the SS. Note: a reconfiguration of a RB from transparent mode to 'normal' mode is not foreseen (i.e. there is no mechanism to restore Ciphering, PDCP sequence numbers and state variables at the SS) (in UL PDCP PDUs are decoded depending on SN_Size)

## NR\_PDCP\_RBTerminating\_Type

TTCN-3 Record Type			
Name	NR_PDCP_RBTerminating_Type		
Comment	RB terminating PDCP configuration: the PDCP may be linked - to a local RLC bearer: RLC bearer is configured for the same cell - to the RLC bearer of some other cell group: LinkToOtherCellGroup is not "None" - the both (in case of split bearer): RLC bearer is configured for the same cell and LinkToOtherCellGroup is not "None"		
RbConfig	<a href="#">NR_PDCP_RbConfig_Type</a>	opt	mandatory for initial configuration; omit means "keep as it is"
LinkToOtherCellGroup	<a href="#">RlcBearerRouting_Type</a>	opt	mandatory for initial configuration; omit means "keep as it is" None: no link to other cell group (normal case, non-split bearer) RAT/cellId: PDCP is linked to RLC bearer of another cell group (same or other RAT): split bearer or PDCP and RLC bearer being configured at different cells NOTE: applicable also for PDCP split bearer test cases when PDCP is in transparent mode => test case body may be implemented at one PTC

## NR\_PDCP\_Proxy\_Type

TTCN-3 Record Type			
Name	NR_PDCP_Proxy_Type		
Comment	proxy to route PDCP data between terminating PDCP entity and RLC bearer of another cell (group)		
LinkToOtherNode	<a href="#">RlcBearerRouting_Type</a>		RAT/cellId to address the radio bearer terminating node (PDCP) (None is not applicable)

## NR\_PDCP\_Configuration\_Type

TTCN-3 Union Type		
Name	NR_PDCP_Configuration_Type	
Comment		
None	<a href="#">Null_Type</a>	for SRB0 no PDCP is configured; furthermore the PDCP may not be configured e.g. for DRBs tested in RLC or MAC test cases
RBTerminating	<a href="#">NR_PDCP_RBTerminating_Type</a>	PDCP entity at the terminating node: handling of PDCP protocol for the given bearer (normal or split bearer)
Proxy	<a href="#">NR_PDCP_Proxy_Type</a>	proxy to be configured above RLC instead of a normal PDCP entity when the RLC bearer is not in the same cell (group) as the terminating PDCP entity

## D.6.3 NR\_PDCP\_DrbDefs

### NR\_PDCP\_DrbDefs: Basic Type Definitions

TTCN-3 Basic Types		
NR_PDCP_SDU_Type	octetstring	
NR_PDCP_CtrlPduType_Type	<a href="#">B3_Type</a>	PDU type according to TS 38.323 clause 6.3.8: 000 PDCP status report 001 Interspersed ROHC feedback 010 EHC feedback 011-111 Reserved

### NR\_PDCP\_SDUList\_Type

TTCN-3 Record of Type	
Name	NR_PDCP_SDUList_Type
Comment	record of <a href="#">NR_PDCP_SDU_Type</a>

### NR\_PDCP\_DataPduSN12Bits\_Type

TTCN-3 Record Type			
Name	NR_PDCP_DataPduSN12Bits_Type		
Comment	Data PDU for DRBs with 12 bits PDCP SN (TS 38.323, clause 6.2.2.2)		
D_C	<a href="#">B1_Type</a>		1 bit, '1'B for Data PDU
Reserved	<a href="#">B3_Type</a>		3 bits reserved
SequenceNumber	<a href="#">B12_Type</a>		12 bits sequence number
SDU	<a href="#">NR_PDCP_SDU_Type</a>		content (octetstring)
MAC_I	<a href="#">B32_Type</a>	opt	message authentication code according to TS 38.323, clause 6.3.4; MAC-I field is present only when the DRB is configured with integrity protection; in this case it is up to TTCN to provide the valid MAC_I in DL and to check it in UL

### NR\_PDCP\_DataPduSN18Bits\_Type

TTCN-3 Record Type			
Name	NR_PDCP_DataPduSN18Bits_Type		
Comment	Data PDU for DRBs with 18 bits PDCP SN (TS 38.323, clause 6.2.2.3)		
D_C	<a href="#">B1_Type</a>		1 bit, '1'B for Data PDU
Reserved	<a href="#">B5_Type</a>		5 bits reserved
SequenceNumber	<a href="#">B18_Type</a>		18 bits sequence number
SDU	<a href="#">NR_PDCP_SDU_Type</a>		content (octetstring)
MAC_I	<a href="#">B32_Type</a>	opt	message authentication code according to TS 38.323, clause 6.3.4; MAC-I field is present only when the DRB is configured with integrity protection; in this case it is up to TTCN to provide the valid MAC_I in DL and to check it in UL

**NR\_PDCP\_CtrlPduStatus\_Type**

TTCN-3 Record Type			
<b>Name</b>	<b>NR_PDCP_CtrlPduStatus_Type</b>		
<b>Comment</b>	Control PDU for PDCP status report (TS 38.323, clause 6.2.3.1)		
D_C	<a href="#">B1_Type</a>		1 bit, '0'B for Ctrl PDU
PDU_Type	<a href="#">NR_PDCP_CtrlPduType_Type</a>		3 bits, '000'B for PDCP status report
Reserved	<a href="#">B4_Type</a>		4 bits reserved
FirstMissingCount	<a href="#">B32_Type</a>		32 bits, TS 38.323, clause 6.3.9 FMC
Bitmap	octetstring	opt	Bitmap according to TS 38.323, clause 6.3.10

**NR\_PDCP\_CtrlPduRohcFeedback\_Type**

TTCN-3 Record Type			
<b>Name</b>	<b>NR_PDCP_CtrlPduRohcFeedback_Type</b>		
<b>Comment</b>	Control PDU for Interspersed ROHC feedback (TS 38.323, clause 6.2.3.2)		
D_C	<a href="#">B1_Type</a>		1 bit, '0'B for Ctrl PDU
PDU_Type	<a href="#">NR_PDCP_CtrlPduType_Type</a>		3 bits, '001'B for Interspersed ROHC feedback
Reserved	<a href="#">B4_Type</a>		4 bits reserved
RohcFeedback	octetstring		ROHC packet that is not associated with a PDCP SDU

**NR\_PDCP\_PDU\_Type**

TTCN-3 Union Type			
<b>Name</b>	<b>NR_PDCP_PDU_Type</b>		
<b>Comment</b>			
DataPduSN12Bits	<a href="#">NR_PDCP_DataPduSN12Bits_Type</a>		
DataPduSN18Bits	<a href="#">NR_PDCP_DataPduSN18Bits_Type</a>		
CtrlPduStatus	<a href="#">NR_PDCP_CtrlPduStatus_Type</a>		
CtrlPduRohcFeedback	<a href="#">NR_PDCP_CtrlPduRohcFeedback_Type</a>		

**NR\_PDCP\_PDUList\_Type**

TTCN-3 Record of Type	
<b>Name</b>	<b>NR_PDCP_PDUList_Type</b>
<b>Comment</b>	record of <a href="#">NR_PDCP_PDU_Type</a>

## D.7 SDAP\_TypeDefs

### D.7.1 SDAP\_Configuration

**SDAP\_Header\_Type**

TTCN-3 Enumerated Type	
<b>Name</b>	<b>SDAP_Header_Type</b>
<b>Comment</b>	
Present	
Absent	



**QFI\_List\_Type**

TTCN-3 Record of Type	
Name	QFI_List_Type
Comment	
record of integer	

**SdapConfig\_Type**

TTCN-3 Record Type			
Name	SdapConfig_Type		
Comment			
Pdu_SessionId	integer		
Sdap_HeaderDL	<a href="#">SDAP_Header_Type</a>	opt	mandatory for initial configuration; omit means "keep as it is" when set to 'Present', unless specifically triggered otherwise, the SS shall set the RDI and RQI fields to 0
Sdap_HeaderUL	<a href="#">SDAP_Header_Type</a>	opt	mandatory for initial configuration; omit means "keep as it is"
MappedQoS_Flows	<a href="#">QFI_List_Type</a>	opt	mandatory for initial configuration; omit means "keep as it is"

**SdapTransparentMode\_Type**

TTCN-3 Record Type			
Name	SdapTransparentMode_Type		
Comment			
Sdap_HeaderUL	<a href="#">SDAP_Header_Type</a>		Indicates to the SS if the UE has been configured to include SDAP UL header

**SdapConfigInfo\_Type**

TTCN-3 Union Type		
Name	SdapConfigInfo_Type	
Comment		
SdapConfig	<a href="#">SdapConfig_Type</a>	SDAP configuration parameters for the DRB
TransparentMode	<a href="#">SdapTransparentMode_Type</a>	SDAP configuration for transparent (test) mode, used for SDAP tests: SS does not add any SDAP headers in DL and does not remove any SDAP headers in UL

**SDAP\_Configuration\_Type**

TTCN-3 Union Type		
Name	SDAP_Configuration_Type	
Comment		
None	<a href="#">Null_Type</a>	
Config	<a href="#">SdapConfigInfo_Type</a>	

**D.7.2 SDAP\_DrbDefs**

**SDAP\_DrbDefs: Basic Type Definitions**

TTCN-3 Basic Types		
SDAP_SDU_Type	octetstring	

**SDAP\_SDUList\_Type**

TTCN-3 Record of Type	
<b>Name</b>	<b>SDAP_SDUList_Type</b>
<b>Comment</b>	
record of <a href="#">SDAP_SDU_Type</a>	

**SDAP\_DL\_PduHeader\_Type**

TTCN-3 Record Type	
<b>Name</b>	<b>SDAP_DL_PduHeader_Type</b>
<b>Comment</b>	TS 37.324 Figure 6.2.2.2-1
RDI	<a href="#">B1_Type</a> TS 37.324 Figure 6.3.7: The RDI bit indicates whether QoS flow to DRB mapping rule should be updated 1 bit: '0'B No action '1'B To store QoS flow to DRB mapping rule
RQI	<a href="#">B1_Type</a> TS 37.324 clause 6.3.6: The RQI bit indicates whether NAS should be informed of the updated of SDF to QoS flow mapping rules 1 bit: '0'B No action '1'B To inform NAS that RQI bit is set to 1
QFI	<a href="#">B6_Type</a> TS 37.324 clause 6.3.4: The QFI field indicates the ID of the QoS flow to which the SDAP SDU belongs

**SDAP\_UL\_PduHeader\_Type**

TTCN-3 Record Type	
<b>Name</b>	<b>SDAP_UL_PduHeader_Type</b>
<b>Comment</b>	TS 37.324 Figure 6.2.2.3-1 or 6.2.3-1
DC	<a href="#">B1_Type</a> TS 37.324 clause 6.3.3: The D/C bit indicates whether the SDAP PDU is an SDAP Data PDU or an SDAP Control PDU 1 bit: '0'B Control PDU '1'B Data PDU
R	<a href="#">B1_Type</a> TS 37.324 clause 6.3.5: Reserved. In this version of the specification reserved bits shall be set to 0. Reserved bits shall be ignored by the receiver
QFI	<a href="#">B6_Type</a> QFI (UL) or PQFI (SL) TS 37.324 clause 6.3.4: The QFI field indicates the ID of the QoS flow to which the SDAP SDU belongs, or TS 37.324 clause 6.3.8: The PQFI field indicates the ID of the PC5 QoS flow to which the SDAP PDU belongs

**SDAP\_PDU\_DL\_Type**

TTCN-3 Record Type	
<b>Name</b>	<b>SDAP_PDU_DL_Type</b>
<b>Comment</b>	TS 37.324 clause 6.2.2 Data PDU
Header	<a href="#">SDAP_DL_PduHeader_Type</a> opt present for DL Data PDU with SDAP header (clause 6.2.2.2), omitted for Data PDU without SDAP header (clause 6.2.2.1)
Data	<a href="#">SDAP_SDU_Type</a>

**SDAP\_PDU\_UL\_Type**

TTCN-3 Record Type			
<b>Name</b>	<b>SDAP_PDU_UL_Type</b>		
<b>Comment</b>	TS 37.324 clause 6.2.2 Data PDU or clause 6.2.3 End-Marker Control PDU		
Header	<a href="#">SDAP_UL_PduHeader_Type</a>	opt	present for: UL Data PDU in default DRB or UL Data PDU with SDAP header in a non-default DRB (clause 6.2.2.3) or End-Marker Control PDU (clause 6.2.3); omitted for UL Data PDU without SDAP header in a non-default DRB (clause 6.2.2.1)
Data	<a href="#">SDAP_SDU_Type</a>	opt	present for UL Data PDU (clause 6.2.2.1 or 6.2.2.3), omitted for End-Marker Control PDU (clause 6.2.3)

**SDAP\_PDU\_Type**

TTCN-3 Union Type		
<b>Name</b>	<b>SDAP_PDU_Type</b>	
<b>Comment</b>	TS 37.324 clause 6.2.2 Data PDU or 6.2.3 End-Marker Control PDU	
DL	<a href="#">SDAP_PDU_DL_Type</a>	Data PDU in DL
UL	<a href="#">SDAP_PDU_UL_Type</a>	Data PDU in UL or End-Marker Control PDU

**SDAP\_PDUList\_Type**

TTCN-3 Record of Type	
<b>Name</b>	<b>SDAP_PDUList_Type</b>
<b>Comment</b>	record of <a href="#">SDAP_PDU_Type</a>

## D.8 NR\_ASP\_VirtualNoiseDefs

ASP definitions for virtual noise generation in NR cells:

- A VNG instance, upon creation, is always associated with an already configured NR cell. This VNG instance therefore operates on the same frequency as the associated NR cell's frequency.
- A VNG instance generates AWGN (Additive white Gaussian noise):
  - Frequency domain: on the whole carrier bandwidth defined for the frequency of the associated NR cell.
  - Time domain: in every slot.
- The AWGN power level is defined as an EPRE in dBm/SCS, corresponding to the 'Noc' value provided in the test case prose.

**NR\_ASP\_VirtualNoiseDefs: Basic Type Definitions**

TTCN-3 Basic Types	
<b>NR_VngConfigConfirm_Type</b>	<a href="#">Null_Type</a>

**NR\_VngConfigInfo\_Type**

TTCN-3 Union Type		
<b>Name</b>	<b>NR_VngConfigInfo_Type</b>	
<b>Comment</b>		
CellNocLevel	integer	CellNocLevel - EPRE level in dBm/SCS for AWGN transmission to model a noise source. The SS shall apply AWGN to the whole carrier bandwidth of the associated NR cell and in every slot

## NR\_VngConfigRequest\_Type

TTCN-3 Union Type		
<b>Name</b>	<b>NR_VngConfigRequest_Type</b>	
<b>Comment</b>	configure/activate noise for a given cell; NOTE: it is assumed the associated NR cell has been created beforehand	
Configure	<a href="#">NR_VngConfigInfo_Type</a>	configuration of the virtual noise generator; regardless of the power level the noise generator is off before it gets activated for this cell; in case the configuration needs to be changed during a test, the noise generator shall be deactivated for this cell
Activate	<a href="#">Null_Type</a>	noise is activated (switched on) for the given cell acc. to the previous configuration; while being active the configuration shall not be modified
Deactivate	<a href="#">Null_Type</a>	deactivate noise for given cell

## NR\_VNG\_CTRL\_REQ

TTCN-3 Record Type			
<b>Name</b>	<b>NR_VNG_CTRL_REQ</b>		
<b>Comment</b>			
Common	<a href="#">NR_ReqAspCommonPart_Type</a>		CellId : as for the associated NR cell RoutingInfo : None RlcBearerRouting : None MacBearerRouting : 'omit' TimingInfo : Now ControllInfo : CnfFlag:=true; FollowOnFlag:=false
Request	<a href="#">NR_VngConfigRequest_Type</a>		

## NR\_VNG\_CTRL\_CNF

TTCN-3 Record Type			
<b>Name</b>	<b>NR_VNG_CTRL_CNF</b>		
<b>Comment</b>			
Common	<a href="#">NR_CnfAspCommonPart_Type</a>		TimingInfo is ignored by TTCN => SS may set TimingInfo to "None"
Confirm	<a href="#">NR_VngConfigConfirm_Type</a>		

## NR\_VNG\_PORT

TTCN-3 Port Type		
<b>Name</b>	<b>NR_VNG_PORT</b>	
<b>Comment</b>	NR BASE PTC: Port for virtual noise generator	
out	<a href="#">NR_VNG_CTRL_REQ</a>	
in	<a href="#">NR_VNG_CTRL_CNF</a>	

---

## D.9 CommonDefs

### CommonDefs: Constant Definitions

TTCN-3 Basic Types			
<b>tsc_UInt16Max</b>	integer	65535	
<b>tsc_UInt32Max</b>	integer	4294967295	

## CommonDefs: Basic Type Definitions

TTCN-3 Basic Types		
<b>B1_Type</b>	bitstring length(1)	
<b>B2_Type</b>	bitstring length(2)	
<b>B3_Type</b>	bitstring length(3)	
<b>B4_Type</b>	bitstring length(4)	
<b>B5_Type</b>	bitstring length(5)	
<b>B6_Type</b>	bitstring length(6)	
<b>B7_Type</b>	bitstring length(7)	
<b>B8_Type</b>	bitstring length(8)	
<b>B12_Type</b>	bitstring length(12)	
<b>B14_Type</b>	bitstring length(14)	
<b>B16_Type</b>	bitstring length(16)	
<b>B18_Type</b>	bitstring length(18)	
<b>B32_Type</b>	bitstring length(32)	
<b>B48_Type</b>	bitstring length(48)	
<b>B128_Type</b>	bitstring length(128)	
<b>B128_Key_Type</b>	<a href="#">B128_Type</a>	128 bit security key
<b>O1_Type</b>	octetstring length(1)	
<b>Null_Type</b>	boolean (true)	dummy type for 'typeless' fields in unions
<b>UInt_Type</b>	integer (0 .. infinity)	
<b>UInt16_Type</b>	integer (0 .. <a href="#">tsc UInt16Max</a> )	
<b>UInt32_Type</b>	integer (0 .. <a href="#">tsc UInt32Max</a> )	
<b>IP_Drbid_Type</b>	integer	DRB identity type common for all RATs: - for EUTRA it corresponds to the ASN.1 type DRB-Identity - for UTRAN it corresponds to the ASN.1 type RB-Identity and values are as defined in TS 34.123-3 Table 8.2.4.1 - for GERAN the NSAPI value (type record NSAPI) may be used NOTE: this is introduced to simplify the dependencies (i.e. to keep IP_ASP_TypeDefs independent from any RAT specific type definitions)
<b>PdcpCountValue_Type</b>	<a href="#">B32_Type</a>	
<b>RNTI_Value_Type</b>	<a href="#">UInt16_Type</a>	corresponds to NR ASN.1: RNTI-Value ::= INTEGER (0..65535)
<b>RNTI_B16_Type</b>	<a href="#">B16_Type</a>	

## B8\_List\_Type

TTCN-3 Record of Type	
<b>Name</b>	<b>B8_List_Type</b>
<b>Comment</b>	
record of <a href="#">B8_Type</a>	

## IntegerList\_Type

TTCN-3 Record of Type	
<b>Name</b>	<b>IntegerList_Type</b>
<b>Comment</b>	
record of integer	

## IndicationAndControlMode\_Type

TTCN-3 Enumerated Type	
Name	IndicationAndControlMode_Type
Comment	
enable	
disable	

## NR\_CellId\_Type

TTCN-3 Enumerated Type	
Name	NR_CellId_Type
Comment	
nr_Cell_NonSpecific	
nr_Cell1	
nr_Cell2	
nr_Cell3	
nr_Cell4	
nr_Cell6	
nr_Cell10	
nr_Cell11	
nr_Cell12	
nr_Cell13	
nr_Cell14	
nr_Cell23	
nr_Cell28	
nr_Cell29	
nr_Cell30	
nr_Cell31	

## NR\_CellIdList\_Type

TTCN-3 Record of Type	
Name	NR_CellIdList_Type
Comment	NOTE: there seems to be no need for any length restriction
record of <a href="#">NR_CellId_Type</a>	

**EUTRA\_CellId\_Type**

TTCN-3 Enumerated Type	
Name	EUTRA_CellId_Type
Comment	
eutra_Cell_NonSpecific	
eutra_Cell1	
eutra_Cell2	
eutra_Cell3	
eutra_Cell4	
eutra_Cell6	
eutra_Cell10	
eutra_Cell11	
eutra_Cell12	
eutra_Cell13	
eutra_Cell14	
eutra_Cell23	
eutra_Cell28	
eutra_Cell29	
eutra_Cell30	
eutra_Cell31	
eutra_CellA	
eutra_CellB	
eutra_CellC	
eutra_CellD	
eutra_CellE	
eutra_CellG	
eutra_CellH	
eutra_CellI	
eutra_CellJ	
eutra_CellK	
eutra_CellL	
eutra_CellM	

**UE\_NR\_DeltaValues\_Type**

TTCN-3 Record Type	
Name	UE_NR_DeltaValues_Type
Comment	
DeltaPrimaryBand	<a href="#">DeltaValues_Type</a>
DeltaSecondaryBand	<a href="#">DeltaValues_Type</a>

**DeltaValues\_Type**

TTCN-3 Record Type	
Name	DeltaValues_Type
Comment	Delta value for each frequency, by default for FR1 or when the frequency is not available the Delta value is set to 0.
DeltaNRf1	integer
DeltaNRf2	integer
DeltaNRf3	integer
DeltaNRf4	integer

## IP\_EUTRA\_DrbInfo\_Type

TTCN-3 Record Type			
Name	IP_EUTRA_DrbInfo_Type		
Comment			
CellId	<a href="#">EUTRA_CellId_Type</a>		data is routed to a specific cell regardless of whether the same DRB is configured in any other cell
DrbId	<a href="#">IP_DrbId_Type</a>	opt	mandatory at the system interface

## IP\_UTRAN\_GERAN\_DrbInfo\_Type

TTCN-3 Record Type			
Name	IP_UTRAN_GERAN_DrbInfo_Type		
Comment			
CellId	integer		
DrbId	<a href="#">IP_DrbId_Type</a>	opt	mandatory at the system interface

## IP\_WLAN\_DrbInfo\_Type

TTCN-3 Record Type			
Name	IP_WLAN_DrbInfo_Type		
Comment			
CellId	integer		

## IP\_ePDG\_IPsecTunnelInfo\_Type

TTCN-3 Record Type			
Name	IP_ePDG_IPsecTunnelInfo_Type		
Comment			
PdnId	<a href="#">PDN_Index_Type</a>		'index name' of PDN associated to the IPsec tunnel, e.g. for SS to distinguish routing of IP packets in case of more than one IPsec tunnel NOTE: In general only 'ePDG_XXX' values shall be used

## QosFlow\_Identification\_Type

TTCN-3 Record Type			
Name	QosFlow_Identification_Type		
Comment			
PDU_SessionId	integer		TS 24.007 clause 11.2.3.1b
QFI	integer		TS 24.501 Table 11.2.3.1c.1

## IP\_NR\_QosFlowInfo\_Type

TTCN-3 Record Type			
Name	IP_NR_QosFlowInfo_Type		
Comment			
CellId	<a href="#">NR_CellId_Type</a>		data is routed to a specific cell regardless of whether the same DRB is configured in any other cell
QosFlow	<a href="#">QosFlow_Identification_Type</a>	opt	mandatory at the system interface



## IP\_EUTRA\_QosFlowInfo\_Type

TTCN-3 Record Type			
Name	IP_EUTRA_QosFlowInfo_Type		
Comment			
CellId	<a href="#">EUTRA_CellId_Type</a>		data is routed to a specific cell regardless of whether the same DRB is configured in any other cell
QosFlow	<a href="#">QosFlow_Identification_Type</a>	opt	mandatory at the system interface

## IP\_NR\_DrbInfo\_Type

TTCN-3 Record Type			
Name	IP_NR_DrbInfo_Type		
Comment			
CellId	<a href="#">NR_CellId_Type</a>		
DrbId	<a href="#">IP_DrbId_Type</a>	opt	mandatory at the system interface

## IP\_DrbInfo\_Type

TTCN-3 Union Type			
Name	IP_DrbInfo_Type		
Comment			
Eutra	<a href="#">IP_EUTRA_DrbInfo_Type</a>		
Eutra5GC	<a href="#">IP_EUTRA_QosFlowInfo_Type</a>		used when SDAP is configured in non-transparent mode at the SS
Utran	<a href="#">IP_UTRAN_GERAN_DrbInfo_Type</a>		
Geran	<a href="#">IP_UTRAN_GERAN_DrbInfo_Type</a>		
Nr5GC	<a href="#">IP_NR_QosFlowInfo_Type</a>		used when SDAP is configured in non-transparent mode at the SS
NrEPC	<a href="#">IP_NR_DrbInfo_Type</a>		used when NR is connected to EPC (S1-U interface) or when SDAP is configured in transparent mode at the SS
Wlan	<a href="#">IP_WLAN_DrbInfo_Type</a>		
IPsecTunnel	<a href="#">IP_ePDG_IPsecTunnelInfo_Type</a>		

### PDN\_Index\_Type

TTCN-3 Enumerated Type	
Name	PDN_Index_Type
Comment	'index name' associated to a PDN: The major purpose is to associate a PDN specific set of IP addresses to the given PDN (e.g. UE addresses, P-CSCF address etc.); in general there are one or two PDNs configured at the same time and - from TTCN point of view - the IMS PDN is considered to be the first one; a second PDN may be configured in case of emergency call or e.g. for XCAP signalling; the 'internet PDN' (according to TS 36.508 clause 4.5.2) is considered as (optional) second PDN during initial registration and gets released after initial registration; in case of WLAN a separate group of index names is used to distinguish the different configuration of the emulated IP network
PDN_1	"default" PDN being kept connected to during a test case (in case of LTE in general the IMS PDN)
PDN_2	second PDN: during initial registration (TS 36.508 clause 4.5.2) for LTE and "multiple PDN" this is the internet PDN; after initial registration it is used if needed according to the test purpose (e.g. emergency call)
PDN_2a	used for the special case when the UE IP address of the second PDN changes in a test case
PDN_Internet	mainly used as alias for PDN2 during initial registration
ePDG_IMS1	WLAN: PDN for 'normal' IMS
ePDG_IMS2	WLAN: PDN for emergency IMS (in general)
ePDG_XCAP	WLAN: PDN for XCAP in case of XCAP server being part of 3GPP-network NOTE: In contrast to LTE for WLAN there is a different IP architecture to be consider by TTCN for XCAP and IMS emergency
ePDG_Internet	place-holder for WLAN-offload scenarios
nrPDN_Internet	mainly used as alias during initial registration in ENDC
PDN_3	used in ENDC and 5GC for the third PDN

## D.10 CommonAspDefs

### D.10.1 Cell\_Configuration\_Common

#### CellTimingInfo\_Type

TTCN-3 Record Type			
Name	CellTimingInfo_Type		
Comment	Cell Timing		
TcOffset	integer (0..63)	opt	For NR according to TS 38.211 clause 4.1 $T_s/T_c = 64$ with $T_c = 1/(480000 * 4096)$ and $T_s = 1/(15000 * 2048)$ as for EUTRA; => for NR to specify granularity per $T_c$ ; for EUTRA to be set to 0 (and/or to be ignored by the SS)
Tcell	integer (0..307199)		frame duration $T_f = 307200 * T_s = 10\text{ms}$ ; System Time Unit $T_s = 1/(15000 * 2048)$
SfnOffset	integer (0..1023)		
HsfnOffset	integer (0..1023)		

### D.10.2 MAC\_Layer

#### ULGrant\_Period\_Type

TTCN-3 Union Type		
Name	ULGrant_Period_Type	
Comment		
OnlyOnce	<a href="#">Null_Type</a>	grant is sent out only once; no period
Duration	integer (1..infinity)	duration of the grant period in number of sub-frames (1ms) for EUTRA and number of slots for NR

## TransmissionRepetition\_Type

TTCN-3 Union Type		
Name	TransmissionRepetition_Type	
Comment		
Continuous	<a href="#">Null_Type</a>	
NumOfCycles	integer (1..infinity)	

## PeriodicGrant\_Type

TTCN-3 Record Type		
Name	PeriodicGrant_Type	
Comment		
Period	<a href="#">ULGrant_Period_Type</a>	time period after which UL Grant need to be automatically transmitted or 'OnlyOnce'
NoOfRepetitions	<a href="#">TransmissionRepetition_Type</a>	number of UL Grant repetitions to be automatically transmitted or continuous repetition

## UL\_GrantConfig\_Type

TTCN-3 Union Type		
Name	UL_GrantConfig_Type	
Comment		
OnSR_Reception	<a href="#">Null_Type</a>	SS transmits UL Grant as configured by DciInfoUL_Type at every reception of SR; to be used in non L2 Test
Periodic	<a href="#">PeriodicGrant_Type</a>	SS transmits UL Grant as configured by DciInfoUL_Type periodically; to be used in L2 tests; MAC tests testing Grants might set the period as infinite and num grant as 1
PeriodicOnSR_Reception	<a href="#">PeriodicGrant_Type</a>	SS transmits UL Grant as configured by DciInfoUL_Type periodically; the periodic grant transmission is started/restarted on reception of a SR from UE to be used in non L2 Test to enable large UL data transmission for lower category UEs (Cat<=1)
None	<a href="#">Null_Type</a>	disable any grant transmission

## RAR\_RapidCtrl\_Type

TTCN-3 Union Type		
Name	RAR_RapidCtrl_Type	
Comment		
Automatic	<a href="#">Null_Type</a>	SS shall automatically use same RAPID as received from the UE
Unmatched	<a href="#">Null_Type</a>	SS shall use RAPID being different from preamble sent by the UE; SS shall calculate this RAPID acc. to $RAPID := (RAPID + 3..63) \bmod 64$ if single RAR is transmitted in a MAC PDU then only 3 is added if multiple RAR's are transmitted in MAC PDU, then for first unmatched RAR 3 is added, second unmatched 4 is added, third unmatched 5 is added and so on

## D.10.3 System\_Indications

### HARQ\_Type

TTCN-3 Enumerated Type	
<b>Name</b>	<b>HARQ_Type</b>
<b>Comment</b>	ack represents HARQ ACK; nack represents HARQ NACK
ack	
nack	

## D.10.4 ASP\_CommonPart

Definition of ASP common parts for REQ-, CNF- and IND-ASPs

### D.10.4.1 ASP\_CommonPart\_Definitions

#### D.10.4.1.1 Routing\_Info

##### CommonAspDefs: Constant Definitions

TTCN-3 Basic Types			
<b>tsc_SRB0</b>	integer	0	
<b>tsc_SRB1</b>	integer	1	
<b>tsc_SRB2</b>	integer	2	
<b>tsc_SRB3</b>	integer	3	
<b>tsc_SRB4</b>	integer	4	

##### Routing\_Info: Basic Type Definitions

TTCN-3 Basic Types		
<b>SRB_Identity_Type</b>	integer ( <a href="#">tsc_SRB0</a> , <a href="#">tsc_SRB1</a> , <a href="#">tsc_SRB2</a> , <a href="#">tsc_SRB3</a> , <a href="#">tsc_SRB4</a> )	

##### RlcBearerRouting\_Type

TTCN-3 Union Type		
<b>Name</b>	<b>RlcBearerRouting_Type</b>	
<b>Comment</b>	data routing e.g. in case of split bearer (split DRB or split SRB); applicable for multi-RAT Dual Connectivity (MR-DC) as well as single-RAT Dual Connectivity	
EUTRA	<a href="#">EUTRA_CellId_Type</a>	
NR	<a href="#">NR_CellId_Type</a>	
None	<a href="#">Null_Type</a>	normal case: PDCP and RLC are configured at the same cell

#### D.10.4.1.2 Timing\_Info

##### Timing\_Info: Basic Type Definitions

TTCN-3 Basic Types		
<b>SystemFrameNumber_Type</b>	integer (0..1023)	
<b>SubFrameNumber_Type</b>	integer (0..9)	
<b>HyperSystemFrameNumberInfo_Type</b>	<a href="#">SystemFrameNumberInfo_Type</a>	

**SubFrameInfo\_Type**

TTCN-3 Union Type		
Name	<b>SubFrameInfo_Type</b>	
Comment		
Number	<a href="#">SubFrameNumber_Type</a>	
Any	<a href="#">Null_Type</a>	no specific sub-frame, in which case the SS may choose the next available subframe (valid for REQ ASPs only)

**SystemFrameNumberInfo\_Type**

TTCN-3 Union Type		
Name	<b>SystemFrameNumberInfo_Type</b>	
Comment		
Number	<a href="#">SystemFrameNumber_Type</a>	
Any	<a href="#">Null_Type</a>	no specific frame number, in which case the SS may choose the next available SFN (valid for REQ ASPs only)

**SlotOffset\_Type**

TTCN-3 Union Type		
Name	<b>SlotOffset_Type</b>	
Comment	slots per subframe according to TS 38.211 Table 4.3.2-1	
Numerology0	<a href="#">Null_Type</a>	mu=0; only one slot per subframe
Numerology1	integer (0..1)	mu=1; 2 slots per subframe
Numerology2	integer (0..3)	mu=2; 4 slots per subframe
Numerology3	integer (0..7)	mu=3; 8 slots per subframe
Numerology4	integer (0..15)	mu=4; 16 slots per subframe

**SlotTimingInfo\_Type**

TTCN-3 Union Type		
Name	<b>SlotTimingInfo_Type</b>	
Comment	EUTRA, NBIOT: REQ ASPs: TTCN shall set the SlotTimingInfo to "FirstSlot" for EUTRA, NBIOT addressing the whole subframe IND ASPs: TTCN shall ignore the SlotTimingInfo sent by the SS for EUTRA, NBIOT NR: REQ ASPs: Any:=true only if the slot number is not relevant, in which case the SS may choose the next available slot of the given subframe IND ASPs: Any:=true only if there is no slot information available for the particular kind of indication	
SlotOffset	<a href="#">SlotOffset_Type</a>	to address a particular slot in a subframe
FirstSlot	<a href="#">Null_Type</a>	to address the first slot independent from the numerology (REQ ASPs only) or for REQ ASPs in EUTRA and NBIOT
Any	<a href="#">Null_Type</a>	for IND ASPs in EUTRA and NBIOT or if slot number is not relevant or not available

**SubFrameTiming\_Type**

TTCN-3 Record Type		
Name	<b>SubFrameTiming_Type</b>	
Comment		
SFN	<a href="#">SystemFrameNumberInfo_Type</a>	
Subframe	<a href="#">SubFrameInfo_Type</a>	
HSFN	<a href="#">HyperSystemFrameNumberInfo_Type</a>	
Slot	<a href="#">SlotTimingInfo_Type</a>	

## TimingInfo\_Type

TTCN-3 Union Type		
Name	TimingInfo_Type	
Comment		
SubFrame	<a href="#">SubFrameTiming_Type</a>	
Now	<a href="#">Null_Type</a>	to be used in REQ ASPs when there is no 'activation time'
None	<a href="#">Null_Type</a>	only to be used in SYSTEM_CTRL_CNF or NR_SYSTEM_CTRL_CNF but not for EnquireTiming

## D.10.4.2 REQ\_ASP\_CommonPart

## ReqAspControllInfo\_Type

TTCN-3 Record Type		
Name	ReqAspControllInfo_Type	
Comment		
CnfFlag	boolean	<p>true =&gt; SS shall send CNF: when the REQ is with no timing information (no activation time), SS shall send the confirmation when the configuration is done, i.e. when the test case may continue. Example: when there is a configuration followed by a send event it shall not be necessary to have a wait timer in between but the CNF triggers the send event. If there are other triggers e.g. like the UE sending a message, CnfFlag shall be set to false by the test case to avoid racing conditions with the CNF and the signalling message. When there is an activation time SS shall send the CNF after the configuration has been scheduled; that means SS shall not wait until the activation time has been expired. When FollowOnFlag is true, CnfFlag shall be set to false.</p>
FollowOnFlag	boolean	<p>false =&gt; no further (related) information true: further related information will be sent to SS (semantics depending on respective ASP)</p>

## D.10.4.3 CNF\_ASP\_CommonPart

## ConfirmationResult\_Type

TTCN-3 Union Type		
Name	ConfirmationResult_Type	
Comment		
Success	<a href="#">Null_Type</a>	
Error	integer	may contain SS specific error code; this will not be evaluated by TTCN

## D.10.4.4 IND\_ASP\_CommonPart

## IntegrityErrorIndication\_Type

TTCN-3 Record Type		
Name	IntegrityErrorIndication_Type	
Comment		
Nas	boolean	NAS Integrity: set to true when received MAC does not match calculated MAC
Pdcp	boolean	PDCP Integrity: set to true when received MAC does not match calculated MAC

**ErrorIndication\_Type**

TTCN-3 Record Type			
Name	<b>ErrorIndication_Type</b>		
Comment			
Integrity	<a href="#">IntegrityErrorIndication_Type</a>		Integrity error: received MAC does not match calculated MAC
System	integer		any other error: may be SS specific error code; this will not be evaluated by TTCN; e.g. an error shall be raised when the UE requests retransmission of an RLC PDU

**IndicationStatus\_Type**

TTCN-3 Union Type			
Name	<b>IndicationStatus_Type</b>		
Comment			
Ok	<a href="#">Null_Type</a>		
Error	<a href="#">ErrorIndication_Type</a>		

**D.11 References to TTCN-3**

References to TTCN-3		
<b>NR_ASP_TypeDefs</b>	NR_Defs/NR_ASP_TypeDefs.ttcn	Rev 31303
<b>NR_ASP_DrbDefs</b>	NR_Defs/NR_ASP_DrbDefs.ttcn	Rev 30633
<b>NR_ASP_SrbDefs</b>	NR_Defs/NR_ASP_SrbDefs.ttcn	Rev 30633
<b>NR_CommonDefs</b>	NR_Defs/NR_CommonDefs.ttcn	Rev 30633
<b>IP_ASP_TypeDefs</b>	IP_PTC/IP_ASP_TypeDefs.ttcn	Rev 27511
<b>NR_PDCP_TypeDefs</b>	Common4G5G/NR_PDCP_TypeDefs.ttcn	Rev 29170
<b>SDAP_TypeDefs</b>	Common4G5G/SDAP_TypeDefs.ttcn	Rev 29170
<b>NR_ASP_VirtualNoiseDefs</b>	NR_Defs/NR_ASP_VirtualNoiseDefs.ttcn	Rev 30633
<b>CommonDefs</b>	Common/CommonDefs.ttcn	Rev 30597
<b>CommonAspDefs</b>	Common/CommonAspDefs.ttcn	Rev 30678

## Annex E (informative): Change history













2020-03	RAN#87	R5-201150	0692	1	F	5G Test Models updates	15.7.0
2020-03	RAN#87	<a href="#">R5s200049</a>	0585	-	B	NR5GC FR1 : Addition of NAS test case 9.1.1.5	15.7.0
2020-03	RAN#87	<a href="#">R5s200051</a>	0586	-	F	Correction to PDCP testcases 7.1.3.2.x and 7.1.3.3.x	15.7.0
2020-03	RAN#87	<a href="#">R5s200052</a>	0587	-	F	Correction to template cs_RadioBearer_Reconfig	15.7.0
2020-03	RAN#87	<a href="#">R5s200053</a>	0588	-	F	Correction to EN-DC RRC test cases 8.2.2.4.1 and 8.2.2.5.1	15.7.0
2020-03	RAN#87	<a href="#">R5s200054</a>	0589	-	F	Corrections for NR RLC test case 7.1.2.3.7	15.7.0
2020-03	RAN#87	<a href="#">R5s200055</a>	0590	-	F	Correction for 5GMM test case 9.1.2.1	15.7.0
2020-03	RAN#87	<a href="#">R5s200056</a>	0591	-	F	Correction to NR cell info intialisation function	15.7.0
2020-03	RAN#87	<a href="#">R5s200057</a>	0592	-	F	Correction to some NR MAC test cases	15.7.0
2020-03	RAN#87	<a href="#">R5s200059</a>	0594	-	F	Correction to NR MAC test case 7.1.1.1.1	15.7.0
2020-03	RAN#87	<a href="#">R5s200062</a>	0597	-	F	Correction to NR MAC test case 7.1.1.3.7	15.7.0
2020-03	RAN#87	<a href="#">R5s200063</a>	0598	-	F	Correction to NR PDCP test case 7.1.3.4.1	15.7.0
2020-03	RAN#87	<a href="#">R5s200067</a>	0601	-	F	Correction to NR5GC Test Case 6.1.2.1	15.7.0
2020-03	RAN#87	<a href="#">R5s200069</a>	0603	-	F	Correction to the function f_NR5GC_RRC_Idle_Steps5_9_AKA	15.7.0
2020-03	RAN#87	<a href="#">R5s200071</a>	0605	-	F	Correction to NR5GC Test Case 7.1.2.2.3, 7.1.2.2.4	15.7.0
2020-03	RAN#87	<a href="#">R5s200072</a>	0606	-	F	Correction to NR5GC Test Case 7.1.1.1.6	15.7.0
2020-03	RAN#87	<a href="#">R5s200074</a>	0608	-	F	Correction to NR5GC testcase 7.1.3.1.1	15.7.0
2020-03	RAN#87	<a href="#">R5s200075</a>	0609	-	F	Correction to MAC testcase 7.1.1.3.3	15.7.0
2020-03	RAN#87	<a href="#">R5s200076</a>	0610	-	F	Correction to NR5GC common template cs_NR_RachProcedureConfig_CRNTI_HO	15.7.0
2020-03	RAN#87	<a href="#">R5s200077</a>	0611	-	F	Correction to NR5GC Test Case 10.1.5.1	15.7.0
2020-03	RAN#87	<a href="#">R5s200078</a>	0612	-	F	Correction to NR5GC Test Case 7.1.1.1.6	15.7.0
2020-03	RAN#87	<a href="#">R5s200079</a>	0613	-	F	Correction to NR measurement test cases	15.7.0
2020-03	RAN#87	<a href="#">R5s200080</a>	0614	-	F	Correction to NR5GC test case 7.1.1.2.3	15.7.0
2020-03	RAN#87	<a href="#">R5s200081</a>	0615	-	B	Addition of NR5GC test case 8.1.3.1.4 in FR1	15.7.0
2020-03	RAN#87	<a href="#">R5s200083</a>	0616	-	B	Addition of NR5GC test case 8.1.3.1.7 in FR1	15.7.0
2020-03	RAN#87	<a href="#">R5s200085</a>	0617	-	B	Addition of NR5GC test case 8.1.3.1.10 in FR1	15.7.0
2020-03	RAN#87	<a href="#">R5s200087</a>	0618	-	F	Correction to NR5GC test case 9.1.7.1	15.7.0
2020-03	RAN#87	<a href="#">R5s200088</a>	0619	-	F	Correction to NR5GC test case 7.1.1.2.4	15.7.0
2020-03	RAN#87	<a href="#">R5s200090</a>	0621	-	B	Addition of NR5GC test case 6.1.1.3 in FR1	15.7.0
2020-03	RAN#87	<a href="#">R5s200092</a>	0622	-	B	Addition of NR5GC test case 6.1.1.7 in FR1	15.7.0
2020-03	RAN#87	<a href="#">R5s200094</a>	0623	-	F	Correction to NR MAC test case 7.1.1.3.7	15.7.0
2020-03	RAN#87	<a href="#">R5s200098</a>	0627	-	F	Correction to NR RLC test case 7.1.2.3.7	15.7.0
2020-03	RAN#87	<a href="#">R5s200101</a>	0630	-	F	Correction in ENDC TC 7.1.1.1.1	15.7.0
2020-03	RAN#87	<a href="#">R5s200102</a>	0631	-	F	Correction to NR SA RRC test case 8.1.1.4.1	15.7.0
2020-03	RAN#87	<a href="#">R5s200104</a>	0633	-	F	Correction to 5GMM test case 9.1.5.2.7	15.7.0
2020-03	RAN#87	<a href="#">R5s200106</a>	0635	-	F	Corrections for SDAP test case 7.1.4.2	15.7.0
2020-03	RAN#87	<a href="#">R5s200108</a>	0637	-	F	Correction to RLC Test Case 7.1.2.3.9	15.7.0

2020-03	RAN#87	<a href="#">R5s200109</a>	0638	-	F	Correction to MAC Test Case 7.1.1.3.7	15.7.0
2020-03	RAN#87	<a href="#">R5s200110</a>	0639	-	F	Correction to NR5GC Test Case 6.1.2.3	15.7.0
2020-03	RAN#87	<a href="#">R5s200111</a>	0640	-	F	Correction to NR MAC test case 7.1.1.1.2	15.7.0
2020-03	RAN#87	<a href="#">R5s200116</a>	0642	-	B	Addition of NR5GC test case 6.1.1.1 in FR1	15.7.0
2020-03	RAN#87	<a href="#">R5s200118</a>	0643	-	B	Addition of NR5GC test case 9.1.6.1.4 in FR1	15.7.0
2020-03	RAN#87	<a href="#">R5s200120</a>	0644	-	F	Correction to ENDC RLC AM TC 7.1.2.3.10	15.7.0
2020-03	RAN#87	<a href="#">R5s200121</a>	0645	-	F	Correction to ENDC RLC UM TC 7.1.2.2.6	15.7.0
2020-03	RAN#87	<a href="#">R5s200122</a>	0646	-	F	Correction to IntraBand Non-Contiguous frequency for DC_41A_n41A	15.7.0
2020-03	RAN#87	<a href="#">R5s200123</a>	0647	-	F	Correction to NR RRC test case 8.2.5.1.1	15.7.0
2020-03	RAN#87	<a href="#">R5s200125</a>	0649	-	F	Correction to 5GC test case 9.1.6.1.2	15.7.0
2020-03	RAN#87	<a href="#">R5s200126</a>	0650	-	F	Correction to NR PDCP test case 7.1.3.4.2	15.7.0
2020-03	RAN#87	<a href="#">R5s200134</a>	0651	-	B	Addition of NR5GC test case 9.1.5.1.10 in FR1	15.7.0
2020-03	RAN#87	<a href="#">R5s200138</a>	0653	-	B	Addition of NR5GC test case 9.1.5.1.12 in FR1	15.7.0
2020-03	RAN#87	<a href="#">R5s200142</a>	0655	-	B	Addition of NR5GC test case 9.1.5.1.13 in FR1	15.7.0
2020-03	RAN#87	<a href="#">R5s200145</a>	0657	-	B	Addition of NR5GC test case 8.1.5.2.1 in FR1	15.7.0
2020-03	RAN#87	<a href="#">R5s200148</a>	0659	-	F	Correction to NR RLC test case 7.1.2.3.5	15.7.0
2020-03	RAN#87	<a href="#">R5s200149</a>	0660	-	B	Addition of EN-DC RRC test case 8.2.2.7.1 in FR2	15.7.0
2020-03	RAN#87	<a href="#">R5s200151</a>	0661	-	B	Addition of EN-DC PDCP test case 7.1.3.4.1 in FR2	15.7.0
2020-03	RAN#87	<a href="#">R5s200153</a>	0662	-	F	Correction to ENDC PDCP Test Case 7.1.3.5.3	15.7.0
2020-03	RAN#87	<a href="#">R5s200154</a>	0663	-	B	NR5GC FR1 : Addition of 5GMM test case 9.1.5.1.8	15.7.0
2020-03	RAN#87	<a href="#">R5s200156</a>	0664	-	B	NR5GC FR1 : Addition of NR Idle Mode test case 6.1.2.9	15.7.0
2020-03	RAN#87	<a href="#">R5s200158</a>	0665	-	F	Correction to ENDC testcase 10.2.1.1	15.7.0
2020-03	RAN#87	<a href="#">R5s200159</a>	0666	-	F	Correction to NR5GC testcase 7.1.1.1.1	15.7.0
2020-03	RAN#87	<a href="#">R5s200160</a>	0667	-	F	Correction to capability check functions	15.7.0
2020-03	RAN#87	<a href="#">R5s200161</a>	0668	-	F	Correction to template cads_NR_ULGrantAllocation_REQ	15.7.0
2020-03	RAN#87	<a href="#">R5s200162</a>	0669	-	F	Correction for common function fl_SDAP_Preamble_Part1()	15.7.0
2020-03	RAN#87	<a href="#">R5s200165</a>	0671	-	B	Addition of NR5GC test case 6.1.1.5 in FR1	15.7.0
2020-03	RAN#87	<a href="#">R5s200169</a>	0673	-	B	Addition of NR5GC test case 6.1.1.4 in FR1	15.7.0
2020-03	RAN#87	<a href="#">R5s200171</a>	0674	-	B	Addition of ENDC test case 8.2.2.8.1 in FR1	15.7.0
2020-03	RAN#87	<a href="#">R5s200173</a>	0675	-	B	Addition of NR5GC test case 6.1.1.2 in FR1	15.7.0
2020-03	RAN#87	<a href="#">R5s200176</a>	0677	-	B	Addition of NR5GC test case 9.1.5.2.6 in FR1	15.7.0
2020-03	RAN#87	<a href="#">R5s200178</a>	0678	-	B	NR5GC FR1: Addition of NR RRC IDLE test case 6.1.2.2	15.7.0
2020-03	RAN#87	<a href="#">R5s200180</a>	0679	-	F	Correction to NR RLC test case 7.1.2.2.6	15.7.0
2020-03	RAN#87	<a href="#">R5s200181</a>	0680	-	F	Correction to NR5GC RRC test case 8.1.3.2.1	15.7.0
2020-03	RAN#87	<a href="#">R5s200182</a>	0351	1	B	Addition of NR5GC test case 7.1.1.1.1 in FR1	15.7.0
2020-03	RAN#87	<a href="#">R5s200183</a>	0361	1	B	Addition of NR MAC test case 7.1.1.4.2.1	15.7.0
2020-03	RAN#87	<a href="#">R5s200184</a>	0395	1	F	Corrections to NR MAC test case 7.1.1.4.1.1	15.7.0

2020-03	RAN#87	<a href="#">R5s200185</a>	0398	1	F	Corrections to NR MAC test case 7.1.1.4.2.1	15.7.0
2020-03	RAN#87	<a href="#">R5s200186</a>	0431	1	F	Corrections to NR MAC test case 7.1.1.3.3	15.7.0
2020-03	RAN#87	<a href="#">R5s200187</a>	0432	1	F	Corrections to NR MAC test case 7.1.1.1.1	15.7.0
2020-03	RAN#87	<a href="#">R5s200189</a>	0452	1	B	Addition of EN-DC MAC test case 7.1.1.1.1 in FR2	15.7.0
2020-03	RAN#87	<a href="#">R5s200190</a>	0463	1	F	Correction to RLC AM test case 7.1.2.3.9	15.7.0
2020-03	RAN#87	<a href="#">R5s200191</a>	0464	1	F	Correction for EN-DC MAC test case 7.1.1.3.7	15.7.0
2020-03	RAN#87	<a href="#">R5s200192</a>	0466	1	B	Addition of EN-DC PDCP test case 7.1.3.5.3 in FR1	15.7.0
2020-03	RAN#87	<a href="#">R5s200193</a>	0467	1	B	Addition of EN-DC PDCP test case 7.1.3.5.3 in FR2	15.7.0
2020-03	RAN#87	<a href="#">R5s200195</a>	0470	1	B	NR5GC FR1 : Addition of NR5GC RRC test case 8.1.1.4.1	15.7.0
2020-03	RAN#87	<a href="#">R5s200196</a>	0472	1	F	Corrections for some NR MAC test cases in NR5GC operation	15.7.0
2020-03	RAN#87	<a href="#">R5s200197</a>	0473	1	B	NR5GC : Addition of NR PDCP test case 7.1.3.4.2 in FR1	15.7.0
2020-03	RAN#87	<a href="#">R5s200198</a>	0474	1	F	Correction to ENDC Test Case 7.1.2.3.8	15.7.0
2020-03	RAN#87	<a href="#">R5s200199</a>	0475	1	F	Correction to MR-DC capability check	15.7.0
2020-03	RAN#87	<a href="#">R5s200202</a>	0476	1	B	NR5GC : Addition of NR RRC test case 8.1.5.6.3 in FR1	15.7.0
2020-03	RAN#87	<a href="#">R5s200204</a>	0477	1	B	NR5GC FR1 : Addition of NR RLC test case 7.1.2.2.5	15.7.0
2020-03	RAN#87	<a href="#">R5s200205</a>	0478	1	B	EN-DC FR1 : Addition of NR RLC test case 7.1.2.2.5	15.7.0
2020-03	RAN#87	<a href="#">R5s200208</a>	0681		B	EN-DC FR1 : Addition of NR MAC test case 7.1.1.4.1.1	15.7.0
2020-03	RAN#87	<a href="#">R5s200211</a>	0483	1	F	Correction for EN-DC ESM test case 10.2.2.1	15.7.0
2020-03	RAN#87	<a href="#">R5s200212</a>	0486	1	F	Correction to NR5GC Test Case 9.1.3.1	15.7.0
2020-03	RAN#87	<a href="#">R5s200213</a>	0487	1	B	NR5GC FR1 : Addition of NR5GC RRC test case 8.1.3.1.3	15.7.0
2020-03	RAN#87	<a href="#">R5s200215</a>	0488	1	B	NR5GC : Addition of NR RRC test case 9.1.5.2.7 in FR1	15.7.0
2020-03	RAN#87	<a href="#">R5s200216</a>	0489	1	B	Addition of EN-DC RLC test case 7.1.2.3.3 in FR2	15.7.0
2020-03	RAN#87	<a href="#">R5s200217</a>	0490	1	B	NR5GC : Addition of NR RRC test case 8.1.1.2.3 in FR1	15.7.0
2020-03	RAN#87	<a href="#">R5s200218</a>	0491	1	B	Addition of EN-DC RLC test case 7.1.2.2.3 in FR2	15.7.0
2020-03	RAN#87	<a href="#">R5s200219</a>	0492	1	B	NR5GC FR1 : Addition of NR5GC RRC test case 8.1.3.1.6	15.7.0
2020-03	RAN#87	<a href="#">R5s200220</a>	0493	1	B	NR5GC FR1 : Addition of NR5GC RRC test case 8.1.3.1.9	15.7.0
2020-03	RAN#87	<a href="#">R5s200221</a>	0494	1	B	Addition of EN-DC MAC test case 7.1.1.3.7 in FR2	15.7.0
2020-03	RAN#87	<a href="#">R5s200222</a>	0495	1	F	Correction of ENDC Intra Band Contiguous frequency initialisation for MAC TBS test cases	15.7.0
2020-03	RAN#87	<a href="#">R5s200223</a>	0682		F	Correction for function fl_Check_featureSetsUplinkPerCC	15.7.0
2020-03	RAN#87	<a href="#">R5s200224</a>	0683		F	Correction to template cs_38508_PCCH_Config	15.7.0
2020-03	RAN#87	<a href="#">R5s200225</a>	0496	1	B	ENDC FR2 : Addition of NR MAC test case 7.1.1.2.1	15.7.0
2020-03	RAN#87	<a href="#">R5s200226</a>	0497	1	B	NR5GC FR1 : Addition of NR5GC/EUTRA Inter-RAT test case 8.1.3.2.1	15.7.0
2020-03	RAN#87	<a href="#">R5s200227</a>	0503	1	B	NR5GC FR1 : Addition of SDAP test case 7.1.4.1	15.7.0
2020-03	RAN#87	<a href="#">R5s200231</a>	0508	1	B	Addition of NR5GC test case 6.1.2.17 in FR1	15.7.0
2020-03	RAN#87	<a href="#">R5s200233</a>	0521	1	B	EN-DC FR1 : Addition of EN-DC RRC Measurement test case 8.2.3.6.1a	15.7.0



2020-03	RAN#87	<a href="#">R5s200234</a>	0522	1	B	EN-DC FR1 : Addition of EN-DC RRC Measurement test case 8.2.3.7.1a	15.7.0
2020-03	RAN#87	<a href="#">R5s200235</a>	0524	1	B	Addition of NR5GC test case 6.1.2.15 in FR1	15.7.0
2020-03	RAN#87	<a href="#">R5s200236</a>	0526	1	F	Correction to EN-DC common handover function	15.7.0
2020-03	RAN#87	<a href="#">R5s200239</a>	0527	1	F	Correction to common NR5GC function f_NR_DRBInfo_RemoveEntry()	15.7.0
2020-03	RAN#87	<a href="#">R5s200240</a>	0529	1	B	NR5GC FR1: Addition of NR RRC IDLE test case 6.1.2.12	15.7.0
2020-03	RAN#87	<a href="#">R5s200241</a>	0531	1	B	Addition of NR5GC test case 7.1.1.2.4 in FR1	15.7.0
2020-03	RAN#87	<a href="#">R5s200242</a>	0535	1	B	EN-DC FR1 : Addition of EN-DC RRC Measurement test case 8.2.3.6.1b	15.7.0
2020-03	RAN#87	<a href="#">R5s200243</a>	0536	1	B	EN-DC FR1 : Addition of EN-DC RRC Measurement test case 8.2.3.7.1b	15.7.0
2020-03	RAN#87	<a href="#">R5s200244</a>	0538	1	B	NR5GC FR1 : Addition of 5GMM test case 9.1.5.1.1	15.7.0
2020-03	RAN#87	<a href="#">R5s200245</a>	0539	1	F	Correction to NR test case 8.1.1.4.2	15.7.0
2020-03	RAN#87	<a href="#">R5s200246</a>	0540	1	B	EN-DC FR2 : Addition of NR RLC test case 7.1.2.2.5	15.7.0
2020-03	RAN#87	<a href="#">R5s200250</a>	0685		F	Correction to ENDC testcase 7.1.2.3.7	15.7.0
2020-03	RAN#87	<a href="#">R5s200252</a>	0546	1	F	Corrections to EN-DC RRC test case 8.2.3.13.1	15.7.0
2020-03	RAN#87	<a href="#">R5s200253</a>	0547	1	F	Corrections to NR RLC test case 7.1.2.3.9	15.7.0
2020-03	RAN#87	<a href="#">R5s200254</a>	0548	1	F	Corrections to NR RLC test case 7.1.2.3.6	15.7.0
2020-03	RAN#87	<a href="#">R5s200255</a>	0549	1	F	Corrections for EN-DC measurements test cases	15.7.0
2020-03	RAN#87	<a href="#">R5s200256</a>	0552	1	F	Correction to NR MAC test case 7.1.1.2.1	15.7.0
2020-03	RAN#87	<a href="#">R5s200257</a>	0554	1	F	Correction to NR MAC test case 7.1.1.3.2	15.7.0
2020-03	RAN#87	<a href="#">R5s200258</a>	0565	1	F	Correction for NR RLC test case 7.1.2.3.8	15.7.0
2020-03	RAN#87	<a href="#">R5s200259</a>	0566	1	F	Correction for EN-DC RRC test cases 8.2.3.3.1	15.7.0
2020-03	RAN#87	<a href="#">R5s200260</a>	0568	1	F	Correction to 5GMM test case 9.1.5.1.5	15.7.0
2020-03	RAN#87	<a href="#">R5s200261</a>	0569	1	F	Correction to the function f_NR5GC_RRC_Idle_Steps5_20	15.7.0
2020-03	RAN#87	<a href="#">R5s200262</a>	0570	1	F	Correction to NR RLC test cases 7.1.2.2.3 and 7.1.2.2.4	15.7.0
2020-03	RAN#87	<a href="#">R5s200263</a>	0571	1	F	Correction for EN-DC capability checking test case 8.2.1.1.1	15.7.0
2020-03	RAN#87	<a href="#">R5s200264</a>	0575	1	B	NR5GC FR1 : Addition of 5GMM test case 9.1.6.2.2	15.7.0
2020-03	RAN#87	<a href="#">R5s200265</a>	0576	1	F	Correction to NR5GC testcase 9.1.3.1	15.7.0
2020-03	RAN#87	<a href="#">R5s200266</a>	0578	1	F	Correction to the function f_NR_CellConfig_Def and template cas_NR_CellConfig_REQ	15.7.0
2020-03	RAN#87	<a href="#">R5s200268</a>	0580	1	F	Corrections to NR MAC test case 7.1.1.1.2	15.7.0
2020-03	RAN#87	<a href="#">R5s200269</a>	0581	1	F	Corrections for NR5GC RRC test case 8.1.2.1.1	15.7.0
2020-03	RAN#87	<a href="#">R5s200270</a>	0582	1	F	Corrections for EN-DC preamble functions	15.7.0
2020-03	RAN#87	<a href="#">R5s200271</a>	0583	1	F	Corrections for NR PDCP test cases 7.1.3.2.x and 7.1.3.3.x	15.7.0
2020-03	RAN#87	<a href="#">R5s200276</a>	0686	-	F	Correction to the function f_NR_SkipMeasGap	15.7.0
2020-03	RAN#87	<a href="#">R5s200277</a>	0687	-	F	Correction to the function fl_Check_Rf_Parameters_NRBand_PICS_Supp	15.7.0
2020-03	RAN#87	<a href="#">R5s200281</a>	0689	-	B	Addition of NR5GC test case 6.1.2.7 in FR1	15.7.0

2020-03	RAN#87	<a href="#">R5s200283</a>	0690	-	B	Addition of NR5GC test case 6.1.2.16 in FR1	15.7.0
2020-03	RAN#87	<a href="#">R5s200287</a>	0693	-	B	Addition of NR5GC test case 6.1.2.4 in FR1	15.7.0
2020-03	RAN#87	<a href="#">R5s200288</a>	0694	-	F	Correction to the templates for EAP message	15.7.0
2020-03	RAN#87	<a href="#">R5s200290</a>	0695	-	B	Addition of NR5GC test case 6.1.2.18 in FR1	15.7.0
2020-03	RAN#87	<a href="#">R5s200292</a>	0696	-	B	Addition of EN-DC RRC RSRQ Measurement test case 8.2.3.2.1 in FR1	15.7.0
2020-03	RAN#87	<a href="#">R5s200294</a>	0697	-	B	Addition of NR5GC test case 8.1.3.1.15a in FR1	15.7.0
2020-03	RAN#87	<a href="#">R5s200296</a>	0698	-	F	Correction to NR MAC test case 7.1.1.2.1	15.7.0
2020-03	RAN#87	<a href="#">R5s200313</a>	0704	-	B	EN-DC FR2 : Addition of NR RLC test case 7.1.2.3.5	15.7.0
2020-03	RAN#87	<a href="#">R5s200319</a>	0707	-	F	Correction to AM RLC test 7.1.2.3.7	15.7.0
2020-03	RAN#87	<a href="#">R5s200383</a>	0741	-	F	Add new verified and e-mail agreed TTCN test cases in the TC lists in 38.523-3 (prose), Annex A	15.7.0
2020-03	RAN#87	<a href="#">R5s200386</a>	0484	1	F	Correction for EN-DC ESM test case 10.2.1.1	15.7.0
2020-03	RAN#87	<a href="#">R5s200387</a>	0500	1	B	NR5GC FR1 : Addition of NR PDCP test case 7.1.3.2.1	15.7.0
2020-03	RAN#87	<a href="#">R5s200389</a>	0507	1	F	Correction to Intra NR measurements test 8.1.3.1.1	15.7.0
2020-03	RAN#87	<a href="#">R5s200390</a>	0509	1	B	Addition of NR5GC test case 9.1.6.1.2 in FR1	15.7.0
2020-03	RAN#87	<a href="#">R5s200391</a>	0511	1	B	NR5GC FR1 : Addition of NR PDCP test case 7.1.3.2.2	15.7.0
2020-03	RAN#87	<a href="#">R5s200392</a>	0512	1	B	NR5GC FR1 : Addition of NR PDCP test case 7.1.3.2.3	15.7.0
2020-03	RAN#87	<a href="#">R5s200393</a>	0513	1	B	Addition of NR5GC IRAT test case 8.1.3.2.2 in FR1	15.7.0
2020-03	RAN#87	<a href="#">R5s200394</a>	0532	1	F	Correction to NR test case 7.1.2.3.6	15.7.0
2020-03	RAN#87	<a href="#">R5s200395</a>	0567	1	F	Correction to NR RLC test case 7.1.2.2.6 for EN-DC	15.7.0
2020-03	RAN#87	<a href="#">R5s200396</a>	0572	1	F	Correction to NR PDCP test case 7.1.3.5.3	15.7.0
2020-03	RAN#87	<a href="#">R5s200397</a>	0574	1	B	NR5GC FR1 : Addition of NR Idle Mode test case 6.1.2.20	15.7.0
2020-03	RAN#87	<a href="#">R5s200398</a>	0584	1	B	NR5GC FR1 : Addition of 5GMM test case 9.1.5.1.2	15.7.0
2020-06	RAN#88	R5-202677	0940	1	F	5G Test Models updates	15.8.0
2020-06	RAN#88	<a href="#">R5s200478</a>	0800	-	F	Correction to 5GMM test case 9.1.5.1.14	15.8.0
2020-06	RAN#88	<a href="#">R5s200479</a>	0801	-	F	Correction for upper tester function for AT+C5GNSSAI	15.8.0
2020-06	RAN#88	<a href="#">R5s200481</a>	0803	-	B	NR5GC FR1 : Addition of NR MAC test case 7.1.1.4.2.3	15.8.0
2020-06	RAN#88	<a href="#">R5s200482</a>	0804	-	F	Correction for function f_Get_PDUSessionIdForDNNTtype	15.8.0
2020-06	RAN#88	<a href="#">R5s200485</a>	0807	-	F	Correction to EN-DC RRC measurement test cases 8.2.3.7.1x	15.8.0
2020-06	RAN#88	<a href="#">R5s200489</a>	0810	-	F	Correction to NR5GC common functions when pc_noOf_PDUsNewConnection > 0	15.8.0
2020-06	RAN#88	<a href="#">R5s200491</a>	0811	-	F	Correction to EN-DC RRC test case 8.2.2.7.1	15.8.0
2020-06	RAN#88	<a href="#">R5s200492</a>	0812	-	B	NR5GC FR1 : Addition of RRC test case 8.1.1.3.3	15.8.0
2020-06	RAN#88	<a href="#">R5s200496</a>	0813	-	F	Correction for NR5GC RRC test case 8.1.1.3.1	15.8.0
2020-06	RAN#88	<a href="#">R5s200499</a>	0815	-	F	Correction for 5GMM test case 9.1.7.1	15.8.0
2020-06	RAN#88	<a href="#">R5s200501</a>	0817	-	F	Correction for upper tester function	15.8.0
2020-06	RAN#88	<a href="#">R5s200504</a>	0819	-	F	Correction to NR Idle Mode test case 6.1.2.9	15.8.0
2020-06	RAN#88	<a href="#">R5s200506</a>	0821	-	F	Correction for EN-DC RRC test case 8.2.1.1.1	15.8.0

2020-06	RAN#88	<a href="#">R5s200509</a>	0823	-	B	NR5GC FR1 : Addition of NR5GC IRAT test case 8.1.4.2.1.1	15.8.0
2020-06	RAN#88	<a href="#">R5s200510</a>	0824	-	F	Correction for 5GMM test case 9.1.5.2.1	15.8.0
2020-06	RAN#88	<a href="#">R5s200511</a>	0825	-	F	Correction to NR MAC test case 7.1.1.3.4	15.8.0
2020-06	RAN#88	<a href="#">R5s200512</a>	0826	-	F	Correction for NR paging configuration	15.8.0
2020-06	RAN#88	<a href="#">R5s200514</a>	0828	-	F	Corrections for NR PDCP test cases 7.1.3.3.x	15.8.0
2020-06	RAN#88	<a href="#">R5s200516</a>	0830	-	B	EN-DC FR2 : Addition of NR PDCP test case 7.1.3.1.2	15.8.0
2020-06	RAN#88	<a href="#">R5s200517</a>	0831	-	F	Correction for NR5GC RRC test case 8.1.1.4.1	15.8.0
2020-06	RAN#88	<a href="#">R5s200518</a>	0832	-	F	Correction for NR5GC Idle Mode test case 6.1.2.4	15.8.0
2020-06	RAN#88	<a href="#">R5s200523</a>	0837	-	F	Correction for NR5GC RRC test case 9.1.2.2	15.8.0
2020-06	RAN#88	<a href="#">R5s200524</a>	0838	-	F	Correction for 5GMM test case 9.1.6.1.2	15.8.0
2020-06	RAN#88	<a href="#">R5s200526</a>	0840	-	F	Correction for NR MAC test cases 7.1.1.1.1 and 7.1.1.1.1a	15.8.0
2020-06	RAN#88	<a href="#">R5s200527</a>	0841	-	F	Corrections for EN-DC measurement test cases 8.2.3.6.1x	15.8.0
2020-06	RAN#88	<a href="#">R5s200529</a>	0843	-	F	Correction for NR RLC test cases 7.1.2.3.3 and 7.1.2.3.4	15.8.0
2020-06	RAN#88	<a href="#">R5s200530</a>	0844	-	F	Correction for NR RLC test cases 7.1.2.2.3 and 7.1.2.2.4	15.8.0
2020-06	RAN#88	<a href="#">R5s200533</a>	0845	-	F	NR/5GC FR1: Re-verification of test case 8.1.1.3.2	15.8.0
2020-06	RAN#88	<a href="#">R5s200537</a>	0848	-	F	Correction to NR Idle mode test case 6.4.2.1	15.8.0
2020-06	RAN#88	<a href="#">R5s200538</a>	0849	-	F	Correction to NR Idle Mode test case 6.1.2.18	15.8.0
2020-06	RAN#88	<a href="#">R5s200539</a>	0850	-	B	Addition of NR5GC test case 9.3.1.3 in FR1	15.8.0
2020-06	RAN#88	<a href="#">R5s200540</a>	0851	-	F	Corrections to testcase 7.1.2.3.7	15.8.0
2020-06	RAN#88	<a href="#">R5s200541</a>	0852	-	F	Corrections to NR5GC testcase 8.1.2.1.1	15.8.0
2020-06	RAN#88	<a href="#">R5s200542</a>	0853	-	F	Correction to functions f_NR_NRFFullCapabilityCheck	15.8.0
2020-06	RAN#88	<a href="#">R5s200543</a>	0854	-	F	Correction for NR5GC RRC test case 8.1.3.2.2	15.8.0
2020-06	RAN#88	<a href="#">R5s200544</a>	0855	-	F	Correction of function f_NR_Resourceallocation0_AllowedNPRB for Band n3	15.8.0
2020-06	RAN#88	<a href="#">R5s200545</a>	0856	-	F	Correction for slot offset calculation in f_NR_ShortMessageIndication_SysinfoMod	15.8.0
2020-06	RAN#88	<a href="#">R5s200546</a>	0857	-	F	Correction to the function f_NR_ConvertSSB_IndexToBit	15.8.0
2020-06	RAN#88	<a href="#">R5s200547</a>	0858	-	F	Correction to NR5GC test case 8.1.1.3.1	15.8.0
2020-06	RAN#88	<a href="#">R5s200548</a>	0859	-	F	Correction to the function f_Get_PDUSessionForDNNTtype	15.8.0
2020-06	RAN#88	<a href="#">R5s200549</a>	0860	-	F	Correction to the template cads_NR_UplinkBWP_List_ConfigCommon_REQ	15.8.0
2020-06	RAN#88	<a href="#">R5s200550</a>	0861	-	F	Correction to NR5GC test case 6.1.1.3	15.8.0
2020-06	RAN#88	<a href="#">R5s200551</a>	0862	-	F	Correction to NR5GC test case 7.1.1.1.3	15.8.0
2020-06	RAN#88	<a href="#">R5s200552</a>	0863	-	F	Correction to the template cs_NR_RachProcedureConfig_71116	15.8.0
2020-06	RAN#88	<a href="#">R5s200553</a>	0864	-	F	Correction to NR5GC test case 7.1.1.3.2	15.8.0
2020-06	RAN#88	<a href="#">R5s200554</a>	0865	-	F	Correction to NR5GC test case 7.1.1.2.1	15.8.0
2020-06	RAN#88	<a href="#">R5s200555</a>	0866	-	F	Correction to NR5GC test case 7.1.1.3.1	15.8.0
2020-06	RAN#88	<a href="#">R5s200556</a>	0867	-	F	Correction to NR5GC test case 7.1.1.1.1a	15.8.0
2020-06	RAN#88	<a href="#">R5s200557</a>	0868	-	F	Correction to the function f_TC_7_1_3_2_X_NR_TestBody	15.8.0

2020-06	RAN#88	<a href="#">R5s200558</a>	0869	-	F	Correction to the function f_NR_CellInfo_SetZeroCorrelationZoneConfig	15.8.0
2020-06	RAN#88	<a href="#">R5s200559</a>	0870	-	F	Correction to NSA test case 10.2.2.1	15.8.0
2020-06	RAN#88	<a href="#">R5s200560</a>	0871	-	F	Correction to definition of EUTRA_PdnInfo_Type	15.8.0
2020-06	RAN#88	<a href="#">R5s200561</a>	0872	-	F	Correction to NR5GC test case 9.1.6.1.3	15.8.0
2020-06	RAN#88	<a href="#">R5s200563</a>	0874	-	F	Correction to NR5GC test case 9.1.6.1.4	15.8.0
2020-06	RAN#88	<a href="#">R5s200564</a>	0875	-	F	NR/5GC FR1: Re-verification of IRAT test case 6.2.3.1	15.8.0
2020-06	RAN#88	<a href="#">R5s200566</a>	0876	-	F	NR/5GC FR1: Re-verification of IRAT test case 6.4.3.1	15.8.0
2020-06	RAN#88	<a href="#">R5s200570</a>	0878	-	F	EN-DC FR2: Re-verification of test case 8.2.2.8.1	15.8.0
2020-06	RAN#88	<a href="#">R5s200571</a>	0879	-	F	Corrections to NR5GC testcases 8.1.1.3.1 and 8.1.2.1.1	15.8.0
2020-06	RAN#88	<a href="#">R5s200573</a>	0880	-	B	NR5GC FR1 : Addition of 5GMM test case 9.1.4.1	15.8.0
2020-06	RAN#88	<a href="#">R5s200575</a>	0882	-	B	NR5GC FR1: Addition of Inter-band CA RRC test case 8.1.5.6.5.2	15.8.0
2020-06	RAN#88	<a href="#">R5s200577</a>	0883	-	B	EN-DC FR1 : Addition of NR MAC test case 7.1.1.4.2.1	15.8.0
2020-06	RAN#88	<a href="#">R5s200579</a>	0884	-	B	NR5GC FR1: Addition of Intra-band contiguous CA RRC test case 8.1.5.6.5.1	15.8.0
2020-06	RAN#88	<a href="#">R5s200582</a>	0885	-	F	Correction to NR5GC test case 8.1.3.1.15a	15.8.0
2020-06	RAN#88	<a href="#">R5s200583</a>	0886	-	F	NR/5GC FR1: Re-verification of IRAT test case 6.2.3.3	15.8.0
2020-06	RAN#88	<a href="#">R5s200585</a>	0887	-	B	Addition of NR5GC test case 10.1.3.2 in FR1	15.8.0
2020-06	RAN#88	<a href="#">R5s200587</a>	0888	-	B	Addition of NR5GC test case 9.1.7.2 in FR1	15.8.0
2020-06	RAN#88	<a href="#">R5s200589</a>	0889	-	B	Addition of NR5GC test case 9.1.2.3 in FR1	15.8.0
2020-06	RAN#88	<a href="#">R5s200591</a>	0890	-	B	Addition of NR5GC test case 9.1.2.4 in FR1	15.8.0
2020-06	RAN#88	<a href="#">R5s200593</a>	0891	-	B	Addition of NR5GC test case 9.1.2.5 in FR1	15.8.0
2020-06	RAN#88	<a href="#">R5s200597</a>	0893	-	B	Addition of NR5GC test case 9.1.2.7 in FR1	15.8.0
2020-06	RAN#88	<a href="#">R5s200601</a>	0895	-	B	Addition of NR5GC test case 6.2.3.7 in FR1	15.8.0
2020-06	RAN#88	<a href="#">R5s200603</a>	0896	-	B	Addition of NR5GC test case 6.1.2.19 in FR1	15.8.0
2020-06	RAN#88	<a href="#">R5s200605</a>	0897	-	B	ENDC FR1: Addition of Intra-band contiguous CA RRC test case 8.2.4.1.1.1	15.8.0
2020-06	RAN#88	<a href="#">R5s200607</a>	0898	-	B	Addition of NR5GC test case 6.2.3.9 in FR1	15.8.0
2020-06	RAN#88	<a href="#">R5s200610</a>	0900	-	B	NR5GC FR1 : Addition of NR Idle Mode test case 6.1.2.8	15.8.0
2020-06	RAN#88	<a href="#">R5s200612</a>	0902	-	F	Correction to EN-DC RRC measurement test cases	15.8.0
2020-06	RAN#88	<a href="#">R5s200614</a>	0904	-	B	NR5GC FR1 : Addition of 5GMM test case 9.1.2.6	15.8.0
2020-06	RAN#88	<a href="#">R5s200617</a>	0905	-	B	NR5GC FR1 : Addition of 5GMM test case 9.1.2.8	15.8.0
2020-06	RAN#88	<a href="#">R5s200619</a>	0906	-	B	NR5GC FR1 : Addition of NR5GC RRC test case 8.1.5.3.4	15.8.0
2020-06	RAN#88	<a href="#">R5s200622</a>	0907	-	B	Addition of NR5GC test case 8.1.3.3.1 in FR1	15.8.0
2020-06	RAN#88	<a href="#">R5s200624</a>	0908	-	B	ENDC FR1: Addition of Inter band CA RRC test case 8.2.4.1.1.3	15.8.0
2020-06	RAN#88	<a href="#">R5s200626</a>	0909	-	F	Corrections to ENDC CA band combinations	15.8.0
2020-06	RAN#88	<a href="#">R5s200627</a>	0910	-	F	Corrections to NR5GC testcase 9.1.5.1.3a	15.8.0
2020-06	RAN#88	<a href="#">R5s200628</a>	0911	-	B	Addition of NR5GC test case 9.3.1.1 in FR1	15.8.0
2020-06	RAN#88	<a href="#">R5s200630</a>	0912	-	B	NR5GC FR1 : Addition of NR5GC RRC test case 8.1.5.4.1	15.8.0

2020-06	RAN#88	<a href="#">R5s200633</a>	0914	-	B	Addition of NR5GC test case 6.1.2.14 in FR1	15.8.0
2020-06	RAN#88	<a href="#">R5s200635</a>	0915	-	B	Addition of NR5GC test case 6.1.2.13 in FR1	15.8.0
2020-06	RAN#88	<a href="#">R5s200638</a>	0917	-	B	Addition of NR5GC test case 6.4.1.2 in FR1	15.8.0
2020-06	RAN#88	<a href="#">R5s200644</a>	0919	-	F	Correction to EN-DC RRC test case 8.2.1.1.1	15.8.0
2020-06	RAN#88	<a href="#">R5s200647</a>	0922	-	F	Correction to common ENDC function for security key exchange	15.8.0
2020-06	RAN#88	<a href="#">R5s200648</a>	0923	-	B	Addition of NR5GC test case 6.2.1.1 in FR1	15.8.0
2020-06	RAN#88	<a href="#">R5s200650</a>	0924	-	B	Addition of EN-DC RRC test case 8.2.2.6.1 in FR1	15.8.0
2020-06	RAN#88	<a href="#">R5s200651</a>	0925	-	B	Addition of EN-DC RRC test case 8.2.2.6.1 in FR2	15.8.0
2020-06	RAN#88	<a href="#">R5s200657</a>	0929	-	B	Addition of NR5GC test case 6.4.1.1 in FR1	15.8.0
2020-06	RAN#88	<a href="#">R5s200659</a>	0930	-	B	Addition of NR5GC test case 6.2.1.2 in FR1	15.8.0
2020-06	RAN#88	<a href="#">R5s200661</a>	0931	-	F	Correction to multiPDN in EN-DC tests	15.8.0
2020-06	RAN#88	<a href="#">R5s200662</a>	0932	-	F	Correction to test case 9.1.7.1	15.8.0
2020-06	RAN#88	<a href="#">R5s200663</a>	0933	-	B	Addition of NR5GC test case 6.3.1.1 in FR1	15.8.0
2020-06	RAN#88	<a href="#">R5s200666</a>	0935	-	B	EN-DC FR1 : Addition of RRC test case 8.2.6.2.1	15.8.0
2020-06	RAN#88	<a href="#">R5s200672</a>	0939	-	B	Addition of NR5GC test case 6.3.1.2 in FR1	15.8.0
2020-06	RAN#88	<a href="#">R5s200676</a>	0942	-	F	Correction to template cas_NR_SRB_NasPdu_REQ	15.8.0
2020-06	RAN#88	<a href="#">R5s200677</a>	0943	-	F	Correction to NR5GC test case 9.1.7.1	15.8.0
2020-06	RAN#88	<a href="#">R5s200680</a>	0945	-	B	Addition of NR5GC test case 6.3.1.3 in FR1	15.8.0
2020-06	RAN#88	<a href="#">R5s200682</a>	0946	-	B	Addition of NR5GC test case 6.3.1.4 in FR1	15.8.0
2020-06	RAN#88	<a href="#">R5s200684</a>	0947	-	B	ENDC FR2: Addition of EN-DC RRC measurement test case 8.2.3.6.1a	15.8.0
2020-06	RAN#88	<a href="#">R5s200686</a>	0948	-	B	ENDC FR2: Addition of EN-DC RRC measurement test case 8.2.3.7.1a	15.8.0
2020-06	RAN#88	<a href="#">R5s200688</a>	0949	-	B	ENDC FR2: Addition of EN-DC RRC measurement test case 8.2.3.8.1a	15.8.0
2020-06	RAN#88	<a href="#">R5s200690</a>	0950	-	B	NR5GC FR1: Addition of NR PDCP test case 7.1.3.4.1	15.8.0
2020-06	RAN#88	<a href="#">R5s200696</a>	0953	-	F	Correction to the function f_NR_ENDC_ReConfigAM_UM	15.8.0
2020-06	RAN#88	<a href="#">R5s200697</a>	0954	-	F	Correction to NR5GC test case 10.1.1.2	15.8.0
2020-06	RAN#88	<a href="#">R5s200701</a>	0956	-	F	Correction to the template cs_NR_PDCP_Config_UIPath	15.8.0
2020-06	RAN#88	<a href="#">R5s200703</a>	0958	-	B	NR5GC FR1 : Addition of NR5GC PWS test case 8.1.5.3.1	15.8.0
2020-06	RAN#88	<a href="#">R5s200705</a>	0959	-	B	NR5GC FR1 : Addition of NR5GC PWS test case 8.1.5.3.2	15.8.0
2020-06	RAN#88	<a href="#">R5s200707</a>	0960	-	B	NR5GC FR1 : Addition of NR5GC PWS test case 8.1.5.3.3	15.8.0
2020-06	RAN#88	<a href="#">R5s200709</a>	0961	-	F	Correction to NR5GC test case 6.1.1.8	15.8.0
2020-06	RAN#88	<a href="#">R5s200710</a>	0962	-	F	Correction to NR5GC/ENDC test case 7.1.2.3.8	15.8.0
2020-06	RAN#88	<a href="#">R5s200715</a>	0966	-	F	Correction for SDAP test case 7.1.4.2	15.8.0
2020-06	RAN#88	<a href="#">R5s200716</a>	0967	-	F	Correction to 5GMM test case 9.1.7.2	15.8.0
2020-06	RAN#88	<a href="#">R5s200717</a>	0968	-	B	NR5GC FR1 : Addition of RRC CA test case 8.1.3.1.17.1	15.8.0
2020-06	RAN#88	<a href="#">R5s200719</a>	0969	-	B	NR5GC FR1 : Addition of RRC CA test case 8.1.3.1.17.2	15.8.0
2020-06	RAN#88	<a href="#">R5s200721</a>	0970	-	B	Addition of NR5GC IRAT test case 6.2.3.2 in FR1	15.8.0

2020-06	RAN#88	<a href="#">R5s200723</a>	0971	-	B	Addition of NR5GC IRAT test case 6.2.3.4 in FR1	15.8.0
2020-06	RAN#88	<a href="#">R5s200725</a>	0972	-	B	Addition of NR5GC IRAT test case 8.1.3.2.3 in FR1	15.8.0
2020-06	RAN#88	<a href="#">R5s200727</a>	0973	-	B	Addition of NR5GC IRAT test case 8.1.3.2.4 in FR1	15.8.0
2020-06	RAN#88	<a href="#">R5s200729</a>	0974	-	B	Addition of NR5GC test case 11.3.3 in FR1	15.8.0
2020-06	RAN#88	<a href="#">R5s200731</a>	0975	-	F	Correction to NR5GC test case 6.1.2.7	15.8.0
2020-06	RAN#88	<a href="#">R5s200732</a>	0976	-	F	Correction to f_EUTRA38_IRAT_NAS_Init	15.8.0
2020-06	RAN#88	<a href="#">R5s200733</a>	0977	-	F	Correction to NR5GC RRC test case 8.1.5.4.1	15.8.0
2020-06	RAN#88	<a href="#">R5s200734</a>	0978	-	B	NR5GC FR1 : Addition of RRC CA test case 8.1.3.1.18.1	15.8.0
2020-06	RAN#88	<a href="#">R5s200736</a>	0979	-	B	NR5GC FR1 : Addition of RRC CA test case 8.1.3.1.18.2	15.8.0
2020-06	RAN#88	<a href="#">R5s200738</a>	0980	-	F	Correction to NR5GC test case 10.1.1.1	15.8.0
2020-06	RAN#88	<a href="#">R5s200744</a>	0983	-	F	Correction to NR5GC test case 8.2.3.2.1	15.8.0
2020-06	RAN#88	<a href="#">R5s200747</a>	0985	-	B	EN-DC FR2 : Addition of NR MAC test case 7.1.1.3.3	15.8.0
2020-06	RAN#88	<a href="#">R5s200750</a>	0987	-	F	Correction to 5GSM test case 9.1.7.1	15.8.0
2020-06	RAN#88	<a href="#">R5s200752</a>	0989	-	F	Correction to the NR5GC testcase 6.1.2.1	15.8.0
2020-06	RAN#88	<a href="#">R5s200753</a>	0990	-	F	Correction to the ENDC testcase 7.1.1.3.7	15.8.0
2020-06	RAN#88	<a href="#">R5s200754</a>	0991	-	F	Correction to NR5GC function f_NR5GC_508RRC_IntraNR_HO_IntraCell_Step1_8	15.8.0
2020-06	RAN#88	<a href="#">R5s200755</a>	0992	-	F	Correction to NR RLC testcase 7.1.2.2.6	15.8.0
2020-06	RAN#88	<a href="#">R5s200756</a>	0993	-	F	Correction to the NR5GC testcase 9.1.5.1.2	15.8.0
2020-06	RAN#88	<a href="#">R5s200757</a>	0994	-	F	Correction to the NR5GC testcase 9.1.7.2	15.8.0
2020-06	RAN#88	<a href="#">R5s200758</a>	0995	-	B	Addition of NR5GC test case 9.1.5.1.3 in FR1	15.8.0
2020-06	RAN#88	<a href="#">R5s200762</a>	0515	1	B	Addition of NR5GC IRAT test case 6.2.3.1 in FR1	15.8.0
2020-06	RAN#88	<a href="#">R5s200763</a>	0641	1	F	Correction to NR5GC RRC test case 8.1.1.2.1	15.8.0
2020-06	RAN#88	<a href="#">R5s200764</a>	0688	1	B	Addition of NR5GC test case 8.1.2.1.2	15.8.0
2020-06	RAN#88	<a href="#">R5s200765</a>	0699	1	B	NR5GC FR1 : Addition of 5GMM test case 9.1.5.1.14	15.8.0
2020-06	RAN#88	<a href="#">R5s200766</a>	0702	1	B	NR5GC FR1 : Addition of NR5GC RRC test case 8.1.4.1.2	15.8.0
2020-06	RAN#88	<a href="#">R5s200769</a>	0708	1	B	EN-DC FR2 : Addition of EN-DC RRC test case 8.2.3.8.1	15.8.0
2020-06	RAN#88	<a href="#">R5s200770</a>	0711	1	B	NR5GC FR1 : Addition of 5GMM test case 9.1.5.2.1	15.8.0
2020-06	RAN#88	<a href="#">R5s200772</a>	0999		B	Addition of NR5GC test case 6.2.1.4 in FR1	15.8.0
2020-06	RAN#88	<a href="#">R5s200774</a>	0714	1	F	Correction of function fl_Check_featureSetsUplinkPerCC	15.8.0
2020-06	RAN#88	<a href="#">R5s200775</a>	0715	1	F	Correction for NR PDCP test case 7.1.3.5.2	15.8.0
2020-06	RAN#88	<a href="#">R5s200776</a>	0716	1	B	NR5GC FR1 : Addition of 5GMM test case 9.1.5.1.3a	15.8.0
2020-06	RAN#88	<a href="#">R5s200777</a>	0717	1	F	Correction to NR5GC RRC test case 8.1.2.1.1	15.8.0
2020-06	RAN#88	<a href="#">R5s200778</a>	0718	1	F	Correction to ENDC RRC test case 8.2.3.13.1	15.8.0
2020-06	RAN#88	<a href="#">R5s200779</a>	0719	1	B	Addition of NR5GC test case 6.1.1.8 in FR1	15.8.0
2020-06	RAN#88	<a href="#">R5s200780</a>	0725	1	B	Addition of NR5GC IRAT test case 6.2.3.5 in FR1	15.8.0
2020-06	RAN#88	<a href="#">R5s200781</a>	0726	1	B	Addition of NR5GC IRAT test case 6.2.3.6 in FR1	15.8.0
2020-06	RAN#88	<a href="#">R5s200784</a>	0730	1	B	Addition of NR5GC test case 6.1.2.22 in FR1	15.8.0

2020-06	RAN#88	<a href="#">R5s200785</a>	0731	1	F	Correction to function fl_NR_InitSIB4_FreqInfoList()	15.8.0
2020-06	RAN#88	<a href="#">R5s200786</a>	0732	1	F	Correction to function f_EUTRA38_NR_Capability()	15.8.0
2020-06	RAN#88	<a href="#">R5s200787</a>	0733	1	F	Correction to NR Idle Mode test case 6.1.2.7	15.8.0
2020-06	RAN#88	<a href="#">R5s200788</a>	0734	1	F	Correction to NR5GC RRC test case 8.1.1.2.1	15.8.0
2020-06	RAN#88	<a href="#">R5s200789</a>	0736	1	B	Addition of NR5GC test case 9.1.1.3 in FR1	15.8.0
2020-06	RAN#88	<a href="#">R5s200790</a>	0737	1	B	Addition of NR5GC IRAT test case 6.2.3.8 in FR1	15.8.0
2020-06	RAN#88	<a href="#">R5s200791</a>	0738	1	B	Addition of NR5GC test case 6.4.2.1 in FR1	15.8.0
2020-06	RAN#88	<a href="#">R5s200792</a>	0739	1	B	Addition of NR5GC IRAT test case 9.3.1.2 in FR1	15.8.0
2020-06	RAN#88	<a href="#">R5s200793</a>	0742	1	B	Addition of NR5GC test case 10.1.1.1 in FR1	15.8.0
2020-06	RAN#88	<a href="#">R5s200794</a>	0743	1	B	Addition of NR5GC test case 10.1.1.2 in FR1	15.8.0
2020-06	RAN#88	<a href="#">R5s200795</a>	0753	1	F	Correction for NR5GC common function f_BuildRRCReconfigParamsNewDRBs()	15.8.0
2020-06	RAN#88	<a href="#">R5s200796</a>	0757	1	F	Corrections for EUTRA registration procedure	15.8.0
2020-06	RAN#88	<a href="#">R5s200798</a>	1001	-	F	Correction to NR5GC testcase 9.3.1.2	15.8.0
2020-06	RAN#88	<a href="#">R5s200799</a>	0759	1	B	EN-DC FR1 : Addition of EN-DC RRC measurement test case 8.2.3.8.1a	15.8.0
2020-06	RAN#88	<a href="#">R5s200800</a>	0760	1	B	EN-DC FR1 : Addition of EN-DC RRC measurement test case 8.2.3.8.1b	15.8.0
2020-06	RAN#88	<a href="#">R5s200801</a>	0767	1	F	Correction for 5GC registration	15.8.0
2020-06	RAN#88	<a href="#">R5s200802</a>	0768	1	F	Correction for NR5GC Idle Mode test cases using SIB3	15.8.0
2020-06	RAN#88	<a href="#">R5s200803</a>	0771	1	F	Correction for NR grant assignment	15.8.0
2020-06	RAN#88	<a href="#">R5s200804</a>	0776	1	B	NR5GC FR1 : Addition of 5GMM test case 9.1.1.6	15.8.0
2020-06	RAN#88	<a href="#">R5s200805</a>	0781	1	F	Correction for common ENDC handover function	15.8.0
2020-06	RAN#88	<a href="#">R5s200806</a>	0786	1	F	Corrections to test frequencies for Intra-band Contiguous NR CA	15.8.0
2020-06	RAN#88	<a href="#">R5s200807</a>	0789	1	F	Correction for NR5GC authentication function	15.8.0
2020-06	RAN#88	<a href="#">R5s200808</a>	0792	1	F	Correction for common NR5GC configuration function()	15.8.0
2020-06	RAN#88	<a href="#">R5s200809</a>	0797	1	F	Correction to function f_GetLastConfiguredInternetPDUSessionID	15.8.0
2020-06	RAN#88	<a href="#">R5s200817</a>	1006	-	F	Correction to NR5GC test case 6.4.3.1	15.8.0
2020-06	RAN#88	<a href="#">R5s200818</a>	1007	-	F	Update to Configuration and Activation of VNG	15.8.0
2020-06	RAN#88	<a href="#">R5s200819</a>	1008	-	F	Correction to NR5GC test case 9.1.6.1.2	15.8.0
2020-06	RAN#88	<a href="#">R5s200823</a>	1009	-	B	EN-DC FR2 : Addition of NR MAC test case 7.1.1.1.2	15.8.0
2020-06	RAN#88	<a href="#">R5s200839</a>	0706	1	B	Addition of EN-DC RRC test case 8.2.2.8.1 in FR2	15.8.0
2020-06	RAN#88	<a href="#">R5s200841</a>	0721	1	B	Addition of NR5GC test case 8.1.3.3.2 in FR1	15.8.0
2020-06	RAN#88	<a href="#">R5s200842</a>	0723	1	B	Addition of NR5GC test case 9.1.6.1.3 in FR1	15.8.0
2020-06	RAN#88	<a href="#">R5s200844</a>	0740	1	B	NR5GC FR1 : Addition of NR Idle Mode test case 6.1.2.5	15.8.0
2020-06	RAN#88	<a href="#">R5s200845</a>	0744	1	B	NR5GC FR1 : Addition of NR Idle Mode test case 6.4.2.2	15.8.0
2020-06	RAN#88	<a href="#">R5s200846</a>	0748	1	F	Correction to EN-DC RRC Measurement tests 8.2.3.1.1 and 8.2.3.3.1	15.8.0
2020-06	RAN#88	<a href="#">R5s200847</a>	0755	1	B	EN-DC FR1 : Addition of RRC test case 8.2.2.1.1	15.8.0

2020-06	RAN#88	<a href="#">R5s200848</a>	0758	1	B	EN-DC FR2 : Addition of RRC test case 8.2.2.1.1	15.8.0
2020-06	RAN#88	<a href="#">R5s200849</a>	0787	1	B	ENDC FR2: Addition of Intra-band Contiguous CA RRC test case 8.2.4.1.1.1	15.8.0
2020-06	RAN#88	<a href="#">R5s200850</a>	0793	1	F	Correction for common NR rounding function()	15.8.0
2020-06	RAN#88	<a href="#">R5s200851</a>	0796	1	B	Addition of NR5GC test case 8.1.3.1.16 in FR1	15.8.0
2020-06	RAN#88	<a href="#">R5s200911</a>	0691	1	B	Addition of NR5GC test case 8.1.1.3.2 in FR1	15.8.0
2020-06	RAN#88	<a href="#">R5s200912</a>	0703	1	B	NR5GC FR1 : Addition of 5GMM SMS over NAS test case 9.1.8.1	15.8.0
2020-06	RAN#88	<a href="#">R5s200913</a>	0749	1	B	EN-DC FR2 : Addition of NR MAC test case 7.1.1.3.1	15.8.0
2020-06	RAN#88	<a href="#">R5s200915</a>	1057	-	F	Add new verified and e-mail agreed TTCN test cases in the TC lists in 38.523-3 (prose), Annex A	15.8.0
2020-06	RAN#88	<a href="#">R5s200918</a>	0516	1	B	Addition of NR5GC test case 6.4.3.1 in FR1	15.8.0
2020-06	RAN#88	<a href="#">R5s200919</a>	0534	1	B	NR5GC FR1 : Addition of NR5GC inter-RAT test case 6.2.3.3	15.8.0
2020-06	RAN#88	<a href="#">R5s200920</a>	0541	1	B	NR5GC FR1: Addition of NR RLC test case 7.1.2.3.11	15.8.0
2020-09	RAN#89	<a href="#">R5s201000</a>	1125	-	F	Correction for NR5GC idle mode test case 6.4.2.1	15.9.0
2020-09	RAN#89	<a href="#">R5s201004</a>	1129	-	F	Corrections for NR5GC IRAT Idle mode test cases	15.9.0
2020-09	RAN#89	<a href="#">R5s201007</a>	1132	-	F	Correction to NR MAC test case 7.1.1.3.5	15.9.0
2020-09	RAN#89	<a href="#">R5s201010</a>	1135	-	F	Correction for NR RLC test cases 7.1.2.3.6 and 7.1.2.3.8 in EN-DC operation	15.9.0
2020-09	RAN#89	<a href="#">R5s201011</a>	1136	-	F	Corrections for NR5GC idle mode test case 6.4.1.2	15.9.0
2020-09	RAN#89	<a href="#">R5s201012</a>	1137	-	F	Correction to NR MAC test case 7.1.1.3.1	15.9.0
2020-09	RAN#89	<a href="#">R5s201013</a>	1138	-	F	Correction to ENDC testcase 8.2.3.2.1	15.9.0
2020-09	RAN#89	<a href="#">R5s201015</a>	1139	-	F	NR5GC FR1 : Re-verification of NR Idle Mode test case 6.1.2.11	15.9.0
2020-09	RAN#89	<a href="#">R5s201017</a>	1140	-	F	Correction to ENDC testcase 8.2.3.12.1	15.9.0
2020-09	RAN#89	<a href="#">R5s201018</a>	1141	-	F	Correction to NR5GC IRAT test case 8.1.3.2.4	15.9.0
2020-09	RAN#89	<a href="#">R5s201019</a>	1142	-	F	Correction to NR PDCP test case 7.1.3.4.1	15.9.0
2020-09	RAN#89	<a href="#">R5s201020</a>	1143	-	F	Correction to function f_ExtendedEAPAKA_PRF	15.9.0
2020-09	RAN#89	<a href="#">R5s201021</a>	1144	-	B	Addition of NR5GC test case 9.1.1.1 in FR1	15.9.0
2020-09	RAN#89	<a href="#">R5s201022</a>	1145	-	F	Correction to NR MAC test case 7.1.1.1.1a	15.9.0
2020-09	RAN#89	<a href="#">R5s201023</a>	1146	-	F	Correction to EN-DC RRC test case 8.2.3.3.1	15.9.0
2020-09	RAN#89	<a href="#">R5s201025</a>	1147	-	B	Addition of NR5GC test case 9.1.1.2 in FR1	15.9.0
2020-09	RAN#89	<a href="#">R5s201028</a>	1149	-	B	Addition of NR5GC test case 10.1.4.1 in FR1	15.9.0
2020-09	RAN#89	<a href="#">R5s201030</a>	1150	-	F	Correction to NR5GC test case 11.3.4	15.9.0
2020-09	RAN#89	<a href="#">R5s201031</a>	1151	-	F	Correction to NR5GC test case 6.1.2.14	15.9.0
2020-09	RAN#89	<a href="#">R5s201032</a>	1152	-	F	Correction to NR5GC test case 9.1.5.2.9	15.9.0
2020-09	RAN#89	<a href="#">R5s201034</a>	1154	-	F	Correction to NR5GC test case 9.1.5.2.6	15.9.0
2020-09	RAN#89	<a href="#">R5s201035</a>	1155	-	F	Correction to NR5GC testcase 8.1.1.3.2	15.9.0
2020-09	RAN#89	<a href="#">R5s201036</a>	1156	-	F	Correction to NR MAC test case 7.1.1.4.2.3	15.9.0
2020-09	RAN#89	<a href="#">R5s201037</a>	1157	-	F	Correction to NR idle mode test case 6.1.2.19	15.9.0
2020-09	RAN#89	<a href="#">R5s201038</a>	1158	-	F	Correction to NR MAC test case 7.1.1.2.4	15.9.0



2020-09	RAN#89	<a href="#">R5s201039</a>	1159	-	F	EN-DC FR1 : Re-verification of NR MAC test case 7.1.1.5.1	15.9.0
2020-09	RAN#89	<a href="#">R5s201041</a>	1160	-	F	EN-DC FR2 : Re-verification of NR MAC test case 7.1.1.5.1	15.9.0
2020-09	RAN#89	<a href="#">R5s201043</a>	1161	-	F	Correction to NR5GC test case 6.3.1.1	15.9.0
2020-09	RAN#89	<a href="#">R5s201044</a>	1162	-	F	Correction to NR5GC test case 6.3.1.2	15.9.0
2020-09	RAN#89	<a href="#">R5s201045</a>	1163	-	F	Correction to NR5GC test case 6.2.1.4	15.9.0
2020-09	RAN#89	<a href="#">R5s201046</a>	1164	-	F	Correction to NR5GC test case 6.2.3.9	15.9.0
2020-09	RAN#89	<a href="#">R5s201047</a>	1165	-	F	Correction to NR5GC test case 6.4.1.1	15.9.0
2020-09	RAN#89	<a href="#">R5s201049</a>	1167	-	F	Correction to NR5GC test case 9.1.2.1	15.9.0
2020-09	RAN#89	<a href="#">R5s201052</a>	1170	-	F	Correction to the NR5GC testcase 9.1.7.1	15.9.0
2020-09	RAN#89	<a href="#">R5s201053</a>	1171	-	F	Correction to the NR5GC testcase 7.1.1.5.3	15.9.0
2020-09	RAN#89	<a href="#">R5s201054</a>	1172	-	B	NR5GC FR1 : Addition of NR5GC IRAT test case 6.2.1.3	15.9.0
2020-09	RAN#89	<a href="#">R5s201060</a>	1175	-	F	Correction to NR5GC IRAT test case 8.1.5.5.1	15.9.0
2020-09	RAN#89	<a href="#">R5s201061</a>	1176	-	F	Correction to 5GMM test case 9.1.2.1	15.9.0
2020-09	RAN#89	<a href="#">R5s201062</a>	1177	-	F	Correction to NR5GC IRAT test case 8.1.1.3.4	15.9.0
2020-09	RAN#89	<a href="#">R5s201063</a>	1178	-	F	Correction to 5GSM test case 10.1.6.1	15.9.0
2020-09	RAN#89	<a href="#">R5s201065</a>	1180	-	F	Correction to the ENDC testcase 7.1.1.3.5	15.9.0
2020-09	RAN#89	<a href="#">R5s201066</a>	1181	-	F	Correction to NR5GC testcase 9.1.4.1	15.9.0
2020-09	RAN#89	<a href="#">R5s201067</a>	1182	-	F	Correction to NR5GC testcase 6.2.1.5	15.9.0
2020-09	RAN#89	<a href="#">R5s201072</a>	1186	-	F	Correction for NR MAC test case 7.1.1.5.3	15.9.0
2020-09	RAN#89	<a href="#">R5s201076</a>	1189	-	F	Correction to NR5GC IRAT test case 8.1.4.1.2	15.9.0
2020-09	RAN#89	<a href="#">R5s201077</a>	1190	-	F	Corrections for NR5GC RRC test case 8.1.5.3.4	15.9.0
2020-09	RAN#89	<a href="#">R5s201079</a>	1192	-	F	Correction for NR5GC IRAT measurement test cases	15.9.0
2020-09	RAN#89	<a href="#">R5s201080</a>	1193	-	B	EN-DC FR1 : Addition of EN-DC RRC test case 8.2.3.16.1	15.9.0
2020-09	RAN#89	<a href="#">R5s201082</a>	1194	-	F	Correction to NR5GC idle mode test case 6.1.1.4	15.9.0
2020-09	RAN#89	<a href="#">R5s201085</a>	1196	-	B	EN-DC FR2 : Addition of EN-DC RRC test case 8.2.3.16.1	15.9.0
2020-09	RAN#89	<a href="#">R5s201090</a>	1198	-	B	NR5GC FR1: Addition of NR5GC CA test case 8.1.3.1.17.3	15.9.0
2020-09	RAN#89	<a href="#">R5s201091</a>	1199	-	B	NR5GC FR1: Addition of NR5GC CA test case 8.1.5.6.5.3	15.9.0
2020-09	RAN#89	<a href="#">R5s201096</a>	1202	-	F	Correction for NR idle mode test case 6.2.1.4	15.9.0
2020-09	RAN#89	<a href="#">R5s201098</a>	1204	-	F	Correction for RRCResume in NR5GC test cases	15.9.0
2020-09	RAN#89	<a href="#">R5s201099</a>	1205	-	F	Corrections for NR5GC RRC test case 8.1.3.1.16	15.9.0
2020-09	RAN#89	<a href="#">R5s201102</a>	1208	-	F	Correction to NR5GC function f_EUTRA38_NR_AdditionalProtocolConfigOptions	15.9.0
2020-09	RAN#89	<a href="#">R5s201103</a>	1209	-	F	Correction for PDCP test case 7.1.3.1.2	15.9.0
2020-09	RAN#89	<a href="#">R5s201106</a>	1212	-	F	Correction for NR inter-frequency test cases	15.9.0
2020-09	RAN#89	<a href="#">R5s201111</a>	1215	-	F	Correction for NR5GC IRAT test case 8.1.3.2.3	15.9.0
2020-09	RAN#89	<a href="#">R5s201112</a>	1216	-	F	Correction to NR5GC testcase 6.4.2.2	15.9.0
2020-09	RAN#89	<a href="#">R5s201113</a>	1217	-	F	Correction to NR5GC testcase 9.1.5.1.8	15.9.0
2020-09	RAN#89	<a href="#">R5s201115</a>	1219	-	F	Correction to ENDC test case 8.2.2.1.1	15.9.0

2020-09	RAN#89	<a href="#">R5s201118</a>	1222	-	F	Correction to NR Idle Mode test case 6.4.2.2	15.9.0
2020-09	RAN#89	<a href="#">R5s201120</a>	1224	-	F	Correction for NR Idle mode test case 6.1.1.1	15.9.0
2020-09	RAN#89	<a href="#">R5s201121</a>	1225	-	F	Correction for PDU SESSION AUTHENTICATION COMMAND	15.9.0
2020-09	RAN#89	<a href="#">R5s201124</a>	1227	-	F	Correction to NR5GC test case 8.1.3.1.11 and 8.1.3.1.12	15.9.0
2020-09	RAN#89	<a href="#">R5s201125</a>	1228	-	F	Correction to NR5GC IRAT test case 8.1.3.2.4	15.9.0
2020-09	RAN#89	<a href="#">R5s201127</a>	1230	-	F	Correction to the ENDC testcases 8.2.2.x.1 and 8.2.3.13.1	15.9.0
2020-09	RAN#89	<a href="#">R5s201128</a>	1231	-	F	Correction to NR5GC test case 9.1.1.6	15.9.0
2020-09	RAN#89	<a href="#">R5s201129</a>	1232	-	F	Correction to NR5GC test case 9.1.7.2	15.9.0
2020-09	RAN#89	<a href="#">R5s201132</a>	1236	-	F	Correction to function f_NR_UE_DeRegisterOnSwitchOff	15.9.0
2020-09	RAN#89	<a href="#">R5s201134</a>	1238	-	F	Correction to NR5GC test case 9.1.5.1.9	15.9.0
2020-09	RAN#89	<a href="#">R5s201136</a>	1240	-	B	NR5GC FR1 : Addition of NR5GC RRC test case 8.1.5.2.2	15.9.0
2020-09	RAN#89	<a href="#">R5s201138</a>	1241	-	F	Correction to NR5GC test case 9.1.5.1.9	15.9.0
2020-09	RAN#89	<a href="#">R5s201139</a>	1242	-	B	Addition of NR5GC test case 6.1.2.21 in FR1	15.9.0
2020-09	RAN#89	<a href="#">R5s201141</a>	1243	-	F	Correction to NR5GC test case 9.1.4.1	15.9.0
2020-09	RAN#89	<a href="#">R5s201142</a>	1244	-	F	Correction to NR5GC test case 9.1.5.1.3	15.9.0
2020-09	RAN#89	<a href="#">R5s201143</a>	1245	-	F	Correction to NR5GC test case 9.1.7.1	15.9.0
2020-09	RAN#89	<a href="#">R5s201144</a>	1246	-	B	NR5GC FR1 : Addition of NR MAC test case 7.1.1.4.2.5	15.9.0
2020-09	RAN#89	<a href="#">R5s201146</a>	1247	-	B	NR5GC FR1 : Addition of NR5GC RRC test case 8.1.2.1.5.1	15.9.0
2020-09	RAN#89	<a href="#">R5s201148</a>	1248	-	B	NR5GC FR1 : Addition of NR5GC RRC test case 8.1.2.1.5.2	15.9.0
2020-09	RAN#89	<a href="#">R5s201150</a>	1249	-	F	Correction to NR5GC test case 7.1.1.1.1	15.9.0
2020-09	RAN#89	<a href="#">R5s201158</a>	0901	1	F	Correction to NR5GC RRC test case 8.1.3.1.10	15.9.0
2020-09	RAN#89	<a href="#">R5s201159</a>	0964	1	F	Correction to NR5GC IRAT test case 8.1.3.3.2	15.9.0
2020-09	RAN#89	<a href="#">R5s201160</a>	0981	1	B	Addition of NR5GC test case 6.3.1.8 in FR1	15.9.0
2020-09	RAN#89	<a href="#">R5s201161</a>	0982	1	B	Addition of NR5GC test case 11.3.4 in FR1	15.9.0
2020-09	RAN#89	<a href="#">R5s201162</a>	0984	1	B	Addition of NR5GC test case 6.3.1.9 in FR1	15.9.0
2020-09	RAN#89	<a href="#">R5s201163</a>	0988	1	F	Corrections for some NR5GC test cases when pc_NoOf_PDU_s = 0 and pc_noOf_PDU_sNewConnection > 0	15.9.0
2020-09	RAN#89	<a href="#">R5s201164</a>	1011	1	B	Addition of NR5GC test case 6.1.2.23 in FR1	15.9.0
2020-09	RAN#89	<a href="#">R5s201165</a>	1013	1	F	Correction to 5GMM test case 9.1.5.1.11	15.9.0
2020-09	RAN#89	<a href="#">R5s201166</a>	1022	1	F	Correction to NR5GC test case 6.2.3.5	15.9.0
2020-09	RAN#89	<a href="#">R5s201167</a>	1023	1	F	Correction to function f_EUTRA38_NR_InitialRegistration	15.9.0
2020-09	RAN#89	<a href="#">R5s201168</a>	1025	1	B	Addition of NR5GC test case 7.1.1.5.3 in FR1	15.9.0
2020-09	RAN#89	<a href="#">R5s201169</a>	1026	1	B	Addition of ENDC test case 7.1.1.5.3 in FR1	15.9.0
2020-09	RAN#89	<a href="#">R5s201170</a>	1030	1	B	Addition of NR5GC test case 8.1.3.1.11 in FR1	15.9.0
2020-09	RAN#89	<a href="#">R5s201171</a>	1031	1	F	Correction for AT command format for S-NSSAI	15.9.0
2020-09	RAN#89	<a href="#">R5s201173</a>	1033	1	B	Addition of NR5GC IRAT test case 8.1.1.3.4 in FR1	15.9.0
2020-09	RAN#89	<a href="#">R5s201174</a>	1255	-	F	Correction to ENDC test case 8.2.2.9.1	15.9.0
2020-09	RAN#89	<a href="#">R5s201180</a>	1034	1	F	Correction to NR Idle Mode test case 6.1.1.1	15.9.0

2020-09	RAN#89	<a href="#">R5s201181</a>	1035	1	F	Correction to NR5GC testcase 6.2.3.6	15.9.0
2020-09	RAN#89	<a href="#">R5s201182</a>	1039	1	B	Addition of NR5GC IRAT test case 8.1.4.2.2.1 in FR1	15.9.0
2020-09	RAN#89	<a href="#">R5s201183</a>	1041	1	F	Correction to NR MAC test case 7.1.1.1.1a	15.9.0
2020-09	RAN#89	<a href="#">R5s201187</a>	1260	-	F	Correction to ENDC RLC Testcase 7.1.2.2.6	15.9.0
2020-09	RAN#89	<a href="#">R5s201188</a>	1042	1	F	Correction to NR Idle mode test case 6.4.1.2	15.9.0
2020-09	RAN#89	<a href="#">R5s201189</a>	1045	1	F	Correction to search space config	15.9.0
2020-09	RAN#89	<a href="#">R5s201190</a>	1048	1	F	Correction to selection expression	15.9.0
2020-09	RAN#89	<a href="#">R5s201191</a>	1049	1	F	Correction to 5GMM test case 9.1.4.1	15.9.0
2020-09	RAN#89	<a href="#">R5s201192</a>	1050	1	F	Correction for 5GMM test case 9.1.5.1.10	15.9.0
2020-09	RAN#89	<a href="#">R5s201193</a>	1055	1	F	Correction to EN-DC RRC test cases 8.2.2.8.1 and 8.2.3.13.1	15.9.0
2020-09	RAN#89	<a href="#">R5s201194</a>	1058	1	F	Correction to NR5GC test case 10.1.2.2	15.9.0
2020-09	RAN#89	<a href="#">R5s201195</a>	1059	1	F	Correction to NR5GC testcase 10.1.1.1	15.9.0
2020-09	RAN#89	<a href="#">R5s201196</a>	1064	1	F	Correction to NR MAC test case 7.1.1.3.1	15.9.0
2020-09	RAN#89	<a href="#">R5s201197</a>	1065	1	F	Correction for NR MAC test case 7.1.1.3.5	15.9.0
2020-09	RAN#89	<a href="#">R5s201198</a>	1070	1	F	Correction to NR5GC test case 9.1.6.1.3	15.9.0
2020-09	RAN#89	<a href="#">R5s201199</a>	1071	1	F	Correction to NR5GC IRAT test case 8.1.4.2.1.1	15.9.0
2020-09	RAN#89	<a href="#">R5s201200</a>	1072	1	F	Correction to NR5GC IRAT test case 6.4.3.1	15.9.0
2020-09	RAN#89	<a href="#">R5s201201</a>	1074	1	F	Correction to the NR5GC test case 6.1.2.7	15.9.0
2020-09	RAN#89	<a href="#">R5s201202</a>	1075	1	F	Correction to the NR5GC test case 9.1.5.2.1	15.9.0
2020-09	RAN#89	<a href="#">R5s201203</a>	1076	1	F	Correction to the NR5GC test case 9.1.5.2.2	15.9.0
2020-09	RAN#89	<a href="#">R5s201204</a>	1077	1	F	Correction to the NR5GC test case 6.1.2.8	15.9.0
2020-09	RAN#89	<a href="#">R5s201205</a>	1084	1	F	Correction to NR5GC test case 9.1.5.2.4	15.9.0
2020-09	RAN#89	<a href="#">R5s201206</a>	1086	1	F	Correction to function f_TC_9_1_2_x_Common	15.9.0
2020-09	RAN#89	<a href="#">R5s201207</a>	1093	1	F	Corrections for 5GMM test case 9.1.5.1.14	15.9.0
2020-09	RAN#89	<a href="#">R5s201208</a>	1095	1	F	Correction to 5GMM test case 9.1.5.1.1	15.9.0
2020-09	RAN#89	<a href="#">R5s201209</a>	1096	1	F	Correction to NR5GC test case 9.1.2.x	15.9.0
2020-09	RAN#89	<a href="#">R5s201210</a>	1097	1	F	Correction to NR5GC test case 9.1.6.1.2	15.9.0
2020-09	RAN#89	<a href="#">R5s201211</a>	1098	1	F	Correction to NR5GC test case 8.1.4.2.1.1	15.9.0
2020-09	RAN#89	<a href="#">R5s201212</a>	1099	1	F	Correction to the NR5GC testcase 6.1.2.2	15.9.0
2020-09	RAN#89	<a href="#">R5s201213</a>	1101	1	F	Correction to the definition of NR_FrequencyBand_Type	15.9.0
2020-09	RAN#89	<a href="#">R5s201214</a>	1102	1	F	Correction to the function f_NR5GC_RRC_Idle_Steps5_9_AKA	15.9.0
2020-09	RAN#89	<a href="#">R5s201215</a>	1103	1	F	Correction to NR5GC test case 6.1.1.7	15.9.0
2020-09	RAN#89	<a href="#">R5s201216</a>	1104	1	F	Correction to NR5GC test case 6.2.1.1	15.9.0
2020-09	RAN#89	<a href="#">R5s201217</a>	1105	1	F	Correction to NR5GC test case 6.2.1.2	15.9.0
2020-09	RAN#89	<a href="#">R5s201219</a>	1111	1	B	Addition of NR5GC IRAT test case 8.1.5.5.1 in FR1	15.9.0
2020-09	RAN#89	<a href="#">R5s201221</a>	1262	-	B	NR5GC FR1 : Addition of NR5GC RRC test case 8.1.4.1.6	15.9.0
2020-09	RAN#89	<a href="#">R5s201264</a>	0996	1	F	Corrections for NR5GC IRAT test case 8.1.4.2.1.1	15.9.0

2020-09	RAN#89	<a href="#">R5s201265</a>	1014	1	B	EN-DC FR2 : Addition of NR MAC test case 7.1.1.5.1	15.9.0
2020-09	RAN#89	<a href="#">R5s201266</a>	1015	1	B	EN-DC FR1 : Addition of NR MAC test case 7.1.1.5.1	15.9.0
2020-09	RAN#89	<a href="#">R5s201267</a>	1107	1	F	Correction to NR Idle mode test case 6.4.2.2	15.9.0
2020-09	RAN#89	<a href="#">R5s201268</a>	1108	1	F	Correction to NR5GC RRC test case 8.1.5.4.1	15.9.0
2020-09	RAN#89	<a href="#">R5s201269</a>	1118	1	F	Correction to NR5GC testcase 10.1.6.1	15.9.0
2020-09	RAN#89	<a href="#">R5s201270</a>	1119	1	F	Correction to NR5GC testcase 10.1.6.2	15.9.0
2020-09	RAN#89	<a href="#">R5s201271</a>	1121	1	F	Correction to NR5GC test case 6.4.3.1	15.9.0
2020-09	RAN#89	<a href="#">R5s201272</a>	1122	1	B	NR5GC FR1 : Addition of NR MAC test case 7.1.1.5.1	15.9.0
2020-09	RAN#89	<a href="#">R5s201274</a>	1123	1	F	Correction to the function f_NR_ENDC_ReConfigAM_UM	15.9.0
2020-09	RAN#89	<a href="#">R5s201275</a>	0926	1	F	Corrections for NR5GC IRAT common functions	15.9.0
2020-09	RAN#89	<a href="#">R5s201276</a>	0944	1	B	NR5GC FR1 : Addition of NR Idle Mode test case 6.1.2.11	15.9.0
2020-09	RAN#89	<a href="#">R5s201277</a>	1005	1	B	Addition of NR5GC test case 8.1.3.1.20 in FR1	15.9.0
2020-09	RAN#89	<a href="#">R5s201279</a>	1018	1	F	Correction for NR MAC test case 7.1.1.2.1 in NR5GC operation	15.9.0
2020-09	RAN#89	<a href="#">R5s201280</a>	1019	1	F	Correction to NR Idle Mode test case 6.1.1.2	15.9.0
2020-09	RAN#89	<a href="#">R5s201281</a>	1029	1	B	Addition of NR5GC test case 9.1.5.1.9 in FR1	15.9.0
2020-09	RAN#89	<a href="#">R5s201283</a>	1036	1	F	Correction to NR5GC testcase 7.1.1.1.2	15.9.0
2020-09	RAN#89	<a href="#">R5s201284</a>	1037	1	B	Addition of NR5GC test case 8.1.3.1.12 in FR1	15.9.0
2020-09	RAN#89	<a href="#">R5s201285</a>	1040	1	B	Addition of NR5GC test case 6.2.1.5 in FR1	15.9.0
2020-09	RAN#89	<a href="#">R5s201289</a>	1046	1	B	Addition of ENDC test case 7.1.1.5.2 in FR1	15.9.0
2020-09	RAN#89	<a href="#">R5s201290</a>	1052	1	F	Correction for NR5GC IRAT test cases 8.1.3.2.3 and 8.1.3.2.4	15.9.0
2020-09	RAN#89	<a href="#">R5s201291</a>	1060	1	B	Addition of NR5GC test case 7.1.1.5.2 in FR1	15.9.0
2020-09	RAN#89	<a href="#">R5s201292</a>	1061	1	B	Addition of NR5GC test case 7.1.1.5.4 in FR1	15.9.0
2020-09	RAN#89	<a href="#">R5s201293</a>	1062	1	B	Addition of ENDC test case 7.1.1.5.4 in FR1	15.9.0
2020-09	RAN#89	<a href="#">R5s201294</a>	1066	1	F	Correction to NR5GC RRC test case 8.1.5.1.1	15.9.0
2020-09	RAN#89	<a href="#">R5s201295</a>	1081	1	B	Addition of NR5GC test case 6.2.2.1 in FR1	15.9.0
2020-09	RAN#89	<a href="#">R5s201296</a>	1082	1	B	Addition of NR5GC test case 6.2.2.2 in FR1	15.9.0
2020-09	RAN#89	<a href="#">R5s201297</a>	1085	1	F	Correction to NR5GC test case 9.1.5.1.1	15.9.0
2020-09	RAN#89	<a href="#">R5s201298</a>	1087	1	F	Correction to NR5GC testcase 10.1.1.2	15.9.0
2020-09	RAN#89	<a href="#">R5s201299</a>	1100	1	F	Correction to NR5GC test case 6.1.2.9	15.9.0
2020-09	RAN#89	<a href="#">R5s201300</a>	1109	1	F	Corrections for NR5GC IRAT test cases	15.9.0
2020-09	RAN#89	<a href="#">R5s201301</a>	1284	-	F	Add new verified and e-mail agreed TTCN test cases in the TC lists in 38.523-3 (prose), Annex A	15.9.0
2020-09	RAN#89	R5-204475	1233	1	F	5G Test Models updates	15.9.0
2020-12	RAN#90	<a href="#">R5s201346</a>	1304	-	B	ENDC FR2: Addition of NR MAC test case 7.1.1.5.3	15.10.0
2020-12	RAN#90	<a href="#">R5s201350</a>	1306	-	F	Correction for NR PDCP test cases in EN-DC	15.10.0
2020-12	RAN#90	<a href="#">R5s201351</a>	1307	-	F	Correction for NR band N257	15.10.0
2020-12	RAN#90	<a href="#">R5s201354</a>	1308	-	F	Correction to the NR function f_EUTRA38_IRAT_Init	15.10.0
2020-12	RAN#90	<a href="#">R5s201355</a>	1309	-	F	Correction to the NR function f_NR_GetSSB_ToMeasureSIB2	15.10.0

2020-12	RAN#90	<a href="#">R5s201356</a>	1310	-	F	Correction to NR5GC test case 9.1.5.1.3 in FR1	15.10.0
2020-12	RAN#90	<a href="#">R5s201357</a>	1311	-	F	Correction to NR5GC test case 9.1.1.3 in FR1	15.10.0
2020-12	RAN#90	<a href="#">R5s201358</a>	1312	-	F	Correction to multiple NR functions	15.10.0
2020-12	RAN#90	<a href="#">R5s201359</a>	1313	-	F	Correction to NR5GC common function f_NR_GetSCGConfigResume	15.10.0
2020-12	RAN#90	<a href="#">R5s201361</a>	1315	-	F	Correction to NR5GC Test cases related to Multiple QoS	15.10.0
2020-12	RAN#90	<a href="#">R5s201362</a>	1316	-	F	Correction to NR5GC testcase 10.1.6.2	15.10.0
2020-12	RAN#90	<a href="#">R5s201363</a>	1317	-	F	Correction to function f_EUTRA38_TAUREqFromN1	15.10.0
2020-12	RAN#90	<a href="#">R5s201366</a>	1318	-	F	Correction to function f_NR_ReceiveMeasurementReports	15.10.0
2020-12	RAN#90	<a href="#">R5s201367</a>	1319	-	F	Correction to NR SDAP testcases 7.1.4.1 and 7.1.4.2	15.10.0
2020-12	RAN#90	<a href="#">R5s201368</a>	1320	-	F	Correction to NR Idle mode testcases	15.10.0
2020-12	RAN#90	<a href="#">R5s201370</a>	1322	-	F	Correction to test case applicability	15.10.0
2020-12	RAN#90	<a href="#">R5s201371</a>	1323	-	F	Corrections for 5GSM test case 10.1.1.1	15.10.0
2020-12	RAN#90	<a href="#">R5s201373</a>	1325	-	F	Corrections for EN-DC test cases with data path check	15.10.0
2020-12	RAN#90	<a href="#">R5s201379</a>	1327	-	F	Correction to NR5GC testcase 10.1.6.1	15.10.0
2020-12	RAN#90	<a href="#">R5s201380</a>	1328	-	F	Correction to NR5GC Inter-RAT testcase 6.4.3.1	15.10.0
2020-12	RAN#90	<a href="#">R5s201381</a>	1329	-	F	Correction to the NR5GC testcase 9.1.5.1.9	15.10.0
2020-12	RAN#90	<a href="#">R5s201382</a>	1330	-	F	Correction to function f_Get_PDUSessionAuthenticationCmd	15.10.0
2020-12	RAN#90	<a href="#">R5s201383</a>	1331	-	F	Correction to NR5GC testcase 9.3.1.3	15.10.0
2020-12	RAN#90	<a href="#">R5s201384</a>	1332	-	F	Correction to function f_NG_SMS_AT_Config_WithPowering_EnterState_0B	15.10.0
2020-12	RAN#90	<a href="#">R5s201385</a>	1333	-	F	Correction to NR testcases 8.1.3.1.11, 8.1.3.1.12 and 8.1.3.1.15A	15.10.0
2020-12	RAN#90	<a href="#">R5s201389</a>	1335	-	F	Correction to the NR5GC testcase 6.2.3.3	15.10.0
2020-12	RAN#90	<a href="#">R5s201390</a>	1336	-	F	Correction to the NR5GC testcase 8.1.4.2.1.1	15.10.0
2020-12	RAN#90	<a href="#">R5s201410</a>	1337	-	F	Correction to NR5GC testcase 9.1.1.1	15.10.0
2020-12	RAN#90	<a href="#">R5s201411</a>	1338	-	F	Correction to the NR5GC testcase 9.1.5.1.3a	15.10.0
2020-12	RAN#90	<a href="#">R5s201412</a>	1339	-	F	Correction to NR5GC testcase 10.1.1.1	15.10.0
2020-12	RAN#90	<a href="#">R5s201416</a>	1341	-	F	Correction to NR5GC testcase 9.1.5.2.1	15.10.0
2020-12	RAN#90	<a href="#">R5s201418</a>	1343	-	F	Correction to NR5GC test case 6.3.1.9	15.10.0
2020-12	RAN#90	<a href="#">R5s201419</a>	1344	-	F	Correction to NR5GC IRAT test case 6.2.3.9	15.10.0
2020-12	RAN#90	<a href="#">R5s201420</a>	1345	-	F	Correction to EN-DC RRC test case 8.2.3.3.1	15.10.0
2020-12	RAN#90	<a href="#">R5s201421</a>	1346	-	F	Correction to OffsetCarrierCORESET#0 for several NR bands for frequencies in mid-range	15.10.0
2020-12	RAN#90	<a href="#">R5s201422</a>	1347	-	F	Correction to NR5GC test case 6.1.2.13	15.10.0
2020-12	RAN#90	<a href="#">R5s201423</a>	1348	-	F	Correction to NR5GC test case 6.1.2.19	15.10.0
2020-12	RAN#90	<a href="#">R5s201424</a>	1349	-	F	Correction to NR5GC test case 9.1.4.1	15.10.0
2020-12	RAN#90	<a href="#">R5s201434</a>	1351	-	F	Correction to NR RLC testcase 7.1.2.3.8	15.10.0
2020-12	RAN#90	<a href="#">R5s201435</a>	1352	-	F	Correction to EN-DC RRC test case 8.2.2.6.1	15.10.0
2020-12	RAN#90	<a href="#">R5s201436</a>	1353	-	F	Correction to NR MAC test case 7.1.1.5.2	15.10.0

2020-12	RAN#90	<a href="#">R5s201437</a>	1354	-	F	Correction to NR MAC test case 7.1.1.5.4	15.10.0
2020-12	RAN#90	<a href="#">R5s201442</a>	1355	-	F	Correction to NR5GC test case 6.3.1.5	15.10.0
2020-12	RAN#90	<a href="#">R5s201443</a>	1356	-	F	Correction to NR5GC test case 9.1.5.2.9	15.10.0
2020-12	RAN#90	<a href="#">R5s201444</a>	1357	-	F	Correction to NR5GC test case 6.1.1.2	15.10.0
2020-12	RAN#90	<a href="#">R5s201450</a>	1360	-	B	Addition of NR5GC test case 8.1.3.1.23 in FR1	15.10.0
2020-12	RAN#90	<a href="#">R5s201453</a>	1365	-	F	Correction to function fl_NR_ENDC_UECapabilityTransfer	15.10.0
2020-12	RAN#90	<a href="#">R5s201454</a>	1366	-	F	Correction to NR5GC test case 7.1.1.1.2	15.10.0
2020-12	RAN#90	<a href="#">R5s201457</a>	1368	-	B	Addition of NR5GC test case 7.1.1.9.1 in FR1	15.10.0
2020-12	RAN#90	<a href="#">R5s201461</a>	1370	-	F	Correction to NR5GC RRC test case 8.1.1.4.1	15.10.0
2020-12	RAN#90	<a href="#">R5s201463</a>	1372	-	F	Corrections for NR5GC CA test cases	15.10.0
2020-12	RAN#90	<a href="#">R5s201464</a>	1373	-	F	Correction for EN-DC RRC test case 8.2.2.1.1	15.10.0
2020-12	RAN#90	<a href="#">R5s201469</a>	1378	-	F	Correction to NR MAC test case 7.1.1.1.1a	15.10.0
2020-12	RAN#90	<a href="#">R5s201472</a>	1381	-	F	Correction to NR5GC idle mode test case 6.1.2.14	15.10.0
2020-12	RAN#90	<a href="#">R5s201474</a>	1383	-	F	Corrections to NR5GC RRC test cases 8.1.3.1.x	15.10.0
2020-12	RAN#90	<a href="#">R5s201475</a>	1384	-	F	Correction to NR5GC RRC test case 8.1.1.3.3	15.10.0
2020-12	RAN#90	<a href="#">R5s201477</a>	1386	-	F	Correction to EN-DC RRC test case 8.2.2.8.1	15.10.0
2020-12	RAN#90	<a href="#">R5s201479</a>	1388	-	B	EN-DC FR1 : Addition of NR MAC test case 7.1.1.4.2.3	15.10.0
2020-12	RAN#90	<a href="#">R5s201481</a>	1390	-	F	Correction to NR MAC test case 7.1.1.5.1	15.10.0
2020-12	RAN#90	<a href="#">R5s201512</a>	1408	-	F	Correction to NR5GC test case 7.1.1.2.4	15.10.0
2020-12	RAN#90	<a href="#">R5s201513</a>	1409	-	F	Correction to NR5GC test case 6.1.2.2	15.10.0
2020-12	RAN#90	<a href="#">R5s201515</a>	1411	-	B	ENDC FR1: Addition of Inter band CA RRC test case 8.2.4.3.1.3	15.10.0
2020-12	RAN#90	<a href="#">R5s201526</a>	1417	-	F	Summary of regression errors for NR5GC ATS in 20wk43 IWD	15.10.0
2020-12	RAN#90	<a href="#">R5s201527</a>	1418	-	F	Correction to NR5GC test case 6.2.3.2	15.10.0
2020-12	RAN#90	<a href="#">R5s201528</a>	1419	-	F	Correction to function f_NR5GC_RRC_Idle_Steps16_20	15.10.0
2020-12	RAN#90	<a href="#">R5s201530</a>	1420	-	F	Correction to NR5GC test case 7.1.2.3.5 and 7.1.2.3.5a	15.10.0
2020-12	RAN#90	<a href="#">R5s201531</a>	1421	-	F	Correction to template cr_NG_GMM_CapAny for 20wk43 IWD	15.10.0
2020-12	RAN#90	<a href="#">R5s201532</a>	1422	-	F	Correction to f_NR5GC_PDUSessionEstablishment_InnerLoop for 20wk43 IWD	15.10.0
2020-12	RAN#90	<a href="#">R5s201546</a>	1435	-	F	Correction for EN-DC test cases in postamble	15.10.0
2020-12	RAN#90	<a href="#">R5s201555</a>	1043	1	F	Correction to NR5GC test case 9.1.5.1.10	15.10.0
2020-12	RAN#90	<a href="#">R5s201556</a>	1051	1	F	Correction to 5GMM test case 9.1.5.1.13	15.10.0
2020-12	RAN#90	<a href="#">R5s201557</a>	1130	1	F	Correction to 5GMM test case 9.3.1.2	15.10.0
2020-12	RAN#90	<a href="#">R5s201558</a>	1148	1	F	Correction to NR5GC test case 8.1.1.3.4	15.10.0
2020-12	RAN#90	<a href="#">R5s201559</a>	1166	1	F	Correction to NR5GC test case 9.1.5.1.3	15.10.0
2020-12	RAN#90	<a href="#">R5s201560</a>	1173	1	B	Addition of NR5GC test case 6.3.1.5 in FR1	15.10.0
2020-12	RAN#90	<a href="#">R5s201561</a>	1184	1	F	Corrections for EN-DC RRC test case 8.2.2.6.1	15.10.0
2020-12	RAN#90	<a href="#">R5s201562</a>	1188	1	F	Correction to 5GMM test case 9.1.8.1	15.10.0
2020-12	RAN#90	<a href="#">R5s201563</a>	1191	1	F	Corrections for NR5GC IRAT test case 8.1.4.2.2.1	15.10.0

2020-12	RAN#90	<a href="#">R5s201564</a>	1200	1	F	Correction for NR5GC IRAT test cases	15.10.0
2020-12	RAN#90	<a href="#">R5s201566</a>	1201	1	F	Correction for NR5GC IRAT test cases	15.10.0
2020-12	RAN#90	<a href="#">R5s201567</a>	1207	1	F	Correction for 5GMM test case 9.1.5.1.9	15.10.0
2020-12	RAN#90	<a href="#">R5s201568</a>	1210	1	B	EN-DC FR2 : Addition of NR MAC test case 7.1.1.5.2	15.10.0
2020-12	RAN#90	<a href="#">R5s201569</a>	1211	1	B	EN-DC FR2 : Addition of NR MAC test case 7.1.1.5.4	15.10.0
2020-12	RAN#90	<a href="#">R5s201570</a>	1237	1	F	Correction to the PDU Session Establishment Accept message	15.10.0
2020-12	RAN#90	<a href="#">R5s201571</a>	1239	1	F	Correction to ENDC test case 8.2.2.6.1	15.10.0
2020-12	RAN#90	<a href="#">R5s201572</a>	1251	1	F	Corrections to NR5GC SoR test case 6.3.1.9	15.10.0
2020-12	RAN#90	<a href="#">R5s201573</a>	1252	1	F	Correction to the NR5GC testcase 8.1.3.1.12	15.10.0
2020-12	RAN#90	<a href="#">R5s201574</a>	1253	1	B	NR5GC FR1: Addition of Intra-band non Contiguous NR RRC CA test case 8.1.3.1.18.3	15.10.0
2020-12	RAN#90	<a href="#">R5s201575</a>	1258	1	B	Addition of NR5GC test case 9.1.8.2 in FR1	15.10.0
2020-12	RAN#90	<a href="#">R5s201577</a>	1261	1	F	Correction to the ENDC Test cases 8.2.3.16.1 and 8.2.2.1.1	15.10.0
2020-12	RAN#90	<a href="#">R5s201578</a>	1263	1	F	Correction to the NR5GC EAP common part	15.10.0
2020-12	RAN#90	<a href="#">R5s201579</a>	1264	1	F	Correction to NR5GC testcase 9.1.5.1.3	15.10.0
2020-12	RAN#90	<a href="#">R5s201580</a>	1266	1	F	Correction to NR5GC testcase 9.1.3.1	15.10.0
2020-12	RAN#90	<a href="#">R5s201581</a>	1267	1	F	Correction to the NR5GC testcase 10.1.4.1	15.10.0
2020-12	RAN#90	<a href="#">R5s201582</a>	1269	1	B	ENDC FR2: Addition of NR RRC test case 8.2.6.2.1	15.10.0
2020-12	RAN#90	<a href="#">R5s201584</a>	1276	1	F	Correction to NR5GC testcase 9.1.8.1	15.10.0
2020-12	RAN#90	<a href="#">R5s201592</a>	1283	1	F	Correction to the NR5GC testcase 7.1.1.2.3	15.10.0
2020-12	RAN#90	<a href="#">R5s201593</a>	1285	1	F	Correction to common functions for ENDC RRC test case 8.2.1.1.1 and NR5GC test case 8.1.5.1.1	15.10.0
2020-12	RAN#90	<a href="#">R5s201594</a>	1286	1	F	Correction to the NR5GC testcase 8.1.4.1.2	15.10.0
2020-12	RAN#90	<a href="#">R5s201595</a>	1287	1	F	Correction to 5GSM test case 10.1.4.1	15.10.0
2020-12	RAN#90	<a href="#">R5s201596</a>	1288	1	F	Correction to NR5GC idle mode test case 6.1.2.23	15.10.0
2020-12	RAN#90	<a href="#">R5s201597</a>	1289	1	F	Correction to NR5GC idle mode test case 6.4.1.1	15.10.0
2020-12	RAN#90	<a href="#">R5s201601</a>	1293	1	F	Correction ENDC MAC testcase 7.1.1.1.2	15.10.0
2020-12	RAN#90	<a href="#">R5s201603</a>	1294	1	F	Correction to the UE capability transfer testcases 8.2.1.1.1 and 8.1.5.1.1	15.10.0
2020-12	RAN#90	<a href="#">R5s201604</a>	1297	1	F	Correction to the NR5GC CA testcase 8.1.2.1.5.1	15.10.0
2020-12	RAN#90	<a href="#">R5s201605</a>	1298	1	F	Correction to the NR function f_Get_NG_PDU Session Establishment Accept	15.10.0
2020-12	RAN#90	<a href="#">R5s201606</a>	1301	1	F	Correction to ENDC testcase 7.1.2.3.11	15.10.0
2020-12	RAN#90	<a href="#">R5s201623</a>	1278	1	B	NR5GC FR1 : Addition of NR RRC CA test case 8.1.4.1.7.1	15.10.0
2020-12	RAN#90	<a href="#">R5s201624</a>	1279	1	B	NR5GC FR1 : Addition of NR RRC CA test case 8.1.4.1.7.2	15.10.0
2020-12	RAN#90	<a href="#">R5s201625</a>	1280	1	F	Correction to ENDC testcase 8.2.6.2.1	15.10.0
2020-12	RAN#90	<a href="#">R5s201627</a>	1292	1	B	EN-DC FR1 : Addition of RRC test case 8.2.4.3.1.1	15.10.0
2020-12	RAN#90	<a href="#">R5s201628</a>	1299	1	F	Correction to NR RLC testcases 7.1.2.3.7 and 7.1.2.3.8	15.10.0
2020-12	RAN#90	<a href="#">R5s201636</a>	1235	1	F	Correction to NR5GC testcase 10.1.3.2	15.10.0

2020-12	RAN#90	<a href="#">R5s201646</a>	1452	-	F	Add new verified and e-mail agreed TTCN test cases in the TC lists in 38.523-3 (prose), Annex A	15.10.0
2020-12	RAN#90	R5-206369	1362	1	-	5G Test Models updates	15.10.0
2020-12	RAN#90	<a href="#">R5s201387</a>	1334	-	F	Rel-16 Sep'20 baseline upgrade for 5GS Test Suites	16.0.0
2021-03	RAN#91	R5-210355	1570	-	F	Guidelines on test execution for bands n14 and n53	16.1.0
2021-03	RAN#91	R5-211417	1568	1	F	5G Test Models updates	16.1.0
2021-03	RAN#91	<a href="#">R5s210042</a>	1484	-	F	Correction for NR5GC idle mode test case 6.4.1.2	16.1.0
2021-03	RAN#91	<a href="#">R5s210043</a>	1485	-	F	Correction for NR5GC IRAT test cases 6.2.2.1 and 6.2.3.3	16.1.0
2021-03	RAN#91	<a href="#">R5s210044</a>	1486	-	F	Correction for NR5GC RRC test case 8.1.3.3.2	16.1.0
2021-03	RAN#91	<a href="#">R5s210049</a>	1491	-	F	Correction for NR5GC idle mode test case 6.3.1.7	16.1.0
2021-03	RAN#91	<a href="#">R5s210051</a>	1493	-	F	Correction for NR RRC test case 8.1.1.2.3	16.1.0
2021-03	RAN#91	<a href="#">R5s210057</a>	1497	-	F	Correction for NR5GC idle mode test case 6.2.1.4	16.1.0
2021-03	RAN#91	<a href="#">R5s210058</a>	1498	-	F	Correction for NR5GC RRC test case 8.1.4.1.2	16.1.0
2021-03	RAN#91	<a href="#">R5s210059</a>	1499	-	F	Correction for NR RRC Deregistration test cases	16.1.0
2021-03	RAN#91	<a href="#">R5s210065</a>	1502	-	F	Correction to ENDC testcase 7.1.3.5.2	16.1.0
2021-03	RAN#91	<a href="#">R5s210066</a>	1503	-	B	Addition of NR5GC test case 7.1.1.7.1.1 in FR1	16.1.0
2021-03	RAN#91	<a href="#">R5s210068</a>	1504	-	B	Addition of NR5GC test case 7.1.1.7.1.2 in FR1	16.1.0
2021-03	RAN#91	<a href="#">R5s210070</a>	1505	-	B	Addition of ENDC test case 7.1.1.7.1.1 in FR1	16.1.0
2021-03	RAN#91	<a href="#">R5s210072</a>	1506	-	F	Correction to NR5GC test case 6.1.2.19	16.1.0
2021-03	RAN#91	<a href="#">R5s210073</a>	1507	-	F	Correction to function f_NR5GC_ModifyPDUSession_AddVoice	16.1.0
2021-03	RAN#91	<a href="#">R5s210074</a>	1508	-	F	Correction to f_BuildDefaultQoSRules	16.1.0
2021-03	RAN#91	<a href="#">R5s210075</a>	1509	-	F	Correction to CA configurations for CA_n260G	16.1.0
2021-03	RAN#91	<a href="#">R5s210077</a>	1511	-	F	Correction for NR5GC IRAT test cases	16.1.0
2021-03	RAN#91	<a href="#">R5s210078</a>	1512	-	F	Correction for 5GMM test case 9.3.1.2	16.1.0
2021-03	RAN#91	<a href="#">R5s210079</a>	1513	-	F	Correction for NR5GC RRC CA test cases 8.1.4.1.7.1 and 8.1.4.1.7.2	16.1.0
2021-03	RAN#91	<a href="#">R5s210082</a>	1516	-	F	Correction to NR PDCP test case 7.1.3.5.3	16.1.0
2021-03	RAN#91	<a href="#">R5s210083</a>	1517	-	F	Corrections for ENDC RRC test case 8.2.2.3.1	16.1.0
2021-03	RAN#91	<a href="#">R5s210084</a>	1518	-	F	Correction for NR5GC idle extension procedure	16.1.0
2021-03	RAN#91	<a href="#">R5s210085</a>	1519	-	F	Corrections for NR5GC idle mode test cases	16.1.0
2021-03	RAN#91	<a href="#">R5s210087</a>	1521	-	F	Correction to NR MAC test case 7.1.1.3.3	16.1.0
2021-03	RAN#91	<a href="#">R5s210088</a>	1522	-	F	Correction to NR MAC test case 7.1.1.1.1a	16.1.0
2021-03	RAN#91	<a href="#">R5s210089</a>	1523	-	F	Correction to ENDC RRC test case 8.2.4.3.1.1	16.1.0
2021-03	RAN#91	<a href="#">R5s210092</a>	1526	-	F	Correction to NR5GC idle mode test case 6.4.2.1	16.1.0
2021-03	RAN#91	<a href="#">R5s210093</a>	1527	-	F	Corrections to NR RLC test case 7.1.2.3.5	16.1.0
2021-03	RAN#91	<a href="#">R5s210094</a>	1528	-	F	Correction to NR idle mode test case 6.4.1.1	16.1.0
2021-03	RAN#91	<a href="#">R5s210103</a>	1531	-	F	Correction to f_EUTRA38_TAUREqFromN1	16.1.0
2021-03	RAN#91	<a href="#">R5s210104</a>	1532	-	F	Correction to function f_NR_GetHighestBandwidthFrequency	16.1.0



2021-03	RAN#91	<a href="#">R5s210110</a>	1538	-	F	Correction for 5GSM test case 10.1.1.1	16.1.0
2021-03	RAN#91	<a href="#">R5s210111</a>	1539	-	F	Correction to NR5GC testcase 9.1.1.2	16.1.0
2021-03	RAN#91	<a href="#">R5s210116</a>	1543	-	F	Correction for NR5GC multilayer test case 11.3.4	16.1.0
2021-03	RAN#91	<a href="#">R5s210123</a>	1545	-	F	Correction to NR5GC test case 9.1.5.1.8	16.1.0
2021-03	RAN#91	<a href="#">R5s210128</a>	1546	-	F	Correction to ENDC test case 8.2.2.3.1	16.1.0
2021-03	RAN#91	<a href="#">R5s210129</a>	1547	-	F	Correction to function f_NR_GetSSB_ToMeasure	16.1.0
2021-03	RAN#91	<a href="#">R5s210130</a>	1548	-	F	Correction function f_NG_GetDNN	16.1.0
2021-03	RAN#91	<a href="#">R5s210134</a>	1550	-	F	Correction to NR5GC testcase 9.1.5.1.3	16.1.0
2021-03	RAN#91	<a href="#">R5s210135</a>	1551	-	F	Correction to NR5GC test case 8.1.4.1.2	16.1.0
2021-03	RAN#91	<a href="#">R5s210138</a>	1552	-	F	Correction to NR5GC test case 7.1.1.9.1	16.1.0
2021-03	RAN#91	<a href="#">R5s210143</a>	1554	-	F	Correction for NR5GC RRC PWS test cases	16.1.0
2021-03	RAN#91	<a href="#">R5s210145</a>	1555	-	F	Correction to NR5GC test case 9.1.5.1.9	16.1.0
2021-03	RAN#91	<a href="#">R5s210147</a>	1557	-	F	Correction to NR5GC test case 7.1.1.2.1 and 7.1.1.3.1	16.1.0
2021-03	RAN#91	<a href="#">R5s210148</a>	1558	-	F	Correction to function f_NR5GC_PDUSessionEstablishment_InnerLoop	16.1.0
2021-03	RAN#91	<a href="#">R5s210153</a>	1560	-	F	Correction to EAP authentication calculation	16.1.0
2021-03	RAN#91	<a href="#">R5s210157</a>	1564	-	F	Correction for NR5GC IRAT test cases	16.1.0
2021-03	RAN#91	<a href="#">R5s210159</a>	1565	-	F	Correction to NR5GC testcase 9.1.7.2	16.1.0
2021-03	RAN#91	<a href="#">R5s210160</a>	1566	-	F	Correction to ENDC test case 8.2.4.3.1.3	16.1.0
2021-03	RAN#91	<a href="#">R5s210161</a>	1567	-	F	Correction function f_EUTRA38_MultiPDN_GetAPN	16.1.0
2021-03	RAN#91	<a href="#">R5s210162</a>	1569	-	B	Addition of NR5GC test case 8.1.4.1.5 in FR1	16.1.0
2021-03	RAN#91	<a href="#">R5s210164</a>	1571	-	F	Correction to function f_NR5GC_RRC_Idle_Steps5_9_AKA	16.1.0
2021-03	RAN#91	<a href="#">R5s210166</a>	1572	-	F	Correction to NR5GC testcase 9.1.1.1	16.1.0
2021-03	RAN#91	<a href="#">R5s210167</a>	1573	-	F	Correction to NR5GC test case 8.1.1.3.4	16.1.0
2021-03	RAN#91	<a href="#">R5s210168</a>	1574	-	F	Correction to NR5GC test case 6.1.1.4	16.1.0
2021-03	RAN#91	<a href="#">R5s210171</a>	1223	1	F	Correction to NR testcase 7.1.2.3.3	16.1.0
2021-03	RAN#91	<a href="#">R5s210172</a>	1277	1	F	Correction to function f_NR_RRCReconfigExistingDRBs	16.1.0
2021-03	RAN#91	<a href="#">R5s210173</a>	1305	1	B	EN-DC FR1 : Addition of RRC test case 8.2.2.3.1	16.1.0
2021-03	RAN#91	<a href="#">R5s210175</a>	1321	2	F	Correction to function f_NR5GC_PDUSessionEstablishment	16.1.0
2021-03	RAN#91	<a href="#">R5s210176</a>	1340	1	F	Correction to NR5GC testcase 9.3.1.2	16.1.0
2021-03	RAN#91	<a href="#">R5s210178</a>	1367	1	B	Addition of NR5GC test case 6.3.1.7 in FR1	16.1.0
2021-03	RAN#91	<a href="#">R5s210179</a>	1374	1	F	Correction for NR5GC IRAT test cases 8.1.1.3.4	16.1.0
2021-03	RAN#91	<a href="#">R5s210180</a>	1375	1	F	Correction to NR5GC IRAT test case 6.2.3.9	16.1.0
2021-03	RAN#91	<a href="#">R5s210181</a>	1376	1	F	Corrections for NR5GC IRAT test case 8.1.4.2.2.1	16.1.0
2021-03	RAN#91	<a href="#">R5s210182</a>	1379	1	F	Correction to NR5GC IRAT test case 6.2.1.4	16.1.0
2021-03	RAN#91	<a href="#">R5s210183</a>	1380	1	F	Correction to EN-DC RRC test case 8.2.4.1.1.x	16.1.0
2021-03	RAN#91	<a href="#">R5s210184</a>	1392	1	F	Correction to 5GMM test case 9.1.1.2	16.1.0
2021-03	RAN#91	<a href="#">R5s210185</a>	1393	1	F	Correction to NR PDCP test case 7.1.3.4.1	16.1.0

2021-03	RAN#91	<a href="#">R5s210186</a>	1395	1	F	Correction to 5GMM test case 9.1.5.1.1	16.1.0
2021-03	RAN#91	<a href="#">R5s210187</a>	1577	-	F	Correction to ENDC testcase 8.2.2.1.1	16.1.0
2021-03	RAN#91	<a href="#">R5s210188</a>	1396	1	F	Correction to NR RLC test case 7.1.2.3.5	16.1.0
2021-03	RAN#91	<a href="#">R5s210190</a>	1398	1	F	Correction to 5GMM test case 9.1.7.2	16.1.0
2021-03	RAN#91	<a href="#">R5s210191</a>	1399	1	F	Correction for NR MAC test case 7.1.1.5.2	16.1.0
2021-03	RAN#91	<a href="#">R5s210192</a>	1401	1	B	EN-DC FR1 : Addition of NR MAC test case 7.1.1.5.5	16.1.0
2021-03	RAN#91	<a href="#">R5s210193</a>	1403	1	B	EN-DC FR2 : Addition of NR MAC test case 7.1.1.5.5	16.1.0
2021-03	RAN#91	<a href="#">R5s210194</a>	1405	1	F	Correction to NR5GC SDAP test cases and RRC test case 8.1.5.4.1	16.1.0
2021-03	RAN#91	<a href="#">R5s210195</a>	1406	1	F	Correction to NR5GC idle more test case 6.3.1.7	16.1.0
2021-03	RAN#91	<a href="#">R5s210196</a>	1410	1	F	Correction to ENDC RLC testcase 7.1.2.3.6	16.1.0
2021-03	RAN#91	<a href="#">R5s210197</a>	1412	1	F	Correction to NR MAC test case 7.1.1.5.4	16.1.0
2021-03	RAN#91	<a href="#">R5s210198</a>	1413	1	F	Correction for template cs_Nr_SS_SpCellConfig	16.1.0
2021-03	RAN#91	<a href="#">R5s210199</a>	1415	1	B	Addition of NR5GC test case 7.1.1.10.1 in FR1	16.1.0
2021-03	RAN#91	<a href="#">R5s210200</a>	1423	1	F	Correction for NR5GC IRAT test cases	16.1.0
2021-03	RAN#91	<a href="#">R5s210201</a>	1425	1	F	Correction for NR MAC test case 7.1.1.5.1	16.1.0
2021-03	RAN#91	<a href="#">R5s210202</a>	1426	1	F	Correction for 5GMM test case 9.1.4.1	16.1.0
2021-03	RAN#91	<a href="#">R5s210203</a>	1434	1	F	Corrections for NR PDCP integrity and ciphering test cases	16.1.0
2021-03	RAN#91	<a href="#">R5s210204</a>	1438	1	F	Correction to f_Check_NG_PDUSessionModificationReq in 20wk43 IWD	16.1.0
2021-03	RAN#91	<a href="#">R5s210205</a>	1439	1	F	Correction to NR5GC testcases 10.1.6.1 and 10.1.6.2 for 20wk43 IWD	16.1.0
2021-03	RAN#91	<a href="#">R5s210206</a>	1441	1	F	Correction to function f_Nr_InitAS_KeyChaining_SKgNB	16.1.0
2021-03	RAN#91	<a href="#">R5s210209</a>	1442	1	F	Correction to NR5GC test case 9.1.5.1.9	16.1.0
2021-03	RAN#91	<a href="#">R5s210210</a>	1445	1	F	Correction to NR5GC test case 9.1.5.1.12	16.1.0
2021-03	RAN#91	<a href="#">R5s210211</a>	1446	1	F	Correction to NR MAC test case 7.1.1.3.3	16.1.0
2021-03	RAN#91	<a href="#">R5s210221</a>	1449	1	B	Addition of NR5GC test case 7.1.1.5.5 in FR1	16.1.0
2021-03	RAN#91	<a href="#">R5s210222</a>	1451	1	F	Correction to NR PDCP integrity test cases	16.1.0
2021-03	RAN#91	<a href="#">R5s210226</a>	1453	1	F	Correction to NR5GC test case 8.1.4.2.2.1	16.1.0
2021-03	RAN#91	<a href="#">R5s210230</a>	1454	1	F	Correction to NR5GC test case 10.1.3.2	16.1.0
2021-03	RAN#91	<a href="#">R5s210234</a>	1580	-	F	Correction to function f_Get_NG_DLNAStTransport	16.1.0
2021-03	RAN#91	<a href="#">R5s210235</a>	1581	-	F	Correction to function fl_TC_9_1_1_3_6_Body	16.1.0
2021-03	RAN#91	<a href="#">R5s210238</a>	1583	-	F	Correction to ENDC test case 10.2.2.1	16.1.0
2021-03	RAN#91	<a href="#">R5s210243</a>	1588	-	B	NR5GC FR1 : Addition of NR5GC RRC test case 8.1.1.2.4	16.1.0
2021-03	RAN#91	<a href="#">R5s210253</a>	1589	-	F	Correction to function f_NR5GC_CellInfo_SetSIB3_start	16.1.0
2021-03	RAN#91	<a href="#">R5s210254</a>	1459	1	F	Correction to function f_Nr_TestcasesIsL2Testcase in 20wk50	16.1.0
2021-03	RAN#91	<a href="#">R5s210255</a>	1460	1	F	Correction to function f_GetPDN_DNNTypeFromAPN in 20wk50	16.1.0
2021-03	RAN#91	<a href="#">R5s210256</a>	1461	1	F	Correction to NR5GC IRAT test case 6.2.1.5	16.1.0
2021-03	RAN#91	<a href="#">R5s210257</a>	1472	1	F	Correction to NR5GC idle mode test case 6.3.1.9	16.1.0

2021-03	RAN#91	<a href="#">R5s210258</a>	1475	1	F	Correction to NR MAC testcase 7.1.1.1.2	16.1.0
2021-03	RAN#91	<a href="#">R5s210259</a>	1476	1	F	Correction for NR RLC test case 7.1.2.3.8 in EN-DC	16.1.0
2021-03	RAN#91	<a href="#">R5s210260</a>	1477	1	F	Correction to ENDC Integrity protection test cases 7.1.3.2.x	16.1.0
2021-03	RAN#91	<a href="#">R5s210261</a>	1478	1	F	Correction for NR PDCP test case 7.1.3.4.1 in EN-DC	16.1.0
2021-03	RAN#91	<a href="#">R5s210263</a>	1590	-	F	Correction to cads_NR_CellConfig_C_RNTI_REQ	16.1.0
2021-03	RAN#91	<a href="#">R5s210265</a>	1591	-	F	Correction to f_EUTRA38_BuildEUTRA_RadioResourceConfigDedicated	16.1.0
2021-03	RAN#91	<a href="#">R5s210267</a>	1592	-	F	Correction to f_NG_GetPDNAddress	16.1.0
2021-03	RAN#91	<a href="#">R5s210271</a>	1594	-	F	Correction to NR5GC test case 8.1.3.1.23	16.1.0
2021-03	RAN#91	<a href="#">R5s210275</a>	1595	-	F	Correction to NR PDCP test 7.1.3.5.2	16.1.0
2021-03	RAN#91	<a href="#">R5s210276</a>	1596	-	F	Correction to NR5GC testcase 6.2.3.4	16.1.0
2021-03	RAN#91	<a href="#">R5s210277</a>	1597	-	F	Correction to the function f_ReconfigureDRBs	16.1.0
2021-03	RAN#91	<a href="#">R5s210282</a>	1598	-	F	Correction to NR5GC test case 7.1.3.4.1	16.1.0
2021-03	RAN#91	<a href="#">R5s210283</a>	1599	-	B	EN-DC FR1 : Addition of EN-DC RRC test case 8.2.2.2.1	16.1.0
2021-03	RAN#91	<a href="#">R5s210312</a>	1443	1	F	Correction to NR5GC test case 8.1.3.2.2	16.1.0
2021-03	RAN#91	<a href="#">R5s210314</a>	1462	1	F	Correction to NR5GC IRAT test case 8.1.4.2.1.1	16.1.0
2021-03	RAN#91	<a href="#">R5s210316</a>	1457	1	B	EN-DC FR1 : Addition of NR MAC test case 7.1.1.4.2.5	16.1.0
2021-03	RAN#91	<a href="#">R5s210319</a>	1614	-	F	Add new verified and e-mail agreed TTCN test cases in the TC lists in 38.523-3 (prose), Annex A	16.1.0
2021-06	RAN#92	R5-213516	1717	1	F	5G Test Models updates	16.2.0
2021-06	RAN#92	<a href="#">R5s210389</a>	1646	-	F	Correction for NR5GC CA inter-cell handover procedure	16.2.0
2021-06	RAN#92	<a href="#">R5s210390</a>	1647	-	B	Addition of NR5GC Idle mode test case 6.1.1.6 in FR1	16.2.0
2021-06	RAN#92	<a href="#">R5s210395</a>	1648	-	F	Correction to the function f_NR_PDCP_SDU_GetList	16.2.0
2021-06	RAN#92	<a href="#">R5s210396</a>	1649	-	F	Correction to cads_NR_UplinkBWP_ConfigCommon_REQ	16.2.0
2021-06	RAN#92	<a href="#">R5s210402</a>	1650	-	F	Correction for NR5GC IRAT test case 8.1.4.2.1.1	16.2.0
2021-06	RAN#92	<a href="#">R5s210403</a>	1651	-	F	Correction for NR 5GC IRAT test case 6.2.3.4	16.2.0
2021-06	RAN#92	<a href="#">R5s210404</a>	1652	-	F	Correction for NR system information modification functions	16.2.0
2021-06	RAN#92	<a href="#">R5s210405</a>	1653	-	F	Correction for NR idle mode test case 6.3.1.9	16.2.0
2021-06	RAN#92	<a href="#">R5s210406</a>	1654	-	F	Correction for NR5GC RRC test case 8.1.1.3.2	16.2.0
2021-06	RAN#92	<a href="#">R5s210407</a>	1655	-	F	Correction for NR5GC common function	16.2.0
2021-06	RAN#92	<a href="#">R5s210408</a>	1656	-	F	Corrections for NR5GC IRAT test cases	16.2.0
2021-06	RAN#92	<a href="#">R5s210409</a>	1657	-	F	Correction for NR idle mode test case 6.4.3.1	16.2.0
2021-06	RAN#92	<a href="#">R5s210410</a>	1658	-	F	Correction for NR5GC IRAT test case 6.2.1.2	16.2.0
2021-06	RAN#92	<a href="#">R5s210412</a>	1660	-	F	Correction for NR5GC IRAT test case 8.1.4.2.2.1	16.2.0
2021-06	RAN#92	<a href="#">R5s210414</a>	1661	-	F	Re-verification of NR5GC IRAT test case 11.1.1	16.2.0
2021-06	RAN#92	<a href="#">R5s210417</a>	1663	-	F	Correction to function f_GetPDN_DNNTypeFromAPN	16.2.0
2021-06	RAN#92	<a href="#">R5s210422</a>	1664	-	F	Correction to a_ApplicationCtrl	16.2.0
2021-06	RAN#92	<a href="#">R5s210426</a>	1666	-	F	Correction for NR MAC test case 7.1.1.2.3	16.2.0

2021-06	RAN#92	<a href="#">R5s210427</a>	1667	-	F	Correction for NR MAC test case 7.1.1.2.4	16.2.0
2021-06	RAN#92	<a href="#">R5s210428</a>	1668	-	F	Correction for NR idle mode test case 6.1.1.3	16.2.0
2021-06	RAN#92	<a href="#">R5s210431</a>	1670	-	F	Correction for 5GMM test case 9.1.5.1.3	16.2.0
2021-06	RAN#92	<a href="#">R5s210432</a>	1671	-	F	Correction for 5GMMtest cases 9.1.8.1 and 9.1.8.2	16.2.0
2021-06	RAN#92	<a href="#">R5s210433</a>	1672	-	F	Correction for NR idle mode test case 6.2.3.11	16.2.0
2021-06	RAN#92	<a href="#">R5s210434</a>	1673	-	F	Correction for NR MAC test cases	16.2.0
2021-06	RAN#92	<a href="#">R5s210435</a>	1674	-	F	Correction for NR5GC measurement test cases	16.2.0
2021-06	RAN#92	<a href="#">R5s210438</a>	1676	-	F	Correction for NR MAC test case 7.1.1.10.1	16.2.0
2021-06	RAN#92	<a href="#">R5s210439</a>	1677	-	F	Correction for EN-DC RRC test case 8.2.2.3.1	16.2.0
2021-06	RAN#92	<a href="#">R5s210440</a>	1678	-	F	Correction for NR idle mode test case 6.1.2.8	16.2.0
2021-06	RAN#92	<a href="#">R5s210444</a>	1679	-	F	Rel-16 Mar'21 partial baseline upgrade for 5GS TTCN-3 Test Suites	16.2.0
2021-06	RAN#92	<a href="#">R5s210445</a>	1680	-	F	Correction for NR idle mode test case 6.2.3.6	16.2.0
2021-06	RAN#92	<a href="#">R5s210446</a>	1681	-	F	Correction for 5GMM test case 9.3.1.2	16.2.0
2021-06	RAN#92	<a href="#">R5s210449</a>	1684	-	F	Correction to NR idle mode test case 6.1.1.4	16.2.0
2021-06	RAN#92	<a href="#">R5s210453</a>	1686	-	F	Corrections for EN-DC RRC test case 8.2.4.3.1.1	16.2.0
2021-06	RAN#92	<a href="#">R5s210454</a>	1687	-	F	Correction for NR idle mode test case 6.4.1.1	16.2.0
2021-06	RAN#92	<a href="#">R5s210456</a>	1689	-	B	Addition of NR5GC test case 8.1.5.6.1 in FR1	16.2.0
2021-06	RAN#92	<a href="#">R5s210463</a>	1692	-	F	Correction to NR5GC testcase 7.1.4.1	16.2.0
2021-06	RAN#92	<a href="#">R5s210471</a>	1694	-	F	Correction to function fl_QoS_MaximumBitRateExtD_2	16.2.0
2021-06	RAN#92	<a href="#">R5s210475</a>	1696	-	F	Re-verification of NR5GC IRAT test case 11.1.3	16.2.0
2021-06	RAN#92	<a href="#">R5s210476</a>	1697	-	F	Correction to NR testcases 7.1.3.1.2.NR5GC and 7.1.3.1.2.ENDC	16.2.0
2021-06	RAN#92	<a href="#">R5s210478</a>	1699	-	B	Addition of NR5GC EPS fall back test case 11.1.4 in FR1	16.2.0
2021-06	RAN#92	<a href="#">R5s210480</a>	1700	-	F	Correction to functions f_NR5GC_ModifyPDUSession_AddVoice and f_NR5GC_ModifyPDUSession_RemoveIMSVoice	16.2.0
2021-06	RAN#92	<a href="#">R5s210483</a>	1702	-	F	Correction to function f_TC_7_1_1_3_3_NR5GC	16.2.0
2021-06	RAN#92	<a href="#">R5s210485</a>	1704	-	F	Correction to NR5GC testcase 6.3.1.5	16.2.0
2021-06	RAN#92	<a href="#">R5s210501</a>	1707	-	F	Correction to the NR5GC Testcase 6.4.2.2	16.2.0
2021-06	RAN#92	<a href="#">R5s210503</a>	1708	-	B	NR5GC FR1 : Addition of 5GMM test case 9.1.5.1.15	16.2.0
2021-06	RAN#92	<a href="#">R5s210509</a>	1710	-	F	Correction to the UE capability transfer testcases 8.2.1.1.1 and 8.1.5.1.1	16.2.0
2021-06	RAN#92	<a href="#">R5s210520</a>	1715	-	F	Correction to NR5GC testcase 6.2.3.8	16.2.0
2021-06	RAN#92	<a href="#">R5s210523</a>	1718	-	F	Correction to NR5GC RRC test case 8.1.3.1.18.x	16.2.0
2021-06	RAN#92	<a href="#">R5s210524</a>	1719	-	F	Correction to NR idle mode test case 6.1.2.2	16.2.0
2021-06	RAN#92	<a href="#">R5s210528</a>	1088	1	B	EN-DC FR1 : Addition of NR RLC test case 7.1.2.3.4	16.2.0
2021-06	RAN#92	<a href="#">R5s210529</a>	1259	1	B	EN-DC FR2 : Addition of NR RLC test case 7.1.2.3.4	16.2.0
2021-06	RAN#92	<a href="#">R5s210530</a>	1295	1	B	Addition of NR5GC test case 7.1.2.3.4 in FR1	16.2.0
2021-06	RAN#92	<a href="#">R5s210531</a>	1456	1	F	Correction to NR5GC test case 9.1.5.1.3	16.2.0
2021-06	RAN#92	<a href="#">R5s210532</a>	1488	1	F	Correction to NR MAC test case 7.1.1.1.2	16.2.0

2021-06	RAN#92	<a href="#">R5s210533</a>	1494	1	F	EN-DC FR1 : Re-verification of NR RLC test case 7.1.2.3.4	16.2.0
2021-06	RAN#92	<a href="#">R5s210534</a>	1495	1	F	EN-DC FR2 : Re-verification of NR RLC test case 7.1.2.3.4	16.2.0
2021-06	RAN#92	<a href="#">R5s210535</a>	1524	1	F	Correction to NR MAC test case 7.1.1.10.1	16.2.0
2021-06	RAN#92	<a href="#">R5s210536</a>	1525	1	F	Correction to NR MAC test case 7.1.1.1.6	16.2.0
2021-06	RAN#92	<a href="#">R5s210537</a>	1536	1	F	Corrections for NR MAC test cases 7.1.1.2.3 and 7.1.1.2.4	16.2.0
2021-06	RAN#92	<a href="#">R5s210538</a>	1544	1	F	NR5GC FR1 : Re-verification of NR RLC test case 7.1.2.3.4	16.2.0
2021-06	RAN#92	<a href="#">R5s210539</a>	1578	1	F	Correction NR5GC test case 6.1.2.14	16.2.0
2021-06	RAN#92	<a href="#">R5s210540</a>	1582	1	F	Correction to NR5GC testcase 6.3.1.7	16.2.0
2021-06	RAN#92	<a href="#">R5s210541</a>	1587	1	F	Correction for NR common function f_NR_InitDL_BWPs()	16.2.0
2021-06	RAN#92	<a href="#">R5s210543</a>	1593	1	F	Encoding enhancement for better TTCN logging	16.2.0
2021-06	RAN#92	<a href="#">R5s210547</a>	1604	1	F	Correction to function f_MTC_IMS_CreateMapAndConnectPTCs_NR5GC	16.2.0
2021-06	RAN#92	<a href="#">R5s210548</a>	1607	1	F	Correction to the Mapped EPS Parameter	16.2.0
2021-06	RAN#92	<a href="#">R5s210550</a>	1611	1	B	NR5GC FR1 : Addition of NR5GC multilayer test case 11.3.9	16.2.0
2021-06	RAN#92	<a href="#">R5s210551</a>	1612	1	F	Correction to NR5GC test case 8.1.1.4.1	16.2.0
2021-06	RAN#92	<a href="#">R5s210552</a>	1613	1	F	Correction to function f_NR_RRC_SetupRequest_Common	16.2.0
2021-06	RAN#92	<a href="#">R5s210556</a>	1619	1	B	Addition of NR5GC test case 7.1.1.3.8.1 in FR1	16.2.0
2021-06	RAN#92	<a href="#">R5s210557</a>	1620	1	B	Addition of NR5GC test case 7.1.1.3.8.2 in FR1	16.2.0
2021-06	RAN#92	<a href="#">R5s210558</a>	1621	1	F	Correction to NR5GC test case 6.3.1.5	16.2.0
2021-06	RAN#92	<a href="#">R5s210560</a>	1624	1	B	Addition of NR5GC test case 8.1.2.1.4 in FR1	16.2.0
2021-06	RAN#92	<a href="#">R5s210561</a>	1625	1	B	Addition of NR5GC CA test case 8.1.4.1.8.1 in FR1	16.2.0
2021-06	RAN#92	<a href="#">R5s210562</a>	1626	1	B	Addition of NR5GC CA test case 8.1.4.1.8.2 in FR1	16.2.0
2021-06	RAN#92	<a href="#">R5s210564</a>	1629	1	B	NR5GC FR1 : Addition of NR IRAT test case 6.2.3.11	16.2.0
2021-06	RAN#92	<a href="#">R5s210565</a>	1631	1	F	Correction for 5GMM test case 9.3.1.2	16.2.0
2021-06	RAN#92	<a href="#">R5s210566</a>	1633	1	F	Correction to function fl_NR_InitialiseSiScheduling	16.2.0
2021-06	RAN#92	<a href="#">R5s210567</a>	1634	1	F	Correction to NR5GC testcase 9.1.5.1.3	16.2.0
2021-06	RAN#92	<a href="#">R5s210568</a>	1635	2	F	Correction for function f_NR5GC_ModifyPDUSession_AddVoice()	16.2.0
2021-06	RAN#92	<a href="#">R5s210570</a>	1638	1	F	Summary of regression errors in 21wk12 TTCN for NR testcases	16.2.0
2021-06	RAN#92	<a href="#">R5s210571</a>	1639	1	F	Correction to Multiple ENDC Measurement testcases	16.2.0
2021-06	RAN#92	<a href="#">R5s210572</a>	1640	1	F	Correction to NR5GC testcase 9.1.5.2.8	16.2.0
2021-06	RAN#92	<a href="#">R5s210574</a>	1724	-	F	Correction for NR5GC RRC test case 8.1.4.1.8.1	16.2.0
2021-06	RAN#92	<a href="#">R5s210575</a>	1725	-	F	Correction to NR Idle Mode test case 6.4.2.1	16.2.0
2021-06	RAN#92	<a href="#">R5s210576</a>	1726	-	F	Correction to the NR5GC Testcase 6.3.1.1	16.2.0
2021-06	RAN#92	<a href="#">R5s210577</a>	1727	-	F	Correction to NR5GC testcase 9.1.5.1.3	16.2.0
2021-06	RAN#92	<a href="#">R5s210578</a>	1729	-	F	Correction to the function f_NR_SendRRCResume_Def	16.2.0
2021-06	RAN#92	<a href="#">R5s210581</a>	1732	-	F	Correction to f_TC_6_4_2_1_NR5GC_TestBody	16.2.0
2021-06	RAN#92	<a href="#">R5s210582</a>	1733	-	F	Correction to function f_TC_7_1_1_5_5_NR_TestBody	16.2.0
2021-06	RAN#92	<a href="#">R5s210594</a>	1738	-	F	Correction to NR5GC MAC DRX test cases	16.2.0

2021-06	RAN#92	<a href="#">R5s210595</a>	1739	-	F	Correction to NR5GC RRC test case 8.1.1.2.4	16.2.0
2021-06	RAN#92	<a href="#">R5s210598</a>	1742	-	F	Correction to the function f_GetTestcaseAttrib_EarlyContentionResolution	16.2.0
2021-06	RAN#92	<a href="#">R5s210602</a>	1745	-	F	Correction for NR5GC RRC test case 8.1.3.3.2	16.2.0
2021-06	RAN#92	<a href="#">R5s210605</a>	1747	-	F	Correction to the testcase 6.4.2.2.NR5GC	16.2.0
2021-06	RAN#92	<a href="#">R5s210638</a>	1559	1	B	Addition of NR5GC EPS fall back test case 11.1.1 in FR1	16.2.0
2021-06	RAN#92	<a href="#">R5s210639</a>	1609	1	B	Addition of NR5GC EPS fall back test case 11.1.3 in FR1	16.2.0
2021-06	RAN#92	<a href="#">R5s210640</a>	1623	1	F	Correction to ENDC test case 10.2.2.1	16.2.0
2021-06	RAN#92	<a href="#">R5s210641</a>	1636	1	F	Correction to NR5GC testcase 8.1.5.4.1	16.2.0
2021-06	RAN#92	<a href="#">R5s210643</a>	1605	1	F	Correction to the function f_NR_CheckDataPath_CA	16.2.0
2021-06	RAN#92	<a href="#">R5s210646</a>	1628	1	B	NR5GC FR1 : Addition of NR IRAT test case 6.2.3.10	16.2.0
2021-06	RAN#92	<a href="#">R5s210648</a>	1764	-	F	Add new verified and e-mail agreed TTCN test cases in the TC lists in 38.523-3 (prose), Annex A	16.2.0
2021-09	RAN#93	R5-214620	1856	-	F	5G Rel-15 Test Models updates	16.3.0
2021-09	RAN#93	R5-214621	1857	-	F	Addition of NR/UTRAN Inter-RAT Test Model	16.3.0
2021-09	RAN#93	<a href="#">R5s210716</a>	1790	-	B	Addition of NR-DC test case 8.2.2.4.2 in FR1+FR2	16.3.0
2021-09	RAN#93	<a href="#">R5s210719</a>	1792	-	F	Correction for NR PDCP test case 7.1.3.4.1	16.3.0
2021-09	RAN#93	<a href="#">R5s210722</a>	1794	-	F	Correction for NR5GC multilayer test case 11.1.4	16.3.0
2021-09	RAN#93	<a href="#">R5s210725</a>	1797	-	F	Correction for NR MAC test case 7.1.1.2.1	16.3.0
2021-09	RAN#93	<a href="#">R5s210727</a>	1798	-	F	Correction for NR MAC CA test cases 7.1.1.7.1.x	16.3.0
2021-09	RAN#93	<a href="#">R5s210729</a>	1800	-	F	Correction for some NR5GC test cases with IMS enabled	16.3.0
2021-09	RAN#93	<a href="#">R5s210730</a>	1801	-	F	Correction for EN-DC RRC test case 8.2.2.2.1	16.3.0
2021-09	RAN#93	<a href="#">R5s210731</a>	1802	-	F	Correction for NR5GC multilayer test case 11.3.7	16.3.0
2021-09	RAN#93	<a href="#">R5s210735</a>	1803	-	F	Correction for ENDC RRC test case 8.2.6.2.1	16.3.0
2021-09	RAN#93	<a href="#">R5s210736</a>	1804	-	F	Correction for NR idle mode test case 6.1.2.8	16.3.0
2021-09	RAN#93	<a href="#">R5s210737</a>	1805	-	B	Addition of NR5GC test case 9.1.2.1 in FR2	16.3.0
2021-09	RAN#93	<a href="#">R5s210739</a>	1806	-	B	Addition of NR5GC test case 9.1.2.2 in FR2	16.3.0
2021-09	RAN#93	<a href="#">R5s210741</a>	1807	-	B	Addition of NR5GC test case 9.1.2.3 in FR2	16.3.0
2021-09	RAN#93	<a href="#">R5s210743</a>	1808	-	B	Addition of NR5GC test case 9.1.2.4 in FR2	16.3.0
2021-09	RAN#93	<a href="#">R5s210745</a>	1809	-	B	Addition of NR5GC test case 9.1.2.5 in FR2	16.3.0
2021-09	RAN#93	<a href="#">R5s210747</a>	1810	-	B	Addition of NR5GC test case 9.1.2.6 in FR2	16.3.0
2021-09	RAN#93	<a href="#">R5s210749</a>	1811	-	B	Addition of NR5GC test case 9.1.2.7 in FR2	16.3.0
2021-09	RAN#93	<a href="#">R5s210751</a>	1812	-	B	Addition of NR5GC test case 9.1.2.8 in FR2	16.3.0
2021-09	RAN#93	<a href="#">R5s210753</a>	1813	-	B	Addition of NR5GC test case 9.1.3.1 in FR2	16.3.0
2021-09	RAN#93	<a href="#">R5s210757</a>	1815	-	F	Correction to NR5GC multilayer test case 11.3.2	16.3.0
2021-09	RAN#93	<a href="#">R5s210758</a>	1816	-	F	Correction to EN-DC RRC CA test case 8.2.4.3.1.1	16.3.0
2021-09	RAN#93	<a href="#">R5s210760</a>	1817	-	B	Addition of NR CA test case 8.1.2.1.5.3 in FR1	16.3.0
2021-09	RAN#93	<a href="#">R5s210763</a>	1818	-	B	Addition of NR5GC test case 9.1.1.1 in FR2	16.3.0

2021-09	RAN#93	<a href="#">R5s210765</a>	1819	-	B	Addition of NR5GC test case 9.1.1.2 in FR2	16.3.0
2021-09	RAN#93	<a href="#">R5s210770</a>	1822	-	F	Correction to NR5GC testcase 11.4.6	16.3.0
2021-09	RAN#93	<a href="#">R5s210771</a>	1823	-	F	Correction to function f_NR5GC_EmergencyCallPDUSession	16.3.0
2021-09	RAN#93	<a href="#">R5s210774</a>	1825	-	B	Addition of NR-DC test case 8.2.5.1.2 in FR1+FR2	16.3.0
2021-09	RAN#93	<a href="#">R5s210776</a>	1826	-	B	Addition of NR-DC test case 8.2.5.2.2 in FR1+FR2	16.3.0
2021-09	RAN#93	<a href="#">R5s210778</a>	1827	-	F	Correction to NR RLC test csase 7.1.2.3.5	16.3.0
2021-09	RAN#93	<a href="#">R5s210786</a>	1830	-	F	Correction to NG NAS template	16.3.0
2021-09	RAN#93	<a href="#">R5s210787</a>	1831	-	F	Correction for NR PDCP test case 7.1.3.5.1	16.3.0
2021-09	RAN#93	<a href="#">R5s210797</a>	1834	-	F	Correction to NR test cases 9.1.5.2.2, 9.1.5.1.1 and 11.3.9 for guard timer extension	16.3.0
2021-09	RAN#93	<a href="#">R5s210804</a>	1838	-	F	Correction to NR5GC testcase 11.3.2	16.3.0
2021-09	RAN#93	<a href="#">R5s210808</a>	1841	-	B	NR5GC FR1 : Addition of NR5GC multilayer test case 11.4.4	16.3.0
2021-09	RAN#93	<a href="#">R5s210810</a>	1842	-	B	NR5GC FR1 : Addition of NR5GC multilayer test case 11.4.8	16.3.0
2021-09	RAN#93	<a href="#">R5s210816</a>	1844	-	B	Addition of NR5GC testcase 9.1.5.2.8 in FR2	16.3.0
2021-09	RAN#93	<a href="#">R5s210818</a>	1845	-	B	Addition of NR5GC testcase 9.1.5.2.7 in FR2	16.3.0
2021-09	RAN#93	<a href="#">R5s210820</a>	1846	-	F	Correction to NR5GC testcase 9.1.5.1.10 in FR1	16.3.0
2021-09	RAN#93	<a href="#">R5s210821</a>	1847	-	B	Addition of NR5GC testcase 9.1.5.2.2 in FR2	16.3.0
2021-09	RAN#93	<a href="#">R5s210823</a>	1848	-	B	Addition of NR5GC testcase 9.1.1.4 in FR2	16.3.0
2021-09	RAN#93	<a href="#">R5s210826</a>	1849	-	B	Addition of NR5GC testcase 9.1.5.1.5 in FR2	16.3.0
2021-09	RAN#93	<a href="#">R5s210828</a>	1850	-	B	Addition of NR5GC testcase 10.1.1.1 in FR2	16.3.0
2021-09	RAN#93	<a href="#">R5s210830</a>	1851	-	B	Addition of NR5GC testcase 6.1.2.15 in FR2	16.3.0
2021-09	RAN#93	<a href="#">R5s210832</a>	1852	-	B	Addition of NR5GC testcase 9.1.5.1.6 in FR2	16.3.0
2021-09	RAN#93	<a href="#">R5s210836</a>	1854	-	B	Addition of NR5GC testcase 9.1.5.1.15 in FR2	16.3.0
2021-09	RAN#93	<a href="#">R5s210838</a>	1855	-	F	Correction to NR test case 7.1.3.4.1	16.3.0
2021-09	RAN#93	<a href="#">R5s210842</a>	1860	-	B	Addition of NR5GC test case 8.1.5.8.2.1 in FR1	16.3.0
2021-09	RAN#93	<a href="#">R5s210844</a>	1861	-	B	Addition of NR5GC test case 8.1.5.8.2.2 in FR1	16.3.0
2021-09	RAN#93	<a href="#">R5s210846</a>	1862	-	F	Correction to ENDC testcases 8.2.4.3.1.1 and 8.2.4.3.1.3	16.3.0
2021-09	RAN#93	<a href="#">R5s210847</a>	1863	-	B	NR5GC FR1 : Addition of NR5GC R16 SON-MDT test case 8.1.6.1.4.1	16.3.0
2021-09	RAN#93	<a href="#">R5s210855</a>	1864	-	B	ENDC FR2 : Addition of ENDC NR MAC test case 7.1.1.7.1.1	16.3.0
2021-09	RAN#93	<a href="#">R5s210857</a>	1865	-	B	ENDC FR1 : Addition of ENDC NR MAC test case 7.1.1.7.1.2	16.3.0
2021-09	RAN#93	<a href="#">R5s210860</a>	1867	-	F	Correction to NR testcase 7.1.1.3.2	16.3.0
2021-09	RAN#93	<a href="#">R5s210862</a>	1869	-	F	Correction to NR5GC testcase 7.1.1.3.5	16.3.0
2021-09	RAN#93	<a href="#">R5s210865</a>	1871	-	F	Correction to NR5GC testcase 7.1.1.7.1.2	16.3.0
2021-09	RAN#93	<a href="#">R5s210872</a>	1877	-	F	Correction to NR testcase 8.1.5.4.1	16.3.0
2021-09	RAN#93	<a href="#">R5s210873</a>	1878	-	B	NR5GC FR1 : Addition of NR5GC RRC test case 8.1.6.1.4.4	16.3.0
2021-09	RAN#93	<a href="#">R5s210883</a>	1881	-	F	Correction to ENDC MAC testcase 7.1.1.3.7	16.3.0
2021-09	RAN#93	<a href="#">R5s210886</a>	1884	-	F	Correction to NR testcases 7.1.2.3.5 and 7.1.2.3.5a	16.3.0

2021-09	RAN#93	<a href="#">R5s210891</a>	1886	-	F	Corrections for NR-DC test cases	16.3.0
2021-09	RAN#93	<a href="#">R5s210892</a>	1887	-	F	Correction of NR5GC test case 6.4.1.2	16.3.0
2021-09	RAN#93	<a href="#">R5s210893</a>	1888	-	F	Correction to NR5GC testcase 7.1.1.7.1.1 in FR1	16.3.0
2021-09	RAN#93	<a href="#">R5s210894</a>	1889	-	B	EN-DC FR1 : Addition of NR MAC test case 7.1.1.3.8.1	16.3.0
2021-09	RAN#93	<a href="#">R5s210896</a>	1890	-	F	Correction to NR5GC testcase 7.1.1.9.1	16.3.0
2021-09	RAN#93	<a href="#">R5s210898</a>	1644	1	F	Correction for IMS voice call procedures	16.3.0
2021-09	RAN#93	<a href="#">R5s210900</a>	1675	1	F	Correction for 5GSM test case 10.1.4.1	16.3.0
2021-09	RAN#93	<a href="#">R5s210901</a>	1714	1	B	NR5GC FR1 : Addition of NR5GC multilayer test case 11.4.3	16.3.0
2021-09	RAN#93	<a href="#">R5s210902</a>	1721	1	F	Correction to NR handover function	16.3.0
2021-09	RAN#93	<a href="#">R5s210903</a>	1730	1	F	Correction to NR testcase 7.1.3.1.2 (ENDC and NR5GC)	16.3.0
2021-09	RAN#93	<a href="#">R5s210904</a>	1731	1	F	Correction for NR idle mode test case 6.2.3.5	16.3.0
2021-09	RAN#93	<a href="#">R5s210905</a>	1740	1	F	Correction for NR idle mode test case 6.1.1.1	16.3.0
2021-09	RAN#93	<a href="#">R5s210906</a>	1746	1	B	NR5GC FR1 : Addition of NR5GC multilayer test case 11.4.7	16.3.0
2021-09	RAN#93	<a href="#">R5s210908</a>	1748	1	F	Correction to NR5GC testcase 11.3.4	16.3.0
2021-09	RAN#93	<a href="#">R5s210909</a>	1749	1	F	Correction to NR5GC testcase 9.1.5.1.3	16.3.0
2021-09	RAN#93	<a href="#">R5s210911</a>	1751	1	F	Correction to NR5GC testcase 7.1.1.5.2	16.3.0
2021-09	RAN#93	<a href="#">R5s210912</a>	1752	1	F	Correction to ENDC test case 8.2.2.6.1	16.3.0
2021-09	RAN#93	<a href="#">R5s210913</a>	1753	1	F	Correction to the NR5GC Testcase 6.3.1.2	16.3.0
2021-09	RAN#93	<a href="#">R5s210914</a>	1754	1	F	Corrections for NR MAC testcase 7.1.1.1.1a	16.3.0
2021-09	RAN#93	<a href="#">R5s210916</a>	1755	1	B	Addition of NR5GC test case 11.1.7 in FR1	16.3.0
2021-09	RAN#93	<a href="#">R5s210917</a>	1756	1	B	Addition of NR5GC test case 11.3.2 in FR1	16.3.0
2021-09	RAN#93	<a href="#">R5s210921</a>	1759	1	B	NR5GC FR1 : Addition of NR5GC multilayer test case 11.3.8	16.3.0
2021-09	RAN#93	<a href="#">R5s210924</a>	1761	1	B	Addition of NR5GC multilayer test case 11.4.6	16.3.0
2021-09	RAN#93	<a href="#">R5s210925</a>	1763	1	F	Corrections for ENDC testcase 8.2.2.2.1	16.3.0
2021-09	RAN#93	<a href="#">R5s210929</a>	1767	1	F	Corrections for NR5GC SOR TCs	16.3.0
2021-09	RAN#93	<a href="#">R5s210930</a>	1771	1	F	Corrections for NR MAC testcase 7.1.1.7.1.1	16.3.0
2021-09	RAN#93	<a href="#">R5s210931</a>	1773	1	F	Correction to function fl_NR5GC_QoSFlowsLength	16.3.0
2021-09	RAN#93	<a href="#">R5s210932</a>	1775	1	F	Correction to NR test cases 7.1.3.5.1 and 7.1.3.5.4	16.3.0
2021-09	RAN#93	<a href="#">R5s210933</a>	1776	1	F	Correction to NR test cases 7.1.2.3.3, 7.1.2.3.4 ,7.1.3.1.1 and 7.1.3.1.2	16.3.0
2021-09	RAN#93	<a href="#">R5s210936</a>	1777	1	F	Correction to function f_TC_7_1_1_5_5_NR_TestBody	16.3.0
2021-09	RAN#93	<a href="#">R5s210938</a>	1778	1	F	Correction to function f_NR_CheckDataPath_CA	16.3.0
2021-09	RAN#93	<a href="#">R5s210939</a>	1781	1	F	Correction for NR5GC IRAT test cases	16.3.0
2021-09	RAN#93	<a href="#">R5s210941</a>	1784	1	F	Corrections for NR MAC testcase 7.1.1.1.2	16.3.0
2021-09	RAN#93	<a href="#">R5s210946</a>	1787	1	F	Correction for NR5GC RRC test cases 8.1.4.1.8.x	16.3.0
2021-09	RAN#93	<a href="#">R5s210954</a>	1665	1	B	NR5GC FR1 : Addition of NR5GC multilayer test case 11.3.7	16.3.0
2021-09	RAN#93	<a href="#">R5s210958</a>	1783	1	F	Correction for NR5GC RRC test case 8.1.1.4.1	16.3.0
2021-09	RAN#93	<a href="#">R5s210960</a>	1789	1	F	Correction for NR5GC RRC test case 8.1.1.2.1	16.3.0



2021-09	RAN#93	<a href="#">R5s211172</a>	1765	1	F	Correction to NR5GC testcase 11.3.9	16.3.0
2021-09	RAN#93	<a href="#">R5s211173</a>	1772	1	B	Addition of NR5GC test case 11.3.6 in FR1	16.3.0
2021-09	RAN#93	<a href="#">R5s211174</a>	1774	1	F	Correction to NR5GC IRAT functions	16.3.0
2021-09	RAN#93	<a href="#">R5s211175</a>	2003	-	F	Add new verified and e-mail agreed TTCN test cases in the TC lists in 38.523-3 (prose), Annex A	16.3.0

---

# History

<b>Document history</b>		
V16.0.0	January 2021	Publication
V16.1.0	April 2021	Publication
V16.2.0	September 2021	Publication
V16.3.0	October 2021	Publication