

# ETSI TS 146 041 V18.0.0 (2024-05)



TECHNICAL SPECIFICATION

**Digital cellular telecommunications system (Phase 2+) (GSM);  
Half rate speech;  
Discontinuous Transmission (DTX) for  
half rate speech traffic channels  
(3GPP TS 46.041 version 18.0.0 Release 18)**



---

**Reference**

RTS/TSGS-0446041 vi00

---

**Keywords**

GSM

**ETSI**

---

650 Route des Lucioles  
F-06921 Sophia Antipolis Cedex - FRANCE

Tel.: +33 4 92 94 42 00 Fax: +33 4 93 65 47 16

Siret N° 348 623 562 00017 - APE 7112B  
Association à but non lucratif enregistrée à la  
Sous-Préfecture de Grasse (06) N° w061004871

---

**Important notice**

The present document can be downloaded from:

<https://www.etsi.org/standards-search>

The present document may be made available in electronic versions and/or in print. The content of any electronic and/or print versions of the present document shall not be modified without the prior written authorization of ETSI. In case of any existing or perceived difference in contents between such versions and/or in print, the prevailing version of an ETSI deliverable is the one made publicly available in PDF format at [www.etsi.org/deliver](http://www.etsi.org/deliver).

Users of the present document should be aware that the document may be subject to revision or change of status.

Information on the current status of this and other ETSI documents is available at

<https://portal.etsi.org/TB/ETSIDeliverableStatus.aspx>

If you find errors in the present document, please send your comment to one of the following services:

<https://portal.etsi.org/People/CommitteeSupportStaff.aspx>

If you find a security vulnerability in the present document, please report it through our  
Coordinated Vulnerability Disclosure Program:

<https://www.etsi.org/standards/coordinated-vulnerability-disclosure>

---

**Notice of disclaimer & limitation of liability**

The information provided in the present deliverable is directed solely to professionals who have the appropriate degree of experience to understand and interpret its content in accordance with generally accepted engineering or other professional standard and applicable regulations.

No recommendation as to products and services or vendors is made or should be implied.

No representation or warranty is made that this deliverable is technically accurate or sufficient or conforms to any law and/or governmental rule and/or regulation and further, no representation or warranty is made of merchantability or fitness for any particular purpose or against infringement of intellectual property rights.

In no event shall ETSI be held liable for loss of profits or any other incidental or consequential damages.

Any software contained in this deliverable is provided "AS IS" with no warranties, express or implied, including but not limited to, the warranties of merchantability, fitness for a particular purpose and non-infringement of intellectual property rights and ETSI shall not be held liable in any event for any damages whatsoever (including, without limitation, damages for loss of profits, business interruption, loss of information, or any other pecuniary loss) arising out of or related to the use of or inability to use the software.

---

**Copyright Notification**

No part may be reproduced or utilized in any form or by any means, electronic or mechanical, including photocopying and microfilm except as authorized by written permission of ETSI.

The content of the PDF version shall not be modified without the written authorization of ETSI.

The copyright and the foregoing restriction extend to reproduction in all media.

© ETSI 2024.  
All rights reserved.

---

# Intellectual Property Rights

## Essential patents

IPRs essential or potentially essential to normative deliverables may have been declared to ETSI. The declarations pertaining to these essential IPRs, if any, are publicly available for **ETSI members and non-members**, and can be found in ETSI SR 000 314: "*Intellectual Property Rights (IPRs); Essential, or potentially Essential, IPRs notified to ETSI in respect of ETSI standards*", which is available from the ETSI Secretariat. Latest updates are available on the ETSI Web server (<https://ipr.etsi.org/>).

Pursuant to the ETSI Directives including the ETSI IPR Policy, no investigation regarding the essentiality of IPRs, including IPR searches, has been carried out by ETSI. No guarantee can be given as to the existence of other IPRs not referenced in ETSI SR 000 314 (or the updates on the ETSI Web server) which are, or may be, or may become, essential to the present document.

## Trademarks

The present document may include trademarks and/or tradenames which are asserted and/or registered by their owners. ETSI claims no ownership of these except for any which are indicated as being the property of ETSI, and conveys no right to use or reproduce any trademark and/or tradename. Mention of those trademarks in the present document does not constitute an endorsement by ETSI of products, services or organizations associated with those trademarks.

**DECT™**, **PLUGTESTS™**, **UMTS™** and the ETSI logo are trademarks of ETSI registered for the benefit of its Members. **3GPP™** and **LTE™** are trademarks of ETSI registered for the benefit of its Members and of the 3GPP Organizational Partners. **oneM2M™** logo is a trademark of ETSI registered for the benefit of its Members and of the oneM2M Partners. **GSM®** and the GSM logo are trademarks registered and owned by the GSM Association.

---

# Legal Notice

This Technical Specification (TS) has been produced by ETSI 3rd Generation Partnership Project (3GPP).

The present document may refer to technical specifications or reports using their 3GPP identities. These shall be interpreted as being references to the corresponding ETSI deliverables.

The cross reference between 3GPP and ETSI identities can be found under <https://webapp.etsi.org/key/queryform.asp>.

---

# Modal verbs terminology

In the present document "**shall**", "**shall not**", "**should**", "**should not**", "**may**", "**need not**", "**will**", "**will not**", "**can**" and "**cannot**" are to be interpreted as described in clause 3.2 of the [ETSI Drafting Rules](#) (Verbal forms for the expression of provisions).

"**must**" and "**must not**" are **NOT** allowed in ETSI deliverables except when used in direct citation.

---

# Contents

Intellectual Property Rights .....	2
Legal Notice .....	2
Modal verbs terminology.....	2
Foreword.....	4
1 Scope .....	5
2 References .....	5
3 Definitions, symbols and abbreviations .....	6
3.1 Definitions .....	6
3.2 Symbols.....	6
3.3 Abbreviations .....	7
4 General .....	7
4.1 General Organisation.....	7
5 Transmit (TX) side .....	8
5.1 General Operation .....	8
5.1.1 Functions of the TX DTX handler .....	8
5.1.2 Functions of the TX radio subsystem .....	9
6 Receive (RX) side .....	11
6.1 General operation .....	11
6.1.1 Functions of the RX radio subsystem .....	11
6.1.2 Functions of the RX DTX handler.....	12
<b>Annex A (informative): Change history .....</b>	<b>13</b>
History .....	14

---

# Foreword

This Technical Specification has been produced by the 3<sup>rd</sup> Generation Partnership Project (3GPP).

The present document is a GSM technical specification version 7 and is part of the 1998 release of the GSM Technical Specifications. The present document is part of a series covering the half rate speech traffic channels as described below:

- GSM 06.02 "Digital cellular telecommunications system (Phase 2+); Half rate speech; Half rate speech processing functions".
- GSM 06.06 "Digital cellular telecommunications system (Phase 2+); Half rate speech; ANSI-C code for the GSM half rate speech codec".
- GSM 06.07 "Digital cellular telecommunications system (Phase 2+); Half rate speech; Test sequences for the GSM half rate speech codec".
- GSM 06.20 "Digital cellular telecommunications system (Phase 2+); Half rate speech; Half rate speech transcoding".
- GSM 06.21 "Digital cellular telecommunications system (Phase 2+); Half rate speech; Substitution and muting of lost frames for half rate speech traffic channels".
- GSM 06.22 "Digital cellular telecommunications system (Phase 2+); Half rate speech; Comfort noise aspects for half rate speech traffic channels".
- GSM 06.41 "Digital cellular telecommunications system (Phase 2+); Half rate speech; Discontinuous Transmission (DTX) for half rate speech traffic channels".**

GSM 06.42 "Digital cellular telecommunications system (Phase 2+); Half rate speech; Voice Activity Detector (VAD) for half rate speech traffic channels".

The contents of the present document are subject to continuing work within the TSG and may change following formal TSG approval. Should the TSG modify the contents of the present document, it will be re-released by the TSG with an identifying change of release date and an increase in version number as follows:

Version x.y.z

where:

- x the first digit:
  - 1 presented to TSG for information;
  - 2 presented to TSG for approval;
  - 3 or greater indicates TSG approved document under change control.
- y the second digit is incremented for all changes of substance, i.e. technical enhancements, corrections, updates, etc.
- z the third digit is incremented when editorial only changes have been incorporated in the document.

---

# 1 Scope

The present document gives a description of the general baseband operation of half rate speech traffic channels in the transmitter and in the receiver of GSM Mobile Stations (MS)s and Base Station Systems (BSS)s during Discontinuous Transmission (DTX).

For clarity, the description is structured according to the block diagrams in figures 1 and 4. Except in the case described below, this structure of distributing the various functions between system entities is not mandatory for implementation, as long as the operation on the air interface and on the speech decoder output remains the same.

In the case of BSSs where the speech transcoder is located remotely in the Base Station Controller (BSC), the implementation of the interfaces between the DTX Handlers and the Radio Sub System (RSS) as described in the present document together with all their flags is mandatory, being a part of the A-bis interface as described in GSM 08.61 [10].

The DTX functions described in the present document are mandatory for implementation in all GSM MSs. The receiver requirements are mandatory for implementation in all GSM BSSs, the transmitter requirements only for those where downlink DTX will be used.

---

# 2 References

The following documents contain provisions which, through reference in this text, constitute provisions of the present document.

- References are either specific (identified by date of publication, edition number, version number, etc.) or non-specific.
- For a specific reference, subsequent revisions do not apply.
- For a non-specific reference, the latest version applies. In the case of a reference to a 3GPP document (including a GSM document), a non-specific reference implicitly refers to the latest version of that document *in the same Release as the present document*.

- [1] GSM 01.04: "Digital cellular telecommunication system (Phase 2+); Abbreviations and acronyms".
- [2] GSM 04.08: "Digital cellular telecommunication system (Phase 2+); Mobile radio interface layer 3 specification".
- [3] GSM 05.05: "Digital cellular telecommunications system (Phase 2+); Radio transmission and reception".
- [4] GSM 05.08: "Digital cellular telecommunication system (Phase 2+); Radio subsystem link control".
- [5] GSM 06.02: "Digital cellular telecommunications system (Phase 2+); Half rate speech Part 1: Half rate speech processing functions".
- [6] GSM 06.20: "Digital cellular telecommunications system (Phase 2+); Half rate speech; Half rate speech transcoding".
- [7] GSM 06.21: "Digital cellular telecommunications system (Phase 2+); Half rate speech; Substitution and muting of lost frames for half rate speech traffic channels".
- [8] GSM 06.22: "Digital cellular telecommunications system (Phase 2+); Half rate speech; Comfort noise aspects for half rate speech traffic channels".
- [9] GSM 06.42: "Digital cellular telecommunications system (Phase 2+); Half rate speech; Voice Activity Detector (VAD) for half rate speech traffic channels".
- [10] GSM 08.61: "Digital cellular telecommunications system (Phase 2+); Inband control of remote transcoders and rate adaptors for half rate traffic channels".

- [11] GSM 06.06: "Digital cellular telecommunications system (Phase 2+); Half rate speech Part 7: ANSI-C code for the GSM half rate speech codec".

---

## 3 Definitions, symbols and abbreviations

### 3.1 Definitions

For the purposes of the present document, the following terms and definitions apply:

**accepted SID frame:** traffic frame which is flagged with SID= "1" or SID= "2" by the Radio Subsystem.

**bad traffic frame:** traffic frame flagged BFI= "1" (Bad Frame Indication) or with UFI= "1" (Unreliable Frame Indication) by the Radio Subsystem.

**frame:** time interval of 20 ms corresponding to the time segmentation of the half rate speech transcoder defined in GSM 06.20 (ETS 300 969) [6]), also used as a short term for a traffic frame.

**good speech frame:** good traffic frame which is not an accepted SID frame.

**good traffic frame:** traffic frame flagged BFI= "0" and UFI= "0" by the Radio Subsystem.

**GS averaging period:** period in which the quantized energy tweak parameters GS are averaged: it corresponds to the hangover period.

**hangover period:** period of 7 frames added at the end of a speech burst in which VAD flag = "0" and SP flag= "1".

**invalid SID frame:** accepted SID frame which was not classified as valid SID frame. This frame is not valid for updating comfort noise parameters, but the frame conveys information that comfort noise generations should be started or continued.

**lost SID frame:** unusable frame received when the RX DTX Handler is generating comfort noise and a SID frame is expected (Time Alignment Flag TAF= "1").

**lost speech frame:** unusable frame received when the RX DTX Handler is passing on traffic frames directly to the speech decoder.

**SID code word:** fixed bit pattern defined in GSM 06.22 [8], for labelling a traffic frame as a SID frame.

**SID field:** bit positions defined in GSM 06.22 [8], of the SID codeword within a SID frame.

**SID frame:** frame characterised by the SID (Silence Descriptor) code word. It conveys information on the acoustic background noise.

**SP flag:** boolean flag, generated by the TX DTX handler, indicating the presence of a speech frame ("1") or the presence of a SID frame ("0").

**speech frame:** traffic frame that cannot be classified as a SID frame.

**traffic frame:** block of 112 information bits transmitted on the half rate speech traffic channel.

**unusable frame:** bad traffic frame that is not an accepted SID frame.

**VAD flag:** boolean flag, generated by the VAD algorithm defined in GSM 06.42 [9], indicating the presence ("1") or the absence ("0") of a speech frame.

**valid SID frame:** good traffic frame flagged with SID= "2" by the Radio Subsystem. This frame is valid for updating comfort noise parameters at any time.

### 3.2 Symbols

For the purposes of the present document, the following symbols apply:

GS	Energy tweak parameter
N <sub>elapsed</sub>	Number of elapsed frames since the last updated SID frame

### 3.3 Abbreviations

For the purposes of the present document, the following abbreviations apply:

BFI	Bad Frame Indicator
BSC	Base Station Controller
BSS	Base Station System
DTX	Discontinuous Transmission
FACCH	Fast Associated Control CHannel
FEC	Forward Error Correction
GSM	Global System for Mobile communications
MS	Mobile Station
RSS	Radio Sub System
RX	Receive
SACCH	Slow Associated Control CHannel
SID	SIllence Descriptor
TAF	Time Alignment Flag
TX	Transmit
UFI	Unreliable Frame Indicator
VAD	Voice Activity Detector

For abbreviations not given in this clause, see GSM 01.04 [1].

---

## 4 General

DTX is a mechanism which allows the radio transmitter to be switched off most of the time during speech pauses for the following two purposes:

- to save power in the MS;
- to reduce the overall interference level over the air interface.

DTX shall be in operation in GSM MS if commanded so by the network, see GSM 04.08 [2].

### 4.1 General Organisation

The overall DTX mechanism described in the present document requires the following functions:

- a Voice Activity Detector (VAD) on the transmit (TX) side;
- evaluation of the background acoustic noise on the TX side, in order to TX characteristic parameters to the receive (RX) side;
- generation on the RX side of a similar noise, called comfort noise, during periods where the radio transmission is switched off.

The VAD is defined in GSM 06.42 [9], the comfort noise functions in GSM 06.22 [8]. Both are based partly on the speech transcoder and its internal variables, defined in GSM 06.20 [6].

In addition to these functions, if the parameters arriving at the (RX) side are detected to be corrupted by errors, the speech or comfort noise shall be generated from substituted data in order to avoid sound defects for the listener. This function is defined in GSM 06.21 [7].

An overall description of the speech processing parts can be found in GSM 06.02 [5].



## 5 Transmit (TX) side

A block diagram of the TX side DTX functions is shown in figure 1.

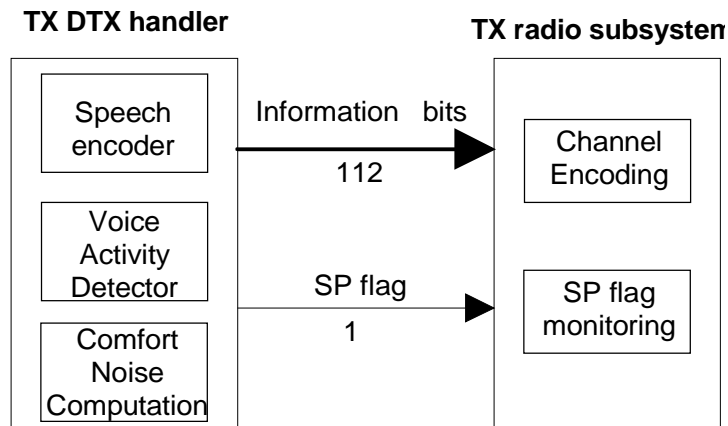

Figure 1: Block diagram of the transmit side DTX functions

### 5.1 General Operation

The TX DTX handler continuously passes traffic frames, individually marked by the SP flag, to the RSS. This binary flag is redundant to the Silence Descriptor (SID) code word labelling. SP flag = "1" indicates a speech frame, SP flag = "0" a SID frame.

The scheduling of the frames for transmission on the air interface is controlled by the RSS alone, on the basis of the SP flag as described in clause 5.1.1.

#### 5.1.1 Functions of the TX DTX handler

To allow verification of the TX DTX handler functions, all frames before the reset of the system are treated as if they were speech frames of an infinitely long time. Therefore, the first 7 frames after the reset are marked with SP flag = "1", even if VAD flag = "0" (hangover period, see figure 2).

The VAD shall operate all the time in order to assess whether the input signal contains speech or not. The output is a binary flag (VAD flag = "1" or VAD flag = "0", respectively) on a frame by frame basis (see GSM 06.42 [9]).

The VAD flag controls indirectly, via the TX DTX handler operations described below, the overall DTX operation on the TX side.

Whenever the VAD flag = "1", the speech encoder output frame shall be passed directly to the RSS, marked with SP flag = "1".

At the end of a speech burst (transition VAD flag = "1" to VAD flag = "0"), it takes 8 consecutive frames to make a new updated SID frame available (see GSM 06.22 [8]). Normally, the first 7 speech encoder output frames after the end of the speech burst shall therefore be passed directly to the RSS, marked with SP flag = "1" ("hangover period"). The first new SID frame is then passed to the RSS as frame 8 after the end of the speech burst, marked with SP flag = "0" (see figure 2).

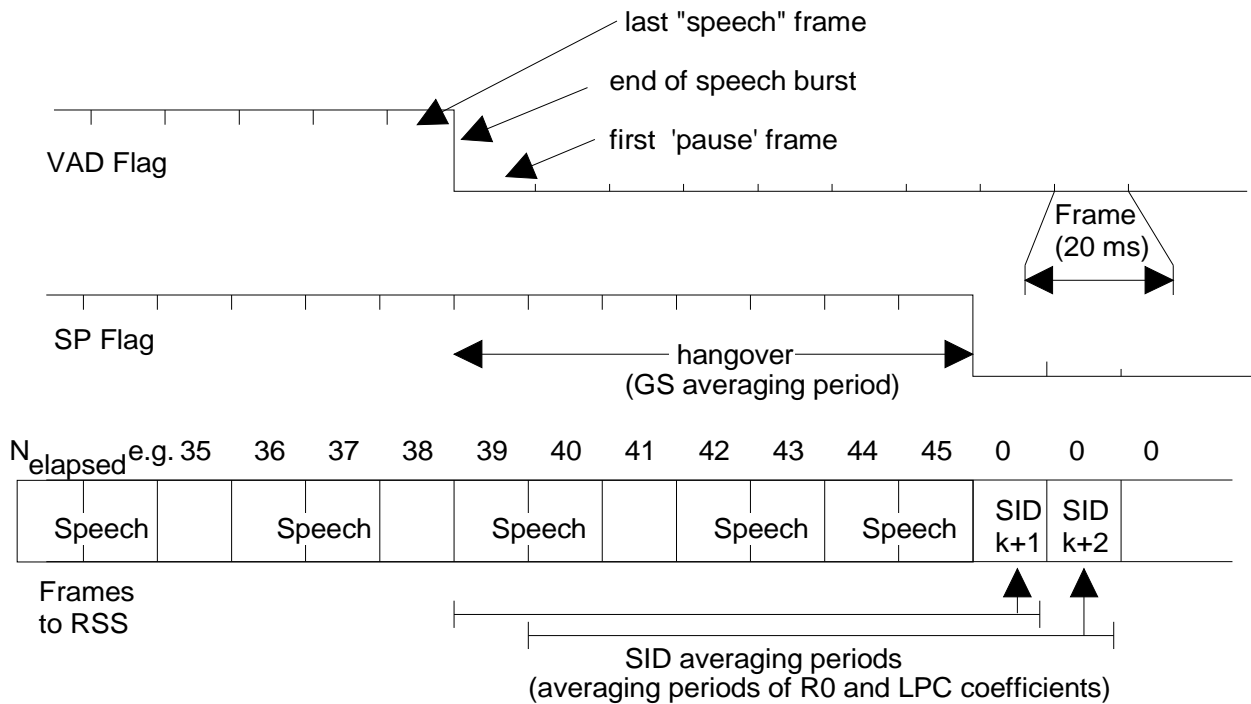

**Figure 2: Normal hangover procedure ( $N_{elapsd} > 23$ )**

If, however, at the end of the speech burst, less than 24 frames have elapsed since the last SID frame was computed and passed to the RSS, then this last SID frame shall repeatedly be passed to the RSS, until a new updated SID frame is available (8 consecutive frames marked with VAD flag = "0"). This reduces the activity on the air interface in cases where short background noise spikes are taken for speech, by avoiding the "hangover" waiting for the SID frame computation (see figure 3).

NOTE: Figure 3 shows an example of the longest possible speech burst without hangover.

Once the first SID frame after the end of a speech burst has been computed and passed to the RSS, the TX DTX Handler shall continuously compute and pass updated SID frames to the RSS, marked with SP flag = "0" as long as the VAD flag = "0".

The speech encoder is operated in full speech modality if SP flag = "1" and in a simplified mode if SP flag = "0", because not all encoder functions are required for the evaluation of comfort noise parameters (see GSM 06.22 [8]).

### 5.1.2 Functions of the TX radio subsystem

The following traffic frames shall be scheduled for transmission:

- all frames marked with SP flag = "1";
- the first one with SP flag = "0" after one or more frames with SP flag = "1";
- those marked with SP flag = "0" and aligned with the Slow Associated Control CHannel (SACCH) multiframe structure as described in GSM 05.08 [4].

This has the overall function, that the radio transmission is turned off after the transmission of a SID frame when the speaker stops talking. During speech pauses, the transmission is resumed at regular intervals for transmission of one SID frame, in order to update the generated comfort noise on the RX side (and to improve the measurement of the link quality by the RSS).

If a SID frame (SP flag = "0"), scheduled for transmission is stolen for Fast Associated Control CHannel (FACCH) signalling purposes, then the subsequent frame shall be scheduled for transmission instead.



## 6 Receive (RX) side

A block diagram of the RX side DTX functions is shown in figure 4.

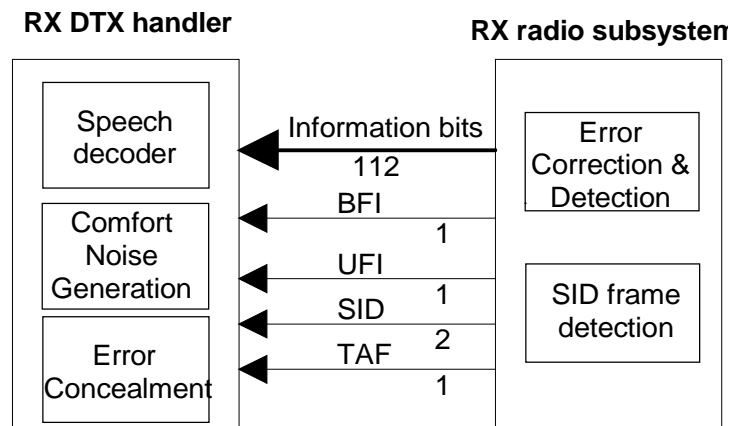

Figure 4: Block diagram of the receive side DTX functions

### 6.1 General operation

Whatever their context (speech, SID, FACCH or none), the RSS continuously passes the received traffic frames to the RX DTX handler, individually marked by various pre-processing functions with 4 flags. These are the Bad Frame Indicator (BFI) flag, the Unreliable Frame Indicator (UFI) flag, the Silence Descriptor (SID) flag and the Time Alignment Flag (TAF) described in clause 6.1.1 and table 1, which serve to classify the traffic frame according to the list of terms defined in clause 3.1. This classification, summarised in table 1, allows the RX DTX handler to determine how the received frame is to be handled.

Table 1 Classification of traffic frames

BFI "OR" UFI*	SID		
	2	1	0
0	Valid SID frame		Good speech frame
1	Invalid SID frame		Unusable frame

\* BFI "OR" UFI indicates a logical OR combination of the BFI and UFI flags.

NOTE: The SID computation is left open to manufacturers with the constraint to meet the performance requirements given in the GSM 05.05 [3]. An example solution is given in the C-code (GSM 06.06 [11]).

#### 6.1.1 Functions of the RX radio subsystem

The binary BFI flag (see GSM 05.05 [3]) indicates whether the traffic frame is considered to contain meaningful information bits (BFI flag = "0") or not (BFI flag = "1"). In the context of the present document, a FACCH frame is considered not to contain meaningful bits and shall be marked with BFI flag = "1". The BFI flag shall fulfil the performance requirements of GSM 05.05 [3].

NOTE: That the BFI flag, which is generated by the channel error correction scheme, will in some cases be modified by the SID frame detection unit.

The UFI flag is the output of the Forward Error Correction (FEC) procedure and give indications about the channel performance. The UFI flag shall fulfil the performance requirements of GSM 05.05 [3].

The SID frame detector compares bit by bit the relevant bits of the received traffic frame (the SID field) with the SID code word defined in GSM 06.22 [8] and gives back the ternary SID flag. The SID flag shall fulfil the performance requirements of GSM 05.05 [3]. The binary TAF flag marks with TAF = "1" those traffic frames that are aligned with the SACCH multiframe structure as described in GSM 05.08 [4].

## 6.1.2 Functions of the RX DTX handler

The RX DTX handler shall be responsible for the overall DTX operation on the RX side.

The DTX operation on the RX side shall be as follows:

- whenever a good speech frame is detected, the DTX Handler shall pass it directly on to the speech decoder;
- when lost speech or lost SID frames are detected, the substitution and muting procedure defined in GSM 06.21 [7] shall be applied;
- valid SID frames shall result in comfort noise generation, as defined in GSM 06.22 [8], until the next SID frame is expected (TAF="1") or good speech frames are detected. During this period, the RX DTX handler shall ignore any unusable frames delivered by the RSS;
- an invalid SID frame shall be substituted by the last valid SID frame and the procedure for valid SID frames be applied.

**NOTE:** If the first SID frame after a speech burst (a series of good speech frames) is invalid, then the comfort noise parameters can be taken from the last valid SID frame or, if the series of good speech frames received was longer than 30 (23+7), from the last received good speech frame which, because of the VAD hangover time (see GSM 06.42 [9]), may be supposed to contain noise only.

## Annex A (informative): Change history

Change history					
SMG No.	TDoc. No.	CR. No.	Section affected	New version	Subject/Comments
SMG#13				4.0.2	ETSI Publication
SMG#20				5.0.1	Release 1996 version
SMG#23	430/97	A001		5.1.1	UAP 60
SMG#27				6.0.0	Release 1997 version
SMG#29				7.0.0	Release 1998 version
				7.0.1	Version update to 7.0.1 for Publication
SMG#31				8.0.0	Release 1999 version
				8.0.1	Update to Version 8.0.1 for Publication

Change history							
Date	TSG #	TSG Doc.	CR	Rev	Subject/Comment	Old	New
03-2001	11				Version for Release 4		4.0.0
06-2002	16				Version for Release 5	4.0.0	5.0.0
12-2004	26				Version for Release 6	5.0.0	6.0.0
06-2007	36				Version for Release 7	6.0.0	7.0.0
12-2008	42				Version for Release 8	7.0.0	8.0.0
12-2009	46				Version for Release 9	8.0.0	9.0.0
03-2011	51				Version for Release 10	9.0.0	10.0.0
09-2012	57				Version for Release 11	10.0.0	11.0.0
09-2014	65				Version for Release 12	11.0.0	12.0.0
12-2015	70				Version for Release 13	12.0.0	13.0.0

Change history							
Date	Meeting	TDoc	CR	Rev	Cat	Subject/Comment	New version
03-2017	SA#75					Version for Release 14	14.0.0
06-2018	SA#80	-	-	-	-	Version for Release 15	15.0.0
2020-07	-	-	-	-	-	Update to Rel-16 version (MCC)	<b>16.0.0</b>
2022-04	-	-	-	-	-	Update to Rel-17 version (MCC)	<b>17.0.0</b>
2024-03	-	-	-	-	-	Update to Rel-18 version (MCC)	<b>18.0.0</b>

---

# History

<b>Document history</b>		
V18.0.0	May 2024	Publication