

## **Telecommunications and Internet converged Services and Protocols for Advanced Networking (TISPAN); NGN integrated IPTV subsystem Architecture**

---



---

**Reference**RTS/TISPAN-02082-NGN-R3

---

**Keywords**architecture, IP, TV

---

**ETSI**

---

650 Route des Lucioles  
F-06921 Sophia Antipolis Cedex - FRANCE

---

Tel.: +33 4 92 94 42 00 Fax: +33 4 93 65 47 16

Siret N° 348 623 562 00017 - NAF 742 C  
Association à but non lucratif enregistrée à la  
Sous-Préfecture de Grasse (06) N° 7803/88

---

**Important notice**

---

Individual copies of the present document can be downloaded from:

<http://www.etsi.org>

The present document may be made available in more than one electronic version or in print. In any case of existing or perceived difference in contents between such versions, the reference version is the Portable Document Format (PDF). In case of dispute, the reference shall be the printing on ETSI printers of the PDF version kept on a specific network drive within ETSI Secretariat.

Users of the present document should be aware that the document may be subject to revision or change of status. Information on the current status of this and other ETSI documents is available at

<http://portal.etsi.org/tb/status/status.asp>

If you find errors in the present document, please send your comment to one of the following services:

[http://portal.etsi.org/chaicor/ETSI\\_support.asp](http://portal.etsi.org/chaicor/ETSI_support.asp)

---

**Copyright Notification**

---

No part may be reproduced except as authorized by written permission.  
The copyright and the foregoing restriction extend to reproduction in all media.

© European Telecommunications Standards Institute 2011.  
All rights reserved.

**DECT™**, **PLUGTESTS™**, **UMTS™**, **TIPHON™**, the TIPHON logo and the ETSI logo are Trade Marks of ETSI registered for the benefit of its Members.

**3GPP™** is a Trade Mark of ETSI registered for the benefit of its Members and of the 3GPP Organizational Partners.

**LTE™** is a Trade Mark of ETSI currently being registered

for the benefit of its Members and of the 3GPP Organizational Partners.

**GSM®** and the GSM logo are Trade Marks registered and owned by the GSM Association.

# Contents

Intellectual Property Rights .....	6
Foreword.....	6
Introduction .....	6
1 Scope .....	7
2 References .....	7
2.1 Normative references .....	7
2.2 Informative references.....	8
3 Definitions and abbreviations.....	9
3.1 Definitions.....	9
3.2 Abbreviations .....	9
4 NGN IPTV subsystem.....	10
4.1 Concept and Architectural Approach .....	11
4.2 High Level Architecture Overview .....	11
4.3 Functional groups.....	11
4.3.1 Application Functions.....	12
4.3.2 IPTV Service Control and Media Delivery Functions .....	12
4.3.3 Transport Functions .....	12
4.3.4 End User Functions.....	12
4.3.5 Management Functions.....	12
4.3.6 Content Provider Functions .....	13
4.4 IPTV services .....	13
5 NGN Integrated IPTV subsystem functional architecture.....	14
5.1 Functional entities .....	16
5.1.1 Core IPTV functions .....	16
5.1.2 Supporting IPTV functions .....	18
5.1.3 Transport functions .....	18
5.1.4 Customer Transport functions.....	19
5.2 Reference points .....	19
5.2.1 Tr - IPTV transactional .....	19
5.2.2 Ct2 - UE facing IPTV control.....	20
5.2.3 Sa - IPTV control and Media Control Function.....	20
5.2.4 Ss - Service selection .....	20
5.2.5 Xc - UE and IPTV Media Control Function .....	20
5.2.6 Xp - IPTV Media Control Function and IPTV Media Delivery Function .....	21
5.2.7 Xd - UE and IPTV Media Delivery Function .....	21
5.2.8 e2 - NASS access.....	21
5.2.9 e4 - NASS and RACS.....	21
5.2.10 Gq' - RACS .....	22
5.2.11 Ud - access to IPTV user data.....	22
5.2.12 Ug - access to NGN user data .....	22
5.2.13 Ss' - access to SD&S data .....	22
5.3 Generic IPTV Capabilities .....	23
5.3.1 Inter-destination media synchronization .....	23
5.3.1.1 Synchronization architecture .....	23
5.3.1.1.1 Functional entities MSAS and SC .....	23
5.3.1.1.2 Mapping onto the IPTV architecture .....	24
5.3.1.1.3 Modification and re-origination of media streams .....	24
5.3.1.2 Synchronization reference points .....	25
5.3.1.2.1 MSAS-SC reference point (Sync) .....	25
5.3.1.2.2 MSAS-SC' reference point (Sync') .....	25
5.4 Elementary functions.....	26
6 Operational framework.....	27

6.1	IPTV delivery modes.....	27
6.2	Operational modes.....	27
6.2.1	Coupled mode.....	28
6.2.2	Decoupled mode.....	29
6.2.3	Redirect mode.....	30
6.2.4	Proxy mode.....	30
6.3	Service initialization.....	31
6.3.1	Functional steps for UE start-up.....	31
6.3.2	Service discovery and selection.....	32
6.4	Nomadism.....	33
6.5	Support of Mobility Capabilities.....	33
7	Security.....	34
7.1	Content Protection.....	34
7.2	Service Protection.....	34
8	Management.....	35
9	User data.....	35
9.1	IPTV profiles.....	35
9.2	User data location.....	36
10	Charging.....	37
11	Procedures.....	37
11.1	Linear TV.....	37
11.2	Multimedia Content on Demand (CoD).....	38
11.2.1	Optimized bandwidth utilization during CoD.....	40
11.3	Media broadcast with trick modes.....	41
11.4	Near CoD.....	42
11.5	Push CoD.....	44
11.5.1	Push CoD procedures using notification.....	44
11.6	User generated content.....	45
11.6.1	Overview.....	45
11.6.2	UGC creation procedure.....	45
11.6.3	UGC watching procedure.....	47
11.7	Pay Per View.....	48
11.8	Messaging and notification services.....	49
11.8.1	Messaging procedures.....	49
11.8.2	Notification procedures.....	49
11.9	Recommendations.....	50
11.9.1	Recommendations overview.....	51
11.9.2	Recommendations procedures.....	51
11.10	Advertising.....	53
11.10.1	Advertising procedures.....	53
11.10.2	Network side unicast based advertisement.....	54
11.10.3	Advertising procedures using notification.....	56
11.11	Procedures for inter-destination media synchronization.....	56
11.11.1	Mapping 1: SC in UE.....	56
11.11.2	Mapping 2: SC in Transport.....	57
11.12	Service continuation.....	57
11.12.1	Procedure for unicast service continuation between NGN IPTV UEs.....	57
11.12.2	Service continuation between fixed NGN between fixed NGN Integrated IPTV UE and 3GPP mobile UE.....	59
11.13	Remote control of IPTV services.....	60
11.13.1	Procedure for Remote Mobile Control of IPTV (Provisioning).....	60
11.13.2	Procedure for Remote Mobile Control of IPTV (Operations).....	61
11.14	Personalized Channel.....	62
11.15	Time Shift TV.....	63
11.16	PVR service.....	63
11.17	Emergency alert.....	64
11.18	Content Bookmark.....	64
11.19	Interactive TV procedures.....	65

<b>Annex A (informative):</b>	<b>Interactions between other TISPAN services and IPTV services.....</b>	<b>67</b>
A.1	Interactions based on an OSA/Parlay/Parlay X SCS.....	67
<b>Annex B (informative):</b>	<b>Interaction procedure between IPTV and other service level subsystems .....</b>	<b>69</b>
<b>Annex C (informative):</b>	<b>Presence attributes for IPTV .....</b>	<b>71</b>
<b>Annex D (informative):</b>	<b>Possible evolution path for NGN Integrated IPTV .....</b>	<b>72</b>
D.1	Evolution of IPTV architectures towards NGN .....	72
D.2	Possible migration and switch over scenarios .....	73
<b>Annex E (informative):</b>	<b>Mapping of elementary functions.....</b>	<b>74</b>
E.1	Mapping between elementary functions and generic capabilities .....	74
E.2	Mapping between elementary functions and functional entities .....	76
E.3	Mapping between elementary functions and IPTV services .....	77
<b>Annex F (informative):</b>	<b>NGN integrated IPTV mapping to other IPTV architectures .....</b>	<b>79</b>
F.1	Mapping between NGN integrated IPTV subsystem and ITU-T non-IMS IPTV architecture .....	79
<b>Annex G (informative):</b>	<b>Interconnection Models supporting Mobility Capabilities .....</b>	<b>81</b>
<b>Annex H (informative):</b>	<b>SCTE based targeted advertising architecture .....</b>	<b>82</b>
H.1	Definitions.....	82
H.2	SCTE-130 based Advertising Architecture .....	82
H.3	Reference points .....	83
H.3.1	IPTV Applications - SCTE-130 ADS (ADx) .....	83
H.3.2	IPTV Media Function (MF) - SCTE-130 ADS (ADy).....	84
H.3.3	MF Ad Splicer - TISPAN Ad MF (ADc) .....	84
H.3.4	IPTV User Equipment (UE) - SCTE-130 ADS (ADz).....	84
H.4	Mapping between TISPAN entities and SCTE-130 entities .....	84
<b>Annex I (informative):</b>	<b>NGN integrated IPTV support for hybrid services .....</b>	<b>86</b>
<b>Annex J (informative):</b>	<b>Bibliography.....</b>	<b>87</b>
<b>Annex K (informative):</b>	<b>Change history .....</b>	<b>88</b>
History .....		90

---

## Intellectual Property Rights

IPRs essential or potentially essential to the present document may have been declared to ETSI. The information pertaining to these essential IPRs, if any, is publicly available for **ETSI members and non-members**, and can be found in ETSI SR 000 314: "*Intellectual Property Rights (IPRs); Essential, or potentially Essential, IPRs notified to ETSI in respect of ETSI standards*", which is available from the ETSI Secretariat. Latest updates are available on the ETSI Web server (<http://webapp.etsi.org/IPR/home.asp>).

Pursuant to the ETSI IPR Policy, no investigation, including IPR searches, has been carried out by ETSI. No guarantee can be given as to the existence of other IPRs not referenced in ETSI SR 000 314 (or the updates on the ETSI Web server) which are, or may be, or may become, essential to the present document.

---

## Foreword

This Technical Specification (TS) has been produced by ETSI Technical Committee Telecommunications and Internet converged Services and Protocols for Advanced Networking (TISPAN).

The present document defines the TISPAN NGN Release 3 IPTV architecture: Integrated subsystem for IPTV functions in NGN.

---

## Introduction

The present document provides an architectural framework for the end-to-end Internet Protocol Television (IPTV) subsystem within the Next Generation Networks architecture. The IPTV framework is designed for interoperability with other NGN service subsystems and components.

The present document identifies functional entities and reference point, which needs to be exposed from IPTV subsystem.

---

# 1 Scope

The present document describes the IPTV functional architecture and functions of an NGN Integrated IPTV system by integrating of IPTV functions into the NGN architecture. For example, interactions and information flows between the IPTV functional entities and other functional entities will be specified. The specification starts from outlining high-level IPTV functional architecture, functional groups and is further developed into the more detailed functional architecture, reference points and operational modes.

The architecture is intended to support requirements defined by the respective ETSI TISPAN requirement definitions [1] and allow integration new or existing IPTV solutions (such as those defined by DVB, ATIS IIF, ITU, etc.) within the NGN architecture.

The resulting architecture should, should rely as much as possible on common components and integrates, coexist with other TISPAN NGN services.

The following areas are covered:

- Authentication and authorization.
- Content Protection (including DRM).
- Capability exchange.
- Resource Management.
- Policy Management.
- Charging.
- User Profiles.

The architecture focuses on closer integration between IPTV services and NGN networks, migration scenarios from existing solutions (i.e. DVB-IPI, ATIS-IIF) into NGN and common components.

---

# 2 References

References are either specific (identified by date of publication and/or edition number or version number) or non-specific. For specific references, only the cited version applies. For non-specific references, the latest version of the reference document (including any amendments) applies.

Referenced documents which are not found to be publicly available in the expected location might be found at <http://docbox.etsi.org/Reference>.

NOTE: While any hyperlinks included in this clause were valid at the time of publication ETSI cannot guarantee their long term validity.

## 2.1 Normative references

The following referenced documents are necessary for the application of the present document.

- [1] ETSI TS 181 016 (Release 3): "Telecommunications and Internet converged Services and Protocols for Advanced Networking (TISPAN); Service Layer Requirements to integrate NGN services and IPTV".
- [2] ETSI TS 102 034: "Digital Video Broadcasting (DVB); Transport of MPEG-2 TS Based DVB Services over IP Based Networks".
- [3] ETSI TS 122 240: "Digital cellular telecommunications system (Phase 2+); Universal Mobile Telecommunications System (UMTS); LTE; Service requirements for 3GPP Generic User Profile (GUP); Stage 1 (3GPP TS 22.240)".

- [4] ETSI TS 123 240: "Universal Mobile Telecommunications System (UMTS); LTE; 3GPP Generic User Profile (GUP) requirements; Architecture (Stage 2) (3GPP TS 23.240)".
- [5] ETSI ES 282 001 (Release 2): "Telecommunications and Internet converged Services and Protocols for Advanced Networking (TISPAN); NGN Functional Architecture".
- [6] ETSI TS 182 027 (Release 3): "Telecommunications and Internet converged Services and Protocols for Advanced Networking (TISPAN); IPTV Architecture; IPTV functions supported by the IMS subsystem".
- [7] IETF RFC 2782: "A DNS RR for specifying the location of services (DNS SRV)".
- [8] ETSI ES 282 007 (Release 2): "Telecommunications and Internet converged Services and Protocols for Advanced Networking (TISPAN); IP Multimedia Subsystem (IMS); Functional architecture".
- [9] ETSI ES 282 004 (Release 2): "Telecommunications and Internet converged Services and Protocols for Advanced Networking (TISPAN); NGN Functional Architecture; Network Attachment Sub-System (NASS)".
- [10] ETSI ES 282 003 (Release 2): "Telecommunications and Internet converged Services and Protocols for Advanced Networking (TISPAN); Resource and Admission Control Sub-system (RACS); Functional Architecture".
- [11] ETSI TS 187 003 (Release 2): "Telecommunications and Internet converged Services and Protocols for Advanced Networking (TISPAN); NGN Security; Security Architecture".
- [12] ETSI ES 282 010 (Release 2): "Telecommunications and Internet converged Services and Protocols for Advanced Networking (TISPAN); Charging management [Endorsement of 3GPP TS 32.240 Release 7, 3GPP TS 32.260 Release 7, 3GPP TS 32.297 Release 7, 3GPP TS 32.298 Release 7 and 3GPP TS 32.299 Release 7, modified]".
- [13] ETSI TS 132 240: "Digital cellular telecommunications system (Phase 2+); Universal Mobile Telecommunications System (UMTS); LTE; Telecommunication management; Charging management; Charging architecture and principles (3GPP TS 32.240)".
- [14] ETSI TS 183 064 (Release 2): "Telecommunications and Internet converged Services and Protocols for Advanced Networking (TISPAN); Dedicated IPTV subsystem stage 3 specification".

## 2.2 Informative references

The following referenced documents are not necessary for the application of the present document but they assist the user with regard to a particular subject area.

- [i.1] "An application-level QoS comparison of inter-destination synchronization schemes for continuous media multicasting", Toshiro Nunome; Shuji Tasaka, IEICE transactions on communications, ISSN 0916-8516, Vol. 87 (2004), No. 10, pp. 3057-3067 (11).
- [i.2] ETSI ES 204 915 (all parts): "Open Service Access (OSA); Application Programming Interface (API) (Parlay 6)".
- [i.3] ETSI ES 202 504 (all parts): "Open Service Access (OSA); Parlay X Web Services; (Parlay X 3)".
- [i.4] ETSI TR 187 013: "Telecommunications and Internet Converged Services and Protocols for Advanced Networking (TISPAN); Feasibility study on IPTV security architecture".
- [i.5] SCTE-130 part 1: "Digital Program Insertion - Advertising Systems Interfaces; Part 1 Advertising Systems Overview".
- [i.6] SCTE-130 part 2: "Digital Program Insertion - Advertising Systems Interfaces; Part 2: Core Data Elements".
- [i.7] SCTE-130 part 3: "Digital Program Insertion - Advertising Systems Interfaces; Part 3: Ad Management Service (ADM) Interface".



- [i.8] SCTE-35: "Digital Program Insertion Cueing Message for Cable".
- [i.9] ETSI TS 182 028 (V2.0.0): "Telecommunications and Internet converged Services and Protocols for Advanced Networking (TISPAN); IPTV Architecture; Dedicated subsystem for IPTV functions".
- [i.10] ITU-T Recommendation Y.1910: "IPTV functional architecture".

---

## 3 Definitions and abbreviations

### 3.1 Definitions

For the purposes of the present document, the following terms and definitions apply:

**Inter-Destination Media Synchronization (IDMS):** feature for exchanging arrival time and delay information, resulting in substantial synchronisation of the media outputs of two or more UEs, as presented to their users

**IPTV content identifier:** super class of the identifiers that identify content in specific IPTV services

**media stream identifier:** identifier carried in a unicast or multicast media stream that identifies that specific media stream

### 3.2 Abbreviations

For the purposes of the present document, the following abbreviations apply:

ADM	Ad Management Service
ADS	Ad Decision Service
ADSS	Ad Selection Service
A-RACF	Access Resource And Admission Control Function
AS	Application Server
ASF	Application Server Function
BC	Broadcast
BCG	Broadcast Content Guide
BPG	Broadcast Program Guide
BTV	Broadcast TV
CA	Conditional Access
CDR	Content Data Records
CF	Customer Facing
CFIA	Customer Facing IPTV Application
CIS	Content Information Service
CM	Content Marking
CoD	Content on Demand
CR	Content Recommendation
CRS	Content and Service Recommendation Service
CSCF	Call Setup Control Function
CSP	Content and Service Protection
DHCP	Dynamic Host Configuration Protocol
DNG	Delivery Network Gateway
DNS	Domain Name Server
DRM	Digital Rights Management
EPG	Electronic Program Guide
FE	Functional Entity
GUP	Generic User Profile
HD	High Definition
ID	IDentification
IDMS	Inter-Destination Media Synchronization
IMS	IP Multimedia Subsystem
IP	Internet Protocol

IPTV	IP Television
IPTVC	IPTV Control
iTV	Interactive TV
IUDF	IP User Data Function
MCF	Media Control Function
MDF	Media Delivery Function
MF	Media Function
MSAS	Media Synchronization Application Server
NASS	Network Attachment SubSystem
NAT	Network Address Translation
nCoD	Near CoD
NGN	Next Generation Network
NPT	Normal Playout Time
nPVR	networked Personal Video Recorder
PCh	Personalized Channel
pCoD	Push CoD
PES	PSTN/ISDN Emulation Subsystem
POIS	Placement Opportunity Information Service
PPV	Pay Per View
PSS	Packet-switched Streaming Service
PVR	Personal Video Recorder
QoE	Quality of Experience
QoS	Quality of Service
RACS	Resource and Admission Control Subsystem
RTCP	Real Time Control Protocol
RTP	Real Time Protocol
SC	Synchronization Client
SCF	Service Control Function
SCP	Service & Content Protection
SCS	Service Capability Server
S-CSCF	Serving CSCF
SCTE	Society of Cable Telecommunications Engineers
SD	Standard Definition
SD&S	Service Discovery and Selection
SDF	Service Discovery Function
SIS	Subscriber Information Service
SKMF	Service Key Management Functions
SMF	Service Membership Functions
SP	Service Provider
SPD	Service Provider Discovery
SPF	Service Protection Functions
SRV	Service Record
SSF	Service Selection Function
TAI	Targeted Advertising
TPF	Transport Processing Function
UCG	User Created Content
UDAF	User Data Access Function
UDF	User Data Function
UE	User Equipment
UGC	User Generated Content
UPSF	User Profile Server Function
URL	Uniform Resource Locator
XDMS	XML Document Management Server

---

## 4 NGN IPTV subsystem

This clause outlines architectural approach adopted in the present document. The approach is then applied to introduce high level IPTV architecture and functional groups in NGN architecture.

## 4.1 Concept and Architectural Approach

The present document focuses on defining flexible functional architecture, which can:

- allow development of new IPTV subsystem in NGN;
- integrate existing IPTV subsystem in NGN;
- extend both to support other NGN services;

as defined in the service level requirements [1].

The support for other NGN services has a wide meaning, e.g. the functional architecture would allow coupling functionality of IPTV subsystem with functionality of PES or IMS subsystem, which in-turn may support some IPTV features as defined in [6].

In order to achieve high level of flexibility, the work is focused on identifying and standardizing functional entities and reference points, which needs to be exposed from IPTV subsystem to the rest of NGN. Internal IPTV functional entities and reference points are identified and described for the completeness of the end to end architecture without intend to standardize them.

The architectural approach considers IPTV subsystem as a functional area, which is integrated into NGN via standardized reference points and delivers service level requirements, while allowing internal flexibility and extensions for new service types.

The IPTV integrated subsystem is based upon IPTV domains defined in TS 181 016 [1], clause 4.1 IPTV Roles.

## 4.2 High Level Architecture Overview

Figure 1 presents high-level NGN IPTV functional overview and location of IPTV capabilities in the TISPAN NGN. The high level overview illustrates principal functional groups for NGN IPTV services. The functional groups map to IPTV roles as defined in clause 4.3.

The functional groups are used to derive more detailed functional architecture, however, allocation of functions across operational and organizational boundaries will vary between implementations.

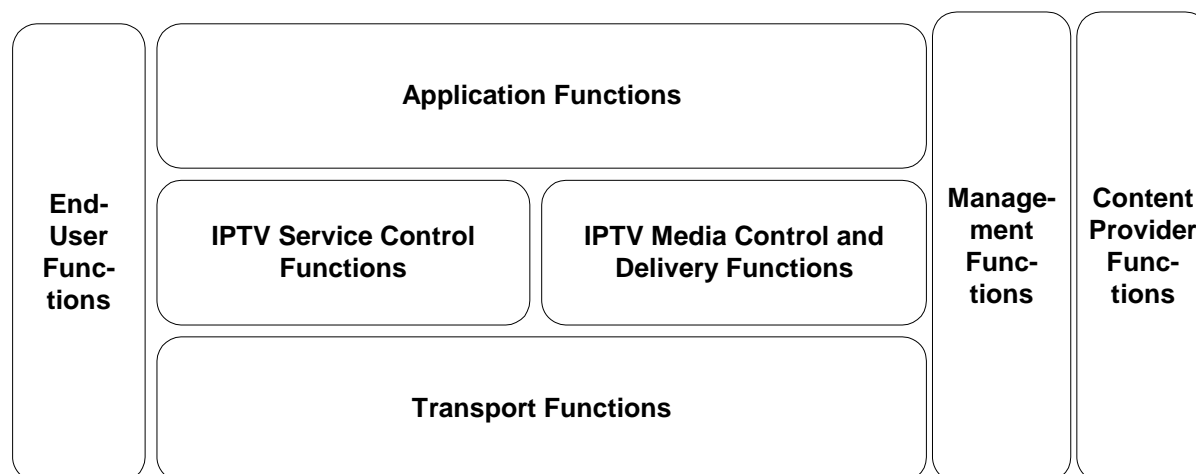

Figure 1: High-level NGN based IPTV functional architecture

## 4.3 Functional groups

In the context of the present document functional groups are used to describe several functional entities grouped together according to some condition, e.g. location in the certain functional layer.

### 4.3.1 Application Functions

Within the present document, the term "Application Functions" includes IPTV and NGN Application Functions.

**NGN Applications:** provides the user with rich multimedia applications distributed across multiple NGN subsystems. For example, session follow up or messaging exchange between fixed and mobile terminals, presentation of incoming calls and phone list management on TV, IPTV or gaming applications based on user presence. NGN applications also provide operators with centralized NGN management interface to multiple subsystems for content management, charging, interactions with IMS services, others. NGN applications may include application functions used across multiple service domains for applications interactions, e.g. IMS and IPTV interactions. NGN applications may include service mediation and coordination functionality.

**IPTV Applications:** customer facing and operator facing.

Customer facing IPTV applications provides the server side functions to enable customer facing IPTV applications, expose IPTV services to other NGN application and manage IPTV subsystem. Customer facing IPTV applications provide service provisioning, selection and authorization of IPTV services.

Operator facing IPTV applications provide operator control over IPTV subsystem in NGN, content preparation and media management, content licensing, subscriber management, offer creation, user profiles.

Server side IPTV applications expose IPTV services to NGN.

### 4.3.2 IPTV Service Control and Media Delivery Functions

Enables operation of IPTV services in NGN. The key functionality of this layer is to provide, but not limited to, media distribution, selection and allocation of media delivery units, IPTV session control and management, interactions with other NGN components for admission control and resource allocation, as well as collecting charging and QoS information.

### 4.3.3 Transport Functions

**Transport Control Functions:** contains common NGN components RACS and NASS, provides policy control, resource reservation and admission control as well as IP address provisioning, network level user authentication and access network configuration as defined in TISPAN. Transport layer definition includes definition from [5].

**Transport Processing Functions:** the Transport Process Functions represents network access links and IP core. The IP core is in charge of data transmission with quality of service support.

### 4.3.4 End User Functions

**Customer transport:** provides connection to one or multiple access networks and one or multiple home network segments.

**UE:** provides user interactions and control over delivery of IPTV and other NGN services. IPTV terminal processes serviced multimedia and presents it in user acceptable format. User interactions may include service discovery, selection and authorization. Multimedia processing may include requesting multimedia asset in supported encoded format, decoding and presenting it to the user in acceptable format, trick mode operators, channel change.

### 4.3.5 Management Functions

The IPTV Management Functions include:

**Service Fulfilment:** the functions required to fulfil the IPTV service to the End-User.

**Service Assurance:** the functions required to assure the IPTV service provided to the End-User.

**Service Billing:** the functions required to ensure proper billing to the end user of delivered IPTV services.

### 4.3.6 Content Provider Functions

The functions provided by the entity that owns or is licensed to sell content or content assets. These are normally the sourcing of content, metadata and usage rights.

## 4.4 IPTV services

NGN integrated IPTV supports the following IPTV services [1]:

- Broadcast TV (with or without trick modes).
- Content on Demand (CoD).
- Personal Video Recording (cPVR, nPVR).
- Pay Per View (PPV).
- Interactive TV (iTV).
- near CoD (nCoD).
- push CoD (pCoD).
- User Generated Content (UGC).
- Profiling and personalization.
- Content Recommendations (CR).
- Advertising (Ad) and Targeted Advertising (TAI).
- Messaging services.
- Notification services.
- Personalized channel.
- Bookmarks or Content Marking (CM).

Table 1A provides list of services and feature supported by NGN integrated architecture.

Table 1A: IPTV services and features supported by NGN integrated IPTV subsystem

NGN IPTV Release Service & Feature Specification	TISPAN R2 NGN dedicated IPTV subsystem TS 182 028 R2 [i.9]	TISPAN R3 NGN integrated IPTV subsystem Present document
Linear/ Broadcast TV	M	M
Linear/ Broadcast TV with Trick Play	M	M
Time Shifted TV	O	O
Content on Demand	M	M
Push CoD	M	M
Near COD	M	M
Network PVR	M	M
Client PVR	NA	O
Audio	M	M
Pay-Per-View	M	M
Interactive TV	M	M
Service discovery	M	M
Service Information (EPG)	M	M
Parental Control	M	M
User Profiling & personalization	O	O
Communications and Messaging	O	O
Notifications	O	O
IPTV Presence	O	O
Interaction between users	O	O
Interaction with NGN services	O	O
Advertising	M	M
Targeted Advertising	NA	O
User Generated Content	NA	O
Internationalization	O	O
Content recommendation	NA	O
Games	NA	O
Picture	NA	O
Bookmarks (Content Marking)	NA	O
Personalized channel	NA	O
Personalized Service Composition	NA	O
Service Portability	NA	O
Service Continuation between IPTV UEs	NA	O
Service Continuation fixed-mobile	NA	O
Remote Control of IPTV services	NA	O
Emergency Information	NA	O
Interaction with 3 <sup>rd</sup> Party application (e.g. Parlay)	NA	O
Interaction with Internet Services	NA	O
Service synchronization	NA	O
Incoming call management	O	O

NOTE: M - Mandatory, O- Optional, NA - not available or not specified (out of scope in release) in architecture.

## 5 NGN Integrated IPTV subsystem functional architecture

The context of the IPTV architecture is represented "end to end" for completeness, starting from the UE on the left to the management functions and content providers functions on the right. However, the functions on the right (e.g. management and content provider) are outside the present document.

Integrated NGN IPTV functional architecture is presented in figure 2.

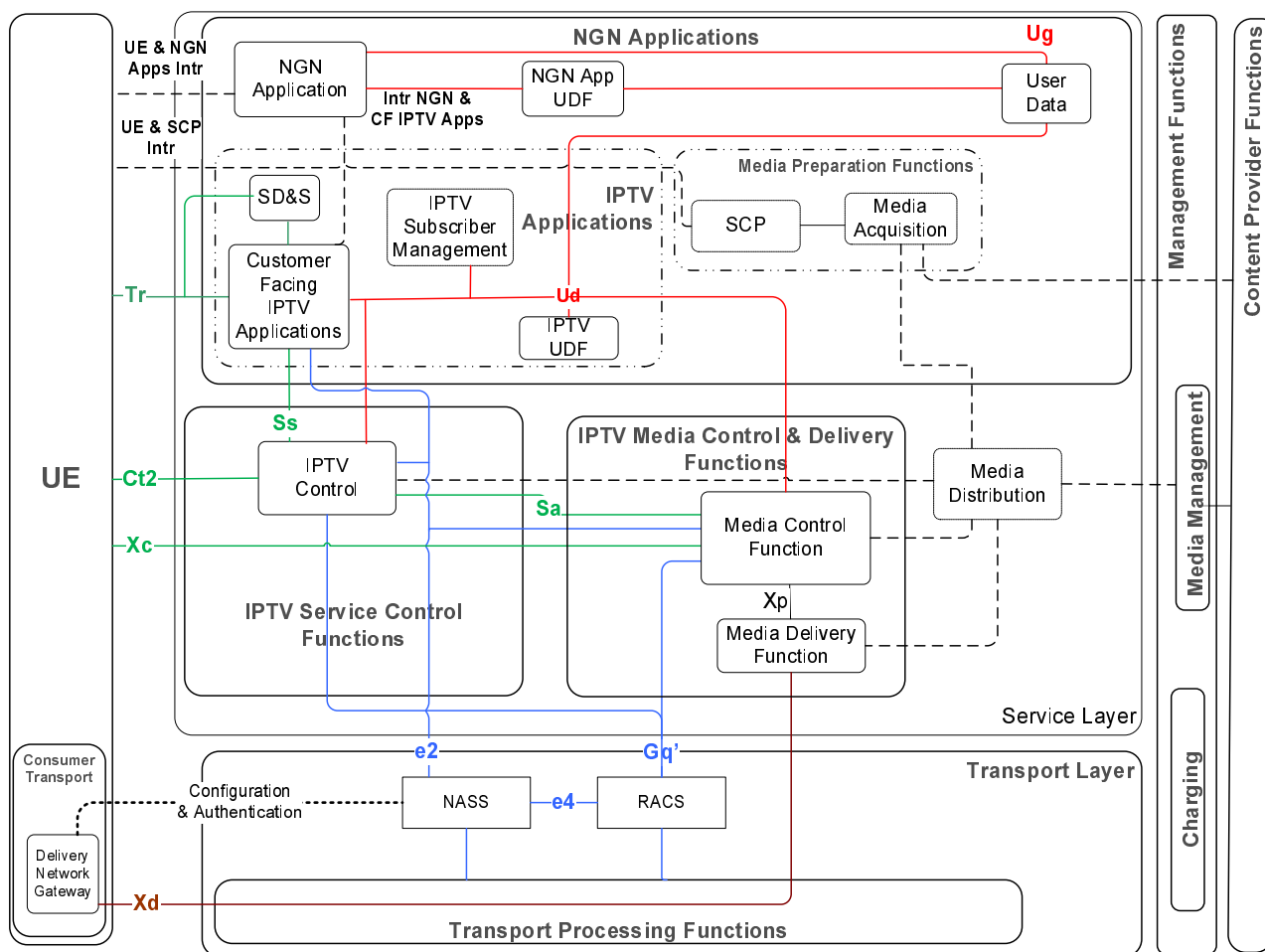

**Figure 2: NGN IPTV functional architecture**

The figure also includes reference points using dotted lines, which are shown for completeness and outside the present document. The two reference point outside the scope of the present document shown for completeness are NGN & Customer facing IPTV application interactions and Configuration and Authentication.

The focus of the present document on the functions in the middle, namely IPTV functions in the **service layer** and in the **transport layer** for integration into NGN.

The functions performed by the **service layer** are grouped into two levels:

- the application functions for **provisioning** an IPTV service consumption by a given user (e.g. service selection, where "selection" is used in a wide sense, e.g. including the parental control rules, others);
- the IPTV service control and delivery functions for the **execution** of a given instance of an IPTV service during service consumption (e.g. the user can experience and control the delivery of a given media content) and for the **selection** of Media Control Function and media delivery during the IPTV service establishment.

The functions performed in the transport layer apply the principles of TISPAN NGN networks transport layer (see definition in [5]) to enable policy control, resource reservation, admission control, IP address provisioning, network level user authentication. The relationship between media management, media distribution and media preparation functions are presented for the completeness. However, interface definitions are outside the scope of the present document, which is represented by the dotted lines.

## 5.1 Functional entities

The functional groups presented on figure 1 contain the following functional entities used to deliver NGN IPTV services.

### 5.1.1 Core IPTV functions

**NGN Application FE:** application providing functionality across single or multiple subsystem, e.g. messaging exchange between fixed and mobile terminals, presentation of incoming calls and phone list management on TV, IPTV gaming applications based on user presence, NGN applications may include service mediation and coordination capabilities.

NGN Integrated IPTV supports two approached to user data location: federated and consolidated, as discussed in details in clause 9.2.

**In the federated approach** user data is located close to application in the following functional entities:

- **NGN Application User Data FE (NGN App UDF):** NGN App user data function is responsible for handling NGN application and user data. NGN App UDF allows integration of application data across NGN applications either using 3GPP data federalization (see [3] and [4]), or known NGN application, e.g. UPSF, or other legacy solution.
- **IPTV User Data FE (IUDF):** IPTV user data function. IPTV user data function is responsible for handling dedicated IPTV user data. IUDF allows integration of user data from IPTV subsystem into NGN either using 3GPP data federalization (see [3] and [4]), or known NGN application, e.g. UPSF, or other legacy solution.

To access user data the following functional entity is used:

- **NGN User Data Access FE (NGN UDAF):** The NGN UDAF knows the location and gives access to user data. An instance of it can be either GUP server if data federalization approach is selected, known NGN application, **or other legacy solutions.**

**In the consolidated approach** user data is located and accessed via **NGN UDAF**, which is:

- **User Profile Server FE (UPSF):** The User Profile Server Function (UPSF), as defined in ES 282 001 [5], is responsible for hosting a set of user related information, amongst service-level user identification, numbering and addressing information, service-level user security information: access control information for authentication and authorization, service-level user location information at inter-system level, service-level user profile information.

**Customer Facing IPTV Application FE (CFIA):** provides IPTV service provisioning, selection and authorization:

- Provide IPTV services offer.
- Enable navigation and selection.
- Verify access right according to the IPTV user profile, e.g. stored in the UPSF.
- Provides authentication and authorization to validate the user's right based on the user profile.
- Authorizes the UE to access the IPTV Service Control and Delivery Functions.
- Provides to the UE initial entry point to the selected service.
- May provide to the UE information on selected IPTV service (e.g. duration, range, etc.).
- May access to the NASS in order to request the geographical user localization. For example, to deliver SD&S metadata according to the localization of the user, support user nomadism.
- May provide application usage control like CoD credit, CoD already purchase with last play range.

**Service Discovery and Selection (SD&S):** provides description information for discovery of the service list for Live TV and selection of these services or on-demand IPTV services. Particular implementation is outside the scope of the present document, e.g. defined in [2] can be used.



**IPTV Control FE (IPTV-C):**

- Checks if UE has been authorized by the Customer Facing IPTV Application to use IPTV Service Control and Delivery Functions.
- Provides selection of the Media Control Function during the IPTV service selection ( optional in case of one to one relationship between IPTV Control entity and Media Control Function entity):
  - Based on location of the Media Control Function (MCF) entity.
  - Based on load of the Media Control Function (MCF) entity.
  - Based on distribution of contents among media delivery entity.
  - Optionally based on resource admission control between UE and media delivery entity.
- May retrieve in NASS the geographical user localization, to select the Media Control Function entity.

**Media Control Function (MCF):**

- Handling media flow control of MDF (not applicable for multicast e.g. Linear TV).
- Monitoring the status of MDF.
- Managing interaction with the UE (e.g. trick mode commands).
- Handling interaction with the IPTV control function.
- Keeping an accurate view on status and content distribution related to the different MDFs that it controls.
- Selecting an MDF, in the case an MCF controls multiple MDFs different criteria, may be applicable as for example as follows:
  - Load balancing of media delivery entities (MDF).
  - Based on distribution of contents among media delivery entities.
  - Optionally location of the UE (may need to access NASS in order to request the geographical user localization, e.g. to select the Media Delivery entity according to the localization of the user and to select nearest MDF).
  - Optionally based on resource admission control between UE and media delivery entity or availability of content/resources in MDF itself.
- May check user authorization to use requested IPTV service.
- May generate charging information, e.g. for end-user charging based on the viewed content.
- May manage the media processing of MDF.
- Controlling advertisement insertion of MDF, e.g. instructing MDF to play the advert, handling synchronization between the advert and IPTV content and synchronization with delay or drift in broadcast TV schedules.
- Providing a direct relationship on the media delivery and media control levels between downstreaming and upstreaming UGC sessions for live UGC consumption.

In IPTV integrated subsystem MCF acts as UE point of contact for requested delivery of the selected IPTV service.

**Media Delivery Function (MDF):**

- Handling media flow delivery (delivering multimedia services to the user).
- Status reporting to MCF (e.g. reporting on established IPTV media session).
- Storing of media (e.g. CoD assets), may store some service information with media for IPTV services.

- In particular, may be used for storing the most frequently accessed content or user specific content (e.g. recording PVR, Time Shifted TV, Pause TV, user generated content) if the same tasks are not performed by UE.
- May additionally process, encode or transcode (if required) media to different required media formats (e.g. TV resolution depending on terminals capabilities or user preferences).
- May perform content protection functionalities (e.g. content encryption).
- May support content ingestion of IPTV media.
- May receive media content from UE, e.g. via upstreaming/upload.
- Handling content download to UE (download CoD content to UE or record BC live stream and subsequently download to UE).
- Performing advert insertion during IPTV content playback, i.e. deliver advert content to the UE during the advert insertion opportunity.
- May support alternative streams for use with an existing broadcast channel or CoD item, e.g. alternative video, audio or subtitle tracks for personalized stream composition.

For BC services MDF may act as source for multicast streams of BC media streams.

### 5.1.2 Supporting IPTV functions

**Media Preparation FE:** a group of functions for manipulating, "preparing", content to enable content delivery to the UE. Examples of content preparation are encryption, encoding, keys and access rights generation. Such processes may be executed off-line, being considered as belonging to media content management, or on-line, in real-time, then being part of the IPTV applications or service delivery and control, e.g. DRM processing may be delegated.

**Service & Content Protection (SCP) functions:** e.g. Digital Rights Management (DRM) Function and/or Conditional Access (CA), implements encryption and/or conditional access for instances of multimedia service delivery. Content security elementary functions are defined in clause 7.

NOTE 1: NGN dedicated IPTV Release 2 refers to SCP as Digital Rights Management (DRM) function.

NOTE 2: SCP may contain more detailed service and content protection elementary functions and used during UE service initiation or service attachment (more detail are in TR 187 013 [i.4]).

**Media Acquisition Function:** belongs to the media preparation functions. Implements media acquisition functionality acquiring the media content from the content providers, may acquire license rights from the content providers to enable media distribution to delivery functions. Media acquisition function can be co-located with media delivery function, e.g. for acquisition of live media streams.

**Media Distribution FE:** implements media distribution functionality, e.g. physical distribution of multimedia assets from centralized location to distributed delivery grid via protocols or life access to broadcast channels.

NOTE 3: There are relationships and interfaces between Media preparation FE, Media distribution FE, MCF/MDF functional elements and content management may be used to purpose manage content ingest as described in management clause 8.

**Charging and Accounting Functions:** manage customer charging and service subscriptions.

**IPTV Subscriber Management FE:** manages IPTV subscriber database.

### 5.1.3 Transport functions

**RACS:** TISPAN resource admission and control subsystem.

**NASS:** TISPAN network attachment subsystem.

**Transport Processing Functions:** as defined in clause 4.3.

## 5.1.4 Customer Transport functions

**Delivery Network Gateway (DNG):** device that is connected to one or multiple access networks and one or multiple home network segments.

**User equipment function:** provides user interactions and control over delivery of IPTV and other NGN services. May include the following elementary functions:

- Broadcast-Client Function.
- On-Demand Client Function - provide interfaces with on demand headend components and enable end user application.
- Audio/Video Decoder Function.
- Audio/Video Decryption Function.
- Optional support for sub-title function.

## 5.2 Reference points

This clause describes reference points for NGN integrated IPTV architecture as shown on figure 2.

Reference points between the core IPTV functional entities are summarized in table 1.

**Table 1: Reference points between core IPTV functional entities**

FE/ Reference point	UE	IPTV-C	CFIA	SD&S	UPSF	IUDF	MCF	MDF
UE	---	Ct2	Tr	Tr	---	---	Xc	Xd
IPTV-C	Ct2	---	Ss	---	Sh	Ud	Sa	---
CFIA	Tr	Ss	Sh	Ss'	---	---	---	---
SD&S	Tr	---	Ss'	---	---	---	---	---
UPSF	---	Sh	Sh	---	---	---	---	---
IUDF	---	Ud	---	---	---	---	Ud	---
MCF	Xc	Sa	---	---	---	Ud	---	Xp
MDF	Xd	---	---	---	---	---	Xp	---

NOTE: As discussed in clause 5, IPTV functional architecture includes reference points, which are shown for completeness, but are outside the scope for the current release. The considerations for deferring assigning reference points to such interfaces are:

- functional interactions on the reference points is not used in the current procedures;
- reference points are optional;
- reference points are left for further study.

### 5.2.1 Tr - IPTV transactional

Reference point between UE and Application Functions:

- Used for UE Authentication and Authorization during initialization.

NOTE: UE authentication may also be done directly via e2 reference point.

- Used for user Authentication and Authorization for IPTV service during initialization.
- Used to provide UE with one or more service offers.
- Used to enable navigation and service selection.

- May instantiate IPTV/converged service offers.
- Can give access to personalized offers from multiple service domains based upon user profile.
- Provides to the UE an initial entry point into the IPTV service level subsystem.
- Provides to the UE information on selected IPTV service.

## 5.2.2 Ct2 - UE facing IPTV control

Optional reference point between UE and IPTV Control:

- Acts as initial UE point of contact to request delivery of the selected IPTV service.
- Returns nominated service (media) delivery control function.
- Provides enough information for IPTV Control to check that UE has been authorized (by the Customer Facing IPTV Application) to access the requested resources.

NOTE: "Optional reference point" refers to a reference point only required in some of the operational modes: proxy, redirect, coupled or decoupled as defined in clause 6.

## 5.2.3 Sa - IPTV control and Media Control Function

Reference point between IPTV control and Media Control Function:

- Used to interact with the Media Control Function (MCF) entity of the IPTV service selected by a user (e.g. provides information to the MCF that the user is authorized to access the selected IPTV service).
- Used to notify the IPTV control with information related to the service selected (e.g. the IPTV service cannot deliver the service because of network reasons such as insufficient bandwidth or no media delivery available).

NOTE: This interface is not used to make the media delivery (MDF) selection; this is the role of the MCF.

## 5.2.4 Ss - Service selection

Optional Ss - Service selection reference point between Customer facing IPTV applications and IPTV control:

- Used to notify the IPTV control entity of the IPTV service selected by the user.
- Used to notify the Customer Facing IPTV Application the UE initial entry point to the selected service (Media Control Function).
- Used to notify to the Customer facing IPTV Application with information related to the service selected (e.g. the IPTV service cannot be delivered because of network reasons - information from the Sa reference point).

## 5.2.5 Xc - UE and IPTV Media Control Function

Xc reference point (media control) - logical end-to-end reference point between the UE and the IPTV Media Control Function (MCF):

- used to exchange media control messages for controlling of the delivery IPTV Media flows.

NOTE: Transport related reference points are used to carry media control messages over underlying transport segment (defined in ES 282 001 [5] and as shown below in figure 3). Depending on the location of the MCF, Xc is decomposed into: the Dj reference point between the UE and the access network, optionally the Di reference point between the access network and the core network, and optionally the Ds or Iz reference point between the core network and the Media Control Function, if the MCF is located behind the Core Network.

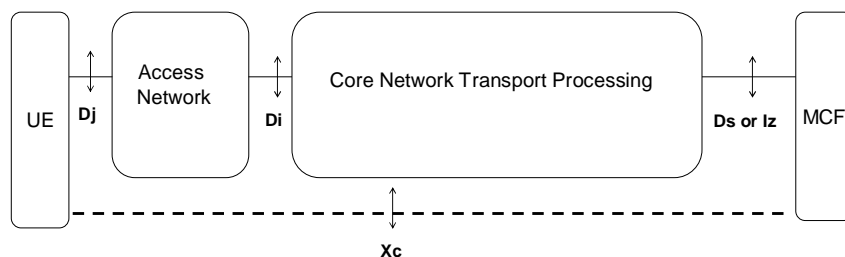

**Figure 3: Decomposition of the Xc reference point when the MCF is after the Core Network**

## 5.2.6 Xp - IPTV Media Control Function and IPTV Media Delivery Function

- Reference point between Media Control Function (MCF) and Media Delivery Function (MDF): used to control media delivery sessions in order to support setup of a media delivery session. The media content can be distributed among one and more media delivery functions.

NOTE: If authorization of the user access to the selected IPTV service is still valid, may be used for transmission of adaptations to session control and/or media control to the previously selected/established media delivery session.

## 5.2.7 Xd - UE and IPTV Media Delivery Function

Xd reference point (media delivery) - logical end-to-end reference point between UE and IPTV Media Delivery Function (MDF):

- carries IPTV media data by appropriate means to the UE (delivers content streams).

NOTE: Transport related reference points are used to carry media delivery data over underlying transport segment (defined in ES 282 001 [5] and as shown in figure 4). Depending on the location of the MDF, Xc can be decomposed into: the Dj reference point between the UE and the access network, optionally the Di reference point between the access network and the core network, and optionally the Ds or Iz reference point between the core network and the Media Delivery Function if the MDF is located after the Core Network.

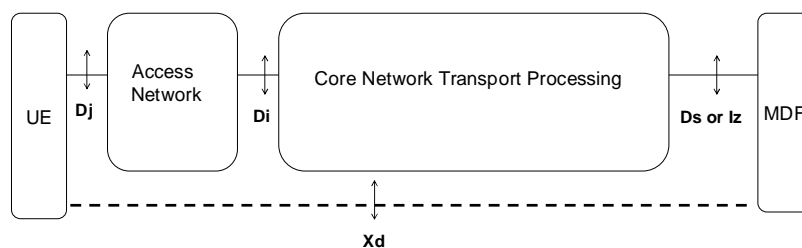

**Figure 4: Decomposition of the Xd reference point**

## 5.2.8 e2 - NASS access

The e2 reference point is defined in ES 282 007 [8] and ES 282 004 [9].

## 5.2.9 e4 - NASS and RACS

The e4 reference point is defined in ES 282 003 [10] and ES 282 004 [9].

### 5.2.10 Gq' - RACS

### 5.2.11 Ud - access to IPTV user data

#### In the federated approach:

- Used by IPTV application server functions, IPTV subscriber management to access subset of IPTV profiles, which are hosted in IUDF.

#### In the consolidated approach:

- User Data implements UPSF functionality.
- Used to access user data located in User Data function. The Reference point is between IPTV applications layer ions and UPSF [5]: As an application server function may choose to use the repository function of the UPSF for hosting service-level user data, as transparent data, the interface should comply with Sh reference point used between this AS Function and UPSF.
- The use of Sh reference point conforms to ES 282 007 [8].
- The IPTV applications represented on Figure 2, that may use the UPSF repository function are: Customer Facing IPTV Applications, IPTV control, IPTV subscriber management.

### 5.2.12 Ug - access to NGN user data

#### In the federated approach:

- Used by IPTV applications to provision and access federalized data from service level subsystems, e.g. IMS, NGN App UDF, mobile, other profile and non-NGN user data.
- Used by converged applications (e.g. communicational features on TV, mobile session handover) to provision and access federalized data from service level subsystems (e.g. IMS, IPTV UDF, mobile, other profile data and non-NGN user data).
- Provides common access among application to profile data models and data components that are common across applications.

#### In the consolidated approach:

- User Data implements UPSF functionality.
- Used to access user data located in User Data function. The Reference point is to access common user data in NGN via UPSF [5]: As an application server function may choose to use the repository function of the UPSF for hosting service-level user data, as transparent data, the interface should comply with Sh reference point used between this AS Function and UPSF.
- The use of Sh reference point conforms to ES 282 007 [8].
- The IPTV applications represented on figure 2, that may use the UPSF repository function are: Customer Facing IPTV Applications, IPTV control, IPTV subscriber management.

### 5.2.13 Ss' - access to SD&S data

Optional Ss' reference point between Customer facing IPTV applications and SD&S used to retrieve service and optionally service provider information from the SD&S server, e.g. EPG, content metadata, service information updates, service provider details.

## 5.3 Generic IPTV Capabilities

This clause describes generic IPTV capabilities - capabilities provided by IPTV functional entities and exposed via interfaces on the high level architecture. The capabilities are used to deliver a variety of IPTV services as defined in the detailed procedures.

IPTV Generic IPTV Capabilities:

- service discovery and selection;
- service control;
- service interaction;
- media control;
- media delivery;
- content protection;
- content management and distribution;
- interactions with other NGN services.

### 5.3.1 Inter-destination media synchronization

Inter-destination media synchronization is an optional generic capability, aimed at servicing corresponding service level requirement as defined in clause A.9.6 of [1].

#### 5.3.1.1 Synchronization architecture

The Media Synchronization Application Server (MSAS) and Synchronization Client (SC) are functions that provide inter-destination media synchronization. These functions are used for synchronization sensitive services for which IPTV delays and delay differences may degrade the quality of experience. The functional entities and reference point of the synchronization mechanism are shown in figure 4A.

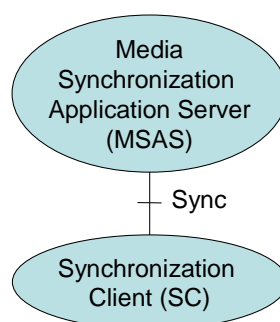

**Figure 4A: Functional entities and reference points for inter-destination media synchronization**

##### 5.3.1.1.1 Functional entities MSAS and SC

The inter-destination media synchronization (IDMS) mechanism uses the concept of synchronization sessions. Each synchronization session involves a Media Synchronization Application Server (MSAS) and multiple Synchronization Clients (SC). A synchronization session is used for the inter-destination synchronization of IPTV content (e.g. BC channel, CoD, UGC) by exchanging synchronization status information (i.e. arrival time information) and delay information in the form of synchronization settings instructions.

- Synchronization status information: timing information on media reception at each SC.
- Synchronization settings instruction: instruction how much an SC should delay the media stream.

Tasks of the SC:

- Setting up and accepting synchronization sessions with/from the MSAS.
- Sending synchronization status information to the MSAS.
- Receiving delay information in the form of synchronization settings instructions from the MSAS.
- Delaying (buffering) a media stream BC channel according to the received synchronization settings instruction.

Tasks of the MSAS:

- Session-oriented tasks:
  - Setting up and accepting synchronization sessions with/from SCs.
- Media-oriented tasks:
  - Collecting synchronization status information from SCs.
  - Calculating delay information and the derived synchronization settings instructions for the SCs.
  - Distributing synchronization settings instructions to SCs.

The MSAS function may be decomposed in session-oriented functions and media-oriented functions.

NOTE: Examples of algorithms to calculate the synchronization settings instructions from collected synchronization status information may be found in [i.1].

#### 5.3.1.1.2 Mapping onto the IPTV architecture

The synchronization architecture can be mapped onto the IPTV architecture in the following ways.

Mapping 1: SC in UE

- The session-oriented part of the MSAS is an elementary function of the IPTV Control. For synchronisation using a direct communication channel between multiple UEs, the MSAS is co-located with the SC.
- The SC is an elementary function of the UE.

Mapping 2: SC in Transport

- The MSAS is an elementary function of the IPTV Control or a stand-alone Application Server.
- The SC is an elementary function of the Transport Functions.

NOTE 1: Mapping 1 is aimed at small-scale deployments of services that require media synchronization and only a limited number of UEs uses media synchronization. Mapping 2 is aimed at large-scale deployment of media synchronization.

NOTE 2: In mapping 2, the SC is an adjunct function that may be co-resident with any of the appropriate elements in the transport layer.

#### 5.3.1.1.3 Modification and re-origination of media streams

In addition to inter-destination media synchronization, additional synchronization measures are needed in case a media stream is modified or re-originated during transport. Examples of these are transcoding, HD-to-SD conversion and user-generated comments to a live broadcast. In such cases, additional media-stream-modifying Synchronization Clients (SC') are placed at the functional entities where media streams are modified, see figure 4B. The Sync' reference point is used to exchange convey synchronization status correlation information between from the media-stream-modifying SC' and to the MSAS on the synchronicity relationship between incoming and outgoing media streams.

- Synchronization correlation information: timing information on the synchronicity relationship between incoming and outgoing media streams at an SC'.



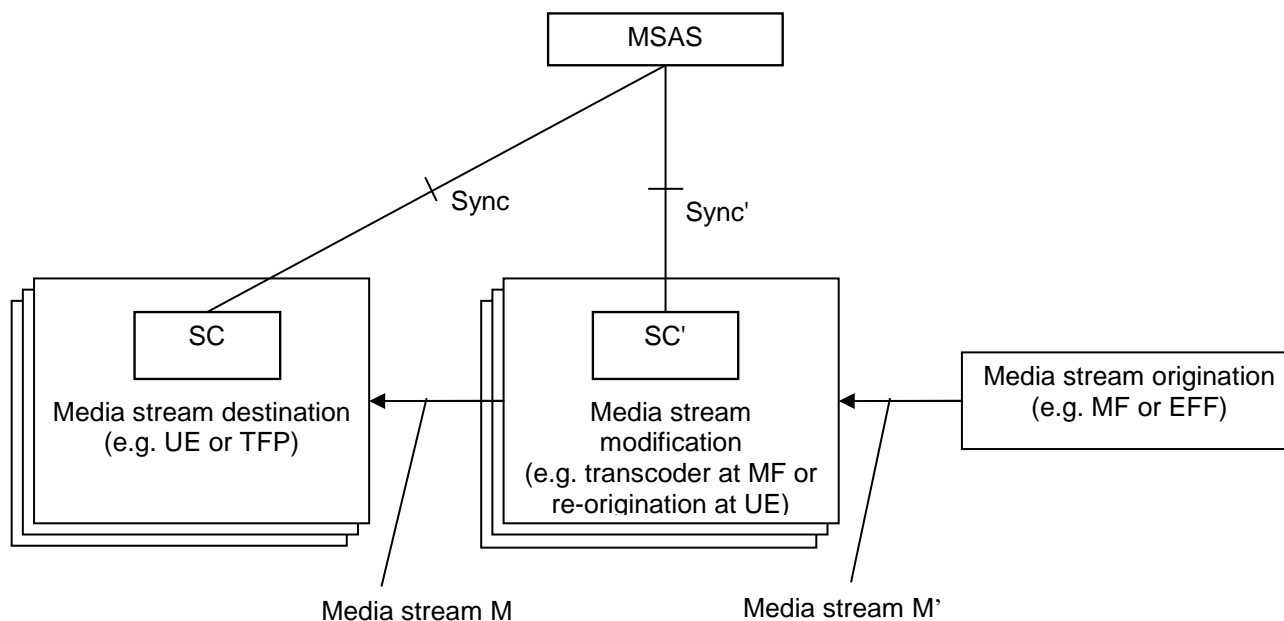

**Figure 4B: Media synchronization in case of media stream modification**

### 5.3.1.2 Synchronization reference points

#### 5.3.1.2.1 MSAS-SC reference point (Sync)

This optional reference point is between Media Synchronization Application Server (MSAS) and media-stream-synchronizing Synchronization Client (SC). It is used to set up synchronization sessions and to exchange synchronization status information and synchronization settings instructions with functional entities in the network where media streams are mutually synchronized.

The Sync reference point is decomposed as follows:

- Synchronization session initiation
- Synchronization status information and settings instruction exchange

The session-oriented part of the Sync reference point is a logical reference point in Mapping 1 from clause 5.3.2, where the synchronization session initiation signalling is tunnelled over the Ct2 reference point. The media-oriented part of the Sync reference point uses the Xd reference points.

If the SC is co-located with the MSAS, then the exchange of synchronization status information and synchronization settings instructions is internal to the functional entity in which they reside. Specification of this internal Sync reference point is out of scope.

**NOTE:** An example of co-located SC+MSAS functionality is when UEs exchange synchronization status information and synchronization settings instructions via a direct communication channel.

#### 5.3.1.2.2 MSAS-SC' reference point (Sync')

This optional reference point is between Media Synchronization Application Server (MSAS) and media-stream-modifying Synchronization Client (SC'). It is used to set up synchronization sessions and to exchange synchronization status information with functional entities in the network where to-be-synchronized media streams are modified.

## 5.4 Elementary functions

This clause describes generic IPTV capabilities - capabilities provided by IPTV functional entities and exposed via interfaces on the high level architecture. The capabilities are used to deliver a variety of IPTV services as defined in the detailed procedures.

### General elementary functions:

- 1) Network attachment
- 2) Registration
- 3) Resource Management
- 4) Charging information

### IPTV elementary functions:

Service related elementary functions:

- 5) Service discovery
- 6) Service authorization
- 7) Service selection
- 8) Service initiation
- 9) Service control
- 10) Service information handling (e.g. Metadata)
- 11) Service configuration

Session related elementary functions:

- 12) Session initiation
- 13) Session modification
- 14) Session termination

Service protection related elementary functions:

- 15) Service key triggering function

Multimedia delivery & control elementary functions

- 16) Multicast based media delivery (media streaming)
- 17) Unicast based media delivery (media streaming, both down- and/or upstream)
- 18) Content download/upload (offline content transfer)
- 19) Control of multicast based media streaming
- 20) Control of unicast based media streaming (both down- and/or upstream)
- 21) Control of content transfer by download/upload
- 22) Content ingestion (receiving content)
- 23) Content recording(capture of live content)
- 24) Content storage
- 25) Content adaptation (e.g. Transcoding, mix, substitute, personalize)

**Content management related elementary functions:**

- 26) Content acquisition
- 27) Content validation
- 28) Content distribution

**Content protection related elementary functions:**

- 29) Content licensing
- 30) Content key management
- 31) Content encryption

**User management elementary functions:**

- 32) User profile/data management
- 33) Accounting/right control

**IPTV Common elementary functions:**

- 34) Status/state (changes) detection/reporting
- 35) Common notification
- 36) Messaging
- 37) Presence Reporting
- 38) Inter-destination Media synchronization

---

## 6 Operational framework

### 6.1 IPTV delivery modes

Integrated IPTV subsystem supports IPTV or NGN service using IP delivery modes:

- Unicast: delivery mode where information packets are sent to a single destination.
- Multicast: delivery mode of forwarding information packets to a group of destinations.
- Combinations and interchanging of both inside a given service.

In order to implement service level requirements defined in [1], integrated IPTV subsystem can use IP unicast delivery mode, for example, for Content on Demand service, or IP multicast delivery mode, for example, for broadcast TV service. More complex service scenarios are possible, where IP delivery modes are interchanged inside a single service, for example, to implement broadcast TV with trick modes.

Unicast and multicast capabilities are expected from the transport layer. However, if only a subset of delivery capabilities is available, the functional architecture would implement functional capabilities build upon the available subset. For example, if transport layer has unicast capabilities only, the functional architecture implements CoD, nPVR and other services build upon unicast delivery.

### 6.2 Operational modes

This clause describes interactions between the UE, the Application functions and the "IPTV Service Control and Media Delivery functions".

There are two aspects of these interactions:

- Interactions between the Application functions and the "IPTV Service Control and Media Delivery functions".
- Interactions between the UE and the "IPTV Service Control and Media Delivery functions".

Concerning the first aspect, there are two possible modes of operations: coupled and decoupled.

**Coupled:** following a request from the UE, the application communicates with the "IPTV Service Control and Media Delivery functions" to allocate and reserve a media delivery function before the content selection is confirmed to the UE. The URL to contact the "IPTV Service Control and Media Delivery functions" is returned to the UE.

**Decoupled:** following a request from the UE, the application returns the URL to contact the "IPTV Service Control and Media Delivery functions" assuming that the "IPTV Service Control and Media Delivery functions" will be able to allocate a media delivery function and associated resources when needed.

Concerning the second aspect, there are two possible modes of operation: proxy and redirect.

**In the redirect mode:** a functional entity receives an input request, performs its actions and redirects UE to the next functional entity in sequence.

**In the proxy mode:** a functional entity receives an input request, performs its actions and proxies the request to the next functional entity in sequence.

The flows for proxy and redirect modes are defined for one of the functional entities from "IPTV service control and media control functions".

IPTV control is defined in redirect mode and MCF is defined in proxy mode.

If one of the functional entities work in either of modes it neither mandates no precludes other functional entities to work in the same or alternative modes.

## 6.2.1 Coupled mode

Operational flow in the coupled mode is presented on figure 5.

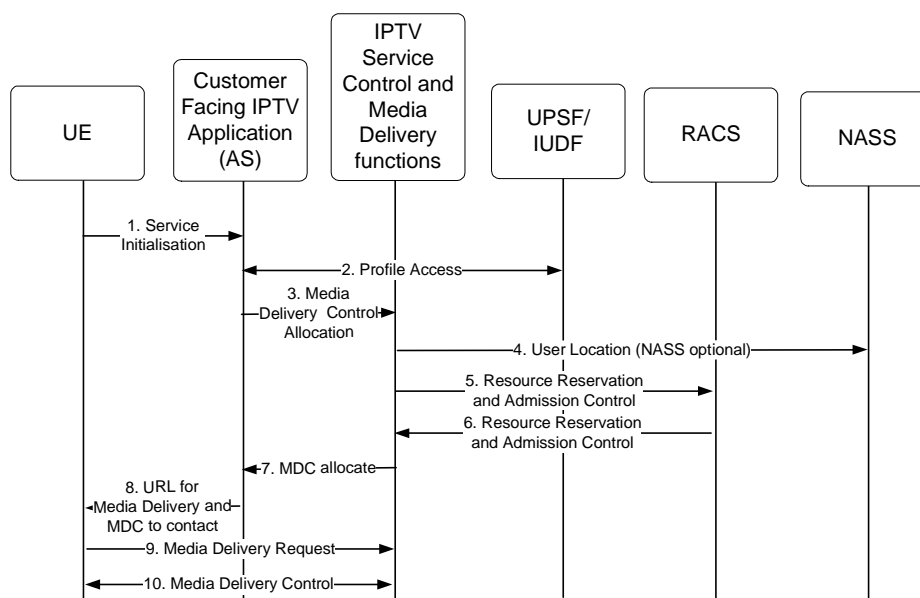

**Figure 5: Operation flow in the coupled mode**

Main functional steps in the coupled mode:

- 1) Service Initialization: UE selects and requests service from the application.
- 2) Profile Access: The application optionally access profile information withers from application data of via data access functions.

- 3) Media Control Function Allocation: The application request a Media Control Function the UE can contact to requested media.
- 4) User location: user location can be requested from NASS or from IPTV UDF in order to select the appropriate Media Delivery Function (and Media Control Function).
- 5) Resources Reservation and Admission Control: IPTV service control and media delivery functions select a MCF and a Media Delivery Function and requests reservation of transport delivery resource (from UE to Media Delivery Function selected).
- 6) Resources Reservation and Admission Control: transport resources reserved and committed.
- 7) Media Control Function Allocation: Allocation of the user contact point in order to request media delivery and for interactive Media Control Function.
- 8) URL for Media Delivery to content Media Control Function functional entity.
- 9) Media Delivery Request: UE requests interactive media delivery.
- 10) Media delivery Function: UE controls interactive media delivery.

## 6.2.2 Decoupled mode

Operational flow in the decoupled mode is presented on figure 6.

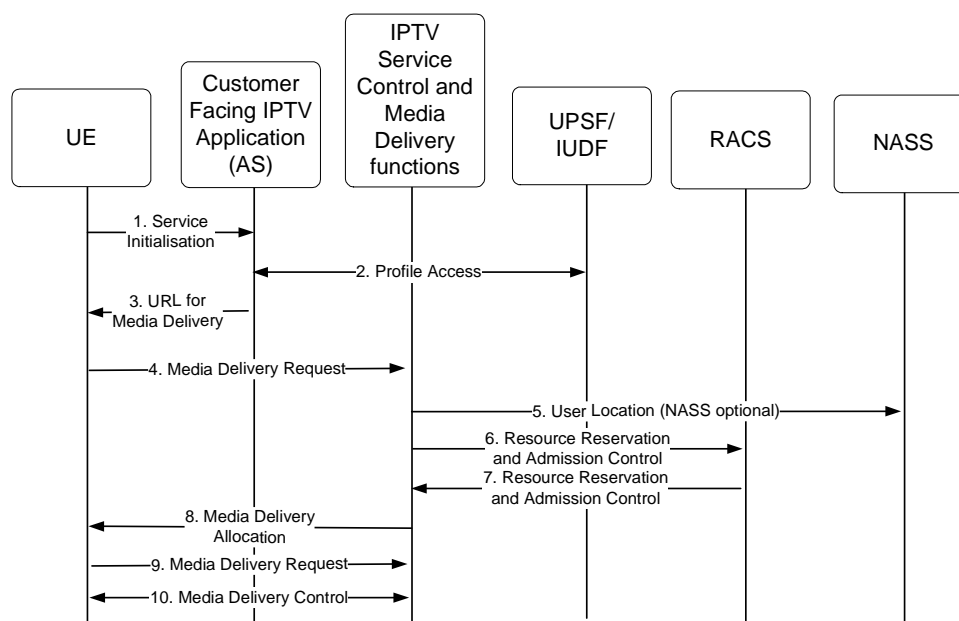

**Figure 6: Operation flow in the decoupled mode**

Main functional steps in the decoupled mode:

- 1) Service Initialization: UE selects and requests service from the application.
- 2) Profile Access: The application optionally access profile information withers from application data of via data access functions.
- 3) URL for Media Delivery.
- 4) Media Control Function Allocation: Media Delivery Request. UE requests interactive media delivery.
- 5) User location: user location can be requested from NASS or from IPTV UDF to select the appropriate Media Delivery Function (and Media Control Function).

- 6) Resources Reservation and Admission Control: IPTV service control functions selects and media delivery functions selects a MCF and a Media delivery entities and requests reservation of transport delivery resources (from UE to Media Delivery Function selected).
- 7) Resources Reservation and Admission Control: transport resources reserved and committed.
- 8) Media Control Function Allocation: Allocation of the user contact point in order to request media delivery and for interactive Media Control Function.
- 9) Media Delivery Request: UE requests interactive media delivery. The UE knows it has to send a second request because request at step 4 has resulted in redirect response as defined in clause 6.2.3.
- 10) Media Delivery Control: UE controls interactive media delivery.

### 6.2.3 Redirect mode

Operational flow of the IPTV control functional entity in the redirect mode is presented on figure 7. The flow represents operational.

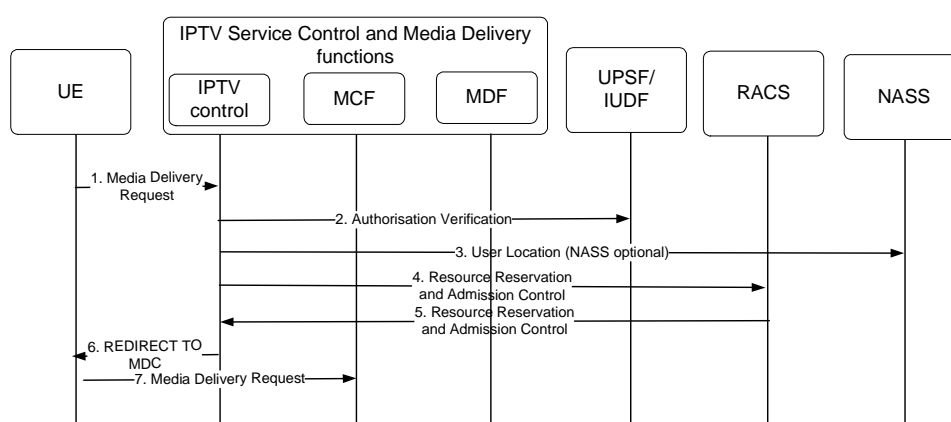

**Figure 7: Operation flow in the redirect mode**

Main functional steps in the decoupled mode:

- 1) Media Delivery Request: UE requests interactive media delivery.
- 2) Authorization Verification: IPTV control optionally verifies user rights to access the service.
- 3) User Location: user location can be requested from NASS or from IPTV UDF.
- 4) Resources Reservation and Admission Control: IPTV control selects media delivery function and optionally requests reservation of transport delivery resources. Note: resource reservation can be alternatively performed by the selected MCF.
- 5) Resources Reservation and Admission Control: transport resources reserved and committed.
- 6) Redirect to MCF: UE is redirected to MCF for the selected MDF function for interactive media delivery.
- 7) Media Delivery Request: UE requests interactive media delivery.

### 6.2.4 Proxy mode

Operational flow of the MCF control functional entity in the proxy mode is presented on figure 8.

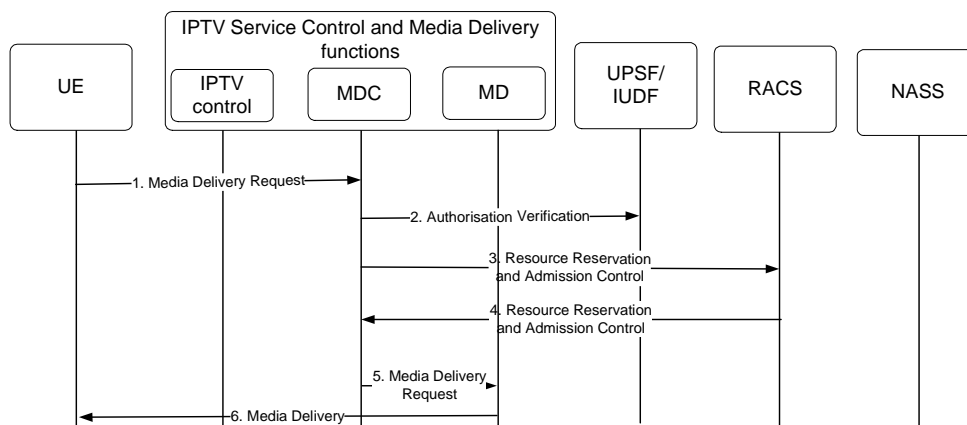

**Figure 8: Operation flow in the proxy mode**

- 1) Media Delivery Request: UE requests interactive media delivery.
- 2) Authorization Verification: MCF optionally verifies user rights to access the service. May access to IPTV UDF for this purpose.
- 3) Resources Reservation and Admission Control: MCF selects media delivery function and optionally requests reservation of transport delivery resources.

NOTE: Resource reservation can be alternatively performed by the IPTV control.

- 4) Resources Reservation and Admission Control: transport resources reserved and committed.
- 5) Media Delivery Request: Media Control Function command is passed to media delivery.
- 6) Media Delivery: media is delivered to the UE.

## 6.3 Service initialization

### 6.3.1 Functional steps for UE start-up

Figure 9 presents functional steps of the UE start-up for IPTV subsystem in NGN.

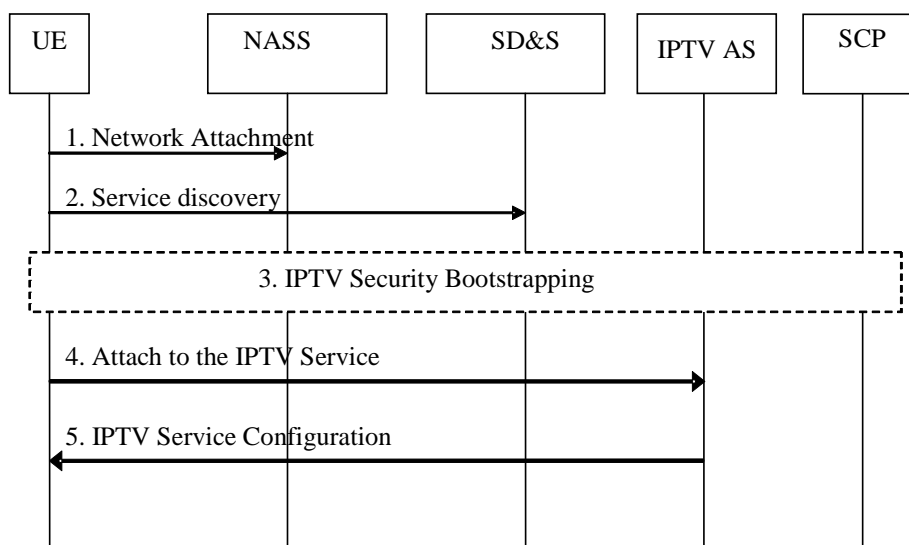

**Figure 9: UE start-up procedure**

1) Network Attachment.

In this step, the UE attaches to the network. The UE may be passed data for Service Provider Discovery (SPD) as defined in clause 5.2.1.

2) Service discovery.

In this step, the UE discovers service providers and services as discussed in clause 5.2.1.

3) IPTV security bootstrapping.

In this step, the UE performs authentication, key management (CSP may be also involved in initial steps of service and content protection). During this procedure IPTV subsystem may register IPTV UE in other service level subsystems on behalf of UE.

4) Attach to the IPTV Service.

5) IPTV Service Configuration.

In steps 4 and 5, the UE navigates and selects a service from available service offers. IPTV AS may update IPTV user profile, presence of behalf of IPTV as a part of the SD&S process. The service navigation and selection can be provided in a generic case via different functional entity as presented on figure 10.

NOTE: The high level service attachment steps can look similar for integrated IPTV subsystem and IMS based IPTV approaches, the exact alignment in procedures is out of the scope of the present document.

### 6.3.2 Service discovery and selection

This clause defines steps in the service discovery and selection process used by the UE to attach to the network, acquire list of service providers and make service selection from the selected service provider.

There is a step preceding SD&S process including setup and initial UE configuration.

Figure 10 presents steps in the SD&S process.

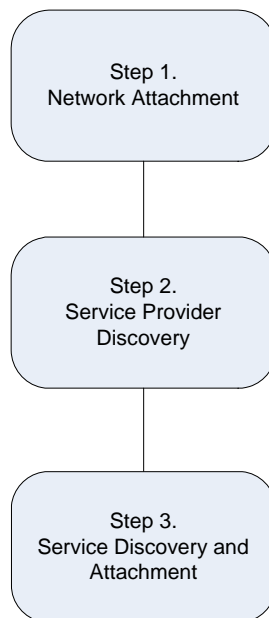

**Figure 10: High Level SD&S Process**

**Network Attachment:** during this step UE establishes connectivity to an IP-network and obtains network-based service configuration data. For example, the following information may be obtained or established by UE: IP address, network mask, DNS, domain name, others. During this step UE may be passed data for SPD, e.g. a container option sent by DHCP server listing the source IP address of the Service Provider server or list of registered IPTV service provider servers using DNS SRV mechanism in accordance with RFC 2782 [7].



**Service Provider Discovery (SPD):** during this step UE collects the location (entry points) for discovering service providers and retrieves information about available IPTV Service Providers, learns the location of their one or more Service Discovery (SD) Server.

**Service Discovery and Attachment:** during this step UE acquires information about available IPTV Services from one or more Service Discovery (SD) Servers, navigate, select service from the service offering and attach to the service. The procedure used to activate a particular IPTV service is typically service specific. Authentication is performed at this step.

Further decomposition for Service Provider Discovery (SPD) is presented on figure 11.

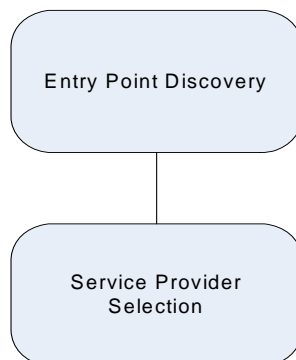

**Figure 11: Service Provider Discovery (SPD) Steps**

**Entry points discovery:** during the step UE determines the entry point(s) for discovering service providers (e.g. bootstrap process).

**Service provider selection:** during this stage UE retrieves information about available IPTV Service Providers, learns the location of their one or more Service Discovery (SD) Servers and makes a selection of the Service Provider.

Different mechanisms are available for Step 2 and Step 3, e.g. those defined in DVB-IP [2] can be used.

Regionalized or personalized delivery of the content metadata can be performed by the Customer Facing IPTV applications by accessing user profiles (as described in the clause 8) and accessing user location (as described in clause 5).

## 6.4 Nomadism

In TISPAN Release 2, nomadism can be provided by relying on the functionality provided by the transport control layer (i.e. RACS and NASS). In this scenario, all functions in the integrated IPTV subsystem are located in the user's home domain and therefore, a UE in a visited access network or access point needs to be provided with:

- IP connectivity to the user's home service control domain.
- A pointer to the Customer Facing IPTV Application in the user's home service control domain (as part of the Service Discovery and Attachment procedures described in clause 6.3.2).

## 6.5 Support of Mobility Capabilities

Annex G discusses interconnection models for IPTV UE mobility.

NOTE: If the UE supports roaming in the visited network to support mobility of IPTV services.

Annex G considers how the UE in the visited network can access IPTV services from the home network.

IPTV Service Provider in the home network may select to use MF in the home network to deliver content to UE in both home and visited networks.

---

## 7 Security

### 7.1 Content Protection

For content protection the following elementary functions are used:

- Content licensing: This elementary function handles the licenses issuing related functions, including generation and distribution of the licenses to the desired entities.
- Key management: This elementary function handles the management of the security keys on behalf of the content usage profiles as defined in the content licensing, including generate and provide the keys and corresponding parameters to the desired entities.
- Content encryption: This elementary function handles the content protection related operations, e.g. content encryption and encapsulation operations, etc.

These three elementary functions may be flexibly located in existing functional entities or new ones as a whole or in independent parts.

NOTE 1: The locations and related reference points of those three elementary functions are defined in TS 187 003 [11].

NOTE 2: Some of these elementary functions may be executed on-line (in real-time) or off-line (in this case could be part of the management).

NOTE 3: Additional details and procedures for IPTV service and content protection of these three elementary functions and other IPTV security functions are described in TR 187 013 [14].

### 7.2 Service Protection

The Service Membership (SMF), Service Key Management (SKMF) and Service Protection (SPF) Functions described in this clause each involve a set of elementary functions required as part of a generic model for service protection. The SMF, SKMF, and SPF do not duplicate, but collaborate and interact with existing elementary functions in order to perform service protection.

For service security the following functions are used:

- Service Membership elementary Functions (SMF): This set of elementary functions handles the granting and revoking of service access rights to access the IPTV services. Metadata related to the service rights management are maintained by the SMF.

NOTE 1: The SMF is handled in an array of existing elementary functions (e.g., service key triggering function) and functional entities. For example, service authorization may be provided by the CFIA or IPTV-C, and meta-data is maintained in the UPSF.

- Service Key Management Function (SKMF): This set of elementary functions acts on behalf of the Service Membership Function and as such manages service security keys, including generating and providing keys and corresponding parameters to the desired entities.
- Service Protection Function (SPF): This (set of elementary) function(s) handles the service protection related options, e.g. service confidentiality, integrity operations and authorization at the service access point, etc, using the keys generated in SKMF.

NOTE 2: The SPF includes group association, e.g. multicast group.

NOTE 3: The locations and related reference points of those three elementary functions are defined in TS 187 003 [11].

NOTE 4: Additional details and procedures for IPTV content protection are described in TR 187 013 [i.4].

## 8 Management

A number of functional entities used to deliver IPTV and NGN services require time synchronization, e.g. to provide time of day reference. Transport layer should support such reference.

Content management functionalities are responsible for managing acquisition of content and service information (e.g. metadata) from sources, controlling validation and/or processing/adaptation to the required format and also to provide management functionalities for supporting distribution of content to the media delivery function.

**NOTE:** Content management is used in the case of offline or online ingest of the content. The online ingest means receiving content directly streamed from the content provider. The offline ingest refers to content files delivered by other means than the online (e.g. such on physical media like DVD, CD, etc.). The content management is used by the IPTV service provider to statically provision the content.

## 9 User data

### 9.1 IPTV profiles

IPTV related data can be grouped into three types of IPTV profiles (see figure 12):

- Content Profile.
- Service Profile.
- User Profile.

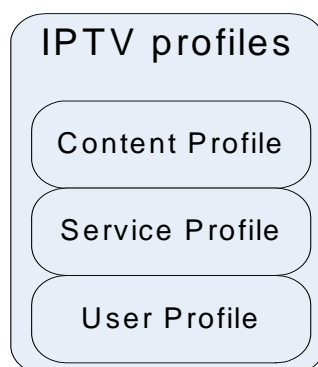

**Figure 12: NGN IPTV profiles**

**Content Profile:** Content profile contains and maintains information about multimedia metadata and multimedia service packaging used for the provisioning of IPTV services.

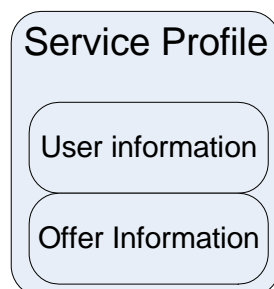

**Figure 13: NGN IPTV Service Profile**

**Service Profile:** Service profile refers to data used to the provisioning of the service to the user. It contains and maintains information about service-level user data and service-level offer data (see figure 13):

- Service-level user data: as defined in NGN Functional Architecture [5], e.g. user identification, numbering, addressing, user security, location information at inter-system level, other.
- Service-level offer data: contains the information for delivery of IPTV services, e.g. EPG/BPG.

**User profile:** User profile refers to user customization and usage metadata. It contains and maintains basic user information, service specific information, e.g. subscription, bookmarks, activities, parental control, etc. and User actions related to service purchase and consumption.

- User subscription data - contains information such as language preference, payment preferences, navigation preferences, etc.

Service actions data - contains and maintains non static data related to the purchase and consumption of services such as list of CoD already consumed, indexes for currently consumed programs, language selection.

## 9.2 User data location

NGN Integrated IPTV supports two approached to user data location: federated and consolidated.

**In the federated approach** user data is located close to associated AS functions in IPTV UDF, NGN Apps UDFs.

User data associated with applications can be access by the AS functions directly on Ud interfaces. If AS function requires access to subset of user data associated with other AS functions, Ug interface should be used. User Data functional acts as data federation agent providing unified approach and federation of user data profiles.

Federated approach is applicable to other data profiles defined in clause 9.1:

- content profiles;
- service profiles.

**In the consolidated approach** user data is located in a single location: User Data Function and can is accessed on Sh interface. Ud and Ug interfaces, in essence, become the same Sh interface.

As discussed above, both IUDF and UPSF may be used for handling the IPTV user data.

IPTV profile information (Content, service, user, as defined in clause 8.1) could be optionally located in the IPTV Application server functions (i.e. IUDF) hosting the IPTV applications, or in the UPSF as transparent data associated to the Application Server functions, or in an XDMS associated with the IPTV Application Function.

The type of user related information necessary for multi-subsystems service blending belongs to the following list: service-level user identification, numbering and addressing information, service-level user security information: access control information for authentication and authorization, service-level user location information at inter-system level, service-level user profile information.

To provide support for converged applications that span across several subsystems of the TISPAN NGN network (e.g. chatting on watched programs, multiple incoming calls management, as listed in TS 181 016 [1]) both federated and consolidated approaches are applicable, and in accordance the location of the user data profile:

- Use UPSF as the host for the set of user related information necessary for multi-subsystems service blending.
- Use of data federalization (represented by UDAF on figure 2).

It is recommended that an NGN (e.g. converged) application, or its corresponding user data functions do not have direct access to IPTV profiles in IUDF (reverse applies respectively). It may however have access to it by other means (e.g. Ug reference point to UDAF, Sh to UPSF for the subpart of IPTV profile that is hosted onto UPSF).

If UPSF is used, several entities will need to be consistently provisioned for:

- user identification (in UPSF and IUDF);
- user authentication (in UPSF and IUDF).

NOTE: Such need for consistent provisioning is to be brought to the attention of WG8.

## 10 Charging

As illustrated in figure 2, the charging belongs to the management domain.

IPTV subsystem collects information related to billing and provides IPTV CDRs (including charging related elements), that can be collected by the billing system for the sake of off-line charging. These CDRs may also be used for other purposes than billing (such as QoS, statistics).

NOTE: CDR means Charging Data Record, as defined in TS 132 240 [13] (endorsed by ES 282 010 [12]). It is a formatted collection of information about chargeable event, knowing that, as a minimum, a chargeable event characterizes the resource/ service usage and indicates the identity of the involved end User (s).

IPTV subsystem integrates with the charging and accounting components of the management domain for having access to the user account (credit, balance, etc.) in order to allow IPTV user facing applications and optionally media delivery control to perform their role with.

## 11 Procedures

### 11.1 Linear TV

This clause provides the flows for the BTV IPTV services integrated into the TISPAN NGN architecture and inter-working with the NGN common functions and components. The flows support linear TV in coupled and decoupled mode. Linear TV in coupled and decoupled mode uses RACS in the "push mode".

The clause presents generic flows and does not mandate placement of functions. DRM flows are not included.

Linear TV procedure for coupled and decoupled mode.

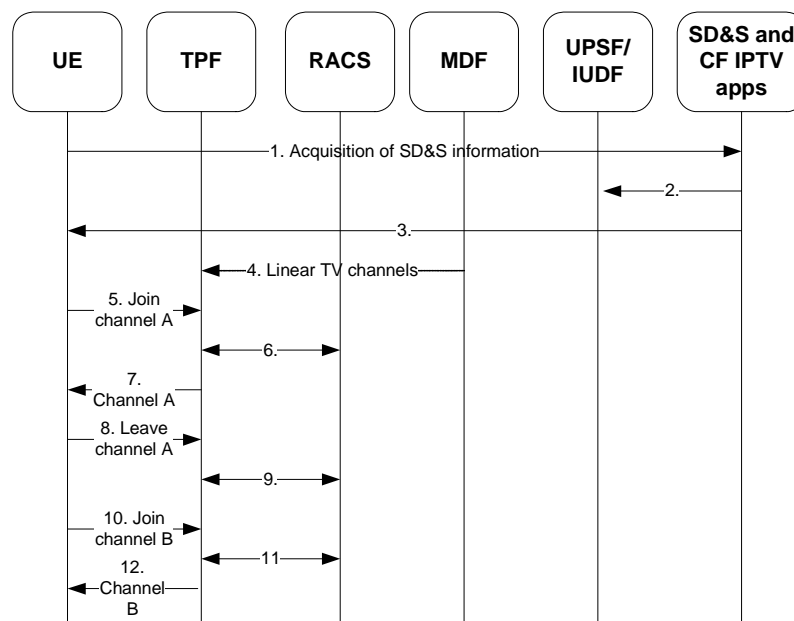

**Figure 14: NGN IPTV Linear TV procedure for coupled and de-coupled mode**

- 1) UE requests SD&S information from SD&S. SD&S format and request methods are outside the scope of the present document and have been researched in other specifications, e.g. [2], others.
- 2) SD&S verifies user profiles from IUDF/UPSF. The location of IUDF/UPSF and data model, e.g. centralized or federated is described in clause 9.

- 3) SD&S replies service offers to UE.
- 4) MDF outputs BTV multimedia stream, such as regular TV channels or scheduled content, to the TPF connected via MGF.
- 5) UE requests TPF to join linear TV channel A (BTV multicast stream).
- 6) Optionally, resource admission control may take place at this stage. For Multicast, this is typically performed by an A-RACF, which can be separately located or collocated with the TPF [10].
- 7) Channel A is delivered.
- 8) UE requests TPF to leave linear TV channel A.
- 9) If resource admission control was executed in Step 6, resource release procedure shall take place at this stage.
- 10) UE requests TPF to join linear TV channel B. Optionally, local admission control can check resource availability before granting the request.
- 11) Optionally, resource admission control may take place at this stage. For Multicast, this is typically performed by an A-RACF, which can be separately located or collocated with the TPF [10].
- 12) Channel B is delivered.

NGN Linear TV IPTV session is a lasting service agreement and reserved network delivery resources for broadcast multimedia service between UE and TPF, e.g. between and including steps 5) and 8) on figure 14.

Typically in the coupled mode UE would access the channel (step 4) immediately after step 3.

In the decoupled mode there could be a time delay between step 3 and step 4, e.g. user may be authenticated to access bTV package at the service initialization stage (steps 1-3), but choose to view channel from the package at the later time (step 4).

NOTE: This and subsequent flows show separate location of the TPF and RACS, they can be co-located as discussed in [10].

## 11.2 Multimedia Content on Demand (CoD)

This clause provides the flows for the CoD IPTV services integrated into the TISPAN NGN architecture and inter-working with the NGN common functions and components.

The clause presents generic flows and does not mandate placement of functions. DRM flows are not included.

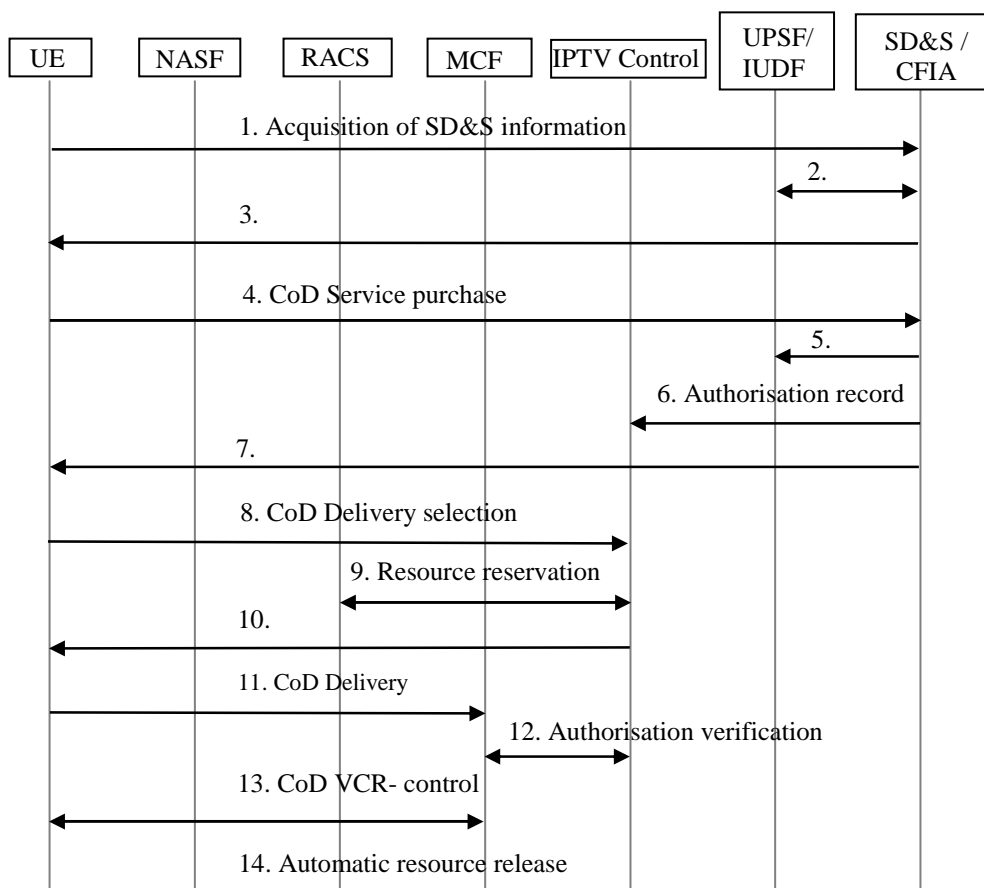

**Figure 15: NGN IPTV CoD procedure**

- 1) UE requests SD&S information from SD&S. SD&S format and request methods are outside the scope of the present document and have been researched in other specifications, e.g. [2], others.
- 2) SD&S verifies user profiles from IUUF/UPSF. The location of IUUF/UPSF and data model, e.g. centralized or federated, is described in clause 9.
- 3) SD&S replies service offers to UE.
- 4) User selects a service from the offers. UE requests the selected service from Customer Facing IPTV Applications.
- 5) Customer Facing IPTV Applications. Optionally creates billing event, e.g. for on-line billing, and sends it to IUUF/UPSF. The location of the billing information and data model are discussed in clause 9.
- 6) Customer Facing IPTV Applications optionally creates authorization record (play ticket) to authorize content delivery.
- 7) Customer Facing IPTV Applications replies the location of IPTV control and optionally ticket data to UE.
- 8) UE requests IPTV control the location of MCF. Optionally ticket data is supplied.
- 9) IPTV Control selects MCF based upon operator defined criterions and requests RACS to allocate resources between the end-points. Distributed RACS interfaces are allowed.
- 10) IPTV Controls replies MCF location to UE.
- 11) UE requests MCF to deliver media using reserved session and associated resources. Optionally ticket data is supplied and the ticket punched.
- 12) MCF optionally verifies user credentials to request multimode delivery.
- 13) UE utilizes VCR style control over media to MCF.

- 14) Automatic resource reservation follows session termination, which can be initiated either by end point UE or MCF, or by an IP network. Although it is not necessary to explicitly tear-down an old reservation, we recommend that during normal operation MCF or IPTV Control send a teardown request to RACS as soon as the session has finished.

NGN CoD IPTV session is a lasting service agreement and reserved delivery resources on server and network levels for multimedia on demand service between UE and MDF.

Cod flows do not cover NAT explicitly, however, standard IP NAT protocols can be used, see [14].

### 11.2.1 Optimized bandwidth utilization during CoD

This clause discusses optimized bandwidth utilization during CoD procedure for UE containing local storage.

The MDF, during media delivery initiated by Step 13 on figure 15, may increase the bandwidth of the session to a higher bandwidth once the session has been opened, to permit delivery of data from MDF to the UE at a rate higher than the nominal reserved rate. The excessive content should be saved on the local storage for further consumption. The content "burst" may come with a different network priority or class of service.

The UE may optionally provide feedback to the delivery server, e.g. the UE may detect missing data and to request missing packets from the delivery server using a retransmission approach and a RTP/RTCP feedback mechanism specified in clause A.3 [1].

The MDF may increase the bandwidth gradually, waiting for the results of feedback received by the delivery service: the MDF increase the bandwidth gradually until a retransmission request is received, and, once the retransmission request has been received, to reduce the bandwidth gradually until retransmission requests are no longer received. The delivery server may cyclically increase and decrease the bandwidth, in accordance with the retransmission requests.

Optimized bandwidth utilization enables more efficient utilization of the network resources and capacity, e.g. since the content can be delivered faster (e.g. at the idle times) and RACS resources to be released earlier (e.g. to meet peak demands).

Figure 15A illustrates Optimized bandwidth utilization during CoD.

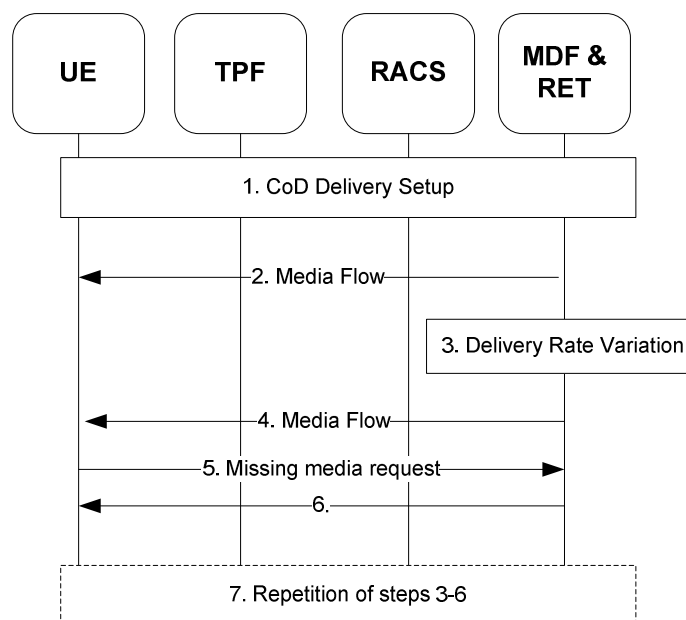

**Figure 15A: Optimized bandwidth utilization during CoD**

- 1) CoD session setup as discussed in clause 11.2. During session setup at SD&S stage the UE has been identified as containing local storage and enabled for optimized network utilization mode.
- 2) Content media flow from MDF to UE.
- 3) MDF increases delivery bandwidth.



- 4) Content media flow from MDF to UE.
- 5) Media loss detected. Request for missing data.
- 6) MDF requested retransmission of missing data.

Steps 3 to 6 can be repeated.

## 11.3 Media broadcast with trick modes

This clause provides the flows for the media broadcast with trick modes IPTV services integrated into the TISPAN NGN architecture and inter-working with the NGN common functions and components.

The clause presents generic flows and does not mandate placement of functions. DRM flows are not included.

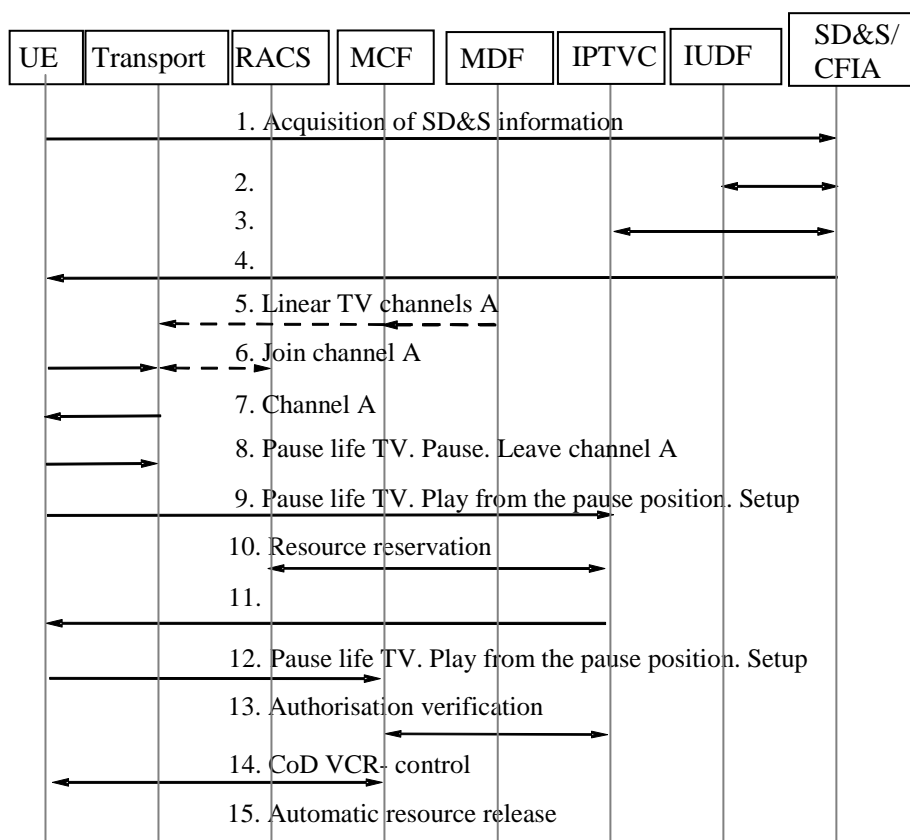

**Figure 16: NGN media broadcast with trick modes procedure**

The flows shows generic case where MDF providing linear TV is not co-located with MCF providing "on-demand" functionality. MCF and MDF can be located in the same place.

- 1) UE requests SD&S information from SD&S.
- 2) SD&S verifies user profiles from IUDF.
- 3) Media broadcast with trick modes is a subscription based service. At the subscription time, Customer Facing IPTV Applications optionally create authorization record (play ticket) to authorize this service.
- 4) SD&S is returned to the user.
- 5) MDF outputs BTV multimedia stream, such as regular TV channels or scheduled content.
- 6) UE requests transport to join linear TV channel A (BTV multicast stream). Optionally, resource admission control may take place at this stage. For Multicast, this is typically performed by an A-RACF, which can be separately located or collocated with the Transport Processing Function [10]. This is shown by a dotted line.

- 7) Channel A is delivered.
- 8) User requests to pause linear TV channel. UE requests transport to leave linear TV channel A.
- 9) User requests to re-start play from the paused position. UE issues setup command and requests IPTV Control the location of the MCF. Optionally ticket data is supplied. This selection is optional, previously selected MCF can be used or the default MCF can be supplied to the UE during service initialization steps.
- 10) IPTV control selects MCF based upon operator defined criterions and requests RACS to allocate resources between the end-points. Distributed RACS interfaces are allowed.
- 11) IPTV control replies MCF location to UE.
- 12) UE issues play command and requests MCF to deliver media from the pause position supplying position.
- 13) MCF optionally verifies user credentials to request multimode delivery.
- 14) UE utilizes VCR style control over media.
- 15) Automatic resource release follows session termination, which can be initiated either by end point UE or MCF, or by an IP network. Although it is not necessary to explicitly tear-down an old reservation, we recommend that during normal operation MCF or IPTV Control send a teardown request to RACS as soon as the session has finished.

Return to live linear TI channel is achieved by repeating steps 6) and 7).

Return to trick mode is archived by repeating steps 8) to 13).

NGN IPTV media broadcast with trick modes service is combination of separate BTV and CoD IPTV sessions joined together at the service level. See clause 11.1 for definition of CoD NGN IPTV session and clause 11.2 for definition of BTV NGN IPTV session.

NGN IPTV media broadcast with trick modes session is a service level aggregation as defined above and is not used for billing purposes.

## 11.4 Near CoD

This clause provides the flows for the Near CoD IPTV services integrated into the TISPAN NGN architecture and inter-working with the NGN common functions and components.

The clause presents generic flows and does not mandate placement of functions. DRM flows are not included.

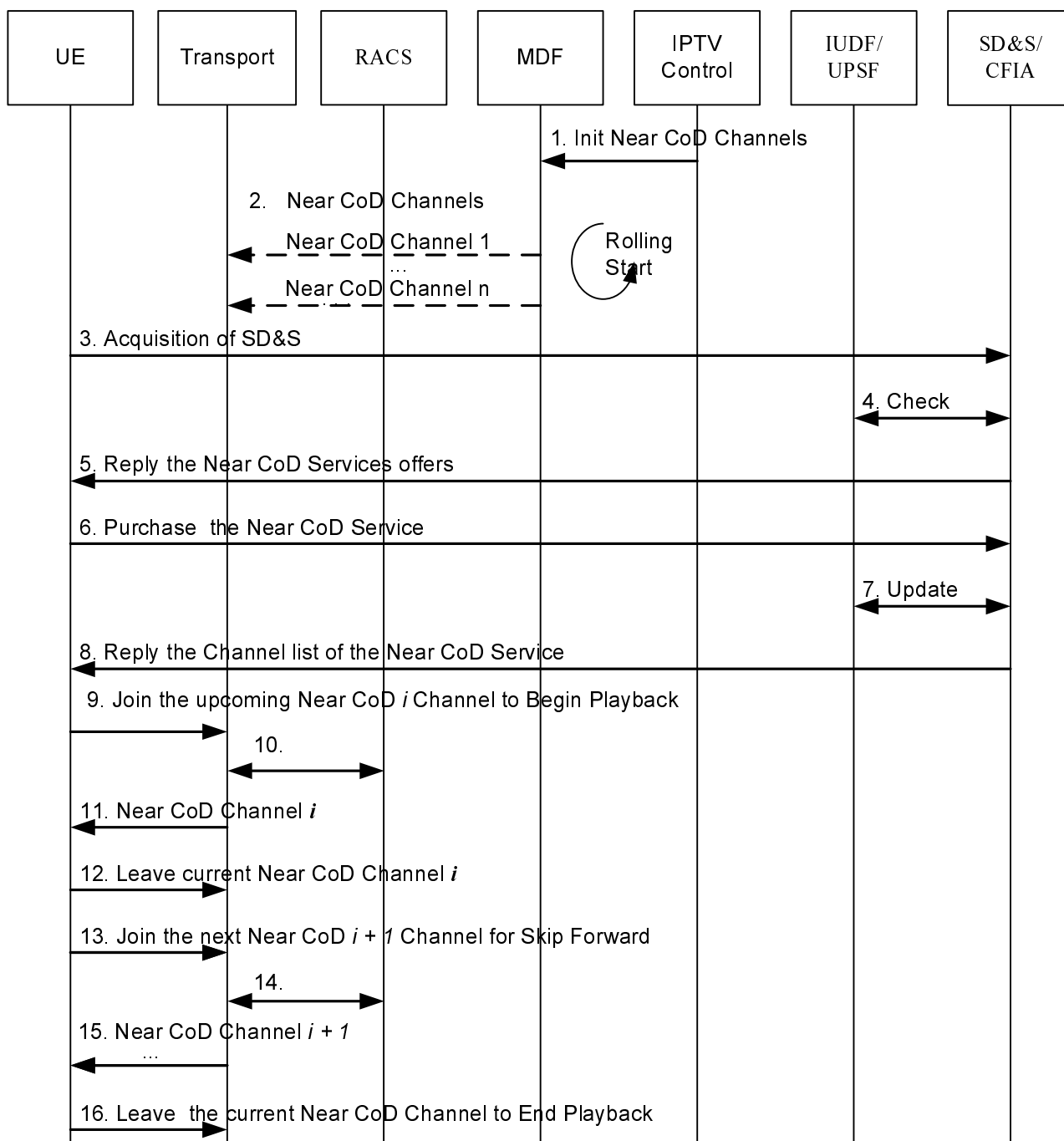

**Figure 17: NGN IPTV near CoD procedure**

The flow represents a generic case where MDF provides a CoD content on a set of multicast channels with a fixed interval, e.g. an interval of 15 minutes.

For example, one content's playback time is 148 minutes.

Near CoD Channel 0 starts output stream at time offset 00 minutes.

Near CoD Channel 1 starts output stream at time offset 15 minutes, and so on until Near CoD Channel 9 starts output stream at time offset 135 minutes.

- 1) IPTV Control requests the MDF to initiate the Near CoD channels.
- 2) MDF outputs Near CoD channel streams to the transport.
- 3) UE requests the Near CoD services information from SD&S.

- 4) SD&S checks the user profiles from IUDF/UPSF.
- 5) SD&S returned Near CoD Services offered.
- 6) UE purchases the Near CoD from CF IPTV Applications.
- 7) CF IPTV Applications updates the user profiles from IUDF/UPSF to record the purchase.
- 8) CF IPTV Applications returned the Channel list of the Near CoD Service which the user just purchased. Each channel has information of Start Time and End Time.
- 9) UE requests transport to join Near CoD channel  $i$  which was the next rolling start channel by the time of the request.
- 10) Optionally, resource admission control may take place at this stage. For Multicast, this is typically performed by an A-RACF, which can be separately located or collocated with the Transport Processing Function [10].
- 11) Near CoD Channel  $i$  is delivered.
- 12) User requests to Skip Forward. UE requests transport to leave Near CoD Channel  $+I$ .
- 13) UE requests transport to join Near CoD channel  $+i+1$  which was the next channel.
- 14) Optionally, resource admission control may take place at this stage. For Multicast, this is typically performed by an A-RACF, which can be separately located or collocated with the Transport Processing Function [10].
- 15) Near CoD Channel  $i+I$  is delivered.
- 16) User requests to Stop or End play the Near Cod. UE requests transport to leave Near CoD Channel  $+i$ .

Step (1) and (2) is the flow of setup of Near CoD.

Step (3) to (8) is the flow of Service Discovery & Selection of Near CoD.

Step (10) to (17) is the flow of UE playback control of Near CoD. Steps (12) to (16) are the optional interaction flow during the playback of Near CoD. Steps 12-15 applicable for other trick mode operations: e.g. skip backward.

## 11.5 Push CoD

### 11.5.1 Push CoD procedures using notification

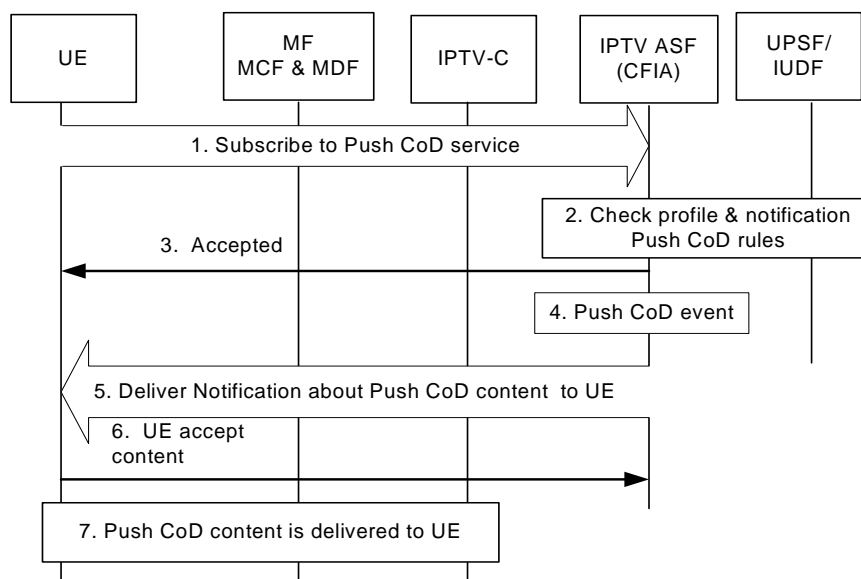

**Figure 18: Push CoD services procedure**

The detailed description of procedure is following:

- 1) User subscribes to Push CoD service.
- 2) According to policies the CFIA may request IPTV sub-profile of federalized user profile from IUDF or UPSF. CFIA decides user authorization to use a service based on received information and service logic.
- 3) CFIA authorizes request and confirms successful subscription to the UE.

NOTE: IPTV Service provider may initiate Push CoD without explicit user subscription in which case 1-3 may be optional.

- 4) New Push CoD event acts as a trigger for CFIA.
- 5) CFIA delivers notification to the UE (including CoD content identifier) using notification framework.
- 6) UE may accept delivery of Push COD.
- 7) UE initiate via IPTV-C either CoD content delivery as described in clause 11.2 or CoD content download from MDF. The content may be either viewed immediately or stored for later viewings.

## 11.6 User generated content

### 11.6.1 Overview

There are two types of User Generated Content (UGC) procedures:

- **creation of the User Generated Content:** this type of procedure allows a user to declare UGC with its metadata and upload/upstream his/her own content to the network as discussed in clause A.9.1.2 [1] and in accordance with the IPTV SP policies for UGC services.
- **watching of User Generated Content:** this type of procedure allows a user to select and watch User Generated Content.

NOTE: The UGC watching procedure may start before the UGC creation procedure has been completed, e.g. as defined in Clause A.9.1.2 of [1].

### 11.6.2 UGC creation procedure

The UGC creation procedure comprises four major steps:

Step 1: Declaration of User Generated Content.

- The UE sends a User Generated Content creation request to the CFIA and receives a content ID for the UGC from the CFIA. The content ID is independent of the address where the UGC can be retrieved by other UEs.

Step 2: Publication of User Generated Content information by the UE.

- The UE sends a request to the CFIA that contains a description of the User Generated Content (name, type, restriction, textual description, special group users, etc.). This request may be combined with the User Generated Content Declaration request in step 1.

Step 3: Creation of User Generated Content.

- The UE initiates a session with the CFIA and MF in order to create the User Generated Content (i.e. upload/upstream (unicast) the content to the MF). The MF provides the CFIA with the location at which the UGC becomes available.

Step 4: Publication of User Generated Content information by the CFIA.

- The CFIA establishes the relationship between UGC content ID, UGC description, and optionally the MF, and publishes this UGC description information to the SD&S. The UGC description publication by the CFIA in step 4 may take place before, during or after the UGC content creation delivery session initiation in step 3.

Step 1 is always the first step. Step 2 may happen at any time during the UGC creation and can be repeated during the lifetime of the content.

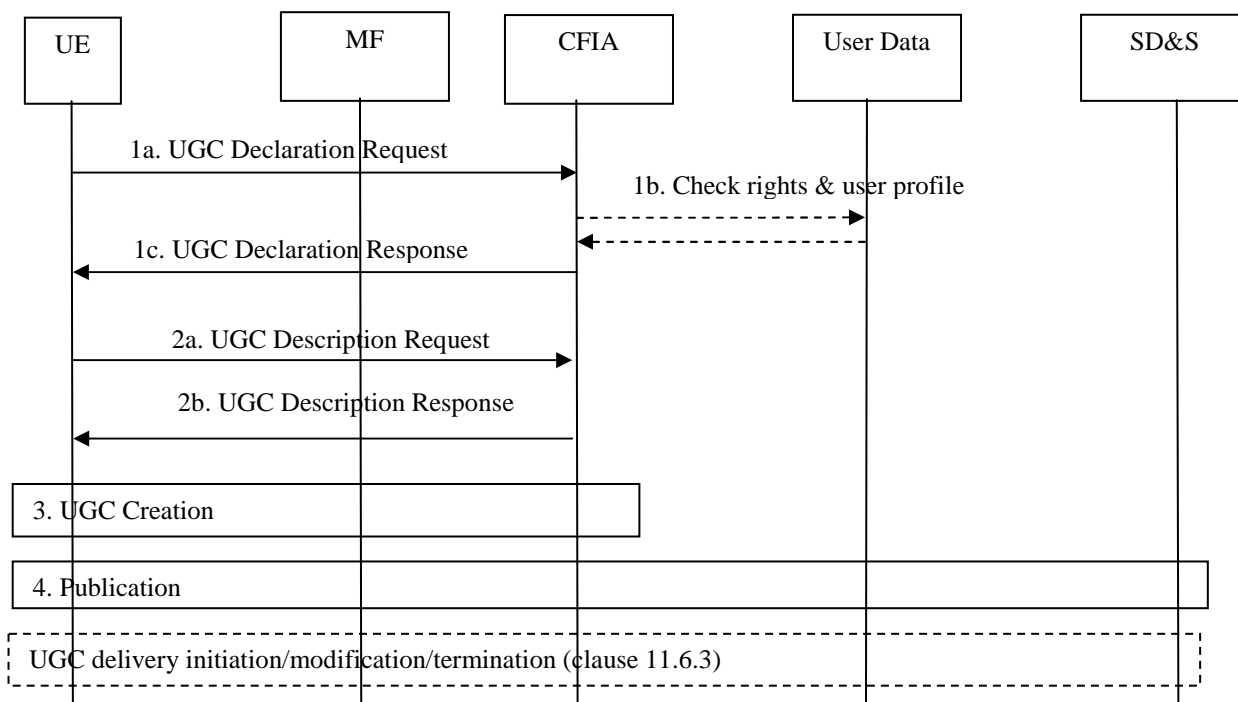

**Figure 19: UGC creation procedure**

The UGC procedure comprises the following major steps:

- 1) The UE sends a request for User Generated Content declaration.
  - 1a) The UE sends a User Generated Content Declaration Request to the CFIA. This request asks for a unique content ID (that is independent of the address where the UGC can be retrieved by other UEs).
  - 1b) The CFIA may check user rights and user profile prior to granting the UE permission to create UGC and generates a unique UGC ID.
  - 1c) The CFIA confirms that the UE can create UGC by sending a Declaration Response containing the UGC ID and the designated MCF/MDF where the UGC can be created (uploaded/upstreamed).
- 2) The UE sends a request for UGC description:
  - 2a) The Description Request contains a description of the User Generated Content (e.g. name, type, restriction, textual description, selected group users, type of content, coding).
  - 2b) The CFIA records the UGC description, establishes the relationship between UGC ID and UGC description and sends a UGC Description Response to the UE.
- 3) UE initiates creation of User Generated Content for uploading or upstreaming the content to the designated MDF and confirms to the CFIA the publication of content (making it available for usage).
- 4) The CFIA establishes the relationship between UGC ID, UGC description and optionally UGC location (address), and publishes this UGC information to the SD&S. The UE can modify or terminate the established UGC creation session at a later stage.

### 11.6.3 UGC watching procedure

The UGC watching procedure comprises two major steps:

Step 1: Selection of UGC:

- The selection of the UGC may be done through the SD&S. Alternatively, UGC selection can be triggered by a content recommendation or a notification. The UE may also pre-select UGC that has already been declared and published (see clause 11.6.2, steps 1, 2 and 4), but not yet created (see clause 11.6.2, step 3).

Step 2: Watching of UGC:

- Session initiation can be performed by the UE or the CFIA in order to watch the selected UGC. The UGC watching session is equivalent to the CoD session. If the UE has previously pre-selected UGC that had already been declared and published but not yet created (see above), then this UGC will be delivered in an Push CoD session (see clause 11.5.1, figure 18) when the UGC is created.

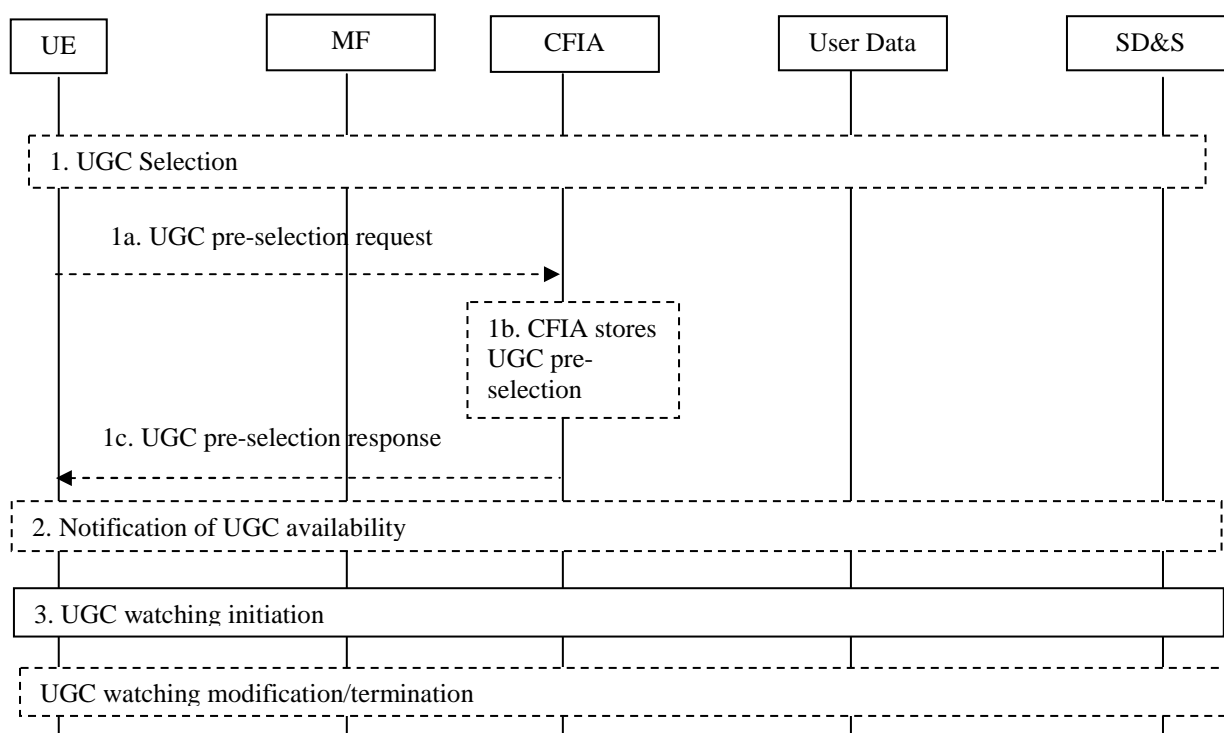

**Figure 19A: UGC watching procedure**

- The UE selects UGC through service selection procedure with SD&S as defined in clause 8.2 step 4. The SD&S may restrict the list of UGC depending on user identity and UE capabilities. Alternatively, UGC availability is triggered through the notification procedure from the CFIA as defined in clause 11.8.2 or recommendation procedure from the CFIA as defined in clause 11.9.2. The UE may also pre-select UGC that has already been declared and published (clause 11.6.2, steps 1, 2 and 4), but not yet created (see clause 11.6.2, step 3). This UGC pre-selection is described in steps 1a) - 1c).
- After publication, the CFIA can send a notification for the availability of UGC to selected UEs (using the existing mechanism from clause 11.8.2).
- The notification can trigger the delivery of UGC to selected UEs of one or more users (e.g. based on a user's subscription) using existing procedures (e.g. Linear TV defined in clause 11.1 or Multimedia CoD defined in clause 11.2). If the user pre-selected UGC, then this UGC will be delivered using Push CoD (see clause 11.5.1, figure 18) and the UE automatically accepts the notification and initiates a watching session to the MF.

The UE can modify or terminate the established UGC creation session later on.

## 11.7 Pay Per View

Thus clause discusses pay per view service. PPV service provides access to regular IPTV content (e.g. BC, CoD, UGC) through packaged service offers (e.g. pay per packages of assets, pay per specific program or pay per series) with pre-defined access conditions (e.g. pay per number of views or access time). PPV service is defined by IPTV SP.

Notification service may be used to notify the UE about available PPV services. Alternatively, the UE may select PPV services from available offer using SD&S.

NOTE: PPV package may contains combination of multiple IPTV content (e.g. BC, CoD, etc.) within single PPV service offer.

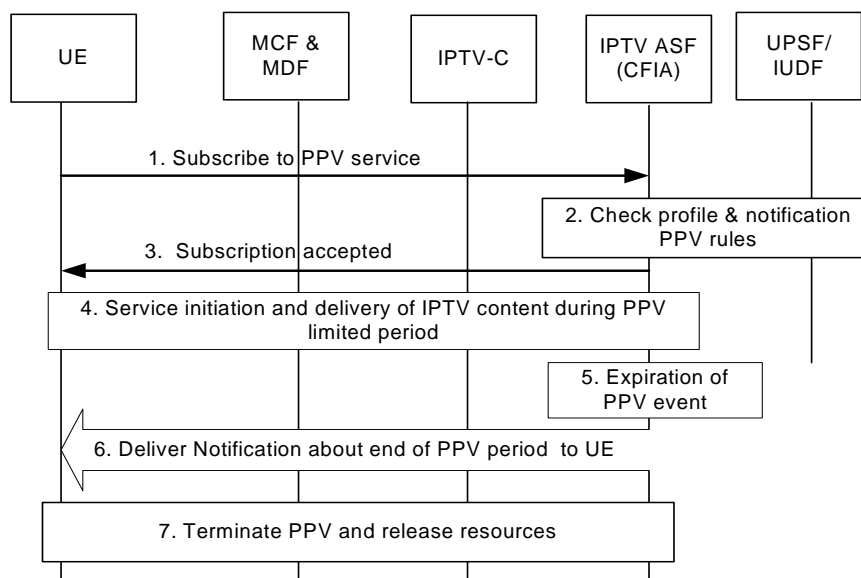

**Figure 19B: PPV services**

High level description of service procedure:

- 1) User subscribes to PPV service.
- 2) The CFIA may request IPTV sub-profile of federalized user profile from IUDF or UPSF. CFIA authorizes access to the service based on User Profile and service access logic (e.g. pay per view /time / number of plays). Payment may be requested and/or user credit may be checked before authorizing service access.
- 3) CFIA authorizes request and confirms successful subscription to the UE.
- 4) UE chooses to use PPV service and requests delivery of PPV content via existing procedures (e.g. Linear TV in 11.1, Multimedia content on demand (CoD) in clause 11.2 or User generated content in 11.6). PPV may provide access for a limited period to the specified content (e.g. TV channels, CoD assets, etc.). CFIA may need to push access control via IPTV-C to RACS and revoke when PPV service expires.
- 5) Expiration of PPV purchase acts as a trigger for CFIA.
- 6) CFIA delivers notification about expiration in advance to the UE (including timeout when service ends or offer to extend PPV period) using notification framework.
- 7) PPV service is terminated and also resources are released using existing procedures (following procedures used for service initiation in step 4).



## 11.8 Messaging and notification services

### 11.8.1 Messaging procedures

If messages are delivered via CFIA, then the role of Common NGN ASF is to terminate and process multiple incoming messages into generic format before passing to CFIA for presentation to the UE. This is illustrated by the figure below. The responses from the UE via CFIA should be passed back to Common NGN ASF, which will route the messages to the appropriate destination.

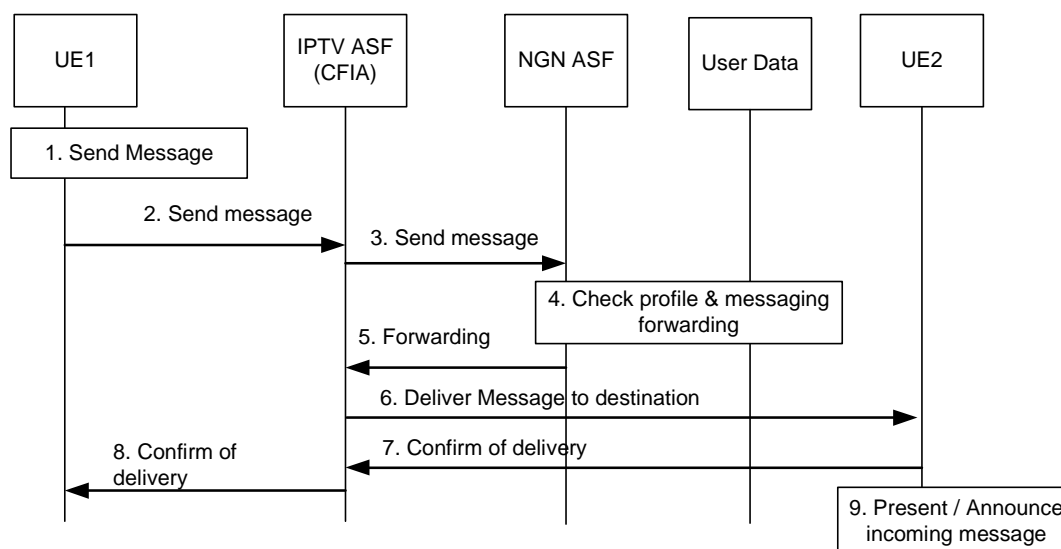

**Figure 20: Messaging between IPTV UEs**

Messaging between IPTV UEs:

- 1) User 1 sends a message from UE1 to the IPTV user 2 at the UE2.
- 2) The UE1 sends request with attached message and recipient identifier to the CFIA.
- 3) The CFIA forwards message to the NGN ASF messaging server.
- 4) According to policies the NGN ASF may request IPTV sub-profile of federalized user profile from NGN IUDF if this information is not stored in NGN ASF. The NGN ASF identified destination UE based on policy and destination information.
- 5) Based on policies the NGN ASF decides that the message should be forwarded to the IPTV UE2. The Common NGN ASF informs CFIA about the incoming message.
- 6) The CFIA delivers message to the UE 2.
- 7) Successful delivery is confirmed to UE 1 via CFIA.
- 8) Successful delivery is confirmed to UE 1 via CFIA.
- 9) The message is presented to user 2.

NOTE: The message can be directly delivered from and to Common NGN ASF.

### 11.8.2 Notification procedures

Common notification framework should be used for notifications about services from internal elements, e.g. CFIA or NGN applications (NGN ASF) to IPTV UE as described in procedures below. Such notifications can include, for example, emergency alerting, advertising, content recommendation or maintenance notification.

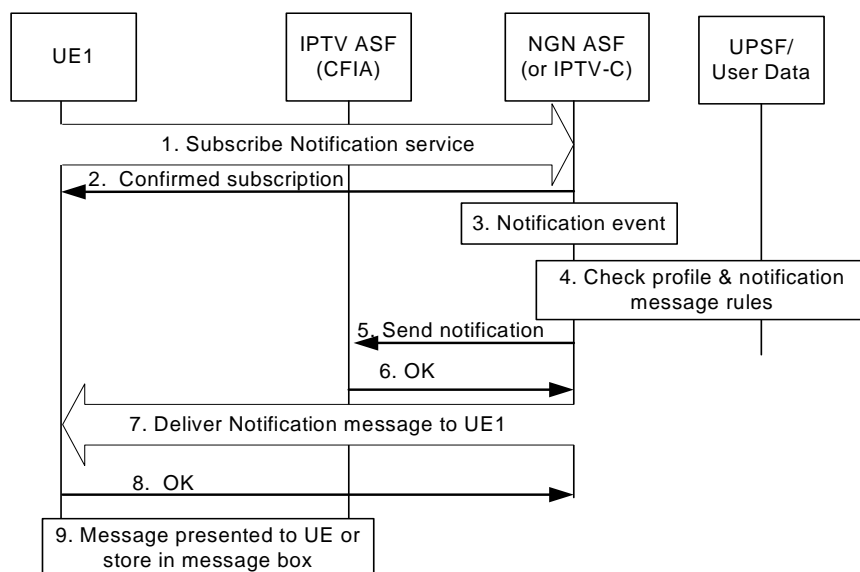

**Figure 21: Procedure for notification services**

Procedure for notification services:

- 1) User 1 subscribe to Notification service.
- 2) IPTV control (or NGN ASF) authorizes and confirms successful subscription to notification service.

NOTE 1: Step 1 and 2 may be performed via CFIA.

NOTE 2: IPTV Service provider may initiate notification service to the UE, e.g. for maintenance purposes without explicit user subscription in which case 1-2 may be optional.

- 3) New notification event acts as a trigger.
- 4) According to policies the IPTV-C may request IPTV sub-profile of federalized user profile from IUDF or UPSF. IPTV-C decides user authorization and the appropriate UE to send notification to.
- 5) IPTV-C inform CFIA about notification event.
- 6) CFIA acknowledges notification event.

NOTE 3: Step 5 and 6 are optional, e.g. when NGN ASF or IPTV-C notifies the UE directly.

- 7) Notification message is delivered to UE (via Tr reference point).
- 8) Successful delivery is confirmed to IPTV-C (or NGN ASF as external notification server).

NOTE 4: Step 1 and 2 may be performed via CFIA.

- 9) Message is present to user or stored on UE for future presentation.

## 11.9 Recommendations

The Content and Service Recommendation Service (CRS) is used for providing recommendations to IPTV users or user groups.

The recommendation service may make recommendations to user/groups based on different criteria which include user profile, preferences settings, current viewing habits, historic user activities as defined in [1].

The recommendation may be in form of text message (notification), multimedia message, content bookmark (pointer to recommended content) or video recommendation streamed from MDF.

The CRS service procedures include 2 main functions:

- 1) Aggregation of metadata for recommendations, e.g.:
  - a) List of users with unique identifiers and associated service profiles.
  - b) Asset metadata for CoD and linear TV, EPG/BCG.
  - c) Historic information about user consumption of IPTV services.
- 2) Generation of recommendations on request of external triggers.

The architecture supports different ways to deliver recommendations to the UE. Typically, content recommendations could be included into customer facing IPTV application. However, other delivery means are possible, e.g. common notifications framework can be used to deliver recommendations as defined in clause 11.8. The notifications framework can be used e.g. to deliver time-sensitive recommendations to the user.

### 11.9.1 Recommendations overview

A high level procedure for content and service recommendations is presented on figure 22.

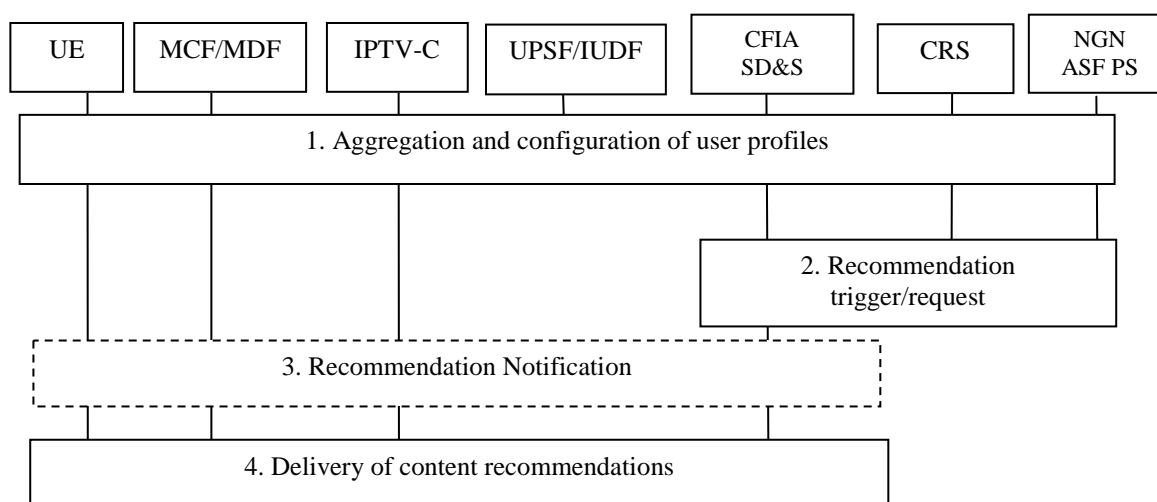

**Figure 22: High Level Procedures for CRS**

- 1) Aggregation and user configuration of profile or preferences for CRS.

NOTE: This user configuration part of the step is optional. The recommendations may be based only on IPTV SP user profile.

- 2) An application detects recommendation opportunity and requests for content recommendations. For example, such an event could be a user action of accessing or navigating CFIA, changes in the presence state or change in the service offers.
- 3) The application after detecting recommendation opportunity may send recommendation notifications to the UE immediately (push based CRS, push from CRS towards UE). Notification framework (described in clause 11.8.2 Notification procedures) is used to deliver CRS recommendation notifications (e.g. as a text message (notification), multimedia message, content bookmark, pointer to recommended content).
- 4) CFIA may provide CRS recommendation data, e.g. in addition to SD&S services information during service navigation the recommendations may be included into the CFIA user interface. In this case step 3 is optional. The UE may request additional data at step 4 (e.g. advertising clips, previews, trailers, etc.).

### 11.9.2 Recommendations procedures

This clause describes intermediate level procedures for content and service recommendations.

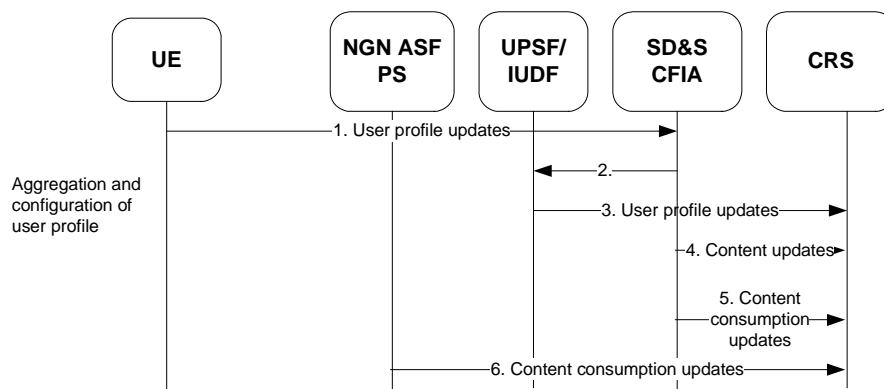
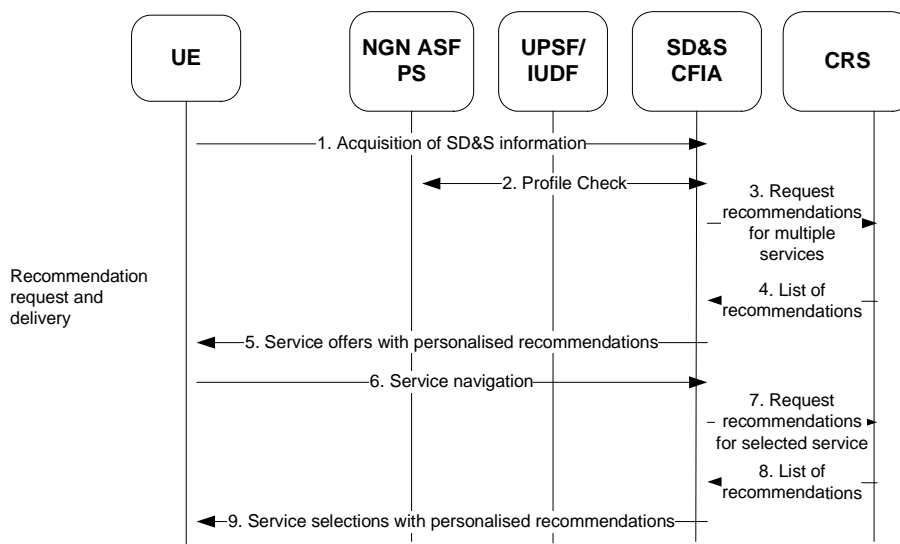

**Figure 23: Aggregation and configuration of user profile**

#### Aggregation of metadata for content recommendations:

- 1) User can update his preferences and profile at the chosen time.
- 2) The updates are incorporated into the user profile.
- 3) User Profile data is pushed to the CRS.
- 4) BTV and CoD asset metadata is pushed to the CRS.
- 5) User consumptions of CoD or BTV content is pushed to the CRS.
- 6) User consumptions of BTV channels and optionally time on the channel is pushed to the CRS.

NOTE 1: Steps 3 to 6 are illustrated in the push mode. Alternatively, CRS can pull this information in the pull mode.



**Figure 24: Recommendation request and delivery**

#### Recommendations Request and Delivery

- 1) UE requests SD&S information from SD&S.
- 2) SD&S verifies user profile from IUDF/UPSF. The location of IUDF/UPSF and data model, e.g. centralized or federated is described in clause 9.
- 3) If service selection is included into CFIA then CFIA can optionally request CRS recommendation in addition to SD&S services according to the user profile.

- 4) CRS returns recommendations for multiple services according to user profile, e.g. recommendations for bTV, CoD.
- 5) Personalized service offers with recommendations are returned to the UE.
- 6) User navigates through IPTV services.
- 7) CFIA requests CRS recommendation for user selected service.
- 8) CRS returns recommendations for the selected service according to user profile.
- 9) Service options with personalized recommendations are delivered to the UE.

NOTE 2: The service delivery itself is not affected by the service recommendations.

## 11.10 Advertising

NGN Integrated IPTV Advertising (Ad) service supports the following procedures:

- 1) **Targeted ad insertion:** Ad content is provided to the UE during the IPTV CoD or bTV session based on the user profile (user preference, historic metadata, location information, presence state). The ad content is provided at the predefined time or place: e.g. during commercial breaks on BTv channels, during PAUSE in the trick mode or as pre-roll/post-roll for CoD asset.
- 2) **Interactive Advertising (push/pull):** Advertising content offered to the user (e.g. red button) and triggered by the UE selection. The UE may be able to interact with some content.
- 3) **Regionalized/localized Ad-insertion:** Ad content (local or regionalized) is inserted into the IPTV broadcast stream without targeting specific users or user groups. However, it may be targeted to regions or zones depending on network topology.

If targeted advertising is supported, the targeting could be towards individual users or specific user groups.

Targeted advertising may be based on multiple criteria, e.g. user profile, preference, presence information, watched content, shopping habits, location. Advertising can contain user actions, e.g. to allow user purchasing advertised content, services or take other actions.

### 11.10.1 Advertising procedures

Ad insertion implies that an IPTV session exists prior to the insertion time. The targeted ad is selected by the ADSS (Ad Selection Service).

The following ad insertion opportunities exist for multicast (e.g. bTV) and unicast (e.g. trick modes, CoD, nPVR, tsTV) based services.

Ad insertion opportunities for unicast based services:

- 1) Pre-roll (a placement opportunity preceding an entertainment asset).
- 2) Post-roll (a placement opportunity following the play out of an entertainment asset).
- 3) Interstitial (a placement opportunity occurring during the play out of an entertainment asset).
- 4) Pause (placement opportunity as a result of a subscriber pressing the pause button).
- 5) Overlay (overlay triggers, e.g. overlaid red button triggering interactive ads).

Ad insertion opportunities for multicast based services:

- 1) Ad breaks (placement opportunity typically indicated by in-band ad-insertion markers within IPTV content, which is allowed to be replaced by ads).
- 2) Overlay (overlay triggers, e.g. overlaid red button triggering interactive ads).
- 3) Interstitial (a placement opportunity occurring during the play out of an entertainment asset).

The ad insertion can be performed at either UE side or MF side:

- When UE performs ad insertion, it is informed or determines ad insertion opportunity, receives both IPTV content and ad content, and renders them in a sequential or simultaneous way.
- When MF performs ad insertion, it is informed or determines of ad insertion opportunity, retrieves ad content and delivers the combined stream to the UE.

The major steps of TAI are as follows:

- Placement opportunity detection.
- Ad content selections.
- Ad content delivery and presentation.

## 11.10.2 Network side unicast based advertisement

This clause defines network side advertisement procedures for pre-roll, post-roll and pause ad placement opportunities discussed in clause 11.10.1.

Figure 25 presents network side pre-roll and post roll advertisement procedure for unicast based services.

The procedure is applicable for the following services:

- Content on Demand.
- Network PVR.
- Time-shift TV.

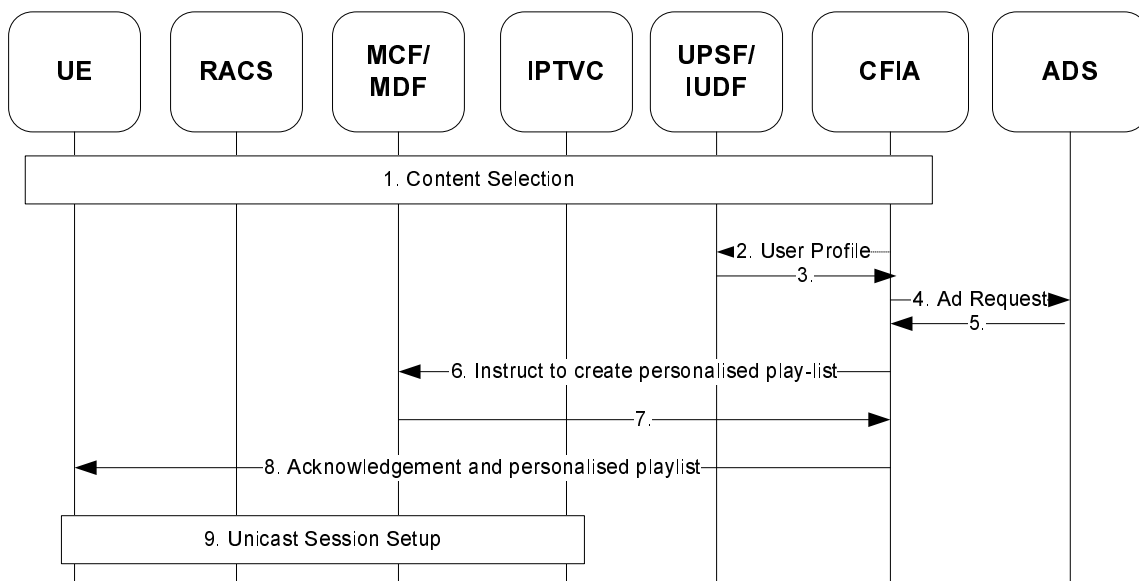

**Figure 25: Pre-roll and post-roll advertisement for unicast based services.**

- 1) User selected a content following SD&S procedure discussed in clause 6.3.
- 2) CFIA optionally requests current profile in order to request an ad.
- 3) UPSF/IUDF returns current profile.
- 4) CFIA requests personalized ads from ADS.
- 5) ADS returned content identifiers for personalized ads.

- 6) CFIA requests MCF(s) to create personalized play lists containing main selected content and ads. Optionally trick mode operations can be disabled for ads sat the time of play-list creation.
- 7) MCF confirms creation of the play-list.
- 8) CFIA returns name of the personalized play-list in the asset URL.
- 9) UE initiates unicast session setup. Normal procedure for corresponding service type (e.g. CoD, nPVR) applies.

Figure 26 presents advertisement "on pause" for unicast based services.

The procedure is applicable for the following services:

- Content on Demand.
- Network PVR.
- Time Shift TV.
- Trick Modes on Broadcast TV when the channel is delivered via unicast.

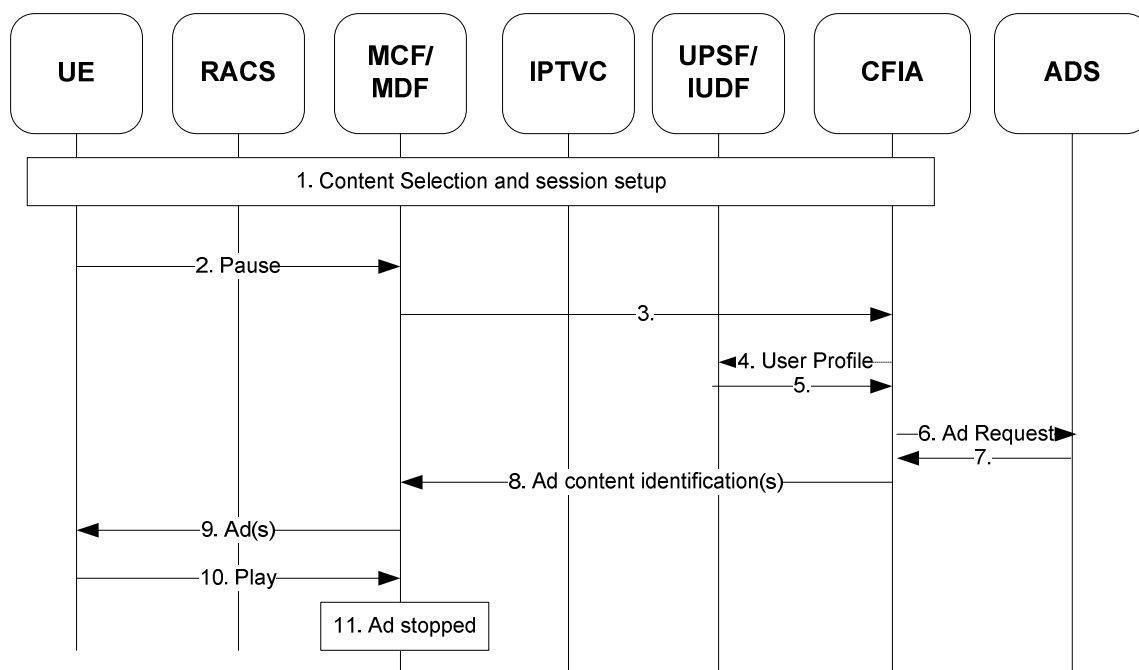

**Figure 26: "On pause" advertisement for unicast based services**

- 1) User selected a content following SD&S procedure discussed in clause 6.3 and starting interactive session.
- 2) User paused content session.
- 3) Pause triggers MCF to request personalized ad from CFIA.
- 4) CFIA optionally requests current user profile in order to request an ad.
- 5) UPSF/IUDF returns current profile.
- 6) CFIA requests personalized ads from ADS.
- 7) ADS returned content identifiers for personalized ads.
- 8) CFIA returns to MCF one or more ad identifiers.
- 9) MCF instructs MDF to play ads. Ads are being played.
- 10) User requests to continue content session.

- 11) Play request triggers MCF/MDF to stop playing ads.

### 11.10.3 Advertising procedures using notification

Same procedures as described in clause 11.9.1 may be applicable for delivering advertising to UE.

## 11.11 Procedures for inter-destination media synchronization

### 11.11.1 Mapping 1: SC in UE

Figure 24 provides an overview of the information flows for inter-destination content synchronization according to Mapping 1 from clause 5.3.1.1.2.

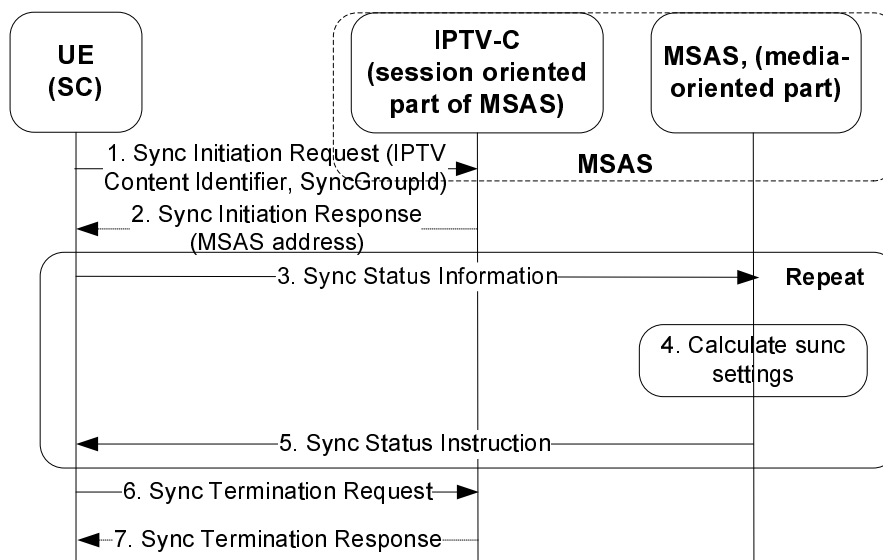

**Figure 27: Procedure for inter-destination content synchronization**

- 1) The UE (SC) sends a synchronization initiation request to the IPTV Control (MSAS), indicating that it wants to participate in the inter-destination synchronization process. The request includes the IPTV content identifier, identifying the to-be-synchronized content. The synchronization group identifier (SyncGroupId), in combination with the IPTV content identifier, identifies the group of UEs (SCs) that is synchronized as a group for the identified IPTV content.

NOTE 1: The ways that a UE can obtain a SyncGroupId are similar to obtaining a phone conference id. For example, one user can request a new SyncGroupId through an off-line process, and share it with other users through an offline process. If the group of users does already have a group identifier, e.g. a phone conference id, they may reuse this identifier.

- 2) The IPTV Control confirms its participation in the inter-destination synchronization process. The response also includes the address of the media-oriented part of the MSAS.
- 3) The UE (SC) sends its synchronization status information to the media-oriented part of the MSAS, using the address obtained in step (2).

NOTE: Direct intra-MSAS communication may be possible, but it is out of scope of the present document.

- 4) The media-oriented part of the MSAS aggregates synchronization status information from multiple UEs (SCs) and calculates the appropriate synchronization settings for each SC.

NOTE 2: Examples of algorithms to calculate the synchronization settings instructions from collected synchronization status information may be found in [i.1].

- 5) The media-oriented part of the MSAS sends a synchronization settings instruction to the UE (SC).



Steps 3) to 5) may be repeated at regular time intervals.

- 6) The UE sends a synchronization termination request, indicating that it is no longer active in the inter-destination synchronization process. This could be e.g. because of a channel change by the UE.
- 7) The IPTV Control confirms the termination of its participation in the inter-destination synchronization process.

NOTE 3: The UE can initiate and terminate multiple synchronization sessions within a broadcast session, both consecutive and simultaneous.

### 11.11.2 Mapping 2: SC in Transport

The procedures according to Mapping 2 from clause 5.3.1.1.2 are the same as above with the following changes:

- Tunnelling over the Ct2 reference point is not applicable.
- The MSAS is an elementary function of the IPTV Control or a stand-alone Application Server.
- The SC is an elementary function of the Transport Functions.
- The request in step (1) includes a media stream identifier.
- The SyncGroupId may be used to identify multiple synchronization groups, or it may be populated with the value "default".

NOTE 1: How the SC obtains the SyncGroupId is not described in the present document.

NOTE 2: If the MSAS serves SCs according to both Mapping 1 and Mapping 2 for a specific IPTV service, then the MSAS has to correlate the IPTV content identifier in Mapping 1, with the appropriate media stream identifier in Mapping 2.

## 11.12 Service continuation

This clause discusses procedures for service continuation.

### 11.12.1 Procedure for unicast service continuation between NGN IPTV UEs

Figures 28 and 29 present procedure for unicast based service continuation between NGN IPTV UEs.

The procedure is applicable for the following services:

- Trick modes on broadcast TV.
- Content on Demand.
- Time-shift TV.
- Network PVR.

Service continuation contains two stages - pause and restart.

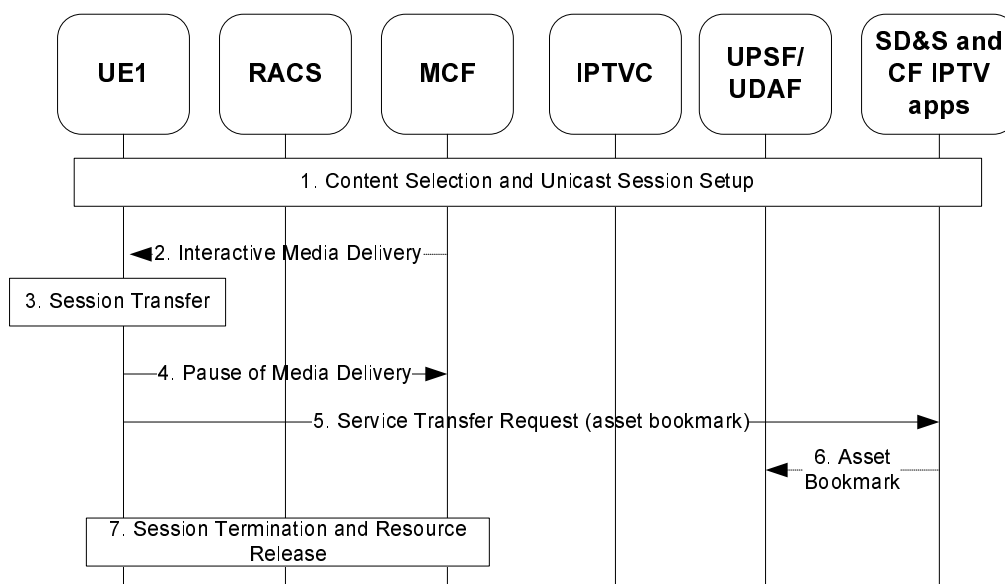
**Service Pause Procedure:****Figure 28: Unicast based service pause**

- 1) Content Selection and Unicast Session Setup. Normal procedure for corresponding service type (e.g. CoD, nPVR) applies.
- 2) Interactive media delivery.
- 3) Session transfer decision.
- 4) UE optionally puts video session on hold.
- 5) UE requests CFIA to put the service on hold passing asset bookmark containing current play time.
- 6) CFIA attached asset bookmark to the service profile for later restart.
- 7) Session is terminated between UE and MF. Normal session termination procedure for corresponding service type (e.g. CoD, nPVR) applies.

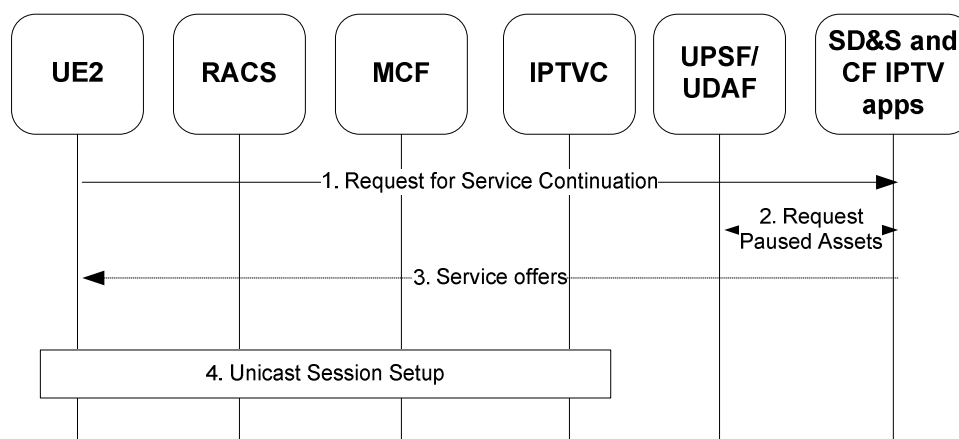
**Service Restart Procedure:****Figure 29: Unicast based service restart**

- 1) UE requests CFIA to restart service (e.g. CoD, nPVR, tsTV session).
- 2) CFIA requests user profile for the available paused assets.
- 3) CFIA returns assets available for restart, asset URLs and bookmarks UE.

- 4) UE initiates unicast session setup. Normal procedure for corresponding service type (e.g. CoD, nPVR) applies, Content delivery is requested from the paused position.

### 11.12.2 Service continuation between fixed NGN between fixed NGN Integrated IPTV UE and 3GPP mobile UE

Figure 30 presents procedure for session continuation between fixed NGN IPTV UE and 3GPP PSS based Streaming Service.

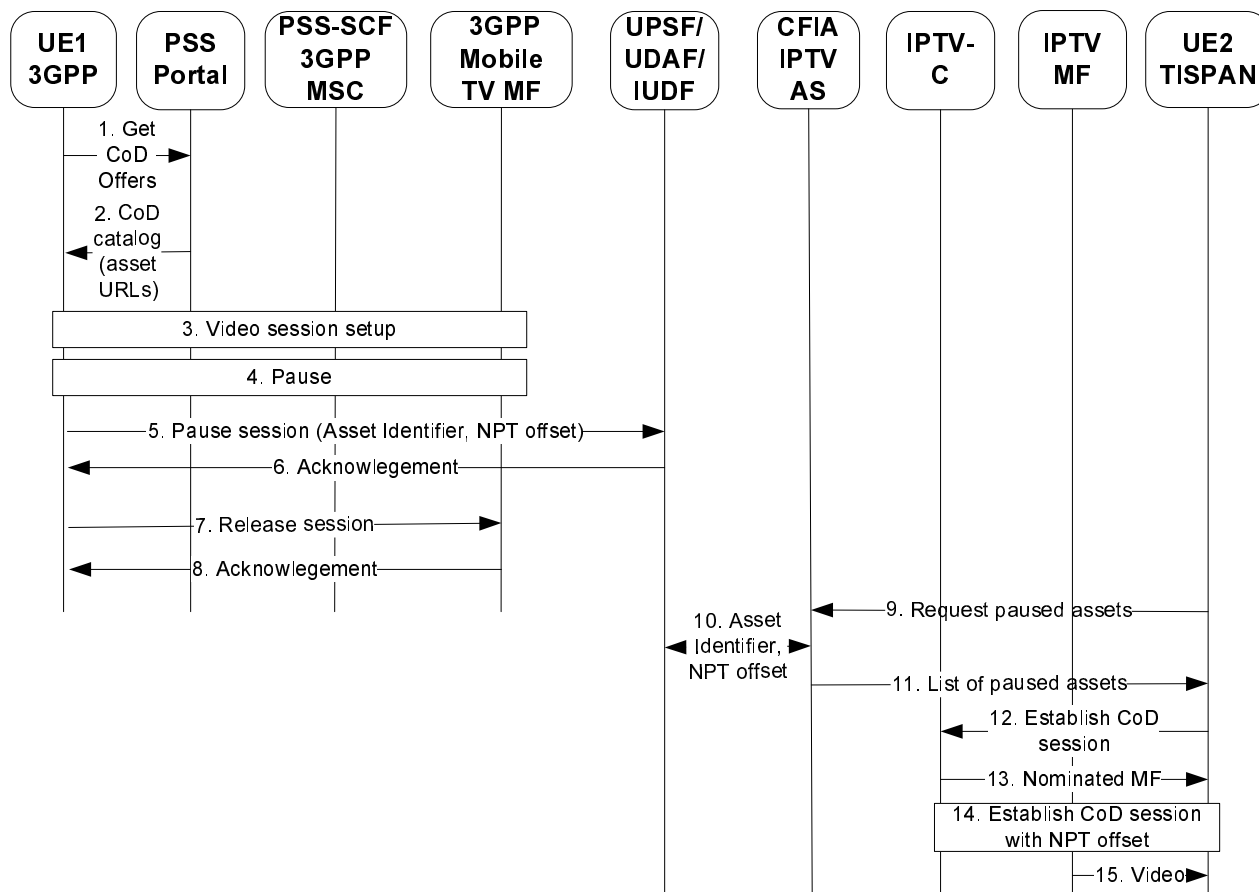

NOTE: PSS - Packet-switched Streaming Service.

**Figure 30: Procedure for session continuation between TISPAN NGN Integrated IPTV UE and IMS based 3GPP mobile UE**

#### Session Pause:

- 1) 3GPP UE1 requests CoD offers.
- 2) CoD offers are returned to the UE1.
- 3) UE1 sets up video delivery session.
- 4) User decides to restart the video later.
- 5) UE requests to pause session to be restarted later. 3GPP PSS-SCF passes asset identifier and NPT time offset to be included into the user profile.
- 6) Session pause is confirmed to the UE.
- 7) The UE1 releases CoD session.
- 8) Session release confirmed to the UE1.

**Session restart:**

- 1) IPTV UE2 requests PAUSED assets from CFIA.
- 2) CFIA requests the assets from the user profile.
- 3) CFIA passes list of paused assets to the UE2.
- 4) UE2 selects the asset and requests IPTVC to establish a video session.
- 5) IPTVC selected MF and informs the UE2.
- 6) UE2 requests selected MF to start video delivery from the pause position.
- 7) Video is delivered using CoD session.

## 11.13 Remote control of IPTV services

### 11.13.1 Procedure for Remote Mobile Control of IPTV (Provisioning)

Figure 31A presents procedures for provisioning aspects for remote control of NGN IPTV services.

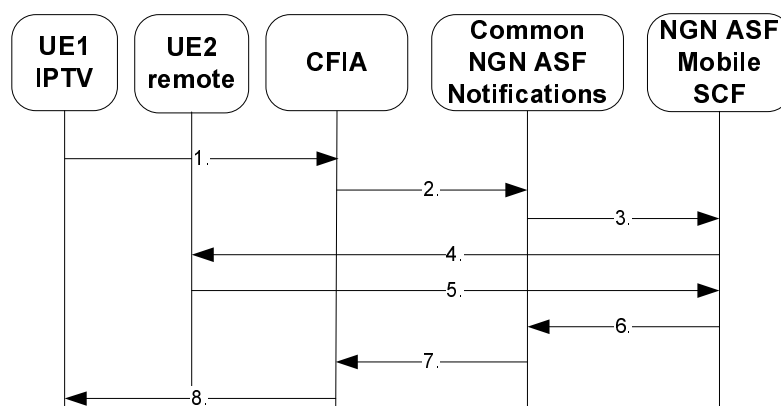

**Figure 31A: Binding mobile terminal to IPTV account**

**Device binding:**

- 1) UE (user) requests to bind new mobile device to IPTV account through CFIA.
- 2) The CFIA notifies common NGN notifications about binding.
- 3) Common NGN ASF (Notifications) asks to the Mobile Service Control Function to acknowledge the binding.
- 4) The Mobile SCF sends an SMS requesting confirmation from the mobile device being bound.
- 5) The remote UE (e.g. mobile) confirms binding.
- 6) The Mobile SCF acknowledges to the Common NGN ASF (Notifications).
- 7) The Common NGN ASF (Notifications) registers the binding internally, and acknowledges to the CFIA.
- 8) End user receives confirmation to IPTV UE.

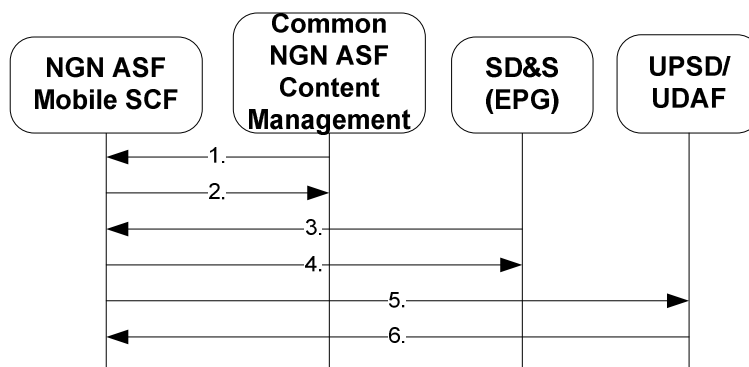

**Figure 31B: Acquisition of content profiles**

#### Acquisition of content profiles:

- 1 and 2) The CMS updates the external NGN ASF Mobile SCF about CoD Catalogue (e.g. via push operation).
- 3 and 4) The SD&S updates the external NGN ASF Mobile SCF about EPG (e.g. via push operation).
- 5 and 6) The NGN ASF Mobile SCF requests updates about PPV offerings available to the UPSF (e.g. via a pull operation).

### 11.13.2 Procedure for Remote Mobile Control of IPTV (Operations)

Figure 32A presents operational aspects for remote control of NGN IPTV services.

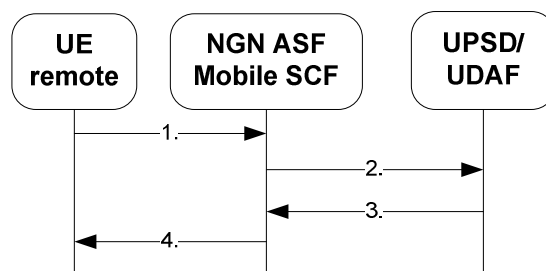

**Figure 32A: IPTV Content Purchase from remote UE**

#### Content purchase:

- 1) Remote UE, e.g. mobile UE, selects content and requests purchase.
- 2) If the content is IPTV content, purchased content is reflected in the IPTV user profile. The content purchased is available immediately, after the profile update, for playback on the IPTV UE.
- 3) IPTV profile update is acknowledged to the Mobile SCF.
- 4) Mobile SCF acknowledges successful content purchase to the remote UE.

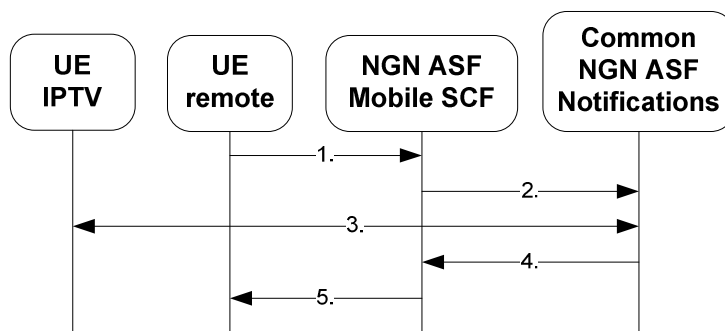

Figure 32B: cPVR management from remote UE

#### Mobile cPVR management:

- 1) Mobile UE schedules a recording on the remote IPTV UE.
- 2) The request is passed by Mobile SCF to common NGN ASF (Notifications).
- 3) The Common NGN ASF (Notifications) targets the appropriate IPTV UE and sends the recording notification. The IPTV UE schedules recording operation and reports back to the notification service the acknowledgement. In this case, the recording operation will be performed onto the IPTV UE local storage.
- 4) The acknowledgement is reported back to Mobile SCF.
- 5) Mobile SCF acknowledges recording schedule.

## 11.14 Personalized Channel

Personalized Channel (PCh) service allows user to define and watch one or multiple pre-configured/scheduled content items as a single (virtual) channel. Personalized Channel information is stored in the user service profile (PCh information).

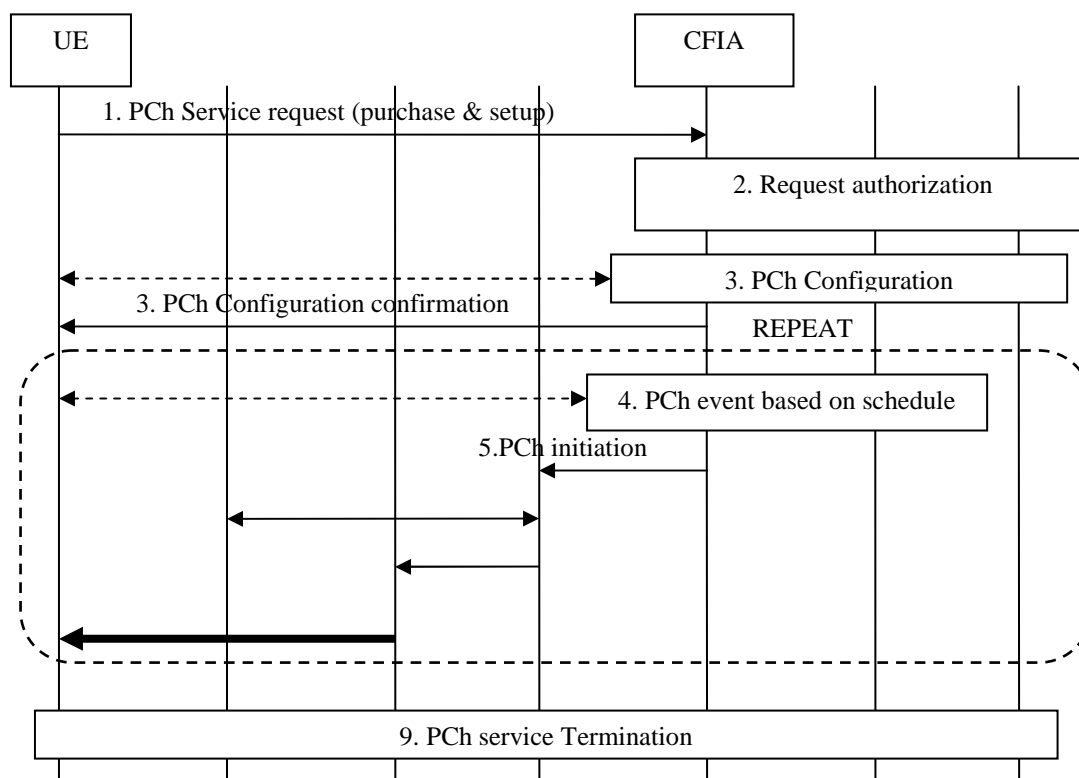

Figure 33: Overview of PCh service procedures

- 1) User selects and purchases content for PCh, e.g. from the offers provided by SD&S. UE requests Customer Facing IPTV Applications to setup PCh service.
- 2) CFIA checks service access authorization with UPSF/IUDF.
- 3) User defines and configures personalized channel with one or more content items discovered via SD&S, e.g. define name for the channel, items on the channel, order, time when each item should be played. Channel definition is confirmed to the UE.
- 4) Optionally, PCh event (e.g. start of the channel or playout of the new scheduled content item) may trigger CFIA notification to the UE, e.g. via notification.
- 5) CFIA initiates PCh service towards IPTV-C based on service logic, PCh schedule and user availability to watch personalized channel.
- 6) IPTV-C reserves required resources.
- 7) IPTV-C notifies MCF to start delivery of the personalized content from MDF.
- 8) MDF delivers the content to UE on Xd interface.

NOTE: Content could be controlled as for any CoD service via Xc reference point.

- 9) PCh can be terminated either by MCF or UE. MCF may terminate PCh when all the content on the channel has been delivered to the UE, or when the channel or user subscription has expired.

## 11.15 Time Shift TV

The Time Shift TV (tsTV) service allows user to view a programme content that has already been broadcasted. In order to enable tsTV IPTV SP needs to record a programme/content in the MDF. IPTV SP may limit BC content available for tsTV.

Timeshift TV service is similar to nPVR. However, it is not necessary for the user (e.g. IPTV UE) to indicate in advance content be recorded. tsTV content is automatically recorded by the MDF.

Timeshift TV may have expiration time for tsTV assets. The expiration time is typically different between tsTV and nPVR assets (tsTV expiration being commonly shorter, e.g. days weeks vs. months to nPVR).

During tsTV service, if a program has not been finished, the UE may catch up with the live broadcasted programme (similar to Media broadcast with trick modes discussed in clause 11.3).

In order to provide time-shift TV service, MDF records allowed TV programs available on the selected broadcast channels. The Time shifted TV programs is later selected by UE from EPG (BCG) via SD&S as discussed in clause 6.3.2. The user selects time shift content from the information provided by the SD&S similarly to other CoD content. Consequently, initiation and termination of time-shift service should follow CoD procedures described in clause 11.2.

## 11.16 PVR service

This clause describes PVR service. In order to provide PVR service, the UE initially selects content from SD&S (EPG/BCG) and requests recording via customer facing IPTV application. Content is recorded in the MDF for nPVR or directly in the UE for cPVR.

NOTE: A specific type of cPVR service can be identified - local PVR. The difference between client PVR and local PVR is the use of IPTV service control functions for recording management, e.g. IPTV CFIA may send notifications regarding the recording of specific content to UE, which then acts upon it for cPVR. Optionally network resources can be allocated following specified procedures, e.g. for broadcast TV.

For the local PVR the recording is controlled by the UE independently of IPTV service control functions. The UE manages recording based on local or external EPG information.

After the recording has been initiated, UE may request either from CFIA (or from local storage) a list of scheduled and recorded content.

nPVR can support both coupled and decoupled mode.

In the coupled mode, client is allocated precise disk quota on a selected MDF. The MCF associated with the MDF is always selected for interactive control over nPVR services.

In decoupled mode of nPVR service, statistical optimizations are possible, e.g. only one or small number of content copies may be created and users are redirected to the nearest copies via Ct2 interface.

The nPVR service initiation or content delivery's procedures shall comply with CoD or time-shift TV procedures defined in clause 11.2.

An MDF can only provides to the UE recordings of nPVR programs available (scheduled and recorded) from the same MDF.

## 11.17 Emergency alert

As discussed in the service level requirements [1], the IPTV architecture shall enable delivery of emergency alert notifications based on different aspects, e.g. type of emergency situation, priority, and locality. IPTV integrated subsystems may also required secure mechanisms to acquire, verify and inject alert content, e.g. alert message or emergency live transmission, after verification of the source.

The emergency alerts shall immediately and with minimum delay be delivered to the UE. An interruption of active content may be required:

- There are three basic procedures for delivering emergency alert to UE: Using dedicated broadcast channel for emergency alert delivery. The UE shall receive the emergency channel for the duration and in parallel to other IPTV service. The delivery mechanism shall comply with linear TV procedure described in Clause 11.1. The notification message format shall comply with the notification schema defined in clause A.4 [14].
- Using notification procedure for message delivery with delivery confirmation. The notification shall follow procedure defined in clause 11.8.2. The notification message format shall comply with the notification schema defined in clause A.4 [14].
- Using advertising procedure for stream insertion or replacement of currently watched content. The procedure for including emergency content shall follow generic advertisement procedure defined in clause 11.10 for delivery live emergency transmission.

NOTE: Emergency alert capability can be subject to local or regional regulation.

## 11.18 Content Bookmark

An IPTV Content Bookmark service consists of two main steps:

- creation of IPTV Content Bookmark: allows a user to create and store configurable pointers to content, e.g. entire or parts of content (favourite scene) to be able to quickly access the content
- retrieving of IPTV Content Bookmark: allows to exchange and share IPTV favourite data.

Figure 33 provides an overview of IPTV Content Bookmark creation and retrieval. This procedure is applicable at any time during IPTV session (e.g. during BC, CoD, nPVR session) or at the SD&S stage (e.g. EPG browsing).



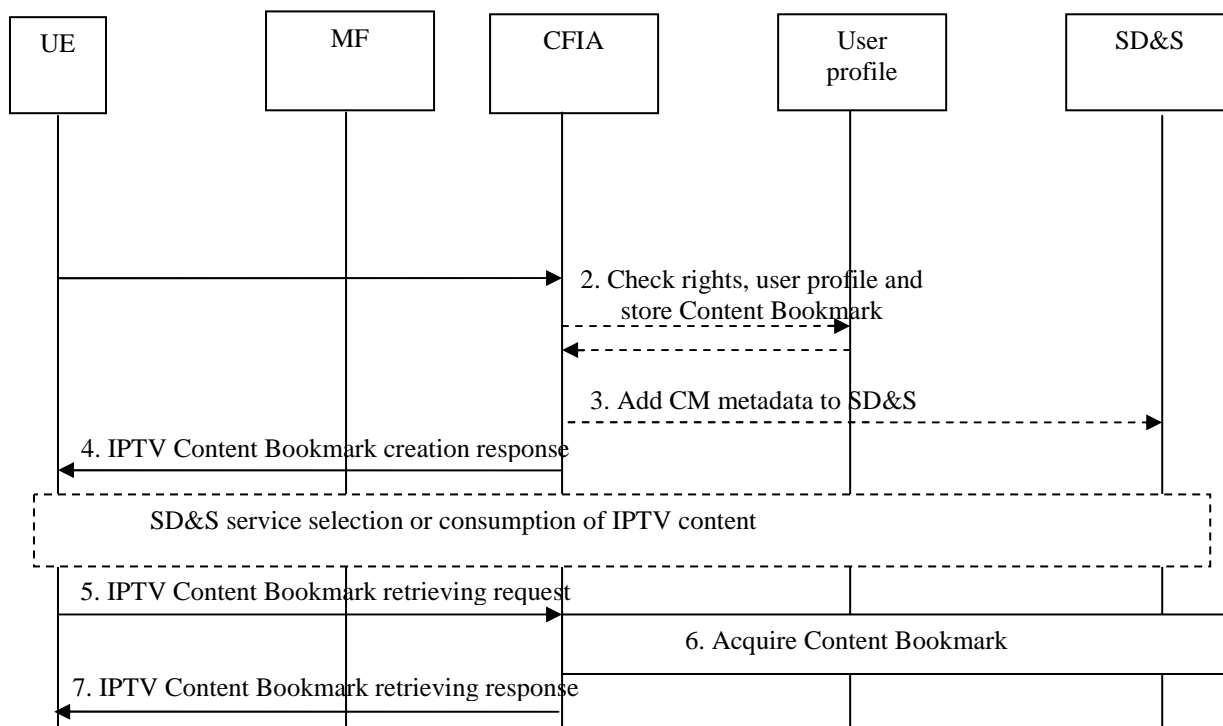

**Figure 34: Creation, storage and retrieval of IPTV Content Bookmark**

- 1) The UE requests CFIA to create Content Bookmark and optionally supplies additional data (e.g. description). The bookmark data may include content information.
- 2) The CFIA may check user profile prior to creating content bookmark. CFIA creates bookmark and generates a unique content bookmark ID. Content Bookmark may be stored in user profile.
- 3) The CFIA may inform SD&S about the Content Bookmark creation and update SD&S metadata.
- 4) The CFIA confirms creation and successful storage of Content Bookmark data.
- 5) The UE sends to CFIA request for retrieval Content Bookmark.
- 6) The CFIA requests Content Bookmark and generate response including content identification, pointer to the bookmarked position, additional metadata. The information should be sufficient to initiate content delivery from the bookmarked position.
- 7) The CFIA send content bookmark to UE.

## 11.19 Interactive TV procedures

Personalized interactive IPTV services and interworking with external ASFs (as discussed in annex A), e.g. with external application, is supported via:

- 1) Common NGN ASF, for interactions between IPTV and:
  - other NGN services as defined in [1];
  - other TISpan service level subsystems, e.g. IMS;
  - other non TISpan services, such as Internet.
- 2) OSA/Parlay/Parlay X SCS, for interactions between IPTV and Parlay services.

Any defined IPTV service may be part of interactive personalized TV service (e.g. in combination with presence, messaging). Interactive TV service may be a combination of existing TV service and external application. High level procedure, which is applicable to:

- Interactive TV (e.g. interactive advertising, shows).
- Games.
- Pictures.
- Educational services (quiz, tests).
- Voting.
- TV shopping.
- Chatting.
- Maps.
- Community and Social network services.
- Internet widgets (e.g. via RSS feed for informational portals with weather, news, horoscopes, stock information, etc.)

is presented in figure 35.

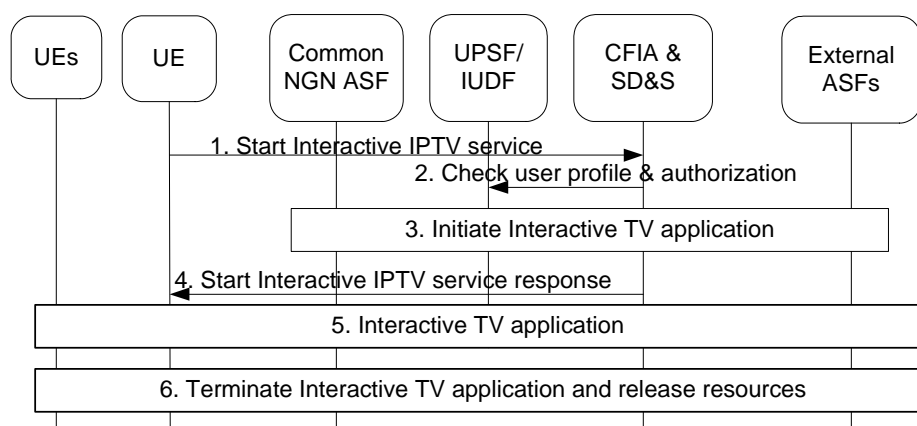

**Figure 35: Personalized Interactive TV applications**

- 1) UE discovers interactive IPTV application via SD&S and request service initiation from CFIA.
- 2) CFIA optionally checks user profile, requests authorization and information for service personalization.
- 3) CFIA requests Common NGN ASF to setup interactions with external ASFs, if external ASFs are used.
- 4) CFIA replies to the UE optionally attaching information for initiating and using interactive TV service.
- 5) UE initiates personalized interactive IPTV service, e.g. interacting with application or with other users.
- 6) UE requests termination of Interactive IPTV application. CFIA releases all resources allocated for the interactive TV applications.

## Annex A (informative): Interactions between other TISPAN services and IPTV services

This approach assumes that service interaction are based on a dedicated Application Server Function (called common ASF) that may explicitly implement the blended service functionality (e.g. pausing the TV on incoming call, e-mail notifications, incoming call notifications). Such an ASF can be seen as an NGN Application with respect to the TISPAN IPTV architecture. As shown on figure A.1.

Common NGN ASF provides interactions between IPTV:

- other NGN services as defined in [1];
- other non TISPAN services, such as Internet;
- with other TISPAN service level subsystems, e.g. between IPTV and IMS.

A common ASF can be used for delivering customized notifications from multiple service domains (notification sources), e.g. IMS-IM, IMS call alert, emergency notification, SMS message, e-mail alert, RSS feed, other to IPTV UE. The notifications could be delivered to the UE based on user profile, location, presence and may require response from the UE as shown on figure A.1.

A common ASF can be used for presence, e.g. presence server as discussed in annex C.

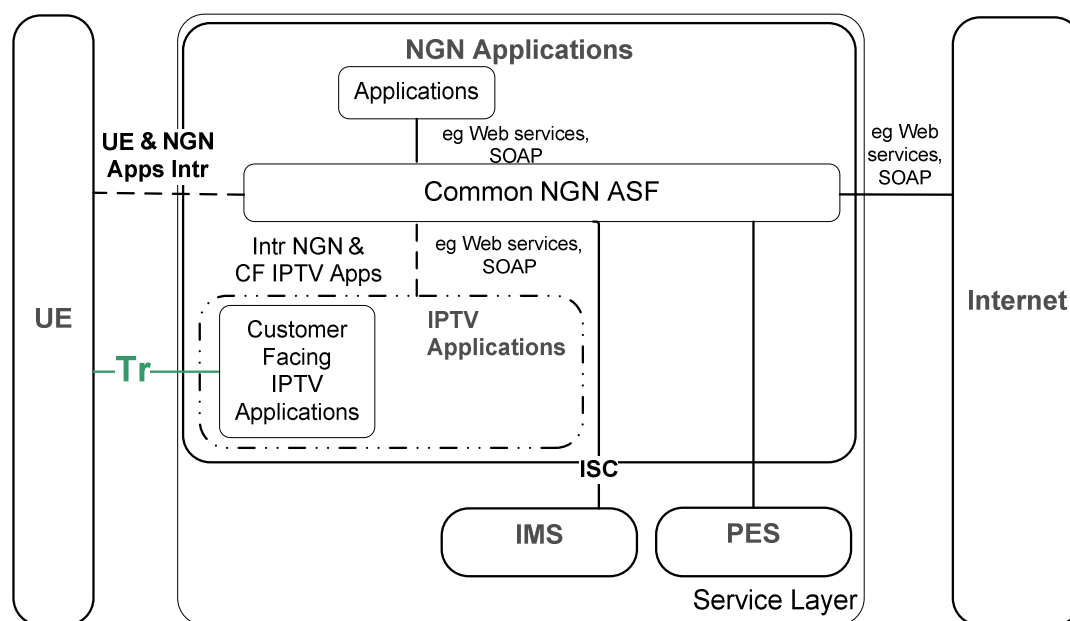

**Figure A.1: Interactions between IPTV and other NGN applications and services**

NOTE: Such interactions are based upon existing interfaces.

### A.1 Interactions based on an OSA/Parlay/Parlay X SCS

This approach is based on an OSA/Parlay/Parlay X Service Capability Server (SCS), that provisions standardized interfaces and APIs to external and third party application servers. The use of such an SCS is described in ES 204 915 [i.2] and ES 202 504 [i.3].

The OSA SCS acts as a secure gateway between the underlying network and the application with the OSA architecture, e.g. it is responsible for providing specific service abilities to third party applications. An SCS further serves to make an abstraction of the functionality offered by the network, in effect offering the service capability features of the underlying network to the third party applications.

Figure A.2 shows a simplified version of NGN integrated IPTV architecture, with interfaces to an SCS and subsequent external applications.

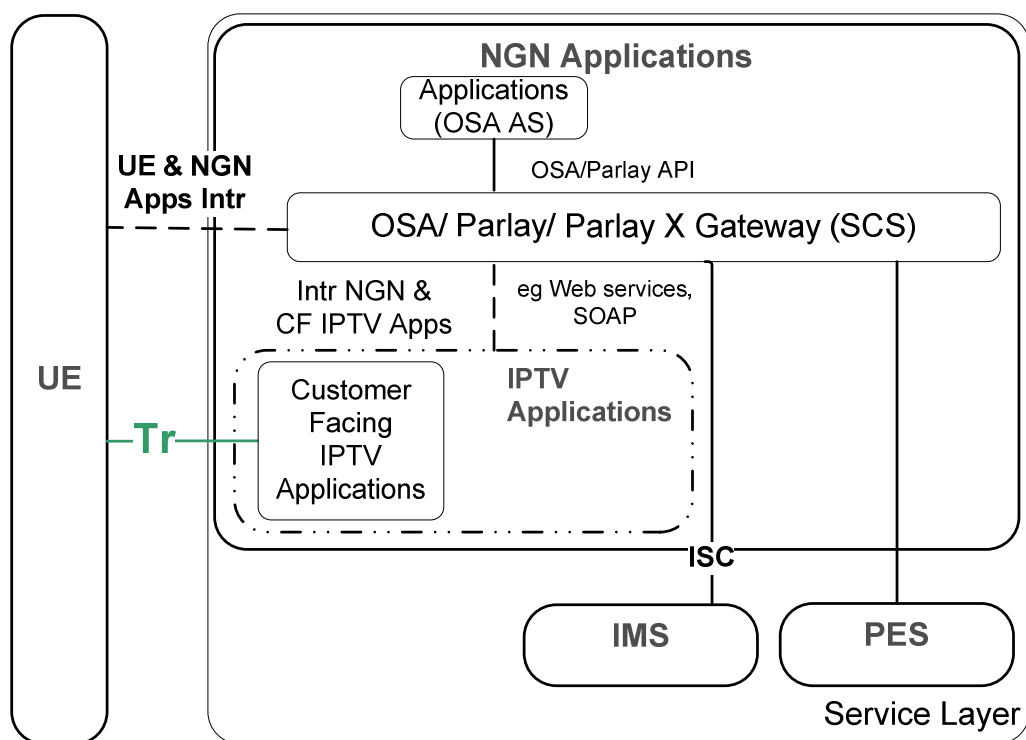

Figure A.2: Interaction between TISPAN Integrated IPTV and an OSA/Parlay/Parlay X SCS

## Annex B (informative): Interaction procedure between IPTV and other service level subsystems

This clause provides interaction procedure between IPTV and other service level subsystems, e.g. IMS, for composite services. The flow assumes that users are registered in IMS subsystem.

The procedure describes multimedia and communication features in converged NGN IPTV applications: caller ID on the TV screen User 1 calls User 2 and both are in IMS domain. User 2 is subscribed to a converged IPTV service - caller ID notification with options to accept, forward or reject incoming call when another IPTV service is active via the IPTV UE.

The clause presents generic functional steps and does not mandate placement of functions. DRM functions are not included.

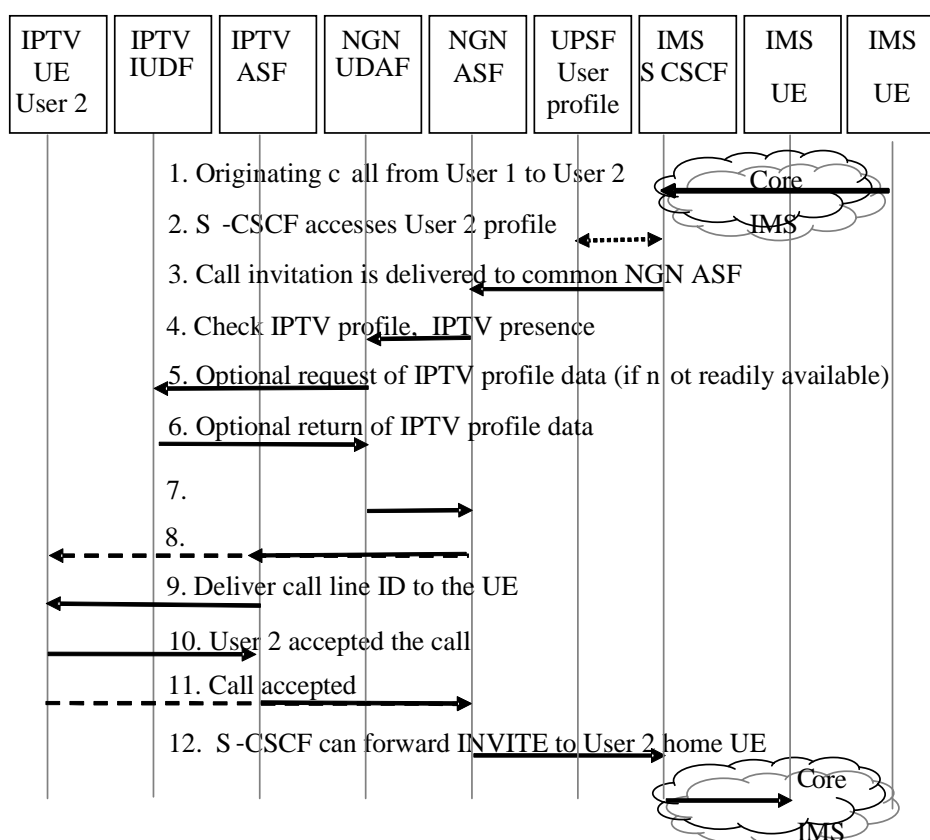

**Figure B.1: High level interactions procedure between IPTV and other service level subsystems - IMS/IPTV inter-working**

- 1) User 1 initiates a call to user 2 from his IMS device UE1. After traversing through the IMS CSCF chain invitation (e.g. SIP INVITE) is delivered to the S-CSCF for User 2.
- 2) S-CSCF access user profile data. Dotted arrows indicate that IMS user profile has been requested from UPSF.
- 3) S-CSCF, based upon IMS user profile, sends the invitation on ISC interface to common NGN ASF-. The NGN ASF is an Application Server Function. Optimizations are possible, e.g. a timer in S-CSCF can automatically deliver call upon no response.
- 4) NGN ASF checks IPTV user profile:
  - a) either by requesting IPTV sub-profile of federalized user profile from NGN IUDF;
  - b) or directly from IPTV subsystem from IUDF.

- 5) NGN IUDF optionally request IUDF for IPTV profile.
- 6) IUDF returns requested information.
- 7) IPTV user profile information is returned to NGN ASF.
- 8) NGN ASF, based on IPTV user profile and presence, delivers incoming call notification either to the IPTV ASF (Customer facing IPTV application) or directly to the IPTV UE. In the first case steps 9) and 10) are optional. Common NGN ASF and other ASF can be located separately, co-located or can be deployed as application package. They are shown separately to cover generic case.
- 9) IPTV ASF invokes IPTV application to show call line ID to IPTV UE2.
- 10) User 2 from IPTV UE chooses to answer the call on IMS UE.
- 11) IPTV ASF (or IPTV UE) notifies NGN ASF that the call setup can be continued.
- 12) NGN ASF returns invitation to S-CSCF to be delivered to User 2 IMS home device.
- 13) S-CSCF delivers invitation to User 2 IMS home device.

---

## Annex C (informative): Presence attributes for IPTV

IPTV services may be combined with the presence service capability.

The following specific IPTV attributes are supported:

- Broadcast TV with or without trick modes service activated.
- CoD service activated.
- PVR service activated.
- Near CoD (nCoD).
- Interactive TV service activated.

The following specific IPTV attributes may also be supported:

- Service currently accessed.
- Content currently accessed.
- Presence filtering for buddy list members.
- Buddy list management.

It is up to user's decision to include specific IPTV attributes in Presence document.

Service level requirements [1] require that IPTV solution should be able to access and provide presence information. It is outside the current release to evaluate whether there is sufficient access to the presence service (i.e. the attribute described) for integrated IPTV subsystem.

## Annex D (informative): Possible evolution path for NGN Integrated IPTV

This annex considers possible migration scenarios from existing solutions (i.e. DVB-IPI, ATIS-IIF) or between NGN based IPTV architectures.

### D.1 Evolution of IPTV architectures towards NGN

For evolution considerations, each evolutionary step provides additional functionality and features for additional values IPTV services. For example, it could be the Quality of Experience (QoE) for the end users, convergence TV with other telecommunications features and interactive multimedia services. An efficient introduction of new services and reduction of the operating costs may be another important motivation to evolve the IPTV systems (as shown in figure D.1).

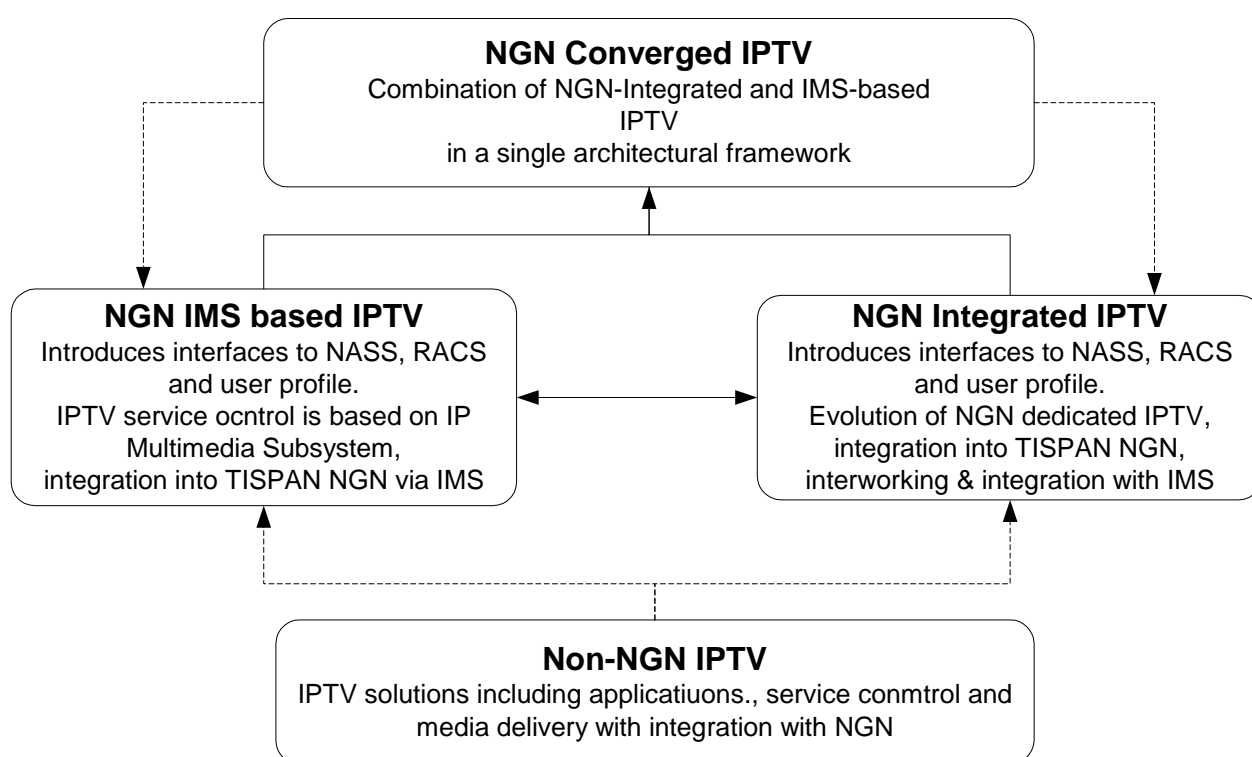

**Figure D.1: The potential IPTV evolution paths for NGN based IPTV architectures**

In comparison with proprietary Non-NGN IPTV solutions, NGN integrated IPTV can provide standardized IPTV services and features with standardized IPTV control and media delivery functions.

NGN based IPTV in both cases enables the integration with User Profile Server Function (UPSF), Network Attachment Subsystem (NASS), Resource and Admission Control Subsystem (RACS) to realize personalized value-added IPTV features and to use network resources more efficiently.

Evolution towards NGN IMS based IPTV is based on the observation that IMS may be used as a unified service control platform for some of the NGN services, consequently it can be used for IPTV control.

NGN based IPTV can either be based on IMS (IMS based IPTV) or interwork with IMS (NGN integrated IPTV).

However, we cannot expect that all NGN services in the future will be only IMS based. Therefore convergence, combination or interaction of IMS with IPTV features can lead to NGN converged IPTV, which can be foreseen in the future as common architecture framework (NGN converged IPTV) for coexistence between NGN Integrated IPTV, IMS based IPTV and new NGN services and subsystems.



## D.2 Possible migration and switch over scenarios

This informative annex discusses migration scenarios from and to NGN integrated IPTV.

**Table D.1: Migration and switch over scenarios**

<b>Evolution step</b>	<b>UE</b>	<b>Transport</b>	<b>MC&amp;DF</b>	<b>Service control</b>	<b>Application</b>
<b>Non-NGN</b>	STB	Content delivery network		IPTV middleware	
<b>TISPAN NGN integrated IPTV</b>	UE	Transport processing, NASS & RACS	MCF & MDF	IPTV-C/AS Interaction with IMS and other NGN subsystems	CFIA, SD&S
<b>TISPAN IMS based IPTV</b>	UE	Transport processing, NASS & RACS	MCF & MDF	IMS	SCF, SSF, SDF
<b>NGN Converged IPTV architecture</b>	UE	Transport processing, NASS & RACS	MCF & MDF	This part is for future study in TISPAN NGN IPTV architectures	

---

## Annex E (informative): Mapping of elementary functions

### E.1 Mapping between elementary functions and generic capabilities

Table E.1 presents mapping between elementary functions identified in clause 5.4 and generic capabilities identified in clause 5.3.

Table E.1: Mapping between elementary functions and generic capabilities

	Elementary function	Discovery & selection	Service control	Service interact	Media control	Deliver media	Content protection	Service Protection	Content mng. & distribution	Service interaction
1	network attachment		X							
2	registration		X							
3	resource management		X							
4	charging information		X							
5	service discovery	X								
6	service authorization		X	X				X		
7	service selection	X						X		X
8	service initiation		X	X				X		
9	service control		X	X				X		X
10	service information handling	X	X	X						X
11	service configuration		X							
12	session initiation		X	X				X		
13	session modification		X	X				X		
14	session termination		X	X				X		
15	multicast based media delivery					X				
16	unicast based media delivery					X				
17	content download/upload					X				
18	control of multicast streaming		X		X					
19	control of unicast streaming			X	X					
20	control of download/ upload									
21	content ingestion/receiving					X			X	
22	content recording				X					
23	content storage				X					
24	content adaptation					X				
25	content acquisition								X	
26	content validation								X	
27	content distribution								X	
28	content licensing						X			
29	key management						X	X		
30	content encryption						X			
31	user profile/data mng.									X
32	accounting/right control		X							X
33	status/state (changes) detection/reporting		X	X		X				X
34	common notification		X	X						X
35	messaging			X						X
36	presence			X						X
37	inter-destination media synchronization			X		X				X
38	Media and data confidentiality/Integrity							X		

## E.2 Mapping between elementary functions and functional entities

Table E.2 presents mapping between elementary functions identified in clause 5.4 and functional entities identified in clause 5.2.

**Table E.2. Mapping of elementary functions to functional entities**

	Elementary function	UE	SD&S	CFIA	IPTV-C	IUDF	UPSF	MCF	MDF
1	network attachment	X							
2	registration	X			X	X			
3	resource management				X			X	
4	charging information				X				X
5	service discovery		X						
6	service authorization				X				
7	service selection	X	X						
8	service initiation	X		X					
9	service control	X			X			X	
10	service information handling	X	X						
11	service configuration	X		X					
12	session initiation								
13	session modification								
14	session termination								
15	multicast based media delivery								X
16	unicast based media delivery	X							X
17	content download/ upload	X							X
18	control of multicast streaming	X						X	
19	control of unicast streaming	X						X	
20	control of download/ upload	X						X	
21	content ingestion/receiving	X							X
22	content recording	X							X
23	content storage	X							X
24	content adaptation								X
25	content acquisition								
26	content validation								
27	content distribution								
28	content licensing								
29	key management								
30	content encryption								X
31	user profile/data mng.	X				X	X		
32	accounting/right control				X	X	X		
33	status/state (changes) detection/reporting	X		X	X			X	X
34	common notification	X		X					
35	messaging	X		X					
36	presence	X		X					
37	inter-destination media synchronization	X		X					

## E.3 Mapping between elementary functions and IPTV services

Table E.3 presents mapping between elementary functions identified in clause 5.4 and IPTV services as defined in [1].

**Table E.3: Mapping between elementary functions and IPTV services [1].**

	Elementary function	BC	CoD	nPVR	cPVR	BCwTP	UGC	Push CoD	Adv	CRS	Notif	Msg	Presence
1	network attachment	x	x	x	x	x	x	x	x	x	x	x	x
2	registration	x	x	x	x	x	x	x	x	x	x	x	x
3	resource management	x	x	x		x	x	x	x				
4	charging information	x	x				x	x				x	
5	service discovery	x		x			x						
6	service authorization	x	x	x	x	x	x	x	x	x	x	x	x
7	service selection	x		x	x	x	x	x					
8	service initiation	x	x	x	x	x	x	x	x	x	x	x	x
9	service control	x	x	x	x	x	x	x	x	x	x	x	x
10	service information handling						x			x			
11	service configuration	x	x	x	x	x	x	x	x	x	x	x	x
12	session initiation	x	x	x				x					
13	session modification	x	x	x		x	x	x					
14	session termination	x	x	x	x	x	x	x	x	x			
15	multicast based media delivery	x				x			x		x		
16	unicast based media delivery		x	x		x	x		x		x		
17	content download/ upload						x	x	x				
18	control of multicast streaming	x	x	x	x	x	x	x					
19	control of unicast streaming	x	x	x	x	x	x	x					
20	control of download/ upload	x	x	x	x	x	x	x					
21	content ingestion/receiving	x	x	x	x	x	x	x					
22	content recording			x	x	x							
23	content storage		x	x	x		x		x				
24	content adaptation	x	x						x				
25	content acquisition	x	x			x	x	x	x				
26	content validation	x	x			x	x	x					
27	content distribution	x	x			x	x	x	x				
28	content licensing	x	x			x	x	x					
29	key management	x	x			x	x	x					
30	content encryption	x	x			x	x	x					
31	user profile/data mng.								x	x			x
32	accounting/right control	x	x	x	x	x	x	x			x	x	
33	status/state (changes)		x	x		x	x	x	x	x	x		x

	Elementary function	BC	CoD	nPVR	cPVR	BCwTP	UGC	Push CoD	Adv	CRS	Notif	Msg	Presence
	detection/reporting												
34	common notification								x	x	x		
35	messaging									x		x	
36	presence									x			x
37	inter-destination media synchronization	x	x			x	x		x				

## Annex F (informative): NGN integrated IPTV mapping to other IPTV architectures

NGN Integrated IPTV subsystem architecture supports IPTV service level requirements defined in [1] and provides integration of new or existing IPTV solutions (such as those defined by DVB, ATIS IIF, ITU etc) into the TISPAN NGN architecture.

This annex describes mapping of other IPTV architectures to NGN Integrated IPTV architecture.

### F.1 Mapping between NGN integrated IPTV subsystem and ITU-T non-IMS IPTV architecture

Comparing ITU-T IPTV architecture [i.10] with ETSI TISPAN NGN integrated IPTV (the present document) the following mapping of functional entities can be identified:

**Table F.1: Mapping between ITU-T non-IMS IPTV functions and TISPAN NGN Integrated IPTV functional entities**

ITU-T non-IMS NGN IPTV	[i.10]	TISPAN NGN Integrated IPTV
IPTV Application Functions	9.2.1	Customer Facing IPTV Application FE (CFIA), Service Discovery and Selection (SD&S)* (in part)
IPTV Service Control Functional Block	9.3.1	IPTV Control (IPTV-C)
Service User Profile Functional Block	9.3.2	User Data Function (UPSF)
Content Distribution & Location Control Functions	9.4.1	Media Control Function (MCF)
Content Delivery & Storage Functions	9.4.2	Media Delivery Function (MDF)
Content Preparation Functions	9.2.3	Content acquisition & preparation functions
Application Profile Functional Block	9.2.2	IPTV User Data FE (IUDF)
Service & content protection		Service & Content Protection (SCP)

NOTE: The in ITU-T non-IMS NGN IPTV application functions enable to UE select and purchase content as well as provide content metadata and other information which are in TISPAN Integrated IPTV functions of Service Discovery & Selection function.

Figure F.1 illustrate mapping between functional entities discussed in table F.1.

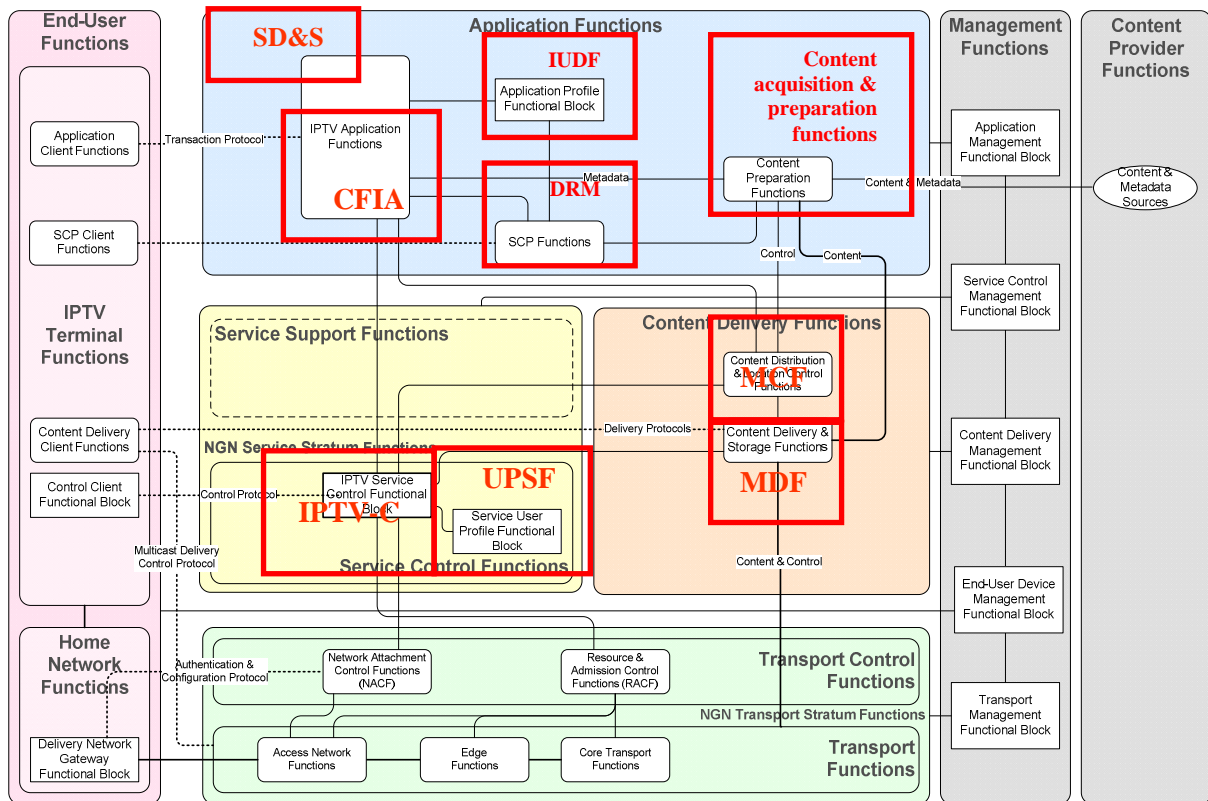

Figure F.1: Mappings of ITU-T non-IMS functional architecture to TISPAN NGN integrated IPTV (ITU-T Recommendation Y.1910 [i.10], figure 10-2: NGN non-IMS IPTV architecture)



---

## Annex G (informative): Interconnection Models supporting Mobility Capabilities

TISPAN NGN integrated IPTV subsystem consider in the future releases the following scenarios for roaming and interconnection to the home network:

- 1) remote data access to IPTV/content provider;
- 2) visited - home network roaming between IPTV providers (served only from home network);
- 3) visited - home network roaming between IPTV providers (served from home or visited network);
- 4) interconnect between NGN integrated IPTV and IMS based IPTV.

### **Scenario A: Remote IPTV user access to home IPTV SP via remote data connection**

The remote IPTV UE can access home IPTV SP via remote IP connection (e.g. via VPN or secure remote access). The control signalling and media delivery can reach directly Home Network IPTV SP. However, remote IP connection goes via third party IP network relying on the functionality provided by the transport control layer and without agreement between home and visited networks the QoS cannot be ensured.

NOTE: This scenario is outside the scope of TISPAN for current release.

### **Scenario B: IPTV roaming by IPTV SP in the Home Network via IPTV SP in the Visited Network (home services)**

In this scenario, IPTV platform is available in the Visited Network. However, it proxies service request to the IPTV SP in the home network and the content and services are delivered only from Home Network. In this scenario, the delivery of the content, metadata, service discovery, selection, service initiation, modification and termination is done from home network. It may be required from Home Network IPTV SP to provide transcoding and content adaptation to adapt media to parameters required for entering the Visited Network (alternatively this could be done at the edge of visited network).

### **Scenario C: IPTV roaming by IPTV SP in the Visited Network with IPTV SP in the Home Network (home and visited services)**

As scenario B, but IPTV SP in the visited network only request content from the home network if it is not available in the visited network.

### **Scenario D: IPTV roaming by IMS based IPTV SP in the visited network**

Scenarios B and C applied to the case when IPTV SP in the visited network is based on IMS.

---

## Annex H (informative): SCTE based targeted advertising architecture

### H.1 Definitions

The SCTE has defined the following advertisement system functional entities [i.6] and [i.7]:

- **Ad Decision Service (ADS):** The Ad Decision Service determines how advertising content is combined with non-advertising (i.e. entertainment) content assets. The decisions made by an ADS may be straightforward (i.e. specific ad content placed at a specific time in a specific asset) or arbitrarily complex (based on subscriber data, advertising zone, etc.).
- **Ad Management Service (ADM):** The Ad Management Service communicates placement opportunity and placement status to the ADS. The message interfaces exposed by an ADM allow for both preconfigured ad decisions as well as real-time fulfilment models. Possible ways for detection of a placement opportunity are discussed in clause 11.10. In addition, the ADM may be a service consumer of a POIS and/or a CIS in order to obtain such information.
- **Content Information Service (CIS):** The Content Information Service manages metadata describing all the assets (both advertising assets and non-advertising assets) available to the other SCTE 130 logical services. The CIS provides query and notification interfaces to the other logical services.
- **Placement Opportunity Information Service (POIS):** The Placement Opportunity Information Service (POIS) holds, maintains, or retains descriptions of placement opportunities.
- **Subscriber Information Service (SIS):** The Subscriber Information Service manages the per-subscriber information relevant to ad placement decisions. The SIS provides mechanisms surrounding privacy issues.

---

### H.2 SCTE-130 based Advertising Architecture

Figure H.1 shows the interfaces between the SCTE-130 advertising specific entities and the TISPAN IPTV architecture.

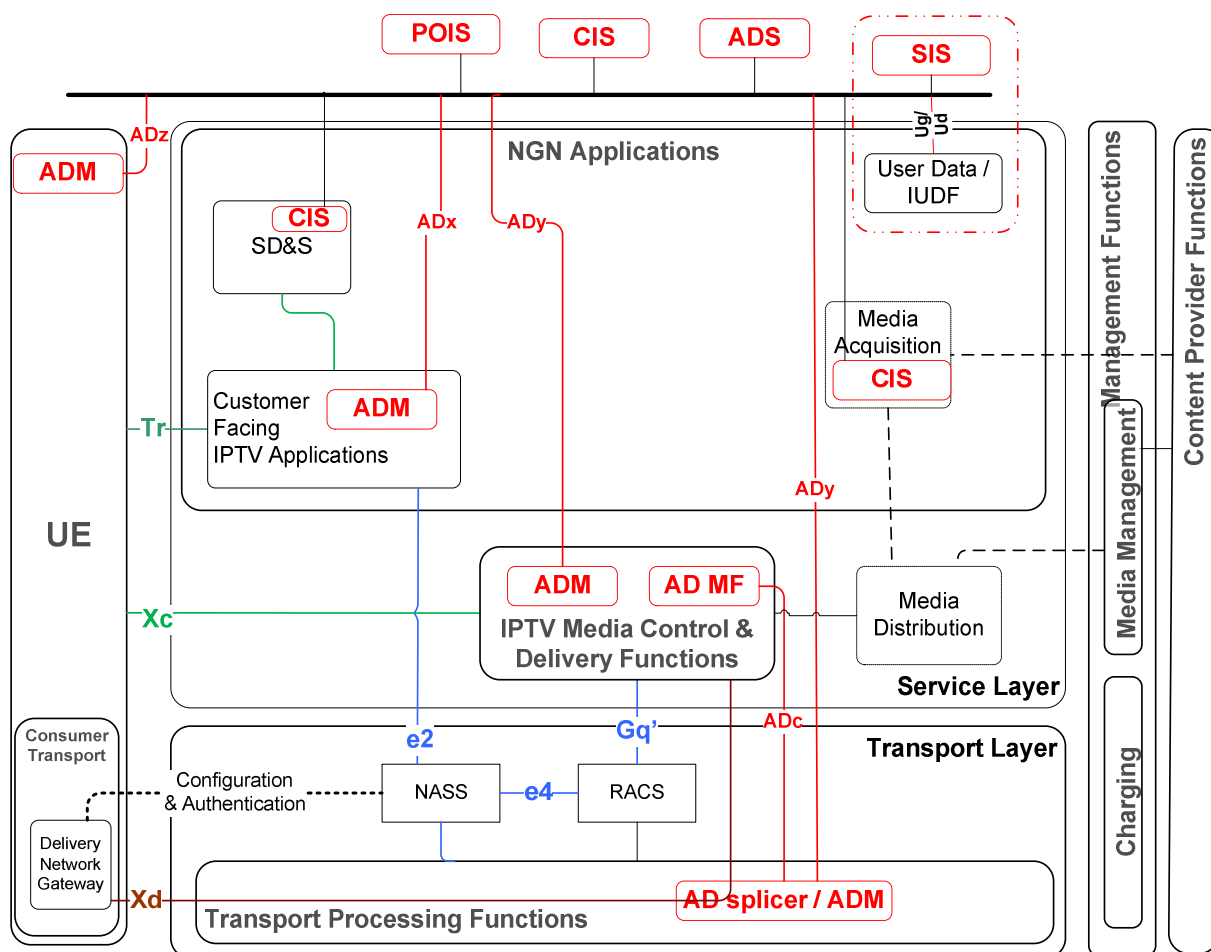

**Figure H.1: Interaction between TISPAN Integrated IPTV architecture and SCTE-130 functional entities**

The IPTV applications are interconnected with the ADS by the ADx reference points to request ad placement decision. The ADM functionality in MF is interconnected with the Ad Decision Service by the ADy reference points to request ad placement decision. As shown on figure H.1, POIS is an external entity. However, ad placement opportunities may be detected by the MF based on cues defined in [i.8]. SIS may be either exposed by IUUF or user Data. ADM located in CFIA, MF and optionally UE can coexist and are not mutually exclusive.

## H.3 Reference points

### H.3.1 IPTV Applications - SCTE-130 ADS (ADx)

This reference point is used to exchange advertising related messages between an ADM in the CFIA and an SCTE-130 Advertising sub-system. ADx reference point should be used to send and receive messages from/to the ADS, POIS and SIS entities and the TISPAN IPTV Applications.

The use of ADx between SCF and ADS conforms to SCTE-130-3 [i.7]. It may be a subset of SCTE-130-3 [i.7] depending on the functionality supported in the CFIA and ADS and that is declared during the discovery and registration phases.

### H.3.2 IPTV Media Function (MF) - SCTE-130 ADS (ADy)

This reference point is used to exchange advertising related messages between MF and an SCTE-130 ADS for unicast and broadcast services. ADy reference point should be used to send and receive messages from/to the ADS and the TISPAN IPTV MF. It may be a subset of SCTE 130-3 depending on the functionality supported in the MF and ADS and that is declared during the discovery and registration phases.

The MF entity is interconnected with the Ad Decision service by the ADy reference point to made ad-selection and ad-placement requests for both broadcast and unicast (e.g. for interstitial, pause opportunities) services.

The use of ADy between MCF and ADS conforms to SCTE-130-3 [i.7]. It may be a subset of SCTE-130-3 [i.7] depending on the functionality supported in the MF and ADS and that is declared during the discovery and registration phases.

### H.3.3 MF Ad Splicer - TISPAN Ad MF (ADc)

This reference point is used to exchange ad streaming related messages in order to control streaming of ads by the ad splicer from Ad MF.

The use of ADc between MF ad splicer and TISPAN Ad MF conforms to SCTE-130.

### H.3.4 IPTV User Equipment (UE) - SCTE-130 ADS (ADz)

This optional reference point is used to exchange advertising related messages between UE and an SCTE-130 external Advertising sub-system. ADz reference point should be used to send and receive messages from/to the ADS and the TISPAN UE. The UE entity is interconnected with the Ad Decision service by the ADz reference point to made ad-selection and ad-placement requests.

The use of ADz between UE and ADS conforms to a relevant subset of SCTE-130-3 [i.7]. It may be a subset of depending on the functionality supported in the ADS and UE and that is declared during the discovery and registration phases.

---

## H.4 Mapping between TISPAN entities and SCTE-130 entities

This clause describes a mapping of the functional entities defined by SCTE with the TISPAN IPTV functional entities.

Placement Opportunity Information Service (POIS) and Ad Decision Service (ADS) are considered out of scope of TISPAN architecture. Interface between ADS and ADM is considered as a reference point in scope of TISPAN.

Table H.1 describes mapping between TISPAN IPTV functional entities and SCTE functional entities.

**Table H.1: Mapping between TISPAN IPTV functional entities and SCTE functional entities**

<b>SCTE-130 entity name</b>	<b>Role</b>	<b>TISPAN Entity</b>	<b>TISPAN entity role</b>
POIS	Provides placement opportunities	MF / External entity	MF tasks from clause 11.10.1 "When MF performs ad insertion, it is informed or determines of ad insertion opportunity, retrieves ad content and delivers the combined stream to the UE."
SIS	Manage subscriber information relevant for Ad	IUDF / User Data / External entity	IUDF/User Data role is defined in clause 5.1.1.
CIS	Manage assets metadata	SD&S / Media Preparation (Acquisition) / External entity	SD&S role is defined in clause 5.1.1. Media Preparation role is defined in clause 5.1.2.
ADM	Provides placement opportunities based on POIS and CIS information Defines messages for Ad insertion Activities	CFIA - applications and unicast TAI MF - unicast and multicast TAI	CFIA role is defined in clause 11.10.2 and on figure 25.
ADS	Decide ad placement relative to content based on ADM placement opportunities	NGN ASF entity/External entity	Defined externally [i.5], [i.6] and [i.7].

---

## Annex I (informative): NGN integrated IPTV support for hybrid services

The present document integrates IPTV/TV systems, e.g. defined in [2], into NGN architecture. Some of IPTV subsystems and service level requirements [1] may include hybrid services.

The present document does not preclude using IP delivery for a consumer's complete IPTV service offering or for partially combined with other TV services in a hybrid service scenario. For example, a service provider may choose to offer broadcast services (e.g. broadcast TV) via an independent channel while providing interactive, download or CoD IPTV services via the IP network.

NGN integrated IPTV may support hybrid delivery of IPTV services, e.g.:

- Live TV delivery over external TV delivery systems such as DVB-T, DVB-S, DVB-C, DVB-H, 3GPP MBMS, other.
- Other IPTV services delivered over NGN integrated IPTV such as CoD, UGC, iTV, other as defined above.

Hybrid approaches can offer advantages both to the service provider and the consumer and widen the application of TISPAN NGN Integrated IPTV, e.g. where a part of the IPTV content is delivered over an independent non-IP delivery network, such as terrestrial broadcast, direct-to-home satellite, hybrid fibre-coax or optical distribution network, which is outside of scope for TISPAN.

---

## Annex J (informative): Bibliography

ETSI TR 187 008: "Telecommunications and Internet converged Services and Protocols for Advanced Networking (TISPAN); NAT traversal feasibility study report".

## Annex K (informative): Change history

Date	WG Doc.	CR	Rev	CAT	Title / Comment	Current Version	New Version
26/09/08	18bTD222r2	001	R1	B	NGN Integrated IPTV new features impacts	3.0.0	3.0.1
26/09/08	18bTD221r3	002		B	NGN integrated IPTV - architecture & migration scenarios	3.0.0	3.0.1
05/11/08	19WTD193r1	003		B	IPTV Elementary functions	3.0.1	3.0.2
05/11/08	19WTD152r2	004		F	Editorial modifications of the Linear TV procedure	3.0.1	3.0.2
05/11/08	19WTD053r2	005		B	WI2074_Synchronization_Architecture	3.0.1	3.0.2
05/11/08	19WTD150r1	006		F	Resource release procedure in the Linear TV	3.0.1	3.0.2
					CRS 001 to 006 TB approved	3.0.2	3.1.0
28/11/08	19bTD132r1	007		B	IPTV Elementary functions mapping	3.1.0	3.1.1
28/11/08	19bTD175r3	008		B	Recommendation service procedures	3.1.0	3.1.1
28/11/08	19bTD174r3	009		D	Linear TV procedure for coupled mode	3.1.0	3.1.1
28/11/08	19bTD176r2	010		B	Advertising	3.1.0	3.1.1
28/11/08	19bTD219r1	011		B	Editor notes for open issues	3.1.0	3.1.1
28/11/08	19bTD134r2	012		B	IPTV Service procedure using notification	3.1.0	3.1.1
28/11/08	19bTD135r3	013		B	IPTV procedures for CRS and Ads	3.1.0	3.1.1
23/01/09	19tTD083r1	014		B	Synchronization Procedures	3.1.1	3.1.2
23/01/09	19tTD176r1	015		C	Functional architecture	3.1.1	3.1.2
23/01/09	19tTD177r1	016		C	R3 tasks for MCF & MDF	3.1.1	3.1.2
23/01/09	19tTD219r1	017		F	Remote control of NGN integrated IPTV services from mobile or other NGN UE	3.1.1	3.1.2
23/01/09	19tTD218r2	018		F	Fixed mobile service continuation	3.1.1	3.1.2
25/02/09	20WTD094r2	019		C	Procedures for User Generated Content	3.1.2	3.1.3
25/02/09	20WTD214r1	020		F	Service continuation between NGN IPTV enabled devices	3.1.2	3.1.3
25/02/09	20WTD216r1	021		F	Unicast based advertisement flows	3.1.2	3.1.3
					CRS 007 to 021 TB approved	3.1.3	3.2.0
20/03/09	20bTD262r1	022		F	Refining of the user data functions	3.2.0	3.2.1
20/03/09	20bTD102r2	023		F	Non specified reference points	3.2.0	3.2.1
20/03/09	20bTD103r3	024		B	Mapping of ITU-T non-IMS NGN IPTV architecture to NGN Integrated IPTV	3.2.0	3.2.1
20/03/09	20bTD104r3	025		C	Supporting entities	3.2.0	3.2.1
20/03/09	20bTD105r2	026		B	Procedures for Personalized Channel	3.2.0	3.2.1
20/03/09	20bTD264r3	027		B	Interactions between other TISPAN services and IPTV services (support for OSA/Parlay/Parlay X)	3.2.0	3.2.1
20/03/09	20bTD265r3	028		B	Optimised bandwidth utilisation during CoD	3.2.0	3.2.1
					Corrections to implementations of CRs 022 to 028	3.2.1	3.2.3
29/04/09	WG2-07-020r1	029	r1	B	User Generated Content Procedures	3.2.3	3.2.4
29/04/09	WG2-07-022r1	030	r1	B	Synchronization Procedures	3.2.3	3.2.4
29/04/09	WG2-07-037r3	031	r3	B	IPTV services R2/R3, M/O	3.2.3	3.2.4
29/04/09	WG2-07-038r1	032	r1	B	Time shifted TV	3.2.3	3.2.4
29/04/09	WG2-07-039r3	033	r3	B	Personal Video Recording service	3.2.3	3.2.4
29/04/09	WG2-07-040r1	034	r1	B	Pay Per View	3.2.3	3.2.4
29/04/09	WG2-07-041r2	035	r2	B	Emergency Alert	3.2.3	3.2.4
29/04/09	WG2-07-042r1	036	r1	B	Content Bookmarks	3.2.3	3.2.4
29/04/09	WG2-07-065r1	037	r1	D	Editorial clarifications	3.2.3	3.2.4
29/04/09	WG2-07-066r1	038	r1	F	Review of editor's notes	3.2.3	3.2.4
29/04/09	WG2-07-067r1	039	r1	B	Ss' reference point	3.2.3	3.2.4
29/04/09	WG2-07-044r1	040	r1	B	Update of annex	3.2.3	3.2.4
29/04/09	WG2-07-045r2	041	r2	B	Interactive IPTV services	3.2.3	3.2.4
29/04/09	WG2-07-046r2	042	r2	B	IPTV interconnection	3.2.3	3.2.4
11/06/09	21WTD180r1	043	R1	B	Emergency notifications using multicast	3.2.5	3.2.6
11/06/09	21WTD184r1	044	R1	B	Hybrid services	3.2.5	3.2.6
11/06/09	21WTD181r1	045	R1	D	Review of Editors note	3.2.5	3.2.6
11/06/09	21WTD185r1	046	R1	F	Service & content protection	3.2.5	3.2.6
11/06/09	21WTD179r4	047	R4	B	SCTE based advertising architecture	3.2.5	3.2.6
11/06/09	21WTD049r4	048	R4	B	IPTV Security	3.2.5	3.2.6
11/06/09	21WTD131r3	050	R3	B	Synchronization Identifier	3.2.5	3.2.6
					Publication	3.2.6	3.3.1
					Input Draft	3.3.1	3.4.0
05-02-10	02(10)0010r3	051		C	Functional_Modification_of_Sync_Architecture	3.4.0	3.4.1



Date	WG Doc.	CR	Rev	CAT	Title / Comment	Current Version	New Version
14-04-10	02(10)0044r1	052		C	Editorial Corrections	3.4.0	3.4.1
					Update of CR numbers and work item reference	3.4.1	3.4.2
					publication	3.4.2	3.5.1

---

## History

<b>Document history</b>		
V2.0.0	January 2008	Publication
V3.3.1	October 2009	Publication
V3.5.1	February 2011	Publication