

ETSI TS 183 036 V3.4.1 (2011-02)

Technical Specification

Telecommunications and Internet converged Services and Protocols for Advanced Networking (TISPAN); ISDN/SIP interworking; Protocol specification



Reference

RTS/TISPAN-03217-NGN-R3

Keywords

IMS, interworking, ISDN, SIP

ETSI

650 Route des Lucioles
F-06921 Sophia Antipolis Cedex - FRANCE

Tel.: +33 4 92 94 42 00 Fax: +33 4 93 65 47 16

Siret N° 348 623 562 00017 - NAF 742 C
Association à but non lucratif enregistrée à la
Sous-Préfecture de Grasse (06) N° 7803/88

Important notice

Individual copies of the present document can be downloaded from:

<http://www.etsi.org>

The present document may be made available in more than one electronic version or in print. In any case of existing or perceived difference in contents between such versions, the reference version is the Portable Document Format (PDF). In case of dispute, the reference shall be the printing on ETSI printers of the PDF version kept on a specific network drive within ETSI Secretariat.

Users of the present document should be aware that the document may be subject to revision or change of status. Information on the current status of this and other ETSI documents is available at

<http://portal.etsi.org/tb/status/status.asp>

If you find errors in the present document, please send your comment to one of the following services:

http://portal.etsi.org/chaicor/ETSI_support.asp

Copyright Notification

No part may be reproduced except as authorized by written permission.
The copyright and the foregoing restriction extend to reproduction in all media.

© European Telecommunications Standards Institute 2011.
All rights reserved.

DECT[™], **PLUGTESTS**[™], **UMTS**[™], **TIPHON**[™], the TIPHON logo and the ETSI logo are Trade Marks of ETSI registered for the benefit of its Members.

3GPP[™] is a Trade Mark of ETSI registered for the benefit of its Members and of the 3GPP Organizational Partners.

LTE[™] is a Trade Mark of ETSI currently being registered

for the benefit of its Members and of the 3GPP Organizational Partners.

GSM[®] and the GSM logo are Trade Marks registered and owned by the GSM Association.

Contents

Intellectual Property Rights	7
Foreword.....	7
1 Scope	8
2 References	8
2.1 Normative references	8
2.2 Informative references.....	11
3 Definitions and abbreviations.....	12
3.1 Definitions.....	12
3.2 Abbreviations	12
4 General	13
5 Interworking for IMS simulation / emulation services.....	14
5.1 Basic Call	14
5.1.1 Actions at the Outgoing AGCF/VGW	14
5.1.1.1 Sending of the Initial INVITE.....	14
5.1.1.1.1 En-bloc sending according to EN 300 403-1, clause 5.1.1	15
5.1.1.1.2 Bearer capability mapping.....	15
5.1.1.1.3 Mapping of Progress indicator/High Layer Compatibility/Low Layer Compatibility IE.....	16
5.1.1.1.4 Request URI/To header field	17
5.1.1.2 Receipt of a Provisional Response 18x	20
5.1.1.2.1 180 Ringing response	20
5.1.1.2.2 Receipt of the 183 (Session Progress) response	23
5.1.1.3 Receipt of the 200 OK INVITE	26
5.1.1.4 Receipt of (BYE or Final Response	28
5.1.1.5 Sending of (BYE or CANCEL)	29
5.1.1.6 Use of Overlap Signalling (Optional)	30
5.1.2 Actions at the Incoming AGCF/VGW.....	30
5.1.2.1 Sending of the SETUP message.....	30
5.1.2.2 Sending of the 18x from the destination VGW/AGCF	34
5.1.2.3 Sending of the 200 OK INVITE	36
5.1.2.4 Receipt of BYE/CANCEL	38
5.1.2.5 Sending of BYE/4xx/5xx	38
5.1.2.6 Sending of the DSS1 INFO (Optional)	39
5.2 Supplementary services	40
5.2.1 Communication Hold (HOLD).....	40
5.2.1.1 Actions at the Incoming AGCF/VGW	40
5.2.1.1.1 Notification received from the network.....	40
5.2.1.1.2 Invocation at coincident S and T reference point	40
5.2.1.1.3 Notification received at T reference point	41
5.2.1.2 Actions at the outgoing AGCF/VGW	41
5.2.1.2.1 Notification received from the network.....	41
5.2.1.2.2 Invocation at coincident S and T reference point	41
5.2.1.2.3 Notification received at T reference point	41
5.2.2 Connected Line Identification Presentation (COLP) / Connected Line Identification Restriction (COLR).....	42
5.2.2.1 Actions at the incoming AGCF/VGW	42
5.2.2.1.1 Connected Line Identification Presentation (COLP).....	42
5.2.2.1.2 Connected Line Identification Restriction (COLR).....	44
5.2.2.2 Actions at the outgoing AGCF/VGW	45
5.2.2.2.1 Connected Line Identification Presentation (COLP).....	45
5.2.2.2.2 Connected line identification restriction (COLR)	47
5.2.3 Calling line Identification Presentation (CLIP) / Calling line Identification Restriction (CLIR)	48
5.2.3.1 Actions at the incoming AGCF/VGW	48
5.2.3.2 Actions at the outgoing AGCF/VGW	50

5.2.4	Conference calling (CONF).....	52
5.2.5	Communication Diversion Services (CDIV)	52
5.2.5.1	Actions at the Outgoing AGCF/VGW	52
5.2.5.1.1	Reception of a "call is diverting" notification	52
5.2.5.1.2	Evaluation of History-Info header	53
5.2.5.1.3	Procedures at the T reference point	55
5.2.5.2	Actions at the incoming AGCF/VGW	56
5.2.5.2.1	Interworking at the AGCF/VGW where a call is diverted within or beyond the private ISDN (T reference point).....	56
5.2.5.2.2	Interworking at the coincident S and T reference point where a diverted call is presented.....	57
5.2.5.2.3	Interworking at the AGCF/VGW where a diverted call is presented to a private ISDN (T Reference point)	59
5.2.5.2.4	Interworking at the AGCF/VGW where partial rerouting is requested from a private ISDN (T Reference point)	60
5.2.6	MCID.....	61
5.2.6.1	Actions at the Outgoing AGCF/VGW	61
5.2.6.2	Actions at the incoming AGCF/VGW	61
5.2.7	Explicit Communication Transfer (ECT)	61
5.2.7.1	Actions at the Outgoing AGCF/VGW	61
5.2.7.1.1	Coincident S and T reference point	61
5.2.7.1.2	T reference point.....	62
5.2.7.2	Actions at the incoming AGCF/VGW	62
5.2.7.2.1	Coincident S and T reference point	62
5.2.7.2.2	T reference point.....	64
5.2.8	Subaddressing (SUB).....	65
5.2.8.1	Actions at the Outgoing AGCF/VGW	66
5.2.8.2	Actions at the incoming AGCF/VGW	66
5.2.9	Closed User Group (CUG)	66
5.2.9.1	Actions at the Outgoing AGCF/VGW	66
5.2.9.2	Actions at the incoming AGCF/VGW	67
5.2.10	User User Service (UUS).....	67
5.2.10.1	Actions at the Outgoing AGCF/VGW	68
5.2.10.1.1	Service 1 (UUS1) implicit	68
5.2.10.1.2	Service 1 (UUS1) explicit.....	68
5.2.10.1.3	Service 2	69
5.2.10.1.4	Service 3	70
5.2.10.2	Actions at the incoming AGCF/VGW	71
5.2.10.2.1	Service 1 (UUS1) implicit	71
5.2.11	Call Waiting (CW).....	71
5.2.11.1	Actions at the Outgoing AGCF/VGW	71
5.2.11.2	Actions at the incoming AGCF/VGW	72
5.2.11.2.1	Procedure at coincident S and T reference point	72
5.2.11.2.2	Notification received at T reference point	72
5.2.12	Terminal Portability (TP).....	73
5.2.12.1	Actions at the outgoing AGCF/VGW	73
5.2.12.1.1	Invocation at coincident S and T reference point	73
5.2.12.1.2	Notification received at T reference point	73
5.2.12.2	Actions at the incoming AGCF/VGW	73
5.2.12.2.1	Invocation at coincident S and T reference point	73
5.2.12.2.2	Notification received at T reference point	74
5.2.13	Three-party (3PTY)	74
5.2.13.1	Notification received from the network	75
5.2.13.2	Invocation at coincident S and T reference point.....	75
5.2.13.3	Notification received at T reference point.....	78
5.2.13.4	Notification received at T reference point.....	78
5.2.14	Completion of Call to Busy Subscriber (CCBS)	79
5.2.14.1	Actions at the outgoing AGCF/VGW	79
5.2.14.2	Actions at the incoming AGCF/VGW	79
5.2.15	Completion of Calls on No Reply (CCNR)	80
5.2.15.1	Actions at the outgoing AGCF/VGW	80
5.2.15.2	Actions at the incoming AGCF/VGW	80
5.2.16	Advice Of Charge AOC.....	80

5.2.16.1	Actions at the outgoing AGCF/VGW	81
5.2.17	Message Waiting Indication (MWI)	82
5.3	DSS1 layer 2 failure	83
5.3.1	DSS 1 data link reset and data link failure procedures in the outgoing AGCF/VGW	83
5.3.2	DSS 1 data link reset and data link failure procedures in the incoming AGCF/VGW	84
5.3.3	Release by the outgoing AGCF/VGW	84
5.3.4	Release by the AGCF/VGW	85
5.4	Service operation	85
5.4.1	Call related service operation	85
5.4.1.1	Malicious Call Identification (MCID)	85
5.4.1.2	Explicit Communication Transfer (ECT)	85
5.4.1.3	Closed User Group (CUG)	86
5.4.1.4	Three Party Service (3PTY)	86
5.4.1.5	Completion of Call to Busy Subscriber (CCBS)	86
5.4.1.6	Completion of Calls on No Reply (CCNR)	86
5.4.2	Call independent service configuration	86
5.4.2.1	Communication Diversion Services (CDIV)	87
5.4.2.1.1	Communication Diversion activation	87
5.4.2.1.2	Communication Diversion deactivation	88
5.4.2.1.3	Communication Diversion interrogation	89
5.4.2.1.4	Activation Status Notification Diversion	90
5.4.2.2	Message Waiting Indication (MWI)	90
5.4.2.2.1	Activation of Message Waiting Indication (MWI)	90
5.4.2.2.2	Deactivation of Message Waiting Indication (MWI)	91
Annex A (normative): Keypad Procedures		92
A.1	Generic procedure at the AGCF/VGW side	92
A.2	Generic procedure at the AS side	92
Annex B (normative): SDP mapping for ISDN 7 kHz service and Inter-working		93
B.1	Originating Side	93
B.2	Terminating side	93
Annex C (normative): Timers		94
Annex D (normative): Overlap Sending		99
D.1	multiple INVITE Overlap Dialling Procedures (Optional)	99
D.1.1	Actions at the originating VGW/AGCF	99
D.1.1.1	Terminating overlap signalling at originating VGW/AGCF	99
D.1.1.2	Sending of INVITE without determining the end of address signalling	99
D.1.1.3	Special handling of 404 Not Found and 484 Address Incomplete responses after sending of INVITE without determining the end of address signalling	100
D.1.2	Actions at the terminating VGW/AGCF	107
D.2	In-Dialog Method (Optional)	107
D.2.1	Actions at the originating VGW/AGCF	107
D.2.1.1	Terminating overlap signalling at originating VGW/AGCF	107
D.2.1.2	Sending of INVITE without determining the end of address signalling	108
D.2.2	Actions at the terminating VGW/AGCF	115
Annex E (normative): Direct Dialling in		116
E.1	Multiple INVITEs Method (Optional)	116
E.1.1	Actions at the incoming AGCF/VGW	116
E.1.1.1	Receipt of Subsequent INVITE messages	116
E.2	In-Dialog Method (Optional)	117
E.2.1	Actions at the incoming AGCF/VGW	117
E.2.1.1	Receipt of Subsequent INVITE messages	117

Annex F (informative):	Handling and interworking of DSS1 messages and Information Elements.....	120
Annex G (informative):	Message flows	122
G.1	Three party	122
G.2	Explicit Communication Transfer (ECT).....	128
Annex H (informative):	Use of progress indicators	130
Annex I (informative):	Bibliography.....	134
Annex J (informative):	Change History	135
History		136

Intellectual Property Rights

IPRs essential or potentially essential to the present document may have been declared to ETSI. The information pertaining to these essential IPRs, if any, is publicly available for **ETSI members and non-members**, and can be found in ETSI SR 000 314: "*Intellectual Property Rights (IPRs); Essential, or potentially Essential, IPRs notified to ETSI in respect of ETSI standards*", which is available from the ETSI Secretariat. Latest updates are available on the ETSI Web server (<http://webapp.etsi.org/IPR/home.asp>).

Pursuant to the ETSI IPR Policy, no investigation, including IPR searches, has been carried out by ETSI. No guarantee can be given as to the existence of other IPRs not referenced in ETSI SR 000 314 (or the updates on the ETSI Web server) which are, or may be, or may become, essential to the present document.

Foreword

This Technical Specification (TS) has been produced by ETSI Technical Committee Telecommunications and Internet converged Services and Protocols for Advanced Networking (TISPAN).

1 Scope

The present document specifies the stage three Protocol Description of the signalling interworking between ISDN DSS1 protocol and SIP based on the concatenation of ES 283 027 [1], ES 283 003 [5] with EN 300 899-1 [2]. The concatenation method describes only the SIP/ISDN parameter mapping without ISUP procedures. In addition direct inter-working not supported by this concatenation of these existing inter-working documents will be described.

2 References

References are either specific (identified by date of publication and/or edition number or version number) or non-specific. For specific references, only the cited version applies. For non-specific references, the latest version of the reference document (including any amendments) applies.

Referenced documents which are not found to be publicly available in the expected location might be found at <http://docbox.etsi.org/Reference>.

NOTE: While any hyperlinks included in this clause were valid at the time of publication ETSI cannot guarantee their long term validity.

2.1 Normative references

The following referenced documents are necessary for the application of the present document.

- [1] ETSI ES 283 027: "Telecommunications and Internet converged Services and Protocols for Advanced Networking (TISPAN); Endorsement of the SIP-ISUP Interworking between the IP Multimedia (IM) Core Network (CN) subsystem and Circuit Switched (CS) networks [3GPP TS 29.163 (Release 7), modified]".
- [2] ETSI EN 300 899-1 (V1.1.2): "Integrated Services Digital Network (ISDN); Signalling System No.7; Interworking between ISDN User Part (ISUP) version 2 and Digital Subscriber Signalling System No. One (DSS1); Part 1: Protocol specification [ITU-T Recommendation Q.699, modified]".
- [3] Void.
- [4] ETSI ES 282 007: "Telecommunications and Internet converged Services and Protocols for Advanced Networking (TISPAN); IP Multimedia Subsystem (IMS); Functional architecture".
- [5] ETSI ES 283 003 (V2.5.1): "Telecommunications and Internet converged Services and Protocols for Advanced Networking (TISPAN); IP Multimedia Call Control Protocol based on Session Initiation Protocol (SIP) and Session Description Protocol (SDP) Stage 3 [3GPP TS 24.229 [Release 7], modified]".
- [6] ETSI TS 183 007: "Telecommunications and Internet converged Services and Protocols for Advanced Networking (TISPAN); PSTN/ISDN simulation services; Originating Identification Presentation (OIP) and Originating Identification Restriction (OIR); Protocol specification".
- [7] ETSI TS 183 008: "Telecommunications and Internet converged Services and Protocols for Advanced Networking (TISPAN); PSTN/ISDN simulation services Terminating Identification Presentation (TIP) and Terminating Identification Restriction (TIR); Protocol specification".
- [8] ETSI TS 183 004: "Telecommunications and Internet converged Services and Protocols for Advanced Networking (TISPAN) PSTN/ISDN simulation services: Communication Diversion (CDIV); Protocol specification".
- [9] ETSI TS 183 005: "Telecommunications and Internet converged Services and Protocols for Advanced Networking (TISPAN); PSTN/ISDN simulation services: Conference (CONF); Protocol specification".

- [10] ETSI TS 183 010: "Telecommunications and Internet converged Services and Protocols for Advanced Networking (TISPAN); NGN Signalling Control Protocol; Communication HOLD (HOLD) PSTN/ISDN simulation services; Protocol specification".
- [11] ETSI EN 300 052-1: "Integrated Services Digital Network (ISDN); Multiple Subscriber Number (MSN) supplementary service; Digital Subscriber Signalling System No. One (DSS1) protocol; Part 1: Protocol specification".
- [12] ETSI EN 300 055-1: "Integrated Services Digital Network (ISDN); Terminal Portability (TP) supplementary service; Digital Subscriber Signalling System No. One (DSS1) protocol; Part 1: Protocol specification".
- [13] ETSI EN 300 058-1: "Integrated Services Digital Network (ISDN); Call Waiting (CW) supplementary service; Digital Subscriber Signalling System No. One (DSS1) protocol; Part 1: Protocol specification".
- [14] ETSI EN 300 061-1: "Integrated Services Digital Network (ISDN); Subaddressing (SUB) supplementary service; Digital Subscriber Signalling System No. One (DSS1) protocol; Part 1: Protocol specification".
- [15] ETSI EN 300 064-1: "Integrated Services Digital Network (ISDN); Direct Dialling In (DDI) supplementary service; Digital Subscriber Signalling System No. One (DSS1) protocol; Part 1: Protocol specification".
- [16] ETSI EN 300 092-1: "Integrated Services Digital Network (ISDN); Calling Line Identification Presentation (CLIP) supplementary service; Digital Subscriber Signalling System No. One (DSS1) protocol; Part 1: Protocol specification".
- [17] ETSI EN 300 093-1: "Integrated Services Digital Network (ISDN); Calling Line Identification Restriction (CLIR) supplementary service; Digital Subscriber Signalling System No. One (DSS1) protocol; Part 1: Protocol specification".
- [18] ETSI EN 300 097-1: "Integrated Services Digital Network (ISDN); Connected Line Identification Presentation (COLP) supplementary service; Digital Subscriber Signalling System No. One (DSS1) protocol; Part 1: Protocol specification".
- [19] ETSI EN 300 098-1: "Integrated Services Digital Network (ISDN); Connected Line Identification Restriction (COLR) supplementary service; Digital Subscriber Signalling System No. One (DSS1) protocol; Part 1: Protocol specification".
- [20] ETSI EN 300 130-1: "Integrated Services Digital Network (ISDN); Malicious Call Identification (MCID) supplementary service; Digital Subscriber Signalling System No. One (DSS1) protocol; Part 1: Protocol specification".
- [21] ETSI EN 300 138-1: "Integrated Services Digital Network (ISDN); Closed User Group (CUG) supplementary service; Digital Subscriber Signalling System No. One (DSS1) protocol; Part 1: Protocol specification".
- [22] ETSI EN 300 141-1: "Integrated Services Digital Network (ISDN); Call Hold (HOLD) supplementary service; Digital Subscriber Signalling System No. One (DSS1) protocol; Part 1: Protocol specification".
- [23] ETSI EN 300 185-1: "Integrated Services Digital Network (ISDN); Conference call, add-on (CONF) supplementary service; Digital Subscriber Signalling System No. One (DSS1) protocol; Part 1: Protocol specification".
- [24] ETSI EN 300 188-1: "Integrated Services Digital Network (ISDN); Three-Party (3PTY) supplementary service; Digital Subscriber Signalling System No. One (DSS1) protocol; Part 1: Protocol specification".
- [25] ETSI EN 300 196-1: "Integrated Services Digital Network (ISDN); Generic functional protocol for the support of supplementary services; Digital Subscriber Signalling System No. One (DSS1) protocol; Part 1: Protocol specification".

- [26] ETSI TS 183 006: "Telecommunications and Internet converged Services and Protocols for Advanced Networking (TISPAN) PSTN/ISDN simulation services Message Waiting Indication (MWD): Protocol specification".
- [27] ETSI EN 300 485 (V1.2.3): "Integrated Services Digital Network (ISDN); Definition and usage of cause and location in Digital Subscriber Signalling System No. One (DSS1) and Signalling System No.7 ISDN User Part (ISUP) [ITU-T Recommendation Q.850 (1998), modified]".
- [28] ETSI TS 183 054: "Telecommunications and Internet converged Services and Protocols for Advanced Networking (TISPAN); PSTN/ISDN simulation services; Protocol specification Closed User Group (CUG)".
- [29] ETSI EN 300 403-1: "Integrated Services Digital Network (ISDN); Digital Subscriber Signalling System No. One (DSS1) protocol; Signalling network layer for circuit-mode basic call control; Part 1: Protocol specification [ITU-T Recommendation Q.931 (1993), modified]".
- [30] Void.
- [31] ETSI TS 183 047: "Telecommunications and Internet converged Services and Protocols for Advanced Networking (TISPAN); NGN IMS Supplementary Services; Advice Of Charge (AOC)".
- [32] ETSI TS 183 028: "Telecommunications and Internet converged Services and Protocols for Advanced Networking (TISPAN); Common Basic Communication procedures; Protocol specification".
- [33] Void.
- [34] ETSI EN 300 207-1: "Integrated Services Digital Network (ISDN); Diversion supplementary services; Digital Subscriber Signalling System No. One (DSS1); Part 1: Protocol specification".
- [35] ETSI EN 300 369-1: "Integrated Services Digital Network (ISDN); Explicit Call Transfer (ECT) supplementary service; Digital Subscriber Signalling System No. One (DSS1) protocol; Part 1: Protocol specification".
- [36] ETSI TS 183 029: "Telecommunications and Internet converged Services and Protocols for Advanced Networking (TISPAN); PSTN/ISDN simulation services: Explicit Communication Transfer (ECT); Protocol specification".
- [37] ETSI EN 300 182-1: "Integrated Services Digital Network (ISDN); Advice of Charge (AOC) supplementary service; Digital Subscriber Signalling System No. One (DSS1) protocol; Part 1: Protocol specification".
- [38] ETSI EN 300 286-1: "Integrated Services Digital Network (ISDN); User-to-User Signalling (UUS) supplementary service; Digital Subscriber Signalling System No. One (DSS1) protocol; Part 1: Protocol specification".
- [39] ETSI EN 300 359-1: "Integrated Services Digital Network (ISDN); Completion of Calls to Busy Subscriber (CCBS) supplementary service; Digital Subscriber Signalling System No. One (DSS1) protocol; Part 1: Protocol specification".
- [40] ETSI EN 301 065-1: "Integrated Services Digital Network (ISDN); Completion of Calls on No Reply (CCNR) supplementary service; Digital Subscriber Signalling System No. One (DSS1) protocol; Part 1: Protocol specification".
- [41] Void.
- [42] ETSI TS 183 043: "Telecommunications and Internet converged Services and Protocols for Advanced Networking (TISPAN); IMS-based PSTN/ISDN Emulation Stage 3 specification".
- [43] ETSI EN 301 798 (V1.1.1): "Services and Protocols for Advanced Networks (SPAN); Anonymous Call Rejection (ACR) Supplementary Service; Service description".
- [44] IETF RFC 4575 (2006): "A Session Initiation Protocol (SIP) Event Package for Conference State".

- [45] IETF RFC 4244: "An Extension to the Session Initiation Protocol (SIP) for Request History Information".
- [46] ETSI TS 183 016: "Telecommunications and Internet converged Services and Protocols for Advanced Networking (TISPAN); PSTN/ISDN simulation services; Malicious Communication Identification (MCID); Protocol Specification".
- [47] IETF RFC 3966: "The tel URI for Telephone Numbers".
- [48] IETF RFC 4825: "The Extensible Markup Language (XML) Configuration Access Protocol (XCAP)".
- [49] ETSI TS 183 023: "Telecommunications and Internet converged Services and Protocols for Advanced Networking (TISPAN); PSTN/ISDN simulation services; Extensible Markup Language (XML) Configuration Access Protocol (XCAP) over the Ut interface for Manipulating NGN PSTN/ISDN Simulation Services".
- [50] IETF RFC 4916: "Connected Identity in the Session Initiation Protocol (SIP)".
- [51] IETF RFC 4040: "RTP Payload Format for a 64 kbit/s Transparent Call".
- [52] IETF RFC 3264: "An Offer/Answer Model with Session Description Protocol (SDP)".
- [53] IETF RFC 3261: "SIP: Session Initiation Protocol".
- [54] ITU-T Recommendation Q.931: "ISDN user-network interface layer 3 specification for basic call control".
- [55] ITU-T Recommendation Q.939: "Typical DSS 1 service indicator codings for ISDN telecommunications services".
- [56] ITU-T Recommendation T.38: "Procedures for real-time Group 3 facsimile communication over IP networks".
- [57] ETSI EN 300 745-1 (V1.2.4): "Integrated Services Digital Network (ISDN); Message Waiting Indication (MWI) supplementary service; Digital Subscriber Signalling System No. one (DSS1) protocol; Part 1: Protocol specification".
- [58] ETSI TS 183 015: "Telecommunications and Internet Converged Services and Protocols for Advanced Networking (TISPAN) NGN Signalling Control Protocol Communication Waiting (CW) PSTN/ISDN simulation services".
- [59] ETSI TS 124 642: "Digital cellular telecommunications system (Phase 2+); Universal Mobile Telecommunications System (UMTS); LTE; Completion of Communications to Busy Subscriber (CCBS) and Completion of Communications by No Reply (CCNR) using IP Multimedia (IM) Core Network (CN) subsystem; Protocol Specification (3GPP TS 24.642 Release 8)".
- [60] ITU-T Recommendation G.711: "Pulse code modulation (PCM) of voice frequencies".
- [61] ITU-T Recommendation Q.850: "Usage of cause and location in the Digital Subscriber Signalling System No. 1 and the Signalling System No. 7 ISDN User Part".

2.2 Informative references

The following referenced documents are not necessary for the application of the present document but they assist the user with regard to a particular subject area.

- [i.1] draft-johnston- sipping-cc-uu-02: "Transporting User to User Information for Call Centers using SIP".
- [i.2] ITU-T Recommendation Q.763: "Signalling System No. 7 - ISDN User Part formats and codes".
- [i.3] ITU-T Recommendation H.221: "Frame structure for a 64 to 1920 kbit/s channel in audiovisual teleservices".

- [i.4] ITU-T Recommendation G.725: "System aspects for the use of the 7 kHz audio codec within 64 kbit/s".
- [i.5] ITU-T Recommendation G.722: "7 kHz audio-coding within 64 kbit/s".

3 Definitions and abbreviations

3.1 Definitions

For the purposes of the present document, the following terms and definitions apply:

en bloc receiving: procedure, used in call establishment of an incoming call, to enable the network to send called party number digits to the user in a single message

NOTE: See EN 300 403-1 [29].

en bloc sending: procedure, used in call establishment of an outgoing call, to enable the user to send called party number digits to the network in a single message

NOTE: See EN 300 403-1 [29].

incoming AGCF/VGW: physical entity, which can be combined with a SIP UNI or NNI, terminates incoming calls using SIP protocol and originates outgoing calls using the DSS1 protocol

outgoing AGCF/VGW: physical entity, which can be combined with an ISDN access device, terminates incoming calls using DSS1 and originates outgoing calls using the SIP protocol

overlap receiving: procedure, used in call establishment of an incoming call, to enable the network to send called party number digits to the user in successive messages, as and when they are made available from the remote network

NOTE: See EN 300 403-1 [29].

overlap sending: procedure, used in call establishment of an outgoing call, to enable the user to send called party number digits to the network in successive messages, as and when they are made available by the user

NOTE: See EN 300 403-1 [29].

SIP Phone 3,1 KHz: native SIP endpoint that supports the G.711 [60] codec. Such an endpoint may inter-work with an ISDN user in the IMS/PSTN for the 3,1 KHz bearer service due to both endpoints commonly supporting the G.711 [60] codec

SIP Phone 7 KHz: native SIP endpoint that supports the G.722 codec. However, such an endpoint may not inter-work with an ISDN user in the IMS/PSTN for the 7 KHz bearer service as the VGW/AGCF/MGCF advertises the CLEARMODE codec (which enables a H.221 [i.3] structure to be carried transparently - as described in G.725 [i.4]) rather than the G.722 [i.5] codec

NOTE: It is assumed that the CLEARMODE codec is not understood by the SIP endpoint.

user: DSS1 protocol entity at the user side of the user-network interface

NOTE: See EN 300 403-1 [29].

3.2 Abbreviations

For the purposes of the present document, the following abbreviations apply:

ACK	ACKnowledgement
AGCF	Access Gateway Control Function
AGW	Access Gateway
AOC-D	Advice of Charge During the call
AOC-E	Advice of Charge at the End of the call

AOC-S	Advice of Charge at call Set-up time
BC	Bearer Capability information element
BRI	Basic Rate Interface
CDIV	Communication Diverting
CFNR	Call Forwarding on No Reply
CLIP	Calling line Identification Presentation
CLIR	Calling line Identification Restriction
COLP	Connected Line Identification Presentation
COLR	Connected Line Identification Restriction
CUG	Closed User Group
CW	Call Waiting
ECT	Explicit Communication Transfer
HLC	High Layer Compatibility Information Element
HOLD	communication HOLD
IMS	IP Multimedia Subsystem
IP	Internet Protocol
ISDN	Integrated Service Data Network
IWF	InterWorking Function
MCID	Malicious Communication Identification
MRFC	Multimedia Resource Function Controller
MWI	Message Waiting Indication
NGN	Next Generation Network
OIP	Originating Identification Presentation
OIR	Originating Identification Restriction
PES	PSTN/ISDN Emulation Subsystem
PRI	Primary Rate Interface
PSTN	Public Switched Telephone Network
S-CSCF	Server-Call Session Control Function
SDP	Session Description Protocol
SIP	Session Initiation Protocol
SUB	SUBaddressing
TIP	Terminating Identification Presentation
TIR	Terminating Identification Restriction
UE	User Equipment
URI	Universal Resource Identifier
UUS	User User Service
VGW	Voice over IP GateWay
XCAP	PSTN/ISDN simulation services Extensible Markup Language (XML) Configuration Access Protocol
XML	eXtensible Markup Language

4 General

The present document describes guiding principles for implementing commonly deployed ISDN basic call and supplementary services using the IMS and IMS-based PES architecture.

- ISDN terminals are connected to VGW or access gateways AGCF using BRI or PRI interfaces. The protocol running on the interfaces between these gateways and the PES is the Session Initiation Protocol (SIP).

The actual service logic resides in the Application Server and is outside the scope of standardization. This clause focuses on the interactions between the IWF.

Full support of supplementary services may be realized by exchanging service information between peer SIP signalling entities via SIP signalling. The DSS1 information necessary to support each individual service is specified by the corresponding ETSI or ITU-T supplementary service specification; see table 4-1. For the management of several supplementary services (e.g. activation or deactivation of a service), two possibilities exist. The usage of the Ut interface allows the transport of the content of the DSS1 Facility in PSTN XML instances as specified in the relevant simulation service to the XCAP server to manipulate the service. In addition, the usage of an empty INVITE to carry service code sequences is also applicable to manipulate the supplementary service. The applicability is a network provider option. The management of supplementary services in PES is out of scope of the present document.

In case of the interworking for IMS simulation the mapping of PSTN XML Attachment parameters (ProgressIndicator, HighLayerCapability, LowLayerCapability, BearerCapability, Display; SendingComplete) and additional P-Early media header are a network provider option, in the IMS based PES they are mandatory.

Table 4-1: Supplementary Service References

Supplementary Service	ETSI Reference
Calling Line Identification Presentation (CLIP)	[16]
Calling Line Identification Restriction (CLIR)	[17]
Connected Line Identification Presentation (COLP)	[18]
Connected Line Identification Restriction (COLR)	[19]
Terminal Portability (TP)	[12]
User-to-User Signalling (UUS)	[38]
Closed User Group (CUG)	[21]
Subaddressing (SUB)	[14]
Malicious Call Identification (MCID)	[20]
Conference Call (CONF)	[23]
Explicit Call Transfer (ECT)	[35]
Call Forwarding Busy (CFB)	[34]
Call Forwarding No Reply (CFNR)	[34]
Call Forwarding Unconditional (CFU)	[34]
Call Deflection (CD)	[34]
Call Hold (HOLD)	[22]
Call Waiting (CW)	[13]
Completion of Calls to Busy Subscriber (CCBS)	[39]
Three-Party (3PTY)	[24]
Completion of Calls on No Reply (CCNR)	[40]
Anonymous Communication Rejection (ACR)	[43]
Multiple Subscriber Numbering (MSN)	[11]
Direct Dialling In (DDI)	[15]
Advice of Charge (AOC)	[37]
Message Waiting Indication (MWI)	[57]

5 Interworking for IMS simulation / emulation services

5.1 Basic Call

5.1.1 Actions at the Outgoing AGCF/VGW

5.1.1.1 Sending of the Initial INVITE

After initiating the normal incoming call establishment procedures, determining the end of address signalling and selecting to route the call to the IMS domain, the originating VGW/AGCF shall send the initial INVITE. As a network option, the originating VGW/AGCF may send INVITE requests without determining the end of address signalling.

The end of address signalling shall be determined by the earlier of the following criteria:

- a) by receipt of a "#" character as a sending complete indication or Sending complete information element;
- b) optional by receipt of the maximum number of digits used in the national numbering plan; or
- c) optional by analysis of the called party number to indicate that a sufficient number of digits has been received to route the call to the called party.

Table 5.1.1.1-1: Mapping of sending complete info element

SETUP/INFO→	INVITE/XXX→
Information element	PSTN XML attachment
sending complete	sendingCompleteIndication

5.1.1.1.1 En-bloc sending according to EN 300 403-1, clause 5.1.1

If en-bloc sending is used, the SETUP message contains the complete called number information. The called party number information is included in the Called party number information element possibly completed by the Called party subaddress information element.

The network shall send a CALL PROCEEDING message to the user. This acknowledges the SETUP message and indicates that the call is being processed and that no further address information is expected.

The AGCF/VGW can contain a configurable digit map which is used to analyse the Called party information element contents received in Called party number information element. Among other purposes, this digit map can be used to identify the required number of digits to be entered for a particular digit sequence for a particular service. The procedures for digit maps are described within TS 183 043 [42], clause 7.3.1.3.1.1.

Even in the absence of a digit map, it is appropriate for the AGCF/VGW to collect dialled digits. The AGCF/VGW shall contain a configurable parameter indicating the minimum number of digits expected in the sequence of Called party number information elements before a Request-URI is constructed and an INVITE request sent. The minimum number could be zero.

If this option does not apply, the VGW has to assume overlap sending.

If en-bloc sending is used, the SETUP message may contain the sending complete indication (IE the Sending complete information element) (see EN 300 403-1 [29]).

It is mandatory for the network to recognize the Sending complete information element.

5.1.1.1.2 Bearer capability mapping

The "information transfer capability" code point of the bearer capability information element in the SETUP message shall be mapped to the SDP in SIP according to table 5.1.1.1.2-1.

Table 5.1.1.1.2-1: Coding of the BC received

SETUP→	INVITE→
Bearer capability information element	Coding of SDP media description lines from BC/HLC to SIP
Information transfer capability	
Speech	see table 5.1.1.1.4-2
3,1 kHz audio	see table 5.1.1.1.4-2
<i>Unrestricted digital inf. W/tone/ann</i>	see table 5.1.1.1.4-2
unrestricted digital information	see table 5.1.1.1.4-2

In addition, the whole bearer capability information element, as received in the SETUP message, shall be mapped to the PSTN XML bearer capability body in SIP, according to table 5.1.1.1.2-2.

If two BC's are received then:

- the BC 2 shall be mapped to the first SDP entry of the SIP INVITE; and
- the BC 1 shall be mapped to the second SDP entry of the SIP INVITE; and
- the AGCF/VGW shall store the BC values.

This is needed for the Fall back mechanism as described within clause 5.1.1.2.2.

Table 5.1.1.1.2-2: Mapping of Bearer capability to PSTN XML BearerCapability

SETUP→ Content	INVITE→ PSTN XML attachment BearerCapability
One BC received: BC	BearerCapability mapped from the BC Information element (see note 2)
Two BC received (see note 1): BC 1 (<i>speech or 3,1 kHz audio</i>) BC 2 (<i>unrestricted digital information with tones and announcements</i>)	BearerCapability 1 mapped from the BC 1 Information element (see note 2) BearerCapability 2 mapped from the BC 2 Information element (see note 2)
NOTE 1: BC 1 is the bearer capability information element received in first position in the SETUP message, BC 2 in the second position. Bearer capability information elements shall be received in ascending order of priority as described in clause 5.11.1.1/ITU-T Recommendation Q.931 [54].	
NOTE 2: Octet 1 (information element identifier) and 2 (length) of the bearer capability information element are not included.	

5.1.1.1.3 Mapping of Progress indicator/High Layer Compatibility/Low Layer Compatibility IE

A progress indicator IE, high layer compatibility IE, or low layer compatibility IE, if received in a SETUP message, shall be mapped to the PSTN XML attachment in SIP, according to table 5.1.1.1.3-1.

Table 5.1.1.1.3-1: Mapping of the Progress indicator/High Layer Compatibility/Low Layer Compatibility IE

SETUP→ Content	INVITE→ PSTN XML Attachment
Progress indicator	ProgressIndicator
High layer compatibility	HighLayerCapability
Low layer compatibility	LowLayerCapability

Table 5.1.1.1.3-2: Mapping of the High Layer Compatibility

SETUP→ Content	INVITE→ PSTN XML
One HLC received: HLC	HighLayerCapability HLC
Two HLC received (see note 1): HLC 1 HLC 2	HighLayerCapability (content of HLC 1) (see note 2) HighLayerCapability (content of HLC 2) (see note 2)
NOTE 1: HLC 1 is the high layer compatibility information element received in first position in the SETUP message, HLC 2 in second position. High layer compatibility information elements shall be received in ascending order of priority as described in clause 5.12.1.1/ITU-T Recommendation Q.931 [54].	
NOTE 2: Octets 1 (information element identifier) and 2 (length) of the high layer compatibility information element are not included.	

Table 5.1.1.1.3-3: Coding of the progress indicator information element

SETUP→	INVITE→
Progress indicator information element	PSTN XML attachment
No. Value of PI (see note 1)	PSTN XML with ProgressIndicator No (Value of PI) PSTN XML with ProgressIndicator. No. 6 (see note 2)
	PSTN XML with ProgressIndicator. No. 6 (see note 2)
NOTE 1: Except value: No. 2 - Indicates that the destination user is not ISDN; No. 8, "in-band information or an appropriate pattern is now available".	
NOTE 2: The ISDN access indicator - "originating access ISDN" is transported in the IMS as PSTN XML ProgressIndicator No.6 (see annex E).	

The calling and called party subaddress information shall be mapped to SIP as described in clause 5.2.8.

5.1.1.1.4 Request URI/To header field

Table 5.1.1.1.4-1: Mapping DSS1 Called Party Number to SIP Request-URI and To header field

SETUP	INVITE
Called Party Number	Request-URI and To header field
Type of number	
Unknown	
Dialled strings	Option a) sip: dialled digits@homehostportion (see note)
E. 164 Number format LN (local number)	Option b) sip: dialled digits; phone-context=<xxxxxx >@homehostportion; user=xxxx (see note)
E. 164 Number format Prefix+NDC+SN (national number)	Option c) sip: dialled digits @homehostportion; user=xxxx (see note)
E. 164 Number format Prefix + CC+NDC+SN (international number)	
Subscriber number	Option a) sip:subscribernumber@homehostportion (see note) Option b) sip: subscribernumber; phone-context=<xxxxxx>@homehostportion; user=xxxx (see note) option c) tel: subscribernumber;phone-context= <xxxxxx> (see note)
Network specific number	Option a) sip: network-specific-number@homehostportion (see note) Option b) sip: network-specific-number;phone- context=<xxxxxx>@homehostportion;user=xxxx (see note)
Abbreviated number	Option a) sip: dialled digits@homehostportion (see note) Option b) sip: dialled digits; phone-context=<xxxxxxx>@homehostportion; user=xxxx (see note)

SETUP	INVITE
Called Party Number	Request-URI and To header field
Type of number	
National number	Option a) sip: national number@homehostportion (see note) Option b) sip: national number; phone-context=< xxxxxx>@homehostportion; user=xxxx (see note) Option c) tel: national number;phone-context=<xxxxxx> (see note)
International number	Option a) sip: "+" dialled digits@homehostportion; user= phone (see note) Option b) tel: "+" dialled digits (see note)
NOTE:	The combination of digits and phone-context parameter shall globally unique in the network as defined in RFC 3966 [47].

Table 5.1.1.1.4-2: Coding of SDP media description lines from BC/HLC to SIP

BC IE (normative)		HLC IE in (Optional)	m= line			b= line	a= line
Information Transport Capability	User Information Layer 1 Protocol Indicator	High Layer Characteristics Identification	<media>	<transport>	<fmt-list>	<modifier>: <bandwidth-value>	rtpmap:<dynamic-PT> <encoding name>/<clock rate>/encoding parameters>
"Speech"	"G.711 μ -law"	Ignore	Audio	RTP/AVP	0 (and possibly 8) (see note 1)	AS:64	rtpmap:0 PCMU/8000 (and possibly rtpmap:8 PCMA/8000) (see note 1)
"Speech"	"G.711 μ -law"	Ignore	Audio	RTP/AVP	Dynamic PT (and possibly a second Dynamic PT) (see note 1)	AS:64	rtpmap:<dynamic-PT> PCMU/8000 (and possibly rtpmap:<dynamic-PT> PCMA/8000) (see note 1)
"Speech"	"G.711 A-law"	Ignore	Audio	RTP/AVP	8	AS:64	rtpmap:8 PCMA/8000
"Speech"	"G.711 A-law"	Ignore	Audio	RTP/AVP	Dynamic PT	AS:64	rtpmap:<dynamic-PT> PCMA/8000
"3,1 kHz audio"	"G.711 μ -law"	Ignore	audio	RTP/AVP	0 (and possibly 8) (see note 1)	AS:64	rtpmap:0 PCMU/8000 (and possibly rtpmap:8 PCMA/8000) (see note 1)
"3,1 kHz audio"	"G.711 A-law"	Ignore	audio	RTP/AVP	8	AS:64	rtpmap:8 PCMA/8000
"3,1 kHz audio"	"G.711 A-law"	"Facsimile Group 2/3"	image	Udptl	t38 [56]	AS:64	Based on ITU-T Recommendation T.38 [56]
"3,1 kHz audio"	"G.711 A-law"	"Facsimile Group 2/3"	image	Tcptl	t38 [56]	AS:64	Based on ITU-T Recommendation T.38 [56] isup_usi mapped from BC IE (see note 4)
"3,1 kHz audio"	"G.711 μ -law"	"Facsimile Group 2/3"	image	Udptl	t38 [56]	AS:64	Based on ITU-T Recommendation T.38 [56] isup_usi mapped from BC IE (see note 4)
"3,1 kHz audio"	"G.711 μ -law"	"Facsimile Group 2/3"	image	Tcptl	t38 [56]	AS:64	Based on ITU-T Recommendation T.38 [56]
"Unrestricted digital inf. W/tone/ann." (see notes 4 and 5)	N/A	Ignore	audio	RTP/AVP	Dynamic PT	AS:64	rtpmap:<dynamic-PT> CLEARMODE/8000
"Unrestricted digital information"	N/A	Ignore	audio	RTP/AVP	Dynamic PT	AS:64	rtpmap:<dynamic-PT> CLEARMODE/8000

NOTE 1: Both PCMA and PCMU could be required.
NOTE 2: CLEARMODE is specified in RFC 4040 [51].
NOTE 3: The mapping of the "Information Transport Capability" to the proper codec is explained in annex B.
NOTE 4: In case of receiving two BC elements and each shall be mapped to an m line. The Fallback possibility is described within clause 5.1.1.2.2.
NOTE 5: After the CLEARMODE codec, an additional speech codec G.711 should be offered in the same m-line.

5.1.1.2 Receipt of a Provisional Response 18x

The SDP answer is described in annex B.

5.1.1.2.1 180 Ringing response

Depending on the following three cases, the AGCF/VGW shall send an ALERTING message across the user-network interface to the calling user, as described in table 5.1.1.2.1-1.

- the reception of the first 180 Ringing response without a P-Early-Media header (authorizing early media); or

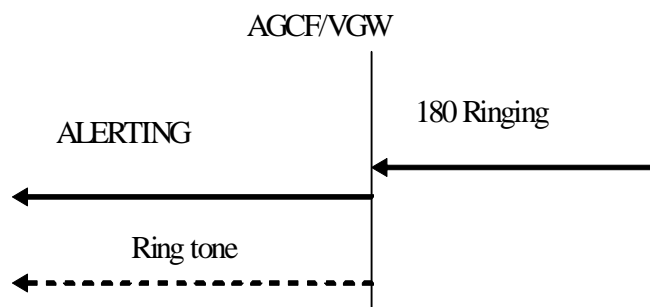

Figure 5.1.1.2.1-1: Sending of ALERTING (Receipt of first 180 Ringing without authorization of early media)

NOTE 1: The ringing tone is sent only for voice services.

- the reception of the first 180 Ringing with a P-Early-Media header (authorizing early media); or

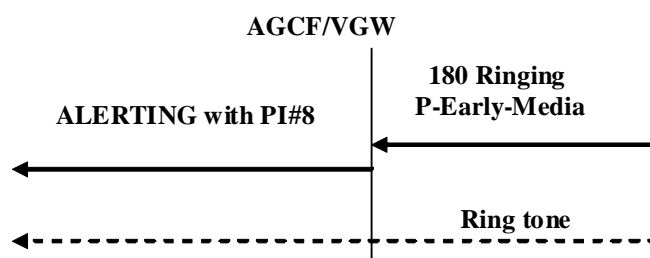

Figure 5.1.1.2.1-2: Sending of ALERTING (Receipt of first 180 Ringing that includes authorization of early media)

NOTE 2: Based on local knowledge that the call is transited to a PSTN network, the AGCF/VGW can make a decision not to generate the awaiting answer indication when receiving the 180 Ringing message without a P-Early-Media header.

- once all the following sub-conditions have been met:
 - the reception of the first 183 Session Progress that includes a P-Early-Media header authorizing early media;
 - the SDP offer/answer procedures are completed; and
 - SDP preconditions are not used, or applicable SDP preconditions have been met.

The support of the reception of the P-Early-Media header is mandatory for the AGCF/VGW.

If the AGCF/VGW receives a 18x response with a P-Early-media header that changes the authorization of early media:

- if the header authorizes early media and if the AGCF/VGW is sending the awaiting answer indication, the AGCF/VGW shall terminate the sending of the awaiting answer indication; and

- if the header removes authorization of early media and if the AGCF/VGW has received the 180 Ringing response, the AGCF/VGW shall initiate the sending of the awaiting answer indication.

In the event of the P-Early-Media header not being present in the 18x message and a media flow being received, such a media flow would ideally not be authorized. However, under these circumstances, a VGW may, as a network option, forward the received media flow and send an ALERTING, CALL PROCEEDING or PROGRESS message with a Progress Indicator set to 8 (*In-band information or appropriate pattern now available*).

NOTE 3: This behaviour enables managing the case when the remote entity generating early media does not support the P-Early-Media header.

Table 5.1.1.2.1-1: Message sent to the DSS 1 upon receipt of first 180

←Message sent to the DSS 1 ALERTING	←180 Ringing
Progress indicator information element	
No. 1 (see note 1) (<i>Call is not end-to-end ISDN: further progress information may be available in-band</i>)	No PSTN XML ProgressIndicator
No. 8 (see note 1) (<i>In-band information or appropriate pattern now available</i>)	P-Earl-Media header (see note 3)
No. Value of PI (see note 2)	PSTN XML with Progress indicator No (Value of PI) and PSTN XML ProgressIndicator No.7 (see note 2)
No. Value of PI	PSTN XML with Progress indicator No (Value of PI)
	PSTN XML with Progress indicator No 7 (see note 2)
NOTE 1: The progress indicator is only sent if the BC received in the SETUP message is coded "speech", "3,1 kHz audio" or "unrestricted digital information with tones and announcements".	
NOTE 2: The ISDN access indicator - "Terminating access ISDN" is transported in the IMS as PSTN XML ProgressIndicator No.7 and is not sent to the access see annex E.	
NOTE 3: The PSTN XML ProgressIndicator No. 8 may also be present, in which case only one PI=8 is signalled to DSS1.	

Table 5.1.1.2.1-2: Message sent to the DSS 1 upon receipt of subsequent 180

←Message sent to the DSS 1 PROGRESS (note 1) Progress indicator information element	←180 Ringing
No. 1 (see note 4) (Call is not end-to-end ISDN: further progress information may be available in-band)	No PSTN XML ProgressIndicator
No. 8 (In-band information or appropriate pattern now available)	P-Earl-Media header (see note 6)
No. Value of PI (see note 3) No. 4 (see note 5) (Call has returned to the ISDN)	PSTN XML with Progress indicator No (Value of PI) and PSTN XML ProgressIndicator No.7 (see note 3)
No. Value of PI (see note 7)	PSTN XML with Progress indicator No (Value of PI)
No. 4 (see note 5) (Call has returned to the ISDN)	PSTN XML with Progress indicator No 7 (see note 3)
NOTE 1: CALL PROCEEDING is sent if not sent previously - else PROGRESS. NOTE 2: The progress indicator is only sent if the BC received in the SETUP message is coded "speech", "3,1 kHz audio" or "unrestricted digital information with tones and announcements". NOTE 3: The ISDN access indicator - "Terminating access ISDN" is transported in the IMS as PSTN XML ProgressIndicator No.7 and is not sent to the access see annex E. NOTE 4: This value is sent if PI=4 was signalled immediately previously. NOTE 5: This value is sent if PI=1 or PI=2 was signalled immediately previously. NOTE 6: The PSTN XML ProgressIndicator No. 8 may also be present, in which case only one PI=8 is signalled to DSS1. NOTE 7: Values 1 ("call is not end-end ISDN") or 2 ("destination address is not ISDN") are sent if Value 4 ("Call has returned to the ISDN") has been sent since value 1 or 2 was previously sent or if no value 1 or 2 was previously sent. Value 4 ("Call has returned to the ISDN") is sent if value 1 ("call is not end-end ISDN") or 2 ("destination address is not ISDN") was sent previously and no value 4 has been signalled since.	

5.1.1.2.1.1 Progress indicator

If the Progress indicator information elements are present in the PSTN XML attachment of the SIP Provisional Response, they shall be transferred in the DSS1 message sent to the calling user.

In addition, progress indicator information elements are created by the originating AGCF/VGW according to tables 5.1.1.2.1-1 and 5.1.1.2.1-2.

In case of fallback to an alternative bearer capability or high layer compatibility, according to EN 300 403-1 [29], clauses 5.11 and 5.12, a progress indicator No. 5 (*interworking has occurred and has resulted in a telecommunication service change*) shall be sent by the ACGF/VGW, as described in tables 5.1.1.3-1 and 5.1.1.3-2.

Every message sent to the DSS1 user (ALERTING, CALL PROCEEDING or PROGRESS) may contain two progress indicator information elements. When more than two progress indicator information elements are to be sent, the subsequent progress indicator information elements are sent in a PROGRESS message.

5.1.1.2.1.2 High layer compatibility

If a high layer compatibility information element is present in the PSTN XML attachment of the SIP Provisional Response, the mapping to the HLC IE is described in table 5.1.1.2.1.2-1.

Table 5.1.1.2.1.2-1: Sending of HLC fallback information

←Message sent to DSS 1 Content HLC	←180 PSTN XML attachment HighLayerCompatibility
NOTE: The HighLayerCompatibility information in the PSTN XML attachment of the SIP body shall be mapped, if present, to the HLC IE (EN 300 403-1 [29], clause 4.5.17, table 4-23/ITU-T Recommendation Q.931 [54]).	

5.1.1.2.1.3 Handling of fallback information

a) Bearer capability selection procedure

According to EN 300 403-1 [29], clause 5.11, the mapping shall be done as described in table 5.1.1.2.1.3-1.

Table 5.1.1.2.1.3-1: Sending of BC fallback information

←Message sent to DSS 1 ALERTING	←180
	PSTN XML attachment
See note 1	BearerCapability (<i>speech or 3,1 kHz audio</i>) (see note 2)
NOTE 1: The AGCF/VGW stores the PSTN XML Bearer Capability element for this dialog.	
NOTE 2: The received BearerCapability information should contain a Speech or 3,1 kHz BC.	

If a high layer compatibility information element is present in the PSTN XML attachment of the 180 Ringing, and if no progress indicator No. 1 (*call is not end-to-end ISDN*) or No. 2 (*destination address is non-ISDN*) has to be sent, table 5.1.1.2.1.3-1 is applicable.

b) High layer compatibility selection procedure

According to EN 300 403-1 [29], clause 5.12, the mapping shall be done as described in table 5.1.1.2.1.3-2.

Table 5.1.1.2.1.3-2: Sending of HLC fallback information

←Message sent to DSS 1 ALERTING	←180
	PSTN XML attachment
See note	HighLayerCapability
NOTE: The AGCF/GW stores the received PSTN XML attachment for this dialog.	

c) SDP selection procedure

When a SDP answer was received indicating no support of the 7 kHz call setup (CLEARMODE codec not the first codec in the m line), the fallback shall not apply as the call may not yet have reached its final destination (e.g. CFNR occurring).

Table 5.1.1.2.1.3-3: No CLEARMODE support in the SDP

←Message sent to DSS 1 ALERTING	←180
	SDP
	CLEARMODE not the first codec on the codec list

5.1.1.2.2 Receipt of the 183 (Session Progress) response

Once all the following sub-conditions have been met:

- if the AGCF/VGW has received the first 183 Session Progress that includes a P-Early-Media header (indicating authorization of early media); and
- SDP preconditions are not used or applicable SDP preconditions have been met.

The AGCF/VGW shall send a CALL PROCEEDING or PROGRESS message according to table 5.1.1.2.2.3-2 to the calling user, as described in table 5.1.1.2.2.3-2.

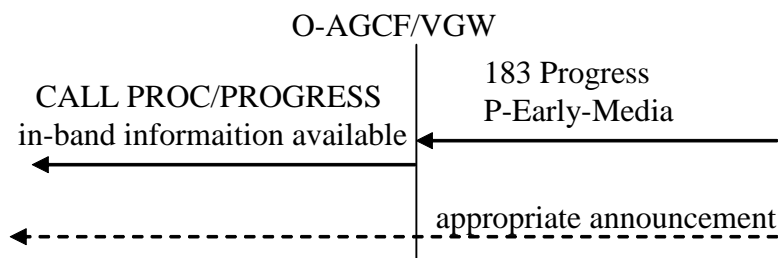

Figure 5.1.1.2.2-1: Sending of Call Proceeding (Receipt of first 183 that includes authorization of early media)

In the event of the P-Early-Media header not being present in the 18x message and a media flow being received, such a media flow would ideally not be authorized. However, under these circumstances, a VGW may, as a network option, forward the received media flow and send an ALERTING, CALL PROCEEDING or PROGRESS message with a Progress Indicator set to 8 (*In-band information or appropriate pattern now available*).

NOTE: This behaviour enables managing the case when the remote entity generating early media does not support the P-Early-Media header.

5.1.1.2.2.1 Progress indicator

Table 5.1.1.2.2.1-1: Message sent to the DSS 1 interface upon receipt of 183 (Session Progress) response

←Message sent to the DSS 1		←183 Session Progress
CALL PROCEEDING when not been sent before (see note 1)	Progress Indicator IE: Progress description No. 8 (see note 3) (In-band information or appropriate pattern now available)	P-Earl-Media header (see note 7)
	Progress Indicator IE: Progress description No. Value of PI (see note 5)	PSTN XML with Progress indicator (Value of PI) and ProgressIndicator No. 7 (see note 5)
	PSTN XML with Progress indicator (Value of PI) (see note 8)	Progress Indicator IE: Progress description No. Value of PI
		PSTN XML ProgressIndicator No. 7 (see note 5)

←Message sent to the DSS 1		←183 Session Progress
PROGRESS if a progress indicator information element is contained in 183 (see note 2)	Progress Indicator IE: Progress description No. 8 (see note 3) (In-band information or appropriate pattern now available)	P-Earl-Media header (see note 7)
	Progress Indicator IE: Progress description No. Value of PI (see note 5) No. 4 (see note 6) (<i>Call has returned to the ISDN</i>)	PSTN XML with Progress indicator (Value of PI) and PSTN XML ProgressIndicator No. 7 (see note 5)
	PSTN XML with Progress indicator (Value of PI) (see note 8)	Progress Indicator IE: Progress description No. Value of PI
	No. 4 (see note 6) (<i>Call has returned to the ISDN</i>)	PSTN XML ProgressIndicator No. 7 (see note 5)
<p>NOTE 1: The receipt from the network of an 183 is interpreted by the network as a sending complete indication, in the case where the network couldn't determine it before.</p> <p>NOTE 2: The sending of a progress indicator information element is described above.</p> <p>NOTE 3: The progress indicator is only sent if the BC received in the SETUP message is coded <i>speech, 3,1 kHz audio</i>.</p> <p>NOTE 4: If a PSTN XML attachment HLC is received, it shall be mapped to the HLC IE.</p> <p>NOTE 5: The ISDN access indicator - "Terminating access ISDN" is transported in the IMS as PSTN XML ProgressIndicator No.7 and is not sent to the access.</p> <p>NOTE 6: This value is sent if PI=1 or PI=2 was signalled immediately previously.</p> <p>NOTE 7: The PSTN XML ProgressIndicator No. 8 may also be present, in which case only one PI=8 is signalled to DSS1.</p> <p>NOTE 8: Values 1 ("call is not end-end ISDN") or 2 ("destination address is not ISDN") are sent if Value 4 ("Call has returned to the ISDN") has been sent since value 1 or 2 was previously sent or if no value 1 or 2 was previously sent. Value 4 ("Call has returned to the ISDN") is sent if value 1 ("call is not end-end ISDN") or 2 ("destination address is not ISDN") was sent previously and no value 4 has been signalled since.</p>		

If more than two progress indicator information elements are to be sent, the subsequent progress indicator information elements shall be sent in a PROGRESS message.

5.1.1.2.2.2 High layer compatibility

If a high layer compatibility information element is present in the PSTN XML attachment of the 183 Session Progress, see handling of fallback information in clause 5.1.1.2.2.3.

5.1.1.2.2.3 Handling of fallback information

a) Bearer capability selection procedure

According to EN 300 403-1 [29], clause 5.11, the mapping shall be done as described in table 5.1.1.2.2.3-1.

Table 5.1.1.2.2.3-1: Sending of BC fallback information

←Message sent to DSS 1	←183 Session Progress
CALL PROCEEDING or PROGRESS	PSTN XML attachment
See note 1	BearerCapability (speech or 3,1 kHz audio) (see note 2)
<p>NOTE 1: The AGCF/VGW stores the received PSTN XML for this dialog.</p> <p>NOTE 2: The received BearerCapability information should contain a Speech or 3,1 kHz BC.</p>	

If a high layer compatibility information element is present in the PSTN XML attachment of the 183 Session Progress, and if no progress indicator No. 1 (call is not end-to-end ISDN) or No. 2 (destination address is non-ISDN) has to be sent, table 5.1.1.2.1.3-1 is applicable.

b) High layer compatibility selection procedure

According to EN 300 403-1 [29], clause 5.12, the mapping shall be done as described in table 5.1.1.2.1.3-2.

Table 5.1.1.2.2.3-2: Sending of HLC fallback information

←Message sent to DSS 1	←183 Session Progress
← CALL PROCEEDING or PROGRESS	PSTN XML attachment
See note	HighLayerCapability Progress indicator No. 5
NOTE: The AGCF/VGW stores the received PSTN XML for this dialog.	

c) SDP selection procedure

When a SDP answer was received indicating no support of the 7 kHz call setup (no CLEARMODE codec in the m line), the fallback shall not apply as the call may not yet have reached its final destination (e.g. application of an indication).

Table 5.1.1.2.2.3-3: Sending of fallback information no support in the SDP

←Message sent to DSS 1	←183 Session Progress
←CALL PROCEEDING or PROGRESS	SDP
Progress Indicator No. 8 (see note)	CLEARMODE not the first codec on the codec list
NOTE: The AGCF/VGW may send the Progress Indicator No.8 also in a PROGRESS message to the user.	

5.1.1.3 Receipt of the 200 OK INVITE

Upon receipt of a 200 OK INVITE and the 200 OK INVITE does not contain the from-change tag in the Supported header, the AGCF/VGW shall send a CONNECT message across the user-network interface to the calling user. If the from-change tag in the Supported header is contained in the 200 OK INVITE, the applicable procedures are described in clause 5.2.2.2.

The SDP answer is described in annex B.

The CONNECT message is coded as follows.

Table 5.1.1.3-1: Sending criteria of the progress indicator information elements created by the VGW/AGCF

← CONNECT	←200 OK
Progress indicator information element	
Progress description No. 1 (see note 2) <i>(Call is not end-to-end ISDN: further progress information may be available in-band)</i>	No PSTN XML ProgressIndicator
Progress description No. Value of PI Progress description No. 4 (see note 3) <i>(Call has returned to the ISDN)</i>	PSTN XML with Progress indicator No (Value of PI) and PSTN XML ProgressIndicator No.7 (see note 1)
Progress description No. Value of PI (see note 4)	PSTN XML with Progress indicator No (Value of PI)
Progress description No. 4 (see note 3) <i>(Call has returned to the ISDN)</i>	PSTN XML ProgressIndicator No.7 (see note 1)
NOTE: 1 The ISDN access indicator - "Terminating access ISDN" is transported in the IMS as PSTN XML ProgressIndicator No.7 and is not sent to the access see annex E. NOTE 2: This value is sent if PI=1 not previously sent or PI=4 was signalled immediately previously. NOTE 3: This value is sent if PI=1 or PI=2 was signalled immediately previously. NOTE 4: Values 1 ("call is not end-end ISDN") or 2 ("destination address is not ISDN") are sent if Value 4 ("Call has returned to the ISDN") has been sent since value 1 or 2 was previously sent or if no value 1 or 2 was previously sent. Value 4 ("Call has returned to the ISDN") is sent if value 1 ("call is not end-end ISDN") or 2 ("destination address is not ISDN") was sent previously and no value 4 has been signalled since.	

NOTE: The PES AS assures that the correct PI and their combination is provided to the AGCF/VGW.

The CONNECT message sent to the access may contain two progress indicator information elements.

When more than two progress indicator information elements are to be sent, the subsequent progress indicator information elements shall be sent in a PROGRESS message.

High layer compatibility

If a high layer compatibility information element is present in the PSTN XML attachment of the 200 OK INVITE, see handling of fallback information at the end of this clause.

Low layer compatibility

The low layer compatibility possibly present in the PSTN XML attachment of the 200 OK INVITE is passed on unchanged.

History-Info header

See clause 5.2.

User-user

See clause 5.2.

P-Asserted-Identity

See clause 5.2.

Connected subaddress

See clause 5.2.

Handling of fallback information

According to EN 300 403-1 [29], clause 5.11, the mapping shall be done as described in table 5.1.1.3-2.

Table 5.1.1.3-2: Sending of BC fallback information

←CONNECT (see note 1)	←200 OK INVITE	
	PSTN XML attachment	SDP m line
BC derived from received BearerCapability (Unrestricted digital information with tones and announcements)	BearerCapability (unrestricted digital information with tones and announcements) (see note 2)	The first stated codec has to be consistent with the PSTN XML BearerCapability
BC derived from received BearerCapability (speech or 3,1 kHz audio) <i>Progress Indicator No. 5</i>	BearerCapability (speech or 3,1 kHz audio) (see note 2)	The first stated codec has to be consistent with the PSTN XML BearerCapability
B C (speech or 3,1 kHz audio) <i>Progress Indicator No. 5</i>	No PSTN XML attachment	The SDP answer has precedence (see note 3)
NOTE 1: If fallback allowed was indicated in the SETUP message, and fallback occurs at the destination, or fallback does not occur, the AGCF/VGW shall include in the CONNECT message the BC IE of the resultant bearer service.		
NOTE 2: If the SDP answer is not consistent with PSTN XML BearerCapability element, the call is released by the AGCF/VGW.		
NOTE 3: The SDP answer must indicate G.711 not CLEARMODE - if not then the AGCF/VGW releases the call.		
NOTE 4: The PSTN XML and SDP may be contained in the 200 OK or else stored from a 18X message in the same dialog.		

According to EN 300 403-1 [29], clause 5.12, the mapping shall be done as described in table 5.1.1.3-3.

Table 5.1.1.3-3: Sending of HLC fallback information

←CONNECT	←200 OK INVITE
Content	PSTN XML attachment
HLC	HighLayerCapability
Progress indicator No. 5	ProgressIndicator No. 5
NOTE 1: If procedures of BC fallback and HLC fallback both require the sending of the progress indicator No. 5, only one progress indicator No. 5 is sent.	
NOTE 2: The PSTN XML may be contained in the 200 OK or else stored from a 18X message in the same dialog.	

5.1.1.4 Receipt of (BYE or Final Response)

Table 5.1.1.4-1: Receipt (BYE or Final Response)

←DISCONNECT	←BYE/3xx/4xx/5xx/6xx
Cause information element	Reason header
Cause value No. X (see notes 1 and 2)	cause value No. X
Progress indicator No. 8 (see note 3) (In-band information or appropriate pattern now available)	
NOTE 1: If the cause value received in the Release message (BYE or Final Response) is unknown in DSS 1, the unspecified cause value of the class is sent. NOTE 2: Some supplementary services, such as CUG or UUS supplementary services, require the mapping of some causes values; see clause 5.2. NOTE 3: The progress indicator is only sent if the BC received in the SETUP message is coded <i>speech, 3,1 kHz audio</i> . NOTE 4: The location is coded '1010' <i>network beyond interworking point</i> . NOTE 5: The Progress Indicator may also be sent in a PROGRESS message. NOTE 6: If the 3xx response is not filtered by the AS, it can be received by the AGCF/VGW.	

The handling of the other parameters is described in clause 5.2.

The receipt of the release message (BYE or Final Response) during the user suspend/resume procedure is described in clause 5.2.

NOTE: For providing tones/announcements in the disconnect indication state (EN 300 403-1 [29]), three possibilities are applicable:

- 1) Provision of tones/announcements by the AGCF autonomously.
- 2) Provision of tones/announcements under the control of the AS, for which the impact on the AGCF/VGW is the receipt of either a reINVITE or REFER.
- 3) The AGCF/VGW has a pre-configured URI of the MRFC and establishes a session for providing the tones/announcements. The session to the MRFC is terminated with a BYE when a RELEASE message is sent or received from/to the DSS1 user.

If a Reason header is included in a 4XX, 5XX, 6XX final response, then the Cause Value of the Reason header shall be mapped to the DSS1 Cause Value sub-field in the DISCONNECT message. Otherwise coding of the Cause parameter value in the DISCONNECT message is derived from the SIP Status code received according to table 5.1.1.4-2. The Cause Values are defined in ETSI endorsement of ITU-T Recommendation Q.850 [27].

Table 5.1.1.4-2: 3xx/4xx/5xx/6xx Received on SIP side of O-AGCF/VGW

←DISCONNECT (cause value)	←3xx/4xx/5xx/6xx SIP final responses
127 (interworking unspecified)	400 Bad Request
127 (interworking unspecified)	401 Unauthorized
127 (interworking unspecified)	402 Payment Required
127 (interworking unspecified)	403 Forbidden
1 (Unallocated number)	404 Not Found
127 (interworking unspecified)	405 Method Not Allowed
127 (interworking unspecified)	406 Not Acceptable
127 (interworking unspecified)	407 Proxy authentication required
127 (interworking unspecified)	408 Request Timeout
22 (Number changed)	410 Gone
127 (interworking unspecified)	413 Request Entity too long
127 (interworking unspecified)	414 Request-URI too long
127 (interworking unspecified)	415 Unsupported Media type
127 (interworking unspecified)	416 Unsupported URI scheme
127 (interworking unspecified)	420 Bad Extension
127 (interworking unspecified)	421 Extension required
127 (interworking unspecified)	423 Interval Too Brief
24 (call rejected due to ACR supplementary service)	433 Anonymity Disallowed
20 Subscriber absent	480 Temporarily Unavailable
127 (interworking unspecified)	481 Call/Transaction does not exist
127 (interworking unspecified)	482 Loop detected
127 (interworking unspecified)	483 Too many hops
28 (Invalid Number format)	484 Address Incomplete
127 (interworking unspecified)	485 Ambiguous
17 (User busy)	486 Busy Here
127 (Interworking unspecified) or not interworked (see note 1)	487 Request terminated
127 (interworking unspecified)	488 Not acceptable here
127 (interworking unspecified)	493 Undecipherable
127 (interworking unspecified)	500 Server Internal error
127 (interworking unspecified)	501 Not implemented
127 (interworking unspecified)	502 Bad Gateway
127 (interworking unspecified)	503 Service Unavailable
127 (interworking unspecified)	504 Server timeout
127 (interworking unspecified)	505 Version not supported
127 (interworking unspecified)	513 Message too large
127 (interworking unspecified)	580 Precondition failure
17 (User busy)	600 Busy Everywhere
21 (Call rejected)	603 Decline
1 (unallocated number)	604 Does not exist anywhere
127 (interworking unspecified)	606 Not acceptable
NOTE 1: No interworking if the O-AGCF previously issued a CANCEL request for the INVITE.	
NOTE 2: The 4xx/5xx/6xx SIP responses that are not covered in this table are not interworked (i.e. mapped to cause 127).	
NOTE 3: The 3xx responses are not interworked (i.e. mapped to cause 127).	

5.1.1.5 Sending of (BYE or CANCEL)

Table 5.1.1.5-1: Call clearing from the user

DISCONNECT, RELEASE RELEASE COMPLETE→	BYE/CANCEL→
Cause information element	Reason header
Cause value No. X	cause value No. X (see notes 1 and 2)
NOTE 1: If the cause value received in the DSS 1 message is unknown in ISUP, the unspecified cause value of the class is sent.	
NOTE 2: Some supplementary services, such as CUG or UUS supplementary services, require the mapping of some cause values; see clause 5.2.	

5.1.1.6 Use of Overlap Signalling (Optional)

If Overlap Signalling is supported between the AGCF/VGW and the originating PES Application Server the Overlap Signalling method used, either the Multiples INVITES method or the IN-Dialog method as described within annexes G and H is dependent on national or network operator option.

5.1.2 Actions at the Incoming AGCF/VGW

5.1.2.1 Sending of the SETUP message

On reception of a SIP INVITE, the AGCF/VGW shall send an SETUP message.

An AGCF/VGW shall support both incoming INVITE requests containing SIP preconditions and 100rel extensions in the SIP Supported or Require headers, and INVITE requests not containing these extensions.

If the SDP in the received INVITE request contains preconditions not met, the AGCF/VGW shall delay sending the SETUP until the SIP preconditions are met.

The AGCF/VGW shall reject an INVITE request for a session only containing unsupported media types by sending a status code 488 (Unsupported media type). If several media streams are contained in a single INVITE request, the AGCF/VGW shall select one of the supported media streams, reserve the codec(s) for that media stream, and reject the other media streams and unselected codecs in the SDP answer, as detailed in RFC 3264 [52]. If supported audio media stream(s) and supported non-audio media stream(s) are contained in a single INVITE request, an audio stream should be selected.

The AGCF/VGW shall include a To tag in the first backward non-100 provisional response, in order to establish an early dialog as described in RFC 3261 [53].

The information elements carried in the PSTN XML attachment of the INVITE are taken into account whatever the order of receipt, except when two bearer capability and/or two high layer compatibility information elements are received: the order of these two information elements shall be treated according to EN 300 403-1 [29], see table 5.1.2.1-1.

Only the information elements involved in the interworking are described hereafter.

The information elements used for the supplementary services are described in clause 5.2.

For the case a PSTN XML SendingCompleteIndicator is received in an INVITE, a Sending Complete information element is contained in the SETUP and INFO, timer T304 is not started.

Bearer capability

NOTE: The message side and direction has been changed to be in-line with the usual mapping as in EN 300 899-1 [2] ISUP-DSS1.

Table 5.1.2.1-1: Coding of the Bearer Capability information element (BC)

INVITE→	SETUP→
Content	Bearer capability information element
PSTN XML BearerCapability	BC information is taken from PSTN XML BearerCapability
PSTN XML BearerCapability 1 <i>Speech, or 3,1 kHz audio</i>	First BC information is derived from first PSTN XML BearerCapability (see note 1)
PSTN XML BearerCapability 2 <i>Unrestricted digital information with tones and announcements</i>	Second BC information is derived taken from second PSTN XML BearerCapability (see note 1)
No PSTN XML BearerCapability	See table 5.1.2.1-2
NOTE 1: BC 1 is the bearer capability information element sent in first position in the SETUP message, BC 2 in second position. Bearer capability information elements shall be sent in ascending order of priority as described in section 5.11.2.1/ITU-T Recommendation Q.931 [54].	
NOTE 2: Basic coding of the Bearer Capability IE.	

If the INVITE does not contain SDP information but a bearer capability information in the PSTN XML body is present, this is an error and the call shall be rejected with the status code 606. If the INVITE message does not contain any bearer information (neither bearer info in SDP nor in PSTN XML body), the AGCF/VGW may postpone the sending of the SETUP message. The AGCF/VGW may send a SDP offer including a media description, the content of which is determined using local policy within a 183 (Session Progress) response message. The SETUP message shall then be sent when the AGCF/VGW has received sufficient information to create the BC/HLC, else the call shall be cleared with status code 606.

Table 5.1.2.1-2: Coding of from SDP: SIP to DSS1

m= line			b= line (see note 4)	a= line	BC IE (normative) (see note 1)		HLC parameter (optional)
<media>	<transport>	<fmt-list>	<modifier>:<bandwidth-value> (see note 5)	Rtpmap:<dynamic-PT> <encoding name>/<clock rate>/encoding parameters>	Information Transport Capability	User Information Layer 1 Protocol Indicator	High Layer Characteristics Identification
Audio	RTP/AVP	0	N/A or up to 64 kbit/s	N/A	"3,1 kHz audio"	"G.711 A-law"	(see note 3)
Audio	RTP/AVP	0	N/A or up to 64 kbit/s	N/A	"3,1 kHz audio"	"G.711 μ -law"	(see note 3)
Audio	RTP/AVP	Dynamic PT	N/A or up to 64 kbit/s	rtpmap:<dynamic-PT> PCMU/8000	"3,1 kHz audio"	"G.711 A-law"	(see note 3)
Audio	RTP/AVP	Dynamic PT	N/A or up to 64 kbit/s	rtpmap:<dynamic-PT> PCMU/8000	"3,1 kHz audio"	"G.711 μ -law"	(see note 3)
Audio	RTP/AVP	8	N/A or up to 64 kbit/s	N/A	"3,1 kHz audio"	"G.711 A-law"	(see note 3)
Audio	RTP/AVP	8	N/A or up to 64 kbit/s	N/A	"3,1 kHz audio"	"G.711 μ -law"	(see note 3)
Audio	RTP/AVP	Dynamic PT	N/A or up to 64 kbit/s	rtpmap:<dynamic-PT> PCMA/8000	"3,1 kHz audio"	"G.711 A-law"	(see note 3)
Audio	RTP/AVP	Dynamic PT	N/A or up to 64 kbit/s	rtpmap:<dynamic-PT> PCMA/8000	"3,1 kHz audio"	"G.711 μ -law"	(see note 3)
Audio	RTP/AVP	Dynamic PT,	AS: 64 kbit/s	rtpmap:<dynamic-PT> CLEARMODE/8000	"Unrestricted digital inf. W/tone/ann." (see notes 6 and 7)	Mapped from the PSTN XML attachment	Mapped from the PSTN XML attachment
Audio	RTP/AVP	Dynamic PT	AS: 64 kbit/s	Rtpmap:<dynamic-PT> CLEARMODE/8000 (see note 2)	"Unrestricted digital information"	Mapped from the PSTN XML attachment	
Image	Udptl	t38 [56]	N/A or up to 64 kbit/s	Based on ITU-T Recommendation T.38 [56]	"3,1 kHz audio"	"G.711 A-law"	"Facsimile Group 2/3"
Image	Tcptl	t38 [56]	N/A or up to 64 kbit/s	Based on ITU-T Recommendation T.38 [56]	"3,1 kHz audio"	"G.711 A-law"	"Facsimile Group 2/3"
Image	Udptl	t38 [56]	N/A or up to 64 kbit/s	Based on ITU-T Recommendation T.38 [56]	"3,1 kHz audio"	"G.711 μ -law"	"Facsimile Group 2/3"
Image	Tcptl	t38 [56]	N/A or up to 64 kbit/s	Based on ITU-T Recommendation T.38 [56]	"3,1 kHz audio"	"G.711 μ -law"	"Facsimile Group 2/3"

NOTE 1: In this table the codec G.711 is used only as an example. Other codecs are possible.

NOTE 2: CLEARMODE is specified in RFC 4040 [51].

NOTE 3: HLC is normally absent in this case. It is possible for HLC to be present with the value "Telephony", although clause 6.3.1/ITU-T Recommendation Q.939 [55] indicates that this would normally be accompanied by a value of "Speech" for the Information Transfer Capability element.

NOTE 4: If the b=line indicates a bandwidth greater than 64 kbit/s then the call may use compression techniques or reject the call with a 415 response indicating that only one media stream of 64 kbit/s is supported.

NOTE 5: <bandwidth value> for <modifier> of AS is in units of kbit/s.

NOTE 6: The mapping of the "Information Transport Capability" to the proper codec is explained in annex B.

NOTE 7: The value "Unrestricted digital inf. w/tones/ann" should only be used if the Clearmode codec appears together with speech codecs in the same m-line.

Progress indicator

Table 5.1.2.1-3: Coding of the progress indicator information element

INVITE→	SETUP→
	Progress indicator information element
PSTN XML attachment	
ProgressIndicator. No. (Value of PI) and PSTN XML and ProgressIndicator No.6 (see note 2)	Progress indicator No. Value of PI (see note 1)
ProgressIndicator No.6 (see note 2)	
No PSTN XML	Progress indicator No. 1
NOTE 1: Except value No. 6 which is not defined in EN 300 403-1 [29].	
NOTE 2: The ISDN access indicator - "originating access ISDN" is transported in the IMS as PSTN XML ProgressIndicator No.6 and is not sent to the access, see annex E.	

Low layer compatibility

If the low layer compatibility information element is present in the PSTN XML attachment, LowLayerCompatibility of the INVITE, it is converted into the LLC in the SETUP message.

High layer compatibility

If the high layer compatibility information element is present in the PSTN XML attachment, HighLayerCompatibility of the INVITE, it is converted into the HLC in the SETUP message.

If two high layer compatibility information elements are received in the PSTN XML attachment, HighLayerCompatibility of the INVITE, they are converted into the HLC in the same order in the SETUP message (the meaning of HLC order is described in clause 5.12.3.2/ITU-T Recommendation Q.931 [54]).

Calling party number

See clause 5.2.

Calling party subaddress

See clause 5.2.

Called party subaddress

See clause 5.2.

User-user

See clause 5.2.

Table 5.1.2.1-4: Mapping SIP Request-URI to DSS1 Called Party Number

INVITE	SETUP
Request-URI	Called Party Number
E164 Address (format "+CC+NDC+SN) (e.g. as User info in SIP URI with user= phone, or as tel URI)	Type of number
	National number NDC+SN
	International number "+CC+NDC+SN
	Subscriber number SN

5.1.2.2 Sending of the 18x from the destination VGW/AGCF

Table 5.1.2.2-1: Interworking of CALL PROCEEDING/PROGRESS

← Message on the SIP 183 Session Progress	←Message sent to the DSS 1 CALL PROCEEDING / PROGRESS Progress indicator information element
PSTN XML with ProgressIndicator Value of PI and PSTN XML ProgressIndicator No.7 (see note 2)	No. Value of PI
PSTN XML ProgressIndicator No.7 (see note 2)	
NOTE 1: The P-Earl-Media header is only sent if the BearerCapability received in the INVITE message is coded <i>speech, 3,1 kHz audio</i> .	
NOTE 2: The ISDN access indicator - "Terminating access ISDN" is transported in the IMS as PSTN XML ProgressIndicator No.7, see annex E.	

The SDP answer is described in annex B.

If *en bloc* sending is used on the DSS 1 side, the SETUP message shall contain all the information required by the called user to process the call.

If overlap sending is used, and if the SETUP message has already be sent and the SETUP ACKNOWLEDGE message received, an INFORMATION message is sent upon receipt of each Subsequent INVITE message.

The following cases are possible trigger conditions of sending the 18x message:

- The destination VGW/AGCF has determined independently of access indications that the complete called party number has been received, a 183 Session Progress is sent.
- Overlap receiving is used on the DSS 1 side and a CALL PROCEEDING is received, a 183 Session Progress is sent.
- En bloc receiving is used on the DSS 1 side and a Progress indicator information element is received in a CALL PROCEEDING message or in a PROGRESS message, a 183 Session Progress is sent. (except with value No. 8, in-band information or an appropriate pattern is now available, No. 3, originating address is non-ISDN is received in a CALL PROCEEDING message or in a PROGRESS message, a 183 Session Progress is sent.
- The first ALERTING message is received a 180 Ringing is sent.
- It has been determined, in case of call failure, that a special in-band tone or announcement has to be returned to the calling party from the destination VGW/AGCF, a 183 Session Progress is sent.

On *speech* or *3,1 kHz* calls, the awaiting answer indication (e.g. ring tone) is sent to the calling party upon receipt of the first ALERTING message.

Table 5.1.2.2-2: Interworking of ALERTING

←180 Ringing	← ALERTING Progress indicator information element
PSTN XML with Progress indicator Value of PI and PSTN XML ProgressIndicator No. 7 (see note 2)	No. Value of PI
P-Early-Media header PSTN XML with Progress indicator 8 (see note 1)	
PSTN XML ProgressIndicator No. 7 (see note 2)	
NOTE 1: The P-Earl-Media header is only sent if the BearerCapability received in the INVITE message is coded "speech", "3,1 kHz audio".	
NOTE 2: The ISDN access indicator - "Terminating access ISDN" is transported in the IMS as PSTN XML ProgressIndicator No.7, see annex E.	

The SDP answer is described in annex B.

If the 180 Ringing has already been sent, the following cases are possible trigger conditions of sending the 183 Session Progress:

- a) It has been determined, in case of call failure, that a special in-band tone or announcement has to be returned to the calling party from the destination VGW/AGCF.
- b) It has been determined that an in-band tone or announcement has to be returned to the calling party from the destination VGW/AGCF.

Table 5.1.2.2-3: Contents of 183 Session Progress message if a 180 Ringing has already been sent

← Message on the SIP 183 Session Progress
P-Early-Media header PSTN XML with Progress indicator 8 (see note 1)
NOTE 1: The P-Earl-Media header is only sent if the PSTN XML BearerCapability received in the INVITE message is coded <i>speech, 3,1 kHz audio</i> .
NOTE 2: This ensures that the originating side receives an indication that the terminating access is ISDN.

MANDATORY PARAMETERS

None.

OPTIONAL PARAMETERS

The P-Early-Media header authorization of early media if it has been determined, that an in-band tone or announcement has to be returned to the calling party from the destination gateway.

NOTE: Tones and announcements can as well provided by the MRFC.

PSTN XML attachment HLC, LLC, Progress indicator, etc

This extension carries the progress indicator information element possibly received from the called user (except the value No. 8).

It may carry other information element as well: see clause 5.2 and tables 5.1.2.2-4 and 5.1.2.2-5.

History-Info header

See clause 5.2.

Handling of fallback information (only applicable at T reference point)

When the *terminating gateway* has knowledge that the fallback capability was requested in the Initial INVITE, and if no progress indicator No. 1 or No. 2 has been received from the DSS 1 side, tables 5.1.2.2-4 and 5.1.2.2-5 are applicable.

Table 5.1.2.2-4: Handling of BC fallback information

←18x	←Message received from the access
PSTN XML attachment	Content
BearerCapability derived from received DSS1 BC (<i>speech or 3,1 kHz audio</i>) ProgressIndicator. No. 5	BC low (<i>speech or 3,1 kHz audio</i>) p.i. No. 5

The SDP answer is described in annex B.

Table 5.1.2.2-5: Handling of HLC fallback information

←18x	←Message received from the access
PSTN XML attachment	Content
HighLayerCompatibility ProgressIndicator. No. 5	HLC Progress indicator No. 5

The SDP answer is described in annex B.

5.1.2.3 Sending of the 200 OK INVITE

Upon receipt of the CONNECT message, the *destination AGCF/VGW* shall:

- stop the sending of the awaiting answer indication (if any);
- send the 200 OK INVITE to the preceding entity.

NOTE: Tones and announcements can as well provided by the MRFC.

The 200 OK INVITE is coded as follows:

OPTIONAL PARAMETERS

P-Asserted-Identity

See clause 5.2.

A second identity is also delivered in a changed From header in an UPDATE request, in detail described in clause 5.2.2.

PSTN XML attachment

Table 5.1.2.3-1: Contents of the PSTN XML attachment

← 200 OK INVITE	←CONNECT
PSTN XML attachment	Information elements
ProgressIndicator No (Value of PI) and ProgressIndicator No 7 (see annex E)	Progress indicator No. Value of PI
LowLayerCompatibility and ProgressIndicator No 7 (see annex E)	Low layer compatibility
High layer compatibility and ProgressIndicator No. 7 (see annex E)	High layer compatibility
Bearer Capability and ProgressIndicator No. 7 (see annex E)	Bearer Capability
ProgressIndicator No 7 (see annex E)	

It may carry other information elements as well: See clause 5.2 and tables 5.1.2.3-2 to 5.1.2.3-5.

The SDP answer is described in annex B.

Handling of fallback information

When the *terminating AGCF/VGW* has knowledge that the fallback capability was requested in the Initial INVITE, and if no progress indicator No. 1 or No. 2 has been received from the DSS 1 side, tables 5.1.2.3-2 to 5.1.2.3-5 are applicable.

Coincident S and T reference point

Table 5.1.2.3-2: Handling of BC fallback information Coincident S and T reference point

← 200 OK INVITE PSTN XML attachment	←CONNECT Content
BearerCapability (unrestricted digital information with tones and announcements)	BC (unrestricted digital information with tones and announcements)
BearerCapability (speech or 3,1 kHz audio)	BC (speech or 3,1 kHz audio)
BearerCapability received in the PSTN XML attachment of the received INVITE request (speech or 3,1 kHz audio)	No BC

The SDP answer is described in annex B.

Table 5.1.2.3-3: Handling of HLC fallback information Coincident S and T reference point

←200 OK INVITE PSTN XML attachment	←CONNECT Content
HighLayerCompatibility	HLC
HighLayerCompatibility received in first position in the PSTN XML attachment of the INVITE request	No HLC

The SDP answer is described in annex B.

T reference point

Table 5.1.2.3-4: Handling of BC fallback information T reference point

← 200 OK INVITE PSTN XML attachment	←CONNECT Content
BearerCapability (unrestricted digital information with tones and announcements)	BC (unrestricted digital information with tones and announcements)
BearerCapability (speech or 3,1 kHz audio)	BC (speech or 3,1 kHz audio)
BearerCapability (speech or 3,1 kHz audio) ProgressIndicator. No. 5	BC (speech or 3,1 kHz audio) p.i. No. 5
BearerCapability received in the PSTN XML attachment of the INVITE request (speech or 3,1 kHz audio) ProgressIndicator No. 5	No BC (see note)
NOTE: In this case, the fallback information coded in the PSTN XML attachment are not repeated if already sent in a previous backward message.	

The SDP answer is described in annex B.

Table 5.1.2.3-5: Handling of HLC fallback information T reference point

←200 OK INVITE PSTN XML attachment	←CONNECT Content
HighLayerCompatibility	HLC
HighLayerCompatibility ProgressIndicator No. 5	HLC Progress indicator No. 5
No HighLayerCompatibility	No HLC

The SDP answer is described in annex B.

5.1.2.4 Receipt of BYE/CANCEL

Table 5.1.2.4-1: Receipt of BYE/CANCEL

BYE/CANCEL→	DISCONNECT →
Reason header	Cause information element
cause No. X	Cause value No. X (see notes 1 and 2)
NOTE 1: If the Reason value received in the Release message (BYE/CANCEL) is unknown in DSS 1, the unspecified cause value of the class is sent.	
NOTE 2: Some supplementary services, such as CUG or UUS supplementary services, require the mapping of some cause values: see clause 5.2.	
NOTE 3: The location is coded '1010' <i>network beyond interworking point</i> .	

The handling of the other parameters is described in clause 5.2.

5.1.2.5 Sending of BYE/4xx/5xx

If a DISCONNECT, RELEASE or RELEASE COMPLETE message is received and a final response (i.e. 200 OK (INVITE)) has already been sent, the I-AGCF/VGW shall send a BYE message. "The Cause Value sub-field received in the DISCONNECT, RELEASE or RELEASE COMPLETE message shall be mapped to the cause value of the Reason header of the BYE message".

If the DISCONNECT, RELEASE or RELEASE COMPLETE message is received and the final response (i.e. 200 OK (INVITE)) has not already been sent, the I-AGCF/VGW shall send a Status-Code 4xx (Client Error) or 5xx (Server Error) response. The Status code to be sent is determined by examining the Cause code value received in the DISCONNECT, RELEASE or RELEASE COMPLETE message. Table 5.1.2.5-2 specifies the mapping of the cause code values to SIP response status codes. Cause code values not appearing in the table shall have the same mapping as the appropriate class defaults according to the ETSI endorsement of ITU-T Recommendation Q.850 [27].

Table 5.1.2.5-1: Call clearing during call establishment

← BYE/4xx/5xx	←DISCONNECT RELEASE RELEASE COMPLETE (see note 1)
Reason header	Cause information element
cause No. X (see note 2)	Cause value No. X
NOTE 1: In case of coincident S and T reference point, clause 5.2.5.3/ITU-T Recommendation Q.931 [54] describes how these messages are taken into account when they are received during call establishment.	
NOTE 2: If the cause value received in the DSS 1 message is unknown in ISUP, the unspecified cause value of the class is sent.	
NOTE 3: Some supplementary services, such as CUG or UUS supplementary services, require the mapping of some cause values: see clause 5.2.	

The handling of the other parameters possibly present in the Release message BYE or 4xx/5xx is described in clause 5.2.

Table 5.1.2.5-2: Receipt of DISCONNECT, RELEASE or RELEASE COMPLETE message

← SIP final response Status code	← DISCONNECT, RELEASE, RELEASE COMPLETE Cause value
404 Not Found	Cause value No. 1 (unallocated (unassigned) number)
500 Server Internal error	Cause value No 2 (no route to network)
500 Server Internal error	Cause value No 3 (no route to destination)
500 Server Internal error	Cause value No. 4 (Send special information tone)
404 Not Found	Cause value No. 5 (Misdialed trunk prefix)
486 Busy Here	Cause value No. 17 (user busy)
480 Temporarily unavailable	Cause value No 18 (no user responding)
480 Temporarily unavailable	Cause value No 19 (no answer from the user)
480 Temporarily unavailable	Cause value No. 20 (subscriber absent)
603 Decline	Cause value No 21 (call rejected), Location = 000 / user (U)
480 Temporarily unavailable	Cause value No 21 (call rejected) , Location <> 000 / user (U)
410 Gone	Cause value No 22 (number changed)
433 Anonymity Disallowed	Cause value No. 24 (call rejected due to ACR supplementary service)
480 Temporarily unavailable	Cause value No 25 (Exchange routing error)
502 Bad Gateway	Cause value No 27 (destination out of order)
484 Address Incomplete	Cause value No. 28 invalid number format (address incomplete)
500 Server Internal error	Cause value No 29 (facility rejected)
480 Temporarily unavailable	Cause value No 31 (normal unspecified) (class default) (see note)
486 Busy here if CCBS-T-Available invoke component is present) else 480 Temporarily unavailable	Cause value in the Class 010 (resource unavailable, Cause value No 34)
500 Server Internal error	Cause value in the Class 010 (resource unavailable, Cause value No's. 38, 41, 42, 43, 44, & 47) (47 is class default)
500 Server Internal error	Cause value No 50 (requested facility no subscribed)
500 Server Internal error	Cause value No 57 (bearer capability not authorised)
500 Server Internal error	Cause value No 58 (bearer capability not presently)
500 Server Internal error	Cause value No 63 (service option not available, unspecified) (class default)
500 Server Internal error	Cause value in the Class 100 (service or option not implemented, Cause value No's. 65, 70 and 79) 79 is class default
500 Server Internal error	Cause value No 88 (incompatible destination)
404 Not Found	Cause value No 91 (invalid transit network selection)
500 Server Internal error	Cause value No 95 (invalid message) (class default)
500 Server Internal error	Cause value No 97 (Message type non-existent or not implemented)
500 Server Internal error	Cause value No 99 (information element/parameter non-existent or not implemented)
480 Temporarily unavailable	Cause value No. 102 (recovery on timer expiry)
500 Server Internal error	Cause value No 110 (Message with unrecognised Parameter, discarded)
500 Server Internal error	Cause value No. 111 (protocol error, unspecified) (class default)
480 Temporarily unavailable	Cause value No. 127 (interworking unspecified) (class default)
NOTE: Class 1 and class 2 have the same default value.	

5.1.2.6 Sending of the DSS1 INFO (Optional)

If Overlap Signalling is supported between the AGCF/VGW and the terminating PES Application Server the Overlap Signalling method used, either the Multiples INVITES method or the IN-Dialog method as described within annexes D and E is dependent on national or network operator option.

5.2 Supplementary services

This clause discusses the impact of supplementary services on the AGCF/VGW. Table 5.2-1 lists the supplementary services covered and the corresponding references to the PES simulation service specifications.

Table 5.2-1: PES Simulation Supplementary Services

Supplementary Service	Reference
Communication Hold (HOLD)	[10]
Connected Line Identification Presentation (COLP) & Connected Line Identification Restriction (COLR)	[7]
Calling Line Identification Presentation (CLIP) & Calling Line Identification Restriction (CLIR)	[6]
Conference Call (CONF)	[9]
Communication Diversion Services (CDIV)	[8]
Malicious Call Identification (MCID)	[46]
Explicit Call Transfer (ECT)	[36]
Subaddressing (SUB)	-
Closed User Group (CUG)	[28]
User-to-User Signalling (UUS)	-
Communication Waiting (CW)	[58]
Terminal Portability (TP)	
Three Party (3PTY)	[9]
Completion of Communications to Busy Subscriber (CCBS) & Completion of Communications by No Reply (CCNR)	[59]
Advice of Charge (AOC)	[31]
Message Waiting Indication (MWI)	[26]

5.2.1 Communication Hold (HOLD)

5.2.1.1 Actions at the Incoming AGCF/VGW

5.2.1.1.1 Notification received from the network

Table 5.2.1.1.1-1: HOLD notification

INVITE/UPDATE →	NOTIFY →
SDP: a=sendonly/inactive	Notification indicator information element
	Notification description
sendonly/inactive	111 1001 <i>Remote hold</i>
sendreceive	111 1010 <i>Remote retrieval</i>

5.2.1.1.2 Invocation at coincident S and T reference point

Table 5.2.1.1.2-1: HOLD invocation

← INVITE/UPDATE	← Message received from the DSS 1
SDP: a=sendonly/inactive	
sendonly/inactive	HOLD
sendreceive	RETRIEVE

5.2.1.1.3 Notification received at T reference point

A HOLD notification may be received at T reference point in the active phase of the call.

Table 5.2.1.1.3-1: Receipt of a HOLD notification from a private network

←INVITE/UPDATE	←NOTIFY
SDP: a=sendonly/inactive	Notification indicator information element
	Notification description
sendonly/inactive	111 1001 <i>Remote hold</i>
sendreceive	111 1010 <i>Remote retrieval</i>

5.2.1.2 Actions at the outgoing AGCF/VGW

5.2.1.2.1 Notification received from the network

Table 5.2.1.2.1-1: Receipt of HOLD notification from the network

←NOTIFY	←INVITE/UPDATE
Notification indicator information element	SDP: a=sendonly/inactive
Notification description	
111 1001 <i>Remote hold</i>	sendonly/inactive
111 1010 <i>Remote retrieval</i>	sendreceive

5.2.1.2.2 Invocation at coincident S and T reference point

Table 5.2.1.2.2-1: HOLD invocation

Message received from the DSS 1 →	INVITE/UPDATE→
	SDP: a=sendonly/inactive
HOLD	sendonly/inactive
RETRIEVE	sendreceive

5.2.1.2.3 Notification received at T reference point

A HOLD notification may be received at T reference point in the active phase of the call.

Table 5.2.1.2.3-1: Receipt of a HOLD notification from a private network

NOTIFY→	INVITE / UPDATE→
Notification indicator information element	SDP: a=sendonly/inactive
Notification description	
111 1001 <i>Remote hold</i>	sendonly/inactive
111 1010 <i>Remote retrieval</i>	sendreceive

5.2.2 Connected Line Identification Presentation (COLP) / Connected Line Identification Restriction (COLR)

5.2.2.1 Actions at the incoming AGCF/VGW

If the Initial INVITE is received and the Supported header contains the "from-change" tag, then the P-Asserted-Identity in the 200 OK INVITE or UPDATE request and the changed From header in the UPDATE are sent as described in tables 5.2.2.1.1-1 and 5.2.2.1.1-2.

5.2.2.1.1 Connected Line Identification Presentation (COLP)

The AGCF/VGW shall sent first a 200 OK INVITE including an option tag "from-change" and after then an UPDATE request as shown in table 5.2.2.1.1-1 according the rules of RFC 4916 [50].

200 OK and UPDATE is sent on the Mw interface

Table 5.2.2.1.1-1: Connected number interworking applies at Mw interface

←200 OK INVITE	←UPDATE	←CONNECT	
		Connected number IE.	
		Numbering plan identification	Type of number
No "from-change" tag in the supported header P-Asserted-Identity containing the value saved from the P-Called-Party-ID header that was received in the INVITE request.	No UPDATE	No or invalid (see note 1) connected number information element	
No "from-change" tag in the supported header P-Asserted-Identity with a value, including the display name if previously stored during registration representing the terminating user indicated in the connected number.	No UPDATE	ISDN/telephony numbering plan or Unknown	unknown
		Address digits	
No "from-change" tag in the supported header P-Asserted-Identity with a value, including the display name if previously stored during registration representing the terminating user indicated in the connected number.	No UPDATE	ISDN/telephony numbering plan or Unknown	Subscriber number
		Address digits	
"from-change" tag in the supported header P-Asserted-Identity with a value, including the display name if previously stored during registration representing the terminating user indicated in the connected number.	Userinfo of the changed From header derived from the Address digits in the format: sip: local-number-digits = Address digits; phone-context=xxxxxx@hostportion; user=phone (see note 2).	ISDN/telephony numbering plan or Unknown	National number
		Address digits	

←200 OK INVITE	←UPDATE	←CONNECT	
		Connected number IE.	
		Numbering plan identification	Type of number
"from-change" tag in the supported header		<i>ISDN/telephony numbering plan or unknown</i>	<i>international number</i>
P-Asserted-Identity with a value, including the display name if previously stored during registration representing the terminating user indicated in the connected number.	Userinfo of the changed From header derived from the Address digits in the format: sip:global-number-digits@hostportion;user=phone.	Address digits	
NOTE 1: Validity conditions of the connected number information element are defined in clause 5.5.2.3/ITU-T Recommendation Q.931 [54].			
NOTE 2: The combination of dialled digits and phone-context parameter shall globally unique in the network as defined in RFC 3966 [47].			

If the "from-change" tag in the Supported header in the Initial INVITE is not received, then no UPDATE is sent. A P-Asserted-Identity header with the value saved from the P-Called-Party-ID header that was received in the request is contained in the 200 OK (INVITE).

Connected subaddress

If provided, the connected subaddress is transported in the changed From header field of the UPDATE request.

200 OK and UPDATE is sent on the Gm interface

Table 5.2.2.1.1-2: Connected number interworking applies at Gm interface

←200 OK INVITE	←UPDATE	←CONNECT	
		Connected number IE.	
		Numbering plan identification	Type of number
No "from-change" tag in the supported header	No UPDATE	No or invalid (see note 1) connected number information element	
No "from-change" tag in the supported header	No UPDATE	ISDN/telephony numbering plan or Unknown Address digits	unknown
No "from-change" tag in the supported header	No UPDATE	ISDN/telephony numbering plan or Unknown Address digits	Subscriber number
"from-change" tag in the supported header		ISDN/telephony numbering plan or Unknown	National number
	Userinfo of the changed From header derived from the Address digits in the format: sip: local-number-digits = Address digits; phone-context=xxxxxx@hostportion; user=phone (see note 2)	Address digits	
		ISDN/telephony numbering plan or unknown	international number
	Userinfo of the changed From header derived from the Address digits in the format: sip: global -number-digits = Address digits @hostportion; user=phone	Address digits	
NOTE 1: Validity conditions of the connected number information element are defined in clause 5.5.2.3/ITU-T Recommendation Q.931 [54].			
NOTE 2: The combination of dialled digits and phone-context parameter shall globally unique in the network as defined in RFC 3966 [47].			

Connected subaddress

If provided, the connected subaddress is transported in the changed From header field of the UPDATE request.

5.2.2.1.2 Connected Line Identification Restriction (COLR)

Table 5.2.2.1.2-1: Coding of the Privacy header field

←200 OK INVITE	←CONNECT
Privacy header field	Connected number information element Presentation indicator
"id", "header", "user"	Presentation restricted
No Privacy header	Absent
"none"	Presentation allowed

5.2.2.2 Actions at the outgoing AGCF/VGW

5.2.2.2.1 Connected Line Identification Presentation (COLP)

NOTE: Depending on national regulations, some networks may define categories of subscribers that have the ability to override the presentation restriction and have the connected party's ISDN number, and subaddress information (if any) presented (e.g. the police). The ability to override the presentation restriction and the protocol to support such a service is a national matter.

The option tag "from-change" is added to the supported header in the initial INVITE.

Only one connected number information element is sent in the CONNECT message.

If a 200 OK final response including the option tag "from-change" is received then T_{TIR1} shall be started if P-Asserted-Identity value is in the format of a tel URI or sip URI and no Privacy (including Privacy value of none) is present. In this case the interworking as described in tables 5.2.2.2.1-1 and 5.2.2.2.1-3 applies. The 200 OK INVITE to a CONNECT shall be held up till the UPDATE containing the changed From and To information is received and timer T_{TIR1} is running ELSE the 200 OK INVITE shall be mapped immediately as described within tables 5.2.2.2.1-1 and 5.2.2.2.1-2. At expiry of T_{TIR1} the 200 OK INVITE shall be mapped as described in table 5.2.2.2.1-2.

If no P-Asserted-Identity header was received and no Privacy "id" or "header" was received in the 200 OK final response this is assumed as the originating user has not subscribed the COLP service.

If several responses contain a P-Asserted-Identity header field, only the latest received P-Asserted-Identity header should be used for a Connected number sent in a CONNECT message to the calling user.

Table 5.2.2.2.1-1: COLP information sent to the calling user

←CONNECT	←200 OK INVITE		
COLP information sent to the calling user	P-Asserted-Identity	Privacy header	Supported header
Connected number IE (see table 5.2.2.2.1-2)	Userinfo in the format of a tel URI	<i>No Privacy present or Priv .value none</i>	No "from-change"
Connected number IE (see table 5.2.2.2.1-3)	Userinfo in the format of a tel URI	<i>No Privacy present or Priv .value none</i>	"from-change"
Connected number IE Type of number <i>Unknown</i> Numbering plan <i>Unknown</i> Presentation ind. <i>Presentation restricted</i> Screening ind. <i>Network provided</i> Number digits <i>No digit</i>	Not present	<i>id or header</i>	Value non-significant
No Connected number IE	No P-Asserted-Identity header field	<i>no Privacy present</i>	Value non-significant

If the P-Asserted-Identity header is received at the AGCF/VGW it is assumed that the originating user subscribes the COLP supplementary service.

Table 5.2.2.1-2: Coding of the connected number information element according to the P-Asserted-Identity header field

←CONNECT	←200 OK INVITE
Connected number IE	P-Asserted-Identity
Type of number (see note) <i>National number</i> <i>International number</i>	userinfo sip: local-number-digits; phone-context=nat @hostportion; user=phone sip: global-number-digits@hostportion; user=phone
Numbering plan identification <i>ISDN/Telephony numbering plan</i>	
Presentation indicator <i>Presentation allowed</i>	
Screening indicator <i>Network provided</i>	
Number digits derived from the userinfo. In case for global number and the country code is the same as the AGCF/VGW or line is located, the country code is removed from the number of the Type of number is set to "national number	
NOTE: As a network option, the type of number may be coded <i>unknown</i> when a prefix is added to the number.	

Table 5.2.2.1-3: Coding of the connected number information element according to the changed From header

←CONNECT	←UPDATE
Connected number IE	From header
Type of number (see note) <i>National number</i> <i>International number</i>	userinfo sip: local-number-digits; phone-context=nat @hostportion; user=phone sip: global-number-digits@hostportion; user=phone
Numbering plan identification <i>ISDN/Telephony numbering plan</i>	
Presentation indicator <i>Presentation allowed</i>	
Screening indicator <i>User provided, not verified</i>	
Number digits derived from the userinfo. In case for global number and the country code is the same as the AGCF/VGW or line is located, the country code is removed from the number of the Type of number is set to "national number	
NOTE: As a network option, the type of number may be coded <i>unknown</i> when a prefix is added to the number.	

Connected subaddress

Table 5.2.2.2.1-4: Sending of the connected subaddress

←CONNECT	←UPDATE	
Content	Changed From isub parameter	Privacy header
Connected subaddress information element	Connected subaddress address string	<i>absent or not "id"</i>
No connected subaddress information element	Connected subaddress address string	<i>"id" or "header"</i> or No connected number parameter
NOTE: As a national option, the presentation restriction indication received in the connected number parameter can be overridden for specific calling access' categories. In such a case, the same actions are taken as if <i>presentation allowed</i> was received.		

5.2.2.2.2 Connected line identification restriction (COLR)

See table 5.2.2.2.1-1.

5.2.3 Calling line Identification Presentation (CLIP) / Calling line Identification Restriction (CLIR)

5.2.3.1 Actions at the incoming AGCF/VGW

Table 5.2.3.1-1: Mapping of SIP From/P-Asserted-Identity/ Privacy header fields to CLI parameters

P-Asserted-Identity	INVITE→		SETUP→
	From header	Privacy	Coding of the calling party number information element
Absent	Value not significant (see note)	No Privacy header	No Calling number IE
Absent	"Anonymous" < sip:anonymous@anonymous.invalid >	"Id" or "Header" or "user"	See table 5.2.3.1-3
Absent	"Unavailable" < "sip:unavailable@unknown.invalid" >	No Privacy header or the header has other values than "Id" or "Header" or "user"	See table 5.2.3.1-2
User portion is in the format of a tel URI	User portion is not in the format of a tel URI	No Privacy header or the header has other values than "Id" or "Header" or "user"	See table 5.2.3.1-4
User portion is in the format of a tel URI	User portion is not in the format of a tel URI	"Id" or "Header" or "user"	See table 5.2.3.1-3
The user portion of the P-Asserted-Identity and the user portion of the From header are in the format of a tel URI and the user portion of the P-Asserted-Identity is not equal to the user portion of the From header		No Privacy header or the header has other values than "Id" or "Header" or "user"	The calling party number information element is repeated As specified in [2] subclause 3.1.2.3 and [16] Annex B.2.1, the first calling party number IE is sent encoded according to table 5.2.3.1-5 and the second according to table 5.2.3.1-4
The user portion of the P-Asserted-Identity and the user portion of the From header are in the format of a tel URI and the user portion of the P-Asserted-Identity is equal to the user portion of the From header		No Privacy header or the header has other values than "Id" or "Header" or "user"	See table 5.2.3.1-4
User portion is in the format of a tel URI	User portion is in the format of a tel URI	"Id" or "Header" or "user"	See table 5.2.3.1-3
NOTE: The Application Server may as a network option set the contents of the From header to a default non significant value which is different from the values in the list below: From: "Anonymous" < sip:anonymous@anonymous.invalid >;tag= xxxxxxx. From: "Unavailable" < "sip:unavailable@unknown.invalid" >;tag= xxxxxxx.			

If no P-Asserted-Identity header is received at the AGCF/VGW it is assumed that the terminating user does not subscribe the CLIP supplementary service.

Table 5.2.3.1-2: Calling party number not presented due to interworking to the called user

Calling party number IE	
Type of number	<i>Unknown</i>
Numbering plan identification	<i>Unknown</i>
Presentation indicator	<i>Not available due to interworking</i>
Screening indicator	<i>Network provided</i>
Number digits	No digits

Table 5.2.3.1-3: Calling party number not presented due to presentation restriction to the called user

Calling party number IE	
Type of number	<i>Unknown</i>
Numbering plan identification	<i>Unknown</i>
Presentation indicator	<i>Presentation restricted</i>
Screening indicator	<i>Network provided</i>
Number digits	No digits

Table 5.2.3.1-4: Coding of the calling party number information element according to the P-Asserted-Identity header field

INVITE→	SETUP→
P-Asserted-Identity header	Calling party number IE
sip: local-number-digits; phone-context=nat @hostportion; user=phone	Type of number (see note) National number
sip: global-number-digits@hostportion; user=phone	Type of number (see note) International number
	Numbering plan identification ISDN/Telephony numbering plan
	Presentation indicator Presentation allowed
If the userinfo of the From header field is equal to the userinfo in the P-Asserted-Identity	Screening indicator User provided, verified and passed
If the userinfo of the From header field is not equal to the userinfo in the and P-Asserted-Identity	Screening indicator Network provided
	Number digits are derived from user portion. In case for global number and the country code is the same as the AGCF/VGW or line is located, the country code is removed from the number of the Type of number is set to "national number"
NOTE: As a network option, the type of number may be coded <i>unknown</i> when a prefix is added to the number.	

Table 5.2.3.1-5: Coding of the calling party number information element according to the From header field

INVITE→	SETUP→
From header field	Calling party number IE
sip: local-number-digits; phone-context=nat @hostportion; user=phone	Type of number (see note) National number
sip: global-number-digits @hostportion; user=phone	Type of number (see note) International number
	Numbering plan identification ISDN/Telephony numbering plan
	Presentation indicator Presentation allowed
	Screening indicator <i>User provided, not verified</i>
	Number digits are derived from user portion. In case for global number and the country code is the same as the AGCF/VGW or line is located, the country code is removed from the number of the Type of number is set to "national number"
NOTE: As a network option, the type of number may be coded <i>unknown</i> when a prefix is added to the number.	

5.2.3.2 Actions at the outgoing AGCF/VGW

Actions at the Gm interface

Table 5.2.3.2-1: Mapping CLI parameters to SIP header fields - Gm interface

SETUP→	INVITE→			
Presentation Restriction Indicator	P-Preferred-Identity header field	From header field:	Privacy header field	Privacy value
Presentation restricted	Addr-spec is derived from Calling Party Number parameter Address Signals (see note 1)	Addr-spec is derived from Calling Party Number parameter Address Signals or (see note 2) "anonymous@anonymous.invalid"	Y	"id" and "header" and "user"
Presentation restricted (see note 3)	Default registered public identity associated with calling party is used	"unavailable@unknown.invalid"	Y	"id" and "header" and "user"
Absent	Default registered public identity associated with calling party is used	"unavailable@unknown.invalid"	N/Y (see note 2)	If present: "id" and "header" and "user"
Allowed	Addr-spec is derived from Calling Party Number parameter Address Signals (see note 1)	Addr-spec is derived from Calling Party Number parameter Address Signals (see note 1)	Y	"none"

NOTE 1: Mapping CLI parameters to SIP header fields see table 5.2.3.2-3.
NOTE 2: As network option.
NOTE 3: Calling party number available but number digits are not included.

Actions at the Mw interface

Table 5.2.3.2-2: Mapping CLI parameters to SIP header fields - Mw interface

SETUP→	INVITE→			
Presentation Restriction Indicator	P-Asserted-Identity header field	From header field	Privacy header field	Privacy value
Presentation restricted	Addr-spec: calling party number address signal is matched with one of the public user identities else if no matched the default public user identity is used	Addr-spec is derived from Calling Party Number parameter Address Signals or (see note 2) "anonymous@anonymous.invalid"	Y	"id" and "header" and "user"
Presentation restricted (see note 3)	Addr-spec is the default public user identity	"unavailable@unknown.invalid"	Y	"id" and "header" and "user"
Absent	Addr-spec is the default public user identity	"unavailable@unknown.invalid"	N/Y (see note 2)	If present: "id" and "header" and "user"
Allowed	Addr-spec: calling party number address signal is matched with one of the public user identities else if no matched the default public user identity is used (see note 1)	Addr-spec is derived from Calling Party Number parameter Address Signals (see note 1)	Y	"none"

NOTE 1: Mapping CLI parameters to SIP header fields see table 5.2.3.2-3.
NOTE 2: As network option.
NOTE 3: Calling party number available but number digits are not included.

Table 5.2.3.2-3: Mapping CLI parameters to SIP header fields at the Gm interface

SETUP→		INVITE→	
Calling party number IE		From Header Field	P-Preferred-Identity
Type of number	Numbering plan identification		
No or invalid (see note 1) calling party number information element		See table 5.2.3.2-1	See table 5.2.3.2-1
<i>National number</i>	<i>ISDN/telephony numbering plan or Unknown</i>	The userinfo is derived from the address string of the calling party number IE sip: local-number-digits; phone-context=xxxxxx@hostportion; user=phone (see note 2)	An attempt is made to match the address string of the calling party number IE to one of the calling party's registered public identities. If no match is determined, a default registered public identity is used.
<i>International number</i>		The userinfo is derived from the address string of the calling party number IE sip: global-number-digits@hostportion; user=phone	The userinfo is derived from the address string of the calling party number IE sip: global-number-digits@hostportion; user=phone
<i>Subscriber</i>		The userinfo is derived from the address string of the calling party number IE sip: local-number-digits; phone-context=xxxxxx@hostportion; user=phone (see note 2)	An attempt is made to match the address string of the calling party number IE to one of the calling party's registered public identities. If no match is determined, a default registered public identity is used.
<i>Unknown</i>		The userinfo is derived from the address string of the calling party number IE sip: local-number-digits; phone-context=xxxxxx@hostportion; user=phone (see note 2)	An attempt is made to match the address string of the calling party number IE to one of the calling party's registered public identities. If no match is determined, a default registered public identity is used.
NOTE 1: Validity conditions of the calling party number information element are defined in clause 3.5.2.2.1/ITU-T Recommendation Q.931 [54].			
NOTE 2: The combination of dialled digits and phone-context parameter shall globally unique in the network as defined in RFC 3966 [47].			

Table 5.2.3.2-4: Mapping CLI parameters to SIP header fields at the Mw interface

SETUP→		INVITE→
Calling party number IE		From Header Field
Type of number	Numbering plan identification	
No or invalid (see note 1) calling party number information element		See table 5.2.3.2-2
<i>National number</i>	ISDN/telephony numbering plan or Unknown	The userinfo is derived from the address string of the calling party number IE sip: local-number-digits; phone-context=xxxxxx@hostportion; user=phone (see note 3)
<i>International number</i>		The userinfo is derived from the address string of the calling party number IE sip: global-number-digits @hostportion; user=phone
<i>Subscriber</i>		The userinfo is derived from the address string of the calling party number IE sip: local-number-digits; phone-context=xxxxxx @hostportion; user=phone (see note 3)
<i>Unknown</i>		The userinfo is derived from the address string of the calling party number IE sip: local-number-digits; phone-context=xxxxxx@hostportion; user=phone (see note 3)
NOTE 1: Validity conditions of the calling party number information element are defined in clause 3.5.2.2.1/ITU-T Recommendation Q.931 [54].		
NOTE 2: When the AGCF receives an SETUP with a Calling party number that matches one of the registered public user identities, the AGCF will insert this public user identity in the P-Asserted-Identity as a result of applying the procedures defined for a UE and the P-CSCF. When the AGCF receives an SETUP with a Calling party number that does not match one of the registered public user identities, or the SETUP does not contain a Calling party number, the AGCF will insert the registered public user identity in the P-Asserted-Identity header.		
NOTE 3: The combination of dialled digits and phone-context parameter shall globally unique in the network as defined in RFC 3966 [47].		

5.2.4 Conference calling (CONF)

This service is for further study.

5.2.5 Communication Diversion Services (CDIV)

As a network option the Activation, Deactivation and Interrogation of call forwarding services is performed using service code commands as described in EN 300 207-1 [34] (ISDN; Diversion supplementary services) and EN 300 196-1 [25] (ISDN; Generic functional protocol for the support of supplementary services).

NOTE: These messages are mapped to the regarding PSTN XML documents described in clause 4.9 of TS 183 004 [8] and are sent via the Ut-interface to the AS.

5.2.5.1 Actions at the Outgoing AGCF/VGW

5.2.5.1.1 Reception of a "call is diverting" notification

According to TS 183 004 [8], the 181 Being Forwarded may be received.

5.2.5.1.1.1 First diversion

The **latest** history-entry, representing the diverted-to-number, contained in the History-Info header is stored.

A notification of diversion is sent to the calling user as shown in table 5.2.5.1.1.1-1.

Table 5.2.5.1.1.1-1: First diversion: notification of diversion sent to the calling user

←DSS 1 message (see note)	←181 (Call Being Forwarded)
Notification indicator information element	
Call is diverting	
NOTE: If no message is to be sent, the notification indicator information element is sent in a NOTIFY message.	

5.2.5.1.1.2 Subsequent diversion

The **latest** history-entry, represents the diverted-to-number, contained in the History-info header field is stored **if the URI of the history-entry is different to the previous received and stored** diverted-to number (i.e. the latest received diverted-to number replaces the one received previously).

If notification of diversion is not allowed, no specific interworking action is required towards the calling user.

If notification of diversion is allowed, table 5.2.5.1.2-1 is applicable.

Table 5.2.5.1.1.2-1: Subsequent diversion: notification of diversion sent to the calling user

←DSS 1 message (see note 1)	←181 Call Being Forwarded
Notification indicator IE	
No notification sent	History-Info header: latest history-entry
Call is diverting	cause=487 (Deflection during alerting) or cause=408 (No reply)
No notification sent	Other cause values
NOTE 1: The determination of the DSS 1 message sent upon 181 Being Forwarded is described in clause 5.1. If no message is to be sent, the notification indicator information element is sent in a NOTIFY message.	
NOTE 2: The latest received diverted-to number replaces the one received previously.	

5.2.5.1.2 Evaluation of History-Info header

If a backward message (provisional response or 200 OK) is received containing a History-Info header and there is no privacy header is included in the URI of the latest history-entry:

- it has been determined, according to TS 183 004 [8], that the notification of diverted-to number is allowed, a redirection number information element is sent to the calling user as shown in table 5.2.5.1.2-1;
- if a **Privacy=history** is included in the latest history-entry, no information is sent to the calling user.

Table 5.2.5.1.2-1: Notification of the diverted-to number

←DSS 1 message (see note 1)	Redirection number parameter stored in the originating entity	←181, 180 or 200 OK
Redirection number information element		History-Info header: Latest History-entry
Type of number According to the nature of address indicator (see note 2) Numbering plan identification <i>ISDN (telephony) numbering plan</i> Presentation indicator <i>Presentation allowed</i> Number digits Digits received in the userinfo	Nature of address indicator <i>National number</i> sip: local-number-digits; phone-context=nat @hostportion; user=phone <i>International number</i> sip: global-number-digits@hostportion; user=phone. Numbering plan indicator <i>ISDN (telephony) numbering plan</i> Address signal: User portion received in the URI; if the country code of the URI: In case for global number and the country code is the same as the AGCF/VGW or line is located, the country code is removed from the number of the Type of number is set to "national number".	Mw or Gm Interface <i>No Privacy header included</i>
Type of number <i>Unknown</i> Numbering plan identification <i>Unknown</i> Presentation indicator <i>Presentation restricted</i> Number digits Not included Digits or no Information Element is sent	Nature of address indicator <i>National number</i> sip: local-number-digits; phone-context=nat @hostportion; user=phone <i>International number</i> sip: global-number-digits@hostportion; user=phone. Numbering plan indicator <i>ISDN (telephony) numbering plan</i> Address signal User portion received in the URI. In case for global number and the country code is the same as the AGCF/VGW or line is located, the country code is removed from the number of the Type of number is set to "national number"	Mw Interface <i>Privacy header included and the value is equal to "history"</i>
Type of number <i>Unknown</i> Numbering plan identification <i>Unknown</i> Presentation indicator <i>Number not available due to interworking</i> Number digits Not included (see note 3) or no Information Element is sent	No redirection number stored	Mw or Gm Interface No History-Info header received
NOTE 1: The determination of the DSS 1 message sent upon the SIP backward message is described in clause 5.1. If no message is to be sent, the redirection number information element is sent in a NOTIFY message. NOTE 2: As a network option, the type of number may be coded <i>unknown</i> . NOTE 3: This redirection number is sent if e 181 was received and no History-Info header was included in any response.		

5.2.5.1.3 Procedures at the T reference point

When the AGCF/VGW receives a SETUP containing a Facility information element including a DivertingLegInformation2 invoke component, an INVITE is sent containing a History-Info header.

Table 5.2.5.1.3-1: Mapping of the DivertingLegInformation2 invoke component into the History-Info header

SETUP →		INVITE →	
DivertingLegInformation2		History-Info header	
diversionCounter	1	History Index Number of diversions are shown due to the number of Index Entries (see note)	Index for divertingNr = 1 Index for Request URI = 1.1
	2		Index for originalCalledNr = 1 Index for divertingNr = 1.1 Index for Request URI = 1.1.1
	N		Index for originalCalledNr = 1 Placeholder History entry with Index = 1.1 ... Fill up ... Index for divertingNr = 1+[(N-1)*".1"] Index for Request URI = 1+N* ".1" (e.g. N=3 → 1.1.1.1)
diversionReason	unknown	Cause parameter in latest History entry	"404"
	cfu		"302"
	cfb		"486"
	cfnr		"408"
	cdAlerting		"487"
	cdImmediate		"480"
divertingNr		2 nd latest entry	
originalCalledNr		first entry	
NOTE: The History index is generated according the rules in subclause 4 in RFC 4244 [45].			

When the AGCF/VGW receives a 18x provisional or 200 OK final response, the AGCF/VGW sends a FACILITY, ALERTING or CONNECT message. The value of the Privacy parameter in the latest contained History-Info header is mapped in a DivertingLegInformation3 invoke component. A FACILITY is only sent, if the 181 contains a History-Info header.

Table 5.2.5.1.3-2: Mapping of the value of the Privacy parameter in latest History Entry into the DivertingLegInformation2 invoke component

←DSS1 Message		←SIP Message	
DivertingLegInformation3: presentationAllowedIndicator		History-Info header: Privacy parameter in the latest History entry	
FACILITY	true	181 (Being Forwarded)	No Privacy parameter
	false		Privacy: "history"
ALERTING	true	180 (Ringing)	No Privacy parameter
	false		Privacy: "history"
CONNECT	true	200 OK (INVITE)	No Privacy parameter
	false		Privacy: "history"

5.2.5.2 Actions at the incoming AGCF/VGW

5.2.5.2.1 Interworking at the AGCF/VGW where a call is diverted within or beyond the private ISDN (T reference point)

When the AGCF/VGW receives a DSS1 PROGRESS or ALERTING message, a Provisional Response is sent. When a FACILITY message is received containing a DivertingLegInformation1 invoke component, a 181 Provisional Response is sent.

If the DSS1 FACILITY, PROGRESS or ALERTING message contains a DivertingLegInformation1 invoke component Information Element, a History-Info header is sent in concerned response. The mapping is described in tables 5.2.5.2.1-1 and 5.2.5.2.1-2.

Table 5.2.5.2.1-1: Interworking of DSS1 messages

←SIP Message	←DSS1 Message
180 (Ringing)	ALERTING
181 (Being forwarded)	FACILITY
183 (Session Progress)	PROGRESS

Table 5.2.5.2.1-2: Mapping of the DivertingLegInformation1 invoke component into History-Info header

←SIP Message 18x		←ALERTING, FACILITY, PROGRESS	
History-Info header		DivertingLegInformation1	
Latest History Entry: cause-param = "cause" EQUAL Status-Code	"404"	diversionReason	unknown
	"302"		cfu
	"486"		cfb
	"408"		cfnr
	"487"		cdAlerting
	"480"		cdImmediate
Privacy parameter in the latest History Entry	"History"	subscriptionOption	noNotification
	No Privacy parameter		notificationWithoutDivertedToNr
			notificationWithDivertedToNr
latest Hi-targeted-to URI		divertedToNumber	

If the DivertingLegInformation1 invoke component: **subscriptionOption** is coded **noNotification**, no History-Info header is sent in the response message. For the same circumstance, a FACILITY message is not interworked.

In addition, if the ALERTING, FACILITY or CONNECT message contains a DivertingLegInformation3 invoke component. The Privacy parameter escaped in the Hi-target-to-uri representing the diverted-to user in the History-Info header (last entry) is set to the value as described in table 5.2.5.2.1-3.

Table 5.2.5.2.1-3: Mapping of the value of the Privacy parameter in latest History Entry into the DivertingLegInformation3 invoke component

←SIP Message		←DSS1 Message	
History-Info header: Privacy parameter in the latest History entry		DivertingLegInformation3: presentationAllowedIndicator	
180 (Ringing)	No Privacy parameter	ALERTING	true
	Privacy: "history"		false
181 (Being forwarded)	No Privacy parameter	FACILITY	true
	Privacy: "history"		false
200 OK (INVITE)	No Privacy parameter	CONNECT	true
	Privacy: "history"		false

5.2.5.2.2 Interworking at the coincident S and T reference point where a diverted call is presented

Table 5.2.5.2.2-1: Redirecting number information element sent to the called user

INVITE→ History-Info header	SETUP→ Content
index = 1.1	Redirecting number information element (see table 5.2.5.2.2-2)
index > 1.1	1 st Redirecting number information element (see table 5.2.5.2.2-3) 2 nd Redirecting number information element (see table 5.2.5.2.2-2)

Table 5.2.5.2.2-2: Coding of the Redirecting number information element containing the information of the first redirection

History-Info header first entry; index=1	Redirecting number information element
No Privacy header included	Type of number (see notes 1 and 5) Numbering plan identification (see notes 2 and 5) Presentation indicator: presentation allowed Reason of diversion: (see note 3) Number digits: (see notes 4 and 5)
Privacy=history included	Type of number: unknown Numbering plan identification: unknown Presentation indicator: presentation restricted Reason of diversion: (see note 3) No Number digits
First entry not included	Type of number: unknown Numbering plan identification: unknown Presentation indicator: number not available due to interworking Reason of diversion: (see note 3) No Number digits
<p>NOTE 1: <i>National</i> if the URI is coded as follows sip: local-number-digits; phone-context=nat @hostportion; user=phone or <i>international</i> if the URI is coded as follows sip: global -number-digits @hostportion; user=phone.</p> <p>NOTE 2: ISDN numbering plan.</p> <p>NOTE 3: If the index of the latest history-entry is set to 1.1: as received in the cause parameter in the latest history-entry. If the index of the latest history-entry is greater than 1.1: unknown.</p> <p>NOTE 4: User portion as received in the second last URI; global-number-digits: if the country code of the URI is the same as the country where the user or line is located, the country code is removed from the user portion.</p> <p>NOTE 5: As a network provider option the prefix is added to the number. In this case the Numbering plan identification and the Type of number are coded unknown.</p>	

Table 5.2.5.2.2-3: Coding of the Redirecting number information element containing the information of the last redirection when index > 1.1

History-Info header second last history-entry	Redirecting number information element
No Privacy header included	Type of number (see notes 1 and 5) Numbering plan identification (see notes 2 and 5) Presentation indicator: <i>presentation allowed</i> Reason of diversion: (see note 3) Number digits: (see notes 4 and 5)
Privacy=history included	Type of number: <i>unknown</i> Numbering plan identification: <i>unknown</i> Presentation indicator: <i>presentation restricted</i> Reason of diversion: (see note 3) No Number digits
First entry not included	Type of number: <i>unknown</i> Numbering plan identification: <i>unknown</i> Presentation indicator: <i>number not available due to interworking</i> Reason of diversion: (see note 3) No Number digits
<p>NOTE 1: -<i>National</i> if the URI is coded as follows sip: local-number-digits; phone-context=nat @hostportion; user=phone or - <i>international</i> if the URI is coded as follows sip: global-number-digits @hostportion; user=phone.</p> <p>NOTE 2: <i>ISDN numbering plan</i>.</p> <p>NOTE 3: As received in the cause parameter of the index of the latest history-entry.</p> <p>NOTE 4: User portion as received in the second last URI; global-number-digits: if the country code of the URI is the same as the country where the user or line is located, the country code is removed from the user portion.</p> <p>NOTE 5: As a network provider option the prefix is added to the number. In this case the Numbering plan identification and the Type of number are coded <i>unknown</i>.</p>	

Table 5.2.5.2.2-4: Mapping of cause parameter in the history-entry to reason of diversion

Cause parameter		Reason of diversion
unknown	"404"	Unknown
unconditional	"302 "	Call forwarding unconditional
User Busy	"486"	Call forwarding busy
No reply	"408"	Call forwarding no reply
Deflection during alerting	"487"	Call deflection during alerting
Deflection immediate response	"480"	Call deflection immediate response
Mobile subscriber not reachable	"503"	Unknown

5.2.5.2.3 Interworking at the AGCF/VGW where a diverted call is presented to a private ISDN (T Reference point)

When the AGCF/VGW receives an INVITE, a SETUP is sent on the network/user interface. If the INVITE contains a History-Info header, the History-Info header is mapped into a DivertingLegInformation2 invoke component. The History-Info header is stored in the AGCF/VGW.

Table 5.2.5.2.3-1: Mapping of the History-Info header into the DivertingLegInformation2 invoke component

INVITE→		SETUP→	
History-Info header		DivertingLegInformation2	
The number of dots in the latest index value represents the diversionCounter value		diversionCounter	
cause-param = "cause" EQUAL Status-Code in latest History entry	"404"	diversionReason	unknown
	"302"		cfu
	"486"		cfb
	"408"		cfnr
	"487"		cdAlerting
	"480"		cdImmediate
2 nd latest entry		divertingNr	
first entry		originalCalledNr (see note)	
NOTE: This element is not sent, if the diversionCounter is sent with the value 1.			

As a response to this call setup, three possibilities are applicable:

a) No further diversion occurs

When a ALERTING, PROGRESS or CONNECT is received, the messages are interworked on a basic call base. The stored History-Info header received in the previous received INVITE is included in the Provisional Response or 200 OK INVITE. A Privacy parameter with value "history" is escaped in the last entry representing the diverted to user.

b) A call diversion in the private network

When a ALERTING, PROGRESS or FACILITY is received containing a DivertingLegInformation1 invoke component, the stored History-Info header received in the previous received INVITE is included in the Provisional Response and a history entry shall be added, interworked from the received DivertingLegInformation1. The sent History-Info header is stored in the AGCF/VGW, the previous stored History-Info header is overwritten.

Table 5.2.5.2.3-2: Mapping of the DivertingLegInformation1 invoke component into added history entry

← SIP Message 18x		← ALERTING, FACILITY, PROGRESS	
History-Info header		DivertingLegInformation1	
Added (latest) History Entry: cause-param = "cause" EQUAL Status-Code	"404"	diversionReason	unknown
	"302"		cfu
	"486"		cfb
	"408"		cfnr
	"487"		cdAlerting
	"480"		cdImmediate
Privacy parameter in the added (latest) History Entry	"History"	subscriptionOption	noNotification
	No Privacy parameter		notificationWithoutDivertedToNr
			notificationWithDivertedToNr
Added (latest) Hi-targeted-to URI		divertedToNumber	

If the DivertingLegInformation1 invoke component: **subscriptionOption** is coded **noNotification**, no History-Info header is sent in the response message. For the same circumstance, a FACILITY message is not interworked.

c) **A further call diversion beyond the private network**

In addition, if the ALERTING, FACILITY or CONNECT message contains a DivertingLegInformation3 invoke component. The Privacy parameter escaped in the Hi-target-to-uri representing the diverted-to user in the History-Info header (last entry) is set to the value as described in table 5.2.5.2.1-3.

5.2.5.2.4 Interworking at the AGCF/VGW where partial rerouting is requested from a private ISDN (T Reference point)

After the SETUP was sent, when a FACILITY containing the CallRerouteing invoke component is received, a 302 (Moved Temporarily) is sent. The calledAddress element of the CallRerouteing invoke component is mapped into the URI of the Contact header. If the CallRerouteing invoke component: **subscriptionOption** is coded **noNotification**, no History-Info header is sent in the 302 response message.

Table 5.2.5.2.4-1: Mapping of the CallRerouteing invoke component into 302 (Moved Temporarily)

← 302 (Moved Temporarily)		← FACILITY	
		CallRerouteing invoke component	
History-Info header:	"404"	rerouteingReason	unknown
Last History Entry:	"302"		cfu
cause-param = "cause"	"486"		cfb
EQUAL Status-Code	"408"		cfnr
	"487"		cdAlerting
	"480"		cdImmediate
Contact header	URI	calledAddress	
History-Info header:	Index for lastRerouteingNr = 1	rerouteingCounter	1
History Index	Index for calledAddress = 1.1		
Number of diversions are shown due to the number of Index Entries (see note)	Index for To header = 1		2
	Index for lastRerouteingNr URI = 1.1		
	Index for calledAddress = 1.1.1		
	Index for To header = 1		
	Placeholder History entry with Index = 1.1		
	...		
	Fill up		
	...		
	Index for lastRerouteingNr URI = 1+[(N-1)*".1"]		N
	Index for calledAddress = 1+N* ".1" (e.g. N=3 → 1.1.1.1)		
PSTN XML body	BearerCapability	q931InfoElement	Bearer Capability
	LowLayerCompatibility		Low layer compatibility
	HighLayerCompatibility		High layer compatibility
User-to-User header			User-user information
History-Info header: 2 nd latest entry		lastRerouteingNr	
History-Info header:	No History-Info header	subscriptionOption	noNotification
Privacy parameter in the last History Entry	"History"		notificationWithoutDivertedToNr
	No Privacy parameter		notificationWithDivertedToNr
No mapping (see note)		callingPartySubaddress	
NOTE:	The calling subaddress is contained in the From header of the original INVITE.		

NOTE: Appropriate handling of the mapped information in the 302 have to be described in the PSTN/ISDN simulation service specification TS 183 004 [8] Communication diversion service. The History-Info header contained in the 302 is not used. Currently only the calledAddress in the Contact header is used.

5.2.6 MCID

5.2.6.1 Actions at the Outgoing AGCF/VGW

There is no interworking requirement relating to the Malicious Call Identification (MCID) supplementary service.

5.2.6.2 Actions at the incoming AGCF/VGW

There is no interworking requirement relating to the Malicious Call Identification (MCID) supplementary service.

Invocation of the service

To invoke the MCID supplementary service, the called user shall send a McidRequest invoke component carried by a Facility information element in a FACILITY message. This invocation can only be sent during the Active state (N10), during the Disconnect Indication state (N12) the invocation is not successful.

To indicate that the service invocation has been accepted, the network shall send a McidRequest return result component carried by a Facility information element in a FACILITY message.

These messages are mapped to a reINVITE as described in clause 4.5.2.12.1 of TS 183 016 [46] and are sent to the AS.

Table 5.2.6.2-1: MCID request

← INVITE	← FACILITY
XML mcid request McidRequestIndicator="1" (network operator option)	McidRequest

Additionally as an option to invoke the MCID service, as a network option it is possible to use service code commands via in-band dialogue or using the service code via keypad protocol. These requirements to using the keypad protocol are described in annex A of the present document. The result is available in-band (announcement).

5.2.7 Explicit Communication Transfer (ECT)

5.2.7.1 Actions at the Outgoing AGCF/VGW

For this service, the separation "incoming call" and "outgoing call" does not apply.

This clause describes the interworking at the AGCF/VGW (i.e. the exchange where the served user is connected to). To simulate ECT in the IMS, the Consultative Transfer is applicable.

5.2.7.1.1 Coincident S and T reference point

5.2.7.1.1.1 Service invocation

The invocation of ECT in the alerting state should be rejected by the AGCF/VGW.

Table 5.2.7.1.1.1-1: ECT invocation

Message received from the served user (user A)	REFER
FACILITY→ Facility information element EctExecute invoke component or ExplicitEctExecute invoke component	The request URI shall contain the SIP URI of the transferee as received in the Contact header field The Refer-To header field shall indicate the public address of the transfer Target. A Replaces header field parameter shall be added to the Refer-To URI together with a Require=replaces header field parameter. Method=INVITE

The ECT procedures are performed by the Application Server and described in TS 183 029 [36] As a network provider option: The REFER may be interworked in a reINVITE to the Transferee and to the Transfer target. These special REFER handling procedures are described in the TS 183 028 [32].

5.2.7.1.2 T reference point

5.2.7.1.2.1 Service invocation

Receipt of a notification from the access:

Table 5.2.7.1.2.1-1: Receipt of a notification from the access

Message received from the access	
FACILITY→ Facility information element	
EctInform invoke component <i>alerting</i>	No mapping
FACILITY→ Facility information element EctInform invoke component <i>active</i> redirectionNumber (see note)	
Facility information element (see note) SubaddressTransfer invoke component	No mapping
NOTE: The Access transport parameter is not interworked sent if the SubaddressTransfer invoke component is received.	

5.2.7.2 Actions at the incoming AGCF/VGW

For this service, the separation "outgoing call" and "incoming call" does not apply.

This clause describes the interworking at the O/I-AGCF/VGW (i.e. the AGCF/VGW where the remote user(s) is(are) connected to).

5.2.7.2.1 Coincident S and T reference point

5.2.7.2.1.1 Messages received from the network

5.2.7.2.1.1.1 Receipt of an INVITE/UPDATE message

The ECT simulation service is performed as described in TS 183 029 [36] with the additions and clarifications described in TS 183 028 [32] in special REFER handling procedures.

Upon receipt of an INVITE or UPDATE:

- a) reINVITE the corresponding remote ECT user is in alerting state

NOTE 1: This interworking is applicable to the user in "active call state, call held auxiliary state" when the corresponding remote ECT user is in alerting state.

Table 5.2.7.2.1.1.1-1: INVITE/UPDATE

Message received from the network		
INVITE →	No mapping	No mapping
NOTE: This can only occur in case of interaction of ECT with ECT.		

b) reINVITE the corresponding remote ECT user is in answered state

NOTE 2: This interworking is applicable to the user in "active call state, call held auxiliary state" or "active call state, idle auxiliary state" or "call delivered state" when the corresponding remote ECT user is in answered state.

Table 5.2.7.2.1.1.1-2: INVITE/UPDATE

INVITE →		
INVITE	P-Asserted-Identity <i>Privacy absent or not "id"</i> Connected Subaddress information element as isub parameter in the P-Asserted- Identity	No mapping
	Other cases (see note 2)	No mapping
NOTE 1: This can only occur in case of interaction of ECT with ECT.		
NOTE 2: Other cases:		
- no subaddress in the reINVITE; or		
- Privacy header value "id"; or		
- no P-Asserted-Identity in the reINVITE.		

Table 5.2.7.2.1.1.1-3: INVITE/UPDATE

INVITE/UPDATE not completing a		
<i>Call transfer, alerting notification</i>		
INVITE/UPDATE →	No mapping	No mapping
P-Asserted-Identity (see note 2)		
NOTE 1: This can only occur in case of interaction of ECT with ECT.		
NOTE 2: The P-Asserted-Identity may be absent.		

5.2.7.2.1.1.2 Receipt of a UPDATE message for a call in alerting phase

This clause applies only for a call in alerting phase.

One case is possible:

- UPDATE.

UPDATE

Upon receipt of such a message, one case is possible:

Table 5.2.7.2.1.1.2-1: UPDATE

UPDATE →		
	P-Asserted-Identity, Privacy header absent or not "id". Connected Subaddress information element as isub parameter in the P-Asserted-Identity	No mapping
	Other cases (see note 2)	No mapping
NOTE 1: This can only occur in case of interaction of ECT with ECT. NOTE 2: Other cases: <ul style="list-style-type: none"> - no subaddress in the UPDATE; or - Privacy header value "id"; or - no P-Asserted-Identity present in the UPDATE. 		

Table 5.2.7.2.1.1.2-2: UPDATE

UPDATE not completing a <i>call-transfer-alerting</i> notification	
UPDATE→ P-Asserted-Identity	No mapping

5.2.7.2.2 T reference point

5.2.7.2.2.1 Service invocation: Messages received from the network

5.2.7.2.2.1.1 Receipt of an INVITE/UPDATE

Upon receipt of an INVITE or UPDATE, two cases are possible:

- a) INVITE the corresponding remote ECT user is in alerting state

NOTE 1: This interworking is applicable to the user in "active call state, call held auxiliary state" when the corresponding remote ECT user is in alerting state.

- b) INVITE the corresponding remote ECT user is in answered state

NOTE 2: This interworking is applicable to the user in "active call state, call held auxiliary state" or "active call state, idle auxiliary state" or "call delivered state" when the corresponding remote ECT user is in answered state.

Table 5.2.7.2.2.1.1-1: INVITE/UPDATE

INVITE/UPDATE →		
	P-Asserted-Identity <i>Privacy header absent or value is not "id"</i> Connected Subaddress information element as isub parameter in the P-Asserted- Identity	No mapping
	Other cases (see note)	No mapping
NOTE: Other cases: - no subaddress in the reINVITE; or - Privacy header value "id"; or - no P-Asserted-Identity present in the reINVITE.		

5.2.7.2.2.1.2 Receipt of a UPDATE for a call in alerting phase

One case is possible:

- UPDATE.
- a) UPDATE

Table 5.2.7.2.2.1.2-1: UPDATE

UPDATE →		
	P-Asserted-Identity, Privacy header absent or value not "id" Connected Subaddress information element as isub parameter in the P-Asserted- Identity	No mapping
	Other cases (see note)	No mapping
NOTE: Other cases: - No subaddress in the UPDATE; or - Privacy header value "id"; or - No P-Asserted-Identity present in the UPDATE.		

5.2.8 Subaddressing (SUB)

The Sub-address (SUB) service allows the called (served) user to expand his addressing capacity beyond the one given by the E.164 user number. Subaddressing (SUB).

The coding rules according RFC 3966 [47] are not supporting the Type of subaddress (NSAP and user specified) as defined in ISDN (ITU-T Recommendation Q.931 [54]). Only the NSAP Type is mapped.

The called party subaddress information element received from the access in the SETUP message is transported in the in the isub parameter of the To header of the INVITE (see RFC 3966 [47]).

5.2.8.1 Actions at the Outgoing AGCF/VGW

Table 5.2.8.1-1: SIP Header information for subaddressing mapping at the I-AGCF/VGW contained in the INVITE

SETUP →	INVITE →
Called party sub-address (NSAP)	To header isub parameter Called party subaddress address string
Calling party sub-address (NSAP)	From header isub parameter Calling party subaddress address string
NOTE: The subaddress with Type of subaddress "User specified" is not transferred.	

Table 5.2.8.1-2: SIP Header information for subaddressing mapping at the I-AGCF/VGW contained in the 200 OK INVITE

← CONNECT	← UPDATE
Connected party sub-address (NSAP)	From header isub parameter Connected subaddress address string
NOTE: The subaddress with Type of subaddress "User specified" is not transferred.	

5.2.8.2 Actions at the incoming AGCF/VGW

The called party subaddress information element received in the isub parameter of the To header of the INVITE (see RFC 3966 [47]) is transferred transparently in the SETUP message. The number type value is a network option, NSAP is recommended.

Table 5.2.8.2-1: Sending of the called party subaddress (SUB)

INVITE→	SETUP→
To header isub parameter	Content
Called party subaddress address string	Called party subaddress information element
NOTE: The number type "NSAP" is recommended; other value is a network option.	

Table 5.2.8.2-2: Sending of the calling party subaddress (SUB)

INVITE→	SETUP→
From header isub parameter	Content
Calling party subaddress address string	Calling party subaddress information element
NOTE: The number type "NSAP" is recommended; other value is a network option.	

Table 5.2.8.2-3: receiving of the connected subaddress (SUB)

← UPDATE	← CONNECT
From isub parameter	Content
Connected party subaddress address string	Connected party subaddress information element
NOTE: The number type "NSAP" is recommended; other value is a network option.	

5.2.9 Closed User Group (CUG)

A XML element containing the identification of the closed user group transferred in the INVITE between two AS is described in the clause 4.9.2 of TS 183 054 [28].

5.2.9.1 Actions at the Outgoing AGCF/VGW

CUG checks at the originating Application Server and determination of the type of call request in correlation with the CUG information received from the calling user in the SETUP message and the CUG attributes of the calling user are described in table 4, EN 300 138-1 [21].

Invocation of Closed User Group

Table 5.2.9.1-1: Invocation of Closed User Group

SETUP→	INVITE→
Facility CUGCallOperation invoke	XML cug cugCallOperation
outgoingAccessRequest	outgoingAccessRequest
cUGIndex	cugIndex

A rejection indication may be received in a 500 Server Internal Error.

Table 5.2.9.1-2: Receipt of a rejection indication

←DISCONNECT		← Final Response
Cause information element	Return error component	Response code
Implicit request: Cause value No. 29 Facility rejected Explicit request: Cause value No. 29 Facility rejected	No return error component Return error value #19 incomingCallsBarredWithinCUG	603
Implicit request or not CUG request: Cause value No. 87 User not member of CUG Explicit request: Cause value No. 29 Facility rejected	No return error component Return error value #20 userNotMemberOfCUG	403
Implicit request: Normal handling of the cause value See 5.1 Explicit request: Normal handling of the cause value See 5.1	No return error component Return error value #8 basicServiceNotProvided	Other Response code
NOTE: The above table provides examples of mapping. Another example of mapping is described in EN 300 138-1 [21], annex C.		

5.2.9.2 Actions at the incoming AGCF/VGW

CUG checks at the destination Application Server and determination of the type of call request in correlation with the CUG information received in the Initial INVITE message and the CUG attributes of the called user are described in TS 183 054 [28]. The call setup sent to the CUG terminating user does not contain any CUG information.

5.2.10 User User Service (UUS)

The coding of the User-user information element is described within ETS 300 286-1 [38]. The User-to-User header is defined within draft-johnston-sipping-cc-uui-02.txt [i.1].

The content of the uuidata field of the User-to-User header shall start with the first octet being the protocol discriminator and followed by the user information octets.

The format of the uuidata field shall be the hexadecimal representation of binary data coded in ascii alphanumeric characters. For example, the 8-bit binary value 0011-1111 is 3F in hexadecimal. To code this in ascii, one 8-bit byte containing the ascii code for the character '3' (0011-0011 or 033H) and one 8-bit byte containing the ascii code for the character 'F' (0100-0110 or 046H) are required. For each byte value, the high-order hexadecimal digit is always the first digit of the pair of hexadecimal digits. The ascii letters used for the hex digits shall always be capital form.

EXAMPLE: User-to-User: 04C81031313232333334343535363637373838FA08303900064630E9E0;
encoding=hex.

Interworking procedures between the User-user information element and User-to-User header are defined in the following clauses.

5.2.10.1 Actions at the Outgoing AGCF/VGW

5.2.10.1.1 Service 1 (UUS1) implicit

Service 1 may be requested implicitly by the presence of the user-user information element in the SETUP message which is mapped into the user-to-user information parameter of the initial INVITE.

Table 5.2.10.1.1-1: Implicit UUS1 transfer

DSS 1 messages	SIP messages
SETUP →	INVITE →
User-user information element Protocol discriminator and User Information	User-to-User header uuidata
PROGRESS, ALERTING, CONNECT, DISCONNECT ←	18x, 200 OK, BYE ←
User-user information element Protocol discriminator and User Information	User-to-User header uuidata
DISCONNECT, RELEASE, RELEASE COMPLETE →	BYE →
User-user information element Protocol discriminator and User Information	User-to-User header uuidata

5.2.10.1.2 Service 1 (UUS1) explicit

Table 5.2.10.1.2-1: Explicit UUS1 invocation

SETUP→
Content
Facility information element UserUserService invoke component <i>Service 1 preferred</i>
User-user information element
Facility information element UserUserService invoke component <i>Service 1 required</i>
User-user information element

A service 1 explicit request preferred or required is rejected as described below.

Service 1 rejection

Rejection initiated by the O-AGCF/VGW when it cannot support the service is not relevant to the interworking and is described in clause 9.1.1.2.2, EN 300 286-1 [38].

Table 5.2.10.1.2-2 describes the handling of a rejection indication received from the network when the service 1 was requested as required.

Table 5.2.10.1.2-3 describes the handling of a rejection indication received from the network when the service 1 was requested as preferred.

Table 5.2.10.1.2-2: Service 1 rejection service requested as "required"

DSS1 messages	SIP messages
←DISCONNECT	
Cause information element Value 69 (<i>requested facility not implemented</i>) Facility information element UserUserService return error component <i>rejectedByNetwork</i>	

Table 5.2.10.1.2-3: UUS1 rejection: service requested as "preferred"

DSS 1 messages	SIP messages
CALL PROCEEDING, ALERTING, PROGRESS, CONNECT, DISCONNECT or RELEASE ←	
Facility information element UserUserService return error component <i>rejectedByNetwork</i>	
NOTE: UUS return error component shall be sent in next regular message.	

5.2.10.1.3 Service 2

Table 5.2.10.1.3-1: UUS2 invocation

SETUP→	SIP messages
Content	
Facility information element UserUserService invoke component <i>Service 2 preferred</i>	
Facility information element UserUserService invoke component <i>Service 2 required</i>	

A service 2 is rejected as described below:

Service 2 rejection

Rejection initiated by the O-AGCF/VGW when it cannot support the service is not relevant to the interworking and is described in clause 9.2.1.2, EN 300 286-1 [38].

Table 5.2.10.1.3-2 describes the handling of a rejection indication received from the network when the service 2 was requested as required.

Table 5.2.10.1.3-3 describes the handling of a rejection indication received from the network when the service 2 was requested as preferred.

Table 5.2.10.1.3-2: UUS2 rejection: service requested as "required"

DSS1 messages	SIP messages
←DISCONNECT	
Cause information element Value 69 (<i>requested facility not implemented</i>) Facility information element UserUserService return error component <i>rejectedByNetwork</i>	

Table 5.2.10.1.3-3: UUS2 rejection: service requested as "preferred"

DSS 1 messages	SIP messages
←ALERTING, DISCONNECT	
Facility information element UserUserService return error component <i>rejectedByNetwork</i>	

5.2.10.1.4 Service 3

Table 5.2.10.1.4-1: UUS3 invocation

SETUP→ Content	SIP messages
Facility information element UserUserService invoke component <i>Service 3 preferred</i>	
Facility information element UserUserService invoke component <i>Service 3 required</i>	

A service 3 request during call setup is rejected as described below.

Table 5.2.10.1.4-2: UUS3 activation received from the calling user in active phase

FACILITY →	SIP messages
Facility information element UserUserService invoke component <i>Service 3 preferred</i>	

Service 3 rejection

Rejection initiated by the O-AGCF/VGW when it cannot support the service is not relevant to the interworking and is described in clause 9.3.1.1.2, EN 300 286-1 [38].

Rejection of service 3 requested during call establishment.

Table 5.2.10.1.4-3 describes the handling of a rejection indication received from the network when the service 3 was requested as required.

Table 5.2.10.1.4-4 describes the handling of a rejection indication received from the network when the service 3 was requested as preferred.

Table 5.2.10.1.4-3: UUS3 rejection: service requested as "required" during call establishment

DSS1 messages	SIP messages
←DISCONNECT	
Cause information element Value 69 (<i>requested facility not implemented</i>) Facility information element UserUserService return error component <i>rejectedByNetwork</i>	

Table 5.2.10.1.4-4: UUS3 rejection: service requested as "preferred" during call establishment

DSS 1 messages	SIP messages
←CONNECT, DISCONNECT	
Facility information element UserUserService return error component <i>rejectedByNetwork</i>	

Rejection of service 3 requested after call establishment

Rejection of service 3 requested after call establishment is not relevant to the interworking and is described in clause 9.3.1.2.2, EN 300 286-1 [38].

Table 5.2.10.1.4-5: Rejection of UUS3 requested by the calling user after call establishment

DSS 1 messages	SIP messages
←FACILITY	
Facility information element UserUserService return error component <i>rejectedByNetwork</i>	

5.2.10.2 Actions at the incoming AGCF/VGW

5.2.10.2.1 Service 1 (UUS1) implicit

Service 1 may be requested implicitly by the presence of the User-to-User header field of the Initial INVITE which is mapped into the user-user information element in the SETUP message.

If service 1 is requested:

Table 5.2.10.2.1-1: Implicit UUS1 transfer

SIP messages	DSS 1 messages
INVITE →	SETUP →
User-to-User header uudata	User-user information element Protocol discriminator and User Information
18x, 200 OK, BYE (see note) ←	ALERTING, CONNECT, DISCONNECT, RELEASE, RELEASE COMPLETE ←
User-to-User header uudata	User-user information element Protocol discriminator and User Information
BYE →	DISCONNECT →
User-to-User header uudata	User-user information element Protocol discriminator and User Information
NOTE: The correspondences between SIP and DSS 1 messages are described in clause 5.1.1.	

If there is no user-user information element in the SETUP message, the Application Server shall discard the User-to-User header field possibly received afterwards from the user or from the SIP side.

5.2.11 Call Waiting (CW)

5.2.11.1 Actions at the Outgoing AGCF/VGW

Table 5.2.11.1-1: Mapping of 18x provisional responses for CW procedure in ISDN access

←ALERTING/PROGRESS/NOTIFY (see note)	←18x
Notification indicator information element	Alert-Info: <urn:alert:service:call-waiting>
Notification description	
110 0000 Call is a waiting call	
NOTE: The criteria of sending of ALERTING or PROGRESS is defined in clause 5.1. If neither ALERTING or PROGRESS has to be sent, a NOTIFY message is sent.	

5.2.11.2 Actions at the incoming AGCF/VGW

5.2.11.2.1 Procedure at coincident S and T reference point

CW indication indicates the call waiting service is activated against the user.

AGCF/VGW uses this CW indication in conjunction with the B-channel busy condition, and if both apply, AGCF/VGW shall send SETUP with "no channel" in the information channel selection field of the Channel identification information element.

If B-channel busy condition is not met, AGCF/VGW should ignore the CW indication and send SETUP according to clause 5.1.2.1.

If CW indication is not present, and B-Channel busy is detected, AGCF/VGW should reject the call with 486 (Busy Here).

If CW indication is not present, and B-Channel busy is detected, AGCF/VGW should reject the call with 486 (Busy Here) or AGCF/VGW shall send SETUP with "no channel" in the information channel selection field of the Channel identification information element as a network option.

Table 5.2.11.2.1-1: Receipt of CW indication

INVITE→	SETUP→ Channel identification information element information channel selection
Content-Type: application/3gpp-ims+xml Content-Disposition: 3gpp-alternative-service MIME XML ims-3gpp version="1" alternative-service action call-waiting-indication	No channel

If the call is presented with indication *no channel* in the information channel selection field of the channel identification information element in the SETUP message, and depending on the subscription options offered by the network, a notification is contained in the Alert-Info header sent in the network upon receipt of the alerting message.

Table 5.2.11.2.1-2: Sending of CW notification

←180	←ALERTING
Alert-Info: <urn:alert:service:call-waiting>	

5.2.11.2.2 Notification received at T reference point

A CW notification may be received at T reference point in the ALERTING message.

Table 5.2.11.2.2-1: Receipt of a CW notification from a private network

←18x (see note)	←ALERTING/PROGRESS/NOTIFY
	Notification indicator information element
	Notification description
Alert-Info: <urn:alert:service:call-waiting>	110 0000 <i>Call is a waiting call</i>
NOTE: In case of receipt of ALERTING or PROGRESS, 180 or 183 is sent as described in clause 5.1.2.2. In case of receipt of NOTIFY, 183 is sent.	

5.2.12 Terminal Portability (TP)

5.2.12.1 Actions at the outgoing AGCF/VGW

5.2.12.1.1 Invocation at coincident S and T reference point

Table 5.2.12.1.1-1: TP invocation

Message received from the DSS 1 →	INVITE / UPDATE→
SUSPEND	SDP: a=sendonly
RESUME	SDP: a=sendrecv

The action taken on the access side upon receipt of SUSPEND and RESUME messages are described in clause 5.6 and figure A.6 of ITU-T Recommendation Q.931 [54].

Upon the T307 expiry, a Release message (BYE or CANCEL) is sent with the cause value No. 102, *recovery on timer expiry*. No action is taken on the DSS 1 side.

5.2.12.1.2 Notification received at T reference point

A TP notification may be received at T reference point from a point-to-point data link in the active phase of the call.

Table 5.2.12.1.2-1: Receipt of a TP notification from a private network

NOTIFY→	INVITE/UPDATE →
Notification indicator information element	
Notification description	
000 0000 User suspended	SDP: a=sendonly
000 0001 User resumed	SDP: a=sendrecv

5.2.12.2 Actions at the incoming AGCF/VGW

5.2.12.2.1 Invocation at coincident S and T reference point

Table 5.2.12.2.1-1: TP invocation

← INVITE /UPDATE	Message received from the DSS 1 ←
SDP: a=sendonly	SUSPEND
SDP: a=sendrecv	RESUME

The actions taken on the access side upon receipt of the SUSPEND and RESUME messages are described in clause 5.2.6 and figure A.6 of ITU-T Recommendation Q.931 [54].

5.2.12.2.2 Notification received at T reference point

A TP notification may be received at T reference point in the active phase of the call.

Table 5.2.12.2.2-1: Receipt of a TP notification from a private network

← INVITE / UPDATE	←NOTIFY
	Notification indicator information element
	Notification description
SDP: a=sendonly	000 0000 <i>User suspended</i>
SDP: a=sendrecv	000 0001 <i>User resumed</i>

5.2.13 Three-party (3PTY)

Based on local policy, the AGCF may subscribe for the conference event package on behalf of the ISDN participant after he is added to a three party.

When the conference event package option is implemented, and one of the following events occurs at the AGCF/VGW:

- a 200 OK is received as a response to an initial INVITE request originated by the AGCF/VGW, where the Contact header field contains an "isfocus" parameter; or
- an ACK message is received which acknowledges a 200 OK response to the initial INVITE request, and the initial INVITE request is originated by the conferencing AS and contains an "isfocus" parameter in the Contact header field.

Then the following steps shall be performed:

- 1) A SUBSCRIBE request shall be created according to RFC 4575 [44].
- 2) The request URI is set to the Contact address of the conferencing AS.
- 3) The P-Asserted-Identity header field, the From header field and the Privacy header field are set with the same value as:
 - the P-Asserted-Identity header field, the From header field and the Privacy header field in the initial INVITE request originated by the AGCF/VGW; or
 - the P-Asserted-Identity header field, the To header field and the Privacy header field in a 1xx or 2xx response sent by the AGCF/VGW to the initial INVITE request from the conferencing AS.

When a full type of notification is received a check is made of the content. If the changes with respect a previous version of the notification have not been sent on to the ISDN user for this session, the AGCF/VGW shall do a DSS1 interaction towards the ISDN user. If the changes with respect a previous version of the notification have been sent to the ISDN user for this session, the AGCF/VGW shall not do an DSS1 interaction towards the ISDN user.

When a partial notification is received then it is assumed that a value of a received notification has changed, so the AGCF/VGW shall do an DSS1 interaction towards the ISDN user.

5.2.13.1 Notification received from the network

Table 5.2.13.1-1: 3PTY notification

←NOTIFY	← INVITE
Notification indicator information element	<conference-info>
Notification description	<conference-state>
100 0010 Conference established	<active>>true< active/>
100 0011 Conference disconnected	<active>>false< active/>
111 1001 Remote hold	SDP a=sendonly

5.2.13.2 Invocation at coincident S and T reference point

Before a three way conversation can be established, one of two existing sessions is set on hold by sending a reINVITE with an a attribute set to sendonly in the SDP. To invoke a three party communication after receipt of the Begin3PTY invoke component, the AGCF/VGW shall send an INVITE request with the conference factory URI for the three-way session towards the conference focus as described in TS 183 005 [9]. It is assumed, that based on an initial filter criterion, the conference AS is involved in the SIP signalling chain. It is assumed, that the conference application server is responsible for the notification "conference-established" etc. The previous basic call sessions are not released.

Option A: 3PTY invoke by sending a REFER request to each participant.

Table 5.2.13.2-1: Three-party (3PTY) invoke using the REFER request

Procedure	Message received from served user →	Messages sent to the Conference AS or remote user →
Beginning the 3PTY	FACILITY→ Facility IE Begin3PTY-Inv Call reference IE Call reference of call A-B	INVITE Request URI: <userCactive@domain.com> SDP: a=sendonly INVITE Request URI: conference factory URI REFER Request URI: conference factory URI Refer-to: <userBonHold@domain.com> Method=invite REFER Request URI: conference factory URI Refer-to: <userCactive@domain.com> Method=invite

Option B: 3PTY invoke by sending an INVITE request with the conference factory URI for the three-way session towards the conference focus including the participant list containing the two 3PTY participants.

Table 5.2.13.2-2: Three-party (3PTY) invoke using the participant list in an INVITE request

Procedure	Message received from served user →	Messages sent to the Conference AS or remote user →
Beginning the 3PTY	FACILITY→ Facility IE Begin3PTY-Inv Call reference IE Call reference of call A-B	INVITE Request URI: <userCactive@domain.com> SDP: a=sendonly INVITE Request URI: conference factory URI To: CONF AS From: userA@domain.com Require: recipient-list-invite <?xml version="1.0" encoding="UTF-8"?> <resource-lists xmlns="urn:ietf:params:xml:ns:resource-lists" xmlns:cp="urn:ietf:params:xml:ns:copyControl"> <list> <entry uri="userBonHold@domain.com?Call-ID=1a& From=userA@domain.com%3Btag%3Da&To=B%3Btag%3Db" cp:copyControl="to"/> <entry uri=userCactive@domain.com?Call-ID=2a& From=userA@domain.com%3Btag%3Da&To=C%3Btag%3Dc" cp:copyControl="to"/> </list> </resource-lists> >

Table 5.2.13.2-3: Three-party (3PTY) invoke

Procedure	Message received from served user →	Messages sent to the Conference AS or remote user →
End of three party	FACILITY→ Facility IE End3PTY-Inv Call reference IE Call reference of call A-B	INVITE Request URI: < userBonHold@domain.com> SDP: a=sendonly (see note) INVITE Request URI: <userCactive@domain.com> <conference-info> <conference-state> <active>>false< active/> SDP: a=sendrecv (see note) BYE Request URI: conference factory URI
Creation of a private communication with B	HOLD→ Call reference IE Call reference of call A-C	INVITE Request URI: <userCactive@domain.com> SDP : a=sendonly
	RETRIEVE→ Call reference IE Call reference of call A-B	INVITE Request URI: < userBonHold@domain.com> <conference-info> <conference-state> <active>>false< active/> SDP: a=sendrecv
Creation of a private communication with C	FACILITY→ Facility IE End3PTY-Inv Call reference IE Call reference of call A-C	INVITE Request URI: < userBonHold@domain.com> <conference-info> <conference-state> <active>>false< active/> SDP: a=sendonly INVITE Request URI: <userCactive@domain.com> <conference-info> <conference-state> <active>>false< active/> SDP : a=sendrecv BYE Request URI: conference factory URI
	DISCONNECT→ Call reference IE Call reference of call A-B	BYE Request URI: userBonHold@domain.com INVITE Request URI: <userCactive@domain.com> <conference-info> <conference-state> <active>>false< active/> SDP : a=sendrecv BYE Request URI: conference factory URI
Disconnect the remote user B	DISCONNECT→ Call reference IE Call reference of call A-C	BYE Request URI: userCactive@domain.com INVITE Request URI: < userBonHold@domain.com> SDP: a=sendonly BYE Request URI: conference factory URI
	RETRIEVE→ Call reference IE Call reference of call A-B	INVITE Request URI: < userBonHold@domain.com> <conference-info> <conference-state> <active>>false< active/> SDP: a=sendrecv

NOTE: The a line attribute depends on the Call reference of the Facility with the End3PTY-Inv component.

Table 5.2.13.2-4 describes the actions taken when user B or user C disconnects.

Table 5.2.13.2-4: user B or user C disconnects

Messages sent to or received from served user	Call A-B: Active-held connection messages sent to B/AS or received from B	Call A-C: Active-idle connection message sent to C/AS or received from C
←DISCONNECT Call reference IE Call reference of call A-B	←BYE Request URI <userA@domain.com>	INVITE → Request URI: <userCactive@domain.com> <conference-info> <conference-state> <active>>false< active/> SDP: a=sendrecv BYE → Request URI: conference factory URI
←DISCONNECT Call reference IE Call reference of call A-C	INVITE → Request URI: < userBonHold@domain.com> SDP: a=sendonly BYE → Request URI: conference factory URI	←BYE Request URI <userA@domain.com>
RETRIEVE→ Call reference IE Call reference of call A-B	INVITE → Request URI: < userBonHold@domain.com> <conference-info> <conference-state> <active>>false< active/> SDP: a=sendrecv	Not applicable

5.2.13.3 Notification received at T reference point

Table 5.2.13.3-1: Receipt of a 3PTY notification from a private network

NOTIFY→	UPDATE/INVITE →
Notification indicator information element	<conference-info>
Notification description	<conference-state>
100 0010 Conference established	<active>>true< active/>
100 0011 Conference disconnected	<active>>false< active/>
111 1001 Remote hold	SDP a=sendonly

5.2.13.4 Notification received at T reference point

Table 5.2.13.4-1: Receipt of a 3PTY notification from a private network

← INVITE/UPDATE	←NOTIFY
<conference-info>	Notification indicator information element
<conference-state>	Notification description
<active>true< active/>	100 0010 <i>Conference established</i>
<active>>false< active/>	100 0011 <i>Conference disconnected</i>
SDP a=sendonly	111 1001 <i>Remote hold</i>

5.2.14 Completion of Call to Busy Subscriber (CCBS)

5.2.14.1 Actions at the outgoing AGCF/VGW

CCBS Invocation

In case the terminating user is busy, a 183 Session Progress is received. The activation of the CCBS service is possible after the announcement is applied by the AS. The user provides the activation by performing in-band dialogue or by sending the proper service code via keypad protocol. The service code received in the Keypad Facility Information Element is used to construct the user part of the Request line of the INVITE request sent to the CCBS Application Server. These requirements are described in annex A of the present document. The result is available in-band (announcement).

After the activation procedure was successful, a 486 is received and the connection is terminated according the procedures as described in clause 5.1.1.4.

Starting CCBS recall

Two procedures are applicable to perform the CCBS recall:

- 1) When the AGCF/VGW receives a REFER request and the Request-URI is set to the URI of the served user from the original communication, including a "m" SIP URI parameter with a value set to "BS" then a SETUP is sent to the DSS1 user equipment. If a DSS1 CONNECT message is received (the served user accepts the recall) then an INVITE request is sent and the Request URI is set equal to the URI received in the Refer-To header of the previous REFER. The DSS1 dialogue and the INVITE dialogue have to be associated.

Table 5.2.14.1-1: Recall procedure by reception of REFER request

← SETUP	← REFER
	Request URI <served user>; m=BS
	Refer-To: <user B>

- 2) When the AGCF/VGW receives an INVITE request including a "m" SIP URI parameter with a value set to "BS", A SETUP is sent to the DSS1 user equipment. When a CONNECT is received, a 200 OK INVITE response is sent. This is the trigger for the AS to send an INVITE request to the monitored user.

Table 5.2.14.1-2: Recall procedure by reception of INVITE request

← SETUP	← INVITE
	Request URI <served user>; m=BS

Revocation of CCBS request

A CCBS request can be cancelled using the keypad facility protocol. These requirements are described in annex A of the present document. The DSS1 connection and the SIP dialogue are terminated after the revocation was successful according normal DSS1 and SIP procedures.

NOTE: All outstanding CCBS requests cancelled.

5.2.14.2 Actions at the incoming AGCF/VGW

No special requirements. Procedures as described in clause 5.1.2.1 apply.

5.2.15 Completion of Calls on No Reply (CCNR)

5.2.15.1 Actions at the outgoing AGCF/VGW

CCNR Invocation

In case the terminating user is not busy, a 180 Ringing is received. The activation of the CCNR service is possible after the announcement is applied by the AS. The user provides the activation by performing in-band dialogue or by sending the proper service code via keypad protocol. The service code received in the Keypad Facility Information Element is used to construct the user part of the Request line of the INVITE request sent to the CCNR Application Server. These requirements are described in annex A of the present document. The result is available in-band (announcement).

Starting CCNR recall

Two procedures are applicable to perform the CCNR recall:

- 1) When the AGCF/VGW receives a REFER request and the Request-URI is set to the URI of the served user from the original communication, including a "m" SIP URI parameter with a value set to "NR" then a SETUP is sent to the DSS1 user equipment. If a DSS1 CONNECT message is received (the served user accepts the recall) then an INVITE request is sent and the Request URI is set equal to the URI received in the Refer-To header of the previous REFER. The DSS1 dialogue and the INVITE dialogue have to be associated.

Table 5.2.15.1-1: Recall procedure by reception of REFER request

← SETUP	← REFER
	Request URI <served user>; m=NR
	Refer-To: <user B>

- 2) When the AGCF/VGW receives an INVITE request including a "m" SIP URI parameter with a value set to "NR", A SETUP is sent to the DSS1 user equipment. When a CONNECT is received, a 200 OK INVITE response is sent. This is the trigger for the AS to send an INVITE request to the monitored user.

Table 5.2.15.1-2: Recall procedure by reception of INVITE request

← SETUP	← INVITE
	Request URI <served user>; m=NR

Revocation of CCNR request

A CCNR request can be cancelled by performing in-band dialogue or using the keypad facility protocol. These requirements are described in annex A of the present document.

The DSS1 connection and the SIP dialogue are terminated after the revocation was successful according normal DSS1 and SIP procedures.

NOTE: All outstanding CCNR requests are cancelled.

5.2.15.2 Actions at the incoming AGCF/VGW

No special requirements. Procedures as described in clause 5.1.2.1 apply.

NOTE: Information received from the served user in the recall phase will not transported to the terminating user.

5.2.16 Advice Of Charge AOC

As described in TS 183 047 [31], three AOC supplementary services exist:

- a) Charging information at communication set-up time (AOC-S)
The AOC-S service enables a user to receive information about the charging rates at communication set-up time and also to receive further information during the communication if there is a change of charging rates.

- b) Charging information during the communication (AOC-D)
The AOC-D service enables a user to receive information on the recorded charges for a communication during the active phase of the communication.
- c) Charging information at the end of the communication (AOC-E)
The AOC-E service enables a user to receive information on the recorded charges for a communication when the communication is terminated.

5.2.16.1 Actions at the outgoing AGCF/VGW

Transfer of AOC-S charging information

The AOC-S charging information is transported during the call establishment, during the call (change in rates).

During the call establishment, the AOC-S information shall be carried in SIP 1xx provisional response or a 200 OK response to an INVITE message, in a MIME body type "application/vnd.etsi.aoc+xml" defined in TS 183 047 [31].

It is mapped to a Facility information element in a DSS1 ALERTING, CALL PROCEEDING, PROGRESS, or CONNECT message.

During the call, the AOC-S information shall be carried in a SIP INFO message in a MIME body type "application/vnd.etsi.aoc+xml" defined in TS 183 047 [31].

It is mapped to a Facility information element in a DSS1 FACILITY message.

Table 5.2.16.1-1: Transport of AOC-S

SIP messages → 1xx, 200 OK (INVITE), INFO	DSS1 messages → ALERTING, CALL PROCEEDING, PROGRESS, CONNECT, FACILITY
MIME body type "application/vnd.etsi.aoc+xml"	Facility Information Element
aoc aoc-s	ChargingRequest chargingInformationAtCallSetup

NOTE: The feature "the served user is the terminating user" does not exist for the ISDN, because of this mapping from the INVITE request to a SETUP message is not possible.

Transfer of AOC-D charging information

The AOC-D charging information is transported during the call.

The AOC-D information shall be carried in a SIP INFO message in a MIME body type "application/vnd.etsi.aoc+xml" defined in TS 183 047 [31].

It is mapped to a Facility information element in a DSS1 FACILITY message.

Table 5.2.16.1-2: Transport of AOC-D

SIP messages → INFO	DSS1 messages → FACILITY
MIME body type "application/vnd.etsi.aoc+xml"	Facility Information Element
aoc aoc-d	ChargingRequest chargingDuringACall

Transfer of AOC-E charging information

The AOC-E charging information is transported during the call clearing.

The AOC-E information shall be carried in a SIP 200 OK response to a BYE message (if the party that has subscribed to the AOC-E service clears the call) or in a SIP BYE message (if the party that has subscribed to the AOC-E service receives the release of the call), in a MIME body type "application/vnd.etsi.aoc+xml" defined in TS 183 047 [31].

It is mapped to a Facility information element in a DSS1 DISCONNECT, RELEASE, RELEASE COMPLETE message.

Table 5.2.16.1-3: Transport of AOC-E

SIP messages → BYE, 200 OK (BYE)	DSS1 messages → DISCONNECT, RELEASE, RELEASE COMPLETE
MIME body type "application/vnd.etsi.aoc+xml"	Facility Information Element
aoc aoc-e	ChargingRequest chargingAtTheEndOfACall

When processing originating sessions with multiple call legs to be charged, e.g. in 3-party calls or when using the conference service, then the Application server shall send charging information separately for each call leg to the AGCF/VGW.

As an alternative dependent on the setting of a network operator option the Application server may send charging information related to the affected call legs in one single AOC xml body in a combined representation.

As a consequence the AGCF/VGW in accordance with the Application server shall process charging information received from the Application Server in one of the following manners:

- The AGCF/VGW shall be able to process bodies with AOC information which are separately received for the different call legs.
- As a network operator option the charging information received may be assumed as a combined representation applying to all call legs. If only one dialog exists between the AGCF/VGW and the AS, the AGCF/VGW is not informed when one of the far parties is released. In order to ensure that charging is accurate, the AS will have to send an INFO request with an XML body each time a far party is added or released, regardless of whether AOC-S, AOC-D, or AOC-E has been chosen as the desired reporting technique.

5.2.17 Message Waiting Indication (MWI)

Upon receipt of a NOTIFY request containing the following headers:

- Event: message-summary.
- Subscription-State: active.
- Content-Type: application/simple-message-summary.
- Messages-Waiting: yes.

A DSS1 FACILITY message is sent to the DSS1 user equipment. The mapping of the Facility I.E is described in table 5.2.17-1.

Table 5.2.17-1: Mapping of NOTIFY into DSS1 FACILITY

NOTIFY →	FACILITY →
Event: message-summary Subscription-State: active Content-Type: application/simple-message-summary Messages-Waiting: yes	Facility Information Element: MWIndicate invoke
Message-Account:	controllingUserProvidedNr
[msg-summary-line] Voice-Message: new/old Fax-Message: new/old Video-Message: new/old (NOTE)	basicService speech telefaxGroup2-3 videotelephony
[msg-summary-line] Voice-Message: new/old Fax-Message: new/old Video-Message: new/old (see note)	basicService speech telefaxGroup2-3 videotelephony
NOTE: All other Internet Message Content Types are not able to map into the basic service. However an ISDN terminal does not have the capability to receive these types.	

Upon receipt of a NOTIFY request a 200 OK (NOTIFY) is send according normal SIP procedures.

5.3 DSS1 layer 2 failure

5.3.1 DSS 1 data link reset and data link failure procedures in the outgoing AGCF/VGW

The data link reset and data link failure procedures are respectively described in clauses 5.2.8.8 and 5.2.8.9, ITU-T Recommendation Q.931 [54].

Table 5.3.1-1: DSS 1 data link reset and data link failure procedures

←DISCONNECT	Trigger event	BYE/CANCEL→
Cause information element (see note 2)		Reason header
Cause value No. 41 (<i>temporary failure</i>)	Data link reset in overlap sending state	Cause value No. 41 (<i>temporary failure</i>)
(see note 1)	Data link failure in another state than active state	Cause value No. 27 (<i>destination out of order</i>)
(see note 1)	Failure of the data link reestablishment procedure after a data link failure in active state	Cause value No. 27 (<i>destination out of order</i>)
NOTE 1: The call is cleared internally. No DISCONNECT message is sent on the access.		
NOTE 2: The location is coded '1010' <i>network beyond interworking point</i> .		

5.3.2 DSS 1 data link reset and data link failure procedures in the incoming AGCF/VGW

The data link reset and data link failure procedures are respectively described in clauses 5.8.8 and 5.8.9, ITU-T Recommendation Q.931 [54].

Table 5.3.2-1: DSS 1 Data link reset and Data link failure procedures

← BYE/4xx/5xx Reason header	Trigger event	DISCONNECT→ Cause information element (see note 2)
cause No. 41 (temporary failure)	Data link reset in overlap receiving state	Cause value No. 41 (temporary failure)
cause No. 27 (destination out of order)	Data link failure in another state than active state	(see note 1)
cause No. 27 (destination out of order)	Failure of the data link reestablishment procedure after a data link failure in active state	(see note 1)

NOTE 1: The call is cleared internally. No DISCONNECT message is sent on the access.
NOTE 2: The location is coded '1010' *network beyond interworking point*.

5.3.3 Release by the outgoing AGCF/VGW

Table 5.3.3-1: Release from the originating AGCF/VGW

←DISCONNECT Cause information element (see note 3)	Trigger event	BYE/CANCEL→ Reason header
Cause value No. 28 Invalid number format (address incomplete)	Determination that the called number information received is incomplete, after an IAM message has already been sent	Cause value No. 28 Invalid number format (address incomplete)
Same cause value as in the REL message (see note 1)	Other cases of failure on the SIP side	Cause value coded according to ES 282 007 [4]
Cause value coded according to TS 183 007 [6]	Other cases of failure on the DSS 1 side	Same cause value as in the DISCONNECT message (see note 2)

NOTE 1: If the cause value sent in the BYE/CANCEL message is unknown in DSS 1, the unspecified cause value of the class is sent.
NOTE 2: If the cause value sent in the DISCONNECT message is unknown in SIP, the unspecified cause value of the class is sent.
NOTE 3: The location is coded '1010' *network beyond interworking point*.

5.3.4 Release by the AGCF/VGW

Table 5.3.4-1: Release from the terminating AGCF/VGW

←Message sent to the SIP	Trigger event	Message sent to the DSS 1 → (see note 3)	
		Point-to-point data link	Broadcast data link
480 Cause value No. 18 <i>No user responding</i>	No response to the SETUP message (T303 expiry)	DISCONNECT Cause value No. 102 <i>Recovery on timer expiry</i>	No action
480 Cause value No. 18 <i>No user responding</i>	No ALERTING, CONNECT or DISCONNECT after CALL PROCEEDING (T310 expiry)	DISCONNECT Cause value No. 102 <i>Recovery on timer expiry</i>	RELEASE Cause value No. 102 <i>Recovery on timer expiry</i>
480 Cause value No. 19 No answer from user (user alerted)	No CONNECT or DISCONNECT after ALERTING (T301 expiry)	DISCONNECT Cause value No. 102 <i>Recovery on timer expiry</i>	RELEASE Cause value No. 102 <i>Recovery on timer expiry</i>
480 Cause value No. 31 <i>Normal, unspecified</i>	Unsuccessful termination of the B-channel selection procedure	RELEASE Cause 6 <i>Channel unacceptable</i>	
500 Cause value coded according to [4]	Other cases of failure on the SIP side	DISCONNECT Same cause value as in the REL message (see note 1)	
500 Same cause value as in the DISCONNECT message (see note 2)	other cases of failure on the DSS 1 side	DISCONNECT Cause value coded according to TS 183 007 [6]	
NOTE 1: If the cause value sent in the 480/500 message is unknown in DSS 1, the unspecified cause value of the class is sent.			
NOTE 2: If the cause value sent in the DISCONNECT message is unknown in SIP, the unspecified cause value of the class is sent.			
NOTE 3: The location is coded '1010' <i>network beyond interworking point</i> .			

5.4 Service operation

5.4.1 Call related service operation

5.4.1.1 Malicious Call Identification (MCID)

The invocation of Malicious Call Identification is described in clause 5.2.6.

When a 200 OK INVITE is received as the final response to the reINVITE containing the MCID request, a **mCIDRequest return result** component is sent to the served user equipment.

If an unsuccessful final response is received, a **mCIDRequest return** error component error code "**notAvailable**" is sent the user equipment.

NOTE: A more accurate mapping between unsuccessful final responses and ISDN operation errors is for further study.

The coding of the FACILITY message and the Facility I.E is described in EN 300 130-1 [20].

5.4.1.2 Explicit Communication Transfer (ECT)

The mapping of Explicit Communication Transfer related Facility components is described in clause 5.2.7.

When a 202 Accepted is received, and the NOTIFY message/sipfrag part for both communications indicates the successful communication between Transfer target and Transferee, an **eCTExecute return result** component is sent to the served user equipment in the DISCONNECT messages.

If an unsuccessful final response was received upon the REFER was sent, an **eCTExecute return error** component value "**notAvailable**" is sent to the served user equipment.

NOTE: A more accurate mapping between unsuccessful final responses and ISDN operation errors is for further study.

The coding of the FACILITY message and the Facility I.E is described in EN 300 369-1 [35].

5.4.1.3 Closed User Group (CUG)

The mapping of the CUG request and the handling of unsuccessful final responses is described in clause 5.2.9.

5.4.1.4 Three Party Service (3PTY)

The mapping of Three Party Service related Facility components is described in clause 5.2.13.

When for the INVITE sent to the conference focus to get a "conference URI" the 200 OK is received and the 202 Accepted for both REFER sent to the remote participants is received, a **Begin3PTY return result** component is sent to the served user equipment.

If an unsuccessful final response was received upon the INVITE to get the "conference URI" was sent, a **Begin3PTY return error** component value "**notAvailable**" is sent to the served user equipment.

If an unsuccessful final response was received upon the REFER to establish the conference was sent, a **Begin3PTY return error** component value "**notAvailable**" is sent to the served user equipment.

NOTE: A more accurate mapping between unsuccessful final responses and ISDN operation errors is for further study.

The coding of the FACILITY message and the Facility I.E is described in EN 300 188-1 [24].

5.4.1.5 Completion of Call to Busy Subscriber (CCBS)

FFS

5.4.1.6 Completion of Calls on No Reply (CCNR)

FFS

5.4.2 Call independent service configuration

Call independent service can be achieved using either the Gm reference point or the Ut reference point. In case of the Gm reference point the MESSAGE method is used to convey the service related information to the relevant target. In general the information to configure a service is embedded in a XML instance document contained in the MESSAGE request. In the case of the Ut reference point, HTTP PUT, HTTP GET or HTTP DELETE requests are used in accordance with RFC 4825 [48] and the supplementary services application usage specified in TS 183 023 [49].

The following clauses specify the mapping between the ROSE components embedded in DSS.1 FACILITY messages and the XML document to be created.

5.4.2.1 Communication Diversion Services (CDIV)

5.4.2.1.1 Communication Diversion activation

On receipt of a DSS1 FACILITY message containing the **ActivationDiversion invoke** component, a SIP MESSAGE request or a HTTP request is sent that contains a XML "**communication-diversion**" instance to the Application Server. The attribute of the communication-diversion element is "true". The mapping of the Facility I.E is described below.

Table 5.4.2.1.1-1: Mapping of conditions

FACILITY →		MESSAGE or HTTP PUT Request →	
ActivationDiversion invoke		<communication-diversion active="true">	
Procedure	cfu	<cp:ruleset>	(see note 1)
	cfb	<cp:rule id="<rule id ">	<busy/>
	cfnr	<cp:conditions>	<no-answer/>
basicService	Speech audio3k 64kbit	<cp:ruleset> <cp:rule id="<rule id "> <cp:conditions> <media>	(see note 2)
servedUserNr	PartyNumber	P-Preferred-Identity or P-Asserted-Identity header (see notes 3 and 4)	
NOTE 1: In case unconditional call forwarding no corresponding <cp:condition> element is included.			
NOTE 2: The list of basic services is contained in EN 300 196-1 [25]. The string value shall be set to ASN1 enumerated numeric value of BasicService type in EN 300 196-1 [25], clause D.6. Activation of call forwarding for all basic services is achieved by omitting the <media> condition.			
NOTE 3: The servedUserNr is mapped to either the P-Preferred-Identity header by a VGW or the P-Asserted-Identity header by an AGCF.			
NOTE 4: Mapping of the ISDN value "allNumbers" requires further study.			

Table 5.4.2.1.1-2: Mapping of actions

FACILITY →		MESSAGE or HTTP PUT Request →	
ActivationDiversion invoke		<communication-diversion active="true">	
forwardedToAddress	Public number	<cp:ruleset> <cp:rule id="<rule id"> <cp:actions> <ss:forward-to> <ss:target>	userC@domain
noReplyTimer	int	<cp:ruleset> <cp:rule id="<rule id"> <cp:actions> <ss:forward-to> <ss:NoReplyTimer>	20

On receipt of a 200 OK MESSAGE or HTTP response, a DSS1 FACILITY message including the **ActivationDiversion return result** component is sent to the DSS1 user equipment.

If an unsuccessful final response is received upon sending a MESSAGE or HTTP Request including a XML **communication-diversion** instance, a DSS1 FACILITY message including the **ActivationDiversion return error** component value "**notAvailable**" is sent to the DSS1 user equipment.

NOTE: A more accurate mapping between unsuccessful final responses and ISDN operation errors is for further study.

Additionally to activate the CDIV service, as a network option it is possible to use service code commands via in-band dialogue or using the service code via keypad protocol. These requirements to using the keypad protocol are described in annex A of the present document. The result is available in-band (announcement).

5.4.2.1.2 Communication Diversion deactivation

On receipt of a DSS1 FACILITY message containing the **DeactivationDiversion invoke** component, a SIP MESSAGE request or a HTTP Request is sent that contains a XML "**communication-diversion**" instance to the Application Server. The attribute of the communication-diversion element is "false". The mapping of the Facility I.E is described below.

Table 5.4.2.1.2-1: Mapping of conditions

FACILITY →		MESSAGE or HTTP PUT Request →	
DeactivationDiversion invoke		<communication-diversion active="false"	
procedure	cfu	<cp:ruleset> <cp:rule id="<rule id "> <cp:conditions>	(NOTE 1)
	cfb		<busy/>
	cfnr		<no-answer/>
basicService	Speech audio3k 64kbit	<cp:ruleset> <cp:rule id="<rule id "> <cp:conditions> <media>	(see note 2)
servedUserNr	PartyNumber	P-Preferred-Identity or P-Asserted-Identity header (see notes 3 and 4)	
NOTE 1: In case unconditional call forwarding no corresponding <cp:condition> element is included.			
NOTE 2: The list of basic services is contained in EN 300 196-1 [25]. The string value shall be set to ASN1 enumerated numeric value of BasicService type in EN 300 196-1 [25], clause D.6. Deactivation of call forwarding for all basic services is achieved by omitting the <media> condition.			
NOTE 3: The servedUserNr is mapped to either the P-Preferred-Identity header by a VGW or the P-Asserted-Identity header by an AGCF.			
NOTE 4: Mapping of the ISDN value "allNumbers" requires further study.			

On receipt of a 200 OK MESSAGE or HTTP successful response, a DSS1 FACILITY message including the **DeactivationDiversion return result** component is sent to the DSS1 user equipment.

If an unsuccessful final response is received upon sending a MESSAGE or HTTP Request including a XML **communication-diversion** instance, a DSS1FACILITY message including the **DeactivationDiversion return error** component value "**notAvailable**" is sent to the DSS1 user equipment.

NOTE: A more accurate mapping between unsuccessful final responses and ISDN operation errors is for further study.

Additionally to deactivate the CDIV service, as a network option it is possible to use service code commands via in-band dialogue or using the service code via keypad protocol. These requirements to using the keypad protocol are described in annex A of the present document. The result is available in-band (announcement).

5.4.2.1.3 Communication Diversion interrogation

On receipt of a DSS1 FACILITY message containing the **InterrogationDiversion invoke** component, a SIP MESSAGE or HTTP request is sent that contains a XML "communication-diversion" instance to the Application Server. The mapping of the Facility I.E is described below.

Table 5.4.2.1.3-1: Mapping of InterrogationDiversion invoke

FACILITY →		MESSAGE request or HTTP GET request →	
InterrogationDiversion invoke		<communication-diversion>	
procedure	cfu	<cp:ruleset> <cp:rule id="<rule id "> <cp:conditions>	(see note 1)
	cfb		<busy/>
	cfnr		<no-answer/>
basicService	Speech audio3k 64kbit	<cp:ruleset> <cp:rule id="<rule id "> <cp:conditions> <ss:media>	(see note 2)
servedUserNr	PartyNumber	P-Preferred-Identity or P-Asserted-Identity header (see notes 3 and 4)	
NOTE 1: In case unconditional call forwarding no corresponding <cp:condition> element is included.			
NOTE 2: The list of basic services is contained in EN 300 196-1 [25]. The string value shall be set to ASN1 enumerated numeric value of BasicService type in EN 300 196-1 [25], clause D.6 Interrogation of call forwarding for all basic services is achieved by omitting the <media> condition.			
NOTE 3: The servedUserNr is mapped to either the P-Preferred-Identity header by a VGW or the P-Asserted-Identity header by an AGCF.			
NOTE 4: Mapping of the ISDN value "allNumbers" requires further study.			

On receipt of a MESSAGE request or HTTP successful response that contains a "communication-diversion" XML instance, a DSS1 FACILITY message is sent to the served user equipment. The mapping of the XML instance into the Facility I.E **InterrogationDiversion** invoke return result is described below.

Table 5.4.2.1.3-2: Mapping of InterrogationDiversion result

← FACILITY		← MESSAGE request or HTTP GET response	
InterrogationDiversion return result		<communication-diversion active="true"	
procedure	cfu	<cp:ruleset> <cp:rule id="<rule id "> <cp:conditions>	(see note 1)
	cfb		<busy/>
	cfnr		<no-answer/>
basicService	Speech audio3k 64kbit	<cp:ruleset> <cp:rule id="<rule id "> <cp:conditions> <ss:media>	(see note 2)
servedUserNr	PartyNumber	P-Preferred-Identity or P-Asserted-Identity header (see notes 4 and 5)	
forwardedToAddress	Public number	<cp:ruleset> <cp:rule id="<rule id"> <cp:actions> <ss:forward-to> <ss:target>	userC@domain (see note 3)
NOTE 1: If the <busy/> and <no-answer/> conditions are absent from the XML document, the "procedure" element is set to "cfu".			
NOTE 2: The list of basic services is contained in EN 300 196-1 [25]. The string value shall be set to ASN1 enumerated numeric value of BasicService type in EN 300 196-1 [25], clause D.6. If the <media> element is absent, the basicService element is set to allServices.			
NOTE 3: If the country code is equal to the country code where the AGCF/VGW is located, the country code is removed from the number string and the Type of Number is set to "national number" else the number string is sent unchanged and the Type of number is set to "international number".			
NOTE 4: The servedUserNr is mapped to either the P-Preferred-Identity header by a VGW or the P-Asserted-Identity header by an AGCF.			
NOTE 5: Mapping of the ISDN value "allNumbers" requires further study.			

If an unsuccessful final response is received upon sending a MESSAGE or HTTP Request including a XML "communication-diversion" instance, a DSS1 FACILITY message including the **InterrogationDiversion return error** component value "**notAvailable**" is sent to the DSS1 user equipment.

NOTE: A more accurate mapping between unsuccessful final responses and ISDN operation errors is for further study.

Additionally to interrogate the status of the CDIV service, as a network option it is possible to use service code commands via in-band dialogue or using the service code via keypad protocol. These requirements to using the keypad protocol are described in annex A of the present document. The result is available in-band (announcement).

5.4.2.1.4 Activation Status Notification Diversion

Mapping of this procedure requires further study.

5.4.2.2 Message Waiting Indication (MWI)

5.4.2.2.1 Activation of Message Waiting Indication (MWI)

On receipt of a DSS1 FACILITY message containing the **MWIActivate invoke** component, a SIP SUBSCRIBE request is sent to the Application Server that contains an Event header and the value is set to "message-summary" additionally the Accept header contains the value "application/simple-message-summary". The Expires header contains the subscription duration. The mapping of the Facility I.E is described below.

Table 5.4.2.2.1-1: Mapping of MWIActivate invoke

FACILITY →	SUBSCRIBE →
Facility Information Element: MWIActivate invoke	Event: message-summary Expires: xxxx (user option) Accept: application/simple-message-summary
receivingUserNr	From:
basicService	
controllingUserProvidedNr	Request URI
controllingUserNr (see note)	Request URI
NOTE: If only the "controllingUserNr" parameter is present, this parameter shall be mapped into the Request URI. In the other case the "controllingUserProvidedNr" parameter has precedence.	

On receipt of a 200 OK (SUBSCRIBE) or 202 OK (SUBSCRIBE) and the Expires header is not equal to zero, a DSS1 FACILITY message including the **MWIActivate return result** component is sent to the DSS1 user equipment. If an unsuccessful final response is received upon sending a SUBSCRIBE, a DSS1 FACILITY message including the **MWIActivate return error** component value "**resourceUnavailable**" is sent to the DSS1 user equipment.

NOTE: A more accurate mapping between unsuccessful final responses and ISDN operation errors is for further study.

Additionally as to activate the MWI service, as a network option it is possible to use service code commands via in-band dialogue or using the service code via keypad protocol. These requirements to using the keypad protocol are described in annex A of the present document. The result is available in-band (announcement).

5.4.2.2.2 Deactivation of Message Waiting Indication (MWI)

On receipt of a DSS1 FACILITY message containing the **MWIDeactivate invoke** component, a SIP SUBSCRIBE request is sent to the Application Server the Event header I set to "message-summary" and the Expires header is set to zero. The mapping of the Facility I.E is described below.

Table 5.4.2.2.2-1: Mapping of MWIDeactivate invoke

FACILITY →	SUBSCRIBE →
Facility Information Element: MWIDeactivate invoke	Event: message-summary Expires: 0
receivingUserNr	From:
basicService	
controllingUserProvidedNr	Request URI
controllingUserNr (see note)	Request URI
NOTE: If only the "controllingUserNr" parameter is present, this parameter shall be mapped into the Request URI. In the other case the "controllingUserProvidedNr" parameter has precedence.	

On receipt of a 200 OK (SUBSCRIBE), a DSS1 FACILITY message including the **MWIDeactivate return result** component is sent to the DSS1 user equipment.

If an unsuccessful final response is received upon sending a SUBSCRIBE, a DSS1FACILITY message including the **MWIDeactivate return error** component value "**resourceUnavailable**" is sent to the DSS1 user equipment.

NOTE: A more accurate mapping between unsuccessful final responses and ISDN operation errors is for further study.

Additionally as to deactivate the MWI service, as a network option it is possible to use service code commands via in-band dialogue or using the service code via keypad protocol. These requirements to using the keypad protocol are described in annex A of the present document. The result is available in-band (announcement).

Annex A (normative): Keypad Procedures

A.1 Generic procedure at the AGCF/VGW side

On receipt of a service code included within a Keypad facility information element included within a SETUP and/or INFO Message(s), the AGCF/VGW sends an INVITE request with the following information:

- A Request-URI structured as follows:
 - A user part containing the service code command, excluding the START and FINISH fields. The same Syntax is used as for PSTN. This is shown in clause C.1.2.1.1 in TS 183 043 [42].
 - A domain name which together with the user part provides sufficient information to the S-CSCF to forward the INVITE request to the appropriate AS, based on Initial Filter Criteria stored in the user profile, e.g.

`"PX SC (SR SI) SX"@pes-scc.operator.com`

NOTE 1: If the service code command includes a square "#" symbol, the userinfo portion of the Request-URI is in the form of a telephone-subscriber. The series of digits that form the service code command is encoded as a local-number. The phone-context attribute is set to a domain name of the PES operator, e.g. `phonecontext=pes-scc.homedomain.com` that is specific enough to enable the application server to interpret the commandcode. Setting the phone-context attribute is required for conformance purposes with RFC 3966 [47]. PES network entities (e.g. CSCF) ignore this attribute.

NOTE 2: In cases where Overlap Signalling is used the regarding rules for Overlap are used. The collection of the Service Code Information is done within the related Application Server.

- To Header: Same info as in R-URI.
- A P-Asserted-Identifier header containing the public user identity of the subscriber issuing the service code command.
- An SDP offer for a voice call.

NOTE 3: The SDP offer may be used by the Application Server in case an announcement has to be delivered.

A.2 Generic procedure at the AS side

The procedures used at the AS Side are the same as for PSTN as described within TS 183 043 [42], clause C.1.2.1.3.

Annex B (normative): SDP mapping for ISDN 7 kHz service and Inter-working

B.1 Originating Side

DSS1 VGW / AGCF		Toward Far End
=> DSS1	SIP INVITE SDP- OFFER =>	DSS1- VGW or DSS1- AGCF or MGCF or SIP Phone 7 kHz or SIP Phone 3,1 kHz
BC1 = 3,1 kHz audio	CLEARMODE, PCMA or PCMU	
BC2 = Unrestricted Digital Info with tones/announce		

DSS1 VGW / AGCF		From Far End
<= DSS1	SIP SDP- ANSWER <=	DSS1- VGW DSS1- AGCF or MGCF SIP Phone 3,1 kHz or SIP Phone 7 kHz (see note)
BC = Unrestricted Digital Info with tones/announce (see note 1)	CLEARMODE, PCMA or PCMU	
BC = 3,1 kHz (see note 2)	PCMA/PCMU	
NOTE: It is assumed that the SIP 7 KHz phone only supports the G.722 codec natively and thus does not understand the CLEARMODE codec.		

B.2 Terminating side

a) Case 1

DSS1 VGW / AGCF (see note 1)		Far end
<= DSS1	SIP INVITE SDP- OFFER<=	DSS1- VGW DSS1- AGCF or MGCF
BC1= 3,1 kHz audio BC2 = Unrestricted Digital Info with tones/announce	CLEARMODE, PCMA or PCMU	
=>DSS1	SIP INVITE SDP- ANSWER=>	
BC2 = Unrestricted Digital Info with tones/announce	CLEARMODE, PCMA or PCMU	

b) Case 2

DSS1 VGW / AGCF (see note 2)		Far end
<=DSS1	SIP INVITE SDP- OFFER <=	SIP Phone 7 kHz
BC = 3,1 kHz	G.722, PCMA, PCMU	
=>DSS1	SIP INVITE SDP- ANSWER=>	
BC = 3,1 kHz	PCMA/PCMU	

c) Case 3

DSS1 VGW / AGCF (see note 2)		Far end
<=DSS1	SIP INVITE SDP- OFFER<=	SIP Phone 3,1 kHz
BC = 3,1 kHz	PCMA, PCMU	
=>DSS1	SIP INVITE SDP- ANSWER=>	
BC = 3,1 kHz	PCMA/PCMU	

NOTE 1: VGW/AGCF Media handling = H.221 structure is carried transparent from end to end.

NOTE 2: VGW/ AGCF media handling = PCMA/PCMU is carried transparent.

Annex C (normative): Timers

This annex specifies the use of the different ISUP, SIP and ISDN timers.

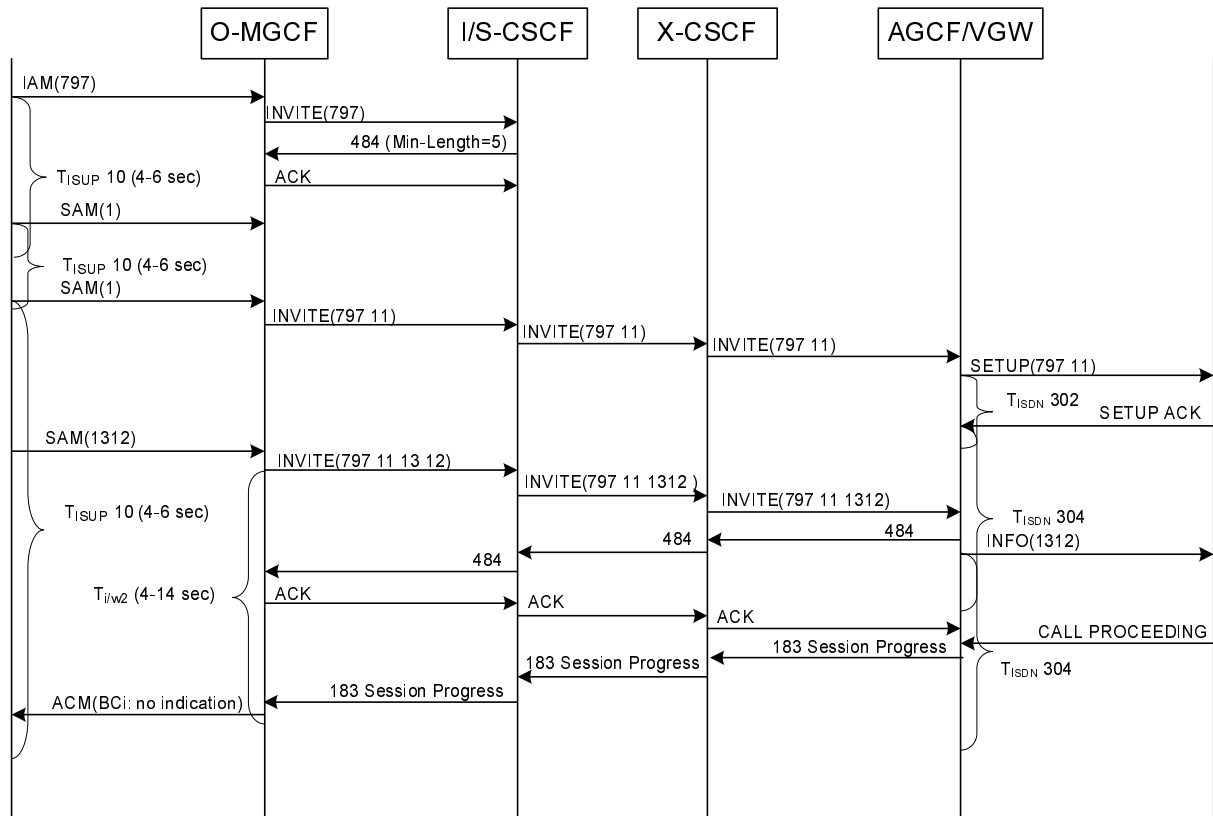

Figure C.1

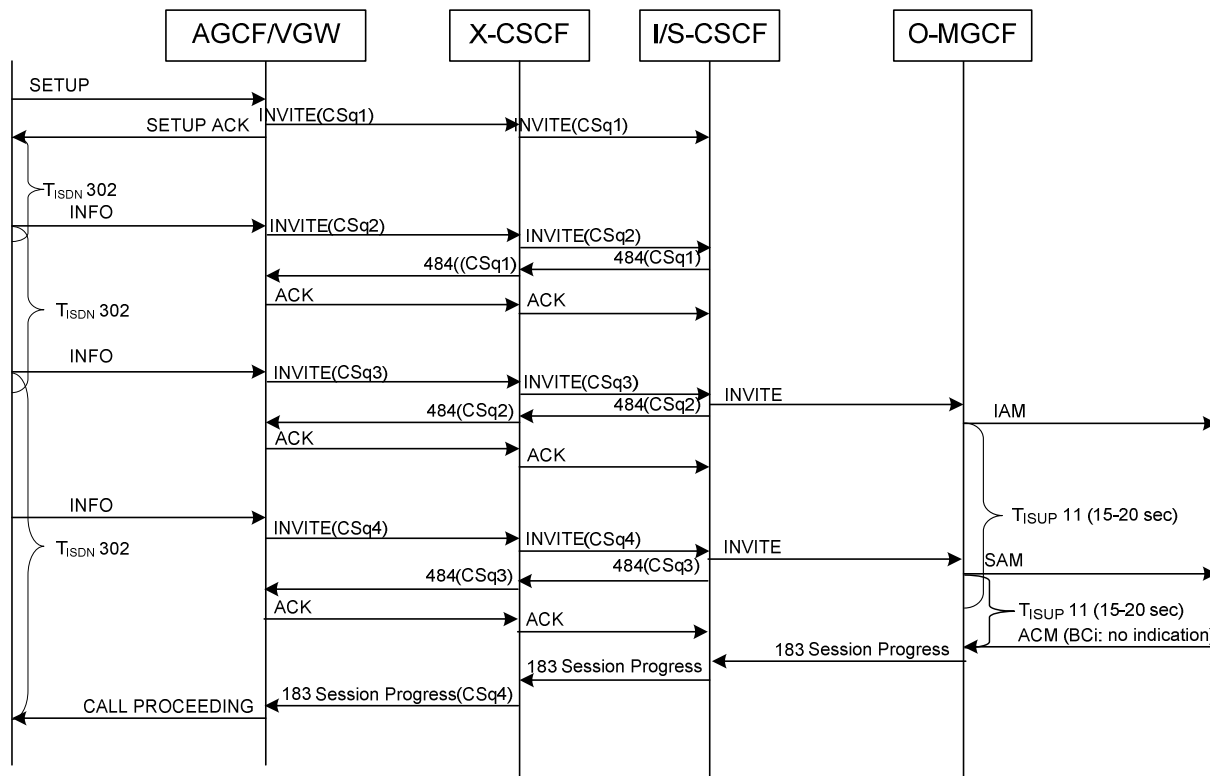

Figure C.2

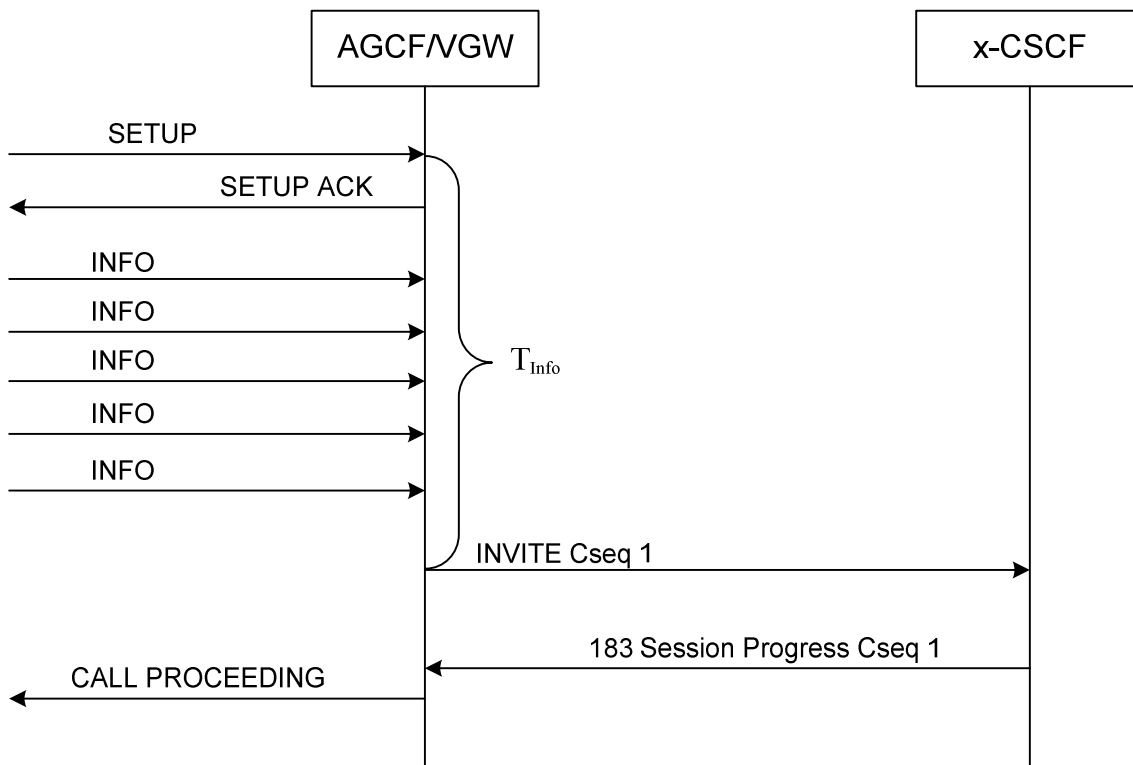

Figure C.3: Overlap with T_{Info} Timer

Table C.1: SIP - Timer in the network side

Timer number	Default time-out value	State of call	Cause for start	Normal stop	At the first expiry	At the subsequent expiry
Tinfo	0,5 s to 2 s	Overlap sending	SETUP Received	Timer expired	INVITE with the collected digits received in the SETUP and INFOs	
Tisdn3	12 s to 17 s (default of 12 s)	Overlap sending	On receipt of 404 Not Found or 484 Address Incomplete on the latest INVITE transactions for the corresponding call.	Subsequent INFO is received, on reception of 180 Ringing, or 183 Session Progress or 200 OK (INVITE).	Release call	
T _{TIR1}	0,1 s to 2 s (default 0,1 s)	Session answering	On receipt of 200 OK INVITE including the option tag "from-change", no privacy header or privacy value none, and Userinfo of P-Asserted-Identity in the format of a tel URI.	At the receipt of an UPDATE	map the received 200 OK INVITE to a CONNECT message	

Table C.2: ISDN Timers in the AGCF/VGW side- overview

Timer number	Default time-out value	State of call	Cause for start	Normal stop	At the first expiry	At the second expiry	Cross-reference
T301	Minimum 3 min	Call received	ALERT received	CONNECT received	Clear call	Timer is not restarted	(see note 2)
T302	10 s to 15 s (see note 3)	Overlap sending	SETUP ACK sent Receipt of INFO, restarts T302	With sending complete indication, or network alert, or connect request received	Clear if call information determined to be definitely incomplete; else send CALL PROC	Timer is not restarted	Mandatory
T303	4 s (see note 1)	Call present	SETUP sent	ALERT, CONNECT CALL PROC or SETUP ACK received, REL COMPLETE received if SETUP sent on point-point data link	Retransmit SETUP; restart T303. If REL COMPLETE has been received, clear the call	Clear network connection. Enter call abort state	Mandatory
T304	20 s (provisional value)	Overlap receiving	SETUP ACK received. Sending of INFO restarts T304	Send INFO; receive CALL PROC, ALERT or CONNECT	Clear the call	Timer is not restarted	Mandatory only if 5.2.4 implemented
<p>NOTE 1: This default value assumes the use of default values at layer 2, i.e. $[N200 + 1]$ times T200. Whether these values should be modified when layer 2 default values are modified by an automatic negotiation procedure is for further study.</p> <p>NOTE 2: The network may already have applied an internal alerting supervision timing function, e.g. incorporated within call control. If such a function is known to be operating on the call, then timer T301 is not used.</p> <p>NOTE 3: The value of timer T302 may vary beyond these limits, e.g. as a result of called party number analysis.</p>							

Table C.3: Q.931 - ISDN Timers in the user side- overview

Timer number	Default time-out value	State of call	Cause for start	Normal stop	At the first expiry	At the second expiry	Cross-reference
T301	Minimum 3 min.	Call Delivered	ALERT received	CONNECT received	Clear call	Timer is not restarted	Mandatory when Annex D is implemented
T302	15 s	Overlap receiving	SETUP ACK sent Restart when INFO received	INFO received with sending complete indication; or internal alerting; or internal connection; or a determination that sufficient information has been received	Clear if call information determined to be incomplete; else send CALL PROC	Timer is not restarted	Mandatory only if 5.2.4 is implemented
T303	4 s	Call Initiated	SETUP sent	ALERT (annex D), CONNECT (annex D), SETUP ACK, CALL PROC or REL COMPLETE received	Retransmit SETUP; restart T303. If REL COMPLETE was received, clear the call (annex D)	Clear internal connection. Send REL COMPLETE. Enter Null state	Mandatory when annex D is implemented; otherwise optional
T304	30 s	Overlap Sending	INFO sent Restarted when INFO sent again	CALL PROC, ALERT, CONNECT, DISC or prog. Ind. 1 or 2 received	DISC sent	Timer is not restarted	Optional

Annex D (normative): Overlap Sending

D.1 multiple INVITE Overlap Dialling Procedures (Optional)

D.1.1 Actions at the originating VGW/AGCF

D.1.1.1 Terminating overlap signalling at originating VGW/AGCF

If overlap sending is used, the SETUP message contains either:

- a) no called number information;
- b) incomplete called number information; or
- c) called number information which the network cannot determine to be complete.

When the VGW/AGCF has received called number information element from the calling user in a SETUP message (possibly followed by INFORMATION messages), it shall send an INVITE request with all the available called number information in the Request line and the originating SDP (derived from the BC and optionally present HLC for the VGW - else as obtained from the originating AGW (and influenced by the BC and optionally present HLC)) - see table 5.1.1.1.4-2.

The AGCF/VGW can contain a configurable digit map which is used to analyse the Called party information element contents received in a sequence of Called party number information elements. Among other purposes, this digit map can be used to:

- Identify the required number of digits to be entered for a particular digit sequence.

The procedures for digit maps are described within TS 183 043 [42], clause 7.3.1.3.1.1. Even in the absence of a digit map, it is appropriate for the AGCF/VGW to collect dialled digits. The AGCF/VGW shall contain a configurable parameter indicating the minimum number of digits expected in the sequence of Called party number information elements before a Request-URI is constructed and an INVITE request sent. The minimum number could be zero.

D.1.1.2 Sending of INVITE without determining the end of address signalling

On receipt of such a SETUP message, the AGCF/VGW starts the ISDN timer T_{302} , sends a SETUP ACKNOWLEDGE message to the user and enters the overlap sending state.

- If no number information is included the network will return dial tone, if required by the tone option.
 - If the received BC in the SETUP message is coded with speech, 3,1 kHz audio, UDI/TA, it shall include progress indicator No. 8, *in-band information or appropriate pattern is now available*, in the SETUP ACKNOWLEDGE message.
- 1) As a network option, the originating VGW/AGCF may send INVITE requests without determining the end of address signalling. If the originating VGW/AGCF sends an INVITE request before the end of address signalling is determined, the originating VGW/AGCF:
- uses the SIP precondition extension within the INVITE request;
 - starts timer Tinfo if not running; and
 - is prepared to process further incoming INFO as described below;
 - is prepared to handle incoming SIP 404 or 484 error responses as detailed in clause D.1.1.3.

- 2) On receipt of a new DSS1 INFO message, the originating VGW/AGCF shall:
- stop timer Tisdn3 (if it is running);
 - send an INVITE request complying to the following:
 - The INVITE request uses the SIP preconditions extension.
 - The INVITE request includes all digits received so far for this call in the Request-URI.
 - If subsequent address information in a DSS1 INFO message is received after the SIP 404 or 484 error responses has been received, the INVITE request additionally includes the digits received.

NOTE: The DSS1 timer 302 is restarted with the receipt of a DSS1 INFO message.

At the receipt of a new DSS1 INFO message, a SIP 18x provisional response, or a SIP 200 OK (INVITE), the originating VGW/AGCF shall stop Tisdn3.

As a network option the Timer T_{info} can be used, in this case the following procedure apply starting with the first digit received by the AGCF/VGW:

- Start timer T_{info} with receiving the SETUP.
- Collect all digits received within INFO messages.
- At expiry of timer T_{info} the initial INVITE is sent out as described under 1.
- If further digits are needed then the AGCF/VGW shall collect further digits until min length has been reached.

As a network Option the first INVITE can be sent with the receipt of the SETUP message and the T_{info} is started.

The T_{info} shall not be used if the INVITE has to be sent immediately because e.g. the hotline feature is provided to the originating user.

D.1.1.3 Special handling of 404 Not Found and 484 Address Incomplete responses after sending of INVITE without determining the end of address signalling

This Clause is only applicable when the network option of Sending of INVITE without determining the end of address signalling is being used (see clause D.1.1.2).

On receipt of a 404 Not Found or 484 Address Incomplete response, the originating VGW/AGCF starts timer Tisdn3, if there are no other pending INVITE transactions for the corresponding call.

At the receipt of fresh address information, or a SIP 18x provisional responses, or a SIP 200 OK (INVITE), the originating VGW/AGCF stops 302 and Tisdn3.

The originating VGW/AGCF shall send a RELEASE message with Cause Value 28 towards the ISDN user if Tisdn3 expires.

Option a) Overlap with T_{info} Timer.

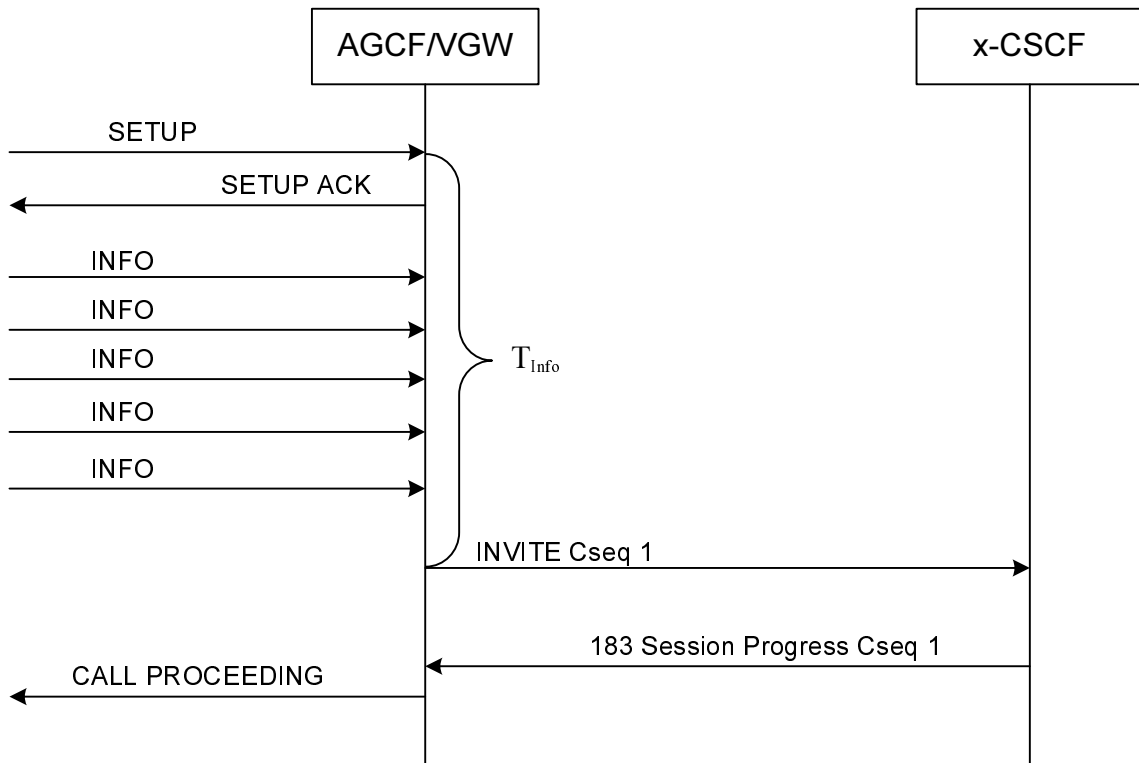

Figure D.1.1.3-1: Overlap with T_{info} Timer- no transaction is pending

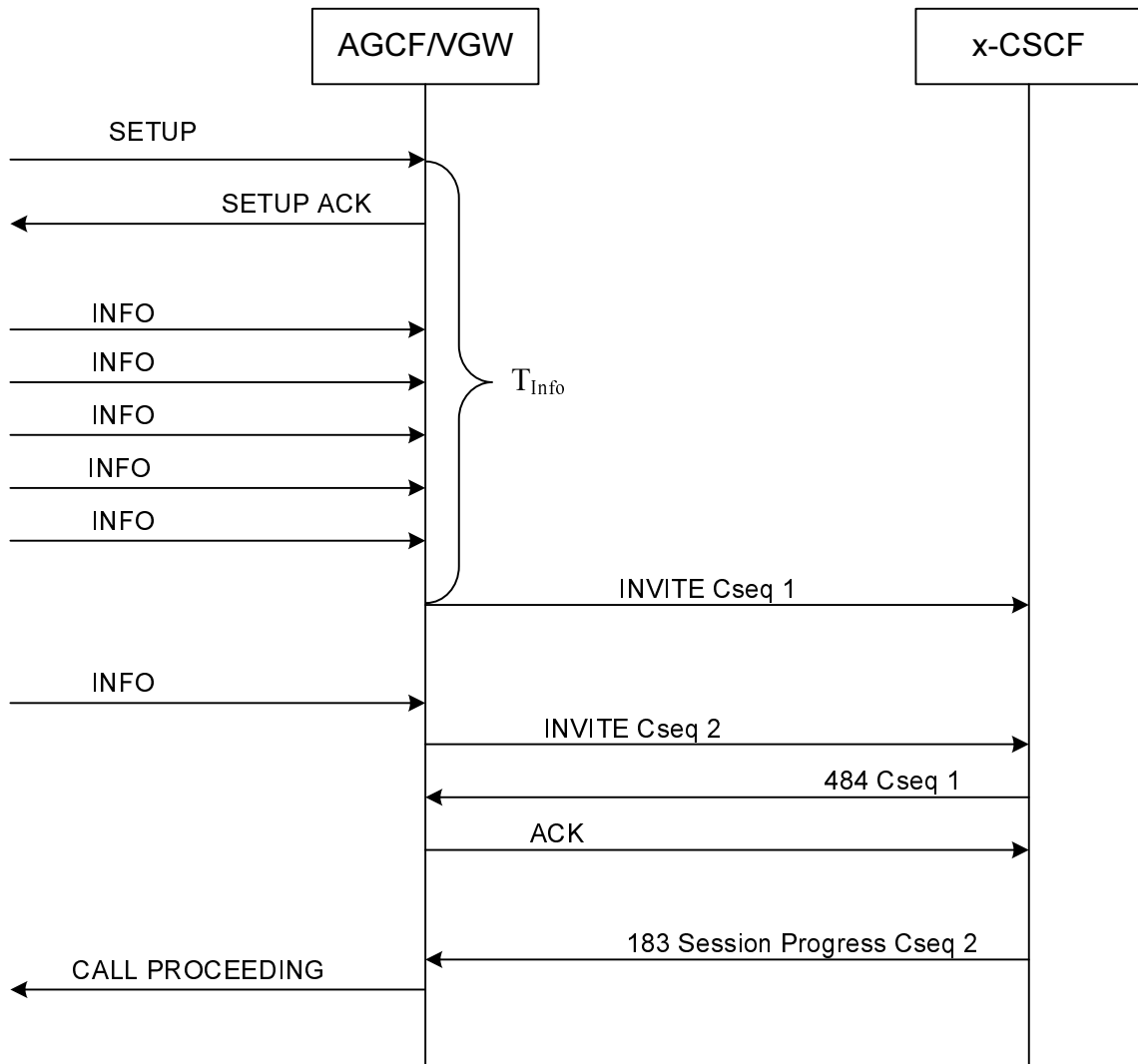

Figure D.1.1.3-2: Overlap with Tinfo Timer one transaction is pending

Option b) Overlap with Digit Map.

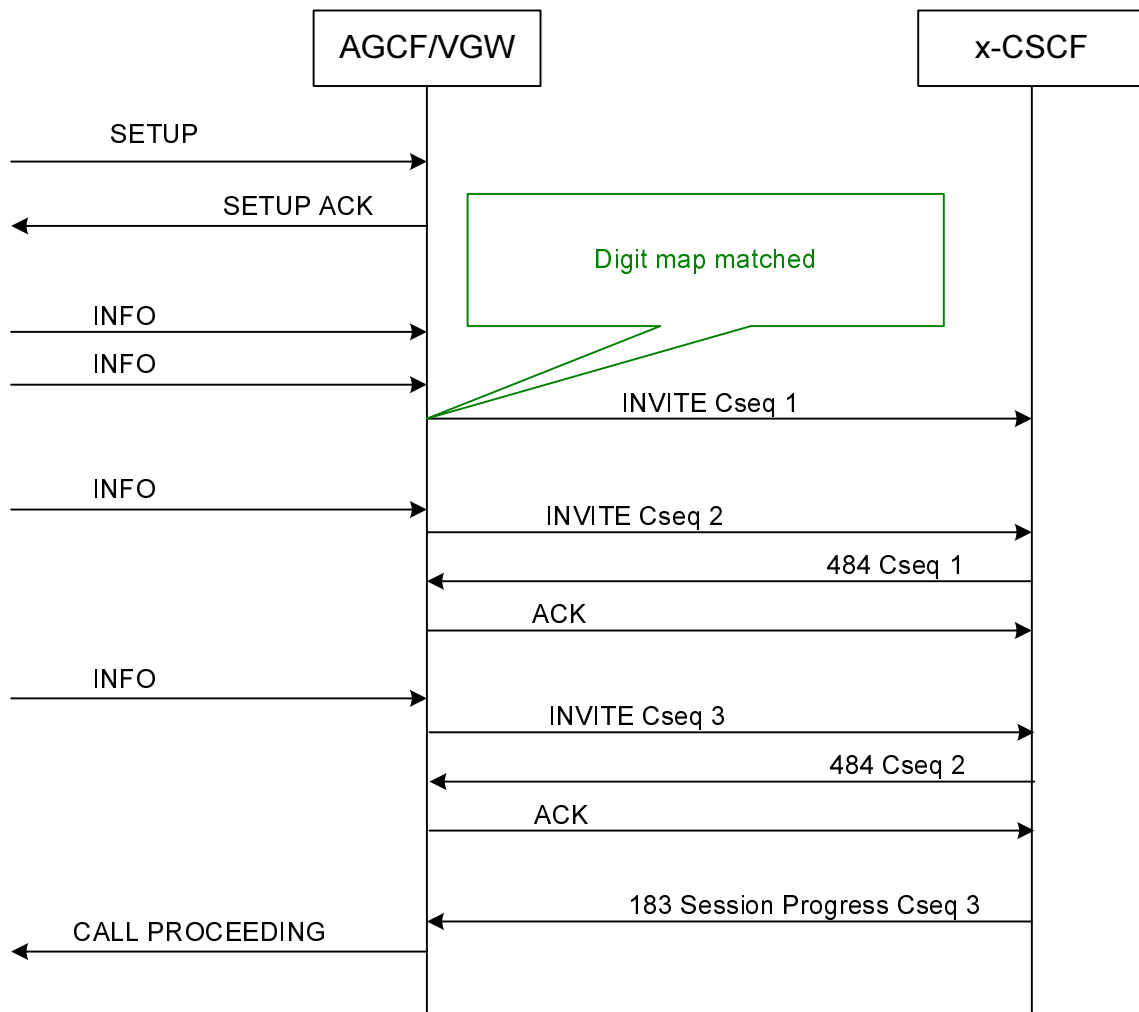

Figure D.1.1.3-3: Overlap with digit map

Option c) Overlap with Digit Map and T_{info} Timer.

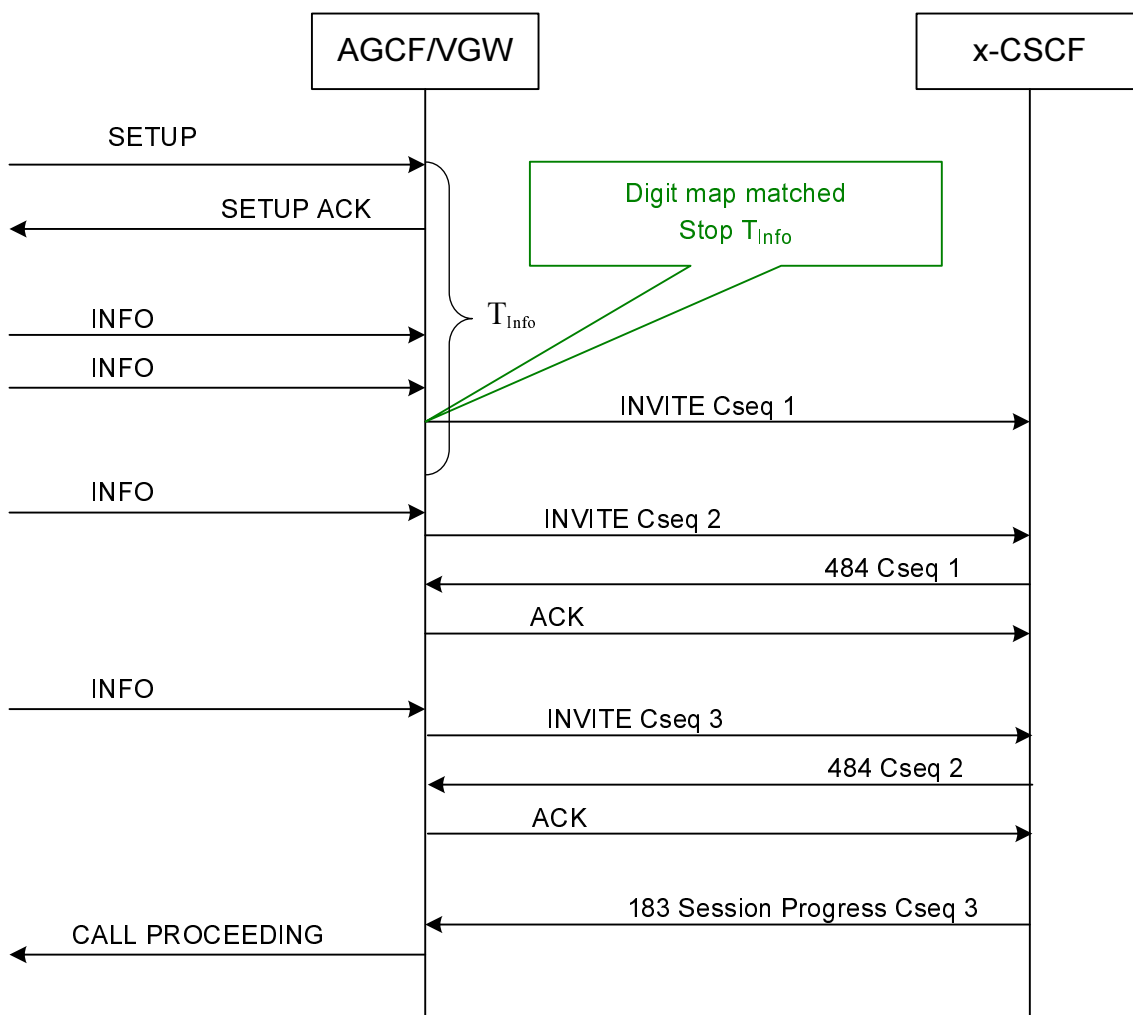

Figure D.1.1.3-4: Overlap with digit map and T_{info} timer
digit map matched before T_{info} expiry

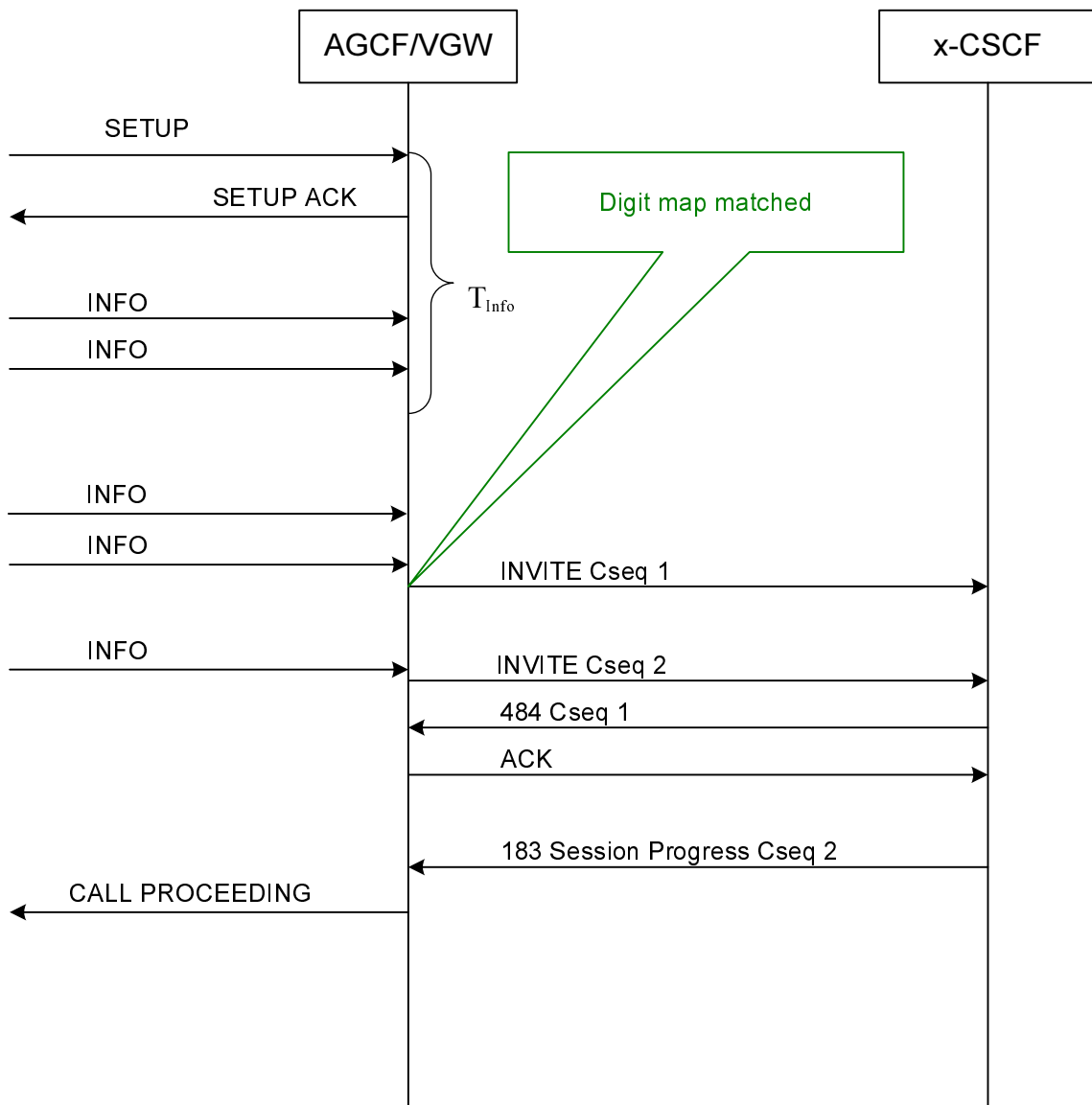

Figure D.1.1.3-5: Overlap with digit map and T_{info} timer
digit map matched after T_{info} expiry

Option d) 484 message with Min-length X parameter.

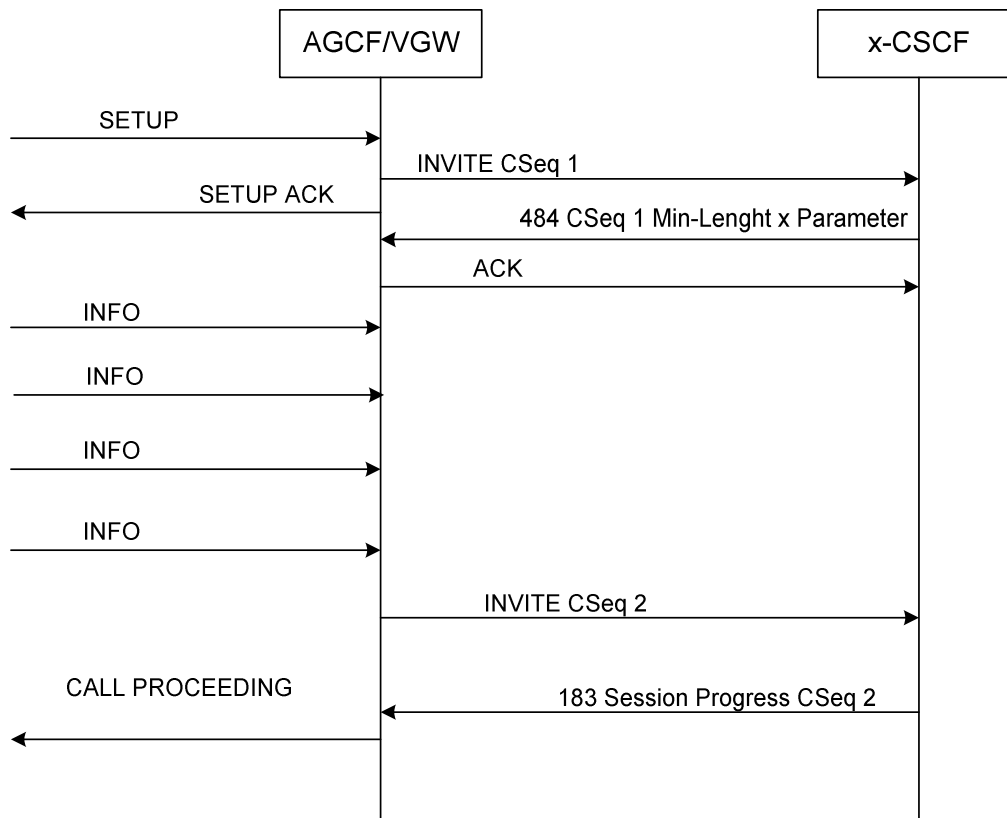

Figure D.1.1.3-6: Overlap option with 484 message with Min-length x parameter

option c) 484 message without Min-length X parameter.

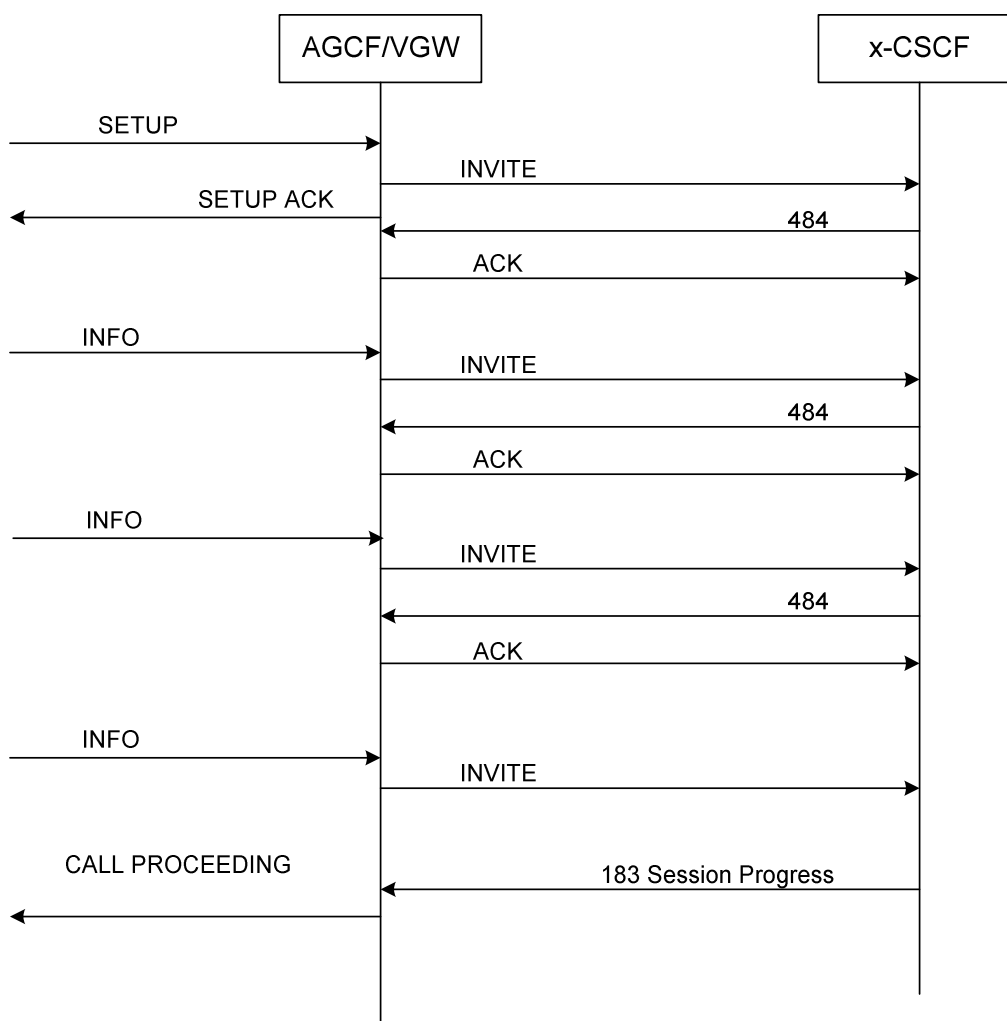

Figure D.1.1.3-7: 484 message without Min-length X parameter

D.1.2 Actions at the terminating VGW/AGCF

See annex H for DDI. For all other no further action is needed.

D.2 In-Dialog Method (Optional)

D.2.1 Actions at the originating VGW/AGCF

D.2.1.1 Terminating overlap signalling at originating VGW/AGCF

If overlap sending is used, the SETUP message contains either:

- a) no called number information;
- b) incomplete called number information; or
- c) called number information which the network cannot determine to be complete.

When the VGW/AGCF has received called number information element from the calling user in a SETUP message (possibly followed by INFORMATION messages), it shall send an INVITE request with all the available called number information in the Request line and the originating SDP (derived from the BC and optionally present HLC for the VGW - else as obtained from the originating AGW (and influenced by the BC and optionally present HLC)) - see table 5.1.1.1.4-2.

The AGCF/VGW can contain a configurable digit map which is used to analyse the Called party information element contents received in a sequence of Called party number information elements. Among other purposes, this digit map can be used to:

- identify the required number of digits to be entered for a particular digit sequence. The procedures for digit maps are described within TS 183 043 [42], clause 7.3.1.3.1.1.

Even in the absence of a digit map, it is appropriate for the AGCF/VGW to collect dialled digits. The AGCF/VGW shall contain a configurable parameter indicating the minimum number of digits expected in the sequence of Called party number information elements before a Request-URI is constructed and an INVITE request sent. The minimum number could be zero.

D.2.1.2 Sending of INVITE without determining the end of address signalling

On receipt of such a SETUP message, the AGCF/VGW starts the ISDN timer T_{302} , sends a SETUP ACKNOWLEDGE message to the user and enters the overlap sending state:

- If no number information is included the network will return dial tone, if required by the tone option.
 - If the received BC in the SETUP message is coded with speech, 3,1 kHz audio, UDI/TA, it shall include progress indicator No. 8, *in-band information or appropriate pattern is now available*, in the SETUP ACKNOWLEDGE message.
- 1) As a network option, the originating VGW/AGCF may send INVITE requests without determining the end of address signalling. If the originating VGW/AGCF sends an INVITE request before the end of address signalling is determined, the originating VGW/AGCF:
 - use the SIP precondition extension within the INVITE request;
 - be prepared to process INFO as described below;
 - be prepared to handle incoming SIP 484 (Address Incomplete) responses;
 - on receipt of 404 Not Found or 484 Address Incomplete start timer T_{isdn3} .
 - 2) On receipt of a new INFO from the DSS1 side, the AGCF/VGW shall:
 - if an early dialog has been established, send a SIP INFO request including the additional digits for this call;
 - if an early dialog has not been established, wait for a final error response for the previous INVITE and send an INVITE request including all digits received so far for this call in the Request-URI.

At the receipt of a new DSS1 INFO message, a SIP 18x provisional response, or a SIP 200 OK (INVITE), the originating VGW/AGCF shall stop T_{isdn3} .

As a network option the Timer T_{info} can be used, in this case the following procedure apply starting with the first digit received by the AGCF/VGW:

- start timer T_{info} with receiving the SETUP;
- collect all digits received within INFO messages;
- at expiry of timer T_{info} the initial INVITE is sent out as described under 1):
 - If further digits are needed then the AGCF/VGW shall collect further digits until min length has been reached.

As a network Option the first INVITE can be sent with the receipt of the SETUP message and the T_{info} is started.

The timer T_{info} shall not be used if the INVITE has to be sent immediately because e.g. the hotline feature is provided to the originating user.

The originating VGW/AGCF shall send a RELEASE message with Cause Value 28 towards the ISDN user if T_{isdn3} expires.

Option a) Overlap with T_{info} Timer.

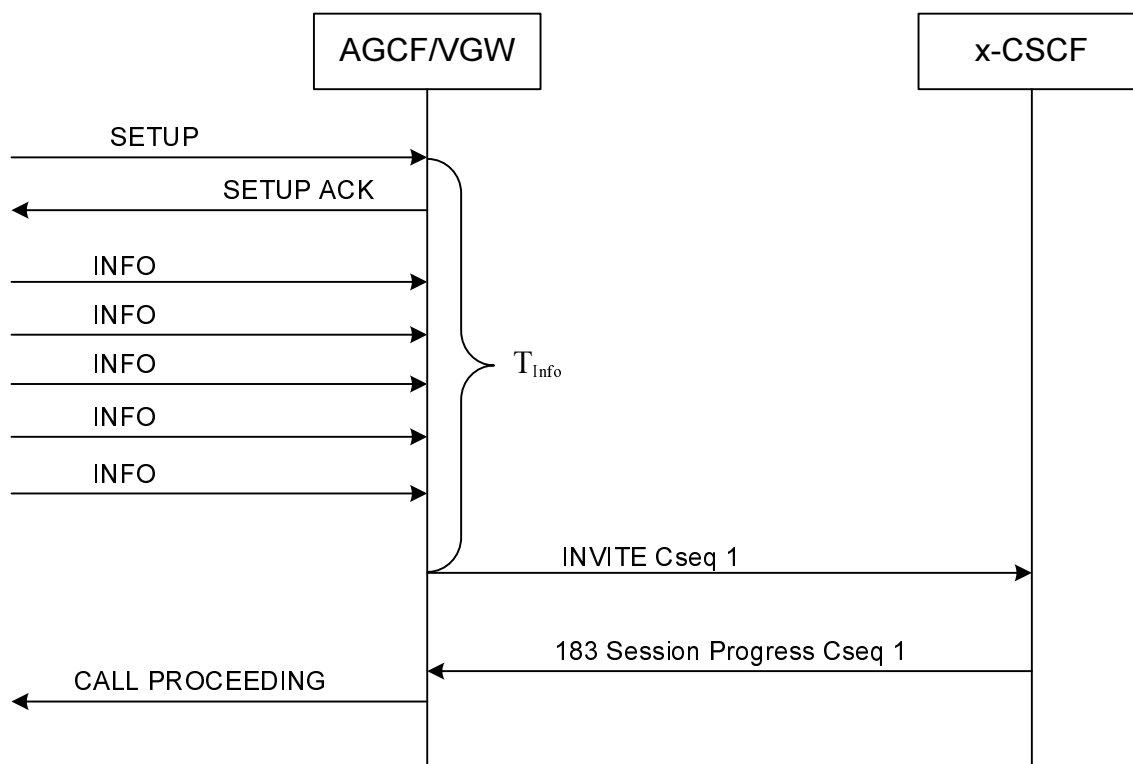

Figure D.2.1.2-1: Overlap with T_{info} Timer- no transaction is pending

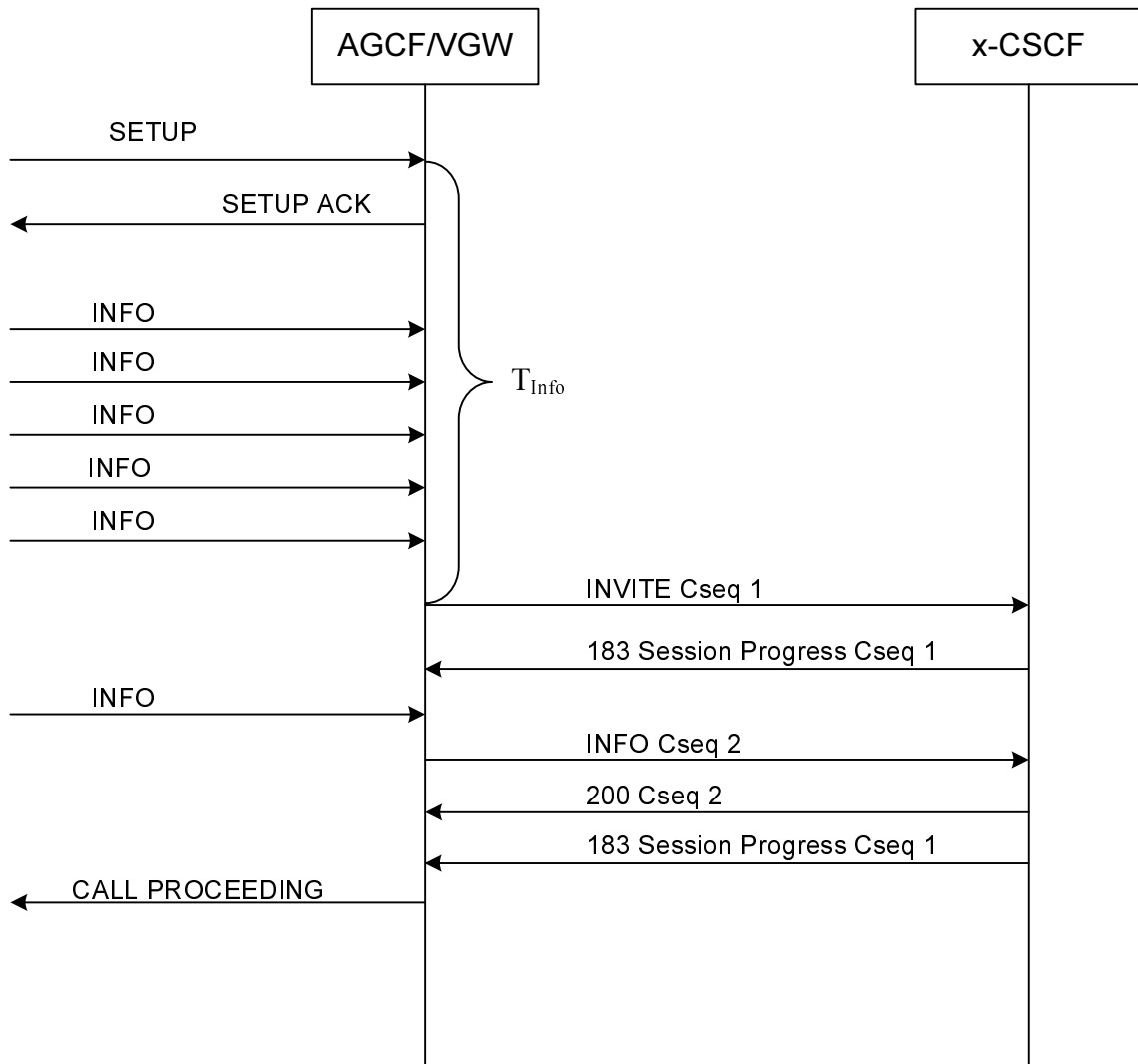

Figure D.2.1.2-2: Overlap with Tinfo Timer no transaction is pending

Option b) Overlap with Digit Map.

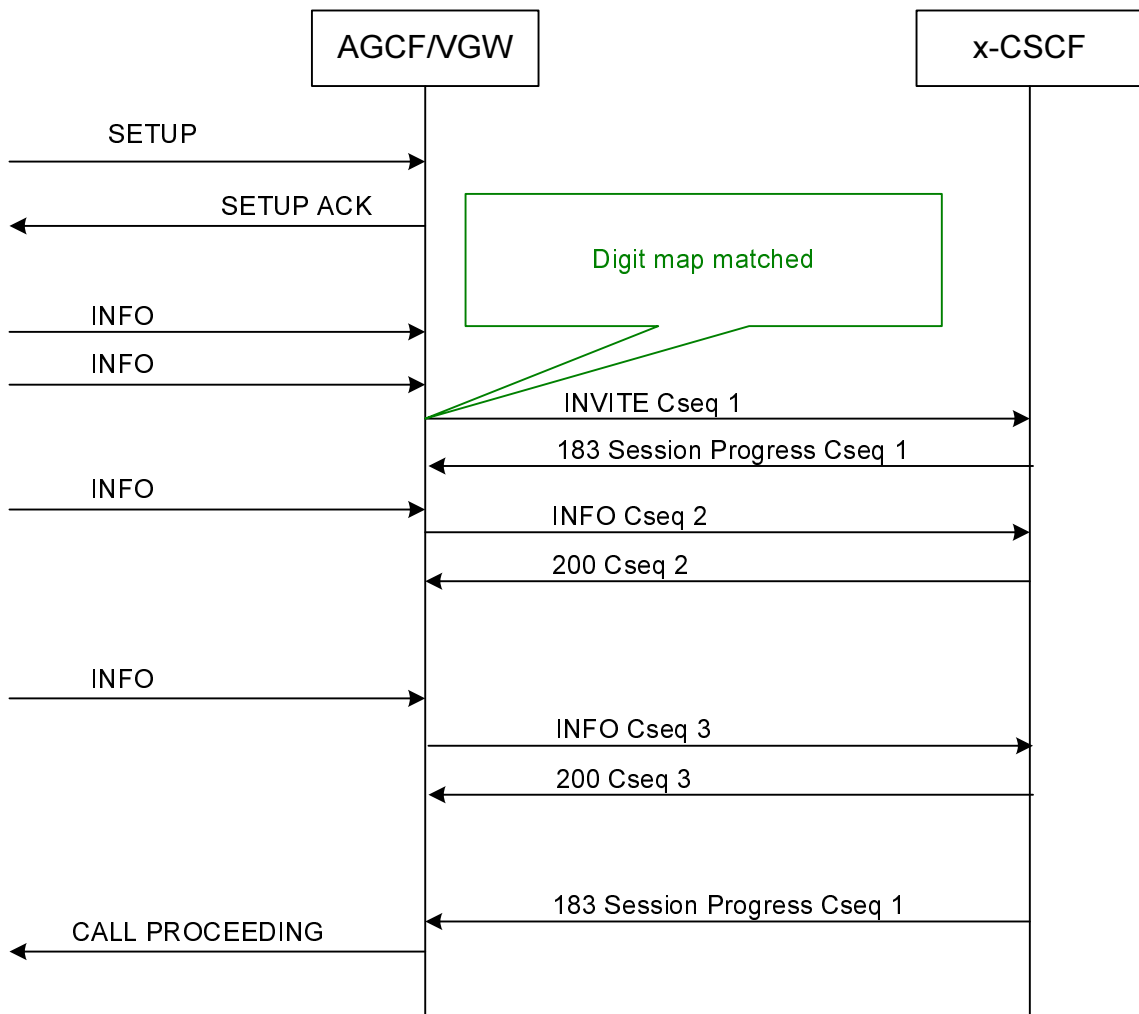

Figure D.2.1.2-3: Overlap with digit map

Option c) Overlap with Digit Map and T_{info} Timer.

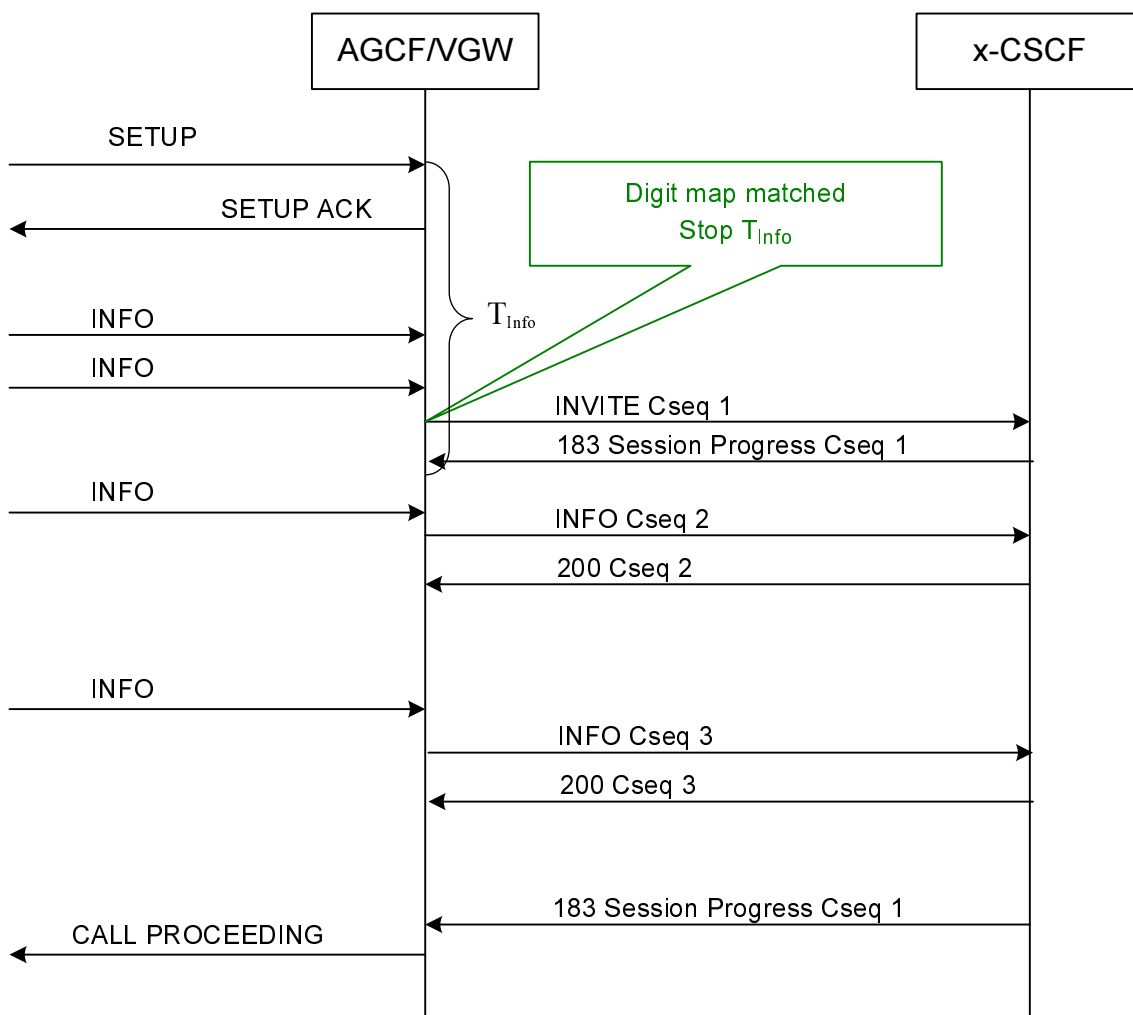

Figure D.2.1.2-4: Overlap with digit map and T_{info} timer
digit map matched before T_{info} expiry

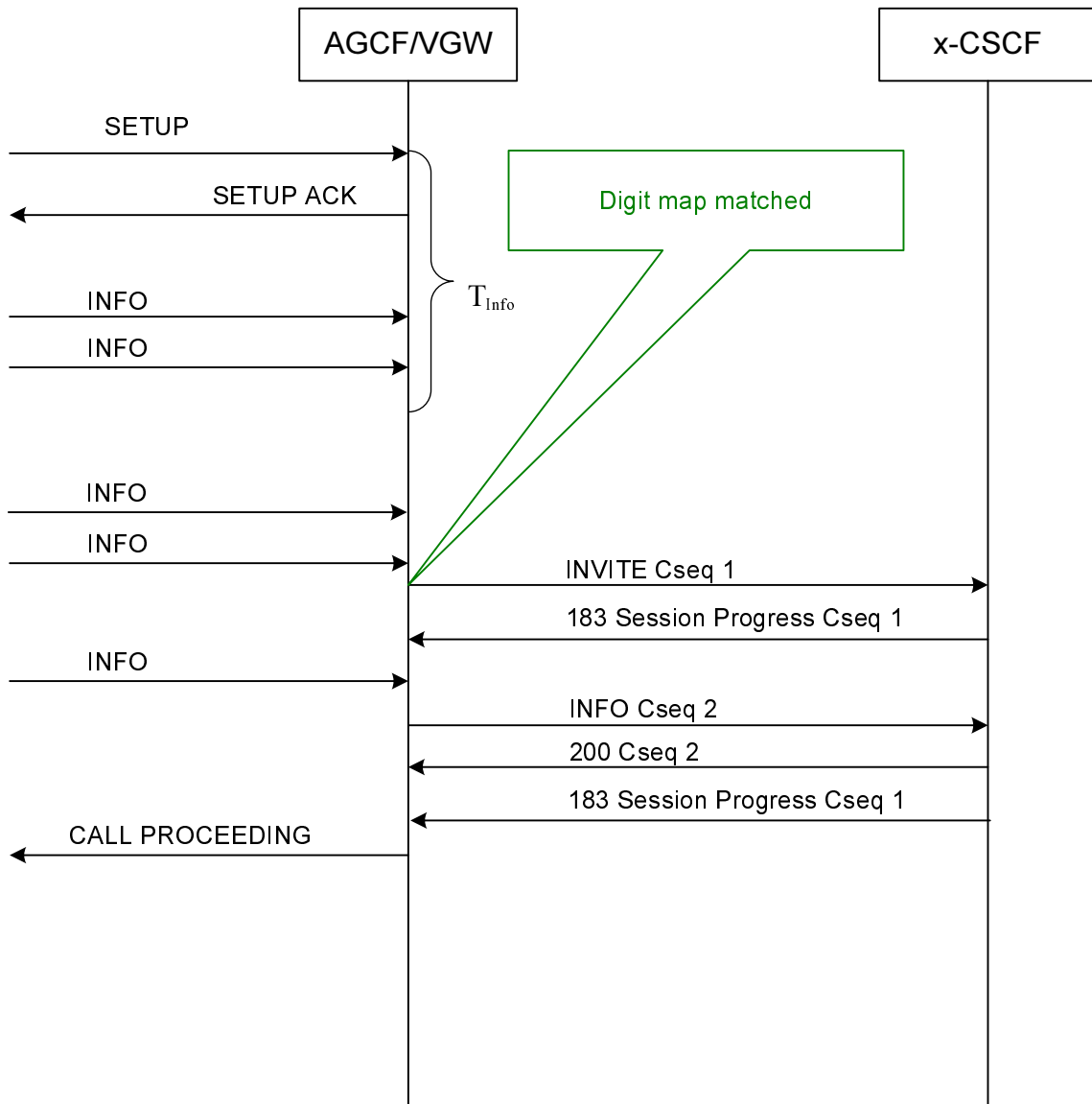

Figure D.2.1.2-5: Overlap with digit map and Tinfo timer
digit map matched after T_{info} expiry

Option d) 484 message with Min-length X parameter.

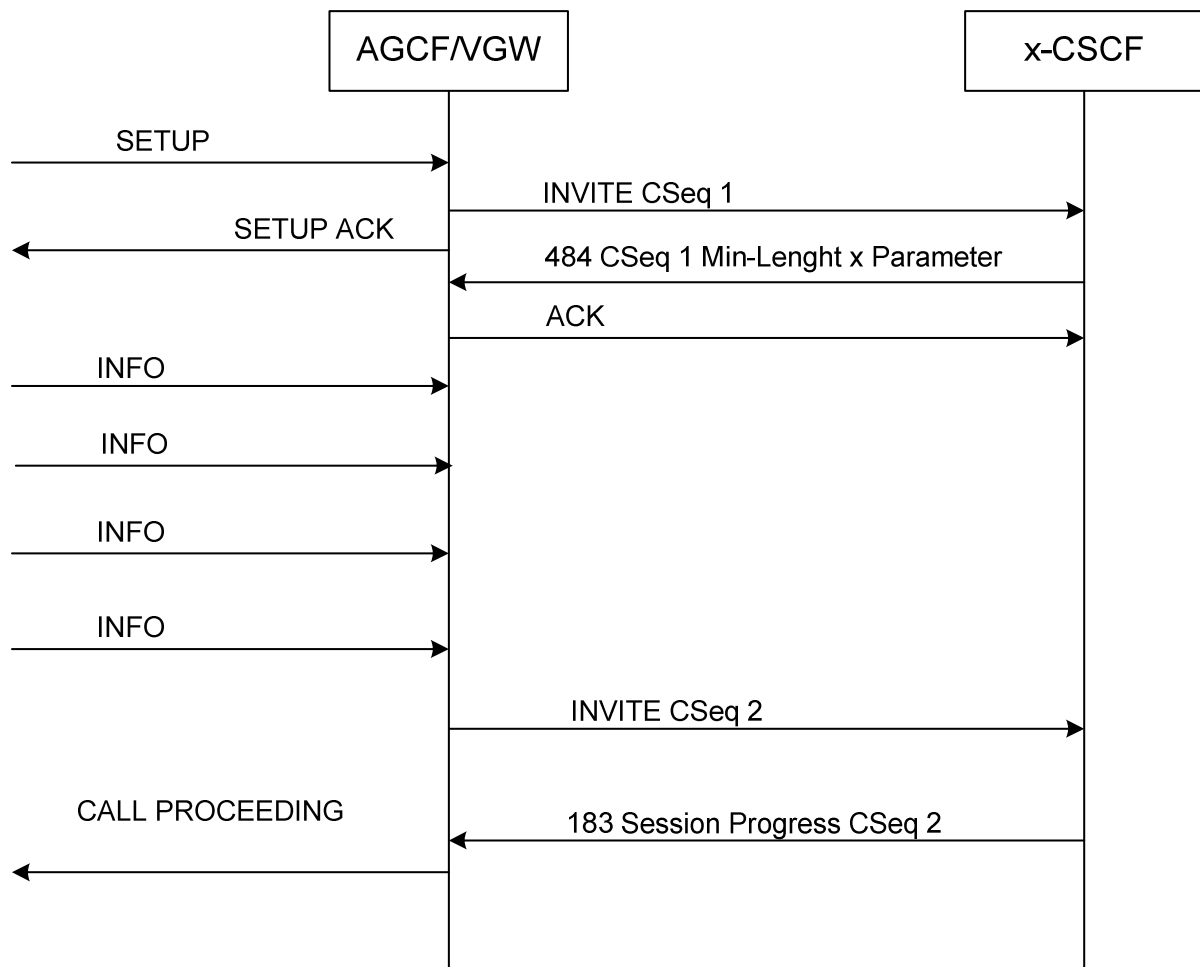

Figure D.2.1.2-6: Overlap option with 484 message with Min-length x parameter

Annex E (normative): Direct Dialling In

This annex describes the handling of Direct Dialling In.

E.1 Multiple INVITEs Method (Optional)

E.1.1 Actions at the incoming AGCF/VGW

E.1.1.1 Receipt of Subsequent INVITE messages

If the SETUP message has already been sent and the SETUP ACKNOWLEDGE message has been received, overlap receiving is used, an INFORMATION message will be sent upon receipt of each Subsequent INVITE.

When the SETUP ACKNOWLEDGE message is received, the AGCF/VGW shall: stop timer T303; start timer T304; enter the Overlap receiving state; and send the remainder of the call information (if any) in one or more INFORMATION messages, starting timer T304 when each INFORMATION message is sent.

At the expiration of timer T304 the network initiates call clearing with cause No. 28, *invalid number format (address incomplete)* to the calling user and cause No. 102, "recovery on timers expiry" to the called user.

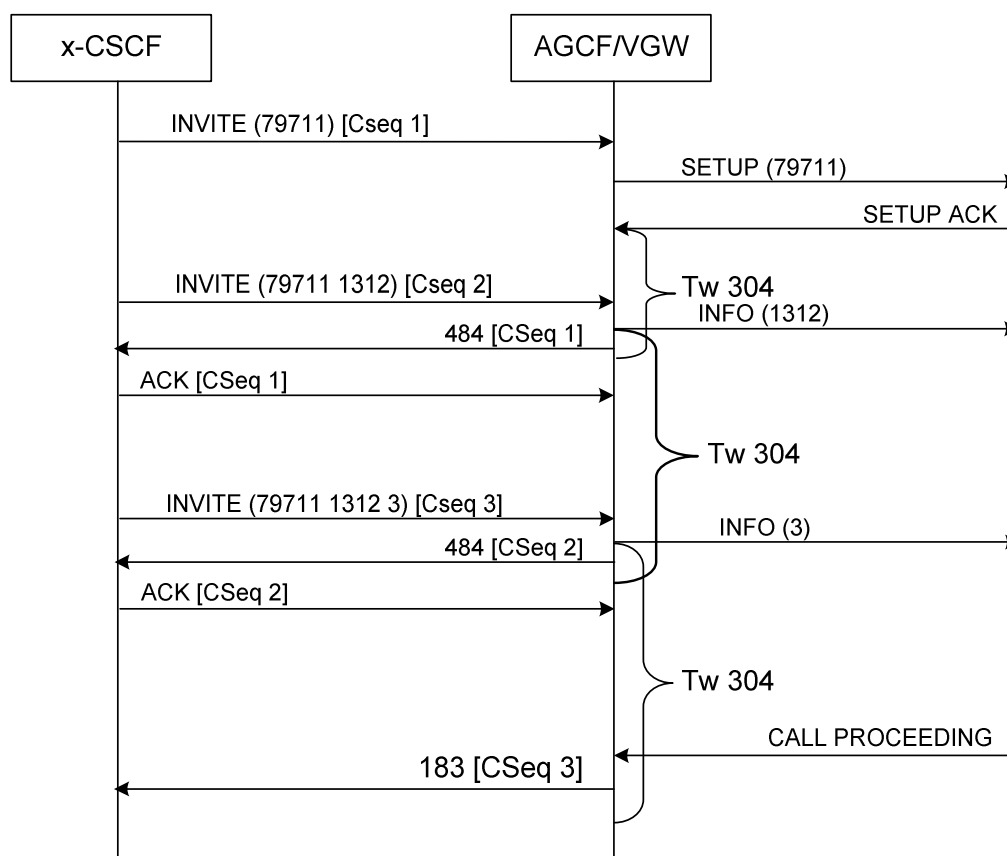

Figure E.1.1.1-1: Receipt of Subsequent INVITE messages

At the expiration of timer T304 the network initiates call clearing with cause No. 28, *invalid number format (address incomplete)* to the calling user and cause No. 102, "recovery on timers expiry" to the called user.

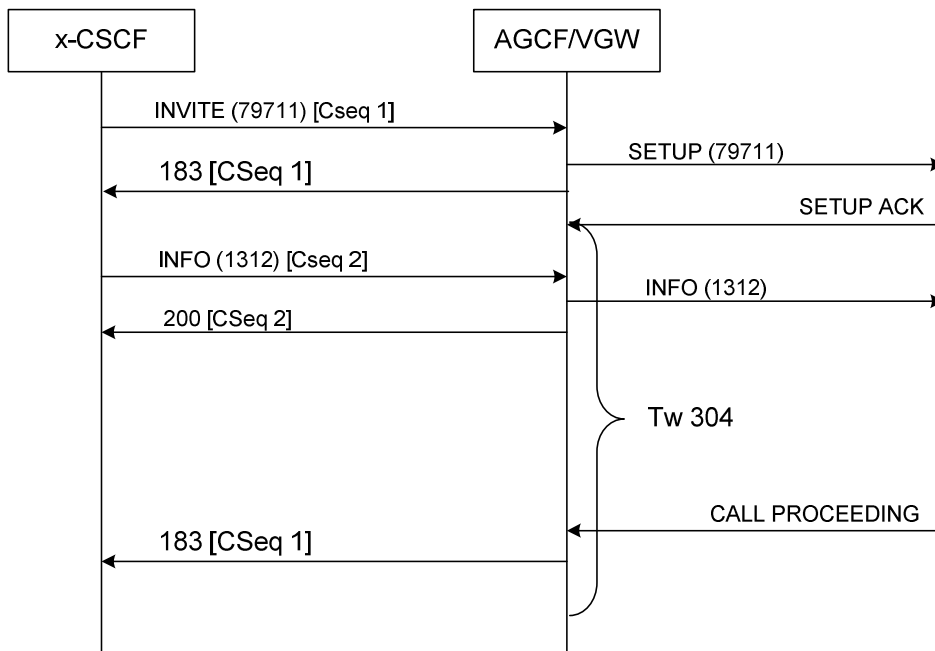

Figure E.2.1.1-1: Receipt of SIP INFO request

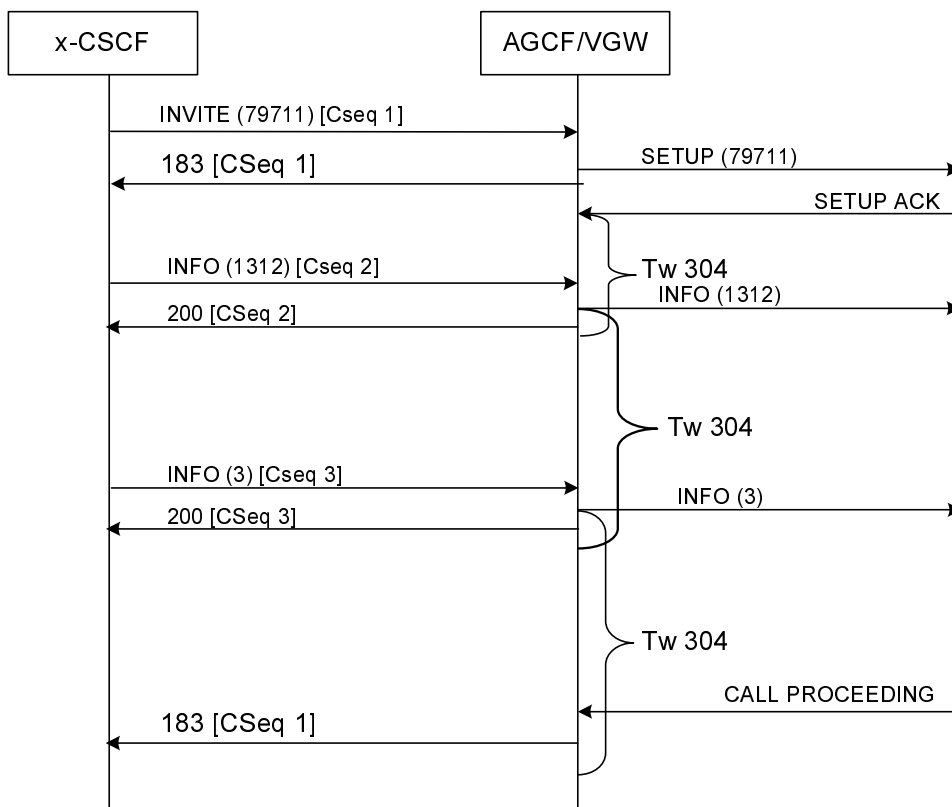

Figure E.2.1.1-2: Receipt of SIP INFO requests

Receipt of SIP INFO requests

This clause applies when overlap operation is supported across the AGCF/VGW. If the AGCF/VGW receives a SIP INFO request within an early dialog created by a previous INVITE, which was associated with a DSS1 call/bearer control instance currently existing on the DSS1 side, then the AGCF/VTW shall generate an INFO and pass it to outgoing DSS1 procedures. The INFO shall contain in its Called party Number parameter only the additional digits, received in the SIP INFO request, compared with the digits already accumulated for the call.

Annex F (informative): Handling and interworking of DSS1 messages and Information Elements

This annex describes the handling and interworking of DSS1 messages and Information Elements at the AGCF/VGW.

Table F.1: DSS1 messages

DSS1 Message	Handling in SIP
ALERTING	Interworking with 180 Ringing
CALL PROCEEDING	Interworking with 183 Session Progress or local significance
CONNECT	Interworking with 200 OK INVITE
CONNECT ACKNOWLEDGE	local significance
PROGRESS	Interworking with 183 Session Progress or local significance
SETUP	Interworking with INVITE
SETUP ACKNOWLEDGE	local significance
RESUME	Interworking with INVITE or UPDATE containing the P-Service-Notification value "user-resumed"
RESUME ACKNOWLEDGE	local significance
RESUME REJECT	
SUSPEND	Interworking with INVITE or UPDATE containing the P-Service-Notification value "user-suspended"
SUSPEND ACKNOWLEDGE	local significance
SUSPEND REJECT	
DISCONNECT	Interworking with BYE, CANCEL or unsuccessful status responses
RELEASE	Interworking with BYE, CANCEL or unsuccessful status responses
RELEASE COMPLETE	Interworking with BYE, CANCEL or unsuccessful status responses or local significance
INFORMATION	Interworking with INVITE in case of overlap procedure
NOTIFY	Interworking with INVITE or UPDATE
SEGMENT	No interworking
STATUS	local significance
STATUS ENQUIRY	local significance
USER INFORMATION	No interworking
CONGESTION CONTROL	local significance
RESTART	local significance
RESTART ACKNOWLEDGE	local significance
HOLD	Interworking with INVITE or UPDATE. HOLD procedure based on TS 183 010 [10]
HOLD ACKNOWLEDGE	local significance
HOLD REJECT	
RETRIEVE	Interworking with INVITE or UPDATE. HOLD procedure based on TS 183 010 [10]
RETRIEVE ACKNOWLEDGE	Local significance
RETRIEVE REJECT	
REGISTER	Interworking with CCBS or CCNR
FACILITY	Operation of the configuration of services or user equipment

Table F.2: DSS1 Information Elements

DSS1 Information Element	Handling in SIP
Protocol discriminator	Local significance
Call reference	Local significance
Message type	Local significance
Channel identification	Local significance
Bearer capability	Interworking with INVITE, 18x, 200 OK
High layer compatibility	Interworking with INVITE
Low layer compatibility	Interworking with INVITE
Progress indicator	Interworking with INVITE, 18x, 200 OK
Display	Interworking with INVITE, 18x, 200 OK CANCEL, BYE
Date/time	Local handling
Signal	
Sending complete	Indication for end of dialling
Keypad facility	Maintenance of services
Called party number	Interworking with INVITE
Calling party number	Interworking with INVITE
Calling party subaddress	Interworking with INVITE
Called party subaddress	Interworking with INVITE
Connected number	Interworking with 200 OK/UPDATE
Connected subaddress	Interworking with 200 OK/UPDATE
Redirecting number	Interworking with INVITE
Redirection number	Interworking with 181, 180, 200 OK
Cause	Interworking with unsuccessful final response, BYE or CANCEL
Notification indicator	Interworking with INVITE, UPDATE, 18x, 200 OK
Facility	Maintenance of services
Call identity	
Network-specific facilities	No interworking
Transit network selection	No interworking
Repeat indicator	
Call state	local
User-user	Interworking with INVITE, 18x, 200 OK, BYE
Information rate	
End-end transit delay	
Transit delay selection and indication	
Packet layer binary parameters	(X25)
Packet layer window size	(X25)
Packet size	(X25)
Closed user group	No interworking
Reverse charging indication	No interworking
More data	
Restart indicator	Local significance
Locking Shift	
Non-locking Shift	

Annex G (informative): Message flows

G.1 Three party

Basic call procedure and HOLD

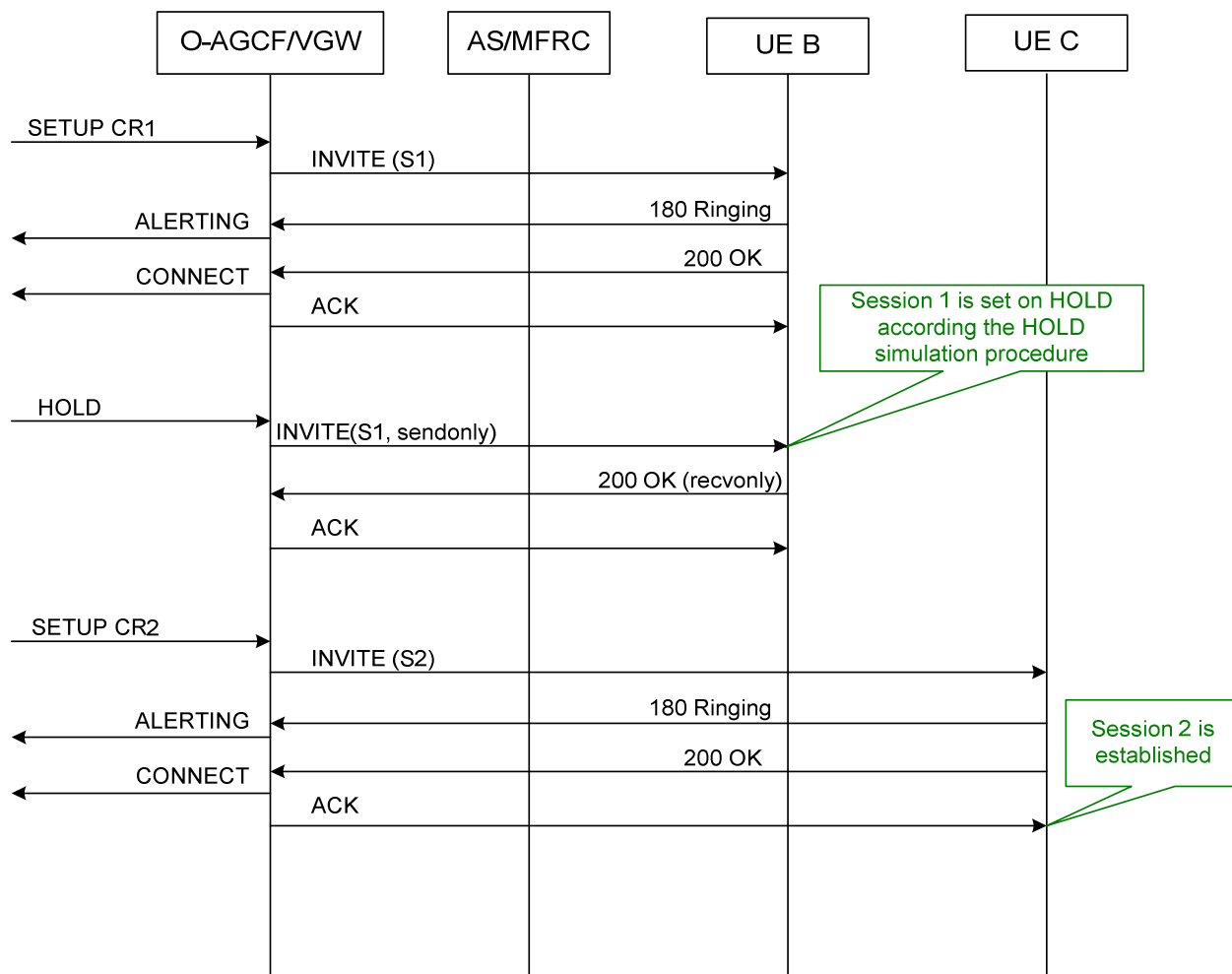

NOTE: Two sessions, one in hold one active.

Figure G.1-1: Initial position before starting the 3PTY service

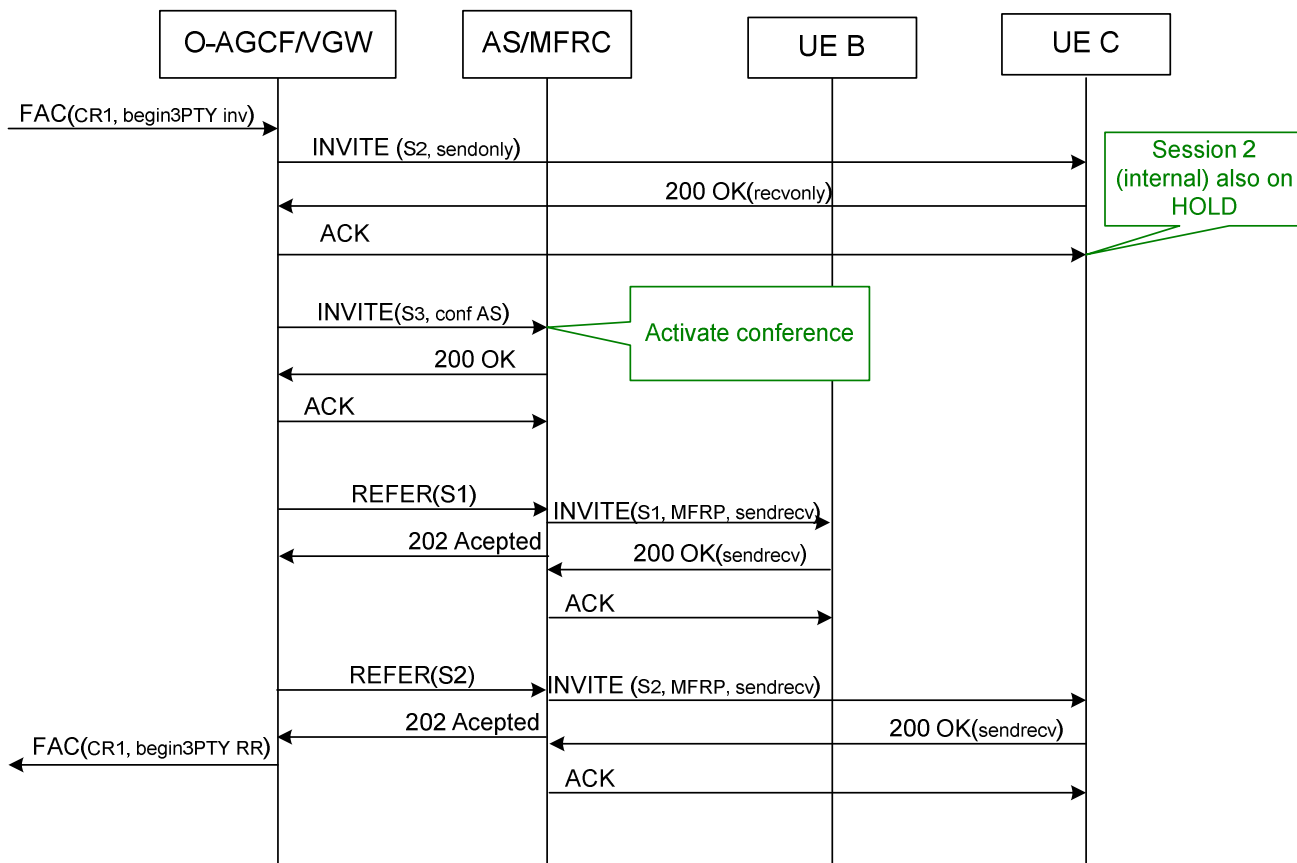

NOTE: The media streams shall be set on hold before.

Figure G.1-2: Invocation of three party session

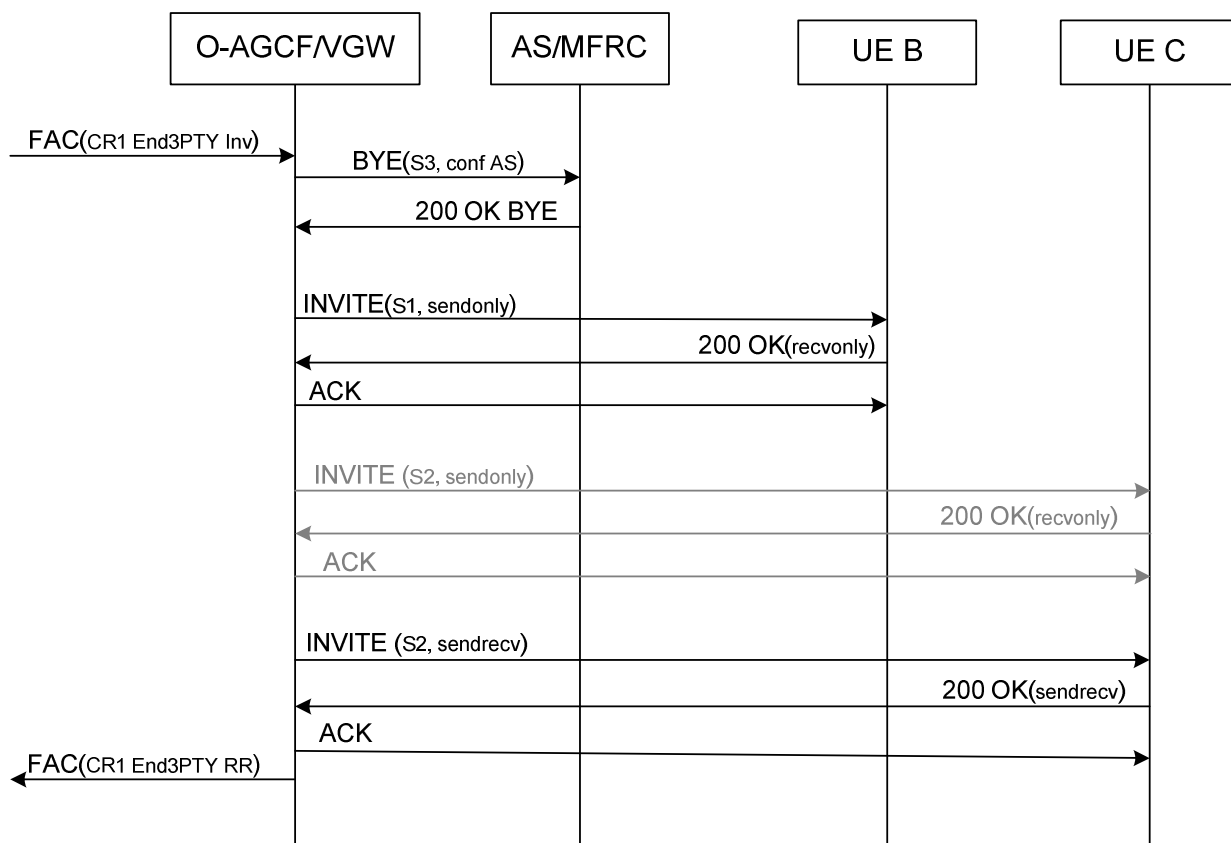

Figure G.1-3: Release the three part conversation to have a private communication with the previous active user

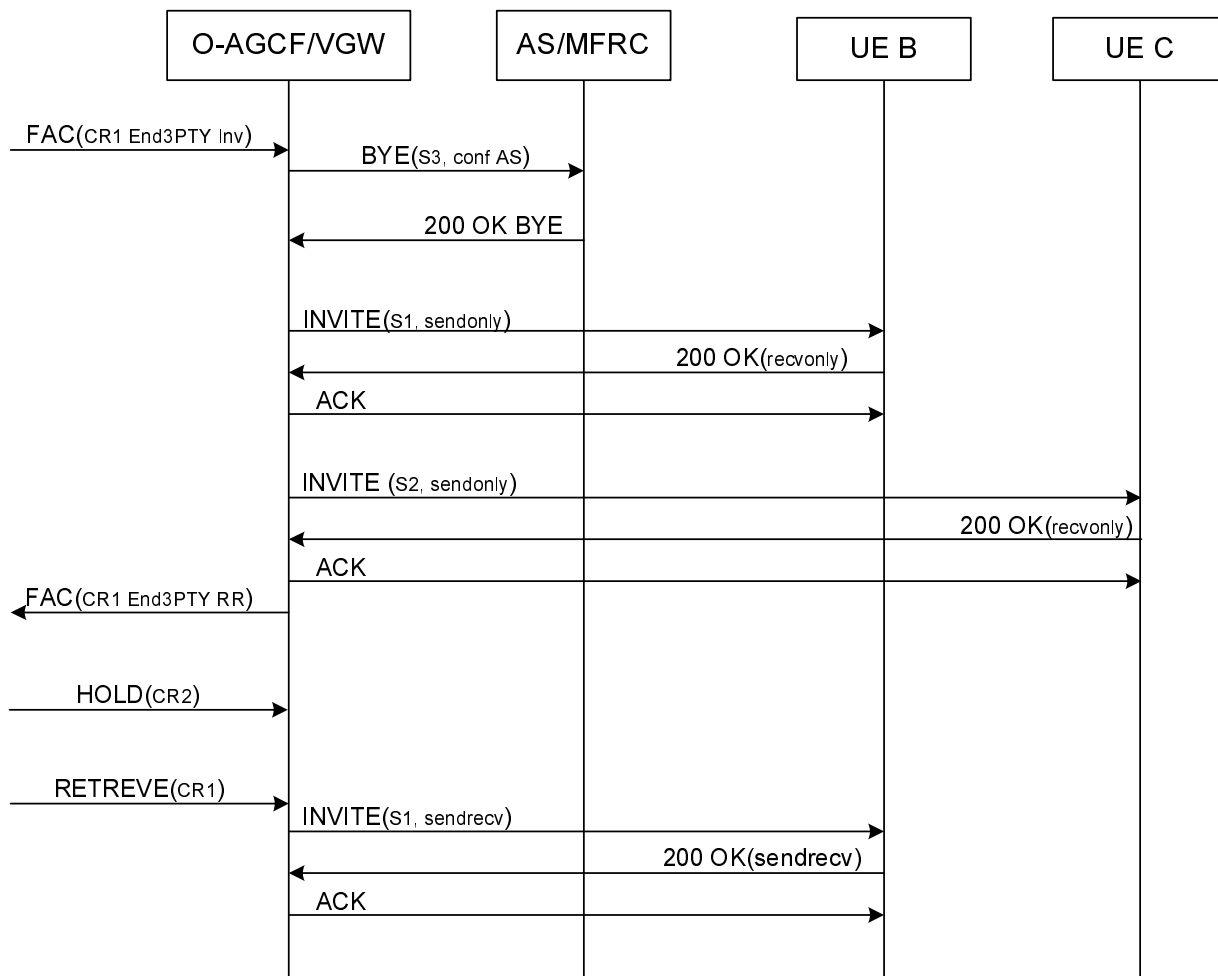

Figure G.1-4: Release the three part conversation to have a private communication with the previous held user

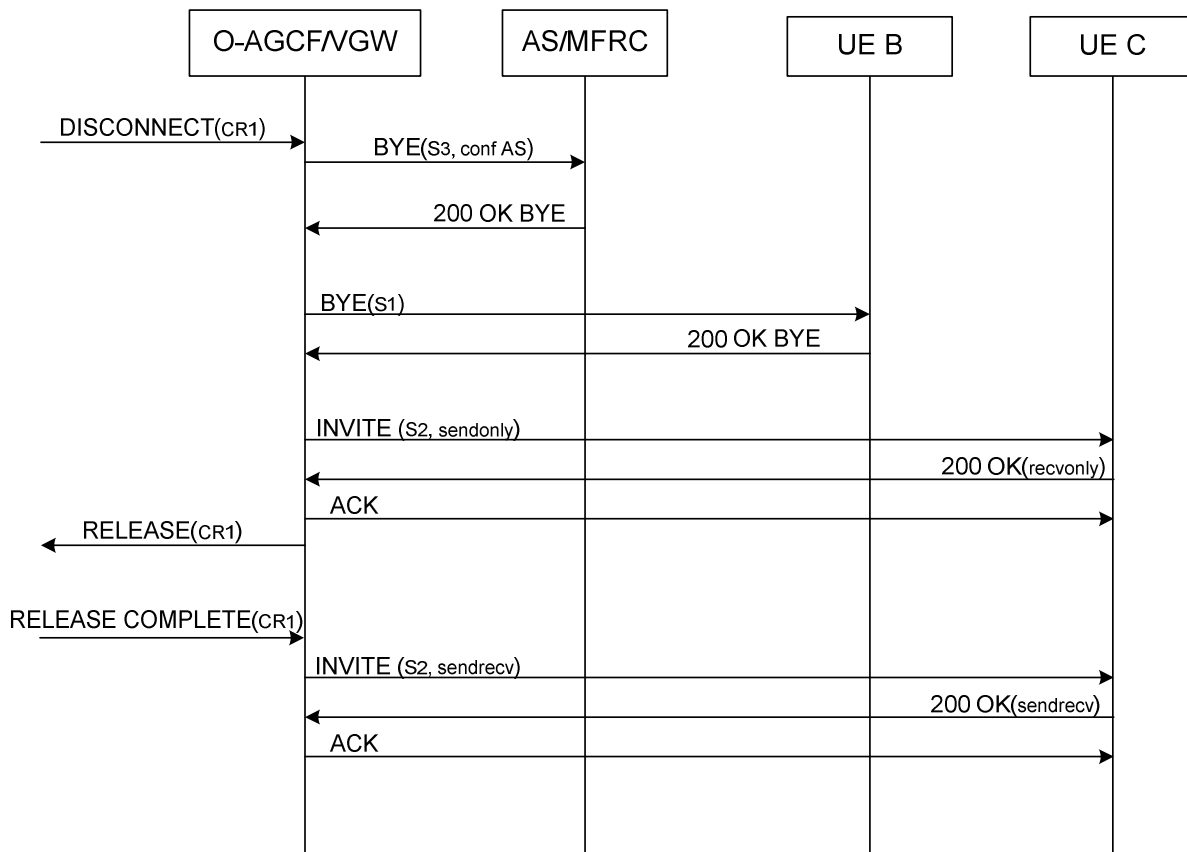

Figure G.1-5: The served user releases the session with the previous held user

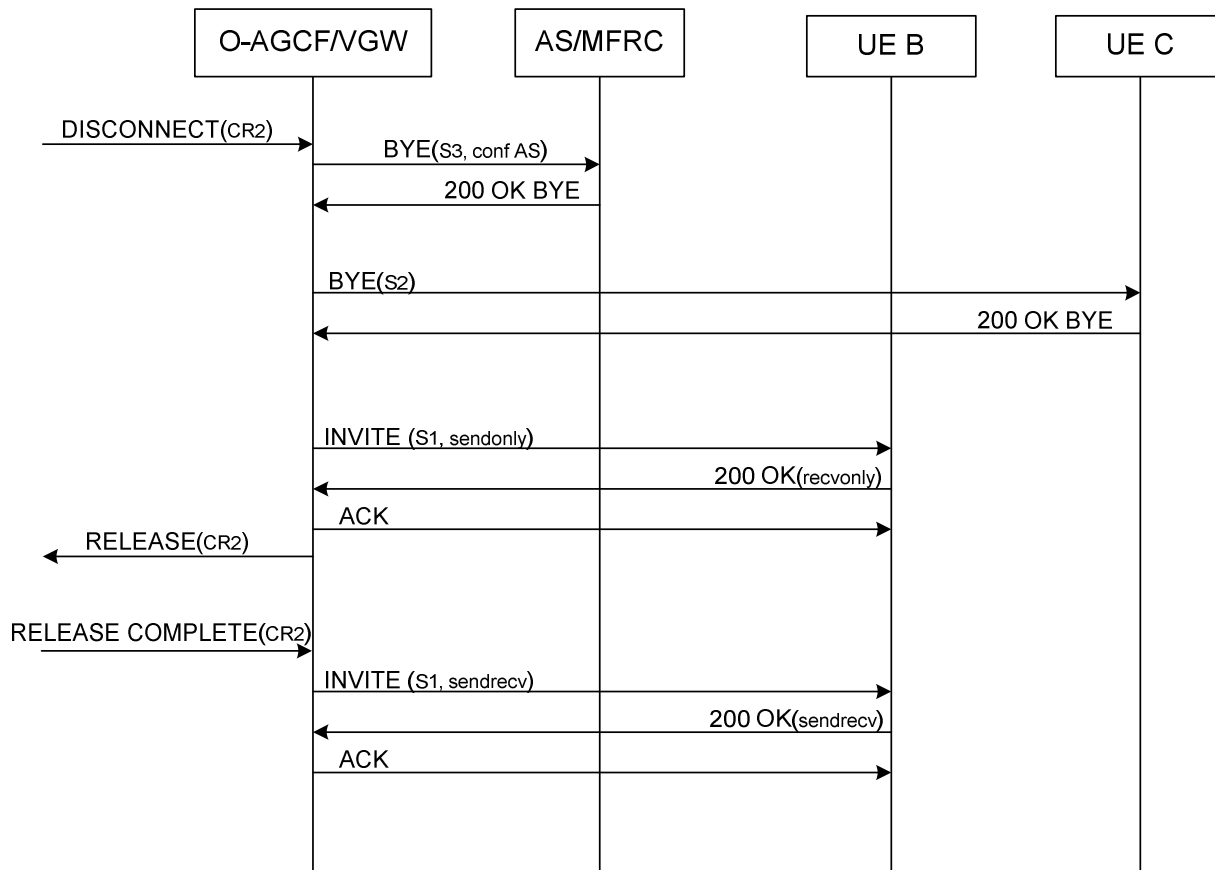

Figure G.1-6: The served user releases the session with the previous active user

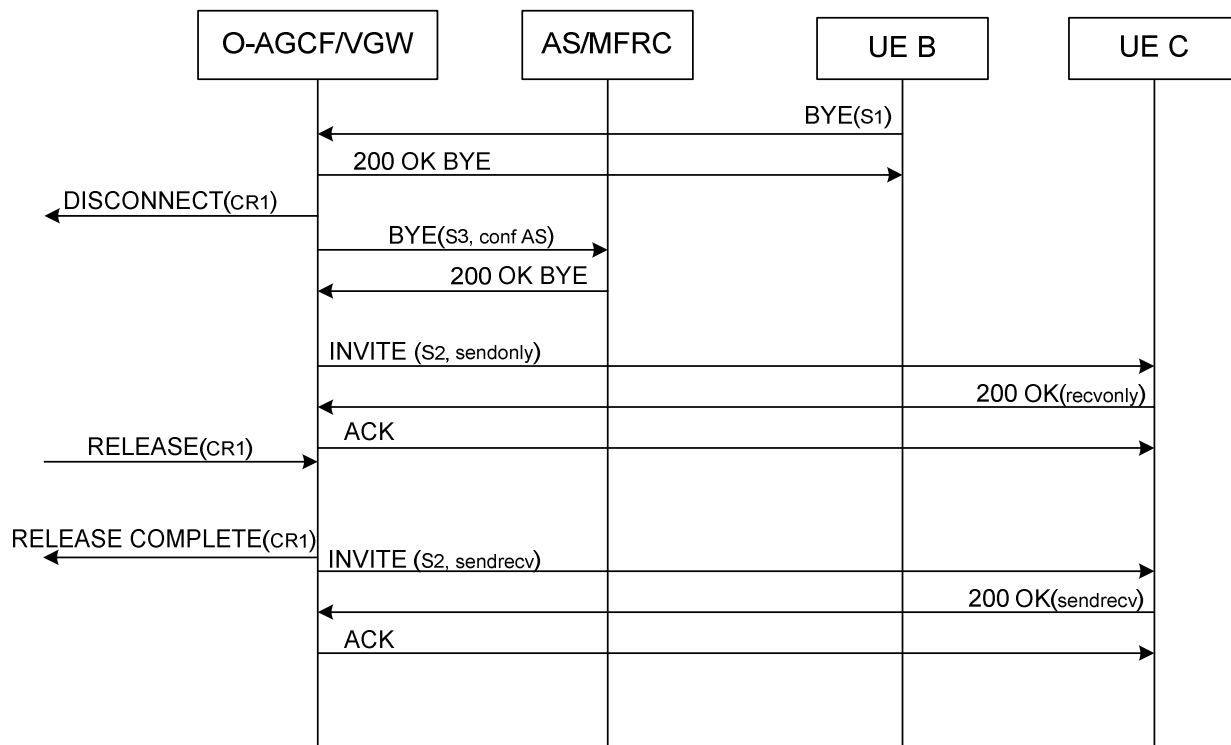

Figure G.1-7: The previous held user disconnects the own session using basic call procedures

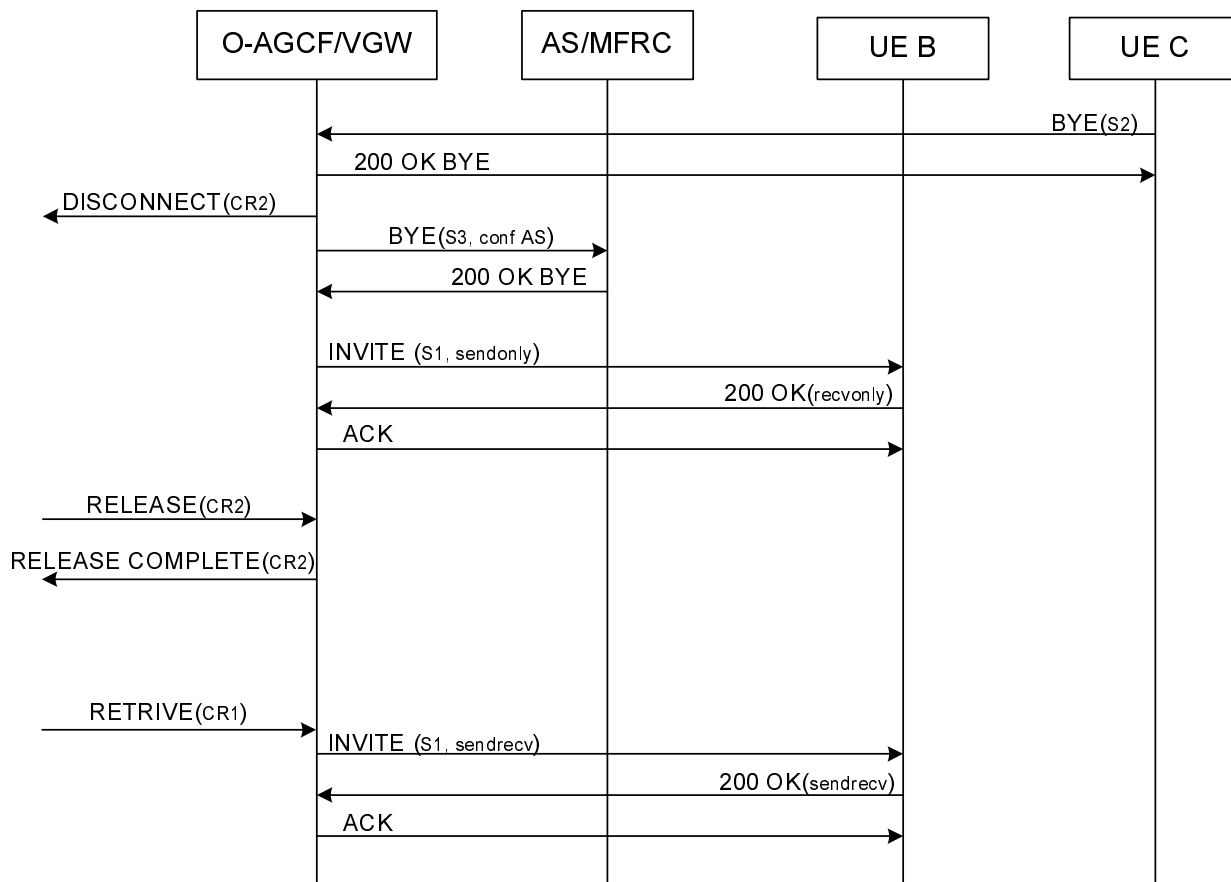

Figure G.1-8: The previous active user disconnects the own session using basic call procedures

G.2 Explicit Communication Transfer (ECT)

Figures G.2.1 to G.2.2 describe the message flow in case of interworking of the ECT supplementary service into the ECT simulation service.

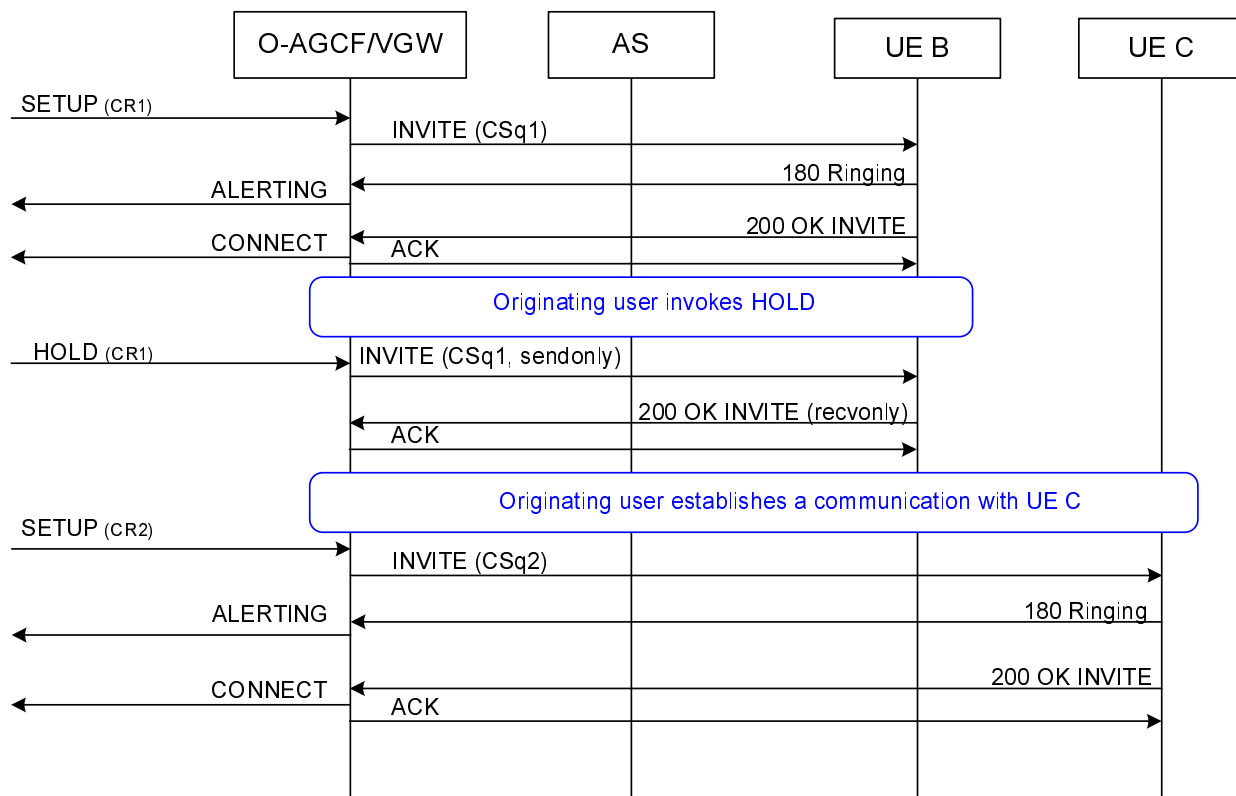

Figure G.2-1: Basic procedure and remote user is set on HOLD

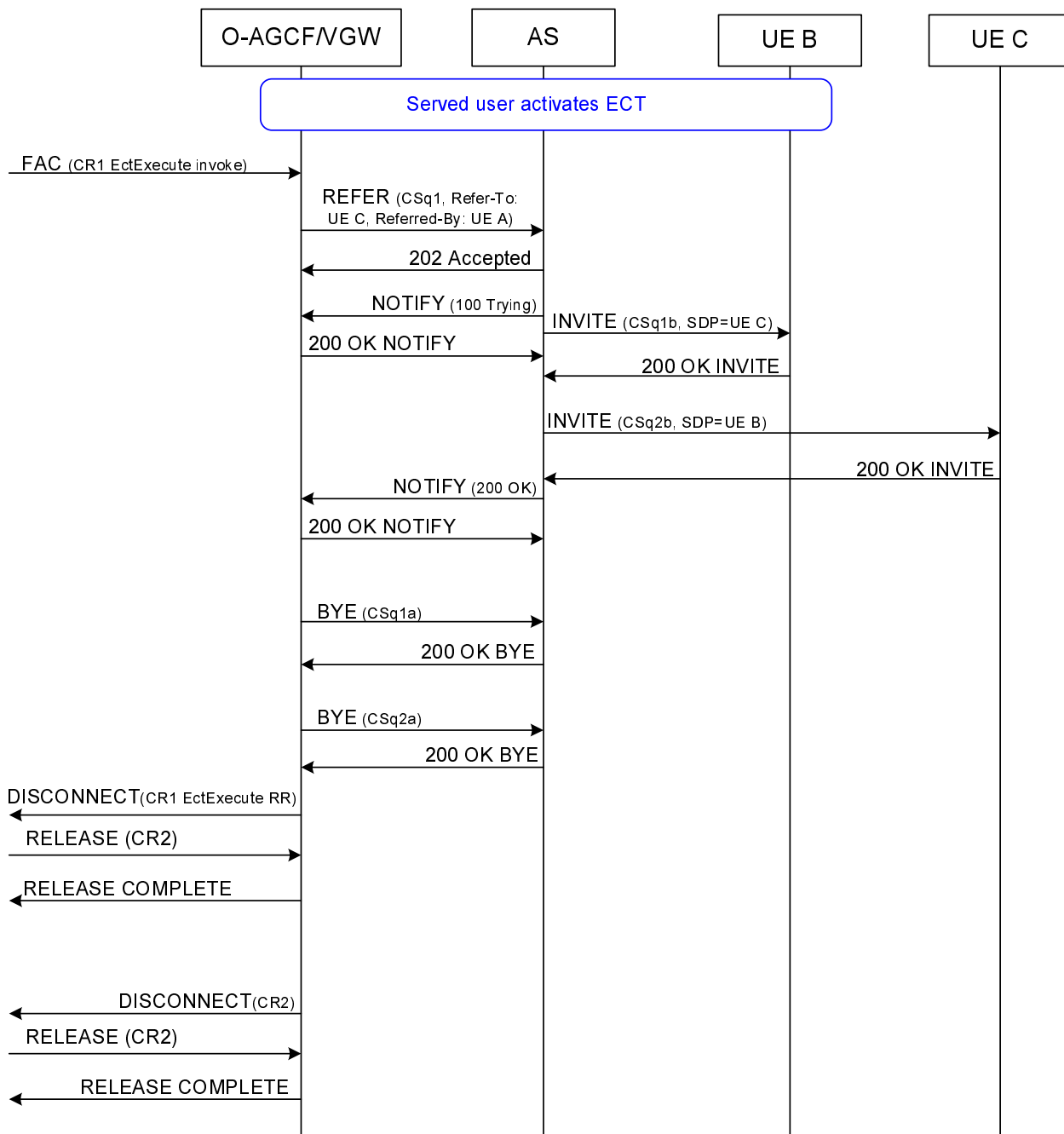

Figure G.2-2: Invocation of ECT

Annex H (informative): Use of progress indicators

This annex describes the use of the different progress indicator values for non-ISDN and IMS terminals. The Progress Indicators for ISDN terminals in the IMS are only applicable for voice connection (speech and 3,1 kHz audio).

Examples of use are given.

- **Progress indicator No. 1** - Indicates that interworking with a non-ISDN has occurred within the network or networks through which the call has traversed.
- **Progress indicator No. 2** - Indicates that the destination user is not ISDN.
- **Progress indicator No. 3** - Indicates that the origination user is not ISDN.
- The **ISDN access indicator** (see note) - "originating access ISDN" is transported in the IMS as PSTN XML ProgressIndicator No.6.
- The **ISDN access indicator** (see note) - "*Terminating access ISDN*" is transported in the IMS as PSTN XML ProgressIndicator No.7

NOTE: The "ISDN access indicator" is defined in the ITU-T Recommendation Q.763 [i.2] in the BCI and FCI and indicates the access type. The access indicator can be not directly mapped to the ISDN progress indicator and is not defined in EN 300 403-1 [29]. The ISDN access indicator can be created only from the network e.g. VGW, AGCF, SIP/ISUP MGCF, not from the UE and prevents the sending of a progress indicator indicating a non-ISDN connection.

The use of progress indicators Nos. 1, 2 and 3 is exemplified in the following.

Several interworking situations are identified in figure H-1:

- a) interworking with another network;
- b) interworking with a non-ISDN user connected to ISDN;
- c) interworking with non-ISDN equipment within the calling or called user's premises;
- d) interworking with another network behind the T reference point;
- e) interworking with an IMS network behind the S/T reference point (simulated service);
- f) interworking with an IMS network behind the S/T reference point (simulated /emulated service in the AGCF);
- g) interworking with an IMS network behind the Gm reference point;
- h) interworking with non-ISDN equipment within the calling or called user's premises which is connected to an IMS network;
- i) interworking with another network behind the T reference point which is connected to an IMS network.

As regards calls **from A** (ISDN access in an ISDN network) the following applies:

Case	Originating Terminal A receives PI	Originating side or SIP/ ISUP MGCF (PI from the BCI) ← PI sent	Terminating side ← PSTN XML ProgressIndicat or sent	Term. Terminal sent
a	PI #1		PI #1	
b	PI #2		PI #2	
c	PI #2 location sub-field = private network			PI #2
d	PI #1 location sub-field = private network			PI #1
IMS				
e			PI #7	
f			PI #7	
g	PI #1	PI #1		
h	PI #2	PI #2	PI #7	PI#2
i	PI #1	PI #1	PI #7	PI #1

As regards calls **towards A** the following applies:

Case	Orig Terminal PI sent	Originating VGW/AGCF PSTN XML ProgressIndicator sent	Originating side or SIP/ ISUP MGCF PI sent in the FCI	Terminating Interworking function (AGCF/VGW)	Dest. Terminal A receives PI
a			PI#1		PI #1
b			PI#3		PI #3
c	PI#3				PI #3 location sub-field = private network
d	PI#1				PI #1 location sub-field = private network
IMS					
e		PI #6			
f		PI #6			
g		PI #6			
h	PI#3	PI #6			PI #3
i	PI#1	PI #6			PI #1

As regards calls **from C or D** (ISDN access in the IMS) the following applies:

Case	Originating C or D Terminal receives PI	O-AGCF/VGW ← PI sent in 18x	← PI sent Destination MGCF	Term. Terminal sent
a	PI #1			
b	PI#2		PI #2	
c	PI#2			PI #2
d	PI #1			PI #1

Case	Originating C or D Terminal receives PI	O-AGCF/VGW ← PI sent in 18x	← PSTN XML ProgressIndicator sent Destination MGCF	Term. Terminal sent
e			PI #7	
f			PI #7	
g	PI #1	PI #1		
h	PI #2			PI#2
i	PI #1			PI#1

As regards calls **towards C or D** (non-ISDN access in an ISDN network) the following applies:

Case	Orig Terminal PI sent	Originating side or SIP/ ISUP IWF PI sent in the FCI	Terminating Interworking function (AGCF/VGW)	Dest. Terminal C or D receives PI
a		PI#1	PI #1	PI #1
b		PI#3	PI #1	PI #1 and PI #3
c	PI#3		PI #1	PI #1 and PI #3
d	PI#1		PI #1	PI #1
e			PI #1	PI #1
f			PI #1	PI #1
g			PI #1	PI #1
h	PI#3		PI #1	PI#1 and PI #3
i	PI#1		PI #1	PI #1

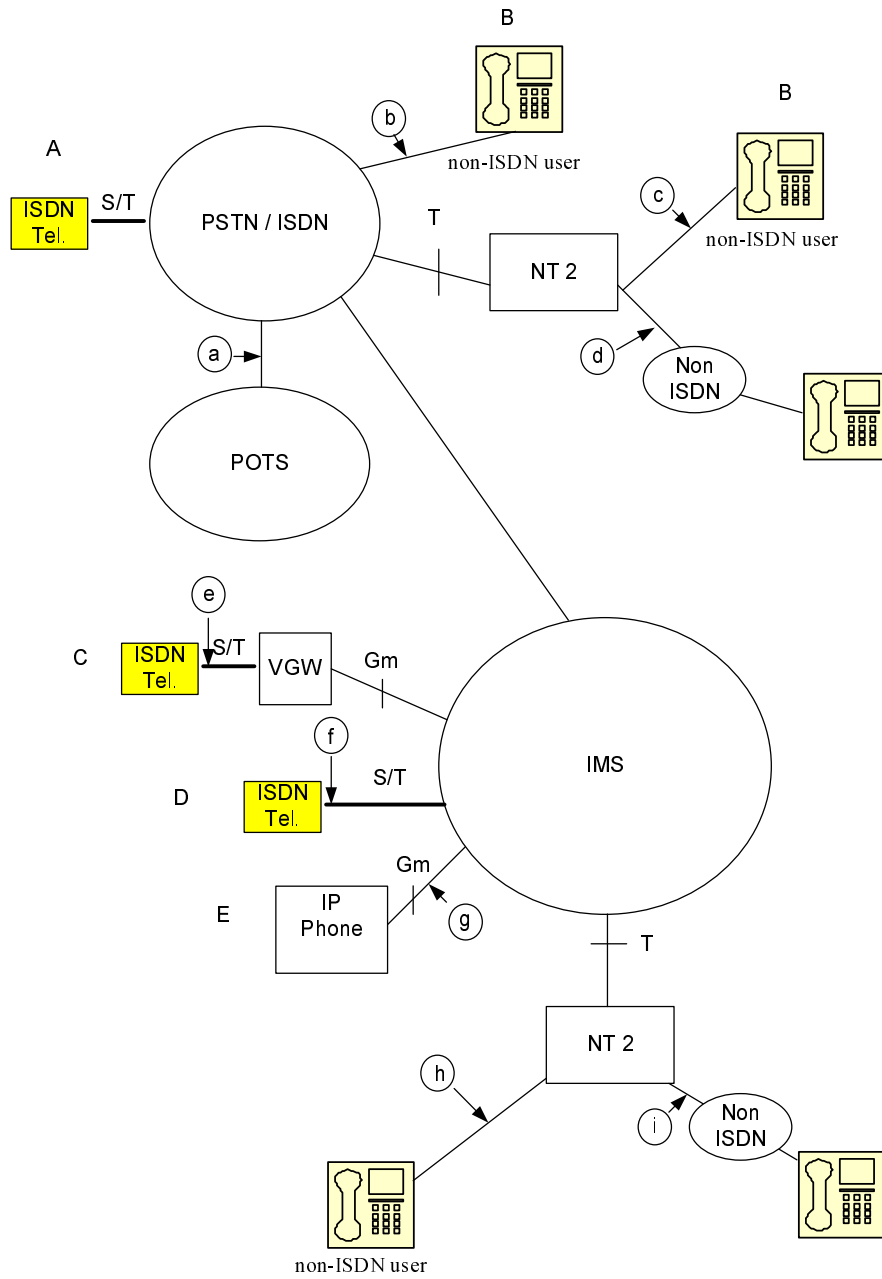

Figure: H.1

Annex I (informative): Bibliography

- ETSI ES 283 003 (V1.8.0): "Telecommunications and Internet converged Services and Protocols for Advanced Networking (TISPAN); IP Multimedia Call Control Protocol based on Session Initiation Protocol (SIP) and Session Description Protocol (SDP) Stage 3 [3GPP TS 24.229 (Release 7), modified]".
- ETSI TS 129 163: "Digital cellular telecommunications system (Phase 2+); Universal Mobile Telecommunications System (UMTS); Interworking between the IP Multimedia (IM) Core Network (CN) subsystem and Circuit Switched (CS) networks (3GPP TS 29.163 version 7.7.0 Release 7)".

Annex J (informative): Change History

Change history							
Date	WG Doc.	CR	Rev	CAT	Title / Comment	Current Version	New Version
10-06-09	21WTD028	001		B	Input draft for Release 3	2.1.1	3.0.0
10-06-09	21WTD028r1	002		B	Service related changes to align with TS 183 043 (PES)	3.0.0	3.0.1
20-08-09	20bTD51r1	003		F	Error in clause 5.1.1.2.1.3.	3.1.0	3.1.1
20-08-09	20bTD52r2	004		F	Error in clause 5.1.1.2.2.3.	3.1.0	3.1.1
20-08-09	20bTD53r1	005		F	Error in annex B	3.1.0	3.1.1
20-08-09	20bTD54r1	006		F	Error in annex references in text	3.1.0	3.1.1
20-08-09	20bTD55r1	007		F	Error in order of multiple BCs	3.1.0	3.1.1
20-08-09	20bTD56r1	008		D	Editorial corrections for PSTN XML.	3.1.0	3.1.1
20-08-09	20bTD57r1	009		F	Repeated table row in table 5.1.2.1-2.	3.1.0	3.1.1
					Update of change history annex to correctly reflect CRs 001 and 002 and update of WI reference	3.1.1	3.1.2
29-09-09	22WTD44r1	010		F	Error in clause 5.1.1.2.2.3.	3.1.2	3.1.3
29-09-09	22WTD45r1	011		D	Additions to Definitions clause.	3.1.2	3.1.3
29-09-09	22WTD175r1	012		F	Error in reference to annex.	3.1.2	3.1.3
					CRS 010 to 012 TB approved at TISPAN#22	3.1.3	3.2.0
05-11-09	22bTD31r1	013		F	Error in clause 5.1.2.2.	3.2.0	3.2.1
05-11-09	22bTD32r1	014		F	Premature fallback.	3.2.0	3.2.1
05-11-09	22bTD40r2	015		B	CCBS/CCNR changes and mapping of cause <-> SIP response codes.	3.2.0	3.2.1
05-11-09	22bTD43r1	016		C	AOC changes for multiple call legs	3.2.0	3.2.1
16-12-09	23WDT033r1	017		F	Errors in Clause 5.1.1.4	3.2.1	3.2.2
16-12-09	23WDT036r1	018		F	Errors in References	3.2.1	3.2.2
16-12-09	23WDT040r3	019		F	Correction of assorted typos / errors	3.2.1	3.2.2
16-12-09	23WDT0139r1	020		F	Sending of multiple Pis to DSS1	3.2.1	3.2.2
02-02-10	TISPAN3(10) 0009r2	021		F	Reception of Pis.	3.2.2	3.2.3
					Publication	3.2.3	3.3.1
27-10-10	TISPAN(10)02 02r1	022		D	Corrections & Clarifications	3.3.1	3.3.2
					Publication	3.3.2	3.4.1

History

Document history		
V2.1.1	January 2009	Publication
V3.3.1	April 2010	Publication
V3.4.1	February 2011	Publication