

ETSI EN 302 065-2-5 V1.1.1 (2026-03)



**HARMONISED EUROPEAN STANDARD**

**Short Range Devices (SRD)  
using Ultra Wide Band technology (UWB);  
Harmonised standard for access to radio spectrum;  
Part 2: Ultra Wide Band location tracking devices;  
Sub-part 5: Requirements for enhanced indoor devices  
within 6,0 GHz to 8,5 GHz**

---

**Reference**

DEN/ERM-TGUWB-622

---

**Keywords**harmonised standard, location, radiodetermination,  
SRD, UWB**ETSI**650 Route des Lucioles  
F-06921 Sophia Antipolis Cedex - FRANCE

Tel.: +33 4 92 94 42 00 Fax: +33 4 93 65 47 16

Siret N° 348 623 562 00017 - APE 7112B  
Association à but non lucratif enregistrée à la  
Sous-Préfecture de Grasse (06) N° w061004871

---

**Important notice**

The present document can be downloaded from the  
[ETSI Search & Browse Standards](#) application.

The present document may be made available in electronic versions and/or in print. The content of any electronic and/or print versions of the present document shall not be modified without the prior written authorization of ETSI. In case of any existing or perceived difference in contents between such versions and/or in print, the prevailing version of an ETSI deliverable is the one made publicly available in PDF format on [ETSI deliver](#) repository.

Users should be aware that the present document may be revised or have its status changed,  
this information is available in the [Milestones listing](#).

If you find errors in the present document, please send your comments to  
the relevant service listed under [Committee Support Staff](#).

If you find a security vulnerability in the present document, please report it through our  
[Coordinated Vulnerability Disclosure \(CVD\)](#) program.

---

**Notice of disclaimer & limitation of liability**

The information provided in the present deliverable is directed solely to professionals who have the appropriate degree of experience to understand and interpret its content in accordance with generally accepted engineering or other professional standard and applicable regulations.

No recommendation as to products and services or vendors is made or should be implied.  
In no event shall ETSI be held liable for loss of profits or any other incidental or consequential damages.

Any software contained in this deliverable is provided "AS IS" with no warranties, express or implied, including but not limited to, the warranties of merchantability, fitness for a particular purpose and non-infringement of intellectual property rights and ETSI shall not be held liable in any event for any damages whatsoever (including, without limitation, damages for loss of profits, business interruption, loss of information, or any other pecuniary loss) arising out of or related to the use of or inability to use the software.

---

**Copyright Notification**

No part may be reproduced or utilized in any form or by any means, electronic or mechanical, including photocopying and microfilm except as authorized by written permission of ETSI.

The content of the PDF version shall not be modified without the written authorization of ETSI.

The copyright and the foregoing restriction extend to reproduction in all media.

© ETSI 2026.  
All rights reserved.

# Contents

Intellectual Property Rights .....	5
Foreword.....	5
Modal verbs terminology.....	6
Introduction .....	6
1 Scope .....	7
2 References .....	7
2.1 Normative references .....	7
2.2 Informative references.....	7
3 Definition of terms, symbols and abbreviations.....	8
3.1 Terms.....	8
3.2 Symbols.....	8
3.3 Abbreviations .....	8
4 Technical requirements specifications .....	8
4.1 Environmental profile.....	8
4.2 Equipment categories .....	9
4.2.1 General.....	9
4.2.2 Summary equipment sub-categories .....	9
4.3 Transmitter requirements .....	10
4.3.1 General.....	10
4.3.2 Operating Frequency Range (OFR).....	10
4.3.2.1 Applicability.....	10
4.3.2.2 Description .....	10
4.3.2.3 Limits .....	10
4.3.2.4 Conformance.....	10
4.3.3 Mean e.i.r.p. spectral density .....	10
4.3.3.1 Applicability.....	10
4.3.3.2 Description .....	10
4.3.3.3 Limits .....	10
4.3.3.4 Conformance.....	11
4.3.4 Peak e.i.r.p. spectral density.....	11
4.3.4.1 Applicability.....	11
4.3.4.2 Description .....	11
4.3.4.3 Limits .....	11
4.3.4.4 Conformance.....	11
4.3.5 TX Unwanted Emissions (TXUE).....	11
4.3.5.1 Applicability.....	11
4.3.5.2 Description .....	11
4.3.5.3 Limits .....	12
4.3.5.4 Conformance.....	12
4.3.6 Duty cycle (DC).....	12
4.3.6.1 Applicability.....	12
4.3.6.2 Description .....	12
4.3.6.3 Limits .....	12
4.3.6.4 Conformance.....	12
4.3.7 Subject to control by an indoor infrastructure and operation within an identifiable network.....	12
4.3.7.1 Applicability.....	12
4.3.7.2 Description .....	12
4.3.7.3 Limits .....	13
4.3.7.4 Conformance.....	13
4.3.8 TX behaviour under the complete environmental profile .....	13
4.3.8.1 Applicability.....	13
4.3.8.2 Description .....	13
4.3.8.3 Limits .....	13
4.3.8.4 Conformance.....	13

4.4	Receiver requirements .....	13
4.4.1	General .....	13
4.4.2	Wanted technical performance criteria .....	14
4.4.2.1	Message success ratio .....	14
4.4.2.2	Automatic recovery .....	14
4.4.3	Receiver Baseline Sensitivity (RBS) .....	14
4.4.3.1	Applicability .....	14
4.4.3.2	Description .....	14
4.4.3.3	Limits .....	14
4.4.3.4	Conformance .....	15
4.4.4	Receiver Baseline Resilience (RBR) .....	15
4.4.4.1	Applicability .....	15
4.4.4.2	Description .....	15
4.4.4.3	Limits .....	15
4.4.4.4	Conformance .....	16
5	Testing for compliance with technical requirements .....	16
5.1	Environmental conditions for testing .....	16
5.1.1	General .....	16
5.1.2	Normal test conditions .....	16
5.1.3	Complete environmental profile test conditions .....	16
5.2	General conditions for testing and conformance test suites .....	16
5.2.1	General conditions for testing .....	16
5.2.2	Conformance test suites .....	17
5.2.3	Test scenarios .....	17
5.3	Conformance methods of measurement for transmitter requirements .....	17
5.3.1	General .....	17
5.3.2	Operating Frequency Range (OFR) .....	17
5.3.3	Mean e.i.r.p. spectral density .....	18
5.3.4	Peak e.i.r.p. spectral density .....	18
5.3.5	TX unwanted emissions .....	18
5.3.6	Duty cycle .....	19
5.3.7	Subject to control by an indoor infrastructure and operation within an identifiable network .....	20
5.3.7.1	General .....	20
5.3.7.2	Setup for a Companion Device with Command & control signal outside the EUT UWB operating frequency range .....	22
5.3.7.3	Setup for a Companion Device with Command & control signal inside the EUT UWB operating frequency range and time gating .....	23
5.3.7.4	Setup for a Companion Device with Command & control signal inside the EUT UWB operating frequency range and spatial separation .....	23
5.3.8	TX behaviour under the complete environmental profile .....	24
5.3.8.1	General .....	24
5.3.8.2	Conformance test procedure .....	24
5.4	Conformance methods of measurement for receiver .....	24
5.4.1	Receiver Baseline Sensitivity (RBS) .....	24
5.4.2	Receiver Baseline Resilience (RBR) .....	25
<b>Annex A (informative):</b>	<b>Relationship between the present document and the essential requirements of Directive 2014/53/EU .....</b>	<b>27</b>
<b>Annex B (informative):</b>	<b>Requirement mapping .....</b>	<b>29</b>
History .....		31

# Intellectual Property Rights

## Essential patents

IPRs essential or potentially essential to normative deliverables may have been declared to ETSI. The declarations pertaining to these essential IPRs, if any, are publicly available for **ETSI members and non-members**, and can be found in ETSI SR 000 314: "*Intellectual Property Rights (IPRs); Essential, or potentially Essential, IPRs notified to ETSI in respect of ETSI standards*", which is available from the ETSI Secretariat. Latest updates are available on the [ETSI IPR online database](#).

Pursuant to the ETSI Directives including the ETSI IPR Policy, no investigation regarding the essentiality of IPRs, including IPR searches, has been carried out by ETSI. No guarantee can be given as to the existence of other IPRs not referenced in ETSI SR 000 314 (or the updates on the ETSI Web server) which are, or may be, or may become, essential to the present document.

## Trademarks

The present document may include trademarks and/or tradenames which are asserted and/or registered by their owners. ETSI claims no ownership of these except for any which are indicated as being the property of ETSI, and conveys no right to use or reproduce any trademark and/or tradename. Mention of those trademarks in the present document does not constitute an endorsement by ETSI of products, services or organizations associated with those trademarks.

**DECT™**, **PLUGTESTS™**, **UMTS™** and the ETSI logo are trademarks of ETSI registered for the benefit of its Members. **3GPP™**, **LTE™** and **5G™** logo are trademarks of ETSI registered for the benefit of its Members and of the 3GPP Organizational Partners. **oneM2M™** logo is a trademark of ETSI registered for the benefit of its Members and of the oneM2M Partners. **GSM®** and the GSM logo are trademarks registered and owned by the GSM Association.

# Foreword

This Harmonised European Standard (EN) has been produced by ETSI Technical Committee Electromagnetic compatibility and Radio spectrum Matters (ERM).

The present document has been prepared under the Commission's standardisation request C(2015) 5376 final [i.4] to provide one voluntary means of conforming to the essential requirements of Directive 2014/53/EU on the harmonisation of the laws of the Member States relating to the making available on the market of radio equipment and repealing Directive 1999/5/EC [i.5].

Once the present document is cited in the Official Journal of the European Union under that Directive, compliance with the normative clauses of the present document given in Table A.1 confers, within the limits of the scope of the present document, a presumption of conformance with the corresponding essential requirements of that Directive and associated EFTA regulations.

The present document is part 2, sub-part 5 of a multi-part deliverable covering Short Range Devices (SRD) using Ultra Wide Band technology (UWB); Harmonised standard for access to radio spectrum. Full details of the entire series can be found in part 1 [i.8].

<b>National transposition dates</b>	
Date of adoption of this EN:	25 February 2026
Date of latest announcement of this EN (doa):	31 May 2026
Date of latest publication of new National Standard or endorsement of this EN (dop/e):	30 November 2026
Date of withdrawal of any conflicting National Standard (dow):	30 November 2027

---

## Modal verbs terminology

In the present document "**shall**", "**shall not**", "**should**", "**should not**", "**may**", "**need not**", "**will**", "**will not**", "**can**" and "**cannot**" are to be interpreted as described in clause 3.2 of the [ETSI Drafting Rules](#) (Verbal forms for the expression of provisions).

"**must**" and "**must not**" are **NOT** allowed in ETSI deliverables except when used in direct citation.

---

## Introduction

In the present document the updated UWB regulation for the EU [i.2] covering enhanced indoor devices is considered. Adequate measurement methods and relevant parameter limits are described in order to support EU market stakeholders in their efforts to ensure conformance of their UWB products based on enhanced indoor devices with the updated EU regulatory rules published in ECC/DEC/(06)04 [i.1] and in (EU) 2024/1467 [i.2].

---

# 1 Scope

The present document specifies technical requirements, limits and test methods for transceivers and transmitters utilizing Ultra WideBand (UWB) technologies for location tracking for enhanced indoor devices within 6,0 GHz to 8,5 GHz.

NOTE: The relationship between the present document and essential requirements of article 3.2 of Directive 2014/53/EU is given in Annex A.

---

## 2 References

### 2.1 Normative references

References are either specific (identified by date of publication and/or edition number or version number) or non-specific. For specific references, only the cited version applies. For non-specific references, the latest version of the referenced document (including any amendments) applies.

Referenced documents which are not found to be publicly available in the expected location might be found in the [ETSI docbox](#).

NOTE: While any hyperlinks included in this clause were valid at the time of publication, ETSI cannot guarantee their long term validity.

The following referenced documents are necessary for the application of the present document.

- [1] [ETSI EN 303 883-1 \(V2.1.1\) \(08-2024\)](#): "Short Range Devices (SRD) and Ultra Wide Band (UWB); Part 1: Measurement techniques for transmitter requirements".
- [2] [ETSI EN 303 883-2 \(V2.1.1\) \(08-2024\)](#): "Short Range Devices (SRD) and Ultra Wide Band (UWB); Part 2: Measurement techniques for receiver requirements".
- [3] [ETSI TS 103 941 \(V1.1.1\) \(01-2024\)](#): "Short Range Devices (SRD) and Ultra Wide Band (UWB); Measurement setups and specifications for testing under full environmental profile (normal and extreme environmental conditions)".
- [4] [ETSI EN 302 065-3-1 \(V3.2.1\) \(02-2025\)](#): "Short Range Devices (SRD) using Ultra Wide Band technology (UWB); Harmonised standard for access to radio spectrum; Part 3: UWB devices installed in motor and railway vehicles; Sub-part 1: Requirements for UWB devices for vehicular access systems within 3,8 GHz to 4,2 GHz or 6 GHz to 8,5 GHz".

### 2.2 Informative references

References are either specific (identified by date of publication and/or edition number or version number) or non-specific. For specific references, only the cited version applies. For non-specific references, the latest version of the referenced document (including any amendments) applies.

NOTE: While any hyperlinks included in this clause were valid at the time of publication, ETSI cannot guarantee their long term validity.

The following referenced documents may be useful in implementing an ETSI deliverable or add to the reader's understanding but are not required for conformance to the present document.

- [i.1] [ECC/DEC/\(06\)04](#): "ECC Decision of 24 March 2006 on the harmonised use, exemption from individual licensing and free circulation of devices using Ultra-Wideband (UWB) technology in bands below 10.6 GHz (ECC Decision (06)04), amended on 6 July 2007, amended 9 December 2011, amended on 8 March 2019 and amended 18 November 2022".

- [i.2] [Commission implementing decision \(EU\) 2024/1467](#) of 27 May 2024 amending Implementation Decision (EU) 2019/785 on the harmonisation of radio spectrum for equipment using ultra-wideband technology in the Union.
- [i.3] [ERC Recommendation 74-01](#): "Unwanted emissions in the spurious domain", Approved 1998 amended 29 May 2019.
- [i.4] [Commission implementing Decision C\(2015\) 5376](#) final of 4.8.2015 on a standardisation request to the European Committee for Electrotechnical Standardisation and to the European Telecommunications Standards Institute as regards radio equipment in support of Directive 2014/53/EU of the European Parliament and of the Council.
- [i.5] [Directive 2014/53/EU](#) of the European Parliament and of the Council of 16 April 2014 on the harmonisation of the laws of the Member States relating to the making available on the market of radio equipment and repealing Directive 1999/5/EC (RE-Directive).
- [i.6] ETSI EG 203 336 (V1.2.1): "Guide for the selection of technical parameters for the production of Harmonised Standards covering article 3.1(b) and article 3.2 of Directive 2014/53/EU".
- [i.7] ETSI TS 103 567 (V1.1.1): "Requirements on signal interferer handling".
- [i.8] ETSI EN 302 065-1: "Short Range Devices (SRD) using Ultra Wide Band technology (UWB); Harmonised Standard covering the essential requirements of article 3.2 of the Directive 2014/53/EU; Part 1: Requirements for Generic UWB applications".

---

## 3 Definition of terms, symbols and abbreviations

### 3.1 Terms

For the purposes of the present document, the terms given in ETSI EN 303 883-1 [1] and the following apply:

**device:** equivalent to equipment

**fixed indoor infrastructure device:** radio equipment intended for non-portable indoor use

**portable device:** radio equipment intended for portable use

### 3.2 Symbols

For the purposes of the present document, the symbols given in ETSI EN 303 883-1 [1] apply.

### 3.3 Abbreviations

For the purposes of the present document, the abbreviations given in ETSI EN 303 883-1 [1] and the following apply:

PROF            Permitted Range of Operating Frequency

---

## 4 Technical requirements specifications

### 4.1 Environmental profile

The technical requirements of the present document apply under the environmental profile for operation of the equipment, which shall be in accordance with its intended use, but as a minimum, shall be as specified in the test conditions contained in the present document. The equipment shall comply with all the technical requirements of the present document at all times when operating within the boundary limits of the operational environmental profile defined by its intended use.

## 4.2 Equipment categories

### 4.2.1 General

The intended use of the equipment covered by the present document is limited to equipment, which is capable to operate indoor within the frequency range 6,0 GHz to 8,5 GHz in accordance with the enhanced indoor devices provisions as specified in ECC/DEC/(06)04 [i.1], annex A1.3.2 and in (EU) 2024/1467 [i.2].

Therefore the present document covers two main equipment categories, which are Portable Devices and Fixed Indoor Devices, see Table 1.

**Table 1: Equipment categories overview**

Equipment category number	Equipment category description
1	Fixed Indoor Infrastructure Device
2	Portable Device

### 4.2.2 Summary equipment sub-categories

In addition to the categories listed in Table 1 in clause 4.2.1 there are two sub-categories identified in category 1: 1.1 UWB TX only and 1.2 UWB RX/TX. A special sub-category of the Fixed Indoor Infrastructure Devices are the UWB TX only devices, for which only a minimal subset of testing is required. In the category 2 there is one sub-category identified: 2.1 Portable Device, see Table 2.

**Table 2: Equipment sub-categories and related requirements overview**

Sub-category	Name	Requirement
1.1	Fixed Indoor Infrastructure Device with UWB TX only	<ul style="list-style-type: none"> <li>• Mean e.i.r.p. spectral density limit: -31,3 dBm/MHz</li> <li>• Peak e.i.r.p. spectral density limit: 10 dBm/50 MHz</li> <li>• PROF: 6 GHz to 8,5 GHz and OFR <math>\geq</math> 50 MHz</li> <li>• Duty cycle: <math>\leq</math> 5 % per second</li> <li>• TXUE below limits (see clause 4.3.5)</li> </ul>
1.2	Fixed Indoor Infrastructure Device with UWB RX/TX	<ul style="list-style-type: none"> <li>• Mean e.i.r.p. spectral density limit: -31,3 dBm/MHz</li> <li>• Peak e.i.r.p. spectral density limit: 10 dBm/50 MHz</li> <li>• PROF: 6 GHz to 8,5 GHz and OFR <math>\geq</math> 50 MHz</li> <li>• Duty cycle: <math>\leq</math> 5 % per second</li> <li>• TXUE below limits (see clause 4.3.5)</li> <li>• Receiver Baseline Sensitivity (RBS)</li> <li>• Receiver Baseline Resilience (RBR)</li> </ul>
2.1	Portable Device	<ul style="list-style-type: none"> <li>• Mean e.i.r.p. spectral density: -41,3 dBm/MHz (note 1 and note 2)</li> <li>• Peak e.i.r.p. spectral density: 0 dBm/50 MHz (note 1 and note 2)</li> <li>• PROF: 6 GHz to 8,5 GHz and OFR <math>\geq</math> 50 MHz</li> <li>• Duty cycle: <math>\leq</math> 100 % per second (note 2)</li> <li>• TXUE below limits (see clause 4.3.5)</li> <li>• Subject to control by an indoor infrastructure</li> <li>• Operate within an identifiable network</li> <li>• Receiver Baseline Sensitivity (RBS)</li> <li>• Receiver Baseline Resilience (RBR)</li> </ul>
NOTE 1: If the equipment is operating within an identifiable network and is subject to control by an indoor infrastructure, then the allowed Mean e.i.r.p. spectral density limit is -31,3 dBm/MHz and the allowed Peak e.i.r.p. spectral density limit is 10 dBm/50 MHz.		
NOTE 2: A duty cycle limitation of maximum of 5 % per second shall be applicable if the Mean e.i.r.p. spectral density limit is higher than -41,3 dBm/MHz or the Peak e.i.r.p. spectral density limit is higher than 0 dBm/50 MHz.		

## 4.3 Transmitter requirements

### 4.3.1 General

See clause 5.1 of ETSI EN 303 883-1 [1] for general guidance on TX measurements and emission concept.

The conformance tests shall be done under normal conditions as defined in clause 5.1.2. of the present document.

### 4.3.2 Operating Frequency Range (OFR)

#### 4.3.2.1 Applicability

The Operating Frequency Range requirement applies to the equipment of sub-categories 1.1, 1.2 and 2.1, see clause 4.2.2.

#### 4.3.2.2 Description

For the description of the Operating Frequency Range (OFR), see ETSI EN 303 883-1 [1], clause 5.2.1.

Following the description in ETSI EN 303 883-1 [1], clause 5.2.1, the present document specifies a value of 10 dB for the parameter X.

#### 4.3.2.3 Limits

The OFR (all frequencies between  $f_L$  and  $f_H$ ) shall be within 6,0 to 8,5 GHz (PROF).

The OFR shall be at least 50 MHz.

NOTE: The minimum OFR requirement comes from the EC Decision on UWB [i.2], Article 2 (a).

#### 4.3.2.4 Conformance

The conformance test for OFR is defined in clause 5.3.2.

## 4.3.3 Mean e.i.r.p. spectral density

### 4.3.3.1 Applicability

The Mean e.i.r.p. spectral density requirement applies to the equipment sub-categories 1.1, 1.2 and 2.1 (if not controlled by an indoor infrastructure or not operating within an identifiable network), see clause 4.2.2.

NOTE: If category 2.1 equipment is subject to control by indoor infrastructure and operating within an identifiable network, this requirement is defined in clause 4.3.7 and tested according to clause 5.3.7.

### 4.3.3.2 Description

For the description of the mean e.i.r.p. spectral density, see ETSI EN 303 883-1 [1], clause 5.3.2.1.

### 4.3.3.3 Limits

The mean e.i.r.p. spectral density shall not exceed the limits provided in Table 3.

**Table 3: Mean e.i.r.p. spectral density limits**

Equipment sub-category	Mean e.i.r.p. spectral density limit
1.1 and 1.2	-31,3 dBm/MHz
2.1	-41,3 dBm/MHz

#### 4.3.3.4 Conformance

The conformance test for Mean e.i.r.p. spectral density is defined in clause 5.3.3.

### 4.3.4 Peak e.i.r.p. spectral density

#### 4.3.4.1 Applicability

The peak e.i.r.p. spectral density requirement applies to the equipment sub-categories 1.1, 1.2 and 2.1, see clause 4.2.2.

#### 4.3.4.2 Description

For the description of the peak e.i.r.p. spectral density see ETSI EN 303 883-1 [1], clause 5.3.3.1.

#### 4.3.4.3 Limits

The peak e.i.r.p. spectral density shall not exceed the limits provided in Table 4.

**Table 4: Peak e.i.r.p. spectral density limits**

Equipment sub-category	Peak e.i.r.p. spectral density limit
1.1 and 1.2	10 dBm/50 MHz
2.1	0 dBm/50 MHz (see note)
NOTE: If the equipment is subject to control by indoor infrastructure and operation within an identifiable network (see clause 4.3.7), then the applicable limit is 10 dBm/50 MHz.	

#### 4.3.4.4 Conformance

The conformance test for Peak e.i.r.p. spectral density is defined in clause 5.3.4.

### 4.3.5 TX Unwanted Emissions (TXUE)

#### 4.3.5.1 Applicability

The TX Unwanted Emissions (TXUE) requirement applies to equipment sub-category 1.1, 1.2 and 2.1, see clause 4.2.2.

#### 4.3.5.2 Description

For the description of the TX unwanted emissions, see ETSI EN 303 883-1 [1], clause 5.5.1.

As requested in ETSI EN 303 883-1 [1], clause 5.5.1 the limit for the parameter  $X_{TXUE}$  for equipment of sub-categories 1.1, 1.2 and 2.1, is specified to:

$$X_{TXUE}: 50 \%$$

NOTE: Based on ETSI EN 303 883-1 [1], clause 5.5.1, and the value of  $X_{TXUE}$  in the present document, there is no OOB-domain applicable.

### 4.3.5.3 Limits

The emissions in the spurious domain shall not exceed the limit values specified in Table 5.

**Table 5: Spurious emissions limits**

Frequency range	Limit values for TXUE (note)
$87,5 \text{ MHz} \leq f \leq 118 \text{ MHz}$	-54 dBm/100 kHz
$174 \text{ MHz} \leq f \leq 230 \text{ MHz}$	-54 dBm/100 kHz
$470 \text{ MHz} \leq f \leq 694 \text{ MHz}$	-54 dBm/100 kHz
otherwise in band $30 \text{ MHz} \leq f \leq 1\,000 \text{ MHz}$	-36 dBm/100 kHz
$1\,000 \text{ MHz} < f \leq 26 \text{ GHz}$	-30 dBm/1 MHz
NOTE: Not applicable for RP emissions within the OFR. Limits are in accordance with ERC/REC 74-01 [i.4].	

### 4.3.5.4 Conformance

The conformance test for TX unwanted emissions is defined in clause 5.3.5.

## 4.3.6 Duty cycle (DC)

### 4.3.6.1 Applicability

The duty cycle requirement applies to equipment sub-categories 1.1, 1.2 and 2.1, if transmitting in the enhanced indoor devices mode with more than -41,3 dBm/MHz Mean e.i.r.p. spectral density or with more than 0 dBm/50 MHz peak e.i.r.p. spectral density, see clause 4.2.2.

### 4.3.6.2 Description

For the description of the duty cycle, see ETSI EN 303 883-1 [1], clause 5.11.1.

### 4.3.6.3 Limits

The duty cycle shall not exceed 5 % per second.

### 4.3.6.4 Conformance

The conformance test for Duty Cycle is defined in clause 5.3.6.

## 4.3.7 Subject to control by an indoor infrastructure and operation within an identifiable network

### 4.3.7.1 Applicability

The Subject to control by an indoor infrastructure and operation within an identifiable network requirement applies to equipment sub-category 2.1, see clause 4.2.2, if the equipment operates with a mean e.i.r.p. spectral density higher than -41,3 dBm/MHz or with a peak e.i.r.p. spectral density higher than 0 dBm/50 MHz.

### 4.3.7.2 Description

Subject to control by an indoor infrastructure and operation within an identifiable network, are closely related requirements and therefore in the context of the present document a combined test is performed. The operation within an identifiable network is confirmed inherently, if the subject to control by an indoor infrastructure can be demonstrated successfully.

Portable devices could be in general, due to their nature, operate indoor and outdoor. In order to ensure, that a portable device is subject to control by an indoor infrastructure, the portable device shall pass tests to verify that fact, if its intended use is to operate under the enhanced indoor devices regulation according to (EU) 2024/1467 [i.2].

#### 4.3.7.3 Limits

The equipment shall fulfil the mean e.i.r.p. spectral density of -31,3 dBm/MHz and the peak e.i.r.p. density limit of 10 dBm/50 MHz under control by an indoor infrastructure and operation within an identifiable network.

Then, with a 10 seconds delay after the loosing of the control by an indoor infrastructure and/or operation within an identifiable network, the equipment shall fulfil the mean e.i.r.p. spectral density limit of -41,3 dBm/MHz and the peak e.i.r.p. spectral density limit of 0 dBm/50 MHz.

#### 4.3.7.4 Conformance

The conformance test for being subject to control by indoor infrastructure and operate within an identifiable network is defined in clause 5.3.7.

### 4.3.8 TX behaviour under the complete environmental profile

#### 4.3.8.1 Applicability

The TX behaviour under the complete environmental profile requirement applies to the equipment sub-categories 1.1, 1.2 and 2.1, see clause 4.2.2.

#### 4.3.8.2 Description

The TX behaviour under the complete environmental profile verifies the conformance of the mean e.i.r.p. spectral density over the environmental profile as specified in clause 5.1.3.

For more information on the TX behaviour under the complete environmental profile, see ETSI TS 103 941 [3], clause 4.3.1.

#### 4.3.8.3 Limits

The TX behaviour is obtained by measuring the mean e.i.r.p. spectral density and OFR across the complete environmental profile (see clause 5.1.3) and assessing the variation with respect to an adjusted Regulated Limit (RL).

The procedure to adjust the regulated limit is described in ETSI TS 103 941 [3], clause 6.4.

#### 4.3.8.4 Conformance

The conformance test for TX behaviour under the complete environment profile is defined in clause 5.3.8.

The conformance test shall be done under the complete environmental profile as defined in clause 5.1.3.

## 4.4 Receiver requirements

### 4.4.1 General

The receiver requirements apply for the equipment sub-categories 1.2 and 2.1. See clause 4.2.2.

- Receiver Baseline Sensitivity (RBS), see clause 4.4.3.
- Receiver Baseline Resilience (RBR), see clause 4.4.4.

NOTE 1: The receiver requirements for EUT's covered by the scope of the present document are justified in ETSI EN 303 883-2 [2], Annex C.

NOTE 2: Equipment of sub-category 1.1 (see clause 4.2.2) is not required to fulfil any receiver requirements, because they are UWB transmit only devices, which do not operate in UWB receive mode.

The conformance tests shall be done under normal conditions as defined in clause 5.1.2.

## 4.4.2 Wanted technical performance criteria

### 4.4.2.1 Message success ratio

Message Success Ratio (MSR) is used as a performance criterion for the RBS and RBR tests.

The equipment shall fulfil a message success ratio better than 90 %.

For the RBR test, the equipment shall meet this requirement also when the interferer is present.

### 4.4.2.2 Automatic recovery

Automatic recovery is used as a performance criterion for the RBR tests only.

The requirements for automatic recovery are listed below:

- The interference shall be present for at least 10 seconds.
- Automatic recovery of performance shall be completed 1 second after interference has been removed.
- 1 second after interference has been removed, the MSR measurement is started and the equipment shall fulfil a message success ratio better than 90 %.

## 4.4.3 Receiver Baseline Sensitivity (RBS)

### 4.4.3.1 Applicability

The Receiver Baseline Sensitivity (RBS) requirement applies to equipment sub-categories 1.2 and 2.1, see clause 4.2.2.

### 4.4.3.2 Description

For the description of the RBS requirement see ETSI EN 303 883-2 [2], clause 5.4.1.

### 4.4.3.3 Limits

The Receiver Baseline Sensitivity (RBS) shall fulfil the following requirement:

Receiver Baseline Sensitivity:  $P_{@EUT} \leq -111,3 \text{ dBm/MHz}$

NOTE 1: Received power at the equipment ( $P_{@EUT}$ ) includes the RX antenna gain (of the integrated or associated or dedicated equipment antenna).

NOTE 2: Reasoning behind Receiver Baseline Sensitivity requirement:  
Reliable operation can be achieved with a good link budget and/or installation of additional UWB nodes. Spectrum efficiency can deteriorate, if link budget due to poor RX sensitivity is traded-off against node count, as this will add unnecessary air traffic. This justifies the requirement for a "Receiver Baseline Sensitivity" requirement.

NOTE 3: Receiver Baseline Sensitivity is defined with the same unit as mean e.i.r.p. spectral density, and therefore the measurement methods for mean e.i.r.p. spectral density can be reused for quantifying the received power at the equipment.

NOTE 4: The limit is derived from a path loss of 80 dB with a mean e.i.r.p. spectral density limit of -31,3 dBm/MHz and a path loss of 70 dB with a mean e.i.r.p. spectral density limit of -41,3 dBm/MHz.

The RBS limit shall be met while fulfilling the message success ratio limit as defined in clause 5.4.2.

#### 4.4.3.4 Conformance

The conformance test for the RBS requirement is defined in clause 5.4.2.

### 4.4.4 Receiver Baseline Resilience (RBR)

#### 4.4.4.1 Applicability

The Receiver Baseline Resilience (RBR) requirement applies to equipment sub-categories 1.2 and 2.1 as described in clause 4.2.2.

#### 4.4.4.2 Description

The description of the RBR is given in ETSI EN 303 883-2 [2], clause 5.5.1.

#### 4.4.4.3 Limits

The present document considers two interference scenarios:

- Weak interference:
  - Power levels as defined in Table 6 and Table 7.
  - Message success ratio (clause 4.4.2.1) shall be fulfilled.
- Strong interference;
  - Power levels as defined in Table 6 and Table 7.
  - Automatic recovery (clause 4.4.2.2) shall be fulfilled.

The equipment shall comply with the limits given in Table 6 and Table 7. Both interference scenarios shall be tested separately for each test frequency specified.

Limits for the interferer within OFR shall be as shown in Table 6.

**Table 6: RBR limits within OFR**

Equipment sub-category	Interference Scenario	Interference power level at equipment	Wanted technical performance criterion	Test frequencies	Modulation of test signals
1.2, 2.1	Weak	-85 dBm	MSR clause 4.4.2.1	<ul style="list-style-type: none"> <li>• <math>f_L</math> (lower edge of OFR)</li> <li>• <math>f_c</math> (centre frequency of wanted signal)</li> <li>• <math>f_H</math> (upper edge of OFR)</li> </ul>	CW
	Strong	-50 dBm	Automatic recovery clause 4.4.2.2		

Limits for the interferer outside OFR shall be as shown in Table 7.

Table 7: RBR limits outside OFR

	Interference Scenario	Interference power level at equipment	Wanted technical performance criterion	Test frequencies	Modulation of test signals
1.2, 2.1	Weak	-85 dBm	MSR clause 4.4.2.1	<ul style="list-style-type: none"> <li>• <math>f_c - 2 \times \text{OFR}</math></li> <li>• <math>f_c - 1 \times \text{OFR}</math></li> <li>• <math>f_c + 1 \times \text{OFR}</math></li> <li>• <math>f_c + 2 \times \text{OFR}</math></li> </ul>	CW
	Strong	-50 dBm	Automatic recovery clause 4.4.2.2		

NOTE: Interfering signals and limits are defined in accordance with ETSI EN 303 883-2 [2], Annex A.

The derivation of the above limits is described in clauses D.1, D.3.1 and D.4.1 of ETSI EN 302 065-3-1 [4].

#### 4.4.4.4 Conformance

The conformance test for Receiver Baseline Resilience (RBR) is defined in clause 5.4.2.

---

## 5 Testing for compliance with technical requirements

### 5.1 Environmental conditions for testing

#### 5.1.1 General

Tests defined in the present document shall be carried out at representative points within the boundary limits of the operational environmental profile defined by its intended use, which, as a minimum, shall be that specified in the test conditions contained in the present document.

Where technical performance varies subject to environmental conditions, tests shall be carried out under a sufficient variety of environmental conditions as specified in the present document to give confidence of compliance for the affected technical requirements.

#### 5.1.2 Normal test conditions

Normal test conditions shall be as defined in clause 4.5.3.1 of ETSI TS 103 941 [3]. The temperature for testing under normal temperature conditions shall be within +15 °C to +35 °C.

#### 5.1.3 Complete environmental profile test conditions

The complete environmental profile test conditions includes both, the normal (see clause 5.1.2) and the extreme test conditions.

Extreme test conditions shall be as defined in clause 4.5.3.2 of ETSI TS 103 941 [3] with a temperature range varying between 5 °C to +40 °C; the primary supply voltage varies from 90 to 110 % of the nominal value.

NOTE: The nominal value of the supply voltage is provided by the user manual of the EUT.

## 5.2 General conditions for testing and conformance test suites

### 5.2.1 General conditions for testing

General guidance on testing TX and RX measurements are given respectively in ETSI EN 303 883-1 [1], clause 5.1.1 for the TX requirements and ETSI EN 303 883-2 [2], clause 5.1 for the RX requirements.

ETSI EN 303 883-1 [1], Annex A provides complementary information on general conditions for testing, e.g. test environment and test conditions, measurement uncertainty and interpretation of the measurement results. An overview is provided in ETSI EN 303 883-1 [1], clause A.1.

ETSI EN 303 883-1 [1], Annex B provides complementary information on test setups for testing, e.g. radiated and conducted measurements. An overview for radiated measurements is provided in ETSI EN 303 883-1 [1], clause B.2.1.

General information on test set-up for measurements under environmental profile are given respectively in ETSI TS 103 941 [3], clause 5.1. More detailed test solutions are provided in:

- ETSI TS 103 941 [3], clause 5.2 with the usage of a temperature chamber; and
- ETSI TS 103 941 [3], clause 5.3 with the usage of a climate dome and anechoic chamber.

## 5.2.2 Conformance test suites

ETSI EN 303 883-1 [1], Annex B provides additional information on test setups for radiated and conducted measurements.

Unless otherwise specified, the conformance tests described in clause 5.3 of the present document for the transmitter and clause 5.4 of the present document for the receiver shall be done on the test site according to ETSI EN 303 883-1 [1], clause B.2.2 under far field conditions according to ETSI EN 303 883-1 [1], clause B.2.3.5. Radiated emission measurements, unless otherwise specified, shall in addition use the test method from ETSI EN 303 883-1 [1], clause B.2.5.

## 5.2.3 Test scenarios

Setup for EUT of equipment sub-categories 1.1. and 1.2 (Fixed Indoor Infrastructure Devices):

- The EUT shall be measured as a stand-alone component.

Setup for EUT of equipment sub-category 2.1 (Portable Devices):

- For the measurement the EUT shall include any typical accessory, e.g. industrial casing.
- The EUT shall be measured as a stand-alone component (e.g. no emulation of attached object or human).
- For conformance methods described in clause 5.3.6 and clause 5.3.7 a companion device shall partially simulate an indoor infrastructure being part of an identifiable network to the extend required to perform the conformance methods.

## 5.3 Conformance methods of measurement for transmitter requirements

### 5.3.1 General

See clause 5.1 of ETSI EN 303 883-1 [1] for general guidance on TX measurements and emission concept.

The transmitter conformance tests shall be done under normal conditions as defined in clause 5.1.2.

### 5.3.2 Operating Frequency Range (OFR)

The OFR conformance test shall be done under normal conditions as defined in clause 5.1.2.

The OFR conformance tests shall be performed on a test site according to ETSI EN 303 883-1 [1], clause B.2.2.2 (anechoic chamber) and the test setup shall be the spherical scan test method as described in ETSI EN 303 883-1 [1], clause B.4.

For the OFR conformance assessment, at the direction of the highest Mean e.i.r.p. spectral density (see clause 5.3.3 of the present document), the conformance test procedure as specified in ETSI EN 303 883-1 [1], clause 5.2.2 shall be used.

The OFR conformance assessment shall be determined with the number for the parameter X as specified in clause 4.3.2.2.

The mean e.i.r.p. spectral density measurement (see clause 5.3.3) shall be the reference for the OFR assessment.

The measurement distance  $d$  is defined as the distance from the EUT to the measurement antenna. For the measurement distance  $d = 3$  m shall be used.

If the noise level of the overall measurement system (ETSI EN 303 883-1 [1], clause B.2.5) has less than 16 dB margin to the highest radiated mean e.i.r.p. spectral density (see clause 5.3.3) due to the low emission levels of the EUT, then a smaller measurement distance  $D$  shall be used, and the measurement distance assessment as described as range length in ETSI EN 303 883-1 [1], clause B.2.3.5 shall be done.

### 5.3.3 Mean e.i.r.p. spectral density

The Mean e.i.r.p. spectral density conformance tests shall be performed on the test site according to ETSI EN 303 883-1 [1], clause B.2.2.2 (anechoic chamber) and the test setup shall be the spherical scan test method as described in ETSI EN 303 883-1 [1], clause B.4.

For the Mean e.i.r.p. spectral density conformance assessment, the conformance test method as specified in ETSI EN 303 883-1 [1], clause 5.3.2.3 ("Mean e.i.r.p. spectral density, averaged over 1 ms") shall be used:

- For a full spherical assessment, the EUT need to be turned by 180 degrees around the horizontal plane (see ETSI EN 303 883-1 [1], clause B.4).
- For angular steps  $\Delta \Theta$  and  $\Delta \Phi$  a value of 15 degrees shall be used.
- The measurement distance  $d$  is defined as the distance from the EUT to the measurement antenna. For the measurement distance  $d = 3$  m shall be used.

If the noise level of the overall measurement system (ETSI EN 303 883-1 [1], clause B.2.5) has less than 10 dB margin to the mean e.i.r.p. spectral density limits (see clause 4.3.3.3), a smaller measurement distance  $d$  shall be used, and the measurement distance assessment as described as range length in ETSI EN 303 883-1 [1], clause B.2.3.5 shall be done.

### 5.3.4 Peak e.i.r.p. spectral density

The peak e.i.r.p. spectral density conformance tests shall be performed on a test site according to ETSI EN 303 883-1 [1], clause B.2.2.2 (anechoic chamber) and the test setup shall be the spherical scan test method as described in ETSI EN 303 883-1 [1], clause B.4.

Conformance shall be tested according to ETSI EN 303 883-1 [1], clause 5.3.4.1.3 ("General method") and RBW of 50 MHz shall be used.

For a full spherical assessment, the EUT need to be turned by 180 degrees around the horizontal plane (see ETSI EN 303 883-1 [1], clause B.4).

For angular steps  $\Delta \Theta$  and  $\Delta \Phi$  a value of 15 degrees shall be used.

The measurement distance  $d$  is defined as the distance from the EUT to the measurement antenna. For the measurement distance  $d = 3$  m shall be used.

### 5.3.5 TX unwanted emissions

The TX unwanted emission conformance tests shall be performed on a test site according to ETSI EN 303 883-1 [1], clause B.2.2.2 (anechoic chamber) and the test setup shall be the spherical scan test method as described in ETSI EN 303 883-1 [1], clause B.4.

For a full spherical assessment, the EUT need to be turned by 180 degrees around the horizontal plane (see ETSI EN 303 883-1 [1], clause B.4).

For angular steps  $\Delta \Theta$  and  $\Delta \Phi$  a value of 15 degrees shall be used.

The measurement distance  $d$  is defined as the distance from the EUT to the measurement antenna. For the measurement distance  $d = 3$  m shall be used.

The conformance test procedure as specified in ETSI EN 303 883-1 [1], clause 5.5.3.1 shall be used.

For the RMS assessment the test procedure step 2a as specified in ETSI EN 303 883-1 [1], clause 5.5.3.1.3 shall be used.

The averaging time for step 2a (Burst duration /  $T_{on}$  time) can be assessed with the conformance test procedure in clause 5.3.6 of the present document.

### 5.3.6 Duty cycle

For the duty cycle conformance test the set-up as specified in clause 5.3.3 and the conformance test procedure as specified in ETSI EN 303 883-1 [1], clause 5.11.2.1 ("Duty cycle, spectrum analyser method") shall be used.

The measurement receiver with the related measurement antenna shall be placed in the direction of highest mean e.i.r.p. spectral density emission (see results of measurements according to clause 5.3.3).

NOTE 1: Duty cycle conformance assessment is only necessary in the direction of the highest Mean e.i.r.p. spectral density emission, because with this test the nature of the TX-signal will be tested and not the complete emission of the EUT (see clause 5.3.3).

For the measurement distance  $d$ , the same distance than for the mean e.i.r.p. spectral density emission conformance test shall be used (see clause 5.3.3).

In order to stimulate the EUT to be operating in the enhanced indoor device mode, where a duty cycle limitation is foreseen, the EUT needs to be subject to control by an indoor infrastructure and to operate within an identifiable network. To generate these conditions the set-up as specified in clause 5.3.3 and the conformance test procedure as specified in ETSI EN 303 883-1 [1], clause 5.11.2.1 ("Duty cycle, spectrum analyser method") shall be extended by the introduction of a Companion Device.

Figure 1 shows the setup, where the EUT is an UWB transmitter with the ability to receive a command & control signal from a companion device. The companion device is simulating a fixed infrastructure to the required extend for performing the tests specified in clause 5.3.6.

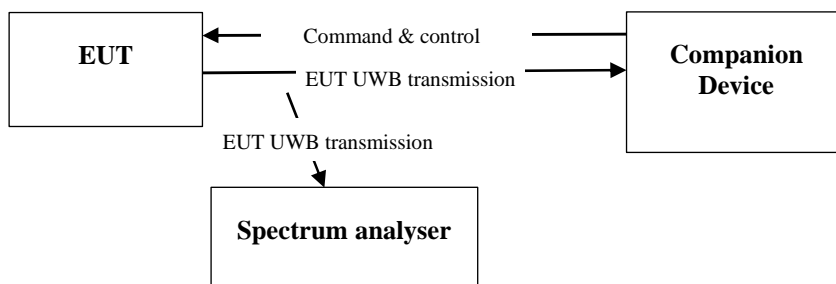

**Figure 1: Extended measurement setup (additional companion device compared to the conformance test method specified in ETSI EN 303 883-1 [1], clause 5.11.2.1)**

The manufacturer shall provide the companion device. The companion device shall provide the necessary Command & control signal to stimulate the EUT to operate under the enhanced indoor devices regulatory rules, see annex 4.2 in (EU) 2024/1467 [i.2].

If the companion device is transmitting UWB signals inside the operating frequency range of the EUT, then the maximum power of UWB signals at the Spectrum analyser received from the companion device shall be at least 16 dB lower compared to the maximum power of the UWB signals received from the EUT at the Spectrum analyser. This can be achieved by a low UWB transmit power at the companion device compared to the EUT UWB transmit power, or by spatial separation of the companion device, or by the antenna directivity of the measurement antenna and the companion device antenna or by a combination of these methods.

If the noise level of the overall measurement system (ETSI EN 303 883-1 [1], clause B.2.5) has less than 16 dB margin to the measured  $P_{\max}$  (see below) due to the low emission levels of the EUT, a smaller measurement distance  $d$  shall be used, and the measurement distance assessment as described as range length in ETSI EN 303 883-1 [1], clause B.2.3.5 shall be done.

Following parameters shall be used for Duty-Cycle tests:

- $T_{\text{obs}} = 1 \text{ s}$
- $T_{\text{dis}} = 10 \text{ } \mu\text{s}$

NOTE 2: This value for disregard time  $T_{\text{dis}}$  is large enough to span pulse-based symbols and include them in the On-time, but small enough to differentiate packets and account the time between as Off-time.

- $\text{RBW} = 1 \text{ MHz}$
- $\text{VBW} = 3 \text{ MHz}$
- Detector mode: Peak
- $P_{\text{thresh}} = P_{\max} - 10 \text{ dB}$

NOTE 3:  $P_{\text{thresh}}$  and  $P_{\max}$  are related to the duty-cycle measurement settings ( $\text{RBW} = 1 \text{ MHz}$ , Peak Detector).  $P_{\max}$  denotes the maximum level of the signal measured.

## 5.3.7 Subject to control by an indoor infrastructure and operation within an identifiable network

### 5.3.7.1 General

An identifiable network in the context of radio communications and the present document is a network with unique identifiers allowing identification of individual networks. For the EUTs a dedicated test shall be performed to verify, that they operate within an identifiable network. In the present document, a combined test is described instead to demonstrate fulfilment of this requirement of operation within an identifiable network separately.

The intention of this regulatory rule is to make sure, that the EUT is under control of a certain (identifiable) network, from which is known, that it is consisting of an indoor infrastructure, if the enhanced rules, e.g. -31 dBm/MHz max. mean e.i.r.p. density, are applied by the EUT. Technically this can be proven by monitoring the changing EUT UWB transmit power (to a power level lower or equal than -41,3 dBm/MHz max. mean e.i.r.p. density) after stopping the transmission of an indoor infrastructure control signal

The portable devices are interacting with the indoor infrastructure devices, the so-called anchor nodes / satellite nodes. These indoor infrastructure devices contain control functionality, which is used for controlling the network structure (e.g. including e.g. the slot scheduling for the portable devices) and for maintaining the network member and characteristics table resources. A discovery and an association of the portable device to the indoor network is mandatory for operation within the network. The indoor infrastructure then is providing information to the portable device, which resources to deploy for UWB transmission (e.g. channel, time slot, ranging round). Therefore the portable device is subject to control by indoor infrastructure.

The indoor infrastructure is providing the information to the portable UWB device, that the portable UWB device is operating within an indoor infrastructure environment, via a control channel. If such information is not received by the portable UWB device, the Portable device shall not operate according to enhanced indoor devices regulations according to (EU) 2024/1467 [i.2].

For the Subject to control by an indoor infrastructure conformance test the set-up as specified in clause 5.3.7.1 shall be used in general. Depending on the features of the EUT and of the companion device one of the variants described in clause 5.3.7.2, 5.3.7.3 or 5.3.7.4 shall be selected.

In any case the measurement antenna shall be placed in the direction of the highest mean e.i.r.p. spectral density emission of the EUT (see results of measurements according to clause 5.3.3).

The command & control signalling from the companion device towards the EUT can be performed within or outside the EUT UWB operating frequency range. In case outside, then the test setup detailed in clause 5.3.7.2 shall be applied.

Depending on the features of the EUT, it is possible, that an EUT is only capable to receive the indoor indicator signal inside the UWB operating frequency range. In this case the indoor indicator signal is transmitted by the companion device inside the UWB operating frequency range. Then there are two test setups possible, either a time gating setup, described in clause 5.3.7.3, or a spatial separation setup, described in clause 5.3.7.4. The time gating setup, described in clause 5.3.7.3, shall be the preferred option. If for any technical reason this setup is not possible to be applied, only then the spatial separation setup, described in clause 5.3.7.4. shall be applied.

Conformance for "Subject to control by an indoor infrastructure and operation within an identifiable network " shall be tested using a procedure as below.

In the following text the spectrum analyser used for the measurements will be named the measurement device.

Figure 2 shows the generic test setup where the EUT has the ability to receive a command & control signal. The difference to the generic conformance test method for the mean e.i.r.p. spectral density, specified in ETSI EN 303 883-1 [1], clause 5.3.2.3 ("Mean e.i.r.p. spectral density, averaged over 1 ms"), is the addition of a companion device in the test scenario, which is transmitting an indoor indicator signal during the measurement time. This indoor indicator signal shall be received by the EUT during the measurement time in the first measurement step (enhanced indoor device mode) and therefore the EUT shall operate in its intended mode of operation, which is the enhanced indoor device mode, with up to -31,3 dBm/MHz mean e.i.r.p. spectral density. The companion device is simulating a fixed indoor infrastructure to the required extend for performing the tests specified in clause 5.3.7.

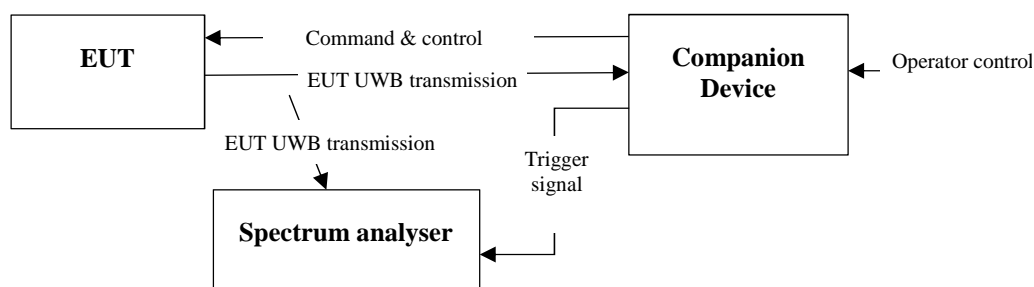

**Figure 2: Generic setup (additional companion device compared to the conformance test method specified in ETSI EN 303 883-1 [1], clause 5.3.2.3)**

The companion device shall contain a trigger output port to trigger the start of the measurement to the measurement device (see Figure 2) 10 seconds after it stopped sending the indoor identifier.

For details of the test setup one of the variants described in clauses 5.3.7.2, 5.3.7.3 and 5.3.7.4 shall be selected according to the features of the EUT and the measurement equipment. The reasoning for the selection shall be noted.

The preferred method is always according to clause 5.3.7.2. If this is not possible for technical reasons the next priority choice is testing according to the method described in clause 5.3.7.3. If both, clause 5.3.7.2 and clause 5.3.7.3 are not applicable for technical reasons, then the test method according to clause 5.3.7.4 shall be applied.

In any of the three test setup cases the following measurement procedure shall be applied:

Procedure:

- 1) Step 1: Enhanced indoor device mode: The Companion device, utilizing an initial network id, is associating the EUT to the Companion device's network. The Companion device is sending an indoor identifier over the Command & control signal and is stimulating the EUT to perform UWB transmissions according to the intended mode of operation:
  - a) Measurement of Mean e.i.r.p. spectral density of EUT as defined in ETSI EN 303 883-1 [1], clause 5.3.2.3 ("Mean e.i.r.p. spectral density, averaged over 1 ms") shall be performed only in the direction of main radiation, if the direction was determined based on the conformance test in clause 5.3.3, otherwise shall be performed with 15 degree steps as in clause 5.3.4.
  - b) The values for the Mean e.i.r.p. power spectral density shall be recorded. The measured values shall comply with the Enhanced Indoor Devices limits of the (EU) 2024/1467 [i.2], -31,3 dBm/MHz max. Mean e.i.r.p. spectral density.

- c) Measurement of Peak e.i.r.p. spectral density of EUT as defined in ETSI EN 303 883-1 [1], clause 5.3.4.1.3 ("General method") with a RBW of 50 MHz, in the direction of main radiation only.
  - d) The values for the Peak e.i.r.p. power spectral density shall be recorded. The measured values shall comply with the Enhanced Indoor Devices limits of the (EU) 2024/1467 [i.2], 10 dBm/50 MHz max. Peak e.i.r.p. spectral density.
- 2) Step 2: The Companion device receives a manually triggered operator control signal from the test operator side to stop sending an indoor identifier via the control signal towards the EUT. After an additional delay of 10 seconds the measurement starts again. Now the EUT shall be not in the enhanced indoor device mode anymore and therefore shall not exceed -41,3 dBm/MHz Mean e.i.r.p. spectral density:
- a) Measurement of Mean e.i.r.p. spectral density of EUT as defined in ETSI EN 303 883-1 [1], clause 5.3.2.3 ("Mean e.i.r.p. spectral density, averaged over 1 ms"), only in the direction of the main radiation (as determined in measurements according to clause 5.3.3).
  - b) The values for the Mean e.i.r.p. power spectral density shall be recorded. The measured values shall comply with the generic UWB limits of the (EU) 2024/1467 [i.2], -41,3 dBm/MHz max. Mean e.i.r.p. density.
- 3) Step 3: Changed network identifier and Enhanced indoor device mode: The Companion device receives a manually triggered operator control signal from the test operator side to start sending an indoor identifier via the Command & control signal and to change its network identifier to a different one from step 1 and 2. After an additional delay of 10 seconds the Companion device is sending the start of measurement signal via the Trigger signal to the measurement device. Due to change of network id of the companion device the EUT has lost its network and is not part of the initial network anymore:
- a) Measurement of Mean e.i.r.p. spectral density of EUT as defined in ETSI EN 303 883-1 [1], clause 5.3.2.3 ("Mean e.i.r.p. spectral density, averaged over 1 ms") in the direction of main radiation (as determined in measurements according to clause 5.3.3).
  - b) The value for the Mean e.i.r.p. power spectral density shall be recorded. The measured values shall comply with the Enhanced Indoor Devices limits of the (EU) 2024/1467 [i.2], -41,3 dBm/MHz max. Mean e.i.r.p. density.
  - c) Measurement of Peak e.i.r.p. spectral density of EUT as defined in ETSI EN 303 883-1 [1], clause 5.3.4.1.3 ("General method") with a RBW of 50 MHz, in the direction of main radiation only.
  - d) The values for the Peak e.i.r.p. power spectral density shall be recorded. The measured values shall comply with the Enhanced Indoor Devices limits of the (EU) 2024/1467 [i.2], 0 dBm/50 MHz max. Peak e.i.r.p. spectral density.

### 5.3.7.2 Setup for a Companion Device with Command & control signal outside the EUT UWB operating frequency range

This is the preferred test setup, because it is the simplest. No time gating and no spatial separation between companion device and measurement device are required. It shall always apply, if the EUT is able to receive Command & control signals outside the EUT UWB operating frequency range.

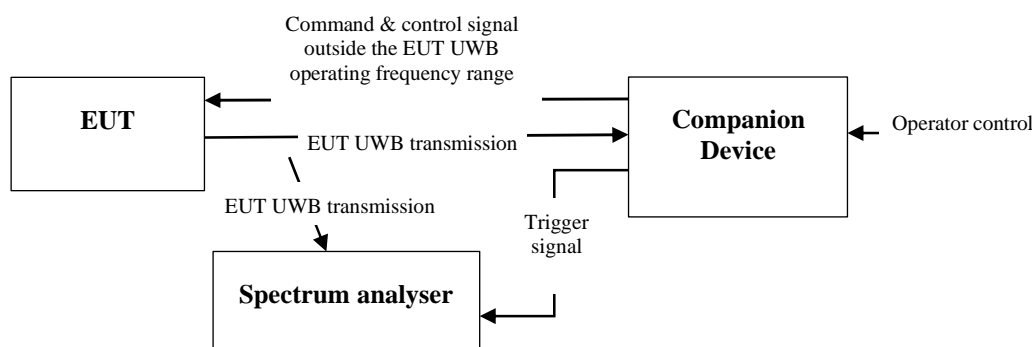

Figure 3: Setup for Command & control signal outside the EUT UWB operating frequency range

The companion device shall be not transmitting any signal inside the UWB operating frequency range during the test, in order not to increase the received power level in the measurement device inside the UWB operating frequency range.

The manufacturer shall provide the special test companion device. The companion device shall transmit the indoor identifier signal outside the EUT UWB operating frequency range. The companion device shall contain a trigger output port to trigger the start of the measurement to the measurement device 10 seconds after changing sending the indoor identifier.

### 5.3.7.3 Setup for a Companion Device with Command & control signal inside the EUT UWB operating frequency range and time gating

There is a gating signal from the companion device towards the measurement device, which is set active during the time, when the companion device is transmitting inside the EUT UWB operating frequency range. It is enabling the measurement device to pause the measurement procedure during the companion device UWB Tx time and therefore the measurement result will not be influenced by the UWB signal power received from the companion device inside the EUT UWB operating frequency range.

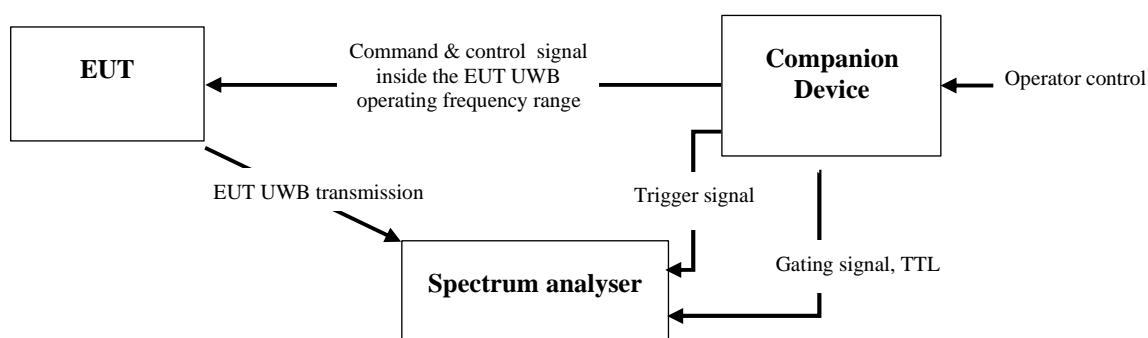
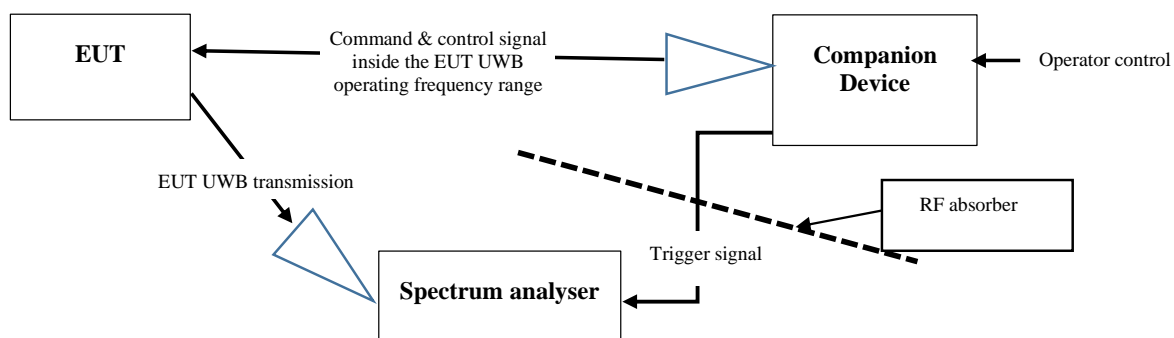

**Figure 4: Gating signal setup for indoor indicator signal inside EUT operating frequency range**

The manufacturer shall provide the special test companion device. The companion device shall transmit the indoor identifier signal inside the EUT UWB operating frequency range and shall signal any transmission inside the EUT UWB operating frequency range with a TTL gating signal. The companion device shall contain a trigger output port to trigger the start of the measurement to the measurement device 10 seconds after changing sending the indoor identifier.

### 5.3.7.4 Setup for a Companion Device with Command & control signal inside the EUT UWB operating frequency range and spatial separation

To achieve the separation of at least 20 dB the directivity of the measurement antenna shall be 20 dBi antenna gain and it shall be pointing towards the EUT with its maximum antenna gain. The transmitting antenna of the companion device shall have a directivity of 20 dBi antenna gain and it should be pointing towards the EUT with its maximum antenna gain. There shall be a RF absorber with an attenuation of at least 20 dB placed between the companion device and the measurement device in order to increase isolation.



**Figure 5: Directivity setup for indoor indicator signal inside EUT operating frequency range**

The manufacturer shall provide the special test companion device. The companion device shall transmit the indoor identifier signal inside the EUT UWB operating frequency range and shall use a directive antenna with at least 20 dBi

antenna gain in the direction towards the EUT. The companion device shall contain a trigger output port to trigger the start of the measurement to the measurement device (see Figure 3) 10 seconds after changing sending the indoor identifier.

## 5.3.8 TX behaviour under the complete environmental profile

### 5.3.8.1 General

A test set-up shall be chosen based on clause 4.3.1 and Figure 1 in ETSI TS 103 941 [3].

### 5.3.8.2 Conformance test procedure

The procedure according to ETSI TS 103 941 [3], clause 6.4 shall be used.

Based on clause 5.1.3 and Figure 6 of ETSI TS 103 941 [3], clause 4.5.4 the parameters for the assessment are specified as follows:

- $t_{low}$  and  $t_{high}$ : see clause 5.1.3.
- $t_{steps}$ : 10 °C.
- supply voltage: see clause 5.1.3, the nominal value is usually provided by the user manual of the EUT.

## 5.4 Conformance methods of measurement for receiver

### 5.4.1 Receiver Baseline Sensitivity (RBS)

The conformance test shall be done under normal conditions as defined in clause 5.1.2.

Conformance of Receiver Baseline Sensitivity shall be a radiated test with integral or specified antenna according to ETSI EN 303 883-2 [2], clause 5.4.3.3 ("Radiated measurements for radio communication devices with power limit"), see Figure 3. The radiated RBS tests shall be carried out in an Anechoic Chamber according to ETSI EN 303 883-1 [1], clause B.2.2.2.

The RBS is determined by measuring the Message Success Ratio (MSR).

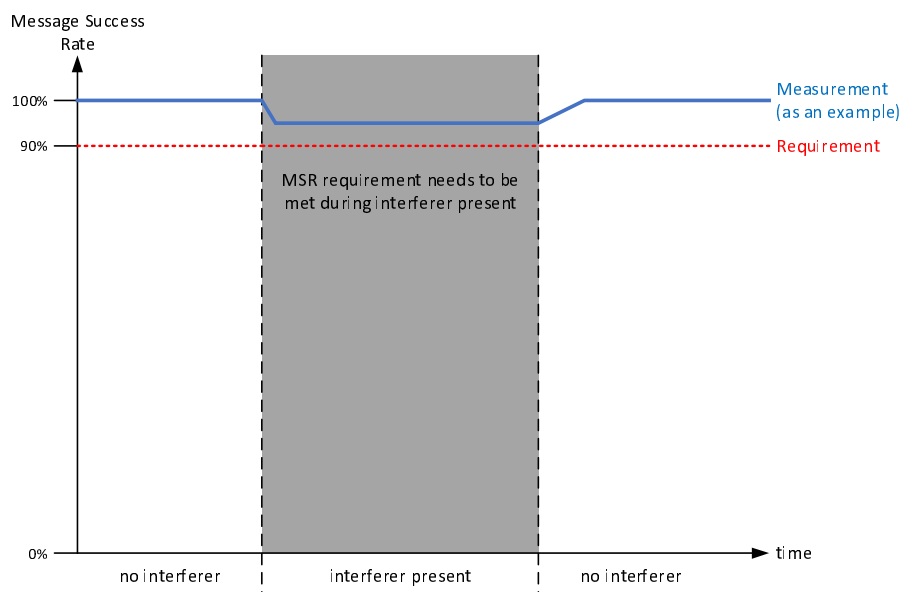

**Figure 6: Message success ratio**

The EUT shall support the determination of the MSR for all relevant test setups in the present document.

The MSR shall be determined with at least 20 messages (e.g. 18 successful message detections out of 20).

NOTE 1: The equipment covered by the present document uses a packet-based exchange for distance bounding and/or location tracking and/or data transfer. This exchange is referred to as "message". The performance requirement is based on the successful detection of messages by the EUT. An adequate Message Success Ratio (MSR), as specified in the present document, is, therefore, an appropriate wanted technical performance criterion.

NOTE 2: For the general case of proprietary protocols, supporting an MSR measurement will require that the manufacturer provides an appropriate companion device or signal generator configuration to generate a "wanted signal", as well as tools to read out successful message detection from the EUT and calculate MSR.

All signal levels ( $P_{out}$ ,  $P_{@EUT}$ ) shall be determined with reference to the Mean e.i.r.p. spectral density and therefore documented with the unit "dBm/MHz".

The wanted technical performance criteria for the test are provided in clause 4.4.2.1.

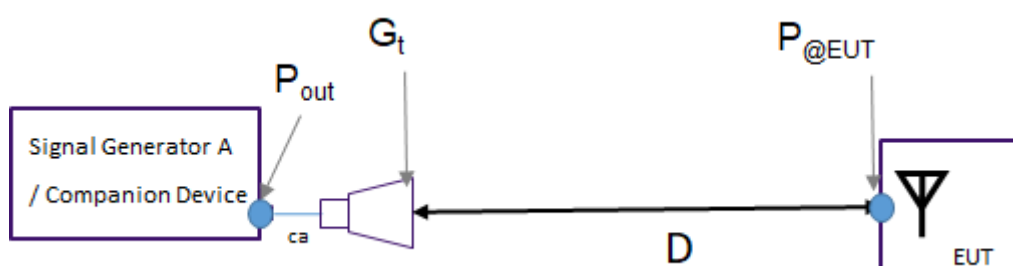

Figure 7: Setup for RBS measurement

## 5.4.2 Receiver Baseline Resilience (RBR)

The conformance test shall be done under normal conditions as defined in clause 5.1.2.

The radiated RBR tests shall be carried out in an Anechoic Chamber according to ETSI EN 303 883-1 [1], clause B.2.2.2. The Conformance of Receiver Baseline Resilience shall be tested according to ETSI EN 303 883-2 [2], clause 5.5.3.3 ("Radiated Measurements for Radio Communication Devices with Power Limit") with the following parameters:

- The wanted technical performance criteria for the tests are provided in clauses 4.4.2.1 and 4.4.2.2. The wanted signal level at the EUT for all RBR tests shall be 10 dB above the Receiver Baseline Sensitivity (see clause 4.4.4.3).

**Sensitivity degradation  $d_g = 10$  dB**

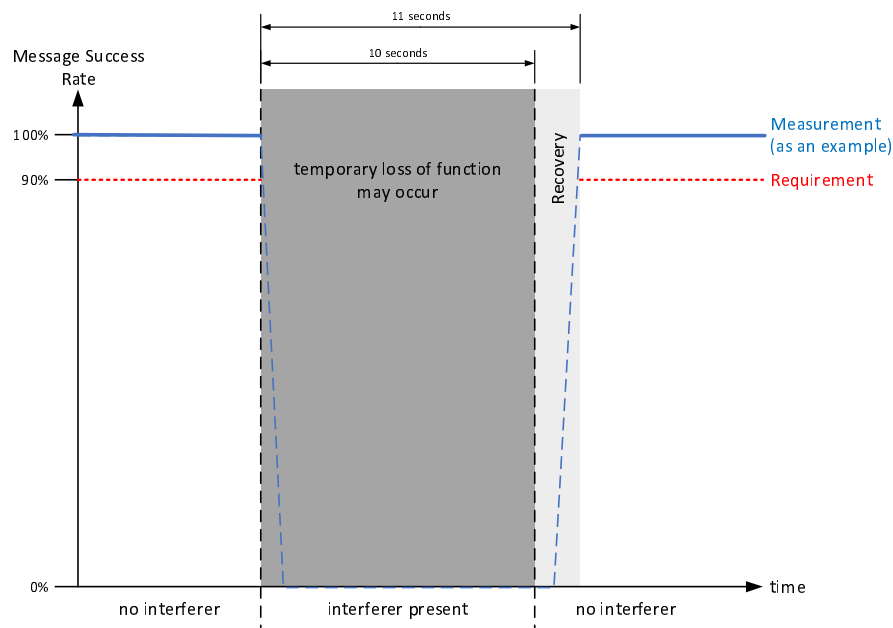

**Figure 8: Recovery without operator intervention**

The wanted signal shall be at its nominal frequency  $f_c$ . Interfering signals within OFR are given in Table 7 of the present document and interfering signals outside OFR in Table 7 of the present document.

The wanted recovery without operator intervention criterion is applied for the RBR tests. This wanted technical performance criterion takes into account the non-protected nature of UWB operations. During the presence of an interferer, the EUT may have a temporary loss of function or degradation of performance. However, when the interferer is removed, the EUT shall recover its normal performance - which is a certain message success ratio better than 90 % (see clause 4.4.2.1 for the limits) - without operator intervention.

## Annex A (informative): Relationship between the present document and the essential requirements of Directive 2014/53/EU

The present document has been prepared under the Commission's standardisation request C(2015) 5376 final [i.4] to provide one voluntary means of conforming to the essential requirements of Directive 2014/53/EU on the harmonisation of the laws of the Member States relating to the making available on the market of radio equipment and repealing Directive 1999/5/EC [i.5].

Once the present document is cited in the Official Journal of the European Union under that Directive, compliance with the normative clauses of the present document given in Table A.1 confers, within the limits of the scope of the present document, a presumption of conformance with the corresponding essential requirements of that Directive and associated EFTA regulations.

**Table A.1: Relationship between the present document and the essential requirements of Directive 2014/53/EU**

Harmonised Standard ETSI EN 302 065-2-5					
Requirement				Requirement Conditionality	
No	Description	Essential requirements of Directive	Clause(s) of the present document	U/C	Condition
1	Operating Frequency Range (OFR)	3.2	4.3.2	U	
2	Mean e.i.r.p. spectral density	3.2	4.3.3	U	
3	Peak e.i.r.p. spectral density	3.2	4.3.4	U	
4	TX unwanted emissions	3.2	4.3.5	U	
5	Duty-Cycle	3.2	4.3.6	U	
6	Subject to control by an indoor infrastructure and operation within an identifiable network	3.2	4.3.7	C	Applies only for EUT category 2
7	TX behaviour under the complete environmental profile	3.2	4.3.8	U	
8	Receiver Baseline Sensitivity (RBS)	3.2	4.4.3	C	Applies only for EUT subcategory 1.2 and category 2
9	Receiver Baseline Resilience (RBR)	3.2	4.4.4	C	Applies only for EUT subcategory 1.2 and category 2

### Key to columns:

#### Requirement:

**No** A unique identifier for one row of the table which may be used to identify a requirement.

**Description** A textual reference to the requirement.

#### Essential requirements of Directive

Identification of article(s) defining the requirement in the Directive.

#### Clause(s) of the present document

Identification of clause(s) defining the requirement in the present document unless another document is referenced explicitly.

#### Requirement Conditionality:

**U/C** Indicates whether the requirement is unconditionally applicable (U) or is conditional upon the manufacturer's claimed functionality of the equipment (C).

**Condition** Explains the conditions when the requirement is or is not applicable for a requirement which is classified "conditional".

Presumption of conformance stays valid only as long as a reference to the present document is maintained in the list published in the Official Journal of the European Union. Users of the present document should consult frequently the latest list published in the Official Journal of the European Union.

Other Union legislation may be applicable to the product(s) falling within the scope of the present document.

## Annex B (informative): Requirement mapping

ETSI EG 203 336 [i.6], clause 5 lists the technical parameters applicable to transmitters and receivers that should be considered when producing Harmonised Standards that are intended to cover the essential requirements in article 3.2 of Directive 2014/53/EU [i.5]. Essential requirements are high level objectives described in European Directives. The purpose of the Harmonised Standard is to translate those high-level objectives into detailed technical specifications. Table B.1 contains the parameters listed in ETSI EG 203 336 [i.6], clause 5 for transmitter and receiver, and cross references these to the clauses within the present document in which the requirements for measurement of such parameters are satisfied or justified.

**Table B.1: Cross reference of clauses in the present document to technical parameters for transmitter and receiver listed in ETSI EG 203 336 [i.6]**

ETSI EG 203 336 [i.6]		Present document		Justification
Clause	Parameter	Clause	Parameter	
5.2.2	Transmitter power limits	4.3.3	Mean power spectral density e.i.r.p.	
		4.3.4	Peak power spectral density e.i.r.p.	
		4.3.8	TX behaviour under the complete environmental profile	
5.2.3	Transmitter power accuracy	-	-	From the latest version of ETSI EG 203 336 [i.6] "When regulatory limits imply only a maximum emission limit (e.g. products that operate under a general licence regime), this parameter need not be considered for inclusion in an HS."
5.2.4	Transmitter spectrum mask	4.3.2 4.3.7	Operating Frequency Range	
5.2.5	Transmitter frequency stability	-	-	NOTE 1: Not applicable for UWB / wideband equipment based on kind of used modulation.
5.2.6	Transmitter intermodulation attenuation	-	-	From latest version of ETSI EG 203 336 [i.6], this parameter is required only "where high levels of quality services are required". This is not relevant for generic short range devices which are operating under licence except regime without any kind of regulatory protection. SRDs have to accept interferences.
5.2.7.2	Transmitter unwanted emissions in the out of band domain	4.3.5	TX Unwanted emissions	
5.2.7.3	Transmitter unwanted emissions in the spurious domain	4.3.5	TX Unwanted emissions	
5.2.8	Transmitter time domain characteristics	4.3.6	Duty cycle	For category 2 only applicable, if enhanced indoor devices power limits are used.
5.2.9	Transmitter transients	4.3.7	Subject to control by an indoor infrastructure	Only applicable for EUT category 2
		4.3.7	Subject to control by an indoor infrastructure and operation within an identifiable network	Only applicable for EUT category 2

ETSI EG 203 336 [i.6]		Present document		Justification
Clause	Parameter	Clause	Parameter	
	Other mitigation, spectrum access requirements not specified in the ETSI Guide but specified in related ECC/EC framework			
5.3.2	Receiver sensitivity	-	Not specified, superseded by RBS test	See justification in ETSI EN 303 883-2 [2], Annex C and the explanation of the interferer signal handling concept, see ETSI TS 103 567 [i.7].
5.3.2.3	Desensitization	-	Not specified, superseded by RBR test	See justification in ETSI EN 303 883-2 [2], Annex C and the explanation of the interferer signal handling concept, see ETSI TS 103 567 [i.7].
5.3.3	Receiver co-channel rejection	-	Not specified, superseded by RBR test	See justification in ETSI EN 303 883-2 [2], Annex C and the explanation of the interferer signal handling concept, see ETSI TS 103 567 [i.7].
5.3.4.2.1	Receiver adjacent channel selectivity	-	Not specified, superseded by RBR test	See justification in ETSI EN 303 883-2 [2], Annex C and the explanation of the interferer signal handling concept, see ETSI TS 103 567 [i.7].
5.3.4.2.2	Receiver adjacent band selectivity	-	Not specified, superseded by RBR test	See justification in ETSI EN 303 883-2 [2], Annex C and the explanation of the interferer signal handling concept, see ETSI TS 103 567 [i.7].
5.3.4.3	Receiver blocking	-	Not specified, superseded by RBR test	See justification in ETSI EN 303 883-2 [2], Annex C and the explanation of the interferer signal handling concept, see ETSI TS 103 567 [i.7].
5.3.4.4	Receiver spurious response rejection	-	Not specified, superseded by RBR test	See justification in ETSI EN 303 883-2 [2], Annex C and the explanation of the interferer signal handling concept, see ETSI TS 103 567 [i.7].
5.3.4.5	Receiver radio-frequency intermodulation	-	Not specified, superseded by RBR test	See justification in ETSI EN 303 883-2 [2], Annex C and the explanation of the interferer signal handling concept, see ETSI TS 103 567 [i.7].
5.3.5	Receiver unwanted emissions in the spurious domain	-	Unwanted emissions in the spurious domain	NOTE 2: If the EUT covered by the EN has "receive only" modes. There are no receive only modes in the EUT device classes in the present document. In mixed Tx/Rx modes the distinction between Tx and Rx unwanted emissions are not possible.
5.3.6.1	Receiver dynamic range	-	Partly by RBS	NOTE 3: Or EN has specific dynamic range test, if not see ETSI EN 303 883-2 [2], Table C.1.
5.3.6.2	Reciprocal mixing	-	Not specified, superseded by RBR test	See justification in ETSI EN 303 883-2 [2], Annex C and the explanation of the interferer signal handling concept, see ETSI TS 103 567 [i.7].
5.3.1	Signal interferer handling	4.4.3 4.4.4	Receiver Baseline Sensitivity (RBS) Receiver Baseline Resilience (RBR)	Interferer signal handling ([i.3] clause 5.3.1) is an alternative method for specifying receiver parameters intended for use for receivers such as UWB and certain types of radar equipment. The present document is following this concept, see ETSI TS 103 567 [i.7] and ETSI EN 303 883-2 [2].

---

## History

Version	Date	Status
V1.1.0	November 2025	SRdAP process EV 20260525: 2025-11-27 to 2026-02-25
V1.1.1	March 2026	Publication