



**Short Range Devices (SRD)  
using Ultra Wide Band technology (UWB);  
Harmonised Standard for access to radio spectrum;  
Part 4: Material Sensing devices;  
Sub-part 1: Building material analysis below 10,6 GHz**

---

**Reference**

REN/ERM-TGUWB-150-4-1

---

**Keywords**

harmonised standard, SRD, UWB

**ETSI**

650 Route des Lucioles  
F-06921 Sophia Antipolis Cedex - FRANCE

Tel.: +33 4 92 94 42 00 Fax: +33 4 93 65 47 16

Siret N° 348 623 562 00017 - APE 7112B  
Association à but non lucratif enregistrée à la  
Sous-Préfecture de Grasse (06) N° w061004871

---

**Important notice**

The present document can be downloaded from the  
[ETSI Search & Browse Standards](#) application.

The present document may be made available in electronic versions and/or in print. The content of any electronic and/or print versions of the present document shall not be modified without the prior written authorization of ETSI. In case of any existing or perceived difference in contents between such versions and/or in print, the prevailing version of an ETSI deliverable is the one made publicly available in PDF format on [ETSI deliver](#) repository.

Users should be aware that the present document may be revised or have its status changed,  
this information is available in the [Milestones listing](#).

If you find errors in the present document, please send your comments to  
the relevant service listed under [Committee Support Staff](#).

If you find a security vulnerability in the present document, please report it through our  
[Coordinated Vulnerability Disclosure \(CVD\)](#) program.

---

**Notice of disclaimer & limitation of liability**

The information provided in the present deliverable is directed solely to professionals who have the appropriate degree of experience to understand and interpret its content in accordance with generally accepted engineering or other professional standard and applicable regulations.

No recommendation as to products and services or vendors is made or should be implied.  
In no event shall ETSI be held liable for loss of profits or any other incidental or consequential damages.

Any software contained in this deliverable is provided "AS IS" with no warranties, express or implied, including but not limited to, the warranties of merchantability, fitness for a particular purpose and non-infringement of intellectual property rights and ETSI shall not be held liable in any event for any damages whatsoever (including, without limitation, damages for loss of profits, business interruption, loss of information, or any other pecuniary loss) arising out of or related to the use of or inability to use the software.

---

**Copyright Notification**

No part may be reproduced or utilized in any form or by any means, electronic or mechanical, including photocopying and microfilm except as authorized by written permission of ETSI.

The content of the PDF version shall not be modified without the written authorization of ETSI.

The copyright and the foregoing restriction extend to reproduction in all media.

© ETSI 2024.  
All rights reserved.

# Contents

|  |    |
|--|----|
| Intellectual Property Rights .....   | 6  |
| Foreword.....  | 6  |
| Modal verbs terminology.....   | 8  |
| Introduction .....   | 8  |
| 1 Scope .....  | 9  |
| 2 References .....   | 9  |
| 2.1 Normative references .....   | 9  |
| 2.2 Informative references.....  | 10 |
| 3 Definition of terms, symbols and abbreviations.....                          | 11 |
| 3.1 Terms.....   | 11 |
| 3.2 Symbols.....   | 11 |
| 3.3 Abbreviations .....  | 12 |
| 4 Technical requirements specifications .....                                  | 12 |
| 4.1 Environmental profile.....   | 12 |
| 4.2 EUT categories .....   | 12 |
| 4.2.1 General.....   | 12 |
| 4.2.2 Categorization by Regulation .....                                       | 12 |
| 4.2.3 Categorization by Modulation .....                                       | 13 |
| 4.2.4 Categorization by Active Mitigation Techniques .....                     | 13 |
| 4.2.5 Summary EUT categories.....  | 13 |
| 4.3 Transmitter requirements .....   | 14 |
| 4.3.1 General.....   | 14 |
| 4.3.2 Operating Frequency Range (OFR).....                                     | 14 |
| 4.3.2.1 Applicability.....   | 14 |
| 4.3.2.2 Description Operating Frequency Range .....                            | 14 |
| 4.3.2.3 Limits for Operating Frequency Range.....                              | 15 |
| 4.3.2.3.1 Limit requirement for BMA2, BMA3, BMA4 and BMA5 categories .....     | 15 |
| 4.3.2.3.2 Limit requirement for BMA1 category.....                             | 15 |
| 4.3.2.4 Conformance.....   | 15 |
| 4.3.3 Mean e.i.r.p. ....   | 15 |
| 4.3.3.1 Applicability.....   | 15 |
| 4.3.3.2 Description Mean e.i.r.p. ....   | 15 |
| 4.3.3.3 Limits for Mean e.i.r.p. ....  | 15 |
| 4.3.3.4 Conformance.....   | 16 |
| 4.3.4 Indirect Emissions .....   | 16 |
| 4.3.4.1 Applicability.....   | 16 |
| 4.3.4.2 Description Indirect Emission.....                                     | 16 |
| 4.3.4.3 Limits for Indirect Emission .....                                     | 16 |
| 4.3.4.3.1 Limits for Indirect Emissions for EUT categories BMA2 and BMA3 ..... | 16 |
| 4.3.4.3.2 Indirect Emissions for EUT categories BMA4 and BMA5 .....            | 17 |
| 4.3.4.4 Conformance.....   | 18 |
| 4.3.5 TX Unwanted Emissions (TXUE).....  | 18 |
| 4.3.5.1 Applicability.....   | 18 |
| 4.3.5.2 Description TX unwanted emissions.....                                 | 18 |
| 4.3.5.3 Limits for TXUE.....   | 18 |
| 4.3.5.3.1 TXUE limit for EUT category BMA1 .....                               | 18 |
| 4.3.5.3.2 TXUE limit for EUT categories BMA2, BMA3, BMA4 and BMA5.....         | 19 |
| 4.3.5.4 Conformance.....   | 19 |
| 4.3.6 Total Radiated Mean e.i.r.p. Spectral Density (TRP <sub>SD</sub> ).....  | 19 |
| 4.3.6.1 Applicability.....   | 19 |
| 4.3.6.2 Description Total Radiated Power .....                                 | 19 |
| 4.3.6.3 Limits for Total Radiated Power .....                                  | 20 |
| 4.3.6.3.1 TRP <sub>SD</sub> limit for EUT categories BMA2 and BMA3.....        | 20 |
| 4.3.6.3.2 TRP <sub>SD</sub> limit for EUT categories BMA4 and BMA5.....        | 20 |
| 4.3.6.4 Conformance.....   | 20 |

|           |   |    |
|-----------|---|----|
| 4.3.7     | Listen Before Talk (LBT).....   | 20 |
| 4.3.7.1   | Applicability.....  | 20 |
| 4.3.7.2   | Description of Listen Before Talk.....                                  | 21 |
| 4.3.7.3   | Limits for Listen Before Talk.....                                      | 21 |
| 4.3.7.4   | Conformance.....  | 21 |
| 4.3.8     | Duty Cycle.....   | 21 |
| 4.3.8.1   | Applicability.....  | 21 |
| 4.3.8.2   | Description of Duty Cycle.....  | 21 |
| 4.3.8.3   | Limits for Duty Cycle.....  | 21 |
| 4.3.8.4   | Conformance.....  | 22 |
| 4.3.9     | TX behaviour under the complete environmental profile (TXb).....        | 22 |
| 4.3.9.1   | Applicability.....  | 22 |
| 4.3.9.2   | Description.....  | 22 |
| 4.3.9.3   | Limits for radiated assessment of the TX behaviour.....                 | 22 |
| 4.3.9.4   | Conformance.....  | 23 |
| 4.4       | Receiver requirements.....  | 23 |
| 4.4.1     | General.....  | 23 |
| 4.4.2     | Wanted technical performance criteria.....                              | 23 |
| 4.4.3     | Receiver Baseline Sensitivity (RBS).....                                | 23 |
| 4.4.3.1   | Applicability.....  | 23 |
| 4.4.3.2   | Description for the RBS requirements.....                               | 23 |
| 4.4.3.3   | Limits.....   | 23 |
| 4.4.3.4   | Conformance.....  | 24 |
| 4.4.4     | Receiver Baseline Resilience (RBR).....                                 | 24 |
| 4.4.4.1   | Applicability.....  | 24 |
| 4.4.4.2   | Description for the RBR requirement.....                                | 24 |
| 4.4.4.3   | Limits.....   | 24 |
| 4.4.4.4   | Conformance.....  | 24 |
| 5         | Testing for compliance with technical requirements.....                 | 24 |
| 5.1       | Environmental conditions for testing.....                               | 24 |
| 5.1.1     | General.....  | 24 |
| 5.1.2     | Normal test conditions.....   | 24 |
| 5.1.3     | Complete environmental profile test conditions.....                     | 24 |
| 5.2       | Conformance test suites and general conditions for testing.....         | 25 |
| 5.2.1     | General.....  | 25 |
| 5.2.2     | Disregard time ( $T_{dis}$ ).....                                       | 25 |
| 5.2.3     | Threshold - level ( $P_{thresh}$ ).....                                 | 25 |
| 5.2.4     | EUT orientation and reference points.....                               | 25 |
| 5.2.5     | Test scenarios and setup for transmitter conformance tests.....         | 26 |
| 5.2.5.1   | For EUT category BMA1.....  | 26 |
| 5.2.5.2   | For EUT categories BMA2, BMA3, BMA4 and BMA5.....                       | 26 |
| 5.3       | Conformance methods of measurement for TX requirements.....             | 28 |
| 5.3.1     | Operating Frequency Range (OFR).....                                    | 28 |
| 5.3.1.1   | OFR assessment parameter X.....   | 28 |
| 5.3.1.2   | OFR conformance test EUT category BMA1.....                             | 28 |
| 5.3.1.3   | OFR conformance test EUT categories BMA2, BMA3, BMA4 and BMA5.....      | 28 |
| 5.3.2     | Mean e.i.r.p.....   | 29 |
| 5.3.3     | Indirect emissions.....   | 30 |
| 5.3.4     | TX unwanted emissions.....  | 31 |
| 5.3.4.1   | General.....  | 31 |
| 5.3.4.2   | TXUE conformance test for EUT category BMA1.....                        | 32 |
| 5.3.4.2.1 | General.....  | 32 |
| 5.3.4.2.2 | Unwanted emissions within spurious domain.....                          | 32 |
| 5.3.4.2.3 | Unwanted missions within out-of-band domain.....                        | 32 |
| 5.3.4.3   | TXUE conformance test for EUT categories BMA2, BMA3, BMA4 and BMA5..... | 32 |
| 5.3.5     | Total Radiated Mean e.i.r.p. Spectral Density ( $TRP_{SD}$ ).....       | 33 |
| 5.3.6     | Listen Before Talk (LBT).....   | 33 |
| 5.3.7     | Duty Cycle.....   | 35 |
| 5.3.8     | TX behaviour under the complete environmental profile.....              | 36 |
| 5.3.8.1   | General.....  | 36 |
| 5.3.8.2   | Conformance test procedures.....  | 36 |

|                               |   |           |
|-------------------------------|---|-----------|
| 5.3.8.2.1                     | Conformance test procedure for EUT category BMA1 .....  | 36        |
| 5.3.8.2.2                     | Conformance test procedure for EUT categories BMA2, BMA3, BMA4 and BMA5 .....                                 | 36        |
| 5.4                           | Conformance methods of measurement for receiver .....   | 37        |
| 5.4.1                         | General for RBS and RBR conformance tests .....   | 37        |
| 5.4.2                         | Receiver Baseline Sensitivity (RBS) .....   | 37        |
| 5.4.2.1                       | RBS test for BMA category .....   | 37        |
| 5.4.3                         | Receiver Baseline Resilience (RBR) .....  | 38        |
| 5.4.3.1                       | RBR test for BMA category .....   | 38        |
| <b>Annex A (informative):</b> | <b>Relationship between the present document and the essential requirements of Directive 2014/53/EU .....</b> | <b>40</b> |
| <b>Annex B (informative):</b> | <b>Selection of technical parameters .....</b>  | <b>42</b> |
| <b>Annex C (normative):</b>   | <b>BMA EUT Category: Use-Case, wanted technical performance criteria and RX-test conditions.....</b>          | <b>45</b> |
| C.1                           | Description .....   | 45        |
| C.2                           | Wanted Technical Performance Criteria (WTPC) and RX - requirement.....  | 45        |
| C.2.1                         | General .....   | 45        |
| C.2.2                         | RBS-requirement and limit.....  | 45        |
| C.2.3                         | RBR requirement and limit .....   | 46        |
| C.3                           | Test-wall for RX-Measurement.....   | 46        |
| C.3.1                         | Description test-wall for RX-measurement.....   | 46        |
| C.3.2                         | Technical Details for RX Test-wall.....   | 47        |
| C.3.2.1                       | Specification of the Gypsum board.....  | 47        |
| C.3.2.2                       | Specification of the Rebar.....   | 47        |
| C.3.2.3                       | Specification of the Wood Frame .....   | 47        |
| <b>Annex D (normative):</b>   | <b>Interferer for RBR test.....</b>   | <b>48</b> |
| D.1                           | Interferer requirements for RBR tests .....   | 48        |
| D.1.1                         | General test frequencies for RBR tests.....   | 48        |
| D.1.2                         | Test frequencies for EUT with OFR < 500 MHz .....   | 48        |
| D.1.3                         | Test frequencies for EUT with OFR ≥ 500 MHz .....   | 49        |
| D.1.4                         | Interferer power levels and modulation.....   | 49        |
| D.2                           | Interferer test signals for EUT category BMA1 .....   | 50        |
| D.3                           | Interferer test signals for EUT categories BMA2, BMA3, BMA4 and BMA5.....                                     | 51        |
| D.3.1                         | Interferer test signals .....   | 51        |
| D.3.2                         | Assessment if no interferer test signal provided at calculated test frequency .....                           | 52        |
| D.4                           | List of interferer for RBR test; assessment procedure.....  | 53        |
| D.4.1                         | General .....   | 53        |
| D.4.2                         | Assessment list of relevant interferer .....  | 54        |
| D.4.2.1                       | Basic considerations .....  | 54        |
| D.4.2.2                       | Several interferer within the same frequency range.....   | 54        |
| D.4.2.3                       | Interferer overlapping in frequency range .....   | 54        |
| D.4.2.4                       | Status of interferer .....  | 55        |
| D.4.3                         | Kind of interferer signal .....   | 55        |
| <b>Annex E (normative):</b>   | <b>Definition of the representative test structure for TX measurements .....</b>                              | <b>56</b> |
| E.1                           | Attenuation of the TX-test structure.....   | 56        |
| E.2                           | Procedure to measure the attenuation.....   | 57        |
| E.3                           | Absorbing materials with lower attenuation.....   | 59        |
| <b>Annex F (informative):</b> | <b>Bibliography.....</b>  | <b>60</b> |
| <b>Annex G (informative):</b> | <b>Change history .....</b>   | <b>61</b> |
| History .....                 |   | 62        |

---

# Intellectual Property Rights

## Essential patents

IPRs essential or potentially essential to normative deliverables may have been declared to ETSI. The declarations pertaining to these essential IPRs, if any, are publicly available for **ETSI members and non-members**, and can be found in ETSI SR 000 314: "*Intellectual Property Rights (IPRs); Essential, or potentially Essential, IPRs notified to ETSI in respect of ETSI standards*", which is available from the ETSI Secretariat. Latest updates are available on the [ETSI IPR online database](#).

Pursuant to the ETSI Directives including the ETSI IPR Policy, no investigation regarding the essentiality of IPRs, including IPR searches, has been carried out by ETSI. No guarantee can be given as to the existence of other IPRs not referenced in ETSI SR 000 314 (or the updates on the ETSI Web server) which are, or may be, or may become, essential to the present document.

## Trademarks

The present document may include trademarks and/or tradenames which are asserted and/or registered by their owners. ETSI claims no ownership of these except for any which are indicated as being the property of ETSI, and conveys no right to use or reproduce any trademark and/or tradename. Mention of those trademarks in the present document does not constitute an endorsement by ETSI of products, services or organizations associated with those trademarks.

**DECT™**, **PLUGTESTS™**, **UMTS™** and the ETSI logo are trademarks of ETSI registered for the benefit of its Members. **3GPP™**, **LTE™** and **5G™** logo are trademarks of ETSI registered for the benefit of its Members and of the 3GPP Organizational Partners. **oneM2M™** logo is a trademark of ETSI registered for the benefit of its Members and of the oneM2M Partners. **GSM®** and the GSM logo are trademarks registered and owned by the GSM Association.

---

# Foreword

This final draft Harmonised European Standard (EN) has been produced by ETSI Technical Committee Electromagnetic compatibility and Radio spectrum Matters (ERM), and is now submitted for the Vote phase of the ETSI Standardisation Request deliverable Approval Procedure (SRdAP).

The present document has been prepared under the Commission's standardisation request C(2015) 5376 final [i.8] to provide one voluntary means of conforming to the essential requirements of Directive 2014/53/EU on the harmonisation of the laws of the Member States relating to the making available on the market of radio equipment and repealing Directive 1999/5/EC [i.6].

Once the present document is cited in the Official Journal of the European Union under that Directive, compliance with the normative clauses of the present document given in table A.1 confers, within the limits of the scope of the present document, a presumption of conformity with the corresponding essential requirements of that Directive and associated EFTA regulations.

The present document is part 4, sub-part 1 of a multi-part deliverable covering Short Range Devices (SRD) using Ultra Wide Band technology (UWB); Harmonised standard for access to radio spectrum, as identified below:

Part 1: "Generic UWB devices":

Sub-part 1: "Communication devices within 3,1 GHz to 4,8 GHz using LDC mitigation or within the 6 GHz to 8,5 GHz".

Part 2: "Ultra Wide Band location tracking devices":

Sub-part 1: "Requirements for devices within 6 GHz to 8,5 GHz";

Sub-part 2: "Requirements for devices in the frequency band between 3,1 GHz to 4,8 GHz utilizing LDC mitigation technique";

Sub-part 3: "Requirements for fixed infrastructure UWB based localization systems in the frequency band between 3,1 GHz to 4,8 GHz deploying Detect-And-Avoid (DAA) mitigation technique";

Sub-part 4: "Requirements for fixed outdoor devices within 6,0 GHz to 8,5 GHz";

Sub-part 5: "Requirements for enhanced indoor devices within 6,0 GHz to 8,5 GHz".

Part 3: "UWB devices installed in motor and railway vehicles":

Sub-part 1: "Requirements for UWB devices for vehicular access systems within 3,8 GHz to 4,2 GHz or 6 GHz to 8,5 GHz";

Sub-part 2: "Requirements for location tracking devices installed in rail and road vehicles operating in the frequency range of 3,1 GHz to 4,8 GHz or 6,0 GHz to 8,5 GHz";

Sub-part 3: "Requirements for UWB radiodetermination applications operating within 6,0 GHz to 8,5 GHz".

**Part 4: "Material Sensing devices":**

**Sub-part 1: "Building material analysis below 10,6 GHz";**

Sub-part 2: "UWB Material Sensing devices for Security Scanning";

Sub-part 3: "Ground humidity and condition sensor below 10,6 GHz";

Sub-part 4: "Exterior material sensing applications for ground based vehicles below 10,6 GHz";

Sub-part 5: "UWB surveillance devices for parking lot sensors below 10,6 GHz".

Part 5: "Devices using UWB technology onboard aircraft";

Part 6: "Ultra Wide Band radio-determination for radar sensing devices":

Sub-part 1: "Requirements for presence detection applications within 6,0 GHz to 8,5 GHz";

Sub-part 2: "Requirements for generic UWB through-air non-contact vital signs applications within 6,0 GHz to 8,5 GHz";

Sub-part 3: "Requirements for fixed outdoor presence detection devices within 6,0 GHz to 8,5 GHz";

Sub-part 4: "Requirements for fixed outdoor through-air non-contact vital signs applications within 6,0 GHz to 8,5 GHz";

Sub-part 5: "Requirements for enhanced indoor presence detection devices within 6,0 GHz to 8,5 GHz";

Sub-part 6: "Requirements for enhanced indoor through-air non-contact vital signs applications within 6,0 GHz to 8,5 GHz".

NOTE 1: The list above shows the planned multi-part deliverable, at the time, when the present document was finalized.

NOTE 2: Part 4, sub-parts 2 (UWB Material Sensing devices for Security Scanning), 3 (Ground humidity and condition sensor below 10,6 GHz) and 5 (UWB surveillance devices for parking lot sensors below 10,6 GHz) of this multi-part deliverable are under discussion (change WI) or will be stopped.

| <b>Proposed national transposition dates</b>   |                                 |
|--|---------------------------------|
| Date of latest announcement of this EN (doa):  | 3 months after ETSI publication |
| Date of latest publication of new National Standard or endorsement of this EN (dop/e): | 6 months after doa              |
| Date of withdrawal of any conflicting National Standard (dow):                         | 18 months after doa             |

---

## Modal verbs terminology

In the present document "**shall**", "**shall not**", "**should**", "**should not**", "**may**", "**need not**", "**will**", "**will not**", "**can**" and "**cannot**" are to be interpreted as described in clause 3.2 of the [ETSI Drafting Rules](#) (Verbal forms for the expression of provisions).

"**must**" and "**must not**" are **NOT** allowed in ETSI deliverables except when used in direct citation.

---

## Introduction

For the present document, the applicable harmonised standard has been ETSI EN 302 065-4 [i.17] (Material Sensing devices using UWB technology below 10,6 GHz) which was published in the OJEU without restriction at 12 April 2017.

Since then ETSI ERM TGUWB decided to develop more specific standards; this means instead of one generic ETSI EN 302 065-4 [i.17] standard for UWB Material Sensing devices a standard family ETSI EN 302 065-4-x [i.17] for UWB Material Sensing devices was started. The present document is sub-part one (ETSI EN 302 065-4-1) of the new standard family.

More details on the changes of the present document to previous versions are provided in annex F.



---

# 1 Scope

The present document specifies technical characteristics, limits and methods of measurements for Material Sensing devices for Building Material Analysis (BMA) below 10,6 GHz.

Additional details of the covered Building Material Analysis (BMA) devices can be found in clause 4.2 of the present document.

NOTE: The relationship between the present document and essential requirements of article 3.2 of Directive 2014/53/EU [i.6] is given in annex A.

---

## 2 References

### 2.1 Normative references

References are either specific (identified by date of publication and/or edition number or version number) or non-specific. For specific references, only the cited version applies. For non-specific references, the latest version of the referenced document (including any amendments) applies.

Referenced documents which are not found to be publicly available in the expected location might be found in the [ETSI docbox](#).

NOTE: While any hyperlinks included in this clause were valid at the time of publication, ETSI cannot guarantee their long term validity.

The following referenced documents are necessary for the application of the present document.

- [1] [ETSI EN 303 883-1 \(V2.1.1\) \(08-2024\)](#): "Short Range Devices (SRD) and Ultra Wide Band (UWB); Part 1: Measurement techniques for transmitter requirements".
- [2] [ETSI EN 303 883-2 \(V2.1.1\) \(08-2024\)](#): "Short Range Devices (SRD) and Ultra Wide Band (UWB); Part 2: Measurement techniques for receiver requirements".
- [3] [EN 520:2004 + A1:2009](#): "Gypsum plasterboards - Definitions, requirements and test methods", (produced by CEN).
- [4] [EN 10080:2005](#): "Steel for the reinforcement of concrete - Weldable reinforcing steel - General", (produced by CEN).
- [5] [EN 15497:2014](#): "Structural finger jointed solid timber - Performance requirements and minimum production requirements", (produced by CEN).
- [6] [ETSI TS 103 941 \(V.1.1.1\) \(01-2024\)](#): "Short Range Devices (SRD) and Ultra Wide Band (UWB); Measurement setups and specifications for testing under full environmental profile (normal and extreme environmental conditions)".

## 2.2 Informative references

References are either specific (identified by date of publication and/or edition number or version number) or non-specific. For specific references, only the cited version applies. For non-specific references, the latest version of the referenced document (including any amendments) applies.

NOTE: While any hyperlinks included in this clause were valid at the time of publication, ETSI cannot guarantee their long term validity.

The following referenced documents are not necessary for the application of the present document but they assist the user with regard to a particular subject area.

- [i.1] [ECC/DEC/\(07\)01](#): "ECC Decision of 30 March 2007 on the harmonised use, exemption from individual licensing and free circulation of Material Sensing Devices using Ultra-Wideband (UWB) technology, approved 30 March 2007, updated 1 July 2022".
- [i.2] [Commission Implementing Decision \(EU\) 2024/1467 of 27 May 2024](#) amending Implementing Decision (EU) 2019/785 on the harmonisation of radio spectrum for equipment using ultra-wideband technology in the Union.
- [i.3] [ERC/REC 70-03 \(8 March 2024\)](#): "ERC Recommendation of 1997 on relating to the use of Short Range Devices (SRD)".
- [i.4] [Commission Implementing Decision \(EU\) 2022/180 of 8 February 2022](#) amending Decision 2006/771/EC as regards the update of harmonised technical conditions in the area of radio spectrum use for short-range devices.
- [i.5] ETSI TR 102 495-1 (V1.1.1) (01-2006): "Electromagnetic compatibility and Radio spectrum Matters (ERM); Short Range Devices (SRD); Technical characteristics for SRD equipment using Ultra Wide Band Sensor technology (UWB); System Reference Document Part 1: Building material analysis and classification applications operating in the frequency band from 2,2 GHz to 8 GHz".
- [i.6] [Directive 2014/53/EU of the European Parliament and of the Council of 16 April 2014](#) on the harmonisation of the laws of the Member States relating to the making available on the market of radio equipment and repealing Directive 1999/5/EC.
- [i.7] [CEPT Report 45](#): "Report from CEPT to the European Commission in response to the Fifth Mandate to CEPT on ultra-wideband technology to clarify the technical parameters in view of a potential update of Commission Decision 2007/131/EC"; Report approved on 21 June 2013 by the ECC.
- [i.8] [Commission Implementing Decision C\(2015\) 5376 final of 4.8.2015](#) on a standardisation request to the European Committee for Electrotechnical Standardisation and to the European Telecommunications Standards Institute as regards radio equipment in support of Directive 2014/53/EU of the European Parliament and of the Council.
- [i.9] Recommendation ITU-R SM.1755: "Characteristics of ultra-wideband technology".
- [i.10] ETSI TR 103 181-2: "Electromagnetic compatibility and Radio spectrum Matters (ERM); Short Range Devices (SRD) using Ultra Wide Band (UWB); Transmission characteristics Part 2: UWB mitigation techniques".
- [i.11] [EN 206:2013+A2:2021](#): "Concrete - Specification, performance, production and conformity", (produced by CEN).
- [i.12] ETSI TS 103 361 (V1.1.1): "Short Range Devices (SRD) using Ultra Wide Band technology (UWB); Receiver technical requirements, parameters and measurement procedures to fulfil the requirements of the Directive 2014/53/EU".
- [i.13] [ECC/DEC/\(20\)01](#): "ECC Decision of 20 November 2020 on the harmonised use of the frequency band 5945-6425 MHz for Wireless Access Systems including Radio Local Area Networks (WAS/RLAN)".

- [i.14] ETSI TS 136 101 (V16.8.0): "LTE; Evolved Universal Terrestrial Radio Access (E-UTRA); User Equipment (UE) radio transmission and reception (3GPP TS 36.101)".
- [i.15] ETSI EG 203 336 (V1.2.1): "Guide for the selection of technical parameters for the production of Harmonised Standards covering article 3.1(b) and article 3.2 of Directive 2014/53/EU".
- [i.16] [ECO Frequency Information System](#).
- [i.17] ETSI EN 302 065-4 (V1.1.1): " Short Range Devices (SRD) using Ultra Wide Band technology (UWB); Harmonised Standard covering the essential requirements of article 3.2 of the Directive 2014/53/EU; Part 4: Material Sensing devices using UWB technology below 10,6 GHz".
- [i.18] ETSI TS 103 567 (V1.1.1): "Requirements on signal interferer handling".
- [i.19] Void.

---

## 3 Definition of terms, symbols and abbreviations

### 3.1 Terms

For the purposes of the present document, the terms given in ETSI EN 303 883-1 [1], ETSI EN 303 883-2 [2], ETSI TS 103 941 [6] and the following apply:

**active mitigation techniques:** mitigation techniques, like listen before talk and detect and avoid

NOTE: For more details see ETSI TR 103 181-2 [i.10].

**material sensing devices for Building Material Analysis (BMA):** building material sensing devices which are designed to detect the location of objects within a building structure or to determine the physical properties of a building material

**measurement side:** side of the EUT which will be pointed to the material/building structure

**user side:** side of the EUT with the user interfaces to operate the EUT and to display the measurement results to the user

### 3.2 Symbols

For the purposes of the present document, the symbols given in ETSI EN 303 883-1 [1], ETSI EN 303 883-2 [2] and the following apply:

|               |  |
|---------------|--|
| $d, d_1, d_2$ | Measurement distance   |
| $d_{TXW}$     | Thickness of the test wall   |
| $f_1$         | RBR test frequency within the middle of the EUT OFR  |
| $f_2$         | RBR test frequency between $f_L$ and $f_C$ of the EUT OFR  |
| $f_3$         | RBR test frequency between $f_C$ and $f_H$ of the EUT OFR  |
| $f_C$         | Centre frequency of the operating frequency range  |
| $f_H$         | Highest frequency of the operating frequency range   |
| $f_{H1,2}$    | RBR test frequency higher $f_H$ of the EUT OFR   |
| $f_L$         | Lowest frequency of the operating frequency range  |
| $f_{L1,2}$    | RBR test frequency lower $f_L$ of the EUT OFR  |
| $f_{HS}$      | Higher frequency border between OOB and spurious domain  |
| $f_{LS}$      | Lower frequency border between OOB and spurious domain   |
| $g_{wall}$    | Attenuation of the test structure for TX measurements; in [dB]                                   |
| $P_{Thresh}$  | Threshold for the duty cycle measurement   |
| $R_{DR}$      | Distance of the specified object within the RX-conformance test scenario for the RBR requirement |
| $R_{DS}$      | Distance of the specified object within the RX-conformance test scenario for the RBS requirement |
| $th$          | Reference point for the assessment of the power level at the EUT                                 |
| $thl$         | Assessed power levels for the LBT test   |
| $TX1,2$       | Categorization of BMA EUT by modulation  |

|                   |  |
|-------------------|--|
| X                 | Parameter in dB to specify the OFR of the EUT in relation to the TX emission                 |
| X <sub>TXUE</sub> | Parameter in percentage to specify the OOB and spurious domain in relation to OFR of the EUT |

### 3.3 Abbreviations

For the purposes of the present document, the abbreviations given in ETSI EN 303 883-1 [1], ETSI EN 303 883-2 [2] and the following apply:

|      |   |
|------|---|
| BMA  | Building Material Analysis                            |
| TXb  | TX behaviour under the complete environmental profile |
| WTPC | Wanted Technical Performance Criteria                 |

---

## 4 Technical requirements specifications

### 4.1 Environmental profile

The technical requirements of the present document apply under the environmental profile for operation of the equipment, which shall be in accordance with its intended use, but as a minimum, shall be that specified in the test conditions contained in the present document. The equipment shall comply with all the technical requirements of the present document at all times when operating within the boundary limits of the operational environmental profile defined by its intended use.

### 4.2 EUT categories

#### 4.2.1 General

The present document covers Material Sensing devices for building material analysis operating below 10,6 GHz. This devices are named as Building Material Analysis (BMA) EUT.

More details about the use-case, wanted technical performance criteria and the RX-requirements and test conditions of the BMA devices is provided in annex C.

The specified BMA EUT categories provide a clear classification for the wanted technical performance criteria, limits requirements and conformance test procedures.

The following criteria were considered for categorization of the EUT covered by the present document:

- Regulation: ECC and EC recommendations and decisions, see clause 4.2.2
- Modulation: kind of modulation of the TX signal, see clause 4.2.3
- Usage of active UWB mitigation techniques (e.g. LBT, DAA), see clause 4.2.4

An overview of the covered EUT categories is provided in clause 4.2.5, table 1a and table 1b.

#### 4.2.2 Categorization by Regulation

The following regulations were considered for categorization of BMA EUT:

- SRD regulations for EUT based on narrowband technologies:
  - 2 400-2 483,5MHz: ERC/REC 70-03 annex 6, band c [i.3] and 2022/180/EU band 57b [i.4]
  - 5 725-5 875 MHz: ERC/REC 70-03 annex 1, band j [i.3] and 2022/180/EU band 61 [i.4].
- UWB regulations for EUT based on UWB technologies: contact based UWB material sensing devices according to ECC/DEC/(07)01 [i.1] and Decision (EU) 2024/1467 [i.2] for BMA EUT based on UWB technology with or without active mitigation techniques.

### 4.2.3 Categorization by Modulation

The following categorization of BMA EUT by modulation (see ETSI EN 303 883-1 [1], annex C) is done for UWB technology only (UWB regulation) due to the different consideration of the modulation in measurement procedures:

- TX1: EUT with FHSS, sequential hopping/stepping or FMCW modulation.
- TX2: for EUT with any other modulation different from TX1.

### 4.2.4 Categorization by Active Mitigation Techniques

BMA EUT covered by ECC/DEC/(07)01 [i.1] and Decision (EU) 2024/1467 [i.2] are categorized by the implementation of the active mitigation techniques "Listen Before Talk" (LBT):

- BMA EUT based on UWB technology without LBT active mitigation technique.
- BMA EUT based on UWB technology with LBT active mitigation technique.

### 4.2.5 Summary EUT categories

5 EUT categories are following from the above categorization:

- BMA1: based on narrowband technologies (SRD regulations)
- BMA2: based on UWB technology without active mitigation techniques using TX1 (UWB regulations)
- BMA3: based on UWB technology without active mitigation techniques using TX2 (UWB regulations)
- BMA4: based on UWB technology with active mitigation techniques using TX1 (UWB regulations)
- BMA5: based on UWB technology with active mitigation techniques using TX2 (UWB regulations)

An overview of requirements for each EUT categories is given in:

- table 1a for EUT category based on SRD regulation; and
- table 1b for EUT categories based on UWB regulation.

**Table 1a: EUT categories based on SRD regulation covered by ERC/REC 70-03 [i.3] and 2022/180/EU [i.4]**

| Category | Modulation      | TX requirements       |        | RX-requirements |               |
|----------|-----------------|-----------------------|--------|-----------------|---------------|
|          |                 | Emission requirements |        |                 |               |
|          |                 |                       | Clause |                 | Clause        |
| BMA1     | TX1<br>&<br>TX2 | OFR                   | 4.3.2  | TWPC            | C.2.1         |
|          |                 | Mean e.i.r.p.         | 4.3.3  | RBS             | 4.4.3 & C.2.2 |
|          |                 | TXUE                  | 4.3.5  | RBR             | 4.4.4 & C.2.3 |
|          |                 | TXb                   | 4.3.9  |                 |               |

**Table 1b: EUT categories based on UWB regulation covered by ECC/DEC/(07)01 [i.1] and Decision (EU) 2024/1467 [i.2]**

| Category  | Modulation | TX requirements       |        |                         |        |                   |        | RX-requirements |               |
|---|------------|-----------------------|--------|-------------------------|--------|-------------------|--------|-----------------|---------------|
|   |            | Emission requirements |        | Additional requirements |        | Active mitigation |        |                 | Clause        |
|   |            |                       | Clause |                         | Clause |                   | Clause |                 |               |
| EUT without any active mitigation technique         |            |                       |        |                         |        |                   |        |                 |               |
| BMA2  | TX1        | OFR                   | 4.3.2  | DC                      | 4.3.8  | Not applicable    |        | TWPC            | C.2.1         |
|   |            | Indirect emissions    | 4.3.4  | TRP <sub>SD</sub>       | 4.3.6  |                   |        | RBS             | 4.4.3 & C.2.2 |
|   |            | TXUE                  | 4.3.5  | TXb                     | 4.3.9  |                   |        | RBR             | 4.4.4 & C.2.3 |
| BMA3  | TX2        | OFR                   | 4.3.2  | DC                      | 4.3.8  | Not applicable    |        | TWPC            | C.2.1         |
|   |            | Indirect emissions    | 4.3.4  | TRP <sub>SD</sub>       | 4.3.6  |                   |        | RBS             | 4.4.3 & C.2.2 |
|   |            | TXUE                  | 4.3.5  | TXb                     | 4.3.9  |                   |        | RBR             | 4.4.4 & C.2.3 |
| EUT implemented the active mitigation technique LBT |            |                       |        |                         |        |                   |        |                 |               |
| BMA4  | TX1        | OFR                   | 4.3.2  | DC                      | 4.3.8  | LBT               | 4.3.7  | TWPC            | C.2.1         |
|   |            | Indirect emissions    | 4.3.4  | TRP <sub>SD</sub>       | 4.3.6  |                   |        | RBS             | 4.4.3 & C.2.2 |
|   |            | TXUE                  | 4.3.5  | TXb                     | 4.3.9  |                   |        | RBR             | 4.4.4 & C.2.3 |
| BMA5  | TX2        | OFR                   | 4.3.2  | DC                      | 4.3.8  | LBT               | 4.3.7  | TWPC            | C.2.1         |
|   |            | Indirect emissions    | 4.3.4  | TRP <sub>SD</sub>       | 4.3.6  |                   |        | RBS             | 4.4.3 & C.2.2 |
|   |            | TXUE                  | 4.3.5  | TXb                     | 4.3.9  |                   |        | RBR             | 4.4.4 & C.2.3 |

## 4.3 Transmitter requirements

### 4.3.1 General

Based on the different possible TX signal modulations for the EUT categories covered by the present documents there are different related conformance test- set-ups necessary. The different categories of EUT (see clause 4.2) require different test setups due to different modulation techniques. Clause 5 elaborates on these differences.

The transmitter requirements for all EUT categories covered by the scope of the present document are justified in annex B, table B.1.

### 4.3.2 Operating Frequency Range (OFR)

#### 4.3.2.1 Applicability

The Operating Frequency Range (OFR) requirement applies to all EUT categories, see clause 4.2.5, table 1a and table 1b.

#### 4.3.2.2 Description Operating Frequency Range

For the description of the Operating Frequency Range (OFR), see ETSI EN 303 883-1 [1], clause 5.2.1.

According to ETSI EN 303 883-1 [1], clause 5.2.1 the limit for the parameter X for the BMA1 category (see clause 4.2.5, table 1a) is specified to:

|    |    |
|----|----|
| X: | 23 |
|----|----|

According to ETSI EN 303 883-1 [1], clause 5.2.1 the limit for the parameter X for the - BMA2, BMA3, BMA4 and BMA5 categories (see clause 4.2.5, table 1b) is specified to:

|    |    |
|----|----|
| X: | 10 |
|----|----|

NOTE: The specification of the parameter X for BMA2, BMA3, BMA4 and BMA5 categories is in accordance with the -10 dB bandwidth for UWB EUT below 10 GHz, as defined in annex 1 of Recommendation ITU-R SM.1755 [i.9].

### 4.3.2.3 Limits for Operating Frequency Range

#### 4.3.2.3.1 Limit requirement for BMA2, BMA3, BMA4 and BMA5 categories

The OFR for the EUT categories BMA2, BMA3, BMA4 and BMA5 (see clause 4.2.5, table 1b) shall be in the permitted frequency range as given in table 2a and the OFR shall be equal or larger than 50 MHz.

**Table 2a: Permitted frequency range for EUT categories BMA2, BMA3, BMA4 and BMA5 according to ECC/DEC/(07)01 [i.1] and Decision (EU) 2024/1467 [i.2]**

|          |   |
|----------|---|
| Transmit | $30 \text{ MHz} \leq f \leq 10,6 \text{ GHz}$ |
| Receive  | $30 \text{ MHz} \leq f \leq 10,6 \text{ GHz}$ |

#### 4.3.2.3.2 Limit requirement for BMA1 category

The OFR for the EUT category BMA1 (see clause 4.2.5, table 1a) shall be in the permitted frequency range as given in table 2b.

**Table 2b: Permitted frequency range EUT category BMA1 based on 2022/180/EU [i.4]**

|          |   |
|----------|---|
| Transmit | $2,4 \text{ GHz} \leq f \leq 2,4835 \text{ GHz}$  |
|          | $5,725 \text{ GHz} \leq f \leq 5,875 \text{ GHz}$ |
| Receive  | $2,4 \text{ GHz} \leq f \leq 2,4835 \text{ GHz}$  |
|          | $5,725 \text{ GHz} \leq f \leq 5,875 \text{ GHz}$ |

### 4.3.2.4 Conformance

The conformance test shall be done under normal conditions as defined in clause 5.1.2; the conformance test suite for OFR shall be as defined in clause 5.3.1.

## 4.3.3 Mean e.i.r.p.

### 4.3.3.1 Applicability

The Mean e.i.r.p. requirement applies to BMA1 category, see clause 4.2.5, table 1a.

NOTE: This is not applicable for equipment based on the UWB regulation (see table 1b), because such equipment is only allowed to be used in contact to a wall/or a material under investigation. Emission requirements for equipment based on the UWB regulation are in clause 4.3.4 on "indirect emissions". Tests for such equipment are performed in contact with the material under investigation, see Commission Implementing Decision (EU) 2024/1467 [i.2].

### 4.3.3.2 Description Mean e.i.r.p.

For the description of the Mean e.i.r.p., see ETSI EN 303 883-1 [1], clause 5.3.1.1.

### 4.3.3.3 Limits for Mean e.i.r.p.

The limits for the mean e.i.r.p. requirement within the OFR, see table 3.

**Table 3: Mean e.i.r.p. for EUT category BMA1 according to 2022/180/EU [i.4]**

| Frequency Range [MHz]         | Mean e.i.r.p. [mW] |
|-------------------------------|--------------------|
| $2\,400 \leq f \leq 2\,483,5$ | 25                 |
| $5\,725 \leq f \leq 5\,875$   | 25                 |

#### 4.3.3.4 Conformance

The conformance test shall be done under normal conditions as defined in clause 5.1.2; the conformance test suite for Mean e.i.r.p. shall be as defined in clause 5.3.2.

### 4.3.4 Indirect Emissions

#### 4.3.4.1 Applicability

The Indirect Emission requirement applies to BMA2, BMA3, BMA4 and BMA5 categories, see clause 4.2.5, table 1b.

In some frequency ranges the limit for the indirect emission depends on the used/not used mitigation techniques.

The additional requirements are applicable if the OFR is partly or fully overlapping with the frequency range for which the mitigation is requested.

An overview of the applicable requirements in relation to the EUT categories is provided in table 4.

**Table 4: Possible applicable requirements for EUT categories BMA2, BMA3, BMA4 and BMA5**

| OFR is partly or full overlapping with frequency range [GHz] | Additional requirement for EUTs without any active mitigation technique | Additional requirements for EUT implementing the mitigation technique LBT |
|--|---|---|
|  | EUT categories: BMA2 & BMA3   | EUT categories: BMA4 & BMA5   |
| $1,215 < f \leq 1,73$  |   | LBT see clause 4.3.7  |
| $2,5 < f \leq 2,69$  | TRP <sub>SD</sub> , see clause 4.3.6                                    | TRP <sub>SD</sub> , see clause 4.3.6                                      |
|  |   | LBT see clause 4.3.7  |
| $2,69 < f \leq 2,7$  | DC, see clause 4.3.8  | DC, see clause 4.3.8  |
|  | TRP <sub>SD</sub> , see clause 4.3.6                                    | TRP <sub>SD</sub> , see clause 4.3.6                                      |
| $2,7 < f \leq 2,9$   |   | LBT see clause 4.3.7  |
| $2,9 < f \leq 3,4$   |   | LBT see clause 4.3.7  |
| $3,4 < f \leq 3,8$   | DC, see clause 4.3.8  | DC, see clause 4.3.8  |
| $4,8 < f \leq 5,0$   | DC, see clause 4.3.8  | DC, see clause 4.3.8  |
|  | TRP <sub>SD</sub> , see clause 4.3.6                                    | TRP <sub>SD</sub> , see clause 4.3.6                                      |

#### 4.3.4.2 Description Indirect Emission

For the Indirect Emission within the OFR two power requirements are regulated by Decision (EU) 2024/1467 [i.2] and ECC/DEC/(07)01 [i.1]:

- Mean Power e.i.r.p. spectral density (defined in 1 MHz)
- Peak e.i.r.p. (defined in 50 MHz)

The limits (see table 5 for EUT categories BMA2 and BMA3 or table 6 for EUT categories BMA4 and BMA5) are to be fulfilled with the device on a representative structure of the investigated material (see clause 5.4.3 and annex E).

Further information on indirect emissions are available in ETSI EN 303 883-1 [1], clause 5.7.1.

#### 4.3.4.3 Limits for Indirect Emission

##### 4.3.4.3.1 Limits for Indirect Emissions for EUT categories BMA2 and BMA3

The limits for the indirect emission requirement for EUT-categories BMA2 and BMA3 which operate without any active mitigation techniques are listed in table 5.



**Table 5: Emission Limit for EUT categories BMA2 and BMA3 (without LBT) according to ECC/DEC/(07)01 [i.1] and Decision (EU) 2024/1467 [i.2]**

| Frequency range [GHz] | Maximum mean e.i.r.p. spectral density [dBm/MHz] | Maximum peak e.i.r.p. [dBm defined in 50 MHz] | Remarks                |
|-----------------------|--|---|------------------------|
| $f \leq 1,73$         | -85  | -45   |                        |
| $1,73 < f \leq 2,2$   | -65  | -25   |                        |
| $2,2 < f \leq 2,5$    | -50  | -10   |                        |
| $2,5 < f \leq 2,69$   | -65  | -25   | note 1                 |
| $2,69 < f \leq 2,7$   | -55  | -15   | note 1, note 2, note 3 |
| $2,7 < f \leq 2,9$    | -70  | -30   |                        |
| $2,9 < f \leq 3,4$    | -70  | -30   |                        |
| $3,4 < f \leq 3,8$    | - 50   | -10   | note 2, note 3         |
| $3,8 < f \leq 4,8$    | - 50   | -10   |                        |
| $4,8 < f \leq 5,0$    | -55  | -15   | note 1, note 2, note 3 |
| $5,0 < f \leq 5,25$   | -50  | -10   |                        |
| $5,25 < f \leq 5,35$  | -50  | -10   |                        |
| $5,35 < f \leq 5,6$   | -50  | -10   |                        |
| $5,6 < f \leq 5,65$   | -50  | -10   |                        |
| $5,65 < f \leq 5,725$ | -50  | -10   |                        |
| $5,725 < f \leq 6,0$  | -50  | -10   |                        |
| $6,0 < f \leq 8,5$    | -41,3  | -0  |                        |
| $8,5 < f \leq 9,0$    | -65  | -25   |                        |
| $9,0 < f \leq 10,6$   | -65  | -25   |                        |
| $10,6 < f$            | -85  | -45   |                        |

NOTE 1: An additional requirement on TRP<sub>SD</sub> applies, see clause 4.3.6.  
NOTE 2: An additional requirement on DC applies, see clause 4.3.8.  
NOTE 3: Reduced limits for mean e.i.r.p. spectral density do apply in case of trading DC and power according to clause 4.3.8.3, table 14.

#### 4.3.4.3.2 Indirect Emissions for EUT categories BMA4 and BMA5

The limits for the indirect emission requirement for EUT categories BMA4 and BMA5 which operate with active mitigation technique LBT are listed in table 6.

**Table 6: Emission Limit for EUT categories BMA4 and BMA5 (with LBT) according to ECC/DEC/(07)01 [i.1] and Decision (EU) 2024/1467 [i.2]**

| Frequency range [GHz] | Maximum mean e.i.r.p. spectral density [dBm/MHz] | Maximum peak e.i.r.p. [dBm defined in 50 MHz] | Remarks                |
|-----------------------|--|---|------------------------|
| $f < 1,215$           | -85  | -45   |                        |
| $1,215 < f \leq 1,73$ | -70  | -30   | note 3                 |
| $1,73 < f \leq 2,2$   | -65  | -25   |                        |
| $2,2 < f \leq 2,5$    | -50  | -10   |                        |
| $2,5 < f \leq 2,69$   | -50  | -10   | note 1, note 4         |
| $2,69 < f \leq 2,7$   | -55  | -15   | note 1, note 2, note 3 |
| $2,7 < f \leq 2,9$    | -50  | -10   | note 4                 |
| $2,9 < f \leq 3,4$    | -50  | -10   | note 4                 |
| $3,4 < f \leq 3,8$    | - 50   | -10   | note 2, note 3         |
| $3,8 < f \leq 4,8$    | - 50   | -10   |                        |
| $4,8 < f \leq 5,0$    | -55  | -15   | note 1, note 2, note 3 |
| $5,0 < f \leq 5,25$   | -50  | -10   |                        |
| $5,25 < f \leq 5,35$  | -50  | -10   |                        |
| $5,35 < f \leq 5,6$   | -50  | -10   |                        |
| $5,6 < f \leq 5,65$   | -50  | -10   |                        |
| $5,65 < f \leq 5,725$ | -50  | -10   |                        |
| $5,725 < f \leq 6,0$  | -50  | -10   |                        |
| $6,0 < f \leq 8,5$    | -41,3  | 0   |                        |
| $8,5 < f \leq 9,0$    | -65  | -25   |                        |
| $9,0 < f \leq 10,6$   | -65  | -25   |                        |
| $10,6 < f$            | -85  | -45   |                        |

| Frequency range [GHz]   | Maximum mean e.i.r.p. spectral density [dBm/MHz] | Maximum peak e.i.r.p. [dBm defined in 50 MHz] | Remarks |
|---|--|---|---------|
| NOTE 1: An additional requirement on TRP <sub>SD</sub> applies, see clause 4.3.6.   |  |   |         |
| NOTE 2: An additional requirement on DC applies, see clause 4.3.8.  |  |   |         |
| NOTE 3: Reduced limits for mean e.i.r.p. spectral density do apply in case of trading DC and power according to clause 4.3.8.3, table 14. |  |   |         |
| NOTE 4: An additional requirement on LBT applies, see clause 4.3.7.   |  |   |         |

#### 4.3.4.4 Conformance

The conformance test shall be done under normal conditions as defined in clause 5.1.2; the conformance test suite for indirect emission shall be as defined in clause 5.3.3.

### 4.3.5 TX Unwanted Emissions (TXUE)

#### 4.3.5.1 Applicability

The TX Unwanted Emission (TXUE) requirement applies to all EUT categories (see clause 4.2.5, table 1a and table 1b).

#### 4.3.5.2 Description TX unwanted emissions

For the description of TX unwanted emissions see ETSI EN 303 883-1 [1], clause 5.5.1.

As requested in ETSI EN 303 883-1 [1], clause 5.5.1 the limit for the parameter  $X_{TXUE}$  for EUT category BMA1 (see clause 4.2.5, table 1a) is specified to:

|              |       |
|--------------|-------|
| $X_{TXUE}$ : | 250 % |
|--------------|-------|

As requested in ETSI EN 303 883-1 [1], clause 5.5.1 the limit for the parameter  $X_{TXUE}$  for EUT categories BMA2, BMA3, BMA4 and BMA5 (see clause 4.2.5, table 1b) is specified to:

|              |      |
|--------------|------|
| $X_{TXUE}$ : | 50 % |
|--------------|------|

#### 4.3.5.3 Limits for TXUE

##### 4.3.5.3.1 TXUE limit for EUT category BMA1

- Spurious Emission: For the spurious emissions following limit shall apply: ETSI EN 303 883-1 [1], clause 5.5.2, table 4.
- Out-Of-Band Emission: For the OOB domain the limit in table 7 and figure 1 applies.

**Table 7: Limits for OOB domain**

| Frequency range (note 2)   | Maximum mean e.i.r.p. spectral density dBm/MHz |
|--|--|
| $f_H$  | 14   |
| $f_H < f < f_{HS}$   | straight line between 14 and -30 (note 1)      |
| $f_L$  | 14   |
| $f_L < f < f_{LS}$   | straight line between 14 and -30 (note 1)      |
| NOTE 1: For example the limit at $f_H + (f_{HS} - f_H) / 2$ is -8 dBm/MHz; also visible in figure 1.                           |  |
| NOTE 2: $f_{HS} = f_c + (2,5 \times OFR)$ and $f_{LS} = f_c - (2,5 \times OFR)$ ; see also ETSI EN 303 883-1 [1], clause 5.5.1 |  |

The limits at  $f_{HL}$  and  $f_{HS}$  are considered as part of the spurious domain, see ETSI EN 303 883-1 [1], clause 5.5.1, table 3.

The limit at these frequencies ( $f_{HL}$  and  $f_{HS}$ ) the limit of -30 dBm/MHz over TXon apply, see ETSI EN 303 883-1 [1], clause 5.5.2, table 4 apply.

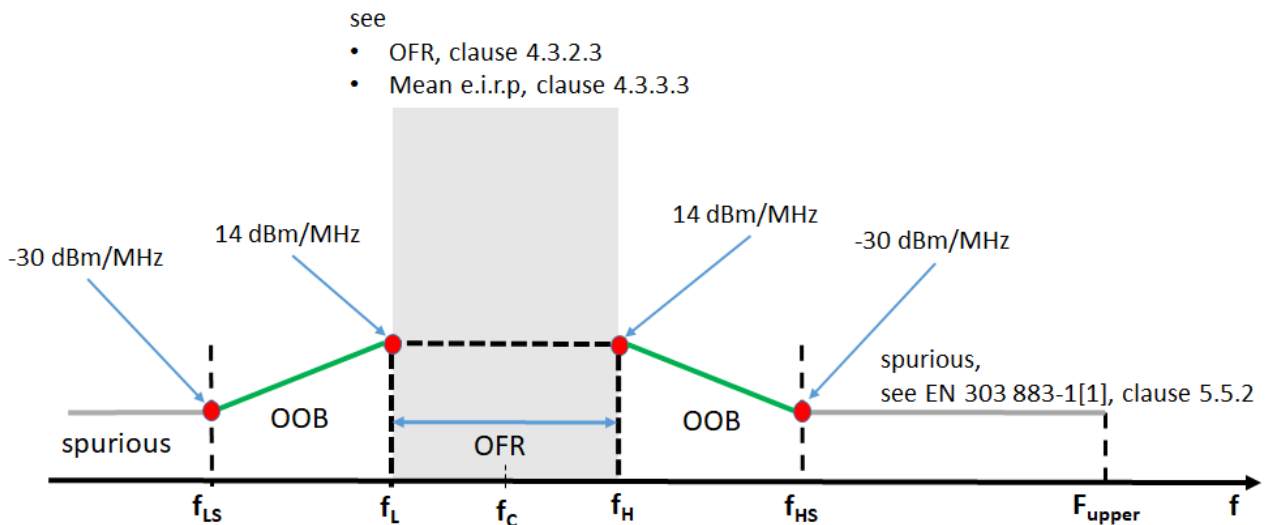

Figure 1: Overview limits for OOB and spurious domain for EUT category BMA1

#### 4.3.5.3.2 TXUE limit for EUT categories BMA2, BMA3, BMA4 and BMA5

- Spurious Emission: For the spurious emissions following limit shall apply: ETSI EN 303 883-1 [1], clause 5.5.2, table 4.
- Out-Of-Band Emission: Based in TXUE specification of 50 % (see clause 4.3.5.2) there is no OOB domain. Therefore, an OOB domain is not applicable and the spurious emission limits apply directly outside the OFR.

#### 4.3.5.4 Conformance

The conformance test shall be done under normal conditions as defined in clause 5.1.2; the conformance test suite for TXUE emission shall be as defined in clause 5.3.4.

### 4.3.6 Total Radiated Mean e.i.r.p. Spectral Density ( $TRP_{SD}$ )

#### 4.3.6.1 Applicability

The Total Radiated Mean e.i.r.p. Spectral Density ( $TRP_{SD}$ ) requirement applies to the EUT categories BMA2, BMA3, BMA4 and BMA5 (see clause 4.2.5, table 1b), if the following two points are applicable:

- OFR is partly or fully overlapping with at least one of the frequency ranges listed in table 8.
- Measured indirect emission level (see clause 4.3.4) is above the value specified in table 8.

Table 8: Generic UWB limits according to ECC/DEC/(07)01 [i.1] and Decision (EU) 2024/1467 [i.2]

| Frequency range [GHz] | Maximum mean e.i.r.p. spectral density | Maximum peak e.i.r.p. (defined in 50 MHz) |
|-----------------------|--|---|
| $2,5 < f \leq 2,69$   | -85 dBm/MHz                            | -45 dBm                                   |
| $2,69 < f \leq 2,7$   | -85 dBm/MHz                            | -45 dBm                                   |
| $4,8 < f \leq 5,0$    | -70 dBm/MHz                            | -30 dBm                                   |

#### 4.3.6.2 Description Total Radiated Power

For the description of the Total Radiated Power ( $TRP_{SD}$ ), see ETSI EN 303 883-1 [1], clause 5.6.2.

### 4.3.6.3 Limits for Total Radiated Power

#### 4.3.6.3.1 TRP<sub>SD</sub> limit for EUT categories BMA2 and BMA3

The limits for the TRP<sub>SD</sub> requirement in table 9 applies for EUT categories BMA2 and BMA3.

**Table 9: TRP<sub>SD</sub> Limit for EUT categories BMA2 and BMA3 according to ECC/DEC/(07)01 [i.1] and Decision (EU) 2024/1467 [i.2]**

| Frequency range [GHz] | Total radiated mean e.i.r.p. spectral density [dBm/MHz] |
|-----------------------|---|
| 2,5 < f ≤ 2,69        | -75   |
| 2,69 < f ≤ 2,7        | -65   |
| 4,8 < f ≤ 5,0         | -65   |

#### 4.3.6.3.2 TRP<sub>SD</sub> limit for EUT categories BMA4 and BMA5

The limits for the TRP<sub>SD</sub> requirement in table 10 applies for EUT categories BMA4 and BMA5.

**Table 10: TRP<sub>SD</sub> Limit for EUT categories BMA4 and BMA5 according to ECC/DEC/(07)01 [i.1] and Decision (EU) 2024/1467 [i.2]**

| Frequency range [GHz] | Total radiated mean e.i.r.p. spectral density [dBm/MHz] |
|-----------------------|---|
| 2,5 < f ≤ 2,69        | -60   |
| 2,69 < f ≤ 2,7        | -65   |
| 4,8 < f ≤ 5,0         | -65   |

NOTE: The LBT mitigation technique will be tested separately in clause 4.3.7.

### 4.3.6.4 Conformance

The conformance test shall be done under normal conditions as defined in clause 5.1.2; the conformance test suite for TRP<sub>SD</sub> requirement shall be as defined in clause 5.3.5.

## 4.3.7 Listen Before Talk (LBT)

### 4.3.7.1 Applicability

The Listen Before Talk (LBT) requirement applies to the EUT categories BMA4 and BMA5 (see clause 4.2.5, table 1b), only if the following two points are applicable:

- OFR is partly or fully overlapping with at least one of the frequency ranges listed in table 11.
- Measured indirect emission level (see clause 4.3.4) is above the indirect emission limit without active mitigation (see table 11).

**Table 11: Indirect emission limits without active mitigation techniques (LBT, see table 5) according to ECC/DEC/(07)01 [i.1] and Decision (EU) 2024/1467 [i.2]**

| Frequency range [GHz] | Maximum mean e.i.r.p. spectral density [dBm/MHz] | Maximum peak e.i.r.p. (dBm defined in 50 MHz) |
|-----------------------|--|---|
| 1,215 < f ≤ 1,73      | -85  | -45   |
| 2,5 < f ≤ 2,69        | -65  | -25   |
| 2,7 < f ≤ 2,9         | -70  | -30   |
| 2,9 < f ≤ 3,4         | -70  | -30   |

#### 4.3.7.2 Description of Listen Before Talk

For the description of the Listen Before Talk (LBT) mitigation, see ETSI EN 303 883-1 [1], clause 5.10.1.

#### 4.3.7.3 Limits for Listen Before Talk

The limits for the LBT requirement for the EUT categories BMA4 and BMA5 are provided in table 12.

**Table 12: Requirement for active mitigation technique LBT according to ECC/DEC/(07)01 [i.1] and Decision (EU) 2024/1467 [i.2]**

| Frequency range [GHz]    | Following LBT requirement shall be fulfilled  | Test signal                              |
|--------------------------|---|--|
| $1,215 \leq f \leq 1,73$ | ETSI EN 303 883-1 [1], clause 5.10.2, table 9 | ETSI EN 303 883-1 [1], clause 5.10.3.4   |
| $2,5 < f \leq 2,69$      |   | ETSI EN 303 883-1 [1], clause 5.10.3.3.1 |
| $2,7 < f \leq 2,9$       |   | ETSI EN 303 883-1 [1], clause 5.10.3.3.2 |
| $2,9 < f \leq 3,4$       |   | ETSI EN 303 883-1 [1], clause 5.10.3.4   |

#### 4.3.7.4 Conformance

The conformance test shall be done under normal conditions as defined in clause 5.1.2; the conformance test suite for LBT mitigation technique shall be as defined in clause 5.3.6.

### 4.3.8 Duty Cycle

#### 4.3.8.1 Applicability

- The Duty Cycle requirement applies to the EUT categories BMA2, BMA3, BMA4 and BMA5 (see clause 4.2.5, table 1b), only if the following two points are applicable: OFR is partly or fully overlapping with at least one of the frequency ranges listed in table 13.
- Measured indirect emission level (see clause 4.3.4) is above the value specified in table 13.

**Table 13: Generic UWB limits according to according to Decision (EU) 2024/1467 [i.2]**

| Frequency range [GHz] | If indirect emission measurement result is above |   |
|-----------------------|--|---|
|                       | Maximum mean e.i.r.p. spectral density           | Maximum peak e.i.r.p. (defined in 50 MHz) |
| $2,69 < f \leq 2,7$   | -85 dBm/MHz                                      | -45 dBm                                   |
| $3,4 < f \leq 3,8$    | -80 dBm/MHz                                      | -40 dBm                                   |
| $4,8 < f \leq 5,0$    | -70 dBm/MHz                                      | -30 dBm                                   |

#### 4.3.8.2 Description of Duty Cycle

For the description of the Duty Cycle (DC) mitigation, see ETSI EN 303 883-1 [1], clause 5.11.1.

#### 4.3.8.3 Limits for Duty Cycle

The limits for the Duty Cycle requirement shall be as given in table 14.

**Table 14: Requirement for Duty Cycle according to ECC/DEC/(07)01 [i.1] and Decision (EU) 2024/1467 [i.2]**

| Frequency range [GHz] | Duty Cycle requirement | Related Maximum mean e.i.r.p. spectral density from table 5 and table 6 |
|-----------------------|------------------------|---|
| $2,69 < f \leq 2,7$   | 10 %/second            | -55 dBm/MHz   |
| $3,4 < f \leq 3,8$    | 10 %/second            | -50 dBm/MHz   |
| $4,8 < f \leq 5,0$    | 10 %/second            | -55 dBm/MHz   |

According to CEPT Report 45 [i.7], clause 3.1.1 and annex 2, a trading between power and duty cycle is. Table 15 shows the resulting relaxed duty cycle requirements when reducing accordingly the mean power spectral density limits.

**Table 15: Requirement for Duty Cycle trade off**

| Frequency range [GHz] | If indirect emission measurement assessment results (see clause 5.4.3) | Following Duty Cycle requirement apply |
|-----------------------|--|--|
| 2,69 < f ≤ 2,7        | < -58 dBm/MHz  | 20 %/second                            |
|                       | < -60 dBm/MHz  | 30 %/second                            |
|                       | < -61 dBm/MHz  | 40 %/second                            |
| 3,4 < f ≤ 3,8         | < -53 dBm/MHz  | 20 %/second                            |
|                       | < -55 dBm/MHz  | 30 %/second                            |
|                       | < -56 dBm/MHz  | 40 %/second                            |
| 4,8 < f ≤ 5,0         | < -58 dBm/MHz  | 20 %/second                            |
|                       | < -60 dBm/MHz  | 30 %/second                            |
|                       | < -61 dBm/MHz  | 40 %/second                            |

#### 4.3.8.4 Conformance

The conformance test shall be done under normal conditions as defined in clause 5.1.2; the conformance test suite for DC requirement shall be as defined in clause 5.3.7.

### 4.3.9 TX behaviour under the complete environmental profile (TXb)

#### 4.3.9.1 Applicability

The TX behaviour under the complete environmental profile (TXb) requirement applies to all EUT categories, see clause 4.2.5, table 1a and table 1b.

#### 4.3.9.2 Description

The TX behaviour under the complete environmental profile verifies the conformance of the mean e.i.r.p. spectral density over the environmental profile as specified in clause 5.1.3.

For more information on the TX behaviour under the complete environmental profile, see ETSI TS 103 941 [6], clause 4.3.1.

#### 4.3.9.3 Limits for radiated assessment of the TX behaviour

The TX behaviour is obtained by measuring the mean e.i.r.p. for EUT category BMA1 and mean e.i.r.p. spectral density for EUT categories BMA2, BMA3, BMA4, BMA5, across the complete environmental profile (see part on operation of the equipment as specified in clause 5.1.3 and assessing the variation with respect to an adjusted Regulated Limit (RL).

The procedure to adjust the regulated limit is described in ETSI TS 103 941 [6]:

- in clause 6.2 for EUT category BMA1; and
- in clause 6.5 for EUT categories BMA2, BMA3, BMA4 and BMA 5 to assess the TX-behaviour against the adjusted regulated limit, see ETSI TS 103 941 [6], clause 6.5.1.9.

In other words:

- For EUT category BMA1: the limits of mean e.i.r.p. from clause 4.3.3 are applied indirectly over the full environmental profile (as specified in clause 5.1.3) with a relative measurements. The difference between each environmental profile relative measurement point (Pstep) and the relative reference value REFpower at normal condition, both expressed in decibels, shall be smaller than the difference between the individual regulated mean e.i.r.p. limit (see clause 4.3.3, table 4) and the maximum measured value obtained in an absolute measurement according to clause 4.3.3.

- EUT categories BMA2, BMA3, BMA4 and BMA 5: the limits of mean e.i.r.p. spectral density from clause 4.3.4 are applied indirectly over the full environmental profile (as specified in clause 5.1.3) with a relative measurements. The difference between each environmental profile relative measurement point (Pstep) and the relative reference value REFpower at normal condition, both expressed in decibels, shall be smaller than the difference between the individual regulated mean e.i.r.p. spectral density limit (see clause 4.3.4 table 5 and table 6) and the maximum measured value obtained in an absolute measurement according to clause 4.3.4.

#### 4.3.9.4 Conformance

The conformance test shall be done under the complete environmental profile (see clause 5.1.3) and the parameters shall be measured within a setup as described in clause 5.3.8.1. The related assessments procedures as described in clause 5.3.8.2.1 for EUT category BMA1 and clause 5.3.8.2.2 for EUT categories BMA2, BMA3, BMA4 and BMA 5 shall be used.

## 4.4 Receiver requirements

### 4.4.1 General

The receiver requirements for all EUT categories covered by the scope of the present document are justified in annex B, table B.2.

The requirement "Receiver Spurious Emissions", as described in ETSI EN 303 883-2 [2], clause 5.1 is not applicable for the following reasons:

- TX and RX are co-located in the same device which is typical for such radiodetermination devices (monostatic radars); and
- for all EUT categories a pure receiver mode or to put the equipment to a receive only mode is not specified (see clause 4.2.1).

Based on this justification following Receiver requirements apply for the EUT categories covered by the present document:

- Receiver Baseline Sensitivity (RBS), see clause 4.4.3.
- Receiver Baseline Resilience (RBR), see clause 4.4.4.

### 4.4.2 Wanted technical performance criteria

The wanted technical performance criteria for all EUT categories specified in clause 4.2 and summarized in clause 4.2.5, table 1a and table 1b of the present document are described and specified in clause C.2.1 of the present document.

### 4.4.3 Receiver Baseline Sensitivity (RBS)

#### 4.4.3.1 Applicability

The Receiver Baseline Sensitivity (RBS) requirement applies to all EUT categories.

#### 4.4.3.2 Description for the RBS requirements

For the description of the RBS requirement, see ETSI EN 303 883-2 [2], clause 5.4.1.

#### 4.4.3.3 Limits

The EUT shall detect the defined object (see clause C.2.2) in the specified scenario (see clause C.3.1) while fulfilling the wanted technical performance criterion in clause 4.4.2.

#### 4.4.3.4 Conformance

The conformance test shall be done under normal conditions as defined in clause 5.1.2; test for all EUT categories for the RBS requirement shall be as defined in clause 5.4.2.1.

### 4.4.4 Receiver Baseline Resilience (RBR)

#### 4.4.4.1 Applicability

The Receiver Baseline Resilience (RBR) requirement shall apply to all EUT categories.

#### 4.4.4.2 Description for the RBR requirement

For the description of the RBR requirement, see ETSI EN 303 883-2 [2], clause 5.5.1.

#### 4.4.4.3 Limits

The EUT shall detect in presence of defined interfering signals (see clause D.2 for BMA1 and clause D.3 for BMA2, BMA3, BMA4, BMA5) the defined object (see clause C.2.3) in the specified scenario (see clause C.3.1) while fulfilling the wanted technical performance criterion in clause 4.4.2.

#### 4.4.4.4 Conformance

The conformance test shall be done under normal conditions as defined in clause 5.1.2; test for all EUT-categories for the RBR requirement shall be as defined in clause 5.4.3.1.

---

## 5 Testing for compliance with technical requirements

### 5.1 Environmental conditions for testing

#### 5.1.1 General

Tests defined in the present document shall be carried out at representative points within the boundary limits of the operational environmental profile defined by its intended use, which, as a minimum, shall be that specified in the test conditions contained in the present document.

Where technical performance varies subject to environmental conditions, tests shall be carried out under a sufficient variety of environmental conditions as specified in the present document to give confidence of compliance for the affected technical requirements.

#### 5.1.2 Normal test conditions

Normal test conditions shall be as defined in clause 4.5.3.1 of ETSI TS 103 941 [6].

#### 5.1.3 Complete environmental profile test conditions

The complete environmental profile test conditions cover both the normal (see clause 5.1.2) and extreme test conditions.

Extreme test conditions shall be as defined in clause 4.5.3.2 of ETSI TS 103 941 [6] with a temperature range varying between -10 °C to +50 °C for all EUT categories. For all EUT categories the primary supply voltage varies from 90 % to 110 % of the nominal value.

NOTE: The nominal value of the supply voltage is usually provided by the user manual of the EUT.



## 5.2 Conformance test suites and general conditions for testing

### 5.2.1 General

General guidance on testing TX and RX measurements are given respectively in ETSI EN 303 883-1 [1], clause 5.1.1 for the TX requirements and ETSI EN 303 883-2 [2], clause 5.1 for the RX requirements.

ETSI EN 303 883-1 [1], annex A provides complementary information on general conditions for testing, e.g. test environment and test conditions, measurement uncertainty and interpretation of the measurement results. An overview is provided in ETSI EN 303 883-1 [1], clause A.1.

ETSI EN 303 883-1 [1], annex B provides complementary information on test setups for testing, e.g. radiated and conducted measurements. An overview for radiated measurements is provided in ETSI EN 303 883-1 [1], clause B.2.1.

General information on test set-up for measurements under environmental profile are given respectively in ETSI TS 103 941 [6], clause 5.1. More detailed test solutions are provided in:

- ETSI TS 103 941 [6], clause 5.2 with the usage of a temperature chamber; and
- ETSI TS 103 941 [6], clause 5.3 with the usage of a climate dome and anechoic chamber.

### 5.2.2 Disregard time ( $T_{dis}$ )

For the conformance tests, a EUT category related  $T_{dis}$ , as specified in table 16, shall be considered. For the definition of  $T_{dis}$  see ETSI EN 303 883-1 [1], annex C.

**Table 16: Disregard time ( $T_{dis}$ ) for conformance tests**

| EUT category  | $T_{dis}$ in [ $\mu$ s] |
|---------------|-------------------------|
| BMA1          | 30                      |
| BMA2 and BMA4 | 30                      |
| BMA3 and BMA5 | 2                       |

### 5.2.3 Threshold - level ( $P_{thresh}$ )

For the conformance tests, a EUT category related Threshold-level ( $P_{thresh}$ ), as specified in table 17, shall be considered. The  $P_{thresh}$  is below a reference level, which is specified for each test set-up. For the definition of  $P_{thresh}$ , see ETSI EN 303 883-1 [1], annex C.

**Table 17: Threshold- level ( $P_{thresh}$ ) for conformance tests**

| EUT category  | $P_{thresh}$ in [dB] |
|---------------|----------------------|
| BMA1          | 10                   |
| BMA2 and BMA4 | 10                   |
| BMA3 and BMA5 | 10                   |

### 5.2.4 EUT orientation and reference points

All EUT covered by the EUT categories (see clause 4.2.5, table 1a and table 1b) are developed in such a way that one side needs to be directed to the "building structure" for analysis. Another side is to handle the EUT and to provide the information according to the intended use and instructions to the user, see figure 2. More information on the intended use will be provided in the EUT user manual.

Clause 5.2.5.1 and clause 5.2.5.2 are providing the relevant test scenarios and setups for transmitter conformance tests, including orientation and the reference points for the transmitter requirement measurements in the test suite.

NOTE: The reference point is the starting point for the assessment of the measurement distance.

The details are on the reference points for are summarized in:

- Figure 3 (see clause 5.2.5.1) is for the EUT covered by EUT category BMA1.
- Figure 4 and figure 5 (see clause 5.2.5.2) is for EUT covered by EUT category BMA2, BMA3, BMA4 and BMA5.

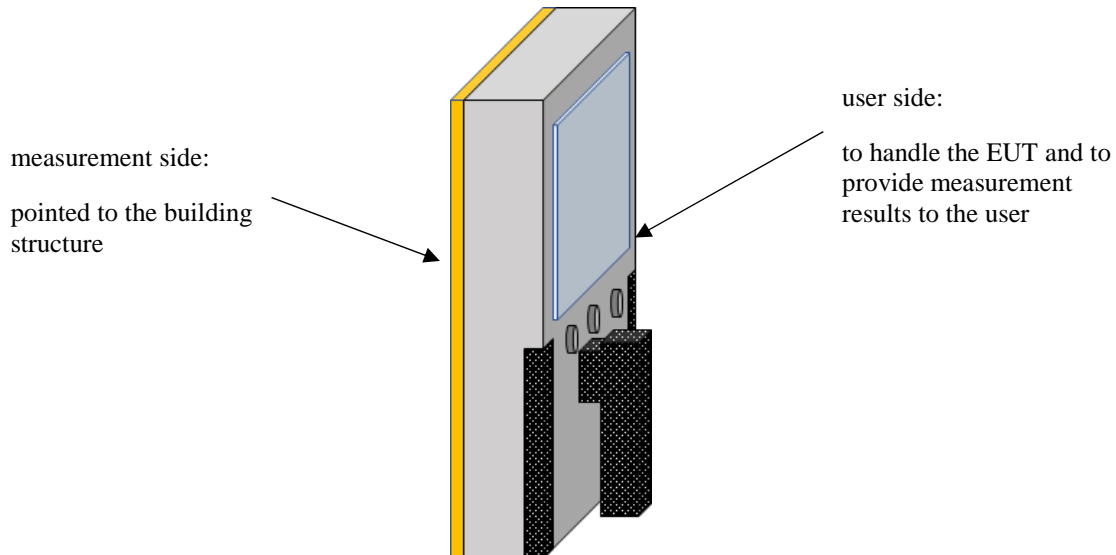
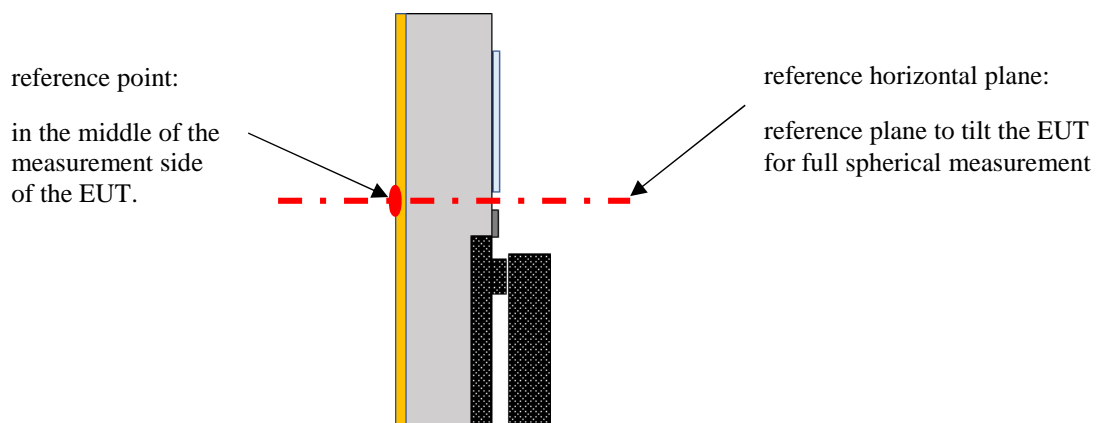

**Figure 2: Example for a BMA EUT**

## 5.2.5 Test scenarios and setup for transmitter conformance tests

### 5.2.5.1 For EUT category BMA1

The transmitter conformance tests shall be inside a test chamber according to ETSI EN 303 883-1 [1], clause B.2.2.2 (anechoic chamber) and the test setup shall be based on the test method as described in ETSI EN 303 883-1 [1], clause B.4. For the assessment of the measurement distance and the orientation of the EUT, see the reference point and horizontal plane in figure 3.



**Figure 3: Reference point and horizontal plane for transmitter requirement measurements for EUT covered by EUT category BMA1**

### 5.2.5.2 For EUT categories BMA2, BMA3, BMA4 and BMA5

The transmitter conformance tests shall be inside a test chamber according to ETSI EN 303 883-1 [1], clause B.2.2.2 (anechoic chamber) and the test setup shall be based on the test method as described in ETSI EN 303 883-1 [1], clause B.4.

Based on the requirements in ECC/DEC/(07)01 [i.1], the EUT categories BMA2, BMA3, BMA4 and BMA5 shall be tested on a representative building structure specified in clause E.1.

The combination of the EUT and the representative structure is shown in figure 4. Figure 5 specifies the reference point and reference plane for the tests.

The representative structure is specified in clause E.1 and the attenuation requirements needs to be verified by the procedure given in clause E.2.

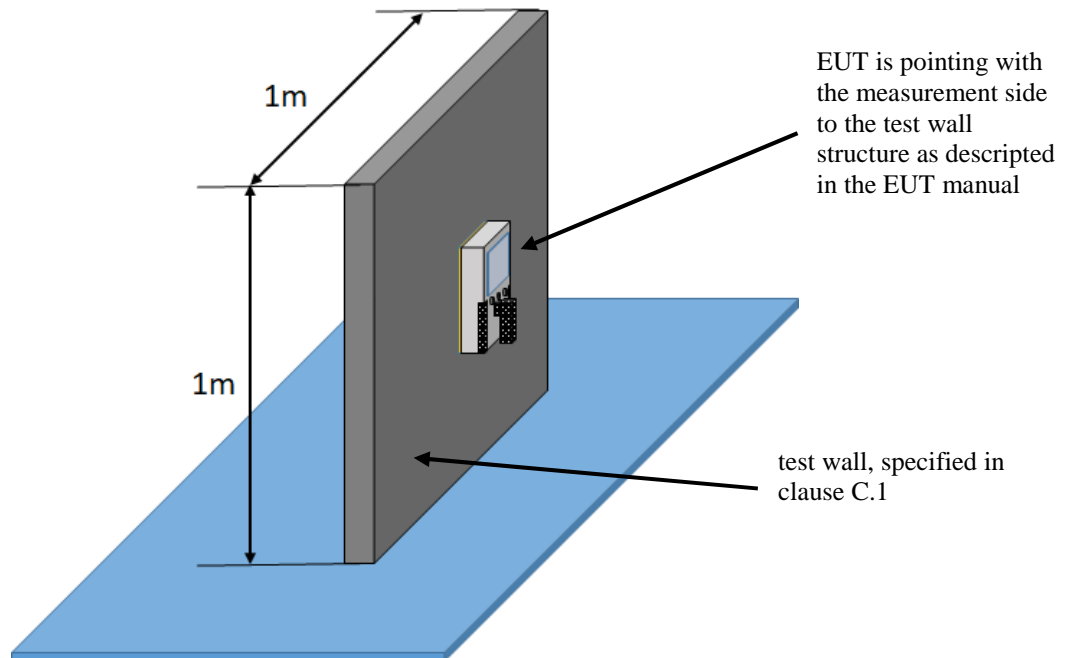

**Figure 4: Test set-up for EUT covered by EUT categories BMA2, BMA3, BMA4 and BMA5**

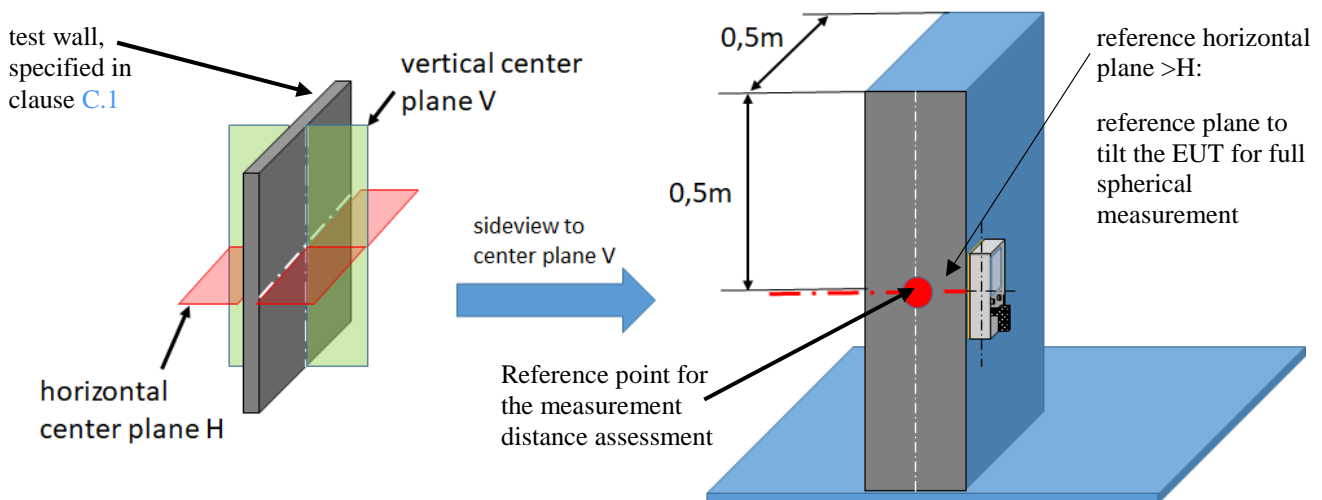

**Figure 5: Reference point and horizontal plane for transmitter requirement measurements for EUT covered by EUT categories BMA2, BMA3, BMA4 and BMA5**

## 5.3 Conformance methods of measurement for TX requirements

### 5.3.1 Operating Frequency Range (OFR)

#### 5.3.1.1 OFR assessment parameter X

For the OFR conformance assessment the numbers for parameter X as the specified in clause 4.3.2.2 shall be used. The value for the parameter X shall be noted in the test report in relation to the of the EUT category.

#### 5.3.1.2 OFR conformance test EUT category BMA1

For the OFR conformance test the set-up as specified in clause 5.2.5.1 shall be used.

OFR measurement should be done in the direction with the highest mean e.i.r.p. emission (see clause 4.3.3) using the conformance test in ETSI EN 303 883-1 [1], clause 5.2.2 and the orientation of the EUT in the conformance test shall be the same as in the mean e.i.r.p. conformance test (see clause 5.4.2, figure 7).

The mean power spectral density method as specified in ETSI EN 303 883-1 [1], clause 5.3.2.3 without signal repetition time assessment shall be used to assess the OFR.

The measurement distance  $d$  is specified from the reference point (as specified in clause 5.2.5.1) to the test antenna.

For the measurement distance  $d = 3$  m shall be used.

The measured results of the OFR shall be recorded.

#### 5.3.1.3 OFR conformance test EUT categories BMA2, BMA3, BMA4 and BMA5

For the OFR conformance test the set-up as specified in clause 5.2.5.2 shall be used.

OFR measurement should be done in the direction of the highest radiated emissions of the indirect emission (see clause 4.3.4 and figure 6) using the conformance test in ETSI EN 303 883-1 [1], clause 5.2.2.

For the measurement the same  $T_{dis}$  and  $P_{thresh}$  as for the indirect emission assessment, see clause 5.4.3, shall be used.

NOTE 1: The indirect emission assessment (see clause 4.3.4) used a specified mean power spectral density method and therefore the required method in ETSI EN 303 883-1 [1], clause 5.2.2. is given.

The measurement distance  $d$  is specified from the reference point (as specified in clause 5.2.5.2 and figure 5) to the test antenna. For the measurement distance  $d = 1$  m shall be used.

If based on the low emission levels of EUT under these categories (BMA2, BMA3, BMA4 and BMA5), the noise level of the overall measurement system (ETSI EN 303 883-1 [1], clause B.2.5) has less than 16 dB margin to the highest radiated emissions of the indirect emission measurement (see clause 5.4.3) for BMA sub-categories BMA2, BMA3, BMA4 and BMA5, a smaller measurement distance  $d$  shall be used, and the measurement distance assessment as described as range length in ETSI EN 303 883-1 [1], clause B.2.3.5 shall be done.

NOTE 2: 1m measurement distance is necessary based on the lower emission levels for material sensing applications  $< -50$  dBm/MHz compared to the generic UWB limits of  $-41,3$  dBm/MHz and the possible brought permitted frequency range up to 10,6 GHz.

A visualization of the OFR conformance assessment is shown in figure 6.

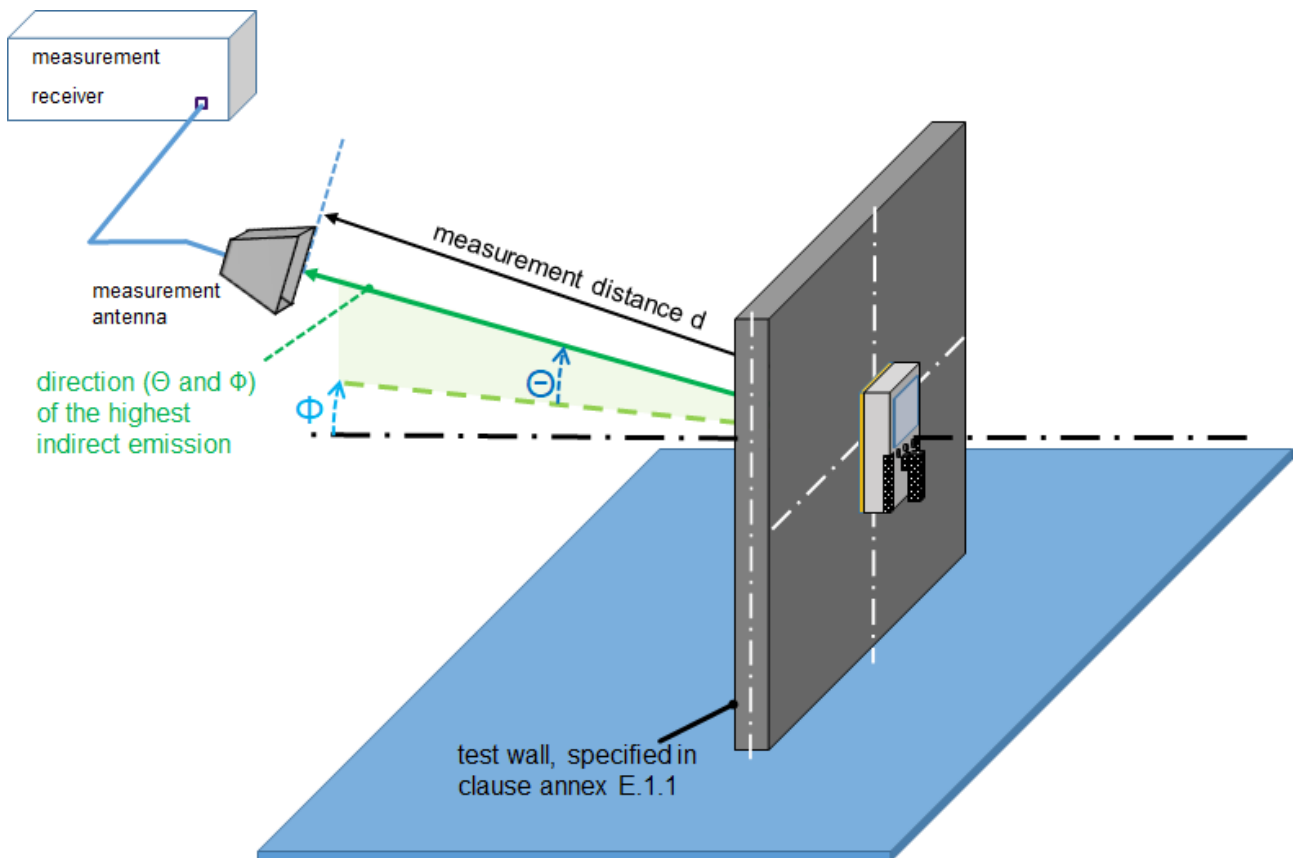

**Figure 6: OFR conformance test assessment**

The measured results of the OFR and the measurement distance shall be recorded.

### 5.3.2 Mean e.i.r.p.

For the mean e.i.r.p. the conformance test the set-up as specified in clause 5.2.5.1 and the conformance test procedure as specified in ETSI EN 303 883-1 [1], clause 5.3.1.3 shall be used.

If necessary for the measurement of the EUT signal repetition time see ETSI EN 303 883-1 [1], clause C.3.

For the measurement a  $T_{dis}$ , as specified in clause 5.2.2, table 16 and a  $P_{thresh}$  as specified in clause 5.2.3, table 17 shall be considered. The reference level for  $P_{thresh}$  is the maximum emission at the frequency  $f_M$  within the OFR.

For the start and stop frequencies the result of the OFR assessment, see clause 5.3.1.2 shall be considered.

The measurement distance  $d$  is specified from the reference point (as specified in clause 5.2.5.1, figure 3) to the test antenna. For the measurement distance  $d = 3$  m shall be used.

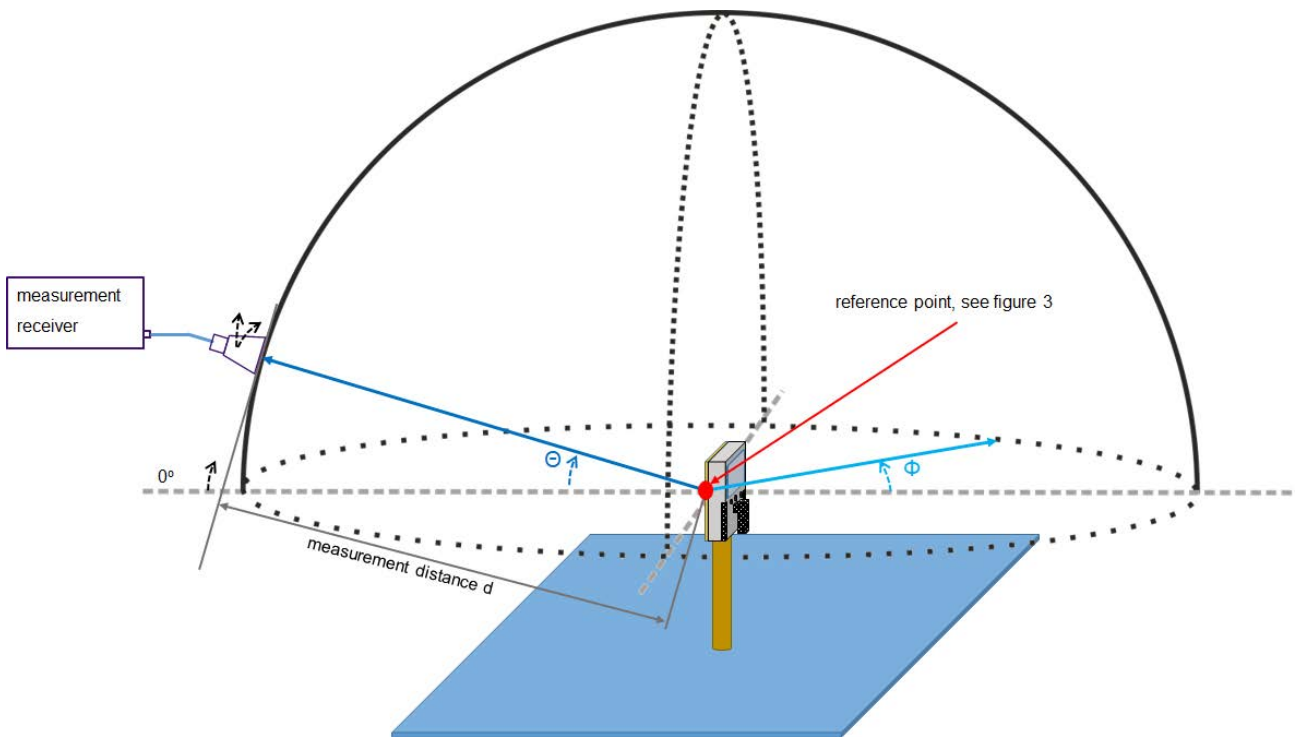

**Figure 7: Mean e.i.r.p. conformance test assessment**

The measured results of the mean e.i.r.p. and the measurement distance shall be recorded.

### 5.3.3 Indirect emissions

For the indirect emissions conformance test the set-up as specified in clause 5.2.5.2 shall be used.

The measurement distance  $d$  is specified from the reference point (as specified in clause 5.2.5.2) to the test antenna.

The complete set-up is shown in figure 8.

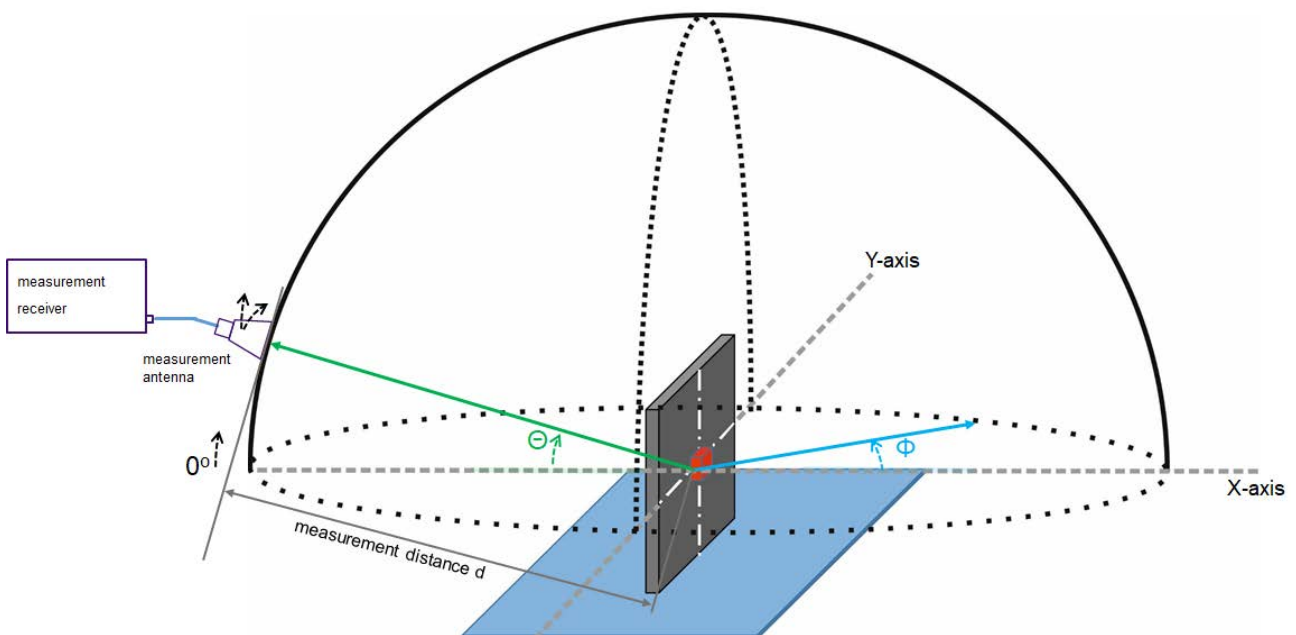

**Figure 8: Set-up for indirect emission conformance assessment**

For a full spherical assessment, the EUT need to be turned by 180 degrees around the horizontal plane H (see figure 5 and ETSI EN 303 883-1 [1], clause B.4).

For angular steps  $\Delta \Theta$  and  $\Delta \Phi$  a value of 15 degrees shall be used.

For the measurement distance  $d = 1$  m shall be used.

If based on the low emission levels of EUT under these categories (BMA2, BMA3, BMA4 and BMA5), the noise level of the overall measurement system (ETSI EN 303 883-1 [1], clause B.2.5) has less than 10 dB margin to the Maximum mean eirp spectral density limits in table 5 for BMA2 and BMA3 (see clause 4.3.4.3.1) or table 6 for BMA4 and BMA5 (see clause 4.3.4.3.2), a smaller measurement distance  $d$  shall be used, and the measurement distance assessment as described as range length in ETSI EN 303 883-1 [1], clause B.2.3.5 shall be done.

NOTE: 1 m measurement distance is necessary based on the lower emission levels for material sensing applications  $< -50$  dBm/MHz compared to the generic UWB limits of  $-41,3$  dBm/MHz and the possible brought permitted frequency range up to 10,6 GHz.

The applicable conformance test procedures are provided for mean power spectral density in table 18 and for peak power in table 19.

**Table 18: Conformance test procedure for the mean power spectral density limit**

| EUT category   | Conformance test procedure  | Signal repetition time assessment              |
|--|---|--|
| BMA2 and BMA4  | ETSI EN 303 883-1 [1], clause 5.3.2.4 and signal repetition time assessment | ETSI EN 303 883-1 [1], clause C.3 (see note 3) |
|  | ETSI EN 303 883-1 [1], clause 5.3.2.3                                       | Not applicable                                 |
| BMA3 and BMA5  | ETSI EN 303 883-1 [1], clause 5.3.2.3                                       | Not applicable                                 |
| NOTE 1: ETSI EN 303 883-1 [1], clause 5.4 and annex D, are providing guidance how to differentiate between emissions in the scope of the present document (article 3.2 of Directive 2014/53/EU [i.6]) and other sources (e.g. EMC).                                |   |  |
| NOTE 2: For the step 2 as described in ETSI EN 303 883-1 [1], clause D.3 the conformance test procedure as specified in ETSI EN 303 883-1 [1], clause 5.3.2.3 shall be used.   |   |  |
| NOTE 3: For the assessment a $T_{dis}$ , as specified in clause 5.2.2, table 16 and a $P_{thresh}$ as specified in clause 5.2.3, table 17 shall be considered. The reference level for $P_{thresh}$ is the maximum emission at the frequency $f_m$ within the OFR. |   |  |

**Table 19: Conformance test procedure for peak power spectral density limit**

| EUT category   | Conformance test procedure                       |
|--|--|
| BMA2 and BMA4  | ETSI EN 303 883-1 [1], clause 5.3.4.2            |
|  | ETSI EN 303 883-1 [1], clause 5.3.4.3 (see note) |
| BMA3 and BMA5  | ETSI EN 303 883-1 [1], clause 5.3.4.2            |
| NOTE: This procedure is only applicable if one spectral line applies within 50 MHz. Therefore, the assessment procedure in ETSI EN 303 883-1 [1], annex E and the measurement of the mean power spectral density (see table 18) shall be used. |  |

The measured results of the indirect emissions (with angular information) and the measurement distance shall be recorded.

## 5.3.4 TX unwanted emissions

### 5.3.4.1 General

The specific sub-category dependent conformance test for:

- TX unwanted emission conformance test for EUT covered by EUT category BMA1 (see clause 4.2.5, table 1a), see clause 5.3.4.2.
- TX unwanted emission conformance test for EUT covered by EUT categories BMA2, BMA3, BMA4 and BMA5 (see clause 4.2.5, table 1b), see clause 5.3.4.3.

### 5.3.4.2 TXUE conformance test for EUT category BMA1

#### 5.3.4.2.1 General

For the TX unwanted emission conformance test the set-up as specified in clause 5.2.5.1 and the conformance test procedure as specified in ETSI EN 303 883-1 [1], clause 5.5.3 shall be used.

- For the measurement of the emissions within the out-of-band domain see clause 5.3.4.2.3.
- For the measurement of the emissions within the spurious domain see clause 5.3.4.2.2.

NOTE: There are different limits specified for the out-of-band and spurious domain, see clause 4.3.5.3.1. and a different averaging time apply (OOB is averaged of signal repetition time, see clause 5.3.4.2.3, spurious is averaged over signal on time ( $T_{on}$ ), see clause 5.3.4.2.2).

For the measurement distance  $d$ , the same distance than for the MEAN e.i.r.p. conformance test shall be used (see clause 5.3.2). The measured results of the TX unwanted emission measurement and the used measurement distance shall be recorded.

#### 5.3.4.2.2 Unwanted emissions within spurious domain

For the test procedure, see ETSI EN 303 883-1 [1], clause 5.5.3.1 step 1 and step 2a for spurious emissions shall be used.

NOTE: For the assessment of the EUT  $T_{on}$  time see ETSI EN 303 883-1 [1], clause C.3. This time is necessary as the averaging time over the burst duration.

Therefore, the same  $T_{dis}$  and  $P_{thresh}$  limits as for the signal repetition time assessment, see clause 5.2.2 (for  $T_{dis}$ ) and clause 5.2.3 (for  $P_{thresh}$ ) shall be used.  $T_{on}$  time assessment (see ETSI EN 303 883-1 [1], clause C.3) the  $P_{thresh}$  is related to the measured power level at the frequency  $f_M$  (frequency with the max emission within OFR, see ETSI EN 303 883-1 [1], clause 5.2.2).

#### 5.3.4.2.3 Unwanted missions within out-of-band domain

For the test procedure, see ETSI EN 303 883-1 [1], clause 5.5.3.2 for out-of-band emissions shall be considered.

With the following additional settings (see ETSI EN 303 883-1 [1], clause 5.5.3.2.2) for the measurement receiver (similar to clause 5.3.2 of the present document):

- Resolution BandWidth (RBW): 1 MHz
- Video bandwidth: VBW equal or greater than the RBW
- Detector mode: RMS
- Display mode: CLEAR WRITE
- Average Time:  $\geq$  than one EUT signal repetition time (see annex C in [1])
- Number of measurement points:  $\geq \frac{\text{Frequency Span}}{\text{RBW}}$
- Sweep Time:  $\geq$  Average Time  $\times$  number of measurement points
- Wait for each measurement until the reading in the display is stable

Same signal repetition time as in clause 5.4.2 shall be considered.

### 5.3.4.3 TXUE conformance test for EUT categories BMA2, BMA3, BMA4 and BMA5

For the TX unwanted emission conformance test the set-up as specified in clause 5.2.5.2 and the conformance test procedure as specified in ETSI EN 303 883-1 [1], clause 5.5.3 shall be used:

- ETSI EN 303 883-1 [1], clause 5.5.3.1 for spurious emissions.



For the measurement distance  $d$ , the same distance than for the indirect emission conformance test shall be used (see clause 5.3.3).

For the  $T_{\text{dis}}$  and  $P_{\text{thresh}}$ , the same limits as specified in clause 5.2.2 (for  $T_{\text{dis}}$ ) and clause 5.2.3 (for  $P_{\text{thresh}}$ ) shall be considered. For the signal repetition and  $T_{\text{on}}$  time assessment (see ETSI EN 303 883-1 [1], clause C.3) the  $P_{\text{thresh}}$  is related to the measured power level at the frequency  $f_M$  (frequency with the max emission within the OFR, see ETSI EN 303 883-1 [1], clause 5.2.2).

The measured results of the TX unwanted emission measurements and the used measurement distance shall be recorded.

### 5.3.5 Total Radiated Mean e.i.r.p. Spectral Density (TRP<sub>SD</sub>)

The Total Radiated Mean e.i.r.p. Spectral Density (TRP<sub>SD</sub>) assessment shall be:

- Based the measured limits of the mean power spectral density of the indirect emissions conformance tests, see clause 5.4.3, table 16 (for the angular steps  $\Delta \Theta$  and  $\Delta \Phi$  a value of 15 degrees); and
- assessment procedure specified in ETSI EN 303 883-1 [1], clause 5.6.4.4 shall be used.

The calculated results of the total radiated Mean e.i.r.p. Spectral Density shall be recorded.

### 5.3.6 Listen Before Talk (LBT)

For the LBT conformance test the procedure specified in ETSI EN 303 883-1 [1], clause 5.10.3 shall be used.

The test the set-up as specified in clause 5.3.3 shall be used as a basis. The signal source with the related test antenna to generate the victim signal shall be placed in the direction of the highest indirect emission (for the LBT frequency ranges) and the main beam of the test antenna shall be pointing to the test wall. The test antenna shall be placed to the point of the highest mean e.i.r.p. spectral density (see clause 4.3.4). The arrangement of the test set-up is shown in figure 9 and figure 10.

NOTE: For each LBT frequency range (see clause 4.3.4, table 11) the direction of the highest indirect emission could be different, see indirect emission conformance test (clause 5.4.3).

The reference point (th) for the assessment of the power level at the EUT is shown in figure 10.

For test signal in Bands 1 and 4 (see ETSI EN 303 883-1 [1], clause 5.10.3.4) a test signal with more than 5 pulses can be used if the requirement: "switch off within 10 ms" after the 5<sup>th</sup> pulse of the test signal is fulfilled.

The assessed power levels (thl), related distance  $d$  and direction (see figure 9) and the LBT detection result shall be recorded.

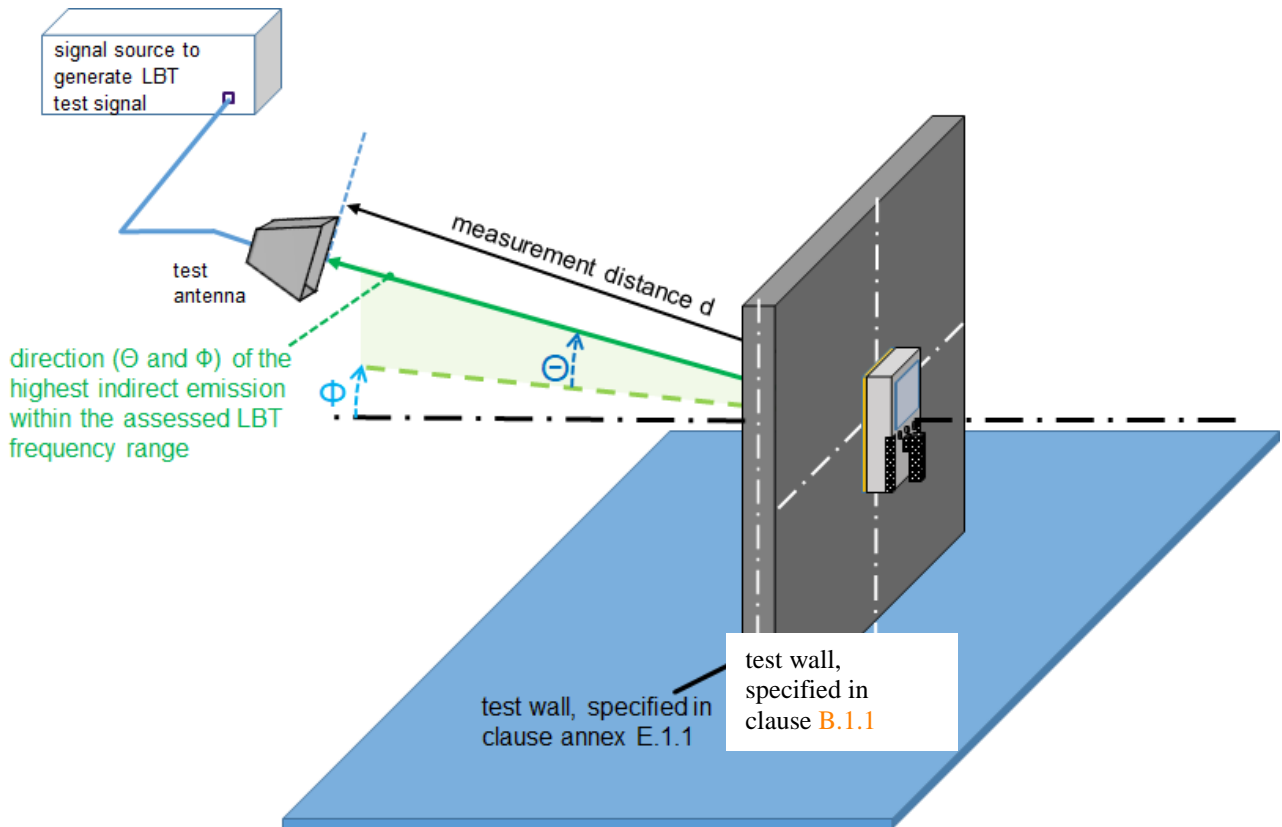

Figure 9: Set-up for LBT conformance test

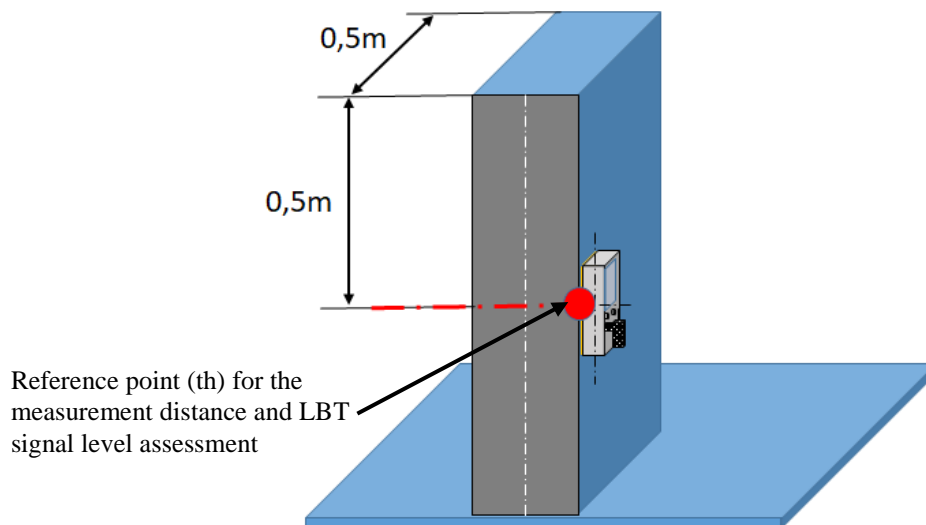

Figure 10: Reference point (th) for the LBT measurement and for the assessment of the LBT test signal level (th)

If the antenna for LBT test signal is pointing from the backside of the test wall to the EUT (see figure 9), the attenuation of the test wall needs to be considered for the calculation of the LBT victim power at the EUT. For such situations formula (42) of ETSI EN 303 883-1 [1], clause 5.10.3.2 needs to correct by the wall attenuation:

$$thl = p_{\text{victim}} + g_A - 20 \times \log \left( 4 \times r \times \pi \times \frac{f}{c_0} \right) - g_{\text{wall}}$$

$$p_{\text{victim}} = thl - g_A + 20 \times \log \left( 4 \times r \times \pi \times \frac{f}{c_0} \right) + g_{\text{wall}}$$

with:

- $g_{\text{wall}}$  attenuation of the test structure for TX measurements; in [dB] (see annex C).

### 5.3.7 Duty Cycle

For the Duty Cycle conformance test the set-up as specified in clause 5.2.5.2 shall be used.

The measurement receiver with the related measurement antenna shall be placed in the on the backside of the test and the measurement antenna shall be pointing to the test wall. The measurement antenna shall be placed in the direction of highest indirect emission within the frequency range which shall be assessed for the duty cycle.

Each frequency range with a DC requirement (see clause 4.3.8.3) shall be assessed separately. The arrangement of the test set-up is shown in figure 11.

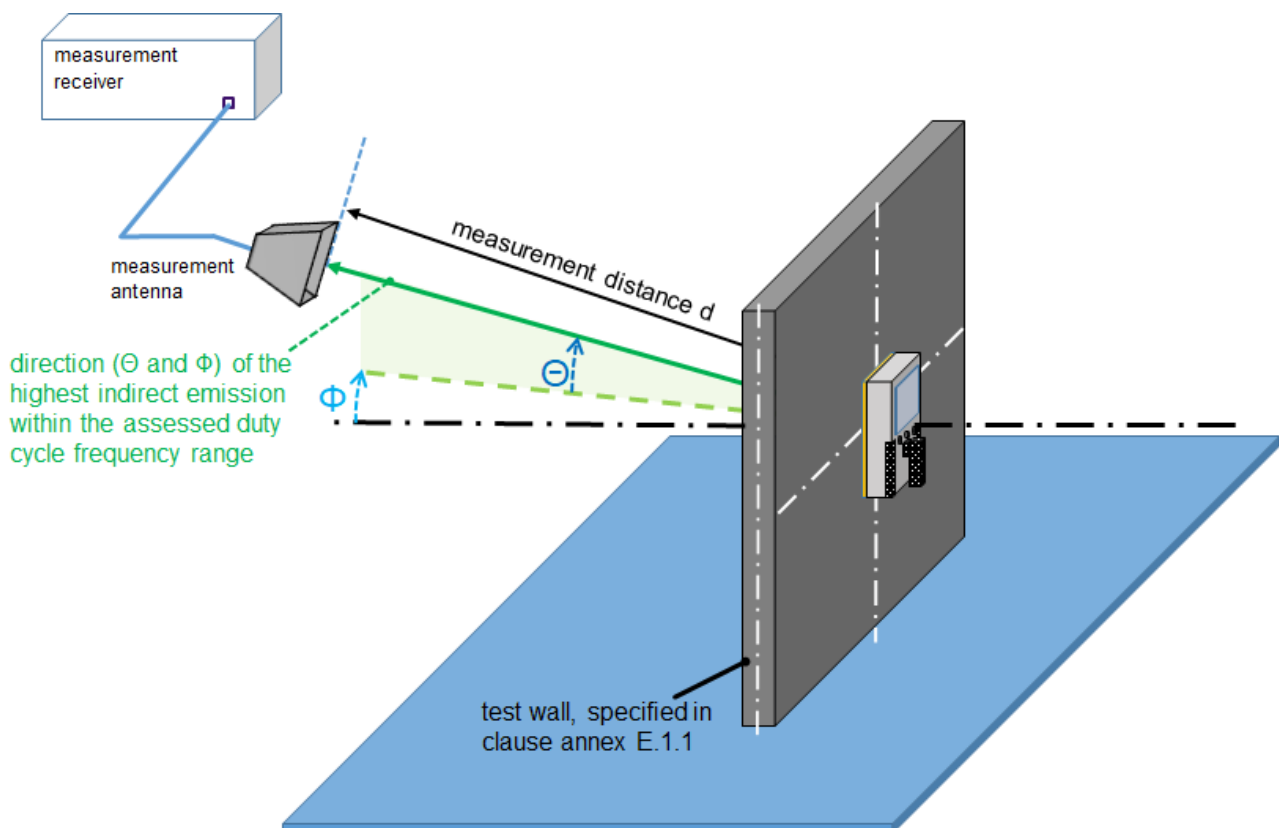

**Figure 11: Set-up for Duty Cycle conformance test**

**NOTE:** Duty Cycle conformance assessment is only necessary in the direction of the highest indirect emission, because with this test the nature of the TX-signal will be tested and not the complete emission of the EUT (see clause 5.4.3).

For the Duty Cycle conformance test the procedures as listed in table 20 shall be used. For the measurement distance  $d$ , the same distance than for the indirect emission conformance test shall be used (see clause 5.4.3).

For the measurement a  $T_{dis}$ , as specified in clause 5.2.2, table 16 and a  $P_{thresh}$  as specified in clause 5.2.3, table 17 shall be considered.

**Table 20: Conformance test procedure for the DC limit**

| EUT category  | Conformance test procedure             | Frequency / power reference for $P_{thresh}$  |
|---------------|--|---|
| BMA2 and BMA4 | ETSI EN 303 883-1 [1], clause 5.11.2.4 | frequency with the maximum emission level within the frequency range the DC shall be measured, see clause 4.3.8.1, table 13 |
| BMA3 and BMA5 | ETSI EN 303 883-1 [1], clause 5.11.2.1 | measured power level at $f_M$   |

The measured results of the Duty Cycle shall be recorded.

## 5.3.8 TX behaviour under the complete environmental profile

### 5.3.8.1 General

A test set-up shall be chosen based on clause 4.3.1 and figure 1 in ETSI TS 103 941 [6].

### 5.3.8.2 Conformance test procedures

#### 5.3.8.2.1 Conformance test procedure for EUT category BMA1

The procedure according to ETSI TS 103 941 [6], clause 6.3 shall be used.

For BMA sub-category BMA1 the reference requirement to be assessed over the environmental profile is the mean e.i.r.p. from clause 5.3.2. of the present document, shall be used.

Based on clause 5.1.3 of the present document and ETSI TS 103 941 [6], clause 4.5.4; figure 6 the parameters for the assessment are specified as follow:

- $t_{low}$ : see clause 5.1.3, set to -10 °C
- $t_{high}$ : see clause 5.1.3, set to +50 °C
- $t_{steps}$ : 10 °C
- supply voltage: see clause 5.1.3 of the present document, the nominal value of the supply voltage is usually provided by the user manual of the EUT.

#### 5.3.8.2.2 Conformance test procedure for EUT categories BMA2, BMA3, BMA4 and BMA5

The procedure according to ETSI TS 103 941 [6], clause 6.5 shall be used.

For BMA sub-categories BMA2, BMA3, BMA4 and BMA5 the reference requirement to be assessed over the environmental profile is the mean e.i.r.p. spectral density from clause 5.3.3 of the present document, shall be used.

Based on clause 5.1.3 of the present document and ETSI TS 103 941 [6], clause 4.5.4; figure 6 the parameters for the assessment are specified as follow:

- $t_{low}$ : see clause 5.1.3, set to -10 °C
- $t_{high}$ : see clause 5.1.3, set to +50 °C
- $t_{steps}$ : 10 °C
- supply voltage: see clause 5.1.3 of the present document, the nominal value of the supply voltage is usually provided by the user manual of the EUT.

## 5.4 Conformance methods of measurement for receiver

### 5.4.1 General for RBS and RBR conformance tests

BMA EUT equipment in the scope of the present document have to be moved over the wall/building structure to detect objects inside the structure.

To perform the receiver tests the handling has to simulate an intended operation. Therefore, the RX-test shall be performed like a "normal" intended use as described for the intended use in the EUT user manual.

For this purpose, a test person/operator shall use the device on the specified test wall (see annex C).

NOTE: To get experience "how" to handle such EUT and in which way the user interface is implemented (e.g. to provide the measurement results to the use) the test person/operator normally runs 5 tests on the test wall (performed before the conformance tests).

### 5.4.2 Receiver Baseline Sensitivity (RBS)

#### 5.4.2.1 RBS test for BMA category

For all EUT categories (designed to detect the location of objects within a building structure), see clause 4.2.5, table 1a and table 1b, the RX-test structure as specified in clause C.3.1 shall be used.

The test object (see table C.2) shall be placed at the distance  $R_{DS}$  (see table C.1) for each EUT category inside the RX-test wall (see clause C.3.1) The set-up is shown in figure 12.

NOTE 1: The RBS procedure is similar to the procedure as described in ETSI EN 303 883-2 [2], clause 5.4.3.5.3.

#### **Test Procedure:**

- Step 1: Place (as described in the user manual) the EUT onto the RX-test structure (e.g. left from the test object).
- Step 2: Perform the measurement to locate the object inside the RX-test structure with the EUT as described in the user manual.
- Step 3: The test person/operator shall check if the object was detected in accordance with the user manual.
- Step 4: Assess the measurement procedure result.

To pass the test:

- The test object shall be detected at least in 2 of 3 tests.

NOTE 2: Detect means: the EUT was able to detect and provide the info about the object inside the RX-test structure to the test operator as specified in the EUT manual.

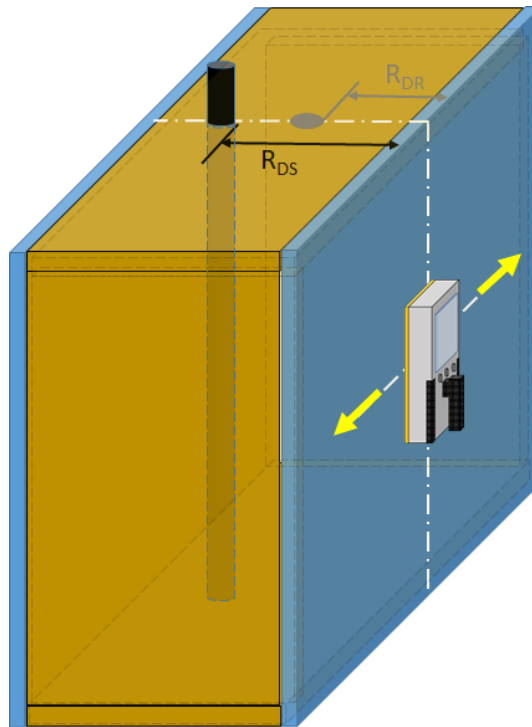

**Figure 12: RBS conformance set-up for EUT designed to detect the location of objects within a building structure**

### 5.4.3 Receiver Baseline Resilience (RBR)

#### 5.4.3.1 RBR test for BMA category

For all EUT categories (designed to detect the location of objects within a building structure), see clause 4.2.5, table 1a and table 1b, the RX-test structure as specified in clause C.3.1 shall be used.

The object (see table D.2) shall be placed at the distance  $R_{DR}$  (see table C.3) for each EUT category inside the RX-test structure as specified for each EUT category. The set-up is shown in figure 13.

NOTE 1: The RBR procedure is similar to the procedure described in ETSI EN 303 883-2 [2], clause 5.5.3.5.

#### Test Procedure:

Step 1: Assessment of the interfering signals for RBR test:

- take OFR and  $f_c$  from the OFR measurement, see clause 5.4.1;
- for the interferer information (frequency, signal, power), see clause D.2 for BMA1 and clause D.3 for BMA2, BMA3, BMA4 and BMA5;
- consider for the interferer assessment the LBT requirement. If the test frequency assessment would consider the same interferer which was tested during the LBT requirement this interferer is not applicable for the RBR test. If the LBT requirement was passed the EUT will not operate as intended (EUT will be not able to detect the object, because if signal is detected the EUT is not allowed to transmit), see LBT requirement description in ETSI EN 303 883-1 [1], clause 5.10.1.

Step 2: Arrange the set-up with the RX-test structure (see RBS test), a signal generator for the interfering signals and a test antenna to radiate the interfering signal to the RX-test scenario (see figure 12). Set the output power of the signal generator so that the interfering power level at the EUT from annex D (D.2 for BMA1 and D.3 for BMA2, BMA3, BMA4 and BMA5) are fulfilled; use the guidance provided in ETSI EN 303 883-2 [2], clause A.3 to calculate the output power of the signal generator.

Step 3: Switch on Interferer source with one interferer signal as assessed in step 1.

Step 4: Place (as described in the manual) the BMA EUT onto the RX-test structure (left from the object).

Step 5: Perform the measurement procedure to locate the object inside the RX-test structure with the BMA EUT as described in the EUT manual.

Step 6: After the measurement procedure the test operator shall check the information on the EUT if the object was detected and the information provided from EUT is similar as specified in the device manual.

Step 7: Assess the measurement procedure result.

To pass the test:

- The EUT shall operate as intended at least in 2 of 3 tests (see manual of the EUT).

NOTE 2: Operate as intended means:

- either the EUT was able to detect and provide the info about the specified test object inside the RX-test structure to the test operator; or the BMA EUT was not able to detect the specified test object inside the RX-test structure under the presence of the interferer, but the EUT provides information to the operator (as described in the manual) that the measurement was not valid.

Step 8: Repeat from step 3 for each interfering signal assessed in step 1.

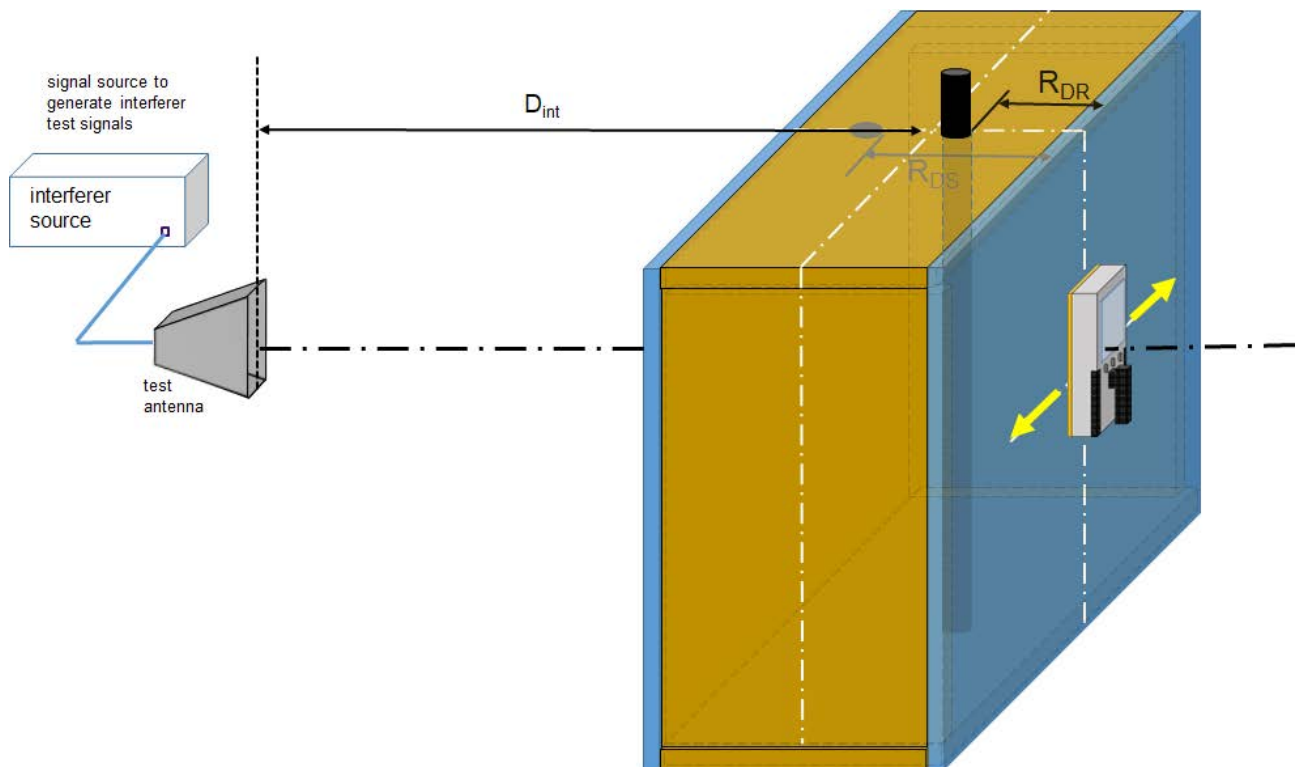

Figure 13: RBR conformance set-up for EUT designed to detect the location of objects within a building structure

## Annex A (informative): Relationship between the present document and the essential requirements of Directive 2014/53/EU

The present document has been prepared under the Commission's standardisation request C(2015) 5376 final [i.8] to provide one voluntary means of conforming to the essential requirements of Directive 2014/53/EU on the harmonisation of the laws of the Member States relating to the making available on the market of radio equipment and repealing Directive 1999/5/EC [i.6].

Once the present document is cited in the Official Journal of the European Union under that Directive, compliance with the normative clauses of the present document given in table A.1 confers, within the limits of the scope of the present document, a presumption of conformity with the corresponding essential requirements of that Directive and associated EFTA regulations.

**Table A.1: Relationship between the present document and the essential requirements of Directive 2014/53/EU**

| Harmonised Standard ETSI EN 302 065-4-1 |   |                                     |                                   |                            |  |
|---|---|-------------------------------------|-----------------------------------|----------------------------|--|
| Requirement                             |   |                                     |                                   | Requirement Conditionality |  |
| No                                      | Description   | Essential requirements of Directive | Clause(s) of the present document | U/C                        | Condition  |
| 1                                       | Operating Frequency Range (OFR)                       | 3.2                                 | 4.3.2                             | U                          |  |
| 2                                       | Mean e.i.r.p.   | 3.2                                 | 4.3.3                             | C                          | All EUT sub-categories based on the SRD regulation                                       |
| 3                                       | Indirect Emissions                                    | 3.2                                 | 4.3.4                             | C                          | All EUT sub-categories based on the UWB regulation                                       |
| 4                                       | TX Unwanted Emissions (TXUE)                          | 3.2                                 | 4.3.5                             | U                          |  |
| 5                                       | Total Radiated Power (TRP)                            | 3.2                                 | 4.3.6                             | C                          | All EUT sub-categories based on the UWB regulation                                       |
| 6                                       | Listen Before Talk (LBT)                              | 3.2                                 | 4.3.7                             | C                          | All EUT sub-categories based on the UWB regulation and implemented active mitigation LBT |
| 7                                       | Duty Cycle  | 3.2                                 | 4.3.8                             | C                          | All EUT sub-categories based on the UWB regulation                                       |
| 8                                       | TX behaviour under the complete environmental profile | 3.2                                 | 4.3.9                             | U                          |  |
| 9                                       | Receiver Baseline Sensitivity (RBS)                   | 3.2                                 | 4.4.3                             | U                          |  |
| 10                                      | Receiver Baseline Resilience (RBR)                    | 3.2                                 | 4.4.4                             | U                          |  |

### Key to columns:

#### Requirement:

**No** A unique identifier for one row of the table which may be used to identify a requirement.

**Description** A textual reference to the requirement.

#### Essential requirements of Directive

Identification of article(s) defining the requirement in the Directive.

#### Clause(s) of the present document

Identification of clause(s) defining the requirement in the present document unless another document is referenced explicitly.



**Requirement Conditionality:**

|                  |   |
|------------------|---|
| <b>U/C</b>       | Indicates whether the requirement is unconditionally applicable (U) or is conditional upon the manufacturer's claimed functionality of the equipment (C). |
| <b>Condition</b> | Explains the conditions when the requirement is or is not applicable for a requirement which is classified "conditional".                                 |

Presumption of conformity stays valid only as long as a reference to the present document is maintained in the list published in the Official Journal of the European Union. Users of the present document should consult frequently the latest list published in the Official Journal of the European Union.

Other Union legislation may be applicable to the product(s) falling within the scope of the present document.

## Annex B (informative): Selection of technical parameters

ETSI EG 203 336 [i.15], clause 5 lists the technical parameters applicable to transmitters and receivers that should be considered when producing Harmonised Standards that are intended to cover the essential requirements in article 3.2 of Directive 2014/53/EU [i.6]. Essential requirements are high level objectives described in European Directives. The purpose of the Harmonised Standard is to translate those high level objectives into detailed technical specifications. Table B.1 contains the transmitter parameters and table B.2 contains the receiver parameter listed in ETSI EG 203 336 [i.15], clause 5 for transmitter and receiver, and cross references these to the clauses within the present document in which the requirements for measurement of such parameters are satisfied or justified.

**Table B.1: Cross-reference of clauses in the present document to technical parameters for transmitter listed in ETSI EG 203 336 [i.15]**

| ETSI EG 203 336 [i.15] |  | Present document |  | Justification  |
|------------------------|--|------------------|--|--|
| Clause                 | Parameter  | Clause           | Parameter  |  |
| 5.2.2                  | Transmitter power limits                                 | 4.3.3            | Mean e.i.r.p.  | Only applicable for BMA1 sub-category based on ECC/EC decision.  |
|                        |  | -                | Mean power spectral density e.i.r.p.<br>Peak power spectral density e.i.r.p. | Not applicable, will be replaced for BMA sub-categories BMA2, BMA3, BMA4 and BMA5 by the indirect emission requirement, see test set-up and specification in ECC/DEC/(07)01 [i.1] and Commission Implementing Decision (EU) 2024/1467 [i.2].   |
|                        |  | 4.3.4            | Indirect emissions   |  |
|                        |  | -                | Antenna pattern, Exterior limits   |  |
|                        |  | 4.3.6            | Total Radiated Power (TRP)   | Based on clause 4.3.4, see ETSI EN 303 883-1 [1] and ECC/DEC/(07)01 [i.1], Commission Implementing Decision (EU) 2024/1467 [i.2]   |
| 4.3.9                  | TX behaviour under the complete environmental profile    |                  |  |  |
| 5.2.3                  | Transmitter power accuracy                               | -                | -  | From the latest version of ETSI EG 203 336 [i.15]<br><i>"When regulatory limits imply only a maximum emission limit (e.g. products that operate under a general licence regime), this parameter need not be considered for inclusion in an HS."</i>  |
| 5.2.4                  | Transmitter spectrum mask                                | 4.3.2            | Operating Frequency Range  |  |
|                        |  | 4.3.9            | TX behaviour under the complete environmental profile                        |  |
| 5.2.5                  | Transmitter frequency stability                          | -                | -  | NOTE: Not explicit applicable for UWB / wideband devices based on kind of UWB modulations.   |
|                        |  | 4.3.9            | TX behaviour under the complete environmental profile                        | TX behaviour requirement assessment shows the behaviour (in frequency) of the OFR over the environmental profile.  |
| 5.2.6                  | Transmitter intermodulation attenuation                  | -                | -  | From latest version of ETSI EG 203 336 [i.15] this parameter is required only "where high levels of quality services are required". This is not relevant for generic short range devices which are operating under licence except regime without any kind of regulatory protection. SRDs have to accept interferences. |
| 5.2.7.2                | Transmitter unwanted emissions in the out of band domain | 4.3.5            | TX Unwanted emissions  |  |

| ETSI EG 203 336 [i.15] |  | Present document |                       | Justification   |
|------------------------|--|------------------|-----------------------|-----------------|
| Clause                 | Parameter  | Clause           | Parameter             |                 |
| 5.2.7.3                | Transmitter unwanted emissions in the spurious domain  | 4.3.5            | TX Unwanted emissions |                 |
| 5.2.8                  | Transmitter time domain characteristics  | 4.3.8            | Duty cycle            |                 |
| 5.2.9                  | Transmitter transients   | -                | -                     | Not applicable. |
|                        | Other mitigation, spectrum access requirements not specified in the ETSI Guide but specified in related ECC/EC framework | 4.3.7            | LBT                   |                 |

**Table B.2: Cross reference of clauses in the present document to technical parameters for receiver listed in ETSI EG 203 336 [i.15]**

| ETSI EG 203 336 [i.15] |  | Present document |   | Justification  |
|------------------------|--|------------------|---|--|
| Clause                 | Parameter  | Clause           | Parameter                                 |  |
| 5.3.2                  | Receiver sensitivity                               | -                | not specified, superseded by RBS test     | See justification in ETSI EN 303 883-2 [2], annex C and the explanation of the interferer signal handling concept, see ETSI TS 103 567 [i.18]. |
| 5.3.2.3                | Desensitization                                    | -                | not specified, superseded by RBR test     | See justification in ETSI EN 303 883-2 [2], annex C and the explanation of the interferer signal handling concept, see ETSI TS 103 567 [i.18]. |
| 5.3.3                  | Receiver co-channel rejection                      | -                | not specified, superseded by RBR test     | See justification in ETSI EN 303 883-2 [2], annex C and the explanation of the interferer signal handling concept, see ETSI TS 103 567 [i.18]. |
| 5.3.4.2.1              | Receiver adjacent channel selectivity              | -                | not specified, superseded by RBR test     | See justification in ETSI EN 303 883-2 [2], annex C and the explanation of the interferer signal handling concept, see ETSI TS 103 567 [i.18]. |
| 5.3.4.2.2              | Receiver adjacent band selectivity                 | -                | not specified, superseded by RBR test     | See justification in ETSI EN 303 883-2 [2], annex C and the explanation of the interferer signal handling concept, see ETSI TS 103 567 [i.18]. |
| 5.3.4.3                | Receiver blocking                                  | -                | not specified, superseded by RBR test     | See justification in ETSI EN 303 883-2 [2], annex C and the explanation of the interferer signal handling concept, see ETSI TS 103 567 [i.18]. |
| 5.3.4.4                | Receiver spurious response rejection               | -                | not specified, superseded by RBR test     | See justification in ETSI EN 303 883-2 [2], annex C and the explanation of the interferer signal handling concept, see ETSI TS 103 567 [i.18]. |
| 5.3.4.5                | Receiver radio-frequency intermodulation           | -                | not specified, superseded by RBR test     | See justification in ETSI EN 303 883-2 [2], annex C and the explanation of the interferer signal handling concept, see ETSI TS 103 567 [i.18]. |
| 5.3.5                  | Receiver unwanted emissions in the spurious domain | -                | Unwanted emissions in the spurious domain | Not applicable, EU covered by the present document has no receive only mode, see clause 4.4.1.   |
| 5.3.6.1                | Receiver dynamic range                             | -                | Receiver dynamic range or partly by RBS   | EN has specific dynamic range test, if not see ETSI EN 303 883-2 [2], table C.1.   |
| 5.3.6.2                | Reciprocal mixing                                  | -                | not specified, superseded by RBR test     | See justification in ETSI EN 303 883-2 [2], annex C and the explanation of the interferer signal handling concept, see ETSI TS 103 567 [i.18]. |

| ETSI EG 203 336 [i.15] |                            | Present document |   | Justification  |
|------------------------|----------------------------|------------------|---|--|
| Clause                 | Parameter                  | Clause           | Parameter   |  |
| 5.3.1                  | Signal interferer handling | 4.4.3<br>4.4.4   | Receiver Baseline Sensitivity (RBS)<br>Receiver Baseline Resilience (RBR) | Interferer signal handling (ETSI EG 203 336 [i.15], clause 5.3.1) is an alternative method for specifying receiver parameters intended for use for receivers such as UWB and certain types of radar equipment. The present document is following this concept, see ETSI TS 103 567 [i.18] and ETSI EN 303 883-2 [2]. |

## Annex C (normative): BMA EUT Category: Use-Case, wanted technical performance criteria and RX-test conditions

### C.1 Description

The Building Material Analysis (BMA) EUT category covered by annex C is designed to detect the location of objects within a building structure.

NOTE 1: More details for this EUT use-case category are provided in ETSI TR 102 495-1 [i.5].

NOTE 2: The intended use/handling of the device is explained in the user-manual of the EUT.

### C.2 Wanted Technical Performance Criteria (WTPC) and RX - requirement

#### C.2.1 General

The minimum wanted technical performance criteria for all BMA EUT shall be to detect a specified object in a given distance (see for RBS scenario, clause C.2.2 and for RBR scenario clause C.2.3) within the specified test-wall (see clause C.3).

This object detection performance offers the possibility to implement additional operational functions into the EUT (e.g. object separation, object depth information). The performance of these additional functions is based on the mode (SRD or UWB) but require the basic detection possibility of the hidden object as specified in the present document.

#### C.2.2 RBS-requirement and limit

The limits for the distance ( $R_{DS}$ ) of the object are provided in table C.1, the kind of object is specified in table C.2.

**Table C.1: Requirement for object distance ( $R_{DS}$ ) for the RBS test**

| BMA category              | $R_{DS}$ [cm] |
|---------------------------|---------------|
| BMA1                      | 5             |
| BMA2, BMA3, BMA4 and BMA5 | 7             |

NOTE 1: The distance is based on typical detection depths for EUT on "unknown" or "light construction" building structure. For some specific scenarios as deeper detection could be possible, but this is EUT specific. The specified light construction wall is for the object detection the worst-case scenario (wave propagation, multi reflection) and therefore provides the worst case.

**Table C.2: Requirement for kind of object for RBS test**

| BMA category              | Kind                      |
|---------------------------|---------------------------|
| BMA1                      | rebar, see clause C.3.2.2 |
| BMA2, BMA3, BMA4 and BMA5 | rebar, see clause C.3.2.2 |

For the detailed specification of the test-wall for RX-measurement, see clause C.3.1.

NOTE 2: ETSI EN 303 883-2 [2] allows for RBS requirement a scaling of the limit. The present document will not consider scaling for the RBS requirement.

## C.2.3 RBR requirement and limit

Based on the specified RBS scenario (see clause C.2.2) and the related RBR requirement, ETSI EN 303 883-2 [2], clause 5.4.1, the limits for the distance ( $R_{DR}$ ) for the RBR test are provided in table C.3.

**Table C.3: Requirement for object distance  $R_{DR}$  for RBR test**

| BMA category              | $R_{DR}$ [cm] |
|---------------------------|---------------|
| BMA1                      | 3,5           |
| BMA2, BMA3, BMA4 and BMA5 | 4,5           |

NOTE: ETSI EN 303 883-2 [2] allows for RBR requirement a scaling of the limit. The present document does not consider scaling for the RBR requirement.

## C.3 Test-wall for RX-Measurement

### C.3.1 Description test-wall for RX-measurement

The test-wall for the assessment of the RX-requirements shall be set-up as described in figure C.1. The test wall consists of the following parts:

- Envelope with wood frame (see clause C.3.2.3) and two gypsum boards (see clause C.3.2.1).
- Two holes in the wood frame for the rebar at distance  $R_{DS}$  (see clause 4.4.3.3) and  $R_{DR}$  (see clause 4.4.4.3).
- Rebar (see clause C.3.2.2).

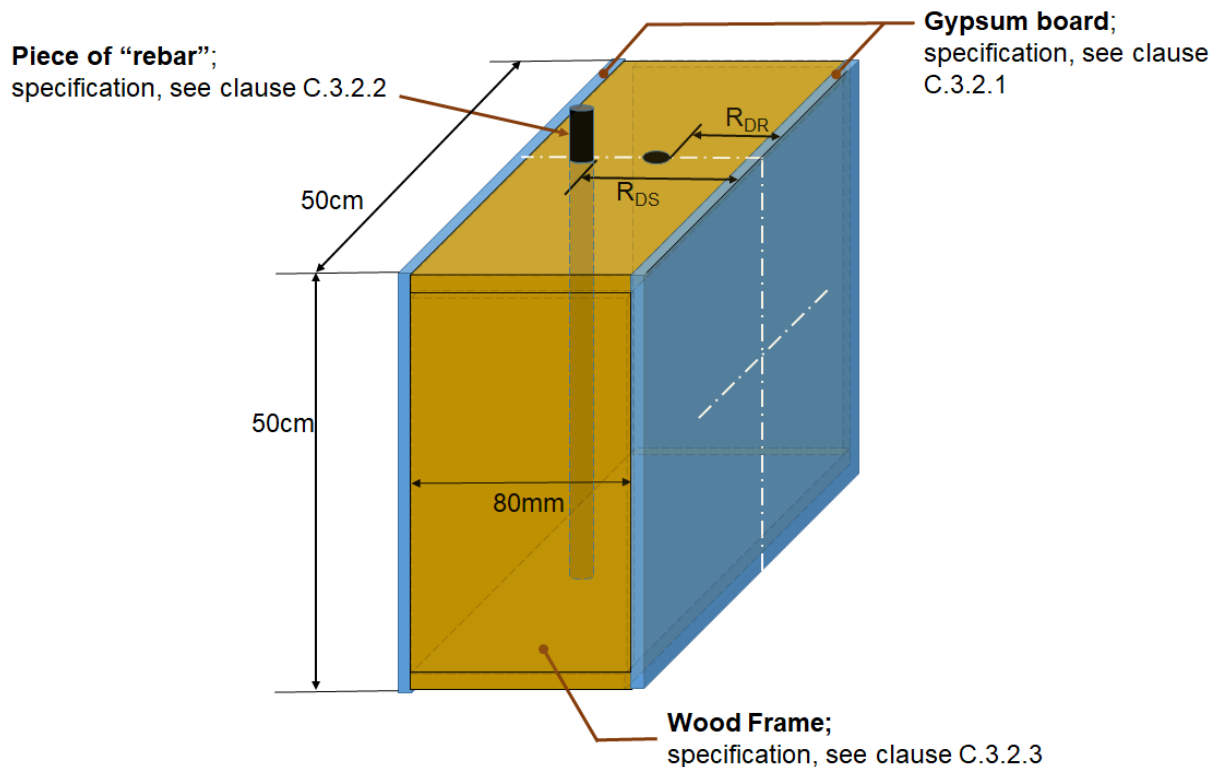

**Figure C.1: Test-wall for RX-assessment**

## C.3.2 Technical Details for RX Test-wall

### C.3.2.1 Specification of the Gypsum board

- Dimension: see clause C.3.1
- Thickness: 12,50 mm
- Gypsum board type: Type A, see clause 3.2.2 in EN 520 [3]

### C.3.2.2 Specification of the Rebar

- Thickness: see table C.4
- Length: same than dimension Test-wall, see clause C.3.1
- Specification: table 6 in EN 10080 [4]

**Table C.4: Requirement for rebar**

| Nominal diameter<br>[mm] | Nominal mass per meter<br>[kg/m] | Nominal cross sectional area<br>[mm <sup>2</sup> ] |
|--------------------------|----------------------------------|--|
| 12,0                     | 0,888                            | 113  |

### C.3.2.3 Specification of the Wood Frame

- Cross-section: 80 mm × 80 mm.
- Length: see dimension RX-test wall, see clause C.3.1.
- Type of the wood frame: KVH<sup>®</sup> structural timber, for non-exposed areas.
- Specification: see KVH<sup>®</sup> structural timber [5].

## Annex D (normative): Interferer for RBR test

### D.1 Interferer requirements for RBR tests

#### D.1.1 General test frequencies for RBR tests

ETSI EN 303 883-2 [2], clause A.2.1, usually defines the test frequencies inside and outside the OFR. One of two methods is selected depending on the OFR of the EUT. However, EUT covered by the present document operate over potentially very large bandwidths and therefore, to get realistic receiver test within the adjacent and blocking domain of the receiver, the test frequencies for the RBR tests shall be adjusted as follows:

- for EUT with OFR < 500 MHz: see clause D.1.2
- for EUT with OFR  $\geq$  500 MHz: see clause D.1.3

Despite the adjustment of the RBR test frequencies, the justification in terms of the of receiver requirements from ETSI EG 203 336 [i.15] given in ETSI EN 303 883-2 [2], clause C.1 is still valid for the EUT covered by the present document.

#### D.1.2 Test frequencies for EUT with OFR < 500 MHz

- Inband: one interferer test at frequency:  $f_L = f_C$
- Outside OFR, four interferer tests at:
  - frequency  $f_{L2} = f_C - 2 \times \text{OFR}$
  - frequency  $f_{L1} = f_C - 0,6 \times \text{OFR}$
  - frequency  $f_{H1} = f_C + 0,6 \times \text{OFR}$
  - frequency  $f_{H2} = f_C + 2 \times \text{OFR}$

For EUT with OFR < 500 MHz the interferer test frequencies in relation to the EUT OFR are shown in figure D.1.

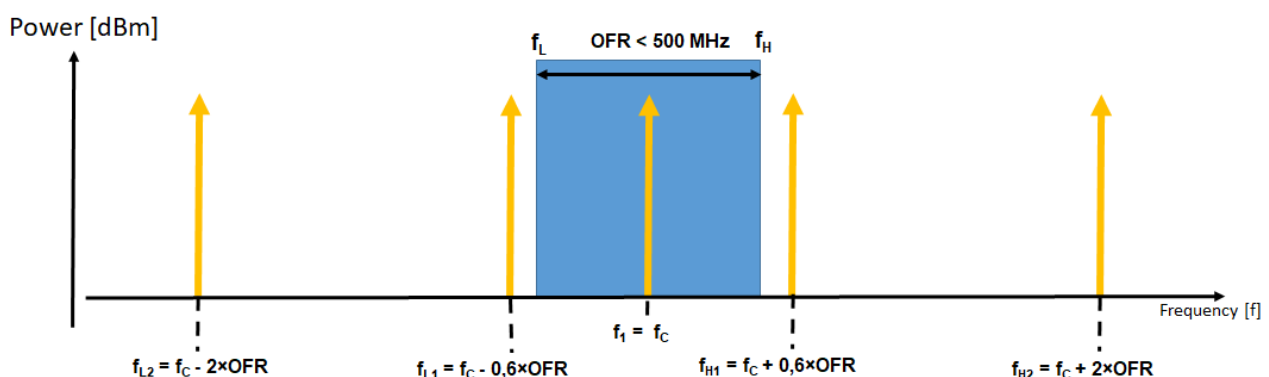

**Figure D.1: Interferer test frequencies in relation to the OFR (for EUT OFR < 500 MHz)**

For BMA sub-category BMA1, which are covered by the SRD regulation (see [i.2]), the factor 1 instead 0,6 shall be used. This is necessary based on the max OFR of 83 MHz and to be with the interfering test signal within the adjacent frequency range.



### D.1.3 Test frequencies for EUT with OFR $\geq 500$ MHz

- Inband: three interferer test at:
  - frequency  $f_1 = f_C$
  - frequency  $f_2 = f_C - 0,4 \times \text{OFR}$
  - frequency  $f_3 = f_C + 0,4 \times \text{OFR}$
- Outside OFR, four interferer tests at:
  - frequency  $f_{L2} = f_C - 1 \times \text{OFR}$
  - frequency  $f_{L1} = f_C - 0,6 \times \text{OFR}$
  - frequency  $f_{H1} = f_C + 0,6 \times \text{OFR}$
  - frequency  $f_{H2} = f_C + 1 \times \text{OFR}$

For EUT with OFR  $\geq 500$  MHz the interferer test frequencies in relation to the EUT OFR are shown in figure D.2.

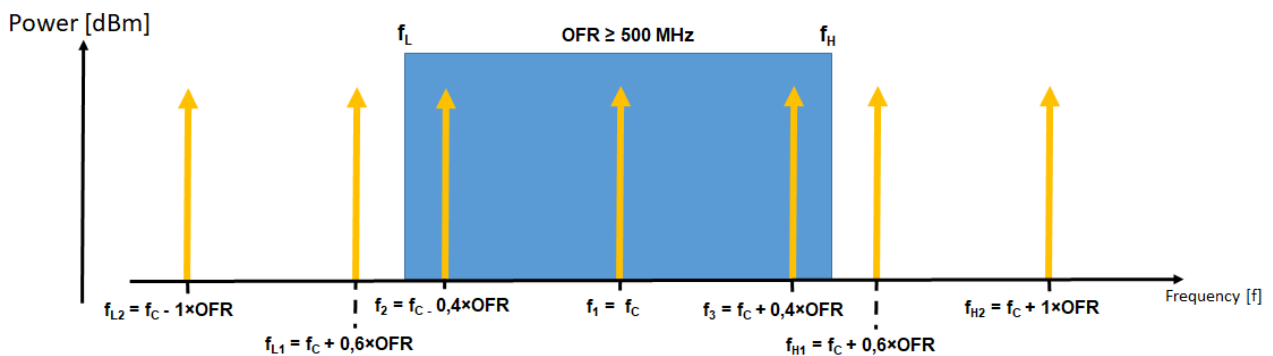

**Figure D.2: Interferer test frequencies in relation to the OFR (for EUT OFR  $\geq 500$  MHz)**

### D.1.4 Interferer power levels and modulation

For the specification of the interfering signals and power levels which shall be used for BMA category RBR tests, following documents were assessed:

- ETSI EN 303 883-2 [2], clause A.2.1.1.
- Application class according to ETSI TS 103 361 [i.12]: BMA devices can be used indoor and outdoor, therefore table 7 in ETSI TS 103 361 [i.12] provides the necessary information for the interferer assessment.
- Power level and duty-cycle according to the interferer assessment in ETSI TS 103 361 [i.12], table 7.

The assessment of the documents is described in clause D.4.

The outcome of the assessment is provided in table D.1. Table D.1 provides the necessary information for the RBR tests inside and outside the OFR in relation with the calculated test frequency.

Table D.1: List of interferers for BMA EUT category RBR test

| Calculated test frequency within range [MHz] | Radio application                    | Maximum EIRP [dBm] | Power @ device [dBm] | Duty cycle              |
|--|--------------------------------------|--------------------|----------------------|-------------------------|
| $30 \leq f \leq 34,995$                      | Active Medical Membrane Implants     | 0                  | -19                  | 6 min On, 54 min Off    |
| $34,995 \leq f \leq 35,225$                  | SRD                                  | 20                 | 1                    | 100 %                   |
| $40 \leq f \leq 40,25$                       | On-site paging systems/Pocket device | 17                 | -4                   | 100 %                   |
| $40,6 \leq f \leq 40,7$                      | SRD/Model control                    | 20                 | -1                   | 1 % within 1 s          |
| $47 \leq f \leq 68$                          | T-DAB                                | 60                 | -18                  | 100 %                   |
| $138,2 \leq f \leq 138,45$                   | Generic SRD                          | 10                 | -21                  | 100 %                   |
| $169,4 \leq f \leq 169,8$                    | SRD/Meter reading                    | 27                 | -6                   | 100 %                   |
| $174 \leq f \leq 240$                        | T-DAB                                | 60                 | -29                  | 100 %                   |
| $400,15 \leq f \leq 406$                     | Meteorological Aids (radiosondes)    | 23                 | -18                  | 100 %                   |
| $433,05 \leq f \leq 434,79$                  | Generic SRD/Non- specific use        | 41                 | -14                  | 100 %                   |
| $450,4 \leq f \leq 457,6$                    | GSM450 UE                            | 39                 | -3                   | 100 %                   |
| $457,6 \leq f \leq 460$                      | On-site paging systems/Pocket device | 17                 | -25                  | 100 %                   |
| $460 \leq f \leq 496$                        | GSM480 UE                            | 39                 | -3                   | 100 %                   |
| $703 \leq f \leq 748$                        | LTE E-UTRA UE                        | 23                 | -24                  | 10 % within 1 s         |
| $758 \leq f \leq 821$                        | LTE E-UTRA BS                        | 55                 | -45                  | 100 %                   |
| $823 \leq f \leq 832$                        | Wireless Microphones                 | 20                 | -27                  | 100 %                   |
| $832 \leq f \leq 862$                        | LTE-E-UTRA UE                        | 23                 | -24                  | 100 %                   |
| $863 \leq f \leq 870$                        | SRD                                  | 27                 | -20                  | 100 %                   |
| $870 \leq f \leq 915$                        | GSM 900 UE                           | 39                 | -8                   | 100 %                   |
| $915 \leq f \leq 921$                        | Generic SRD/RFID                     | 36                 | -12                  | 100 %                   |
| $921 \leq f \leq 960$                        | GSM 900 BS                           | 58                 | -44                  | 100 %                   |
| $1\,452 \leq f \leq 1\,492$                  | T-DAB                                | 60                 | -46                  | 100 %                   |
| $1\,710 \leq f \leq 1\,785$                  | LTE (E-UTRA UE)                      | 23                 | -30                  | 10 % within 1 s         |
| $1\,785 \leq f \leq 1\,805$                  | Wireless Microphones                 | 17                 | -37                  | 100 %                   |
| $1\,805 \leq f \leq 1\,880$                  | LTE (E-UTRA BS)                      | 55                 | -53                  | 100 %                   |
| $1\,920 \leq f \leq 1\,980$                  | IMT                                  | 24                 | -30                  | 100 %                   |
| $2\,010 \leq f \leq 2\,025$                  | IMT (UTRA UE)                        | 24                 | -31                  | 10 % within 1 s         |
| $2\,025 \leq f \leq 2\,110$                  | PMSE                                 | 23                 | -66                  | 100 %                   |
| $2\,110 \leq f \leq 2\,170$                  | IMT (UTRA BS)                        | 55                 | -54                  | 100 %                   |
| $2\,200 \leq f \leq 2\,290$                  | PMSE                                 | 23                 | -66                  | 100 %                   |
| $2\,300 \leq f \leq 2\,400$                  | IMT (E-UTRA UE)                      | 23                 | -33                  | 10 % within 1 s         |
| $2\,400 \leq f \leq 2\,483,5$                | Wideband data transmission           | 20                 | -36                  | 50 %, 5 ms On, 5 ms Off |
| $2\,500 \leq f \leq 2\,570$                  | IMT (UTRA UE)                        | 24                 | -33                  | 10 % within 1 s         |
| $2\,585 \leq f \leq 2\,600$                  | IMT (UTRA BS)                        | 55                 | -56                  | 100 %                   |
| $2\,570 \leq f \leq 2\,620$                  | IMT (E-UTRA UE)                      | 23                 | -34                  | 10 % within 1 s         |
| $2\,570 \leq f \leq 2\,620$                  | IMT (UTRA UE)                        | 24                 | -33                  | 10 % within 1 s         |
| $2\,620 \leq f \leq 2\,690$                  | IMT (BS)                             | 55                 | -56                  | 100 %                   |
| $3\,400 \leq f \leq 3\,600$                  | IMT (E-UTRA UE)                      | 26                 | -31                  | 10 % within 1 s         |
| $3\,600 \leq f \leq 3\,800$                  | IMT (E-UTRA UE)                      | 23                 | -34                  | 10 % within 1 s         |
| $4\,400 \leq f \leq 4\,800$                  | PMSE                                 | 23                 | -73                  | 100 %                   |
| $4\,800 \leq f \leq 4\,990$                  | BBDR-PPDR Terminal                   | 26                 | -70                  | 100 %                   |
| $4\,990 \leq f \leq 5\,000$                  | PMSE                                 | 12                 | -73                  | 100 %                   |
| $5\,150 \leq f \leq 5\,875$                  | RLAN                                 | 27                 | -36                  | 5 % within 1 s          |
| $5\,875 \leq f \leq 5\,945$                  | ITS                                  | 33                 | -45                  | 5 ms On, 50 ms Off      |
| $5\,945 \leq f \leq 6\,425$                  | RLAN                                 | 23                 | -39                  | 5 % within 1 s          |
| $6\,425 \leq f \leq 8\,500$                  | Fixed links                          | 85                 | -75                  | 100 %                   |
| $8\,500 \leq f \leq 10\,150$                 | Radiodetermination applications      | 30                 | -92                  | 100 %                   |
| $10\,150 \leq f \leq 10\,300$                | Fixed                                | 85                 | -78                  | 100 %                   |
| $10\,300 \leq f \leq 10\,500$                | PMSE                                 | 67                 | -56                  | 100 %                   |
| $10\,500 \leq f \leq 10\,650$                | BFWA                                 | 85                 | -38                  | 100 %                   |

## D.2 Interferer test signals for EUT category BMA1

The OFR for EUT category BMA1 is between 2,4 GHz to 2,4835 GHz or 5,725 GHz to 5,875 GHz (see table 2b) and therefore much less than 500 MHz. Accordingly clause D.1.2 applies for an OFR of < 500 MHz with one interferer test signal inside OFR and four interferer test signals outside the OFR.

Table D.2 and table D.3 are providing the interferer test signals for the RBR test of EUT category BMA1.

**Table D.2: List of interferers test signals for RBR tests for EUT category BMA1 within 2,4 GHz to 2,4835 GHz**

| Radio Service  | Test frequency [MHz]                 | Power @ device   | Signal modulation | Duty Cycle        |
|--|--------------------------------------|--|-------------------|-------------------|
| Interferer within OFR                                  | $f_1 = f_c$                          | -36 dBm  | CW                | 5 ms On, 5 ms Off |
| Interferer outside OFR                                 | $f_{L2} = f_c - 2 \times \text{OFR}$ | -33 dBm for OFR < 75 MHz (note 2)                      | CW                | 100 %             |
|  |                                      | -66 dBm for 75 MHz $\leq$ OFR $\leq$ 83,5 MHz (note 2) | CW                | 100 %             |
|  | $f_{L1} = f_c - 1 \times \text{OFR}$ | -33 dBm  | CW                | 10 % within 1 s   |
|  | $f_{H1} = f_c + 1 \times \text{OFR}$ | -33 dBm  | CW                | 10 % within 1 s   |
|  | $f_{H2} = f_c + 2 \times \text{OFR}$ | -33 dBm for OFR < 60 MHz (note 3)                      | CW                | 100 %             |
| -56 dBm for 60 MHz $\leq$ OFR $\leq$ 83,5 MHz (note 3) |                                      | CW   | 100 %             |                   |

NOTE 1: The related test frequencies can be calculated based on the measured  $f_c$  and OFR (see clause 4.3.2). The power levels for the interfering signals are derived from the interferer table D.1, clause D.1.4.  
NOTE 2: This difference comes from the adjacent IMT 2 300 MHz to 2 400 MHz and PMSE below 2 300 MHz.  
NOTE 3: This differentiation comes from the adjacent IMT UE from 2 500 MHz to 2 620 MHz and IMT BS above 2 620 MHz.

**Table D.3: List of interferers test signals for RBR tests for EUT category BMA1 within 5,725 GHz to 5,875 GHz**

| Radio Service                        | Test frequency [MHz]                 | Power @ device                                       | Signal modulation | Duty Cycle         |
|--------------------------------------|--------------------------------------|--|-------------------|--------------------|
| Interferer within OFR                | $f_1 = f_c$                          | -36 dBm  | CW                | 5 % within 1 s     |
| Interferer outside OFR               | $f_{L2} = f_c - 2 \times \text{OFR}$ | -36 dBm  | CW                | 5 % within 1 s     |
|                                      | $f_{L1} = f_c - 1 \times \text{OFR}$ | -36 dBm  | CW                | 5 % within 1 s     |
|                                      |                                      | -45 dBm for OFR < 140 MHz (note)                     | CW                | 5 ms On, 50 ms Off |
|                                      | $f_{H1} = f_c + 1 \times \text{OFR}$ | -39 dBm for 140 MHz $\leq$ OFR $\leq$ 150 MHz (note) | CW                | 5 % within 1 s     |
| $f_{H2} = f_c + 2 \times \text{OFR}$ |                                      | -39 dBm  | CW                | 5 % within 1 s     |

NOTE: This differentiation comes from the adjacent ITS from 5 875 MHz to 5 945 MHz and RLAN above 5 945 MHz.

## D.3 Interferer test signals for EUT categories BMA2, BMA3, BMA4 and BMA5

### D.3.1 Interferer test signals

The OFR for EUT categories BMA2, BMA3, BMA4 and BMA5 can be within 30 MHz and 10,6 GHz (see table 2a). Depending on the OFR measurement for EUT categories BMA2, BMA3, BMA4 and BMA5 (see clause 5.3.1.3) either clause D.1.2 (if OFR < 500 MHz) or clause D.1.3 (if OFR  $\geq$  500 MHz) applies.

Table D.4 provides the requirements for the RBR test if the OFR is < 500 MHz.

Table D.5 provides the requirements for the RBR test if the OFR is  $\geq$  500 MHz.

**Table D.4: List of interferers test signals for RBR tests for EUT with OFR < 500 MHz**

| Radio Service   | Test frequency [MHz]                                      | Power @ device [dBm] | Signal modulation | Duty Cycle    |
|---|---|----------------------|-------------------|---------------|
| Interferer within OFR   | $f_1 = f_c$   | See table D.1        | CW                | See table D.1 |
| Interferer outside OFR  | $f_{L2} = f_c - 2 \times \text{OFR}$<br>(notes 1 and 2)   | See table D.1        | CW                | See table D.1 |
|   | $f_{L1} = f_c - 0,6 \times \text{OFR}$<br>(notes 1 and 2) | See table D.1        | CW                | See table D.1 |
|   | $f_{H1} = f_c + 0,6 \times \text{OFR}$<br>(note 1)        | See table D.1        | CW                | See table D.1 |
|   | $f_{H2} = f_c + 2 \times \text{OFR}$<br>(note 1)          | See table D.1        | CW                | See table D.1 |
| NOTE 1: If no requirements are provided in table D.1 for interferer at the calculated test frequencies, then choose the following approach: <ul style="list-style-type: none"> <li>– <math>f_1</math>: choose in table E.1 the strongest of both adjacent interferer in frequency.</li> <li>– <math>f_{L2}</math>, <math>f_{L1}</math>: next interferer below the calculated frequency, see clause D.3.2.</li> <li>– <math>f_{H1}</math>, <math>f_{H2}</math>: next interferer higher than the calculated frequency, see clause D.3.2.</li> </ul> |   |                      |                   |               |
| NOTE 2: If based on calculation the test frequency would be below 0 Hz, then this test is not applicable.   |   |                      |                   |               |

**Table D.5: List of interferers test signals for RBR tests for EUT with OFR  $\geq$  500 MHz**

| Radio Service   | Test frequency [MHz] (note 1)                      | Power @ device [dBm] (note 3) | Signal modulation | Duty Cycle (note 3) |
|---|--|-------------------------------|-------------------|---------------------|
| Interferer within OFR   | $f_1 = f_c$  | See table D.1                 | CW                | See table D.1       |
|   | $f_2 = f_c - 0,4 \times \text{OFR}$                | See table D.1                 | CW                | See table D.1       |
|   | $f_3 = f_c + 0,4 \times \text{OFR}$                | See table D.1                 | CW                | See table D.1       |
| Interferer outside OFR  | $f_{L2} = f_c - 1 \times \text{OFR}$<br>(note 2)   | See table D.1                 | CW                | See table D.1       |
|   | $f_{L1} = f_c - 0,6 \times \text{OFR}$<br>(note 2) | See table D.1                 | CW                | See table D.1       |
|   | $f_{H1} = f_c + 0,6 \times \text{OFR}$             | See table D.1                 | CW                | See table D.1       |
|   | $f_{H2} = f_c + 1 \times \text{OFR}$               | See table D.1                 | CW                | See table D.1       |
| NOTE 1: If no requirements are provided in table D.1 for interferer at the calculated test frequencies, choose the following approach: <ul style="list-style-type: none"> <li>– <math>f_1</math>: choose the strongest of both adjacent interferer in frequency.</li> <li>– <math>f_2</math>: next interferer higher than the calculated frequency, see clause D.3.2.</li> <li>– <math>f_3</math>: next interferer lower than the calculated frequency, see clause D.3.2.</li> <li>– <math>f_{L2}</math>, <math>f_{L1}</math>: next interferer lower than the calculated frequency, see clause D.3.2.</li> <li>– <math>f_{H1}</math>, <math>f_{H2}</math>: next interferer higher than the calculated frequency, see clause D.3.2.</li> </ul> |  |                               |                   |                     |
| NOTE 2: If based on calculation the test frequency would be below 0 Hz, then this test is not applicable.   |  |                               |                   |                     |
| NOTE 3: If the calculated test frequency would be below 30 MHz or above 10,6 GHz following interferer test signals shall be taken: <ul style="list-style-type: none"> <li>– for test frequencies &lt; 30 MHz: power at the EUT: -30 dBm; signal CW with DC 100 %.</li> <li>– for test frequencies &gt; 10,6 GHz: power at the EUT: -30 dBm; signal CW with DC 100 %.</li> </ul>   |  |                               |                   |                     |

NOTE: The related test frequencies can be calculated based on the measured  $f_c$  and OFR (see clause 4.3.2). The power levels for the interfering signals are derived from the interferer in clause D.1.4, table D.1.

### D.3.2 Assessment if no interferer test signal provided at calculated test frequency

If no requirements are provided in table D.1 for interferer at the calculated test frequencies, choose the next interferer requirements from table D.1 and adjust the test frequency in relation to the frequency range of the interferer.

Figure D.3 and figure D.4 show the assessment procedure for the cases:

- Figure D.3 for the case "next interferer higher than the calculated frequency".
- Figure D.4 for the case "next interferer lower than the calculated frequency".

For the frequency  $f_1 = f_c$  it is requested to choose closest interferer in frequency, here the distance in frequency to the next interferer is relevant. The "closest" range shall be chosen. This could lead either to the case next interferer higher (see figure D.3) or the next interferer lower (see figure D.4) than the calculated frequency.

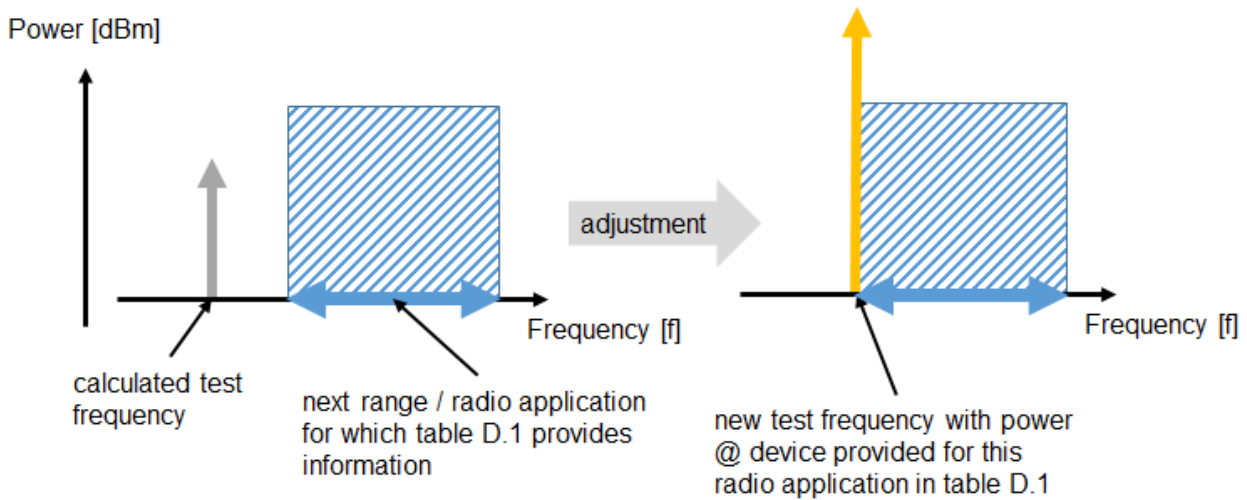

**Figure D.3: Interferer test signal adjustment for the case "next interferer higher than the calculated frequency"**

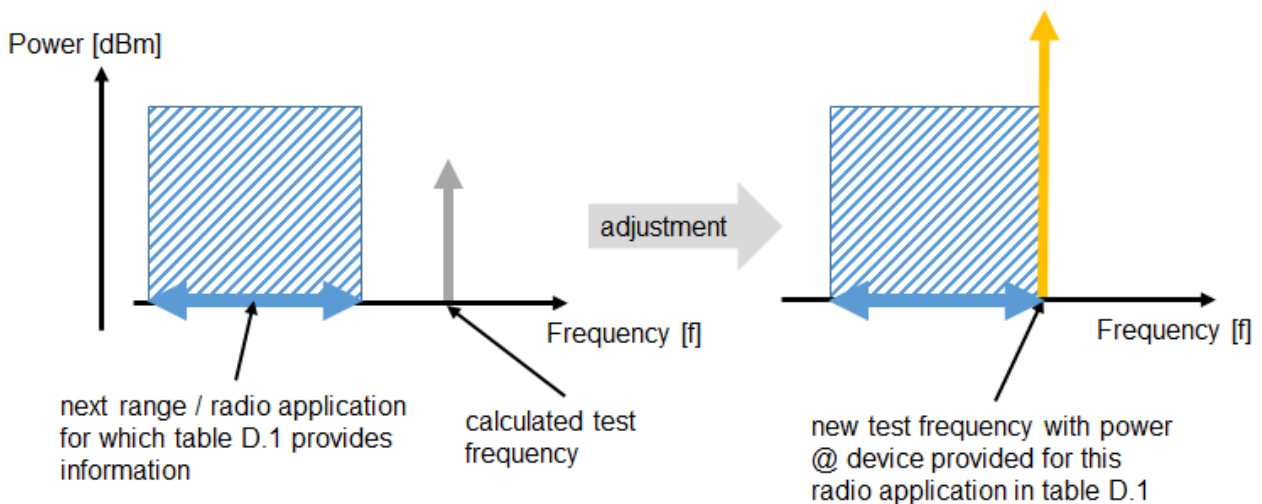

**Figure D.4: Interferer test signal adjustment for the case "next interferer lower than the calculated frequency"**

## D.4 List of interferer for RBR test; assessment procedure

### D.4.1 General

The RBR limits in the present document are derived based on ETSI EN 303 883-2 [2], clause A.2.1.1.

Clause A.2.1.1 of ETSI EN 303 883-2 [2] is referencing to ETSI TS 103 361 [i.12], which includes the list of interferers from which the highest interferer for the in-band and out-of-band test are chosen.

The list of interferers from table 1 of ETSI TS 103 361 [i.12] and specified for the indoor usage in table 7 of ETSI TS 103 361 [i.12], clause 7.6 ("Interferers for mobile (indoor and outdoor) applications") have been evaluated for the two permitted frequency bands of the present document and the highest level was taken as the limit. Even though there are several interferers present in some frequency ranges, only the highest interferer inside a frequency range is applicable. Therefore, the possible list of interferers was revised and amended, the result of the assessment is provided in clause D.1.4, table D.1.

The assessment procedure for the interference power level at the EUT is described in ETSI TS 103 361 [i.12] and was used for the new interferer added to the list of possible interferer, see clause D.4.2.4.

## D.4.2 Assessment list of relevant interferer

### D.4.2.1 Basic considerations

To consider only the relevant interferers the tables provided in ETSI TS 103 361 [i.12] were reviewed.

The following points were considered:

- If several interferers are present within the same frequency range, only the highest shall be considered for the RBR test, see clause D.4.2.2 for details.
- If there is a partial overlap in the frequency ranges of interferers, the range of the interferer with the lower power level at the EUT has been adjusted, see clause D.4.2.3 for details.
- Review of the list of possible interferers, deletion of interferers which are no longer present or addition of newly allocated services, see clause D.4.2.4 for details.

### D.4.2.2 Several interferer within the same frequency range

In case several interferers could be present in one frequency range, only the interferer with the highest power of interference at the EUT (based on the usage scenario) was kept.

As an example, table D.6 shows an excerpt from the "complete" list of the possible interferers (ETSI TS 103 361 [i.12], table 1 and table 7).

**Table D.6: Excerpt from ETSI TS 103 361 [i.12], table 1 and table 7**

| Radio Service              | Frequency [MHz] |         | Power @ device [dBm] |
|----------------------------|-----------------|---------|----------------------|
| SRD, Radiodetermination    | 2 400           | 2 483,5 | -42                  |
| Wideband data transmission | 2 400           | 2 483,5 | -36                  |
| RFID                       | 2 446           | 2 454   | -43                  |
| RFID (in building only)    | 2 446           | 2 454   | -43                  |

After the amendment, based on power level and probability of interference this is in table D.7.

**Table D.7: Example result after assessment considering highest interferer within a frequency range**

| Radio Service              | Frequency [MHz] |         | Power @ device [dBm] |
|----------------------------|-----------------|---------|----------------------|
| Wideband data transmission | 2 400           | 2 483,5 | -36                  |

### D.4.2.3 Interferer overlapping in frequency range

In case of a (partial) overlap of interferers in frequency, the frequency range of the interferer with the higher emissions was kept, while the range with the lower level was reduced.

As an example, table D.8 shows an excerpt from the "complete" list of the possible interferers (ETSI TS 103 361 [i.12], table 1 and table 7).

**Table D.8: Excerpt from ETSI TS 103 361 [i.12], table 1 and table 7**

| Radio Service              | Frequency [MHz] | Test Frequency [MHz] | max. EIRP [dBm] | Power @ device [dBm] | Radio Service |
|----------------------------|-----------------|----------------------|-----------------|----------------------|---------------|
| IMT (UTRA FDD Band XVI UE) | 2 010 - 2 025   | 2 017,5              | 24              | -31                  | 3,84          |
| PMSE                       | 2 015 - 2 110   | 2 062                | 23              | -66                  | 10            |

After the assessment, the overlapping frequency range was removed, see table D.9.

**Table D.9: Example result after assessment considering frequency range overlap of interferer**

| Radio Service              | Frequency [MHz] | Power @ device [dBm] | Radio Service |
|----------------------------|-----------------|----------------------|---------------|
| IMT (UTRA FDD Band XVI UE) | 2 010 - 2 025   | -31                  | 3,84          |
| PMSE                       | 2 025 - 2 110   | -66                  | 10            |

#### D.4.2.4 Status of interferer

During the revision of the list of possible interferers ("complete" list (ETSI TS 103 361 [i.12], table 1 and table 7), the following changes were considered:

- GSM, CDMA, UMTS, DCS, PCS and WIMAX systems are or soon will be no longer in service, I-UTRA, LTE systems will be considered instead.
- New RLAN allocation in 5 945 MHz to 6 425 MHz (see ECC/DEC/(20)/01 [i.13]) was added.
- Changes in the usage of 3 400 MHz to 3 800 MHz, frequency range is still not used by WIMAX, in this range I-UTRA, LTE systems will be considered, see ETSI TS 136 101 [i.14].

#### D.4.3 Kind of interferer signal

Based on the fact the OFR of the EUT categories covered by the present document are mostly broader than the bandwidth of a possible interfering signal, it can be assumed that in the interference case the bandwidth of the interfering signal will be completely within the OFR of the UWB EUT. Therefore, only the power level and the duty cycle of the interfering signal would be relevant. Therefore, a CW signal with the related DC shall be taken for the RBR tests within the OFR.

For the DC requirement the related ECC compatibility reports were considered to choose the typical transmission behaviour, see EFIS; ECO Frequency Information System [i.16].

## Annex E (normative): Definition of the representative test structure for TX measurements

### E.1 Attenuation of the TX-test structure

ECC/DEC(07)01 [i.1] provides the following definition of a representative test structure: "The radiations into the air as a result of the operation of material sensing devices are highly dependent on the operational conditions and are only meaningful if coupled with the material being investigated; therefore a measurement scenario with a representative structure is necessary and is defined within the related document for material sensing devices investigating wall structures; the representative wall has to meet the wall attenuation values within table 4 of this Decision ECC/DEC(07)01". The wall attenuation values from [i.1] are given in table E.1.

**Table E.1: Representative TX-test structure attenuation values**

| Frequency<br>(GHz) | Attenuation values for the representative test structure in dB |         |         |
|--------------------|--|---------|---------|
|                    | Minimum  | average | maximum |
| 1                  | 5  | 7,00    | 9,00    |
| 2                  | 8  | 10,00   | 12,00   |
| 3                  | 10   | 12,00   | 14,00   |
| 4                  | 12   | 14,00   | 16,00   |
| 5                  | 14   | 16,00   | 18,00   |
| 6                  | 16   | 18,00   | 20,00   |
| 7                  | 18   | 20,00   | 22,00   |
| 8                  | 20   | 22,00   | 24,00   |

If the attenuation of the TX-test structure is lower than the minimum value given in table E.1 the provisions of clause E.3 apply.

The size of the representative wall shall be  $1 \times 1$  meter, see figure E.1.

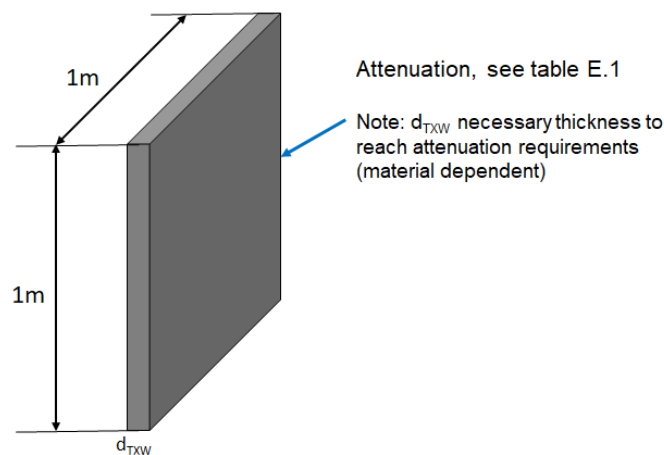

**Figure E.1: Dimensions test wall**



## E.2 Procedure to measure the attenuation

The measurement principle is shown in figure E.2 and figure E.3. The measurement of the attenuation of the representative structure shall be inside an anechoic chamber, see ETSI EN 303 883-1 [1], clause B.2.2.2.

In a first step, calibration is performed using the setup shown in figure E.2.

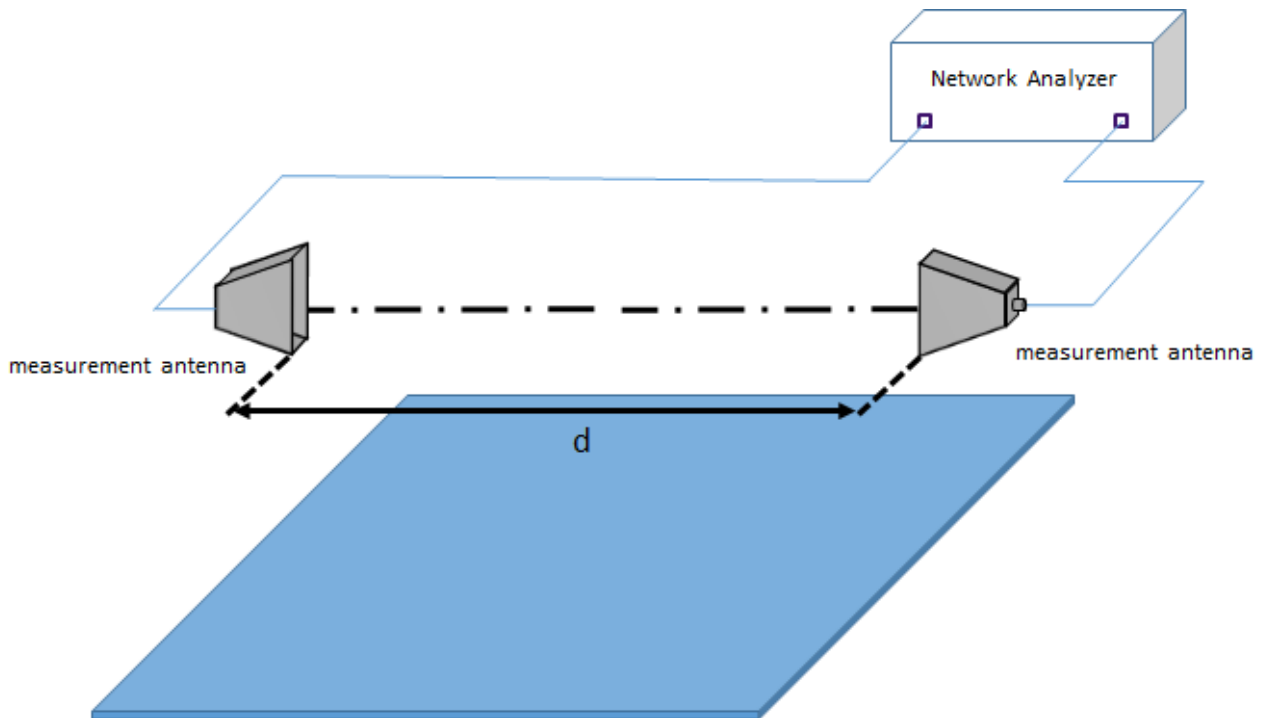

**Figure E.2: Calibration setup**

It is important that the antenna main beam of both measurement antennas are exactly aligned to each other and the distance ( $d$ ) between the two identical antennas shall be larger than  $2 \times$  minimal far field distance (see ETSI EN 303 883-1 [1], clause B.2.3.5).

The beamwidth "ant\_beam" of the measurement antennas shall be lower than the requirement specified in equation (E.1):

$$ant\_beam < 2 \times \arctan\left(\frac{size\_of\_wall}{d}\right) \quad (E.1)$$

Calibration Steps:

- 1) Set the start and stop frequencies of the network analyser to  $f_L$  and  $f_H$  as derived from the OFR measurements (see clause 4.3.2) The frequency range depends on the measurement antennas.
- 1) Calibrate the system in the S21 Mode.

After calibration of the setup, the representative wall shall be placed between the two antennas, with  $d_1 = d_2$ , see figure E.3.

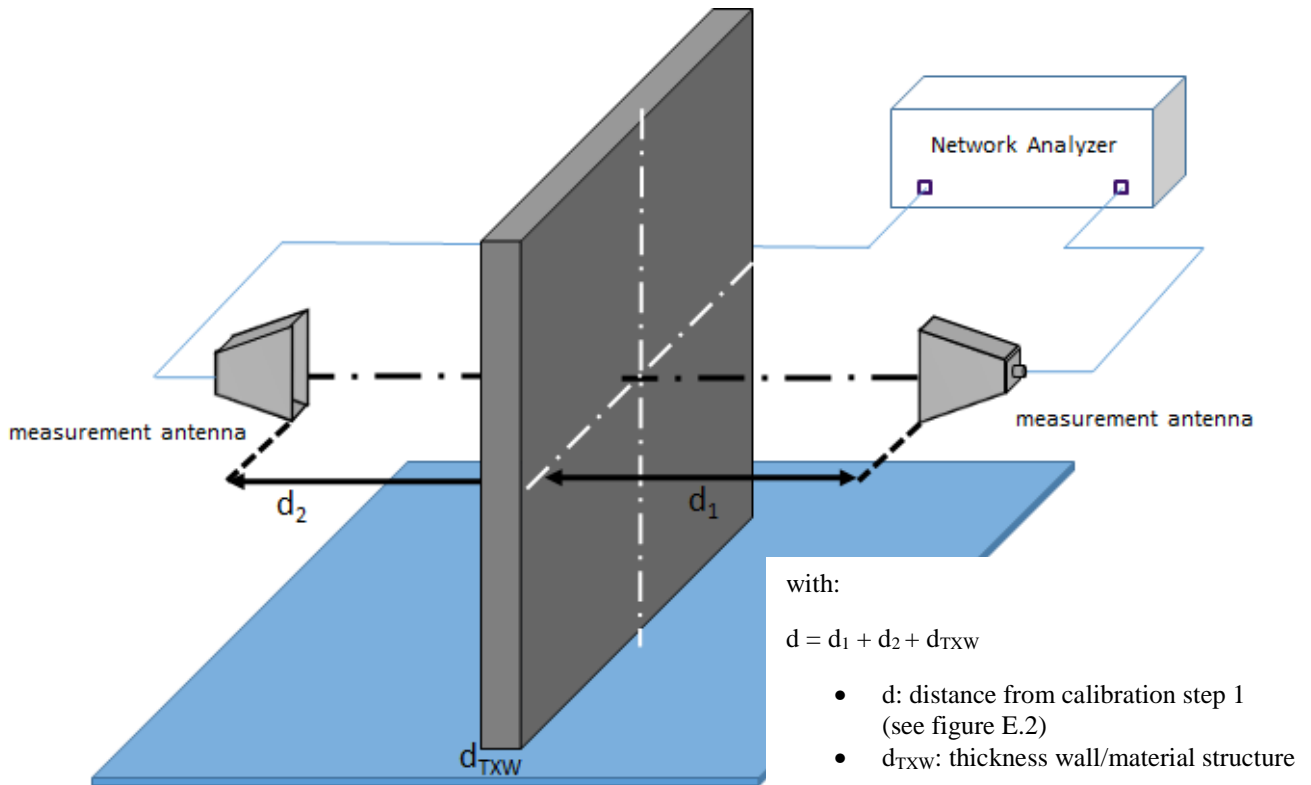

**Figure E.3: Attenuation measurement of the wall/material structure**

The network analyser shows now the attenuation of the wall ( $g_{wall}$ ) in dB.

The network analyser shall then be used with the time gating option. This is important because with this option it is possible to obtain the necessary signal parts for the attenuation measurement (more signal components or more signal reflexions can yield to wrong results).

Other setups can be used if the presented method in this clause is not feasible for the typical absorbing material used for the measurements of the devices under test.

An example of a measurement result of a representative wall, as described in clause E.1 is shown in figure E.4.

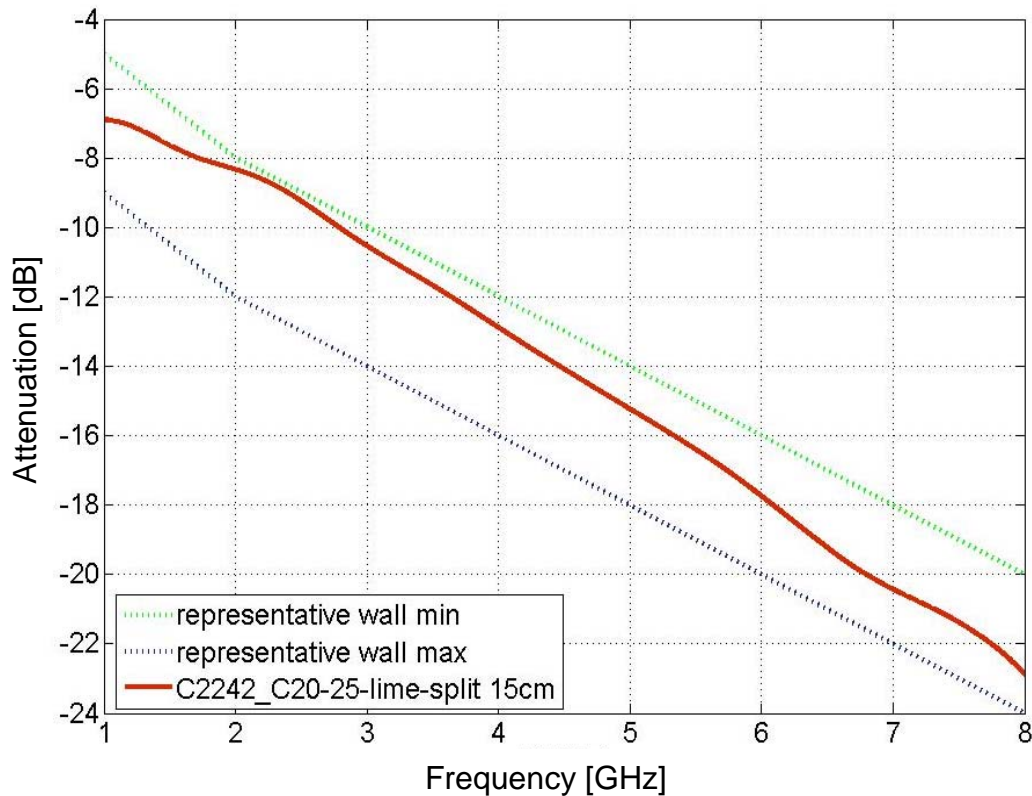

**Figure E.4: Typical result for a typical absorbing material, here as example: concrete as specified in EN 206 [i.11] with a thickness  $d_{TXW}$  of 15 cm**

### E.3 Absorbing materials with lower attenuation

For other absorbing material the attenuation characteristics as exemplified in table E.1 of the representative TX-test structure used in the measurements specified in the present document shall match the characteristics of the typical target absorbing material. Justifications shall be provided in the test report.

If it is impractical to match the absorption characteristics for the TX-test structure, lower attenuation values can be utilized.

In this case:

- the indirect emission requirement, the limit values in clause 4.3.4; and
- the total power requirement, the limit value in clause 4.3.6;

can be increased by the difference between the real attenuation of the TX-test structure (see clause E.2) and requested average attenuation values, see table E.1;

- for the DC conformance assessment (see clause 4.3.8), the limit values for the indirect emissions can be increased by the difference between the real attenuation of the TX-test structure (see clause E.2) and requested average attenuation values, see table E.1.

Higher attenuation values than requested as in table E.1 are not permitted.

---

## Annex F (informative): Bibliography

[ECC/DEC\(06\)04](#): "ECC/DEC/(06)04 of 24 March 2006 on the harmonised use, exemption from individual licensing and free circulation of devices using Ultra-Wideband (UWB) technology in bands below 10.6 GHz", latest amended on 18 November 2022.

## Annex G (informative): Change history

| Version                      | Information about changes  |
|------------------------------|--|
| ETSI EN 302 065-4 (V1.1.1)   | <p>First version of ETSI EN 302 065-4 for Material Sensing devices using UWB technology below 10,6 GHz; listed in the OJEU for Art. 3.2 of 2014/53/EU without restriction at 12 April 2017. It was a merge of ETSI EN 302 435-1/-2 and ETSI EN 302 498 -1/-2 into one EN. The main changes compared to the previous version(s) are:</p> <ul style="list-style-type: none"> <li>• Out-sourcing of standard measurement procedures into a separate ETSI EN 303 883 (V1.1.1).</li> <li>• Harmonisation of description of material sensing, building material sensing and object discrimination applications.</li> <li>• New requirement on receiver interferer signal handling.</li> <li>• New annex B "Application form for testing".</li> <li>• New annex C "Equivalent Mitigation techniques".</li> </ul>  |
| ETSI EN 302 065-4-1 (V2.2.1) | <p>First version of ETSI EN 302 065-4-1 for Material Sensing devices for building material analysis below 10,6 GHz; Revision on request of the EC to improve the standard, especially regarding receiver requirements; see more details in the introduction. The main changes compared to the previous version are:</p> <ul style="list-style-type: none"> <li>• Add a measurement mode for BMA devices based on SRD regulation.</li> <li>• Change the EN structure to allow other use-cases with other intended use-case requirements than BMA.</li> <li>• Clear categorization of EUT covered by the present document based on regulation, technical implementations and intended use-case requirements.</li> <li>• RX-requirements based on the signal interferer handling concept.</li> <li>• Adding TX-requirement over environmental profile.</li> </ul> |

## History

| <b>Document history</b> |               |   |
|-------------------------|---------------|---|
| V1.1.1                  | November 2016 | Publication as ETSI EN 302 065-4                            |
| V2.1.0                  | July 2021     | EN Approval Procedure AP 20211024: 2021-07-26 to 2021-10-25 |
| V2.1.1                  | July 2024     | SRdAP process EV 20241024: 2024-07-26 to 2024-10-24         |
| V2.1.5                  | December 2024 | SRdAP process VA 20250218: 2024-12-20 to 2025-02-18         |
|                         |               |   |