

ETSI EN 303 489 V1.1.1 (2026-01)



HARMONISED EUROPEAN STANDARD

**Air Traffic Control Surveillance;
Wide Area Multilateration (WAM) systems operating
at 1 030 MHz and 1 090 MHz;
Harmonised Standard for access to radio spectrum**

Reference

DEN/ERM-TGAERO-36

Keywords

aeronautical, harmonised standard, radio

ETSI

650 Route des Lucioles
F-06921 Sophia Antipolis Cedex - FRANCE

Tel.: +33 4 92 94 42 00 Fax: +33 4 93 65 47 16

Siret N° 348 623 562 00017 - APE 7112B
Association à but non lucratif enregistrée à la
Sous-Préfecture de Grasse (06) N° w061004871

Important notice

The present document can be downloaded from the
[ETSI Search & Browse Standards](#) application.

The present document may be made available in electronic versions and/or in print. The content of any electronic and/or print versions of the present document shall not be modified without the prior written authorization of ETSI. In case of any existing or perceived difference in contents between such versions and/or in print, the prevailing version of an ETSI deliverable is the one made publicly available in PDF format on [ETSI deliver](#) repository.

Users should be aware that the present document may be revised or have its status changed, this information is available in the [Milestones listing](#).

If you find errors in the present document, please send your comments to the relevant service listed under [Committee Support Staff](#).

If you find a security vulnerability in the present document, please report it through our [Coordinated Vulnerability Disclosure \(CVD\)](#) program.

Notice of disclaimer & limitation of liability

The information provided in the present deliverable is directed solely to professionals who have the appropriate degree of experience to understand and interpret its content in accordance with generally accepted engineering or other professional standard and applicable regulations.

No recommendation as to products and services or vendors is made or should be implied. In no event shall ETSI be held liable for loss of profits or any other incidental or consequential damages.

Any software contained in this deliverable is provided "AS IS" with no warranties, express or implied, including but not limited to, the warranties of merchantability, fitness for a particular purpose and non-infringement of intellectual property rights and ETSI shall not be held liable in any event for any damages whatsoever (including, without limitation, damages for loss of profits, business interruption, loss of information, or any other pecuniary loss) arising out of or related to the use of or inability to use the software.

Copyright Notification

No part may be reproduced or utilized in any form or by any means, electronic or mechanical, including photocopying and microfilm except as authorized by written permission of ETSI.

The content of the PDF version shall not be modified without the written authorization of ETSI.

The copyright and the foregoing restriction extend to reproduction in all media.

© ETSI 2026.
All rights reserved.

Contents

Intellectual Property Rights	7
Foreword.....	7
Modal verbs terminology.....	8
Introduction	8
1 Scope	9
2 References	9
2.1 Normative references	9
2.2 Informative references.....	10
3 Definition of terms, symbols and abbreviations.....	10
3.1 Terms.....	10
3.2 Symbols.....	12
3.3 Abbreviations	12
4 Technical requirements specifications	12
4.1 Environmental profile.....	12
4.2 Conformance requirements	13
4.2.1 Applicability	13
4.2.1.1 Equipment with and without integral antenna.....	13
4.2.1.2 Equipment with multiple functions	13
4.2.2 Transmitter requirements.....	13
4.2.2.1 Operating frequency and frequency error	13
4.2.2.1.1 Definition.....	13
4.2.2.1.2 Limits	13
4.2.2.1.3 Conformance	13
4.2.2.2 Spectrum mask.....	13
4.2.2.2.1 Definition.....	13
4.2.2.2.2 Limits	14
4.2.2.2.3 Conformance	15
4.2.2.3 Residual power output.....	15
4.2.2.3.1 Definition.....	15
4.2.2.3.2 Limits	15
4.2.2.3.3 Conformance	16
4.2.2.4 Spurious emissions in active mode	16
4.2.2.4.1 Definition.....	16
4.2.2.4.2 Limits	16
4.2.2.4.3 Conformance	16
4.2.2.5 Intermodulation attenuation	16
4.2.2.5.1 Definition.....	16
4.2.2.5.2 Limits	16
4.2.2.5.3 Conformance	16
4.2.2.6 Pulse Shape and Spacing.....	17
4.2.2.6.1 Definition.....	17
4.2.2.6.2 Limits	17
4.2.2.6.3 Conformance	19
4.2.2.7 Duty cycle	19
4.2.2.7.1 Definition.....	19
4.2.2.7.2 Limits	19
4.2.2.7.3 Conformance	20
4.2.2.8 Peak output power.....	20
4.2.2.8.1 Definition.....	20
4.2.2.8.2 Limits	20
4.2.2.8.3 Conformance	20
4.2.3 Receiver requirements	20
4.2.3.1 Sensitivity variation over the operating frequency range.....	20
4.2.3.1.1 Definition.....	20

4.2.3.1.2	Limits	20
4.2.3.1.3	Conformance	20
4.2.3.2	RF selectivity and spurious response rejection	21
4.2.3.2.1	Definition.....	21
4.2.3.2.2	Limits	21
4.2.3.2.3	Conformance	21
4.2.3.3	Inter-modulation response rejection.....	21
4.2.3.3.1	Definition.....	21
4.2.3.3.2	Limits	21
4.2.3.3.3	Conformance	21
4.2.3.4	Co-channel rejection	22
4.2.3.4.1	Definition.....	22
4.2.3.4.2	Limits	22
4.2.3.4.3	Conformance	22
4.2.3.5	Blocking.....	22
4.2.3.5.1	Definition.....	22
4.2.3.5.2	Limits	22
4.2.3.5.3	Conformance	22
4.2.3.6	Sensitivity	22
4.2.3.6.1	Definition.....	22
4.2.3.6.2	Limits	22
4.2.3.6.3	Conformance	22
4.2.3.7	Receiver spurious emissions	23
4.2.3.7.1	Definition.....	23
4.2.3.7.2	Limits	23
4.2.3.7.3	Conformance	23
4.2.3.8	Dynamic range	23
4.2.3.8.1	Definition.....	23
4.2.3.8.2	Limits	23
4.2.3.8.3	Conformance	23
5	Testing for compliance with technical requirements.....	23
5.1	Environmental conditions for testing	23
5.1.1	General requirements.....	23
5.1.2	Test conditions.....	24
5.1.2.1	Thermal Balance	24
5.1.2.2	Normal Test Conditions	24
5.1.2.2.1	Temperature and humidity.....	24
5.1.2.2.2	Power supply	24
5.1.2.3	Extreme Test Conditions	24
5.1.2.3.1	Temperature and humidity.....	24
5.1.2.3.2	Power supply	25
5.2	Test and general conditions	25
5.2.1	Transmitter test signals	25
5.2.1.1	General considerations	25
5.2.1.2	Test signal 1	25
5.2.1.3	Test signal 2	25
5.2.1.4	Test signal 3	26
5.2.1.5	Test signal 4	26
5.2.1.6	Test signal 5	26
5.2.2	Simulated received test signals	27
5.2.2.1	General Considerations	27
5.2.2.2	Test signal 6	27
5.2.2.3	Test signal 7	27
5.2.2.4	Test signal 8	28
5.3	Transmitter tests	28
5.3.1	Operating frequency and frequency error	28
5.3.1.1	Description	28
5.3.1.2	Test conditions	28
5.3.1.3	Method of measurement.....	28
5.3.1.4	Measurement procedure	29
5.3.2	Spectrum mask.....	29

5.3.2.1	Description	29
5.3.2.2	Test conditions	29
5.3.2.3	Method of measurement	29
5.3.2.4	Measurement procedure	30
5.3.3	Residual power output	30
5.3.3.1	Description	30
5.3.3.2	Test conditions	30
5.3.3.3	Method of measurement	30
5.3.3.4	Measurement procedure	31
5.3.4	Spurious emissions in active mode	31
5.3.4.1	Description	31
5.3.4.2	Test conditions	31
5.3.4.3	Method of measurement	31
5.3.4.4	Measurement Procedure	31
5.3.4.4.1	Part 1: Measurement of PEP and determination of spurious emission limit	31
5.3.4.4.2	Part 2: Spurious emission measurement procedure	32
5.3.5	Intermodulation attenuation	33
5.3.5.1	Description	33
5.3.5.2	Test Conditions	33
5.3.5.3	Method of Measurement	33
5.3.5.4	Measurement Procedure	34
5.3.6	Pulse Shape and Spacing	35
5.3.6.1	Description	35
5.3.6.2	Test Conditions	35
5.3.6.3	Method of Measurement	35
5.3.6.4	Measurement procedure	36
5.3.7	Duty cycle	36
5.3.7.1	Description	36
5.3.7.2	Test Conditions	36
5.3.7.3	Method of Measurement	37
5.3.7.4	Measurement procedure	37
5.3.8	Peak output power	37
5.3.8.1	Description	37
5.3.8.2	Test Conditions	37
5.3.8.3	Method of Measurement	37
5.3.8.4	Measurement procedure	38
5.3.8.4.1	Equipment containing a 1 030 MHz interrogation function	38
5.3.8.4.2	Equipment containing a 1 090 MHz reference/test transmission function	38
5.4	Receiver tests	38
5.4.1	Sensitivity and sensitivity variation over the operating frequency range	38
5.4.1.1	Description	38
5.4.1.2	Test Conditions	38
5.4.1.3	Method of Measurement	38
5.4.1.4	Measurement procedure	39
5.4.2	RF selectivity and spurious response rejection	39
5.4.2.1	Description	39
5.4.2.2	Test Conditions	39
5.4.2.3	Method of Measurement	39
5.4.2.4	Measurement procedure	40
5.4.3	Inter-modulation response rejection	40
5.4.3.1	Description	40
5.4.3.2	Test Conditions	41
5.4.3.3	Method of Measurement	41
5.4.3.4	Measurement procedure	41
5.4.4	Co-channel rejection	42
5.4.4.1	Description	42
5.4.4.2	Test Conditions	42
5.4.4.3	Method of Measurement	42
5.4.4.4	Measurement procedure	42
5.4.5	Blocking	43
5.4.5.1	Description	43
5.4.5.2	Test Conditions	43

5.4.5.3	Method of Measurement	43
5.4.5.4	Measurement procedure	43
5.4.6	Receiver spurious emissions	44
5.4.6.1	Description	44
5.4.6.2	Test Conditions	44
5.4.6.3	Method of Measurement	44
5.4.6.4	Measurement procedure	44
5.4.7	Dynamic range	45
5.4.7.1	Description	45
5.4.7.2	Test Conditions	45
5.4.7.3	Method of Measurement	45
5.4.7.4	Measurement procedure	45
Annex A (informative):	Relationship between the present document and the essential requirements of Directive 2014/53/EU	46
Annex B (informative):	Checklist	48
Annex C (informative):	Maximum measurement uncertainty	49
History		50

Intellectual Property Rights

Essential patents

IPRs essential or potentially essential to normative deliverables may have been declared to ETSI. The declarations pertaining to these essential IPRs, if any, are publicly available for **ETSI members and non-members**, and can be found in ETSI SR 000 314: "*Intellectual Property Rights (IPRs); Essential, or potentially Essential, IPRs notified to ETSI in respect of ETSI standards*", which is available from the ETSI Secretariat. Latest updates are available on the [ETSI IPR online database](#).

Pursuant to the ETSI Directives including the ETSI IPR Policy, no investigation regarding the essentiality of IPRs, including IPR searches, has been carried out by ETSI. No guarantee can be given as to the existence of other IPRs not referenced in ETSI SR 000 314 (or the updates on the ETSI Web server) which are, or may be, or may become, essential to the present document.

Trademarks

The present document may include trademarks and/or tradenames which are asserted and/or registered by their owners. ETSI claims no ownership of these except for any which are indicated as being the property of ETSI, and conveys no right to use or reproduce any trademark and/or tradename. Mention of those trademarks in the present document does not constitute an endorsement by ETSI of products, services or organizations associated with those trademarks.

DECT™, **PLUGTESTS™**, **UMTS™** and the ETSI logo are trademarks of ETSI registered for the benefit of its Members. **3GPP™**, **LTE™** and **5G™** logo are trademarks of ETSI registered for the benefit of its Members and of the 3GPP Organizational Partners. **oneM2M™** logo is a trademark of ETSI registered for the benefit of its Members and of the oneM2M Partners. **GSM®** and the GSM logo are trademarks registered and owned by the GSM Association.

Foreword

This Harmonised European Standard (EN) has been produced by ETSI Technical Committee Electromagnetic compatibility and Radio spectrum Matters (ERM).

The present document has been prepared under the Commission's standardisation request C(2015) 5376 final [i.2] to provide one voluntary means of conforming to the essential requirements of Directive 2014/53/EU on the harmonisation of the laws of the Member States relating to the making available on the market of radio equipment and repealing Directive 1999/5/EC [i.1].

Once the present document is cited in the Official Journal of the European Union under that Directive, compliance with the normative clauses of the present document given in Table A.1 confers, within the limits of the scope of the present document, a presumption of conformity with the corresponding essential requirements of that Directive, and associated EFTA regulations.

National transposition dates	
Date of adoption of this EN:	20 January 2026
Date of latest announcement of this EN (doa):	30 April 2026
Date of latest publication of new National Standard or endorsement of this EN (dop/e):	31 October 2026
Date of withdrawal of any conflicting National Standard (dow):	31 October 2027

Modal verbs terminology

In the present document "shall", "shall not", "should", "should not", "may", "need not", "will", "will not", "can" and "cannot" are to be interpreted as described in clause 3.2 of the [ETSI Drafting Rules](#) (Verbal forms for the expression of provisions).

"**must**" and "**must not**" are **NOT** allowed in ETSI deliverables except when used in direct citation.

Introduction

Wide Area Multilateration (WAM) Systems provide cooperative surveillance service for all types of airspace covering 1 030 MHz / 1 090 MHz transponder equipped aircraft in flight. WAM systems typically extend over a larger region with multiple ground stations that are equipped with a receive function, an interrogation function, or both. A central processor coordinates and schedules interrogation activity and performs position calculation. WAM systems provide their RF interface via non-rotating omni-directional or sectorial antennas. Multiple transmitters are simultaneously operated both for redundancy and to cover disjunctive parts of the designated coverage volume. Interrogations serve to perform range measurements supporting position calculation as well as for soliciting the downlink of aircraft derived data.

An additional function is used for built-in end-to-end integrity testing of the WAM system. This test transmission function provides 1 090 MHz Mode S signals at regular intervals for the WAM receivers to receive and process.

The test transmission function may also be used to establish a precise common time base throughout the entire WAM system, in a similar way as this is done for airport Multilateration systems (MLAT). This function is then referred to as "reference transmission".

The 1 090 MHz test/reference transmission function may be integrated with the interrogation function, i.e. as a 1 030/1 090 MHz transmit function in some ground stations or implemented as a separate test transmitter or transponder. As the WAM system elements (ground stations) can be distributed across a larger region, there can be multiple test transmission sources distributed throughout the system.

1 Scope

The present document specifies technical characteristics and methods of measurements for the following equipment used in ground-based ATC Surveillance for civil air navigation:

- Wide Area Multilateration (WAM) systems with Mode S capabilities which may include Mode A/C, transmitting at 1 030 MHz and at 1 090 MHz, and receiving at 1 090 MHz, used for air traffic control with or without 1 090 MHz phase overlay.

The system operates in the frequencies as indicated in Table 1 below.

Table 1: WAM service frequencies

Signals	Service frequencies
Interrogation Transmission	1 030 MHz
Reference/Test Transmission	1 090 MHz
Receive	1 090 MHz

Antennas for this equipment are passive.

Remote Field Monitors (RFM) as described in ETSI EN 303 363-2 [i.6] as well as Vehicle transmitters as described in ETSI EN 303 213-5-2 [i.7] are not covered in the present document.

NOTE: The relationship between the present document and essential requirements of article 3.2 of Directive 2014/53/EU [i.1] is given in Annex A.

2 References

2.1 Normative references

References are either specific (identified by date of publication and/or edition number or version number) or non-specific. For specific references, only the cited version applies. For non-specific references, the latest version of the referenced document (including any amendments) applies.

Referenced documents which are not found to be publicly available in the expected location might be found in the [ETSI docbox](#).

NOTE: While any hyperlinks included in this clause were valid at the time of publication, ETSI cannot guarantee their long-term validity.

The following referenced documents are necessary for the application of the present document.

- [1] [ICAO Annex 10, Volume IV](#): "Aeronautical Telecommunications - Surveillance Radar and Collision Avoidance Systems", 5th edition, July 2014, including amendments up to amendment 91.
- [2] [ETSI EN 300 019-1-3 \(V2.4.1\) \(04-2014\)](#): "Environmental Engineering (EE); Environmental conditions and environmental tests for telecommunications equipment; Part 1-3: Classification of environmental conditions; Stationary use at weatherprotected locations". .
- [3] [ETSI EN 300 019-1-4 \(V2.2.1\) \(04-2014\)](#): "Environmental Engineering (EE); Environmental conditions and environmental tests for telecommunications equipment; Part 1-4: Classification of environmental conditions; Stationary use at non-weatherprotected locations".

2.2 Informative references

References are either specific (identified by date of publication and/or edition number or version number) or non-specific. For specific references, only the cited version applies. For non-specific references, the latest version of the referenced document (including any amendments) applies.

NOTE: While any hyperlinks included in this clause were valid at the time of publication, ETSI cannot guarantee their long-term validity.

The following referenced documents may be useful in implementing an ETSI deliverable or add to the reader's understanding, but are not required for conformance to the present document.

- [i.1] [Directive 2014/53/EU](#) of the European Parliament and of the Council of 16 April 2014 on the harmonisation of the laws of the Member States relating to the making available on the market of radio equipment and repealing Directive 1999/5/EC.
- [i.2] [Commission Implementing Decision C\(2015\) 5376 final of 4.8.2015](#) on a standardisation request to the European Committee for Electrotechnical Standardisation and to the European Telecommunications Standards Institute as regards radio equipment in support of Directive 2014/53/EU of the European Parliament and of the Council.
- [i.3] ETSI EG 203 336 (V1.2.1) (05-2020): "Guide for the selection of technical parameters for the production of Harmonised Standards covering article 3.1(b) and article 3.2 of Directive 2014/53/EU".
- [i.4] [ERC/Recommendation 74-01 \(May 2022\)](#): "Unwanted emissions in the spurious domain".
- [i.5] ITU-R Radio Regulations (2024).
- [i.6] ETSI EN 303 363-2 (V1.1.1) (10-2023): "Air Traffic Control Surveillance Radar Sensors; Secondary Surveillance Radar (SSR); Harmonised Standard for access to radio spectrum; Part 2: Far Field Monitor (FFM)".
- [i.7] ETSI EN 303 213-5-2 (V1.1.1) (04-2022): "Advanced Surface Movement Guidance and Control System (A-SMGCS); Part 5: Harmonised Standard for access to radio spectrum for Multilateration (MLAT) equipment; Sub-part 2: Reference and Vehicle Transmitters".
- [i.8] EUROCAE ED-102B (2020) + Change 1 (2022): "MOPS for 1090 MHz Extended Squitter ADS-B and TIS-B".
- [i.9] EUROCAE ED-142 (2010): "Technical Specification for Wide Area Multilateration (WAM) Systems".

3 Definition of terms, symbols and abbreviations

3.1 Terms

For the purposes of the present document, the following terms apply:

conducted measurements: measurements which are made using a wired connection to the EUT

duty cycle: ratio, expressed as a percentage, of the cumulative duration of transmissions within an observation interval and the interval itself, as measured in an observation bandwidth

equipment under test: system of constituents for qualification under the present document

ground station: remote ground based multilateration equipment intended for use as a component in a multilateration system

NOTE: Multilateration equipment can include receiver, interrogator and/or transponder components. It can be fixed or mobile, or even space-based.

integral antenna: antenna which is integrated into a piece of equipment without the use of an external connector, and which is considered to be part of the equipment itself

interrogator: aeronautical station equipment including at least one transmitter designed to produce aeronautical mobile service signals at 1 030 MHz

mode A: interrogation triggering a Mode A reply allowing the identification of aircraft

NOTE: For any Mode S-based system including WAM systems, a Mode A interrogation consists of P1, P3 and P4 pulses transmitted on the sum port of the WAM interrogator. In some cases, an ACAS Whisper-Shout technique is applied and then an S1 pulse is used to suppress unwanted replies. Details are defined in ICAO Annex 10, Volume IV [1].

mode C: interrogation triggering a Mode C reply containing encoded pressure-altitude information

NOTE: For any Mode S-based system including WAM systems, a Mode C interrogation consists of P1, P3 and P4 pulses transmitted on the sum port of the WAM interrogator. In some cases, an ACAS Whisper-Shout technique is applied and then an S1 pulse is used to suppress unwanted replies. Details are defined in ICAO Annex 10, Volume IV [1].

mode S: interrogation triggering a Mode S reply allowing the addressing of individual aircraft and the retrieving of information with higher integrity

NOTE 1: A Mode S interrogation consists of P1, P2 and P6 pulses.

NOTE 2: The addressing method consists of a unique 24 bit Mode-S address for each individual aircraft transponder.

multilateration: surveillance technique which provides position derived from the Secondary Surveillance Radar (SSR) transponder signals (replies or squitters) primarily using Time Difference Of Arrival (TDOA) techniques

NOTE: Additional information, including identification, can be extracted from the received signals.

necessary bandwidth: width of the frequency band which is just sufficient to ensure the transmission of information at the rate and with the quality required under specified conditions

operating channel: frequency range in which the transmission from the equipment occurs, or in which the equipment is intended to receive transmissions

operating frequency: centre of the operating channel

operational: characteristic of a fielded system

NOTE: A given piece of equipment can operate using different transmission rates and power levels, in which case it is configurable.

probability of detection: ratio of received and successfully decoded RF messages

receiver: equipment which includes the capability to convert RF signals into binary content

reference sensitivity: minimum level of the wanted signal that can be received with a Pd of at least 90 %

resolution bandwidth: bandwidth that is used for spectral measurements

sensor: aeronautical station equipment including at least one receiver designed to receive aeronautical mobile service signals at 1 090 MHz

spurious domain: frequency range beyond the out-of-band domain in which spurious emissions generally predominate

NOTE: This definition is taken from ITU Radio Regulation [1.5].

squitter: broadcast of aircraft-tracking data that is transmitted periodically by a Mode S transponder without interrogation from controller's radar

transmission: radio emission consisting of one uplink or downlink message

transmitter: equipment which includes the capability to convert binary content into RF signals

transponder: aeronautical station equipment including at least one transmitter designed to produce aeronautical mobile radionavigation service signals at 1 090 MHz and zero or more receivers designed to receive aeronautical mobile radionavigation service signals at 1 030 MHz

unwanted signal: any signal other than the wanted signal or as described in a specific test case

wanted signal: in-band signal modulated

NOTE: According to the present document.

3.2 Symbols

For the purposes of the present document, the following symbols apply:

<i>dB</i>	decibel
<i>dBm</i>	dB with respect to 1 mW
<i>dBpep</i>	dB with respect to peak envelope power
<i>f_{c1030}</i>	1 030 MHz carrier frequency
<i>f_{c1090}</i>	1 090 MHz carrier frequency
<i>P_d</i>	Probability of detection
<i>P_{d 1090}</i>	Probability of detection at 1 090 MHz
<i>P_{d offset}</i>	Probability of detection at a frequency offset from 1 090 MHz
Ω	Ohm

3.3 Abbreviations

For the purposes of the present document, the following abbreviations apply:

AC	Alternating Current
ADS-B	Automatic Dependant Surveillance Broadcast
CRC	Cyclic Redundancy Check
CW	Continuous Wave
DME	Distance Measuring Equipment
EUT	Equipment Under Test
ICAO	International Civil Aviation Organization
ITU	International Telecommunication Union
MLAT	MultiLATeration
OoB	Out-of-Band
PEP	Peak Envelope Power
RBW	Reference BandWidth
RF	Radio Frequency
RFM	Remote Field Monitor
SSR	Secondary Surveillance Radar
VBW	Video BandWidth
WAM	Wide Area Multilateration

4 Technical requirements specifications

4.1 Environmental profile

The technical requirements of the present document apply under the environmental profile for operation of the equipment, which shall be in accordance with its intended use, but as a minimum, shall be that specified in the test conditions contained in the present document. The equipment shall comply with all the technical requirements of the present document at all times when operating within the boundary limits of the operational environmental profile defined by its intended use.

4.2 Conformance requirements

4.2.1 Applicability

4.2.1.1 Equipment with and without integral antenna

A 50 Ω antenna connection point shall be provided for test purposes. For equipment with integral antenna, this connection point shall correspond to the input of the integral antenna.

4.2.1.2 Equipment with multiple functions

Any ground station which includes a transmission function shall comply with the requirements in clause 4.2.2.

Any ground station which includes the receiver function shall comply with the requirements in clause 4.2.3.

4.2.2 Transmitter requirements

4.2.2.1 Operating frequency and frequency error

4.2.2.1.1 Definition

The operating frequency is the nominal value of the carrier frequency.

Interrogations are defined as transmissions sent over the 1 030 MHz carrier frequency.

Reference/Test transmissions are defined as transmissions sent over the 1 090 MHz carrier frequency.

The frequency error is the difference between the actual carrier frequency and its nominal value of either 1 030 MHz or 1 090 MHz.

4.2.2.1.2 Limits

If the equipment contains a 1 030 MHz interrogation function, the nominal value of carrier frequency of the interrogations shall be 1 030 MHz. The absolute value of the frequency error shall not exceed 0,01 MHz.

NOTE 1: The interrogation limits are specified in ICAO Annex 10, Volume IV [1], clause 3.1.2.1.1 and are stricter than the requirement defined in the ITU Radio Regulations [i.5], Appendix 2.

If the equipment contains a 1 090 MHz reference/test transmission function, the nominal value of carrier frequency of the control transmissions shall be 1 090 MHz. The absolute value of the frequency error shall not exceed 0,05 MHz.

NOTE 2: For a 1 090 MHz transmission of 100 W or less, Appendix 2 of the ITU Radio Regulations [i.5] specifies a tolerance of 100 ppm for fixed stations, which agrees with the reference/test transmission limits specified in ICAO Annex 10 Volume IV [1], clause 3.1.2.2.1. For a transmission exceeding 100 W, Appendix 2 of the ITU Radio Regulations [i.5] specifies a tighter tolerance of 50 ppm.

NOTE 3: These limits are stricter than the requirement defined in Appendix 2 of the ITU Radio Regulations [i.5].

4.2.2.1.3 Conformance

The conformance tests are defined in clause 5.3.1.

4.2.2.2 Spectrum mask

4.2.2.2.1 Definition

A spectrum mask is a set of limit lines applied to a plot of a transmitter spectrum.

If the equipment contains a 1 030 MHz interrogation function, the out-of-band domain extends to ± 125 MHz from the nominal operating frequency.

If the equipment contains a 1 090 MHz reference/test transmission function, the out-of-band domain extends to ± 78 MHz from the nominal operating frequency.

The frequencies outside the out-of-band domain are defined as the spurious domain.

4.2.2.2.2 Limits

If the equipment contains a 1 030 MHz interrogation function, then the measured spectrum shall be below the limit lines shown in Figure 1.

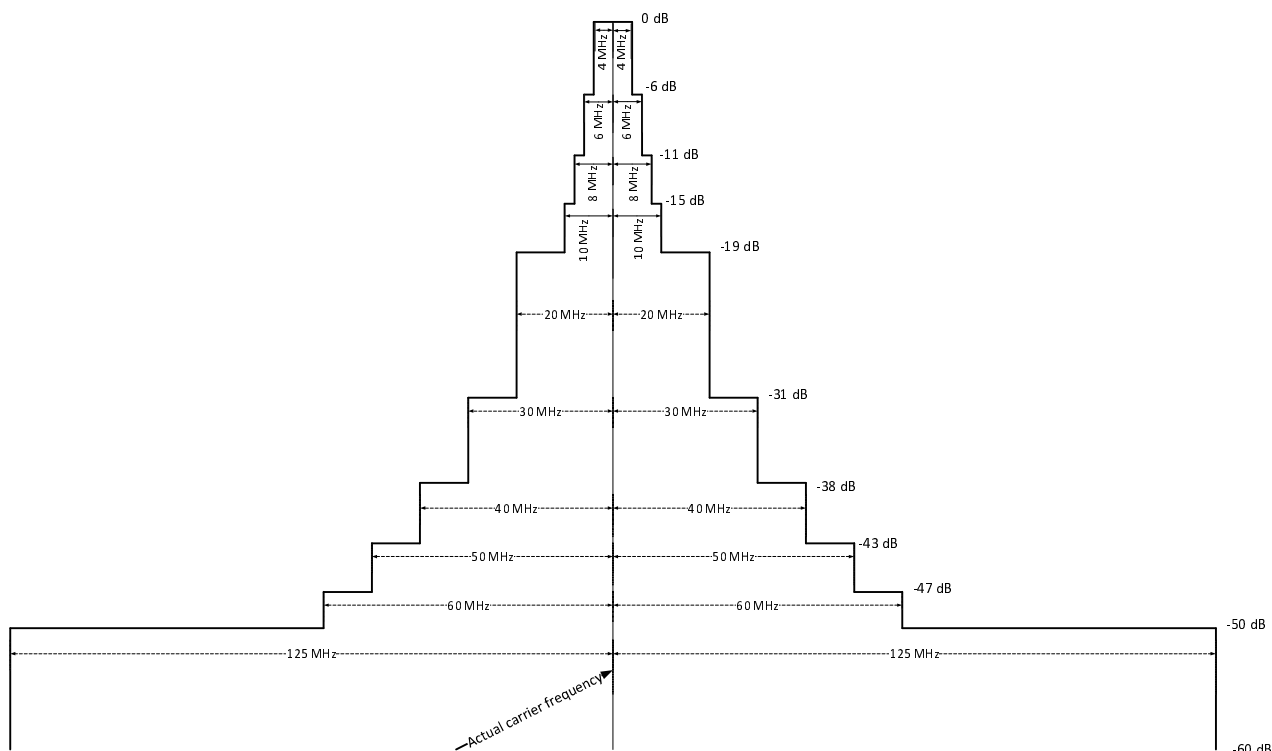

Figure 1: Spectrum mask for an interrogator transmitter

NOTE 1: The spectrum mask specified in ICAO Annex 10, Volume IV [1], Figure 3-2 has been modified in order to be consistent with the ITU Radio Regulations [i.5], Appendix 3. The ICAO mask was extrapolated from the last three steps to determine when the mask would intercept the -60 dB point. A value of approximately 125 MHz was reached.

If the equipment contains a 1 090 MHz reference/test transmission function, then the measured spectrum shall be below the limit lines shown in Figure 2.

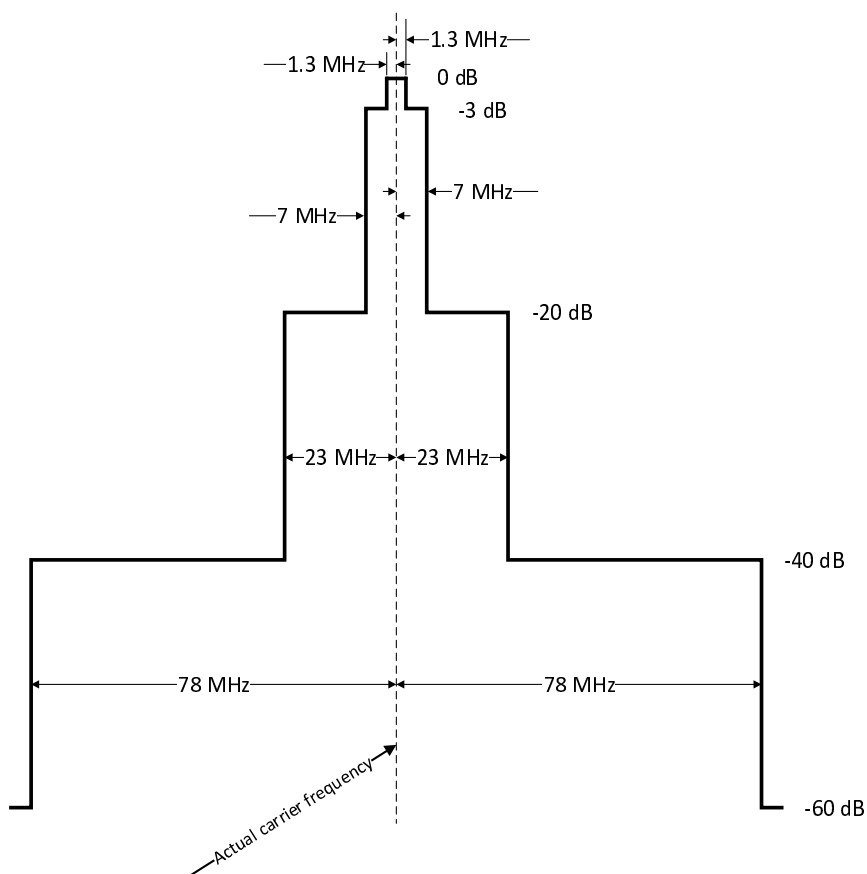

Figure 2: Spectrum mask for a reference/test transmitter

NOTE 2: The spectrum mask is consistent with the mask specified in ICAO Annex 10 Volume IV [1], Figure 3-5.

NOTE 3: Figure 1 and Figure 2 show the spectrum centred on the actual carrier frequency and will therefore shift in its entirety up to the tolerance specified in clause 4.2.2.1.

4.2.2.2.3 Conformance

The conformance tests are defined in clause 5.3.2.

4.2.2.3 Residual power output

4.2.2.3.1 Definition

The residual power output is the power output when not in the active state.

4.2.2.3.2 Limits

The residual power output shall not exceed the limits specified in Table 2.

Table 2: Limits and measurement bands for the residual power output

Frequency Range	Limits
$9 \text{ kHz} \leq f \leq 1\,000 \text{ MHz}$	-57 dBm
$1\,000 \text{ MHz} < f \leq 6\,000 \text{ MHz}$ (see note 1)	-47 dBm

NOTE 1: The upper band measurement limit corresponds to the 5th harmonic (5 150 MHz) as defined in ERC/Recommendation 74-01 [i.4], Table 1 plus a margin.
 NOTE 2: These limits are specified in ERC/Recommendation 74-01 [i.4], Table 2.

4.2.2.3.3 Conformance

The conformance tests are defined in clause 5.3.3.

4.2.2.4 Spurious emissions in active mode

4.2.2.4.1 Definition

Spurious emissions are unwanted emissions in the spurious domain. For active transmitters, the spurious domain is all frequencies beyond the operating channel and the out-of-band domain.

4.2.2.4.2 Limits

The power of any unwanted emission in the spurious domain shall not exceed $43 + 10 \cdot \log(\text{PEP})$ or 60 dB below PEP (whichever is less stringent) in the frequency range defined in Table 3.

NOTE 1: For $\text{PEP} \leq 50 \text{ W}$, the limit is equal to -13 dBm.

Table 3: Measurement bands for the emissions in the spurious domain

Transmission function	Lower band	Upper band
1 030 MHz Interrogation	$9 \text{ kHz} \leq f < 905 \text{ MHz}$ (see note 1 and note 3)	$1\ 155 \text{ MHz} < f \leq 6\ 000 \text{ MHz}$ (see note 2 and note 4)
1 090 MHz Reference/Test	$9 \text{ kHz} \leq f < 1\ 012 \text{ MHz}$ (see note 1 and note 5)	$1\ 168 \text{ MHz} < f \leq 6\ 000 \text{ MHz}$ (see note 2 and note 4)
NOTE 1: The lower band measurement limits are defined in ERC/Recommendation 74-01 [i.4]. NOTE 2: The upper band measurement limit corresponds to the 5 th harmonic (5 150 MHz) as defined in ERC/Recommendation 74-01 [i.4], Table 1 plus a margin. NOTE 3: The lower edge of the out-of-band domain equals $f_{c1030} - 125 \text{ MHz} = 905 \text{ MHz}$. NOTE 4: The upper edge of the out-of-band domain equals $f_{c1030} + 125 \text{ MHz} = 1\ 155 \text{ MHz}$. NOTE 5: The lower edge of the out-of-band domain equals $f_{c1090} - 78 \text{ MHz} = 1\ 012 \text{ MHz}$. NOTE 6: The upper edge of the out-of-band domain equals $f_{c1090} + 78 \text{ MHz} = 1\ 168 \text{ MHz}$.		

NOTE 2: These limits are specified in the ITU-R Radio Regulations [i.5], Appendix 3.

4.2.2.4.3 Conformance

The conformance tests are defined in clause 5.3.4.

4.2.2.5 Intermodulation attenuation

4.2.2.5.1 Definition

The transmitter intermodulation attenuation is a measure of the capability of a transmitter to inhibit the generation of signals in its non-linear elements caused by the presence of the transmitter power and an interfering signal entering the transmitter via its antenna. It is expressed by the intermodulation attenuation ratio specified as the ratio, in dB, of the PEP level to the power level of the third order intermodulation product.

4.2.2.5.2 Limits

The intermodulation attenuation ratio shall be at least 50 dB in the presence of an external unmodulated CW signal at a power level of +20 dBm or PEP-30 dB (whichever is lower) within the frequency range from 960 MHz to 1 215 MHz.

4.2.2.5.3 Conformance

The conformance tests are defined in clause 5.3.5.

4.2.2.6 Pulse Shape and Spacing

4.2.2.6.1 Definition

The WAM transmitter function is able to transmit different signal types, each one consisting of a series of modulated pulses. Each pulse of the sequence has specific characteristics in terms of shape and timing in the sequence, depending on the transmitted mode.

4.2.2.6.2 Limits

If the equipment contains a 1 030 MHz interrogator function, pulse shape and spacing shall be as in Table 4 and Table 5 (see also Figure 3 and Figure 4).

Table 4: 1 030 MHz pulse shape

Pulse	Pulse length Duration (μ s)		Rise Time (μ s)		Decay Time (μ s)	
	Min	Max	Min	Max	Min	Max
S1, P1, P2, P3	0,71	0,89	0,05	0,1	0,05	0,2
P4	0,71	0,89	0,05	0,1	0,05	0,2
P6	16,05	16,45	0,05	0,1	0,05	0,2
Phase reversal		0,08	-		-	
NOTE 1: This table is derived from ICAO Annex 10, Volume IV [1], Table 3-1 and Table 3-11.						
NOTE 2: The P4 (long) is not specified in the present document as the transmission of P4 (long) is not used after 1 January 2020 as defined in ICAO Annex 10, Volume IV [1].						
NOTE 3: P2 and S1 are optional pulses for Mode A/C interrogations.						

Table 5: 1 030 MHz pulse spacing

Pulses	Interrogation Mode	Pulse spacing (μ s)	
		Min	Max
P2 to P1 delay	Mode S		
P1 to S1 delay, if used P2 to P1 delay, if used	Mode A, C	1,96	2,04
P3 to P1 delay	Mode A	7,82	8,18
P3 to P1 delay	Mode C	20,82	21,18
P4 to P3 delay	Inter-mode	1,96	2,04
P6 to sync phase reversal delay	Mode S	1,21	1,29
NOTE: This table is derived from ICAO Annex 10, Volume IV [1], section 3.1.2.1.5.1 and section 3.1.2.1.5.2.			

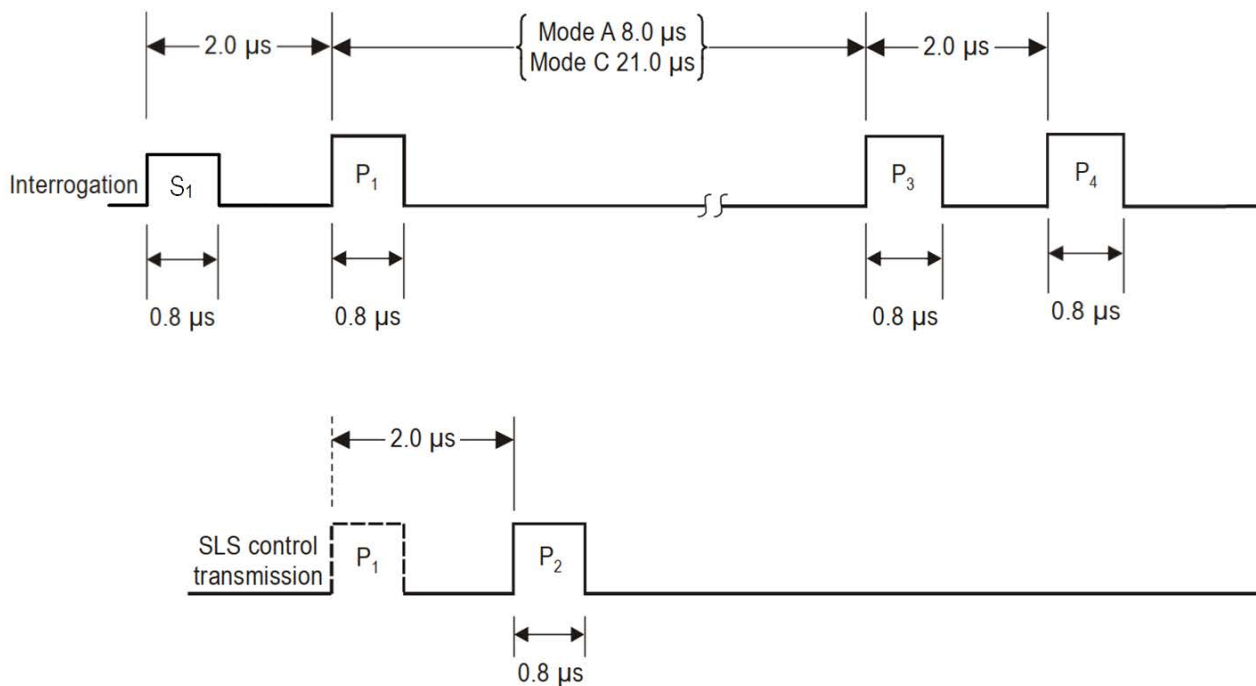

Figure 3: Pulse sequence of a 1 030 MHz Mode A/C/S Intermode Interrogation

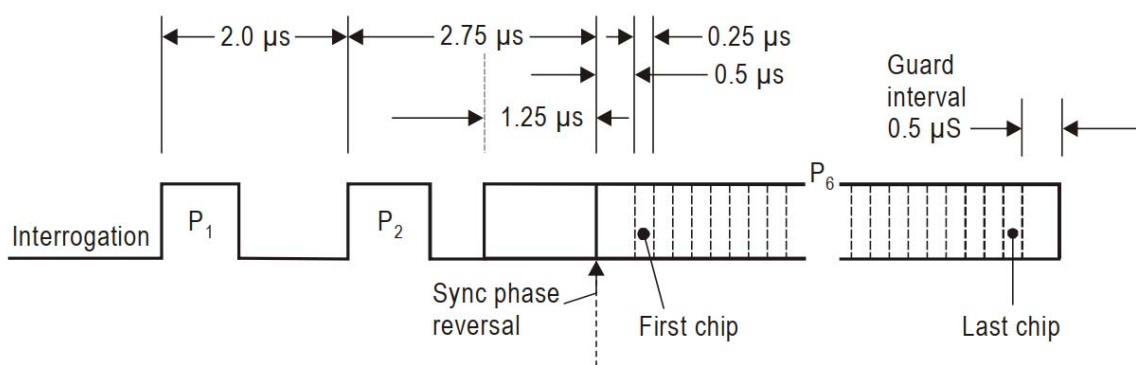

Figure 4: Pulse sequence of a 1 030 MHz Mode S Interrogation

If the equipment contains a reference/test transmission function, pulse shape and spacing shall be as in Table 6 and Table 7 (see also Figure 5).

Table 6: 1 090 MHz pulse shape

Pulse	Pulse length Duration (μs)		Rise Time (μs)		Decay Time (μs)	
	Min	Max	Min	Max	Min	Max
0,5 μs	0,45	0,55	0,05	0,1	0,05	0,2
1,0 μs	0,95	1,05	0,05	0,1	0,05	0,2

NOTE 1: This table is derived from ICAO Annex 10, Volume IV [1], Table 3-2.
 NOTE 2: Mode A/C replies are not covered by this function.

Table 7: 1 090 MHz pulse spacing

Pulses	Pulse spacing (μs)	
	Min	Max
Preamble pulse 1 to preamble pulse 2	0,95	1,05
Preamble pulse 1 to preamble pulse 3	3,45	3,55
Preamble pulse 1 to preamble pulse 4	4,45	4,55
Preamble pulse 1 to data block bit 1 = 1	7,95	8,05
Preamble pulse 1 to data block bit 1 = 0	8,45	8,55
Preamble pulse 1 to data block bit N = 1	N+6,95	N+7,05
Preamble pulse 1 to data block bit N = 0	N+7,45	N+7,55
Preamble pulse 1 to data block bit 112 = 1	118,95	119,05
Preamble pulse 1 to data block bit 112 = 0	119,45	119,55

NOTE: This table is derived from ICAO Annex 10, Volume IV [1], section 3.1.2.2.5.1.

NOTE: Use of 1 090 MHz Phase Overlay for reference/test transmissions is currently not anticipated for WAM systems.

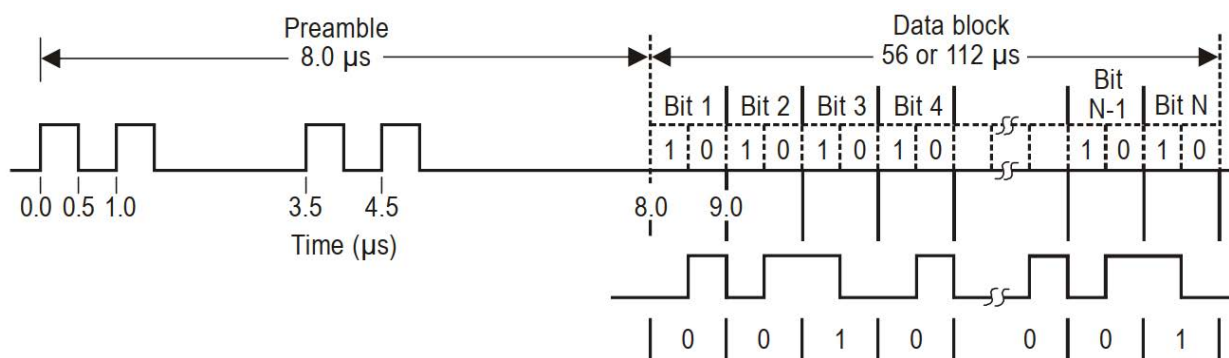

*Example.— Reply data block
corresponding to bit sequence
0010 001*

Figure 5: Pulse sequence of a 1 090 MHz Mode S Reference/Test Transmission

4.2.2.6.3 Conformance

The conformance tests are defined in clause 5.3.6.

4.2.2.7 Duty cycle

4.2.2.7.1 Definition

The duty cycle is the ratio expressed as a percentage, of the cumulative duration of transmissions within an observation interval and the interval itself. The duty cycle is calculated based on the half power point of the individual pulses within a message with the maximum number of allowable pulses. This threshold takes into account maximum allowable pulse widths and expected random variation in transmission timing.

The duty cycle of 1 090 MHz transmitters is controlled to limit the impact of each transmitter in a multi transmitter environment.

4.2.2.7.2 Limits

If the equipment contains a reference/test transmission function, the duty cycle of the transmitter shall not exceed 0,05 %.

NOTE 1: This limit is consistent with the maximum average squitter rates as specified in ICAO Annex 10 [1], clause 3.1.2.8 and EUROCAE ED-102B [i.8], clause 2.2.3.3.2.10. The squitter rate for transmitters used for this purpose is 6,2 messages per second. Squitters are scheduled with some randomness so any individual second may vary. The squitter rate of the transmitter could be up to 11 messages per second.

NOTE 2: The 1 030 MHz Interrogation Transmission function is part of a WAM distributed system. A duty cycle requirement is not imposed on 1 030 MHz transmissions because WAM systems may take advantage of passive multilateration where transmissions are generated only as needed to establish 3-D locations of targets within the visible airspace. Additionally, the necessary interrogation rate to achieve an accurate, nominal update period is geographically dependent on the location of the 1 030 MHz interrogator.

4.2.2.7.3 Conformance

The conformance tests are defined in clause 5.3.7.

4.2.2.8 Peak output power

4.2.2.8.1 Definition

The peak output power is the power level measured at the highest point in the time domain of the power envelope of the transmitted message.

4.2.2.8.2 Limits

If the equipment contains a 1 030 MHz transmission function, the peak output power shall not exceed 75 dBm.

If the equipment contains a 1 090 MHz reference/test transmission function, the peak output power shall not exceed 57 dBm (500 W).

NOTE 1: The limit for equipment containing a reference/test transmission function is consistent with ICAO Annex 10, Volume IV [1], clause 3.1.1.7.11.1 and Table 5-2.

4.2.2.8.3 Conformance

The conformance tests are defined in clause 5.3.8.

4.2.3 Receiver requirements

4.2.3.1 Sensitivity variation over the operating frequency range

4.2.3.1.1 Definition

The receiver sensitivity is the ability to receive a wanted signal at low input signal levels while providing a pre-determined level of performance. The operating frequency range is the frequency range around the nominal operating frequency over which reception of signals can be achieved.

4.2.3.1.2 Limits

The sensitivity shall not degrade by more than 3 dB as the incoming signal is offset by 1 MHz.

4.2.3.1.3 Conformance

The conformance tests are defined in clause 5.4.1.

4.2.3.2 RF selectivity and spurious response rejection

4.2.3.2.1 Definition

Receiver selectivity and spurious response rejection are the ability of the equipment to avoid erroneous reception of signals from outside the required frequency band.

Limits are evaluated assuming the signal is constructed as a valid Mode S waveform except that the frequency is altered. Although a 1 090 MHz system has only a single frequency channel, DME systems may occupy adjacent frequency allocations within the aviation band. It is important that the receiver rejects signals which are out-of-band while retaining sufficient bandwidth for acceptable multilateration performance.

4.2.3.2.2 Limits

The equipment shall reject signals such that the signal level of a valid message shall be increased by at least the value given for the frequency offset in Table 8 before the signal is received with the same Probability of detection or less.

EXAMPLE: The equipment receives a valid signal at 1 090 MHz with 90 % Pd at a level of -88 dBm. With a frequency offset of 19 MHz, the same probability of detection may be achieved only if the injected signal has a level of at least -68 dBm (20 dB higher). This shows that the receiver has at least 20 dB of rejection at the 19 MHz frequency offset.

NOTE: The limits were derived from receiver out-of-band rejection characteristics that are used within the industry for receivers that are used for both ADS-B and multilateration.

Table 8: Minimum rejection level for messages

Frequency Offset (MHz) with respect to the operating frequency	Minimum Rejection level (dB)
$-19 < f \leq -12,5$ and $+12,5 \leq f < +19$	3
$-29 < f \leq -19$ and $+19 \leq f < +29$	20
$-46 < f \leq -29$ and $+29 \leq f < +46$	40
$f \leq -46$ and $f \geq +46$	60

4.2.3.2.3 Conformance

The conformance tests are defined in clause 5.4.2.

4.2.3.3 Inter-modulation response rejection

4.2.3.3.1 Definition

The intermodulation response rejection is a measure of the capability of the receiver to receive a wanted modulated signal without exceeding a given degradation due to the presence of two or more unwanted signals that produce a third order intermodulation product equal to the receiver frequency.

4.2.3.3.2 Limits

For combinations from -78 MHz to -20 MHz and from +20 MHz to +78 MHz that produce a third order 1 090 MHz signal, the unwanted signals shall not reduce the probability of detection Pd (calculated with a level of the wanted signal equal to 20 dB above the reference sensitivity) by more than 5 percentage points when their signal level is 40 dB above the reference sensitivity.

4.2.3.3.3 Conformance

The conformance tests are defined in clause 5.4.3.

4.2.3.4 Co-channel rejection

4.2.3.4.1 Definition

Co-channel rejection is the receiver's ability to receive a wanted signal in the presence of an unwanted signal, with both signals being at the nominal receiver frequency.

4.2.3.4.2 Limits

An unwanted signal with a level of 12 dB below a level of the wanted signal equal to 20 dB above the reference sensitivity shall not reduce the rate of correctly received and decoded wanted Mode S signals by more than 5 percentage points.

4.2.3.4.3 Conformance

The conformance tests are defined in clause 5.4.4.

4.2.3.5 Blocking

4.2.3.5.1 Definition

Blocking is a measure of the capability of the receiver to receive a wanted signal without exceeding a given degradation due to the presence of a strong unwanted signal.

4.2.3.5.2 Limits

The rate of correctly received and decoded wanted Mode S signals shall be reduced by no more than 5 percentage points in the presence of unwanted signals specified in Table 9, where the level of the wanted signal shall be 6 dB above the reference sensitivity.

Table 9: Unwanted signal characteristics

Frequency range	Level
1 090 MHz - 78 MHz to 1 090 MHz - 15 MHz	20 dB above the level of the wanted signal
1 090 MHz + 15 MHz to 1 090 MHz + 78 MHz	20 dB above the level of the wanted signal

4.2.3.5.3 Conformance

The conformance tests are specified in clause 5.4.5.

4.2.3.6 Sensitivity

4.2.3.6.1 Definition

The receiver sensitivity is the ability to receive a wanted signal at low input signal levels while providing a pre-determined level of performance.

4.2.3.6.2 Limits

Receivers shall operate for signals with a carrier frequency of 1 090 MHz with a Pd of not less than 90 % at a desired signal level of -88 dBm.

NOTE: This number reflects a sensitivity for surveillance systems in order to support the requirements for Probability of Position Detection in EUROCAE ED-142 [i.9].

4.2.3.6.3 Conformance

The conformance tests are defined in clause 5.4.1.

4.2.3.7 Receiver spurious emissions

4.2.3.7.1 Definition

Spurious emissions are unwanted emissions in the spurious domain. For Receivers the spurious domain is all frequencies, as they are not supposed to transmit any signal.

4.2.3.7.2 Limits

The power of any unwanted emission in the spurious domain shall not exceed the limits specified in Table 10.

Table 10: Limits and measurement bands for the receiver spurious emissions

Frequency Range	Limits
$9 \text{ kHz} \leq f \leq 1\,000 \text{ MHz}$	-57 dBm
$1\,000 \text{ MHz} < f \leq 6\,000 \text{ MHz}$ (see note 1)	-47 dBm
NOTE 1: The upper band measurement limit corresponds to the 5 th harmonic (5 150 MHz) as defined in ERC/Recommendation 74-01 [i.4], Table 1 plus a margin.	
NOTE 2: These limits are specified in ERC/Recommendation 74-01 [i.4], Table 2.	

4.2.3.7.3 Conformance

The conformance tests are specified in clause 5.4.6.

4.2.3.8 Dynamic range

4.2.3.8.1 Definition

The receiver dynamic range is the ability to receive a wanted signal across a range of signal levels while providing a pre-determined level of performance. The minimum signal level is defined as the receiver sensitivity specified in clause 4.2.3.6, which sets the nominal detectable distance in a WAM environment. The receiver dynamic range ensures continuous coverage for en-route aircraft, which determines the maximum signal level of continued coverage.

4.2.3.8.2 Limits

Receivers shall operate for signals with a carrier frequency of 1 090 MHz with a Pd of not less than 90 % for signal levels that range from the defined sensitivity (-88 dBm) to a desired signal level of -18 dBm. This corresponds to a dynamic range of 70 dB.

4.2.3.8.3 Conformance

The conformance tests for this requirement are defined in clause 5.4.7.

5 Testing for compliance with technical requirements

5.1 Environmental conditions for testing

5.1.1 General requirements

Tests defined in the present document shall be carried out at representative points within the boundary limits of the operational environmental profile which, as a minimum, shall be that specified in the test conditions contained in the present document.

Where technical performance varies subject to environmental conditions, tests shall be carried out under a sufficient variety of environmental conditions as specified in the present document to give confidence of compliance for the affected technical requirements.

5.1.2 Test conditions

5.1.2.1 Thermal Balance

Before measurements are made, the equipment shall have reached thermal balance in the test chamber. The thermal balance shall be checked by temperature measurements. When the equipment temperature is not changing more than 1 °C per minute thermal balance is reached.

5.1.2.2 Normal Test Conditions

5.1.2.2.1 Temperature and humidity

For equipment intended to be operated indoors (partly temperature-controlled locations as defined in clause 4.2 of ETSI EN 300 019-1-3 [2]), the temperature and humidity conditions for tests shall be a combination of temperature and humidity as defined in ETSI EN 300 019-1-3 [2], clause 4.2, Figure 2 (Climatogram for class 3.2) and Table 1 (class 3.2).

For equipment intended to be operated in an on-site equipment room (temperature-controlled locations as defined in clause 4.1 of ETSI EN 300 019-1-3 [2]), the temperature and humidity conditions for tests shall be a combination of temperature and humidity as defined in ETSI EN 300 019-1-3 [2], clause 4.1, Figure 1 (Climatogram for class 3.1) and Table 1 (class 3.1, normal).

For equipment intended to be operated outdoors (on-site outdoors locations), the temperature and humidity conditions for tests shall be a combination of temperature and humidity as defined in ETSI EN 300 019-1-4 [3], clause 4.1, Figure 1 (Climatogram for class 4.1) and Table 1 (class 4.1).

The actual values during the tests shall be recorded in the test report.

5.1.2.2.2 Power supply

The power supply for testing shall be the nominal voltage. For the purpose of the present document, the nominal voltage shall be the intended supply voltage for which the equipment was designed.

The actual values during the test shall be recorded in the test report.

5.1.2.3 Extreme Test Conditions

5.1.2.3.1 Temperature and humidity

For equipment intended to be operated indoors (partly temperature-controlled locations as defined in clause 4.2 of ETSI EN 300 019-1-3 [2]), measurements shall be made, as a minimum, at the lowest and highest temperatures defined in ETSI EN 300 019-1-3 [2], clause 4.2, Figure 2 (Climatogram for class 3.2) and Table 1 (class 3.2). Relative humidity shall be as in that same Table 1 for class 3.2.

For equipment intended to be operated in an on-site equipment room (temperature-controlled locations as defined in clause 4.1 of ETSI EN 300 019-1-3 [2]), measurements shall be made, as a minimum, at the lowest and highest temperatures defined in ETSI EN 300 019-1-3 [2], clause 4.1, Figure 1 (Climatogram for class 3.1) and Table 1 (class 3.1, normal). Relative humidity shall be as in that same Table 1 for class 3.1 (normal).

For equipment intended to be operated outdoors (on-site outdoors locations), measurements shall be made, as a minimum, at the lowest and highest temperatures defined in ETSI EN 300 019-1-4 [3], clause 4.1, Figure 1 (Climatogram for class 4.1) and Table 1 (class 4.1). Relative humidity shall be as in that same Table 1 for class 4.1.

The actual values during the tests shall be recorded in the test report.

If the equipment is capable of operating in more than one of these environments, it shall be tested for the most extreme environment only.

5.1.2.3.2 Power supply

The power supply for testing shall be the nominal mains voltage $\pm 10\%$ (for AC power supply) or $\pm 20\%$ (for DC power supply). For the purpose of the present document, the nominal voltage shall be the declared voltage or any of the declared voltages for which the equipment was designed.

For an AC power supply, the frequency offset of the nominal mains frequency shall be 2 Hz.

The actual values during the tests shall be recorded in the test report.

5.2 Test and general conditions

5.2.1 Transmitter test signals

5.2.1.1 General considerations

For the purposes of the present document a transmitter test signal is a modulated carrier generated by the EUT to facilitate a particular test. The EUT shall be capable of generating the following test signals:

- Test signal 1: short Mode S interrogations with all "0" data content - see clause 5.2.1.2.
- Test signal 2: short Mode S interrogations with all "1" data content - see clause 5.2.1.3.
- Test signal 3: Mode A interrogation - see clause 5.2.1.4.
- Test signal 4: Mode C interrogation - see clause 5.2.1.5.
- Test signal 5: long Mode S Reference/Test transmission - see clause 5.2.1.6.

Test signals may be generated autonomously by the EUT when configured for test mode, or by applying external commands or other stimulation.

5.2.1.2 Test signal 1

When test signal 1 is specified below, a signal shall be generated with the following characteristics:

- Transmission rate: 100 transmissions per second or the maximum rate the EUT is capable of, whichever is less.
- Waveform: short ($P_6 = 16,25 \mu\text{s}$) Mode S Interrogation as defined in ICAO Annex 10, Volume IV [1], clause 3.1.2.1 and clause 3.1.2.11.
- Frequency: 1 030 MHz.
- Message content: All "0" (i.e. the minimum number of phase transitions).
- Amplitude: Maximum rated power level as measured in clause 5.3.8 unless otherwise specified by the test.

NOTE: As an example, the calculation of the transmission rate for a rated maximum duty cycle of 1 % is as follows: the short Mode S interrogation contains the P1, P2 and P6 pulses as defined in ICAO Annex 10, Volume IV [1], Figure 3-4. The cumulative time from the 50 % point of the rising edge of P1 to the 50 % point on the falling edge of P6 is $(0,8 + 0,8 + 16,25) = 17,85 \mu\text{s}$. The maximum transmission rate that does not exceed 1 % (i.e. 10 milliseconds per second of transmission time) is 560 Hz.

5.2.1.3 Test signal 2

When test signal 2 is specified below, a signal shall be generated with the following characteristics:

- Transmission rate: 100 transmissions per second or the maximum rate the EUT is capable of, whichever is less.

- Waveform: short ($P_6 = 16,25 \mu\text{s}$) Mode S Interrogation as defined in ICAO Annex 10, Volume IV [1], clause 3.1.2.1 and clause 3.1.2.11.
- Frequency: 1 030 MHz.
- Message content: All "1" (i.e. the maximum number of phase transitions).
- Amplitude: Maximum rated power level as measured in clause 5.3.8 unless otherwise specified by the test.

5.2.1.4 Test signal 3

When test signal 3 is specified below, a signal shall be generated with the following characteristics:

- Transmission rate: 100 transmissions per second or the maximum rate the EUT is capable of, whichever is less.
- Waveform: Mode A Interrogation as defined in ICAO Annex 10, Volume IV [1], clause 3.1.1.1 and clause 3.1.2.11.
- Frequency: 1 030 MHz.
- Message content: Mode A interrogation.
- Amplitude: Maximum rated power level as measured in clause 5.3.8 unless otherwise specified by the test.

5.2.1.5 Test signal 4

When test signal 4 is specified below, a signal shall be generated with the following characteristics:

- Transmission rate: 100 transmissions per second or the maximum rate the EUT is capable of, whichever is less.
- Waveform: Mode C Interrogation as defined in ICAO Annex 10, Volume IV [1], clause 3.1.1.1 and clause 3.1.2.11.
- Frequency: 1 030 MHz.
- Message content: Mode C interrogation.
- Amplitude: Maximum rated power level as measured in clause 5.3.8 unless otherwise specified by the test.

5.2.1.6 Test signal 5

When test signal 5 is specified below, a signal shall be generated with the following characteristics:

- Transmission rate: 100 transmissions per second or the maximum rate the EUT is capable of, whichever is less.
- Waveform: long (112 bits) Mode S Reply as defined in ICAO Annex 10, Volume IV [1], clause 3.1.2.2.
- Frequency: 1 090 MHz.
- Message content: DF18 as defined in ICAO Annex 10, Volume IV [1], clause 3.1.2.8.7.3, and constant data content with valid parity, $CL = 0$ and $IC = 0$.
- Amplitude: Maximum operational power level as measured in clause 5.3.8.

EXAMPLE: 0x90867530F9020004004B20500460 is a valid DF-18 squitter with the Aircraft Address of "867530".

5.2.2 Simulated received test signals

5.2.2.1 General Considerations

For the purposes of the present document a receiver test signal is an unmodulated or modulated carrier applied to the EUT to facilitate a particular test. The EUT shall be capable of receiving and decoding the desired signal in the presence of the undesired signals as described in the test procedures.

- Test signal 6: Modulated Mode S Extended Squitter message (desired signal) - see clause 5.2.2.2.
- Test signal 7: Modulated Mode S Extended Squitter message (undesired signal) - see clause 5.2.2.3.
- Test signal 8: Unmodulated CW signal (undesired signal) - see clause 5.2.2.4.

When multiple test signals are used in the same test, the frequency sources for each test signal shall be non-coherent.

The EUT shall be able to report each message received. The report shall include the complete Mode S message and the time of receipt at the receiver or the recording device with at least 10 millisecond resolution. Message reports from multilateration receivers can generally be collected using a computer and standard communication network analysis software.

5.2.2.2 Test signal 6

When test signal 6 is specified below, a signal shall be injected with the following characteristics:

- Transmission rate: 100 Hz, unless otherwise specified by the test.
- Waveform: Mode S Extended squitter as defined in ICAO Annex 10, Volume IV [1], clause 3.1.2.2.
- Frequency: 1 090 MHz, unless otherwise specified by the test.
- Message content: Arbitrary data content with a known Aircraft Address and valid CRC.
- Amplitude: As specified by the test.
- Pulse on/off ratio: At least 40 dB.

EXAMPLE: 0x88234567125054D4C72CF4 is a valid DF-17 squitter with the Aircraft Address of "234567".

5.2.2.3 Test signal 7

When test signal 7 is specified below, a signal shall be injected with the following characteristics:

- Transmission rate: 6 000 Hz.
- Waveform: Mode S Extended squitter as defined in ICAO Annex 10, Volume IV [1], clause 3.1.2.2.
- Frequency: As specified by the test.
- Message content: Arbitrary data content with a known Aircraft Address and valid CRC.
- Amplitude: As specified by the test.
- Pulse on/off ratio: At least 40 dB.

NOTE: The data content is distinct from Test signal 5.

EXAMPLE: 0x8DAE05B6281005069606049611E1 is a valid DF-17 squitter with the Aircraft Address of "AE05B6".

5.2.2.4 Test signal 8

When test signal 8 is specified below, a signal shall be injected with the following characteristics:

- Transmission rate: Not applicable.
- Waveform: Continuous wave.
- Frequency: As specified by the test.
- Message content: Not applicable.
- Amplitude: As specified by the test.
- Pulse on/off ratio: Not applicable.

5.3 Transmitter tests

5.3.1 Operating frequency and frequency error

5.3.1.1 Description

The purpose of this test is to establish that the transmitter is operating at the correct frequency and within the required frequency error.

5.3.1.2 Test conditions

The EUT shall be configured to generate test signal 1 and/or test signal 5 as indicated in the procedure.

The measurement shall be performed according to clause 5.1.2.2 and clause 5.1.2.3.

The spectrum analyser shall have a frequency error (uncertainty) not exceeding 1 ppm.

NOTE: The test procedure ignores frequency excursions during the phase reversal of the 1 030 MHz transmission. Further information is given in ICAO Annex 10, Volume IV [1], clause 3.1.2.1.1.

5.3.1.3 Method of measurement

The test setup shall be as in Figure 6.

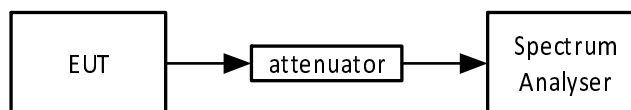

Figure 6: Test setup for operating frequency and frequency error

The measurement shall use the connection to the EUT antenna interface.

Unless otherwise noted below, the spectrum analyser shall be configured to the following settings:

- Trigger level: As appropriate for input power and attenuation.
- Trace properties: Normal (e.g. not max hold).
- Sweep properties: As needed to capture a waveform without interruptions due to duty cycle.

5.3.1.4 Measurement procedure

The test procedure for the 1 030 MHz interrogation function and/or the 1 090 MHz reference/test transmission function shall be as follows:

- 1) Attach the EUT antenna port to the spectrum analyser as shown in Figure 6. The attenuation of the attenuator shall be such that the power level is in the working range of the spectrum analyser.
- 2) Set up the spectrum analyser with a resolution bandwidth of 30 kHz and a video bandwidth of 100 kHz.
- 3) If the EUT does not contain a 1 030 MHz interrogation transmission function, skip to step 7.
- 4) Configure the EUT to produce test signal 1.
- 5) Measure the frequency of the peak of the spectrum and verify that the measured value does not exceed the 1 030 MHz limits specified in clause 4.2.2.1.2.
- 6) If the EUT does not contain a 1 090 MHz interrogation transmission function, this test procedure is complete.
- 7) Configure the EUT to produce test signal 5.
- 8) Measure the frequency of the peak of the spectrum and verify that the measured value does not exceed the 1 090 MHz limits specified in clause 4.2.2.1.2.

5.3.2 Spectrum mask

5.3.2.1 Description

The in band and out-of-band domains are measured for compliance of the EUT with the spectrum mask.

5.3.2.2 Test conditions

The EUT shall be configured to generate test signal 1/test signal 2 and/or test signal 5 as indicated in the procedure.

The measurement shall be performed with the EUT operating at its maximum rated power level and minimum rated power level.

The measurement shall be performed according to clause 5.1.2.2 and clause 5.1.2.3.

5.3.2.3 Method of measurement

The test setup shall be as in Figure 7.

The measurement shall use the connection to the EUT antenna interface.

Unless otherwise noted below, the spectrum analyser shall be configured to the following settings:

- Trigger level: As appropriate for input power and attenuation.
- Trace properties: Normal (e.g. not max hold).
- Sweep properties: As needed to capture a waveform without interruptions due to duty cycle.

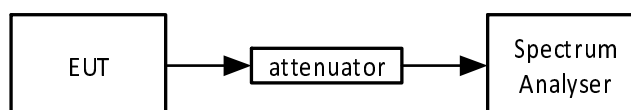

Figure 7: Test setup for spectrum mask

5.3.2.4 Measurement procedure

The test procedure shall be as follows:

- 1) Set up the spectrum analyser with a resolution bandwidth of 1 MHz and a video bandwidth of 3 MHz.
- 2) Attach the EUT antenna port to the spectrum analyser as shown in Figure 7. The attenuation of the attenuator shall be such that the power level is in the working range of the spectrum analyser.
- 3) If the EUT does not contain a 1 030 MHz interrogation transmission function, skip to step 8.
- 4) Configure the EUT to produce test signal 1.
- 5) Measure the spectrum from 905 MHz to 1 155 MHz and record the peak amplitude of the spectrum as a reference for 0 dBc.
- 6) Switch the EUT to produce test signal 2.
- 7) Measure the spectrum from 905 MHz to 1 155 MHz and verify that it does not exceed the spectrum mask limits for an interrogator transmitter defined in clause 4.2.2.2, taking into account the attenuation of the attenuator and the measured cable losses.
- 8) If the EUT does not contain a 1 090 MHz reference/test transmission function, skip to step 12.
- 9) Configure the EUT to produce test signal 5.
- 10) Measure the spectrum from 1 012 MHz to 1 168 MHz and record the peak amplitude of the spectrum as a reference for 0 dBc.
- 11) Verify that the measurement of the spectrum mask does not exceed the limits for a reference/test transmitter defined in clause 4.2.2.2.
- 12) Repeat steps 2 to 11 setting the power level of the test signals (test signal 1, test signal 2, and test signal 5) to the minimum rated power level.

5.3.3 Residual power output

5.3.3.1 Description

The purpose of this test is to verify that the output power of the transmitter, when not in the active state, does not exceed the specified maximum.

5.3.3.2 Test conditions

The EUT shall be ready to transmit, but with no transmissions commanded externally and with no transmissions generated internally.

The measurement shall be performed according to clause 5.1.2.2.

5.3.3.3 Method of measurement

The measurement shall use the connection to the EUT antenna interface. All amplitudes shall be adjusted for cable loss.

The test setup shall be as in Figure 8

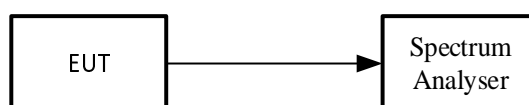

Figure 8: Test setup for residual power output

5.3.3.4 Measurement procedure

The test procedure shall be as follows:

- 1) Set the EUT so that it is ready to transmit, but no transmissions are generated.
- 2) Connect the spectrum analyser to the EUT antenna connector.
- 3) Taking into account the measured cable losses, verify that the residual power output does not exceed the limits specified in clause 4.2.2.3.2 when the spectrum analyser is tuned over the frequency range shown in Table 11 below.

All measurements shall be made with a Reference Bandwidth (RBW) and a Video Bandwidth (VBW) as shown in Table 11. The resolution bandwidth of the spectrum analyser shall be equal to the Reference Bandwidth.

Table 11: Measurement Bandwidths

Frequency Range	RBW	VBW
$9 \text{ kHz} \leq f < 150 \text{ kHz}$	1 kHz	3 kHz
$150 \text{ kHz} \leq f < 30 \text{ MHz}$	10 kHz	30 kHz
$30 \text{ MHz} \leq f \leq 1\,000 \text{ MHz}$	100 kHz	300 kHz
$1\,000 < f \leq 6\,000 \text{ MHz}$	1 MHz	3 MHz

NOTE 1: f is the measurement frequency.
 NOTE 2: 6 000 MHz corresponds to the 5th harmonic of either a 1 030 MHz or 1 090 MHz transmission (5 150 MHz or 5 450 MHz) plus a margin.
 NOTE 3: The Reference Bandwidths (RBWs) are defined in ERC/Recommendation 74-01 [i.4].

5.3.4 Spurious emissions in active mode

5.3.4.1 Description

The purpose of this test is to verify that emissions in the spurious domains (depending on carrier frequency) do not exceed the specified limits.

5.3.4.2 Test conditions

The EUT shall be configured to generate test signal 1 and/or test signal 5 as indicated in the procedure.

The measurement shall be performed according to clause 5.1.2.2 and clause 5.1.2.3.

5.3.4.3 Method of measurement

The measurement shall use the connection to the EUT antenna interface. All amplitudes shall be adjusted for the attenuation of the attenuator and cable losses.

5.3.4.4 Measurement Procedure

5.3.4.4.1 Part 1: Measurement of PEP and determination of spurious emission limit

The test setup shall be as in Figure 9.

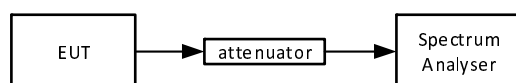

Figure 9: Test setup for the measurement of EUT PEP

The test procedure shall be as follows:

- 1) Connect the spectrum analyser to the EUT antenna connector with an attenuator such that the power level is in the acceptable range of the spectrum analyser.

- 2) Make the following settings in the spectrum analyser:
 - a) Set RBW to 1 MHz and VBW to 3 MHz (see Table 11).
 - b) Set the centre frequency to the frequency of the peak value of the spectrum.
 - c) Set the "frequency span" to zero.
 - d) Set the sweep time to a value equal to or greater than the width of the selected pulse.
- 3) If the EUT does not have a 1 030 MHz interrogation function, skip to step 7.
- 4) Configure the EUT to transmit test signal 1.
- 5) Taking into account the attenuation of the attenuator and the measured cable losses, measure and record the 1 030 MHz PEP by reading the power value at the crest of the envelope.
- 6) Calculate the limit l_{1030} (the less stringent between $43 + 10 \cdot \log(\text{PEP})$ and 60 dB below PEP where PEP is the measured 1 030 MHz PEP - see clause 4.2.2.4.2).
- 7) If the EUT does not have a 1 090 MHz reference/test function, skip to Part 2 (clause 5.3.4.4.2).
- 8) Configure the EUT to transmit test signal 5.
- 9) Taking into account the attenuation of the attenuator and the measured cable losses, measure and record the 1 090 MHz PEP by reading the power value at the crest of the envelope.
- 10) Calculate the limit l_{1090} (the less stringent between $43 + 10 \cdot \log(\text{PEP})$ and 60 dB below PEP where PEP is the measured 1 090 MHz PEP - see clause 4.2.2.4.2).

5.3.4.4.2 Part 2: Spurious emission measurement procedure

The test setup shall be as in Figure 10.

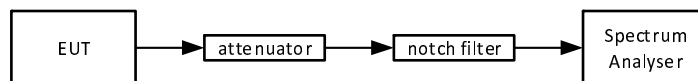

Figure 10: Test setup for spurious emissions of transmitter in active mode

The test procedure shall be as follows:

- 1) Connect the spectrum analyser to the EUT antenna connector with an attenuator such that the power level is in the acceptable range of the spectrum analyser. A 1 030/1 090 MHz notch filter is also necessary to avoid intermodulation effects that might be generated by the measurement equipment.
- 2) Tune the spectrum analyser subsequently to the frequency range shown in Table 12.
- 3) If the EUT does not have a 1 030 MHz interrogation function, skip to step 7.
- 4) Configure the EUT to transmit test signal 1.
- 5) Taking into account the insertion losses of all components, verify that the power levels do not exceed the limit specified in clause 4.2.2.4.2 and determined as described in clause 5.3.4.4.1 (l_{1030}).
- 6) If the EUT does not have a 1 090 MHz interrogation function, this test procedure is complete.
- 7) Tune the spectrum analyser subsequently to the frequency range shown in Table 13.
- 8) Configure the EUT to produce test signal 5.
- 9) Taking into account the insertion losses of all components, verify that the power levels do not exceed the limit specified in clause 4.2.2.4.2 and determined as described in clause 5.3.4.4.1 (l_{1090}).

All measurements shall be made with a Reference Bandwidth (RBW) and a Video Bandwidth (VBW) as shown in Table 12 for an EUT with a 1 030 MHz interrogation function and as shown in Table 13 for an EUT with a 1 090 MHz interrogation function.

In both cases, the resolution bandwidth of the spectrum analyser shall be equal to the Reference Bandwidth.

Table 12: Measurement Bandwidths for 1 030 MHz

Frequency Range	RBW	VBW
$9 \text{ kHz} \leq f < 150 \text{ kHz}$	1 kHz	3 kHz
$150 \text{ kHz} \leq f < 30 \text{ MHz}$	10 kHz	30 kHz
$30 \text{ MHz} \leq f < f_{m1}$	100 kHz	300 kHz
$f_{m2} < f \leq 6\,000 \text{ MHz}$	1 MHz	3 MHz

NOTE 1: f is the measurement frequency.
 NOTE 2: f_{m1} is the lower edge of the out-of-band domain and equals $f_{c1030} - 125 \text{ MHz}$.
 NOTE 3: f_{m2} is the upper edge of the out-of-band domain and equals $f_{c1030} + 125 \text{ MHz}$.
 NOTE 4: The out-of-band domain is defined in clause 4.2.2.2.2 (Spectrum mask).
 NOTE 5: The Reference Bandwidths (RBWs) are defined in ERC/Recommendation 74-01 [i.4].
 NOTE 6: 6 000 MHz corresponds to the 5th harmonic of a 1 030 MHz transmission (5 150 MHz) plus a margin.

Table 13: Measurement Bandwidths for 1 090 MHz

Frequency Range	RBW	VBW
$9 \text{ kHz} \leq f < 150 \text{ kHz}$	1 kHz	3 kHz
$150 \text{ kHz} \leq f < 30 \text{ MHz}$	10 kHz	30 kHz
$30 \text{ MHz} \leq f < 1\,000 \text{ MHz}$	100 kHz	300 kHz
$1\,000 \text{ MHz} \leq f < f_{m1}$	1 MHz	3 MHz
$f_{m2} < f \leq 6\,000 \text{ MHz}$	1 MHz	3 MHz

NOTE 1: f is the measurement frequency.
 NOTE 2: f_{m1} is the lower edge of the out-of-band domain and equals $f_{c1090} - 78 \text{ MHz}$.
 NOTE 3: f_{m2} is the upper edge of the out-of-band domain and equals $f_{c1090} + 78 \text{ MHz}$.
 NOTE 4: The out-of-band domain is defined in clause 4.2.2.2.2 (Spectrum mask).
 NOTE 5: The Reference Bandwidths (RBWs) are defined in ERC/Recommendation 74-01 [i.4].
 NOTE 6: 6 000 MHz corresponds to the 5th harmonic of a 1 090 MHz transmission (5 450 MHz) plus a margin.

5.3.5 Intermodulation attenuation

5.3.5.1 Description

The purpose of this test is to establish that the transmitter does not generate unwanted signals in the presence of an external signal entering the transmitter via the antenna due to inter-modulation effects in the transmitter's non-linear elements.

5.3.5.2 Test Conditions

The interfering test signal shall be test signal 8 (see clause 5.2.2.4).

The EUT shall be configured to generate test signal 2 and/or test signal 5 as indicated in the procedure.

The measurement shall be performed according to clause 5.1.2.2.

5.3.5.3 Method of Measurement

The measurement shall use the connection to the EUT antenna interface.

The test setup shall be as in Figure 11.

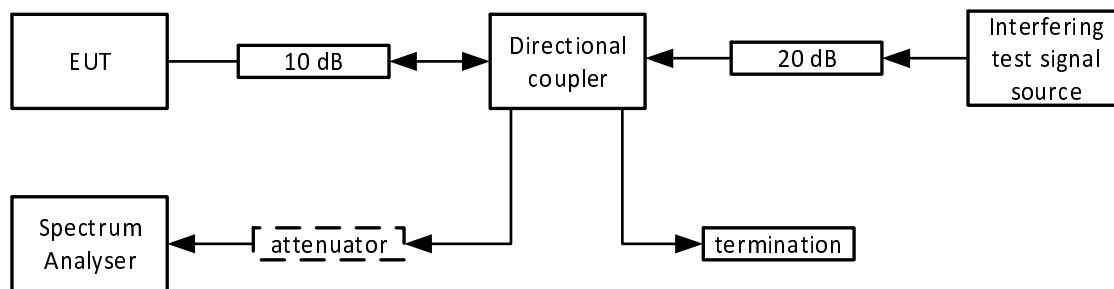

Figure 11: Test setup for transmitter intermodulation attenuation

The EUT shall be connected to a 10 dB power attenuator and via a directional coupler to a spectrum analyser. An optional attenuator may be required between the directional coupler and the spectrum analyser to avoid overloading the spectrum analyser. The termination of the directional coupler shall be a 50 Ω termination.

The interfering test signal source is connected to the other end of the directional coupler via a 20 dB power attenuator.

The interfering signal source shall be a signal generator and a linear power amplifier capable of delivering the same output power as the EUT.

The directional coupler shall have an insertion loss of less than 1 dB, a bandwidth of at least 520 MHz and a directivity of more than 20 dB.

The EUT and the test signal source shall be physically separated by at least 2 meters to limit the influence of direct radiation.

5.3.5.4 Measurement Procedure

- 1) If the EUT does not have a 1 030 MHz interrogation function, skip to step 10).
- 2) The EUT shall be set to transmit test signal 2 and the spectrum analyser adjusted to give a maximum indication with a resolution bandwidth of 1 MHz and a scan range of 1 030 MHz \pm 260 MHz.
- 3) With the spectrum analyser settings as in clause 5.3.4.4.1 step 2), record the peak of the spectrum as the carrier reference level.
- 4) The interfering test signal (test signal 8) source shall be unmodulated (CW) and the frequency shall be within 962 MHz to 1 020 MHz and 1 040 MHz to 1 215 MHz.
- 5) The power output of the interfering test signal source shall be such that the measured level of this signal at the input of the EUT is equal to 20 dBm or PEP-30 dB (whichever is lower).
- 6) The interfering signal frequency shall be set to 1 040 MHz and then increased in steps of 1 MHz up to 1 215 MHz
- 7) The peak of the intermodulation component shall be measured by direct observation on the spectrum analyser and the ratio of the largest third order intermodulation component to the recorded carrier reference level.
- 8) This measurement shall be repeated with the interfering test signal source at a frequency starting at 962 MHz and then increased in steps of 1 MHz up to 1 020 MHz.
- 9) Verify that for each frequency, the inter-modulation attenuation ratio does not exceed the limit specified in clause 4.2.2.5.2.
- 10) If the EUT does not have a 1 090 MHz Reference/Test Transmission function, skip the remaining procedure.
- 11) Set the EUT to transmit test signal 5 and the spectrum analyser adjusted to give a maximum indication with a resolution bandwidth of 1 MHz and a scan range of 1 090 MHz \pm 260 MHz.
- 12) Record the peak of the spectrum as the carrier reference level.

- 13) The interfering test signal source shall be unmodulated (CW) and the frequency shall be within 962 MHz to 1080 MHz and 1 100 MHz to 1 215 MHz.
- 14) The power output of the interfering test signal source shall be adjusted and verified to be either 50 dBm or the same amplitude of the EUT PEP (whichever is lower) by the use of a power meter (the required 30 dB attenuation is produced by the test setup).
- 15) The interfering signal frequency shall be set to 1 100 MHz and then increased in steps of 1 MHz up to 1 215 MHz
- 16) The peak of the intermodulation component shall be measured by direct observation on the spectrum analyser and the ratio of the largest third order intermodulation component to the recorded carrier reference level.
- 17) This measurement shall be repeated with the interfering test signal source at a frequency starting at 962 MHz and then increased in steps of 1 MHz up to 1 080 MHz.
- 18) Verify that for each frequency, the inter-modulation attenuation ratio does not exceed the limit specified in clause 4.2.2.5.2.

5.3.6 Pulse Shape and Spacing

5.3.6.1 Description

The purpose of this test is to establish that the transmitter produces Mode S and Mode A/C interrogation waveforms that meet the required modulation thresholds.

5.3.6.2 Test Conditions

The EUT shall be configured to generate test signal 1, test signal 3, test signal 4, and/or test signal 5 as indicated in the procedure.

The measurement shall be performed according to clause 5.1.2.2 and clause 5.1.2.3.

5.3.6.3 Method of Measurement

The measurement shall use the connection to the EUT antenna interface.

Pulse length measurements shall be determined by taking the time difference between the 50 % voltage amplitude point on the falling edge of the pulse to the 50 % voltage amplitude point on the rising edge of the pulse.

Pulse rise time measurements shall be determined by taking the time difference between the 90 % voltage amplitude to the 10 % voltage amplitude points on the rising edge of the pulse.

Pulse decay time measurements shall be determined by taking the time difference between the 10 % voltage amplitude to the 90 % voltage amplitude points on the falling edge of the pulse.

Pulse spacing measurements shall be determined by taking the time difference between the 50 % voltage amplitude point on the rising edge of the second pulse to the 50 % voltage amplitude point on the rising edge of the first pulse.

The phase reversal delay measurement shall be determined by taking the time difference between the minimum point of the phase transient amplitude and the 50 % voltage amplitude point on the rising edge of the P6 pulse.

The phase reversal width measurement shall be determined by taking the time difference between the 80 % voltage amplitude points at the phase transient.

The test setup shall be as in Figure 12.

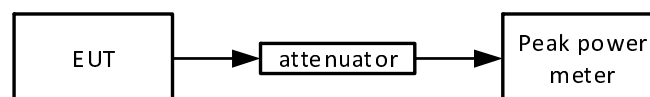

Figure 12: Test setup for pulse shape and spacing

5.3.6.4 Measurement procedure

The test procedure shall be as follows:

- 1) Attach the EUT antenna port to the peak power meter with an attenuator such that the power level is in the working range of the power meter.
- 2) If the EUT does not have a 1 030 MHz Mode S interrogation function, skip to step 7.
- 3) Configure the EUT to produce test signal 1.
- 4) Capture the waveform on the peak power meter.
- 5) Verify that each of the pulse shape parameters is within the thresholds specified in clause 4.2.2.6.2, Table 4 (for P1, P2 and P6).
- 6) Verify that each of the pulse spacing parameters is within the thresholds specified in clause 4.2.2.6.2, Table 5 (for SSR Mode = Mode S).
- 7) If the EUT does not have a 1 030 MHz Mode A/C interrogation function, skip to step 16.
- 8) Configure the EUT to produce test signal 3.
- 9) Capture the waveform on the peak power meter.
- 10) Verify that each of the pulse shape parameters is within the thresholds specified in clause 4.2.2.6.2, Table 4 (for S1, P1, P3, and P4).
- 11) Verify that each of the pulse spacing parameters is within the thresholds specified in clause 4.2.2.6.2, Table 5 (for SSR Mode = Mode A and Inter-mode).
- 12) Configure the EUT to produce test signal 4.
- 13) Capture the waveform on the peak power meter.
- 14) Verify that each of the pulse shape parameters is within the thresholds specified in clause 4.2.2.6.2, Table 4 (for S1, P1, P3, and P4).
- 15) Verify that each of the pulse spacing parameters is within the thresholds specified in clause 4.2.2.6.2, Table 5 (for SSR Mode = Mode C and Inter-mode).
- 16) If the EUT does not have a 1 090 MHz Reference/Test Transmission function, skip the remaining procedure.
- 17) Configure the EUT to produce test signal 5.
- 18) Capture the waveform on the peak power meter.
- 19) Verify that each of the pulse shape parameters is within the thresholds specified in clause 4.2.2.6.2, Table 6.
- 20) Verify that each of the pulse spacing parameters is within the thresholds specified in clause 4.2.2.6.2, Table 7.

5.3.7 Duty cycle

5.3.7.1 Description

The transmitter duty cycle is evaluated so that it does not exceed the specified maximum.

5.3.7.2 Test Conditions

This test applies only to EUT that has a 1 090 MHz Reference/Test Transmission function.

The EUT shall use the highest operational transmission rate for 1 090 MHz transmissions.

The measurement shall be performed according to clause 5.1.2.2.

5.3.7.3 Method of Measurement

The measurement shall use the connection to the EUT antenna interface.

The test setup shall be as in Figure 13.

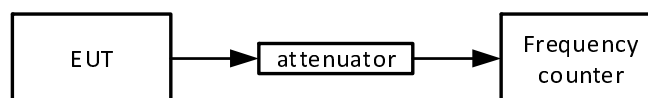

Figure 13: Test setup for duty cycle

5.3.7.4 Measurement procedure

The test procedure shall be as follows:

- 1) Attach the EUT antenna port to a frequency counter as shown in Figure 13. The attenuation of the attenuator shall be such that the power level is in the working range of the frequency counter. The frequency counter shall have a sampling rate of at least 100 MHz.
- 2) Configure the frequency counter to accumulate the time when signal is present from the EUT at above the half power level in the frequency range of $1\,090\text{ MHz} \pm 8\text{ MHz}$.
- 3) Set the EUT to transmit mode.
- 4) Monitor the frequency counter for no less than 120 seconds.

NOTE: Some counters may support a duty cycle measurement directly.

- 5) Calculate the duty cycle by dividing the number of counts by the sampling rate, and multiply by 100 to get percentage.
- 6) Verify that the duty cycle does not exceed the limit specified in clause 4.2.2.7.2.

5.3.8 Peak output power

5.3.8.1 Description

This test evaluates the transmitter peak envelope power to show that the measured power does not exceed the specified maximum.

5.3.8.2 Test Conditions

The measurements shall be performed according to clause 5.1.2.2 and clause 5.1.2.3.

5.3.8.3 Method of Measurement

The measurement shall use the connection to the EUT antenna interface.

The test setup shall be as in Figure 14.

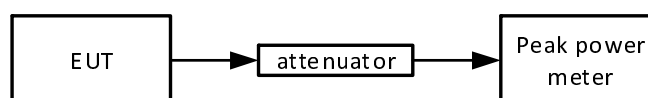

Figure 14: Test setup for peak output power

5.3.8.4 Measurement procedure

5.3.8.4.1 Equipment containing a 1 030 MHz interrogation function

The test procedure shall be as follows:

- 1) Attach the EUT antenna port to the power meter with an attenuator to keep the power level in the range of the power meter.
- 2) Set the EUT to generate Test Signal 1 at the EUT maximum rated power for 1 030 MHz transmissions.
- 3) Measure the peak envelope power.
- 4) Taking into account the measured cable losses and the attenuation of the attenuator, verify that the power level does not exceed the limit specified in clause 4.2.2.8.2 for a 1 030 MHz transmission.

5.3.8.4.2 Equipment containing a 1 090 MHz reference/test transmission function

The test procedure shall be as follows:

- 1) Attach the EUT antenna port to the power meter with an attenuator to keep the power level in the range of the power meter.
- 2) Set the EUT to generate Test Signal 5 at the EUT maximum rated power for 1 090 MHz transmissions.
- 3) Measure the peak envelope power.
- 4) Taking into account the measured cable losses and the attenuation of the attenuator, verify that the power level does not exceed the limit specified in clause 4.2.2.8.2 for a 1 090 MHz transmission.

5.4 Receiver tests

5.4.1 Sensitivity and sensitivity variation over the operating frequency range

5.4.1.1 Description

The purpose of this test is to establish that the EUT is able to receive a wanted signal at low input signal levels while providing a pre-determined level of performance (measuring the Pd) and is also able to tolerate a certain degree of frequency offset (measuring the Pd variation).

5.4.1.2 Test Conditions

The measurement shall be performed according to clauses 5.1.2.2 and 5.1.2.3.

5.4.1.3 Method of Measurement

The test setup shall be as in Figure 15. The test waveform shall be injected into the EUT antenna interface. A signal generator shall be used to stimulate the EUT with test signal 6 at the amplitudes indicated in the procedure. A Network Traffic Analyser shall be used to collect the reception reports for each injected message. All amplitudes shall be adjusted for cable losses.



Figure 15: Test setup for sensitivity over operating frequency

5.4.1.4 Measurement procedure

The test procedure shall be as follows:

- 1) Configure the EUT to receive and report messages for recording.
- 2) Verify that no message reports are being generated.
- 3) Configure the signal generator to produce test signal 6 at the operating frequency and with the amplitude specified in clause 4.2.3.6.2 (-88 dBm).
- 4) Configure the Network Traffic Analyser to record message reports.
- 5) Inject 1 000 messages per second for at least 100 seconds.
- 6) Review the recorded reports to count the number of reports which match the expected message content.
- 7) Divide the number of successfully received messages by the expected number of input messages (i.e. elapsed time multiplied by message rate) and verify that the required Pd as defined in clause 4.2.3.6.2 (at least 90 %) is achieved.
- 8) Decrease the signal level in 1 dB steps until the probability of detection limit as defined in clause 4.2.3.6.2 is no longer achieved. The lowest amplitude at which the required Pd (clause 4.2.3.6.2) is achieved will be used as the reference signal level (i.e. the reference sensitivity) for the following steps and subsequent tests.
- 9) Change the signal level of test signal 6 to the reference sensitivity measured in step 8 plus the degradation level specified in clause 4.2.3.1.2 (i.e. add 3 dB).
- 10) Repeat steps 4 to 7 with the signal generator configured to produce test signal 6 to the operating frequency plus 1 MHz as specified in clause 4.2.3.1.2.
- 11) Repeat steps 4 to 7 with the signal generator configured to produce test signal 6 to the operating frequency minus 1 MHz as specified in clause 4.2.3.1.2.

5.4.2 RF selectivity and spurious response rejection

5.4.2.1 Description

The purpose of this test is to establish the selectivity of the receiver by measuring the rate of detection of properly formed messages injected outside of the intended operating frequency. The amplitude of injected messages is adjusted to verify that an appropriate number of messages are rejected. Both RF selectivity and spurious response rejection requirements will be addressed with this test.

5.4.2.2 Test Conditions

The measurement shall be performed according to clause 5.1.2.2.

5.4.2.3 Method of Measurement

The test setup shall be as in Figure 16. The test waveform shall be injected into the EUT antenna interface. A signal generator shall be used to stimulate the EUT with test signal 6 at the amplitudes and frequencies indicated in the procedure. A Network Traffic Analyser shall be used to collect the reception reports for each injected message. The message receipt reports shall be collected and the average rate of message receipt shall be calculated. All amplitudes shall be adjusted for cable losses.



Figure 16: Test setup for RF selectivity

5.4.2.4 Measurement procedure

The test procedure shall be as follows:

- 1) Configure the EUT to receive and report messages for recording.
- 2) Configure the signal generator to produce test signal 6 at a rate of 1 000 messages per second. The level of the wanted signal from generator shall be adjusted to the level of the reference sensitivity measured in the test specified in clause 5.4.1.
- 3) Configure the Network Traffic Analyser to record message reports for a period of at least 10 seconds.
- 4) Divide the number of successfully received messages by the expected number of input messages (i.e. elapsed time multiplied by message rate) and evaluate the 1 090 MHz Probability of Detection (Pd_{1090}).
- 5) Change the signal generator power to (reference sensitivity + 3 dB), and inject in the EUT test signal 6 at the following frequencies:
 - 1 102,5 MHz, 1 104 MHz, 1 105 MHz, 1 106 MHz, 1 107 MHz, 1 108 MHz,
 - 1 077,5 MHz, 1 076 MHz, 1 075 MHz, 1 074 MHz, 1 073 MHz, 1 072 MHz
- 6) For each of the frequencies at step 5, evaluate the Probability of Detection of the injected scenario (Pd_{offset}) at the injected amplitude as done for Pd_{1090} .
- 7) Change the signal generator power to (reference sensitivity + 20 dB), and inject in the EUT test signal 6 at the following frequencies:
 - 1 109 MHz to 1 118 MHz at 1 MHz steps
 - 1 071 MHz to 1 062 MHz at 1 MHz steps
- 8) For each of the frequencies at step 7, evaluate the Probability of Detection of the injected scenario (Pd_{offset}) at the injected amplitude as done for Pd_{1090} .
- 9) Change the signal generator power to (reference sensitivity + 40 dB), and inject in the EUT test signal 6 at the following frequencies:
 - 1 119 MHz to 1 135 MHz at 1 MHz steps
 - 1 061 MHz to 1 045 MHz at 1 MHz steps
- 10) For each of the frequencies at step 9, evaluate the Probability of Detection of the injected scenario (Pd_{offset}) at the injected amplitude as done for Pd_{1090} .
- 11) Change the signal generator power to (reference sensitivity + 60 dB), and inject in the EUT test signal 6 at the following frequencies:
 - 1 136 MHz to 1 168 MHz at 1 MHz steps
 - 1 044 MHz to 1 012 MHz at 1 MHz steps
- 12) For each of the frequencies at step 11, evaluate the Probability of Detection of the injected scenario (Pd_{offset}) at the injected amplitude as done for Pd_{1090} .
- 13) Verify that the test results are in accordance with the requirements specified in clause 4.2.3.2.2 ($Pd_{offset} \leq Pd_{1090}$).

5.4.3 Inter-modulation response rejection

5.4.3.1 Description

The purpose of this test is to establish that inter-modulation caused by two unwanted Out-of-Band signals does not degrade the reception probability when their signal level is below the specified limit.

5.4.3.2 Test Conditions

The measurement shall be performed according to clause 5.1.2.2.

5.4.3.3 Method of Measurement

The test setup shall be as in Figure 17. The test waveforms shall be injected into the EUT antenna interface via a combiner. A Network Traffic Analyser shall be used to evaluate the Pd.

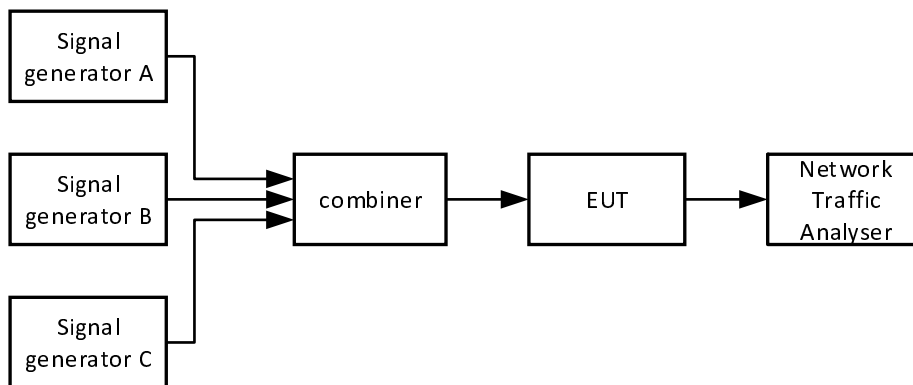

Figure 17: Test setup for intermodulation response rejection

5.4.3.4 Measurement procedure

The measurement procedure shall be as follows:

- 1) Three signal generators, A, B and C, shall be connected to the EUT via a combiner and shall be configured to produce test signals at a rate of 1 000 messages per second as follows:
 - The wanted signal, provided by signal generator A, shall be at the nominal frequency of the receiver and shall produce test signal 6.
 - The first unwanted signal, provided by signal generator B, shall be test signal 8 and adjusted to a frequency f_1 at 20 MHz above the nominal frequency of the receiver.
 - The second unwanted signal, provided by signal generator C, shall be test signal 7 and adjusted to a frequency f_2 at 40 MHz above the nominal frequency of the receiver.
- 2) Initially, signal generators B and C (unwanted signals) shall be switched off (maintaining the output impedance):
 - The level of the wanted signal from generator A shall be adjusted to the level which is 20 dB above the reference sensitivity measured in the test specified in clause 5.4.1.
- 3) Divide the number of successfully received messages by the expected number of input messages (i.e. elapsed time multiplied by message rate) and record the Pd of the wanted signal.
- 4) Signal generators B and C shall then be switched on and set to a level 40 dB above the reference sensitivity measured in the test specified in clause 5.4.1.
- 5) Divide the number of successfully received messages by the expected number of input messages (i.e. elapsed time multiplied by message rate) and record the Pd of the wanted signal.
- 6) Verify that the Pd from step 5 is degraded by no more than the limit specified in clause 4.2.3.3.2.
- 7) The measurement shall be repeated with the unwanted signal generator B at the frequency 20 MHz below that of the wanted signal and the frequency of the unwanted signal generator C at the frequency 40 MHz below that of the wanted signal.

- 8) Repeat the test steps 1 to 7 with at least the 4 frequencies below fulfilling $f_c = 2 \times f_1 - f_2$ (with an offset of f_1 and f_2 in the range of +20 MHz to +78 MHz and -20 MHz to -78 MHz):
- $f_1 = 1\ 051$, $f_2 = 1\ 012$ ($f_2 = 1\ 090$ MHz - 78 MHz)
 - $f_1 = 1\ 060$, $f_2 = 1\ 030$ ($f_2 = 1\ 090$ MHz - 60 MHz)
 - $f_1 = 1\ 108$, $f_2 = 1\ 126$ ($f_2 = 1\ 090$ MHz + 36 MHz)
 - $f_1 = 1\ 129$, $f_2 = 1\ 168$ ($f_2 = 1\ 090$ MHz + 78 MHz)

NOTE: The frequency $f_2 = 1\ 030$ MHz is included since it corresponds to another interrogator.

5.4.4 Co-channel rejection

5.4.4.1 Description

This test verifies that the receiver's reception probability is not degraded in the presence of an unwanted modulated signal at the same frequency when its signal level does not exceed the limit specified in clause 4.2.3.4.2.

5.4.4.2 Test Conditions

The measurement shall be performed according to clause 5.1.2.2.

5.4.4.3 Method of Measurement

The test setup shall be as in Figure 18. The test waveforms shall be injected into the EUT antenna interface via a combiner. A Network Traffic Analyser shall be used to evaluate the Pd.

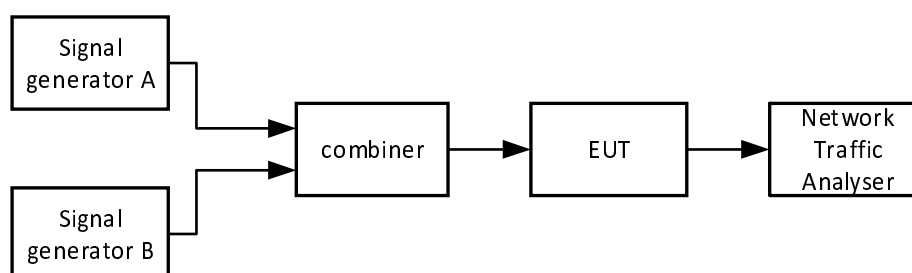

Figure 18: Test setup for co-channel rejection

5.4.4.4 Measurement procedure

The test procedure shall be as follows:

- 1) Two signal generators A and B shall be connected to the EUT via a combiner and shall be configured to produce test signals at a rate of 1 000 messages per second. The wanted signal, represented by signal generator A, shall be at the nominal frequency of the receiver (i.e. 1 090 MHz) and shall be test signal 6.
- 2) The unwanted signal, represented by signal generator B, shall be at the nominal frequency of the receiver (i.e. 1 090 MHz) and shall be a test signal 7.
- 3) Initially the unwanted signal shall be switched off.
- 4) The level of the wanted signal from generator A shall be adjusted to a level which is 20 dB above the reference sensitivity measured in the test specified in clause 5.4.1.
- 5) Divide the number of successfully received messages by the expected number of input messages (i.e. elapsed time multiplied by message rate) and record the Pd for the wanted signal.
- 6) The unwanted signal from generator B shall then be switched on and its level shall be adjusted to 12 dB below the wanted signal as referenced at the input of the EUT.

- 7) Divide the number of successfully received messages by the expected number of input messages (i.e. elapsed time multiplied by message rate) and record the Pd for the wanted signal.
- 8) Verify that the Pd from step 8 is degraded by no more than the limit specified in clause 4.2.3.4.2.
- 9) The measurement shall be repeated for displacements of the unwanted signal from Generator B at 1 088,7 MHz and 1 091,3 MHz.

NOTE: The test is repeated at frequencies 1 088,7 and 1 091,3 MHz to span the -3 dB spectrum width depicted in Figure 2.

5.4.5 Blocking

5.4.5.1 Description

This test verifies that a single unwanted signal in the Out-of-Band domain cannot degrade the reception probability when its signal level is below the limit specified in clause 4.2.3.5.2.

5.4.5.2 Test Conditions

The measurement shall be performed according to clause 5.1.2.2.

5.4.5.3 Method of Measurement

The test setup shall be as in Figure 19. The test waveforms shall be injected into the EUT antenna interface via a combiner. A Network Traffic Analyser shall be used to evaluate the Pd.

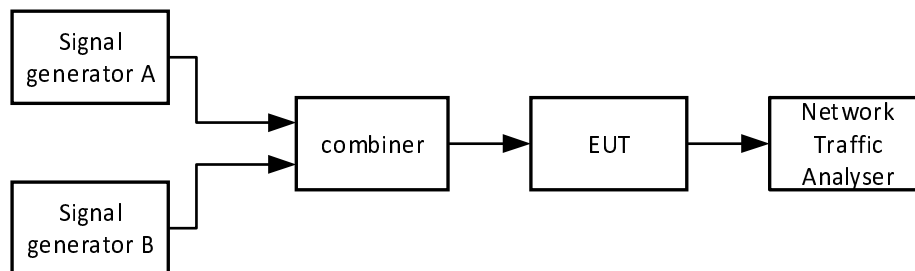

Figure 19: Test setup for blocking

5.4.5.4 Measurement procedure

The test procedure shall be as follows:

- 1) Two signal generators A and B shall be connected to the EUT via a combiner and shall be configured to produce test signals at a rate of 1 000 messages per second.
- 2) The wanted signal, represented by signal generator A, shall be at the nominal frequency of the receiver (i.e. 1 090 MHz) and shall be a test signal 6.
- 3) The unwanted signal, provided by signal generator B, shall be test signal 8 (continuous wave) at the minimum frequency specified in clause 4.2.3.5.2 (i.e. 1 090 MHz - 78 MHz = 1 012 MHz).
- 4) Initially the unwanted signal shall be switched off.
- 5) The level of the wanted signal from generator A shall be adjusted to a level which is 6 dB above the reference sensitivity measured in the test described in clause 5.4.1.
- 6) Divide the number of successfully received messages by the expected number of input messages (i.e. elapsed time multiplied by message rate) and record the Pd of the wanted signal.

- 7) The unwanted signal shall then be switched on and its level shall be adjusted to the level specified in clause 4.2.3.5.2.
- 8) Divide the number of successfully received messages by the expected number of input messages (i.e. elapsed time multiplied by message rate) and record the Pd of the wanted signal.
- 9) Verify that the Pd from step 8 is degraded by no more than the limit specified in clause 4.2.3.5.2 (i.e. 5 %).
- 10) The measurement shall be repeated for frequencies throughout the range defined in clause 4.2.3.5.2 at 1 MHz steps.

5.4.6 Receiver spurious emissions

5.4.6.1 Description

For receivers, or EUT in receive mode, the spurious domain is all frequencies.

5.4.6.2 Test Conditions

The measurement shall be performed according to clause 5.1.2.2.

5.4.6.3 Method of Measurement

All amplitudes shall be adjusted for cable loss.

The test setup shall be as in Figure 20.

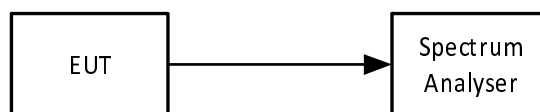

Figure 20: Set setup for receiver spurious emissions

5.4.6.4 Measurement procedure

The test procedure shall be as follows:

- 1) Connect the spectrum analyser to the EUT antenna connector.
- 2) Tune the spectrum analyser subsequently to the frequency range shown in Table 14.
- 3) Note the detected power levels at the spectrum analyser.
- 4) Taking into account the measured cable losses, verify that the power level does not exceed the limits specified in clause 4.2.3.7.2.

All measurements shall be made with a Reference Bandwidth (RBW) and a Video Bandwidth (VBW) as shown in Table 14.

Table 14: Measurement Bandwidths

Frequency Range	RBW	VBW
$9 \text{ kHz} \leq f < 150 \text{ kHz}$	1 kHz	3 kHz
$150 \text{ kHz} \leq f < 30 \text{ MHz}$	10 kHz	30 kHz
$30 \text{ MHz} \leq f \leq 1 \text{ GHz}$	100 kHz	300 kHz
$1 \text{ GHz} < f \leq 6\,000 \text{ MHz}$	1 MHz	3 MHz
NOTE 1: f is the measurement frequency.		
NOTE 2: The Reference Bandwidths (RBWs) are defined in ERC/Recommendation 74-01 [i.4].		

5.4.7 Dynamic range

5.4.7.1 Description

The purpose of this test is to establish that the receiver is able to correctly decode input signals with amplitudes across the dynamic range. A -88 dBm sensitivity is established, and detectability is then verified through the dynamic range up to the maximum required amplitude.

5.4.7.2 Test Conditions

The measurement shall be performed according to clauses 5.1.2.2 and 5.1.2.3.

5.4.7.3 Method of Measurement

The test setup shall be as in Figure 21. The test waveform shall be injected into the EUT antenna interface. A signal generator shall be used to stimulate the EUT with test signal 6 at the amplitudes and frequencies indicated in the procedure. A Network Traffic Analyser shall be used to collect the reception reports for each injected message. The message receipt reports shall be collected and the average rate of message receipt shall be calculated at each amplitude. All amplitudes shall be adjusted for cable losses.



Figure 21: Test setup for receiver dynamic range

5.4.7.4 Measurement procedure

The test procedure shall be as follows:

- 1) Configure the EUT to receive and report messages for recording.
- 2) Configure the Network Traffic Analyser to record message reports.
- 3) Verify that no message reports are being generated.
- 4) Configure the signal generator to produce test signal 6 at the amplitude specified in clause 4.2.3.6.2 (i.e. -88 dBm). Inject at least 1 000 messages per second for at least 100 seconds.
- 5) Review the recorded reports to count the number of reports which match the expected message content.
- 6) Divide the number of successfully received messages by the expected number of input messages (i.e. elapsed time multiplied by message rate) and verify that the required Pd as specified in clause 4.2.3.8.2 is achieved.
- 7) Repeat the test 7 times increasing the signal level of the test signal 6 by 10 dB each time (i.e. -78 dBm, -68 dBm, -58 dBm, -48 dBm, -38 dBm, -28 dBm, -18 dBm) and verify that the probability of detection is no less than 90 %.

Annex A (informative): Relationship between the present document and the essential requirements of Directive 2014/53/EU

The present document has been prepared under the Commission's standardisation request C(2015) 5376 final [i.2] to provide one voluntary means of conforming to the essential requirements of Directive 2014/53/EU on the harmonisation of the laws of the Member States relating to the making available on the market of radio equipment and repealing Directive 1999/5/EC [i.1].

Once the present document is cited in the Official Journal of the European Union under that Directive, compliance with the normative clauses of the present document given in Table A.1 confers, within the limits of the scope of the present document, a presumption of conformity with the corresponding essential requirements of that Directive, and associated EFTA regulations.

**Table A.1: Relationship between the present document and
the essential requirements of Directive 2014/53/EU**

Harmonised Standard ETSI EN 303 489					
Requirement				Requirement Conditionality	
No	Description	Essential requirements of Directive	Clause(s) of the present document	U/C	Condition
1	Operating frequency and frequency error	3.2	4.2.2.1	C	Equipment with Interrogation Transmission function or Reference/Test Transmission function
2	Spectrum mask	3.2	4.2.2.2	C	Equipment with Interrogation Transmission function or Reference/Test Transmission function
3	Residual power output	3.2	4.2.2.3	C	Equipment with Interrogation Transmission function or Reference/Test Transmission function
4	Spurious emissions in active mode	3.2	4.2.2.4	C	Equipment with Interrogation Transmission function or Reference/Test Transmission function
5	Intermodulation attenuation	3.2	4.2.2.5	C	Equipment with Interrogation Transmission function or Reference/Test Transmission function
6	Pulse Shape and Spacing	3.2	4.2.2.6	C	Equipment with Interrogation Transmission function or Reference/Test Transmission function
7	Duty cycle	3.2	4.2.2.7	C	Equipment with Reference/Test Transmission function
8	Peak output power	3.2	4.2.2.8	C	Equipment with Interrogation Transmission function or Reference/Test Transmission function
9	Sensitivity variation over the operating frequency range	3.2	4.2.3.1	C	Equipment with Receive function
10	RF selectivity and spurious response rejection	3.2	4.2.3.2	C	Equipment with Receive function

Harmonised Standard ETSI EN 303 489					
Requirement				Requirement Conditionality	
No	Description	Essential requirements of Directive	Clause(s) of the present document	U/C	Condition
11	Inter-modulation response rejection	3.2	4.2.3.3	C	Equipment with Receive function
12	Co-channel rejection	3.2	4.2.3.4	C	Equipment with Receive function
13	Blocking	3.2	4.2.3.5	C	Equipment with Receive function
14	Sensitivity	3.2	4.2.3.6	C	Equipment with Receive function
15	Receiver spurious emissions	3.2	4.2.3.7	C	Equipment with Receive function
16	Dynamic range	3.2	4.2.3.8	C	Equipment with Receive function

Key to columns:

Requirement:

No A unique identifier for one row of the table which may be used to identify a requirement.

Description A textual reference to the requirement.

Essential requirements of Directive

Identification of article(s) defining the requirement in the Directive.

Clause(s) of the present document

Identification of clause(s) defining the requirement in the present document unless another document is referenced explicitly.

Requirement Conditionality:

U/C Indicates whether the requirement is unconditionally applicable (U) or is conditional upon the manufacturer's claimed functionality of the equipment (C).

Condition Explains the conditions when the requirement is or is not applicable for a requirement which is classified "conditional".

Presumption of conformity stays valid only as long as a reference to the present document is maintained in the list published in the Official Journal of the European Union. Users of the present document should consult frequently the latest list published in the Official Journal of the European Union.

Other Union legislation may be applicable to the product(s) falling within the scope of the present document.

Annex B (informative): Checklist

This annex provides a traceability of the technical parameters for article 3.2 of Directive 2014/53/EU [i.1] defined in ETSI EG 203 336 [i.3] with the technical requirements for conformance defined in clause 4 of the present document.

If a technical parameter for article 3.2 of Directive 2014/53/EU [i.1] defined in ETSI EG 203 336 [i.3] has not been included in the present document, an explanation is provided.

An explanation is also provided whenever a technical parameter defined in ETSI EG 203 336 [i.3] is covered by an alternative technical requirement.

Table B.1: Checklist

Technical Parameters defined in ETSI EG 203 336 [i.3]	Clauses of the present document	Comments
Transmitter Parameters		
Transmit power (and possible accuracy)	4.2.2.8	
Spectrum mask	4.2.2.2	
Transmitter Frequency stability	4.2.2.1	
Transmitter Intermodulation attenuation	4.2.2.5	
Unwanted emissions (OoB and spurious domains)	4.2.2.4 4.2.2.3	
Transmitter Time domain characteristics (e.g. the duty cycle, turn-on and turn-off, frequency hopping cycle, dynamic changes of modulation scheme and others)	4.2.2.6 4.2.2.7	
Transmitter Transients	4.2.2.2	This requirement is covered by the spectrum mask.
Receiver Parameters		
Receiver sensitivity	4.2.3.6 4.2.3.1	
Receiver co-channel rejection	4.2.3.4	The operating frequency of WAM system receivers is the same everywhere in the world.
Adjacent band/channel Selectivity	4.2.3.2	
Spurious response Rejection	4.2.3.2	Image frequencies are evaluated as part of the selectivity.
Receiver blocking	4.2.3.5	
Receiver radio-frequency intermodulation	4.2.3.3	
Receiver dynamic range	4.2.3.8	
Reciprocal mixing	4.2.3.2 4.2.3.5 4.2.3.6	Reciprocal mixing is covered by the Selectivity, the receiver blocking as well as the sensitivity.
Receiver unwanted emissions in the spurious domain	4.2.3.7	

Annex C (informative): Maximum measurement uncertainty

The measurements described in the present document are based on the following assumptions:

- the measured value related to the corresponding limit is used to decide whether an equipment meets the requirements of the present document;
- the value of the measurement uncertainty for the measurement of each parameter is included in the test report.

Table C.1 shows the recommended values for the maximum measurement uncertainty figures.

Table C.1: Maximum measurement uncertainty

Parameter	Uncertainty
Environment measurements	
Temperature	± 1 °C
Relative humidity	± 5 %
Mains Supply Voltage	± 2 %
Transmitter measurements	
Transmitter power	$\pm 1,5$ dB
Intermodulation attenuation	± 1 dB
Duty cycle	± 20 ns (see note)
Pulse Shape and Spacing	± 1 ns
Spectrum mask	± 4 dB
Spurious emissions	± 4 dB
Receiver measurements	
Selectivity and spurious response rejection	± 1 dB
Sensitivity and sensitivity variation	± 1 dB
Dynamic range	± 1 dB
Blocking	± 1 dB
Inter-modulation response rejection	± 1 dB
Co-channel rejection	± 1 dB
Receiver Spurious emissions	± 4 dB
NOTE: Frequency counter gate accuracy.	

History

Version	Date	Status	
V1.0.0	May 2025	SRdAP process	EV 20250804: 2025-05-06 to 2025-08-04
V1.1.0	November 2025	SRdAP process	VA 20260120: 2025-11-21 to 2026-01-20
V1.1.1	January 2026	Publication	