

Draft **ETSI EN 303 753** V1.0.0 (2023-06)



**Wideband Data Transmission Systems (WDTs)  
for Mobile and Fixed Radio Equipment  
operating in the 57 - 71 GHz band;  
Harmonised Standard for access to radio spectrum**

---

**Reference**

DEN/BRAN-230026

---

**Keywords**

60 GHz, access, broadband, radio, SRD

**ETSI**

---

650 Route des Lucioles  
F-06921 Sophia Antipolis Cedex - FRANCE

Tel.: +33 4 92 94 42 00 Fax: +33 4 93 65 47 16

Siret N° 348 623 562 00017 - APE 7112B  
Association à but non lucratif enregistrée à la  
Sous-Préfecture de Grasse (06) N° w061004871

---

**Important notice**

The present document can be downloaded from:  
<https://www.etsi.org/standards-search>

The present document may be made available in electronic versions and/or in print. The content of any electronic and/or print versions of the present document shall not be modified without the prior written authorization of ETSI. In case of any existing or perceived difference in contents between such versions and/or in print, the prevailing version of an ETSI deliverable is the one made publicly available in PDF format at [www.etsi.org/deliver](http://www.etsi.org/deliver).

Users of the present document should be aware that the document may be subject to revision or change of status. Information on the current status of this and other ETSI documents is available at <https://portal.etsi.org/TB/ETSIDeliverableStatus.aspx>

If you find errors in the present document, please send your comment to one of the following services:  
<https://portal.etsi.org/People/CommitteeSupportStaff.aspx>

If you find a security vulnerability in the present document, please report it through our Coordinated Vulnerability Disclosure Program:  
<https://www.etsi.org/standards/coordinated-vulnerability-disclosure>

---

**Notice of disclaimer & limitation of liability**

The information provided in the present deliverable is directed solely to professionals who have the appropriate degree of experience to understand and interpret its content in accordance with generally accepted engineering or other professional standard and applicable regulations.

No recommendation as to products and services or vendors is made or should be implied. In no event shall ETSI be held liable for loss of profits or any other incidental or consequential damages.

Any software contained in this deliverable is provided "AS IS" with no warranties, express or implied, including but not limited to, the warranties of merchantability, fitness for a particular purpose and non-infringement of intellectual property rights and ETSI shall not be held liable in any event for any damages whatsoever (including, without limitation, damages for loss of profits, business interruption, loss of information, or any other pecuniary loss) arising out of or related to the use of or inability to use the software.

---

**Copyright Notification**

No part may be reproduced or utilized in any form or by any means, electronic or mechanical, including photocopying and microfilm except as authorized by written permission of ETSI.

The content of the PDF version shall not be modified without the written authorization of ETSI. The copyright and the foregoing restriction extend to reproduction in all media.

© ETSI 2023.  
All rights reserved.

# Contents

|   |    |
|---|----|
| Intellectual Property Rights .....  | 6  |
| Foreword.....   | 6  |
| Modal verbs terminology.....  | 7  |
| Introduction .....  | 7  |
| 1 Scope .....   | 8  |
| 2 References .....  | 8  |
| 2.1 Normative references .....  | 8  |
| 2.2 Informative references.....   | 8  |
| 3 Definition of terms, symbols and abbreviations.....                       | 9  |
| 3.1 Terms.....  | 9  |
| 3.2 Symbols.....  | 10 |
| 3.3 Abbreviations .....   | 10 |
| 4 Technical requirements specifications .....                               | 10 |
| 4.1 Environmental profile.....  | 10 |
| 4.2 Conformance requirements .....  | 11 |
| 4.2.1 Occupied channel bandwidth.....                                       | 11 |
| 4.2.1.1 Definition .....  | 11 |
| 4.2.1.2 Limit.....  | 11 |
| 4.2.1.3 Conformance.....  | 11 |
| 4.2.2 RF output power .....   | 11 |
| 4.2.2.1 Definition .....  | 11 |
| 4.2.2.2 Limit.....  | 11 |
| 4.2.2.3 Conformance.....  | 11 |
| 4.2.3 Power Spectral Density.....   | 12 |
| 4.2.3.1 Definition .....  | 12 |
| 4.2.3.2 Limit.....  | 12 |
| 4.2.3.3 Conformance.....  | 12 |
| 4.2.4 Transmitter unwanted emissions.....                                   | 12 |
| 4.2.4.1 Transmitter unwanted emissions in the out-of-band domain .....      | 12 |
| 4.2.4.1.1 Definition.....   | 12 |
| 4.2.4.1.2 Limit .....   | 12 |
| 4.2.4.1.3 Conformance .....   | 13 |
| 4.2.4.2 Transmitter unwanted emissions in the spurious domain.....          | 13 |
| 4.2.4.2.1 Definition.....   | 13 |
| 4.2.4.2.2 Limit .....   | 13 |
| 4.2.4.2.3 Conformance .....   | 14 |
| 4.2.5 Receiver spurious emissions .....                                     | 14 |
| 4.2.5.1 Definition .....  | 14 |
| 4.2.5.2 Limit.....  | 14 |
| 4.2.5.3 Conformance.....  | 14 |
| 4.2.6 Spectrum sharing mechanisms.....                                      | 14 |
| 4.2.6.0 General .....   | 14 |
| 4.2.6.1 Beamforming .....   | 15 |
| 4.2.6.1.1 Definition.....   | 15 |
| 4.2.6.1.2 Limit .....   | 15 |
| 4.2.6.1.3 Conformance .....   | 15 |
| 4.2.6.2 Automatic Transmit Power Control and Automatic Link Adaptation..... | 15 |
| 4.2.6.2.1 Definition.....   | 15 |
| 4.2.6.2.2 Limit .....   | 15 |
| 4.2.6.2.3 Conformance .....   | 15 |
| 4.2.7 Receiver sensitivity.....   | 16 |
| 4.2.7.1 Definition .....  | 16 |
| 4.2.7.2 Performance Criteria .....  | 16 |
| 4.2.7.3 Limit.....  | 16 |

|                               |   |           |
|-------------------------------|---|-----------|
| 4.2.7.4                       | Conformance .....   | 16        |
| 4.2.8                         | Receiver Adjacent Channel Selectivity.....  | 16        |
| 4.2.8.1                       | Definition .....  | 16        |
| 4.2.8.2                       | Limit.....  | 16        |
| 4.2.8.3                       | Conformance.....  | 16        |
| 5                             | Testing for compliance with technical requirements.....   | 17        |
| 5.1                           | Environmental conditions for testing .....  | 17        |
| 5.1.1                         | General.....  | 17        |
| 5.1.2                         | Normal test conditions .....  | 17        |
| 5.1.2.1                       | Normal temperature and humidity .....   | 17        |
| 5.1.2.2                       | Normal power source .....   | 17        |
| 5.1.3                         | Extreme test conditions.....  | 17        |
| 5.2                           | Interpretation of the measurement results .....   | 17        |
| 5.3                           | Test procedure for the essential radio test suites .....  | 17        |
| 5.3.0                         | General.....  | 17        |
| 5.3.0a                        | Product Information.....  | 18        |
| 5.3.0b                        | Test modulation, frequency and configuration .....  | 18        |
| 5.3.1                         | Occupied channel bandwidth.....   | 18        |
| 5.3.1.1                       | Test conditions .....   | 18        |
| 5.3.1.2                       | Test method.....  | 18        |
| 5.3.2                         | RF output power .....   | 19        |
| 5.3.2.1                       | Test conditions .....   | 19        |
| 5.3.2.2                       | Test method.....  | 19        |
| 5.3.3                         | Power Spectral Density.....   | 20        |
| 5.3.3.1                       | Test conditions .....   | 20        |
| 5.3.3.2                       | Test method.....  | 20        |
| 5.3.4                         | Transmitter unwanted emissions.....   | 21        |
| 5.3.4.1                       | Transmitter unwanted emissions in the out-of-band domain .....  | 21        |
| 5.3.4.1.1                     | Test conditions .....   | 21        |
| 5.3.4.1.2                     | Test method .....   | 21        |
| 5.3.4.2                       | Transmitter unwanted emissions in spurious domain .....   | 22        |
| 5.3.4.2.1                     | Test conditions .....   | 22        |
| 5.3.4.2.2                     | Test method (general).....  | 22        |
| 5.3.4.2.3                     | Pre-scan .....  | 22        |
| 5.3.4.2.4                     | Identified frequencies .....  | 23        |
| 5.3.5                         | Receiver spurious emissions .....   | 23        |
| 5.3.5.1                       | Test conditions .....   | 23        |
| 5.3.5.2                       | Test method.....  | 24        |
| 5.3.5.2.1                     | Pre-scan .....  | 24        |
| 5.3.5.2.2                     | Identified emissions.....   | 24        |
| 5.3.6                         | Spectrum sharing mechanism .....  | 25        |
| 5.3.6.1                       | Test conditions .....   | 25        |
| 5.3.6.2                       | Test method (beamforming).....  | 25        |
| 5.3.6.3                       | Test method (ATPC).....   | 25        |
| 5.3.6.4                       | Test method (ALA).....  | 26        |
| 5.3.7                         | Receiver sensitivity.....   | 27        |
| 5.3.7.1                       | Test conditions .....   | 27        |
| 5.3.7.2                       | Test method.....  | 27        |
| 5.3.8                         | Receiver Adjacent Channel Selectivity.....  | 28        |
| 5.3.8.1                       | Test conditions .....   | 28        |
| 5.3.8.2                       | Test method.....  | 28        |
| <b>Annex A (informative):</b> | <b>Relationship between the present document and the essential requirements of Directive 2014/53/EU .....</b> | <b>30</b> |
| <b>Annex B (informative):</b> | <b>Maximum Measurement Uncertainty.....</b>   | <b>32</b> |
| <b>Annex C (normative):</b>   | <b>Test sites and arrangements for radiated measurements.....</b>   | <b>33</b> |
| C.1                           | Test sites.....   | 33        |
| C.1.0                         | General .....   | 33        |
| C.1.1                         | Open air test sites .....   | 33        |

|   |  |           |
|---|--|-----------|
| C.1.2   | Anechoic chamber .....   | 34        |
| C.1.2.1   | General.....   | 34        |
| C.1.2.2   | Description.....   | 34        |
| C.1.2.3   | Influence of parasitic reflections.....  | 34        |
| C.1.2.4   | Calibration and mode of use .....  | 35        |
| C.2   | Test antenna.....  | 36        |
| C.3   | Substitution antenna .....   | 37        |
| <b>Annex D (normative):    General description of measurement .....</b>                               |  | <b>38</b> |
| D.1   | Radiated measurements.....   | 38        |
| D.2   | Substitution measurement .....   | 39        |
| <b>Annex E (informative):    Measurements procedure for verification of maximum power limits.....</b> |  | <b>40</b> |
| E.0   | Radiated metrics and compliance with the harmonised technical conditions ..... | 40        |
| E.1   | Metrics for radiated measurements .....  | 40        |
| E.2   | TRP estimation.....  | 41        |
| E.2.1   | General .....  | 41        |
| E.2.2   | Pre-scan .....   | 41        |
| E.2.3   | Methods based on spherical grid sampling.....                                  | 41        |
| E.2.4   | Beam-based directions .....  | 42        |
| E.2.5   | Peak method .....  | 42        |
| E.2.6   | Equal sector with peak average .....   | 42        |
| <b>Annex F (informative):    Bibliography.....</b>  |  | <b>43</b> |
| <b>Annex G (informative):    Change history .....</b>   |  | <b>44</b> |
| History .....   |  | 45        |

# Intellectual Property Rights

## Essential patents

IPRs essential or potentially essential to normative deliverables may have been declared to ETSI. The declarations pertaining to these essential IPRs, if any, are publicly available for **ETSI members and non-members**, and can be found in ETSI SR 000 314: "*Intellectual Property Rights (IPRs); Essential, or potentially Essential, IPRs notified to ETSI in respect of ETSI standards*", which is available from the ETSI Secretariat. Latest updates are available on the ETSI Web server (<https://ipr.etsi.org/>).

Pursuant to the ETSI Directives including the ETSI IPR Policy, no investigation regarding the essentiality of IPRs, including IPR searches, has been carried out by ETSI. No guarantee can be given as to the existence of other IPRs not referenced in ETSI SR 000 314 (or the updates on the ETSI Web server) which are, or may be, or may become, essential to the present document.

## Trademarks

The present document may include trademarks and/or tradenames which are asserted and/or registered by their owners. ETSI claims no ownership of these except for any which are indicated as being the property of ETSI, and conveys no right to use or reproduce any trademark and/or tradename. Mention of those trademarks in the present document does not constitute an endorsement by ETSI of products, services or organizations associated with those trademarks.

**DECT™**, **PLUGTESTS™**, **UMTS™** and the ETSI logo are trademarks of ETSI registered for the benefit of its Members. **3GPP™** and **LTE™** are trademarks of ETSI registered for the benefit of its Members and of the 3GPP Organizational Partners. **oneM2M™** logo is a trademark of ETSI registered for the benefit of its Members and of the oneM2M Partners. **GSM®** and the GSM logo are trademarks registered and owned by the GSM Association.

# Foreword

This draft Harmonised European Standard (EN) has been produced by ETSI Technical Committee Broadband Radio Access Networks (BRAN), and is now submitted for the combined Public Enquiry and Vote phase of the ETSI standards EN Approval Procedure.

The present document has been prepared under the Commission Implementing Decision C(2015) 5376 final [i.1] to provide one voluntary means of conforming to the essential requirements of Directive 2014/53/EU on the harmonisation of the laws of the Member States relating to the making available on the market of radio equipment and repealing Directive 1999/5/EC [i.2].

Once the present document is cited in the Official Journal of the European Union under that Directive, compliance with the normative clauses of the present document given in table A.1 confers, within the limits of the scope of the present document, a presumption of conformity with the corresponding essential requirements of that Directive and associated EFTA regulations.

| <b>Proposed national transposition dates</b>   |                                 |
|--|---------------------------------|
| Date of latest announcement of this EN (doa):  | 3 months after ETSI publication |
| Date of latest publication of new National Standard or endorsement of this EN (dop/e): | 6 months after doa              |
| Date of withdrawal of any conflicting National Standard (dow):                         | 18 months after doa             |

---

## Modal verbs terminology

In the present document "**shall**", "**shall not**", "**should**", "**should not**", "**may**", "**need not**", "**will**", "**will not**", "**can**" and "**cannot**" are to be interpreted as described in clause 3.2 of the [ETSI Drafting Rules](#) (Verbal forms for the expression of provisions).

"**must**" and "**must not**" are **NOT** allowed in ETSI deliverables except when used in direct citation.

---

## Introduction

Radio equipment operating in the 60 GHz band are capable of supporting data rates of multiple-gigabit per second.

The spectrum usage conditions for this equipment are set in ERC Recommendation 70-03 [i.3], annex 3 frequency band c2, frequency band c3 and Commission Decision 2019/1345/EU [i.4] bands 75a and 75b.

# 1 Scope

The present document specifies technical characteristics and methods of measurements for Wideband Data Transmission Systems (WDTS) fixed equipment installations intended for mobile network applications and mobile equipment operating indoor and outdoor in the 57 GHz to 71 GHz frequency range.

The scope of the present document includes equipment in this frequency range in compliance with ERC Recommendation 70-03 [i.3], annex 3 frequency band c2, frequency band c3 and Commission Decision 2019/1345/EU [i.4] bands 75a and 75b.

Radio equipment within the scope of the present document are capable of operating in all or any part of the frequency bands given in table 1.

**Table 1: Radiocommunications service frequency band**

| Transmit/Receive | Radiocommunications service frequency band |
|------------------|--|
| Transmit         | 57 GHz to 71 GHz                           |
| Receive          | 57 GHz to 71 GHz                           |

NOTE: The relationship between the present document and essential requirements of article 3.2 of Directive 2014/53/EU is given in annex A.

## 2 References

### 2.1 Normative references

References are either specific (identified by date of publication and/or edition number or version number) or non-specific. For specific references, only the cited version applies. For non-specific references, the latest version of the referenced document (including any amendments) applies.

Referenced documents which are not found to be publicly available in the expected location might be found at <https://docbox.etsi.org/Reference/>.

NOTE: While any hyperlinks included in this clause were valid at the time of publication, ETSI cannot guarantee their long term validity.

The following referenced documents are necessary for the application of the present document.

Not applicable.

### 2.2 Informative references

References are either specific (identified by date of publication and/or edition number or version number) or non-specific. For specific references, only the cited version applies. For non-specific references, the latest version of the referenced document (including any amendments) applies.

NOTE: While any hyperlinks included in this clause were valid at the time of publication, ETSI cannot guarantee their long term validity.

The following referenced documents are not necessary for the application of the present document but they assist the user with regard to a particular subject area.

- [i.1] [Commission Implementing Decision C\(2015\) 5376 final of 4.8.2015](#) on a standardisation request to the European Committee for Electrotechnical Standardisation and to the European Telecommunications Standards Institute as regards radio equipment in support of Directive 2014/53/EU of the European Parliament and of the Council.



- [i.2] [Directive 2014/53/EU of the European Parliament and of the Council of 16 April 2014](#) on the harmonisation of the laws of the Member States relating to the making available on the market of radio equipment and repealing Directive 1999/5/EC.
- [i.3] [ERC Recommendation 70-03 \(Tromsø 1997 and subsequent amendments\)](#): "Related to the Use of Short Range Devices (SRD)".
- [i.4] [Commission Implementing Decision \(EU\) 2019/1345 of 2 August 2019](#) amending Decision 2006/771/EC updating harmonised technical conditions in the area of radio spectrum use for short-range devices.
- [i.5] [ERC Recommendation 74-01 \(Approved 1998 and subsequent amendments\)](#): "Unwanted emissions in the spurious domain".
- [i.6] ETSI TS 138 141-2 (V16.10.0) (2022-03), "5G; NR; Base Station (BS) conformance testing Part 2: Radiated conformance testing (3GPP TS 38.141-2 version 16.10.0 Release 16)".
- [i.7] [ECC Report 288 \(approved 25 January 2019\)](#): "Conditions for the coexistence between Fixed Service and other envisaged outdoor uses/applications in the 57 - 66 GHz range".

## 3 Definition of terms, symbols and abbreviations

### 3.1 Terms

For the purposes of the present document, the terms given in Directive 2014/53/EU [i.2] and the following apply:

**60 GHz band:** the frequency range from 57 GHz to 71 GHz

**antenna assembly:** combination of the antenna (integral or dedicated), its coaxial cable and if applicable, its antenna connector and associated switching components

NOTE 1: This term (antenna assembly) refers to an antenna connected to one transmit chain.

NOTE 2: The gain of an antenna assembly does not include the additional gain that may result out of beamforming.

**beamforming gain:** additional (antenna) gain realized by using beamforming techniques in smart antenna systems

NOTE: Beamforming gain as used in the present document does not include the gain of the antenna assembly.

**channel separation:** minimum separation (in MHz) between the centre frequencies of two adjacent channels in the channel plan of the radio equipment

**integral antenna:** antenna which is declared to be part of the radio equipment by the manufacturer

NOTE 1: In some cases, it may not be possible to remove an integral antenna or expose an antenna connector without changing the output characteristics of the radio equipment.

NOTE 2: Even with an integral antenna, it might still be possible to separate the antenna from the equipment using a special tool.

**mean power:** (transmitted or received) power averaged during the On Time of the signal

**nominal channel bandwidth:** bandwidth assigned to a single channel

NOTE: The nominal channel bandwidth is part of the product information as outlined in clause 5.3.0a.

**occupied bandwidth:** bandwidth of the signal containing 99 % of the transmitted mean power

NOTE: Both below the lower and above the upper frequency limits, the mean power emitted is equal to 0,5 % of the total mean power of the emission.

**smart antenna system:** equipment that combines multiple transmit and/or receive antenna elements with a signal processing function to increase its radiation and/or reception capabilities

## 3.2 Symbols

For the purposes of the present document, the symbols apply:

|         |   |
|---------|---|
| D       | directivity   |
| dB      | decibel   |
| dBc     | decibels relative to the maximum power spectral density of the transmitted signal |
| dBi     | decibels relative to the gain of an isotropic antenna                             |
| dBm     | decibel relative to one milliwatt   |
| dBr     | decibel relative to a given maximum power level                                   |
| G       | gain of the antenna assembly  |
| GHz     | thousand millions of cycles per second  |
| kHz     | thousands of cycles per second  |
| MHz     | Mega Hertz  |
| $\eta$  | antenna efficiency  |
| $\mu$ s | millionths of seconds   |
| W       | Watt  |

## 3.3 Abbreviations

For the purposes of the present document, the abbreviations apply:

|                   |  |
|-------------------|--|
| AAS               | Active Antenna Systems                                   |
| ACM               | Adaptive Code and Modulation                             |
| ALA               | Automatic Link Adaptation                                |
| ATPC              | Automatic Transmit Power Control                         |
| BW                | BandWidth  |
| CW                | Continuous Wave  |
| DC                | Duty Cycle   |
| EFTA              | European Free Trade Association                          |
| EIRP              | Equivalent Isotropically Radiated Power                  |
| EIRP <sub>0</sub> | Equivalent Isotropically Radiated Power Spectral Density |
| ERP               | Effective Radiated Power                                 |
| EUT               | Equipment Under Test FER Frame Error Rate                |
| MCS               | Modulation and Coding Scheme                             |
| OTA               | Over The Air   |
| PSD               | Power Spectral Density                                   |
| RBW               | Resolution BandWidth                                     |
| RF                | Radio Frequency  |
| RMS               | Root Mean Square   |
| SRD               | Short Range Devices                                      |
| TP                | ThroughPut TRP Total Radiated Power                      |
| UUT               | Unit Under Test  |
| VBW               | Video BandWidth  |
| WDTS              | Wideband Data Transmission Systems                       |

---

# 4 Technical requirements specifications

## 4.1 Environmental profile

The technical requirements of the present document apply under the environmental profile for operation of the equipment, which shall be in accordance with its intended use. The equipment shall comply with all the technical requirements of the present document at all times when operating within the boundary limits of the operational environmental profile defined by its intended use. Conformance tests shall be carried out under environmental conditions as defined in clause 5.1.

## 4.2 Conformance requirements

### 4.2.1 Occupied channel bandwidth

#### 4.2.1.1 Definition

The occupied channel bandwidth is the bandwidth containing 99 % of the power of the signal.

#### 4.2.1.2 Limit

The occupied channel bandwidth shall be less than the nominal channel bandwidth for any transmission. The device shall support a mode of transmission with a necessary bandwidth at least 70 % of the nominal channel bandwidth. In case of smart antenna systems (devices with multiple transmit chains) each of the transmit chains shall meet this requirement.

When equipment has simultaneous transmissions in adjacent channels, these transmissions may be considered as one signal with a nominal channel bandwidth of "n" times the individual nominal channel bandwidth where "n" is the number of adjacent channels. When equipment has simultaneous transmissions in non-adjacent channels, each power envelope shall be considered separately.

#### 4.2.1.3 Conformance

Conformance tests as defined in clause 5.3.1 shall be carried out and result compared to the limit.

### 4.2.2 RF output power

#### 4.2.2.1 Definition

The RF output power is defined by the mean Equivalent Isotropically Radiated Power (EIRP) and Total Radiated Power (TRP) for the equipment during a transmission burst.

#### 4.2.2.2 Limit

The maximum RF output power shall not exceed the applicable limit indicated in table 2. The limit applies to a device including its antenna assembly. For a smart antenna system, the limit applies to any supported antenna configuration. In case of multiple (adjacent or non-adjacent) channels the total RF output power of all channels shall be less than or equal to the applicable limit in table 2.

**Table 2: RF output power limit**

| Maximum power level EIRP | Maximum power level TRP | Additional conditions   |
|--------------------------|-------------------------|---|
| 40 dBm                   | 25 dBm                  |   |
| 55 dBm                   | 25 dBm                  | Only fixed outdoor installations with $\geq 30$ dB transmit directivity |

NOTE: Radiated measurements are used in all cases given the use of integral antennas and the lack of suitable methods for conducted measurements for this type of equipment. As a consequence, the requirement at antenna port or ports is verified with the test metric of TRP, and the requirement of transmit antenna gain with the test metric of directivity. See annex E for information regarding the relationship between conducted power and TRP, and transmit antenna gain and directivity.

#### 4.2.2.3 Conformance

Conformance tests as defined in clause 5.3.2 shall be carried out and results compared to the limits.

## 4.2.3 Power Spectral Density

### 4.2.3.1 Definition

The power spectral density is the mean Equivalent Isotropically Radiated Power (EIRP) density during a transmission burst.

### 4.2.3.2 Limit

The maximum power spectral density shall not exceed the applicable limit indicated in table 3. The limit applies to a device including its antenna assembly. For a smart antenna system, the limit applies to any supported antenna configuration.

**Table 3: Power Spectral Density limit**

| Maximum power spectral density (EIRP) | Additional conditions   |
|---------------------------------------|---|
| 23 dBm/MHz                            |   |
| 38 dBm/MHz                            | Only fixed outdoor installations with $\geq 30$ dB transmit directivity |

### 4.2.3.3 Conformance

Conformance tests as defined in clause 5.3.3 shall be carried out and result compared to the limit.

## 4.2.4 Transmitter unwanted emissions

### 4.2.4.1 Transmitter unwanted emissions in the out-of-band domain

#### 4.2.4.1.1 Definition

Transmitter unwanted emissions in the out-of-band domain are emissions when the equipment is in transmit mode, on frequencies immediately outside the nominal bandwidth which results from the modulation process but excluding spurious emissions.

#### 4.2.4.1.2 Limit

The mean power level of transmitter unwanted emissions in the out-of-band domain as measured with a 1 MHz reference bandwidth shall be less than or equal to the relative limits specified in figure 1 or an absolute TRP level of -30 dBm, whichever is greater. The abscissa is the ratio of relative frequency ( $F - f_C$ ) to nominal channel BandWidth (BW), where  $f_C$  is the nominal centre frequency of the transmission.

In case of multiple adjacent channels, the transmit spectrum mask in figure 1 shall apply for the nominal channel bandwidth of the multiple adjacent channels.

The boundary between the out-of-band domain and spurious emission domain shall be as specified in clause 4.2.4.2.2.

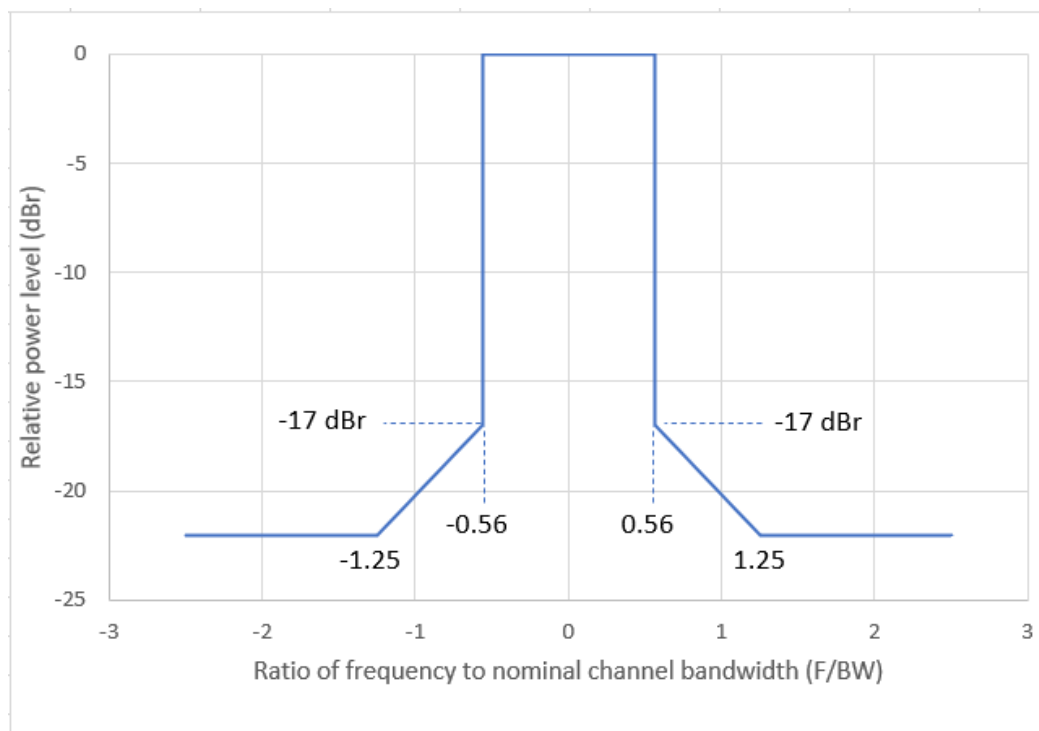

**Figure 1: Transmit spectral power mask**

#### 4.2.4.1.3 Conformance

Conformance tests as defined in clause 5.3.4.1 shall be carried out and result compared to the limit.

#### 4.2.4.2 Transmitter unwanted emissions in the spurious domain

##### 4.2.4.2.1 Definition

Transmitter unwanted emissions in the spurious domain are emissions when the equipment is in transmit mode, on frequencies below  $F_L$  and above  $F_H$  defined in clause 4.2.4.2.2.

##### 4.2.4.2.2 Limit

The level of unwanted emissions in the spurious domain shall be less than or equal to the limits specified in table 4.

The lower boundary between the spurious domain and the out-of-band domain shall be at frequency

$$F_L = \min \{ 57\,000; f_C - \min(2,5 \times \text{nominal channel bandwidth}, 1,5 \times \text{nominal channel bandwidth} + 500) \} [\text{MHz}]$$

and the upper boundary between the spurious domain and the out-of-band domain shall be at frequency

$$F_H = \max \{ 71\,000; f_C + \min(2,5 \times \text{nominal channel bandwidth}, 1,5 \times \text{nominal channel bandwidth} + 500) \} [\text{MHz}]$$

where  $f_C$  is the nominal centre frequency of the transmission and with all notions in units of MHz.

**Table 4: Transmitter unwanted emissions in the spurious domain**

| Frequency range                                | Emission limit TRP | Measurement bandwidth |
|--|--------------------|-----------------------|
| $30 \text{ MHz} \leq f < 87,5 \text{ MHz}$     | -36 dBm            | 100 kHz               |
| $87,5 \text{ MHz} \leq f \leq 118 \text{ MHz}$ | -54 dBm            | 100 kHz               |
| $118 \text{ MHz} < f < 174 \text{ MHz}$        | -36 dBm            | 100 kHz               |
| $174 \text{ MHz} \leq f \leq 230 \text{ MHz}$  | -54 dBm            | 100 kHz               |
| $230 \text{ MHz} < f < 470 \text{ MHz}$        | -36 dBm            | 100 kHz               |
| $470 \text{ MHz} \leq f \leq 694 \text{ MHz}$  | -54 dBm            | 100 kHz               |
| $694 \text{ MHz} < f \leq 1 \text{ GHz}$       | -36 dBm            | 100 kHz               |
| $1 \text{ GHz} < f < F_L \text{ GHz}$          | -30 dBm            | 1 MHz                 |
| $F_H \text{ GHz} < f \leq 142 \text{ GHz}$     | -30 dBm            | 1 MHz                 |

NOTE: The limits for transmitter unwanted emissions in the spurious domain are based on ERC Recommendation 74-01 [i.5].

#### 4.2.4.2.3 Conformance

Conformance tests as defined in clause 5.3.4 shall be carried out and result compared to the limit.

### 4.2.5 Receiver spurious emissions

#### 4.2.5.1 Definition

These are unwanted emissions in the spurious domain while the equipment is receiving a transmission.

#### 4.2.5.2 Limit

The level of unwanted emissions in the spurious domain shall be less than or equal to the limits given in table 5.

**Table 5: Receiver spurious emissions**

| Frequency band                             | Emission Limit TRP | Measurement Bandwidth |
|--|--------------------|-----------------------|
| $30 \text{ MHz} \leq f \leq 1 \text{ GHz}$ | -36 dBm            | 100 kHz               |
| $1 \text{ GHz} < f \leq 142 \text{ GHz}$   | -30 dBm            | 1 MHz                 |

NOTE: The limits for receiver unwanted emissions in the spurious domain are based on ERC Recommendation 74-01 [i.5] for transmitter unwanted emissions for SRD and for equipment using AAS and beamforming with integrated antennas for which specific limits for receiver spurious emissions are not defined, and the same limits apply separately for the transmitting and receiving phases of operation (see ERC Recommendation 74-01 [i.5], table 6).

#### 4.2.5.3 Conformance

Conformance tests as defined in clause 5.3.5 shall be carried out and result compared to the limit.

### 4.2.6 Spectrum sharing mechanisms

#### 4.2.6.0 General

Spectrum sharing mechanisms are intended to facilitate sharing between the various technologies and applications in the frequency band. The equipment within the scope of the present document shall fulfil the limits in clause 4.2.6.1, and when operating at a maximum EIRP exceeding 40 dBm, one or a combination of the spectrum sharing mechanisms defined in clause 4.2.6.2.

## 4.2.6.1 Beamforming

### 4.2.6.1.1 Definition

Beamforming reduces the interference caused to other devices and facilitates spectrum sharing by directing the radiated energy towards the intended spatial direction. The beamforming limits are specified in terms of minimum antenna directivity.

### 4.2.6.1.2 Limit

Fixed equipment operating at a power level above 40 dBm EIRP shall have a directivity expressed in logarithmic scale  $D = \text{EIRP} - \text{TRP}$  of at least 30 dB. The power limits in clause 4.2.2 shall not be exceeded.

Equipment operating up to a maximum power level of 40 dBm EIRP with a TRP exceeding 20 dBm shall have a directivity expressed in logarithmic scale  $D = \text{EIRP} - \text{TRP}$  of at least  $\max(\text{EIRP} - 25, 11)$  dB. The power limits in clause 4.2.2 shall not be exceeded.

### 4.2.6.1.3 Conformance

The conformance tests as defined in clause 5.3.6.2 shall be carried out.

## 4.2.6.2 Automatic Transmit Power Control and Automatic Link Adaptation

### 4.2.6.2.1 Definition

Automatic Transmit Power Control (ATPC) and Automatic Link Adaptation (ALA), also known as Automatic Adaptive Coding and Modulation (ACM), are adaptivity (medium access protocol) mechanisms designed to facilitate spectrum sharing with other devices. ATPC automatically reduces transmit power when there is excess link margin such that link performance (throughput and FER) are not impacted. ALA automatically adapts the coding and modulation to maximize spectral efficiency, thus reducing the transmission time of a given amount of payload. Equipment may support either, or both, types of adaptivity mechanisms.

### 4.2.6.2.2 Limit

#### 4.2.6.2.2.0 General

ATPC and/or ALA shall be implemented by equipment capable of operating at a maximum EIRP exceeding 40 dBm and shall be active under all circumstances, except that the transmission of control, management, and synchronization frames are permitted without the use of ATPC or ALA.

The limits given below apply to all equipment within the scope of the present document capable of operating at a maximum EIRP exceeding 40 dBm.

#### 4.2.6.2.2.1 Automatic Transmit Power Control

For devices equipped with transmitter power control, the difference in the average output power between the highest power setting and lowest power setting shall be greater than or equal to 3 dB for a given constant data rate and nominal channel bandwidth.

#### 4.2.6.2.2.2 Automatic Link Adaptation

For devices equipped with automatic link adaptation, the difference in the average output power between that measured for highest data rate and that measured for the lowest data rate should be greater than or equal to 3 dB for a given constant path loss and nominal channel bandwidth. Alternatively, the duty cycle of the transmissions measured for highest data rate shall be reduced by 10 % compared to that measured for the lowest data rate.

### 4.2.6.2.3 Conformance

The conformance tests as defined in clause 5.3.6.3 for ATPC and in clause 5.3.6.4 for ALA shall be carried out.

## 4.2.7 Receiver sensitivity

### 4.2.7.1 Definition

The receiver sensitivity level is the minimum mean power received at the UUT at which the performance criterion defined in clause 4.2.7.2 is met.

### 4.2.7.2 Performance Criteria

The minimum performance criterion shall be a FER of less than or equal to 10 %.

### 4.2.7.3 Limit

The measured sensitivity level shall not exceed  $-83 \text{ dBm/MHz} + 10 \log_{10}$  (nominal channel bandwidth), where the nominal channel bandwidth is expressed in MHz. The requirement shall be measured using a test site as described in annex C and applicable measurement procedures in annex D.

### 4.2.7.4 Conformance

Conformance tests described in clause 5.3.7 shall be carried out.

## 4.2.8 Receiver Adjacent Channel Selectivity

### 4.2.8.1 Definition

The receiver adjacent channel selectivity is a measure of the receiver's ability to receive a wanted signal at its assigned channel frequency in the presence of an unwanted signal at a given frequency offset from the centre frequency of the assigned channel, without this unwanted signal causing a degradation of the performance of the receiver beyond minimum performance criteria as specified in clause 4.2.7.2.

### 4.2.8.2 Limit

The minimum performance criteria as defined in clause 4.2.7.2 shall be met. The levels of the unwanted signal power shall be equal to or greater than the limits defined in table 6. The unwanted signal power shall be the smaller of  $-65 \text{ dBm}$  and  $P_{\text{min}} (\text{dBm}) + 8 \text{ dB}$  where  $P_{\text{min}}$  is the minimum level of the wanted signal required to meet the minimum performance criteria in the absence of any interference signal.

**Table 6: Receiver Adjacent Channel Selectivity: wanted and unwanted signal levels**

| Wanted signal mean power from companion device (dBm) at the input of UUT | Unwanted signal frequency (GHz)                         | Unwanted signal power (dBm) at the input of UUT  | Type of unwanted signal |
|--|---|--|-------------------------|
| $P_{\text{min}} + 6 \text{ dB}$  | Operating Channel Centre Frequency - Nominal Channel BW | $\text{min}(-65, P_{\text{min}} + 8 \text{ dB})$ | CW                      |
| $P_{\text{min}} + 6 \text{ dB}$  | Operating Channel Centre Frequency + Nominal Channel BW | $\text{min}(-65, P_{\text{min}} + 8 \text{ dB})$ | CW                      |

### 4.2.8.3 Conformance

Conformance tests described in clause 5.3.8 shall be carried out.



---

## 5 Testing for compliance with technical requirements

### 5.1 Environmental conditions for testing

#### 5.1.1 General

Tests defined in the present document shall be carried out at representative points within the boundary limits of the operational environmental profile defined by its intended use.

Where technical performance varies subject to environmental conditions, tests shall be carried out under a sufficient variety of environmental conditions (within the boundary limits of the operational environmental profile defined by its intended use) to give confidence of compliance for the affected technical requirements.

For each test defined in the present document, the environmental condition(s) at which the test has to be performed is specified in the clause on test conditions for that particular test.

#### 5.1.2 Normal test conditions

##### 5.1.2.1 Normal temperature and humidity

The normal temperature and humidity conditions for tests shall be any combination of temperature and humidity within the following ranges:

- temperature: +15 °C to +35 °C;
- relative humidity: 20 % to 75 %.

The actual values during the tests shall be recorded.

##### 5.1.2.2 Normal power source

The normal test voltage for the equipment shall be the nominal voltage for which the equipment was designed.

#### 5.1.3 Extreme test conditions

Where testing under extreme test conditions is required in the present document, measurements shall be performed at both the lower extreme temperature and the upper extreme temperature.

Unless otherwise specified by the intended use of the equipment (see clause 5.3.0a, item e)), the lower extreme temperature shall be -10 °C and the upper extreme temperature shall be +55 °C.

The lower extreme temperature and the upper extreme temperature may be specified by the operating temperature range as required by the intended use of the equipment (see clause 5.3.0a, item e)). The lower extreme temperature shall not be higher than +15 °C and the upper extreme temperature shall not be lower than +35 °C.

The extreme temperatures used in the actual measurements shall be recorded in the test report.

### 5.2 Interpretation of the measurement results

For measurement uncertainty see annex B.

### 5.3 Test procedure for the essential radio test suites

#### 5.3.0 General

Radiated measurements shall be used for all tests outlined in clause 5.

## 5.3.0a Product Information

The information requested in this clause shall be included in the test report. The following information is required in order to carry out the test suites:

- a) The channel plan(s), being the centre frequencies that the UUT is capable of tuning. If the equipment is capable of supporting multiple channel plans in the course of normal operation (e.g. offering different sizes of normal wideband operation), each distinct channel plan and its related nominal channel bandwidth for normal wideband operation shall be stated.
- b) The test modulation(s) used by the UUT.
- c) Transmit and Receive Gain of the integral antenna including beamforming gain if supported.
- d) Nominal channel bandwidth.
- e) The operating temperature that applies to the intended use of the equipment, if different from -10 °C to +55 °C.

## 5.3.0b Test modulation, frequency and configuration

The test modulation used should be representative of normal use of the equipment. Where the equipment is not capable of continuous RF transmission, the test modulation shall be such that the generated RF transmission is the same for each transmission.

If the equipment uses multiple modulation methods with different RF characteristics, the modulation method adopted for each test shall be reported in the test report.

All tests shall be conducted at the following channels within the stated channel plan(s):

- a) The channel with the lowest operating frequency.
- b) The channel with the highest operating frequency.
- c) The channel with the frequency closest to the midpoint of the stated operating frequency range.

If the UUT is capable of supporting multiple nominal channel bandwidths for wideband normal operations, tests shall be conducted for each one of them.

The Channel Separation value shall be calculated based on the minimum separation (in MHz) between any two centre channel frequencies in the channel plan.

In the case that the RF power level is adjustable, all measurements shall be made with the highest power level available.

In the case of smart antenna systems, the UUT should be configured to deliver the highest RF output power to the measurement equipment, and the method to do this shall be documented in the test report.

Radiated measurements shall be used in all cases given the use of integral antennas and the lack of suitable methods for conducted measurements for this type of equipment.

## 5.3.1 Occupied channel bandwidth

### 5.3.1.1 Test conditions

These measurements shall be performed at normal and extreme test conditions. The device shall be configured to operate at its maximum output power level. If the device can operate with different nominal channel bandwidths, then for each nominal channel bandwidth the mode of transmission with the largest necessary bandwidth shall be used for this test.

### 5.3.1.2 Test method

The occupied channel bandwidth shall be measured using applicable measurement procedures in annex D for conformance with the requirements in clause 4.2.1.

The occupied channel bandwidth shall be determined using a spectrum analyser of adequate bandwidth for the type of modulation being used in combination with a RF power meter.

For the purpose of this test, the minimum transmitter on time shall be 10  $\mu$ s. For equipment where the transmitter on time is less than 10  $\mu$ s, the method of measurement shall be documented in the test report.

The test procedure shall be as follows:

**Step 1:**

The spectrum analyser shall use the following settings:

- a) Start/Stop frequencies: As needed per figure 1.
- b) Resolution bandwidth: 1 MHz.
- c) Video bandwidth: 3 MHz.
- d) Sweep time: 1 minute.
- e) Detector: RMS Average, Sample, or Average (excepting Video Average).
- f) Trace mode: Max hold.

**Step 2:**

When the trace is complete, capture the trace, for example, using the "View" option on the spectrum analyser.

Use the 99 % bandwidth function of the spectrum analyser to measure the occupied channel bandwidth. This value shall be recorded.

## 5.3.2 RF output power

### 5.3.2.1 Test conditions

These measurements shall be performed at normal and extreme test conditions.

For a device having making use of both RF output power limits listed in clause 4.2.2.2, table 2, both operating modes shall be tested separately.

The device shall be configured to operate at its maximum output power level (EIRP) of its operating mode in clause 4.2.2.2, table 2.

Radiated measurement shall be performed in an anechoic chamber, see clause C.1.2.

### 5.3.2.2 Test method

The RF output power, subject to the conditions outlined in clause 5.1 and clause 5.3.0b, shall be measured using a test site as described in clause C.1.2 and applicable measurement procedures in annex D.

The RF output power in EIRP shall be measured and recorded for conformance with the requirements in clause 4.2.2.

The centre frequency of all equipment shall be verified as being in the 57 GHz to 71 GHz range.

**Step 1:**

- a) Using suitable attenuators, the measurement equipment shall be coupled to a matched diode detector or equivalent thereof. The output of the diode detector shall be connected to the vertical channel of an oscilloscope or equivalent power measurement equipment.
- b) The combination of the diode detector and the oscilloscope shall be capable of faithfully reproducing the duty cycle of the transmitter output signal.

- c) The duty cycle of the transmitter (Tx on / (Tx on + Tx off)) shall be noted as  $x$  ( $0 < x \leq 1$ ) and recorded in the test report. For the purpose of testing, the equipment shall be operated with a duty cycle that is equal to or greater than 0,1.

**Step 2:**

- a) The RF output power of the transmitter when operated at the highest power level shall be measured using a spectrum analyser with an integration factor that exceeds the repetition period of the transmitter by a factor of 5 or more. The observed value shall be noted as "A" (in dBm).
- b) The EIRP shall be calculated from the above measured power output A (in dBm) and the duty cycle  $x$  according to the formula below shall be recorded:

$$P = A + 10 \times \log_{10} (1 / x).$$

- c) The TRP shall be either measured, or calculated from the above measured EIRP by deducting the Transmit Gain of the integral antenna (including beamforming gain if supported) as indicated in the product information. The TRP shall be recorded in the test report.

NOTE: the TRP can be measured with a methodology according to annex E or equivalent methods.

The EIRP and TRP results obtained shall be compared to the limits in clause 4.2.2.2 in order to show compliance.

### 5.3.3 Power Spectral Density

#### 5.3.3.1 Test conditions

These measurements shall be performed at normal and extreme test conditions.

For a device having making use of both RF output power limits listed in clause 4.2.2.2, table 2, both operating modes shall be tested separately for power spectral density.

The device shall be configured to operate at its maximum output power level (EIRP) of its operating mode in clause 4.2.2.2, table 2.

Radiated measurement shall be performed in an anechoic chamber, see clause C.1.2.

#### 5.3.3.2 Test method

The power spectral density, subject to the conditions outlined in clause 5.1 and clause 5.3.0b, shall be measured using a test site as described in clause C.1.2 and applicable measurement procedures in annex D.

The power spectral density (EIRP) shall be measured and recorded for conformance with the requirements in clause 4.2.3.

The centre frequency of all equipment shall be verified as being in the 57 GHz to 71 GHz range.

**Step 1:**

- a) Using suitable attenuators, the measurement equipment shall be coupled to a matched diode detector or equivalent thereof. The output of the diode detector shall be connected to the vertical channel of an oscilloscope or equivalent power measurement equipment.
- b) The combination of the diode detector and the oscilloscope shall be capable of faithfully reproducing the duty cycle of the transmitter output signal.
- c) The duty cycle of the transmitter (Tx on / (Tx on + Tx off)) shall be noted as  $x$  ( $0 < x \leq 1$ ), and recorded in the test report. For the purpose of testing, the equipment shall be operated with a duty cycle that is equal to or greater than 0,1.

**Step 2:**

- a) The power spectral density of the transmitter when operated at the highest power level shall be measured using a spectrum analyser with an integration factor that exceeds the repetition period of the transmitter by a factor of 5 or more. The observed value shall be noted as "B" (in dBm/MHz).
- b) The EIRP power spectral density shall be calculated from the above measured power output A (in dBm) and the duty cycle x according to the formula below shall be recorded.

$$\text{PSD} = B + 10 \times \log_{10}(1 / x).$$

Where the spectrum analyser bandwidth is non-Gaussian, a suitable correction factor shall be determined and applied.

The results obtained shall be compared to the limits in clause 4.2.3.2 in order to show compliance.

## 5.3.4 Transmitter unwanted emissions

### 5.3.4.1 Transmitter unwanted emissions in the out-of-band domain

#### 5.3.4.1.1 Test conditions

These measurements shall only be performed at normal test conditions.

For a device having making use of both RF output power limits listed in clause 4.2.2.2, table 2, both operating modes shall be tested separately.

The device shall be configured to operate at its maximum output power level (EIRP) of its operating mode in clause 4.2.2.2, table 2.

Radiated measurement shall be performed in an anechoic chamber or open air test site, see annex C.

#### 5.3.4.1.2 Test method

The transmitter unwanted emissions in the out-of-band domain shall be measured using applicable measurement procedures in annex D for conformance with the requirements in clause 4.2.4.1.

**NOTE:** Annex E provides information about TRP measurements procedures.

The transmitter unwanted emissions in the out-of-band domain shall be determined using a spectrum analyser of adequate bandwidth for the type of modulation being used in combination with a RF power meter.

For the purpose of this test, the minimum transmitter on time shall be 10 µs. For equipment where the transmitter on time is less than 10 µs, the method of measurement shall be documented in the test report.

The test procedure shall be as follows:

**Step 1:**

The spectrum analyser shall use the following settings:

- a) Start/Stop frequencies: As needed per figure 1.
- b) Resolution bandwidth: 1 MHz.
- c) Video bandwidth: 3 MHz.
- d) Sweep time: 1 minute.
- e) Detector: RMS Average, Sample, or Average (excepting Video Average).
- f) Trace mode: Max hold.

**Step 2:**

When the trace is complete, capture the trace, for example, using the "View" option on the spectrum analyser.

Find the peak value of the trace and place the analyser marker on this peak. The value from the above corrected by the duty cycle  $x$ , according to the formula in clause 5.3.2.2, step 2 shall be recorded in the test report.

#### 5.3.4.2 Transmitter unwanted emissions in spurious domain

##### 5.3.4.2.1 Test conditions

These measurements shall only be performed at normal test conditions.

For a device having making use of both RF output power limits listed in clause 4.2.2.2, table 2, both operating modes shall be tested separately.

The device shall be configured to operate at its maximum output power level (EIRP) of its operating mode in clause 4.2.2.2, table 2.

Radiated measurement shall be performed in an anechoic chamber or open air test site, see annex C.

##### 5.3.4.2.2 Test method (general)

The transmitter unwanted emissions in the spurious domain shall be measured using applicable measurement procedures in annex D for conformance with the requirements in clause 4.2.4.2.

NOTE: Annex E provides information about TRP measurements procedures.

##### 5.3.4.2.3 Pre-scan

The test procedure below shall be used to identify potential unwanted emissions of the UUT.

###### Step 1:

The sensitivity of the spectrum analyser should be such that the noise floor is at least 6 dB below the limits given in table 4.

###### Step 2:

The emissions shall be measured over the range 30 MHz to 1 GHz:

- a) Resolution bandwidth: 1 MHz.
- b) Video bandwidth: 1 MHz.
- c) Detector mode: Average.
- d) Trace mode: Max hold.
- e) Sweep time: For non-continuous transmissions, the sweep time shall be sufficiently long, such that for each 1 MHz frequency step, the measurement time is greater than two transmissions of the UUT.

The emissions shall be measured over the range 1 GHz to  $F_L$  and  $F_H$  to 142 GHz as defined in clause 4.2.4.2.2:

- f) Resolution bandwidth: 1 MHz.
- g) Video bandwidth: 1 MHz.
- h) Detector mode: Average.
- i) Trace mode: Max hold.
- j) Sweep time: For non-continuous transmissions, the sweep time shall be sufficiently long, such that for each 1 MHz frequency step, the measurement time is greater than two transmissions of the UUT.

Any emissions identified during the sweeps above that fall within the 6 dB range below the applicable limit shall be individually measured using the procedure in clause 5.3.4.2.4 and compared to the limits given in table 4. If measurements are conducted at a different distance than specified, then calculations for the equivalent field strength values shall be shown.

#### 5.3.4.2.4 Identified frequencies

Unwanted emissions within the lower spurious domain or the upper spurious domain that are identified during the pre-scan measurements above shall be accurately measured per the procedure below.

The lower spurious domain is defined as the range from the minimum frequency measured to  $F_L$ .

The upper spurious domain is defined as the range from  $F_H$  to the maximum frequency measured.

Step 1 and step 2 below shall be used to accurately measure the individual unwanted emissions identified during the pre-scan measurements above.

For continuous transmit signals, a measurement using the Video Average detector of the spectrum analyser is permitted. Otherwise, the measurement shall be made only over the "on" part of the transmission.

##### Step 1:

The level of the emissions shall be measured in the time domain, using the following spectrum analyser settings:

- |                          |   |
|--------------------------|---|
| a) Centre frequency:     | Frequency of emission identified during the pre-scan. |
| b) Resolution bandwidth: | 100 kHz if $\leq 1$ GHz; 1 MHz if $> 1$ GHz.          |
| c) Video bandwidth:      | 100 kHz if $\leq 1$ GHz; 1 MHz if $> 1$ GHz.          |
| d) Frequency span:       | 0 Hz.   |
| e) Sweep time:           | Suitable to capture one transmission burst.           |
| f) Trigger:              | Video trigger.  |
| g) Detector:             | Average.  |
| h) Trace mode:           | Clear write.  |

The centre frequency (fine tune) shall be adjusted to capture the highest level of one burst of the emission to be measured.

##### Step 2:

Change the following setting on the spectrum analyser:

- |              |                                       |
|--------------|---------------------------------------|
| a) Detector: | Video average, minimum of 100 sweeps. |
|--------------|---------------------------------------|

The measured value is the TRP average power of this emission during the on-time of the burst. The value shall be recorded and compared with the limit in table 4.

### 5.3.5 Receiver spurious emissions

#### 5.3.5.1 Test conditions

These measurements shall only be performed at normal test conditions.

Radiated measurement shall be performed in an anechoic chamber or open-air test site, see annex C.

The receiver unwanted emissions, subject to the conditions outlined in clause 5.1 and clause 5.3.0b, shall be measured using a test site as described in annex C and applicable measurement procedures in annex D, shall be measured and recorded for conformance with the requirements in clause 4.2.5.

In case of radiated measurements on antenna array systems using identical receive chains, the UUT should, where possible, be configured so that only one receive chain (antenna) is activated while the other receive chains are disabled. Where this is not possible, the method used shall be documented in the test report.

If only one receive chain was tested, the result for the active receive chain shall be corrected to be valid for the whole system (all receive chains).

The emission power for one receive chain shall be multiplied with the number of receive chains to obtain the total emission power of the system.

The UUT shall be configured to a continuous receive mode or operated in a mode where no transmissions occur.

### 5.3.5.2 Test method

#### 5.3.5.2.1 Pre-scan

The test procedure below shall be used to identify potential unwanted emissions of the UUT.

##### **Step 1:**

The sensitivity of the spectrum analyser should be such that the noise floor is at least 6 dB below the limits given in table 5.

##### **Step 2:**

The emissions shall be measured over the range 30 MHz to 1 GHz:

- a) Resolution bandwidth: 100 kHz.
- b) Video bandwidth: 100 kHz.
- c) Detector mode: Average.
- d) Trace mode: Max hold.

The emissions shall be measured over the range 1 GHz to 142 GHz:

- a) Resolution bandwidth: 1 MHz.
- b) Video bandwidth: 1 MHz.
- c) Detector mode: Average.
- d) Trace mode: Max hold.

Any emissions identified during the sweeps above that fall within the 6 dB range below the applicable limit shall be individually measured using the procedure in clause 5.3.4.2.2 and compared to the limits given in table 5.

#### 5.3.5.2.2 Identified emissions

Unwanted emissions that are identified during the pre-scan measurements above shall be accurately measured per the procedure below.

The measured values shall be recorded and compared with the limits in table 5. If measurements are conducted at a different distance than specified, then calculations for the equivalent field strength values shall be shown.

The following spectrum analyser settings shall be used:

- a) Centre frequency: Frequency of emission identified during the pre-scan.
- b) Resolution bandwidth: 100 kHz if < 1 GHz; 1 MHz if > 1 GHz.
- c) Video bandwidth: 100 kHz if < 1 GHz; 1 MHz if > 1 GHz.
- d) Detector mode: Average.
- e) Trace mode: Max hold.



## 5.3.6 Spectrum sharing mechanism

### 5.3.6.1 Test conditions

These measurements shall only be performed at normal test conditions.

Measurements of beamforming limits shall be carried out for fixed equipment capable of operating at a maximum EIRP exceeding 40 dBm and for equipment capable of operating up to a maximum power level of 40 dBm EIRP with a TRP exceeding 20 dBm as specified in clause 4.2.2.2, table 2.

### 5.3.6.2 Test method (beamforming)

The beamforming limit is specified in terms of minimum antenna directivity obtained as  $D = \text{EIRP} - \text{TRP}$  (in logarithmic scale), where the EIRP and the TRP of the UUT shall be measured using applicable measurement procedures in annex D for conformance with the limits in clause 4.2.6.1.2.

NOTE: Annex E provides information about TRP measurements procedures.

The EIRP is measured in the beam peak for two power levels along with the corresponding TRP as follows:

#### Step 1:

- Measure the EIRP and the corresponding TRP at the maximum EIRP power level supported by the UUT.

#### Step 2:

- If the UUT can be configured for a power level lower than the maximum (e.g. by ATPC), measure the EIRP and the corresponding TRP for a second EIRP power level:
  - a) as close as possible to 40 dBm but exceeding this level for fixed equipment capable of exceeding 40 dBm;
  - b) as close as possible to 31 dBm but exceeding this level for other equipment subject to the beamforming limit.

The directivity shall be met for both power levels.

### 5.3.6.3 Test method (ATPC)

This method is used for equipment implementing ATPC. The measurement is carried out in the beam peak of the UUT.

Figure 2 describes an example test set-up.

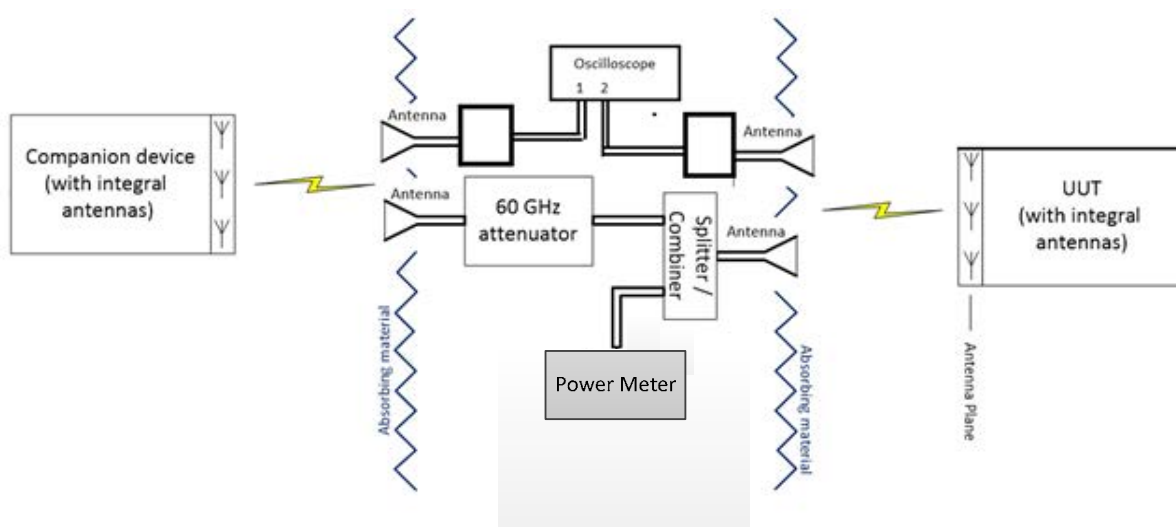

Figure 2: Test setup for verifying ATPC of an equipment

The power meter can be a true Power Meter or a spectrum analyser operated in power measurement mode.

Steps 1 through 5 below define the procedure to verify the ATPC requirement as described in clause 4.2.6.2.2.1. The performance criterion is that specified in clause 4.2.7.2, or if not corresponding to the intended use of the equipment, according to clause 5.3.0a.

**Step 1:**

- Setup the devices and let them associate, perform beamforming training and start transmission at data rate, using a medium value attenuation which emulates the link loss.

**Step 2:**

- Adjust the attenuator value until the maximum output power of the UUT is reached for the maximum data rate (throughput) or any other MCS that can be kept constant.
- Confirm that increasing the attenuator does not increase the output power while still maintaining the throughput and the performance criterion.

**Step 3:**

- Record the attenuation at the value obtained in step 2.
- Measure the average power transmitted by the UUT over the entire nominal channel bandwidth for the test duration of 30 seconds and record it as P1.

**Step 4:**

- Gradually decrease the attenuator by 20 dB while maintaining the data rate (MCS) in step 2.

**Step 5:**

- Measure the average power transmitted by the UUT over the entire nominal channel bandwidth for the test period of 30 seconds and record it as P2. Confirm that the performance criterion is met.
- Compute the difference  $P1 - P2$ .
- Verify, and record in the test report, that the difference is greater than or equal to 3 dB.

#### 5.3.6.4 Test method (ALA)

This method is used for equipment implementing ALA. The measurement is carried out in the beam peak of the UUT.

Figure 2 describes an example test set-up.

Duty Cycle (DC) is defined as the ratio of the total transmitter 'on'-time to an observation period.

Steps 1 through 5 below define the procedure to verify the ALA requirement as described in clause 4.2.6.2.2.2. The performance criterion is that specified in clause 4.2.7.2, or if not corresponding to the intended use of the equipment, according to clause 5.3.0a.

**Step 1:**

- Setup the devices and let them associate, perform beamforming training and start transmission at data rate, using a medium value attenuation which emulates the link loss.

**Step 2:**

- Increase the attenuator value until sensitivity is reached, as described in clause 5.3.8.

**Step 3:**

- Reduce the attenuator by 3 dB, and let the link stabilize.
- Record the throughput from the UUT to the companion device as TP\_s or set a payload that corresponds to this TP for the MCS used.

(The sensitivity is measured with infinite buffer load. The UUT or Companion device shall allocate enough resources to this link. The TP\_s is the amount of throughput that can be transferred at this link setup).

- Measure the duty cycle as DC\_s within the 30 second test period.
- Measure the average power transmitted by the UUT over the entire nominal channel bandwidth for the test duration of 30 seconds and record it as P1.

#### Step 4:

- At 30 second, reduce the link attenuation gradually by 16 dB to enable a higher data rate (e.g. an MCS) at the performance criterion.
- Set the amount of payload sent from the UUT to TP\_s.

#### Step 5:

- Measure the duty cycle as DC\_ala for the next 30 seconds test period.
- Measure the average power transmitted by the UUT over the entire nominal channel bandwidth for the test duration of 30 seconds and record it as P2.

#### Step 6:

- Compute the ratio  $DC_{ala} / DC_s$  and the power difference  $P1 - P2$ .
- Verify, and record in the test report, that the ratio is less than 0,9 or that the power difference is 3 dB or greater.

## 5.3.7 Receiver sensitivity

### 5.3.7.1 Test conditions

These measurements shall only be performed at normal test conditions.

If the equipment can operate with different nominal channel bandwidths, then the smallest channel bandwidth shall be used. The equipment shall be configured in a mode that results in the lowest data rate for this channel bandwidth.

### 5.3.7.2 Test method

Figure 3 describes an example test set-up.

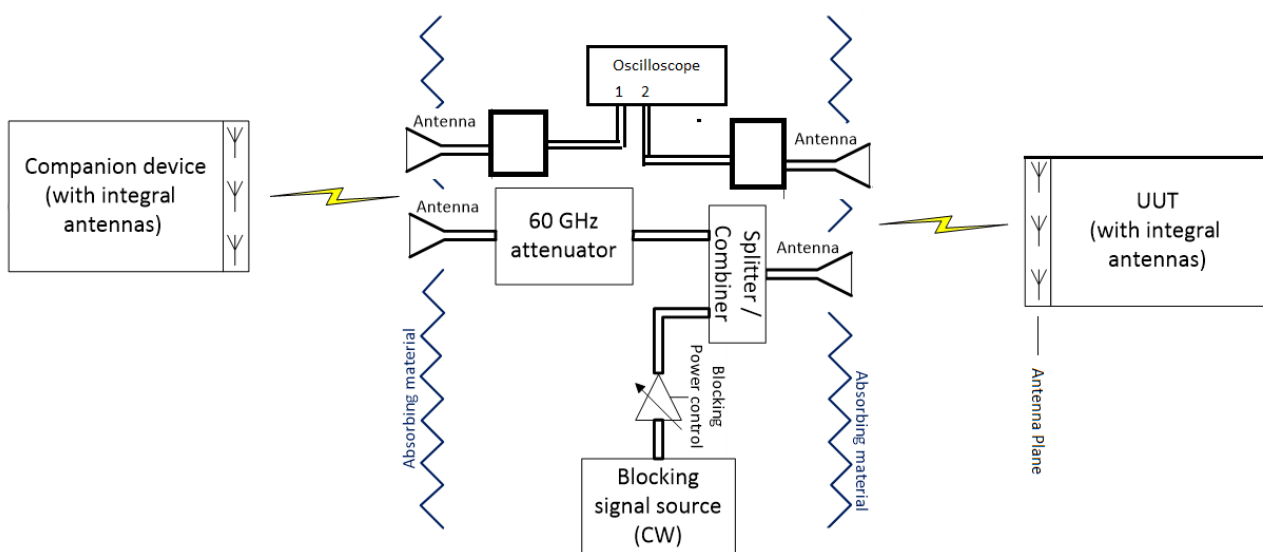

Figure 3: Test Set-up for verifying the sensitivity and adjacent channel selectivity of an equipment

Step 1 and step 2 below define the procedure to verify the Receiver Sensitivity requirement as described in clause 4.2.8.

**Step 1:**

- The signal source, the UUT and the companion device are connected using the set-up given by figure 3 with the signal source switched off.
- Adjust the level of the wanted signal, by controlling the 60 GHz attenuator to the lowest possible level at which the performance criteria as specified in clause 4.2.7.2 is met. Alternatively, it is possible to reduce Tx Power of companion device.
- The level of the wanted signal measured at the UUT antenna plane is the Receiver Sensitivity ( $P_{min}$ ) for the UUT.

**Step 2:**

- Repeat step 1 for each channel used by the equipment.

The results obtained shall be compared to the limits in clause 4.2.8.3 in order to show compliance.

## 5.3.8 Receiver Adjacent Channel Selectivity

### 5.3.8.1 Test conditions

These measurements shall only be performed at normal test conditions.

If the equipment can operate with different nominal channel bandwidths, then the smallest channel bandwidth shall be used. The equipment shall be configured in a mode that results in the lowest data rate for this channel bandwidth.

The type of interference used for testing shall be continuous wave.

### 5.3.8.2 Test method

Figure 3 of clause 5.3.7.2 describes an example test set-up.

The Receive Power of the CW Unwanted Signal shall be calibrated, e.g. by replacing the UUT with a standard reference antenna connected to a Power Meter.

Step 1 to step 4 below define the procedure to verify the Adjacent Channel Selectivity requirement as described in clause 4.2.9.

**Step 1:**

- The signal source, the UUT and the companion device are connected using the set-up given by figure 3 although the signal source is switched off at this moment.
- Adjust the level of the wanted signal, by controlling the 60 GHz attenuator to the lowest possible level at which the performance criteria as specified in clause 4.2.7.2 is met. Alternatively, it is possible to reduce Tx Power of companion device.
- The level of the wanted signal measured at the UUT input is the Receiver Sensitivity ( $P_{min}$ ) for the UUT.

**Step 2:**

- Adjust the received (wanted) signal level at the UUT to be 6 dB above the level  $P_{min}$ , by reducing the attenuation by 6 dB.
- Configure the signal source for the first frequency and power as in table 6.

**Step 3:**

- It shall be verified and recorded in the test report that the performance criteria as specified in clause 4.2.7.2 is met.

**Step 4:**

- Repeat step 3 for each of the signals (frequency and power) contained in table 6 and for each channel used by the equipment.

## Annex A (informative): Relationship between the present document and the essential requirements of Directive 2014/53/EU

The present document has been prepared under the Commission's standardisation request C(2015) 5376 final [i.1] to provide one voluntary means of conforming to the essential requirements of Directive 2014/53/EU on the harmonisation of the laws of the Member States relating to the making available on the market of radio equipment and repealing Directive 1999/5/EC [i.2].

Once the present document is cited in the Official Journal of the European Union under that Directive, compliance with the normative clauses of the present document given in table A.1 confers, within the limits of the scope of the present document, a presumption of conformity with the corresponding essential requirements of that Directive and associated EFTA regulations.

**Table A.1: Relationship between the present document and the essential requirements of Directive 2014/53/EU**

| Harmonised Standard ETSI EN 303 753 |   |                                     |                                   |                            |  |
|-------------------------------------|---|-------------------------------------|-----------------------------------|----------------------------|--|
| Requirement                         |   |                                     |                                   | Requirement Conditionality |  |
| No                                  | Description   | Essential requirements of Directive | Clause(s) of the present document | U/C                        | Condition  |
| 1                                   | Occupied channel bandwidth                              | 3.2                                 | 4.2.1                             | U                          |  |
| 2                                   | RF output power   | 3.2                                 | 4.2.2                             | C                          | RF power level (EIRP) larger than 40 dBm and up to 55 dBm should be only allowed for fixed outdoor installations with $\geq 30$ dB transmit directivity.   |
| 3                                   | Power spectral density                                  | 3.2                                 | 4.2.3                             | C                          | Power spectral density (EIRP) larger than 23 dBm/MHz and up to 38 dBm/MHz should be only allowed for fixed outdoor installations with $\geq 30$ dB transmit directivity.   |
| 4                                   | Transmitter unwanted emission in the out-of-band domain | 3.2                                 | 4.2.4.1                           | U                          |  |
| 5                                   | Transmitter unwanted emission in the spurious domain    | 3.2                                 | 4.2.4.2                           | U                          |  |
| 6                                   | Receiver spurious emission                              | 3.2                                 | 4.2.5                             | U                          |  |
| 7                                   | Spectrum sharing mechanisms                             | 3.2                                 | 4.2.6.1                           | C                          | Measurements of beamforming limits should be carried out for fixed equipment capable of operating at a maximum EIRP exceeding 40 dBm and for equipment capable of operating up to a maximum power level of 40 dBm EIRP with a TRP exceeding 20 dBm.                                    |
|                                     |   |                                     | 4.2.6.2                           | C                          | ATPC and/or ALA should be implemented by equipment capable of operating at a maximum EIRP exceeding 40 dBm and should be active under all circumstances, except that the transmission of control, management, and synchronization frames are permitted without the use of ATPC or ALA. |

| Harmonised Standard ETSI EN 303 753 |                                       |                                     |                                   |                            |           |
|-------------------------------------|---------------------------------------|-------------------------------------|-----------------------------------|----------------------------|-----------|
| Requirement                         |                                       |                                     |                                   | Requirement Conditionality |           |
| No                                  | Description                           | Essential requirements of Directive | Clause(s) of the present document | U/C                        | Condition |
| 8                                   | Receiver sensitivity                  | 3.2                                 | 4.2.7                             | U                          |           |
| 9                                   | Receiver adjacent channel selectivity | 3.2                                 | 4.2.8                             | U                          |           |

**Key to columns:****Requirement:**

**No** A unique identifier for one row of the table which may be used to identify a requirement.

**Description** A textual reference to the requirement.

**Essential requirements of Directive**

Identification of article(s) defining the requirement in the Directive.

**Clause(s) of the present document**

Identification of clause(s) defining the requirement in the present document unless another document is referenced explicitly.

**Requirement Conditionality:**

**U/C** Indicates whether the requirement is unconditionally applicable (U) or is conditional upon the manufacturer's claimed functionality of the equipment (C).

**Condition** Explains the conditions when the requirement is or is not applicable for a requirement which is classified "conditional".

Presumption of conformity stays valid only as long as a reference to the present document is maintained in the list published in the Official Journal of the European Union. Users of the present document should consult frequently the latest list published in the Official Journal of the European Union.

Other Union legislation may be applicable to the product(s) falling within the scope of the present document.

---

## Annex B (informative): Maximum Measurement Uncertainty

The measurements described in the present document are based on the following assumptions:

- the measured value related to the corresponding limit is used to decide whether an equipment meets the requirements of the present document;
- the value of the measurement uncertainty for the measurement of each parameter is included in the test report.

Table B.1 shows the recommended values for the maximum measurement uncertainty figures.

**Table B.1: Maximum measurement uncertainty**

| <b>Parameter</b>             | <b>Uncertainty</b> |
|------------------------------|--------------------|
| Radio Frequency              | ±1 ppm             |
| RF power, radiated           | ±6 dB              |
| Spurious emissions, radiated | ±6 dB              |
| Humidity                     | ±5 %               |
| Temperature                  | ±1 °C              |
| Time                         | ±10 %              |



---

## Annex C (normative): Test sites and arrangements for radiated measurements

### C.1 Test sites

#### C.1.0 General

This annex describes the use of test sites (including antennas) to perform radiated measurements in accordance with the present document.

All the test sites and measurement arrangements described in this annex, when considered with their associated measurement uncertainty within that recommended in annex B, provide equivalent test results for the purpose of demonstrating compliance with the present document.

The information provided in annex B should be used for the interpretation of the results for the radiated measurements performed using these test sites and arrangements.

#### C.1.1 Open air test sites

The term "open air" should be understood from an electromagnetic point of view. Such a test site may be really in open air or alternatively with walls and ceiling transparent to the radio waves at the frequencies considered.

An open air test site may be used to perform the measurements using the radiated measurement methods described in clause 5.3. Absolute or relative measurements may be performed on transmitters or on receivers; absolute measurements of field strength require a calibration of the test site.

A measuring distance of at least 3 m shall be used for measurements at frequencies up to 1 GHz. For frequencies above 1 GHz, any suitable measuring distance may be used. The equipment size (excluding the antenna) shall be less than 20 % of the measuring distance. The height of the equipment or of the substitution antenna shall be 1,5 m; the height of the test antenna (transmit or receive) shall vary between 1 m and 4 m.

Sufficient precautions shall be taken to ensure that reflections from extraneous objects adjacent to the site do not degrade the measurement results, in particular:

- no extraneous conducting objects having any dimension in excess of a quarter wavelength of the highest frequency tested shall be in the immediate vicinity of the site;
- all cables shall be as short as possible; as much of the cables as possible shall be on the ground plane or preferably below; and the low impedance cables shall be screened.

The general measurement arrangement is shown in figure C.1.

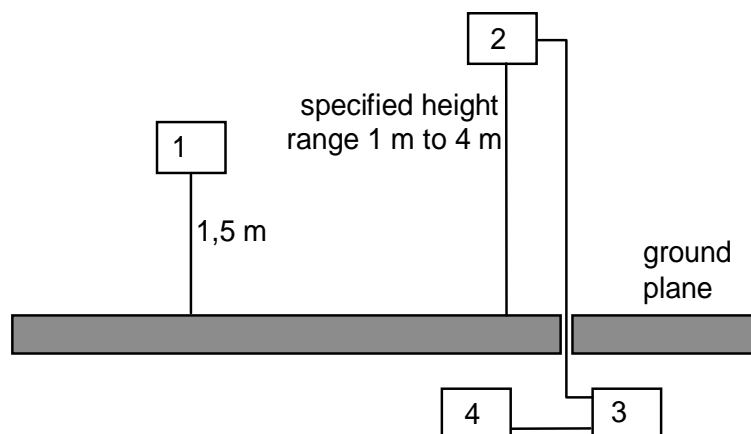

- 1) Equipment under test.
- 2) Test antenna.
- 3) High pass filter (as required).
- 4) Spectrum analyser or measuring receiver.

**Figure C.1: Measuring arrangement**

## C.1.2 Anechoic chamber

### C.1.2.1 General

An anechoic chamber is a well shielded chamber covered inside with radio frequency absorbing material and simulating a free space environment. It is an alternative site on which to perform the measurements using the radiated measurement methods described in clause 5.3. Absolute or relative measurements may be performed on transmitters or on receivers. Absolute measurements of field strength require a calibration of the anechoic chamber. The test antenna, equipment under test and substitution antenna are used in a way similar to that at the open air test site, but are all located at the same fixed height above the floor.

### C.1.2.2 Description

An anechoic chamber should meet the requirements for shielding loss and wall return loss as shown in figure C.2. Figure C.3 shows an example of the construction of an anechoic chamber having a base area of 5 m by 10 m and a height of 5 m. The ceiling and walls are coated with pyramidally formed absorbers approximately 1 m high. The base is covered with special absorbers which form the floor. The available internal dimensions of the chamber are 3 m × 8 m × 3 m, so that a maximum measuring distance of 5 m in the middle axis of this chamber is available. The floor absorbers reject floor reflections so that the antenna height need not be changed. Anechoic chambers of other dimensions may be used. Alternatively, an anechoic chamber having a base area of 2,5 m × 3 m and a height of 5 m may also be used.

### C.1.2.3 Influence of parasitic reflections

For free-space propagation in the far field, the relationship of the field strength  $E$  and the distance  $R$  is given by  $E = E_0 \times (R_0 / R)$ , where  $E_0$  is the reference field strength and  $R_0$  is the reference distance. This relationship allows relative measurements to be made as all constants are eliminated within the ratio and neither cable attenuation nor antenna mismatch or antenna dimensions are of importance.

If the logarithm of the foregoing equation is used, the deviation from the ideal curve may be easily seen because the ideal correlation of field strength and distance appears as a straight line. The deviations occurring in practice are then clearly visible. This indirect method shows quickly and easily any disturbances due to reflections and is far less difficult than the direct measurement of reflection attenuation.

With an anechoic chamber of the dimensions given above at low frequencies below 100 MHz there are no far field conditions, but the wall reflections are stronger, so that careful calibration is necessary. In the medium frequency range from 100 MHz to 1 GHz the dependence of the field strength to the distance meets the expectations very well. Above 1 GHz, because more reflections will occur, the dependence of the field strength to the distance will not correlate so closely.

#### C.1.2.4 Calibration and mode of use

The calibration and mode of use is the same as for an open air test site, the only difference being that the test antenna does not need to be raised and lowered whilst searching for a maximum, which simplifies the method of measurement.

Below 142 GHz the shielding and return loss shall be as described in figure C.2.

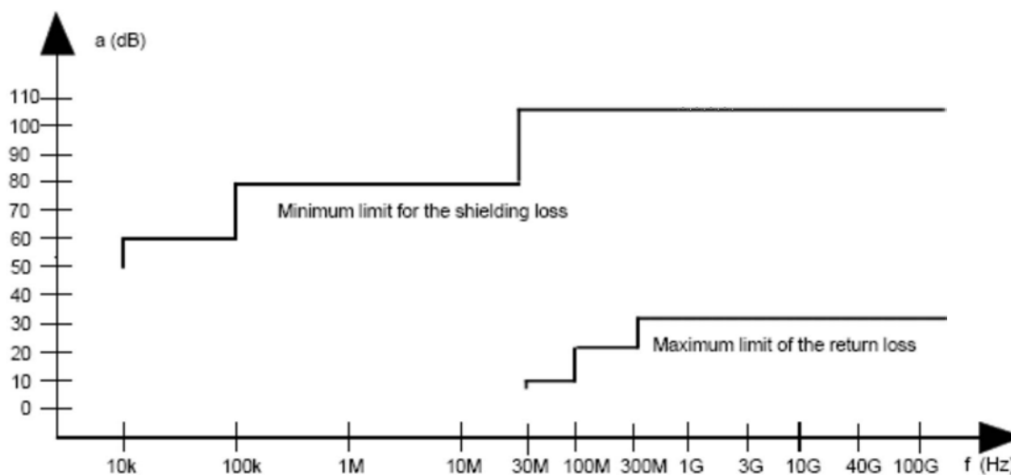
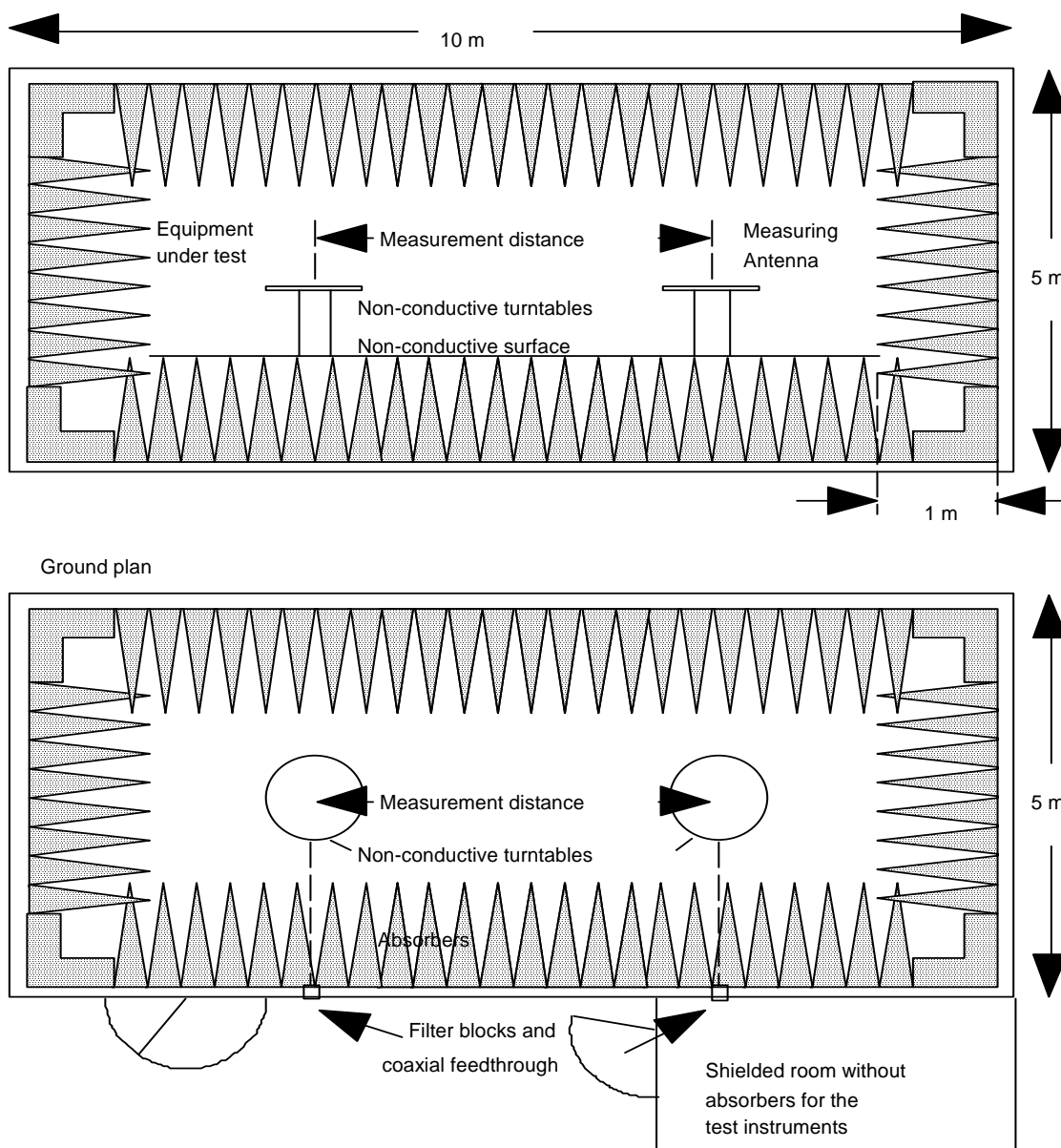

Figure C.2: Specification for shielding and reflections



**Figure C.3: Anechoic shielded chamber for simulated free space measurements**

## C.2 Test antenna

When the test site is used for radiated measurements the test antenna shall be used to detect the field from both the test sample and the substitution antenna. When the test site is used for the measurement of receiver characteristics the antenna shall be used as a transmitting antenna. This antenna shall be mounted on a support capable of allowing the antenna to be used in either horizontal or vertical polarization and for the height of its centre above the ground to be varied over the specified range. Preferably test antennae with pronounced directivity should be used. The size of the test antenna along the measurement axis shall not exceed 20 % of the measuring distance. The antenna shall include any necessary up/down conversion to an intermediate frequency for practical signal transport to/from related test equipment.

---

## C.3 Substitution antenna

The substitution antenna shall be used to replace the equipment under test in substitution measurements. For measurements below 1 GHz the substitution antenna shall be a half wavelength dipole resonant at the frequency under consideration, or a shortened dipole, calibrated to the half wavelength dipole. For measurements between 1 GHz and 4 GHz either a half wavelength dipole or a horn radiator may be used. For measurements above 4 GHz a horn radiator shall be used. The centre of this antenna shall coincide with the reference point of the test sample it has replaced. This reference point shall be the volume centre of the sample when its antenna is mounted inside the cabinet, or the point where an outside antenna is connected to the cabinet.

The distance between the lower extremity of the dipole and the ground shall be at least 30 cm.

NOTE: The gain of a horn antenna is generally expressed relative to an isotropic radiator.

## Annex D (normative): General description of measurement

### D.1 Radiated measurements

Radiated measurements shall be performed with the aid of a test antenna and measurement instruments as described in annex C. The test antenna and measurement instrument shall be calibrated according to the procedure defined in this annex. The equipment to be measured and the test antenna shall be oriented to obtain the maximum emitted power level. This position shall be recorded in the measurement report. The frequency range shall be measured in this position.

Preferably, radiated measurements shall be performed in an anechoic chamber. For other test sites corrections may be needed (see annex C). The following test procedure applies:

- a) A test site which fulfils the requirements of the specified frequency range of this measurement shall be used. The test antenna shall be oriented initially for vertical polarization unless otherwise stated and the transmitter under test shall be placed on the support in its standard position (clause C.1.1) and switched on.
- b) For average power measurements a non-selective voltmeter or wideband spectrum analyser shall be used. For other measurements a spectrum analyser or selective voltmeter shall be used and tuned to the measurement frequency.

In either case a) or case b), the test antenna shall be raised or lowered, if necessary, through the specified height range until the maximum signal level is detected on the spectrum analyser or selective voltmeter.

The test antenna need not be raised or lowered if the measurement is carried out on a test site according to clause C.1.2.

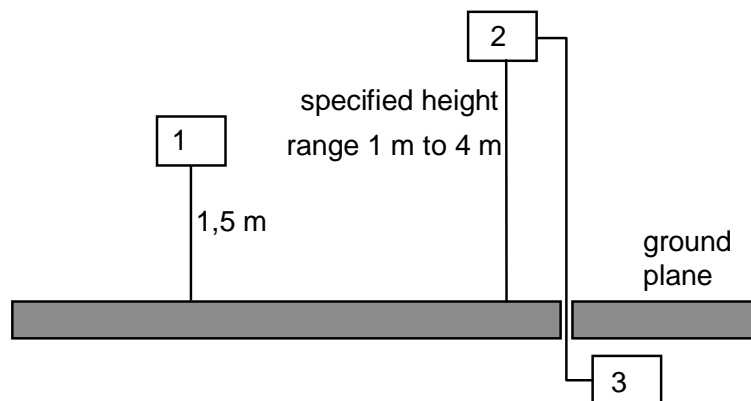

- 1) Equipment under test.
- 2) Test antenna.
- 3) Spectrum analyser or measuring receiver.

**Figure D.1: Measurement arrangement No. 1**

- c) The transmitter shall be rotated through 360° about a vertical axis until a higher maximum signal is received.
- d) The test antenna shall be raised or lowered again, if necessary, through the specified height range until a maximum is obtained. This level shall be recorded. This maximum may be a lower value than the value obtainable at heights outside the specified limits. The test antenna need not be raised or lowered if the measurement is carried out on a test site according to clause C.1.2. This measurement shall be repeated for horizontal polarization.

## D.2 Substitution measurement

The actual signal generated by the measured equipment may be determined by means of a substitution measurement in which a known signal source replaces the device to be measured, see figure D.2.

Preferably, this method of measurement shall be used in an anechoic chamber. For other test sites corrections may be needed, see annex C.

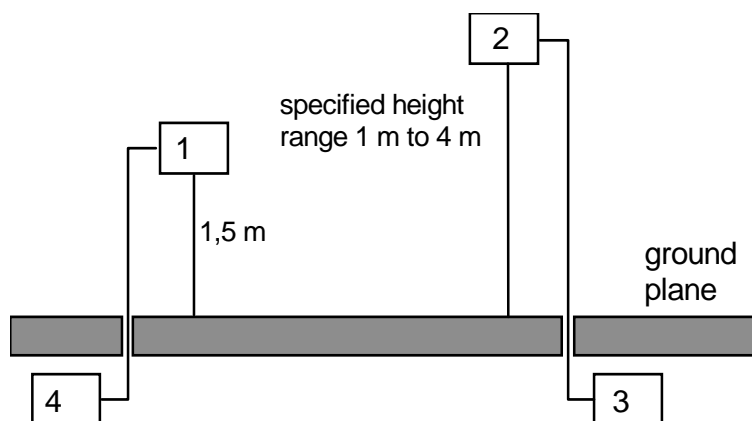

- 1) Substitution antenna.
- 2) Test antenna.
- 3) Spectrum analyser or selective voltmeter.
- 4) Signal generator.

**Figure D.2: Measurement arrangement No. 2**

- a) Using measurement arrangement No. 2, the substitution antenna shall replace the transmitter antenna in the same position and in vertical polarization. The frequency of the signal generator shall be adjusted to the measurement frequency. The test antenna shall be raised or lowered, if necessary, to ensure that the maximum signal is still received. The input signal to the substitution antenna shall be adjusted in level until an equal or a known related level to that detected from the transmitter is obtained in the test receiver:
  - the test antenna need not be raised or lowered if the measurement is carried out on a test site according to clause C.1.2;
  - the radiated power is equal to the power supplied by the signal generator, increased by the known relationship if necessary and after corrections due to the gain of the substitution antenna and the cable loss between the signal generator and the substitution antenna.
- b) This measurement shall be repeated with horizontal polarization.

For test sites with a fixed setup of the measurement antenna(s) and a reproducible positioning of the UUT, correction values from a verified site calibration can be used alternatively.

## Annex E (informative): Measurements procedure for verification of maximum power limits

### E.0 Radiated metrics and compliance with the harmonised technical conditions

The maximum transmit power limits in the Decision (EU) 2019/1345 [i.4] are specified in terms of EIRP, antenna gain and maximum transmit power at the antenna port or ports. These limits are based on the conclusions of the ECC Report 288 [i.7] and the relationship between EIRP and antenna gain derived therein; the EIRP is increased gradually with the antenna directivity up to a maximum EIRP limit [i.7], clause 9.

ECC Report 288 [i.7] suggests that appropriate antennas with sufficiently narrow beamwidths can improve coexistence in difficult topologies and environments, coexistence is facilitated by increased antenna directivity. Unlike for the antenna gain, radiated measurements can be used for verifying directivity as described in the clauses below.

The additional condition on transmit antenna gain in the Decision (EU) 2019/1345 [i.4] can be considered verified by an antenna directivity measurement against an identical limit, with the understanding that equating the minimum antenna directivity with the antenna gain limit captures the intention of the harmonised technical condition of [i.4] for bands 75a and 75b with regard to interference into radio services (this also applies for the antenna gain implied by the relation of the maximum EIRP and the maximum transmit power at the antenna port or ports for band 75a). This allows testing of radio equipment without the need for declaration of maximum transmit power levels into antenna ports internal to the equipment under test.

### E.1 Metrics for radiated measurements

This annex describes the key relationship between conducted and radiated measurements, and focuses on TRP measurement procedures. The technical content of this annex is mostly based on ETSI TS 138 141-2 [i.6]. The metrics used in this annex are expressed in linear domain.

TRP is a measure of how much power is radiated by an antenna when the antenna is connected to an actual radio (or transmitter). When measuring the TRP in an anechoic chamber, the measurement can be performed by measuring the EIRP at every angle, and then integrating the EIRP measurements over the sphere. Therefore, the relationship between EIRP and TRP can be expressed as:

$$TRP = \frac{1}{4\pi} \int_{\theta=0}^{\pi} \int_{\phi=0}^{2\pi} EIRP(\theta, \phi) \sin(\theta) d\phi d\theta$$

Considering the the vertical and horizontal polarization components, TRP can be expressed by the sum of the two polarization powers, i.e.:

$$TRP = \frac{1}{4\pi} \int_{\theta=0}^{\pi} \int_{\phi=0}^{2\pi} [EIRP_{\theta}(\theta, \phi) + EIRP_{\phi}(\theta, \phi)] \sin(\theta) d\phi d\theta$$

The relationship between TRP and EIRP can also be expressed as a function of the antenna directivity  $D$ . In linear domain, the following relationship holds:

$$TRP = \frac{EIRP}{D}$$

The directivity  $D$  is related to the antenna gain through the antenna efficiency  $\eta$  as follows:

$$G = \eta \cdot D$$



The antenna gain accounts for antenna efficiency, thus  $G \leq D$  since  $0 \leq \eta \leq 1$ . In other words, the gain is a scaled version of the directivity considering non-ideal antenna behaviour (only in case of lossless antenna  $G=D$ ). The directivity represents the ability of the antenna systems to focus the radiation to a particular direction, thus determining the spatial radiation across the sphere. It is worth noting that in specific regulations a minimum antenna gain is required as a mitigation technique to limit the spatial spread of interference. In this case, the coexistence criteria required by the regulation is met if the directivity is measured and the directivity level is equal or larger than the minimum gain requirement.

## E.2 TRP estimation

### E.2.1 General

Several procedures can be adopted to estimate TRP values, see ETSI TS 138 141-2 [i.6]. Some procedures lead to an accurate estimate, while other procedures provide a coarse over-estimate on TRP. There is typically a trade-off between accuracy and testing time. If a TRP requirement does not need accurate TRP estimate then the procedures for overestimation of TRP may be used in order to have a reasonable Over The Air (OTA) test time. Pre-scan does not provide an accurate TRP estimate or overestimate of TRP. Pre-scan is a fast but coarse method that is used to identify the spurious emission frequencies with emission power as described in clause E.2.2. A sequential measurement is then made at the emission frequencies to assess the TRP with methods as described in clauses E.2.3, E.2.4 and E.2.6.

### E.2.2 Pre-scan

Pre-scan is used to identify frequencies with unwanted emission power levels above a certain threshold, see ETSI TS 138 141-2 [i.6]. The pre-scan does not provide an estimate of TRP. An emission frequency identified by a pre-scan may be further investigated by any of the TRP measurement methods in the following sections.

The procedure for pre-scan is as follows:

- 1) Scan the entire surface around EUT.
- 2) Rotate test antenna to cover all possible polarizations of emissions to detect maximum emissions.
- 3) Record the list of frequencies and corresponding unwanted emission power levels, EUT spatial positions, and test antenna polarization for which the maximum emission levels occur.
- 4) Emissions which are - e.g. 20 dB or more below the specified limit - would not require further measurements.

### E.2.3 Methods based on spherical grid sampling

$TRP_{Estimate}$  is defined based on a discrete sampling over the sphere, as:

$$TRP_{Estimate} = \frac{\pi}{2NM} \sum_{n=0}^{N-1} \sum_{m=0}^{M-1} EIRP(\theta_n, \phi_m) \sin \theta_n$$

when EIRP measurements is used or as:

$$TRP_{Estimate} = 4\pi d^2 \frac{\pi}{2NM} \sum_{n=1}^{N-1} \sum_{m=0}^{M-1} P_D(\theta_n, \phi_m) \sin \theta_n$$

when power density measurements are used, and  $d$  is the test distance.  $N$  and  $M$  are the number of samples in the  $\theta$  and  $\phi$  angles. Each  $(\theta_n, \phi_m)$  is a sampling point.

Different methods can be adopted to determine the sampling point and the sampling angular intervals

$$\Delta\theta = \frac{\pi}{N} \text{ and } \Delta\phi = \frac{2\pi}{M}.$$

In ETSI TS 138 141-2 [i.6], several approaches are defined for the definition of the sampling grid, namely spherical equal angle grid, spherical equal area grid, spherical Fibonacci grid, orthogonal cut grid, wave vector space grid, full sphere with sparse sampling.

## E.2.4 Beam-based directions

Beam-based direction can be used in the equipment *operating band* only if the directivity of the radiation pattern of the emissions being measured is known.  $TRP_{Estimate}$  is defined as:

$$TRP_{Estimate} = \frac{EIRP_{peak}}{D_{EUT}},$$

where  $EIRP_{peak}$  is the maximum EIRP in the beam peak direction within a particular beam direction pair and  $D_{EUT}$  is the directivity of the EUT.

## E.2.5 Peak method

The peak method can be used when frequencies with unwanted peak emissions are identified during pre-scan, see ETSI TS 138 141-2 [i.6]. The method does not provide an estimate of TRP.

For each peak emission frequency identified during pre-scan, measure peak EIRP or power density as follows:

- 1) Move EUT and test antenna to the same position where the peak emission is recorded during the pre-scan.
- 2) Move the EUT around the position and test antenna orientation to find the final peak EIRP or power density.
- 3) The measured peak power density or EIRP could be used to demonstrate conformance.

NOTE: Peak EIRP is the linear sum of two orthogonal polarized components.

## E.2.6 Equal sector with peak average

Equal sector with peak average can be performed on frequencies with unwanted peak emission, which are considered by the peak method for further measurements, see ETSI TS 138 141-2 [i.6].

The spherical angle  $\phi$  is divided into  $K$  equal sectors. If the largest dimension of EUT is less than 60 cm, then each sector is a half quadrant of  $45^\circ$ .

For each peak emission frequency, measure peak EIRP of beams belonging to different sectors of the sphere as follows:

- 1) Move EUT and test antenna to the same position where the emission peak is recorded during the pre-scan.
- 2) Move EUT around the position and test antenna orientation to find the final peak EIRP.
- 3) Repeat steps 1 to 2 above until all sectors are covered.
- 4) Calculate  $TRP_{Estimate}$  as:

$$TRP_{Estimate} = \frac{1}{K} \sum_{k=1}^K EIRP_k, \text{ where } EIRP_k \text{ is the peak EIRP in the } k\text{th sector.}$$

NOTE: Peak EIRP is the linear sum of two orthogonal polarized components.

---

## Annex F (informative): Bibliography

- Electromagnetic Compatibility (EMC) Directive 2014/30/EU of the European Parliament published in the Official Journal of the European Union L 96/79, 29 March 2014 and repealing Directive 2004/108/EC as from 20 April 2016.
- Low Voltage Directive 2014/35/EU of the European Parliament and of the Council of 26 February 2014 and repealing Directive 2006/95/EC as of 20 April 2016.
- ETSI EG 203 336: "Electromagnetic compatibility and Radio spectrum Matters (ERM); Guide for the selection of technical parameters for the production of Harmonised Standards covering article 3.1(b) and article 3.2 of Directive 2014/53/EU".

## Annex G (informative): Change history

| Version | Information about changes   |
|---------|---|
| V0.0.1  | First draft updating the skeleton of the EN and including the scope based on input contribution in BRAN(20)107029.  |
| V0.0.2  | Updated the skeleton based on the change request in BRAN(20)108007.   |
| V0.0.3  | Implemented CR agreed in BRAN #109: BRAN(21)109033, BRAN(21)109034r1, BRAN(21)109035. Implemented updates based on the discussion on the working document discussed in BRAN #109 (document BRAN(21)109015).   |
| V0.0.4  | Implemented the updates based on BRAN(21)110022r1 accepted in BRAN #110.  |
| V0.0.5  | Implemented the CRs agreed in BRAN #112: BRAN(21)112039, BRAN(21)112025, BRAN(21)111n003r1.   |
| V0.0.6  | Implemented the CRs agreed in BRAN #113: BRAN(22)113012, BRAN(22)113014r2, , BRAN(22)113015r2, , BRAN(22)113016r1, BRAN(22)113019.  |
| V0.0.7  | Implemented the CRs agreed in BRAN #114: BRAN(22)114010r1, BRAN(22)114011r2, BRAN(22)114013r1, BRAN(22)114020r1; BRAN(22)114014r2<br>Deleted "Short Control Signalling" Transmissions clause;<br>Introduced clause D.2 ("Substitution measurement");<br>Editorial improvements. |
| V0.0.8  | Implemented the outcome of BRAN #115 from BRAN(22)115017r4.   |
| V0.0.9  | Implemented the outcome of BRAN #118 from BRAN(23)117b004r4 addressing HASTAC comments.   |

---

## History

| <b>Document history</b> |           |                       |                                       |
|-------------------------|-----------|-----------------------|---------------------------------------|
| V1.0.0                  | June 2023 | EN Approval Procedure | AP 20230914: 2023-06-16 to 2023-09-14 |
|                         |           |                       |                                       |
|                         |           |                       |                                       |
|                         |           |                       |                                       |
|                         |           |                       |                                       |