

**ETSI EN 303 883-1** V2.1.1 (2024-08)



**Short Range Devices (SRD) and  
Ultra Wide Band (UWB);  
Part 1: Measurement techniques  
for transmitter requirements**

---

**Reference**REN/ERM-TGUWB-618

---

---

**Keywords**SRD, testing, UWB

---

**ETSI**

650 Route des Lucioles  
F-06921 Sophia Antipolis Cedex - FRANCE

---

Tel.: +33 4 92 94 42 00 Fax: +33 4 93 65 47 16

Siret N° 348 623 562 00017 - APE 7112B  
Association à but non lucratif enregistrée à la  
Sous-Préfecture de Grasse (06) N° w061004871

---

**Important notice**

---

The present document can be downloaded from the  
ETSI [Search & Browse Standards](#) application.

The present document may be made available in electronic versions and/or in print. The content of any electronic and/or print versions of the present document shall not be modified without the prior written authorization of ETSI. In case of any existing or perceived difference in contents between such versions and/or in print, the prevailing version of an ETSI deliverable is the one made publicly available in PDF format on [ETSI deliver](#).

Users should be aware that the present document may be revised or have its status changed,  
this information is available in the [Milestones listing](#).

If you find errors in the present document, please send your comments to  
the relevant service listed under [Committee Support Staff](#).

If you find a security vulnerability in the present document, please report it through our  
[Coordinated Vulnerability Disclosure \(CVD\)](#) program.

---

**Notice of disclaimer & limitation of liability**

---

The information provided in the present deliverable is directed solely to professionals who have the appropriate degree of experience to understand and interpret its content in accordance with generally accepted engineering or other professional standard and applicable regulations.

No recommendation as to products and services or vendors is made or should be implied.  
In no event shall ETSI be held liable for loss of profits or any other incidental or consequential damages.

Any software contained in this deliverable is provided "AS IS" with no warranties, express or implied, including but not limited to, the warranties of merchantability, fitness for a particular purpose and non-infringement of intellectual property rights and ETSI shall not be held liable in any event for any damages whatsoever (including, without limitation, damages for loss of profits, business interruption, loss of information, or any other pecuniary loss) arising out of or related to the use of or inability to use the software.

---

**Copyright Notification**

---

No part may be reproduced or utilized in any form or by any means, electronic or mechanical, including photocopying and microfilm except as authorized by written permission of ETSI.

The content of the PDF version shall not be modified without the written authorization of ETSI.

The copyright and the foregoing restriction extend to reproduction in all media.

© ETSI 2024.  
All rights reserved.

# Contents

Intellectual Property Rights .....	8
Foreword.....	8
Modal verbs terminology.....	8
Introduction .....	9
1 Scope .....	10
2 References .....	10
2.1 Normative references .....	10
2.2 Informative references.....	10
3 Definition of terms, symbols and abbreviations.....	13
3.1 Terms.....	13
3.2 Symbols.....	16
3.3 Abbreviations .....	18
4 Overview .....	20
4.1 Information.....	20
4.2 Basic information about UWB .....	21
5 TX requirements.....	21
5.1 General .....	21
5.1.1 General Guidance on TX measurements .....	21
5.1.2 Emission Concept .....	21
5.1.2.1 General .....	21
5.1.2.2 UWB - EUT .....	22
5.2 Operating Frequency Range (OFR).....	23
5.2.1 Definition.....	23
5.2.2 Conformance Test.....	23
5.3 Radiated Power (RP) .....	24
5.3.1 Mean e.i.r.p. ....	24
5.3.1.1 Description .....	24
5.3.1.2 Conformance.....	24
5.3.1.3 Method with a Spectrum Analyser.....	25
5.3.1.4 Method with an RMS Power Meter .....	26
5.3.1.5 Method with a Spectrum Analyser for Mean e.i.r.p. averaged over $T_{on}$ .....	26
5.3.2 Mean e.i.r.p. Spectral Density.....	27
5.3.2.1 Description, Mean e.i.r.p. Spectral Density within 1 MHz .....	27
5.3.2.2 Guidance for Mean e.i.r.p. Spectral Density Conformance Tests .....	27
5.3.2.3 Mean e.i.r.p. Spectral Density, averaged over 1 ms .....	28
5.3.2.4 Mean e.i.r.p. Spectral Density, known signal repetition time, averaged over 1 ms.....	29
5.3.2.5 Mean e.i.r.p. Spectral Density, known signal repetition time, averaged over signal repetition time .....	31
5.3.2.6 Mean e.i.r.p. Spectral Density, known signal on - time ( $T_{on}$ ), averaged over signal on - time.....	32
5.3.3 Peak e.i.r.p. ....	33
5.3.3.1 Description .....	33
5.3.3.2 Conformance.....	33
5.3.3.3 Peak e.i.r.p.: Method with a Spectrum Analyser.....	34
5.3.3.4 Peak e.i.r.p. method with a Peak Power Meter.....	34
5.3.4 Peak e.i.r.p. Spectral Density .....	34
5.3.4.1 Peak e.i.r.p. Spectral Density within 50 MHz .....	34
5.3.4.1.1 Description .....	34
5.3.4.1.2 Conformance .....	34
5.3.4.1.3 Peak e.i.r.p. Spectral Density, General Method .....	35
5.3.4.1.4 Peak e.i.r.p. Spectral Density, Sparse Spectral Line Method.....	37
5.3.4.2 Peak e.i.r.p. within 1 GHz for FMCW .....	37
5.3.4.2.1 Description .....	37
5.3.4.2.2 Conformance .....	37
5.4 Other Emissions (OE) .....	38

5.5	TX Unwanted Emissions (TXUE).....	39
5.5.1	Description.....	39
5.5.2	Limits for the TX Unwanted Emission.....	40
5.5.3	Conformance Test for TX Unwanted Emission.....	40
5.5.3.1	Conformance Test for the Spurious domain of TX Unwanted Emission.....	40
5.5.3.1.1	General.....	40
5.5.3.1.2	Step 1: Measurement with Peak Detector.....	41
5.5.3.1.3	Step 2a: RMS assessment over Burst duration ( $T_{on}$ ).....	42
5.5.3.1.4	Step 2b: RMS assessment over signal repetition/measurement cycle.....	42
5.5.3.2	Conformance Test for the OOB domain of TX Unwanted Emission.....	43
5.5.3.2.1	General.....	43
5.5.3.2.2	Conformance test.....	43
5.6	Total Radiated Power (TRP).....	44
5.6.1	Introduction.....	44
5.6.2	Description of Total Radiated Power ( $TRP_{XX}$ ).....	45
5.6.3	General $TRP_{XX}$ assessment based on radiated (e.i.r.p.) measurement.....	47
5.6.4	Conformance Test.....	51
5.6.4.1	General.....	51
5.6.4.2	Total Radiated Mean Power ( $TRP_{MP}$ ) Conformance Assessment in steps.....	51
5.6.4.3	Total Radiated Peak Power ( $TRP_{PP}$ ) Conformance Assessment in steps.....	52
5.6.4.4	Total Radiated Mean e.i.r.p. Spectral Density ( $TRP_{SD}$ ) Conformance Assessment in steps.....	53
5.7	Indirect Emissions.....	54
5.7.1	Description.....	54
5.7.2	Guidance for Conformance Test.....	58
5.8	Transmit Power Control.....	58
5.8.1	Description.....	58
5.8.2	Guidance for Conformance Test.....	59
5.9	Detect and Avoid.....	59
5.9.1	Description.....	59
5.9.2	Limits.....	59
5.9.2.1	DAA Parameters.....	59
5.9.2.2	DAA NIM parameters.....	60
5.9.2.3	DAA test parameters.....	60
5.9.3	Conformance Test.....	60
5.9.3.1	Introduction.....	60
5.9.3.2	Initial Start-Up Test.....	62
5.9.3.2.1	Start-up Procedure.....	62
5.9.3.2.2	Test without a victim test signal during the <i>Minimum Initial Channel Availability Check</i> <i>Time, <math>T_{avail\_time\_min}</math></i> .....	62
5.9.3.2.3	Test with a victim test signal at the beginning of the <i>Minimum Initial Channel Availability</i> <i>Check Time, <math>T_{avail\_time\_min}</math></i> .....	63
5.9.3.2.4	Test with a victim test signal at the end of the <i>Minimum Initial Channel Availability Check</i> <i>Time, <math>T_{avail\_time\_min}</math></i> .....	64
5.9.3.3	In-Operation Test.....	65
5.9.3.3.1	General Points for In-Operation Test.....	65
5.9.3.3.2	In-Operation Test Procedure.....	66
5.10	Listen Before Talk (LBT).....	67
5.10.1	Description.....	67
5.10.2	Limits.....	70
5.10.3	Conformance.....	70
5.10.3.1	Measurement Procedure.....	70
5.10.3.2	Test Set-Up.....	70
5.10.3.3	Test Signal Definition for LBT Mechanism in Band 2 and 3.....	71
5.10.3.3.1	Band 2: Mobile Satellite Service (MSS) Test Signal.....	71
5.10.3.3.2	Band 3: Land Mobile Service Test Signal.....	72
5.10.3.4	Test Signal Definition for LBT Mechanism in Band 1 and 4.....	72
5.10.3.5	Conformance Test to Measure the Timing for LBT within bands 1 and 4.....	73
5.11	Duty Cycle.....	75
5.11.1	Description.....	75
5.11.2	Conformance Test.....	75
5.11.2.1	Duty Cycle, Spectrum Analyser Method.....	75
5.11.2.2	Duty Cycle, Oscilloscope Method.....	76

5.11.2.3	Duty Cycle Measurement procedures for FMCW, stepped-frequency and Pulsed Systems.....	78
5.11.2.3.1	General .....	78
5.11.2.3.2	Method 1: Diode Power Detector .....	78
5.11.2.3.3	Method 2: Spectrum Analyser .....	79
5.11.2.3.4	Method 3: Synchronized Spectrum Analysers.....	80
5.11.2.4	Duty Cycle Measurement Procedures within a frequency band for FMCW and stepped-frequency systems .....	82
5.11.2.4.1	General .....	82
5.11.2.4.2	Synchronized Spectrum Analysers .....	82
5.12	Antenna pattern/Antenna gain .....	84
5.12.1	Description.....	84
5.12.2	Conformance tests for external antennas .....	86
5.12.2.1	General .....	86
5.12.2.2	Determination against a known reference antenna.....	86
5.12.2.2.1	General .....	86
5.12.2.2.2	Measuring distance .....	87
5.12.2.2.3	Measurement equipment requirements.....	87
5.12.2.2.4	Test procedure .....	87
5.12.2.3	Test based on a radiated measurement .....	88
5.12.2.3.1	General .....	88
5.12.2.3.2	Measuring distance .....	89
5.12.2.3.3	Measurement equipment requirements.....	89
5.12.2.3.4	Test procedure .....	90
5.12.3	Conformance tests for integral antennas .....	90
5.12.4	Guidance to assess emissions levels above regulated elevations .....	91
<b>Annex A (normative): General Considerations and test conditions .....</b>		<b>94</b>
A.1	Overview .....	94
A.2	Product Information .....	94
A.3	Guidance on EUT Modulation for Testing.....	95
A.4	Requirements in Case of EUT with Scanning Antennas .....	95
A.4.1	Classification .....	95
A.4.2	Measurement of Fixed Beam EUT .....	95
A.4.3	Measurement of Constant Pattern EUT .....	95
A.4.4	Measurement of Variable Pattern EUT .....	96
A.5	Test Conditions, Power Supply and Ambient Temperatures .....	96
A.5.1	General .....	96
A.5.2	Power Sources .....	96
A.5.2.1	Power Sources for Stand-Alone Equipment .....	96
A.5.2.2	Power sources for plug-in radio devices .....	96
A.5.3	Normal and Extreme Test Conditions .....	96
A.5.4	Test set-ups under environmental profile .....	96
A.5.5	Assessment procedures over environmental profile .....	96
A.6	Choice of Equipment for Test Suites .....	97
A.6.1	Choice of Model.....	97
A.6.2	Presentation .....	97
A.7	Testing of Host Connected Equipment and Plug-In Radio Devices .....	97
A.7.1	General .....	97
A.7.2	The Use of a Host or Test Fixture for Testing Plug-In Radio Devices.....	97
A.8	Interpretation of the measurement results .....	98
A.8.1	General points on interpretation of the measurement results .....	98
A.8.2	Measurement uncertainty is equal to or less than maximum acceptable uncertainty .....	98
A.8.3	Measurement uncertainty is greater than maximum acceptable uncertainty .....	99
<b>Annex B (normative): Test setups .....</b>		<b>100</b>
B.1	Introduction .....	100

B.2	Radiated measurements .....	100
B.2.1	General .....	100
B.2.2	Test Sites and General Arrangements for Measurements Involving the Use of Radiated Fields .....	101
B.2.2.1	General.....	101
B.2.2.2	Fully Anechoic Room (FAR).....	101
B.2.2.3	Semi Anechoic Chamber (SAC).....	102
B.2.2.4	Open Area Test Site (OATS).....	103
B.2.2.5	Measurement Antenna .....	104
B.2.2.6	Substitution Antenna.....	104
B.2.2.7	Test Antenna.....	105
B.2.2.8	Minimum Requirements for Test Sites for Measurements above 18 GHz .....	105
B.2.3	Guidance on the Use of a Radiation Test Site .....	106
B.2.3.1	General on Guidance on the Use of a Radiation Test Site .....	106
B.2.3.2	Verification of the Test Site.....	106
B.2.3.3	Preparation of the EUT .....	106
B.2.3.4	Power Supplies to the EUT.....	107
B.2.3.5	Range Length and measurement distance.....	107
B.2.3.5.1	General.....	107
B.2.3.5.2	Practical Test Distances for Accurate Measurements .....	108
B.2.3.6	Site Preparation.....	108
B.2.4	Coupling of Signals .....	108
B.2.4.1	General.....	108
B.2.4.2	Data Signals .....	108
B.2.5	Standard Radiated Test Methods.....	109
B.2.5.0	Initial Measurement Steps .....	109
B.2.5.1	General Information on Test Methods .....	109
B.2.5.2	Pre-substitution / calibrated method .....	109
B.2.5.3	Substitution Method.....	110
B.2.6	Method for determination of the correction factor .....	110
B.3	Conducted Measurements .....	112
B.3.1	General .....	112
B.3.2	Conducted measurement via cable connection.....	112
B.3.3	Conducted measurement via waveguide connection.....	113
B.3.4	Determination of a radiated power e.i.r.p. based on a conducted measurement.....	114
B.4	Spherical Scan .....	115
B.4.1	General .....	115
B.4.2	Different measurement systems .....	115
B.4.3	Pre-substitution / calibrated method.....	123
B.4.4	Substitution Method.....	123
<b>Annex C (normative):</b>	<b>Signal Timing parameters.....</b>	<b>125</b>
C.1	Descriptions.....	125
C.2	Signal Types.....	125
C.2.1	Pulsed signals .....	125
C.2.1.1	General.....	125
C.2.1.2	Consideration for pulsed based signals if $T_{dis} > T_{PRT}$ .....	126
C.2.1.3	Consideration for pulsed based signals if $T_{dis} < T_{PRT}$ .....	126
C.2.2	FMCW signals.....	127
C.2.2.1	General.....	127
C.2.2.2	Single FMCW sweep within signal repetition time .....	127
C.2.2.3	Multiple FMCW sweeps within $T_{rep}$ and $T_{dis} > t_{sweep;off}$ .....	129
C.2.2.4	Multiple FMCW sweeps within $T_{rep}$ and $T_{dis} < t_{sweep;off}$ .....	130
<b>Annex D (normative):</b>	<b>All Emission Measurement .....</b>	<b>134</b>
D.1	General .....	134
D.2	First step .....	134
D.3	Second step.....	136

<b>Annex E (normative):</b>	<b>Guidance for a pre-scan of EUT operating frequency range(s) .....</b>	<b>137</b>
<b>Annex F (informative):</b>	<b>Measurement of peak e.i.r.p. and mean (average) e.i.r.p. of constant duty cycle wideband pulsed signals .....</b>	<b>138</b>
F.1	General .....	138
F.2	Exemplary measurement of pulse signals .....	138
F.3	Mean e.i.r.p. measurements .....	139
F.3.1	General .....	139
F.3.2	Method I: Zero span mode .....	139
F.3.3	Method II: Channel power measurement .....	140
F.3.4	Method III: Average power meters .....	141
F.4	Peak e.i.r.p. measurements .....	141
F.4.1	General .....	141
F.4.2	Method I: Zero span mode - direct measurement .....	141
F.4.3	Method II: Peak e.i.r.p. calculation .....	142
F.5	Max and mean PSD .....	143
<b>Annex G (normative):</b>	<b>TX Unwanted Emissions (TXUE) for EUT under ECC/DEC/(22)03 .....</b>	<b>145</b>
<b>Annex H (informative):</b>	<b>Parameter and Specification in related Standards .....</b>	<b>149</b>
<b>Annex I (informative):</b>	<b>Change history .....</b>	<b>152</b>
History .....		153

# Intellectual Property Rights

## Essential patents

IPRs essential or potentially essential to normative deliverables may have been declared to ETSI. The declarations pertaining to these essential IPRs, if any, are publicly available for **ETSI members and non-members**, and can be found in ETSI SR 000 314: "*Intellectual Property Rights (IPRs); Essential, or potentially Essential, IPRs notified to ETSI in respect of ETSI standards*", which is available from the ETSI Secretariat. Latest updates are available on the ETSI Web server (<https://ipr.etsi.org/>).

Pursuant to the ETSI Directives including the ETSI IPR Policy, no investigation regarding the essentiality of IPRs, including IPR searches, has been carried out by ETSI. No guarantee can be given as to the existence of other IPRs not referenced in ETSI SR 000 314 (or the updates on the ETSI Web server) which are, or may be, or may become, essential to the present document.

## Trademarks

The present document may include trademarks and/or tradenames which are asserted and/or registered by their owners. ETSI claims no ownership of these except for any which are indicated as being the property of ETSI, and conveys no right to use or reproduce any trademark and/or tradename. Mention of those trademarks in the present document does not constitute an endorsement by ETSI of products, services or organizations associated with those trademarks.

**DECT™**, **PLUGTESTS™**, **UMTS™** and the ETSI logo are trademarks of ETSI registered for the benefit of its Members. **3GPP™** and **LTE™** are trademarks of ETSI registered for the benefit of its Members and of the 3GPP Organizational Partners. **oneM2M™** logo is a trademark of ETSI registered for the benefit of its Members and of the oneM2M Partners. **GSM®** and the GSM logo are trademarks registered and owned by the GSM Association.

# Foreword

This European Standard (EN) has been produced by ETSI Technical Committee Electromagnetic compatibility and Radio spectrum Matters (ERM).

The present document is part 1 of a multi-part deliverable covering Short Range Devices (SRD) and Ultra Wide Band (UWB), as identified below:

**Part 1: "Measurement techniques for transmitter requirements";**

Part 2: "Measurement techniques for receiver requirements".

National transposition dates	
Date of adoption of this EN:	12 August 2024
Date of latest announcement of this EN (doa):	30 November 2024
Date of latest publication of new National Standard or endorsement of this EN (dop/e):	31 May 2025
Date of withdrawal of any conflicting National Standard (dow):	31 May 2025

# Modal verbs terminology

In the present document "**shall**", "**shall not**", "**should**", "**should not**", "**may**", "**need not**", "**will**", "**will not**", "**can**" and "**cannot**" are to be interpreted as described in clause 3.2 of the [ETSI Drafting Rules](#) (Verbal forms for the expression of provisions).



"**must**" and "**must not**" are **NOT** allowed in ETSI deliverables except when used in direct citation.

---

## Introduction

Ultra Wide Band (UWB) radio technology enables a new generation of high-speed data devices for short-range communication purposes as well as location tracking and Sensor devices and opens new markets with a variety of innovative applications.

UWB devices may form an integral part of other portable electronic equipment such as future generation cellular phones or laptops equipped with UWB enabled short-range air interfaces.

In addition, UWB devices with an operating frequency range of several hundreds of MHz up to several GHz allow tens of centimetre-level accuracy real time localization and positioning even in the presence of severe multipath effects caused by walls, furniture or any other harsh radio propagation environments.

Based on the broad variety of different applications and the broad possible frequency range of operation the number of possible deployed physical signal formats can be very large. The existing range of physical signal and modulation formats range from traditional carrier based systems like OFDM over spread spectrum based system to carrier less systems based on base band pulses. The frequency regulation on the other side only defines a single set of transmission limits and values, which have to be fulfilled by all systems under the UWB regulation. Furthermore, the very high channel bandwidth of a UWB signal gives a specific challenge to the needed measurement setup and the procedures. Existing measurement procedures need to be extended and new possible techniques should be described in the present document.

The present document is structured as follows:

- Clauses 1 through 3 provide a general description on the types of equipment covered by the present document and the definition of terms, symbols and abbreviations used.
- Clause 4 provides an overview on the technical and technology basics which were considered during the preparation of the present document.
- Clause 5 specifies EUT TX requirements and the related conformance procedure.
- Annex A provides information on test conditions, used test sites and procedures.
- Annex B provides necessary information on radiated test procedures.
- Annex C provides information on TX signal types.
- Annex D provides information on the all emission concept.
- Annex E provides information for a pre-scan radiated power measurement test procedure.
- Annex F provides information on differences between the different emission power measurements.
- Annex G provides information on Out-of-band and spurious requirements for EUT covered by ECC/DEC/(22)03 [i.40].
- Annex H provides information what specifications, parameters, need to be considered in the related standard.
- Annex I provides a change history table containing the major technical changes.

---

# 1 Scope

The present document summarizes the available information of possible measurement techniques and procedures for the conformance measurement of various signal formats (e.g. Ultra Wide Band (UWB)) in order to comply with the given transmission limits given in the current regulation.

---

## 2 References

### 2.1 Normative references

References are either specific (identified by date of publication and/or edition number or version number) or non-specific. For specific references, only the cited version applies. For non-specific references, the latest version of the referenced document (including any amendments) applies.

Referenced documents which are not found to be publicly available in the expected location might be found at <https://docbox.etsi.org/Reference/>.

NOTE: While any hyperlinks included in this clause were valid at the time of publication, ETSI cannot guarantee their long term validity.

The following referenced documents are necessary for the application of the present document.

- [1] [ETSI TS 102 754 \(V1.3.1\) \(03-2013\)](#): "Electromagnetic compatibility and Radio spectrum Matters (ERM); Short Range Devices (SRD); Technical characteristics of Detect And Avoid (DAA) mitigation techniques for SRD equipment using Ultra Wideband (UWB) technology".
- [2] [ETSI TS 102 321 \(V1.1.1\)](#): "Electromagnetic compatibility and Radio spectrum Matters (ERM); Normalized Site Attenuation (NSA) and validation of a fully lined anechoic chamber up to 40 GHz".
- [3] [ETSI TS 103 941 \(V.1.1.1\)](#): "Ultra Wide Band (ERM); Radiated tests for UWB technology-based devices under extreme environmental conditions".

### 2.2 Informative references

References are either specific (identified by date of publication and/or edition number or version number) or non-specific. For specific references, only the cited version applies. For non-specific references, the latest version of the referenced document (including any amendments) applies.

NOTE: While any hyperlinks included in this clause were valid at the time of publication, ETSI cannot guarantee their long term validity.

The following referenced documents are not necessary for the application of the present document, but they assist the user with regard to a particular subject area.

- [i.1] ETSI TS 103 060 (V1.1.1) (09-2013): "Electromagnetic compatibility and Radio spectrum Matters (ERM); Short Range Devices (SRD); Method for a harmonized definition of Duty Cycle Template (DCT) transmission as a passive mitigation technique used by short range devices and related conformance test methods".
- [i.2] [ITU Radio Regulations](#).
- [i.3] [ECC/DEC/\(06\)04](#): "The harmonised conditions for devices using UWB technology in bands below 10.6 GHz", 24 March 2006, amended 9 December 2011 and amended 8 March 2019.
- [i.4] [ECC/DEC/\(07\)01](#): "The harmonised use, exemption from individual licensing and free circulation of Material Sensing Devices using Ultra-Wideband (UWB) technology", 30 March 2007, amended on 26 June 2009, corrected on 18 November 2016 and amended on 8 March 2019.

- [i.5] [Decision \(EU\) 2019/785](#): "Commission Implementing Decision (EU) 2019/785 of 14 May 2019 on the harmonisation of radio spectrum for equipment using ultra-wideband technology in the Union and repealing Decision 2007/131/EC" (notified under document C(2019) 3461).
- [i.6] [ECC/DEC/\(11\)02](#): "Industrial Level Probing Radars (LPR) operating in frequency bands 6-8.5 GHz, 24.05-26.5 GHz, 57-64 GHz and 75-85 GHz", 11 March 2011, updated on 17 November 2017 and amended on 5 July 2019.
- [i.7] [ERC/REC 70-03](#): "Relating to the use of Short Range Devices (SRD)".
- [i.8] [Decision \(EU\) 2022/180](#): "Commission Implementing Decision (EU) 2022/180 of 8 February 2022 amending Decision 2006/771/EC as regards the update of harmonised technical conditions in the area of radio spectrum use for short-range devices".
- [i.9] [ERC/REC 74-01](#): "Unwanted Emissions in the spurious domain", latest amendment on 29 May 2019".
- [i.10] Recommendation ITU-R SM.329-12 (09/2012): "Unwanted emissions in the spurious domain".
- [i.11] [ECC/DEC/\(06\)08](#): "The conditions for use of the radio spectrum by Ground- and Wall- Probing Radar (GPR/WPR) imaging systems", December 2016, updated on 26 October 2018.
- [i.12] ETSI EN 302 372 (V2.1.1) (12-2016): "Short Range Devices (SRD); Tank Level Probing Radar (TLPR) equipment operating in the frequency ranges 4,5 GHz to 7 GHz, 8,5 GHz to 10,6 GHz, 24,05 GHz to 27 GHz, 57 GHz to 64 GHz, 75 GHz to 85 GHz; Harmonised Standard covering the essential requirements of article 3.2 of the Directive 2014/53/EU".
- [i.13] [ECC/DEC/\(04\)03](#): "The frequency band 77-81 GHz to be designated for the use of ground based vehicular radars" 19 March 2004, corrected 6 March 2015.
- [i.14] ETSI TR 103 181-2 (V1.1.1) (06-2014): "Electromagnetic compatibility and Radio spectrum Matters (ERM); Short Range Devices (SRD) using Ultra Wide Band (UWB); Transmission characteristics Part 2: UWB mitigation techniques".
- [i.15] ETSI TR 103 181-1 (V1.1.1) (07-2015): "Short Range Devices (SRD) using Ultra Wide Band (UWB); Technical Report Part 1: UWB signal characteristics and overview CEPT/ECC and EC regulation".
- [i.16] [ECC Report 120 \(06/2008\)](#): "Technical requirements for UWB DAA (Detect and Avoid) devices to ensure the protection of radiolocation services in the bands 3.1 - 3.4 GHz and 8.5 - 9 GHz and BWA terminals in the band 3.4 - 4.2 GHz".
- [i.17] ETSI EG 203 367 (V1.1.1) (06-2016): "Guide to the application of harmonised standards covering articles 3.1b and 3.2 of the Directive 2014/53/EU (RED) to multi-radio and combined radio and non-radio equipment".
- [i.18] ETSI TR 100 028 (all parts) (V1.4.1) (12-2001): "Electromagnetic compatibility and Radio spectrum Matters (ERM); Uncertainties in the measurement of mobile radio equipment characteristics".
- [i.19] Recommendation ITU-R SM.1754-0 (05-2006): "Measurement techniques of ultra-wideband transmissions".
- [i.20] ANSI C63.5-2017/Cor 1-2019: "American National Standard for Electromagnetic Compatibility--Radiated Emission Measurements in Electromagnetic Interference (EMI) Control - Calibration and Qualification of Antennas (9 kHz to 40 GHz) - Corrigendum 1".
- [i.21] ETSI TR 102 273 (all parts) (V1.2.1) (12-2001): "Electromagnetic compatibility and Radio spectrum Matters (ERM); Improvement on Radiated Methods of Measurement (using test site) and evaluation of the corresponding measurement uncertainties".
- [i.22] ETSI TR 102 215 (V1.3.1) (11-2004): "Electromagnetic compatibility and Radio spectrum Matters (ERM); Recommended approach, and possible limits for measurement uncertainty for the measurement of radiated electromagnetic fields above 1 GHz".

- [i.23] [ECC Report 064](#): "The protection requirements of radiocommunications systems below 10.6 GHz from generic UWB applications".
- [i.24] Recommendation ITU-R SM.1755-0 (05/2006): "Characteristics of ultra-wideband technology".
- [i.25] ETSI TR 102 347 (V1.1.2) (01-2005): "Electromagnetic compatibility and Radio spectrum Matters (ERM); Short Range Devices (SRD); Equipment for Detecting Movement; Radio equipment operating around e.g. 5,8 GHz, 10 GHz, 25 GHz, 61 GHz, 77 GHz; System Reference Document for Tank Level Probing Radar (TLPR)".
- [i.26] [ECC Report 139](#): "Impact of Level Probing Radars (LPR), using Ultra-Wideband Technology on Radiocommunications Services".
- [i.27] Recommendation ITU-R SM.1541-6 (08/2015): "Unwanted emissions in the out-of-band domain; SM Series".
- [i.28] ETSI EN 303 446-1 (V1.2.1) (10-2019): "ElectroMagnetic Compatibility (EMC) standard for combined and/or integrated radio and non-radio equipment; Part 1: Requirements for equipment intended to be used in residential, commercial and light industry locations".
- [i.29] ETSI EN 303 446-2 (V1.2.1) (10-2019): "ElectroMagnetic Compatibility (EMC) standard for combined and/or integrated radio and non-radio equipment; Part 2: Requirements for equipment intended to be used in industrial locations".
- [i.30] [RBW influence on peak or mean power measurement of pulsed signals](#), Application Note 6.2019-1EF106-1E, 06.06.2019.
- [i.31] ETSI EN 302 729-1 (V1.1.2) (05-2011): "Electromagnetic compatibility and Radio spectrum Matters (ERM); Short Range Devices (SRD); Level Probing Radar (LPR) equipment operating in the frequency ranges 6 GHz to 8,5 GHz, 24,05 GHz to 26,5 GHz, 57 GHz to 64 GHz, 75 GHz to 85 GHz; Part 1: Technical characteristics and test methods".
- [i.32] [Directive 2014/53/EU](#) of the European Parliament and of the Council of 16 April 2014 on the harmonisation of the laws of the Member States relating to the making available on the market of radio equipment and repealing Directive 1999/5/EC (RED).
- [i.33] CISPR 16-1-6:2014: "Specification for radio disturbance and immunity measuring apparatus and methods - Part 1-6: Radio disturbance and immunity measuring apparatus - EMC antenna calibration".
- [i.34] Michael D. Foegelle: "Antenna Pattern Measurement: Concepts and Techniques", Compliance Engineering, Annual Reference Guide 2002.
- [i.35] "Total Radiated Power Measurement above 1 GHz with Partially-Spherical Scanning of a Probe", EMC'09/Kyoto.
- [i.36] "Sampling points reduction in spherical scanned TRP measurement", 2014 IEEE<sup>TM</sup> Conference on Antenna Measurements & Applications (CAMA), Electronic ISBN:978-1-4799-3678-6.
- [i.37] "A CTIA approved antenna measurement system for over-the-air testing of wireless devices", published in 2004 IEEE<sup>TM</sup> Antenna Measurements and SAR, AMS 2004, Print ISBN:0-86341-415-X.
- [i.38] IEEE 149-2021<sup>TM</sup>: "IEEE Recommended Practice for Antenna Measurements".
- [i.39] CISPR 16-1-4 (Edition 4; 2019-01): "Specification for radio disturbance and immunity measuring apparatus and methods -Part 1-4: Radio disturbance and immunity measuring apparatus - Antennas and test sites for radiated disturbance measurements".
- [i.40] [ECC/DEC/\(22\)03](#): "Technical characteristics, exemption from individual licensing and free circulation and use of specific radiodetermination applications in the frequency range 116-260 GHz", 18 November 2022.
- [i.41] IEC 60153-2:2016: "Hollow metallic waveguides - Part 2: Relevant specifications for ordinary rectangular waveguides".

- [i.42] [ECC Report 334](#): "UWB radiodetermination applications in the frequency range 116-260 GHz", amended 3 February 2023".
- [i.43] [ECC Report 351](#): "UWB radiodetermination applications within the frequency range 116 GHz to 148.5 GHz for vehicular use".
- [i.44] EN 55016-2-3:2017 + A1:2019: "Specification for radio disturbance and immunity measuring apparatus and methods - Part 2-3: Methods of measurement of disturbances and immunity - Radiated disturbance measurements" (produced by CENELEC).

## 3 Definition of terms, symbols and abbreviations

### 3.1 Terms

For the purposes of the present document, the following terms apply:

**All Emissions (AE)**: related UWB Emission of the transmitter (RP), Transmitter Unwanted Emissions (TXUE) and Other Emissions (OE) of the EUT

NOTE: See emission concept in clause 5.1.2.1.

**antenna cycle**: one complete sweep of a mechanically or electronically scanned antenna beam along a predefined spatial path

**antenna port (or antenna connector)**: physical port, for connection of an antenna used for intentional transmission and/or reception of radiated RF energy

NOTE: The connector is typically a standardized coaxial or a hollow waveguide connector.

**antenna positioner**: mechanical structure to place and move the measurement/test antenna in the test set-up

NOTE: For example a mechanical arm (see figure B.13 and figure B.14) or measurement tower (see figure B.12) or curved runner to adjust measurement/test antenna along a adjusted azimuth angle  $\Phi$  (at the adjusted measurement distance) and the possibility to move the test/measurement antenna along the polar angle  $\theta$  from  $0^\circ \leq \theta \leq 90^\circ$ . Positioners are typically consisting on material which create low reflections or are coated with radio absorbing material (absorbers).

**antenna scan duty factor**: ratio of the solid angle of the antenna beam (measured at its 3 dB point) to the total solid angle scanned by the antenna

**associated antenna**: antenna and all its associated components which are designed as an indispensable part of the equipment

**avoidance level**: maximum amplitude to which the UWB transmit power is set for the relevant protection zone

**burst**: emitted signal whose time duration ( $T_{on}$ ) is not related to its bandwidth

**co-located receiver**: receiver is located in the same device housing as the transmitter

**combined equipment**: any combination of non-radio equipment and a plug-in radio device that would not offer full functionality without the radio device

**dedicated antenna**: specified antenna which is part of the EUT

NOTE: For example, a removable antenna supplied and tested with the radio equipment, designed as an indispensable part of the equipment. It is a specified external antenna by the manufacturer (within the EUT manual) to operate as intended with the rest of the EUT.

**default avoidance bandwidth**: portion of the victim service bandwidth to be protected if no enhanced service bandwidth identification mechanisms are implemented in the DAA enabled devices

**detect and avoid time**: time duration between a change of the external RF environmental conditions and adaptation of the corresponding UWB operational parameters

**duty cycle:** ratio, expressed as a percentage, of  $\Sigma(T_{on})/(T_{obs})$  where  $T_{on}$  is the "on" time of a single transmitter device and  $T_{obs}$  is the observation period

NOTE: See ETSI TS 103 060 [i.1].

**Effective Radiated Power (E.R.P):** product of the power supplied to the antenna and its gain relative to a half-wave dipole in a given direction (RR 1.162)

**equivalent isotopically radiated power (e.i.r.p.):** product of the power supplied to the antenna and the antenna gain in a given direction relative to an isotropic antenna (absolute or isotropic gain)

NOTE: See ITU Radio Regulations [i.2], RR 1.161.

**far field measurement:** measurement at a distance from an antenna sufficient to ensure that the electro-magnetic field approximates a plane wave

NOTE: See clause B.2.1.

**frequency span:** frequency range between the start and stop frequency of the RP measurement set-up

**gating:** transmission that is intermittent or of a low duty cycle referring to the use of burst transmissions where a transmitter is switched on and off for selected time intervals

**Half Power Beam Width (or Beamwidth):** angular separation, in which the magnitude of the radiation pattern decreases by 50 % (or -3dB) from the peak of the main beam

**hopping:** spread spectrum technique whereby individual radio links are continually switched from one subchannel to another

**hopping cycle:** number of hopping positions for a full frequency hopping sequence

**host equipment:** any equipment which has complete user functionality when not connected to the radio equipment part and to which the radio equipment part provides additional functionality and to which connection is necessary for the radio equipment part to offer functionality

**impulse:** pulse whose width is determined by its step risetimes and whose maximum amplitude is determined by its step value

NOTE: See clause 5.10.

**indirect emissions:** emissions radiated in all directions in a specified scenario

NOTE: See clause 5.7 including direct emissions from the housing/structure of the equipment and emissions reflected or passing through a media under inspection or through a scenario.

NOTE: These emissions are sometimes also named an exterior limit or unwanted emissions.

**integral antenna:** permanent fixed antenna, which may be built-in, designed as an indispensable part of the equipment

**main beam direction (or mainbeam):** direction of maximum gain of a directional antenna

NOTE: EUT may have different main beam direction for TX and RX antennas.

**mean power:** power during an interval of time sufficiently long compared with the lowest frequency encountered in the modulation envelope

**measurement antenna:** antenna to measure the emission radiated from the EUT

NOTE: See clause B.2.2.5.

**measurement cycle:** whole-numbered multiple of signal repetition time

**minimum avoidance bandwidth:** portion of the victim service bandwidth requiring protection

**minimum initial channel availability check time:** minimum time the UWB radio device spends searching for victim signals after power on, Parameter:  $T_{avail, Time}$

**Non-Interference Mode operation (NIM):** operational mode that allows the use of the radio spectrum on a non-interference basis without active mitigation techniques

**operating frequency range:** frequency range over which the EUT is intentionally transmitting

NOTE 1: The operating frequency range of the EUT is determined by the lowest ( $f_L$ ) and highest frequency ( $f_H$ ).

NOTE 2: For analogue or discrete frequency modulated systems (FSK, FMCW) the operating frequency range covers the difference between minimum and maximum of all carrier frequencies on which the equipment can be adjusted.

**peak power:** power measured with the peak detector using a filter the width and shape of which is sufficient to accept the signal bandwidth

NOTE: See Recommendation ITU-R SM.1541-6 [i.27].

**permitted frequency range(s):** frequency range(s) within which the device is authorized to operate

**plug-in radio device:** radio equipment module intended to be used with or within host, combined or multi-radio equipment, using their control functions and power supply

**Power Spectral Density (PSD):** ratio of the amount of power within a specified bandwidth

**pulse:** short transient signal whose time duration is nominally the reciprocal of its -10 dB bandwidth

**(mean) Pulse Repetition Frequency (PRF):** inverse of the Pulse Repetition Interval, averaged over a time sufficiently long as to cover all PRI variations

**Pulse Repetition Interval (PRI):** time between the rising edges of the transmitted (pulsed) output power

**Radar Cross Section (RCS):** cross-sectional area of a perfectly reflecting sphere that would produce the same strength reflection as would the object in question

**reference plane or reference point:** virtual plane or point in a measurement setup which is used to refer a measurement or calculation to (e.g. end of a cable, antenna connector)

**rf carrier:** fixed radio frequency prior to modulation

**scanning (steerable) antenna:** directional antenna which can move its beam along a predefined spatial path

NOTE: Scanning can be realized by mechanical, electronic or combined means. The antenna beamwidth may stay constant or change with the steering angle, dependent on the steering method.

**second (2<sup>nd</sup>) harmonic:** twice the frequency of the fundamental (e.g. 48 GHz for a 24 GHz device)

**signal detection threshold set:** set of amplitudes of the victim signal which defines the transition between adjacent protection zones

**signal off time ( $T_{off}$ ):** one or more time periods within the signal repetition time, where no transmission occurs

**signal repetition time:** length of the time between subsequent transmission patterns of the system

NOTE: Also known as cycle time, frame repetition time or frame duration.

**stand-alone radio equipment:** equipment intended primarily as communications equipment and that is normally used on a stand-alone basis

**transmission:** sequence of emissions separated by intervals shorter than  $T_{dis}$

NOTE: See ETSI TS 103 060 [i.1].

**transmitter timeout functionality:** internal functionality that switches off the system in order to reduce power consumption or for regulatory reasons

**temporary antenna connector:** EUT hardware design provide connector mounting option

EXAMPLE: Landing pads on PCB.

NOTE: The connector is either a standardized coaxial or a hollow waveguide connector, and the technical documentation of the EUT needs to provide guidance on how to install the connector.

**test antenna:** antenna to radiated a specified test signal toward the EUT

**victim signal:** signal(s) of the service to be detected and protected by the DAA mitigation technique

**wideband:** emission whose occupied bandwidth is greater than the test equipment measurement bandwidth

## 3.2 Symbols

For the purposes of the present document, the following symbols apply:

$\Omega$	ohm
$\lambda$	wavelength
$\sigma$	standard deviation
$\Theta$	elevation angle or polar angle
$\Phi$	azimuth angle
$\eta$	antenna efficiency
$att_{ae}$	attenuation ancillary equipment (cable)
$A_r$	effective area of the receiving antenna/measurement antenna
$b_{wrel}$	relation of the bandwidth
$bw$	modulated carrier/bandwidth of a single step/hop

NOTE: See clause C.2.3.

$c_{ATT\ total}$	attenuation from the EUT reference plane to the spectrum analyser
$ca$	cable loss
$Corr_{dB}$	correction in dB for peak e.i.r.p. spectral density measurement
$d$	measurement distance
$D_{ap}$	aperture size

NOTE: The maximum dimension of the antenna orthogonal to the direction of propagation.

$d_{ant}$	antenna directivity
dB	decibel
dBc	decibel below the maximum
dB <sub>i</sub>	gain in decibels relative to an isotropic antenna
dB <sub>m</sub>	gain in decibels relative to one milliwatt
$D_f$	range length is the minimum measurement distance
DC	Duty Cycle
dc	duty cycle in [dB]
$E_{RMS}$	RMS value electric field strength
$ E $	amplitude of the electric field
EIRP	kind of radiated e.i.r.p. emission measurement considering both "polarisations" (recorded) one point of the sphere depending on $\Theta$ and $\Phi$ and the kind of power, in [W]
eirp	EIRP in [dB]
$\Delta f_{step}$	step width (between two steps (hops))

NOTE: See annex C.

$f$	frequency
$f_0$	Start frequency of the Signal (centre of the first step/hop)

NOTE: See clause C.2.3.

$f_c$	centre frequency for the filter
$f_E$	top frequency of the Signal (centre of the last step/hop)

NOTE: See clause C.2.3.

$f_L$	lowest frequency of the operating frequency range
$f_{LS}$	start spurious domain below $f_c$



$f_H$	highest frequency of the operating frequency range
$f_{LS}$	start spurious domain above $f_C$
$f_C$	centre frequency of the operating frequency range
$f_M$	frequency for peak power measurement
$f[t]$	filter coefficients at time $t$ , centred on $f_M$
$F_{LOWER}$	lowest frequency for the spurious emission assessment
$F_{UPPER}$	highest frequency for the spurious emission assessment
FSL	free space loss
$g$	gain
$G_A$	gain test antenna
$g_A$	gain test antenna in [dB]
$g_{ATT}$	attenuator loss [dB]
$g_{LNA}$	gain low noise amplifier [dB]
$g_{AEUT}$	gain of the antenna under test in main beam direction in the respective plane
$g_{SRA}$	gain of the Standard Reference Antenna (SRA) in main beam direction in the respective measurement plane
$g_{TX}$	antenna gain in dB of the calibrated test antenna
$g_{RX}$	antenna gain in dB of the test arrangement measurement antenna
I	isolation in dB
$n$	number of $T_{on}$ and $T_{off}$ within $T_{obs}$
$n_{step}$	number of steps during one signal repetition time

NOTE: See clause C.2.3.

$m_{stpes}$  number of "hopping sequences in  $T_{obs}$

NOTE: See clause C.2.3.

P	power in dBm
$P_{abs}$	absolute power (in e.g. dBm) of the EUT (e.i.r.p.)
$P_{AEUT}$	power level detected by the spectrum analyser during the radiation pattern measurement of the AEUT in the respective measurement plane in the second step of the procedure
$P_{av}$	mean e.i.r.p. power spectral density
$P_{EUT\_con}$	conducted EUT output power at the reference plane of the EUT in [dBm]
$P_{meas\_con}$	measured conducted power at the reference plane of the measurement receiver
$P_{OUT}$	input power to the EUT (transmitting) antenna [dB]
$P_{peak,filtered}$	peak power in filter bandwidth
$P_{peak,max}$	maximum peak power in filter bandwidth
$P_{pk}$	peak e.i.r.p. spectral density power
$P_{(\Theta,\Phi)}$	Radiated emission measurement on one points of the sphere depending on the steps of $\Theta$ and $\Phi$ and the kind of power, in [W]
$P_r$	radiated power [W] of the EUT in a certain direction
$P_{reading}$	absolute power level (in e.g. dBm) noted from the power meter/spectrum analyser
$P_{SRA}$	power level detected by the spectrum analyser using ideal alignment of measurement antenna and standard reference antenna in the respective measurement plane in the first step of the procedure
$P_{thresh}$	threshold level
$p_{victim}$	power level [dB] of the victim source for LBT mitigation test
$PSD_{real}$	corrected mean e.i.r.p. spectral density value
$PSD_{meas}$	measured mean e.i.r.p. spectral density value
$r_{LBT}$	distance between victim source test antenna and EUT reference point
$r$	radius of the sphere/measurement distance
$RBW_{used}$	used RBW during peak e.i.r.p. spectral density measurement
S	average power flux density
$T_{avail\_time\_min}$	minimum initial channel availability check time
$T_{avoid}$	detect and avoid time

NOTE: Actual Detect and Avoid time of a EUT, can be negative.

$T_{avoid\_max}$	maximum allowed Detect and avoid time
$T$	time
$T_E$	stop time

NOTE: See clause C.2.3.

t	discrete time variable
t <sub>0</sub>	Start time of the UWB Signals = 0 second
NOTE:	See clause C.2.3.
$\Delta t_{\text{hopp}}$	Time for one step; = $\Delta t_{\text{on\_step}} + \Delta t_{\text{off\_step}}$
NOTE:	See clause C.2.3.
$\Delta t_{\text{on\_step}}$	Time transmission on/one step (hopp)
NOTE:	See clause C.2.3.
$\Delta t_{\text{off\_step}}$	Time between two step (hopp)
NOTE:	See clause C.2.3.
t <sub>aweeo;off</sub>	time between two FMCW sweeps
NOTE:	See clause C.2.2.
T <sub>dis</sub>	time interval below which interruptions within a transmission are considered part of T <sub>on</sub> (disregard time)
NOTE:	See ETSI TS 103 060 [i.1].
T <sub>PRT</sub>	Pulse Repetition time
NOTE:	See clause C.2.1.
T <sub>PULSE</sub>	Pulse Length
NOTE:	See clause C.2.1.
T <sub>obs</sub>	reference interval of time (observation period)
NOTE:	See ETSI TS 103 060) [i.1].
T <sub>off</sub>	time interval between two consecutive bursts when the UWB emission is kept idle
NOTE:	T <sub>off</sub> is defined as "the time duration between two consecutive transmissions", ETSI TS 103 060 [i.1].
T <sub>on</sub>	transmission "on"-time
NOTE:	See annex C.
T <sub>rep</sub>	repetition time
th	threshold level for LBT mitigation [dB]
TX <sub>out</sub>	transmitter output power [dB]
V <sub>peak,filtered</sub>	peak voltage in filter bandwidth
X	number of different sweeps during one signal repetition time
X	parameter to specify the OFR of the emission
X <sub>TXUE</sub>	parameter tp specify the spurious domain of the EUT emission
Z <sub>FO</sub>	$120\pi\Omega$ represents the wave impedance of free space
Z <sub>0</sub>	characteristic impedance

### 3.3 Abbreviations

For the purposes of the present document, the following abbreviations apply:

AC	Alternating Current
AE	All Emissions

NOTE: AE used to be referred to as "Total Emission" (TE) in previous versions of the present document.

AEUT	Antenna of Equipment Under Test
------	---------------------------------

APC	Adaptive Power Control
BW	Beam Width
BWA	Broadband Wireless Access
CDR	Contour Determination and acquisition Radar
CON	Connector
COR	Correction factor
CTIA	Cellular Telecommunications and Internet Association
CW	Continuous Wave
DAA	Detect And Avoid
DC	Duty Cycle
DEC	DECision
e.i.r.p.	equivalent isotropically radiated power

NOTE: Based on kind of power, e.g. mean power, peak power or mean power spectral density.

EC	European Commission
ECC	European Communication Committee
EIRP <sub>xx,θ,φ</sub>	kind of radiated e.i.r.p. emission measurement considering both "polarisations" (recorded) one point of the sphere depending on $\Theta$ and $\Phi$ and the kind of power
EMC	Electromagnetic Compatibility
EN	European Norm
ERC	European Radiocommunications Committee
ERM	Electromagnetic compatibility and Radio spectrum Matters
ETSI	European Telecommunications Standards Institute
EU	European Union
EUT	Equipment Under Test
EVR	Exterior Vehicular Radar
FAR	Full Anechoic Room
FH	Frequency Hopping
FMCW	Frequency Modulated Continuous Wave
FSK	Frequency Shift Keying
FSL	Free Space Loss
GPR	Ground Probing Radar
HPBW	Half Power BeamWidth
HS	Harmonised Standard
IF	Intermediate Frequency
ITU	International Telecommunications Union
IVR	In-cabin Vehicular Radar
LBT	Listen Before Talk
LDC	Low Duty Cycle
LNA	Low Noise Amplifier
LPR	Level Probing Radar
MSS	Mobile Satellite Service
NIM	Non-Interference Mode operation
OATS	Open Area Test Site
OE	Other Emissions of the radiated emissions
OFDM	Orthogonal Frequency Division Multiple
OFR	Operating Frequency Range
OOB	Out-Of-Band
PC	Personal Computer
PCB	Printed Circuit Board
P <sub>OUT</sub>	input power to the EUT (transmitting) antenna
PPM	Part Per Million
PRF	Pulse Repetition Frequency
PRI	Pulse Repetition Interval
PRT	Pulse Repetition Time
PSD	Power Spectral Density
RBW	Resolution BandWidth
RCS	Radar Cross Section
RDI-(S)	RadioDetermination systems for Industry automation
RDI-S	RadioDetermination systems for Industry automation in Shielded environment
REC	RECommendation

RF	Radio Frequency
RMS	Root Mean of Squares
RP	Radiated Power

NOTE: RP refers to the wanted signal emission. Previous versions of the present document used to refer to this as UWB Emissions (UE).

rS	related Standard
RX	Receiver
SAC	Semi Anechoic Chamber
SMA	SubMiniature version A
SNR	Signal to Noise Ratio
SRA	Standard Reference Antenna
SRD	Short Range Device
SWT	Sweep Time
TH	Threshold
TLPR	Tank Level Probing Radar
TPC	Transmit Power Control
TPR	Total Radiated Power
TRP	Total Radiated Power
TRP <sub>MP</sub>	Total Radiated Mean Power
TRP <sub>PP</sub>	Total Radiated Peak Power
TRP <sub>SD</sub>	Total Radiated Power Spectral Density
TRP <sub>XX</sub>	a kind of Total Radiated Power, e.g. TRP <sub>MP</sub> , TRP <sub>PP</sub> or TRP <sub>SD</sub>
TX	Transmitter
TX <sub>OUT</sub>	EUT transmitter output power
TXUE	Transmitter Unwanted Emissions
UE	UWB Emissions
UUT	Unit Under Test
UWB	Ultra Wide Band
VBW	Video BandWidth
VoIP	Voice over IP
VSWR	Voltage Standing Wave Ratio
WPR	Wall Probing Radar

---

## 4 Overview

### 4.1 Information

The present document provides practical information and guidance for the compliance tests of UWB and Short Range technology and devices. The applicability of the procedures described in the present document is not limited to EUT covered for example by following regulations:

- ECC/DEC/(06)04 [i.11].
- ECC/DEC/(07)01 [i.4].
- DEC (EU) 2019/785 [i.5].
- ECC/DEC/(11)02 [i.6].
- DEC (EU) 2022/180 [i.8].
- ECC/DEC/(04)03 [i.13].
- ECC/DEC/(22)03 [i.40]

Or radio determination applications realized based on:

- ERC/REC 70-03 [i.7].

## 4.2 Basic information about UWB

More information on UWB technology is available in ETSI TR 103 181-1 [i.15] (UWB signals) and ETSI TR 103 181-2 [i.14] (UWB mitigation techniques). The basic regulatory studies for UWB < 10 GHz are available in ECC Report 064 [i.23] and ITU Recommendation ITU-R SM.1755-0 [i.24].

---

## 5 TX requirements

### 5.1 General

#### 5.1.1 General Guidance on TX measurements

The test procedures in clauses 5.2 to 5.11 can directly be used for EUT with a permanent or temporary antenna connector without additional requirements on measurement antennas, test sites etc., clause B.3 provides relevant information for conducted measurements.

More information on how to perform radiated tests, including on EUT without a permanent or temporary antenna connector, is provided in clause B.2.

Further important information for TX measurements is provided in annex A, for example:

- Test modulation (see clause A.3).
- Test conditions, power supply and ambient temperatures (see clause A.5).
- Measurement uncertainty and the interpretation of the measurement results (see clause A.8).

#### 5.1.2 Emission Concept

##### 5.1.2.1 General

The measured emissions in transmit mode of the EUT are the combination of:

- 1) Radiated Power from the transmitter (see clause 5.3).
- 2) Other Emissions (OE) from the transmitter, receiver and other analogue or digital circuitry (see clause 5.4).
- 3) TX Unwanted Emissions (TXUE) from the transmitter (out-of-band and spurious domain, see clause 5.5).
- 4) Total radiated power (see clause 5.6).
- 5) Indirect emissions (see clause 5.7).

The UWB Radiated Power (RP) are the emissions related to the signal radiated into free space (see clause 5.3) during the transmit mode(s) of operation or radiated indirectly into the air (see clause 5.7).

For some EUT the UWB Radiated Power (RP) and TX Unwanted Emissions (TXUE) cannot be measured independently of the Other Emissions (OE) (e.g. narrow-band spurious emissions and the analogue or digital control circuitry emissions). That is because in some frequency ranges the regulated UWB RP emissions are very low power radio signals, comparable to the power limits of emissions from digital and analogue circuitry. If based on a measurement as described in annex D it can be assessed that an emission from the EUT is not the UWB RP emission limited in the relevant harmonised standards or it can clearly be assessed that it is impossible to differentiate between other emissions OE and the UWB RP emissions, the emission shall be considered as other emissions OE.

For such cases the RP, TXUE and OE from the EUT together are specified for such purpose of the test: as All Emissions (AE) see annex D.

### 5.1.2.2 UWB - EUT

The test concept is based on operating frequency range including the relevant UWB TX requirements. Figure 1 shows an overview of the TX emissions and mitigations.

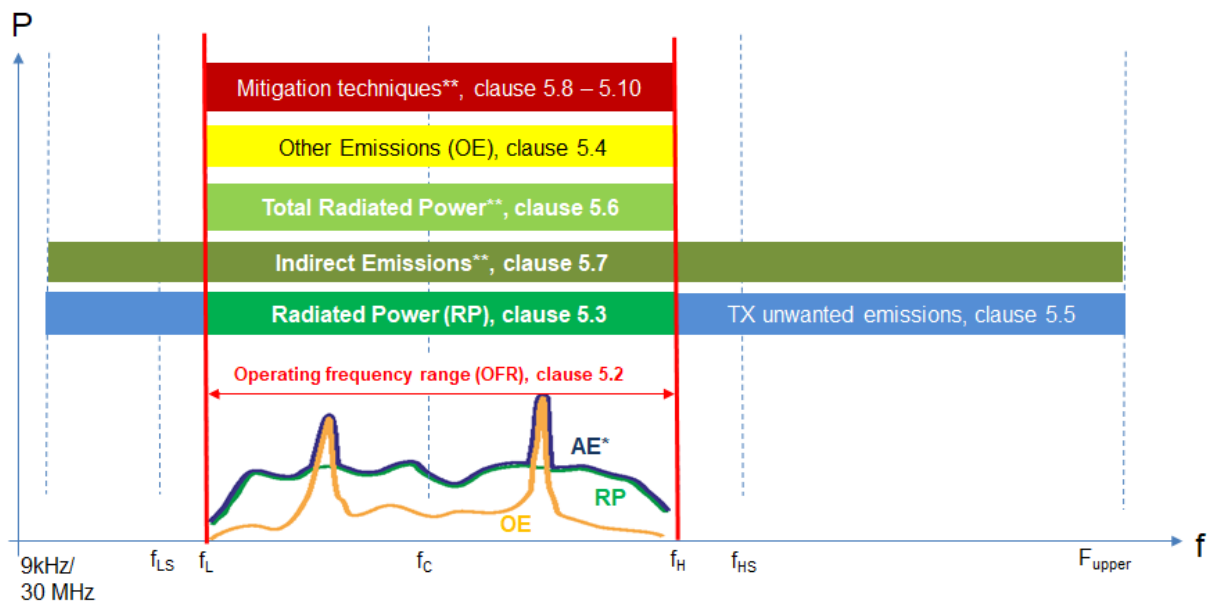

\*: AE; All Emissions, requirement is not mandatory for all EUT, details see annex D or related standard.  
 \*\*: Not mandatory for all EUT, see related standard.

**Figure 1: TX emission concept**

## 5.2 Operating Frequency Range (OFR)

### 5.2.1 Definition

The operating frequency range is the frequency range over which the EUT is intentionally transmitting (see clause 5.3, radiated power). The operating frequency range of the EUT is determined by the lowest ( $f_L$ ) and highest frequency ( $f_H$ ), see figure 2a.

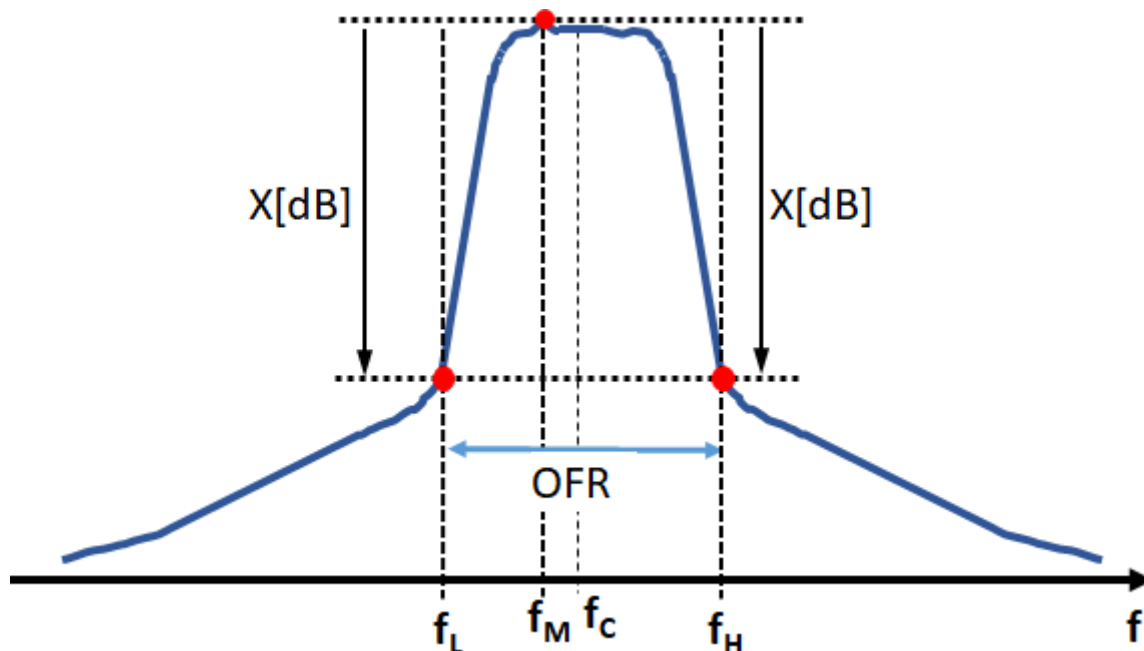

Figure 2a: Operating Frequency Range (OFR)

The lowest ( $f_L$ ) and highest frequency ( $f_H$ ) shall be measured based on a specified value  $X$  (in [dB]) below the max emission at frequency  $f_M$  (see figure 2a). The value for  $X$  is given in the related standard. If no value for  $X$  is provided in the related standard, then the value of 23 dB shall be used.

An EUT can have more than one operating frequency range. In that case each operating frequency range shall be tested separately.

### 5.2.2 Conformance Test

A radiated power spectral density measurements should be conducted first. One of the radiated power spectral density measurements from clause 5.3.2.2 or 5.3.3.3 should be specified, if not otherwise specified in the harmonised standard.

NOTE 1: The OFR assessment is only necessary in the direction of the highest emission (for radiated tests, see clause B.2 and B.4).

The operating frequency range assessment procedure shall be as follows (based on a power spectral density measurement):

- find the frequency ( $f_M$ ) at which the highest emission level occurs, this frequency shall be recorded, for examples see figure 2b;
- find the lowest frequency ( $f_L$ ) below  $f_M$  at which emission decrease to the level defined in clause 5.2.1, for examples see figure 2b. This frequency shall be recorded;

NOTE 2: The related standard could specify if the related emission level at  $f_L$  needs be recorded to derive a  $P_{\text{thresh}}$  for signal timing measurements, see annex C or clause 5.11 (Duty Cycle measurement).

- find the highest frequency ( $f_H$ ) above  $f_M$  at which the emission level decreases to the level defined in clause 5.2.1, for example the figure 2b. This frequency shall be recorded;
- the difference between the lowest frequency ( $f_L$ ) and highest frequency ( $f_H$ ) is the Operating Frequency Range (OFR) which shall be calculated (see equation (1)) and recorded:

$$\text{OFR} = f_H - f_L \quad (1)$$

- the addition of the lowest frequency and highest frequency divided by two is the centre frequency ( $f_C$ ) which shall be calculated (see equation (2)) and recorded:

$$f_C = \left( \frac{f_L + f_H}{2} \right) \quad (2)$$

- the values for  $f_H$ ,  $f_L$  and OFR shall be assessed with the OFR requirements specified in the related standard.

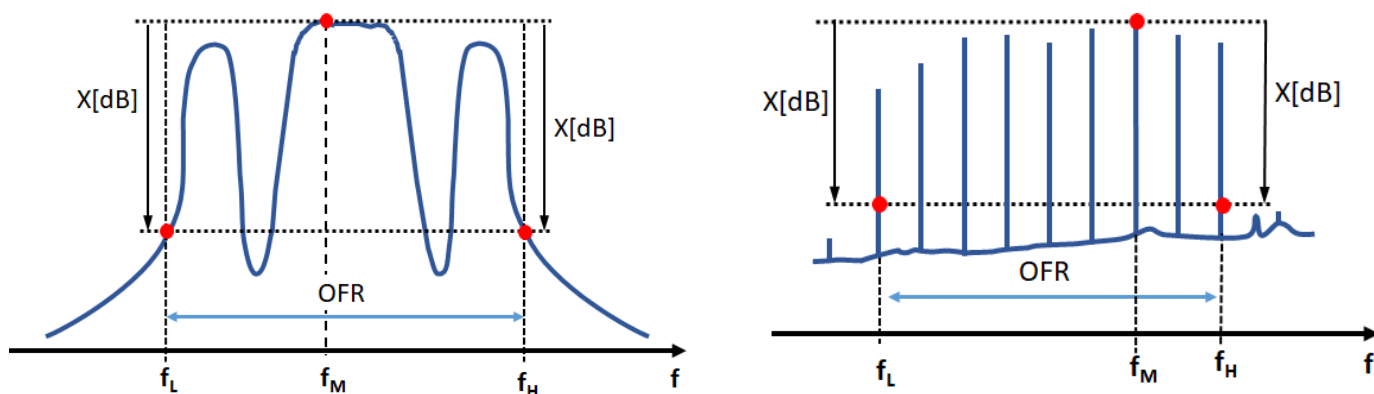

Figure 2b: Examples for Operating Frequency Range (OFR) assessment

## 5.3 Radiated Power (RP)

### 5.3.1 Mean e.i.r.p.

#### 5.3.1.1 Description

The radiated mean e.i.r.p. of the EUT, at a particular frequency is the product of the mean power supplied to the antenna and the antenna gain in a given direction relative to an isotropic antenna.

The maximum mean e.i.r.p. is the mean power radiated in the direction of the maximum level (usually the boresight of the antenna).

This radiated power shall be measured in the operating frequency range (see clause 5.2).

#### 5.3.1.2 Conformance

Measurement procedures for mean e.i.r.p. are described in clauses 5.3.1.3, 5.3.1.4 and 5.3.1.5.

The following clause offer different Mean e.i.r.p. tests based on the different regulatory requirements. The related EN shall specify which conformance test is appropriate for the testing.

In addition the related standard shall specify the test setup (see clause B.1). The conformance test for Mean e.i.r.p. (clauses 5.3.1.3 to 5.3.1.5) shall be used to measured/assed the emission in each direction around the EUT as specified in the related standard (see test setups in clauses B.1 and B.4).

For the Mean e.i.r.p. conformance following options are currently specified, see table 1.



**Table 1: Guidance to choose right mean e.i.r.p. measurement procedure**

Measurement receiver	averaging time	Related regulation (examples, but not limited to)	Clause	Comment
Spectrum Analyser	signal repetition time/measurement cycle of the EUT	DEC (EU) 2022/180 [i.8] band 74a, 79a, 80a, 80b and 81; ERC/REC 70-03 [i.7] annex 6	5.3.1.3	Could be combined with OFR measurement
RMS Power Meter	signal repetition time/measurement cycle of the EUT	DEC (EU) 2022/180 [i.8] band 74a, 79a, 80a, 80b and 81; ERC/REC 70-03 [i.7] annex 6	5.3.1.4	
Spectrum Analyser	burst duration/during $T_{on}$	ERC/REC 70-03 [i.7] annex 6	5.3.1.5	Could be combined with OFR measurement and for repeating signals with $T_{off} < T_{dis}$ (see annex C) (see note)
NOTE: The related standard shall specify how to assess $T_{on}$ .				

### 5.3.1.3 Method with a Spectrum Analyser

The spectrum analyser shall be connected to the measurement antenna (see clause B.2.2.5).

When measuring mean power from the EUT, the spectrum analyser (or equivalent) shall be configured as follows (an overview of this procedure is provided in the flowchart in figure 3), unless otherwise stated in the related standard:

- Start frequency: Lower edge of the permitted range of operation (see related standard). If nothing is specified in the related standard the pre-scan method (annex E) should be used.
- Stop frequency: Upper edge of the permitted range of operation (see related standard). If nothing is specified in the related standard the pre-scan method (annex E) should be used.
- RBW: 1 MHz, if not otherwise specified in the related standard.
- Video bandwidth: VBW equal or greater than the RBW.
- Detector mode: RMS.
- Display mode: CLEAR WRITE.
- Average Time:  $\geq$  than one EUT signal repetition time (see annex C), if not otherwise specified in the related standard.

NOTE: An integer number of signal repetitions, (e.g. 1 or 2) is recommended to provide consistent results in the shortest possible time.

- Sweep time:  $\geq$  Average Time  $\times$  number of measurement points.
- Number of measurement points: At least equal to frequency span divided by RBW, see equation (3).

$$\text{Number of measurement points} \geq \frac{\text{Frequency Span}}{\text{RBW}} \quad (3)$$

The Channel Power function of a spectrum analyser shall be used to calculate the mean power within the specified boundaries. Boundaries for the calculation shall be defined in the related standard. This is typically the operating frequency range defined by  $f_L$  and  $f_H$ .

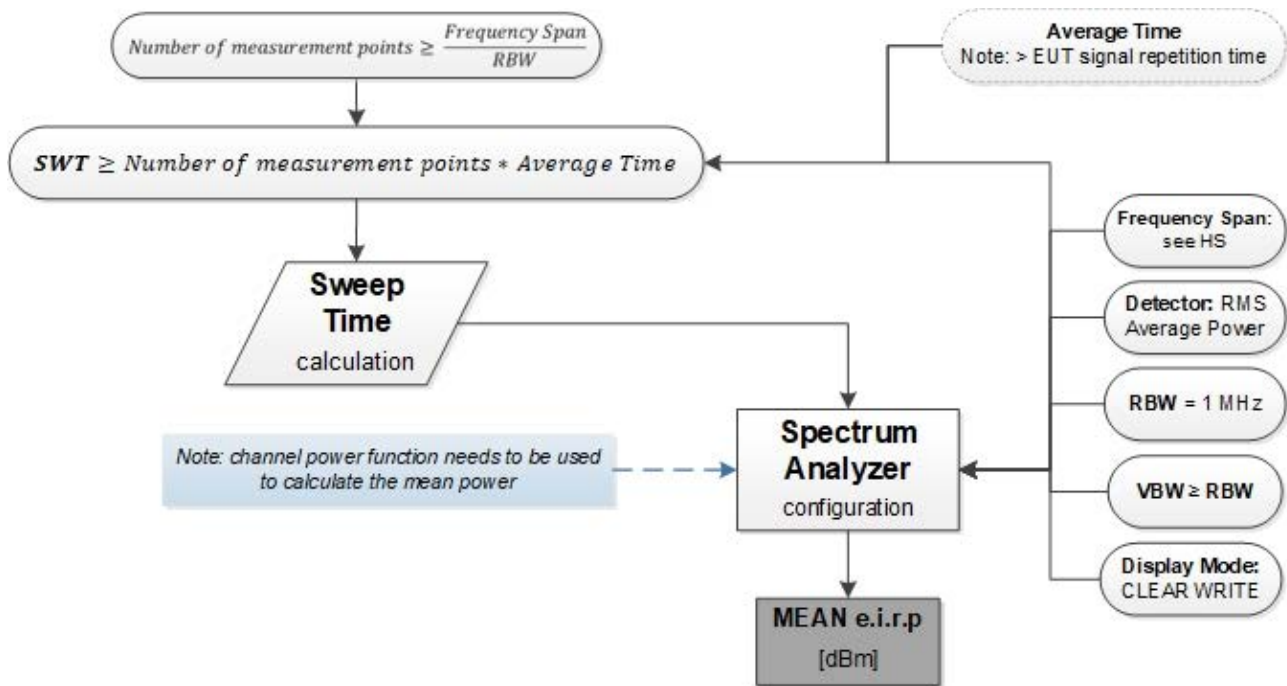

Figure 3: Test Procedure for Mean Power

#### 5.3.1.4 Method with an RMS Power Meter

The RMS power meter shall be connected to the measurement antenna (see clause B.2.2.5).

The measurement time shall be equal or longer than the EUT signal repetition time (see annex C).

#### 5.3.1.5 Method with a Spectrum Analyser for Mean e.i.r.p. averaged over $T_{on}$

The spectrum analyser shall be connected to the measurement antenna (see clause B.2.2.5).

When measuring mean power from the EUT, the spectrum analyser (or equivalent) shall be configured as follows (an overview of this procedure is provided in the flowchart in figure 4), unless otherwise stated in the related standard:

- Start frequency: Lower edge of the permitted range of operation (see related standard). If nothing is specified in the related standard the pre-scan method (annex E) should be used.
- Stop frequency: Upper edge of the permitted range of operation (see related standard). If nothing is specified in the related standard the pre-scan method (annex E) should be used.
- RBW: 1 MHz.
- Video bandwidth: VBW equal or greater than the RBW.
- Detector mode: RMS.
- Display mode: Max Hold.
- Average Time:  $T_{on}$  (sweep time per measurement point).

NOTE: "Average Time" may not be an explicit setting. In some cases, it may be determined by setting the number of measurement points and the time taken for a sweep (see equation (4) below).

- Number of measurement points: At least equal to frequency span divided by 1 MHz, see equation (4).

$$\text{Number of measurement points} \geq \frac{\text{Frequency Span}}{1 \text{ MHz}} \quad (4)$$

- Sweep Time: Time for spectrum analyser sweep (over one span) shall be calculated with the following equations (4) and (5):

$$\text{Sweep Time (SWT)} \leq \text{Number of measurement points} \times T_{on} [\text{ms}] \quad (5)$$

The initial measurement sweep will not give the final result. Therefore, several sweeps with display mode "max hold" are necessary to get the final, stable result. This can be assumed to be achieved if a further increase of time for the max hold measurement will not further change the result anymore. The minimum number of sweeps necessary may be calculated with the knowledge of the signal repetition time by the following equation (6):

$$\text{Number of sweeps} \geq \frac{\text{maximum signal repetition time}}{T_{on}} \quad (6)$$

The Channel Power function of a spectrum analyser shall be used to calculate the mean power within the specified boundaries. Boundaries for the calculation shall be defined in the related standard. This is typically the operating frequency range defined by  $f_L$  and  $f_H$ .

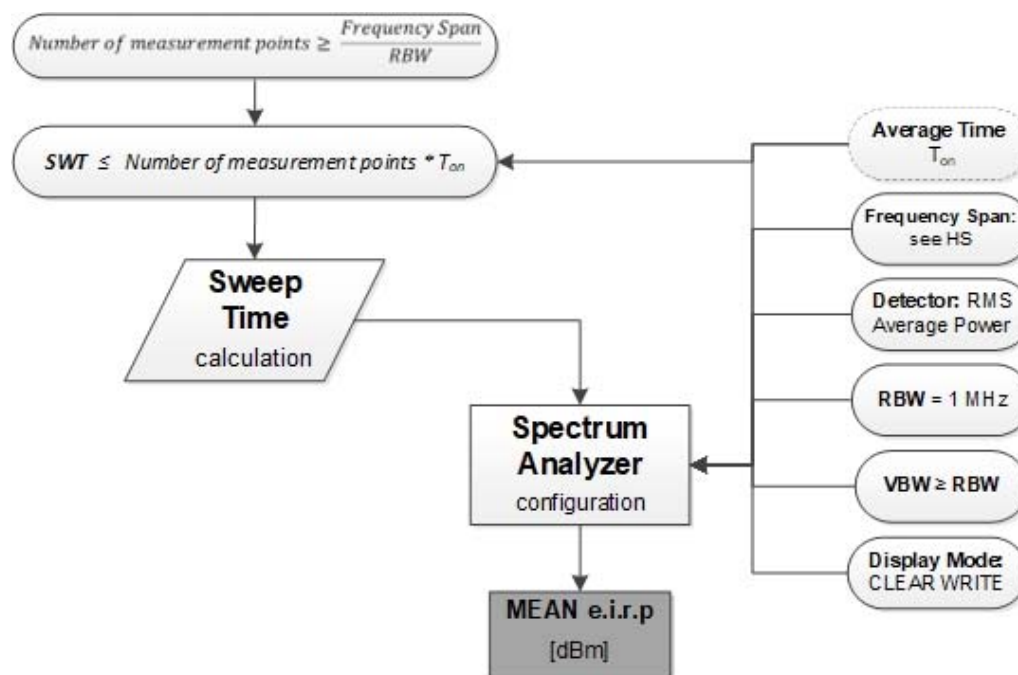

Figure 4: Test Procedure for Mean Power

## 5.3.2 Mean e.i.r.p. Spectral Density

### 5.3.2.1 Description, Mean e.i.r.p. Spectral Density within 1 MHz

The mean e.i.r.p. spectral density is defined as the emitted power spectral density over a defined bandwidth of the transmitter including antenna gain radiated in the direction of the maximum level.

### 5.3.2.2 Guidance for Mean e.i.r.p. Spectral Density Conformance Tests

Guidance to choose the right measurement procedure, see table 2.

In addition the related standard shall specify the test setup (see clause B.1). The conformance test for Mean e.i.r.p. Spectral Density (see table 2) shall be used to measured/asses the emission in each direction around the EUT as specified in the related standard (see test setups in clause B.1 and clause B.4).

**Table 2: Guidance to choose right mean e.i.r.p. spectral density measurement procedure**

Kind of signal characteristic	Related regulation (examples, but not limited to)	Clause 5.3.2.3	Clause 5.3.2.4	Clause 5.3.2.5	Clause 5.3.2.6
CASE 1: Any signal which has to be averaged over 1 ms	EUT based on the ECC and EC UWB regulatory framework below 10 GHz ECC/DEC/(06)04 [i.3] ECC/DEC/(07)01 [i.4] ECC/DEC/(11)02 [i.6] DEC (EU) 2019/785 [i.5] ECC/DEC/(11)02 [i.6] ECC/DEC/(22)03 [i.40] (for generic indoor)	X			
CASE 2: Alternative for type 1 (1 ms averaging time) for signals with signal repetition time (> 1 ms) and constant in time	EUT based on the ECC and EC UWB regulatory framework below 10 GHz ECC/DEC/(06)04 [i.3] ECC/DEC/(07)01 [i.4] DEC (EU) 2019/785 [i.5] ECC/DEC/(11)02 [i.6]	(X) See note	X		
CASE 3: Without requirement on measurement time in regulation; averaged over one or more integer multiple of the signal repetition time	For all other EUT ECC/DEC/(22)03 [i.40] ((T)LPR, RDI-(S), CDR, EVR and IVR) Generic SRDs based on ERC/REC 70-03 [i.7] and DEC (EU) 2022/180 [i.8]			X	
CASE 4: Any signal which has to be averaged over $T_{on}$	ECC/DEC/(04)03 [i.13]				X

NOTE: The measurement procedure is an alternative to clause 5.3.2.4, but could lead to a very long measurement time.

### 5.3.2.3 Mean e.i.r.p. Spectral Density, averaged over 1 ms

The following measurements shall be applied to the combination(s) of the radio device and its intended antenna(s). In the case that the RF power level is user adjustable, all measurements shall be made with the highest power level available to the user for that combination.

When measuring maximum mean power spectral density from the EUT, the spectrum analyser (or equivalent) shall be configured as follows (an overview of this procedure is provided in the flowchart in figure 5), unless otherwise stated in the related standard:

- Start frequency: Lower edge of the permitted range of operation (see related standard). If nothing is specified in the related standard the pre-scan method (annex E) should be used.
- Stop frequency: Upper edge of the permitted range of operation (see related standard). If nothing is specified in the related standard the pre-scan method (annex E) should be used.
- RBW: 1 MHz.
- Video Bandwidth: VBW equal or greater than the RBW.
- Detector Mode: RMS.
- Display Mode: Max. Hold.
- Average Time: 1 ms (sweep time per measurement point).

NOTE: "Average Time" may not be an explicit setting. In some cases, it may be determined by setting the number of measurement points and the time taken for a sweep (see equation (8) below).

- Number of measurement points: At least equal to frequency span divided by RBW, see equation (7).

$$\text{Number of measurement points} \geq \frac{\text{Frequency Span}}{\text{RBW}} \quad (7)$$

- Sweep Time: Time for spectrum analyser sweep (over one span) shall be calculated with the following equations (7) and (8):

$$\text{Sweep Time (SWT)} \leq \text{Number of measurement points} \times 1 \text{ ms} \quad (8)$$

Wait for each measurement until the reading in the display is stable.

In case of signals with a repetition time (see annex C) greater than 1 ms the initial measurement sweep will not give the final result. Therefore, several sweeps with display mode "max hold" are necessary to get the final, stable result. This can be assumed to be achieved if a further increase of time for the max hold measurement will not further change the result anymore. The minimum number of sweeps necessary shall be calculated with the knowledge of the signal repetition time by the following equation (9):

$$\text{Number of sweeps} \geq \frac{\text{maximum signal repetition time}}{1\text{ms}} \quad (9)$$

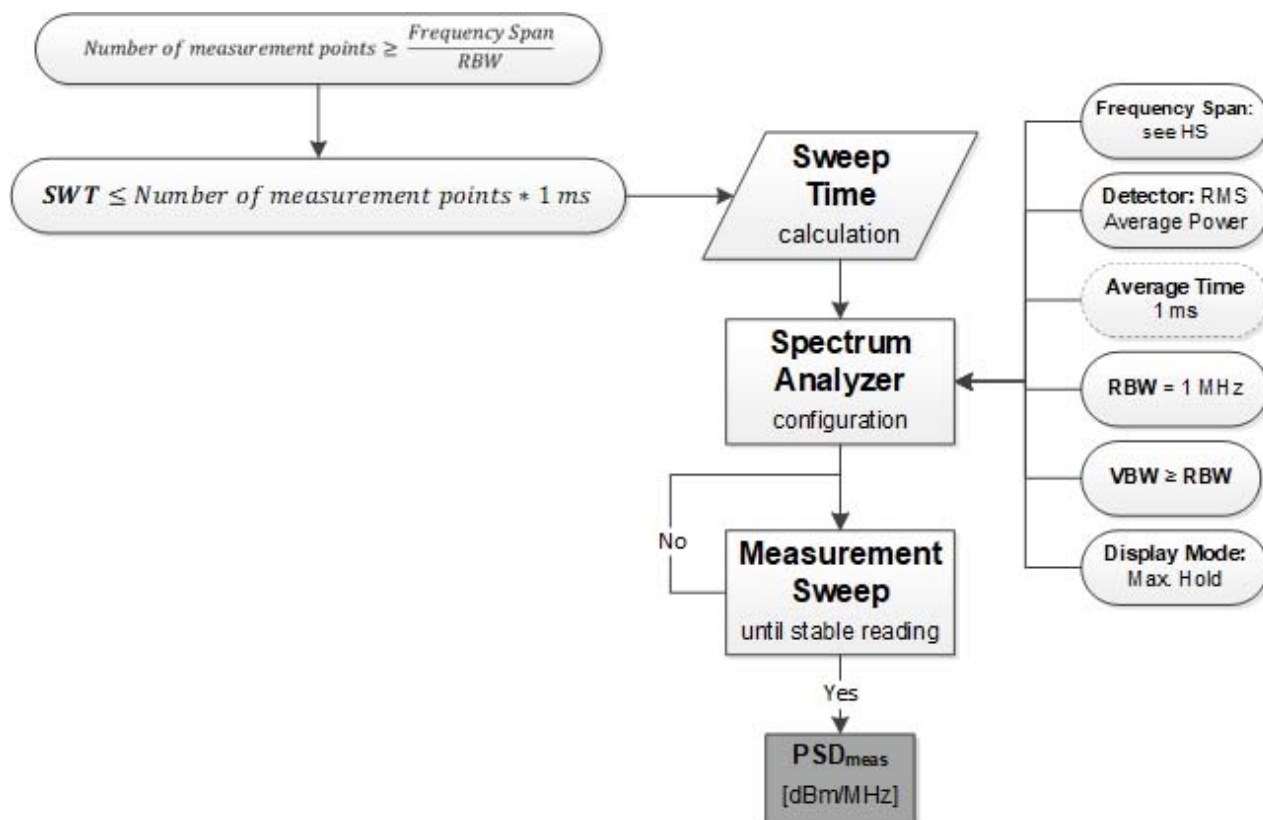

**Figure 5: Test Procedure for Mean e.i.r.p. spectral density, CASE 1**

The measurement results shall be recorded and used to determine the OFR and to assess the Mean e.i.r.p. spectral density limits within the OFR.

#### 5.3.2.4 Mean e.i.r.p. Spectral Density, known signal repetition time, averaged over 1 ms

The following measurements shall be applied to the combination(s) of the radio device and its intended antenna(s). In the case that the RF power level is user adjustable, all measurements shall be made with the highest power level available to the user for that combination.

When measuring maximum mean power spectral density from the EUT, the spectrum analyser (or equivalent) shall be configured as follows (an overview of this procedure is provided in the flowchart in figure 6), unless otherwise stated in the related standard:

- Start frequency: Lower edge of the permitted range of operation (see related standard). If nothing is specified in the related standard the pre-scan method (annex E) should be used.
- Stop frequency: Upper edge of the permitted range of operation (see related standard). If nothing is specified in the related standard the pre-scan method (annex E) should be used.
- RBW: 1 MHz.

- Video Bandwidth: VBW equal or greater than the RBW.
- Detector Mode: RMS.
- Display Mode: Max. Hold.
- Average Time: Equal or larger than signal repetition time (see annex C).

NOTE: "Average Time" may not be an explicit setting. In some cases, it may be determined by setting the number of measurement points and the time taken for a sweep.

- Number of measurement points: at least equal to frequency span divided by RBW.
- Sweep Time: Time for spectrum analyser sweep (over one span) shall be calculated with the following equation (10):

$$\text{Sweep Time (SWT)} \geq \text{EUT signal repetition time} \times \text{Number of measurement points} \quad (10)$$

- Signal repetition time: See annex C.

Based on the longer averaging time than 1 ms, there is a need to correct the measured and recorded values with the following equations (11) to (12):

$$\text{Correction [dB]} = 10 \log \left( \frac{\text{Averaging time [ms]}}{1 \text{ [ms]}} \right) \quad (11)$$

$$\text{PSD}_{\text{real}} \left[ \frac{\text{dBm}}{\text{MHz}} \right] = \text{PSD}_{\text{meas}} \left[ \frac{\text{dBm}}{\text{MHz}} \right] + \text{Correction [dB]} \quad (12)$$

The radiation measured values (PSDmeas) shall be corrected with the calculated correction factor (Correction[dB]). The resulting PSDreal has to comply with the related limits in the relevant harmonised standard.

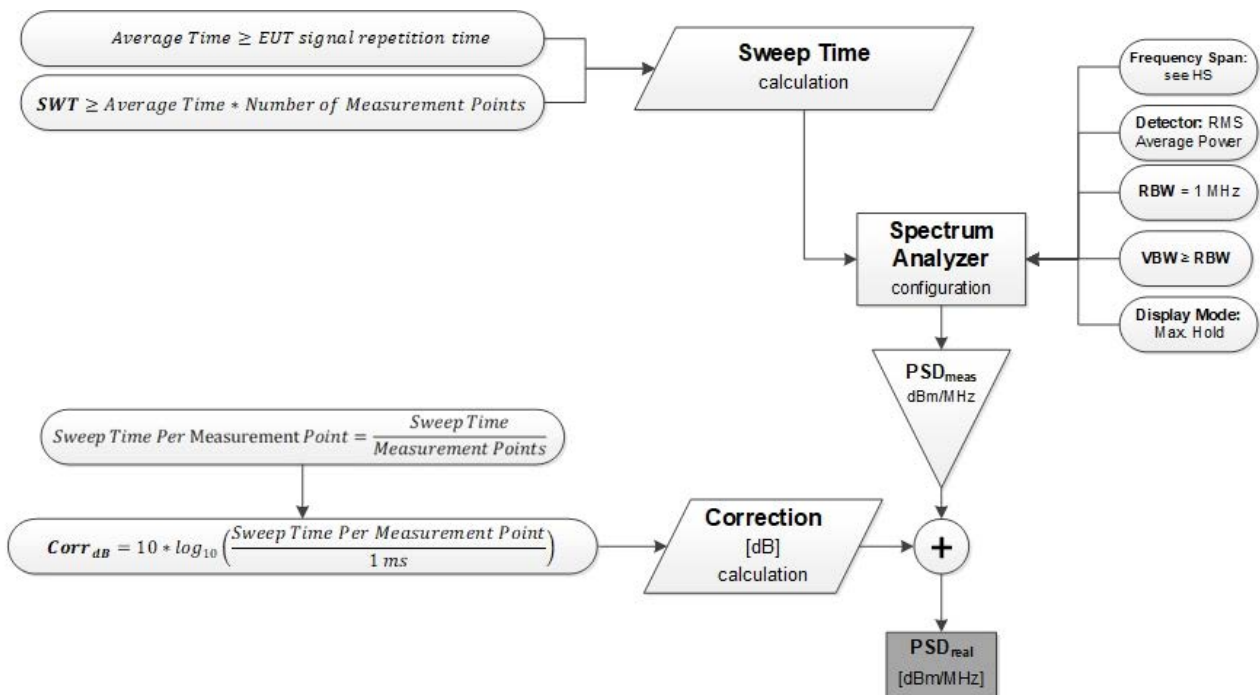

Figure 6: Test Procedure Mean e.i.r.p. spectral density, CASE 2

The measurement results shall be recorded and used to determine the OFR and to assess the mean power spectral density limits within the OFR.

### 5.3.2.5 Mean e.i.r.p. Spectral Density, known signal repetition time, averaged over signal repetition time

The following measurements shall be applied to the combination(s) of the radio device and its intended antenna(s). In the case that the RF power level is user adjustable, all measurements shall be made with the highest power level available to the user for that combination.

When measuring maximum mean power spectral density from the EUT, the spectrum analyser (or equivalent) shall be configured as follows (an overview of this procedure is provided in the flowchart in figure 7), unless otherwise stated in the related standard:

- Start frequency: Lower edge of the permitted range of operation (see related standard). If nothing is specified in the related standard the pre-scan method (annex E) should be used.
- Stop frequency: Upper edge of the permitted range of operation (see related standard). If nothing is specified in the related standard the pre-scan method (annex E) should be used.
- RBW: 1 MHz.
- Video Bandwidth: VBW equal or greater than the RBW.
- Detector Mode: RMS.
- Display Mode: Max. Hold.
- Average Time: Equal or larger than signal repetition time.

NOTE: "Average Time" may not be an explicit setting. In some cases, it may be determined by setting the number of measurement points and the time taken for a sweep.

- Number of measurement points: At least equal to frequency span divided by RBW.
- Sweep Time: Time for spectrum analyser sweep (over one Frequency Span) shall be calculated with the following equation (13):

$$\text{Sweep Time (SWT)} \geq \text{signal repetition time} \times \text{Number of measurement points} \quad (13)$$

- Signal repetition time: See annex C.

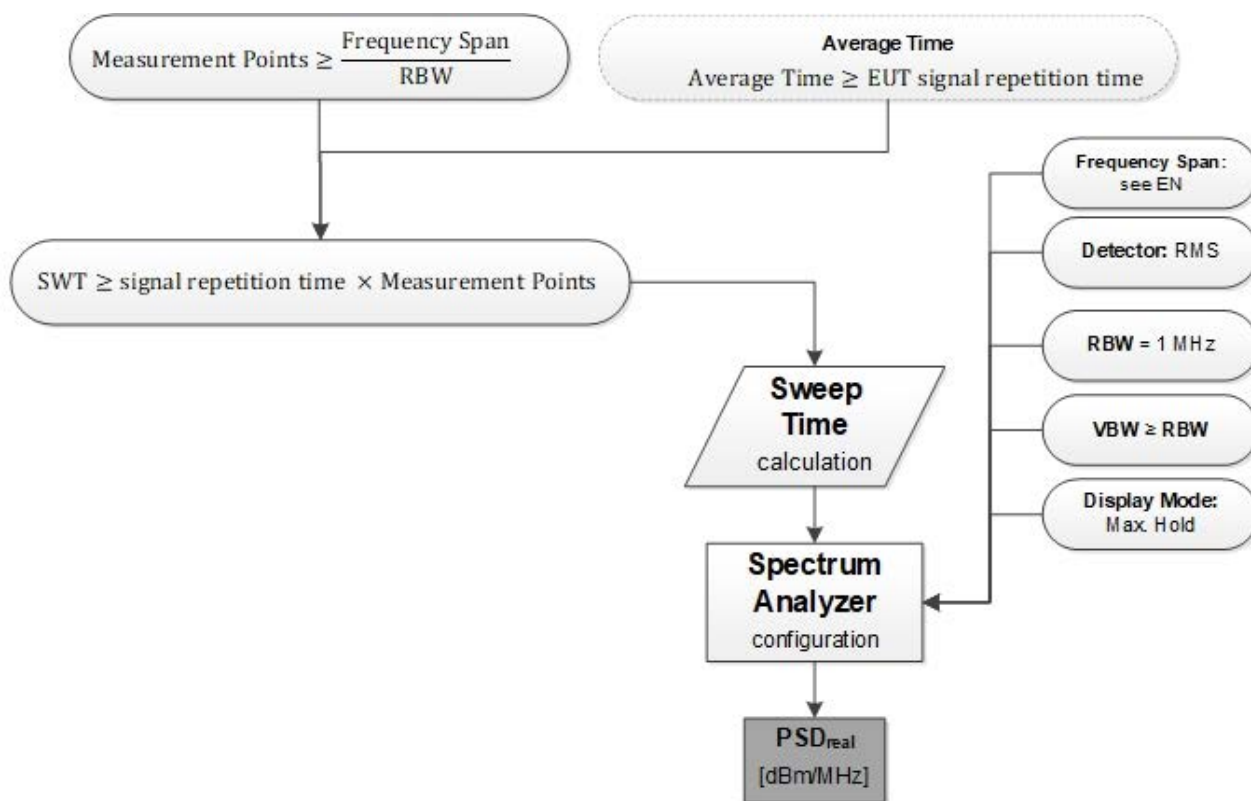

**Figure 7: Test Procedure Mean e.i.r.p. spectral density, CASE 3**

The measurement results shall be recorded and used to determine the OFR and to assess the mean power spectral density limits within the OFR.

### 5.3.2.6 Mean e.i.r.p. Spectral Density, known signal on - time ( $T_{on}$ ), averaged over signal on - time

The following measurements shall be applied to the combination(s) of the radio device and its intended antenna(s). In the case that the RF power level is user adjustable, all measurements shall be made with the highest power level available to the user for that combination.

When measuring maximum mean power spectral density from the EUT, the spectrum analyser (or equivalent) shall be configured as follows (an overview of this procedure is provided in the flowchart in figure 8), unless otherwise stated in the related standard:

- Start frequency: Lower edge of the permitted range of operation (see related standard). If nothing is specified in the related standard the pre-scan method (annex E) should be used.
- Stop frequency: Upper edge of the permitted range of operation (see related standard). If nothing is specified in the related standard the pre-scan method (annex E) should be used.
- RBW: 1 MHz.
- Video Bandwidth: VBW equal or greater than the RBW.
- Detector Mode: RMS.
- Display Mode: Max. Hold.
- Average Time: Equal or larger than signal on-time ( $T_{on}$ ).

NOTE: "Average Time" may not be an explicit setting. In some cases, it may be determined by setting the number of measurement points and the time taken for a sweep.

- Number of measurement points: At least equal to frequency span divided by RBW.



- Sweep Time: Time for spectrum analyser sweep (over one Frequency Span) shall be calculated with the following equation (14):

$$\text{Sweep Time (SWT)} \geq \text{signal on-time} \times \text{Number of measurement points} \quad (14)$$

- Signal on- time ( $T_{on}$ ): See annex C.

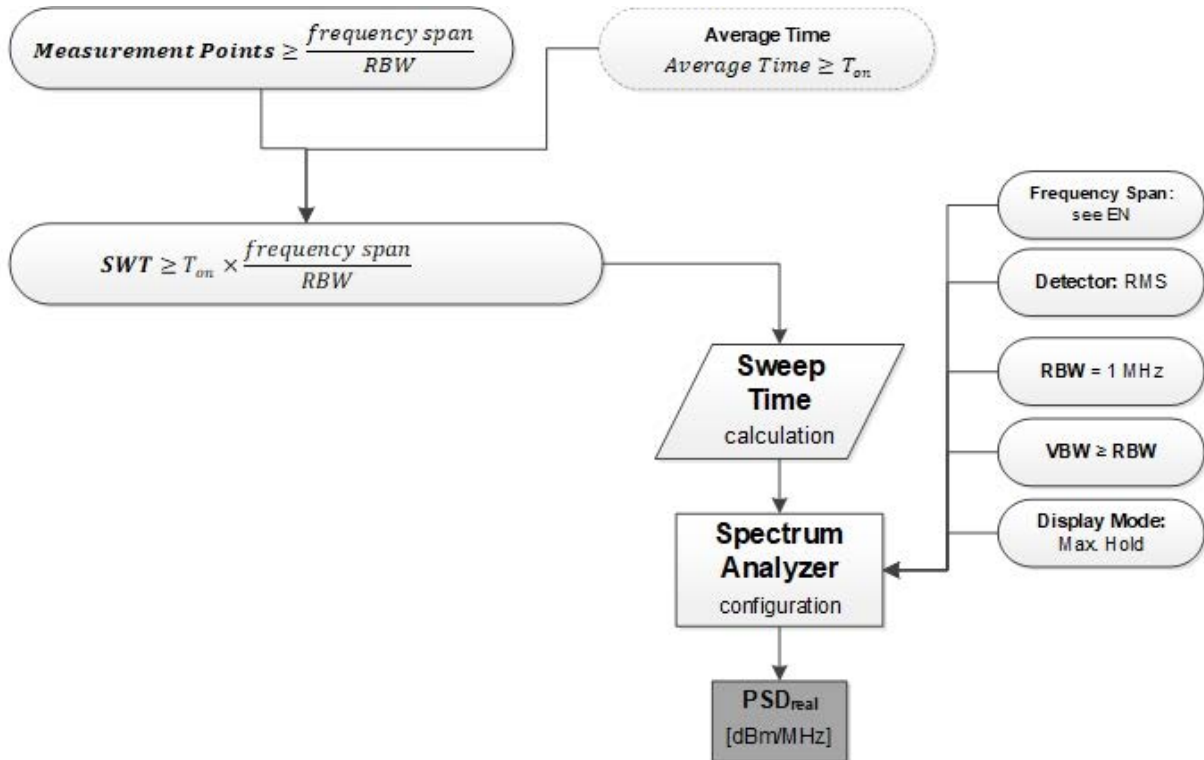

**Figure 8: Test Procedure Mean e.i.r.p. spectral density, CASE 4**

The measurement results shall be recorded and used to determine the OFR and to assess the mean power spectral density limits within the OFR.

### 5.3.3 Peak e.i.r.p.

#### 5.3.3.1 Description

The radiated peak power (e.i.r.p.) is the highest instantaneous power radiated by the equipment. It is measured in the permitted range of operating frequency range.

#### 5.3.3.2 Conformance

Two methods are described for measuring the peak e.i.r.p.:

- In clause 5.3.3.3 with a spectrum analyser
- In clause 5.3.3.4 with peak power meter

In addition the related standard shall specify the test setup (see clause B.1). The conformance test for Peak e.i.r.p. (see clauses 5.3.3.3 to 5.3.3.4) shall be used to measure/assess the emission in each direction around the EUT as specified in the related standard (see test setups in clause B.1 and clause B.4).

### 5.3.3.3 Peak e.i.r.p.: Method with a Spectrum Analyser

The spectrum analyser shall be connected to the measurement antenna (see clause B.2.2.5).

A spectrum analyser with the following settings is used as measuring receiver:

- Start frequency: Lower edge of the permitted range of operation (see related standard). If nothing is specified in the related standard the pre-scan method (annex E) should be used.
- Stop frequency: Upper edge of the permitted range of operation (see related standard). If nothing is specified in the related standard the pre-scan method (annex E) should be used.
- RBW: 1 MHz, if not otherwise specified in the related standard.

NOTE 1: The settling time of the filter should be respected; for an RBW of 1 MHz, the maximum time resolution is 1 MHz/μs. For example, a generally accepted criterion for a pulsed transmitter is  $RBW \geq 2/T_{on}$ . For an FMCW system a maximum frequency ramp of 1 MHz/μs can be measured with an RBW of 1 MHz with corresponding increases in the RBW for faster frequency ramp rates. For more information see "RBW influence on peak or mean power measurement of pulsed signals" [i.30].

- Video bandwidth: VBW equal or greater than the RBW.
- Detector mode: Peak or auto peak detector.
- Display mode: Max. Hold.
- Measurement Time: Larger than one EUT signal repetition time (see annex C).
- Sweep time: Measurement Time × number of measurement points.
- Number of measurement points: At least equal to frequency span divided by RBW, see equation (15).

$$\text{Number of measurement points} \geq \frac{\text{Frequency Span}}{\text{RBW}} \quad (15)$$

The peak power to be considered is the maximum value recorded.

### 5.3.3.4 Peak e.i.r.p. method with a Peak Power Meter

The peak power meter shall be connected to the measurement antenna (see clause B.2.2.5).

The measurement time shall be sufficiently long to cover at least the EUT signal repetition time (see annex C).

## 5.3.4 Peak e.i.r.p. Spectral Density

### 5.3.4.1 Peak e.i.r.p. Spectral Density within 50 MHz

#### 5.3.4.1.1 Description

The maximum peak e.i.r.p. spectral density contained within a 50 MHz bandwidth.

#### 5.3.4.1.2 Conformance

For the peak power spectral density measurements there are two different measurement procedures available. While the method in clause 5.3.4.1.3 applies generally, the method in clause 5.3.4.1.4 applies only if there is only one spectral line in 50 MHz bandwidth at one time and the bandwidth of the spectral line is smaller than the smallest RBW used for the measurements.

In addition the related standard shall specify the test setup (see clause B.1). The conformance test for Peak e.i.r.p. Spectral density (defined within 50 MHz, see clause 5.3.4.1.3 or 5.3.4.1.4) shall be used to measured/asses the emission in each direction around the EUT as specified in the related standard (see test setups in clauses B.1 and B.4).

#### 5.3.4.1.3 Peak e.i.r.p. Spectral Density, General Method

When using resolution bandwidths below 50 MHz, this method overestimates the peak power result for most UWB signals due to the worst-case correction factor (see equation (16)). However, it is the simplest and most general measurement procedure.

NOTE 1: If only one spectral line per 50 MHz occurs and those lines are narrower than the available resolution bandwidth, the method in clause 5.3.4.1.4 is an equivalent measurement procedure that avoids the correction factor. Manufacturers with EUTs that satisfy these conditions may use the equivalent method instead of the one outlined in this clause.

The spectrum analyser shall be connected to the measurement antenna (see clause B.2.2.5).

When measuring maximum peak power from the EUT, the spectrum analyser used shall be configured as follows (an overview of this procedure is provided in the flowchart in figure 9) unless otherwise stated in the related standard:

- Start frequency: Lower edge of the permitted range of operation (see related standard). If nothing is specified in the related standard the pre-scan method (annex E) should be used.
- Stop frequency: Upper edge of the permitted range of operation (see related standard). If nothing is specified in the related standard the pre-scan method (annex E) should be used.

NOTE 2: For EUT covered by the DEC (EU) 2019/785 [i.5] the measurement is only required to be performed at the frequency of the maximum mean power spectral density as recorded under clause 5.3.2.2, a specific flowchart is shown in figure 10.

- RBW: Bandwidth equal or greater than 3 MHz and less or equal than 50 MHz.

NOTE 3: It is recommended to use the highest available bandwidth for the signal to be measured because choosing a lower bandwidth could lead to an overestimate of the peak power.

- Video Bandwidth: Not less than the resolution bandwidth.
- Detector Mode: Peak.
- Display Mode: Max. Hold.

Wait for each measurement until the reading in the display is stable (this can be assumed to be achieved if a further increase of time for the max hold measurement will not further change the result anymore).

When the measurements have been performed using a lower bandwidth than 50 MHz, the following correction factor (see equation (16)) shall be added to the measured value before comparison with the peak power limits given in the related standard:

$$\text{Corr}_{\text{dB}} = 20 \times \log_{10} \left( \frac{50 \text{ MHz}}{\text{RBW}_{\text{used}} [\text{MHz}]} \right) \quad (16)$$

The measurement results shall be recorded and shall be assessed against the peak power spectral density limits in the related standard. If the correction based on equation (16) was considered, this shall be recorded in the measurement test report.

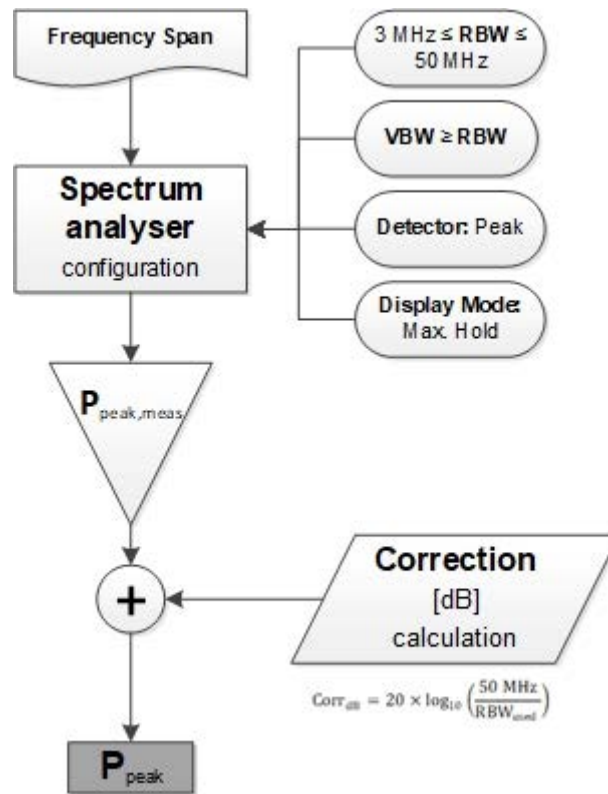

Figure 9: Test Procedure for Peak Power Measurement; General Method

In some standard and related regulations only the peak power shall be measured at the emissions of the highest mean power spectral density, the related procedure is shown in figure 10.

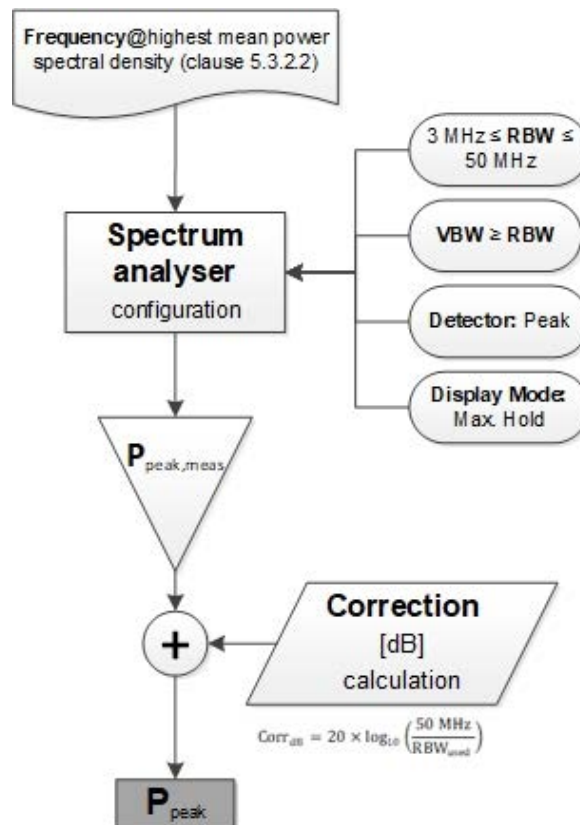

Figure 10: Test Procedure for Peak Power Measurement at the highest mean power spectral density emission

#### 5.3.4.1.4 Peak e.i.r.p. Spectral Density, Sparse Spectral Line Method

##### Restriction:

This method can only be applied, if there is only one spectral line in 50 MHz bandwidth at one time and the bandwidth of the spectral line is smaller than the RBW used for the measurements.

##### EXAMPLES:

- Pulse signal with PRF > 50 MHz and bandwidth of spectral lines < RBW used for measurement.
- Stepped-frequency and FMCW signals with bandwidth of spectral lines < RBW used for measurement. The distance of the spectral lines may be smaller than 50 MHz, if only one spectral line is emitted at one time.

The spectrum analyser shall be connected to the measurement antenna (see clause B.2.2.5).

When measuring maximum peak power from the EUT, the spectrum analyser used shall be configured as follows, unless otherwise stated in the related standard:

- Start frequency: Lower edge of the permitted range of operation (see related standard). If nothing is specified in the related standard the pre-scan method (annex E) should be used.
- Stop frequency: Upper edge of the permitted range of operation (see related standard). If nothing is specified in the related standard the pre-scan method (annex E) should be used.
- RBW: Maximum available bandwidth equal or greater than 3 MHz and less or equal 50 MHz.
- Video Bandwidth: Not less than the resolution bandwidth.
- Detector Mode: Peak.
- Display Mode: Max. Hold.

To validate if the restriction described is fulfilled the measurement procedure shall be done with two different resolution bandwidths. The measurement result shall be the same independent of the RBW used.

The measurement results shall be recorded and shall be assessed against the peak power spectral density limits in the related standard.

#### 5.3.4.2 Peak e.i.r.p. within 1 GHz for FMCW

##### 5.3.4.2.1 Description

The maximum peak e.i.r.p. within 1 GHz bandwidth.

NOTE: This method is intended to be used for harmonised standards applying ECC/DEC/(22)03 [i.40].

##### 5.3.4.2.2 Conformance

This method applies for FMCW modulated signals only.

In addition the related standard shall specify the test setup (see clause B.1). The conformance test spectral need to be used to measured/asses the emission in each direction around the EUT as specified in the related standard (see test setups in clauses B.1 and B.4).

If an EUT has a signal modulation other than FMCW the related standard shall specify the conformance test to assess the peak e.i.r.p. within 1 GHz for this modulations.

This method can only be applied for FMCW signals which have only one spectral line in 1 GHz bandwidth at one time, and the bandwidth of the spectral line is smaller than the RBW used for the measurements.

As a RBW of 50 MHz is the technical limit of spectral analysers, a direct measurement with a RBW of 1 GHz is not feasible. Instead a validation procedure shall be applied here which is possible due to the spectral line nature of FMCW signals. Hence, to validate if the restriction described is fulfilled the measurement procedure shall be done with two different resolution bandwidths. The two measurement results shall not differ by more than 2 dB. If the 2 dB condition is not fulfilled the RBW could be further increased.

When measuring maximum peak power from the EUT, the spectrum analyser used shall be configured as follows, unless otherwise stated in the related standard:

- Start frequency: Lower edge of the permitted range of operation (see related standard). If nothing is specified in the related standard the pre-scan method (annex E) should be used.
- Stop frequency: Upper edge of the permitted range of operation (see related standard). If nothing is specified in the related standard the pre-scan method (annex E) should be used. The stop frequency shall be at least 1 GHz higher than the start frequency.
- RBW: 3 MHz and 10 MHz, if not otherwise specified the related standard.

NOTE: for the RBW specification in a related standard: two explicit values, of at least a factor two (x2) between needs to be considered.

- Video Bandwidth: VBW equal or greater than the RBW.
- Detector Mode: Peak.
- Display Mode: Max. Hold.

The measurement results shall be recorded and shall be assessed against the peak power spectral density limits in the related standard.

## 5.4 Other Emissions (OE)

UWB transmitters emit very low power radio signals, comparable with the power of spurious emissions from digital and analogue circuitry within the operating frequency range.

If it can be clearly demonstrated based on test procedures specified in the related standard (or based on annex D) that an emission from the (Ultra Wide Band) radio device is not the (Ultra Wide Band) emission identified in clause 5.3 (e.g. by disabling the radio device's (UWB) transmitter or disconnecting and terminating, internally or externally the antenna of the device) or it can clearly be demonstrated that it is impossible to differentiate between Other Emissions (OE) and the UWB transmitter emissions (see clause 5.3), then that emission or aggregated emissions shall be considered against the emission limits defined in the harmonised standard that applies to the OE source.

## 5.5 TX Unwanted Emissions (TXUE)

### 5.5.1 Description

TX Unwanted Emissions (TXUE) are emissions on frequencies outside the Operating Frequency Range (OFR), see clause 5.2.1. TXUE include harmonic emissions, parasitic emissions, intermodulation products and frequency conversion products related to the RP emissions. TXUE can be split into out-of-band emissions and spurious emissions (see figure 11).

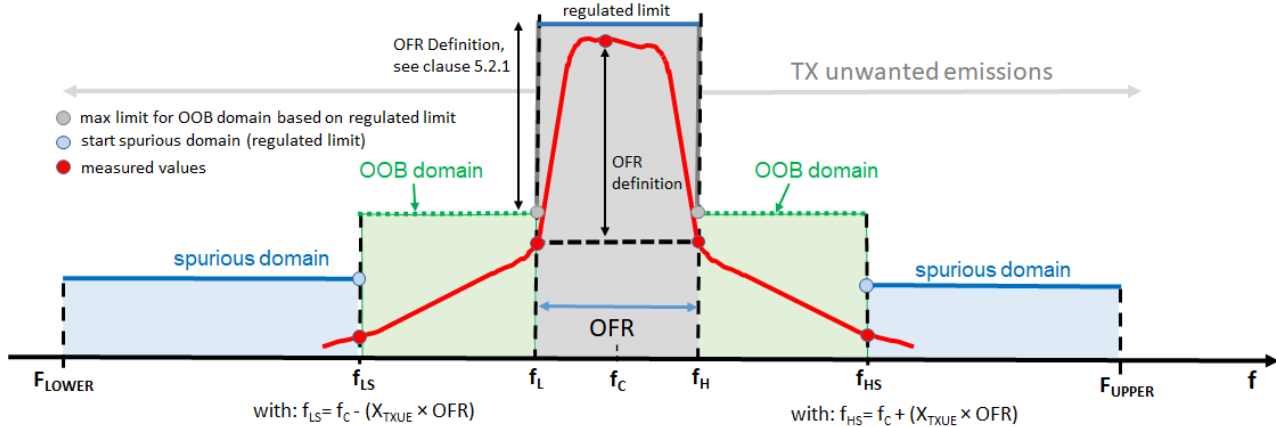

**Figure 11: Overview OOB/spurious, depending on OFR**

Based on figure 11 the related frequencies for the different domains are summarized in table 3.

**Table 3: Overview of the related conformance tests, requirements for the TX unwanted domains**

Domain	Frequencies	Conformance test	Limits
OFR/in band	$f_L \leq f \leq f_H$	based on OFR and power measurement requirements (in band) specified in harmonized standard	related ECC/EC regulation See note 1
Out-of-band (OOB)	$f_{LS} < f < f_L$ $f_H < f < f_{HS}$	requirement specified in harmonized standard (see clause 5.5.3.2)	either ECC/EC regulation or specified by related standard
spurious	$F_{LOWER} \leq f \leq f_{LS}$ $f_{HS} \leq f \leq F_{UPPER}$	requirement specified in harmonized standard (see clause 5.5.3.1)	basis ERC/REC 74-01 [i.9] or specific in related ECC/EC regulation See note 2

If not otherwise specified in the related standard and regulation:

NOTE 1: The maximum emissions at the border from OFR ( $f_L$  and  $f_H$ ) to OOB domain will be derived from the regulated limit (OFR definition), see related standard and reference regulation.

NOTE 2: The requirement at  $f_{LS}$  and  $f_{HS}$  are part of the spurious domain.

The relevant parameters to determine the OOB and spurious domain can be calculated based the measured values  $f_H$  and  $f_L$  from clause 5.2 and on specified values  $X_{TXUE}$  (in %) from the centre frequency of the OFR:

- Calculation centre frequency of the OFR, see equation (18):

$$f_C = \left( \frac{f_L + f_H}{2} \right) \quad (18)$$

- Operating frequency range (see clause 5.2), calculated with equation (19):

$$\text{OFR} = f_H - f_L \quad (19)$$

- Calculation  $f_{LS}$  (low boundary between spurious and OOB domain), see equation (20):

$$f_{LS} = f_C - \left( \frac{X_{TXUE} [\%]}{100\%} \times \text{OFR} \right) \quad (20)$$

- Calculation  $f_{HS}$  (high boundary between spurious and OOB domain), see equation (21):

$$f_{HS} = f_c + \left( \frac{X_{TXUE} [\%]}{100\%} \times OFR \right) \quad (21)$$

NOTE 1: The dimension for the frequencies and bandwidths in the above equations needs to be equal, e.g. MHz.

For wideband and Ultra Wide Band systems, the boundary value ( $X_{TXUE}$  (in %)) can vary and will be provided in the related harmonised standard. Unless otherwise specified in the related standard,  $X_{TXUE}$  shall be set to 250 % of OFR.

NOTE 2: According to ERC/REC 74-01 [i.9], and Recommendation ITU-R SM.329-12 [i.10], the boundary between the out-of-band and spurious domains is  $\pm 250\%$  of the Operating Frequency Range (OFR) from the centre frequency of the emission.

## 5.5.2 Limits for the TX Unwanted Emission

The limits for the OOB-domain and spurious domain below shall apply unless otherwise specified in the related standard, see table 4 and table 5.

For the TX unwanted emission limits for EUT's under ECC/DEC/(22)03 [i.40] see annex G. The unwanted emission limits are different to the generic limits specified in ERC/REC 74-01 [i.9], see table 4. The specific requirements shall be considered in the related standard.

**Table 4: Spurious emissions limits in line with ERC/REC 74-01 [i.9]**

Frequency range	Limit values for TXUE (note)
$87,5 \text{ MHz} \leq f \leq 118 \text{ MHz}$	-54 dBm/100 kHz
$174 \text{ MHz} \leq f \leq 230 \text{ MHz}$	-54 dBm/100 kHz
$470 \text{ MHz} \leq f \leq 694 \text{ MHz}$	-54 dBm/100 kHz
otherwise in band $30 \text{ MHz} \leq f \leq 1\,000 \text{ MHz}$	-36 dBm/100 kHz
$1\,000 \text{ MHz} < f \leq F_{\text{upper}}$ (see table 5)	-30 dBm/1 MHz
NOTE: Not applicable for RP emissions within the OFR. The limits are mean power averaged over the burst duration	

**Table 5: Lower and upper frequency for the spurious emissions test based on the EUT OFR in line with ERC/REC 74-01 [i.9]**

Fundamental frequency range defined by $f_L$ and $f_H$ (note 2)	Frequency range for measurements	
	Lower frequency ( $F_{\text{LOWER}}$ ) (note 3)	Upper frequency ( $F_{\text{UPPER}}$ )
$300 \text{ MHz} \leq f < 600 \text{ MHz}$	30 MHz	3 GHz
$600 \text{ MHz} \leq f < 5,2 \text{ GHz}$	30 MHz	5 <sup>th</sup> harmonic (note 1)
$5,2 \leq f < 13 \text{ GHz}$	30 MHz	26 GHz
$13 \leq f < 150 \text{ GHz}$	30 MHz	2 <sup>nd</sup> harmonic (note 1)
$150 \leq f < 300 \text{ GHz}$	30 MHz	300 GHz
NOTE 1: $F_{\text{UPPER}}$ is the stated harmonic of $f_H$ (the upper edge of the OFR, which is measured in clause 5.2).		
NOTE 2: $F_{\text{LOWER}}$ has to be selected based on $f_L$ and $F_{\text{UPPER}}$ based on $f_H$ ( $f_L$ and $f_H$ can be measured according to clause 5.2); for receive only devices $f_H$ and $f_L$ of the related EUT/companion device shall be used.		
NOTE 3: For EUT operating below 300 MHz the spurious emissions limits below 30 MHz shall be specified in the related standard.		

## 5.5.3 Conformance Test for TX Unwanted Emission

### 5.5.3.1 Conformance Test for the Spurious domain of TX Unwanted Emission

#### 5.5.3.1.1 General

The spurious emission part of the TX unwanted emission of the EUT, at a particular frequency is in a given for any direction around the EUT.



The following conformance test shall be used for spurious emission part of the TX unwanted emissions, if not otherwise specified in the related standard.

In addition the related standard shall specify the test setup (see clause B.1). The conformance test for TX unwanted emission shall be used to measure/assess the emission in each direction around the EUT as specified in the related standard (see test setups in clause B.1).

The conformance test for the spurious domain shall be performed in two steps:

NOTE 1: The split in two steps is done because: a complete scan with RMS could take a long time. The measurement with peak detector is an "overestimation" of the emission and is only to find the frequencies with the highest emissions.

- **Step 1:** pre-scan with peak detector (see clause 5.5.3.2).
- **Step 2:** RMS measurement.

Depending on the specified averaging time for the RMS measurement there are two different conformance tests specified. The related standard shall specify which Step 2 (Step 2a or Step 2b) applies for which frequency range.

- Step 2a: for RMS measurement (see clause 5.5.3.1.3) over burst duration of the emission.
- Step 2b: RMS measurement (see clause 5.5.3.1.4) over signal repetition/measurement cycle of the device.

NOTE 2: Difference between Step 2a and Step 2b: Step 2b is for the measurement of the unwanted emissions is only for some EUT covered by ECC/DEC/(22)03 [i.40]. In the related standard it is necessary to specify which Step 2 is relevant based on the TX-unwanted domain requirement related rules in the decision. Step 2a is applicable for all other tests if not otherwise specified in the related standard.

#### 5.5.3.1.2 Step 1: Measurement with Peak Detector

The spectrum analyser shall be connected to the measurement antenna (see clause B.2.2.5).

The following spectrum analyser settings shall be used:

- For TXUE measurement below OFR:
  - Start frequency:  $F_{\text{LOWER}}$
  - Stop frequency:  $f_{\text{LS}}$
- For TXUE measurement above OFR
  - Start frequency:  $f_{\text{HS}}$
  - Stop frequency:  $F_{\text{UPPER}}$

NOTE 1: There could be a need to split the measurement into different frequency ranges depending on the measurement set-up (e.g. external mixers, bandwidth of antennas and waveguides, RBW).

For both measurements:

- Resolution BandWidth (RBW):
  - $\geq 100$  kHz between 30 MHz and 1 GHz
  - $\geq 1$  MHz above 1 GHz
- Video BandWidth: VBW equal or greater than the RBW
- Detector mode: Peak
- Trace mode: Max.Hold
- Measurement Time: Larger than one EUT signal repetition time (see annex C)

- Sweep time: Measurement time  $\times$  number of measurement points
- Number of measurement points: At least equal to frequency span divided by RBW, see equation (22)

$$\text{Number of measurement points} \geq \frac{\text{Frequency Span}}{\text{RBW}} \quad (22)$$

NOTE 2: The peak detector is sensitive to corruption by events occurring only once or for a very small amount of time by different devices than the EUT.

#### Assessment of step 1:

Compare the measurement results with the limit (see related standard and table 4) and record the frequencies where the limit is exceeded. For these frequencies go to Step 2 (clause 5.5.3.1.3 or clause 5.5.3.1.4, depending specification in related standard).

#### 5.5.3.1.3 Step 2a: RMS assessment over Burst duration ( $T_{on}$ )

The spectrum analyser shall be connected to the measurement antenna (see clause B.2.2.5).

- Set the spectrum analyser to zero span mode
- Resolution Bandwidth (RBW):
  - 100 kHz between 30 MHz and 1 GHz
  - 1 MHz above 1 GHz
- Video Bandwidth: VBW equal or greater than the RBW
- Detector mode: Peak
- Trace mode: Clear write
- Averaging time: Burst duration (if not otherwise specified in the related standard)

NOTE: See definition of continuous transmissions, burst transmission and burst duration in annex C.

- Sweep time: Burst duration
- Procedure:

Step 2a-1: Set the spectrum analyser to the first recorded frequency from step 1 (clause 5.5.3.1.2).

Step 2a-2: Measure and record the spurious emission value over the sweep time.

Step 2a-3: Calculate the RMS value over the burst duration, using the post processing capability (e.g. RMS time domain power) function of the spectrum analyser.

Step 2a-4: Compare the calculated result with the limit (see related standard and table 4).

Step 2a.5: Repeat step 2a-2 to step 2a-4 for all frequencies from step 1 (clause 5.5.3.1.2).

The measurement results shall be recorded and shall be assessed against limits in table 4 or the limits in the related standard.

#### 5.5.3.1.4 Step 2b: RMS assessment over signal repetition/measurement cycle

The spectrum analyser shall be connected to the measurement antenna (see clause B.2.2.5).

- Set the spectrum analyser to zero span mode
- Resolution Bandwidth (RBW):
  - 100 kHz between 30 MHz and 1 GHz
  - 1 MHz above 1 GHz

- Video Bandwidth (VBW): VBW equal or greater than the RBW
- Detector mode: Peak
- Trace mode: Clear write
- Averaging time: Signal repetition time/measurement cycle

NOTE: See signal definition in annex C.

- Sweep time: Signal repetition time/measurement cycle
- Procedure

Step 2b-1: Set the spectrum analyser to the first recorded frequency from step 1 (clause 5.5.3.1.2).

Step 2b-2: Measure and record the spurious emission value over the sweep time.

Step 2b-3: Calculate the RMS value over the signal repetition time/measurement cycle, using the post processing capability (e.g. RMS time domain power) function of the spectrum analyser.

Step 2b-4: Compare the calculated result with the limit (see related standard and table 4).

Step 2b-5: Repeat step 2b-2 to step 2b-4 for all frequencies from step 1 (clause 5.5.3.1.2).

The measurement results shall be recorded and shall be assessed against limits in table 4 or the limits in the related standard.

### 5.5.3.2 Conformance Test for the OOB domain of TX Unwanted Emission

#### 5.5.3.2.1 General

The OOB emission part of the TX unwanted emission of the EUT, at a particular frequency is in a given for any direction around the EUT.

The following conformance test shall be used for OOB part of TX unwanted emissions, if not otherwise specified in the related standard.

In addition the related standard shall specify the test setup (see clause B.1). The conformance test for TX unwanted emission shall be used to measured/asses the emission in each direction around the EUT as specified in the related standard (see test setups in clause B.1).

#### 5.5.3.2.2 Conformance test

The spectrum analyser shall be connected to the measurement antenna (see clause B.2.2.5).

The following spectrum analyser settings shall be used:

- For the measurement below OFR:
  - Start frequency:  $f_{LS}$

NOTE 1: The emission directly at  $f_{LS}$  will be measured during the spurious emission measurement, see clause 5.5.3.1.

- Stop frequency:  $f_L$

NOTE 2: The emission directly at  $f_L$  will be measured during the OFR measurement, see clause 5.2 and as specified in the related standard.

- For the measurement above OFR:
  - Start frequency:  $f_H$

NOTE 3: The emission directly at  $f_H$  will be measured during the OFR measurement, see clause 5.2 as specified in the related standard.

- Stop frequency:  $f_{HS}$

NOTE 4: The emission directly at  $f_{HS}$  will be measured during the spurious emission measurement, see clause 5.5.3.1.

- For both measurements:
  - For the listed settings parameters below the same setting as for the in band emission test shall be used (if not otherwise specified in the related standard).
  - RBW: see related standard.
  - Video bandwidth: equal or greater than the RBW.
  - Detector mode: see related standard.
  - Display mode: see related standard.
  - Average Time: see related standard.
  - Number of measurement points: see related standard.
  - Sweep Time: see related standard.
  - Wait for each measurement until the reading in the display is stable.

The measurement results shall be recorded and shall be assessed against limits in table 4 (if not otherwise specified in related standard).

## 5.6 Total Radiated Power (TRP)

### 5.6.1 Introduction

SRD/UWB or mmW technology-based devices are mainly highly integrated and therefore do not provide an antenna connector and therefore the emissions could only be measured radiated.

The highly integration as has several reasons, e.g.:

- size of the device based on the intended use (handheld/mobile); or
- the integration into another device (combined device/hitting mounting);
- to reach a good antenna matching over the large OFR.

Therefore, there is a need to specify a requirement to limit the TX-output power on the one side, but this requirement shall be assessable via radiated test. This real radiated power is also the power which could cause interference to other radio devices.

Therefore, the related radio regulation requires a limit for the transmitter output power or specifies directly the Total Radiated Power ( $TRP_{XX}$ ).

For those reasons a limitation of:

- the total radiated Mean e.i.r.p. power ( $TRP_{MP}$  based on Mean e.i.r.p. power see clause 5.3.1);
- total radiated Peak power ( $TRP_{PP}$  based on Peak e.i.r.p. power see clause 5.3.3); or
- the Total Radiated Power Spectral Density ( $TRP_{SD}$  based on Mean e.i.r.p. spectral density, see clause 5.3.2);

could be used as a the requirement for the EUT.

## 5.6.2 Description of Total Radiated Power (TRP<sub>XX</sub>)

Total Radiated Power (TRP<sub>XX</sub>) is a Radio Frequency (RF) engineering term used to describe the sum of all power radiated by an antenna connected to a transmitter. Total Radiated Power is closely related to the efficiency of the antenna and is in fact tied to the definition of efficiency.

In figure 12 the relation between TX output power (P<sub>TX</sub>) and TRP<sub>XX</sub> is shown:

- TRP<sub>XX</sub> is comparable to the related radiated Output Power (Mean e.i.r.p. (see clause 5.3.1), Peak e.i.r.p. (see clause 5.3.3) or Mean e.i.r.p. spectral density (see clause 5.3.2)), or named as P<sub>out</sub>.
- TX<sub>out</sub> is the transmitter output power.
- Antenna efficiency (η) of the antenna, is the ratio of output power to input power, see equation (23a) and figure 12.

$$\eta = \frac{TRP_{XX}}{P_{OUT}} \quad (23a)$$

With:

- TRP<sub>XX</sub> is expressed in terms of power: Watts (W), milliwatts (mW), or the logarithmic terms for W and mW (dBW, dBm, dBm/MHz).
- Antenna efficiency is expressed either in percentage or dB.

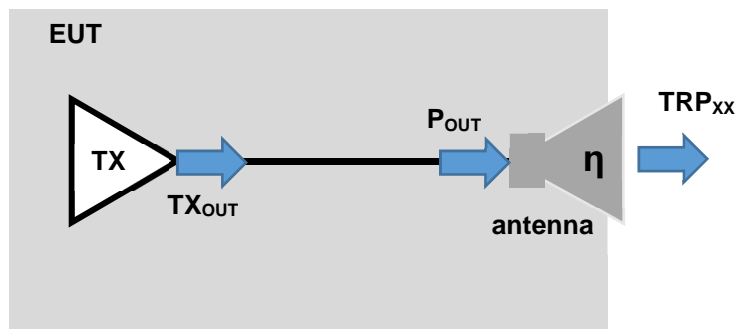

**Figure 12: Relation TRP<sub>XX</sub> with Transmitter output power (TXout)**

In reality there will be some losses between the transmitter output and the radiated power, and therefore the transmitter output is higher than the real radiation. These losses are expressed by the antenna efficiency η. For simplification (worst case) these losses will be set to zero and it is assumed that the antenna has an efficiency of 100 %, η = 1. This leads to the following simplified relation, see equation (23b):

$$TRP_{XX} = P_{OUT} = TX_{OUT} \quad (23b)$$

An additional relation of the TRP<sub>XX</sub> could also be given with the antenna directivity/antenna gain. This would also allow to specify/regulate a minimum antenna gain in the regulation.

In case the directivity D<sub>ant</sub> of the transmit antenna including all surrounding parts is known, the TRP<sub>XX</sub> derives from the radiation e.i.r.p. (based on kind of power, e.g. Mean e.i.r.p., Peak e.i.r.p. or Mean e.i.r.p. spectral density), the following way, see equation (24):

$$TRP_{XX} = \frac{e.i.r.p.}{d_{ant}} \quad (24)$$

Where e.i.r.p. means the complete radiated power (based on mean power, peak power or mean power spectral density measurements) in all directions.

As an example in figure 13, the directivity is 9,3 dBi and the 0 dBi circle represents the TRP<sub>XX</sub>. As an example for an e.i.r.p. of -55,7 dBm/MHz the TRP<sub>SD</sub> derives to -65 dBm/MHz. For a lossless antenna the gain G equals the directivity D<sub>ant</sub>. This example is taken from ETSI TR 103 181-2 [i.14].

For real antennas the gain equals, see equation (25):

$$g = \eta \cdot d_{ant} \tag{25}$$

where  $\eta$  is the efficiency of the antenna.

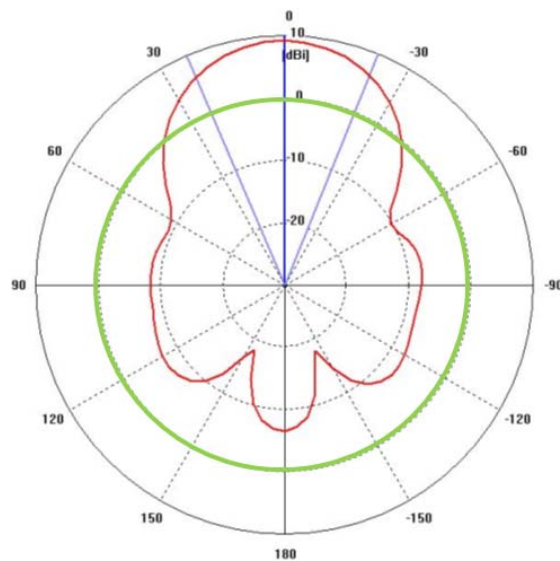

**Figure 13: Example radiation pattern of an antenna in free-space with a directivity of  $d_{ant} = 9,3$  dBi**

An additional example is shown in figure 14 which is for an 10 dBi patch antenna.

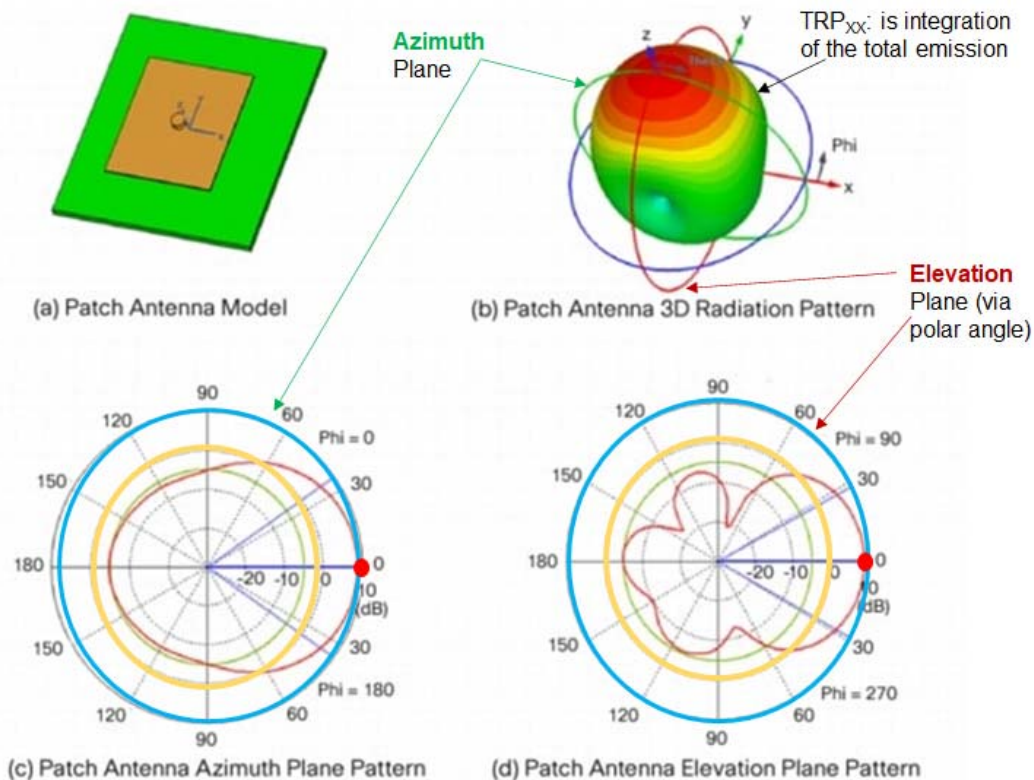

- Blue circle:** max regulated limit
- Red curve:** max real emission of the device
- Red dot:** point where the device reaches the max regulated limit (worst case assumption)
- Orange line:** calculated  $TRP_{xx}$  value

**Figure 14: Connection between Total Radiated Power ( $TRP_{xx}$ ) (example has an antenna gain of 10 dBi)**

### 5.6.3 General TRP<sub>XX</sub> assessment based on radiated (e.i.r.p.) measurement

The Total Radiated Power (TRP<sub>XX</sub>) of the EUT is the integration of the time-averaged power flux density  $S$  of the EUT emissions across the entire spherical surface enclosing the EUT. The result of this measurement is the effective radiated TX power taking into account the antenna efficiency.

Measuring the electric field strength, the average power flux density is given by equation (26):

$$S = \frac{|E_{\text{RMS}}|^2}{Z_{F0}} \quad (26)$$

with:

$Z_{F0} = 120\pi\Omega$  represents the wave impedance of free space.

The RMS value of the field strength can be obtained using equation (27):

$$E_{\text{RMS}} = \frac{|E|}{\sqrt{2}} \quad (27)$$

with:

$|E|$  is the amplitude of the electric field.

Using a spectrum analyser, the power flux density is given by equation (28):

$$S = \frac{P_r}{A_r} \quad (28)$$

with:

- $P_r$  is the radiated power [W] of the EUT in a certain direction; and
- $A_r$  is the effective area of the receiving antenna.

The Total Power is then given by equation (29), see figure 15:

$$\text{TRP}_{XX} = \int_{\theta=0}^{\pi} \int_{\phi=0}^{2\pi} S \times r^2 \times \sin(\theta) \, d\theta \, d\phi \quad (29)$$

with:

- $r$  is the radius of the sphere;
- $\theta$  is the polar angle;
- $\phi$  is the azimuth angle.

And with the measured radiated emissions ( $P_{\theta,\phi}$ ), see equation (230):

$$\text{TRP}_{XX} = \int_{\theta=0}^{\pi} \int_{\phi=0}^{2\pi} \frac{P_{\theta,\phi}}{A_r} \times r^2 \times \sin(\theta) \, d\theta \, d\phi \quad (30)$$

with:

- Radiated emission  $P_{\theta,\phi}$  measurement (recorded) one points of the sphere depending on the steps of  $\theta$  and  $\phi$  and the kind of power, in [W].
- $r$  is the radius of the sphere/measurement distance.
- $\theta$  is the polar angle.
- $\phi$  is the azimuth angle.

- $A_r$  is the effective area of the receiving antenna (measurement antenna).

When measuring the Total Radiated Power in an anechoic chamber and measuring the EIRP (in [W]) at every angle, and then averaging it over the sphere (recall that the surface area of a sphere is  $4\pi$ ). TRP can be calculated from EIRP (in [W]) see equation (31):

$$TRP_{XX} = \frac{1}{4\pi} \int_{\Theta=0}^{\pi} \int_{\Phi=0}^{2\pi} (EIRP_{XX}(\Theta_n, \Phi_m)) \times \sin(\Theta) d\Theta d\Phi \quad (31)$$

with:

- $EIRP_{XX,\Theta,\Phi}$  : kind of radiated e.i.r.p. emission measurement considering both "polarisations" (recorded) one point of the sphere depending on  $\Theta$  and  $\Phi$  and the kind of power, in [W].
- $\Theta$  is the polar angle.
- $\Phi$  is the azimuth angle.

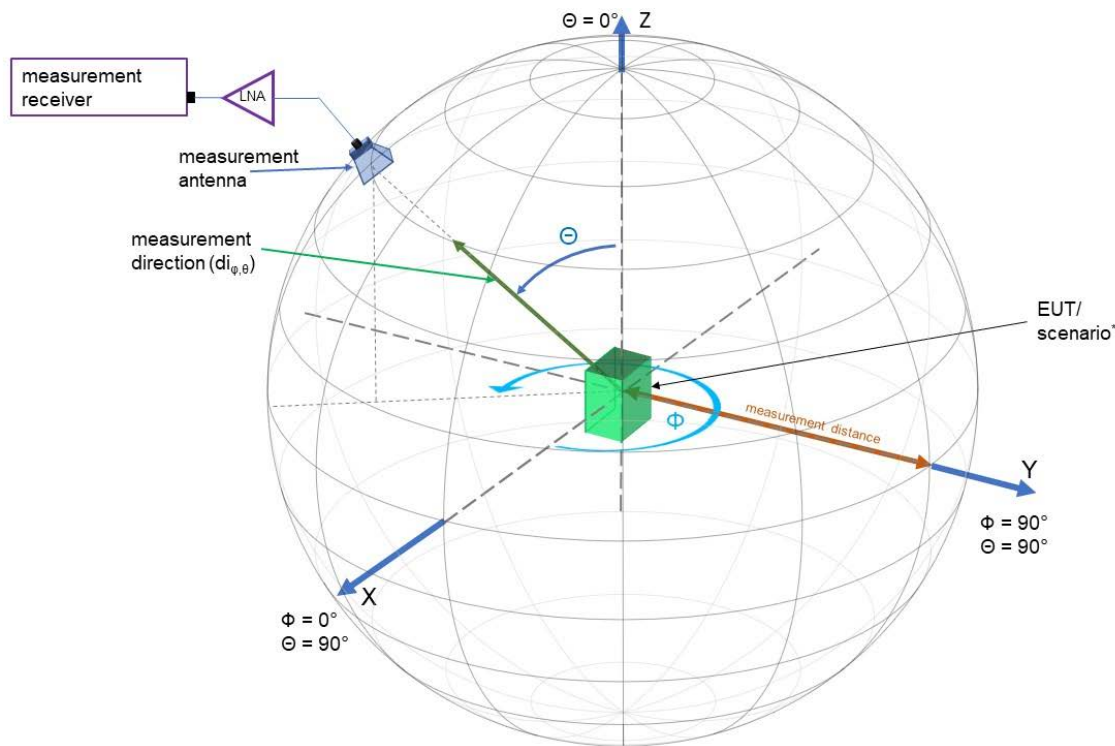

\* EUT/scenario: could be a single device or a complex scenario (e.g. indirect emissions, see clause 5.7).

**Figure 15: Schematic TRP measurement and angle definition (Azimuth and Polar Angle)**

Assuming that the EIRP measurement will be on angular steps (see figure 16)  $N/M$  even steps between  $0^\circ$  and  $180^\circ$ , with  $\theta_0 = 0^\circ$ ,  $\theta_N = 180^\circ$ ,  $\phi_0 = 0^\circ$ , and  $\phi_M = 360^\circ$ , then the total surface integral can be calculated from the following equation (32):

$$TRP_{XX} = \frac{\pi}{2NM} \sum_{n=0}^{N-1} \sum_{m=0}^{M-1} (EIRP_{XX}(\Theta_n, \Phi_m)) \times \sin \Theta_n \quad (32)$$

EIRP is measured at each spherical point (considering both polarizations) for a total of  $N \cdot M$  measurement points.

NOTE: That the  $\theta_0 = 0^\circ$ ,  $\theta_N = 180^\circ$  points do not actually appear in the sum. That is because the  $\sin(\Theta)$  term at each of those points is zero.



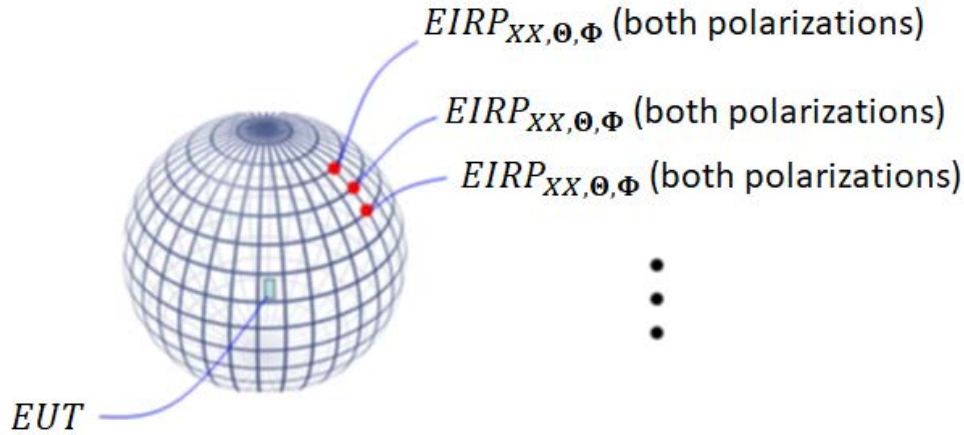

**Figure 16: Example to show a uniform TRP measurement grid (regular angular steps for both angles)**

If EIRP is measured in [dB] ( $eirp_{XX}$ ) and the measurement is based on a uniform grid (see figure 16) on the coordinate, the equation (33) can be as simple as follows:

$$TRP_{XX} \approx \frac{1}{NM} \sum_{n=1}^N \sum_{m=0}^{M-1} eirp_{XX}(\theta_n, \Phi_m) \quad (33)$$

More detailed (considering both polarizations), see equation (34):

$$TRP_{XX} \approx \frac{1}{NM} \sum_{n=1}^N \sum_{m=0}^{M-1} ((eirp_{\theta_{XX}}(\theta_n, \Phi_m)) + (eirp_{\Phi_{XX}}(\theta_n, \Phi_m))) \quad (34)$$

With a total number of measurement points (also considering  $\theta_0 = 0^\circ$ ,  $\theta_N = 180^\circ$ ), see table 4 and equation (35):

$$TRP_{XX} \approx \frac{1}{Z} \sum_{z=1}^Z eirp_{XX}(\theta_z, \Phi_z) \quad (35)$$

with:

- $z$ : number of measurement point (/Sampling points on spherical surface), as example see figure 16 and the total number for  $Z$  are listed in table 6.

**Table 6: Number of measurement point  $Z$ , based on angular step width**

$\Delta\theta$	$\Delta\Phi$	<b>Z = measurement points based on angular steps (N*M) + 2 @ <math>\theta_0 = 0^\circ</math>, <math>\theta_N = 180^\circ</math></b>
90°	90°	4+2
45°	45°	24+2
30°	30°	52+2
<b>15°</b>	<b>15°</b>	<b>264+2 (see note)</b>
10°	10°	612+2

NOTE: The 15 degree steps as specified in clause B.4.2 is sufficient to provide a TRP result with an error less than 0,1 dB (see the literature Sampling points reduction in spherical scanned TRP measurement [i.36]) and figure 16.

Based on the measurement set-up in figure 15 there are two ways to go along the measurement points on the sphere:

- 1) First to go along the polar angle and increase the azimuth angle (step) if one circle around the EUT is measured, also named as great-circle method, see figure 17.

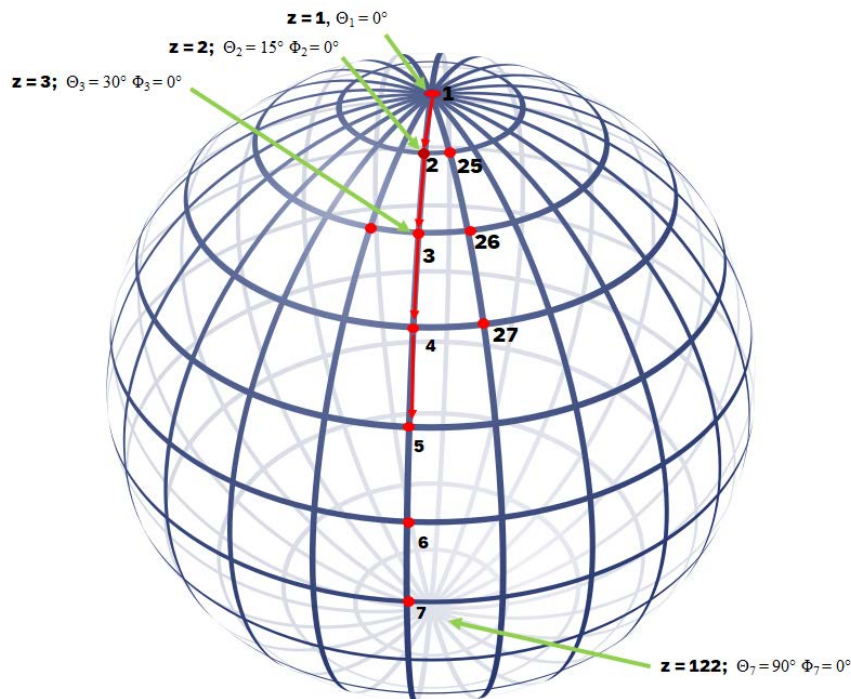

**Figure 17: Measurement points based on the great-circle method**

- 2) Second to measure first azimuth turn and afterwards increase the polar angle by one step, also named conical-section method, see figure 18.

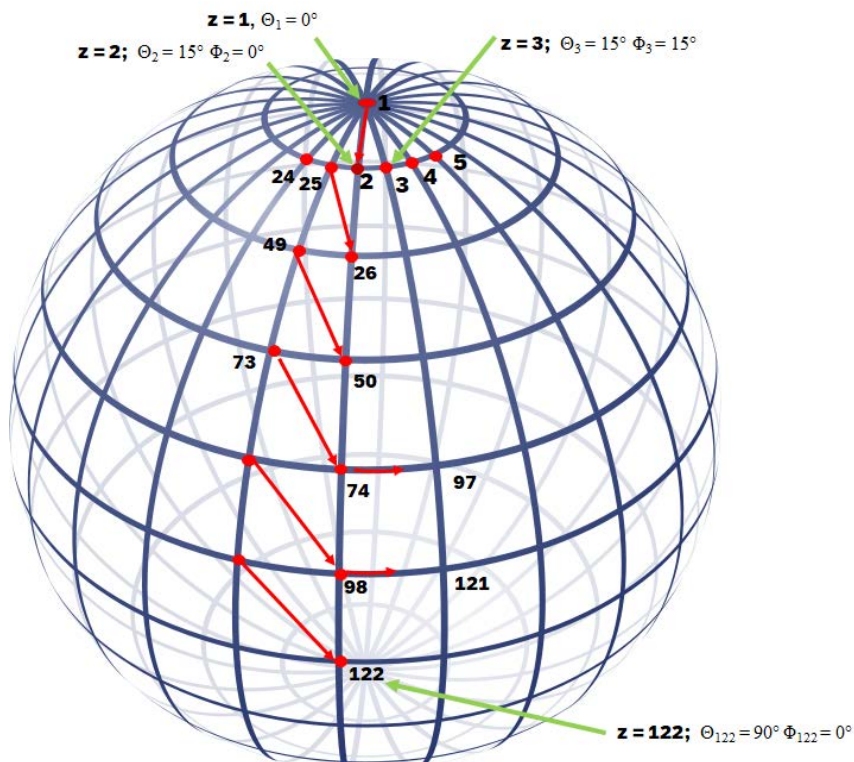

**Figure 18: Measurement points based on the conical-section method**

More details on TRP measurement and background information are provided in the literature Annual Reference Guide 2002 [i.34], EMC'09/Kyoto [i.35] and IEEE 149-2021 [i.38].

## 5.6.4 Conformance Test

### 5.6.4.1 General

The requirements shall be calculated (see equation (28)) based on the recorded radiated e.i.r.p. measurement from clause 5.3.1 (Mean e.i.r.p.) or clause 5.3.2 (Mean e.i.r.p. Spectral Density) or clause 5.3.3 (Peak e.i.r.p.) for each point on the sphere around the EUT. The kind of the power for the TRP<sub>XX</sub> assessment, the angular steps delta  $\Theta$  and delta  $\Phi$  are specified in the related standard.

The radiated power values are required to be recorded for the full half or sphere around the EUT.

NOTE: If the assessment is over the half or full sphere then it is related to the specification of the scenario (see also indirect emissions clause 5.7) in the related standard.

### 5.6.4.2 Total Radiated Mean Power (TRP<sub>MP</sub>) Conformance Assessment in steps

The spectrum analyser shall be connected to the measurement antenna (see clause B.2.2.5).

Step 1: Consider the test scenario for Mean e.i.r.p. requirement (see clause 5.3.1) of the EUT in related standard. If no test scenario is specified in the related standard, a set-up based on figure 15 shall be realized. If not otherwise specified in the related standard a measurement distance of 3 m shall be used.

NOTE 1: For a full spherical test the test could be split into two "half" spherical assessment (see figure 15). After the first half spherical test the EUT device could be turned by 180° in the horizontal plane (see figure 15). For a TRP<sub>MP</sub> measurement, based on the "half" spherical assessment, it has to be considered that the "horizontal plane ( $\Theta = 90^\circ$ ) needs to be measured only on time. As an equivalent alternative the set-up in clause B.4.2, figure B.15 could be used. Also, with this set-up the same emissions (at the same points around the EUT) could be measured. The used set-up depends on the availability in the test house and the frequency range (chamber size).

Step 2: Start with the first emission measurement at one point of the sphere based on the set-up and mechanical orientation of the test system. For the emission measurement use the same Mean e.i.r.p. conformance test (see clause 5.3.1) as specified in the related standard for the RP or indirect emission test (see clause 5.7).

The measurement result shall be recorded.

NOTE 2: Both polarizations need to be considered/measured.

Step 3: Increase one angle by the X°. The value for X is given in the related standard. If no value for X is provided in the related standard, then the value of 15° shall be used.

NOTE 3: The order of the measurement points is depending on the used set-up and based on the set-up manufacturer and the implemented software. It is only important to consider only each measurement point one time. The mainly used implementations are shown in figure 17 or figure 18.

Step 4: Measure the emission as per step 2.

Step 5: Step 3 and step 4 shall be repeated until the complete emissions values on each measurement point around the EUT (see step 1) are measured and recorded.

Step 6: Integrate all recorded measurement results, see equation (36):

$$\text{TRP}_{MP} = \frac{1}{4 \times \pi} \int_{\Theta=0}^{\pi} \int_{\Phi=0}^{2\pi} (\text{EIRP}_{MP}(\Theta_n, \Phi_m)) \times \sin(\Theta) \, d\Theta \, d\Phi \quad (36)$$

with:

- $\text{EIRP}_{MP}(\Theta_n, \Phi_m)$  measurement Mean e.i.r.p. (recorded) in [W] at one point of the sphere depending on the steps of  $\Theta$  and  $\Phi$ .
- $\Theta$  is the polar angle.
- $\Phi$  is the azimuth angle.

NOTE 4: That the  $\Theta_0 = 0^\circ$ ,  $\Theta_N = 180^\circ$  points do not actually appear in the sum in equation (36). That is because the  $\sin(\Theta)$  term at each of those points is zero.

In most of the related standards *Mean e.i.r.p* is specified to be measured in [dBm/MHz] with angular steps  $\Delta\Theta$  and  $\Delta\Phi$  a value of X degrees (see step 3), the  $TRP_{MP}$  can therefore be calculated based on the Mean e.i.r.p. measurement (see equation 37):

$$TRP_{XX} \approx \frac{1}{Z} \sum_{z=1}^Z eirp_{MP}(\Theta_z, \Phi_z) \quad (37)$$

with:

- $eirp_{MP}(\Theta_n, \Phi_m)$  is the measured and recorded Mean e.i.r.p. in [dBm/MHz] (considering both polarizations) at the sphere around the EUT (at the points based on the specified angular steps for  $\Delta\Theta$  and  $\Delta\Phi$ ).

Step 7: Compare the TRPMP result out of equation (37) with the requirement in the related standard.

NOTE 5: If during the radiated Mean e.i.r.p. or indirect emission assessment of the EUT all results will be recorded and the requirement for the angle steps for these test is smaller or similar to the  $TRP_{MP}$  angle requirements, the results can be used to the  $TRP_{MP}$  assessment based on equations (37) and (35). In this case the angular steps of the radiated Mean e.i.r.p. or indirect emission assessment is used (see clause B.4.2).

### 5.6.4.3 Total Radiated Peak Power ( $TRP_{PP}$ ) Conformance Assessment in steps

The spectrum analyser shall be connected to the measurement antenna (see clause B.2.2.5).

Step 1: Consider the test scenario for Peak e.i.r.p. requirement (see clause 5.3.3) of the EUT in related standard. If no test scenario is specified in the related standard, a set-up based on figure 15 shall be realized. If not otherwise specified in the related standard a measurement distance of 3 m shall be used.

NOTE 1: For a full spherical test the test could be split into two "half" spherical assessment (see figure 15). After the first half spherical test the EUT device could be turned by  $180^\circ$  in the horizontal plane (see figure 15). For a  $TRP_{PP}$  measurement, based on the "half" spherical assessment, it has to be considered that the "horizontal plane ( $\Theta = 90^\circ$ ) needs to be measured only on time. As equivalent alternative the set-up in clause B.4.2, figure B.15 could be used. Also, with this set-up the same emissions (at the same points around the EUT) could be measured. The used set-up depends on the availability in the test house and the frequency range (chamber size).

Step 2: Start with the first emission measurement at one point of the sphere based on the set-up and mechanical orientation of the test system. For the emission measurement use the same Peak e.i.r.p. conformance test (see clause 5.3.3) as specified in the related standard for the RP or indirect emission test (see clause 5.7).

The measurement result shall be recorded.

NOTE 2: Both polarizations need to be considered/measured.

Step 3: Increase one angle by the  $X^\circ$ . The value for X is given in the related standard. If no value for X is provided in the related standard, then the value of  $15^\circ$  shall be used.

NOTE 3: The order of the measurement points is depending on the used set-up and based on the set-up manufacturer and the implemented software. It is only important to consider only each measurement point one time. The mainly used implementations are shown in figure 17 or figure 18.

Step 4: Measure the emission as per step 2.

Step 5: Step 3 and step 4 shall be repeated until the complete emissions values on each measurement point around the EUT (see step 1) are measured and recorded.

Step 6: Integrate all recorded measurement results, see equation (38):

$$TRP_{PP} = \frac{1}{4\pi} \int_{\Theta=0}^{\pi} \int_{\Phi=0}^{2\pi} (EIRP_{PP}(\Theta_n, \Phi_m)) \times \sin(\Theta) \, d\Theta \, d\Phi \quad (38)$$

with:

- $EIRP_{PP}(\Theta_n, \Phi_m)$  measurement Peak e.i.r.p. (recorded) in [W] at one point of the sphere depending on the steps of  $\Theta$  and  $\Phi$ .
- $\Theta$  is the polar angle.
- $\Phi$  is the azimuth angle.

NOTE 4: That the  $\Theta_0 = 0^\circ$ ,  $\Theta_N = 180^\circ$  points do not actually appear in the sum in equation (38). That is because the  $\sin(\Theta)$  term at each of those points is zero.

In most of the related standards **Peak e.i.r.p.** is specified to be measured in [dBm/MHz] with angular steps delta  $\Theta$  and delta  $\Phi$  a value of X degrees (see step 3), the  $TRP_{PP}$  can therefore be calculated based on the Peak e.i.r.p. measurement (see equation (39)):

$$TRP_{PP} \approx \frac{1}{Z} \sum_{z=1}^Z eirp_{PP}(\Theta_z, \Phi_z) \quad (39)$$

with:

- $eirp_{PP}(\Theta_n, \Phi_m)$  is the measured and recorded Peak e.i.r.p. in [dBm/MHz] (considering both polarizations) at the sphere around the EUT (at the points based on the specified angular steps for delta  $\Theta$  and delta  $\Phi$ ).

Step 7: Compare the  $TRP_{PP}$  result out of equation (39) with the requirement in the related standard.

NOTE 5: If during the radiated Peak e.i.r.p. or indirect emission assessment of the EUT all results will be recorded and the requirement for the angle steps for these test is smaller or similar to the  $TRP_{PP}$  angle requirements, the results can be used to the  $TRP_{PP}$  assessment based on equations (39) and (35). In this case the angular steps of the radiated Peak e.i.r.p. or indirect emission assessment is used (see clause B.4.2).

#### 5.6.4.4 Total Radiated Mean e.i.r.p. Spectral Density ( $TRP_{SD}$ ) Conformance Assessment in steps

The spectrum analyser shall be connected to the measurement antenna (see clause B.2.2.5).

Step 1: Consider the test scenario for Mean e.i.r.p. Spectral Density requirement (see clause 5.3.2) of the EUT in related standard. If no test scenario is specified in the related standard, a set-up based on figure 15 shall be realized. If not otherwise specified in the related standard a measurement distance of 3 m shall be used.

NOTE 1: For a full spherical test the test could be split into two "half" spherical assessment (see figure 15). After the first half spherical test the EUT device could be turned by  $180^\circ$  in the horizontal plane (see figure 15). For a  $TRP_{SD}$  measurement, based on the "half" spherical assessment, it has to be considered the "horizontal plane ( $\Theta = 90^\circ$ ) needs to be measured only on time. As equivalent alternative the set-up in clause B.4.2, figure B.15 could be used. Also, with this set-up the same emissions (at the same points around the EUT) could be measured. The used set-up depends on the availability in the test house and the frequency range (chamber size).

Step 2: Start with the first emission measurement at one point of the sphere based on the set-up and mechanical orientation of the test system. For the emission measurement use the same Mean e.i.r.p. Spectral Density conformance test (see clause 5.3.2) as specified in the related standard for the RP or indirect emission test (see clause 5.7).

The measurement result shall be recorded.

NOTE 2: Both polarizations need to be considered/measured.

Step 3: Increase one angle by the  $X^\circ$ . The value for X is given in the related standard. If no value for X is provided in the related standard, then the value of  $15^\circ$  shall be used.

NOTE 3: The order of the measurement points is depending on the used set-up and based on the set-up manufacturer and the implemented software. It is only important to consider only each measurement point one time. The mainly used implementations are shown in figure 17 or figure 18.

- Step 4: Measure the emission as per step 2.
- Step 5: Step 3 and step 4 shall be repeated until the complete emissions values on each measurement point around the EUT (see step 1) are measured and recorded.
- Step 6: Integrate all recorded measurement results, see equation (40):

$$TRP_{SD} = \frac{1}{4 \times \pi} \int_{\Theta=0}^{\pi} \int_{\Phi=0}^{2\pi} (EIRP_{SD}(\Theta_n, \Phi_m)) \times \sin(\Theta) \, d\Theta \, d\Phi \quad (40)$$

with:

- $EIRP_{SD}(\Theta_n, \Phi_m)$  measurement Mean e.i.r.p. Spectral Density (recorded) in [W] at one point of the sphere depending on the steps of  $\Theta$  and  $\Phi$ .
- $\Theta$  is the polar angle.
- $\Phi$  is the azimuth angle.

NOTE 4: That the  $\Theta_0 = 0^\circ$ ,  $\Theta_N = 180^\circ$  points do not actually appear in the sum in equation (40). That is because the  $\sin(\Theta)$  term at each of those points is zero.

In most of the related standards Mean e.i.r.p. Spectral Density is specified to be measured in [dBm/MHz] with angular steps  $\Delta\Theta$  and  $\Delta\Phi$  a value of X degrees (see step 3), the  $TRP_{MP}$  can therefore be calculated based on the Mean e.i.r.p. measurement (see equation 41):

$$TRP_{SD} \approx \frac{1}{Z} \sum_{z=1}^Z eirp_{SD}(\Theta_z, \Phi_z) \quad (41)$$

with:

- $eirp_{SD}(\Theta_n, \Phi_m)$  is the measured and recorded Mean e.i.r.p. Spectral Density [dBm/MHz] (considering both polarizations) at the sphere around the EUT (at the points based on the specified angular steps for  $\Delta\Theta$  and  $\Delta\Phi$ ).

Step 7: Compare the  $TRP_{SD}$  result out of equation (41) with the requirement in the related standard.

NOTE 5: If during the radiated Mean e.i.r.p. Spectral Density or indirect emission assessment of the EUT all results will be recorded and the requirement for the angle steps for these test is smaller or similar to the  $TRP_{SD}$  angle requirements, the results can be used to the  $TRP_{SD}$  assessment based on equations (41) and (35). In this case the angular steps of the radiated Mean e.i.r.p. Spectral Density or indirect emission assessment is used (see clause B.4.2).

## 5.7 Indirect Emissions

### 5.7.1 Description

Indirect emissions are radiated in all directions out of a specified scenario (see figure 19), including direct emissions from the housing/structure of the equipment and emissions reflected or passing through a media under inspection or through a scenario. This requirement is also named an exterior limit or undesired emissions.

The indirect emissions measured outside a specified scenario during the transmit mode of the EUT are the sum of:

- Reflections of the radiated power from the transmitter (see clause 5.3) within the scenario.
- Other Emissions (OE) from the transmitter, receiver and other analogue or digital circuitry (see clause 5.4).
- TX Unwanted Emissions (TXUE) from the transmitter (out-of-band and spurious domain, see clause 5.5).

The related limit of the indirect emission and the related source for the requirement (RP, TXUE; OE) and the related test scenario shall be specified in the related standard.

Based on the possible different levels of emission limits it could be necessary that a conformance assessment has to be performed in two steps, see annex D.

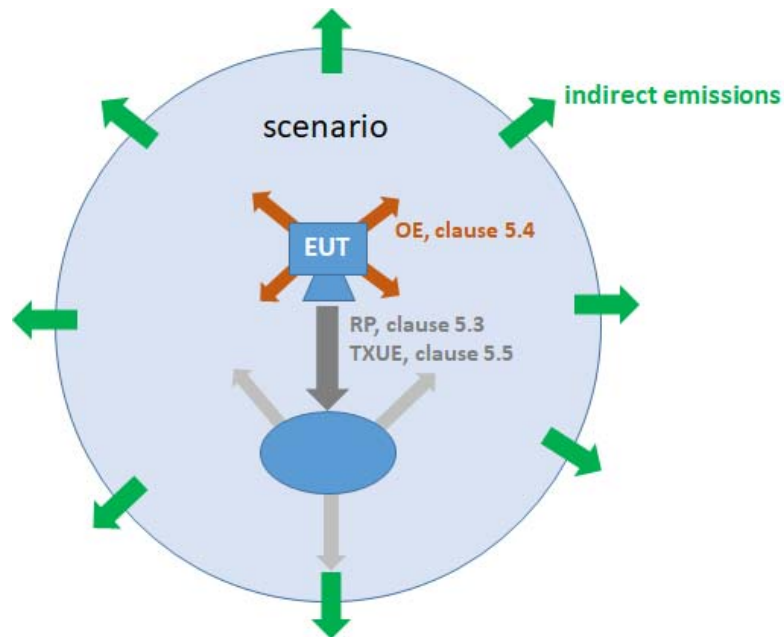

**Figure 19: Indirect emissions**

For GPR/WPR case (see ECC/DEC/(06)08 [i.11]): Indirect emissions are all emissions radiated in all directions above the ground from the GPR/WPR equipment, see figure 20.

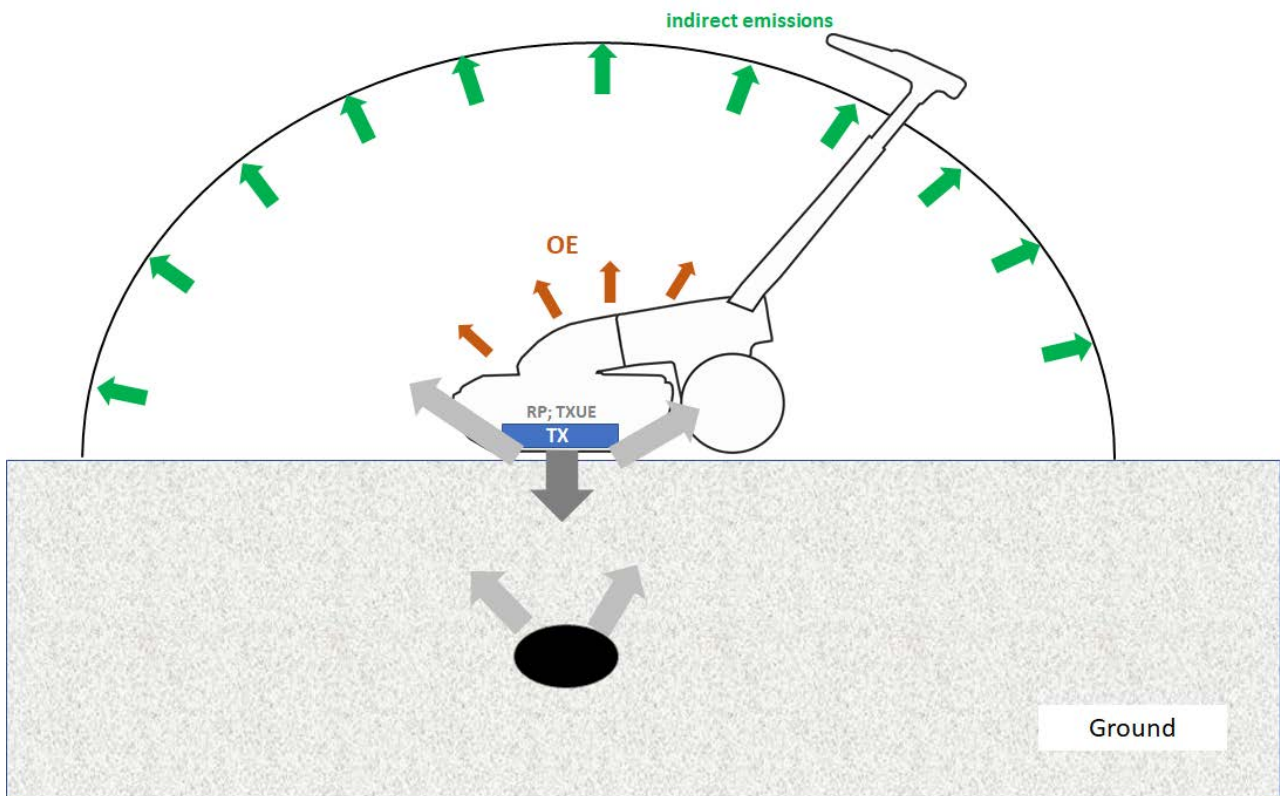

**Figure 20: Indirect emissions for a GPR scenario**

For Tank Level Probing Radar (TLPR, see ETSI EN 302 372 [i.12] or ETSI TR 102 347 [i.25]): Indirect emissions are all emissions radiated in all directions outside a given test tank with an installed EUT, see figure 21.

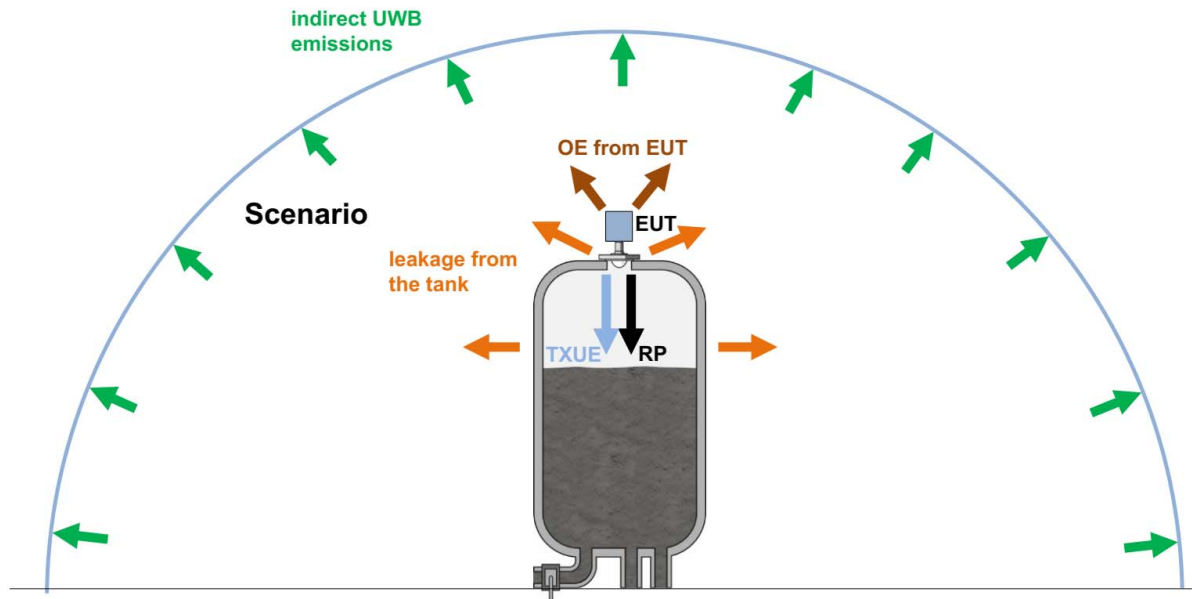

**Figure 21: Illustration of indirect (UWB) emissions for Tank Level Probing Radar (TLPR)**

For Level Probing Radar (LPR, see ECC/DEC/(11)02 [i.6] or ECC Report 139 [i.26]): Indirect emissions are all emissions radiated in all directions outside the LPR scenario. Conformance of indirect emissions can also be fulfilled by measuring in boresight direction following the half-sphere-concept according to ETSI EN 302 729-1 [i.31], see figure 22.

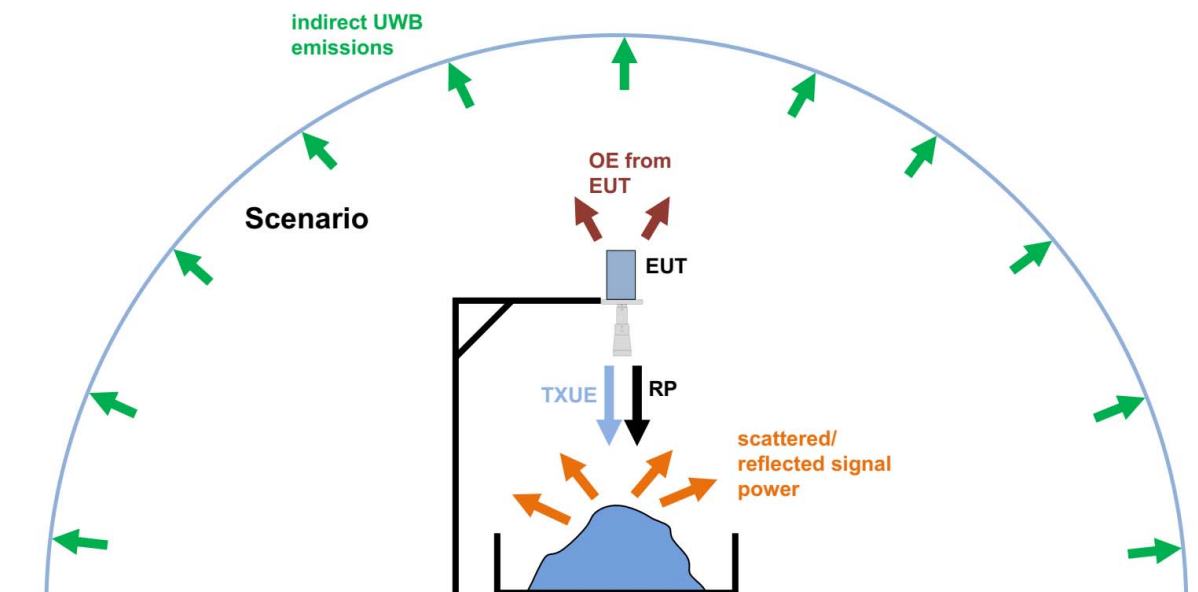
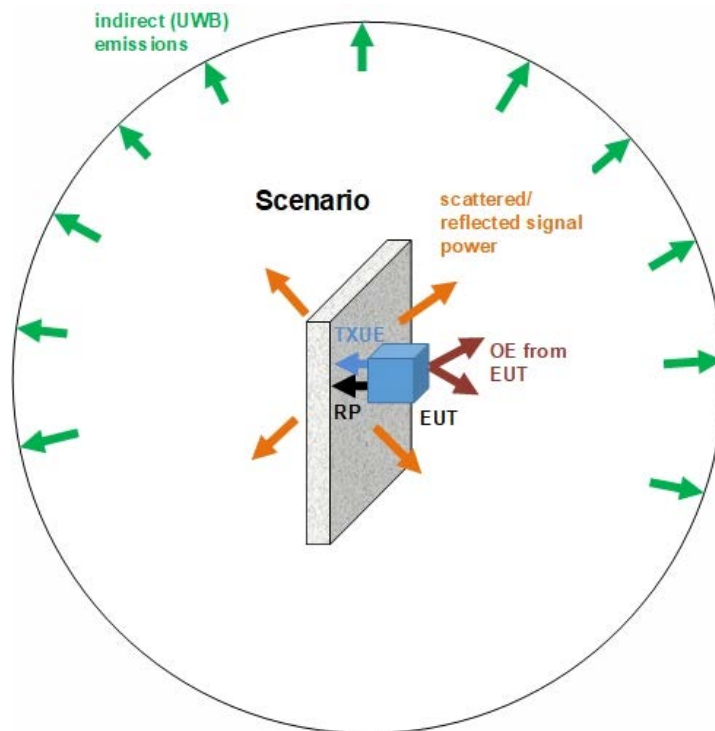

**Figure 22: Illustration of indirect (UWB) emissions for Level Probing Radar (LPR)**

For contact based material sensing devices (see ECC/DEC/(07)01 [i.4]): Indirect emissions are all emissions radiated in all directions outside a given scenario (e.g. sensor on a test wall structure).

One example could be a wall scanning device, see figure 23.

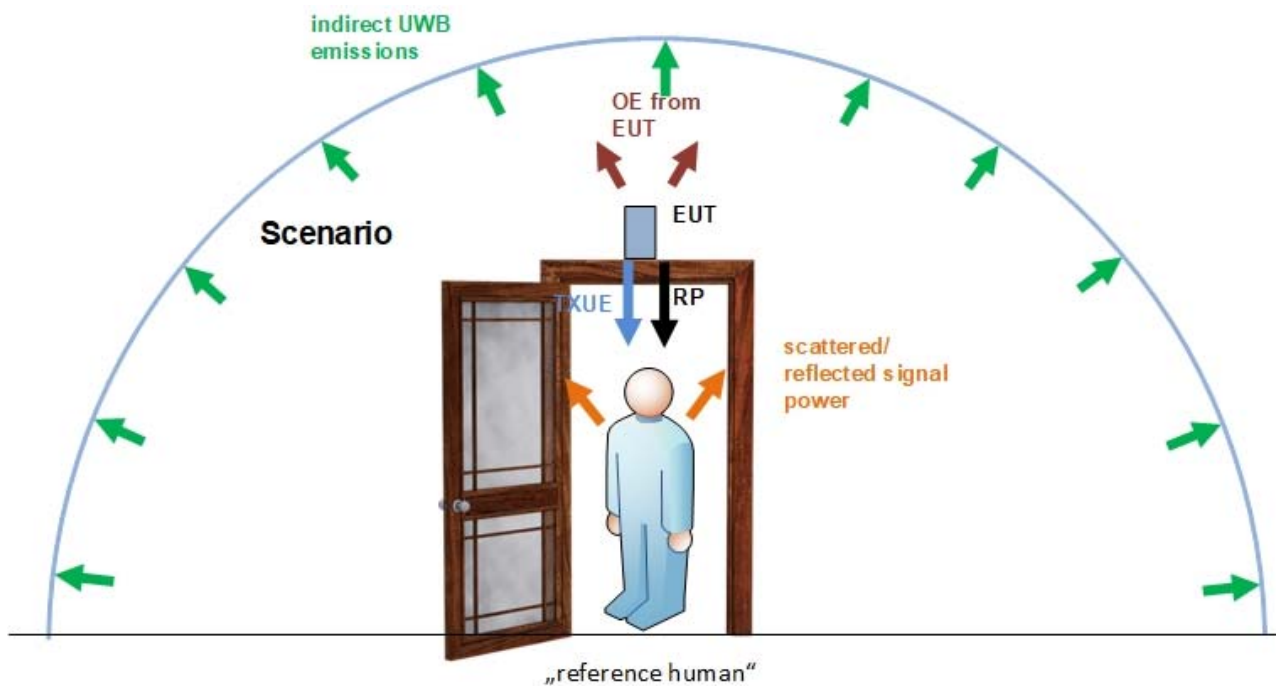



**Figure 23: Illustration of indirect emissions for wall scanning scenario**

For non-contact based material sensing devices (see ECC/DEC/(07)01 [i.4]): Indirect emissions are all emissions radiated in all directions outside a given scenario. The UWB transmitter is only switched on when in close proximity with the investigated material and the UWB transmitter is directed into the direction of the material under investigation (e.g. manually, by using a proximity sensor or by mechanical design).

One example for such scenario could be a security scanning application, see figure 24.



**Figure 24: Illustration of indirect emissions for a security scanning scenario**

For in-vehicular applications (see ECC/DEC/(06)04 [i.3], annex A.1.2): Indirect emissions are all emissions radiated outside the vehicle scenario, see figure 25 and related standard:

- Short explanation:
  - Above the horizontal plane the indirect emissions limit outside the vehicle: -53,3 dBm/MHz.
  - Below the horizontal plane: -41,3 dBm/MHz.

NOTE: A UWB device inside a vehicle is allowed to transmit up to -41,3 dBm/MHz if the exterior limit/indirect emission requirement is fulfilled, see the related standard.

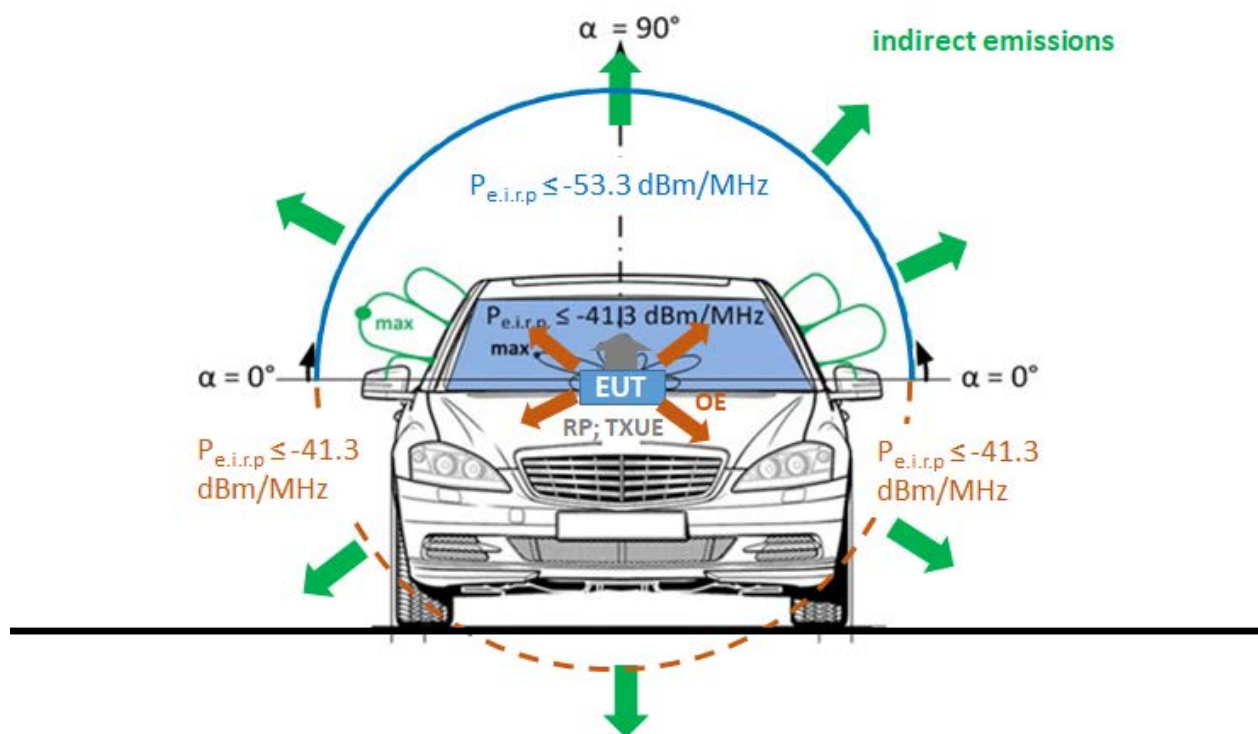

Figure 25: Illustration of indirect emissions for a scenario with EUT inside a vehicle

## 5.7.2 Guidance for Conformance Test

The conformance test is in close relation with the use-cases scenario and the wanted technical performance criteria. Therefore, the conformance test shall be specified in the related standard, see overview in clause 4.1.

For the power measurement the related procedure based on the requested parameter (e.g. mean or peak power) shall be chosen, see clause 5.3.

## 5.8 Transmit Power Control

### 5.8.1 Description

Transmit Power Control (TPC) is a mechanism to be used to ensure an interference mitigation on the aggregate power from a large number of radio devices. The TPC mechanism shall provide the full range from the highest to the lowest power level of the radio device ETSI TR 103 181-2 [i.14]. This could be realized within one step or with an adaptive mechanism. Sometimes this mitigation technique also names as Adaptive Power Control (APC).

## 5.8.2 Guidance for Conformance Test

For TPC mitigation the conformance test is dependent on the wanted technical performance criteria (e.g. RX-requirements) and the use-case of the EUT. Therefore, the conformance procedure for TPC mitigation shall be specified in the related standard.

For the power measurement the related procedure based on the requested parameter (e.g. mean or peak power) shall be chosen, see clause 5.3.

## 5.9 Detect and Avoid

### 5.9.1 Description

The detect and avoid mechanism is an active mitigation technique for the protection of sensitive potential victim systems in the vicinity of the UWB device based on a sensing approach including an active reduction of the interference potential if required (see ETSI TR 103 181-2 [i.14] and ETSI TS 102 754 [1]).

This optional mitigation technique is applicable for EUTs considered under ECC/DEC/(07)01 [i.4] or ECC/DEC/(06)04 [i.3].

### 5.9.2 Limits

#### 5.9.2.1 DAA Parameters

The limits apply for all EUT which implemented Detect and Avoid Mitigation technique for the part(s) of the operating frequency range (see clause 5.2) that overlaps with the DAA frequency ranges (see table 7).

**Table 7: Technical parameters UWB DAA mitigation in line with ECC Report 120 [i.16]**

DAA frequency ranges [GHz]	3,1 - 3,4	3,4 - 3,8	3,8 - 4,8	8,5 - 9
Minimum initial channel availability check time ( $T_{\text{avail\_time\_min}}$ ) [s]	14	5,1		14
Signal test pattern, see ETSI TS 102 754 [1]	clause D.4	clause E.4		clause D.4
$T_{\text{avoid\_max}}$ [s], see ETSI TS 102 754 [1]	150	<ul style="list-style-type: none"> <li>• VoIP: 2</li> <li>• Web surfing: 15</li> <li>• Sleep mode: 60</li> <li>• Multimedia broadcasting: 15</li> </ul>		150
<b>Zone 1</b> for Signal (S) detection level $S > A$				
Maximum mean e.i.r.p. spectral density [dbm/MHz]	-70	-80	-70	-65
Default Avoidance bandwidth [MHz]	300	200		500
Signal Detection threshold A [dBm]	-38	-38		-61
<b>Zone 2</b> for Signal (S) detection level $A > S > B$				
Maximum mean e.i.r.p. spectral density [dbm/MHz]	-41,3	-65		-41,3
Default Avoidance bandwidth [MHz]	-	200		-
Signal Detection threshold B [dBm]		-61		
<b>Zone 3</b> for Signal detection level $S < B$				
Maximum mean e.i.r.p. spectral density [dBm/MHz]	-	-41,3		-
Definitions of the parameters in table 7 can be found in ECC Report 120 [i.16].				

### 5.9.2.2 DAA NIM parameters

**Table 8: Non-Interference Mode (NIM) parameters in the band 3,1 GHz to 9,0 GHz according to ETSI TS 102 754 [1]**

DAA frequency ranges	NIM Power levels (e.i.r.p.)	NIM Power levels (e.i.r.p.) with LDC implemented
3,1 GHz $\leq$ f < 3,4 GHz	-70 dBm/MHz average -36 dBm peak (see note)	-41,3 dBm/MHz average 0 dBm peak Standard LDC parameters as in ECC/DEC/(06)04 [i.3]
3,4 GHz $\leq$ f < 3,8 GHz	-80 dBm/MHz average - 40 dBm peak (see note)	-41,3 dBm/MHz average 0 dBm peak Standard LDC parameters as in ECC/DEC/(06)04 [i.3]
3,8 GHz $\leq$ f < 4,2 GHz	-70 dBm/MHz average -30 dBm peak (see note)	-41,3 dBm/MHz average 0 dBm peak Standard LDC parameters as in ECC/DEC/(06)04 [i.3]
4,2 GHz $\leq$ f $\leq$ 4,8 GHz	-70 dBm/MHz average -30 dBm peak (see note)	-41,3 dBm/MHz average 0 dBm peak Standard LDC parameters as in ECC/DEC/(06)04 [i.3]
8,5 GHz $\leq$ f $\leq$ 9,0 GHz	-65 dBm/MHz average -25 dBm peak (see note)	-41,3 dBm/MHz average 0 dBm peak Standard LDC parameters as in ECC/DEC/(06)04 [i.3]
NOTE: Devices fitted with DAA mitigation may operate to the maximum permissible limit of -41,3 dBm/MHz average and 0 dBm peak.		

### 5.9.2.3 DAA test parameters

If nothing different is specified in the related standard, following values for the test parameters shall be used during the conformance tests (see clause 5.9.3):

- m = 10
- n = 5

## 5.9.3 Conformance Test

### 5.9.3.1 Introduction

In the present clause the test procedure for the DAA test is depicted. The UWB DAA radio device under test shall be verified under normal operational conditions.

The DAA test is split into two main test conditions:

- start-up test with and without victim test signal; and
- in-operation test.

The start-up test verifies the operation of the UWB DAA radio device during the initial start-up when the DAA UWB radio device intends to operate directly in a non NIM. Thus the UWB DAA radio device need to be set in an operational condition in which this is guaranteed. The test verifies that the UWB DAA radio device respects the defined *Minimum Initial Channel availability Check Time*.

The in-operation test is intended to verify the dynamic behaviour of the UWB DAA radio device under test. During this test the UWB DAA radio device under test shall operate in a normal dynamic operational mode.

The radiated test configuration is shown in figure 26 and the conducted test configuration is shown in figure 27.

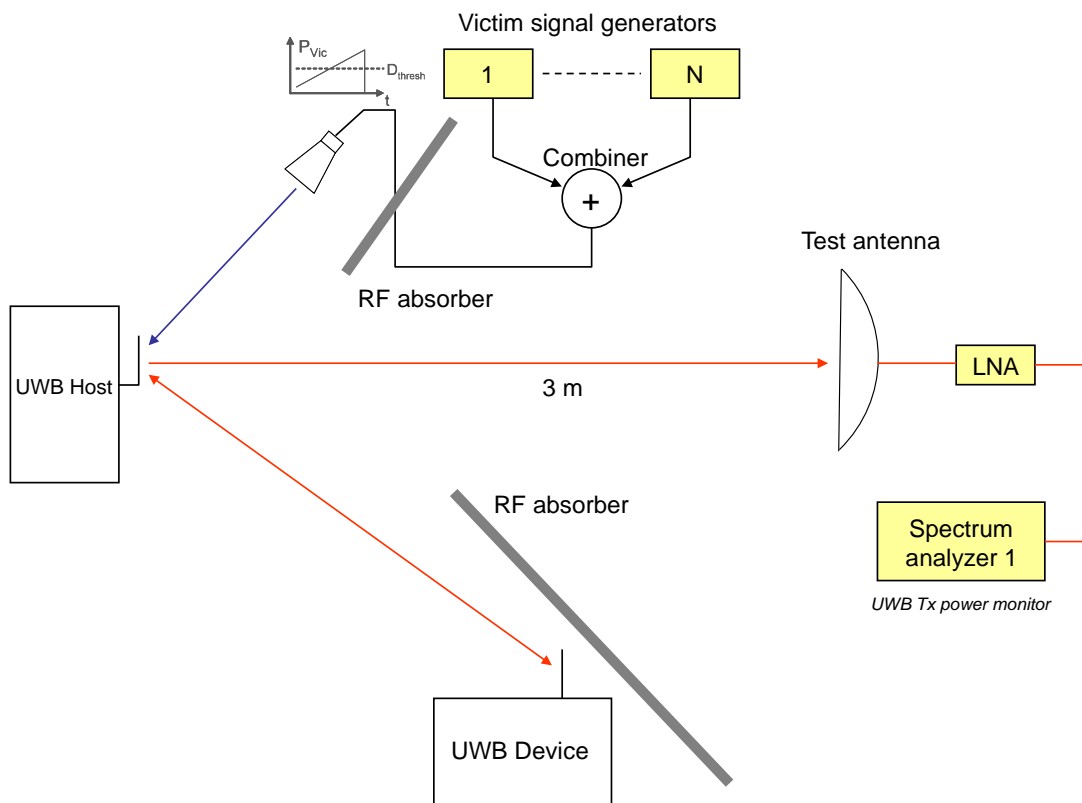

Figure 26: Example Setup for radiated DAA measurements

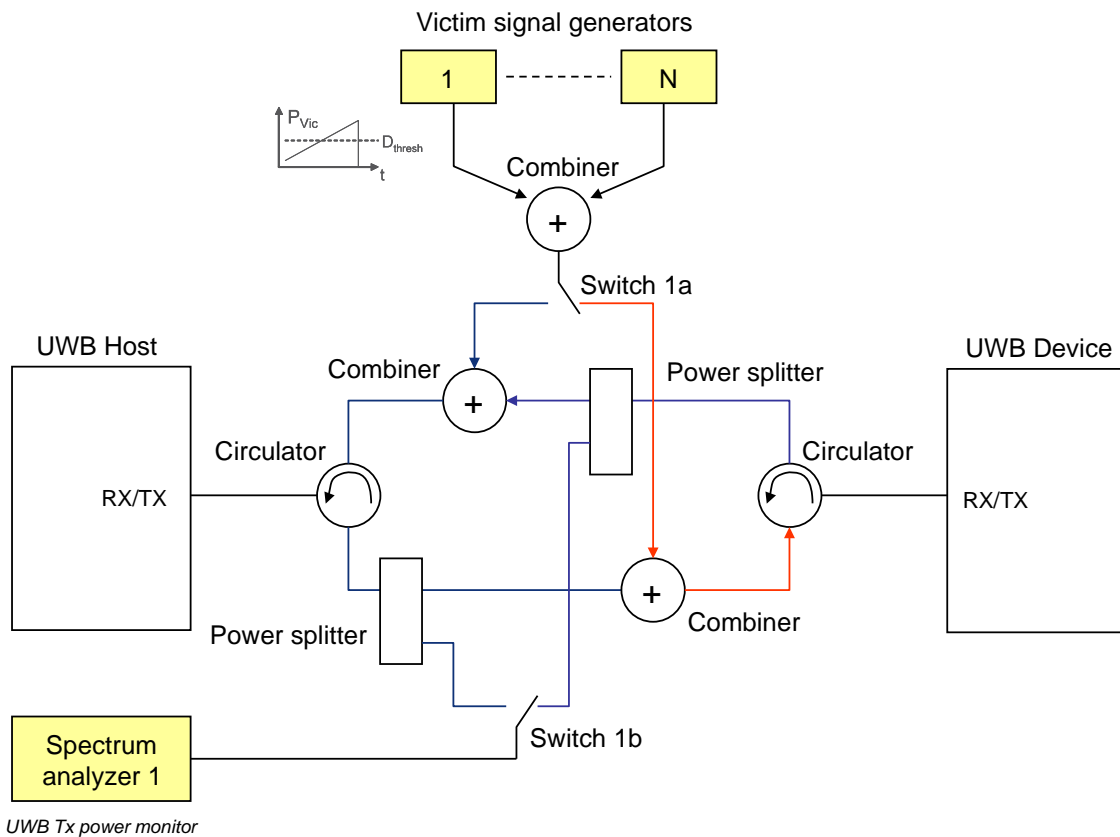

Figure 27: Example Setup for conducted DAA measurements

## 5.9.3.2 Initial Start-Up Test

### 5.9.3.2.1 Start-up Procedure

The clauses below define the procedure to verify the *Minimum Initial Channel Availability Check* by ensuring that the UWB DAA radio device is capable of detecting victim system signals at the beginning and at the end of the *Minimum Channel Availability Check Time*. Furthermore, one initial test shall guarantee that the UWB radio device does not switch out of a NIM operation before the end of the *Minimum Initial Channel Availability Check time*.  $T_{avail\_time\_min}$ .

### 5.9.3.2.2 Test without a victim test signal during the *Minimum Initial Channel Availability Check Time*, $T_{avail\_time\_min}$

Summary:

Verify the UWB DAA radio device will not start transmitting in a non NIM operation before the end of the *Minimum Initial Channel Availability Check Time* when no victim test signal is present. This is illustrated for a radiolocation signal in figure 28.

Pre-test Condition:

- UWB radio device supporting DAA.
- UWB radio device switched off.

Test sequence:

- a) The UWB DAA radio device will be switched off. No signal generator is connected to the test setup or the signal generator is switched off.
- b) The UWB DAA radio device is powered on at  $T_0$ .  $T_1$  denotes the instant when the UWB DAA radio device has completed its power-up sequence ( $T_{power\_up}$ ), enters into a NIM mode, ready to start the victim signal detection.

**CON-1:** The UWB DAA radio device shall not switch into a non-NIM mode before the end of  $T_{avail\_time\_min}$  after switch on of the radio device, where the NIM operation is either the LDC mode or the power level defined in relevant harmonised standards for the relevant victim band.

**NOTE:** Additional verification may be needed to define  $T_1$  in case it is not exactly known or indicated by the UWB DAA radio device. For example,  $T_1$  could be determined by taking into account  $T_{avail\_time\_min}$  and the instance the device switches to a non-NIM mode in clause 5.9.3.2.2 Test without a victim test signal present.

**CON-2:** A timing trace or description of the observed timing and behaviour of the UWB DAA radio device shall be recorded.

- c) Repeat a) and b) for  $n$  times in a row. The values for  $n$  shall be defined in the relevant harmonised standard.

**CON-3:** CON-1 and CON-2 shall be fulfilled in all  $n$  tests. If one failure occurs go to d). For more than one failure the test has not been passed.

- d) Repeat a) and b) for  $m$  times in a row. The values for  $m$  shall be defined in the relevant harmonised standard.

**CON-4:** CON-1 and CON-2 shall be fulfilled in all  $m$  tests.

- e) End of test.

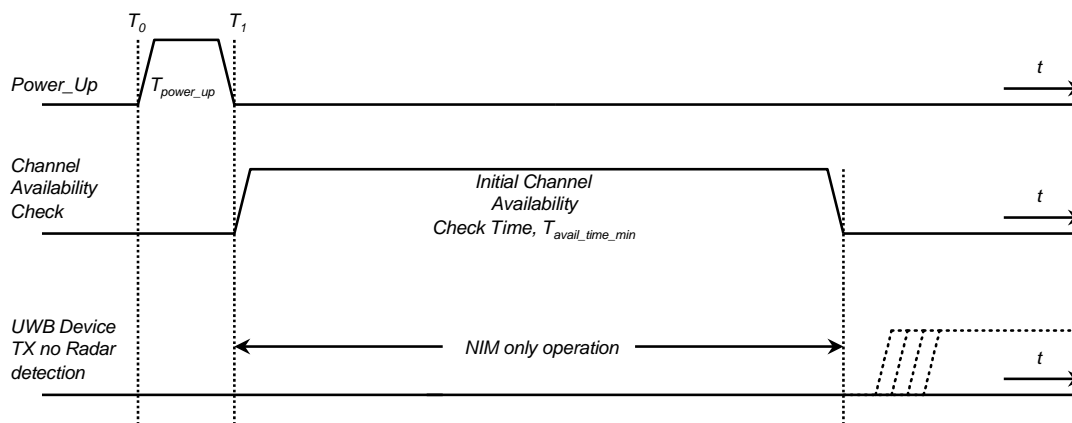

**Figure 28: Example of timing for a radiolocation testing of the Minimum Initial Channel Availability Check Time  $T_{avail\_time\_min}$  UWB DAA device intent to operate in a non NIM mode**

### 5.9.3.2.3 Test with a victim test signal at the beginning of the *Minimum Initial Channel Availability Check Time*, $T_{avail\_time\_min}$

#### Summary:

Verify the victim signal detection and avoidance capability for the selected UWB operational frequency when a victim signal occurs at the beginning of the *Minimum Initial Channel Availability Check Time*.

#### Pre-test Condition:

- UWB radio device supporting DAA.
- UWB radio device switched off.

#### Test Sequence:

- The UWB DAA radio device will be switched off. The signal generator used to generate the test patterns see table 4 will be connected to an antenna of suitable characteristics to permit the UWB DAA radio device to be illuminated with a field equal to the signal detection threshold limit (see table 4) or connected to the corresponding connectors in the case of a conducted measurement setup.
- The UWB DAA radio device is powered on at  $T_0$ .  $T_1$  denotes the instant when the UWB DAA radio device has completed its power-up sequence ( $T_{power\_up}$ ), enters a NIM mode, ready to start the victim signal detection.
- The victim system test signal will be switched on at  $T_1 + \Delta t$  (with  $\Delta t < 2$  s) with the test pattern (see table 4), timing behaviour and power levels in accordance with table 4.

**CON-1:** The *Minimum initial Channel Availability Check* is expected to commence at  $T_1$  and is expected to end no sooner than  $T_1 + T_{avail\_time\_min}$  unless a victim signal is detected sooner.

**NOTE:** Additional verification may be needed to define  $T_1$  in case it is not exactly known or indicated by the UWB DAA radio device. For example,  $T_1$  could be determined by taking into account  $T_{avail\_time\_min}$  and the instance the device switches to a non-NIM mode in clause 5.9.3.2.2 Test without a victim test signal present.

**CON-2:** It shall be recorded if the victim test signal was detected. This can be done by verifying that the UWB DAA radio device is switched into an avoid operation corresponding to the investigated threshold level in the relevant operational band or stays in a corresponding NIM operation. The following avoid operation parameters shall be verified:

- *default avoidance bandwidth* for the victim system service identified and where relevant, see ETSI TS 102 754 [1];
- *optional avoidance mechanisms* identified by the manufacturer for the victim system service identified, see ETSI TS 102 754 [1];

- LDC operational parameter if applicable.

**CON-3:** A timing trace or description of the observed timing and behaviour of the UWB DAA radio device shall be recorded for each avoidance mechanism.

- d) Repeat a) to c) for  $n$  times in a row. The values for  $n$  shall be defined in the relevant harmonised standard.

**CON-4:** CON-1, CON-2 and CON-3 shall be fulfilled in all  $n$  tests. If CON-3 is fulfilled go to f). If one failure occurs go to e). For more than one failure the test has not been passed.

- e) Repeat a) to c) for  $m$  times in a row. The values for  $m$  shall be defined in the relevant harmonised standard.

**CON-5:** CON-1, CON-2 and CON-3 shall be fulfilled in all  $m$  tests.

- f) Repeat b) to e) for each of the relevant victim test pattern (see table 4) depending on the UWB operating frequency range (see clause 5.2) at the threshold levels as defined in table 4.

**CON-6:** A timing trace or description of the observed timing and behaviour of the UWB DAA radio device shall be recorded.

#### 5.9.3.2.4 Test with a victim test signal at the end of the *Minimum Initial Channel Availability Check Time*, $T_{\text{avail\_time\_min}}$

Summary:

Verify the victim signal detection and avoidance capability for the selected UWB operational frequency when a victim signal occurs at the end of the *Minimum Initial Channel Availability Check Time*.

Pre-test Condition:

- UWB radio device supporting DAA.
- UWB radio device switched off.

Test Sequence:

- a) The UWB DAA radio device will be switched off. The signal generator used to generate the test patterns (see table 4) and will be connected to an antenna of suitable characteristics to permit the UUT to be illuminated with a field equal to the threshold detection limit or connected to the corresponding connectors in the case of a conducted measurement setup.
- b) The UWB DAA radio device is powered up at  $T_0$ .  $T_1$  denotes the instant when the UWB DAA radio device has completed its power-up sequence ( $T_{\text{power\_up}}$ ), enters into a NIM mode, ready to start the victim signal detection.

**CON-1:** The *Minimum Initial Channel Availability Check*  $T_{\text{avail\_time}}$  is expected to commence at instant  $T_1$  and is expected to end no sooner than  $T_1 + T_{\text{avail\_time}}$  unless a victim signal is detected sooner.

NOTE: Additional verification may be needed to define  $T_1$  in case it is not exactly known or indicated by the UWB DAA radio device. For example,  $T_1$  could be determined by taking into account  $T_{\text{avail\_time\_min}}$  and the instance the device switches to a non-NIM mode in clause 5.9.3.2.2 Test without a victim test signal present.

- c) The victim system test signal will be switched on at  $T_0$  with the test pattern (see table 4), timing behaviour and power levels in accordance with the relevant harmonised standard.



**CON-2:** It shall be recorded if the victim test signal was detected. This can be done by verifying that the UWB DAA radio device is switched into an avoid operation corresponding to the investigated threshold level in the relevant operational band or stays in a corresponding NIM operation. The following avoid operation parameter shall be verified:

- *default avoidance bandwidth* for the victim system service identified and where relevant, see ETSI TS 102 754 [1];
- *optional avoidance mechanisms* identified by the manufacturer for the victim system service identified, see ETSI TS 102 754 [1];
- LDC operational parameter if applicable.

**CON-3:** A timing trace or description of the observed timing and behaviour of the UWB DAA radio device shall be recorded for each avoidance mechanism.

- d) Repeat a) to c) for  $n$  times in a row. The values for  $n$  shall be defined in the relevant harmonised standard.

**CON-4:** CON-1, CON-2 and CON-3 shall be fulfilled in all  $n$  tests. If CON-3 is fulfilled go to f). If one failure occurs go to e). For more than one failure the test has not been passed.

- e) Repeat a) to c) for  $m$  times in a row. The values for  $m$  shall be defined in the relevant harmonised standard.

**CON-5:** CON-1, CON-2 and CON-3 shall be fulfilled in all  $m$  tests.

- f) Repeat a) to e) for each of the relevant radar test signals for the UWB operational frequency range as defined in the relevant harmonised standard at a level of 10 dB above the defined threshold level given in the relevant harmonised standard and at exactly the threshold levels given in the relevant harmonised standard.

**CON-6:** A timing trace or description of the observed timing and behaviour of the UWB DAA radio device shall be recorded.

### 5.9.3.3 In-Operation Test

#### 5.9.3.3.1 General Points for In-Operation Test

This series of tests evaluates the UWB radio device's response to the presence of different payload types which the victim service may carry. The relevant services are defined in table 8.

In the in-operation test set up the UWB pair will be actively exchanging data under the presence of a victim signal pattern as defined table 8. In this test the *Detect and Avoid time* will be recorded and the corresponding avoidance operation will be verified.

During the test, the existing data link might be disrupted. This should then not lead to an uncontrolled operation but to an operation equivalent to the NIM mode.

Depending on the test pattern definition in the relevant harmonised standards a power ramping of the victim signal might be necessary. An example for that ramping is given in figure 29.

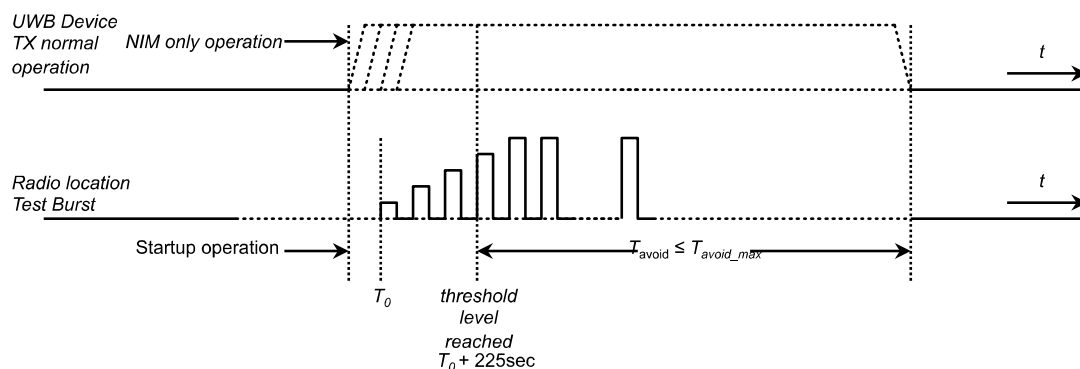

**Figure 29: Example of timing for victim signal in-operation testing of the Detect and Avoid Time, here with increasing Radiolocation test signal**

### 5.9.3.3.2 In-Operation Test Procedure

#### Summary:

The procedure below verifies the victim signal detection and avoidance capability for the selected UWB operational frequency in normal UWB operation using an increasing victim test signal level. In this test the *Detect and Avoid time* and the corresponding avoidance operation will be verified.

#### Pre-test Condition:

- Two UWB radio devices at least one supporting DAA.
- Both UWB radio devices switched on.
- UWB radio device in normal communication mode.

#### Test Sequence:

- a) Both UWB DAA radio devices shall be switched on and in a stable operational mode as defined in relevant harmonised standard. The signal generator used to generate the test patterns given in the relevant harmonised standard will be connected to an antenna of suitable characteristics to permit the UUT to be illuminated with a field equal to the threshold detection limit or connected to the corresponding connectors in the case of a conducted measurement setup.
- b) The victim system test signal will be switched on at  $T_0$  with the test pattern, timing behaviour and power levels in accordance with table 8.

**CON-1:** The measurement of the actual "Detect and Avoid Time"  $T_{\text{avoid}}$  of the EUT is expected to commence at an instant after  $T_0$  as given in the relevant harmonised standard. The actual detect and avoid time of the radio device under test shall be smaller or equal to the Maximum Detect and Avoid time  $T_{\text{avoid\_max}}$  as defined in the relevant standard. The actual Detect and Avoid time  $T_{\text{avoid}}$  of the radio device under test can be negative. The following avoid operations shall be verified:

- *default avoidance bandwidth* for the BWA service identified and where relevant, see ETSI TS 102 754 [1];
- *optional avoidance mechanisms* identified by the manufacturer for the BWA service identified, see ETSI TS 102 754 [1];
- L0 operational parameter if applicable.

**CON-2:** It shall be recorded if the victim test signal was detected before the time instance given in the relevant standard.

- c) Repeat a) and b) for  $n$  times in a row. The values for  $n$  shall be defined in the relevant harmonised standard.

**CON-3:** CON-1 and CON-2 shall be fulfilled in all  $n$  tests, then go to e). If one failure occurs go to d). For more than one failure the test has not been passed.

- d) Repeat a) and b) for  $m$  times in a row. The values for  $m$  shall be defined in the relevant harmonised standard.

**CON-4:** CON-1 and CON-2 shall be fulfilled in all  $m$  tests.

- e) Repeat b) to d) for each threshold given in the relevant harmonised standard.

**NOTE:** Instead of repeating the test for each threshold, continuous testing for the different thresholds can also be performed. Depending on the implemented avoidance strategy, some threshold tests may be redundant, i.e. one test already covers another case.

- f) Repeat b) to e) for each of the relevant victim test pattern for the UWB operating frequency range and threshold levels as defined in table 8.

## 5.10 Listen Before Talk (LBT)

### 5.10.1 Description

Listen Before Talk (LBT) is a mechanism to protect other operating services from interference in the same band.

LBT under clause 5.10 is only applicable for EUTs considered under ECC/DEC/(07)01 [i.4] and for the specified frequency bands (see table 9) if:

- the EUT-OFR is partly or fully overlapping with the frequency ranges listed in table 9.
- the radiated emissions within the specified frequency bands are above the limit as specified in table 9.

**Table 9: Frequency ranges for which LBT active mitigation technique apply**

Frequency range [GHz]		If emission measurement result is above (see related standard)	
		Maximum mean e.i.r.p. spectral density [dBm/MHz]	Maximum peak e.i.r.p. (dBm defined in 50 MHz)
$1,215 \leq f \leq 1,73$	Band 1	-85	-45
$2,5 \leq f \leq 2,69$	Band 2	-65	-25
$2,7 \leq f < 2,9$	Band 3	-70	-30
$2,9 \leq f \leq 3,4$	Band 4	-70	-30

NOTE 1: The OFR and the radiated emission (mean/peak e.i.r.p spectral density or indirect emission) measurement will provide the necessary information to decide in which bands the LBT mitigation has to be implemented.

The LBT function identifies the presence of signals within the band of operation and only allows activation of the UWB emission when no signals are detected above a defined threshold level.

Figure 30 depicts the basic operation of LBT mitigation function for EUT implementing LBT mitigation for contact based UWB material sensing devices.

Figure 31 depicts the operation for non-contact based UWB material sensing devices.

The test scenario shall be specified in the related standard.

NOTE 2: The EUT manual has to describe the way the EUT user will be informed about a positive detection result of the LBT mitigation (e.g. via display and the message "measurement temporarily not possible")

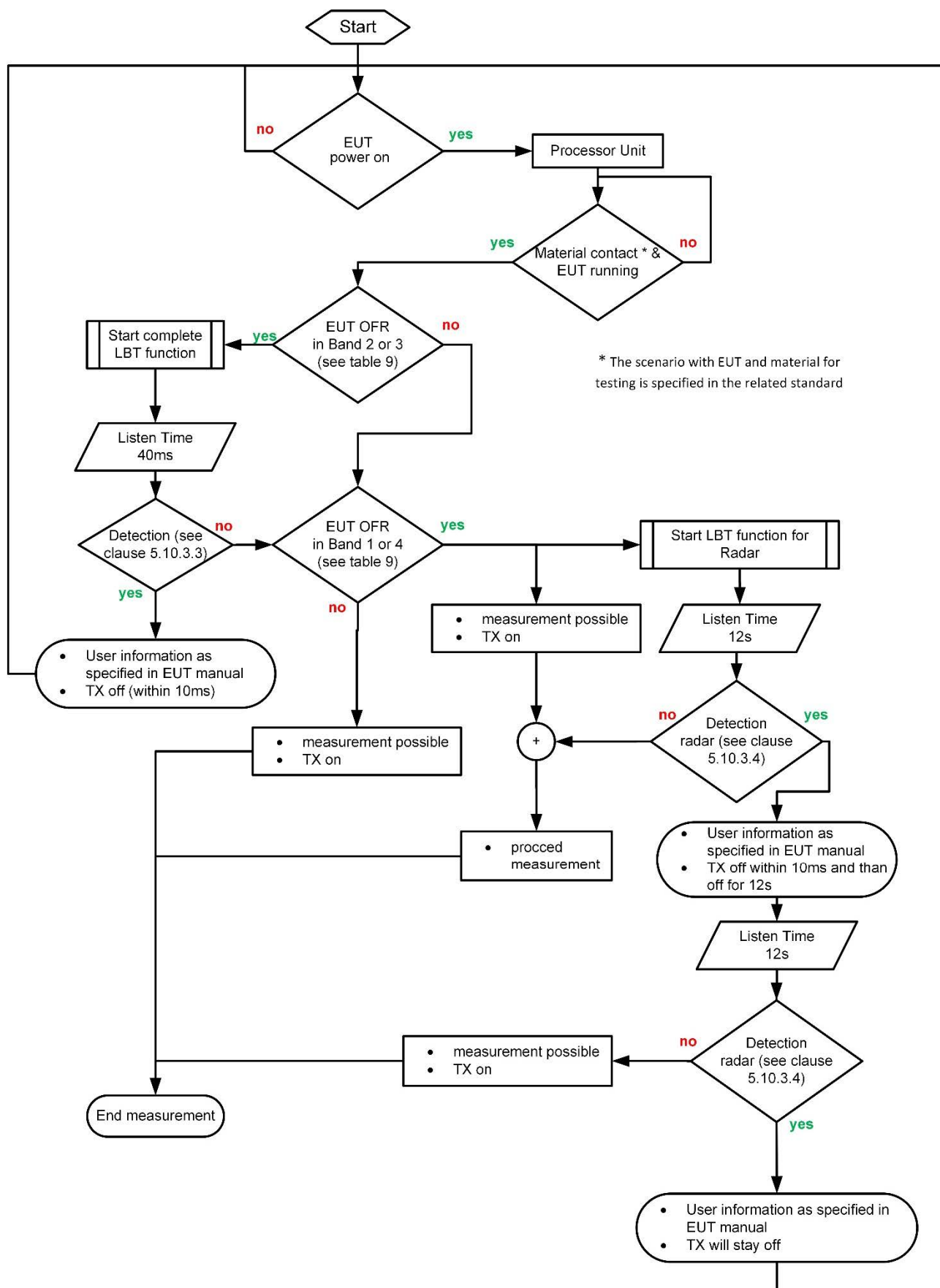

Figure 30: Flow diagram of LBT mitigation for contact based UWB material sensing devices

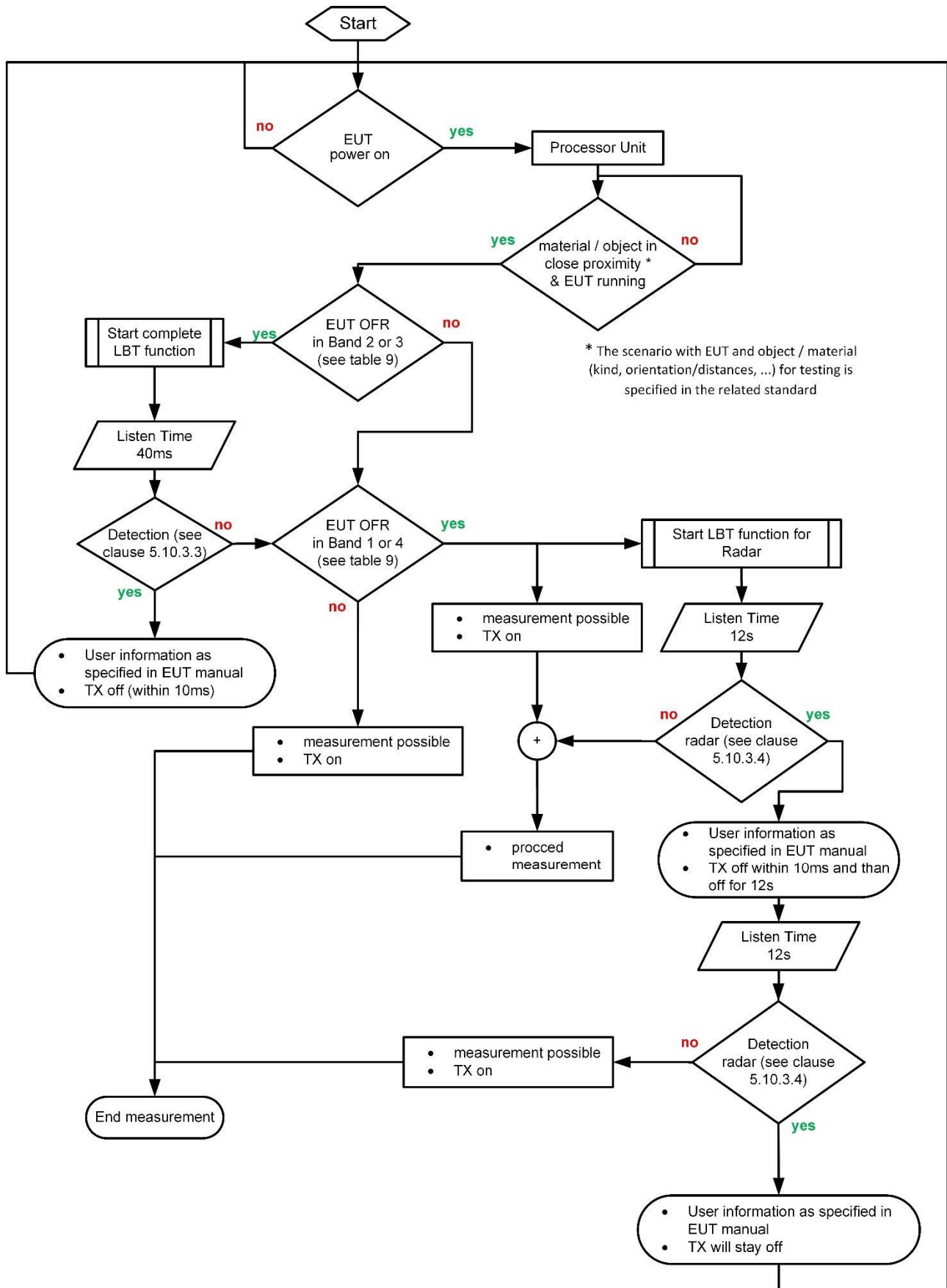

Figure 31: Flow diagram of LBT mechanism for non-contact based UWB material sensing devices

## 5.10.2 Limits

The LBT mechanism of the UWB receiver shall ensure that the UWB transmitter is switched off, if the threshold level at the EUT as defined in table 10 are exceeded.

In case the UWB equipment covers only part of the frequency range of table 10, the LBT function shall only be implemented for the OFR of the EUT as specified in the related harmonised standard.

The limits given in table 10 shall be measured in the measurement scenarios defined in the related standard. A generic procedure is described in clause 5.10.3.

**Table 10: LBT threshold limits in line with ECC/DEC/(07)01 [i.4]**

Band	Frequency range	Peak power threshold value (TH) (dBm/MHz)	Reaction time
1	Radar L-Band $1,215 \text{ GHz} \leq f \leq 1,4 \text{ GHz}$	+8	Continuous listening of 12 s is required and automatic switch-off feasible each 10 ms if the threshold value is exceeded. In the case of detecting and switching off the transmitter, a silent time of at least 12 s while listening continuously is necessary.
2	MSS $1,61 \text{ GHz} \leq f \leq 1,66 \text{ GHz}$	-43	Minimum continuous listening time of 40 ms before initial transmission of the device.
3	Land mobile service $2,5 \text{ GHz} \leq f \leq 2,69 \text{ GHz}$	-50	Minimum continuous listening time of 40 ms before initial transmission of the device.
4	Radar S-Band $2,7 \text{ GHz} \leq f \leq 3,4 \text{ GHz}$	-7	Continuous listening of 12 s is required and automatic switch-off feasible each 10 ms if the threshold value is exceeded. In the case of detecting and switching off the transmitter, a silent time of at least 12 s while listening continuously is necessary.
NOTE: If the RP in the respective band is lower than the limit as defined in the related standard, the threshold value can be increased by the difference.			

## 5.10.3 Conformance

### 5.10.3.1 Measurement Procedure

Within each LBT frequency range, the frequency and direction of the maximum mean power spectral density of the EUT within the scenario (indirect emission, see clause 5.7 and related standard) shall be recorded.

A test transmitter simulating the victim shall transmit a calibrated signal with the output power  $P_{\text{Victim}}$  which meets the threshold level (TH) of clause 5.10.2 at the reference point (see figure 32 and equation (45)). The EUT shall be operated within the specified scenario (see related standard) in a continuous mode.

The transmitter simulating the victim shall be set to the recorded frequency and point to the EUT at the recorded direction of maximum mean power spectral density. The EUT is tested for the deactivation threshold to stop UWB emissions at the defined threshold levels as defined in clause 5.10.2.

### 5.10.3.2 Test Set-Up

Figure 24 shows the test set-up for the LBT measurements for a generic EUT within a measurement scenario (indirect emissions see clause 5.7). The "Reference Point" will be specified in the related standard (use-case and wanted technical performance criteria dependent). The details of the test scenario shall be specified in the related standard.

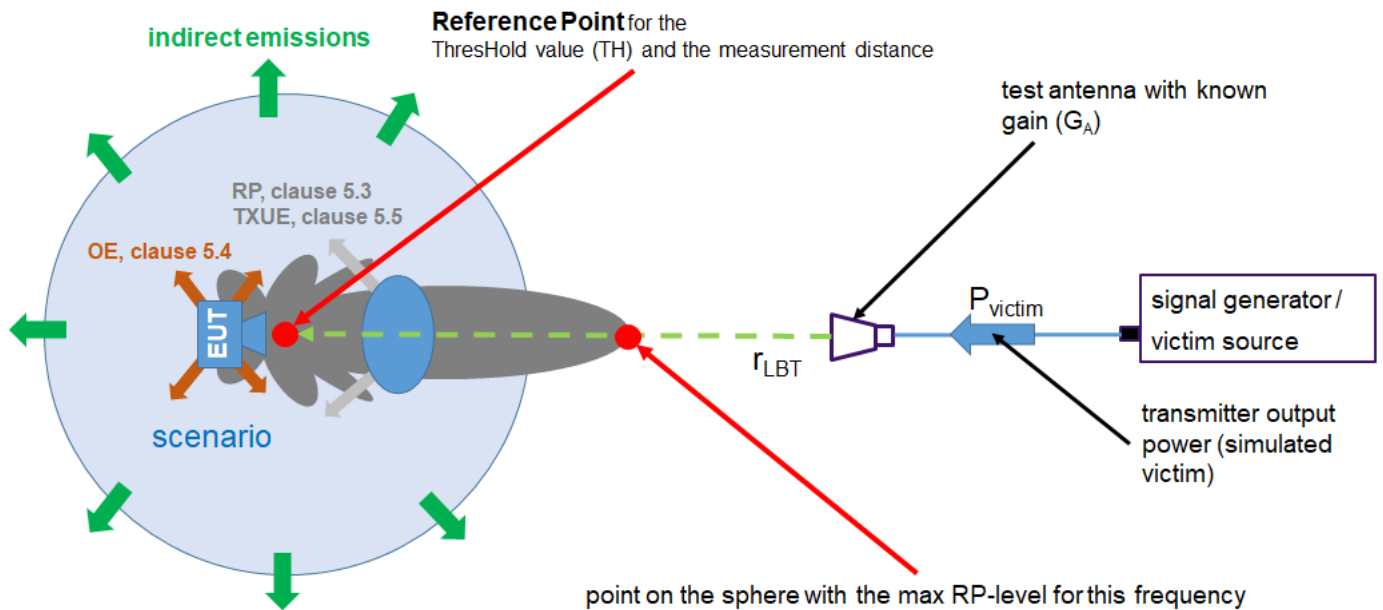

**Figure 32: Test set-up for LBT function**

Threshold (TH) power level at the reference point of the EUT (dBm/MHz), see equation (42):

$$TH = P_{\text{victim}} + g_A - 20 \times \log\left(4 \times r_{LBT} \times \pi \times \frac{f}{c_0}\right) \quad (42)$$

with equation (43) for the antenna gain of test antenna ( $g_A$ )

$$g_A = 10 \times \log(G_{A(f)}) \quad (43)$$

and equation (44) for the output power of the signal generator ( $P_{\text{victim}}$ ):

$$P_{\text{victim}} = 10 \times \log(P_{\text{victim}}) \quad (44)$$

and:

- $f$  is the carrier frequency of the victim source;
- $c_0$  the vacuum speed of light; and
- $r_{LBT}$  the distance between victim source test antenna and EUT reference point.

Thus, to reach the threshold power at the EUT, the power of the victim signal generator has to be set to the following power level, see equation (45):

$$P_{\text{victim}} = th - g_A + 20 \times \log\left(4 \times r_{LBT} \times \pi \times \frac{f}{c_0}\right) \quad (45)$$

### 5.10.3.3 Test Signal Definition for LBT Mechanism in Band 2 and 3

#### 5.10.3.3.1 Band 2: Mobile Satellite Service (MSS) Test Signal

For the Band 2: MSS test signal, see table 11.

- Victim signal power: see clause 5.10.3.2.

**Table 11: MSS test signal**

f [GHz]	See clause 5.10.3.1
test signal	unmodulated carrier (CW)
Peak power threshold value at the EUT [dBm/MHz]	-43

### 5.10.3.3.2 Band 3: Land Mobile Service Test Signal

For the Band 3: Land mobile service test signal, see table 12.

- Victim signal power: see clause 5.10.3.2.

**Table 12: Land mobile service test signal**

f [GHz]	See clause 5.10.3.1
test signal	unmodulated carrier (CW)
Peak power threshold value at the EUT [dBm/MHz]	-50

### 5.10.3.4 Test Signal Definition for LBT Mechanism in Band 1 and 4

For radar services, the LBT mechanism has to be as quick as possible to avoid the second suppression of an echo of a target at the second rotation of the antenna dish (see figure 33). Normally, the air traffic control uses 3 consecutive echoes each received during the next consecutive rotation to validate "target" as "true" (the response of a transponder by a secondary radar is not taken into account here). Radar devices emit its PSD with a certain PRF, for example with a PRF of 1 100 Hz and a rotational speed of 0,25 Hz (1 rotation per 4 seconds). The radar main beam width is typically 1,5°, in this example the EUT beam width may be 20° (with a directivity/gain of 5 dB it is approximately 60°). Every 0,9 ms (= 1/PRF) the radar device emits 1 impulse. The criteria to switch off the sensor is to receive 5 times the main beam of the radar (5 × 1/PRF), in this example 5 × 1/1 100 = 4,5 ms. That means after detection of the 5 radar impulses plus a reaction time, the EUT switches off (display might show a "hit", e.g. "interference signal"). Now a latency time of 12 seconds has to be introduced during which the EUT only receives (no transmission, i.e. to cover the window for the slowest rotation rate of radar device). If during this 12 s the main beam is detected again, the display hint will continue. If not, the measurement procedure can start again, because the interferer does not belong to a radar service.

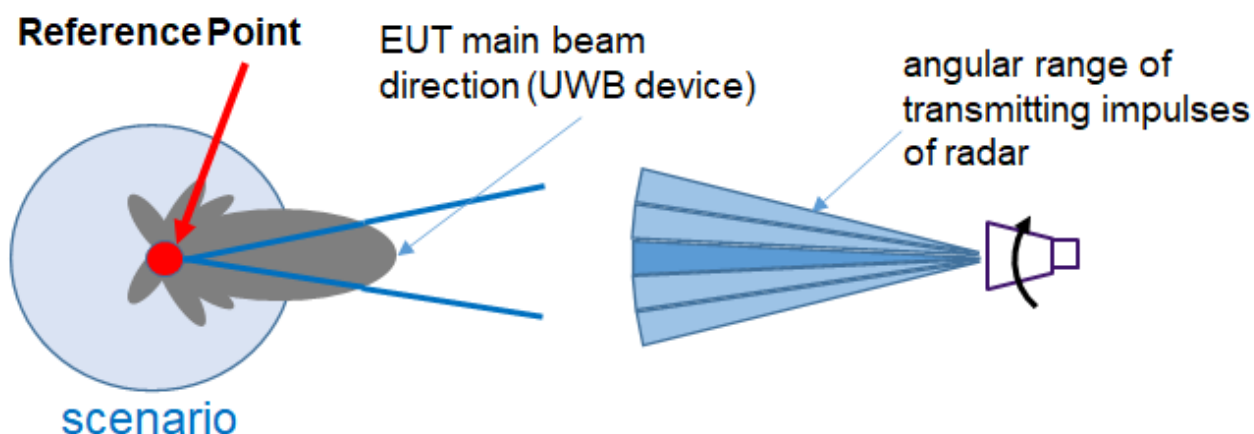
**Figure 33: LBT - radar scenario for Bands 1 and 4**

If such a radar signal (impulse train of 5 pulses, see figure 34) is detected, then the EUT transmitter shall be switched off within maximum 10 ms. After detecting of the radar signal a waiting time of > 12 seconds shall be implemented in which the EUT is only receiving. If a next radar signal is detected the timer (12 seconds) shall be triggered again.

Based on the timing of the radar active in the two bands following test signals (with 5 impulses) shall be implemented within a signal generator to simulate a possible "radar signal" at the UWB device (see figure 34).



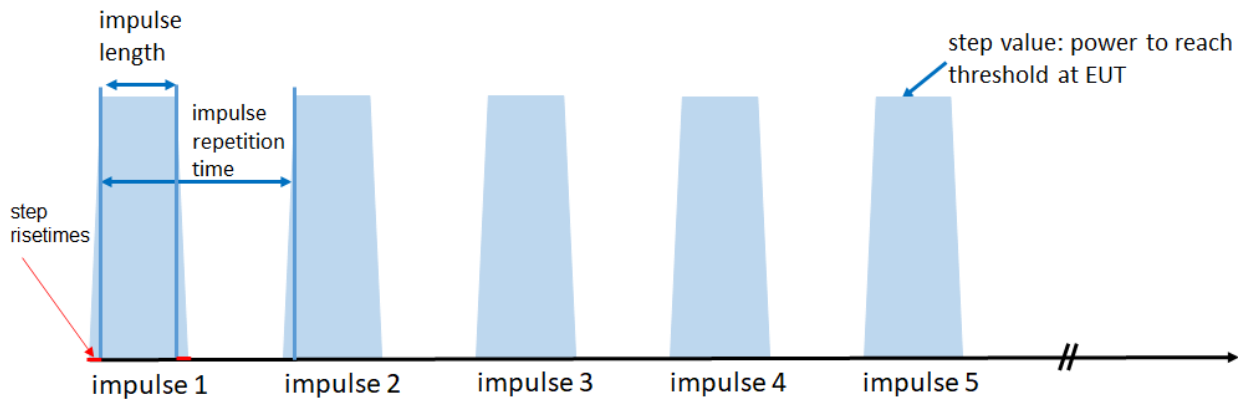

Figure 34: LBT - radar scenario, test pattern

Test pattern 1: see table 13

Table 13: Test pattern 1

Impulse length	0,4 $\mu$ s
Impulse repetition time	0,8 ms

Test pattern 2: see table 14

Table 14: Test pattern 2

Impulse length	90 $\mu$ s
Impulse repetition time	1,5 ms

#### Radar Test signals:

For the band 1 and band 4 test signals see table 15.

- Impulse power: see clause 5.10.3.2.

Table 15: Radar test signals

	Band 1	Band 4
Test pattern	1 (table 13) and 2 (table 14)	1 (table 13) and 2 (table 14)
f [GHz]	See clause 5.10.3.1	See clause 5.10.3.1
Peak power threshold at the EUT [dBm/MHz]	8	-7

#### 5.10.3.5 Conformance Test to Measure the Timing for LBT within bands 1 and 4

For the LBT mechanism within Radar bands 1 and 4, the following timings shall be measured:

- EUT switch off time < 10 ms after radar signal detection.
- Silent time of 12 s of the EUT after radar signal detection.

The measurement procedure and test setup follow clauses 5.10.3.1 and 5.10.3.2 with the following modifications: In addition to the victim source pointing at the EUT, the EUT emissions shall be measured with a measurement antenna. The setup is shown in figure 35.

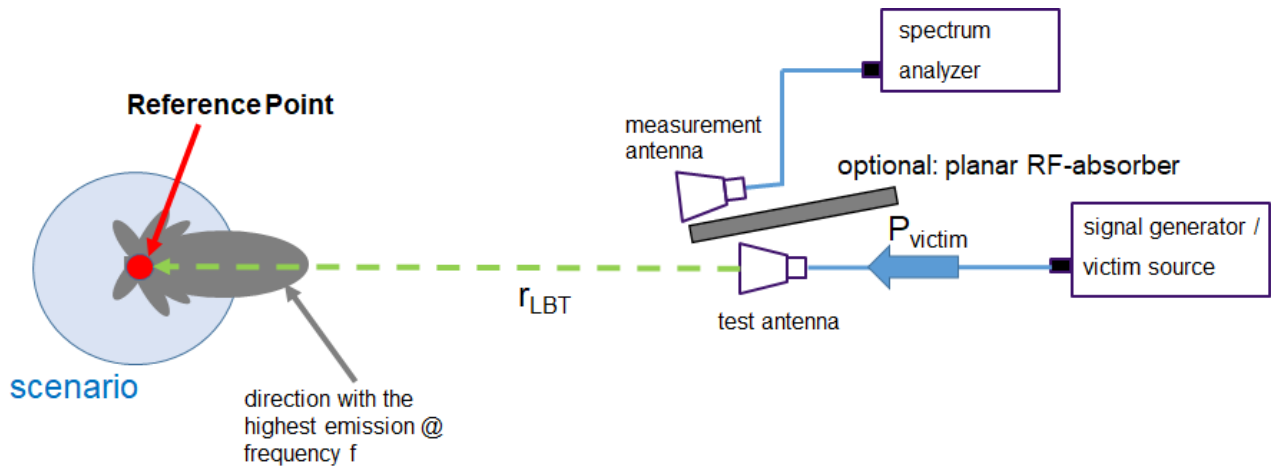

**Figure 35: Test-set-up to assess the LBT timing for band 1 and band 4**

The planar RF-absorber is optional to reduce the cross talk between victim test antenna and measurement antenna. If such planar RF-absorber will be used, the victim threshold power level at the EUT shall be checked again, see clause 5.10.3.2.

Both the victim test antenna and the antenna measuring the EUT emissions shall point to the EUT in the recorded direction of maximum mean power spectral density within the LBT frequency bands 1 or 4 according to clauses 5.10.3.1 and 5.10.3.2 (see figure 32).

A spectrum analyser is used to measure the EUT emissions. Because of reflections and cross talk between the victim source antenna and the antenna measuring the EUT emissions, also the victim signal is measured by the spectrum analyser in addition to the EUT emissions.

The victim source test signal is set as defined in clause 5.10.3.4.

The following spectrum analyser settings shall be applied:

- Zero span mode/time domain mode.
- Frequency: Frequency of maximum mean power spectral density of the EUT (clause 5.10.3.1).
- Resolution bandwidth: 1 MHz.
- Detector: RMS.

Both EUT emissions and victim source signal need to be simultaneously seen at the spectrum analyser and need to be distinguishable.

If the dynamic range of the spectrum analyser does not allow to observe both EUT emissions and victim source signal with the same settings, the victim source signal might be offset in frequency to adapt the received power in the resolution bandwidth of the spectrum analyser.

The two timings specified above shall be measured with the spectrum analyser.

Figure 36 shows an example of the measured Spectrum Analyser signals for of the EUT switch off.

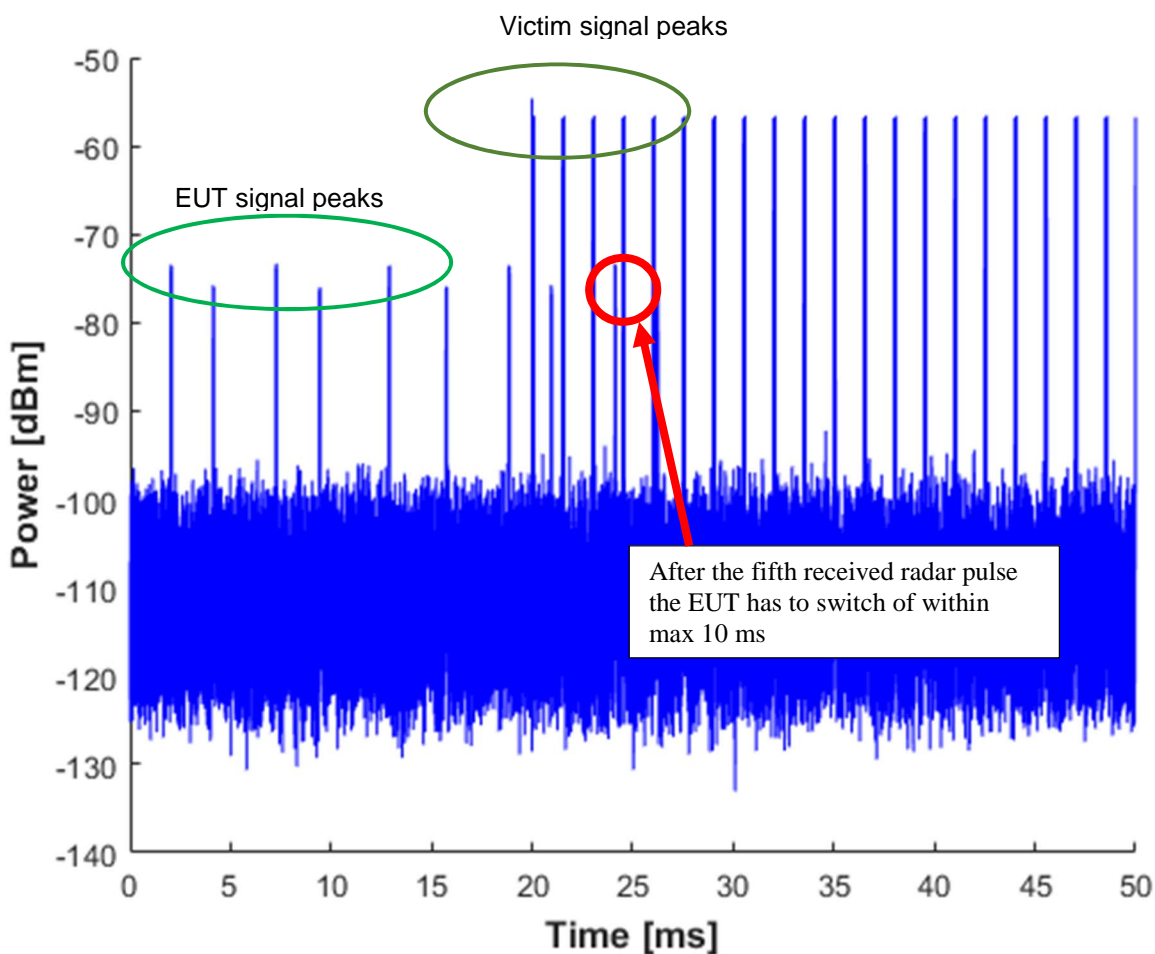

Figure 36: Example signals for the LBT timing measurements

## 5.11 Duty Cycle

### 5.11.1 Description

Duty Cycle (DC) is a passive mitigation technique often used in radio regulation and harmonised standards in order to enable spectrum sharing between different radio devices and/or radio applications. A duty cycle regulation is normally stated as a limitation to activity of a transmitter within certain time and power boundaries, e.g. allowing a defined percentage of transmission activity at some predefined levels of transmitted power during the  $T_{on}$ . (see annex C for further information on DC and  $T_{on}$ ).

### 5.11.2 Conformance Test

#### 5.11.2.1 Duty Cycle, Spectrum Analyser Method

The method in this clause is intended for duty cycle requirements over short observation periods, as specified in the relevant standard (usually over 1 second). Conformance for duty cycle requirements over long-term periods (usually over 1 hour) is addressed in clause 5.11.2.4.

The method is based on ETSI TS 103 060 [i.1].

When measuring the EUT duty cycle, the spectrum analyser or equivalent shall be configured as follows unless otherwise stated in the relevant harmonised standard:

- RBW: As specified in the related harmonised standard

- Video Bandwidth: VBW equal or greater than the RBW
- Display Mode: CLEAR WRITE
- Detector Type: Peak
- Frequency Span: Zero span
- Centre Frequency: The frequency of the maximum mean e.i.r.p. spectral density as recorded under clause 5.3.2.2

To optimize the signal-to-noise ratio, it is recommended that radiated measurements are taken in the direction of the maximum level of the mean power spectral density.

The duty cycle timings may vary because of different coding schemes. The first sweep(s) should be an overview of the duty cycle timings. The manufacturer should also declare these timings.

For further evaluation, choose an observation period with maximum "on" time,  $T_{on}$ , and minimum "off" time,  $T_{off}$ , taking into account the disregard time,  $T_{dis}$ , see annex C.

Calculate the  $T_{on}$  and  $T_{off}$  times taking into account the  $T_{dis}$  and  $P_{thresh}$  as defined in ETSI TS 103 060 [i.1] and annex C and as specified in the relevant standard. From these, the duty cycle is calculated as equation (46):

$$\text{Duty Cycle} = \frac{\sum T_{on}}{T_{obs}} = \frac{\sum T_{on}}{\sum T_{on} + \sum T_{off}} \quad (46)$$

The related standard shall specify:  $T_{obs}$ ,  $T_{dis}$  and  $P_{thresh}$ .

If additional parameter are requested (min  $T_{off}$ , max  $T_{on}$ ,...) e.g. for EUT's under ECC/DEC/(06)04 [i.3] which implemented the "low duty cycle mitigation". These additional requirement could be read out from the measurement above.

The oscilloscope method in clause 5.11.2.2 can be used as an alternative, but the EN shall provide a clear guidance which method shall be used for which EUT category.

### 5.11.2.2 Duty Cycle, Oscilloscope Method

The method in this clause is intended for duty cycle requirements over short observation periods, as defined in the relevant harmonised standard (usually over 1 second). Conformance for duty cycle requirements over long-term periods is addressed in clause 5.11.2.4.

The method is based on ETSI TS 103 060 [i.1].

Unless otherwise stated in the harmonised standard, the spectrum analyser method in clause 5.11.2.1 is equivalent and may be used as an alternative.

The following tools shall be used to execute the time domain procedure for DC measurement:

- One 50  $\Omega$  cable in case of conducted testing.
- One Oscilloscope with the following minimum requirements:
  - Sampling frequency  $> 2 B$  (where  $B$  is the pulse bandwidth): this requirement is enough to detect the envelope of the signal and ensure the correct operation of the measurement procedure.
  - Input bandwidth  $> f_H$  (where  $f_H$  is the highest frequency, i.e. the upper boundary to the operating frequency range).
- One Personal Computer with installed a Post Processing Tool.

#### Conducted emission

Figure 37 illustrates the general test setup to execute the time domain procedure for DC measurement in the case of conducted emission.

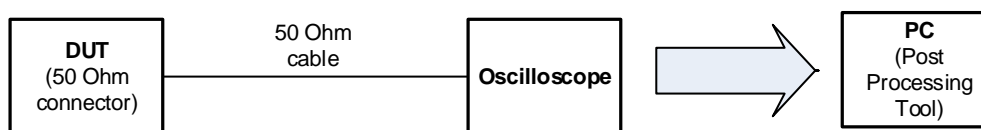

**Figure 37: General test setup to execute the time domain procedure for DC measurement in the case of conducted emission**

#### Radiated emission

Figure 38 illustrates the general test setup to execute the time domain procedure for DC measurement in the case of radiated emission. To optimize the signal-to-noise ratio, it is recommended that radiated measurements are taken in the direction of the maximum level of the mean power spectral density.

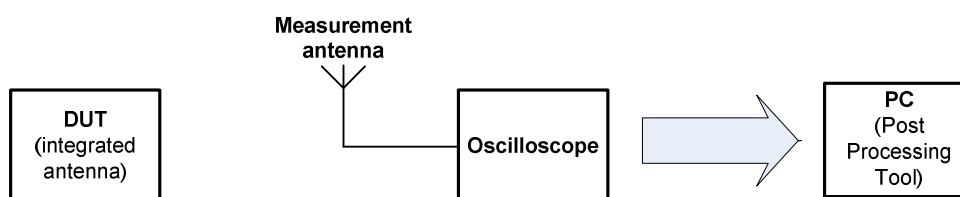

**Figure 38: General test setup to execute the time domain procedure for DC measurement in the case of radiated emission**

For EUT which implement DC mitigation, the manufacturer shall provide information about the different possible DC timings (within the different modes).

Configure the oscilloscope as follows:

- Set the signal sampling frequency  $f_c$  of the oscilloscope such that  $f_c \geq 2(f_H - f_L)$ , where  $f_H$  and  $f_L$  are the boundaries to the operating frequency range from clause 5.2.
- Adjust the time division such that the entire observation period fits within the memory storage capability of the oscilloscope. Verify that the sampling period of the scope is smaller than or equal to  $T_{dis}/2$ .
- Adjust the vertical scale of the oscilloscope to the lowest value that still displays the entire dynamic range of the signal.

The duty cycle timings may vary because of different coding schemes. The first sweep(s) should be an overview of the duty cycle timings. The manufacturer should also declare these timings.

For further evaluation, choose an observation period with maximum "on" time,  $T_{on}$ , and minimum "off" time,  $T_{off}$ , taking into account the disregard time,  $T_{dis}$ .

Calculate the  $T_{on}$  and  $T_{off}$  times taking into account the  $T_{dis}$  and  $P_{thresh}$  specified in the related standard and ETSI TS 103 060 [i.1]. From these, the duty cycle is calculated as shown in equation (47):

$$\text{Duty Cycle} = \frac{\sum T_{on}}{T_{obs}} = \frac{\sum T_{on}}{\sum T_{on} + \sum T_{off}} \quad (47)$$

The related standard shall specify:  $T_{obs}$ ,  $T_{dis}$  and  $P_{thresh}$ .

### 5.11.2.3 Duty Cycle Measurement procedures for FMCW, stepped-frequency and Pulsed Systems

#### 5.11.2.3.1 General

The methods in this clause are intended for duty cycle requirements for FMCW, stepped-frequency and pulsed systems. Observation periods are defined in the relevant harmonised standard. These periods are typically in the range of 0,1 to 10 s. But these methods cover also other periods.

There are three methods described which all can be used depending on the system parameters and the available measurement equipment. The measurement results will be the same within the measurement uncertainty for each measurement procedure if applied as described below:

- The first method (see clause 5.11.2.3.2) uses a diode power detector and can be used for pulsed, stepped-frequency and FMCW systems.
- The second method (see clause 5.11.2.3.3) uses a spectrum analyser in zero span mode. This can also be used for pulsed and FMCW systems.
- The last method (see clause 5.11.2.3.4) uses a spectrum analyser synchronized with another one and is only suited for FMCW and stepped-frequency systems.

The methods can be used also if there are more than one pulse train or more than one FMCW or stepped-frequency sweep within the signal repetition time, as long as the bandwidth of each pulse train/FMCW or stepped-frequency sweep is the same. If the bandwidth differs within the signal repetition time, the pulse trains/FMCW or stepped-frequency sweeps have to be measured separately.

If the EUT has an integrated RF antenna a further RX measurement antenna is needed for the measurement setup. This can be a standard gain horn antenna suited for the frequency range to be measured. If the EUT is equipped with a 50  $\Omega$  connector or a wave guide connector it can be connected directly to the measurement device.

If not otherwise specified in the related standard: For measurements with the spectrum analyser the threshold level  $P_{\text{Thresh}}$  as defined in ETSI TS 103 060 [i.1] shall be set to 10 dB below the max emission limit (see clause 5.3).

#### 5.11.2.3.2 Method 1: Diode Power Detector

This method can be used for pulse, stepped-frequency and FMCW signals. The measured  $T_{\text{on}}$  on the Oscilloscope represents the burst duration of the FMCW burst in FMCW systems, the emission duration in stepped-frequency systems, or the duration of the pulse train in pulsed systems respectively.

Measurement device:

- RF power detector based on detector diodes (thermal detectors are not appropriate as these are usually too slow), covering a frequency range which at least include the OFR of the EUT.
- Oscilloscope.

When measuring the EUT duty cycle, the measurement equipment shall be configured as follows unless otherwise stated in the relevant harmonised standard:

- Step 1: Connect the RX measurement antenna to the RF power detector. Adjust the position of the RX measurement antenna and the antenna of the EUT to have maximum RF coupling.  
Alternatively, if possible, connect the EUT directly to the RF power detector by cable or wave guide.
- Step 2: Connect the oscilloscope to the output of the RF power detector.
- Step 3: Switch on the EUT.
- Step 4: Adjust the oscilloscope settings (time base, voltage range, trigger) to see the detected pulse from the power detector.

- Step 5: Measure  $T_{on}$ . If there is more than one pulse within the signal repetition time (see annex C) measure  $T_{on}$  for every single pulse.
- Step 6: Measure the signal repetition time  $T_{rep}$ , see annex C.
- Step 7: Calculate the Duty Cycle with equation (48):

$$\text{Duty Cycle}[\%] = \frac{\sum T_{on}}{T_{rep}} \times 100 \quad (48)$$

### 5.11.2.3.3 Method 2: Spectrum Analyser

#### 5.11.2.3.3.1 General

This method can be used for pulsed systems and FMCW systems.

Method 2a: is for pulsed systems and for FMCW where the operating frequency range is smaller than the resolution bandwidth of the spectrum analyser, see clause 5.11.2.3.3.2.

Method 2b: is for FMCW where the operating frequency range is equal to or larger than the resolution bandwidth of the spectrum analyser, see clause 5.11.2.3.3.3.

#### 5.11.2.3.3.2 Method 2a

Measurement device:

- Spectrum analyser in zero span mode on centre frequency of the OFR.

When measuring the EUT duty cycle, the measurement equipment shall be configured as follows unless otherwise stated in the relevant harmonised standard:

- Step 1: Connect the RX measurement antenna to the spectrum analyser. Adjust the position of the RX measurement antenna and the antenna of the EUT to have maximum RF coupling.  
Alternatively, if possible, connect the EUT directly to the spectrum analyser.
- Step 2: Set spectrum analyser frequency to the centre frequency of the OFR.
- Step 3: Set spectrum analyser to zero span mode.
- Step 4: Set spectrum analyser resolution bandwidth as large as possible, up to a maximum of 50 MHz.
- Step 5: Set spectrum analyser detector mode to peak.
- Step 6: Switch on the EUT.
- Step 7: Adjust the spectrum analyser settings (sweep time, amplitude range, trigger on RF power) to see the complete signal repetition time  $T_{rep}$  in zero span mode, see annex C.
- Step 8: Measure the signal repetition time  $T_{rep}$ , see annex C
- Step 9: Set the sweep time of the spectrum analyser to show one pulse in one sweep with high resolution.
- Step 10: Measure the pulse length  $T_{on}$ . This is the time between the points where rising and falling edge are crossing the threshold level of X dB the maximum level. The value for X is given in the related standard. If no value for X is provided in the related standard, then the value of 3 dB shall be used. This 3 dB correspond to the RBW definition of the spectrum analyser. If there is more than one pulse within the signal repetition time (see annex C,) measure  $T_{on}$  for every pulse (see equation (49)):

$$\text{Duty Cycle}[\%] = \frac{\sum T_{on}}{T_{rep}} \times 100 \quad (49)$$

### 5.11.2.3.3.3 Method 2b

This method can be used for FMCW systems where the operating frequency range is larger than the resolution bandwidth of the spectrum analyser see equations (50) until (52):

- Step 1: Measure the peak e.i.r.p. spectral density power  $P_{pk}$  [dBm] of the FMCW signal according to clause 5.3.4.1.3.
- Step 2: Measure the mean e.i.r.p. spectral density  $P_{av}$  [dBm] of the FMCW signal according to clause 5.3.2.5.
- Step 3: The difference between mean e.i.r.p. power spectral density and peak e.i.r.p. power spectral density is the sum of the duty cycle and the relation of the RBW of the spectrum analyser and the modulation bandwidth of the FMCW signal which is equal to the OFR according to clause 5.2.

Equation (50) calculates the bandwidth relation in dB ( $b_{wrel}$ ):

$$b_{wrel} [\text{dB}] = 10 \times \log\left(\frac{\text{OFR} [\text{MHz}]}{1 [\text{MHz}]}\right) \quad (50)$$

Equation (51) calculates the duty cycle in dB:

$$dc [\text{dB}] = P_{av} [\text{dBm}] + b_{wrel} [\text{dB}] - P_{pk} [\text{dBm}] \quad (51)$$

Equation (51) calculates the duty cycle in %:

$$DC [\%] = 100 \times 10^{\frac{dc [\text{dB}]}{10}} \quad (52)$$

### 5.11.2.3.4 Method 3: Synchronized Spectrum Analysers

This method is only appropriate for FMCW and stepped-frequency systems. Two spectrum analysers are used. The first one is used to detect the start of the FMCW or stepped-frequency sweep and to generate a trigger signal for the second spectrum analyser. The second one is used to measure the timing  $T_{on}$  and  $T_{rep}$ . Both spectrum analysers have to be connected either to two measurement antenna (see figure 39) or to one measurement antenna via a power splitter (see figure 40), or if possible a connected set-up, via a power splitter and cable or wave guide (see figure 41).

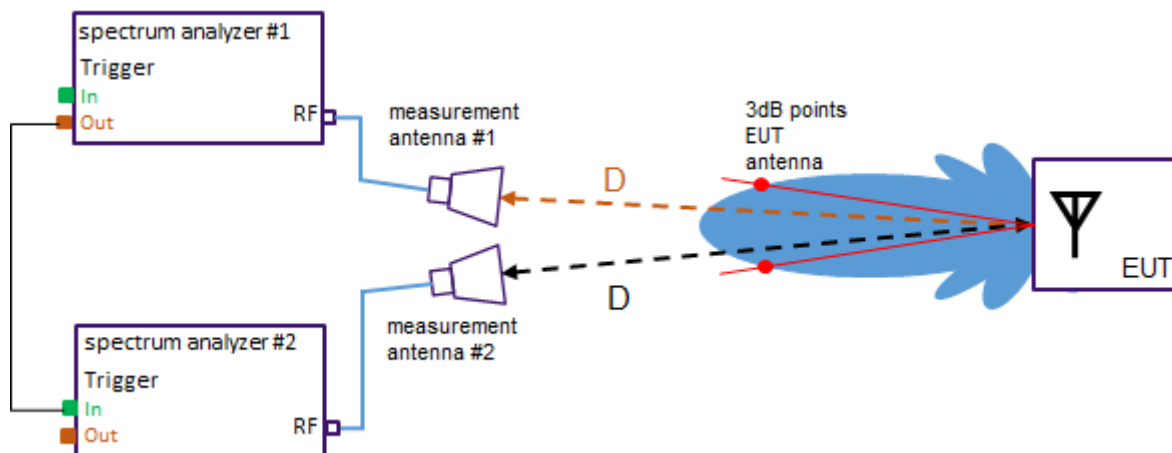
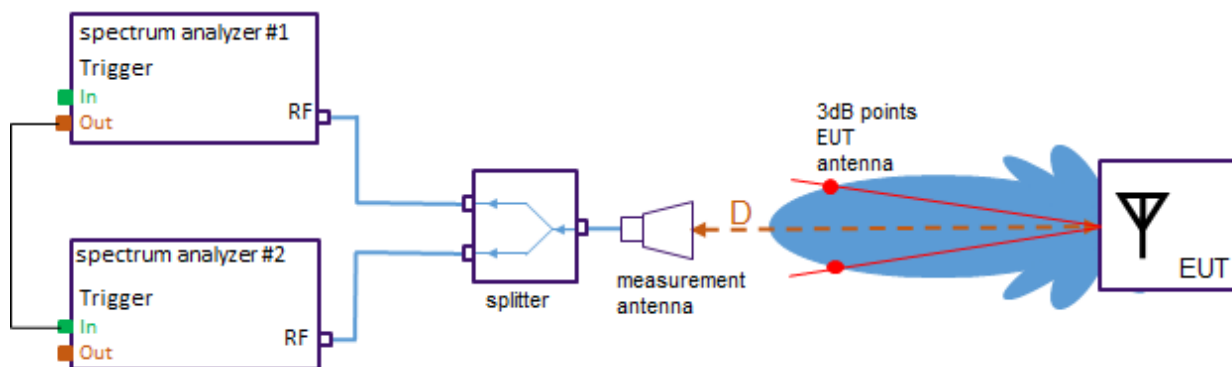
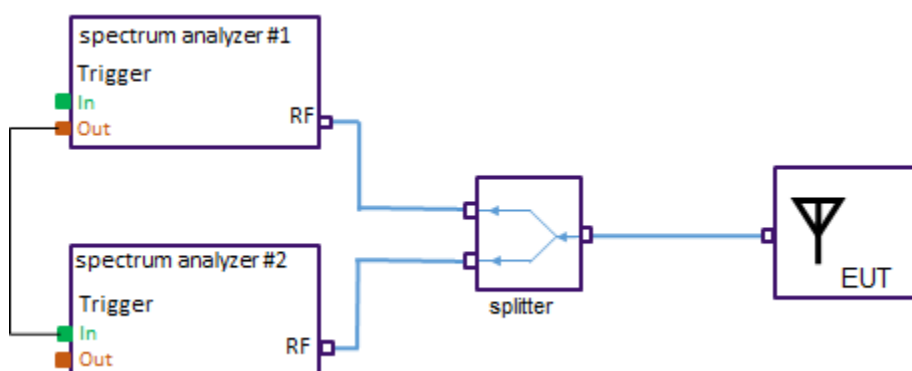

Figure 39: Synchronized Spectrum Analysers set-up with two measurement antennas





**Figure 40: Synchronized Spectrum Analysers set-up with one measurement antenna and power splitter**



**Figure 41: Synchronized Spectrum Analysers connected set-up with power splitter**

Measurement device:

- Two spectrum analysers in zero span mode.

When measuring the EUT duty cycle from the radio device, the measurement equipment shall be configured as follows unless otherwise stated in the relevant harmonised standard:

- Step 1: Connect one RX measurement antenna to each of both spectrum analysers. Adjust the positions of the RX measurement antennas and the antenna of the EUT to have maximum RF coupling for both measurement antennas.
- If the EUT provide a antenna connector, connect the EUT directly to both spectrum analysers via a power splitter and cable or wave guide.
- Step 2: Set spectrum analyser 1 resolution bandwidth to as large as possible.
- Step 3: Set spectrum analyser 1 detector mode to peak.
- Step 4: Set spectrum analyser 1 to zero span mode.
- Step 5: Set spectrum analyser 1 frequency to  $f_L$ .
- Step 6: Set spectrum analyser 2 resolution bandwidth to 1 MHz.
- Step 7: Set spectrum analyser 2 detector mode to peak.
- Step 8: Set spectrum analyser 2 to zero span mode.
- Step 9: Set spectrum analyser 2 frequency to  $f_L$ .
- Step 10: Switch on the EUT.

- Step 11: Adjust the spectrum analyser 1 settings (time span, amplitude setting range, trigger on RF power) to see the detected pulse in zero span mode.
- Step 12: Connect the trigger output or video output of the spectrum analyser 1 to the external trigger input of spectrum analyser 2.
- Step 13: Adjust the spectrum analyser 2 settings (time span, amplitude setting range, trigger on external) to see the detected pulse in zero span mode.
- Step 14: Measure the absolute time  $t_1$  at the rising edge of the pulse related to the trigger signal. (can be positive or negative but should be close to zero).
- Step 15: Set spectrum analyser 2 frequency to  $f_H$ .
- Step 16: Measure the absolute time  $t_2$  at the falling edge of the pulse related to the trigger signal (see equation (53)):

$$T_{ON} = t_2 - t_1 \quad (53)$$

- If there are more than one FMCW sweep within the signal repetition time ( $T_{rep}$ ), there will be more than 1 pulse on frequency  $f_L$  and  $f_H$ .  $T_{on}$  for every sweep has to be measured separately.  $T_{on}$  for every sweep start with rising edge of the pulse on  $f_L$  and ends with the first following pulse on  $f_H$ .

- Step 17: Enlarge the time span to see the complete signal repetition time ( $T_{rep}$ ). Measure the signal repetition time ( $T_{rep}$ ) and the duty cycle could be calculates as (see equation (54)):

$$\text{Duty Cycle}[\%] = \frac{\sum T_{on}}{T_{rep}} \times 100 \quad (54)$$

#### 5.11.2.4 Duty Cycle Measurement Procedures within a frequency band for FMCW and stepped-frequency systems

##### 5.11.2.4.1 General

The method in this clause is intended for duty cycle requirements within a frequency band for FMCW and stepped-frequency systems. The requirement to limit the duty cycle in certain sub-frequency bands within the permitted range of operation is defined in the relevant harmonised standard, as well as the observation periods. These observation periods are typically in the range of 0,1 to 10 s. But the method covers also other periods.

The measurement procedure (see clause 5.11.2.4.2) uses a spectrum analyser synchronized with another one and is only suited for FMCW and stepped-frequency systems.

The method can be used also if there is more than one FMCW or stepped-frequency sweep within the signal repetition time, as long as the bandwidth of each sweep is the same. If the bandwidth differs within the signal repetition time, the sweeps have to be measured separately.

If the EUT has an integrated RF antenna a further RX measurement antenna is needed for the measurement setup. This can be a standard gain horn antenna suited for the frequency range to be measured. If the EUT is equipped with a 50  $\Omega$  connector or a wave guide connector it can be connected directly to the measurement device.

If not otherwise specified in the related standard: For measurements with the spectrum analyser the threshold level  $P_{Thresh}$  as defined in ETSI TS 103 060 [i.1] shall be set to 10 dB below the max emission limit (see clause 5.3).

##### 5.11.2.4.2 Synchronized Spectrum Analysers

This method is appropriate for FMCW and stepped-frequency systems. Two spectrum analysers are used. The first one is used to detect the start of the FMCW or stepped-frequency sweep within the sub-frequency band and to generate a trigger signal for the second spectrum analyser. The second one is used to measure the timing  $T_{on}$  and  $T_{rep}$ . Both spectrum analysers have to be connected either to two measurement antenna (see clause 5.11.2.3.4 figure 39) or to one measurement antenna via a power splitter (see clause 5.11.2.3.4 figure 40), or if possible a connected set-up, via a power splitter and cable or wave guide (see clause 5.11.2.3.4 figure 41).

Measurement device:

- Two spectrum analysers in zero span mode.

When measuring the EUT duty cycle from the radio device, the measurement equipment shall be configured as follows unless otherwise stated in the relevant harmonised standard:

- Step 1: Connect one RX measurement antennas to each of both spectrum analysers. Adjust the positions of the RX measurement antennas and the antenna of the EUT to have maximum RF coupling for both measurement antennas.
- Step 2: If the EUT provide a coaxial connector or a wave guide connector connect the EUT directly to both spectrum analysers via a power splitter and cable or wave guide.
- Step 3: Set spectrum analyser 1 resolution bandwidth to as large as possible.
- Step 4: Set spectrum analyser 1 detector mode to peak.
- Step 5: Set spectrum analyser 1 to zero span mode.
- Step 6: Set spectrum analyser 1 frequency to the lowest emission frequency within the sub-frequency band.
- Step 7: Set spectrum analyser 2 resolution bandwidth to 1 MHz.
- Step 8: Set spectrum analyser 2 detector mode to peak.
- Step 9: Set spectrum analyser 2 to zero span mode.
- Step 10: Set spectrum analyser 2 frequency to the lowest emission frequency within the sub-frequency band.
- Step 11: Switch on the EUT.
- Step 12: Adjust the spectrum analyser 1 settings (time span, amplitude setting range, trigger on RF power) to see the detected pulse in zero span mode.
- Step 13: Connect the trigger output or video output of the spectrum analyser 1 to the external trigger input of spectrum analyser 2.
- Step 14: Adjust the spectrum analyser 2 settings (time span, amplitude setting range, trigger on external) to see the detected pulse in zero span mode.
- Step 15: Measure the absolute time  $t_1$  at the rising edge of the pulse related to the trigger signal. (can be positive or negative but should be close to zero).
- Step 16: Set spectrum analyser 2 frequency to the highest emission frequency within the sub-frequency band.
- Step 17: Measure the absolute time  $t_2$  at the falling edge of the pulse related to the trigger signal (see equation (55)):

$$T_{ON} = t_2 - t_1 \quad (55)$$

- If there is more than one sweep within the signal repetition time, there will be more than 1 pulse on the lowest and highest emission frequency within the sub-frequency band.  $T_{on}$  for every sweep has to be measured separately.  $T_{on}$  for every sweep start with rising edge of the pulse on the lowest emission frequency within the sub-frequency band and ends with the first following pulse on the highest emission frequency within the sub-frequency band.
- Step 18: Enlarge the time span to see the complete signal repetition time  $T_{rep}$ . Measure the signal repetition time  $T_{rep}$  and the duty cycle could be calculates as (see equation (56)):

$$\text{Duty Cycle}[\%] = \frac{\sum T_{on}}{T_{rep}} \times 100 \quad (56)$$

The observation period of the individual measurement can be reduced if max hold is used during at least the specified observation time. The max hold function has the effect to capture the max.  $T_{on}$  and the min.  $T_{rep}$  and thus leads to the worst case duty cycle.

Remark: If the frequency sweeps are not increasing in frequency, the temporally first and last emission frequency within the sub-frequency band have to be set to measure  $t_1$  and  $t_2$ .

Example measurement for a stepped-frequency system, (see figure 42) evaluated the Duty Cycle requirement for a material sensing device, covered by the ECC/DEC/(07)01 [i.4] in the 3,4 - 3,8 GHz frequency band.

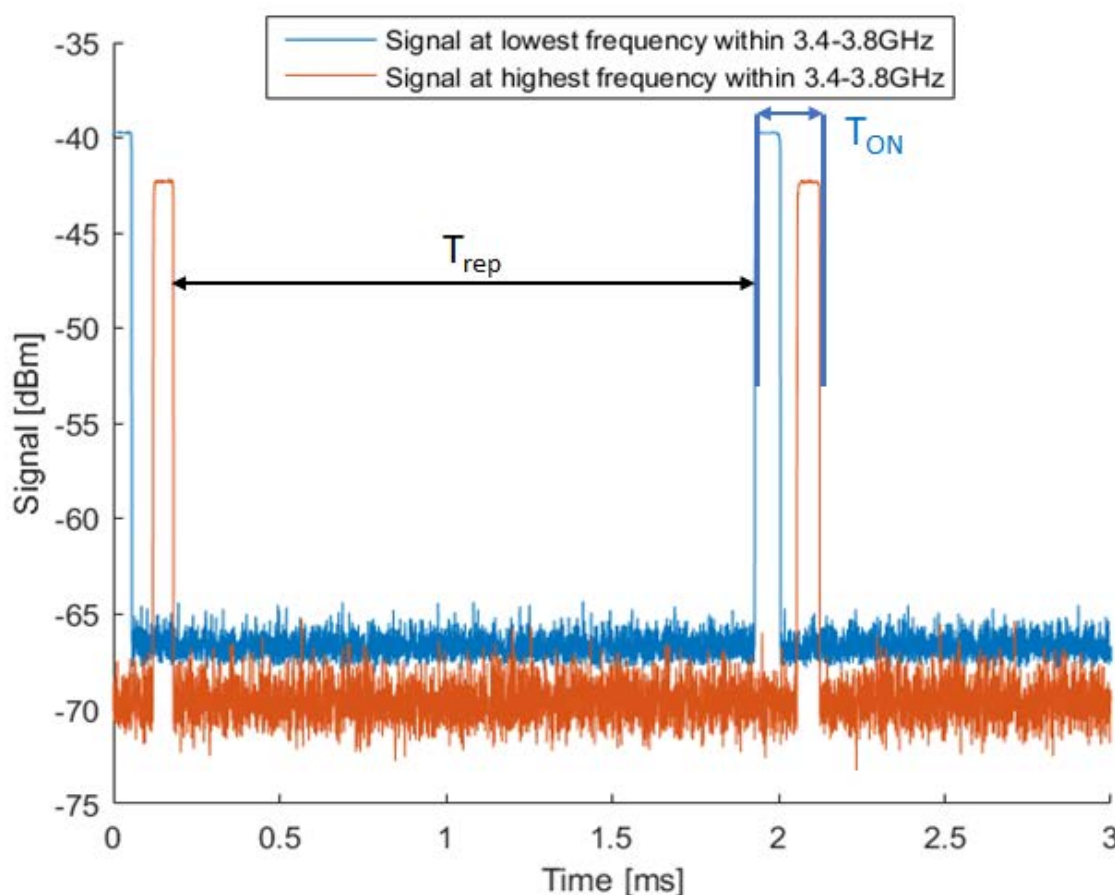

**Figure 42: Example measurement for a stepped-frequency system, evaluated in the 3,4 - 3,8 GHz frequency band**

The assessment of the measurement in figure 42 provide following results:

NOTE: The max hold was used for at least 1 s.

- $T_{rep}$ : 1,94 ms
- $T_{on}$  within the range 3,4 to 3,8 GHz: 0,18 ms

Result: with equation (56) this would lead to a DC within 3,4 to 3,8 GHz of: 9,3 %.

## 5.12 Antenna pattern/Antenna gain

### 5.12.1 Description

In the field of antenna design the term antenna pattern (or radiation pattern or far-field pattern) refers to the directional (angular) dependence of the strength of the radio waves from the antenna or other source.

The antenna pattern is defined as the antenna radiating efficiency in all directions relative to the antenna boresight.

The antenna pattern requirement is necessary to get a EUT emissions specified as e.i.r.p. based on the transmitter output power or vice versa, see clause 5.6.2. Typical the antenna gain/pattern is shown within a polar diagram (for on plane, see figure 43 and figure 44)

The Half-Power Beam Width (HPBW) is a relevant parameter to describe the directivity of an antenna, see for example figure 43 and figure 44.

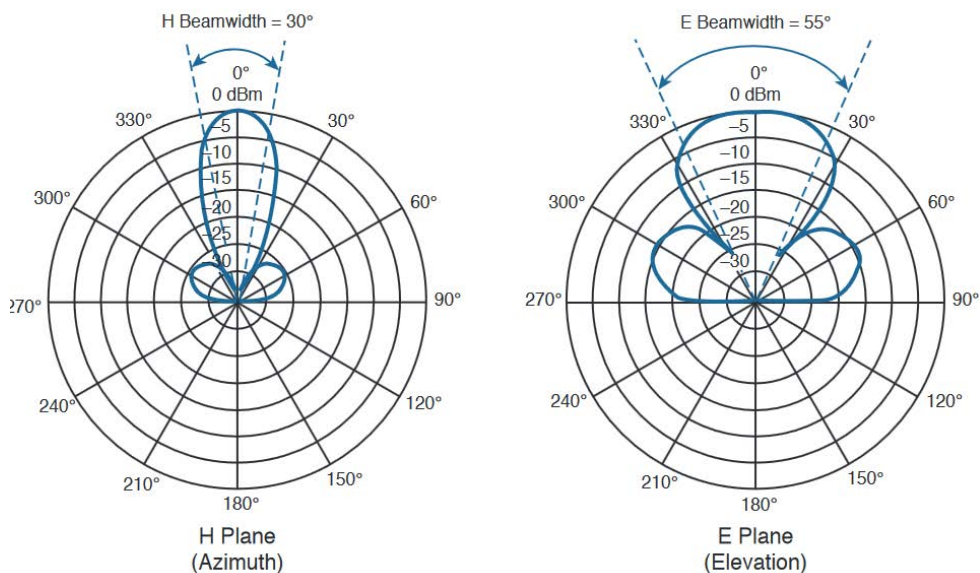

**Figure 43: Antenna pattern shown in a polar diagram (normalized H- and E-Plane) of an antenna**

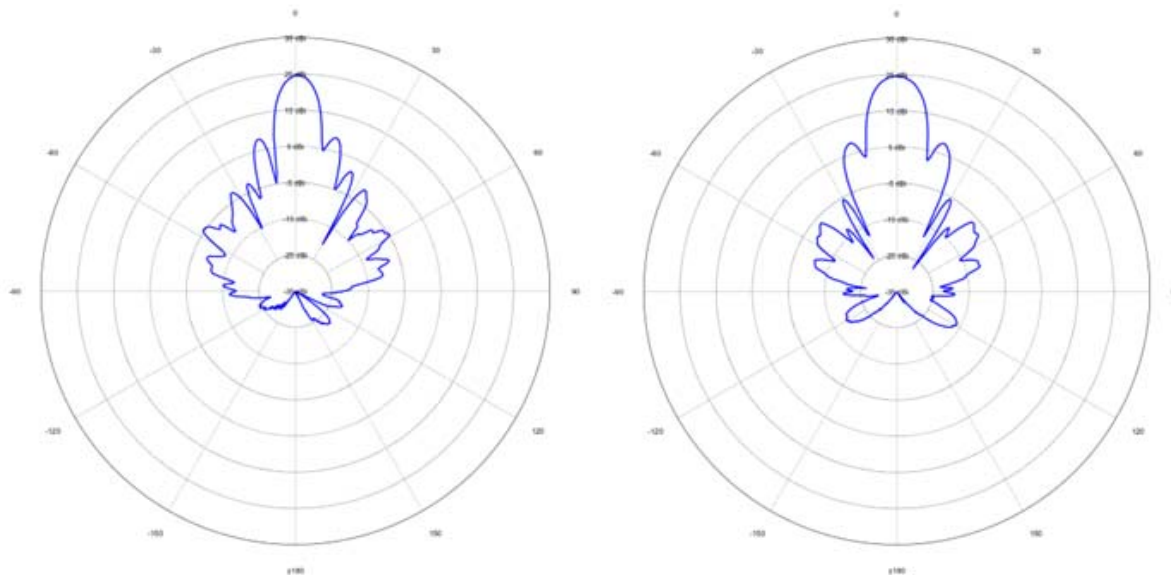

**Figure 44: Typical radiation patterns of a high directive (LPR) antenna at a centre frequency of 26 GHz (left: E-plane, right: H-plane)**

Generally, EUT can be equipped either with integral antennas or dedicated external antennas. Integral antennas often do not exhibit an antenna connector and can therefore not be accessed from the outside for measurement purposes.

External antennas (partly dedicated for the EUT) on the contrary are always equipped with a connector which can also be used for measurement purposes. EUTs with antenna connector (50  $\Omega$  or waveguide) shall use the procedure described in clause 5.12.2.

For EUTs without antenna connector (with integral antenna) the procedure described in clause 5.12.3 shall be used.

## 5.12.2 Conformance tests for external antennas

### 5.12.2.1 General

For conformance test for external antennas there are two different generic tests specified:

- Clause 5.12.2.2 describes the conformance test based on a determination against a known reference antenna.
- Clause 5.12.2.3 describes the conformance test based on a radiated measurement.

In addition, the related standard shall specify if needed use case specific details of the conformance test.

The measurement shall be at the centre frequency  $f_c$  (if nothing different is specified in the related standard, e.g. with a CW signal at different frequencies over the OFR range).

General requirements for all antenna measurement procedures (if nothing else is specified in the related standard):

- Angular measurement range for vertical and horizontal plane:  $-180^\circ$  to  $+180^\circ$  (with main lobe at  $0^\circ$ ).
- Angular resolution for both planes:
  - Within HPBW an angular resolution of  $= 1^\circ$ ; for antennas with a HPBW of  $< 5^\circ$  at least 5 uniformly distributed measurement points.
  - Outside HPBW an angular resolution of  $= 5^\circ$ .

### 5.12.2.2 Determination against a known reference antenna

#### 5.12.2.2.1 General

The measurements shall be made in an anechoic chamber and the set-up in figure 45 shall be used (different technical solutions are shown in clause B.4.1).

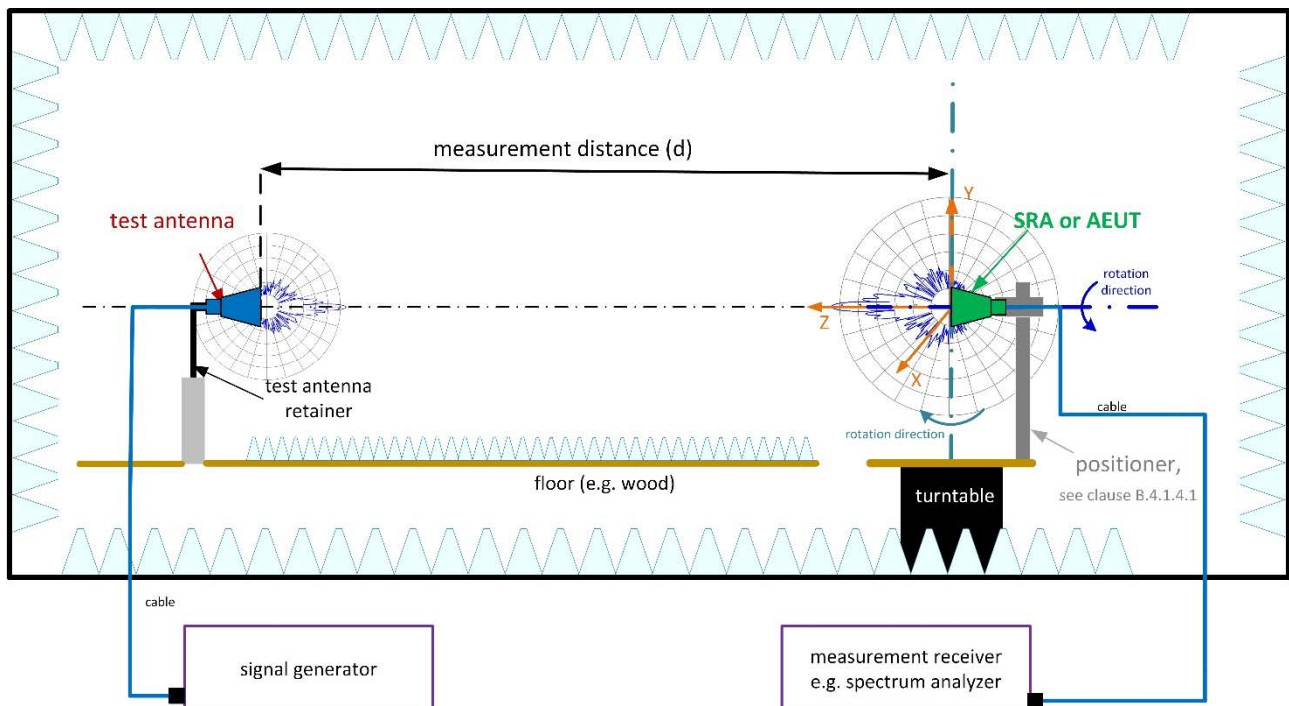

Figure 45: Test set-up for measurement of antenna pattern

The Standard Reference Antenna (SRA) shall be a linear polarized antenna with a well-known gain and radiation pattern. The exact antenna parameters of the SRA can be extracted from the manufacturer's datasheet. The antenna shall be able to be rotated around its radiating axis, see figure 40. The test antenna is connected to a signal generator. The SRA or AEUT are connected to a measurement receiver (spectrum analyser).

#### 5.12.2.2.2 Measuring distance

The measuring distance ( $d$ ) (see figure 40) should be greater than  $2D_{ap}^2/\lambda$  or  $\lambda/2$ , whichever is greater, at the frequency of measurement where  $D_{ap}$  is the largest transmitting aperture dimension (far-field conditions).

#### 5.12.2.2.3 Measurement equipment requirements

##### 5.12.2.2.3.1 Measurement receiver setting

The following spectrum analyser settings shall be used:

- Centre frequency:  $f_c$
- Span: Zero Span
- Detector mode: Peak
- Resolution bandwidth (RBW):  $\leq 30$  kHz
- Video bandwidth (VBW): VBW equal or greater than the RBW
- Sweep time: AUTO

##### 5.12.2.2.3.2 Signal generator

The signal generator shall use a Continuous Wave (CW) test signal tuned to the identified centre frequency  $f_c$  of the EUT's Operating Frequency Range (OFR) (if nothing else is specified in the related standard).

##### 5.12.2.2.3.3 Test antenna

The characteristics of the test antenna need not precisely to be known. However, the test antenna shall be a high directive antenna with a gain of at least 15 dBi (if nothing else is specified in the related standard) at the specified test frequencies.

#### 5.12.2.2.4 Test procedure

The following steps shall be followed:

- Step 1: In a first step the attenuation of the test site shall be determined by conducting a reference measurement using a known Standard Reference Antenna (SRA), e.g. a standard gain horn. The SRA will be mounted on the receiver side turntable in vertical polarisation, see figure 40. The antenna parameters of the SRA can be extracted from the manufacturer's datasheet. The SRA is connected to a spectrum analyser, see figure 45.

The test antenna is mounted on a fixed retainer in vertical polarisation in the same height as the SRA and is connected to the signal generator, as illustrated in figure 45. Now frequency of the signal generator will be set to  $f_c$  with CW modulation (or as specified in the related standard)

The power level detected by the spectrum analyser is noted as  $P_{SRA}$ . It is later used to normalise the radiation pattern and to determine the gain of the AEUT (see equation (55)).

- Step 2: In a second step, for the radiation pattern measurement of the AEUT, the SRA on the receiver side turntable is replaced with the AEUT which is also connected to the spectrum analyser. The signal generator setting will remain unchanged compared to step 1. The polarisation of the AEUT shall match the vertical polarisation of the measurement antenna.

The AUT is rotated horizontally in the defined angular measurement range (see clause 5.12.2.1) supporting the desired step width of the angular resolution. The signal level detected by the spectrum analyser shall be recorded for every angular step as  $P_{AUT}(a)$ . The maximum signal level shall be noted as  $P_{AUTmax}$ . This procedure results in the H-plane radiation pattern of the AEUT.

- Step 3: The above-described measurement procedure a) and b) shall be repeated with horizontal polarization of the three involved antennas. This procedure results in the E-plane gain and radiation pattern of the AEUT (all antennas will be rotated by 90° around the main beam direction).
- Step 4: The gain of the AEUT in main beam direction in the two measured planes (E-plane and H-plane) can be determined as follows (see equation (57)):

$$g_{AEUT}[dBi] = g_{SRA}[dBi] - P_{SRA}[dBm] + P_{AEUT}[dBm] \quad (57)$$

With:

- $g_{AUT}$ : gain of the antenna under test in main beam direction in the respective plane [dBi];
- $g_{SRA}$ : gain of the Standard Reference Antenna (SRA) in main beam direction in the respective measurement plane [dBi];
- $P_{SRA}$ : power level detected by the spectrum analyser using ideal alignment of measurement antenna and standard reference antenna in the respective measurement plane in the first step of the procedure [dBm];
- $P_{AEUTmax}$ : maximum power level detected by the spectrum analyser during the radiation pattern measurement of the AUT in the respective measurement plane in the second step of the procedure [dBm].

The measured radiation pattern  $G_{AEUT}(a)$  can then be calculated (see equation (58)) as follows:

$$g_{AUT}(a)[dBi] = g_{AEUT}[dBi] - P_{AEUTmax}[dBm] + P_{AEUT}(a)[dBm] \quad (58)$$

### 5.12.2.3 Test based on a radiated measurement

#### 5.12.2.3.1 General

The measurements shall be made in an anechoic chamber and the set-up in figure 46 shall be used (different technical solutions are shown in clause B.4.1).



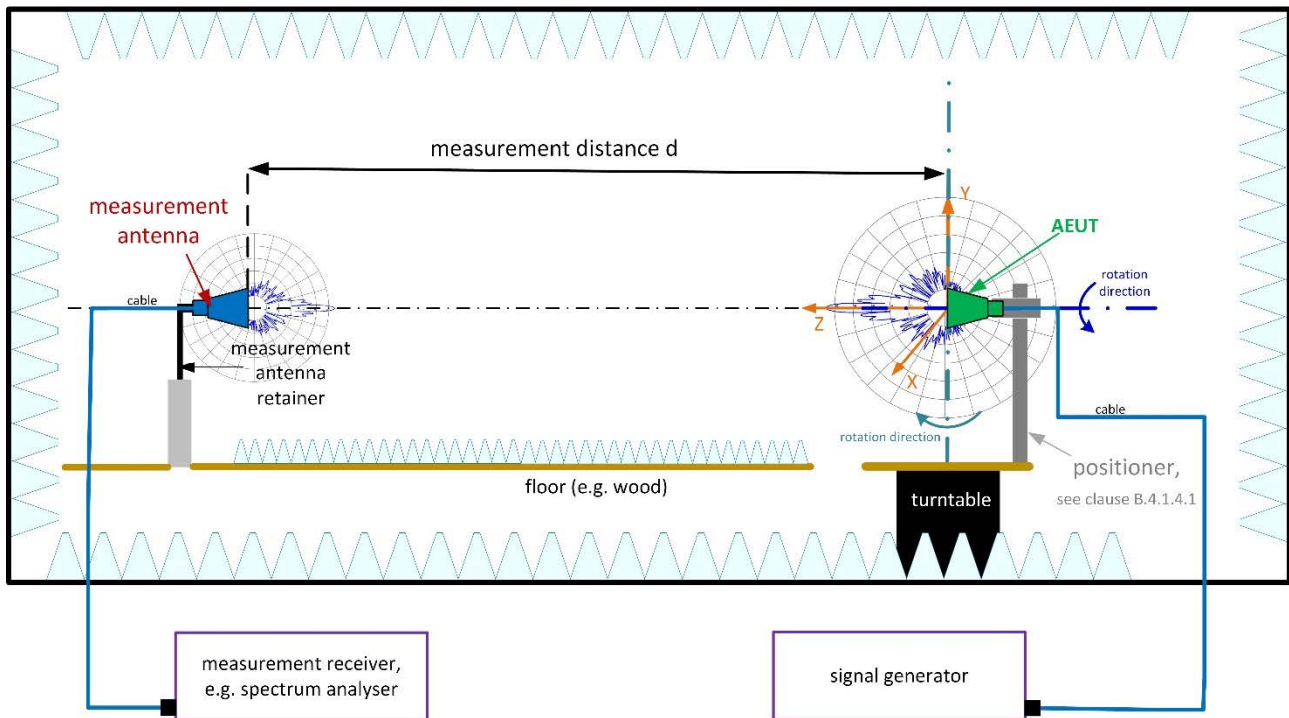

**Figure 46: Test set-up for measurement of antenna pattern**

The antenna shall be a linear polarized horn with at least 15 dBi gain (if nothing is specified in the related standard). The measurement antenna shall be able to be rotated around its radiating axis, see figure 46. The AEUT is connected to a signal generator. The measurement antenna is connected to a measurement receiver (spectrum analyser).

#### 5.12.2.3.2 Measuring distance

Under the conditions provided in this clause, measurement frequencies will be above 25 MHz and the measuring distance should be greater than  $2D_{ap}^2/\lambda$  or  $\lambda/2$ , whichever is greater, at the frequency of measurement where  $D_{ap}$  is the largest transmitting aperture dimension (far-field conditions).

#### 5.12.2.3.3 Measurement equipment requirements

##### 5.12.2.3.3.1 Measurement receiver setting

The following spectrum analyser settings shall be used:

- Centre frequency:  $f_c$
- Span: Zero Span
- Detector mode: Peak
- Resolution bandwidth (RBW):  $\leq 30$  kHz
- Video bandwidth (VBW): VBW equal or greater than the RBW
- Sweep time: AUTO

##### 5.12.2.3.3.2 Signal generator

The signal generator shall use a Continuous Wave (CW) modulated test signal tuned to the identified centre frequency  $f_c$  of the EUT's Operating Frequency Range (OFR) (if nothing else is specified in the related standard).

Instead, the related standard could specify other signal sources. For this test the related EUT could be used as signal source as well. In this case the related standard shall specify the measurement receiver setting.

#### 5.12.2.3.3 Measurement antenna

The characteristics of the measurement antenna need not precisely to be known. However, the measurement antenna shall be a high directive antenna with a gain of at least 15 dBi at the specified test frequencies.

#### 5.12.2.3.4 Test procedure

- Step 1: The following steps are to be carried out: The signal generator shall be switched-on.
- Step 2: The AEUT shall be adjusted in the direction of maximum reading at the measurement antenna (see clause 5.12.2.3.3.3). The direction on the rotating table is set as the reference direction (0° (degrees) on the rotating table).
- Step 3: The measurement antenna is rotated around its axis for maximum reading at the measurement receiver. The reading is the reference reading (0 dB).
- Step 4: The rotating table is rotated as specified in clause 5.12.2.1 and the corresponding readings on the measurement receiver shall be recorded. Any peaks reading of sidelobes shall specifically be recorded.
- Step 5: The measurement antenna is rotated 90° around its axis.
- Step 6: The measurement point d) shall be repeated.
- Step 7: The transmitter is switched-off. In case of EUT implementing more than one transmitter operating simultaneously, all the transmitters shall be switched off.
- Step 8: The AUT is mounted sideways on the rotating table (tilted by 90°) to simulate measurements of vertical antenna elevation, see figure 46.
- Step 9: The transmitter shall be switched-on again.
- Step 10: In case of the related EUT will be used as signal source and the EUT has implemented more than one transmitter operating simultaneously, all the transmitters shall be switched on.
- Step 11: Check: The measurement antenna shall still be adjusted to same height as the AEUT. An adjustment could be necessary based on different mechanical dimension of the AEUT.
- Step 12: The equipment antenna shall be adjusted in the direction of maximum reading at the measurement antenna. The direction on the rotating table is the reference direction (0°(degrees) on the rotating table).
- Step 13: The measurements antenna is rotated around its axis for maximum reading at the measurement receiver. The reference reading is the same as in step 4 above (0 dB).
- Step 14: The rotating table is rotated as specified in clause 5.12.2.1 and the corresponding readings on the measurement receiver shall be recorded. Any peaks reading of sidelobes shall specifically be recorded.
- Step 15: The measurement antenna is rotated 90° around its axis.
- Step 16: The transmitter is switched-off.

The above results in total four antenna pattern measurements. The measurements step 1 to step 9 cover the horizontal antenna pattern measurements. The measurements step 11) to step 15 cover the vertical antenna pattern.

The results shall be noted in the test report.

### 5.12.3 Conformance tests for integral antennas

For integral antennas a full spherical e.i.r.p. measurement could be used to calculate/assess the antenna gain and the antenna pattern information (e.g. beamwidth).

The antenna gain in boresight direction can be calculated as the difference between the radiated power in direction of the highest emission and the calculated TRP of the EUT (see clause 5.6.2).

The beamwidth and other pattern information (e.g. max emissions on the back side of the EUT) could be read out from the e.i.r.p. measurement, for one example see figure 47.

The same angular resolution requirements as for the previous antenna measurements do apply here (see clause 5.12.2.1).

In figure 47 the horizontal plane is X-Y plane ( $\theta = 90^\circ$ ) and the vertical plane is Y-Z plane ( $\theta = 0^\circ$ ) and the direction with the max emission (value for the gain assessment) is the negative Y-axis.

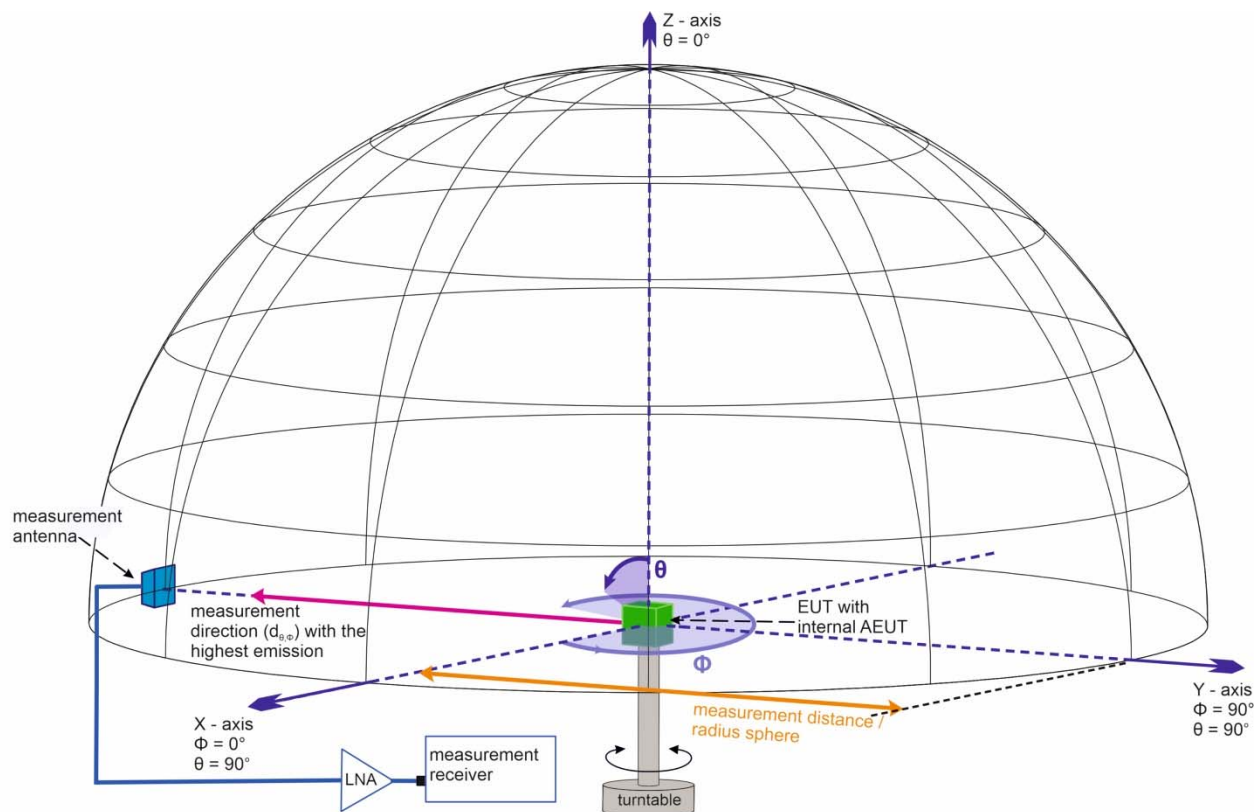

**Figure 47: Example for half spherical scan setup using automatic measurement antenna placement and a turntable to measure the antenna pattern of an internal antenna**

NOTE: Figure 47 shows only one test arrangement with related angle for a half spherical scan. Other measurement and scanning possibilities are described in clause B.4.



#### 5.12.4 Guidance to assess emissions levels above regulated elevations

In some regulations there are installations requirements or emission limits over a specified elevation angle required see table 16.

This requirement is difficult to measure within a related standard because each device could have other mounting specifications provided by the related manufacturer inside the manual. Therefore, the manufacturer needs to provide clear installation requirements for the user/installer.

This guidance will support the manufacturer in writing the specification for the EUT mounting in such a way that such emission requirement in relation to the EUT orientation in space is fulfilled. This radiation requirement could be combined with other requirements or measurements of e.g. TRP, antenna gain, other measurable radiation pattern requirements, shielding effects of the host device or real EUT e.i.r.p emissions.

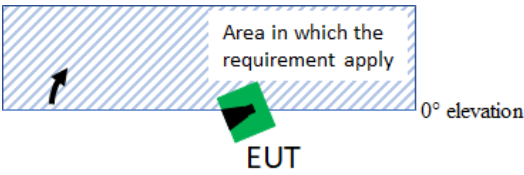
Table 16: Some examples to assess emissions levels above regulated elevations

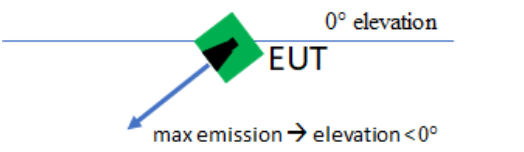
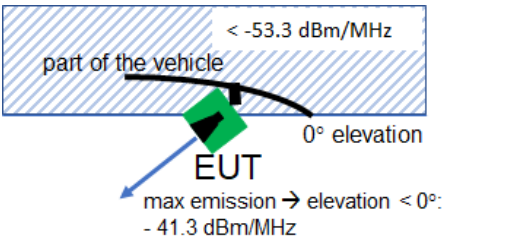
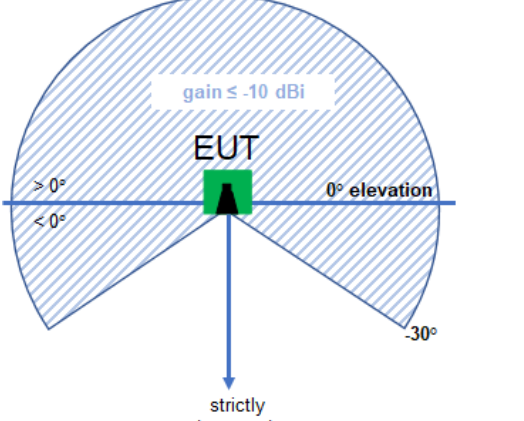
Regulation	Application	Requirement	In figure
ECC/DEC/(22)03 [i.40]	Fixed generic indoor	X dBm > 0° elevation Or X dBm/MHz > 0° elevation	
	LPR/CDR	peak e.i.r.p. for elevations above 0° shall be limited to 0 dBm	
ECC/DEC/(06)04 [i.3]	Vehicular tracking; A.1.2.3 and A.1.3.1	Antennas are directive, down tilted ....	
ECC/DEC/(06)04 [i.3]	Vehicle exterior limit	Exterior limit of -53,3 dBm/MHz over 0° elevation  The exterior limit of -53,3 dBm/MHz is outside the vehicle body. The max emission of the EUT is -41,3 dBm/MHz and outside the vehicle body (below 0° elevation) if fixed at the vehicle	
ECC/DEC/(11)02 [i.6]	LPR	Strictly downward operation  Sidelobe suppression above -30° shall be limited to -10 dBi	

Regulation	Application	Requirement	In figure
ECC/DEC/(11)02 [i.6]	Tilted LPR	<p>Downward Operation with tilt angle <math>-90^{\circ} \pm 45^{\circ}</math></p> <p>Max. Mean e.i.r.p. spectral density above <math>-30^{\circ}</math> shall be limited to <math>-41,3</math> dBm/MHz</p> <p>Max. Mean e.i.r.p. spectral density between <math>-30^{\circ}</math> and <math>-66^{\circ}</math> shall be limited to <math>-35</math> dBm/MHz</p>	

Based on the e.i.r.p. measurement and antenna pattern information the manufacturer is now able to assess the direction of the main beam or EUT orientation that these emission requirements in space are fulfilled. In other words the emissions of the side lobe emissions (still measured during e.i.r.p. or calculable via the antenna pattern information) around the EUT shall be below the emission requirement in space (over  $0^{\circ}$  elevation).

---

# Annex A (normative): General Considerations and test conditions

## A.1 Overview

In this annex, all general considerations for the testing of UWB devices will be given. These considerations and requirements are related to:

- Product Information (see clause A.2).
- Test Modulation (see clause A.3).
- Guidance on EUT Modulation for Testing (see clause A.4).
- Test Conditions (see clause A.5).
- Choice of Equipment for Test Suites (see clause A.6).
- Testing of Host Connected Equipment and Plug-In Radio Devices (see clause A.7).
- Interpretation of the measurement results (see clause A.8).
- Specific test setup and test scenarios, see related standard.

---

## A.2 Product Information

The following product information from the technical documentation file is necessary to perform the test:

- The environmental profile as declared by the manufacturer and user/installation information (conformity documentation, annex V of the RED [i.32]), see related standard.
- The type of (UWB) technology implemented in the equipment (e.g. carrier-based, impulse, etc.).
- If known the signal repetition time of the used (UWB) modulations.
- The type of modulation schemes available (e.g. OFDM modulation, pulsed modulation like PPM or Pulse Polarity Modulation or any other type of modulation, etc.).
- For all modulation schemes the modulation parameters need to be provided.
- The intended operating frequency range(s) of the equipment.
- If known the duty cycle or the duty cycle range of the EUT.
- The type of the equipment (e.g. stand-alone equipment, plug-in radio device, combined equipment, etc.), and if required the necessary companion devices.
- The intended combination(s) of the radio equipment power settings and one or more antenna assemblies and their corresponding e.i.r.p. levels.
- The nominal power supply voltages of the stand-alone radio equipment or the nominal power supply voltages of the host equipment or combined equipment in case of plug-in radio devices.
- The inclusion and any necessary implementation details of features such as gating or hopping.
- The inclusion and any necessary implementation details of any mitigation or equivalent mitigation techniques.
- In case of conducted measurements, the antenna port characteristics as well as maximum antenna gain characteristics (frequency response) over the relevant frequency range covered in the related standard.

- The manufacturer shall provide the means to operate and monitor the EUT during the tests.

---

## A.3 Guidance on EUT Modulation for Testing

The EUT modulation used should be representative of normal use of the equipment and which results in the highest RP which would be available in normal operation. The manufacturer provides the information of the modulations utilized within the technical documentation file of the EUT.

The highest mean transmit power spectral density is also likely to be affected by frame/packet length, inter-packet gaps, normal and burst modes. The manufacturer shall provide this information and the settings that were used which are considered to lead to the highest mean transmit power spectral density available in normal operation.

Implemented transmitter timeout functionality should be disabled for the sequence of the test suite.

Where radio devices are equipped with LDC mitigation, the LDC operation may be disabled for the duration of the RP test.

---

## A.4 Requirements in Case of EUT with Scanning Antennas

### A.4.1 Classification

For the purposes of the present document, EUTs are divided into three types according to the behaviour in time of the transmit antenna:

- **Fixed beam.** In this type of EUT the antenna radiation pattern is constant, and the boresight direction is fixed relative to the housing of the EUT.
- **Constant pattern.** In this type of EUT the radiation pattern of the antenna is constant, and the boresight direction varies with time. The scanning of the boresight direction is at a constant angular rate of change.
- **Variable pattern.** This type of EUT is all those that are not fixed or constant pattern. Either the antenna radiation pattern varies with time and/or direction or the scanning is not at a constant rate.

For the purposes of the above classification, fixed and constant mean within 1° or 1 % as appropriate in normal operation.

NOTE 1: The classification depends only on the transmit antenna behaviour.

NOTE 2: In general, mechanically scanned antennas will be constant pattern and electronically scanned antennas will be variable pattern.

NOTE 3: Although the terms beam and pattern are used in the singular the same considerations and classifications apply to EUT with multiple beams.

### A.4.2 Measurement of Fixed Beam EUT

No special considerations apply. Measurements shall be made on the boresight unless otherwise specified.

### A.4.3 Measurement of Constant Pattern EUT

The scanning may be inhibited, and measurements made on the boresight unless otherwise specified. The parameters of the EUT in normal operation may be calculated based on knowledge of the antenna behaviour. The manufacturer shall declare the relevant antenna parameters.

## A.4.4 Measurement of Variable Pattern EUT

Measurements shall be made with the antenna scanning. It may be necessary to perform a set of measurements over the full sphere or half sphere. For measurements of radiated energy (e.g. peak power, mean power, duty cycle) the direction shall be chosen which gives the highest value result.

---

## A.5 Test Conditions, Power Supply and Ambient Temperatures

### A.5.1 General

General information on Test Conditions, Power Supply and Ambient Temperatures are given respectively in ETSI TS 103 941 [3], clause 4.5.1.

### A.5.2 Power Sources

#### A.5.2.1 Power Sources for Stand-Alone Equipment

General information on Power Sources for Stand-Alone Equipment are given respectively in ETSI TS 103 941 [3], clause 4.5.2.1.

#### A.5.2.2 Power sources for plug-in radio devices

General information on Power sources for plug-in radio devices are given respectively in ETSI TS 103 941 [3], clause 4.5.2.2

### A.5.3 Normal and Extreme Test Conditions

General information on Normal and Extreme Test Conditions to test a EUT und the environmental profile are given respectively in ETSI TS 103 941 [3], clause 4.5.3.

### A.5.4 Test set-ups under environmental profile

General information's on test set-up for measurements under environmental profile are given respectively in ETSI TS 103 941 [3], clause 5.1. More detailed test solutions are provided in:

- ETSI TS 103 941 [3], clause 5.2 with the usage of an temperature chamber; and
- ETSI TS 103 941 [3], clause 5.3 with the usage of an climate dome and anechoic chamber.

### A.5.5 Assessment procedures over environmental profile

Assessment procedures for TX-behaviour under environmental profile are given respectively in ETSI TS 103 941 [3], clause 6.

Currently four assessment procedures depending on the kind of power (mean and peak) are provided:

- ETSI TS 103 941 [3], clause 6.2: Assessment of the radiated power based on a Mean e.i.r.p. or Peak e.i.r.p. requirement.
- ETSI TS 103 941 [3], clause 6.3: Assessment of the radiated power based on a Mean e.i.r.p. or Peak e.i.r.p. requirement and frequencies within the permitted range.



- ETSI TS 103 941 [3], clause 6.4: Full assessment over OFR and Mean e.i.r.p. spectral density.
- ETSI TS 103 941 [3], clause 6.5: Assessment over OFR and based on Mean e.i.r.p. spectral density requirement (this assessment is for EUT operating under normal usage conditions in close proximity to materials or within a complex scenario, see clause 5.7).
- ETSI TS 103 941 [3], clause 7: Assessment of power (Mean e.i.r.p. or Peak e.i.r.p.) requirement and frequencies within the permitted range based on a conducted set-up, see clause B.3.

---

## A.6 Choice of Equipment for Test Suites

### A.6.1 Choice of Model

The tests shall be carried out on one or more production models or equivalent preliminary models, as appropriate. If testing is performed on (a) preliminary model(s), then the corresponding production models shall be identical to the tested models in all respects relevant for the purposes of the present document.

### A.6.2 Presentation

Stand-alone equipment shall be tested complete with any ancillary equipment.

Plug-in radio devices may be tested together with a suitable test fixture and/or typical host equipment.

---

## A.7 Testing of Host Connected Equipment and Plug-In Radio Devices

### A.7.1 General

For combined equipment and for radio parts for which connection to or integration with host equipment is required to offer functionality to the radio, ETSI EG 203 367 [i.17], ETSI EN 303 446-1 [i.28] and ETSI EN 303 446-2 [i.29] provide necessary guidance for the assessment for such devices.

### A.7.2 The Use of a Host or Test Fixture for Testing Plug-In Radio Devices

Where the radio part is a plug-in radio device which is intended to be used within a variety of combinations, a suitable test configuration consisting of either a test fixture or typical host equipment shall be used. This shall be representative for the range of combinations in which the radio device may be used. The test fixture shall allow the radio equipment part to be powered and stimulated as if connected to or inserted into the host or combined equipment. Measurements shall be made to all requirements given in the relevant harmonised standards.

NOTE: For further information on this topic, see ETSI EG 203 367 [i.17].

## A.8 Interpretation of the measurement results

### A.8.1 General points on interpretation of the measurement results

The measurements described in the present document are based on the following assumptions:

- the measured value related to the corresponding limit will be used to decide whether an equipment meets the requirements of the present document;
- the value of the measurement uncertainty for the measurement of each parameter will be included in the test report; table A.1 below shows the recommended values for the maximum measurement uncertainty figures.

For the test methods, according to the present document, the measurement uncertainty figures are assumed to correspond to an expansion factor (coverage factor)  $k = 1,96$  or  $k = 2$  (which provide confidence levels of respectively 95 % and 95,45 % in the case where the distributions characterizing the actual measurement uncertainties are normal (Gaussian)). Principles for the calculation of measurement uncertainty are contained in ETSI TR 100 028 [i.18], in particular in annex D of the ETSI TR 100 028-2 [i.18].

Table A.1 is based on such expansion factors.

**Table A.1: Maximum measurement uncertainty**

Parameter	Maximum expanded measurement Uncertainty
Frequency stability	$\pm 1 \times 10^{-7}$
Frequency during RF power measurement	$\pm 1 \times 10^{-5}$
Radiated RF power (up to 40 GHz)	$\pm 6$ dB
Radiated RF power (above 40 GHz up to 66 GHz)	$\pm 8$ dB
Radiated RF power (above 66 GHz up to 100 GHz)	$\pm 10$ dB (see note 1)
Radiated RF power (above 100 GHz)	See note 2
Conducted RF power (up to 18 GHz)	$\pm 1,5$ dB
Conducted RF power (up to 40 GHz)	$\pm 2,5$ dB
Conducted RF power (up to 100 GHz)	$\pm 4$ dB
Conducted RF power (above 100 GHz)	See note 2
Temperature	$\pm 1$ °C
Temperature drift during environmental profile tests	$\pm 2$ K
Time	$\pm 2$ %
Humidity	$\pm 5$ %
Direct current and low frequency voltages	$\pm 3$ %
<p>NOTE 1: Achieved sensitivity and measurement uncertainty are a direct result of the chosen test suites. The values mentioned together with the concerns should therefore be considered illustrational rather than absolute for radiated measurements above 66 GHz, given the absence of some relevant information. For radiated emissions above 66 GHz the given measurement uncertainties are based on the assumption of the deployment of a cable based measurement set-up.</p> <p>NOTE 2: For measurements above 100 GHz, the expanded measurement uncertainty shall also be recorded in the test report and a detailed calculation shall be added. A future revision of the present document may include a value for frequencies above 100 GHz for expanded measurement uncertainty that is still under development.</p>	

### A.8.2 Measurement uncertainty is equal to or less than maximum acceptable uncertainty

The interpretation of the results when comparing measurement values with specification limits shall be as follows:

- When the measured value does not exceed the limit value the equipment under test meets the requirements of the present document.

- b) When the measured value exceeds the limit value the equipment under test does not meet the requirements of the present document.
- c) The measurement uncertainty calculated by the test technician carrying out the measurement shall be recorded in the test report.
- d) The measurement uncertainty calculated by the test technician may be a maximum value for a range of values of measurement or may be the measurement uncertainty for the specific measurement undertaken. The method used shall be recorded in the test report.

### A.8.3 Measurement uncertainty is greater than maximum acceptable uncertainty

The interpretation of the results when comparing measurement values with specification limits should be as follows:

- a) When the measured value plus the difference between the measurement uncertainty calculated by the test technician and the maximum acceptable measurement uncertainty does not exceed the limit value, the equipment under test meets the requirements of the present document.
- b) When the measured value plus the difference between the measurement uncertainty calculated by the test technician and the maximum acceptable measurement uncertainty exceeds the limit value the equipment under test does not meet the requirements of the present document.
- c) The measurement uncertainty calculated by the test technician carrying out the measurement shall be recorded in the test report.
- d) The measurement uncertainty calculated by the test technician may be a maximum value for a range of values of measurement or may be the measurement uncertainty for the specific measurement undertaken. The method used shall be recorded in the test report.

---

# Annex B (normative): Test setups

## B.1 Introduction

In this clause the required test setups, test and measurement antennas and test methods for the testing of SRD and UWB devices are described. Two test setups are provided:

- radiated measurements, see clause B.2; and
- conducted measurements for equipment providing a 50  $\Omega$  antenna connector, see clause B.3.

---

## B.2 Radiated measurements

### B.2.1 General

The following information for radiated measurements is provided in clause B.2:

- Clause B.2.2: Test sites and measurement antennas used for radiated measurements
- Clause B.2.3: Guidance on the use of a radiation test site
- Clause B.2.4: Information on the coupling of signals
- Clause B.2.5: Standard test methods used for radiated measurements

A more detailed descriptions of radiated measurement arrangements for UWB radio devices can be found in Recommendation ITU-R SM.1754-0 [i.19].

All reasonable efforts should be made to clearly demonstrate that emissions from the UWB and SRD transmitter do not exceed the specified levels, with the transmitter in the far field. To the extent practicable, the radio device under test shall be measured at the distance specified in clause B.2.3.5 and with the specified measurement bandwidths. However, in order to obtain an adequate signal-to-noise ratio in the measurement system, radiated measurements may have to be made at distances less than those specified in clause B.2.3.5 and/or with reduced measurement bandwidths.

The revised measurement configuration should be stated on the test report, together with an explanation of why the signal levels involved necessitated measurement at the distance employed or with the measurement bandwidth used in order to be accurately detected by the measurement equipment and calculations demonstrating compliance.

Where it is not practical to further reduce the measurement bandwidth either because of limitations of commonly-available test equipment or difficulties in converting readings taken using one measurement bandwidth to those used by the limits given in the relevant harmonised standard, and the required measurement distance would be so short that the radio device would not clearly be within the far field, the test report shall state this fact, the measurement distance and bandwidth used, the near field/far field distance for the measurement setup (see clause B.2.3.5), the measured radio device emissions, the achievable measurement noise floor and the frequency range(s) involved.

## B.2.2 Test Sites and General Arrangements for Measurements Involving the Use of Radiated Fields

### B.2.2.1 General

This clause introduces the test site which may be used for radiated tests. The test site is generally referred to as a free field test site. Both absolute and relative measurements can be performed in these sites. Where absolute measurements are to be carried out, the chamber should be verified. A detailed verification procedure is described in ETSI TS 102 321 [2]. Additional information on test sites and measurement antenna arrangement are available in CISPR 16-1-4 [i.39].

### B.2.2.2 Fully Anechoic Room (FAR)

An anechoic chamber is the preferred test site to be used for radiated testing in accordance with the present document above 1 GHz. However, an anechoic chamber with ground plane as described in clause B.2.2.3 may be used above 1 GHz providing that suitable anechoic material is placed on the chamber floor to suppress any reflected signal.

An anechoic chamber is an enclosure, usually shielded, whose internal walls, floor and ceiling are covered with radio absorbing material, normally of the pyramidal urethane foam type. The chamber usually contains an antenna support at one end and a turntable at the other. A typical anechoic chamber is shown in figure B.1.

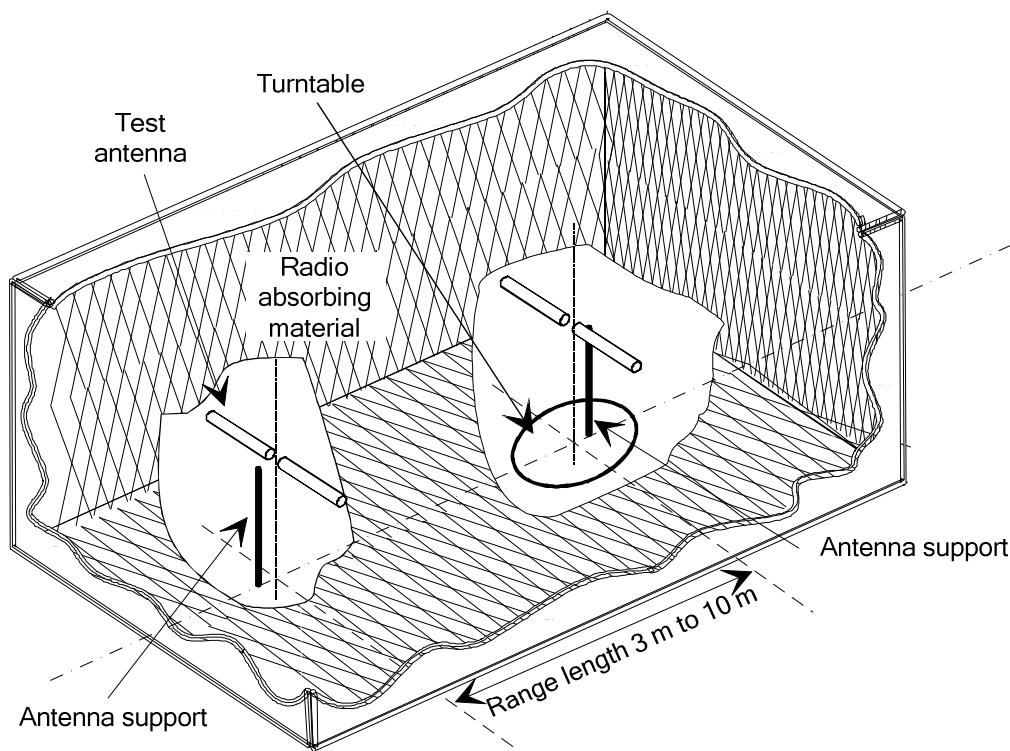

**Figure B.1: A typical anechoic chamber**

The chamber shielding and radio absorbing material work together to provide a controlled environment for testing purposes. This type of test chamber attempts to simulate free space conditions.

The shielding provides a test space, with reduced levels of interference from ambient signals and other outside effects, whilst the radio absorbing material minimizes unwanted reflections from the walls and ceiling which can influence the measurements. In practice it is relatively easy for shielding to provide high levels (80 dB to 140 dB) of ambient interference rejection, normally making ambient interference negligible.

A turntable is capable of rotation through 360° in the horizontal plane and it is used to support the test sample (EUT) at a suitable height (e.g. 1 m) above the ground plane. The range length shall be in accordance with clause B.2.3.5.

The anechoic chamber generally has several advantages over other test facilities. There is minimal ambient interference, minimal floor, ceiling and wall reflections, and it is independent of the weather. It does however have some disadvantages which include limited measuring distance and limited lower frequency usage due to the size of the pyramidal absorbers. To improve low frequency performance, a combination structure of ferrite tiles and urethane foam absorbers is commonly used.

All types of emission testing can be carried out within an anechoic chamber without limitation.

### B.2.2.3 Semi Anechoic Chamber (SAC)

An anechoic chamber with a conductive ground plane shall be used for radiated testing in accordance with the present document below 1 GHz.

An anechoic chamber with a conductive ground plane is an enclosure, usually shielded, whose internal walls and ceiling are covered with radio absorbing material, normally of the pyramidal urethane foam type. The floor, which is metallic, is not covered and forms the ground plane. The chamber usually contains an antenna mast at one end and a turntable at the other. A typical anechoic chamber with a conductive ground plane is shown in figure B.2.

This type of test chamber attempts to simulate an ideal Open Area Test Site whose primary characteristic is a perfectly conducting ground plane of infinite extent.

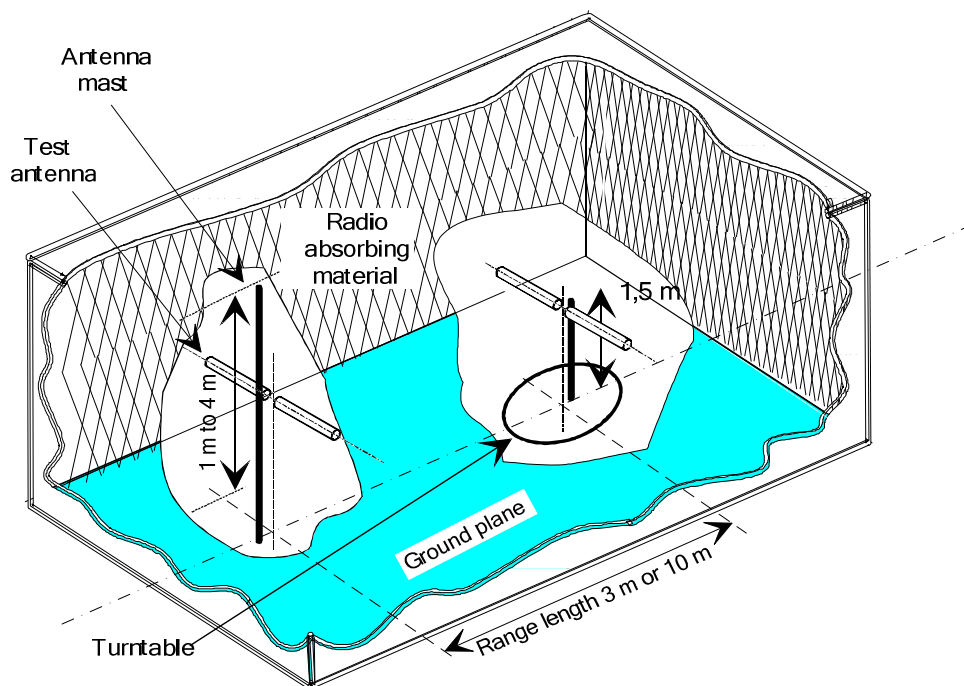

**Figure B.2: A typical anechoic chamber with a conductive ground plane**

In this facility the ground plane creates the wanted reflection path, such that the signal received by the receiving antenna is the sum of the signals from both the direct and reflected transmission paths. This creates a unique received signal level for each height of the transmitting antenna (or EUT) and the receiving antenna above the ground plane.

The antenna mast provides a variable height facility (from 1 m to 4 m) so that the position of the test/measurement antenna can be optimized for maximum coupled signal between antennas or between a EUT and the measurement antenna.

A turntable is capable of rotation through 360° in the horizontal plane and it is used to support the test sample (EUT) at a specified height, usually 1,5 m above the ground plane. The chamber shall be large enough to allow the measuring distance of at least 3 m or  $2(d_1 + d_2)^2 / \lambda$  (m), whichever is greater (see clause B.2.3.5). However, it shall be noted that due to the low radiated power density for some equipment (e.g. UWB) its transmit spectrum can only be measured at approximately 1 m. The distance used in actual measurements shall be recorded with the test results.

Emission testing involves firstly searching for the maximum field strength from the EUT by raising and lowering the receiving antenna on the mast (to obtain the maximum constructive interference of the direct and reflected signals from the EUT) at every azimuth position by using a turntable. At the position of maximum field strength, the amplitude of the received signal at the measuring receiver is noted. Secondly the EUT is replaced by a substitution antenna (positioned at the EUT's phase or volume centre), which is connected to a signal generator. The signal generator output will be adjusted until the level at the measuring receiver is at the same level as noted in stage one.

#### B.2.2.4 Open Area Test Site (OATS)

An Open Area Test Site comprises a turntable at one end and an antenna mast of variable height at the other end above a ground plane, which in the ideal case, is perfectly conducting and of infinite extent. In practice, whilst good conductivity can be achieved, the ground plane size has to be limited. A typical OATS is shown in figure B.3.

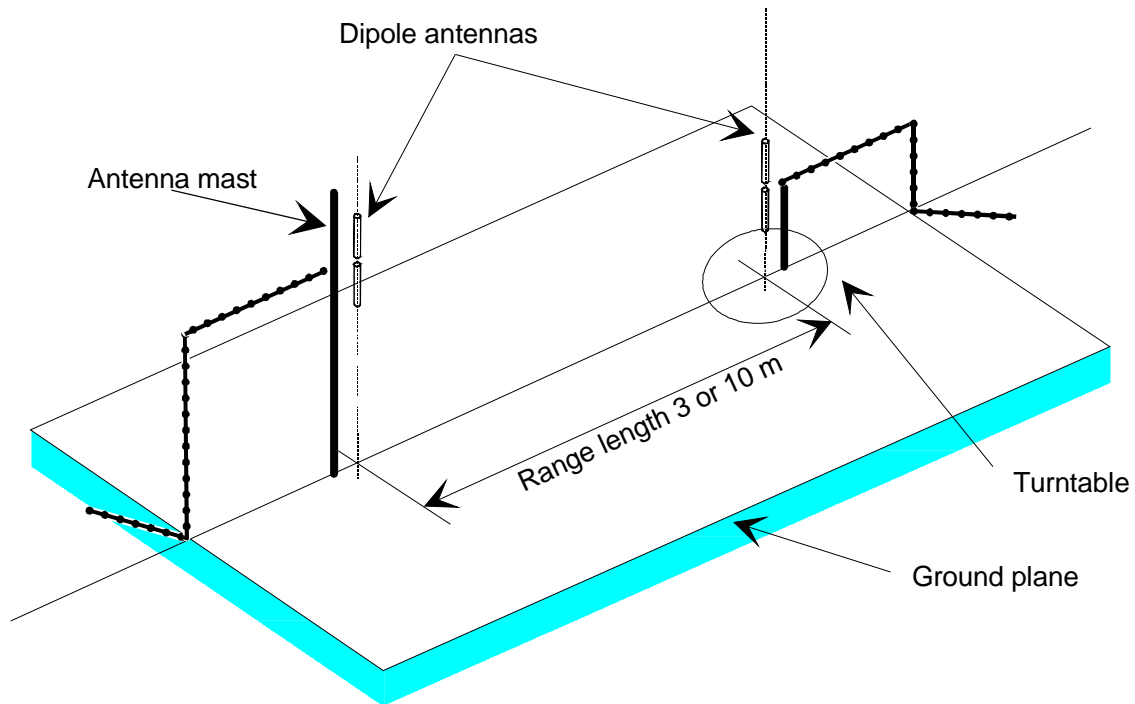

**Figure B.3: A typical Open Area Test Site**

The ground plane creates a wanted reflection path, such that the signal received by the receiving antenna is the sum of the signals received from the direct and reflected transmission paths. The phasing of these two signals creates a unique received level for each height of the transmitting antenna (or EUT) and the receiving antenna above the ground plane.

Site qualification concerning antenna positions, turntable, measurement distance and other arrangements are same as for anechoic chamber with a ground plane. In radiated measurements an OATS is also used by the same way as anechoic chamber with a ground plane.

**NOTE:** Annex A of EN 55016-2-3 [i.44] provides information on how to perform measurements in presence of interfering signals (ambient signals) from the environment.

Typical measuring arrangement common for ground plane test sites is presented in figure B.4.

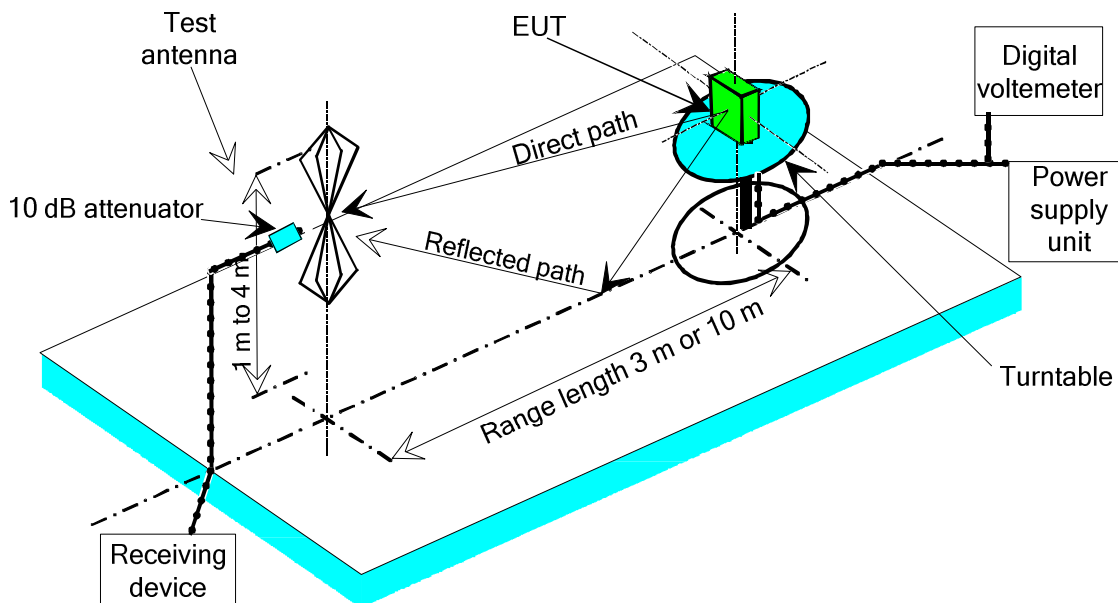

**Figure B.4: Measuring arrangement on ground plane test site (OATS set-up for spurious emission testing)**

### B.2.2.5 Measurement Antenna

A measurement antenna is always used in radiated test methods. In emission tests (i.e. effective radiated power, spurious emissions) the measurement antenna is used to detect the field from the EUT in one stage of the measurement and from the substitution antenna in the other stage. When the test site is used for the measurement of receiver characteristics (i.e. sensitivity and various immunity parameters) the antenna is used as the transmitting radio device.

The measurement antenna should be mounted on a support capable of allowing the antenna to be used in either horizontal or vertical polarization which, on ground plane sites (i.e. anechoic chambers with ground plane) should additionally allow the height of its centre above the ground to be varied over the specified range (usually 1 m to 4 m).

In the frequency band 30 MHz to 1 000 MHz, dipole antennas (constructed in accordance with ANSI C63.5 [i.20]) are generally recommended. For frequencies of 80 MHz and above, the dipoles should have their arm lengths set for resonance at the frequency of test. Below 80 MHz, shortened arm lengths are recommended. For spurious emission testing, however, a combination of bicones and log periodic dipole array antennas (commonly termed "log periodic") could be used to cover the entire 30 MHz to 1 000 MHz band. Above 1 000 MHz, waveguide horns are recommended although, again, log periodic could be used.

NOTE: The gain of a horn antenna is generally expressed relative to an isotropic radiator.

### B.2.2.6 Substitution Antenna

The substitution antenna is used to replace the EUT for tests in which a transmitting parameter (i.e. frequency error, effective radiated power, spurious emissions and adjacent channel power) is being measured. For measurements in the frequency band 30 MHz to 1 000 MHz, the substitution antenna should be a dipole antenna (constructed in accordance with ANSI C63.5 [i.20]). For frequencies of 80 MHz and above, (resonant) dipoles should have their arm lengths set for resonance at the frequency of test. Below 80 MHz, shortened arm lengths are recommended (when resonant dipoles are used). For measurements above 1 000 MHz, a waveguide horn is recommended. For broadband dipoles, such as ANSI C63.5-compliant [i.20] or CISPR 16-1-6 [i.33] biconical antennas, such adjustment is unnecessary.



### B.2.2.7 Test Antenna

The test antenna is used in tests on a EUT in which a receiving parameter (i.e. sensitivity and various immunity tests) is being measured. Its purpose is to enable a measurement of the electric field strength in the vicinity of the EUT. For measurements in the frequency band 30 MHz to 1 000 MHz, the test antenna should be a dipole antenna (constructed in accordance with ANSI C63.5 [i.20]). For frequencies of 80 MHz and above, the dipoles should have their arm lengths set for resonance at the frequency of test. Below 80 MHz, shortened arm lengths are recommended. The centre of this antenna should coincide with either the phase centre or volume centre (as specified in the test method) of the EUT.

### B.2.2.8 Minimum Requirements for Test Sites for Measurements above 18 GHz

Generally, the test site shall be adequate to allow for testing in the far field of the EUT. The test site should therefore consist of an electromagnetic anechoic room where either at least the ground surface is covered with radio absorbing material or up to six surrounding surfaces are covered with radio absorbing material. The absorbing material shall have a minimum attenuation of 30 dB. It shall be verified that reflections are sufficiently reduced. The test site shall have the following dimensions:

- Width of 2 m.
- Length of 3 m.
- Height of 2 m (only applicable for a room with more than one reflecting surface).

Highly directional receiving antennas help in reducing reflections. The use of standard gain horn antennas is recommended. It shall be noted that if the antenna aperture is smaller than the EUT, sufficient measurements in both azimuth and elevation shall be conducted in order to ensure that the maximum radiation is determined.

The measuring distance shall be selected in such way that antenna coupling effects are avoided. A distance of at least 0,5 m is therefore recommended. The EUT may be positioned at any height that minimizes reflections from the floor.

Due to high loss of coaxial cables at higher frequencies, the connection from the receiving antenna to the measuring receiver should not exceed 1 m, thus making it necessary to place the measuring receiver very close. This is especially the case when using external harmonic mixers with very short connections to the measuring receiver. Therefore, the measuring receiver should somehow be covered with radio absorbing material in direction to the measuring field in order to reduce reflections. Figure B.5 shows an example of a test site above 18 GHz with one reflecting surface.

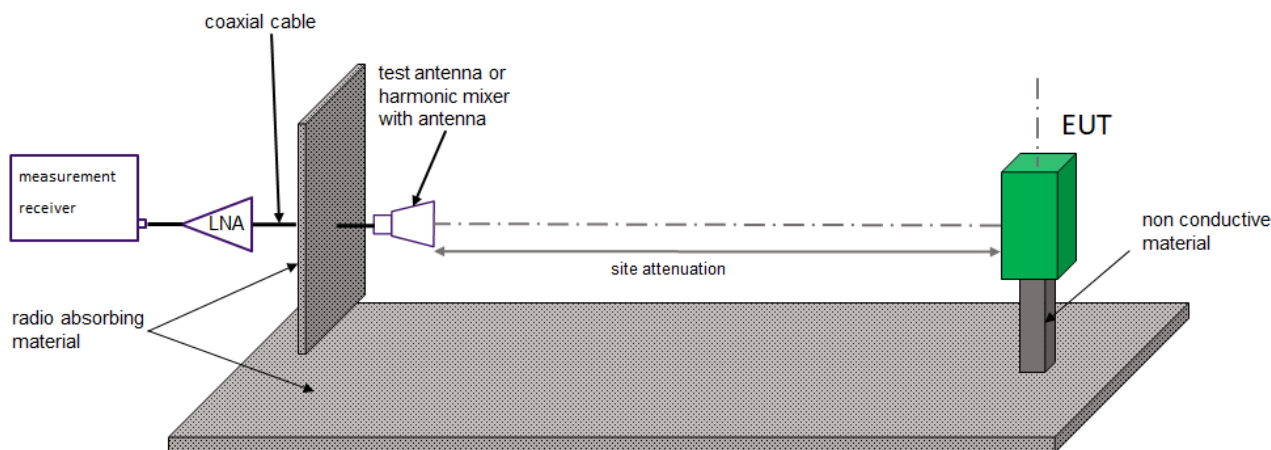

**Figure B.5: Example of a test site above 18 GHz with one reflecting surface**

The site attenuation of the test site can be determined. Should the test site in its characteristics be nearly ideal, it may be possible to use the theoretical Free Space Loss (FSL, see equation (B.1)) as site attenuation as shown in the examples in table B.1, table B.2 and table B.3.

**Table B.1: Example of Free Space Loss at 1 m distance**

Measuring distance/m	F [GHz]	$\lambda$ [m]	FSL [dB]
1	24,2	0,012397	60,12
	48,4	0,006198	66,14
	72,6	0,004132	69,66
	96,8	0,003099	72,16

**Table B.2: Example of Free Space Loss at 0,5 m distance**

Measuring distance/m	F [GHz]	$\lambda$ [m]	FSL [dB]
0,5	24,2	0,012397	54,1
	48,4	0,006198	60,12
	72,6	0,004132	63,64
	96,8	0,003099	66,14

**Table B.3: Example of Free Space Loss at 0,25 m distance**

Measuring distance/m	F [GHz]	$\lambda$ [m]	FSL [dB]
0,25	72,6	0,004132	57,62
	96,8	0,003099	60,12

$$FSL = 20 \log \left( \frac{4\pi r}{\lambda} \right) \quad (\text{B.1})$$

Whereas wavelength:

$$\lambda = \frac{c}{f} \quad (\text{B.2})$$

## B.2.3 Guidance on the Use of a Radiation Test Site

### B.2.3.1 General on Guidance on the Use of a Radiation Test Site

This clause details procedures, test equipment arrangements and verification that should be carried out before any of the radiated tests are undertaken.

### B.2.3.2 Verification of the Test Site

No test should be carried out on a test site which does not possess a valid certificate of verification. The verification procedures for the different types of test sites described in clause B.2.2 (i.e. FAR in clause B.2.2.2 and SAC in clause B.2.2.3) are given in the relevant parts of ETSI TR 102 273 [i.21] or equivalent.

### B.2.3.3 Preparation of the EUT

The manufacturer should supply information about the EUT covering the operating frequency, polarization, supply voltage(s) and the reference face. Additional information, specific to the type of EUT should include, where relevant, carrier power, channel separation, whether different operating modes are available (e.g. high and low power modes) and if operation is continuous or is subject to a maximum test duty cycle (e.g. 1 minute on, 4 minutes off).

Where necessary, a mounting bracket of minimal size should be available for mounting the EUT on the turntable. This bracket should be made from low conductivity, low relative dielectric constant (i.e. less than 1,5) material(s) such as expanded polystyrene, balsawood, etc.

### B.2.3.4 Power Supplies to the EUT

Where possible, all tests should be performed using power supplies, including tests on EUT designed to include battery-only use. However, devices may be tested with internal batteries in that casing materials, components, and sealants used for assembly, can affect test results.

If a battery supply is used, fully-charged batteries shall be used. The batteries used shall be as supplied or recommended by the manufacturer. If internal batteries are used, at the end of each test the voltage shall be within a tolerance of  $\pm 5\%$  relative to the voltage at the beginning of each test. If the battery is not accessible (for example, it is internal to a sealed unit), then it is acceptable to determine the battery voltage at the start and end of the test by indirect means (e.g. battery health messages sent from the unit itself). In all cases, in which power leads are used, they should be connected to the EUT's supply terminals (and monitored with a digital voltmeter) but the battery should remain present, electrically isolated from the rest of the equipment, possibly by putting tape over its contacts.

The presence of these power cables can, however, affect the measured performance of the EUT. For this reason, they should be made to be "transparent" as far as the testing is concerned. This can be achieved by routing them away from the EUT and down to either the screen, ground plane or facility wall (as appropriate) by the shortest possible paths. Precautions should be taken to minimize pick-up on these leads (e.g. the leads could be twisted together, loaded with ferrite beads at 0,15 m spacing or otherwise loaded).

### B.2.3.5 Range Length and measurement distance

#### B.2.3.5.1 General

The range length ( $D_f$ ) is the minimum measurement distance which allows testing in the far field of the EUT. The measurement distance shall be equal or larger (see equation (B.3)):

$$D_f = \frac{2(d_1 + d_2)^2}{\lambda} \quad (\text{B.3})$$

Where:

- $D_f$  the range length is the minimum measurement distance
- $d_1$  is the largest dimension of the EUT/dipole after substitution (m);

NOTE 1: Dimension of the EUT antenna or EUT (for e.g. hand held device).

- $d_2$  is the largest dimension of the measurement antenna (m);
- $\lambda$  is the test frequency wavelength (m).

It should be noted that in the substitution part of this measurement, where both test and substitution antennas are half wavelength dipoles, this minimum range length for far-field testing would be:

$$D_f = 2\lambda \quad (\text{B.4})$$

It should be noted in test reports when either of these conditions is not met so that the additional measurement uncertainty can be incorporated into the results.

NOTE 2: For the fully anechoic chamber, no part of the volume of the EUT should, at any angle of rotation of the turntable, fall outside the "quiet zone" of the chamber at the nominal frequency of the test.

NOTE 3: The "quiet zone" is a volume within the anechoic chamber (without a ground plane) in which a specified performance has either been proven by test or is guaranteed by the designer/manufacturer. The specified performance is usually the reflectivity of the absorbing panels or a directly related parameter (e.g. signal uniformity in amplitude and phase). It should be noted however that the defining levels of the quiet zone tend to vary.

### B.2.3.5.2 Practical Test Distances for Accurate Measurements

It may not be possible to measure at the power limits without low-noise amplification to reduce the overall noise figure of the overall measurement system at a separation of approximately 3 m in an RF quiet environment. A move to lower separation distance or reduced measurement bandwidth may be required since the instrumentation noise floor should be below the limit within the instrument bandwidth.

The far field condition may imply impossible distances for accurate measurement of power limits or conventional antenna-pattern. For this purpose, a lower range length is applicable if the additional measurement uncertainty contributions in Table B.4 are considered for the related range length.

**Table B.4: Uncertainty contribution: range length (test methods) according to ETSI TR 102 215 [i.22]**

Range length (i.e. the horizontal distance between phase centres)	Standard measurement uncertainty of the contribution
$D_i/8 \leq \text{range length} < D_i/4$	1,26 dB
$D_i/4 \leq \text{range length} < D_i/2$	0,30 dB
$D_i/2 \leq \text{range length} < D_r$	0,10 dB
range length $\geq D_r$ (far field conditions)	0,00 dB

Further information can be found in ETSI TR 102 215 [i.22].

### B.2.3.6 Site Preparation

The cables for both ends of the test site should be routed horizontally away from the testing area for a minimum of 2 m and then allowed to drop vertically and out through either the ground plane or screen (as appropriate) to the test equipment. Precautions should be taken to minimize pick up on these leads (e.g. dressing with ferrite beads, or other loading). The cables, their routing and dressing should be identical to the verification set-up.

Calibration data for all items of test equipment should be available and valid. For test, substitution and measuring antennas, the data should include gain relative to an isotropic radiator (or antenna factor) for the frequency of test. Also, the VSWR of the substitution and measuring antennas should be known.

The calibration data on all cables and attenuators should include insertion loss and VSWR throughout the entire frequency range of the tests. All VSWR and insertion loss figures should be recorded in the logbook results sheet for the specific test.

Where correction factors/tables are required, these should be immediately available.

For all items of test equipment, the maximum measurement uncertainty they exhibit should be known along with the distribution of the uncertainty.

At the start of measurements, system checks should be made on the items of test equipment used on the test site.

## B.2.4 Coupling of Signals

### B.2.4.1 General

The presence of leads in the radiated field may cause a disturbance of that field and lead to additional measurement uncertainty. These disturbances can be minimized by using suitable coupling methods, offering signal isolation and minimum field disturbance (e.g. optical and acoustic coupling).

### B.2.4.2 Data Signals

Isolation can be provided by the use of optical, ultrasonic or infrared means. Field disturbance can be minimized by using a suitable fibre optic connection. Ultrasonic or infrared radiated connections require suitable measures for the minimization of ambient noise.

## B.2.5 Standard Radiated Test Methods

### B.2.5.0 Initial Measurement Steps

In a first step the relevant frequency band for the measurement of the System under test has to be identified by using the product information from clause A.2 and a coarse peak power measurement using a spectrum analyser. After the identification of the relevant band of the EUT the further measurement steps can be performed. The identification step is independent of the system to be measured and the measurement to be performed (mean power or peak power, radiated or conducted).

The settings of the instrument have to be chosen based on the description of the signal provided, so as to ensure that the highest values of peak power and mean PSD are captured. This is particularly important for a scanning instrument (spectrum analyser) and a signal that has complex variation in time or over frequency. It is suggested that the signal should initially be observed with both peak and mean measuring modes, over its full bandwidth, to confirm the description and to establish where the highest values can and cannot be in RF. This will permit subsequent measurements to be made with a narrower RF span. Where there is any doubt about the effect of frequency scanning, a measurement at a single RF (zero spans) will provide confirmation.

### B.2.5.1 General Information on Test Methods

Two methods of determining the radiated power of a radio device are described in clause B.2.5.2 (pre-substitution / calibrated method) and clause B.2.5.3 (substitution method).

### B.2.5.2 Pre-substitution / calibrated method

The measurement receiver, measurement antenna and all associated equipment (e.g. cables, filters, amplifiers, etc.) shall have been recently calibrated against known standards at all the frequencies on which measurements of the equipment are to be made.

- Step 1: A test site according to clause B.2.2 shall be selected based on the guidance in clause B.2.3. The equipment shall be placed at the specified height on a support, and in the position closest to normal use of the EUT.
- Step 2: The measurement antenna shall be at the same height as the EUT and oriented initially for vertical polarization.
- Step 3: The output of the measurement antenna shall be connected to the spectrum analyser.
- Step 4: The EUT shall be switched on (in the mode as specified in the related standard).
- Step 5:
- For SAC (clause B.2.2.3) or OATS (clause B.2.2.4), the measurement antenna shall be raised and lowered through the specified range of height until a maximum signal level is detected by the spectrum analyser. When a test site according clause B.2.2.2 is used, the height of the measurement antenna shall not be varied.
  - The EUT shall then be rotated through 360° in the horizontal plane, until the maximum signal level is detected by the spectrum analyser.
  - For SAC (clause B.2.2.3) or OATS (clause B.2.2.4), the measurement antenna shall be raised and lowered again at the place of maximum emission in the horizontal plane from previous measurement through the specified range of height until a maximum signal level is detected by the spectrum analyser.
- Step 6: Step 5 shall be repeated for horizontal polarized measurement antenna orientation.
- Step 7: The maximum signal level from step 5 and 6 shall be noted and converted into the radiated power by applying the method in clause B.2.6.

The above procedure is to be performed with both polarizations: vertical and horizontal.

### B.2.5.3 Substitution Method

- Step 1: A test site according to clause B.2.2 shall be selected based on the guidance in clause B.2.3.
- Step 2: The EUT shall be placed at the specified height on a radio transparent support, and in the position closest to normal use of the EUT. The measurement antenna shall be oriented initially for vertical polarization.
- Step 3: The output of the measurement antenna shall be connected to the spectrum analyser. The measurement antenna shall be at the same height as the EUT (for FAR according to clause B.2.2.2 this height remains for the full test, while this changes for SAC (clause B.2.2.3) and OATS (clause B.2.2.4) due to their height scan).
- Step 4: The EUT shall be switched on (in the mode as specified in the related standard).
- Step 5:
- For SAC (clause B.2.2.3) or OATS (clause B.2.2.4), the measurement antenna shall be raised and lowered through the specified range of height until a maximum signal level is detected by the spectrum analyser. When a FAR (clause B.2.2.2) is used, the height of the measurement antenna shall not be varied.
  - The EUT shall then be rotated through 360° in the horizontal plane, until the maximum signal level is detected by the spectrum analyser.
  - For SAC (clause B.2.2.3) or OATS (clause B.2.2.4), the measurement antenna shall be raised and lowered again at the place of maximum emission in the horizontal plane from previous measurement through the specified range of height until a maximum signal level is detected by the spectrum analyser.
- Step 6: Step 5 shall be repeated for horizontal polarized measurement antenna orientation.
- Step 7: The maximum signal level from step 5 and 6 shall be noted.
- Step 8: The EUT shall be replaced by a substitution antenna as defined in clause B.2.2.6. The mainbeam of the substitution antenna shall point to the measurement antenna.
- Step 9: The substitution antenna shall be orientated for vertical polarization.
- Step 10: The substitution antenna shall be connected to a calibrated signal generator and the signal generator shall be switched on.
- Step 11: For SAC (clause B.2.2.3) or OATS (clause B.2.2.4), the measurement antenna shall be raised and lowered through the specified range of height to ensure that the maximum signal is received. When a test site according clause B.2.2.2 is used, the height of the measurement antenna shall not be varied.
- Step 12: The output power and frequency of the signal generator shall be adjusted to the level from step 7.
- Step 13: The output power of the signal generator shall be recorded.
- Step 14: The measurement from step 4 to step 14 shall be repeated with the measurement antenna and the substitution antenna orientated for horizontal polarization.
- Step 15: The radiated power of the EUT is the larger of the two levels recorded at step 14, corrected by the gain of the substitution antenna and the cables losses between signal generator and substitution antenna (radiated power = output power of the signal generator - gain of substitution antenna + substitution antenna cable loss).

### B.2.6 Method for determination of the correction factor

The method below aims to derive a data base of correction factors (COR) for each possible combination of substitution antenna and measurement antenna position. It can be used to derive the radiated power  $P_{\text{abs}}$  for the measurements in clause B.2.5.2 and B.4.3.

The setup is shown in figure B.6.

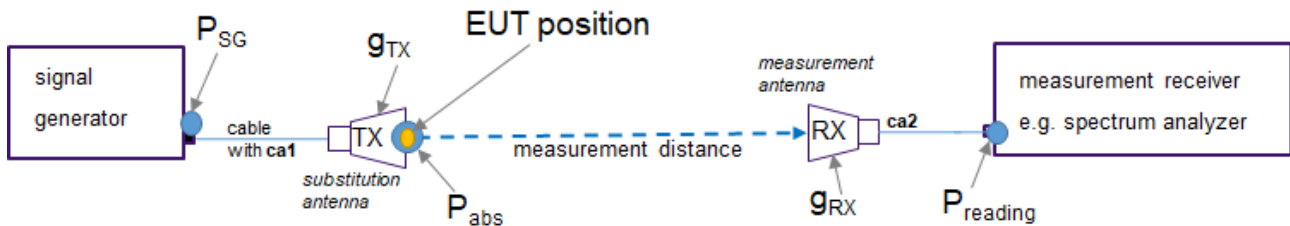

**Figure B.6: Calibration set-up configuration**

With:

$P_{reading}$  = the absolute power level (in e.g. dBm) noted from the measurement receiver.

$g_{TX}$  = antenna gain in dB of the substitution antenna.

$g_{RX}$  = antenna gain in dB of the measurement antenna.

$P_{abs}$  = the radiated power (in e.g. [dBm]) of the EUT (e.i.r.p.).

$ca_{1,2}$  = cable attenuation [dB].

$P_{SG}$  = the power (in e.g. [dBm]) of the signal generator.

- Step 1: The maximum signal levels ( $P_{reading}$ ) of the EUT including the related frequency, antenna polarisation and measurement antenna heights (for SAC and OATS) from a pre-substitution radiated power measurement method as specified in a harmonised standard are needed for this procedure (e.g. as in step 7 of clause B.2.5.2 or B.4.3).
- Step 2: Based a pre-substitution radiated power measurement method as specified in a harmonised standard (e.g. as in clause B.2.5.2 or B.4.3), replace the EUT by a substitution antenna at the same position of the EUT in the test set-up (phase centre of substitution antenna at the centre of the EUT). Orientate the substitution antenna in the test set-up towards the measurement antenna. The reference plane of the substitution antenna shall coincide with the EUT reference plane. The distance between the substitution antenna and the measurement antenna, the measurement antenna and the measurement receiver shall be as specified in the measurement procedure from step 1.
- Step 3: Connect a signal generator to the substitution antenna in the test set-up and switch it on.
- Step 4: Calculate and record the correction factor COR based on equation (B.5).

$$COR = P_{reading} - P_{SG} \quad (B.5)$$

as a function of:

- the frequency range of the substitution antenna;
- the chosen test distance;
- horizontal/vertical polarisation of substitution and measurement antenna;
- test sites (different antenna heights of measurement antenna at SAC/OATS).

The result is a multi-dimensional matrix of COR.

- Step 5: The radiated power can be calculated with equation (B.6) as:

$$P_{abs} = COR + P_{reading} - ca_3 + g_{TX} \quad (B.6)$$

## B.3 Conducted Measurements

### B.3.1 General

Conducted measurements are permitted when specific requirements are fulfilled:

- The EUT is equipped with a permanent antenna connector or the EUT could be equipped with a temporary antenna connector (EUT design provide connector mounting). In both cases the connector shall be a standardized coaxial or a hollow waveguide connector.

NOTE: For EUTs with integral antennas and no intended interface to attach a standardised temporary antenna connector, it is not possible to perform a conducted TX power measurement in a reproduceable way. The power can only be assessed via a TRP measurement, see clause 5.6.

- The measurement receiver should be set according to the specified power requirement in the related standard (mean or peak). The kind of power shall be measured as described in the related clause 5.3 and specified in the related standard.

Set up of the measurement receiver for:

- Mean power see clause 5.3.1.
- Mean spectral density power see clause 5.3.2.
- Peak power see clause 5.3.3.
- Peak power defined in 50 MHz, see clause 5.3.4.
- There are two different possibilities for the conducted measurement:
  - With cable (coaxial), see clause B.3.2.
  - With a waveguide connection, see clause B.3.3.

### B.3.2 Conducted measurement via cable connection

In the case of a coaxial connector, this shall be designed as a standardised connector (e.g. SMA, MCX, etc.) with a defined impedance (e.g. 50 Ω) for the frequency range under consideration (as specified in the related standard). The connector, the used cables and the measurement receiver shall have the same impedance.

The principle of the setup is shown in figure B.7. The attenuation of all ancillary equipment (e.g. cables, etc.) used in the measurement shall be known.

The attenuation of all parts can be measured with a network analyser or can be taken from the corresponding data sheet. The sum of the attenuation of all ancillary equipment shall be summarised and noted as  $att_{ae}$ .

The relation between the EUT output power [dBm] at the EUT reference plane and the reference plane of the measurement receiver is given by (see equation (B.7)):

$$P_{meas\_con} = P_{EUT\_con} - att_{ae} \quad (B.7)$$

with:

- $P_{meas\_con}$ : measured conducted power at the reference plane of the measurement receiver in [dBm].
- $att_{ae}$ : attenuation ancillary equipment (cable) in [dB].
- $P_{EUT\_con}$ : conducted EUT output power at the reference plane of the EUT in [dBm].



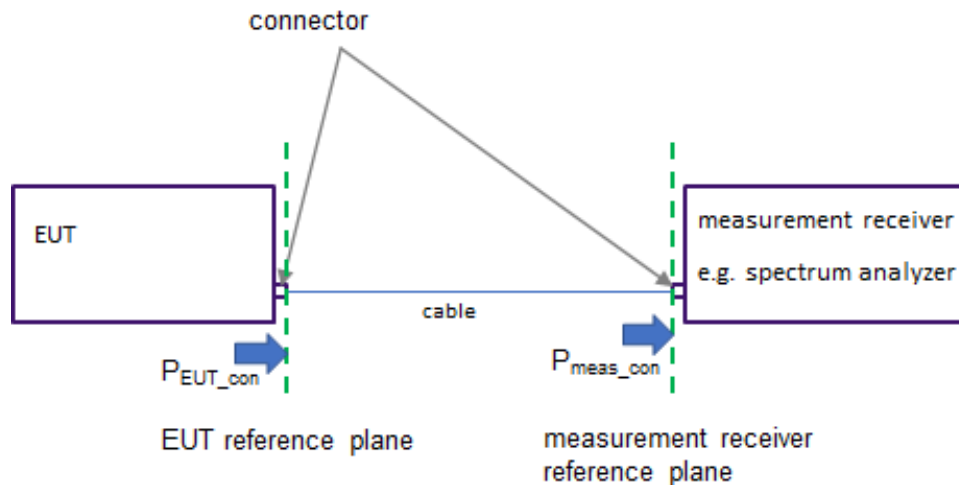

**Figure B.7: Principle for a conducted measurements set-up with a cable connection and a spectrum analyser**

### B.3.3 Conducted measurement via waveguide connection

In the case of a hollow waveguide connector, it shall be designed as a rectangular or circular waveguide. In the case of a rectangular waveguide, the ratio of the edge length of the rectangular cross-section shall be in accordance with IEC 60153-2 [i.41], table 3. The measurement receiver shall be equipped with a standardised rectangular hollow waveguide and shall be able to cover the whole waveguide band provided by the cross section of the EUT's waveguide.

For circular waveguides an adaption from circular to rectangular waveguide shall be applied to connect to the measurement receiver. The measurement receiver can be equipped with an external mixer to extend the frequency range of the spectrum analyser. The external mixer can have either a coaxial connector or a hollow waveguide connector.

The principle of the setup with a pure interconnection based on waveguides is shown in figure B.8. An alternative setup with a waveguide adapter and an interconnection with a cable is shown in figure B.9.

The attenuation of all ancillary equipment (e.g. waveguides, cables, adapters, etc.) used in the measurement shall be known.

The attenuation of all parts can be measured with a network analyser or can be taken from the corresponding data sheet. The sum of the attenuation of all ancillary equipment (cable, waveguide adapter, etc.) shall be summarized and be noted as  $att_{ae}$ .

The relation between the EUT output power [dBm] at the EUT reference plane and the reference plane of the measurement receiver is given by (see equation (B.6)):

$$P_{meas\_con} = P_{EUT\_con} - att_{ae} \quad (B.6)$$

with

- $P_{meas\_con}$ : measured conducted power at the reference plane of the measurement receiver in [dBm].
- $att_{ae}$ : attenuation ancillary equipment (cable) in [dB].
- $P_{EUT\_con}$ : conducted EUT output power at the reference plane of the EUT in [dBm].

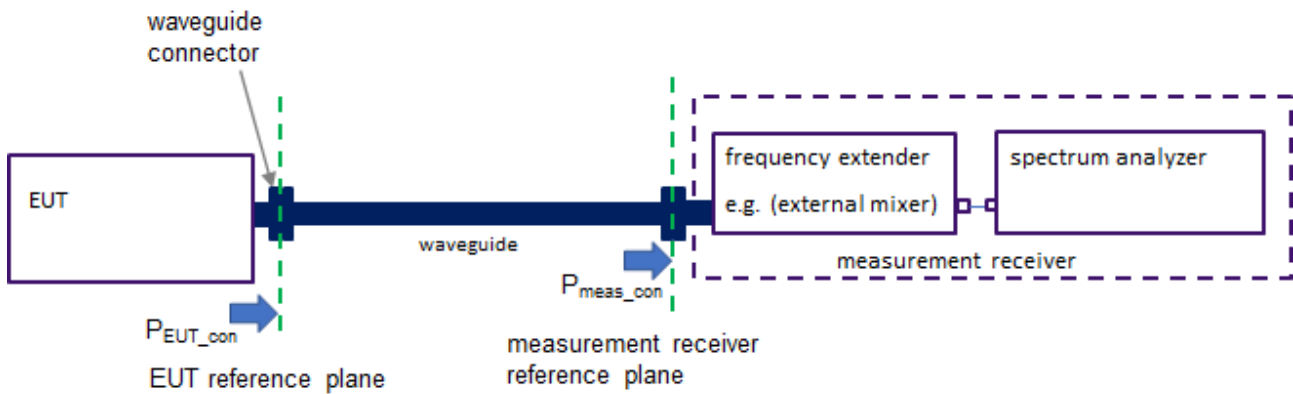

**Figure B.8: Principle for measurement setup of conducted measurements with a waveguide interconnection and a measurement receiver (including mixer)**

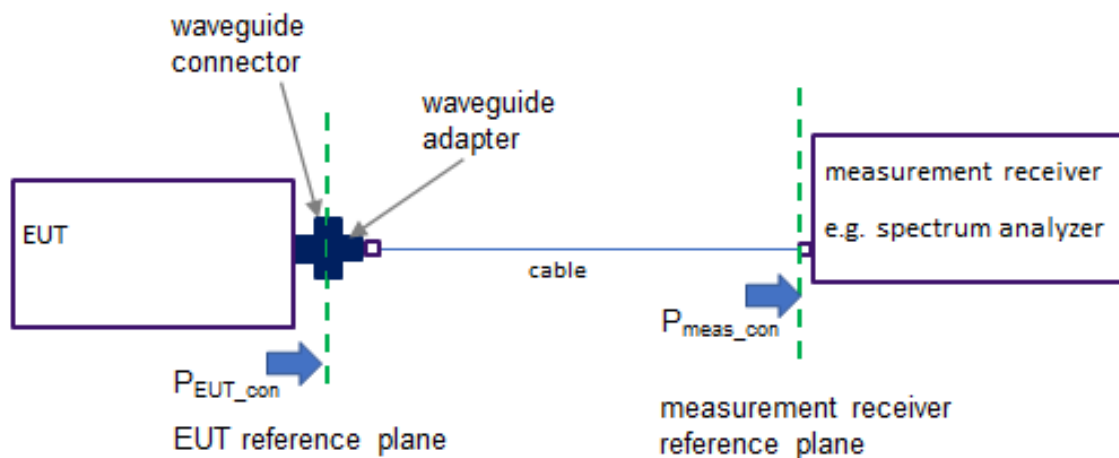

**Figure B.9: Principle for measurement setup of conducted measurements with a waveguide adapter and interconnection with cable and a spectrum analyzer**

### B.3.4 Determination of a radiated power e.i.r.p. based on a conducted measurement

To calculate the mean/peak e.i.r.p. from a conducted measurement, proceed as follows:

- Step 1: Check if the general points for such an assessment are fulfilled as specified in clause B.3.1.
- Step 2: The conducted mean/peak power shall be measured at the reference plane (coaxial- or waveguide port) of the EUT. For this measurement the EUT shall be connected to the measurement receiver via dedicated cables (see clause B.3.2) or waveguides (see clause B.3.3). The basis requirements for a conducted measurement is given in clause B.3.1.
- Step 3: The attenuation of all ancillary equipment (e.g. cables, waveguides, waveguide transitions from circular to rectangular waveguide, etc.) used in the measurement shall be known.
- Step 4: The attenuation of all parts can be measured with a network analyser or can be taken from the corresponding data sheet. The sum of the attenuation of all ancillary equipment shall be noted as  $att_{ae}$ .
- Step 5: The antenna gain/antenna pattern in [dBi] of the dedicated antennas of the EUT is known. Conformance tests to measure antenna gain/antenna pattern are specified in clause 5.12. The gain characteristics (antenna pattern) of the related dedicated antenna shall be provided as specified in the related standard.

Step 6: The emission of the kind of power (mean/peak) e.i.r.p. in a given direction versus frequency is calculated as follows (in dB values), see equation (B.7):

$$P_{e.i.r.p.} = P_{meas\_con} + G_{Ant} + att_{ae} \quad (B.7)$$

with:

- $P_{e.i.r.p.}$ : kind of power (peak/mean) e.i.r.p. in [dBm] in assessed direction.
- $P_{meas\_con}$ : measured conducted power at the reference plane of the measurement receiver in [dBm].
- $G_{Ant}$ : antenna gain/antenna pattern in [dBi] for assessed direction (see clause 5.12).
- $att_{ae}$ : attenuation ancillary equipment (cable/waveguide) in [dB].

And simplified based on the relationship between the measured power ( $P_{meas}$ ) and EUT output power ( $P_{EUT}$ ) (see equation (B.6)) would lead to: (see equation (B.8)):

$$P_{e.i.r.p.} = P_{EUT\_con} + G_{Ant} \quad (B.8)$$

with:

- $P_{e.i.r.p.}$ : kind of power (peak/mean) e.i.r.p. in [dBm] in assessed direction.
- $P_{EUT\_con}$ : conducted EUT output power at the reference plane of the EUT in [dBm].
- $G_{Ant}$ : antenna gain/antenna pattern in [dBi] for assessed direction (see clause 5.12).

## B.4 Spherical Scan

### B.4.1 General

Examples of possible measurement systems for fully spherical measurements are summarised in clause B.4.2.

Two different radiated power measurement procedures are provided in clause B.4.3 (field strength method) and clause B.4.4 (substitution method).

### B.4.2 Different measurement systems

Figure B.10 shows the spherical measurement procedure using automatic measurement antenna placement. The RX antenna is moveable and it is mounted for example on an automatic arm, which moves the antenna stepwise on a sphere around the EUT.

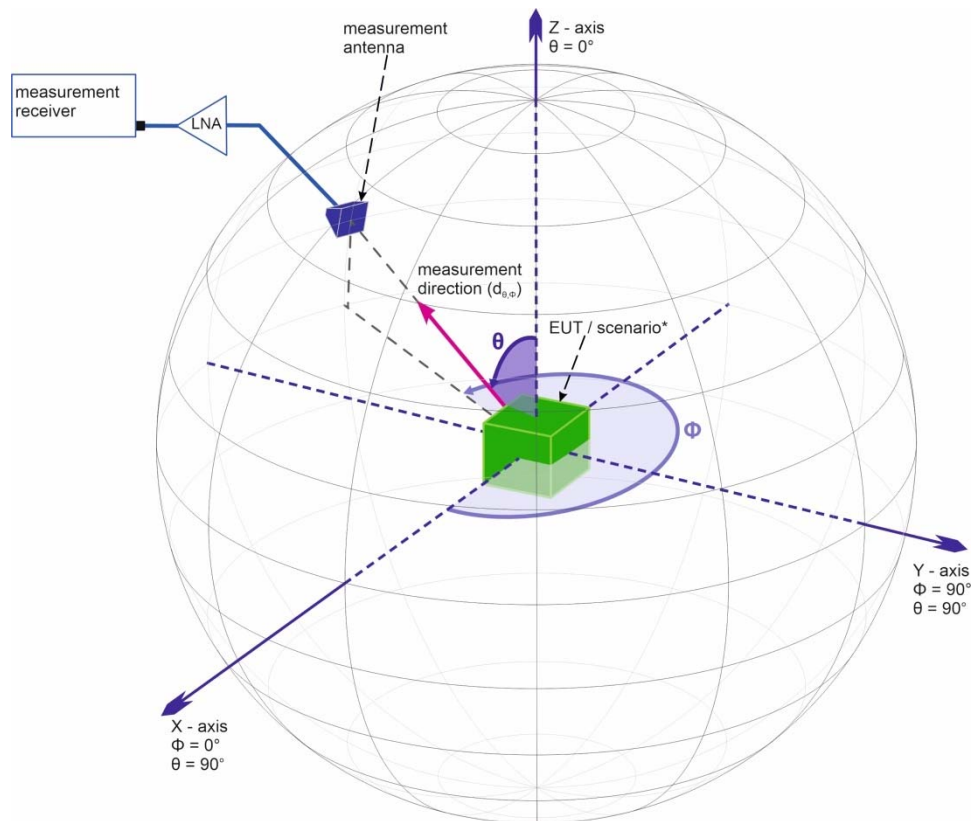
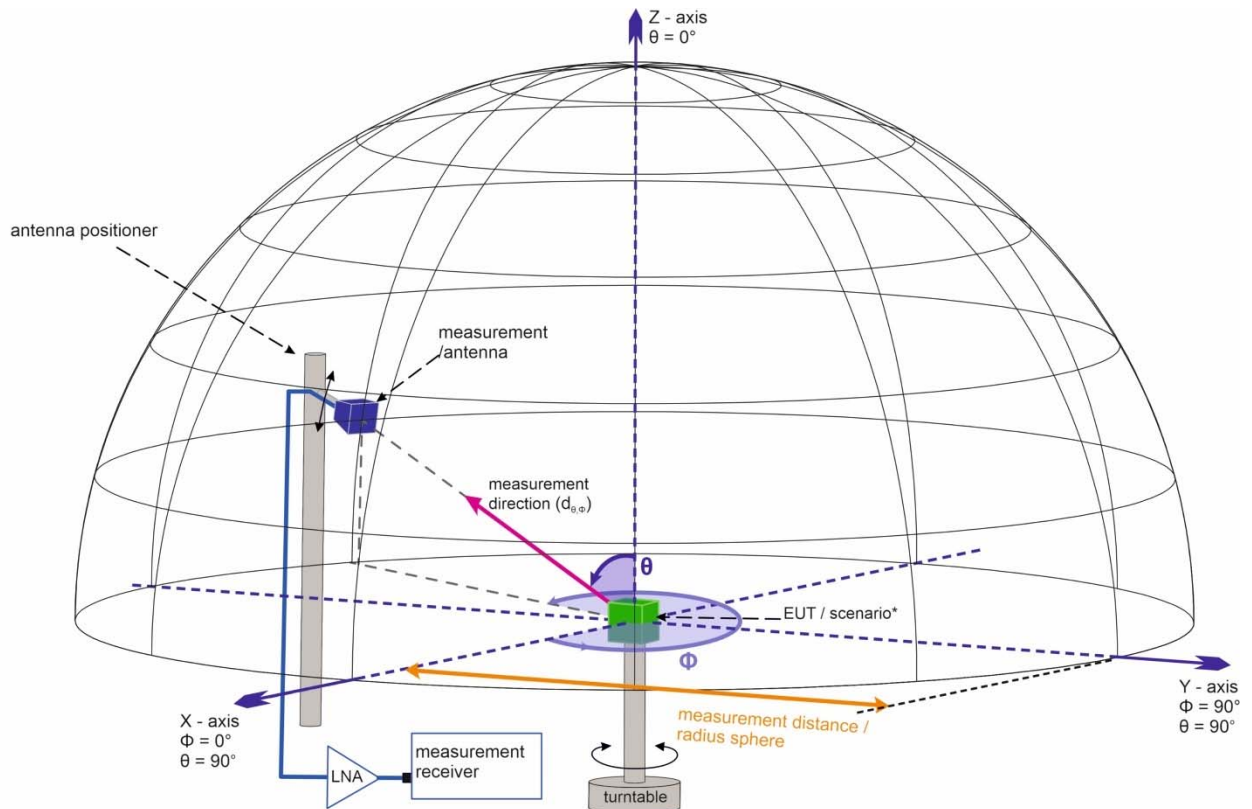

**Figure B.10: Spherical scan setup using automatic measurement antenna placement**

The maximum measurement step size for the azimuth angle  $\Phi$  and for the elevation angle  $\Theta$  is smaller or equal to  $15^\circ$ .

In most of the available test sites (test chambers) a complete full spherical scan is not possible. Therefore, the EUT could be mounted according to the related standard and (on a turn table) and the half sphere above the EUT could be measured, see figure B.11.

In such a half full sphere scan  $\Phi$  (azimuth angle) is varied from  $0^\circ$  to  $360^\circ$  and  $\Theta$  (polar angle) is varied from  $0^\circ$  to  $180^\circ$ .



**Figure B.11: Half spherical scan setup using automatic measurement antenna placement and a turntable**

For a full spherical scan (second half sphere) the EUT has to be tilted by  $180^\circ$ . For the tilting the orientation and direction of the EUT emission shall be considered that at the end the both measurement results could be added together (either tilting around X- or Y-axes).

In a half spherical scan  $\Phi$  is varied from  $0^\circ$  to  $360^\circ$  and  $\Theta$  is changed from  $0^\circ$  to  $90^\circ$ . But the X-Y plane;  $\Theta = 90^\circ$  (polar angle) needs to be measured one time.

NOTE: Another relation of the angles is possible, but the coverage of the whole spheres should be ensured.

Today three solutions are available at test chambers to make such spherical measurements:

- With a movable/steerable antenna on an antenna positioner, see figure B.12.
- With an automatic arm, see figure B.13.
- With a system rotating the EUT in two dimensions, see figures B.14 to B.17.

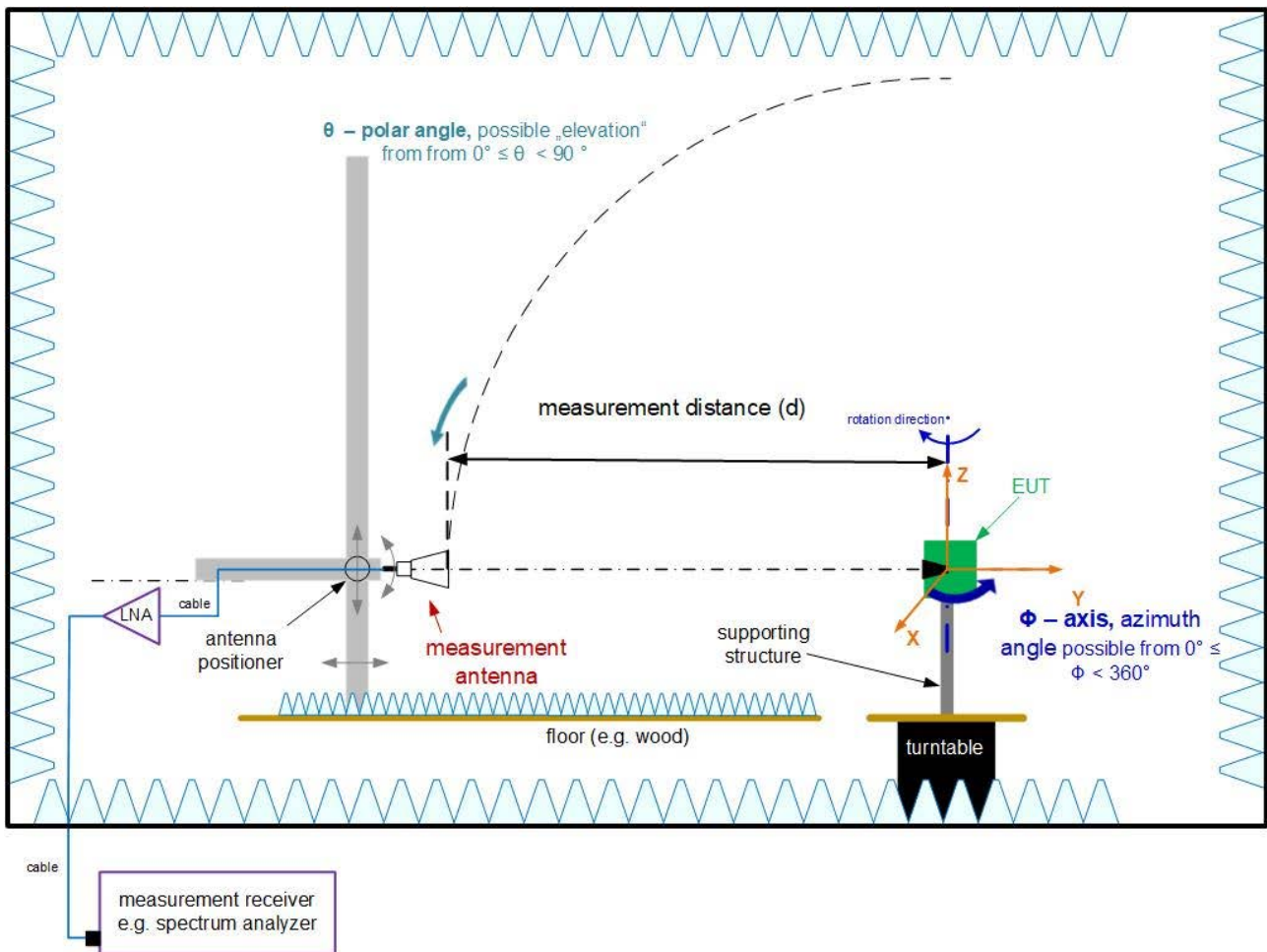
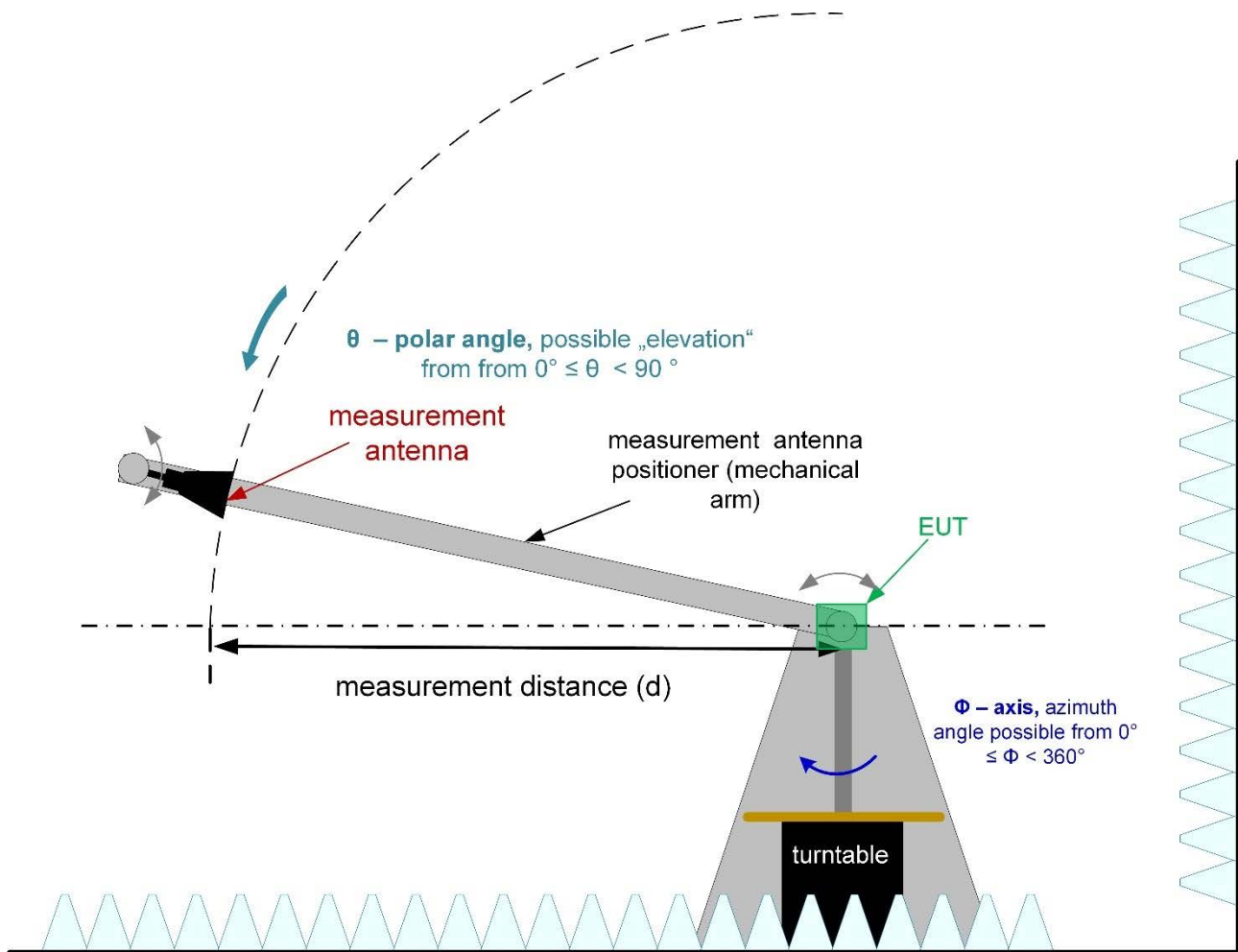

Figure B.12: Half spherical scan setup using movable/steerable antenna on an antenna positioner



**Figure B.13: Half spherical scan setup using automatic arm**

Instead of using an antenna positioner, it is also possible to rotate the EUT via two axis, see figures B.14 and B.15.

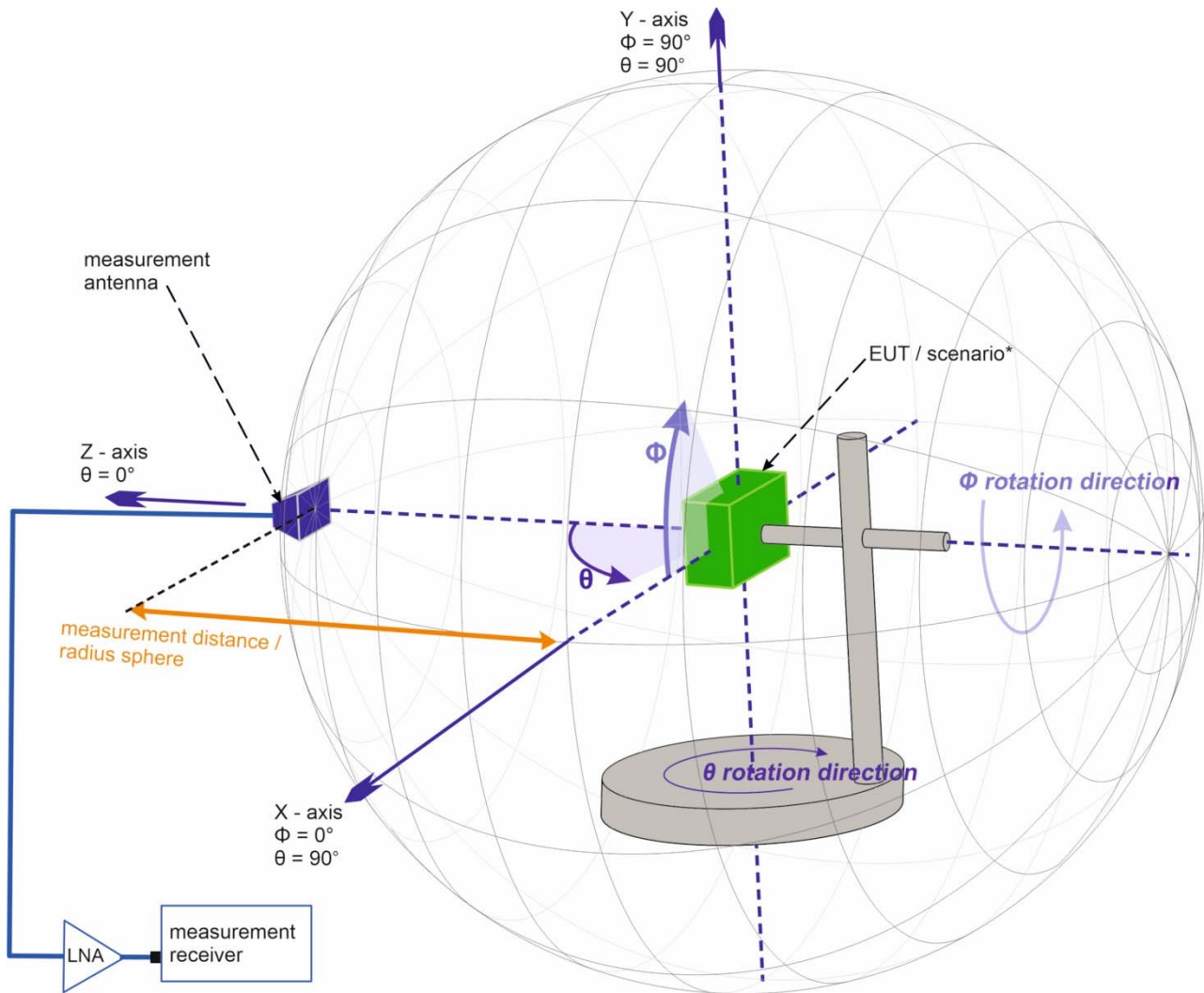
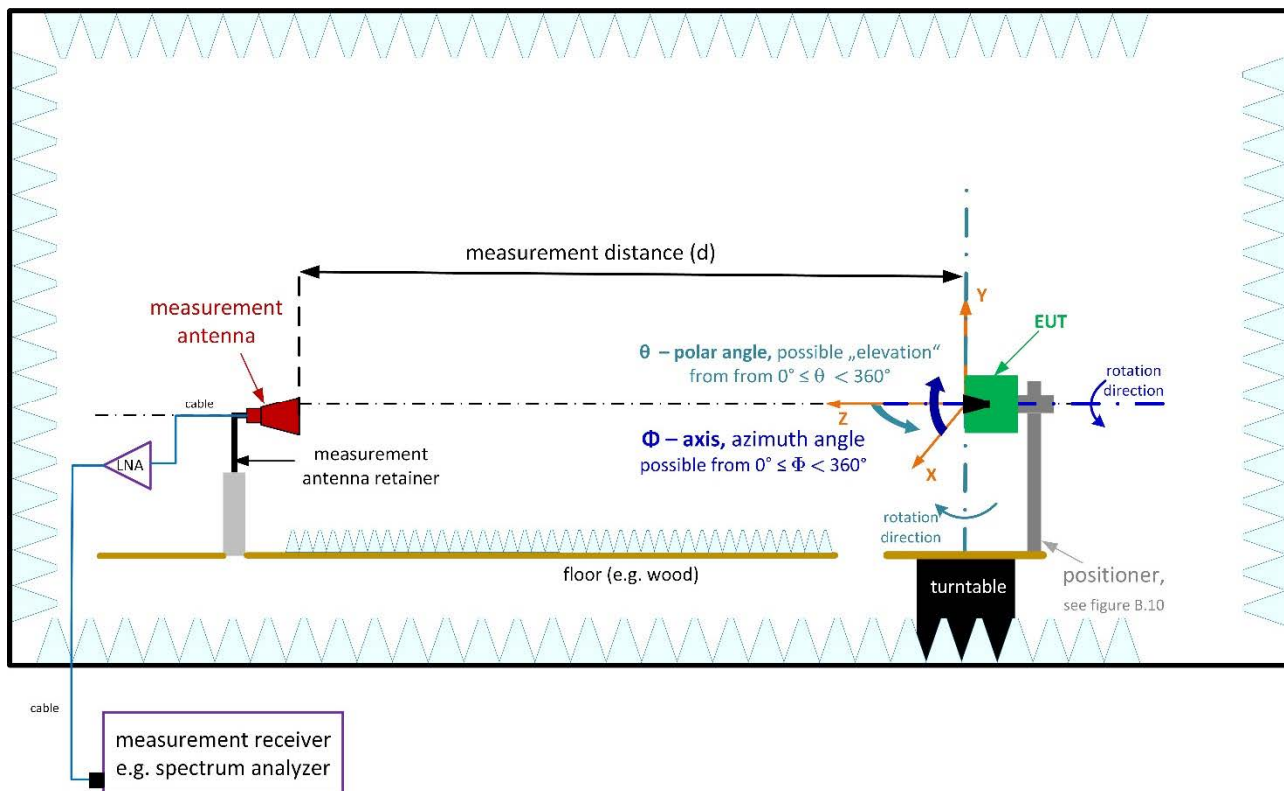

Figure B.14: General spherical scan setup with the rotation of the EUT over two axes





**Figure B.15: Spherical scan setup with the rotation of the EUT over two axes, typical realization inside a full anechoic chamber**

For such a measurement set-up a so called "Two/Multi-Axis Positioners" (see figure B.16) will be used, for more information see the literature Annual Reference Guide 2002 [i.34], A CTIA approved antenna measurement system for over-the-air testing of wireless devices [i.37] and IEEE 149-2021 [i.38].

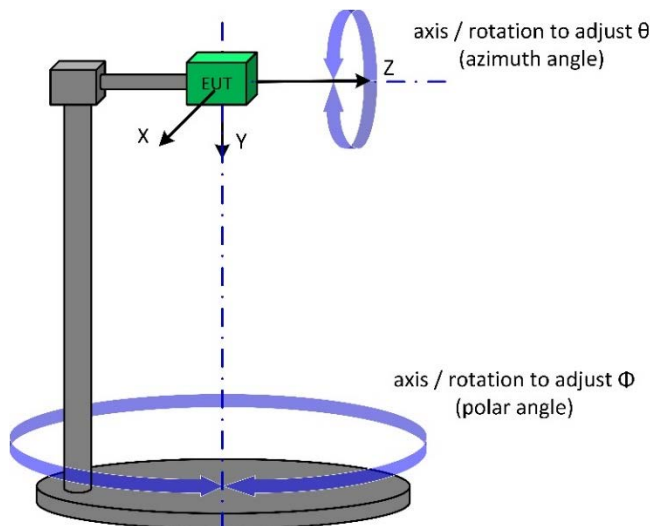

**Figure B.16: Example of a two-axis positioner setup for radiated measurement within the polar coordination system**

Thus, the same sphere can be measured as with the automatic arm. In contrast to the previous method both angles could be changed from  $0^\circ$  to  $360^\circ$ . Depending on the order to angular steps there are two ways to measure all points on the sphere around the EUT.

**Way 1:** By rotating (in steps) the table (polar/elevation) by  $360^\circ$  and stepping the horizontal axis (azimuth) of the set-up between each turntable rotation, the great-circle method (see figure B.17) the emissions on the spherical grid around the EUT could be measured.

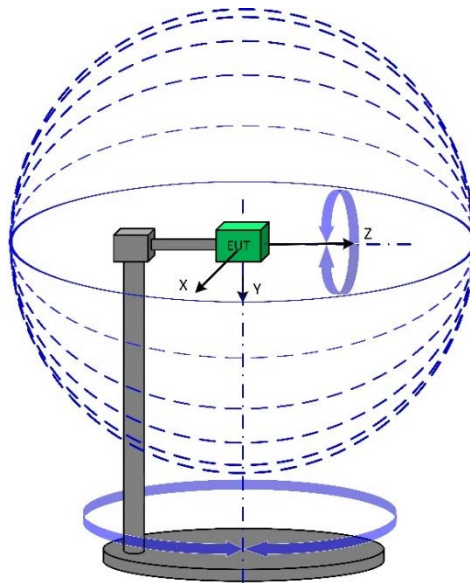

**Figure B.17: Great-circle method measurement points on spherical surface for equal-angle method with angular steps**

**Way 2:** By rotating (in steps) the horizontal axis (azimuth) by  $360^\circ$  and stepping the turntable (polar/elevation) of the EUT, named as the conical-section method (see figure B.18) the emissions on the spherical grid around the EUT could be measured.

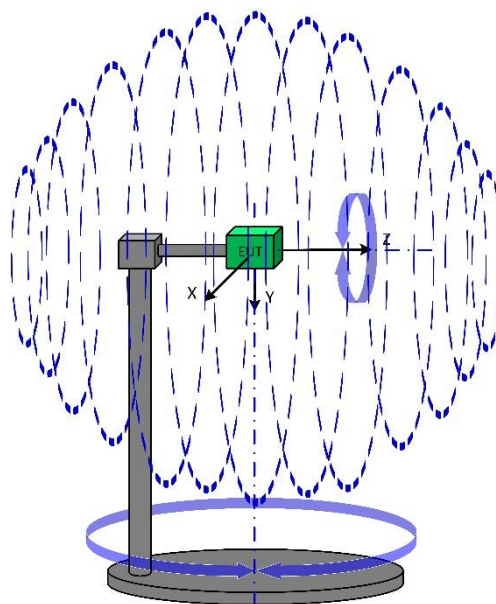

**Figure B.18: Conical-section method with sampling/measurement points spherical surface for equal-angle method with angular steps**

The measurement distance  $d$  is given by clause B.2.3.5.

For measurements (e.g. TRP, see clause 5.6 or indirect emissions, see clause 5.7) angular steps for  $\Theta$  and  $\Phi$  shall be specified in the related standard. If no value for angular steps for the increase of  $\Theta$  and  $\Phi$  is provided in the related standard, then the value of  $15^\circ$  shall be used.

**NOTE 1:** In this setup (see figure B.12), other relationships of the angles to the EUT is possible (depending manufacturer of the test equipment and the arrangement in the test software). For example: The  $\phi$  axis may be a vertical axis fixed to the turntable, yet passing through the EUT, while the angle  $\theta$  is about an axis fixed to the EUT. This configuration is also valid to ensure a full spherical measurement.

NOTE 2: In addition, it needs to be considered/assessed if based on the mechanical set-up there will be limitations (e.g. shielding effects, measurement point cannot be adjusted, etc.) one or the other measurement point could be not measured. In such cases it could be necessary to turn the EUT in the set-up to measure these points as well.

### B.4.3 Pre-substitution / calibrated method

The measurement receiver, measurement antenna and all associated equipment (e.g. cables, filters, amplifiers, etc.) shall have been recently calibrated against known standards at all the frequencies on which measurements of the equipment are to be made.

- Step 1: the related standard shall specify the test site, see clause B.2.2. For SAC (clause B.2.2.3) and OATS (clause B.2.2.4) the ground shall be covered by absorbing material in the area of the direct ground reflection from the EUT to the measurement antenna. The equipment shall be placed at the specified height on a support, and in the position closest to normal use of the EUT.
- Step 2: The measurement antenna shall be oriented initially for vertical polarization.
- Step 3: The output of the measurement antenna shall be connected to the spectrum analyser.
- Step 4: The EUT shall be switched on.
- Step 5: The measurement antenna shall be moved stepwise on the sphere and in each location the signal level and its coordinates shall be noted.
- Step 6: Step 5 shall be repeated for horizontal polarized measurement antenna orientation.
- Step 7: The maximum signal level from step 5 and 6 shall be noted and converted into the radiated power by applying the method in clause B.2.6

NOTE: "horizontal" and "vertical" polarization here refer to the initial polarizations of the antennas when they are situated at  $\theta = 0$  (i.e. with boresight parallel to the ground plane).

### B.4.4 Substitution Method

- Step 1: the related standard shall specify the test site, see clause B.2.2. For SAC (clause B.2.2.3) and OATS (clause B.2.2.4) the ground shall be covered by absorbing material in the area of the direct ground reflection from the EUT to the measurement antenna. The equipment shall be placed at the specified height on a support, and in the position closest to normal use of the EUT.
- Step 2: The measurement antenna shall be oriented initially for vertical polarization
- Step 3: The output of the measurement antenna shall be connected to the spectrum analyser.
- Step 4: The EUT shall be switched on.
- Step 5: The measurement antenna shall be moved stepwise on the sphere and in each location the signal level and its coordinates shall be noted.
- Step 6: Step 5 shall be repeated for horizontal polarized measurement antenna orientation.
- Step 7: The maximum signal level from step 5 and 6 and its coordinate shall be noted.
- Step 8: The EUT shall be replaced by a substitution antenna as defined in clause B.2.2.6. The mainbeam of the substitution antenna shall point to the measurement antenna, which is located at the position from step 7.
- Step 9: The substitution antenna shall be orientated for vertical polarization.
- Step 10: The substitution antenna shall be connected to a calibrated signal generator and the signal generator shall be switched on.
- Step 11: The measurement antenna shall be moved around this position of the substitution antenna within at least five times the wavelength of the centre frequency on the sphere to find the local maximum.

- Step 12: The output power and frequency of the signal generator shall be adjusted to the level from step 7
- Step 13: The output power of the signal generator shall be recorded
- Step 14: The measurement from step 4 to step 13 shall be repeated with the measurement antenna and the substitution antenna orientated for horizontal polarization.
- Step 15: The radiated power of the EUT is the larger of the two levels recorded at step 14, corrected by the gain of the substitution antenna and the cables losses between signal generator and substitution antenna (radiated power = output power of the signal generator - gain of substitution antenna + substitution antenna cable loss).

NOTE: "horizontal" and "vertical" polarization here refer to the initial polarizations of the antennas when they are situated at  $\theta = 0$  (i.e. with boresight parallel to the ground plane).

---

# Annex C (normative): Signal Timing parameters

## C.1 Descriptions

The following descriptions are relevant for the definition of signal timing parameters:

- Burst duration or "Signal on Time" ( $T_{on}$ ): the time duration of a continuous radio emission, or sequence of emissions separated by intervals shorter than a specified disregard time ( $T_{dis}$ ).
- Disregard time ( $T_{dis}$ ): time interval below which interruptions within a transmission are considered part of  $T_{on}$ , see ETSI TS 103 060 [i.1]. This is mainly important for pulsed based signals or modulations with several  $T_{on}$  - times. This value shall be specified in the related standard.
- Observation time ( $T_{obs}$ ): reference interval of time (observation period, see ETSI TS 103 060) [i.1]. In regulations there are specification of 1 second, 1 minute or 1 hour (depends on regulation) or based on the "signal repetition time" ( $T_{rep}$ ) or during  $T_{on}$ .
- Signal OFF-time ( $T_{off}$ ): time in between emissions with a duration longer than  $T_{dis}$ .
- Threshold- level  $P_{thresh}$ : power level above which the measurement equipment will "detect" the signal as on".
- Duty Cycle (DC): the ratio, expressed as a percentage, of  $\Sigma(T_{on})/(T_{obs})$  where  $T_{on}$  is the "on" time of a single transmitter device and  $T_{obs}$  is the observation period, see ETSI TS 103 060 [i.1].

For radiodetermination/radar devices the two additional parameters are relevant in addition:

- Signal repetition time ( $T_{rep}$ ): specified as:  $T_{rep} = \Sigma T_{on} + \Sigma T_{off}$ ; or in words: length of the time between subsequent transmission patterns of the system.

NOTE: Also known as cycle time, frame repetition time or frame duration.

- Measurement cycle time: whole-numbered multiple of signal repetition time.

---

## C.2 Signal Types

### C.2.1 Pulsed signals

#### C.2.1.1 General

For pulsed based signals therefore, two different considerations based on the specified  $T_{dis}$  are possible.

- For pulsed based signals there are additional parameter necessary to consider:
  - Pulse Repetition time ( $T_{PRT}$ ): time between the beginning of one pulse and the start of the next pulse.
  - Pulse Length ( $T_{PULSE}$ ): time for one pulse of the signal.
- This leads to two different considerations for pulsed based signals:
  - See clause C.2.1.2 if  $T_{dis} > T_{PRT}$ .
  - See clause C.2.1.3 if  $T_{dis} < T_{PRT}$ .

### C.2.1.2 Consideration for pulsed based signals if $T_{dis} > T_{PRT}$

In figure C.1 the case for  $T_{dis} > T_{PRT}$  and with a signal repetition time is shown.

NOTE: For the case where the signal consists of a single, continuously repeated pulse, the transmitter is regarded as continuously repeating. As such,  $T_{on} = 1$ ,  $T_{off} = 0$  during the continuously operation.

For the Duty Cycle measurement for such cases (see figure C.1) the following equation (C.1) applies:

$$DC = \frac{\sum T_{on}}{T_{obs}} = \frac{\sum_1^n T_{on}}{\sum_1^n T_{on} + \sum_1^n T_{off}} \quad (C.1)$$

with:

- $n$  = number of  $T_{on}$  and  $T_{off}$  within  $T_{obs}$

And the Duty Cycle measurement/assessment in case  $T_{obs} = T_{rep}$  can be calculated with equation (C.2) if this signal is continuously repeated:

$$DC = \frac{T_{on}}{T_{on} + T_{off}} \quad (C.2)$$

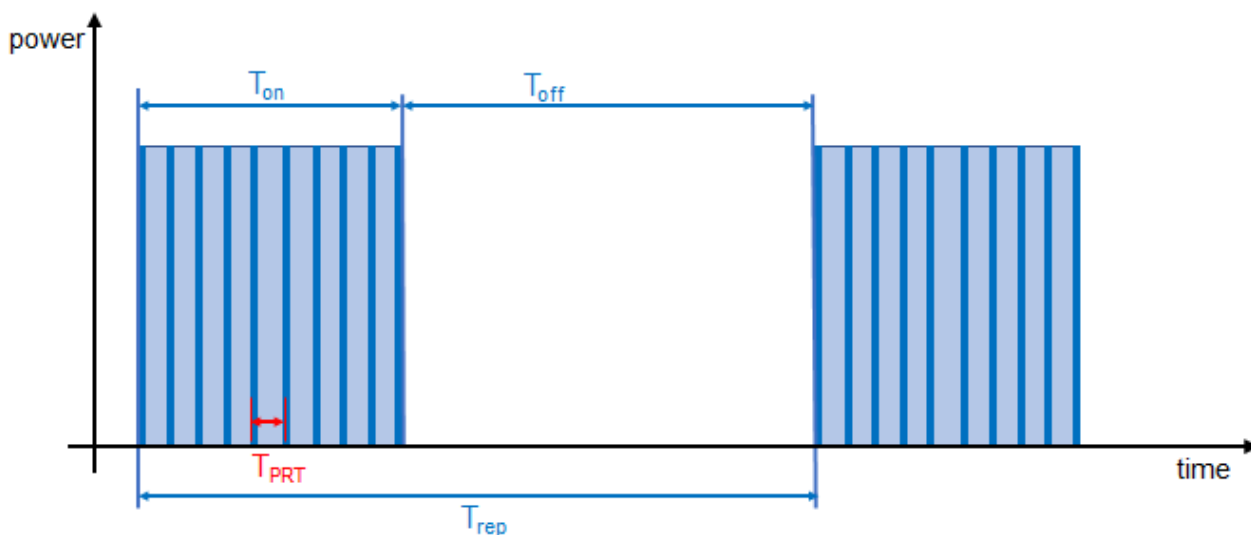

Figure C.1: Pulsed based signal if  $T_{dis} > T_{rep}$

### C.2.1.3 Consideration for pulsed based signals if $T_{dis} < T_{PRT}$

For the DC measurement for such cases (see figure C.2) the following equation (C.3) applies:

$$DC = \frac{\sum T_{on}}{T_{obs}} = \frac{\sum_1^n T_{on}}{\sum_1^n T_{on} + \sum_1^n T_{off}} = \frac{\sum_1^n T_{PULSE}}{\sum_1^n T_{PULSE} + \sum_1^n T_{off}} \quad (C.3)$$

with:

- $n$  = number of  $T_{on}$  (number of pulses with  $T_{PULSE}$ ) and  $T_{off}$  within  $T_{obs}$
- and:
  - $T_{PRT} = T_{rep}$
  - $T_{PULSE} = T_{on}$
  - $T_{off} = T_{PRT} - T_{on}$

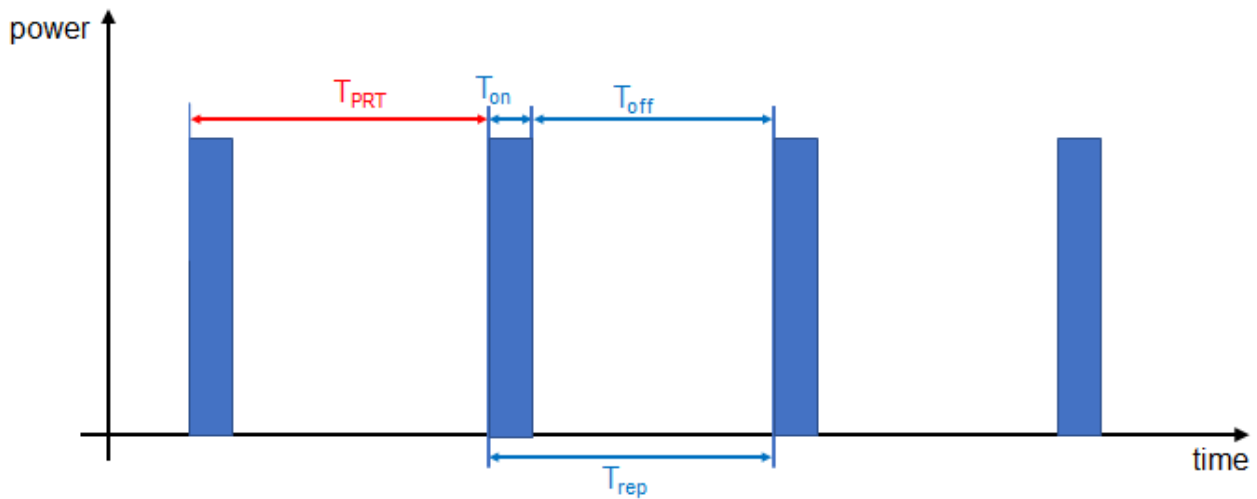

Figure C.2: Pulsed based signal if  $T_{\text{dis}} < T_{\text{rep}}$

## C.2.2 FMCW signals

### C.2.2.1 General

- Clause C.2.2.2 applies if there is only one frequency modulated sweep within the signal repetition time.
- Clause C.2.2.3 applies if there are more than one frequency modulated sweep within the signal repetition time and  $T_{\text{dis}}$  is larger than the time between the different sweeps ( $t_{\text{sweep;off}}$ ).
- Clause C.2.2.4 applies if there are more than one frequency modulated sweep within the signal repetition time and  $T_{\text{dis}}$  is smaller than the time between the different sweeps ( $t_{\text{sweep;off}}$ ).

### C.2.2.2 Single FMCW sweep within signal repetition time

Figure C.3 and figure C.4 are showing the timing parameters for a single frequency sweep FMCW signal within signal repetition time ( $T_{\text{rep}}$ ).

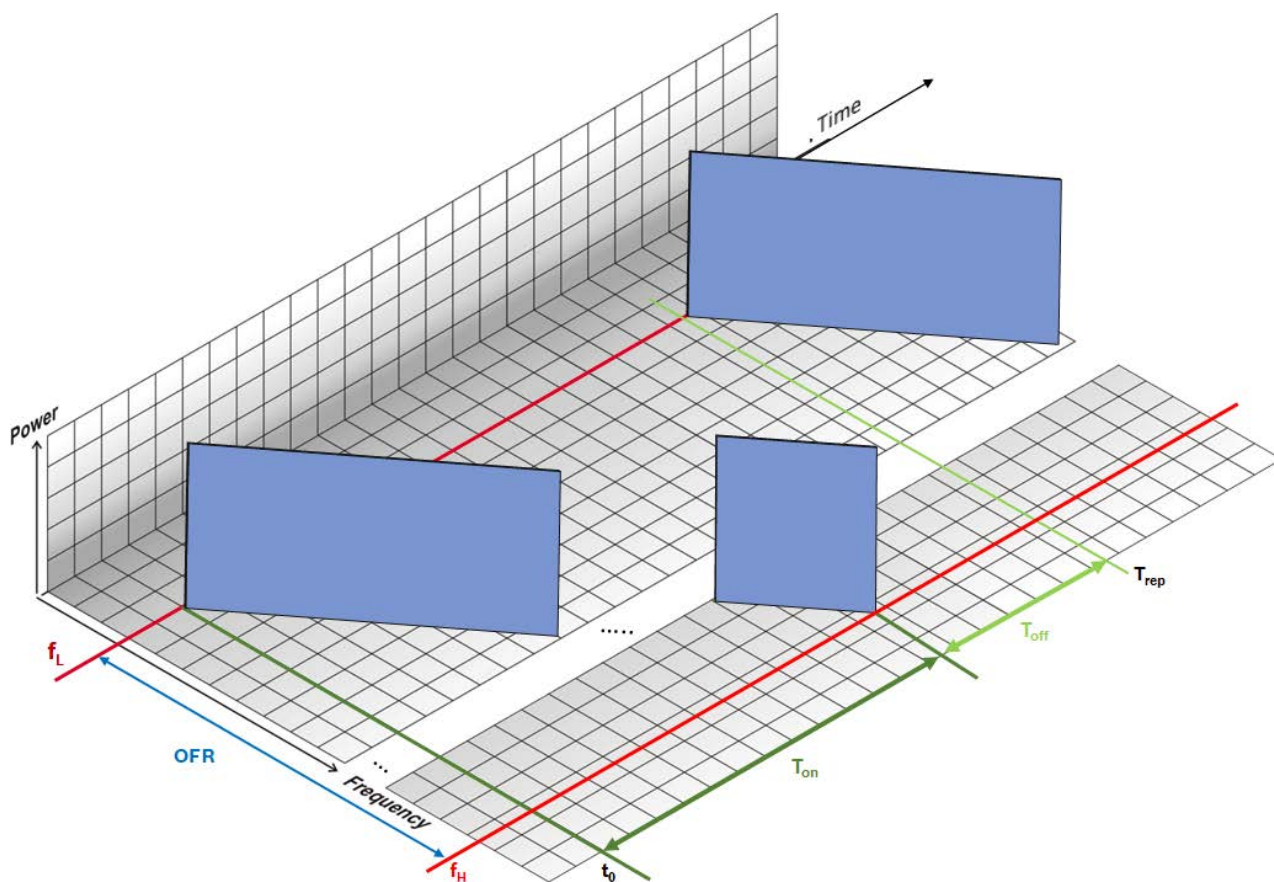

**Figure C.3: FMCW signal, one single frequency sweep**

Figure C.4 is more simplified for two modulation sweeps (one during  $T_{on}$ ) and it is assumed that  $T_{dis} < T_{off}$ .

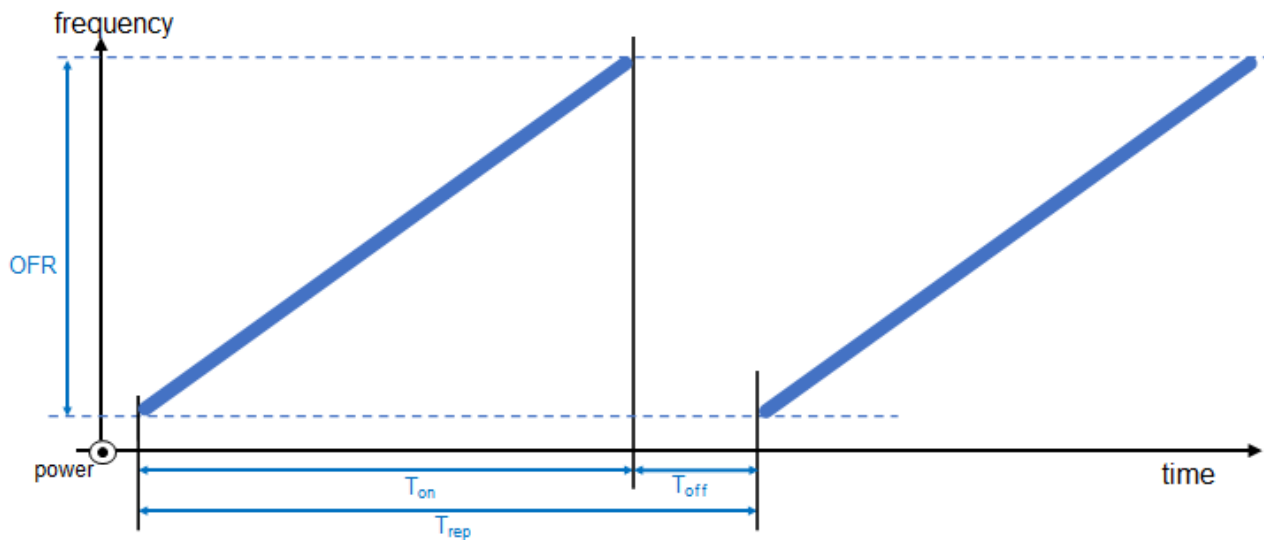

**Figure C.4: FMCW signal, one single frequency sweep (simplified)**

For the DC measurement for such cases (see figure C.4) the following equation (C.4) applies:

$$DC = \frac{\sum_1^n T_{on}}{T_{obs}} = \frac{\sum_1^n T_{on}}{\sum_1^n T_{on} + \sum_1^n T_{off}} \tag{C.4}$$



with:

- $n = \text{number of } T_{\text{on}} \text{ and } T_{\text{off}} \text{ within } T_{\text{obs}}$
- $T_{\text{obs}} > T_{\text{rep}}$

and for the case  $T_{\text{obs}} = T_{\text{rep}}$ , the Duty Cycle measurement/assessment over signal repetition time in equation (C.5) applies:

$$DC = \frac{T_{\text{on}}}{T_{\text{rep}}} = \frac{T_{\text{on}}}{T_{\text{on}} + T_{\text{off}}} \quad (\text{C.5})$$

### C.2.2.3 Multiple FMCW sweeps within $T_{\text{rep}}$ and $T_{\text{dis}} > t_{\text{sweep;off}}$

Figure C.5 shows the case if  $T_{\text{dis}}$  is larger than the time between the sweeps ( $t_{\text{sweep;off}}$ ).

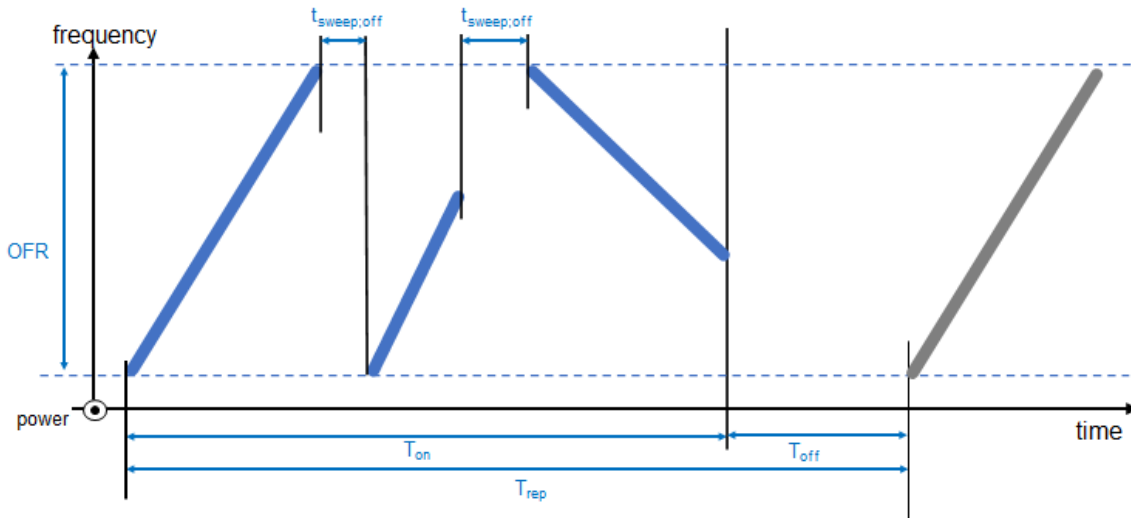

**Figure C.5: FMCW with three sweeps during signal repetition time ( $T_{\text{dis}} > t_{\text{sweep;off}}/T_{\text{dis}} < T_{\text{off}}$ )**

For the DC measurement for such cases (see figure C.5) the following equation (C.6) applies:

$$DC = \frac{\sum_1^n T_{\text{on}}}{T_{\text{obs}}} = \frac{\sum_1^n T_{\text{on}}}{\sum_1^n T_{\text{on}} + \sum_1^n T_{\text{off}}} \quad (\text{C.6})$$

with:

- $n = \text{number of } T_{\text{on}} \text{ and } T_{\text{off}} \text{ within } T_{\text{obs}}$

and for the case  $T_{\text{obs}} = T_{\text{rep}}$ , the Duty Cycle measurement/assessment over signal repetition time in equation (C.7) applies:

$$DC = \frac{T_{\text{on}}}{T_{\text{rep}}} = \frac{T_{\text{on}}}{T_{\text{on}} + T_{\text{off}}} \quad (\text{C.7})$$

### C.2.2.4 Multiple FMCW sweeps within $T_{\text{rep}}$ and $T_{\text{dis}} < t_{\text{sweep;off}}$

Figure C.6 shows the case if  $T_{\text{dis}}$  is smaller than the time between the sweeps ( $t_{\text{sweep;off}}$ ).

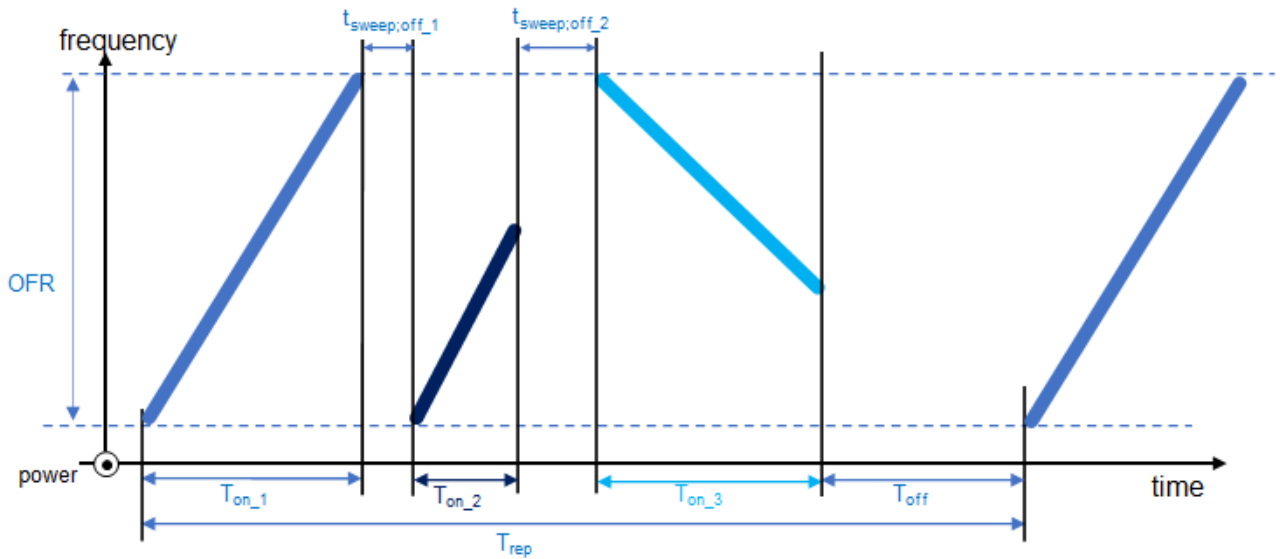

**Figure C.6: FMCW with three sweeps during signal repetition time ( $T_{\text{dis}} < t_{\text{sweep;off}}$  /  $T_{\text{dis}} < T_{\text{off}}$ )**

For the DC measurement for such cases (see figure C.6) the following equation (C.8) applies:

$$DC = \frac{\sum T_{\text{on},x}}{T_{\text{obs}}} = \frac{\sum T_{\text{on},x}}{\sum T_{\text{on},x} + \sum t_{\text{sweep;off},x} + \sum T_{\text{off}}} \quad (\text{C.8})$$

with:

- $x$  = number of different sweeps during one signal repetition time
- $\sum T_{\text{on},x}$ : Sum of all  $T_{\text{ON}}$  during observation time
- $\sum T_{\text{off}}$ : Sum of all  $T_{\text{off}}$  during observation time
- $\sum t_{\text{sweep;off},x}$ : Sum of all  $t_{\text{sweep;off}}$  during observation time

NOTE: The total number of  $t_{\text{sweep;off}}$  will be  $x-1$ ; together with  $T_{\text{off}}$  this will lead to the same number of "OFF-times" than sweeps ("On-times"), see figure C.6

For the case  $T_{\text{obs}} = T_{\text{rep}}$ , the Duty Cycle definition in equation (C.9) applies:

$$DC = \frac{\sum T_{\text{on},x}}{T_{\text{rep}}} = \frac{T_{\text{on},1} + T_{\text{on},2} + \dots + T_{\text{on},x}}{(T_{\text{on},1} + T_{\text{on},2} + \dots + T_{\text{on},x}) + (t_{\text{sweep;off},1} + \dots + t_{\text{sweep;off},(x-1)}) + T_{\text{off}}} \quad (\text{C.9})$$

with:

- $x$  = number of different sweeps during one signal repetition time

## C.2.3 Stepped/Hopping Frequency Signals

This clause explains the signal timing based on a linear hopping/stepping modulation. For the understanding of the modulation the following parameters need to be considered:

- $bw$ : modulated carrier/bandwidth of a single step/hop
- $n_{\text{step}}$ : number of steps during one signal repetition time
- $f_0$ : Start frequency of the Signal (centre of the first step/hop)

- $f_E$ : Stop frequency of the Signal (centre of the last step/hop)
- OFR: Frequency Range of the signal (frequency range over which the step/hop go)
- $\Delta f_{\text{step}}$ : step width (between two steps (hops))
- $t_0$ : Start time of the UWB Signals = 0 s
- $T_E$ : Stop Time/Time the signal needs to with:  $T_E = (n_{\text{steps}} \times \Delta t_{\text{on\_step}}) + ((n_{\text{step}}-1) \times \Delta t_{\text{off\_step}})$
- $\Delta t_{\text{hopp}}$ : Time for one step; =  $\Delta t_{\text{on}} + \Delta t_{\text{off}}$
- $\Delta t_{\text{on\_step}}$ : Time transmission on/one step
- $\Delta t_{\text{off\_step}}$ : Time between two step
- $m_{\text{steps}}$  : Number of "hopping sequences in  $T_{\text{obs}}$

All these parameters are shown in figure C.7.

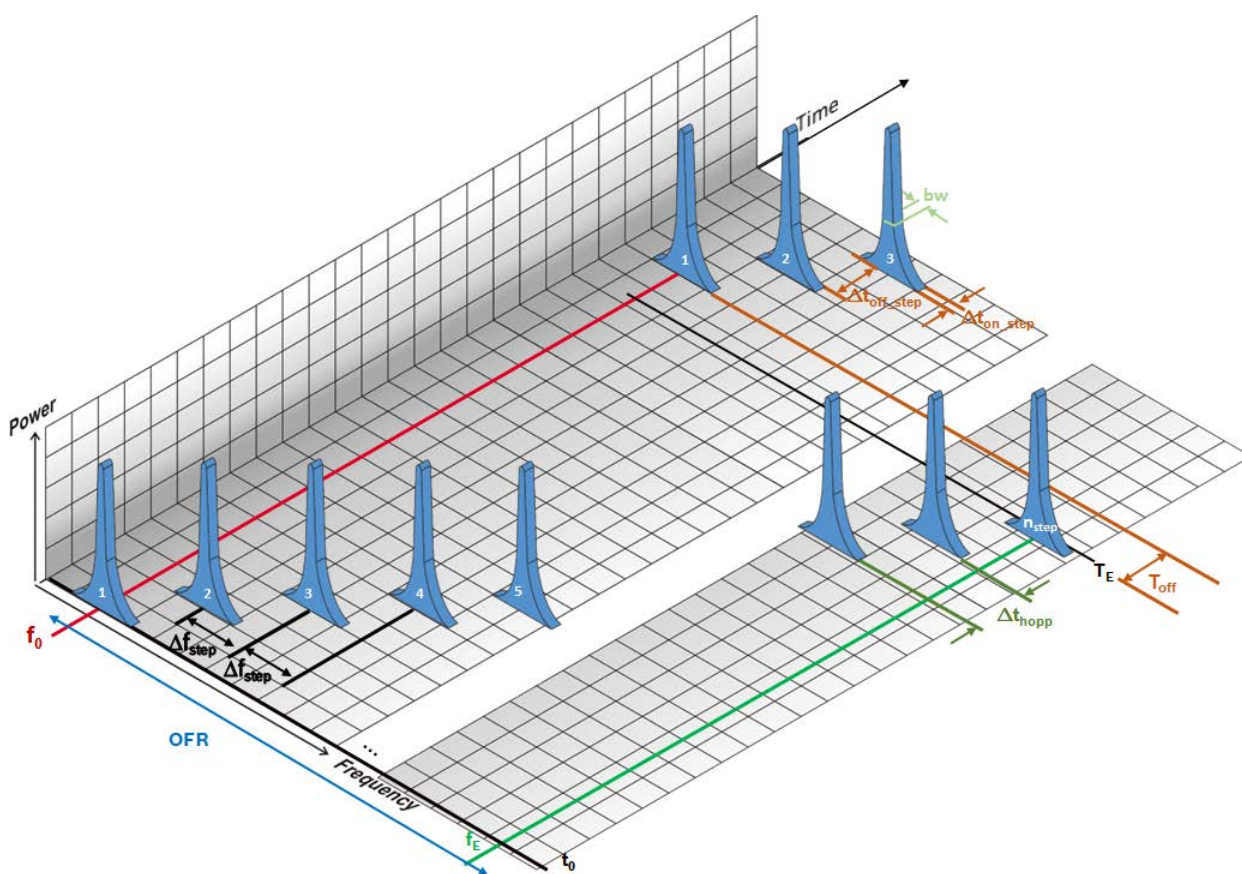

**Figure C.7: Linear step/hop modulation**

Figure C.8 and figure C.9 are showing the timing parameters in relation to the  $T_{\text{dis}}$ :

- Figure C.8 shows a simplified figure in the case  $T_{\text{dis}}$  is larger than the time between two hops;  $T_{\text{dis}} > \Delta t_{\text{off}}$ . Also named as fast hopping.
- Figure C.9 shows the simplified figure in case  $T_{\text{dis}}$  is smaller than the time between two hops;  $T_{\text{dis}} < \Delta t_{\text{off}}$ . Also named as slow hopping.

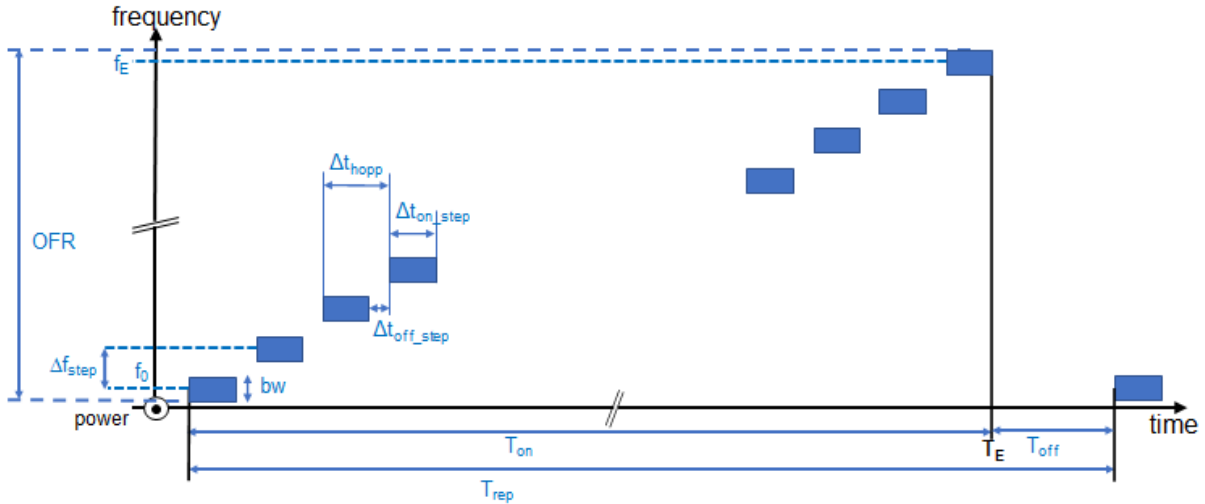

**Figure C.8: hopping modulation with  $T_{dis} > \Delta t_{off}$**

For the DC measurement for such cases (see figure C.8) the following equation (C.10) applies:

$$DC = \frac{\sum T_E}{T_{obs}} = \frac{\sum T_{on}}{\sum T_{on} + \sum T_{off}} \quad (C.10)$$

and for the case  $T_{obs} = T_{rep}$ , the Duty Cycle measurement/assessment over signal repetition time in equation (C.11) applies:

$$DC = \frac{T_{on}}{T_{rep}} = \frac{T_{on}}{T_{on} + T_{off}} \quad (C.11)$$

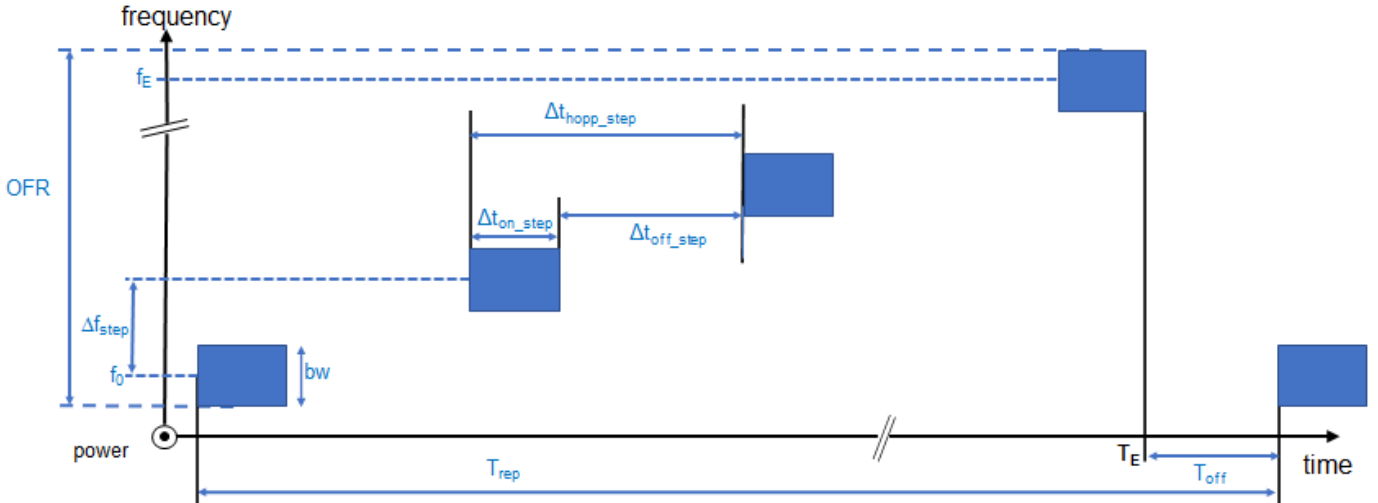

**Figure C.9: Hopping modulation with  $T_{dis} < \Delta t_{off}$**

For the DC measurement for such cases (see figure C.9) the following equation (C.12) applies:

$$DC = \frac{\sum \Delta t_{on\_step}}{T_{obs}} = \frac{\sum (n_{step} \times \Delta t_{on\_step})}{\sum (n_{step} \times \Delta t_{on\_step}) + \sum ((n_{step}-1) \times \Delta t_{off\_step}) + \sum T_{off}} \quad (C.12)$$

and for the case  $T_{obs} = T_{rep}$ , the Duty Cycle measurement/assessment over signal repetition time in equation (C.13) applies:

$$DC = \frac{\sum \Delta t_{on\_step}}{T_{obs}} = \frac{(n_{step} \times \Delta t_{on\_step})}{(n_{step} \times \Delta t_{on\_step}) + ((n_{step}-1) \times \Delta t_{off\_step}) + T_{off}} = \frac{(n_{step} \times \Delta t_{on\_step})}{T_{rep}} \quad (C.13)$$

with:

- $n_{\text{step}}$  = number of hops during one signal repetition time (hopping sequence)

---

## C.3 Measurement procedure for time parameters

The Duty cycle measurement procedures in clause 5.11.2 can be used to assess the signal parameters (signal repetition time,  $T_{\text{on}}$ ,  $T_{\text{off}}$ , etc.).

The related standard shall specify the  $T_{\text{dis}}$ , and  $P_{\text{trsh}}$  for the measurement of the signal timing.

# Annex D (normative): All Emission Measurement

## D.1 General

This specific assessment procedure is for the (indirect) UWB emissions conformity assessment for EU. The regulated UWB emission level is lower than the power level of spurious emissions/EMC emissions from digital and analogue circuitry within the operating frequency range.

For such EUT, the UWB Radiated Power (RP) and TX Unwanted Emissions (TXUE) cannot be measured independently of the Other Emissions (OE) (e.g. narrow-band spurious emissions and the analogue or digital control circuitry emissions). That is because in some frequency ranges the regulated UWB RP emissions are very low power radio signals, comparable to the power limits of emissions from digital and analogue circuitry. If based on a measurement as described in this annex it can be assessed that an emission from the EUT is not the UWB RP emission limited in the relevant harmonised standards or it can clearly be assessed that it is impossible to differentiate between other emissions OE and the UWB RP emissions, the emission shall be considered as other emissions OE.

For such cases the RP, TXUE and OE from the EUT together are specified for such purpose of the test:

- as All Emissions (AE).

The limits for the OE emissions within the OFR (see table D.1 below) shall apply unless otherwise specified in the related standard.

**Table D.1: OE emissions limits within the OFR in line with ERC/REC 74-01 [i.9]**

Frequency range	Limit values for OE within the OFR
100 Hz (note 1) $\leq f < 10$ MHz	46,5 dB $\mu$ A/m at 100 Hz descending 3 dB/oct at 10 m
10 MHz $\leq f < 30$ MHz	-3,5 dB $\mu$ A/m at 10 m
87,5 MHz $\leq f \leq 118$ MHz	-54 dBm/100 kHz
174 MHz $\leq f \leq 230$ MHz	-54 dBm/100 kHz
470 MHz $\leq f \leq 694$ MHz	-54 dBm/100 kHz
otherwise in band 30 MHz $\leq f < 1\ 000$ MHz	-36 dBm/100 kHz
1 000 MHz $\leq f \leq f_H$ (note 2)	-30 dBm/1 MHz
NOTE 1: For the frequency range below 9 kHz: the limits are on voluntary basis, based on an EC request. ETSI proposed the limits to ECC to be implemented in ERC/REC 74-01 [i.9]. For the frequency range above 9 kHz: the limits are in line with ERC/REC 74-01 [i.9], annex 2.	
NOTE 2: For the OFR assessment, see clause 5.2 and related standard.	

NOTE: The limits for the OE are similar to the TXUE requirement outside the OFR (spurious emissions requirement for SRD which are comparable to EMC requirements for SRDs as well).

## D.2 First step

As a first step All Emissions (AE) of the EUT shall be measured as specified in the related standard (direct or indirect scenario). This measurement will include the related UWB Emission (within the OFR), the Transmitter Unwanted Emissions (TXUE) outside the OFR and Other Emissions (OE) (within and outside the OFR) of the EUT. These measurements shall be performed as specified in the related standard. The results shall be recorded.

Assessment of the emissions within the OFR:

- Case 1: AE measurement fulfils the limits of mean e.i.r.p. spectral density and peak e.i.r.p. spectral density requirement for the UWB emission within the OFR, specified in the relevant standard. For this case no further assessment for the emission is necessary, see figure D.1.

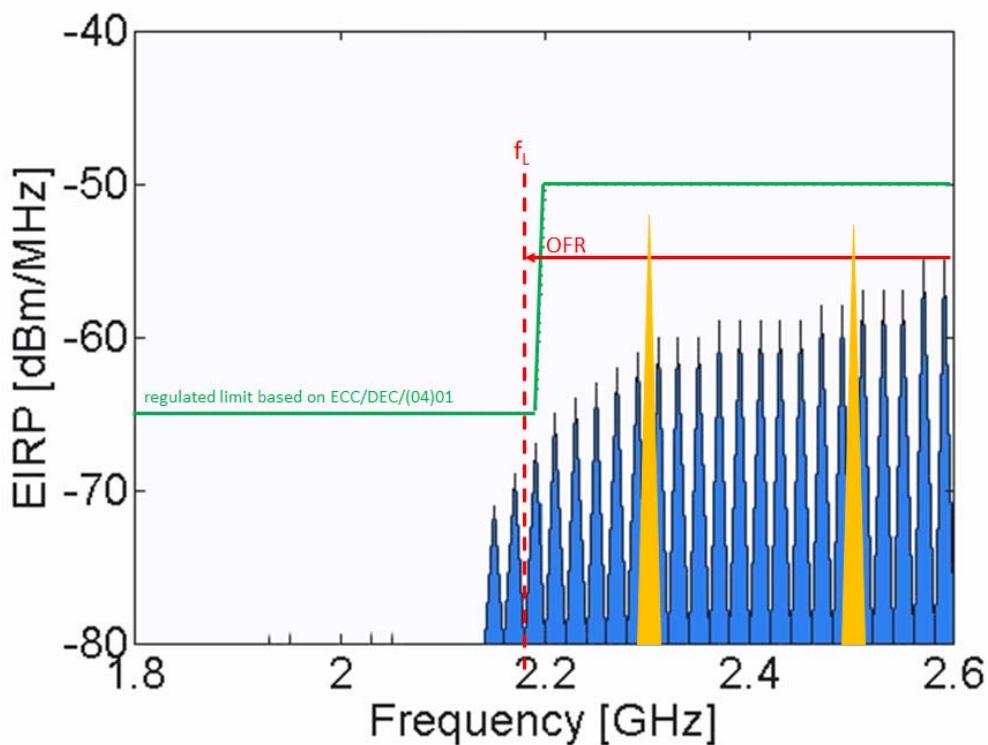

Figure D.1: Example for an AE measurement in the frequency range 1,8 GHz to 2,6 GHz for an EUT covered by ECC/DEC/(07)01 [i.4]

- Case 2: If the recorded AE emission of the UWB device exceeds the corresponding UWB emission requirement (see related standard) within the OFR an additional assessment would be necessary (see figure D.2), second step, see clause D.3.

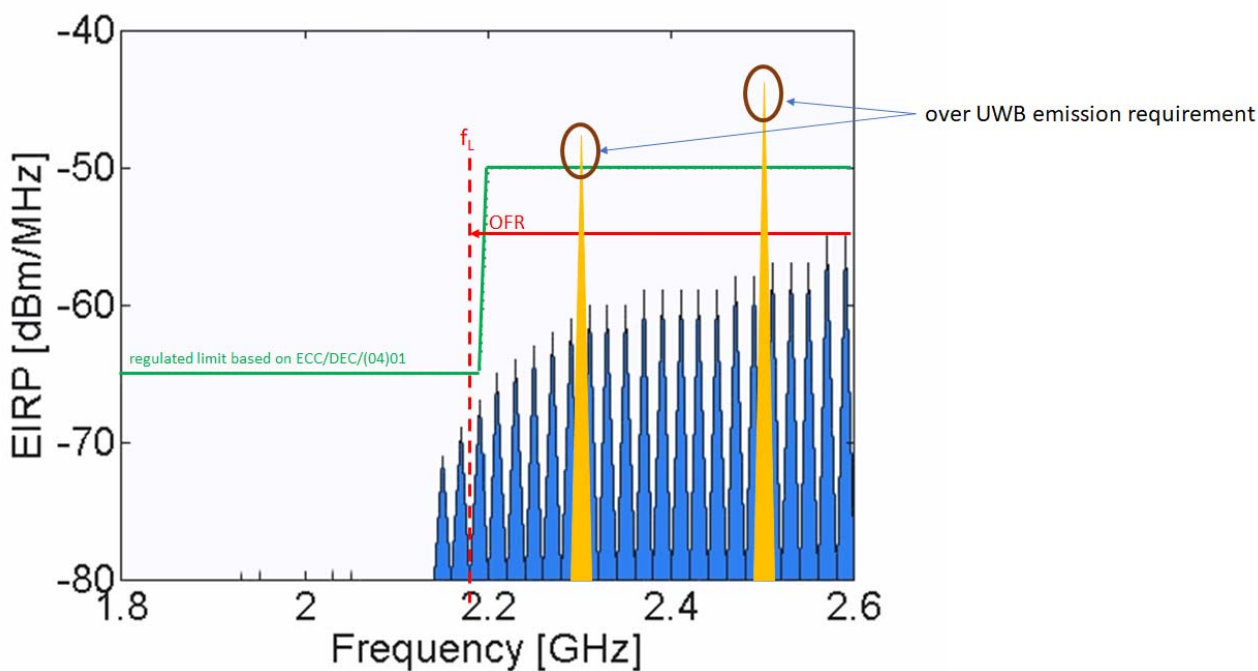

Figure D.2: Example for an AE measurement in the frequency range 1,8 GHz to 2,6 GHz for an EUT covered by ECC/DEC/(07)01 [i.4]

Assessment of the emissions outside OFR:

- AE measurement shall fulfil the limits of the TXUE requirement within the related standard.
- Case 1: Measurement result below the related TXUE limits (see in addition clause 5.5): test passed.
- Case 2: Measurement results above the related TXUE limits (see in addition clause 5.5): test failed.

## D.3 Second step

The second step is mandatory if the recorded AE emission of the UWB device exceeds the corresponding UWB emission requirement within the Operating Frequency Range (OFR, see clause 5.2), given in the relevant standard.

For the frequencies, where the All Emissions (AE) exceed the limits of the RP, the Other Emissions (OE) shall be measured by disabling the UWB transmitter or removing the antenna and terminating the transmitter. The rest of the UWB device shall be kept into the transmit mode.

Emissions that are present in OE as well as in AE with the similar amplitude within the measurement uncertainty are considered to be OE. This OE measurement shall be performed using the same measurement procedure than for step 1.

The principle of such case is illustrated in figure D.3.

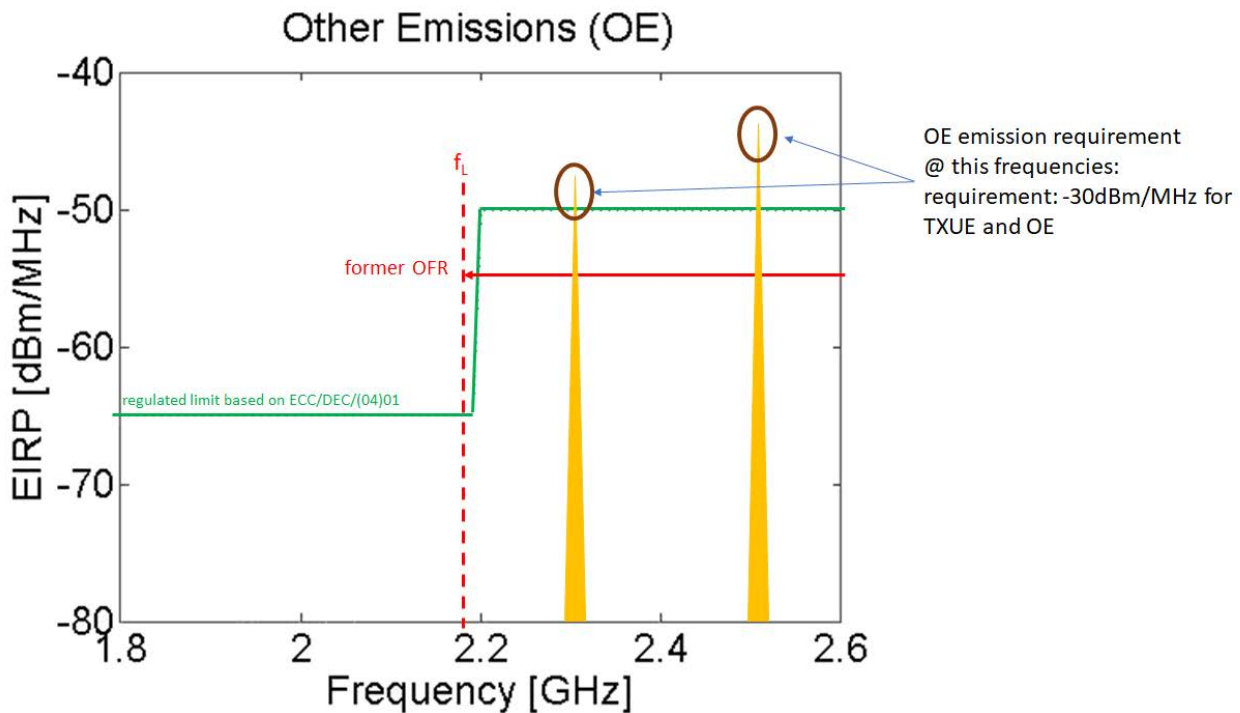

Figure D.3: Example for an AE measurement (only OE components) in the frequency range 1,8 GHz to 2,6 GHz for an EUT covered by ECC/DEC/(07)01 [i.4]



---

## Annex E (normative): Guidance for a pre-scan of EUT operating frequency range(s)

To verify the start and stop frequencies for the OFR measurements in clause 5.3.2, a pre-scan shall be performed as follows:

The spectrum analyser shall be connected to the measurement antenna (see clause B.2.2.5).

Spectrum analyser settings:

- Any RBW deemed suitable.
- VBW equal to or greater than the RBW.
- Start/stop frequency:
  - Around the start/stop frequencies of the specified operating frequency range(s) if known.
  - Otherwise, sweep over intended frequency range of the related harmonised standard.
- Detector mode: Peak.
- Display mode: max hold.
- Any suitable sweep time and number of points are accepted.

A first measurement without the EUT transmissions present is performed as a reference measurement.

A second measurement is then performed with the EUT transmission present. A comparison between both will show the EUT operating frequency range.

The start and stop frequencies for the actual compliance measurements shall be at least as wide as the 10 dBc points found during this pre-scan.

## Annex F (informative): Measurement of peak e.i.r.p. and mean (average) e.i.r.p. of constant duty cycle wideband pulsed signals

### F.1 General

For the sake of simplicity, the following descriptions concern "classical" pulsed signals with a rectangular shape, a constant duty cycle and an unmodulated carrier signal.

With respect to these restrictions, the relationships between the key pulse parameters are well known:

- The pulse peak e.i.r.p. is given by the power of the carrier during the on period.
- The pulse peak e.i.r.p. and the pulse mean e.i.r.p. are connected via the duty cycle.
- The pulse spectrum is connected to the pulse peak e.i.r.p. via the "pulse desensitization factor" as described in the literature Application Note 6.2019-1EF106-1E [i.30].
- For  $RBW \ll PRF$ , the mean and max PSD are identical.

### F.2 Exemplary measurement of pulse signals

In this example, it is shown how to measure a pulse train signal with constant duty cycle with different measurement procedures and which results to expect. Therefore, a signal generator (pulse train signal source) and a spectrum analyser are connected, see figure F.1.

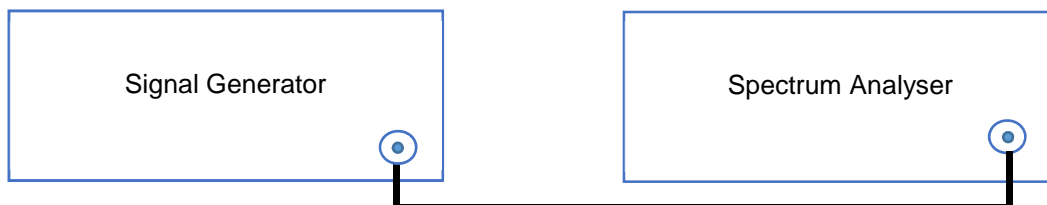

**Figure F.1: Measurement setup for method I/method II in clauses F.3.2 and F.3.3**

In a second setup, the Signal Generator is connected to a power meter, see figure F.2.

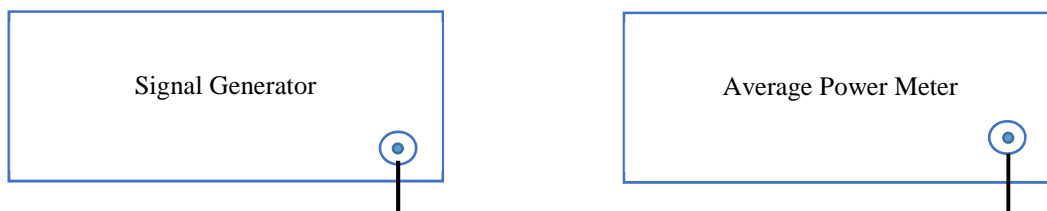

**Figure F.2: Measurement setup for method III in clause F.3.4**

The mean e.i.r.p. and peak e.i.r.p. are measured with three different methods and the results are shown.

Unless specified otherwise, the spectrum analyser RBW is chosen as  $RBW \ll PRF$ . This ensures that only one line of the pulse train's spectrum falls into the RBW at a time. The cable attenuation was measured as 1 dB and is compensated accordingly.

The signal generator is configured with the following pulse modulation settings, see table F.1.

**Table F.1: Pulse modulation settings**

Parameter	Value
Centre frequency, $f_c$	5,5 GHz
Power P	-20 dBm
Pulse width, $T_{on}$	250 ns
Operating frequency range, OFR	4 MHz
Pulse repetition interval, PRI	2,5 $\mu$ s
Pulse repetition frequency, PRF	400 kHz
Duty cycle [%]	10 %
Duty cycle [dB]	10 dB
Duty cycle <sup>2</sup> [dB]	20 dB

The expected measurement results based on figure F.1 are shown in table F.2.

**Table F.2: Expected measurement values**

Parameter	Reference	Value
Peak e.i.r.p.	= Signal generator level	-20 dBm
Mean e.i.r.p.	= Peak e.i.r.p.* Duty cycle	-30 dBm
Mean PSD at $f_c$	= Peak e.i.r.p.* Duty cycle <sup>2</sup>	-40 dBm
Max PSD at $f_c$	=  Mean PSD at $f_c$   <sup>2</sup>	-40 dBm
NOTE: Max PSD: Mean e.i.r.p. Spectral Density, see clause 5.3.2.		

## F.3 Mean e.i.r.p. measurements

### F.3.1 General

This clause explains and describes three methods to measure mean e.i.r.p. of a pulse signal with constant duty cycle. Two of these methods use a spectrum analyser (clauses F.3.2 and F.3.3), one uses a power meter (see clause F.3.4).

### F.3.2 Method I: Zero span mode

The following settings for the spectrum analyser in figure F.1 were used:

- RBW = 10 MHz
- VBW = 10 MHz
- RMS detector
- Zero span mode
- Number of points = 1 001
- Sweep time (SWT) = PRI  $\times$  Number of points  $\rightarrow$  SWT = 2,5  $\mu$ s  $\times$  1 001  $\approx$  2,5 ms

The measurement result is shown in figure F.3. The measured mean e.i.r.p. is -30,39 dBm.

NOTE: The SWT has to be set to PRI  $\times$  number of points in order to measure the mean e.i.r.p. correctly.

Choosing the SWT in this manner ensures that the RMS detector averages the video signal over exactly one PRI.

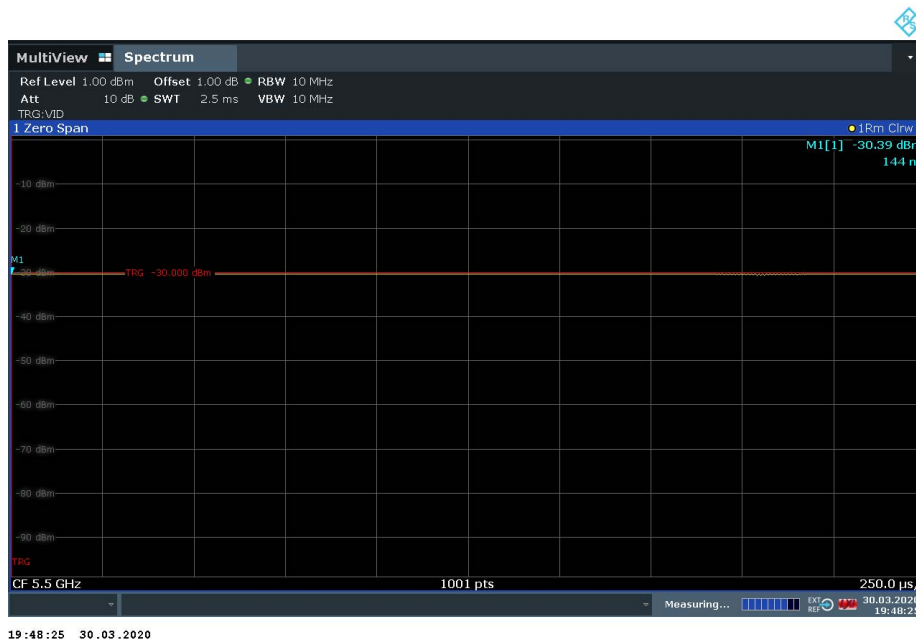

Figure F.3: Measurement result, Mean e.i.r.p.

This method requires the RBW to be wider than the pulse bandwidth. Consequently, for UWB pulses this method is in general not suitable.

### F.3.3 Method II: Channel power measurement

Settings for measurement setup of figure F.1:

- Channel power function
- RMS detector
- Channel bandwidth = 40 MHz

As shown in figure F.4 the channel power measurement estimates the mean e.i.r.p. to be -29,93 dBm.

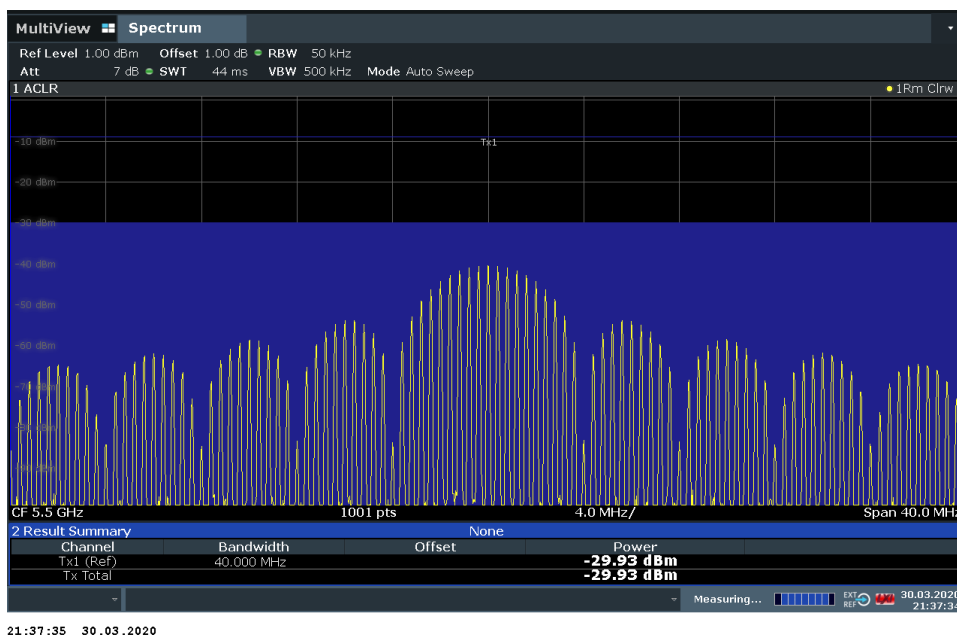

Figure F.4: Measurement results, channel power

## F.3.4 Method III: Average power meters

Table F.3 compares the results of Method I (clause F.3.2) and Method II (clause F.3.3) with two types of average power meters (measurement setup according to figure F.2). There are diode based and thermal based average power meters available.

**Table F.3: Comparison of mean e.i.r.p. measurement procedures**

Approach	Mean e.i.r.p.	Main drawback
Theory	-30 dBm	
Average power meter - diode based	-30,9 dBm	Depends on modulation, not frequency selective
Average power meter - thermal	-29,79 dBm (note)	Low dynamic range, not frequency selective
Spectrum analyser - zero span	-30,39 dBm	Narrow band, accuracy
Spectrum analyser - channel power	-29,93 dBm	Accuracy
NOTE: Close to the sensor's dynamic range limit.		

## F.4 Peak e.i.r.p. measurements

### F.4.1 General

This clause describes and shows an example how to measure the Peak e.i.r.p. of the signal generator in setup shown in figure F.1. Obtaining the peak e.i.r.p. can be achieved in two different ways. One approach using a direct measurement and secondly by applying correction factors to other pulse parameters.

### F.4.2 Method I: Zero span mode - direct measurement

The direct measurement with a spectrum analyser (see figure F.1) is only possible where pulse signals have small bandwidths that fit into the RBW of the spectrum analyser. Consequently, this is not possible for most UWB devices.

RBW and VBW have to be wide enough to be able to capture the envelope of the pulse (operating frequency range).

Requirement:  $RBW > OFR$

Settings:

- RBW = 10 MHz
- VBW = 10 MHz
- Peak detector
- Zero span mode

Figure F.5 shows the result of the peak e.i.r.p. measurement. The peak e.i.r.p. is measured as -19,92 dBm. Since the operating frequency range is 4 MHz and the RBW is 10 MHz, the pulse can be measured without additional corrections.

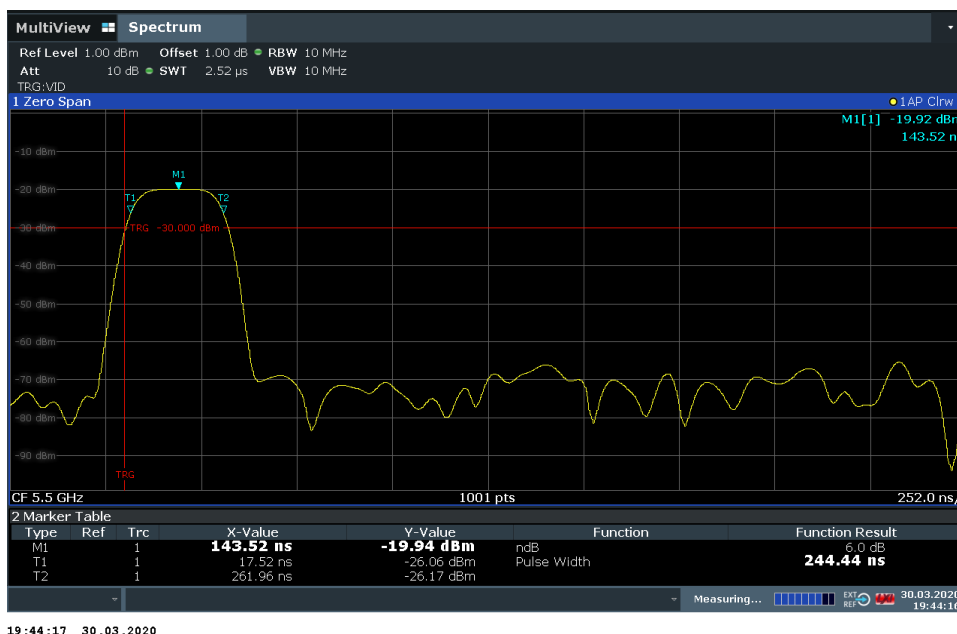

Figure F.5: Peak e.i.r.p. measurement with direct measurement where RBW > OFR

### F.4.3 Method II: Peak e.i.r.p. calculation

There are two ways to calculate the peak e.i.r.p. One way is to use the duty cycle and the mean e.i.r.p. according to equation (F.1).

$$Peak\ e.i.r.p = \frac{Mean\ e.i.r.p}{Duty\ cycle} \tag{F.1}$$

In this example the *Duty cycle* is 10 % (= 0,1 → - 10 dB) which yields to (equation (F.2):

$$Peak\ e.i.r.p\ [dBm] = -30\ dBm - (-10\ dB) = -20\ dBm \tag{F.2}$$

For the different measurement approaches of the mean e.i.r.p., the following results for the peak e.i.r.p. are obtained.

Table F.4: Comparison of peak e.i.r.p. for different measurement approaches

Approach	Mean e.i.r.p.	Peak e.i.r.p.
Theory	-30 dBm	-20 dBm
Average power meter - diode based	-30,9 dBm	-20,9 dBm
Average power meter - thermal	-29,79 dBm (see note)	-19,7 dBm
Spectrum analyser - zero span	-30,38 dBm	-20,38 dBm
Spectrum analyser - channel power	-29,93 dBm	-19,93 dBm

NOTE: Close to the sensor's dynamic range limit.

Alternatively, the peak e. i. r. p. can be calculated from the Max or Mean PSD via the pulse desensitization factor. This is only possible if the Fourier transform of the pulsed signal is known analytically. The pulse shape has to be known as a consequence (see equation (F.3)).

$$Peak\ e.i.r.p = \frac{Mean\ PSD\ at\ f_c\ (Carrier\ Power)}{Duty\ cycle^2} \tag{F.3}$$

In the exemplary case, this gives (see equation (F.4)):

$$Peak\ e.i.r.p\ [dBm] = -40\ dBm + 20\ dB = -20\ dBm \tag{F.4}$$

**Table F 5: Comparison of peak e.i.r.p. for different measurement approaches**

Approach	Mean PSD at $f_c$	Peak e.i.r.p.
Theory	-40 dBm	-20 dBm
Spectrum analyser - Max PSD	-40,10 dBm	-20,10 dBm

Based on this example, if the pulse bandwidth is small, a peak power meter could also be used to measure the peak e.i.r.p. For UWB pulses this is typically not possible as peak power meters usually have a video bandwidth of less than 200 MHz. Pulse bandwidths greater than 1 GHz, however, are not uncommon in UWB applications.

Even if the peak power meter could rectify the UWB pulse correctly (and thus track the pulse's power envelope) the following video filter would average out the majority of the pulse envelope. The resulting power reading would most likely be far off from the true peak e.i.r.p. value and much closer to the mean e.i.r.p.

## F.5 Max and mean PSD

Figure F.6 shows the (positive) peak detector (trace 1) and RMS detector (trace 2) traces of the generated pulse signal. As can be seen, the max and mean PSD give almost identical results.

**Figure F.6: Max and mean PSD of a pulse train line spectrum**

The reason for this behaviour is that in case of the  $RBW \ll PRF$ , only one line of the pulse spectrum fits in the spectrum analyser's RBW at a time. Consequently, the output of the envelop detector is constant as indicates in figure F.7.

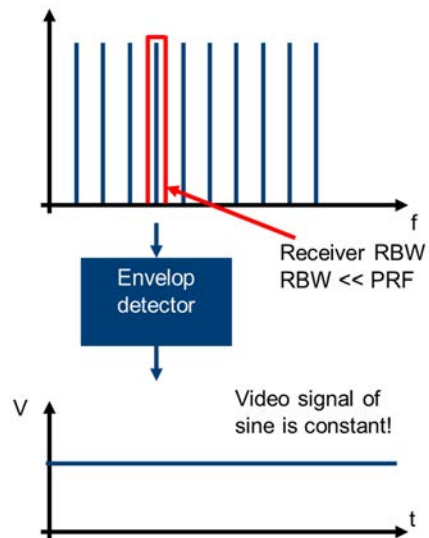

**Figure F.7: Pulse spectrum as seen by a spectrum analyser with an  $RBW \ll PRF$**

A (positive) peak detector calculates the displayed pixel value from the highest available sample. An RMS detector calculates the displayed pixel value from the RMS of all available samples.

For a constant video signal, the peak and the RMS detector yield the same results.



## Annex G (normative): TX Unwanted Emissions (TXUE) for EUT under ECC/DEC/(22)03

For EUT under ECC/DEC/(22)03 [i.40] the OFR was specified by  $X = 20$  dB (see clause 5.2.1) below the regulated in band limit. This specific limit applies for the frequency range 116 to 260 GHz, see ECC report 334 [i.42] and ECC report 351 [i.43]. Based on ECC/DEC/(22)03 the spurious and OOB domain limits within the ranges " $116\text{GHz} < f < f_L$ " and " $f_H < f < 260$  GHz" would be different to the generic spurious limits under ERC/REC 74-01 [i.9].

NOTE: For unwanted emission specification for RDI-S (table 10 of ECC/DEC/(22)03 [i.40]) see related standard.

For the frequency ranges " $F_{\text{LOWER}} \leq f \leq 116$  GHz" and " $260$  GHz  $\leq f \leq F_{\text{UPPER}}$ " the limits in clause 5.5.2; table 4 and the conformance test in clause 5.5.3 apply.

The following tables providing the limits for the unwanted emissions within the range 116 GHz to 260 GHz.

- Table G.1: for generic indoor surveillance radar
- Table G.2: for radiodetermination systems for industry automation (RDI)
- Table G.3: for Level Probing Radar (LPR)
- Table G.4: for Contour Determination and acquisition Radar (CDR)
- Table G.5: for Tank Level Probing Radar (TLPR)
- Table G.6: for exterior Vehicular Radar (EVR)
- Table G.7: for In-cabin Vehicular Radar (IVR)

**Table G.1: Summary for the unwanted emissions for generic indoor radiodetermination devices within 116 GHz - 260 GHz covered by ECC/DEC/(22)03 [i.40]; studied in ECC report 334 [i.42]**

Regulation for	Permitted range [GHz]	Limit for wanted emission within OFR (e.i.r.p.)	Unwanted emission limit within 116 GHz $< f < f_L$ and $f_H < f < 260$ GHz	
			Limit	for conformance test
Generic Indoor, see table 3 of [i.40]	$122,25 \leq f \leq 130$	-20 dBm/MHz	-40 dBm/MHz	RMS with 1 MHz RBW, averaged over 1 ms
	$134 \leq f \leq 148,5$	-20 dBm/MHz	-40 dBm/MHz	
Fixed generic indoor, see table 4 of [i.40]	$122,25 \leq f \leq 130$	-10 dBm/MHz	-30 dBm/MHz	
	$134 \leq f \leq 148,5$	-10 dBm/MHz	-30 dBm/MHz	

**Table G.2: Summary for the unwanted emissions for RDI devices within 116 GHz - 260 GHz covered by ECC/DEC/(22)03 [i.40]; studied in ECC report 334 [i.42]**

Regulation for	Permitted range [GHz]	Limit for wanted emission within OFR (e.i.r.p.)  See note	Unwanted emission limit within 116 GHz < f < f <sub>L</sub> and f <sub>H</sub> < f < 260 GHz	
			Limit	for conformance test
RDI, see table 5 of [i.40]	174,8 ≤ f ≤ 182	-13,8 dBm/MHz	-33,8 dBm/MHz	RMS with 1 MHz RBW, averaged over T <sub>rep</sub>
		31 dBm peak	11 dBm peak	Peak measured with 1 MHz
	185 ≤ f ≤ 190	-13,8 dBm/MHz	-33,8 dBm/MHz	RMS with 1 MHz RBW, averaged over T <sub>rep</sub>
		31 dBm peak	11 dBm peak	Peak measured with 1 MHz
	231,5 ≤ f ≤ 250	-25,6 dBm/MHz	-45,6 dBm/MHz	RMS with 1 MHz RBW, averaged over T <sub>rep</sub>
		31 dBm peak	11 dBm peak	Peak measured with 1 MHz

NOTE: Peak e.i.r.p. for the wanted emission within OFR shall be measured/evaluated in 1 GHz bandwidth.

**Table G.3: Summary for the unwanted emissions for LPR devices within 116 GHz - 260 GHz covered by ECC/DEC/(22)03 [i.40]; studied in ECC report 334 [i.42]**

Regulation for	Permitted range [GHz]	Limit for wanted emission within OFR (e.i.r.p.)  See note	Unwanted emission limit within 116 GHz < f < f <sub>L</sub> and f <sub>H</sub> < f < 260 GHz	
			Limit	for conformance test
LPR, see table 6 of [i.40]	116 ≤ f ≤ 148,5	-8 dBm/MHz	-28 dBm/MHz	RMS with 1 MHz RBW, averaged over T <sub>rep</sub>
		37 dBm peak	17 dBm peak	Peak measured with 1 MHz
	167 ≤ f ≤ 182	-6 dBm/MHz	-26 dBm/MHz	RMS with 1 MHz RBW, averaged over T <sub>rep</sub>
		37 dBm peak	17 dBm peak	Peak measured with 1 MHz
	231,5 ≤ f ≤ 250	-6 dBm/MHz	-26 dBm/MHz	RMS with 1 MHz RBW, averaged over T <sub>rep</sub>
		37 dBm peak	17 dBm peak	Peak measured with 1 MHz

NOTE: Peak e.i.r.p. for the wanted emission within OFR shall be measured/evaluated in 1 GHz bandwidth.

**Table G.4: Summary for the unwanted emissions for CDR devices within 116 GHz - 260 GHz covered by ECC/DEC/(22)03 [i.40]; studied in ECC report 334 [i.42]**

Regulation for	Permitted range [GHz]	Limit for wanted emission within OFR (e.i.r.p.)  See note	Unwanted emission limit within 116 GHz < f < f <sub>L</sub> and f <sub>H</sub> < f < 260 GHz	
			Limit	for conformance test
CDR with digital beamforming, see table 7 of [i.40]	116 ≤ f ≤ 148,5	-32,6 dBm/MHz	-52,6 dBm/MHz	RMS with 1 MHz RBW, averaged over T <sub>rep</sub>
		15 dBm peak	-5 dBm peak	Peak measured with 1 MHz
	167 ≤ f ≤ 182	-29 dBm/MHz	-49 dBm/MHz	RMS with 1 MHz RBW, averaged over T <sub>rep</sub>
		15 dBm peak	-5 dBm peak	Peak measured with 1 MHz
	231,5 ≤ f ≤ 250	-23,0 dBm/MHz	-43,0 dBm/MHz	RMS with 1 MHz RBW, averaged over T <sub>rep</sub>
		15 dBm peak	-5 dBm peak	Peak measured with 1 MHz
CDR operating with multiple antenna elements, see table 8 of [i.40]	116 ≤ f ≤ 148,5	-12 dBm/MHz	--32 dBm/MHz	RMS with 1 MHz RBW, averaged over T <sub>rep</sub>
		28,6 dBm peak	8,6 dBm peak	Peak measured with 1 MHz
	167 ≤ f ≤ 182	-9 dBm/MHz	-29 dBm/MHz	RMS with 1 MHz RBW, averaged over T <sub>rep</sub>
		34,6 dBm peak	14,6 dBm peak	Peak measured with 1 MHz
	231,5 ≤ f ≤ 250	-6,0 dBm/MHz	-26,0 dBm/MHz	RMS with 1 MHz RBW, averaged over T <sub>rep</sub>
		37 dBm peak	17 dBm peak	Peak measured with 1 MHz

NOTE: Peak e.i.r.p. for the wanted emission within OFR shall be measured/evaluated in 1 GHz bandwidth.

**Table G.5: Summary for the unwanted emissions for TLPD devices within 116 GHz - 260 GHz covered by ECC/DEC/(22)03 [i.40]; studied in ECC report 334 [i.42]**

Regulation for	Permitted range [GHz]	Limit for wanted emission within OFR (e.i.r.p.)  See note	Unwanted emission limit within 116 GHz < f < f <sub>L</sub> and f <sub>H</sub> < f < 260GHz	
			Limit	Measured
TLPD, See table 9 of [i.40]	116 ≤ f ≤ 148,5	12 dBm/MHz	-8 dBm/MHz	RMS with 1 MHz RBW, averaged over T <sub>rep</sub>
		42 dBm peak	22 dBm peak	Peak measured with 1 MHz
	167 ≤ f ≤ 182	12 dBm/MHz	-8 dBm/MHz	RMS with 1 MHz RBW, averaged over T <sub>rep</sub>
		42 dBm peak	22 dBm peak	Peak measured with 1 MHz
231,5 ≤ f ≤ 250	12 dBm/MHz	-8 dBm/MHz	RMS with 1 MHz RBW, averaged over T <sub>rep</sub>	
	42 dBm peak	22 dBm peak	Peak measured with 1 MHz	

NOTE: Peak e.i.r.p. for the wanted emission within OFR shall be measured/evaluated in 1 GHz bandwidth.

**Table G.6: Summary overview of the unwanted/wanted emissions and frequency ranges for EVR devices within 116 GHz - 260 GHz covered by ECC/DEC/(22)03 [i.40]; studied in ECC report 351 [i.43]**

Regulation for	Frequency range [GHz]	Unwanted emissions limits	Additional requirements
EVR operating within 122,25 GHz - 130 GHz  See table 11 of [i.40]	116 ≤ f < 122,25	-50 dBm/MHz ≤ 35 deg elevation	for all kind of EUT with DC ≤ 50 %; T <sub>obs</sub> = T <sub>rep</sub>
		-76 dBm/MHz > 35 deg elevation	for all kind of EUT with DC ≤ 50 %; T <sub>obs</sub> = T <sub>rep</sub>
		-53 dBm/MHz ≤ 35 deg elevation	for all kind of EUT with DC > 50 %; T <sub>obs</sub> = T <sub>rep</sub>
		-79 dBm/MHz > 35 deg elevation	for all kind of EUT with DC > 50 %; T <sub>obs</sub> = T <sub>rep</sub>
	122,25 ≤ f < f <sub>L</sub>	see related standard	unwanted domain could be specified in relation to EUT category and OFR/BW specification, see clause 5.5.1
	f <sub>L</sub> ≤ f ≤ f <sub>H</sub>	In band	see table 1 of ECC/DEC/(22)03 [i.40] and related standard
	f <sub>H</sub> < f ≤ 130	see related standard	unwanted domain could be specified in relation to EUT category and OFR/BW specification, see clause 5.5.1
	130 < f ≤ 134	-33 dBm/MHz	for front radar; RMS with 1 MHz RBW, averaged over T <sub>rep</sub>
		2dBm peak	for front radar; Peak evaluated within 1 GHz
		-36 dBm/MHz	corner and short/ultra-short range radars; RMS with 1 MHz RBW, averaged over T <sub>rep</sub>
		-1 dBm peak	corner & short/ultra-short range radars; Peak evaluated within 1 GHz
	134 < f ≤ 148,5	-30 dBm/MHz	see clause 5.5.2; table 4
	148,5 < f ≤ 151	-44 dBm/MHz ≤ 35 deg elevation	for all kind of EUT with DC ≤ 50 %; T <sub>obs</sub> = T <sub>rep</sub>
		-70 dBm/MHz > 35 deg elevation	for all kind of EUT with DC ≤ 50 %; T <sub>obs</sub> = T <sub>rep</sub>
-47 dBm/MHz ≤ 35 deg elevation		for all kind of EUT with DC > 50 %; T <sub>obs</sub> = T <sub>rep</sub>	
-73 dBm/MHz > 35 deg elevation		for all kind of EUT with DC > 50 %; T <sub>obs</sub> = T <sub>rep</sub>	
151 < f ≤ 260	-30 dBm/MHz	see clause 5.5.2; table 4	
EVR operating within 134 GHz - 141 GHz or 141 GHz - 148,5 GHz  See table 11 of [i.40]	116 ≤ f < 122,25	-50 dBm/MHz ≤ 35 deg elevation	for all kind of EUT with DC ≤ 50 %; T <sub>obs</sub> = T <sub>rep</sub>
		-76 dBm/MHz > 35 deg elevation	for all kind of EUT with DC ≤ 50 %; T <sub>obs</sub> = T <sub>rep</sub>
		-53 dBm/MHz ≤ 35 deg elevation	for all kind of EUT with DC > 50 %; T <sub>obs</sub> = T <sub>rep</sub>
		-79 dBm/MHz > 35 deg elevation	for all kind of EUT with DC > 50 %; T <sub>obs</sub> = T <sub>rep</sub>
	122,25 ≤ f ≤ 130	-30 dBm/MHz	see clause 5.5.2; table 4

Regulation for	Frequency range [GHz]	Unwanted emissions limits	Additional requirements
	130 < f < 134	-33 dBm/MHz	for front radar; RMS with 1 MHz RBW, averaged over T <sub>rep</sub>
		2dBm peak	for front radar; Peak evaluated within 1 GHz
		-36 dBm/MHz	corner and short/ultra-short range radars; RMS with 1 MHz RBW, averaged over T <sub>rep</sub>
		-1 dBm peak	corner and short/ultra-short range radars; Peak evaluated within 1 GHz
	134 ≤ f < f <sub>L</sub>	see related standard	unwanted domain could be specified in relation to EUT category and OFR/BW specification, see clause 5.5.1
	f <sub>L</sub> ≤ f ≤ f <sub>H</sub>	inband	see table 11 of ECC/DEC/(22)03 [i.40] and related standard
	f <sub>H</sub> < f ≤ 148,5	see related standard	unwanted domain could be specified in relation to EUT category and OFR/BW specification, see clause 5.5.1
	148,5 < f ≤ 151	-44 dBm/MHz ≤ 35 deg elevation	for all kind of EUT with DC ≤ 50 %; T <sub>obs</sub> = T <sub>rep</sub>
		-70 dBm/MHz > 35 deg elevation	for all kind of EUT with DC ≤ 50 %; T <sub>obs</sub> = T <sub>rep</sub>
		-47 dBm/MHz ≤ 35 deg elevation	for all kind of EUT with DC > 50 %; T <sub>obs</sub> = T <sub>rep</sub>
-73 dBm/MHz > 35 deg elevation		for all kind of EUT with DC > 50 %; T <sub>obs</sub> = T <sub>rep</sub>	
151 < f ≤ 260	-30 dBm/MHz	see clause 5.5.2; table 4	

**Table G.7: Summary overview of the unwanted/wanted emissions and frequency ranges for IVR devices within 116 GHz - 260 GHz covered by ECC/DEC/(22)03 [i.40]; studied in ECC report 351 [i.43]**

Regulation for	Frequency range [GHz]	Unwanted emissions limits	Additional requirements
IVR operating within 122,25 GHz - 130 GHz  See table 12 of [i.40]	116 < f < 122,25	-45 dBm/MHz	RMS with 1 MHz RBW, averaged over T <sub>rep</sub>
	122,25 ≤ f < f <sub>L</sub>	see related standard	Unwanted domain could be specified in relation to EUT category and OFR/BW specification, see clause 5.5.1
	f <sub>L</sub> ≤ f ≤ f <sub>H</sub>	In band	See table 11 of ECC/DEC/(22)03 [i.40] and related standard
	f <sub>H</sub> < f ≤ 130	see related standard	Unwanted domain could be specified in relation to EUT category and OFR/BW specification, see clause 5.5.1
	130 < f < 134	-17 dBm/MHz	RMS with 1 MHz RBW averaged over T <sub>rep</sub>
		-4dBm peak	Peak evaluated within 1 GHz
	134 ≤ f ≤ 148,5	-30 dBm/MHz	See clause 5.5.2; table 4
	148,5 < f ≤ 151	-39 dBm/MHz	RMS with 1 MHz RBW. averaged over T <sub>rep</sub>
151 < f < 260	-30 dBm/MHz	See clause 5.5.2; table 4	
IVR operating within 134 GHz - 141 GHz or 141 GHz - 148,5 GHz  See table 12 of [i.40]	116 ≤ f < 122,25	-45 dBm/MHz	RMS with 1 MHz RBW, averaged over T <sub>rep</sub>
	122,25 ≤ f < 130	-30 dBm/MHz	See clause 5.5.2; table 4
	130 ≤ f < 134	-17 dBm/MHz	RMS with 1 MHz RBW averaged over T <sub>rep</sub>
		-4 dBm peak	Peak evaluated within 1 GHz
	134 ≤ f < f <sub>L</sub>	see related standard	Unwanted domain could be specified in relation to EUT category and OFR/BW specification, see clause 5.5.1
	f <sub>L</sub> ≤ f ≤ f <sub>H</sub>	inband	See table 11 of ECC/DEC/(22)03 [i.40] and related standard
	f <sub>H</sub> < f ≤ 148,5	see related standard	Unwanted domain could be specified in relation to EUT category and OFR/BW specification, see clause 5.5.1
	148,5 < f ≤ 151	-39 dBm/MHz	RMS with 1 MHz RBW. averaged over T <sub>rep</sub>
151 < f ≤ 260	-30 dBm/MHz	See clause 5.5.2; table 4	

## Annex H (informative): Parameter and Specification in related Standards

This clause provides a short overview on parameter or other relevant points for TX conformance testing (e.g. test set-up, test site) which need to be considered by the related standard. A kind of checklist is provided in table H.1 (general issues) and table H.2.

**Table H.1: Checklist on general issues to be considered in related standard**

<b>General issues for all TX requirements</b>		
<b>issue</b>	<b>the related standard (rS) need to consider and specify</b>	<b>See clause</b>
Test site	For each requirement one test site. See note 1.	clause B.2.2
Kind of conformance test (radiated or conducted) measurement procedure	If the TX requirement of the EUT needs to be tested radiated or conducted. And if there are different options necessary (depending on e.g. EUT categories) the rS need to specify the circumstances under which situation which test site and measurement procedure apply. For radiated tests the rS specifies: <ul style="list-style-type: none"> <li>• angular steps</li> <li>• measurement distance</li> </ul> and if there is a need to specify a test scenario (additional parts) e.g. indirect emissions testing.	clause B.3 for conducted clause B.4 for radiated clause B.4 clause 5.7
Environmental conditions	a environmental profile (based on the intended use of the EUT) and the related test site.	ETSI TS 103 941 [3]
EUT categories	EUT categories based on the intended use (if there are different requirements depending EUT categories (intended use) which are leading to different requirements, test sites, measurement procedures, etc.).	
<b>General issues for measurement</b>		
Disregard time $T_{dis}$	Important for timing measurements (Duty Cycle, signal repetition time, $T_{on}$ ) and has an impact on the averaging time of e.g. over burst duration/ $T_{on}$ .	clause C.1
Threshold Level $P_{thresh}$	Important for timing measurements (Duty Cycle, signal repetition time, $T_{on}$ ). See note 2.	clause C.1
NOTE 1: This could be different for EUT categories (intended use).		
NOTE 2: If nothing is specified the noise floor level (sensitivity level) of the measurement equipment is used.		

Table H.2: Checklist on technical issues to be considered in related standard

Requirements specific issues for emission (radiated/conducted) measurements		
Requirement	The related standard (rS) need to consider and specify	See clause
OFR	X (if other limit than 23 dB) for the OFR. In addition clarifies: <ul style="list-style-type: none"> <li>If the measured emission level at <math>f_L</math> or <math>f_H</math> are used to derive <math>P_{\text{thresh}}</math> and the way to come to the related limit.</li> <li>Which power (emission) measurement is used for the OFR assessment.</li> </ul>	5.2.1
Mean e.i.r.p.	<ul style="list-style-type: none"> <li>Specify kind of measurement procedure based on required averaging time.</li> <li>Provide measurement solutions to assess signal repetition and/or <math>T_{\text{on}}</math> time.</li> <li>Start and stop frequency.</li> <li>RBW.</li> </ul>	5.3.1 and C.3
Mean e.i.r.p. Spectral Density	<ul style="list-style-type: none"> <li>Specify kind of measurement procedure based on required averaging time.</li> <li>Provide measurement solutions to assess signal repetition and/or <math>T_{\text{on}}</math> time.</li> <li>Start and stop frequency.</li> <li>RBW.</li> </ul>	5.3.2 and C.3
Peak e.i.r.p.	<ul style="list-style-type: none"> <li>Specify kind of measurement procedure.</li> <li>Start and stop frequency.</li> </ul>	5.3.3
Peak e.i.r.p. Spectral Density	kind of measurement procedure: <ul style="list-style-type: none"> <li>Start and stop frequency.</li> <li>RBW for the peak requirement assessment.</li> </ul>	5.3.4
Other Emissions	For UWB EUT (< 10 GHz) based on ECC/DEC/(06)04 [i.3] and ECC/DEC/(07)01 [i.4] other emissions could be an issue. The rS need to consider if there is an issue based on intended use of the EUT (e.g. indirect emission, OFR, etc.).	5.4 and annex D
TX unwanted emissions	Spurious emissions: <ul style="list-style-type: none"> <li><math>X_{\text{TXUE}}</math> to specify spurious domain and OOB (<math>f_{\text{LS}}</math> and <math>f_{\text{HS}}</math>).</li> <li>The averaging time for the spurious domain measurement e.g. Burst/<math>T_{\text{on}}</math> or signal repetition time.</li> </ul>	5.5.1 5.5.3.1.1
	Out-of-Band Domain: <ul style="list-style-type: none"> <li>Limits for the OOB domain. See note1.</li> <li>The rS need to specify necessary parameter for the measurement procedure (averaging time, detector, etc.).</li> </ul>	5.5.1
	See note 2.	

Requirements specific issues for emission (radiated/conducted) measurements		
Requirement	The related standard (rS) need to consider and specify	See clause
Indirect emissions	the test set-up and all necessary part which are relevant to "re-build" scenario. Therefore it is important to consider: <ul style="list-style-type: none"> <li>• What are the different parts including size, thickness and kind of material.</li> <li>• Distances/Spaces between the different parts of the scenario.</li> </ul> See note 3.	5.7
Antenna Pattern	<ul style="list-style-type: none"> <li>• Frequencies at which the antenna pattern needs to be assessed.</li> <li>• For external antennas which conformance tests.</li> <li>• Angular steps.</li> </ul> See note 4. <ul style="list-style-type: none"> <li>• measurement distance.</li> <li>• Minimum requirement for gain/pattern of the measurement antenna.</li> <li>• Minimum requirement for gain/pattern of the SRA (standard reference antenna).</li> <li>• Signal source (CW at which frequencies) and measurement receiver (clause 5.12.2.3) if EUT will be not used as signal source.</li> </ul>	5.12
NOTE 1: The OOB domain is dependent, and limits are linked with the EUT OFR requirements and spurious domain.		
NOTE 2: For EUT based on ECC/DEC/(22)03 [i.40], the TX unwanted domain requirement is different specified than in clause 5.5.1, the related limits and requirements (measurement methods) are defined in annex G.		
NOTE 3: Based on that the scenario reflects the environment for intended use of the EUT the rS need to consider if the test-set-up can be used for RX test as well of if based on the wanted technical performances and the intended use another (similar) RX test set-up is necessary.		
NOTE 4: For internal antennas it would be "clever" to use the same steps than for the e.i.r.p. measurement and allow a simple gain calculation via TRP assessment, see clause 5.6.		

Table H.3

Mitigation techniques		
Total Radiated Power	The rS need to specify the necessary e.i.r.p. emissions measurement (mean, mean power density, peak or peak power density) for the assessment of the TPR requirement	See clause 5.6
Transmit Power Control		See clause 5.8
Detect and Avoid	Depending EUT OFR and EUT categories (intended -use) the rS need to specify if DAA tests are necessary. The rS needs to consider and could specify this in differentiations in the EUT categories	See clause 5.9
Listen Before Talk	Depending EUT OFR and EUT categories (intended use) the rS need to specify if LBT tests are necessary. The rS need to consider and could specify this in differentiations in the EUT categories	See clause 5.10
Duty Cycle	In addition to $T_{dis}$ and $P_{thresh}$ the rS need to consider and specify the Observation time for the DC assessment and if the regulation requires a DC template assessment or a duty cycle assessment within a sub-range of the OFR. In addition the rS need to specify the RBW of the measurement procedure and the measurement procedure itself (e.g. conducted, with spectrum analyser, etc.)	See clause 5.11

## Annex I (informative): Change history

Version	Information about changes
1.2.1	<ul style="list-style-type: none"> <li>• The previous version of the present document was ETSI EN 303 883 (V1.1.1). For the revision of ETSI EN 303 883 it was decided to split the transmitter and receiver parts into two different documents: ETSI EN 303 883-1 (V1.2.1) (the present document) for transmitter, and ETSI EN 303 883-2 (V1.2.1) for receiver.</li> <li>• Addition of "mean power" measurement procedure.</li> <li>• Changes.</li> </ul>
2.1.1	<ul style="list-style-type: none"> <li>• Revision power measurement to reflect changes in informative referenced ECC/DEC/s</li> <li>• Updating Total radiated power measurement to reflect changes in informative referenced ECC/DEC/s</li> <li>• Adding new chapter for antenna measurement</li> <li>• Transfer environmental profile information to ETSI TS 103 941</li> <li>• Update annex B to reflect state of the art measurement test set-ups (radiated and conducted)</li> <li>• New annex G on specific unwanted emission requirements for EUT under ECC/DEC/(22)03</li> <li>• Update annex C</li> <li>• New annex H to provide guidance on necessary specifications (to be considered) during preparation of related standards</li> </ul>



---

## History

<b>Document history</b>		
V1.1.1	September 2016	Publication as ETSI EN 303 883
V1.2.1	February 2021	Publication
V2.1.0	January 2024	EN Approval Procedure AP 20240411: 2024-01-12 to 2024-04-11
V2.1.1	June 2024	Vote V 20240810: 2024-06-11 to 2024-08-12
V2.1.1	August 2024	Publication