



**Short Range Devices (SRD) to be used
in the 40 GHz to 260 GHz frequency range;
Harmonised Standard for access to radio spectrum;
Part 5: Ultra Short Range Communication (USRC)
equipment operating within 57 GHz to 64 GHz**

Reference

DEN/ERM-TGUWB-605EN 305 550-5

Keywords

RADIO, radio measurements, SRD

ETSI

650 Route des Lucioles
F-06921 Sophia Antipolis Cedex - FRANCE

Tel.: +33 4 92 94 42 00 Fax: +33 4 93 65 47 16

Siret N° 348 623 562 00017 - APE 7112B
Association à but non lucratif enregistrée à la
Sous-Préfecture de Grasse (06) N° w061004871

Important notice

The present document can be downloaded from the
[ETSI Search & Browse Standards](#) application.

The present document may be made available in electronic versions and/or in print. The content of any electronic and/or print versions of the present document shall not be modified without the prior written authorization of ETSI. In case of any existing or perceived difference in contents between such versions and/or in print, the prevailing version of an ETSI deliverable is the one made publicly available in PDF format on [ETSI deliver](#) repository.

Users should be aware that the present document may be revised or have its status changed, this information is available in the [Milestones listing](#).

If you find errors in the present document, please send your comments to the relevant service listed under [Committee Support Staff](#).

If you find a security vulnerability in the present document, please report it through our [Coordinated Vulnerability Disclosure \(CVD\)](#) program.

Notice of disclaimer & limitation of liability

The information provided in the present deliverable is directed solely to professionals who have the appropriate degree of experience to understand and interpret its content in accordance with generally accepted engineering or other professional standard and applicable regulations.

No recommendation as to products and services or vendors is made or should be implied. In no event shall ETSI be held liable for loss of profits or any other incidental or consequential damages.

Any software contained in this deliverable is provided "AS IS" with no warranties, express or implied, including but not limited to, the warranties of merchantability, fitness for a particular purpose and non-infringement of intellectual property rights and ETSI shall not be held liable in any event for any damages whatsoever (including, without limitation, damages for loss of profits, business interruption, loss of information, or any other pecuniary loss) arising out of or related to the use of or inability to use the software.

Copyright Notification

No part may be reproduced or utilized in any form or by any means, electronic or mechanical, including photocopying and microfilm except as authorized by written permission of ETSI.

The content of the PDF version shall not be modified without the written authorization of ETSI.

The copyright and the foregoing restriction extend to reproduction in all media.

© ETSI 2025.
All rights reserved.

Contents

Intellectual Property Rights	5
Foreword.....	5
Modal verbs terminology.....	6
Introduction	6
1 Scope	7
2 References	7
2.1 Normative references	7
2.2 Informative references.....	7
3 Definition of terms, symbols and abbreviations.....	8
3.1 Terms.....	8
3.2 Symbols.....	9
3.3 Abbreviations	9
4 Technical requirements specifications	9
4.1 Environmental profile.....	9
4.2 Equipment categories	10
4.3 Transmitter requirements	12
4.3.1 General.....	12
4.3.2 Operating Frequency Range (OFR)	12
4.3.2.1 Applicability.....	12
4.3.2.2 Description	12
4.3.2.3 Limits	12
4.3.2.4 Conformance.....	12
4.3.3 Mean e.i.r.p.	12
4.3.3.1 Applicability.....	12
4.3.3.2 Description	12
4.3.3.3 Limits	13
4.3.3.4 Conformance.....	13
4.3.4 Transmitter unwanted emissions (TXUE)	13
4.3.4.1 Applicability.....	13
4.3.4.2 Description.....	13
4.3.4.3 Limits for TXUE.....	13
4.3.5 TX behaviour under the complete environmental profile	14
4.3.5.1 Applicability.....	14
4.3.5.2 Description	14
4.3.5.3 Limits for radiated assessment of the TX behaviour.....	14
4.3.5.4 Conformance.....	15
4.4 Receiver requirements	15
4.4.1 General.....	15
4.4.2 Wanted technical performance criterion	15
4.4.3 Receiver spurious emissions	15
4.4.3.1 Applicability.....	15
4.4.3.2 Description	15
4.4.3.3 Limits	15
4.4.3.4 Conformance.....	16
4.4.4 Receiver Baseline Sensitivity (RBS)	16
4.4.4.1 Applicability.....	16
4.4.4.2 Description	16
4.4.4.3 Limits	16
4.4.4.4 Conformance.....	16
4.4.5 Receiver Dynamic Range	16
4.4.5.1 Applicability.....	16
4.4.5.2 Description	16
4.4.5.3 Limits	16

4.4.5.4	Conformance	17
4.4.6	Receiver Baseline Resilience (RBR)	17
4.4.6.1	Applicability	17
4.4.6.2	Description	17
4.4.6.3	Limits	17
4.4.6.4	Conformance	18
5	Testing for compliance with technical requirements.....	18
5.1	Environmental conditions for testing	18
5.1.1	General.....	18
5.1.2	Normal test conditions	18
5.1.3	Complete environmental profile test conditions	18
5.2	Conformance test suites and general conditions for testing	18
5.3	Test scenarios	19
5.4	Conformance methods of measurement for TX requirements.....	22
5.4.1	Operating Frequency Range (OFR)	22
5.4.2	Mean e.i.r.p.....	23
5.4.3	TX unwanted emissions	23
5.4.3.1	General	23
5.4.3.2	Unwanted emission in the Out-Of-Band (OOB) domain	23
5.4.3.3	Unwanted emission in the spurious domain.....	24
5.4.4	TX behaviour under the complete environmental profile	24
5.5	Conformance methods of measurement for receiver.....	25
5.5.1	Receiver Spurious Emissions.....	25
5.5.2	Receiver Baseline Sensitivity (RBS)	25
5.5.3	Receiver Dynamic range.....	25
5.5.4	Receiver Baseline Resilience (RBR)	26
Annex A (informative):	Relationship between the present document and the essential requirements of Directive 2014/53/EU	28
Annex B (informative):	Requirement mapping.....	30
Annex C (informative):	Interferer for RBR test.....	32
Annex D (informative):	Change history	34
Annex E (informative):	History	35

Intellectual Property Rights

Essential patents

IPRs essential or potentially essential to normative deliverables may have been declared to ETSI. The declarations pertaining to these essential IPRs, if any, are publicly available for **ETSI members and non-members**, and can be found in ETSI SR 000 314: "*Intellectual Property Rights (IPRs); Essential, or potentially Essential, IPRs notified to ETSI in respect of ETSI standards*", which is available from the ETSI Secretariat. Latest updates are available on the [ETSI IPR online database](#).

Pursuant to the ETSI Directives including the ETSI IPR Policy, no investigation regarding the essentiality of IPRs, including IPR searches, has been carried out by ETSI. No guarantee can be given as to the existence of other IPRs not referenced in ETSI SR 000 314 (or the updates on the ETSI Web server) which are, or may be, or may become, essential to the present document.

Trademarks

The present document may include trademarks and/or tradenames which are asserted and/or registered by their owners. ETSI claims no ownership of these except for any which are indicated as being the property of ETSI, and conveys no right to use or reproduce any trademark and/or tradename. Mention of those trademarks in the present document does not constitute an endorsement by ETSI of products, services or organizations associated with those trademarks.

DECT™, **PLUGTESTS™**, **UMTS™** and the ETSI logo are trademarks of ETSI registered for the benefit of its Members. **3GPP™**, **LTE™** and **5G™** logo are trademarks of ETSI registered for the benefit of its Members and of the 3GPP Organizational Partners. **oneM2M™** logo is a trademark of ETSI registered for the benefit of its Members and of the oneM2M Partners. **GSM®** and the GSM logo are trademarks registered and owned by the GSM Association.

Foreword

This draft Harmonised European Standard (EN) has been produced by ETSI Technical Committee Electromagnetic compatibility and Radio spectrum Matters (ERM), and is now submitted for the combined Public Enquiry and Vote phase of the ETSI Standardisation Request deliverable Approval Procedure (SRdAP).

The present document has been prepared under the Commission's standardisation request C(2015) 5376 final [i.3] to provide one voluntary means of conforming to the essential requirements of Directive 2014/53/EU on the harmonisation of the laws of the Member States relating to the making available on the market of radio equipment and repealing Directive 1999/5/EC [i.4].

Once the present document is cited in the Official Journal of the European Union under that Directive, compliance with the normative clauses of the present document given in Table A.1 confers, within the limits of the scope of the present document, a presumption of conformity with the corresponding essential requirements of that Directive and associated EFTA regulations.

The present document is part 5 of a multi-part deliverable covering Short Range Devices (SRD) to be used in the 40 GHz to 260 GHz frequency range; Harmonised standard for access to radio spectrum, as identified below:

- Part 1: "Communication devices within 57 GHz to 64 GHz, 122 GHz to 123 GHz or 244 GHz to 246 GHz";
- Part 2: "Radiodetermination for industrial applications (RDI & RDI-S) equipment operating within 116 GHz to 260 GHz";
- Part 3: "Radiodetermination for consumer applications within 57 GHz to 64 GHz, 122 GHz to 130 GHz, 134 GHz to 148,5 GHz or 244 GHz to 246 GHz";
- Part 4: "Radiodetermination devices at vehicles within 57 GHz to 64 GHz";
- Part 5: "Ultra Short Range Communication (USRC) equipment operating within 57 GHz to 64 GHz";**
- Part 6: "Specific radiodetermination applications - Tank Level Probing Radar (TLPR) and Level Probing Radar (LPR) equipment operating in the frequency ranges 116 GHz to 148,5 GHz; 167 GHz to 182 GHz and 231,5 GHz to 250 GHz".

Part 7: "In-cabin radiodetermination devices in vehicles within 122,25 GHz to 130 GHz and 134 GHz to 148,5 GHz".

Part 8: "Exterior radiodetermination devices on vehicles within 122,25 GHz to 130 GHz and 134 GHz to 148,5 GHz".

Part 9: "Radiodetermination for industrial applications (like RDI & RDI-S) equipment operating within 57 GHz to 64 GHz".

NOTE: The list above shows the planned multi-part deliverables, at the time, when the present document was finalized.

Proposed national transposition dates

Date of latest announcement of this EN (doa):	3 months after ETSI publication
Date of latest publication of new National Standard or endorsement of this EN (dop/e):	6 months after doa
Date of withdrawal of any conflicting National Standard (dow):	18 months after doa

Modal verbs terminology

In the present document "**shall**", "**shall not**", "**should**", "**should not**", "**may**", "**need not**", "**will**", "**will not**", "**can**" and "**cannot**" are to be interpreted as described in clause 3.2 of the [ETSI Drafting Rules](#) (Verbal forms for the expression of provisions).

"**must**" and "**must not**" are **NOT** allowed in ETSI deliverables except when used in direct citation.

Introduction

The present document is the first version of the harmonised standard ETSI EN 305 550-5 for Ultra Short Range Communication (USRC) equipment within 57 GHz to 64 GHz, and it is part of the standard family ETSI EN 305 550-x for Short Range Devices between 40 GHz and 260 GHz, see foreword in the present document

1 Scope

The present document specifies technical characteristics, limits and methods of measurements for Ultra Short Range Communication (USRC) equipment operating in the 57 GHz to 64 GHz frequency range.

Further details for the covered Ultra Short Range Communication (USRC) equipment can be found in clause 4.2 of the present document.

NOTE: The relationship between the present document and essential requirement of article 3.2 of Directive 2014/53/EU [i.4] is given in Annex A.

2 References

2.1 Normative references

References are either specific (identified by date of publication and/or edition number or version number) or non-specific. For specific references, only the cited version applies. For non-specific references, the latest version of the referenced document (including any amendments) applies.

Referenced documents which are not found to be publicly available in the expected location might be found in the [ETSI docbox](#).

NOTE: While any hyperlinks included in this clause were valid at the time of publication, ETSI cannot guarantee their long term validity.

The following referenced documents are necessary for the application of the present document.

- [1] [ETSI EN 303 883-1 \(V2.1.1\) \(2024-08\)](#): "Short Range Devices (SRD) and Ultra Wide Band (UWB); Part 1: Measurement techniques for transmitter requirements".
- [2] [ETSI EN 303 883-2 \(V2.1.1\) \(2024-08\)](#): "Short Range Devices (SRD) and Ultra Wide Band (UWB); Part 2: Measurement techniques for receiver requirements".
- [3] [ETSI TS 103 941 \(V1.1.1\) \(2024-01\)](#): "Short Range Devices (SRD) and Ultra Wide Band (UWB); Measurement setups and specifications for testing under full environmental profile (normal and extreme environmental conditions)".

2.2 Informative references

References are either specific (identified by date of publication and/or edition number or version number) or non-specific. For specific references, only the cited version applies. For non-specific references, the latest version of the referenced document (including any amendments) applies.

NOTE: While any hyperlinks included in this clause were valid at the time of publication, ETSI cannot guarantee their long-term validity.

The following referenced documents are not necessary for the application of the present document, but they assist the user with regard to a particular subject area.

- [i.1] [Commission Implementing Decision \(EU\) 2025/105](#) of 22 January 2025 amending Decision 2006/771/EC updating harmonised technical conditions in the area of radio spectrum use for short-range devices and repealing Implementing Decision 2014/641/EU on harmonised technical conditions of radio spectrum use by wireless audio programme making and special events equipment in the Union.
- [i.2] [ERC Recommendation 74-01](#): "Unwanted emissions in the spurious domain", Approved 1998 Corrected 23 May 2022.

- [i.3] [Commission Implementing Decision C \(2015\) 5376 final of 05.08.2015](#) on a standardisation request to the European Committee for Electrotechnical Standardisation and to the European Telecommunications Standards Institute as regards radio equipment in support of Directive 2014/53/EU of the European Parliament and of the Council.
- [i.4] [Directive 2014/53/EU of the European Parliament](#) and of the Council of 16 April 2014 on the harmonisation of the laws of the Member States relating to the making available on the market of radio equipment and repealing Directive 1999/5/EC.
- [i.5] ETSI EG 203 336 (V1.2.1) (2020-05): "Guide for the selection of technical parameters for the production of Harmonised Standards covering article 3.1(b) and article 3.2 of Directive 2014/53/EU".
- [i.6] ETSI TS 103 567 (V1.1.1) (2019-09): "Requirements on signal interferer handling".
- [i.7] [ECC Report 173](#): "Fixed Service in Europe Current use and future trends post 2022", approved 04 April 2012, last updated: 9 June 2023.
- [i.8] [ECC Decision \(11\)02](#): "Industrial Level Probing Radars (LPR) operating in frequency bands 6-8.5 GHz, 24.05-26.5 GHz, 57-64 GHz and 75-85 GHz", approved 11 March 2011, latest amended on 5 July 2019 (ECC#52).
- [i.9] [ECC Decision \(09\)01](#): "Harmonised use of the 63.72-65.88 GHz frequency band for Intelligent Transport Systems (ITS)", approved 13 March 2009, latest amended on 5 July 2019 (ECC#51).
- [i.10] [ECO Frequency Information System](#).

3 Definition of terms, symbols and abbreviations

3.1 Terms

For the purposes of the present document, the terms given in ETSI EN 303 883-1 [1], ETSI EN 303 883-2 [2] and the following apply:

advertising mode: waiting for companion equipment (companion equipment is not present)

companion equipment: equipment, which is intended to be used in conjunction with the equipment under test for communication as the second part of the USRC system

integral antenna: antenna designed to be connected to the equipment without the use of an external connector and considered to be part of the equipment

NOTE: An integral antenna is fixed internally or externally to the equipment housing.

receiver: USRC equipment with a receive only mode

transceiver: USRC equipment with a transmit and receive mode (simultaneously or sequentially)

transmitter: USRC equipment with a transmit only mode

Ultra Short Range Communication Equipment (USRC): one transceiver, or one transmitter, or one receiver of a USRC system

USRC system: combination of two USRC equipment with at least one USRC equipment with transmit mode capability (transmitter or transceiver) and one USRC equipment with receive mode capability (transceiver or receiver) (covered by the present document) with integral antennas which are able to operate in conjunction with each other over an ultra short distance (according to the categories in Table 1) between both equipment

3.2 Symbols

For the purposes of the present document, the symbols given in ETSI EN 303 883-1 [1], ETSI EN 303 883-2 [2] and the following apply:

D	Distance between the enclosure of the equipment under test and the enclosure of the companion equipment in the orientation according to its intended use (see also clause 4.2)
D_{\min}	Minimum distance between the enclosure of the equipment under test and the companion equipment in the orientation according to its intended use (see also clause 4.2)
D_{\max}	Maximum distance between the enclosure of the equipment under test and the companion equipment in the orientation according to its intended use (see also clause 4.2)
D_{sens}	Minimum distance between the enclosure of the equipment under test and the companion equipment used for receiver baseline sensitivity test and dynamic range in the orientation according to its intended use (see also clause 4.4.5 and 4.4.6)
D_{dyn}	Maximum distance between the enclosure of the equipment under test and the companion equipment in the orientation according to its intended used within its performance criteria (see clause 4.4.2)
f_c	Center frequency of the OFR
f_H	step higher edge of the OFR within the relative measurement at one environmental profile point
f_{H_abs}	higher edge of the OFR within the absolute measurement under normal conditions
f_{H_REF}	higher edge of the OFR within the relative measurement under normal conditions
f_{H_step}	higher edge of the OFR within the relative measurement at one environmental profile point
f_{L_abs}	lower edge of the OFR within the absolute measurement under normal conditions
f_{L_REF}	lower edge of the OFR within the relative measurement under normal conditions
f_{L_step}	lower edge of the OFR within the relative measurement at one environmental profile point
P_{step}	measured emission level (at each environmental profile point)
REF_{f_L}	measured relative reference for f_L
REF_{f_H}	measured relative reference for f_H
RBW	resolution band width of the spectrum analyser
SWT	Sweep time of the spectrum analyser
t_{low}	lowest value of the environmental profile
t_{high}	highest value of the environmental profile
t_{steps}	steps in deg [°C or kelvin] from one to the next environmental profile point
t_{step}	environmental profile point
T_{dis}	Time interval below which interruptions within a transmission are considered part of T_{on} (disregarded time)
T_{on}	Transmission "on" time

3.3 Abbreviations

For the purposes of the present document, the abbreviations given in ETSI EN 303 883-1 [1], ETSI EN 303 883-2 [2] and the following apply:

DC	Duty Cycle
RL	Regulated Limit
USRC	Ultra Short Range Communication
VBW	Video BandWidth of the spectrum analyser

4 Technical requirements specifications

4.1 Environmental profile

The technical requirements of the present document apply under the environmental profile for operation of the equipment, which shall be in accordance with its intended use, but as a minimum, shall be that specified in the test conditions contained in the present document. The equipment shall comply with all the technical requirements of the present document at all times when operating within the boundary limits of the operational environmental profile defined by its intended use.

4.2 Equipment categories

The equipment categories are defined based on the distance D which is defined as the distance between the enclosure of the equipment under test and the companion equipment (see Table 1) in the orientation according to its intended use.

Based on the short distance between the equipment under test and the companion equipment the transmitted e.i.r.p. power is limited to 10 mW e.i.r.p. This reduces the necessary rf power and increases the efficient use of spectrum. The reduction in limitation of the radiated e.i.r.p. power to 10 mW makes the test of transmitter conducted output power obsolete, see EC Decision (EU) 2025/105 [i.1].

However, for this equipment categorization each equipment shall be treated separately.

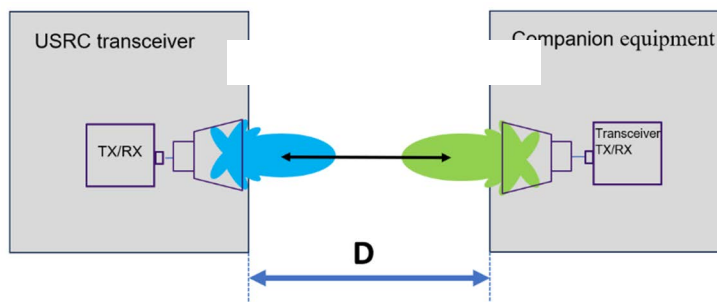

Figure 1: Orientation of USRC transceiver and companion equipment for testing

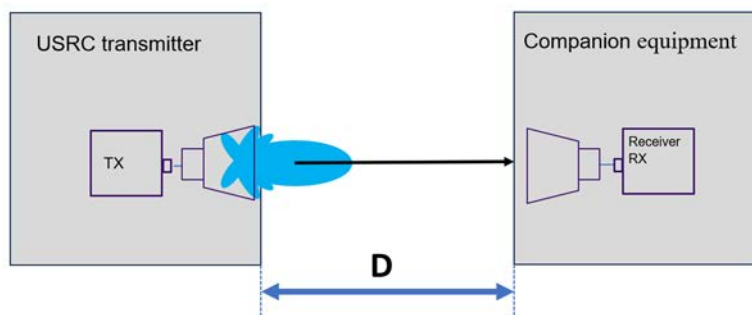

Figure 2: Orientation of USRC transmitter and companion equipment for testing

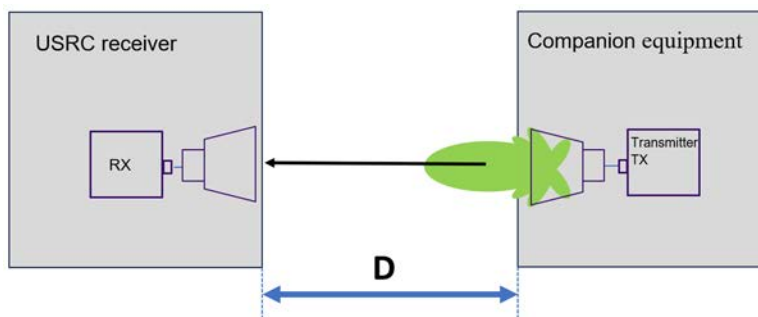

Figure 3: Orientation of USRC receiver and companion equipment for testing

The present document covers therefore four different kinds of USRC equipment:

- 1) USRC Transceiver without a receive only mode with the abbreviation: TR
- 2) USCR Transceiver with a receive only mode with the abbreviation: TRR
- 3) USRC transmitter only equipment with the abbreviation: T
- 4) USRC receive only equipment with the abbreviation: R

The manufacturer shall indicate which kind of equipment category shall be considered for each equipment to operate in the USRC system. Both equipment of a USRC system shall be in the same D_{max} category, see Table 1. The following categories of USRC equipment are defined:

Table 1: Equipment categories

Equipment category	Description	D_{min}	D_{max}
TR.1	USRC transceiver without a receive only mode	0 mm	$5 \text{ mm} \leq D < 10 \text{ mm}$
TRR.1	USRC transceiver with a receive only mode	0 mm	$5 \text{ mm} \leq D < 10 \text{ mm}$
T.1	USRC transmitter	0 mm	$5 \text{ mm} \leq D < 10 \text{ mm}$
R.1	USRC receiver	0 mm	$5 \text{ mm} \leq D < 10 \text{ mm}$
TR.2	USRC transceiver without a receive only mode	0 mm	$10 \text{ mm} \leq D < 50 \text{ mm}$
TRR.2	USRC transceiver with a receive only mode	0 mm	$10 \text{ mm} \leq D < 50 \text{ mm}$
T.2	USRC transmitter	0 mm	$10 \text{ mm} \leq D < 50 \text{ mm}$
R.2	USRC receiver	0 mm	$10 \text{ mm} \leq D < 50 \text{ mm}$
TR.3	USRC transceiver without a receive only mode	0 mm	$50 \text{ mm} \leq D \leq 100 \text{ mm}$
TRR.3	USRC transceiver with a receive only mode	0 mm	$50 \text{ mm} \leq D \leq 100 \text{ mm}$
T.3	USRC transmitter	0 mm	$50 \text{ mm} \leq D \leq 100 \text{ mm}$
R.3	USRC receiver	0 mm	$50 \text{ mm} \leq D \leq 100 \text{ mm}$

Table 2: Overview of the equipment categories and applicable requirements

Applicable for equipment category	Requirements	Environmental conditions		Clause(s) of the present document
		normal	extreme	
TR.1, TRR.1, T.1, TR.2, TRR.2, T.2, TR.3, TRR.3, T.3	Operating Frequency Range	x		4.3.2
TR.1, TRR.1, T.1, TR.2, TRR.2, T.2, TR.3, TRR.3, T.3	Mean e.i.r.p.	x		4.3.3
TR.1, TRR.1, T.1, TR.2, TRR.2, T.2, TR.3, TRR.3, T.3	TX unwanted emissions (TXUE)	x		4.3.4
TR.1, TRR.1, T.1, TR.2, TRR.2, T.2, TR.3, TRR.3, T.3	TX behaviour under the complete environmental profile		x	4.3.4
TRR.1, R.1, TRR.2, R.2, TRR.3, R.2	Receiver spurious emissions	x		4.4.3
TR.1, TRR.1, R.1, TR.2, TRR.2, R.2, TR.3, TRR.3, R.3	Receiver Baseline Sensitivity (RBS)	x		4.4.4
TR.1, TRR.1, R.1, TR.2, TRR.2, R.2, TR.3, TRR.3, R.3	Receiver Dynamic range	x		4.4.5
TR.1, TRR.1, R.1, TR.2, TRR.2, R.2, TR.3, TRR.3, R.3	Receiver Baseline Resilience (RBR)	x		4.4.6

4.3 Transmitter requirements

4.3.1 General

The transmitter requirements for equipment covered by the scope of the present document are justified in Annex B. Based on this justification the following transmitter requirements apply for the equipment covered by the present document:

- Operating Frequency Range (OFR), see clause 4.3.2
- Mean e.i.r.p. see clause 4.3.3
- Transmitter unwanted emissions, see clause 4.3.4

4.3.2 Operating Frequency Range (OFR)

4.3.2.1 Applicability

The Operating Frequency Range (OFR) requirement applies only to the equipment categories TR.1, TRR.1, T.1, TR 2, TRR.2, T.2, TR.3, TRR.3, T.3 as specified clause 4.2, Table 1 and Table 2.

4.3.2.2 Description

The operating frequency range is described in clause 5.2.1 of ETSI EN 303 883-1 [1].

For the OFR conformance assessment, the parameter X (as specified in ETSI EN 303 883-1 [1], clause 5.2.1) is defined with 23 dB.

4.3.2.3 Limits

The OFR (all frequencies between f_L and f_H) shall be within the permitted frequency range as defined in Table 3.

Table 3: Permitted frequency range

	Frequency Range [GHz]
transmit and receive	$57 \leq f \leq 64$
NOTE: The frequency range is according to Decision (EU) 2025/105 [i.1], band 74a.	

4.3.2.4 Conformance

The conformance test for the Operating Frequency Range (OFR) requirement is defined in clause 5.4.1 of the present document.

4.3.3 Mean e.i.r.p.

4.3.3.1 Applicability

The Mean e.i.r.p. requirement applies to the equipment categories TR.1, TRR.1, T.1, TR 2, TRR.2, T.2, TR.3, TRR.3, T.3 as specified clause 4.2, Table 1 and Table 2.

4.3.3.2 Description

The Mean e.i.r.p. is described in clause 5.3.1.1 of ETSI EN 303 883-1 [1].

4.3.3.3 Limits

Within the OFR the Mean e.i.r.p. shall not exceed the limits in Table 4.

Table 4: Mean e.i.r.p. limit

Band No. acc. [i.1]	Frequency Band	Mean e.i.r.p. limit
74a	57 GHz - 64 GHz	10 mW e.i.r.p.
NOTE: Decision (EU) 2025/105 [i.1] contains in band 74a an e.i.r.p. limit of 100 mW and a max transmit power of 10 mW (which is a conducted power); in Table 4 only 10 mW e.i.r.p. is tested since this fulfils the 10 mW transmit power limit (see ETSI EN 303 883-1 [1], clause 5.6.1) also and since equipment in the scope of the present document does just require 10 mW e.i.r.p.		

4.3.3.4 Conformance

The conformance test for Mean e.i.r.p. shall be performed as defined in clause 5.4.2 of the present document.

4.3.4 Transmitter unwanted emissions (TXUE)

4.3.4.1 Applicability

The transmitter unwanted emissions (TXUE) requirement applies only to the equipment categories TR.1, TRR.1, T.1, TR.2, TRR.2, T.2, TR.3, TRR.3, T.3 as specified clause 4.2, Table 1 and Table 2.

4.3.4.2 Description

For the description of the TXUE emissions, see ETSI EN 303 883-1 [1], clause 5.5.1.

As requested in ETSI EN 303 883-1 [1], clause 5.5.1 the limit for the parameter X_{TXUE} for all equipment categories is defined as:

$$X_{TXUE}: \quad 250 \%$$

4.3.4.3 Limits for TXUE

The frequency ranges and limit tables for spurious emissions and Out-Of-Band (OOB) emissions are provided in Figure 4.

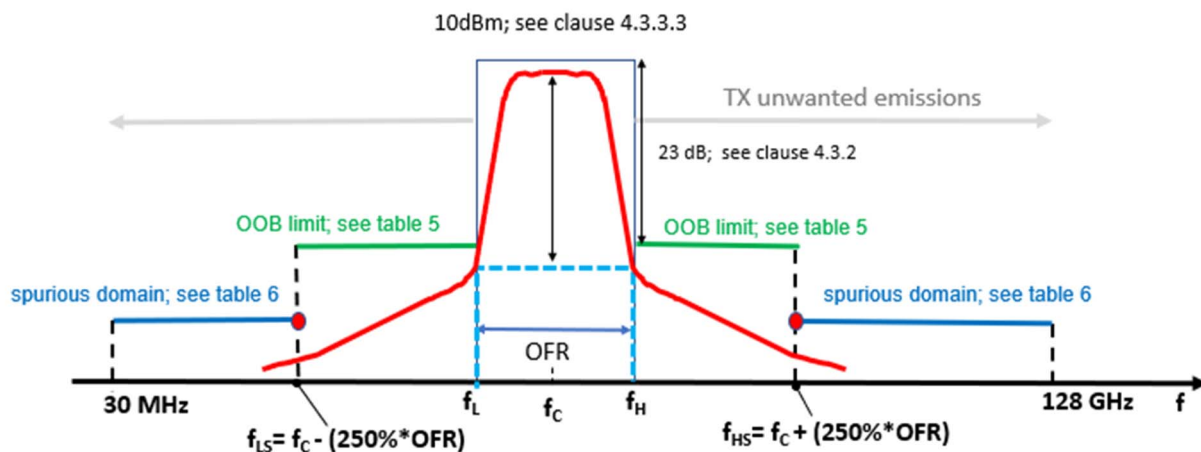

Figure 4: Overview limits for OOB and spurious domain

For the OOB domain the limit from Table 5 apply.

The limit for the OOB domain is specified based on the measured equipment OFR (see clause 4.3.2) and the limit (see clause 4.3.3.3, Table 4).

The limits below (see table 5) shall apply to the power of any unwanted emission in the OOB domain. The OOB limits are derived from the limit of 10 dBm (see clause 4.3.3.3, the OFR definition (see clause 4.3.2.2) and the measured OFR (see clause 4.3.2.4). The contiguity is shown in equation (1)

$$OOB \text{ limit [dBm/MHz]} = 10 \text{ dBm} - 23 \text{ dB} - 10 \times \log_{10} \left(\frac{OFR_{EUT} [\text{MHz}]}{RBW [\text{MHz}]} \right) \quad (1)$$

Table 5: OOB domain limits

Equipment category	Frequency range [GHz]	OOB limit [dBm]	Measurement bandwidth
TR.1, TRR.1, T.1, TR 2, TRR.2, T.2, TR.3, TRR.3, T.3	$f_{LS} < f \leq f_L$	See equation (1)	1 MHz
	$f_H \leq f < f_{HS}$	See equation (1)	1 MHz

For the spurious emissions the limits from Table 6 apply.

Table 6: Spurious emissions limits

Frequency range	Limit values for TXUE (note 1)
$87,5 \text{ MHz} \leq f \leq 118 \text{ MHz}$	-54 dBm/100 kHz
$174 \text{ MHz} \leq f \leq 230 \text{ MHz}$	-54 dBm/100 kHz
$470 \text{ MHz} \leq f \leq 694 \text{ MHz}$	-54 dBm/100 kHz
otherwise in band $30 \text{ MHz} \leq f < 1\,000 \text{ MHz}$	-36 dBm/100 kHz
$1 \text{ GHz} \leq f \leq 128 \text{ GHz}$ (note 2)	-30 dBm/1 MHz

NOTE 1: The limits are according to ERC/REC 74-01 [i.2], Annex 2.
NOTE 2: ERC/REC 74-01 [i.2] recommends the 2nd harmonic of the entire band as the upper frequency edge. 128 GHz will cover the 2nd harmonic (of f_c) including the OFR.

4.3.4.4 Conformance

The conformance test for the transmitter unwanted emissions (TXUE) shall be performed as defined in clause 5.4.3.1 of the present document.

4.3.5 TX behaviour under the complete environmental profile

4.3.5.1 Applicability

The TX behaviour under the complete environmental profile requirement applies only to the equipment categories TR.1, TRR.1, T.1, TR 2, TRR.2, T.2, TR.3, TRR.3, T.3 as specified clause 4.2, Table 1 and Table 2.

4.3.5.2 Description

For the description of the TX behaviour under the complete environmental profile, see ETSI TS 103 941 [3], clause 4.3.1.

4.3.5.3 Limits for radiated assessment of the TX behaviour

The TX behaviour is obtained by measuring the maximum mean e.i.r.p. (P_{step}) and OFR frequencies ($f_{L_{\text{step}}} / f_{H_{\text{step}}}$) across the complete environmental profile (see clause 5.1.3) and assessing the variation with respect to maximum mean e.i.r.p. adjusted reference value (Adjusted_RL) and for the frequency changes of the OFR to (REF_{fL} / REF_{fH}).

If for each environmental measurement point (t_{step}) over the complete environmental profile the measured values for P_{step} and $f_{L_{\text{step}}} / f_{H_{\text{step}}}$ will be below the adjusted reference values(s) the limit for the TX behaviour assessment is passed.

4.3.5.4 Conformance

The conformance test for the TX behaviour under the complete environmental profile shall be performed as defined in clause 5.4.4 of the present document.

4.4 Receiver requirements

4.4.1 General

The receiver requirements for equipment covered by the scope of the present document are justified in ETSI EN 303 883-2 [2], Annex C.

Based on this justification the following Receiver requirements apply for the equipment covered by the present document:

- Receiver Spurious Emissions, see clause 4.4.3
- Receiver Baseline Sensitivity (RBS), see clause 4.4.4
- Receiver Dynamic Range, see clause 4.4.5
- Receiver Baseline Resilience (RBR), see clause 4.4.6

4.4.2 Wanted technical performance criterion

The equipment covered by the present document uses wide band data communication. The performance requirement is based on Packet Error Rate (PER).

The minimum wanted technical performance criterion shall be a PER of less than or equal to 10 %.

Transceivers (bidirectional applications) shall be monitored so that the PER in each direction is measured.

4.4.3 Receiver spurious emissions

4.4.3.1 Applicability

The receiver spurious emissions requirement applies only to the equipment categories TRR.1, R.1, TRR.2, R.2, TRR.3, R.2 as specified clause 4.2, Table 1 and Table 2.

4.4.3.2 Description

The description of receiver spurious emissions is given in clause 5.2 of ETSI EN 303 883-2 [2].

4.4.3.3 Limits

The receiver spurious emissions shall comply with limits in Table 7.

Table 7: Receiver spurious emissions limits

Frequency range	Limit values (note 1)
30 MHz to 1 000 MHz	-57 dBm
1 GHz < f ≤ 128 GHz (note 2)	-47 dBm
NOTE 1: The limits are in accordance with ERC/REC 74-01 [i.2].	
NOTE 2: ERC/REC 74-01 [i.2] recommends the 2 nd harmonic of the entire band as the upper frequency edge.	

4.4.3.4 Conformance

The conformance test for receiver spurious emission shall be performed as defined in clause 5.5.1 of the present document.

4.4.4 Receiver Baseline Sensitivity (RBS)

4.4.4.1 Applicability

The Receiver Baseline Sensitivity (RBS) requirement applies only to the equipment categories TR.1, TRR.1, R.1, TR.2, TRR.2, R.2, TR.3, TRR.3, R.3 as specified clause 4.2, Table 1 and Table 2.

4.4.4.2 Description

The description of receiver baseline sensitivity is given in clause ETSI EN 303 883-2 [2], clause 5.4.1.

4.4.4.3 Limits

The receiver baseline sensitivity is defined as the maximum distance between the equipment under test and the companion equipment, while fulfilling the wanted technical performance criteria from clause 4.4.2.

The limits for the Receiver Baseline Sensitivity (RBS) are provided in Table 8.

Table 8: Limits Receiver Baseline Sensitivity (RBS)

Equipment category	Distance limit (D_{sens}) [mm]
TR.1, TRR.1, R.1	5
TR.2, TRR.2, R.2	10
TR.3, TRR.3, R.3	50
NOTE: The limits from Table 8 are derived from the equipment categories in clause 4.2.	

4.4.4.4 Conformance

The conformance test for Receiver Baseline Sensitivity (RBS) shall be performed as defined in clause 5.5.2 of the present document.

4.4.5 Receiver Dynamic Range

4.4.5.1 Applicability

The receiver dynamic range requirement applies only to the equipment categories TR.1, TRR.1, R.1, TR.2, TRR.2, R.2, TR.3, TRR.3, R.3 as specified clause 4.2, Table 1 and Table 2.

4.4.5.2 Description

Receiver "dynamic range" is a generic term broadly defined as the range of input signal levels over which a receiver functions at a specified performance level.

4.4.5.3 Limits

The equipment shall fulfil the wanted performance criteria as defined in clause 4.4.2 at minimum separation distance D_{min} and D_{dyn} for the relevant category see clause 4.2 between associated transmitter and the equipment under test.

Table 9: Limits receiver dynamic range

Equipment category	D _{min} [dB]	D _{dyn} [dB]
TR.1, TRR.1, R.1	0	5
TR.2, TRR.2, R.2	0	10
TR.3, TRR.3, R.3	0	50

4.4.5.4 Conformance

The conformance test for receiver dynamic range shall be performed as defined in clause 5.5.3 of the present document.

4.4.6 Receiver Baseline Resilience (RBR)

4.4.6.1 Applicability

The Receiver Baseline Resilience (RBR) applies only to the equipment categories TR.1, TRR.1, R.1, TR.2, TRR.2, R.2, TR.3, TRR.3, R.3 as specified clause 4.2, Table 1 and Table 2.

4.4.6.2 Description

For the description of the Receiver Baseline Resilience (RBR) see ETSI EN 303 883-2 [2], clause 5.5.1.

4.4.6.3 Limits

The interferer signals within the OFR are specified in Table 10 (for OFR < 500 MHz) and Table 11 (for OFR ≥ 500 MHz).

The interferer signals outside OFR are specified in Table 12.

The equipment shall meet the wanted technical performance criteria in clause 4.4.2 with all these test signals.

Table 10: RBR limits within OFR if OFR < 500 MHz

Interference power level at equipment	Test frequencies	Modulation of test signals
-47 dBm (note 1)	f_c (centre frequency of wanted signal)	CW (note 2)
NOTE 1: Equivalent to an EIRP of 40 dBm e.i.r.p. @ 10 m distance at 57 GHz; this simulates the likely case of a wideband data transmission equipment according to EC Decision for SRDs [i.1], band Number 75 and 75a in 10 m distance.		
NOTE 2: The equivalence to use CW instead of a wide band data signal was assessed in ETSI TS103 567 [i.6].		

Table 11: RBR limits within OFR if OFR ≥ 500 MHz

Interference power level at equipment	Test frequencies	Modulation of test signals
-47 dBm (note 1)	f_c centre frequency of wanted $f_c \pm 0,3 \times \text{OFR}$	CW (note 2)
NOTE 1: Equivalent to an EIRP of 40 dBm e.i.r.p. @ 10 m distance at 57 GHz; this simulates the likely case of a wideband data transmission equipment according to EC Decision for SRDs [i.1], band Number 75 and 75a in 10 m distance.		
NOTE 2: The equivalence to use CW instead of a wide band data signal was assessed in ETSI TS103 567 [i.6].		

Table 12: RBR limits outside OFR

Interference power level at equipment	Test frequencies	Modulation of test signals
-47 dBm (note 1)	fc - 2*OFR fc - 1*OFR fc + 1*OFR fc + 2*OFR	CW (note 2)
NOTE 1: Equivalent to an EIRP of 40 dBm e.i.r.p. @ 10 m distance at 57 GHz; this simulates the likely case of a wideband data transmission equipment according to EC Decision for SRDs [i.1], band Number 75 and 75a in 10 m distance.		
NOTE 2: The equivalence to use CW instead of a wide band data signal was assessed in ETSI TS 103 567 [i.6].		

4.4.6.4 Conformance

The conformance test for Receiver Baseline Resilience (RBR) shall be as defined in clause 5.5.4 of the present document.

5 Testing for compliance with technical requirements

5.1 Environmental conditions for testing

5.1.1 General

Tests defined in the present document shall be carried out at representative points within the boundary limits of the operational environmental profile defined by its intended use, which, as a minimum, shall be that specified in the test conditions contained in the present document.

Where technical performance varies subject to environmental conditions, tests shall be carried out under a sufficient variety of environmental conditions as specified in the present document to give confidence of compliance for the affected technical requirements.

5.1.2 Normal test conditions

Normal test conditions shall be as defined in ETSI TS 103 941 [3], clause 4.5.3.1.

5.1.3 Complete environmental profile test conditions

The complete environmental profile test conditions includes both the normal and extreme test conditions.

Normal test conditions shall be as defined in clause 4.5.3.1 of ETSI TS 103 941 [3].

Extreme test conditions shall be as defined in clause 4.5.3.2 of ETSI TS 103 941 [3] with a temperature range varying between 0 °C to +40 °C; the primary supply voltage varies from 90 % to 110 % of the nominal value.

NOTE: The nominal value of the supply voltage is usually provided by the user manual of the equipment under test.

5.2 Conformance test suites and general conditions for testing

General guidance on testing TX and RX measurements are given respectively in ETSI EN 303 883-1 [1], clause 5.1.1 for the TX requirements and ETSI EN 303 883-2 [2], clause 5.1 for the RX requirements.

ETSI EN 303 883-1 [1], annex A provides complementary information on general conditions for testing, e.g. test environment and test conditions, measurement uncertainty and interpretation of the measurement results. An overview is provided in ETSI EN 303 883-1 [1], clause A.1.

ETSI EN 303 883-1 [1], annex B provides complementary information on test setups for testing, e.g. radiated and conducted measurements. An overview for radiated measurements is provided in ETSI EN 303 883-1 [1], clause B.2.1.

General information on test set-up for measurements under environmental profile are given respectively in ETSI TS 103 941 [3], clause 5.1. More detailed test solutions are provided in:

- ETSI TS 103 941 [3], clause 5.2 with the usage of a temperature chamber; and
- ETSI TS 103 941 [3], clause 5.3 with the usage of a climate dome and anechoic chamber.

5.3 Test scenarios

The following 12 test scenarios shall be used for conformance testing:

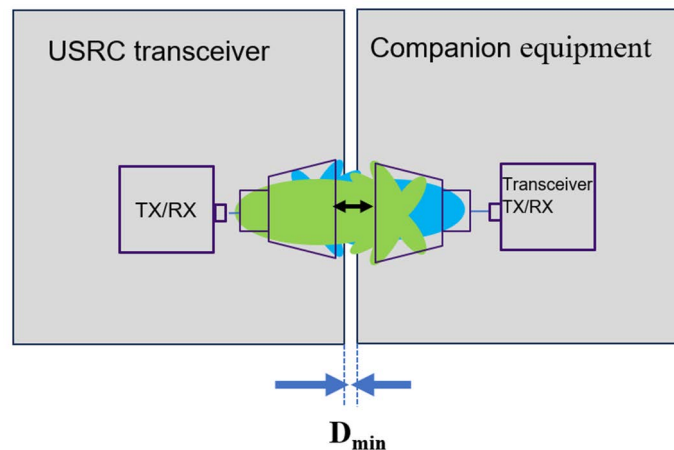

Figure 5: Scenario 1a: Setup for USRC transceiver (category TR.1, TRR.1, TR.2, TRR.2, TR.3, TRR.3) and companion equipment in closest distance (D_{min})

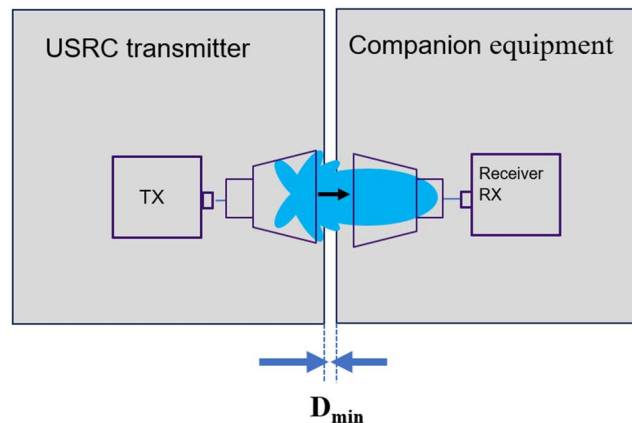

Figure 6: Scenario 1b: Setup for USRC transmitter (category T.1, T.2, T.3) and companion equipment in closest distance (D_{min})

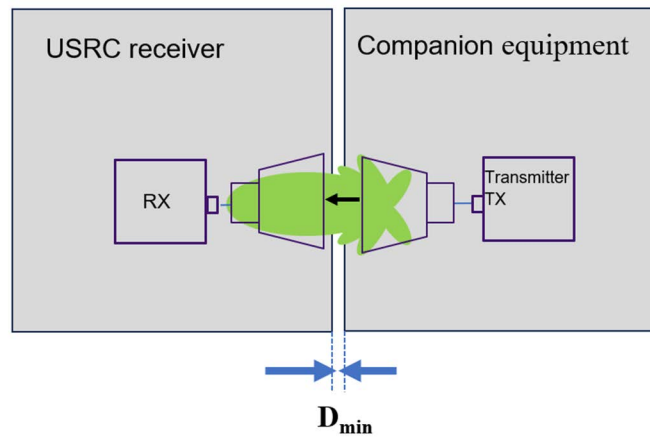

Figure 7: Scenario 1c: Setup for USRC receiver (category R.1, R.2, R.3) and companion equipment in closest distance (D_{min})

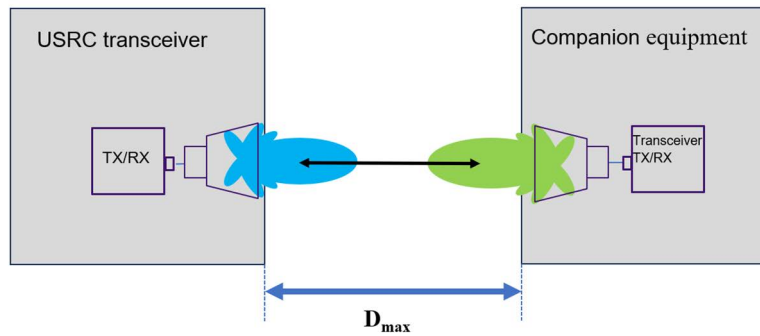

Figure 8: Scenario 2a: Setup for USRC transceiver (category TR.1, TRR.1, TR.2, TRR.2, TR.3, TRR.3) and companion equipment in maximum distance (D_{max})

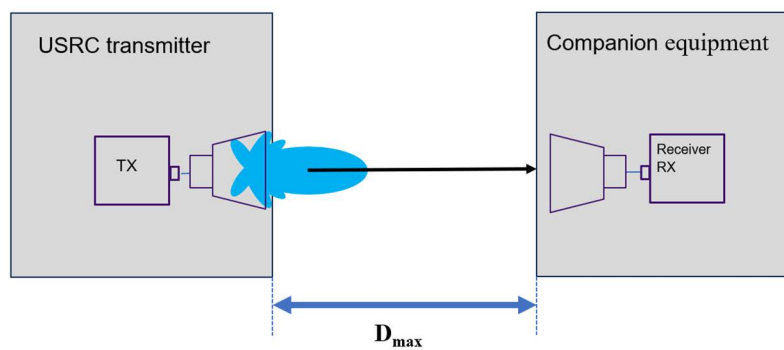

Figure 9: Scenario 2b: Setup for USRC transmitter (category T.1, T.2, T.3) and companion in maximum distance (D_{max})

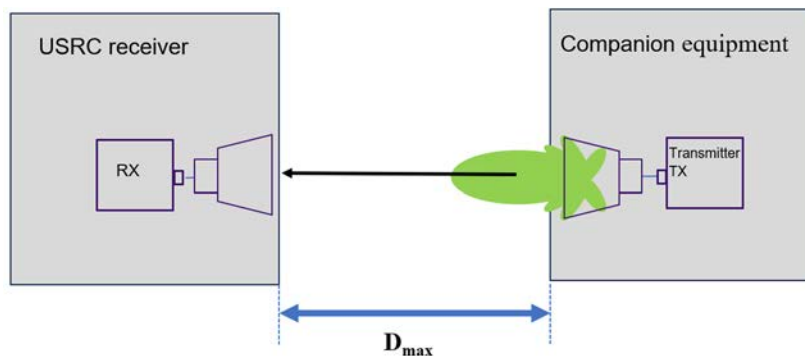

Figure 10: Scenario 2c: Setup for USRC receiver (category R.1, R.2, R.3) and companion equipment in maximum distance (D_{max})

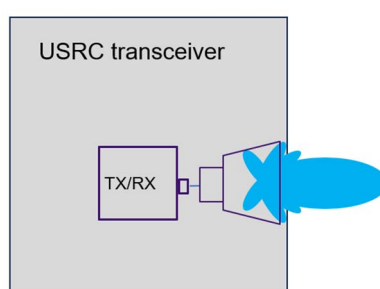

Figure 11: Scenario 3a: Setup for USRC transceiver (category TR.1, TRR.1, TR.2, TRR.2, TR.3, TRR.3) without companion equipment

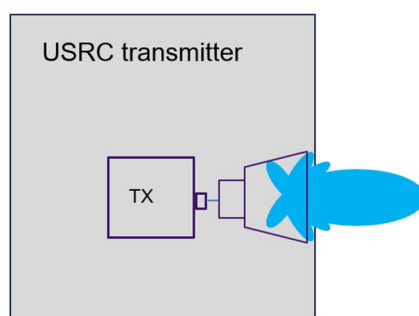

Figure 12: Scenario 3b: Setup for USRC transmitter (category T.1, T.2, T.3) without companion equipment

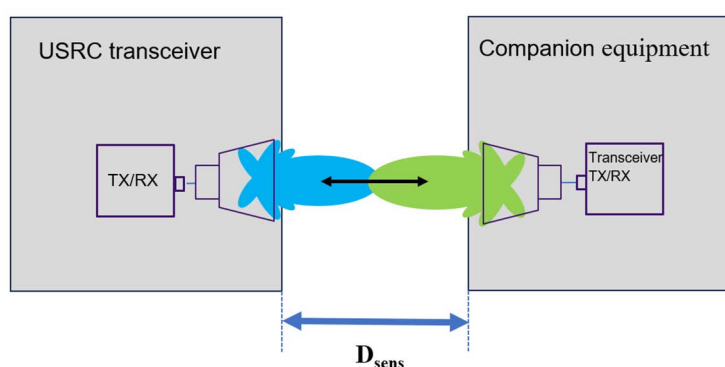

Figure 13: Scenario 4a: Setup for USRC transceiver (category TR.1, TRR.1, TR.2, TRR.2, TR.3, TRR.3) and companion equipment in a distance (D_{sens})

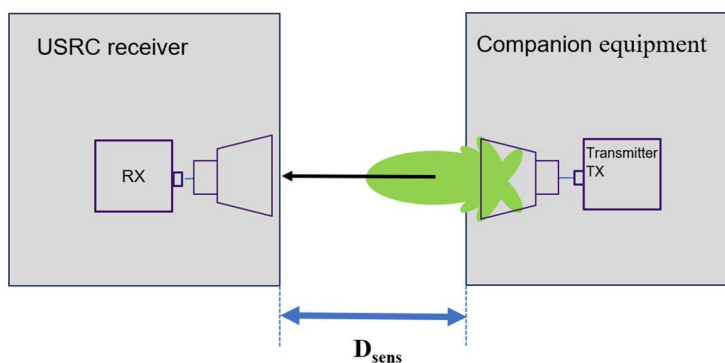

Figure 14: Scenario 4b: Setup for USRC receiver (category R.1, R.2, R.3) and companion equipment in a distance (D_{sens})

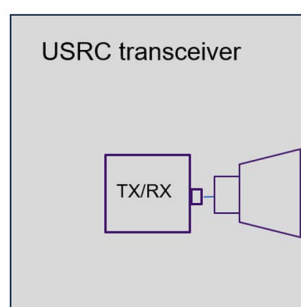

Figure 15: Scenario 5a: Setup for USRC transceiver (category TRR.1, TRR.2, TRR.3) in receive only mode

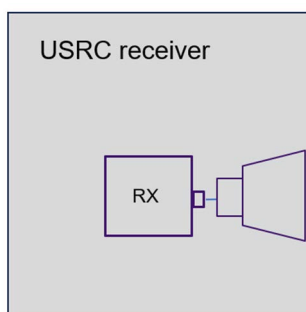

Figure 16: Scenario 5b: Setup for USRC receiver (category R.1, R.2, R.3)

5.4 Conformance methods of measurement for TX requirements

5.4.1 Operating Frequency Range (OFR)

The conformance test of the Operating Frequency Range (OFR) shall be done under normal conditions as defined in clause 5.1.2 of the present document.

The tests shall be performed on a test site according to ETSI EN 303 883-1 [1], clause B.2.2.2 (anechoic chamber) and the test setup shall be based on the standard test method as described in ETSI EN 303 883-1 [1], clause B.4.

The conformance test procedure as specified in ETSI EN 303 883-1 [1], clause 5.2.2 in combination with mean e.i.r.p. conformance test (see clause 5.4.2 of the present document).

The test shall be performed in the test scenarios 1a, 1b, 2a, 2b, 3a and 3b as specified in clause 5.3 (depending on the equipment category see Table 1).

The measurement shall be done in the direction of the highest mean e.i.r.p. emission (see clause 4.3.3) of each scenario.

The measurement shall be performed under far field conditions see ETSI EN 303 883-1 [1], clause B.2.3.5.

The measurement distance d is specified from the EUT to the measurement antenna and shall be documented in the test report.

The OFR conformance assessment shall be determined with the number for the parameter X as specified in clause 4.3.2.2.

5.4.2 Mean e.i.r.p.

The conformance test of the Mean e.i.r.p. shall be done under normal conditions as defined in clause 5.1.2 of the present document.

The conformance tests shall be performed on a test site according to ETSI EN 303 883-1 [1], clause B.2.2.2 (anechoic chamber) and the test setup shall be based on the standard test method as described in ETSI EN 303 883-1 [1], clause B.4.

The conformance test procedure as specified in ETSI EN 303 883-1 [1], clause 5.3.1.3 shall be used.

The test shall be performed in the test scenarios 1a, 1b, 2a, 2b, 3a and 3b as specified in clause 5.3 (depending on the equipment category see Table 1).

The measurement shall be done in the direction of the highest emission (see clause 4.3.3) of each scenario.

The direction of the maximum e.i.r.p. emission shall be determined by scanning the complete sphere.

The measurement shall be performed under far field conditions see ETSI EN 303 883-1 [1], clause B.2.3.5.

The measurement distance d is specified from the EUT to the measurement antenna and shall be documented in the test report.

The measured results of the mean e.i.r.p. and the measurement distance shall be recorded.

5.4.3 TX unwanted emissions

5.4.3.1 General

The conformance for the TX unwanted emission in the Out-Of-Band domain (OOB) shall be tested according to clause 5.4.3.2.

The conformance for the TX unwanted emission in the spurious domain shall be tested according to clause 5.4.3.3.

5.4.3.2 Unwanted emission in the Out-Of-Band (OOB) domain

The conformance test of the unwanted emission in the Out-Of-Band (OOB) domain shall be done under normal conditions as defined in clause 5.1.2 of the present document.

The conformance tests shall be performed on a test site according to ETSI EN 303 883-1 [1], clause B.2.2.2 (anechoic chamber) and the test setup shall be based on the standard test method as described in ETSI EN 303 883-1 [1], clause B.4.

The conformance test procedure according to ETSI EN 303 883-1 [1], clause 5.5.3.2.2. shall be used.

The test shall be performed in the test scenarios 1a, 1b, 2a, 2b, 3a and 3b as specified in clause 5.3 (depending on the equipment category see Table 1).

The specifications for the measurement are:

Resolution Bandwidth (RBW): 1 MHz

Video bandwidth:	VBW equal or greater than the RBW
Detector mode:	RMS
Display mode:	Max Hold
Average Time:	Equal or larger than signal repetition time
Number of measurement points:	At least equal to frequency span divided by RBW
Sweep Time:	Time for spectrum analyser sweep (over one Frequency Span). The setting shall be calculated with the following equation (2):
	$\text{Sweep Time (SWT)} \geq \text{signal repetition time} \times \text{Number of measurement points} \quad (2)$
Signal repetition time:	See annex C of ETSI EN 303 883-1 [1].

5.4.3.3 Unwanted emission in the spurious domain

The conformance test of unwanted emission in the spurious domain shall be done under normal conditions as defined in clause 5.1.2 of the present document.

The conformance tests shall be performed on a test site according to ETSI EN 303 883-1 [1], clause B.2.2.2 (fully anechoic room) and the test setup shall be based on the standard test method as described in ETSI EN 303 883-1 [1] clause B.4.

The conformance test procedure according to ETSI EN 303 883-1 [1], clause 5.5.3.2.2. shall be used.

The test shall be performed in the test scenarios 1a, 1b, 2a, 2b, 3a and 3b as specified in clause 5.3 (depending on the equipment category see Table 1).

The measurement shall be performed according ETSI EN 303 883-1 [1], clause 5.5.3.1 step 1. For measurement results of step 1 which are above the limit of clause 4.3.4.3, Table 6 the assessment shall proceed with step 2a according to ETSI EN 303 883-1 [1], clause 5.5.3.1.3.

For the assessment of the burst duration use the DC measurement as in ETSI EN 303 883-1 [1], clause 5.11.2.1 with the following parameters:

- T_{dis} : 10 ms
- P_{thresh} : power level above which the measurement equipment will "detect" the signal as on"

The measurement shall be performed under far field conditions see ETSI EN 303 883-1 [1], clause B.2.3.5.

The measurement distance d is specified from the EUT to the measurement antenna and shall be documented in the test report.

The measured results of the TX unwanted emission measurement shall be recorded.

5.4.4 TX behaviour under the complete environmental profile

The conformance test of the TX behaviour under the complete environmental profile shall be done under normal and extreme test conditions as defined in clause 5.1.3 of the present document.

The conformance test shall be performed with a test set-up based on ETSI TS 103 941 [3], clause 4.3.1 and Figure 1.

The test shall be performed in the test scenarios 1a, 1b, 2a, 2b, 3a and 3b as specified in clause 5.3 (depending on the equipment category see Table 1).

The conformance shall be assessed based on the test results and limits of clauses 4.3.2 and 4.3.3 and the assessment procedure according to ETSI TS 103 941 [3], clause 6.3 shall be used.

For the spectrum analyser setting the set-up as specified in clause 5.4.2 shall be used.

Based on clause 5.1.3 of the present document and ETSI TS 103 941 [3], clause 4.5.4, Figure 6, the parameters for the assessment are specified as follows:

- t_{low} : +0 °C
- t_{high} : +40 °C
- t_{step} : 10 °C
- supply voltage: see clause 5.1.3.

5.5 Conformance methods of measurement for receiver

5.5.1 Receiver Spurious Emissions

The conformance test of the receiver spurious emissions shall be done under normal conditions as defined in clause 5.1.2 of the present document.

The conformance test shall be performed on a test site according to ETSI EN 303 883-1 [1], clause B.2.2.2 (fully anechoic room) and the test setup shall be based on the standard test method as described in ETSI EN 303 883-1 [1], clause B.4.

The conformance test procedure according to ETSI EN 303 883-2 [2], clause 5.2.3 shall be used.

The test shall be performed in the test scenarios 5a and 5b as specified in clause 5.3 (depending on the equipment category see Table 1).

Equipment of category 1.2, 2.2 or 3.2 shall be set into the receive only mode.

5.5.2 Receiver Baseline Sensitivity (RBS)

The conformance test receiver baseline sensitivity (RBS) shall be done under normal conditions as defined in clause 5.1.2 of the present document.

The conformance test shall be performed on a test site according to ETSI EN 303 883-1 [1], clause B.2.2.2 (fully anechoic room).

The test shall be a radiated test with integral antenna according to ETSI EN 303 883-2 [2], clause 5.4.3.4.

The test shall be performed in the test scenarios 4a and 4b as specified in clause 5.3 (depending on the equipment category see Table 1).

5.5.3 Receiver Dynamic range

The conformance test of the receiver dynamic range shall be done under normal conditions as defined in clause 5.1.2 of the present document.

The conformance test shall be performed on a test site according to ETSI EN 303 883-1 [1], clause B.2.2.2 (fully anechoic room).

The test shall be performed radiated.

The measurement shall be performed in the test scenarios 1a, 1c, 4a and 4b as specified in clause 5.3 (depending on the equipment category see Table 1).

- Step 1: Separate the base EUT and the companion equipment to D_{min} see clause 4.4.5.3 as described in scenario 1a or 1c according to clause 5.3 (depending on the equipment category see Table 1).
- Step 2: The PER shall be monitored and the wanted technical performance criterion from clause 4.4.2 shall be met.

- Step 3: Separate the base EUT and the companion equipment to D_{dyn} see clause 4.4.5.3 (scenario 4a or 4b according to clause 5.3).
- Step 4: The PER shall be monitored and the wanted technical performance criterion from clause 4.4.2 shall be met.

5.5.4 Receiver Baseline Resilience (RBR)

The conformance test of the receiver baseline resilience (RBR) shall be done under normal conditions as defined in clause 5.1.2 of the present document.

The conformance test shall be performed on a test site according to ETSI EN 303 883-1 [1], clause B.2.2.2 (fully anechoic room).

The test shall be performed in the test scenarios 4a and 4b as specified in clause 5.3 (depending on the equipment category see Table 1).

The test shall be performed according to ETSI EN 303 883-2 [2], clause 5.5.3.4 with the following parameters:

Procedure:

- Step 1: Assessment of the interfering signals for RBR test:
- take OFR and f_c from the OFR measurement, see clause 5.4.1
 - for the interferer information (frequency, signal, power), see clause 4.4.6.3
- Step 2: Arrange the set-up with the scenario 4a and 4b as specified in clause 5.3 (depending on the equipment category see Table 1) and a signal generator for the interfering signals and a test antenna to radiate the interfering signal to the RX-test scenario (see Figure 17 for scenario 4a and Figure 18 for scenario 4b respectively)

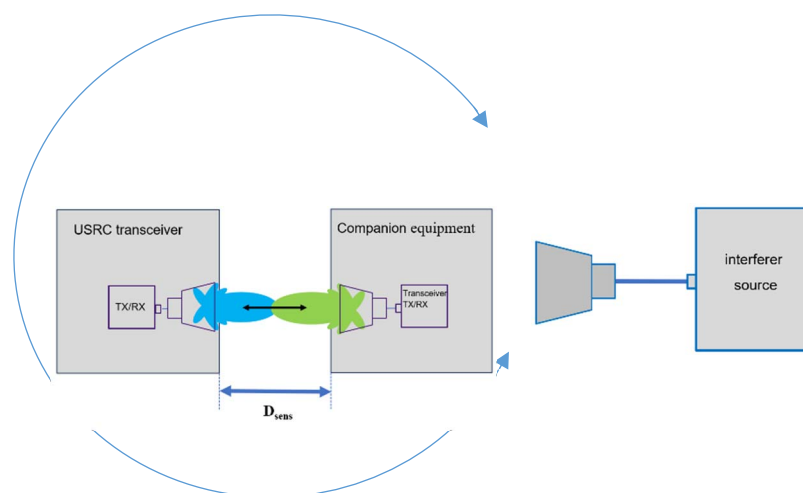

Figure 17: Setup for RBR test of USRC transceiver

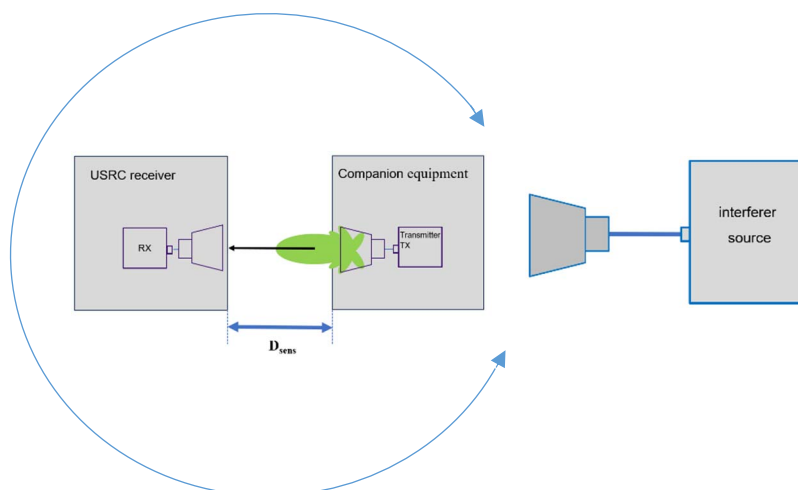

Figure 18: Setup for RBR test of USRC receiver

- Step 3: Switch on the interferer source with one interferer signal as assessed in step 1.
- Step 4: Set the test antenna to horizontal polarization.
- Step 5: Set the output power of the signal generator so that the interfering power level at the EUT from clause 4.4.6.3 are fulfilled; use the guidance provided in ETSI EN 303 883-2 [2], clause A.3 to calculate the output power of the signal generator.
- Step 6: Rotate the setup in azimuth from 0° to 360° to identify the most sensible position.
- Step 7: The EUT shall fulfil the minimum performance criterion as defined in clause 4.4.2 in all azimuth angles.
- Step 8: Repeat from step 5 for each interfering signal assessed in step 1.
- Step 9: Repeat step 5 to step 8 with the test antenna in vertical polarization.

Annex A (informative): Relationship between the present document and the essential requirements of Directive 2014/53/EU

The present document has been prepared under the Commission's standardisation request C(2015) 5376 final [i.3] to provide one voluntary means of conforming to the essential requirements of Directive 2014/53/EU on the harmonisation of the laws of the Member States relating to the making available on the market of radio equipment and repealing Directive 1999/5/EC [i.4].

Once the present document is cited in the Official Journal of the European Union under that Directive, compliance with the normative clauses of the present document given in Table A.1 confers, within the limits of the scope of the present document, a presumption of conformity with the corresponding essential requirements of that Directive and associated EFTA regulations.

**Table A.1: Relationship between the present document and
the essential requirements of Directive 2014/53/EU [i.4]**

Harmonised Standard ETSI EN 305 550-5					
Requirement				Requirement Conditionality	
No	Description	Essential requirements of Directive	Clause(s) of the present document	U/C	Condition
1	Operating Frequency Range	3.2	4.3.2	C	All equipment categories with a transmit mode as specified in clause 4.2, Table 1 and Table 2
2	Mean e.i.r.p.	3.2	4.3.3	C	All equipment categories with a transmit mode as specified in clause 4.2, Table 1 and Table 2
3	TX unwanted emissions (TXUE)	3.2	4.3.4	C	All equipment categories with a transmit mode as specified in clause 4.2, Table 1 and Table 2
4	TX behaviour under the complete environmental profile	3.2	4.3.5	C	All equipment categories with a transmit mode as specified in clause 4.2, Table 1 and Table 2
5	Receiver spurious emissions	3.2	4.4.3	C	All equipment categories with a receive only mode, see clause 4.2, Table 1 and Table 2
6	Receiver Baseline Sensitivity (RBS)	3.2	4.4.4	C	All equipment categories with a receive mode, see clause 4.2, Table 1 and Table 2
7	Receiver Dynamic Range	3.2	4.4.5	C	All equipment categories with a receive mode, see clause 4.2 Table 1, and Table 2
8	Receiver Baseline Resilience (RBR)	3.2	4.4.6	C	All equipment categories with a receive mode, see clause 4.2, Table 1 and Table 2

Key to columns:

Requirement:

No A unique identifier for one row of the table which may be used to identify a requirement.

Description A textual reference to the requirement.

Essential requirements of Directive

Identification of article(s) defining the requirement in the Directive.

Clause(s) of the present document

Identification of clause(s) defining the requirement in the present document unless another document is referenced explicitly.

Requirement Conditionality:

U/C Indicates whether the requirement is unconditionally applicable (U) or is conditional upon the manufacturer's claimed functionality of the equipment (C).

Condition Explains the conditions when the requirement is or is not applicable for a requirement which is classified "conditional".

Presumption of conformity stays valid only as long as a reference to the present document is maintained in the list published in the Official Journal of the European Union. Users of the present document should consult frequently the latest list published in the Official Journal of the European Union.

Other Union legislation may be applicable to the product(s) falling within the scope of the present document.

Annex B (informative): Requirement mapping

ETSI EG 203 336 [i.5], clause 5 lists the technical parameters applicable to transmitters and receivers that should be considered when producing Harmonised Standards that are intended to cover the essential requirements in article 3.2 of Directive 2014/53/EU [i.4]. Essential requirements are high level objectives described in European Directives. The purpose of the Harmonised Standard is to translate those high-level objectives into detailed technical specifications. Table B.1 contains the parameters listed in ETSI EG 203 336 [i.5], clause 5 for transmitter and receiver, and cross references these to the clauses within the present document in which the requirements for measurement of such parameters are satisfied or justified.

Table B.1: Cross reference of clauses in the present document to technical parameters for transmitter and receiver listed in ETSI EG 203 336 [i.5]

ETSI EG 203 336 [i.5]		Present document		Justification
Clause	Parameter	Clause	Parameter	
5.2.2	Transmitter power limits	4.3.3	Mean e.i.r.p	
5.2.3	Transmitter power accuracy	-	-	From the latest version of ETSI EG 203 336 [i.5]: <i>"When regulatory limits imply only a maximum emission limit (e.g. products that operate under a general licence regime), this parameter need not be considered for inclusion in an HS."</i>
5.2.4	Transmitter spectrum mask	4.3.2	Operating Frequency Range	
5.2.5	Transmitter frequency stability	4.3.5	TX behaviour under the complete environmental profile	.
5.2.6	Transmitter intermodulation attenuation	-	-	From latest version of ETSI EG 203 336 [i.5] this parameter is required only "where high levels of quality services are required". This is not relevant for generic short range devices which are operating under licence except regime without any kind of regulatory protection. SRDs have to accept interferences.
5.2.7.2	Transmitter unwanted emissions in the out of band domain	4.3.4	Transmitter unwanted emissions (TXUE)	
5.2.7.3	Transmitter unwanted emissions in the spurious domain	4.3.4	Transmitter unwanted emissions (TXUE)	
5.2.8	Transmitter time domain characteristics	-	-	Not applicable because for this frequency band no transmitter time domain requirement are defined.
5.2.9	Transmitter transients	-	-	Not applicable because for this frequency band no requirements for transmitter transient are defined. Due to not duty cycle limitations it is assumed that transmitter operate more or less continuous.

ETSI EG 203 336 [i.5]		Present document		Justification
Clause	Parameter	Clause	Parameter	
5.3.2	Receiver sensitivity	4.4.4	Not specified, superseded by RBS test	See justification in ETSI EN 303 883-2 [2], Annex C and the explanation of the interferer signal handling concept, see ETSI TS 103 567 [i.6].
5.3.2.3	Desensitization		Not specified, superseded by RBR test	See justification in ETSI EN 303 883-2 [2], Annex C and the explanation of the interferer signal handling concept, see ETSI TS 103 567 [i.6].
5.3.3	Receiver co-channel rejection		Not specified, superseded by RBR test	See justification in ETSI EN 303 883-2 [2], Annex C and the explanation of the interferer signal handling concept, see ETSI TS 103 567 [i.6].
5.3.4.2.1	Receiver adjacent channel selectivity		Not specified, superseded by RBR test	See justification in ETSI EN 303 883-2 [2], Annex C and the explanation of the interferer signal handling concept, see ETSI TS 103 567 [i.6].
5.3.4.2.2	Receiver adjacent band selectivity		Not specified, superseded by RBR test	See justification in ETSI EN 303 883-2 [2], Annex C and the explanation of the interferer signal handling concept, see ETSI TS 103 567 [i.6].
5.3.4.3	Receiver blocking		Not specified, superseded by RBR test	See justification in ETSI EN 303 883-2 [2], Annex C and the explanation of the interferer signal handling concept, see ETSI TS 103 567 [i.6].
5.3.4.4	Receiver spurious response rejection		Not specified, superseded by RBR test	See justification in ETSI EN 303 883-2 [2], Annex C and the explanation of the interferer signal handling concept, see ETSI TS 103 567 [i.6].
5.3.4.5	Receiver radio-frequency intermodulation		Not specified, superseded by RBR test	See justification in ETSI EN 303 883-2 [2], Annex C and the explanation of the interferer signal handling concept, see ETSI TS 103 567 [i.6].
5.3.5	Receiver unwanted emissions in the spurious domain	4.4.3	Receiver spurious emissions	If the equipment covered by the present document has "receive only" modes (see Equipment categories: <ul style="list-style-type: none"> • TRR.1, R.1, • TRR.2, R.2, • TRR.3, R.2).
5.3.6.1	Receiver dynamic range	4.4.5	Receiver Dynamic Range	
5.3.6.2	Reciprocal mixing		Not specified, superseded by RBR test	See justification in ETSI EN 303 883-2 [2] Annex C and the explanation of the interferer signal handling concept, see ETSI TS 103 567 [i.6].
5.3.1	Signal interferer handling	4.4.4	Receiver Baseline Resilience (RBR)	Interferer signal handling (ETSI EG 203 336 [i.5], clause 5.3.1) is an alternative method for specifying receiver parameters intended for use for receivers such as short range devices. The present document is following this concept, see ETSI TS 103 567 [i.6] and ETSI EN 303 883-2 [2].
		4.4.6	Receiver Baseline Resilience (RBR)	

Annex C (informative): Interferer for RBR test

Table C.1 provides information on radio applications relevant for RBR tests.

Table C.1: Radio applications according to ECO Frequency Information System [i.10]

Lower Frequency	Upper Frequency	- Europe (ECA) -	Dominant interferers	Power level at equipment under test according to dominant interferer see Table C.2
52,4 GHz	52,6 GHz	Radio astronomy / Fixed	Fixed service	-52 dBm
52,6 GHz	54,25 GHz	Radio astronomy / Passive sensors (satellite)	/	
54,25 GHz	55,78 GHz	Passive sensors (satellite)	/	
55,78 GHz	56,9 GHz	Passive sensors (satellite) / Fixed	Fixed service	-52 dBm
56,9 GHz	57 GHz	Fixed / Passive sensors (satellite)	Fixed service	-52 dBm
57 GHz	58,2 GHz	Passive sensors (satellite) / Non-specific SRDs / Radiodetermination applications / Wideband data transmission systems / Fixed	Non-specific SRDs / Radiodetermination applications / Wideband data transmission systems / Fixed	-47,6 dBm
58,2 GHz	59 GHz	Wideband data transmission systems / Fixed / Radiodetermination applications / Non-specific SRDs / Radio astronomy / Passive sensors (satellite)	Non-specific SRDs / Radiodetermination applications / Wideband data transmission systems / Fixed	-47,6 dBm
59 GHz	59,3 GHz	Passive sensors (satellite) / Non-specific SRDs / Radiodetermination applications / Wideband data transmission systems / Fixed	Non-specific SRDs / Radiodetermination applications / Wideband data transmission systems / Fixed	-47,6 dBm
59,3 GHz	64 GHz	Fixed / ISM / Non-specific SRDs / Wideband data transmission systems / ITS / Radiodetermination applications	Fixed / ISM / Non-specific SRDs / Wideband data transmission systems / ITS / Radiodetermination applications	-47,6 dBm
64 GHz	65 GHz	Radio astronomy / ITS / Fixed / Wideband data transmission systems	ITS / Fixed / Wideband data transmission systems	-47,6 dBm
65 GHz	66 GHz	Wideband data transmission systems / Fixed / ITS / Land mobile	Wideband data transmission systems / Fixed / ITS / Land mobile	-47,6 dBm
66 GHz	71 GHz	Wideband data transmission systems	Wideband data transmission systems	-47,6 dBm
71 GHz	74 GHz	Fixed	Fixed	-52 dBm

Table C.2: Parameters for calculation of interferer levels

	Reference	e.i.r.p. [dBm]	Lowest frequency [GHz]	Assumed minimum interference distance [m]	Calculated received power Note [dBm]
Fixed service	ECC Report 173 [i.7]	55	53	100	-51,99
Non-specific Short Range Devices and ISM Equipment	EC Decision (EU) 2025/105 [i.1] bands 74a and 76	20	57	2	-53,64
Wideband data transmission systems	2022/180/EC [i.1] bands 75 and 75a,	40	57	10	-47,62
Radiodetermination applications	Level probing radars according to ECC/DEC(11)02 [i.8], 0 dBm peak power in 50 MHz bandwidth assumed	0	57	10	-87,62
Intelligent Transport Systems	ECC/DEC(09)01 [i.9]	40	63,7	100	-68,58
NOTE: Line of sight conditions assumed.					

Annex D (informative): Change history

Version	Information about changes
0.0.1	Initial draft by Rapporteur
0.0.2	New draft for discussion during TGUWB#59
0.0.3	New draft for TGUWB Rapporteur meeting 19 th January
0.0.4	Outcome Rapporteur meeting 19 th January
0.0.5	Update numbering
0.0.6	New draft for discussion during TGUWB#60
0.0.7	Outcome of TGUWB#60
0.0.8	Outcome Rapporteur meeting 15 th March
0.0.9	Outcome of drafting meeting 18 th March 2022
0.1.0	Clean Version based on 0.0.9
0.1.1	Update on the basis of the new template and environmental profile
0.1.2	Outcome of Rapporteur meeting 21 st August 2024
0.1.3	Revised version of Outcome of Rapporteur meeting 21 st August 2024
0.1.4	Outcome of TGUWB#69
0.1.5	Final approved by TGUWB#69 for 1. HASC assessment
0.1.6	Outcome of the review of the technical officer
0.1.7	Editorial work during TGUWB#70
0.1.8	Outcome of TGUWB#70
0.1.9	CR ERMTGUWB(24)070047r1 included
0.2.0	Version for TG UWB RC to approve for 2 nd HASTAC
0.2.1	Outcome TG UWB RC, approved for 2 nd HASTAC assessment
0.2.2	Outcome TG UWB #71 resolution of 2 nd HASTAC with revision marks
0.2.3	Clean version of 0.2.2, approved by TGUWB#71 for requesting SRdAP

Annex E (informative): History

Document history			
V1.0.0	March 2025	SRdAP process	EV 20250623: 2025-03-25 to 2025-06-23