

# ETSI ES 204 114 V1.1.1 (2025-10)



ETSI STANDARD

**Access, Terminals, Transmission and Multiplexing (ATTM);  
Meta-model entities/relationships opendthX  
data/applications interoperability**

---

**Reference**DES/ATTM-0020013

---

**Keywords**

application, data interoperability,  
data management, intelligent homes & buildings,  
interoperability, management, smart cities

**ETSI**

650 Route des Lucioles  
F-06921 Sophia Antipolis Cedex - FRANCE

---

Tel.: +33 4 92 94 42 00 Fax: +33 4 93 65 47 16

Siret N° 348 623 562 00017 - APE 7112B  
Association à but non lucratif enregistrée à la  
Sous-Préfecture de Grasse (06) N° w061004871

---

**Important notice**

---

The present document can be downloaded from the  
[ETSI Search & Browse Standards](#) application.

The present document may be made available in electronic versions and/or in print. The content of any electronic and/or print versions of the present document shall not be modified without the prior written authorization of ETSI. In case of any existing or perceived difference in contents between such versions and/or in print, the prevailing version of an ETSI deliverable is the one made publicly available in PDF format on [ETSI deliver](#) repository.

Users should be aware that the present document may be revised or have its status changed,  
this information is available in the [Milestones listing](#).

If you find errors in the present document, please send your comments to  
the relevant service listed under [Committee Support Staff](#).

If you find a security vulnerability in the present document, please report it through our  
[Coordinated Vulnerability Disclosure \(CVD\)](#) program.

---

**Notice of disclaimer & limitation of liability**

---

The information provided in the present deliverable is directed solely to professionals who have the appropriate degree of experience to understand and interpret its content in accordance with generally accepted engineering or other professional standard and applicable regulations.

No recommendation as to products and services or vendors is made or should be implied.

No representation or warranty is made that this deliverable is technically accurate or sufficient or conforms to any law and/or governmental rule and/or regulation and further, no representation or warranty is made of merchantability or fitness for any particular purpose or against infringement of intellectual property rights.

In no event shall ETSI be held liable for loss of profits or any other incidental or consequential damages.

Any software contained in this deliverable is provided "AS IS" with no warranties, express or implied, including but not limited to, the warranties of merchantability, fitness for a particular purpose and non-infringement of intellectual property rights and ETSI shall not be held liable in any event for any damages whatsoever (including, without limitation, damages for loss of profits, business interruption, loss of information, or any other pecuniary loss) arising out of or related to the use of or inability to use the software.

---

**Copyright Notification**

---

No part may be reproduced or utilized in any form or by any means, electronic or mechanical, including photocopying and microfilm except as authorized by written permission of ETSI.

The content of the PDF version shall not be modified without the written authorization of ETSI.

The copyright and the foregoing restriction extend to reproduction in all media.

© ETSI 2025.  
All rights reserved.

# Contents

Intellectual Property Rights .....	5
Foreword.....	5
Modal verbs terminology.....	5
Executive summary .....	5
1 Scope .....	7
2 References .....	7
2.1 Normative references .....	7
2.2 Informative references.....	8
3 Definition of terms, symbols and abbreviations.....	9
3.1 Terms.....	9
3.2 Symbols.....	12
3.3 Abbreviations .....	12
4 Introduction to the data interoperability format for connected buildings.....	13
5 Cases of information in the construction industry.....	13
5.1 Inventory of players involved in construction data exchange .....	13
5.2 Inventory of targeted use cases.....	14
5.3 Inventory of types of construction data exchanged .....	15
6 Lifecycle of an object as part of a construction project and its operation .....	17
6.1 Introduction to the Object Lifecycle in the BIM process .....	17
6.1.1 From Design to Operation: An Integrated Vision based on ISO 19650 Standards.....	17
6.1.2 A Structuring Duality: PIM and AIM .....	18
6.1.3 Progressive Maturation in PIM.....	18
6.1.4 The Specific Object as the Foundation of AIM .....	18
6.1.5 An integrated approach to optimizing the entire life cycle .....	18
6.2 The Evolution of BIM Objects in the PIM Cycle: From Conceptual to Concrete.....	19
6.2.1 Introduction.....	19
6.2.2 Progressive Information Maturation .....	19
6.2.3 Information continuity and traceability.....	19
6.2.4 A collaborative, multi-stakeholder approach .....	20
6.2.5 Conclusion: A Solid Foundation for the Full Life Cycle .....	20
6.3 The Generic Object Model (GOM) .....	20
6.3.1 Definition and role of the GOM.....	20
6.3.2 Property group structure .....	20
6.3.3 GOM Creation Process .....	21
6.3.4 Transition to Later Phases.....	21
6.3.5 The Importance of the GOM in the BIM Process .....	21
6.4 The Generic Object: Making Requirements a Reality in the BIM Process Lifecycle .....	22
6.4.1 From Abstraction to Concretization: The Evolution from GOM to Generic Object.....	22
6.4.2 Collaborative Enrichment by Different Actors .....	22
6.4.3 Property valuation mechanisms .....	22
6.4.4 Interdependency and arbitrage management.....	22
6.4.5 Position in the PIM Process .....	23
6.4.6 Transition to Later Phases.....	23
6.5 The Specific Object: Technical Realization in the BIM Process Lifecycle.....	23
6.5.1 Transition from Requirement to Concrete Solution.....	23
6.5.2 Dual Property Structure .....	23
6.5.3 Selection and Specification Process.....	24
6.5.4 Enrichment by Value Chain Actors .....	24
6.5.5 Manufacturer data integration.....	24
6.5.6 Managing variants and alternatives.....	25
6.5.7 Preparing the transition to AIM .....	25
6.5.8 Strategic position in the BIM process .....	25

6.6	The Role of the Specific Object in the AIM Phase .....	25
6.6.1	Transition from Specific Object to AIM.....	25
6.6.2	AIM Information Foundation .....	25
6.6.3	Enrichment and Evolution in AIM .....	26
6.6.4	Maintenance Operations Support.....	26
6.6.5	Contribution to Performance Analysis and Decision Making .....	26
6.6.6	Preparing for Renewal and Evolution.....	26
6.7	Conclusion: Towards integrated, continuous information management .....	27
6.7.1	Overview of the BIM Object Lifecycle Approach.....	27
6.7.2	Benefits an Integrated Approach .....	27
6.7.3	Challenges.....	27
6.7.4	Outlook .....	28
6.7.5	The New Horizon of Digital Construction.....	28
7	Data interoperability.....	28
7.1	Challenges .....	28
7.2	The advantages .....	28
7.3	The benefits of dynamic dictionaries for the specific use case of data exchange.....	29
8	Complementarities and synergies between opendthX and SAREF for connected buildings .....	29
8.1	Introduction .....	29
8.2	SAREF4BLDG Example .....	31
9	Semantic, organizational and technical interoperability .....	34
9.1	Semantic interoperability: The COPO method.....	34
9.2	Organizational interoperability: CIQO process .....	34
9.3	Technical interoperability.....	36
9.3.1	Language construction .....	36
9.3.2	IFC files: a first revolution in construction.....	36
9.3.3	IFC files have several essential characteristics:.....	36
9.3.4	File-based exchange: from XML to JSON-LD.....	36
9.3.5	API exchanges: fluidity and responsiveness .....	37
9.3.6	Converging and complementary approaches .....	37
9.3.7	Future prospects.....	37
9.3.8	Conclusion / opendthX meta-model .....	38
9.3.8.1	opendthX metamodel JSON v3.0.....	38
9.3.8.1.1	Schema: .....	38
9.3.8.1.2	Description of the datBIM v3 API.....	38
9.3.8.2	Open REST API of the opendthX JSON v4.0 meta model .....	42
9.3.8.3	opendthX meta model similar JSON LD self-discoverable V1.0.....	42
9.3.8.4	Summary diagram .....	43
9.3.9	OpenCDE.....	43
<b>Annex A (informative):</b>	<b>Metamodel opendthX JSON-LD v1.0 .....</b>	<b>47</b>
<b>Annex B (informative):</b>	<b>Schematics .....</b>	<b>52</b>
<b>Annex C (informative):</b>	<b>Bibliography.....</b>	<b>55</b>
<b>Annex E (informative):</b>	<b>Change history .....</b>	<b>56</b>
History .....		57

---

# Intellectual Property Rights

## Essential patents

IPRs essential or potentially essential to normative deliverables may have been declared to ETSI. The declarations pertaining to these essential IPRs, if any, are publicly available for **ETSI members and non-members**, and can be found in ETSI SR 000 314: "*Intellectual Property Rights (IPRs); Essential, or potentially Essential, IPRs notified to ETSI in respect of ETSI standards*", which is available from the ETSI Secretariat. Latest updates are available on the [ETSI IPR online database](#).

Pursuant to the ETSI Directives including the ETSI IPR Policy, no investigation regarding the essentiality of IPRs, including IPR searches, has been carried out by ETSI. No guarantee can be given as to the existence of other IPRs not referenced in ETSI SR 000 314 (or the updates on the ETSI Web server) which are, or may be, or may become, essential to the present document.

## Trademarks

The present document may include trademarks and/or tradenames which are asserted and/or registered by their owners. ETSI claims no ownership of these except for any which are indicated as being the property of ETSI, and conveys no right to use or reproduce any trademark and/or tradename. Mention of those trademarks in the present document does not constitute an endorsement by ETSI of products, services or organizations associated with those trademarks.

**DECT™**, **PLUGTESTS™**, **UMTS™** and the ETSI logo are trademarks of ETSI registered for the benefit of its Members. **3GPP™**, **LTE™** and **5G™** logo are trademarks of ETSI registered for the benefit of its Members and of the 3GPP Organizational Partners. **oneM2M™** logo is a trademark of ETSI registered for the benefit of its Members and of the oneM2M Partners. **GSM®** and the GSM logo are trademarks registered and owned by the GSM Association.

---

# Foreword

This ETSI Standard (ES) has been produced by ETSI Technical Committee Access, Terminals, Transmission and Multiplexing (ATTM).

---

# Modal verbs terminology

In the present document "**shall**", "**shall not**", "**should**", "**should not**", "**may**", "**need not**", "**will**", "**will not**", "**can**" and "**cannot**" are to be interpreted as described in clause 3.2 of the [ETSI Drafting Rules](#) (Verbal forms for the expression of provisions).

"**must**" and "**must not**" are **NOT** allowed in ETSI deliverables except when used in direct citation.

---

# Executive summary

The openm2M open meta-model is designed to ensure interoperability between digital content and construction industry software, enabling all parties involved in a construction project to contribute to the BIM process (see Figure B.1), in particular for:

- access to all types of content via all types of applications, regardless of the tools used;
- enriching objects for advanced collaborative construction;
- standardize input data in construction software avoid the GIGO effect (i.e. Garbage In → Garbage Out) (see Figure B.3);

- with the aim of creating a "CIQO-ready" collaborative environment: "Collaboration In → Quality Out" (see Figure B.2):
  - optimize data transfers using the concept of data on demand, thus meeting the need for digital sobriety;
  - establish digital continuity throughout the lifecycle of the project: design-construction-operations, including the use of connected objects.

---

# 1 Scope

The present document presents the `opendthX` entity/relationship meta-model for interoperability between data and applications.

The purpose of the present document is to establish a framework to ensure interoperability between digital content and software applications in the construction industry. It aims to facilitate access to various types of content through different applications, regardless of the tools used, thereby promoting advanced collaborative construction practices. The standard aims to standardize input data to construction software in order to avoid the "Garbage In Garbage Out" (GIGO) effect, by ensuring that quality input data and applications result in quality output data.

The main objectives are to optimize data transfers through the concept of data on demand, which promotes digital sobriety, and to establish digital continuity throughout the lifecycle of construction projects, from design and construction to operation, including the use of connected objects. The standard introduces the `opendthX` open meta-model, designed to enable seamless interoperability and collaboration between all stakeholders in a construction project.

In addition, the standard addresses the integration of semantic, organizational and technical interoperability, providing methodologies and frameworks such as the use Cases-use Objects-Properties-modelled Objects (COPO) method for semantic interoperability and the Collaboration In Quality Out (CIQO) process for organizational interoperability. It also covers technical aspects such as the context for using IFC files, JSON-LD and APIs for efficient data exchange.

Overall, the standard aims to improve the efficiency, sustainability and adaptability of the construction sector by harnessing the full potential of the digital transformation from appli-centrism to open data-centrism through data-application interoperability.

---

## 2 References

### 2.1 Normative references

References are either specific (identified by date of publication and/or edition number or version number) or non-specific. For specific references, only the cited version applies. For non-specific references, the latest version of the referenced document (including any amendments) applies.

Referenced documents which are not found to be publicly available in the expected location might be found in the [ETSI docbox](#).

NOTE: While any hyperlinks included in this clause were valid at the time of publication, ETSI cannot guarantee their long-term validity.

The following referenced documents are necessary for the application of the present document.

- [1] [ETSI TS 103 673](#): "SmartM2M; SAREF Development Framework and Workflow, Streamlining the Development of SAREF and its Extensions".
- [2] [ISO 16739-1:2024](#): "Industry Foundation Classes (IFC) for data sharing in the construction and facilities management industries — Part 1: Data schema".
- [3] [ISO 23386:2020](#): "Building information modelling and other digital processes used in construction — Methodology to describe, author and maintain properties in interconnected data dictionaries".
- [4] [ISO 19650 \(all parts\)](#): "Organization and digitization of information about buildings and civil engineering works, including building information modelling (BIM) — Information management using building information modelling".
- [5] [ETSI TS 103 548](#): "SmartM2M; SAREF reference ontology patterns".
- [6] buildingSMART: "[Industry Foundation Classes \(IFC\) - Version 4 - Addendum 1](#)".
- [7] [ETSI TS 103 410-3 \(V1.1.1\)](#): "SmartM2M; Smart Appliances Extension to SAREF; Part 3: Building Domain".

## 2.2 Informative references

References are either specific (identified by date of publication and/or edition number or version number) or non-specific. For specific references, only the cited version applies. For non-specific references, the latest version of the referenced document (including any amendments) applies.

NOTE: While any hyperlinks included in this clause were valid at the time of publication, ETSI cannot guarantee their long-term validity.

The following referenced documents may be useful in implementing an ETSI deliverable or add to the reader's understanding but are not required for conformance to the present document.

[i.1] [Directive 2014/24/EU](#) of the European Parliament and of the Council of 26 February 2014 on public procurement and repealing Directive 2004/18/EC.

[i.2] French decree n 2018-1075 of December 3, 2018, Article R2132-10.

NOTE: The law authorizes the buyer to use electronic building data modelling tools. In this case, it offers the means access mentioned in article R. 2132-14, until such time as these tools and devices have become commonly accessible to economic operators.

[i.3] Under Belgian law: June 17, 2016 - Public Procurement Act.

[i.4] Legal approach to interoperability: Interoperability is a right of use within the meaning of article L122-6-1 of the French Intellectual Property Code, in the version in force on November 26, 2021.

NOTE: Software is protected by copyright, except as interoperability.

[i.5] [European Data Governance Act](#) 30/05/2022.

[i.6] [Proposal for European Data Protection Act](#) - 23/02/2022.

[i.7] Study report on the comparative cost of creating a technical database of digital mock-up components. BIM virtual workshop project carried out as part of the French government's digital building transition plan. Version 2 of the document dated 11/04/2017.

NOTE: See figures 4 and 5. [Doc1\\_Etude2\\_ABV\\_BDD\\_20170411.pdf](#).

[i.8] Michel Léglise and Bernard Ferrière: "Evaluation of the costs of interoperability borne by contractors, project owners and operators in the construction and operation of buildings". Final report of study 08E86 commissioned by the FFB (Fédération Française du Bâtiment), LAURENTI. December 2009.

NOTE: See figures 4 and 5. [Doc2\\_Rapp\\_Final\\_FFB\\_35\\_cout\\_interoperability2009.pdf](#).

[i.9] "The Référentiel Général d'Interopérabilité Version 2.0", December 2015 developed by the French government's Direction Interministérielle de l'Economie Numérique et du Système d'Information et de Communication.

NOTE: This is a list of standards for given use cases.  
Scope of exchanges:

- between administrations;
- between administrations and companies;
- between administrations and citizens.

[i.10] W3C® Semantic Web: "Resource Description Framework (RDF)".

[i.11] W3C® Recommendation 16 July 2020: "JSON-LD 1.1 - A JSON-based Serialization for Linked Data".

[i.12] W3C® editor's project: "The JSON-LD vocabulary".

[i.13] JSON for Linking Data.

- [i.14] Schema.org.
- [i.15] JDN: "Data centricity", 27/03/2019.
- [i.16] ETSI TR 103 781 (V1.1.1): "SmartM2M; Study for SAREF ontology patterns and usage guidelines".
- [i.17] [EN 13501-1](#): "Fire classification of construction products and building elements - Part 1: Classification using data reaction to fire tests", (produced by CEN).
- [i.18] NF XP P07-150 (12-2014): "Properties of products and systems used in construction - Definition of properties, method of creation and managing properties in a harmonized system of reference".
- [i.19] [ISO 23387](#): "Building information modelling (BIM) — Data templates for construction objects used in the life cycle of built assets — Concepts and principles".
- [i.20] OPIIEC: "[Study on skills, employment and training requirements for the digital twin in France](#)", 05/01/2024.
- [i.21] "[Open formats, what for?](#)", April.org.

## 3 Definition of terms, symbols and abbreviations

### 3.1 Terms

For the purposes of the present document, the following terms apply:

**appli-centrism:** IT development method based on developing an application using data that can only be used in that application

NOTE: This characterizes a computer application development method which involves integrating input data via a dedicated graphical interface for the processing envisaged by the application and rendering the processing in a native format. In this case, the application acts as a data repository. In this logic, the user should have as many data repositories as applications, and therefore as many use cases, which implies re-entering information or developing specific connectors for each link envisaged.

**attribute:** data element used to describe a property or a group of properties a computer-suitable way

**authorization:** function specifying access rights to resources linked to information security and information systems security in general, and to access in particular

NOTE: More formally, "authorizing" means defining an access policy.

**Avis Technique (AT) (technical notice):** document formalizing the opinion issued by a group of experts on the suitability for use of innovative construction processes

NOTE: The CSTB is involved in the technical opinion procedure at several levels and provides the secretariat. CSTB has carried out a study demonstrating the ability of the opendthX format to describe the AT.

**Building Information Modelling (BIM):** use of a shared digital representation of a built asset (buildings, bridges, roads, factories, etc.) to facilitate the design, construction and operation processes and provide a reliable basis for decision-making

NOTE: See ISO 19650 [4].

**class:** group of properties

**computer object:** instance of the class that can be considered as the digital representative of a construction object

NOTE: In the remainder of the present document, the object will be considered as a computer object. The object or object model is defined for the purpose of exchanging data for a specific use case.

**construction object:** object of interest in a construction process

NOTE: In accordance with ISO 23387 [i.19].

**data-centricity:** IT development method involving the development applications using standardized data that can be used in other applications

NOTE: Behind this name lies an approach that places data at the heart of the company and requires it to be considered an asset in its own right, in the same way as patents, for example. It would be frustrating and incomprehensible to create an entirely new business without mastering this asset. The data-centric approach aims to turn the tables and make data the cardinal point of a company's strategy.  
Source JDN 27/03/2019 [i.15].

**datBIM<sup>®</sup>:** company that developed the opendthX format and then licensed it to the Alliance du bâtiment association to govern and promote it

**digital content:** library or catalogue of objects that are collections of objects

**digital twin:** digital duplication of a physical entity or product

NOTE: The digital twin is the digital double of a real object, process or system, made up of interoperable applications and data and developed to meet well-defined uses.

It is fed by data flows from the real entity at a defined frequency, to adjust to needs and uses in real conditions. The digital twin makes it possible to understand, analyse and predict the behaviour of the real entity, in order to support decision-making in its management and operation [i.20].

**entity:** thing capable of existing independently, uniquely identifiable and capable of storing data

NOTE: In the context of the entity-relationship model, an entity has properties or attributes.

**eXtensible Markup Language (XML):** subset of the Standard Generalized Markup Language (SGML)

NOTE: Its syntax is said to be "extensible" because it can be used to define different languages, each with its own vocabulary and grammar, such as XHTML, XSLT, RSS, SVG, opendthX and so on.

**Garbage In Garbage Out (GIGO):** well-identified risk in systems engineering: poor-quality input data produces poor-quality output data (results)

**generic object:** set of property/value pairs that are dissociated from a manufacturer's product brand and whose values may be requirement values or correspond to generic, standard range values

**generic object model or object description model:** set of value-free properties that can also be assimilated to a class

**identification:** means of "knowing" the identity an entity

NOTE: Often by means of an identifier such a user name (distinct from identity, or authentication).

**Industry Foundation Classes (IFC):** standardized object-oriented file format [2] used by the construction industry to exchange and share information between software programs

NOTE: Promoted by the international organization buildingSMART International and its national chapters.

**integrity:** state of data which, during processing, storage or transmission, is not altered or destroyed, whether intentionally or accidentally, and retains a format that allows it to be used

NOTE 1: Data integrity comprises four elements completeness, precision, accuracy/authenticity and validity.

NOTE 2: Integrity is one of the basic requirements of IT security, document management and archiving.

**JavaScript Object Notation (JSON):** textual data format derived from the object notation of the JavaScript language

NOTE: It competes with XML for the representation and transmission of structured information.

**JavaScript Object Notation for Linked Data (JSON LD):** method encoding structured data using JSON

NOTE: The aim is to provide developers with a simple way of transforming existing JSON data into JSON-LD. This enables data to be serialized in the same way as with traditional JSON. JSON-LD is a recommendation of the World Wide Web Consortium and is therefore considered a standard. Source: Wikipedia®.  
See [i.10], [i.11], [i.12], [i.13] and [i.14].

**metadata:** data used to define or describe another piece of data, determining its medium

NOTE: Term derived from the Greek prefix meta, meaning "beyond" or "about".

EXAMPLE: Metadata can indicate the date of creation or recording a piece of data, or the geographic coordinates associated with a photograph.

**opendthX:** open data format designed to ensure interoperability between digital content and software in the construction sector

NOTE This format is governed by the construction industry through the non-profit association Alliance du bâtiment.

**open format:** freely usable data format

NOTE: Open format files can be read and modified by yourself or by third parties. Readability is guaranteed over time. Open formats are freely usable in any software, making software interoperable. Open formats promote freedom of choice by not favouring the format of a particular company (known as the native or proprietary format), thus avoiding the monopoly of a publisher who would like to make users captive to the proprietary format it has designed [i.21].

**property:** inherent or acquired characteristic of an element (project, system, product, etc.)

NOTE 1: ISO 23386 [3] (produced based on the French experimental standard NF XP P07-150 [i.18] published in 2015) provides an exhaustive list of 40 attributes used to manage a property in a data dictionary.

EXAMPLE: Reaction to fire measured in accordance with EN 13501-1 [i.17].

A property can be:

- **Static:** the value is predefined by the object designer.
- **Configurable or parameterizable:** the value is defined by the user.
- **Dynamic:** the value changes according to the object's physical state. Example: temperature measured by a thermometer-type sensor.
- **Relation:** association.

NOTE 2: According to the entity-relationship model, a relationship is a link between two or more entities. A relationship can have properties or attributes.

- **Traceability:** situation in which the necessary and sufficient information is provided to know (possibly retrospectively) the composition of an object throughout its production, transformation and distribution chain

**property group:** set of properties with no value

NOTE: According to ISO 23386 [3], there are different categories of property groups:

- Class.
- Compound property.
- Domain.
- Reference document.
- Other uses.

**specific object:** set of property/value pairs whose values are the performances of a manufacturer's product

## 3.2 Symbols

Void.

## 3.3 Abbreviations

For the purposes of the present document, the following abbreviations apply:

ABV	Atelier BIM Virtuel (Virtual BIM Workshop)
AI	Artificial Intelligence
AIM	Asset Information Model
APD	Avant Projet Détaillé (detailed design)
API	Advanced Programming Interface
APS	Avant Projet Sommaire (Preliminary design)
AT	Avis Technique (technical notice)
BIM	Building Information Modelling
BMS	Building Management System
CAD	Computer-Aided Design
CIQO	Collaboration In Quality Out
COPO	use Cases, use Objects, Properties, modelled Objects
CRUD	Create, Read, Update, Delete
CSTB	Scientific and Technical Centre for Building
DatSPIN	Données actualisées techniques pour une Stratégie du Patrimoine Immobilier Numérique (pp-to-date technical data for a digitized real estate strategy)
DCE	Dossier de Consultation des Entreprises (specification booklet)
DOE	Dossier des Ouvrages Exécutés (completed works file )
DTU	Unified Technical Documents
ERP	Enterprise Resource Planning
FDES	Fiche de Données Environnementales et Sanitaires
GDP	Gross Domestic Product
GIGO	Garbage In Garbage Out
GO	Generic Object
GOM	Generic Object Model
IFC	Industries Foundation Classes
IOT	Internet Of Things
JDN	Journal Du Net
JSON	JavaScript Object Notation
JSON-LD	JavaScript Object Notation for Linked Data
opendthX	Open Dictionnaire Technique Harmonisé eXchange (exchange of technical dictionaries harmonized)
PCBIM	Building Permit BIM
PIM	Project Information Model or Product Information Management
POBIM	Properties of BIM Objects
RSS	Really Simple Syndication
SAREF	Smart Applications REference ontology
SGML	Standard Generalized Markup Language
SO	Specific Object
SVG	Scalable Vector Graphics
XHTML	eXtensible HyperText Markup Language
XML	eXtensible Markup Language
XP	eXperimental Standards

NOTE: Identified by the prefix "XP".

XSLT eXtensible Stylesheet Language - Transformations

---

## 4 Introduction to the data interoperability format for connected buildings

The digital transformation of the construction sector can accelerate its environmental transformation, provided that it enables everyone to work together, which presupposes that data is interoperable with applications.

The specific characteristics of the construction sector that need to be taken into account to make this transformation a success:

- A fragmented sector: A large majority of construction companies have fewer than 20 employees.
- The political stakes are high:
  - the environment: the biggest consumer of energy and the biggest producer of waste;
  - economic: exchanges of construction data represent 25 % of GDP in Europe, based on studies carried out in France;
  - social: 3<sup>rd</sup> in terms of direct recruitment, after services and industry.
- Digital modelling of construction projects is encouraged by public procurement regulations (see [i.1], [i.2] and [i.3]), provided that this requirement does not create technological barriers for any of the players involved.
- The costs attributable to the lack of interoperability in Europe are estimated at over one hundred billion euros per year, extrapolated from studies carried out in France (see [i.7] and [i.8]).
- The operating cost a building represents 70 to 80 % of its total cost.
- Convergence between buildings and telecommunications via the Internet of Things (IOT) or connected objects.
- Numerous software applications: over 300 construction software publishers in France alone.
- The digital transition in the construction sector means moving from an application-centric to an open data-centric [i.15] approach.
- The need to develop a common language to ensure data interoperability with applications, in line with the principles of the European data directives (see [i.1], [i.5] and [i.6]) and the French initiative for a general interoperability reference framework (see [i.9]).

---

## 5 Cases of information in the construction industry

### 5.1 Inventory of players involved in construction data exchange

The method consisted in defining a classification of some twenty families of players involved in the production and consumption of construction data throughout the life cycle of the structure, with a view to consultation:

- Architects
- Insurance companies
- Engineering offices
- Control offices
- Technical centres
- Diagnosticians
- Distributors

- Economists
- Eco-organizations
- Companies
- Operators
- Manufacturers
- Land surveyors
- Project owners
- Notaries
- Financing organizations
- Programmers
- Urban planning authorization instruction services
- Building users
- IOT

## 5.2 Inventory of targeted use cases

A consultation some fifty stakeholders representing the categories identified enabled to produce a summary table including:

- in the first column, information-providing players;
- in the front line, the same actors who receive information;
- the cells at the row/column intersection containing the type of information exchanged.

Table 1 summarizes the information exchanged.

**Table 1**

<b>Information exchanged</b>	<b>Computer application</b>	<b>Input data</b>
Deed of ownership	Business software	text/digital
Approval	Business software	text/digital
Project authorization	Business software	text/digital
Notice for execution	Business software	text/digital
Opinions on the work	Business software	text/digital
Technical notice	Business software	text/digital
Technical specifications	Business software	text/digital
Contract	ERP	text/digital
Agreement	Business software	text/digital
All-inclusive price breakdown	Business software	text/digital
Description for waste disposal	Business software	text/digital
Project description	Business software	text/digital
Quote	ERP	text/digital
Diagnostics (asbestos, lead, electrical, DPE, termites, PEMD, resources (deconstruction re-use))	Business software	text/digital
Qualification study of re-used materials	Business software	text/digital
Dimensioning studies (object requirements)	Business software	text/digital
Soil/fauna/flora surveys	Business software	text/digital
Invoice	ERP	text/digital
Environmental and health data sheet	Business software	text/digital
Product sheet	Business software	text/digital
Weather file	Business software	text/digital
Financing	Business software	text/digital

Information exchanged	Computer application	Input data
Application form for planning permission	Business software	text/digital
Information / waste collection	Business software	text/digital
Usage information	IOT	digital
Money order	Business software	text/digital
3D models	CAD	geometry/text/digital
Point clouds	CAD	geometry
Work order	ERP	text/digital
Payment by money order	Business software	text/digital
Floor plan,	CAD	geometry
Plans	CAD	geometry
Execution drawings	CAD	geometry
Surveying plans	CAD	geometry
Delivery point	Business software	text/digital
Program	Business software	text/digital
PV tests	Business software	text/digital
Quantitative	Business software	text/digital
Reports and certificates	Business software	text/digital
Rules for drawing up unified technical documents	Business software	text/digital
Network surveys	CAD	geometry
Topographic surveys	CAD	geometry
Reuse and waste reporting	Business software	text/digital
Product test feedback	Business software	text/digital
Risks to structures	Business software	text/digital
Surface uses	Business software	text/digital

### 5.3 Inventory of types of construction data exchanged

The computer applications used by those who need to exchange information about the project are of different kinds:

- Business software
- CAD
- ERP
- Applications managing connected objects (IOT)

The breakdown of use cases by type of IT application is:

Computer application	Use case CU	%
Business software	33	72 %
CAD	8	17 %
ERP	4	9 %
IOT	1	2 %
Total	46	100 %

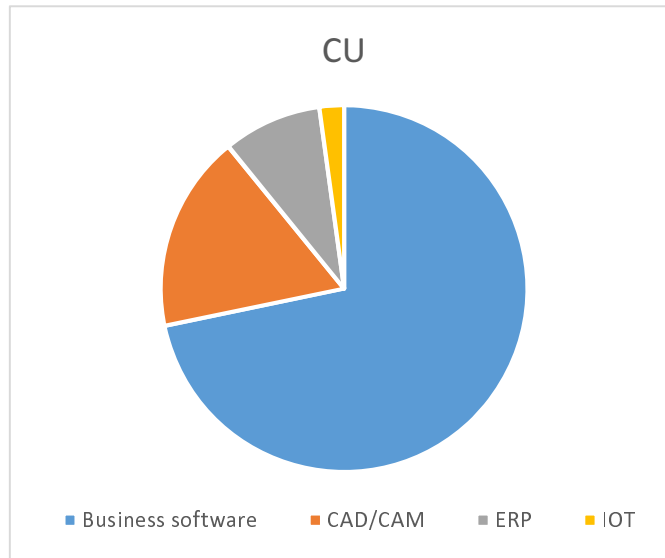

**Figure 1**

The business software class, which is the largest in terms of numbers, does not represent a single application, but as many applications as there are use cases.

The types of data exchanged are mainly:

- Text
- Digital
- Geometric

The breakdown of use cases by data type is:

Input data types	CU	%
Text/digital	38	83 %
Geometric	8	17 %
Total	46	100 %

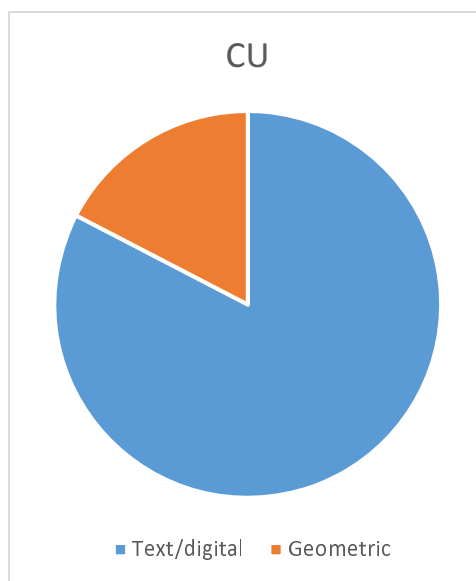

**Figure 2**

The diagram in Figure 3 illustrates the interactions between players by a line whose colour represents the type of data exchanged.

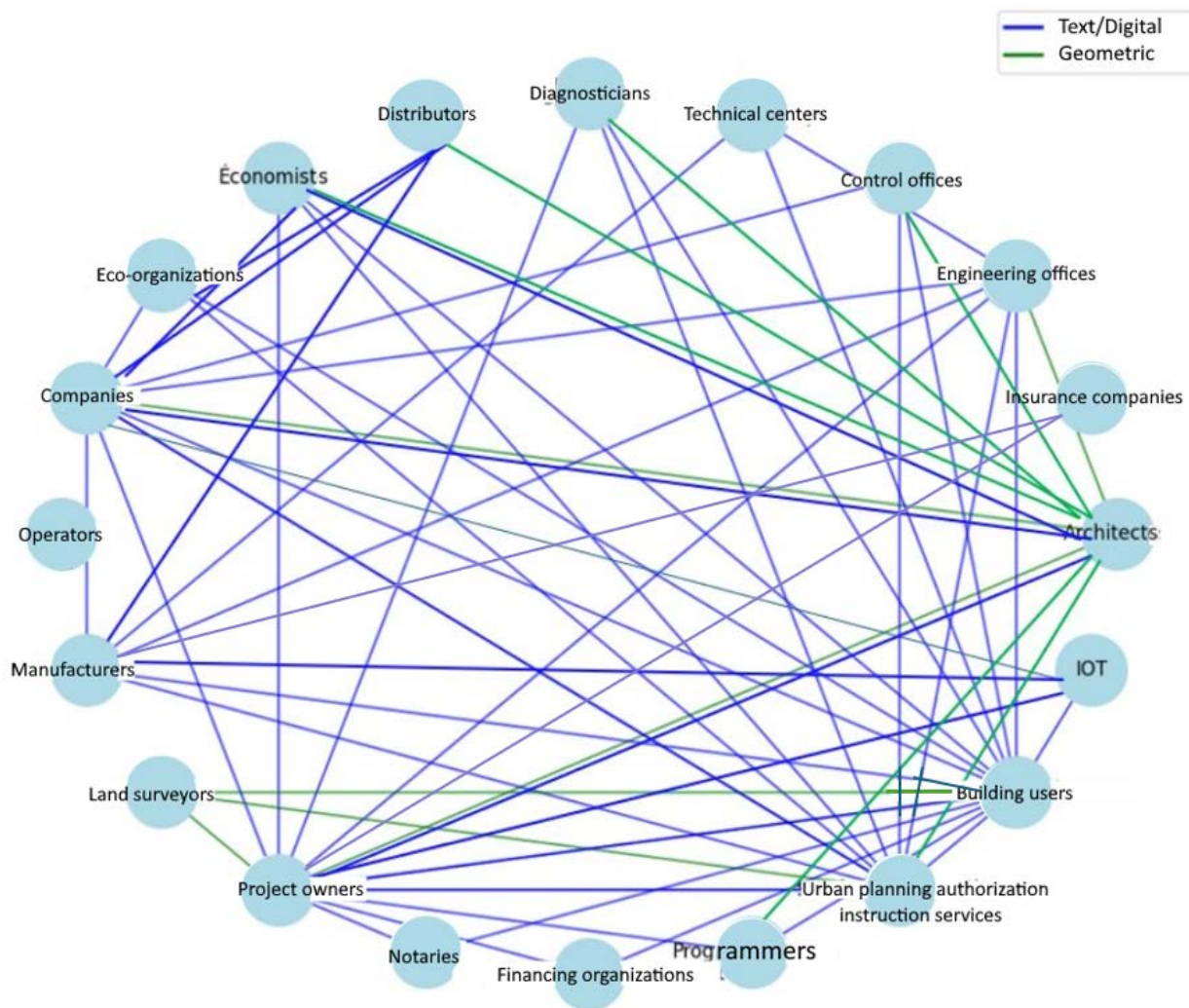

**Figure 3**

This analysis shows the diversity of exchanges between stakeholders and also the diversity of applications used by stakeholders, and the need for a data/application interoperability format that takes into account all types of data, without privileging one over another.

## 6 Lifecycle of an object as part of a construction project and its operation

### 6.1 Introduction to the Object Lifecycle in the BIM process

#### 6.1.1 From Design to Operation: An Integrated Vision based on ISO 19650 Standards

The construction sector is undergoing an unprecedented digital revolution, catalysed by the growing adoption of Building Information Modeling (BIM) and framed by international standards ISO 19650 [4]. This digital transformation is fundamentally redefining the way information about structures is created, shared and used throughout their lifecycle, from design to demolition.

At the heart of this approach lies the concept of construction objects, digital entities that represent the physical components of a structure. Far from being mere geometric representations, a concept still too often reduced to by the vast majority of those involved in modelling, these objects are veritable containers information that evolve, enrich and transform over the course of project phases and the life of the structure.

### 6.1.2 A Structuring Duality: PIM and AIM

The informational life cycle of a construction object unfolds through two major phases defined by the ISO 19650 [4] standards:

- Project Information Model (PIM) - which covers the design and construction phase, where the object gradually evolves from an abstract concept to a precise technical solution.
- Asset Information Model (AIM) - which extends to the operation and maintenance phase, where the object is enriched with operational data and potentially becomes a connected element within an Internet of Things (IOT) ecosystem.

This structuring duality ensures informational continuity while adapting to the specific needs of each phase.

### 6.1.3 Progressive Maturation in PIM

In the PIM phase, the object undergoes a methodical evolution in three key stages:

- The Generic Object Model (GOM) - an initial conceptual framework consisting of an organized structure of properties without assigned values, defining the fundamental characteristics expected without specifying technical solutions.
- The Generic Object (GO) - an evolution of the GOM where properties receive quantified requirement, the result of collaborative work between different construction players, while remaining independent a specific technical solution.
- The Specific Object (SO) - technical embodiment corresponding to a specific product from a manufacturer, simultaneously preserving the requirement values and actual performance of the selected product.

This progression ensures complete traceability of decisions and ongoing verification of compliance with initial requirements.

### 6.1.4 The Specific Object as the Foundation of AIM

In the transition to the AIM phase, the Specific Object plays a fundamental role, providing a rich, structured information base for asset management. It is no longer just a design element, but a genuine support for operation and maintenance, which:

- Provides precise technical specifications and complete documentation.
- Gradually enriched with operating and maintenance data.
- Supports day-to-day technical management operations.
- Contributes to performance analysis and decision-making.
- Efficiently prepares for future equipment renewal.

This transformation of the Specific Object into the AIM represents the essential informational continuity between the project phase and the operational phase, maximizing the value of the data generated during design and construction.

### 6.1.5 An integrated approach to optimizing the entire life cycle

This integrated vision of the lifecycle of objects, from their conceptual design to their connected operation, represents a paradigm shift in the construction sector. It enables to optimize not only the design and construction phase, but also operating period, which makes up the major part of a structure's life and accounts for the bulk of its overall costs.

By ensuring the continuity and consistency of information throughout this cycle, ISO 19650 [4] standards provide a structuring framework that maximizes the value created at each stage and facilitates informed decision-making throughout the asset's lifecycle.

This holistic approach, which reconciles the physical and digital dimensions of structures, is a major lever in meeting the sector's contemporary challenges: improving productivity, optimizing environmental performance, adapting to new uses and anticipating future needs.

## 6.2 The Evolution of BIM Objects in the PIM Cycle: From Conceptual to Concrete

### 6.2.1 Introduction

As part of the Building Information Modeling (BIM) approach governed by ISO 19650 [4] standards, construction objects follow a process of progressive information maturation. This methodical evolution, part of the Project Information Model (PIM) phase of the information lifecycle, ensures the traceability of requirements and the consistency of decisions from programming through to completion.

The information flow follows a logic of increasing specification, passing through three key stages that gradually transform an abstract concept into a precise technical solution:

- The generic object model (GOM) - initial conceptual framework.
- The Generic Object (GO) - a quantified expression of requirements.
- The Specific Object (SO) - a concrete, high-performance technical solution.

This methodical progression offers a structured approach in which each stage enriches the object, preserving the memory of initial intentions and functional requirements. This process, which mobilizes different players at each phase, guarantees informed decision-making and optimized design.

### 6.2.2 Progressive Information Maturation

The evolution cycle of a BIM object reflects the fundamental philosophy of ISO 19650 [4] standards: clearly define "*what you want*" before specifying "*how you're going to get it*". This approach translates into a progressive enrichment of information:

- At the GOM stage, the object is defined by its value-free property structure, establishing the conceptual framework that will guide subsequent phases.
- The transition to the Generic Object marks the attribution of precise requirement to these properties, the fruit of collaborative work between different specialties. The object acquires a quantitative definition, while remaining independent any particular technical solution.
- The evolution towards the Specific Object gives concrete expression to these requirements by the choice of a precise product or technical solution, while maintaining traceability with the initial requirements. The object then integrates the manufacturer's technical data, while retaining the memory of requirement values.

This progression is not simply an accumulation of information, but a qualitative transformation of the very nature of the information: The information life cycle consists of moving from "what the object should do" to "how it will do it", then to "what precise product will be used".

### 6.2.3 Information continuity and traceability

One of the fundamental principles of this evolution is the preservation of informational continuity. At each transition from one stage to the next, previous information is preserved and enriched, never replaced. This approach guarantees:

- Full traceability of design decisions.
- The ability to continuously check compliance with initial requirements.

- Documented justification of technical choices.
- Clear identification of responsibilities at every stage of the process.

This continuity of information is a major advantage during the validation and regulatory control phases, and later during the transition to the AIM phase of operation and maintenance.

## 6.2.4 A collaborative, multi-stakeholder approach

The progression from GOM to Specific Object involves various players in the value chain, intervening at strategic points in the process:

- Owners and programmers define the foundations of the GOM.
- Architects and engineers value the properties of the Generic Object.
- Economists, technical specialists and manufacturers contribute to the definition of the Specific Object.

This sequential involvement of the various players, each enriching the object according to his or her expertise, perfectly illustrates the collaborative dimension of the BIM approach. It allows choices to be optimized at every stage, by mobilizing the appropriate skills at the right moment.

## 6.2.5 Conclusion: A Solid Foundation for the Full Life Cycle

This gradual maturation of information in the PIM phase lays the foundations for efficient information management throughout the structure's lifecycle. By establishing a continuous information chain from the GOM to the Specific Object, it paves the way for a smooth transition to the AIM phase, where this information will serve as a reference for operation and maintenance.

The rigor and methodology applied to this evolution directly condition the quality of the data available for subsequent phases, illustrating the strategic importance of this progressive approach in the overall optimization of the building's life cycle.

# 6.3 The Generic Object Model (GOM)

## 6.3.1 Definition and role of the GOM

In the ISO 19650 [4] compliant BIM process, the Generic Object Model (GOM) is the first iteration of a construction object in its informational life cycle. This initial phase, located upstream of the PIM, represents the stage where designers define the fundamental characteristics of the object prior to its detailed technical specification.

The GOM is distinguished by its abstract, conceptual nature. It is a theoretical framework that establishes the functional bases and performance requirements that the object will have to satisfy, without specifying the precise technical solutions to achieve them.

## 6.3.2 Property group structure

The creation of a GOM is based on the structured organization of property groups. These groups can be categorized according to different logics:

- Functional properties: defining what the object shall do.
- Dimensional properties: establishing spatial constraints.
- Regulatory properties: reflecting applicable standards and regulations.
- Environmental properties: determining energy performance and environmental impact.
- Economic properties: setting budget constraints.

At this stage, these properties only constitute a framework of requirements without precise numerical or qualitative values. They form a "constraint envelope" that future iterations of the object will have to respect.

### 6.3.3 GOM Creation Process

The GOM development process generally follows the following stages:

- Needs identification: analysis of the client's requirements and project constraints.
- Property structuring: organizing properties into coherent, hierarchical groups.
- Establishing interdependencies: defining relationships between different properties.
- Requirements documentation: formalizing expectations without specifying technical solutions.
- Conceptual validation: checking the overall consistency of the GOM.

### 6.3.4 Transition to Later Phases

The GOM serves as a foundation for the subsequent phases of the life cycle. Its transition follows a clearly defined progression:

- Towards the Generic Object: The GOM first evolves into a Generic Object when the various construction stakeholders start assigning precise values to the properties initially defined. This stage transforms the conceptual framework into a repository of quantified requirements, while keeping independence from specific technical solutions. Architects, engineers and other specialists collectively enrich the object, each in their own field expertise, by translating functional requirements into measurable technical parameters.
- Towards the Specific Object: The Generic Object then evolves into a Specific Object, representing a concrete product from a manufacturer or a precise technical solution. This last stage retains both the previously defined requirement values and the actual performance of the selected product, enabling direct verification of compliance with initial expectations.

This methodical progression guarantees complete traceability from conceptual definition to concrete technical solution. The GOM thus plays a crucial role in establishing the structural framework that will guide entire process, ensuring that the initial intentions and fundamental requirements remain constant references throughout the object's evolution.

The rigor with which the GOM is drawn up directly conditions the quality of subsequent phases, by providing a common language for all those involved, and facilitating ongoing verification that the proposed solutions match the needs initially expressed.

### 6.3.5 The Importance of the GOM in the BIM Process

The rigorous establishment of a GOM offers several strategic advantages:

- It favours a requirements-driven rather than a solution-driven approach.
- It allows to explore different technical alternatives to meet the same needs.
- It facilitates traceability between the needs expressed and the solutions proposed.
- It provides a stable reference for assessing the conformity of the technical solutions envisaged.

By clearly defining "what the object should do" before determining "how it will do it", the GOM embodies the performance-based approach advocated by ISO 19650 [4] standards, contributing to the overall optimization of the construction project.

## 6.4 The Generic Object: Making Requirements a Reality in the BIM Process Lifecycle

### 6.4.1 From Abstraction to Concretization: The Evolution from GOM to Generic Object

The Generic Object represents a crucial maturing stage in the informational life cycle of a construction object. Whereas the Generic Object Model (GOM) established a conceptual framework made up of properties without values, the Generic Object takes a significant step towards concretization by associating precise requirement values with these properties.

This transformation marks the transition from a purely theoretical model to a reference system of quantified and qualified requirements, which now clearly guides design choices. However, the Generic Object remains independent of a specific manufacturer or technical solution, thus preserving design freedom.

### 6.4.2 Collaborative Enrichment by Different Actors

The properties of the Generic Object are enhanced through a collaborative process involving various players in the construction industry, each contributing their specific expertise:

- The architect assigns values to dimensional, aesthetic and functional properties.
- The structural engineer defines the mechanical strength and stability requirements.
- The fluids engineer specifies the thermal, hydraulic or aerodynamic requirements.
- The acoustician specifies acoustic requirements to meet regulatory, functional or comfort needs.
- The economist establishes target values for cost and economic sustainability.
- The environmental expert quantifies the expected environmental performance.
- The safety specialist sets the requirements in terms of fire protection and safety use.

This multi-disciplinary contribution ensures that the Generic Object integrates all the business requirements needed for subsequent phases of the project.

### 6.4.3 Property valuation mechanisms

Property values are generally assigned in several complementary ways:

- Translation of functional requirements into measurable technical parameters.
- Application of current standards and regulations in the context of the project.
- Consideration of site constraints and interfaces with other systems.
- Integration of performance targets set by the client.
- Analysis of feedback from similar projects.

Assigned values can take various forms: precise numerical values, ranges of acceptable values, minimum or maximum values, standardized qualitative requirements, or reference to performance standards.

### 6.4.4 Interdependency and arbitrage management

One of the major challenges of this phase lies in managing interdependencies between properties. The valuation of a property by one player can have an impact on the requirements of other specialties, necessitating a process of arbitration and multi-criteria optimization.

**EXAMPLE:** Thermal performance can influence the thickness of a component, thus affecting dimensional and structural properties. These interactions require close coordination between the various contributors, generally orchestrated by the project manager who ensures the overall consistency of the Generic Object.

### 6.4.5 Position in the PIM Process

The Generic Object lies at the junction between the programming phase and the detailed technical design phase of the PIM. It constitutes the contractual frame of reference for the technical requirements to be met by the proposed solutions, serving as the basis for:

- Evaluation of alternative technical solutions.
- Verification of conformity of items offered by manufacturers.
- Traceability of design decisions.
- Validation of technical choices by the project owner.

### 6.4.6 Transition to Later Phases

Once finalized and validated, the Generic Object will serve as a support for the search and selection of manufactured products (Specific Objects) capable of meeting the valued requirements. This transition marks the shift from a logic of requirements to a logic of concrete solutions, continuing the maturation of information within the BIM cycle.

Rigor and precision in defining the Generic Object largely determine the quality of subsequent phases, underlining the strategic importance of this stage in the overall success of the project.

## 6.5 The Specific Object: Technical Realization in the BIM Process Lifecycle

### 6.5.1 Transition from Requirement to Concrete Solution

The Specific Object represents a decisive stage in the informational life cycle of a construction element. It marks the transition from generic requirements model to a precise, identifiable and quantifiable technical solution. At this stage, the object is no longer defined solely by what it has to achieve, but by the concrete way in which it will meet the requirements, based on industrial or custom-built products or systems proposed by manufacturers.

This development is fully in line with the progressive maturation of information recommended by ISO 19650 [4] standards, guaranteeing complete traceability of decisions throughout the design process.

### 6.5.2 Dual Property Structure

The fundamental characteristic of the Specific Object lies in its dual informational structure, which simultaneously preserves:

- The requirement values defined in the Generic Object, representing the minimum required performance.
- The actual performance values of the product or technical solution chosen.

This dual approach makes it possible to immediately assess the product's compliance with requirements, and to identify areas where the product exceeds expectations or, on the contrary, requires adaptation. It also makes it easier to justify technical choices to the client and to the supervisory authorities.

### 6.5.3 Selection and Specification Process

Creating a Specific Object generally involves the following steps:

- Market research to identify products likely to meet requirements.
- Collection of technical data from manufacturers (technical data sheets, FDES, DOE, etc.).
- Comparative analysis of available solutions according to requirements.
- Verification of compatibility with other project systems and components.
- Selection of the product offering the best technical-economic compromise.
- Integration of specific data in the BIM model.
- Documentation of discrepancies between actual performance and initial requirements.

### 6.5.4 Enrichment by Value Chain Actors

The specification of the object mobilizes various players in the construction value chain:

- The designers, who define the selection criteria and technical suitability.
- Manufacturers and suppliers who offer their products and provide technical data.
- Economists who assess financial impact of technical choices.
- Maintenance specialists who analyse the implications for future operations.
- Contractors who check the feasibility of implementation.

Each player contributes to enriching the Specific Object with information relevant to his or her field expertise, thus preparing the transition to the realization phase.

### 6.5.5 Manufacturer data integration

The Specific Object integrates a wide range of data from the manufacturer:

- Precise dimensional characteristics.
- Certified technical performance.
- Environmental data (LCA, recycled content, emissions, etc.).
- Maintenance and care information.
- Estimated lifetime and warranty conditions.
- Normative references and certifications.
- Implementation constraints.
- Detailed geometric representation.

This data considerably enriches the BIM model and paves the way for the transition to the AIM phase, already incorporating essential information for future operation.

## 6.5.6 Managing variants and alternatives

In many cases, several products can satisfy the defined requirements. The Specific Object can then be broken down into main and alternative variants, each maintaining the link with the Generic Object from which it is derived. This approach makes it possible to:

- Maintain flexibility in technical choices right through to the advanced phases of the project.
- Anticipate supply by identifying fallback solutions.
- Optimize costs through competitive bidding.
- Adapt to emerging constraints during the project.

## 6.5.7 Preparing the transition to AIM

The Specific Object is the information base that will later feed the AIM (Asset Information Model). It already includes essential data for operation and maintenance:

- Precise references for future replacement.
- Maintenance procedures recommended by the manufacturer.
- Life expectancy of components.
- Consumables and spare parts required.
- Accessibility constraints for maintenance.

This anticipation of information needs during the operational phase contributes significantly to the continuity of information flow throughout the project's life cycle, a fundamental objective of ISO 19650 [4] standards.

## 6.5.8 Strategic position in the BIM process

The Specific Object is at the crossroads between design and realization in the PIM process. It marks the transition from a conceptual approach to a precise technical definition, enabling the procurement and prefabrication processes to be initiated. Its quality and completeness directly determine the efficiency of the construction and, later, operation phases.

# 6.6 The Role of the Specific Object in the AIM Phase

## 6.6.1 Transition from Specific Object to AIM

The Specific Object, defined in the PIM phase as the concrete technical solution meeting established requirements, plays a fundamental role when integrated into the AIM model. This transition marks a crucial point where the object, hitherto mainly oriented towards design and construction, becomes a central element of asset management.

## 6.6.2 AIM Information Foundation

The Specific Object provides AIM with a rich, structured information base comprising:

- The precise technical specifications of the installed product.
- Full manufacturer documentation (technical data sheets, certifications, warranties).
- The history of the design decisions that led to its selection.
- Traceability between initial requirements and actual performance.
- Implementation data (installation date, company, specific conditions).

This information forms the basis for the entire operation and maintenance phase.

### 6.6.3 Enrichment and Evolution in AIM

In the AIM phase, the Specific Object gradually enriched with new layers of information:

- Commissioning and start-up data.
- History of preventive and corrective maintenance operations.
- Performance and operating reports.
- Modifications and adaptations to the initial state.
- Incidents and malfunctions.

For connected objects, this evolution is particularly dynamic, with the continuous integration of data captured in real time, complementing static properties.

### 6.6.4 Maintenance Operations Support

The Specific Object in AIM provides essential support for maintenance operations:

- It provides precise information for identifying and locating equipment.
- It indicates the maintenance procedures recommended by the manufacturer.
- It provides access to compatible spare parts.
- It documents previous interventions, facilitating diagnosis.
- It establishes links with related systems impacted by the equipment.

This centralized information greatly optimizes the efficiency of maintenance teams.

### 6.6.5 Contribution to Performance Analysis and Decision Making

The data associated with the Specific Object in the AIM feeds into analyses of the asset's overall performance:

- Evaluation of total cost of ownership (acquisition, operation, maintenance).
- Reliability and failure rate analysis.
- Identify opportunities energy optimization.
- Planning future replacements and renovations.
- Comparison of expected and actual performance.

These analyses enable to make informed decisions on short-, medium- and long-term asset management strategies.

### 6.6.6 Preparing for Renewal and Evolution

At the end of the equipment's life cycle, the Specific Object in the AIM provides essential information to prepare for its renewal:

- Full feedback on use.
- Identification of product strengths and weaknesses.
- Changes in requirements since initial installation.
- New technologies available on the market.
- Constraints to be taken into account for replacement.

This process then feeds into the creation of a new Generic Object for the next cycle, bringing the complete information cycle full circle.

The Specific Object in AIM therefore represents much more than mere technical documentation: it constitutes a dynamic informational asset that evolves in parallel with the physical asset, optimizing its management throughout its operational life and effectively preparing for its future renewal.

## 6.7 Conclusion: Towards integrated, continuous information management

### 6.7.1 Overview of the BIM Object Lifecycle Approach

The study of object lifecycles in the context of ISO 19650 [4] standards reveal a profoundly transformed vision of information management in the construction sector. By following the evolution of an object from its initial conceptualization as a Generic Object Model, through its valorization as a Generic Object and its concretization as a Specific Object, to its potential integration as a connected object in an IOT ecosystem, highlighting an unprecedented informational continuum.

This global approach goes far beyond simple 3D modelling to embrace holistic design, where information becomes the common thread linking all phases of a structure's lifecycle.

### 6.7.2 Benefits an Integrated Approach

The methodology presented offers considerable advantages for all those involved in construction:

- For project owners: complete traceability from the expression of needs to operation, facilitating compliance control and cost optimization throughout the entire life cycle.
- For designers: a structured framework that clarifies requirements and facilitates the justification of technical choices, while preserving creativity in the search for solutions.
- For companies: precise, reliable information that reduces uncertainties during construction and minimizes rework and modifications.
- For managers: a rich information repository that facilitates the operation, maintenance and optimization of asset performance.
- For the entire value chain: a reduction in information loss and re-typing, major sources of inefficiency and errors.

### 6.7.3 Challenges

Despite its promise, this integrated approach raises several challenges that require special attention:

- Interoperability: ensuring the smooth exchange of data between different systems and platforms throughout the lifecycle.
- Information governance: clearly define responsibilities for data creation, validation and maintenance.
- Adaptability: designing information structures that are flexible enough to adapt to changing technologies and needs.
- Training and acculturation: developing the skills needed at all levels of the value chain to take full advantage of this approach.
- Security and confidentiality: protect sensitive data while facilitating its sharing between legitimate players.

## 6.7.4 Outlook

The future of this lifecycle approach promises to be rich in promising developments:

- Artificial intelligence: automated data analysis to identify optimizations and anticipate maintenance needs.
- Blockchain: unalterable traceability of information changes throughout its life cycle.
- Augmented reality: contextual visualization of information directly on site for maintenance operations.
- Advanced sensors: continuous enrichment of AIM with increasingly precise and diversified data.
- Digital Twins: convergence towards complete digital twins integrating physical, functional and behavioural aspects.

## 6.7.5 The New Horizon of Digital Construction

Ultimately, the object lifecycle approach based on ISO 19650 [4] standards represent not just a technical evolution, but a genuine paradigm shift. It redefines construction not simply as the realization physical structures, but as the creation and management of information assets that accompany these structures throughout their existence.

This holistic vision, by reconciling the project (PIM) and asset (AIM) dimensions, paves the way for a construction industry that is more efficient, more sustainable and better adapted to contemporary challenges. It is an essential lever for improving the productivity of a traditionally fragmented sector and optimizing the overall performance of the built environment over its entire lifecycle.

Mastering this informational continuity, from initial design connected operation, now represents a major strategic challenge for all players wishing to position themselves at the forefront of the digital transformation of the construction sector.

# 7 Data interoperability

## 7.1 Challenges

Interoperability is a regulatory requirement (see [i.4]).

However, a number of challenges remain before data interoperability becomes widespread in practice:

- Make users aware of the value of data interoperability.
- Work with the entire industry to establish dictionaries of properties of general interest (regulatory requirements, generic use cases such as DTU, standards, AT, quantities, BMS, etc.).
- Reconcile the numerous use implemented during the design, construction and operation phases.
- Make generic use compatible with shared semantics and specific use cases compatible with proprietary semantics using a common grammar.
- Produce property dictionaries, generic object model libraries and content catalogues in a universal format to encourage publishers to standardize input data for their applications.
- Publish an open-source connector for content databases in a universal format so that connector development can be shared.

## 7.2 The advantages

There are a number of advantages to developing and standardizing a format guarantees data interoperability with applications:

- Standardize input data in construction software to facilitate exchanges.

- Enrich objects as the project progresses, using systems engineering approach ensure digital continuity from design to operation of the building structure.
- Make digital exchanges common practice, whatever the applications used.
- Facilitate the production and use of digital content.
- Reduce digital content production and distribution costs.
- Control the carbon cost of digital content.
- Encourage competition and innovation.
- Reduce all forms of dependency.
- Apply interoperability.

### 7.3 The benefits of dynamic dictionaries for the specific use case of data exchange

The data exchange format remains operational, while responding to changing needs through the use of dynamic property dictionaries:

- Responding to the evolution of digital uses, while keeping data formats and the connectors that use them operational.
- Use existing standards to manage dynamic property dictionaries (see ISO 23386 [3]).
- Apply the use Cases, use Objects, Properties, modelled Objects (COPO) method to develop new digital use cases.
- Enable the use of multiple dictionaries produced by a multitude of communities, such as professional organizations or a community of project stakeholders, thanks to the agnostic nature of the opendthX format in terms of which dictionaries are used and where they are stored.

---

## 8 Complementarities and synergies between opendthX and SAREF for connected buildings

### 8.1 Introduction

This clause contains an overview of the SAREF4BLDG and the standard opendthX specifications, highlighting their similarities, including:

- the definition of any new concepts to be included in SAREF4BLDG to adequately cover the knowledge defined by opendthX;
- correspondence between SAREF4BLDG concepts and opendthX elements;
- patterns used to represent opendthX information using SAREF4BLDG.

This clause contains a summary of the SAREF4BLDG technical specification [7] defined as an extension to the SAREF which ontology was created on the basis of the Industry Foundation Classes (IFC) standard for building information. It should be noted that it is not the entire standard that has been transformed, as it exceeds the scope of this extension, which is limited to devices and appliances in the building domain.

SAREF4BLDG extension was developed in the context of an ETSI Technical Committee, using updated reference ontology models specified in ETSI TS 103 548 [5] to solve harmonization needs identified in ETSI TR 103 781 [i.16], with updated framework development tools defined in ETSI TS 103 673 [1]. ETSI TS 103 410-3 [7] has been developed in the context of an SmartM2M ETSI Technical Committee set up to provide SAREF Core V2 and extend SAREF id for the environment, buildings and energy domains. The IFC specification is developed and maintained by buildingSMART International as a "data" and standard since version IFC4, has been published as ISO 16739-1 [2]. SAREF4BLDG is intended to facilitate interoperability (currently lacking) between the various players (architects, engineers, consultants, contractors and manufacturers, among others) and applications managing building information involved in the different phases of the lifecycle of a building (planning and design, construction, commissioning, operation, renovation/refitting/reconfiguration, and demolition/recycling). Using SAREF4BLDG, intelligent devices from manufacturers that support the IFC data model will communicate easily with each other. To this end, SAREF4BLDG should be used to annotate (or generate) descriptions neutral device to be shared between different stakeholders.

SAREF4BLDG is an OWL-DL ontology that extends SAREF with 72 classes (67 defined in SAREF4EBLDG and 5 reused from the SAREF and geo ontologies), and 77 data type (76 properties defined in SAREF4EBLDG and 1 reused from the ontology SAREF). SAREF4BLDG focuses on extending the SAREF ontology to include devices defined by IFC version 4 -Addendum 1 [6] and to enable the representation of these and other physical objects in construction. The prefixes and namespaces used in SAREF4BLDG and in the present document are listed in Table 2.

**Table 2: Prefixes and namespaces used in the ontology SAREF4BLDG**

Prefix	Name space
base (s4bldg)	<a href="https://saref.etsi.org/saref4bldg/">https://saref.etsi.org/saref4bldg/</a>
saref	<a href="https://saref.etsi.org/core/">https://saref.etsi.org/core/</a>
owl	<a href="http://www.w3.org/2002/07/owl">http://www.w3.org/2002/07/owl</a>
prov	<a href="http://www.w3.org/ns/prov">http://www.w3.org/ns/prov</a>
rdf	<a href="http://www.w3.org/1999/02/22-rdf-syntax-ns">http://www.w3.org/1999/02/22-rdf-syntax-ns</a>
rdfs	<a href="http://www.w3.org/2000/01/rdf-schema">http://www.w3.org/2000/01/rdf-schema</a>
xsd	<a href="http://www.w3.org/2001/XMLSchema">http://www.w3.org/2001/XMLSchema</a>
dcterms	<a href="http://purl.org/dc/terms/">http://purl.org/dc/terms/</a>
vann	<a href="http://purl.org/vocab/vann/">http://purl.org/vocab/vann/</a>
xml	<a href="http://www.w3.org/XML/1998/namespace">http://www.w3.org/XML/1998/namespace</a>

Figure 4 shows an overview of the classes (only the upper levels of the hierarchy) and properties included in the extension SAREF4BLDG. As can be seen, the classes `s4bldg:Building`, `s4bldg:BuildingSpace` and `s4bldg:PhysicalObject` have been declared as subclasses of the `geo:SpatialThing` class in order to reuse the conceptualization of places already proposed by the geographic ontology. The modelling of building objects and spaces was adapted from the ontology SAREF; in addition, a new class was created, `s4bldg:Building`, to represent buildings.

The concepts `s4bldg:Building` and `s4bldg:BuildingSpace` are linked by the `s4bldg:hasSpace` and `s4bldg:isSpaceOf` properties, which are defined as inverse properties. These properties can also be used to declare that a `s4bldg:BuildingSpace` has other spaces belonging to the `s4bldg:BuildingSpace` class.

The relationship between building and spaces and devices and building objects has also been transferred and generalized from the ontology SAREF. In this respect, an `s4bldg:BuildingSpace` can contain (represented by the `s4bldg:contains` property) individuals belonging to the `s4bldg:PhysicalObject` class. This generalization has been implemented to allow building spaces to contain both building devices and objects. Consequently, classes `s4bldg:BuildingObject` and `saref:Device` are declared as subclasses of `s4bldg:PhysicalObject`.

Finally, the class representing building devices `s4bldg:BuildingDevice`, is defined as a subclass of `saref:Device` and `s4bldg:BuildingObject`. This class is likely to replace the `saref:BuildingRelated` class.

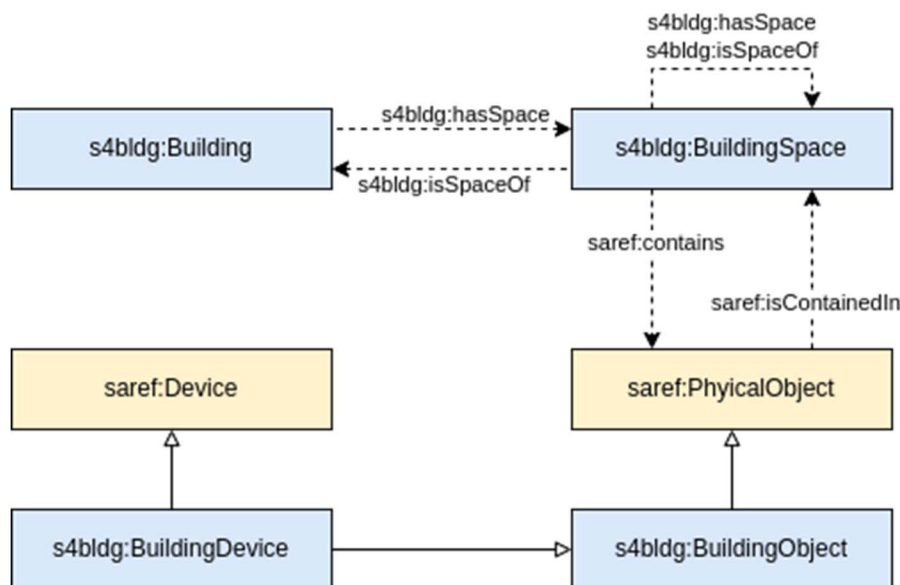

Figure 4: Overview of the upper levels of the SAREF4BLDG extension

## 8.2 SAREF4BLDG Example

Below, it is provided an example about how SAREF4BLDG can be used to describe a building and a corresponding set of elements included in it.

```

@prefix : <https://saref.etsi.org/saref4bldg/v1.1.2/example/example1BLDG/> .
@prefix owl: <http://www.w3.org/2002/07/owl#> .
@prefix rdf: <http://www.w3.org/1999/02/22-rdf-syntax-ns#> .
@prefix xml: <http://www.w3.org/XML/1998/namespace> .
@prefix xsd: <http://www.w3.org/2001/XMLSchema#> .
@prefix prov: <http://www.w3.org/ns/prov#> .
@prefix rdfs: <http://www.w3.org/2000/01/rdf-schema#> .
@prefix saref: <https://saref.etsi.org/core/> .
@prefix s4bldg: <https://saref.etsi.org/saref4bldg/> .
@prefix s4ener: <https://saref.etsi.org/saref4ener/> .
@prefix dcterms: <http://purl.org/dc/terms/> .
@prefix geo: <http://www.w3.org/2003/01/geo/wgs84_pos#> .
@prefix time: <http://www.w3.org/2006/time#> .
@prefix wurvoc: <http://www.wurvoc.org/vocabularies/om-1.8/> .
@prefix dctype: <http://purl.org/dc/dcmitype/> .
@base <https://saref.etsi.org/saref4bldg/v1.1.2/example/example1BLDG/> .

<https://saref.etsi.org/saref4bldg/v1.1.2/example/example1BLDG#> a dctype:Dataset ;
  dcterms:creator <http://purl.org/net/mpoveda> ,
    <http://www.garcia-castro.com/foaf.rdf#me> ;
  dcterms:license <https://forge.etsi.org/etsi-software-license> ;
  dcterms:conformsTo <https://saref.etsi.org/saref4bldg/v1.1.2/> ;
  dcterms:conformsTo <https://saref.etsi.org/saref4ener/v1.1.2/> ;
  dcterms:title "Example of use for the SAREF extension for building devices"@en ;
  dcterms:description "Example of use for the SAREF extension for building devices"@en .

geo:SpatialThing a owl:Class .
geo:long a owl:DatatypeProperty .
geo:lat a owl:DatatypeProperty .

:Compressor001SIERRA02-0434C3 rdf:type owl:NamedIndividual ,
  s4bldg:Compressor ;
  s4bldg:compressorSpeed :CompressorSpeedCompressor001SIERRA02-0434C3 ;
  s4bldg:idealCapacity :IdealCapacityCompressor001SIERRA02-0434C3 ;
  s4bldg:impellerDiameter :ImpellerDiameterCompressor001SIERRA02-0434C3
;

s4bldg:isContainedIn :RefrigerationStoreComputerScienceBuilding1 ;
s4bldg:nominalCapacity :NominalCapacityCompressor001SIERRA02-0434C3 ;
geo:location :LocationCompressor001SIERRA02-0434C3 ;
s4ener:exposes :PowerProfileCompressor001SIERRA02-0434C3 ;
s4bldg:hasHotGasBypass "false"^^xsd:boolean ;
s4bldg:powerSource "MotorDriven"^^xsd:string ;

```

```
s4bldg:refrigerantClass "HFC"^^xsd:string ;
saref:hasManufacturer "SIEMENS"^^xsd:string ;
rdfs:label "CompressorSIERRA02-0434C3"@en .
```

```
:CompressorSpeedCompressor001SIERRA02-0434C3 rdf:type owl:NamedIndividual ,
saref:Measurement ;
saref:isMeasuredIn :cyclesPerSecond ;
saref:hasValue "3.0"^^xsd:float ;
rdfs:label "Compressor speed of compressor001 SIERRA02-
0434C3"@en .
```

```
:ComputerScienceBuilding1 rdf:type owl:NamedIndividual ,
s4bldg:Building ;
geo:location :LocationComputerScienceBuilding1 ;
rdfs:label "Computer Science Building 1"@en .
```

```
:IdealCapacityCompressor001SIERRA02-0434C3 rdf:type owl:NamedIndividual ,
saref:Measurement ;
saref:isMeasuredIn wurvoc:watt ;
saref:hasValue "1800.0"^^xsd:float ;
rdfs:label "Ideal capacity of compressor001 SIERRA02-
0434C3"@en .
```

```
:ImpellerDiameterCompressor001SIERRA02-0434C3 rdf:type owl:NamedIndividual ,
saref:Measurement ;
saref:isMeasuredIn wurvoc:inch-international ;
saref:hasValue "5.9"^^xsd:float ;
rdfs:label "Impeller diameter of compressor001
SIERRA02-0434C3"@en .
```

```
:LocationCompressor001SIERRA02-0434C3 rdf:type owl:NamedIndividual ,
geo:SpatialThing ;
geo:lat "40.405155" ;
geo:long "-3.839203" ;
rdfs:label "Location of compressor001 SIERRA02-0434C3"@en .
```

```
:LocationComputerScienceBuilding1 rdf:type owl:NamedIndividual ,
geo:SpatialThing ;
geo:lat "40.405013" ;
geo:long "-3.839349" ;
rdfs:label "Location of Computer Science Building 1"@en .
```

```
:LocationRefrigerationStoreComputerScienceBuilding1 rdf:type owl:NamedIndividual ,
geo:SpatialThing ;
geo:lat "40.405152" ;
geo:long "-3.839209" ;
rdfs:label
"LocationRefrigerationStoreComputerScienceBuilding1"@en .
```

```
:NominalCapacityCompressor001SIERRA02-0434C3 rdf:type owl:NamedIndividual ,
saref:Measurement ;
saref:isMeasuredIn wurvoc:watt ;
saref:hasValue "680.0"^^xsd:float ;
rdfs:label "Nominal capacity of compressor001 SIERRA02-
0434C3"@en .
```

```
:PowerCompressor001SIERRA02-0434C3 rdf:type owl:NamedIndividual ,
saref:Measurement ;
saref:isMeasuredIn wurvoc:watt ;
saref:hasValue "902.0"^^xsd:float ;
rdfs:label "Power of compressor 001 SIERRA02-0434C3"@en .
```

```
:PowerProfileCompressor001SIERRA02-0434C3 rdf:type owl:NamedIndividual ,
s4ener:PowerProfile ;
rdfs:label "Power profile of compressor 001 SIERRA02-
0434C3"@en .
```

```

:RefrigerationStoreComputerScienceBuilding1 rdf:type owl:NamedIndividual ,
                                              s4bldg:BuildingSpace ;
                                              s4bldg:isSpaceOf :ComputerScienceBuilding1 ;
                                              geo:location
:LocationRefrigerationStoreComputerScienceBuilding1 ;
                                              rdfs:label "Refrigeration store of Computer Science
Building 1"@en .

:cyclesPerSecond rdf:type owl:NamedIndividual ,
                        saref:UnitOfMeasure ;
                        rdfs:label "cycles per second"@en .

wurvoc:inch-international rdf:type owl:NamedIndividual ,
                                  saref:UnitOfMeasure ;
                                  rdfs:label "inch international"@en .

wurvoc:watt rdf:type owl:NamedIndividual ,
                  saref:PowerUnit .

```

The example shows how SAREF4BLDG can be used as an interoperability layer to represent building content databases and to expose different type of information within an operational environment. 5 shows an abstract overview of an interoperability framework enabling the alignment between SAREF4BLDG and opendthX and the retrieval of building data produced through these two formats. The yellow block represents the whole content database of building elements. Such elements can be instantiated in three different ways: "Building Model" (i.e. geometric information about buildings), "Building Data" (i.e. property-wise information of a building), and "IoT Smart Data" (i.e. information related to the smart devices installed within a building and the associated data generated by them). Then, the green block represents the API service able to return data by using a data format that is compliant with both SAREF4BLDG and opendthX.

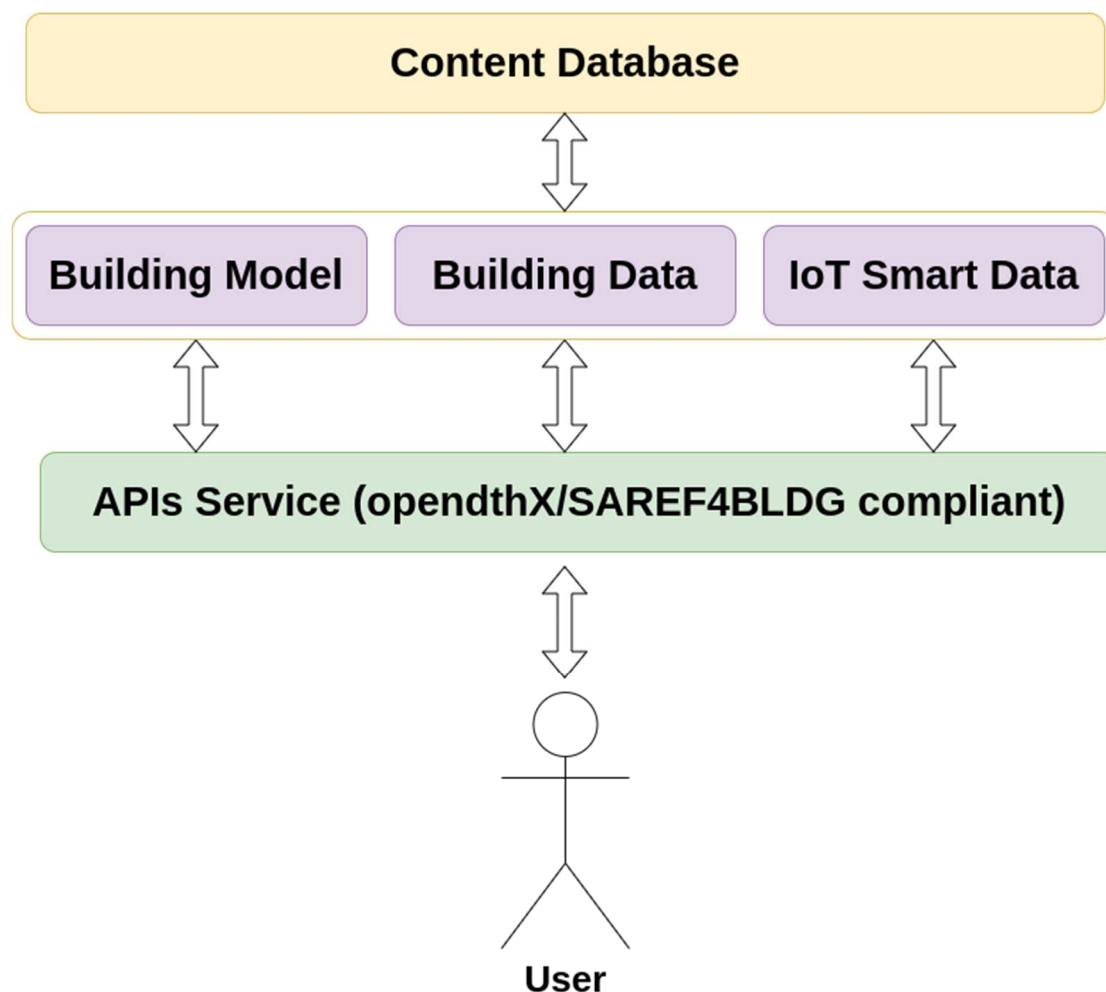

Figure 5

## 9 Semantic, organizational and technical interoperability

### 9.1 Semantic interoperability: The COPO method

Semantic interoperability is based on the shared use of property dictionaries.

ISO 23386 [3] covers this subject for construction.

The COPO method (Figure 6 aims to determine the semantics required to handle a pre-defined use case).



**Figure 6**

A use case could be formulated as follows: "*In the context of ....., as ....., I would like actors such as customers, prospects or prescribers to be able to .....*".

Links to property reference systems produced by the industry for targeted use cases:

- POBIM (Specification: DCE): <https://bit.ly/3paoKXA>.
- FEDENE (Documentation: DOE tertiary & industry): <https://bit.ly/3vFlgil>.
- Atelier BIM virtuel (APS-APD-PRO-DOE Multi-family housing): <https://bit.ly/3c8Xvap>.
- PCBIM (planning permission): <https://vu.fr/cseH>.

### 9.2 Organizational interoperability: CIQO process

This concept refers to the way in which stakeholder organizations on a construction project align their business processes, responsibilities and expectations to achieve mutually agreed objectives. In practice, organizational interoperability involves documenting and integrating or harmonizing business processes and the relevant information exchanged. Organizational interoperability also aims to meet the requirements of the user by making services available, easily identifiable, accessible and user-centric.

To enable different project organizations to work together effectively to deliver better services, it may be necessary to harmonize their existing business processes or even define and implement new ones. Harmonizing business processes means documenting them, in a concerted manner and according to commonly accepted modelling techniques, including the information exchanged, so that all organizations contributing to service delivery can understand the overall business process and the role they play in it.

To ensure optimal organizational interoperability, organizational relationships, and particularly those between service providers and their users, need to be clearly established.

The Collaboration In Quality Out (CIQO) process enables a stakeholder to contribute to the digital model of the structure (digital twin) described in IFC format, by enriching the objects with structured data using the opendthX JSON V3.0 API REST.

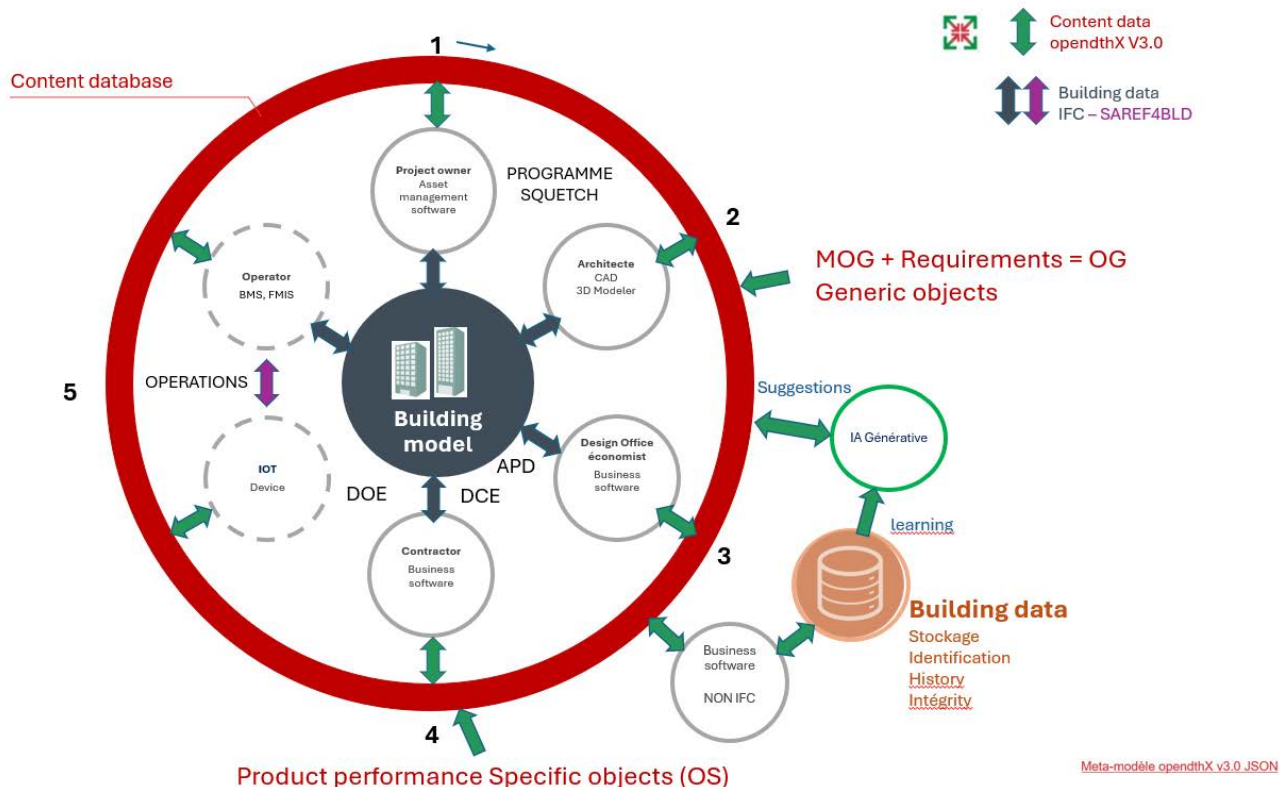

Figure 7

Example of a model production process (Figure 8) for the building model containing information useful for the use case the technical control mission (Award-winning project for the French government's BIM 2022 plan).

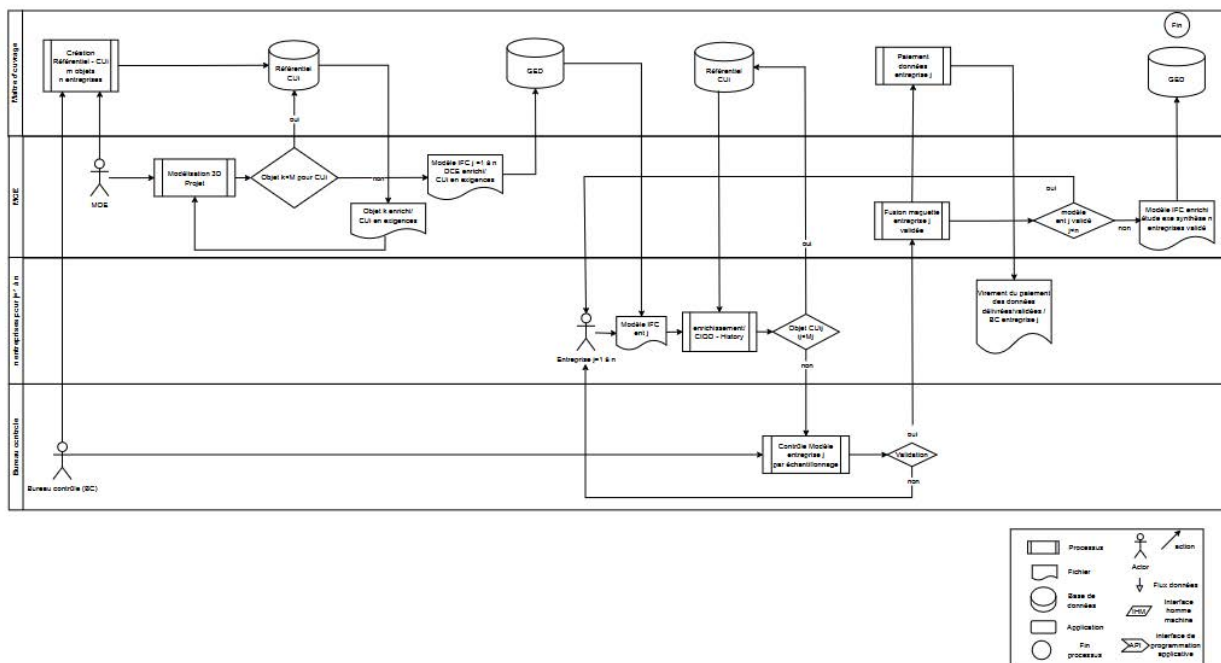

Figure 8

## 9.3 Technical interoperability

### 9.3.1 Language construction

A language has 2 components:

- Vocabulary that defines the meaning of words.
- Grammar, which defines the order of words in a sentence, giving meaning to sentences.

Technical interoperability can be likened to language grammar, just as semantic interoperability can be likened to vocabulary.

In the construction industry, the efficient exchange information between different players has become a major issue for the success of projects. Over time, several exchanges have emerged and continue evolve to meet the growing need for collaboration and interoperability.

### 9.3.2 IFC files: a first revolution in construction

Even before the widespread adoption of XML, the Industry Foundation Classes (IFC) format marked a crucial step in the standardization of data exchange in the construction sector. Developed by buildingSMART International in the 1990s, IFC has become an international standard (ISO 16739-1 [2]) for Building Information Modeling (BIM) data exchange.

### 9.3.3 IFC files have several essential characteristics:

- Independence from software publishers: The IFC format enables the exchange of data between different software programs, whatever their origin.
- Full description: An IFC file can contain all the information about a building, from its geometry to the properties of its components.
- Hierarchical organization: Data is structured according to a hierarchy reflecting building's physical and functional organization.

Although revolutionary in its day, the IFC format has certain limitations, notably in terms of content description, file size and interpretation complexity, which have led to the exploration of other exchange formats.

### 9.3.4 File-based exchange: from XML to JSON-LD

Following the emergence of IFC files, the exchange information between those involved in construction also took place via eXtensible Markup Language (XML) files. This format has been favoured because of its hierarchical structure, adapted to complex building and civil engineering data, and its greater flexibility compared with the IFC format. These files, which are often voluminous, contain all the information relating to a project or a collection of construction objects.

However, the industry is now moving towards JavaScript Object Notation for Linked Data (JSON-LD), which offers several significant advantages:

- Greater readability: JSON-LD is easier to read and interpret than XML, for both humans and machines.
- Reduced size: JSON-LD files are generally lighter than their XML equivalents.
- Contextualization: Linked Data allows to define a semantic context for your data.

JSON-LD's major advantage lies in its ability to reference external data recognized by the business. This functionality is essential in an industry where standardization of information is crucial to ensure uniform understanding among all stakeholders. For example, a structural element can be defined according to shared industry standards and references, guaranteeing its correct interpretation by all those involved in the project.

### 9.3.5 API exchanges: fluidity and responsiveness

The second, more recent and growing strategy is to exchange data via APIs (Application Programming Interfaces), in particular REST APIs. This approach is characterized by:

- More frequent exchanges: Communications are more frequent, enabling near real-time updates.
- Shorter messages: Unlike large files, APIs transmit targeted, precise information.
- Improved responsiveness: changes are quickly communicated to all stakeholders.

In this paradigm, the computer systems of the various participants communicate directly with each other, without requiring human intervention for each exchange. An architect can modify a building component, and this modification is automatically transmitted to the structural engineer or manufacturer concerned.

As with JSON-LD, it is essential that APIs refer to external data recognized by the business. This requirement ensures that all systems "speak the same language" and correctly interpret the information exchanged.

### 9.3.6 Converging and complementary approaches

These different strategies are not mutually exclusive, but rather complementary. Modern construction projects often feature:

- The use of IFC files for exchanges between different BIM design software.
- The use of JSON-LD for massive information transfers to a wide variety of systems.
- API integration for regular updates and one-off modifications.

This combination makes it possible to optimize information flows according to the specific needs of each stage of the project and the capabilities of the various players involved.

### 9.3.7 Future prospects

The evolution exchange strategies in the construction sector is moving towards ever greater integration of digital technologies, making it possible to anticipate the following scenarios:

- The development a new generation of lighter, more flexible IFC formats.
- The emergence semantic APIs that natively integrate references to business ontologies.
- The creation of collaborative platforms that centralize exchanges while respecting the access rights of each participant.
- The growing integration of blockchain technologies to guarantee the traceability and authenticity of exchanged data.

These advances will contribute to a more fluid exchange information between the various players in the construction industry, leading to improved project quality and reduced lead times and costs.

The transition of exchange formats from IFC and XML files to more modern formats such as JSON-LD, combined with the growing use of APIs, represents a major evolution in the construction sector. This digital transformation, based on shared business references significantly improves collaboration between the various players and optimizes the life cycle of construction projects.

To improve competitiveness, industry professionals can now integrate these new exchange strategies into their daily practices and anticipate future developments in these technologies, while preserving compatibility with established standards such as IFC, which remain essential in the BIM ecosystem.

## 9.3.8 Conclusion / opendthX meta-model

### 9.3.8.1 opendthX metamodel JSON v3.0

#### 9.3.8.1.1 Schema:

The opendthX metamodel JSON V3.0 is currently used by datBIM in version 3.0 of the JSON REST API illustrated in Figure 9.

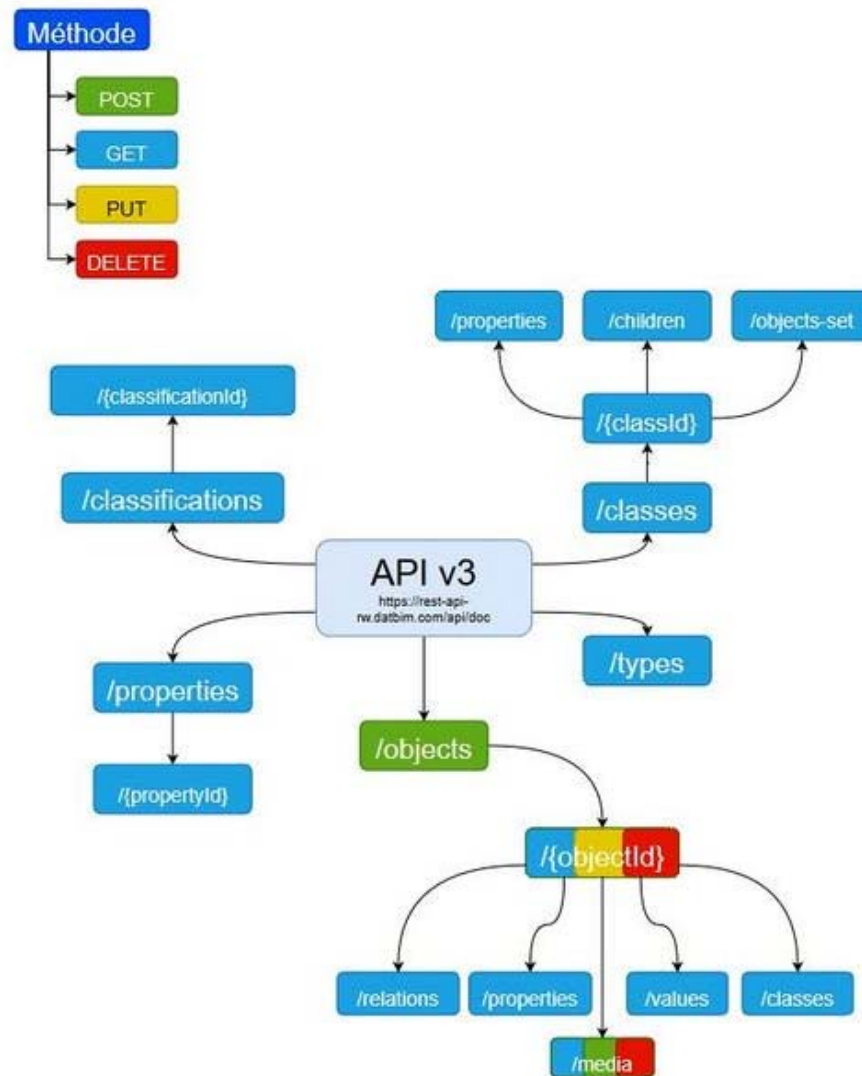

Figure 9

API documentation is available at: <https://rest-api-rw.datbim.com/api/doc>.

#### 9.3.8.1.2 Description of the datBIM v3 API

##### Introduction

The datBIM REST v3 API (accessible via <https://rest-api-rw.datbim.com/api/doc>) is a programmatic interface for interacting with the datBIM platform. This API follows the principles of REST architecture and offers a set of entry points for managing Building Information Modelling (BIM) data. It enables the manipulation of classifications, classes, properties and objects through a well-defined hierarchical structure.

## General architecture

The API is structured around a central point (API v3) which branches out into several main branches, each representing a specific functional area. This organization enables intuitive and logical navigation through the various resources available.

## HTTP methods supported

The API supports the four standard HTTP methods, based on Create, Read, Update, Delete (CRUD) principles:

- POST (shown in green): Creation of new resources.
- GET (shown in blue): Retrieving existing information.
- PUT (shown in yellow): Update existing resources.
- DELETE (shown in red): Deleting resources.

## Main entry points

### 1) Classifications (/classifications):

This entry point provides access to the various classifications available in the system. Classifications are an organizational system for categorizing BIM objects.

- /classifications: Management of the list of available classifications.
- /classificationId: Access to the details of a specific classification via its identifier.

### 2) Classes (/classes):

Classes represent categories of objects with common properties.

- /classes: Management of the list of available classes.
- /classId: Access to the details of a specific class.

From a specific class, several sub-resources are accessible:

- /classId/properties: Management of properties associated with this class.
- /classId/children: Access to sub-classes (children).
- /classId/objects-set: Management of all the objects belonging to this class.

### 3) Types (/types):

This entry point manages the different types of data in the system.

- /types: Access to available types.

### 4) Properties (/properties):

Properties define the characteristics that can be associated with objects or classes.

- /properties: Management of the list of available properties.
- /propertyId: Access to the details of a specific property.

### 5) Objects (/objects):

The entry point dedicated to objects is one of the core functionalities of the API, enabling complete management of BIM objects.

- /objects: Creation and retrieval of objects.

For a specific object, identified by its ID, several operations and sub-resources are available:

- /objectId: Access, modify and delete a specific object.

In addition, each object has several sub-entry points:

- /objectId/relations: Manage the object's relationships with other objects.
- /objectId/properties: Accessing and modifying the object's properties.
- /objectId/values: Manages the values associated with the object.
- /objectId/classes: Manipulate the classes associated with the object.
- /objectId/media: Manage media files associated with the object.

### Typical use cases

Creating and managing BIM objects.

The API allows to create BIM objects, assign properties to them, associate them with classes and define their relationships with other objects. For example:

- 1) Create a new object (POST/objects).
- 2) Assign properties to it (POST/objectId/properties).
- 3) Associate it with a specific class (POST/objectId/classes).
- 4) Define its relationships with other objects (POST/objectId/relations).
- 5) Add associated media (POST/objectId/media).

Navigating the classification hierarchy.

The API allows to navigate through the hierarchy of classifications and classes to understand the organization of BIM data:

- 1) Retrieve the list of classifications (GET/classifications).
- 2) Access a specific classification (GET/classificationId).
- 3) Explore the associated classes (GET/classes).
- 4) Examine the sub-classes of a specific class (GET/classId/children).

### Conclusion

The datBIM API v3 offers a complete and structured interface for managing BIM data. Its hierarchical design and adherence to REST principles make it easy to use for developers wishing to integrate BIM functionality into their applications. Multiple entry points and support for CRUD operations enable flexible and powerful manipulation of the system's various resources.

The opendthx.org connector is released as open source: <https://github.com/alliance-batiment/Open-dthX-web-app>. It is configured to process structured content stored in a database accessible via the datBIM v3.0 API REST JSON.

The following is a presentation of the class diagram (Figure 10) for a database model enabling object according to the opendthX v3.0 metamodel.

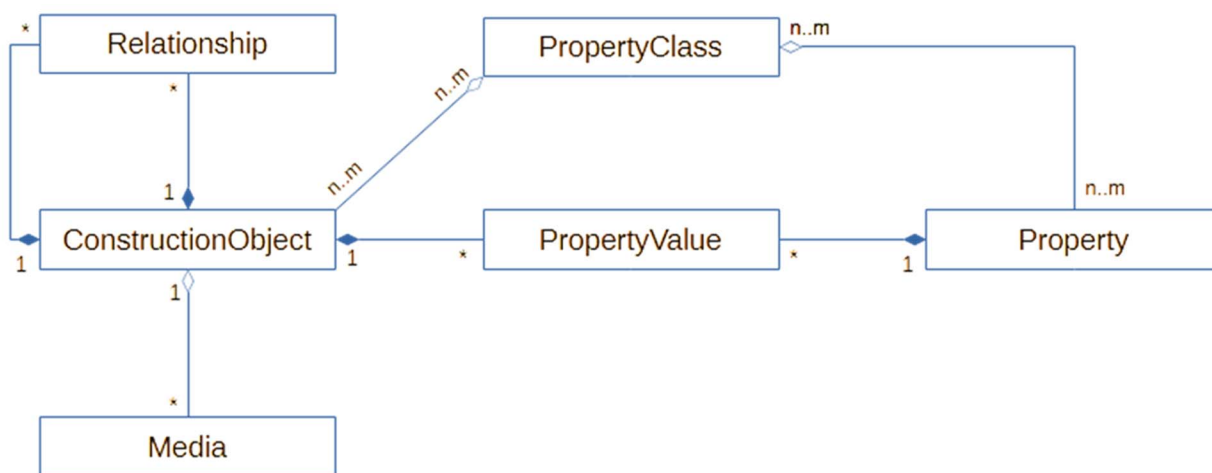

Figure 10

Legend:

- a) Multiplicity (cardinality): indicated at the ends of the associations using the following notation:
  - 1: exactly one occurrence
  - 0..1: zero or one occurrence (optional)
  - \* or 0..\*: zero to several occurrences
  - 1..\*: one to several occurrences
  - n..m: from n to m occurrences
- b) Types of association:
  - Simple association: continuous line between two classes
  - Aggregation: line with an empty diamond on the "container" class side
  - Composition: line with a solid diamond on the "container" class side
  - Inheritance: arrow with an empty triangle pointing to the parent class
  - Dependency: dotted arrow
- c) Association names: generally placed on the association line
  - May include roles at each end
  - Can indicate a direction with a navigation arrow
- d) Association classes: used when the association itself has attributes

The operational chain illustrating this interoperability using API REST is shown in Figure 10.

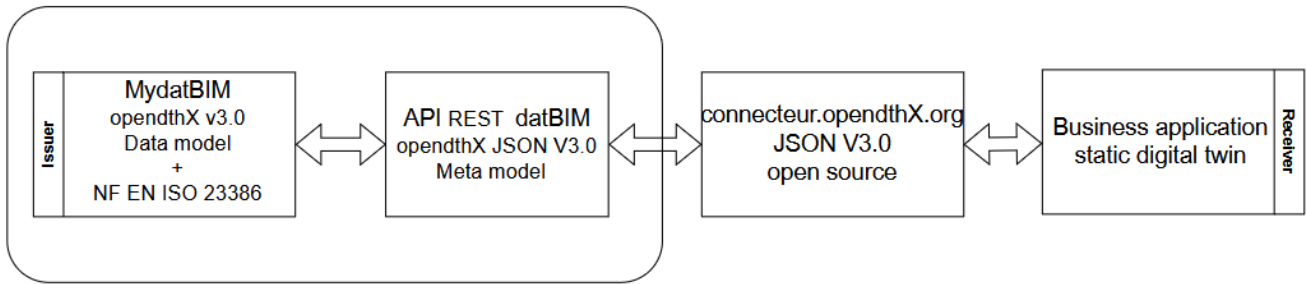

Figure 11

### 9.3.8.2 Open REST API of the opendthX JSON v4.0 meta model

Future developments will involve transposing the datBIM REST API v3.0 into an open REST API of the opendthX JSON v4.0 meta model in the form a software library translated into different languages such as C#, C++, Java, JavaScript, Kotlin or Python, to make it easier for developers to integrate it into their applications according to the following schema in Figure 12.

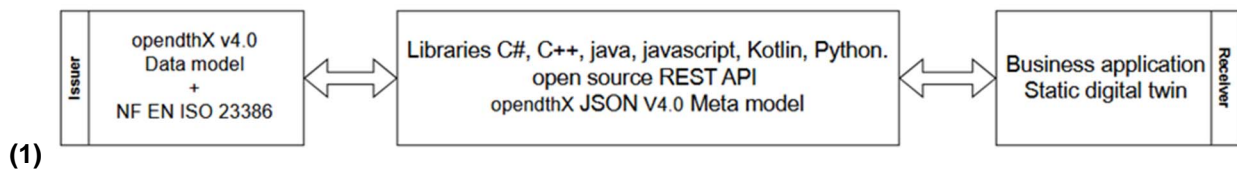

Figure 12

### 9.3.8.3 opendthX meta model similar JSON LD self-discoverable V1.0

A complementary action will consist in developing the opendthX meta-model, similar to JSON LD, which is self-discoverable in the form of a software library translated into different languages such as C#, C++, Java, JavaScript, Kotlin or Python according to the following schema in Figure 13 described in appendix B.

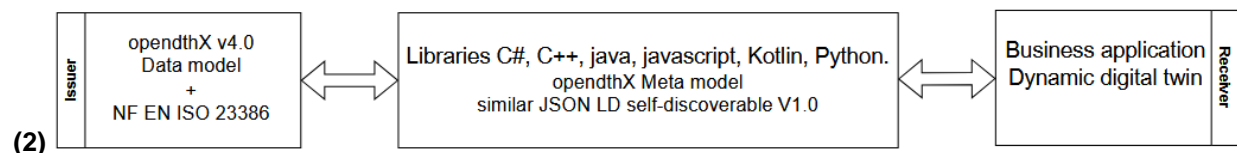

Figure 13

## 9.3.8.4 Summary diagram

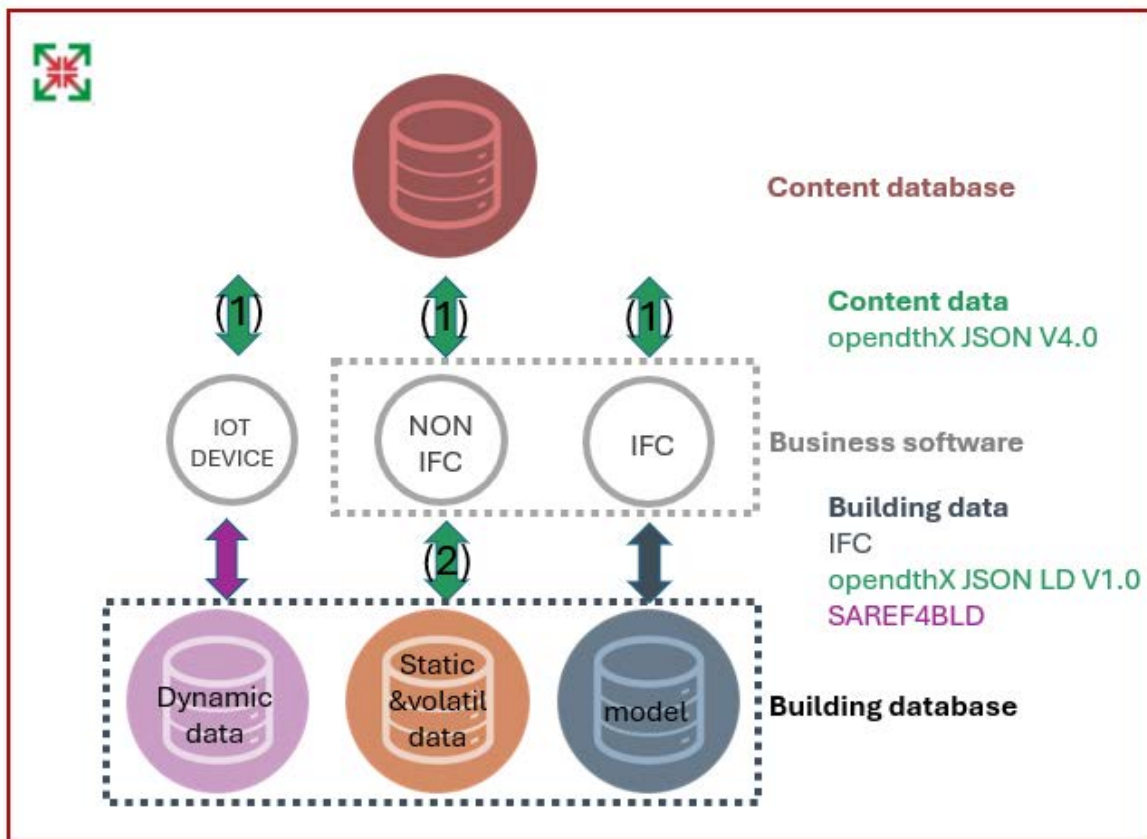

Figure 14

## 9.3.9 OpenCDE

openCDE is a Common Data Environment for interoperability in construction.

It consists of 3 application modules:

- LibreBIM.fr (Figure 15): open collaborative platform for sharing and organizing the construction process.



Figure 15

- CiQo.eu opensource viewer for editing digital mock-ups in IFC format and enriching objects with structured data accessible via the openthX V3.0 meta-model (Figure 16).



Figure 16

- BIM object repositories (alliance-batiment.MydatBIM.com: Figure 17) with structured data accessible via the openpdx V3.0 meta-model.

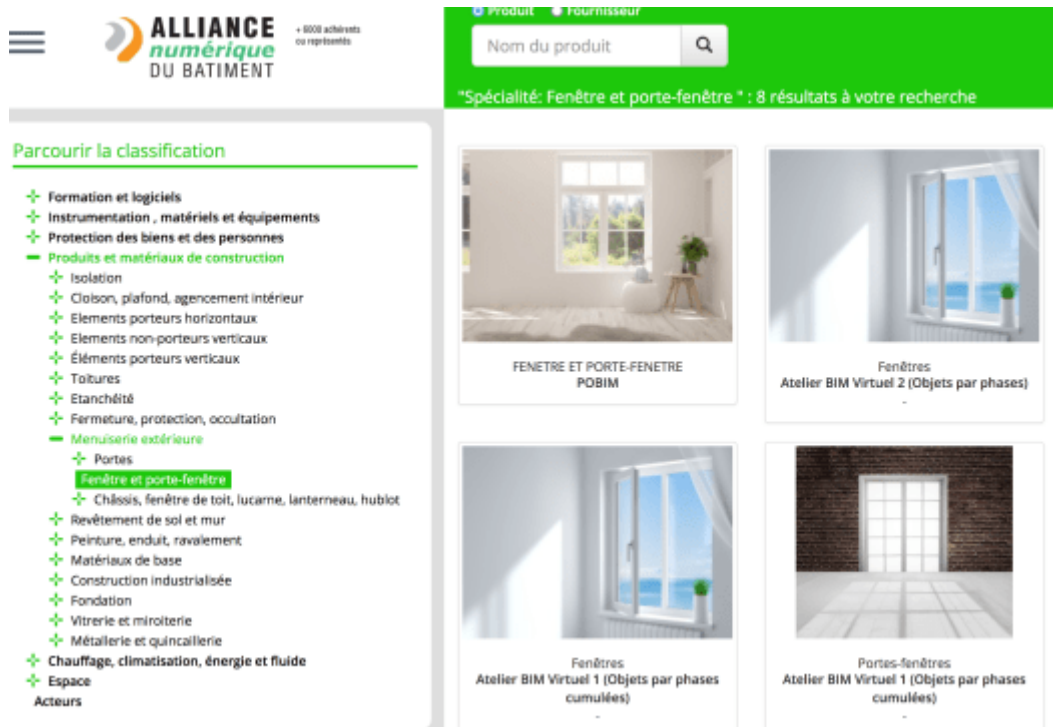

Figure 17

- On-line input forms (Figure 18) for filling in objects or generating BIM objects in open format with a simple browser.

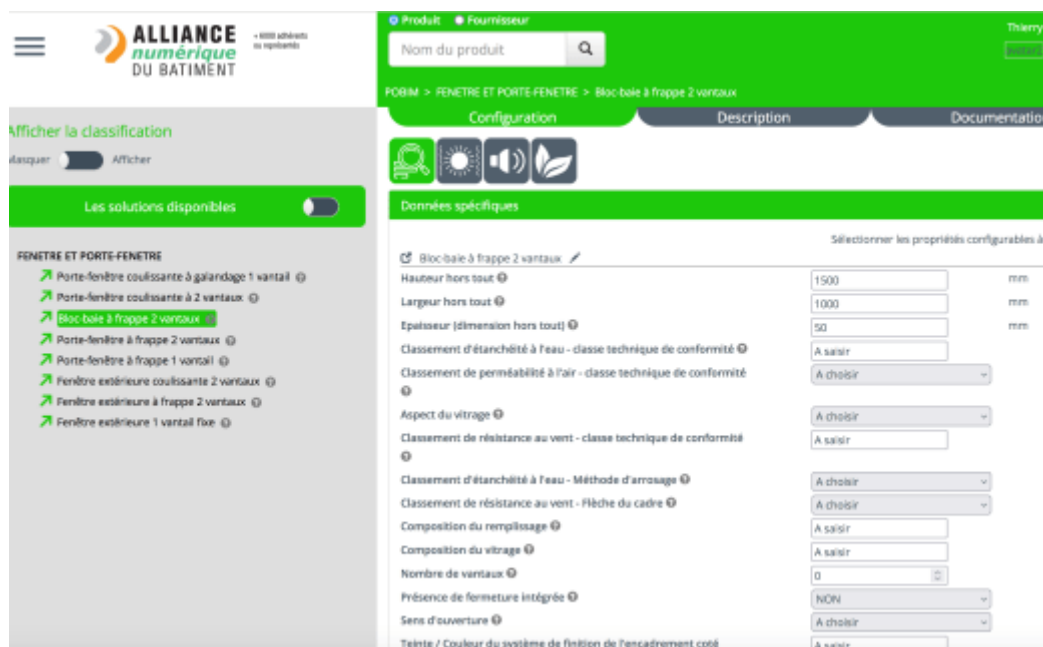

Figure 18

- Overview (Figure 19).

## Open CDE

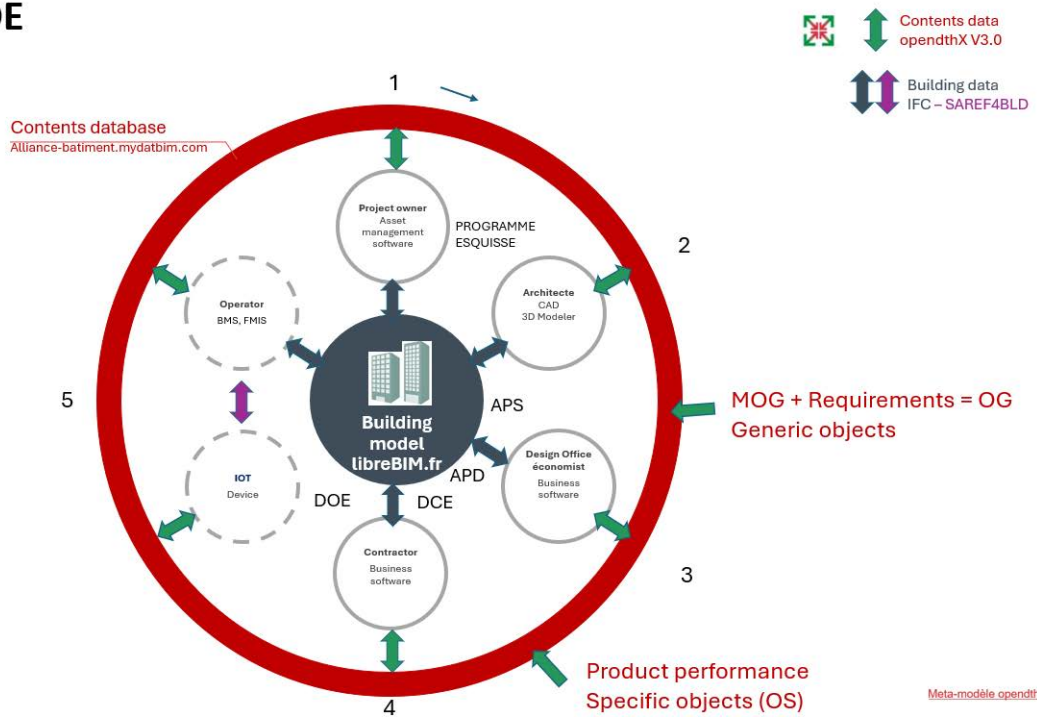

Figure 19

## Annex A (informative): Metamodel opendthX JSON-LD v1.0

The essence of what trusted linked Data Sources could mean for the building industry and the reason this should be explored in more depth.

The development of this common language opendthX enables the construction of a complete and comprehensive Digital Twin of any building. Such a comprehensive Digital Twin comprises multiple aspects, provided and controlled by different stakeholders, throughout the full lifecycle of the building. It is a collaborative process. At each step, the resources created at the previous step are re-used with linked data sources, rather than copying them. opendthX JSON-LD is instrumental in this. It transfers only the required data and makes the - in some cases permanent - link. Data sobriety is key. Single Source of Truth (SSoT). One uses all kinds of different Applications in the process, like AR Development Software, Model Development Software (BMS). Some, to build the Digital Twin, others to consult it, such as AR Glasses.

Those Data Sources, used or established in the process, can moreover be strengthened over time. On initiative of the provider or even on request by a user, who can ask to add Data for a certain Application he wants to use. The user can also add other Sources or can replace Data Sources or enlarge the Data Source of Building Data at the Building Server with data such as calculated instance values. opendthX JSON-LD is the language for building trustworthy comprehensive Digital Twins.

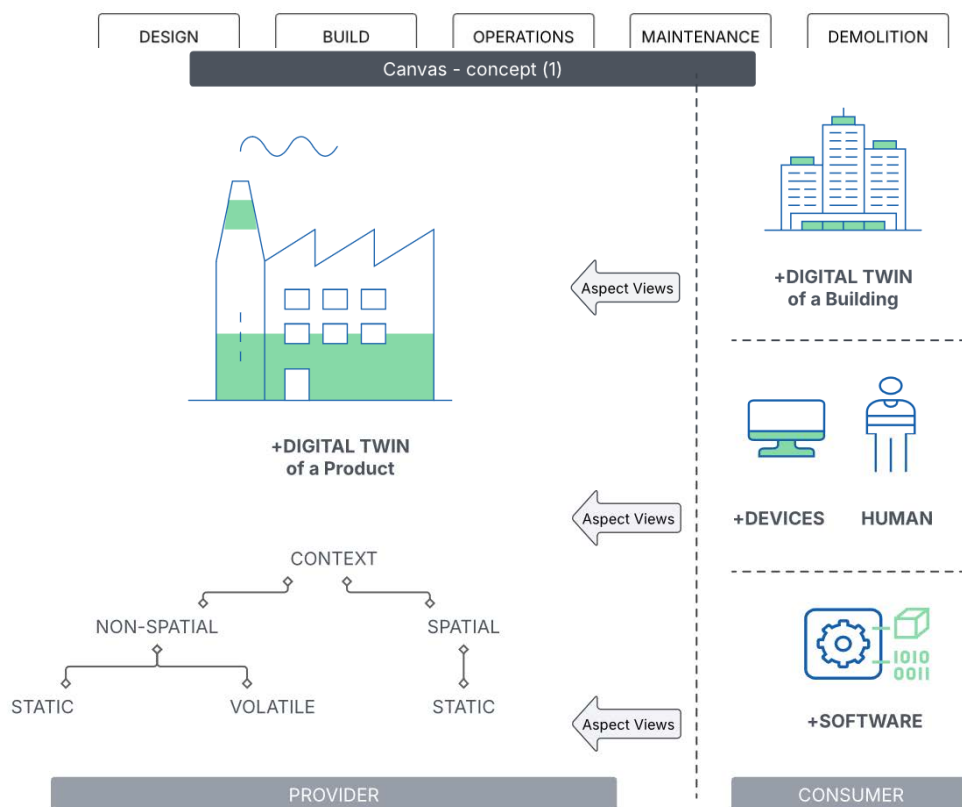
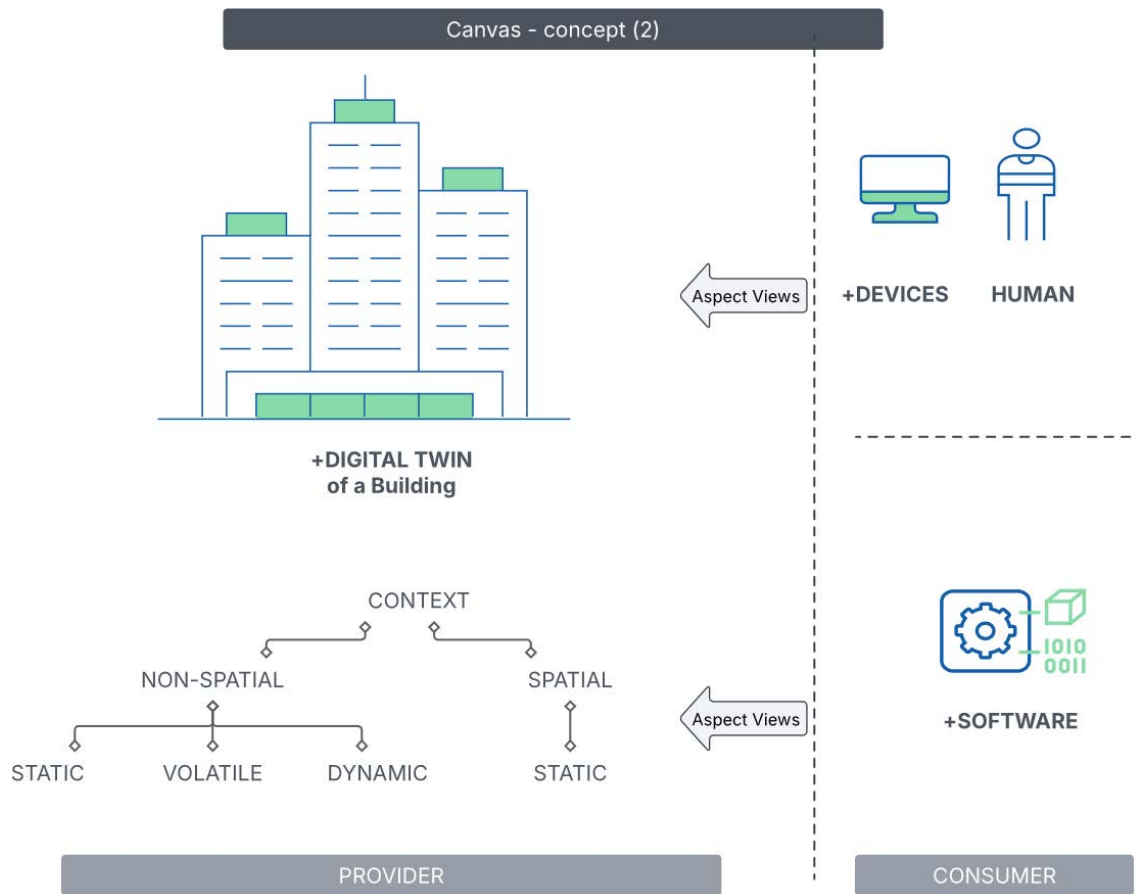

Figure A.1: In the design phase



**Figure A.2: In the operations phase**

NOTE: SAREF4Building is situated at the 'DYNAMIC' branch.



To illustrate some possible uses, here are some examples, taking into account 5 different data and definition sources:

#### Relationship

```
{
  "@context": {
    "FL2_PrD_S_1": "https://library_of_definitions_2.org/property_definitions/",
    "FL1_EnD_S_1": "https://entity_definitions.org/entity_definitions/",
    "FL2_ReD_S_1": "https://library_of_relationship_definitions_1.org/relationship_definitions",
    "DF1_DAT_S_1": "https://manufacturer_1.com/",
    "DF1_DAT_S_2": "https://manufacturer_2.com/"
  },
  "@id": "DF1_DAT_S_1:products/Product%201",
  "@type": "FL1_EnD_S_1:Product",
  "FL2_PrD_S_1:width": 100,
  "FL2_PrD_S_1:nameOfOwner": "Manufacturer 1",
  "FL2_ReD_S_1:isCompatibleWithProduct": {
    "@id": "DF1_DAT_S_2:products/Product%205",
    "FL2_PrD_S_1:weightOfTheRelationship": 3
  }
}
```

#### Relationship - digital - product - functional (instances - IoT)

```
{
  "@context": {
    "FL2_PrD_S_1": "https://library_of_definitions_2.org/property_definitions/",
    "FL1_EnD_S_1": "https://entity_definitions.org/entity_definitions/",
    "FL2_ReD_S_1": "https://library_of_relationship_definitions_1.org/relationship_definitions",
    "DF1_DAT_S_1": "https://manufacturer_1.com/",
    "DF1_DAT_S_2": "https://manufacturer_2.com/"
  },
  "@graph": [
    {
      "@id": "DF1_DAT_S_1:products/Product%201",
      "@type": "FL1_EnD_S_1:Product",
      "FL2_PrD_S_1:width": 100,
      "FL2_PrD_S_1:nameOfOwner": "Manufacturer 1",
      "FL2_ReD_S_1:hasProductInstance": [
        {"@id": "SmokeDetector1"},
        {"@id": "SmokeDetector2"}
      ]
    },
    {
      "@id": "SmokeDetector1",
      "@type": "FL1_EnD_S_1:ProductInstance",
      "FL2_PrD_S_1:room": "dressing",
      "FL2_PrD_S_1:internetOfThingsCommunicationPort": "coap://153.12.45.7",
    },
    {
      "@id": "SmokeDetector2",
      "@type": "FL1_EnD_S_1:ProductInstance",
      "FL2_PrD_S_1:room": "corridor",
      "FL2_PrD_S_1:internetOfThingsCommunicationPort": "coap://153.12.45.8",
    }
  ]
}
```

## Simple - Property third-party (1a)

```

{
  "@context": {
    "FL2_PrD_S_1": "https://library_of_definitions_2.org/property_definitions/",
    "FL1_End_S_1": "https://entity_definitions.org/entity_definitions/",
    "DF1_DAT_S_1": "https://manufacturer_1.com/",
    "DW1_DAT_V_2": "https://wholesaler_1.com/",
    "DW1_DAT_V_3": "https://wholesaler_2.com/",
    "prov": "http://www.w3.org/ns/prov#"
  },
  "@id": "DF1_DAT_S_1:products/Product%201",
  "@type": "FL1_End_S_1:Product",
  "FL2_PrD_S_1:width": 100,
  "FL2_PrD_S_1:nameOfOwner": "Manufacturer 1",
  "FL2_PrD_S_1:price": ["@DW1_DAT_V_2", "@DW1_DAT_V_3"]
}

{
  "@context": {
    "FL2_PrD_S_1": "https://library_of_definitions_2.org/property_definitions/",
    "FL1_End_S_1": "https://entity_definitions.org/entity_definitions/",
    "DF1_DAT_S_1": "https://manufacturer_1.com/",
    "DW1_DAT_V_2": "https://wholesaler_1.com/"
  },
  "@id": "DF1_DAT_S_1:products/Product%201",
  "@type": "FL1_End_S_1:Product",
  "prov:wasDerivedFrom": {
    "@id": "DW1_DAT_V_2",
    "@type": "prov:Entity",
    "prov:generatedAtTime": "2025-01-16T12:00:00Z",
    "prov:wasAttributedTo": "External Price Provider",
    "prov:properties": {
      "FL2_PrD_S_1:price": 150.00
    }
  }
}

```

## Annex B (informative): Schematics

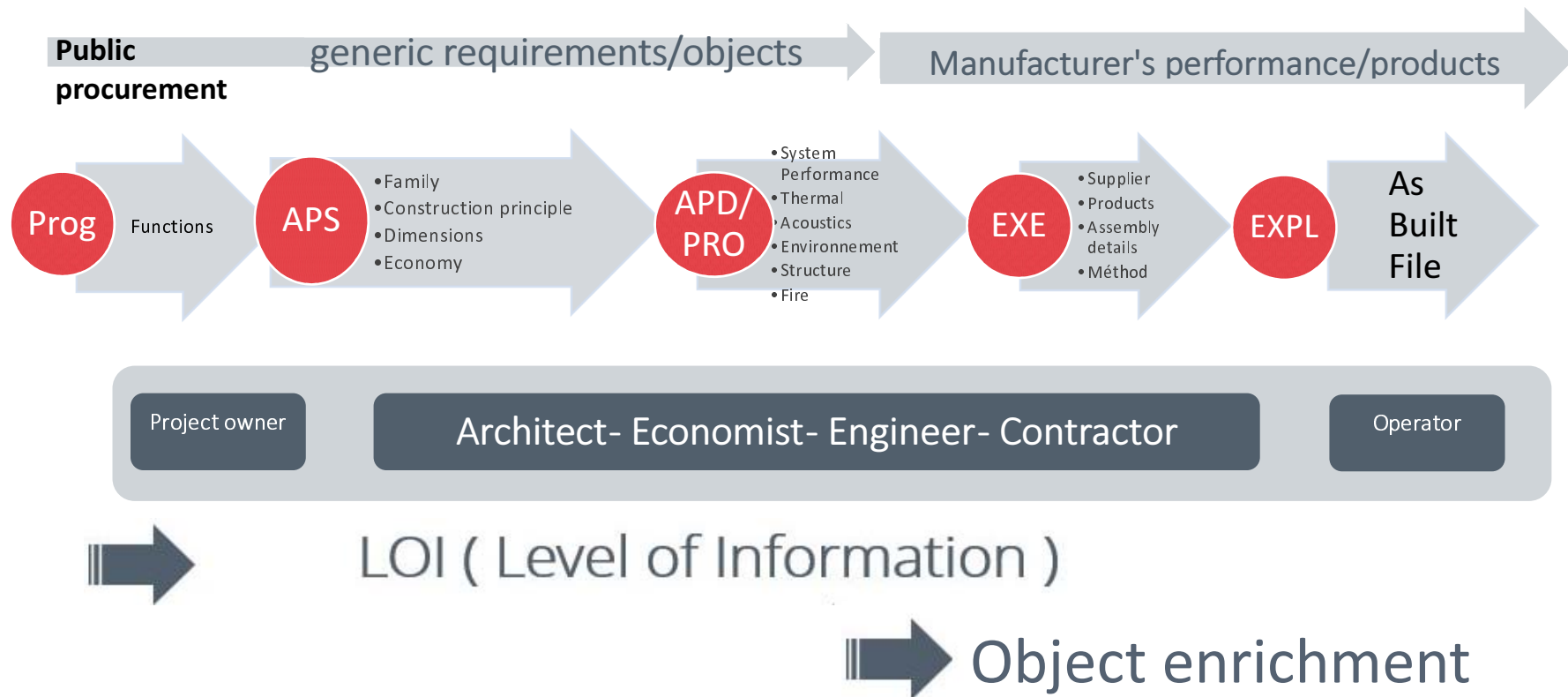
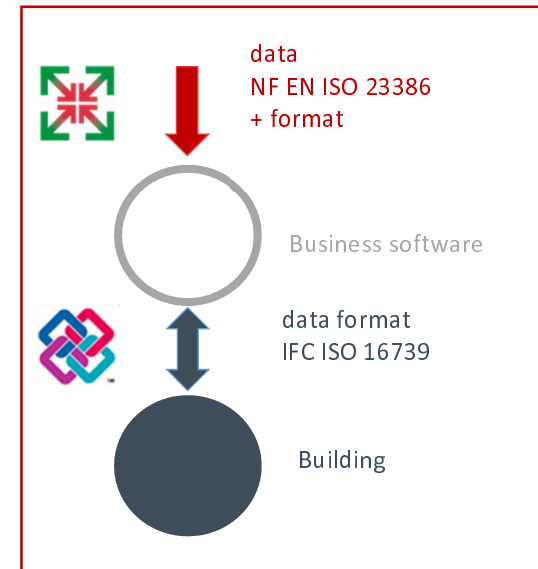
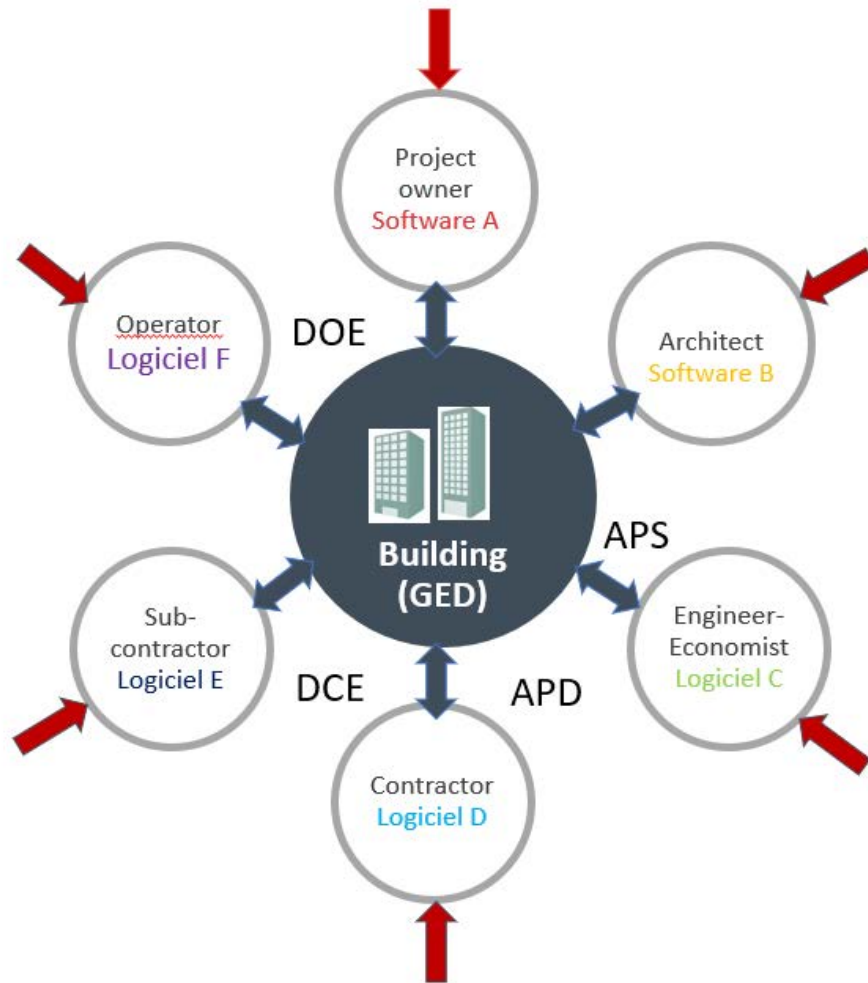

Figure B.1

# OPEN DATA-CENTRIME = CIQO



CIQO = Collaboration In → Quality Out

Figure B.2

## APP-CENTRISM = GIGO

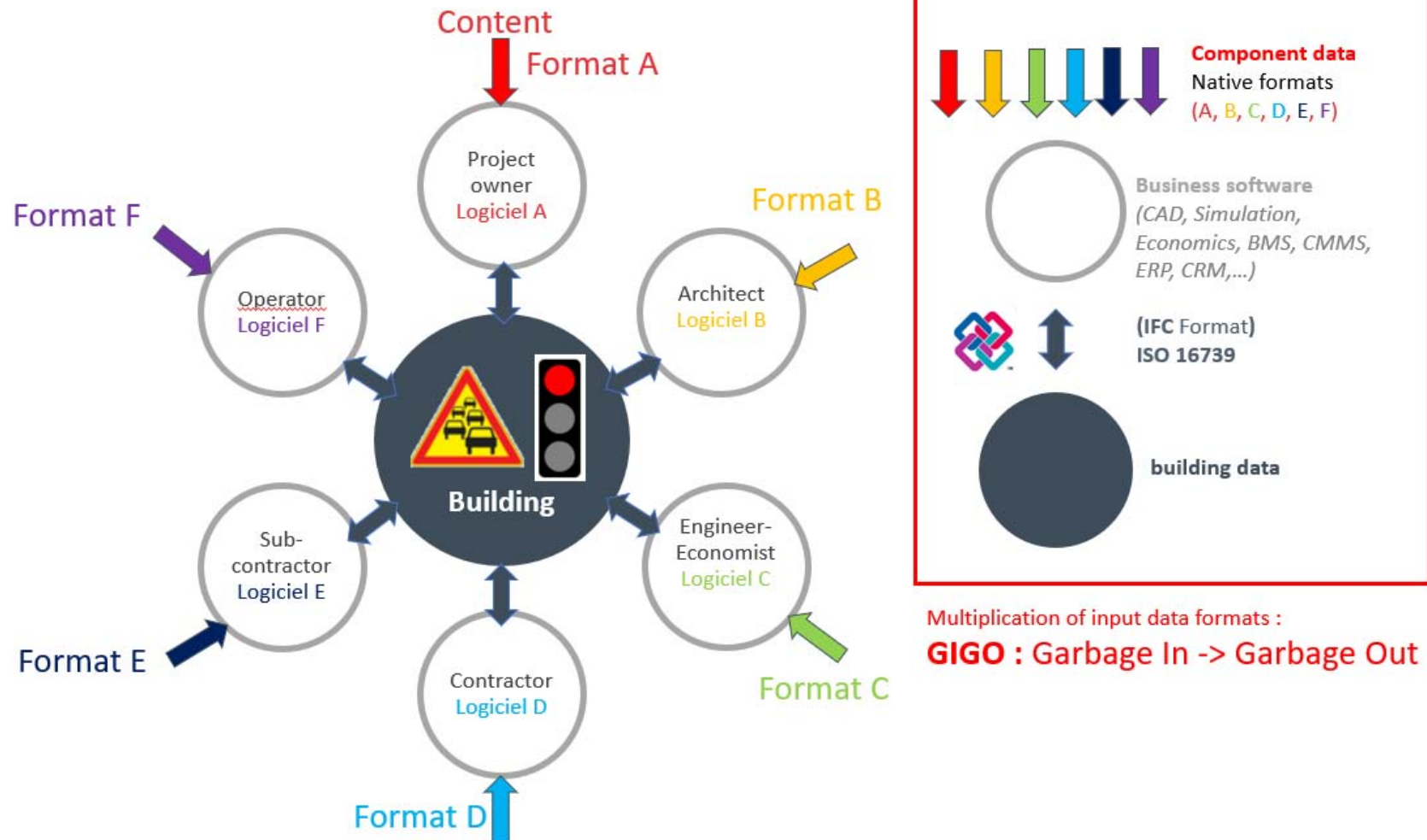

Figure B.3

---

## Annex C (informative): Bibliography

- [Regulation \(EU\) 2022/868](#) of the European Parliament and of the Council of 30 May 2022 on European data governance and amending Regulation (EU) 2018/1724.
- [Proposal for a Regulation of the European Parliament and of the Council on harmonised rules on fair access to and use of data.](#)
- [Report on the comparative cost estimate for the creation a technical database of digital mock-up components.](#)
- [General reference framework for interoperability \(CGRI\).](#)
- [Evaluation of the costs of interoperability borne by companies, project owners and operators in the construction and operation of buildings.](#)
- [CSTB study report showing the ability of the opendthX format to describe technical notices.](#)
- [Open format documentation.](#)
- [Entity-relationship model.](#)
- [Version 1.0 opendthX format.](#)
- [Version 1.5 opendthX format.](#)
- [POBIM deposit.](#)
- [ABV deposit.](#)
- [PCBIM repository.](#)
- [Open source opendthX connector.](#)
- [opendthX documentation.](#)
- [datBIM API documentation.](#)

---

## Annex E (informative): Change history

Date	Version	Information about changes
October 22, 2024	V0.0.1	Preliminary draft publication meeting 5 STF 687
October 23, 2024	V0.0.2	Preliminary draft publication meeting 6 STF 687
October 23, 2024	V0.0.3	Preliminary draft publication meeting 7 STF 687
March 25, 2025	V0.0.4	Stable draft publication meeting 20 STF 687
April 25, 2025	V0.0.5	Final draft publication meeting 23 STF 687
May 15, 2025	V0.0.9	Final draft for <b><i>editHelp!</i></b>

---

## History

<b>Document history</b>		
V1.0.0	August 2025	Membership Approval Procedure    MV 20251014: 2025-08-15 to 2025-10-14
V1.1.1	October 2025	Publication