



EUROPEAN
TELECOMMUNICATION
STANDARD

ETS 300 446

June 1996

Source: ETSI TC-RES

Reference: DE/RES-09012

ICS: 33.100, 33.060.20, 33.060.50

Key words: CT2, EMC, radio

**Radio Equipment and Systems (RES);
Electro-Magnetic Compatibility (EMC) standard
for second generation Cordless Telephone (CT2) apparatus
operating in the frequency band 864,1 MHz to 868,1 MHz,
including public access services**

ETSI

European Telecommunications Standards Institute

ETSI Secretariat

Postal address: F-06921 Sophia Antipolis CEDEX - FRANCE

Office address: 650 Route des Lucioles - Sophia Antipolis - Valbonne - FRANCE

X.400: c=fr, a=atlas, p=etsi, s=secretariat - **Internet:** secretariat@etsi.fr

Tel.: +33 92 94 42 00 - Fax: +33 93 65 47 16

*

Copyright Notification: No part may be reproduced except as authorized by written permission. The copyright and the foregoing restriction extend to reproduction in all media.

© European Telecommunications Standards Institute 1996. All rights reserved.

Contents

Foreword	5
1 Scope	7
2 Normative references	7
3 Definitions and abbreviations	8
3.1 Definitions	8
3.2 Abbreviations	9
4 General test conditions.....	9
4.1 Test conditions.....	9
4.2 Arrangements for test signals at the input of the transceiver	9
4.2.1 Speech equipment	9
4.3 Normal test modulation.....	10
4.4 Connection of test signals for transceivers	10
4.4.1 Radio Frequency (RF) connection	10
4.5 Connection of test signals for receiver-only equipment	10
4.5.1 RF connection	10
4.6 Receiver test signal level	10
4.7 Narrow band responses on receivers or receivers which are part of transceivers	10
4.8 Exclusion bands.....	11
4.8.1 Exclusion band for CT2 receivers and CT2 receiver parts of transceivers ...	11
4.8.2 Exclusion band for CT2 transmitter parts of transceivers	11
5 Performance assessment	11
5.1 General	11
5.2 Equipment classification	12
5.3 Ancillary equipment.....	12
5.4 Assessment of host connected equipment and plug-in cards	12
5.4.1 Alternative A: composite equipment.....	12
5.4.2 Alternative B: use of a test jig and three hosts	12
5.5 Performance assessment test procedure to verify no loss of user control functions or stored data for CT2 transceivers	13
5.6 Performance assessment of audio breakthrough.....	13
6 Performance criteria.....	14
6.1 Performance criteria for Continuous phenomena applied to CT2 Transceivers (CT)	15
6.2 Performance criteria for Transient phenomena applied to CT2 Transceivers (TT).....	15
6.3 Performance criteria for Continuous phenomena applied to CT2 Receive-only equipment (CR)	15
6.4 Performance criteria for Transient phenomena applied to CT2 Receive-only equipment (TR).....	15
7 Applicability overview tables.....	15
7.1 Emission	16
7.2 Immunity	16
8 Test methods and limits for emission tests of transceivers and/or receivers and/or ancillary equipment.....	17
8.1 Test configuration	17
8.2 Enclosure	17
8.2.1 Definition	17
8.2.2 Test method	17
8.2.3 Test limit	17
8.3 DC power input/output port	18

	8.3.1	Definition.....	18
	8.3.2	Test method.....	18
	8.3.3	Test limit	18
8.4		AC mains power input/output port.....	18
	8.4.1	Definition.....	18
	8.4.2	Test method.....	19
	8.4.3	Test limit	19
9		Test methods and levels for immunity tests of transceivers and/or receivers and/or ancillary equipment.....	19
9.1		Test configuration.....	19
9.2		Radio frequency electro-magnetic field (80 to 1 000 MHz)	20
	9.2.1	Enclosure.....	20
		9.2.1.1 Definition	20
		9.2.1.2 Test method and level.....	20
		9.2.1.3 Performance criteria.....	20
9.3		Electrostatic discharge	20
	9.3.1	Definition.....	20
	9.3.2	Test method and levels.....	20
	9.3.3	Performance criteria	21
9.4		Fast transients common mode.....	21
	9.4.1	Definition.....	21
	9.4.2	Test method and levels.....	21
	9.4.3	Performance criteria	21
9.5		RF common mode, 0,15 MHz to 80 MHz (current clamp injection)	22
	9.5.1	Definition.....	22
	9.5.2	Test method and level	22
	9.5.3	Performance criteria	22
9.6		Transients and surges, vehicular environment	23
	9.6.1	Definition.....	23
	9.6.2	Test method and level	23
	9.6.3	Performance criteria	24
9.7		Voltage dips and interruptions.....	24
	9.7.1	Definition.....	24
	9.7.2	Test method and levels.....	24
	9.7.3	Performance criteria	24
9.8		Surges, common and differential mode	25
	9.8.1	Definition.....	25
	9.8.2	Test method and levels.....	25
	9.8.3	Performance criteria	26
		History.....	27

Foreword

This European Telecommunication Standard (ETS) has been prepared by the Radio Equipment and Systems (RES) Technical Committee of the European Telecommunications Standards Institute (ETSI).

Other standards cover radio communications equipment not listed in the scope.

This ETS is based upon the Generic Standards EN 50081-1 [1] and EN 50082-1 [2], and other standards, where appropriate.

Transposition dates	
Date of adoption of this ETS:	30 June 1996
Date of latest announcement of this ETS (doa):	30 September 1996
Date of latest publication of new National Standard or endorsement of this ETS (dop/e):	31 March 1997
Date of withdrawal of any conflicting National Standard (dow):	31 March 1997

Blank page

1 Scope

This European Telecommunication Standard (ETS) covers the assessment of radio communication and ancillary equipment in respect of Electro-Magnetic Compatibility (EMC). Technical specifications related to the antenna port and emissions from the enclosure port of radio equipment are found in the related product standards I-ETS 300 131 (1992) [3], and I-ETS 300 131 (1994) second edition [4].

This ETS specifies the minimum performance and the methods of measurements of EMC on second generation Cordless Telephone (CT2) apparatus and ancillary equipment.

This ETS specifies the applicable EMC tests, the limits, and the performance criteria for digital radio equipment as described in I-ETS 300 131 [3] or [4], operating in the frequency range 864,1 to 868,1 MHz, and for the associated ancillary equipment.

The environment classification used in this ETS refers to the environment classification used in the Generic Standards EN 50081-1 [1], EN 50082-1 [2], except the vehicular environment class which refers to ISO 7637 [6].

The EMC requirements have been selected to ensure an adequate level of compatibility for apparatus at residential, commercial, light industrial and vehicular environments. The levels however, do not cover extreme cases which may occur in any location but with a low probability of occurrence.

This ETS may not cover those cases where a potential source of interference which is producing individually repeated transient phenomena, or a continuous phenomena, is permanently present, e.g. a radar or broadcast site in the near vicinity. In such a case it may be necessary to use special protection applied to either the source of interference, or the interfered part, or both.

Compliance of radio equipment to the requirements of this ETS does not signify compliance to any requirement related to the use of the equipment (i.e. licensing requirements).

Compliance to this ETS does not signify compliance to any safety requirements. However, it is the responsibility of the assessor of the equipment that any observation regarding the equipment becoming dangerous or unsafe as a result of the application of the tests of this ETS, should be recorded in the test report.

2 Normative references

This ETS incorporates, by dated or undated reference, provisions from other publications. These normative references are cited at the appropriate places in the text and the publications listed hereafter. For dated references, subsequent amendments to or revisions of any of these publications apply to this ETS only when incorporated in it by amendment or revision. For undated references, the latest edition of the publication referred to applies.

- [1] EN 50081-1 (1992): "Electromagnetic compatibility - Generic emission standard - Part 1: Residential, commercial and light industry".
- [2] EN 50082-1 (1992): "Electromagnetic compatibility - Generic immunity standard - Part 1: Residential, commercial and light industry".
- [3] I-ETS 300 131 (1992): "Radio Equipment and Systems (RES); Common air interface specification to be used for the interworking between cordless telephone apparatus in the frequency band 864.1 MHz to 868.1 MHz, including public access services".
- [4] I-ETS 300 131 (1994): 2nd Edition "Radio Equipment and Systems (RES); Common air interface specification to be used for the interworking between cordless telephone apparatus in the frequency band 864,1 MHz to 868,1 MHz, including public access services".
- [5] I-ETS 300 176: "Radio Equipment and Systems (RES); Digital European Cordless Telecommunications (DECT); Approval test specification".

- [6] ISO 7637 (1990): "Road vehicles - Electrical disturbance by conducting and coupling; Part 1: Passenger cars and light commercial vehicles with nominal 12 V supply voltage"; and "Part 2: Commercial vehicles with nominal 24 V supply voltage - Electrical transient conduction along supply lines only".
- [7] EN 55022 (1994): "Limits and methods of measurement of radio interference characteristics of information technology equipment".
- [8] CISPR Publication No. 16: "Specification for radio disturbance and immunity measuring apparatus and methods"; Part 1: "Radio disturbance and immunity measuring apparatus".
- [9] ENV 50140: "Electromagnetic compatibility - Basic immunity standard - Radiated, radio frequency electromagnetic field; Immunity test".
- [10] EN 60801-2 (1993): "Electromagnetic compatibility for industrial-process measurement and control equipment - Part 2: Electrostatic discharge requirements".
- [11] IEC 801-4 (1988): "Electromagnetic compatibility for industrial process measurement and control equipment; Part 4: Electrical fast transients / burst requirements".
- [12] ENV 50141: "Electromagnetic compatibility - Basic immunity standard - Conducted disturbances induced by radio-frequency fields".
- [13] EN 61000-4-11: "Electromagnetic compatibility (EMC) - Part 4: Testing and measurement techniques - Section 11: Voltage dips, short interruptions and voltage variations immunity tests".
- [14] ENV 50142: "Electromagnetic compatibility - Basic immunity standard - Surge immunity test".

3 Definitions and abbreviations

3.1 Definitions

For the purposes of this ETS, the following definitions apply:

ancillary equipment: Equipment (apparatus), used in connection with a receiver or transceiver is considered as an ancillary equipment (apparatus) if:

- the equipment is intended for use in conjunction with a receiver, or transceiver to provide additional operational and/or control features to the radio equipment (e.g. to extend control to another position or location); and
- the equipment cannot be used on a stand alone basis to provide user functions independently of a receiver or transceiver; and
- the receiver or transceiver to which it is connected, is capable of providing some intended operation such as transmitting and/or receiving without the ancillary equipment (i.e. it is not a sub-unit of the main equipment essential to the main equipment basic functions).

base station equipment: Used to describe CT2 equipment including CFPs (cordless fixed parts) and/or CPPs (cordless portable parts) as defined in I-ETS 300 131 [3] [4] which are powered via an ac power input port or a dc power input port.

CT2 equipment: Apparatus which includes one or more transceivers and/or receivers and/or parts thereof which conform to the requirements of clause 4 of I-ETS 300 131 [3] [4].

host equipment: Any equipment which has a complete user functionality when not connected to the CT2 radio equipment, and to which the CT2 radio equipment provides additional functionality, and to which connection is necessary for the CT2 radio equipment to offer functionality.

integral antenna: An antenna designed to be connected to the equipment without the use of an external connector and considered to be part of the equipment. An integral antenna may be fitted internally or externally to the equipment.

manufacturer: The legal entity responsible for placing the product on the market.

mobile equipment: Used to describe all CT2 equipment powered by a vehicular power supply.

port: A particular interface of the specified equipment (apparatus) with the external electro-magnetic environment.

portable equipment: Used to describe all CT2 equipment powered by an internal battery.

NOTE: More than one of the equipment classifications may apply to certain equipment, as described in subclause 5.2, dependent upon the manufacturer's declaration of normal intended use.

3.2 Abbreviations

For the purposes of this ETS, the following abbreviations apply:

FP	Cordless Fixed Part
CT2	second generation Cordless Telephone
CPP	Cordless Portable Part
EMC	Electro-Magnetic Compatibility
ESD	Electro-Static Discharge
EUT	Equipment Under Test
LISN	Line Impedance Stabilisation Network
RF	Radio Frequency
RMS	Root Mean Square
SPL	Sound Pressure Level

4 General test conditions

4.1 Test conditions

The equipment shall be tested under normal test conditions contained in the relevant product and basic standards or in the information accompanying the equipment, which are within the manufacturer's declared range of humidity, temperature, and supply voltage.

The test conditions shall be recorded in the test report.

The test configuration shall be as close to normal intended use as possible and shall be recorded in the test report.

Whenever the Equipment Under Test (EUT) is provided with a detachable antenna, the EUT shall be tested with the antenna fitted in a manner typical of normal intended use.

For CT2 equipment parts for which connection to a host equipment is necessary to offer functionality the test configuration shall be as defined in subclause 5.4.

4.2 Arrangements for test signals at the input of the transceiver

4.2.1 Speech equipment

Audio input signals may be connected to the EUT either by a non-metallic acoustic tube or, if provided, by electrical connections. The CT2 equipment shall not be modified to provide any electrical connection ports

for the purposes of this test. Suitable test arrangements for the acoustic tube are described in I-ETS 300 176 [5].

4.3 Normal test modulation

The wanted input signal shall have the maximum peak frequency deviation which is specified in I-ETS 300 131 [3] and [4], subclause 4.5.2.

4.4 Connection of test signals for transceivers

4.4.1 Radio Frequency (RF) connection

Where the equipment incorporates an external antenna connector, the wanted signal to establish communications shall be delivered to that connector by a coaxial cable.

The source of the wanted input signal shall be located outside of the test environment.

Where the equipment does not incorporate an external RF connector (integral antenna equipment), the wanted signal to establish communications shall be delivered from the equipment to an antenna located within the test environment.

4.5 Connection of test signals for receiver-only equipment

4.5.1 RF connection

Where the equipment incorporates an external antenna connector, the wanted signal to establish communications shall be presented to that connector by a coaxial cable.

The source of the wanted input signal shall be located outside of the test environment.

Where the equipment does not incorporate an external RF connector (integral antenna equipment), the wanted signal, to establish communications, shall be presented to the equipment from an antenna located within the test environment. Adequate measures shall be taken to protect the measuring equipment from the effect of all the radiated fields within the test environment.

4.6 Receiver test signal level

For tests on receivers and the receiver parts of transceivers the level of the wanted input signal shall be adjusted to approximately 40 dB above the radio receiver sensitivity limit as defined in I-ETS 300 131 [3] and [4].

The source of the wanted input signal shall be located outside of the test environment.

4.7 Narrow band responses on receivers or receivers which are part of transceivers

No immunity tests shall be carried out on frequencies of identified narrow band responses (i.e. spurious responses) of the receiver parts of the CT2 equipment.

A spurious response is defined as a failure of the communications state between a CFP or CPP and its corresponding CPP or CFP due to the introduction of interfering radio signals, at any frequency within a continuous frequency band of width 1 MHz or less at a lower field strength than given as the limiting value in I-ETS 300 131 [3] and [4], subclause 4.6.3.1 at that frequency equal to the centre frequency of this band.

The procedure by which a narrow band response is distinguished from a wide band response is as follows:

- if during testing the communications link is dropped, or there is an increase above the permitted level in the measured value of speech output signal level, the frequency of the unwanted signal shall be recorded and then increased by 1 MHz and the test repeated. Similarly, the frequency of the unwanted signal shall be set to the frequency recorded in the previous test, and then decreased by 1 MHz and the test repeated;

- if the communications link is maintained and the speech output signal of the EUT as measured is within the permitted limit at the two test frequencies described in the previous paragraph, then the response observed at the recorded frequency of the unwanted signal shall be considered a narrow band response and shall not be used in determining the EMC compliance of the EUT;
- if the communications link is dropped or the speech output signal level of the EUT as measured is outside the permitted limits at the two test frequencies, then the test shall be repeated using frequency offsets of plus and minus 1,5 MHz. If at one or both of this second set of test frequencies the communications link is dropped or the speech output signal level as measured is still outside the permitted limits, then the response is considered to be a wide band phenomena and the EUT fails the test.

4.8 Exclusion bands

Frequencies on which the EUT is intended to operate are excluded from immunity tests with either conducted or radiated unwanted RF signals. For the purposes of this ETS these frequencies are referred to as "exclusion bands".

4.8.1 Exclusion band for CT2 receivers and CT2 receiver parts of transceivers

The exclusion band for a receiver or a receiver part of a transceiver shall extend from 820,9 MHz to 911,5 MHz.

4.8.2 Exclusion band for CT2 transmitter parts of transceivers

The exclusion band for the transmitter part of a transceiver shall extend from 820,9 MHz to 911,5 MHz.

NOTE: The product operates on a single frequency in a time-division multiplex mode. For this reason, it is not practical to configure test equipment to use an exclusion band for the transmitter that is narrower than that used for the receiver. As a result, the specified exclusion band for transmitters has been set equal to the exclusion band for receivers.

5 Performance assessment

5.1 General

The manufacturer shall at the time of submission of the equipment for test, declare the following information which shall be recorded in the test report:

- in the case of receive-only equipment, the primary functions of the radio equipment to be tested during and after the EMC testing;
- the intended functions of the EUT which shall be in accordance with the documentation accompanying the equipment;
- the ancillary equipment and/or host equipment to be used with the radio equipment for testing;
- the user-control functions and stored data that are required for normal operation and the method to be used to assess whether these have been lost after EMC stress;
- an exhaustive list of ports, classified as either power or signal/control. Power ports shall further be classified as ac or dc power;
- the edition of the performance standard I-ETS 300 131 [3] or [4] which the EUT is intended to meet;
- the volume setting required to provide nominal operation of the product as defined in I-ETS 300 131 [3] or [4].

5.2 Equipment classification

Portable equipment or combinations of equipment declared as capable of being powered for intended use by the battery in the vehicle shall additionally be considered as vehicular mobile equipment.

Portable or mobile equipment or combinations of equipment declared as capable of being powered for intended use by ac mains shall additionally be considered as base station equipment.

5.3 Ancillary equipment

At the manufacturer's discretion an ancillary equipment may be:

- declared compliant separately from a receiver or transceiver to all the applicable immunity and emission clauses of this ETS;
- declared compliant to another appropriate harmonised EMC standard;
- tested with it connected to a receiver or transceiver, in which case compliance shall be demonstrated to the appropriate clauses of this ETS.

In each case, compliance enables the ancillary equipment to be used with different receivers, transmitters, or transceivers.

5.4 Assessment of host connected equipment and plug-in cards

For CT2 equipment parts for which connection to or integration with a host equipment is necessary in order to offer functionality two alternative approaches are permitted. The manufacturer shall declare which alternative shall be used.

5.4.1 Alternative A: composite equipment

A combination of CT2 radio equipment part and a specific type of host equipment may be used for assessment according to this ETS.

Where more than one such combination is intended, each combination shall be tested separately.

Where a specific combination of host equipment and a CT2 radio equipment part is tested as a composite system for compliance, repeat testing shall not be required for:

- those other combinations of hosts and CT2 radio equipment parts which are based on substantially similar host models in the circumstance that the variations in mechanical and electrical properties between such host models are unlikely to significantly influence the intrinsic immunity and unwanted emissions of the CT2 radio equipment part;
- the CT2 radio equipment part which cannot be used without mechanical, electrical, or software modification in variations of host equipment different from those represented by the units for which compliance to this ETS has been demonstrated.

5.4.2 Alternative B: use of a test jig and three hosts

Where the CT2 radio equipment part is intended for use with a variety of host equipment, the manufacturer shall supply a suitable test jig to enable compliance with this ETS to be assessed.

The test jig shall be designed such that alteration of the CT2 radio equipment part's intrinsic immunity and unwanted emissions is minimised.

Where connection between the CT2 radio equipment part and the host equipment control and/or power ports is by cables, optical fibres, or other similar means, this connection to the host shall be considered as a suitable test jig.

The test jig shall allow the CT2 radio equipment part to be powered and stimulated in a way representative of the way in which it would be powered and stimulated when connected to or inserted into the host equipment.

In addition to tests using the test jig the CT2 radio equipment part shall be tested when connected to or inserted into three different host equipment. These hosts shall be provided by the manufacturer and shall be selected from the list of compatible hosts published by the manufacturer as part of the user documentation supplied with the CT2 radio equipment part.

The selection of hosts shall be by agreement with the Notified Body.

Notified bodies shall have the discretion to require the manufacturer to inform them of each deletion from, or addition to, the list of compatible hosts published in the user documentation.

5.5 Performance assessment test procedure to verify no loss of user control functions or stored data for CT2 transceivers

The test system shall set up a link in the same manner as the EUT's normal intended use.

Any user defined data fields shall be filled in a way representative of normal intended use.

The test procedure shall verify that the CT2 link is maintained and that there is no loss of user control functions declared by the manufacturer or loss of the stored user defined data.

5.6 Performance assessment of audio breakthrough

This test is used to measure the effect of continuous EMC phenomena on the analogue speech circuits of CT2 equipment so fitted.

The test system shall be arranged as shown in figure 1 such that the level of the output signals from the EUT's speech channels can be recorded on suitable test instruments, though not necessarily in each channel simultaneously. For a Cordless Portable Part (CPP) with an acoustic transducer this will require the measurement of Sound Pressure Level (SPL). Pick-up of extraneous back-ground noise by the EUT's speech transducer (microphone) shall be minimised.

Prior to the test sequence, the reference level of the speech output signal shall be recorded on the test instrumentation as shown in figure 2. For a CPP with an acoustic speech transducer this shall be equivalent to 0 dBPa at 1 kHz, applied to the ear reference point in the receive path, and - 5 dBPa at 1 kHz applied to the mouth reference point. For an Cordless Fixed Part (CFP) with analogue speech circuits and other implementations of CT2 equipment with analogue speech circuits, the reference level shall be equivalent to these acoustic signals.

At each test frequency the level of the acoustic output signal relative to the reference level shall be measured.

Where it is necessary to interface to the acoustic transducers of the EUT care shall be taken to ensure that the disturbance to the electro-magnetic field is minimised. The use of a non-metallic acoustic coupler as described in I-ETS 300 176 [5] is recommended.

The precise arrangements shall be recorded in the test report.

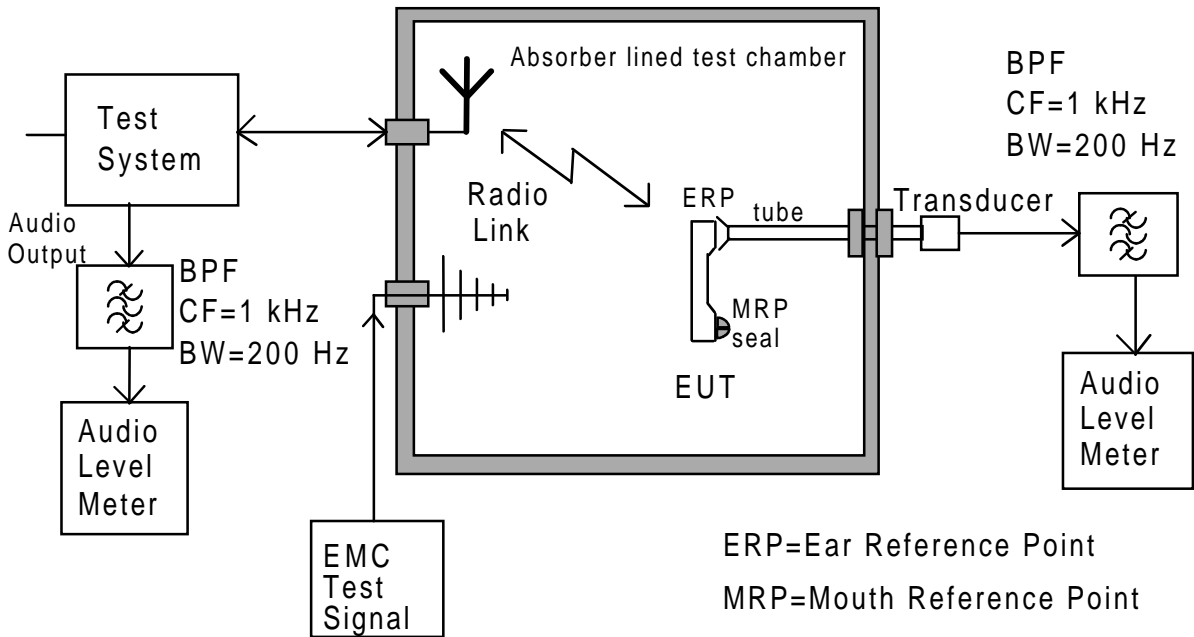
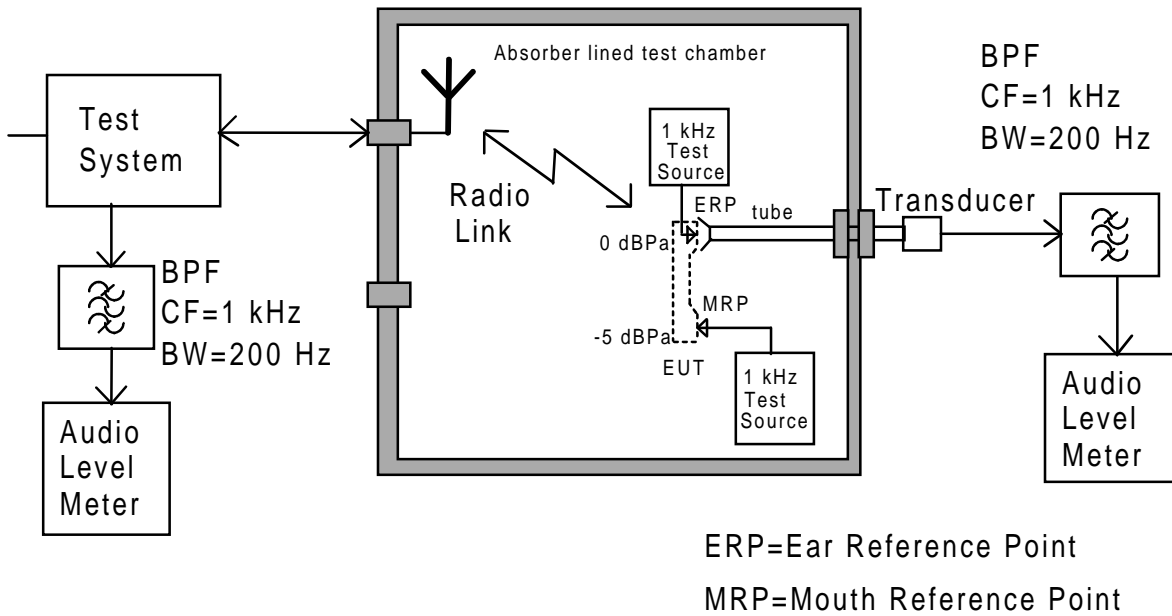

Figure 1: Audio breakthrough measurement, test set-up



NOTE: The EUT is in position during calibration of the uplink, but not during calibration of the downlink.

Figure 2: Audio breakthrough measurement, calibration set-up

6 Performance criteria

The definition of the primary functions to be checked during and after the EMC testing shall be declared by the manufacturer and recorded in the test report.

The equipment shall meet the minimum performance criteria as specified in subclauses 6.1, 6.2, 6.3 and 6.4 and additionally the primary functions as declared by the manufacturer.

Equipment powered by the battery in the vehicle shall also fulfil the applicable requirements set out in this ETS for vehicular mobile equipment.

Equipment powered by ac mains shall also fulfil the applicable requirements set out by this standard for base station equipment, although the input/output arrangements of the equipment and the performance criteria may remain as for the original class, as appropriate.

6.1 Performance criteria for Continuous phenomena applied to CT2 Transceivers (CT)

The communications link shall be maintained during the test sequence.

Additionally for equipment containing analogue speech circuits the speech output signal level shall be at least 35 dB less than the previously recorded reference level, when measured through an audio bandpass filter of width 200 Hz, centred on 1 kHz. This shall be verified by the procedure in subclause 5.6.

At the conclusion of the test, the EUT shall operate as intended with no loss of user control functions or stored data and the communications link shall have been maintained during and after the tests. This shall be verified by the procedure in subclause 5.5.

Where the EUT is capable of transmission, tests shall be performed to ensure that unintentional transmission does not occur.

6.2 Performance criteria for Transient phenomena applied to CT2 Transceivers (TT)

At the conclusion of each exposure the EUT shall operate with no user noticeable loss of the communications link.

At the conclusion of the total test comprising the series of individual exposures the EUT shall operate as intended with no loss of user control functions or stored data, as declared by the manufacturer, and the communications link shall have been maintained. This shall be verified by the procedure in subclause 5.5.

Where the EUT is capable of transmission, tests shall be performed to ensure that unintentional transmission does not occur.

6.3 Performance criteria for Continuous phenomena applied to CT2 Receive-only equipment (CR)

The primary functions shall be verified during each individual exposure in the test sequence.

Additionally for equipment containing analogue speech circuits the speech output signal level shall be at least 35 dB less than the previously recorded reference level, when measured through an audio bandpass filter of width 200 Hz, centred on 1 kHz. This shall be verified by the procedure in subclause 5.6.

At the conclusion of the test, the EUT shall operate as intended with no loss of user control functions or stored data, and the communications link shall have been maintained. This shall be verified by checking the primary functions.

6.4 Performance criteria for Transient phenomena applied to CT2 Receive-only equipment (TR)

At the conclusion of each exposure the EUT shall operate with no user noticeable loss of the communications link.

At the conclusion of the total test comprising the series of individual exposures the EUT shall operate as intended with no loss of user control functions or stored data, as declared by the manufacturer, and the communications link shall have been maintained. This shall be verified by checking the primary functions.

7 Applicability overview tables

Definitions in clause 3 define the terms "base station equipment", "mobile equipment", and "portable equipment" as they apply to this ETS.

7.1 Emission

Table 1: Emission applicability

Application	Equipment test requirement			Reference subclause in this ETS	Reference document
	Base station and ancillary equipment for fixed use	Mobile and ancillary equipment for vehicular use	Portable and ancillary equipment for portable use		
Enclosure	applicable for ancillary equipment not integrated into receivers, or transceivers	applicable for ancillary equipment not integrated into receivers, or transceivers	applicable for ancillary equipment not integrated into receivers, or transceivers	8.2	EN 55022 [7]
DC power in/out	applicable	applicable	not applicable	8.3	EN 55022 [7], CISPR 16-1 [8]
AC mains	applicable	not applicable	not applicable	8.4	EN 55022 [7]

7.2 Immunity

Table 2: Immunity applicability

Phenomena	Application	Equipment test requirement			Reference subclause in this ETS	Reference document
		Base station and ancillary equipment for fixed use	Mobile and ancillary equipment for vehicular use	Portable and ancillary equipment for portable use		
RF electro-magnetic field (80 MHz to 1 000 MHz)	Enclosure	applicable	applicable	applicable	9.2	ENV 50140 [9]
Electrostatic discharge	Enclosure	applicable	applicable	applicable	9.3	EN 60801-2 [10]
Fast transients common mode	Signal and control ports, dc and ac power input ports	applicable	not applicable	not applicable	9.4	IEC 801-4 [11]
RF common mode 0,15 to 80 MHz (current clamp injection)	Signal and control ports, dc and ac power ports	applicable	applicable	not applicable	9.5	ENV 50141 [12]
Transients and surges, vehicular environment	DC power input ports	not applicable	applicable	not applicable	9.6	ISO 7637 Parts 1 and 2 [6]
Voltage dips and interruptions	AC mains power input ports	applicable	not applicable	not applicable	9.7	EN 61000-4-11 [13]
Surges, common and differential mode	AC mains power input ports	applicable	not applicable	not applicable	9.8	ENV 50142 [14]

8 Test methods and limits for emission tests of transceivers and/or receivers and/or ancillary equipment

8.1 Test configuration

This subclause defines the requirements for test configurations described in the following subclauses. The requirements are as follows:

- the measurement shall be made in the operational mode producing the largest emission in the frequency band being investigated consistent with normal applications;
- the equipment shall be configured in a manner which is representative of normal/typical operation, where practical;
- an attempt shall be made to maximise the detected radiated emission, for example by moving the cables of the equipment;
- if the equipment is part of a system, or can be connected to ancillary equipment, then it shall be acceptable to test the equipment while connected to the minimum configuration of ancillary equipment necessary to exercise the ports;
- for CT2 equipment parts for which connection to a host equipment is necessary to offer functionality, the manufacturer shall select which of the alternative performance assessment configurations described in subclause 5.4 shall be used;
- the configuration and mode of operation during measurements shall be precisely noted in the test report;
- if the equipment has a large number of ports, then a sufficient number shall be selected to simulate actual operation conditions and to ensure that all the different types of termination are tested;
- ports which in normal operation are connected, shall be connected to an ancillary equipment or to a representative piece of cable terminated to simulate the impedance of the ancillary equipment. RF input/output ports shall be correctly terminated;
- the tests shall be carried out at a point within the specified operating environmental range and at the rated supply voltage for the equipment.

8.2 Enclosure

This test is applicable for ancillary equipment not integrated into the receiver or transceiver.

This test shall be performed on a representative configuration of the equipment or a representative configuration of the combination of radio and ancillary equipment.

8.2.1 Definition

This test assesses the ability of ancillary equipment to limit any spurious radiation from the enclosure.

8.2.2 Test method

The test method shall be in accordance with EN 55022 [7].

8.2.3 Test limit

The EUT shall meet the Class B limits of EN 55022 [7] shown in table 3 (10 m measuring distance).

Table 3: Limits

Frequency range	Limit (quasi-peak)
30 - 230 MHz	30 dB μ V/m
> 230 - 1 000 MHz	37 dB μ V/m

8.3 DC power input/output port

This test is applicable for base station, mobile, and ancillary equipment which may have dc cables longer than 3 m.

This test shall be performed on a representative configuration of the equipment or a representative configuration of the combination of radio and ancillary equipment.

8.3.1 Definition

This test assesses the ability of receivers, transceivers and ancillary equipment to limit its internal noise from being present on the dc power input/output ports.

8.3.2 Test method

The test method shall be in accordance with EN 55022 [7]. The Line Impedance Stabilisation Network (LISN) specified in EN 55022 [7] shall be used connected to a dc power source.

The equipment shall be installed with a ground plane as defined in EN 55022 [7] subclause 10.3. The reference earth point of the LISNs shall be connected to the reference ground plane with a conductor as short as possible.

The measurement receiver shall be in accordance with the requirements of section one of CISPR Publication No. 16-1 [8].

8.3.3 Test limit

The equipment shall meet the limits below (including the average limit and the quasi-peak limit) when using, respectively, an average detector receiver and a quasi-peak detector receiver and measured in accordance with the method described in subclause 8.3.2. If the average limit is met when using a quasi-peak detector, the equipment shall be deemed to meet both limits and measurement with the average detector receiver is unnecessary.

The EUT shall meet the Class B limits of EN 55022 [7] shown in table 4.

Table 4: Limits

Frequency range	Quasi-peak	Average
0,15 - 0,5 MHz	66 - 56 dB μ V	56 - 46 dB μ V
> 0,5 - 5 MHz	56 dB μ V	46 dB μ V
> 5 - 30 MHz	60 dB μ V	50 dB μ V
NOTE: The limit decreases linearly with the logarithm of frequency in the range 0,15 MHz to 0,50 MHz.		

8.4 AC mains power input/output port

This test is applicable for base station and fixed ancillary equipment.

This test shall be performed on a representative configuration of the equipment or a representative configuration of the combination of radio and ancillary equipment.

8.4.1 Definition

This test assesses the ability of receivers, transceivers and ancillary equipment to limit its internal noise from being present on the ac mains power input/output ports.

8.4.2 Test method

The test method shall be in accordance with EN 55022 [7].

8.4.3 Test limit

The EUT shall meet the Class B limits of EN 55022 [7] shown in table 5.

Table 5: Limits

Frequency range	Quasi-peak	Average
0,15 - 0,5 MHz	66 - 56 dB μ V	56 - 46 dB μ V
> 0,5 - 5 MHz	56 dB μ V	46 dB μ V
> 5 - 30 MHz	60 dB μ V	50 dB μ V
NOTE: The limit decreases linearly with the logarithm of frequency in the range 0,15 MHz to 0,50 MHz.		

9 Test methods and levels for immunity tests of transceivers and/or receivers and/or ancillary equipment

9.1 Test configuration

This subclause defines the requirements for test configurations described in the following subclauses. The requirements are as follows:

- for the immunity tests of receivers, the wanted input signal coupled to the receiver shall be modulated with normal test modulation (subclauses 4.2 and 4.5). Communications shall be established (subclause 4.4);
- if the equipment is part of a system, or can be connected to ancillary equipment, then it shall be acceptable to test the equipment while connected to the minimum configuration of ancillary equipment necessary to exercise the ports;
- for the immunity tests of transceivers, the EUT shall have a radio link set-up with the testing system;
- for the immunity tests of ancillary equipment, without a separate pass/fail criteria, the receiver or transceiver coupled to the ancillary equipment shall be used to judge whether the ancillary equipment passes or fails;
- for CT2 equipment parts for which connection to a host equipment is necessary to offer functionality the manufacturer shall select which of the alternative performance assessment configurations described in subclause 5.4 shall be used;
- the configuration and mode of operation during measurements shall be precisely noted in the test report;
- if the equipment has a large number of ports, then a sufficient number shall be selected to simulate actual operation conditions and to ensure that all the different types of termination are covered;
- ports which in normal operation are connected shall be connected to an ancillary equipment or to a representative piece of cable terminated to simulate the impedance of the ancillary equipment. RF input/output ports shall be correctly terminated;
- the tests shall be carried out at a point within the specified normal operating environmental range and at the rated supply voltage for the equipment.

9.2 Radio frequency electro-magnetic field (80 to 1 000 MHz)

9.2.1 Enclosure

This test is applicable for base station, mobile, portable, and ancillary equipment.

This test shall be performed on a representative configuration of the equipment or a representative configuration of the combination of radio and ancillary equipment.

9.2.1.1 Definition

This test assesses the ability of receivers, transceivers, and ancillary equipment to operate as intended in the presence of a radio frequency electro-magnetic field disturbance.

9.2.1.2 Test method and level

The test method shall be in accordance ENV 50140 [9], except that the following requirements shall apply:

- the test level shall be 3 V/m RMS amplitude modulated to a depth of 80 % by a sinusoidal audio signal of 1 kHz;
- the stepped frequency increments shall be 1 % of the previous frequency;
- the test shall be performed over the frequency range 80 to 1 000 MHz with the exception of an exclusion band for transmitters and receivers, subclause 4.8;
- responses on receivers and receiver parts of transceivers occurring at discrete frequencies which are narrow band responses, shall be disregarded, subclause 4.7;
- the frequencies selected during the test shall be recorded in the test report.

9.2.1.3 Performance criteria

For transceivers the general performance criteria CT (subclause 6.1) shall apply.

For stand alone receivers the general performance criteria CR (subclause 6.3) shall apply.

For ancillary equipment the pass/fail criteria supplied by the manufacturer shall apply, unless the ancillary equipment is tested in connection with receivers or transceivers in which case the corresponding performance criteria above shall apply.

9.3 Electrostatic discharge

This test is applicable for base station, mobile, portable, and ancillary equipment.

This test shall be performed on a representative configuration of the equipment or a representative configuration of the combination of radio and ancillary equipment.

9.3.1 Definition

This test assesses the ability of receivers, transceivers and ancillary equipment to operate as intended in the event of an electrostatic discharge.

9.3.2 Test method and levels

The test method shall be in accordance with EN 60801-2 [10].

The following requirements shall apply:

- the test severity level for Electro-Static Discharge (ESD) contact discharge shall be 4 kV; and for air discharge shall be 8 kV. Refer to the basic standard for all other details, including intermediate test severity levels;

- electrostatic discharges shall be applied to all exposed surfaces of the EUT except where the user documentation specifically indicates a requirement for appropriate protective measures (EN 60801-2 [10] subclause 8.3.1).

9.3.3 Performance criteria

For transceivers the general performance criteria TT (subclause 6.2) shall apply.

For stand alone receivers the general performance criteria TR (subclause 6.4) shall apply.

For ancillary equipment the pass/fail criteria supplied by the manufacturer shall apply, unless the ancillary equipment is tested in connection with receivers or transceivers in which case the corresponding performance criteria above shall apply.

9.4 Fast transients common mode

This test is applicable for base station and fixed ancillary equipment.

This test shall be performed on ac mains power input ports.

This test shall be performed on signal ports, control ports and dc power input/output ports if the cables may be longer than 3 m.

Where this test is not carried out on any ports because the manufacturer declares that it is not intended to be used with cables longer than 3 m, a list of ports which were not tested for this reason shall be included in the test report.

This test shall be performed on a representative configuration of the equipment or a representative configuration of the combination of radio and ancillary equipment or host equipment.

9.4.1 Definition

This test assesses the ability of receivers, transceivers, and ancillary equipment to operate as intended in the event of fast transients present on one of the input/output ports.

9.4.2 Test method and levels

The test method shall be in accordance with IEC 801-4 [11], except that the following requirements shall apply:

For receivers, transceivers and ancillary equipment, which have cables longer than 3 m, or are connected to the ac mains:

- the test level for signal and control ports shall be severity level 2 corresponding to 0,5 kV open circuit voltage as given in clause 5 of IEC 801-4 [11];
- the test level for dc power input/output ports shall be severity level 2 corresponding to 1 kV open circuit voltage as given in clause 5 of IEC 801-4 [11];
- the test level for ac mains power input ports shall be severity level 3 corresponding to 2 kV open circuit voltage as given in clause 5 of IEC 801-4 [11];
- for ac power input and dc power input /output ports the transients shall be applied (in parallel) to all the wires in the cable with reference to the cabinet reference ground, i.e. line-to-ground, (true common mode), with a source impedance of 50 Ω .

9.4.3 Performance criteria

For transceivers the general performance criteria TT (subclause 6.2) shall apply.

For stand alone receivers the general performance criteria TR (subclause 6.4) shall apply.

For ancillary equipment the pass/fail criteria supplied by the manufacturer shall apply, unless the ancillary equipment is tested in connection with receivers or transceivers in which case the corresponding performance criteria shall apply.

9.5 RF common mode, 0,15 MHz to 80 MHz (current clamp injection)

This test is applicable for base station, mobile and ancillary equipment.

This test shall be performed on signal ports including antenna ports, control ports and dc power input/output ports of mobile and ancillary equipment, which may have cables longer than 2 m.

This test shall be performed on signal ports including antenna ports, control ports and dc power and ac mains power input/output ports of base station and fixed ancillary equipment which may have cables longer than 1 m.

Where this test is not carried out on any ports because the manufacturer declares that it is not intended to be used with cables longer than 2 m (mobile and ancillary equipment) or 1 m (base station and fixed ancillary), a list of ports which were not tested shall be included in the test report.

This test shall be performed on a representative configuration of the equipment or a representative configuration of the combination of radio and ancillary equipment or host equipment.

9.5.1 Definition

This test assesses the ability of receivers, transceivers, and ancillary equipment to operate as intended in the presence of a radio frequency electromagnetic disturbance on the input/output ports.

9.5.2 Test method and level

The test method shall be the current clamp injection method in accordance with ENV 50141 [12] except that the following requirements shall apply:

- the test signal shall be amplitude modulated to a depth of 80 % by a sinusoidal audio signal of 1 kHz;
- the stepped frequency increments shall be 50 kHz in the frequency range 150 kHz to 5 MHz and 1 % stepped frequency increments of the momentary frequency in the frequency range 5 MHz to 80 MHz;
- the test level shall be severity level 2 as given in ENV 50141 [12] corresponding to 3 V RMS, at a transfer impedance of 150 Ω ;
- no intrusive or direct connection shall be made to any of the lines of any input/output port, therefore the current clamp injection method shall be used;
- the test shall be performed over the frequency range 150 kHz to 80 MHz;
- responses on receivers and receiver parts of transceivers occurring at discrete frequencies which are narrow band responses, shall be disregarded, subclause 4.6;
- the frequencies selected during the test shall be recorded in the test report.

9.5.3 Performance criteria

For transceivers the general performance criteria CT (subclause 6.1) shall apply.

For stand alone receivers the general performance criteria CR (subclause 6.3) shall apply.

For ancillary equipment the pass/fail criteria supplied by the manufacturer shall apply, unless the ancillary equipment is tested in connection with receivers or transceivers in which case the corresponding performance criteria above shall apply.

9.6 Transients and surges, vehicular environment

These tests are applicable to mobile and ancillary equipment intended for use in a vehicular environment.

These tests shall be performed on 12 V and 24 V dc power input ports of mobile and ancillary equipment, intended for vehicular use.

These tests shall be performed on a representative configuration of the equipment or a representative configuration of the combination of radio and ancillary equipment.

9.6.1 Definition

These tests assess the ability of transmitters, receivers, transceivers and ancillary equipment to operate as intended in the event of transients and surges present on the dc power input ports in a vehicular environment.

9.6.2 Test method and level

The test method shall be in accordance with ISO 7637 Part 1 [6] for 12 V dc powered equipment and ISO 7637 Part 2 [6] for 24 V dc powered equipment.

a) the following requirements shall apply for 12 V dc powered equipment:

1) where the manufacturer in his installation documentation requires the EUT to have a direct connection to the 12 V main vehicle battery the following requirements in accordance with ISO 7637 [6] Part 1 shall apply:

- pulse 3a and 3b, level II, with the test time reduced to 5 min for each;
- pulse 4, level II, 5 pulses, with the characteristics as follows:

$$V_s - 5 \text{ V}, \quad V_a - 2.5 \text{ V}, \quad t_6 - 25 \text{ ms}, \quad t_8 - 5 \text{ s}, \quad t_f - 5 \text{ ms};$$

2) where the manufacturer does not require the EUT to have a direct connection to the 12 V main vehicle battery, the following pulses apply, in addition to the pulses in a) 1):

- pulse 1, level II $t_1 - 2,5 \text{ s},$ 10 pulses;
- pulse 2, level II $t_1 - 2,5 \text{ s},$ 10 pulses;
- pulse 7, level II 5 pulses.

Where the manufacturer declares that the EUT requires a direct connection to the vehicle battery, and therefore the tests in accordance with a) 2) are not carried out, this shall be stated in the test report.

b) the following requirements shall apply for 24 V dc powered equipment:

1) where the manufacturer in his installation documentation requires the EUT to have a direct connection to the 24 V main vehicle battery the following requirements in accordance with ISO 7637 [6] Part 2 shall apply:

- pulse 3a and 3b, level II, with the test time reduced to 5 min for each;
- pulse 4, level II, 5 pulses, with the characteristics as follows:

$$V_s - 10 \text{ V}, \quad V_a - 5,0 \text{ V}, \quad t_6 - 25 \text{ ms}, \quad t_8 - 5 \text{ s}, \quad t_f - 5 \text{ ms};$$

The test for this pulse 4 shall be carried out as specified in ISO 7637 [6] Part 1.

2) where the manufacturer does not require the EUT to have a direct connection to the 24 V main vehicle battery, the following pulses apply, in addition to the pulses in a) 2):

- pulse 1a, level II $t_1 - 2,5 \text{ s},$ $R_i - 25 \Omega,$ 10 pulses;
- pulse 1b, level II $t_1 - 2,5 \text{ s},$ $R_i - 100 \Omega,$ 10 pulses;
- pulse 2, level II $t_1 - 2,5 \text{ s},$ 10 pulses.

Where the manufacturer declares that the EUT requires a direct connection to the vehicle battery, and therefore the tests in accordance with b) 2) are not carried out, this shall be stated in the test report.

For radio and ancillary equipment designed to operate at both dc power voltages both requirements a) and b) shall apply.

For radio equipment designed to operate at 12 V dc power supply, but operating from a 24 V dc power adapter ancillary, then the radio equipment shall comply with the requirements in a) and the configuration of the radio equipment and the power adapter shall comply with the requirements of b).

9.6.3 Performance criteria

For transmitters, pulses 3a and 3b, the performance criteria CT (subclause 6.1) shall apply. For pulses 1, 1a, 1b, 2, 4 and 7 the performance criteria TT (subclause 6.2) shall apply, with the exception that the link need not have been maintained during exposure and may have to be re-established.

For stand alone receivers or receivers which are part of transceivers, pulses 3a and 3b the performance criteria CR (subclause 6.3) shall apply. For pulses 1, 1a, 1b, 2, 4 and 7 the performance criteria TR (subclause 6.4) shall apply, with the exception that the link need not have been maintained during exposure and may have to be re-established.

For ancillary equipment the pass/fail criteria supplied by the manufacturer shall apply, unless the ancillary equipment is tested in connection with receivers, transmitters or transceivers in which case the corresponding performance criteria above shall apply.

9.7 Voltage dips and interruptions

These tests are applicable for base station and fixed ancillary equipment powered by ac mains.

These tests shall be performed on ac mains power input ports.

These test shall be performed on a representative configuration of the equipment or a representative configuration of the combination of radio and ancillary equipment or host equipment.

9.7.1 Definition

These tests assess the ability of receivers, transceivers and ancillary equipment to operate as intended in the event of voltage dips and interruptions present on the ac mains power input ports.

9.7.2 Test method and levels

The following requirements shall apply.

The test method shall be in accordance with EN 61000-4-11 [13].

The test levels shall be:

- a voltage dip corresponding to a reduction of the supply voltage of 30% for 10 ms;
- a voltage dip corresponding to a reduction of the supply voltage of 60% for 100 ms;
- a voltage interruption corresponding to a reduction of the supply voltage of > 95% for 5 000 ms.

9.7.3 Performance criteria

For a voltage dip corresponding to a reduction of the supply voltage of 30% for 10 ms the following performance criteria shall apply:

- for transceivers the performance criteria CT (subclause 6.1);
- for stand alone receivers the performance criteria CR (subclause 6.3);

- for ancillary equipment the pass/fail criteria supplied by the manufacturer shall apply, unless the ancillary equipment is tested in connection with receivers or transceivers in which case the corresponding performance criteria above shall apply.

For a voltage dip corresponding to a reduction of the supply voltage of 60% for 100 ms the following performance criteria shall apply:

- for transceivers the performance criteria TT (subclause 6.2);
- for receivers the performance criteria TR (subclause 6.4);
- for ancillary equipment the pass/fail criteria supplied by the manufacturer shall apply, unless the ancillary equipment is tested in connection with receivers or transceivers in which case the corresponding performance criteria above shall apply.

In addition, when equipment is powered solely from the ac mains supply (without the use of a parallel battery back-up) communications need not have been maintained and may have to be re-established, and volatile user data may have been lost.

In the event of loss of communications and/or user data, this fact shall be recorded in the test report, the product description and the user documentation.

For a voltage interruption corresponding to a reduction of the supply voltage of more than 95% for 5 000 ms the following performance criteria shall apply:

- for equipment fitted with or connected to a battery back-up the performance criteria TT (subclause 6.2) or TR (subclause 6.4) as appropriate;
- for equipment powered solely from the ac mains supply (without the use of a parallel battery back-up) communications need not have been maintained and may have to be re-established, and volatile user data may have been lost.

In the event of loss of communications and/or user data, this fact shall be recorded in the test report, the product description and the user documentation.

9.8 Surges, common and differential mode

These tests are applicable for base station and fixed ancillary equipment.

These tests shall be performed on ac mains power input ports.

These tests shall be performed on a representative configuration of the radio equipment or a representative configuration of the combination of radio and ancillary equipment or host equipment.

9.8.1 Definition

These tests assess the ability of receivers, transceivers and ancillary equipment to operate as intended in the event of surges present on the ac mains power input ports.

9.8.2 Test method and levels

The test method shall be in accordance with ENV 50142 [14].

The following requirements shall apply:

- the test level shall be severity level 2 corresponding to 1 kV open circuit voltage for line-to-ground and severity level 2 corresponding to 0,5 kV open circuit voltage for line-to-line;
- the transients shall be applied (in parallel) to all the wires in the cable with reference to the cabinet reference ground, for line-to-ground tests, i.e. true common mode, with a series resistance of 10 Ω .

9.8.3 Performance criteria

For transceivers the general performance criteria TT (subclause 6.2) shall apply.

For receivers the general performance criteria TR (subclause 6.4) shall apply.

For ancillary equipment the pass/fail criteria supplied by the manufacturer shall apply, unless the ancillary equipment is tested in connection with receivers or transceivers in which case the corresponding performance criteria above shall apply.

History

Document history			
September 1994	Public Enquiry	PE 70: WITHDRAWN	1994-09-05 to 1994-12-30
September 1994	Public Enquiry	PE 71:	1994-09-19 to 1995-01-13
March 1996	Vote	V 100:	1996-03-25 to 1996-05-17
June 1996	First Edition		