



EUROPEAN
TELECOMMUNICATION
STANDARD

DRAFT
pr **ETS 300 450**

September 1994

Source: ETSI TC-BTC

Reference: DE/BTC-02028

ICS: 33.020, 33.040.40

Key words: ONP, leased line

**Business TeleCommunications (BTC);
Ordinary and Special quality voice bandwidth
2-wire analogue leased lines (A2O and A2S)
Terminal equipment interface**

ETSI

European Telecommunications Standards Institute

ETSI Secretariat

Postal address: F-06921 Sophia Antipolis CEDEX - FRANCE

Office address: 650 Route des Lucioles - Sophia Antipolis - Valbonne - FRANCE

X.400: c=fr, a=atlas, p=etsi, s=secretariat - **Internet:** secretariat@etsi.fr

Tel.: +33 92 94 42 00 - Fax: +33 93 65 47 16

Copyright Notification: No part may be reproduced except as authorized by written permission. The copyright and the foregoing restriction extend to reproduction in all media.

© European Telecommunications Standards Institute 1994. All rights reserved.

Contents

Foreword	5
Introduction	5
1 Scope	7
2 Normative references	7
3 Definitions and abbreviations	7
3.1 Definitions	7
3.2 Abbreviations	8
4 Requirements	8
4.1 Physical characteristics	8
4.2 Electrical characteristics	9
4.2.1 Return loss	9
4.2.2 Longitudinal conversion loss	9
4.2.3 Transmission signals	10
4.2.3.1 Equipment depending on variable acoustic input	10
4.2.3.1.1 Sending loudness rating (SLR)	10
4.2.3.2 Equipment with internally generated electrical signals	10
4.2.3.2.1 Maximum mean power	10
4.2.3.2.2 Maximum instantaneous power (peak voltage)	10
4.2.3.2.3 Maximum power in a 10 Hz bandwidth	10
4.2.3.3 Equipment depending on variable electrical input	11
4.2.4 Maximum sending power outside the voice bandwidth (spectral density)	12
4.2.5 Power feeding	13
4.3 Safety	13
4.4 Electro-magnetic compatibility	13
Annex A (normative): Test methods	14
A.1 General	14
A.1.1 Equipment connection	14
A.1.2 Reference impedance	14
A.1.3 Non-reactive termination	15
A.1.4 Measurement frequency	15
A.2 Test methods	15
A.2.1 Electrical characteristics	15
A.2.1.1 Return loss	15
A.2.1.2 Longitudinal conversion loss	16
A.2.1.3 Transmission signals	17
A.2.1.3.1 Equipment depending on variable acoustic input	17
A.2.1.3.1.1 Sending loudness rating	17
A.2.1.3.2 Equipment with internally generated electrical signals	18
A.2.1.3.2.1 Maximum mean power	18
A.2.1.3.2.2 Maximum instantaneous power (peak voltage)	19
A.2.1.3.2.3 Maximum power in a 10 Hz bandwidth	20
A.2.1.4 Maximum sending power outside the voice bandwidth (spectral density)	21
A.2.1.5 Power feeding	22

Annex B (informative): Bibliography 23

History 24

Foreword

This draft European Telecommunication Standard (ETS) has been produced by the Business Telecommunications (BTC) Technical Committee of the European Telecommunications Standards Institute (ETSI), and is now submitted for the Public Enquiry phase of the ETSI standards approval procedure.

This ETS resulted from a mandate from the Commission of the European Community (CEC) to provide harmonized standards for the support of the Directive on Open Network Provision (ONP) of leased lines (92/44/EEC).

There are two other standards directly related to this ETS:

ETS 300 448: "Business Telecommunications (BTC); Ordinary quality voice bandwidth 2-wire analogue leased line (A2O); Connection characteristics and network interface presentation".

ETS 300 449: "Business Telecommunications (BTC); Special quality voice bandwidth 2-wire analogue leased line (A2S); Connection characteristics and network interface presentation".

Proposed transposition dates	
Date of latest announcement of this ETS (doa):	3 months after ETSI publication
Date of latest publication of new National Standard or endorsement of this ETS (dop/e):	6 months after doa
Date of withdrawal of any conflicting National Standard (dow):	6 months after doa

Introduction

This ETS is based on information from CCITT Recommendations and ETSI publications and the relevant documents are quoted where appropriate.

The Council Directive on the application of Open Network Provision to leased lines (92/44/EEC) concerns the harmonization of conditions for open and efficient access to, and use of, the leased lines provided over public telecommunications networks, and the availability throughout the Community (EEC) of a minimum set of leased lines with harmonized technical characteristics.

The consequence of the Directive is that Telecommunications Organizations within the EEC shall make available a set of leased lines within and between points in these countries with specified connection characteristics and specified interfaces.

Two classes of standard will be used for the interfaces of terminal equipment designed for connection to the ONP leased lines. European Telecommunication Standards (ETs), which are voluntary, give the full technical specifications for these interfaces, whereas Technical Basis for Regulations (TBRs) give the essential requirements under the Second Phase Directive (91/263/EEC) for attachment to the leased lines. This standard, which is an ETS, belongs to the first category. The TBR (TBR 15) is a subset of this corresponding ETS.

CCITT Recommendations M.1020 (1988) and M.1040 (1988) are used as the basis for the leased line standards to which this terminal equipment interface relates.

Blank page

1 Scope

This European Telecommunication Standard (ETS) specifies the full physical and electrical characteristics and corresponding test principles for a terminal equipment interface for connection to the network termination points of Open Network Provision (ONP) ordinary quality or special quality voice bandwidth 2-wire analogue leased lines defined by ETS 300 448 and ETS 300 449. This ETS is not written for regulatory purposes.

This ETS is written only to ensure that the interface of the terminal equipment is compatible with the ONP ordinary quality or special quality voice bandwidth 2-wire analogue leased line. It is applicable to all interfaces designed for connection to these leased lines, however in the cases of apparatus that carries a particular service, of complex apparatus and of apparatus in private networks, other ETSs may apply in addition to this ETS.

Customer premises wiring and installation between the terminal equipment and the NTP are outside the scope of this ETS.

2 Normative references

This ETS incorporates by dated and undated reference, provisions from other publications. These normative references are cited at the appropriate places in the text and the publications are listed hereafter. For dated references, subsequent amendments to or revisions of any of these publications apply to this ETS only when incorporated in it by amendment or revision. For undated references the latest edition of the publication referred to applies.

- [1] CCITT Recommendation P.64 (1988): "Determination of sensitivity/ frequency characteristics of local telephone systems to permit calculation of their loudness ratings".
- [2] EN 28877 (1989): "Information processing systems - Interface connector and contact assignments for ISDN basic access interface located at reference points S and T".
- [3] EN 60950 (1992): "Safety of information technology equipment including electrical business equipment".

NOTE: This ETS also contains a number of informative references which have been included to indicate the sources from which material has been derived, hence they do not have an associated normative reference number. Details of these publications are given in Annex B. In some cases the same publication may have been referenced in both a normative and an informative manner.

3 Definitions and abbreviations

3.1 Definitions

For the purposes of this ETS, the following definitions apply:

Leased lines: the telecommunications facilities provided by a public telecommunications network that provide defined transmission characteristics between network termination points and that do not include switching functions that the user can control, (e.g. on-demand switching).

Network Termination Point (NTP): all physical connections and their technical access specifications which form part of the public telecommunications network and are necessary for access to and efficient communication through that public network.

Reference impedance Z_R : is a complex impedance made up of a resistance of 275 Ω in series with a parallel combination of 850 Ω and 150 nF. See also Annex A, subclause A.1.2.

Terminal Equipment (TE): equipment intended to be connected to the public telecommunication network; i.e.:

- a) to be connected directly to the termination of a public telecommunication network; or
- b) to interwork with a public telecommunication network being connected directly or indirectly to the termination of a public telecommunication network,

in order to send, process, or receive information.

Voice bandwidth: the band of frequencies over which the communication of voice signals takes place. For the purpose of this ETS, this is defined to be the range 300 Hz to 3 400 Hz.

3.2 Abbreviations

For the purposes of this ETS, the following abbreviations apply:

<i>a</i>	Return loss
dc	direct current
DTMF	Dual Tone Multi-Frequency
EMC	Electro-Magnetic Compatibility
NTP	Network Termination Point
ONP	Open Network Provision
PABX	Private Automatic Branch eXchange
p_m	Sound pressure at the mouth reference point (used in the calculation of SLR)
rms	root mean square
SLR	Sending Loudness Rating
S_{mj}	Sending sensitivity (used in the calculation of SLR)
S_{mjn}	Sending sensitivity at frequency f_n (used in the calculation of SLR)
TE	Terminal Equipment
TNV	Telecommunications Network Voltage (see EN 60950 [3], subclause 3.4)
W_{sn}	Sending weighting factor (used in the calculation of SLR)
Z_R	Reference impedance
Z_T	Termination impedance

4 Requirements

4.1 Physical characteristics

Requirement: The terminal equipment shall provide an 8-contact plug of the type specified in EN 28877 [2] with contact assignments as specified in table 1. In addition the terminal may provide an alternative method of connection.

Table 1: Contact assignments

Contact number	TE
1	Unused
2	Unused
3	Unused
4 & 5	Pair
6	Unused
7	Unused
8	Unused

NOTE: The alternative connection method is primarily for the purpose of permitting hardwired presentations of the leased line using insulation displacement terminals and wire with solid conductors having diameters in the range 0,4 to 0,6 mm.

Test: There shall be a visual inspection that the plug is of the correct type. The contact assignments are tested indirectly through the tests in Annex A.

4.2 Electrical characteristics

4.2.1 Return loss

Requirement: The return loss of the impedance presented by the terminal equipment interface with respect to the reference impedance, in the frequency range 200 Hz to 4 000 Hz, shall be greater than or equal to 8 dB throughout the range when tested using a stimulus signal at a voltage equivalent to that of a signal power of -9 dBm at 1 020 Hz.

Test: The test shall be conducted according to Annex A, subclause A.2.1.1.

4.2.2 Longitudinal conversion loss

Requirement: The longitudinal conversion loss of the terminal equipment interface shall be greater than or equal to the values given in table 2 and figure 1.

NOTE 1: The longitudinal conversion loss concerns the unwanted signal detected by the terminal equipment when a signal is applied equally to the terminals of the interface.

NOTE 2: The impedance unbalance about earth is expressed as the longitudinal conversion loss.

Longitudinal conversion loss dB

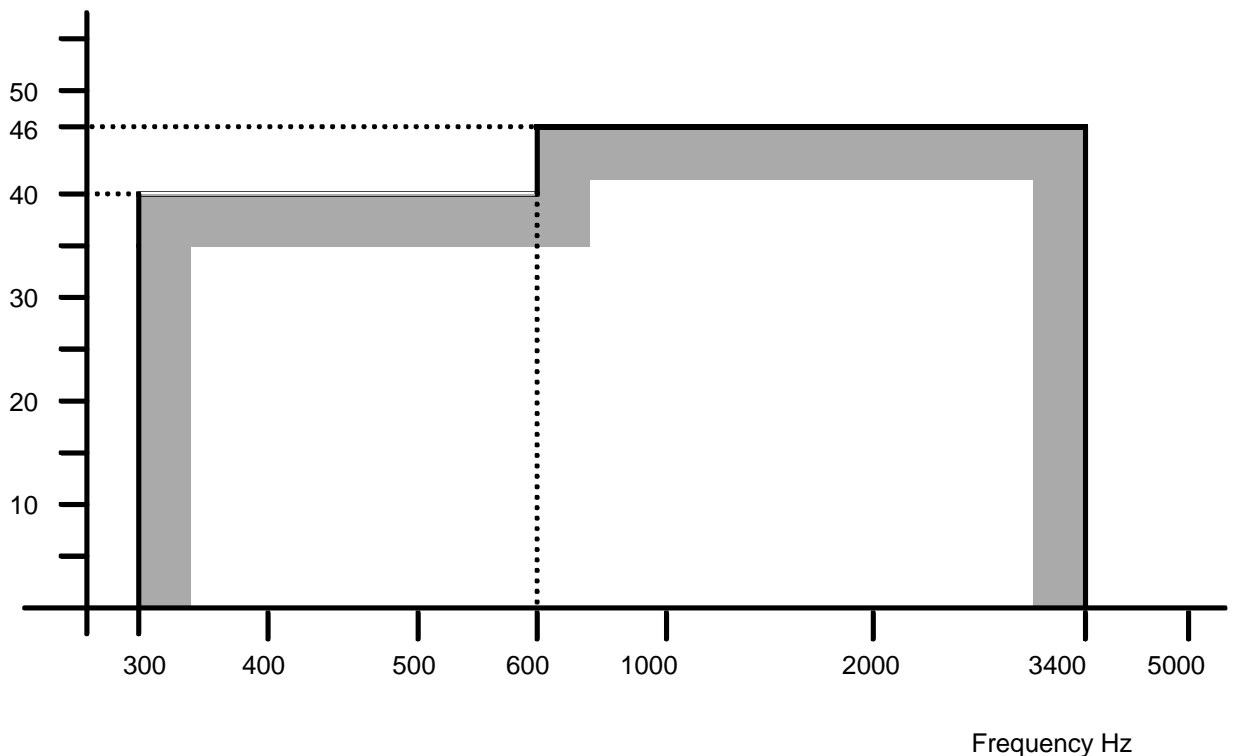

Figure 1: Longitudinal conversion loss, minimum values

Table 2: Longitudinal conversion loss, minimum values

Frequency range	Minimum value
300 Hz to 600 Hz	40 dB
600 Hz to 3 400 Hz	46 dB

Test: The test shall be conducted according to Annex A, subclause A.2.1.2.

4.2.3 Transmission signals

The source and nature of the signal can be classified in several different ways thus dividing the TEs into several, non-exclusive categories. One type of TE may therefore need to be treated as a member of more than one of the categories. For the purposes of this ETS the general categories requiring identification are defined as follows:

- a) any terminal equipment where the output signal is derived from an integral acoustic interface. See subclause 4.2.3.1;
- b) any terminal equipment where the output signal is generated electrically within the terminal equipment. See subclause 4.2.3.2;
- c) any through connecting terminal equipment where the output signal is derived from another electrical interface. See subclause 4.2.3.3.

NOTE: Terminal equipments may belong to more than one category. A telephone may be in both category a) for telephony purposes and category b) for the generation of DTMF tones. A terminal equipment where the output is synthetic or recorded speech or music (e.g. answering machines, electronic mail) is included in category b).

4.2.3.1 Equipment depending on variable acoustic input

4.2.3.1.1 Sending loudness rating (SLR)

Requirement: The minimum SLR of the TE when terminated in 600 Ω shall be greater than or equal to -2 dB.

NOTE: The minimum SLR refers to the actual measured value rather than the nominal value, i.e. there is no tolerance on the specified value.

Test: The test shall be conducted according to Annex A, subclause A.2.1.3.1.1.

4.2.3.2 Equipment with internally generated electrical signals

4.2.3.2.1 Maximum mean power

Requirement: The mean power level in the frequency range 200 Hz to 3 800 Hz in any one minute period shall be not greater than -9 dBm when the terminal equipment interface is terminated with 600 Ω .

Test: The test shall be conducted according to Annex A, subclause A.2.1.3.2.1.

4.2.3.2.2 Maximum instantaneous power (peak voltage)

The maximum instantaneous power is expressed in terms of the peak voltage.

Requirement: The peak voltage from the terminal equipment interface shall not be greater than 2,0 volts over the frequency range 200 Hz to 3 800 Hz when the terminal equipment interface is terminated with 600 Ω .

Test: The test shall be conducted according to Annex A, subclause A.2.1.3.2.2.

4.2.3.2.3 Maximum power in a 10 Hz bandwidth

Requirement: The maximum power within a 10 Hz bandwidth centred at any frequency within the frequency band 0 Hz to 4 300 Hz, and wholly contained within that frequency band, shall not exceed the limits given in table 3 and figure 2 when the terminal equipment interface is terminated with 600 Ω .

Exceptionally when sending DTMF tones, the maximum power in a 10 Hz bandwidth between the frequencies 1 200 Hz and 1 700 Hz shall not exceed -3 dBm.

Table 3: Maximum power in a 10 Hz bandwidth

Points	Frequency range kHz	Maximum sending power dBm
	0,0	-33
A	0,03	-33
B	0,1	-16
C	0,3	-6
D	3,4	-6
E	3,8	-15
F	4,3	-44

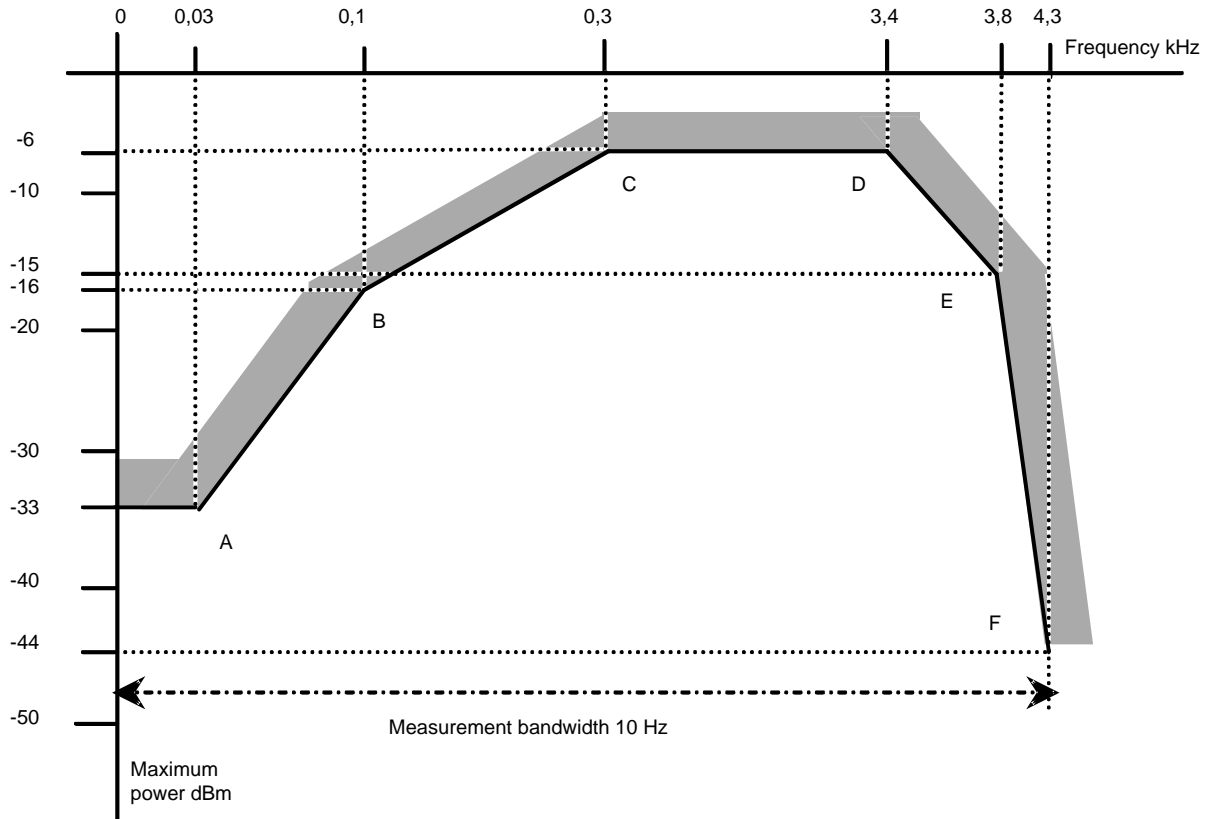

Figure 2: Maximum power in a 10 Hz bandwidth

Test: The test shall be conducted according to Annex A, subclause A.2.1.3.2.3.

4.2.3.3 Equipment depending on variable electrical input

There is no requirement on equipment where the output signal is dependent on a variable electrical input.

NOTE: It is not practical to limit the level of signals that originate from another interface on the terminal equipment and therefore there is no requirement on this category of equipment within this ETS. It is recommended that the equipment supplier should indicate allowed input signal levels at other ports to which through connection is allowed.

4.2.4 Maximum sending power outside the voice bandwidth (spectral density)

This requirement applies to those terminal equipments where the output signal is generated electrically within the terminal equipment or is derived from an electrical signal at another interface. It does not apply to those terminal equipments where the signal is exclusively derived from an integral acoustic interface.

NOTE: Where the output signal can be derived from both an electrical source and an acoustic source (e.g. a telephone with DTMF tone generation) the requirement applies in the case of the electrically generated signal.

Requirement: The power spectral density in a bandwidth defined in table 4 wholly contained within the frequency range 4,3 kHz to 2 MHz, arising from normal operation of the terminal equipment when terminated with 120 Ω , shall not exceed the limits shown in table 4 and figure 3.

Exceptionally, individual signals of a single frequency shall be allowed to have a power level that exceeds the limit but shall not exceed -35 dBm.

NOTE 1: The terminating impedance of 120 Ω is chosen for the outband requirement as this is a better approximation to the impedance seen by the terminal equipment at these frequencies.

NOTE 2: "Normal operation of the terminal equipment" is defined in the test, see Annex A, subclause A.2.1.4.

Table 4: Maximum sending power outside the voice bandwidth (spectral density)

Points	Frequency range	Maximum sending power spectral density relative to 1 mW/Hz	Measurement bandwidth
G to H	4,3 kHz to 5 kHz	-54 dB decreasing to -61 dB	300 Hz
H to I	5 kHz to 7 kHz	-61 dB decreasing to -71 dB	300 Hz
I to J	7 kHz to 100 kHz	-71 dB	1 kHz
J to K	100 kHz to 200 kHz	-71 dB	10 kHz
L to M	200 kHz to 2 000 kHz	-85 dB	10 kHz

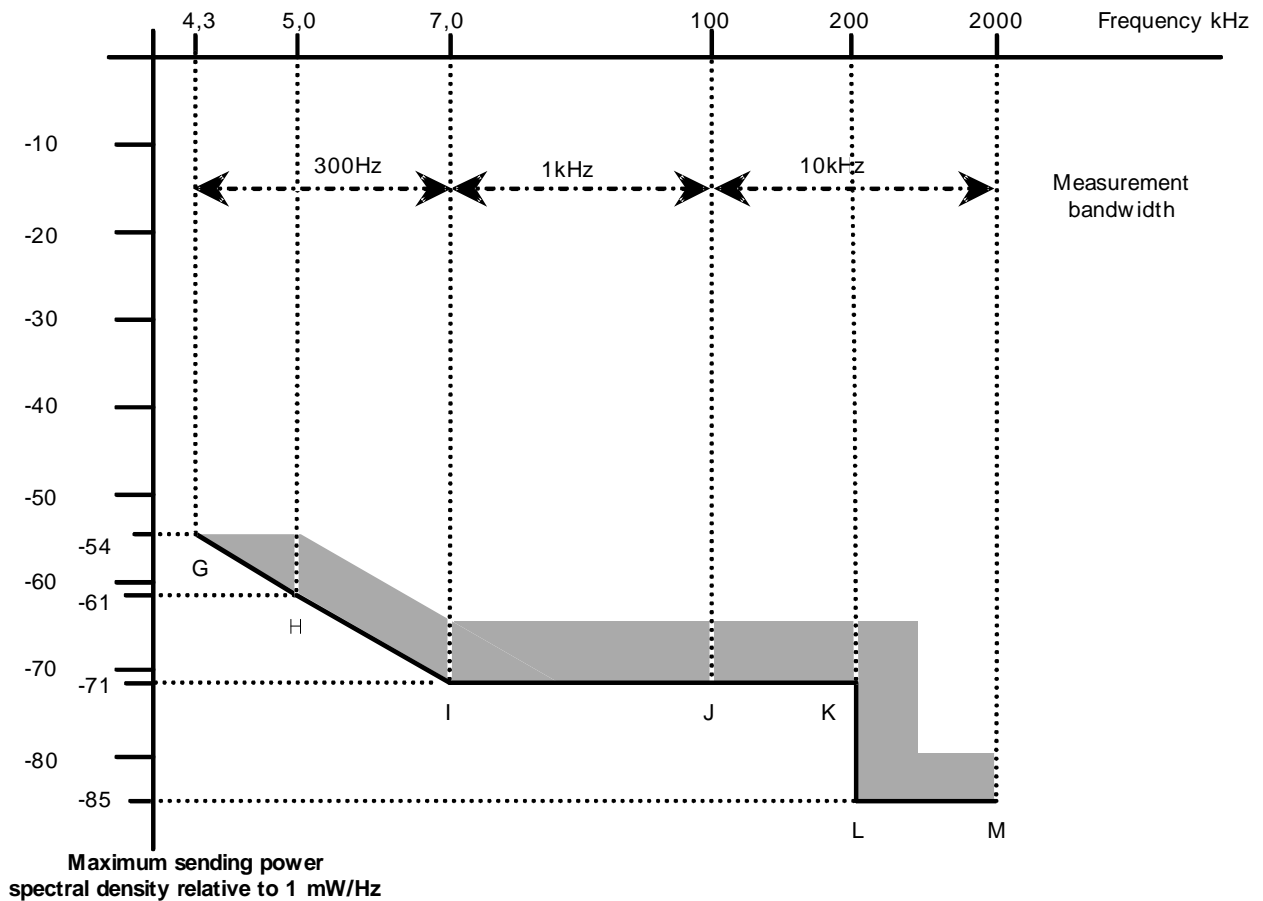

Figure 3: Maximum sending power outside the voice bandwidth (spectral density)

Test: The test shall be conducted according to Annex A, subclause A.2.1.4.

4.2.5 Power feeding

Requirement: The terminal equipment interface shall not be designed to support power feeding capabilities to or from the network interface.

Test: The test for power output to the network interface shall be conducted according to Annex A, subclause A.2.1.5. The test for the requirement not to support power feeding from the network interface is tested indirectly through the various tests of Annex A since no power is supplied over the TE interface from the test equipment.

4.3 Safety

Requirement: The terminal equipment interface shall comply with the requirements for connection to TNV circuits of telecommunications networks given in Clause 6 of EN 60950 [3].

Test: The test shall be conducted according to Clause 6 of EN 60950 [3].

4.4 Electro-magnetic compatibility

There are no EMC requirements under this ETS.

NOTE: General EMC requirements are imposed under the EMC Directive (89/336/EEC). Requirements specific to terminal equipment will be added to this ETS when appropriate specifications become available.

Annex A (normative): Test methods

A.1 General

This annex describes the test principles to be used to determine the compliance of a terminal equipment against the requirements of this ETS.

It is outside the scope of this annex to identify the specific details of the implementation of the tests.

A terminal equipment may be designed for through-connecting and may fulfil the electrical requirements only if through-connected. In these cases the requirements of this ETS are valid and the tests are carried out with the through-connection terminated as specified by the manufacturer.

Details of test equipment accuracy and the specification tolerance of the test devices are not included in all cases. Where such details are provided, they shall be complied with, but the way they are expressed shall not constrain the method of implementing the test.

NOTE: Attention is drawn to the issue of measurement uncertainty which may be addressed in future documents. Not all the required test results make allowance for spurious events during testing (e.g. errors due to EMC effects), which may make it necessary to repeat a test.

The test configurations given do not imply a specific realization of test equipment or test arrangement, or the use of specific test devices for conformance testing. However any test configuration used shall provide those test conditions specified under "interface state", "stimulus" and "monitor" for each individual test.

The test equipment shall be a device, or group of devices, that is capable of generating a stimulus signal conforming to this ETS and capable of monitoring the signal received from the interface.

A.1.1 Equipment connection

The tests shall be applied at the plug for connection to the NTP.

A.1.2 Reference impedance

Where the test defines the use of the reference impedance then this shall be as follows:

Reference impedance Z_R : This is a complex impedance made up of a resistance of 275 Ω in series with a parallel combination of 850 Ω and 150 nF. This is shown in figure A.1. Specific realizations of the reference impedance required for the performance of the tests shall have a return loss against Z_R better than 40 dB over the range 300 Hz to 4 000 Hz.

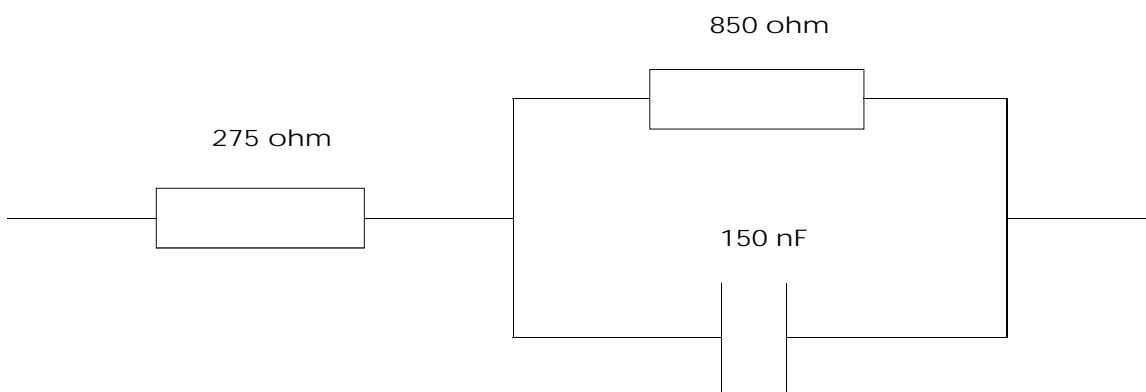

Figure A.1: Reference impedance

A.1.3 Non-reactive termination

Where a termination impedance (Z_T) of 600 Ω is specified, this shall be a non-reactive resistance of 600 $\Omega \pm 0,25 \%$.

Where a termination impedance (Z_T) of 120 Ω is specified, this shall be a non-reactive resistance of 120 $\Omega \pm 0,25 \%$.

A.1.4 Measurement frequency

Many of the requirements specify a test signal frequency of 1 020 Hz. Where this is the case, the specified reference frequency tolerance shall be -7 Hz to +2 Hz (range 1 013 Hz to 1 022 Hz).

A.2 Test methods

One test may cover more than one requirement. The scope of each test is defined under the heading "purpose".

A.2.1 Electrical characteristics

A.2.1.1 Return loss

Requirement: Subclause 4.2.1.

Purpose: To measure the return loss of the input impedance of the terminal equipment with respect to the reference impedance Z_R .

Test configuration: The terminal equipment is connected as shown in figure A.2.

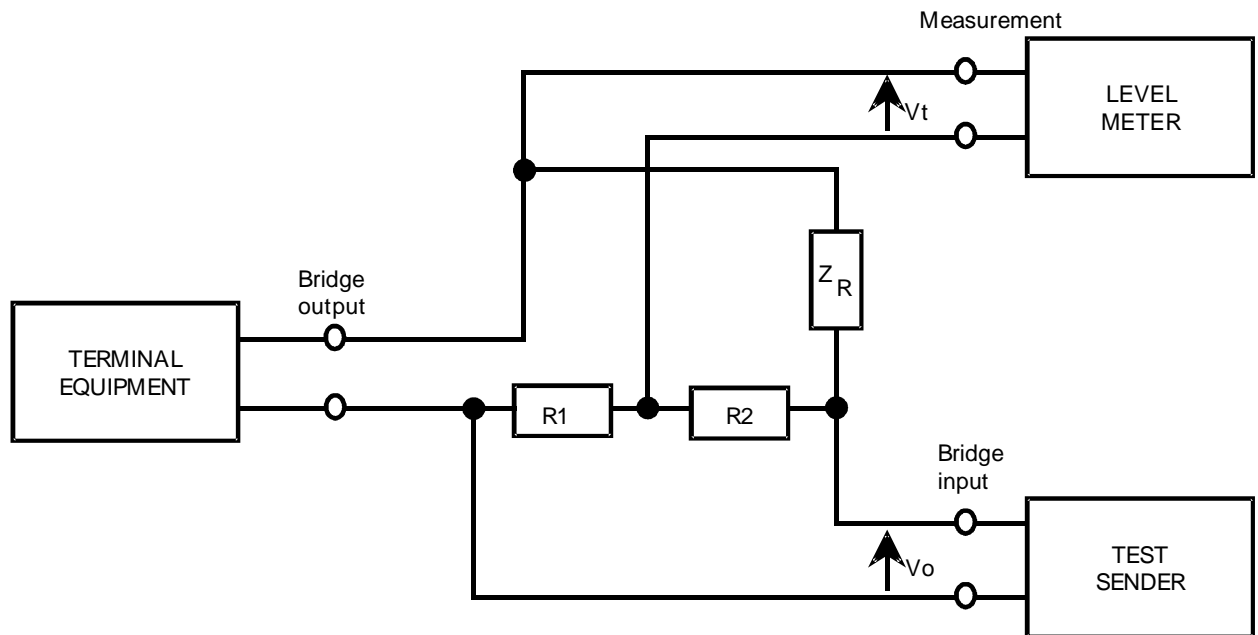

$R1 = R2$; between 100 Ω and 800 Ω , preferably 600 Ω , matched to better than 0,2 %
 Test sender output impedance < 10 Ω
 Level meter input impedance > 1 M Ω

Figure A.2: Return loss measurement

Interface state: Powered.

Stimulus: A sinusoidal signal with a constant voltage is applied to the input of the bridge at various frequencies between 300 Hz and 3 400 Hz. The constant voltage is that required to give a power level of -9 dBm at 1 020 Hz into a reference impedance connected to the output of the bridge. Each measurement frequency shall be spaced by not more than one third of an octave from the next frequency of measurement.

Monitor: The level of voltages V_t and V_o with the terminal equipment output connected to the output of the bridge, as shown in figure A.2. The voltage measurement is conducted using suitable high impedance measuring equipment.

Result: The return loss a shall meet the requirement of subclause 4.2.1 across the frequency range, where:

$$a = 20 \log \left| \frac{V_o}{2V_t} \right| \text{dB}$$

where V_o is the test signal level

and V_t is the level measured across the bridge.

A.2.1.2 Longitudinal conversion loss

Requirement: Subclause 4.2.2.

Purpose: To measure the longitudinal conversion loss.

NOTE: The test is based on the method defined in CCITT Recommendation O.9.

Test configuration: Figure A.3

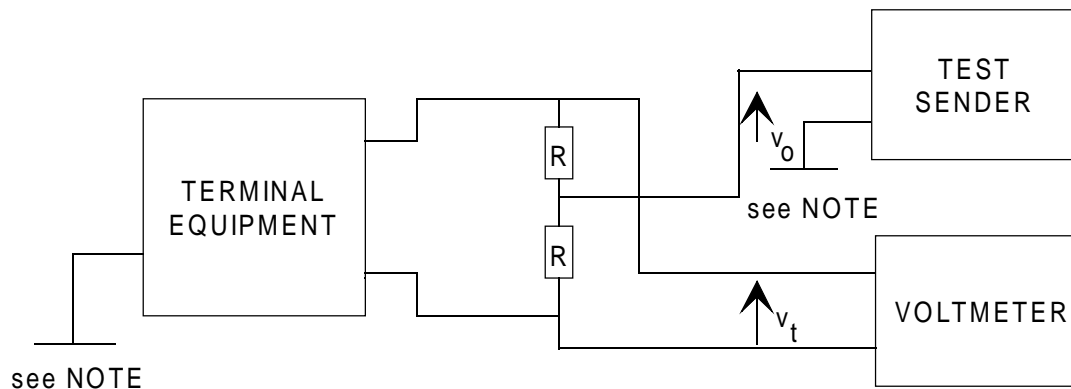

The resistors R shall be $300 \Omega \pm 1 \%$ and matched to better than 0,1 %.

The test sender output impedance is not critical.

The voltmeter input impedance shall be greater than 100 k Ω .

NOTE: This point shall be connected to the terminal equipment common reference point or test reference point. In the absence of such a connection point, this shall be a 1 m square copper plate upon which the terminal equipment shall rest.

Figure A.3: Longitudinal conversion loss

- Interface state: Powered.
- Stimulus: The test sender is swept through the specified frequency range with its output voltage V_o kept constant at 775 mV rms. Measurement of the longitudinal voltages V_t is performed with a suitable frequency selective level measuring instrument.
- Monitor: The maximum value of V_t . This value is used to calculate the minimum value of longitudinal conversion loss from the equation:

$$\text{Longitudinal conversion loss} = 20 \log \left| \frac{V_o}{V_t} \right| \text{dB}$$

- Result: The longitudinal conversion loss in dB shall be greater than or equal to the figures shown in table 2 and figure 1.

A.2.1.3 Transmission signals

A.2.1.3.1 Equipment depending on variable acoustic input

A.2.1.3.1.1 Sending loudness rating

- Requirement: Subclause 4.2.3.1.1.
- Purpose: To check the sending loudness rating of the terminal equipment. The test consists of the performance of a sending sensitivity test at various frequencies and calculating the SLR from the results of the test.
- Test configuration: Figure A.4.

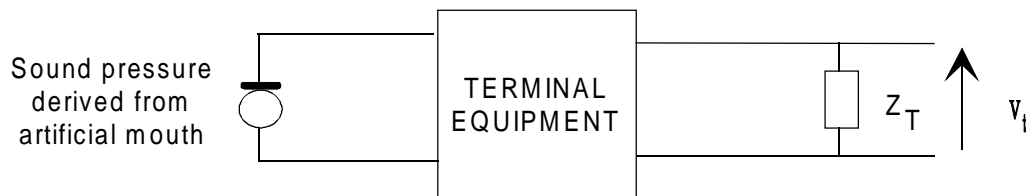

$Z_T =$ Termination impedance 600 Ω

Figure A.4: Measurement of sending sensitivity

- Interface state: Powered.
- Stimulus: An acoustic signal at one of the frequencies shown in table A.1 and at a sound pressure level expressed in dB relative to 1 Pa.
- Monitor: The output voltage V_t measured at the fundamental frequency of the stimulus. The sending sensitivity S_{mj} is determined using the method described in CCITT Recommendation P.64 [1], § 6 and, where carbon microphones are involved, CCITT Recommendation P.64 [1], Annex B.
- Result: The value of the SLR, derived as stated below, shall be in accordance with the requirement of subclause 4.2.3.1.1.

The sending sensitivity S_{mj} at a specified frequency or in a narrow frequency band is expressed as follows:

$$S_{mj} = 20 \log \frac{V_t}{P_m} \text{dB, relative to 1 V/Pa}$$

where V_t is the voltage across the termination

and p_m is the sound pressure at the mouth reference point.

The SLR is derived from the measurements of S_{mj} obtained at the 14 frequencies shown in table A.1, from the formula:

$$SLR = -\frac{10}{0,175} \log \sum_{n=1}^{14} 10^{0,0175(S_{mjn} - W_{sn})}$$

where W_{sn} is the sending weighting factor for frequency f_n , given in table A.1

and S_{mjn} is the measured sending sensitivity at frequency f_n .

Table A.1: Parameters required to calculate SLR

Item n	Frequency f_n Hz	Sending weighting factor W_{sn} dB
1	200	76,9
2	250	62,6
3	315	62,0
4	400	44,7
5	500	53,1
6	630	48,5
7	800	47,6
8	1 000	50,1
9	1 250	59,1
10	1 600	56,7
11	2 000	72,2
12	2 500	72,6
13	3 150	89,2
14	4 000	117,0

NOTE: The values of W_{sn} are taken from CCITT Recommendation P.79 (table 2/P.79) and reduced by 0,3 dB to take into account the reduced measurement bandwidth.

A.2.1.3.2 Equipment with internally generated electrical signals

A.2.1.3.2.1 Maximum mean power

Requirement: Subclause 4.2.3.2.1.

Purpose: To check the maximum mean power from the terminal equipment.

Test configuration: Figure A.5.

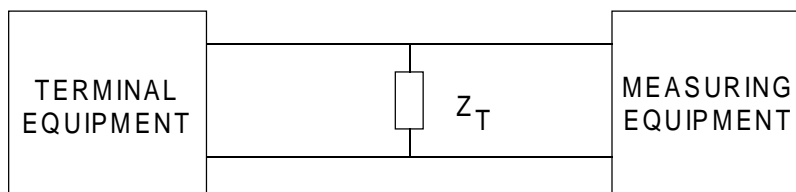

Z_T = terminating impedance 600 Ω
Measuring equipment input impedance > 100 k Ω

Figure A.5: Maximum mean power

- Interface state: Powered.
- Stimulus: Terminal equipment with adjustable output level is set up in accordance with the manufacturer's instructions, or, in the absence of instructions, is set to send at its maximum level. The terminal equipment is then exercised to send to line representative combinations of its declared output capabilities. Such representative samples may be a recording or, in the case of data equipment (e.g. modems), a test message consisting of a representative bit pattern or a scrambled signal.
- Where a terminal equipment is transmitting DTMF tones, there shall be no more than 20 digits in each one minute period, with each digit being less than 500 ms duration and the digits separated by a period greater than 500 ms.
- Monitor: The mean power level integrated over a one minute period.
- Result: The maximum mean power in any one minute period shall not exceed the requirement defined in subclause 4.2.3.2.1.

A.2.1.3.2.2 Maximum instantaneous power (peak voltage)

- Requirement: Subclause 4.2.3.2.2.
- Purpose: To check the maximum instantaneous power, specified in terms of a peak voltage, from the terminal equipment.
- Test configuration: See figure A.6.

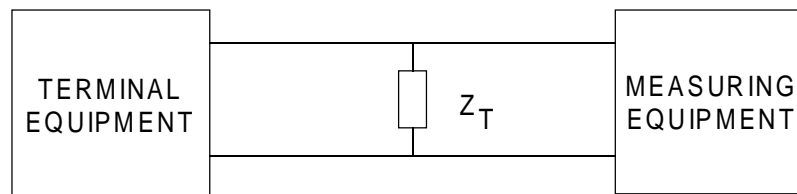

Z_T = terminating impedance 600 Ω
Measuring equipment input impedance > 100 kil Ω

Figure A.6: Maximum instantaneous power

- Interface state: Powered.
- Stimulus: Terminal equipment with adjustable output level is set up in accordance with the manufacturer's instructions, or, in the absence of instructions, is set to send at its maximum level. The terminal equipment is then exercised to send to line representative combinations of its declared output capabilities. Such representative samples may be a recording or, in the case of data equipment (e.g. modems), a test message consisting of a representative bit pattern or a scrambled signal.
- Monitor: The maximum instantaneous voltage level from the terminal equipment, using measuring equipment which has a rise time no greater than 50 μ s and a detection bandwidth from 200 Hz to 3 800 Hz.
- Result: The maximum instantaneous voltage level shall not exceed the requirement defined in subclause 4.2.3.2.2.

A.2.1.3.2.3 Maximum power in a 10 Hz bandwidth

Requirement: Subclause 4.2.3.2.3.
Purpose: To check the maximum power in a 10 Hz bandwidth from the terminal equipment.
Test configuration: See figure A.7.

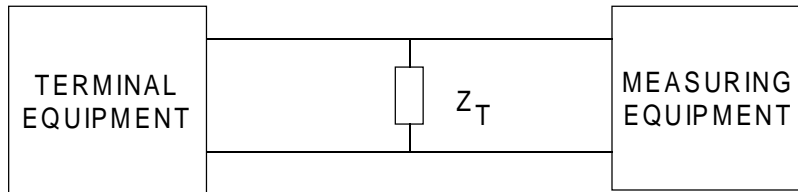

Z_T = terminating impedance 600 Ω
Measuring equipment input impedance > 100 kil Ω

Figure A.7: Maximum power in a 10 Hz bandwidth

Interface state: Powered.

Stimulus: Terminal equipment with adjustable output level is set up in accordance with the manufacturer's instructions, or, in the absence of instructions, is set to send at its maximum level. The terminal equipment is then exercised to send to line representative combinations of its declared output capabilities. Such representative samples may be a recording or, in the case of data equipment (e.g. modems), a test message consisting of a representative bit pattern or a scrambled signal.

Where the terminal equipment is capable of sending DTMF tones, these tones shall be sent continuously where this is supported by the terminal equipment, otherwise DTMF digits shall be sent at the maximum rate allowed.

Monitor: The maximum power from the terminal equipment in a 10 Hz bandwidth.

Result: The maximum power in any 10 Hz bandwidth shall not exceed the requirements stated in table 3 and figure 2 of subclause 4.2.3.2.3. Exceptionally, when testing with DTMF tones, the maximum power in a 10 Hz bandwidth between the frequencies 1 200 Hz and 1 700 Hz shall not exceed -3 dBm.

A.2.1.4 Maximum sending power outside the voice bandwidth (spectral density)

Requirement: Subclause 4.2.4.

Purpose: The test is used to measure the maximum sending power, in terms of the spectral density, outside the voice bandwidth.

Test configuration: Figure A.8.

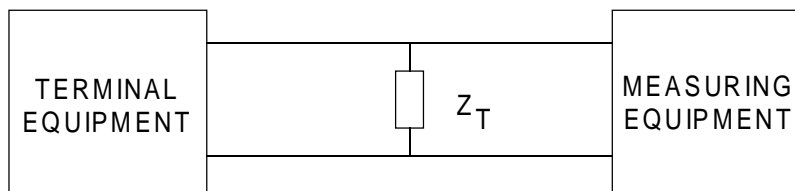

Z_T = terminating impedance 120 Ω
Measuring equipment input impedance > 100 k Ω

Figure A.8: Maximum sending power outside the voice bandwidth (spectral density)

Interface state: Powered.

Stimulus: The nature of the stimulus differs according to the category of the terminal equipment detailed in subclause 4.2.3.

Category b): Equipment depending on internally generated electrical input. Terminal equipment with adjustable output level is set up in accordance with the manufacturer's instructions, or, in the absence of instructions, is set to send at its maximum level. The terminal equipment is then exercised to send to line representative combinations of its declared output capabilities. Such representative samples may be a recording or, in the case of data equipment (e.g. modems), a test message consisting of a representative bit pattern or a scrambled signal.

Category c): Equipment depending on variable electrical input. Where there is a means of adjusting the output level, this shall be set up in accordance with the manufacturer's instructions, or, in the absence of instructions, is set to its maximum level.

Monitor: The power spectral density over the frequency range 4,3 kHz to 2 MHz across the 120 Ω load Z_T and arising from any form of excitation.

The measuring equipment shall use a bandwidth as specified in table A.2 which shall be wholly contained within the specified frequency range.

The power spectral density at each frequency shall be the power measurement obtained when the bandwidth is centred at that frequency, divided by the measurement bandwidth.

Table A.2: Measurement bandwidth for power spectral density outside the voice bandwidth

Frequency range	Measurement bandwidth
4,3 kHz to 7 kHz	300 Hz
7 kHz to 100 kHz	1 kHz
100 kHz to 2 000 kHz	10 kHz

Result: The power spectral density shall not exceed the limits shown in table 4 and figure 3.

NOTE: For category b), equipment depending on internally generated electrical input, the outband power below the voice bandwidth is measured by the test in subclause A.2.1.3.2.3.

A.2.1.5 Power feeding

Requirement: Subclause 4.2.5.

Purpose: To verify that the terminal equipment is not designed for power feeding by measuring the output current from the terminal equipment into an impedance of 300 Ω .

Test configuration: Figure A.9.

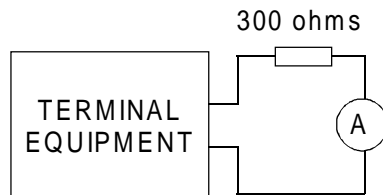

Figure A.9: Power feeding

Interface state: Powered.

Stimulus: None.

Monitor: The current through a resistance of 300 Ω .

Result: The current through 300 Ω shall be less than 1 mA.

Annex B (informative): Bibliography

- 1) 89/336/EEC: "Council Directive of 3 May 1989 on the approximation of the laws of Member states relating to electromagnetic compatibility".
- 2) 91/263/EEC: "Council Directive of 29 April 1991 on the approximation of the laws of Member States concerning telecommunications terminal equipment, including the mutual recognition of their conformity".
- 3) 92/44/EEC: "Council Directive of 5 June 1992 on the application of Open Network Provision to leased lines".
- 4) CCITT Recommendation M.1020 (1988): "Characteristics of special quality international leased circuits with special bandwidth conditioning".
- 5) CCITT Recommendation M.1040 (1988): "Characteristics of ordinary quality international leased circuits".
- 6) CCITT Recommendation O.9 (1988): "Measurement arrangements to assess the degree of unbalance about earth".
- 7) CCITT Recommendation P.79 (1988): "Calculation of loudness ratings".
- 8) prETS 300 448: "Business TeleCommunications (BTC); Ordinary quality voice bandwidth 2-wire analogue leased line (A2O); Connection characteristics and network interface presentation".
- 9) prETS 300 449: "Business TeleCommunications (BTC); Special quality voice bandwidth 2-wire analogue leased line (A2S); Connection characteristics and network interface presentation".
- 10) prTBR 15: "Business TeleCommunications (BTC); Ordinary and special quality voice bandwidth 2-wire analogue leased lines (A2O and A2S); Attachment requirements for terminal equipment interface".

History

Document history	
September 1994	Public Enquiry PE 70: 1994-09-05 to 1994-12-30
October 1995	Converted into Adobe Acrobat Portable Document Format (PDF)